

an "honest"

\$1.00

February 1974

# 73

**magazine**  
for radio amateurs



"I cannot tell a lie . . ."



Your assurance of Performance and Quality



# FTdx401

# B Transceiver



## More For Your Money

### FTdx401

- Built-in AC Power Supply
- Built-in WWV 10 MHz Band
- Built-in Noise Blanker
- 25 and 100 KHz Calibrators
- VOX
- Clarifier
- Break-in CW with Sidetone
- 1 kHz Readout
- Selectable SSB
- 6 Month Warranty by Dealer
- Cooling fan
- AM Position

**\$599.00**

- No charge
- No charge
- No charge
- No charge
- No charge
- No charge
- No charge
- No charge
- No charge
- No charge
- No charge
- No charge
- No charge
- No charge

**Total only \$599.00**

Amateur Price Net  
Price Subject To Change

**Tomorrow's Transceiver Today:** 20 tubes plus 50 silicon semiconductors, passive crystal filter (6 pole), velvet smooth tuning, superb noise blanker, standard electrical parts. This is truly the best buy in the amateur field today. See your local dealer for brochure & demonstration.

**Factory Service is available even after your warranty has expired for the cost of labor and parts.**

### YAESU DEALERS:

**ADIRONDACK RADIO SUPPLY**  
518-842-8350  
185 W. Main St., Amsterdam NY 12010

**AMATEUR ELECTRONIC SUPPLY**  
414-442-4200  
4828 W. Fond du Lac Ave., Milwaukee WI 53216

**AMATEUR ELECTRONIC SUPPLY**  
305-894-3238  
621 Commonwealth Ave., Orlando FL 32803

**FRECK RADIO SUPPLY** 704-254-9551  
38 Biltmore Ave., Asheville NC 28807

**GRAHAM ELECTRONICS** 317-634-8486  
133 S. Pennsylvania St., Indianapolis IN 46204

**HAM RADIO CENTER** 800-325-3636  
8342 Olive Blvd., St. Louis MO 63132

**HAM RADIO OUTLET** 415-342-5757  
999 Howard Ave., Burlingame CA 94010

**HAMTRONICS** 215-357-1400  
4033 Brownsville Rd., Treviso PA 19047

**HARRISON RADIO** 516-293-7990  
20 Smith St., Farmingdale LI NY 11735

**HENRY RADIO** 213-272-0861  
11240 W. Olympic Blvd., Los Angeles CA 90064

**ED JUGE ELECTRONICS** 817-926-5221  
3850 S. Freeway, Fort Worth TX 76110

**RACOM ELECTRONICS** 206-255-6656  
15051 S.E. 128th St., Renton WA 98055

**WEBSTER RADIO** 209-224-5111  
2602 Ashlan, Fresno CA 97326

**WILSON ELECTRONICS** 702-451-6650  
P.O. BOX 116, Pittman NV 89044

**ELECTRONIC EXCHANGE CO.** 508-834-9000  
608 Papworth, Metairie LA 70005

**QUEEN CITY ELETE** 513-931-1577  
1583 McMaken Ave., Cincinnati OH 45231



## YAESU MUSEN USA INC.

7625 E. Rosecrans Avenue, Unit #29  
Paramount, California 90723

Phone 213-633-4007

### FEATURES

#### EDITORIAL STAFF

Wayne Green W2NSD/1  
Ron Subka WA9FPP/1  
Yvette Grimes WA8ULU/1

#### ASSOCIATES

Gus Browning W4BPD  
Tom DiBiase WB8KZD  
Bill Hoisington K1CLL  
Dave Ingram K4TWJ  
Joe Kasser G3ZCZ/W3  
Jon Tara WB8DBN  
Bill Turner WA0ABI

#### PRODUCTION

Ruthmary Davis  
Karen Hebert  
Biff Mahoney  
Peri Mahoney  
Janet Oxley  
Lynn Panciera—Fraser  
Bob Sawyer  
Bill Sundberg

#### BUSINESS

Knud E. M. Keller KV4GG/1

#### CIRCULATION

Barbara Block  
Dorothy Gibson

#### TRANSPORTATION

Walter Pence

#### DRAFTING

T. M. Graham W8FKW  
Bill Morello  
Wayne Peeler K4MVW

- |                         |                                  |
|-------------------------|----------------------------------|
| 2 Never Say Die W2NSD/1 | 10 QSL Contest                   |
| 4 Social Events         | 11 Caveat Emptor                 |
| 4 Hamburglar            | 14 Repeater Atlas Registration   |
| 4 Virginia QSO Party    | 14 Repeater Update               |
| 6 AMSAT News            | 14 Looking West                  |
| 6 Ham Help              | 16 New Products                  |
| 6 Traveling Ham         | 18 DX Footnotes                  |
| 7 Leaky Lines           | 99 Letters                       |
| 8 SSTV Scene            | 100 Circuits, Circuits, Circuits |
| 10 50 MHz Band          | 128 Ad Index                     |
|                         | 128 Propagation                  |

### CONTENTS

- 20 Understanding the Slow Scan Monitor .....K4TWJ  
It's awfully simple . . . really.
- 25 Integrated Circuit Audio Amplifiers .....Kenney  
IC Audio Amplifiers Handbookette.
- 32 A Simple Sweep Generator for Monitor Scopes ..... WA2H NJ  
Very, very simple.
- 34 New Regulations (1938) ..... K2PMM/F8  
A dated article.
- 37 Quick 'n Easy 15 or 20 Meter Vertical .....KH6HDM  
Using el cheapo TV masts.
- 41 Telephone Control and Monitor System .....K1CLL  
Operate your rig by phone.
- 50 Modifications to Heathkit GC-1005 Digital Readout ClockWA0KHV  
You're out of luck if your day has only 23 hrs and 56 mins in it.
- 52 Cook a Better Circuit Board .....WB4MYL  
Don't forget to use a dash of cardamom.
- 54 A Variable Q Audio Filter .....WA4DCN  
For CW.
- 57 Another Blown Fuse Indicator for Low Voltage .....K6HKB/1  
Using an LED.
- 60 Building with Ten-Tec Modules .....WB2WYO  
A 20/40m QRP transmitter using modules.
- 69 Simple Audio Preamp .....W6JDD  
How to increase your intelligibility and live a fuller and more  
useful life.
- 71 An Integrated Circuit SWL Receiver ..... W1GQG  
Hey, here's an easy and fun project!
- 77 432'er Final Assembly, on the Air .....K1CLL  
At last!
- 90 Transistor Keying Circuit ..... K6OLG  
You'll never use relays again.
- 95 Low Cost Seven Segment Readout .....WA2A00  
Interfaced with Nixie driver.

73 Magazine is published monthly by 73, Inc., Peterborough, New Hampshire 03458. Subscription rates are \$7 for one year in North America and U.S. Zip Code areas overseas, \$8 per year elsewhere. Two years, \$12 and \$13 overseas. Three years, \$15, and \$16 overseas. Second class postage paid at Peterborough NH 03458 and at additional mailing offices. Printed at Menasha, Wisconsin 54952 USA. Entire contents copyright 1974 by 73 Inc., Peterborough NH 03458. Phone: 603-924-3873. Microfilm edition of 73 available from University Microfilms, Ann Arbor, MI 48106. Magnetic tapes available from Science for the Blind, 332 Rock Hill Rd., Bala Cynwyd PA 19904.



NEVER SAY DIE

...de W2NSD/I

EDITORIAL BY WAYNE GREEN

## IRS

It took quite a bit to get my attention, but now the IRS has definitely got my attention and, if you're interested, I'll pass along some of the fascinating things that I've been finding out about them. Some of the stories are right out of the Nazi storm trooper notebooks.

In addition to the tales of horror of persecution by the IRS there are the stories of brave people who have been standing up to these tyrants and winning. I didn't realize that thousands upon thousands of people have been in revolt against the income tax... successfully! I'll be looking more and more into this phase and reporting back to you... if you're interested.

I think that all of us are honest enough to agree that we should pay our share of the cost of running our town, our state and our country. I think most of us feel that these things are not being run very efficiently at present and are unhappy over the whole situation. I've read some interesting proposals for alternates to the income tax. There are enough different ideas — some of them very good — on better ways to pay for the services we need so I can sympathize with many of the people who are in revolt against the present system.

Many people are quite angry about continuing tax loopholes which permit people and businesses which you might expect to be helping to pay for the country to run to pay little or no taxes. Did you know that the middle income people pay over 80% of the income taxes? Did you know that 71.4% of the tax income of the government for 1973 came from income and social security taxes — out of your paycheck? Corporation taxes furnish only 16.1% of receipts! There *must* be some better system than this!

## IRS HARRASMENT

One of the "witnesses" in the trumped-up case against 73 Magazine called recently to tell a story of how the IRS needlessly forced him to lose a \$25,000 business deal. Does he have any recourse against the IRS special agent for this lost income? Of course not.

Briefly, this person sold a small item to 73 Magazine several years ago which the special agent decided he would disallow as a business expense.

The purpose of the "witness" was to prove that 73 Magazine did indeed buy the item. 73's counsel offered to stipulate that 73 did indeed purchase the item so that it would be completely unnecessary for the "witness" to testify. The special agent, apparently much more interested in having a host of unneeded witnesses to impress a jury and to carry out the Taxpayer Compliance Program refused to accept the stipulation or to let the witness leave the country to make his business deal. This shows the callous disregard for the taxpayers that this special agent has.

Whether the item in question should have been disallowed or not is not relevant to this witness and his personal loss. It was just a small thing that was used for decoration of the 73 Magazine waiting room and it was sold when the room was redecorated... sold for the same price that was paid for it.

## BEWARE OF TAX REFUNDS

One of the things that can flag an IRS audit is a substantial tax refund. Since there is virtually no way to go through an audit without it costing you money, it should be obvious that an audit is to be avoided like a swim in the rapids of the Colorado River.

This is an interesting piece of news for people who understate their dependents on their withholding as a form of enforced savings. Then they claim the right number of dependents at tax time and get the difference in withholding tax. They also stand a big chance of an audit which will lose them everything they saved and more.

Just how much does the IRS take away from you as a result of an audit? The *average* for 1973 on taxpayer audits was \$796 each! Perhaps you can see why an audit is to be avoided if at all possible. Add to that \$800 your cost in lost time at work and the wear and tear on your ulcers.

The IRS can't audit all returns, of course, so they pick out about two million to get the works. If your number comes up you are in for a big headache. About \$800 worth, on the average. Of course the chances are that you are a little above average in income, so you'll get hit even harder. The average amateur should assay out to about \$926.

How do you win the golden ante award? Assuming that you are not singled out by the administration to be screwed, or by a vindictive governor, or by a business competitor with political pull, and you're not a journalist who needs the fear of God put in him, or a judge or other person against whom the IRS has a vendetta, then all you have to worry about is not having the big IRS computer light up tilt when your form is processed.

The computer is programmed to balk when certain standards of deductions are exceeded. If you overdo on medical expenses, for instance, you're up for an audit. It makes no difference that your expenses were completely legitimate. The computer only knows that you deducted more than was set as "reasonable" by the IRS. The IRS figures of what is reasonable are very closely guarded for if they were known the taxpayers could take the limit of reasonable deductions and save a whole lot of money.

Once your return has been rejected by the computer you stand a good chance of being in for an audit and a nice big bill. Worse than that, once you've been hit for an extra payment, you are a pidgeon and you can expect to have them looking to you for continued big profits in the future. These are called "subsequent audits" and are a goldmine for the IRS. In the last few months of 1972 the IRS picked up an average of almost \$4000 each from 13 thousand people in this group.

They also do a rousing business with this group in going over their back returns and figure that this yields about \$5000 per man hour spent on that.

Obviously it is extremely important not to have your return light up tilt.

One more statistic for you...in 1973 the people who asked for substantial refunds ended up paying an average additional tax of \$234! That's right, not only didn't they get their expected refund, they had to shell out a bundle.

How can such a thing be, you are asking? Very simple, your revenue agent knows all the tricks with the tax returns and you don't. He not only makes this sort of extortion his business...and his progress within the IRS depends to a large degree on how much he brings in...the rules he goes by are unavailable to you...they're secret. All else failing, he can blithely disallow any deductions he wants, and what are you going to do about it? If you don't pay, he can come to your house and take your car, your son's car, your watch, etc., and put them up for public auction. You may even find yourself ridiculed in the newspapers in an ad for the sale of your confiscated

property as one California chap did.

Don't make waves if you don't want trouble with the IRS.

On the other hand, there is a growing number of people who are intentionally making waves...and with some success...revolting against the IRS.

### TAX REVOLT

The people who have been leading the way toward a revolt against the IRS and the whole tax system have worked out some interesting ways of doing things. I'm not sure how well they are getting away with it, but the claims are that no one has yet gone to prison that has done it just right.

One of the basics seems to be a matter of crossing out the perjury statement on the tax return. If you stop and think about it, there should be a Miranda warning right there above that perjury statement for it is truly said that you are signing a ticket to jail when you sign the tax form. You already know that no two IRS agents filling out the same tax form come up with the same results. Several newspapers have exposed this in tests, much to the embarrassment of the IRS. You also know that the IRS can put almost anyone they want in jail for fraud on the basis of their tax returns, no matter how honest they were.

When you sign that return you are guaranteeing that it is accurate and complete and there is no possible way for you to know that...so you are lying when you sign it and you are immediately up for grabs, if they want you.

The tax revolt people cross out the perjury statement on the return, thereby making the job of the IRS extremely difficult if not impossible when it comes to prosecuting them, if it ever comes to that.

Another group has been trying to make headway via the route of pointing out that it is unconstitutional for the IRS, which is part of the executive branch of the government, to confiscate property without going through the judicial branch of the government...with no court order, etc. The fact that the protesters appear to be clearly right has not yet enabled them to win. Chalk up one more to the incredible power of the IRS...even the United States Constitution has not been able to stop them.

One of the major problems with regard to tax revolt is that it depends entirely upon little people and they don't have the resources to put up much of a fight. The big corporations like the present system...after all, they don't have to pay much in taxes, so why should they rock the boat? The big load is on the middle income

taxpayer and the small businessman, the ones that can't afford to fight.

### IRS & YOU?

If you've had any QRM from the IRS you might send along some details...we'll keep your name confidential. The best way to get this bunch of pirates to shape up is to put the spotlight on them and expose their methods. Let's back them down.

### MORE?

The more research I do the more horrified I am at the callous lengths some IRS agents have gone in harrasing people who were unable to buck their raw power. If you'd like to here more about this and the ways people are fighting back, just give me some encouragement.

### MIDEAST TENSIONS

As long as the mideast is as tense as it is, even though it is entirely safe to visit Jordan, it seems likely that many amateurs will want to wait for things to cool down in the neighboring countries. Thus, reluctantly, it has been decided to delay our ham tour to Jordan until fall, hoping that some solutions to the problems will have been found by that time.

During the war between Israel, Egypt and Syria there was little disturbance in Jordan. Amateur radio continued without interruption, as did everything else. There was some nervousness because of the nearness of the conflict, of course. It is interesting that the border between Israel and Jordan remained open throughout the war.

And, lest you forget what a fantastic experience you will have visiting Jordan, here is a photo of Martha Blackburn, the wife of Blackie JY9BB, with Lin (my wife), eating at the beautiful and clean restaurant at Karak with the head of the boy's club and Hisham JY5HA.



We have some late news from Amman...it seems that the repeater I brought over in June and helped set up has been popular and a second repeater is being installed. Quite a few hand transceivers have been purchased, so activity will be increasing there.

Hisham writes that a new class for beginning hams will be starting in January and a large number of youngsters are already signed up...so look for more and more active hams in Jordan.

Several U.S. amateurs have already packed up some unused gear and sent it along to the embassy in Washington to be forwarded to the clubs in Jordan. If you have any good equipment that you want to offer to some kids that will very much appreciate it, this is a good route to go. The address is: Embassy of Jordan, 2319 Wyoming Ave., N.W., Washington DC. Let's get these great kids some rigs, some receivers, and parts for building and experimenting.

### NON-HAM SCM ELECTED!

A note from a reader out in Nevada brings fascinating news of the ARRL and its election of Leonard Norman as SCM. Norman is the chap who runs the yearly Saroc ripoff.

The FCC called up Norman, who had a Conditional license, for re-exam in July 1972 and he failed *both* the General and Technician exams. Though ARRL HQ knew Norman had failed both license tests they still ran him for SCM in the September election, where he beat out W7SJR by only 17 votes.

When word of Norman losing his license got to the local League membership, Norman was finally forced to resign. Norman appointed his buddy K7ZOK at SCM, thus finessing W7SJR out of the job.

This is all fact, backed up by letters from Walker testifying that Norman had failed the exams, and from Huntoon saying he knew that Norman had failed, but that since Norman had not yet surrendered his license to the FCC, he was still eligible to run for SCM.

### FCC LIMITATIONS

A letter from a reader out in Arizona told about how he had gone to a lot of trouble to direction find and smoke out quite a bunch of illegal CBers (are there any legal ones left?) and turned their names, addresses, psuedonyms and car license plate numbers over to the FCC. He suggested that other concerned amateurs do likewise.

From New Mexico another reader wrote to tell us that the amateurs there had also become concerned with interference to radio communications on the sheriff's frequencies. This consisted of jamming, profane language and attempts to misguide or confuse officers. When it was proposed to the FCC inspector, he told them they were spinning their wheels, and even if

(Continued on page 12)



### IN-ARC

The LaPorte IN, Amateur Radio Club will hold its annual Swapfest-Auction on February 10, 1974, inside the LaPorte Civic Auditorium, beginning at 10AM; auction beginning at 1 PM. Talk-in will be on .94 Simplex and 22/82. For further information contact: Alan Rutz WA9GKA, R.R.2, P. O. Box 410, LaPorte IN 46350.

### INTERCITY AUCTION

The Intercity Radio Club annual auction will be held Friday February 1, at the Naval Reserve Training Center on Ashland Road. Doors open at 6 PM. Look, swap, buy at 7:30 PM. No flea fees or commission charged. Auction at 8 PM Eats. Donation of \$1 at the door. For more information write K8JPF, 120 Homewood, Mansfield OH 44906.

### CUYAHOGA FALLS AUCTION

The Cuyahoga Falls Radio Club proudly announces the annual Cuyahoga Falls Radio Club Auction to be held Friday, February 22, at the United Electronics Institute Building, 1225 Oplen Ave., Cuyahoga Falls OH. Hours are 7 PM to 11 PM. Flyers bearing more details are available from Tom Carroll WA8ZGL, Cuyahoga Falls Radio Club, P. O. Box 106, Cuyahoga Falls OH 44222.

### TOLEDO AUCTION

On Saturday, March 9, 1974, the Toledo Mobile Radio Association will hold its 19th annual amateur radio auction at the Lucas County Recreation Center in Maumee OH. For more information contact: Barry C. Leeper, 1811 Wellsley Dr., Toledo OH 43606.

### FOREST VIEW FEST

The Forest View ARC Hamfest will be held on Sunday, February 3, at Forest View High School, 2121 Goebert Road, Arlington Heights, Des Plaines IL, from 8 AM to 5 PM. Features include free parking, all indoor facilities, food and refreshment stand, manufacturer's display and a brand new Drake TR-22 for a door prize. Bring gear to swap, sell or auction. Talk-in on .94. Advance registration \$1.50 or \$2.00 at the door. For advance reservations or more information write to Tony Mazzeffi WB9GEC, 490 Easy St., Des Plaines IL 60016.

### WHEATON SWAP & SHOP

The Wheaton Community Radio Amateurs (WCRA) will hold their 12th Annual Midwinter Swap and Shop on Sunday, February 10, at the DuPage County Fairgrounds Wheaton IL. Hours are 8 AM to 5 PM. Tickets \$1.50 advance; \$2.00 at the door. Two buildings again this year and unlimited parking. Bring your own tables. Free coffee and donuts 9:00 - 9:30 AM. For more information and advance tickets contact: L. O. Shaw W9OKE, 433 S. Villa Ave., Villa Park IL 60181. Advance ticket orders must be postmarked no later than February 3, 1974.

### SOUTHERN TIER FEST

The 15th Annual Hamfest sponsored by the Southern Tier Amateur Radio Club, is scheduled for 2:00 PM, March 30, 1974, at St. John's Ukrainian Hall, Johnson City NY. Admission to lectures and flea market is free; awards and excellent dinner, \$6.00. For tickets or further information write to STARC, P.O. Box 11, Endicott NY 13760. Advance ticket sales only by March 27, 1974.

### PLAYGROUND SWAPFEST

The Playground Amateur Radio Club of Fort Walton Beach FL, announces the Fourth Annual North Florida Swapfest to be held on March 31, 1974, from 3 AM to 5 PM at the Community Center located on U.S. Highway 98 in the downtown Beach area. Tickets and details are available from the P.A.R.C., P. O. Box 873, Fort Walton Beach FL 32548.

### WOODWARD SWAPFEST

The Great Plains Amateur Radio Club of Woodward OK, is happy to announce its second annual Woodward Hamfest-Swapfest will be held on March 30-31, 1974. The event will be held at the Woodward County Fairbuilding in Woodward. For more information contact: Tyler L. Todd WA5YQP, Hamfest Promotion Chairman, P. O. Box 893, Woodward OK 73801.

### MIDWINTER SWAP

The Tri-County ARC Midwinter Swapfest is March 10, 9 AM to 5 PM, at the National Guard Armory, White-water WI. \$1 advance, \$1.50 at the door (additional \$1 reserves one display table). Advance tickets eligible for special prize. Talk-in on .94. Refreshments, free parking, everything indoors. For tickets and details contact: Dan Servais WA9AJW, Rt. 4, P.O. Box 309AA, Elkhorn WI 53121. Tel. 414-723-2227, SASE.



### The Hamburglar STRIKES AGAIN!

List from Past Issues: Mfr., Model, Ser. No.	Owner	Issue
AF68 No. 10888	K5LKL	1/73
PMR8 No. 10918		
M1070 pwr supply		
Trio TR2200 No. 241969	WA2ZBV	1/73
Clegg 22er No. 1900-578	WIDHP	2/73
Standard 826M, No. 112007	WA8PCG	3/73
FM27B No. 27013-1141	W2LNI	4/73
FM-144-10L No. F459	WA6WOA	4/73
NPC 107m pwr supply		
2, 5AJ-IPL Onan Gen., No. 327885		
R4B No. 11578G	WA8GVK	6/73
T4XB No. 17801 G		
W4 wattmeter No. 8390		
Swan 250 No. F154806		
Swan ac pwr. sup. No. 0653556		
HR-2 No. 04-C2879	W6GSR	6/73
SB-34 No. 211828		
STD 826 No. 011268	WA2FSD	6/73
HT220 No. GJ7327	State Univ. of NY (Albany)	6/73
Yaesu FT-101 No. 82G12279/CW	W4GF	7/73
HR-2 No. 0302030		
Clegg 27B No. 72013-1068	W3BXL	7/73
Std. 826MA No. 208078	WB2DEW	7/73
Drake ML-2 No. 10582	W3MSN	8/73
Tektronics 453 Scope	WB2FZU	8/73
Sonar FR-2528 No. 21-4250	Doherty	12/73
Std. src-851-SH No. 9725		
Std. src-707C No. 2833		
TPL PA-6-IDE No. 1092		
RP MEA-22 No. 212		
Two Larsen antennas		
Swan 270 No. M-252616	W4NTB	12/73
Std. src-146A No. 208070	W7DKB	12/73
Marker Luxury No. 2296	W7BVP/6	2/74

### VIRGINIA QSO PARTY



The Virginia QSO Party, sponsored by the Sterling Park Amateur Radio Club, will be held from 1800 GMT March 9, to 0200 GMT March 11, 1974. For further information contact: Don Wiles W4IML, 9801 Lomond Dr., Manassas, Virginia 22110.

# ANATOMY OF A GREAT 2-METER RADIO

sr-c 826MA

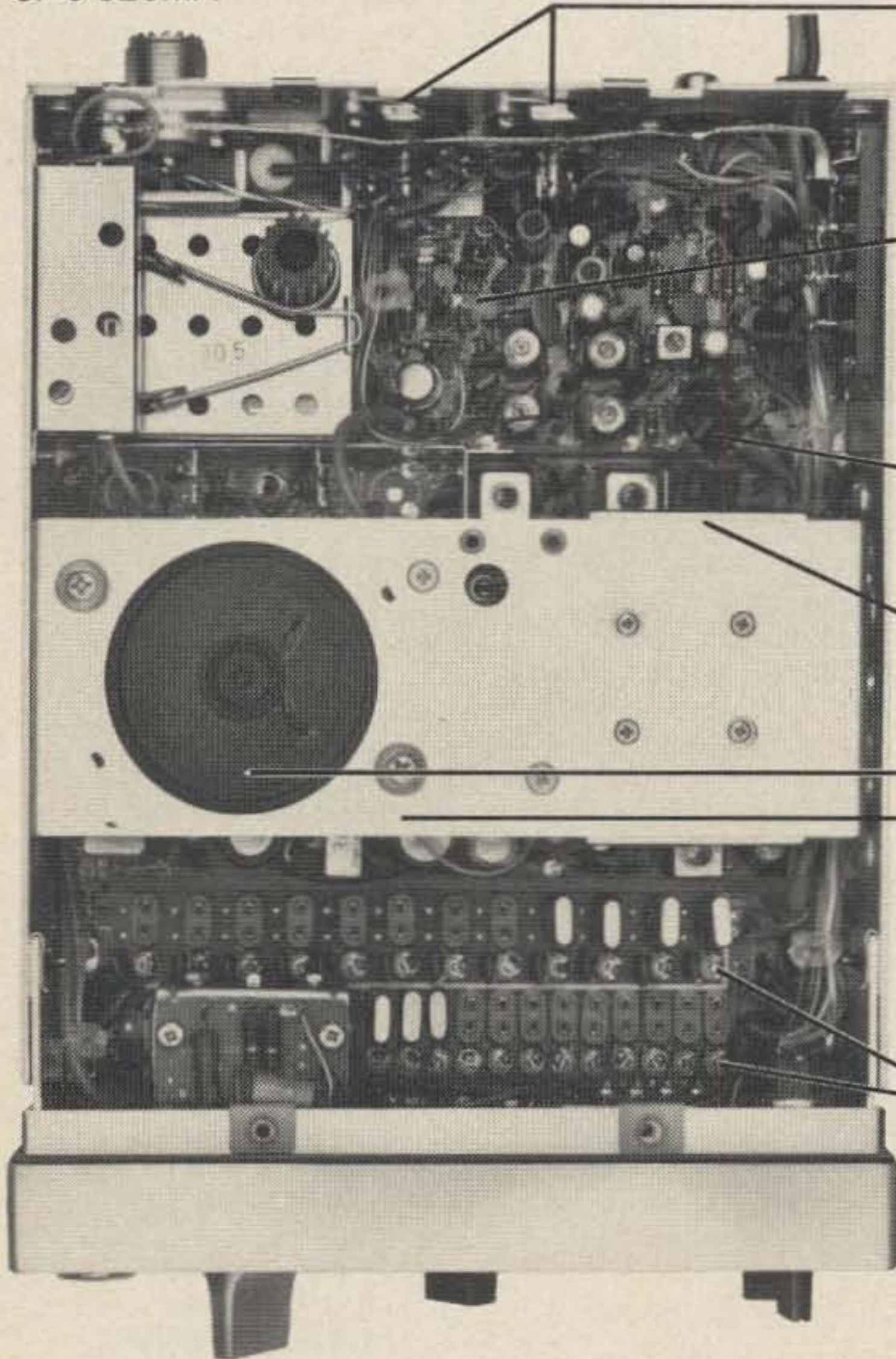

Rear panel test jacks for complete Tx and Rx metering and discriminator output for crystal netting; Input for external tone burst and Touchtone®; Provision for external speaker.

Conservative 10 Watt transmitter with an effective IDC circuit to maintain narrow band deviation ( $\pm 5$ KHz) for today's repeaters; Automatic current Control and final protection against high VSWR.

Provision for front panel selectable "Private Channel" tone coded squelch (CTCSS) on both receive and transmit.

Triple tuned receiver "Helical Resonators" for maximum intermodulation interference rejection.

Built-in speaker.

The heart of a quality radio—a commercial grade receiver featuring Front-end MOS-FETS and a highly selective 9 section ceramic I.F. filter—necessary for today's active 2 Meter band; Reserve audio for noisy environments.

Individual "Netting" capacitors on both Tx and Rx crystals; 12 channel provision with popular channels 94/94, 34/94, 16/76 and 52/52 included; Easy access to crystal deck through "snap-open" trap door.

Touchtone®—trademark of A.T.&T. Co.

## ASTROPOINT = TOTAL PERFORMANCE

STANDARD's "ASTROPOINT" system gives the no compromise performance for the active amateur, unlike the claims made by the "cheapies." Don't be misled by gimmicks or gadgets—it's what's inside that counts. Reliable, solid state circuitry and Glass-Epoxy

PC boards used throughout, backed by our 6 month warranty. **INSIST ON TOTAL PERFORMANCE—INSIST ON STANDARD.**

The 826MA comes complete with microphone, mounting brackets, 4 channels and line filter.

*For detailed information on the 826MA, the complete Standard line and the name of your nearest dealer write:*

 **Standard  
Communications**

213/835-3134 • 639 North Marine Avenue, Wilmington, California 90744

# AMSAT NEWS

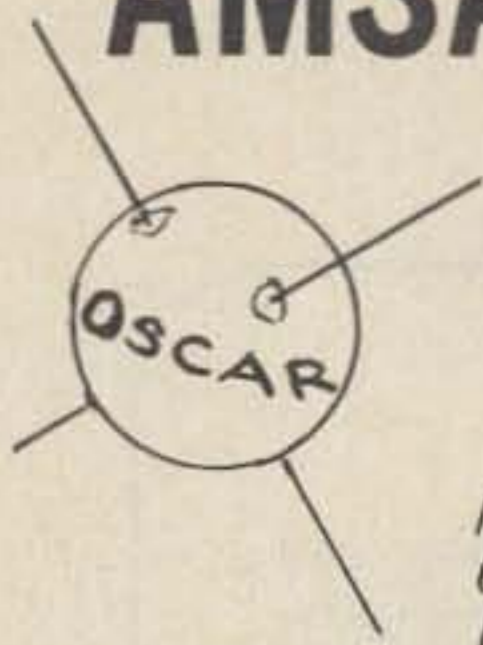

Mike Frye WB8LBP  
640 Dauville Dr.  
Dayton OH 45429

## AMSAT Expands OSCAR 6 Operating Schedule

AMSAT has announced a change in OSCAR 6's operating schedule, effective December 1 the new schedule is: Thursdays, Saturdays, Mondays (GMT days) — Satellite repeater ON for communications during south-to-north passes only (same as present). These ascending node passes occur in the late afternoon and evenings. Tuesdays, Fridays, Sundays (GMT days) — Beginning Dec. 2, the repeater will be ON during north-to-south (local morning) passes, primarily for use in educational demonstrations.

Telemetry data will continue to be taken on the reference orbits, i.e., about 5–15 minutes after the first equatorial crossing of each Greenwich day.

AMSAT is expecting greatly increasing temperatures during the next four months, and this new operating schedule is intended to prevent the battery from overcharging and overheating during this critical period.

## ORBITAL INFORMATION

Orbit	Date (Feb.)	Time (GMT)	Longitude of Eq. Crossing °W
5927	1	0002.4	48.3
5940	2	0057.3	62.0
5953	3	0152.2	75.8
5965	4	0052.2	75.8
5978	5	0147.1	74.5
5990	6	0047.0	59.5
6003	7	0142.0	73.2
6015	8	0041.9	58.2
6028	9	0136.8	71.9
6040	10	0036.8	56.9
6053	11	0131.7	70.6
6065	12	0031.6	55.6
6078	13	0126.6	69.3
6090	14	0026.5	54.3
6103	15	0121.4	68.1
6115	16	0021.4	53.0
6128	17	0116.3	66.8
6140	18	0016.2	51.8
6153	19	0111.2	65.5
6165	20	0011.1	50.5
6178	21	0106.0	64.2
6190	22	0006.0	64.2
6203	23	0100.9	62.9
6215	24	0000.8	47.9
6228	25	0055.7	61.6
6241	26	0150.7	75.4
6253	27	0050.6	60.4
6266	28	0145.5	74.1

This month I am including a summary of the AMSAT-OSCAR 6 Users List, as a commemorative to the 1816 amateurs in 74 countries who made successful QSO's through OSCAR 6 during the first year of its operation. This list indicates the high interest and dedication of amateurs throughout the world who have worked long and hard in achieving their goal.

Total USA: 737 (40%)  
Total Outside USA: 1079 (60%)  
Total Countries: 74  
Total Stations: 1816 -- 1025 confirmed

Ranking of AMSAT-OSCAR 6 Users by Country on a Per-Amateur Capita Basis (As of Oct. 15, 1973).

Rank	Country	Total Amateurs	OSCAR 6 Users	Percentage of hams using OSCAR 6
1	New Zealand	4,641	70	1.5%
2	Australia	6,461	85	1.3%
3	Finland	2,000	23	1.15%
4	France	7,500	81	1.1%
5	Sweden	4,400	44	1.0%
6	Czechoslovakia	2,070	20	0.97%
7	W. Germany	20,380	168	0.82%
8	England	16,837	113	0.67%
9	Japan	14,576	90	0.61%
10	Canada	12,892	57	0.44%
11	Italy	6,000	24	0.4%
12	USA	282,850	737	0.26%
13	USSR	15,085	30	0.20%
14	Argentina	17,500	22	0.13%

Total: 1564  
(86% of all OSCAR users)

...WB8LBP

# HAM HELP

This column is for those needing help in obtaining their amateur radio license.

If you are interested, send 73 your name, address and phone number. Don't be bashful — remember, it's always easier when you have someone to give you that added bit of confidence.

73 would appreciate amateurs and clubs looking this list over and helping whoever they can. Do you remember when you needed help?

Ardeth Lawson  
1317 Scoville Ave.,  
Pomona, California  
91767

Davy Rinker  
10961 S.W. 121st St.  
Miami FL 33156  
251-6503

Allen Reed  
808 Oliver St.  
Gastonia NC 18052  
867-6532

Eric Williams  
410 Woodland Dr.  
Santa Cruz CA 95066  
408-353-3142

Thomas G. Valosin  
RD 1, Warrior Way  
Middleburgh NY 12122  
518-827-4800

Rodney Patches  
R.D. 1, Box 78  
Lebanon PA 17042  
717-949-6552



Joe Kasser  
1701 East-West Highway, Apt. 205  
Silver Spring MD 20910

This month we shall take a look at 2m FM activity along a narrow strip of road between Washington and Cleveland OH. Leaving Washington and driving up I-70s the 31/91 and 28/88 Washington area repeaters are easily workable. A few miles up the road the 13/73 machine on a mountain in Frederick MD is available. It has an extremely wide range. The next repeater is the 34/94 machine in Hagerstown. Now up to



the Pennsylvania Turnpike and along it to Pittsburgh. Stay on 94 or 52. Although snatches of activity can be heard on 76, there does not appear to be anything within range. There is activity on 94 both from passersby and from the locals. Also you never know, you may be warned of backups well ahead of time and be able to get off the restricted access highway in time.

Pittsburgh has repeaters on 19/79, 28/88 and 37/97. The majority of the users on the 37/97 machine are the KDKA gang. And a friendly crowd they were when I worked them as I passed through the area last Thanksgiving weekend. The city repeaters are a bit spotty along the turnpike, but can be readily worked for quite some distance.

A little further along the 25/85 repeater at Beaver Valley comes into range. It has its best coverage between exits 3 and 4 in the big city area and is located near exit 2. Crossing the border into Ohio the 31/91 Youngstown machine is heard at good strength as it is a new one on 37/97. When I passed through they were testing it, running about 3 watts at a low site (one of the QTH's of one of the group's members). It was workable for a good 30 miles. Just wait until they get that thing up in the air!

Cleveland has three repeaters. The 16/76 machine is PL or tone controlled to avoid QRM from Detroit MI. The 28/88 and 34/94 repeaters are open to anyone.

2m FM seems to be great for driving vacations or trips of any kind. Most operators are very friendly to strangers and willing to pass out helpful and useful information to travelers. Some will even call up your friends or relatives on the landline and inform them that you have arrived in town and that you can be expected shortly. They will even dial up the autopatch for you if the repeater is so equipped.

However, driving through the rush hour to work in your home town and listening to the repeater is another story. In many places it is impossible to get a word in edgeways. What's the matter, more repeaters? At one time one Detroit group figured out that the number of users on their repeater was such that everyone was entitled to ten minutes a day and anyone exceeding his allotment was gently reminded of that fact by the other users. After a while the repeater began to remain idle with everybody listening rather than transmitting and QSO's between two stations were kept short. Perhaps that sort of time division usage may come into vogue.

What is the coverage of your local repeater like? I'd very much like to

hear from *you* so that I can pass on the information to any prospective visitors to your area. After all spring is on its way, and in spring a young man's fancy is supposed to turn to...

G3ZCZ

---

## LEAKY LINES

*David Mann K2AGZ  
Daniel Lane  
Kinnelon NH 07405*

It need not even be stated, but almost every single amateur is aghast at the prospect of the unwarranted proposal to grant a significant portion of one of our VHF bands to a group of idlers and dilettantes who have demonstrated little or no qualification for its stewardship. This group, (with some exceptions, of course, but not many), has demonstrated over and over again that it is unfit to be entrusted with so precious a resource. Their record of lawlessness and irresponsibility is a glaring matter of public knowledge. It is perhaps regrettable that the few responsible and conscientious individuals among them must bear the onus and stigma brought about by the iniquities and misdeeds of the many. But the plain truth is that the 11 meter band which they have been occupying for some fifteen years, and which was taken away from amateurs in a similar way (and for similar reasons as those now cited), is as rife with lawlessness as a dark street in any crime-infested city slum.

The violators far outnumber the law-abiding users, at least so far as their noticeable presence on the air is concerned, and there is little reason to suppose that a mere transposition to another band would cause any significant change, either in attitude of contempt toward regulations, or in excessively poor operating practices.

The sole worthwhile accomplishment of this change would be the elimination of the skip condition which contributes greatly to the most persistent violation category. But this would cut off only one opportunity to flout the regulations which govern the Citizens Band. There would still remain many areas open for continued infractions, and there is virtually no justification to imagine that they would stop their misbehavior. There would still be antenna-height infractions, use of unauthorized VFOs (should crystal

control operation be continued), illegal use of linear amplifiers in open defiance of power limitations, outrageous disregard of identification requirements and procedures, total flouting of prescribed standards of decency in content and context of communications, and many other perfectly obvious violations which are now so widespread in CB operations. Any idea that these evils would automatically vanish with this frequency change, would be unrealistic indeed.

The most glaring problem lies in the apparent inability of the FCC to police the presently allocated Citizens Band, due to a lack of funding and a shortage of adequate manpower to do the job. Unquestionably, there is good reason to think that there is as much (or more) dire need of stiff enforcement on this band than on almost any other slice of FCC administered spectrum space. In fact, the problem of repeater violations on CB has become exacerbated in direct proportion to the CBer's growing awareness that the Commission is either unable or unwilling to deal with them as severely as the regulations call for. What, we'd like to know, makes the FCC think that when this bedlam shifts over to 220, it's going to get better?

How, just for a frinstance, could the Commission employ sanctions or penalties against those numberless stations which are being operated without any licenses at all? There have been various estimates concerning this, and apparently it runs into astronomical proportions. CB licenses cost a great deal of money, and if they can operate clandestinely, why should the Commission expect them to comply with the law? This is especially true in cases where illicit use is the rule...people using identifying names like Pussy cat, the Swamp Rat, the Rambling Redskin, Alligator Pete, and Sam the Man? They may be forced to stop their DXing due to the forced change to a ground wave band, but they will find some other way to operate illegally, for that is apparently the way they get their "jollies." The move to 220 will not foster any appreciable improvement.

If an amateur operator, through repeated violations, is deemed by the FCC to be an incorrigible case, he is summarily deprived of his ticket, perhaps fined, and may even face imprisonment. There is a record on file of his identity and his whereabouts. Also, he is required to know and understand the regulations, for there is a body of questions relating to this subject matter in the exam which he is required to pass in order to obtain his

*(Continued on page 97)*

# SSTV SCENE

Dave Ingram K4TWJ  
Rte. 11, Box 499, Eastwood Vil. 50N  
Birmingham AL 35210

One of the biggest innovations in SSTV, the Direct Slow to Fast Scan Digital converter, is slowly but surely approaching reality and 1974 may be the year for it. Although this is a many year project, it is growing in a number of steps, which has accelerated its development, and there is a possibility that a prototype may be displayed at Dayton this April.

Basically the conversion process consists of reading a digitalized copy of the complete Slow Scan TV video frame into computer memory ICs, and then playing back the picture at a high speed into a regular TV receiver. Memory capacity requirements for this unit are large, (between 100,000 and 200,000 bits) and previous memory cost of 1 or 2 cents per bit have made this unit too expensive for the average ham (\$2000). Recently, however, these chips have begun to show up on the surplus market as "seconds" at approximately 5/100 cents per bit, thus lowering memory cost to between \$35 and \$50. Adding to this the support ICs and additional parts gives an approximate overall cost of \$200. The scan converter will work something like this: The first 8 second SSTV picture will load the memory unit, then during the second 8 second period this will read out at Fast Scan rates into a regular big, bright TV. A frame hold switch can be used for continually reading a picture out of the memory while the transmitting station describes that particular picture. Succeeding phases of the scan converter will include image enhancement (averaging out the noise component by integrating the incoming video with the video already received and stored), color SSTV (color frames loaded sequentially into memory, then played back all at once into the home color TV set) plus some other "stunts." Those present working on the converter include W0LMB, W9NTP and W6MXV. Our thanks to W0LMD for the previous information.

The "joint" Worldwide Slow Scan contest is coming up on the 9th and 10th of this month (see following rules for specific details) and activity promises to be good. The contest is scheduled a little earlier this year to avoid conflict with other major contests. Further, the U.S. is exempt from video only contacts, *however* a Slow Scan picture containing the call sign, report and QSO number must be exchanged. Audio only contacts do

not count. Since these rules were published, it has come to our attention that a few other countries also require identification of SSTV transmission on audio (Australia is a good example). Although I have not yet cleared this with Professor Fanti, I'm sure those countries will also be exempt from the SSTV only clause. (Obviously we don't want anyone getting citations!) Remember I will be tallying U.S. logs and sending the scores on to Franco, so that we (73 Magazine) can issue certificates to the top U.S.A. contenders. My deadline is March 10, so I will have time to mail the results on to Franco, whose deadline is the 20th. I wish you all the best of luck in the contest, and would like to hear your comments and opinions when you send in your logs, along with any pictures you might lend for use in this column. Watch for these "results and comments" in a few months!

Another weather satellite was placed into sun synchronous orbit during November, and was due to begin operation by mid-January. The satellite is termed NOAA-3 and is capable of Automatic Picture Transmission, thus hopefully replacing the dying NOAA-2 satellite. I understand it will use the same frequencies as NOAA-2. More information on this as it becomes available.

## RULES

The Italian Magazine CQ Elettronica and 73 Magazine takes pleasure in announcing the 4th Worldwide Slow Scan Television Contest. The purpose of this Contest is to promote increased interest in the SSTV mode of operation as used by Radio Amateurs.

### 1) PERIOD OF CONTEST

Part 1: 1500-2200 GMT on February 9th, 1974.

Part 2: 0700-1400 GMT on February 10th, 1974.

### 2) BANDS

All authorized frequencies within the 3.5-7.0-14.0-21.0 and 28.0 MHz bands.

### 3) MESSAGES

Messages will consist of: Exchange of pictures and also included are a) the call sign: b) report (RST): 3) serial number.

The serial number must start at 001 and is increased by one for each successive contact during the period of the Contest and the serial number is irrespective of the Band(s) used.

Exchange must be made exclusively with the SSTV mode. For the "W" are accepted the FCC Rules.

### 4) EXCHANGE POINTS AND MULTIPLIER

a) Contact score 1 point per contact on the 3.5, 7.0, 14.0, 28.0

MHz Bands. 2 points per contact on the 28.0 MHz Band, can be utilized on each Band. In addition to the ARRL Countries the W call areas W0 to W9 and VE Call areas from VO to VE7.

The same Continents and Country are only valid once on each Band. The same station can only be worked once on each band (Max 5 contacts) during Contest period.

### 5) SCORING

Total exchange points multiplied by the multiplier total.

### 6) SECTIONS

a) Entrants transmitting and receiving video.

b) Entrants receiving video only. For this purpose the same general rules apply and the same stations heard is valid once only on each Band.

A separate results table will be made for each of these two classes of entry.

### 7) LOGS

Logs should contain: Date, Time of contact (GMT), Band in use, Call sign, Report (RST) sent and received. Serial numbers sent and received, points, multipliers and final score.

Although not essential, it would be appreciated if entrants could enclose a cover sheet with a short description of the Station (With photo if possible) together with any comments on the Contest.

All entrants are kindly requested to report on any serious Contest irregularities, e.g. Exchanges in other modes.

For entrants in the b. Classification it is only necessary to record the message of the station heard.

Send U.S. logs to:

Dave Ingram K4TWJ

### 8) RULES OF BEHAVIOR AND PENALISATION

The Logs must be compiled in accordance with the Rules listed in section 7. The contacts must be made by means of the SSTV mode and it is not permitted to use another mode of transmission either before, during or after the exchange of the message by Slow Scan Television.

During the Contest it is expected that Amateurs will observe the fundamental rules of courtesy and good operating during contacts.

Failure to observe any of the above Rules will result in the exclusion of the entry from the final results and any such Logs received will be considered as check Logs.

All Logs received become the property of the Edition CD and will not be returned.

The decision of the organising Committee in any dispute will be final and any subsequent controversy cannot be referred to the Civil Court.

K4TWJ



# the buck passing stops here!

No more buck passing—trading or shopping once you acquire a Hustler two-meter colinear. It is the ultimate in mobile antenna performance—electrical and mechanical—the answer to your search for effective power gain—transmitting and receiving!

## SPECIFICATIONS

- 5.2 gain compared to 1/4 wave ground plane
- Frequency coverage - 143 to 149 MHz
- SWR at resonance - 1.2:1 or better
- Bandwidth for 6 MHz - 1.5:1 or better
- Power Rating - 200 watts FM
- Radiator - 85" consisting of 1/4 wave lower section, phasing transformer and 5/8 wave upper section

**MODEL CGT-144**—Easy—no holes to drill installation with trunk lip mount on side or edge of trunk lid. 180 degree swivel ball for optimized vertical positioning of antenna. Stainless steel radiator. Includes 17' MIL SPEC RG-58/U coax with all connectors attached. Antenna is removable from mount.

PRICE: \$37.95

**MODEL CG-144**—Antenna supplied with 3/8"-24 base to fit all standard mobile ball mounts (mount or cable not included).

PRICE: \$24.95

AVAILABLE FROM ALL DISTRIBUTORS WHO RECOGNIZE THE BEST!

## THE QUICK — QUICK DISCONNECT

**MODEL QD-1**—For easy press and twist removal of your two meter colinear or Hustler HF mobile, add this assembly between antenna base and mount. It's 100% stainless steel, rugged and precision.

PRICE: \$10.95



QD-1

CG-144



CGT-144

**new  
tronics  
corporation**

15800 commerce park drive,  
brook park, ohio 44142

# 50 MHz BAND

Bill Turner WA0ABI  
Five Chestnut Court  
St. Peters MO 63376

WA1EXN worked a short aurora the 12th of November, only 3's were active during the 30 minute opening. Art is looking for scatter contacts — he remarks of having worked K8LEE and WB4YAB but "Where have all the scatter stations gone? Hear K8MMM occasionally on Sunday. K8BBN is conspicuous by his absence."

Paul K1TOL was active from Lewiston, Maine during December before returning to UCLA to finish up his masters degree. His father (K1GPJ) will be operating the SB-110A and modified SB-200 for a while (heard Paul working WB4VLH around 0345Z the 12th).

Late November and early December brought several openings to the Missouri area. November 26th heard and/or worked W1GAO, W5TDZ, WB2PSV, K2LCK, K1ZFE and WA1ILN. The last two were making the most of new SBE SB-50's. The 27th worked WA4GM, the 29th WA1EXN, K2LCK again plus others. December 9th worked WA0VPY, Bruce in Sioux Falls, heard K2ZYX (working WA5RBI), WB2DNE, WA2SAZ and others.

WB2KLD writes that he is back on 6m following an absence of five years. Tom is running a Swan 250 with an FET preamp and five elements at 695' AMSL and monitors 50.110 daily from 0730-0830 and 2130-2300 local. Tom is looking for schedules, tropo or scatter. You may contact him at RD No.1 Warrior Way, Middleburgh NY 12122.

The Six Meter International Radio Klub, "SMIRK," has been established by W5QDB, K5ZMS, K5HVC, K5OOJ, WA5CBT and K5WIB in an effort to increase band activity. The group plans to issue a membership certificate and publish a newsletter. For details contact W5QDB.

Another club with similar aims is "SPECM," the Society for the Preservation and Encouragement of Six Meters. As the name implies, the object is to keep Six active and encourage more hams to try our first love. The club holds its meetings on 50.125 at 9 pm Central time Sunday evenings, in the event of a contest or band opening the frequency is shifted to 50.150. All stations, AM, SSB, and FM are welcome to check in. At present the membership includes hams in Illinois, Wisconsin, Michigan and Indiana. Those interested in member-

ship (at \$2.00) and receiving the club newsletter and certificate should contact the secretary, Raymond J. Schmidt WA9FXT, 1450 Windsor Circle, Carpentersville IL 60110



The boom to element clamp of the new KLM six meter antennas. The aluminum is all 6063-T832, the hardware stainless steel.

KLM Electronics, 1600 Decker Avenue, San Martin CA 95046 manufactures two versions of the Oliver Swan bandpass antenna design. Available in 8 and 11 element versions, these antennas are made of 6063-T832 aluminum with stainless steel hardware. The booms are 2" in diameter, the elements 1/2". The frequency range is 49.5 to 52.5 with a maximum VSWR of 1.15:1. The impedance in both cases is 50Ω balanced. Other specifications are as follows:

Gain over isotropic	8 ele.	11 ele.
Boom length	14.3	16.3
3 dB points	18'3"	30'
Weight	24	21
Price,	12 lbs	27 lbs
Fo.O.B. San Martin		
F.O.B. San Martin	\$55.95	\$89.95

WA0ABI

## QSL CONTEST



Tom DiBiase WB8KZD  
708 6th Avenue  
Steubenville OH 43952

- Feb. 9-10 Ten-Ten International Net Contest
- Feb. 23-25 Vermont QSO Party
- Mar. 9-10 Worldwide VHF Activity
- Apr. 12-15 Counter Hunters SSB Contest
- Apr. 20-22 Zero District QSO Party

### THIS MONTH

#### Ten-Ten International Net Contest

Starts 0000Z Feb. 9, ends 2400Z Feb. 10. Exchange name, QTH, and 10X nr. Score 1 pt. for each member contacted, 1 extra pt. if DX member, Y1-XYL, or Chapter Head. Appropriate awards. Logs go to Grace Dunlap K5MRU, Contest Manager, Box 445, La Feria, Texas 78559, and must be received by Mar. 15, 1974. SASE for results.

#### Vermont QSO Party

From 2100Z Feb. 23 to 0100Z Feb. 25. Stations may be worked once per band/mode. Frequencies are 3685, 3909, 3932, 7060, 7290, 14060, 14290, 14325, 21060, 21375, 28100, 28600, 50260, 50360, 144-144.5, 145.8. Out-of-state stations score 3 pts. per VT QSO and multiply by total Vt. counties worked on each band. Vermont stations score 1 pt. per QSO and multiply by total ARRL sections and countries worked. Exchange QSO nr., RS/T and ARRL section (County for Vermont). Send logs with SASE before Mar. 31 to Peter Kragh, W1AYK, 170 Summit Ave., Ramsey NJ 07446.

...WB8KZD

Ronald Pitts KH6HFJ, wins the QSL Contest this month. Pictured on the right of his card is the Haleakala Crater. On the left are the West Maui Mountains, the Pacific Ocean and the Kealia Fish Pond where the Humunu-kuhapuhaha love to swim. You too can win a one year subscription to 73!

Send your QSL to: QSL Contest, 73 Magazine, Peterborough NH 03458.

# Caveat Emptor?

Price — \$2 per 25 words for non-commercial ads; \$10 per 25 words for business ventures. No display ads or agency discount. Include your check with order.

Deadline for ads is the 1st of the month two months prior to publication. For example: January 1st is the deadline for the March issue which will be mailed on the 10th of February.

Type copy. Phrase and punctuate exactly as you wish it to appear. No all-capital ads.

We will be the judge of suitability of ads. Our responsibility for errors extends only to printing a correct ad in a later issue.

For \$1 extra we can maintain a reply box for you.

We cannot check into each advertiser, so Caveat Emptor....

**FREE:** 18 crystals of your choice with the purchase of a new Genave GTX-200 at \$259.95. Send cashier's check or money order for same-day shipment. For equally good deals on Drake, Swan, Standard, Clegg, Regency, Hallicrafters, Tempo, Kenwood, Midland, Ten-Tec, Galaxy, Hy-Gain, CushCraft, Mosley, Sony, and Hustler, write to Hoosier Electronics, your ham headquarters in the heart of the Midwest. Become one of our many happy and satisfied customers. Write or call today for our low quote and try our individual, personal service. Hoosier Electronics, R.R. #25, Box 403, Terre Haute, Indiana 47802. 813-894-2397

**WE BUY** late model Collins-Drake-Swan. Top prices, cash. Associated RAdio, 8012 Conser, Overland Park, Kansas 66204. Call: 913-381-5901.

**KLM AND MADISON ELECTRONICS** present the finest in VHF antennas. 144-148 MHz, 7 elements to 16 elements; 9 elements \$31.95; 14 elements \$45.95; 16 elements \$49.94; 420-450 MHz, 14 elements, \$19.95; 27 elements \$41.95. Write for literature. Shipping charges collect either factory shipment or Houston stock. Madison Electronics, 1508 McKinney, Houston TX 77002. 713-224-2668, Nite/Weekend 713-497-5683

**DAYTON HAMVENTION** expands to three days April 26, 27, 28, 1974 at HARA ARENA and Exhibition Center. Brochures mailed March 15th. Write for information if you have not attended the last two years. P.O. Box 44, Dayton, Ohio 45401.

**MITE UGC-41 TTY** with spare case and PC cards; 3 speed gears, brand new condition; ST-6 converter built from HAL kit, wide and narrowshift, autostart; all manuals; \$450 for package; you pay shipping. W1BRJ, 7 Pickwick, Marblehead MA 01945. 617-631-1308.

## EQUIPMENT FROM 73

The following list of gear, unless otherwise noted, consists of brand new equipment purchased for testing purposes only. Some have been tested, some remain unopened in original cartons. We are offering this gear at a considerable discount on a first-come-first-served basis. Please send Money Orders or Certified Checks only to 73 Magazine, Peterborough NH 03458.

Cap Com 40M solid state SSB xcvr	\$150.00
Gladding 12V power supply	\$60.00
SBE Scanavision	\$650.00
Midland 13509 220 xcvr	\$200.00
Tempo CL-220 220 xcvr	\$200.00
Clegg FM-21 220 scvr	\$255.00
TME-H-LMU 16 channel rcvr	\$255.00
Digital logic-clocks	\$80.00
Wilson 7 element 10 and 15M beam pick up only	\$250.00
Waller 60A power supply	\$105.00
Pickering KB-1 keyboard	\$200.00
Heath HWA-202-1	\$30.00
Heath HA-2022 amplifier	\$70.00
Gladding HI Scan	\$150.00
Regency TMR-8-U Scanner	\$140.00
Tempo fmh charger	\$25.00
GTX-2 FM rcvr	\$225.00
Newsome 2M KW amplifier	\$350.00
Heath IC-2009 calculator	\$90.00
SBE 450 FM xcvr	\$340.00
Mits 908M w/ac and case	\$130.00
Memory Matic 8000	\$320.00
IC-30	\$450.00
IC-60	\$400.00
RP Synthesizer MFA 22	\$225.00
AX 190 amateur xcvr	\$200.00
Pickering KB-1 keyboard	\$200.00
FPM 300 SSB rcvr	\$480.00
SBE-450 FM xcvr	\$340.00
GYX-200 (slightly modified)	\$200.00
Heath 1B-101 counter with Vanguard scaler	\$250.00
Standard SRC-120/5 power supply	\$44.00

**CALCULATOR OWNERS:** Use your  $+x\div$  calculator to compute square roots, cube roots,  $\sin(x)$ ,  $\cos(x)$ ,  $\tan(x)$ ,  $\arcsin(x)$ ,  $\arccos(x)$ ,  $\arctan(x)$ , logarithms, exponentials and more! Quickly, accurately, easily! Send today for the IMPROVED AND EXPANDED EDITION of the First and Best Calculator Manual — now in use throughout the world...only \$2.00. Unconditional moneyback guarantee — and FAST service! Mallmann Optics and Electronics, Dept. -E2, 836 South 113, West Allis WI 53214.

**"I LOVE THE BANJO"** my latest Stereo LP 36 tunes Dixie to Classic banjo solo \$4.95 PP. Richelieu, The Banjo Man, W9JS, 215 S. Washington, Wheaton, Ill. 60187.

**GENERAL ELECTRIC TPL**, 80 watt 2m with PL, \$175. RCA Supercarfone 450 MHz, \$195. Both are solid-state except for finals and are in excellent condition. Robert Bliss, Jr., 1440 Lakeview Ave., Minneapolis MN 55416.

**HALLICRAFTER HT32A**, mint with manual, W1JSS. 617-762-5252.

**TEKTRONIX OSCILLOSCOPE-531A** Rack Mount with CA dual trace plug-in, 15 MHz Bandwidth. Both mint condition, \$475. J. R. McNeil, 617A Groton CT, Dayton OH 45431.

**GLADDING 25** with GE preamp, all crystals and pad, 25 watt 2m FM transceiver, \$150. Bill Montag, P. O. Box 788, Cologne NJ 08213. 609-296-44711

**SELL:** Heath SB-310 receiver with best CW and SSB filters and with SBA-310-3 13 & 15m modification kit, all for \$200...Heath DX-60B transmitter with extra final, for \$50. Bill Morse, 901 N. Halifax Apt. B., Daytona Beach FL 32018. 904-253-8859

**GREATEST** of them all! That's the ARRL 1974 National Convention, sponsored by Hudson Amateur Radio Council. Remember the dates — July 19, 20, 21 at the Waldorf-Astoria, New York City. Three days of exciting events!! Wide array of demonstrations, exhibits and forums featuring latest in FM, SSTV, ATV, RTTY, FAX, Satellites, Antenna design, Transistors, Integrated Circuits, DX, MARS, ARPSC and much more. Something to do every exciting minute for YLs & XYLs — Tours, New York sightseeing, visits to popular TV shows, Parties, Fashion Shows. Meet the ARRL President, Vice-presidents, and all 16 Directors! Famous-name Speakers at Saturday Night Banquet! Everything for the Non-Ham, New Ham and Old Timer. For Info, Contact: ARRL Convention, 303 Tenafly Road, Englewood, N.J. 07631.

**ANTIQUA RADIO BUFFS.** Do you need a schematic for your radio? For information send S.A.S.E. showing make and model number. Joseph C. Crockett K3KUL, 762 S. Gulph Road, King of Prussia PA 19406.

**FOR SALE:** Drake T4XB R4B, AC-4, MS-4. Excellent condition with all cables and manuals, \$750, shipped postpaid. Jim Gysan W1VYB, 617-922-3850.

**PRINTED CIRCUIT TECHNIQUES FOR THE HOBBYIST.** Ferric chloride "suspension Etching," cutting epoxy glass, screen printing, etc., BOOKLET \$2.00. Trumbull, 833 Balra Dr., El Cerrito CA 94530.

**VERY INTERESTING!** Next 5 issues \$1. "The Ham Trader", Sycamore, IL 60178. (Ask about our "HAM EQUIPMENT BUYERS GUIDE" covering Receivers, Transmitters, Transceivers, Amplifiers 1945-74. Indispensable!)

**GALAXY R-530** receiver, Mint. Tunes 500 kHz through 50 MHz continuously. AM, CW, RTTY, SSB. Has .5, 2.1 and 6 kHz filters. Noise blanker. Picture in most current ham magazines. \$495 firm you ship. Bryan Davidson, P.O. Box 119, Salem, Illinois 62881. 618-548-21888

**R-290 WITH MANUAL \$450.** Eico 753 with ac supply \$125. BRPEB-6 eight level teletype punch \$80. HT-32 with manual \$100. W1GBO, North Falmouth MA 02556.

**FAX PAPER:** For Desk-Fax, new (not surplus), precut (not rolls), \$15 per thousand sheets, postpaid worldwide. Bill Johnston, 1808 Pomona, Las Cruces, New Mexico 88001.

**MOTOROLA PORTABLES** — Expert repairs, reasonable prices, fast turn-around time. More details and flat rate catalog FREE. Ideal Services, 6663 Industrial Loop, Greendale WI 53129.

*(Continued from page 3)*

he, as an FCC inspector, should walk in and find the violator in the act, the FCC would be powerless to do anything. He said that the only way the interference could be stopped would be for the state legislature to pass a law prohibiting such operation and then have the local officers clean it up.

The visit of another FCC inspector to a local broadcast station to give them a citation for having a power meter 10% out of tolerance (reading high!) provided an opportunity to discuss this jamming business at greater length.

The answer given was that the FCC has a signed contract with licensed stations and they intend to enforce it, but do not have a contract with unlicensed people. This might explain the lack of aggressiveness with CB bootleggers.

Alas, for the days of yore, when amateurs looked up to the FCC as sitting on the right hand of God They seem to have changed their location.

#### ANOTHER COLUMN?

Is there anyone out there who keeps up on the latest solid state developments? The new gadgets are coming along so fast these days that it isn't possible to keep up with them via articles. Perhaps a short monthly column in the newspapers would bridge the gap.

If there are any engineers out there who would like considerable fame, some money and lots of free samples, then let us hear from you. It is beneficial if you already know how to write.

**2m AMPLIFIER**, 1 watt in — 25 watts out, \$40; 10 watts in — 45 watts out, \$35. SASE for details. Griff K4IAE, 203A Branson St., Chapel Hill, North Carolina 27514.

**GOOD NEWS** — The SRRRC Hamfest June 2, 1974 at fabulous new site in Princeton, Illinois Fairgrounds. SRRRC/W9MKS, RFD No.1, Box 171, Oglesby, Illinois 61348.

**MOBILE IGNITION** shielding gives more range, no noise. Everything from economical suppression kits to custom shielding. Literature. Estes Engineering, 543-A West 184th St., Gardena CA 90248.

**ACTIVE HAMS** — monthly mailer of reconditioned and new equipment specials. Sell — Buy — Trade. Write: Associated Radio, 8012 Conser, Overland Park, Kansas 66204.

**CLEGG 22er FM** with repeater crystals \$295. Clegg 22er AM \$297. More goodies. Send address to: Dale Hutchinson WA9KQD, 824 Read Street, Lockport IL 60441.

#### MOBILE DXing

As if it isn't difficult enough to rack up the countries, there are a few masochists who are managing the feat while operating mobile — on the order of rowing the Channel with one arm tied behind your back.

The hands down leader of the super-mobiles is Glen Tillack W6KZL/M6, who now has 253 countries confirmed! Glen claims that these are all honest contacts, made while he was in the car and using the car antenna, not backed up to a 20 element beam on a 200 foot tower on a mountain overlooking the ocean. Glen is also extremely active on slow scan television, with one of the world's better SSTV signals and no few countries racked up on that mode. He was one of the few to drop trying to work a JA while I was active on slow scan from Navassa last year, thus getting one more on the less wide-awake brethren.

The number two man, world wide, in mobile DXing is Jacques Boisanfray F3DJ/M with 221 countries confirmed.

Our old friend Edgar Wagner G3BID/M is holding down third place with 205 confirmed. I wonder if he is still mobiling in his Bentley? Edgar would have a lot more if he didn't spend so much time tooling around in other countries — he must have operated from a couple dozen or more mobile so far. If you're into wines, you're good for an hour contact with Edgar.

Eric Stöss DL6UH/M has 189 confirmed, making him fourth. Fred Hock WA3HDU/M3 is fifth with 168

**COLLINS FOR SALE:** Complete S-Line purchased new in December 1972. Very very mint conditions: 75S-3C, 32S-3A, 516F-2, 312B-4, 30L-1, SM-3 mic. Receiver includes 200 Hz filter and MARS crystals — cost today over \$4000. Will sell complete package for \$2,950. R. O. Lions K6ZWG/7, 326 Morris Avenue So., Renton WA 98055.

**BUY-SELL-TRADE.** Write for monthly mailer. Give name, address, call letters. Complete stock of major brands, new and reconditioned equipment. Call us for best deals. We buy Collins, Drake, Swan, etc., SSB & FM. Associated Radio, 8012 Conser, Overland Park, Kansas 66204. 913-381-5901

**TECH MANUALS** for Government surplus gear, \$6.50 each: R-220/URR, R-274/FRR, R-390/URR, URM-25D, URM-32, TT-63A/FGC, TS-382D/U, USM-16, BC-779B, TS-497B/URR. W3IHD, 7218 Roanne Drive, Washington, DC 20021.

confirmed and Bob Kaplan WA4WTG/M4 is sixth with 150 confirmed.

There's only about fourteen members of the Mobile Century Club, so maybe you'd better think about giving that one a try? You can get info and awards from N.A.S. Fitch G3FPK, 40 Eskdale Gardens, Purley, Surrey, CR2 1EZ, England.

#### RUSSIAN BOOTLEGGERS

A stringer for the Los Angeles Times had an interesting story, sent in by WB6ZGF (and thanks, Dave) about the big rise in bootleg radio stations within the USSR these days. Apparently the restrictions are so severe on getting ham licenses that many youngsters who become interested in radio turn to building rigs that interfere with aircraft communications, railroad traffic information, and things like that. The largest number are set up as broadcast stations on the medium and short wave bands where they run disc jockey programs and talk shows.

The radio officials are about as effective as our FCC vs CB, which is about as ineffective as is possible. In one area 115 illegal broadcasts were heard in one evening. Some of the illegal stations have sizable audiences as a result of the boring programs of the government stations. There are no commercial broadcast stations in the USSR, of course.

The illegal operators complain that there is one and only one ham club for the country and that it is almost impossible to get a license if you are a teenager.

*(Continued on page 98)*

Wilson Electronics Presents The Finest 2 Meter Handie Talkie  
With the Hottest Rx Front End on The Market.

**2 METER FM TRANSCEIVER MODEL 1402SM**



FREQUENCY .....140 - 150 MHZ  
(2 MHZ SPREAD)

NUMBER OF CHANNELS .....6  
Supplied with 146.94 Simplex  
146.34/94 - 146.16/76

R.F. Output ..... 2 Watts minimum

Sensitivity .....better than 0.3  
MV/20 DB Q.S.

Audio Output .....500 mv

Meter .....Monitors battery voltage  
on Tx, S meter on Rx

Weight .....1 lb. 4 ounces  
without  
batteries

Current drain ..... 15 MA Rx  
410 MA Tx

Size 8 7/8" x 1 7/8" x 2 7/8"

Includes Adjustable Whip Ant

**\$239<sup>00</sup>** Amateur  
Net Price

**MODEL # ACCESSORIES**

**1410A** 12 Watt Power Amplifier  
Also Includes Steel Case  
For 1402SM - Charges 1402 SM  
When Plugged into Cigarette  
Lighter **99.00**

**LCL LEATHER CASE** .....12.00  
**14BC BATTERY CHARGER** ...29.95  
**SM1 SPEAKER MIKE** .....24.00

WRITE FOR COMPLETE SPEC SHEETS.  
SEE YOUR NEAREST DEALER FOR  
THE FINEST AMATEUR HANDIE  
TALKIE ON THE MARKET

DEALER INQUIRIES INVITED  
COMMERCIAL VERSION AVAILABLE **1410A**

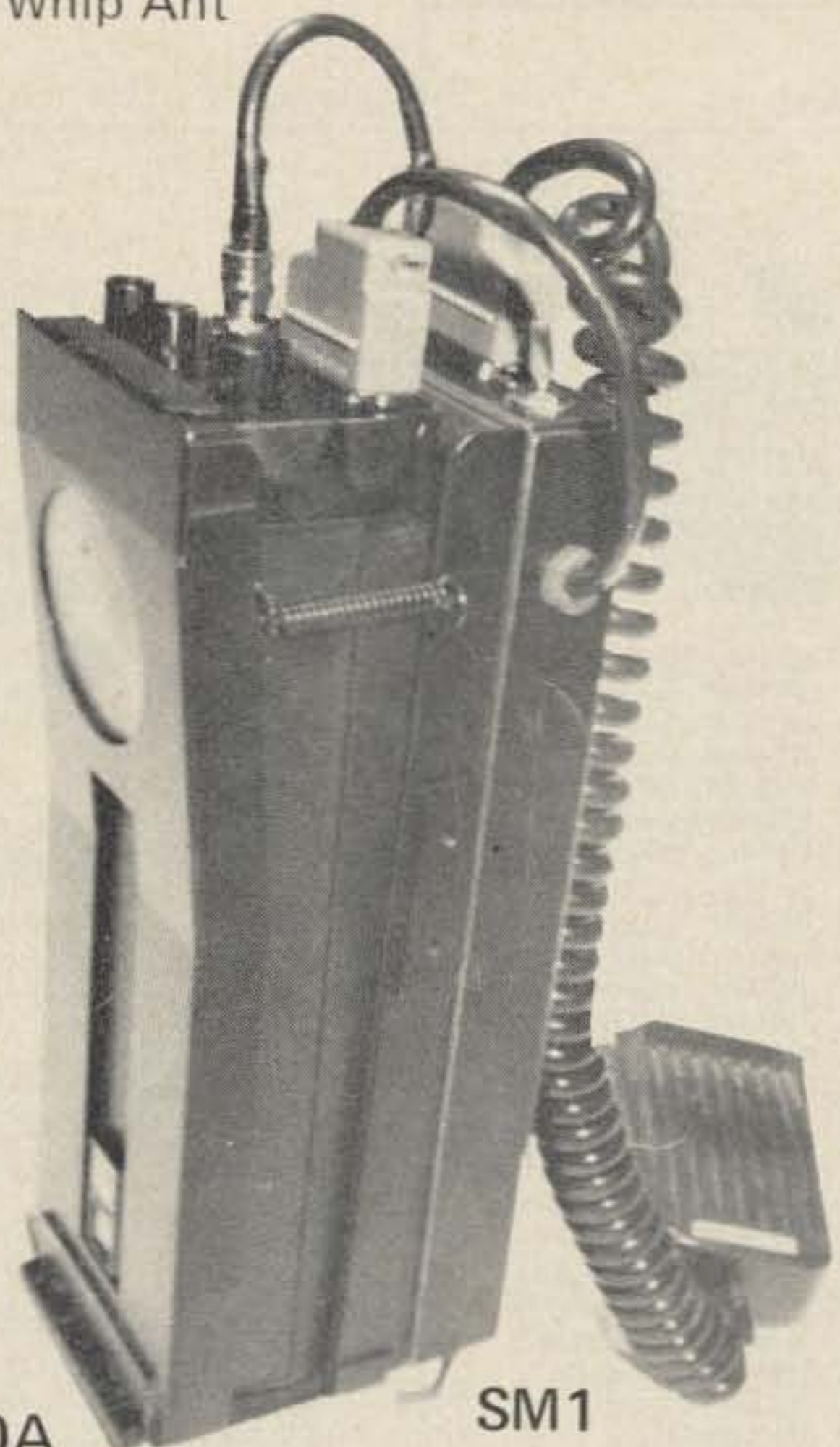

***Wilson Electronics***

**P.O. Box 794**

**Henderson, Nevada 89015**

**Telephone (702) 451-5791 451-6650**

# 73 REPEATER ATLAS REGISTRATION

REPEATER CALL (WR only)		FORMER CALL		LOCATION (City)		STATE
INPUTS	OUTPUTS	TT Wh TB PL	FM AM RTTY	AUTO PATCH	ERP	USEFUL RANGE (RADIUS)
		Hz				
		Hz				
		Hz				
		Hz				
EQUIPMENT						ANTENNAS & HEIGHT <input type="checkbox"/> SPLIT SITE <input type="checkbox"/> DIPLEXER
REPEATER GROUP/SPONSOR		TRUSTEE		ID-TYPE OR MFR.		
<input type="checkbox"/> I certify that I have received no outside assistance while completing this form.						
DATE	SOURCE (NAME/CALL)		SPECIAL OR EMERGENCY FUNCTIONS			



- WA WR7ACE Mt. Spokane 146.34-146.94
- WI WR9ABF Milwaukee 147.99-147.39  
52.800-52.525  
449.50-444.50  
1250.0-1220.0  
146.28-146.88
- WV WR8ACD Charlestown

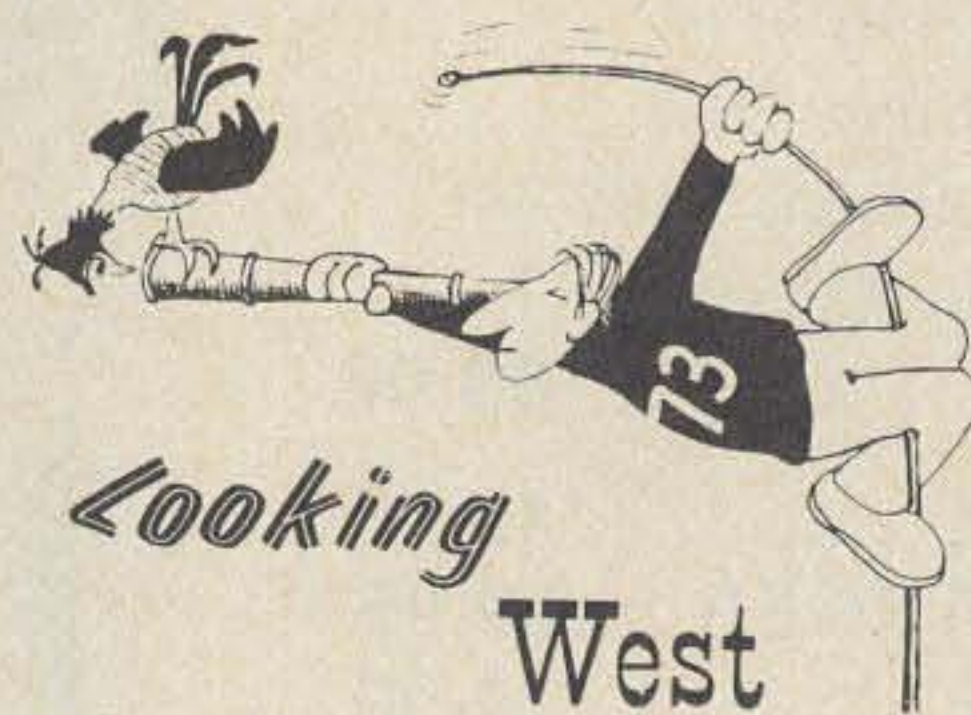

*Bill Pasternak WA2HVK/6  
14732 Blythe Street #17  
Panorama City CA*

"Visiting a large overcrowded sardine can," I suppose that about sums up my personal feelings about going back to New York. Not that I dislike the place — far from it. It's just that in the past year and a half we have become so accustomed to the spread out design of Los Angeles that seeing the way we used to live just about gave me a case of claustrophobia. But, there were many good times in the two and a half weeks we spent back

East, including being able to have an active part in getting the new Brooklyn Repeater (now located in Manhattan at the same site as WR2AA) on the air. As most of you already know, I was one of the people who put up the original Brooklyn machine about two years ago. Unfortunate circumstances led to its "leaving the air" in early 1973, and I made a pledge to myself to try my best to get both the machine and the Kings County Repeater Association going again. When we put up the original machine, it became more than just another repeater to us. Rather, it was assuming an important responsibility to those who had shown the KCRA support and had contributed their hard earned green stuff to make WA2ZWP a reality. Since many of these supporters were friends, I took this responsibility personally. Luckily there were others back in New York who felt the way I did and refused to let the project die. A new Kings County Repeater Association was formed, mostly out of the members of the old group and work was begun on getting both a new site and a new machine.

Under the guiding hand of Lou Belsky K2VMR, the new trustee, Phil

*(Continued on page 16)*

- CT WR1AAF Oxford 147.49-146.49
- IL WR9AAF Chicago 146.34-146.94
- IN WA9ZFM Evansville W 52.920-52.575
- KS WR0ABW Merriam 448.1-449.1
- MD WR3ABQ Baltimore 146.07-146.67
- MI WR8ABI Oshtemo 146.19-146.79
- NC WA4NUO Asheville 146.22-146.82
- NC WR4ABK Charlotte 146.16-146.76
- NC WR4ABT Charlotte 146.22-146.82
- NC WB4QFT Durham 146.22-146.82
- NC W4EHF Fayetteville 146.31-146.91
- NC WR4ABL Greensboro 146.16-146.76
- NC WR4ABP Grifton 146.16-146.76
- NC WR4ABY Hendersonville 146.04-146.64
- NC WR4ABX Lexington 146.31-146.91
- NC WA4BVW Mt. Pisgah 146.16-146.76  
222.34-223.94
- NC WR4ACF Raleigh 146.04-146.64
- NC WR4ABF Shelby 146.28-146.88
- NC WA4ZAT Wilmington 146.22-146.82
- NC WR4ACA Winston-Salem 146.04-146.64
- PA WR3ABZ Center Point 147.66-147.06
- PA WR3ACH Pittsburgh 146.22-146.82
- PA WR3ABY Erie W1477 146.22-146.82
- PA WR3ACA Erie 146.34-146.94  
146.19-146.94  
146.10-146.70
- SC WR4ABM Lancaster 146.10-146.70
- TX WR5ABN Midland 146.16-146.76
- TX WR5ABZ San Antonio 147.30-147.18
- TX WR5ACF Lufkin 146.34-146.93
- VA WB4QFS Roanoke 146.38-146.98
- VA WR4ABU Lexington 146.01-146.61
- VA WA4ZAU Norfolk 146.19-146.79
- WA WR7ACF Spokane 146.28-146.88  
449.85-444.85



# Tired of Inflated Prices?

Check Sentry's Pre-Season Offer to hold down your 2 Meter FM crystal expenses.

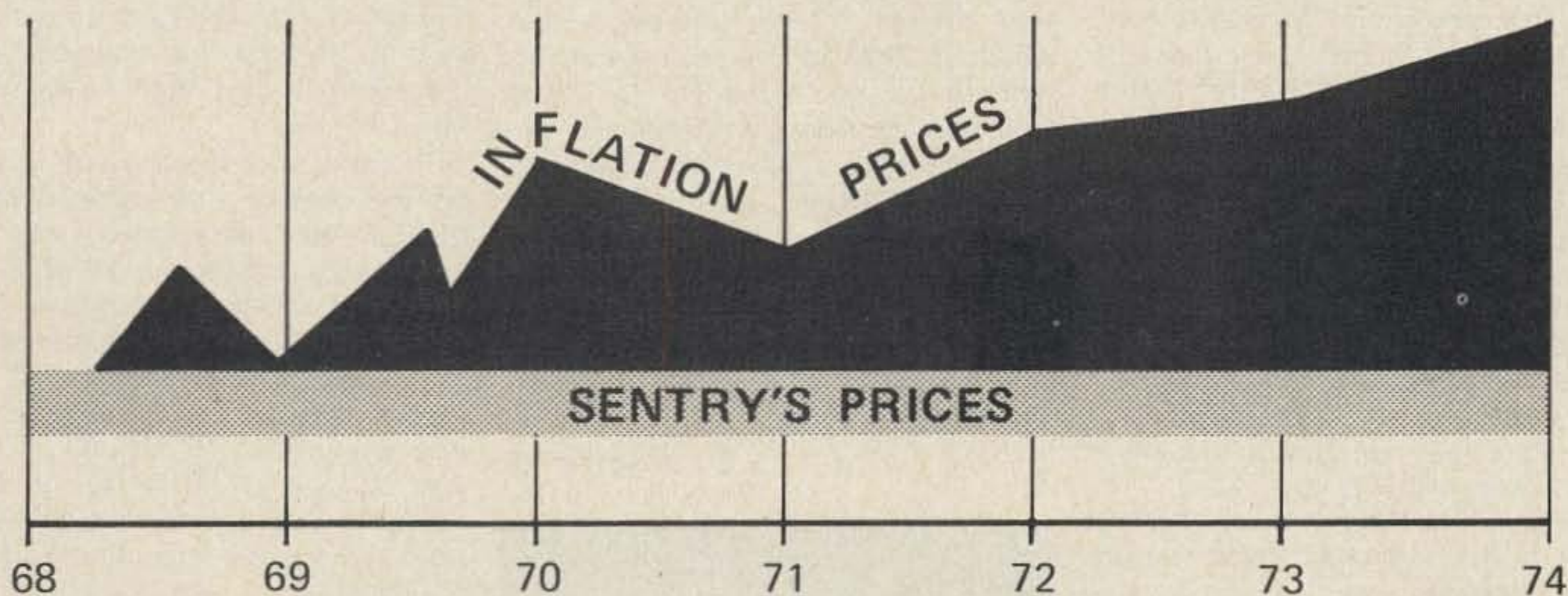

**BUY ANY THREE** Repeater or 2 Meter FM crystals at the regular price and receive **ONE CRYSTAL AT 25% OFF!**

**NO PRICE CHANGE IN THE LAST 5 YEARS** — and in some cases, volume prices have been slashed.

#### **UNCHANGING POLICY OF:**

- *Warranty* — Sentry guarantees any Sentry crystal to be free of defects in workmanship for an unlimited time.
- *Customer Service* — When you buy a Sentry crystal, service is part of the package.
- *Ease of Ordering* — You need only specify manufacturer, model and channel frequency. Sentry maintains up-to-the-minute files on all fixed station, mobile, aircraft and marine radios.
- *One Stop Shopping* — Sentry offers a complete series of amateur, general purpose, commercial, precision, CB, I.F., 2M FM, aircraft and marine crystals (32 KHz to 210 MHz) crystals to MIL 3098 also.
- *Fast Delivery* — Any tolerance on any crystal, 5 working days for one to three crystals.

All of this "PLUS" Inflation Fighting Prices.

*If you don't have our 1974 catalog, write for yours today.*

**SENTRY MANUFACTURING COMPANY**  
Crystal Park, Chickasha, Oklahoma 73018

PHONE: (405) 224-6780 TWX - 910-830-6425

When you order,  
just say you  
read it in  
73 Magazine.



Knoll WB2VGK, and Abe Schwartz WB2PQR, a number of meetings open to all interested parties were held last spring and enough money was collected to purchase a duplexer, antenna and assorted accessories. In the interim I had written both Lou and Abe threatening to come to New York and put up the machine myself if no one else would do it. I didn't think they would take my threat literally, but in part they did. Abe and Stu WA2JNF had started building a solid state repeater from a Sonar hand held transceiver. Before they could finish the job, Abe had to take a personnel leave from the group. Though the unit would repeat, it had a tendency to desense itself and lacked other refinements. I was volunteered to do what I could to remedy the situation. When I left NY, all that was left to do was run the coax and connect the control lines. I had hoped to finish the entire job, but time and obligations would not permit it. It gave me a personal sense of satisfaction to know that I had been of some small amount of help to a real nice group of people; people I am proud to call friends.

Help in the form of a repeater site came from other unexpected sources. After looking vainly for several months for a place to put the machine, another friend made his presence known. George Le Doux K1TKJ (who owns several repeaters in the Northeast including WR2AAA) offered to make space available for the KCRA machine at his location in lower Manhattan. In addition, he also offered to help with the necessary paperwork to get a license for the repeater. So, now there are two VHF repeaters operating about 20 feet from one another without any interference to each other. According to George the secret of this success is in the one meg split that both machines use. WR1AAA is on 73/73 and the KCRA uses 43/43. When the KCRA machine gets its license and goes into full time operation it will be open for all to use. I have been asked to invite visiting VHF FMers to use it. By the time you read this, they should be "on the air."

Back East, I got a chance to say hello to many old friends and make a couple of new ones. I operated a number of different machines including WR2AAA (ex WA2SUR), WR2ACD (ex WA2KEC) and the WA2UWC machine in New Jersey. On every machine I used, I found the atmosphere warm and the greetings friendly. I even got a chance to pull a "Wayne Green" and operate Subway Mobile using a Standard SRC146 while crossing the Manhattan Bridge on the BMT "N" train. You should have seen some of the startled looks

from fellow passengers when my back pocket started to talk. "Rubber Duckie" antennas are a definite advantage if you ever decide to try your hand at this one.

Another high point of our trip was a visit to the town of Woodstock about 90 miles north of New York City. Sharon and I spent three delightful days with our non-ham friends Abby and Jim, just relaxing and taking in the scenery of this most picturesque community. It is best known as an artist colony and home of the famous Woodstock Rock Festival a few years ago. Most important, though, it's the kind of place in which you can still do your own thing without having to explain to others why you are doing it. Where else can you sit for five hours over a couple of cups of coffee in a restaurant and just talk. They also have some of the finest galleries and craft shops to be found anywhere, and only about 1½ hours from the heart of Manhattan. If you ever get the chance, visit Woodstock. You won't be sorry.

...WA2HVK/6



#### THE HAL MORSE KEYBOARD

Having tried out just about every code typing device to be put on the market, we couldn't pass up the chance to have a go at the HAL unit.

To save some suspense, it is superb. It is the easiest to use of any that we've tried, and by a wide margin over some of them. The keyboard works very smoothly and positively.

One other keyboard that we've used quite a bit recently was okay, but some keys had to be pushed hard, others lightly, and you had to remember which were which to prevent double letters being sent.

It doesn't take long to get used to using the keyboard. You do have to listen to what you are typing, for there is no memory in the unit and this means that you have to listen for each character to be started before you move your finger to another key.

The variation in length of the characters means that you have to wait quite a while for the zero to be completed and the next character started, and you have to be nimble when sending an "e", for it is no sooner started than it has ended and, if you are not attentive, you're sending a string of e's.

The HAL unit was particularly handy for the making of the 73 Morse Code cassettes. We calibrated the code speed on the basis of the length of an "f", which seemed median and found that the keyboard would send from about 4.5 to 30 wpm. We could manage to type and keep up with it to around 15 wpm, but had some problems with perfect sending above that speed.

In order to not make any mistakes on the cassette code courses we did them at half tape speed (seven and 10.5 wpm) and then doubled the tape speed for making the cassettes.

One of the real pleasures of the HAL unit is the inclusion of eight special amateur keys to give such combinations as KN, SK, BT, CQ, DX, AR, AS and DE. The DE key also is available with your call so that if you hold it down you get the works... DE W2NSD/1... in our case. It certainly makes calling CQ easy, as well as CQ DX.

The philosophical argument over whether it is better to send using a straight key or a keyer or a keyboard is one that can go on for ever. Each has its staunch adherents who are emotionally tied to their favorite. Some CW men feel that it is the ability to copy that is important, not how you send. For that matter, any way you do send will take skill and practice, and that includes the keyboards when you get up over 10 wpm.

The HAL keyboard has outputs for cathode keying a rig, for grid-block keying, and for tone output. It has a built in monitor speaker. The controls vary the speed, the weight, the tone and the volume. There is also a jack to plug in your hand key for times when you want to send manually.

The HAL MKB-1 is available for \$175 in kit form and for \$275 complete. If you're into CW, this is a way to have a lot of fun for a reasonable price.

#### NEW FILTER FOR HTs

Crystal filters have reached a new miniaturity in the Spectrum International XF-102. This complete crystal filter is built into an HC-18/U crystal can. It consists of a single 10.7 MHz crystal with two resonators plated on it, thus forming a two pole filter. The bandwidth is only 14 kHz, so with this filter added to your hand transceiver you can be sure of avoid-

ing spillover from the next channel, so often a misery with these small rigs.

Now how much do you think this remarkable filter costs? One would expect it to run around \$20, but the fact is it sells for only \$8.50 from *Spectrum International, Box 1084, Concord MA 01742.*

The insertion loss is only 1.5 dB, so you'll hardly know it is in the circuit. The shoulders are fairly steep on the filter, with the signal down 20 dB at 50 kHz and 80 dB at 80 kHz.

If you're looking for an even sharper filter there is the XM-107, a four pole filter mounted in an HC-6/U crystal can. This one has the same 15 kHz passband, but is down 40 dB at 42 kHz, which is way, way down there.

We're looking for someone with some good lab gear to try out one of these crystal filters and come up with good before and after bandpass curves using a Tempo FMH or a Standard 146... and volunteers? Write 73 and tell us how soon you'll be able to provide the story.

### NEW SILICON RECTIFIER HANDBOOK

Motorola's new 216 page Silicon Rectifier Handbook is a true technical handbook, not a catalog type "data book."

The easily absorbed text is well illustrated, with tables, graphs, and circuits on almost every page. Much material is presented that has never appeared in a rectifier handbook before.

Progressing from basics through the latest rectifier applications, this book is well suited for self study as well as technical reference use. At \$2.50 it should be a welcome addition to the solid state bookshelf.

The Silicon Rectifier Handbook may be ordered for \$2.50 per single copy, from *Motorola Inc., P.O. Box 20924, Phoenix, Arizona 85036,* or from your nearest Motorola Franchised Distributor.

### DX QSL GUIDE

Now you can fill out all of your QSL cards in the language of the chap you've worked... well, in most of the languages. The K3CHP Guide gives translations into 54 different languages, and that really should just about take care of anything.

The Guide includes not only the basic QSL information in translation, but also such personal things as your age and things like that.

The Guide is available from *K3CHP, 6913 Furman Pky, Riverdale MD 20840* for \$3.95 or 30 IRCs.

### K ENTERPRISES PRESCALER



A prescaler, in case you're a little behind current technology like the rest of us, is a helpful little piece of test equipment that divides by ten. The fact is it is most useful for anyone messing with the VHF or UHF bands.

You are no doubt aware that counters are so inexpensive and ubiquitous today that frequency meters have been rendered virtually obsolete... a very sad development for hams who have invested in General Radio frequency meters (which used to sell used for over \$2000). One of the limitations of most counters is that they cut off somewhere in the 20-30 MHz range. This is dandy for the low band op, but creates some problems for the chap who wants to put his two meter rig on channel or who wants to try and help fend off the EIA by populating 220 MHz.

The prescaler is just the thing for extending the range of a 30 MHz counter to 300 MHz... and K Enterprises happens to have one of the most reasonable and excellent working units yet available. You can also scale down to a low band receiver and do a reasonable job of adjusting VHF frequencies. If you want to zero in on 146.19 you just tune your receiver to 14,619 and you're ready to go.

When the crew at 73 Magazine were setting up the Clegg 220 MHz repeater recently there was a problem... how to get the repeater and the transceivers to be used with it all exactly on channel. Even with three different counters on hand, plus two other prescalers (which went to about 150 MHz), nothing worked way up there on 220 MHz. The K-Enterprises prescaler did the job and worked just fine with all three of the counters (Heath, Miida, and Regency).

The PD-301 prescaler comes with built in power supply and pre-amplifier. It will read a hand transceiver all the way across the room, so it is sensitive... and that is one of the problems many ops report with some of the less expensive prescalers. You can't ask for a much better price either, for at \$55.50, this is a real bargain today.

More info on the PD-301 and other K-Enterprises gadgets is available from them at *1401 North Tucker, Shawnee OK 74801.*

### MULTI-PURPOSE RECTIFIER

The Rectifier Components Corporation of Union, New Jersey has re-

cently introduced a new series of 8 pin octal base plug in rectifiers. This series designed "Multi-Purpose Rectifier" (MRP) can be programmed into various rectifier configurations such as center-taps, bridges, voltage multipliers, half wave elements, etc, by simply wiring the 8 pin sockets per the instructions.

The "MPR" series consists of four voltage types with each type containing 4 independent/electrically isolated diode elements. Basic peak reverse voltages at 500, 1000 1500 and 2000 volts are available. Depending on the type of rectifier configuration and device type being programmed rectified current output currents from 0.05 to 3.0 amperes average are obtainable.

Pricing in 1 to 4 quantities is \$4.85 \$7.35, \$9.60 and \$12.25 for respective MPR105 (500V), MPR110 (1000V), MPR115 (1500V) and MPR120 (2000V). For more information, contact: *Rectifier Components Corp., 1112 Lousons Rd., Union N.J. 07083.*

### MINIATURE PULSE TONE ENCODER

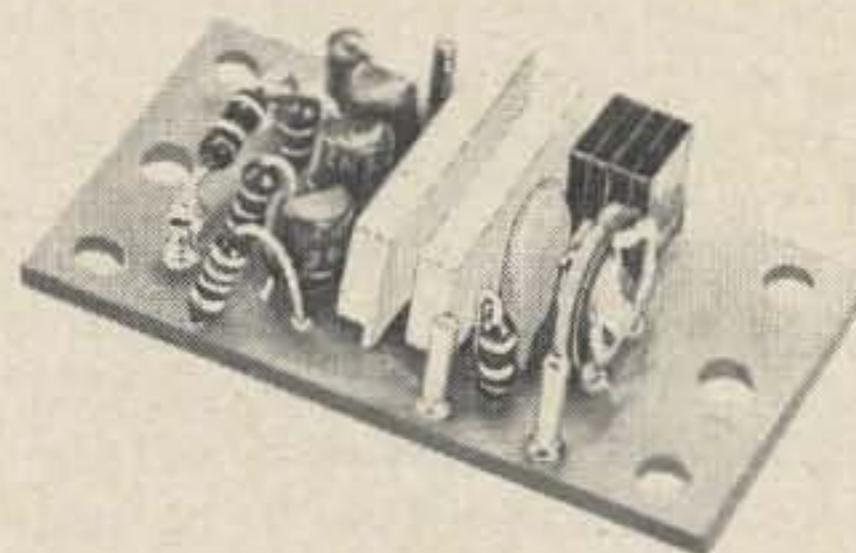

Alpha Electronics Services has been at it again and has come up with an even smaller tone burst oscillator. This one is small enough to fit inside an HT-220 and will provide any frequency from 20-3000 Hz, for a duration of from 0.1-15 seconds. It will even provide a continuous tone if desired. The size is 1 1/2" x 15/16" x 1/2". Up to eight tones can be generated from one unit. For more info contact *Alpha at 8431 Monroe, Stanton CA 90680.* The AE-50 uses a plug-in thick film hybrid module for frequency determination instead of old fashioned reeds or other mechanical systems.

Alpha also has an encoder-decoder unit which will handle up to six frequencies of tone, from 20-250 Hz. This will fit in most mobile units, but is a bit big for HTs. Ask about the SS-80J-192-F.



Gus Browning W4BPD  
 Drawer "DX"  
 Cordova, SC 29039

Now with your travelling curtailed on account of the gasoline situation I would think there is more interest in working DX, but, if they start cutting down your power line voltage you had better get yourself some sort of a transformer "arrangement" to boost your line voltage back up to at least enough to make the rig work. Being an old hand in the electronic business all my life I have had many occasions to either need more or maybe less line voltage and this is no problem at all. Get one of those filament transformers out of the attic. If your rig uses about a KW get one that will put out about ten amps or so with the filament voltage you need to boost your line up to. Just put whatever line voltage you have on its primary and correctly polarize the filament voltage in series with the line voltage that goes to your rig. Of course if you need more voltage you can use two transformers or you can use two (or more) windings on the same transformers as long as each winding will put out the amperage your rig needs. (will send anyone a drawing of all this if they send me an sase.)

DX conditions have been pretty good considering the low sunspot count, all you have to do is do a little deeper digging and hunting for the rare ones..They are in there and they are being worked by the serious DX'er. The prefix chasers should be having a real busy time trying-not to miss any of the many FB prefixes that seem to keep changing. Any kind of a big celebration or special event brings out many new prefixes, these are usually a "one shot" deal, if you miss them you may never get another chance to work that prefix again. Some of the prefixes that have been used in the past few months include: ZY2, VA6, SK0, HW3, VA1, 4K1, XQ3, VA6, CV4, VA7, PT2, PT1, JX4, XG1, 3D6, HA0, XF4, XX6, JE1, VA0, HG5, EX5, SY5, VI8, JF1, IB3, DT9, DT0, WP1, LJ2, KE6, ZM2, KJ3, KJ7 and the list keeps right on growing. The prefix chasers are a busy lot and they can always keep busy if they make up their mind that they don't want to miss any prefixes that pop-up.

Our good friend who lives in Greece near the Mount Athos border has been fairly busy and goes over to Mt. Athos quite frequently where he operates SY5MA. He was W3AG back in the states, he has moved over to Greece now. His QSL manager is

W4KA whose CBA is all O.K. He has been quite active on both 20 and 40, seems to like CW better than SSB.

I have received some wonderful mail from readers of this column and I would like to thank them very much. The response regarding our new award The Super WTW, the one that will really proves who Works The World, the AWARD that calls the various DX places, "DX Areas" and doesn't use the word countries any more. By the time you are reading this I will have the rules and DX Area lists made up and printed in the form of a "check list" and entry form. I will be glad to send any of you two sets of forms on the receipt of 50c to cover printing & mailing costs. You keep one set for your records and mail me one, we both can keep these forms and use them as you work more DX from the Super WTW list. Of course we will issue you a nice, pretty certificate if you qualify and will have stickers that can be attached to the certificate as you work more from the list. I can definitely state that the fellow who has the highest score in our new Super WTW is the one who has worked more and better DX than anyone else in the world, thats why we call it The Super Worked The World Award ! Do not confuse it with our regular WTW award, they are two completely different awards and the rules are completely different.

If you still need Old VS9K Kamaran Island (in the Red sea, off the coast of Yemen about 3 miles or so) you might keep your eyes and ears open for either (or both), 4W1AF and FL8OM who may go there at a moments notice almost any time, it is possible they may at times also go to other islands in the Red Sea. (ed.-and how about a trip now and then to South Yemen (that's Old Aden-VS9-land, remember them ?). As to when you will hear any activity from Iraq, your guess is as good as mine (maybe better). While we are talking about "rare ones", how about Clipperton Island, just a few hundred miles out in the Pacific from the west coast of northern Mexico. I have as yet to hear a "plausable" explanation why it seems to be "off limits" to hams, why is this anyhow ?, I wonder if there is something "hidden" down there ? Maybe one of these days our Ole Buddy, Barry Goldwater will button hole the French Ambassador up in Washington and get the truth out from him (or would it be more beating around the bush ?). Then there is that place right in the middle of Rome, called The Royal Order of the Knights of Malta. ARRL once told me that it had all the are-marks of being a new country if someone was to go there and operate. Someone who knows

their was around and knows the right "official" over there can turn this trick I am sure. They did it with Mount Athos which looked a lot harder than The Royal Order of The Knights of Malta set-up. How about it IIRB ? You seem to "know your way around" pretty well and you know the excitement on the bands when a brand new country shows up.

Does anyone have a circuit of a transistorized multi-vibrator that will lock in on 5 and (by turning a switch) also 10 kc from a sub-harmonic of a 100kc crystal osc. ? I have tried many and have had not much of a success so far. Would like it to be for NPN (of course a FET would be FB too). All I have tried so far are very "touchy" and don't want to start osc. unless you snap power on and off quite a nr of times to get them started. Any help. anyone ?

If you work one of these stations in Turkey and get his address be sure to not mention the word radio on any mail you send him. It seems that all of these ham stations have no legal license and are actually working under cover. In fact it is a good idea to not mention the word radio in quite a few countries, maybe they are legal, but do not want to "rock the boat" ! In fact I know a few stations right here in the U.S.A. that don't want the fact that they are a ham advertised. They would be blamed for every streat, cross-hatch, snow, or even TV trouble their neighbors have ! One fellow down in Miami, Florida has up an "invisable" antenna, it's made of number 28 wire and runs from his 28th. floor hotel room to a building across the street, and he works FB DX and runs a KW. It's really "invisable" that's a fact ! He has been using it for a number of years.

I would like to make up a list of the most needed countries, so how about sending me a list of the ones you need. I will tabulate them all and give the results in this column. It would be a sort of guide to fellows making DXpedition plans and just might activate some of the places you need. Send the list directly here to me and while you are writing me you might send along a few choice DX tidbits, but keep in mind that what I write is not in print for about 2 months. You might also suggest any ways you have in mind to improve this column. We are always open to suggestions.

This is the DX season and I hope you are getting your share. The sun spot cycle are about to start on it's up-hill climb so things should be improving almost anytime now.

on. See you next month, 73 es DX-

*Gus* BPD

**IF YOU REALLY WANT THE BEST,  
YOU'LL JUST HAVE TO ACCEPT THE FACT  
THAT IT'S GOING TO COST YOU A LITTLE LESS**

*It's the little things that  
make a GTX the value it is:*

- Operation over the entire 2-meter band (including MARS and CAP frequencies) *without* tuning
- No automatic shutdown on SWR bridge. Operate with mismatched antenna *without* damage, due to balanced emitter output transistors
- Lowest AM detection level of any comparable unit (including many commercial rigs)
- Power: the GTX-2 and GTX-200 boast 30 watts nom. output
- Lightweight: manufactured to aviation industry standards
- High-sensitivity receiver pre-amp included as standard (GTX-2 and GTX-200)
- 1/4" phone jack included as standard (GTX-2 and GTX-200)



**Don't Let An Honest Price Scare You Away—  
See Your Amateur Dealer Today!**

General Aviation Electronics, Inc., 4141 Kingman Drive, Indianapolis, Indiana 46226 — Area 317 - 546-1111



**GTX-200**

**\$269.95\***

(30 watts output power, nom., up to 100 channel combinations)

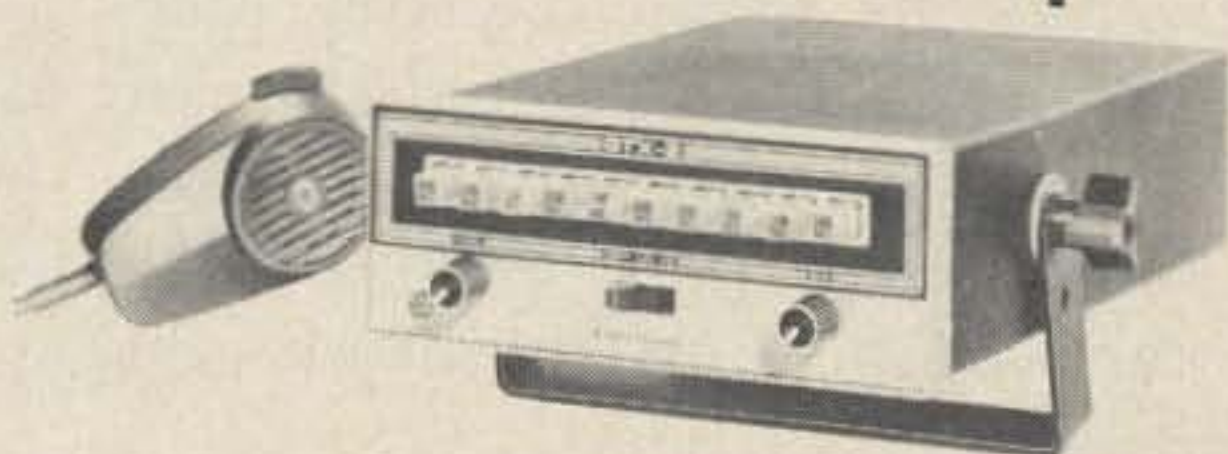

**GTX-2**

**\$259.95\***

(30 watts output power, nom., accommodates 10 channels)



**GTX-10**

**\$209.95\***

(10 watts output power, nom., accommodates 10 channels)

\* Includes 146.94 MHz.  
Add'l. crystals \$6.50 ea.

# UNDERSTANDING THE SLOW SCAN MONITOR

Dave Ingram K4TWJ  
Rte. 11, Box 499, Eastwood Vil. 50N  
Birmingham AL 35210

*Our Slow Scan Editor takes us by the hand.*

Often prospective Slow Scanners shy away from the fascinating world of SSTV under the misconception that complicated video circuitry is utilized. Other times, Slow Scanners would like to build a monitor of their own design, but are not absolutely sure how to go about it.

It is the objective of this article to describe the simple circuitry used, and give you enough knowledge of the basic monitor so you can plan and/or trouble shoot a typical unit, plus evaluate a monitor's effectiveness by its block diagram or schematic.

Scan monitors are basically simple, while the additional circuitry which makes them more elaborate makes them more complicated. An ideal monitor might be expandable — simple circuitry and spaciouly laid out, which we can add onto as desired for increased performance.

Let's start with the basic monitor, which we will divide into two sections for simplicity, and call the "front end" and the "display end." Since the front end is the "business end," (actual Slow Scan circuitry) and the remainder is basically conventional

sweep and high voltage circuitry, let's start our discussion with the front and work back. Later we will consider "frills" and troubleshooting techniques.

## Monitor Front End

Figure 1 is the block diagram of a typical basic monitor. The Slow Scan TV audio signal first enters a conventional amplifier, which also limits the signal. This gives us a high level, constant amplitude signal we can run through some frequency sensitive circuits, (discriminators) and retrieve the sync and video information.

The pulses appearing at the sync discriminator output are now amplified, detected, and separated (vertical integrator) so they can trigger the proper sweep circuits, either in an oscilloscope or a monitor. During this same period, the signal being fed to the video discriminator (which should pass only 1500 Hz to 2300 Hz) is slope detected: high output for 2300 Hz, low (or zero) for 1500 Hz. Notice that any sync pulses (1200 Hz) making it through the video discriminator still will not be seen, as they will not

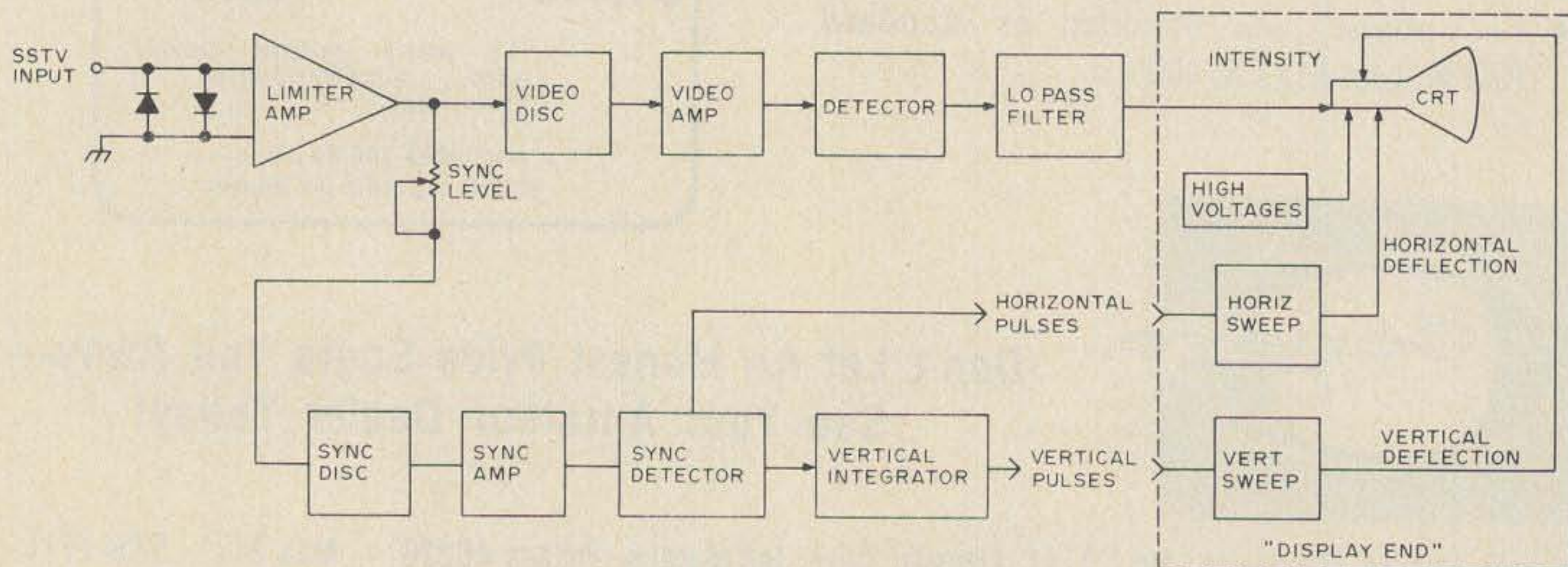

Fig. 1. Block diagram of a typical SSTV monitor.

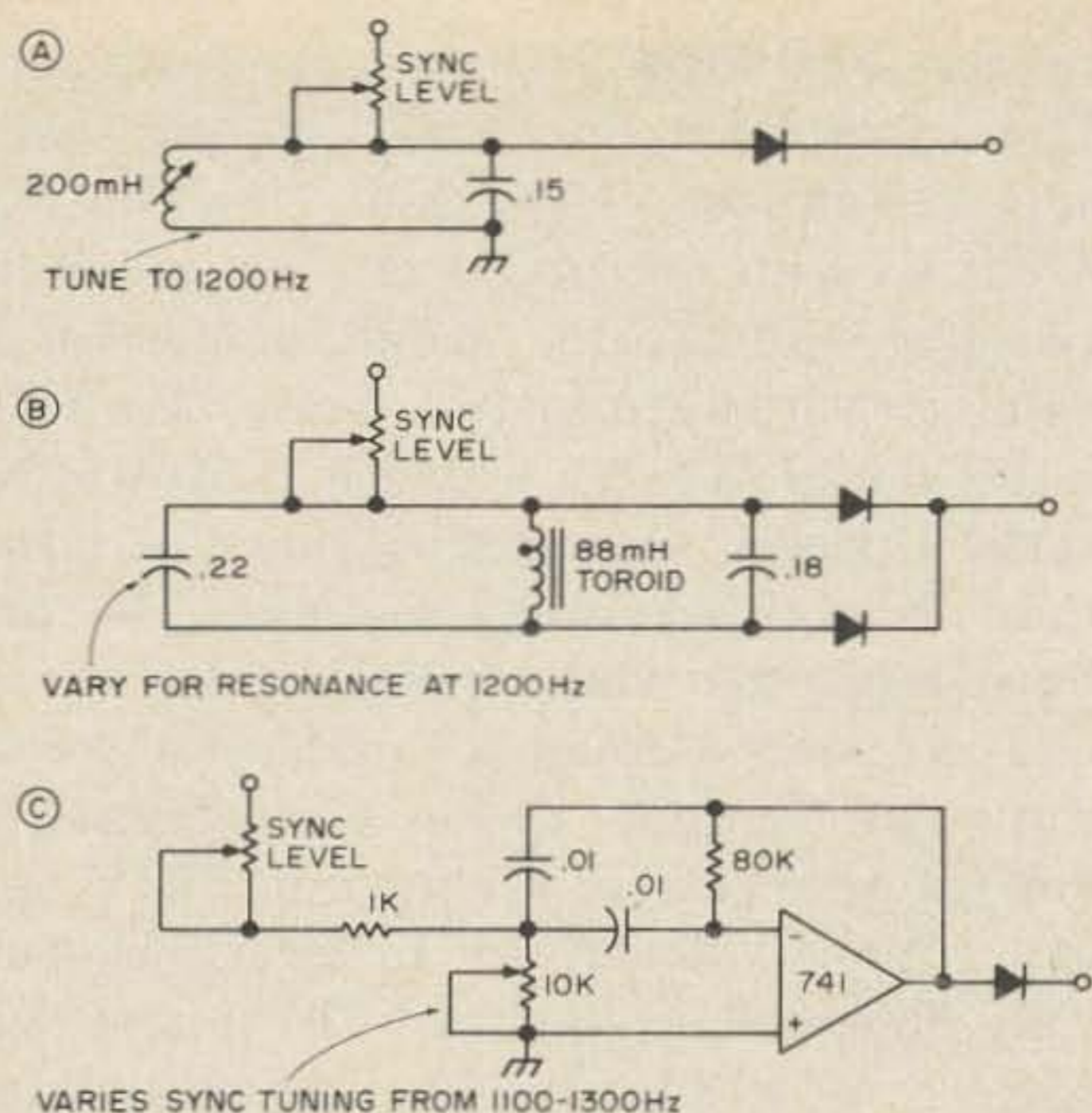

Fig. 2 Typical band pass filters used in sync discriminators.

produce as much voltage as even black frequency (1500 Hz). The voltage now proportional to our received video frequency is amplified, detected, ran through a low pass filter (the last thing we need is "trash" in the video) and then used to intensity modulate the cathode ray tube. Basically, this describes the "front end" operation.

Now let's consider some specifics. The first block the limiter/amplifier, may be any reasonably good audio amplifier, from a one or two tube job to a ua709 integrated circuit unit. All we are after is boosting the level high enough to use. Limiting is necessary so varying levels will not upset picture quality. This is easiest accomplished with back-to-back diodes. (I have the diodes in front of the amplifier because it is easier to clip before amplification.) Next is the sync discriminator, which is a sharply tuned circuit for 1200 Hz. Figure 2 gives some typical examples. Although you can use simple "loopstick" coil/capacitor tuned circuits here, toroidal bandpass filters have a higher Q and better selectivity. Naturally, tunable IC bandpass filters (see *73 Slow Scan TV Handbook*) would be even better and three or four pole filters would be optimum. Resonance may be checked on *any* of our homebrew circuits by connecting it as in Fig. 3, and shifting the audio oscillator's output frequency while comparing on a VOM to find the effectiveness and shaping factor of the tuned circuit. In order to attain the

proper level of drive through the tuned circuit, a variable resistor could be used (shown in Fig. 1 as the "sync level pot"). Typical values are 0 to 500K. Once you've obtained the proper level, take the pot out, measure its resistance, and replace it with a fixed resistor of this value. Following the sync discriminator is a straightforward dc amplifier followed by a simple diode detector. This detector converts the output of the sync amplifier into dc pulses, for pulsing our sweep sections. The vertical pulses are separated from the horizontal in the vertical integrator, thus obtaining separate horizontal and vertical pulses. The video discriminator may be a tuned circuit which is broadly resonant (1500 Hz to 2300 Hz) but "peaked" at 2300 Hz, so 1500 Hz gives low output, and 2300 Hz gives high output. Above 2300 Hz this tuned circuit will drop off in output. This voltage is now amplified in a simple dc amplifier. The output is then rectified (interstage transformer probably needed here) then passed through a simple lo-pass filter before being applied to the control grid of the crt (lo-pass filter design for the crt is covered in detail in the *73 Slow Scan TV Handbook*). Full wave rectification would be preferable for both the video and sync detectors for maximum output, and less ripple. I suggest you compare the monitor circuit you are considering to the (typical) block diagram in Fig. 1 for actual circuitry values.

Now assuming you would like to expand an existing monitor, you could add more features as desired. For example, a 1200 Hz bandpass filter might be added between the limiter and the sync discriminator. If we made this a tunable filter, like in the W6MXV monitor, we not only would have a very sharp filter, for eliminating QRM, we could also "move around" slightly in frequency to avoid QRM. A lo-pass filter could

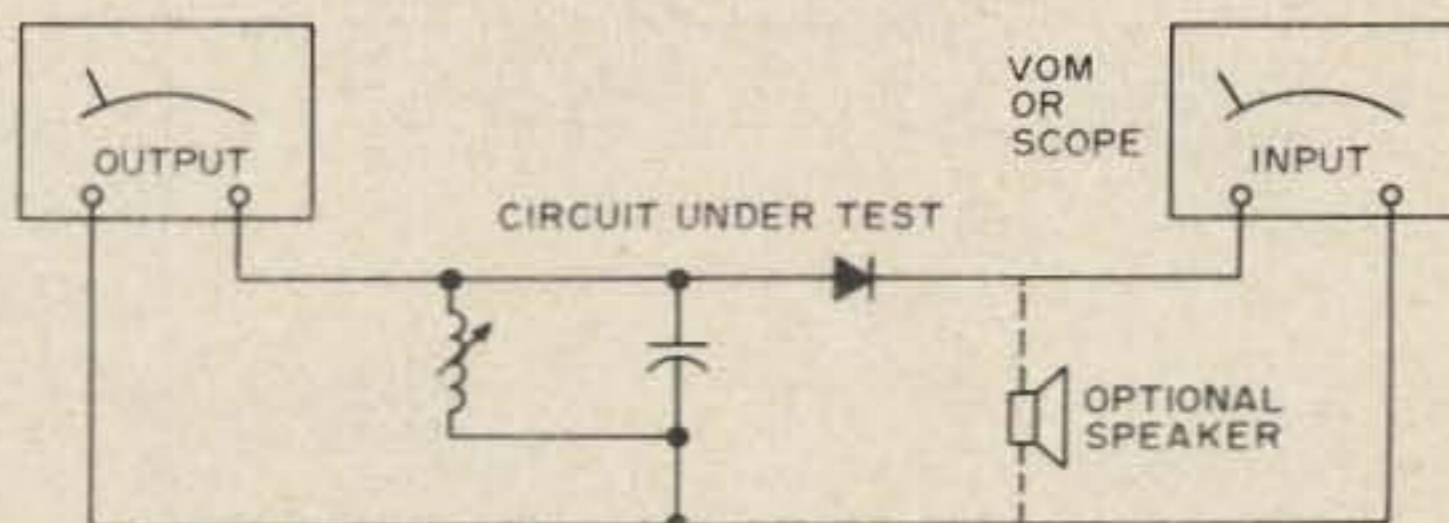

Fig. 3 Test setup for aligning the sync filters.

also be added on the output of the sync discriminator thus making our sync practically noise and QRM free. (Again, specific circuits will be found in the Slow Scan TV Handbook, appx. pg. 46). A pulse shaping integrated circuit could be added in series with the output of the horizontal and vertical "pulse" lines, thus gaining perfect syncing even when only "half a sync pulse" is received. An example of this is WB8DQT's monitor which appeared in August, 1973 *73 Magazine*. A bandpass filter to pass 1500 Hz to 2300 Hz could be placed on the output of the video discriminator to assure only 1500 to 2300 Hz is applied to the video amplifier, thus eliminating QRM to the video. Again, these are "accessories," and not necessary for perfect monitor operation. (However they do help!) The output of our "front end" now consists of horizontal, vertical, and intensity voltages which we may use to drive the "display end."

### The Display End

Figure 4 is a basic schematic of a "display end" of a Slow Scan monitor (circuit from WB8DQT circuit in August 1973 *73 Magazine*) and can be driven from any of the

conventional Slow Scan circuitry front ends. One example is the 'scope adapter which appeared in June, 1970 *QST*. Note that Fig. 4 has its own horizontal and vertical sweep circuitry, and also the 'scope adapter has its own vertical sweep section (since this is not in oscilloscopes) so we would skip back to the vertical trigger, when rigging these up, rather than having two sweep sections. The outputs, horizontal and vertical, of our "front end" connect through a variable resistor, as shown on the input of Fig. 4. A typical high voltage arrangement is shown in Fig. 5, and can supply voltages to an electromagnetically deflected crt like the 5FP7. I have built some 5 to 10 kV supplies, and always used any "junk" flyback I could find. They all worked fine... some had more output voltage than others, but we're not too particular... just get some high voltage on the accelerator, and it'll work fine.

Basically, the above is the theory behind all Slow Scan monitors. Some are more sophisticated, but our outline still shows the main parts. Note that any of the front ends may be connected to this, or any other typical display end provided we do it through a variable resistor. Adjust it like

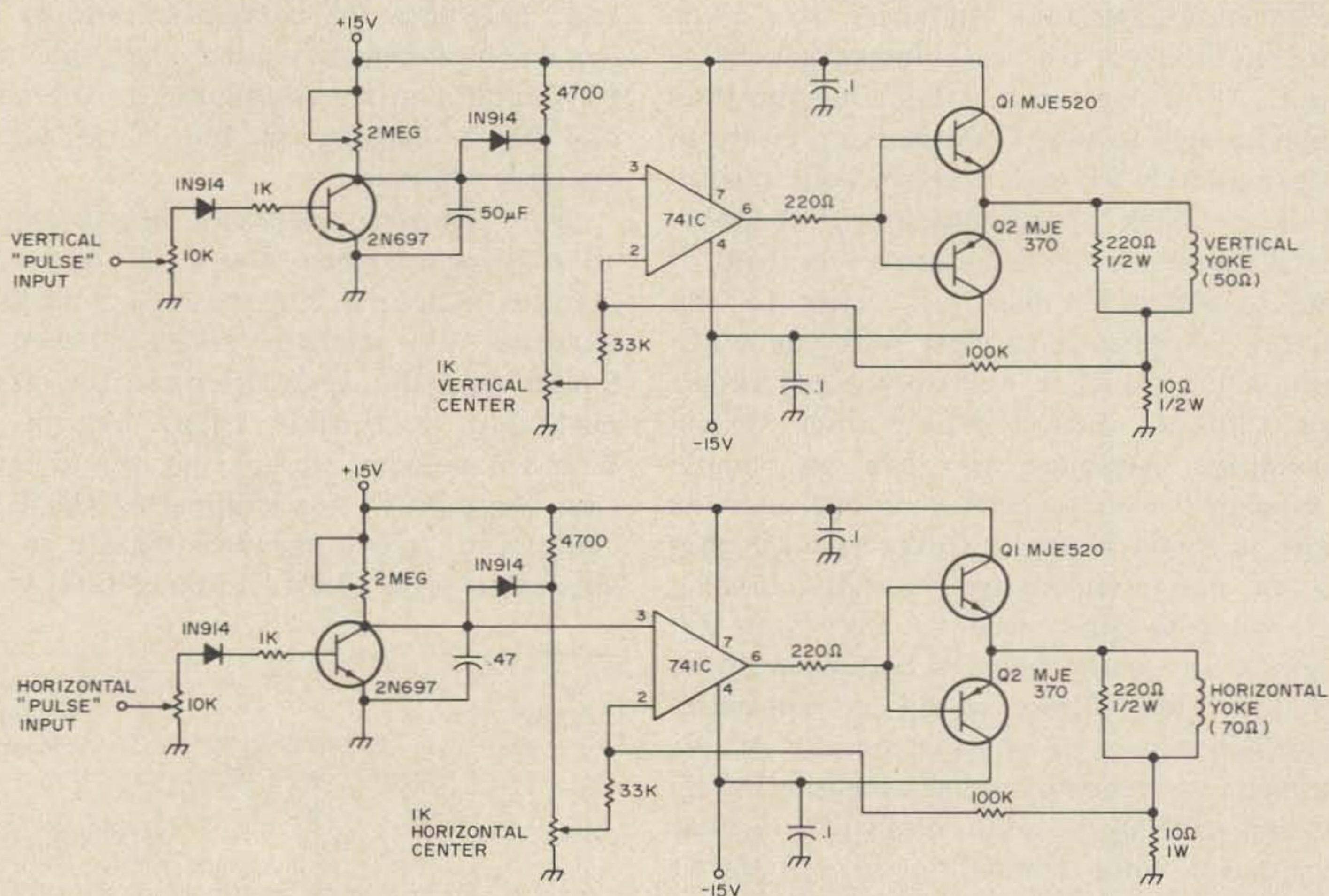
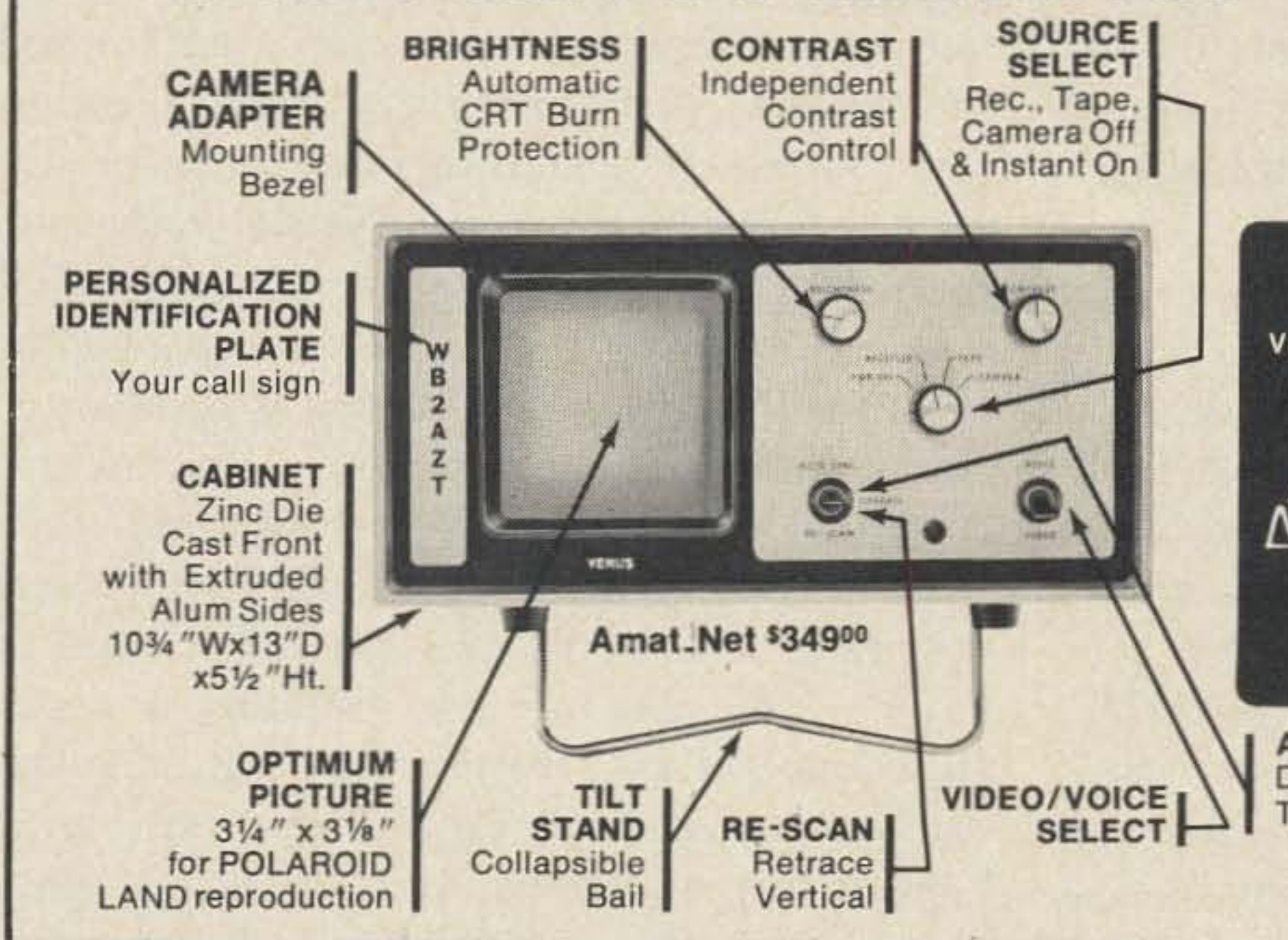

Fig. 4. Vertical and horizontal sweep sections from the "display end."



# 2<sup>nd</sup> generation slo-scan system

## Venus Slo-Scan TV monitor



Actual unretouched photo taken from the Venus SS2 using a Polaroid Color Pack II Camera mounted on the Venus P-1 Camera Adapter

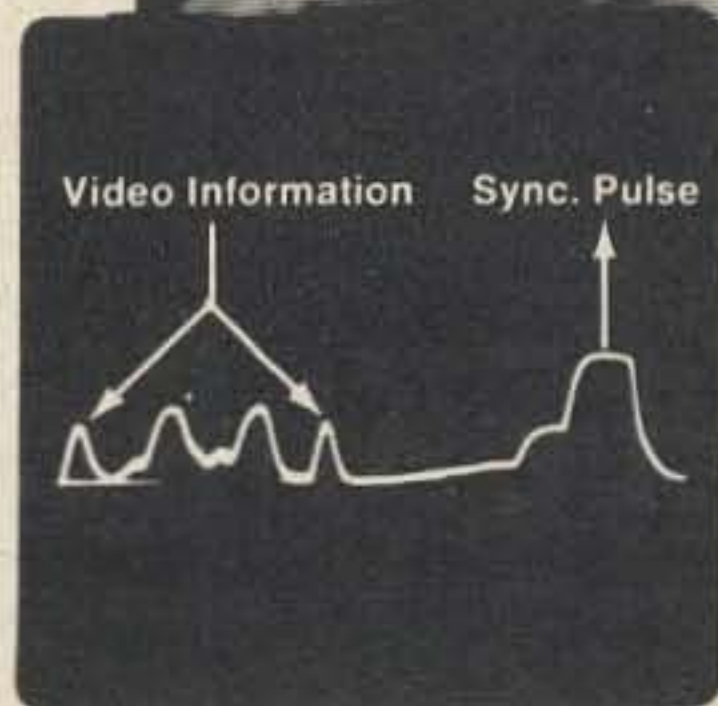

**ACCU SYNC**  
Diagnostic and Tuning Aid

**CAMERA ADAPTER P-1** enables you to take photographs "right-off-the-air" and accepts a Polaroid Color Pack or a Polaroid Square Shooter.

- Allows photographing in a lit room
- Simple-snap mounting for quick and accurate picture taking
- Simultaneous hood viewing of picture being taken by camera
- Instant QSL via SSTV
- Amat. Net \$34<sup>50</sup>

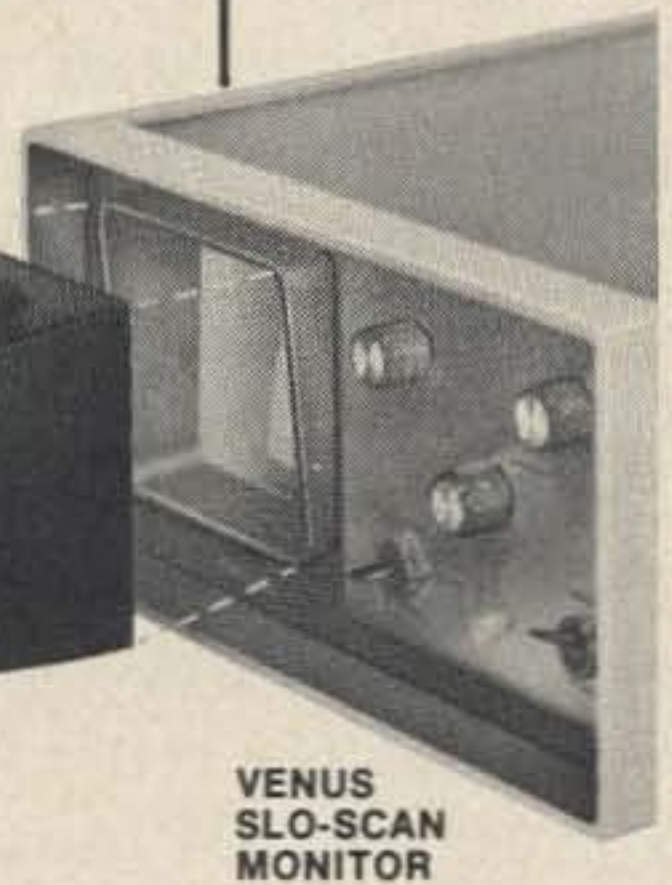
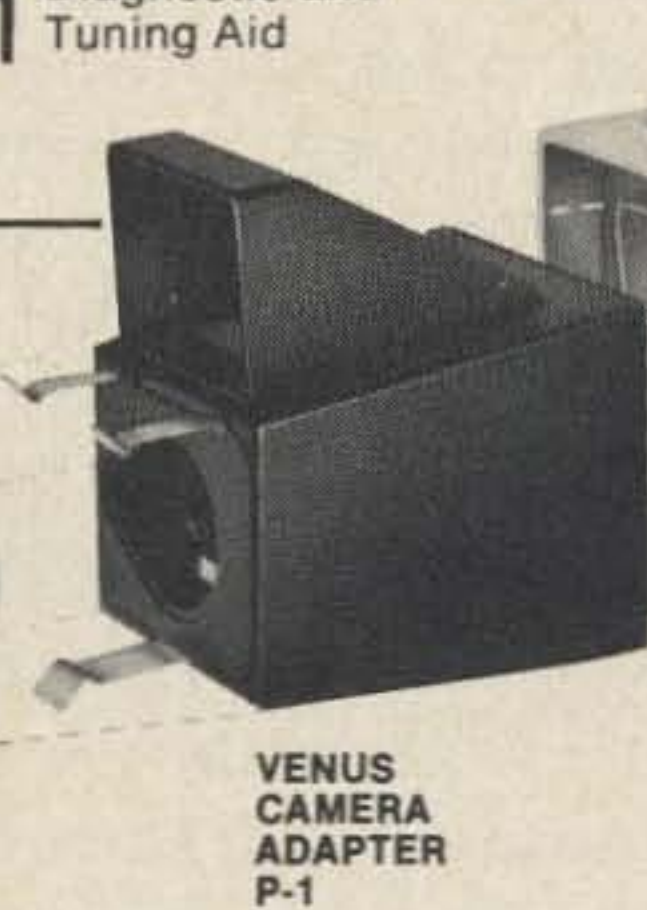

### VENUS' SLO-SCAN CAMERA has arrived!

VENUS' Slo-Scan Camera will project FAST SCAN VIDEO real-time on any conventional home TV and with a simple flip of a switch converts the FAST SCAN VIDEO to Slo-Scan.

- Full, Half and Quarter Frame • Positive Negative Reversal
- RF output for viewing on conventional home TV set.
- Built-in BAR GENERATOR for foolproof means of setting your brightness and contrast controls.

Write today for detailed information on

VENUS SLO-SCAN CAMERA C-1

I would also like more information on:

VENUS SLO-SCAN TV MONITOR SS2

VENUS CAMERA ADAPTOR P-1

VENUS SLO-SCAN ACCESSORIES

NAME \_\_\_\_\_ CALL \_\_\_\_\_

STREET \_\_\_\_\_

CITY \_\_\_\_\_ STATE \_\_\_\_\_ ZIP \_\_\_\_\_

ORDER DIRECT FROM FACTORY OR AUTHORIZED DISTRIBUTOR AS FOLLOWS:  
 NEW YORK (Metropolitan Area) Barry Radio • MASS. (Melford) A. W. Electronics • CALIFORNIA (Burlingham) Ham Radio Outlet • FLORIDA (Pensacola) Goldstein's • NEBRASKA (Omaha) Radiosmith

# Venus Scientific Inc.

The company that put high voltage on the moon, now brings you expanding amateur radio technology.

399 Smith Street  
 Farmingdale, N.Y. 11735  
 Phone 516-293-4100  
 TWX 510-224-6492

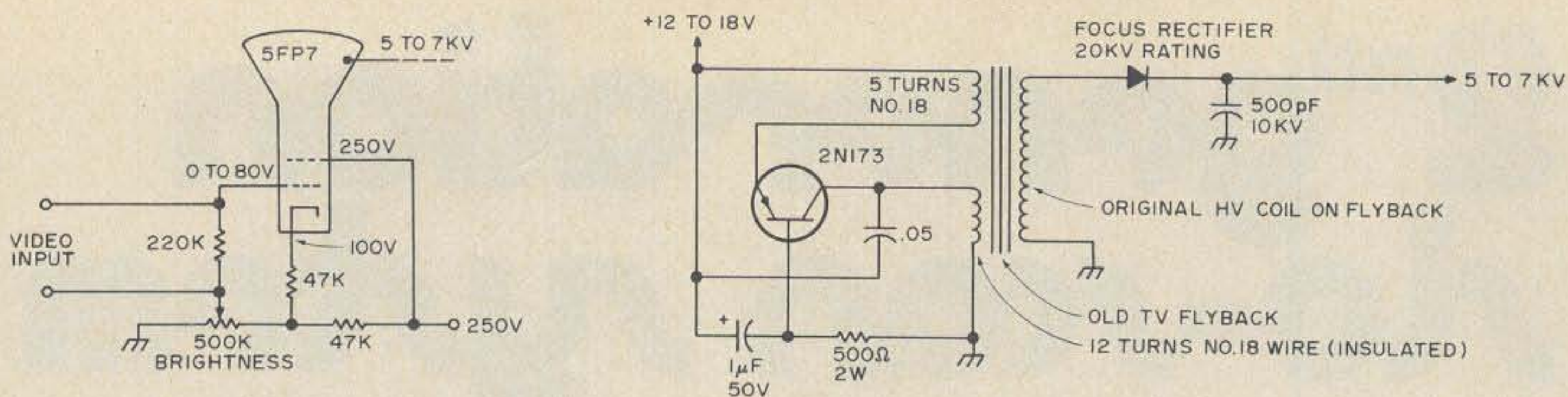

Fig. 5. The crt circuitry and its power supply that will develop 5–7 kV from 12–18V dc.

previously described on the “sync level pot” to drop the level feeding the display end, as overdriving will result in improper syncing and underdriving will not produce sweep.

### Monitor Operating Characteristics

Looking at the block diagram in Fig. 1, let’s consider what should be happening in a typical monitor upon reception of a Slow Scan signal. The input voltage to the monitor will be too low to read (appx. .05V). The limiter’s output should be high and probably square wave (appx. 24V peak to peak, or at least 12V as read on a v.o.m.) A pair of phones between here and ground should blow your ears off with audio; The output of the sync amplifier will probably be low (less than .5V) and best measured using an oscilloscope. The output from the sync detector should be pulses at a 15 Hz rate, again measured on an oscilloscope. The output of the vertical integrator should show a pulse every 8 seconds also. The output of the video amplifier should be approximately 0V with an input frequency of 1500 Hz; however, this output should increase (at least above 15V) when the input frequency swings to 2300 Hz. This indicates the resonance of the video discriminator and the slope detection increasing in output as the input SSTV frequency increases. A lo-pass filter will not affect this voltage, thus the video voltage should be apparent at the crt control grid lead.

Moving now to the “display end” we find the two transistors in the horizontal and vertical sweep circuits (Q1 and Q2) used as “triggers,” thus the collector on each of these circuits (they are identical except for time constants) will give some indication of

pulses, on a vom; the horizontal at a 15 Hz rate (fast “jiggling” of meter pointer) and the vertical with one every eight seconds. The output of the integrated circuits will vary also when scanning. Typical values are  $\pm 1V$  to  $\pm 12V$  (or vice versa – just so it crosses through zero). This voltage will be used to bias the complimentary transistors. The complimentary transistor output circuit (between emitters and ground) will then vary between positive and negative supply voltages, which in this particular case is  $\pm 12V$ . You can almost visualize a raster sweeping (on any monitor) by watching this voltage on a vom. Again, the horizontal “jiggles” up and down at a 15 Hz rate on a vom, while the vertical kicks to approximately 12V and slowly decays down to zero in four seconds, at which time you can turn the meter over and see it start from zero and go up to 4V in the other direction. Should you want to sweep the monitor screen vertically, merely pulse the input to the vertical IC, which will cause the circuit to sweep.” Ditto the horizontal.

One of the best ways to assure long, reliable use of Slow Scan gear is to make typical operating measurements, like previously outlined, and record these on a schematic. When future questions arise, we have a known reference guide to then consider.

This article has tried to present, in simple terms, a basic outline on SSTV, primarily focused on the monitor. As you become involved in Slow Scan you will see how these principles may also be applied to the camera and flying spot scanner. I sincerely hope you will find this information useful in future experimentation of this outstanding mode.

...K4TWJ

# INTEGRATED CIRCUIT AUDIO AMPLIFIERS

**W**e are now several years into the age of integrated circuits. They are beginning to appear very frequently in schematics in amateur publications. One of the commoner special purpose circuits is the audio amplifier. After all, every receiver has an audio stage, and there is no question that an IC stage requires less space than its discrete component amplifiers in terms of cost and performance. They are getting cheaper and better all the time.

Audio amplifier ICs are therefore of interest to the amateur and experimenter. This article discusses audio amplifier ICs in general, presents some comparative data on some of the commoner varieties, and presents some circuits.

Audio amplifier ICs have a fairly wide variety of configurations and capabilities. Comparisons are complicated because each type (even different types from the same manufacturer) seems to have different types of information specified on its data sheet. Table I attempts to summarize the information from data sheets for a number of devices. Most values are direct from the data sheet. An attempt has been made to convert the sensitivity figures to a common basis from the wide variety of systems used by manufacturers. Table II lists some other audio amplifier ICs for which no data sheets are available.

It will be observed that ICs will deliver moderate powers of 250 mW to 5W. These powers are adequate for amateur usage. (By way of comparison, my HQ-160 is rated at 1W audio output.) Usually they contain an

internal amplifier capable of considerable gain. Most are matched to low impedance ( $4-16\Omega$ ) loads, but some require matching transformers. The higher power units will require heat sinking. So far as I know, no chips include built-in overload protection, a feature sometimes built into Hi Fi amplifiers.

Audio ICs are, like other integrated circuits, complete circuit subsystems built on a single silicon chip. The "classical" configuration consists of a differential amplifier feeding a Class B final stage. The use of a Class B final is mandatory because the major problem in integrated circuit design is the dissipation of internally generated heat. The Class B circuit is not only three times as efficient as the Class A configuration, but also it draws only a small idling current at zero drive whereas the Class A configuration must actually dissipate more power at zero drive than at full output. This situation recom-

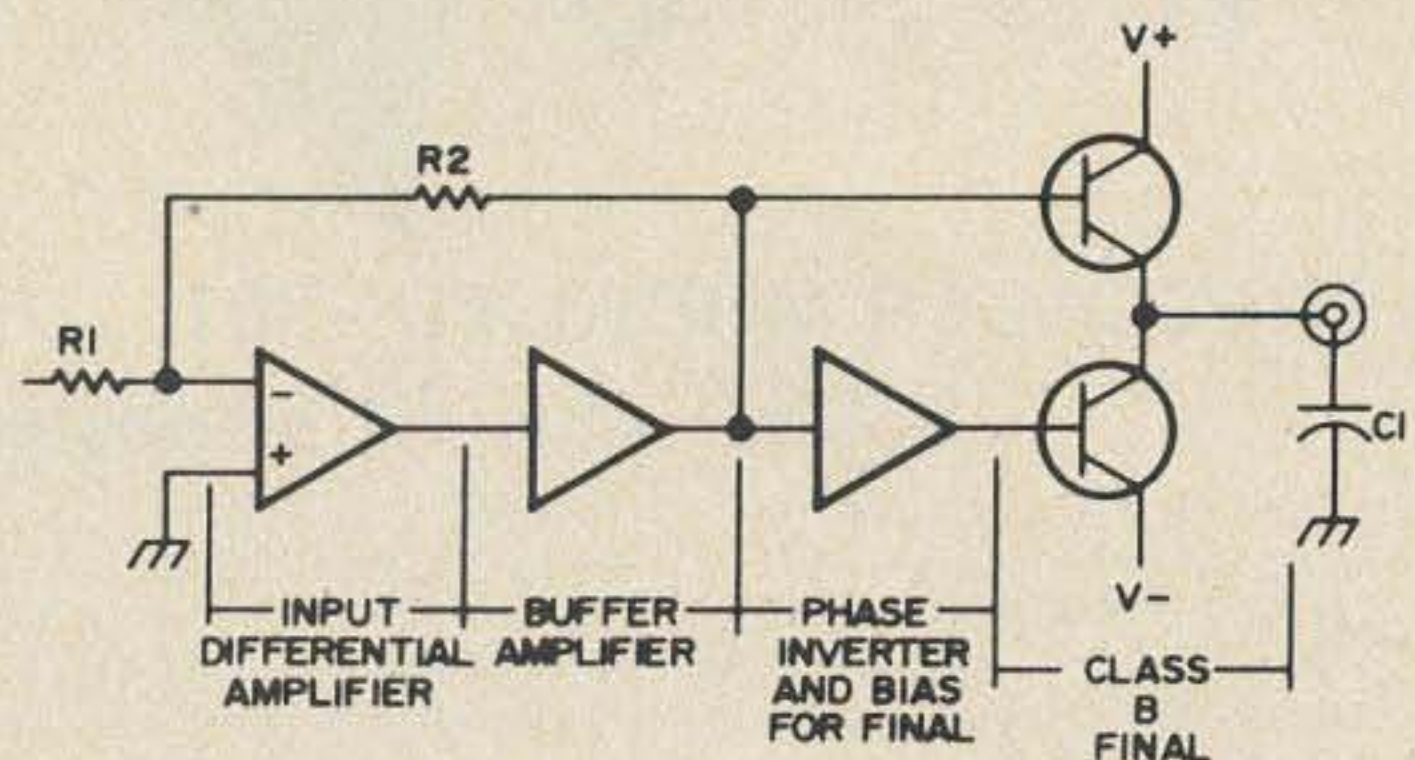

Fig. 1. Basic audio IC.  $R_1$  and  $R_2$  control voltage gain.  $C_1$  is not required if a dual power supply is used (as is shown) but is required for single supply operation. For single supply operation the non-inverting input terminal must be biased above ground.

mends against the use of voltage regulator ICs such as the UL723 as audio amplifiers. Voltage regulator ICs utilize Class A output stages.

In addition to the input amplifier and output stages, there will be an intermediate phase inverter and possibly a low impedance intermediate amplifier stage. The output from the latter will be brought out to a terminal so that the input amplifier may be treated as an operational amplifier whose gain and frequency response may then be controlled by negative feedback in normal op-amp fashion.

In addition to the input, output, B+, and ground terminals which appear mandatory, a number of other internal points may be brought out to external pins. The op-amp output has already been mentioned. Both the inverting and non-inverting differential amplifier inputs may be brought out to terminals. Whether the latter is true depends to some extent upon another problem. The Class B final will, when driven, produce a signal which varies about a voltage half way between B+ and the most negative voltage applied. If the most negative voltage is

ground, considerable biasing is required internally (or externally) to obtain a voltage reference half way between B+ and ground. The circuit can be considerably simplified by the use of a dual power supply — at the cost of requiring two power supplies. Operational amplifiers generally require dual power supplies. IC audio amplifiers on the other hand are designed for consumer products and have (generally) been designed for single supply operation. This requires the use of a high value capacitor in the output circuit and (often) other external biasing components.

There are two special problems in dealing with these ICs — power supplies and feedback. We'll discuss feedback first. Many of these chips have gain capabilities which border on the fantastic. The Amperex TAA300 is spec'd to be able to deliver 1W output given 10 mV into its input impedance of 10K. This amounts to an 80 dB power gain which is somewhat greater than the difference between its 1W output and the power output of the world's most powerful broadcast transmitters. 80 dB is a lot of gain to package in a TO5 case. A little

# K-ENTERPRISES



**PRESCALER MODEL PD-301**  
**\$55.50 plus \$1.50 postage**

Model PD 301 is a 300 MHz prescaler designed to extend the range of your counter ten times. This prescaler has a built in preamp with a sensitivity of 50 mV at 150 MHz, 100 mV at 260 MHz, 175 mV at 300 MHz. The 95H90 scaler is rated at 320 MHz. To insure enough drive for all counters, a post amp. was built in. The preamp has a self contained power supply regulated at 5.2V + .08%. (Input 50 Ohms, Output Hi Z)

All prescalers are shipped in a 4" by 4" by 1" cabinet. All are wired and calibrated.

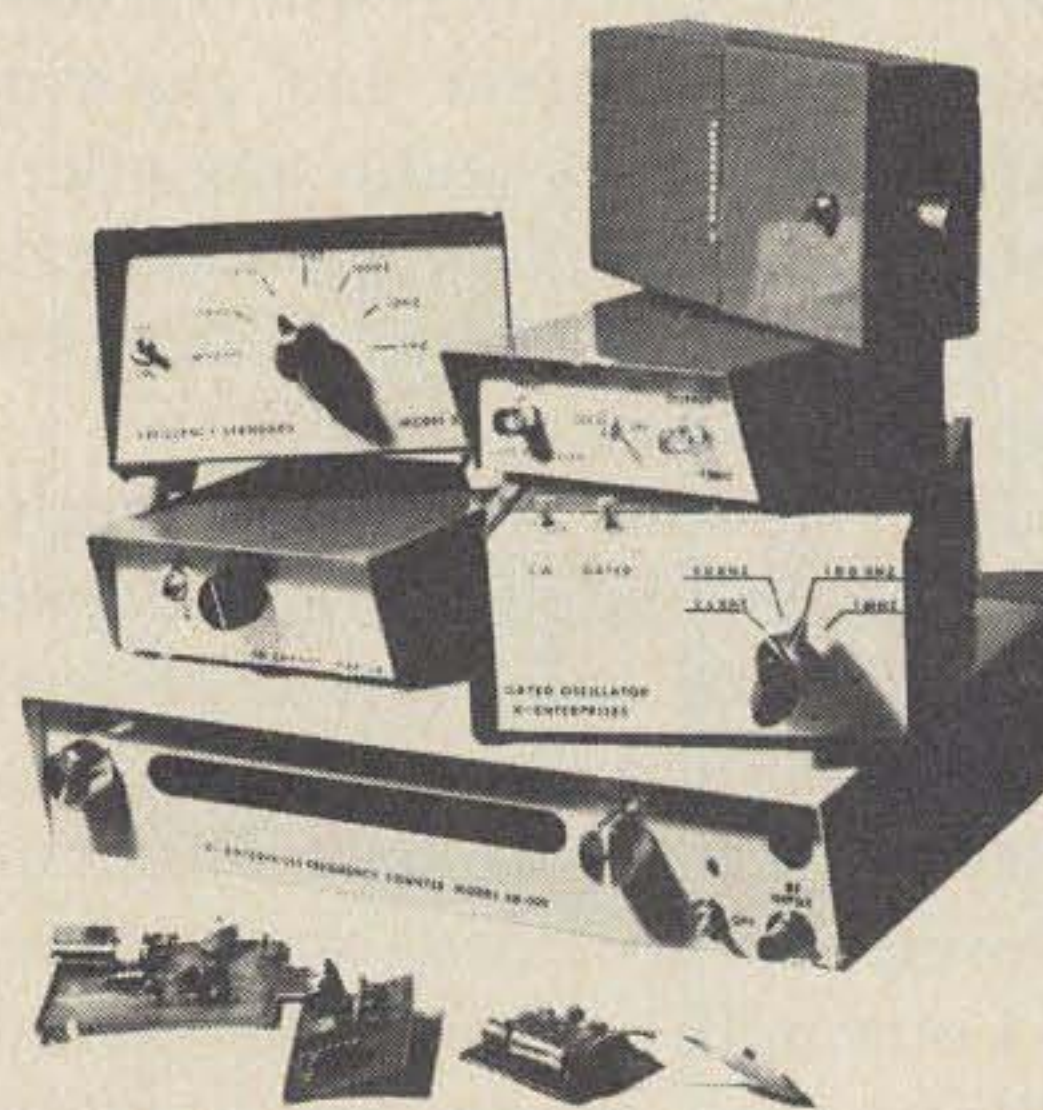

*Counters . . . 300 MHz . . . \$350.00*

*Oscillators*

*Marker Generators*

*Frequency Standards*

*Electronic Clocks*

**Write for Catalog**

# K-ENTERPRISES

**1401 NORTH TUCKER • SHAWNEE, OKLAHOMA 74801**

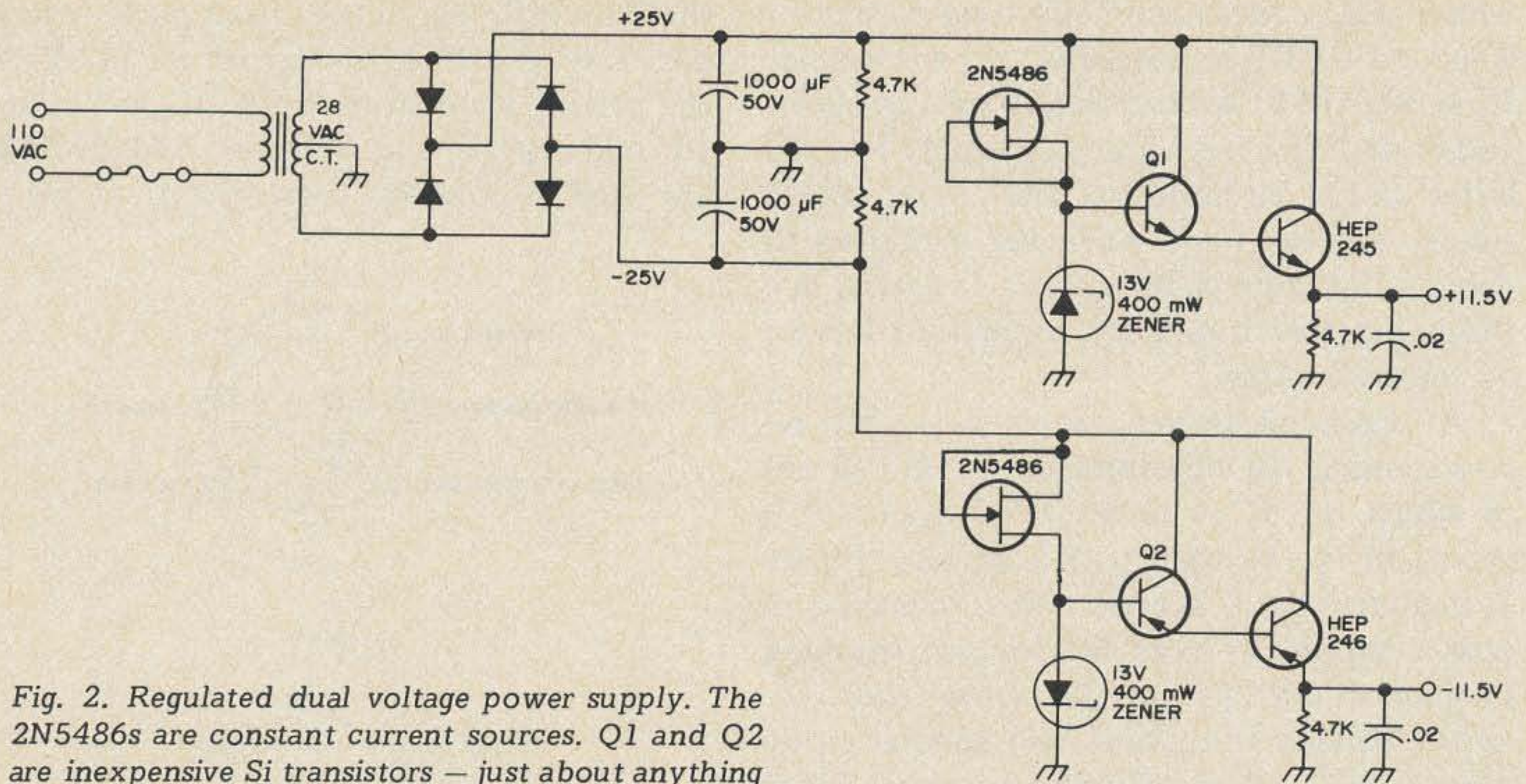

Fig. 2. Regulated dual voltage power supply. The 2N5486s are constant current sources. Q1 and Q2 are inexpensive Si transistors — just about anything will do, although some units will regulate better than others. The HEP245 and HEP246 must be heatsunk using silicon grease.

analysis will show that at higher audio frequencies (20 kHz or so), a few pF of capacity back to a non-inverting input terminal is quite sufficient to kick the amplifier into oscillation. Careful circuit layout is important. The obvious (and advisable) alternative of reducing the gain is somewhat alien to the average experimenter. In the world of ICs, gain is cheap and the user is expected to apply some restraint in his design.

The amateur confronted with an oscillating amplifier has several alternatives:

1. Reduce the B+ voltage.
2. Reduce the gain (the data sheet will indicate how).
3. Employ negative feedback to reduce the gain.

Oscillations don't have to be caused by audio feedback. Most of the chips we are discussing will operate very well at several hundred kHz, or even up to a few dozen MHz. If a few pF can cause feedback problems at audio frequencies, it isn't hard to imagine what a few fractions of a pF can do at a couple of megahertz unless steps are taken to limit the high frequency response. The necessary bypass components (if any) will be indicated on the manufacturer's data sheet. If the IC is to be used in a receiver, one must not forget to put a low pass filter between the detector and the IC if one is not

to end up delivering a watt or so of i-f to the amplifier output.

Not all oscillations are caused by feedback through the input stage. They may be caused by the power supply. An output of 1W into an  $8\Omega$  load will generate a 3.2V signal drawing 280 mA. Those are rms volts and milliamperes. At the peak, 4.5V at 360 mA will be required on each side of zero. For a single supply, the peak voltage and current will be 9V and 720 mA. 720 mA may not sound very impressive, but it is more than two-thirds of an ampere. Suddenly slapping a 720 mA load on a power supply imposes a load on that power supply, and in typical usage, that load is being turned on and off hundreds of times a second. When a load is imposed on a power supply, the output voltage drops. Depending on the type of supply, the transformer powering it, etc., — the voltage drop might be negligible or it might be catastrophic. A semiconductor regulated supply can be built with a negligible voltage drop. A fresh, large capacity battery will do well also. On the other hand, an unregulated power supply, a low capacity battery, or an old, partially depleted battery will change voltage drastically. In a test, a 750 mA drain on a semiconductor supply showed a drop from 11 to 10.5V. On the other hand, a 330 mA load on a battery

which was (and is) normally used to deliver 3 mA to a FET preamplifier, cut the voltage from 5 to 0.5V. Attempting to operate an IC audio amplifier from a power supply like the latter would be hopeless. The circuit would simply cut itself off whenever it started to deliver any appreciable power, resulting in a thumping low frequency oscillation known as "motorboating."

A regulated power supply is highly recommended for development of the circuit in which the IC is to be run — even if it is eventually to be used with a battery. Figure 2 includes the schematic for a satisfactory power supply. It does not include overload protection except in the sense that the epoxy driving transistors will generally pop before the output transistors expire. Since

the Allied/Radio Shack quad pack (catalog 276-530) provides 24 transistors for \$1.98, the driving transistors can be socket mounted, and regarded as 8¢ fuses. The 2N5486s are used as constant current sources for the

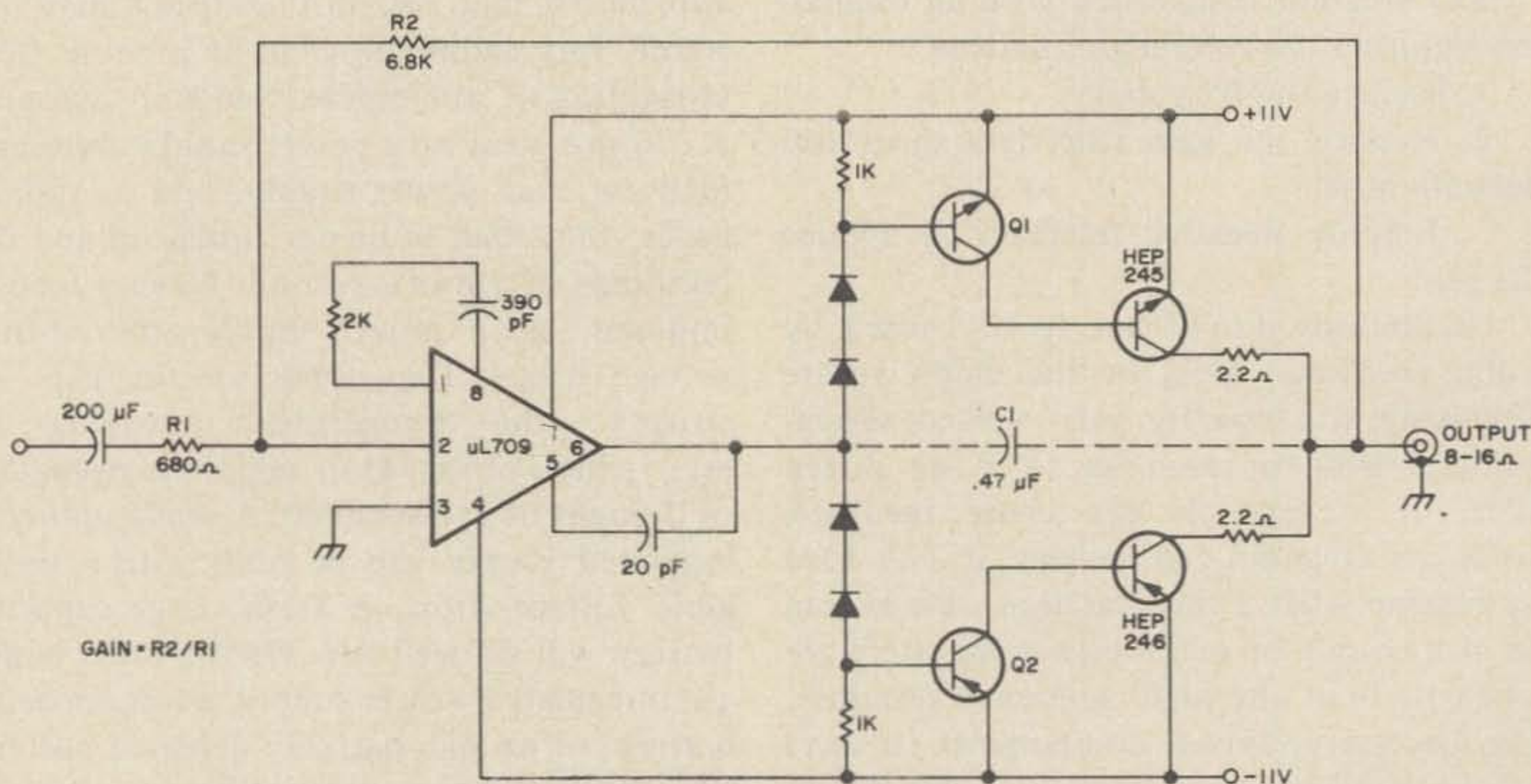
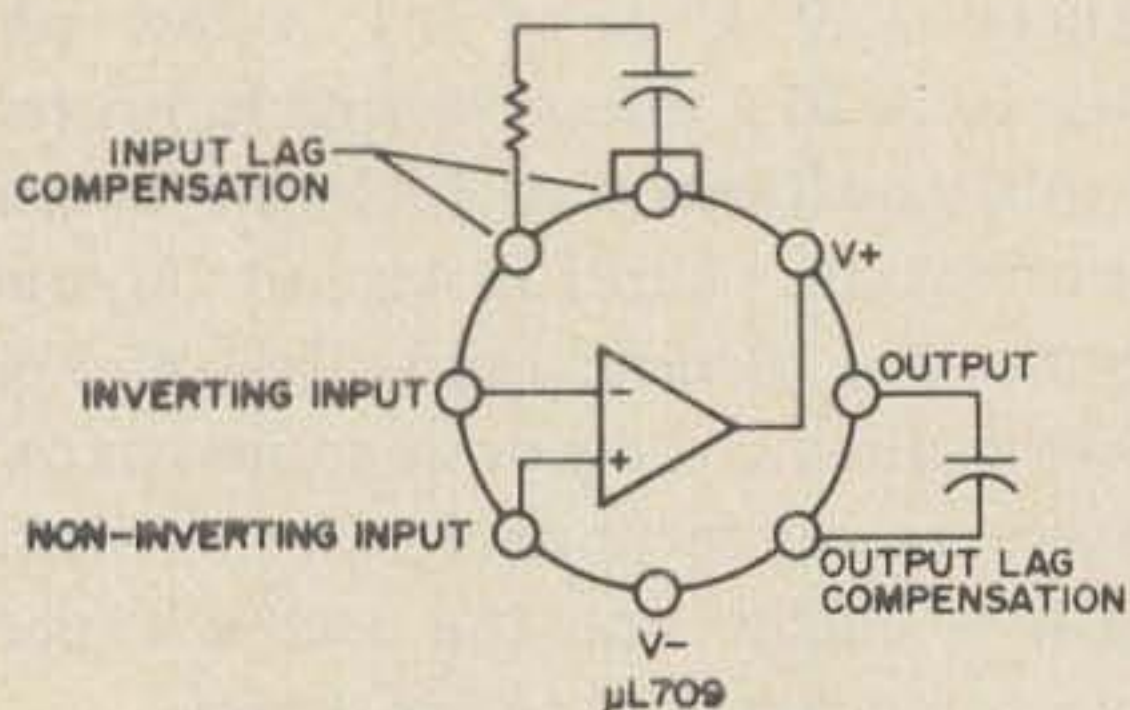
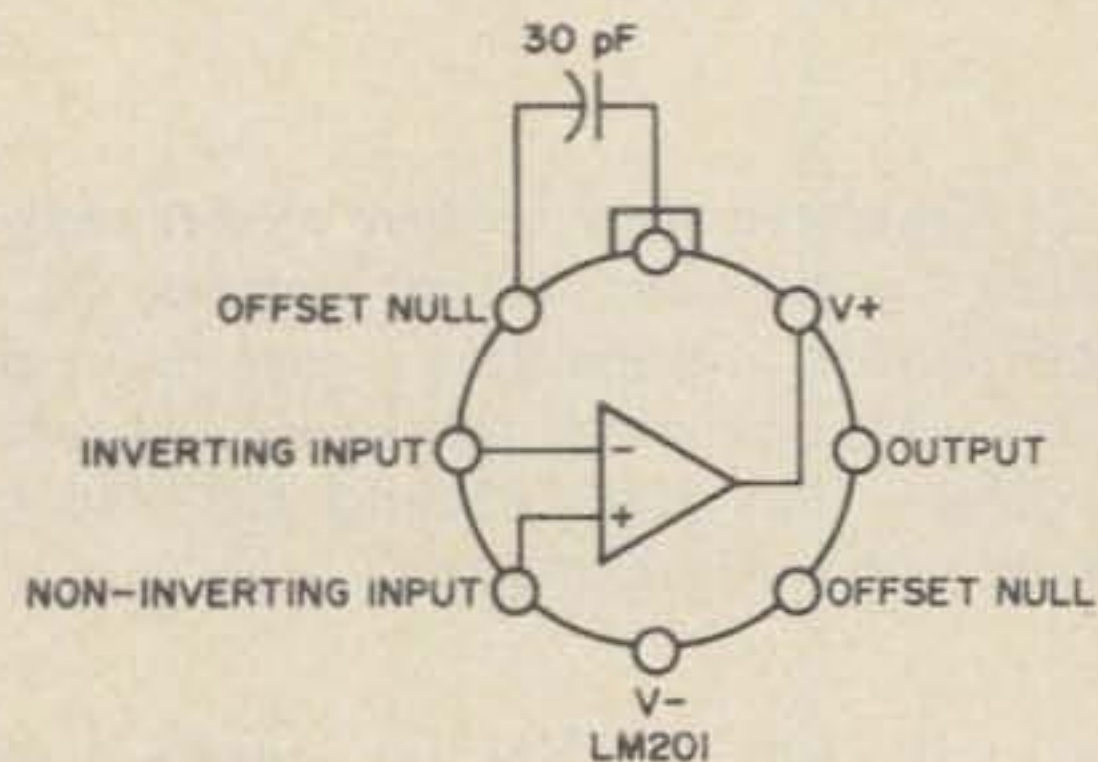
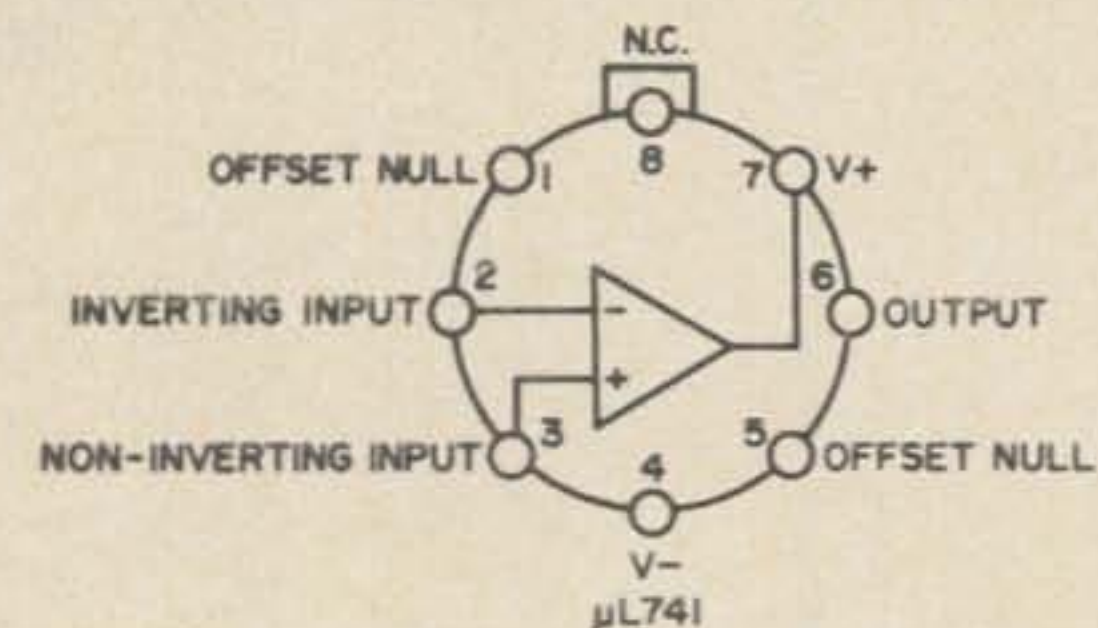
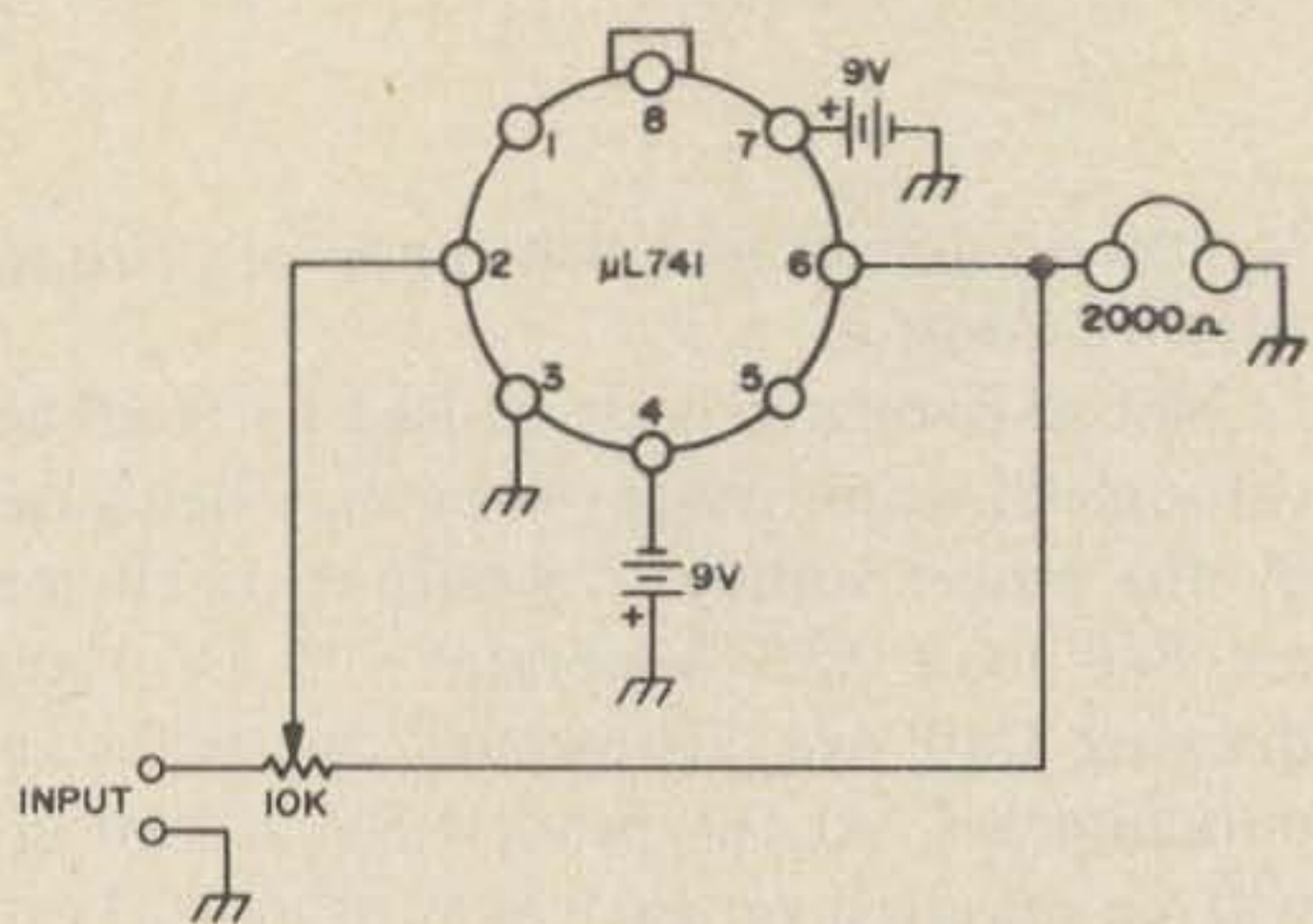

Fig. 3. (a) A very simple op-amp amplifier. (b) Base diagrams for three popular op-amps. (c) An op-amp used as a driver for a high powered output stage.

Table I — Audio Amplifier Integrated Circuit Data

Amplifier Type	Power Output	Power Supply	Manufacturer /Source (See Table III)	Input Impedance	Output Impedance	Input for Full Output (Into 8Ω except CA3020)	Zero Output Current Drain	Distortion (Percentage Distortion/Power)	Price
Discrete	1.4W	Single 9-12V	—/2	2K	8 & 16Ω	6mV	12mA	10%/.8W	6.95
Op Amp	.2-.5W	Dual ±3-18V	Many/1,3,4,6	50K	150-400Ω	See Text	3-5 mA	Unknown	.35¢ up
CA3020 ) CA3020A ) KD2115 )	.550 W 1W .55W	Single 3-9V Single 3-25V Single 3-9V	RCA/3 RCA/3 RCA/4,5	1K or 50K	200Ω		(8-35 mA (14-30 mA (	10%/.55W 10%/1W	2.99 3.49 see text
MC1454 MC1554 HEP 593	1.4W 1.8W See text	Dual ±8V Dual ±8V Dual ±8V	Motorola/3 Motorola/3 Motorola/many	3-10K 7-10K ---	0.4Ω 0.2Ω ---	Optional for all three 280 mV, 155 mV 75 mV	11-20 mA 11-15 mA ---	5%/1W 5%/1.1W ---	3.50 17.10 7.95
MC1306	.2W	Single 9-12V	Motorola/3	High	0.5Ω	3 mV	4 mA	1%/.2W	1.10
MFC4000P	.25W	Single 3-12V	Motorola/3	Moderate	---	15 mV	6 mA	3%/.2W	.99
TAA300	.8W	Single 6-9V	Amperex/2	10K	1Ω	10 mV	9 mA	3%/.5W	3.95
PA237	2W	Single 9-27V	G.E./unk.	40K	.85Ω	8 mV	3-15 mA	5%/2W	unknown
TT-1W	1W	Single 20V	Westinghouse/1	50-400K	0.3Ω	140 mV	---	5-10%/1W	1.98

Table II — Additional Audio ICs

Ident	Manufacturer/Source (See Table III)	Power	Price
PA263	G.E./1	1W	2.95
MFC9020	Motorola/3	2W	2.50
C6004	Motorola/3	1W	2.90
C6005	Motorola/3	2W	4.35
C6006	Motorola/3	4W	5.60
SE540L	Signetics/7	Driver	Unknown
NE540L	Signetics/7,1	Driver	2.50
SL630	Plessey/3	Unknown	5.35
SN76001	Texas Inst/3	1W	Unknown
SN76003	Texas Inst/3	3W	Unknown
SN76005	Texas Inst/3	5W	Unknown
SN76013	Texas Inst/3	3W	Unknown
SGS4	Sanken	4W	2.50

Table III — IC Suppliers  
(Numbers refer to "source" in Tables I and II)

1. Polypaks P.O. Box 942R Lynnfield MA 01940.	Price does not include postage. 25% deposit on C.O.D.s. No minimum order. Often (but not always) includes data sheets on ICs.
2. Allied/Radio Shack.	Nationwide franchised stores — check your telephone directory. Advertises that items from industrial catalog may be ordered from local stores, which would make most ICs available from them.
3. Circuit Specialists Box 3043 Scottsdale AZ 85257	Add 35¢ for shipping. No minimum order. Sometimes includes data sheets. They indicate they can supply just about any semiconductor or IC, and therefore they may be a good source for Signetics, Motorola, etc., which are not carried by Allied.
4. Allied Industrial 2400 W. Washington Blvd. Chicago IL	Postage is not included. Minimum order is \$5, with a \$1 handling charge on orders up to \$10. Thanks to the nationwide existence of Allied/Radio Shack stores, sales tax is required in most states. Data sheets are not included. See 2 above for an alternative ordering method.
5. Lafayette Corp. 111 Jericho Turnpike Syosset, L.I., NY 11791	Postage not included. Add 50¢ handling charge on orders of less than \$5.00. Probably will ship UPS despite explicit request for parcel post.
6. HAL Devices Box 365H Urbana IL 61801	Postage not included, add 75¢. Will ship UPS unless otherwise specified.
7. Signetics Corp 811 East Arques Ave. Sunnyvale CA 94086	Signetics suppliers are hard to come by. A polite letter to this address may produce an indication of who can supply the circuit for you. Alternatively, try source 3 above.

zeners. They require a 4 to 5V voltage drop for proper operation. They can be replaced with resistors selected to set zener current at 5 mA or more at maximum load. The zeners may have to be replaced with higher power units.

If an overload protected supply is to be used, the current limit must be set high enough to permit maximum power peaks to pass. If the amplifier is eventually to be run from a battery supply, a large value capacitor across the power leads will help some in extending the amount of internal resistance which can be tolerated in the battery — thereby extending the useful life of the battery.

One final note before we get into discussion of the individual ICs. Audio amplifier ICs are intended for speech reproduction. This means they must handle voice peaks without distortion. Sine waves pack a lot more energy than typical voice waves. When testing an amplifier with an audio oscillator and a scope, avoid driving the amplifier for any length of time at anywhere near the level at which the wave peaks start to be clipped, since it will probably be delivering far more power than it was designed to deliver, and will shortly correct that situation by melting after which it will not deliver any power at all.

### The Amplifiers in Table I.

*Discrete.* This is a four transistor, transformer coupled amplifier. It requires about six cubic inches of space. It was included to

demonstrate that ICs are competitive with discrete amplifiers in all significant areas.

*Op-Amp.* We do not ordinarily think of operational amplifiers as audio output stages, primarily because their package dissipations are rather low and their output impedance is rather high. However, when used with high impedance phones or transformer coupled to low impedance phones they will produce all the earphone volume which could possibly be desired. Loudspeaker volume is marginal, but satisfactory for a quiet environment. The amplifier of Fig. 3a has got to be about as simple as you can get: two batteries, a pot, an IC and headphones. It provides a comfortable listening level on 1 mV input. Figure 3c shows the use of an op-amp as a driver. Q1 and Q2 are inexpensive epoxy transistors. The diodes are silicon computer types. The output transistors require heatsinks. R1 and R2 control gain — in Fig. 3c it is set to 10. The capacitor C1 may be required to cut a tendency toward high frequency oscillation. Power output is more than adequate and the fidelity is excellent. Frequency response is flat from 5 Hz to above 100 kHz.

*CA3020, CA3020A, KD2115.* These are three versions of the same chip which is nominally a high power, wideband amplifier. The KD2115 is sold in a package with 2-KD2114 and 2-KD2116. The price is \$5.90, which isn't too bad since the KD2114 is the CA3018 transistor array. The KD2116 seems to be the same as the CA3036 dual darlington array. The CA3020 is somewhat unusual. Among its peculiarities are an optional emitter follower input stage which permits a choice of input impedances; the connection of the final emitters to external contacts to allow emitter resistors to be provided, and a high output impedance which requires transformer coupling. Although excellent for such uses as QRP 40 and 80 meter transmitters, etc., this chip would not be my choice for a receiver audio amplifier.

*MC1454, MC1554, HEP593.* Again the same chip in three different guises. The MC1554 is the premium version, the MC1454 the commercial version, and the HEP593 is the experimenter's version. An examination of the prices shows that

patience in waiting for a mail-ordered MC1454 instead of rushing down to the store to buy an HEP593 is well rewarded. The principal drawback of this IC is the requirement for dual power supplies. If, however, the equipment already had dual supplies and more power was required than the 200 mW or so that can be coaxed out of an op-amp, this would probably be the IC to choose.

*MC1306.* This is listed in some places as a 500 mW IC, and the maximum package dissipation is even higher. However, the harmonic distortion curve goes through a right angle bend and heads straight up between 200 and 300 mW. Within its power limitations, this is an outstanding bargain at \$1.10. The specs are very good. It seems an excellent choice for portable equipment (although my own choice would be the op-amp of Fig. 1a), and for receivers which are generally used with earphones, but may occasionally be used with speakers when demonstrating the radio to friends.

*MFC4000P.* This is intended for portable radios. It is a four terminal device, which is about as simple as you can get. In general, one would be inclined to use it in the same sorts of applications as the MC1306P. It has a lot of gain, and (unlike the MC1306P) no obvious way to control the gain. This could make it somewhat hard to tame.

*TAA300.* This widely-available IC frequently appears in articles. It requires a heat sink for maximum power output. It will deliver enough power for any reasonable application. Certainly a better choice than the CA3020 for a receiver output stage, the worst problem in using it will probably be that of trying to get anything like the potential sensitivity out of it without feedback problems.

*PA237.* This IC has appeared as the output stage of many receivers in 73, QST, and Ham Radio during the past two years. The specs are excellent. The greatest difficulty is finding a supplier. You might try your local GE distributor or Circuit Specialists (see Table III).

*TT-1W.* The specs on this look fine and the price is certainly moderate enough.

Kenney



# GET TO THE FAST TOP!

NOW YOU CAN CHANGE, ADJUST OR JUST PLAIN WORK ON YOUR ANTENNA AND NEVER LEAVE THE GROUND!

ROHN manufactures towers that are designed and engineered to do specific jobs and that is why we have the FOLD-OVER TOWER . . . designed for the amateur. When you need to "get at" your antenna just turn the handle and there it is. Like other ROHN big communication towers, they're hot dip galvanized **after** fabrication to provide a maintenance free, long lived and attractive installation. ROHN towers are known and used throughout the world . . . for almost a quarter century . . . in most every type of operation. You'll be in good company. Why not check with your distributor today?



**ROHN** MANUFACTURING

®

DIVISION OF

**UNARCO**

INDUSTRIES, Inc.

P.O. Box 2000 / Peoria, Ill. 61601

# A SIMPLE SWEEP GENERATOR FOR MONITOR SCOPES

A short time ago I finished building a monitor scope for my SSB rig and I found that I needed a 30 Hz sweep generator. It had to be a sawtooth wave, so that let out using a 60 Hz sine wave. Not needing a fancy generator I thought back to a simplex experiment that I performed at college using a neon bulb as a relaxation oscillator for producing a sawtooth wave.

This is a simple circuit to understand if a few basic facts are known about neon bulbs. First is its resistance. When the neon bulb is not firing, the resistance is in the megohm range. But when the bulb is firing, heavy conduction occurs which means that the resistance is low. Second, there is a certain

voltage that these bulbs will fire at, usually about 70 volts.

Referring to the circuit diagram, R2, R3 and C1 is just a simple RC timing circuit. The rate in which the condenser charges, depends on the values of R2, R3 and C1. However, when C1 charges to a certain value of voltage, the neon bulbs which are connected across it will fire and the condenser will then discharge through the neon bulb. Then the condenser will start charging again and the cycle starts over, and a sawtooth wave is being generated.

R1 is a pot which is used as a voltage control for the circuit. The top end of the pot is connected to a voltage source of about 500 volts. The polarity makes no difference. The value of this pot should be at least 500 K $\Omega$ .

The neon bulbs are NE-2 type, or what have you. For C1 I used a .005  $\mu$ F with an adequate voltage rating.

The larger the sweep width you want the more neon bulbs should be placed in series. I found that four bulbs in series gave me a good sweep width.

This circuit I found was the simplest and the cheapest that could be built to produce the sweep needed to make my monitor go.

...WA2HJN

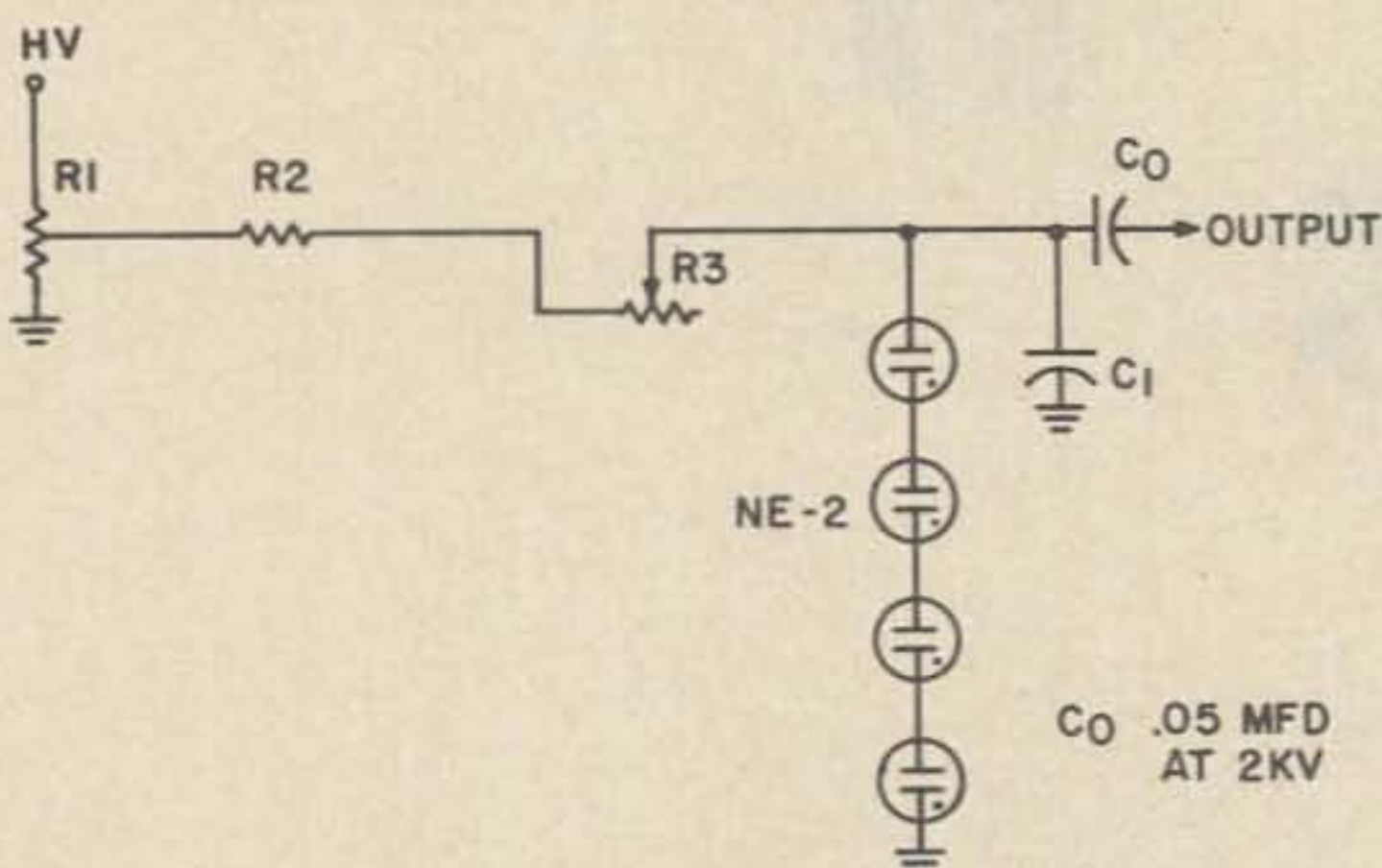

Fig. 1. Circuit diagram.

# good things come in small packages



That description fits the INOUE IC-22. What other 2 meter unit has 22 channel capability in a 2¼" X 6" X 8½" package for under \$300.00?

The IC-22 incorporates the latest in miniaturization and printed circuitry. Once you look inside an IC-22, you will immediately realize why INOUE is rated tops in the 2 meter FM field.

Supplied with five channels, this little package is ready to go at \$289.00 plus sales tax if applicable, UPS pre-paid to your door.

Call us today or better still, drop in for a demonstration. BankAmericard accepted . . . PHONE 518-842-8350

## ADIRONDACK

RADIO SUPPLY, INC.  
Serving the radio amateur since 1936

185 W. Main St. Amsterdam, NY 12010 Tel. (518) 842-8350

# NEW REGULATIONS (1938)

**T**hose new repeater regulations remind me of a time in ham history, another time in which we were given the business by new regulations. We didn't need them then, either.

On October 4, 1938, the FCC adopted a set of new amateur regulations, effective December 1, 1938. This was a complete rewrite of Chapter XII. Of particular interest to us were Parts 152.41 and 152.42. To quote from *QST*, December 1938, page 14: "No more modulated oscillators and raw ac in the 5-meter band. The requirement to use adequately-filtered dc supply, have stable signals and to avoid over-modulation and frequency modulation is now extended to 60 MHz. The same rules now apply to this band that have previously applied being 30 MHz. *QST* recently took a poll of membership sentiment on this question and found about 87% of the replies in favor of the change, so we are sure it will be generally acceptable. Simple transceivers and self-excited oscillators and other experimental apparatus may still be used above 112 MHz."

The new regulations were the direct result of the ARRL requesting a change of rules.

The "poll of membership sentiment" mentioned above was taken from QSL or post-card mail returns in answer to the proposal (No. 1) made in the July 1938 issue of *QST*, on page 26. The poll was open only to members of the League. Answers could not be qualified; they had to be "Yes" or "No" and they had to be received at ARRL Headquarters by noon of September 1, 1938. It is interesting to note that the ARRL request to change these rules was acted upon by the FCC on October 4, 1938!

Our 5 meter band in those days was 56 to 60 MHz, years later to become part of TV Channel 2 as we were shifted to 50-54 MHz to form the 6 meter band. And these were the pre-World War II depression years. Like most other teen-age hams of that era we had no money to spend on expensive communication receivers, high power tubes and parts required to get us on phone on the lower frequency bands where the action was. However, on 5 meters we could use receiving tubes and other parts scrounged from old broadcast radios. On 5 meters we could talk with our contemporaries, other teenagers with that same inexplicable desire to build,

**NURMI ELECTRONIC SUPPLY**

Departments 28

1727 Donna Road · West Palm Beach, Florida 33401

PHONE — (305) 686-8553



**HEP 170's**



**THE "DO EVERYTHING" 2½ AMP, 1000 VOLT DIODE**

Motorola is catching up on the backlog and we've got thousands of them back in stock. 10/\$3.00 — 100/\$25.00

**RCA 40673'S**

THE MOST POPULAR DUAL GATE PROTECTED MOS FET around. Good to over 400 MHZ. We got 'em and you get 'em for only ..... 5/\$6.00

**OTHER FET'S**

2N4220A	N - JFET	\$2.07
2N4221A	N - JFET	2.03
2N4222	N - JFET	1.70
2N4222A	N - JFET	2.03
2N5454	N - JFET	2.00
2N5592	N - JFET	2.00
2N5593	N - JFET	2.00
MFE3004	N - MOSFET	1.80

**RG - 174/U**

WE WENT THROUGH 20 MILES OF IT LAST TIME! We are authorized Belden Distributors and new shipments have come in from the factory. Split a 500' spool with a friend and save \$\$\$\$\$

BELDEN NO. 8216 100'/\$4.80 — 500'/\$17.85

**LED Readouts**



	SIZE	COLOR	DECIMAL	EACH	SPECIAL
OPCOA SLA-1	.33	Red	Yes	2.95	4/\$11
OPCOA SLA-11C	.33	Green	Yes	4.95	4/\$16
OPCOA SLA-3H	.70	Red	Yes	4.50	4/\$16

All use 7447 Drivers. Specs included.

**RF POWER TRANSISTORS**

We did it again - All brand new with standard markings and most were manufactured this year. A major manufacturer dropped his RF power line and we bought his inventory.

2N5589	3 Watts Out	\$ 3.50
2N5590	10 Watts Out	6.00
2N5591	25 Watts Out	12.00
2N6080	4 Watts Out	5.00
2N6082	25 Watts Out	10.00
2N6083	30 Watts Out	12.00
2N6084	40 Watts Out	15.00

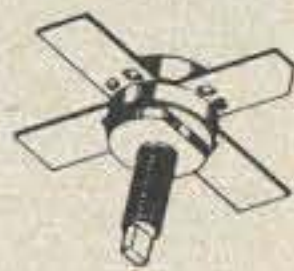

All are Silicon NPN and power output ratings are good to 175 MHZ. Hurry some quantities are limited.

**KEYSTONE PERF BOARD**

G-10 Glass Epoxy Perf Board 3/64" Thick.

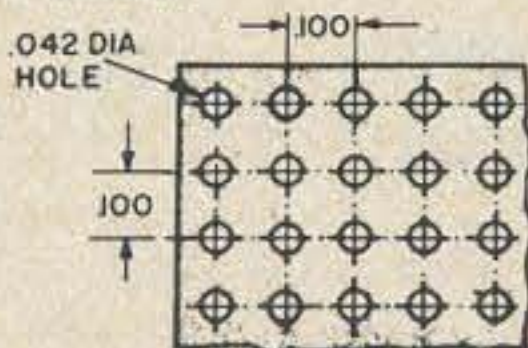

No.	Size (in.)	Price
--UNCLAD--		
4229	2 x 4½	\$ .85
4230	2 x 6	1.09
4231	4½ x 6	1.55
4232	17 x 6	5.75
--COPPER CLAD ONE SIDE----		
4238	2 x 4½	1.35
4239	2 x 6	1.85
4240	4½ x 6	3.20
4241	17 x 6	6.70

**WE GUARANTEE WHAT WE SELL!!!!**

We ship UPS whenever possible. Give street address. Include enough for postage, excess refunded in cash. Florida residents include 4% Tax.

create, and talk via radio. Most of us were *not* ARRL members and only an occasional 25¢ was spent for a newsstand copy of *QST*. The \$2.50 per year for a subscription and membership in the ARRL was more than this teenager earned in a week with his newspaper route.

But we were all having a ball on 5 meters! Receivers were simple super-regens with a 56, 76, or a 6J5 as the detector, followed by two stages of audio. Transmitters were nearly all of the uncomplicated self-excited "TNT" type, using 76's, 45's, or 10's; later the dual triode 53 or the 6A6. Modulators were of the Heising type, where we could use a filter choke as a modulation choke. (Who could afford a modulation transformer?) And the antennas were something. Towers — hah! We used fence wire guyed wood masts made from hand-cut 2 X 2's or spliced bamboo rug poles. Trees, if handy, were also utilized. We built our antennas out of copper wire usually; sometimes we were even able to scrounge (?) an 8-foot piece of ½-inch copper pipe. Coax was something we read about. We used 2-inch spaced open wire feeders with waxed wood spreaders, delta-matched to a vertical half-wave radiator. Twisted lamp cord was frequently used to feed a "J" antenna. Antenna relays were virtually nonexistent. A good many of us used two blade porcelain-base knife switches stocked by hardware stores for antenna changeover. The more sophisticated 5 meter stations had *two* antennas, one for receiving and the other for transmitting. With this arrangement we found we could work *duplex*! Here was the height of hamming!

Then the roof fell in on December 1, 1938. Suddenly 5 meters became a vast, almost empty, wasteland. Where was that 87%? We suspected they had never left 20 and 75 meters in the first place. Too late we realized that limiting that poll to ARRL members was decidedly unfair. Right up to our entry into World War II in December of 1941, 5 meters remained unused for all practical purposes.

Will we see a similar fate result in repeater activity?

...K2PMM/F8

# TPL is the answer to your amplifier needs



PA3 - 1AE/1AB (2 meters)  
(220 coming soon)

TPL 20 to 35W Amp. If your needs are 450, this is your amp. Up to 35 watts or more when driven by your mobile or handheld.

## TPL REPEATER CONFIGURATION

If repeaters are your thing, TPL has the answer. Order any TPL amp in the repeater configuration. Designed to mount in standard 19" rack. Completely RF shielded with AC supply and forced air cooling.



PA3 - 1EE/1AE/1DE (2 meters)

## Now here is some great news from TPL...



TPL 5010

Swan MB 40

**20W PEP = 140W PEP OUTPUT**

Put a pair of shoes on your new solid state transceiver from Swan on any low power rig between 2 to 30MHz.

TPL carries a complete line of amplifiers up to 400 watts between 2MHz and 516MHz.

talk  
power  
by

**TPL**

COMMUNICATIONS INC.

13125 YUKON AVENUE / HAWTHORNE, CALIF. 90250 / (213) 679-0131

# QUICK 'N EASY 15 OR 20 METER VERTICAL

*For quick'n easy contacts.*

**A** vertical for 15 or 20 meter operation is real easy and inexpensive to put up. In a clear and open space, drive a wooden stake in the earth for about one foot. This is the base for a TV pole which has been loosely attached to a second pole with two "U" clamps (see Fig. 1 and Parts List). By sliding the second pole trombone-style, one can adjust the second pole from the ground for later tuning with an swr meter. I set the height off the ground of the lower end of the vertical at three feet more or less.

Now three lengths of nylon line are attached to the upper "U" clamp and the vertical is elevated by lashing the TV pole to the driven stake and fixing the lengths of nylon line to the driven steady stakes. Your vertical is now in the air and can be firmed up at the base and with the nylon guys.

Pick out your choice of operation of either 15 or 20 meters and fix the TV pole length at a test length of 320 cm for 15 meters or 470 cm for 20 meters. Put the third and last "U" clamp at the base around the wooden stake and the TV pole. A short length of wire from the "U" clamp to one side of the coax connector will complete the vertical part of this antenna.

## The Radial System

Your quarter wave ground plane vertical will work best with a wire radial system which is quick and easy to make. For

instance, for 15 meters cut four radials 320 cm long and fix insulators with connecting nylon lines. One end of the nylon line is attached to the wooden stake base of the vertical. A lead from each radial is joined to fix to the other side of the coax connector. Each end of the radial is fanned out to 90° and stakes support the other end of the radial wires which are attached to the insulators. Wire length for 20 meter operation I found to be 470 cm.

## Adjustment

With your swr meter and a transmitted signal you can bring your Quick 'N Easy vertical quite close to 1:1 by adjusting the length of the vertical element. Then tighten the "U" clamps which hold the two poles together.

Raising and lowering the radial attachment at the base of the vertical will give a good impedance match with improved swr reading. From the tie down, the radials are parallel with the ground.

## Modifications

There are several modifications with which you might experiment.

First, you could try substituting a water pipe, sprinkler system, or a rod driven in the earth for the radial system. Also, I've added a base tuner to this type of grounding system. Chicken wire stretched from the vertical base will act almost as well as the radial wires. In your shack, you could use a

## KITS

Sub-Audible tone



Encoder \$8.95

Decoder \$9.95



- Compatible with all sub-audible tone systems such as Private Line, Channel Guard, Quiet Channel, etc.
- Glass epoxy PCB's & silicon xstrs throughout.
- Any reeds, except special dual coil types may be used: Motorola, G.E., RCA, S.D.L., Bramco, etc.
- All are powered by 12 vdc.
- Use on any tone frequency 67 Hz to 250 Hz
- Small size 1.5 x 4 x .75"
- All parts included except reed and reed socket
- Postpaid - Calif. residents add 5% sales tax

### COMMUNICATIONS SPECIALISTS

P.O. Box 153 Brea CA 92621

## ACTIVE AUDIO FILTERS

IC'S FOR SUPER HIGH PERFORMANCE

**CW FILTER (CWF-2)** Get razor sharp selectivity; No impedance matching! BW (selectable) 80 Hz, 110 Hz, 180 Hz; Center frequency F=750 Hz; Skirts 60 db down at 1/2F and 2F; 4 op amps; 2"x3" PC board; \$14.95 wired, tested, guaranteed; \$12.95 kit.



CWF-2: \$12.95 KIT, \$14.95 WIRED

**CW MINI FILTER (CWF-3)** 1 1/2"x2" PC board; Center frequency F=750 Hz; 30 db down at 1/2F and 2F; BW 110 Hz; 2 op amps; \$8.95 wired, tested, guaranteed; \$7.95 kit.

**LOW PASS FILTER (LPF-1)** Resistors set cutoff 500 Hz to 20 KHz; Factory set to 2.5 KHz; Rolloff 48 db per octave; Input imp 1 M; Gain=1; 5 op amps; 2"x3" PC board; \$16.95 wired, tested, guaranteed; \$14.95 kit.

\*\*\*\*please include 55¢ postage on all orders\*\*\*\*

WRITE FOR FREE SPEC SHEETS!!!

## MFJ ENTERPRISES

P.O. Box 494 C  
Miss. State, Ms 39762

long wire tuner with any of these arrays. With my long wire tuner I have worked both 15 and 20 meters with this vertical and a good water pipe ground. A variation here with your long wire tuner might be that you could join together the center, and the braid of the coax, so that the verticals, radials, and the transmission line might act as a quarter wave for tuning in all of the amateur bands. All this can be worked and tuned against a ground obtained from a water pipe.

Beautiful gain can be obtained by constructing a second antenna a correct distance away for directional phasing. Tapped coils at the base and in line traps could find you enough research challenges to keep you off that third stool in Joe's Bar for several months.

TV poles can be easily fitted into each other and guyed so that a 40 and 80 meter vertical can be constructed. I haven't tried this yet.

### Comparison

I've had a chance to compare the Quick 'N Easy vertical with a commercial vertical which is 550 cm high with 1000 cm radials

operating as a type of compromise on both 15 and 20 meters. My vertical will outperform this unit and has a better swr across the band.

### Advantages

This type of antenna has many advantages.

First, one builds this antenna in the absence of formulas, slide rules, calculators, a lot of real estate or a great knowledge of electronics. Your transmitter, an swr meter and a little limberness is all that is needed.

Second, the vertical is built just off the ground with no necessity of poles, towers or high trees. This reduces the costs and the objections of your XYL or neighbors.

Third, there is no need to climb ladders, towers, trees, the roof, or fences.

Adjustments for improved frequency and impedance are done by merely tilting the vertical element after loosening the supports. The radials are right at hand for changing lengths, direction, height above the earth and the angle at which the radials leave the vertical element. The placing of the antenna

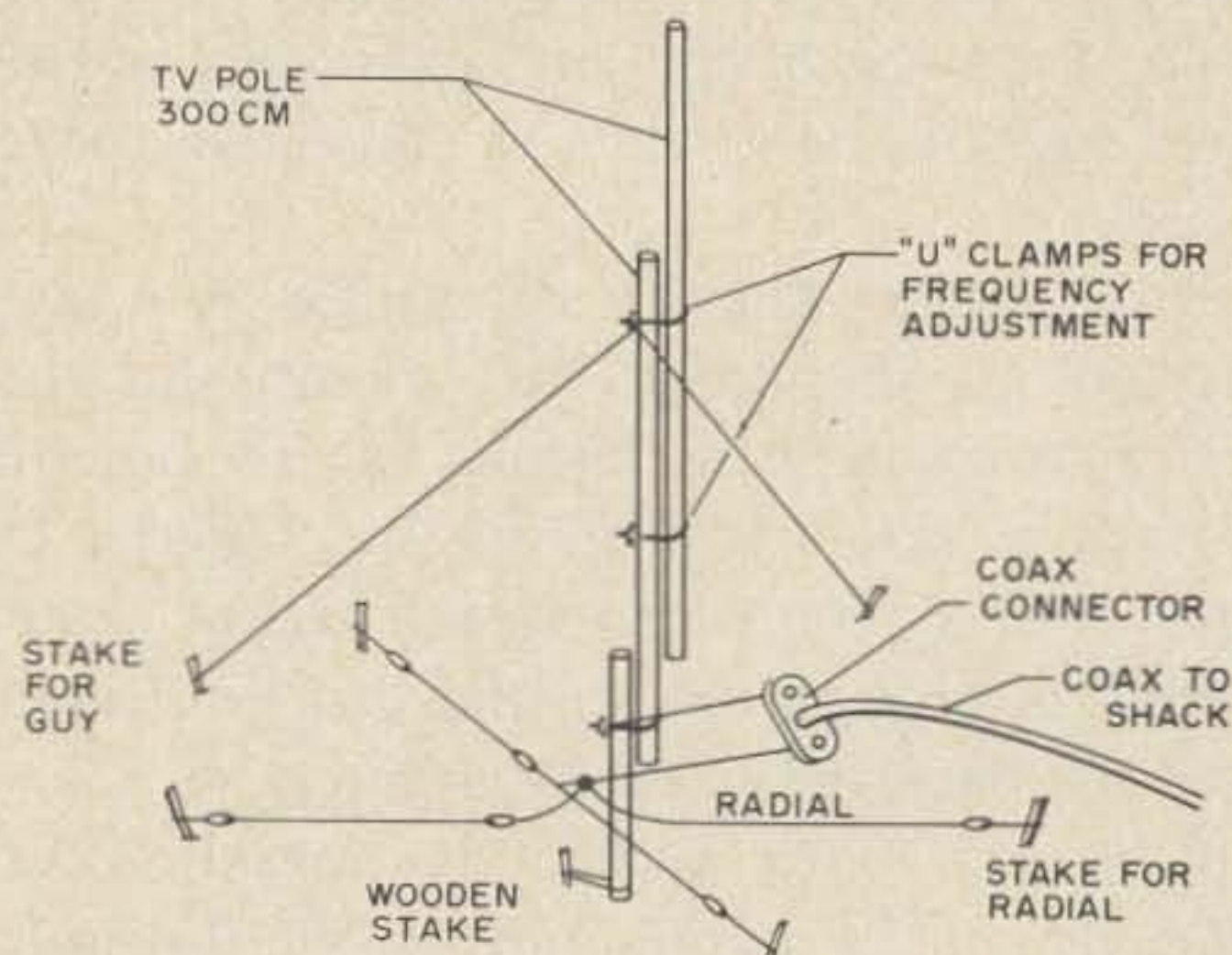

Fig. 1. Quick 'N Easy 15 or 20 meter vertical made with two 300 cm TV poles and a ground radial system.

### Parts List

- 2 - 300 cm TV poles.
- 3 - "U" clamps to fit across the poles.
- 5 - wooden stakes.
- 1 - coax connector (such as HQ1, Budwig Manufacturing Company, Box 97, Ramona CA 92065. Price \$2.95).
- 1 - roll of nylon line (#20, Sears Roebuck & Company. Price \$1.29).
- 1 - 1500 cm of #12 or thereabouts wire.
- 8 - insulators.



in its functioning position is simple, with minimal effort, with no pulleys, cranks, climbing or other hazards.

Some arrays costing manyfold more than this simple antenna are often out of resonance plus other problems which reduce the efficiency, causing TVI and other critical situations. Solutions and corrections to these problems in more complicated arrays take instruments and experience which aren't easy to come by.

This vertical depends on its radials, with no need for a particular type of ground or earth and the radials bring a simple ground right up to the level of antenna function.

Be sure to put the antenna out in the clear, as the maximal current at the base of the vertical with the low angle of radiation will defeat this type of installation in a

Table I

	15m	20m
Vert. el.	320 cm	470 cm
Radial length	320 cm	470 cm
Height of base from ground	90 cm	120 cm

Four radials are used on each band.

boxed-in location. For example, I once installed a store-bought vertical close to the house near a tree. After I cut the limbs off the tree and made my XYL hopping mad, I moved it into the clear. The antenna worked great, but I still get static on that darned tree.

Last summer I constructed two phased 40 meter verticals in the border of our yard. The rf was so completely absorbed that a strong wind would only carry my signal a couple of blocks.

Lastly, I tried an aluminum rod over the balcony of this steel monster high-rise condominium. This tipped-over vertical pushed all of the rf into the building. I now use my fish-pole antenna which clears the building and it works great.

So, be sure to put the Quick 'N Easy in the clear. I've learned.

The measurements in Table I give you the set of figures in my QTH with its set of circumstances. You may need to try your own measurements. So pick up courage and be with it.

...KH6HDM

## A FASCINATING HOBBY!

VINTAGE RADIO brings you the pioneer days of wireless and radio in pictures. The collector's bible, it opens the doors to a new hobby. Great browsing, too. Over 1,000 pictures, 263 pages. 1887-1929.



AVOID DELAY; SEND TODAY

Mail check to Vintage Radio, Dep't 7,  
Box 2045, Palos Verdes Peninsula, CA., 90274

Vintage Radio, hard cover \$6.95

Vintage Radio, handbook 4.95

Radio Collectors Guide 3.95

Postage Paid, California residents add 5% Tax.

Name \_\_\_\_\_

Street \_\_\_\_\_

City \_\_\_\_\_ State \_\_\_\_\_ Zip \_\_\_\_\_

## ENJOY THE OLD DAYS!

## HAL COMMUNICATIONS

HOT CARRIER DIODES:	HP2800.....\$ .90, 12/S10.00	Matched by HAL.....4/S4.25
ZENERS:	1N4729(3.6v), 1N4733(5.1v), 1N4735(6.2v), 1N4738(8.2v), 1N4739(9.1v), 1N4742(12v), 1N4742(12v), 1 watt.....\$ .75	
LINEAR ICs:	709N.....\$ .75 709L, 710N.....\$1.25 741N.....\$1.50 MC1429G.....\$3.75 MC1496G.....\$3.25 MC1590G.....\$5.60	
DIGITAL ICs:	F, L923.....\$ .90 MC767P.....\$3.30 MC723P.....\$ .95	
MRTL:	MC788P.....\$1.30 MC880P.....\$3.50 MC890P.....\$2.00 MC724P, MC725P, MC789P, MC792P.....\$1.05 MC771P.....\$1.75 MC970P.....\$3.30 MC9760P.....\$5.45	
DIP TTL:	7400, 7401, 7402, 7410, 7420, 7430, 7440.....\$ .48 7404, 7405.....\$ .60 7441, 7495, 7496.....\$3.00 7442.....\$2.25 7472.....\$ .75 7473, 7474.....\$1.05 7475.....\$2.40 7486.....\$1.15 7490, 7492, 7493.....\$2.10 74121.....\$1.40 FETS: 40673 MOSFET.....\$1.60 MPF102.....\$ .60 2N3819.....\$ .55	
TOROIDs:	Indiana General CF102-Q6, CF102-Q1, CF101-Q2.....\$ .50 CF102-Q3.....\$1.25 FERROXUBE FERRITE BEADS...10/S1.25	
CINCH IC SOCKETS:	8-ICS, 14-DIP.....\$ .60 10-ICS, 16-DIP.....\$ .70	

MANY OTHER DEVICES AND COMPONENTS IN STOCK. WRITE FOR CATALOG.

## HAL COMMUNICATIONS

Box 365L, Urbana IL 61801 ● 217-359-7373

## HAL COMMUNICATIONS HAL ID-1 REPEATER IDENTIFIER

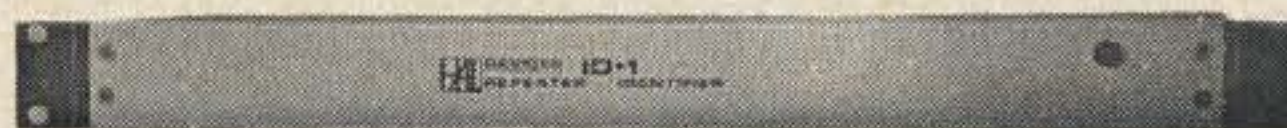

Circuit board wired & tested . . . . \$75.00

With rack w/cabinet . . . . . \$115.00

TTL logic. Power line frequency counter for 3 minute or less timing and control. Easily re-programmable diode ROM uses only 27 diodes (depending on call) to send DE "any call". Low impedance audio with volume and tone control. All circuitry including PS on small G10 glass PC board. Write for full details. HAL COMMUNICATIONS, Box 365L, Urbana IL 61801



# New Heathkit 2-meter Transceiver ONLY \$179<sup>95</sup>\*

**HW-202 SPECIFICATIONS—RECEIVER—Sensitivity:** 12 dB SINAD\* (or 15 dB of quieting) at .5 $\mu$ v or less. **Squelch threshold:** 0.3 $\mu$ v or less. **Audio output:** 2 W at less than 10% total harmonic distortion (THD). **Operating frequency stability:** Better than  $\pm$ .0015%. **Image rejection:** Greater than 55 dB. **Spurious rejection:** Greater than 60 dB. **IF rejection:** Greater than 75 dB. **First IF frequency:** 10.7 MHz  $\pm$ 2 kHz. **Second IF frequency:** 455 kHz (adjustable). **Receiver bandwidth:** 22 kHz nominal. **De-emphasis:** -6 dB per octave from 300 to 3000 Hz nominal. **Modulation acceptance:** 7.5 kHz minimum. **TRANSMITTER—Power output:** 10 watts minimum. **Spurious output:** Below -45 dB from carrier. **Stability:** Better than  $\pm$ .0015%. **Oscillator frequency:** 6 MHz, approximately. **Multiplier factor:** X 24. **Modulation:** Phase, adjustable 0-7.5 kHz, with instantaneous limiting. **Duty cycle:** 100% with  $\infty$  VSWR. **High VSWR shutdown:** None. **GENERAL—Speaker impedance:** 4 ohms. **Operating frequency range:** 143.9 to 148.3 MHz. **Current consumption: Receiver (squelched):** Less than 200 mA. **Transmitter:** Less than 2.2 amperes. **Operating temperature range:** -10° to 122° F (-24° to +50° C). **Operating voltage range:** 12.6 to 16.0 VDC (13.8 VDC nominal). **Dimensions:** 2 $\frac{3}{4}$ " H x 8 $\frac{1}{4}$ " W x 9 $\frac{7}{8}$ " D.

\*SINAD =  $\frac{\text{Signal} + \text{noise} + \text{distortion}}{\text{Noise} + \text{distortion}}$

It's an all solid-state design that you can build and completely align without special instruments. And this compact little beauty gives you 36 channel capability with independent push-button selection of 6 transmit and 6 receive crystals. 10 watts minimum output. Operates into an infinite VSWR without failure. And for the ultimate in convenience there's the optional tone burst encoder for front panel selection of four presettable tones. The HW-202 kit includes two crystals for set-up and alignment and simplex operation on 146.94; push-to-talk mike; 12-volt hook-up cable; heavy duty clips for use with temporary battery; antenna coax jack; gimbal bracket, and mobile mounting plate.

- Kit HW-202, 11 lbs., mailable .....17<sup>95</sup>\*
- Kit HWA-202-2, Tone Burst Encoder, 1 lb. ....24.35\*
- Kit HWA-202-1, AC Power Supply, 7 lbs. ....29.95\*
- Kit HWA-202-3, Mobile 2-Meter Antenna, 2 lbs. ....17.95\*
- Kit HWA-202-4, Fixed Station 2-Meter Antenna, 4 lbs. ....15.95\*

## ... and here's 40 watts out for your 10 watts in

The Heathkit HA-202 2-Meter Amplifier works with any 2-meter exciter delivering 5-15 watts while pulling a meager 7 amps from any 12 VDC system. No additional power supplies are required. All solid-state components mount on a single circuit board for easy two-evening assembly. Manual shows exact alignment procedures using a VOM or VTVM. Connecting cable and antenna cable are included.

Kit HA-202, 4 lbs. ....69.95\*

**HA-202 SPECIFICATIONS—Frequency range:** 143-149 MHz. **Power output:** 20W @ 5 W in, 30W @ 7.5W in, 40W @ 10 W in, 50W @ 15 W in. **Power input (rf drive):** 5 to 15W. **Input/output impedance:** 50 ohms, nominal. **Input VSWR:** 1.5:1 max. **Load VSWR:** 3:1 max. **Power supply requirements:** 12 to 16 VDC, 7 amps max. **Operating temperature range:** -30° F. to +140° F. **Dimensions:** 3" H x 4 $\frac{1}{4}$ " W x 5 $\frac{1}{2}$ " D.



\$69<sup>95</sup>\*

## ... then there's this perfect 2-meter tune-up tool



\$29<sup>95</sup>\*

The Heathkit VHF/SWR Bridge tests transmitter output in power ranges of 1 to 25 watts and 10 to 250 watts  $\pm$  10% of full scale. 50 ohm nominal impedance permits placement in transmission line permanently with little or no loss. Built-in SWR bridge for tuning 2-meter antenna for proper match, has less than 10-watt sensitivity.

Kit HM-2102, 4 lbs. ....29.95\*

**HM-2102 SPECIFICATIONS—Frequency range:** 50 MHz to 160 MHz. **Wattmeter accuracy:**  $\pm$ 10% of full-scale reading.\* **Power capability:** To 250 W. **SWR sensitivity:** less than 10 W. **Impedance:** 50 ohms nominal. **SWR bridge:** Continuous to 250 W. **Connectors:** UHF type SO-239. **Dimensions:** 5 $\frac{1}{4}$ " W, 5 $\frac{1}{8}$ " H and 6 $\frac{1}{2}$ " D, assembled as one unit.

\*Using a 50  $\Omega$  noninductive load.

## See them at your Heathkit Electronic Center —

**HEATHKIT ELECTRONIC CENTERS — ARIZ.:** Phoenix; **CALIF.:** Anaheim, El Cerrito, Los Angeles, Pomona, Redwood City, San Diego (La Mesa), Woodland Hills; **COLO.:** Denver; **CONN.:** Hartford (Avon); **FLA.:** Miami (Hialeah); **GA.:** Atlanta; **ILL.:** Chicago, Downers Grove; **IND.:** Indianapolis; **KANSAS:** Kansas City (Mission); **MD.:** Baltimore, Rockville; **MASS.:** Boston (Wellesley); **MICH.:** Detroit; **MINN.:** Minneapolis (Hopkins); **MO.:** St. Louis; **N.J.:** Fair Lawn; **N.Y.:** Buffalo (Amherst), New York City, Jericho; **L.I.:** Rochester; **OHIO:** Cincinnati (Woodlawn), Cleveland; **PA.:** Philadelphia, Pittsburgh; **R.I.:** Providence (Warwick); **TEXAS:** Dallas, Houston; **WASH.:** Seattle; **WIS.:** Milwaukee.

HEATH

Schlumberger

HEATH COMPANY, Dept. 11-2  
Benton Harbor, Michigan 49022

Please send FREE Heathkit Catalog.

Enclosed is \$\_\_\_\_\_, plus shipping

Please send model(s)\_\_\_\_\_

Name\_\_\_\_\_

Address\_\_\_\_\_

City\_\_\_\_\_ State\_\_\_\_\_ Zip\_\_\_\_\_

\*Mail order prices; F.O.B. factory AM-287R

# AN AUTOMATIC AND PHONE MONITOR CONTROL SYSTEM

*Control everything in your shack from miles away via the telephone wires.*

**H**ow would you like to dial your home phone (from anywhere), cut out the ring, listen to what's going on in your shack, turn your receiver or transmitter on or off, etc.?

This article tells you how to build your own automatic phone monitoring and remote control system. Basic items are a ring-blocking, 2 kHz narrow band amplifier, with simulated handset lift-off, and a pocket beeper to carry with you away from home. Just connect the red and green wires to the input. Incoming and outgoing calls from

anywhere proceed as usual, until you call from outside and actuate the pocket beeper. This 2 kHz signal goes through the amplifier, and turns on an SCR (silicon controlled rectifier) which terminates the line with around  $300\Omega$  which causes central office to prevent any bell ring, and make the connection. In effect, an electronic, non-mechanical, handset-lifter.

With a high-gain mike and amplifier built into the system, you can now listen in, even to very minute sounds, in your shack. Also, with more af transformers connected in, or

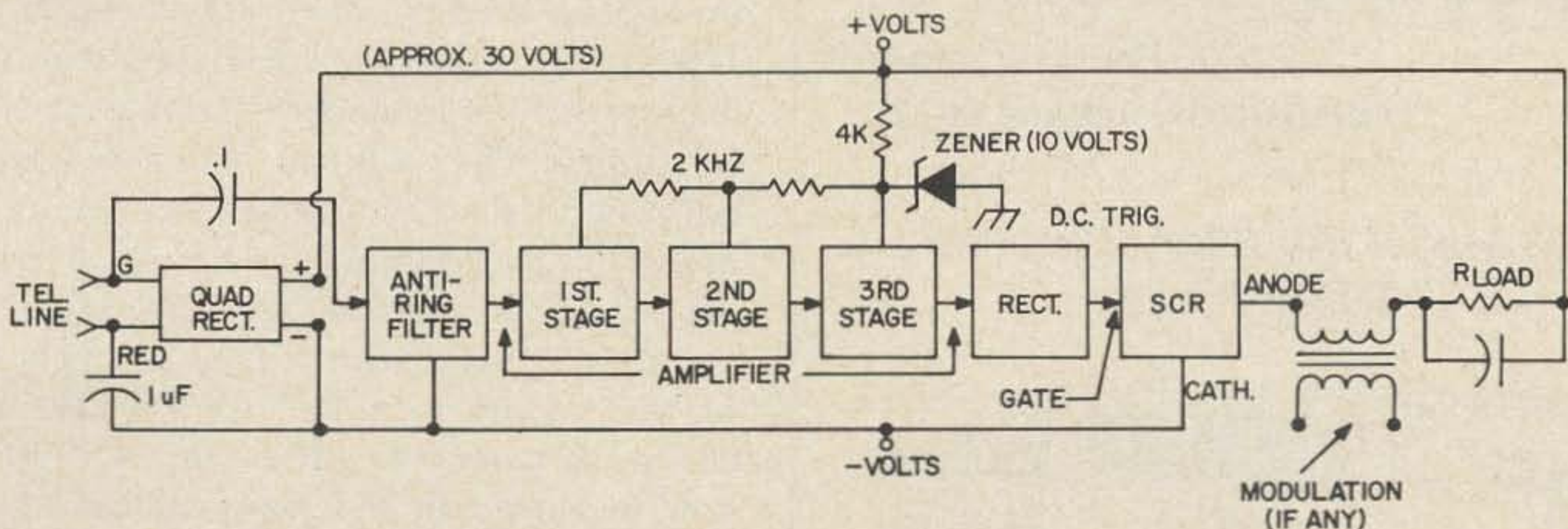

Fig. 1. Block diagram, 2 kHz amplifier.

**Regency** <sup>HR-2B</sup> gives  
a lot to talk over



American Made Quality at Import Price

**Full 12 Channel, 15 Watts  
with HI/LO power switch**

Here is everything you need, at a price you like, for excellent 2 meter FM performance. The 12 transmit channels have individual trimmer capacitors for optimum workability in point-to-point repeater applications. Operate on 15 watts (minimum) or switch to 1 watt. 0.35 uv sensitivity and 3 watts of audio output make for pleasant, reliable listening. And the compact package is matched by its price.

**\$229<sup>00</sup>**  
Amateur Net

**Regency** <sup>ELECTRONICS, INC.</sup>  
7707 Records Street  
Indianapolis, Indiana 46226

*An FM Model For Every Purpose . . .  
Every Purse*

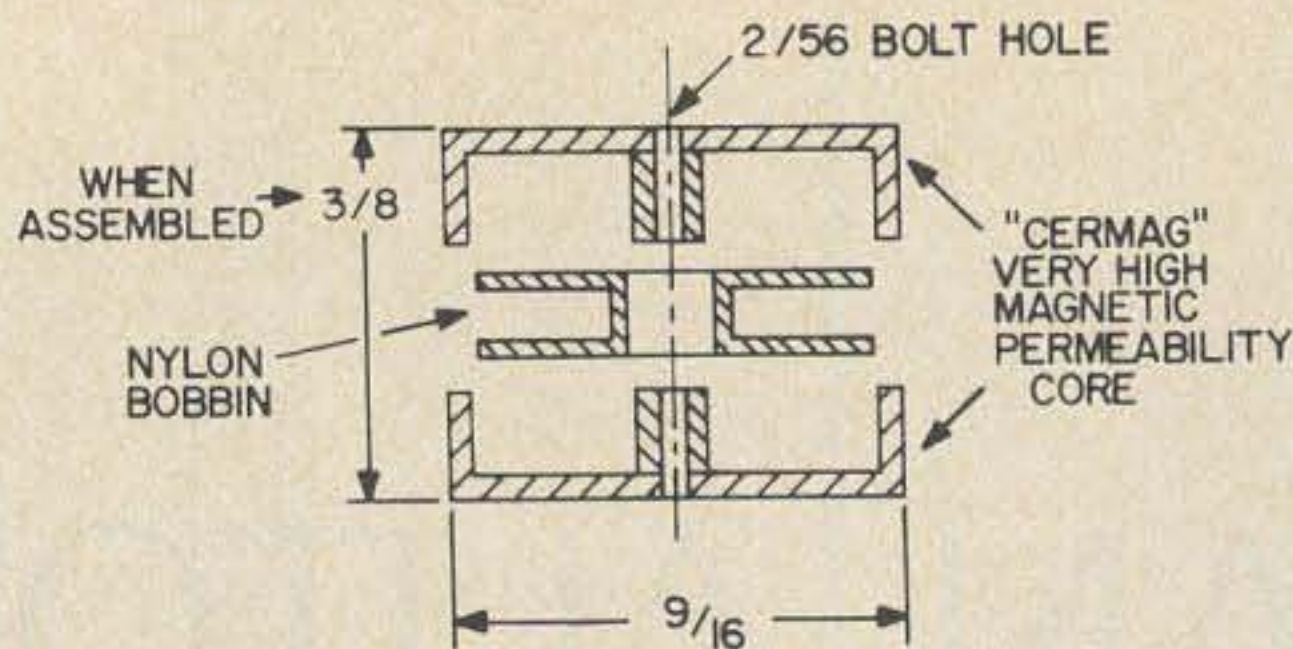

Fig. 2. Cup core for 2 kHz amplifier.

branched off, you can actuate, by different beeper tones, almost anything you want, including your rig. So, start building.

Figure 1, block diagram, shows the essentials of the amplifier, where the input and output circuit are the principal items differing from "radio" work. The amplifier itself is essentially the same as an i-f job, just on a lower frequency. So low in fact that you can listen to it if you want to, being on 2000 Hz.

The coils can be wound by the amateur builder once the high-permeability (magnetic) cup-cores are obtained. Addresses of suppliers are included.

Various additional telephone circuits are shown to give you a few ideas of what can be done for systems you might like to dream up yourself. The input and output circuits will be detailed last because these will be of your own choice, and not necessarily the same as the examples shown here.

**The Tuned Amplifier**

Tuned circuits are the bread and butter, also the main course, in radio work by the home-brewer. Before the days of crystal filters for everybody, sound waves in metal, and the newer ceramic resonators, i-f circuits for narrow band CW work were put on 50 kHz with expensive transformers using Litz (many strands of enamelled wire forming one wire) wire and air-variable capacitors for tuning. They worked, but were large and not low cost. Then came the era of high magnetic permeability materials, which, in the shape of a small cup-core, see Fig. 2, about 1/2" cube with as little as thirty turns of wire, could be tuned to 100 kHz. From this work came the little 1/4" 455 kHz i-f jobs produced in the many millions by the "Nagasaki Hardware" companies. Also,

sticking closer to home, "Cermag" cores, and similar items with a magnetic permeability several thousand times greater than air became available. Figure 2 shows size and shape of one of these, with a nice little bobbin for winding the coil included by some suppliers.

This particular design does not have the familiar i-f tuning slug but does allow you to wind up a tuned circuit for 2 kHz which is the goal in this article. The lack of the tuning slug can be overcome by the use of several fixed capacitors across the coil, the value of these capacitors being determined by the handy little item shown in Fig. 3 which takes the place of a variable capacitor quite nicely at those frequencies. Steps of 1000 pF are quite adequate for use at 2 kHz or whichever of the telephone audio frequencies you wish to use. You can see the problem at a glance; 455 kHz coils need capacitors in the range of 100 – 500 pF, 135 kHz units can use up to 2000 pF or more, but at 2 kHz you need tuning capacitors in the 50,000 to 100,000 range.

I have seen, in days gone by, variable electrolytic capacitors that could tune those values, even up to several  $\mu\text{F}$ , but doubt very much if any are now available today. At any rate they would not do a good job here being made of a pool of electrolyte with a coating (anodic) of thin insulation on the rotary vane dipping into it.

So, let's get into the coil details. On the bobbin shown in Fig. 2, wind some 240 turns of #36 enamel wire. The exact number is not too important because you have to tune them up individually with fixed capaci-

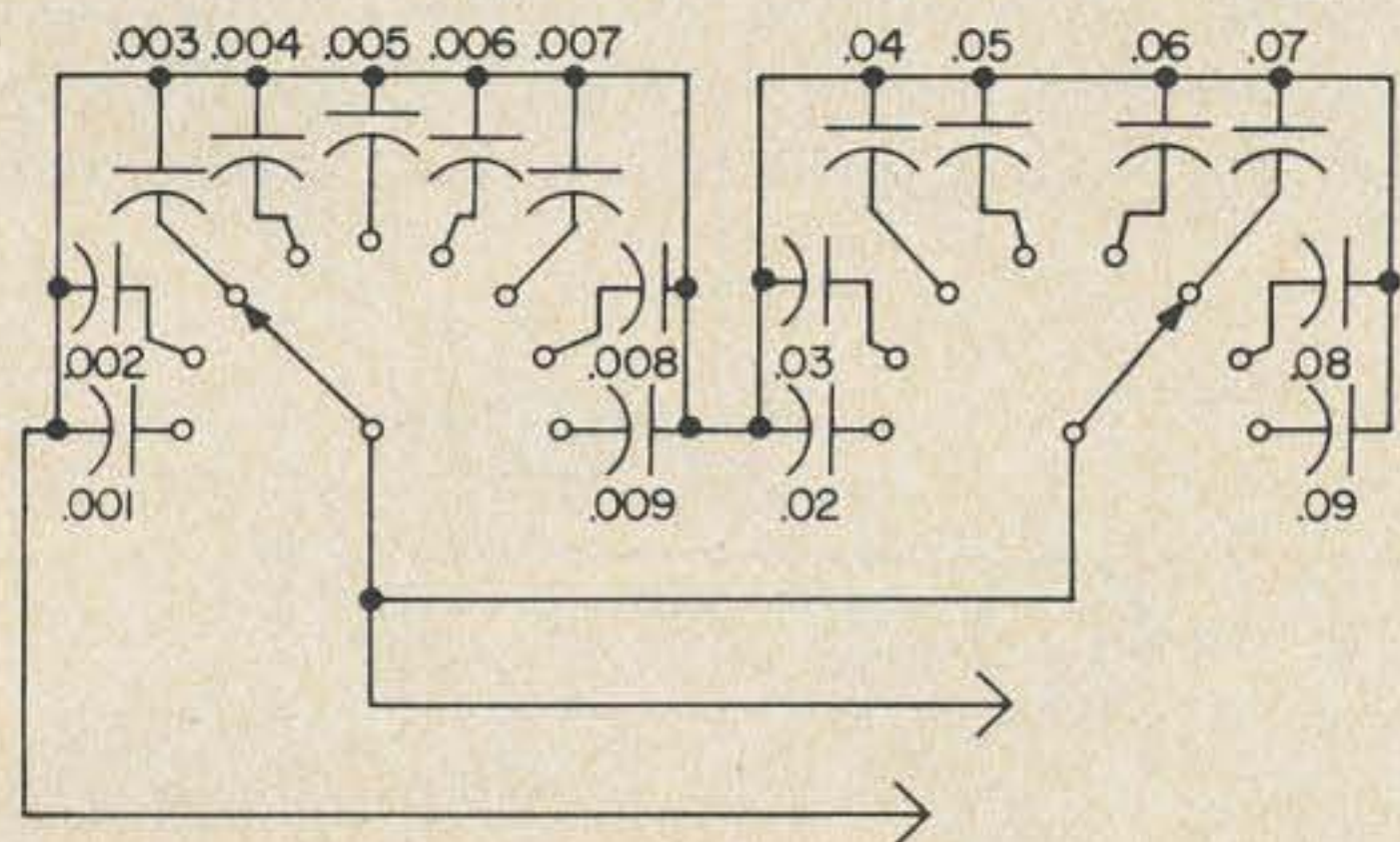

Fig. 3. Variable capacitor, 1000 – 100,000 pF (2 kHz amplifier).

**HERE IS A FIST FULL  
of 2 METER POWER**



**NEW**

*American Made  
Quality at Import Price*

## **Model HRT-2 5 Channel, Narrow Band 2.2 watt FM Transceiver**

This light weight, "take anywhere" transceiver has the "Regency-type" interior componentry to give you what others are looking for in portable communications. You get a heavyweight 2.2 watt signal . . . or if you want, flip the HI/LO switch to 1 watt and the receiver gives you 0.7 uv sensitivity and 0.5 watts audio. Both transmitter and receiver employ band-pass circuitry so that power and sensitivity are maintained across the entire band. Get one to go. . . . only

**\$179<sup>00</sup>**

Amateur Net

**Regency** ELECTRONICS, INC.

7707 Records Street  
Indianapolis, Indiana 46226

*An FM Model For Every Purpose . . .  
Every Purse*



**HR-2MS** 8 Channel Transcan  
**HR-212** 12 Channel-20 Watt  
**AR-2** 2 Meter FM  
2 Meter FM Transceiver 2 Meter FM Transceiver Power Amplifier

tors, using the capacity box of Fig. 3. You can, of course, do without that item but it takes longer and that box is very handy to have around an experimenter-builder's shack anyway. The winding can be done by hand using the setup shown in Fig. 4, which is the way I did it, and it is not too hard. Fasten a hand drill in a vise on the edge of the table, use a 2/56 bolt as in Fig. 4b, and wind. The hand drill I have gives about four turns of the chuck to one turn of the crank, so that makes counting easier. After winding on the 240 turns, wind the secondary on top of that, being sure to use different wire, or at least be sure and identify the windings. You can easily tell with an ohmmeter, but it's better to be sure first about such things. I used single silk-covered #38 for the secondary.

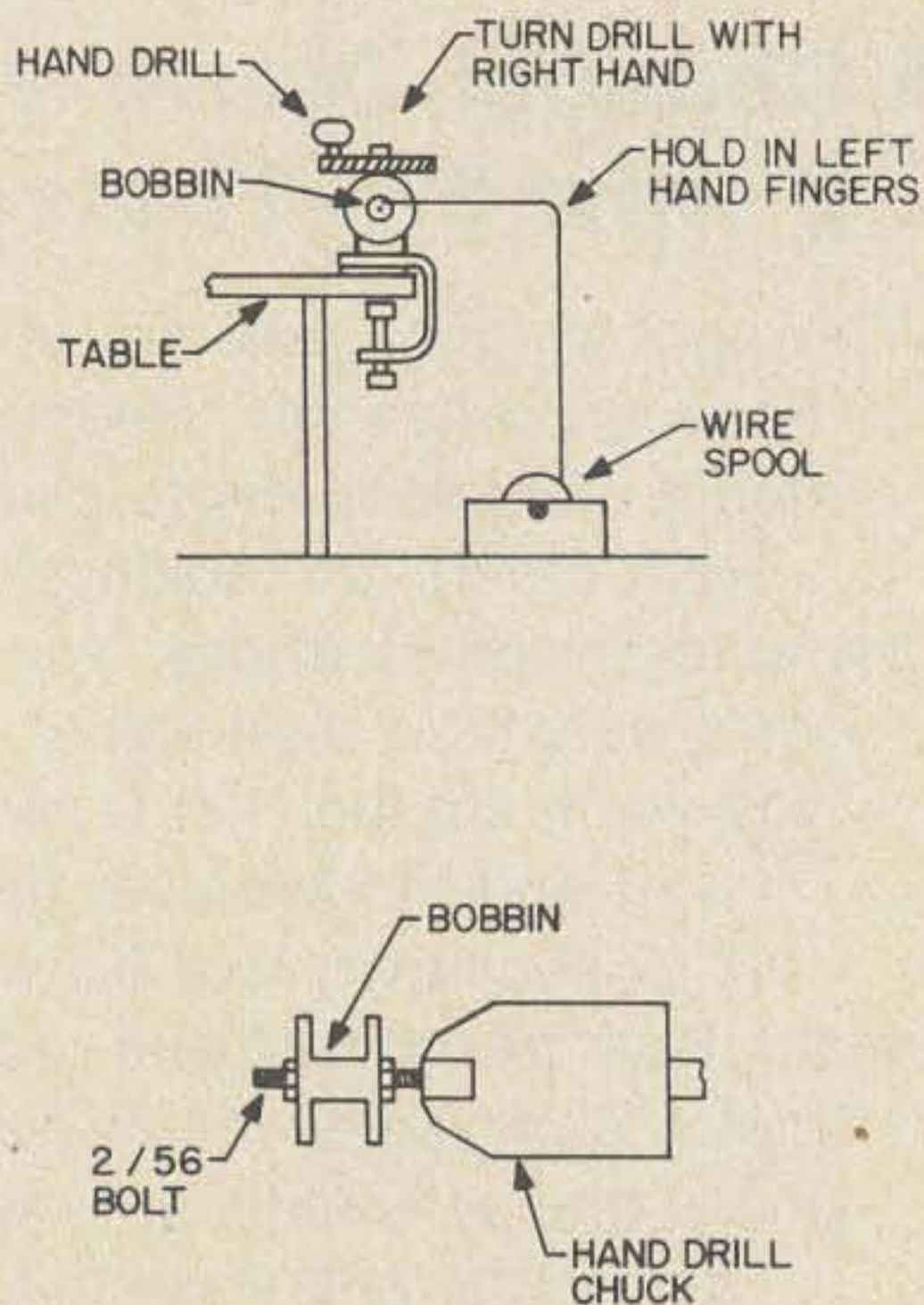

Fig. 4. Hand winding set-up (2 kHz amplifier).

The number of turns on the secondary, which will feed the next base input, can be very important. I found ten turns to be enough for the interstage transformers, and eighty turns for the last transformer feeding the diode. The number of these turns plus the coupling capacitor to the base, have a large effect on the gain, reduction of self-oscillation caused by feedback, and rejection of the ringing voltage. A tendency towards more coupling turns, and less capacitor is probably best.

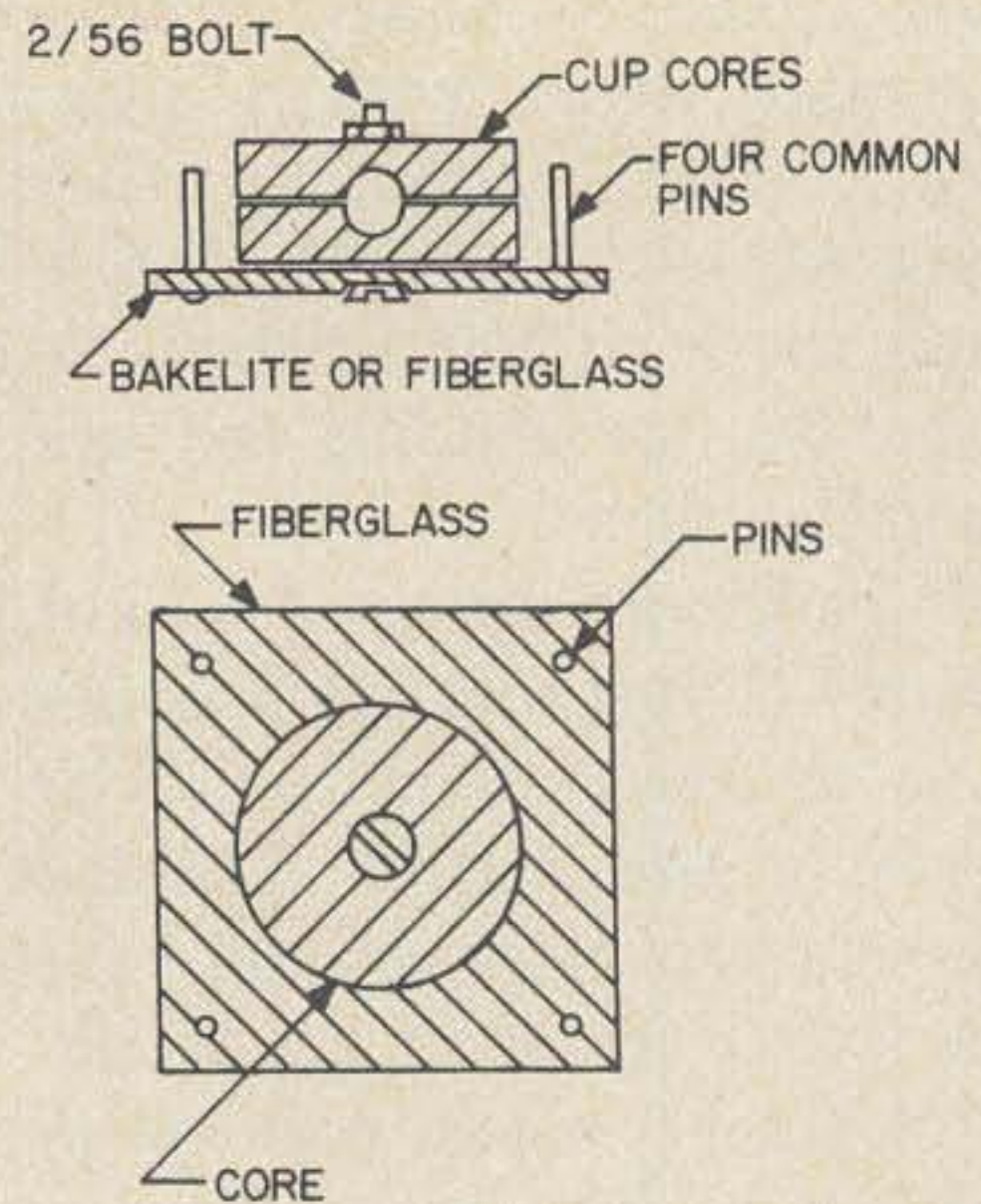

Fig. 5. Transformer core mount (2 kHz amplifier).

After winding, insert the bobbin carefully into one of the cup cores and place the other half over it, taking care to line up the core slots so that the four wires can be brought easily out. Keeping the slots lined up (see Fig. 5a) insert and tighten the 2/56 bolt and nut through the center of the cores. In case you wish to make a miniature job out of it, the transformer mounting method shown in Fig. 5 may help. Drill the pin holes shown one size smaller than a common pin, which may call for an .020 hole and a number 76 drill, and hammer them carefully into the bakelite or fiberglass squares using soft soap for lubrication. You will probably have to use a micrometer in this work. Put a piece of insulation, such as 5 mil fiberglass under the square plate to keep the pin heads from touching the copper, if you use a copper-clad board to mount them on.

Figure 6 shows one of the transformer circuits with several fixed capacitors for tuning. After finding the correct value using the method shown in Fig. 3, DO NOT rely on the values printed on said capacitors,

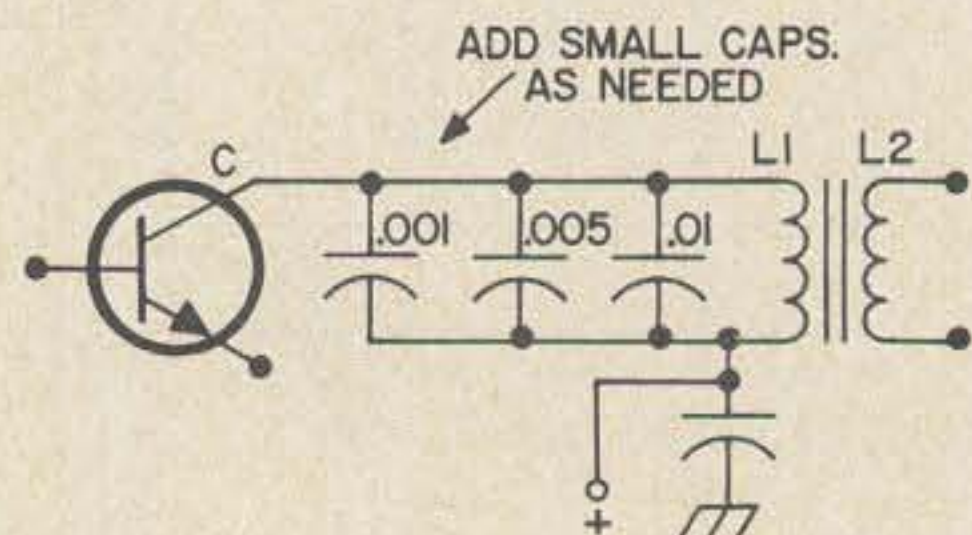

Fig. 6. Added capacitors for 2 kHz tuning of transformers.

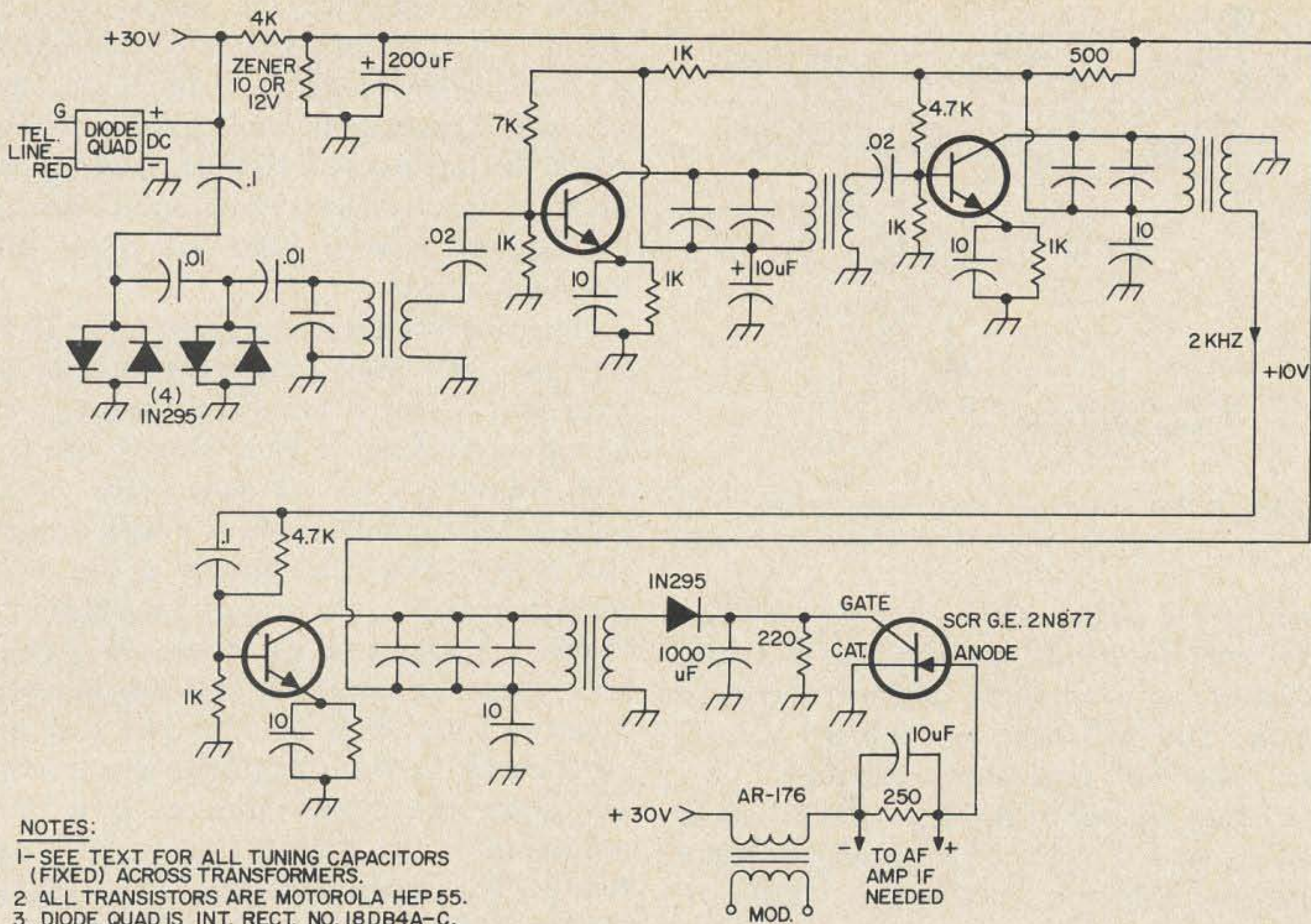

Fig. 7. Schematic of 2 kHz amplifier.

unless they are high precision, high cost jobs, which is not necessary. Just use your signal generator carefully and watch your ac voltmeter across the last secondary, put them all on the same frequency, and check after all three stages are working. DO NOT rely on guess work for this item. With a selection of .001, .01, and possibly .02 or .05 capacitors, you will do alright. If you need some of these in a hurry, you can find a selection at one of the Radio Shack stores. You can, of course, use a variety of loose capacitors and clip leads if you don't want to make up the box shown in Fig. 3.

### The Circuit

Figure 7 shows the complete circuit including the anti-ring input filter, the dc power leads, and the scr output section, any of which you may or may not want.

Note the series B plus filtering to each stage which is quite essential at these frequencies. The total gain available with three transistors is quite high but is kept down, along with self-oscillation, and the bandwidth sharpness is kept up, by the use of small secondaries on the interstage transfor-

mers and careful choice of base input capacitors. Anti-ringing is greatly controlled by the size of the base capacitors, so watch this point. Between about 1–5 mV at the input gives 5 or 6V at the output, with clean and stable amplification and no oscillation.

Do not be surprised if, on listening to the output, you hear a two kHz tone without the signal generator being connected! Remember that you can tune in on the output of a high gain i-f system with a suitable receiver. Well, you can do just this here but as the amplifier is on an audible frequency you will now be able to hear it directly by ear.

Due to the large number of turns of small wire in the collector circuits, with 100 – 200Ω of dc resistance, do not expect too much power in each stage. All we need for turning on the solid state relay (scr) (pick the right one in the G.E. catalog, 2N877 is used here) is some 4 – 5/10V and not too many μA.

### Low Frequency Signal Generator

A low cost sine wave/square wave generator running from 20 – 200 kHz was used

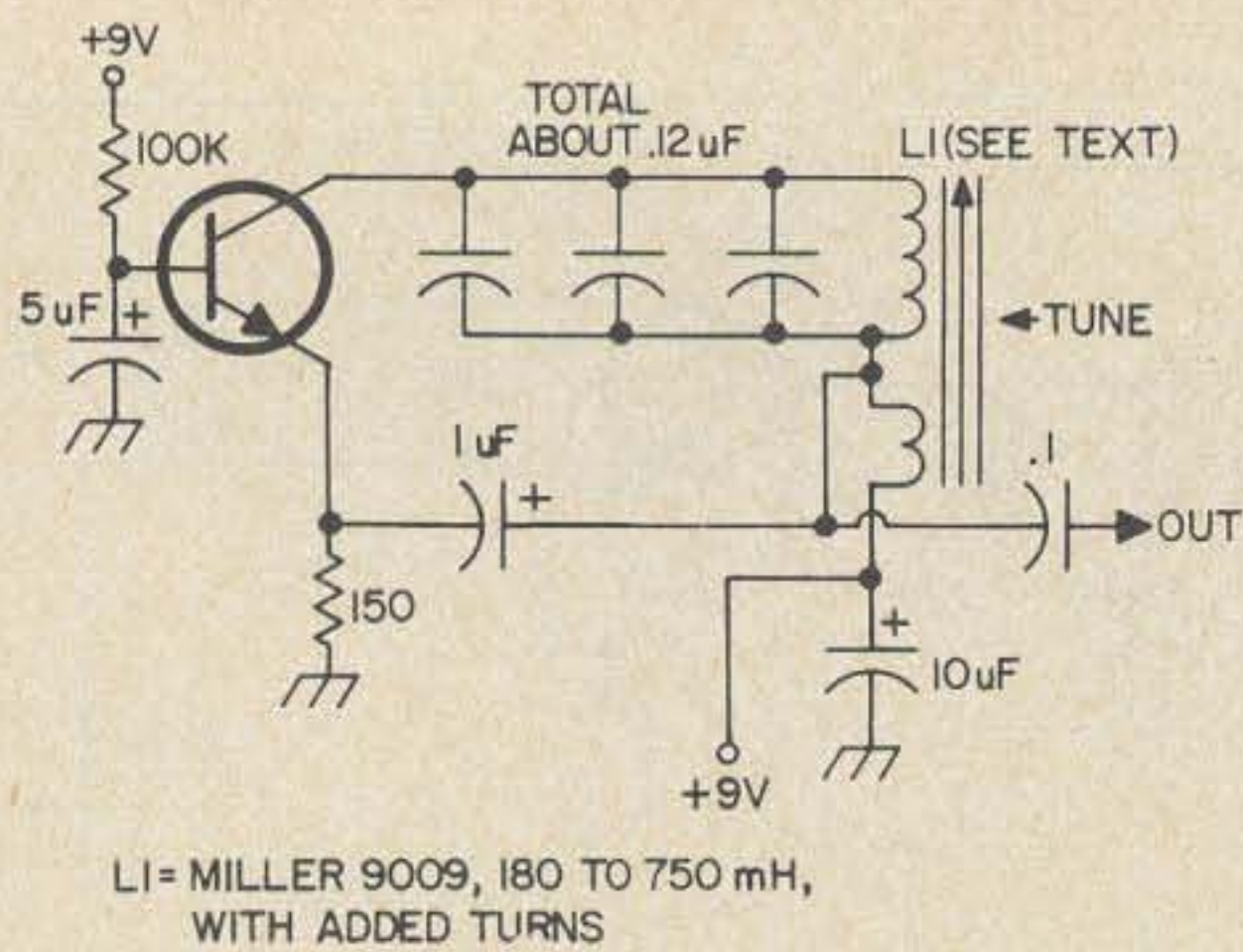

Fig. 8. Test oscillator — sig. — gen. 2 kHz.

here for the signal source, but if you don't have one on hand you can use a 2 kHz oscillator, an example of which is shown in Fig. 8. You will have to calibrate it from some other lad's generator in this case.

L1 may be one of the cup cores shown in Figs. 2 and 5, or you can use a Miller adjustable inductor, #9009, 180 — 750 mH, by adding some 80 turns as shown in Fig. 8. Be sure and add them in the same direction and connect them so they add. You can then tune it with the adjustable core to match the precise frequency of the amplifier. One circuit is easier to tune than four!

I find about 5 — 6V ac (2000 Hz) at the collector and about .1V at the output tap shown. I also used a variable attenuator, audio type, to cut this down to a few mV for use as the amplifier gain grew towards its final figure. I should mention here that you can plan on four stages if you like, to give you more of everything you need, like gain, narrower bandwidth, more ring rejection, etc., but this is up to you.

If you are going to do much of this low frequency work you will probably have considerable need for a "store-bought" generator, which generally will have both sine and square wave outputs and run from 20 — 20,000 Hz in frequency.

### Input Filter

If you wish to operate your decoder without being troubled by the terrific 70 — 100V ac at 20 Hz plus some inductive cut-off pulses much higher in voltage than that (and in frequency components too!)

which come in with the ringing signal, I found that three items were needed besides good selectivity in the main amplifier. These are, the Zener diode and bypass to hold down the line-derived 10V dc power supply for the amplifier; the scr gate input filter and its turn-off resistor; and the input filter being described.

The ring voltage is supposed to be 20 Hz, but just wait until you see that inductive kick on a scope! It has a real bang to it and it is hard to keep it from ringing the coils and triggering the scr gate. One of the biggest aids to cutting these pulses down to size is the input filter shown in Fig. 7, the main schematic. The use of capacitors that "favor" 2 kHz and cut down 20 cycles is seen, plus four diodes in between, in reverse polarity pairs. You have to put this item right up in the front end otherwise it would cut down the 2 kHz also. As it is, some reduction of the desired tone signal occurs, but is not severe, whereas removing the diodes does let the ring voltage kick off the scr gate. If you do let one of those big ring pulses hit the resonant 2 kHz coils, you'll never be able to stop them ringing on pulses, which you do not want. As it is, some of the pulse does get through but greatly reduced by the four diodes.

The 2 kHz, at a relatively low input level of a few mV gets by those diodes with only a little attenuation, and by integration (steady addition and build up) through the amplifier builds up to some 5 or 6V ac at the third stage collector pin. Nothing stops you from putting more sections in the input filter if you want, but as shown the whole circuit triggers every time on tone and never triggers on the ring. What more could you want?

### The Zener Diode

The ring voltage, that 70V plus ac across the line, acting on the quad automatic polarity reversing switch, caused a build-up in the line-derived amplifier B+ circuit from, for example, 10V up to 15V. Then, when that big cut-off pulse arrived on top of the 15V, the scr sometimes triggered. You couldn't live with this, so a zener diode of 10V was installed across the plus 10V, and also a large capacitor of 200  $\mu$ F. This did the



ORDER

RUSH

RUSH

RUSH

(check one)

Name \_\_\_\_\_

Call \_\_\_\_\_

Address \_\_\_\_\_

City \_\_\_\_\_ State \_\_\_\_\_ ZIP \_\_\_\_\_

\$ \_\_\_\_\_ enclosed

# TRANSCEIVER

- |                                      |                                       |
|--------------------------------------|---------------------------------------|
| <input type="checkbox"/> Drake TR-22 | <input type="checkbox"/> Swan FM2X    |
| <input type="checkbox"/> Drake TR-72 | <input type="checkbox"/> Tempo FMH    |
| <input type="checkbox"/> Drake ML-2  | <input type="checkbox"/> Tempo FMP    |
| <input type="checkbox"/> Ken KP 202  | <input type="checkbox"/> Tempo FMV    |
| <input type="checkbox"/> Regency HR  | <input type="checkbox"/> Tempo FMA    |
| <input type="checkbox"/> Simpson     | <input type="checkbox"/> Tempo FMC    |
| <input type="checkbox"/> SB-144      | <input type="checkbox"/> Trio 2200    |
| <input type="checkbox"/> Sonar 3601  | <input type="checkbox"/> Trio TR 7200 |
| <input type="checkbox"/> Standard    |                                       |

TRANSMIT	PAIR	RECEIVE
<input type="checkbox"/>	146.01-61	<input type="checkbox"/>
<input type="checkbox"/>	146.04-64	<input type="checkbox"/>
<input type="checkbox"/>	146.07-67	<input type="checkbox"/>
<input type="checkbox"/>	146.10-70	<input type="checkbox"/>
<input type="checkbox"/>	146.13-73	<input type="checkbox"/>
<input type="checkbox"/>	146.16-76	<input type="checkbox"/>
<input type="checkbox"/>	146.19-79	<input type="checkbox"/>
<input type="checkbox"/>	146.22-82	<input type="checkbox"/>
<input type="checkbox"/>	146.25-85	<input type="checkbox"/>
<input type="checkbox"/>	146.28-88	<input type="checkbox"/>
<input type="checkbox"/>	146.31-91	<input type="checkbox"/>
<input type="checkbox"/>	146.34-94	<input type="checkbox"/>
<input type="checkbox"/>	146.37-97	<input type="checkbox"/>
<input type="checkbox"/>	146.40-147.00	<input type="checkbox"/>
<input type="checkbox"/>	146.52-52	<input type="checkbox"/>
<input type="checkbox"/>	146.94-94	<input type="checkbox"/>
<input type="checkbox"/>	147.00-00	<input type="checkbox"/>
<input type="checkbox"/>	147.99-39	<input type="checkbox"/>
<input type="checkbox"/>	147.96-36	<input type="checkbox"/>
<input type="checkbox"/>	147.93-33	<input type="checkbox"/>
<input type="checkbox"/>	147.90-30	<input type="checkbox"/>
<input type="checkbox"/>	147.87-27	<input type="checkbox"/>
<input type="checkbox"/>	147.84-24	<input type="checkbox"/>
<input type="checkbox"/>	147.81-21	<input type="checkbox"/>
<input type="checkbox"/>	147.78-18	<input type="checkbox"/>
<input type="checkbox"/>	147.75-15	<input type="checkbox"/>
<input type="checkbox"/>	147.72-12	<input type="checkbox"/>
<input type="checkbox"/>	147.69-09	<input type="checkbox"/>
<input type="checkbox"/>	147.66-06	<input type="checkbox"/>
<input type="checkbox"/>	147.63-03	<input type="checkbox"/>
<input type="checkbox"/>	147.60-00	<input type="checkbox"/>

TOTAL \_\_\_\_\_

VALPEY FISHER CORP. 75 SOUTH STREET, HOPKINTON, MA 01748

The only way we can make crystals available at the \$3.75 price is by making them in large quantities — so we ask that you order from the above list — and ONLY from the above list. Special orders can be handled, but we don't encourage them since they take much longer to fill and cost considerably more. If your order can be checked off on the above order blank it can be filled quickly.

## just \$3.<sup>75</sup> each

...plus 50¢ per complete order for postage and handling.

Eastern customers may appreciate our fast mail service . . . it can save you days to weeks on your order. Western customers may appreciate getting crystals that work on channel the very first time and don't have to be returned for further compensation to match your set.

Valpey Fisher — 40 long hard years of experience.

# VALPEY FISHER

CORP.

Dealers — *Have we got a deal for you!!!*

A VALTEC CORPORATION

75 SOUTH STREET, HOPKINTON, MA 01748

617-435-6831

job in fine style. The 10V stays at ten right through the ring and that item was cured.

The large scr gate capacitor of 1000  $\mu\text{F}$  was the final nail that held those ringing pulses down from triggering the scr. The tone signal of course, holds on for a time determined by the finger on the tone signal oscillator, which may be miles away. The total integration through the system, including that 1000  $\mu\text{F}$  job, is long enough to keep the pulses down but allow the desired 2 kHz through and build up the dc on the gate to where it will trigger the scr. This takes a certain number of milliseconds, as you will see.

However, once you put that 1000  $\mu\text{F}$  on the gate you have to think about how you're going to turn off the scr when you want to. Those smart little "controlled rectifiers" are nicely controlled as to turn-on, but not at all so for the turn-off! Not only does the gate lose control when the anode is latched on, but even a momentary break in the anode voltage will do no good if the gate is still positive. With the scr indicated and 1000  $\mu\text{F}$  across the gate I found that over 450 $\Omega$  for R1 in Fig. 9 would discharge C1 fast enough to cut off the anode latch-up, while less than 100 $\Omega$  would prove too low for a good dc trigger build up. 250 $\Omega$  for R1 does work "de-latching" the scr nicely every time you hang up the remote handset, which causes a reversal of the input polarity of the line. This causes a momentary drop to zero of the scr anode, which is long enough for R1 to discharge C1.

### The SCR

These little wonders require a little getting used to but are quite likeable devices once you get the hang of them. They do turn on every time the gate hits about 4/10V positive, at quite a low number of  $\mu\text{A}$ , and they also turn off every time you break the anode circuit for even a few microseconds. That is, providing the gate is not left hanging up on positive dc. Just be sure and use the right scr for the job. The one in the schematic is the G.E. 2N877.

The books on these marvels, and even the specs included with the package, are in themselves marvels of obscurantism (the practice of pretending to let you know what

is going on, but making sure that only the initiated can actually make anything useful out of what you are saying) and I only hope you can wade through them and find out what they mean. In fairness to G.E., and others too, I should say that this is a very common fault. A specialized branch of semiconductor technique such as silicon controlled rectifiers has to develop new words in order to talk about something never before made. However, they do not explain either the new words or the new methods with anything like the clarity needed by someone starting in to work with scr.

You will find things like graphs with big shaded areas indicating "minimum turn on voltage from minus so and so C to plus so and so C." Don't worry about that one unless you're going to take the amplifier to Alaska and then down to the equator. In planes or in space that's a different thing.

Figure 9 shows the scr circuit I used which works fine for the purpose shown. Once the scr is triggered it stays on, but good. The 220 $\Omega$  load shown looks like the handset you did not lift off the cradle (because you weren't there) and central office can't tell the difference so it obligingly accepts the line termination (220 $\Omega$ ) cuts off the ringing, and gives a busy signal to anyone else that calls afterwards, and lets you proceed with your remote business as needed by your system. As mentioned, you can also talk on the air, and receive voice also.

Note that the anode voltage must drop or pass through zero level for the scr to turn off. This occurs automatically when you hang up so that's taken care of.

There is a slight question of different telephone companies having perhaps different voltages and sensitivities to line termination resistances, but I have been assured that

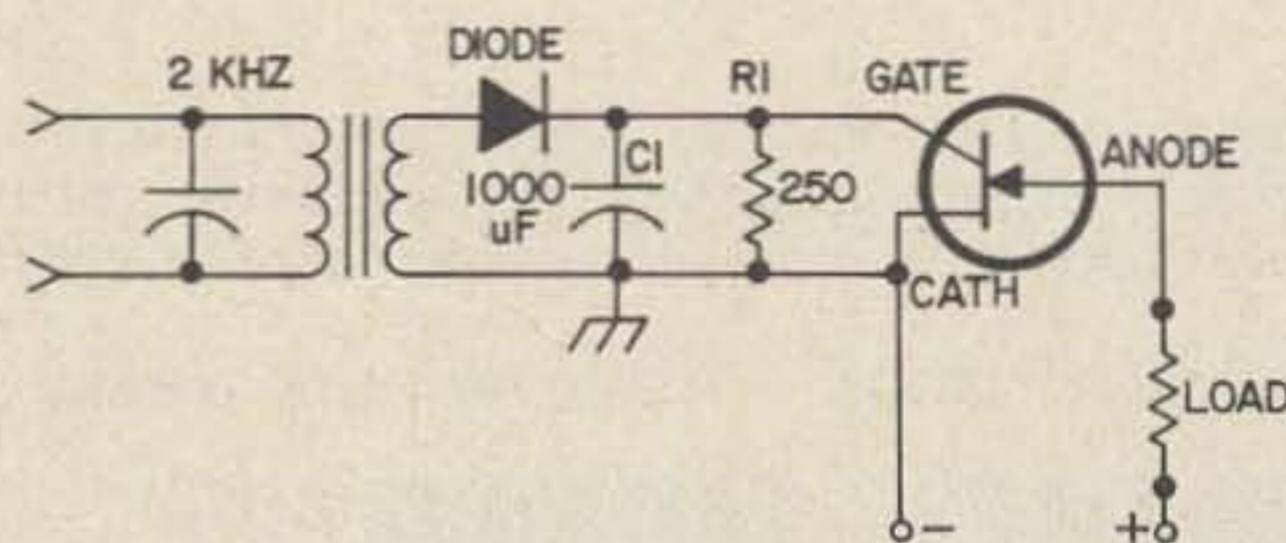

Fig. 9. SCR circuit.

most of them are pretty well standardized on these points. The line I use is in northern New England.

### Power Supply

This can get a little tricky. First of all it is perfectly possible to use the telephone line as the power supply because you can find a nice 42V waiting for you across the red and green wires. However, as soon as the connection is made to the desired number and either the line is terminated by the 220 $\Omega$  resistor, or the handset is picked up, the polarity reverses with a bang. This is called "tipping" by telephone companies. This in itself is not too bad as the diode quad switch automatically gives you plus on one of its dc output wires, and a 4K resistor brings this down to 10V, and the zener diode holds it there. However, there is one little fly in the ointment, if the telephone company checks this line and finds a resistance of something like 5 to 10 thousand  $\Omega$  across your line and a merry little 10 mils draining out on a steady state basis? I have been told that they may have a slight aversion to this state of affairs, so don't say I didn't warn you. It just means you might have to furnish your own 10V. At a tenth of a watt a 100 ampere hour charged battery would last 10,000 hours, unless my arithmetic fails me (which is quite easy). So that's about 400 days.

Also, most repeaters have an ac line around anyway. If you have to run one up to a mountain, be prepared for a lot of hard work. I did this for 1/2 mile up the last 1000 feet of elevation of a 3000 footer in 1950, and I know.

### Bandwidth

On this parameter depends the number of tone code channels you can build into a proposed system. Here are the figures I found for the finished unit exactly as shown in Fig. 7: 10 dB down at 280 Hz (140 each side of center), and 25 dB down at 600 Hz. Granted, you are hemmed in on the low frequency side by the increasing size of the tuned circuits, and on the high frequency side by the inherent cut-off of a normal telephone voice circuit. However, you could get ten channels in between 500 and 4000 Hz, with luck. Some lads go lower than 500

also, I understand. For normal repeater work you won't need that many anyway.

### Talk Back

You can modulate the line very easily, to listen to a receiver on the air, or whatever use you may wish. Figure 7 shows the easy way to do it by simply including a Lafayette, or similar, AR-176 transformer in series with the line. This has about 62 $\Omega$  ac impedance on the line side and 8 $\Omega$  on the modulation side. This 8 $\Omega$  is because my favorite small af amplifier at the moment is the Amperex TAA-300, which has an 8 $\Omega$  transformerless output impedance.

The bypass across the termination resistor avoids audio loss when modulating. You can use a medium power transistor for the load resistor and modulate it, but your power supplies get more involved then. As shown in Fig. 7 you can take the voltage for the af amplifier right off of the termination resistor because of the isolation provided by the modulation transformer.

### Overall System Use

The main body of the amplifier is one thing, which is a good tuned job for telephone work. The input and output circuits are shown as a particular example of one particular system that can be made up using this amplifier. From there on you can figure out (if you're lucky) what system you may need for your particular use.

For instance, you can use a power transistor to key on a single relay or a stepping relay. This transistor will not latch-up like the scr and is thus easier to use in certain cases. On the other hand it must be keyed on all the time, while the scr does not require this. Also the scr can be keyed and you can talk over the circuit. As mentioned, this article is essentially about a low cost 1 - 4000 Hz tuned amplifier.

### Critical Supply Items

Cup Cores. Arnold Engineering Co., Marengo, IL or Stackpole Carbon Co., St. Marys St., St. Marys, PA.

SCR. G.E. No. 2N877, Gerber Electronics, 852 Providence Highway, Dedham, MA.

Quad Rectifier Stack. No. 18DB4A-C. International Rectifier Co., 233 Kansas St., El Segundo, CA.

AR-176, AF transformer. Lafayette Radio.

...K1CLL

# HEATHKIT GC-1005 DIGITAL READOUT CLOCK

The new Heathkit GC-1005 digital readout clock makes a nice addition to the modern hamshack, since you can use it to indicate 24 hour time, local or GMT, and can synchronize it with WWV quite easily.

However, the readability of the face leaves something to be desired, since there is only a narrow space between the hours and minutes, and another space of the same width between minutes and seconds. That is, an indicated time of 12:34 plus 56 seconds would be displayed: 12 34 56. What is needed, obviously, is some means of separating the hours and minutes from the seconds.

It would be a major project, and probably somewhat doubtful of success, to try to move the display tubes apart any appreciable distance to achieve this condition.

The problem can be solved, or at least improved upon, by attacking it from another direction with a relatively simple modification.

It was done in my shack by mounting a pair of Motorola HEP type P2001 Light

Emitting Diodes on a small piece of perforated fiberglass board and wiring them into the low voltage B+ circuit, via a pair of limiting resistors. This assembly was then inserted into the space between the display tubes for the hours and the minutes.

The result was 12:34 56 instead of 12 34 56.

The P2001 LED is rated by the manufacturer at a maximum current of 40 mA, and emits a reddish light at an intensity depend-

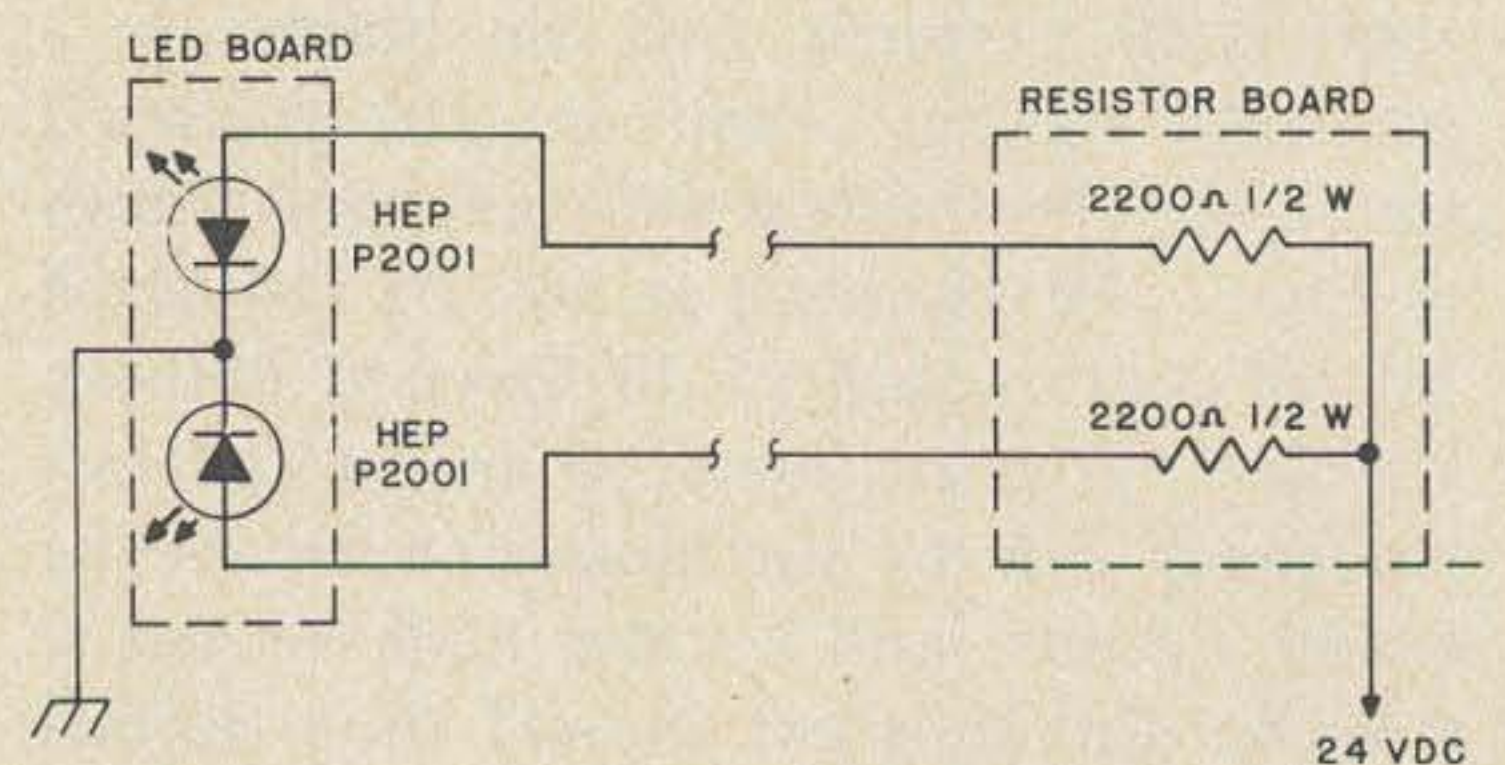
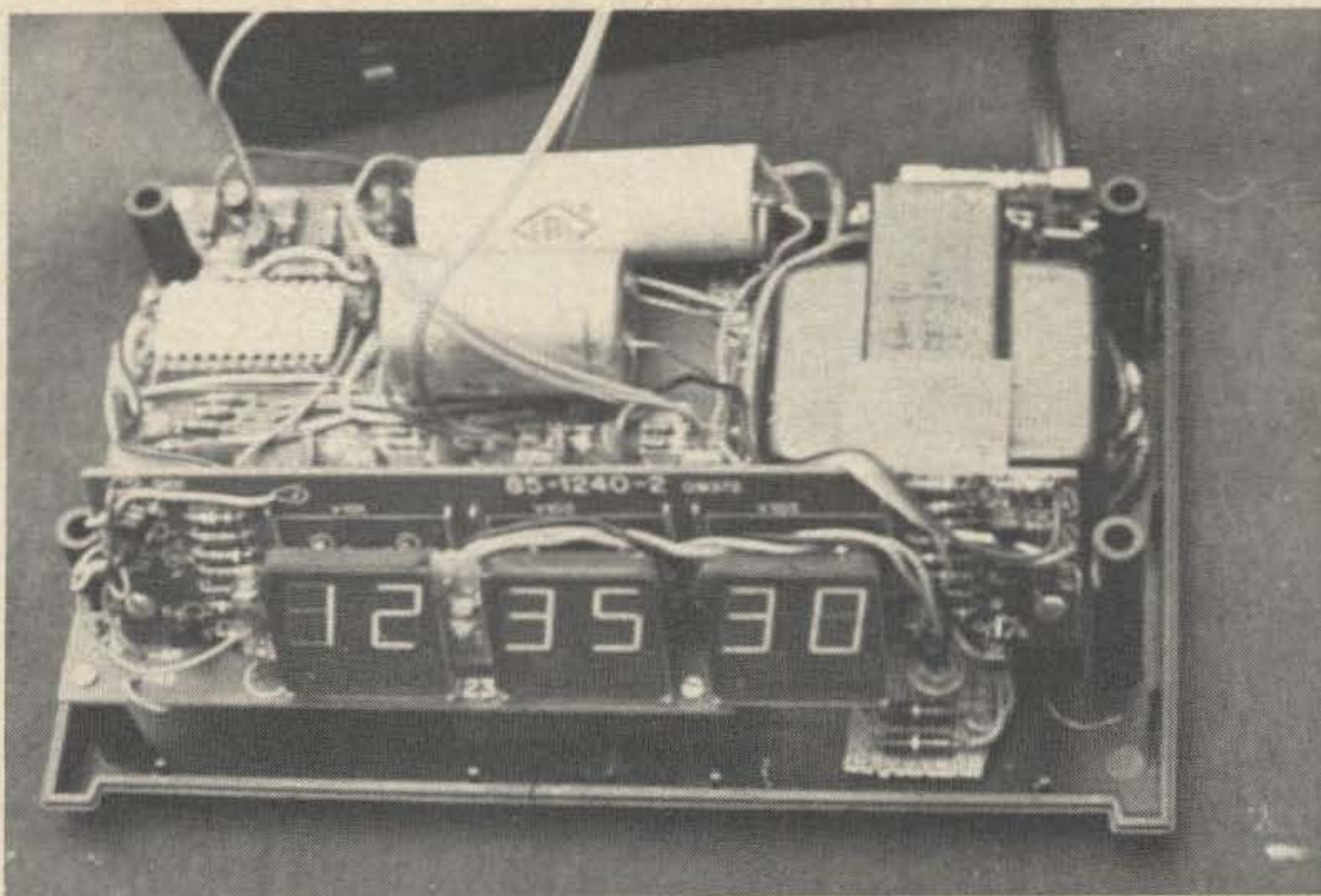

Fig. 1. Schematic used in adding the LED's to the clock.



*The LED board is visible between the display tubes for the hours and minutes. The resistor board is visible at the lower right hand corner of the chassis, directly underneath the right side of the seconds display tube.*

ing upon the amount of current passing through it.

After experimenting with different values of limiting resistors I finally settled on a current of about 9 mA, flowing through a 2.2 k $\Omega$  half watt resistor. This combination yields a light intensity approximately equal to that of the numerals on the clock, although slightly redder in color, and is well within the ratings of the LED.

The LED's are mounted on a piece of perforated fiberglass circuit board approximately 2.5 cm long by 0.75 cm wide, and are offset slightly so they assume a slanted attitude of about the same angle as the numerals. They are mounted vertically about 0.75 cm apart.

The edges of the board were carefully shaved down with a small file until it could be pressed into place between the adjacent edges of the hour and minute display tubes. A drop or two of epoxy glue was used to secure the board, once positioning was satisfactory. Be sure to position the board so the LED's are vertically centered with respect to the numerals.

The cathode leads of the diodes are connected together, and a single wire runs from this point to ground. In addition, a lead runs from each diode's anode to its limiting resistor, both of which are mounted on another piece of circuit board.

Since this is entirely a dc circuit, there is nothing critical about the layout or lead

dress. The positive leads can be simply run along the back of the top of the minute and second display tubes and down to the floor of the clock, where they are connected to the resistors.

The resistors are mounted on a piece of circuit board about 2.5 cm by 2.5 cm in size which is secured to the same bolt which holds down one end of the power transformer.

From this point a single lead runs to the source of voltage, about +24V dc, which is tapped by connecting directly to the exposed positive lead of the 1200  $\mu$ F filter capacitor.

Be sure you connect to the right capacitor, as 230V is present on the other one. If in doubt, use a voltmeter.

The ground lead from the LED board is dressed with the positive leads until they connect to the resistor board, at which point it separates and goes back along the top of the chassis to a ground point. Any exposed ground point can be used, but I grounded the wire by connecting to the negative lead of the filter capacitor, since it is also exposed and convenient to solder to.

In use, the two LED's are lit at all times the clock is in use, and form a double dot between hours and minutes. Their intensity is approximately the same as the numerals, but the color is slightly redder, although not enough to be objectionable.

...WAØKHV

# COOK A BETTER CIRCUIT BOARD

...one that fits YOUR parts!

**S**o you saw a swell article in 73 Magazine you would like to build? Of course, being consistent with today's technology, most of these fine articles incorporate a print for an etched circuit board. If you have never made your own board, *read on*. If you have etched your own, you have then probably encountered the following difficulty — *my parts won't fit the author's board #\*@%¢\$@*. So read on anyway.

Over the past several years I have used the following procedure for altering circuit boards or even creating a completely new layout. It's simple, does not require any special equipment and in many cases designing a new board takes little or no more time than using the one suggested. The end result is a project to be proud of, no bunched up components, no messy lead extensions and the darn thing really looks professional.

## Step #1

Having selected a project, assemble all the components before you. Compare your parts with the space allotted in the author's circuit board layout. Most layouts provided are full size and this comparison is simply a matter of laying your parts on the drawing. Assuming there are only minor discrep-

ancies, the original drawing may be altered before the board is coated with the resist paint (airplane dope, fingernail polish, etc.). However, if many of your parts just won't fit, as mine often don't, then design your own board as follows.

## Step #2

Take a flat piece of styrofoam, available everywhere nowadays (packing material, hobby or dime stores, or borrow the picnic cooler lid). On the styrofoam lay a plain sheet of paper. Using the schematic of your project, build the circuit by inserting the component leads through the paper and into the styrofoam, in the same manner you would mount parts on the board itself. In most instances the physical placement of the parts and the schematic layout will be very similar. The major advantage of this operation is you may alter the size or shape of the final board to fit a box you already have or fit a particular space requirement.

Figure 1 shows a flat schematic type layout which is not only neat, but should you at some future date wish to modify it, all parts are accessible. Should you wish to miniaturize a circuit, the vertical mounting of parts may be utilized. As you are constructing your circuit, should an area of

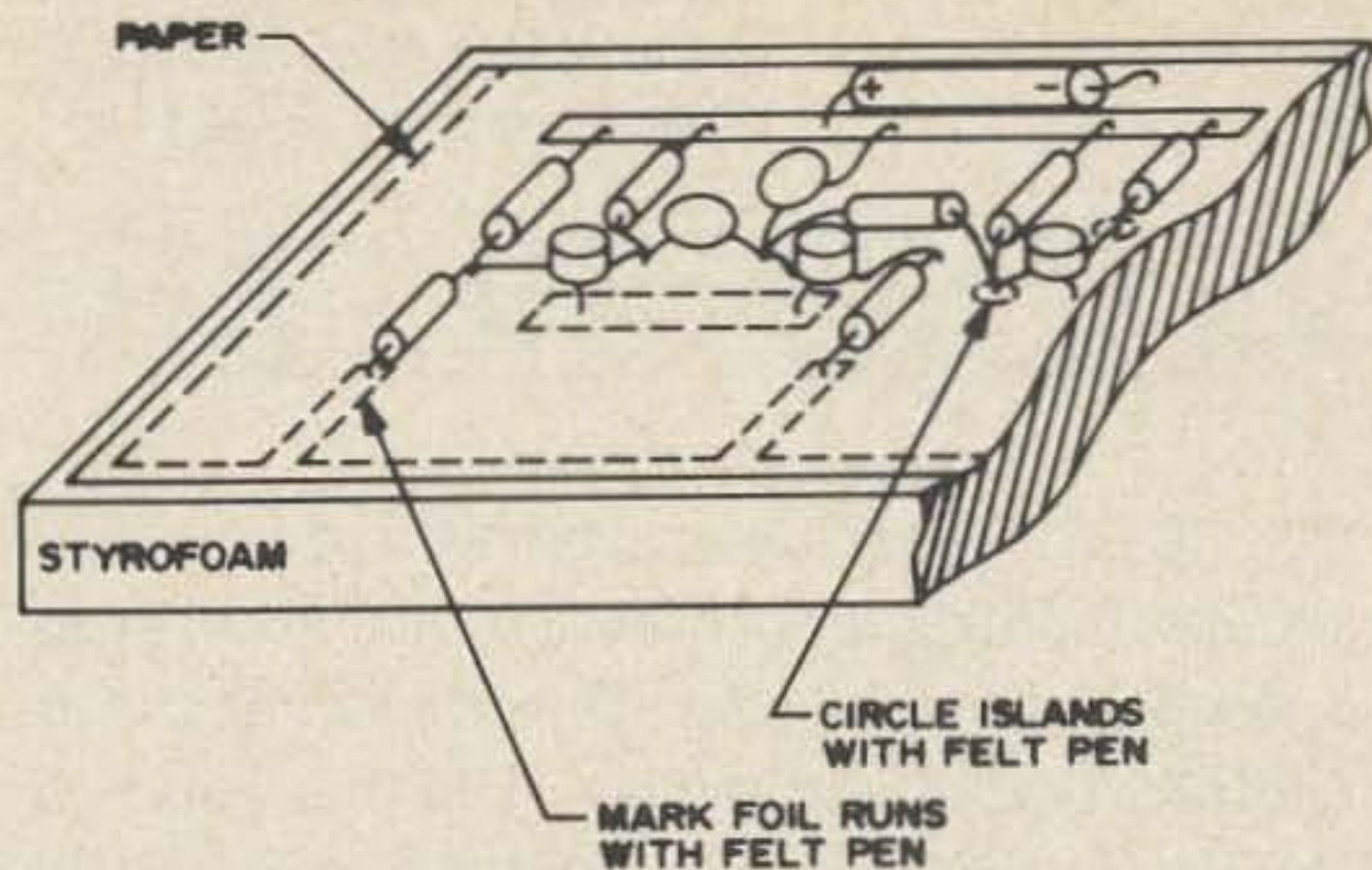

Fig. 1. Typical layout on styrofoam and paper, as described in Step #2 above.

the board become jammed, at this stage it is a simple matter to remove the components involved and reorient them to eliminate the problem.

### Step #3

Now that you have simulated the circuit on the paper covered block, use a felt tip pen to circle all the areas where parts are to be soldered. Draw in the connecting foil runs and any islands where leads from parts not mounted on the board are to be connected. Should foil runs have to cross merely break one run and mark it for a jumper to be installed later. An alternate but somewhat more complicated method is to etch the reverse side of the board to supply these crossing foil runs.

### Step #4

Remove all the components from the board and, using a hobby knife or razor blade, cut out all the marked islands and foil runs, as though you were making a template. As a matter of fact you *are* making a template. Take the paper template and steam one side over boiling water until it is limp, but not really wet. Immediately lay the template on the blank circuit board stock. Steaming allows it to lay flat and gives some degree of adhesion.

### Step #5

Spray a light coating of clear Krylon or similar material on the template covered stock. Common spray enamel may also be used, but any notes you may have made on the template will no longer be legible. Allow 2 or 3 minutes for the paint to set

and remove the template. Check over the board for any unwanted spray or runs. If any are noted they are easily removed with the wood portion of a broken pencil. Do *not* attempt to use solvent, as a fine film will remain and incomplete etching will occur.

Once the paint has dried completely, about 30 minutes (or hurry it along with a hair dryer), etch your board with any of the solutions commonly available at mail order houses. I etch in a Pyrex glass dish, borrowed from the kitchen, and heated on the range to about 150°. A combination of heat and gentle rocking will cut the etching time by about 50%. Using surplus board which generally has rather heavy copper, takes about 20 to 30 minutes.

### Step #6

Now that your custom board is etched, remove the remaining paint with a Brillo pad and hot water. This clean-up takes only seconds and leaves a nice shiny circuit to go to work on. In the interest of keeping the board's appearance new, before soldering I give the complete board a light coat of clear Krylon spray. No problem soldering will be encountered as a result of this spray and should you desire to mark connections, values, or other identification on the board with a felt pen, these will also be protected.

There is really nothing *sacred* about circuit boards, and no one ever said you must riddle it with holes for component mounting. I generally mount the parts on the foil side, eliminating all the drilling. It looks just as neat and now you don't even need a chassis. Several of my projects are circuit boards laying flat as a base with a front panel made from the same stock (no need for hardware as the panel may be soldered in place) and a wrap-around cover with front panel overhang. Thin aluminum covered with stick-on vinyl makes an attractive and inexpensive cabinet.

Well, that's the story. If you can sweet-talk the XYL into letting you use her hair dryer, range, dish, and nail polish, let's make a board.

...WB4MYL

# A VARIABLE Q AUDIO FILTER

The selectivity of modern amateur receivers has become quite good in recent years but there is still room for improvement, especially with the bands as crowded as they are. The following audio filter was designed and built to improve the selectivity of my Heath SB-303, but can be used with any receiver provided it is reasonably stable. The filter's bandwidth at -6 dB, for a center frequency of 1 kHz, is variable from approximately 400 Hz to less than 50 Hz. The entire unit is solid state, requires no bulky L-C components, and is built as an external receiver accessory. Cost of the project using all new components is about \$35.

## The Circuit

The filter is a tuned amplifier using inverse feedback. Audio from the receiver enters through emitter follower Q1 and is passed on to amplifier Q3, which inverts the signal's phase. Part of this inverted signal is then fed back to twin-T network, R1, R2, R3 and C1, C2, C3. The particular network presents high impedance to ground at all frequencies except its resonant frequency, similar to a series tuned L-C circuit. The unattenuated signal next enters emitter follower Q2, and without further phase shift, is added to the uninverted input at the base of

Q3. Since there are now two out-of-phase signals feeding amplifier Q3, its net output is severely reduced. The degree of cancellation, therefore the selectivity, can be controlled by the setting of R4, which determines the amount of inverted signal reaching the base of Q3. This process occurs at all frequencies except the chosen resonant frequency. At resonance no inverted signal will be passed by the twin-T network, allowing the original input signal to be amplified by Q3. The filtered output is then boosted by amplifiers Q4 and Q5 to drive a small speaker or phones.

Since it is possible to overdrive Q3, it is necessary to have some way to know when the input level is correct. This is accomplished by sampling a portion of Q3's output with meter amplifier Q6 and rectifying it to drive a 1 mA meter. The meter is calibrated by the setting of R5 so that 4V p-p at the collector of Q3 reads 0.4 on the meter. This is just below the overdrive point of the tuned amplifier.

## Construction Notes

Most of the circuit (excluding transformers) was constructed on Vectorboard using press-fit terminals, but could be built on a PC board with the accompanying reduction



The filter can be assembled for rack mounting as shown or in its own box as a receiver accessory.



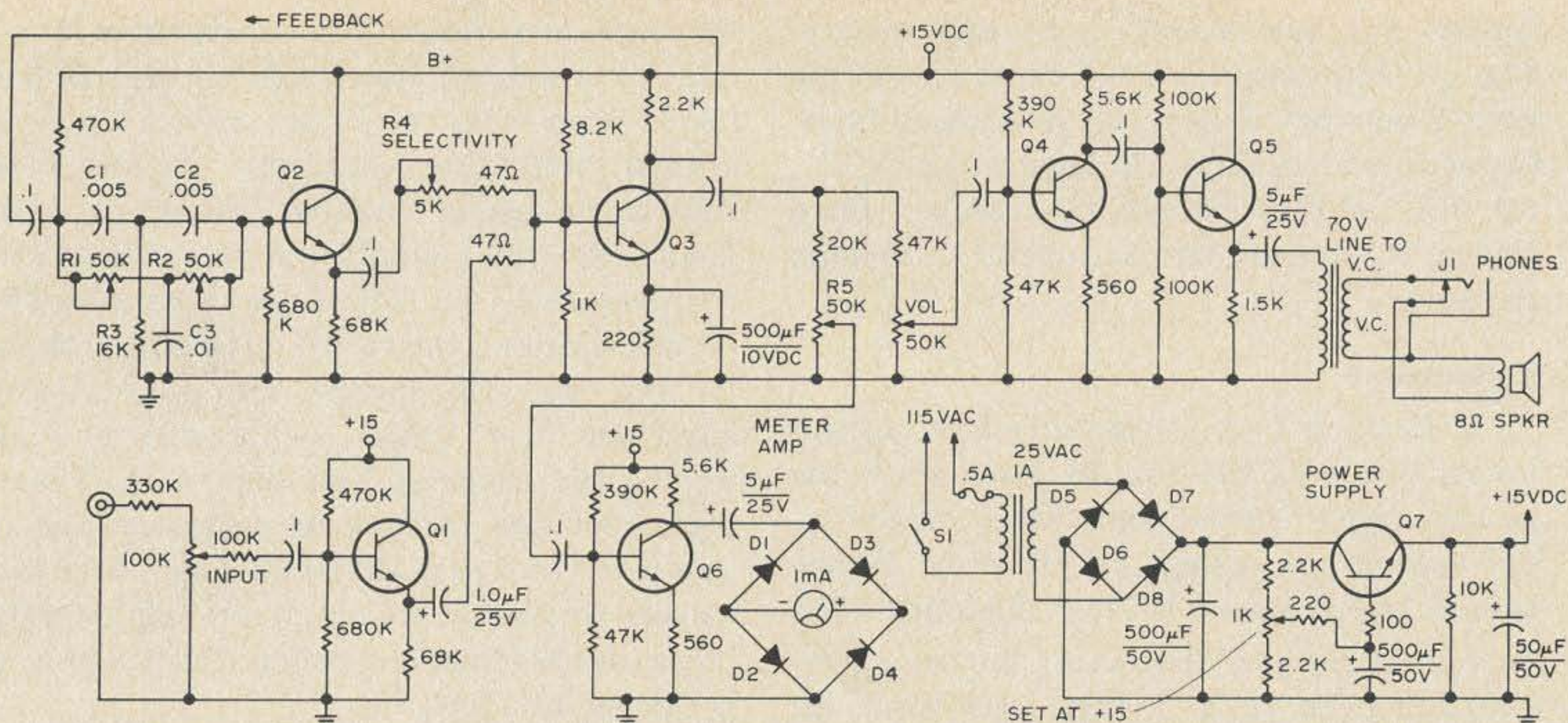
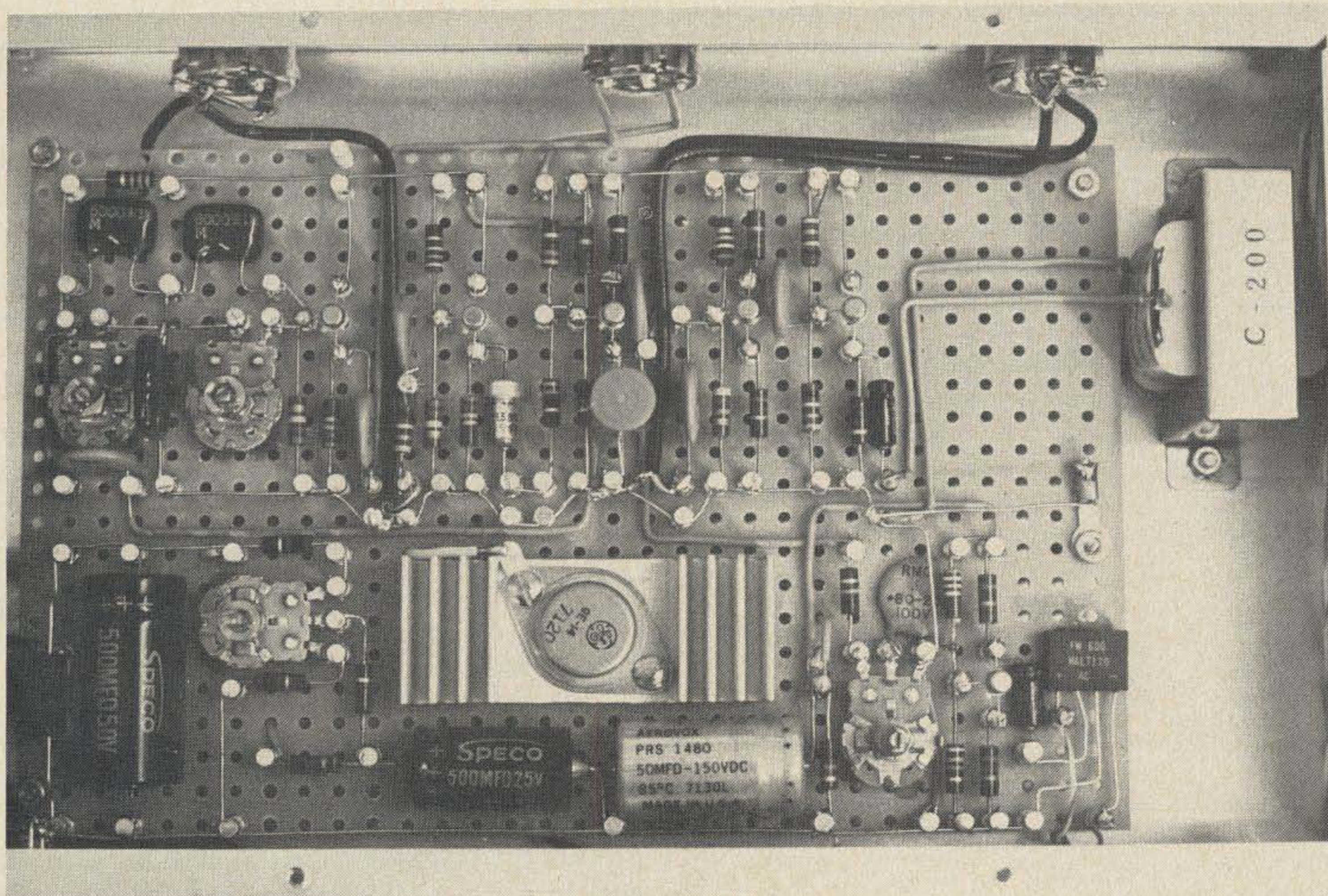

Fig. 1. Schematic of the Variable Q Audio Filter. Although it is designed around a center frequency of 1000 Hz, information is given in the text to modify the frequency to suit any need. Q1 through Q6 are GE-20 transistors, and Q7 may be a GE-14 or GE-28.

in size. The circuit board and output transformer were housed in a 7 x 11 x 2 inch chassis, which was too small to accommodate the power transformer too, so it was mounted outboard on the rear of the chassis. The front panel is a rack panel, which turned

out to be just wide enough to mount all the controls, meter, and a small speaker. The 1500Ω output of the amplifier was matched to the speaker by using a 70V line transformer connected at the 5W tap. The heat sink for the regulator transistor in the power



This view shows the assembly on a piece of Vectorboard. The size can be reduced considerably with miniature components and denser packaging.

supply was later found to be unnecessary. The use of poorly matched capacitors in the twin-T network will result in a low-Q filter. Capacitors should be 1% silver mica for C1, C2, C3, or they should be matched on a bridge. Do not attempt to substitute ceramic capacitors.

### Calibration

A scope is best for making final adjustments but a VTVM will do. Disconnect the power supply output and switch on the ac. Set the output voltage at +15V dc. Ripple should be less than 6 mV p-p. Reconnect the power supply and disconnect the selectivity control. Feed in a 1 kHz tone from the receiver or a generator and adjust the input level control for 4V p-p output at the collector of Q3. Adjust the meter amplifier to read 0.4 mA on the meter. Preset the two pots in the arms of the twin-T to 32K. Reconnect the selectivity control, set it at 12 o'clock, and alternately trim the pots in the twin-T for a peak at or near 1 kHz. In my filter the peak occurred at 950 Hz as measured on a GR 1191 frequency counter. Advance the selectivity and repeak the twin-T, retuning the receiver or generator to keep on the nose of the filter's selectivity curve. Turning the selectivity control up all

the way may result in a regenerative howl due to excessive feedback in the circuit itself, even with no input signal. This is normal, and the selectivity is too narrow to be useful anyhow (40 Hz or less). Under the right conditions the circuit will narrow down to a ridiculous 11 Hz at -6 dB.

When tuning the twin-T, you will probably find that the circuit will peak almost anywhere near 1 kHz, which may or may not be the point of best selectivity. Therefore, rock the receiver or generator dial as you tune for a peak in the output. There will be one frequency which gives a significantly larger output than any other. This frequency is the one to adjust to.

### Operation

Tune in a signal in a noisy, crowded portion of a CW band without using the filter. Set the filter's volume at 3 o'clock and the selectivity at about 12 o'clock. Now turn up the input level on the filter and retune the receiver until the desired signal suddenly peaks up in the filter and reads 0.4 mA on the meter. Set the selectivity as desired, 100 Hz (2 o'clock) being a good starting place. While peaked on a signal, switch off the receiver's speaker and listen on the filter instead. Tuning is quite sharp, peaking the desired station and severely attenuating all other noise and adjacent QRM. To resume normal operation, reduce the filter's volume setting and switch the regular station speaker back on. This system will allow for switching from "normal" to "sharp" selectivity with a minimum of effort.

Some operators may prefer a different frequency of filter responses, such as 900 Hz instead of 1 kHz. Or, perhaps filters for two different frequencies are needed, as in RTTY conversion. If this is the case, the values of C1, C2, and C3 must be altered using the following method.

Let R3 equal 16K. R1 and R2 are then twice this value. C3 is calculated so that at the frequency of resonance, its reactance equals R3, or 16 KΩ.

$C = 1/2\pi fX_c$  where  $X_c = 16 K\Omega$ , or more simply  $C = 1/0.1f$  where C is in microfarads and f is in Hz. C1 and C2 are each half of the value of C3.

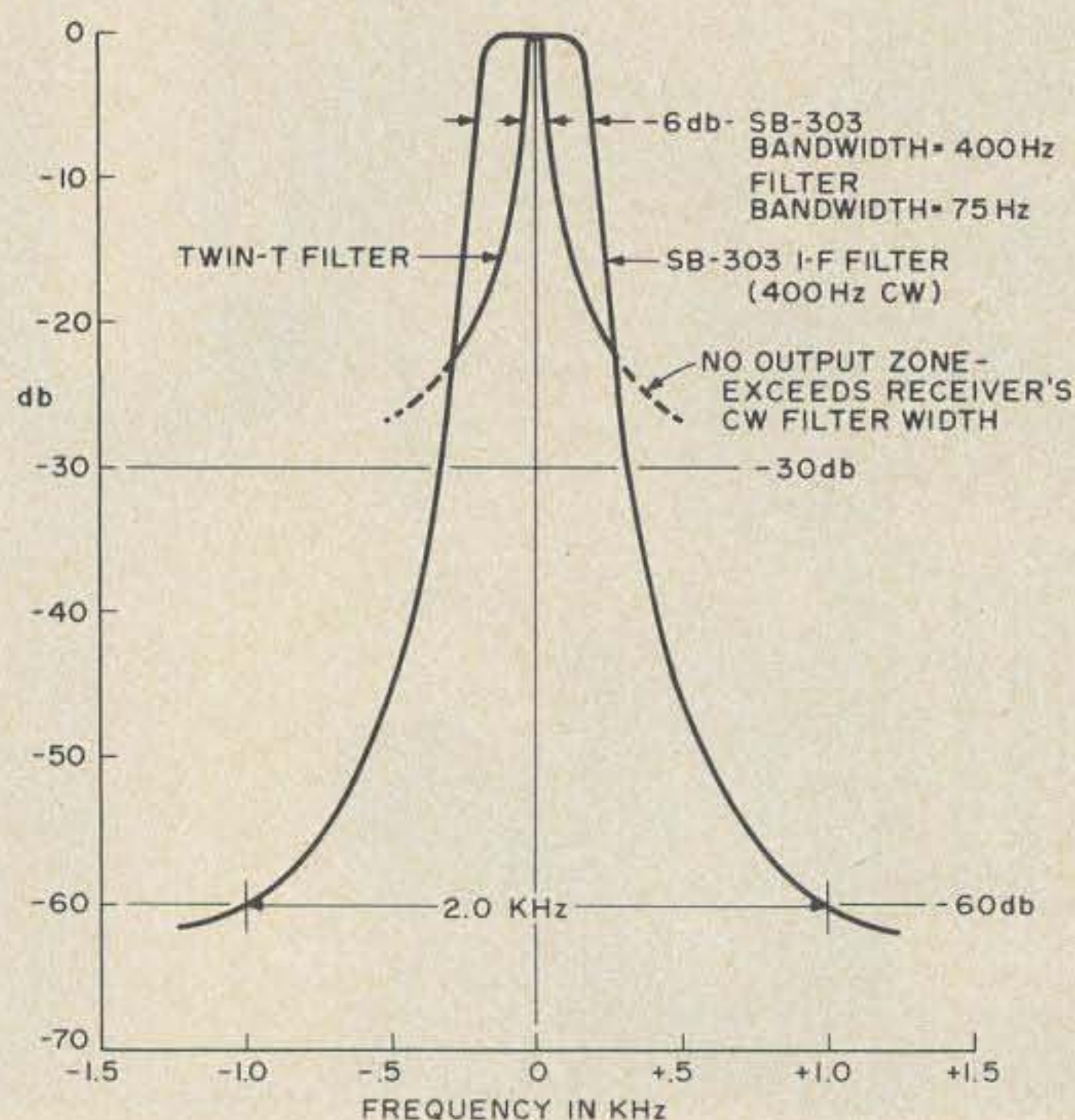

Fig. 2. Graph showing the filter's effect on the bandwidth of a receiver with an internal 400 Hz filter.

...WA4DCN

# ANOTHER BLOWN FUSE INDICATOR FOR LOW VOLTAGE

John A. Carroll K6HKB/1  
18 Ferguson Road  
Malden MA 02148

In the March '72 issue of 73, WØEDO described a method of using incandescent lamps to detect blown fuses in low-voltage equipment. Light emitting diodes can do the same thing, using the circuit shown. The main advantages are small size, very low indicator current after the fuse blows, and high reliability. The disadvantage is cost.

Since LED's haven't been heard from very much in ham gear, a few words about their characteristics are in order before looking at the circuitry.

Like rectifying diodes, LED's have a nearly constant forward voltage drop across a wide range of currents (typically about 1.2V). This means that an external resistor is necessary to control the current when operating from a constant voltage supply. The safe reverse voltage is generally only about 3V. Light is emitted only when forward current is applied, so polarity must be observed. The negative terminal is usually marked with a wide lead, a color dot, or a notch in the rim of the case. I've found that 3 mA will produce just about enough light to see when looking closely at the LED, while 20 mA will make a bright enough glow to draw attention in a well-lit room. The maximum safe current is in the range of 50-100 mA. The operating current should be chosen somewhere within these limits, consistent with the needs of the situation and the maximum safe current under blown fuse conditions. No socket is used.

The voltage across the series resistor is the supply voltage less the LED forward drop, so

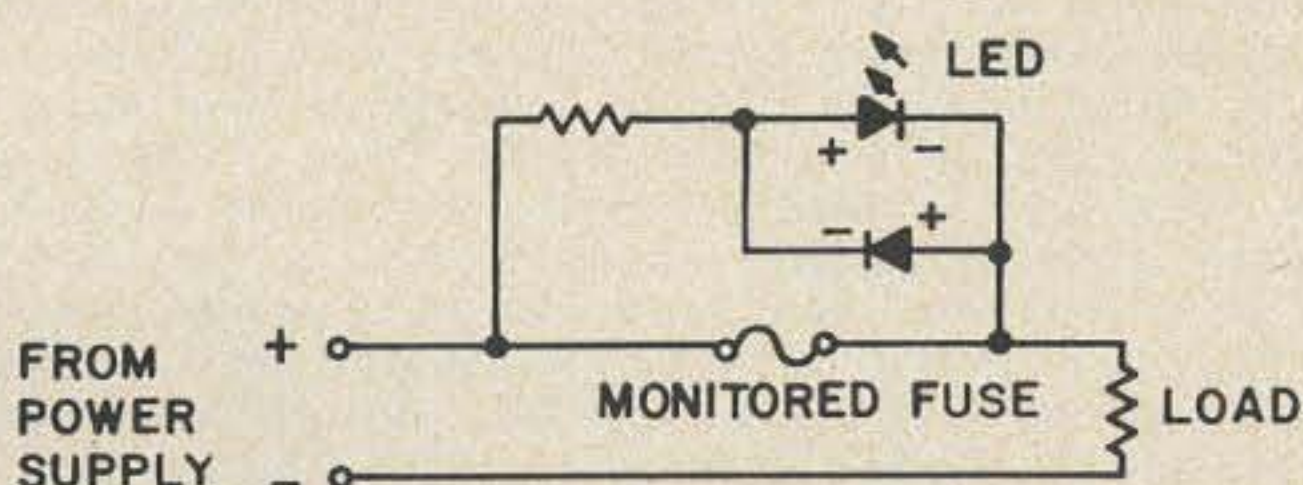

Fig. 1. Blown fuse indicator.

the resistance is  $R = (E - 1.2V)/I$  and the power dissipation is  $P = I^2 R$ . In an ac circuit, a capacitor or inductor may be substituted, with a reactance equal to the resistance given above.

The reversed diode across the LED is needed in an ac circuit to short it during the reverse half of the cycle and prevent reverse voltage from appearing across the LED. While it isn't necessary for dc, it does serve as insurance in case the circuit is initially installed backwards. In the rare case of a dc supply of unpredictable or changeable polarity, it would be possible to use another LED for the protective diode, so that each would protect the other and one would always light, or else place a single LED in a 4-diode rectifying bridge.

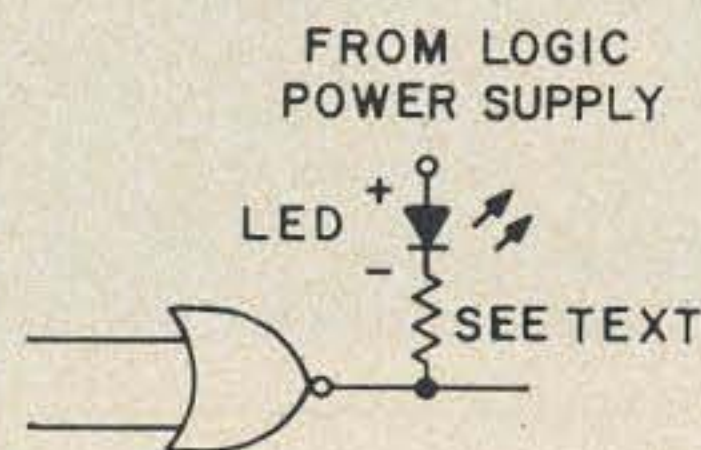

Fig. 2. Logic readout.

Most industrial electronics dealers carry such LED's as the Monsanto MV50 or its panel-mounting equivalent the MV5020. These are priced in the 75¢ to \$1.50 range. Almost any inexpensive red-emitting LED should work equally well. As for the reverse protection diode, practically anything should be satisfactory, though a small silicon diode would have the smallest leakage. I prefer the 1N4148 because it's available for as little as 8¢.

Another use for LED's worth mentioning is readout from logic circuits. They will run directly from a logic gate and need no special driver or power supply.

...K6HKB/1

# WHEN YOU BUY KENWOOD ...YOU BUY PRIDE, PLEASURE & PERFORMANCE

Pride in knowing that you own today's ultimate in state-of-the-art technology . . . pleasure in operating a rig whose day in, day out performance will show you why the Kenwood name is world-famous for reliability and value.

Kenwood's superb  
solid state SSB transceiver

## TS-900

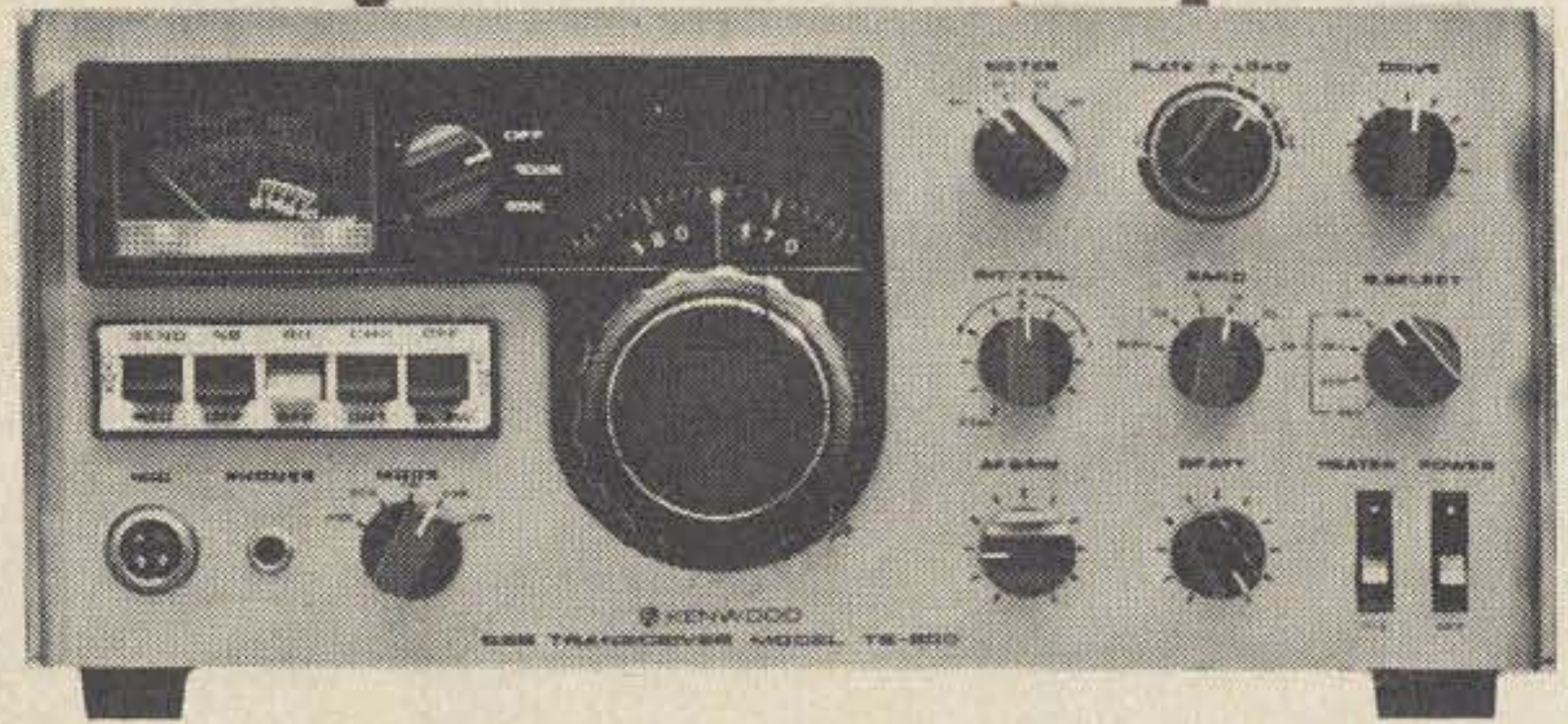

. . . the ultimate transceiver. The promise of the transistor has been fulfilled. Here is the transceiver you will want to own . . . whatever you have now, get ready to trade up. Its important features are far

too numerous to list. Its specifications are superb. The TS-900 is unquestionably the best transceiver of its kind ever offered. The price . . . \$795.00 PS-900 (AC Supply) \$120.00, the DS-900 \$140.00



## TS-520 Kenwood's go every place . . . do everything transceiver

The new TS-520 is the transceiver you have wanted, but could not buy until now. It is a non-compromise, do everything, go everywhere 5 band transceiver for SSB or CW that performs equally well at home, in an automobile, airplane, boat or trailer. The TS-520 features built-in AC power supply, built-in 12 volt DC power supply, built-in VOX with adjustable gain delay and anti-VOX.

The price . . . \$599.00

## Kenwood's winning pair

The R-599A is the most complete receiver ever offered. It is solid state, superbly reliable, small and lightweight, covers the full amateur band . . . 10 thru 160 meters, CW, LSB, USB, AM,

AM, N and FM.

The price . . . \$439.00

The T-599A is mostly solid state . . . only 3 tubes, has built-in power supply, full metering (ALC, Ip, RF output and high voltage), CW-LSB-USB-AM operation.

The price . . . \$459.00

See the Kenwood line at the following dealers: CALIFORNIA Communications Headquarters, San Diego ● Gary Radio, Inc., San Diego ● Ham Radio Outlet, Burlingame ● Henry Radio, Anaheim ● Henry Radio, Los Angeles ● Sequoia Stereo, Arcata ● Webster Radio, Fresno ● FLORIDA Amateur Electronic Supply, Orlando ● Amateur-Wholesale Electronics, Miami ● IDAHO United Electronics Wholesale, Twin Falls ILLINOIS Erickson Communications, Chicago ● Klaus Radio, Inc., Peoria ● INDIANA Graham Electronics, Indianapolis ● Hoosier Electronics, Terre Haute ● Radio Distributing Company, South Bend ● IOWA Hobby Industry, Council Bluffs ● KANSAS Associated Radio Communications, Overland Park ● LOUISIANA Tri-omics, Inc., New Orleans ● MARYLAND Electronic International Service Corp., Wheaton ● Professional Electronics, Baltimore ● MICHIGAN Electronic Distributors, Muskegon ● Radio Supply & Engineering Company, Detroit ● MINNESOTA Electronic Center, Minneapolis ● MISSOURI Ham Radio Center, St. Louis ● Henry Radio, Butler ● MONTANA Conley Radio Supply, Billings ● NEW JERSEY Simon Side Band Company, Oak Ridge ● NEW YORK Adirondack Radio Supply, Inc., Amsterdam ● Harrison Radio Corp., Farmingdale NORTH CAROLINA Vickers Electronics, Durham ● OHIO Amateur Electronic Supply, Cleveland ● Communications World, Cleveland ● Queen City Electronics, Cincinnati ● Srepco Electronics, Dayton ● OKLAHOMA Derrick Electronics, Broken Arrow ● Radio, Inc., Tulsa ● OREGON Portland Radio Supply, Portland PENNSYLVANIA JRS Distributors, York ● Kass Electronics, Drexel Hill ● SOUTH CAROLINA Accutek, Inc., Greenville ● SOUTH DAKOTA Burghardt Amateur Center, Watertown ● TEXAS Douglas Electronics, Corpus Christi ● Electronics Center, Inc., Dallas ● Industrial Distributors, Dallas ● Ed Juge Electronics, Inc., Fort Worth ● Madison Electronics, Houston ● UTAH Manwill Supply Company, Salt Lake City ● WASHINGTON Amateur Radio Supply Company, Seattle ● WISCONSIN Amateur Electronic Supply, Milwaukee

Prices subject to change without notice.

# tempo IS THE fm line

..THE finest quality.. THE best value

Tempo's Commercial Line VHF transceivers offer commercial performance at amateur prices. Compare these transceivers with any other available. Compare their performance, their quality of construction, their ease of maintenance, and then compare prices. Your choice will have to be Tempo.



## TEMPO/CL 146

The CL-146 offers operation on the 146 MHz amateur band. The price includes a microphone, power cord, mounting bracket and one pair of crystals. A full line of accessories is also available.

- 12 channel capability • 13 watts or a power saving 3 watts • All solid state, 12 VDC • 144 to 148 MHz (any two MHz without retuning)
- Supplied with one pair of crystals • RF output meter, S-meter, receiver detector meter
- Provisions for external oscillator • Monitor feature • Audio output at front panel • Internal speaker • The Price: \$299.00

## TEMPO/CL 220



As new as tomorrow! The superb CL-220 embodies the same general specifications as the CL-146, but operates in the frequency range of 220-225 MHz (any two MHz without retuning). At \$329.00 it is undoubtedly the best value available today.

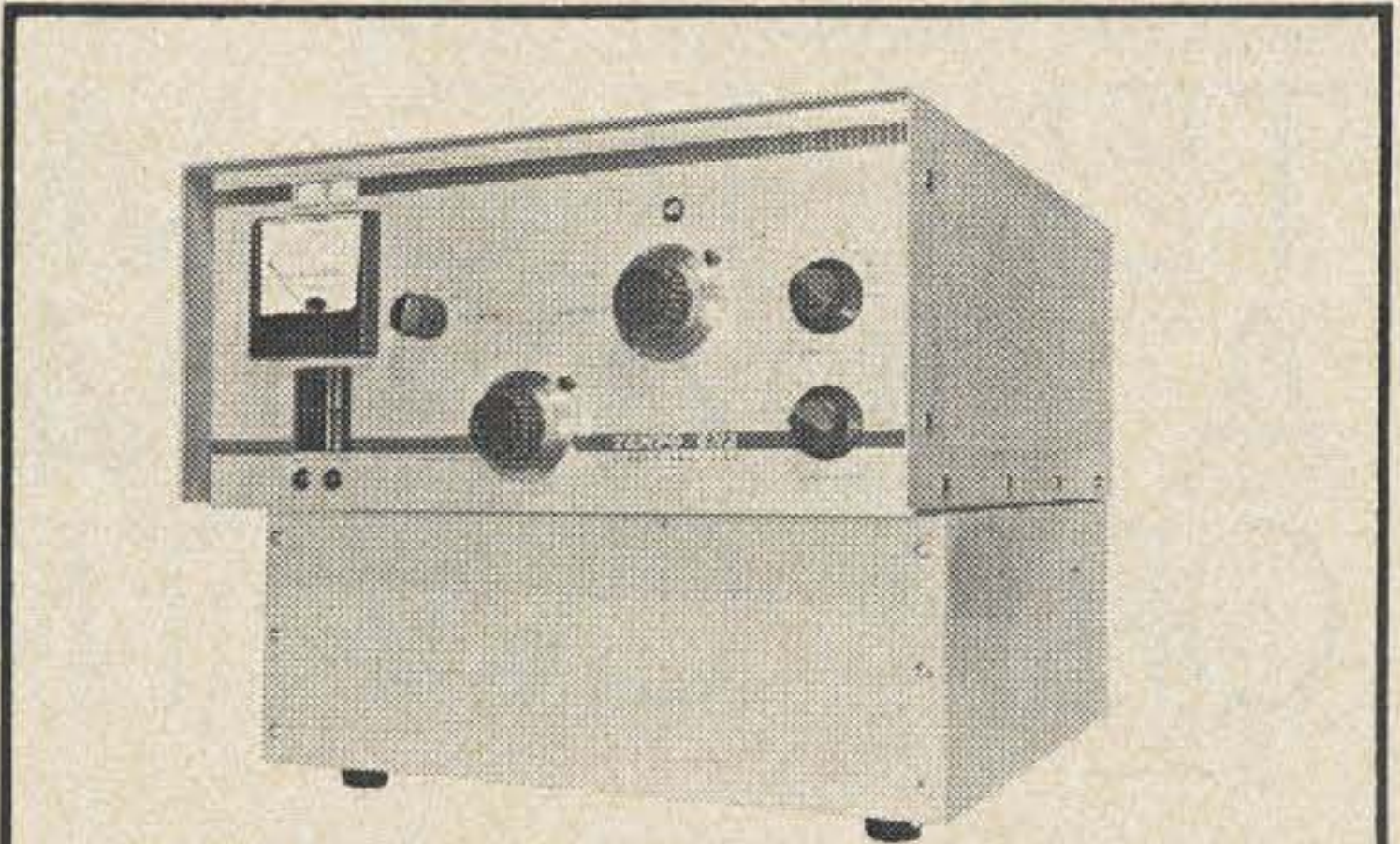

## TEMPO/6N2

The Tempo 6N2 meets the demand for a high power six meter and two meter power amplifier. Using a pair of Eimac 8874 tubes it provides 2000 watts PEP input on SSB and 1000 watts input on CW and FM. Completely self-contained in one small desk mount cabinet with internal solid state power supply, built in blower and RF relative power indicator. \$695.00



## TEMPO/fmh

So much for so little! 2 watt VHF/FM hand held. 6 Channel capability, solid state, 12 VDC, 144-148 MHz (any two MHz), includes 1 pair of crystals, built-in charging terminals for ni-cad cells, S-meter, battery level meter, telescoping whip antenna, internal speaker & microphone. \$199.00

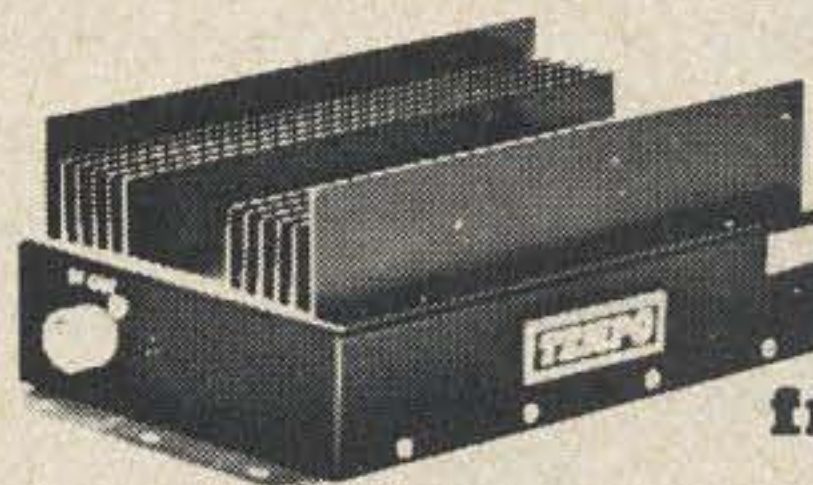

## TEMPO/TPL high power fm amplifiers

MODEL NUMBER	POWER INPUT	POWER OUTPUT (min)	BAND
TPL1002-3	5 to 25W	100-135W	2M
TPL1002-3B	1-3W	80W	2M
TPL802	5W	80W	2M
TPL802B	1 to 3W	80W	2M
TPL502	5 to 15W	35-55W	2M
TPL502B	1 to 3W	45W	2M
TPL252-A2	1W	25W	2M
TPL445-10	1 to 2.5W	12W	440MHz
TPL445-30	4W	30W	440MHz
TPL445-30B	1W	30W	440MHz
TCP 12 Control Head			

Prices subject to change without notice.

# Henry Radio

11240 W. Olympic Blvd., Los Angeles, Calif. 90064 213/477-6701  
 931 N. Euclid, Anaheim, Calif. 92801 714/772-9200  
 Butler, Missouri 64730 816/679-3127

AVAILABLE AT SELECT DEALERS THROUGHOUT THE U.S.

# BUILDING WITH TEN-TEC MODULES A 40/20 METER QRP CW TRANSCEIVER

**W**hat's this — another QRP transceiver? The magazines are full of them these days. What's the sudden interest in flea-power operation?

QRP has indeed made a strong comeback. And there are good reasons. Simple but efficient transistor circuits make possible compact rigs that appeal to the traveler and camper. Stable vfo's are replacing those old-time rockbound peanut whistles we used a while back. (Remember the 3V4 and a handful of crystals? For every rock you had, there were a dozen guys on the same frequency, each running a gallon!)

And there is another reason. More and more fellows are finding that you *can* communicate with only a few watts. And what's more, it's fun and challenging. When the band is open, and you get a 589 from that OH in Helsinki, and your input power is only 2W, well, what more is there to say?

But QRP isn't for everyone, and before I lead you astray, it's only fair to point out that the calls-vs-contact ratio can be pretty low, especially during the crowded evening hours. It takes skill, special techniques and

patience to operate low power successfully. So, if you are just getting started in ham radio, or if your frustration level is low, perhaps you had best leave QRP alone for a while.

Ten-Tec Corporation of Sevierville, Tennessee, offers a line of solid-state modules

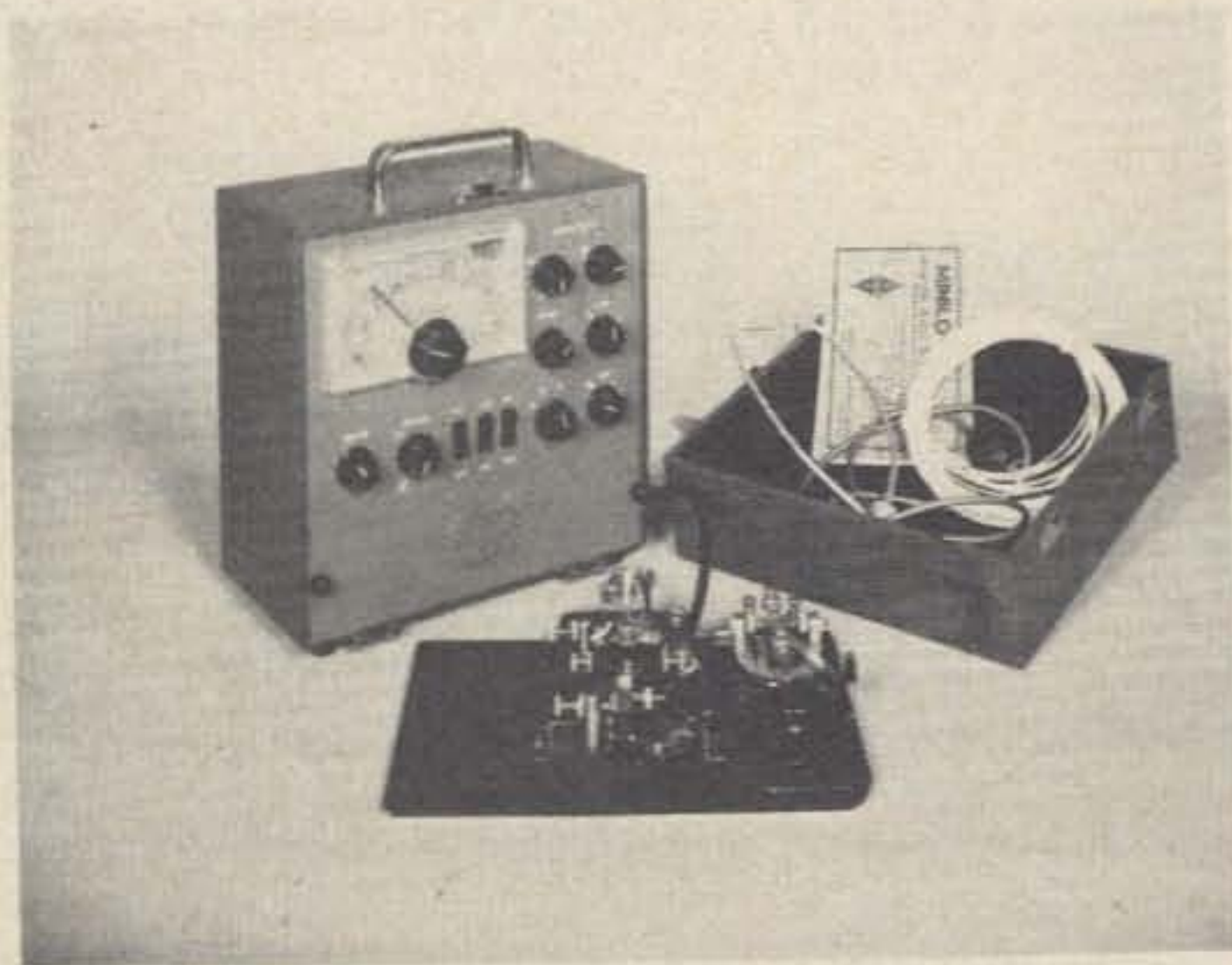

*Complete QRP station in a box. Key, headphones, antenna and logbook fit into deep cover on author's transceiver. Two lantern batteries fit alongside loudspeaker, under bottom panel.*

that lets you put together QRP CW transceivers covering 80 through 15 meters. You can buy their MR1 kit with which you can make a 2W rig covering 80, 40, 20 or 15 meters. Or you can buy their basic modules and build a 5 watt rig for 40 and 20 meters. Either transceiver can be powered from 12V lantern, motorcycle or auto batteries. Of course, you can also buy these rigs already built and in a handsome cabinet, but if you like to tailor your rigs to your own particular style, the modules are the way to go.

For my camping trips I chose to build a 5W transceiver to cover 40 and 20 meters, but the general construction tips and accessories described here can be applied to the other rigs possible using the Ten-Tec modules. My rig features one-knob band-switching, CW sidetone, a built-in antenna tuner and swr bridge (a must for those random length antennas), dial lamps for nighttime operation and a loudspeaker. In addition, I selected a cabinet with enough room to house the batteries, headphones, key, logbook, scratch pad and other odds and ends, truly giving me a "station in a box."

### Circuit Description

A block diagram of the transceiver is shown in Fig. 1. The receiver utilizes the synchrodyne principle, also known as direct conversion. A bfo, operating at the receiving frequency, beats with the incoming signal in a product detector. The resultant frequency is an audio signal which is processed by a high-gain audio amplifier to drive the loudspeaker or headphones. A filter in the

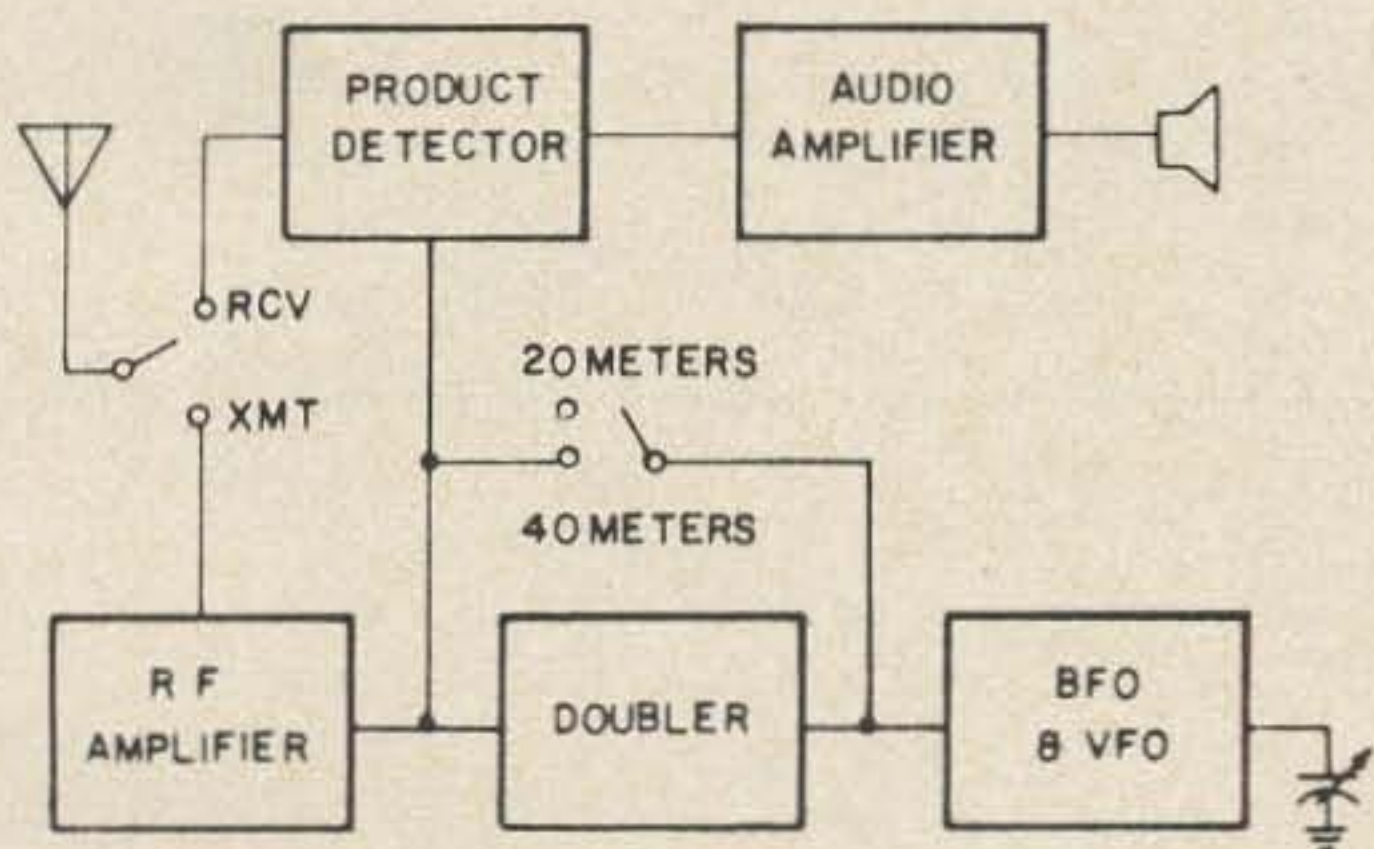

Fig. 1. Block diagram

### PARTS LIST

#### Transceiver

MODULES: (Order from Ten-Tec, Inc., Sevierville TN 37862)

VO1 Oscillator

MX1 Mixer

AA1 Audio Amplifier

AC6 20 meter double & sidetone oscillator

TX2 40/20 meter transmitter

T1 — 1000 ohm to 8 ohm miniature output transformer (Radio Shack No.1380)

R1 — 220 ohm ½W

R2 — 3300 ohm ½W

R3 — 25,000 volume control with on/off switch (Radio Shack No.094)

R4 — 6,800 ohm ½W

C1, C3, C4 — 365 pF variable (Radio Shack No.1344, Lafayette No.11034)

C2 — 560 pF mica

C5 — .22 μF 35V

C6, C7 — .1 μF 35V

C8 — 82 pF mica

Speaker — 2" diameter 8 ohm (Radio Shack No.245)

Dial — Radio Shack No.388 (5"), Lafayette No.25660 (4¼")

Cabinet — Glenwood Sales, 594 Hague St., Rochester NY 14609

S1 — SPST (part of R3)

S2 — Five pole, two position rotary (Mallory 3263J or 4M2323 usable)

S3, S4 — DPDT rocker switches (Radio Shack No.030 kit of two)

LMP1, LMP2 — 6.3V panel lamps, No.47

output of the product detector establishes the selectivity of the receiver, which is around 2 kHz. The sensitivity of this simple receiver is surprisingly good, and it appears to be comparable in performance to medium-priced communications receivers.

In the transmitter portion, the bfo functions as a vfo, and you transmit on the same frequency you receive on. A buffer stage isolates the vfo from the driver and power amplifier. (For 20-meter operation, a doubler circuit is switched in between the buffer and the driver.) The output comprises a push-pull power amplifier feeding a pi network designed to work into 50–75Ω loads.

The antenna tuner and swr bridge circuits were taken from various articles in recent magazines. The tuner comprises a tapped toroid coil and a single 365 pF variable capacitor. The swr bridge also uses a toroid coil to boost the sensitivity to provide adequate meter deflection at these low power levels.

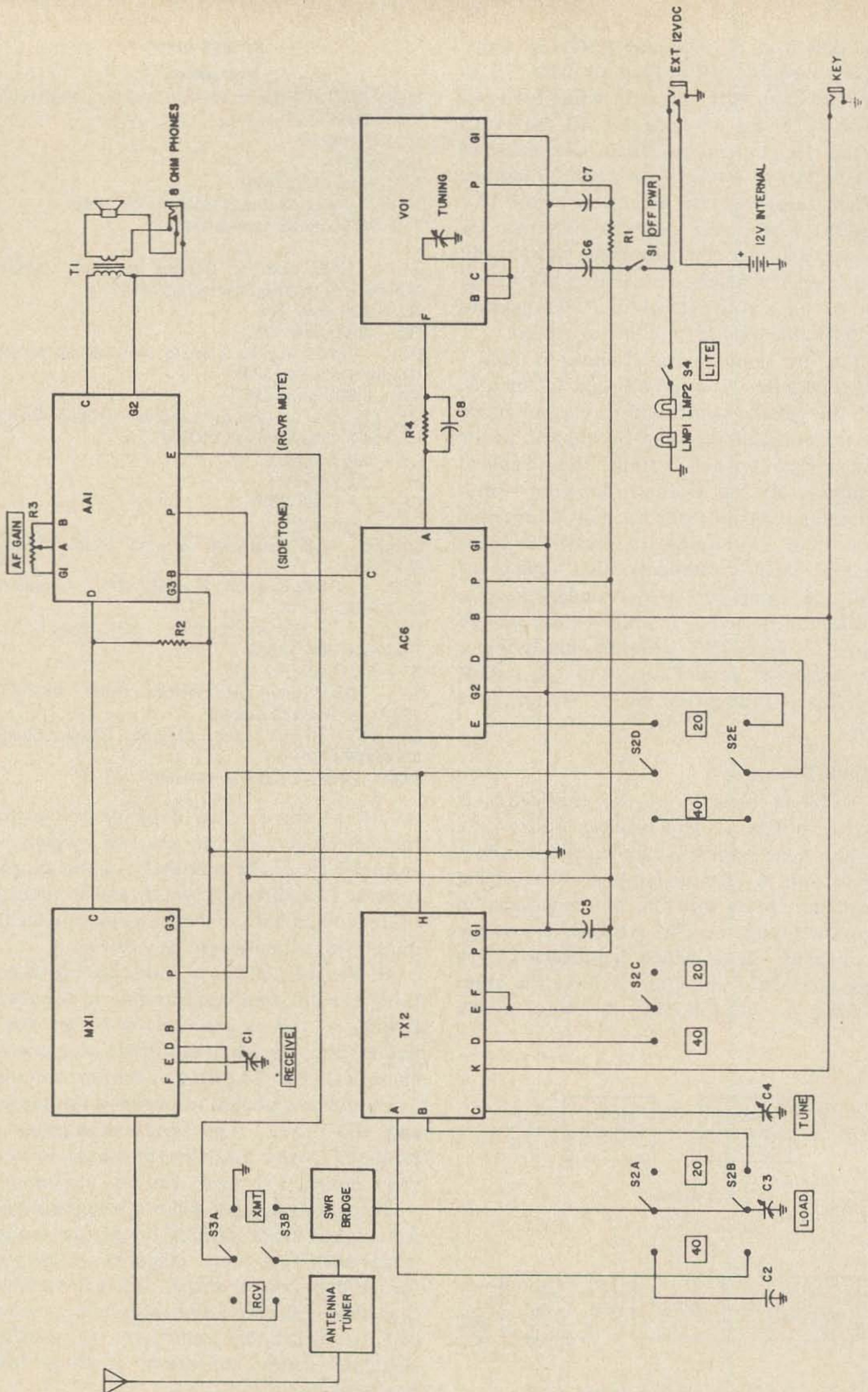

Fig. 2. Wiring diagram for transceiver.



## CONCORD 1/2" VIDEO TAPE RECORDERS

Exclusive sale to licensed Amateur Only

—While they last—

	NOW
1/2" VTR (was \$1050) .....	\$350
1/2" VTR/solenoid operated (was \$1295) .....	\$400
Service Manual .....	\$ 10

### SPECIFICATIONS

*RECORDING SYSTEM:* Helical Scan, dual rotating heads (long-life pressure sintered ferrite), 12in./sec., 30 frames/sec., 2 fields/frame. *VIDEO INPUT:* 1 volt p-p, 75 ohm unbalanced, composite video, sync neg. *VIDEO OUTPUT:* 1 volt p-p, 75 ohm unbalanced, composite video, sync neg. *HORIZONTAL RESOLUTION:* Better than 260 lines. *VIDEO AMP. FREQ. RESPONSE:* 2 MHz at higher than -6 dB. *SIG/NOISE RATIO:* Better than 40 dB. *AUDIO*

*FREQ. RESPONSE:* 50–12,000 Hz. *POWER CONSUMPTION:* 80 watts. *RECORDING TIME:* 40 min. *DIMENSIONS:* 16½x16½x10 :. *WEIGHT:* 60 lbs. *ACCESSORIES INCLUDED:* Empty reel, monitor cable, power cord, splicing tape.



### CONDITIONS OF SALE:

These video tape recorders are sold as new or factory reconditioned. Should any operating failure occur during the first 60 days after purchase due to manufacturers' defect, the VTR will be repaired or replaced at no cost to the purchaser (except shipping charges), by Concord Communications Systems of Jacksonville. Check with order. Shipped freight collect.

## CONCORD COMMUNICATIONS SYSTEMS OF JACKSONVILLE

869 Townsend Blvd. Jacksonville, Fla. 32211  
Attn: Jerry Anderson W4IQT

Watch for our ad next month featuring limited quantity specials on the famous Concord vidicon cameras including their hand-held 2/3" separate mesh view-finder camera. If you can't wait, call Jerry at  
(904) 724-6844

References to articles containing details of the synchrodyne principle, basic Ten-Tec transceivers and the other circuits are provided at the end of the article.

### Construction

Connections are made to solder pins on the boards, which are coded for easy identification. The boards come packed with spacers for mounting, aligning tools (where required) and data sheets giving the schematic of the board and signal specifications.

It is doubtful that you will want to duplicate my cabinet layout, so I won't go into the nitty-gritty details of chassis dimensions, etc. — the photos give you a good idea of my particular construction. Placement of boards with respect to one another is not critical, but common sense should be used to prevent unnecessarily long leads, especially from the boards to the bandswitch. The vfo board *must* be mounted as rigidly as possible for frequency stability.

The variable capacitor that comes mounted on the VO1 board opens counterclockwise. If you couple it to a vernier dial of the type shown in the photos, the lower frequencies will be at the right hand side, and the higher frequencies at the left, contrary to normal practice. If you want the frequencies to be in keeping with the "logical" rotation of the knob, this can be easily

corrected by substituting a 365 pF or 405 pF capacitor that opens clockwise.

A wire is wrapped around the MOSFET leads on the mixer board for protection against voltage spikes which may occur during construction. Be sure you leave this wire in place while you construct the rig. Remove the wire prior to operation, after all soldering is complete.

In retrospect I found the dial lamps to be a nonessential addition. However, should you decide to use lights, keep in mind they draw more current than does the receiver! For this reason I included an on/off switch just for the lights, to keep from depleting the lantern batteries.

I had never wound toroid coils before, so it was an interesting learning experience making the coils for the antenna tuner and the swr bridge. It's really very simple. Take a short length of wire of the size you will be using for the coil, and wrap one turn around the core. Unwind the wire and flatten it out, then measure its length. Multiply the length by the number of turns, and add a few inches for safety. Place the toroid core in the center of this length of wire and begin winding the turns, carefully forming each turn around the core snugly by hand. When you have wrapped one-half the number of turns, begin with the other end of the wire. Be careful not to kink the wire. This technique reduces the number of twists and



Two front views of the transceiver, one showing battery compartment behind loudspeaker panel. Note how panel space is conserved by placing SWR meter within dial assembly.

turns on the wire, and makes the overall job easier. In the case of the antenna tuner, taps are made to the coil using stiff copper wire which is soldered to the 11-position rotary switch. This provides the mechanical mounting for the coil.

The parts for the swr bridge should be laid out as symmetrically as possible for accurate results. The toroid transformer provides more than sufficient drive for the meter, which in my rig is a 500  $\mu$ A movement. Once the bridge is built and wired in place, it must be nulled; this is covered later on in the article.

### Testing

Once wiring is complete, remove the shorting wire from around the MOSFET on the mixer board. Connect the battery and antenna and place the bandswitch to 40 meters. With the mode switch in RECEIVE, turn the unit on and peak the receive control for best reception. Switch to 20 meter operation and repeak the receive control; you will notice it is a bit touchy on this band, but you should have no problem in getting good reception on 20 meters.

Since you are probably itching to see whether the transmitter section works, connect a 5 watt non-inductive load to the

antenna to serve as a dummy antenna and, with the swr meter control at mid range, close the key and adjust the tune and load controls for an indication of rf on the meter. If you get an indication, fine and dandy. Leave the transmitter for now, and let's calibrate the little fellow.

### Calibration

You can use a communications receiver for calibration — one whose calibration you can trust — or a signal generator. The following calibration procedure is based on using a receiver.

Check that the tuning capacitor on the vfo board is fully meshed when the vernier dial pointer is at zero. Place the transceiver bandswitch to 40 meters, then set the calibrating receiver's dial to exactly 7.0 MHz and turn on the transceiver. Using the plastic alignment tool that came with the vfo board, carefully place it in the metal can on the board, down past the first slug (there are two slugs — the top one is for 80-meter use). Slowly adjust the bottom slug until you hear the bfo signal in the communications receiver's speaker. You will be amazed at how strong the radiation of this little oscillator is! Adjust the slug for zero beat and mark the dial face with a pencil.

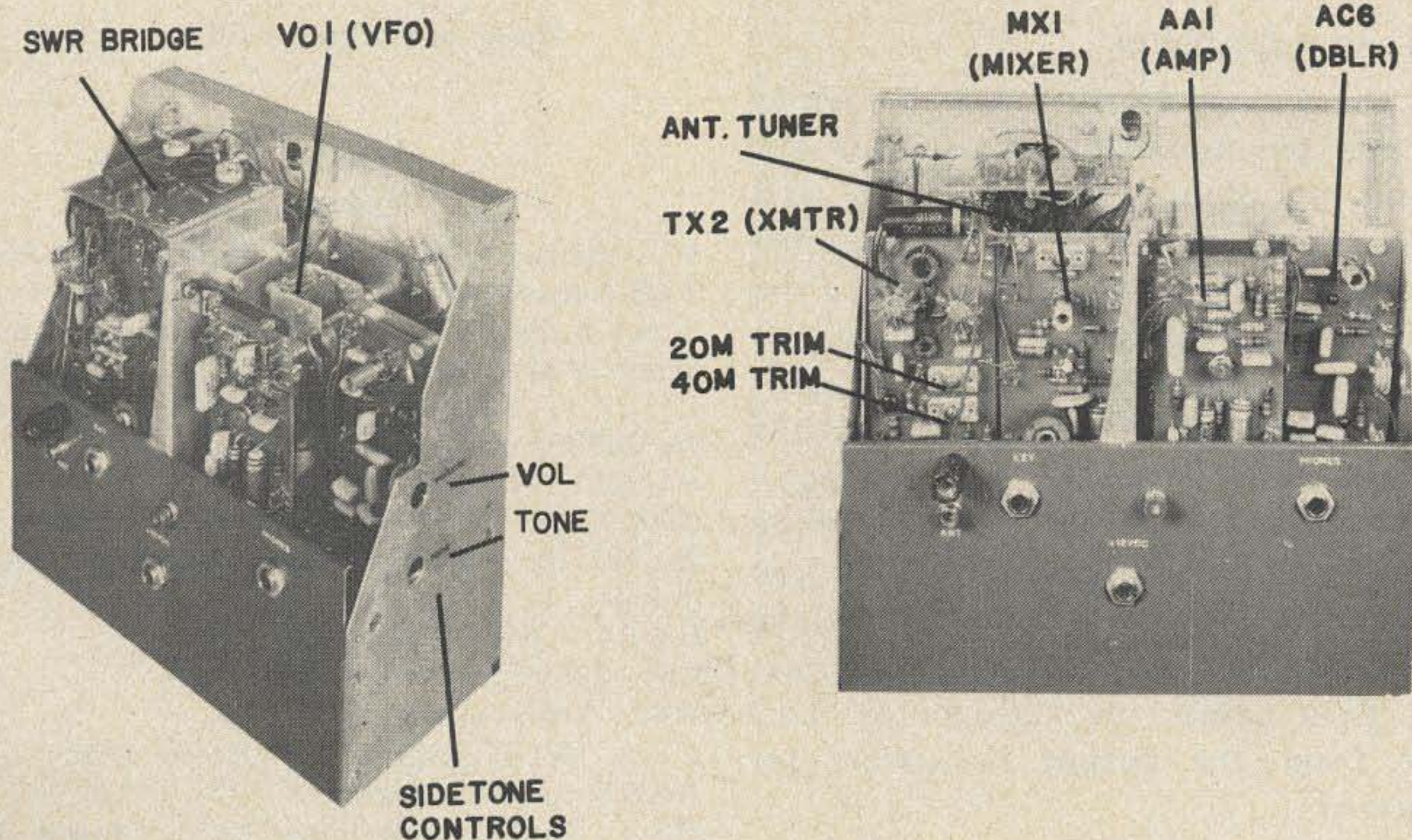

Two views showing placement of Ten-Tec modules in the author's unit. Thumbnut above external 12 V jack is ground terminal

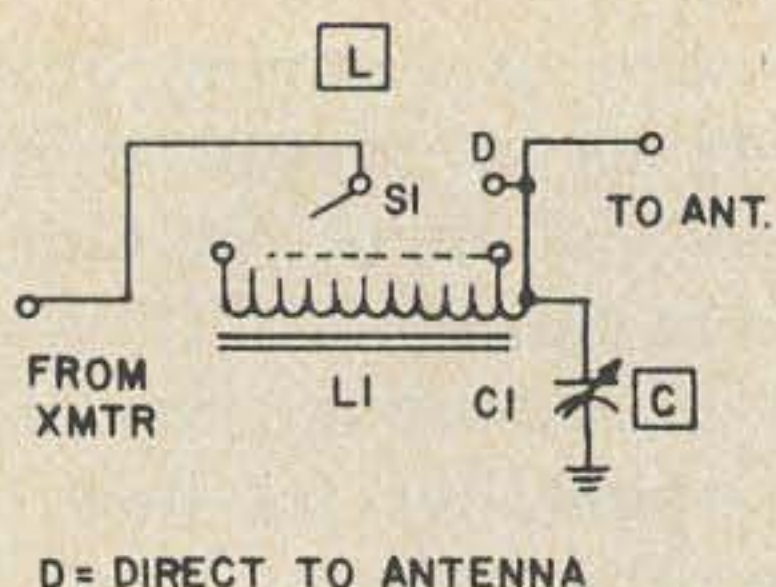

Fig. 3. Schematic of antenna tuner.

## PARTS LIST

### Antenna Tuner

L1 — 30 turns No.20 enameled wire over Amidon T-130-2 toroid core (Amidon Associates, 12033 Otsego St., N. Hollywood CA 91607). Taps every 3 or 4 turns. Space turns evenly.

S1 — 11 position rotary switch (Mallory 4M21111)

C1 — 365 pF variable (Radio Shack No.1344, Lafayette No.11034)

Now, by moving the calibrating receiver's dial, a division at a time (the increment is up to you — I used every 10 kHz), and positioning the transceiver dial until you get a zero beat in the calibrating receiver, you can mark the transceiver dial from 7.0 to 7.3 MHz. Repeat this operation for the 20-meter band, keeping in mind that the frequency spread is one-half of the 40-meter display (you're doubling the frequency, remember?). If you are lazy, you can transfer the calibration marks from the 40-meter dial to the 20-meter dial, keeping in mind that 7.01 will be 14.02 and so on.

### Tuneup and Adjustment

With the dummy load in place, switch to 20 meters and tune the transmitter for maximum rf output using the TUNE and LOAD controls (make sure the antenna tuner is out of the circuit). Don't keep the key down for prolonged periods of time; just enough to get a reading. Adjust the trimmer capacitor nearest to the output transistors on the transmitter board (TX2) for maximum rf output on the meter, maintaining resonance with the TUNE and LOAD controls. Switch to 40 meters and adjust the TUNE and LOAD controls for maximum rf output, then adjust the trimmer on TX2 farthest from the output transistors for maximum rf.

Switch back to 20 meters and adjust the slug in the coil on the AC6 doubler board for maximum rf output. For CW operation,

peak the coil with the transceiver set at 14.050 MHz; the setting will hold for the CW portion of the band.

To null the swr bridge, use the dummy load, and tune the transmitter. Adjust the bridge for full-scale deflection in FWD. Switch to REF and adjust the trimmer capacitor at the input end of the bridge (C1) for a null on the meter. Temporarily unsolder the input and output to the bridge and reverse them, then null C2, with the switch in FWD. (Don't lose any sleep if you can't get a perfect null; remember you are looking for relative front-to-back readings.)

### Power Supplies

The transceiver requires a 12V power supply. Current drain in receive is about 30 mA, and in transmit, can run 480 mA. You can use a pair of 6V lantern batteries in

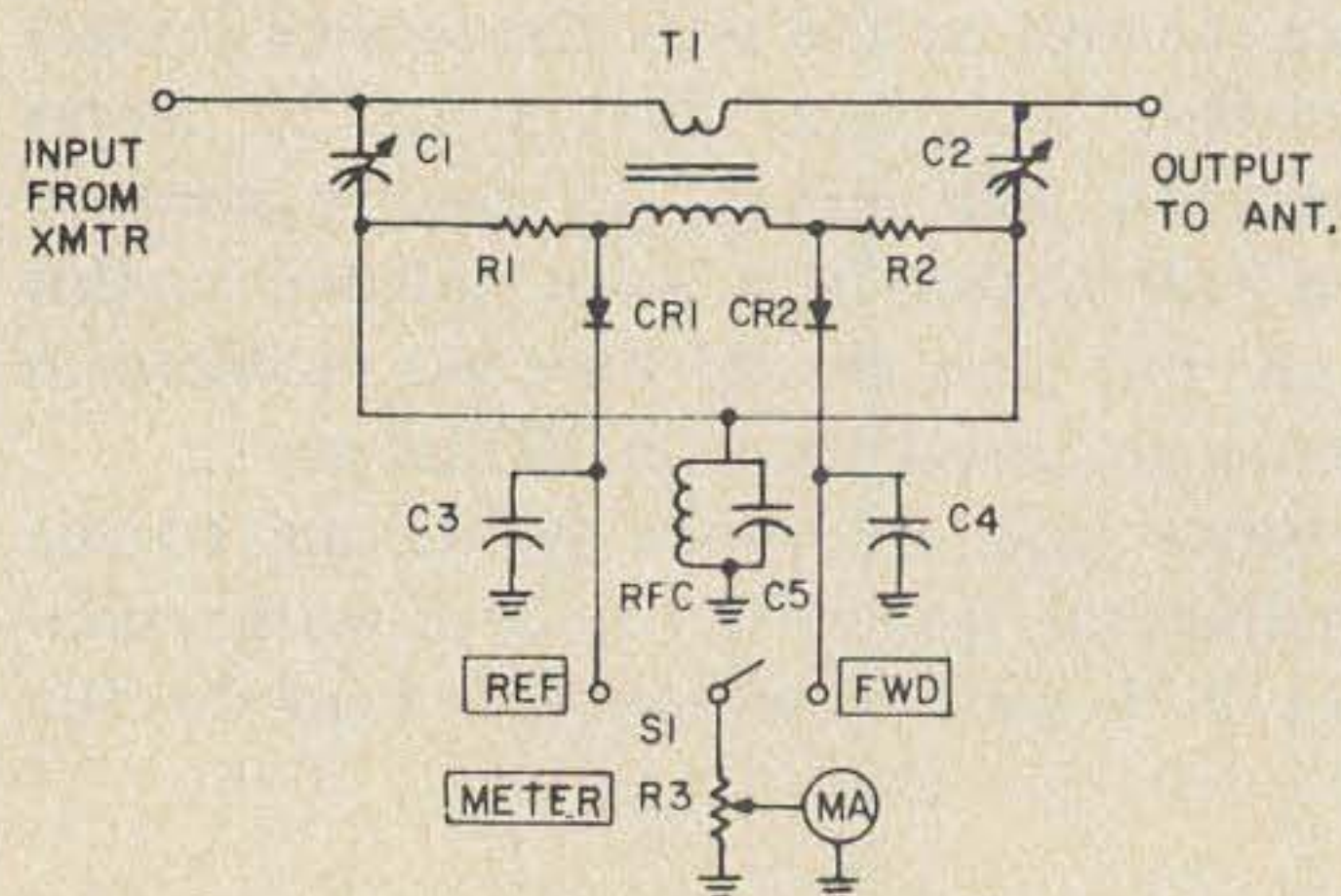

Fig. 4. Schematic of SWR bridge.

## PARTS LIST

### SWR Bridge

T1 — 60 turns No.30 enameled wire over Amidon T-68-2 toroid core. Close wind the turns. Primary is two turns No.22 or 24 hookup wire wound over center of secondary.

C1 C2 — 1.5–7 pF ceramic trimmer (Lafayette No.68386 mica usable)

R1, R2 — 120 ohm 1/2W

CR1, CR2 — 1N34A or equivalent (Radio Shack No.821 for pack of 10; select two that match the closest).

C3, C4 — .005  $\mu$ F disc type

C5 — 330 pF ceramic or silver mica

RFC - 1 mH choke

S1 — SPDT (Use DPDT Radio Shack rocker; No.030 for kit of two)

R3 — 25,000 ohm linear taper control (Radio Shack No.094)

Meter — 50  $\mu$ A to 1 mA movement (Lafayette 500  $\mu$ A No. 50361 a good size)



Motorcycle batteries make good portable power supplies. Two 6 volt, 2 amp/hour units such as this can fit into case along with a small battery charger. Care must be taken to keep batteries upright to prevent acid spillage.

series or a 12V lantern battery and get pretty good performance from them. But it is highly recommended that you use a power source that presents a "stiffer" load to the rig, such as an automobile battery or motorcycle storage battery. These sources will go a long way in preventing unwanted deviations in supply voltage and the possibility of chirpy signals. You can buy two 6V 2 amp/hr batteries for a small Honda motorbike from Sears or Montgomery-Ward for around \$4 each. The batteries are small enough to fit into the cover of the cabinet I used, along with a small charger.

#### Antennas

The built-in antenna tuner will let you load a variety of radiators. I often use just a 65 ft long piece of wire, tying one end to a length of nylon builder's twine and a rock, and tossing it into a tree. By tuning the transmitter, watching the FWD and REF readings, and adjusting the L and C, a bit at a time, you can usually get a good match and make worthwhile contacts. But you may find the rig is "hot" with rf, and touching the case may detune the rig!

A better solution to the antenna problem is to use a simple trap dipole covering 40 and 20 meters. The improvement over the long wire justifies the extra work involved in setting up such an antenna. Of course you could also use a vertical, such as the 14AVQ, as long as you use a good ground rod or make a set of radials.

## R-X NOISE BRIDGE



- Learn the truth about your antenna.
- Find its resonant frequency.
- Find R and X off-resonance.
- Independent R & X dials greatly simplify tuning beams, arrays.
- Compact, lightweight, battery operated.
- Simple to use. Self contained.
- Broadband 1-100 MHz.
- Free brochure on request.
- Order direct. \$39.95 PPD U.S. & Canada (add sales tax in Calif.)

## PALOMAR ENGINEERS

BOX 455, ESCONDIDO, CA 92025

## SUPER CRYSTAL THE NEW DELUXE DIGITAL SYNTHESIZER!! FROM



#### MFA-22 DUAL VERSION

Also Available MFA-2 SINGLE VERSION

- **Transmit and Receive Operation:** All units have both Simplex and Repeater Modes
- **Accurate Frequency Control:** .0005% accuracy
- **Stable Low Drift Outputs:** 20 Hz per degree C typical
- **Full 2 Meter Band Coverage:** 144.00 to 147.99 MHz. in 10KC steps
- **Fast Acting Circuit:** 0.15 second typical settling time
- **Low Impedance (50 ohm) Outputs:** Allow long cable runs for mobiles
- **Low Spurious Output Level:** similar to crystal output
- **PRICES**

MFA-22	\$275.00
MFA-2	\$210.00
Shipping	\$3.00

 **Electronics**

Box 1201 B  
Champaign, IL 61820

**SEND FOR FREE DETAILS**

# MORE RANGE . . . with NO NOISE

FOR ALL  
MOBILE UNITS

ENGINEERING  
ESTES  
COMPANY

CUSTOM SYSTEMS  
KITS • ACCESSORIES

ELECTRO-  
SHIELD

ELIMINATE IGNITION NOISE  
**ELECTRO - SHIELD®**  
YOUR ENGINE

FROM \$44.95

**ESTES ENGINEERING CO.**

543 W. 184th St., Gardena, Calif. 90247

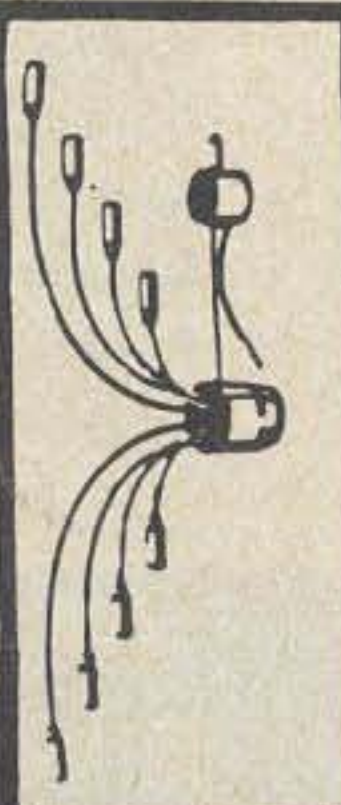

## Operating Tips

You will learn very quickly that it takes a bit of patience and a slightly different operating technique to be a successful QRP man. Experience has proven it's better to answer a CQ than to call one yourself. You will usually do better when the band isn't too crowded, and before the noise level gets up. My best operating has been early morning through late afternoons. And with so many transceivers on the air these days, if you tune to the high-frequency side of the other fellow's signal, you will establish the correct frequency offset so he will be able to hear you without having to retune his receiver.

On 20 meters, you may hear foreign broadcast stations all over the band, regardless of the position of the main tuning dial. This is due to overloading of the simple receiver front end, and can be reduced by carefully peaking the RECEIVE control. If they still leak through, and adjusting the antenna tuner doesn't attenuate them into the noise level, you may need a trap in the antenna lead to the receiver. I've been able to peak up the controls so that while the BCI is still there, it is far enough down in dB so as not to bother my operation.

One last comment. Please use tact when you receive better signal reports from fellows running 100 times the power you are, than you give them. They'll most likely call you a liar when you repeat for the third time that you are only running a few watts input. It's just that they haven't learned yet that you can get out with your little flea power job almost as well as they can!

A special thanks is in order to Mr. Jack Birchfield of Ten-Tec, Inc., for his invaluable technical assistance, and to Mr. Court Packer for his photography.

. . .WB2WYO

## References

Equipment Report - Ten-Tec PM2, June 1970 QST (DeMaw)  
Direct Conversion - November 1968 QST (Hayward, Bingham)  
Synchrodyne Detectors, April 1969 QST (DeMaw)  
Antenna Tuner - Windowsill Vertical, June 1967 QST (McCoy)  
SWR Bridge - QRP Console, September 1970 QST (DeMaw)  
Toroid Coils "The Whole of the Doughnut", June 1967 73 (Klein)



## For FREQ. STABILITY

Depend on JAN Crystals. Our large stock of quartz crystal materials and components assures Fast Delivery from us.

### CRYSTAL SPECIALS

2-METER FM for most Transceivers ea. \$3.75  
144-148 MHz — .0025 Tol.

#### Frequency Standards

100 KHz (HC 13/U) 4.50  
1000 KHz (HC 6/U) 4.50

Almost all CB Sets, Tr. or Rec. 2.50  
(CB Synthesizer Crystal on request)

Any Amateur Band in FT-243 1.50  
(80-meter, \$3.00 - 160-meter not avail.) 4 for 5.00

For 1st class mail, add 20c per crystal. For Airmail, add 25c. Send check or money order. No dealers, please.

**JAN**  
CRYSTALS

Division of Bob Whan  
& Son Electronics, Inc.  
2400 Crystal Drive  
Ft. Myers, Florida  
33901

All Phones  
(813) 936-2397

Send 10c for new catalog with 12 oscillator circuits and lists of frequencies in stock.

# SIMPLE AUDIO PREAMP

*Increase your average talk-power with this simple device.*

**L**ike a "Mini-Linear" for under ten bucks? That would be *almost* something for nothing, now, wouldn't it? Of course you can't build a linear for that price but you can dramatically increase the effectiveness of your single sideband signal at low cost, with a little careful experimentation. How? With speech processing — call it pre-amplification with clipping, compression — whatever you will, the name of the game is higher average level, increased intelligibility of communications. There have been all kinds of circuits published for accomplishing this. The secret though, whatever approach you use, is to do plenty of experimenting for best results tailored to your particular voice, your microphone, your exciter.

You can't do this blindfolded, any more than you could expect to repair a complicated piece of electronic gear with a wad of chewing gum. But the kind of tools you need are not that difficult to come by . . . and you may have some of them already on hand in the shack: a good output meter (rf bridge or wattmeter); a monitor scope; and a pair of good ears, preferably belonging to an unprejudiced friend in the amateur fraternity. Better yet, instead of somebody else's ears, why not a tape recorder? You don't have to argue with it . . . it is up to you to accept or reject the recorder's completely unbiased judgment!

Where do you start? Comb through the past two or three years of articles in the various ham publications if you like. But if you'd prefer to make it a little easier on yourself, and inexpensive, play around with the circuit shown below. It has worked wonders with Swan's, SBE's and many other transceivers.

The basic circuit is pretty simple and straightforward: the correct use and adjustment of it, not necessarily so. Here are the guide rules: when the unit is properly aiding your average talk-power level, an rf bridge on forward power or a wattmeter will clearly "hang up," like delayed AVC action on the "S" meter reading of a strongly received signal. Your "Christmas tree" pattern on a scope will demonstrate the difference, too. And a brother ham can confirm this on his "S" meter at a distant receiving point.

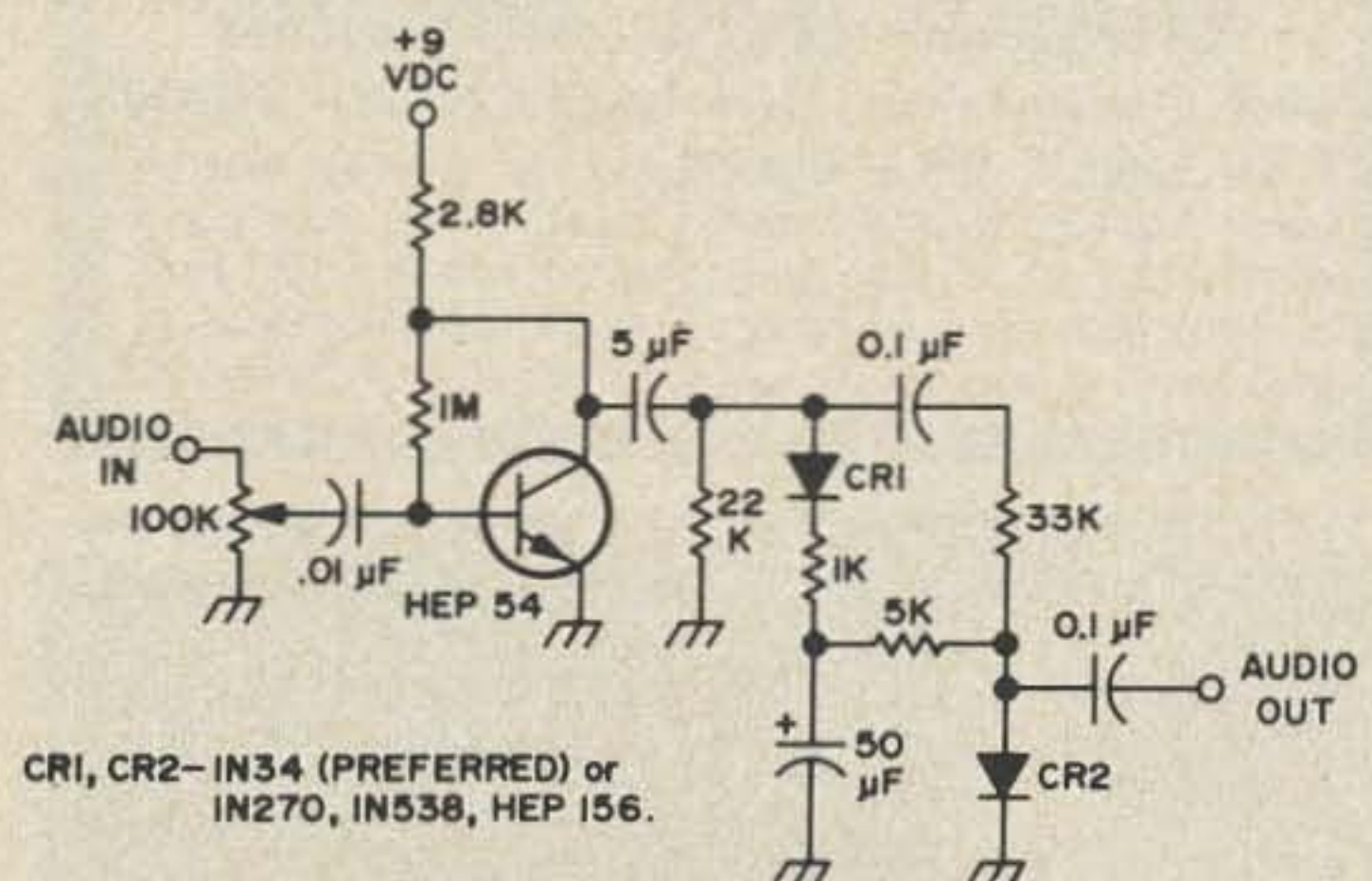

Fig. 1. W6JDD's audio preamp compressor.

## CFP ENTERPRISES

866 Ridge Road  
Lansing, NY 14882

Central Upstate New York's  
Mail-Order Headquarters  
Specializing in Two-Meter FM  
and Quality Used Gear

Office and Salesroom Hours by Appointment Only

24-Hour Phone: 607-533-4297

Send SASE for Bi-Monthly Listing of:

Used Equipment and Bargain Goodies

Trade-ins accepted on both new and used equipment. Cash deals get prepaid shipping in the Continental USA plus a 15% discount on the items on our regular listing!!!!

## CLEARANCE SALE

Send for *FREE* list of select used equipment at a special discount of 40% off regular prices. Savings galore!!

T.T. Freck, W4WL

## FRECK RADIO & SUPPLY CO.

40 Biltmore Avenue  
P.O. Box 7287  
Asheville, North Carolina, 28807  
Telephone: 704-254-9551

## FM Schematic Digest

A COLLECTION OF  
MOTOROLA SCHEMATICS  
Alignment, Crystal, and Technical Notes  
covering 1947-1960  
136 pages 11½" x 17" ppd \$6.50

S. Wolf  
Box 535  
Lexington, MA 02173

## WORLD QSL BUREAU

5200 Panama Ave., Richmond CA USA 94804  
THE ONLY QSL BUREAU to handle all of your QSLs to anywhere; next door, the next state, the next county, the whole world. Just bundle them up (please arrange alphabetically) and send them to us with payment of 5¢ each.

## SPACE-AGE TV CAMERA KITS & PLANS



BE A PIONEER IN HOME TELECASTING! Build your own TV CAMERA, Model XT-1A, Series D, \$116.95 pp. Solid-State. Step-by-step construction manual. High quality. Connects to any TV without modification. Ideal for hams, experimenters, education, industry, etc.

PHONE or WRITE for CATALOG.

DIAL 402-987-3771

Many other kits, parts and plans available including starter kits, focus/defl. coils, vidicon tubes, const. plans, etc.

1300 N. BROADWAY **ATV Research** DAKOTA CITY, NEBR. 68731

You can control the degree of compression to some extent by setting the mike level into the circuit through adjustment of the 100K input potentiometer. Then compensate for the overall level by readjustment of your exciter's own mike level control. The outboard circuitry ends up with passive diode compression. The number of dB's of compression will vary here if you experiment with various types of diodes. Since the time constant is controlled by the 50  $\mu$ F capacitor and the 5K resistor, some experimentation here too will provide some different and measurable results in the output.

Regardless of what the output meter says, the acid test is how it sounds. Distorted compression is worse than no compression at all! Here's where your friendly tape recorder is better than your friendly "friend's" ears. If you hanker for some of that old D-104 penetrating quality with high talk-power punch for mowing down the DX, you can get it. Depending on your mike and your voice, experiment with input coupling capacitors ranging from .001 to .1  $\mu$ F. Run a test through a tape recorder...you'll know when it's right. The .01 is just right for my voice; it may not be for yours.

This type of circuit will perform with almost any kind of an audio transistor at voltages ranging from two penlight cells to a standard 9V transistor battery. Germanium diodes are preferred to silicon diodes due to operating reference levels.

One final word of caution. Always shield such a circuit well in a suitable minibox. An rf choke and small bypass filter is desirable in the hot input mike lead. If you run a linear keep an eye on a scope for "fuzzing" of the pattern as an indicator of rf leakage into the unit. Circuits like this lend themselves ideally to perfboard layout and construction.

If you possibly can, play with matching the critical components to your custom tailored requirements, utilizing the tape recorder as the judge. Then put it on the air...and better yet...*don't* use a linear. That will prove to you (if you have done your homework right) that you really have gotten something - almost - for nothing!

...W6JDD



# AN INTEGRATED CIRCUIT SWL RECEIVER

**M**any hams received their introduction to radio through listening to the international short wave listening (SWL) bands. The thrill of sitting in your own home listening to a broadcast by a station in a foreign land was only exceeded by the realization that one could become a ham and conduct an international two-way conversation.

The trends to SSB and all ham band transceivers increased the effectiveness and pleasure of hamming. However, the capability to browse the international broadcast bands is often missed. Building a simple converter ahead of a SSB receiver is not sufficient since the broadcast stations use AM.

In addition to the construction of a receiver converting the SWL bands, I wanted to build a receiver using integrated circuits to the maximum extent possible. Design objectives included: coverage of the 9, 11, and 15 MHz bands plus WWV at 10 and 15 MHz; Sufficient selectivity to adequately separate signals on the often crowded bands; good sensitivity without the use of an external antenna; reasonable fidelity and stability; and simplicity and low cost.

The receiver described in the following sections met these objectives and has provided many hours of pleasant listening to stations in foreign lands.

## The Integrated Circuit

Upon review of the numerous analog of ICs available, the Amperex TAD-100 was selected. This device provides all the active components needed for a complete AM broadcast receiver except for the complementary pair audio output transistors. The internal oscillator is only operable to about 3 MHz but the mixer gives good results to 27 MHz when driven by an external oscillator.

The circuit of the TAD-100 is shown in Fig. 1. Q1 and Q2 comprise a long-tailed-pair mixer and Q3 is a dc coupled oscillator. In the SWL receiver, Q3 is prevented from oscillating and the external oscillator injection is applied to the emitters of Q1 and Q2. An external ceramic filter provides selectivity between the mixer and i-f amplifier.

A three stage i-f, consisting of Q4, Q5, and Q6 provides amplification. A dc feedback circuit (pins 10 and 11 are dc connected) aids stability. Q7 is the AM detector and Q8 and Q9 form a long-tailed-pair audio preamplifier section. A Darlington circuit, Q10 and Q11, drive a 2N4107 complemen-

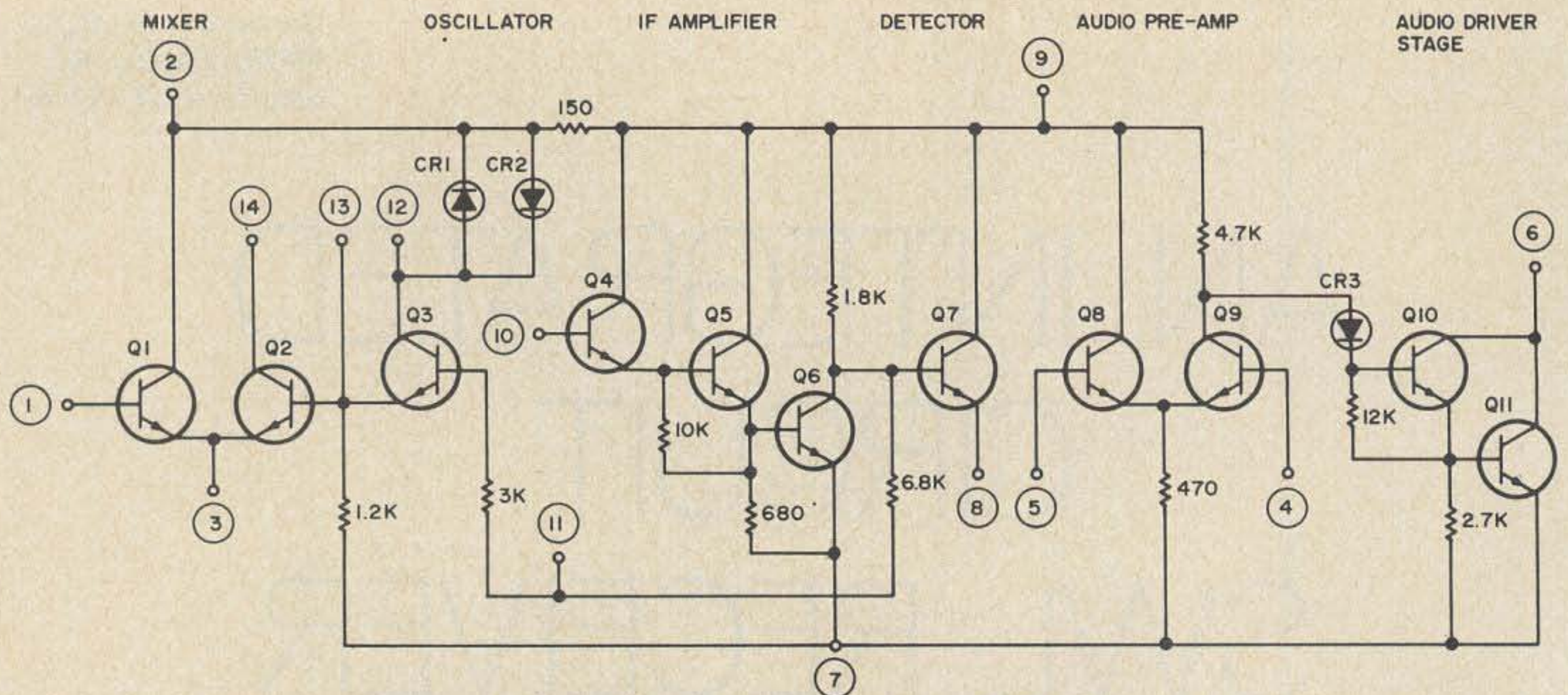

Fig. 1. Internal circuitry of the TAD-100.

tary pair to 0.7 watt audio output with a 6 volt supply.

External circuitry provides 20 dB negative feedback from the external audio output stage to the audio preamp to ensure consistent performance and to reduce the effect of supply voltage fluctuations. The agc voltage derived from the emitter of the detector controls the gain of the mixer through an external decoupling network and gives approximately 60 dB of agc range.

The ceramic i-f filter has a 3 dB bandwidth of 5 kHz and is 33 dB down at  $\pm 9$  kHz. Ultimate attenuation is 90 dB. Audio distortion is under 2% at 0.6 watts output. Sensitivity for a 10 dB signal-to-noise ratio is just under  $1 \mu\text{V}$  into  $50\Omega$  at 1 MHz. This figure will degrade somewhat at the frequencies covered by the SWL receiver. The sensitivity is quite adequate and signals from all over the world are easily received that are well above the noise even though an external antenna is not used.

### Circuit

Figure 2 shows the circuit of the SWL receiver. Where possible, junk box or surplus parts were used to hold down cost. The values shown for the components in the audio and agc circuits are the recommended values from Amperex's Report No. S-144. In my receiver, substitute values were often used which closely approximated recommended values.

A ferrite rod antenna gives the receiver some degree of portability. This also allows an increased Q of the coil to improve selectivity. The ferrite rod was scrounged from a transistor radio so its characteristics are unknown. Some experimentation with the number of turns may be required to achieve proper coverage with different rods. If the receiver is used near a transmitter, back-to-back diodes should be connected across L1 to prevent damage to the IC.

The receiver tunes from 9.3 to 18 MHz. The elimination of bandswitching reduces circuit complexity. An imported dial from Allied Radio Shack serves as the main tuning dial. Bandspread is a little marginal using this approach but it takes only a few minutes to develop the necessary skill.

C1 is a surplus variable which has 3 sections of 50 pF per section. Only two sections were used. Similar capacitors can be substituted. C1A tunes the antenna circuit while C1B tunes the high frequency oscillator. C2 is a trimmer which achieves tracking between the antenna circuit and the oscillator.

The oscillator uses an RCA 40240 transistor. This inexpensive unit has a high beta and a high ft. Numerous oscillators have been constructed with this device and it always performs flawlessly. To cover the wide frequency range, a Hartley circuit was designed. The tuning capacitor comprises almost the entire tuned circuit capacitance

# The Ultimate F.M. Transceiver

Here it is, the FMer's dream, a fully synthesized transceiver that'll cover the entire two meter band, PLUS a built-in scanning receiver that'll locate any repeater frequency in your area that's in use.

*And get a load of these other features that make the ultimate rig:*

- Operates on FM, AM or Modulated CW
- Built-in DC and AC power supplies
- Frequency Range of 143.5 to 148.5 MHz in 5 KHz increments
- Autoscan in 5 KHz steps across entire band, with adjustable speed and frequency limits.
- Synthesizer flexibility that offers choice of 600 KHz up or down, 1 Meg up or down, simplex, frequency split, or any nonstandard split (programmable) all from a single function switch.
- Receiver Sensitivity of 0.35 Mv for 12 db SINAD on FM
- Dual power output of 20 watts or 5 watts across entire band
- Adjacent channel rejection (30 KHz) 100 db minimum
- Image spurious and intermodulation (EIA) 80 db minimum
- 10 pole, 13 KHz crystal filter
- Receiver Superhet, single conversion
- Frequency stability of 0.0005%
- Built-in tone burst and PL encoders and decoders
- Built-in touch tone pad
- Full LED Digital readout
- Built-in S Meter also serves as VSWR bridge, power output meter, battery indicator, deviation indicator and discriminator meter.
- Audio output 4 watts @ 10% THD
- Speaker built-in to left side of cabinet for maximum mobile reception
- Headphone jack for noise-free mobile operation
- Independent selectable priority channel
- Built-in Auto CQ
- Temperature range from  $-20^{\circ}$  to  $170^{\circ}$  Fahrenheit
- Size: 4" H x 8" W x 10" D                      Weight: 10 pounds
- One million channels (1000 Rec. x 1000 Trans.)



**\$995.00**

\$100 deposit will insure  
early delivery and guarantee  
price

**You owe it to yourself to go first class. Try an EBC 144 —  
You deserve it !**

---



**emergency  
beacon corp.**

15V River Street

New Rochelle, NY 10801

(914) 235-9400

AMATEUR PRODUCTS DIVISION

---

and thus permits the coverage of the wide frequency range. The oscillator operates at 455 kHz higher than the desired signal. This places its harmonics within the range of an all ham-band receiver at critical points to assist in receiver calibration.

A curious problem developed in the initial receiver design. L2 approaches self-resonance in the commercial FM band. Harmonics from the oscillator were strong enough to produce FM signals all over the dial. A simple low pass filter, consisting of L3, L4, L5, L7 and C8, eliminates the problem except for a few weak spurious signals outside the SWL bands. My location is within a few miles of some very high power commercial FM stations. If your location is less severe, the filter may not be needed.

The signal input is applied to the base of Q1 and is mixed with the oscillator signal applied to the emitters of Q1 and Q2. The 455 kHz i-f signal is taken from the collector of Q1 and passed through the ceramic filter, FL1. C26 must be a high quality bypass and should be connected directly between pin 11 and pin 7 of the TAD-100 using short leads. Some i-f instability was present using the manufacturer's recommended circuit. This was cured by using an additional bypass, C17, connected between pins 11 and 7 of the i-f filter using short leads.

After i-f amplification and detection by Q4, Q5, Q6, and Q7, the audio and agc voltage are present at pin 8. R1, R2, and C4 comprise a decoupling network with the proper agc time constant. The agc voltage is fed back to the mixer through L2. Bypass capacitor C13 is connected to the dc line rather than grounded to avoid i-f feedback. R5 and C18 form a decoupling network to prevent the 455 kHz i-f signal from entering the audio stages.

The audio stages are fairly straight forward. The RC networks are designed to provide proper bias for the stages, to provide negative feedback for improved stability, and to limit the frequency response to about 12 kHz. Amperex recommends the use of a potentiometer in parallel with a thermistor for R13. The author found no heating of Q12 and Q13 under normal operating conditions so the thermistor was eliminated.

#### Parts List

- C1A,B Dual-section variable capacitor, 50 pF per section.
- C2 1.5-7 pF trimmer.
- FL1 Ceramic filter, Amperex part No. 8222 410 42010.
- L1 11 turns no. 16 spaced over 2½" of a 5" x 1/4" ferrite rod.
- L2 1 turn link wound over the cold end of L1.
- L3, L5 19 turns no. 24 close wound on ¼" diameter form (use an old resistor 1 megohm or larger).
- L4 Ohmite Z-144.
- L6 27 turns no. 24 wound on 3/8" diameter slug-tuned form.
- L7 4 turns no. 24 wound over the cold end of L6.
- L8 1 turn no. 24 wound over L7.
- Q12, 13 2N4107 (consists of one each 2N4105 and 2N4106).
- Q14 40240.
- Q15 Any NPN transistor in TO-5 can.
- S1 On-off switch on R6.
- T1 117 V.A.C. to 6.3 V.A.C. transformer, Olson T-76.
- U1 Amperex TAD-100 integrated circuit.

Also, the quiescent operating point of these transistors did not appear to be critical so a fixed resistor was substituted.

The power supply circuit is standard with the exception of the filtered supply to the oscillator. The audio stages draw fairly heavy peak current causing the base-emitter impedance of Q15 to vary. This leads to enough change in output voltage to cause the oscillator frequency to vary if it is connected to the same line. Thus, voltage for the oscillator is taken from the zener diode, D5, which is much steadier. Q15 is an unmarked NPN junk box transistor. The requirements are not critical and nearly anything in a TO-5 can will suffice. If Q15 does not overheat when testing the receiver, it is probably good enough.

#### Construction

A homemade "L" shaped chassis and panel was formed from an aluminum cookie sheet. A surplus walnut cabinet from a small stereo receiver housed the unit. The tuning variable, C1, is mounted in the center of the chassis. The TAD-100 and its associated parts are mounted on one side of C1, and the oscillator and power supply are on the other side. The ferrite rod antenna runs parallel to the front panel on the rear lip of the chassis.

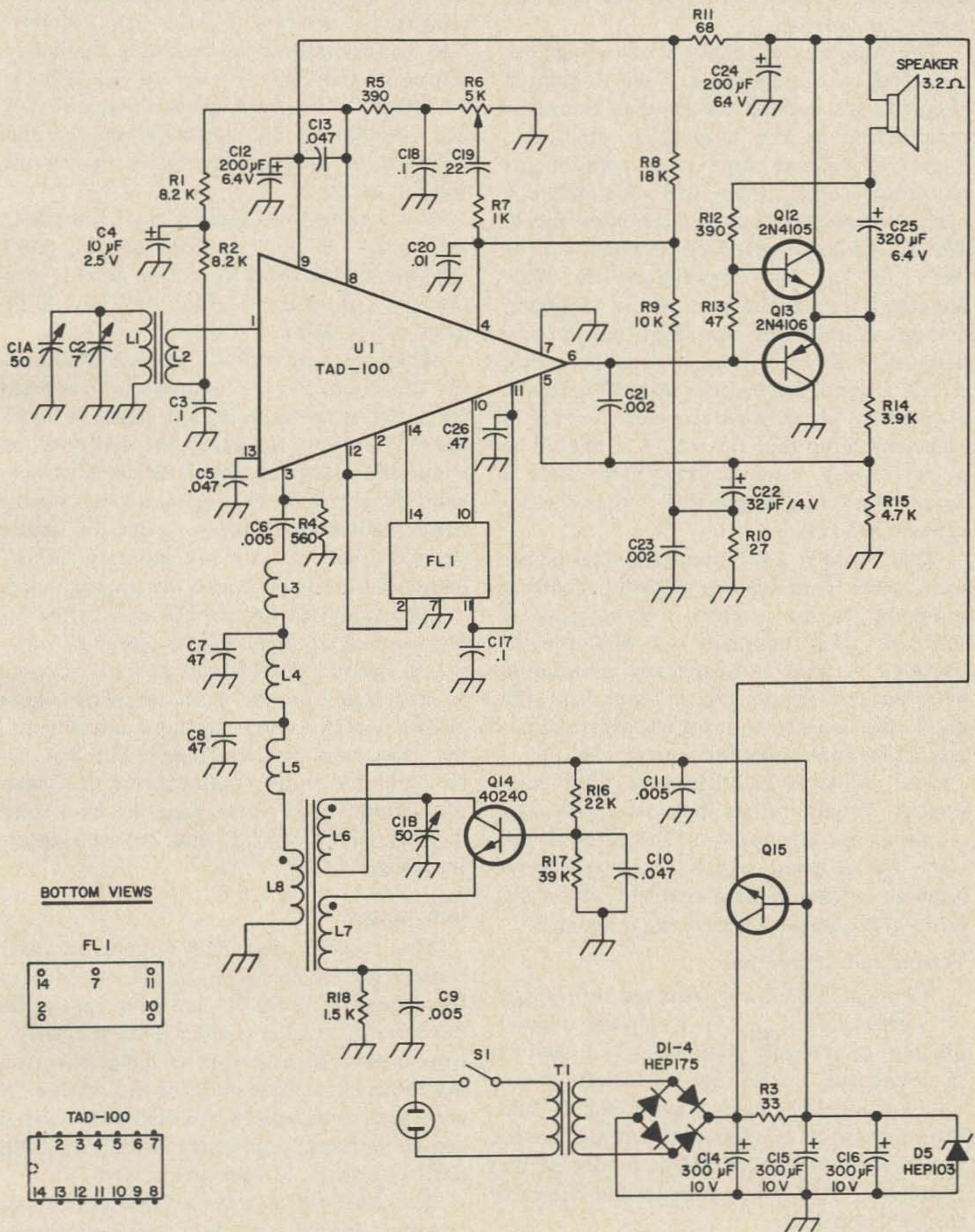

Fig. 2. Circuit diagram of the SWL receiver incorporating the TAD-100 IC chip.

Layout is not particularly critical but good rf practice should be followed. Be sure not to enclose the unit in a metal box or signals will be prevented from reaching the ferrite rod antenna.

The Amperex application note suggests mounting the components on a printed circuit board and the use of small transistor radio parts. In the interest of simplicity, direct wiring was used with components physically larger than the recommended parts. No unusual troubles were experienced. The TAD-100 is turned on its back with its "legs" in the air. Connections are made directly between the pins (use a minimum amount of soldering iron heat and application time) and several nearby terminal strips.

All ground connections should be made as directly as possible to pin 7. This is especially important for C26. C13 should be a small size ceramic capacitor and is mounted as close as possible to pins 8 and 9 of the TAD-100.

The ferrite rod is mounted several inches from other components to avoid feedback problems. In my receiver, a short piece of shielded cable connects L2 and the IC circuitry. A small vertical shield is mounted between the ferrite rod antenna and the oscillator circuitry to prevent oscillator harmonics from reaching the antenna circuit.

The oscillator and harmonic filter components should be securely mounted. The requirements are not too critical, however, since the received signals are AM. Several hundred cycles of drift will not cause any noticeable change in the received signal.

### Testing and Calibration

All semiconductor devices are unforgiving of wiring errors and it is always a good practice to recheck your wiring job against the schematic. Also inspect carefully for solder bridges between pins on the IC and shorts between components. Apply power and check for approximately 6 volts at the emitter of Q15. Some noise should be heard from the speaker.

Calibration can best be accomplished at night when plentiful signals are present on the bands. The oscillator calibration is the first task to be accomplished. Tune a ham band receiver to 29.265 MHz and place a

hookup wire antenna from the ham receiver to a point near the SWL receiver. With the plates of C1 fully meshed, tune the slug in L6, L7, L8 until the third harmonic of the oscillator is received by the ham receiver. This corresponds to an incoming frequency setting of the SWL receiver of 9.3 MHz. If no signal can be heard, check the polarity of the windings on the oscillator coil. L6 and L7 must be phased properly or the circuit will not oscillate.

Next, place your fingers on L1 to de-Q the circuit. As you tune up the dial, the 9 MHz shortwave band should be present over the first 20% of the dial and WWV should be heard at 10 MHz.

While listening to WWV at 10 MHz, adjust the spacing of L1, by compressing or spreading turns, until the signal strength is maximized. Continue tuning up the dial until, at about the midpoint, the 11 MHz shortwave band is received. Picking a strong, steady signal, adjust C2 for a peak in signal strength. This is only a temporary adjustment of C2 to get it into the proper range.

Next tune further up the dial to the 15 MHz shortwave band. Finally, peak C2 on a strong signal. The trimmers in FL1 can now be adjusted for the best sounding signal quality. After rechecking these adjustments, the receiver is properly tuned. The dial can be calibrated using combinations of oscillator harmonics as received on the ham band receiver, WWV signals, and received shortwave signals.

### Conclusions

The receiver performs remarkably well considering its simplicity. Sensitivity is more than adequate to fill the dial with signals and the ceramic i-f filter ensures good selectivity. Not surprisingly, the lack of image rejection on the higher frequencies is noticeable. A very weak image on the 15 MHz WWV signal can be received for instance. Within the SWL bands, however, few problems exist.

The TAD-100 is a remarkable device and certainly should have broader applications. For example, by using the internal oscillator and tuning the input frequency to 1.5–2 MHz, an excellent back end for a portable two meter AM set could be constructed.

...W1GQG

# FINAL ASSEMBLY AND FIRST NIGHT ON THE AIR

Bill Hoisington K1CLL  
Far Over Farm  
Peterborough NH 03458

(with the 432'er)

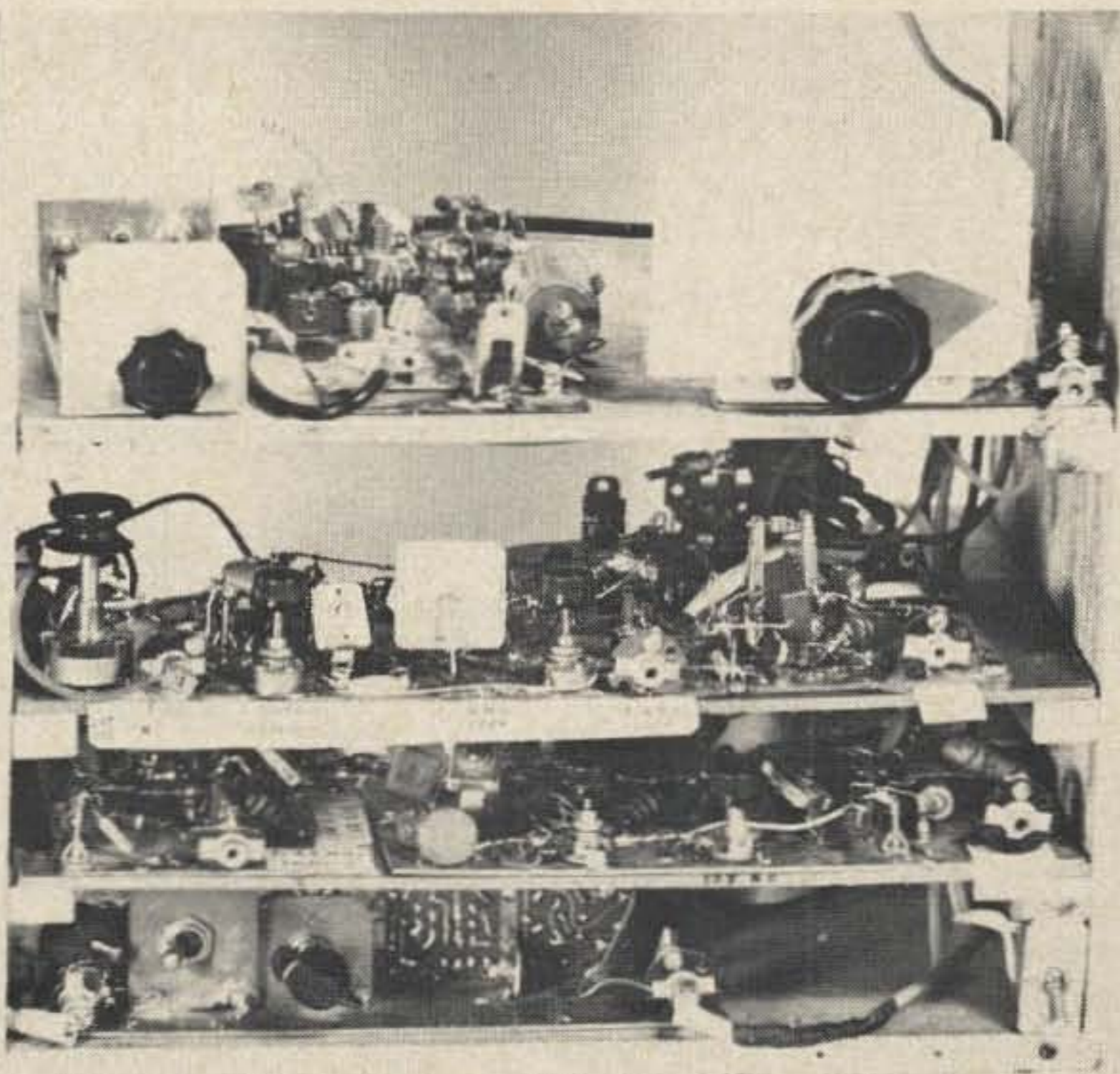

**A**t last into the home-stretch with only a few trials and tribulations ahead. You wouldn't expect a complete station to go together just like that would you? It almost did. Nothing really serious, but it might hit you too, so here are the details.

My only 54 MHz rock, left over from dry-cell battery tube work of ten years ago, has always had a big "W" inked on it. This is my symbol for weak, and it was. Worse than that it developed a particularly virulent form of nastiness. You couldn't exactly call it intermittent, it just faded away or wouldn't come on at all.

I plugged in a good 53 MHz crystal and the output power jumped as did the exciter mils as the multiplier stages got plenty of drive. This was fine, but of course the last doubler was now on 424 instead of on 432.

There remained the tripler exciter, which showed an insufficient amount of driver, as mentioned before. The obvious answer was another rf stage, a "pre-driver" as it is called in solid-state circles. There are four rf stages in the shack now, so one was tried out and worked even better than the doubler exciter alone, like *over* 150 mW output on the final. All four of these little planks are in use however, so I had to throw another one together for this pre-driver stage.

Figure 1 shows the details which by now with the use of lumped circuits constitute practically a standard schematic for 432 MHz. At least they all work well.

Now we have a tripler crystal exciter and three rf stages, but we also have increased drive and more output.

Another knotty one. Or rather two together. When running high gain low frequency selective circuits, nuisance feedback is easy to come by. This is one you may well encounter, so we'll warn you now, and furnish the remedy also. The 135 i-f strip and af were running fine, but as soon as the 1.65 MHz i-f was plugged in, zilch... S meter dropped near zero, and the darndest low af rumble and warble you ever heard came out of the speaker with a hashed-up signal also. With separate batteries — fine — but that's no solution. Inclusion of a 100Ω resistor in the plus battery lead to the B plus bus in the strip did the job, except for the second part of the trouble which was the resistance of the outer conductor of some old thin braided microphone cable being used to connect the two i-f strips. The outer conductor actually measured 1/10thΩ, so beware of that stuff. Even a good piece of new RG-58 cable when used with connectors which were not absolutely new and shiny

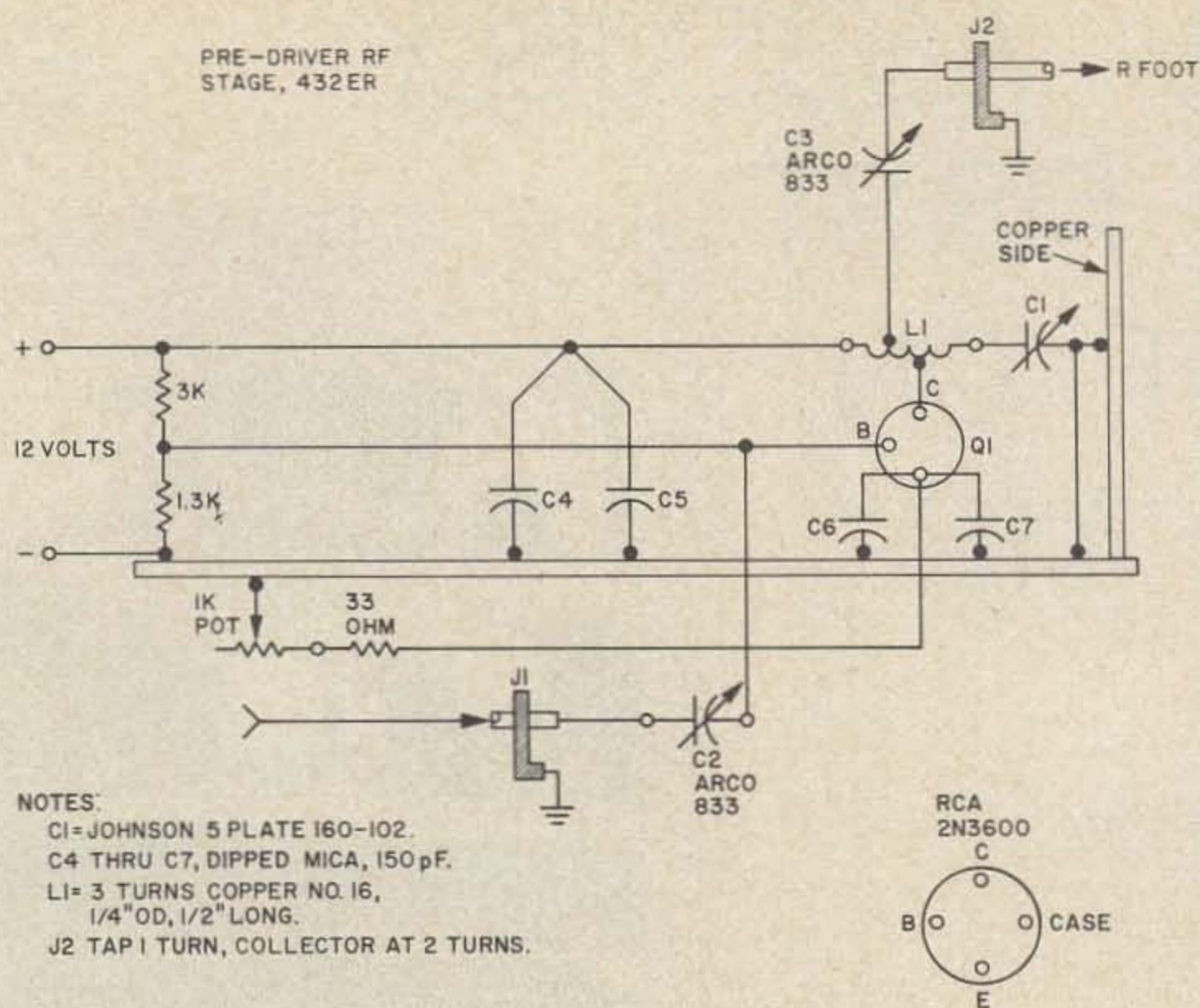

Fig. 1. Pre-driver rf stage, 432'er.

caused trouble. I mean the connectors, of course. A good short ground between the two strips did the job right. When you want smooth, trouble-free operation of high gain stages, you must take certain precautions.

There is something fascinating about a good double-frequency i-f that handles well, is free of feedback, has good avc, and doesn't cost too much, so your buddy can duplicate it and take it with him to another mountain 100 miles away. That is, it's fascinating once you get the bugs out of it.

Sorry, OM, but there's another i-f to connect to that same battery, and yes, I know, don't tell me, the same thing occurred again. Low frequency burble and rumble, when the ten meter receiver-tunable i-f was plugged into the 1.65 MHz i-f strip, and also into that one battery. This time the remedy was soon applied with another 100Ω resistor doing its stuff in the B plus load. There was a 100 μF capacitor to ground already in the strip from that bus.

### Improving the I-F Stages

The i-f stages were originally built with some five year-old PNP devices I had around, and in the interests of battery compatibility, it was thought best to change over to NPN jobs. Improvements in burn-out and better

noise figures were obtained with these, as well as less confusion in circuitry and battery polarity. A negative ground can now be used throughout, and you can forget about PNP transistors except possibly for high power modulators later on.

No change in the coil windings was needed, other than to lift the collector return from ground and bring it to the plus 12 volt bus. Figure 2 gives the final i-f circuit which works like a charm.

### DC Levels

When changing transistors in an i-f strip or of course when making up a new one, it is very important to set up the dc levels on the emitter and base of each device including the diodes. I say diodes because once having tried separate diodes for af and avc I'll never go back to a single one again.

Referring to Fig. 2, the base dc level of Q1 is set by R2 and R8. These are not critical but must be set properly. A balance between R2 and R8 is important for proper avc action. If R2 is too small too much current will go through Q1. If R8 is too large too much avc voltage will be lost in it. The values shown work fine with 2N918's. A one millimeter in the emitter lead of Q1 should drop from 6 or 8 mils to less than 100 μA



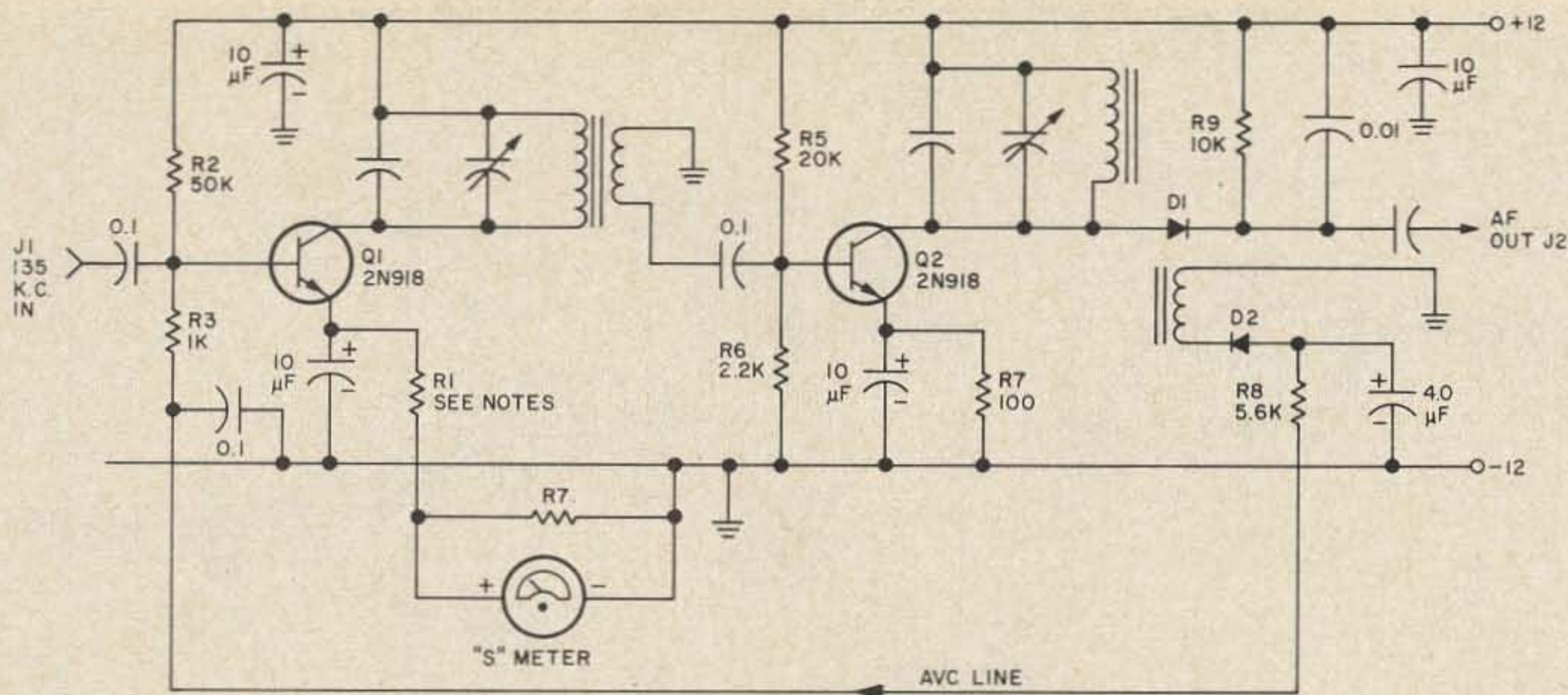

Fig. 2. 135 kHz i-f strip reworked for NPN transistors.

with almost any kind of a good signal at J1. I use a little homebrewed attenuator box as in Fig. 3 with the Lafayette signal generator on 135 kHz for those low signal level tests. Do not expect to be able to do this on the higher frequencies though. Those kind of shielded generators are in the \$300 to \$400 range instead of the \$30 to \$40 one.

The two emitter pots in Fig. 2 are practically standard items, 500Ω or 1K, with limited resistors of 33–100Ω, depending on just what devices you are using to keep maximum current below 10 mils (in most receivers under test here). Final good, smooth-working values are given in Fig. 2, using the 2N918's I have at the moment in the 135 Hz i-f strip. These are higher frequency devices than needed. 2N916's would be just as good.

Once you get them adjusted to where you want them, you can of course go to only one pot for the i-f gain control.

### Choice of Bandwidth and Gain Handling of the two I-F Strips

This has worked out fine. Each of these strips originally had a pot in each emitter of each stage and one for both stages together. In use on the air I find that the last two stages which make up the narrow band high selectivity strip on 135 kHz can be left alone at a fixed gain, and the over-all gain can be set by the pot which controls both the emitters of the 1.65 MHz strip. This one also serves to set for maximum the gain of that strip when it is used alone. So much for i-f gain.

The choice of i-f bandwidth can be very useful at times. The narrow band i-f requires careful tuning and can be subject to certain crystal and other oscillator drifts, not only in your rig but the other lad's as well, and also with temperature changes and possible voltage drops. It is smooth and steady when used on the air, as you will see later, but when it comes to making all sorts of antenna and rf stage tests there's nothing like a little bandwidth. By "little" I mean a "good little amount of it." The 1.65 MHz strip provides just that with about 100 kHz bandwidth. All you have to do with the rig (as now put together) is change over the af plug from the narrow band to the broad band strip, *et voila*, instant ease of adjustment. There happens to be an "S" meter in this strip also, so all kinds of relative measurements can be made on antennas, cables, rf, etc. The sharp i-f rules the roost though with the band loaded (on 432 that's more than one other station!). And of course when the band opens it is an absolute must.

### Installing the Two Low Noise Stages in the Rack.

Just for security against feedback these were mounted on a single copper-clad base-

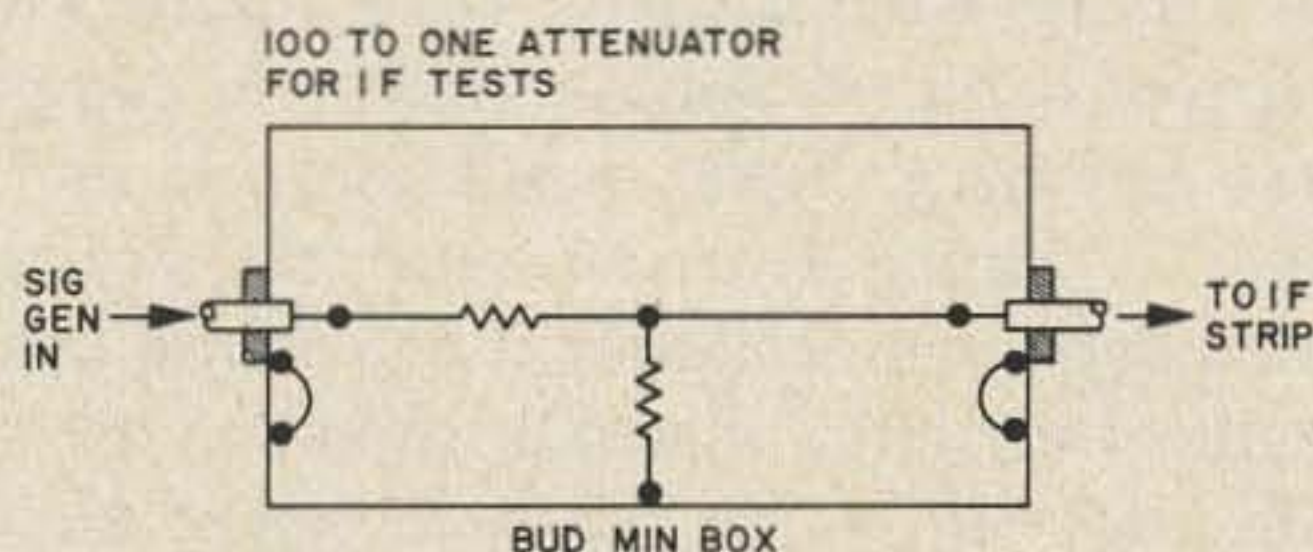
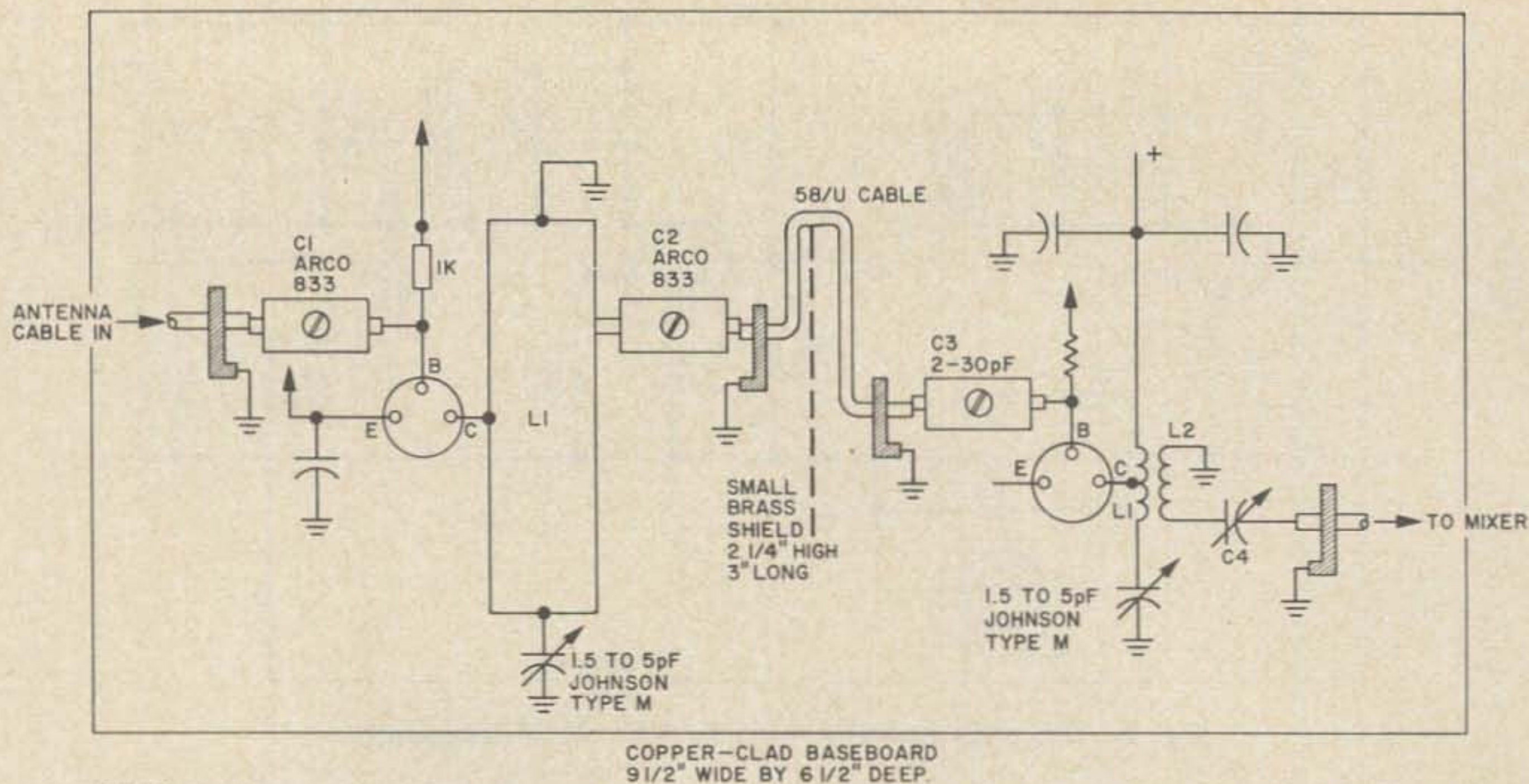

Fig. 3. 100:1 attenuator for i-f tests.



NOTES:  
 L1 = 2 TURNS NO. 14.  
 L2 = 2 TURNS INSULATED INTERLEAVED IN L1.  
 C4 = JOHNSON TYPE U 5 PLATES (ABOUT 1 TO 5pF).  
 FOR ALL OTHER DETAILS SEE LOW NOISE SECTION.

Fig. 4. Final layout, low-noise rf stages, receiver, 432'er.

board on the top shelf and given the filter treatment in each plus 12 volt lead. A small shield near the coil job removed a slight trace of rf feedback under certain tuning conditions. The layout is shown in Fig. 4, with the main points for tuneup and adjustment being C1, C2, C3 and C4. No bugs showed up here. The manufacturer of these low noise devices, KMC Semi-Conductor, Inc., Long Valley, N.J., states that for the best noise figure use only a few mils, like 2 or 3. This was found to be true, although the gain goes up when 10 mils are used. Remember though, gain we've already got, low-noise is that illusive thing we're after. On this subject, the 1 mW test signal on just a dipole was still coming in five miles away.

### Bonding

This may sound like a low frequency thing, but it goes for both high and low and in between. On the low frequencies you can get that nasty af rumble with the S meter going toward zero without any signal; on hf you can get hand capacity when tuning with a narrow band i-f; and on UHF you can get most anything. Like oscillations in an rf stage, rf tuning reaction onto the crystal-controlled local oscillator. (Yep!) Don't forget the frequency multiplication for the 48 MHz rock up to 432 is nine times, and a mere 300 cycles can throw you out of the

receiver pass band. After mounting everything on the carrying rack shelves, beginning at the bottom, with the af and battery, then the 135 kHz strip; next the 1.65 MHz job; tunable i-f mixer, and local oscillator on the third shelf, and the two low noise rf strips on top. Bonding was installed piece by piece, checking on that weak signal all the time, as well as for tuning and handling. For this type of bonding I use No. 12 solid copper wire in pieces only 2-4 in. long between the copper-clad baseboards on the shelves. While some of this bonding cut down the signal slightly due to elimination of nuisance rf feedback, the entire job brought the signal up and eliminated remaining traces of feedback and hand capacity.

It is hard to draw the line between a collection of miniboxes and 100 lbs of iron (I mean copper or aluminum) clad construction costing you-know-how-much. What I'm after, and I think most readers would like also, is to finally have a good battery-operated, low-cost receiver that you hear DX with on 432 that handles well, not too touchy or jumpy, and still has room for improvement and growth. Sounds like a pretty big order, and it has been actually that because - including the transmitter - it has taken over *three* months to build all the units, work out the bugs, draw up the circuits and layouts, and get everything

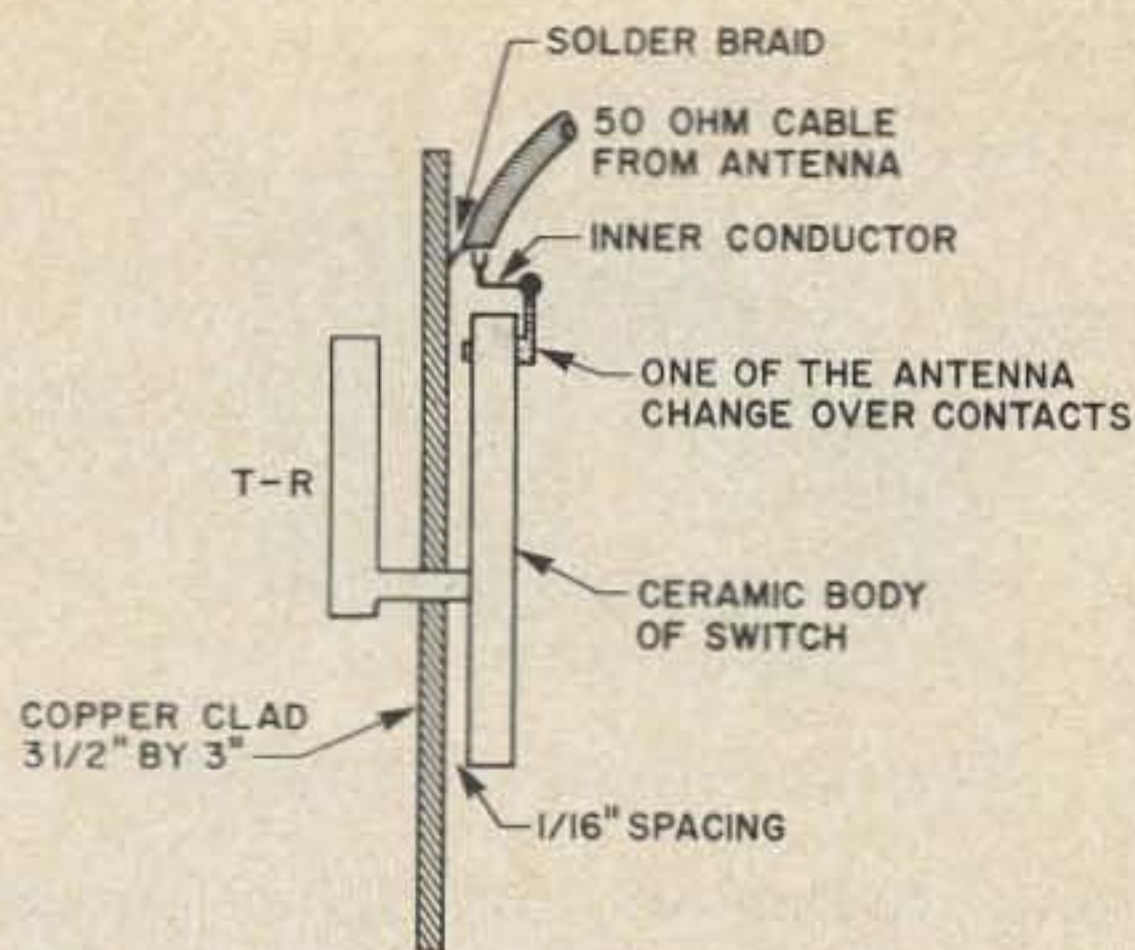

NOTE:  
KEEP INNER CONDUCTOR WIRES TO CONTACTS EXTREMELY SHORT.

Fig. 5A. TR switch, 432'er solid state.

running smoothly. That three months, I might mention, is on a six-and-a-half days per week basis. And it won't take *you* that long because we've worked almost everything out for you, and you can start from there.

### The T-R Switch

There is an easy way to handle this in a battery-powered rig; just use a rotary ceramic switch, reworked a little for UHF. Proof of the pudding is on the air.

The main deal is to keep the contacts as close as possible to a flat ground-plane backing for the switch, as in Figs. 5A and B. I have tested this out on 432 MHz, and there is no noticeable loss involved in going through the switch. Use one set of contacts, as in Fig. 5B, for the antenna changeover section; the rest can be used "as is" for dc connections to turn on the transmitter, turn off the receiver, etc., with no special precaution needed in their wiring.

The switch is mounted on the transmitter, although it could be put on the receiver rack just as well.

With medium size beams and (see later) antenna mounts for use on the sides of both the transmitting and receiving racks, along with the T-R switch, considerable flexibility of operation is obtained. Either the transmitter or the receiver can be used separately with their own portable beam in the car or shack, or with a really big beam for serious mountain-topping. With the latter the T-R is right there ready to be used.

The transmitter and receiver assemblies have phono jacks across their turn-on switches which allow cables and plugs from

## RECEIVERS, OK GRTO, WITH BOOKS:

SP-600-JX: AM, CW, 0.54-54 MHz continuous	275.00
P388/URR: AM, CW, 1/2-30 1/2 MHz linear dial, PTO	325.00
R390A/URR: 1/2-32 MHz by digits, PTO tuning	595.00
AN/FRR-59B (later version of WRR-2): 2-32 MHz digital tune each 500 Hz or continuous. A1, 2, 3, 9, F1, 4, FAX FSTTY, SSB, carrier suppressed either band or both for 2 different intelligences. Stable and accurate enough to use as freq. meter! Net wt. 276 lbs. in 2 cabinets in rack cradle	750.00
WWVB 60 KHz recvr/comparator	295.00
WWVB 1 kHz tones at 1 second intervals	175.00
38-1000 MHz by Band Switching, 4 bands: Separate antenna for each band. AN/ALR-5 modified for 117 v 50/60 cy line. AM/FM. The Tuner is a plug-in converter; the receiver is 30 MHz IF and all that follows IF. Choose selectivities 200 KHz or 2 MHz each side of center. Factory checkout sheet, typical for the original-pack tuner you get, says sensitivity ranges from 1.1 μV at 28 MHz to 7 at 1 GHz. IF attenuator is calibrated in 6 dB steps to -74 dB. Diode current meter makes this rcvr useful for relative field strength measurements and harmonic finder. Rcvr unit is exc. used and checked out OK	375.00
30 MHz PANADAPTER may be useful with above	295.00
A.I.L. = 132 30 MHz rcvr/amplifier/atten. calib.	99.50
EDDYSTONE AM/CW/FM/NBFM 19-165 MHz rcvr	295.00
CV-591A: SSB Converter either sideband	137.50
MOTOROLA 3 MHz OSCIL. 5 parts in 10 to 11th	199.50

### ATTENTION!

Buyers, Engineers, Advanced Technicians:

We have the best test-equipment & oscilloscope inventory in the country so ask for your needs . . . don't ask for an overall catalog . . . we also buy, so tell us what you have. Price it.

**R. E. GOODHEART CO., Inc.**  
Box 1220 GC, Beverly Hills, Calif. 90213  
Phones: Area Code 213, Office 272-5707

### NEW FOR 74

### ECM 5A FM Modulation Meter

Only \$85.00 less batteries and crystal

- Operates 30-500 Mhz
- Crystal controlled for fast and easy operation
- Peak reading
- Battery powered with AA pencils



Phone or write "Skip" W9HAK for complete information Dial 812-476-2121



Available by direct mail only. ORDER INFO: Send check or money order for \$85.00 plus \$1.25 for handling. Indiana residents add 4% sales tax. Crystals for 146.94 Mhz: \$3.95 ea. All other freqs: \$7.10

# ECM

ECM Corporation  
412 N. Weinbach Ave.  
Evansville, Indiana 47711

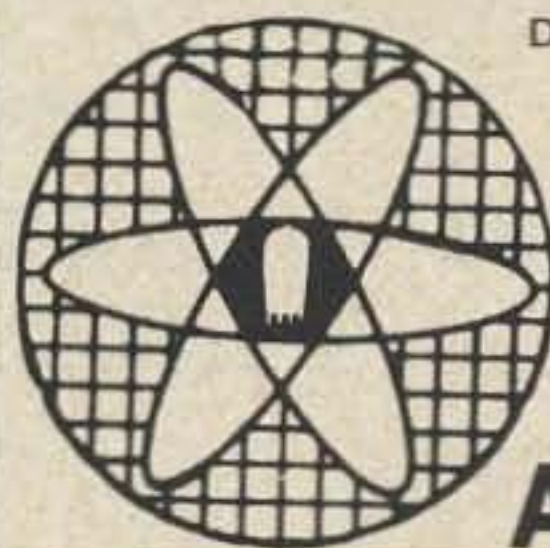

DRAKE • REGENCY • HALLICRAFTERS  
ANT. SPEC. • TEN TEC  
CUSH-CRAFT • MOSLEY • HUSTLER  
WA9CFU LEE (217) 735-1265 new and used  
WA9OGD ROD  
555 WOODLAWN ROAD LINCOLN, IL 62656

## A-A-A SALES

**PARTS! CORNELL TUBES!**

FREE Send For FREE  
CORNELL'S New Color Catalog  
48 Pgs. New Items

**33¢** per tube  
IN LOTS OF 100

**36¢** per tube  
ORDER FREE IF NOT SHIPPED IN 24 HOURS!

4215 S University Ave. San Diego, Calif. 92105

# vhf uhf CONVERTERS

START HEARING the WEAK ONES . . . .

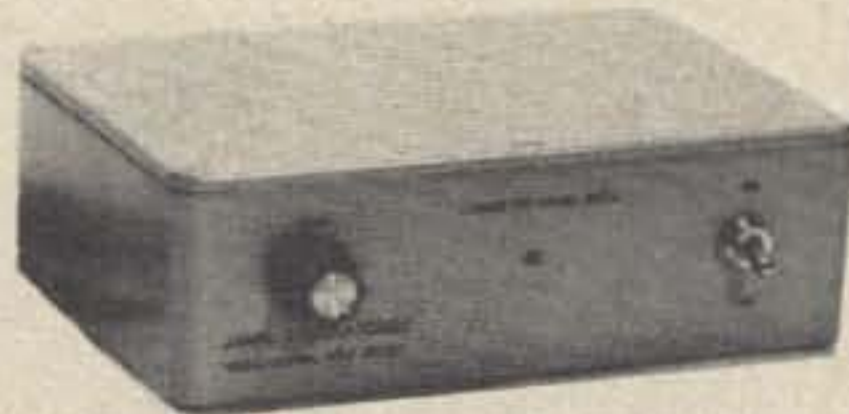

Very sensitive crystal controlled converters for receiving the VHF bands with your present receiver or transceiver. Ideal for DX, FM, Satellite reception or for just talking to the gang. All have built-in supplies for operation from either 117 VAC or 12 VDC. 10 Meter output is standard. Beautifully built and carefully tested with modern equipment.

50 CA, 50 - 52 MHz	\$74.95
144 CA, 144 - 148 MHz	\$74.95
220 CA, 220 - 225 MHz	\$79.95
432 CA, 432 - 436 MHz	\$74.95

JANEL can also supply a wide variety of receiving equipment for industrial applications. Write or call for details.

All items are postpaid and guaranteed. Please order direct or write for our free catalog.

ALSO - We stock a full line of sensitive PREAMPS!

**JANEL laboratories**

BOX 112, SUCCASUNNA, NJ 07876  
Telephone: 201-584-6521

## WHY FIGHT QRM & QRN ?

The NEW DE-101 family of Signal Discriminators is designed to fight QRM and QRN for you without rig modifications. Each discriminator unit consists of two 3 pole operational amp. filters stagger tuned for a flat 100 hz bandpass at 1,000 hz. A buffer amp. is included for ear-phones, or a 3 W pwr amp. for an 8 ohm spkr. No adjustments, factory tuned, plug in installation, one year warranty, and 15 day return privilege.



DE-101 For earphones only, 115 VAC	\$29.95 + \$2 ship.
DE-101A For Spkr & phones, 115 VAC	\$39.95 + \$2 ship.
DE-101B For Spkr & phones 12 VDC	\$29.95 + \$1 ship.
DE-101C For earphones only, 12 VDC	\$19.95 + \$1 ship.
CB-1 Wired & tested DE-101C circuit bd.	\$14.95 ppd.
CB-2 3 Watt Audio PWR Amp. for 8 ohm Spkr. 12 VDC Kit	\$8.95 ppd.
	Wired & tested \$10.95 ppd.

*dynamic electronics inc.*

Box 1131 Decatur, AL 35601 Alabama residents add 5% tax

## QUADS! QUADS! QUADS!

\$56.35 up for quad kits. \$79.95 for complete quads (pre-drilled and pre-tuned). \$269.95 up for our new super quad (pre-drilled and pre-tuned. (Quads for special purposes 7 to 150 MHz, ask for estimate) E-Z WAY POWERS at SPECIAL DISCOUNT PRICES

Free literature upon request. (813) 988-4213  
**SKYLANE PRODUCTS** 406A Bon Air Ave.  
Temple Terrace, FL 33617

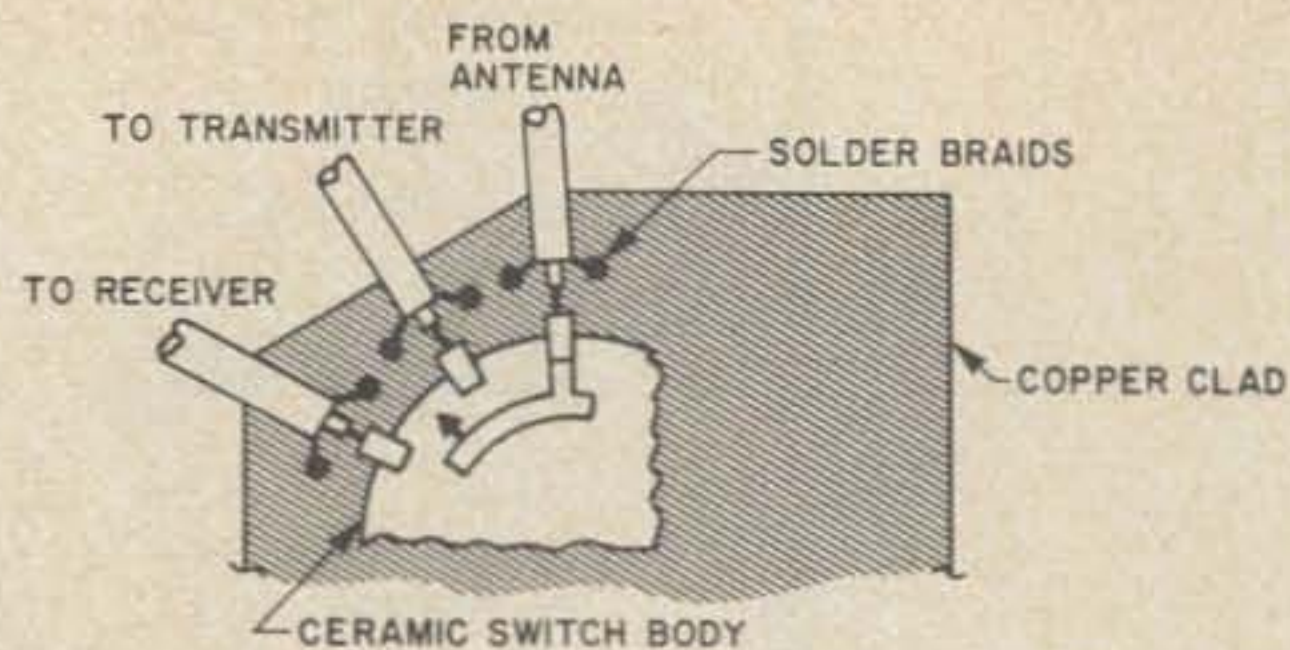

Fig. 5B. Rear view, TR switch.

the T-R switch to turn them on and off along with the antenna changeover. I haven't seen any low-cost battery-operated relays as yet, but with the power available for UHF solid state at present this can be omitted.

The use of two racks in the car is not so handy, but the units will soon be boiled down in size to where they can go on one rack. First and foremost is the circuit and its components. When you have these and they work well, then you can plan how to put them into little boxes, but not before.

## Car-top Antenna Mounts for the 432'er

The first thing to do is make a visit to Sears & Roebuck for a \$8.95 car-top carrier. They have one with wood cross bars which is just fine for mobile beam mounts, as well as for carrying big beams if you're the ambitious type. I generally position the two transverse bars in the normal fashion on the car roof and then bolt on a 1 x 8 in. plank running fore and aft for the beam mount which is hand-rotated from the driver's window. See Fig. 6.

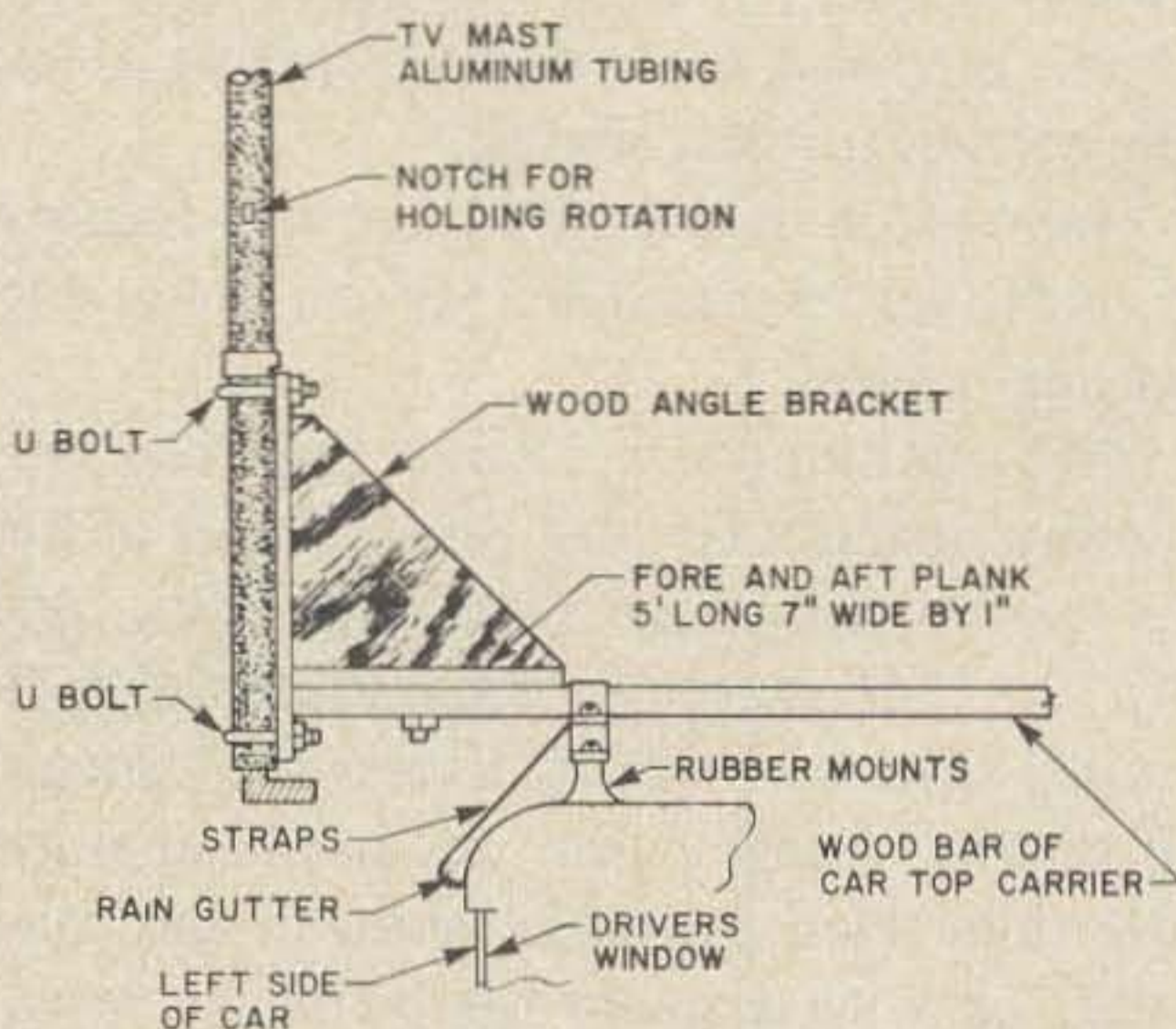

Fig. 6A. Car-top antenna mount, 432'er. View from rear of car.

The use of a beam antenna on a car is to me a very intriguing affair. You will find

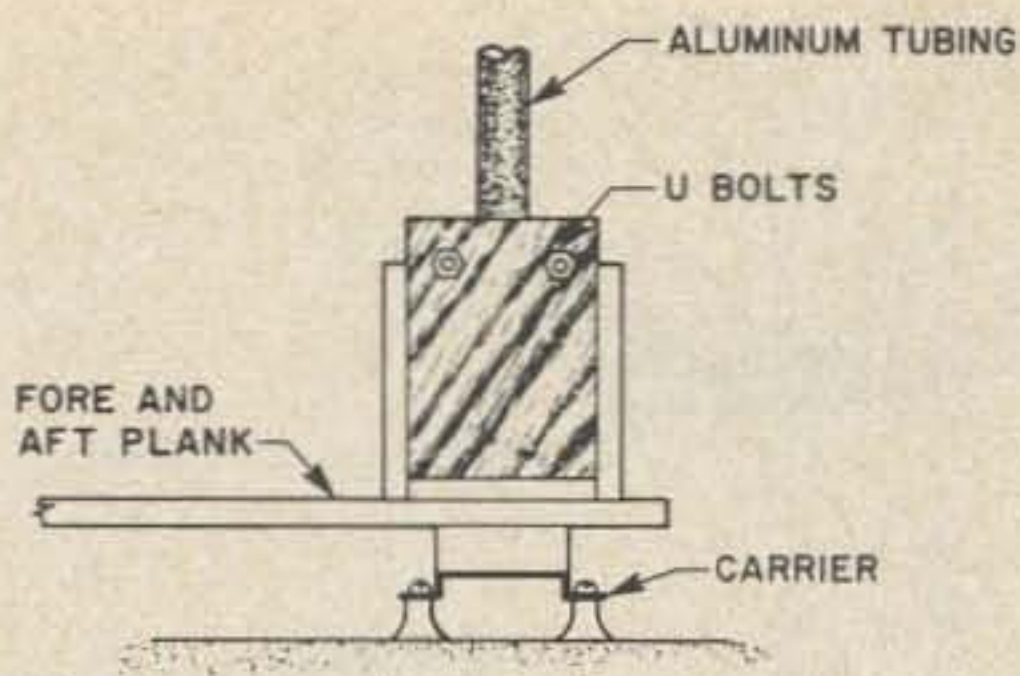

Fig. 6B. View from right side of car.

that most of the time on the main highways, the direction of the beam stays pretty well put, and only changes over reasonable periods of time. For example, when coming into a city from 30 to 40 miles out, you keep the beam pointed mainly ahead for half an hour, and then while you're going through or around town, the signal is loud enough almost anywhere you point the beam; as soon as you get out of town, you point the beam astern and leave it that way for another length of time. The advantages are great! The beam reduces flutter almost entirely with some 9/10ths of your power going toward the other lad and not bounding all over the scenery. There is 10 dB of gain for a good 4 element on two for example, and it can tell you where your friend's house is if you want to drop in for a visit and see what he looks like!

I have started out from Boston at 5 pm on two meters with a 4 element beam, going to Washington, D.C., and wound up near the Bay Bridge in Maryland at 2 am with steady QSO's one after the other all the way.

Using a plug-in type of mast mount you can run a 4 or 8 element beam on the car and change to a much bigger one when you get to your favorite hill-top. You can also plug in beams for other bands, or even two big "wheels" stacked if you really want to excite comments.

Figure 6 shows details of the car mount, almost all wood, and after the use of a can of aluminum spray paint (do this off the car) it looks fine.

You can use a good height above ground like the big truck trailers, but watch out for places like the Merritt Parkway toll booths. They were *not* made for trucks. You have to stop out on the side and cart your dime over to the man on foot.

When you use this mount with a larger

beam on a mountain-top location, better carry along three small guy ropes for emergency use, with a rotating collar. Those winds come up in minutes, and they blow. In many places you don't need extra elevation, but sometimes you will find yourself in a parking lot just enough down off the top of the hill to cause you trouble and will need that extra 10 ft of height. Mt. Cadillac is one of them, Down East in Maine.

### Handy Beam Mounts and Fittings

As usual the TV boys help us amateurs out with mass-produced handy items such as the 1 1/4 in. OD aluminum masting for \$1.25 per 5 ft or \$2.09 for 10 ft, plain. The \$1.25 bit is for "gold anodized" whatever that might mean. The new style plumbing lads also help with their black plastic PVC (polyvinylchloride) pipe which fits just nice and snug inside the aluminum masting.

Figure 7 shows a handy rig for portable work with the shelf racks, either transmitter or receiver or both. The same antennas that plug into these mounts also plug into the car-top mount, as you will see.

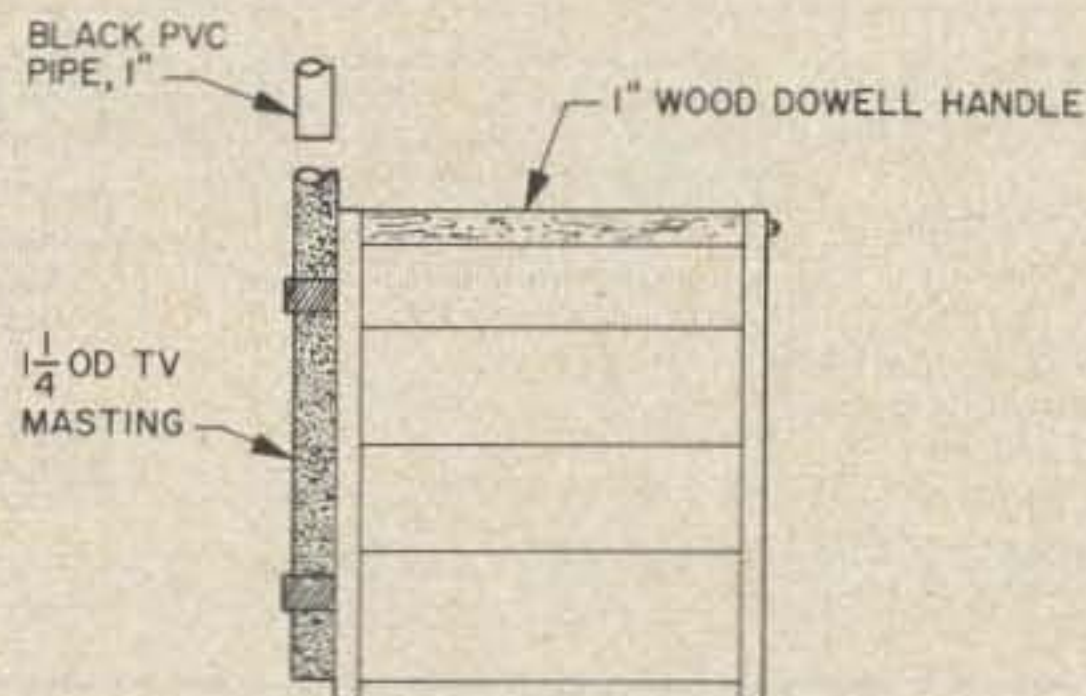

Fig. 7A. Wood rack antenna-mount, front view.

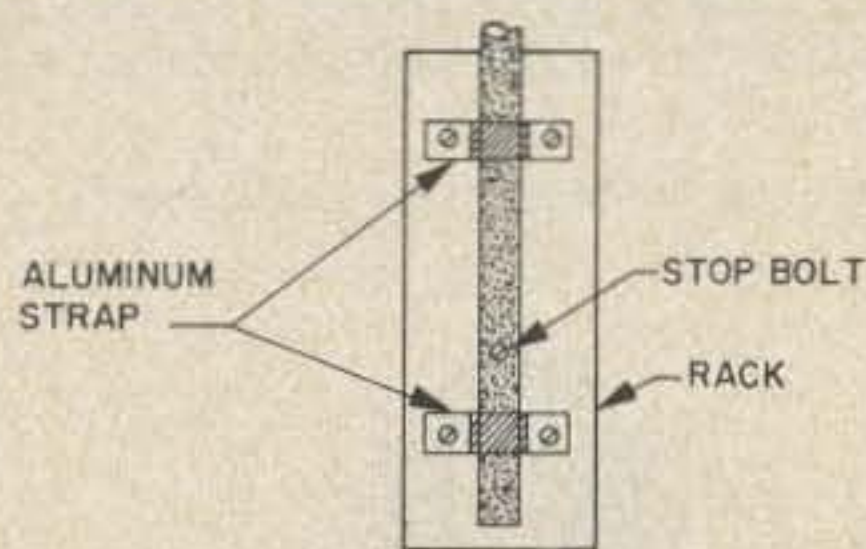

Fig. 7B. Side view.

### Medium Size Beams for Portable and Car Use with the 432'er

Two and three element designs (Figs. 8 and 9) are given to start you off portable, car, and in the shack. A high gain 14 element job that you can install on your roof or carry up the hills on the car is shown in Fig. 10.

Figure 8 shows the 2 element unit. This is



**TRI-tek, inc.**

P.O. BOX 14206 DEPT 7  
PHOENIX, ARIZONA 85063

**VOLTAGE REGULATORS**

- MFC-6034... VARIABLE UP TO 20V, 200mA.....\$1.00
- MC7805, 7812, 7815, FIXED +VOLTAGE, 1A... \$2.50
- MC7912, 7915..... FIXED -VOLTAGE, 1A... \$2.50

**DTL INTEGRATED CIRCUITS**

- 930.... DUAL 4 INPUT NAND GATE.....\$ .30
- 946.... QUAD 2 INPUT NAND GATE.....\$ .30
- 962.... TRIPLE 3 INPUT NAND GATE.....\$ .30

**TTL, NEW..HOUSE NUMBERED..**

- SN7400, SN7402, SN7410, SN7430.....\$ .25

**TRANSISTORS**

- 2N3905.. HIGH SPEED PNP. HOUSE NUMBERED 5/\$1.
- MJE 1093.. PNP DARLINGTON, 70W, 80V.....\$2.25
- JAN2222A.. HIGH SPEED NPN SWITCH.....\$ .39
- MPF 120... DUAL GATE MOS FET.....\$ .75
- MFE 2000... VHF/UHF N CHANNEL JFET.....\$ .75
- MFE 2001... VHF/UHF N CHANNEL JFET.....\$ .80

**CAPACITORS**

- GLASS SEAL TANTALUMS... 6V....NEW
- .47uf, 12/\$1.00...4.7uf, 10/\$1.00...6.8uf, 8/\$1
- ELECTROLYTICS, COMPUTER GRADE, BRAND NEW
- 720uf/150V, \$1.25..... 36,000uf/15V, \$2.25

- 12V, 1/2A TRANSFORMER..... \$1.50
- 1N3289...200V/100A SILICON RECTIFIER..... \$10.00
- MM5314 CLOCK CHIP WITH SPECIFICATIONS..... \$9.50
- 7 SEGMENT LED READOUT. 7/10in CHARACTER...\$4.00
- RED WIDE ANGLE LED #TOSL3.....\$ .25
- RED NARROW ANGLE HI-LUM LED #TOSL6.....\$ .25
- GREEN HI-LUM CLEAR LENS LED #TOSL16.....\$ .50

ALL ORDERS POSTPAID. MINIMUM \$3 U.S., \$15 FOREIGN  
LATEST LISTS, 10c STAMP.....PLEASE ADD INSURANCE

# TRANSFORMERS

225 VA.  
117V. Pri. 60 Cyc.

CUSTOM MANUFACTURING  
FAST SERVICE

**\$9.50**  
plus  
post on 8 lbs.

- specify sec. voltage between 12 & 300V.
- specify sec. current between 20 & .75 amp. - total Ex l all sec's 225VA. Max.
- specify mount • add \$1.00 for covers • add \$1.00 for each

QUANTITY  
DISCOUNT

HOBBYFORMER MFG. Tel. 1-713-983-1555  
P.O. BOX 222 - PORT ARTHUR, TEXAS 77640

**QUAD OWNERS** The perfect marriage - your favorite tri-band quad and an "H & H RING TRANSFORMER". Designed specifically for quads, this balun offers the optimum impedance match using a single 50 ohm co-ax feedline.

Now available in three new lightweight weatherproof models:

- 2 element
- boomless
- 3 or 4 element

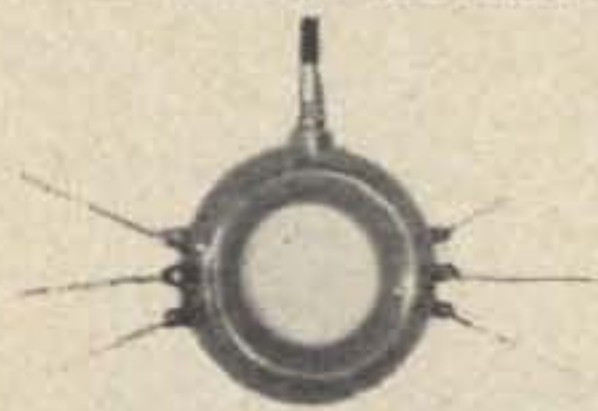

**\$24.95 pp**

## H & H engineering

p.o. box 68  
la mirada, ca 90637

also available thru Skylane Products  
& Cubex Company

### Isolated - Pad - Drill - Mill

Precision circuit board construction without etching. Fits hand drill, electric drill. Simple, fast, economical, safe.  
Sizes: .20, .15, .10 inch dia.  
With replaceable #60 drill.



**\$6.95 ea.**

Calif. residents add 5%.



**A F STAHLER Co**

PO BOX 354 CUPERTINO, CALIF 95014

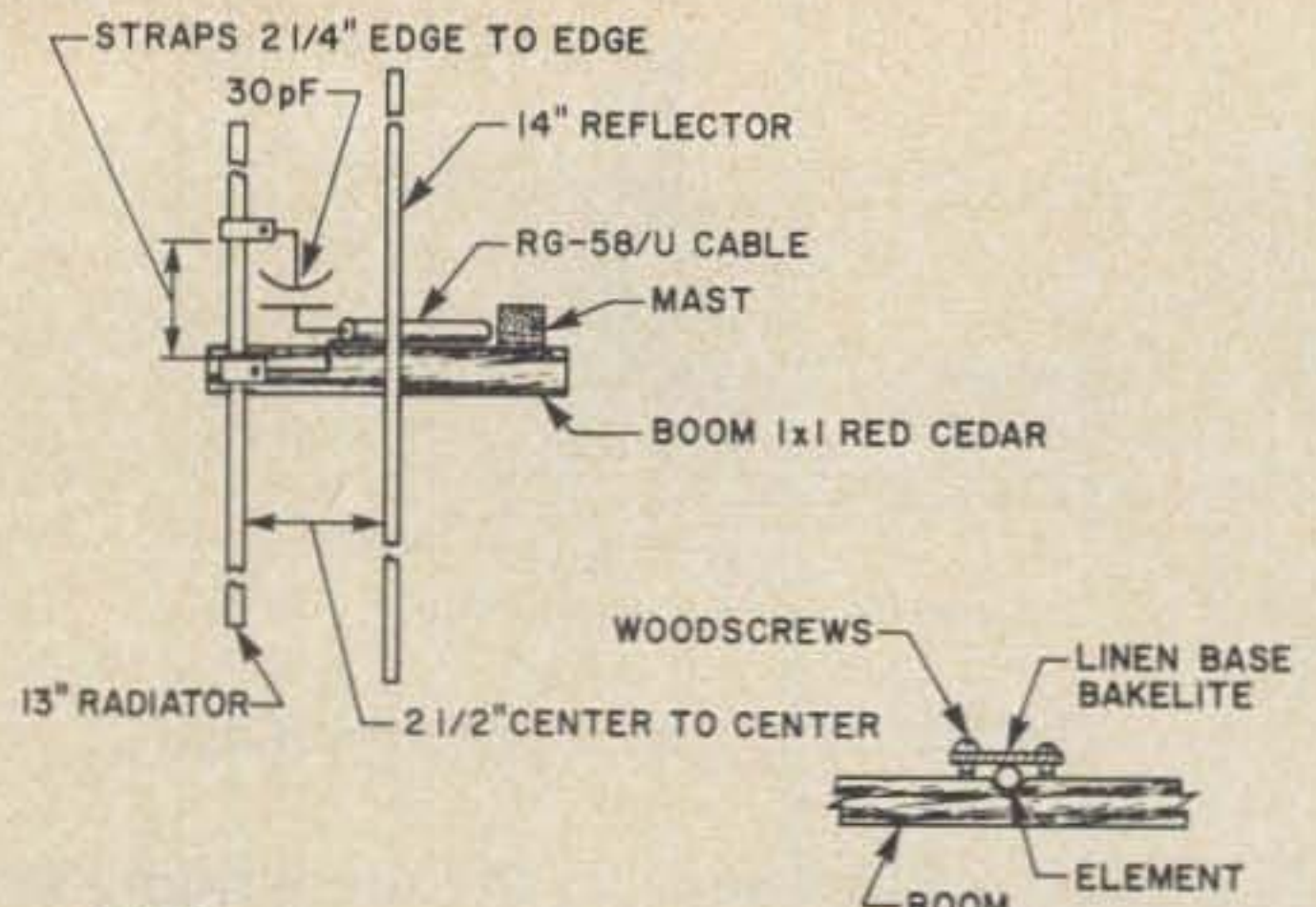

**NOTES:**

1. 1/8" CLOTHSLINE ALUMINUM USED FOR ELEMENTS.
2. SMALL BRASS STRAPS AND 2/56 NUTS AND BOLTS FASTEN COAX CABLE TO RADIATOR.

**Fig. 8. 2-element portable beam 432 MHz, top view.**

handy for test use, hidden transmitter hunts by your club, and what have you. It's also good for making up multi-element flat shaped beams which carry nicely on the car.

Next comes the 3-element one, naturally, with Fig. 9 showing details. Don't forget you can hoist one of these up 20 ft in the air at a moment's notice in an emergency with a couple of 10 ft aluminum masts.

We then make a jump to a 14 element job because the red cedar boom is still only 10 ft long.

The elements are the same 1/8th in. clothesline (aluminum, that is) and the time involved for building should run around half a day if you have all the material. The gain appears to be over 15 dB and of course you can always stack up two of them - although the car-top carrying and mounting gets quite a bit more difficult.

### First Mobile Tests

With everything working (I hoped) the 14 element was mounted 10 ft from the second floor porch and pointed out along the road to the south, plugged into the transmitter, and the af gain opened up to give some modulation. The little 3 element beam was installed 5 ft over the car roof on the hand-rotated mount of Fig. 6, plugged into the receiver, and away we went.

Sounded good as the air conditioner motors in the shack came through the af. Yes, it does get over 80 up here sometimes, but the difference is you run a heater first at 5 or 6 am (when I start writing!) and then at 11 am you have to turn on the air conditioner. All in the same morning!

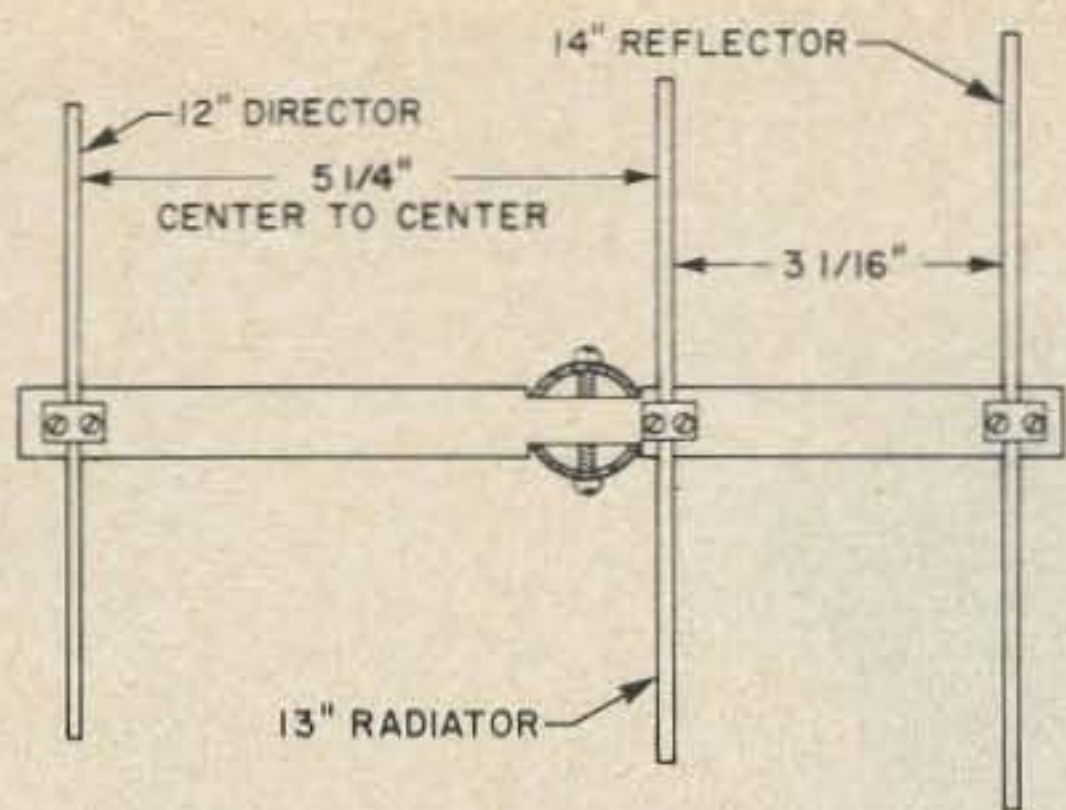
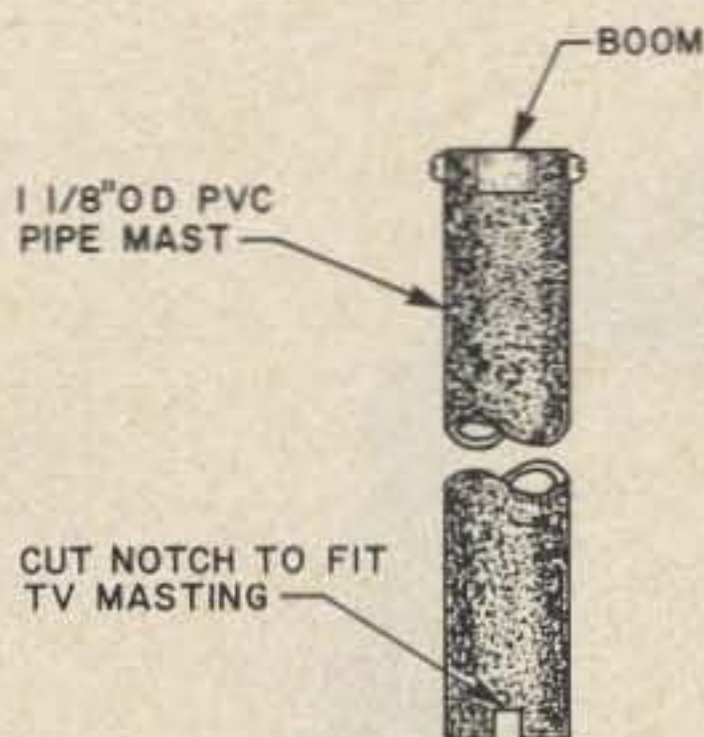

Fig. 9A. 3-element portable beam, 432 MHz, top view.



The enhanced shadow-effect of 432 as compared to 2 meters was quite noticeable, at least to yours truly with quite a few years of 2 meter beam mobile work. An 8 element, 4 high by 2 wide, will be tried soon on 432 on the car. Possibly even a 4 by 4 would be interesting on 432 mobile. This one will have to be set back into the middle of the car roof, though. CUL with ideas on that one.

### First Evening on the Air

All I can say, as in the Olson and Johnson shows, is "What a night, what a night." After all, this all-solid state rig has been some months building, has a triple-conversion receiver, three amplifiers in the transmitter section, and had never been on the air yet. Would I even hear anyone?

I did. Up on Monadnock, with the 14 element on top of the car with a 5 ft extension I started listening and calling, a little early so it happened. After the usual radar signals, FM harmonics from out Springfield, Mass. way, and some odd sloppy-pulse jobs at about ten cycles (anyone know what they are?) finally a good CW station came on, peaking fine on the beam, pounding in, real good, "K3EAV portable one." I didn't raise him. Evidently doesn't listen for fone.

Then at last "CQ from W1SNN, Waltham, Mass.," over 50 miles anyway. The receiver works well. So does the transmitter, because we then had a nice QSO, my first on 432 for quite a while. I did a lot of switching back and forth between the two bandwidths on the receiver, with the following results. With the broad band i-f you can hear all the stations fine but with all of them being close to 432, you can hear several at once, naturally enough.

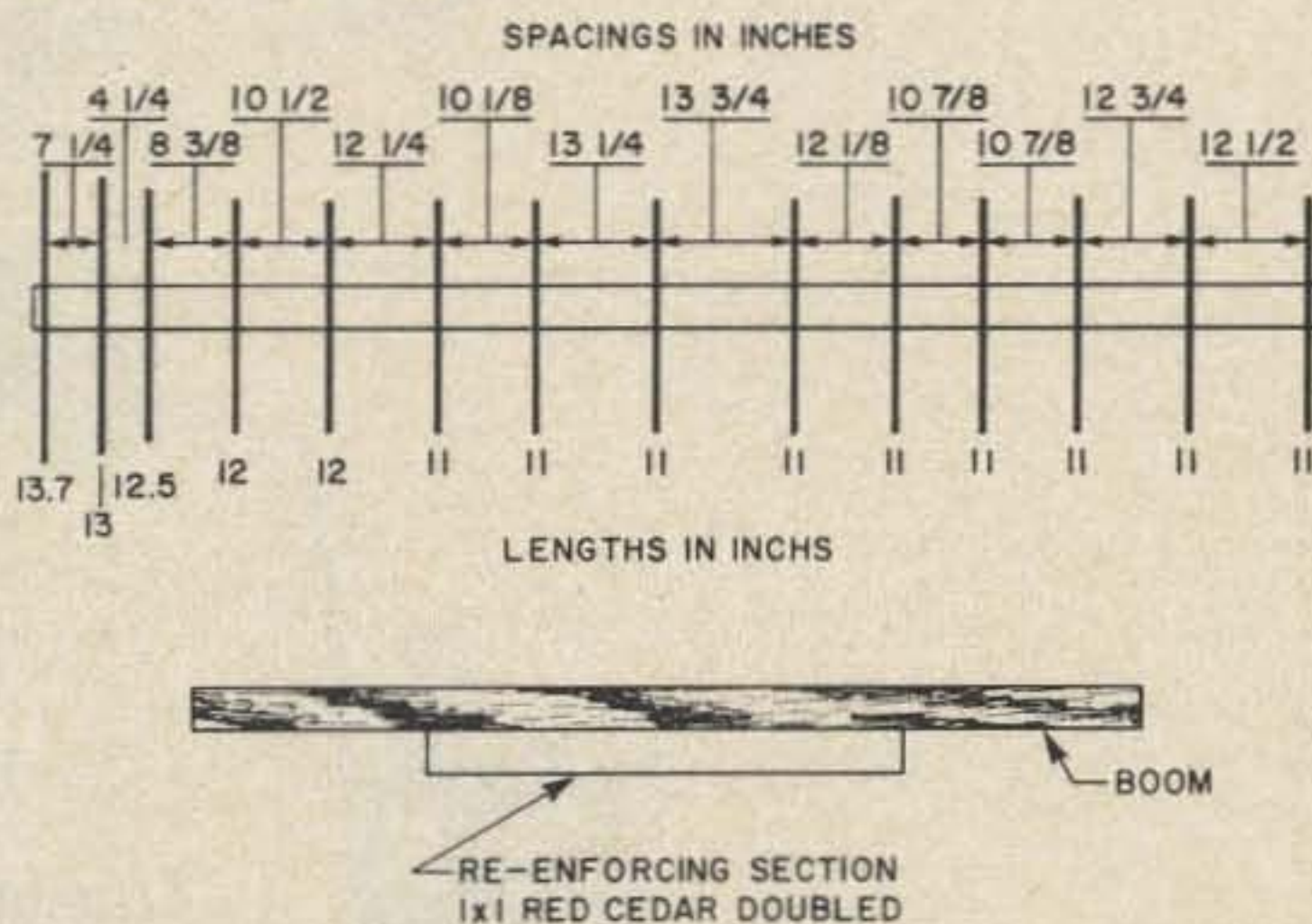

NOTES:  
ALL ELEMENTS 1/8" ALUMINUM CLOTHSLINE.  
MOUNTING DETAILS AS IN 3 ELEMENT BEAM.

Fig. 10. 14-element beam, 432 MHz.

At six miles through trees and small hills, the signal was still plenty loud and showed signs of going further, but the shadow effects of large hills prevented further tests that day. Also I wanted to get the whole rig into the car with one of those 14 element jobs ready for an evening on Pack Monadnock Mountain, as it was Wednesday evening which is 432 night on the East Coast at least.

The sharpness of the 135 kHz strip showed up well, separating even heterodyning stations. Yes, even QRM developed on the band as the evening wore on. The rest of the log for the evening reads, K1BFA, Westford, Mass.; W1JIZ Harvard, Mass., WA1JTK Nashua, N.H., and W1EUI, Tyngsboro, Mass. So the rig does work and it's lots of fun.

I'm not crowing, and I don't intend to keep them in the rig forever, but "RCA type" 5¢ phono jacks and plugs are used throughout the rig, as well a 10-year-old RG-58/U cable. Again, I'm not advocating their use, but it shows what can be done on 432 if you really try.

...K1CLL

SUBSCRIBE TO 73  
AND HELP SEND  
ME TO SUMMER  
CAMP

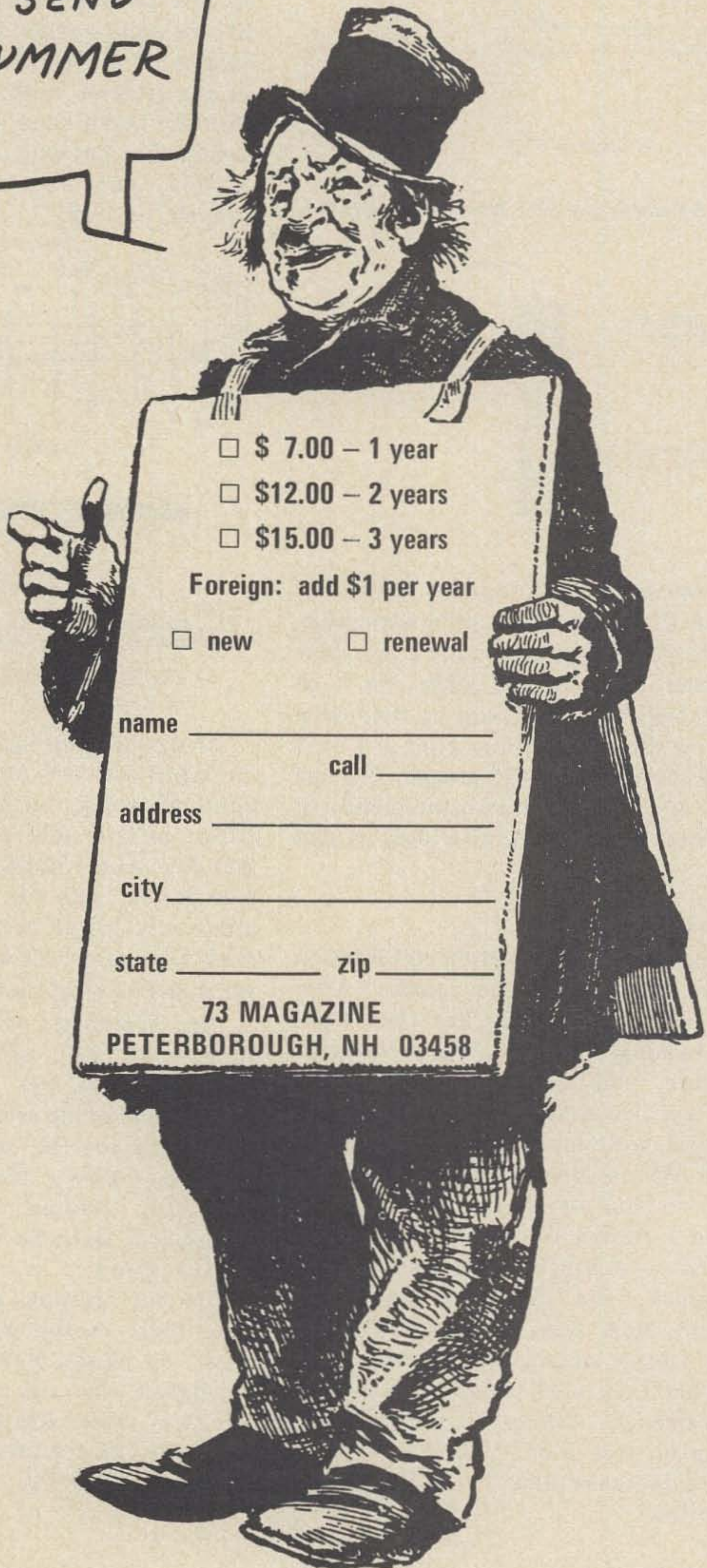

\$ 7.00 – 1 year

\$12.00 – 2 years

\$15.00 – 3 years

Foreign: add \$1 per year

new

renewal

name \_\_\_\_\_

call \_\_\_\_\_

address \_\_\_\_\_

city \_\_\_\_\_

state \_\_\_\_\_ zip \_\_\_\_\_

73 MAGAZINE  
PETERBOROUGH, NH 03458



# Jordan 74



*The beach at Aqaba.*

In September you read about Wayne's fabulous trip to Jordan. Now, you too can be a world traveler and adventurer. Come with us to Jordan next May for one fun filled fabulous week (plus two days traveling). We'll make the arrangements for you and take care of all the finicky details. The very low price of \$695 (less than what you would normally pay for air fare alone) will bring you this once in a lifetime opportunity. Sign up now.



*Treasury at Petra, carved out of the rose colored rock of the mountain.*

- Air transportation to and from Jordan departing from New York
- Accomodations at Jordan's Intercontinental Hotel, the most luxurious hotel in Jordan
- Sightseeing trips to the antiquities (Jarash, Aqaba, Karak, Petra, Madaba, Irbid, Al Hamma, Jerusalem)
- Ham banquets
- One of the most memorable experiences you're ever likely to have
- JY8 call (if you are a ham)

- 
- Yes, sign me up. Enclosed is my \$695 payment in full\* for this once in a lifetime Jordan Tour.
- Yes, sign me up. Enclosed is my \$100 deposit for this once in a lifetime Jordan Tour. I will send the remaining \$595\* at least 30 days before our departure. (My \$100 deposit is refundable up to 30 days before the departure date.)
- Yes, I would like a JY8 call. I have enclosed a photocopy of my ham license.  
The JY8 call I would like is:  
My alternate choice is:

NAME \_\_\_\_\_ CALL \_\_\_\_\_

ADDRESS \_\_\_\_\_ TELEPHONE NO. \_\_\_\_\_

CITY \_\_\_\_\_ STATE \_\_\_\_\_ ZIP \_\_\_\_\_

*\*Our price is subject to change in direct relation to the expenses we incur dealing with airlines, hotels, etc\* Those who have paid \$695 in full will not be charged any additional amount should the price of the tour package increase. Everyone will benefit should we be able to lower the price.*

# BOOKS

# & STUFF

# 73

Fascinating World of Radio Communications . . . . .	\$4.00
Novice Class Study Guide . . . . .	\$4.00
General Class Study Guide . . . . .	\$6.00
Advanced Class Study Guide . . . . .	\$4.00
Extra Class Study Guide, reduced price . . . . .	\$5.00
VHF Projects for Amateur & Experimenter . . . . .	\$5.00
VHF Antenna Handbook . . . . .	\$3.00
How to Use FM, an introduction . . . . .	\$1.50
FM Repeater Atlas, worldwide w/maps . . . . .	\$1.50
*FM Repeater Circuits Manual . . . . .	\$5.00
*Digital Control of Repeaters, new . . . . .	\$5.00
RTTY Handbook, radio teletype A to Z . . . . .	\$6.00
ATV Anthology, fast scan VHF TV . . . . .	\$3.00
*SSTV Handbook, new, only slow scan avail. . . . .	\$5.00
Diode Circuits Handbook, galore . . . . .	\$1.00
73 Transistor Circuits, all useful . . . . .	\$1.00
Transistor Projects, mucho . . . . .	\$3.00
Solid State Projects . . . . .	\$4.00
IC Projects . . . . .	\$4.00
108 Q & A, transmitting, receiving, ant. . . . .	\$2.00
TVI Handbook, why suffer . . . . .	\$1.50
Coax Handbook, cables & connectors . . . . .	\$3.00
DX Handbook, w/map . . . . .	\$3.00
World DX Map, wall size, rolled . . . . .	\$2.00
Custom DX Bearing Charts, beam headings . . . . .	\$4.00
U.S. Maps, for WAS, etc (4 ea) . . . . .	\$1.00
Call Sign Badges, for lapel, black or red . . . . .	\$1.00
Magnetic Call Signs, for autos . . . . .	\$4.00
73 Magazine Binders, beautiful red . . . . .	\$5.00

\*Hardbound versions available @ \$2.00 more. All items postpaid.

## BOOKS ORDER FORM

Name \_\_\_\_\_ \$ \_\_\_\_\_ enclosed

Call \_\_\_\_\_

Books wanted:

Address \_\_\_\_\_

City \_\_\_\_\_

State \_\_\_\_\_ Zip \_\_\_\_\_

73 Magazine, Peterborough NH 03458 USA

# 73

# CERTIFICATES and AWARDS

## WAAS Certificate

This Worked Almost All States certificate is proof of your having worked 49 of the 50 states. It is for those who are just unable to get that last state confirmed. Printed on good paper, 8½ x 11, dated and numbered and signed by Wayne Green. Ordering this certificate is proof enough that you need it. Light green, black printing . . . . . \$1



## SSTV-DXDC

Dress up the shack with this award for 2-way slow scan television communications with 10 countries. Endorsement provisions for separate bands. Dated and signed by Wayne Green, Editor and Publisher of 73 Magazine. Enclose postage for return of QSLs. 8½ x 11, light green color, dark green printing, \$1.



## RRCC Certificate

This Real Rag Chewers certificate is awarded only for the feat of a non-stop QSO for a period exceeding six hours with no time out for anything. Order must be accompanied with date/time (GMT) of start/end of contact, station contacted, and your call. Signed by Wayne Green. Light orange color, black printing . . . . . \$1



## All Mode DXDC

How many can qualify for this one? An award for 2-way communications with 10 countries using CW-SSB-RTTY-SSTV modes. Certificate dated and signed by Wayne Green, Editor and Publisher of 73 Magazine. Enclose sufficient postage for return of QSLs. 8½ x 11, light red color, black printing, . . . . . \$1.



## DXDC Certificate

Available for those who present proof of contact (copy of log) with 10 different countries. Awarding this certificate makes you a member of the DX Decade Club. Numbered and dated and personally signed by Wayne Green, Editor and Publisher of 73 Magazine. Printed on good paper, light purple color, black printing, 8½ x 11, suitable for framing. . . . . \$1.



## Understanding XYL/OM

An unusual certificate — get one and keep your mate happy. An award to those who have the good fortune of having an understanding partner who appreciates all good things about amateur radio (staying up all night, spending money for rigs, etc.). Sworn statement attesting to this must be submitted. 8½ x 11, light blue color, dark blue printing . . . . . \$1



## RTTY-DXDC

Frame and hang this one above your machine. An operating award for those who have submitted proof of 2-way teletype communications with 10 countries. Endorsement provisions for different bands. Dated and signed by Wayne Green, Editor and Publisher of 73 Magazine. Enclose postage for return of QSLs. 8½ x 11, light blue color, black printing, . . . . . \$1



## CHC Certificate

Presented to those who submit a sworn statement that they have never received a certificate for radio operating and if they ever receive one, they will hate it. This certificate should be your first before you accidentally do something and receive a certificate for it. This attests to your membership in the Certificate Haters Club. Light purple, black printing, 8½ x 11 . . . . . \$1



# TRANSISTOR KEYING CIRCUIT

**I**n the last several years a number of excellent electronic key designs have been presented to the amateur. Whether they have memories, dot insertion, or a variety of other features, they all have been second-rate in one respect. The actual keying of a grid-blocked transmitter is unsatisfactory.

## Relay keying of transmitters

Most keys use a relay for transmitter keying. This allows a wide range of voltages of either polarity to be keyed. There are many drawbacks to this system, however. Unless the relay is a high-speed type and is properly driven it may not follow even moderate sending speeds without bias. The fact that the integrated circuit keys do not have a weight adjustment means you cannot compensate for this relay problem.

Reed relays have been used to obtain faster operation. Unfortunately the contacts of reed relays are delicate and tend to weld together or "stick" if a protection network is not connected across them. This network must be tailored to the voltage and current being keyed.

Even the reed relay has contact bounce. This contact bounce can be overcome by using a mercury wetted reed. However, the welding problem of dry reed contacts remains and in addition the wetted reed relays must be operated vertically at all times. Of course all relays make annoying clicking noises.

## Transistor keying of transmitters

Transistors offer an excellent way to key the transmitter. They are extremely fast, quiet, have no contact bounce and will operate almost forever. Transistors do have one practical drawback. They will not tolerate voltages in excess of their "breakdown" voltage. In the last few years many NPN transistors have been introduced which can key in excess of +350V at low cost. They will perform cathode keying flawlessly.

Grid block keying cannot be done quite as easily. The transistor used in this service is nearly always a 2N398. This is an old germanium transistor, very leaky, and capable of switching only about -100V. The leakage tends to cause backwave or incomplete cutoff of the final amplifier in some transmitters. If the key-up voltage of the transmitter is higher than -100V several 2N398s must be "stacked" to prevent transistor breakdown. The usual result of the stacking procedure is the loss of several transistors at one time.

## The 3N4888

Having gone through every problem mentioned above in a series of keys using tubes, transistors, and finally integrated circuits, the need for a high voltage PNP transistor for grid-block keying was obvious. Silicon transistors were desirable for their low leakage current. The cost of silicon

transistors capable of withstanding a few hundred volts was very high — on the order of \$10 a piece. Then Bob Felton K7WLX, “discovered” the 2N4888. This is a silicon PNP transistor in an epoxy case. It has virtually no leakage and can withstand about -300V in the proper circuit. Best of all, it costs only about \$1, less than the relay it outperforms!

### Breakdown voltages

The 2N4888 is guaranteed to withstand at least -150V. While this is adequate for many transmitters, it is possible to extend the breakdown to over -300V. This is because of the fact that the voltage at which a transistor breaks down is dependent upon the circuit into which it is placed. If a voltage is applied between the collector and emitter of a transistor while the base lead is left unconnected, the breakdown voltage is called  $BV_{ceo}$ . If the base is then shorted to the emitter and voltage is applied between collector and emitter the breakdown voltage is called  $BV_{ces}$ . The fact of importance to us is that  $BV_{ces}$  is always higher than  $BV_{ceo}$ . It may be as much as twice as high for some transistors. For the ten 2N4888 transistors I have tested  $BV_{ces}$  ranged from -275 to -350V, quite sufficient to key any transmitter in my experience.

In a practical circuit the base of the 2N4888 will be shorted to the emitter by a second transistor to achieve the higher  $BV_{ces}$  rating. The keying would be inverted by this two-transistor circuit so a third transistor is needed to return keying to the same sense as that of a relay.

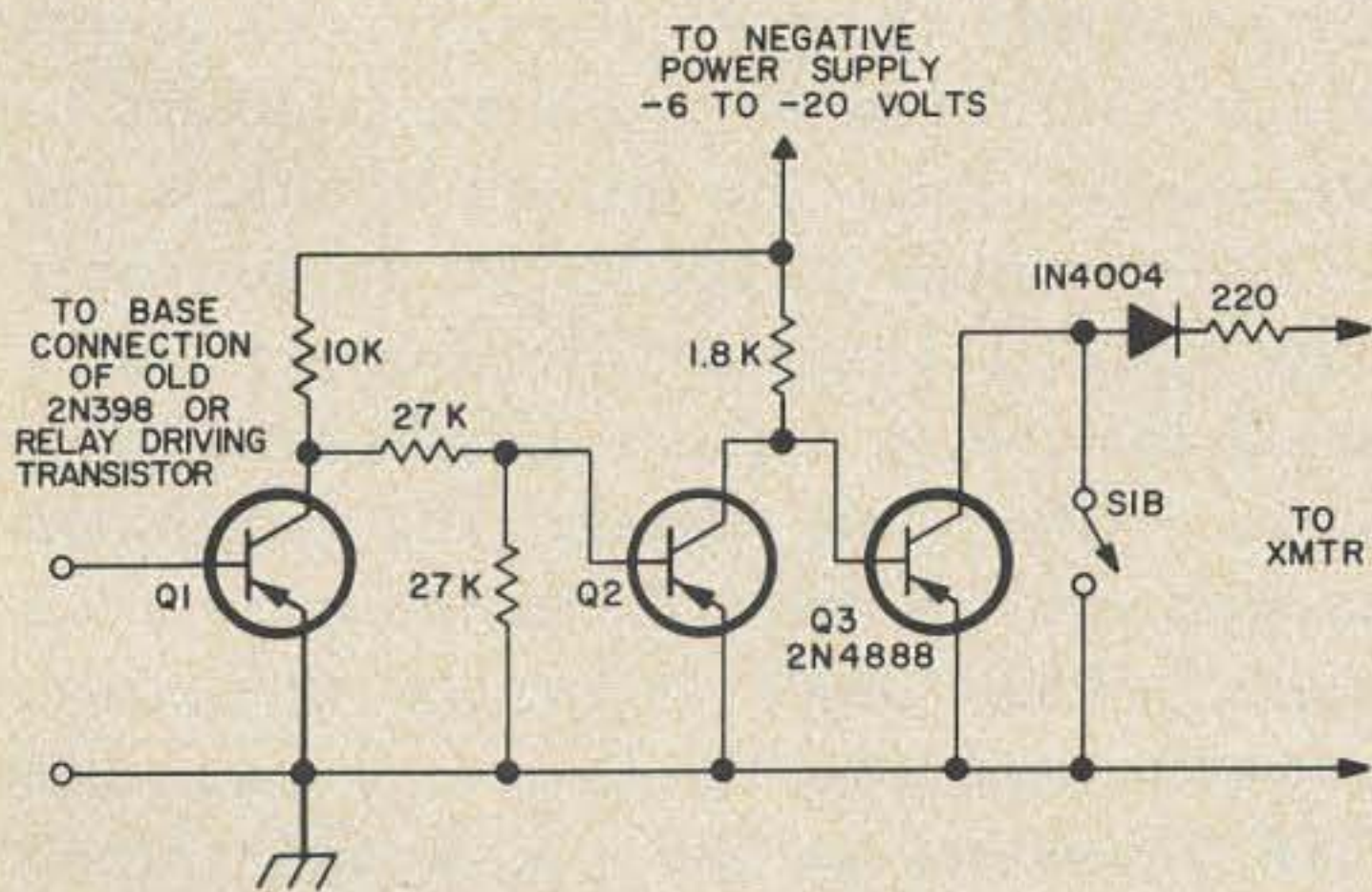
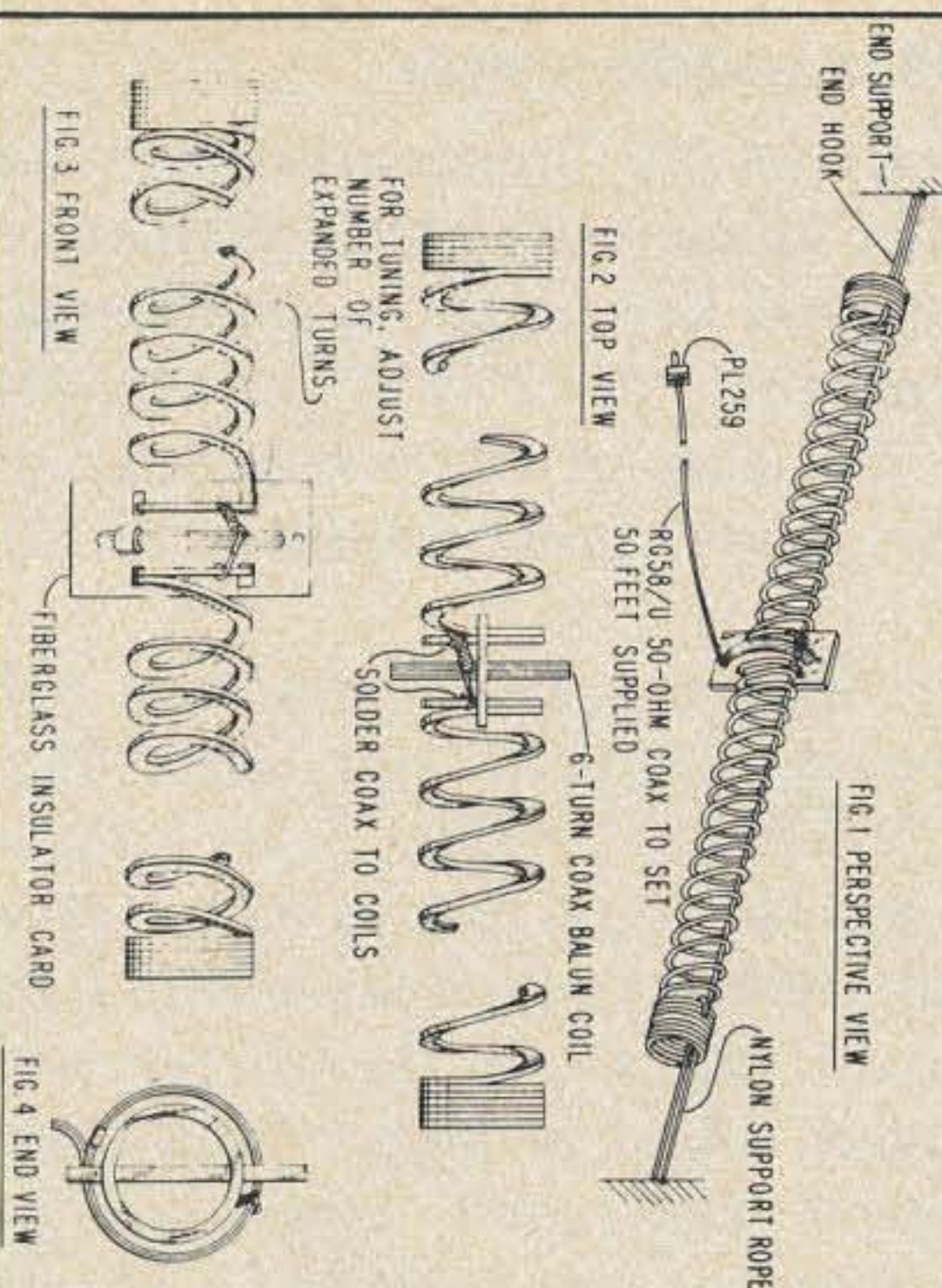

Fig. 1. Grid block keying the PNP transistor keys.

*\*patents pending*  
**new Slinky® dipole\* with helical loading**  
**radiates a good signal at 1/10 wavelength long!**



this electrically small 80/75,40 & 20 meter antenna operates at any length from 24 to 70 feet ● no extra balun or transmatch needed ● portable — erects & stores in minutes ● small enough to fit in attic or apartment ● full legal power ● low SWR over complete 80/75, 40, & 20 meter bands ● much lower atmospheric noise pickup than a vertical ● kit includes special 4" coils, balun, 50 ft. RG58/U coax, PL259 connector, & nylon rope ● this new antenna was developed for a government application, and really works ●  
**EXPORT: 2200 Shames Dr., Westbury, NY 11590**  
**CABLE: "CHURCHIN", Westbury, NY**

**Teletron**

**CODE 73**

**CORPORATION**

2950 Veterans Memorial Highway  
 Bohemia, L.I., N.Y. 11716  
 (516) 981-8333

- kit #80-40-20 . . . . . \$29.95 plus \$1 shipping
- coils only (pair of 4" dia. special coils) \$17.95 plus \$1 shipping

**NY residents add 7% sales tax**

name \_\_\_\_\_

address \_\_\_\_\_

city \_\_\_\_\_ state \_\_\_\_\_ zip \_\_\_\_\_

Enclose check with order —  
 We ship UPS upon receipt of order

## The 2N4888 in transistor keys

Figure 1 shows the three-transistor circuit as it would be connected to a PNP transistor key. The original key circuit is immaterial, usually consisting of 2N107 or 2N404 transistors. The base of Q1 is connected in place of the relay keying transistor or the 2N398.

All three new transistors are silicon. Q1 and Q2 were 2N3638, but MPS3638, 2N4125, 2N3702, 2N3703, or similar transistors should work just as well. Q3 is the 2N4888. Resistor values are not critical and the circuit works with the usual power supply voltages found in keys of this type.

To prevent inadvertent application of positive voltages to the 2N4888, a silicon power diode was placed in series with the collector. To prevent current surges from fusing the 2N4888, a  $220\Omega$  resistor is also placed in series with the collector.

The ac switch of the key should have two sections. The added section, labeled S1B, shorts the 2N4888 collector when the power switch is turned off. This protects the transistor if the transmitter is left on and the key is turned off. Remember, unless the 2N4888 has its base and emitter shorted by Q2 the breakdown voltage will be only  $BV_{ce0}$ . In such a case if the key-up voltage of the transmitter exceeds  $-150V$  the 2N4888 could be damaged. S1B prevents this possibility.

Before using the key, measure the voltage between the base and emitter of Q3 with key power turned on, but not operating the key lever. The voltage should be less than a few tenths of a volt. Next, with a VTVM, measure the key-up voltage of the transmitter. Since this may depend upon "spotting" or tune positions be sure to look for such differences. If the highest voltage does not exceed  $-250V$  plug in the key and start enjoying transistor keying.

If your voltage lies between  $-250$  and  $-325V$  it is a good idea to buy several 2N4888 transistors and test them to find one having highest breakdown voltage. Figure 2 shows a test setup which can be used to test  $BV_{ce0}$  and  $BV_{ces}$ . The test should be performed carefully as follows to

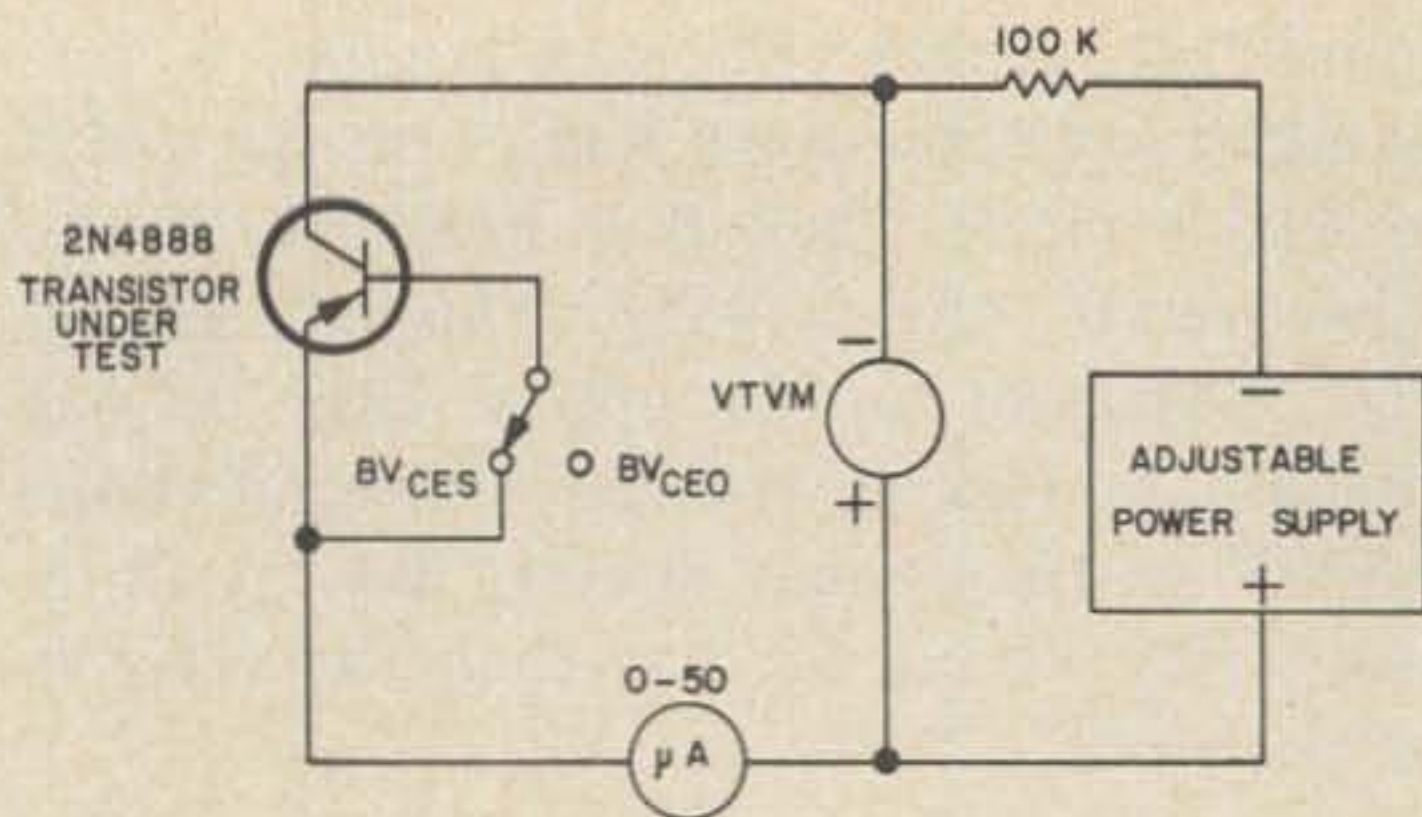

Fig. 2. Testing the breakdown voltages of the 2N4888.

prevent damage to the transistor: power supply voltage should be raised slowly while watching the microammeter like a hawk. The moment a microampere or two is indicated on the meter, read the VTVM and remove the test voltage. High voltage transistors have different failure modes than the low voltage types and appreciable current should not be allowed to flow.

## Adapting IC keys with the 2N4888

Figure 3 shows the 2N4888 in a simple integrated circuit key, the "Micro-TO" described in the August 1967 issue of *QST*. Common IC's such as those used in the Micro-TO require  $+3.6V$ . The PNP nature of the 2N4888 demands negative voltages. These conflicting requirements can be satisfied without adding another power supply by changing the ground reference terminal of the whole Micro-TO circuit.

All points which were originally grounded (including the key lever, power supply transformer center tap, and filter capacitors) are bussed together and lifted from chassis ground. This becomes the  $-3.6V$  terminal for powering the new circuitry. All points which were formerly  $+3.6V$  are grounded to the chassis. Since the ground terminals and  $+3.6V$  terminals of the circuit are probably buss wires on a printed circuit or perforated board the change requires moving only a few wires. After this change the integrated circuits are, in effect, "standing on their heads." They don't know the difference, however, and operate just as before. The PNP transistors see the  $-3.6V$  they require so everyone is happy. Total cost of the conversion is held to about \$2.50 by this trick.

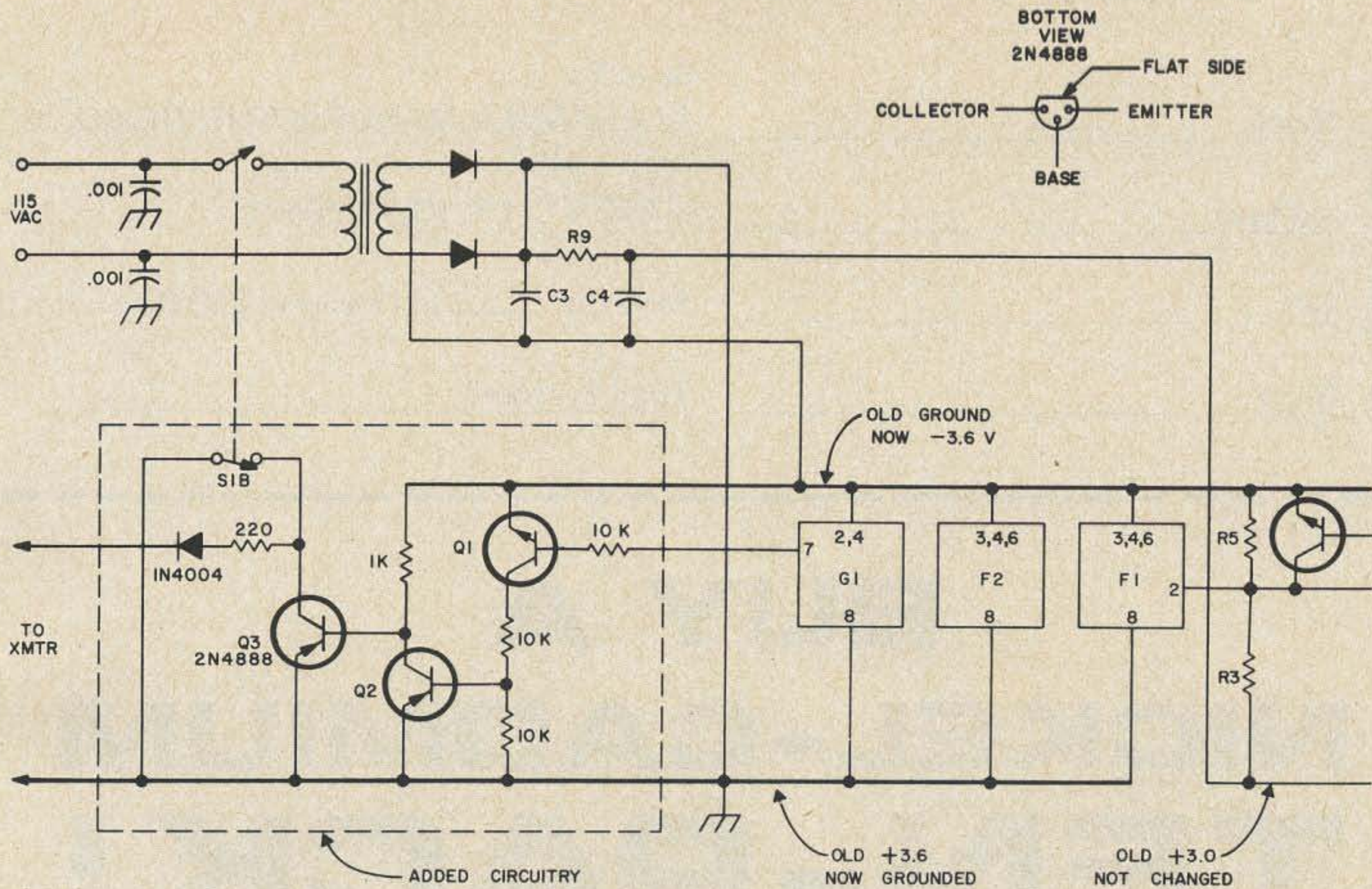

Fig. 3. Grid block keying with the "Micro-TO."

Four 0.001  $\mu$ F bypass capacitors are used in the Micro-TO. Two are used to bypass the ac line, two bypass the key lever contacts. These bypass capacitors should be excluded from the ground change: they remain between their respective wires and ground in order to prevent stray rf from entering the key.

Note that Fig. 3 does not show all of the Micro-TO circuitry, just the power supply and power connections of the ICs. Interconnecting wires between portions of the circuit were not changed in any way from the original schematic.

Q1 is a silicon NPN transistor. Almost anything will work here, the 2N3392-93-94 series, 2N3704-05-06 series, 2N5183, and 2N706 being suitable types which are very inexpensive. Q2 is a silicon PNP, 2N3638 or equivalent types discussed in the transistor key adaptation. Resistors are not critical and anything within 20% of the indicated values will be fine.

The protective diode, resistor, and switch are used in the IC key modification just as they were used in the transistor key modification. Again, any silicon power diode

with a PIV of about 400V could be substituted for the 1N4004.

Testing procedure for both key and transmitter are the same as was described for the transistor key modification.

Other types of IC keys can use the 2N4888 by changing the ground reference as was done here with the Micro-TO. My integrated iambimatic key (IIKEY) uses this identical technique and circuit.

#### Finding the 2N4888

The 2N4888 is a Fairchild resistor and may be hard to find. A letter to Fairchild Marketing Services, Box 1058, Mountain View, California, asking for their "Fairchild Stocking Distributors List" will give you a source for their transistors and integrated circuits.

#### Results

I've used two homebrew transmitters, an Apache, and an SB101 with four different keys using the 2N4888. Results have been uniformly successful. Transistor keying is quick and flawless — a definite improvement over the clickety-clack of relays.

...K6OLG

ORDER FORM

Name \_\_\_\_\_  
Address \_\_\_\_\_  
City \_\_\_\_\_  
State \_\_\_\_\_

Send To:  
ALEXANDER MANUFACTURING CO.  
BOX 1645  
MASON CITY, IOWA 50401

Send me \_\_\_\_\_ ten packs at \$30.80 ea.

Total Enclosed \_\_\_\_\_

# BUY A NICKEL-CADMIUM TEN-PACK!



These fast charge Nickel-Cadmiums are just the ticket for your hand unit. You can charge them up as often as you like. Buy two sets and keep one charged up for emergency purposes . . . a re-fill, as it were. In this way you'll have twice the use from your hand unit and never be out of action. Also have huge stock of Nickle-Cadmium AA size Pen-lites, \$1.50 each.

**Buy Two! \$30.80 ea.**



**ALEXANDER manufacturing co.**

Box 1645 - Mason city, Iowa 50401

Phone (515) 423-8955/ TWX 910-523-6978





# USING A SEVEN-SEGMENT READOUT WITH A NIXIE DRIVER

**D**uring the construction of an electronic clock or frequency counter, the type of readout employed can be a deciding factor in the overall price of the unit. The LED (Light Emitting Diode) type of seven segment readout is quite a bit more expensive than those of the "Nixie" type. The driver integrated circuit for the LED readout generally is more expensive than the driver for the "Nixie" tubes. Most of the LED readouts are low voltage devices (approximately 5V) and work with a low voltage type of driver such as the Texas Instruments SN7447 IC.

One of the better deals we have discovered is the SP-733 readout which is manufactured by Sperry Rand. The SP-733 is used by Heathkit in their new IC-2008A calculator and sells for about \$7.35 through Heathkit outlets. Of course these are intended for replacement use in the calculators. The SP-733 contains *three* complete readouts in a single flat enclosure. Therefore, the price per readout comes to \$2.45 each. The SP-733 is a seven segment device; however, it is not compatible with either the SN7447 which is a low voltage seven segment driver, or the SN7441 which drives individual numeric high voltage "Nixie" tubes. The SP-733 requires approximately 200V dc on each of the seven segments through a 22,000Ω ½W current limiting resistor in order to illuminate the segments.

Due to the reasonable price and compactness of the SP-733 (4.2 x 2.8 x 0.5 cm) we were prompted to try and make it compatible with a "high voltage" Nixie driver such as the SN 7441. The SN 7441 was constructed to ground only the single nu-

merals of the Nixie tubes. Therefore it was necessary to come up with a proper diode matrix that would interface the SN 7441 and SP-733.

We were fortunate enough to find some computer boards on the surplus market that contained over 300 glass bead type of silicon switching diodes. These boards sold for less than \$1 each. The silicon diodes were pressed into service and worked very well without a single failure. The voltage across

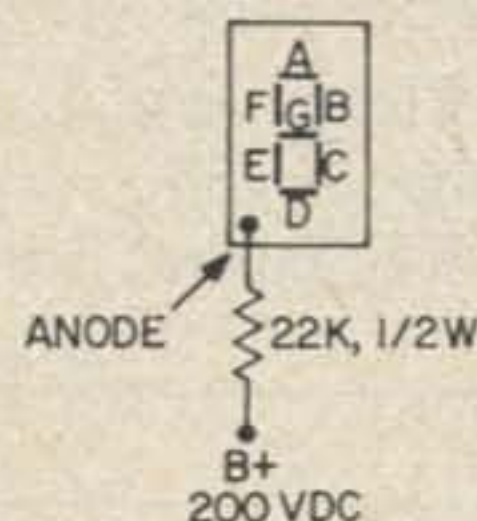
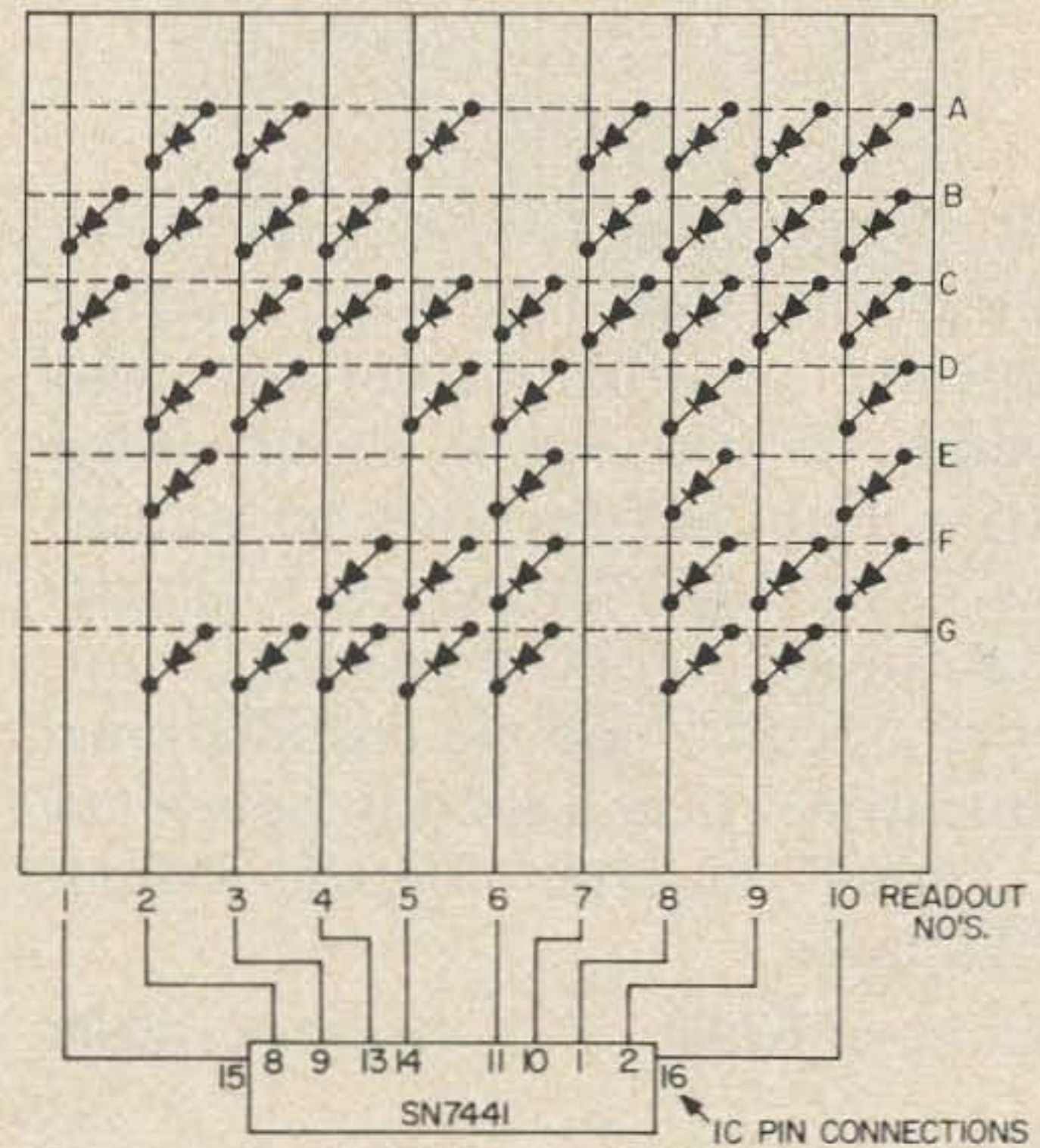
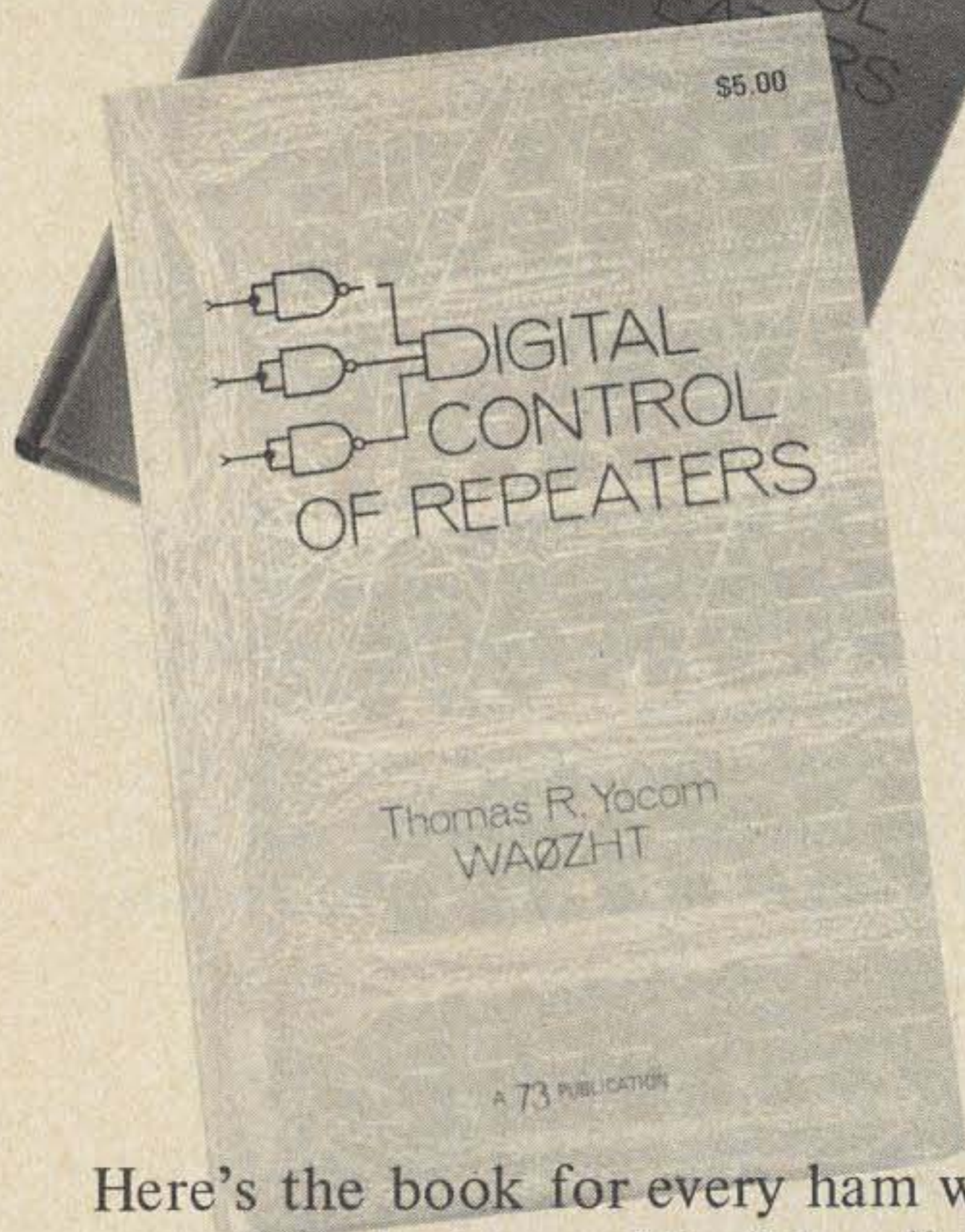

Fig. 1.

# NEWEST BOOK for FMers!



Here's the book for every ham who wants to design and build a digital repeater control system (or who wants to just think about doing that). Contains sections on repeaters, basic logic functions, logic circuit design, control systems, support circuits, mobile installations, touchtone, plus a special section on a "mini" repeater control system. 224 pages.

Hardcover \$7.00      Paperback \$5.00

73 Magazine, Peterborough NH 03458  
 Enclosed is \$ \_\_\_\_ . Please send  hardcover (\$7)/ paperback (\$5) copies of "Digital Control of Repeaters" to:  
 Name \_\_\_\_\_ Call \_\_\_\_\_  
 Address \_\_\_\_\_  
 City \_\_\_\_\_  
 State \_\_\_\_\_ ZIP \_\_\_\_\_

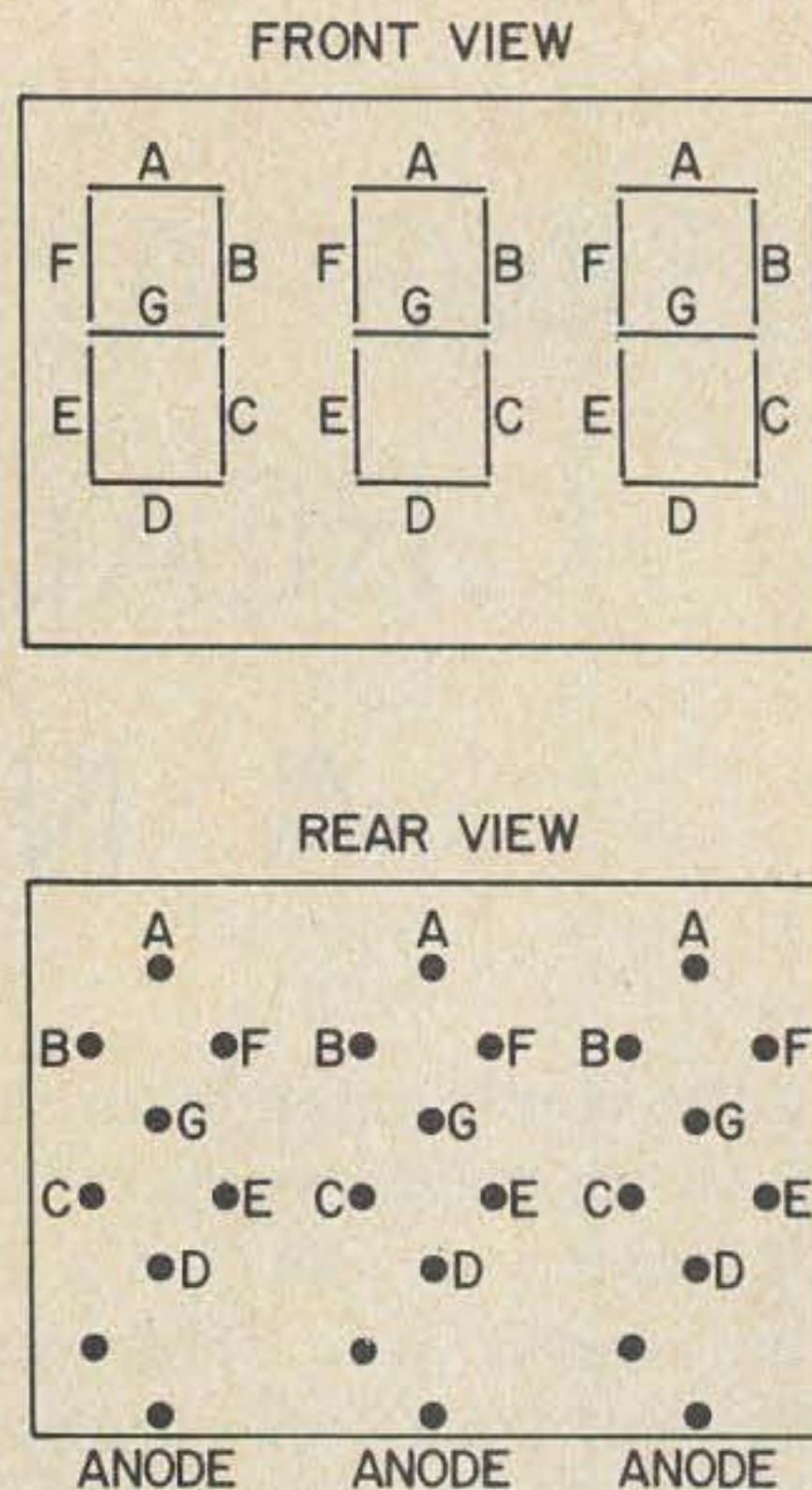

Fig. 2. SP-733 pin numbers.

the diodes in the matrix varies from 10–15V with a 200V potential on the SP-733's. Another garden variety of silicon diode that may be used are those that are sold by Radio Shack in packs of 50. These are untested and should be checked before placing them in the matrix. We found that usually one out of the 50 would be shorted or open.

Figure 1 illustrates the printed board construction. Our boards measure 5 x 7.5 cm and could have been made such smaller by standing the diodes on end. Use double sided PC board stock (copper plated on both sides) and follow the Fig. 1 pattern. The solid lines indicate top side conductor lines and the dotted indicate bottom conductors.

The easiest way to drill the double sided board so that the holes match after etching is to hold the board up to a lamp so that the bottom lines show through the board. Mark your drill hole positions with a pencil and then drill. Figure 2 illustrates the SP-733 segment pin connections.

The completed diode matrix units are thin and can be easily stacked in a small area.

Do not hesitate to experiment with different types of silicon diodes. Almost any high speed switching type of diode will function.

...W2A00

privileges in the first place.

On the other hand, CBers are not required to do anything more than to file an application plus the required fee. In many cases it has been shown that these applications have been and are being falsified. It has been a very common practice for persons to sign for others, often offspring whose insufficient years would disqualify them. A person who signs such a false application is guilty of a serious crime; that of attesting to untrue statements, to wit: that he (the signator) is applying for operating privileges, when in reality he is filing for an individual who is not eligible. Through this means an out-and-out example of lawless behavior on the part of his parent or other adult is the juvenile's initial impression regarding the relative unimportance of observing the communication laws and obeying them. This is a compelling impression which often molds and sets his conduct from that time forward. If the adult in question has been able to falsify the application document with such ease, why should the recipient of the license view legal operating regulations with any respect?

This lamentable condition which has always infected the Citizens Band, is a direct outgrowth of the FCC's utter failure to understand that they must insist upon more than just the mere filing of an application, with absolutely no further qualifying criteria. Though it is entirely possible for administrative miscalculations to occur when new modes or services are first inaugurated, to fail to take forceful corrective measures when the error is discovered, is a monumental dereliction of responsibility. CB, with all its evils and problems, is the creature of the FCC, and they cannot blame anyone for the mess but themselves. Why then, should we amateurs be made to pay for the mistake? We paid dearly once, with the loss of one of our bands. Are we expected to pay all over again, simply because the FCC refuses to acknowledge that CB has been a miserable fiasco? Why don't they move the CBers to somebody else's band, rather than to yet another ham band?

A long time ago this correspondent suggested in the pages of this magazine that if the FCC was truly interested in some constructive suggestions, one of the very best would be the granting of CW privileges somewhere on the HF bands for the Technicians so that those who might desire to upgrade their tickets would be afforded an opportunity to do so with more ease. The Commission evidently recognized no merit in this

proposal although it was no secret that many Techs were far more interested in becoming communicators than in being builders and experimenters, (for which purpose the Tech class was originally established). As it now stands, Techs have to struggle in order to get enough code under their belts to handle the required speed and facility.

At one point an ill-advised proposal was made which would have granted Techs phone privileges only in the 28 MHz band, but no CW was included. LEAKY LINES opposed this on the basis that such a free grant, with no code exam involved, would amount to an unconscionable breach of faith with those who had been forced to accept the validity of the incentive licensing principle, which had previously been piously pushed by both the FCC and the ARRL, under the pretext that it was altogether proper for amateurs to justify their privilege by continuing to advance their skills under pain of (again...it seems to rear its head as a solution for every problem...) under pain, as I said, of a loss of operating frequencies! Most hams were so thoroughly brainwashed and so battered from pillar to post, that they finally concurred and accepted the doctrine of incentive licensing. Fine! But at the time when it was proposed that this hanky-panky about giving the Techs a back-door entrance into privileges on 29.5-29.7 MHz, most of us were of the opinion that such a grant would have been an abrogation of the incentive licensing principle, and would have afforded unfair preferential favor to the disadvantage of all who had been forced into working hard enough to upgrade.

Literally hordes of Technicians wrote indignant protests to this magazine, accusing this writer of prejudice, unfairness and a score of other selfish motives. It was claimed that the article was aimed solely at slamming the door of equal opportunity in the faces of Technicians. Well, of course, that door has always been possible to open. Thousands of Techs had successfully upgraded their license through the ordinary process of studying their code and theory, then going to an FCC examining point and passing the test. We simply happened to feel strongly that any Tech who really felt the desire to extend his operating privileges could easily do so by exerting himself to that limited extent, and if he was unwilling to exert this small effort, he certainly did not deserve preferential treatment. We termed the proposal "giving a lollipop to a kid at the barber shop."

I can state confidently that if the

FCC had offered CW privileges only to the Techs, either as a shared proposition with the Novices, or on some other segment of the HF bands, there are not many hams who would have objected to it. It has always seemed incomprehensible to this writer that the FCC has not seen fit to provide some CW space for the express purpose of aiding Techs who wished to upgrade themselves by participating in on-the-air CW operation. The present CW privilege they are assigned simply has an insufficient number of CW operators to be considered adequate.

Having failed to perceive any validity in adopting this and other reasonable plans that would effectively improve and consolidate the amateur service, one wonders by what manner of "double-think" the FCC finds merit in a proposal to hand CB another portion of the spectrum on a silver platter, which it will undoubtedly destroy, just as they destroyed their present band. There is not a scintilla of reasonable evidence to show that a relocation to the 220 MHz band would cause them to mend their ways and begin to observe regulations which they have never before heeded...do not observe now...and are not even remotely taking seriously.

Another criticism can be levelled. In a country in which financial profit is the name of the game, it would be extremely naive to imagine that such a proposal could grow out of the sole idea that it would really be meritorious from the aspect of valid need. We all know whose brainstorm this proposal was...there is no doubt that it was spawned by the manufacturers of electronic equipment, who stand to reap millions in windfall profits, should the proposal be approved. The very moment it becomes okayed, sales of new equipment will begin to burgeon, and the enormous sales figures which ensue are likely to make the old CB business look like penny-ante stuff! In order to avoid being misunderstood, let's get this clear, at least. I certainly do not begrudge manufacturers their right to build and sell gear. But it seems that in this case it was the main object in proposing the change. And while the economic aim may be perfectly acceptable, I think the loss of an amateur band is much too high a price for us to be forced to pay! If this change were motivated primarily for the purpose of improving and benefiting the radio spectrum, then secondarily, for assisting the electronics industry to reap a harvest, then the proposal might be viewed as acceptable by some. But the move is advantageous to manufacturers and the CBers alone. The amateurs stand

(Continued on page 98)

(Continued from page 12)

### FCC HEARING REPORT

Copies of the three page report made to the FCC Commissioners on the need for repeal of the repeater regulations are available from 73 Magazine, Peterborough NH 03458... send sase. Many amateurs who are not well informed on the seriousness of the impact of the new regulations would do well to read this report and see why it is so important that these regs be changed.

### CONGRESS REPORT

There are still copies of the Congress Newsletter — a report written for you to send along to your Senator or Congressman, together with a covering letter, asking for his influence in helping amateur radio fight off the new restrictive regulations and the assaults on our 220 and 450 MHz bands.

### 73 VS IRS

The first of a series of newsletters covering this interesting development is in print and available if you send a sase. If there is enough interest in the inside dope on the IRS and the whole tax situation, this series of letters will eventually be put into book form. Looking into the administration of the IRS has turned out to be about like turning over an innocent looking log and finding all sorts of scrambling maggots and black beetles scurrying around.

### SUPERLICENSED

A note from WA5CON suggests some sort of special amateur call prefix for ops who have managed to pass all FCC exams. Ticket collectors will have a tough job keeping up with this chap who now has first phone with radar endorsement, first telegraph with radar, six months maritime service endorsement, aircraft telegraph, and amateur extra class. With all those licenses on the wall is there any room for QSL cards? And how do you decide which band to use when you have a spare moment between tests?

#### WANTS TO BUY

All types of military electronics equipment and parts. Call collect for cash offer.

SPACE ELECTRONICS division of  
MILITARY ELECTRONICS CORP.

76 Brookside Drive, Upper Saddle River  
New Jersey 07458 / (201) 327-7640

(Continued from page 97)

only to lose still another slice of frequency. And what will we gain? Precisely nothing!

"But listen," say the proponents of the grab. "This particular band is not even being used." They try to argue that the idle frequencies should be re-assigned to people who will make better use of them. We once made an analogy...supposing you are storing your winter overcoat in a cedar closet. All of a sudden, in the middle of July, some guy waltzes in and takes your overcoat away, using as justification the argument that you aren't using it. You'd surely feel a sense of outrage. And rightly so! This rationale is as cockeyed as it can be. The coat is stored in the closet to be used at some later time, when conditions warraant. Similarly, the 220 MHz band seems likely to become more important to amateurs in the future because of the rapid growth of VHF repeater techniques. It could easily become one of ham radio's most valuable assets. Like the overcoat in the closet, it will serve its purpose in due course. It would be a tragic error to hand it over without a struggle to opportunists who will make it a shambles, and to entrepreneurs who will profit by the misuse.

While I'm on the subject of repeaters, a haunting thought races through my head. Could it possibly be that the FCC, anticipating the advancing repeater technology, and realizing that sooner or later it must inevitably become indispensable to 220 MHz, has chosen to implement its idiotic and totally illogical position vis-a-vis the Docket which pertains to repeaters, in order to create the fundamental structure within whose condition of disuse on that band? In this manner the Commission could almost guarantee that when the proper time came along, and it decided to reassign 220 to another service, it could point to the fact that amateurs are not utilizing it, and that therefore it would be a justifiable reassignment. In these days of elaborate finagling on the part of government agencies and bureaus, and all sorts of conspiracies and coverups, this sort of a cabalistic arrangement would not be as bizarre and arcane as it appears on the surface. We could very easily find ourselves right smack dab in the middle of our own little Watergate.

I'm perfectly willing to grant the fact that in the beginning, back in the 40's when it was first proposed, CB sounded like a reasonably good idea. And I'm further willing to agree that there are many legitimate users of that service who need and deserve a band of frequencies in which to operate.

But *never*, from the outset, was a hobby-type operation envisioned or contemplated. Amateur radio has existed for that purpose, and it has always been available for those who were interested from a hobby standpoint. To change our fundamental understanding now, and take the position that radio communications are two hobbies...one, a group of technically minded devotees of an ongoing science, who are vitally concerned with being a part of its growth...and two, a group of unconcerned diletantes whose only purpose is to contact one another in a sort of surrogate wireless telephone system, without the slightest inclination to probe into the theoretical and the public service aspects of the thing, is an abrogation of a concept which has earned the respect and confidence of all thoughtful people, throughout the world. No matter how the FCC seeks to rationalize this projected change, it can never explain away the horrid inconsistency embodied in the very character and nature of the idea. On the one hand it licenses a service which has always risen to every challenge, and has justified its existence by participating in thousands of public service activities. On the other hand it has created a mare's nest...a Pandora's Box of atrocious horrors, which has never abided by the concepts which gave it life, has created problems of its own, and which constitutes an insoluble mess so vile that nobody can decide what can be done to clear it up! Then they have the unutterable gall to suggest that this cancer must be allowed to spread to another part of the spectrum.

Citizens Band has been a failure on 27 MHz. Wherever they chose to put it, it will continue to be a fiasco, unless they stiffen the requirements and begin to enforce some adult responsibility onto the shoulders of these freeloading parasites who have corrupted it. They must be made accountable, finally, for their undisciplined excesses. But this can never happen so long as a naive Federal Communications Commission continues to believe in the preposterous notion that the present form of loose criteria in licensing and operational regulations and enforcement should be maintained.

It's a certainty that this proposal represents a giant step backward for the world of amateur radio. And every ham should be aware of his or her solemn obligation to make known to the Commission exactly how he or she feels about the matter. This one issue is probably the most important single piece of legislative action an amateur can take, providing his hobby means anything at all to him.

73 de K2AGZ

ou goons don't ever proofr  
easy men scripps from bab  
bunch of rocks pre on  
you ignored my comments in  
I insist that you print ev

#### RE: DECEMBER COVER

The December cover with Linda makes an attractive presentation to the public as well as to us "old timers." Such an idea put into a monthly calendar would increase the DXing. You all are to be complimented for an attractive cover done in fine taste.

Art Greenleaf WA1EQI  
Montpelier VT

#### NO MORE COVER-UPS

You've done it again — a terrific cover and a terrific package of articles and ads!

I'm game! She's a beautiful gal and what is behind the box is most tantalizing! Here's my \$3, and if you only get \$1 of it you'll be a millionaire over night. In some future issue you might tell us just how close to a million you came!

Lon Allbright W6SLF

#### MORE ON THE COVER

Your November 73 cover is in very poor taste, but does indicate the mentality of the Staff of 73.

Although I am not in agreement with Mr. Walker in many instances, amateur magazines are not the place for your kind of politics.

Jo Wood W1AYG

*I do wonder where you think the place is for amateur radio politics if not in the ham magazines? Perhaps you are used to letting the government trod you into the ground and wish to just give up without a fight, whether you are right or not. Thank heavens not all amateurs are that willing to knuckle under.*

...wayne

#### MORE OFF THE COVER

Enclosed is the \$3 I'm willing to pay to see what's behind the PACKAGE. Also, I hope it helps build up your anti-IRS fund. If needed I'll pay newsstand prices for your magazine just to keep you going. Keep up the good work.

Al B. Caplan K4AVQ/3

#### D DEC ENTRY BOFFO

IBravo! Now *that's* a magazine cover.

Bob Wier WB0IMC/5  
Fort Worth TX

#### DIGITAL IC ARTICLES WANTED

How about some articles on digital IC's and their basic operations? Maybe how counters work, how to use a diode memory for generating code for an automatic identifier (The ARRL FM and Repeater Handbook is poor in this area). Also, maybe an article on capture area, antenna gain, and how they're related (I haven't been able to find anything on this). Maybe an article on regulated power supplies (transistor) too.

Keep up the good work on the magazine.

Jim Kocsis WA9PYH  
South Bend IN 46628

#### ADDITIONAL CALCULATOR ARTICLES WANTED

Enjoyed very much the article in the December issue on Calculators. I would like more articles on the same subject, e. g., checking out a machine, how to tell if it is defective, etc.

Jo Westheimer WB6KUC

#### GOOD WORK

Keep the presses rolling, your magazine is not only good reading but has convinced several friends to put down the CB rig and start reading the license manual. Keep up the good work.

Mike Makowski WA1QMK/3  
Arnold MA

#### CONGRESS PAPER

Please send me the Congress Paper. I will forward them to my Senator, as soon as I receive them.

Hopefully a large percentage of the amateurs will do the same.

You have a very fine magazine, keep up the fine articles. Lots of luck to Wayne in his battle with the IRS.

David W. Jubb WA7KAI

#### CBers TAKE NOTE

The FCC *does* take action on tips against CBers. I have been listening and logging about 15-30 minutes a day on 11m since February 1973. Recently I identified by "handle" (pseudonym), address, auto license number and name 31 good old CBers. I sent my information to the Commission and have since heard from them. Guess where their mobile enforcement unit is going to strike soon?

Joe Schlatter K4FPT/7  
Tucson AZ

#### IRS/FCC KEEP UP THE FIGHT

I appreciated your rambling dissertation on the perils of the IRS — keep up the fight. I also appreciated your work in fighting the FCC and in keeping us posted on the latest.

Lewis L. Munn  
Roseville MN

*we goofed again*

#### LOG-PERIODIC UPDATE

There is one item regarding the construction of L-Ps (September 73) which should be stressed. This is the importance of *transposing* between the elements to make it an end-fire array.

This is accomplished by either of two methods: 1. "Criss-Cross" or "roll over" the two-wire center feeder, between elements (180° phase reversal), or, 2. Alternately transpose the feed to the elements.

I have illustrated both methods in my articles but have evidently failed to stress the importance of this.

I have received two letters stating that the writers had constructed L-Ps but did not get any forward gain, or rather there appeared to be no forward lobe. One writer who put up a vertical mono-pole L-P said it was bi-directional off the sides with no gain off the front. This, of course, occurs if the transposition is not made since the array is not then an end-fire L-P, but is a bi-directional broadside array since all elements are then in phase.

In the case of a horizontal (dipole type) L-P, maximum radiation would be straight up and straight down (into the ground) if the elements are in phase or are non-transposed. There would be no forward lobe, nor would there be any gain except straight up. Under this condition the antenna is *not a Log-Periodic* but is merely the old "fishbone" antenna.

F. E. Smith W4AEO  
Camden SC

*and again . . .*

#### CALCULATOR CORRECTIONS

Here are some corrections to my December 73 Calculator article:

p. 98, 2nd col., line 25: \$.010 should be \$0.10.

p. 102, 2nd col., line 8: 0.001 second should be 0.0001 second.

p. 102, 2nd col., line 28: 552.85957 should be 552.861277.

p. 105: In the two tables, the lefthand column has a number of duplications. Whenever two consecutive lines have the same text in column 1, cross out the text in this column on the second line of each pair.

p. 106, 2nd col., line 4: should read, ". . . is 2.718055, whereas it is supposed to be 2.7182818.

Peter A. Stark K2OAW  
Mt. Kisco NY

# CIRCUITS, CIRCUITS, CIRCUITS...

The following circuits have appeared in the referenced books, magazines, application notes, etc. While we try to reproduce all of the information that should be needed by an experienced constructor, readers may want to avail themselves of the original sources for peace of mind.

Readers are requested to pass along any interesting circuits that they discover in sources other than U.S. ham magazines. Circuits should be oriented toward amateur radio and experimentation rather than industrial or computer technology. Submit circuit with all parts values on it, a very brief explanation of the circuit and any additional parts information required, give the source and a note of permission to reprint from the copyright holder, if any, and the reward for a published circuit will be a choice of a 73 book. Send your circuits to 73 Circuits Page, 73 Magazine, Peterborough NH 03458.

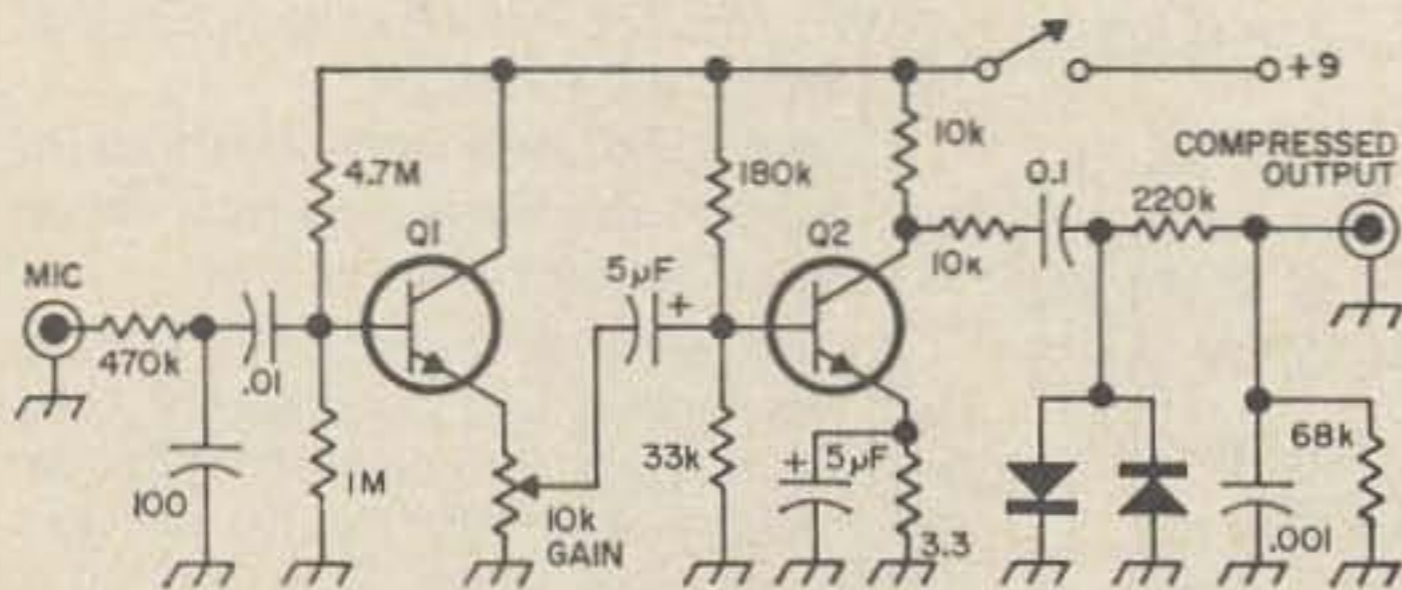

Two stage clipper/preamp will increase the talk power of your rig. Transistors Q1 and Q2 are HEP-54. The diodes are IN456 or HEP-158.

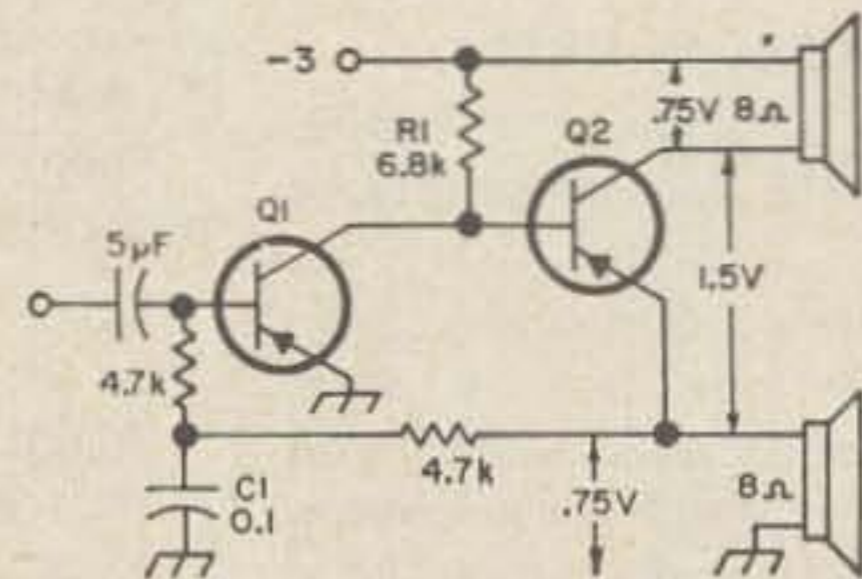

An audio power amplifier with push pull output using a single transistor in the final stage may be obtained with this simple circuit. Only about 50 mW is available from this amplifier, but the gain is flat up to 30 kHz. Both Q1 and Q2 should be germanium audio transistors such as the 2N404, SK3004 or HEP-253.

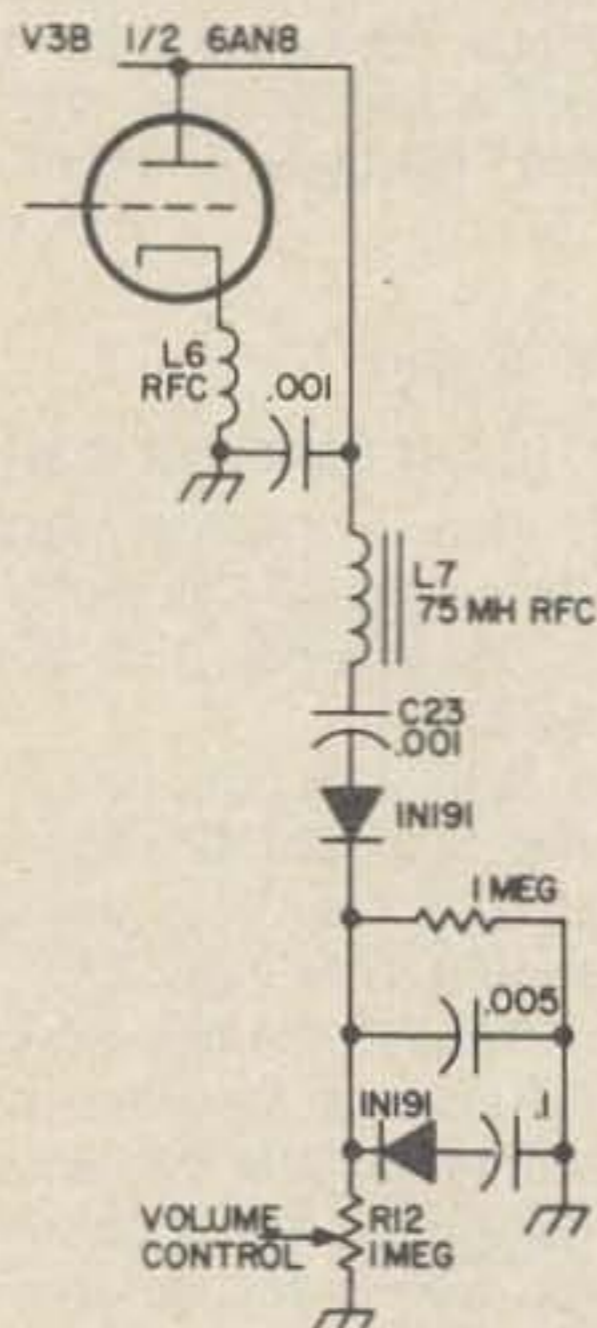

A simple noise limiter that can be used with superregen detectors similar to those in the Two'er and Six'er.

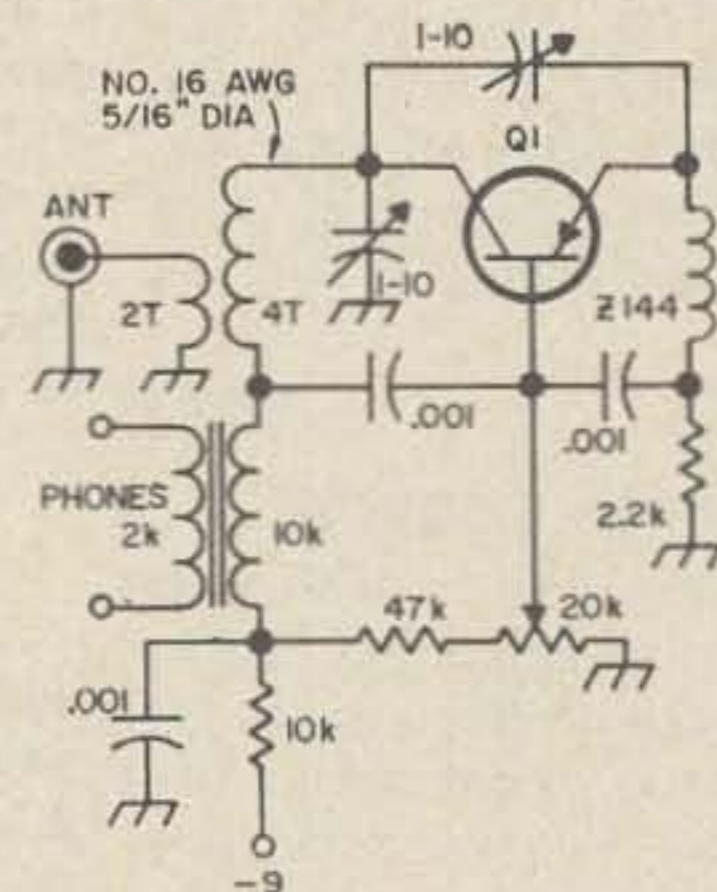

This simple one transistor superregenerative receiver for two meters may be used for copying many local signals. With the components shown this receiver will tune from about 90 to 150 MHz. It may be used on other frequencies by changing the inductor and capacitor Q1 is a GE-9 or HEP-2.

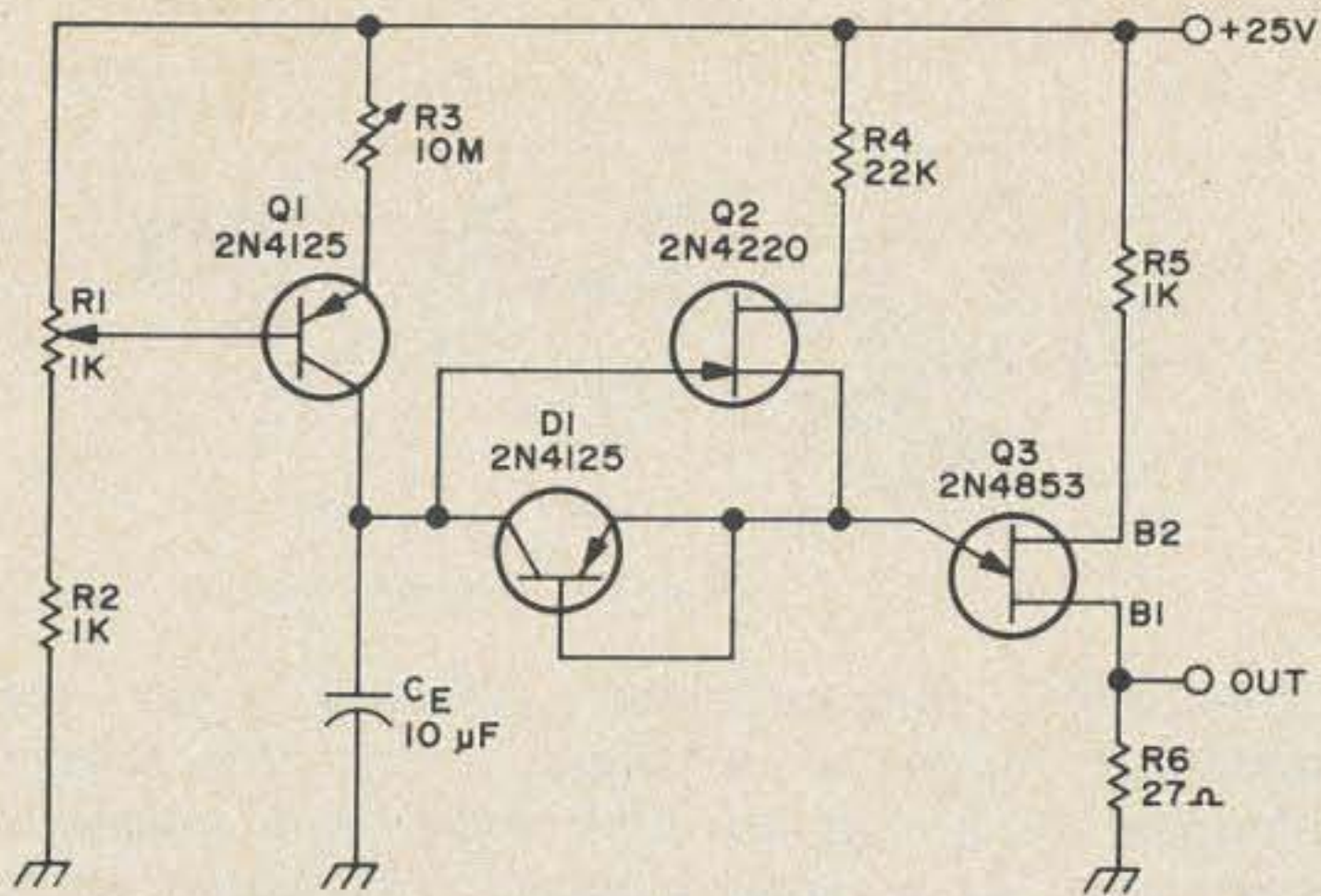

Long duration FET timer which will give a delay up to 10 hours. Circuit courtesy Motorola Semiconductor Power Circuits Handbook.

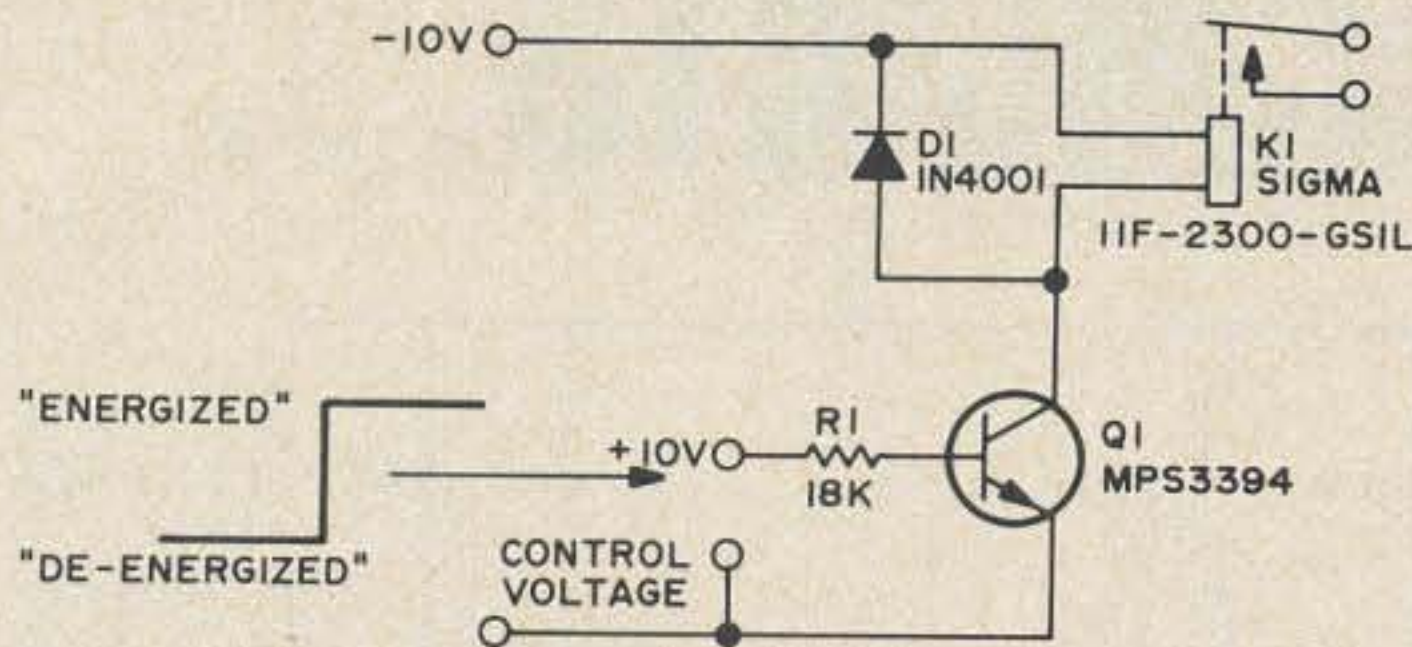

Electronic control of a dc relay. Circuit courtesy Motorola Semiconductor Power Circuits Handbook.

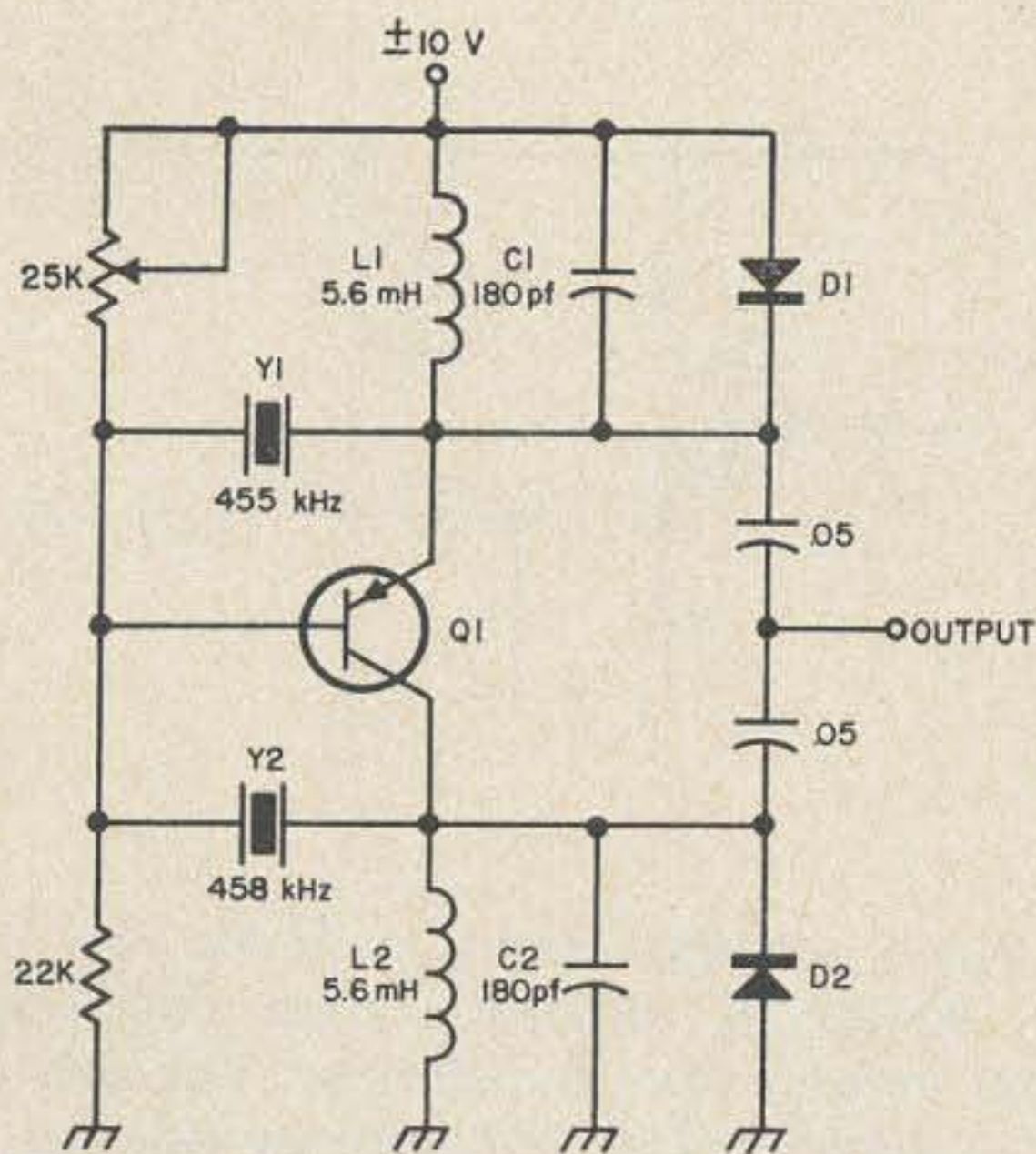

Q1 - 2N384, 2N525, SK3004, T1-XM03  
D1, D2 - GENERAL PURPOSE SILICON DIODES

This two frequency crystal oscillator changes frequency by simply reversing the supply voltage. When the supply voltage is changed, the transistor inverts itself; usually transistors may not be used in the inverted mode, but in an oscillator a gain of only 1 or 2 is needed and this circuit provides a novel and simple way of obtaining two frequencies from a single stage with a minimum of switching.

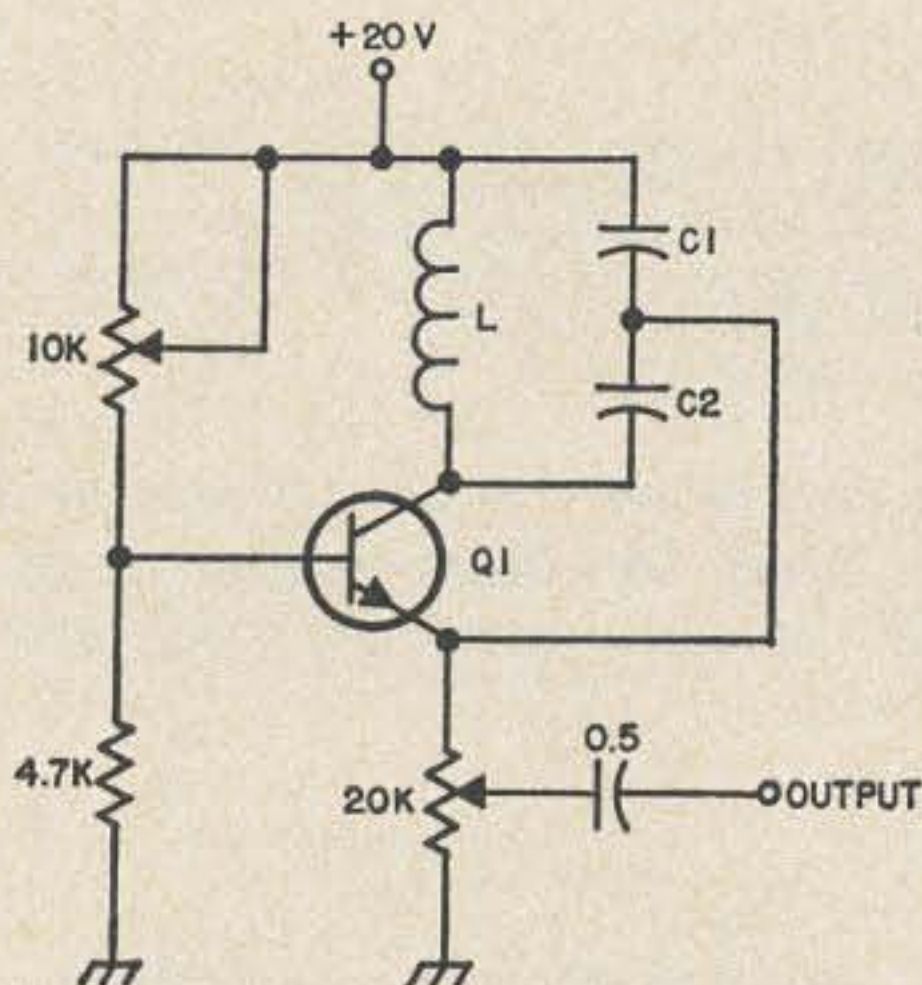

Q1 - 2N2925, 2N3392

FREQUENCY	C1	C2	L
50 kHz	3500 pf	1500 pf	10 mH
80 kHz	2200 pf	910 pf	6.2 mH
100 kHz	1800 pf	750 pf	4.7 mH
200 kHz	910 pf	390 pf	2.2 mH
455 kHz	390 pf	160 pf	1 mH
1000 kHz	180 pf	75 pf	0.47 mH

This simple circuit provides an extremely stable BFO. The frequency of oscillation may be tailored to your needs by simply choosing the proper tank components listed in the table.

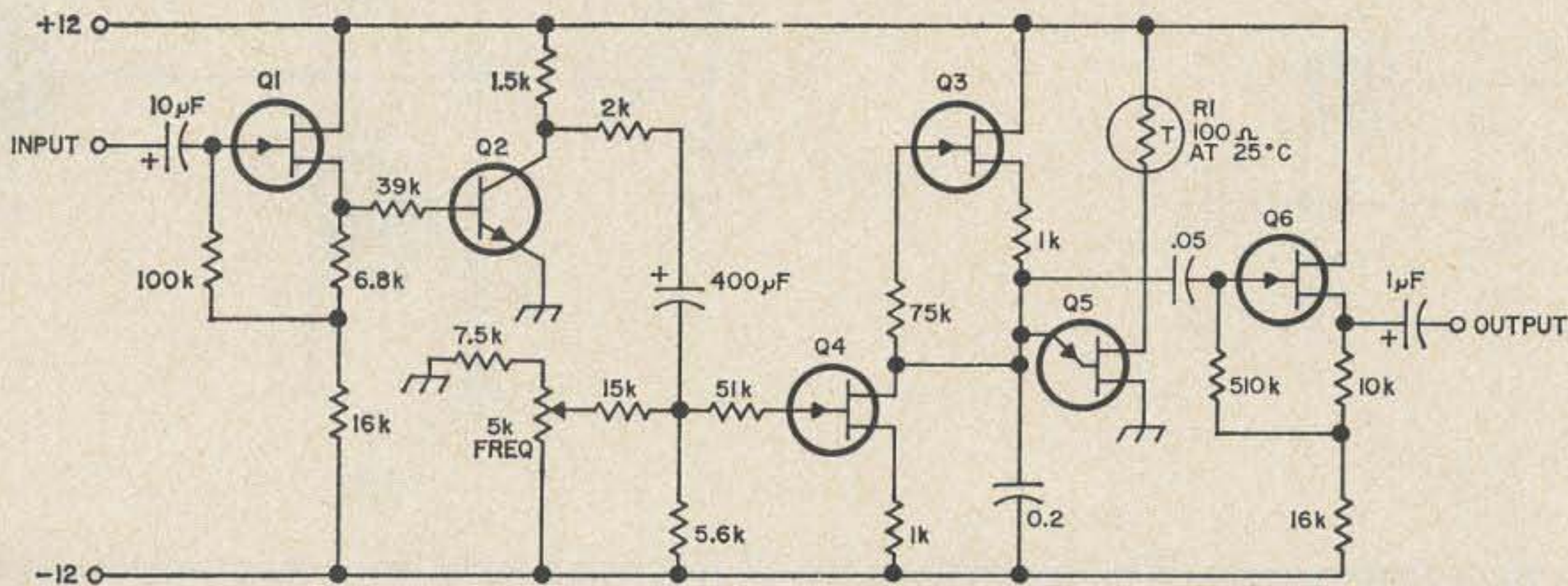

Although this capacitance meter will not measure electrolytic capacitors, it will measure any other type from zero to 0.1 μF with reasonable accuracy. On the lower end 4 pF can be read accurately and 2 pF easily estimated. Transistors Q1 and Q2 are 2N168, 2N1605, 2N2926, SK3011 or HEP-54; the meter is a 0-50 microampere unit and the range switch a Centralab PA1021.

# MORE CIRCUITS...

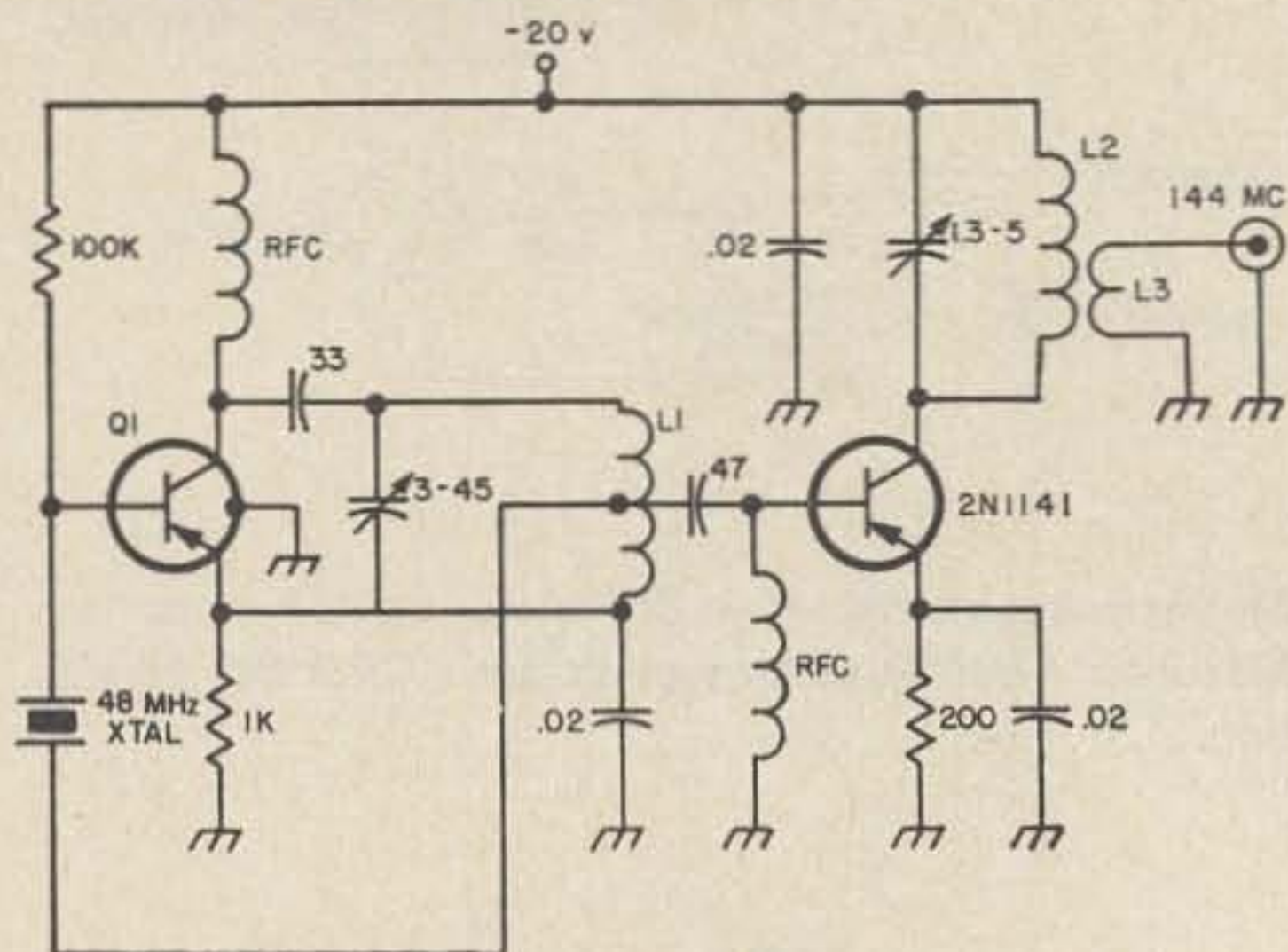

- L1 8 TURNS B&W 3003 (16 TURNS PER INCH, 1/2" DIAM.) TAPPED AT 4 TURNS FROM COLD END.
- L2 8 TURNS NO. 16, 5/16" DIAM, 1" LONG
- L3 3 TURNS NO. 16 BIFILAR WOUND ON COLD END OF L2.
- Q1 2N384, SK3008, TIXM03
- RFC 1.8 μH (OHMITE Z-144)

This simple two meter transmitter may be used as a driver for a larger 144 MHz transmitter or a signal source for testing receivers, converters and antennas.

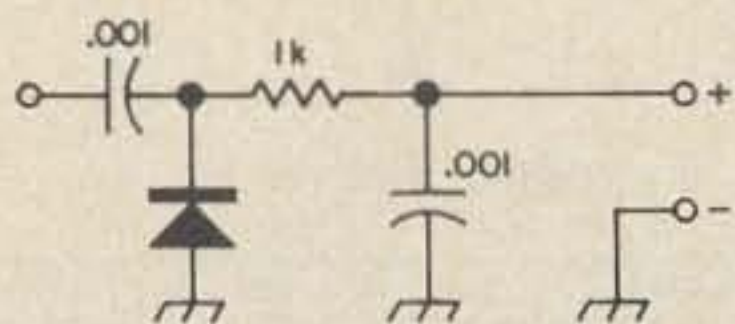

A general-purpose rf detector probe for use with an oscilloscope or voltemeter.

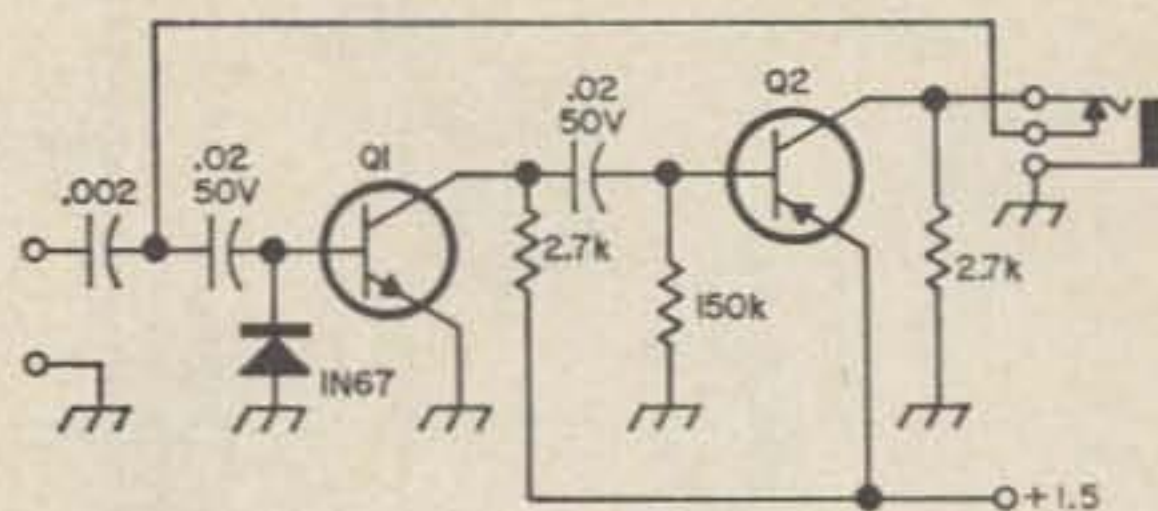

This signal injector/tracer switches from the injection mode to a signal tracer by simply plugging in a pair of high impedance magnetic earphones. As a tracer it works from audio up to 432 MHz. Transistor Q1 is a 2N170, 2N388A, 2N1605, SK3011 or GE-7; Q2 is a 2N188A, 2N404, 2N2953, SK3004 or HEP-253.

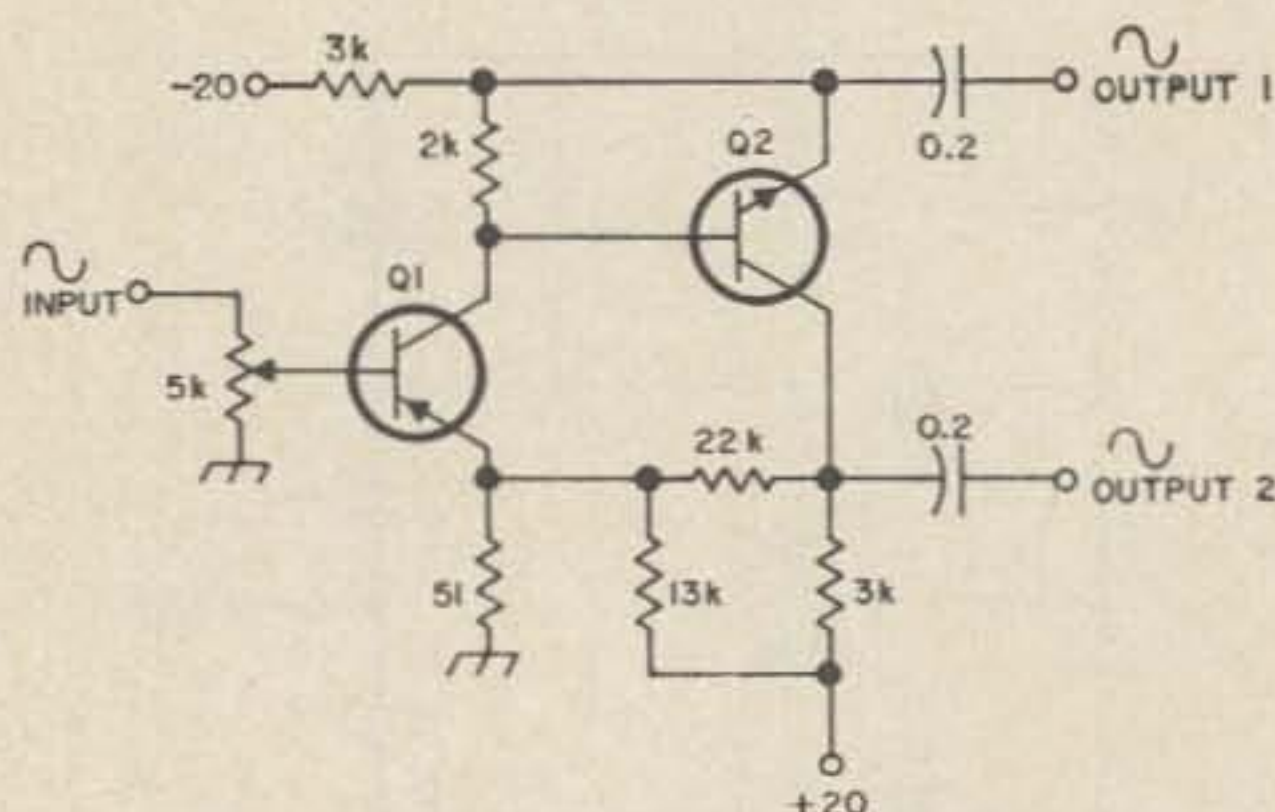

This phase splitting circuit provides two out of phase signals for driving a push pull amplifier without an expensive transformer. The gain of the stage as shown is 150, but this may be adjusted by changing the value of the 22K feedback resistor. Q1 and Q2 are a complimentary pair such as the 2N652 and 2N388 or 2N2430 and 2N2706.

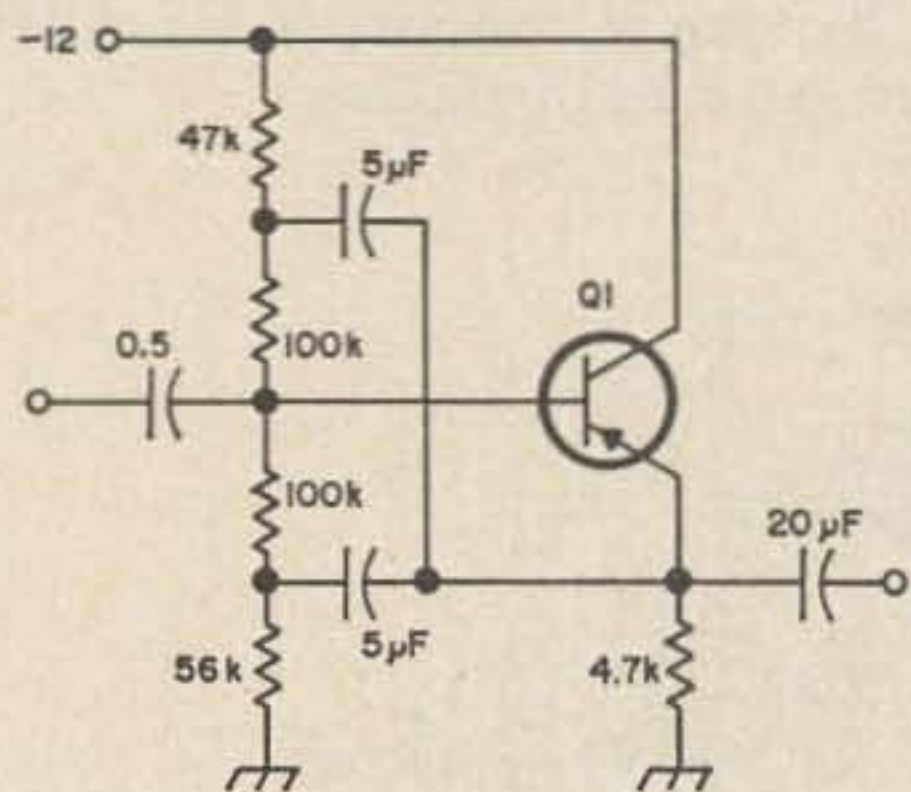

(A)

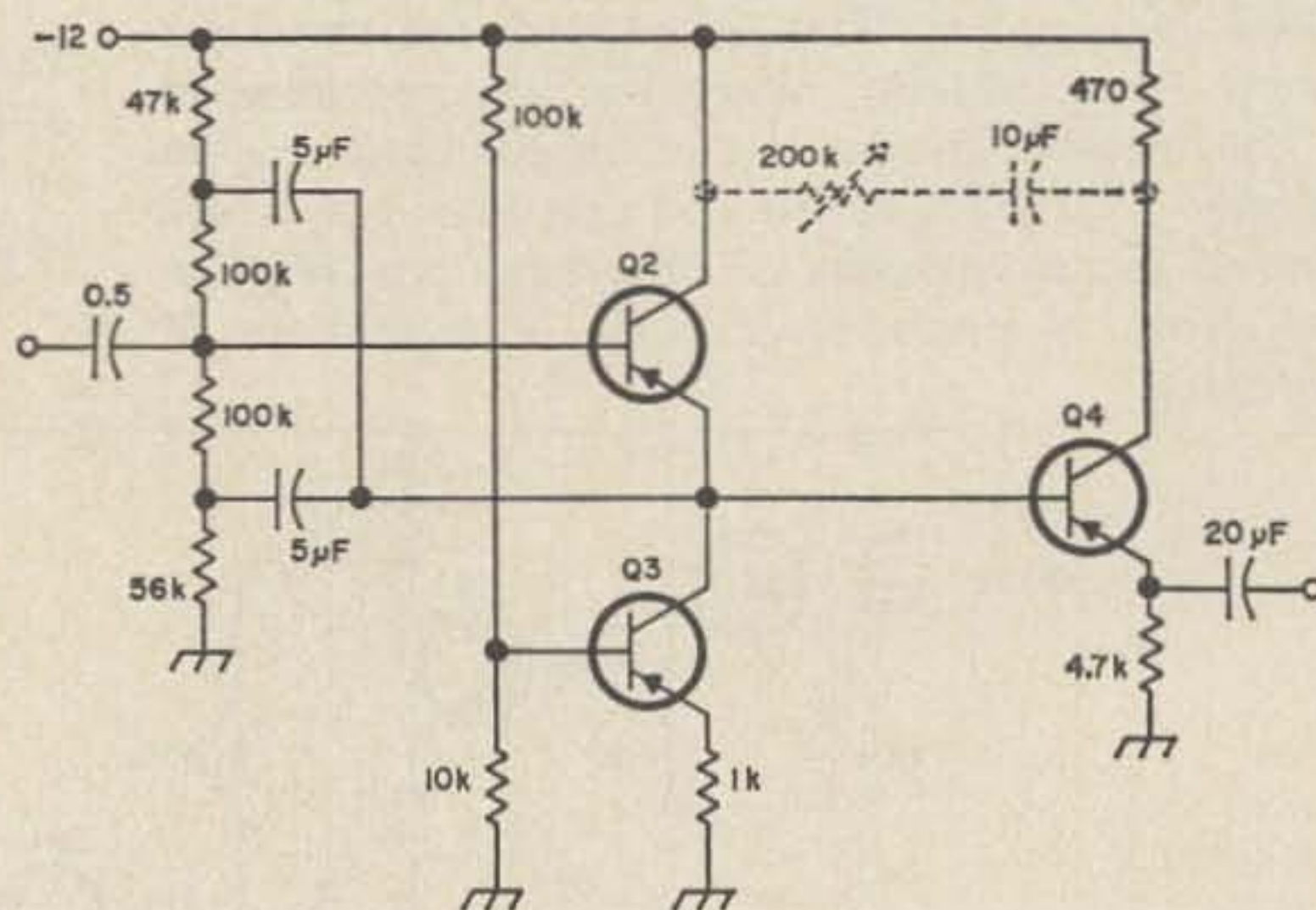

(B)

This high impedance preamplifier provides up to 20 megohms input impedance and has a frequency response from 10 Hz to 220 kHz. Circuit B was developed from circuit A by replacing the emitter resistor in A with Q3 and adding an emitter follower to reduce loading. The input impedance is further increased by the components shown by the dashed line. All transistors are 2N2188, SK3005, GE-9 or HEP-2.



# SAVE \$80.



## SBE SB-144

Reg. \$259.—NOW only \$179.

Top performing 2-meter FM transceiver, outfeatures everything in its class—stands apart as the exceptional dollar value in VHF/FM gear for the radio amateur. Beautifully constructed—compact and conveniently installed, SB-144 has what it takes for rock solid, "through the repeater" contacts. 12 separate crystal positions for both transmitter and receiver allow all-repeater pair off or combo repeater/inter-mobile operation. Three sets of crystals are supplied with frequencies most widely used nationally for repeaters. Extra power too—10 watts output at only 2.5A from 12V car battery. "Hot" double conversion receiver features FET front end for high sensitivity, low cross modulation. Panel meter shows relative power output or receive signal strength. Set is all solid state including an FET and three I-C's. Supplied with quality dynamic mic w/coil cord/plug.

Freq. range: 144-148MHz.

Channels: 12

Power output: 10 watts

Emission: F3

Max. deviation: ±15kHz.

Mod. system: Phase

Osc. freq. range: 6MHz band

Operating voltage/power:

Transmit: 13.8V @ 1.9A approx.

Receive: 13.8V @ 0.35A approx.

Size: 6-11/16"W, 2-3/8"H, 9-1/16"D.

Antenna impedance: 50 ohms

Rec. sensitivity:

0.5 μV for 20 db quieting.

AF output: 1 watt.

Selectivity:

± 12.5 kHz @ 6db.

Filter: Ceramic type

Crystals supplied:

34-94, 94-94, 16-76.

Add \$5 for shipping. Extra xtals \$5 each.

## Closeout Special!

Reg. \$16 —

Now  
only \$12

Add \$2.00  
for shipping  
& handling



Pennwood 100E-24H 24 hr. Clock (ebony case)

# SAVE \$100.



## Clegg FM-27B

Purchase a Clegg FM-27B for the Regular price of \$479.00 with No Trade and you may take a \$100 credit towards the purchase of any other new merchandise of your choice. Following are some possible suggestions of other merchandise you might take:

- ★ Clegg AC Supply for FM-27B \$79.95
- ★ Cushcraft, Gam, Hy-Gain, Larsen Antennas
- ★ Bird Ham-Mate 4352 wattmeter \$79.00
- ★ If you can't think of anything — Phone us or write for our "Condensed listing of Amateur Radio Equipment".

# SAVE \$40.



## DRAKE TR-22

Reg. \$219.—NOW only \$179.

Portable 6 channel, 1 watt, 2m FM Xcvr. With Nicads, Xtals for 34/94, 34/76 & 94, Carrying case, Antenna, 12 & 120v cords. Extra Xtals \$5 ea. Add \$5 for shipping.

SIX EZ-WAYS TO PURCHASE

1. CASH
2. C.O.D. (20% DEPOSIT)
3. MASTER CHARGE
4. BANK AMERICARD
5. AMERICAN EXPRESS
6. GECC REVOLVING CHARGE



# AMATEUR ELECTRONIC SUPPLY

4828 West Fond du Lac Ave. Milwaukee, Wis. 53216

Phone (414) 442-4200

STORE HOURS: Mon & Fri 9-9, Tues, Wed & Thurs 9-5:30, Sat 9-3

CHARGE IT  
ON



CHARGE IT  
ON



**CALL  
FREE**

**CALL  
FREE**

**TRADE  
ON  
NEW**

**CALL**

**TRADE  
ON  
USED**

**Bill Du Bord, WØKF**

**(9 A.M.—5 P.M. Central, daily except Sunday)**

**FOR  
A SQUARE DEAL  
ON**

- **DRAKE**
  - **TEMPO/ONE**
  - **HALLICRAFTERS**
  - **CLEGG**
  - **STANDARD**
- **YAESU**
  - **SWAN**
  - **COLLINS**
  - **KENWOOD**
  - **REGENCY**

*We carry all major brands and a large stock of used reconditioned equipment*

**Write for used list**

**HAM RADIO CENTER INC.**

**8342 OLIVE BL.**

**ST. LOUIS, MO 63132**

# Semiconductor Supermart

• MOTOROLA • RCA • FAIRCHILD • NATIONAL • HEP • PLESSEY

## POPULAR IC's

MC1550	Motorola RF amp	\$1.80
CA3020	RCA 1/2 W audio	\$3.07
CA3020A	RCA 1 audio	\$3.92
CA3028A	RCA RF amp	\$1.77
CA3001	RCA	\$6.66
MC1306P	Motorola 1/2 W audio	\$1.10
MC1350P	High gain RF amp/IF amp	\$1.15
MC1357P	FM IF amp Quadrature det	\$2.25
MC1496	Hard to find Bal. Mod.	\$3.25
MFC9020	Motorola 2-Watt audio	\$2.50
MFC4010	Multi-purpose wide band amp	\$1.25
MFC8040	Low noise preamp	\$1.50
MC1303P	Dual Stereo preamp	\$2.75
MC1304P	FM multiplexer stereo demod	\$4.95

## FETs

MPF 102	JFET	\$.60
MPF 105/2N5459	JFET	\$.96
MPF 107/2N5486	JFET VHF/UHF	\$1.26
MPF 121	Low-cost dual gate VHF RF	\$.85
MFE3007	Dual-gate	\$1.98
40673	Dual-gate	\$1.75
3N140	Dual-gate	\$1.95
3N141	Dual-gate	\$1.85

## NEW FAIRCHILD ECL HIGH SPEED DIGITAL IC'S

9258 Dual "D" FF toggles beyond 160 MHz	\$4.65
9582 Multi-function gate & amplifier	\$3.15
95H90 300 MHz decade counter	\$16.00
A 95H90 & 9582 makes an excellent prescaler to extend low frequency counters to VHF — or use two 9528s for a 160 MHz prescaler.	

## SIGNETICS PHASE LOCK LOOP

NE561B	Phase Lock Loop	\$4.75
NE562B	Phase Lock Loop	\$4.75
N5111A	FM/IF Demodulator	\$1.50
NE566V	Function Generator	\$4.75
NE567V	Tone Decoder	\$4.75

## TTL BARGAINS

7400	\$.28
7401	\$.30
7404	\$.30
7410	\$.30
7420	\$.30
7446/7447	\$1.50
7475	\$1.00
7490	\$1.00
74192	\$2.00

**NATIONAL CLOCK CHIP \$12.50**

Set of circuit boards to build a digital clock **\$5.00**

## CORES AND BEADS

T200-2	\$2.00
KW Balun kit only	\$3.50
T68-2 3 cores	\$1.00
T50-2 3 cores	\$1.00
T50-6 3 cores	\$1.00
T50-10 3 cores	\$1.00
T44-10 3 cores	\$1.00

## BEAD SPECIAL

Ferrite Beads 1 doz. \$1.00

**NEW!**

## INTRODUCING DEVICES AT NEW LOW PRICES

LA3018 (Replaces CA3018)	\$1.60
LA3046 (Replaces CA3046)	1.60
LS370 (Replaces LM370)	4.00
LS1496 (Improved MC1496)	2.00
LS3028A (Replaces CA3028)	1.60
LP1000 (A new fun-type device to make LED flashers, audio osc, timer etc.)	1.60
LP2000 Microtransmitter	16.00

THINKING



**DRAKE**



R-4C

TR-4C

T-4XC

TR-22

Check us out

## NOW OPEN FOR LOCAL SHOPPING STOP BY AND CHEW THE RAG

1110 N. Scottsdale Road  
Hayden Plaza East

Please add 35¢ for shipping

## Circuit Specialists

Box 3047, Scottsdale, AZ 85257

FACTORY AUTHORIZED DISTRIBUTOR FOR  
Motorola HEP — Circuit-Stick — Plessey  
All devices are first quality and are fully guaranteed.

# VIDEO TAPE RECORDERS



## BELL & HOWELL MODEL 2965

(Records Only)

This is a portable system and comes with recorder, camera and charger. Camera includes built-in Microphone and Zoom lens. Recording time is 20 minutes on 5" tape. Recording is both video and audio.

## SPECIFICATIONS

### RECORDER:

Built-in 2:1 EIA Sync Generator  
 AGC: Audio & Video  
 RESOLUTION: 525 lines, HOR. RESOLUTION: 300 lines  
 AUDIO RESPONSE: 80-10,000 Hz  
 POWER REQUIREMENTS: 12V DC, 10 watts  
 BATTERIES: 2/3G x 3/U Rechargeable (not included)  
 CHARGER: Model 105905 included

### CAMERA:

RESOLUTION: 525 lines HOR. RESOLUTION: 500 lines  
 VERT. FREQ: 60 Hz (EIA)  
 HOR. FREQ: 15,750 Hz (EIA)  
 VIDEO OUTPUT: 1.0 p-p, 75 ohm, unbalanced  
 MIN. ILLUMINATION: 30 lux.  
 VIEWFINDER: 1 1/2" (1" CRT w/magnifier)  
 LENS: 5:1 zoom F2 - 22  
 SHIPPING WT: 35 lbs.

LIST: \$1595

OUR PRICE (NEW) \$550.00

RECHARGEABLE BATTERIES - New, for Porta Pak . \$36.00 a set.

COLOR ADAPTERS - limited number available, will work with almost any Black and White VTR to convert to NTSC color, record-playback does not impair monochrome use. \$450.00 ea. prepaid.

NEW NAME BRAND VIDEO TAPES - 2400 ft. (1 hr.) any quantity available, shipping wt. 2 lbs. \$29.00 each.  
 1200 ft. (1/2 hr.) \$19.00 each.

### CONDITIONS OF SALE:

NEW EQUIPMENT - sold new, as is.

USED EQUIPMENT - sold as is in good working order. NO warranty. All units checked prior to shipment.

EXPERIMENTER'S DELIGHT - used as is repairable. Physically intact not beat to hell, but requiring some work. Problems and probable causes listed with each machine.

PARTS - available at near giveaway prices, through us.

SERVICE - units can be serviced by any competent video technician, as well as Shibaden in Melrose Park, Illinois.

QUANTITY DISCOUNT - on orders of more than 10 machines.

DEALER INQUIRIES - are invited for sale of new equipment.

New machines have standard Japan EIA 8P connector to mate with all popular VTR monitors. Used machines have all coax and camcorder connectors. Used machines do not have AGC or edit ability, but are otherwise identical and interchangeable.

All sales are final. Cash with order. Shipped best way. Freight charges collect.



## BELL & HOWELL Model 2966

This video recorder will record directly from a standard TV set or a TV camera. It will play back over your home TV set. Audio may be dubbed onto the tape. A 7" reel (2400') will record 1 hr. No home VTR unit under \$1000 can match the quality and capabilities of this unit.

### SPECIFICATIONS

RESOLUTION: 525 lines, Standard TV or CCTV recording  
 VIDEO: Input and output: 1.0V p-p, 75 ohms, unbalanced. Greater than 3.0 MHz freq. response. 300 lines plus Hor. resolution  
 AUDIO: Mike or line inputs. 60-10,000 Hz freq. range  
 POWER REQUIREMENTS: 110V AC, 95 watts  
 DIMENSIONS: 18 3/8" W. x 10 3/16" H. x 15 11/16 D.  
 WEIGHT: 60 lbs.

MAINTENANCE  
 MANUAL \$5.00

LIST PRICE (1972) \$995.00  
 OUR PRICE NEW \$450.00  
 USED \$250.00

# COMMUNICATIONS UNLIMITED

All equipment sold as is.

NO CODs.

For catalog, send SASE.

9519 MAIN STREET P.O. BOX 463  
 WHITMORE LAKE, MICHIGAN 48189

(313) 449-4367

# MIT S Presents The New 908M Series Handheld Calculator

**...8 Functions Mean a Handful of Features!**

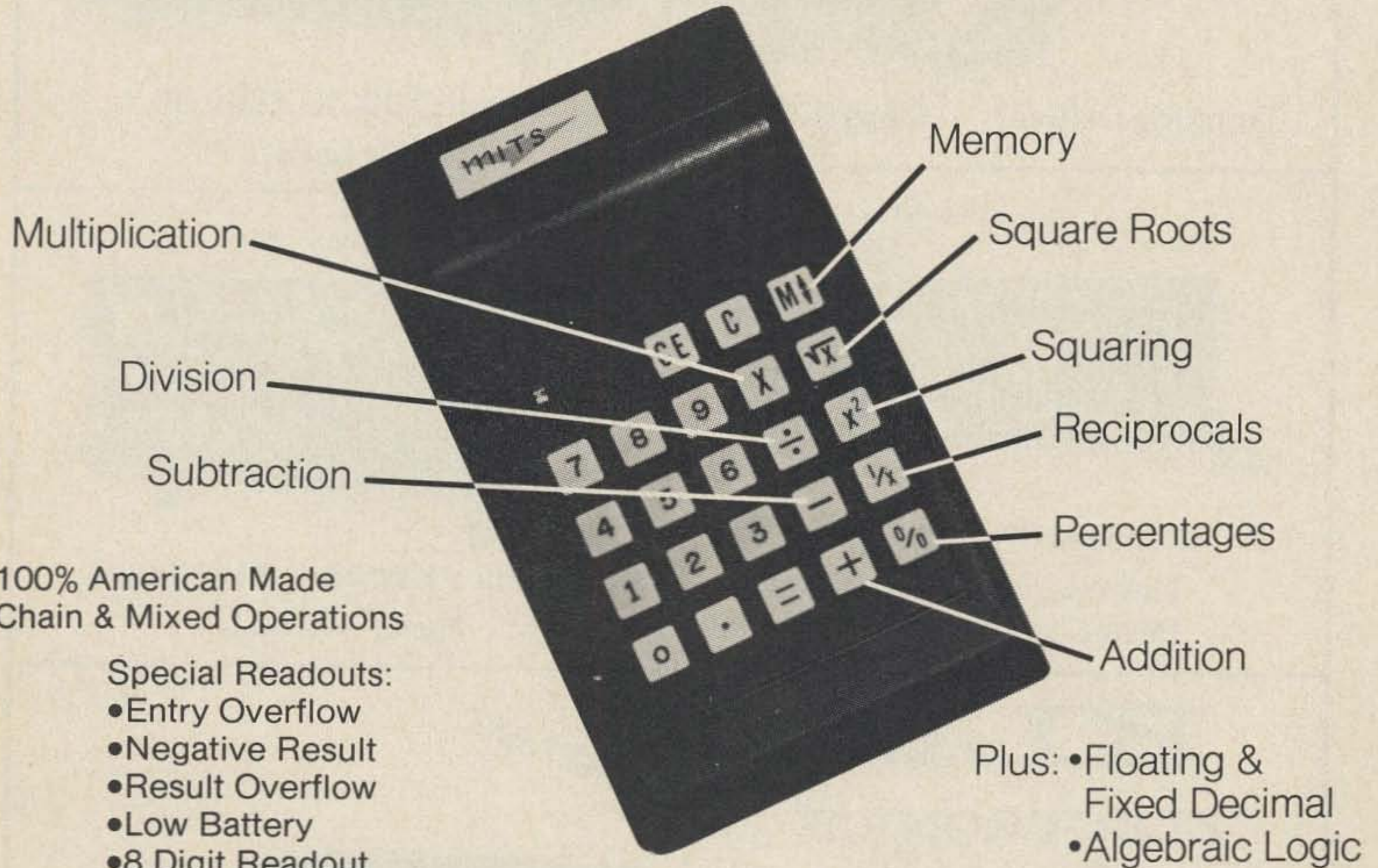

100% American Made  
Chain & Mixed Operations

Special Readouts:

- Entry Overflow
- Negative Result
- Result Overflow
- Low Battery
- 8 Digit Readout  
(Always the most significant digits)
- Bright Led Display

- Plus:
- Floating & Fixed Decimal
  - Algebraic Logic

SIZE: 5-3/4" x 3-1/4" x 1-1/2"

**PRICES\*** \$129.95 Assembled  
\$ 99.95 Kit  
Full 1 Year Warranty

**AC Adapter** for 110VAC Operation \$6.95  
**Carrying Case** (leatherette) \$5.95

\*Prices subject to change without notice.

## MIT S<sup>®</sup>

**Micro Instrumentation &  
Telemetry Systems, Inc.**

6328 Linn, N.E., Albuquerque, New Mexico 87108  
505/265-7553 Telex Number 660401

Enclosed is a Check for \$ \_\_\_\_\_  
or  Bar kAmericard # \_\_\_\_\_  
or  Masier Charge # \_\_\_\_\_  
Credit Card Expiration Date \_\_\_\_\_  
Include \$5.00 for Postage and Handling

Kit     Assembled

Please Send Information on Entire MIT S Line.

NAME \_\_\_\_\_  
ADDRESS \_\_\_\_\_  
CITY \_\_\_\_\_  
STATE & ZIP \_\_\_\_\_ Dept. 73-2

**MIT S/** 6328 Linn, N.E., Albuquerque, New Mexico 87108 505/265-7553 Telex # 660401

# Washington's Birthday Specials?

Call George about his  
incredibly low prices —  
**GEORGE WON'T LIE!**



Thinking Deluxe? Clegg 27B



Swan 700CX \$569.95 ?  
Don't believe it!



Standard SR-C14U \$595.00 ?  
Not on your cherry tree!  
Better call George



Collins KWM2A \$1493.00 ?  
No sir — CALL!

## KLM ELECTRONICS

*2 meter*

FREQUENCY (MHz)	MODEL	INPUT RANGE (w)	NOMINAL P <sub>0</sub> (w)
144	PA2-12B	1-4	12
	PA10-40B	5-15	40
	PA10-70B	5-15	70
	PA2-70B	1-4	70
	PA10-140B	5-15	140
	PA2-140B	1-4	140

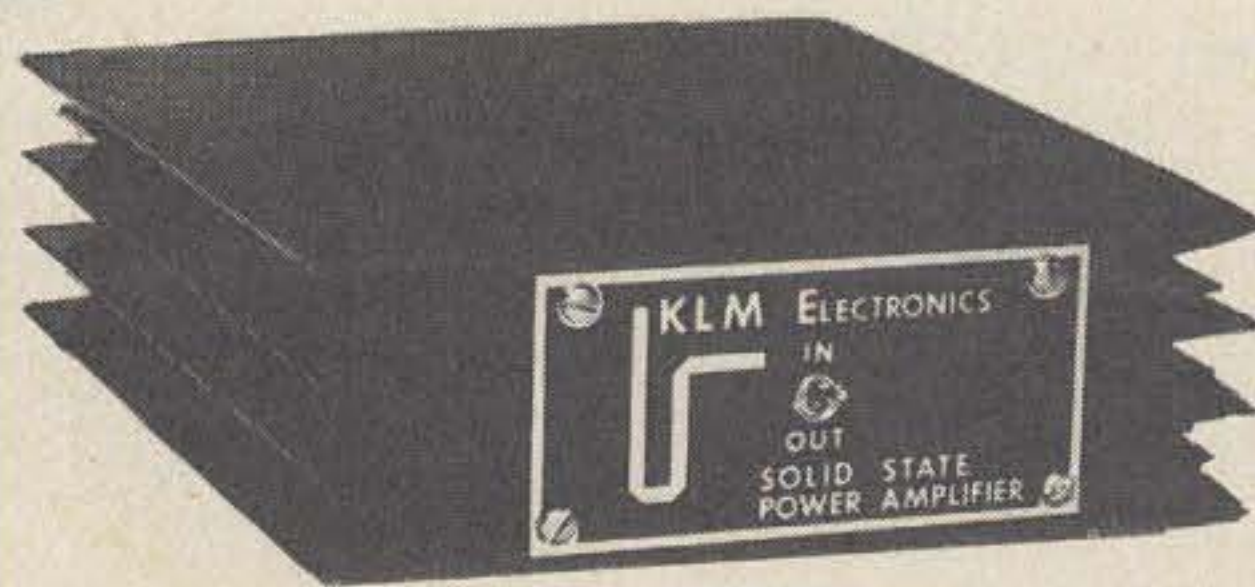

### The Hamtronics Crystal Bank \$4.95 ea.

Now there is no chance of you ever having outdated crystals. Make a deposit in the Hamtronics Crystal Bank today.

All you need is your sales slip and a crystal — get another crystal — no questions asked!

### The Hamtronics Exchange Program

We will exchange Bird wattmeter slugs (in good condition) bought from Hamtronics (sales slip needed) for anyother slug that you may need in the future — no charge, except for shipping. Your wattmeter can never be outdated!

## HAMTRONICS

4033 BROWNSVILLE RD.,  
TREVOSÉ, PA. 19047  
(215) 357-1400 • (215) 757-5300

# Tried 160m Lately?

YAESU FT101B includes  
160m — at no extra charge!

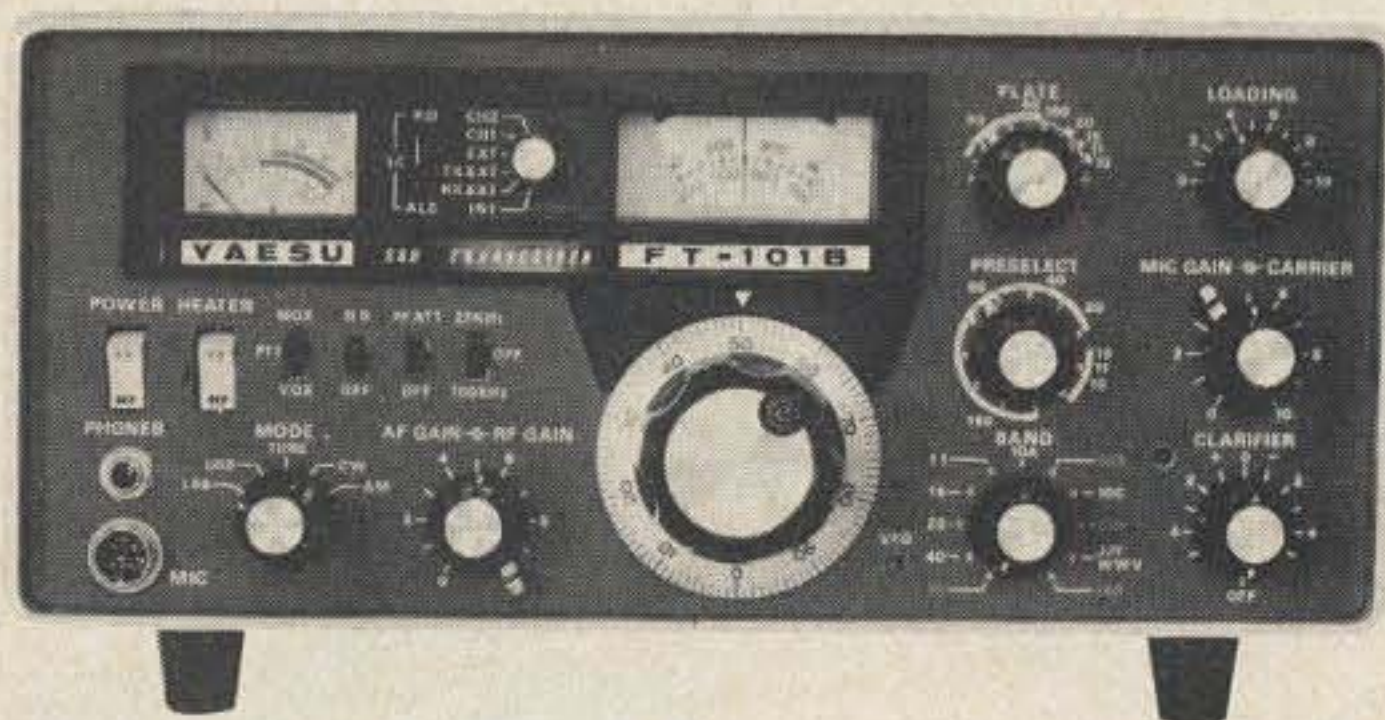

- Antitrip input **only \$649**
- Sidetone output
- VFO (warning lite) on or off
- Clarifier (warning lite) on or off
- Noise blanker on insert card
- 8 pole filter for better reception

Amateurs and Maritime operators around the world have discovered the FT101's versatility and reliability. Many of the outstanding signals you hear are using the FT101. It's all here—AM, CW, SSB. Receiver sensitivity 0.3 microvolts 10dB signal to noise ratio. 160 meters through 10 meters. Citizen's Band, WWV, 25 and 100 kc calibrators, 5 kc clarifier for net or mobile operation. The built-in noise blanker assures in-motion mobile-peak performance with minimum of noise.

Transmitter stability under most adverse conditions is superb. PEP 260 watts SSB, 80 watts AM, 180 watts CW. 117 V AC supply built-in. 12 V DC fused power cable, AC cable, all accessory plugs are furnished. Matching units available for FT101B, FP101 patch, FP101, speaker FV101 VFO, FL2100 linear. See your local dealer for demo and brochure.

WORK ALL REPEATERS with the

## ICOM IC-230!



- 162+ channels, simplex or offset (600 kHz) for repeaters
- All modular construction
- Super hot MOSFET/helical coil .4μV receiver
- AVAILABLE NOW! . . . only \$447.50

# The BIRD?



Get the BIRD from HAMTRONICS

We have a complete stock of all Bird wattmeters and slugs on hand . . . immediate delivery. Order a new BIRD Ham-mate wattmeter for only \$79, but please specify if you want the 200/1000 watt model or the 200/2000 watt model.

## TEMPO 2M FM AMPS



MODEL	DRIVE POWER	OUTPUT POWER	PRICE
1002-3	5-25 watts	100-135 watts	\$220
1002-3B	1-2.5 watts	120-130 watts	\$235
802	5-12 watts	70-90 watts	\$180
802B	1-2.5 watts	80-90 watts	\$195
502	5-15 watts	35-55 watts	\$105
502B	1-2.5 watts	45-50 watts	\$130

220 Amps also available

# HAMTRONICS

A DIVISION OF TREVOSE ELECTRONICS

4033 BROWNSVILLE ROAD, TREVOSE, PA. 19047 PHONES: (215) 357-1400/(215) 757-5300

The most popular three  
band beam in the world!

# ### *hy-gain* TH3Mk3

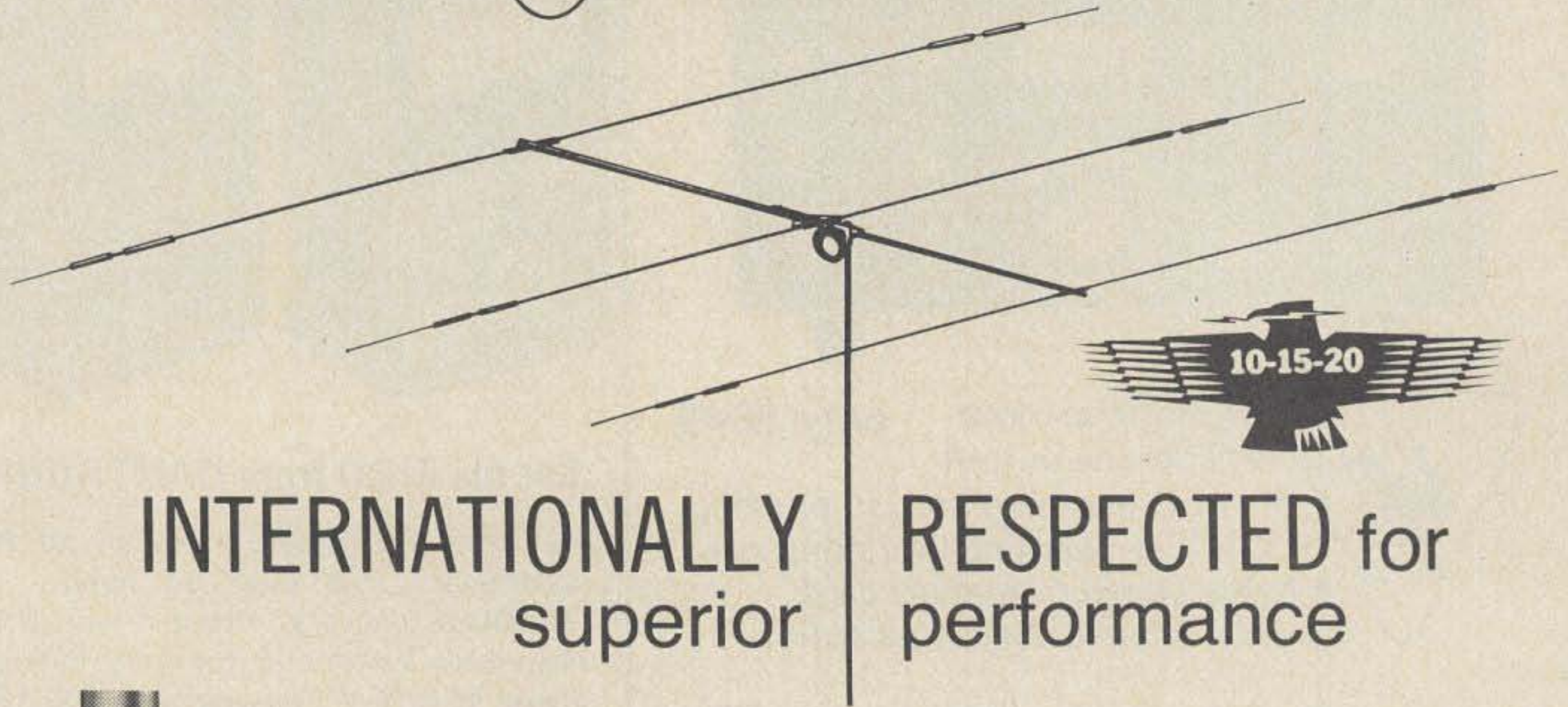

INTERNATIONALLY  
superior

RESPECTED for  
performance

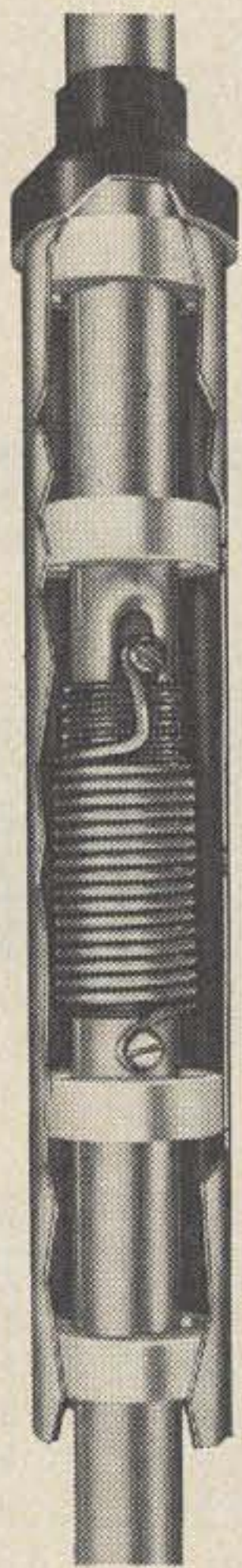

Superior construction and performance make the difference in Hy-Gain's popular 3-element Thunderbird.

- Thunderbird's "Hy-Q" traps provide separate traps for each band. "Hy-Q" traps are electronically tuned at the factory to perform better at any frequency in the band — either phone or CW. And you can tune the antenna, using charts supplied in the manual, to substantially outperform any other antennas made.
  - Thunderbird's superior construction includes a new, cast aluminum, tilt-head universal boom-to-mast bracket that accommodates masts from 1¼" to 2½". Allows easy tilting for installation, maintenance and tuning and provides mast feed-thru for beam stacking.
- Taper swaged, slotted tubing on all elements allows easy adjustment and re-adjustment. Taper swaged to permit larger diameter tubing where it counts! And less wind loading. Full circumference compression clamps are mechanically and electrically superior to self-tapping metal screws.
- Thunderbird's exclusive Beta Match achieves balanced input, optimum matching on all 3 bands and provides DC ground to eliminate precipitation static.
  - Up to 8 db gain
  - 25 db front to back ratio
  - Power capability 1Kw AM, 2Kw PEP
  - SWR less than 2:1
  - Extra heavy gauge, machine formed, element to boom brackets with plastic sleeves used only for insulation. Bracket design allows full mechanical support.

**Model 388 \$154.95**

**Other tri-band beams to choose from:**

- |                                      |                           |
|--------------------------------------|---------------------------|
| • 6-element Super Thunderbird TH6DXX | <b>Model 389 \$189.95</b> |
| • 3-element Thunderbird Jr. TH3JR    | <b>Model 221 \$109.95</b> |
| • 2-element Thunderbird TH2Mk3       | <b>Model 390 \$ 99.95</b> |

AVAILABLE FROM AMATEUR DEALERS THROUGHOUT THE WORLD



## ELECTRONICS CORPORATION

Dept. CB, 8601 Northeast Highway Six, Lincoln, NE 68507  
402/464-9151 Telex 48-6424

Distributed in Canada by: LECTRON RADIO SALES, LTD. 211 Hunter Street West, Peterborough, Ontario



# ### *hy-gain* 402BA

## DX DEMON!

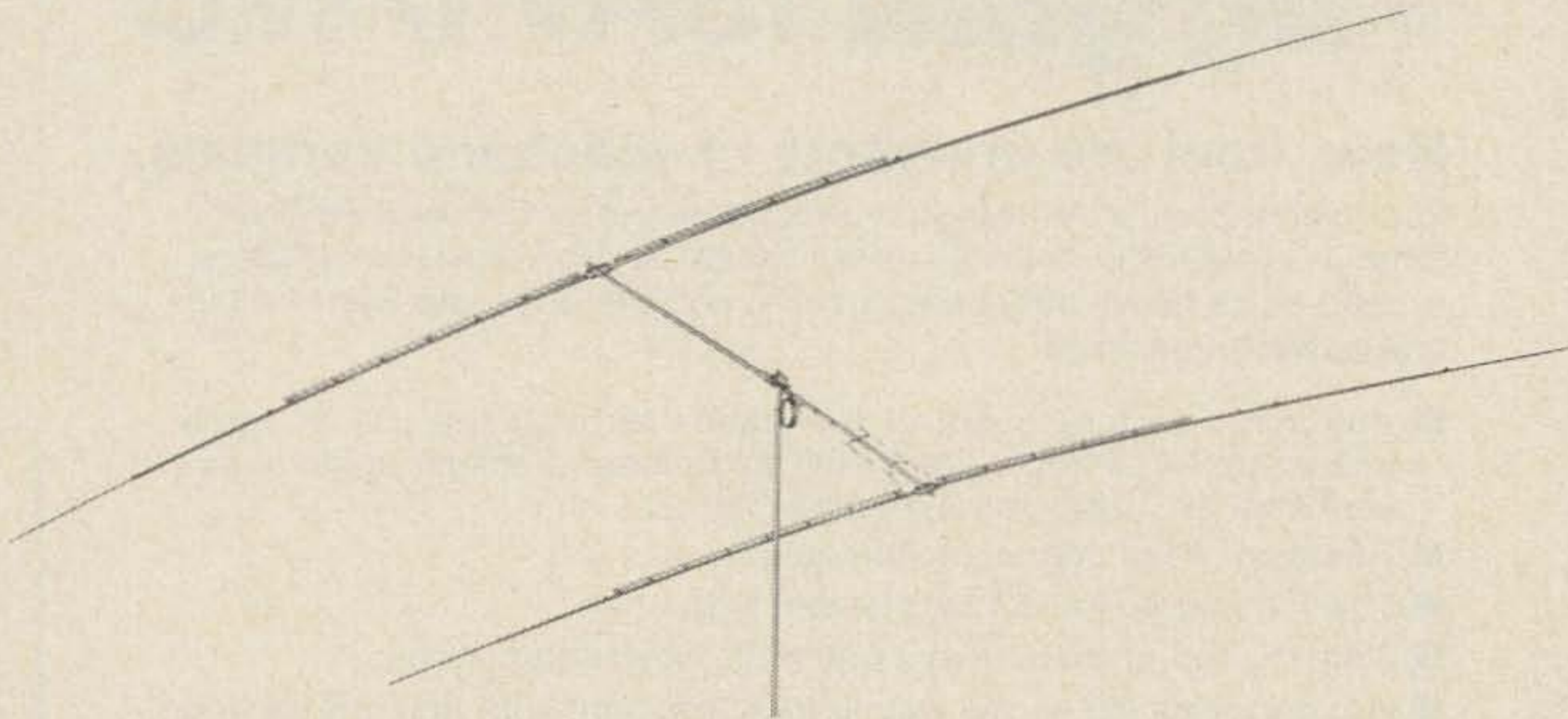

## 40 METERS

If 40 meters is your bag, try this one for best 40 meter performance...you'll work signals on 40 meters that you never knew existed!

The Model 402BA attenuates unwanted signals off the side and back at 12 to 25 db while amplifying signals for 4.9 db minimum forward gain. Unique linear loading stub delivers maximum performance without lossey center coils. Easily stacks with tribander or 20 meter beam; requires only 10' separation. 52 ohm feed. Beta Matched. 16 ft. boom, 43 ft. elements. Maximum power input 1 kw, AM.

**Order No. 397**

**\$179.95**

**Hy-Gain 402BA...the 40 meter DX Demon!**

### *hy-gain*

**ELECTRONICS CORPORATION**

Dept. CB, 8601 Northeast Highway Six, Lincoln, NE 68507  
402/464-9151

Telex 48-6424

Distributed in Canada by: LECTRON RADIO SALES, LTD. 211 Hunter Street West, Peterborough, Ontario

the most powerful antennas under the sun!



## The Best Vertical There IS! 80 through 10 meters

# Hy-gain 18AVT/WB

### New, from the inventors of wideband verticals.

Pack some punch! All the omnidirectional performance of Hy-Gain's famous 14AVQ/WB...plus 80 meter capability! Unrivaled performance, rugged extra heavy duty construction, and the price you want...all in one powerful package!

- Automatic switching on all five bands through the use of three beefed-up Hy-Q traps...featuring extra large diameter coils for exceptional L/C ratio and extremely high Q.
- Recessed coax connector furnished.
- Top loading coil and four element static hat.
- Constructed of extra heavy wall high tensile aluminum.
- Hot performance all the way across the band with just one setting (10 through 40).
- Hy-Q traps effectively isolate antenna sections for full 1/4 wave resonance on all bands.
- No dissimilar metals to cause noise.
- SWR 2:1 or less at band edges.
- Maximum legal power with low frequency drift.
- Exceedingly low radiation angle makes DX and long haul contacts a cinch...whether roof or ground mounted.
- Very low RF absorption from insulating materials.

The 18AVT/WB is constructed of extra heavy duty, taper swaged, seamless aircraft aluminum with full circumference, corrosion resistant compression clamps at all tubing joints. This antenna is so rigid, so rugged...that its full 25' height may be mounted using only a 12" double grip mast bracket...no guy wires, no extra support...the 18AVT/WB just stands up and dishes it out!

**Order No. 386**

**\$79.95**

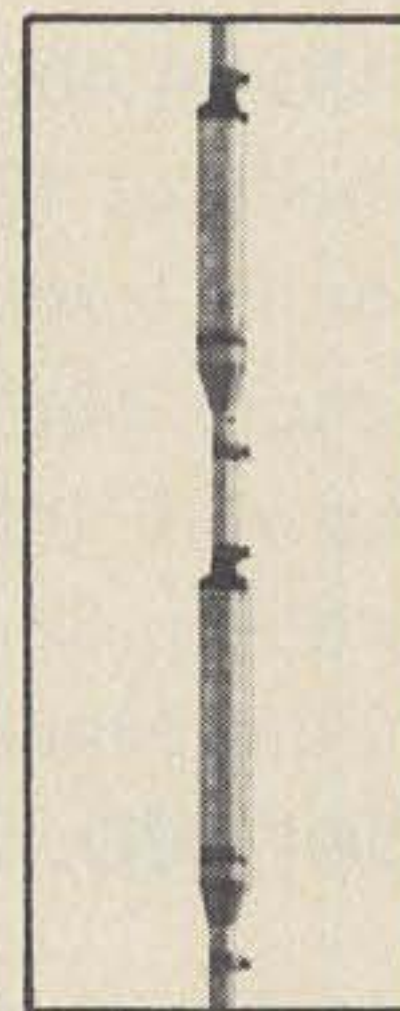

Get the strength, the performance and the price you want...from the man who sells the complete line of quality Hy-Gain equipment.

### HY-GAIN ELECTRONICS CORPORATION

Dept. CB 8601 Northeast Highway Six  
402/464-9151

Lincoln, NE 68507  
Telex 48-6424

# hy-gain

## REPEATER LINE

All you need to know about  
2 meter mobile antennas!

**263** Special no-hole trunk lip mount. 3 db gain. 130-174 MHz. 5/8 wave. 16' coax. DC ground. Base matching coil for 52 ohm match. 17-7 ph stainless steel whip.

**264** High efficiency, vertically polarized omnidirectional roof top whip. 3 db gain. Base matching coil for perfect 52 ohm match. DC ground. Coax and connector furnished.

**265** Special magnetic mount. 3 db gain. Performance equal to permanent mounts. 12' coax and connector. Base matching coil for 52 ohm match. 17-7 ph stainless steel whip. DC ground.

Rugged, continuously loaded, flexible VHF portable antennas. Completely insulated with vinyl coating. Bend at all angles without cracking or breaking. Cannot be accidentally shorted out.

**723N** With UHF connector.

**269** With 5/16-32 base for Motorola HT; Johnson; RCA Personalphone; Federal Sign & Signal; and certain KAAR, Aerotron, Comco and Repco units.

**723A** With BNC connector.

**260** Commercial duty, 1/4 wave, claw mount, roof top whip. Precision tunable to any discrete frequency 108-470 MHz.

**261** Same as above, with 18' coax and connector.

**262** Magnetic mount whip, 108-470 MHz. 52 ohm match. Complete with coax and connector.

*Write for details*

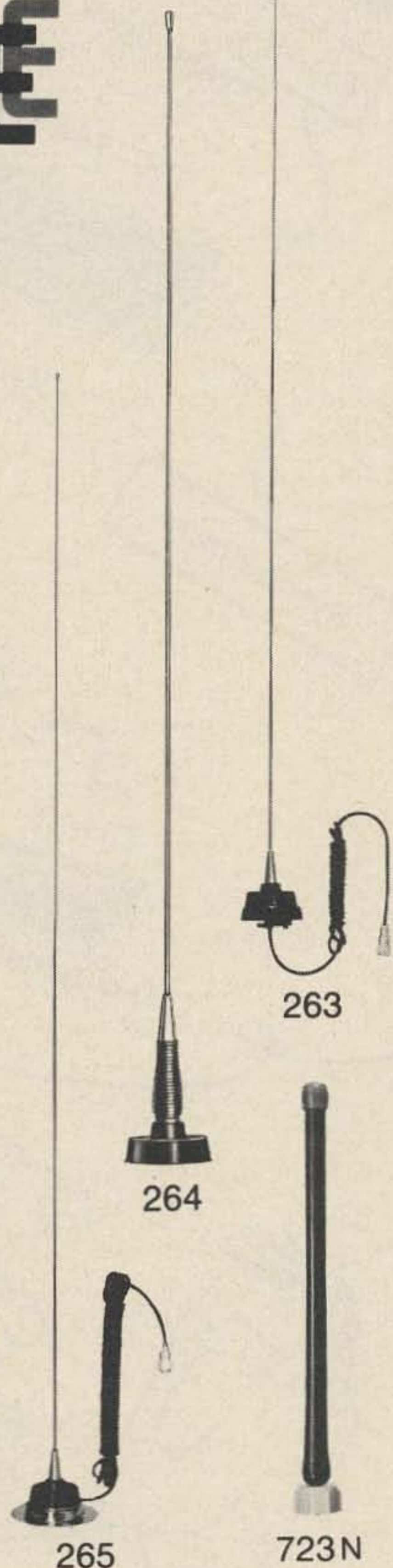

# hy-gain

## ELECTRONICS CORPORATION

Dept. CB, 8601 Northeast Highway Six, Lincoln, NE 68507  
402/464-9151

Telex 48-6424

Distributed in Canada by: LECTRON RADIO SALES, LTD. 211 Hunter Street West, Peterborough, Ontario

# BUILD YOUR "DREAM MACHINE"

CD-2  
crystal deck

Tone Pad

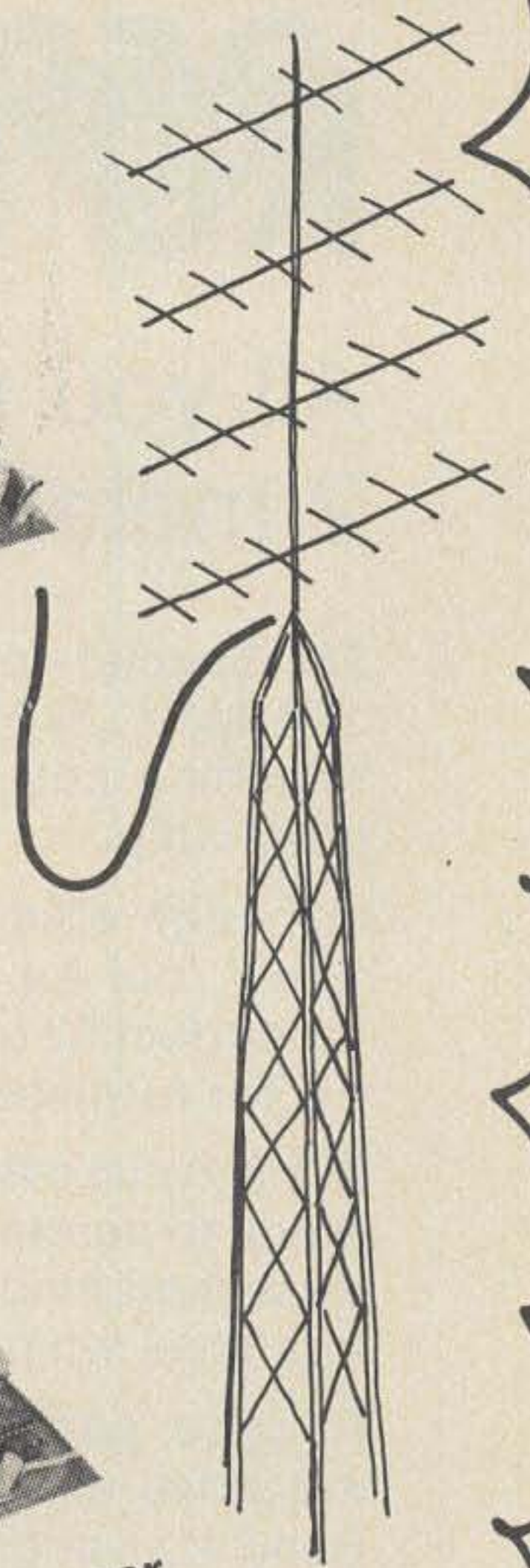
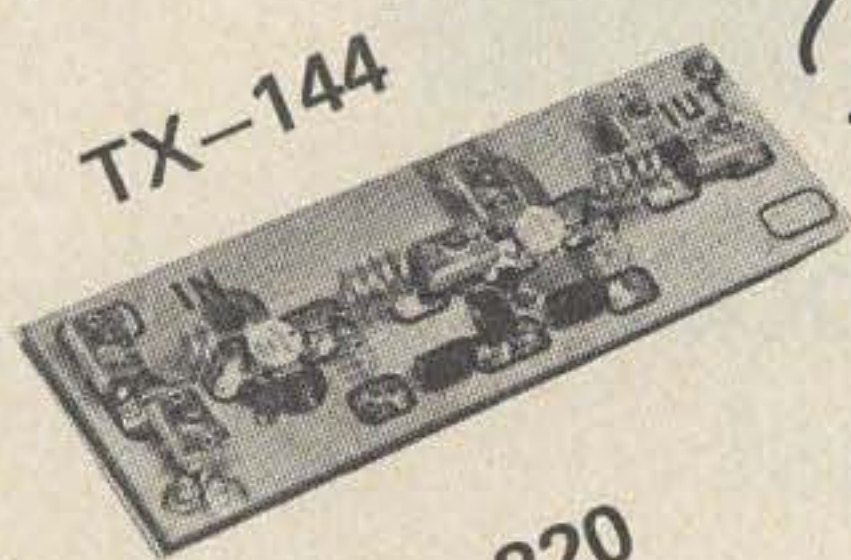

TX-220

PA-220

Synthesizer

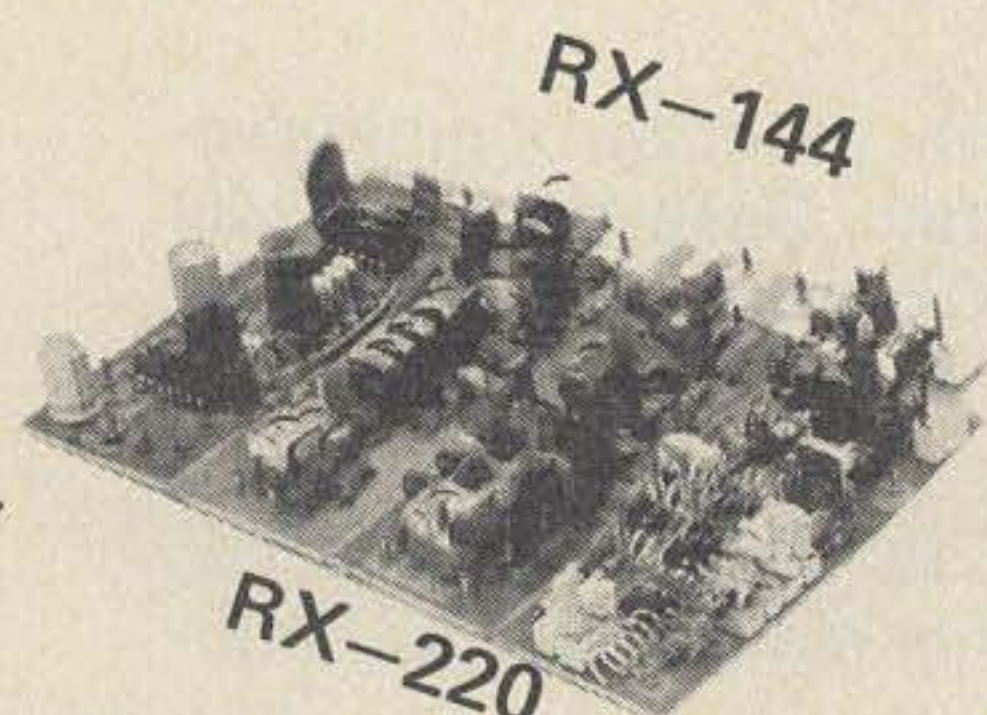

CD-1  
10 channel crystal deck

SC-1 Scanner



The possibilities are virtually unlimited and the prices are unbelievable!!!!!!!!!!!!

Start with the basics and pay as you go.

Write or call for details . . .

"your inspiration is our motivation"



## VHF ENGINEERING

- DIV. of BROWNIAN ELECT. CORP. -

320 WATER ST. POB 1921 BINGHAMTON, NY 13902 607-723-9574

# LIKE FM OR CW ?

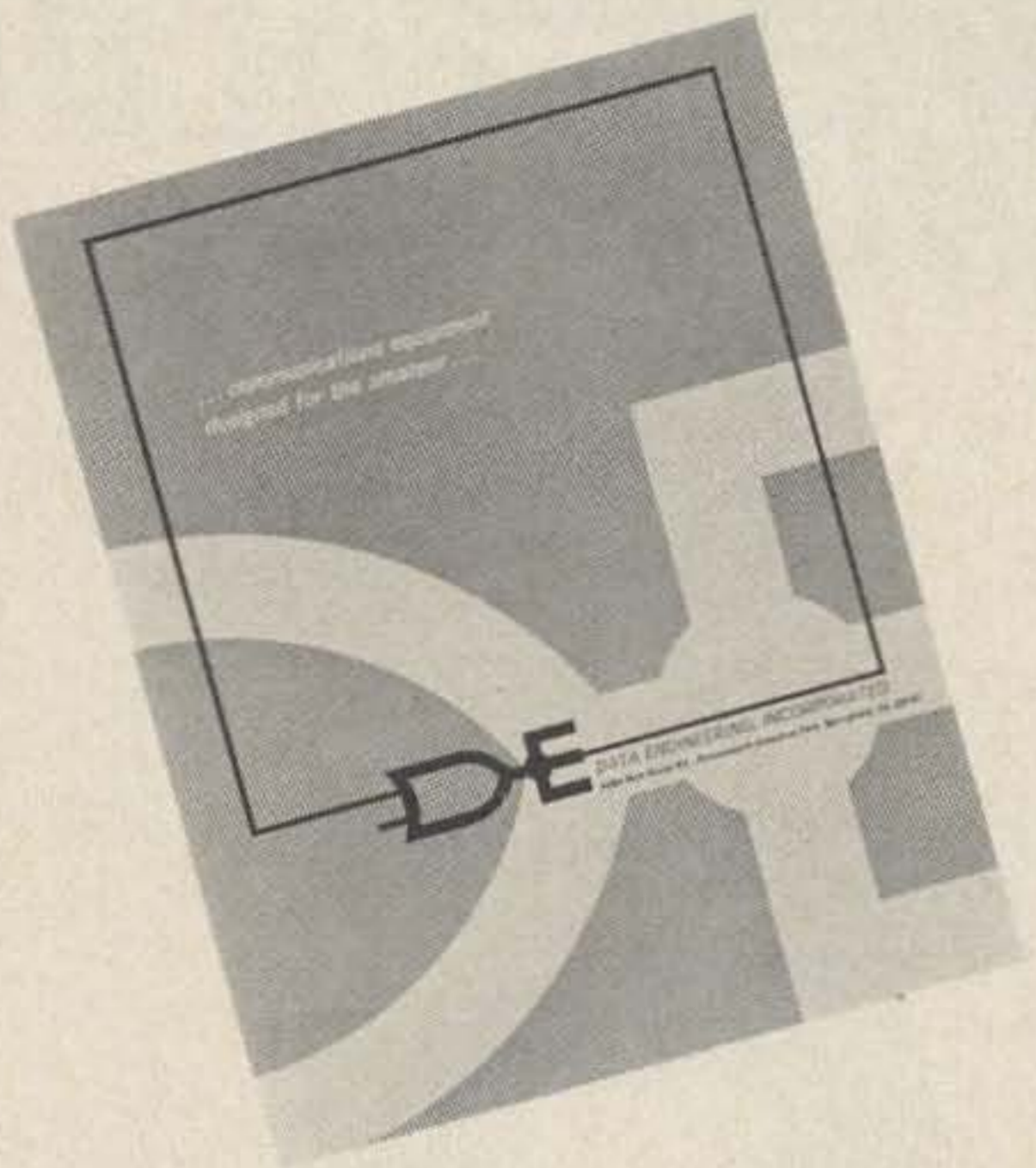

*Then you'll love  
Data Engineering's  
new catalog*

Write for your free copy today!

## TOUCH TONE PADS

More features than any other pad including built-in monitor speaker and latest Phase-Lock loop circuitry.

TTP-1 Standard pad for portable transceiver mounting.

TTP-2 Standard pad in attractive case for home or mobile use.

TTP-3 Mini-pad in attractive case for home or mobile use.

TTP-4 Mini-pad for portable transceiver mounting.

TTP-1, 2, 3 & 4, Sh. wt. 1 lb. .... \$44.50

TTP-1K, 2K, 3K & 4K, Sh. wt. 1 lb. .... \$34.50

## CRICKET 1

A popularly priced IC keyer with more features for your dollar. Cricket 1 is a small size, solid state keyer designed for the beginner as well as the most advanced operator. It provides the user with fatigue-free sending and its clean, crisp CW allows for easy copying at all speeds. Turned on its side, the Cricket can be used as a straight key for manual keying.

CRICKET 1 Sh. Wt. 3 lbs. \$49.95

## 2-METER PREAMP

Specially made for both OLD and NEW receivers. The smallest and most powerful preamp available. Provides 20dB gain at 2.5 N.F. to bring in the weakest signals.

Sh. wt. 4 oz. \$9.50 kit  
\$12.50 wired

Please include sufficient postage for shipping.

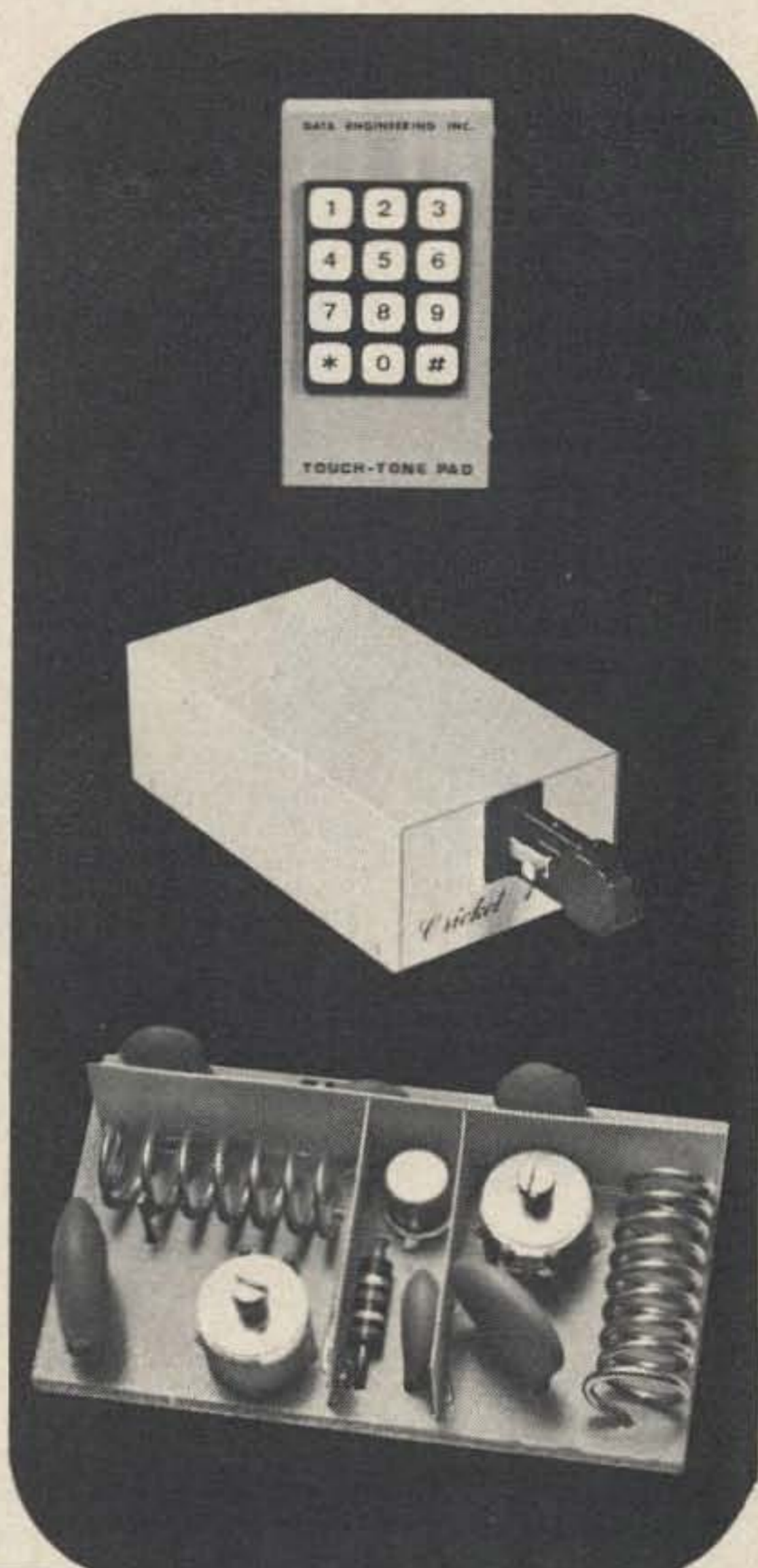

# DATA ENGINEERING INC.



Ravenswood Industrial Park, Springfield, Va. 22151

5554 Port Royal Road • 703-321-7171

# DuPage FM

**WILL NOT BE UNDERSOLD!**

Here is a SPECIAL DEAL for 6 and 10 meter fans . . .

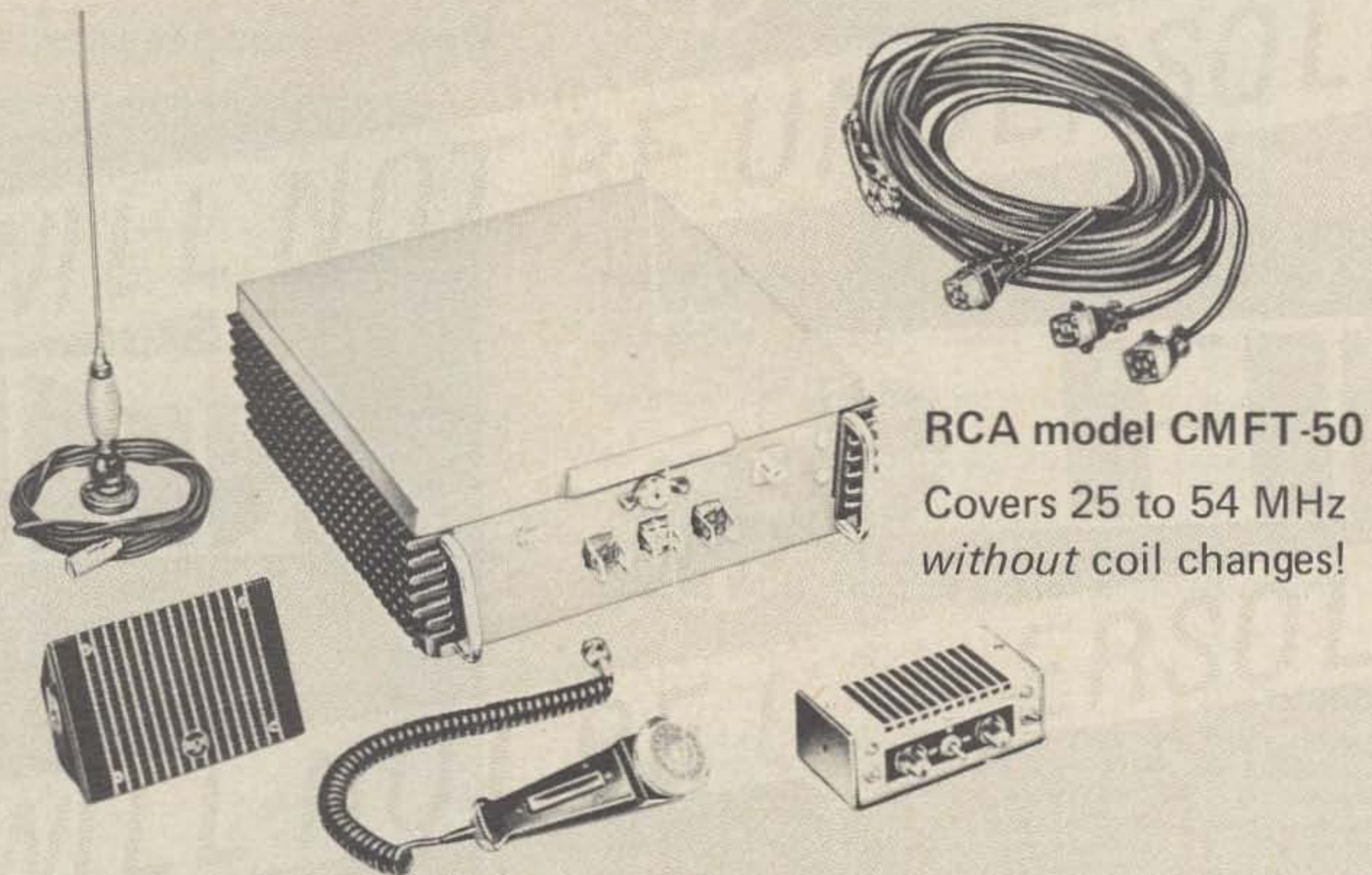

RCA model CMFT-50  
Covers 25 to 54 MHz  
*without* coil changes!

50 watts output, with transistor power supply and partly transistorized receiver. Standby drain is only 2.2 amps.

Regularly \$125.00

— this month only \$100.00, with accessories.

We still have a few 30 watt TPLs left for only \$155.00.  
These are for use in the two meter band.

**TERMS:** All items sold as is. Accessories do not include antennas or crystals. If equipment is not as represented, return for exchange within five days of receipt, shipping charges prepaid. Illinois residents add 5% sales tax.

DuPage FM, Inc.  
P.O. Box 1  
Lombard, Ill. 60148  
312-627-3540

# TOMORROW'S RIG ...available TODAY!

*The exciting all new  
INOUE IC-230!*



TAKE A SLICE OUT OF THE FUTURE . . .

. . . and put 67+ CHANNELS\* of 2-meter FM pleasure in the palms of your hands . . . with the SUPER COMPACT (2.3" x 6.1" x 9.7") IC-230.

Feature-wise . . . the IC-230 is *fully synthesized* (with the new exclusive "Phase Lock Loop System") . . . *all modular construction* (servicing is a snap—in and out) . . . a receiver that is *very sensitive and selective* as to what it hears (better than 0.4UV / 20db), with unique Inoue helical filters to eliminate intermod . . . plus a super E filter mosfet front end, making copy a pleasure.

\* And not a crystal to buy with the exclusive "Phase Lock Loop System".  
(That's close to \$650.00 worth of xtals!)

— GRAB HOLD OF THE IC-230 AT YOUR LOCAL DEALER TODAY —

Distributed by:



— Dealerships Available —

**ICOM WEST, INC.**  
Suite 232 — Bldg. II  
300 - 120th Ave. N.E.  
Bellevue, Wash. 98005  
(206) 454-2470

**ADIRONDACK  
RADIO SUPPLY**  
185 West Main Street  
Amsterdam, N.Y. 12010

**ICOM EAST**  
Div ACS, Inc.  
Box 331  
Richardson, Tex. 75080  
(214) 235-0479

**Do you have the latest  
parts information from**

## **SOLID STATE SYSTEMS, INC.?**

Those of you who do not have our latest catalog really ought to send for it. You'll be surprised and impressed at the new items we have added. For example:

- ★ **A COMPLETE LINE OF 5% RCR TYPE RESISTORS**
- ★ **A WIDER RANGE OF ELECTROLYTIC CAPACITORS**
- ★ **SEVERAL ITEMS OF IC INTERFACE HARDWARE**
- ★ **ONE CHIP CALCULATOR AND CLOCK CHIP**
- ★ **A TO D AND D TO A CONVERTERS**
- ★ **A WIDE VARIETY OF PUSH BUTTON SWITCHES**

These, added to our already full range of digital and linear IC's, 10% resistors, ceramic disc capacitors, dual-in-line IC sockets, LED and incandescent displays, diodes, and other items, make us a very complete supplier. Why not write or phone our order desk today for your free copy of our Winter 1973 catalog and see for yourself? 800-325-2595 and 800-325-2981 (Toll Free)

**WRITE:**

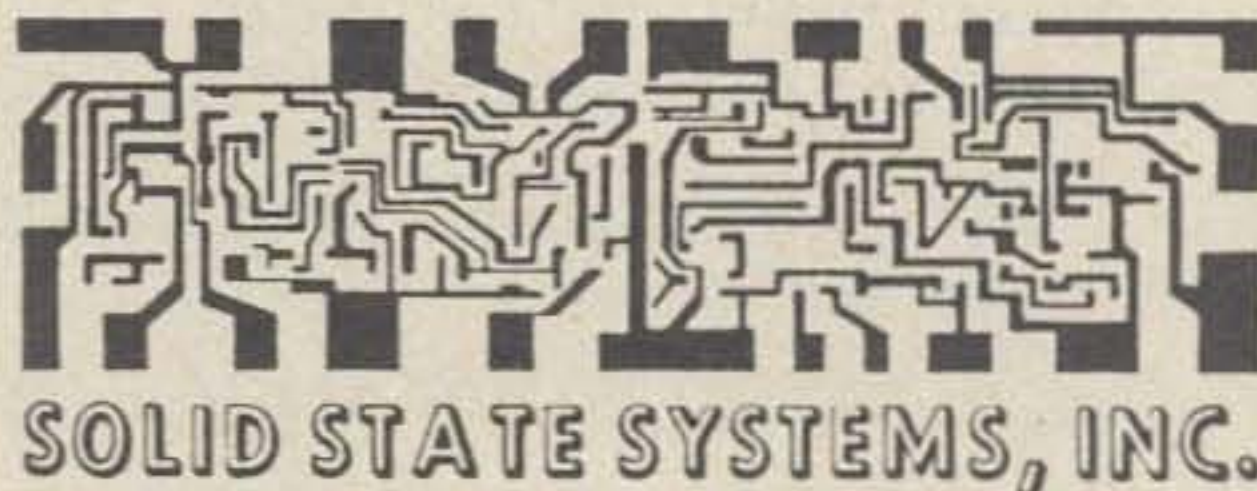

**P. O. BOX 773 COLUMBIA, MISSOURI 65201**



# INTERNATIONAL ELECTRONICS UNLIMITED

## TTL

7400	\$.25	7446	\$1.45	74121	\$.65
7401	.25	7447	1.45	74122	.55
7402	.25	7448	1.50	74123	1.15
7403	.25	7450	.29	74126	.95
7404	.29	7451	.32	74145	1.25
7405	.27	7453	.32	74150	
7506	.55	7454	.45	74151	1.05
7407	.53	7455	.32	74153	1.45
7408	.29	7460	.30	74154	1.75
7409	.29	7461	.30	74155	1.35
7410	.25	7464	.45	74156	1.50
7411	.35	7465	.45	74157	1.50
7413	.95	7470	.50	74161	1.65
7415	.50	7472	.45	74163	1.80
7416	.50	7473	.55	74164	2.95
7417	.50	7474	.55	74165	2.95
7420	.25	7475	.95	74166	1.95
7421	.32	7476	.55	74173	1.95
7422	.32	7478	.89	74175	1.95
7423	.37	7483	1.25	74176	.95
7425	.39	7485	1.20	74177	.95
7426	.35	7486	.55	74180	1.15
7427	.39	7489	3.25	74181	4.25
7430	.25	7490	1.25	74182	1.10
7432	.30	7491	1.40	74190	
7437	.50	7492	1.05	74192	1.65
7438	.55	7493	1.05	74193	1.65
7440	.25	7494	1.10	74194	1.65
7441	1.25	7495	1.05	74195	1.15
7442	1.15	7496	1.05	74196	1.35
7443	1.25	74100	1.65	74197	1.15
7444	1.30	74105	.55	74198	
7445	1.25	74107	.55	74199	2.50

### Low Power TTL

74L00	\$.40	74L42	\$1.75	74L85	\$1.25
74L02	.40	74L45	1.45	74L86	.95
74L03	.40	74L51	.40	74L90	1.75
74L04	.40	74L71	.60	74L91	1.50
74L06	.40	74L72	.60	74L93	1.75
74L10	.40	74L73	.80	74L95	1.75
74L20	.40	74L74	.80	74L164	2.95
74L30	.40	74L78	.80		

### 8000 Series TTL

8054	\$.45	8123	\$1.75	8570	\$2.95
8060	.30	8182	1.75	8600	1.15
8091	.69	8214	1.95	8810	.95
8092	.69	8230	2.95	8812	1.25
8093	.69	8280	.95	8822	2.95
8094	.69	8288	1.05	8830	.69
8122	1.05	8520	1.45	8831	2.95

### ALL DIP PKGS.

Specify spec. sheets required with order. Add \$.50 per spec sheet for items less than \$1.00 ea.

## Linear

LM309	Pos V Reg (super 723)	TO-5	\$.95 ea.
LM 301	Hi performance AMPL	TO-5 or MINI-DIP	.45 ea.
LM 302	Voltage Follower	TO-5	.95 ea.
LM 304	Negative Voltage Regulator	TO-5	1.25 ea.
LM 305	Positive Voltage Regulator	TO-5	1.25 ea.
LM 307	Op AMP (super 741)	TO-5 or MINI-DIP	.45 ea.
LM 308	Micro Power Op Amp	TO-5 or MINI-DIP	1.25 ea.
LM 309H	5 V Regulator	TO-5	1.25 ea.
LM 309K	5 V 1A Regulator	TO-3	1.95 ea.
LM 310	Voltage Follower Op Amp	TO-5	1.45 ea.
LM 311	Hi perf. Voltage Comparator	TO-5 or MINI-DIP	1.25 ea.
LM 319	Hi Speed Dual Comparator	DIP	1.65 ea.
LM 320	-5.2 V Negative Regulator	TO-3	1.95 ea.
LM 320	-12 V Negative Regulator	TO-3	1.95 ea.
LM 320	-15 V Negative Regulator	TO-3	1.95 ea.
LM 340T	Positive Voltage Regulator (6V, 8V, 15V or 24V)	TO-220	2.25 ea.
LM 370	AGC/Squelch AMPL	TO-5 or DIP	1.29 ea.
LM 372	AF-IF Strip-detector	DIP	.85 ea.
LM 373	AM/FM/SSB Strip	DIP	3.60 ea.
LM 376	Pos. Volt Regulator	MINI DIP	.65 ea.
LM 380	2 Watt Audio Regulator	DIP	1.75 ea.
LM 382	Low Noise Dual Pre-Amp	DIP	2.25 ea.
LM 550	Precision Voltage Regulator	DIP	.95 ea.
LM 709	Operational AMPL	TO-5 or DIP	.39 ea.
LM 711	Dual Differential Comparator	DIP	.39 ea.
LM 723	Voltage Regulator	DIP	.75 ea.
LM 739	Dual Hi Performance Op AMP	DIP	1.25 ea.
LM 741	Comp. Op AMP	TO-5 or MINI-DIP	.45 ea.
LM 747	Dual 741 Op AMP	TO-5 or DIP	.95 ea.
LM 3900	Quad Amplifier	DIP	.50 ea.
LM 3905	Precision Timer	MINI-DIP	.75 ea.
LM 9601	Retriggerable One Shot	DIP	.95 ea.
LM 75451	Dual Peripheral Driver	MINI-DIP	.49 ea.
LM 75452	Dual Peripheral Driver	MINI-DIP	.49 ea.
LM 75453	(LM 351) Dual Peripheral Driver	MINI-DIP	.49 ea.

### Specify TO-5, DIP or MINI-DIP Package

Specify Spec. Sheet Required with order. Add \$.50 per spec sheet for items less than \$1.00 ea.

## Phase Locked Loops

NE 560	Phase Locked Loop	DIP	\$2.95 ea.
NE 561	Phase Locked Loop	DIP	2.95 ea.
NE 562	Phase Locked Loop	DIP	2.95 ea.
NE 565	Phase Locked Loop	DIP	2.95 ea.
NE 566	Function Generator	MINI DIP OR TO-5	2.95 ea.
NE 567	Tone Decoder	MINI DIP OR TO-5	2.95 ea.

Specify TO-5, Dip or Mini-Dip Package

## FEBRUARY SPECIALS

MM 74C00	Quad two-input NAND gate	\$.60 ea.
SN 74193	Up/down Binary Counter	1.39 ea.
MM 1101	256 Bit static random access memory	2.00 ea.
LM 385K	Similar to LM 309K except input voltage limited to 20 V - no current limiting - while they last	1.35 ea.
LM 739	Hi performance operational amplifier DIP	1.15 ea.
LM 741	Hi performance operational amplifier	5 for 2.00
MV 10B	Visible red led TO-18	100 for \$15.95
ME4	Infra red (invisible) diff. dome TO-18	10 for \$3.95
MV5020	Jumbo clear dome visible red	100 for \$19.95

### MM5313 CLOCK CHIP WITH LED's

28 pin any readout  
6 digit IPS BCD with  
6 MAN 3M LED's  
Complete with Data ..... \$17.50/set

### FLAT PACK GRAB BAG

7400 Series - Assorted  
Military Temp. Spec. Fall-Out  
Electrically good ..... 25 for \$1.95

## 4000 Series - RCA Equivalent

CD 4001	\$.65	CD 4012	\$.65	CD 4023	\$.65
CD 4002	.65	CD 4013	1.50	CD 4025	.65
CD 4009	1.00	CD 4016	1.50	CD 4027	1.35
CD 4010	.65	CD 4017	2.95	CD 4030	.65
CD 4011	.65	CD 4019	1.35	CD 4035	2.85

## CMOS

74C00	\$.65	74C76	\$1.70	74C162	\$3.25
74C02	.65	74C107	1.50	74C163	3.25
74C04	.95	74C151	2.90	74C164	3.50
74C10	.65	74C154	3.50	74C173	2.90
74C20	.65	74C157	2.25	74C192	3.25
74C42	2.15	74C180	3.30	74C195	3.00
74C73	1.70	74C161	3.25	80C97	1.50
74C74	1.50				

## Calculator Chips

5001 LSI (40 pin)	Add, subtract, multiply & divide 12 digit	
Data supplied with chip	.....	\$6.95 ea.
Data only-Refundable w/purchase	.....	1.00 ea.
5002 LSI Similar to 5001 except designed for battery power		
Data supplied with chip	.....	\$8.95 ea.
Data only-Refundable w/purchase	.....	1.00 ea.
5005 LSI (28 pin)	Full four function memory. 12 digit display and calc. 7 segment multiplexed output	
Data supplied with chip	.....	\$10.95
Data only-Refundable w/purchase	.....	1.00 ea.

## LED

MV10B	Visible red SUPER SPECIAL	\$.25 ea.
MV50	type red emitting	.25 ea. 5/\$1.00
MV5020	type Large red	.35 ea. 3/\$1.00
ME4	Infra red TO18	.69 ea.
MAN 1	The original	3.95 ea.
MAN 3	type	1.95 ea. 3 or more 1.49 ea.
MAN 4	type	2.75 ea. 3 or more 2.50 ea.
Data-Lite 707 (MAN 1 repl)		3.25 ea.

## Opto Isolators

MCA 2-30	Darlington	\$.95 ea.
MCD 2	Diodes	1.95 ea.
MCT 2	Transistor	1.45 ea.

## Memories

1101	256 bit RAM MOS (2501)	\$2.50 ea.
1103	1024 bit RAM MOS	7.95 ea.
7489	64 bit RAM TTL	3.25 ea.
8223	Programmable ROM	6.95 ea.

### \* NEW ITEM \*

MM 5260	1024 bit RAM Second generation version of 1103 ... Featuring 16 pin DIP rather than 18 pin ... 30% less power consumption ...	Introductory Price ... 9.95 ea.
---------	---	---------------------------------

## Digital clock ... on a Chip

MM 5311 (28 pin)	Any readout 6 digit BCD with spec. sheet	\$11.95 ea.
MM 5312 (24 pin)	Any readout 4 digit ipps BCD with spec. sheet	8.95 ea.
MM 5313 (28 pin)	Any readout 6 digit ipps BCD with spec. sheet	10.95 ea.
MM 5314 (24 pin)	LED-incandescent readout 6 digit with spec sheet	10.95 ea.
MM 5316 (40 pin)	Normal alarm, snooze alarm, sleep timer 12 or 24 hr. operation with spec. sheet	15.95 ea.

## MOS

MM1404	1024-bit dynamic shift register	\$2.25 ea.
MM5013	1024-bit dynamic shift Register/Accumulator	2.25 ea.
MMS240	2560-bit static character generator	4.95 ea.
MM5241	3072-bit static read-only memory	7.95 ea.

## Untested IC's

UNTESTED MOS		
MM1403	1024-bit dynamic shift register	DIP .65 ea.
MM1404	1024-bit dynamic shift register	DIP .65 ea.
MMS013	1024 bit dynamic shift register/accum.	DIP-TO-5 .55 ea.
MMS016	512 bit dynamic shift register	DIP-TO-5 .25 ea.
MMS019	Dual 256 bit mask prog. shift register	TO-5 .25 ea.
MMS050	Dual 32-bit static shift register	TO-5 .35 ea.
MMS054	Dual 64/72/80-bit static shift register	DIP .35 ea.

MOS Shift Registers 2500 Series  
2502 2506 2509 2510 2511 2518 2519 2521 2522  
Untested seconds ..... 4/1.00

Grab Bag Specials  
15 Assorted TTL's (dips) ..... \$1.00/bag  
25 Assorted DTL's (dips) ..... \$1.00/bag

## ON ORDERS OVER \$25.00 DEDUCT 10%

Satisfaction guaranteed. All items except as noted are fully tested. Minimum order \$5.00 prepaid in U.S. and Canada. Calif. residents add sales tax. Orders filled within three days from receipt.

## INTERNATIONAL ELECTRONICS UNLIMITED

P.O. BOX 1708R  
Monterey, Calif. 93940

**LED READOUTS OPCOA SLA-1** Similar to MAN-1. .33" high. 20 mA per segment. With decimal point. Every one checked — all segments operating.

Red — \$2.65 each, 6/\$15.00

Green — \$3.50

.7 inch readouts . . . \$5.55 each

**CLOCK I.C.**, National MM5314, for 12 or 24 hours, 50 or 60 Hz, 4 or 6 digits. **Only \$11.95 each**

**LED** — molded plastic dome shape with leads. .312 inches in diameter. Red — \$.35 each, 3/\$1.00

Green — \$.50 each, 6/\$1.00

**KODAK RED Wratten Filters** Perfect for light filter over red LEDs. 4" sq., .005" thick.

\$\$.35 each, 3/\$1.00

**LM 309 Voltage Regulator IC.** 5 volts at 1 Amp. max. current.

\$2.00 each

**PRINTED CIRCUIT BOARD** 2 oz. copper on glass epoxy base, approx. 5" x 6". Your choice copper on one or both sides. **3/\$1.25**

**ETCHANT FOR P.C. BOARDS** Ammonium persulfate, 1 lb. of crystals, just dissolve in H<sub>2</sub>O. **\$1.25**

**IN 914 DIODES**

\$\$.10 each, \$1.00 a dozen

**PLUG-INS for Tektronix scopes:** \$40.00 each. Type A, Wide-band; D, High-gain DC differential, 1 mv./cm. (Hickok); E, High-gain AC Differential; G, Wide-band Differential; K, Fast-rise; Type P, Fast-rise Mercury pulser test unit **\$25.00**

**HUGHES WB-4 Preampifier Plug-in**

\$25.00

**PLUG-INS for H-P 524 Counters.** 526-A Video Amplifier, \$40.00; 526-B Time Interval Unit. **\$25.00**

**FILAMENT TRANSFORMER,** 6.3 v. ct. @25 amps., 115/230 v. 60 Hz pri. Herm sealed. Shpg. wt.

14 lbs.

\$4.00 each, 4/\$14.00

**SILICON RECTIFIER** International Rect. R-210-F, epoxy, 1000 PIV, 2 amps. **\$.40 each, 10/\$3.50**

**Matrix Plug-Board.** Wired in 25 horizontal & 24 vertical rows. By inserting jumper plugs, any hor. row can be connected to any vert. row. Constructed of Elco "Varicons." Can be disassembled or rewired for other applications. Great for breadboarding, switching, programming, I.C. testing. Dimensions: 8 3/4" x 16 3/4". Shpg. wt. 8 lbs. Used, exc. cond. with 30 shorting plugs. **Only \$10.00**

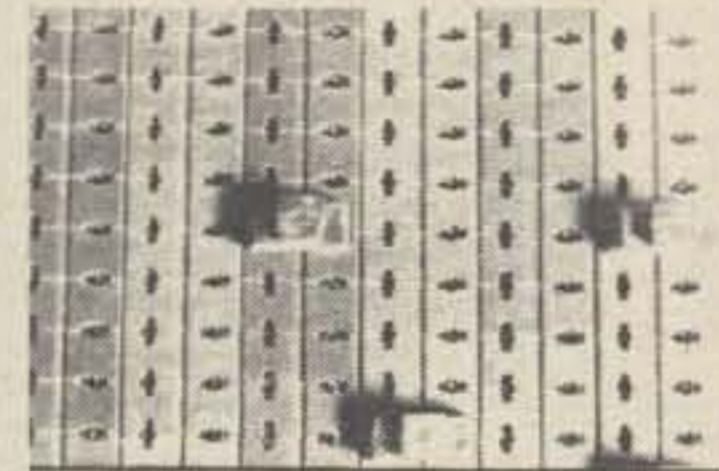

**Matrix Board** with 25 x 12 rows. (Half of above board.) With 15 plugs. **\$5.50**

**Teletype Model 28 Tape Equipment.** Tape reader LBXD & Perforator BRPE on LRXB9 Base, mounted on LTHS Tape Handling Unit. Reader is 60-75-100 wpm. Perforator is high-speed (600 wpm). Exc. Cond., as removed from service. Shpg. wt. 100 lbs. **\$75.00 each**

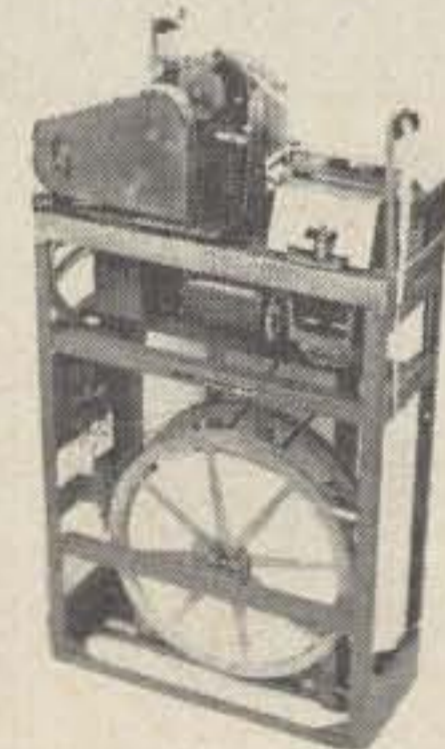

**H-P 5221-A Digital Counter,** Solid-State, 10 MHz. Like new. **\$150.00**

**Empire Devices (Singer) NF-105 Receiver** with T-2, T-3, T-A Tuners, Exc. Cond. **\$1800.00**

**Stoddart NM-20B Radio Interference & Field Intensity Receiver,** with power supply, loop antennas, cables. Exc. Cond. **\$385.00**

**P.C. Board Edge Sockets.** Amphenol. 3/16" contact spacing. 6-contacts, with solder terminals. **25¢**  
15-contacts, with wire-wrap terminals, used, exc. **25¢ ea, 5 for \$1.00**

### TTL ICs

7400 . . . . .	\$ .30	7473 . . . . .	.55
7402 . . . . .	.30	7474 . . . . .	.55
7404 . . . . .	.35	7475 . . . . .	.85
7408 . . . . .	.30	7476 . . . . .	.60
7441 . . . . .	1.75	7490 . . . . .	1.00
7447 . . . . .	1.60	74121 . . . . .	.60
7448 . . . . .	1.65	74192 . . . . .	1.90
		741 op amp . . . . .	.55

**MINIMUM MAIL ORDER \$2.00** — Please add shipping charges

• Mastercharge •

# JEFF-TRONICS

1916 Clark Avenue Cleveland, Ohio 44109

**TABLE CASE & TOP CALCULATOR KEYBOARD ONLY**

Attractively designed! Excellent craftsmanship. Case and keyboard (designed as one unit). Cabinet is made of high-impact plastic beige color with black bezel and amber window. Keyboard consists of a 3-position slide switch and 25 keys, 5 of which are used for memory function. 20 keys gray, 5 keys orange. All keys mounted on one printed circuit board. This modular unit is well suited for our calculator chips. Ideal for the CT5005. Case and Keyboard Complete: ONLY \$29.95

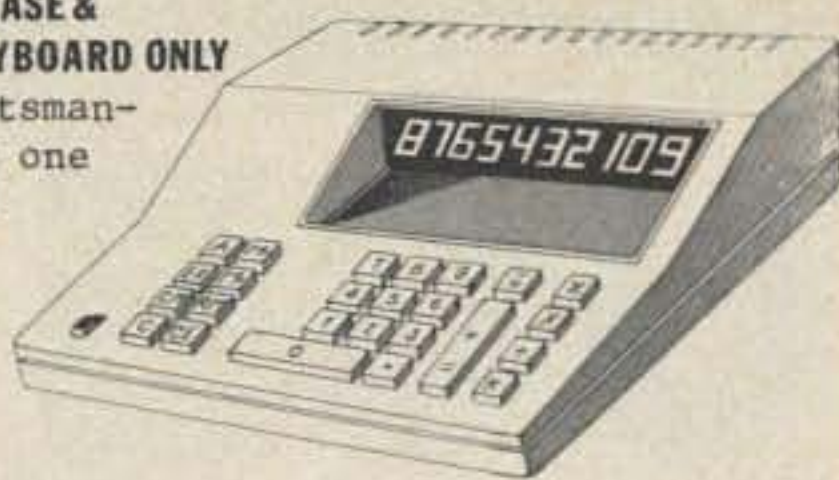

**RCA NUMITRON**

EACH.....\$ 5.00  
SPECIAL: 5 FOR \$20.00



**3-CHIP CALCULATOR**

This calculator set provides all of the electronics for an 8-digit, floating point calculator with left-hand entry. Keyboard, display, clock generator, and display driver is all that need be added to make a calculator that will add, subtract, multiply and divide. Overflow and negative signals are also provided. Complete instructions to build a calculator included.

CHIPS AND DATA.....\$8.95  
DATA ONLY (Refundable).... 1.00

**CT5005 CALCULATOR**

This calculator chip has a full four-function memory, which is controlled by four keys, +M (adds entry into memory), -M (subtracts entry from memory), CM (clear memory, without clearing rest of registers), RM (read memory or use as entry).

12-Digit display and calculate  
Fixed decimal at 0, 1, 2, 3, 4, or 5  
Leading zero suppression  
7-Segment multiplexed output  
True credit sign display  
Single 28-pin chip  
CHIP AND DATA.....ONLY \$9.95  
DATA ONLY (Refundable)..... 1.00

**5001 CALCULATOR**

40-Pin calculator chip will add, subtract, multiply, and divide. 12-Digit display and calculate. Chain calculations. True credit balance sign output. Automatic over-flow indication. Fixed decimal point at 1, 2, 3, or 4. Leading zero suppression. Complete data supplied with chip.  
CHIP AND DATA.....ONLY \$9.95  
DATA ONLY (Refundable).... 1.00

All ICs are new and fully-tested; leads are plated with gold or solder. Orders for \$5 or more will be shipped prepaid. Add 35¢ for handling and postage for smaller orders; residents of California add sales tax. IC orders are shipped within 2 workdays--kits are shipped within 10 days of receipt of order. \$10.00 minimum on C.O.D.s (phone in).

MAIL ORDERS:  
P. O. Box J 4811 Myrtle Ave.  
Carmichael, CA Sacramento, CA  
95608 (916) 334-2161

**MONEY BACK GUARANTEE ON ALL GOODS!**  
SEND FOR FREE FLYER LISTING 100's OF MONEY-SAVING BARGAINS!

**BABYLON ELECTRONICS**

**LED's**

MV50 red emitting 10-4 ma @ 2V	\$ .25 5 FOR 1.00
MV5024 red TO-18 high dome	\$ .75 10 FOR 6.50
MV10B visible red 5-7 ma @ 2V	\$ .30 10 FOR 2.50

**SPECIAL 874**

256-BIT RANDOM ACCESS MEMORY  
TTL bi-polar fully-decoded 256 x 1 bit:

- Single 5V supply
- 80 NS access time
- Simple memory expansion thru 3-chip select lines

Data with chip. 16-Pin DIP.  
\$5.00 10 FOR \$39.95

**3-Amp Power Silicon Rectifiers  
Marked Epoxy Axial Package**

PRV	PRICE	PRV	PRICE
100.....	\$.10	800.....	\$.30
200.....	.15	1000....	.40
400.....	.18	1200....	.50
600.....	.23	1500....	.65

**CMOS**

CD4001 \$ .75	CD4023 \$ .75
CD4002 .75	74C00 .75
CD4010 1.00	74C20 .75
CD4011 .75	74C160 3.25
CD4012 .75	

**7400 Series DIP**

7400 \$ .25	74L51 \$ .30
74H00 .35	74H51 .35
7401 .25	7453 .20
7402 .35	7454 .25
74H01 .35	74L54 .35
7403 .30	74L55 .35
7404 .28	7460 .20
74H04 .35	74L71 .30
7405 .28	7472 .40
7406 .70	74L72 .50
74H05 .35	7473 .60
7408 .35	74L73 .75
74H08 .35	7474 .65
7410 .25	74L74 .80
74L10 .35	74H74 .80
74H11 .35	7475 1.40
7413 1.25	7476 .60
7417 .40	74L78 .80
7420 .25	7480 .65
74L20 .35	7483 1.00
74H20 .35	7489 4.00
74H22 .35	7490 1.20
7430 .25	7491 1.00
74H30 .35	7492 .90
74L30 .40	7493 1.15
7440 .25	7494 1.15
74H40 .35	7495 1.15
7441 1.25	74L95 2.00
7442 1.20	74121 1.25
7446 1.20	74123 1.50
7447 1.20	74154 2.30
7448 1.00	74161 2.00
7450 .25	74163 2.00
74H50 .35	74193 1.50
7451 .25	74195 1.00

**RECTIFIERS**



VARO FULL-WAVE BRIDGES

V5447	2A	400V	\$ .90
V5647	2A	600V	1.10
MR810 Rect.	50V	1A	.10

**Special 811: Hex Inverter**

TTL DIP Hex Inverter; pin interchangeable with SN 7404. Parts are brand new and are branded Signetics and marked "811."

Data	EACH.....\$ .30
Sheet	10 FOR..... 2.50
Supplied	100 FOR.... 23.00
	1000 FOR... 220.00

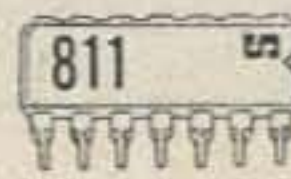

**MAN 3M**

0-9 plus letters. Right-hand decimal point. Flat-pack type case. Long operating life. IC voltage requirements. Ideal for pocket calculators!



EACH	\$2.50
10 OR MORE	1.90
W/O DECIMAL	1.50

**MAN4**

Seven-segment, 0-9 plus letters. Right-hand decimal point. Snaps in 14-pin DIP-socket or Molex. IC voltage requirements. Ideal for desk or pocket calculators!

EACH.....	\$2.75
TEN OR MORE	2.50 EACH

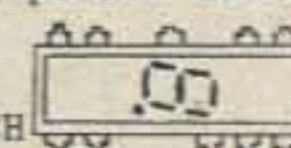

**CD-2 Counter Kit**

This kit provides a highly sophisticated display section module for clocks, counters, or other numerical display needs. The unit is .8" wide and 4 3/8" long. A single 5-volt power source powers both the ICs and the display tube. It can attain typical count rates of up to 30 MHz and also has a lamp test, causing all 7 segments to light. Kit includes a 2-sided (with plated thru holes) fiberglass printed circuit board, a 7490, a 7475, a 7447, a DR 2010 RCA Numitron display tube, complete instructions, and enough Molex pins for the ICs. NOTE: boards can be supplied in a single panel of up to 10 digits (with all interconnects); therefore, when ordering, please specify whether you want them in single panels or in one multiple digit board. Not specifying will result in shipping delay.

COMPLETE KIT,  
ONLY \$11.95  
FULLY-ASSEMBLED  
UNIT \$13.00



Boards can be supplied separately @ \$2.00 per digit.

**LINEARS**

NE540	70-watt power driver amp.....	\$2.00
NE555	precision timer.....	1.50
NE560	phase lock loop DIP.....	3.25
NE561	phase lock loop DIP.....	3.25
NE565	phase lock loop TO-5.....	3.25
NE566	function generator TO-5.....	4.00
NE567	tone decoder.....	4.00
NE5558	dual 741 op amp MINI DIP.....	1.00
709	popular op amp DIP.....	.45
710	voltage comparator DIP.....	.75
711	dual comparator DIP.....	.40
723	precision voltage regulator DIP.	1.00
741	op amp TO-5/MINI DIP.....	.55
747	dual 741 op amp DIP.....	1.00
748	op amp TO-5.....	1.00
CA3018	2 isolated transistors and a Darlington-connected transistor pair	1.00
CA3045	5 NPN transistor array.....	1.00
CA3026	dual differential amp.....	1.00
LM100	positive DC regulator TO-5.....	1.00
LM105	voltage regulator.....	1.25
LM302	op amp voltage follower TO-5....	1.25
LM307	op amp.....	.50
LM308	op amp TO-5.....	2.00
LM311	comparator TO-5.....	1.75
LM370	AGC amplifier.....	2.00
LM703	RF-IF amp epoxy TO-5.....	.45
LM309K	5V-1A power supply module TO-3..	2.00
LM3900	quad op amp.....	2.00
LM1595	4-quadrant multiplier.....	2.00
8038	sine square triangle function generator.....	4.95



It's High Time . . .

# SOMETHING NEW

. . . Amateurs had access to a good, up-to-date used gear list.

For too long now, most used gear lists have been made up no more than once a month. Because used equipment stocks change daily, most distributors "pad" their lists with prices of items which may not be in stock, but which do come through fairly often. This is not intended to mislead the customer, but does often result in orders which can't be filled. These lists are actually lists of "what it will cost you, if we happen to have it when you order".

NOW — we have put in a new Hewlett-Packard data processing system, which will cure all of this.

When you write us for a used gear list, you will receive a list which is current — as of the previous day's close of business!

Of course this means our list won't be as big as others, because it won't be "padded". Also, items listed will be subject to prior sale, but you can be sure that we do have it the day we mail your list, so don't be disappointed the next time you want to buy a used item . . .

## Write for Our Used Gear List First!

*Write our Ft. Worth store today for your list.*

### ED JUGE ELECTRONICS, INC.

3850 S. FREEWAY  
FT. WORTH, TEX 76110

11181 HARRY HINES BLVD.  
DALLAS, TEX 75229

Closed Sun. & Mon.

# GODBOUT

BILL GODBOUT ELECTRONICS

BOX 2673, OAKLAND AIRPORT, CA 94614

LED 7 segment similar to DL 704 pins same as MAN 4, .3 char

- .....\$2.75 ea 10/\$22.50
- 7 SEGMENT** assembly 3 in 1 dip pac sim to MAN 33. Ideal for calculators. 8 digits and minus sign ..... \$7.95
- 11 digits and minus sign ..... \$10.50
- 7 SEGMENT** readouts 2 in 1 pac plus space. Ideal for clocks. 6 digits for .... \$5.95
- CLOCKS** shipped with prints #5314 ..... \$9.50
- #5316 alarm clock ..... \$13.50
- CALCULATORS** shipped with prints 5001 basic 4 function ..... \$6.95
- 5002 4 function/low power drain ..... \$7.95
- 5005 4 function w/memory register ..... \$9.95
- Low noise dual FETs.** Ideal for stereo preamp sim to 2N5454 ..... 2/1.00
- RF FETS** sim to 2N4416 ..... 2/1.00
- RF dual FETS** ..... \$1.00
- 2N2907** ..... 5/\$1.00
- 2N2222** ..... 5/\$1.00

**Bipolar memory 1x256 Bit 74200** ..... \$9.50

**1000 Assorted Resistors, Capacitors, Diodes** including over 100 TTL DTL & Linear ICs on PC boards ..... (include postage for 4 lbs.) **10.00**

**12V 8A REGULATED power supply parts kit.** Ideal for powering FM rigs. Everything except the chassis ... (include postage for 8 lbs.) **12.95**

*ICs, most TTL & LINEAR in stock – Send Stamp for FREE Catalog*

CMOS DIGITAL		LINEAR	
74C00	.60	LM370	1.25
74C02	.60	LM371	1.25 Replaces HEP 590
74C04	.85	LM372	1.25
74C10	.60	LM374	2.00
74C20	.60	LM382	1.75
74C73	1.65	741T	.45
74C74	1.25	741 Mini	.45 10/3.95
74C76	1.75	CA3028	.75
74C107	1.75	CA3065	.75
74C151	3.30	CA3086	.45
74C160	3.25		
74C161	3.25		
74C162	3.25		
74C163	3.25		
74C195	3.15		
5558	1.00		
CD4001	.60		
CD4002	.60		
CD4009	1.00		
CD4010	1.00		
CD4011	.60		
CD4012	.60		
CD4013	1.25		
CD4016	1.25		
CD4019	1.45		
CD4023	.60		
CD4025	.60		
CD4035	3.10		

**Feb. special for 73 readers only**

555 timers, \$.85.  
4194 adjustable dual tracking regs. DIP \$2.00

Buy 10 IC's – 10% discount  
Buy 100 IC's – 20% discount  
All IC's tested and guaranteed

## LINEAR VOLTAGE REGS

- LM 309K 5V 1A REG ..... 2.00
- LM 320K NEG Reg available in 5V 12V & 15V ..... 2.25
- LM 340K POS Reg available in 6V 12V & 15V ..... 2.25
- LM 723 Adjustable precision reg ..... 1.00
- 556 DUAL TIMERS** ..... 1.60
- TRANSISTOR GRAB BAG** mixed NPN PNP 100 for ..... 2.95

**ALL ITEMS IN STOCK** and will be shipped within 24 working hours of receipt of order!  
*Include 50¢ postage and handling on orders under \$10.00, all others postpaid.*

*Sorry, NO C.O.D.'s. CALIFORNIA RESIDENTS ADD sales tax.*

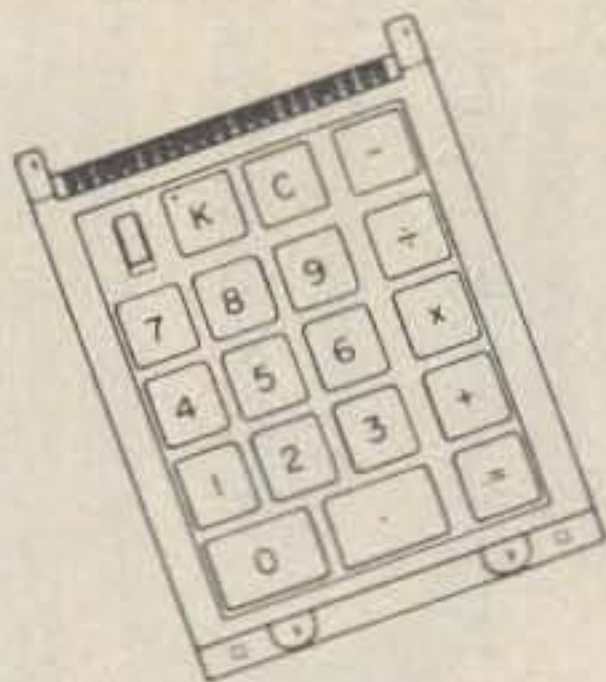

### CALCULATOR KEYBOARDS

Brand new keyboards for hand held calculators. Two styles available. One for CAL TEX 5001-5002-5012 or MOSTEK 5010-5012. Another for use with GEN INSTR C500.

**\$8.00 each, 2/\$15.00**

### CT 5005 CALCULATOR ON A CHIP

Single MOS chip with all logic required for 12 digit 4 function desk top calculator with extra storage register for memory or constant. Multiplexed 7 segment outputs for LED, Incandescent, Fluorescent or Gas Discharge displays. Brand new and bargain priced. With Specs.

**\$8.00 each, 2/\$15.00**

### HP LED DISPLAYS

Brand new 4-on-strip LED display. End butt two strips and come up with 8 digit readout. An unheard of SUPER VALUE at \$8.00 per strip of 4 digits. Two strips (8 digits) \$15.00. Another strip . . . this one a clock readout. The strip has 2 digits . . . space . . . 2 digits. Perfect for reading hours & minutes.

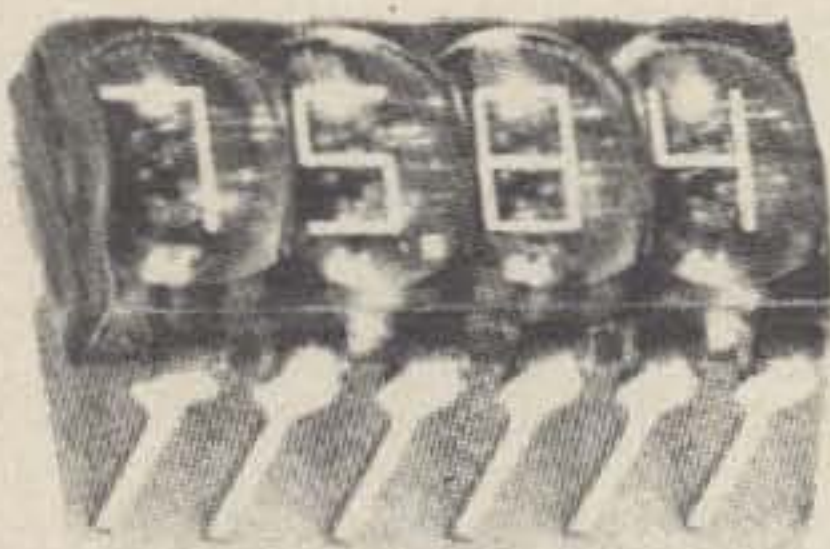

**\$8.00 per strip, 2/\$15.00**

### CMOS 4814 HEX INVERTER

DIP with operation 3-18 Volts. Dual diode protection against static charge destruction. Dielectrically isolated complimentary MOS.

**\$1.00 each, 12/\$10.00**

### DUAL 16 BIT MEMORY

Serial MOS by PHILCO in TO-5 case. Brand new with 2 page specs.

#PLR 532 **\$1.00 each, 12/\$1.00**

### PHONE PATCH KIT

Includes all parts, instructions, cabinet.

AM PATCH - \$5.00      SSB PATCH - \$9.00

### 2048 BIT MOS MEMORY

MOS LSI random access memory #NEC 6003. All inputs except clock are TTL compatible. 2048 word by 1 bit. 22 pin ceramic DIP. With specs.

**\$9.00 each, 2/\$17.00**

### VOLTAGE CONTROLLED OSCILLATOR

Rare item. See Pop. Elect. Mag. Oct. 1973 for uses. In 14 pin DIP package.

#8038C **\$9.95 each, 2/\$18.00**



### ASCII KEYBOARDS W/ENCODER

From Raytheon, new or like new. 5 extra function buttons each side. Open faced, no cabinet. Schematic provided. Price is postpaid world wide.

**\$46.00**

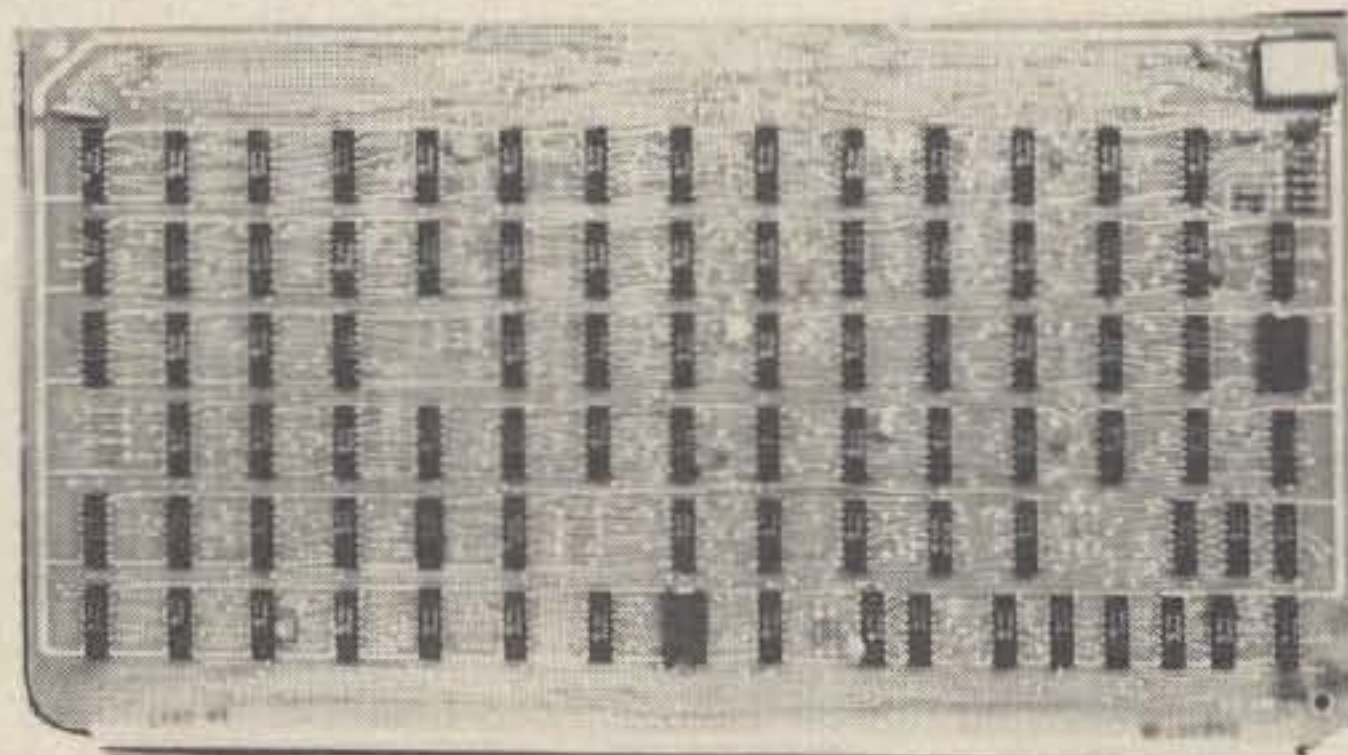

### 7400 SERIES ICs

Talk about bargains . . . this is a whopper. Due to quantity on hand, we are reducing this item to a new MESHNA MESHU GINA deal. About 100 devices, all marked and easily removed. With shrinking supplies and upward direction of prices, this makes it well worth going into the salvage business. This Super Mother Board can be stolen for \$6.00 each or 6 for \$25.00. We also have these in ST 600 series DTL. So give your choice . . . 7400 series or ST 600 series. Mix-N-Match if you wish.

#SAN **\$6.00 each, 6/\$25.00**

Postage extra on above. MESHNA PO Bx 62 E. Lynn Mass. 01904

### COMPLETE MEMORY SYSTEM

Measures 12 x 7 x 1 inches. Utilizes TTL ICs. 10240 memory cores. 9 installed sense amps, addressed as 1024 locations. I/O lines include 9 data-in, 9 data-out, 10 address-in, powering status and control. Only 40 systems on hand. Schematics included.

# DCU ..... \$150pp

### AUTOMOBILE REVERB

Brand new fully assembled, ready to install in your car to give 3rd dimension concert hall effect. Complete with instructions, rear seat speaker, grill, wires, plugs.

# 05 ..... \$7.00

### 15 AMP BATTERY CHARGER

Brand new GE transformer, 25 amp fullwave bridge. Output approximately 15 volts up to 15 amps. Ideal battery charger or DC source for general use. With instructions, assembled in minutes.

PK-4 ..... \$7.50

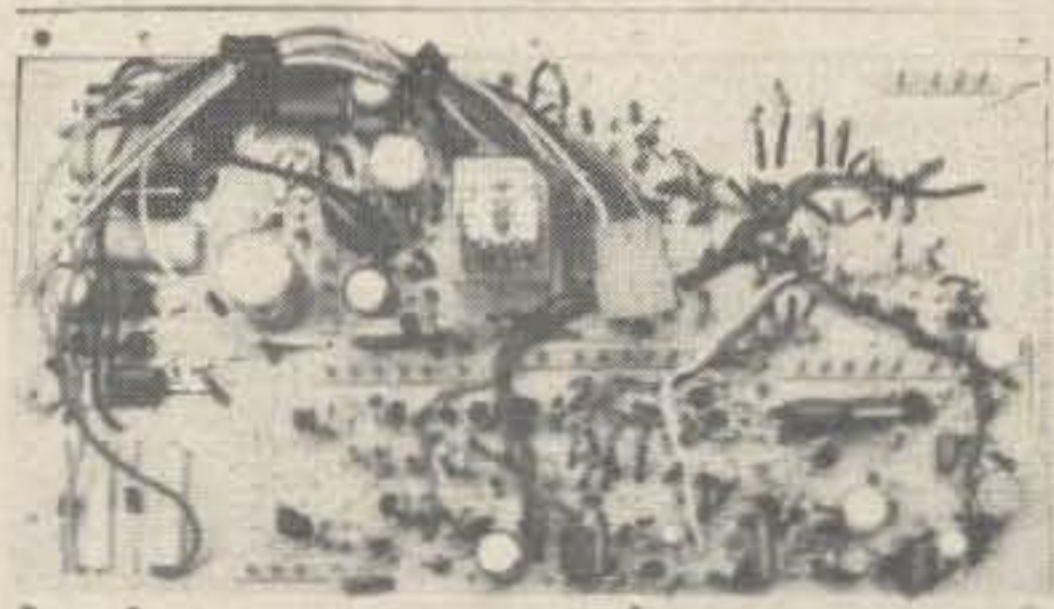

### TV POWER SUPPLY & TRANSPORT CIRCUIT

A complete assembled PC board, spares from a video tape machine. Many many fine components to be found. One section of the board used as a 12 volt and 24 volt regulated power supply. You add the transformer and output will be 24 volts transistor regulated as well as another output of 12 volts transistor regulated. 3 amps on the 12 volts and 1 amp on the 24 volt section. Full schematic of the complete board included. These are unused and cost in excess of \$200.

# B74-1 ..... \$6 or 3/\$15

### 8 TRACK STEREO TAPE DECK

With built-in stereo pre-amp, 115 volt drive motor, channel indicator lamps. Unused, original boxed, less cabinet. Customize your stereo music center with one of these tape decks.

# 46 ..... \$14.00

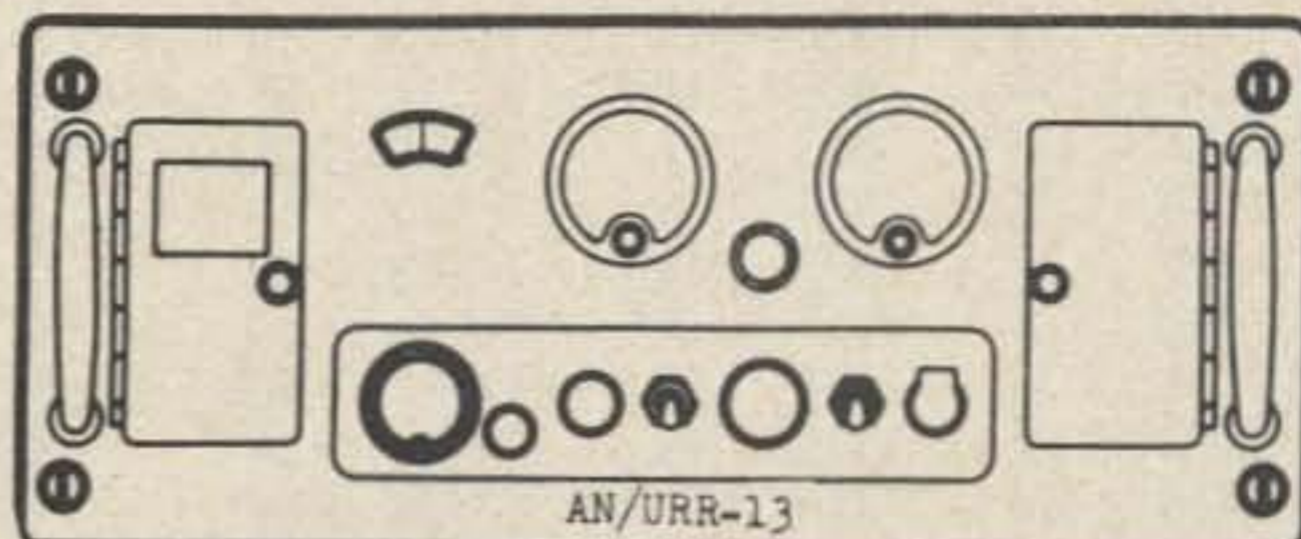

### URR-13 RECEIVER

Listen in to jet planes, Air Force 1, U-2 spy planes, FBI, etc. They use the frequency covered by this receiver . . . 220 to 400 mc. Possibilities of covering the 220-450 mc band by re-tuning. Operates from regular 115 Volt 60 cycle, requires only antenna and speaker. Tuneable through the frequency, direct reading dial. Schematic and write up on this set furnished.

Visually OK condition . . . URR-13 - \$50.00

### RCA TD-XI TUNNEL DIODE

Original packaged, each factory marked, with spec sheet.

\$1.25 each, 5/\$5.00.

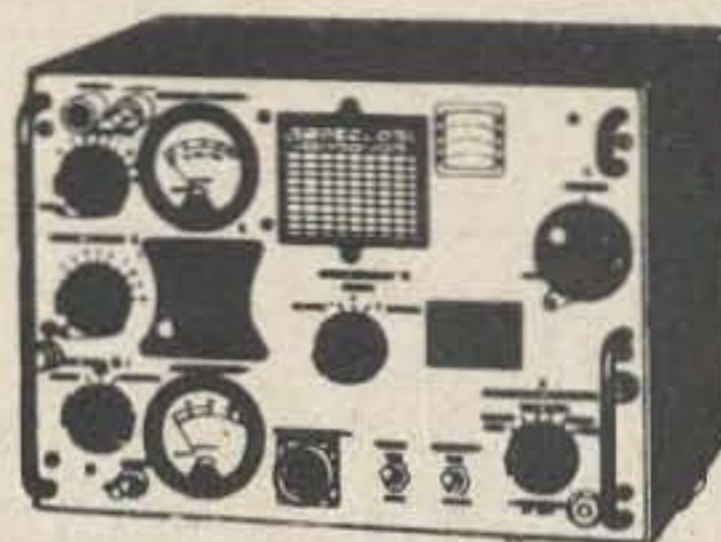

### TCS RCVR or XMTR

Used, look good, with schematic, receiver or transmitter. Frequency range 1.5 to 12 MC. Three bands, VFO or crystal, voice and CW. These sets Collins design, becoming scarce.

RCVR or XMTR ..... \$35.00

Postage extra on above MESHNA PO Bx 62 E. Lynn Mass. 01904

*Meshna*

# RGS ELECTRONICS

## wants a valentine

7400 \$ .25	7440 .25	7496 1.00
7401 .25	7442 1.10	74107 .60
7402 .25	7446 1.35	74121 .60
7403 .25	7447 1.25	74122 .60
7404 .30	7448 1.25	74123 1.10
7405 .30	7450 .25	74125 .65
7406 .50	7451 .25	74126 .65
7407 .50	7453 .25	74141 1.25
7408 .30	7454 .25	74151 1.10
7409 .30	7473 .50	74153 1.40
7410 .25	7474 .50	74154 1.70
7411 .30	7475 1.00	74157 1.40
7413 .85	7476 .65	74164 2.00
7416 .50	7483 1.25	74165 2.00
7417 .50	7486 .50	74166 2.00
7420 .25	7489 3.25	74181 4.50
7430 .25	7490 1.00	74192 1.75
7432 .30	7492 1.00	74193 1.50
7437 .50	7493 .80	74195 1.15
7438 .50	7495 1.00	74200 9.00

### 7 SEGMENT DISPLAYS

MAN3 \$2.00 4/\$6.00  
com. cat., .125 in. high  
Man 4 \$2.75 4/\$8.00  
com. cat., 2 in. high

MISSING SEGMENT/NO DECIMAL POINT  
(take your chances; no choice)

MAN3 \$.25  
MAN4 .50

<b>DISCRETE RED LEDs</b>	1-9	10+
MV10 TO-18	\$.25	.20
MV50 tiny	.35	.30
MV5024 diffused	.35	.30
bright red lens		.50
clear lens, fisheye		.50
<b>DISCRETE COLORED LEDs</b>		
MV1 amber		.50
MV5020 type, amber		.50
MV2 TO-18 green	.75	.70
MV5222 green		1.00
MV5322 yellow		2.00

### JUNCTION FETs, TO-18 case

<b>N-CHANNEL:</b>	<b>SIMILAR TO:</b>	
NJF10	2N4416, MPF102	3/\$1.00
NJF11	2N4091-93	4/\$1.00
NJF12	2N4338-41	4/\$1.00
NJF13	2N3089	3/\$1.00
NJF14	2N4221-22	4/\$1.00

<b>P-CHANNEL:</b>		
PJF11	2N3382-86	4/\$1.00
PJF14	2N2608	4/\$1.00

All FETs come with data sheets.

### TRANSISTORS

NPN TO-18 general purpose	
silicon	.15
10 or more,	.10
PNP TO-18 general purpose	
silicon	.15
10 or more,	.10
2N2222 (NPN) TO-18	.25
10 or more,	.20
2N2907 (PNP) TO-18	.25
10 or more,	.20

### UNTESTED DTL

All marked units, dual in-line packages. 20/\$1.00

### POWER SUPPLY KIT PS 5-1

5 volt 1 amp regulated power supply kit with p.c. board and instructions. Board measures 2"x6"; completed kit is 2" high. Transformer has internal r.f. shield.

\$10.00

### WIRE WRAP SOCKETS

14 pin	\$ .50
16 pin	.60
24 pin	1.25
28 pin	1.35
40 pin	1.80
wire-wrap socket pins	.05
100 or more,	.04

### LEDS

LED 10R - Pack of 10 discrete red lens LEDs, various MV5020-series types. \$1.50  
LED 10C - Pack of 10 discrete clear lens LEDs, various MV5020-series types. \$1.50  
Application note included.

### RECTIFIERS & DIODES

1amp 50PIV silicon rectifier	\$ .10
3amp 400PIV silicon rectifier	.25
FB50 lamp 50PIV bridge rectifier	.60
40429 triac 4amp 200PIV, brand new	1.00
	1-9 10-99 100+
1N914, brand new	\$.10 .07 .05

### MEMORIES

MM1101 256-bit static RAM	\$2.25
MM5260 1024-bit dynamic RAM	8.00

### 1/4 WATT RESISTORS

all values listed are \$.05; 10 or more, .04  
We have: 150Ω, 2.2K, 2.7K, 10K, 12K, 18K, 47K, 220K  
Please specify how many you want and of which values.

**RGS ELECTRONICS (408) 247-0158**  
3650 Charles St., Suite K, Santa Clara, CA 95050

We sell many ICs and components not listed in this ad. Send a stamp for our free flyer. **TERMS OF SALE:** All orders prepaid; we pay postage. \$1.00 handling charge on orders under \$10.00. California residents add 5% sales tax. Please include name, address and zip code on all orders and flyer requests.



# Lowest Prices Largest Selection TTL IC's

Buy 3 or more, 10% discount

Brand New	"DIP" Packages	Order by type number!	Spec sheets on request "ONLY"
SN7400 \$0.30	SN7437 .55	SN7472 .50	SN74112 .95
SN7401 .30	SN7438 .55	SN7473 .55	SN74113 .95
SN7402 .30	SN7440 .30	SN7474 .55	SN74114 .95
SN7403 .30	SN7441 1.40	SN7475 1.00	SN74121 .60
SN7404 .35	SN7442 1.50	SN7476 .65	SN74122 .95
SN7405 .35	SN7443 1.50	SN7478 .95	SN74123 1.20
SN7406 .45	SN7444 1.50	SN7480 .65	SN74125 .71
SN7407 .55	SN7445 1.50	SN7481 1.25	SN74126 .71
SN7408 .35	SN7446 1.65	SN7482 .99	SN74139 1.25
SN7410 .30	SN7447 1.45	SN7483 1.25	SN74140 1.25
SN7411 .35	SN7448 1.50	SN7485 1.41	SN74145 1.55
SN7413 .95	SN7450 .30	SN7486 .55	SN74148 4.50
SN7415 .55	SN7451 .30	SN7489 4.50	SN74150 1.61
SN7416 .55	SN7453 .30	SN7490 1.49	SN74151 1.25
SN7417 .55	SN7454 .30	SN7491 1.35	SN74152 4.95
SN7420 .30	SN7455 .55	SN7492 1.35	SN74153 1.60
SN7421 .55	SN7460 .30	SN7493 1.35	SN74154 2.10
SN7422 .35	SN7461 .35	SN7494 1.35	SN74155 1.55
SN7425 .50	SN7462 .35	SN7495 1.35	SN74156 1.45
SN7426 .36	SN7464 .30	SN7496 1.35	SN74157 1.55
SN7430 .30	SN7465 .50	SN7496 1.35	SN74158 1.55
SN7432 .35	SN7470 .50	SN7496 1.35	SN74160 1.95
	SN7471 .55	SN7496 1.35	SN74161 1.95

• Factory Marked

\* Money Back Guarantee

Buy 100 — Take 20%

## SANKEN HYBRID AUDIO POWER AMPS

Mfgr's Type	Watts	Sale
SI-1010Y	10	\$ 8.88
SI-1025E	25	18.88
SI-1050E	50	29.95



HI-FI 1" SQUARE MINI METERS \$1.49 3 for \$3.75

- \* Plastic case \* Red needle indicators
- Balancing, stereo, tape, amps.
- VU, side mtg, plus 3 minus 20 db.
- VU, front mtg, plus 3 minus 20 db.

## Op Amps

Buy Any 3 Take 10% Discount!

- 531 Hi slew rate op-amp (TO-5) \$2.50
- 532 Micro power 741 (TO-5) 2.50
- 533 Micro power 709 (TO-5) 2.50
- 536 FET input op amp (TO-5) 2.95
- 556 5 Times faster than 741C 2.10
- 558 Dual 741 (TO-5) 1.00
- 560 Phase lock loops (DIP) 2.95
- 561 Phase lock loops (DIP) 2.95
- 562 Phase lock loops (DIP) 2.95
- 565 Phase lock loops (A) 2.95
- 566 Function generator (TO-5) 2.95
- 567 Tone decoder (A) 2.95
- 702C Hi-grain, DC amp (TO-5) .49
- 703C RF-IF, amp, 14 ckts (TO-5) .69
- 704 TV sound IF system 1.50
- 709C Operational amp (A) .47
- 709CV Op amp (mini DIP) .47
- 710C Differential amp (A) .47
- 711C Dual diff. comp (A) .47
- 723C Voltage regulator (A) .75
- 733 Diff. Video Amp 1.75
- 741C Frequency compensator 709 (A) .49
- 741CV Freq. comp 709 (Mini DIP) .49
- 747C Dual 741C (A) .95
- 748C Freq. adj. 741C (A) .49
- 753 Gain Block 1.75
- 709-709 Dual 709C (DIP) 1.00
- 739-739 Dual stereo preamp 1.98
- 741-741 Dual 741C (A) 1.00
- PA265 5-Watt voltage regulator 1.95
- ULN2300M Op amp with SCR 1.50
- CA3065 Video Audio system 1.05
- 75451 Dual peripheral driver .88
- 75491 Quad seg driver for LED readouts 1.65
- 75492 Hex driver w/col. out 250 ma. 1.85

## LITRONIX-OPCOA-MAN "7-SEGMENT" LED Readouts

All fit 14-pin IC sockets. All 7-segments. MAN Series "all LED" and made by well-known West Coast mfr. Others Reflective Bar type made by OPCOA and LITRONIX. The Reflective Bar types are low-cost versions of the MAN's except .33 character height! If one LED blows you lose a segment. MAN's you DO NOT! All readouts 0-to-9 numerals, plus letters and decimal. \*\*Opcoa and Litronix products pin-for-pin replacements for MAN-1 MAN-4. All 5V TTL compatible.

ALL LED READOUTS — TYPE	character	Color	Decimal	Mils	Driver	Each	Special
MAN-1 equal	.27	Red	Yes	20	SN7447	\$3.95	3 for \$10.
MAN-1A equal*	.27	Red	Yes	20	SN7447	3.95	3 for \$10.
MAN-3 equal	.115	Red	Yes	10	SN7448	1.69	3 for 4.50
MAN-3A equal*	.115	Red	Yes	10	SN7448	1.69	3 for 4.50
MAN-3M equal*	.127	Red	Yes	10	SN7448	1.69	3 for 4.50
MAN-3 equal	.115	Red	***	10	SN7448	1.50	3 for \$4.
MAN-3M equal*	.127	Red	Yes***	10	SN7448	1.50	3 for \$4.
MAN-4 equal*	.190	Red	Yes	15	SN7448	2.50	3 for \$6.
MAN-4 equal*	.190	Red	Yes***	15	SN7448	2.25	3 for \$5.

### "REFLECTIVE LITE BAR" (Segment LED Readouts)

707** (MAN-1)	.33	Red	Yes	20	SN7447	2.75	3 for \$6.
704** (MAN-4)	.33	Red	Yes	20	SN7448	2.75	3 for \$6.
SLA-1** (MAN-1)	.33	Red	Yes	20	SN7447	2.75	3 for \$6.
SLA-1** (MAN-1)	.33	Red	No	20	SN7447	2.25	3 for \$5.
SLA-2 + - 1	.33	Red	No	15	SN7447	2.75	3 for \$6.
SLA-3H Giant	.70	Red	Yes	20	SN7447	6.50	3 for \$18.
SLA-11C** (MAN-5.33)	Green	Yes	40	SN7447	4.95	3 for \$13.	
SLA-12** ±1	.33	Green	No	40	SN7447	3.50	3 for \$ 9.

\* Red epoxy case, others clear. \*\* Litronix and Opcoa's pin-for-pin equals and electrical specs as MAN-1 or MAN-4. \*\*\* LED "dot" missing

10-pc. kit, 0-to-9 only, 3.50  
**CALCULATOR KEYBOARD SWITCH KITS**

Same as our famous Oak 415 but 5/8 square top, for those who wish to design all types of touch-tone systems, number control for Ham work, equipment of all types, alarm or intrusion systems of all types.

**Semiconductors GUARANTEED SATISFACTION**

## WEST COAST MAKER OF LED'S

4-MV5054	Jumbo red lens, red lite	TO-18	\$1.00
1-MV5222	Jumbo green lens, green lite	TO-18	1.49
1-MV5322	Jumbo yellow lens, yellow lite	TO-18	1.98
4-MV5080	Micro red dome red lite	TO-18	1.00

## INTEGRATED CIRCUIT SOCKETS

14-Pin, DIP	\$.45
14-Pin, Wire Wrap	.59
14-Pin, Side Mount	1.00
16-Pin, DIP	.50 Buy 3 —
TO-5, 8 or 10-Pins	.29 Take 10%

## LED MITY DIGIT "DCM'S"

Scientific Devices "Digital Counting Modules" outperform any other DCM on the market today. More features than ever before! Not gaseous, not incandescents, not nixie but the modern LED. Choose from such famous manufacturers as Monsanto's MAN-1, MAN-4, Litronix 707 and 704, Opcoa's SLA-1 (the last 4 having character heights of 0.33 at no extra charge). Each kit includes 3x2" p.c board with fingers for a FREE edge connector, side-mounting dip socket, LED readout of your choice, resistors, 3 IC's, and Molex connectors (this ELIMINATES SOLDERING YOUR IC'S) and booklet. INCLUDES P.C. EDGE CONNECTOR — FREE!

\* Pin-for-pin MAN-1, \*\* Pin-for-pin MAN-4, elec. char. same

**'HAM' UHF 400 MC HIGH POWER TRANSISTORS 3.95**  
3 for \$10.  
By RCA or equal 2N3632  
NPN, 23 watts, 3 amps,  
TO-60 case, with stud mtg.  
VCEV max 65.



Buy 3 — Take 10%

READOUT	Char. Maker
MAN-1	.27 h. Monsanto
MAN-4	.19 h. Monsanto
707*	.33 h. Litronix
704**	.33 h. Litronix
SLA-1*	.33 h. Opcoa

## Potter & Brumfield KAP RELAYS

Excellent for "HAM" use as antenna switching, latching, transmit, receive, etc., and 100's of commercial or industrial uses. Includes plastic dust-cover with diagram and hookup info, 11-pin plug-in base. Contacts movable gold flashed silver, stationary overlay, with silver cadmium oxide movables. All contacts 10 amp 3PDT. Coil data, 115VAC 2250 ohms, 17.5 ma. 12 VDC 21 mils 168 ohms. Size: 2 1/4" x 1 5/16". Wt. 4 ozs. Center pin missing. Comar Mfg. type equal too.

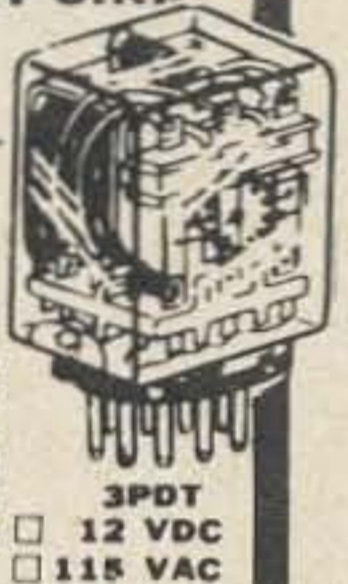

## NATIONAL EQUALS ON "DIGITAL CLOCK on a CHIP"

Mfrs #	Description	Sale
5311	28-pin, ceramic, any readout, 6-digits: A-B-D	\$8.88
5312	24-pin, ceramic, any readout, 4-digits: C-D	\$8.88
5313	28-pin, ceramic, any readout, 6-digits: A-C	\$8.88
5314	24-pin, plastic, LED and incandescent readouts, 6-digits: A-B	\$8.88
5316	40-pin, normal alarm, snooze alarm, sleep timer, 4-digits:	\$14.95

Code: A—Hold Count. C—1 PPS Output. B—Output Strobe. D—BCD

1-MM5316, DIGITAL ALARM CLOCK FACTORY FALLOUT — \$1.49 EACH

Any "Chip" \$8.88

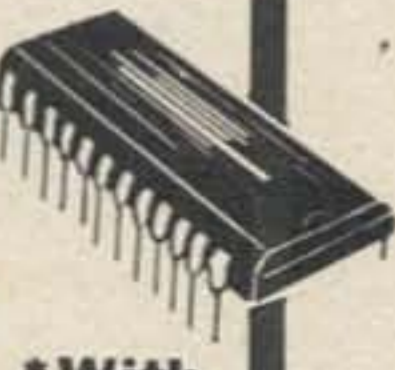

Terms: add postage Rated: net 30  
Phone Orders: Wakefield, Mass. (617) 245-3829  
Retail: 16-18 Del Carmine St., Wakefield, Mass. (off Water Street) C.O.D.'S MAY BE PHONED

15¢ CATALOG on Fiber Optics, 'IC's', Semi's, Parts

## POLY PAKS

P.O. BOX 942A LYNNFIELD, MASS. 01940

## READER SERVICE

Please either tear out this list of advertisers and send it in to 73 with as many boxes checked off as you would like to see brochures, data sheets or catalogs... or else make a copy and send that in. Include your zip code, please. Send money directly to advertisers.

## ADVERTISER INDEX

- |  |   |
|--|---|
| <input type="checkbox"/> AAA Sales 81            | <input type="checkbox"/> Janel 82             |
| <input type="checkbox"/> Adirondack 33           | <input type="checkbox"/> Jefftronics 120      |
| <input type="checkbox"/> Alexander 94            | <input type="checkbox"/> Juge 122             |
| ★ <input type="checkbox"/> ATV Research 70       | <input type="checkbox"/> K Enterprises 26     |
| <input type="checkbox"/> Babylon 121             | <input type="checkbox"/> Meshna 124, 125      |
| <input type="checkbox"/> CFP 70                  | <input type="checkbox"/> MFJ 38               |
| <input type="checkbox"/> Circuit Specs 105       | <input type="checkbox"/> MITS                 |
| <input type="checkbox"/> Comm. Spec. 38          | <input type="checkbox"/> Newtronics 9         |
| <input type="checkbox"/> Comm. Unlimited 106     | <input type="checkbox"/> Nurmi 35             |
| <input type="checkbox"/> Cornell 81              | <input type="checkbox"/> Palomar 67           |
| <input type="checkbox"/> Concord Comm. 63        | <input type="checkbox"/> Poly Paks 127        |
| <input type="checkbox"/> Data Engineering 115    | <input type="checkbox"/> Regency 42, 43       |
| <input type="checkbox"/> DuPage FM 116           | <input type="checkbox"/> RGS 126              |
| <input type="checkbox"/> Dynamic Elec. 82        | <input type="checkbox"/> Rohn 31              |
| <input type="checkbox"/> ECM Corp 81             | ★ <input type="checkbox"/> R P Electronics 67 |
| <input type="checkbox"/> Emergency Beacon        | <input type="checkbox"/> Savoy Cover III      |
| <input type="checkbox"/> Estes 68                | <input type="checkbox"/> Sentry 15            |
| <input type="checkbox"/> Freck 70                | <input type="checkbox"/> Skylane 82           |
| <input type="checkbox"/> Genave 19               | <input type="checkbox"/> Solid State 118      |
| <input type="checkbox"/> Godbout 123             | <input type="checkbox"/> Space Electronics 98 |
| <input type="checkbox"/> Goodheart 81            | <input type="checkbox"/> Stahler 84           |
| <input type="checkbox"/> Hal 39                  | <input type="checkbox"/> Standard Comm. 5     |
| <input type="checkbox"/> Hamtronics 108, 109     | <input type="checkbox"/> Teletron 91          |
| <input type="checkbox"/> Heath 40                | <input type="checkbox"/> Tri Tek 84           |
| <input type="checkbox"/> Henry 58, 59            | <input type="checkbox"/> Valpey 47            |
| <input type="checkbox"/> H & H 84                | <input type="checkbox"/> Venus Scientific 23  |
| <input type="checkbox"/> Hobbyformers 84         | <input type="checkbox"/> VHF Engineering 114  |
| <input type="checkbox"/> Hy-Gain 110-113         | <input type="checkbox"/> Vintage Radio 39     |
| <input type="checkbox"/> Icom 117                | <input type="checkbox"/> Wilson 13            |
| <input type="checkbox"/> International Elec. 119 | <input type="checkbox"/> Wolf 70              |
| <input type="checkbox"/> Jan 68                  | <input type="checkbox"/> World QSL 70         |
|  | <input type="checkbox"/> Yaesu Cover II       |

### 73 STUFF

- Subscriptions 86
- Jordan 87
- Books 88
- Certificates 89
- Digital Control 96
- QSL/Code Course CIV

\*Reader service inquiries not solicited. Correspond directly to company.

FEBRUARY 1974

Mail to:

Reader's Service  
73 Inc., Peterborough NH 03458

Please Print or Type

Name \_\_\_\_\_ Call \_\_\_\_\_

Address \_\_\_\_\_

City \_\_\_\_\_ State \_\_\_\_\_ Zip \_\_\_\_\_

Coupon expires in 60 days . . . . .

## PROPAGATION CHART

J.H. Nelson

Good (Open) Fair (□) Poor (O)

# February 1974

SUN	MON	TUES	WED	THUR	FRI	SAT
					1	2
3	4	5	6	7	8	9
10	11	12	13	14	15	16
17	18	19	20	21	22	23
24	25	26	27	28		

### EASTERN UNITED STATES TO:

	GMT:	00	02	04	06	08	10	12	14	16	18	20	22
ALASKA	14	7	7	3	3	3	3	3	7	14	14	14A	
ARGENTINA	14	7B	7B	7	7	7	14	21	21	21	21	21	
AUSTRALIA	14A	14	7B	7B	7B	7	7	14	14	14B	14	21	
CANAL ZONE	14	7	7	7	7	7	7A	21	21	21	21	21	
ENGLAND	7	7	7	3	7	7	14	14A	14A	14	14	7	
HAWAII	14A	14	7B	7	7	7	7	7	7B	14	21	21	
INDIA	7	7	7B	7B	7B	7B	7B	14	14	7B	7B	7	
JAPAN	14	7B	7B	7B	7	7	7	7	7	7B	7B	7	
MEXICO	14	7	7	7	7	7	7	14	14A	21	14A	14	
PHILIPPINES	14	7B	7B	7B	7B	3B	7	7	7	7B	7B	7B	
PUERTO RICO	7A	7	7	7	7	7	7A	14	14	14	14	14	
SOUTH AFRICA	7A	7	7	7	7B	7B	14	21	21	21	14A	14	
U. S. S. R.	7	7	3	3	7	7B	14	14	14	7B	7B	7	
WEST COAST	14	14	7	7	7	7	7	14	14	14A	21	14A	

### CENTRAL UNITED STATES TO:

	GMT:	00	02	04	06	08	10	12	14	16	18	20	22
ALASKA	14	14	7	3	3	3	3	3	7	14	14	14A	
ARGENTINA	14	14	7B	7	7	7	7	14A	21	21	21	21	
AUSTRALIA	21	14	7B	7B	7B	7	7	7	7	14B	14	21	
CANAL ZONE	14A	14	7	7	7	7	7	14A	21	21	21	21	
ENGLAND	7	7	7	3	7	3	7B	14	14A	14	7B	7	
HAWAII	21	14	7B	7	7	7	7	7	7B	14	21	21	
INDIA	7	7	7B	7B	7B	7B	3B	7	7A	7	7B	7B	
JAPAN	14	14	7B	7B	7	7	3	7	7	7B	7B	14	
MEXICO	14	7	7	3A	7	3	3	7	14	14	14	14	
PHILIPPINES	14	14	7B	7B	3B	7B	7	7	7	7	7B	7B	
PUERTO RICO	14	7	7	7	7	7	7	14	14A	14A	14	14	
SOUTH AFRICA	14B	7	7	7	7B	7B	7B	14	21	21	14A	14	
U. S. S. R.	7	3	3	3	7	7	7B	7A	14	7B	7B	7B	

### WESTERN UNITED STATES TO:

	GMT:	00	02	04	06	08	10	12	14	16	18	20	22
ALASKA	14	14	7	3	3	3	3	3	7	14	14	14	
ARGENTINA	21	14	7B	7	7	7	7	14	21	21	21	21	
AUSTRALIA	21	21	14	7B	7	7	7	7	7	7B	14	21	
CANAL ZONE	14A	14	7	7	7	7	7	14	21	21	21	21	
ENGLAND	7	7	7	3	7	7	3B	7B	14	14	7B	7B	
HAWAII	21A	21	14	7	7	7	7	3A	7	14	21	21	
INDIA	7B	14	14B	3B	3B	3B	3B	3A	7	7	7B	7B	
JAPAN	21	14	14	7	7	7	3	7	7	7B	14		
MEXICO	14	14	7	7	7	7	7	7	14	14A	14A	14	
PHILIPPINES	21	14	14	7B	3B	7B	7B	3A	7	7	7B	14	
PUERTO RICO	14	7	7	7	7	7	7	14	14A	21	21	14A	
SOUTH AFRICA	14B	7	7	7	7B	7B	7B	7B	14	14A	14A	14	
U. S. S. R.	7	7	3	3	3	7	7	7	7A	7B	7B	7B	
EAST COAST	14	14	7	7	7	7	7	14	14	14A	21	14A	

A = Next higher frequency may be useful also.  
B = Difficult circuit this period.

# Savoy

## BASSETT

High efficiency mobile and portable antennas for all amateur bands, AP, MARS, CB, SECURITY, PUBLIC SERVICE, MARINE, AND GOVERNMENT USE.

2-6-10-15-20-40-75

Identical size, cost, and appearance

FULLY ADJUSTABLE TO FREQUENCY IN FIELD

Low weight, low drag, high strength fiberglass

Polished chrome brass standard 3/8-24 thread

High gain collinear on 2 meters

MODEL DGA-2M

\$29.50 postpaid

in U.S.A.



\$3.75

Postpaid in U.S.A.

TYPE 900 A

TYPE 901

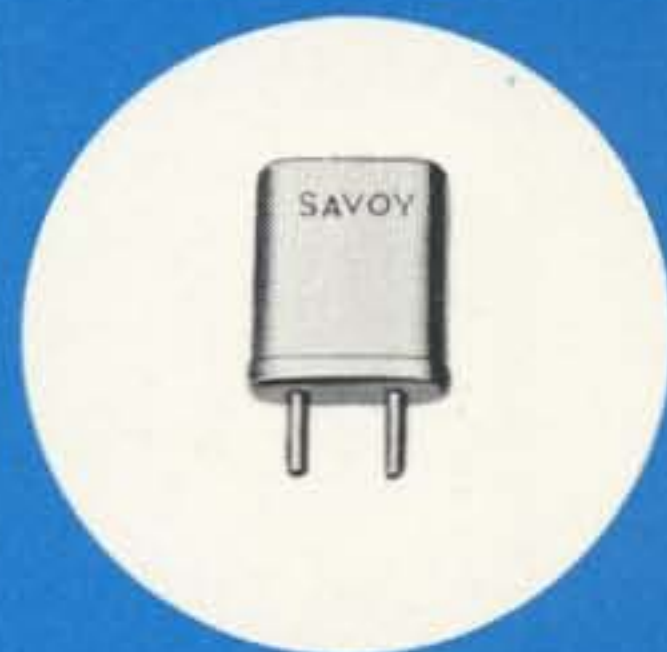

## HIGH ACCURACY CRYSTALS FOR OVER 30 YEARS

Either type for amateur VHF in Regency, Swan, Standard, Drake, Vari-tronics, Tempo, Yaesu, Galaxy, Trio, Sonar, Clegg, SBE, Genave.

Quotes on request for amateur or commercial crystals for use in all other equipments.

Specify crystal type, frequency, make of equipment and whether transmit or receive when ordering.



### BASSETT VACUUM TRAP ANTENNA SYSTEM

Complete packaged multi-band antenna systems employing the famous Bassett Sealed Resonators and Balun from which air has been removed and replaced with pure helium at one atmosphere. Operating bands are indicated by model designation.

MODEL DGA-4075	\$59.50
MODEL DGA-204075	\$79.50
MODEL DGA-2040	\$59.50
MODEL DGA-152040	\$79.50

## BASSETT VACUUM BALUN



The famous sealed helium filled Balun . . . employed with the DGA Series Antenna Systems. Solderless center insulator and easily handles more than full legal power while reducing unwanted coax radiation. Equipped with a special SO-239 type coax connector and available either 1:1 or 4:1.

MODEL DGA-2000-B . . . \$12.95  
Postpaid in U.S.A.

CONTACT YOUR DISTRIBUTOR OR WRITE FOR DATA

# Savoy Electronics, Inc.

P.O. Box 5727- Fort Lauderdale, Florida - 33310

Tel: 305-563-1333 or 305-947-9925



# Cassette Code Courses

With these code courses from 73 the average person can learn the International Morse Code fast enough to pass the Novice or Tech exam in a few painless hours! One of the beauties of cassette tape is that you can take them with you anywhere — at work for lunch break — even in the car while you are driving. With the help of these tapes, you can pass the exam as easy as - one - two - three:

**1 Basic 5 WPM Code** — this cassette code course will teach the IMC at five words per minute, all letters, numbers and punctuation. The tape not only gives all these characters, but gives them in a very simple order so you can start copying code within one minute of hearing it. This has got to be the easiest way to learn code ever invented. The cassette actually has the code being sent at 6 WPM, allowing a margin for operator panic when the chips are down and the real exam is at hand.

Basic Code 5 WPM — 90 min. **\$3.95**

**2 6 WPM Practice Tape** — (also known as The Back Breaker) this is a toughie — five character code groups sent in no particular order, so there is no way to memorize the tape. It is sent at six words per minute to give you that margin for error you'll need when faced with a stern examiner at THE EXAM. Practice in your head or on paper wherever you are, whenever you have a minute or two.

BB-6 WPM — 60 min. **\$3.95**

**3** Now you're ready to go out and pass that exam.

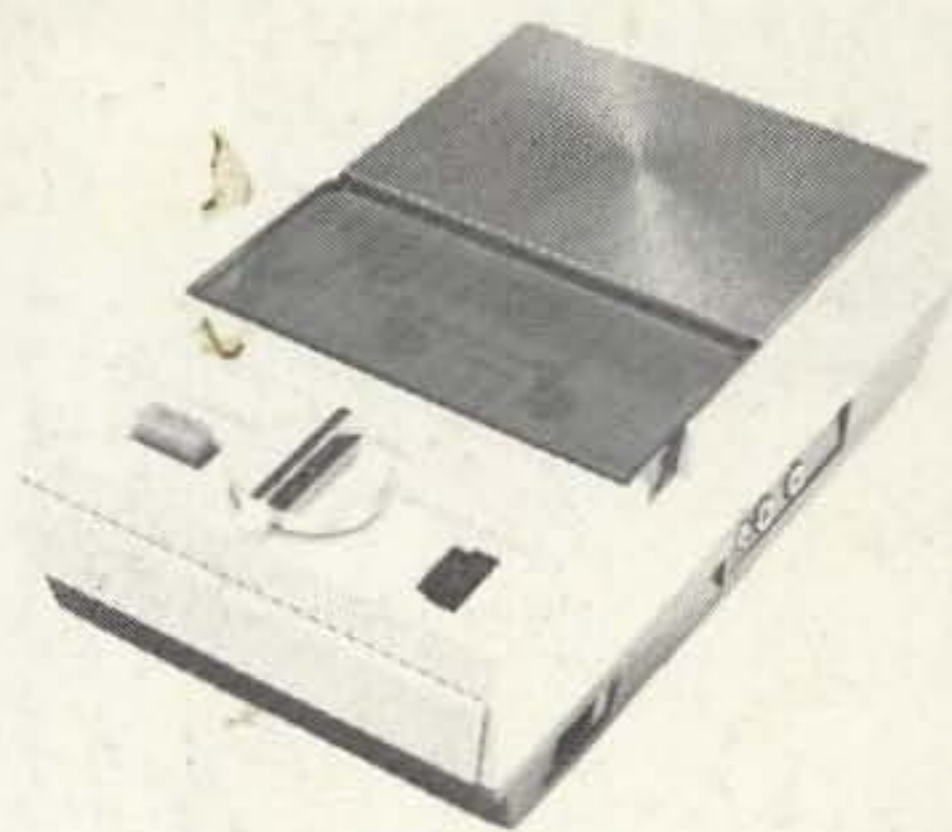

## Cassette Recorder

Here is a cassette recorder that is ideal for use with the code courses since it can be operated anywhere.

Comes complete with four "D" batteries, AC power cord, earphone and mike and is useful for dozens of ham applications. Cassette tape recorder is available for only **\$23.95** (plus \$1.00 for shipping and handling).

Order from 73 Magazine

## QSLs for 1¢

- two colors
- QSO info back
- LOW PRICES

### ORDER and PAY

250 . . .	\$6 (2.5¢ ea.)
500 . . .	\$10 (2¢ ea.)
1000 . .	\$15 (1.5¢ ea.)
2000 . .	\$20 (1¢ ea.)

These cards are printed on High Quality Glossy Card Stock and are as good, or better than cards sold elsewhere for two or three times the price. By ganging up QSL printing between other jobs in our own print shop, we are able to offer you this fantastic low price. At this price do you really have an excuse for not getting in a supply of these nice QSLs? Don't be one to give U.S. amateurs a bad name by not sending a card when requested.

Wayne Green



# W2NSD/1

73 Pine Street  
Peterborough, NH 03458

### ORDER BLANK

Name \_\_\_\_\_ Call \_\_\_\_\_  
(First and last name is most friendly)

2

Address \_\_\_\_\_  
(as brief as possible and still get through the mail)

City \_\_\_\_\_ State \_\_\_\_\_ ZIP \_\_\_\_\_ County \_\_\_\_\_  
(a must) (if desired on the card)

Awards to be listed on card \_\_\_\_\_

250  500  1000  2000 cards Amount enclosed \$ \_\_\_\_\_