

# 73<sup>®</sup>

# Amateur Radio

Issue #309  
June 1986  
USA \$2.95  
CAN. \$3.95

A WGE Publication

**Join 73's Asian DXpedition!** page 4

**FCC Proposes: Novice Phone** page 7

## Table of Contents

<b>Never Say Die</b> <i>Nine full pages of W2NSD/1!</i> .....	4	<b>Digital Simplex Repeaters</b> New-wave ham radio—a marriage of packet and digital-voice technology ..	K4YKZ 48
<b>A Walk Through the VHF/UHF Spectrum</b> Is there life after 40 meters? .....	KT2B 26	<b>Messing With Microwaves</b> Wonderfully cheap, and incredibly fun! .....	Neal 52



## Above the Crowds : VHF and UHF

**NASA Talks— A Permanent Ham in Space?** page 34

**Dirt Cheap Microwaves** page 52

**Annual "Fun!" Poll Results** page 83

**140–160 MHz On the IC-02AT** page 60

<b>Hams In Space</b> W5LFL & W0ORE talk about the past, present, and future of ham radio ..	KW1O 34	<b>They Threw What Away?</b> Our favorite uncle is dumping his UHF swr bridges .....	WA8WTE 58
<b>Two to Ten</b> A quick way to get on 10 FM with a big signal .....	WB5IPM 38	<b>Those Tantalizing Twos</b> Guess what? Your IC-2AT or IC-02AT is also a versatile scanner! .....	AL7DS 60
<b>Some Guys Make It</b> Classic humor from 73's cellar.....	K2ORS 46	<b>Computer Rotor Control</b> The first step toward an automatic shack .....	WB2UVU 64

## Reviews

<b>Head to Head:</b> ICOM's IC-471A versus Kenwood's TS-811A .....	KT2B 20
<b>MFJ's new packet TNC, the MFJ-1270</b> .....	N1BLH 24

## Departments

82 Barter 'N' Buy	18 New Products
72 Contests	76 NK6K Packet
110 Dealer Directory	110 Propagation
83 Fun!	88 QRP
73, 108 Ham Help	10 QSL of the Month
17 Letters	74 RTTY Loop
81 List of Advertisers	79 Satellites
84 Looking West	98 73 International
4 Never Say Die	78 Special Events





# NEW!

## ICOM Dual Bander

# IC-3200A



## The Most Compact Dual Bander at the Smallest Price

Finally there's a compact full featured 25 watt FM dual bander that's simple in design and operation, plus very affordable...the IC-3200A.

**Dual Bands.** The IC-3200A covers both the 2-meter (140.000-150.000MHz) and 70cm (440.000-450.000MHz) bands. The IC-3200A also features fully programmable offsets in 5KHz steps for MARS and CAP repeater operation.

**25 Watts.** The IC-3200A delivers 25 watts of output on both bands. Or the low power can be adjusted to one to ten watts.

**Compact.** The IC-3200A is only 5½"W x 2"H x 8½"D.

**Simple to Operate.** With only 14 front panel controls, the IC-3200A is by far the easiest dual bander to use.

**Memory Lockout.** For scanning only certain memory channels, ICOM utilizes a memory skip (M SKIP) function.

**10 Tunable Memories.** To store your favorite frequencies, 10 memories are provided. Each memory will store the receive frequency, transmit offset, offset direction and PL tone. Each memory can be tuned up or down when

selected, yet automatically returns to the original frequency when reselected. All memories are backed up with a lithium battery.

**Scanning.** The IC-3200A has four scanning systems... memory scan, band scan, program scan and priority scan.

### Other Outstanding Standard Features:

- New LCD display, easy to read in bright sunlight
- Tone encoder (all PL/subaudible tones built-in)
- IC-HM14 mic with up/down scan and DTMF

- One antenna connector (Duplexer already installed!)
- Variable tuning increments 5 and 15KHz (2-meters) 5 and 25KHz (70cm)
- Frequency dial lock
- Dual VFO's
- Mounting bracket

**Optional Accessories.** An optional IC-PS30 system power supply, voice synthesizer and IC-SP10 speaker are available.

See the IC-3200A at your local ICOM dealer for the best buy on a full featured dual bander.



First in Communications

ICOM America, Inc., 2380-116th Ave NE, Bellevue, WA 98004 / 3331 Towerwood Drive, Suite 307, Dallas, TX 75234

All stated specifications are approximate and subject to change without notice or obligation. All ICOM radios significantly exceed FCC regulations limiting spurious emissions. 3200A385



WORLDWIDE DISTRIBUTION



# HAM RADIO OUTLET

LARGEST HAM OUTLET IN THE WORLD

**ICOM DAY!**  
JUNE 14th — ATLANTA

## 7 STORE BUYING POWER

### ICOM IC-R71A



Superior Grade General Coverage Receiver

**SALE! CALL FOR PRICE**

### ICOM IC-3200A

DUAL BANDER

Covers Both 2 Meters & 70 cm



**LATEST EDITION**

### ICOM IC-1271A



1.2 GHz Transceiver: The First Full-featured 1240-1300 MHz Transceiver

**AT GREAT LOW, LOW PRICES**

### ICOM IC-28A/28H

**NEW**



2-METER MOBILES  
IC-28A (25w) IC-28H (45w)

**SPECIAL NEW PRICE!**

NOW! RAPID DELIVERIES FROM OUR OUTLETS

**COAST TO COAST**

To Our Customers

### ICOM HAND-HELDS



IC-02AT  
IC-04AT

VHF/UHF



IC-2AT  
IC-4AT



IC-3AT

**WE SHIP DIRECT TO YOU FROM ANY ONE OF OUR NATIONWIDE OUTLETS.**

### ICOM IC-735



The Latest in ICOM's Long Line of HF Transceivers

**CALL FOR LOW, LOW PRICE**

### ICOM DAY!

June 14 at New Atlanta Store

- Drawings for free goods at Atlanta Store
- Special Pricing for ICOM available at all Ham Radio Outlet Locations & through our 800 number.

## All Major Brands in Stock Now!



**Bob Ferrero W6RJ**  
President

**Jim Rafferty N6RJ**  
VP So. Calif Div.  
Anaheim Mgr.

ANAHEIM, CA 92801  
2620 W. La Palma  
(714) 761-3033, (213) 860-2040  
Between Disneyland & Knotts Berry Farm

**NEW**  
ATLANTA, GA 30340  
6071 Buford Hwy.  
(404) 263-0700  
Neil, Mgr. KC4MJ  
Doraville, 1 mi. north of I-285

BURLINGAME, CA 94010  
999 Howard Ave.  
(415) 342-5757  
George, Mgr. WB6DSV  
5 miles south on 101 from SFO

OAKLAND, CA 94606  
2210 Livingston St.  
(415) 534-5757  
Joe, Mgr. K5OS  
17N-5th Ave. / 17S-16th Ave.

PHOENIX, AZ 85015  
1702 W. Camelback Rd.  
(602) 242-3515  
Bob, K7RDH  
East of Hwy. 17

SAN DIEGO, CA 92123  
5375 Kearny Villa Rd.  
(619) 560-4900  
Glenn, Mgr. K6NA  
Hwy. 163 & Claremont Mesa Blvd.

VAN NUYS, CA 91401  
6265 Sepulveda Blvd.  
(818) 988-2212  
Al, Mgr. K6YRA  
San Diego Fwy.  
at Victory Blvd.

**STORE HOURS**  
10 AM-5:30 PM  
CLOSED SUNDAYS



# CALL TOLL FREE (800) 854-6046

Toll free including Alaska & Hawaii. Phone Hrs: 7:00 a.m. to 5:30 p.m. Pacific Time. California and Arizona customers call or visit nearest store. California and Arizona residents please add sales tax. Prices, specifications, descriptions subject to change without notice.

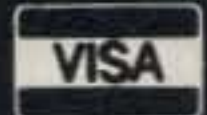
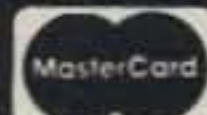



## THINGS TO LOOK FOR (AND LOOK OUT FOR) IN A PHONE PATCH

- One year warranty.
- A patch should work with any radio. AM, FM, ACSB, relay switched or synthesized.
- Patch performance should not be dependent on the T/R speed of your radio.
- Your patch should sound just like your home phone.
- There should not be any sampling noises to distract you and rob important syllables. The best phone patches do not use the cheap sampling method. (Did you know that the competition uses VOX rather than sampling in their \$1000 commercial model?)
- A patch should disconnect automatically if the number dialed is busy.
- A patch should be flexible. You should be able to use it simplex, repeater aided simplex, or semi-duplex.
- A patch should allow you to manually connect any mobile or HT on your local repeater to the phone system for a fully automatic conversation. Someone may need to report an emergency!
- A patch should not become erratic when the mobile is noisy.
- You should be able to use a power amplifier on your base to extend range.
- You should be able to connect a patch to the MIC and EXT. speaker jack of your radio for a quick and effortless interface.
- You should be able to connect a patch to three points inside your radio (VOL high side, PTT, MIC) so that the patch does not interfere with the use of the radio and the VOL. and SQ. settings do not affect the patch.
- A patch should have MOV lightning protectors.
- Your patch should be made in the USA where consultation and factory service are immediately available. **(Beware of an inferior offshore copy of our former PRIVATE PATCH II.)**

**ONLY  
PRIVATE PATCH III  
GIVES YOU ALL  
OF THE ABOVE**

# PRIVATE PATCH III

## SIMPLEX SEMI-DUPLEX INTERCONNECT



**The telephone is the most powerful mode of communications... PRIVATE PATCH III gives you full use of your home telephone from your mobile and HT radios!**

With only three simple connections to your base station radio, PRIVATE PATCH III will give you more communications power per dollar than you ever imagined possible.

Suddenly the utility of your radio is drastically increased. There are new sounds... dial tones, ring tones, CW ID and the sound of voices you never expected to hear on your mobile or HT radio! What a convenience!

PRIVATE PATCH III frees you from memberships, cliques and other hassles common to many repeater autopatches. You can call who you want, when you want and for as long as you want. You can even receive your incoming calls!

**To Learn more about PRIVATE PATCH III and the advantages of the VOX concept, call or write for our four page brochure today!**

### PARTIAL LIST OF FEATURES

- OPERATES SIMPLEX, THROUGH REPEATERS, OR DUPLEX ON REPEATERS • VOX BASED • TOLL RESTRICT (Digit counting and programmable first digit lockout) • SECRET CODE DISABLES TOLL RESTRICT FOR ONE TOLL CALL—Automatic re-arm • AUTOMATIC BUSY SIGNAL DISCONNECT
- CONTROL INTERRUPT TIMER (Maintains positive mobile control) • CW ID When you connect again on disconnect. Free ID chip. • SELECTABLE TONE OR PULSE DIALING • MOV LIGHTNING PROTECTORS • THREE DIGIT ACCESS CODE (e.g. \*91) • RINGOUT (Reverse patch) Ringout inhibit if channel busy.
- RESETTABLE THREE MINUTE TIMER • SPARE RELAY POSITION • 115VAC SUPPLY

Options:  
FCC approved coupler  
12 VDC or 230 VAC power

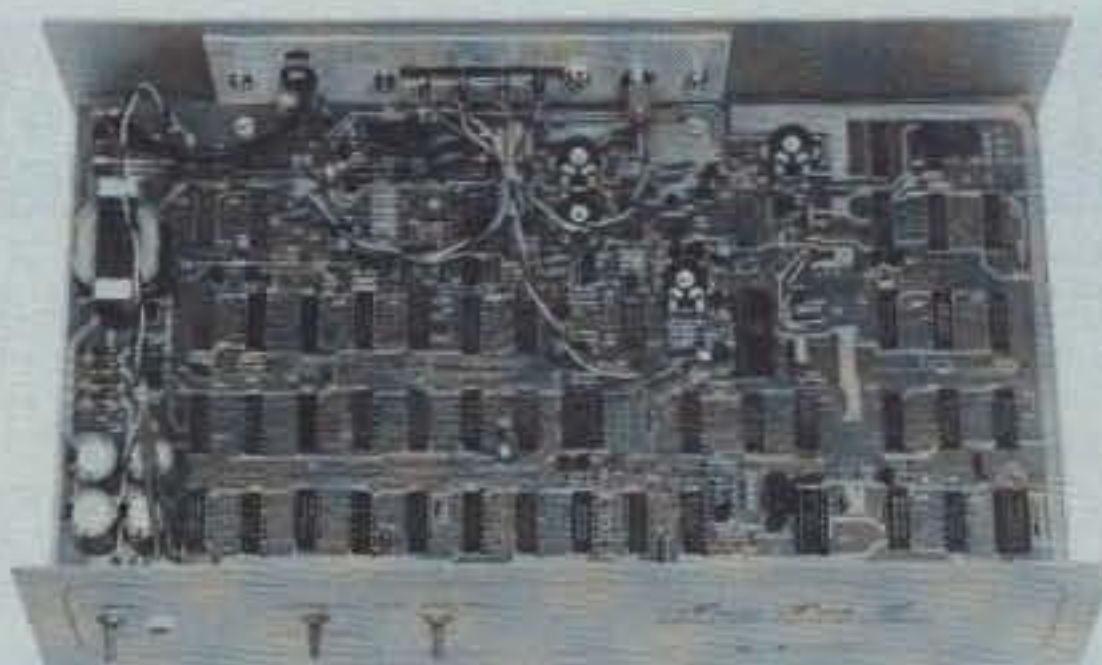

12



**CONNECT  
SYSTEMS  
INCORPORATED**

(213) 373-6803

23731 Madison St., Torrance, CA 90505

### VOX... the right choice!

VOX based phone patches offer many performance and operational advantages over the sampling method. These include operation through repeaters, compatibility with any radio, no lost words or syllables, greater range, smooth audio free of continual noise bursts, etc., etc.

Most amateurs are not aware that the competition's top of the line patch is VOX based. (You know... the \$1000 model they enthusiastically call "our favorite commercial simplex patch" on page 3 of their SP brochure.)

PRIVATE PATCH III offers about the same capability, performance and features as their top model but is priced closer to their bottom of the line (SP) model!

**So why settle for SP when top of the line costs little more?**

### DEALERS

- |  |   |
|--|---|
| AMATEUR ELECTRONIC SUPPLY<br>Milwaukee WI, Wickliffe Oh,<br>Orlando FL, Clearwater FL,<br>Las Vegas NV | MADISON ELECTRONICS SUPPLY<br>Houston, TX       |
| BARRY ELECTRONICS CORP.<br>New York, NY  | MIAMI RADIO CENTER CORP.<br>Miami FL            |
| COLES COMMUNICATIONS<br>San Antonio TX   | MIKES ELECTRONICS<br>Ft. Lauderdale, Miami FL   |
| EGE, INC.<br>Woodbridge, VA  | N&G DISTRIBUTING CORP.<br>Miami FL              |
| ERICKSON COMMUNICATIONS<br>Chicago IL  | PACE ENGINEERING<br>Tucson AZ                   |
| HAM RADIO OUTLET<br>Anaheim CA, Burlingame CA,<br>Oakland CA, Phoenix AZ,<br>San Diego CA, Van Nuys CA | THE HAM STATION<br>Evansville IN                |
| HENRY RADIO<br>Los Angeles CA  | TEXAS TOWERS<br>Plano, TX                       |
| INTERNATIONAL RADIO<br>SYSTEMS<br>Miami, FL  | TNT RADIO SALES<br>Robbinsdale, MN              |
| JUNS ELECTRONICS<br>Culver City CA   | WESTCOM<br>San Marcos, CA                       |
|  | CANADA:<br>DOLLARD ELECTRONICS<br>Vancouver, BC |
|  | SKYWAVE RADIO SYSTEMS, LTD.<br>Burnaby, B.C.    |



# 73 Amateur Radio

ISSUE #309

JUNE 1986



A 2 to 10 Transverter

## A WALK THROUGH THE VHF/UHF SPECTRUM 26

This is for all of you who've spent the last forty years on 75-meter AM. KT2B takes us on a guided tour through the five most popular bands above 50 MHz, explaining who's there and just what they're doing.

## NASA INTERVIEWS 34

73 asked hams-in-space Owen Garriott W5LFL and Tony England W0ORE what they've been up to since their historic flights. You'll be surprised by their answers!

## TWO TO TEN 38

Have you tried ten-meter FM? Repeaters are popping up all over the country, and the range is sometimes startling. WB5IPM's little gadget lets you use your two-meter gear to check out the action.

## SOME GUYS MAKE IT... 46

OK, we cheated. Those of you who have been reading 73 for the past twenty years have seen this one before. You'll laugh just as hard this time as you did before.

## DIGITAL SIMPLEX REPEATERS 48

This combination of packet radio and FM voice repeaters might be a way to ease the overcrowding on our VHF allocation. The system's creator looks at the how and why of store-and-forward voice repeaters.

## MESSING WITH MICROWAVES 52

You won't believe how simple it is to play with frequencies in the GHz range. You won't spend a fortune, either, so you can build up two of these stations and have someone to talk with.

## THEY THREW WHAT AWAY? 58

Yes, Uncle Sam is up to it again...for the price of scrap aluminum you can get dandy UHF swr bridge. Never mind that you've already paid for it...

## THOSE TANTALIZING TWOS 60

Sorry about that title. Get out your tweezers and screw up your courage!

Now pop the cover off of your beloved IC-2 or IC-02. A snip here, a tuck there, and *voila* you're holding a 140-162-MHz scanner.

## REVIEWS 20, 24

Two reviews for you this month. Above and Beyond columnist Pete Putman KT2B pits ICOM's IC-471A and Kenwood's TS-811A against each other in a head to head battle of the UHF multi-modes. And Marc Stern N1BLH presents the first look at MFJ's hot new packet TNC, the MFJ-1270. Is it the TNC for the masses?

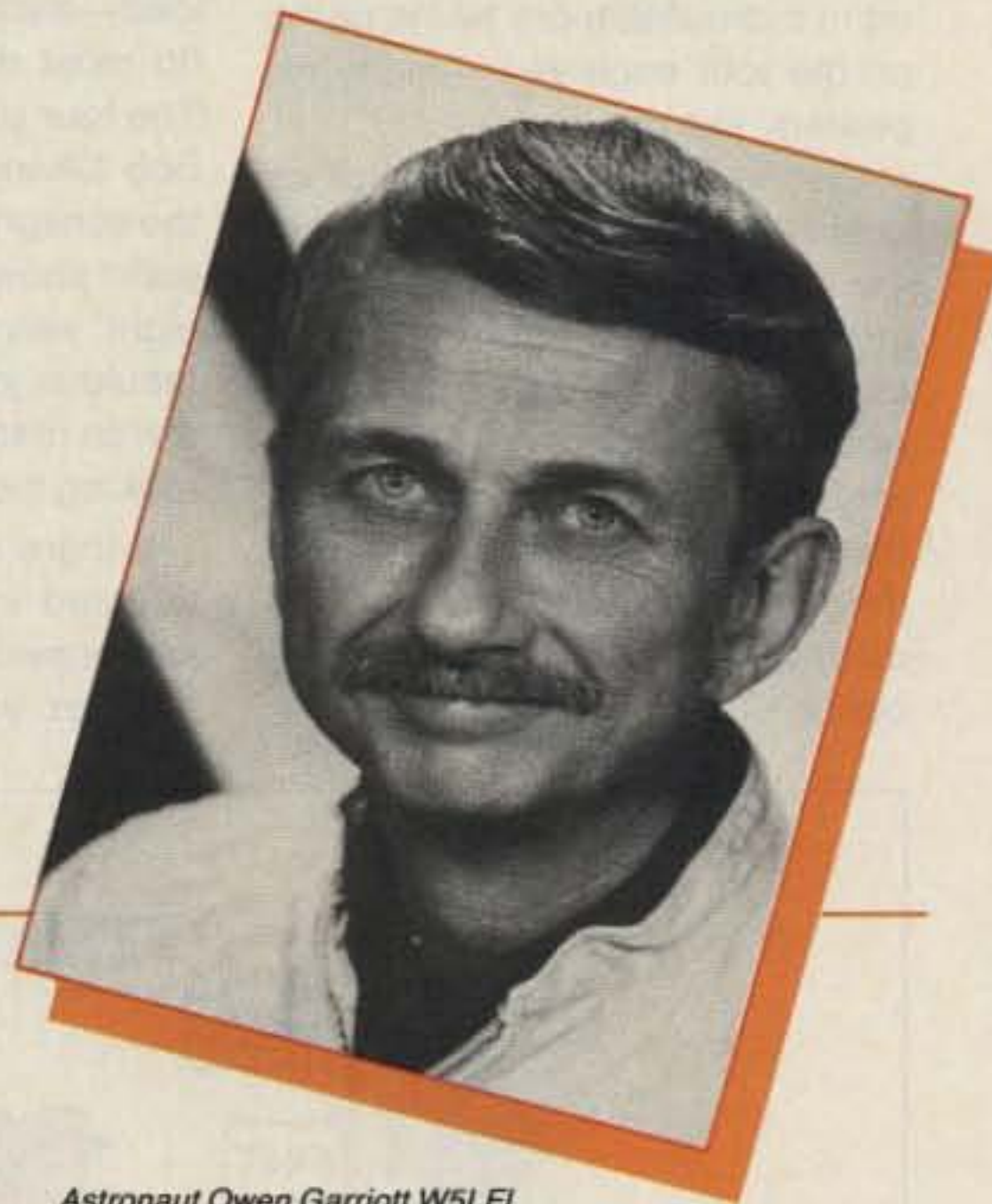

Astronaut Owen Garriott W5LFL

## DEPARTMENTS

### LOOKING WEST & QRP 84, 88

These columns bring back an old friend and introduce a new one. QRP and antenna enthusiast Bill Stocking W0VM opens shop with a monthly feature, mercifully *not* called "Stocking's Stuffers". And we welcome back Bill Pasternak WA6ITF to his old spot in Looking West. Bill has been with 73 since the beginning, and always manages to find something unusual happening on the West Coast. Sometimes he tells us about it.

### FUN! 83

KI2U has done it again. The annual Fun! poll, that is. This is the pulse of amateur radio, the heartbeat of hamdom, the...well, you get the idea. This year the poll turned out some unexpected results.

### RTTY LOOP 74

Must reading for June. Marc Leavey has come up with an incredible poem about finding a program for the Macintosh. Suitable for framing.

### NEVER SAY DIE 4

Really must reading for June. Contains the "missing editorial" absent from the May issue. (OK, since you asked, due to an "editorial oversight" we, ah, forgot to run part of Wayne's column. Just a little part. It's the first time in NSD—*don't miss it!*)

**Legal Contract:** The mere opening of the pages of this magazine, even for a hasty glance at the contents, is hereby declared to be a legally binding contract between the purchaser, whether by paid subscription, newsstand purchase, or purchase at an electronics store, and the publisher. This is every bit as legally binding a contract as signing your name, nodding your head in agreement, or tearing the plastic wrapping from a software package. Under penalty of copyright infringement, considered virtually a hanging crime by many courts, you are hereby forbidden from reproducing choice articles from this magazine for distribution to low-life hams who are too cheap to buy their own subscriptions. You are further, under severe penalties, proscribed from lending your copy of 73 to a licensed amateur friend, acquaintance, neighbor, or even enemy for other than the purpose of a brief scanning of the table of contents, which should include supportive comments by yourself and an offering of the blow-in subscription card. Heavy penalties, including, but not completely restricted to a lifetime of crushing guilt, an increasing paranoia that the dedicated minions of 73 will discover your perfidy, or that Wayne Green, in a bad moment (of which he has plenty), will put a curse on you and your issue for 73 years. You are further directed by the terms of this contract to speak enthusiastically of 73 Magazine at least once during every radio contact you make. While it is not absolutely imperative that you include a 73 subscription blank and your personal endorsement with your every QSL card, your conscience will be much clearer if you do this. Suitable subscription blanks are available from 73 for only \$1 per hundred. The extension of your subscription by two issues for each of these subscription cards received by 73 (with credit card payment) is not to be construed as a bribe of any sort. Please just consider it a personal thank-you from Wayne for your help.

**Editorial Offices:** WGE Center, Peterborough NH 03458-1194, phone: 603-924-9261. **Advertising Offices:** WGE Center, Peterborough NH 03458-1194. **Circulation Offices:** WGE Center, Peterborough NH 03458-1194, phone: 603-924-9261. **Manuscripts:** Contributions in the form of manuscripts with drawings and/or photographs are welcome and will be considered for possible publication. We can assume no responsibility for loss or damage to any material. Please enclose a stamped, self-addressed envelope with each submission. Payment for the use of any unsolicited material will be made upon acceptance. All contributions should be directed to the 73 editorial offices. "How to Write for 73" guidelines are available upon request. US citizens must include their social security number with submitted manuscripts. **Subscription Information:** Rates: in the United States and Possessions: One Year (12 issues) \$24.97; Two Years (24 issues) \$45.47. Elsewhere: Canada and Mexico—\$39.00/1 year only. US funds. Foreign surface mail—\$45.00/1 year only. US funds drawn on US bank. Foreign air mail—please inquire. To subscribe, renew or change an address: Write to Subscription Department, PO Box 931, Farmingdale NY 11737. Send Canadian changes of address to: 73, PO Box 1051, Fort Erie, Ontario CANADA L2A 5N8. Return postage guaranteed. For renewals and changes of address, include the address label from your most recent issue of 73. For gift subscriptions, include your name and address as well as those of gift recipients. For questions concerning your subscription and to place subscription orders, please call us toll free at 1-800-645-9559 between 9 am and 5 pm or write to 73, Subscription Department, PO Box 931, Farmingdale NY 11737. **73 Amateur Radio** (ISSN 0745-080X) is published monthly by WGE Publishing, WGE Center, Peterborough NH 03458-1194. Second class postage paid at Peterborough NH 03458 and at additional mailing offices. Canadian second class mail registration number 9566. Entire contents copyright © 1986, WGE Publishing. All rights reserved. No part of this publication may be reprinted or otherwise reproduced without written permission from the publisher. Microfilm Edition—University Microfilm, Ann Arbor MI 48106. **Postmaster:** Send address changes to 73 Amateur Radio, Subscription Services, PO Box 931, Farmingdale NY 11737. Nationally distributed by International Circulation Distributors.



# NEVER SAY DIE



## COME FLY WITH ME

Are you game to sit down at a rig in a rare DX spot and face the pileups?

A few years ago I started going to Asia every October to see what was new at their yearly consumer electronic shows. It was so much fun that I wrote about it in 73, urging readers to join me. This resulted in more and more hams going on the tour each year—many repeaters, like me.

On the 1985 trip several of us got to talking about how much fun the trip was, and that got us thinking in terms of organizing a ham expedition for 1986—one which would take us to Korea, Taiwan, and Hong Kong. We thought about including Japan, but with the present cost of the yen—the difficulty of getting a ham license—better off without it.

We should be able to get a license for everyone to operate in Korea, Taiwan, and Hong Kong, so it would be a real ham trip. Also, I think we'll be able to get the local hams to host us, allowing our group to see how it feels to sit and work DX from Asia.

Bob Norman K4GRD was particularly enthusiastic about this idea—excited enough to agree to do most of the work (heh, heh). The tour part will be organized by Bob Chang, who's been running the consumer electronic and computer show tours to Asia for about eight years now. Chang does a fabulous job—which is why there are so many of us who have been making the trip year after year.

If there are enough readers interested in the DXpedition, Bob will organize a hamfest in each city for you to meet the local

hams—and perhaps get invited to their homes and operate their station.

I ran a ham tour in 1963 that was a corker. 73 of us—hams and wives—went to London, Paris, Geneva, Rome, and Berlin. I still run into hams at hamfests who tell me that was the best trip they've ever taken. We had a banquet/hamfest with the hams in every city but Rome. We got to visit ham homes and operate.

In Rome we had an audience with the Pope and went on a tour of Vatican radio. In Geneva we got to operate 4U1ITU and in London many of us operated GV2SM at the Science Museum, then the only station in England permitted to handle third-party traffic.

For younger hams—and old ones with short memories—it was while we were working on this tour that the ARRL filed its Incentive Licensing proposal with the FCC—the docket which almost instantly stopped the growth of amateur radio—put 85% of the ham dealers and almost 100% of the manufacturers out of business. With amateur radio self-destructing, that put an end to ham tours.

By the time amateur radio had recovered enough so that a tour might be practical again, I was up to here in computers and starting new computer magazines. I'm not sure that even now we have enough hams with the spirit it takes to go on a DXpedition to Asia.

The tour part is fun in itself. We'll be able to get to the consumer electronic shows in Seoul and Taipei. I enjoy these because I often find products worthy of being imported by my Wayne Green International division—you may have seen ads for Pico Products. It only takes one hot mail-order product to make millions, you know—lots of people have done it.



"While we were diggin' you a deeper ground, we struck oil!"

Continued on page 10

# STAFF

**PUBLISHER**  
Wayne Green W2NSD/1  
**ASSOCIATE PUBLISHER**  
Stuart Norwood

**EDITOR**  
Perry Donham KW1O  
**MANAGING EDITOR**  
Chris Schmidt KA1MPL  
**PRODUCTION EDITOR**  
Steve Jewett KA1MPM  
**INTERNATIONAL EDITOR**  
Richard Phenix

**COPY EDITOR**  
Robin Florence  
**EDITORIAL ASSISTANT**  
Carole Macioci

**ART DIRECTOR**  
Dianne Ritson  
**DESIGNER**  
Susan Hays

**ASSOCIATES**  
Robert Baker WB2GFE  
John Edwards KI2U  
Bill Gosney KE7C  
Jim Gray W1XU  
Dr. Marc Leavey WA3AJR  
Bill Pasternak WA6ITF  
Harold Price NK6K  
Peter Putman KT2B  
William Stocking W0VM

**ADVERTISING**  
1-603-924-9261  
1-800-722-7790

**SALES MANAGER**  
Nancy Ciampa  
**ADVERTISING SALES**  
Penny Brooks KA1GAW  
**MARKETING MANAGER**  
Hope Currier

## WGE PUBLISHING, INC.

**PUBLICATIONS DIRECTOR**  
James S. Kendrick  
**CIRCULATION/  
MARKETING DIRECTOR**  
Harry Dermody  
**OPERATIONS MANAGER**  
David P. Raether  
**PRODUCTION SUPERVISOR**  
Bruce Hedin  
**PRINTING SERVICES MANAGER**  
Tedd A. Cluff  
**SYSTEMS MANAGER**  
Sara B. Philbin  
**TYPESETTING/PAGINATION**  
Bob Dukette, Mike Thompson  
**GRAPHICS SERVICES**  
Sue B. Flanagan, Dan Croteau,  
Liz McGrath, Cindy Pirkey  
**CIRCULATION MANAGER**  
Kristin Joslin

**Editorial Offices**  
WGE Center  
Peterborough, NH 03458-1194  
603-924-9261

Wayne Green Enterprises is a division of International Data Group.

73 Amateur Radio (ISSN 0745-080X) is published monthly by WGE Publishing, Inc., a division of Wayne Green Enterprises, Inc., WGE Center, Peterborough NH 03458-1194. Entire contents © 1986 by WGE Publishing, Inc. No part of this publication may be reproduced without written permission from the publisher.



# KENWOOD

...pacesetter in Amateur radio

All New  
Compact HF!

## “DX-citing!”

### TS-440S Compact high performance HF transceiver with general coverage receiver

Kenwood's advanced digital know-how brings Amateurs world-wide “big-rig” performance in a compact package. We call it “Digital DX-citement”—that special feeling you get every time you turn the power on!

#### Covers All Amateur bands

General coverage receiver tunes from 100 kHz—30 MHz. Easily modified for HF MARS operation.

#### Direct keyboard entry of frequency

All modes built-in USB, LSB, CW, AM, FM, and AFSK. Mode selection is verified in Morse Code.

#### Built-in automatic antenna tuner (optional)

Covers 80-10 meters.

#### VS-1 voice synthesizer (optional)

#### Superior receiver dynamic range

Kenwood DynaMix™ high sensitivity direct mixing system ensures true 102 dB receiver dynamic range. (500 Hz bandwidth on 20 m)

#### 100% duty cycle transmitter

Super efficient cooling permits continuous key-down for periods exceeding one hour. RF input power is rated at 200 W PEP on SSB, 200 W DC on CW, AFSK, FM, and 110 W DC AM. (The PS-50 power supply is needed for continuous duty.)

- Adjustable dial torque
- 100 memory channels

Frequency and mode may be stored in 10 groups of 10 channels each. Split frequencies may be stored in 10 channels for repeater operation.

#### TU-8 CTCSS unit (optional)

Subtone is memorized when TU-8 is installed.

#### Superb interference reduction

IF shift, tuneable notch filter, noise blanker, all-mode squelch, RF attenuator, RIT/XIT, and optional filters fight QRM.

#### MC-42S UP/DOWN mic. included

#### Computer interface port

#### 5 IF filter functions

#### Dual SSB IF filtering

A built-in SSB filter is standard. When an optional SSB filter (YK-88S or YK-88SN) is installed, dual filtering is provided.

#### VOX, full or semi break-in CW; AMTOR compatible.



#### Optional accessories:

- AT-440 internal auto. antenna tuner (80 m—10 m)
- AT-250 external auto. tuner (160 m—10 m)
- AT-130 compact mobile antenna tuner (160 m—10 m)
- IF-232C/IC-10 level translator and modem IC kit
- PS-50 heavy duty power supply
- PS-430/PS-30 DC power supply
- SP-430 external speaker
- MB-430 mobile mounting bracket
- YK-88C/88CN 500 Hz/270 Hz CW filters
- YK-88S-88SN 2.4 kHz/1.8 kHz SSB filters
- MC-60A/80/85 desk microphones
- MC-55 (8P) mobile microphone
- HS-4/5/6/7 headphones
- SP-40/50 mobile speakers
- MA-5/VP-1 HF 5 band mobile helical antenna and bumper mount
- TL-922A 2 kw PEP linear amplifier
- SM-220 station monitor
- VS-1 voice synthesizer
- SW-100A/200A/2000 SWR/power meters
- TU-8 CTCSS tone unit
- PG-2C extra DC cable.

Kenwood takes you from HF to OSCAR!



25th Anniversary

# KENWOOD

Complete service manuals are available for all Trio-Kenwood transceivers and most accessories. Specifications and prices are subject to change without notice or obligation.

TRIO-KENWOOD COMMUNICATIONS  
1111 West Walnut Street  
Compton, California 90220



# KENWOOD

...pacesetter in Amateur radio

Here Now  
TM-3530A  
220 MHz

## Power-Full...70 Watts!

### TM-2570A/2550A/2530A/3530A

#### Sophisticated FM transceivers

**Kenwood sets the pace again!**  
The all-new "25-Series" brings the industry's first compact 70-watt 2-meter FM mobile transceiver. There is even an *auto dialer* which stores 15 telephone numbers! There are four versions to choose from: The TM-2570A 70-watt, TM-2550A 45-watt, TM-2530A 25-watt and the TM-3530A 220 MHz, 25-watt.

- **First** 70-watt FM mobile (TM-2570A)
- **First** mobile transceiver with telephone number memory and auto-dialer (up to 15 seven-digit phone numbers)
- Direct keyboard entry of frequency
- Automatic repeater offset selection — a **Kenwood exclusive!**
- Extended frequency coverage for MARS and CAP (142-149 MHz; 141-151 MHz modifiable)
- 23 channel memory for offset, frequency and sub-tone
- Big multi-color LCD and back-lit controls for excellent visibility

- Front panel programmable 38-tone CTCSS encoder **includes 97.4 Hz** (optional)
- 16-key DTMF pad, with audible monitor
- Center-stop tuning — **another Kenwood exclusive!**
- Frequency lock switch
- **New** 5-way adjustable mounting system
- **Unique** offset microphone connector — relieves stress on microphone cord

Large heatsink with built-in cooling fan (TM-2570A)



- High performance GaAs FET front end receiver
- HI/LOW Power switch (adjustable LOW power)
- TM-3530A covers 220-225 MHz



#### Introducing... Digital Channel Link

Compatible with Kenwood's DCS (Digital Code Squelch), the DCL system enables your rig to **automatically** QSY to an open channel. Now you can automatically switch over to a simplex channel after repeater contact! Here's how it works:

The DCL system searches for an open channel, remembers it, returns to the original frequency and transmits control information to another DCL-equipped station that switches **both** radios to the open channel. Micro-processor control assures fast and reliable operation. The whole process happens in an instant!



Actual size front panel

#### Optional Accessories

- **TU-7** 38-tone CTCSS encoder
- **MU-1** DCL modem unit
- **VS-1** voice synthesizer
- **PG-2K** extra DC cable
- **PG-3A** DC line noise filter
- **MB-10** extra mobile bracket
- **CD-10** call sign display
- **PS-430** DC power supply for TM-2550A/2530A/3530A
- **PS-50** DC power supply for TM-2570A
- **MC-60A/MC-80/MC-85** desk mics.
- **MC-48** extra DTMF mic. with UP/DWN switch
- **MC-42S** UP/DWN mic.
- **MC-55** (8-pin) mobile mic. with time-out timer
- **SP-40** compact mobile speaker
- **SP-50** mobile speaker
- **SW-200A/SW-200B** SWR/power meters
- **SW-100A/SW-100B** compact SWR/power meters
- **SWT-1** 2m antenna tuner

# KENWOOD

TRIO-KENWOOD COMMUNICATIONS  
1111 West Walnut Street  
Compton, California 90220

Complete service manuals are available for all Trio-Kenwood transceivers and most accessories. Specifications and prices are subject to change without notice or obligation. Specifications guaranteed on Amateur bands only.



## Novice Phone

THE FCC has proposed an enhancement to the present Novice-class license. The Notice of Proposed Rule Making, **PR Docket 86-161**, calls for data privileges from 28.1 to 28.3 MHz, SSB from 28.3 to 28.5 MHz, all amateur privileges from 220 to 225 MHz, and simplex and repeater privileges from 1246 to 1260 MHz. Power restrictions would be 200-Watt PEP on ten meters, 25 Watts on 1-1/4 meters, and 5 Watts on 23 centimeters. Higher-class stations would be allowed to run the full legal limit in the Novice portions of these bands. Further, Novice licensees would not be allowed to be trustees of a repeater station, although they would be allowed to operate through a repeater. Technicians, because of the structure of the license system, would gain the additional privileges of the Novice enhancement. The FCC is very interested in hearing ideas on several points. Should the Novice-license term be reduced to two or five years to encourage upgrading? Should questions be added to the Novice test to cover the new privileges? Should more than one person administer the test, or should Novices be tested through the volunteer-examination program? Should Element 3 (the General-class exam) be broken into two parts—part A to cover VHF and repeaters and part B to cover HF operation—to make it easier to upgrade from Novice to Technician? Comments on the proposal are due at the commission by July 16th, and reply comments must arrive by August 20th. Send your original comment plus five copies (11 copies if you want each commissioner to have one) to the FCC, 1919 M Street NW, Washington DC 20554. Please include the Docket number in the head of your document.

## Albania Mania

GUS BROWNING W4BPD, writing in his *DX'ers Magazine*, reports that OK2RZ and five other Czechoslovakian amateurs have obtained permission to operate from Albania. The DXpedition to ZA is expected to begin around the 20th of September—watch QRX for details. Gus also mentions expeditions to Vietnam and Yemen. . . it looks as though DX is beginning to pick up a bit. The *DX'ers Magazine* is a great source for up-to-minute news; you can write to Gus at PO Drawer DX, Cordova SC 29039. (Tell him you think 73 deserves a kickback for plugging his rag.)

## Techno-Tantrums

WHO WOULD HAVE THOUGHT that our announcement of the first 900-MHz amateur communication (QRX, January, 1986) would trigger a range war? Chuck Gollnick KA7QEN/0 of the Iowa State University Cy-

clone Amateur Radio Club contends that they, not Mike Krzystniak K9MK/5, are the rightful holders of the title. Now, this would not be so bad so long as one or the other could produce documentation of the exact time of the contact. Chuck and the boys at Iowa State drew first blood by describing their system: "Our first transmission was keyed by time signals received from WWV. Considering the propagation delay between WWV and Ames (Iowa), the delay in our decoder circuit, and the key time of our transmitter, the signal was transmitted no more than 50 milliseconds after the legal band opening, and probably less than that." To which Mike countered, "I have no doubt that we [members of the Motorola Radio Club in Ft. Worth] beat your alleged 50-milliseconds-after-the-band-opened claim by at least 49.999999 milliseconds. I cannot disclose the commercial techniques that we used to do this with as they are. . . currently proprietary." In the second round, Chuck and the Cyclones pointed out that, "Our first transmissions. . . were made *after* the band was legally open. If. . . your clock was not calibrated to the NBS standard and was, say, just 5 nanoseconds fast, . . . then your first transmissions would have occurred at least 4 nanoseconds *before* the 900-MHz band was open for legal use by amateurs, which would qualify you as the first amateur to earn a pink slip on 900 MHz." In the interest of fair play, and in the spirit of ham fellowship, I think we should point out that Iowa State's transmission was the first AM transmission, and the Motorola club's was the first FM transmission. Give or take a nanosecond.

## OSCAR's Out

AMSAT-OSCAR 10 will not be available for this year's ARRL Field Day exercise, according to the *Amateur Satellite Report*. AO-10 Command Station ZL1AOX indicates that the bird will be visible only during perigee and that it probably will not be turned on due to eclipses during that period. Meanwhile, work is progressing on the next Phase III satellite, which is scheduled for launch aboard an Ariane booster later this year.

## Turkey and Ham

AMATEUR RADIO ACTIVITY in Turkey is still increasing, with more than 20 stations now licensed. Salim Unuver TA1B details some of the action: "Lots of [Turkish hams] are usually on 14-MHz SSB or CW. Every night, U.S. hams can find TA stations on 14.200 MHz at 1900 UTC. You will hear perhaps TA1C or TA1E, because they are using 3-element beams and running the legal limit of 400 Watts PEP. Other TAs are running 200 Watts to a dipole or ground plane, like me and TA1F, and we are running RTTY on 14.180 each night at



Salim Unuver TA1B at his station in Ankara.

1900, and all day on Saturday and Sunday." Salim points out that TA1 stations are located on the European side of Turkey, while TA2-9 indicates stations on the Asian side. TA0 calls are assigned to stations on Turkish islands.

## New SIN

IF YOU PARTICIPATED in the National Six-Meter Invitational Net Activity Day Contest [whew!] on May 31st-June 1st, please mail your logs to Lisa Lowell KA0NNO's new address: PO Box 547, Hugo CO 80821.

## Malibu Good Guy

DANIEL GOODKIN KA6VVS, Novice at age 7 and General at age 11, has become the youngest member of the Los Angeles County Disaster Communications Service (a part of the Radio Amateur Civil Emergency Service). Daniel has already earned two commendations from the Malibu Sheriffs Department for his work during the recent Lake Sherwood and Carbon Canyon fires, where he worked for several days carrying messages between key command centers. Belonging to the DCS is a family affair for the Goodkins; Daniel's father Norm is the District Communications Officer for the organization, and Daniel's mother Naomi WB6OHW, brother Brian N6FKG, and sister Mari KA6PTV are all members.

## Eagle Droppings

HAVE YOU SEEN the latest catalog from Innovations? They're one of those companies that offer high-tech goodies like wine computers and 127-function watches. On page 38 of the catalog, right between Wet Tunes the Shower Radio and the Bionic Ear, is a little item called the Eagle 1 Professional Transceiver. "Not a toy or Citizens Band walkie-talkie. FCC approved, license information included. The Eagle 1 packs 200 milliwatts of output power for clear, sharp transmissions up to 4 miles. Useful in warehouses, farms, and factories. Choice of 3 crystal-controlled channels within 10-MHz band for privacy (one crystal supplied with each unit)."



**Brent Cordes AE6R** checked with Samhill Corp., the manufacturer, and discovered that the crystal supplied with each unit is for 446.000 MHz, the national calling frequency for the amateur 440-MHz band! The other two channels are 446.200 and 445.800. I telephoned Samhill in New York and asked what sort of license was required to operate the Eagle 1. "Oh, amateur," was the reply. I can see it now. . . thousands of yuppies buying chic little HTs, only to find a note in the box telling them that they can't use the radio until they learn Morse code and get an amateur license! We've dropped Innovations a polite note, and will let you know what happens.

## Pubs Merge

**BOB GROVE**, Editor of *Monitoring Times*, and **Larry Miller**, Editor of *International Radio* (formerly *Shortwave Guide*), have announced plans to merge their publications. Starting with the July, 1986, issue, the new *Monitoring Times* will feature an expanded 60-page format and improved laser printing. A one-year subscription is \$14, available from 140 Dog Branch Road, PO Box 98, Brasstown NC 28902; (704)-837-9200.

## Expo '86

**THIRTEEN MILLION VISITORS** to Canada's World's Fair of Transportation and Communication will be exposed to the amateur radio virus, thanks to the members of the **VE7EXPO Amateur Radio Society**. The all-volunteer effort will feature SSB, CW, RTTY, AMTOR, packet, FM, ATV, and SSTV at five operating positions—two for HF and one each for packet, OSCAR, and VHF/UHF. The Exposition, which will run through October 13th, is housed on the Canada Pavilion, "anchored" in Vancouver harbor. The ham station, using special call VE7EXPO, will operate from 10 a.m. to 10 p.m. each day. Local repeaters (146.94, 224.30, and 443.525 MHz) will be monitored to provide directions and assistance to visiting amateurs. If you would like to work from the station, or if your club would like

to come up as a group, contact the **VE7EXPO Amateur Radio Society** at 202-13640 67 Avenue, Surrey, British Columbia Canada V3W 6X5.

## Glowing Report

**73 INTERNATIONAL** correspondent **Rudolf Karaba OK3KFO** sent us the results of a UHF aurora marathon recently completed in the Soviet Union. For two years, Soviet experimenters have participated in a competition designed to examine UHF aurora propagation. The top three single-op stations are UA3BMJ with 155 QSOs and 5,442 points, UR2RQ with 139/3,795, and UA9XQ with 149/3,159. The top club station is UZ9CXM with 23 QSOs, and the top SWL is UA3-142-198 with 9 reports.

## No Note Needed

**THE FCC**, in a letter to the PHD Amateur Radio Club of Missouri, said that no doctor's statement is required when special amateur testing procedures are needed due to an applicant's physical disability. The statement was necessary under the old testing system when an applicant was unable to travel to an FCC testing site, but the requirement was not carried over to the new volunteer testing program.

## 4X4 Foray

**A TWO-WEEK TRIP** to the Holy Lands is being arranged by the Chaverim, an international group dedicated to fostering goodwill among Jewish hams and their friends. The tour will depart from J.F.K. International Airport on Monday, October 27th, and will return to the States on Monday, November 10th. The group will visit Muslim, Jewish, and Christian shrines and will have the opportunity to operate from 4X4 during its stay. There also will be meetings with the Israeli Amateur Radio Club and the Quarter Century Wireless Association. Space is limited, so contact **Bill Soble W3QXT**, 9357

Hoff Street, Philadelphia PA 19115; (215)-676-6769.

## Motorola Morgue

**HERE'S A GREAT OPPORTUNITY** to get rid of all that junk in your shack (sorry, I meant "valuable communication equipment"). **Don Parker**, Motorola's Branch Manager for Alaska, is the curator of the new **Museum of Early Two-Way Radio Equipment** in Anchorage. Don has already gathered a number of vintage VHF/UHF radios, but is looking for more. If you think you might have something that belongs in a museum, get in touch with Don at Motorola, Inc., 5333 Fairbanks Street, Suite Ibsgn1, Anchorage AK 99502, or call (907)-562-2111.

## Write-In Vote

**THIS MONTH YOU'LL FIND** a special Feedback card next to page 80. Use it to rate the articles and columns in this month's 73. When all of the votes are in, we'll award a free one-year subscription (or extension) to the person whose name is on the card we draw out of a hat. While you're filling things out, take a second to complete the Product Report Card, too. In July we will begin publishing a running tally of your favorite radios . . . or least-favorite, for that matter.

## Log Jam

**LOGS FROM THE DP0SL** Hams-In-Space mission of last year have been released. An automatic logging machine aboard the shuttle captured the following U.S. call signs: AA6G, AJ5L, K1PXE, K6CO, K6NLP, K6RTC, K7PYK, KA0NVT, KA0DO, KA1DUX, KA2RBX, KA6CR, KA7SJP, KB4CRT, KB6FFJ, KB7RV, KC7EM, KD5RO, KD6PY, KD6WG, KD7AW, KG6GF, KG6KO, KG6LC, N1DBB, N2BKT, N3FL, N6CAV, N6FF, N6GVP, N6IDN, N6RW, N7GDW, N7ZL, N9AB, NA6E, ND2X/5, NF6S, NK6K, NN0V, W0BPP, W1HH, W1NU, W2JNO, W3IP, W3PM, W4BE, W4MOP, W5AQQ, W5CBT, W5EBH, W5HQQ, W5HUQ, W5RRR, W5VY, W5ZIB, W6KH, W6MFO, W7MCU, W7OHF, W7QLC, W7US, W9ODI, WA0RCX, WA1FCK, WA1OMM, WA3HUP, WA3WBU, WA4BUS, WA5NOM, WA5RCL, WA5ZIB, WA6YBT, WA7GCS, WB4KXB, WB5BSH, WB5GLD, WB7AYU, WB5LBJ/DU6, WB7OHF, WB8OTH, WD4AHZ, WD4BCS, WD4NAE, WD4PQN, WD5EZR, and WD9IIC.

## QSL

That's all for this month. Thanks to *Westlink*, the *W5YI Report*, *Amateur Satellite Report*, **Tad Cook KT7H**, **Robert Smits VE7EMD**, and the *DX'ers Magazine* for help with this month's column. Send your news and photos to 73 Magazine, WGE Center, Peterborough NH 03458, Attn: QRX.



Canada Place, site of the Canada Pavilion and special-event station VE7EXPO.





# FM-X40 Series

FM-240 2 Meters

FM-740 70 cm

# SPECTACULAR MOBILE SIMPLICITY



- Superior features, simpler to use for 2 meters, MARS, CAP
- Compact size for better fit in today's automobile
- 16 fully programmable memory channels, plus priority call channel, plus 2 VFOs for today's user
- Subaudible encode and decode standard for today's 2 meter bands
- Subaudible frequency programmed by freq, no chart needed
- Speech synthesis option for voice VFO
- Superior man machine interface—one knob and one button, program all of the features easily—alphanumeric LCD prompts
- 16 button speaker/mic with UP/DN lock-out switch
- VFO Steps Size—2.5-40KHz, programmable (x 10 with Speed on)
- Band Scan—Programmable limits and modes, CARRIER, AUTO & DELAY. Scan steps same as set for VFO steps.
- Memory Scan—Programmable modes, SKIP, CARRIER, AUTO & DELAY.



Specifications KDK FM-240 (and FM-740)	
<b>General</b>	
Supply Voltage	13.8v ± 15%, negative ground.
Consumption	Transmit: 1.5A @ 5w, 5.5A @ 25w Receive: .4A @ 0 sig., .6A @ max volume.
Temp. Range	- 10 deg. C to 60 deg. C.
Dimensions	40H x 140W x 170D mm (Body only)
Weight	1.0Kg (Body only)
<b>Transmitter</b>	
Freq. Range	FM-240 142.000 - 150.00 MHz (FM-740 440.00 - 449.975 MHz)
Output	High = 25 watts, Low = 5 watts (High = low, (Low = 1W) (FM-740 High = Low)
Modulation	Variable reactance frequency modulation
Max. Deviation	± 5KHz
Spur. Emis	More than 60dB down from carrier
Duplex Offset	Programmable ± .1 to 12.7MHz (set at ± .6KHz ex-factory)
Tone	Programmable 74-250.3 (34 EIA tones) Encode and Decode
<b>Receiver</b>	
Int. Freq	1st = 10.7MHz, 2nd = 455KHz (1st-21.4MHz 2nd-455KHz)
Sensitivity	Better than 12dB SINAD @ .2uV
Squelch Sens	Better than .15uV
Bandwidth	+ 6KHz @ - 6dB
Selectivity	+ 12.5KHz @ - 60dB
Image Ratio	Better than 70dB
Audio Output	More than 2w, 8 ohms load, 10% THD
<b>Standard Accessories</b>	
Speaker Microphone	Speaker = 8 ohms, Mike = Condenser type. SM-34A: UP/DOWN plus tone encoder.
Power Cable	2 meters, with 7A fuse.

FM-240  
Suggested Retail \$369

FM-740  
Suggested Retail \$429

Limited time offer - Free MS-20 external speaker with purchase of FM-240 or FM-740. See your dealer now.



1506 CAPITAL AVENUE, PLANO, TEXAS 75074 PHONE · 214-423-0024 GIII FAX · 214-423-0081  
NATIONAL DISTRIBUTION FOR SANTEC · KDK · KENPRO · THL · WELZ PRODUCTS



# NEVER SAY DIE

from page 4

We stay in the best hotels and get great breakfasts every morning as part of the tour package. The tour includes air fares, land transportation, airport taxes, and so on. The ham DXpedition will include at least one hamfest dinner in each city. Chang also organizes reasonably priced dinner parties for those interested in trying local foods—such as the delicious Mongolian Barbeque in Taipei. Or perhaps, by the time you get to incredible Hong Kong, you'll be ready for a Mexican dinner. That was my choice last October—dragging along a young ham, Chris Peterson KB9YT, and Rod McKuen (the poet), going to the restaurant via the Start Ferry, then a ride on a 75-year-old trolley car. You won't forget a trip around Hong Kong like that—especially at night. We went back to our hotel on the new ultramodern subway.

They've got a 2m repeater in Hong Kong, so we'll all be able to keep in touch from anywhere in the colony. Bob and I were talking about bringing a portable repeater to Taipei, but we don't know whether Tim Chen BV1A will be able to get it okayed or not. It'd be fun, if we could swing it. We might be able to do that in Seoul, too. I got a license there a few years ago as HL9WG and worked all over the city with my HT via a repeater run by Army MARS. Everyone should bring an HT, naturally.

The DXpedition will take about

ten days, which almost everyone should be able to finagle.

I should be satisfied with a DXpedition to Korea, Taiwan, and Hong Kong, but I wondered if, as long as we're in the area anyway, you might not want to take just a few more days and make it not just a trip you'll never forget, but one your friends will never forget either. My sneaky plan is to take those with the time and guts on from Hong Kong to Sabah 9M6, Brunei V85, and Sarawak 9M8.

I made this trip three years ago and it was one of the most interesting I've ever made. Along the Borneo north coast is Kota Kinabalu, Sabah, where we'll stay at the Kinabalu Hyatt. KK, as they call it, is a lovely, fascinating town. The hams are incredibly friendly. Until you've gotten on the air from Sabah, you don't know what a pileup really is from the DX end.

The next stop is Bandar-Seri-Begawan, the capital of Brunei—the wealthiest country per capita in the world. We'll stay at the Brunei Sheraton. The hams there are also ultra-friendly. This is the country where people are able to get interest-free loans from the government for cars and houses. The Sultan is the richest man in the world. I wonder if he'll shake hands with us—he might if we have a good-sized group.

In Kuching, the capital of Sarawak, we'll be staying at the new Hilton. On my last trip I got on the air and had a ball. I also made a side trip up into the hills to visit a

long-house—a whole village built on stilts, including the sidewalks. There were still skulls hanging from the days, just a generation ago, when these people were still head hunters.

The whole trip—Seoul, Taipei, Hong Kong, Kota Kinabalu, Bandar-Seri-Begawan, Kuching—will take twenty days—about three weeks for an experience you'll never forget. If you go for it, Bob and I have an eye on getting you to China and Macao next year—and probably to Singapore and Bangkok in 1988—unless you'd like to get up to see Father Moran in Nepal and see what it's like to operate from 9N1MM. Yep, I've done that, too. I've operated from all those places... ho hum... yawn.

Of course it's always possible that amateur radio has been so decimated by its lack of growth for the last 23 years that there aren't enough adventurous spirits left to make a DXpedition like this feasible.

Take a look at your calendar and see if you can get away from October 5th to 16th for the three-country DXpedition—or until October 25th for the six-country DXpedition. The costs aren't firm yet, but should run around \$3,000 for the three countries and \$5,000 for the six countries.

If you've got enough left to bring your wife, I guarantee she'll enjoy it. There are plenty of things to see and a lot of shopping to do. You probably already know about buying electronic gadgets in Hong Kong—by far the cheapest place in the world for 'em. HK is also a great place for clothes—providing you manage to get past the tailor in the hotel in Taipei where most of the group this last trip bought \$150 custom-made suits (I bought two). Custom-made shirts are \$10. You've seen the Seoul bargain fur ads in many American magazines.

In Sarawak you get some great batik paintings and batik shirts. I like the batik shirt I bought in Kuching so much I wear it just about all summer. Each country has interesting things to buy. The prices are surprisingly low—except in Manila where they are much, much lower.

Tell your wives that Sherry was with me on the trip and loved every minute of it. She will never forget our sitting at dusk by the Sarawak River having a "steamboat" dinner—all sorts of meats and vegetables you dip in boiling broth and cook at the table. It's a

lot like shabu-shabu, if you've had that.

We also won't forget the short intense rain shower which dumped maybe four inches of water in an hour and then went away as quickly as it came. Sure, these Borneo countries are only about a hundred miles from the equator, but they're comfortable, running around 82–85 degrees year round. Don't bring your heavy coats—just a raincoat or umbrella for that occasional shower.

Let's see, I didn't mention a visit to the Korean Village, just outside Seoul—you'll need lots of film for this. It's a recreated old Korean village, showing how people used to live. There are plenty of food vendors and their food is superb—cooked while you watch.

In Taipei you'll want to allow some time to see their incredible museum—and maybe, if you have the stomach for it, a trip to Snake Alley. Yecch. You'll certainly want to try a Wendy's hamburger at the Wendy's next to the hotel in Taipei and the one at Etweon in Seoul—the only Wendy's in the world I know of with hookers sitting around the tables looking for business. Yep, they serve Frosties there too. If you get hooked on Wendy's, there's a nice one in Hong Kong now, too, complete with salad bar. Lordy! It's all there, McDonalds, Pizza Hut, Kentucky Fried—even Chuck E Cheese's Pizza Time Theatre. Of course just down the street you can get a great Indonesian ristofle.

I'm trying to arrange to have some QSL cards we can take along with us—if I can get my print shop in gear. If you sign up in time we'll have your QSL cards for the trip—showing your six-country DXpedition on a map.

You'll have to make a decision on this early so Bob will be able to send a copy of your ham license to each of the seven countries involved and get the paper work done. These government bureaucrats don't rush for anyone, so get me a \$1,000 down payment for the trip and eight copies of your ham license.

I am planning on personally escorting the DXpedition—so I'll be able to give you inside info on where to go, what to see, what to shop for, and what to do. Be warned that I also talk a blue streak and got surly the only time anyone out-talked me.

I have this peculiar problem—when I find something which is fun I have an urge to share my fun with as many people as possible. DX-



## QSL OF THE MONTH

To enter your QSL, mail it in an envelope to 73, WGE Center, 70 Rte. 202 N., Peterborough NH 03458, Attn: QSL of the Month. Winners receive a one-year subscription (or extension) to 73. Entries not in envelopes cannot be accepted.



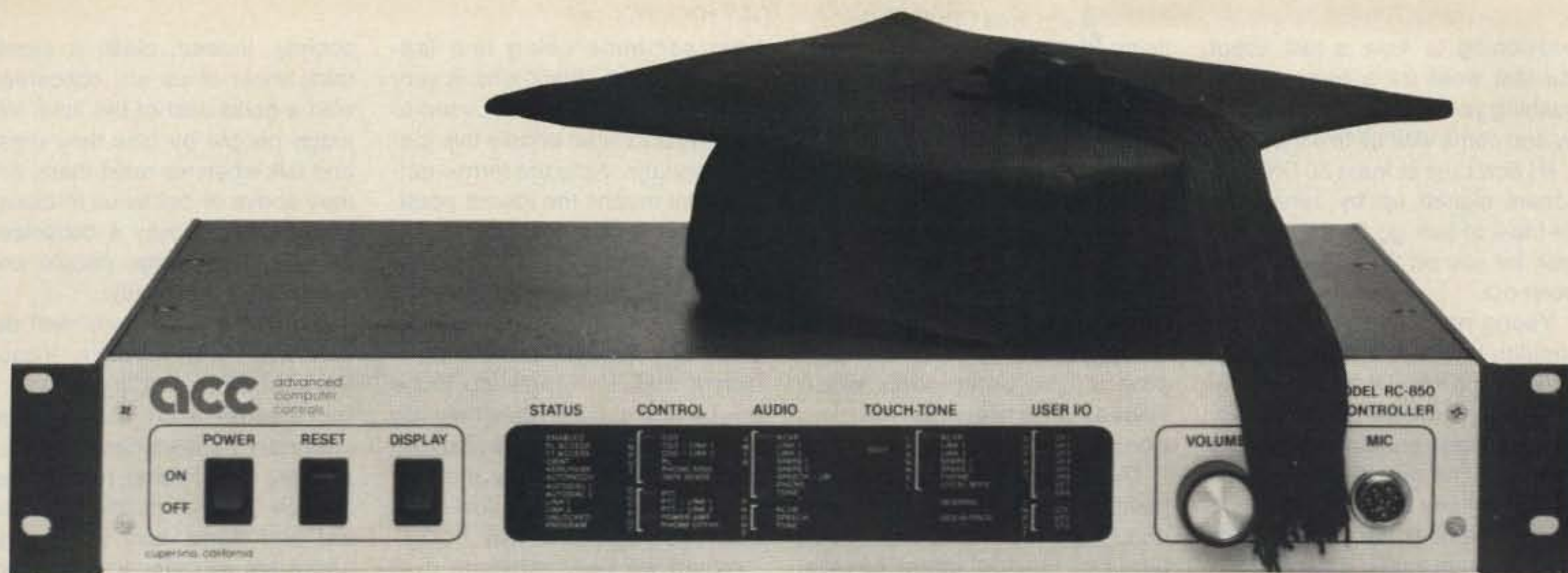

## The RC-850 Repeater Controller just got a whole lot smarter.

Our new Version 3 software makes the best repeater controller **EVEN BETTER**.

The autopatch now supports remote telephone lines linked by radio, so that you can extend your autopatch coverage to match your RF coverage. You can have autopatch even if you can't get a phone line at your site. The 250 autodial numbers meet the needs of even the largest groups, with up to 35 digit storage for MCI and Sprint.

The easy-to-use Electronic Mailbox lets you include phone numbers, times, or frequencies as parts of messages. And it's so smart, it'll leave you a message if you miss a reverse patch, or if an alarm condition occurs.

Selective call and signalling capabilities range from two-tone sequential to numeric display paging, so you'll always be available. And its voice response metering is enhanced to continuously store low and high readings – so you can find out how cold it gets, how high the reflected power reads . . . and *when*.

Of course, a controller so feature-packed gives you **secure control**. Individual user access codes, with user callsign readback, can control access to selected functions to completely prevent horseplay.

ACC's amateur radio controllers are anything but "amateur". They're used by the U.S. Army, Navy, Forest Service, and other government and commercial users around the country. But, of course, you'll also find them on the leading amateur radio repeaters in North America and abroad.

There's never been a better time to upgrade your repeater system with an ACC controller, unmatched anywhere in quality, sophistication, and performance, with documentation and support to match.

Please call or write now for the rest of the story on all our repeater products, including controllers, digital voice storage units, and other Touch-Tone control products.

You'll be GLAD you did.



advanced  
computer  
controls, inc.

10816 Northridge Square, Cupertino, CA 95014

(408) 749-8330



peditioning to Asia is just about the last word for a ham, so I'm pushing you to take the egg money and come with us this October.

If I don't get at least 50 DXpeditioners signed up by June 30th I'll have to just go by myself and look for you on 20m, eating your heart out.

Young hams, if there are any, shouldn't waste their money on a house or a car—they should invest it in the memory of a lifetime. Retired hams should dig into the sugar tin and get on this DXpedition while they still have some life left. Remember, the average life span of men these days is 72—which means that by the time you're 72 half your friends are dead and the other half are too sick to travel anymore.

So, as I asked in the beginning, are you ready to come with me—sit down at a rig in a rare country and face the pileups? Write to me—Wayne Green W2NSD/1, DXpedition '86, WGE Center, Peterborough NH 03458 USA, so we can get moving.

#### THOSE FOUR-LETTER WORDS

Mercy me, the good old days are back—I've just had an indignant letter complaining about my

using four-letter words in my editorial—words like hell and damn. Well, the letter got me to thinking, so it wasn't completely wasted. Oh, as far as getting me to change my writing vocabulary, it was a waste. The purpose of words is to convey ideas, so I'm going to use what I feel are the appropriate words to express my ideas. When I'm expressing anger or exasperation, I'll be using words which convey my feelings—strong words.

There's a big difference in my mind between effectively communicating ideas and gratuitous cursing. Having spent several years in the Navy, I'm quite at home with everything our language has to offer in so-called dirty words.

Which brings me to profanity over the air—of which I am not a big fan. In case you haven't noticed, the FCC has backed off on this. Every attempt to keep broadcasters "clean" has resulted in our courts backing free speech. The end result is that legally, the last I heard, you can use any of the four-letter words you like.

Before you trot out your version of Navy language and bray it on 75m, let's think about this. When I

hear someone using foul language, I hardly think s/he is very intelligent. We're just not used to hearing educated people talk gutter language. Note the term—gutter. That means the lowest possible class—gutter people.

Just as we dress for the impression it makes on other people—dress for success, as it were—we also use language for the impression it makes. People *do* judge you by your clothes when they see you. Conversely, you are showing people who you are by the way you dress. If you are a low-class bum you'll dress that way.

When we hear someone over the air the only way we have to judge that person is by the language s/he uses. We judge by their vocabulary, their accent, and the way they express themselves. Have you ever made a tape of your voice making a ham contact and then listened to it critically—listened as if this were someone else you were judging purely by what you're hearing? Tape recorders are cheap these days—in fact, most of you have at least one around. Try taping yourself for an hour and see how you come out when you judge yourself.

We have a far from classless

society. Indeed, class is something most of us are concerned with a good deal of the time. We judge people by how they dress and talk when we meet them. Are they above or below us in class? Oh, it's not usually a conscious thing, but we judge people and treat them accordingly.

Class has been fairly well described in many books. Vance Packard did a fine job of this a generation ago. Class is ingrained—it shows clearly in your clothes, car, house, furnishings, speech, recreation, the food you eat and drink, and your work. There are so many lifetime training factors involved that few people are able to change class. We're familiar with lower-class people who've gotten rich—the "Beverly Hillbillies" syndrome. We make fun of them.

When we hear fellow hams talking we can't help but look for clues as to class. We get 'em from their language. If we hear four-letter words—or even that dread 13-letter word—we know what you are. Remember, you only have one chance to make a good first impression—and when you're on

*Continued on page 91*

## Dan's Got It All

**ICOM**  
IC-751, IC-745, IC-02A

**YAESU**  
FT-980 CAT, FT-757 GX, FT-209 RH

**KANTRONICS**  
KPC-2 PACKET COMMUNICATOR II

**WELZ CORP.**  
VSWR/POWER METERS

**KENWOOD**  
TR-2600, TH-21A, TH-21AT

**SAANTEC**  
ST-200ET, ST-400ET

**PAKRATT** PK-64

**TS-930S**, **TS-940S**

**TM-2570A**

**Britt's 2-Way Radio Sales & Service**  
2508 Atlanta Street  
Smyrna, Georgia 30080  
Belmont Hills Shopping Center  
(404) 432-8006

All Of These "Goodies" And Many More At Super Savings.  
Come See Us Or Call 1-800-241-2027.



# 1986 CALLBOOKS

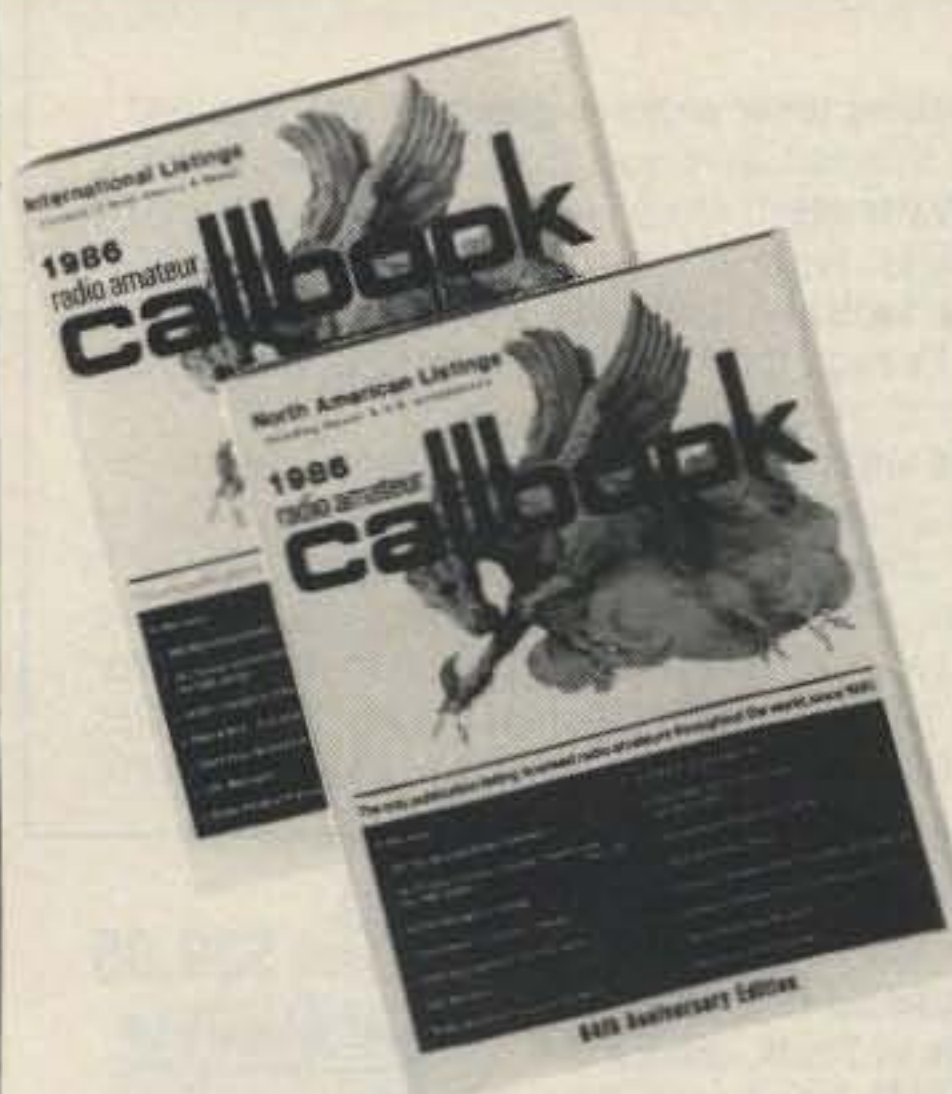

## The "Flying Horse" has a great new look!

It's the biggest change in Callbook history!  
Now there are 3 new Callbooks for 1986.

The North American Callbook lists the amateurs in all countries in North America plus those in Hawaii and the U.S. possessions.

The International Callbook lists the calls, names, and address information for licensed amateurs in all countries outside North America. Coverage includes Europe, Asia, Africa, South America, and the Pacific area (exclusive of Hawaii and the U.S. possessions).

The Callbook Supplement is a whole new idea in Callbook updates. Published June 1, 1986, this Supplement will include all the activity for both the North American and International Callbooks for the preceding 6 months.

Publication date for the 1986 Callbooks is December 1, 1985. See your dealer or order now directly from the publisher.

- North American Callbook  
incl. shipping within USA \$25.00  
incl. shipping to foreign countries 27.60
- International Callbook  
incl. shipping within USA \$24.00  
incl. shipping to foreign countries 26.60
- Callbook Supplement, published June 1st  
incl. shipping within USA \$13.00  
incl. shipping to foreign countries 14.00

### SPECIAL OFFER

- Both N.A. & International Callbooks  
incl. shipping within USA \$45.00  
incl. shipping to foreign countries 53.50

\*\*\*\*\*

Illinois residents please add 6 1/4% sales tax.  
All payments must be in U.S. funds.

RADIO AMATEUR  
**callbook** INC.



Dept. B  
925 Sherwood Dr., Box 247  
Lake Bluff, IL 60044, USA

31

Tel: (312) 234-6600

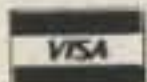

## In repeaters, there's **NO COMPARISON**

For your new or upgraded Repeater System, you won't find a better quality or higher performance machine than the New SCR2000X.

This highly advanced unit includes a wide array of DTMF Remote Control Functions, Automatic Digital Controls, and a full complement of front panel local control, test and metering functions. The 2000X is a commercial grade repeater which provides RF performance superior to any competitive unit. *And it's built to last—for years and years—by Spectrum...the people with over a decade's experience in worldwide repeater/link systems.*

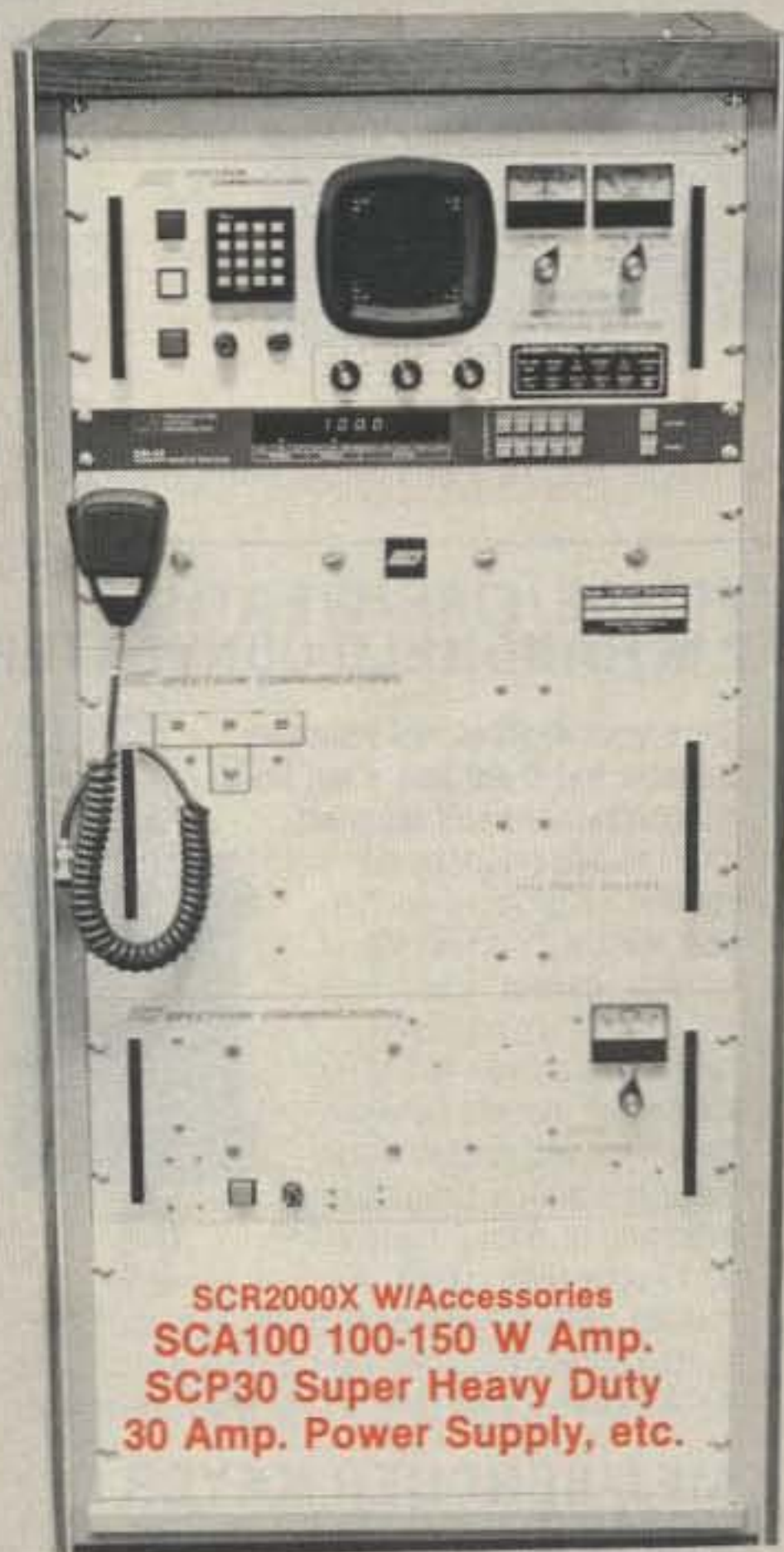

SCR2000X w/Accessories  
SCA100 100-150 W Amp.  
SCP30 Super Heavy Duty  
30 Amp. Power Supply, etc.

### SPECTRUM'S 2000X Microprocessor controlled repeater

"The Repeater of the Future"—Available Today!

FCC Type Accepted for Commercial Service

## And that's not all... We also make SCR770 Desktop/Portable Repeaters

- Ideal for low power local use
- Portable/Mobile at the scene of an Emergency
- Increase coverage at parades or other Public Service events
- "Mountaintopping" with battery pack
- Full Duplex Computer/Data-Links
- Compact, Rugged
- Self Contained



- 10W UHF. Built-in Duplexer
- 15W VHF External Dplx.
- Optional Autopatch & P.L.
- AC or 12 VDC Input



Rcvr., Xmtr., Control Boards, Duplexers, Antennas, Cabinets, Xcvrs, etc., also available. Amateur & Commercial.

**SPECTRUM COMMUNICATIONS**

DEPT. S6 • 1055 W. GERMANTOWN PIKE • NORRISTOWN, PA 19403 • (215) 631-1710 • TLX 846-211



# MFJ ACCESSORIES

**300 WATT ANTENNA TUNER HAS SWR/WATTMETER, ANTENNA SWITCH, BALUN. MATCHES VIRTUALLY EVERYTHING FROM 1.8 TO 30 MHz.**



**\$99.95** MFJ-941D

**NEW FEATURES**

MFJ's fastest selling tuner packs in plenty of new features!

- **New Styling!** Brushed aluminum front. All metal cabinet.
- **New SWR/Wattmeter!** More accurate. Switch selectable 300/30 watt ranges. Read forward/reflected power.
- **New Antenna Switch!** Front panel mounted. Select 2 coax lines, direct or through tuner, random wire/balanced line or tuner bypass for dummy load.
- **New airwound inductor!** Larger more efficient 12 position airwound inductor gives lower losses and more watts out. Run up to 300 watts RF power output. Matches everything from 1.8 to 30 MHz: dipoles, inverted vee, random wires, verticals, mobile whips, beams, balanced and coax lines. Built-in 4:1 balun for balanced lines. 1000V capacitor spacing. Black. 11x3x7 inches. Works with all solid state or tube rigs. Easy to use, anywhere.

## RTTY/ASCII/CW COMPUTER INTERFACE

MFJ-1224  
**\$99.95**



Free MFJ RTTY/ASCII/CW software on tape and cable for VIC-20 or C-64. Send and receive computerized RTTY/ASCII/CW with nearly any personal computer (VIC-20, Apple, TRS-80C, Atari, TI-99, Commodore 64, etc.). Use Kantronics or most other RTTY/CW software. Copies both mark and space, any shift (including 170, 425, 850 Hz) and any speed (5-100 WPM RTTY/CW, 300 baud ASCII). Sharp 8 pole active filter for CW and 170 Hz shift. Sends 170, 850 Hz shift. Normal/reverse switch eliminates retuning. Automatic noise limiter. Kantronics compatible socket plus exclusive general purpose socket. 8x1 1/4x6 in. 12-15 VDC or 110 VAC with adapter, MFJ-1312. \$9.95.

## RX NOISE BRIDGE

Maximize your antenna performance!



**\$59.95** MFJ-202B

Tells whether to shorten or lengthen antenna for minimum SWR. Measure resonant frequency, radiation resistance and reactance.

**New Features:** individually calibrated resistance scale, expanded capacitance range ( $\pm 150$  pf). Built-in range extender for measurements beyond scale readings. 1-100 MHz. Comprehensive manual. Use 9 V battery. 2x4x4 in.

## INDOOR TUNED ACTIVE

**NEW! IMPROVED! ANTENNA** with higher gain "World Grabber" rivals or exceeds reception

of outside long wires! Unique tuned Active Antenna minimizes intermode, improves selectivity, reduces noise outside tuned band, even functions as preselector with external antenna. Covers 0.3-30 MHz. Tele scoping antenna. Tune, Band, Gain, On-off bypass controls. 6x2x6 in. Uses 9V battery, 9-18 VDC or 110 VAC with adapter, MFJ-1312, \$9.95. **MFJ-1020A \$79.95**



## POLICE/FIRE/WEATHER 2 M HANDHELD CONVERTER

Turn your synthesized scanning 2 meter handheld into a hot Police/Fire/Weather band scanner!

**\$39.95**

144-148 MHz handhelds receive Police/Fire on 154-158 MHz with direct frequency readout. Hear NOAA maritime coastal plus more on 160-164 MHz. Converter mounts between handheld and rubber ducky. Feedthru allows simultaneous scanning of both 2 meters and Police/Fire bands. No missed calls. Crystal controlled. Bypass/Off switch allows transmitting (up to 5 watts). Use AAA battery. 2 1/4x1 1/2x1 1/2 in. BNC connectors.



## MFJ/BENCHER KEYS COMBO

MFJ-422  
**\$119.95**

The best of all CW worlds - a deluxe MFJ Keyer in a compact configuration that fits right on the Bencher iambic paddle! MFJ Keyer - small in size, big in features. Curtis 8044-B IC, adjustable weight and tone, front panel volume and speed controls (8-50 WPM). Built-in dot-dash memories. Speaker, sidetone, and push button selection of semi-automatic/tune or automatic modes. Solid state keying. Bencher paddle is fully adjustable; heavy steel base with non-skid feet. Uses 9 V battery or 110 VAC with optional adapter, MFJ-1305, \$9.95.



## VHF SWR/WATTMETER

Low cost VHF SWR/Wattmeter!

Read SWR (14 to 170 MHz) and forward/reflected power at 2 meters. Has 30 and 300 watts scales. Also read relative field strength. 4x2x3 in.

**MFJ-812 \$29.95**

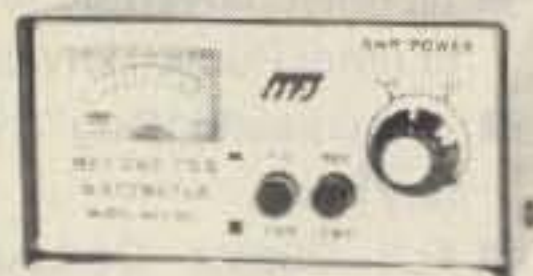

## 1 KW DUMMY LOAD

MFJ-250 **\$39.95**

Tune up fast, extend life of finals, reduce QRM! Rated 1KW CW or 2KW PEP for 10 minutes. Half rating for 20 minutes, continuous at 200 W CW, 400 W PEP. VSWR under 1.2 to 30 MHz, 1.5 to 300 MHz. Oil contains no PCB. 50 ohm non-inductive resistor. Safety vent. Carrying handle. 7 1/2x6 3/4 in.



## 24/12 HOUR CLOCK/ID TIMER

MFJ-106  
**\$19.95** NEW

Switch to 24 hour UTC or 12 hour format! Battery backup maintains time during power outage. ID timer alerts every 9 minutes after reset. Red LED .6 inch digits. Synchronizable with WWV. Alarm with snooze function. Minute set, hour set switches. Time set switch prevents mis-setting. Power out, alarm on indicators. Gray and black cabinet. 5x2x3 inches. 110 VAC, 60 Hz.



## DUAL TUNABLE SSB/CW/RTTY FILTER

MFJ-752B **\$99.95**



Dual filters give unmatched performance! The primary filter lets you peak, notch, low pass or high pass with extra steep skirts. Auxiliary filter gives 70 db notch, 40 Hz peak. Both filters tune from 300 to 3000 Hz with variable bandwidth from 40 Hz to nearly flat. Constant output as bandwidth is varied; linear frequency control. Switchable noise limiter for impulse noise. Simulated stereo sound for CW lets ears and mind reject QRM. Inputs for 2 rigs. Plugs into phone jack. Two watts for speaker. Off bypasses filter. 9-18 VDC or 110 VAC with optional adapter, MFJ-1312, \$9.95.

ORDER ANY PRODUCT FROM MFJ AND TRY IT-NO OBLIGATION. IF NOT SATISFIED, RETURN WITHIN 30 DAYS FOR PROMPT REFUND (less shipping).

- One year unconditional guarantee
- Made in USA
- Add \$5.00 each shipping/handling
- Call or write for free catalog, over 100 products.

# MFJ

MFJ ENTERPRISES, INC.  
Box 494, Mississippi State, MS 39762

TO ORDER OR FOR YOUR NEAREST DEALER, CALL TOLL-FREE  
**800-647-1800**. Call 601-323-5869 in Miss. and outside continental USA  
Telex 53-4590 MFJ STKV





# MFJ TUNERS

This may be the world's most popular 3 KW roller inductor tuner because it's small, compact, reliable, matches virtually everything and gives you SWR/Wattmeter, antenna switch, dummy load and balun — all at a great price!

Meet "Versa Tuner V". It has all the features you asked for, including the new smaller size to match new smaller rigs—only 10 3/4" W x 4 1/2" H x 14 7/8" D.

Matches coax, balanced lines, random wires—1.8 to 30 MHz. 3 KW PEP—the power rating you won't outgrow (250pf-6KV caps).

Roller inductor with a 3-digit turns counter plus a spinner knob for precise inductance control to get that SWR down to minimum every time.

Built-in 300 watt, 50 ohm dummy load, built-in 4:1 ferrite balun.



MFJ-989

**\$329.95**

Accurate meter reads SWR plus forward and reflected power in 2 ranges (200 and 2000 watts). Meter light requires 12 VDC. Optional AC adapter, MFJ-1312 is available for \$9.95.

6 position antenna switch (2 coax lines, through tuner or direct, random/balanced line or dummy load). SO-239 connectors, ceramic feed-throughs, binding post grounds.

Deluxe aluminum low-profile cabinet with sub-chassis for RFI protection, black finish, black front panel with raised letters, tilt bail.

## MFJ's Fastest Selling TUNER

MFJ-941D **\$99.95**



MFJ's fastest selling tuner packs in plenty of new features. New styling! Brushed aluminum front. All metal cabinet. New SWR/Wattmeter! More accurate. Switch selectable 300/30 watt ranges. Read forward/reflected power.

New antenna switch! Front panel mounted. Select 2 coax lines, direct or through tuner, random wire/balanced line or tuner bypass for dummy load.

New airwound inductor! Larger more efficient 12 position airwound inductor gives lower losses and more watts out. Run up to 300 RF power output.

Matches everything from 2.8 to 30 MHz! dipoles, inverted vee, random wires, verticals, mobile whips, beams, balanced and coax lines.

Built-in 4:2 balun for balanced lines. 1000 V capacitor spacing. Black. 11 x 3 x 7 inches. Works with all solid state or tube rigs. Easy to use anywhere.

## MFJ's 1.5 KW VERSA TUNER III

MFJ-962 **\$229.95**



Run up to 1.5 KW PEP and match any feedline continuously from 1.8 to 30 MHz: coax, balanced line or random wire.

Built-in SWR/Wattmeter has 2000 and 200 watt ranges, forward and reflected power. 2% meter movement. 6 position antenna switch handles 2 coax lines (direct or through tuner), wire and balanced lines. 4:1 balun 250 pf 6 KV variable capacitors. 12 position inductors. Ceramic rotary switch. All metal black cabinet and panel gives RFI protection, rigid construction and sleek styling. Flip stand tilts tuner for easy viewing. 5 x 14 x 14 in.

## MFJ's Best VERSA TUNER

MFJ-949C **\$149.95**



MFJ's best 300 watt tuner is now even better! The MFJ-949C all-in-one Deluxe Versa Tuner II gives you a tuner, cross-needle SWR/Wattmeter, dummy load, antenna switch and balun in a new compact cabinet. You get quality conveniences and a clutter-free shack at a super price.

A new cross-needle SWR/Wattmeter gives you SWR, forward and reflected power—all at a single glance. SWR is automatically computed with no controls to set. Has 30 and 300 watt scale on easy-to-read 2 color lighted meter (needs 12 V).

A handsome new black brushed aluminum cabinet matches all the new rigs. Its compact size (10 x 3 x 7 inches) takes only a little room.

You can run full transceiver power output—up to 300 watts RF output—and match coax, balanced lines or random wires from 1.8 thru 30 MHz. Use it to tune out SWR on dipoles, vees, long wires, verticals, whips, beams and quads.

A 300 watt 50 ohm dummy load gives you quick tune ups and a versatile six position antenna switch lets you select 2 coax lines (direct or thru tuner), random wire or balanced line and dummy load.

A large efficient airwound inductor—3 inches in diameter—gives you plenty of matching range and less losses for more watts out. 100 volt tuning capacitors and heavy duty switches gives you safe arc-free operation. A 4:1 balun is built-in to match balanced lines.

Order your convenience package now and enjoy.

## 2 KW COAX SWITCHES

MFJ-1702 **\$19.95**



MFJ-1702. \$19.95. 2 positions. 60 dB isolation at 450 MHz. Less than .2 dB loss. SWR below 1:1.2.

MFJ-1701, \$29.95.

6 positions. White markable surface for antenna positions.



## MFJ's Smallest VERSA TUNER

MFJ-901B **\$59.95**



MFJ's smallest 200 watt Versa Tuner matches coax, random wires and balanced lines continuously from 1.8 thru 30 MHz. Works with all solid state and tube rigs. Very popular for use between transceiver and final amplifier for proper matching. Efficient airwound inductor gives more watts out. 4:1 balun for balanced lines. 5 x 2 x 6 inches. Rugged black all aluminum cabinet.

## MFJ's Random Wire TUNER

MFJ-16010 **\$39.95**



MFJ's ultra compact 200 watt random wire tuner lets you operate all bands anywhere with any transceiver using a random wire. Great for apartment, motel, camping operation. Tunes 1.8-30 MHz. 2 x 3 x 4 inches.

## MFJ's Mobile TUNER

MFJ-945C **\$79.95**



Designed for mobile operation! Small, compact. Takes just a tiny bit of room in your car. SWR/dual range wattmeter makes tuning fast and easy. Careful placement of controls and meter makes antenna tuning safer while in motion.

Extends your antenna bandwidth so you can operate anywhere in a band with low SWR. No need to go outside and readjust your mobile whip. Low SWR also gives you maximum power out of your solid state rig—runs cooler for longer life.

Handles up to 300 watts PEP RF output. Has efficient airwound inductor, 1000 volt capacitor spacing and rugged aluminum cabinet. 8x2x6 inches. Mobile mounting bracket available for \$5.00.

ORDER ANY PRODUCT FROM MFJ AND TRY IT-NO OBLIGATION. IF NOT SATISFIED, RETURN WITHIN 30 DAYS FOR PROMPT REFUND (less shipping).

• One year unconditional guarantee • Made in USA • Add \$5.00 each shipping/handling • Call or write for free catalog, over 100 products.

# MFJ

MFJ ENTERPRISES, INC.  
Box 494, Mississippi State, MS 39762

TO ORDER OR FOR YOUR NEAREST DEALER, CALL TOLL-FREE

**800-647-1800**

Call 601-323-5869 in Miss. and outside continental USA Telex 53-4590 MFJ STKV

VISA

MasterCard



**The BEST is still  
"made in U.S.A."**



# MIRAGE/KLM

Under New Ownership

**American made RF Amplifiers and Watt/SWR Meters  
of exceptional value and performance.**

• 5 year warranty • prompt U.S. service and assistance

## RF AMPLIFIERS

### 2 METERS-ALL MODE

**B23** 2W in = 30W out  
(useable in: 100 mW-5W)

**B108** 10W in = 80W out  
(1W = 15W, 2W = 30W) RX preamp

**B1016** 10W in = 160W out  
(1W = 35W, 2W = 90W) RX preamp

**B3016** 30W in = 160W out  
(useable in: 15-45W) RX preamp  
(10W = 100W)

### 220 MHz ALL MODE

**C106** 10W in = 60W out  
(1W = 15W, 2W = 30W) RX preamp

**C1012** 10W in = 120W out  
(2W = 45W, 5W = 90W) RX preamp

**C22** 2W in = 20W out  
(useable in: 200mW-5W)

### RC-1 AMPLIFIER

### REMOTE CONTROL

Duplicates all switches, 18' cable

## WATT / SWR METERS

- peak or average reading
  - direct SWR reading
- MP-1** (HF) 1.8-30 MHz  
**MP-2** (VHF) 50-200 MHz

### 430-450 MHz ALL MODE

**D24** 2W in = 40W out  
(1W = 25W)

**D1010** 10W in = 100W out  
(1W = 25W, 2W = 50W)

Available at local dealers throughout the world.

**MIRAGE/KLM**  
COMMUNICATIONS EQUIPMENT, INC.

16890 Church St., Morgan Hill, CA 95037, (408) 779-7363



# LETTERS

## WIRE ON FIRE

I found that the W3MT antenna bridge described in the April, 1986, issue does indeed put more fire in the wire. Running a mere two candlepower input, my CW signal is reported to have pegged the S-meter at ZS6NN. Amateur radio needs more revolutionary circuits like this one.

Howard Sahl WB0IWN  
Lakewood CO

## STONE STONER

I was in total shock and dismay over your support of RM-5241 (QRX, March, 1986) to take away the upper two MHz of our six-meter band for the creation of Don Stoner's Public Digital Radio Service (PDRS). Stoner's contention that "less than 1,000 are active on the band" is preposterous! The 2,500 members of the Six Meter International Radio Klub (SMIRK) and the approximately 300 repeaters on six (there were slightly over 50 in 1978) are evidence of this. There are a sizeable number of users of six in the club to which I belong (Goddard ARC) and if my calculations are correct there are tens of thousands of six-meter users. My interest in amateur radio began on six meters as a teenager in the middle seventies, primarily because of the varied propagation one can experience on the band. Six got me into amateur radio, and it can continue to lure others, particularly with the sunspot cycle headed upward.

Six is healthy, and use of it is growing. Recent access to the band by the British, with other European countries soon to follow, can only accelerate this growth. While there may be a lot of hams who don't use six, there are many of us out here who do. No, six meters is not dead; there are a lot of us out here who enjoy it, thank you. We intend to keep it that way.

Richard Penc NE2J  
Laurel MD

*Come on, Richard, there are barely tens of thousands of hams on the air to begin with, and you want me to believe that most of them are on six meters? I don't buy it. It seems to me that the current (and projected) level of activity could be handled in a 2-MHz-wide band. I think the overall benefit to ham radio from a PDRS outweighs the loss of a few MHz of spectrum.—KW10.*

## CAN SCAN

I totally agree with the comment about the ICOM IC-02AT in the February issue. I bought mine a year ago and have found it to be an extremely nice radio, but its scanning speed leaves much to be desired! With today's technology I can't understand why it scans so slowly. I've noticed the speed of my friend's Kewood HT; it greatly outperforms the 02AT in the scanning department. Could you do an article on how to speed it up?

Chris Suleske N4LZG  
Stafford VA

*While you're waiting for the speed-up mod, check out the article by AL7DS in this issue to find out how to cover 144 to 165 MHz on your 02AT.—Ed.*

## DSB NEEDED

Glad to see Wayne back in the arena, handling the flaming sword in defense of the radio amateur!

AM is through, we must recognize, but SSB is very difficult to home-brew, especially outside the United States, due to troubles finding crystal filters and so on. I think that double-sideband (DSB) might be the answer we are looking for. It's much easier to design than SSB, with no crystal filters—beginners could have their fun again! What the world needs is an easy-to-build transceiver—make it DSB!

Carlos Vianna Carneiro PY1CC  
Rio de Janeiro, Brazil

*Let's forget the PDRS on six meters and give 52-54 MHz to the*

*AMers and DSBers... they can QRM each other as much as they like, and I bet nobody would miss them on HF.—KW10.*

## THE GREAT EXCLUDER

I usually agree with you concerning amateur radio. We need to get the rest of our hobby's members to open their eyes and ears and put their brains into gear and look into the future of our pastime.

I am a retired Air Force flyer. I have been teaching in the electronics program at East Tennessee State University for the past few years and have watched many a potential ham go away, probably never to return. We offer a course in ham radio, for one semester-hour credit. The student must earn a Novice ticket and make contacts on the university radio station. The course is conducted by K4SE. The results have been so-so.

I have conducted several Novice classes over the past few years and, to tell the truth, I feel that most of it has been a waste of time. Several people have obtained their licenses, but to my knowledge only one has used it. He has upgraded and is active. The rest, put bluntly, have no desire to use the code and don't even give it a try.

We worry that we will let the wrong element into ham radio if we relax and drop the great excluder, CW. I have news for the worry warts: We are doing what we want to avoid by keeping the code as an entry requirement. It is a common practice for one person in a group to go get a legit Novice ticket, then upgrade to General and then get all his friends into the hobby via the Novice route. They are usually into electronics and computers and have no trouble getting a Tech. ticket. Most of them make good hams. It's a shame we force them to be unethical to get into our hobby.

I hope you can get back on the bandwagon and lead us on. We need to badger the ARRL and FCC until we get the no-code through. If we don't, I'm afraid our hobby is doomed.

Why did I become a ham? It sure wasn't to communicate! I wanted to be able to fly my model airplanes and be able to

conduct legal on-the-air experiments with radio control. Involvement with hamming in the traditional sense came later. I was involved with emergency communications in the early 60s when a hurricane ripped up the outer banks area of North Carolina. AM on a BC-610 from the MARS station. I don't get on the air very much even though I have 160-2 all-mode capability. When I do it I'm usually working some Novice. I get a thrill out of being the first contact for a new ham.

In teaching we try to develop a rationale for learning from the point of view of the student. If the student does not have a good reason for learning, he will not learn much. If he does have, you can't help him enough. We must find a reason why Joe Ham in the United States should want the no-code ticket and the thousands of new hams it would attract.

I have not heard much discussion about the influence that the Japanese no-code ticket had on the availability of ham gear in the United States, but I'll bet not many of us have thought about it. More hams will bring more crowding on the bands. Yes. But it will also bring more makers into the equipment markets and more and better equipment for us to buy. When we develop the newer techniques such as spread spectrum, as we did with SSB, the congestion will disappear. The new people will bring with them new ideas and we will all benefit.

One last bit: I teach a course called electronic circuit fabrication. The typical student comes into the course with the usual fears of not being able to do it, and then after a few successful laboratory experiences, during which skills such as soldering, wire-wrapping, parts testing, and such are introduced, the student becomes enthusiastic about it. We go from a schematic to a completed project that must include a PCB. When the semester is over, we have a group that has found the joy of making something that works and is ready to give something else a try. Too bad we exclude them from ham radio with Morse code. If we don't make room for them in our bands, someone else will! Remember 11 meters?

Donald H Lettrell W4VBH  
Bluff City TN



# NEW PRODUCTS



Free tool catalog available from Jensen.

## NEW JENSEN CATALOG

Jensen Tools, Inc., has released its latest catalog featuring many additions to the Jensen line of tools, tool kits, and test equipment.

The 82-page catalog is available free from *Jensen Tools, Inc.*, 7815 S. 46th Street, Phoenix AZ 85044; (602)-968-6241. Reader Service number 157.

## KALGLO CONDITIONED UPS

Kalglo Electronics has added a new standby uninterruptible power supply to their Aegis™ line of power-conditioning equipment. The model LS250 Line-Saver-SREGTR uses pulse-width modu-

lation to regulate the 250-Watt rms ac output for greater efficiency under various load conditions. The PWM ac output also increases battery efficiency to extend backup time: 5-10 minutes at full load, 20-25 minutes at half load, and 35-40 minutes at one-third load.

The unit comes with an internal 12-V sealed rechargeable battery, two voltage-surge-protected ac outlets, and audible and visual power failure indicators. The suggested retail price is \$549.

For more information, please contact *Kalglo Electronics Company, Inc.*, Dept. CP, 6584 Ruch Rd. E. Allen Twp., Bethlehem PA 18017; (215)-837-0700. Reader Service number 159.

## LOW-TEMP ALUMINUM BRAZING ROD

Medford Specialized Services markets an aluminum brazing rod for repairing and welding aluminum, copper, and brass joints. The rod's low melting point (732 degrees) makes it easy to use with a propane torch. Low-resistance joints may be formed on antennas, tank circuits, and matching networks as simply as soldering.

For further details, contact *MSS Wonder Rods*, N3401 Castle Rd., Medford WI 54451. Reader Service number 153.

## ICOM HIGH-POWER 2M MOBILES

ICOM has announced two new packet-compatible 2m mobile



ICOM's IC-28H 45-Watt 2m mobile transceiver.

rigs, the IC-28A (25 Watts) and the IC-28H (45 Watts). Both radios are small, only 5-1/4" x 5-1/2" x 2" (the IC-28H is 7-1/4" deep). They feature a large liquid-crystal display with automatic dimming, wideband (138-174-MHz) coverage for MARS and CAP operation, 21 memory channels, and band or memory scanning.

For more information, contact *ICOM America, Inc.*, PO Box C-90029, Bellevue WA 98009-9029. Reader Service number 152.

## OVONIC SILENT GENERATOR

Ovonic ThermoElectric Company, a division of Energy Conservation Devices, Inc., is now marketing the Compact Silent Generator. This lightweight, silent, solid-state generator obtains its energy from any source of heat and can produce up to 6 Watts of dc at 9 volts or up to 5 Watts at 6 or 12 volts. The CSG can directly power light loads or be used to charge external batteries.

For complete information, write or call *Ovonic ThermoElectric Company*, 1864 Northwood, Troy MI 48084; (313)-362-3140. Reader Service number 154.

## ACTICON MINI RS-232 PORT

Rapitech Systems, Inc., has developed a DB-25 connector which

includes a complete RS-232 communication circuit. The Acticon™ connector was designed to free up space on computer circuit boards by placing all of the hardware necessary for RS-232 communications inside the DB-25.

For complete details, contact *Rapitech Systems, Inc.*, 75 Montebello Rd., Suffern NY 10901. Reader Service number 156.

## ETRON RF NOTES 3

Rf Notes 3, Volume 1 is a new software package from Etron Enterprises which aids in the design of Butterworth-response filters to the seventh order. Based on network modeling, the program designs low-pass, high-pass, band-pass, and band-reject filters as a function of input/output impedance ratios and user-defined input parameters. The output of the program is a schematic diagram labeled with circuit constants.

Rf Notes 3, Volume 1 is available for IBM DOS 2.1; for further details contact *Etron Rf Enterprises*, PO Box 4042, Diamond Bar CA 91765; (714)-594-8741. Reader Service number 158.

## LARSEN 450-MHZ KULGLASS™ ANTENNA

Larsen Electronics has announced the model KG-450 on-



The LS250 standby UPS from Kalglo Electronics.

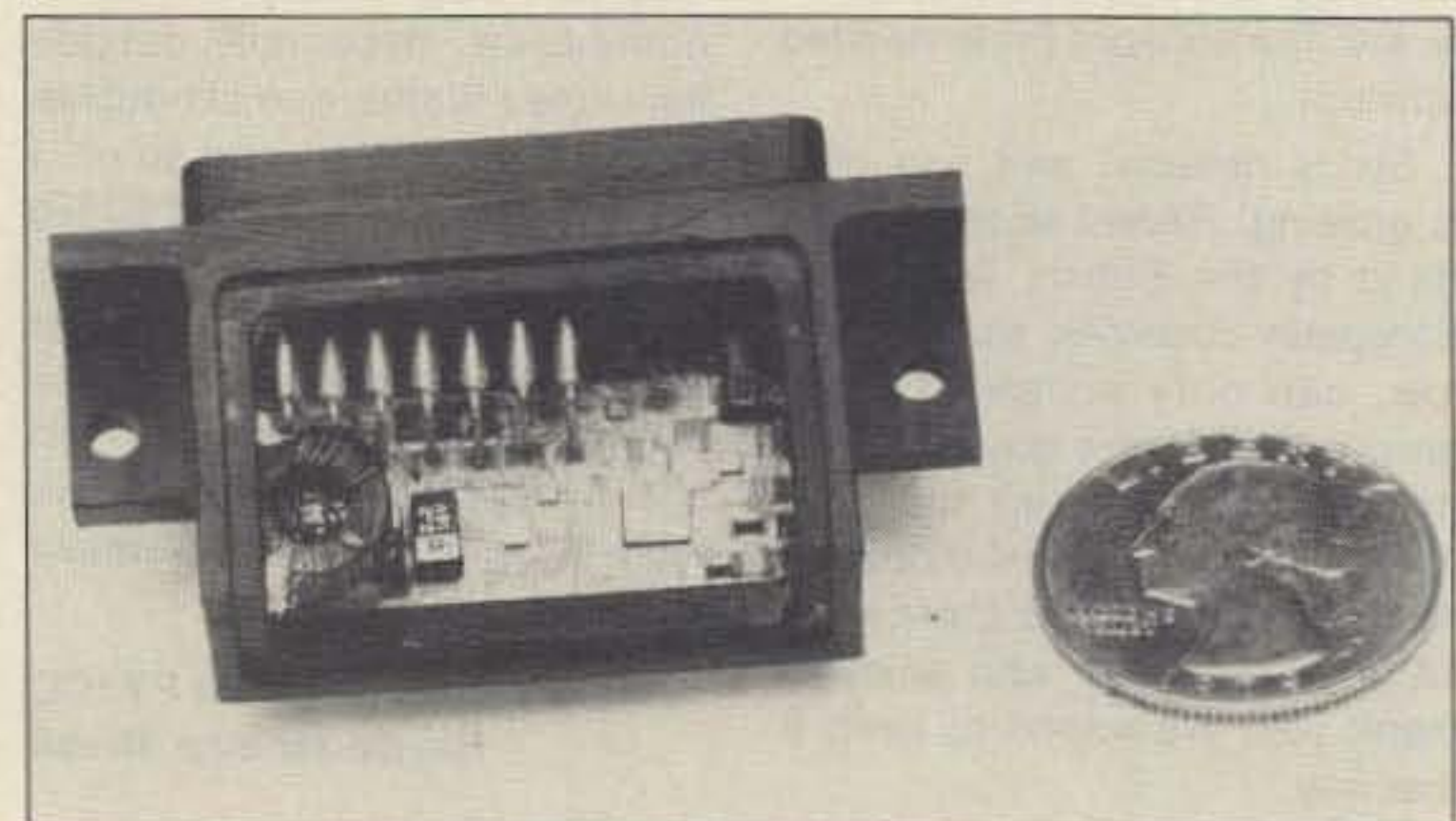

The Acticon active connector from Rapitech Systems.



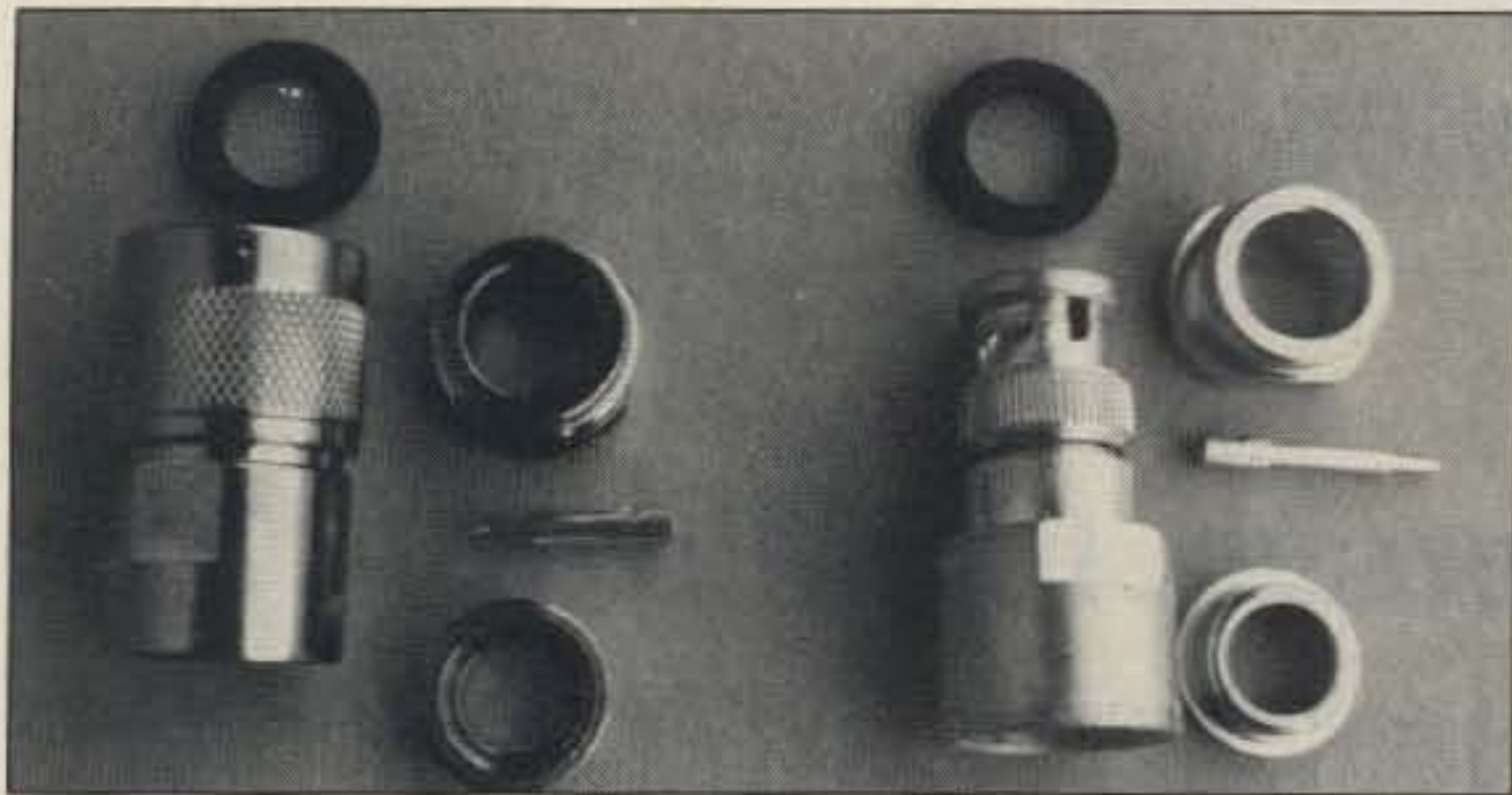

Nemal connectors for Belden 9913 and 8214 cables.

glass antenna for the 450-512-MHz range. The KG-450 is a half-wave, unity-gain element without a ground plane, and offers up to 2.4 dB gain in most mobile installations. The antenna is tuned by cutting the whip according to a chart provided by Larsen. The antenna kit includes 14 feet of RG-58A/U low-loss coax.

For more details, write or call Larsen Electronics, PO Box 1799, Vancouver WA 98668; (206)-573-2722. Reader Service number 161.

#### NEMAL CONNECTORS

Nemal Electronics has introduced a new line of connectors

designed to fit Belden 9913 and 8214 style cables. The connectors are available in both type-N and BNC and accommodate a 9-1/2-to-11-gauge center conductor. Both styles meet MIL-C-39012 specs and incorporate silver-plated contacts and Teflon™ insulation.

For more information, contact Nemal Electronics International, 12240 NE 14th Avenue, North Miami FL 33161; (305)-893-3924. Reader Service number 155.

#### MERCER VOM

Mercer Electronics, a division of Simpson Electric Co., has introduced the model 9120 VOM. The

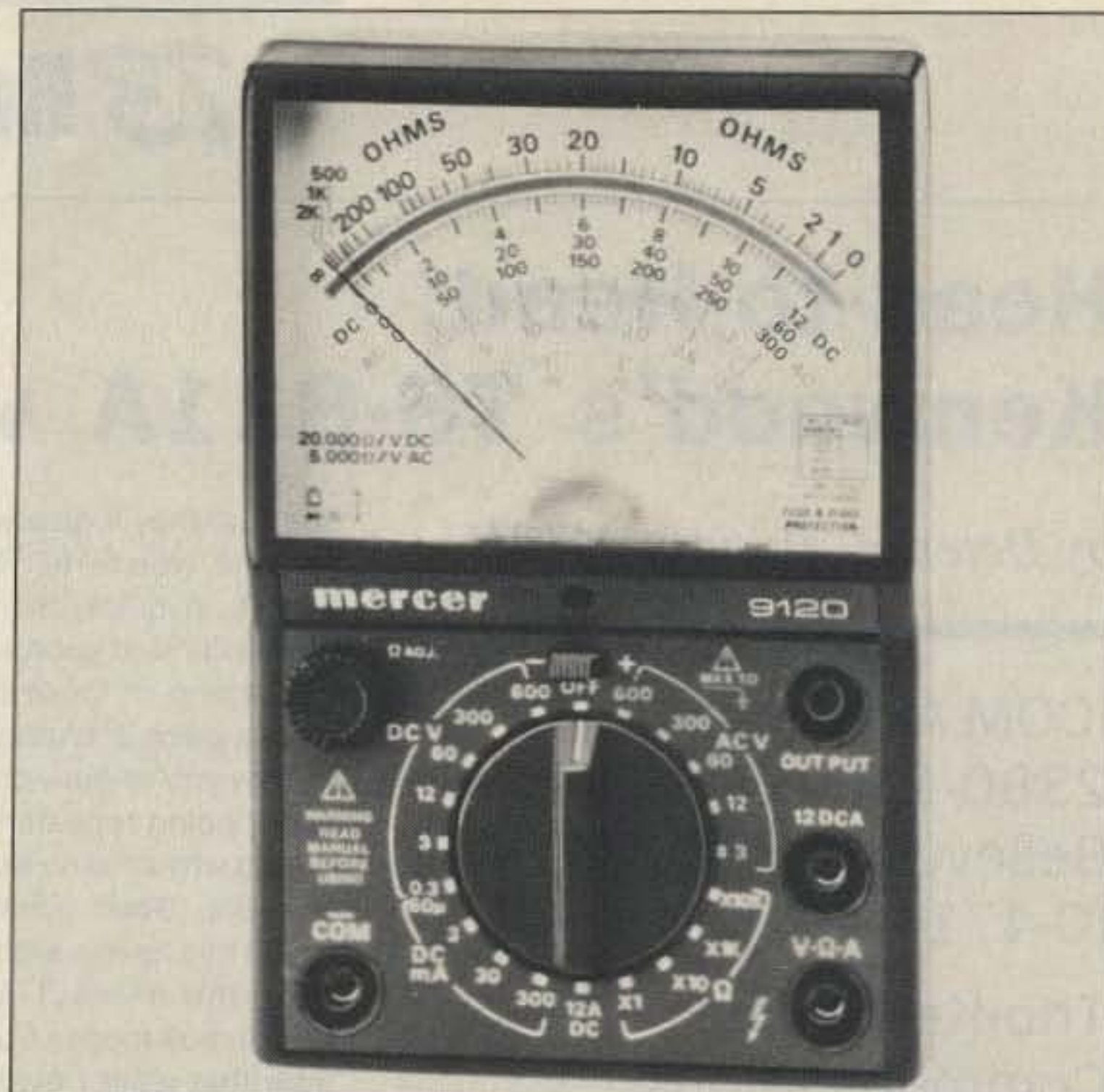

The Mercer model 9120 VOM.

new instrument features 25 ranges (including dB), 20,000 Ohms/volt dc sensitivity, 5,000 Ohms/volt ac sensitivity, and a frequency response of 100 kHz on the 3-, 12-, and 60-volt ac ranges. The model 9120 will measure up

to 12 Amps dc.

For additional information on the model 9120 VOM, contact Mercer Electronics, 859 Dundee Ave., Elgin IL 60120; (312)-697-2265. Reader Service number 160.

# Hi Pro Repeaters ELCO

MAGGIORE ELECTRONIC LAB.

Manufacturers of Quality Communications Equipment

- Repeaters
- Links
- Remote Base
- Low Band, VHF, UHF
- Receivers
- Transmitters
- Antennas



- Standard and Computerized Controllers
- Standard and Computerized Auto Patches
- Duplexers

## Hi Pro 'E'

### EXPANDABLE REPEATER SYSTEM

- A NEW CONCEPT IN REPEATER DESIGN, THE Hi Pro "E" IS AN EXPANDABLE REPEATER WITH THE FOLLOWING FEATURES: A BASIC REPEATER WHICH WOULD INCLUDE A COMPLETE RECEIVER, TRANSMITTER, COR, FRONT PANEL CONTROLS AND INDICATORS, LOCAL SPEAKER AND MIC JACK AND CAPABLE OF FUTURE EXPANSION. ALL HOUSED IN AN EXTREMELY RUGGED, ENCLOSED, 19-INCH RACK MOUNTABLE CABINET.
- THIS SYSTEM CAN BE EXPANDED AT TIME OF PURCHASE OR CAN BE AN AFTER-PURCHASE ADD ON. THE ADD ONS ARE—HIGHER POWER, 110/220 VAC POWER SUPPLY, IDENTIFIER, AUTO PATCH, OR COMPUTER CONTROLLERS. IN ADDITION TO THESE ADD ONS AN ADDITIONAL RECEIVER AND TRANSMITTER CAN BE MOUNTED INTERNALLY FOR USE AS CONTROL LINKS, REMOTE BASE OR DUAL BAND OPERATION, ETC.
- AN EXTENSION PANEL IS AVAILABLE FOR LOCAL MONITORING OF THE REPEATER AND CONTAINS ALL NECESSARY METERING, STATUS LIGHTS AND INDICATORS. ALL ADD ONS ARE AVAILABLE FROM THE COMPANY AND ARE COMPLETE INCLUDING INSTRUCTIONS. THE Hi Pro "E" IS AVAILABLE IN NOVEMBER.

MAGGIORE ELECTRONIC LAB.

600 Westtown Rd.

West Chester, PA 19382

Phone (215) 436-6051

Telex 499 0741 MELCO

✓47

WRITE OR CALL FOR OUR COMPLETE CATALOG



## Head-to-Head: Kenwood's TS-811A versus ICOM's IC-471A

by Peter H. Putman KT2B

ICOM America, Inc.  
2380-116th Avenue NE  
Bellevue WA 98004  
IC-471A—\$799

Trio-Kenwood  
Communications  
1111 West Walnut Street  
Compton CA 90220  
TS-811A—\$899

Here's the dilemma: You'd like to get on the 70-cm band, and in a big way. You've set your sights on weak-signal operation, ATV, OSCAR, and even some FM repeater and simplex operation. Then you read in a VHF column that "nothing beats using a transverter with your multimode HF transceiver." Sounds Good! Then you discover that using a transverter with your HF radio at best yields only about 4 MHz of the band to play with in the vicinity of 432 to 436 MHz. Hey, that won't work at all!

So you peruse the catalogs and come across the wondrous 70-cm multimodes various manufacturers (all Japanese) make and

see that they'll give you what the transverter scheme won't—full band coverage and all modes. A quick call to the local authorized distributor and soon you're the proud possessor of one of these beauties. Bet it set you back a piece of change, too!

Now you're busy chasing OSCAR contacts and tripping repeaters all over the area, wondering why anyone would prefer the transverter route. Good question, and among those which this review will try to answer!

For this review, I obtained two off-the-shelf 70-cm multimodes from local amateurs, to ensure that what I evaluated is what you'd be likely to buy. I wasn't able to obtain the Yaesu FT-726 with 70-cm module, but at least you'll get an idea how the state-of-the-art from ICOM and Kenwood compare to your present setup—not to mention each other! No doubt about it, these radios will set you back a few dollars. Are they worth it? Let's find out.

### A Comparison of Features

The ICOM 471A lists for \$799. For this, you get 25 Watts rf output, dual vfo's, 32 independent programmable memories, and three different scanning modes. The Kenwood TS-811A lists for \$899. This buys you 25 Watts rf output, dual vfo's, 40 independent programmable memories, and three different scanning modes. Pretty close so far.

Both radios offer USB, LSB, CW, and FM operation over the 430–450-MHz band. Both have continuously adjustable power output. Both are capable of ac operation (an ac power supply is standard on the TS-811A, whereas on the IC-471A it's an option) and can use

"scanning" microphones for remote tuning. That's where the similarity ends.

ICOM and Kenwood have, in their own peculiar ways, included and excluded from these radios certain features that you might either wish to have or have no use for whatsoever! In many cases, the feature present on one radio is missing or unavailable on the other. Perhaps the best way to show this is with Table 1.

Obviously, there's a difference of opinion here regarding just what the 70-cm operator needs in a multimode transceiver. It makes it more difficult to review the units from a comparison standpoint, as well! When possible, I'll touch on how well these features worked for the particular radio under test.

Photo A is a front view of the two radios. They're comparable in size, with the ICOM being slightly larger. Both displays are easy to read and contain a multitude of information regarding operating mode, scan mode, RIT position, simplex/duplex operation, and tuning speed on the vfo. Both employ push-button function and mode selection.

Here's where I make my first subjective evaluation: The TS-811A's multifunction buttons make its front panel somewhat confusing, and it takes a second to find your way around the rig. On the other hand, the IC-471A is very user-friendly, and anyone could begin to use this radio right out of the box without referring to the manual.

Speaking of manuals: I've gotten quite used to the strange English that peeks through Japanese manuals on occasion. However, there is no excuse for the spelling errors in the



Photo A. The ICOM IC-471A and Kenwood TS-811A 430-MHz transceivers.



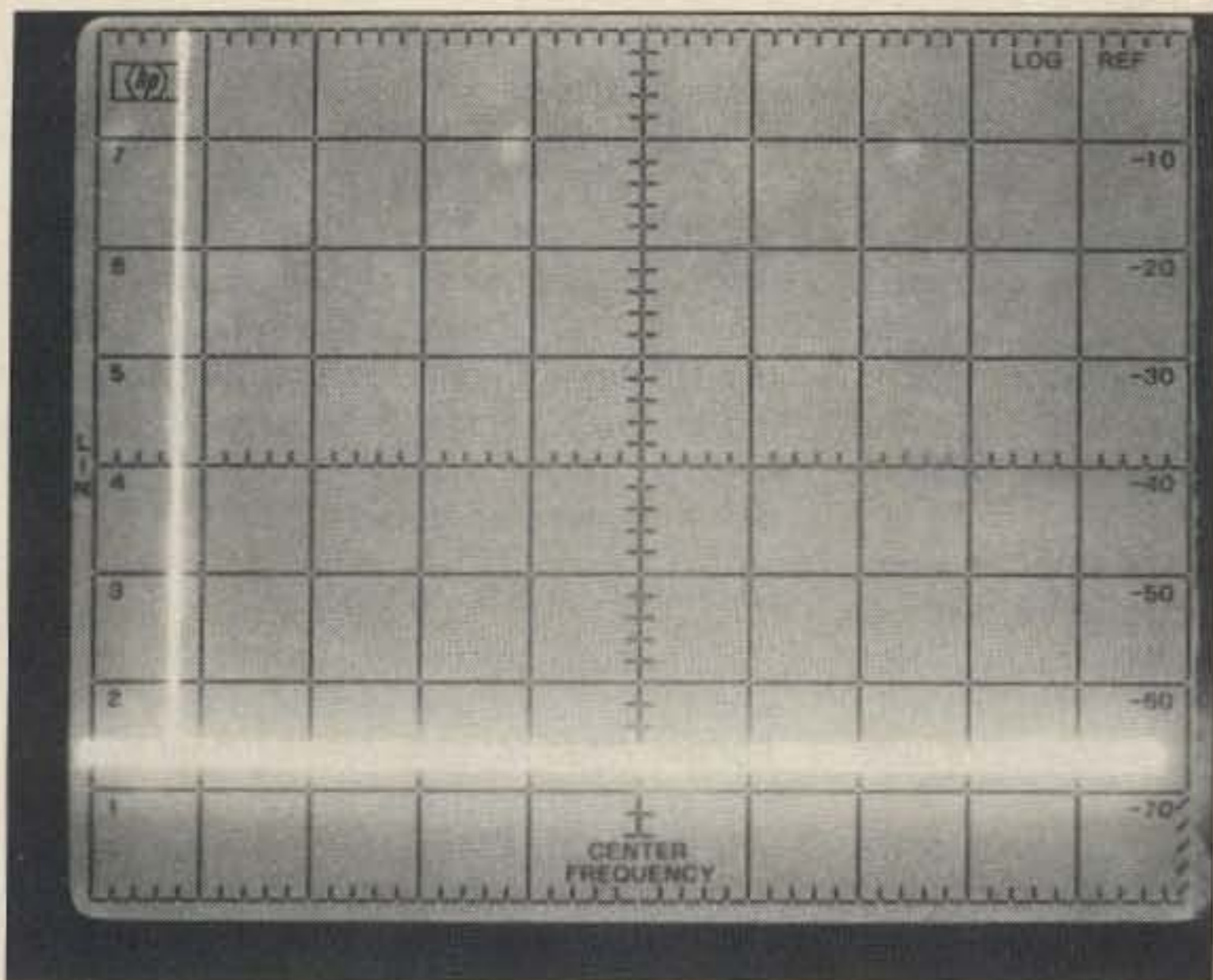

Photo B. Spectral display of the TS-811A running 25 Watts at 432.100 MHz. The second harmonic is down more than 70 dB.

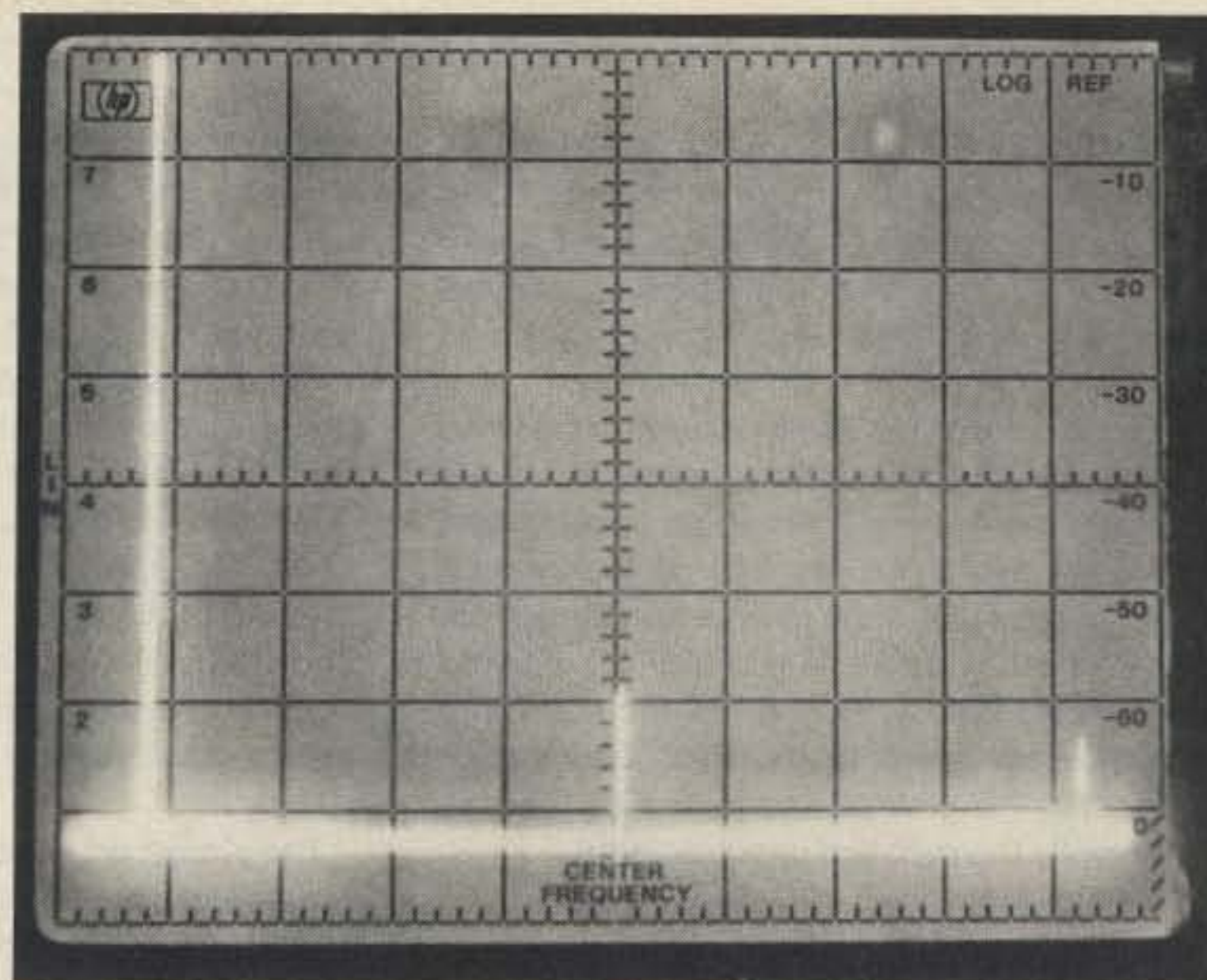

Photo C. Spectral display of the IC-471A running 25 Watts at 432.100 MHz. The second harmonic is down 60 dB.

TS-811A manual. Come on, guys! "Microprocessor?" Both manuals are fairly thorough, to their credit. The Kenwood manual is quite detailed regarding the front-panel controls and the use of the vfo's, memories, and scan features. The ICOM is equally thorough with its explanation of the front-panel controls, but it uses fewer words to get the job done.

Both radios have the complement of bells and whistles you'd expect for the price. The ICOM's bells and whistles, however, have more practical value and Kenwood's are more hi-tech for technology's sake. (I'll elaborate on that momentarily.) Kenwood has also included its new DCS (Digital Coded Squelch) system, which is becoming standard equipment on its VHF/UHF radios. Since it didn't compare to anything on the ICOM, I chose not to test and review it.

#### The Kenwood TS-811A

Okay, on to the controls! Starting with the Kenwood, one feature I found downright clever is the switch marked CH.Q. When you press this switch, the vfo dial steps in 5-kHz increments with a positive detent feedback through the dial—it really clicks with each step! Apparently, this is accomplished with a solenoid system, as you hear a rather loud relay "click" when you press the switch. With the switch out, the vfo dial tunes silky smooth in 10-Hz increments. I've never seen anything like this before on any radio!

The FM, USB, LSB, and CW push-buttons provide for more multimode selection. In addition, the Morse verification through the speaker of the push-button selected is useful if you're not looking at the radio directly. Next to this control is one marked AUTO, which automatically selects the mode of transmission depending on where you are in the band. Only problem is it's based on some sort of Japanese band plan that doesn't jive with ours, at least below the OSCAR subbands, so this control is useless and can be ignored.

Below these buttons are controls for SCAN start/stop; M.IN to save memories; REV &

LOCK to lock up the dial and provide for reversed offsets in memory channels 36, 37, and 38; AL to turn on/off the channel 1 priority circuit alert; and CH.S to operate the channel-select position for dialing up memories. Phew!

On the right of the vfo knob are controls for the previously mentioned CH.Q function, A/B to select the two vfo's, STEP to select tuning rate, SPLIT to split the vfo's, M>V to transfer data from the selected memory to the vfo, and A=B to reset the two vfo's to each other. Below these are controls to select either vfo or memory position and a control marked COM, which is for a preset frequency of 433.000 MHz (apparently some sort of simplex net frequency in Japan). You can reprogram this if necessary.

The complement of controls is rounded out by a continuously variable RIT control, which a second switch from the front panel can cancel. RIT excursions are in the range of 9.9 kHz either side of center frequency. Also found are MIC and RF PWR controls, IF SHIFT, SQL for squelch, noise blanker, AF gain, RF gain, Up/Down 1-MHz frequency selection, and VOICE for an optional VS-1 voice synthesizer.

On the far left, two of the three tiny switches select repeater offsets and subaudible tones (with the optional TU-5 board installed); the

other activates the tone circuit. Below these are three larger switches for speech processing, ALC meter display, and ACC—which activates a rear-panel connector with dry-contact closures rated at 0.2 Amps. Enough switches for you? I thought so.

And, would you believe with all that there's no front-panel transmit/receive switch? Instead, you have to either insert a subminiature plug and switch into the rear-panel jack marked ST BY or use the PTT switch on the microphone. (Why do you need a separate T/R switch? How about when you're checking swr on antenna lines! Since the TS-811A has no VOX circuit, you need to use the ST BY circuit to switch to transmit when operating CW. A front-panel switch would have been more convenient!)

Kenwood receives another bad grade for using a "UHF" SO-239 connector instead of the standard type-N at this frequency. Come on, Kenwood. Type-N connectors aren't that hard to make up. At least ICOM doesn't think so, as they did use a type-N fitting on their antenna connection. (But I'm getting ahead of myself!) Other rear-panel connections include external speaker, Key jack for a CW key, ACC 1 for a computer interface, ACC 2 for an external RTTY interface (this wasn't quite ex-

Feature	Kenwood TS-811A	ICOM IC-471A
Speech processor	Yes	No
Adjustable agc	No	Yes
Noise blanker	Yes	No
Transmit switch	No*	Yes
RIT	Yes	No
Preamp option	No	Yes
I-f shift	Yes	No
VOX operation	No	Yes
Multi-speed tuning	Yes	Yes
Ac power supply	Included	Option
* See text.		

Table 1. Feature comparison.



plained in the manual), and finally, ac and dc power connections.

As I said earlier, the TS-811A comes with a power supply as standard equipment. One note here: The owner of this radio, Bill DiCarlo KA2QEP, mentioned that the area around the power supply gets quite hot when it's been on for awhile.

I didn't notice that the transformer became dangerously hot over a two-hour period, but it did get very warm, so I would recommend adequate ventilation when using the internal supply. If the unit must be in a confined area, use a muffin fan to keep cool air flowing through the supply. Bill mentioned that other TS-811A users mentioned this condition as well when he worked them on OSCAR, so apparently the problem is not isolated.

### The ICOM IC-471A

Enough of Kenwood. Let's go over to the ICOM and review its controls in the same fashion.

Starting with the front-panel layout, you see concentric controls for AF/RF GAIN, SQUELCH/TONE (yes, an actual tone control on receive audio!), and MIC GAIN/RF PWR. Directly above these are push-button switches for VOX, noise blanker, AGC time constant, METER (in FM it's a discriminator meter), PREAMP for the optional AG-1 mast-mounted preamp, and mode selective scan, which selects only those stored memories for the mode in use to be scanned.

Directly to the left of these controls are the mode switches (FM, USB, LSB, and CW) and the desired front-panel TRANSMIT switch. Above it are the offset write control, CHECK control (a repeater reverse switch), +Duplex and -Duplex switches, tone encoder control, and tone select (which selects the subaudible tones available on the built-in subaudible encoder).

To the right of the vfo are controls for tuning speed; dial function select, which chooses either vfo or memory-select operation; SPLIT to split vfo's; UP/DOWN for stepping through the band in 1-MHz steps; a continuously variable RIT that has an excursion range of 9.9 kHz either side of the center frequency. Finally, the upper right corner contains the A=B, A/B, WRITE, SCAN, VFO/M, and M>VFO switches, which function as their counterparts on the TS-811A do.

The display on the 471A contains a lot of information similar to the TS-811A display and is equally easy to read. It displays frequency in use, along with the mode selected, offsets, memories in use, tone switch on, and RIT engaged with frequency excursion displayed. The vfo selected is also displayed.

Looking at the rear panel, you find the antenna jack (type-N), CW key jack, dc power socket, external speaker jack, and the provision for an optional computer interface unit, as well as the cover plate for the optional IC-PS25 power supply which fits quite snugly inside the transceiver.

Now for the human engineering part: The IC-471A wins hands down when it comes to the sensible layout and engineering of its controls. Nothing is confusing, and the most

needed and frequently used controls are the biggest and are very accessible. The two hams who accompanied me to our test lab site felt much the same way—that the Kenwood had way too many "bells and whistles" and was confusing to operate. I did like the detent tuning option on FM built into the TS-811A, however. It's quite easy to overshoot your intended station with the silky smooth dial on the IC-471A, which isn't needed when tuning in FM stations 15 kHz apart.

The fact that the IC-471A is a bit larger doesn't hurt either! Having more room to space out all of those controls makes selecting them less confusing. Call it what you will, I maintain that the IC-471A is simply more user-friendly.

The Kenwood does get good marks for the audio reinforcement of the mode selected via audible Morse code. This feature is good when changing to SSB from CW during a contest and making sure you've picked the right sideband. The vfo dial is very smooth and a little tighter than the IC-471A dial, which I prefer since it's similar to the vfo knob on my Kenwood TS-430S.

### Performance

Now let's move on to performance evaluation. For the critical tests, I used a Hewlett-Packard 8640 rf signal generator and 8554 Spectrum Analyzer with a 141T i-f unit. The power source was an Astron RS35M at 13.8 volts dc. The output of each radio was fed through a 200-Watt, 30-dB, 50-Ohm attenuator and into the analyzer for transmitter spectral purity measurements.

As you can see from Photo B, the Kenwood is phenomenally clean! It exceeds the FCC requirement of spurious emissions, being more than 60 dB below the carrier. We couldn't find the second harmonic! The IC-471A, on the other hand, just barely made the FCC spec (see Photo C) and hovered right at the -60-dB mark as shown on the scope display. The third harmonic is not much more attenuated at -65 dB.

Both radios feature continuously variable power output. In the minimum position, the TS-811A had 1.8 Watts of rf across 50 Ohms. This swung smoothly up to a maximum of 28 Watts with the control at maximum. On the IC-471A, the minimum power was 6 Watts; with the control fully open, the power output was 30 Watts. Both radios met the claimed power specification of 25 Watts. These tests were made with a Bird Model 43 wattmeter, using a 10- and a 100-Watt slug into a Terma-line coaxial resistor and short 9913 coaxial jumper.

### Receivers

Now, on to the receivers. We first evaluated minimum discernible signal (MDS) on both receivers. For the TS-811A and the IC-471A, that number was the same at -140 dBm, or .023 uV. A reading of S1 took .26 uV of signal on the IC-471A, while a similar reading on the TS-811A required .5 uV. Neither radio met its claimed performance specifications for sensitivity (less than 0.30 uV for 10 dB S+N/N for the IC-471A and less than 0.14 uV for 10 dB

S+N/N for the TS-811A), although the ICOM was a bit closer.

In FM mode, the MDS for the TS-811A was -130 dBm (.07 uV), while the IC-471A needed -123 dBm (.16 uV) to register. The TS-811A achieved full quieting signal (20 dB of quieting) with -103 dBm or 1.5 uV of signal, and it took the same amount to create 20 dB of quieting on the IC-471A. This figure was not as good as ICOM claimed, and the Kenwood didn't measure up either.

### Selectivity and Sensitivity

As regards selectivity, both radios passed with flying colors and exceeded their claims. For the TS-811A, selectivity of more than 2.2 kHz @ -6 dB in SSB/CW and more than 12 kHz @ -6 dB in FM was in agreement with our measurements. Same thing for the IC-471A, with claims of more than 2.4 kHz @ -6 dB in SSB/CW and more than 15 kHz @ -6 dB in FM mode. These radios are selective, indeed.

Squelch sensitivity was next. For the TS-811A, the claim was less than 0.16 uV at the threshold level. We measured .2 uV in SSB/CW, and .09 uV in FM mode. On the IC-471A, the claim was less than 1.0 uV in SSB/CW mode and less than .3 uV in FM mode. We showed .23 uV to break the squelch in SSB/CW and .1 uV in FM mode. Incidentally, the S-meter readings varied wildly between units. It took .026 mV to register S9 on the IC-471A and .01 mV to make the grade on the TS-811A. Finally, we measured FM bandwidth to be about 9 kHz on the IC-471A with some noticeable distortion and 7 kHz on the TS-811A with noticeable distortion.

Summing up, both radios exaggerate their sensitivity claims, but are better than their claimed selectivity figures. Both units would definitely benefit from a well-designed preamplifier ahead of the front end. (The front end in the TS-811A is a 3SK129, while the IC-471A uses a 3SK48 MOSFET.) There's no reason why these units could not have been outfitted with a well-designed GaAsFET front end. Kenwood is already putting GaAsFETs in its 144-MHz FM rigs! The 3SK48 is a good MOSFET, but it really doesn't have the noise figure of a good microwave transistor or GaAsFET. The casual user might not notice the difference on FM, but it'd be very obvious in the SSB/CW mode. My advice? Buy a good external preamp.

### Testing

Last but not least, I put the units on the air for comparison. The control station was my Kenwood TS-430S with a Microwave Module ahead of it, using a microwave transistor in the front end. I used a Bird Coaxial Switch to instantly switch the antennas—4 x 21 element F9FT beams—to the three radios.

Reports were surprising. Using identical microphones on the TS-430S and TS-811A, the stations I worked preferred the audio quality of the TS-811A better. But the IC-471A gathered the best reviews for audio with the standard HM-12 microphone from every station polled except one. I discovered that the speech processor made little or no difference on the TS-811A as compared to the TS-430S. The IC-





P.C. ELECTRONICS 2522 S. PAXSON LN. ARCADIA CA 91006 (818) 447-4565  
 TOM W6ORG MARYANN WB6YSS  
 Compuserve 72405,1207

28



## AMATEUR TELEVISION

**ATV MADE EASY WITH OUR SMALL ALL IN ONE BOX TC70-1 TRANSCEIVER AT A SUPER LOW \$299 DELIVERED PRICE.**

### TC70-1 FEATURES:

- 10 pin VHS color camera and RCA phono jack video inputs.
- Crystal locked 4.5 MHz sound subcarrier.
- PTL (Push To Look) T/R switching.
- Sensitive UHF GaAsfet tuneable downconverter.
- Two frequency 1 watt pep xmtr. 1 crystal included.
- Xmit video monitor outputs to camera and phono jack.
- Small 7 x 7 x 2.5" for portable, mobile, or base.
- Draws only 500 ma (exc. camera) at 13.8 vdc.

Just plug in your camera, VCR, or computer composite video and audio, 70 cm antenna, 12 to 14 vdc, and you are ready to transmit live action color or black and white pictures. Sensitive downconverter tunes the whole 420-450 MHz band down to channel 3 on your TV set to receive. Both video carrier and sound subcarrier are crystal controlled. Specify 439.25, 434.0, or 426.25 MHz. Extra crystal \$15.

### WHAT ELSE DOES IT TAKE TO GET ON ATV?

Any tech class or higher amateur can get on ATV. If you already have a source of video and a TV, it costs about the same as getting on 2 meters. Now you can be seen as well as heard.

DX with TC70-1s and KLM 440-27 antennas line of sight and snow free is about 22 miles, 7 miles with the 440-6 for portable use such as parades, races, search and rescue, etc. You can add one of the two ATV engineered linear amps listed below for greater DX.

At 70 cm, antenna height and gain is all important. Foliage can absorb much of the power. Also low loss tight braided coax such as the Saxton 8285 must be used along with type N connectors.

The TC70-1 has full bandwidth for color, sound, and computer graphics. You can now show the shack, computer programs, home video tapes and movies, repeat SSTV or even space shuttle video if you have a Home Satellite Receiver.

### 20 WATT SPECIAL . . \$399

SAVE \$9 on the TC70-1 & ELH-730G when purchased together.

All prices include UPS surface shipping in cont. USA.

### ACCESSORIES:

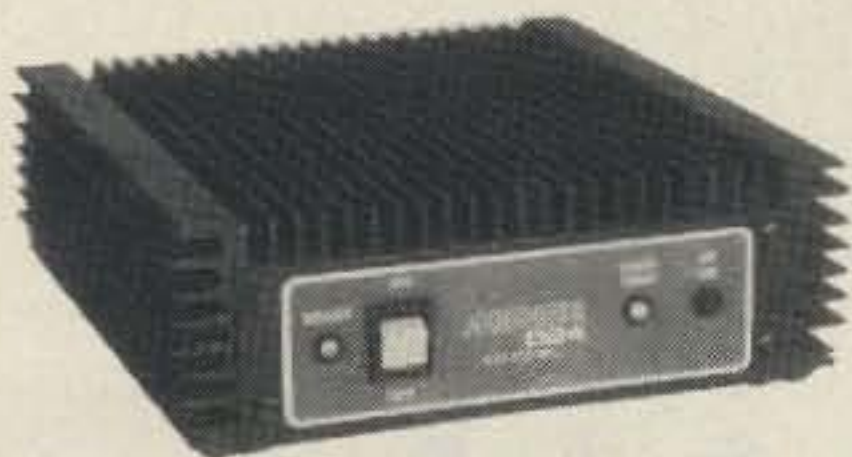

Mirage D24N-ATV 50 watt amp . . . . . \$189  
 ATV, SSB, FM. 9 amps.

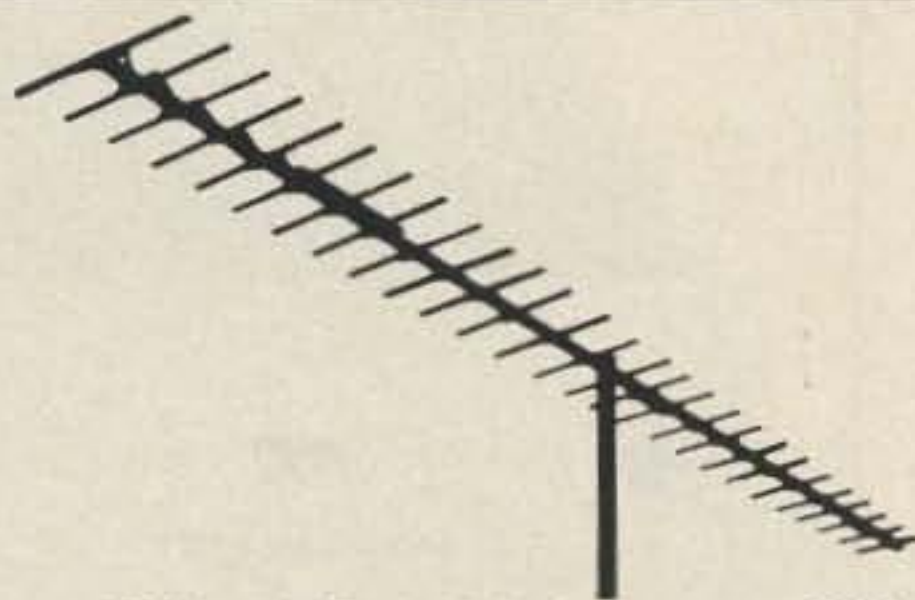

KLM 440-27 14.5 dbd antenna . . \$89  
 KLM 440-6 8 dbd antenna . . . . . \$38

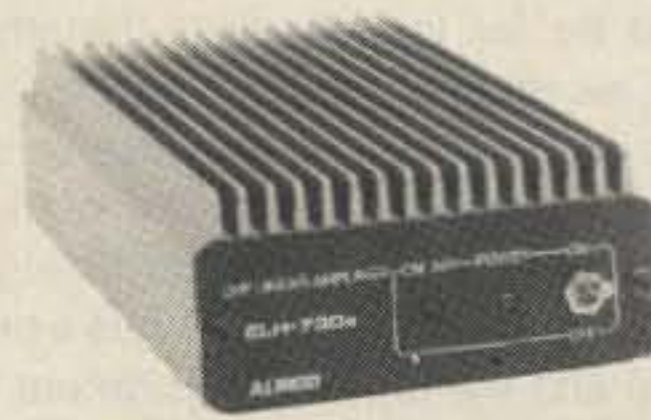

Alinco ELH-730G 20 watt amp . . . . . \$109  
 ATV, SSB, FM. 4.5 amps

**HAMS! Call or write for for full line ATV Catalog.**



471A, of course, has no processor. Received audio sounded best to me on the TS-430S, with the TS-811A second and the IC-471A a distant third. The unit really does need the tone control, as the ICOM's audio is very bassy on receive.

I measured the starting frequency to be 432.100 for our tests, confirmed with the station on the other end using a counter. The display on the TS-811A read 432.100.1 and the IC-471A read 432.099.2. We noticed some drift on both radios, and after about one hour, my TS-430 system and the listening station's system were still on frequency to each other at 432.100, but the 471A had to be readjusted to 432.099.1 and the 811A to 432.100.3. Acceptable, considering the frequency.

I switched to CW and all three radios received nice reports for the waveform with no perceived key clicks. The TS-430 and IC-471A both offset nicely in the CW mode, giving the listening station an 800-Hz note. The TS-811A had no offset whatsoever and had to be tuned in to obtain the beat note, which is a pain in the neck. A steady signal to produce an S9 +10 signal here on the TS-430S registered about S7 on the TS-811A and S9 on the IC-471A, confirming our previous measurements. As stated earlier, the agc is adjustable on the IC-471A but not on the TS-811A, being selected with the mode in use, so I couldn't evaluate it fairly.

All told, the two multimodes performed about as I expected against the transverter/HF-radio combination. Both multimodes really need preamplifiers to make the grade on 70 cm. Both acquitted themselves well in a short period of FM repeater operation, receiving good audio reports. Note that the microphone gain on FM with the TS-811A is fixed and not controlled by the front-panel MIC control! Now, why the heck is that? It's adjustable in all modes on the IC-471A, which is a real plus. Another strange engineering design from Kenwood, perhaps?

### The Final Evaluation

Overall, if I had to buy one or the other, I'd go with the ICOM IC-471A over the Kenwood TS-811A for two reasons: First, the front panel is very well laid out and the controls easy to use. Second, the receiver is a bit more sensitive than the TS-811A, and ICOM makes a companion mast-mounted preamp for the unit, which Kenwood either doesn't make or isn't importing at this time. The quality of the ICOM transmit audio also impressed me.

Although the Kenwood has some clever features and by far the cleanest transmitter, I wouldn't use most of the bells and whistles in day to day operation, and they are so closely integrated into the basic operation of the radio that they become somewhat confusing. I will say in its favor that the TS-811A has a nice feel on the vfo and the channelized detent tuning option is great to have on FM, as opposed to a smooth spinning dial.

Thanks to Joe Dolan KA2KWS for the use of his IC-471A and to Bill DiCarlo KA2QEP of QEP's Electronics for the use of his TS-811A. ■

# MFJ-1270 TAPR-2 Packet TNC

by Marc Stern N1BLH

MFJ Enterprises, Inc.  
Box 494  
Mississippi State  
MS 39762  
MFJ-1270—\$129.95

**A**t last, someone has made packet radio available to the common ham. MFJ Enterprises of State College, Mississippi, has introduced a TAPR TNC-2 clone that's every bit as good, if not better, than the original.

And, in what may come as a surprise to many who expected the MFJ unit to work well but be inexpensively made, the MFJ-1270 Packet Radio Terminal Node Controller (Photo A) is a very well made unit. MFJ has done it right.

Look at the printed circuit board (Photo B). It's a class act and definitely not a simple phenolic board. Instead, it is double silver-plated with plated-through holes. The motherboard looks as if it comes right from a computer room. All of the components are socketed, which is another plus because it allows you to keep up with the latest changes in software. All MFJ has to do, in this case, is burn new programmable read-only memory chips and send them out to customers who can then insert the new software.

As it is, the MFJ TAPR-2 clone has the latest revision of the TAPR-2 software. The date on my evaluation unit read 12/30/85, and I have to believe that this is the latest or one of the latest revisions of the TNC software.

A tiny unit, it is 7-3/8" wide by 1-1/2" high by 9-1/2" deep, and it weighs about two pounds. This puts it on a par with other low-powered, portable units on the market. In fact, the MFJ TNC is built to run off 13.8 V dc. That means it is perfect for portable low-power operation,

such as in an emergency when you have to move and handle high-speed traffic in the field.

It's a far cry from the TNCs of a year or so ago that were anchored to 120 V ac and wall outlets. This definitely limited the effectiveness of the TNC.

Essentially, the MFJ board is a plug-and-play unit. Since it contains the latest TNC program, all you need is a computer and a terminal program in the computer. The TAPR board acts as if it were a remote system—which it is, really—and the computer communicates through its telecommunications program with the TNC. You don't need any special program to use the MFJ TNC because everything is built in.

Connecting the TNC and computer is easy because a standard serial interface has been implemented. This means that a straight-through RS-232C cable attached to a serial port will work quite nicely. MFJ also includes an eight-pin Kantronics-style connector and cable, as well as a five-pin DIN cable with which you connect your radio and the TNC.

A series of DIP switches on the rear (see Photo C) sets the speed of the TNC's serial port. I left the evaluation unit set for 1200-baud, a 7-bit word length, and 1 stop bit. I then reconfigured my computer's communications software to conform, which was the easy way of doing things from my point of view.

You needn't do it that way, of course, because the TNC is actually a tiny computer in its own right. And since it is a computer, it's programmable. That programming is handled via the built-in terminal software used by the TNC to communicate with the computer. You hit the CTRL-C combination (on an IBM PC, anyway) which puts you into command mode where you can set just about any parameter you care to think of—including word length, parity, and the like.

This programming also sets up the TNC for use at your station. Your station's call is used as the TNC's identifier to the packet network. It recognizes the standard AX.25 network protocol and, like any TNC, will also act as a digipeater, as well as a beacon. This feature is

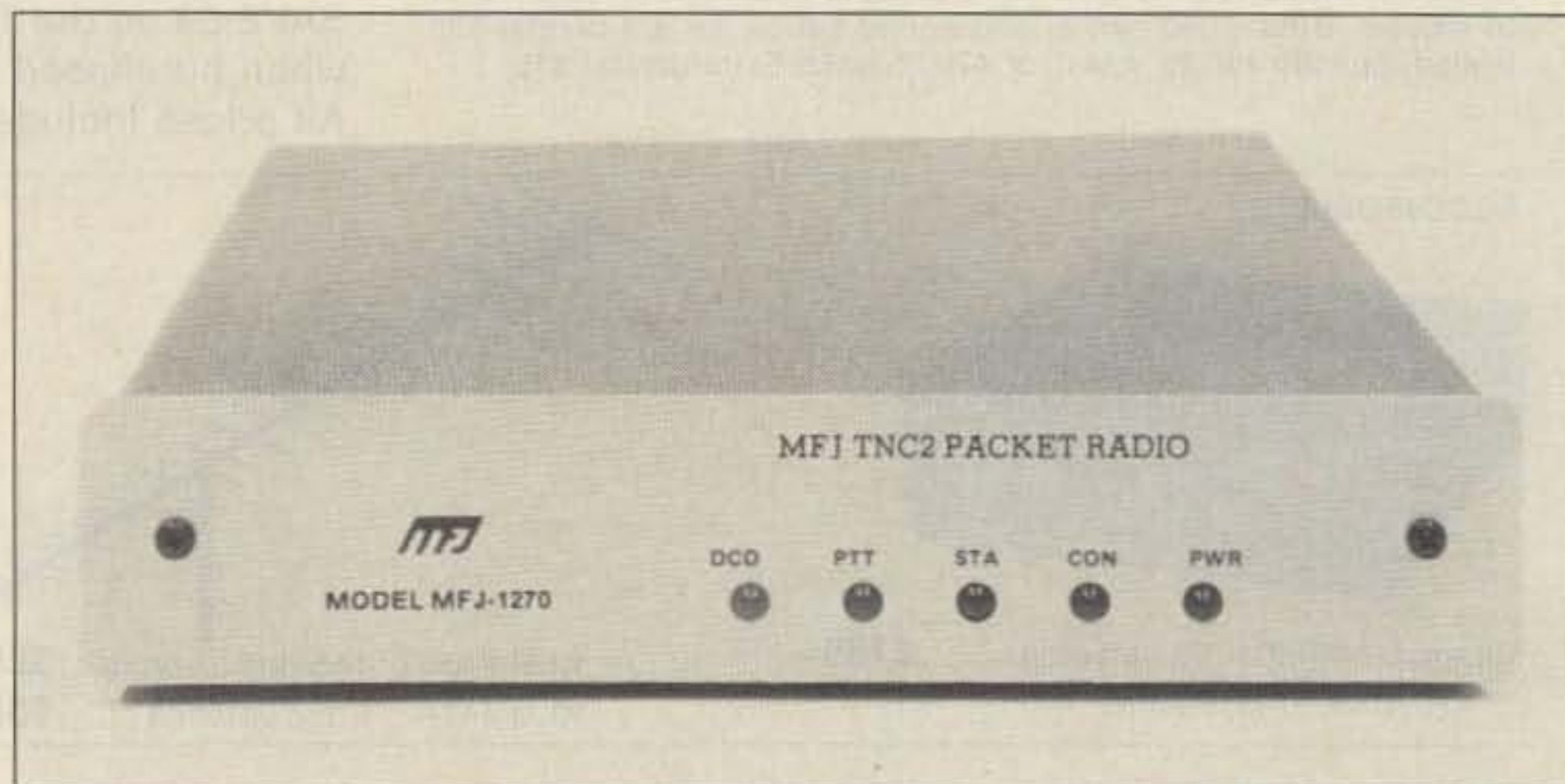

Photo A. The MFJ-1270 TNC-2.



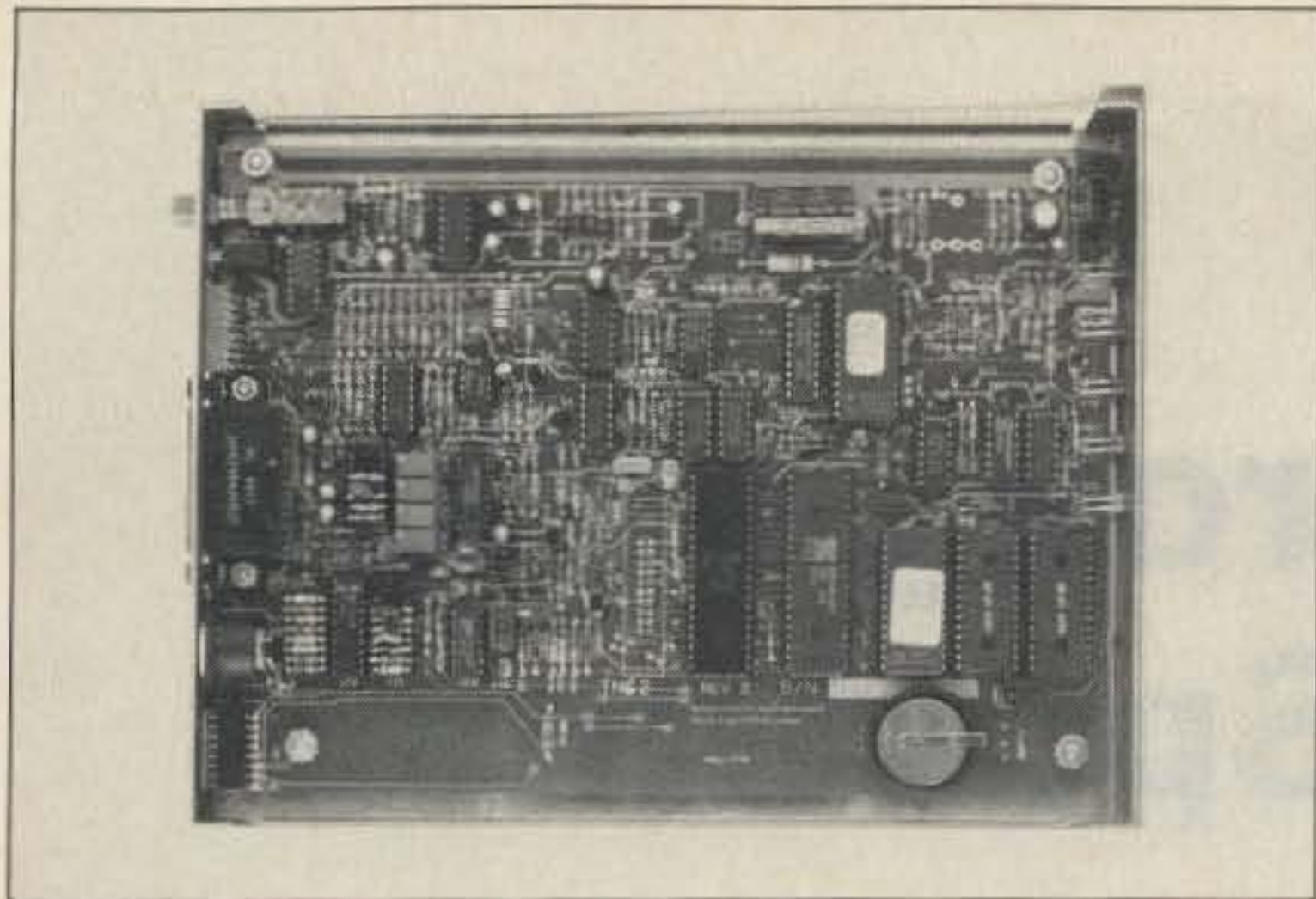

Photo B. The printed circuit board.



Photo C. A rear view of the MFJ-1270.

user-selectable, as is the TNC's ability to recognize both V 1.0 and V 2.0 of AX.25. Just about every feature of this TNC is user-selectable.

The CPU of the MFJ-1270 TNC-2 is a Z-80. It is backed by 16K of RAM and 32K of ROM. The ROM holds the monitor routine for the TNC, as well as the firmware program. The RAM is the user scratchpad.

There are so many features to the TNC-2 that I'll just have to touch on the highlights. In action, the MFJ-1270 TNC-2 is ready to go right from the box. It's simply a matter of wiring up a microphone connector for your VHF FM rig and putting it on the air. MFJ notes correctly in its manual that using the TNC in this manner is inconvenient if you use the rig for FM phone work, too. It offers an interface box which allows you both packet and phone options. It looks like a good idea. Not only does MFJ offer such a unit, it also gives you the schematic so you can build your own. It's a nice touch.

I found that the 1270 was set up to work correctly from power-up. To MFJ's credit, though, the manual does tell how to remedy problems if the tones aren't set up correctly.

The switching time of my evaluation 1270 matched the Kenwood TR-7930 with which it was primarily used. Both the radio and the TNC handled my input with no problems. I used shielded cables for all the cabling; this also helped ensure reliability because it kept noise interference to a minimum—which can be a problem when you're dealing with cabling several pieces of computer equipment together. I suspect ribbon cable would create noise problems and would urge anyone considering packet to use shielded cabling.

I did run into one problem, though, when it came to cabling, and that was due to pilot error. As most hams do, I usually attempt to do something before reading the documentation thoroughly. Most of us will read enough to find the on-off switch and then start playing.

I did this with the 1270 when it came to cabling up the microphone connector, then followed the diagram rather than reading the text closely. After I had finished wiring the cable, I found it didn't work. When I read the documentation, I found that it noted that ca-

bles would vary from the diagram and that each buyer would have to check out the connections with a volt ohmmeter for continuity. The only correction I would urge is keeping all the cabling the same or just providing a DIN connector and a picture of the 1270's requirements. Leave the color-coding off the diagram because many people will follow it rather than read the documentation.

The manual is the best I've ever seen from MFJ. Over 200 pages long, it is readable and covers every aspect of the TNC from interfacing (with a comprehensive discussion of serial

interfacing for major computers through setup—and a two-part tutorial) to a detailed discussion of the command set and error messages, as well as a technical discussion of the TNC. It also covers—as do all of MFJ's manuals—the TNC's theory of operation and provides a comprehensive set of schematics.

MFJ has done it and I still wonder how. The Mississippi ham radio manufacturing firm has brought in a sub-\$130 TNC that's worth much more. It deserves a look by anyone serious about packet. Reader Service number 152. ■

## GET A BIRD'S EYE VIEW

From GrafTrak II™ and your IBM® PC

1985 July 16 16:02  
From Moon  
390522 km over  
27.2 n 76.1 u

19833 km across  
SSI GrafTrak II

NRUNR KEA OSCAR 10 → 1985 JUL 11 18:44:48

LAT	0.5° n	ECHO	197 ms	ELEV	61.7°
LON	141.7° u	FRQ	145.8093	AZIM	143.3°
HGT	28938 km	DOP	-697 Hz	ORBIT	1562
RNG	29571 km	DRFT	5 Hz/m		70

HOUSTON OSCAR 11 → 1985 JUL 11 03:44:33

LAT	38.2° n	ECHO	8 ms	ELEV	29.5°
LON	93.5° u	FRQ	145.8228	AZIM	9.9°
HGT	691 km	DOP	-2628 Hz	ORBIT	7253
RNG	1245 km	DRFT	-528 Hz/m		27

LONDON OSCAR 9 → 1985 JUL 11 04:41:24

LAT	49.2° n	ECHO	6 ms	ELEV	28.9°
LON	10.8° e	FRQ	145.8246	AZIM	182.4°
HGT	484 km	DOP	-432 Hz	ORBIT	20889
RNG	929 km	DRFT	-1669 Hz/m		92

GrafTrak II™ provides realtime graphic display of a flat projection map which moves under the selected Satellite/Sun/Moon/Star coverage circle and updates once per second. Spherical projection views and graphic screen dumps to an IBM/Epson/Okii printer can also be produced. Requires an IBM PC, PC/XT, PC/AT, or true compatible, an IBM Color/Graphics Monitor Adapter or true compatible, 8087 math coprocessor, minimum 256K RAM with 512K recommended, DOS 2.0 or later, and either two 360K floppy drives or one 360K floppy and one hard drive.

SILICON EPHEMERIS™ provides tabular data output to the screen, printer, or disk file for the following operating modes: 1 observer to 16 satellites, 16 observers to 1 satellite, schedule for 1 observer to 1 satellite, window between 2 observers and 1 satellite, rise and set times for 1 satellite, time ordered rise and set times for 16 satellites, Almanac for Sun and Moon, 16 observers to Sun/Moon, schedule for 1 observer to Moon, window between 2 observers and Moon, schedule for 1 observer to Sun. Requires either an IBM PC, PC/XT, PC/AT, or true compatible, and IBM Monochrome or IBM Color/Graphics Monitor Adapter or true compatible, an optional 8087 math coprocessor, 256K RAM, DOS 2.0 or later, and one 360K floppy drive.

Each package includes SED, an editor program to construct and modify Satellite/Observer database files. These products can be run from a hard disk and are not copy protected.

GrafTrak II™ and SILICON EPHEMERIS™ are priced at \$119.95 each or \$199.95 for both. Texas residents add sales tax. Order by check, money order, MasterCard, or VISA.

Silicon Solutions, Inc. • P.O. Box 742546 • Houston, Texas 77274-2546 • (713) 661-8727

IBM is a registered trademark of IBM Corporation. GrafTrak II and Silicon Ephemeris are trademarks of Silicon Solutions, Inc.



# A Walk Through the VHF/UHF Spectrum

*KT2B surveys ham radio's biggest allocation—the bands and modes above 50 MHz.*

In this article, I'll try to provide a brief but concise overview of the amateur spectrum space above 50 MHz. In doing so, I'll try to answer questions such as: (1) How many frequencies do we have up there? (2) Who's using them? (3) How can I (the reader) better use them? (4) Who makes equipment for those bands anyway? (5) You mean I can actually work England and South America on 6 meters?

Actually, we in the amateur service are quite fortunate with our spectrum allocations. Table 1 shows the most active bands. The only group with access to more spectrum space is the U.S. government itself! Yet, much of this spectrum space lies largely dormant, either due to ignorance or just laziness. As time marches on and pressure mounts from groups outside the amateur radio service, we'll be hard pressed to justify retaining these privileges unless we make better use of them, for as you well know "possession is nine-tenths of the law!"

## The 6-Meter Band

For starters, consider the lowest frequency allocation: 6 meters. This band occupies the frequencies from 50–54 MHz and is a rather unusual animal. For example, although it is truly a VHF band based on spectrum position, it often behaves like an HF band owing to different types of propagation that may occur. The most common is sporadic-E, *Es* for short. This condition is prompted by sunspot activity and results in sporadic ionization of the E layer of the ionosphere. (Typical HF propagation occurs in the F layer of the ionosphere.) When this happens, contacts may be made with stations located thousands of miles away, often with low power levels. Severe thunderstorm cells frequently accompany this phenomenon, which has been extensively researched over the years.

A type of propagation that occurs less frequently nowadays on this band is F2 layer



Photo A. ICOM's IC-1271A 1.2-GHz transceiver.

propagation, similar to that which occurs on the lower frequencies. Right now, the sunspot cycle has bottomed out but is climbing up again; so in about five years, F2 propagation will be at its peak on this band. Here the possibilities are greater for DX: It's quite common to work into Japan from the West Coast or into England and Africa from the East Coast. One fine example of what F2 can provide is a contact made by Mike Crawford WA2VUN from his home in N.J. to a ZL in New Zealand, running 80 Watts to a single seven-element yagi.

Many 6-meter fans have WAC certificates, largely due to F2 propagation. Now that amateurs in Great Britain have received 6-meter privileges (although somewhat limited), it will be possible to make the W2-G2 contact path more readily when the sunspot cycle peaks out. Many stations have already worked the British Isles via *Es*, which occurred several times last summer, forming paths from the Atlantic Coast states 3,000 miles across the sea to England. With the eventual abandonment of TV channel 1 in Europe in favor of UHF color channels, most of the continent should receive the 50-MHz allocation in time for the next sunspot peak, providing new DX enjoyment for 6-meter types.

Aside from these modes, another popular form of DX and one that takes a considerable amount of skill is Meteor Scatter, which involves the use of ionized meteor trails to reflect 50-MHz signals over several-hundred-mile paths. It takes a lot of patience and repetition to make a scatter contact since most of these meteor "bursts" or "pings" are very short in duration and occur during the early morning hours or during intense meteor showers.

Normal 6-meter propagation is on the order of a few hundred miles at best. You can detect enhanced propagation by watching TV channel 2, 3, or 4 for distorted, breaking-up video with heterodyne beats as another distant signal is received. Often during *Es*, the distant signal will replace the local station completely for a few minutes, and you'll have the rare pleasure of watching a Miami weather report on your screen in Cleveland! (Neighbors who know you're a ham will blame *you* for this condition by attributing it to TVI!)

For the average station, 50 to 100 Watts and a single five-to-seven-element yagi will do the trick for SSB/CW work. The higher your antenna, the better. (This also helps to reduce possible TVI, as the increased vertical spacing between your 6-meter antenna and the nearby TV yagi also increases the attenuation of out-of-band overload products.) Most transceivers made for 50 MHz could stand the help of a good, well-designed MOS-FET preamplifier with 12–16 dB of gain. Some of the transceivers available (like the ICOM 551/551D series) make provision for such a preamp.

Don't let TVI scare you away from the band, either. In many areas, the penetration of cable service has all but eliminated this problem (assuming the system operator runs a clean shop!). Most often TVI is caused by using high-gain yagis and placing them at the



same height as most of the neighboring TV antennas, which is just asking for trouble. Get it up in the air as high as you can! Of course, there's no reason why you can't go 6-meter mobile or portable with horizontally polarized antennas as well, and take advantage of the nearby hills to chase DX on 50 MHz.

Another mode of operation that has achieved some popularity on the band is FM operation. Although there aren't many, 6-meter repeaters are distributed throughout the United States and can be accessed with a few Watts from a portable or mobile rig. When Es is present, you can have quite a time with FM, working through repeaters hundreds of miles away! Unfortunately, there aren't too many FM mobile rigs being made these days by the major manufacturers, so you'll have to dig around to see what you can come up with used. The 50-MHz band is a valid allocation in Japan; so, when the sunspot cycle was at its peak, we were flooded with all sorts of 6-meter radios—portables, mobiles, and multimode base stations. They're still around at flea markets for a good price.

Right now, the choices for new 50-MHz radios are somewhat limited to the ICOM 551D, ICOM 505, and Yaesu FT-726R with 6-meter module installed. You can also go the transverter route with Microwave Modules' MMT-50-28 or 50-144 units, the new Mutek TVVF-50 transverter, or kits from SSB Electronics and Hamtronics. Used radios that fit the bill include the Kenwood TS-600, Drake TR-6, Heath SB-110, Yaesu 627RA, and ICOM 560 mobile radios. Portable choices include the ICOM 502 and the Yaesu FT-690. Kenwood and Yaesu also make transverters to match their HF radios, which you can often purchase very reasonably. Antenna manufacturers include KLM, Hy-Gain, and Cushcraft. Sources for amplifiers are somewhat limited. Mirage is the only U.S. manufacturer making a 100-Watt solid-state unit at this time—perhaps more will come on the market as the sunspot cycle approaches its next peak.

### The 2-Meter Band

Moving up the dial, switch your attention to the 144-MHz or 2-meter band, as it is more commonly called. This is the most densely populated amateur allocation in the entire world, largely due to the phenomenal popularity of FM and repeater operation. It's also the band on which the OSCAR Mode B downlink frequencies are located. In North America, South America, and Japan, the 2-meter allocation runs from 144–148 MHz, while in Europe it's limited to 144–145 MHz.

Normal propagation is considered to be line of sight on this band, and with gain antennas and some power, the average distance worked is in the range of about 50–100 miles. Most of the activity on 2 meters consists of FM repeater operation, with SSB/CW operators usually found down around 144.100–144.200 MHz. Packet operators have carved out frequencies near 145.000 MHz for their

<b>6 METERS</b>	
50.000–50.100	CW, Beacons
50.100–50.500	CW, SSB, AM
50.110	Calling Frequency
51.000–51.100	
and	
52.000–52.100	Pacific Calling Frequency
50.500–54.000	FM and Repeaters
53.1, 53.2, 53.3,	
53.4, 53.5	Radio Control
<b>2 METERS</b>	
144.000–144.050	EME (Moonbounce, CW only)
144.050–144.060	Beacons (CW)
144.060–144.100	CW
144.100–144.300	SSB, CW
144.200	Calling Frequency
144.600–144.900	FM Repeater Inputs
144.900–145.100	Simplex, Packet
145.100–145.500	Repeater Outputs
145.800–146.000	OSCAR Mode B Outputs
146.000–148.000	FM, Repeaters
<b>1-1/4 METERS</b>	
220.000–220.050	EME (Moonbounce)
220.050–220.060	Beacons
220.060–220.500	SSB, CW
220.110	Calling Frequency
220.500–222.000	Link Frequencies
222.000–223.300	Mixed Use (all modes)
223.300–223.500	FM, Repeaters
<b>70 CENTIMETERS</b>	
430.000–432.070	EME (Moonbounce)
432.070–432.200	CW, SSB
432.110	Calling Frequency
432.200–435.000	Mixed Use, Link Frequencies
435.000–438.000	OSCAR Inputs (Mode B), Outputs (Mode L)
438.000–440.000	ATV, ATV Repeaters
439.250	National ATV Simplex Frequency
440.000–450.000	FM, Repeaters
<b>23 CENTIMETERS</b>	
1260.000 MHz–1270.000 MHz	ATV, FM, Mixed Use
1269.000 MHz	OSCAR Mode L Input
1270.000 MHz–1290.000 MHz	Mixed Use, FM, Repeater Inputs
1295.000 MHz–1297.000 MHz	CW, SSB
1296.090 MHz	Calling Frequency
1297.000 MHz–1300.000 MHz	Mixed Use

Table 1. Modes used on the most active VHF/UHF bands.

simplex operations. Moonbounce types frequent the area below 144.050, and the OSCAR downlinks are in the range near 145.800 MHz. More equipment is sold for this amateur band than for any other in the world, as well!

Enhanced propagation on 144 MHz comes in many forms: First and most commonly encountered is tropospheric propagation, or tropo for shorthand. This phenomenon occurs when temperature inversions are present—that is, for a given increase in altitude, the air temperature actually increases instead of decreases. When this happens, layers of warm air are often sandwiched between layers of cold air and a duct is formed along the boundaries, carrying signals along much like a waveguide. Users of repeaters are very familiar with this condition in the late summer and early fall, usually in the morning hours.

Strong storm systems in the area can induce tropo, with the intensity of the ducting effect proportional to the areas of the cold and warm air masses as they overlap. Tropo ducts also form at higher altitudes, and stations below the duct are often unaware of activity inside the duct. In this country, most tropo occurs along the coastal regions—mainly the Atlantic Coast and the Gulf of Mexico, and the Pacific Coast to a lesser degree. The path from Hawaii to Southern California has been worked many times on 144 MHz via tropo.

A form of propagation that can show up at any time on 2 meters (and on 6 meters, as well) is aurora, which is related to sunspot activity. During auroral propagation, signals are reflected off the auroral curtain and received 800–1,000 miles away, depending on the intensity of the aurora. This type of propagation occurs more frequently at higher



latitudes, with stations in the Northeast, Upper Midwest, and Canada able to take best advantage of it most of the time. When aurora is very intense, stations from the southern United States will often be heard off the curtain.

Still another form of enhancement is Es, which occurs much the same way as it does on 50 MHz, but far less often. Usually strong storm cells over the Midwest and Southwest provide the best conditions for long-haul DX, observed mainly during the months of June and July. You can often detect sporadic-E by listening to FM broadcast stations or watching TV channels 7-13 for interfering stations outside the normal coverage area. The higher the channel it's observed on, the more intense the Es. A rule of thumb is to watch the Es on 6 meters, and when it becomes quite short—200 to 300 miles—move to 2!

Just as on 6 meters, you can work meteor scatter with patience and determination. It's more fruitful to pick a major shower to do it, though, as the pings from everyday meteorite trails are harder to detect than on 10 and 6 meters. Good, high-gain antennas and schedules are a must, as well as a fair amount of power to make it worthwhile. And as I mentioned earlier, moonbounce operation, or EME (Earth-Moon-Earth), is very popular on 2 meters. Stations here usually run large four-bay or larger antenna arrays with legal limit amplifiers to overcome the 200+ dB path loss from here to the moon. Low-noise GaAsFET preamplifiers find favor in this application.

There is a bewildering array of equipment for 2 meters currently available! At least eight Japanese and one U.S. manufacturer have FM handie-talkies available for the band, not to mention mobile FM radios. In addition, there is a preponderance of 2-meter multimode radios for both base station and car, as well as the world's only multimode handie-talkie (Santec LS-202). Three companies in Europe have gone the other route and manufacture transverters for the band, so as to employ HF multimode transceivers as i-f frequency TX/RX sources, most often in the 10-meter band. Examples of these would include the popular Microwave Modules' MMT series, as well as Mutek and SSB Electronics.

There's a plethora of antennas to choose from as well—KLM, Cushcraft, Jaybeam, CueDee, Hy-gain, and Tonna to name a few. Most users of FM employ vertically polarized antennas, such as ground planes and J-poles, while SSB/CW users employ horizontally polarized yagis, with as many as 19 or 20 elements. This is often the reason why newcomers to weak-signal work can't hear any activity, as they are still using their vertical arrays!

There are many manufacturers of amplifiers for 144 MHz as well, with Mirage, TET, Alinco, THP, and Microwave Modules being among the more popular solid-state models. Henry Radio manufactures several versions of a 2-meter amplifier using 3CX800 and 8877 tubes, which find use largely with the moonbounce set and weak-signal enthusiasts.



Photo B. The Kenwood TM-2570A 2m mobile radio.

As far as the OSCAR users are concerned, multimode transceivers for 432 MHz and 144 MHz or transverters are the order of the day, with "twist" polarization (antennas using both horizontal and vertical elements) yagis and 100-Watt amplifiers.

Two meters is a perfect example of what happens when amateurs take to a certain band and populate it: The amount of equipment available goes up in direct proportion! It's probably the most secure allocation we have above the HF bands, directly due to the activity. Unfortunately, the same cannot be said for the next band, 220 MHz, which has long been the stepchild of our VHF allocations. In fact, you can consider 220 MHz to be a UHF allocation in the scheme of things, lying above TV channel 13 at 220-225 MHz.

#### The 1-1/4-Meter Band

The 1-1/4-meter band is a rather unique allocation; in all the world, only we in North America can use it! This certainly explains the lack of commercially made equipment for the band, with nothing being manufactured here in the United States and the only transceivers coming in from Japan—where the allocation doesn't exist. At present, only ICOM makes a mobile FM transceiver for the market. Kenwood, ICOM, and Yaesu make hand-helds for 220, as well. In addition, for some time Hans Peters VE3CRU of Transverters Unlimited has been making modified 220 Microwave Modules that work with HF multimode radios. SSB Electronics is also introducing equipment for this market.

What can you work on 220? For one thing, the propagation under normal conditions closely resembles 144 MHz, with line-of-sight conditions being the rule on low power. With a gain antenna and some power, 50-100 miles is possible. Enhanced prop-



Photo C. Yaesu's FT-726R multimode, multi-band transceiver.

agation takes several forms, with the most common being tropospheric propagation as on 2 meters. This occurs mostly from late summer through fall and can result in contacts in excess of 500 miles, mostly along coastal areas.

During periods of sunspot activity, 220 contacts can be made via aurora, again in the same manner as 2 meters, with stations in the northern regions of the United States having the best propagation. Meteor Scatter is also quite popular on 220 during strong showers, such as the Perseids in early August. Again, schedules are a must here; otherwise, you'd never hear the minute-to-minute "pings" from random meteorites entering the atmosphere. As far as Es is concerned, there haven't been any strong documentable cases for it lately, though this will likely change when the sunspot cycle peaks out in about five years.

Operation on 220 mainly consists of FM and repeaters. In fact, many users of 220 have tired of the crowded conditions on 2 meters and have moved up to what they consider to be a more "civilized" band, especially in urban areas. In those areas, most of the coordinated repeater pairs have long been assigned, yet many of the machines are "dormant" much of the time. Down at the far end, you'll find the weak signal chasers and moonbouncers, with the former around 220.110 and the latter around 220.050. Moonbouncers in particular like this band since it is relatively "quiet" as opposed to its lower frequency brother. And with the band falling above TV channel 13, TVI is rarely, if ever, a problem, even with high power levels.

These advantages haven't been lost on other potential users of the band, so 220 continues under siege from a variety of special interests, who've come up with all sorts of "shared spectrum" proposals, as well as schemes to take the band away from hams outright and parcel it out to commercial users. The big problem is activity—there just isn't enough to ensure the long-term use of the band. So the big manufacturers in Japan are loath to come out with lines of full-featured multimode radios for 220, not trusting in its staying power. It's up to us to determine the fate of 220, and the old saw "use it or lose it" certainly applies here.

One group that appreciates the "quiet" on 220, as well as the abundance of repeaters, is the packeteers, who are multiplying on this band. Without the bother of continuous voice transmissions to contend with, the packet mode is a very viable alternative. Of course, the Novice Enhancement Docket before the FCC may change all of that, giving voice privileges on 28 MHz, 220 MHz, and 1260 MHz. It would result in more Novices on the band and in the long run may be what it takes to keep 220 in the amateur table of allocations.

As I said before, the equipment situation is somewhat tight. In addition to the 220 Microwave Modules, SSB Electronics will soon import a 220 transverter to the United States. As far as amplifiers go, Mirage and Tokyo HighPower make 220 units for 50-120-Watt



# SPRING SPECIALS POWERFUL PACKET.

New rigs and old favorites, plus the best essential accessories for the amateur.

3621 FANNIN ST.  
HOUSTON, TX 77004-3913



CALL FOR ORDERS  
1-713-520-7300 OR  
1-713-520-0550

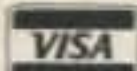

ALL ITEMS ARE GUARANTEED OR SALES PRICE  
REFUNDED

## EQUIPMENT

Kenwood	Call for prices on all Kenwood
Kenwood TS940S, contesters' delight	Call
Kenwood TS 440	Call for trade
Icom R7000 25-2000 MHz	849.00
Icom IC3200	489.95
Santec ST20T Handi Talkie	289.00
Icom IC735	799.00
Ten-Tec 2510 (Easy OSCAR)	489.00

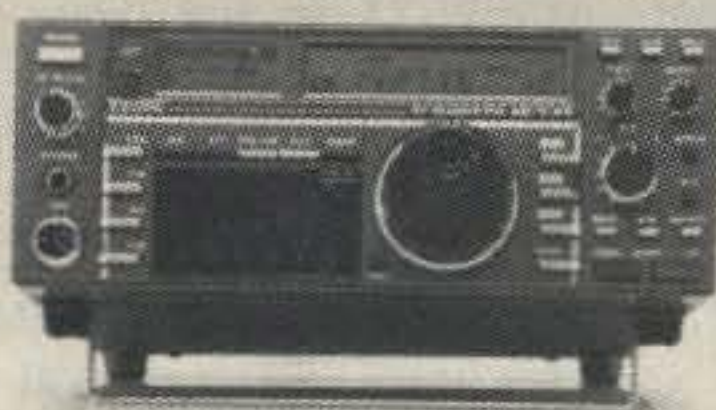

## ACCESSORIES

B&W VIEWSTAR ANTENNA TUNER	89.95
Heil HC3/HC4/HC5	Stock
Heil BM10 Boom Mike headset	59.95
CSI Private Patch III	469.95
FLUKE 77 auto-ranging digital multimeter	125.00
Bird 43 Wattmeter	Call
Bird Elements	In Stock, Call
Daiwa CN620B, 20-200, 2000W	109.95
Stabylex 20SR, 25 amp 12VDC, 16 amp cont. overvoltage protected	99.00
Alinco ELH 230D- Excellent buy	79.00
Nye MB5-A (for the big boys!)	529.00
Shure 444D	54.95
Wahl 7470 Soldering Station	49.00
Kenwood IF 10A, B, C	Stock
Kenwood IF 232C Level translator	49.00
Miller C514T Low pass filter	43.50

## "NEW" ALPHA DELTA 4 HEAVY DUTY COAX SWITCH

with ground pos. & lightning protection.....69.00  
Collins KWM2/S line xtals.....10.00 each



751A.....List 1499.00.....Your Cost 1299.00

## KEYS

Bencher & Vibroplex.....Less 10%  
Bencher is now improved. Screws & springs, all stainless steel and extra hand polishing.  
Trade in your old hand key on new Vibroplex/Bencher 5.00  
Nye ESK-001 Keyer.....58.00

## TUBES

Collins & Drake Replacement tubes	stock
GE 6146B	11.95
Eimac 3-500Z	109.95
GE Industrial Tubes	Call
GE 12BY7A	7.00
GE 6JS6C	12.95
Cetron 572B	69.00
GE 8950	14.00

CALRAD 65-287 SWR, Relative Power Meter.....32.95  
3-150MHz, KW+

## BOOKS

We stock SAMS, TAB, ARRL, RSGB, Ameco Radio  
Pubs.....Call  
Some of the best buys are the RSGB books.

## ANTENNAS

Isopole	44.95
A4	269.00
402CD	279.95
424B	84.00
215WB New, 15 EI, 2M beam	79.95
AOP-1, Complete Oscar Antenna	149.95
Butternut HF6V, 80-10 vertical	125.00
HF2V, 80 & 40 vertical	119.00
HF4B	189.00
Hustler G7-144	119.95
Hustler 6BTU	139.00
Ham4 Rotator, T2X, CD45-2	Call
KLM HF World Class Series Antennas	Call Don
Alpha Delta Twin Sloper	49.00
Coax Seal	2.00/roll
B&W Dipoles	Less 10%
Hy-Gain TH7DXS	489.00
Explorer 14	349.00
Discoverer 1 element 40M	169.00
2 element 40M	369.00
3 element only	249.00
CD 45-2 Great Tribander Rotor	169.00
V2S (2meter)	59.00
HG52SS 52 ft. crankup tower	1199.00
Prepaid freight when you order other Hy-Gain items with tower	
KLM KT-34A	339.00
40M-2	299.00

## OTHER ANTENNAS

Larsen Kulduck	17.00
Larsen 440 HW 1/2 wave Kulduck	25.00
Avanti AP151.3G on Glass Antenna	36.00
Anteco 2M, 5/8, Mag. Mount, Comp	25.00
Avanti APR450-5G on glass	39.00
Orion 2M 1/2 wave handy Antenna	19.00
Van Gordon SLA-1 160-80-40 Sloper	34.00
Valor AB-5 Mobile	79.95
Stoner DA100 D Active Rx Antenna	190.00

## SURPLUS

24 Pin Solder tail dip sockets	25/each
150MFD/400V DC	1.95
1.5 Amp/400V full wave bridge rectifier	1.95
2.5A/1000PIV Epoxy diode	29 each or 19.00/100
.0015/10KV or .001/20KV	1.95 each
3N201	.95
4 inch ferrite rod	1.95
365pF cap	1.95
Sanyo AAA, AA Nicads w/tabs	2.00
2,4,5,6,8 pin mic plugs	3.00
1/8, 1/4, watt carbon resistors	.05 each
Meters 0-3000 VDC 2 1/2" Square 0-1 Amp DC	9.95
Drake—Collins mike plug	2.00
Miniature toggles, 5A/125VAC	1.50 each
Close out on rigs & accessories. All the time	Call
We may have what you're looking for.	

## BELDEN

9913 low loss, solid center, foil/braid shield	51c/ft.
8214 RG8 Foam	45c/ft.
8237 RG8	39c/ft.
8267 RG213	55c/ft.
8000 14 Ga stranded copper ant. wire	13c/ft.
8448 8 conductor rotor cable	33c/ft.
9405 Heavy duty 2-16 Ga 6-18 Ga	56c/ft.
9258 RG8x	26c/ft.
9269 RG-62A/U	16c/ft.
8403 Mic Cable, 3 condctr & shield	45c/ft.
100 feet 8214 w/ends installed	54.00
8669 7/16" tinned copper braid	1.00/ft.
International Wire RG214, non-mil. good cable	70c/ft.
International Wire 9086 exact replacement for Belden 9913	36c/ft.
International 16 Ga stranded antenna wire	6c/ft.

## AMPHENOL

831SP-PL259 Silverplate	1.25
UG176 reducer RG8X	.30
831J Double Female UHF	2.00
82-61 N Male	3.00
82-97 N Female Bulkhead	3.00
82-63 Inline Female N	4.00
82-98 N elbow	9.00
31-212 BNC-RG59	1.50
31-2 BNC-RG58	1.50
34025 N Male, RG58	3.00
34125 N Female-UHF male	9.00
3128 BNC Female-PC259	3.00

## TOWER ACCESSORIES

1/4" E.H.S. Guy cable, Rohn US, 1000 ft.	250.00
3/16" E.H.S. cable, Rohn US, 1000 ft.	210.00
1/4" Guy Cable, 6100 #7 x 7 strand, import	15c/ft.
3/16" Guy Cable, 3700 #7 x 7 strand, import	12c/ft.
3/8 x 6 E&J Turnbuckle	7.95
3/16" Wire Rope Clips	40
1/4" wire clips	50
1/4 Thimbles	45
Porcelain 500D Guy Insulator (3/16)	1.99
Porcelain 502 Guy insulators (1/4)	3.39

## COMPUTER STUFF

Kantronics UTU-XT	319.00
Fits any computer (even yours!)	
Morse University (Great CW program for C-64)	39.00

## PACKET POWER

AEA PK-64, does RTTY, ASCII, AMTOR also	199.00
AEA PK-80 TAPR II	199.00
NEW Kantronics Packet II	199.00
Icom 271A Great packet radio	Call

## SERVICES

Alignment, any late model rig	50.00
Flat fee Collins rebuild	Call

## USED EQUIPMENT

All equipment, used, clean, with 90 day warranty and 30 day trial. Six months full trade against new equipment. Sale price refunded if not satisfied.

## POLICIES

Minimum order \$10.00. Mastercard, VISA, or C.O.D. All prices FOB Houston, except as noted. Prices subject to change without notice. Items subject to prior sale. Call anytime to check the status of your order. Texas residents add sales tax. All items full factory warranty plus Madison warranty.

# BIRD

## STOCK ITEMS CALL

Power Range	Frequency Bands (MHz)					
	2-30	25-60	50-125	100-250	200-500	400-3000
5 watts	—	5A	5B	3C	5D	5E
10 watts	—	10A	10B	10C	10D	10E
25 watts	—	25A	25B	25C	25D	25E
50 watts	50H	50A	50B	50C	50D	50E
100 watts	100H	100A	100B	100C	100D	100E
250 watts	250H	250A	250B	250C	250D	250E
500 watts	500H	500A	500B	500C	500D	500E
1000 watts	1000H	1000A	1000B	1000C	1000D	1000E
2500 watts	2500H					
5000 watts	5000H					

# MADISON

## Electronics Supply

3621 FANNIN  
HOUSTON, TEXAS 77004  
1-713-520-7300 OR 1-713-520-0550





Photo D. Microwave Modules' MMT 144/28 R 2m multimode transverter.

output, using HTs or mobile rigs as exciters. In the higher power range, Henry Radio makes a version of the popular 2004 for this band, using the 3CX800. Antennas are available from both Cushcraft and KLM, as well as mobile whips from Larsen. A good deal of the operators on 220 have rolled their own equipment, for obvious reasons.

### The 70-Cm Band

Now, let's take a big step up to our next allocation: the 70-cm band, or 430-450 MHz. Originally, this band included the range 420-430, but recent FCC restructuring has removed the lower 10 MHz from amateur use. Here's a band that's larger than 6, 2, and 1-1/4 meters combined. It's also a worldwide allocation, so equipment is plentiful and not that expensive. Whatever your fancy—from weak-signal work to ATV, OSCAR, FM, and repeaters—there's plenty of room to engage in it on 70 cm.

Here is a true UHF band. Signals travel line of sight and can be affected by objects of varying density in the signal path, such as trees, buildings, and even clouds of moist air. Yet, since the 70-cm band is largely unaffected by sunspot activity (and subsequently any sporadic-E), it's a preferred choice for such services as commercial television in Europe. Since the wavelength is so small, high-gain multiple-element yagi antennas are possible using only 15 feet or so of boom length.

Propagation enhancement usually occurs via tropo. In some cases, it's so intense that astounding distances can be covered. For example, during the hurricane last September that hit along the East Coast of the United States, signals from Florida were heard into Connecticut and Massachusetts! Tropo ducting is quite common at this frequency, although you usually have to be up a bit in elevation to hook into the duct. Signals can also be worked via aurora on rare occasion, as happened this past February when intense sunspot activity resulted in auroral activity from 50 MHz through 432 MHz! Stations were heard working grid squares from the East Coast into Illinois, Ohio, Michigan, and Indiana via the "buzz."

Starting at the low end of the band around 432.010-432.050, you'll find the moonbouncers. This is a very popular band for EME since you can construct high-gain arrays that don't take up much room. Many European and Japanese EME enthusiasts go mobile or portable for their contacts, towing



Photo E. The LT 23 S 1296-MHz transverter from SSB Electronics.

their arrays along on trailers. Power becomes somewhat more difficult to generate on 70 cm as many of the popular ceramic power tubes don't carry full ratings through 400 MHz. However, the problem of Faraday rotation, the slow shift of polarization on reflected signals from the moon, is less pronounced on this band. It takes longer for the wave to shift—often minutes—as opposed to 2 meters, where the shift occurs at a rapid rate.

Next, you find the weak-signal types around 432.110 MHz, the national calling frequency. SSB and CW work is plentiful on 70 cm, especially during contests. Many operators use multimode transceivers to cover these modes, and, of course, there are many transverters made for the band.

Going further up, you run into the OSCAR uplink frequencies in the range 435-437 MHz. These are the inputs for Mode B with corresponding outputs on 2 meters. The ATV crowd is next, for the 70-cm band is the lowest frequency allocation that permits Fast Scan Amateur Television. Many stations are on in color, and there are ATV repeaters located on tall buildings in urban areas.

Finally, you run into the FM crowd above 440 MHz. Like 220, the 440 allocations are largely used up in the major urban areas, but many of these repeaters are closed repeaters, using PL or tones to unlock the machine for use by members. The national simplex calling frequency on FM is 446.000.

As you might expect, there's no shortage of equipment to choose from on 70 cm. All of the major Japanese manufacturers make both hand-helds and multimodes for base and mobile operation. The major European manufacturers offer transverters for the band, as well as ATV transmitting and receiving converters. Since many of the radios on the market usually suffer from less-than-acceptable front-end sensitivity, there's an abundance of preamplifiers available for both station-mount and mast-mount application. Serious users of the band employ low-loss cables such as 9913 and hardline for transmission lines, since the average coax used at HF is too "lossy" here. Also standard in most cases is the use of low-loss 50-Ohm connectors, such as type N and BNC.

Amplifiers are also plentiful. Alinco, Mirage, TET, Microwave Modules, and Lunar make solid-state versions with outputs up to 140 Watts. For the higher power requirements, Henry makes the 2004 and 3004 using 3CX800 and 8877 tubes. Antennas are available through a variety of sources, including

KLM, Cushcraft, Hy-gain, Larsen, CueDee, Tonna, and Jaybeam. OSCAR operators will employ the "twist" type of antenna for the uplink mode, while ATV operators will go for horizontally polarized yagis, along with the moonbouncers and weak-signal operators. All FM operation uses vertical polarization.

OSCAR Mode L, used less frequently than Mode B, employs uplinks on 1269 MHz and downlinks on 436 MHz. At this time, packet operation on 70 cm is sketchy at best. But due to the combination of spectrum space, worldwide popularity, and availability of equipment, 70 cm could easily become the next most popular band after 2 meters! Already in Japan, reports are made of the type of congestion we experience here on 144 MHz, with FM being again the predominant mode.

### The 23-Cm Band and Above

Before closing, I'll touch briefly on the SHF bands, namely 23 cm and above. The 1260-to-1300-MHz band is coming on fast, especially in Europe and Japan. Here's a band that's twice as big as 70 cm! Again, the popular modes are SSB/CW, ATV, OSCAR, and FM. Propagation is essentially limited to tropo. I've never heard of any auroral contacts via 23 cm, although during the February conditions, there were those who certainly waited patiently to be the first!

Moonbouncers also like 23 cm since Faraday rotation is even slower here and they can construct high-gain arrays or dishes in a relatively small square area. Of course, power is more difficult to generate here, so most of the amplifiers you'll hear are home-brew, generally employing triodes such as the 7289/3CX100. Even 9913 exhibits high losses at this frequency, so hardline is the transmission medium of choice.

Equipment available includes the new ICOM IC-1271A 10-Watt multimode base for SSB, CW, FM, and ATV. ICOM also makes the IC-120 mobile FM radio with 1 Watt of output. Kenwood makes the TR-50 FM portable, also running 1 Watt from a self-contained battery-operated unit. High performance transverters are readily available from Microwave Modules and SSB Electronics, makers of the popular LT-23S 10-Watt transverter. GaAsFET preamplifiers abound at this frequency, since they are a necessary evil for serious weak-signal work.

Antennas are made by Tonna of France and Jaybeam. DownEast Microwave manufactures a fine line of loop yagis for 23 and 13 cm. Larsen makes a 23-cm mobile antenna, based on a cellular design for 800 MHz.

Most often, the inhabitants of this band like to roll their own antennas, but it's a tricky task as mast supports often exceed the length of the driven and parasitic elements! Hence, most users place the beams at the very top of their masts or make up side arms with vertical supports. Frequently, users of the band will experience reflection from such objects as airplanes and large buildings! Often refraction can occur over mountainous areas, and it's not unusual to hear lots of multipath on the signals when living in such an area.



# All Mode Communication Terminal

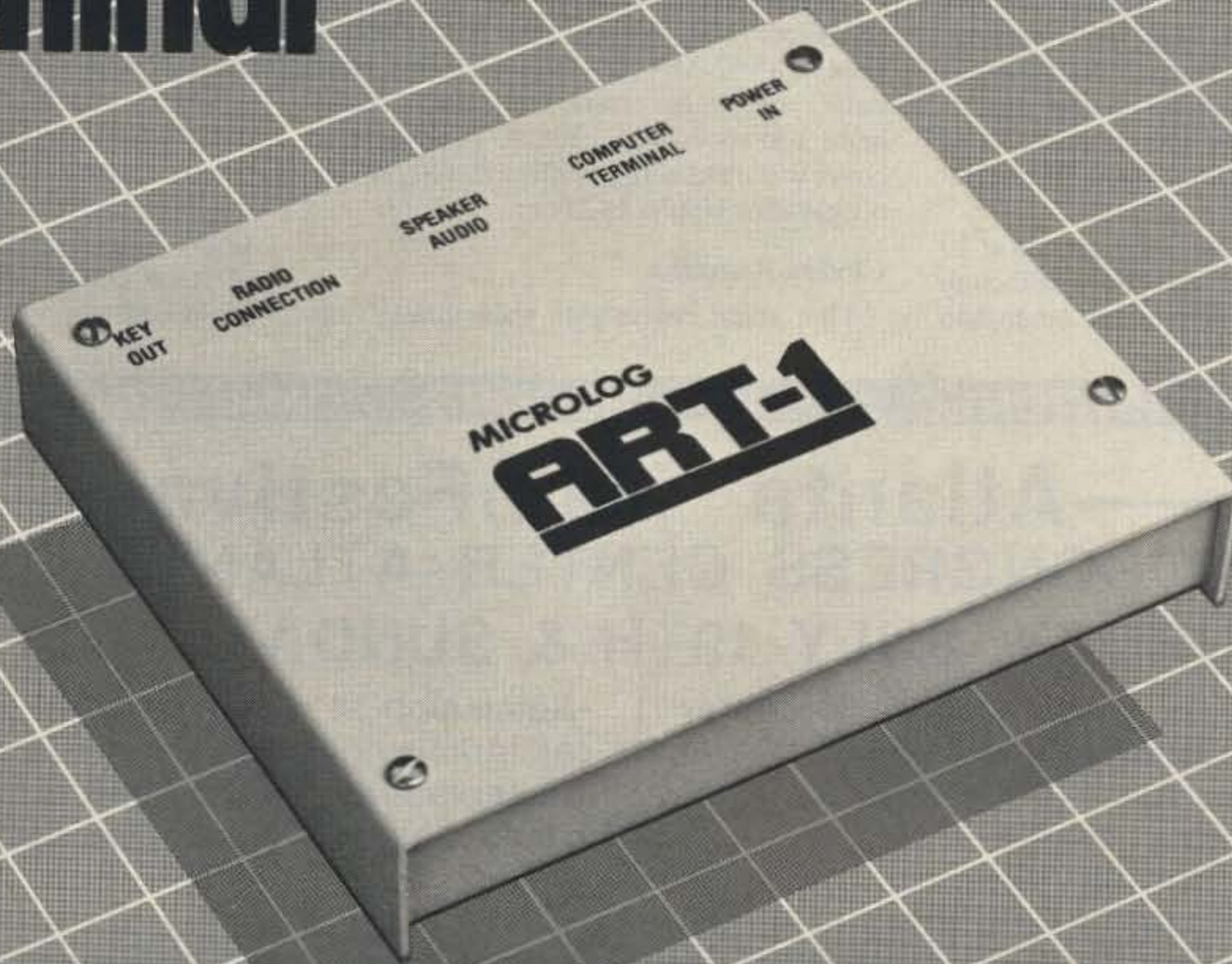

## When is Microlog going to get into Packet?

Thanks for waiting, you'll be glad you did. We've packed a lot into the ART-1, because we knew you wanted a truly ALL-MODE Remote Terminal, without any extra pieces or RATTS nest of wiring required, and, 'NO COMPROMISE' performance. Start now with full capability Receive & Transmit on RTTY, CW, & AMTOR for \$199, and later add Packet capability *inside* the shielded, all-metal ART-1 case. Plug in the ART-1 with one cable to your computer, make the connections to your radios, and forget it. All control functions and tuning indicators are via the keyboard and video. Small enough to go anywhere, and available now for your Commodore 64/128. Packet operation uses either TAPR compatible, or easy Microlog direct control commands not possible with conventional ASCII terminals. Packet option includes a separate internal computer enhanced demodulator optimized for 1200 baud, and *dual-radio* support for HF & VHF. It's like having two interactive terminals. (What good is a multimode unit that can only connect to ONE

radio?) You've come to expect performance *and* value from MICROLOG, the ART-1 delivers!

### Here are a few of its many features:

- on screen tuning indicators
- full or split-screen on all modes
- auto-load memories
- output to commodore printers
- full speed operation, morse to 99 wpm. Baudot to 132 wpm, ASCII to 300 Baud
- 4 mode AMTOR
- WRU
- independent RX/TX normal/invert
- pitch reference CW tuning
- real-time disk communication
- break buffer
- random code generator
- RX/TX of basic programs
- 24 hr. clock
- no extra power supply needed when used with Commodore Computers
- unshift on space
- foxtest and more.

## MICROLOG

INNOVATORS IN DIGITAL COMMUNICATION

18713 Mooney Drive Gaithersburg, Md. 20879  
301 258-8400

✓70



At 13 cm, much the same conditions prevail, except very little is available for the band commercially except from Europe and a few specialty houses in this country. Loop yagis are very popular at this frequency, as are dish antennas. Transverters are available from such manufacturers as SSB Electronics of Germany, which sells a unit for 13 cm with an i-f at 144 MHz, running 3-Watt output. EME Electronics of Germany makes beautiful cavity amplifiers for both 23 and 13 cm, using two 7289 tubes to achieve 50-to-100-Watt output.

Amateurs have additional allocations at 10 GHz, 24 GHz, 48 GHz, and above, although it's hard to say who's active here other than

the diehard experimenter and occasional contest stations. In addition, I've sidestepped the 902-MHz band, simply because it's such a new allocation that I'm not very familiar with it. I can tell you that there is activity on 902, as a repeater group was on the band the day it became available (from Texas—it figures!). SSB Electronics has indicated the availability soon of a 902-MHz transverter, as has Hans Peters of Transverters Unlimited. Many hams are modifying cellular equipment to cover this band with excellent results, seeing propagation similar to 23 cm.

**Closing Remarks**

That about covers our walk through the

VHF/UHF spectrum, and as you can see there's plenty of room for expansion and experimentation. Indeed, these frequencies are the key to the future of the hobby, as we continue to try new modes that require greater bandwidths than our already-crowded HF bands can provide. If you haven't given one of these bands a try lately, why not pick up a transverter or HT and have a go! Many activities exist for the VHF/UHF operator, with no less than six national contests and many certificates to be had, such as the popular VUCC (VHF/UHF Century Club). It needn't take a lot of money, or a lot of space either. Set your sights high, for a change! ■

**- AIR CONDITIONED - ALL INDOORS - AIR CONDITIONED -**

**---Atlanta HamFestival---**  
**WORLD CONGRESS CENTER-ATLANTA GEORGIA**  
**SATURDAY, JULY 19TH & SUNDAY, JULY 20TH**

- Location-Georgia World Congress Center
- Indoor Airconditioned FleaMarket
- License Exams Given Both Days
- Plenty of Parking Nearby

- Admission-\$6 Advance-\$7 at the Door  
(All Admissions Valid Both Days of HamFestival)
- Reservations Encouraged & Accepted
- Make Checks Payable to: Atlanta HamFestival

FOR INFORMATION WRITE:

**ATLANTA HAMFESTIVAL-P.O. BOX 77171-ATLANTA, GA. 30357**

**- AIR CONDITIONED - ALL INDOORS - AIR CONDITIONED -**

 <p><b>the HAM STATION</b></p> <p>P.O. Box 4405 220 N. Fulton Ave. Evansville, IN 47710</p> <p>Store Hours MON-FRI 9AM-6PM SAT 9AM-3PM</p>	 <p><b>YAESU</b> 10 Memories 45 Watts With FTS-8 <b>ORDER NOW</b></p> <p>FT270R</p>	 <p><b>ICOM</b></p> <ul style="list-style-type: none"> <li>•25 watts</li> <li>•large LCD readout</li> <li>•wideband coverage</li> <li>•21 memory channels</li> </ul> <p><b>NEW!</b> IC-28A 2 Meter Mobile <b>Ham Net \$419.00 Call for Special Introductory Price</b></p>
<p>WARRANTY SERVICE CENTER FOR: ICOM, YAESU, TEN-TEC</p>	 <p><b>TEN-TEC</b> 2510 Mode B Satellite Station</p>	 <p><b>WELZ</b> Lots of Welz Meters in Stock Call for Special Pricing and Details</p> <p>Welz Meters</p>
<p><b>TERMS:</b> Prices Do Not Include Shipping. Price and Availability Subject to Change Without Notice UPS COD \$2.50 Per Package</p>	 <p><b>ICOM</b></p> <ul style="list-style-type: none"> <li>•all modes built in</li> <li>•QSK up to 40 wpm</li> <li>•built-in 500 Hz CW filter</li> <li>•electronic keyer included</li> <li>•100% duty cycle</li> </ul> <p><b>NEW!</b> IC-751A HF Transceiver <b>Ham Net \$1499.00 Call for Special Introductory Price</b></p>	 <p><b>YAESU</b> YAESU FT209RH 5 watts Free FTS-6 10 Memories <b>CALL FOR YOUR SPECIAL PRICE</b></p>
<p><b>MOST ORDERS SHIPPED SAME DAY</b></p>	<p>AEA • ARRL • ALINCO • ALLIANCE • ALPHA DELTA • AMECO • AMERITRON • ANTENNA SPECIALISTS • ASTRON • B&amp;W • BENCHER • BUTTERNUT • CSI • CALLBOOK • COMMUNICATION SPECIALISTS • CUSHCRAFT • DAIWA • DATASCAN • HEIL • HUSTLER • HYGAIN • ICOM • KDK • KLM • KANTRONICS • KEN PRO • LARSEN • MFJ • MICROLOG • MIRAGE • NYE • ROHN • SANTEC • SHURE • TEN TEC • TOKYO HY-POWER • UNADILLA • VALOR • VIBROPLEX • WELZ • YAESU</p>	
<p>ORDERS AND PRICE CHECKS ONLY, PLEASE INFORMATION AND INDIANA SERVICE DEPT.</p>	<p>1-800-523-7731 812-422-0231 812-422-0252</p>	 <p><b>the HAM STATION</b></p>



# I'M BACK! . . . WAYNE W2NSD/1

## Here are ten reasons why you're going to be all upset with yourself if you don't subscribe to 73—Now!

- 1.) If we're going to get amateur radio growing again I'm going to need your help. I can do it, but not alone.
- 2.) You're going to enjoy the new life in 73—articles on how and why you can get involved with packet radio, OSCAR, traffic handling, DXing, cross-band repeaters, RTTY, slow-scan, and so on.
- 3.) You won't want to miss 73's bargain DXpeditions—starting with Asia this October—going to Sarawak 9MB, Brunei V85 and Sabah 9M6.
- 4.) Will I be able to get 800,000 new hams licensed *per year* in China? I think I can—and you will want to read how I'm going to do it. I'll even tell you how to get such a program going in the U.S. We sure could use it!
- 5.) Are you interested in 73 reader evaluations of ham gear? Now you can vote on your gear and read what the other 73 readers think of theirs.
- 6.) Want to find out just how bad an operator you are? Read the LID list in 73 and weep. Better yet, shape up!
- 7.) How about building stuff? I'll be running all the simple construction projects I can get in 73. Better get out your soldering pencil and tin it.
- 8.) I have a whale of a lot of fun building gadgets, typing away on RTTY, working high-speed CW, making DX contacts on 10 GHz from a local mountain (DX being a new state), working a new country on 20m, getting on the air from some very rare spot . . . stuff like that. Don't stay in a rut with your hamming, there are just too many fun things to do—and I'll be writing about 'em in 73.
- 9.) I've forgotten what this was, but it was very important and persuasive. If I could remember it you'd call my 800 operator immediately with your subscription. You'll never forgive yourself if you miss out on this one . . . I remember that much! I think it had something to do with a whole lot of money—perhaps a free trip somewhere. Check 73 for the details.
- 10.) We're going to be reprinting some of the funniest ham humor from 73's sordid past. A medical checkup is recommended before reading.
- 11.) (bonus) Yes, I know 73 got pretty dull last year—well, well, I'm back and whatever 73 is, it won't be dull. Better get a refill on your Diazide so you won't be after me for giving you apoplexy when you read my editorials.

**Call: 1-800-722-7790**

Send in the coupon—or call my 800 operator and get started with 73. It's only \$19.97 a year, or three years for \$50. (Three's obviously the best deal. Three years from now you'll wish you'd bought six.) You can send a check or your credit card info. Remember, procrastination is the thief of 73, so do it now. Look, you've got my guarantee: Either you enjoy 73 or you can ask for your money back. Y'all write, y'hear?

**Wayne Green W2NSD/1  
Editor/Publisher—again**

**YES!** Enter my subscription to  
**73 Magazine starting with the next issue.**

Name \_\_\_\_\_

Call \_\_\_\_\_

Address \_\_\_\_\_

City \_\_\_\_\_ State \_\_\_\_\_ Zip \_\_\_\_\_

Check       Amex.       MC       BA

# \_\_\_\_\_

Expiration date: \_\_\_\_\_

**CALL: 1-800-722-7790**

73 Magazine WGE Center Peterborough, NH 03458 USA

98SW86

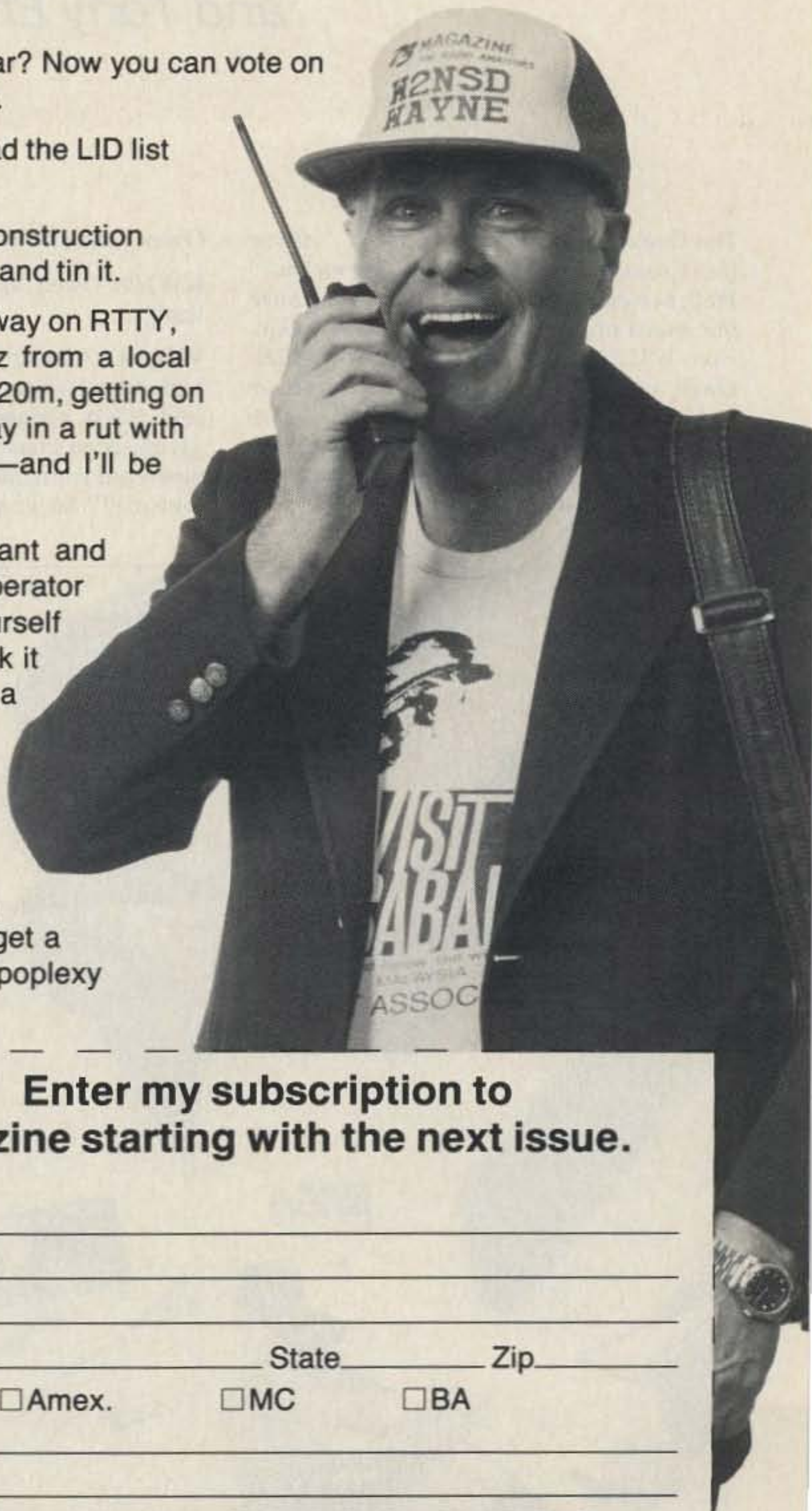



# Hams in Space

*An interview with Owen Garriott W5LFL  
and Tony England W0ORE.*

*The theme for this month's issue is "Above the Crowd—VHF and UHF Operation." Well, two guys who have certainly been above the crowd are NASA astronauts Owen Garriott W5LFL and Tony England W0ORE. Owen and Tony both have carried amateur radio into orbit aboard the space shuttle; we asked them to reflect a bit on their experiences, and on the past, present, and future of ham radio.—KW10.*

## Owen Garriott W5LFL

**KW10:** Owen, how long have you been a ham?

**W5LFL:** A looong time! I was still in junior high school when my father came home and said, "Son, a friend at the office is going to be giving code classes—would you like to go down and learn the International Morse code with me?" So we started; I was in 9th grade.

Then a little while later it was, "How would you like to go to theory classes?" We ended up getting our tickets together...that was during the latter part of World War II.

**KW10:** Was there a club at school?

**W5LFL:** No, not at school. As far as I know there was no one else at school who was interested in this sort of thing. I took my classes at the local club in Enid, Oklahoma.

**KW10:** Did your interest in radio lead you to a career as an astronaut?

**W5LFL:** Yes, I think that ham radio took me into electrical engineering and radio propagation—the heart of amateur radio. After graduating from the University of Oklahoma I had a three-year Navy obligation, and then went back to graduate school at Stanford and ended up in the radio propagation laboratory. After that I stayed on the faculty doing space research based on radio propagation, sending satellite transmissions through the ionosphere. Then NASA said they wanted people with my sort of skills involved in the manned space program. There's a pretty clear line of interest going from that code class to my present job.

**KW10:** How much trouble was there talking NASA into letting ham radio aboard the shuttle?

**W5LFL:** Well, it wasn't an easy job. It isn't so much convincing people that it's a good idea as convincing them that there's nothing wrong with the idea. There are so many people who can say no, and that's so much easier for them to do. It's simple to get someone to say, "Yeah, that's a great idea, I hope it works." It's a much tougher job to convince people that this great idea of yours is not going to cost more, or interfere with the schedule, or reduce the time that their experiment might get, or set a precedent, or any number of objections that can be raised. And all along they're saying, "That's a great idea, I hope it works." There were at least a half dozen wickets to get through before the project left the ground. It's also very important

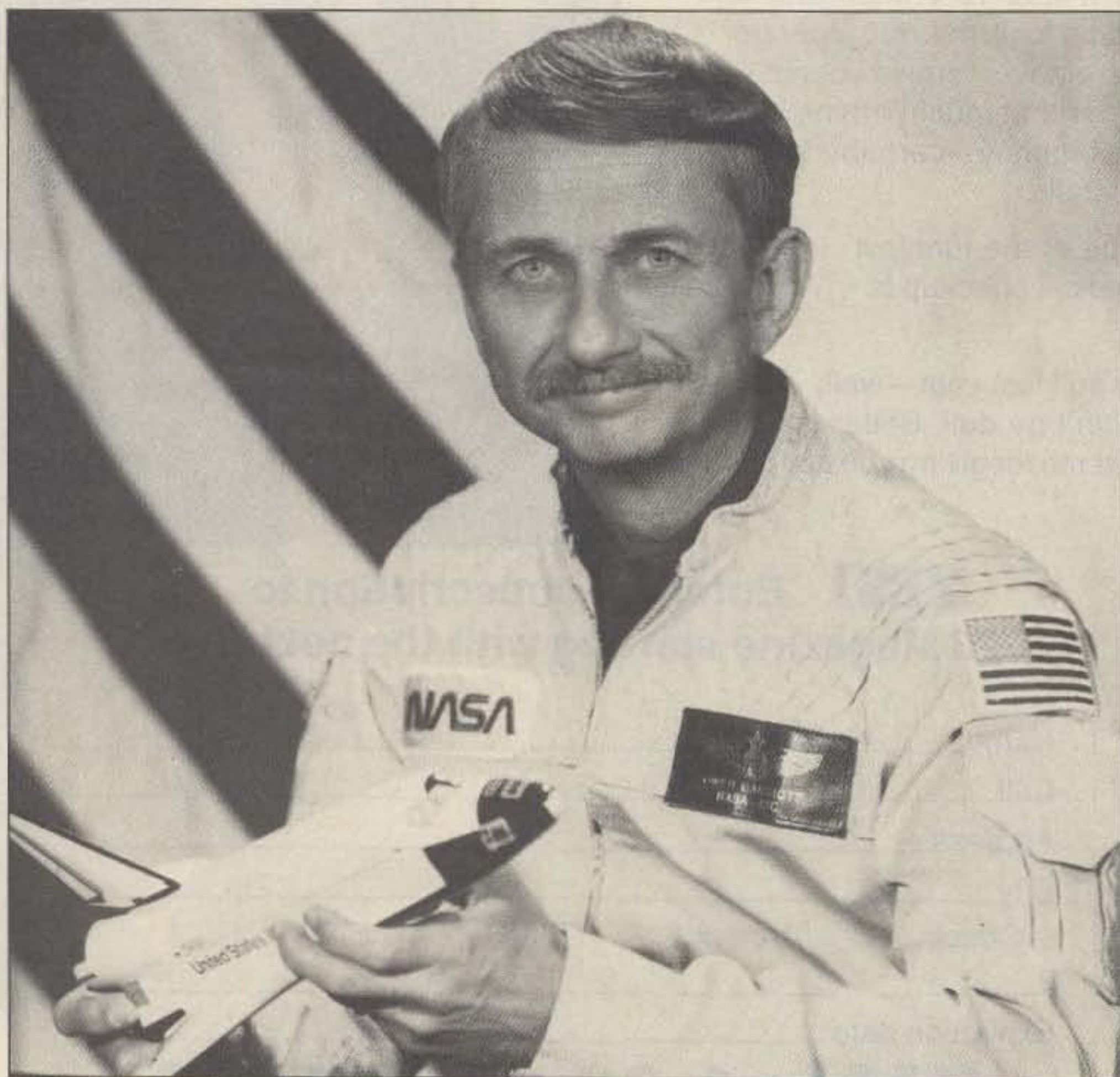

*Owen Garriott W5LFL.*



to have people supporting your project that are well-respected in the system—General Abrams, who was at that time head of the Office of Manned Space Flight, and Roy Neal K6DUE come to mind.

**KW1O:** You used a special Motorola-built hand-held with a window-mount antenna. Did Tony [W00RE] take the same rig up?

**W5LFL:** It was either physically the same unit, or one functionally identical.

**KW1O:** How did it work?

**W5LFL:** We had a little antenna that attached to one of the windows. Of course, the rig had been pretty extensively ground-checked for interference and so on. Overall, it functioned very well.

**KW1O:** Would you do anything different if you took ham radio back into space?

**W5LFL:** Well, you always try to build on what you've done before. I think that for the first effort on Spacelab 1 we did just about the right thing. There are a few details that I might have changed, like letting people know not to transmit on the downlink frequency, but I think it went off pretty well.

**KW1O:** You worked a heck of a lot of people.

**W5LFL:** Yes, over 300. For the second effort, Tony went beyond that and took up SSTV. For the next time we should try something like packet, or a fast-scan TV uplink with a slow-scan TV downlink. Part of the trouble Tony had was that he couldn't hold a signal long enough to get a full frame of SSTV. It would have been OK if only one person had transmitted at a time, but that's not a very satisfactory way to operate. With a fast-scan uplink you only need to hold the signal for less than a second.

**KW1O:** What are you involved with at NASA?

**W5LFL:** I'm working on the space station project, making sure that the station design is an appropriate one for the various kinds of activities we'd like to do on it.

**KW1O:** Will there be a ham shack on the space station?

**W5LFL:** I would be very surprised if there was not. However, it is premature to start pushing in that direction. I think we'll get it on the basis of providing off-duty activities for the crew. There's a very good chance we'll have one for that purpose. We won't know for certain for three or four years—the station is scheduled for launch in 1992.

**KW1O:** Sounds like you have your hands full. Is there much time for on-the-air activity?

**W5LFL:** No, not really. I get on the local [Houston] repeater now and then, but that's about it.

**KW1O:** Well, Owen, thanks for chatting. And good luck with the space shack!

**W5LFL:** Thanks, it's been fun.

#### Tony England W00RE

**KW1O:** Tony, you've been a ham for quite a number of years. What got you started?

**W00RE:** Well, I started when I was about twelve. A buddy of mine and I built a couple of "secret transmitters" that we took to school. We got the plans out of one of the ham

magazines. They were small CW transmitters, and the speaker was actually a vibrator that you could put against your arm.

**KW1O:** You must have done pretty well in class!

**W00RE:** It certainly kept our interest up! But ham radio for me has been a series of peaks and valleys; when my professional life is particularly busy, hamming slides a bit. And when there's a lull in my professional life, I pick it right back up. My wife Kathi has always appreciated my hobby—it tends to keep me home.

**KW1O:** Is Kathi a ham?

**W00RE:** No, she's not. I've tried, but I can't talk her into it. Actually, Kathi bought my last rig for me. When I was at school working on my doctorate, she thought it would help me keep from climbing the walls. Kathi thought talking on the radio was a lot of fun, but she just wasn't interested in getting a license.

**KW1O:** I wonder if some sort of Novice voice privilege would appeal to people like that?

**W00RE:** I haven't been following all of the various proposals, but I can say that I'm very much in favor of some sort of digital class of amateur license. There are a lot of people who could really benefit from being amateurs, and who would bring their special skills to the hobby. Of course, there will always be people around who feel that the old way is the best way.

**KW1O:** Have you read of Don Stoner's proposal for a consumer packet service on six meters?

**W00RE:** Yes, I have. I'm concerned that the service would be outside of amateur radio,

essentially setting up a separate system of ham operators. Even worse, if we did establish a non-code digital class of license within the amateur service, I can see them being treated as second-class hams until they "grew up" and got a "real" ham license.

**KW1O:** Tony, are you on the bands much these days?

**W00RE:** Well, I have more time than I have facilities. My neighborhood doesn't allow antennas, so I have to hide them. Most of them don't work, so I put 'em up and tear 'em down. I had a pretty good 40-meter wire beam up for a while, but the last hurricane we had wiped out the oak tree that was supporting it. I built a trap dipole, wound the coils and everything; it was a lot of pain and the antenna didn't work worth a darn. So I've taken that down and my next one is another wire antenna with an open-wire feed.

**KW1O:** You're using ladder line?

**W00RE:** Oh, no, I'm going to make my own feedline. I've got about 30 of those little insulators and a big hunk of wire for it.

**KW1O:** You're one of a dying breed!

**W00RE:** Well, I've got some spare time and don't know what to do with myself, so I thought I'd give it a try.

**KW1O:** I was surprised to read that your ham-in-space demo of slow-scan was the first instance of ground-to-spacecraft TV transmission. Doesn't the shuttle have two-way television?

**W00RE:** I'm surprised too. Considering all of its facilities, the shuttle really should have two-way video. Part of the problem is the way the ground stations are configured...they just aren't set up for video. We're going now to a satellite-based commu-



Tony England W00RE.



**OUR  
20 YRS.**

of manufacturing quality crystals for the industry, military services, radio amateur and citizens band and experimenters

**IS YOUR ASSURANCE OF STABILITY**

**TO SAVE MONEY GET THIS FREE CATALOG**



Call or Write  
**JAN CRYSTALS**  
P.O. Box 06017  
Fort Myers  
FL 33906-6017  
(813) 936-2397

Since 1965

VISA MasterCard

# HOT ROD ANTENNA

Achieve 1 or 2 db gain over ANY 1/2 wave two meter telescopic antenna. The AEA model HR-1 Hot Rod™ antenna was designed by Dr. D.K. Reynolds (designer of the IsoPole) to deliver maximum performance for any hand-held transceiver with a BNC fitting.

The factory-tuned HR-1 is 20% shorter, lighter and places far less stress on your hand-held connector and case. It will easily handle over 25 watts of power, making it an excellent emergency base or mobile antenna. In the collapsed position, the Hot Rod antenna will perform like a helical quarter wave.

The Hot Rod antennas can be expected to make the same improvement to hand-held communications that the IsoPole brand antennas have made to base station operations. Why pay more when the best costs less?

Prices and Specifications subject to change without notice or obligation.

ADVANCED ELECTRONIC APPLICATIONS, INC.  
P.O. Box C-2160,  
Lynnwood, WA 98036  
(206) 775-7373  
Telex: 152571 AEA INTL

**AEA** Brings you the Breakthrough!

nications system—part of it is in place right now—and that might handle video. We have a sort of FAX unit on the shuttle, but the thing weighs a ton; it's really low-quality. A real monster.

**KW10:** Since your SSTV demo went so well, is NASA looking into replacing the FAX unit with a slow-scan system?

**W00RE:** No, they're not. It's not that they don't appreciate the good results we had with SSTV, it's just incredibly expensive to design a unit and integrate it into the shuttle. The most expensive part would be updating all of the documentation for the orbiter. . . there are enormous piles of manuals.

**KW10:** Had you tried SSTV before the flight?

**W00RE:** No, I hadn't.

**KW10:** It went pretty smoothly, didn't it?

**W00RE:** Yes, very smooth. There's a lot to it, with all of the various formats and such. I practiced quite a bit on the ground with the local club station, and that helped. We had about a dozen two-way SSTV QSOs from space.

**KW10:** Were most of those with youth groups?

**W00RE:** Actually, no. The youth groups were tough for slow-scan; by the time we had established contact on voice and answered the kids' questions and so forth, the orbiter was out of range. The orbit was low to begin with, and there wasn't a lot of time for SSTV frames.

**KW10:** Did the kids come up with crazy questions?

**W00RE:** No, not at all. Mostly "What is it like?" and "What does it feel like?" and "What do you see?" They wanted to know which experiments were working best, and what we were finding out that we didn't know before. They were really good questions.

**KW10:** How did the unpublished frequencies work out? Was there any trouble?

**W00RE:** No, not too much trouble. There were a few guys on them that shouldn't have been, but it worked out just fine. On the published frequencies, an interesting thing happened. I started out by working like Owen did. I would listen for a minute or so, and then transmit all of the calls that I had heard during that minute. What happened was that nobody was stopping to listen to me! I would get some callsigns, and transmit them down, and the next minute these same guys would still be calling! I said, "Hey, this isn't going to work," and started doing it contest-style, acknowledging stations one at a time. That seemed to work much better. I also found that I really didn't need all of the channels on the radio. I think maybe two or three would do, so I could QSY if some ham had switched his receiver off.

**KW10:** Gordon Fullerton made some QSOs. Is he psyched up for ham radio again? [Gordon once held a Novice license.]

**W00RE:** Well, I tried to have that happen. He enjoyed making the contacts, but I don't think he's going to run out and get a license.

**KW10:** Tony, it's been great talking with you.

**W00RE:** Likewise, Perry. 73! ■

## SPECIALIZED COMMUNICATIONS FOR TODAY'S RADIO AMATEUR!



If you are ACTIVE in FSTV, SSTV, FAX, OSCAR, RTTY, EME, LASERS or COMPUTERS, you need

**"THE SPEC-COM JOURNAL™"**

Published 10 Times Per Year By WB0QCD

**CALL TOLL-FREE 1-800-628-2828 ext. 541**

...and place your subscription order today! Our Membership Services HOTLINE is good for all 50 U.S. States including Hawaii & Alaska and ALL of CANADA! U.S. subscriptions \$20 per year. Foreign slightly higher. Back issues are also available for \$2.00 each prepaid.

**THE SPEC-COM JOURNAL**  
P.O. BOX H,  
LOWDEN, IOWA 52255

MasterCard VISA

Credit Card Orders (5% added) Iowa Residents Add 4% State Sales Tax



# THE MOST AFFORDABLE REPEATER

ALSO HAS THE MOST IMPRESSIVE PERFORMANCE FEATURES

(AND GIVES THEM TO YOU AS STANDARD EQUIPMENT!)

BAND	KIT	WIRED
6M, 2M, 220 440	\$630 \$730	\$880 \$980

(Also available for commercial bands)

## FEATURES:

- SENSITIVITY SECOND TO NONE; 0.15 uV (VHF), 0.2 uV (UHF) TYP.
- SELECTIVITY THAT CAN'T BE BEAT! BOTH 8 POLE XTAL FILTER & CERAMIC FILTER FOR > 100dB AT ± 12KHZ. HELICAL RESONATOR FRONT ENDS TO FIGHT DESENSE & INTERMOD.
- OTHER GREAT RECEIVER FEATURES: FLUTTER-PROOF SQUELCH, AFC TO COMPENSATE FOR OFF-FREQ TRANSMITTERS, SEPARATE LOCAL SPEAKER AMPLIFIER & CONTROL.
- CLEAN, EASY TUNE TRANSMITTER; UP TO 20 WATTS OUT (UP TO 50W WITH OPTIONAL PA).



## HIGH QUALITY XMTR & RCVR MODULES FOR REPEATERS, LINKS, TELEMETRY, ETC.

- **R144/R220 FM RCVRs** for 2M or 220 MHz. 0.15uV sens., 8 pole xtal filter & ceramic filter in i-f, helical resonator front end for exceptional selectivity, > 100dB at ± 12kHz, best available today. Flutter-proof squelch. AFC tracks drifting xmtrs. Xtal oven avail. Kit only \$138.
- **R451 FM RCVR** Same but for uhf. Tuned line front end, 0.3 uV sens. Kit only \$138.
- **R76 FM RCVR** for 10M, 6M, 2M, or 220. As above, but w/o AFC or hel. res. Kits only \$118. Also avail w/4 pole filter, only \$98/kit.
- **R110 VHF AM RECEIVER** kit for VHF aircraft or ham bands or Space Shuttle. Only \$98.
- **TA51 VHF FM EXCITER** for 10M, 6M, 2M, or 220 MHz. 2 Watts continuous, up to 3W intermittent. Kit only \$68
- **TA451 UHF FM EXCITER** 2W cont., up to 3W intermittent. Kits only \$68. Xtal oven avail.
- **VHF & UHF LINEAR AMPLIFIERS.** For either FM or SSB. Power levels from 10 to 45 Watts to go with exciters & xmtg converters. Several models. Kits from \$78.

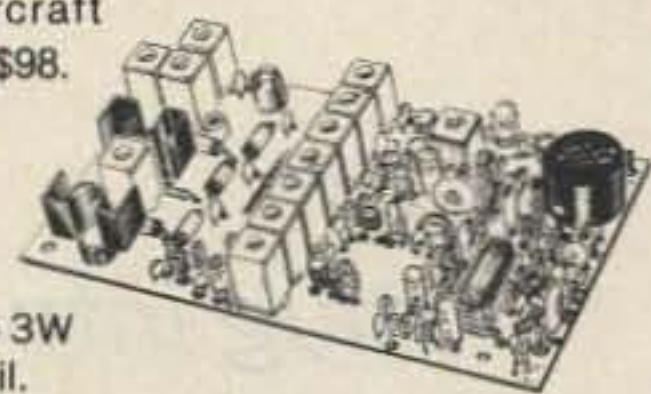

NOW—FCC TYPE ACCEPTED TRANSMITTERS, RECEIVERS, AND REPEATERS AVAILABLE FOR HIGH-BAND AND UHF. CALL FOR DETAILS.

## RECEIVING CONVERTERS

Models to cover every practical rf & if range to listen to SSB, FM, ATV, etc. NF = 2dB or less.



Antenna Input Range	Receiver Output
28-32	144-148
50-52	28-30
50-54	144-148
144-146	28-30
145-147	28-30
144-144.4	27-27.4
146-148	28-30
220-222	28-30
220-224	144-148
222-226	144-148
220-224	50-54
222-224	28-30
902-928	422-448

### VHF MODELS

Kit with Case	\$49
Less Case	\$39
Wired	\$69

### UHF MODELS

Kit with Case	\$59	432-434	28-30
Less Case	\$49	435-437	28-30
Wired	\$75	432-436	144-148
		439.25	50-54
			61.25

SCANNER CONVERTERS Copy 806 MHz band on any scanner. Wired/tested ONLY \$88.

## TRANSMIT CONVERTERS

For SSB, CW, ATV, FM, etc. Why pay big bucks for a multi mode rig for each band? Can be linked with receive converters for transceive. 2 Watts output vhf, 1 Watt uhf.

For VHF,  
Model XV2  
Kit \$79  
Wired \$149  
(Specify band)

Exciter Input Range	Antenna Output
28-30	144-146
28-29	145-146
28-30	50-52
27-27.4	144-144.4
28-30	220-222*
50-54	220-224
144-146	50-52
144-146	28-30

For UHF,  
Model XV4  
Kit \$79  
Wired \$139

28-30	432-434
28-30	435-437
61.25	439.25
144-148	432-436*

\*Add \$20 for 2M input

VHF & UHF LINEAR AMPLIFIERS. Use with above. Power levels from 10 to 45 Watts. Several models, kits from \$78.

## LOW-NOISE PREAMPS

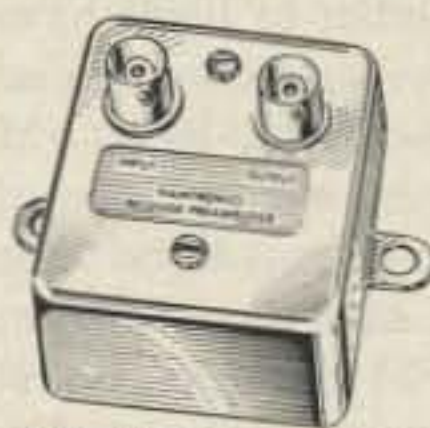

Hamtronics Breaks the Price Barrier!

\*

No Need to Pay \$80 to \$125 for a GaAs FET Preamp.

### FEATURES:

- Very Low Noise: 0.7dB VHF, 0.8dB UHF
- High Gain: 13 to 20dB, Depending on Freq.
- Wide Dynamic Range for Overload Resistance
- Latest Dual-gate GaAsFET, Very Stable

MODEL	TUNES RANGE	PRICE
LNG-28	26-30 MHz	\$49
LNG-50	46-56 MHz	\$49
LNG-144	137-150 MHz	\$49
LNG-160	150-172 MHz	\$49
LNG-220	210-230 MHz	\$49
LNG-432	400-470 MHz	\$49
LNG-800	800-960 MHz	\$49

## HELICAL RESONATOR PREAMPS

Low-noise preamps with helical resonators reduce intermod and cross-band interference in critical applications. 12dB gain.

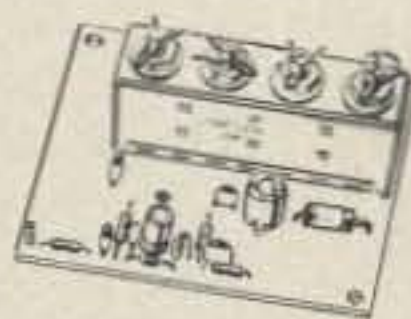

MODEL	TUNING RANGE	PRICE
HRA-144	143-150 MHz	\$49
HRA-(*)	150-174 MHz	\$49
HRA-220	213-233 MHz	\$49
HRA-432	420-450 MHz	\$64
HRA-(*)	450-470 MHz	\$64

\*Specify Center frequency desired

## MINIATURE PREAMPS

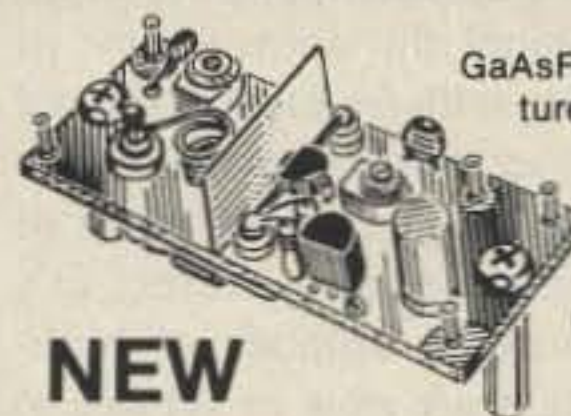

GaAsFET Preamps with features similar to LNG, except designed for LOW COST and SMALL SIZE: only 5/8"W x 1-5/8"L x 3/4"H. Easily mounts inside many radios.

NEW

Model LNW-(\*) ..... Only \$19/kit, \$34wired

Models available to tune the following bands: 25-35, 35-55, 55-90, 90-120, 120-150, 150-200, 200-270, and 400-500 MHz.

\*Specify band

## IN-LINE PREAMPS

NEW



GaAsFET Pre-amp with features like LNG. Automatically switches out of line during transmit. Use with base or mobile transceivers up to 25W. Tower mtg hdwr incl.

MODEL	TUNES RANGE	KIT	WIRED
LNS-144	120-175 MHz	\$59	\$79
LNS-220	200-240 MHz	\$59	\$79
LNS-432	400-500 MHz	\$59	\$79

## ACCESSORIES

- **MO-202 FSK DATA MODULATOR.** Run up to 1200 baud digital or packet radio signals through any FM transmitter.
- **DE-202 FSK DATA DEMODULATOR**
- **COR-2 KIT** With audio mixer, local speaker amplifier, tail & time-out timers.
- **COR-3 KIT** with "courtesy" beep".
- **DTMF DECODER/CONTROLLER KITS**
- **AUTOPATCH KITS.** Provide repeater auto-patch, reverse patch, phone line remote control of repeater, secondary control.
- **CWID KITS**
- **SIMPLEX AUTOPATCH**

- **Send \$1 for Complete Catalog** (Send \$2.00 or 4 IRC's for overseas mailing)
- **Order by phone or mail • Add \$3 S & H per order** (Electronic answering service evenings & weekends)
- **Use VISA, MASTERCARD, Check, or UPS COD.**

# hamtronics, inc.

65-D MOUL ROAD • HILTON NY 14468

Phone: 716-392-9430

Hamtronics® is a registered trademark



# Two to Ten

*Plug into the excitement of 10 FM—your HT is the key!*

**T**en-meter FM is a unique operating experience. It combines the convenience of channelized operation with frequent DX band openings. Mobile operation is very successful on 10-meter FM, as just a few Watts of transmitter power are needed for direct DX contacts. Furthermore, a number of high-performance repeaters are now in service to support 10-meter FM operation worldwide.

While many of the new HF transceivers feature FM as a standard or optional mode, the availability of inexpensive low-power

equipment for mobile or portable operation is somewhat limited. A number of hams have successfully adapted low-band commercial FM rigs and CB transceivers to 10-meter FM operation. Often, however, one or more of the following desirable features is found to be difficult to implement in such a conversion: tuning of all 10-meter FM channels, direct and repeater mode selection, good quality audio, and clean limiting (good noise rejection) in the receive mode.

This article presents an alternate approach

to 10-meter FM equipment—a 2-meter-to-10-meter transverter. "2 to 10" is designed to translate the operation of a 2-meter FM transceiver to 10 meters. All the features of the 2-meter transceiver (synthesized tuning, memory, scanning, touchtone™ pad, etc.) can be used on 10 meters. 2 to 10 includes both direct and repeater offset modes. The inherent audio quality of the FM transceiver is preserved in its translation to and from 10 meters. The transverter operates from 12 to 14 V dc, making mobile and portable operation straightforward. 2 to 10 was designed with 2-meter HTs in mind, but it should work with any modern 2-meter FM transceiver with a low power output in the 150-mW-to-1-W range.

2 to 10 uses low-cost components which are readily available from suppliers that cater to the individual rf experimenter. Construction costs for 2 to 10 run about \$65, not counting junk-box discounts. If you already have a 2-meter transceiver, 2 to 10 can be an effective and inexpensive approach to getting on 10-meter FM.

## Operation

When using 2 to 10, the 2-meter FM transceiver is placed in the direct (simplex) mode and is set for low power. The 2-meter transceiver is operated in the frequency band of 146.40–146.48 MHz. 2 to 10 translates this frequency band to 29.60–29.68 MHz for direct operation and offsets the transmit frequency –100 kHz for repeater operation. Note that the repeater offset is done by 2 to 10; the 2-meter rig is *always* operated in the direct (simplex) mode. Increasing the frequency setting on the 2-meter transceiver increases the operating frequency on 10 meters a like amount. (Note that this is different from satellite translator operation; do not get confused.)

## Block Diagram

Let's first look at 2 to 10's block diagram, Fig. 2. We will then look at the circuits in

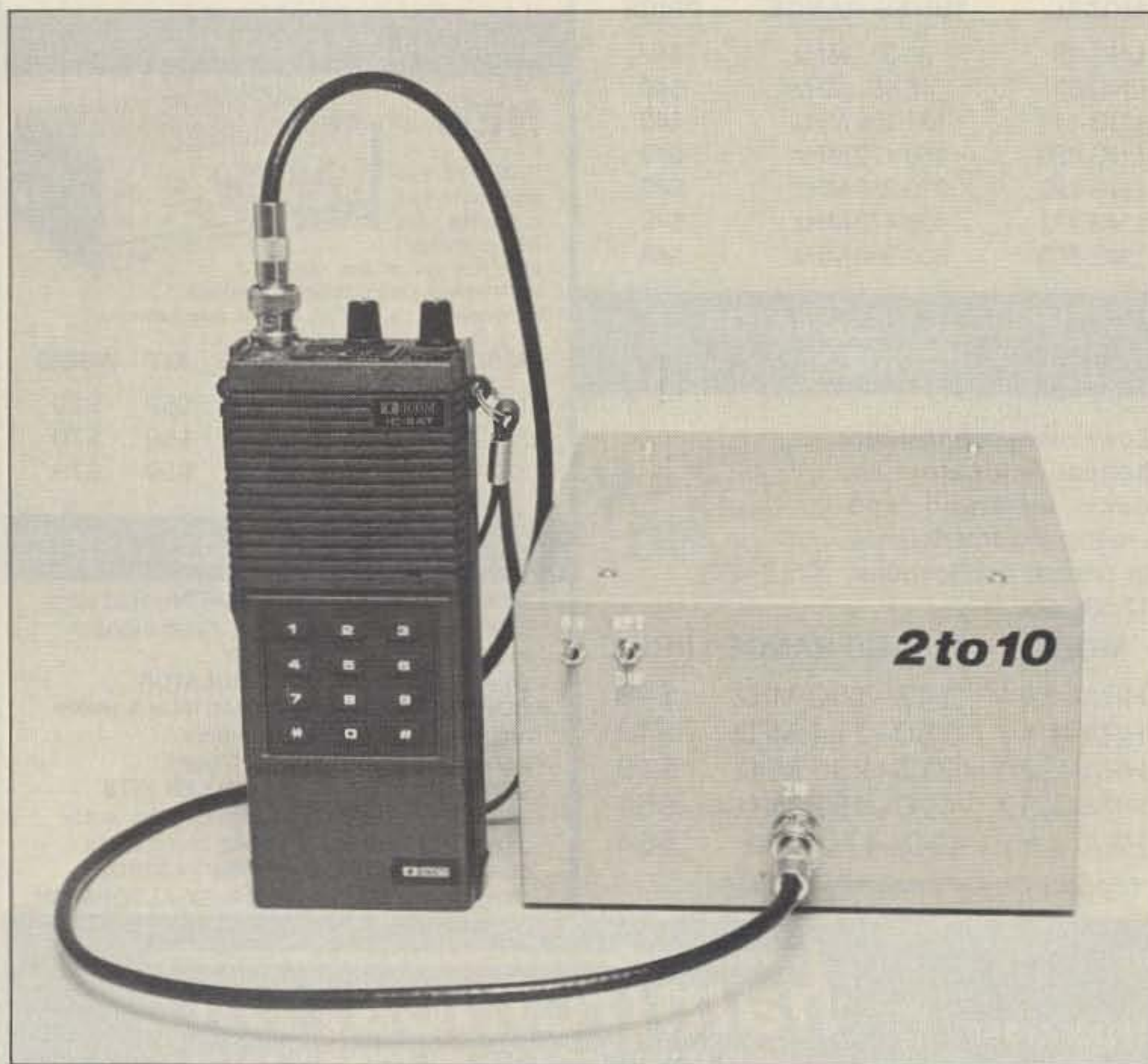

Photo A. 2 to 10 is a transverter that places your 2-meter FM rig on 10-meter FM.



each block in detail. A dummy load is provided to present a reasonable match to the 2-meter transceiver during transmit. T-R switch circuitry senses the presence of 2-meter rf power and switches 2 to 10 to the transmit mode. A small sample of 2-meter rf is mixed with the local oscillator (116.80 MHz for the direct mode or 116.90 MHz for the repeater mode) in the transmit mixer, developing a difference frequency at 10 meters. Tuned circuits in the mixer and preamplifier stages reject other unwanted mixer outputs. The driver and final-amplifier stages boost the 10-meter output to about 3.5 Watts. The rf output is then low-pass-filtered and output at the 10-meter connector.

In the receive mode, the incoming 10-meter signal is mixed with the local oscillator (always 116.80 MHz for receive) in the receive mixer, developing a sum frequency output on 2 meters. This signal is bandpass-filtered and applied to the 2-meter connector.

The local-oscillator chain consists of a 58.4-MHz oscillator, a doubler stage, and switching to route the local oscillator to either the transmit or receive mixer. One or two crystals are switched in to control the oscillator, depending on the mode of operation. All T-R and rf switching is solid state.

#### Dummy Load and T-R Voltages

For the following discussion, please refer to the schematic diagram, Fig. 3. R1 and R2 provide a dummy load for the 2-meter transceiver. When transmitting, R38 delivers 2-meter rf to the clamp network consisting of CR15-CR18. These diodes level the rf voltage detected by CR19 and C35 for various input power levels within 2 to 10's operating range. The detected rf switches Q8 on, which switches Q9 on to provide +T voltage. At the same time, Q8 switches Q10 and Q11 off, dropping the +R voltage. During receive, Q8 and Q9 are off and Q10 and Q11 are on, so that +R voltage is provided instead of +T. The diodes used in the T-R circuit are 1N914s or equivalent. The MPS2222 and MPS2907 are inexpensive plastic-package versions of the 2N2222 and 2N2907.

#### Transmit Chain

During transmit, R3 supplies 2-meter rf to clamping diodes CR1 and CR2, which provide a leveled rf signal of about 1.6 V p-p. This signal is further attenuated by the R4-R6 network and applied to gate 1 of Q1, a 3N211 dual-gate MOSFET mixer. About 3.5 V p-p of local-oscillator voltage is applied to gate 2 through C2. C4 and T1 resonate at 29.6 MHz, the 10-meter difference-frequency output of the mixer. The signal level across C4-T1 is about 600 mV p-p. Q2, an MPS918 rf transistor, provides about 20 dB of voltage gain, and C36-T2 provide additional filtering. Driver Q3 provides another 17 dB of gain. Broadband transformer T3 provides a suitable match between the collector of Q3 and the base of Q4. R14 helps ensure driver stability, as the 2N3866 is a high-

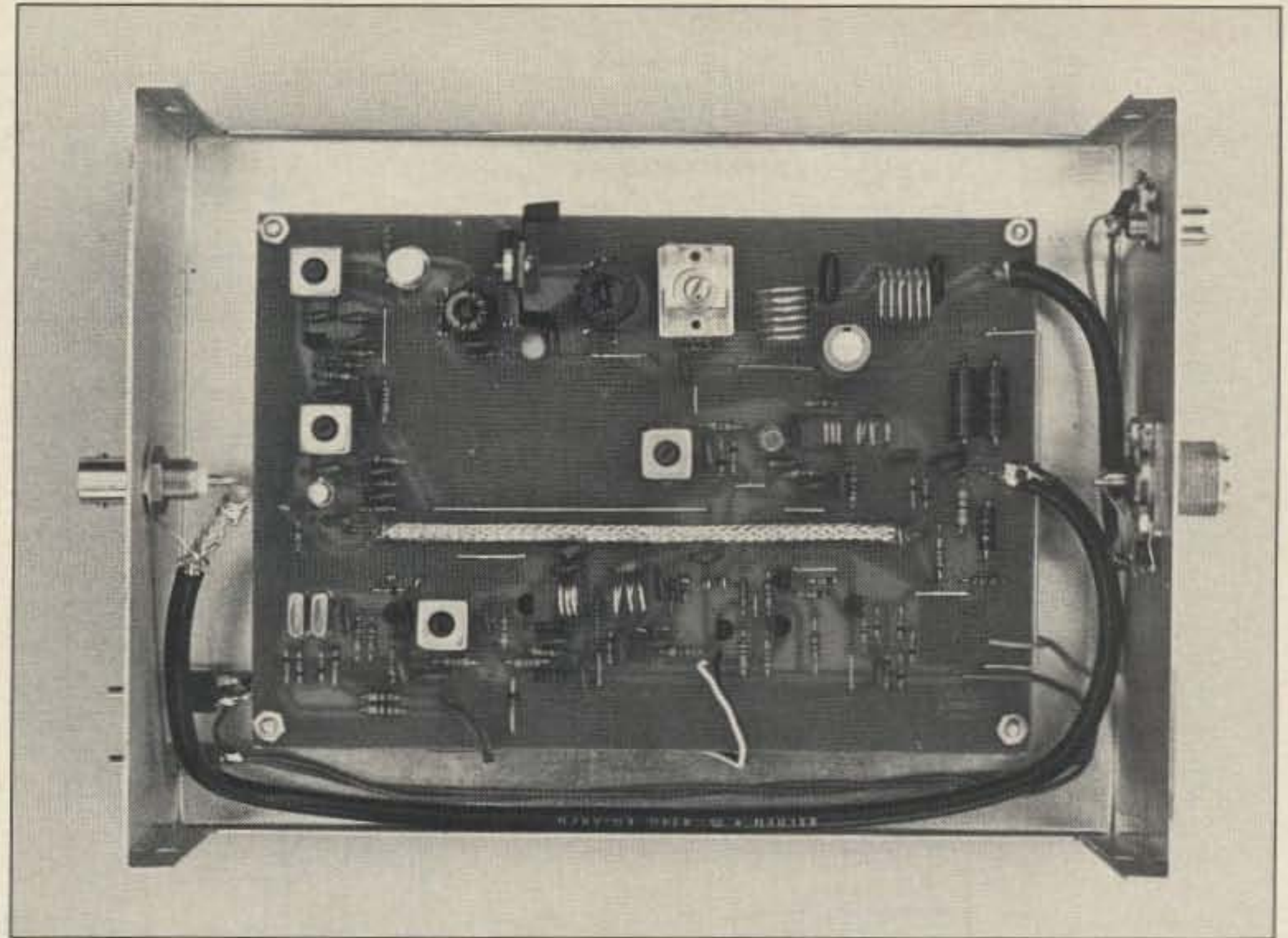

Photo B. Interior view of 2 to 10.

gain device. Q4 further amplifies the 10-meter FM signal to about 3.5 Watts. The transistor chosen here is a rugged and inexpensive 2SC1909 which is used in many CB rigs. Broadband transformer T4 provides a suitable match between the 50-Ohm antenna load and the collector of Q4. C13-C15 and L1-L2 form a low-pass filter to attenuate harmonics of the 10-meter output.

reject signals below 10 meters. CR4-CR5 clamp the rf voltage at gate 1 of Q5 during transmit to avoid damaging the transistor. Gate 2 of Q5 is driven from the local oscillator through C37. Drive level is about 4 V p-p. The drain of Q5 drives a double-tuned bandpass filter consisting of L4-C21 and L5-C22. The double-tuned filter attenuates local-oscillator feedthrough and other unwanted signals

#### Receive Mixer

The incoming 10-meter signal is first low-pass-filtered by C13-C15 and L1-L2, which attenuates unwanted signals above 30 MHz. C16 lightly couples the incoming signal from the low-pass filter to resonant circuit C17-L3. This type of coupling has a high-pass-filter characteristic, which helps

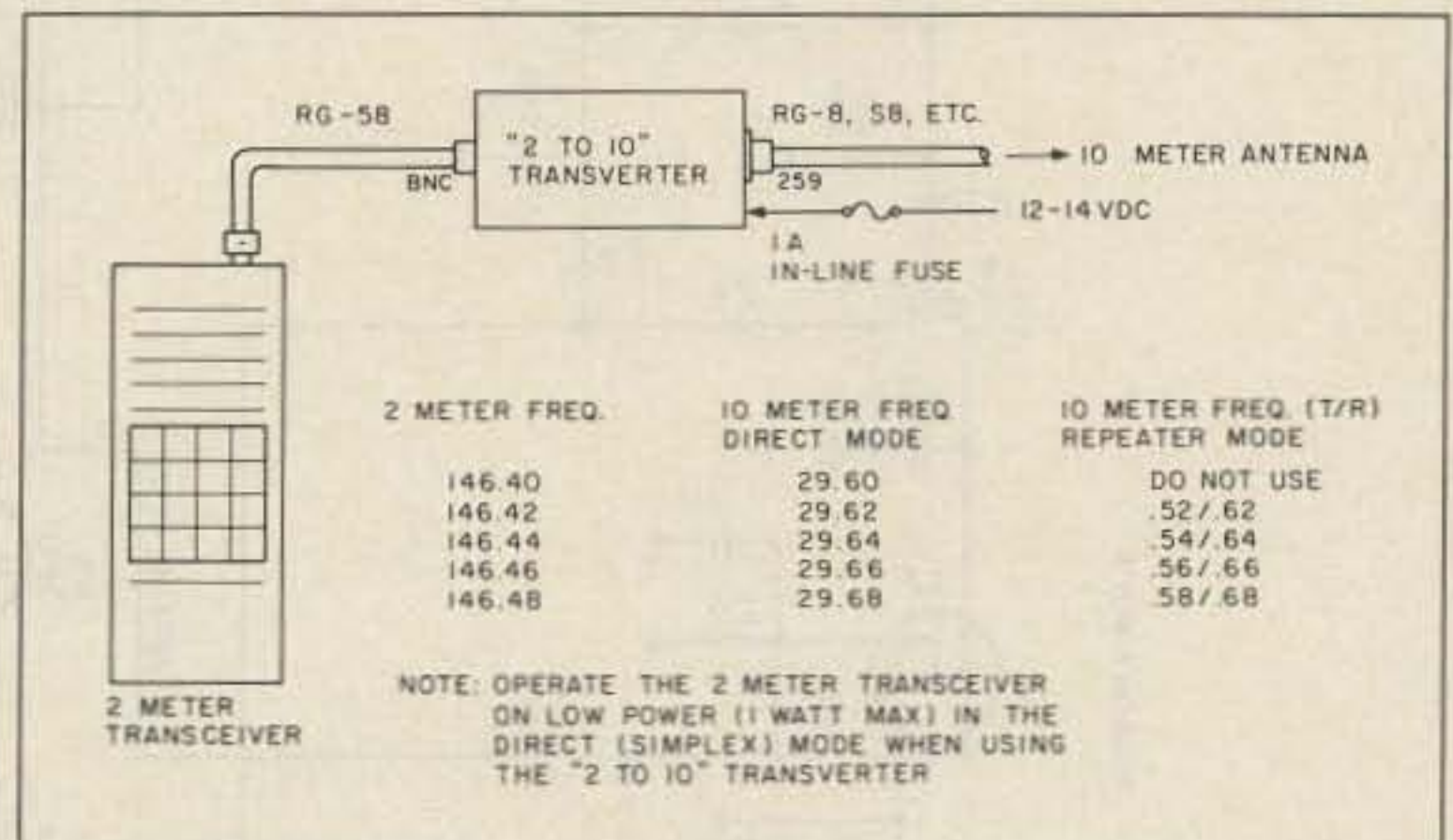

Fig. 1. 2 to 10 hookup.

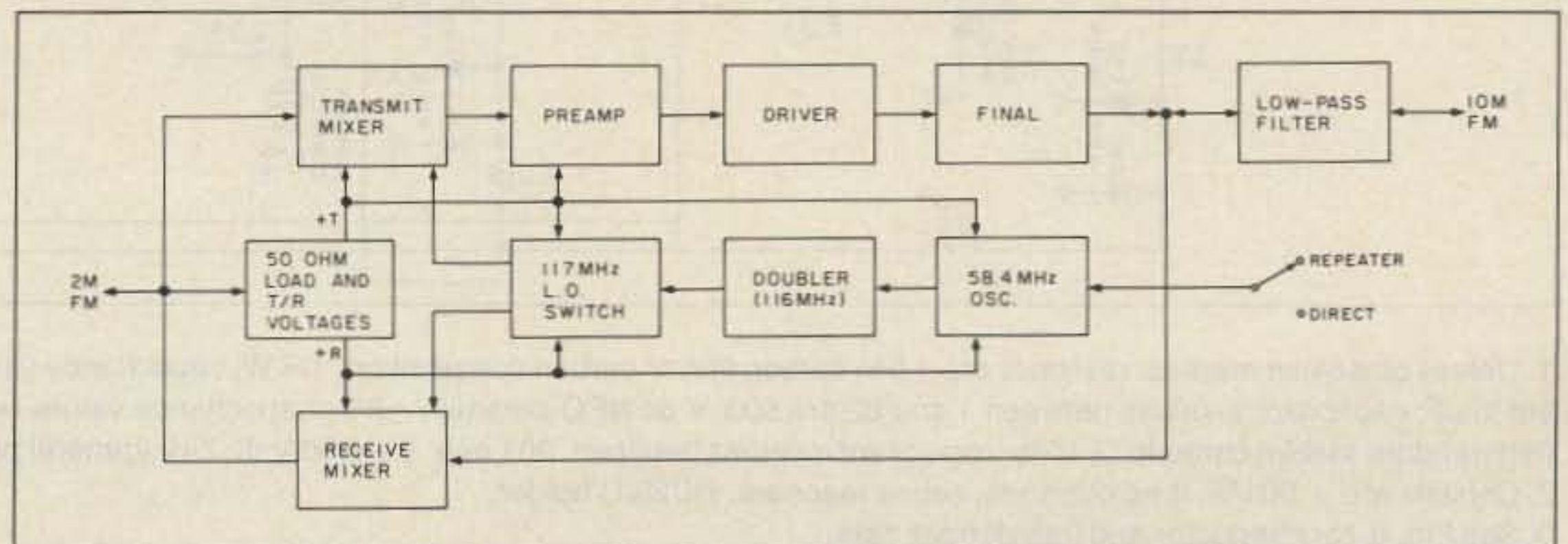
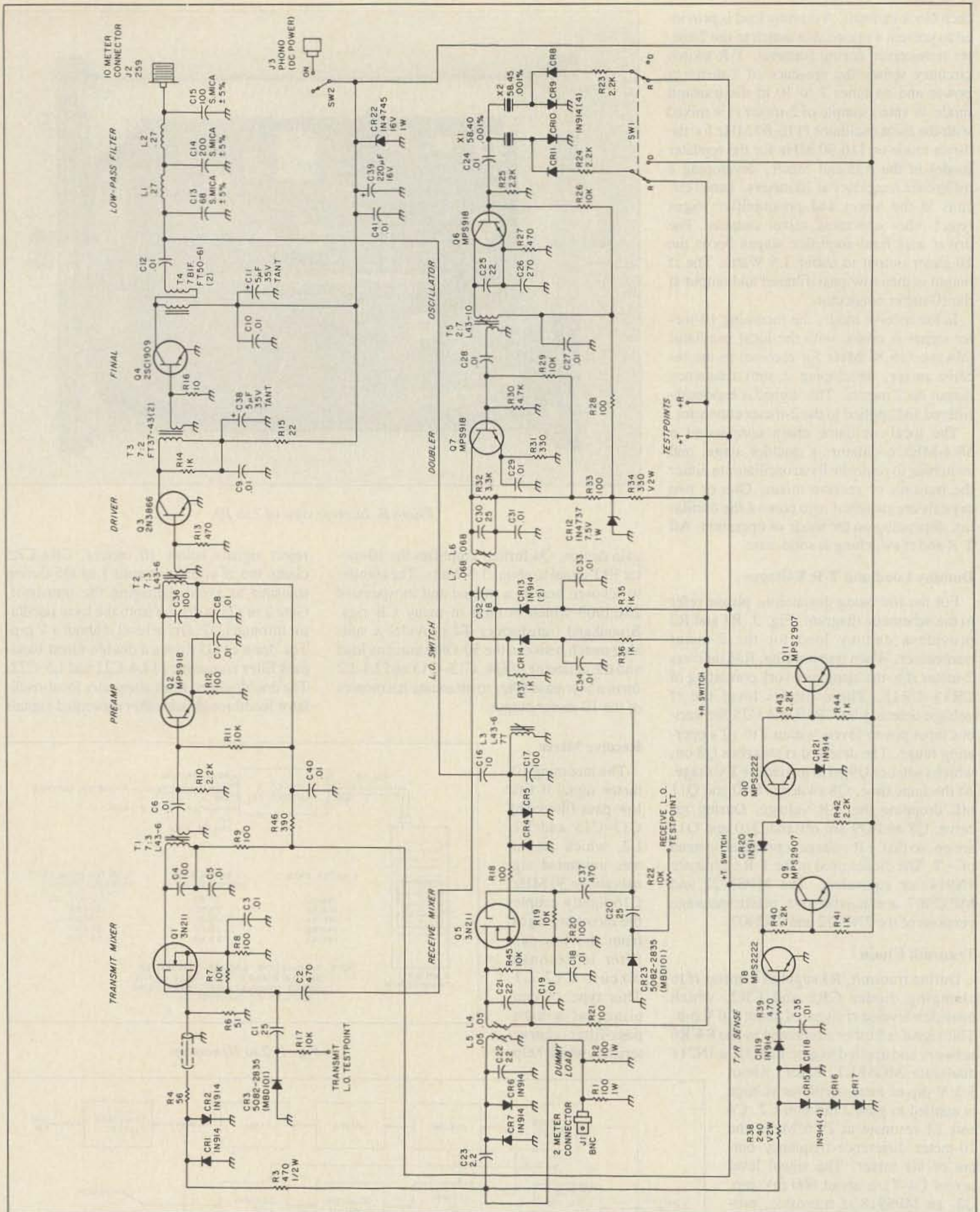

Fig. 2. Block diagram.





1. Unless otherwise marked: resistors are  $\pm 5\%$  carbon film or carbon composition, 1/4 W; capacitance values greater than 1 are in pF, less than 1 are in uF; capacitance values between 1 and 82 are 500 V dc NPO ceramic,  $\pm 5\%$ ; capacitance values between 100 and 1800 are 500 V dc Y5P (temperature stable) ceramic,  $\pm 10\%$ ; capacitance values between .001 and .1 are 50 V dc Z4V (general purpose) ceramic, +80, -20%.
2. Crystals are  $\pm .001\%$ , third overtone, series resonant, HC25/U holder.
3. See Fig. 8. for rf inductor and transformer data.

Fig. 3. Schematic.



in the mixer output before they reach the 2-meter receiver and cause intermodulation problems. C23 lightly couples the mixer output to the 2-meter connector. CR6-CR7 clamp the rf voltage fed back toward the drain of Q5 during transmit. The light coupling and clamp circuits on each side of Q5 allow 2 to 10 to switch from receive to transmit without needing isolation relays.

The conversion gain through the receive mixer is about 0 dBm, due mainly to the light coupling in and out. I wanted no conversion gain through the receive mixer to avoid overdriving the 2-meter receiver and creating intermodulation problems. I felt this was especially necessary for HTs, as they must often sacrifice "strong" front ends for low power drain and compactness. On-the-air testing with 2 to 10 using my ICOM IC-2AT has demonstrated satisfactory sensitivity and no evidence of intermodulation. A signal of -113 dBm (0.5 uV) at the 10-meter input of 2 to 10 will cleanly break the squelch of my 2AT.

#### Local-Oscillator Chain

Q6 operates as a grounded-base 58.4-MHz Colpitts oscillator. The ground path for the base of Q6 is through the series resonance (3rd overtone) of the crystal selected to control the oscillator. Adjusting the slug in T5 allows a slight frequency adjustment of the oscillator for "netting" it on frequency. CR9 and CR10 operate as current-controlled switches that select either crystal X1 (58.40 MHz) or X2 (58.45 MHz). When switch SW1 is in the direct mode, X1 is selected to control the oscillator in both transmit and receive. When SW1 is switched to the repeater mode, X1 is selected for receive by the +R voltage and X2 is selected for transmit by the +T voltage (providing the needed transmit offset).

The output of the 58.4-MHz oscillator is doubled by the Q7 stage. The collector of Q7 drives a double-tuned 117-MHz filter consisting of C30-L6 and C32-L7, which attenuates the 58.4-MHz fundamental and the unwanted oscillator harmonics. This is necessary to suppress unwanted responses in the mixers.

CR13 and CR14 are used as current-controlled switches to route the 117-MHz local-oscillator output to the transmit or receive mixer. In transmit, CR13 conducts, rf grounding the receive-mixer side of C32-L7 through bypass capacitor C33. Local-oscillator voltage is then routed from the ungrounded side of C32-L7 to Q1. During receive, CR14 conducts, rf grounding the transmit-mixer side of C32-L7 through C34. Local-oscillator voltage from the receive side of C32-L7 is now supplied to Q5. C20-CR23-R22 provide a dc sample of the receive-mixer local-oscillator voltage for tune-up and testing. C1-CR3-R17 provide the same function for the transmit-mixer local-oscillator voltage.

#### Components

As I mentioned earlier, the components used in 2 to 10 are readily available. Fig. 4

provides a listing of mail-order distributors for the components in 2 to 10. I recommend that you avoid substitutions. One exception would be C23. You can use a 2-pF silver-mica capacitor if you have difficulty finding a 2.2-pF NPO ceramic capacitor.

#### Construction

Above 100 MHz, the circuit board itself becomes an important component. For this reason, I strongly recommend that you duplicate the circuit-board layout shown in Fig. 5. Fig. 6 provides recommended hole sizes and corresponding number drills. Use .062"-thick G-10 glass-epoxy circuit board with 1-oz. copper on one side. Be sure to fully etch the board and inspect it carefully before beginning construction.

#### Rf Inductors and Transformers

I recommend winding all transformers and inductors before you start to load the circuit board. The winding data is provided in Fig. 8. All air-core inductors are wound on screw mandrels. You can pick up a set of screws (2- to 3-inch lengths) at your local hardware store. Radio Shack markets a packet of magnet wire (278-1345) which includes one roll each of 22, 24, and 30 gauge. The enamel on this wire can be stripped with hot solder, so it is ideal for rf-coil and transformer winding. Notice that T4 is bifilarly wound. I used a variable-speed electric drill (go slow!) to twist a pair of wires to about 5-6 turns per inch. Epoxy the two stacked cores used in T3 and T4 together before winding. Use an ohmmeter to identify each winding of T4 at both ends. I painted a small dab of black enamel on each end of the primary winding for later identification.

All slug-tuned transformers and inductors are wound on L43-style Micrometals forms. The primaries of these transformers and inductors are close-wound single-layer solenoids. They are wound at the bottom of the form. Secondary windings are also single-layer solenoids, wound over the primary windings at the bottom of the form. Note that there are 3 pins on one side of the L43 form and 2 pins on the other. A primary winding will always have its leads terminate on the side with 2 pins; the leads of a secondary winding will terminate on the outer posts of the 3-pin side. The circuit board is keyed this way, so do it right.

All air-wound coils are made from 18-gauge bus wire. As mentioned, the mandrels make winding these coils a snap. Dimensions are also given in millimeters, in parentheses, if you are more familiar with the metric system.

#### Circuit-Board Loading

Fig. 7 details the component placements on the circuit board. Photo B will also help (slight changes have been made since the photo was taken—note that C13 is now a fixed-value capacitor). I prefer to first install the jumper wires and the coax between the 2-meter input area and Q1. Note that the coax is RG-58 with the outer insulating jacket removed. Watch diode polarity and transistor

Parts List	
Component	Supplier #
Crystals	2
MPS transistors	3,4
2SC1909	6
3N211	5
5082-2835 (MBD101)	3,6
NPO ceramic capacitors	4
Y5P ceramic capacitors	4
Silver-mica capacitors	3,5
Other capacitors	3,4,6
Resistors	3,4,6
1N914	3,4,6
FT37-43 and FT50-61 toroids	1
L43-6 and L43-10 coil forms	1
Connectors and switches	6
Bud CU-3009A minibox	5
Note: The above components are available from many suppliers in addition to those listed below.	
<b>Suppliers:</b>	
1. Amidon Associates, 12033 Otsego Street, N. Hollywood CA 91607, (213)-760-4429.	
2. Jan Crystals, 2400 Crystal Drive, Fort Myers FL 33906, (813)-936-2397.	
3. KCS Electronics Corporation, Box 33205, Phoenix AZ 85067, (602)-274-2885.	
4. Digi-Key Corp., Box 677, Thief River Falls MN 56701, (800)-346-5144.	
5. Allied Electronics, 401 E. 8th Street, Fort Worth TX 76102, (817)-336-5401.	
6. Radio Shack.	

Fig. 4.

orientation carefully. Keep leads short. Be extra careful in installing T4. Note that it is hooked up as a step-up autotransformer. Install Q1 and Q5 in the circuit board after all other components have been installed. This will reduce the chance of damaging these static-sensitive parts.

All circuit-board components are installed through the top of the board except R23, which is tack-soldered across L6 on the bottom (solder side) of the board. Note that resistors R17 and R22 are standing up as test points. Make a small loop in the top lead of these resistors. Note the ground reference points next to these resistors. Make small bus-wire loops for these points. It is best to use 1k resistors as test points for the +R and +T voltages. This will avoid a catastrophe if the test points are shorted together.

Make the hook-up wire leads going to and from the circuit board to SW1 about 6 inches long. Install one end of a 4-inch length of RG-58 at the 2-meter input/output point on the circuit board. Use a half loop of 22-gauge bus wire to both ground the coax shield and strain-relief it. Install a 13-inch length of RG-58 at the 10-meter input/output point of the circuit board. Be sure to ground and strain-relief this coax also.

Be sure to install a lightweight finned heat sink on Q4. Depending on the heat-sink design, you may need to clip one fin off the bottom of the heat sink to avoid mechanical



interference with C10 and C11. Secure T3 and T4 to the circuit board with RTV or Silastic compound if you are going to operate mobile.

After the circuit board is loaded, check carefully for solder bridges and cold solder joints. I found that shining a desk lamp through the component side of the circuit board helped in looking for solder bridges.

### Enclosure

2 to 10's enclosure is made from a 6" wide by 3.5" high by 8" long aluminum minibox (Bud CU-3009A). Use the general layout shown in the photographs. I strongly recommend that you "key" the 2-meter connector by making it a BNC and use a 259 connector for 10 meters.

The circuit board is held in place with 4-40 screws, using 0.75"-long pieces of aluminum tubing slipped over each screw as spacers. The tubing has an inside diameter a little larger than 0.125 inches. Coordinate the mounting-hole locations of SW1 and SW2 with the length of the spacers to avoid mounting interference between the switches and the circuit board. Ditto on the connectors. Use bus wire to ground the coax shields at the connectors. Dress all wiring down one side of the chassis so that the circuit board can be stood up vertically for tune-up and testing.

Make a final careful check of the chassis

wiring. Be sure all connectors and switches are tight.

### Test Equipment

The equipment required to tune up 2 to 10 includes a 12-14-V-dc regulated power supply, a 2-meter transceiver, a sensitive 150-MHz counter, a FET multimeter or DVM, a sensitive swr meter and dummy load, a 29.6-MHz signal source, a tuning dowel, and a plastic tuning wand. Access to a good 30-MHz scope is desirable. A wide-range step attenuator(s) is also very useful. Refer to Fig. 9 for construction details of a suitable 29.6-MHz source and tuning dowel.

### Coil Knifing

By now you may have noticed, and possibly with some concern, that there is not a single trimmer capacitor used in 2 to 10. This is deliberate. If you are going to use trimmer capacitors above 100 MHz, they must be good ones. Such trimmers are expensive and sometimes difficult to find. To avoid trimmer problems, I avoided using trimmers!

OK, how do we adjust those double-tuned circuits in the outputs of Q5 and Q7? We use a technique called knifing. Basically, we adjust the value of an inductor by stretching it out or compressing it. While it may sound crude, it is an excellent technique. Knifing is used extensively to adjust tuned circuits in TV tuners, broadcast radios, VHF/UHF ham

equipment, etc. When done correctly it is both precise and stable. Best of all, it's inexpensive and easy to duplicate.

So much for the sales pitch. You need two tools for coil knifing—a tuning dowel and a stiff plastic tuning wand. A tuning dowel is a wooden (or plastic) stick with a ferrite slug on one end and an aluminum ring on the other. Bringing the ferrite-slug end of the dowel near the end of an air-core inductor will increase its inductance, whereas bringing the aluminum-ring end near the inductor will decrease its inductance. By monitoring a test point related to the tuning of the inductor, a decision as to how to adjust the dimensions of the inductor can be easily made by using the tuning dowel. You can think of the tuning dowel as a temporary inductor core.

Let's consider an example, the tuning of L6-C30 and L7-C32, the double-tuned collector load of Q7. The top end of R22 provides a dc test point for tuning (receive). Preset L6 by compressing it to a length of 0.20" (5 mm) and stretch L7 to a length of 0.25" (6.4 mm). With oscillator Q6 running, some dc voltage will be detected at R22 (0.5-2.25 V dc). We will tune for peak voltage.

Bring the ferrite-slug end of the dowel into the Q7 end (physical circuit-board layout) of L6. Note if the test-point voltage tends to rise or fall. If the voltage rises, compress L6 a bit and recheck the voltage. If the voltage decreased as the ferrite slug was brought near

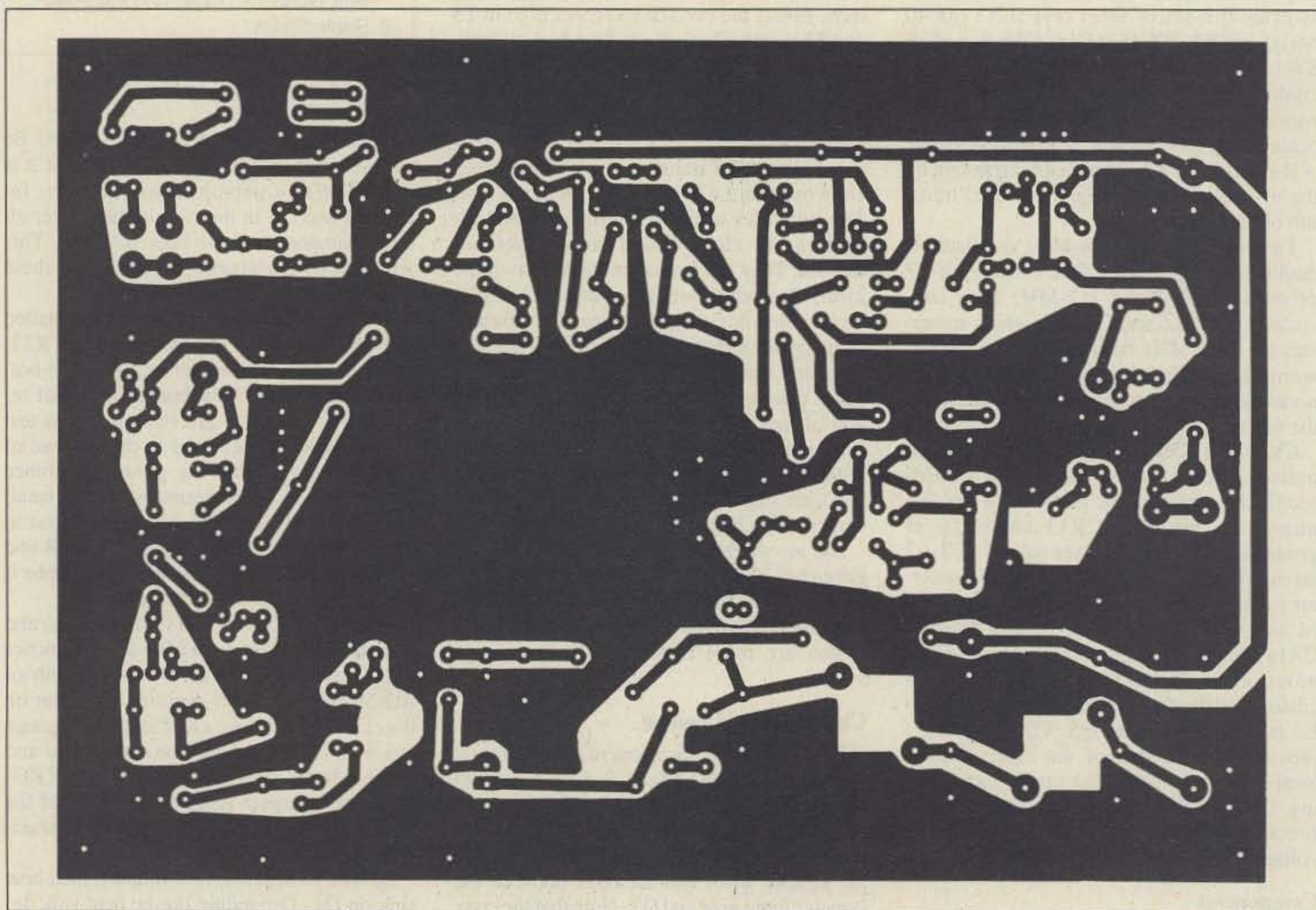

Fig. 5. Circuit-board artwork.



L6, try the aluminum-ring end. If the voltage rises, then stretch the coil a bit and recheck. When the coil is tuned on resonance, the test-point voltage will tend to decrease when either end of the dowel is brought near the end of the coil. After L6 is tuned, peak L7. The tuning of the two coils causes some interaction, so repeat the tuning process a couple of times. Once the coils are tuned closely, you can dispense with the tuning dowel and compress and expand the coils slightly with the plastic tuning wand (knife) while watching the test-point voltage. Push the coil far enough past the peak to take a physical "set" and let off. After about a minute of experience, you will be able to tune a coil by knifing about as fast as you could adjust a tuning slug or trimmer!

### Tuning Setup

Hook up the regulated dc supply to the transverter, being sure to use a 1-Amp in-line fuse. Hook the 2-meter transceiver to the 2-meter connector of 2 to 10. Set the transceiver on low power (1 Watt maximum) and set it in the direct (simplex) mode. Tune to 146.400 MHz. Hook a dummy load to the 10-meter connector of 2 to 10 through a sensitive SWR meter. Set the meter to read forward power.

### T-R Voltage Check

Turn both the dc supply and 2 to 10 on. A lack of smoke at this point is a good

sign. (You did get the polarity correct?) Check the +R test point. It should read within one volt of the dc supply voltage. The +T voltage should be off at this point. Bridge a 1k resistor between the supply voltage and the junction of CR19-C35-R39. Note that +T is now on and +R is off. Remove the 1k resistor.

### Oscillator-Doubler Tune-Up

Back the tuning slug out of T5 so that it is about 0.20" (5 mm) above the top of the shield. Monitor the R22 test point. As the slug is slowly screwed in, the voltage at R22 should "jump" on, indicating oscillation. Bring the counter-sense loop near Q6. Adjust the slug for 58.400 MHz. Now tune L6 and L7 for a peak reading of at least 2 V dc (this corresponds to about 5 V p-p of rf) as discussed in the "Coil Knifing" section. Bring the counter-sense loop near L7. You should read 116.800 MHz. Fine-tune T5 as needed to obtain a 116.800-MHz reading at L7.

References	Diameter (drill)	Number
A	.035 (#65)	282
B	.040 (#60)	17
C	.052 (#55)	40
D	.082 (#45)	8
E	.125 (1/8")	4
		351

Material is green G-10 epoxy-glass, 0.062-inch nominal thickness, 1-oz. copper, single-sided. Reference hole A is unmarked.

### Receive-Mixer Tune-Up

To adjust the receive mixer, a suitable 29.600-MHz source is needed. If you have access to a commercial signal generator with an adjustable output (down to 1 uV), use it. Otherwise use the source shown in Fig. 9. A step attenuator (or set of attenuators) with a 130-dB range is the best way to interface 2 to 10 with the source. If an attenuator is not available, leave 2 to 10 hooked to the dummy load and put a 2" bus-wire antenna into the BNC connector on the source. Move the source just close enough to the transverter so that the 2-meter receiver noise begins to quiet. (The bottom of 2 to 10's case is off for tuning.)

Remember, an increasing signal level quiets the background noise in an FM receiver. You adjust 2 to 10's receive mixer by tuning to "quiet" the noise output of the 2-meter receiver.

Start by compressing L4 to a length of 0.15" (3.8 mm) and stretching L5 to a length of 0.25" (6.4 mm). Back the slug in L3 out until it's about 0.05" (1.3 mm) above the top of L3's shield. You should be able to hear the 2-meter receiver quiet when you turn on your 29.600-MHz source. Start at 30 uV if you are using a signal generator, or switch in about 88 dB of attenuation if you are using the source in Fig. 9 with attenuators. Keep reducing (or increasing, if necessary) the signal level until some quieting is heard in the 2-meter receiver.

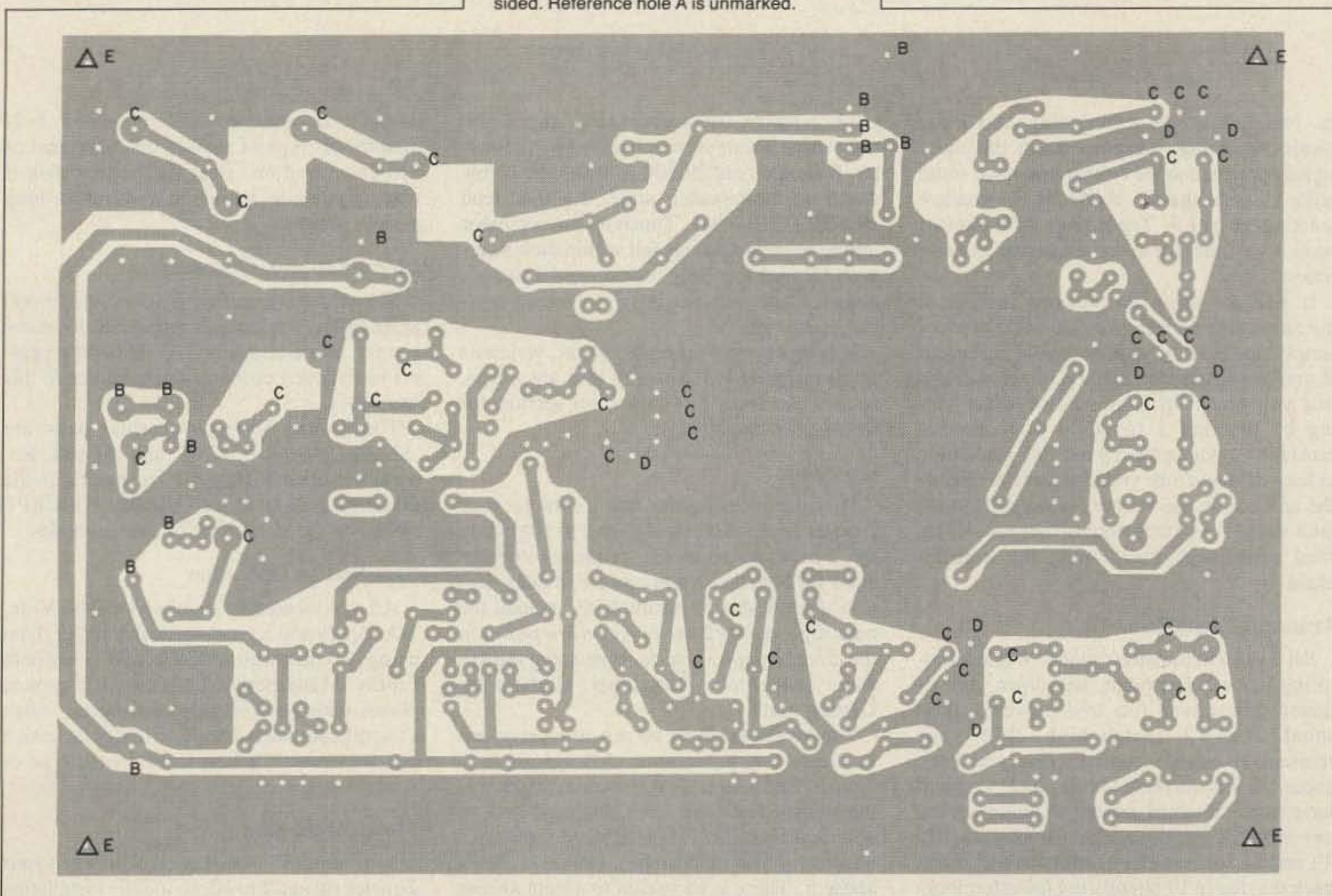

Fig. 6. Hole-size data.



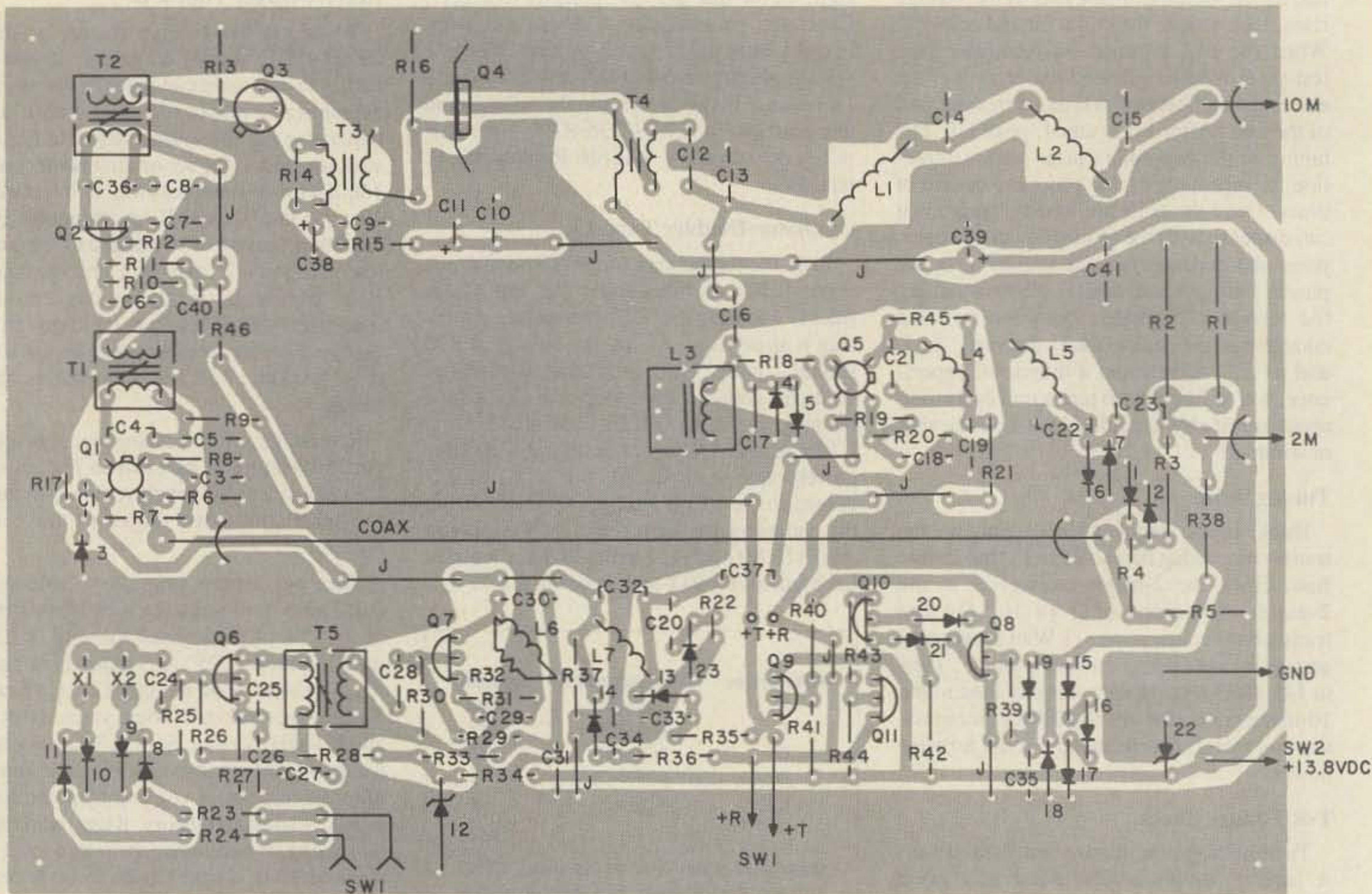

Fig. 7. Component placement.

er. Now adjust the tuning slug in L3 for greatest quieting. Keep reducing the input signal level as needed so that you have some noise to work against. Knife L4 for greatest quieting, then L5. These coils will interact some, so tune them in sequence several times.

If you are using the antenna instead of the attenuator with the 29.600-MHz source, simply move it to adjust signal strength. If you are using this method, I recommend that you touch up your receive-mixer tuning by hooking 2 to 10 to your 10-meter station antenna and by moving the source at least 30 feet from your transverter. Prune the antenna on the source (as needed) to reduce signal strength. I suggest that you do this final adjustment after tuning the transmit chain.

#### Transmit-Chain Tune-Up

Set 2 to 10 in the direct mode. While monitoring the +T test point, key down your 2-meter transceiver (on low power!). You should see +T switch high. With your transceiver keyed, confirm that you have about 1.5 V dc on the R17 test point. You will have some forward power showing on the swr meter. Carefully peak the tuning slugs in T1 and T2 for maximum output power. Then back the slug in T1 slightly out (counterclockwise) until the power just begins to decrease. Expect 3.5 Watts of output power. Key down

your 2-meter transceiver and check the transverter's output frequency with the counter. It should read  $29.600 \pm .001$  MHz. Now switch to the repeater mode. It should read  $29.500 \pm .001$  MHz. Touch up the oscillator tuning so both readings fall within their tolerance. Notice that they tune up and down together. (You did use .001% tolerance crystals, didn't you?)

If things have worked out so far, welcome to 10-meter FM! If you run into any snags, review the theory of operation section for troubleshooting hints.

#### Operation

It is useful to tape a small card to your 2-meter rig (or the top of your 2 to 10) listing the 2-meter-to-10-meter frequency conversions for both direct and repeater modes. It is also a good idea to prominently include the note: *Operate the 2-meter rig on low power in the direct (simplex) mode when using the 10-meter transverter.* Remember: Garbage in, Garbage out!

2 to 10 draws about 50 mA in receive and less than 1 A in transmit. Always use a 1-Amp in-line fuse in the dc power lead going to the transverter. The 2SC1909 used in 2 to 10's final amplifier is reasonably forgiving of temporary load mismatches. However, don't abuse it. There is no reason to accept an swr greater than 1.3:1 since operation is quite narrowband. The lightweight heat sink used

on the final is fine for the 1-minute-on, 1-2-minutes-off type of service that is typical of FM conversations. Beef up the heat sink if you are going to operate in transmit for long periods of time.

#### Direct/Repeater Operation

Most direct operation is found on 29.600 MHz. This frequency is monitored by many people, and a number of VHF/UHF repeaters have added crossband capabilities to this frequency.

The normal 10-meter repeater pairs are .52/.62, .54/.64, .56/.66, and .58/.68. Remember, *always* leave the 2-meter rig in the direct (simplex) mode. Use the DIR/RPT switch on the transverter to change modes!

#### Base-Station Operation

All you need is a regulated 12-14-V-dc, 1-A supply and a good vertical antenna. I am using a Cushcraft AR-10 with excellent results. Many people cut down CB ground planes with good success. As there is often a significant loss due to cross-polarization on 10 meters, it's best to use some type of vertical.

#### Mobile Operation

You can run 3-4 feet of coax between your 2-meter rig and 2 to 10, so mobile installation is fairly flexible. You will want comfortable access to the ON switch and the DIR/RPT



switch of the transverter. I prefer to take dc power from a point that disconnects automatically when the motor is cranked. This reduces the chance of damage due to an electrical transient. If you get a case of alternator whine, try a dc power filter such as the Radio Shack 270-050. 2 to 10 was not designed for operation at extreme temperatures. I suggest an operating temperature range of 40-100° F. On very cold or warm days, let 2 to 10's temperature normalize before operating.

Choosing a good antenna is the key to success for 10-meter mobile operation. If you already have a Hustler antenna, get the 10-meter resonator and use it. It's OK to trim down a CB antenna, but start with a good one! I am very skeptical of short antennas. I hope some of you antenna designers out there will work up a set of effective antennas for 10-meter mobile FM—maybe a good DDDR roof mount. Oh yes, avoid using crummy CB coax.

#### From Here

Ten has always been my favorite HF band because it provides local rag-chewing, surprising low-power DX contacts, and many operating modes. 10-meter FM ices the cake. I hope I have encouraged you to get on 10-meter FM some way. If you would like to write and ask a question about 2 to 10, please include an SASE. Please hold phone calls to Friday evenings, 7:30 to 10:30 p.m. Central time. No collect calls, please! See you on 10-meter FM. ■

#### Reference

Dave Ingram, *10-Meter FM for the Radio Amateur*, Tab Publication 1189.

Coil Reference #	Nominal Inductance	# of Turns-N	Wire Gauge AWG.	Inside Coil Diameter D	Coil Length L	Spacing S	Mandrel
L1	.27 uH	6	#18 (1)	.45" (11.4)	.45" (11.4)	N/A	1/2-13
L2	.27 uH	6	#18 (1)	.45" (11.4)	.45" (11.4)	N/A	1/2-13
L4	+ .05 uH	3	#18 (1)	.22" (5.6)	.15" (3.8)	.2" (5.1):L5	1/4-20
L5	- .05 uH	3	#18 (1)	.22" (5.6)	.25" (6.35)	see above	1/4-20
L6	+ .068 uH	3	#18 (1)	.28" (7.1)	.20" (5.1)	.2" (5.1):L7	3/8-16
L7	- .068 uH	3	#18 (1)	.28" (7.1)	.25" (6.35)	see above	3/8-16

Parenthetical values are in millimeters.

- L3 7 turns of #30 (.25) close-wound at the base of a Micrometals, Inc. L43-6 form, .40 uH.
- T1,T2 Primary—7 turns of #30 (.25) close-wound at the base of a Micrometals, Inc. L43-6 form, .40uH; secondary—3 turns of #30 (.25) wound over primary.
- T3 Primary—7 turns of #26 (.40) wound 75% around two stacked FT37-43 ferrite toroid cores; secondary—2 turns of #26 (.40) wound over the middle of the primary.
- T4 7 bifilar turns of #26 (.40) wound 75% around two stacked FT50-61 ferrite toroid cores; interconnect for 1:4 step-up.
- T5 Primary—7 turns of #30 (.25) close-wound at the base of a Micrometals Inc., L43-10 form, .34 uH; secondary—2 turns of #30 (.25) wound over primary.

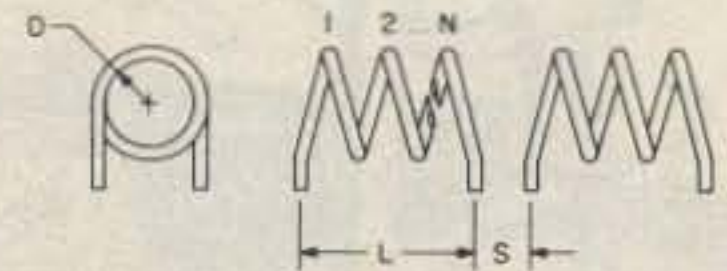

Fig. 8. Rf inductor and transformer data.

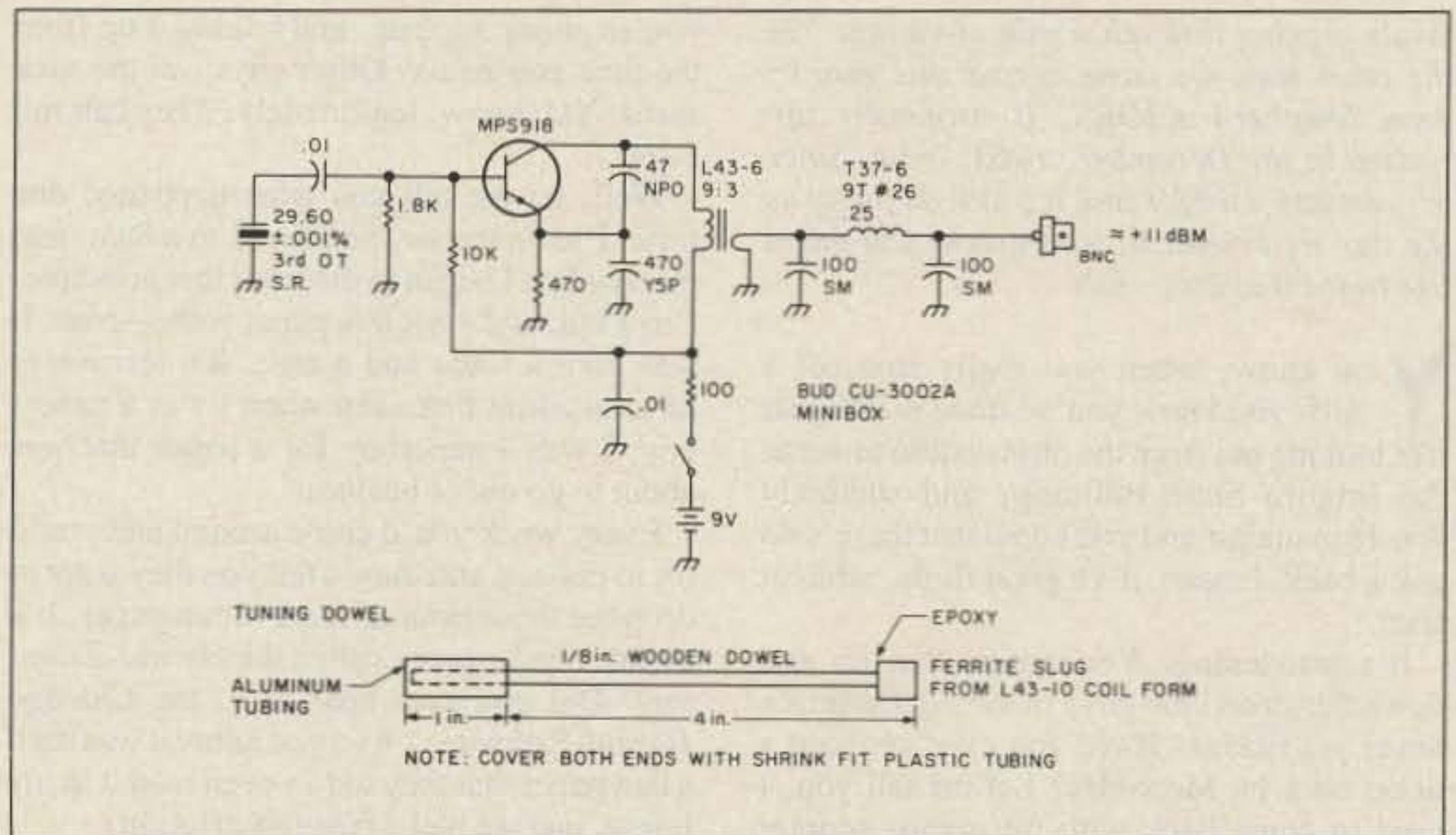

Fig. 9. 29.600-MHz alignment oscillator.

## Fox Crystal Filters

### NEW FOR FT-757GX!

Improve selectivity by replacing your stock 2700 & 600 bandwidth filters with genuine Fox Tango 8-pole drop ins; 2100Hz for SSB, 500 or 250 for CW.

#### STILL ONLY

\$60 ea., 2 for \$110

SHIPPING: \$5 (US and CANADA), \$12 elsewhere • Order by mail or phone VISA/MC or COD accepted

Ask About Our Filters For Many Other Rigs.

**FOX-TANGO Corp.**

Box 15944, W. Palm Bch, FL 33416  
Telephone: (305) 683-9587

European Agent: INGOIMPEX, postfach 2449, D-8070 Ingolstadt.

## IRON POWDER and FERRITE PRODUCTS

# AMIDON Associates

Fast, Reliable Service Since 1963

Small Orders Welcome

Free 'Tech-Data' Flyer

Toroidal Cores, Shielding Beads, Shielded Coil Forms  
Ferrite Rods, Pot Cores, Baluns, Etc.

12033 OTSEGO STREET, NORTH HOLLYWOOD, CALIFORNIA 91607



# Some Guys Make It

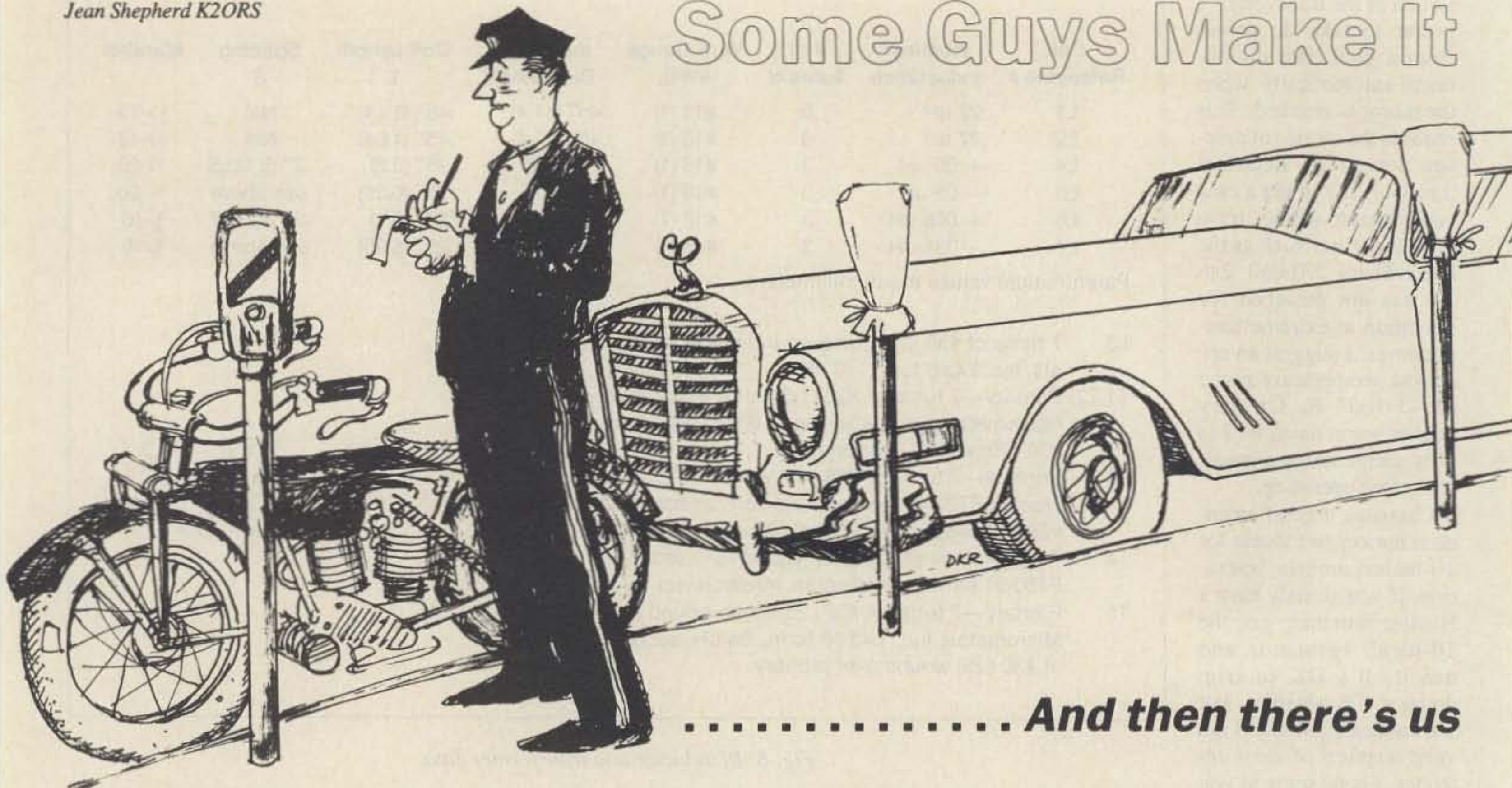

## ..... And then there's us

While digging through a pile of vintage 73s the other day, we came across this gem by Jean Shepherd K2ORS. It originally appeared in the December, 1963, issue. Since it's already paid for and it's still as funny as the day we bought it, we thought you might like to see it again. —Eds.

**Y**ou know, when you really step off a cliff, you know you've done it. It's just like looking out from the observation tower at the Empire State Building, and suddenly you're in midair and you know that there's no going back. I mean, it's a great flight, while it lasts.

It's maddening. You notice that up and down the street, the guys in the big Cadillacs never get tickets? Have you ever yet seen a ticket on a fat Mercedes? Let me tell you, I used to come back with my motor scooter decorated like a Christmas tree. You know, all those little green tags hanging like tinsel all over it. And in front of me would be a tagless Cadillac, and behind me a tagless Mercedes. Both parked there since last Easter. My scooter... I'd slow down, and the fuzz would be running alongside me, tying 'em on.

Well, that goes in all directions. There are guys who always get it you-know-where, and there are guys who don't. It's just that way. Now I don't know how it's set. I don't know whether it's predestination. I don't know whether it's preordained, but some guys from the very minute they're born—and they can be born in a rotten neighborhood—but from the very minute they're born, they are preordained or something to Make It. And there are other guys who are born to be Sunk. I mean just born to it. Your ship is leaking. From the very minute you start to walk. Your shoes squeak. And

you're phonying it up, and hoking it up from the time you're six. Other guys win the sack races. You know, legitimately. They can run faster.

Well, let me tell you what happened one time. I'm on the air, you see. I'm a ham, and this is when I began to discover this principle. I'm a kid, and I got this paper route—rout. It was both a route and a rout. It's terrible to have to admit that even when I was a paperboy, I was a paperboy for a paper that was about to go out of business.

Every week you'd come around and you'd try to collect, and they'd tell you they want to drop the subscription, it's a rotten paper. It's awful. I had a paper called the *Herald-Examiner*. Did you ever hear of it, the *Chicago Herald-Examiner*? And you know it was such a bad paper that they didn't even read it in my house, and we had a free subscription.

---

**"I am calling CQ from 9 o'clock at night till 4 o'clock the next morning. All I am raising is our light bill."**

---

I used to go running around the neighborhood at four o'clock in the morning, delivering this rotten paper. It was a losing battle. And on Saturdays, every morning, I would go up and I'd knock on every third door, trying to collect the dough, and they'd say:

"Here's forty cents for last week. Please don't deliver the paper any more."

Well, then I'd have to go back and tell

George The Paper Man that they quit down there, on Cleveland Street, those people down there, and he'd say:

"Ah, they're rotten people."

George was fighting a losing battle, too, because he had the *Herald-Examiner* franchise in the neighborhood and he was going down with the ship. And all these poor little kids who were 12 years old and who were getting knobby knees from running around with this paper, they were going down, too. Whereas right across the street from us there were a bunch of wiseguy kids who had the *Tribune*. And this big fat guy who had the franchise for the *Trib*. And they all got fat. All those kids are Republicans today. And Cub fans. All of the rest of us kids that had the *Herald-Examiner*, look at us. Ha! Democrats, following the White Sox till the day we die.

So anyway, I'm a kid and I get my ticket, and I figure I'm licensed, like all the rest of the guys. Except, of course, the Cadillac has the same kind of license on it that you've got, you know. It's the same piece of metal on the back, but Boy, what a difference.

So I get my ticket. I'm really gonna swing. I'm on 40 CW for about six or eight months, when I get on phone. Now I'll tell you what I was doing as far as phone is concerned. I figure I'm gonna try and make it in the big leagues. And I have a single 2A5. Final driven by a 56 tri-tet osc. Do you know anything about the 2A5? Well, it was a Pentode, a Power Pentode. Receiving type. I got ahold of this 2A5, and I was using a Majestic B Eliminator, which I had found in the basement of somebody's house, to power this thing. And it put out 135 volts. I can tell you exactly what I was running, it was 135 volts on the plate at 10 mils. So you can figure out what my input was. Into an RCA mismatched



receiving doublet SWL antenna. A special design they had to mismatch on everything. Didn't match anything. I could have done better with the bedsprings.

And so I've got this thing tuned up, and I'm running a cool 135 volts at 10 mils on the plate. I built a modulator. Oh, when I think of it... how sad.

The modulator was another 2A5, and I am grid-modulating the final. Well, you can realize the kind of output I have. I'm probably running about 7/10ths of a Watt, and you will never guess what band I'm running it on. I'm on 160 meters. Where a low-power guy was running 200 Watts and the high-power guys ran all the way up to, well, I would say WNBC standards.

I had this poor little receiver. I don't know whether you ever heard 160 meters when it really was wild. You know what you could do on 160? You could tune into the band, and when you hit the band it was one heterodyne from one end to the other. One *solid* heterodyne, without a break. And the heterodyne was of such a magnitude that your S-meter was on the pin all the way across the band. It never fell off.

So one night I'm on there. I throw my 7/10ths of a Watt right into the middle of it all. I have a very vocal special sound, the bored sound of a high-power man, calling CQ. Nonchalantly:

"Hello CQ, CQ 160. Hello CQ, hello CQ, hello CQ." Then there's a little silence while I'm tuning. [Sound of arc being drawn by pencil from final plate.]

"Hello. One Two Three...hello. Hello CQ, hello CQ, hello CQ."

Where you really sound like a big leaguer is when you turn the radio in the next room all the way up, so you sound like you've got so much power and so much gain, so much preamp gain that you can't cut down the background noise in your house. It sounds real great.

I've got the cans on. I'm wearing cans monitoring myself on my receiver. I am the only guy who can hear me, the only guy who could hear my signal.

"Hello CQ, hello CQ, hello CQ, hello CQ."

It's 9 o'clock at night, and everybody in the country is on. Believe me, that band was so insane and my rig so weak that with my signal on and my receiver on, I could hear the heterodynes through my carrier. If you know what I mean.

"Hello CQ, hello CQ, hello CQ, hello CQ 160, hello CQ."

I am calling CQ from 9 o'clock at night till 4 o'clock the next morning. All I am raising is our light bill. That's all that's happening. So the next night I come on again. I get on the air again, and it's great, you know, just to throw on all the switches. The one thing I had that was heartwarming was that my BH tube was leaky. I had a gassy BH. Did you ever hear of the BH cold-cathode rectifier? Well, it was leaky. It was gassy; it made a beautiful blue light like an 866 when I talked. Made me feel like I had real power.

"Hello CQ, hello CQ, hello CQ, hello CQ,

"When You Buy, Say 73"

hello CQ." And I'd see that blue light flickering. It was just great.

"Hello CQ, hello CQ, hello CQ, hello CQ."

Well, this goes on for one solid week. They can't even hear me in the next room. I haven't raised even a BCL.

"Hello CQ, hello CQ, hello CQ."

Finally Friday night comes along. And my friend Chuck down the street is W9AHS. He is running 6/10ths of a Watt on 20. He has not worked anybody on 20 since the preceding spring, when he worked a guy who was mobile and who drove right past his house. So the two of us are in the same leaky rowboat.

Chuck comes home from school, and he says:

"You're on 160, huh? How're you doing?" And I say:

"Ah, pretty good, Chuck. How are you doing on 20?" Twenty is a real Big League band. He says:

"Oh, not bad. Not bad."

We both made Class A, you see, but I didn't have the guts to go on 20 yet, because the band scared me.

Chuck says, "What do you say we work a little crossband tonight?" Chuck lived 10 blocks away from me. So I say:

"Okay, Chuck."

So Chuck has got his receiver tuned to 160 and I'm listening on 20 and sure enough, between all the heterodynes I hear Chuck come in:

"Hello, hello W9QWN, hello W9QWN, W9QWN. W9AHS calling W9QWN." So I throw on my transmitter. I'm on 160:

"Hello W9AHS, W9AHS." And Chuck comes back to me! Fantastic! He could hear me. Right in between all the heterodynes he says he could hear this little squeak, this little thing. He says:

"You're coming in. You're about an S2. About an S2. Readability is very low. About an R3, I'd say, about every 3rd or 4th syllable."

So, without thinking about it, we slip into crossband work, into duplex. And I leave my transmitter on, Chuck leaves his on, and I'm talking to Chuck. We worked crossband, *duplex*, for not more than 30 seconds.

Illegal.

And I'm talking to Chuck, Chuck's talking to me, back and forth. It was great. Finally:

"73, Chuck."

"Okay, Dad."

"Hello CQ, hello CQ, hello CQ, 160 phone—hello CQ, hello CQ."

Six or eight weeks go by. When suddenly, in the mail, would you believe it? I get a card from the FCC. They got a listening station in San Diego. And they have ticketed me for crossband illegal operation. I am coming in there 599 XXXX. A ton of bricks! On 160!

Well, I figured, you know, there's some guys get ticketed and then there's others that don't. About that time I realized that there are born losers and there are born winners.

Oh well, it doesn't matter. It only gets worse. But the thing you got to keep saying to yourself is that it gets worse for everybody, simultaneously, all of the time. Maybe. ■

## TOWER VALUES



Rugged TRYLON ABC\* towers designed and fabricated in Canada to survive the severe northern climate, now available in the USA at **REASONABLE PRICES** ranging from \$330 to \$2500 and heights between 32 and 160 feet.

**EASY ASSEMBLY:** Lightweight 8-foot triangular sections in a modular tapering design.

**MADE TO LAST:** High tensile strength steel and quality zinc coating (ASTM A-526 specification). Painting available. Zinc-plated steel bolts. Virtually maintenance free.

Guyed and free-standing versions available; shipped Factory Direct and guaranteed **ONE FULL YEAR** after installation.

Write or call **BJX SUPPLY CO.** for full information and price sheet.

For Dealer Information write TRYLON MANUFACTURING COMPANY, LTD.  
21 Howard Avenue, Elmira, Ontario  
CANADA N3B 2C9

\*ABC CONDITIONS: Wind loading in pounds per square foot, wind velocity in miles per hour: A: 20 mph/70 mph; B: 30 mph/85 mph; C: 40 mph/100 mph.

**BJX SUPPLY COMPANY**  
P.O. BOX 388, CORFU, NY 14036  
Tel.: (716) 599-3791 after 6 PM

148 PAGES  
100'S OF NEW  
PRODUCTS



**GET IT NOW!**

More pages, more products—and it's hot off the press! Get the new 1986/7 DICK SMITH ELECTRONICS Catalog and find anything for the electronics enthusiast. The data section alone is worth the price of admission. Send for your copy today.

Please reserve my copy of the 1986 Dick Smith Catalog. I enclose \$1 to cover shipping.

Name .....

Address .....

City .....

Zip .....

DICK SMITH ELECTRONICS INC.  
P.O. Box 2249 Redwood City CA 94063  
EVERYTHING FOR THE ELECTRONICS ENTHUSIAST





# Simplex Repeaters?

*What are they? And why would you want to use one?*

CES, Inc., and local radio amateurs in Winter Park, Florida, have been testing and evaluating a simplified version of the simplex equipment discussed in this article. The purpose of this article is to generate more discussion and ideas on this subject, and not to set down any absolute standard or definition for such a machine.

With the advent of low-cost digital storage for voice retransmission, a new product to serve special amateur needs has become feasible—the Digital Simplex Repeater. The concept is very simple: A base

station serves as the repeater, monitoring a standard simplex frequency and storing the received audio transmissions. Whenever a transmission ends, the receiver's carrier-operated relay (COR) signal goes off and the station transmitter will send out the previously recorded message. In its most basic form, the repeater automatically retransmits every received message. While obviously not a great way to carry on rapid-fire rag-chews and nets, this is a simple way for a base station to greatly increase the range of any hand-held or mobile radio unit. By using only simplex operation, all of the costs and technical drawbacks of full-duplex operation are eliminated. There is no input desensitization and no extra signal losses due to a duplexer.

Adding one slight refinement to the system makes it more than just a calling and testing machine: Reset On New COR. What this feature does is reset the digital store-and-retransmit logic whenever a second transmission is detected within two seconds of the first. This allows two stations to carry on

direct communication without the delay or interference of the repeater. However, between buildings or in some other "dead zone" the operator needs only to delay two seconds, and the lost or garbled direct message is repeated loud and clear. The first station knows immediately when it is reaching the limits of direct communication when it hears the retransmission. The two stations now have the option of continuing with the repeater's help, signing, or coordinating a switch to an available duplex machine.

When no direct-path signals can be heard between two stations using the repeater, care must be taken to alternate turns using the machine so that doubling—or worse yet, both stations pausing for the other—does not occur. Since this is a valid and very useful mode, it makes sense to limit the storage time to a short period to minimize the "is he replying?" time. Fifteen seconds seems to be the maximum wait tolerance for "A-Type" (impatient) personalities. Fifteen seconds is actually quite a bit of time to relay information and ideas. The repeater, therefore, will only repeat the first 15 seconds of the last transmission. This may seem harsh to those who find two- or three-minute timeouts too fast on duplex machines, but it can be adjusted; it may even improve your operating habits. For a calling-frequency machine, 15 seconds is ideal.

Another possible feature of a simplex repeater is frequency sharing. This is possible when another refinement is added to the controller: Access Code Enable. Assume that the repeater can be activated by a single DTMF tone, such as "1." The tone should be required for two seconds to activate the repeater. This prevents voice "falsing" from inadvertently activating the repeater. Since for most applications the range of the repeater should not greatly exceed the range of the hand-helds or mobiles calling into it, most simplex repeaters should be modest—20 Watts to a 5/8-wave vertical, not a kW to a 200-foot-high yagi.

This modest (cellular-like) operation means that several simplex repeaters could be located on the same channel within overlapping areas, giving continuous coverage

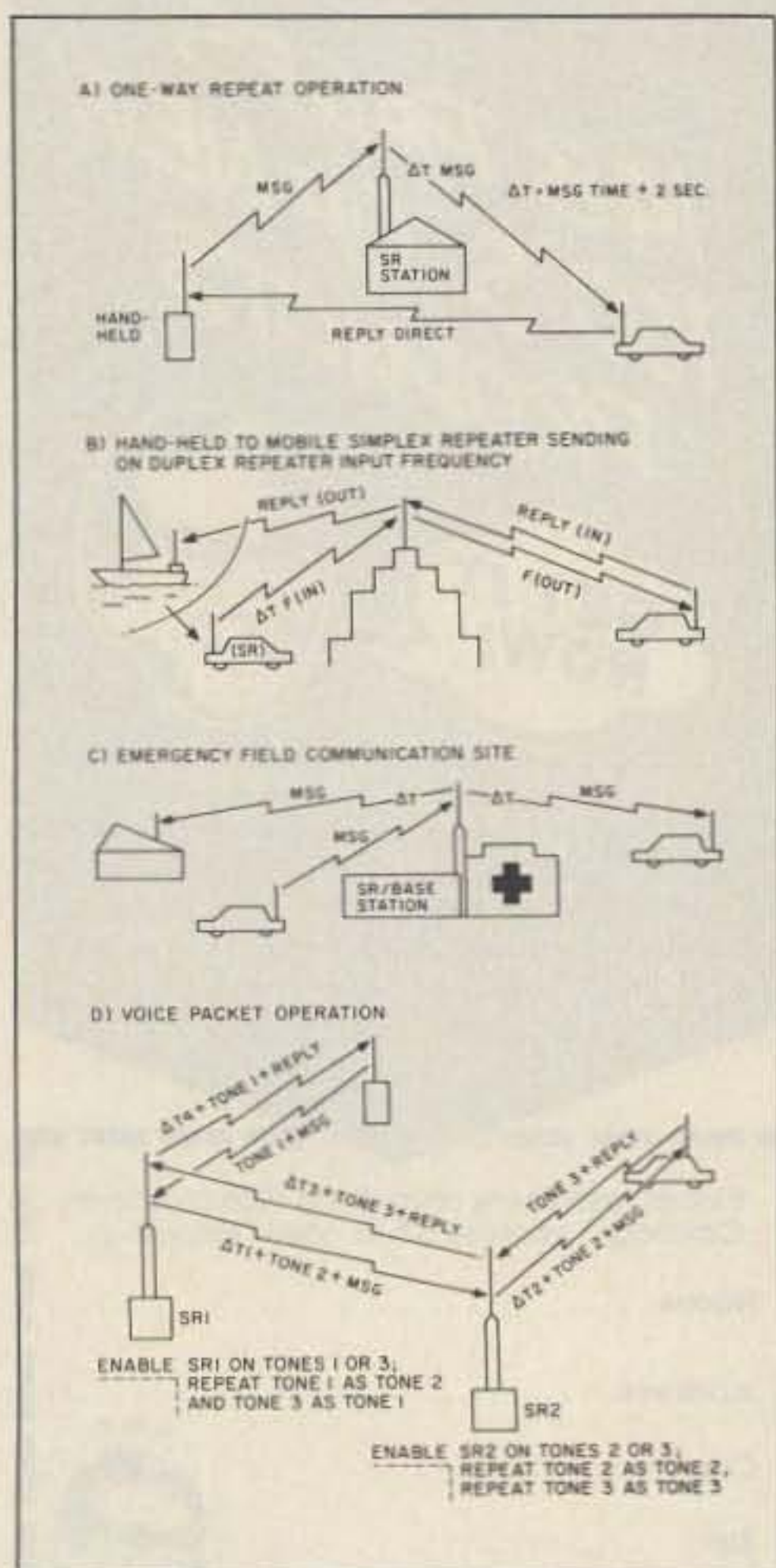

Fig. 1. Simplex repeater configurations.

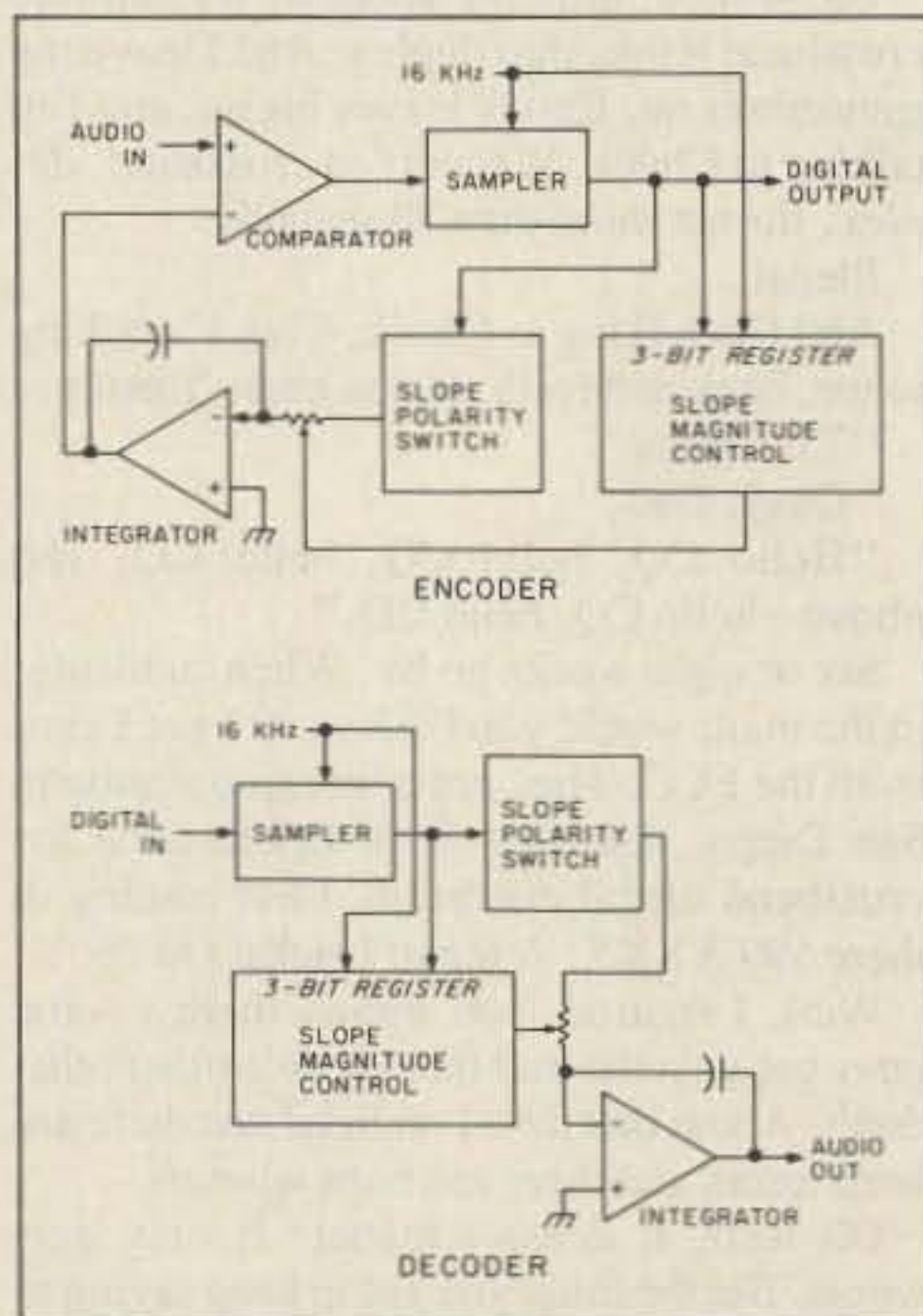

Fig. 2. CVSD encoder and decoder.







The experimental system works on 146.4 MHz, using 17 Watts to a vertically polarized gain antenna at approximately 100 feet. The repeater operates under station call WA4HHZ. Here are a few of the comments from on-the-air users:

- Hilory K3VMG: "I get a lot of calls on the hand-held I can't answer direct. With the simplex repeater, I can answer back without running over to the main rig."
- Bob N4NDW: "The vehicular simplex repeater will be great for me as an outdoorsman. The possibilities are tremendous."
- Dave K7AFK: "Every club should have one as an on-the-air test machine."
- Jack WD4AWV: "It works fine, but what do you do with it?"
- Andy K4YKZ: "I like the built-in bloop reset feature—just release push-to-talk and start again."
- Al N4BUS: "I would much rather carry a hand-held than a radio in the car. Now my hand-held has the range of my home station."

original input. Companding consists of loading the last three bits from the encoder into a 3-bit shift register and digital comparator. If all three bits in the register are 1's, the reference integrator's output will be set to ramp up faster; if all three bits are 0's, the output will be set to decrease faster than if the two previous bits were not 0's. This simple fudge control over the integrator's gain increases the ability of the CVSD to respond to rapid changes in amplitude without increasing the overall memory requirements.

Fig. 3 shows a simplified block diagram of the simplex repeater. The only signals needed to control the system are COR from the radio and PTT to the radio. COR is the internal radio signal that disables the radio's squelch. Some transceivers provide this signal to a

connector output, but the signal must be found from the schematic on most amateur radios. A few radios do not have a signal that is suitable for use by the repeater. For these radios, COR must be generated by an additional circuit that senses background noise on the unsquelched audio signal.

The receive signals to the repeater's CVSD decoder can be speaker audio or unsquelched audio. If the speaker audio is used, the volume setting cannot be changed once it is adjusted for the proper output deviation level for transmission. So, if the repeater is also to be used as a base control station, the audio to the repeater should come from the audio circuitry that precedes the volume control.

The PTT signal to the transmitter is activated to the radio two seconds after the COR

goes off and remains off. The timing control must also ignore false COR inputs that normally occur immediately after PTT is released.

Fig. 4 shows a more detailed block diagram for a system that includes more bells and whistles. In addition to the basics shown in Fig. 3, the following seven functions are shown: (1) DTMF decoder for repeater activation/deactivation, (2) analog pre-filter and post-filter for CVSD, (3) auxiliary microphone input with gain control, (4) 2-second "wait for COR" timer, (5) 30-second deactivation timer, (6) 5-minute timer and ID generator, and (7) optional ping-pong squelch generator.

With the cost and complexity of the digital encoder/decoder and with memory no longer a major factor, the success of the simplex repeater depends on two important factors:

- Acceptance of the concept and constraints by the amateur community
- Technical improvements resulting in more sophisticated operation and reduced costs

Other factors that will weigh heavily on the spread of the simplex repeater are the FCC and ARRL. The "voice packet" concept is bound to be tried using simplex repeaters. This operation most likely will require regulatory sanction before it can grow. The basic one-repeater system, however, should be well within the limits of the current regulations. The challenge today is to try it, then improve it, and—some day—standardize it. ■

## the HAM STATION

P.O. Box 4405  
220 N. Fulton Ave.  
Evansville, IN 47710

Stores Hours  
MON-FRI 9AM-6PM  
SAT 9AM-3PM

WARRANTY SERVICE CENTER FOR:  
ICOM, YAESU, TEN-TEC

### TERMS:

Prices Do Not Include Shipping.  
Price and Availability Subject to  
Change Without Notice  
UPS COD \$2.50 Per Package

### USED EQUIPMENT

AEA	
MBA-RO Reader	\$ 129.95
MM-2 Morse Matic	149.95
CP-1 Interface	139.95
COLLINS	
75S-3 Rcvr/CW	\$ 209.95
32S-3 Xmtr/516F-2 P.S.	399.95
DENTRON	
Clipperton L-Amp	\$ 475.00
MLA 2500B-Amp	575.00

DRAKE	
TR5/P.S./1.8 SSB Filt.	\$ 489.95
T4XC, R4C, AC4, MS4	519.95
TR4C, AC4	299.95
RV4C	84.95
R4C, MS4	219.95
TR6, AC4	374.95
UV-3 (2M & 440) TT Mic, P.S.-3	399.95
ENCOMM	
ST-142 2M H.T.	\$ 209.95
ST-144 2M H.T.	179.95
ST-144/PL Encoder	189.95
HT1200 2M H.T.	139.95
HL-120U 10/120W 440Mhz	319.95
HL-90U 10/90W 440Mhz	289.95
HL-160V 10/160W 2M	279.95
HL-82V 10/80W 2M	139.95
HL-32V 2/30W 2M	49.95
HC-2000 2KW Tuner	269.95
KDK FM-240/Voice 2Mtr.	279.95
HAL	
MPT-3100 (No Monitor)	CALL
CRI-200 Interface	189.95
HEATHKIT	
SB-200 Amp	\$ 329.95
HD-3030 Interface w/Options	179.95
ICOM	
745/FL52 Xcvr.	\$ 654.95
745 Gen. Cov. Xcvr.	619.95
740/PS	599.95
740 Xcvr.	499.95
730 Pb/CW	489.95
730 Xcvr.	459.95
730/EX 202	464.95
PS-15 Power Supply	99.95
Phone Patch (720, 30)	89.95
2AT 2M H.T.	159.95
735 Xcvr.	649.95
560 6M Xcvr.	339.95
451A 430-440Mhz Xcvr.	449.95
KANTRONICS	
Interface II	\$ 169.95
Interface I	69.95
Field Day 2 Reader	109.95
KENWOOD	
TS-520 SE Xcvr.	\$ 399.95

KENWOOD	
TS-520 D Xcvr.	349.95
TS-520 Xcvr.	349.95
T-599/R599 w/2 & 6M/Spkr.	299.95
2600 2M H.T.	219.95
2400 2M H.T.	149.95
VFO-280	99.95
VFO-520	89.95
VFO-240 (830)	114.95
700A 2M All Mode W/Vox	275.00
R-300 Short Wave Rcvr.	149.95
TS 620S/CW	499.95
MICRO LOG	
Air 1 W/Amtor-C-64	\$ 159.95
SWAN	
1500ZA Amp Very Nice	\$ 375.00
TEN-TEC	
Titan Amp	\$1875.00
Triton IV	269.00
Century 21	199.95
263 VFO-Corsair	134.95
544 Triton (Digital)	329.00
262M Power Supply	89.00
VFO-Triton	124.95
YAESU	
FT-980/Keyer	\$1175.00
FT-980/Gen. Cov. Xmt.	1150.00
FT-980/Gen. Cov. Xmt/AM Filter	1189.00
FT 107M/DMS, FP-107E P.S.	569.00
FT902DM	699.00
FT101ZD, CW, Fan	549.95
FT101ZD	499.95
FT101ZD, Warc Bands	524.95
FT101ZD, Fan	524.95
FT101Z, CW, Fan	499.95
FV101Z Remote VFO	99.95
FT101E, Fan	429.95
FT101E, Fan, CW	449.95
FT101EE	399.95
FTV-250 2M Xvtr.	149.95
FTV-650B 6M Xvtr.	149.95
FT225RD 25W 2M All Mode	469.00
FT221R 2M All Mode	259.95
FT221/Pre-Amp	239.95
FT221 All Mode	229.95
FRG-7700/Mem. Gen. Cov. Rcvr.	349.95

YAESU	
FT208R 2M H.T.	169.95
FT708R 440 H.T.	179.95
FRG 9600 60-905 MHZ Rcvr.	389.95
MISC.	
KLM PAIO-70B 2M	\$ 69.95
Robot 800CH	299.95

### CLOSE OUT

AEA	
Amt-1 Interface	\$ 229.95
KI-3 Keyer-Trainer	89.95
MP-20 Interface/MBA-Text	119.95
MP-64 Interface/MBA-Text	119.95
MAP-64 Interface/MBA-TOR	169.95

DENTRON	
QRO 2KW Amp	\$ 650.00

ENCOMM	
ST-440 440MHZ H.T.	\$ 254.95
ST-222 220MHZ H.T.	254.95
KDK7033 440MHZ 10-W	279.95

KANTRONICS	
Hamtext Vic 20	49.95
Hamtext C-64	49.95

### DEMONSTRATORS

HAL CRI-200 Interface	\$ 194.95
HAL CRI-100 Interface	169.95
VOCOMM 25/100W 2 Mtr Amp.	104.95
YAESU 2700 RH w/Voice	479.95

30 Day Warranty on Used Equip. except items on Consignment (C).

Send SASE for our new & used equipment list.

AMEX, MC, VISA & C.O.D.'s WELCOME

For Orders and Price Checks Call 800-523-7731

Indiana call 1-812-422-0231  
Service Dept. 1-812-422-0252



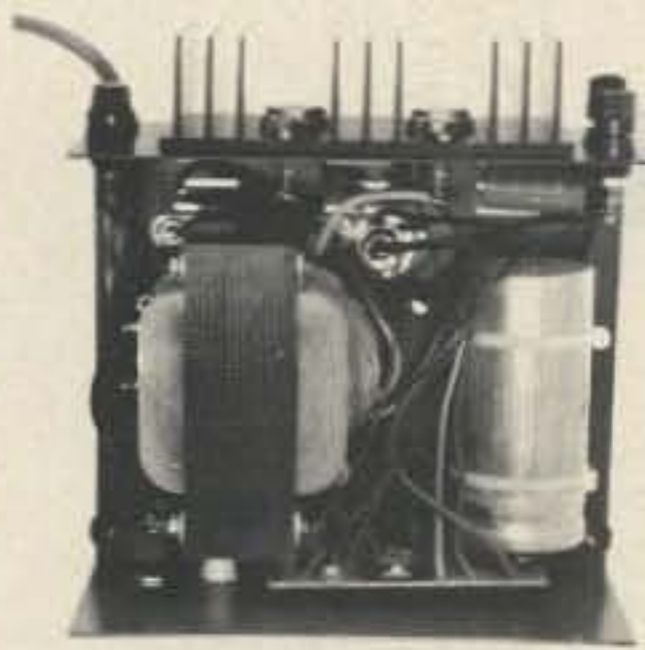

INSIDE VIEW - RS-12A

## ASTRON POWER SUPPLIES

• HEAVY DUTY • HIGH QUALITY • RUGGED • RELIABLE •

### RS and VS SERIES SPECIAL FEATURES

- SOLID STATE ELECTRONICALLY REGULATED
- FOLD-BACK CURRENT LIMITING Protects Power Supply from excessive current & continuous shorted output.
- CROWBAR OVER VOLTAGE PROTECTION on all Models except RS-4A.
- MAINTAIN REGULATION & LOW RIPPLE at low line input Voltage.
- HEAVY DUTY HEAT SINK • CHASSIS MOUNT FUSE
- THREE CONDUCTOR POWER CORD
- ONE YEAR WARRANTY • MADE IN U.S.A.

### PERFORMANCE SPECIFICATIONS

- INPUT VOLTAGE: 105 - 125 VAC
- OUTPUT VOLTAGE: 13.8 VDC  $\pm$  0.05 volts (Internally Adjustable: 11-15 VDC)
- RIPPLE: Less than 5mv peak to peak (full load & low line)



MODEL RS-50A



MODEL RS-50M



MODEL VS-50M

### RM-A Series



MODEL RM-35A

### 19" X 5 1/4" RACK MOUNT POWER SUPPLIES

Model	Continuous Duty (AMPS)	ICS* (AMPS)	Size (IN) HXWXD	Shipping Wt. (lbs.)
RM-35A	25	35	5 1/4 x 19 x 12 1/2	38
RM-50A	37	50	5 1/4 x 19 x 12 1/2	50
• SEPARATE VOLT & AMP METERS				
RM-35M	25	35	5 1/4 x 19 x 12 1/2	38
RM-50M	37	50	5 1/4 x 19 x 12 1/2	50

### RS-A SERIES



MODEL RS-7A

MODEL	Continuous Duty (Amps)	ICS* (Amps)	Size (IN) H x W x D	Shipping Wt (lbs)
RS-4A	3	4	3 3/4 x 6 1/2 x 9	5
RS-7A	5	7	3 3/4 x 6 1/2 x 9	9
RS-7B	5	7	4 x 7 1/2 x 10 3/4	10
RS-10A	7.5	10	4 x 7 1/2 x 10 3/4	11
RS-12A	9	12	4 1/2 x 8 x 9	13
RS-20A	16	20	5 x 9 x 10 1/2	18
RS-35A	25	35	5 x 11 x 11	27
RS-50A	37	50	6 x 13 3/4 x 11	46

### RS-M SERIES



MODEL RS-35M

- Switchable volt and Amp meter

MODEL	Continuous Duty (Amps)	ICS* (Amps)	Size (IN) H x W x D	Shipping Wt (lbs)
RS-12M	9	12	4 1/2 x 8 x 9	13
RS-20M	16	20	5 x 9 x 10 1/2	18
RS-35M	25	35	5 x 11 x 11	27
RS-50M	37	50	6 x 13 3/4 x 11	46

### VS-M SERIES



MODEL VS-20M

- Separate Volt and Amp Meters
- Output Voltage adjustable from 2-15 volts
- Current limit adjustable from 1.5 amps to Full Load

MODEL	Continuous Duty (Amps)			ICS* (Amps)	Size (IN) H x W x D	Shipping Wt (lbs)
	@13.8VDC	@10VDC	@5VDC			
VS-20M	16	9	4	20	5 x 9 x 10 1/2	20
VS-35M	25	15	7	35	5 x 11 x 11	29
VS-50M	37	22	10	50	6 x 13 3/4 x 11	46

### RS-S SERIES



MODEL RS-12S

- Built in speaker

MODEL	Continous Duty (Amps)	ICS* Amps	Size (IN) H x W x D	Shipping Wt (lbs)
RS-7S	5	7	4 x 7 1/2 x 10 3/4	10
RS-10S	7.5	10	4 x 7 1/2 x 10 3/4	12
RS-10L (For LTR)	7.5	10	4 x 9 x 13	13
RS-12S	9	12	4 1/2 x 8 x 9	13
RS-20S	16	20	5 x 9 x 10 1/2	18



# Messing With Microwaves

*Build a simple microwave transmitter and receiver  
for just pennies a MHz.*

One area of electronics that seems to be sadly neglected by amateurs is microwave communication. This is due to the high cost of microwave components and the difficulties associated with microwave circuit construction. If this is what's holding you back from experimenting in this fascinating field, I think you'll enjoy this article on the construction of a simple microwave transmitter and receiver.

The transmitter and receiver described here are of such simple design that it is possible to build both in only a few hours and at a cost of less than \$30. And since the design doesn't use exotic parts, you should be able to get all the components necessary to build both the receiver and the transmitter at Radio Shack.

First, let's begin with the transmitter since it's the more difficult of the two. Begin by getting a square piece of single-sided copper-clad PC board about 8 cm in diameter. In the center of this board, drill a hole large enough to accommodate a 1" 6-32 nylon screw. Before inserting this screw, take a small brass tube about 3.2 cm long and about 3 mm in diameter and solder it to the PC board—centering it just below the center hole (see Photo A). A good source for the brass tubing is a ball-point pen that uses the old brass ink cartridges. Once the brass tubing has been soldered to the PC board, you can insert the 1" 6-32 nylon screw in the center hole. This screw will be used to support the antenna once the components have been laid out on the PC board.

The next step in the construction of the transmitter is to drill another hole, in line with the first, 2 cm below the brass tubing. This hole will help form the variable capacitor which will be used to vary the frequency and power of the transmitter. A thin square piece of copper or brass, measuring  $\frac{1}{4}$  cm along each side, is used to form the top plate of the capacitor. In the center of this small square, drill a hole that matches in size the hole drilled below the brass tube. Place a square piece of mica, somewhat larger than the square piece of brass, between the brass

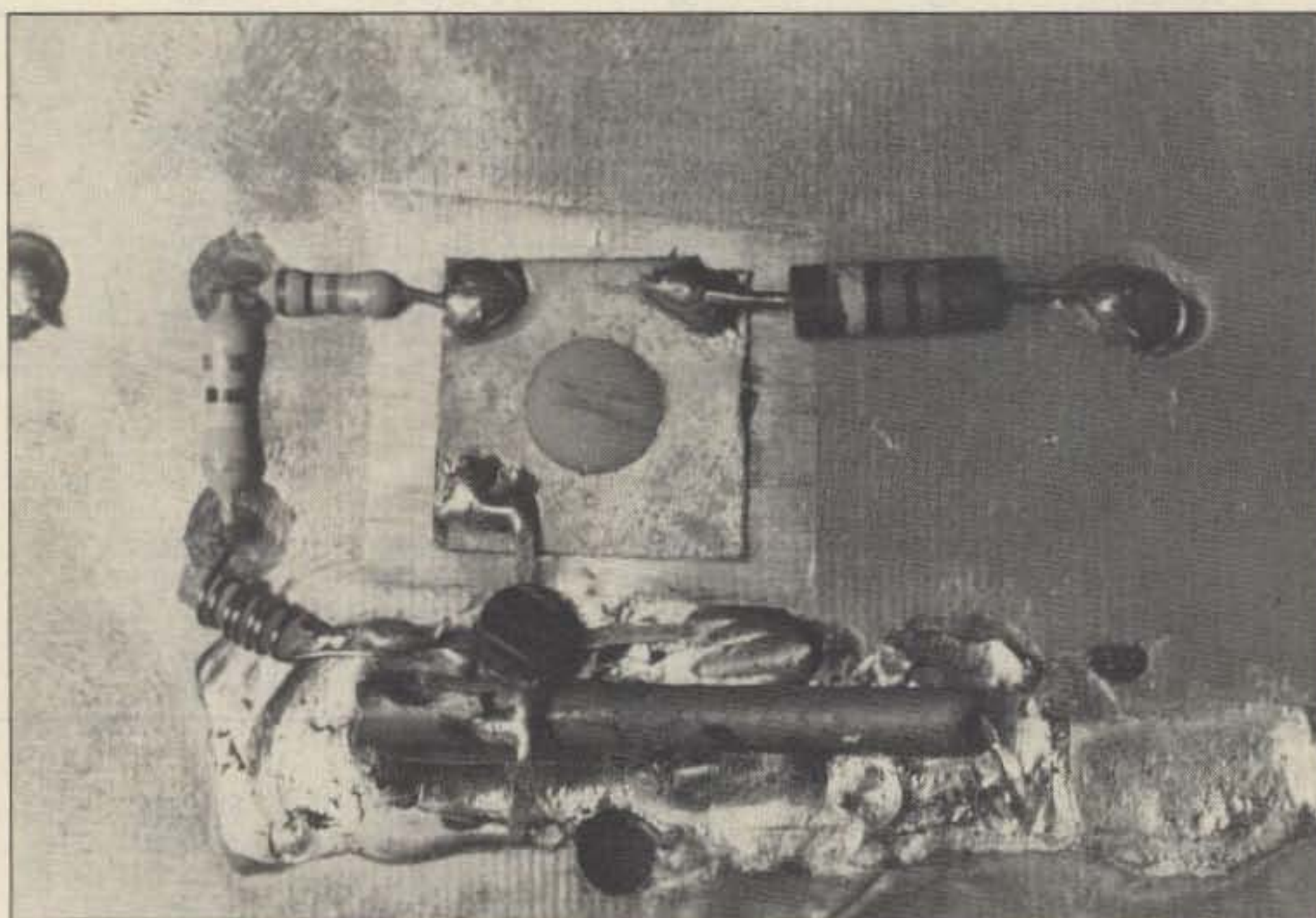

Photo A. The transmitter. The homemade capacitor is in the center, L1 is the long tube at the bottom and L2 is to the left of Q1.

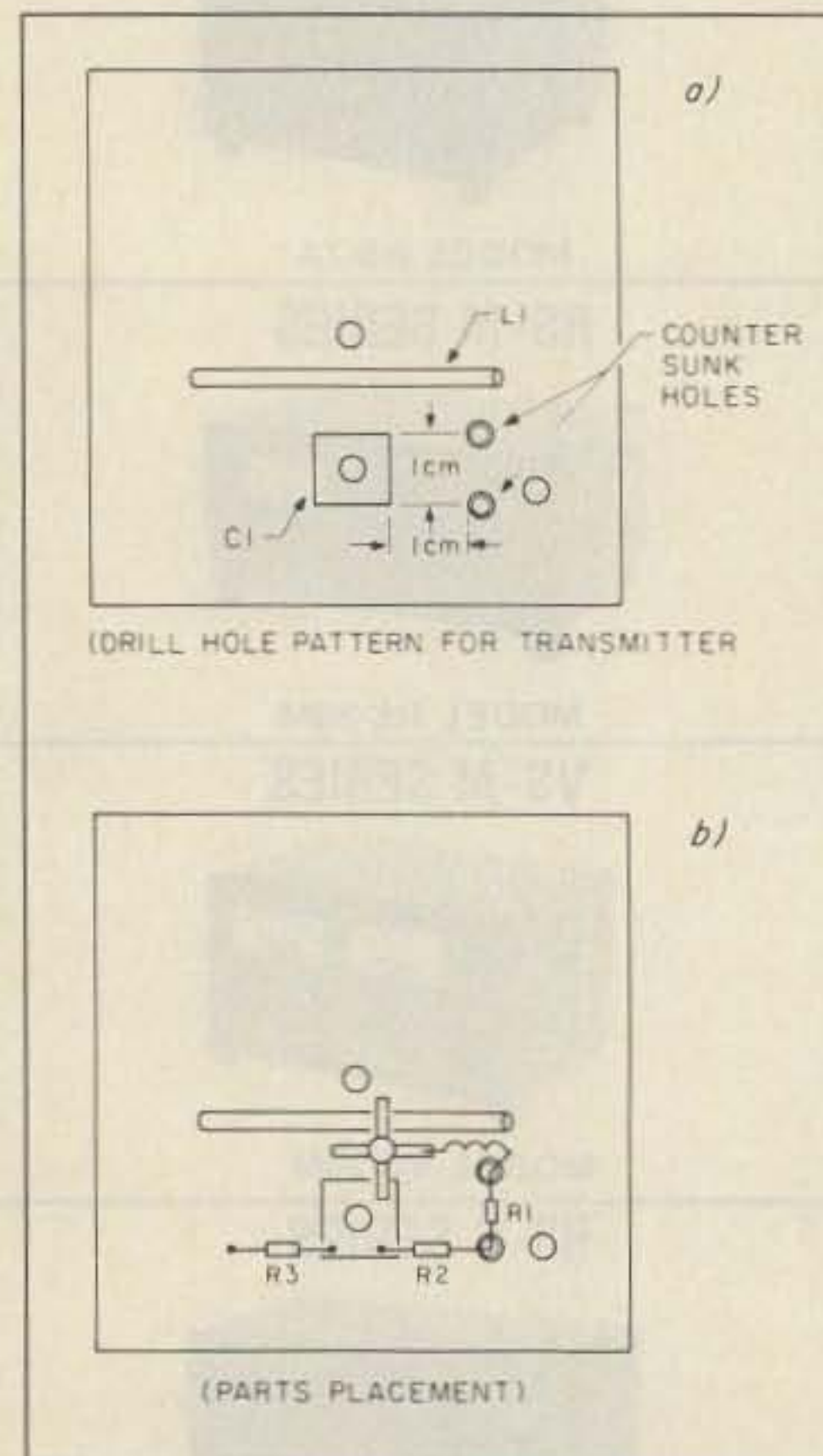

Fig. 1. (a) Drilling pattern for the transmitter board. (b) Parts placement.



square and the PC board. Transistor mounting kits sold in electronic supply houses are one source for the mica. A nylon screw is then inserted through the brass square, the mica, and the PC board. Complete the construction of the capacitor by attaching a nut to the screw on the back side of the board. By tightening or loosening the nut you'll be able to vary the capacitance on the homemade capacitor, and thus tune the transmitting frequency and vary the power.

After completing the variable capacitor, we must drill three more holes into the PC board to mount the four remaining parts. As you can see from Fig. 1, these holes are in line with two of the four edges of the variable capacitor. Two of these holes, 1 cm from the edge of the capacitor, must be drilled in a special way. Start by drilling two 1/32" holes 1 cm to the right of the right-edge corners of the capacitor (see Fig. 1a).

After these two holes are drilled, it will be necessary to countersink them by drilling in the same spot with a larger drill bit. With a 1/4" bit, drill from about 1/4 to 1/2 way through the PC board. The countersinking process is necessary for the removal of copper from around the holes, which prevents short-circuiting of the resistors to the ground plane. The third hole can be drilled anywhere along the bottom of the PC board, preferably close to the 1k-Ohm resistor.

Once the holes are drilled, the resistors are inserted as shown in Fig. 1b. On the right-hand lower corner of the capacitor, one lead of a 1k-Ohm resistor is soldered. The other end of the resistor is inserted through the hole immediately to the right. Directly to the left of this resistor (the lower-left corner of capacitor) a 4.7k-Ohm resistor is soldered to the top capacitor plate, with the other lead soldered to the PC board.

The final component, a 47-Ohm resistor, is installed in the two holes drilled that run parallel to the right hand side of the capacitor. After the leads of the resistor are inserted, you may at this time turn the board over and solder the leads of the 47- and 1k-Ohm resistors together. The other end of the 47-Ohm resistor is connected to a small inductor of your own making. It is formed by wrapping five turns of 30-gauge wire around a match stick. Once the wrapping is finished, slide it off the match and attach one end to the 47-Ohm resistor. The remaining end of the inductor is soldered to the emitter of the MRF 901 transistor (see Photo A). The base lead of the transistor is attached to the top plate of the capacitor, and the collector is attached to inductor L1 (the 3-cm-long tube).

The last bit of work involves soldering the power leads to the transmitter and installing an antenna. First, insert a red wire through the third hole, which we have not used as of yet, and solder it to the front of the PC board. Then take a black wire and solder it to the junction of the 47- and 1k-Ohm resistors.

This just about finishes the construction of the transmitter except for the antenna. The antenna is made by taking a thin strip of metal

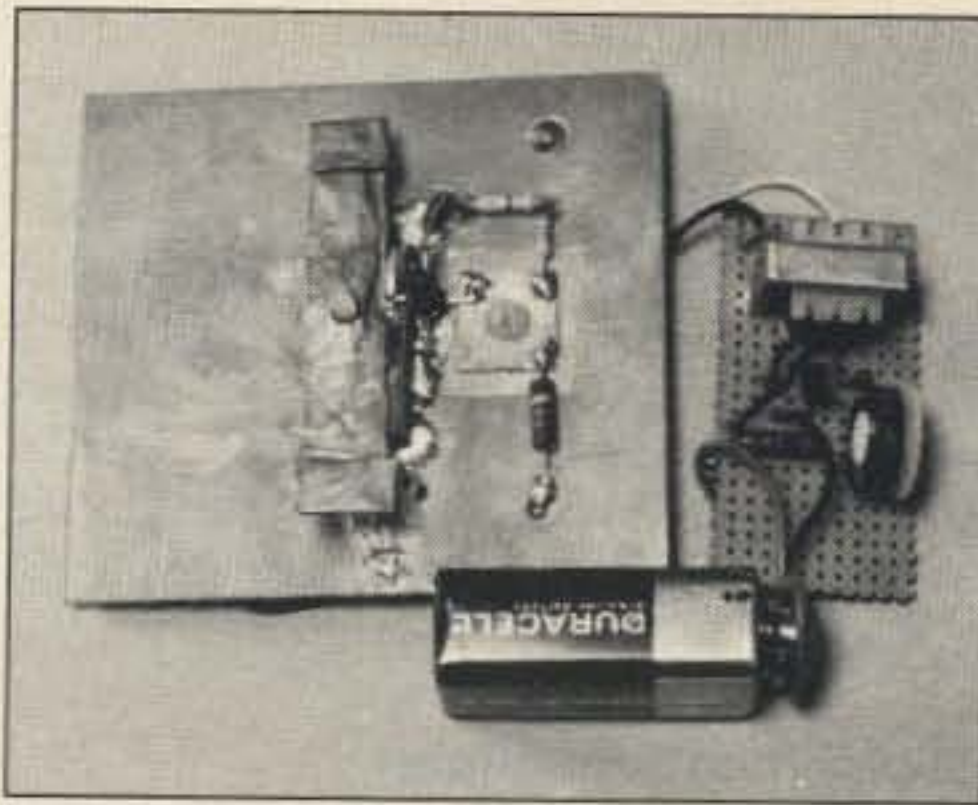

Photo B. With a power source, a modulator, and an antenna, the transmitter is ready to tune.

about 1 cm in diameter and 6 cm in length. At its center drill a hole to fit the nylon screw that formed the antenna mount described earlier. The height of the antenna should be adjusted (by the use of nuts) to a height of 1 cm above the ground plane for maximum signal transmission. For the antenna to function properly, it shouldn't touch any metal—such as the ground plane or inductor L1 (see Photo B). You may ask, how does the antenna work if it doesn't make contact with anything? It turns out that the microwave signal is transferred to the antenna by the inductive coupling with L1.

At this point our transmitter is fully functional and could be operated simply by applying power to it. However, I have found that many times it's more desirable to have the

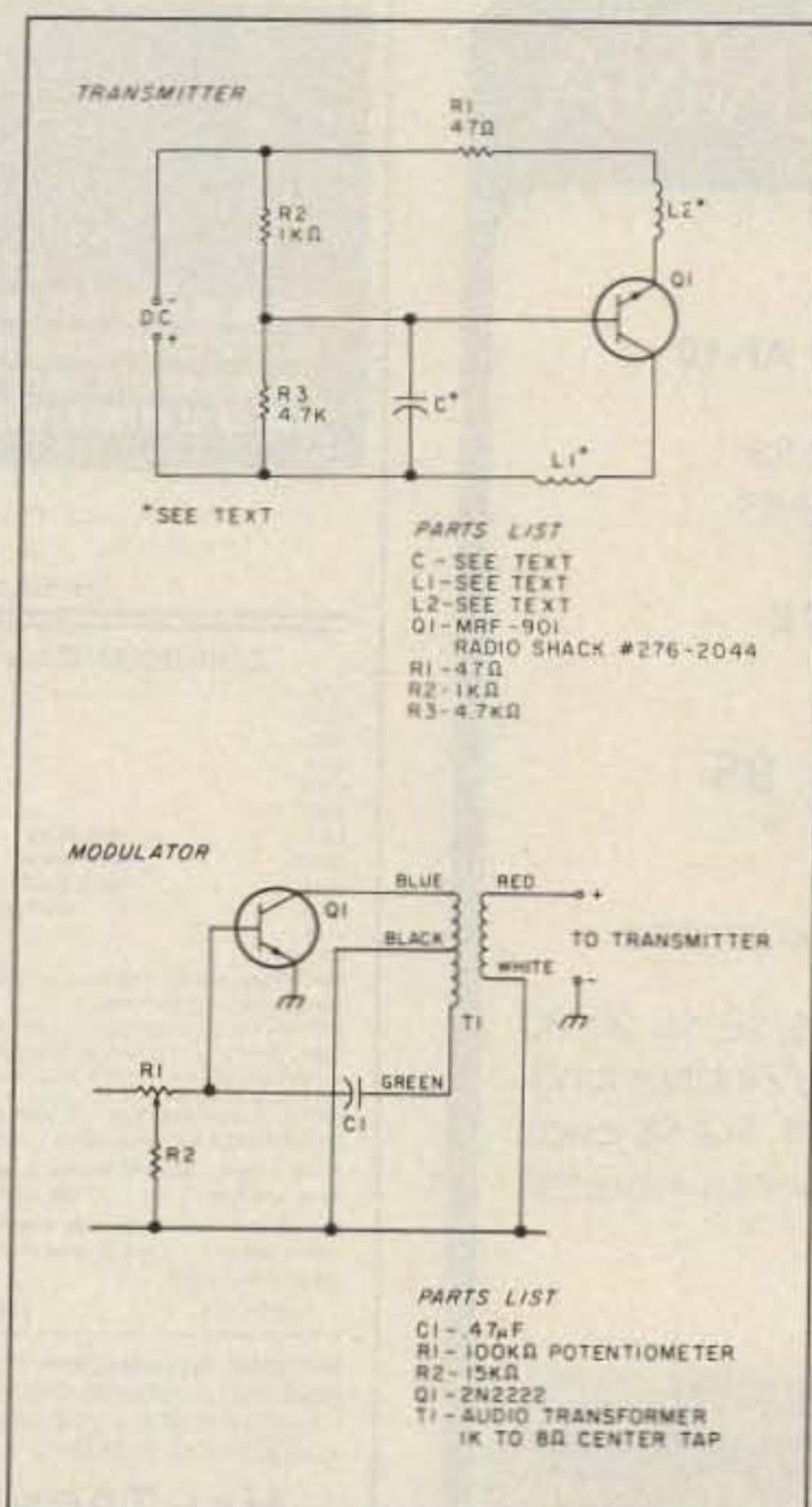

Fig. 2. Schematic diagram of the microwave transmitter and its companion modulator.

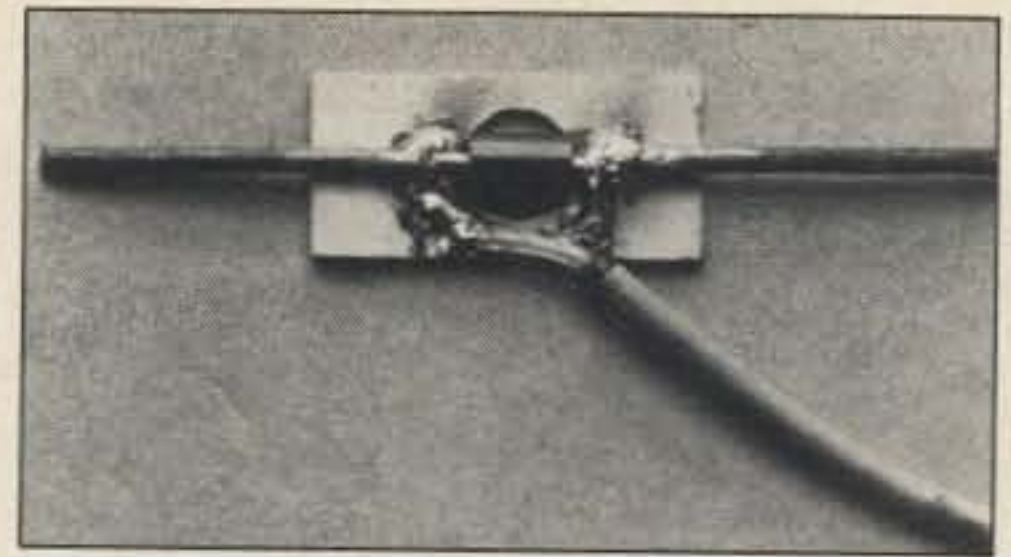

Photo C. The microwave receiver is a simple crystal detector.

transmitter modulated by the circuit shown in Fig. 2. This circuit is basically an oscillator that uses one side of an audio transformer as an inductor to provide the necessary feedback for oscillation to occur. To control the frequency of the oscillator you need only vary the resistance of potentiometer R2.

### The Receiver

Once the modulator is constructed, the transmitter section of the project is finished. Now you are left with only the construction of the receiver. The receiver isn't far from the type built by most electronics enthusiasts at one time or another. It's the basic crystal radio receiver! The major difference is the length of the antenna and the type of diode used to detect the signal.

Start by finding the wavelength of the transmitter by using the following formula:  $\lambda = v/f$ , where  $f$  is the frequency in MHz,  $v$  is

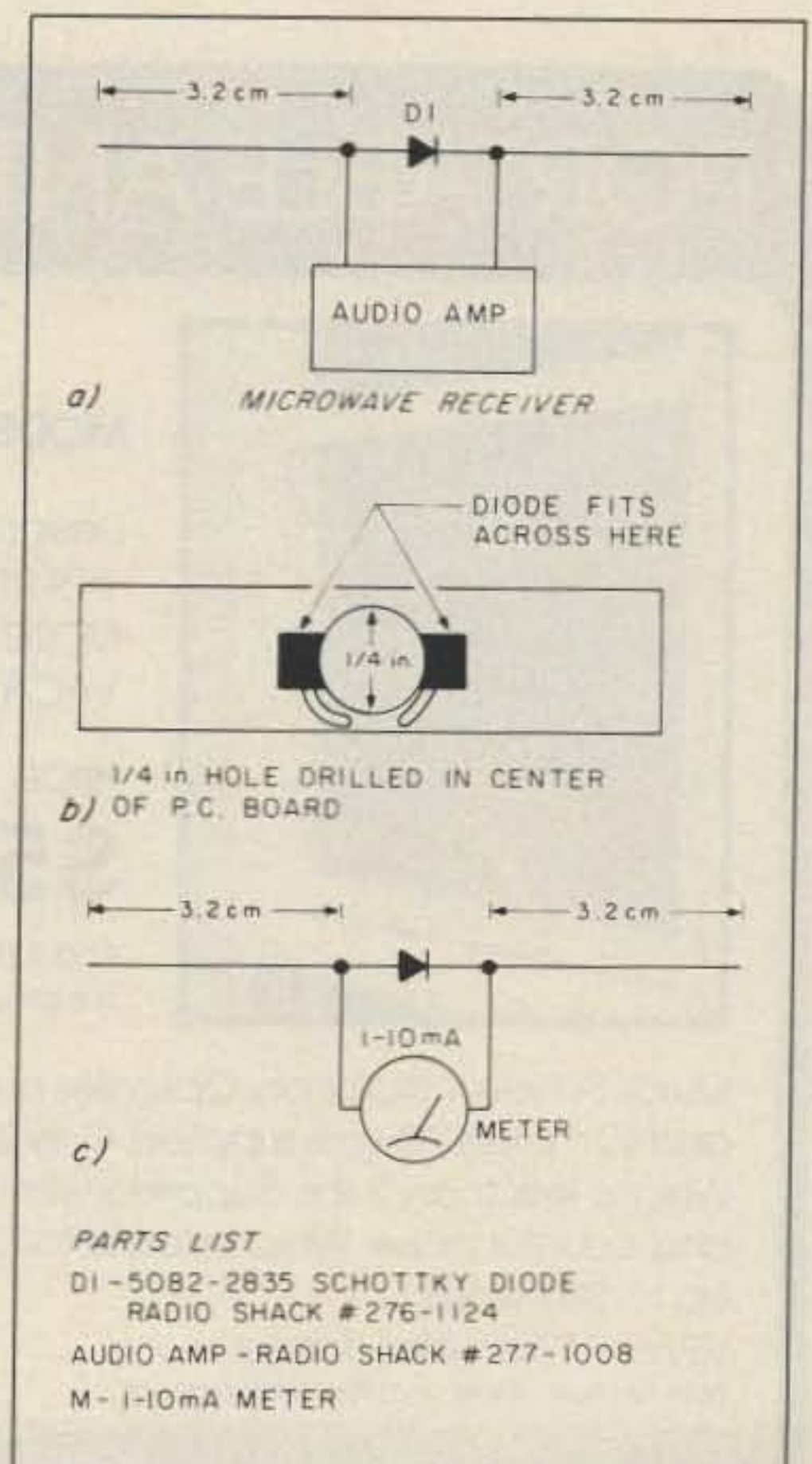

Fig. 3. (a) Schematic diagram of the microwave receiver. (b) Optional receiver PC board. (c) Using the receiver as a field-strength meter.



the speed of light in km/sec (300), and  $\lambda$  is the wavelength in meters. Using these values we find  $\lambda = 300/2400 = 0.125$ , or about 13 cm. For a dipole antenna, each leg should be  $\frac{1}{4}$  of a wavelength long. So divide your answer by 4, giving you a value of 3.25 cm for each leg of the dipole. In truth, the antenna should be slightly shorter than this value due to end effects. However, since the transmitter can vary several MHz above and below the stated frequency of 2.4 GHz, this makes a good first guess.

To detect the signal generated by your microwave source, you must choose a diode capable of operating in the microwave spectrum. The diode that I use is the 5082 Schottky diode, available at most Radio Shack stores at relatively low cost. Other diodes designed for microwave use should work equally well, but as of this writing the only other diode I have tested is the 1N82A. This diode worked well, but it may be more difficult to obtain than the 5082. As can be seen from Fig. 3a and Photo C, construction of the receiver is trivial. Two stiff pieces of wire measuring 3.25 cm in length are attached to the ends of the diode to form the dipole antenna. A short piece of shielded cable is then connected across the diode, leading to an audio amplifier. In Fig. 3b, a PC board is shown for the receiver, if you wish to use it.

In Fig. 3c, the receiver is shown connected to a 1-mA meter for the purpose of peak-

ing the transmitter output. This is done by first applying power to the transmitter and then placing the receiver at such a distance that the meter reads about half scale. The capacitor on the transmitter is then adjusted until the meter shows that maximum power is being transmitted. To truly maximize the power of the transmitter, it may be necessary to trim or lengthen the antenna, but in general the lengths given will work just fine.

### Applications/Experiments

The first experiment is to measure the wavelength of the transmitter by a method called interferometry. Here we place the transmitter and receiver side by side, separated by a flat piece of metal to reduce interference with each other. A second piece of metal, somewhat larger, is placed a couple of meters away in front of the transmitter-receiver pair. This is done to cause the formation of a standing wave between the second reflector and the transmitter-receiver pair. To measure the wavelength of the transmitter a small third plate is inserted between plate number 2 and the transmitter-receiver pair. This third plate is then moved back and forth in between plate 2 and the transmitter-receiver. As this is done, a series of high and low tones will rush forth from the receiver. These tones, caused by constructive and destructive interference, will correspond to the nodes and antinodes of the standing

wave. By simply measuring the distance that the plate is moved from one low tone to another, we can get a good estimate of the wavelength.

One possible use of the microwave transmitter-receiver came to me when I was performing the preceding experiment. As I was setting up the experiment, I noticed that as I walked around the room the same high/low tones were generated. It seems that standing waves are generated in the room as they bounce off the wall. As I walked around the room, some of the microwaves were bouncing off of me and causing the constructive/destructive interference needed to produce the high/low tones. But these tones were generated only when I walked about the room! So one possible use for the transmitter-receiver is for a very crude motion detector.

Another possible use is to construct a small radar system to measure the speed that objects are moving away from or toward you! Then, of course, there is always microwave communication to keep you busy. At this point, it's up to you to experiment and find uses for it.

One final word: The transmitter described here is one of low power output. However, its output is above the leakage level considered safe on microwave ovens. *Do not treat this as a toy!* It has great potential as a tool for learning about microwave radiation, but it should be respected at all times. ■

## PORTABLE ANTENNA

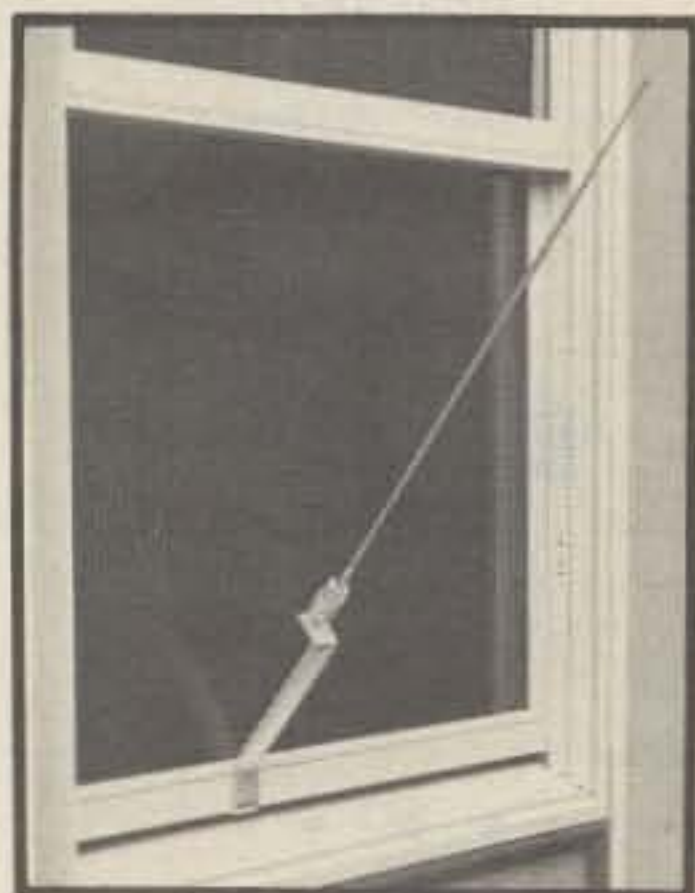

### MODEL AP-10

Designed for  
APARTMENTS  
MOTELS  
VACATIONS

PRICE  
**\$51.95**

Add \$3.00  
Shipping and Handling

Quick Simple Installation. Operates on 2, 6, 10, 15, 20, 30 and 40 meters. All coils supplied. Only 22-1/2 inches long. Weighs less than 2 lbs. Supplied with 10 ft. RG 58 coax and counter poise. Whip extends to 57 inches. Handles up to 300 watts.

VSWR—1.1:1 when tuned

Write for more details and other B&W products

ALL OUR PRODUCTS MADE IN USA



**BARKER & WILLIAMSON**

Quality Communication Products Since 1932

At your Distributors write or call

10 Canal Street, Bristol PA 19007

(215) 788-5581

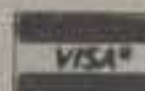

**WOW!** AT LAST!! A VERY AFFORDABLE COMPUTER  
AT A VERY AFFORDABLE PRICE

POWERFUL FULLY PROGRAMMABLE WITH 2K OF MEMORY—PORTABLE—6.78" x 1.38" INCH MODULE SINGLE KEY ENTRY COMMANDS—DURABLE 40 KEY MEMBRANE TYPE KEYBOARD—Z80A BASED FOUR CHIP DESIGN—EDUCATIONAL—UNIQUE SYNTAX CHECK REPORT CODES FOR ERROR IDENTITY—GRAPH DRAWING AND ANIMATED DISPLAY—ACCURATE TO 9-1/2 DECIMAL PLACES FOR FULL RANGE MATH AND SCIENTIFIC FUNCTIONS—AT AN AFFORDABLE PRICE

WE CANNOT TELL YOU THE MAKE OF THE COMPUTER BUT IT WAS MADE BY A FAMOUS WATCH COMPANY THEY USED TO SELL FOR \$99.95

WE BOUGHT OUT WHAT THE FACTORY HAD LEFT IN STOCK AND HAD TO REMOVE THE LABELS. THESE UNITS ARE UNPACKAGED. LESS THE 9V WALL ADAPTER AND MANUAL. BECAUSE THIS IS A DISCONTINUED ITEM THERE IS NO WARRANTY

GET THEM WHILE THEY LAST LIMITED SUPPLY

BUY 1st UNIT FOR \$19.95	BUY 2nd FOR \$16.95	9V DC WALL ADAPTOR	\$4.95
BUY THE 3rd UNIT FOR \$14.95	BUY 4th FOR \$10.95	MANUAL	\$2.95

See September 1984 issue of 73 for TIMEX/RTTY article

---

**CHIP BONANZA (AT THESE PRICES THEY ARE A STEAL)**

2708	\$1.00 EA OR 10 FOR \$9.00
2716	\$2.25 EA OR 10 FOR \$20.00
2732	\$3.25 EA OR 10 FOR \$30.00
2764	\$4.00 EA OR 10 FOR \$35.00
27136	\$7.00 EA OR 10 FOR \$60.00
6602	\$4.95 EA OR 10 FOR \$45.00
6610	(REG \$3.95) \$1.95 EA OR 10 FOR \$18.00
66A09	(REG \$18.95) \$5.95 EA OR 10 FOR \$50.00
66A21	(REG \$9.95) \$2.95 EA OR 10 FOR \$25.00
4116	(or equivalent) 8 FOR \$ 5.95
4134	9 FOR \$12.95
XR-2211	(SPECIAL) \$ 2.95
TMS 9900NL MICRO-P 64 PIN 8 BIT DIB x 16 BIT CPU	\$ 4.95
TMS 9901NL MICRO-P PSI	\$ 2.95
TIM 9904ANL MICRO-P CLOCK GEN. AND DRIVER	\$ 5.95
TMS 9918ANL MICRO-P COLOR GRAPHICS AND DISPLAY	\$ 9.95
KEYBOARD (99/4) 48 KEYS MEASURE 4 x 10 (HYTEK)	\$ 9.95

APPLE II and APPLE II+ COMPUTER MAINFRAMES (fully populated) \$150

Power supply, case and keyboard, separately available Call or Write

Unit as described above, fully assembled & tested \$225.00 plus shipping

APPLE POWER SUPPLIES \$29.95

**Cassette Software:**

I have cassette software—send for list (reg. \$9.95—\$14.95)

Hal's Special Price: 1 for \$3.95; 3 for \$10.95; 6 for \$19.50; 10 for \$29.50; 20 for \$50.00

or let Hal select 25 different cassettes (my choice) at 25 for \$50.00!!

---

**SHIPPING INFORMATION:** PLEASE INCLUDE 10% OF ORDER FOR SHIPPING AND HANDLING CHARGES (MINIMUM \$2.50, MAXIMUM \$10). CANADIAN ORDERS, ADD \$7.50 IN US FUNDS. MICHIGAN RESIDENTS ADD 4% SALES TAX. FOR FREE FLYER, SEND 22c STAMP OR SASE.

**HAL-TRONIX, INC.**

P.O. BOX 1101 DEPT. N  
12671 DIX-TOLEDO HWY  
SOUTHGATE, MICH. 48195 PHONE (313) 281-7773

**SPECIALS**

IBM Compatible Computers  
Flip-Top Case, Keyboard, Power Supply, and Motherboard. Up and Running  
\$399.00 complete  
(plus \$5.00 for shipping)  
CALL FOR DETAILS

LNA  
90° Kelvin, self-contained electronic polarizer, and feedhorn \$59.95 each  
or 2 for \$100.00 (plus \$5.00 for shipping)

"HAL"  
HAROLD C. NOWLAND  
W8ZXH

54 73 Amateur Radio • June, 1986



WE SHIP WORLDWIDE

# Barry Electronics Corp.

WORLD WIDE AMATEUR RADIO SINCE 1950

Your one source for all Radio Equipment!

For the best buys in town call:  
**212-925-7000**  
Los Precios Mas Bajos en  
Nueva York...



**MAY We Help You With the Best in Commercial and Amateur Radios?** Jan KB2RV, Toni, Kitty WA2BAP, Mark K2CON  
See You at HOSA Hamfest Queens, NY/Newington, CT June 8th See You at W2QW Hamfest Dunellen, NJ June 21st

**KITTY SAYS: WE ARE NOW OPEN 7 DAYS A WEEK. Saturday & Sunday 10 to 5 P.M.**

Monday-Friday 9 to 6:30 PM Thurs. to 8 PM  
Come to Barry's for the best buys in town.

## KENWOOD



TS440S/AT, R-1000, R-2000, TS-940 S/AT  
TM-201B, TR26/3600A, TM2570A/50A/30A  
TR-751A Kenwood Service/Repair  
TH21/31/41AT, TM-211A/  
411A & TS-711A/811A  
TM-3530A

COMPU-FIRE EXTINGUISHERS  
EXL-5000E RTTY/AMTOR TERMINAL

VoCom/Mirage/Daiwa  
Tokyo Hy-Power  
Amplifiers &  
5/8λ HT Gain  
Antennas IN STOCK



**Soldering Station,**

48 Watts, \$68

JBC soldering line in stock.  
MICROLOG-AIR I, Air Disk,  
SWL, Morse Coach

## KANTRONICS

UTU, Interface II, UTU-XT,  
Challenger, Packet Comm. II

EIMAC  
3-500Z  
572B, 6JS6C  
12BY7A &  
4-400A



AEA 144 MHz  
AEA 220 MHz  
AEA 440 MHz  
ANTENNAS

BIRD  
Wattmeters &  
Elements  
In Stock

## Antennas

A-S  
Cushcraft  
Hy-Gain  
Hustler  
KLM  
METZ  
Mini-Products  
Mosley



**Alinco Power Supplies**

## AMERITRON AMPLIFIER AUTHORIZED DEALER



Computer Interfaces  
stocked: MFJ-1224  
AEA CP-1, PK-80, DR.DX  
CP-100, PK-64, Dr. QSO,  
Morse Univ., PM-1



**ALPHA AMPLIFIERS**

**Complete Butternut Antenna Inventory In Stock!**

## DIGITAL FREQUENCY COUNTERS

Trionyx- Pro-Corn Engineering  
Model TR-1000 0-1 GHz 1200HH  
0-600 MHz 0-1.3 GHz 1296HH

Long-range Wireless  
Telephone for export in stock

**BENCHER PADDLES,  
BALUNS, AUDIO FILTERS,  
IN STOCK**

MIRAGE AMPLIFIERS  
ASTRON POWER SUPPLIES  
Saxton Wire & Cable



**ONV Safety belts-in stock**

## YAESU

FT-ONE, FT-980, FT-757GX, FRG-8800  
FT-726R, FRG-9600 FT-270/77ORH, FT-2700RH

YAESU ICOM Land-Mobile H/T  
FT-1/2/703R IC2AT Midland/Standard  
FT-2/709R/H IC02AT Wilson Maxon  
FT-1903/1123 IC-04AT Yaesu FTC-2203, FT-4703  
IC-A2/U16 Icom IC-M12 (Marine) M700  
Tempo M-1



**ICOM**

IC-R71A, 751A, 745, 28A/H, 37A, 47A, R-7000,  
1271A, 271A/H, 3200A, 471A/H, 735

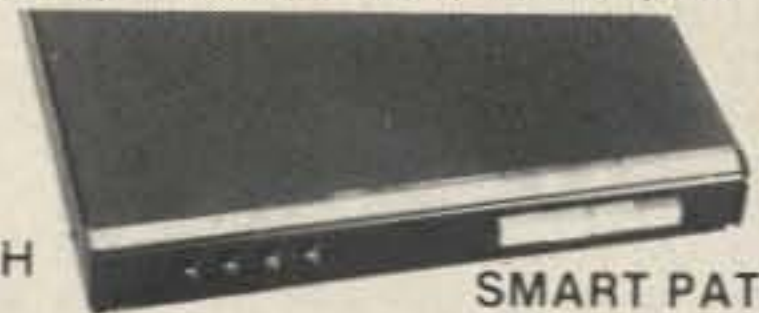

**SMART PATCH**

CES Simplex Autopatch 510-SA Will Patch FM  
Transceiver To Your Telephone. Great For  
Telephone Calls From Mobile To Base. Simple  
To Use - \$319.95

**PRIVATE PATCH III in stock**

## FLUKE 77 Multimeter



**Nye MBV-A 3 Kilowatt Tuner**



SANTEC  
ST-222/UP  
ST-20T  
ST-442/UP  
HT-7

**MFJ Models**  
422, 313, 989B, & 941D

**MURCH Model**  
2000 A,  
A-LS, B  
in stock



**SANGEAN Portable Shortwave Radios**



**HEIL EQUIPMENT IN STOCK**



**New TEN-TEC**

2591HT, Corsair II, Argosy II, Century 22, 2510

Tri-Ex Towers  
Hy-Gain Towers  
& Antennas, and  
Rotors will be  
shipped direct to  
you FREE of  
shipping cost.

MAIL ALL ORDERS TO BARRY ELECTRONICS CORP., 512 BROADWAY, NEW YORK CITY, NY 10012.

**New York City's LARGEST STOCKING HAM DEALER  
COMPLETE REPAIR LAB ON PREMISES**

## "Aqui Se Habla Espanol"

BARRY INTERNATIONAL TELEX 12-7670  
MERCHANDISE TAKEN ON CONSIGNMENT  
FOR TOP PRICES

Monday-Friday 9 A.M. to 6:30 P.M. Thursday to 8 P.M.  
Saturday & Sunday 10 A.M. to 5 P.M. (Free Parking)

AUTHORIZED DIST. MCKAY DYMEK FOR  
SHORTWAVE ANTENNAS & RECEIVERS.

IRT/LEX-"Spring St. Station"

Subways: BMT-"Prince St. Station"

IND-"F" Train-Bwy. Station"

Bus: Broadway #6 to Spring St.  
Path-9th St./6th Ave. Station.

Commercial Equipment  
Stocked: ICOM, MAXON,  
Midland, Standard, Wil-  
son, Yaesu. We serve  
municipalities, busi-  
nesses, Civil Defense,  
etc. Portables, mobiles,  
bases, repeaters...

Experienced  
HELP WANTED  
Young or Old

We Stock: AEA, ARRL, Alpha, Ameco, Antenna Specialists, Astatic, Astron, B & K, B & W, Bencher, Bird, Butternut, CDE, CES, Collins, Communications Spec. Connectors, Covercraft, Cushcraft, Daiwa, Dentron, Digimax, Drake, ETO (Alpha), Eimac, Encomm, HeilSound, Henry, Hustler (Newtronics), Hy-Gain, Icom, KLM, Kantronics, Larsen, MCM (Daiwa), MFJ, J.W. Miller, Mini-Products, Mirage, Newtronics, Nye Viking, Palomar, RF Products, Radio Amateur Callbook, Rockwell Collins, Saxton, Shure, Telex, Tempo, Ten-Tec, Tokyo Hi Power, Trionyx TUBES, W2AU, Waber, Wilson, Yaesu Ham and Commercial Radios, Vocom, Vibroplex, Curtis, Tri-Ex, Wacom Duplexers, Repeaters, Phelps Dodge, Fanon Intercoms, Scanners, Crystals, Radio Publications.

WE NOW STOCK COMMERCIAL COMMUNICATIONS SYSTEMS  
DEALER INQUIRIES INVITED. PHONE IN YOUR ORDER & BE REIMBURSED.

**COMMERCIAL RADIOS stocked & serviced on premises.**  
Amateur Radio Courses Given On Our Premises, Call  
Export Orders Shipped Immediately. **TELEX 12-7670**

ALL  
SALES  
FINAL



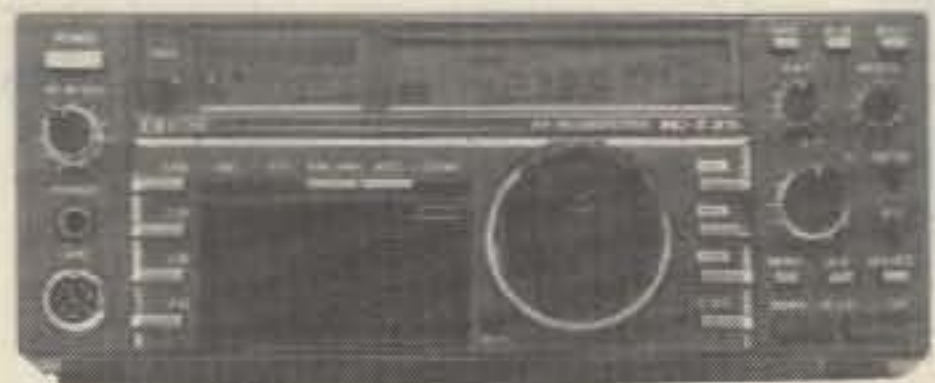

HF Equipment	Regular	SALE
IC-735 HF transceiver/SW rcvr/mic	889.00	769 <sup>95</sup>
PS-55 External power supply	169.00	149 <sup>95</sup>
AT-150 Automatic antenna tuner	399.00	359 <sup>95</sup>
FL-32 500 Hz CW filter	59.50	
EX-243 Electronic keyer unit	50.00	
UT-30 Tone encoder	TBA	
IC-745 9-band xcvr w/.1-30 MHz rcvr	999.00	799 <sup>95</sup>
PS-35 Internal power supply	169.00	149 <sup>95</sup>
EX-241 Marker unit	20.00	
EX-242 FM unit	39.00	
EX-243 Electronic keyer unit	50.00	
FL-45 500 Hz CW filter (1st IF)	59.50	
FL-54 270 Hz CW filter (1st IF)	47.50	
FL-52A 500 Hz CW filter (2nd IF)	96.50	89 <sup>95</sup>
FL-53A 250 Hz CW filter (2nd IF)	96.50	89 <sup>95</sup>
FL-44A SSB filter (2nd IF)	159.00	144 <sup>95</sup>
SM-6 Desk microphone	40.00	
HM-12 Extra hand microphone	39.50	
MB-12 Mobile mount	21.99	



IC-751 9-band xcvr/1-30 MHz rcvr	1399.00	999 <sup>00</sup>
PS-35 Internal power supply	160.00	149 <sup>95</sup>
FL-32 500 Hz CW filter (1st IF)	59.50	
FL-63 250 Hz CW filter (1st IF)	48.50	
FL-52A 500 Hz CW filter (2nd IF)	96.50	89 <sup>95</sup>
FL-53A 250 Hz CW filter (2nd IF)	96.50	89 <sup>95</sup>
FL-33 AM filter	31.50	
FL-70 2.8 kHz wide SSB filter	46.50	
HM-12 Extra hand microphone	39.50	
SM-6 Desk microphone	40.00	
RC-10 External frequency controller	35.00	
MB-18 Mobile mount	21.99	

IC-720A 9-band xcvr • (CLOSEOUT) •	1349.00	689 <sup>95</sup>
PS-15 20A external power supply	149.00	134 <sup>95</sup>
FL-32 500 Hz CW filter	59.50	
FL-34 5.2 kHz AM filter	49.50	
BC-10A Memory back-up	8.50	
SM-5 8-pin electret desk mic	40.00	
MB-5 Mobile mount	21.99	

Other Accessories:	Regular	SALE
PS-15 20A external power supply	149.00	134 <sup>95</sup>
CF-1 Cooling fan for PS-15	45.00	
EX-144 Adaptor for CF-1/PS-15	6.50	
PS-30 Systems p/s w/cord, 6-pin plug	259.95	234 <sup>95</sup>
OPC Opt. cord, specify 2, 4 or 6-pin	10.00	
SP-3 External speaker	54.50	
SP-7 Small external speaker	49.00	
CR-64 High stab. ref. xtal (745/751)	56.00	
PP-1 Speaker/patch (specify radio)	139.00	129 <sup>95</sup>
SM-8 Desk mic - two cables, Scan	69.95	
SM-10 Compressor/graph EQ, 8 pin mic	119.00	109 <sup>95</sup>
AT-100 100W 8-band auto. antenna tuner	399.00	359 <sup>95</sup>
AT-500 500W 9-band auto. antenna tuner	499.00	449 <sup>95</sup>



### Check the Prices at AES!

Other Accessories cont.	Regular	SALE
AH-2 8-band tuner w/mount & whip	549.00	489 <sup>95</sup>
AH-2A Antenna tuner system, only	429.00	389 <sup>95</sup>
GC-4 World clock • (CLOSEOUT) •	99.95	69 <sup>95</sup>
GC-5 World clock	79.95	
HF linear amplifier	Regular	SALE
IC-2KL 160-15m solid state amp w/ps	1795.00	1389

6-meter VHF Portable	Regular	SALE
IC-505 3/10W 6m SSB/CW portable	469.00	419 <sup>95</sup>
BP-10 Internal Nicad battery pack	79.50	
BP-15 AC charger	12.50	
EX-248 FM unit	49.50	
LC-10 Leather case	34.95	

VHF/UHF base multi-modes	Regular	SALE
IC-551D 80W 6-meter SSB/CW	735.00	649 <sup>95</sup>
EX-106 FM option	125.00	112 <sup>95</sup>
BC-10A Memory back-up	8.50	
IC-271A 25W 2m FM/SSB/CW	735.00	649 <sup>95</sup>
AG-20 Internal preamplifier	56.95	
IC-271H 100W 2m FM/SSB/CW	944.00	789 <sup>95</sup>
AG-25 Mast mounted preamplifier	84.95	
IC-471A 25W 430-450 SSB/CW/FM xcvr	839.00	729 <sup>95</sup>
AG-1 Mast mounted preamplifier	89.00	
IC-471H 75W 430-450 SSB/CW/FM	1149.00	989 <sup>95</sup>
AG-35 Mast mounted preamplifier	84.95	

Accessories common to 271A/H and 471A/H	Regular	SALE
PS-25 Internal power supply for (A)	99.00	89 <sup>95</sup>
PS-35 Internal power supply for (H)	169.00	149 <sup>95</sup>
PS-15 External power supply	149.00	134 <sup>95</sup>
SM-6 Desk microphone	40.00	
EX-310 Voice synthesizer	41.25	
TS-32 CommSpec encode/decoder	59.95	
UT-15 Encoder/decoder interface	12.50	
UT-15S UT-15S w/TS-32 installed	79.95	

VHF/UHF mobile multi-modes	Regular	SALE
IC-290H 25W 2m SSB/FM, TTP mic	549.00	479 <sup>95</sup>
IC-490A 10W 430-440 SSB/FM/CW	649.00	569 <sup>95</sup>

VHF/UHF/1.2 GHz FM	Regular	SALE
IC-27A Compact 25W 2m FM w/TTP mic	389.00	349 <sup>95</sup>
IC-27H Compact 45W 2m FM w/TTP mic	429.00	379 <sup>95</sup>
IC-37A Compact 25W 220 FM, TTP mic	449.00	349 <sup>95</sup>
IC-47A Compact 25W 440 FM, TTP mic	489.00	429 <sup>95</sup>
PS-45 Compact 8A power supply	112.95	99 <sup>95</sup>
UT-16/EX-388 Voice synthesizer, 47A	31.00	
SP-10 Slim-line external speaker	31.95	
IC-3200A 25W 2m/440 FM w/TTP	569.00	499 <sup>95</sup>
UT-23 Voice synthesizer	31.00	
AH-32 2m/440 Dual Band antenna	32.95	
Larsen PO-K Roof mount	20.00	
Larsen PO-TLM Trunk-lip mount	20.18	
Larsen PO-MM Magnetic mount	19.63	

IC-1271A 10W 1.2 GHz SSB/CW Base	1049.00	929 <sup>95</sup>
PS-25 Internal power supply	99.00	89 <sup>95</sup>
EX-310 Voice synthesizer	41.25	
TV-1200 ATV interface unit	115.00	106 <sup>95</sup>
UT-15S CTCSS encoder/decoder	79.95	
IC-120 1W 1.2 GHz FM Mobile	499.00	449 <sup>95</sup>
ML-12 1.2 GHz 10W amplifier	339.00	299 <sup>95</sup>

Repeaters	Regular	SALE
RP-3010 440 MHz, 10W FM, xtal cont.	1049.00	949 <sup>95</sup>
RP-1210 1.2 GHz, 10W FM, 99 ch. synth	1259.00	1129
Cabinet for RP-1210 or 3010	269.00	

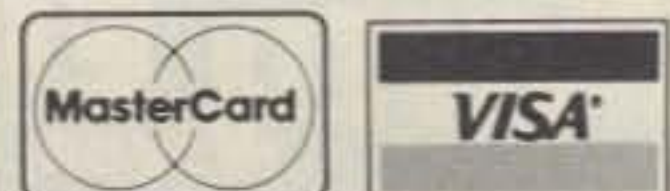

Hand-held Transceivers	Regular	SALE
Deluxe models	Regular	SALE
IC-02AT for 2m	369.00	299 <sup>95</sup>
IC-04AT for 440 MHz	399.00	339 <sup>95</sup>
Standard models	Regular	SALE
IC-2A for 2m	239.00	189 <sup>95</sup>
IC-2AT with TTP	269.50	209 <sup>95</sup>
IC-3AT 220 MHz, TTP	299.95	249 <sup>95</sup>
IC-4AT 440 MHz, TTP	299.95	249 <sup>95</sup>

Accessories for Deluxe models	Regular	SALE
BP-7 425mah/13.2V Nicad Pak - use BC-35	67.50	
BP-8 800mah/8.4V Nicad Pak - use BC-35	62.50	
BC-35 Drop in desk charger for all batteries	74.95	
BC-60 6-position gang charger, all batts	SALE 349.95	
BC-16U Wall charger for BP7/BP8	19.95	
LC-11 Vinyl case	18.49	
LC-14 Vinyl case for Dlx using BP-7/8	18.49	
LC-02AT Leather case for Dlx models w/BP-7/8	39.95	

Accessories for both models	Regular	SALE
BP-2 425mah/7.2V Nicad Pak - use BC35	42.50	
BP-3 Extra Std. 250 mah/8.4V Nicad Pak	31.25	
BP-4 Alkaline battery case	13.75	
BP-5 425mah/10.8V Nicad Pak - use BC35	49.50	
CA-5 5/8-wave telescoping 2m antenna	18.95	
FA-2 Extra 2m flexible antenna	10.00	
CP-1 Cig. lighter plug/cord for BP3 or Dlx	10.75	
CP-10 Battery separation cable w/clip	19.99	
DC-1 DC operation pak for standard models	18.75	
EX-390 Bottom slide cap	4.95	
MB-16D Mobile mtg. bkt for all HTs	21.99	
LC-2AT Leather case for standard models	39.95	
RB-1 Vinyl waterproof radio bag	30.00	
HH-SS Handheld shoulder strap	14.95	
HM-9 Speaker microphone	39.00	
HS10 Boom microphone/headset	19.50	
HS-10SA Vox unit for HS-10 & Deluxe only	19.50	
HS-10SB PTT unit for HS-10	19.50	
ML-1 2m 2.3w in/10w out amplifier	SALE 89.95	
SS-32M Commspec 32-tone encoder	29.95	

Receivers	Regular	SALE
R-71A 100 kHz-30 MHz, 117V AC	\$849.00	689 <sup>95</sup>
RC-11 Infrared remote controller	59.95	49 <sup>95</sup>
FL-32 500 Hz CW filter	59.50	
FL-63 250 Hz CW filter (1st IF)	48.50	
FL-44A SSB filter (2nd IF)	159.00	144 <sup>95</sup>
EX-257 FM unit	38.00	
EX-310 Voice synthesizer	41.25	
CR-64 High stability oscillator xtal	56.00	
SP-3 External speaker	54.50	
CK-70 (EX-299) 12V DC option	10.95	
MB-12 Mobile mount	21.99	
R-7000 25 MHz-2 GHz scanning rcvr	969.00	849 <sup>95</sup>
RC-12 Infrared remote controller	TBA	
Voice synthesizer	TBA	
AH-7000 Radiating antenna	89.95	(6)

**HOURS • Mon. thru Fri. 9-5:30; Sat. 9-3**  
 Milwaukee WATS line: 1-800-558-0411 answered evenings until 8:00 pm Monday thru Thursday.  
**Please use WATS lines for Ordering**  
 use Regular lines for other Info and Service dept.

All Prices in this list are subject to change without notice.

**Order Toll Free: 1-800-558-0411** In Wisconsin (outside Milwaukee Metro Area) 1-800-242-5195

# AMATEUR ELECTRONIC SUPPLY<sup>®</sup> Inc.

4828 W. Fond du Lac Avenue; Milwaukee, WI 53216 • Phone (414) 442-4200

## AES<sup>®</sup> BRANCH STORES Associate Store

**WICKLIFFE, Ohio** 44092  
 28940 Euclid Avenue  
 Phone (216) 585-7388  
 Ohio WATS 1-800-362-0290  
 Outside Ohio 1-800-321-3594

**ORLANDO, Fla.** 32803  
 621 Commonwealth Ave.  
 Phone (305) 894-3238  
 Fla. WATS 1-800-432-9424  
 Outside Florida 1-800-327-1917

**CLEARWATER, Fla.** 33575  
 1898 Drew Street  
 Phone (813) 461-4267  
 No In-State WATS  
 No Nationwide WATS

**LAS VEGAS, Nev.** 89106  
 1072 N. Rancho Drive  
 Phone (702) 647-3114  
 No In-State WATS  
 Outside Nevada 1-800-634-6227

**CHICAGO, Illinois** 60630  
 ERICKSON COMMUNICATIONS  
 5456 N. Milwaukee Avenue  
 Phone (312) 631-5181  
 Outside Illinois 1-800-621-5802



# SAVE on these AES/KENWOOD Specials!

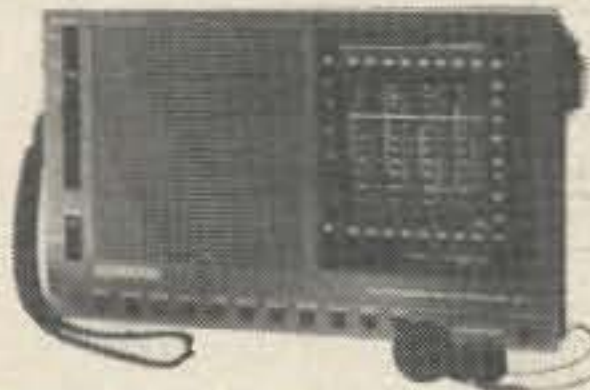

**\$50 Off!**

Headphones \$19<sup>95</sup>

**KENWOOD R-11 Receiver:** 11 bands - AM, FM broadcast + 13, 16, 19, 22, 25, 31, 41, & 49m SW. No BFO! Bandspread tuning, meter, 3" speaker, record & phone jacks, whip & ferrite antennas, 7 1/2" w x 4 1/2" h x 1 1/2" d. Carrying case & earphone, uses 4 'AA' cells. Shown w/optional headphones..... **Closeout \$69<sup>95</sup>**



**FREE FM Unit!**

with **KENWOOD TS-430S**

For a Limited time - purchase a TS-430S at our normal Low Sale Price & get the optional **FM-430\*** FM Unit at **NO EXTRA CHARGE.**

\*The FM-430 option provides FM transmit and receive capability on HF bands where authorized.

**Call for our Low Sale Price!**

Due to changing prices and limited quantities, all listings on this page are subject to change without notice. Please check with salesperson when ordering.



**FREE Extra Battery!**

For a Limited time!

Purchase a TR-2600A (shown) at our normal Low Sale Price and receive an extra PB-26 battery • **FREE!**

OR

Purchase a TH-21A/AT, TH-31A/AT or TH-41A/AT at our Low Sale Price and receive an extra PB-21 180 ma. battery • **FREE!**

Call for Sale Prices



**KENWOOD TM-201A • CLOSEOUT**

Ultra compact! Covers 142-149.005 MHz in 5 kHz steps, 25W out. GaAs FET RF amplifier, dual digital VFO'S, 5 memories plus "com" channel w/back-up. Priority alert scan, memory and programmable band scan. Yellow LED display, LED S/RF meter, Ext. spkr, 16-key TTP UP/DN microphone, mobile mount. 5 1/2" w x 1 1/2" h x 7 1/2" d, 2.8 lbs. List \$329<sup>95</sup>..... **Closeout \$259<sup>95</sup>**



Only a few left!

**KENWOOD DFC-230 Digital Frequency Controller** for TS-120S, 130S/SE, 530S, 830S. 20 Hz steps, 4 memories, scan, UP/DN mic..... **Closeout \$169<sup>95</sup>**

**Order Toll Free: 1-800-558-0411**

In Wisconsin (outside Milwaukee Metro Area) 1-800-242-5195

**AMATEUR ELECTRONIC SUPPLY<sup>®</sup> Inc.**

4828 W. Fond du Lac Avenue; Milwaukee, WI 53216 - Phone (414) 442-4200

**AES BRANCH STORES**

**Associate Store**

**WICKLIFFE, Ohio 44092**  
28940 Euclid Avenue  
Phone (216) 585-7388  
Ohio WATS 1-800-362-0290  
Outside Ohio 1-800-321-3594

**ORLANDO, Fla. 32803**  
621 Commonwealth Ave.  
Phone (305) 894-3238  
Fla. WATS 1-800-432-9424  
Outside Florida 1-800-327-1917

**CLEARWATER, Fla. 33575**  
1898 Drew Street  
Phone (813) 461-4267  
No In-State WATS  
No Nationwide WATS

**LAS VEGAS, Nev. 89106**  
1072 N. Rancho Drive  
Phone (702) 647-3114  
No In-State WATS  
Outside Nevada 1-800-634-6227

**CHICAGO, Illinois 60630**  
ERICKSON COMMUNICATIONS  
5456 N. Milwaukee Avenue  
Phone (312) 631-5181  
15 min. from O'Hare!

Please use WATS line for Ordering and Price Checks. For other Info and Service Dept., please use our Regular lines.

**Contact AES<sup>®</sup>**  
**for all of your**  
**KENWOOD needs!**

- ★ Low Prices ★ Large Stocks ★ Fast Service
- ★ Top Trades ★ Toll Free Ordering line
- ★ **AES<sup>®</sup>** Ships Coast to Coast

**HOURS: Mon. thru Fri. 9-5:30; Sat 9-3**



**USE YOUR CREDIT CARD**



Note: Our TOLL FREE Ordering line 1-800-558-0411 is answered until 8 pm CST Monday thru Thursday.

Clip out this handy Coupon and Mail Today!

**TO: AMATEUR ELECTRONIC SUPPLY<sup>®</sup>**  
4828 W. Fond du Lac Avenue  
Milwaukee, WI 53216

I am interested in the following new KENWOOD Equipment:

\_\_\_\_\_

\_\_\_\_\_

I have the following to TRADE (What's your DEAL?)

\_\_\_\_\_

\_\_\_\_\_

Rush me your quote - I understand that I am under no obligation.

Name \_\_\_\_\_

Address \_\_\_\_\_

City/State \_\_\_\_\_ Zip \_\_\_\_\_



# They Threw What Away?

*Your tax dollars at work: This time it's a UHF swr bridge.*

I want to stress right at the beginning that this is intended to be a fairly serious article, not a sarcastic put-on of the "101 Uses for a Dead... (Transmitter, Computer, Battery, etc.)" variety. My intent is to alert the ham community to a particularly useful piece of military surplus gear and to suggest some innovative applications. Granted, not all of these are strictly limited to amateur radio, but then, most active amateurs have other hobbies as well.

First to the device itself. It's called a "Transmitter Performance Monitor R.F. Failure Alarm," and the model number is LDWS 00685 AD000. It consists of an aluminum rack-mount panel 1-3/4" high mounted to a 9-1/2" x 5-1/2" x 1-1/2" chassis with a cover plate. Inside, there are two small circuit boards; a dc alarm buzzer; three precision crystal-can relays; an assortment of pots, switches, and lamps; and the "Main Goodie" (see Photo A).

The Main Goodie is the reason I became interested in this item and purchased several at a surplus house near a big Air Force base in northern Michigan. It is a very high-quality UHF swr bridge with N series connectors mounted on the back wall of the chassis. The bridge is about 1" square and 4-1/2" long and is conservatively rated at 60 Watts @ 225-400 MHz, though I've used one on 2 meters with no problem (see Fig. 1).

The manufacturer's label identifies the Main Goodie as a Directional Power Indicator, model 3023 made by Coaxial Dynamics, Inc., of Cleveland, Ohio. From talking to one of the alarm manufacturer's employees at a hamfest and from the four-digit serial numbers on the ones I purchased, it's my guess that there are at least several thousand of these floating around out there in the surplus community, so keep your eyes peeled. The dealer from whom I got mine was selling

them for the scrap price of the aluminum, about \$1.40 a pound!

The original purpose of the device was to measure the carrier output of an Air Force UHF transmitter and to sound the alarm if the output to the antenna array fell below or rose

---

***"The dealer from whom I got mine was selling them for the scrap price of aluminum, about \$1.40 a pound!"***

---

above certain limits, preset by the pots on the front panel. Only the forward current side of the bridge was utilized; the reverse, or reflected, side was not connected. Hooking the bridge up to a 2-Watt Wilson 1402 HT on 2 meters generated about 1.5 mils on the 50-milliamp scale of my VOM for about 1-3/4 Watts of forward power at 146.52 MHz; reverse current as measured on the other terminal was negligible.

Besides giving a good relative F/R power indication for tuning and matching antennas and the like, another application immediately suggests itself to the ingenious amateur on a budget. Borrow somebody else's high quality precision UHF power meter, such as a Bird. Put it in series with the model 3023, a good resistive dummy load, and your UHF or VHF transmitter. Using either a surplus meter movement or the appropriate scale on your VOM, calibrate the model 3023 for a useful range of forward and reverse power levels. Then when you return the borrowed meter, as you eventually must, you will still have a highly accurate

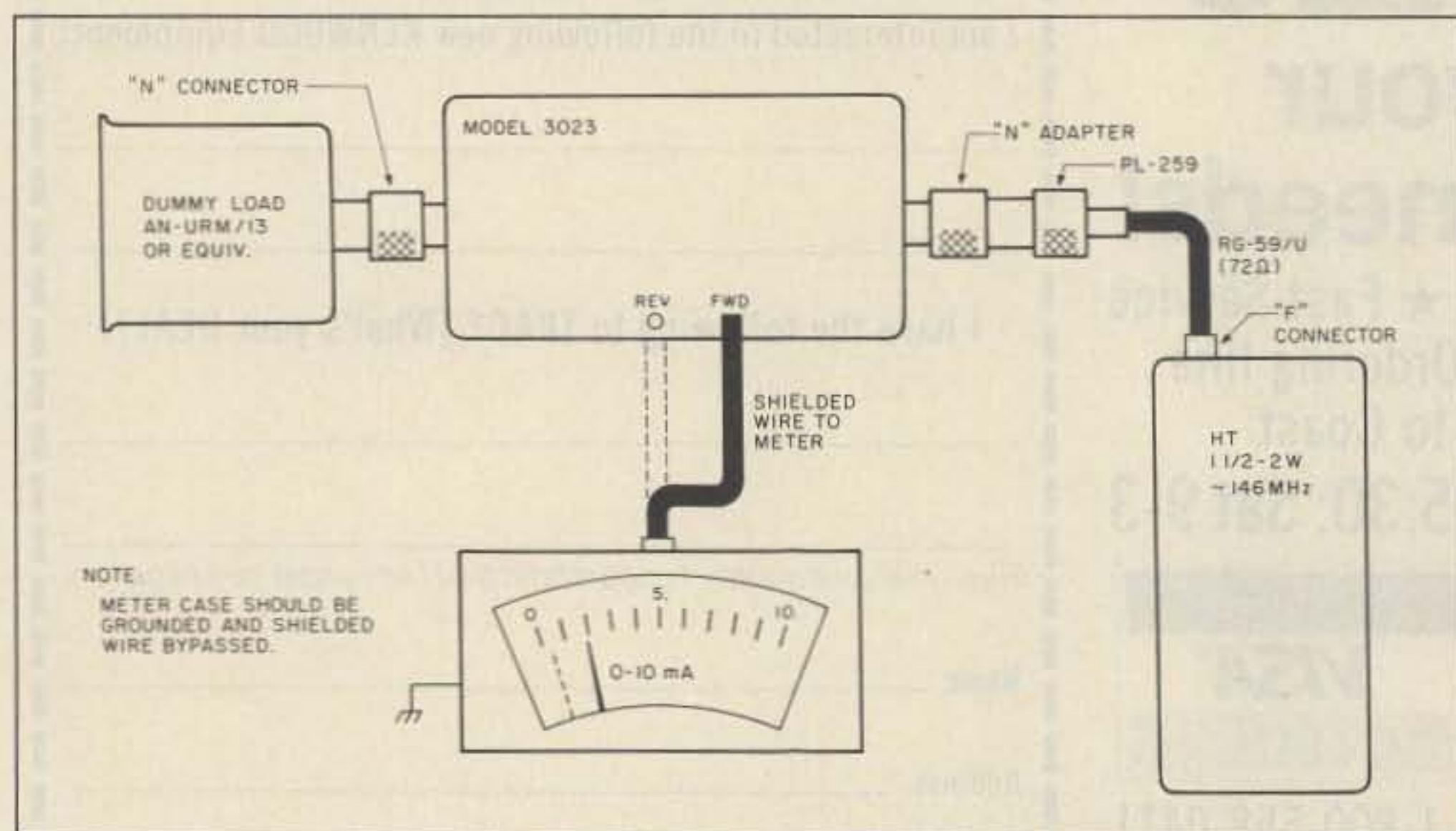

Fig. 1. Low-power 2-meter test setup.



power meter, adequate for most amateur purposes.

I have sold or traded several of these to other hams at hamfest flea markets. Most planned to use them as swr bridges or repeater monitors on 220 MHz. Besides the Main Goodie and its associated expensive silver-plated N connectors, several other parts in the assembly are worth scrounging. There are two very nice illuminated cartridge fuse holders, though you need to change the dropping resistor for the panel lamps if you use the fuse at some voltage other than 28 V dc. As is, the indicators are very dim when used at 12 V dc and *very* bright (but short-lived) at 110 V ac! There is also a matched pair of 2N3819s, common values of 5% resistors, etc.

Once you have salvaged the UHF bridge itself, there is one other small obstacle to be overcome before you put it directly into service. The current from the matched pair of diodes in the bridge is brought out to the alarm itself on a pair of miniature shielded coax connectors. Mating connectors for attaching your metering circuit are usually gold-plated and very expensive if purchased new. However, the same family of connectors is used in a lot of old avionics and other military surplus from the 1960s. I scrounged a few sets from some old Iranian terrain-following radar gear that a surplus dealer was going to melt down for the scrap gold. If you don't just happen to have an F-4 Phantom or similar jet fighter plane in your junk box, try the flea market at one of the big hamfests like Dayton or Orlando.

As a last resort, you can get out a small propane torch or a hefty (200-Watt+) soldering iron and carefully open up the cover of the silver-plated brass cavity of the bridge itself. It's perfectly possible to do this without destroying the diodes if you are careful. Once the plumbing is open, you can replace the connectors with insulated feedthroughs, RCA phono jacks, or some other more practical connectors. While you're at it, you might want to replace the N connectors with SO-239s or BNC fittings, though the N fittings are better. Adapters to UHF or BNC hardware are readily available in most surplus catalogs.

All right. Suppose you've got your hands on one of these and have pried out the UHF bridge for that new 220 FM repeater the local club is going to get on the air one of these days. You've carefully stripped the little circuit boards, and the miniature relays are going into the repeater controller. The 9-1/2" x 5-1/2" chassis will make a nice shielded enclosure for a home-brew direct-conversion or regenerative receiver for some Novice, maybe using the 2N3819s for the front end, if they're still good. That leaves the front panel, a 1-3/4" x 19" strip of 1/8" aluminum with some holes punched in it.

Before throwing the strip of aluminum away, or using it to beat the dog, reflect on the possible constructive applications. With the original chassis and shielded cover attached, the panel is almost a perfect fit for the standard 6-1/2" x 4-1/2" size circuit



Photo A. The Main Goodie.

board with enough room left over in one end of the box for a hefty power supply. This size card is used by a number of different computer, video, and robotics companies and also fits several standard sizes of prototyping and perforated boards. It's hard to imagine a better way to mount a repeater controller, autopatch system, satellite antenna controller, etc. If you find that the 9-1/2" x 5-1/2" box is too small, almost any chassis up to about 17" wide can be installed on the panel utilizing the mounting holes already punched.

Even if you already have an excess of rack panel enclosures of all sizes, most amateurs can think of something to do with the panel itself with a little effort and ingenuity. A heavy strip of aluminum almost exactly a quarter wave long on 2 meters lends itself to all sorts of things, from a tuned line filter to a heavy-duty antenna element. Many times, I have been frustrated when I found that I needed a ruler or straightedge that was just a little longer than the standard 1-foot kind, but not so long and clumsy as the yardsticks that lumber yards give away. Scratching or etch-

ing metric or English measurements into a strip of aluminum like this takes only a few minutes and yields a very durable and versatile draftsman's aid.

If you have two strips like this, you can bolt them together by putting a counter-sunk flat-head machine screw through the central hole, the one originally intended for the alarm buzzer. This makes a great adjustable angle gauge for putting framing rafters on the new roof for a hamshack, tool shed, garage, etc. or for setting the angles when building antenna mounts, spiders for quad antennas, etc.

It has been my experience that 1-3/4" strip aluminum like this is very versatile, as it is soft and narrow enough for you to bend with pliers and a vise to make all sorts of brackets, mounting hardware, gamma match capacitors, and so forth. Heating the strip slightly with a propane torch to soften it before bending makes forming complex curved shapes like CRT mounting brackets and cable clamps even easier, though you should be very careful when doing this and take sensible safety precautions. ■



16th ANNUAL  
**INDIANAPOLIS HAMFEST™**  
And INDIANA STATE ARRL CONVENTION



July 12-13, 1986

Marion County Fairgrounds — Gates open 6:00 AM both days

**2 Full Days of:**

Commercial Exhibitors  
Large Flea Market  
Hourly Awards  
Forums

**FREE:**

Parking  
Kids Awards  
Camping  
Womens Awards

**Indiana's Largest Electronic Flea Market  
and Amateur Radio Display**

INDIANAPOLIS HAMFEST, P. O. Box 11776, Indianapolis, IN 46201  
OR CALL: (317) 745-6389



# Those Tantalizing Twos

*ICOM's 2-meter HTs have a secret! For about a buck your IC-2AT will cover 145–155 MHz. Have an IC-02AT? It's really a 140–163-MHz scanner. And the audio can be boosted. . .*

**H**ow would you like to have a VHF high-band receiver and a 2-meter handie-talkie all in one? If your answer is yes, do I have good news for you. ICOM makes it easy.

Several years ago I purchased an ICOM 2AT hand-held. Being a curious type, I had the schematic out and the back cover off almost before I got it out of the box (not recommended if you like the convenience of warranty service should anything go wrong). Upon closer examination, I discovered that the 2AT could be made to cover a portion of the 150-MHz spectrum. It's simple, and it's cheap—now *that* should appeal to a few people!

## The Procedure

First, remove the battery pack. Then remove the four screws that hold the battery-retaining bracket and set it aside. Remove the two screws that retain the rear cover, and carefully separate the front and rear assemblies from the chassis. Carefully unplug the flex board going to the DTMF unit on the front cover. A small pick or screwdriver will make this easier to reach. Be careful not to break the small wires going to the speaker and the mike! Now remove the two Phillips-head screws on the side of the chassis nearest the

PTT switch. The chassis will now open up like a book.

Refer to the schematic and the parts placement diagram in your manual; I have included sections of these in Fig. 1 in case you've

---

***"One of the combinations I hit upon allows the 02AT to initialize at 00.00 MHz and range to about 327 MHz."***

---

lost yours. Notice that there are some unused pads on the circuit board going to pin 15 of the TC9122 PLL divider chip. This is the D1 pin, in ICOM nomenclature. If it is tied high (+5 V), the PLL will tune from 150 to 159.99 MHz. Another pad is ground. What you need to do is put a small bypass capacitor from pin 15 to ground, and a switch from pin

15 to the R5V line (receive +5 V since the object is to receive and not transmit). FCC rules prohibit the use of non-type-accepted gear for transmitting on these new frequencies.

## Switching

Here's where your creativity comes into play. You may want to mount a switch differently than I did, so feel free to do so. Here's one way: Since I do not use a speaker-mike option with my radio, I borrowed the mike jack position to mount a switch (Photo A). First, disconnect and tape the wires going to the jack. Then remove it from the radio. In its place you can mount a small toggle switch. (You will see what I mean by small when you open the radio and see the cramped quarters!) I found mine at Radio Shack. Connect a small wire (wire-wrap wire will do) from one switch terminal to pin 15 of the PLL chip. Connect the other terminal to the R5V line. See Fig. 1 for details. Use a small, low-wattage iron.

There is one more wiring change if you have one of the earlier 2ATs. To enable all switch positions on the thumbwheel switch,



Photo A. Install the range switch in the microphone jack position.

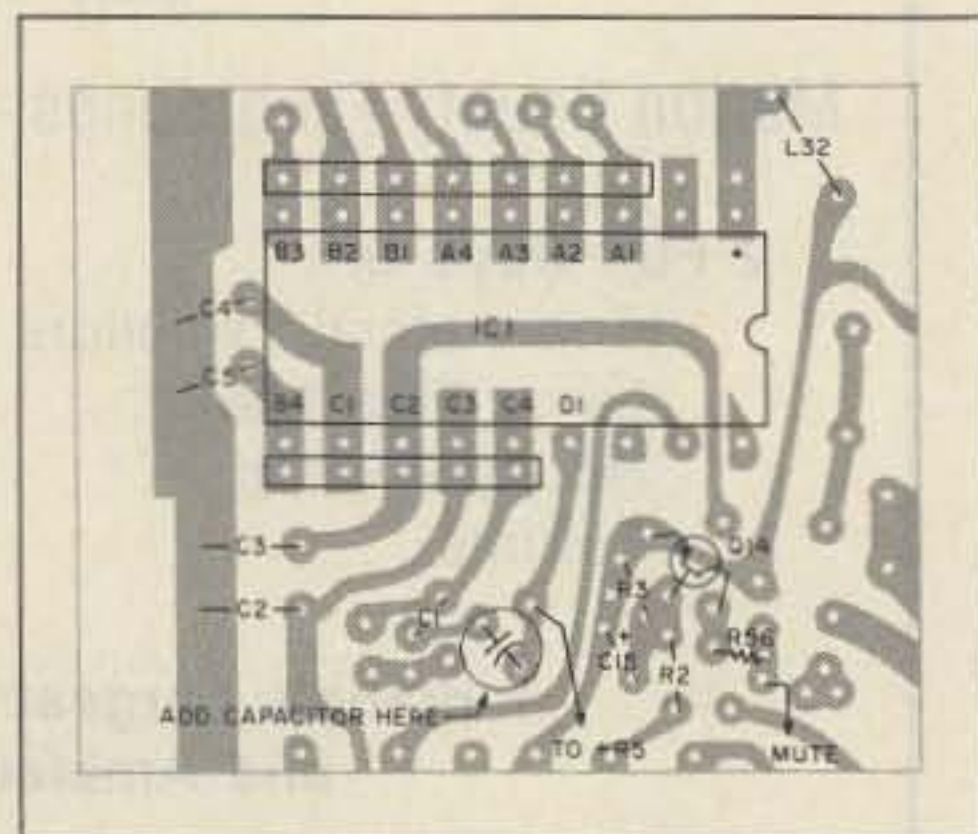

Fig. 1. Pulling pin 15 of the PLL divider chip high will cause the PLL to tune from 150 to 159.99 MHz.

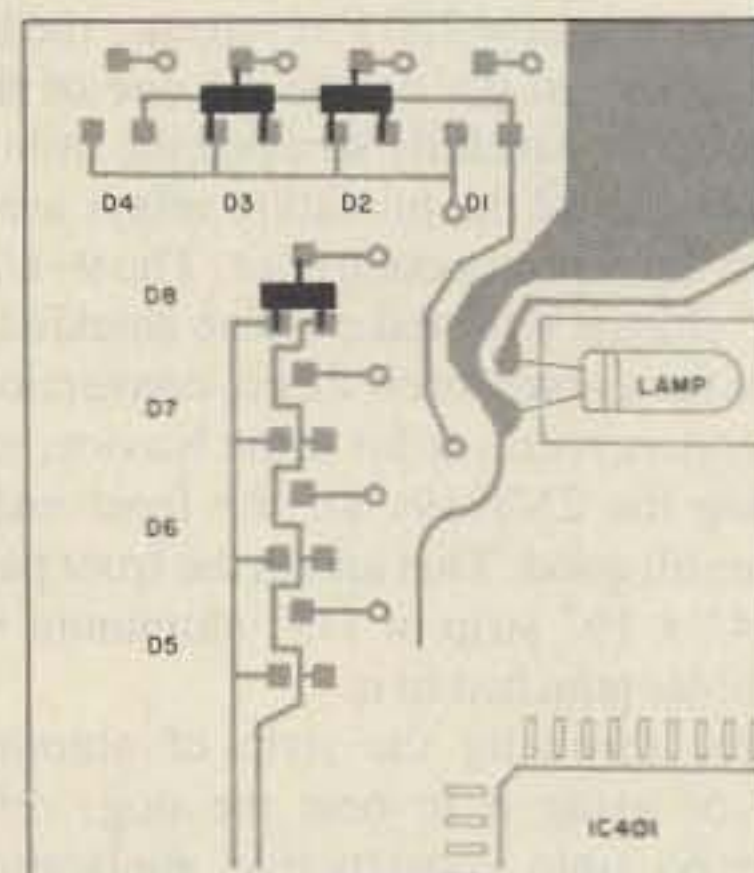

Fig. 2. Remove diodes D2 and D3 from the IC-02AT initialization matrix board.



do this: Find the flexible board running from the PLL divider to the thumbwheel switch. At the switch end, remove the jumper wire (see Photo B), and at the PLL end, bridge the gap in the trace at C4.

With the wiring done, you can close the chassis back up and replace the two Phillips screws. Replace the front cover. Don't forget to plug in the DTMF unit. Now temporarily replace the battery-retaining bracket using two of the four remaining screws. Install the battery pack. Now it's time to tune the PLL free-run frequency so the PLL will track over the new frequency range. Locate L3 in the vco can and, using a soft tuning tool, adjust for a voltage of about 0.75 volts at the lowest frequency desired at the test point. The proper resistor is identified by its lack of paint on the top lead.

The PLL will tune only over a 10-MHz range, so you can see that to get to 155 MHz you have to give up 144 MHz. This is not a problem in southeast Alaska since we have only one or two active frequencies, and all are at 146 MHz or above.

Receive sensitivity will be poor at the high end of the new frequency range but should be adequate for local listening. If you desire more sensitivity and have access to the proper test equipment, you can retune the receiver to favor the higher frequencies.

To use the modified ICOM 2AT, think of the switch as toggling between 140 and 150 MHz. Then just dial in the rest of the frequency as normal.

#### IC-02AT

As you can see, there are some limitations to this modification. After a year of using my modified 2AT I felt it was time to upgrade. Being partial to ICOM, I purchased the new 02AT. With the schematic in hand before the radio, I discovered that the microprocessor had an external initialization diode matrix. Aha, time to see what it would do!

After some experimenting, I discovered that I could make the microprocessor think it was an aircraft-band radio, a two-meter radio, a business-band radio, a 220-MHz radio, a 440-MHz radio, a 450-MHz business radio, a 1.2-GHz radio, and on it went. ICOM had designed a universal software program that would make the same processor work in all current and future products. Now remember, the actual radio is limited by tuned circuits to operation over a specific range of frequencies. Only the processor was being changed, not the radio. (Before you dig into your 02AT, check the serial number: It appears that rigs with numbers higher than 35,000 utilize different software. I'm working on a mod for these radios.)

One of the combinations I hit upon allows the 02AT to initialize at 00.00 MHz (dc) and range to about 327 MHz. In the middle of that range is two meters.

Changes to the initialization matrix cause the following to happen:

1. Direct frequency entry from 144 MHz to 165 MHz.
2. Offsets of up to 20 MHz.

The vco circuit will track over a 20-MHz

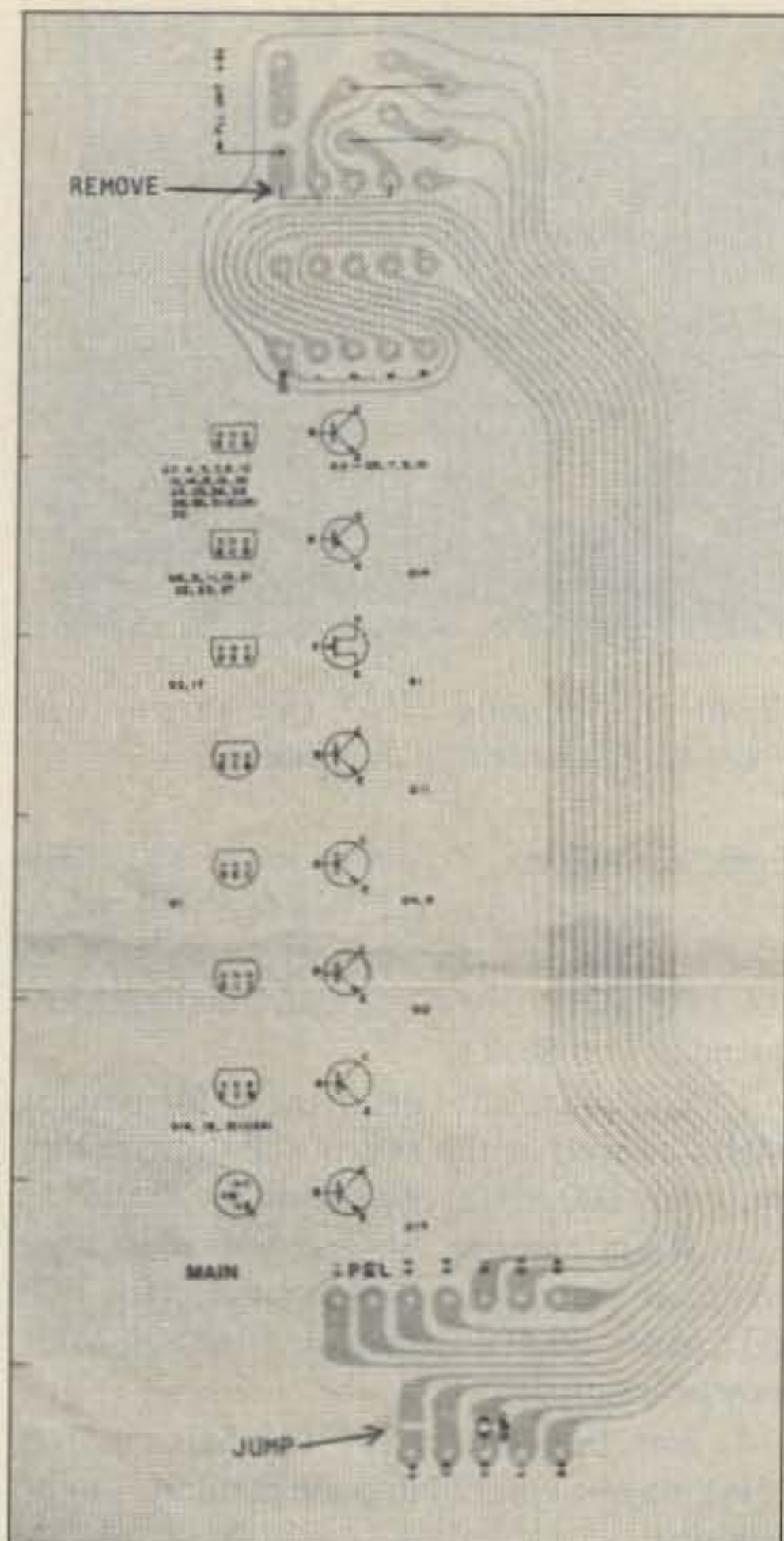

Photo B. If you have an early model of the 2AT, these two changes will enable all of the digits of the thumbwheel switch.

range, but the bottom 4 MHz is not very linear, causing excessive deviation of the transmitted signal and a 1-kHz tone to appear on the audio. Deviation in the upper 5 MHz or so begins to fall off slowly with an increase in frequency, but that is of no matter since you won't be transmitting up there anyway.

#### How to Modify Your 02AT

1. Remove the battery pack, back cover, battery plate, and front cover, in that order. The front cover does not come free, but is attached with a ribbon cable to the main chassis.

2. In the front cover, locate the DTMF unit and remove the two screws holding it in place. Bend the metal tab of the matrix shield out of the way; then lay the DTMF unit over to the side.

3. Take out the three screws holding the matrix shield and remove it. These screws are tiny; don't lose them!

4. Using solder wick and a small flat-bladed soldering iron, remove diodes D2 and D3 (Fig. 2). Use an iron with a gounded tip since this circuitry is CMOS. Save the diode labeled with a "D."

5. Add three silicon diodes, 1N914, 1N4148, or equivalent, as shown in Fig. 3.

6. Solder the "D" diode you saved to the D5 position (Fig. 3) as shown in Fig. 1.

7. Replace the shield, taking care to look for solder bridges or short circuits.

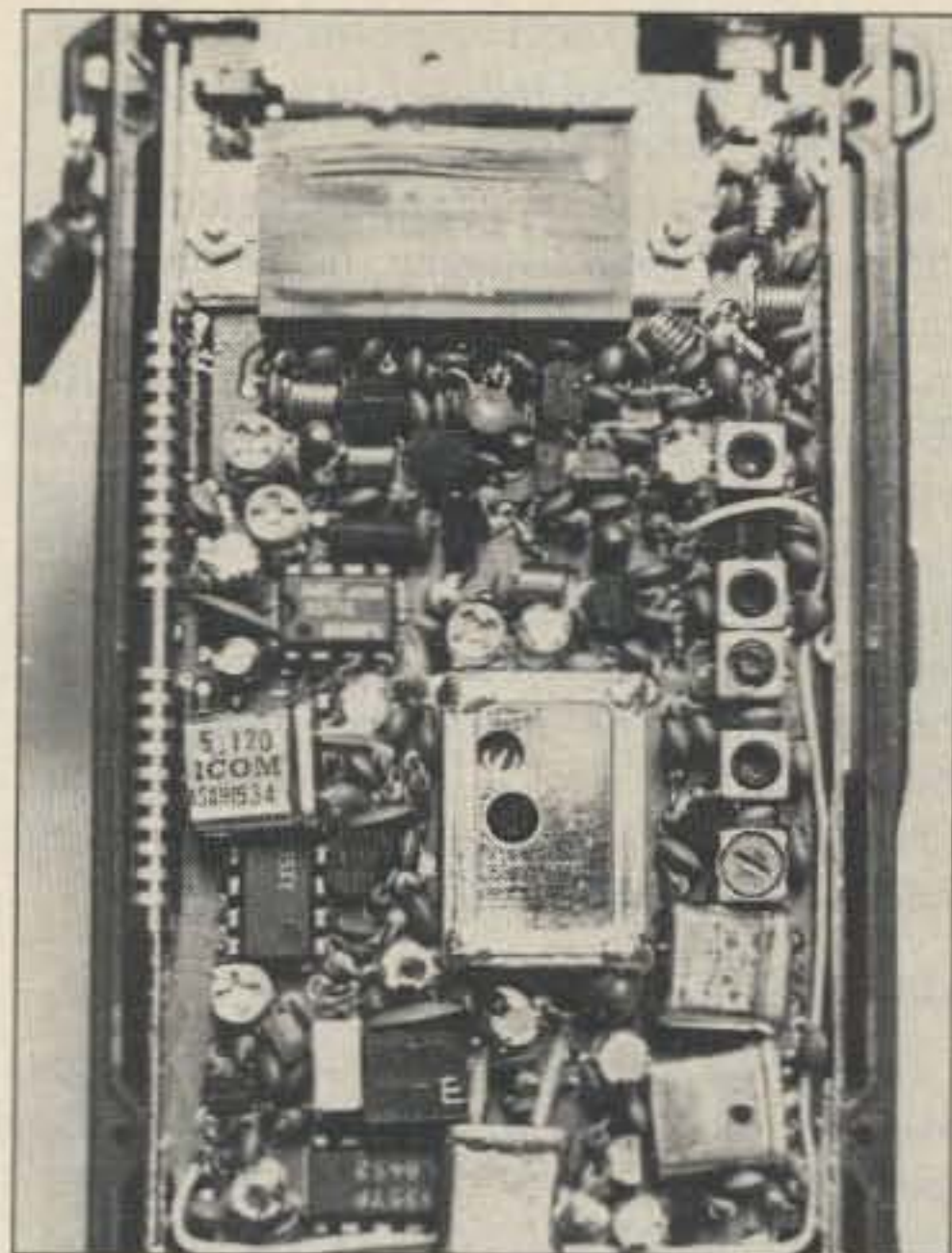

Photo C. L218, the vco frequency control, is located in the large silver box; the coil is under the lower hole.

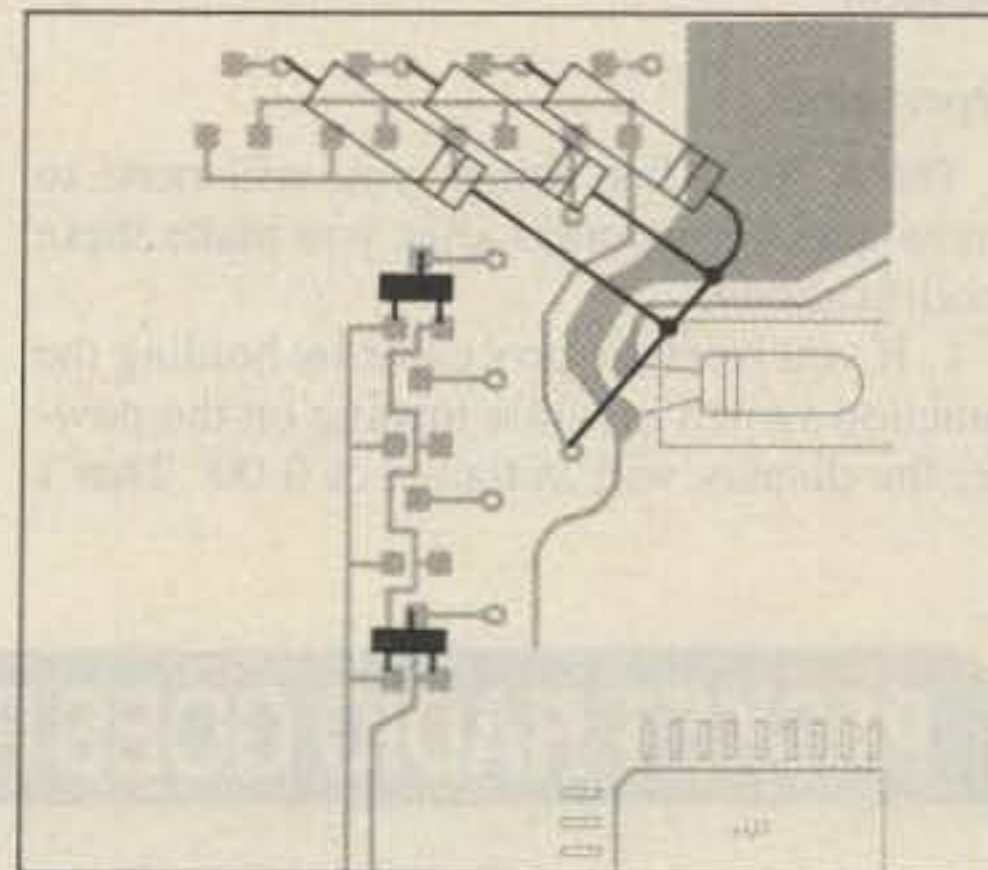

Fig. 3. Diode placement for steps 4-6.

8. Replace the DTMF unit.

9. Replace the front cover, the battery plate, and the battery pack. Leave the back cover off for now.

10. Turn on the radio and enter 140.00 MHz. Attach a dummy load to the BNC antenna jack. This is important as you will be testing out of the ham bands.

11. Key the transmitter using high power and adjust the vco free-run frequency so the display begins to flash. Adjust L218 (see Photo C). Usually the slug will have to be turned out of the can. Unkey and key the transmitter several times to refine the adjustment.

12. Enter 162.80 MHz and key the transmitter. The display should not blink (if it does it's not phase-locked).

13. Replace the back cover when you are satisfied with the range. If you wish to favor a different portion of the spectrum, just pick a frequency 4 MHz below the lowest frequency you normally will want to use and set the lower limit there. Total vco lock range is about 20 MHz on a typical 02AT. But remember that the bottom 4 MHz is nonlinear and not really suitable if you want a clean signal. If you are tempted to tune for a higher



range, and then expect to use the bottom end, beware the wrath of fellow hams, as you will over-deviate and splatter.

Receive sensitivity will be adequate above 155 MHz for local listening, but if you have access to a service monitor, this can be improved to better than 0.5 microvolts for 10-dB Sinad from 144 MHz to 161 MHz, and typically, 0.25 microvolts can be obtained over this range. I measured 0.15 uV for tight squelch at 145.00 MHz, and 0.60 uV for tight squelch at 162.00 MHz. I also noticed that transmit power was at the rated 5 Watts over this same range. This is, of course, only academic since you can legally transmit only in the ham bands with this radio, anyway.

### More Audio

Now for a simple audio modification that will give an approximate 6-dB boost to the speaker volume. A quick check of the schematic will show that there is a 0.22-uF capacitor across the audio right after the detector. It is C117. While you have the front off the radio for the other mods, just snip this capacitor out of the circuit. See Photo D for the location.

### Operation

There are a few things you will need to know about your radio after you make these modifications:

1. If you reset the processor by holding the function switch in while turning on the power, the display will initialize at 0.00. That's



Photo D. Snipping C117 (see arrow) will boost the audio sent to the speaker.

right, zero Hertz. To get up to the 100-MHz range, enter 9999; the display will show 99.99. Then use the up arrow to step to 100.000 MHz. Now you can enter the frequencies you desire.

2. You must now enter the 4 for tens of MHz, as well as the rest of the digits. Only the 1 (for 100 MHz) remains in the display.

3. When entering offsets, you must now enter all the digits. For example, for 600 kHz, enter 00.60. Offsets up to 20.00 MHz may be entered.

4. Any frequency from 140 MHz to 163 MHz may be entered into the memories to be scanned.

5. When entering a frequency outside of the ham bands, it is best to also enter an offset



Photo E. The fruit of your labor—an 02AT receiving weather broadcasts on 162.55 MHz.

so that if you accidentally transmit, the frequency will fall in the ham bands.

There you have it. At least a dozen hams in this area have made these modifications to their ICOM 02ATs and all praise the mods and wonder how they did without. ■

## PACKET RADIO GOES PORTABLE

### GLB ELECTRONICS

presents



#### Model PK1-L

- LOW 25 mA Current drain.
- Designed for portable or solar-powered stations.
- Miniature size—Lightweight
- Rugged all metal, shielded enclosure.
- On-board Lithium Battery RAM backup.
- On-board watchdog for reliability.
- Standard DB-25 Connectors.
- Output signal indicates "Connected" Status.
- Does not require squelched audio.
- Comes with 8K of RAM.
- Remote Command Mode for Unattended operation.
- Hardware command lockout for security.
- Commands compatible with our Model PK1.
- Retains all other features of the Model PK1.
- Extra I/O lines for special applications.

Power requirement:  
9 to 15 Volts DC @ 25 mA typical

Dimensions:  
4.6 X 5.90 X 1.0 inches

Total Weight:  
12 ozs.

PK1L—Wired and Tested  
List— \$239.95  
Amateur net— \$209.95

#### GLB MODEL TNC-2A KIT

Just when you thought TAPR TNC-2 Kits were a thing of the past, GLB — the first commercial producer of Packet Controllers — Joins the "TAPR Revolution" at last!

GLB is now the exclusive supplier of TNC-2 Kits.

Hardware  
Software  
Documentation

by TAPR



#### GLB Model TNC-2A Kit

#### COMPLETE KIT ONLY

\$154.95 NMOS

\$169.95 CMOS

+ shipping

Contact GLB for information on our full line of Packet Controllers



## GLB ELECTRONICS, INC.

151 Commerce Pkwy.,  
Buffalo, NY 14224  
716-675-6740 9 to 4

HOT!!



OSCILLOSCOPE

Turn Your Computer Into A

### DIGITAL STORAGE OSCILLOSCOPE

And More With The

### MB230 WORKSHOP

\$129.95

(C64 Version)



INTERFACE UNIT

The MB230 is designed for use with your home or personal computer. It is a complete Electronic Instrument and Electro-Mechanical Workshop which contains Interface Unit, D.C. Motors, Gears, Sensors, Construction Components, Disk Based Software and instructions for 50 sample projects.

Included are:

- Digital Storage Oscilloscope
- Digital Voltmeter
- Digital Speech & Sound (Record/Playback)
- A/D-D/A Conversion
- D.C. Motor Control (Var. Speed)
- Infrared Control
- Motors, Gears, Generators
- Motorized Mechanical Robotics
- Cars, Cranes, Toys, Etc.



VOLTMETER



MOTOR AND GEARS

The heart of the MB230 Workshop is the B100 Interface Unit which connects to all types of sensors and is able to control lights, motors, relays and other external devices. The MB230 manual contains suggestions and instructions for many advanced projects such as antenna positioning and relay control.

Available for the following computers:  
Commodore 64 (\$129.95), Apple 2+, 2E (\$159.95),  
Atari 800 (\$139.95).  
Coming soon for IBM, Amiga, Atari 520ST.

To order or for more information call toll free 1-800-824-2549.  
Cashier's check, Money order, VISA, or Mastercard orders accepted.

Order now to avoid delay!

ALL ORDERS SHIPPED UPS BLUE  
AT NO EXTRA CHARGE

84

## MULTIBOTICS, INC.

2561 South 1560 West  
Woods Cross, Utah 84087



# NEW! Lower Price Scanners

Communications Electronics™, the world's largest distributor of radio scanners, introduces new lower prices to celebrate our 15th anniversary.

## Regency® MX7000-EA

List price \$699.95/CE price \$399.95/SPECIAL  
**10-Band, 20 Channel • Crystalless • AC/DC**  
Frequency range: 25-550 MHz. continuous coverage and 800 MHz. to 1.3 GHz. continuous coverage. The Regency MX7000 scanner lets you monitor military, F.B.I., Space Satellites, Police and Fire Departments, Drug Enforcement Agencies, Defense Department, Aeronautical AM band, Aero Navigation Band, Fish & Game, Immigration, Paramedics, Amateur Radio, Justice Department, State Department, plus thousands of other radio frequencies most scanners can't pick up. The Regency MX7000 is the perfect scanner for intelligence agencies that need to monitor the new 800 MHz. cellular telephone band. The MX7000, now at a special price from CE.

## Regency® Z60-EA

List price \$299.95/CE price \$179.95/SPECIAL  
**8-Band, 60 Channel • No-crystal scanner**  
Bands: 30-50, 88-108, 118-136, 144-174, 440-512 MHz. The Regency Z60 covers all the public service bands plus aircraft and FM music for a total of eight bands. The Z60 also features an alarm clock and priority control as well as AC/DC operation. Order today.

## Regency® Z45-EA

List price \$259.95/CE price \$159.95/SPECIAL  
**7-Band, 45 Channel • No-crystal scanner**  
Bands: 30-50, 118-136, 144-174, 440-512 MHz. The Regency Z45 is very similar to the Z60 model listed above however it does not have the commercial FM broadcast band. The Z45, now at a special price from Communications Electronics.

## Regency® RH250B-EA

List price \$613.00/CE price \$329.95/SPECIAL  
**10 Channel • 25 Watt Transceiver • Priority**  
The Regency RH250B is a ten-channel VHF land mobile transceiver designed to cover any frequency between 150 to 162 MHz. Since this radio is synthesized, no expensive crystals are needed to store up to ten frequencies without battery backup. All radios come with CTCSS tone and scanning capabilities. A monitor and night/day switch is also standard. This transceiver even has a priority function. The RH250 makes an ideal radio for any police or fire department volunteer because of its low cost and high performance. A UHF version of the same radio called the RU150B covers 450-482 MHz. but the cost is \$449.95. To get technician programming instructions, order a service manual from CE with your radio system.

## NEW! Bearcat® 50XL-EA

List price \$199.95/CE price \$114.95/SPECIAL  
**10-Band, 10 Channel • Handheld scanner**  
Bands: 29.7-54, 136-174, 406-512 MHz. The Uniden Bearcat 50XL is an economical, hand-held scanner with 10 channels covering ten frequency bands. It features a keyboard lock switch to prevent accidental entry and more. Also order part # BP50 which is a rechargeable battery pack for \$14.95, a plug-in wall charger, part # AD100 for \$14.95, a carrying case part # VC001 for \$14.95 and also order optional cigarette lighter cable part # PS001 for \$14.95.

## NEW! Regency® XL156-EA

List price \$239.95/CE price \$129.95/SPECIAL  
**6-Band, 10 Channel • No-crystal Scanner**  
Search • Lockout • Priority • AC/DC  
Bands: 30-50, 144-174, 440-512 MHz. Cover your choice of over 15,000 frequencies on 10 channels at the touch of your finger. Display messages. External speaker jack. Telescoping antenna. External antenna jack. AC/DC.

## NEW! Regency® R1060-EA

List price \$149.95/CE price \$92.95/SPECIAL  
**6-Band, 10 Channel • Crystalless • AC only**  
Bands: 30-50, 144-174, 440-512 MHz. Now you can enjoy computerized scanner versatility at a price that's less than some crystal units. The Regency R1060 lets you in on all the action of police, fire, weather, and emergency calls. You'll even hear mobile telephones.

## Bearcat® DX1000-EA

List price \$649.95/CE price \$349.95/SPECIAL  
Frequency range 10 KHz. to 30 MHz. The Bearcat DX1000 shortwave radio makes tuning in London as easy as dialing a phone. It features PLL synthesized accuracy, two time zone 24-hour digital quartz clock and a built-in timer to wake you to your favorite shortwave station. It can be programmed to activate peripheral equipment like a tape recorder to record up to five different broadcasts, any frequency, any mode, while you are asleep or at work. It will receive AM, LSB, USB, CW and FM broadcasts.

There's never been an easier way to hear what the world has to say. With the Bearcat DX1000 shortwave receiver, you now have direct access to the world.

## NEW! Regency® HX1200-EA

List price \$369.95/CE price \$214.95/SPECIAL  
**8-Band, 45 Channel • No Crystal scanner**  
Search • Lockout • Priority • Scan delay  
Sidelit liquid crystal display • EAROM Memory  
New Direct Channel Access Feature  
Bands: 30-50, 118-136, 144-174, 406-420, 440-512 MHz.

The new handheld Regency HX1200 scanner is fully keyboard programmable for the ultimate in versatility. You can scan up to 45 channels at the same time including the AM aircraft band. The LCD display is even sidelit for night use. Order MA-256-EA rapid charge drop-in battery charger for \$84.95 plus \$3.00 shipping/handling. Includes wall charger, carrying case, belt clip, flexible antenna and nicad battery.

## NEW! Bearcat® 100XL-EA

List price \$349.95/CE price \$203.95/SPECIAL  
**9-Band, 16 Channel • Priority • Scan Delay**  
Search • Limit • Hold • Lockout • AC/DC  
Frequency range: 30-50, 118-174, 406-512 MHz.

The world's first no-crystal handheld scanner now has a LCD channel display with backlight for low light use and aircraft band coverage at the same low price. Size is 1 1/2" x 7 1/2" x 2 1/2". The Bearcat 100XL has wide frequency coverage that includes all public service bands (Low, High, UHF and "T" bands), the AM aircraft band, the 2-meter and 70 cm. amateur bands, plus military and federal government frequencies. Wow...what a scanner!

Included in our low CE price is a sturdy carrying case, earphone, battery charger/AC adapter, six AA ni-cad batteries and flexible antenna. Order your scanner now.

## Bearcat® 210XW-EA

List price \$339.95/CE price \$209.95/SPECIAL  
**8-Band, 20 Channel • No-crystal scanner**  
Automatic Weather • Search/Scan • AC/DC  
Frequency range: 30-50, 136-174, 406-512 MHz. The new Bearcat 210XW is an advanced third generation scanner with great performance at a low CE price.

## NEW! Bearcat® 145XL-EA

List price \$179.95/CE price \$102.95/SPECIAL  
**10 Band, 16 channel • AC/DC • Instant Weather**  
Frequency range: 29-54, 136-174, 420-512 MHz. The Bearcat 145XL makes a great first scanner. Its low cost and high performance lets you hear all the action with the touch of a key. Order your scanner from CE today.

### TEST ANY SCANNER

Test any scanner purchased from Communications Electronics™ for 31 days before you decide to keep it. If for any reason you are not completely satisfied, return it in original condition with all parts in 31 days, for a prompt refund (less shipping/handling charges and rebate credits).

## NEW! Bearcat® 800XLT-EA

List price \$499.95/CE price \$317.95  
**12-Band, 40 Channel • No-crystal scanner**  
Priority control • Search/Scan • AC/DC  
Bands: 29-54, 118-174, 406-512, 806-912 MHz. The Uniden 800XLT receives 40 channels in two banks. Scans 15 channels per second. Size 9 1/4" x 4 1/2" x 1 1/2".

### OTHER RADIOS AND ACCESSORIES

Panasonic RF-2600-EA Shortwave receiver ..... \$179.95  
RD95-EA Uniden Remote mount Radar Detector ..... \$128.95  
RD55-EA Uniden Visor mount Radar Detector ..... \$98.95  
RD9-EA Uniden "Passport" size Radar Detector ..... \$239.95  
BC210XW-EA Bearcat 20 channel scanner SALE ..... \$209.95  
BC-WA-EA Bearcat Weather Alert™ ..... \$49.95  
DX1000-EA Bearcat shortwave receiver SALE ..... \$349.95  
PC22-EA Uniden remote mount CB transceiver ..... \$99.95  
PC55-EA Uniden mobile mount CB transceiver ..... \$59.95  
R1060-EA Regency 10 channel scanner SALE ..... \$92.95  
MX3000-EA Regency 30 channel scanner ..... \$198.95  
XL156-EA Regency 10 channel scanner SALE ..... \$129.95  
UC102-EA Regency VHF 2 ch. 1 Watt transceiver ..... \$124.95  
RH250B-EA Regency 10 ch. 25 Watt VHF trans. .... \$329.95  
RH600B-EA Regency 10 ch. 60 Watt VHF trans. .... \$454.95  
RU150B-EA Regency 10 channel UHF transceiver ..... \$449.95  
RPH410-EA 10 ch. handheld no-crystal trans. .... \$399.95  
LC10-EA Carrying case for RPH410 transceiver ..... \$34.95  
MA181-EA Ni-cad battery pack for RPH410 trans. .... \$34.95  
P1405-EA Regency 5 amp regulated power supply ..... \$69.95  
P1412-EA Regency 12 amp reg. power supply ..... \$164.95  
BC10-EA Battery charger for Regency RPH410 ..... \$84.95  
MA256-EA Drop-in charger for HX1000 & HX1200 ..... \$84.95  
MA257-EA Cigarette lighter cord for HX1200 ..... \$19.95  
MA917-EA Ni-Cad battery pack for HX1200 ..... \$34.95  
EC10-EA Programming tool for Regency RPH410 ..... \$24.95  
SMRH250-EA Service man. for Regency RH250 ..... \$24.95  
SMRU150-EA Service man. for Regency RU150 ..... \$24.95  
SMRPH410-EA Service man. for Regency RPH410 ..... \$24.95  
SMMX7000-EA Svc. man. for MX7000 & MX5000 ..... \$19.95  
SMMX3000-EA Service man. for Regency MX3000 ..... \$19.95  
B-4-EA 1.2 V AAA Ni-Cad batteries (set of four) ..... \$9.95  
FB-E-EA Frequency Directory for Eastern U.S.A. .... \$12.95  
FB-W-EA Frequency Directory for Western U.S.A. .... \$12.95  
TSG-EA "Top Secret" Registry of U.S. Govt. Freq. .... \$14.95  
TIC-EA Techniques for Intercepting Comm. .... \$14.95  
RRF-EA Railroad frequency directory ..... \$10.95  
CIE-EA Covert Intelligence, Elect. Eavesdropping ..... \$14.95  
A60-EA Magnet mount mobile scanner antenna ..... \$35.00  
A70-EA Base station scanner antenna ..... \$35.00  
USAMM-EA Mag mount VHF/UHF ant. w/ 12' cable ..... \$39.95  
USAK-EA 3/4" hole mount VHF/UHF ant. w/ 17' cable ..... \$35.00  
USATLM-EA Trunk lip mount VHF/UHF antenna ..... \$35.00  
Add \$3.00 shipping for all accessories ordered at the same time.  
Add \$12.00 shipping per shortwave receiver.  
Add \$7.00 shipping per scanner and \$3.00 per antenna.

### BUY WITH CONFIDENCE

To get the fastest delivery from CE of any scanner, send or phone your order directly to our Scanner Distribution Center. Michigan residents please add 4% sales tax or supply your tax I.D. number. Written purchase orders are accepted from approved government agencies and most well rated firms at a 10% surcharge for net 10 billing. All sales are subject to availability, acceptance and verification. All sales on accessories are final. Prices, terms and specifications are subject to change without notice. All prices are in U.S. dollars. Out of stock items will be placed on backorder automatically unless CE is instructed differently. A \$5.00 additional handling fee will be charged for all orders with a merchandise total under \$50.00. Shipments are F.O.B. Ann Arbor, Michigan. No COD's. Most products that we sell have a manufacturer's warranty. Free copies of warranties on these products are available prior to purchase by writing to CE. Non-certified checks require bank clearance.

Mail orders to: Communications Electronics, Box 1045, Ann Arbor, Michigan 48106 U.S.A. Add \$7.00 per scanner for U.P.S. ground shipping and handling in the continental U.S.A. For Canada, Puerto Rico, Hawaii, Alaska, or APO/FPO delivery, shipping charges are three times continental U.S. rates. If you have a Visa or Master Card, you may call and place a credit card order. Order toll-free in the U.S. Dial 800-USA-SCAN. In Canada, order toll-free by calling 800-221-3475. Telex CE anytime, dial 810-223-2422. If you are outside the U.S. or in Michigan dial 313-973-8888. Order today.

Scanner Distribution Center™ and CE logos are trademarks of Communications Electronics Inc.  
† Bearcat is a registered trademark of Uniden Corporation.  
‡ Regency is a registered trademark of Regency Electronics Inc. AD #040186-EA

Copyright © 1986 Communications Electronics Inc.

For credit card orders call  
**1-800-USA-SCAN**

**COMMUNICATIONS  
ELECTRONICS INC.**

Consumer Products Division  
P.O. Box 1045 □ Ann Arbor, Michigan 48106-1045 U.S.A.  
Call 800-USA-SCAN or outside U.S.A. 313-973-8888

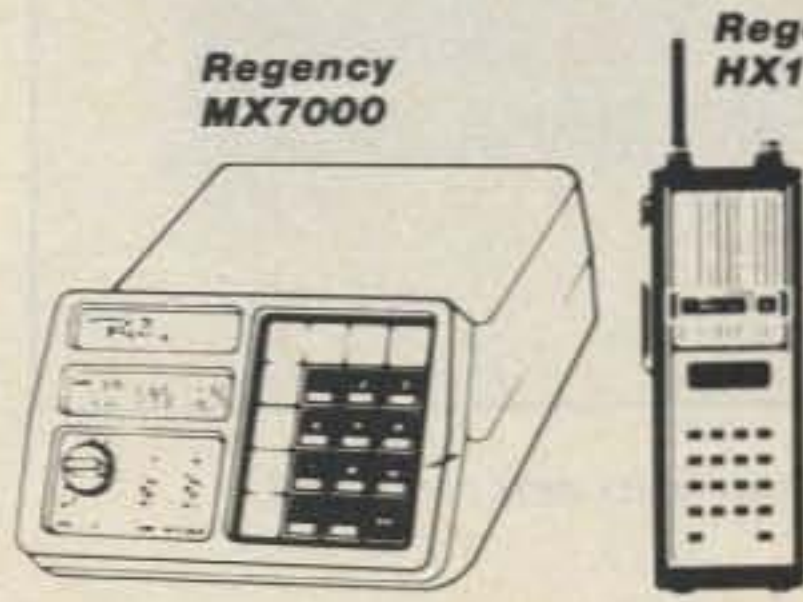



# Computer Rotor Control

*The first step toward automating your shack.*

Over the past few years, I have had the pleasure of spending many hours in the shack of a close friend who is a seasoned DXer. Watching him operate is always interesting, especially when an unusual call shows up on the band. Within the first minute after hearing the station, he has checked the log to see if he needs the contact, turned the antenna, and quite often established contact. Over the summer, he added a personal computer to

the shack to help out with beam headings and the log. Not long thereafter, we got to discussing how great it would be if he could just type the DX station's call on the keyboard and have the computer rotate the antenna to the correct heading and display pertinent logging information. An interface between the computer and rotor control box was what we needed. An interface like this would also make satellite tracking easier and be a major

step toward total computer control of the shack.

I have constructed an interface which will allow any personal computer with a serial port to talk to the control box of a CDE antenna rotor, such as the CD-45, Ham IV, or Taitwister. The computer need only output a single character representing the beam heading desired. The interface will then close the rotation contacts of the control box, bringing the rotor to the desired direction. The control box requires no modification, functions normally, and can be used instead of the computer to turn the antenna. Switching between operator and computer control of the rotor box is automatic, eliminating the need for the operator to do so. The circuit, an extension of K9AZG's "Automatic Beam Aimer" (73, November, 1982), uses 13 ICs and can be constructed by anyone with familiarity with digital circuits. I suggest reading K9AZG's article as it reviews the operation of the CDE control box.

## Theory of Operation

The interface will begin to rotate the rotor as soon as a character is received from the computer. This character contains 8 data bits and can be calculated using a small subroutine or can be obtained from a lookup table.

As shown in Fig. 1, serial data is received by a Universal Asynchronous Receiver/Transmitter (UART) which converts the character to 8 parallel bits. Seven of the bits represent the desired beam heading and are transferred to the input of a digital-to-analog converter (D/A converter, or DAC).

The DAC generates a precise dc voltage specified by the digital input. This voltage represents what the control-box meter should read when the rotor is correctly aimed. This voltage is applied to one input of a comparator, with the other comparator input connected to the control-box meter. These two voltages are compared and an output voltage is generated which is equal to the voltage difference between the comparator inputs.

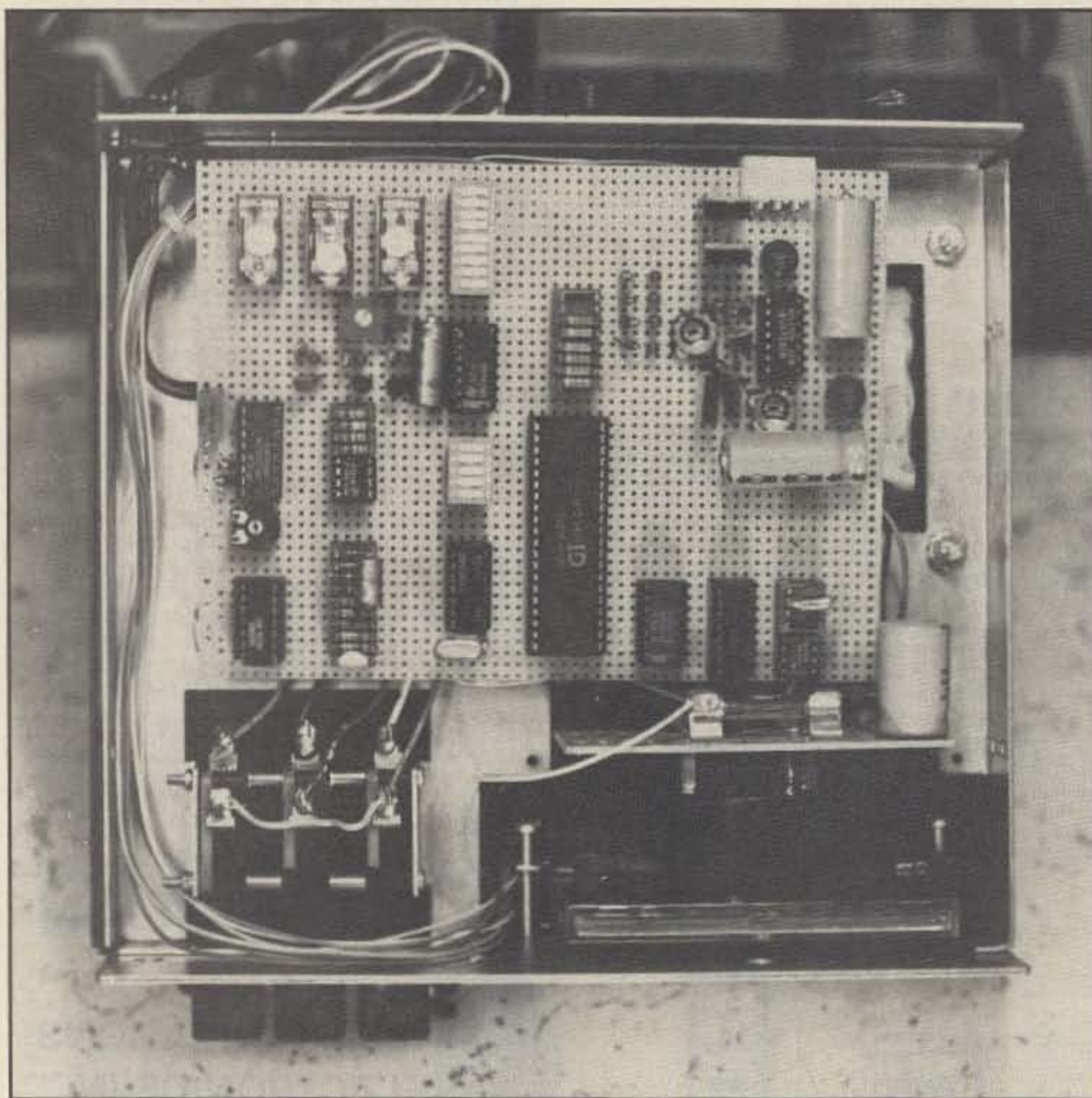

*The rotor control board, tucked neatly inside, awaiting its next command.*



A negative output voltage indicates the rotor must be turned clockwise (CW). A positive output voltage indicates the rotor must be turned counterclockwise (CCW). Sensing the polarity of the voltage is accomplished using two comparators, one to sense negative polarity and one to sense positive polarity.

One comparator output drives the CW relay and the other drives the CCW relay. The contacts of these relays are in parallel across the rotation switches in the control box and therefore are able to turn the rotor. Brake release begins as soon as a character is received and ends shortly after the correct heading is reached in order to allow for rotor coasting.

### Construction

I have several suggestions which will save a great deal of time in building and testing this project. I strongly recommend that those building this project use wire-wrap construction. Point-to-point wiring is slow and messy, while design of a PC board requires a great deal of time. Wire-wrapping is fast, clean, and easy to learn. An electric wrap gun is cheap and will pay for itself within the first few hours of construction. Along with the gun, you will need an unwrap tool for correcting inevitable mistakes, as well as a special tool for stripping the wire.

The wire comes in different colors to make construction easy. Three small spools, each a different color, will be sufficient for this project. Use a different color wire for each stage and you will work faster with fewer mistakes. These items are available at Radio Shack and will become valued tools in the shack. [I use an OK wrapping pencil available for about \$30 from Jameco—it automatically strips the wire.—Ed.]

Of equal importance is the construction technique. Since this circuit has several stages, I built and tested them one at a time. This way I knew exactly what worked as I went along. The most important benefit of this method is the opportunity for the reader to completely understand what each stage does. Other people's designs can be tough to get working without a logical approach. Build and test one stage at a time and you will be glad you did. In the following sections of this article, I have used this method so that testing can be performed as each stage is built.

### Power Supplies

Four power-supply voltages are required, as shown in Fig. 2. The output of a 12.6-volt transformer is rectified and filtered to produce approximately +15 volts dc. This voltage is applied to the input of the positive voltage regulators and the relay coils. It's good practice to obtain relay

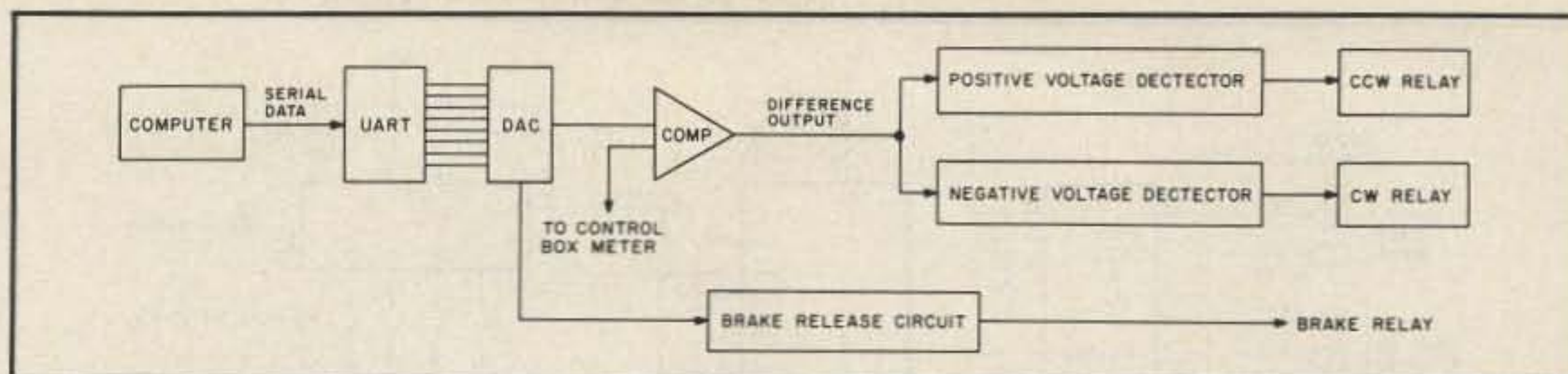

Fig. 1. Block diagram.

drive voltage before the regulators since the relay coils present a heavy load in comparison to the logic and can produce transients on the supply lines.

+5- and +12-volt outputs are easily obtained using Texas Instruments regulators from Radio Shack. They should be heat-sunk to avoid thermal failure.

The +10-volt reference output supply may be obtained either of two ways. I used a 723 regulator and adjusted R2 to obtain 10 V. I had intended to use the less complicated LH0070 regulator, but none was to be found locally. If it's available, it will save some time and space; however, the 723 works equally well.

The -12-volt supply consists of a 12-volt transformer rectified and filtered to obtain approximately -15 volts for driving the negative regulator.

In order to test the supplies, disconnect the outputs from any loads and apply 120 V ac to the transformers. Feel the four regulators to be sure that they are not hot (warm is OK). Measure the unregulated voltage at the output of the bridge rectifiers. It should be at +15 or +20 V dc for the positive supply and -15 to -20 V dc for the negative supply.

Next, measure the +12-, +5-, and -12-volt regulator outputs. Finally, measure the output from the 723 regulator and adjust R1 for exactly +10-volts output from the regulator. Any supply output which is over the specified output probably has a wiring error or a bad IC. Any supply with a low output voltage should be checked to see if its output

is being heavily loaded (it would also be very hot). Also check the input voltage to see if it's at least 2 volts greater than the rated output.

### Serial-Data Port

I designed the serial-data input shown in Fig. 3 to be as flexible as possible for easy connection to various computers. Only two wires are required by the interface: receive data and ground. The serial-data input expects to see either EIA RS-232-level mark and space (-3 to -12 and +3 to +12 volts, respectively) or TTL-level input (0 volts and +5 volts). If an RS-232 interface is used, it may be necessary to make the interface look like a modem to the computer by connecting pins together on the DB-25 connector at the interface. This is accomplished by connecting pin 5 (clear to send), pin 6 (data set ready), and pin 8 (data carrier detect) to +12 volts. An alternate approach is to connect pin 4 to 5 and pin 6 to 20, as shown in Fig. 3. These jumpers are only required if the computer requires handshaking in order to output data.

RS-232-level data is converted to TTL-level (5 volts) data with an MC1489 line receiver and applied to the input of a UART. If the computer outputs TTL-level data rather than RS-232, it will be necessary to check whether the output data is inverted. In order to do this, measure the voltage at the computer's serial-data output. When no characters are being sent, the line should be in the mark state and be at +5 volts. When a character is being sent, the line should alternate between +5

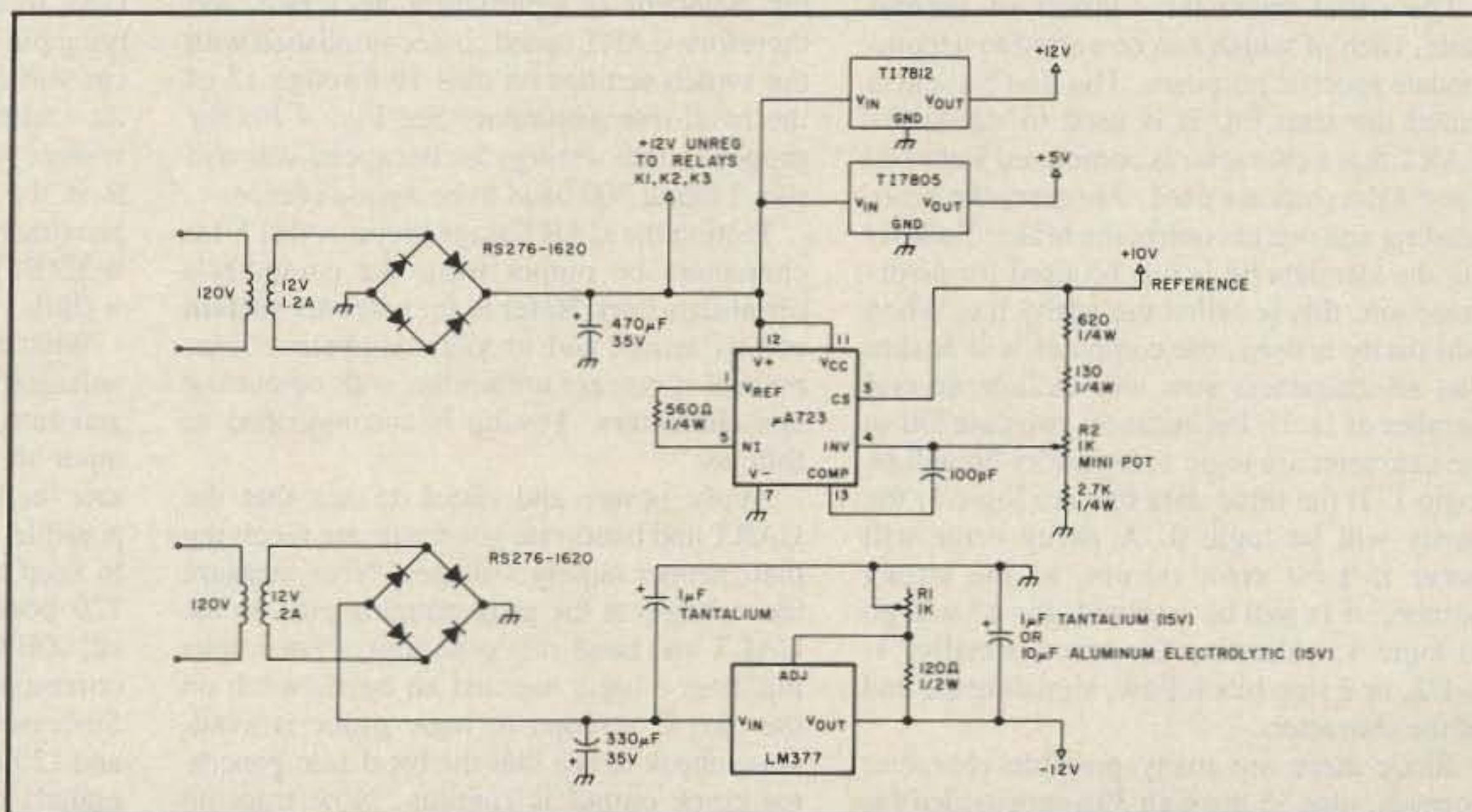

Fig. 2. Power supply.







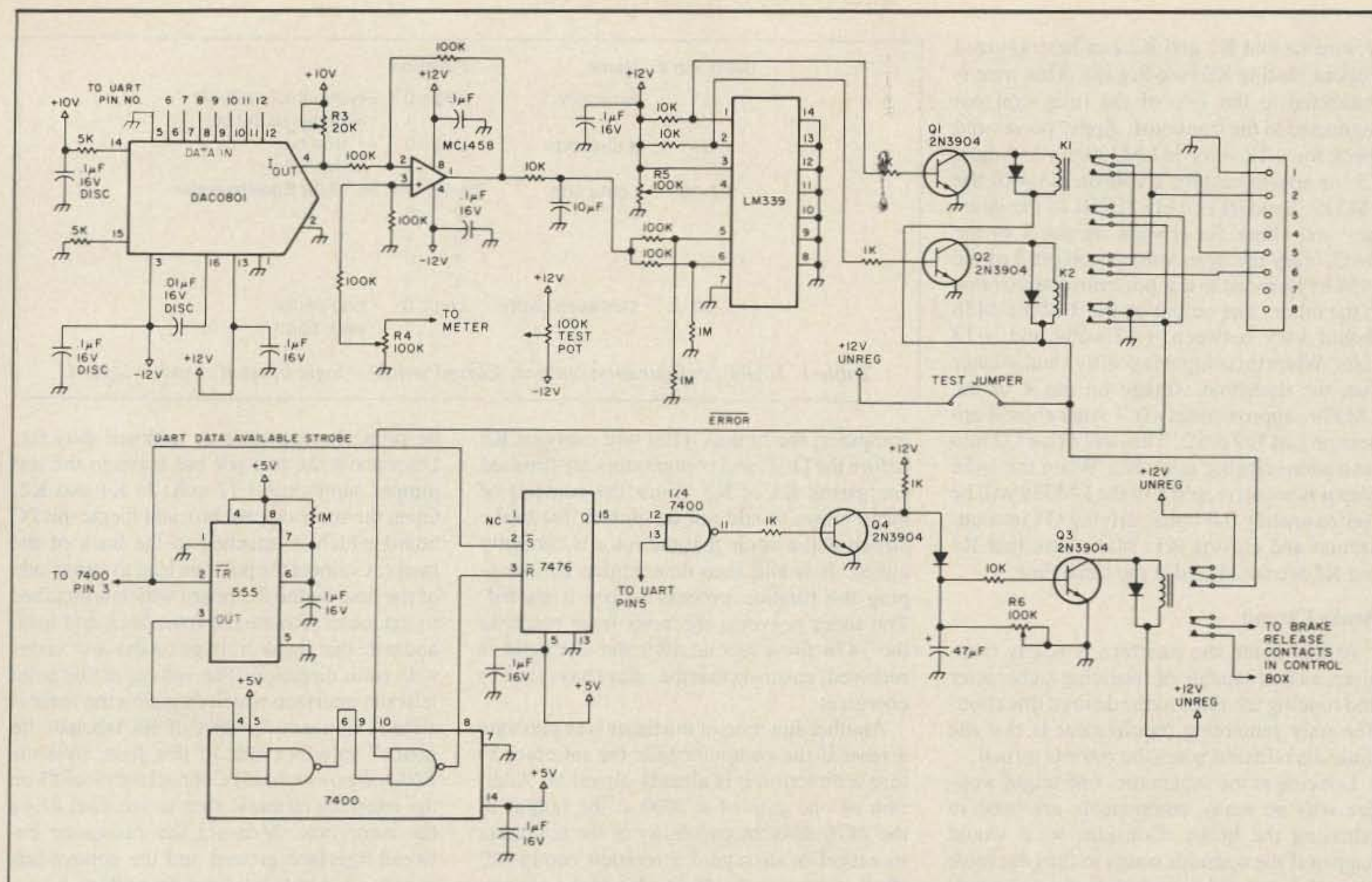

Fig. 5. DAC, rotation control, and brake circuit.

Pin #				Baud Rate
10	11	12	13	
0	0	0	0	50
0	0	0	1	75
0	0	1	0	110
0	0	1	1	134.5
0	1	0	0	150
0	1	0	1	300
0	1	1	0	600
0	1	1	1	1200
1	0	0	0	1800
1	0	0	1	2000
1	0	1	0	2400
1	0	1	1	3600
1	1	0	1	4800
1	1	0	1	7200
1	1	1	0	9600
1	1	1	1	19200

Fig. 4. Baud-rate-generator truth table. Closed switch = logic 0, open switch = logic 1.

to send the characters 80H to F7H to the interface.

In order to test the DAC, check to see that its +12-, +10-, and -12-volt supply inputs are operational. Now send 1111 0111 (F7H) to the UART and check to see that the DAC pins 6 through 8 and 10 through 12 are at logic 1. Pin 9 should be at logic 0 due to the 0 in the input word and pin 5 should be at logic 0 since it is grounded. Now measure the output voltage on DAC pin 4 and adjust R3 for exactly zero volts. This is the only way that R3 can be correctly adjusted. Now send 1000

0000 (80H) to the UART and check to see that DAC pin 4 is approximately +10 volts. Do not adjust R3 to set this 10-volt level. By setting this resistor, the DAC has been adjusted to output between 0 and +10 volts for digital inputs from 77H to 00H.

The output from the DAC is applied to the inverting input of a 1458 comparator. The non-inverting input is connected through a pot to the rotor-box meter. These inputs are compared and an output voltage is produced which is equivalent to the difference between input voltages. The polarity of the comparator output will be either negative or positive depending upon which input voltage is greater. For example, if the DAC output is +2.5 volts and the meter is +1.0 volts, the comparator output will be -1.5 volts.

Construct a test pot by connecting one side of a 100k pot to +12 volts and the other side to -12 volts. Connect the wiper of the test pot to the side of pot R4 labeled "meter input." The control-box meter should not be connected. With the test pot, it will be possible to simulate the voltages which appear on the meter of the rotor box. In order to test the 1458 comparator circuit, first check pins 4 and 8 to see that they are getting power. Send 1011 1111 (BFH) to the interface and check to see that DAC pin 4 is 5 volts. Adjust the test pot so that +5 volts appears on its wiper. Next adjust R44, the input attenuator pot, for +5 volts on its wiper so that it is not attenuating the meter input during testing.

Since the DAC is outputting +5 volts to the comparator and the meter input is at +5

volts, the comparator output should be 0 volts. Reduce the test-pot wiper voltage to +4 volts and check to see that the comparator output on pin 1 is -1 volt. Remember, 5 volts on the input from the DAC minus 4 volts on the input from the wiper equals -1 volt. Adjust the test pot for +10 volts on its wiper and check comparator pin 1 for +15 volts.

In short, the comparator output contains two pieces of information. First, the polarity of its output indicates which direction the rotor must be turned. Second, the magnitude of the output indicates how big the difference is between the actual and the desired direction.

#### Rotation Control

In order to translate the 1458 comparator output to contact closures for the rotor-control box, two comparators are used. One closes the CCW relay, K2, when the 1458 output is positive, and the other closes the CW relay, K1, when the 1458 output is negative. The contacts of relays K1 and K2 are in parallel across the CW and CCW rotation switches in the rotor-control box. R5 is a threshold adjustment which sets the maximum difference output on the 1458, which can occur before K1 or K2 is closed to rotate the antenna. In operation, this pot will determine how close to the desired direction the rotor will come before coasting to a stop.

Testing of this stage should be performed without any connection between the interface and the rotor-control box. Connect a jumper from unregulated +12 volts to the relay pow-



er wire so that K1 and K2 can be energized without closing K3 (see Fig. 5). This wire is connected to the side of the relay coil not connected to the transistor. Apply power and check for +12 volts on LM339 pin 3. Adjust R5 for approximately 1 volt on pin 4 of the LM339. Send 0111 1111 (F7H) to the interface and check for 0 volts on pin 4 of the DAC. Vary the input voltages on pin 3 of the 1458 by turning the test pot from one extreme to the other. The output on pin 1 of the 1458 should vary between +12 volts and -12 volts. When this output is positive and greater than the threshold voltage on pin 4 of the LM339, approximately 0.7 volts should appear on LM339 pin 2. This will drive Q2 into saturation, closing relay K2. When the 1458 output is negative, pin 1 of the LM339 will be approximately 0.7 volts, driving Q1 into saturation and closing K1. Make sure that K1 and K2 are not closed at the same time.

### Brake Circuit

At this point, the interface is nearly complete, as it is capable of receiving a character and rotating the rotor to the desired direction. The only remaining requirement is that the brake be released when the rotor is turned.

Looking at the schematic, one might wonder why so many components are used in releasing the brake. Consider what would happen if the operator wants to turn the rotor using the control box rather than the computer. After the rotor turns several degrees, the interface will detect that the rotor is no longer aimed in the direction last specified by the computer. The result would be that it would energize relay K1 or K2 in order to turn the rotor back to the correct direction.

This problem can be overcome by controlling K1 and K2 with the brake circuit. Coil voltage for these relays is interrupted by a set of contacts in K3, the brake relay. Unless K3 is energized, relays K1 and K2 will not close, regardless of what the comparators dictate. The purpose of the 555 timer and 7476 flip-flop is to energize K3 only for as long as is required to bring the rotor to the correct heading after a command from the computer. Once the rotor turns to the correct heading, the relays cannot be re-energized unless a character is received from the computer. Therefore, the rotor control box may be used without interference from the interface.

Operation of the brake circuit commences as soon as a character is received by the UART and the data-available reset is generated on pin 3 of the 7400. This strobe, which will occur every time a character is received, is applied to the 555 and 7476. The 7476 toggles to the on state, outputting a logic 1 on pin 15 which releases the brake. It will remain on until a logic 0 reset pulse is received on pin 3. The reset is normally generated when the rotor reaches the correct direction and K1 and K2 de-energize, allowing 7400 pin 10 to go to logic 1. Pin 8 of the 7400 will then go to logic 0, resetting the 7476 and applying the brake.

Several parts of this stage require explanation. When a character is received from the

UART Pin #	Name	Function		
35	No parity	Logic 0	eliminates parity bit	
		1	includes parity bit	
36	# stop bits	Logic 0	1 stop bit	
		1	2 stop bits	
37-38	# data bits	Pin 37	Pin 38	Data Bits/character
		0	0	5
		0	1	6
		1	0	7
39	Odd/even parity	Logic 0	odd parity	
		1	even parity	

Table 1. UART configuration options. Closed switch = logic 0, open switch = logic 1.

computer, the brake circuit will energize K3 before the DAC and comparators are finished energizing K1 or K2. Since the contacts of these relays would not be closed, the brake circuit will assume that the rotor is correctly aimed. It would then de-energize K3, stopping the rotation process before it started. The timer prevents the reset from reaching the 7476 for a second after the character is received, ensuring that the relays have time to energize.

Another function of the timer is to generate a reset if the computer tells the interface to turn a direction it is already aimed at. Addition of one gate of a 7400 at the output of the 7476 adds the capability of the computer to cancel or disregard a rotation command. Bit 8, the most significant bit of the character received by the UART, is used as a rotate-enable bit. It is applied to 7400 pin 13 and prevents the 7476 from releasing the brake unless it is at a logic 1. Therefore, to stop rotation, send any character to the interface with the most significant bit set to logic 0 (00H thru 7FH) and the relays will de-energize.

Testing of the brake circuit should begin by checking the 555 and 7476 for proper power-supply input. Turn the test pot to one extreme of its rotation and send 1011 1100 (BCH) to the UART in order to produce a large difference voltage at the output of the 1458 comparator. Notice the MSB is a logic 1 to release the brake. As soon as the character is received, 7476 pin 2 and 555 pin 2 should momentarily go to logic 0. Pin 3 of the 555 should go to logic 1. After a second, 555 pin 3 should return to logic 0. K3 as well as K1 or K2 should be energized due to difference-voltage output from the 1458.

Slowly rotate the test pot so that both K1 and K2 de-energize (the interface will think the antenna is correctly aimed). After a short coasting delay, K3 will also de-energize. The length of this delay should be set to at least a second by adjusting R6. In order to check to see that rotation can be canceled, turn the test pot to one extreme and send 1011 1100 (BCH) to the UART. K3 and either K1 or K2 will energize in order to rate the antenna. Send 0000 0000 (00H) to the UART and see that the relays drop out since the MSB is logic 0.

### Installation and Adjustment

Before connecting the interface to the rotor control box, it is necessary that the interface

be properly operating as outlined thus far. Disconnect the test pot but leave in the test jumper supplying +12 volts to K1 and K2. Open the rotor control box and locate the PC board which is attached to the back of the meter. Connect the positive lead to either side of the fuse on the PC board which is attached to the meter. Rotate the rotor back and forth and note that the dc voltage on the fuse varies with rotor direction. The voltage at this point tells the interface which direction the rotor is aimed. Connect the side of R4 labeled "to meter" to either side of this fuse. (*Not the 120-volt power fuse!*) Connect terminal #1 on the interface terminal strip to terminal #1 on the rotor box. Measure the resistance between interface ground and the control-box chassis. It should be about zero Ohms.

Apply power to the interfaced and turn to the rotor control box. Adjust R5 to obtain 1 volt on pin 4 of the LM339. Send 1111 0111 (F7H) to the interface and adjust R3 for exactly 0 volts on pin 4 of the DAC0801. Send 1000 0000 (80H) to the interface and check that the voltage on pin 4 of the DAC is between +8 and +10 volts. Using the control box, rotate the rotor fully clockwise to the south. The meter output voltage should be between +8 and +10 volts. With the rotor turned clockwise to the south, adjust R4 so that wiper voltage is exactly the same as the voltage on pin 4 of the DAC0801. An easy way to do this is to measure the difference-voltage output on pin 1 of the 1458 comparator. Adjust R4 so that this voltage is exactly 0 volts. These adjustments have set the DAC and meter outputs to operate over the same range of voltages.

Instruct the interface to turn the rotor north by sending 1011 1100 (BCH) to the interface. K3 and K2 should energize. Turn the rotor north using the control box and note that K2 followed by K3 will drop out at some point during the rotation. The exact point at which K2 will de-energize is dependent upon the threshold setting of R5. This adjustment set how much before the desired heading is reached the rotor will begin to coast to a stop. Setting too tight a tolerance will cause the interface to hunt back and forth for an exact heading. I found a tolerance of about 5 degrees works reliably. The adjustment is made by turning the rotor 5 degrees clockwise from north using the control box and then sending 1011 1100 (BCH) to the interface. Adjust R5 so that K2 is just on the border of de-energizing.



ROTOR HEADING ON CONTROL BOX METER		
183° 210° 240° 270° 300° 330° 360° 30° 60° 90° 120° 150° 180°		
F7 EE E4 DA DO C6 BC B2 A8 9E 94 8A 80		
HEX CHARACTER SENT TO INTERFACE		
Rotor Direction	Hex Character	Decimal Character
0	BC	188
3	BB	187
6	BA	186
.	.	.
.	.	.
180	80	128
183	F7	247
186	F6	246
.	.	.
.	.	.
354	BE	190
357	BD	189
360	BC	188

Fig. 6. Matrix look-up table.

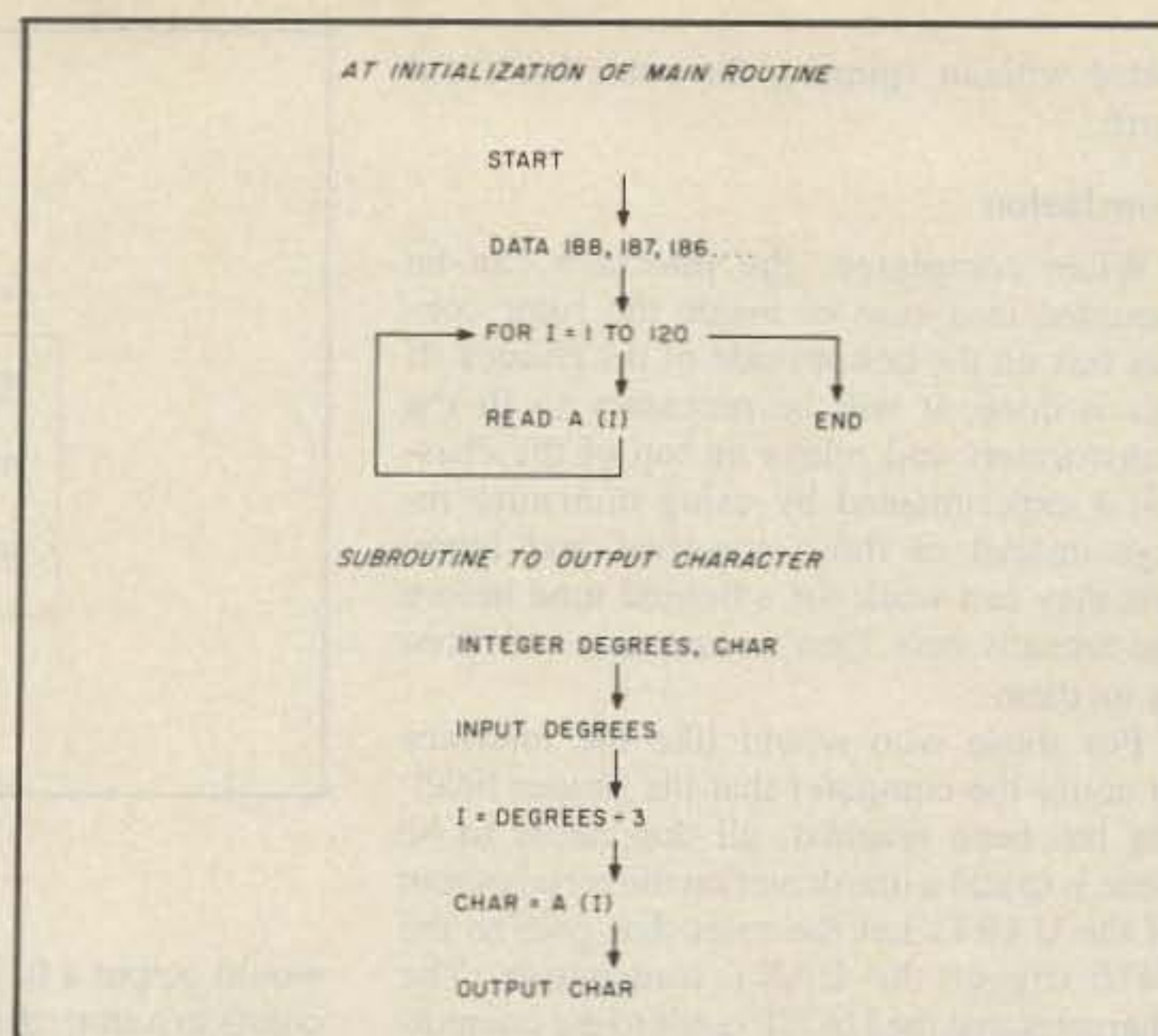

Fig. 7. Flowchart for look-up table in Basic.

Disconnect the test jumper and connect terminals 2, 5, and 6 on the interface terminal strip to terminals 2, 5, and 6 respectively on the rotor control box. Do not disconnect the wires already on these terminals. Relay K3 has two wires connected to its normally-open contacts labeled "to brake relay." These wires should be connected in parallel across the contacts of the brake-release switch in the rotor box. This will release the brake when K3 energizes.

Apply power to the interface and the rotor control box and send 1000 0000 (80H) to the interface and note that K3 and K1 will energize, turning the rotor clockwise to the south. After rotation has stopped, send 1011 1100 (BCH) to the interface and note that K3 and K2 will close, turning the antenna to north, where it will stop. Send 1111 0111 (F7H) to the interface and the rotor will turn counterclockwise to the south. Finally, test the stop function by sending the interface a command to turn followed by a 0000 0000 (00H). This will stop the rotation.

#### Software

Before reviewing the program which will send data to the interface, it is necessary to understand the software requirements. Normally, rotor direction is expressed as 360 points on a circle (called degrees). Zero degrees is north and the number of degrees increases with clockwise rotation. The interface uses a different system, however. This is due to the design of the meter circuit in the rotor control box. In this system there are 120 directions, each of which is 3 degrees in width. The software is able to control rotor direction by telling the interface to go to one of these direction.

Communication between the computer and the interface is in a binary string of 1s and 0s. Seven binary bits are required to specify 120 rotor headings, and the 8th (MSB) bit is used for brake control. The way the program specifies the string of bits varies with different computers and software packages.

In the hexadecimal system, 4 bits are

grouped together to form a hex digit. Since 4 bits can form 16 different combinations, the hex digit must be able to represent all possibilities. This is accomplished by counting as follows: 0, 1, 2, 3, 4, 5, 6, 7, 8, 9, A, B, C, D, E, F. Since we need to represent 8 bits, it will be necessary to form a word containing 2 hex digits. For use with the interface, the range of the word will be from 80 hex (1000 0000) to F7 hex (1111 0111), as shown in Fig. 6. Those that are writing the program in assembly language will send a hex word to the communications port of the computer.

A different method is used when running Basic. In this system, the decimal value of the output word is placed on the serial port. The decimal equivalent of the output string is calculated by assigning values to bit positions. The value of the 8 bit positions is as follows; 128, 64, 32, 16, 8, 4, 2, and 1. For instance, the equivalent of 1000 0010 is 128 + 2 or 130. Only 128 and 2 were counted since these were the positions where 1s occurred in the bit string. The decimal outputs corresponding to different directions are shown in Fig. 6. Check your software manual to determine how to send the character to your serial port.

I will describe two ways which the output character can be generated in software. Regardless of which method is chosen, I suggest that the program be implemented as a subprogram or subroutine. This way the software for driving the interface can be accessed at multiple points in a main program. The software will also remain constant regardless of which main program it is used with.

A simple program to implement is one which uses a look-up table to obtain the character to be sent to the interface. The table contains either hex or decimal output characters associated with different directions. The most elementary way of using the table would be for it to consist of 360 entries, each associated with a rotor heading in degrees. If, for instance, the software must turn the rotor to 70 degrees, it would go to the 70th entry in the table, obtain the character at that location, and send it to the interface. The output

character for 250 degrees would be contained at the 250th memory location and so on. This system is easy to use because there is no need to relate rotor heading in degrees to the direction number and then convert to an output character. This is done when the table is written.

Since there are only 120 different directions, and therefore output characters, a table of this type would have each output character repeated 3 times in 3 adjacent memory locations. Since no purpose is served by wasting memory, the table can be reduced to 120 entries. The flowchart in Fig. 7 shows how a look-up-table program can be implemented in Basic. When the main program is started, the variables A(0) to A(120) are loaded with the decimal-output characters in the look-up table of Fig. 6. A(0) is loaded with 188, A(1) with 187, etc.

Also shown in Fig. 7 is a subroutine which retrieves output characters from the look-up table. When a rotor heading is received by this routine, an integer division is performed to obtain "I"—which is used as a subscript for A(I). The decimal-output character stored in A(I) is then output to the serial port. For example, suppose the rotor is to turn south to 180 degrees. The routine receives 180, then divides by 3 to obtain the integer 60. The decimal stored in A(60) is loaded into the variable "char" and sent to the serial port.

It is also possible to write this routine in assembly language. If this is done, the value of "I" is used as an offset from the base address of the look-up table.

Another way to generate the output character is to calculate it. Although more time will be required to run this routine, it requires less memory than the look-up table method. Fig. 8 shows the flowchart which creates the character through successive substitutions.

Regardless of which method is chosen, the software can be tested for proper output by inputting a rotor heading in degrees. Have the program print the character it would output to the interface. This way the software can be



tested without spinning the rotor back and forth.

### Conclusion

When completed, the interface can be mounted in a case or inside the rotor control box on the bottom side of the chassis. If this is done, it will be necessary to fit the transformers and relays on top of the chassis. I experimented by using miniature relays instead of those specified and found that they can work for a limited time before the contacts melt. Don't waste time and money on them.

For those who would like the interface to notify the computer that the proper heading has been reached, all that needs to be done is to add a line driver on the serial output of the UART. Let the reset that goes to the 7476 trigger the UART transmitter. The character that the UART sends to the computer can be selected using the UART transmit-data pins.

Another idea that I've been thinking about is an improved brake circuit that detects when the rotor has coasted to a stop (rather than waiting several seconds and applying the brake). A differentiator could be constructed so that it outputs a logic 1 as long as there is a change taking place on the meter. When the meter stops changing, the circuit

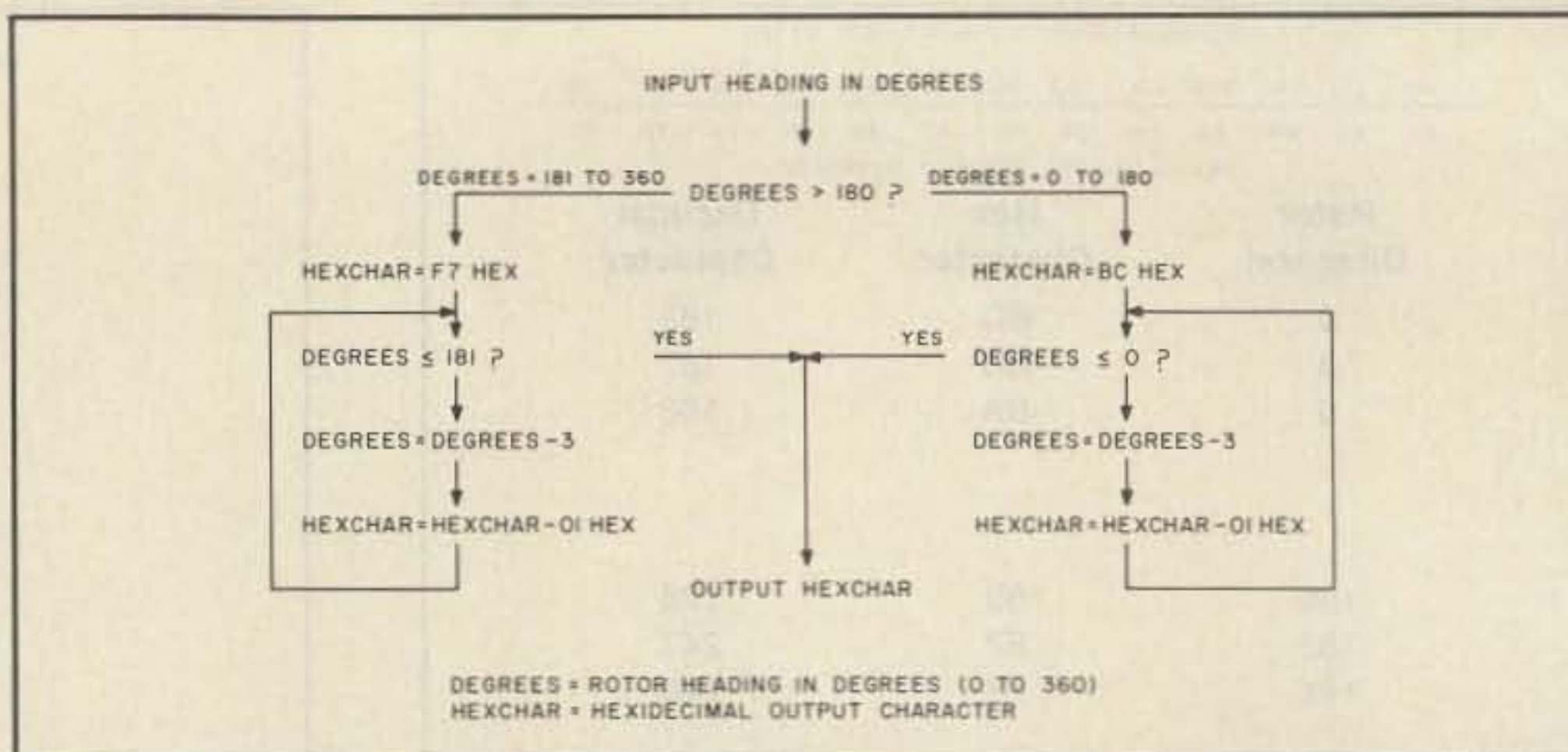

Fig. 8. Calculation of output character.

would output a 0. Therefore, when the rotor coasts to a stop, the differentiator output goes to logic 0 and the interface applies the brake. If the differentiator output were then connected to a circuit which looks at the comparator output voltage from the 1458, it would be possible to detect a stalled rotor. Stalling would be indicated if the comparator had a difference voltage present on its output but rotor motion was stopped. I did not include this in the article as it wasn't essential to operation.

A final thought regarding the computer software. There are numerous applications for this circuit which can be implemented in the main program: rotation linked to a great circle program, direct heading entry via keyboard, timed rotation slaved to the computer clock (satellite tracking), etc. Who will be the first to implement total computer control of the shack? All the pieces are available: computer-interfaced HF rigs, CW/RTTY readers/generators, and now an antenna.

Good luck, and happy rotoring! ■

### Parts List

ICs		Resistors		Capacitors		Miscellaneous	
1	T17812 regulator (12v)	RS276-1771	\$1.59	3	1 megohm, 1/4 W		.10
1	T17805 regulator (5v)	276-1770	1.59	<b>Variable Resistors</b>			
1	µa723 regulator		2.79	2	1k mini-pot	271-0333	.49
1	LM337 regulator	276-1179	3.99	1	20k mini-pot	271-0336	.49
1	DAC0801 D/A converter	276-1791	3.49	4	100k mini-pot	271-0338	.49
1	MC1458 op amp		1.69	<b>Capacitors</b>			
1	LM339 op amp	276-1712	1.59	1	100 pF	272-123	1.39
1	NE555 timer	276-1723	.99	1	.01-µF, 16-V disc	272-131	.39
1	7476 JK flip-flop		1.59	10	.1-µFD, 16-V disc	272-135	.49
1	7400 NAND gate	276-1801	.59	2	1-µF tantalum, 15 V		1.59
1	1489 line receiver	276-2521	1.79	1	1-µF, 16-V electrolytic	272-996	.79
1	AY-3-1015-D or equivalent UART	276-1794	5.95	1	10-µF nonpolarized electrolytic	272-999	.99
1	COM5046 or equivalent baud-rate generator		3.00	1	47-µF electrolytic	272-1027	.69
<b>IC Sockets</b>				1	470-µF, 35-V electrolytic	272-1081	.99
5	14-pin, wire-wrap		.30	<b>Miscellaneous</b>			
3	16-pin, wire-wrap		.30	1	Female DB-25 connector		3.00
3	8-pin, wire-wrap		.30	1	Data cable from computer to interface		
2	40-pin, wire-wrap		1.75	4	Diodes (pkg. of 50)	276-1620	1.39
<b>Resistors</b>				4	2N3904 transistors (pkg. of 15)	276-1603	
1	120 Ohms, 1/4 W		.10	3	DPDT 12-volt relays	276-206	3.99
1	130 Ohms, 1/4 W		.10	1	8-switch DIP switch	275-1301	1.99
1	560 Ohms, 1/4 W		.10	1	4-switch DIP switch	275-1304	1.99
1	620 Ohms, 1/4 W		.10	1	12-V, 1.2-A transformer	273-1505	3.99
4	1k Ohms, 1/4 W		.10	1	12-V, 0.2-A transformer	273-1785	3.29
5	1.2k Ohms, 1/4 W		.10	2	Bridge rectifier packs, 50 V, 2 A	276-1151	1.59
1	2.7k Ohms, 1.4 W		.10	1	5.0688-MHz crystal, (Northern Engineering Labs, Burlington WI, (414)-763-3591; or Bulova Frequency Control Products, Woodside NY, (212)-335-6000.)		3.00
2	5k Ohms, 1/4 W		.10				\$75.81
4	10k Ohms, 1/4 W		.10				
6	100k Ohms, 1/4 W		.10				



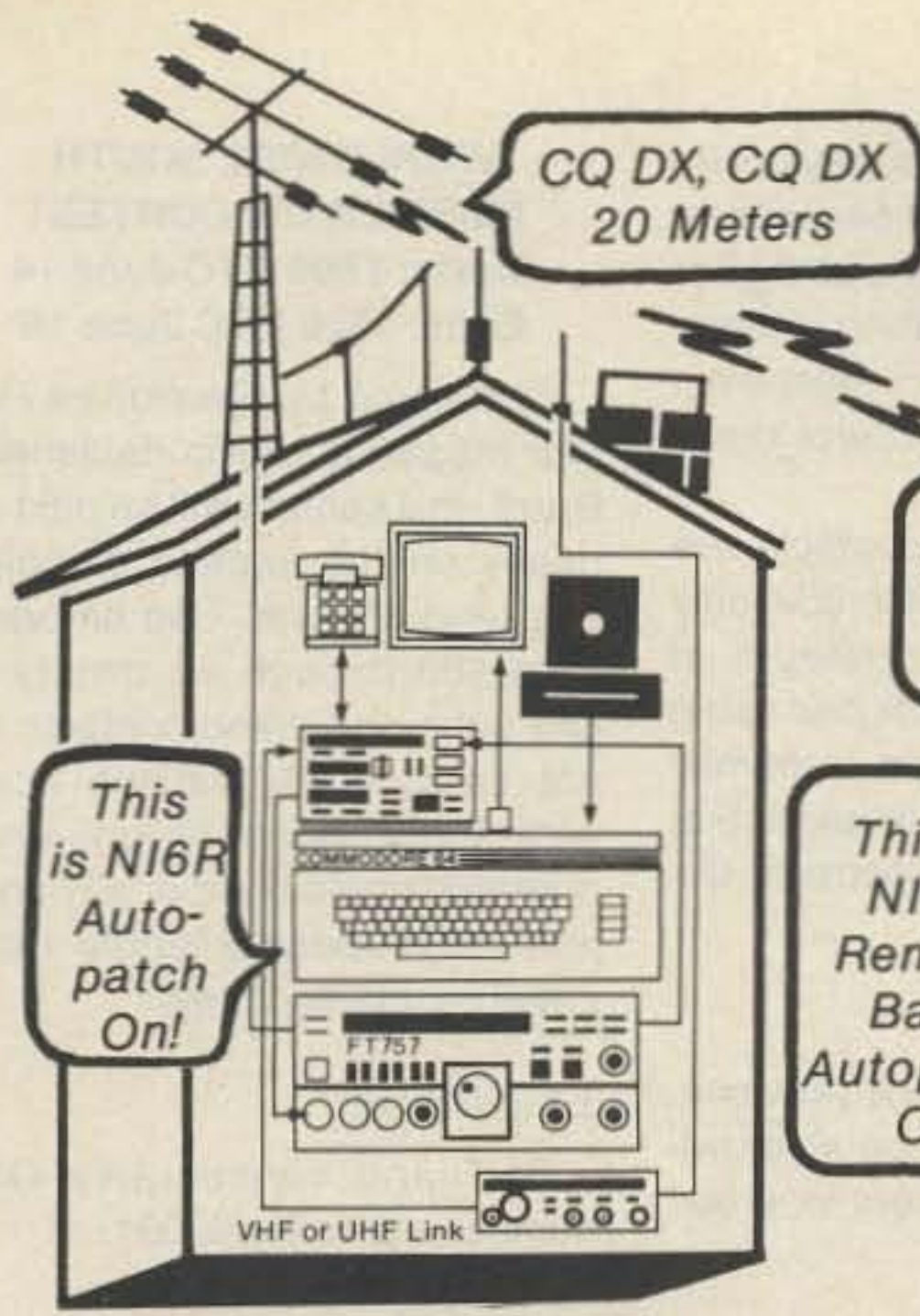

## COM-SHACK 64 SIMPLEX AUTO-PATCH & REMOTE H.F. BASE

MODEL CS-64

**\$229<sup>95</sup>**

Includes Software  
[Program Disk],  
Hardware Interface  
& Instruction  
Manual



Telephone  
**(714) 671-2009**

- Simplex autopatch and H.F. remote base with clear voice messages
- Control your Yaesu FT 757 transceiver or ICOM-IC735 with your VHF/UHF portable or mobile
- Switch between the H.F. remote and the autopatch with DTMF tones
- Voice ID & all control functions & H.F. frequency are voice announced with your programmable access codes
- Autopatch works on any telephone line — tone or dial pulse
- Call waiting compatibility — after beep answer second incoming call while on the patch!
- Automatic redial last number (in dial pulse mode)
- Ring detect & automatic voice alert of incoming telephone call
- Inactivity timer turns off system (user programmable)
- Store 8 H.F. memory frequencies + shift VFO's & change bands
- Fast scan & slow scan + dial up any frequency with DTMF tones all from your handheld VHF/UHF portable or mobile
- Use the autopatch or the remote base both for the price of one!
- User defined timing window, access codes, call sign
- Simple to install hardware interface cables, connectors supplied
- Hook mic input, PTT, spkr outputs & FM squelch connection 3 pin H.F. data cable and you are in control
- You supply — 1 Commodore 64 or 128 & 1 disk drive + base station
- No additional power supply required
- With human voice synthesized by Covox™.

Remote H.F.  
Now available for  
**ICOM-IC735 and Yaesu FT757.**

### TOUCHTONE™ DECODER KIT



MODEL TTK  
**\$22<sup>95</sup>**

- SSI201 DTMF Receiver
- Receive all 16 DTMF digits
- No additional filtering
- Output BCD or hex format
- Low power (29 ma @ 12V)
- Kit includes 3.58 Mhz crystal, 22 pin IC socket, resistor, capacitors, data sheet and schematics

### 4-DIGIT SEQUENCE DECODER

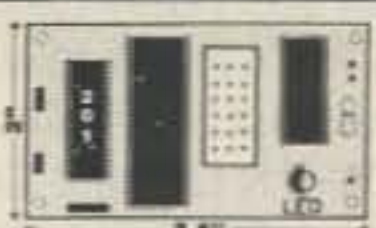

WIRED & TESTED  
MODEL TSD  
**\$59<sup>95</sup>**

- Completely wired & tested
- User programmable
- LED status indicator
- Open collector output
- Control relays; mute audio
- Control link on/off
- Custom IC insures high reliability & small size!
- Fits inside most rigs: runs on 12 VDC (35 ma)
- All 16 digits allow more than 50,000 combinations
- Makes excellent private call on busy repeaters!
- Use it to turn on audio or sound an alarm
- Momentary and latching outputs

Mastercard and Visa accepted  
Prices include postage & handling, U.S.A.  
California addresses add 6%.

### "DECODE-A-PAD"

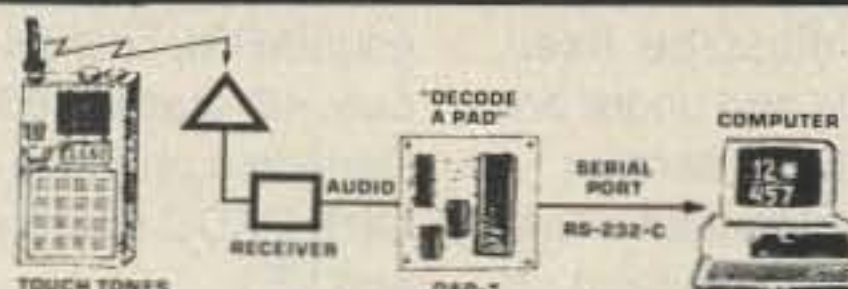

TOUCHTONE™ DTMF  
to RS-232-C  
300 BAUD INTERFACE  
MODEL DAP-1  
**\$89<sup>95</sup>**

- Use your computer to decode DTMF touchtones
- Receive all 16 digits as fast as they can be transmitted
- Easily program your computer in BASIC to decode multidigit "strings", display digits, sound alarms, observe secret codes, control relays
- Simple to use; just provide +12 VDC and audio, hook two wires to the RS-232-C serial input on your computer, enter a simple BASIC program and begin to decode
- Sample BASIC program and instructions included
- Data indicator
- Wired and tested



### TUNE THE WORLD FROM YOUR HANDHELD VHF/UHF RADIO

2 FOUR DIGIT DTMF DECODERS, PLUS 16 DIGIT KEYPAD CONTROL

Model RAP-1  
**REMOTE-A-PAD® \$149<sup>95</sup>**

- Audio tones from any source, are converted to solid state switches which control any 16 digit keypad of a radio or other device
- Some examples you can control include the Pro-Search™ Rotator (rotate beam remotely); Remote controls: ICOM IC-701 or ICOM IC-211 when using the RM-2 controller; Kenwood 7950, IC751; Azden PCS 4000; handhelds such as Yaesu FT-208; FT-708; ICOM IC-02AT; and many more...
- Two (four-digit) pro-

REPEATER OWNERS/HAM CLUBS  
The CS-64 will function in the  
simplex or duplex mode.

### ICOM IC-02AT USER'S "AUDIO BLASTER"™ MODULE

1000's of Satisfied Customers  
Now Available for  
MODEL AB-1  
**\$19<sup>95</sup>**  
IC-2AT & IC-04AT



- Module installs inside the radio in 10 minutes
- Boost audio to nearly one watt!
- Low power drain (4ma stand-by)
- Complete step-by-step instructions included
- Corrects the LOW audio problem!
- Drive external speakers to full volume, even signals with low deviation!

programmable access codes are used to operate relays or other on/off functions
- LED decoder status indicators and momentary plus steady state decoder outputs are provided
- All CMOS low power drain (30ma); S.S.I. 201 Decoder
- Hook eight wires (4 rows and 4 columns) in parallel with the existing keypad of the radio you wish to control remotely. Connect audio from any source, 12 volts D.C. and you are in control
- The dual 4 digit decoders will turn your links on and off using your programmable access code.

Name \_\_\_\_\_  
Address \_\_\_\_\_  
City \_\_\_\_\_ State \_\_\_\_\_ Zip \_\_\_\_\_  
MC/VISA No. \_\_\_\_\_ Exp. \_\_\_\_\_

**ENGINEERING CONSULTING**  
583 CANDLEWOOD ST., BREA, CA 92621, (714) 671-2009

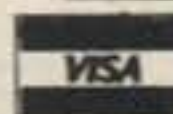

Qty.	Model No.	Total
_____	CS-64	_____
_____	TTK	_____
_____	TSD	_____
_____	DAP-1	_____
_____	AB-1	_____
_____	RAP-1	_____
_____	Tax (CA)	_____
_____	<b>Total</b>	_____



# CONTESTS

Robert W. Baker WB2GFE  
15 Windsor Dr.  
Atco NJ 08004

## ARRL VHF QSO PARTY

Starts: 1800 UTC June 14  
Ends: 0300 UTC June 15

The object of this ARRL-sponsored contest is to work as many amateur stations in as many different ARRL sections and countries as possible using authorized amateur frequencies above 50 MHz. Note that these rules were taken from previous year's contests, with 902 MHz now counting 3 points. No other changes were anticipated. Check *QST* for any last-minute changes.

Operating categories include single operator using multi- or single band, or multi-operator. Single-operator stations must use one person for all operating and logging functions. Single-operator stations may submit single-band scores for 50, 144, 220, 432, and 1296-and-up categories. Contacts may be made on any and all bands without jeopardizing single-band entry status. Such additional contacts are encouraged and should be reported.

Multi-operator stations must locate all equipment (including antennas) within a 300-meter circle.

Stations may be worked once per band regardless of mode. Each QSO must be acknowledged; one-way exchanges do not count. Foreign stations may

work only stations in the U.S., Canada, and U.S. possessions for contest credit.

Retransmitting either or both signals, or use of repeater frequencies is not permitted. Contest entrants may not transmit on repeaters or repeater frequencies on 2 meters to solicit contacts. Use of the national calling frequency, 146.52, or immediate adjacent guard frequencies is also prohibited. Only recognized simplex frequencies may be used, such as 144.90-145.10; 146.49, .55, and .58; and 147.42, .45, .48, .51, .54, and .57. Local option simplex channels and frequencies adjacent to the above that do not violate the intent of the contest rules or the spirit and intent of the band plans as recommended in the *ARRL Repeater Directory* may be used for contest purposes.

All operation must be fixed, portable, or mobile and under one call from one ARRL section. A transmitter used to contact one or more stations cannot be used under any other call during the contest period, with the exception of family stations where more than one call is assigned to one location by FCC/DOC. Also, one operator may not give out contest QSOs using more than one call-sign from any one location.

Only one signal per band at any given time is permitted, regardless of mode. While no minimum distance is specified for contacts, equipment should be capable of real communications (i.e., able to communicate over at least a mile).

Multi-operator stations may not include QSOs with their own operators except on frequencies higher than 2.3 GHz. Even then, a complete, different station must exist for each QSO made under these conditions.

Above 300 MHz, contacts are permitted for contest credit only between licensed amateurs of Technician class or higher using coherent radiation on transmission (e.g., laser) and employing at least one stage of electronic detection on receive.

### EXCHANGE:

Name of section, VE province, or DX country. Must be acknowledged by both operators for credit by either.

### SCORING:

Count one point for each complete 50- or 144-MHz QSO, 2 points for a 220- or 420-MHz QSO, and 3 points for 902-MHz or 1215-MHz-and-above QSO. Crossband QSOs do not count.

Multippliers count once per band: each ARRL section in the contiguous 48 states (63 max.), each Canadian province (12 max.), and each DXCC country (excluding W and VE).

### REPORTING:

Entries must be postmarked no later than July 11th and sent to: ARRL Headquarters, Newington CT 06111. Official entry forms are available from the same address for an SASE. Usual ARRL disqualification rules apply. Usual awards to top scorers in each ARRL section, some limited to where significant effort or competition is evidenced. Multi-operator entries are not eligible for single-band awards.

## WORLDWIDE SOUTH AMERICA CW CONTEST

Starts: 1500 UTC June 14  
Ends: 1500 UTC June 15

Sponsored by *Electronica Popular* magazine of Rio de Janeiro, Brazil, this contest will be held annually on the second complete weekend of June. Use all bands from 160 through 10 meters on CW only; crossband contacts are not valid. Work stations worldwide. Entry classes include single operator/single band or all bands, and multi-operator/single transmitter (multiband only).

### EXCHANGE:

RST and consecutive QSO number starting with 001.

### SCORING:

Each QSO within your own country counts zero points—it only counts as a multiplier. QSOs within same continent are 2 points; QSOs outside your continent are 4 points each. Contacts with South American stations (only for outside South America) count 8 points per QSO. Multipliers are the number of different DXCC countries and different South American prefixes worked on each band. Final score is the total QSO points multiplied by the sum of total multipliers in each band.

### AWARDS AND ENTRIES:

Certificates will be awarded to the three top-scoring stations in each class for each country with a reasonable score provided. A separate log for each worked band must be sent no later than August 31st to WWSA Contest Committee, PO Box 18003, 20772 Rio de Janeiro, RJ, Brazil. Include a self-

## CALENDAR

Jun 14-15	ARRL VHF QSO Party
Jun 14-15	Worldwide South America CW Contest
Jun 28-29	ARRL Field Day
Jul 1	CARF Canada Day Contest
Jul 12-13	IARU Radiosport Championship
Aug 2-3	ARRL UHF Contest
Aug 16-17	New Jersey QSO Party
Aug 16-17	New Mexico QSO Party
Sep 13-14	ARRL VHF QSO Party
Oct 11-12	Rio CW DX Party
Nov 1-2	ARRL Sweepstakes—CW
Nov 15-16	ARRL Sweepstakes—Phone
Dec 5-7	ARRL 160-Meter Contest
Dec 13-14	ARRL 10-Meter Contest
Dec 28	CARF Canada Contest

## ZERO BEAT



### NEWSLETTER OF THE MONTH

This month's winner is Zero Beat, the newsletter of the Hampden County (Massachusetts) Radio Association. Most of the most recent issue is taken up with a reprint of an article from 73 (that isn't why it won—we're trying to make a point here). If you see something in 73 that you'd like to reprint in your newsletter, drop us a note saying what you'd like to do. That's what Zero Beat did, and we were only too happy to help 'em out.

To enter your club's publication in 73's Newsletter of the Month Contest, send it to 73 Magazine, WGE Center, Peterborough NH 03458, Attn: Newsletter of the Month.



addressed envelope with IRCs for a copy of the results. (Note: See *Brazil column in 73 International.*)

### ARRL FIELD DAY

**Starts: 1800 UTC June 28**

**Ends: 2100 UTC June 29**

Note that these rules were taken from previous years' contests and no changes were anticipated other than the availability of the 24-MHz band. Check *QST* for any last-minute changes.

Sponsored by the ARRL, the contest is open to all amateurs in the ARRL Field Organization plus Yukon and NWT. Foreign stations may be contacted for credit, but are not eligible to compete. The object is to work as many stations as possible under less-than-ideal conditions. Operating times are limited depending on your operating class; check rules below.

Entry categories are classified by the maximum number of simultaneous transmitted signals, followed by the designation of the nature of the individual or group participation. Below 30 MHz, a transmitter must remain on a particular band for at least 15 minutes once used for a contact on that band. During this 15-minute period, the transmitter is considered to be transmitting a signal (even if it is not) for purposes of determining transmitter class. Switching devices are prohibited.

Class-A consists of club and non-club portable stations specifically set up for Field Day. Such stations must be located in places that are not regular station locations. They must use neither facilities installed for permanent station use nor any structures installed permanently for FD use. Stations must be operated under one callsign and under the control of a single licensee or trustee for each entry. All equipment (including antennas) must lie within a 300-meter circle. All contacts must be made with transmitters and receivers operating independently of commercial mains. Entrants who, for any reason, operate a transmitter or receiver from commercial mains for any contacts will be listed separately at the end of their class.

Any Class-A group whose entry classification is two or more transmitters (non-Novice) may also use one Novice/Technician operating position (Novice bands only) without changing its basic entry classification. This station (including antennas) should be set up and operated by Novice and Technician licensees and should use the

callsign of one of these operators.

Class-B consists of non-club portable stations set up and operated by not more than two licensed amateurs. Other provisions are the same as for Class-A.

Class-C consists of mobile stations in vehicles capable of operation while in motion and normally operated in this manner, including antenna. This includes maritime and aeronautical mobiles.

Class-D consists of stations operating from permanent or licensed station locations using commercial power. This group of stations may count only contacts made with Class A, B, C, and E Field Day groups for points.

Class-E stations are the same as Class-D except they use emergency power for transmitters and receivers. They can work stations in all classes.

Operators participating in FD may not contact for point credit the FD portable station of a group with which they participate. Any station used to contact one or more FD stations may not be used under any other call during the FD period, except for family stations.

Each phone and each CW segment is considered a separate band. All voice contacts are equivalent, and RTTY/ASCII is counted as CW. A station may be worked once on each band; crossband contacts are not allowed. The use of more than one transmitter at the same time in a single band is prohibited, except that a Novice/Technician position may operate on any Novice band segment at any time. No repeater contacts—but the 24-MHz band may now be used.

#### EXCHANGE:

Stations in any ARRL section send Field Day operating class and ARRL section. A four-transmitter station in NJ would send "4A NJ." Foreign stations send RS(T) and QTH.

#### SCORING:

Scores are based on the number of valid contact points times the multiplier corresponding to the highest power used at any time during the FD period, plus bonus points. Phone contacts are one point each; CW contacts are two points each. Power multipliers are: 5 for using a dc input power of 10 W (20 W PEP) or less (or 5-W-dc output/10-W-PEP output) if a power source other than commercial mains or motor-driven generator is used; 2 for using a dc input power of 200 W or less on CW and

400 W PEP or less on SSB; 1 for using anything higher.

Batteries may be charged while in use for Class-C entries only. For other classes, batteries charged during the FD period must be charged from a power source independent of the commercial mains.

Bonus points will be added to the score (after the multiplier is applied) to determine the final score. Only Class-A and -B stations are eligible for bonuses:

1) *100% Emergency Power*—100 points per transmitter for 100% emergency power. All equipment and facilities at the FD site must be operated from a source independent of the commercial mains.

2) *Public Relations*—100 points for public relations. Publicity must be obtained or a bona fide attempt to obtain publicity must be made, or operation must be conducted from a public place (such as a shopping center). Evidence must be submitted in the form of a clipping, a memo from a BC/TV station that publicity was given, or a copy of material that was sent to news media for publicity purposes.

3) *Message Origination*—100 points for origination of a message by the club president or other FD leader, addressed to the SM or SEC, stating the club name (or non-club group), number of operators, field location, and number of ARES members participating. The message must be transmitted during the FD period, and a fully serviced copy of it must be included with the FD report. The message must be in standard ARRL message form or no credit will be given.

4) *Message Reply*—10 points for each message received and relayed during the FD period, up to a maximum of 100 points. Copies of each message, properly serviced, must be included with the FD report.

5) *Satellite QSO*—100 points can be earned by completing at least one QSO via satellite during the FD period. The repeater provi-

sion is waived for satellite QSOs and a satellite station does not count as an additional transmitter. Show satellite QSOs as a separate band on the summary sheet.

6) *Natural Power*—FD groups making a minimum of 5 QSOs without using power from commercial mains or petroleum derivatives can earn 100 points. This alternative power source also includes batteries charged by natural means (not dry cells). The natural-power station counts as an additional transmitter. If you do not want to change your entry class, take one of your other transmitters off the air while making the natural-power QSOs. A separate list of natural-power QSOs should be enclosed with your entry.

7) *W1AW Message*—A bonus of 100 points will be earned by copying a special ARRL FD bulletin sent over W1AW on its regularly announced frequencies just before and during FD. This message can be received directly from W1AW or by any relay method. An accurate copy of the received message should be included in your FD report.

#### REPORTING:

Entries must be postmarked by July 24th; no late entries can be accepted. A complete entry consists of a summary sheet and a list of stations worked on each band/mode during FD, plus bonus proof. The list of stations worked on each band or mode may take the form of official ARRL dupe sheets or an alphanumeric listing of callsigns worked per band and mode. This list may be computer generated. Incomplete or illegible entries will be classified as check logs. A copy of FD logs should be kept by your FD group but should not be sent in unless specifically requested by ARRL. Normal ARRL disqualification rules apply.

All entries and requests for official forms should be addressed to: ARRL, Newington CT 06111. Include a 9 x 12 self-addressed envelope with 3-oz. postage for a complete Field Day entry package. ■

## HAM HELP

Does anyone know where I can get two of the vinyl cases that were available in Canada for awhile for the ICOM 2AT and 4AT with BP-5 batteries? I'm also looking for information on SSTV—

right now I can only receive. I need active frequencies to monitor.

**Scott Harvey KA7FVV**  
N. 5011 Idaho Rd.  
Newman Lake WA 99025







ther the original WordPak nor the newer WordPak II will be produced any longer, and that "owners of WordPaks, WordPak IIs, and WordPak-RSs should contact the individual software houses with respect to specific applications software."

While there will be updated drivers to install older WordPaks and PC-Paks into newer systems, "there will be no driver module or update for the 2SP-Pak. The reason for this is that the driver is built into OS-9 Ver. 2.00.00."

I cannot speak as to any of the new drivers; I have yet to see any of them myself. I am aware of several posted in the data libraries of CompuServe but have not looked at those yet, either. If you are a user of one or more of these boards, you might want to drop PBJ a line at their new address, 503 East 40th Street, Paterson NJ 07504, attention Mr. Donald Beane. Be sure to tell him you are interested in the information printed in this column.

Hardly a month goes by that one ham or another does not write me and request information on press wireless frequencies that can be copied on RTTY. Often, my response has been a reference to one of the several books on the market that provide extensive lists of such frequencies. This time is different. Thanks to Scott, the sysop of CompuServe's HamNet, Table 1 is a rather extensive list of some of the signals he has logged over the last few years. This list is from personal monitoring over the last 10 years and is not copied from any other lists. These press stations all transmit in English—some all the time, others just occasionally.

In the table, the "SB" column indicates USB or LSB to be selected for normal copy. The apostrophe next to the L or U indicates that the station is still on the air as of the beginning of last year.

The "SH" column indicates the shift (Mark-to-Space frequency difference) used. Note that most use 425-Hz shift.

The "BD" column indicates the baud rate, not words per minute. This is standard Baudot RTTY code. Most foreign stations use "FIGS J" as the bell and "FIGS S" as the apostrophe, which is the reverse of American machines.

The "M" in the BD column indicates that the station is a frequency-division multiplex (FDM) transmission, usually with 16 sub-carriers. The shift is usually 85 Hz, and many terminal units will not

copy this. Receiving these FDM stations with the bfo off sounds like a buzz-saw. These stations are the best source of AP/UPI news, quite similar in format to the wire-line press service sent to radio stations. The best way to tune these in is to select USB and tune onto the station from the high-frequency side to the uppermost subcarrier. This subcarrier is usually the one carrying the news.

The "SVC" column shows the abbreviation of the news service.

The "CALL" column is obvious. Not all stations give identify with a callsign. Some use the same callsign on all frequencies at once, and some have calls for each frequency in use, but do not indicate which call is for which transmitter.

Not all stations of a particular service carry the same text. The VOA, for example, carries as many as four different "programs" at the same time. The ARF, however, has the same text on all four frequencies at once.

I have not given times of transmissions. That is too difficult to pin down accurately. Many stations are on continuously.

The frequencies given are within 2 kHz. Some stations do slide up or down a little and reverse their mark and space frequencies on occasion. My receiver readout also does not include the amount of bfo offset (about 1.5 kHz).

Happy tuning. . . de K9EUI!

Now, if all of my stateside readers will forgive me, let me stay overseas for awhile. Jose Vargas HP1XJZ has been trying to get on to RTTY from Panama City, Panama, with his friend Peter HP1XPM. He has a few questions about specific items of equipment advertised for RTTY and packet interfacing. I know I have said this before, Jose, but I try to print whatever information I receive. If you have not seen a particular piece of gear mentioned here, it is because I have not received anything—not personal experience, users' input, or even a manufacturer's blurb—on that item. I try not to review from ads. Check through some back issues and see if what you're looking for is not there; be sure to let the manufacturers know that you would appreciate reading about their products in RTTY Loop before plunking down hard-earned money.

Bill Pearson writes from Upper Hutt, New Zealand, (I have a dermatologist friend by that name, who happens to be a ham as well, here in the Baltimore area) asking about several RTTY programs for

AA	Turkey press	KCNA	N. Korea press
AAP	Australian press	KUNA	Kuwait press
ADN	E. German press (DDR)	KYODO	Japan press
AFP	French press	LPS	London Press Svc
AFRTS	U.S. Armed Forces	MAP	African press
AGER	Rumanian press	MENA	Egypt press
ANA	Yemen press	MFA	E. German diplo
ANGOP	Angolan press	MINREX	Cuban embassy
ANS	Argentine press	MON	Mongolian press
ANSA	Italian press	MTI	Hungary press
ANT	Indonesia press	NA	Argentina press
AP	Associated Press	NSF	Nat. Science Found.
APA	Austrian press	PAP	Polish press
APN	USSR press	PET	Jordan press
APS	Algerian press	PL	Latin Press (Cuba)
ARF	U.S. State Dept.	PTI	India press
ATA	Albanian press	REUTER	British press
AZAP	Zaire press	SANA	Syrian press
BAK	USSR press	SAP	Algerian press
BTA	Bulgarian press	SLBC	Sri Lanka press
CETEK	Czech. press	SPA	Saudi press
CNA	China press	SUNA	Sudan press
DIPLO	diplo/embassy	TANJUG	Yugoslavia press
DPA	W. German press (FRG)	TAP	Tunisia press
DYN	Argentina press	TASS	USSR press
EFE	European file	TELAM	Argentina
FRC	Firestone Co.	U.N.	United Nations
GNA	Ghana press	UPI	United Press Int'l.
IINA	Italian press	USCG	Coast Guard
INA	Iraq press	VENPRES	Venezuela press
INDINFO	India press	VNA	Vietnam press
IRNA	Iran press	VOA	Voice of America
JANA	Libya press	WX	Weather
JJI	Japan press	XINHUA	China press
JNA	Jordan press	YONHAP	S. Korea press
JUEGOS	Latin America	ZANA	Zambia press

Table 2. SVC abbreviations.

the Apple II+ computer. I mentioned the new source for one of them, SuperRATT, a few months back but have heard nothing about the so-called "Galfo" program. He relates that one of the difficulties he faces is that a program which costs \$140 here sells for NZ\$280 there, and he has to pay for it before even seeing if he likes the way it works. Anybody around willing to stick a hand out and help a brother on the other side of the world?

Another reader in yet another corner of the globe is Gilbert Marazzini in Milan, Italy. Gilbert relates his enjoyment with the materials presented in this column and appears to be interested in learning more about some of the RTTY basics. Don't go anywhere else, Gilbert, there will be more to come, right here.

Dr. Girish Shah, in Ahmedabad, India, has been trying to put a C-64 computer onto RTTY, and it seems that this column and the magazine that contains it are about the only sources for RTTY information available to him. I do hope that some of the material presented here over the last few months has helped, and I look forward to hearing about your success on the Green Keys.

"Green Keys." I wonder how many of you newcomers know where that one comes from? I think I'll just let it dangle for now.

Another Apple user in another land is Geoff Dover G4AFJ in Leicestershire, England. I am sending Geoff the current reprint list, at his request, which details

some of the materials gleaned from past columns. The list can be yours, as well; just send a me a self-addressed, stamped envelope to the address at the head of this column and ask for the current reprint list. Naturally, other comments, questions, and prods are welcome at the same time.

The last ham on this whirlwind trip around the world is Alex Deligiannis SV8QG in Chios, Greece. Alex is the proud owner of a CoCo and believes he is the only one in SV-land trying to put one on the air. Well, again, I hope that some of the material I have presented here helps. I have planned some specific programming help for the CoCo if there is sufficient interest. With the paucity of programs comparable to those on other systems, there should be some demand here for a CoCo RTTY program that would be able to access disk functions and have a few bells and whistles to boot. Let me hear all of your opinions.

Now, take a deep breath folks and hear this. This month begins the *tenth year* of this column in 73 Magazine! That's right, TEN YEARS! Wow! I do want to take a moment to thank Wayne Green, without whose foresight many of the developments we take for granted might not have come to pass and who helped me get this column started—back in the dark ages. And my sincere thanks to each and every one of you, the readers of 73, who have pushed our hobby to the technological limit, then broken even that limit, only to push ahead to a new future.



As always, I remain available to you, either by mail at the address at the top of the column or on CompuServe, with my user number 75036,2501. If you want to get to me on CIS, EasyPlex (E-mail) is the best way. Messages

left on HamNet or the CoCo or OS-9 SIGs may get to me as well, but they depend on my being there to see them before they scroll off the system. Remember, for those of you who send questions via the USPS, a self-ad-

dressed, stamped envelope is required if you would like a personal reply; otherwise, watch the column for a reply. Don't forget that I write each column about two to three months before you see it, though.

Summer's coming, with Field Day, picnics, and swimming parties. Who's going to be the first with a terminal at poolside? Send me a picture, then look for it in next winter's RTTY Loop! ■

# NK6K > PACKET

Harold Price NK6K  
1211 Ford Ave.  
Redondo Beach CA 90278

## COMING ATTRACTION

Wake the kids and call the neighbors. The August issue of 73 is going to be all packet! And no, it won't just be this column with a thyroid condition. Nine or ten packet people will address such topics as: Intro to Packet, Intro to Networking, Better HF Operations, Packet Common Sense Operating Guide, Packet in Space, How to maintain digipeaters up where the air is thin, How to be a bulletin board/mailbox sysop, and more. For those of you who are worried that the inmates have finally taken over the asylum, don't worry; 73 will return to its regular fare the next month.

## Packet Basics

For this section, I take as my text 73 Magazine, April 1986, page 82, RTTY Loop column. I'll review the question "What does packet provide to justify the cost?" and touch on some of the differences between RTTY, AMTOR, and packet. We know that packet is used to move characters between ham stations—something RTTY and AMTOR already do. What makes packet different?

Digression one. It is not my goal here to rate one mode over the other. Comparing the three modes is a bit like comparing apples to oranges to pears anyway. Each was designed for a different purpose—to solve different problems at widely separated points in history. More importantly, the actual implementation of each mode by the hardware and software in whatever device you've chosen to use can have a far greater effect on performance than the mode itself. A poorly implemented version of AMTOR software, or a packet controller with an inferior modem, will result in less data, or more bad

data, than a well executed RTTY package.

Digression two. If you like using RTTY, don't let anyone talk you out of using it just because he says the mode is outdated. Whether it is or isn't is not the point, and that topic will not be debated here. Even though many in the RTTY world have changed over to the quiet tube-based RTTY systems, people still like using the old moving-parts gear for the challenge of bringing it up and keeping it running. The RTTY Loop column still carries information on how to get vintage electromechanical teleprinters on the air. If it's fun, I'm all for it. Some folks like whirring gears, others like flashing lights. While Part 97 tells us to provide emergency communications, extend the radio art, improve our skills, and enhance international goodwill, nowhere does it say that we can't have a good time doing it.

Recall the question "What does packet provide, and what is the cost?" Let's look at the easy part first: What does it cost? To get an idea of what the RTTY-experienced ham would consider cost-effective, I went to see my friend Lee Hallin WB7SND. He has managed to stay single and hasn't been forced to throw away things he'd rather save. His archives of 73, therefore, are much larger than mine. We went back to the issue containing the first appearance of the RTTY Loop column, June 1977. This was a time when computer-based RTTY was just gathering steam. I'll compare RTTY prices in that year to the price of getting on packet in the year that this packet column first appeared, when packet was beginning to gather momentum. In the June 1977 issue, I found two references to the price of RTTY gear. The column intro said, "a complete RTTY station can be assembled for under \$100." An ad near the middle had recently new

TTY-33s (usable on RTTY by the strong-willed) for \$850. Comparing the purchasing power of the dollar between 1977 and June 1985 (I got this data from the 1986 *World Almanac and Book of Facts*, page 51, the closest I could find in '86), you'd need at least \$158 in 1985 money to equal \$100 in 1977; \$850 in 1977 is \$1347 now.

Can you get on packet for \$158 now? Sure can! A \$50 surplus Xerox 820 board, a \$10 keyboard, a \$15 monitor, a FAD board from TAPR, the FADPAD software from FADCA, a \$20 surplus modem, and you're on the air. In 1986, this is known as "the hard way." There are several complete TNC kits available in the \$160 range. Put it together, plug it into the computer you probably already have, and you're on the air. Don't have a computer? Check the next swap meet; you should be able to pick up a glass-TTY (dumb terminal) for way under \$100. Commodore C-64s are around \$99. Don't like kits? Some assembled and tested TNCs are only \$30 more.

If you already have a C-64, \$219 gets you CW/RTTY/AMTOR and packet with AEA's PK-64 (reviewed in February's 73). That's \$129 in 1977 money. The same price or less gets you a packet-only unit that will work with any computer that draws less than 30 mA. You can run your TNC from the same 9-volt cell that you use to run your flashing LED callsign badge. A manufacturer new to the packet market has been advertising an assembled and tested packet controller for a price in the low hundred dollar range, but since I haven't seen one yet (3/31/86), I can't comment on it.

The price for a good packet unit and the price of a good RTTY or AMTOR unit are about the same. Depending on the features you can live without and how hard you are willing to work to scrounge parts, packet can be had for less than \$158. Note that the above discussion, like the one in 1977, assumes you already have a radio. Just as RTTY would soon boom after 1977, packet is in a rapid growth phase

now. Expect to see minimum featured TNCs available for less than \$100 soon, while TNCs with more features will be in the \$150 to \$300 price range. All of the prices mentioned here may be different by the time you see this, so check around.

Now to the more interesting part of the question, "What does packet provide?" Last month's column gave references to technical information on what packet provides. This month, I'll discuss some of the major obvious features the operator sees.

The most obvious differences stem from "packetizing," breaking up your data into chunks. Packet controllers (TNCs) move your data around in chunks of 80 to 128 characters on the average. This process goes on in the background. In most cases, you need not be aware that it is happening; you just keep feeding characters to the TNC.

There are several methods you can use to control the packetizing process. One way is by the use of a special character that tells your TNC to take up all of the characters you've entered to that point and make them into a packet. The special end-of-packet character can be specified by the user (with a command called SENDPAC on TAPR-like TNCs). Most users select the return key, <cr>. This causes a packet to be sent each time you hit <cr> as you type. A second way is to specify a maximum length for a packet (PACKLEN). The best length to pick depends on several factors—the mode (HF, VHF, OSCAR 10), the number of digipeaters you're using, the load on the channel, the signal strength, etc. When you have entered the specified number of characters, a packet will be sent. A third way is based on time. You can tell your TNC to send a packet every "n" seconds or after you have stopped typing for "n" seconds. You can use these three methods in any combination on most TNCs.

The end effect is that you just type on your keyboard, and the TNC takes care of sending the packets. Because of the packet-



ization process, there is always an occasional gap in your transmissions on the air. During these gaps, packets from the other station can be received. You can choose to see characters from the other station as soon as they are received, although most people use the FLOW ON command to get the TNC to hold characters from the other station until you have entered a complete line. What you then see on the screen are lines that you have entered interspersed with lines transmitted from the other station.

At least one TNC automatically performs a split-screen function. This gives you maximum flexibility in how you want to conduct your conversations. You can still talk in a paragraph mode, in which you finish a complete thought before the other station begins to respond. Or, you can rapidly trade short comments without having to make sure that the other station has dropped its carrier before you turn yours on and without having to use procedural signals such as OVER, K, AR, BK, or SO HW CPY OM. The TNC is taking care of that automatically. Full break-in RTTY is a joy to operate. We've all sat helplessly as a three-minute 60-wpm transmission has come in, answering a question we didn't ask. Packet gives you the opportunity to say, "Wait, you misunderstood the question."

A second benefit of packetization is more positive control over computer bulletin board systems (BBS). If you're an active RTTY mailbox user, how many times have you accidentally initiated a far longer dump from a mailbox than you intended? RTTY mailboxes can't hear while they're transmitting. A packet BBS can, once every 128 characters or so. You can write RTTY software that will turn off the transmitter and listen for a "go ahead" command, but that takes more software and will slow down someone who is getting what he asked for.

The third benefit of packetization I'll discuss this month is channel sharing. Digital devices can send characters faster than most hams can type. Whether you're sending on RTTY at 60 to 100 wpm or on packet at 360, 1,440, or more wpm, you can't keep the pipe full by hand, and sooner or later your type-ahead buffer runs dry. On

RTTY and AMTOR, dead space between entered characters is filled with idles, diddles, or straight tone. The frequency is "in use" even though no useful information is being sent. If your typing speed is 30 wpm and the channel speed is 60 wpm, 50% of the channel time is being wasted.

On packet, all characters are queued up in the TNC until a packet is sent. Only then does your station go on the air. If your typing speed is 30 wpm and the channel speed is 1,440 wpm, your station will only be on the air 2% of the time, or actually closer to 4% counting overhead. This leaves 96% of the channel free for other conversations, even though you are "using the frequency." Thus, there is room for 24 other 30-wpm typists on the same channel at the same time. Federal law requires me to tell you that, just as with EPA mileage, your rates may differ. The mechanics of sharing the channel tend to eat up some of the time. Future columns will discuss this matter in detail. To answer the first question that always comes up when channel sharing is discussed, your TNC takes care of showing you only those packets being sent to you. But yes, you can choose to see packets that aren't directed at you (reading the mail), and yes, there is a way to send CQ.

So, there we have three things packet provides that have nothing to do with linked digipeaters or error-free communications. I'll name a few more and save detailed discussion for future months.

Packet uses the full 8-bit ASCII character set. That means you can use all of the special characters, as well as lowercase. This tends to make conversations more expressive, since shouting is usually done in uppercase, LIKE THIS. As a more practical matter, it also makes connecting computers to radio easier, since you don't have to worry about mapping a 7- or 8-bit code set to a 5-bit one. You can use the control-C character to abort a message in progress on BBS systems, for instance. It is easy to connect other computer-based devices to packet, such as SSTV converters, because the TNC is taking care of all of the communications aspects.

Packetization makes nondirect-

ed round-tables possible. That's where everyone on the channel talks to everybody all at once, as in a Dayton hospitality suite. A duplex packet repeater is used for that purpose out here, and until you've actually taken part in a 28-way simultaneous conversation, you won't understand why you'd want to.

One last thing for this month that packet provides: fun. As I was writing this, Utah hams were putting up a new digipeater or two so that it was possible to get to Salt Lake City from southern California. One of the southern California packeteers, AA6TN, was having such a good time he didn't know which to do, work Utah or contact other local hams to let them know what was happening. He used packet to Utah with one hand and passed the news on a local voice repeater with the other. Although an eight-digipeater path is tenuous, it does establish future networking sites. The hard part of a nationwide VHF network is getting all the antennas, radio, TNCs, and Forest Service permits in place. Once the hardware is running, software improvements like those announced at the Orlando conference in March will provide the solid performance that packet promises.

### Orlando

The 5th Amateur Radio Computer Networking Conference, sponsored by the ARRL, was held in Orlando, Florida in March. These conferences attract hams from all over North America and abroad to discuss packet radio issues and plan for the future. They are scheduled at roughly one-year intervals and usually trade coasts each year. During the conference, there were several demonstrations of software that will provide the next level of network linking. These "smart digipeaters" will spring up like wildfire as soon as final testing is complete. As is usual, there is more than one way to skin a cat. Two different methods of networking were shown, and each method had a camp of loyal followers. The whole topic of networking will be discussed in an article in the August issue of 73, so reserve your copy now. The technical papers that were presented at the conference have been bound and published by the ARRL and are available from the League, as are the Proceedings of the 5th Networking Conference.

### Up To Date News

Due to the publication delays in large magazines, you won't see many news-breaking items here first. I'll try to provide background and commentary for major news items, though. The job of this column is to take a more leisurely look at things, to answer your questions, and to fill in the gaps. There are several excellent ways to keep track of the fast-moving world of packet as things happen, however.

The best way is to take the plunge and get on packet. Even if you primarily want to rag-chew, the various BBS systems in your area carry the latest news. One of the newsletters you usually find on packet BBS systems is the GATEWAY newsletter. The ARRL publishes this newsletter every two weeks and permits the reproduction and dissemination of the information on packet systems. The newsletter is also available by subscription. If you do read it on a packet system, please drop them a line to let them know so they can continue to justify the expense of releasing it "for free." Another way to get current information is via CompuServe's HAMNET. This will cost you some bucks, but most of the news and technical information finds its way to HAMNET sooner or later. I'm on HAMNET, and so are the Fun! and RTTY Loop columnists and the 73 Editor, but don't let that dissuade you.

For international packet users, as well as local folks, the UoSAT-OSCAR-9 and UoSAT-OSCAR-11 spacecraft carry plain-text ASCII bulletins that include major packet news. A future column will contain information on how to copy the digital satellites. I have at least a year's backlog of things to talk about, so I hope no one catches me having a good time and shuts me down before then. The AMSAT publications provide satellite information. Ask an AMSAT member for a peek at his back issues, or better yet, become a member yourself. There will be two packet-related amateur satellite launches this year.

That's all for this month, next month I'll discuss FCC RM 85-105, the automatic control order, plans for an STA request for automatic control of HF store-and-forward message systems, and the Dayton packet activities. Until then, see you on packet. ■



# SPECIAL EVENTS

Listings in this column are provided free of charge on a space-available basis. The following information should be included in every announcement: sponsor, event, date, time, place, city, state, admission charge (if any), features, talk-in frequencies, and the name of whom to contact for further information. Announcements must be received by 73 Magazine by the first of the month, two months prior to the month in which the event takes place. Mail to Editorial offices, 73 Magazine, WGE Center, Peterborough, NH 03458-1194.

## PICCOLO SPOLETO FESTIVAL MAY 24-JUN 7

The Trident ARC will operate N4EE to commemorate the Piccolo Spoleto Festival's ninth season of presenting local and south-eastern regional talent from every artistic discipline, as follows: 1400 UTC to 2400 UTC on May 24-25, May 31-June 1, and June 7. SSB—7.249, 14.240, 21.340, and 28.540; CW—7.120 and 21.120. Certificate for QSL and large SASE to TARA, PO Box 73, Summerville SC 29484-0073.

## BLOSVALE NY JUN 1

The Rome (New York) Radio Club, Inc., will sponsor its 34th annual Ham Family Day on June 1, beginning at 9 a.m., at Becks Grove, Blosvale, New York. Talk-in on 146.28/.88 and 146.34/.94. For more information or for reservations, write the Rome Radio Club, Inc., Box 721, Rome NY 13440, or call William Effland at (315)-853-5700.

## HUMBOLDT TN JUN 1

The Humboldt ARC will sponsor its annual hamfest on Sunday, June 1, at Bailey Park, 22nd Avenue, Humboldt, from 8 a.m. to 4 p.m. Admission is \$1. Talk-in on .37/.97. For further information, contact Ed Holmes W4IGW, 501 N. 18th Avenue, Humboldt TN 38343.

## CHELSEA MI JUN 1

The Chelsea Communications Club will sponsor its ninth annual Swap 'N' Shop on June 1, from 8

a.m. to 2 p.m., at the Chelsea Fairgrounds, Chelsea, Michigan. Admission is \$2.50 in advance and \$3 at the door. YLs, XYLs, and kids under 12 are free. Table space (8 feet) is \$8; trunk sale space is \$2. Talk-in on 147.255. For more information, call (517)-764-5785, or write William Altenberndt, 3132 Timberline, Jackson MI 49201.

## MILESTONES OF MEMORIES JUN 6-8

The Wichita (Kansas) ARC will operate special-event station W0SOE from Lewis, Kansas, on June 6-8 to help celebrate its centennial. The Milestones of Memories operation will be on approximately 3.875, 7.250, 14.250, and 21.325 MHz. QSL via W0SOE, Wichita ARC, 707 N. Main, Wichita KS 67203.

## LIGHTSHIP PORTSMOUTH JUN 6-8

The Portsmouth (Virginia) ARC will operate W4POX on June 6-8, 1500-0800 UTC daily, from the Lightship Portsmouth at the Portsmouth Seawall Festival. Frequencies are 7.230 and 14.290. For a commemorative QSL, send a QSL and an SASE to W4POX, 4800 Manor Avenue, Portsmouth VA 23703. For a QSL and a certificate, send your card and a 9 x 12 envelope with 44 cents postage.

## GUELPH ONT JUN 7

The Kitchener-Waterloo ARC will sponsor the 12th annual Central Ontario Amateur Radio Flea Market and Computerfest on Saturday, June 7, from 8 a.m. to 2 p.m., at the Col. John McRae Legion Hall, Guelph, Ontario. Admission is \$2. Inside space is \$8 (table included). Outside space is \$3. Talk-in on 147.960/.360 and .52. For more information, write the Kitchener-Waterloo ARC, PO Box 812, Kitchener, Ontario, Canada N2J 4C2, or call Paul VE3CHM at (519)-579-3057.

## NORTH GEORGIA JUN 7

The John Ross ARC will sponsor the fourth annual North Georgia Hamfest on Saturday, June 7, beginning at 8 a.m., at Lakeview Fort Oglethorpe High School, five miles south of Chattanooga, Ten-

nessee. Admission is \$1; flea-market spaces are \$6; tailgating spaces are \$2. Exams will be given. For more information, write the John Ross ARC, PO Box 853, Rossville GA 30741, or call Murel Winans KA4LMG at (404)-867-7739.

## ST. PAUL MN JUN 7-8

The North Area Repeater Association will sponsor its Amateur Fair on the weekend of June 7 and 8 at the Minnesota State Fairgrounds in St. Paul, Minnesota. Admission is \$4 in advance or \$5 at the Fair. Amateur license exams will be given. Giant outdoor flea market, exhibits, commercial dealers. Free overnight parking June 6 and 7 for self-contained campers. Talk-in on .25/.85 or .16/.76 repeaters. For dealer inquiries, tickets, and further information, write Amateur Fair, PO Box 857, Hopkins MN 55343, or call (612)-566-4000.

## OHIO WINE MONTH JUN 7-8

WINO (Wireless Institute of Northern Ohio), an organization sponsored by the Lake County Amateur Radio Association, will be on the air from a winery in Madison, Ohio, with the call KO8O, to commemorate Ohio Wine Month. Operation will be on 3.860 and 7.235 from 2300 UTC to 0300 UTC, Saturday, June 7, and on 7.235 and 14.235 from 1500 UTC to 1900 UTC on Sunday. For a special 8-1/2 x 11 certificate, send a legal-size SASE to KO8O WINO Weekend, 7126 Andover Drive, Mentor OH 44060.

## 25TH ANNIVERSARY FAIR LAWN NJ ARC JUN 7-8

The Fair Lawn ARC will operate the club station under founding member Frank Leonard's call, W2NPT, to commemorate the 25th anniversary of the club. Operation will be from 1300 to 2200 UTC on the 7th and from 1400 to 1500 UTC on the 8th. Frequencies: CW—7.050, 7.110, 14.050, and 21.050 ( $\pm 10$  kHz); phone—7.285, 14.285, and 21.385 ( $\pm 10$  kHz). For a certificate, send a QSL and an SASE to Frank Leonard W2NPT, 17-12 Well Drive, Fair Lawn NJ 07410.

## LOVELAND CO JUN 7-8

The Northern Colorado ARC will sponsor Superfest VIII on June 7-8, beginning at 9 a.m., at

the Larimer County Fairgrounds, Loveland, Colorado. Admission is \$3; tables are \$5; tailgating is \$5. For more information, contact Cliff Baker W0ITD, 2623 52nd Avenue, Greeley CO 80634; (303)-330-3548.

## ERLANGER KY JUN 7-8

The Northern Kentucky ARC will sponsor Ham-O-Rama '86 on June 7-8, beginning at 8 a.m., at the Best Western Vegas Convention Center, Erlanger, Kentucky. Admission for both days is \$5; children under 13 are free. Indoor and outdoor flea market—contact AF4Y or WD4PBF at the gate for spaces and prices. Talk-in on 147.855/.255. For more information, call Joe Dunnett WA4WNF at (606)-371-2255 or write NKARC at PO Box 1062, Covington KY 41012.

## SJRA 70TH JUN 7-16

The South Jersey Radio Association, the oldest radio club in the U.S., will operate special-event station K2AA from 1200 UTC on June 7 until 1200 UTC on June 16 in celebration of the club's 70th birthday. Frequencies: phone—3.890, 7.240, 14.280, 21.360, 28.600; CW—3.590, 7.050, 14.050, 21.090, 28.150; two meters; Novice bands. For a commemorative QSL, send an SASE and a QSL (or log info) to the South Jersey Radio Association, PO Box 1026, Haddonfield NJ 08033.

## LEWISBURG PA JUN 8

The Milton ARC will hold its 12th annual hamfest on Sunday, June 8, from 8 a.m. to 4 p.m., at the Winfield Firemen's Fairground, four miles south of Lewisburg, Pennsylvania. Admission is \$3; women and children are free. Talk-in on 146.37/.97 or 146.025/.625. For more information, contact Jerry Williamson WA3SXQ, 10 Old Farm Lane, Milton PA 17847; (717)-742-3027.

## ROANOKE VOYAGES JUN 8, 10

The Raleigh Amateur Society, in conjunction with the hams of North Carolina and in cooperation with the North Carolina State Department of Cultural Resources, will celebrate the 400th anniversary of Sir Walter Raleigh's Roanoke Voyages by operating special-event station W4DW. Operation will be on 3.905, 7.250,



and 14.335 MHz ( $\pm$ QRM) from 1500 to 2100 UTC on both Sunday, June 8, and Tuesday, June 10. For a commemorative QSL card and historic literature, send your QSL card and a #10 SASE to W4DW RARS, PO Box 17124, Raleigh NC 27619. Your card and our logs will become a permanent part of the log of *Elizabeth II*, a sailing replica of the original craft.

**QUEENS NY  
JUN 8**

The Hall of Science ARC will sponsor a hamfest on June 8, from 9 a.m. to 4 p.m., at the Hall of Science Parking Lot, Flushing Meadow Park, 47-01 111th Street, Corona, Queens, New York. Admission is \$3 for buyers; \$5 for sellers. Talk-in on 144.300 simplex link, 223.600 repeat, and 445.225 repeat. For more information, call John Powers KA2AHJ at (718)-847-8007, or Arnie Schiffman WB2YXB at (718)-343-0172.

**GRANITE CITY IL  
JUN 8**

The Egyptian Radio Club will hold its 57th annual hamfest on Sunday, June 8, from 8 a.m. to 3 p.m., at the ERC clubhouse and grounds. Admission is \$1 in advance; \$2 at the door. The first flea-market space is free; each additional space is \$5. Directions: I-270 to IL Route 3 South, turn right at Chain of Rocks Road, then follow signs. Talk-in on 146.16/.76 or 146.52. For tickets or more information, send an SASE to the Egyptian Radio Club, PO Box 562, Granite City IL 62040.

**DREXEL HILL PA  
JUN 8**

The Delaware County ARA will sponsor its seventh annual hamfest on June 8, beginning at 8 a.m., at the Drexel Hill Middle School, Drexel Hill PA. Admission is \$3. Indoor tables with power are \$3; outside tailgating is free. Exams will be given. Talk-in on 147.96/.36, 224.5, and 146.52. For more information, write to Hamfest, DCARA, PO Box 236, Springfield PA 19064, or call Barbara N3DLG at (215)-535-1616.

**NEWINGTON CT  
JUN 8**

The Newington ARL will hold its third annual flea market on Sunday, June 8, from 9 a.m. to 2 p.m., at Newington High School, Willard Avenue (Route 173), Newington, Connecticut. Admission is \$2. Tables are \$10; tailgating is \$5. Talk-in on 146.52, 144.85/

145.45, and 223.24/224.84. For more information, send an SASE to Les Andrew KA1KRP, 23 Grove Street, West Hartford CT 06110; (203)-523-0453.

**WRIGHTSTOWN PA  
JUN 8**

The Warminster ARC will sponsor its 12th annual hamfest on Sunday, June 8, beginning at 7 a.m., at the Middletown Grange Fairgrounds, Penns Park Road, Wrightstown, Pennsylvania. Admission is \$3; XYLS and children are free. Outdoor tailgating spaces are \$5; indoor spaces with 8-foot table and power are \$5 (pre-registration suggested). Talk-in on 147.69/.09 and 146.52. For information or pre-registration, contact Chuck Dunn KA3FQQ, 1414 Bradley Lane, Warminster PA 18974; (215)674-8567.

**LOUISVILLE KY  
JUN 11-14**

The Antique Radio Club of America will hold its annual national convention on June 11-14 in Louisville, Kentucky. All interested people are invited. ARCA has about 1000 members who collect and restore antique wireless and radio equipment and who study and record the history of early radio. For more information on the convention or ARCA membership, contact ARCA, 81 Steeplechase Road, Devon PA 19333; (215)-688-2976.

**CORTLAND NY  
JUN 14**

The Skyline ARC will sponsor a hamfest and flea market on Saturday, June 14, from 8 a.m. to 5 p.m., at the Cortland County Fairgrounds, Cortland, New York. Admission is \$3; under 12 free. Outdoor flea-market space is \$1; an indoor table is \$5. For more information, call Billy N2AGF at (607)-749-3766, or Bud K2ZER at (607)-753-3994.

**BSA SCOUT-O-RAMA  
JUN 14**

The Chicago Suburban Radio Association will operate its third annual special-event amateur-radio station, N9BAT, from the Brookfield Zoo, Brookfield, Illinois, on June 14, from 1500 to 2300 UTC, as part of the West Suburban Council, BSA, annual Scout-O-Rama. Frequencies: 7.250 and 14.250 MHz. A special full-color QSL card available for a QSL card and business-size SASE to N9BAT Special Event, PO Box 88, Lyons IL 60534.

**TWIN FALLS ID  
JUN 14-15**

The Magic Valley Chapter of the Idaho Society of Radio Amateurs will sponsor a swap meet on June 14-15, from 10 a.m. to 5 p.m. on Saturday and from 8 a.m. to 12 noon on Sunday, at the Moose Lodge, 835 Falls Avenue, Twin Falls, Idaho. Admission is free. Talk-in on 146.16/.76. For more information, write the Idaho Society of Radio Amateurs, Magic Valley Chapter, PO Box 294, Twin Falls ID 83303.

**CROWN POINT IN  
JUN 15**

The Lake County ARC will

sponsor its 14th annual Fathers' Day Hamfest on Sunday, June 15, from 8 a.m. to 2 p.m., at the Lake County Fairgrounds Industrial Building, Crown Point, Indiana. Admission is \$3. Tables will be available. Talk-in on 147.84/.24 or 146.52. For more information, write Bill DeGeer W9TY, 3601 Tyler Street, Gary IN 46408, or call (219)-887-5413 after 6 p.m.

**FREDERICK MD  
JUN 15**

The Frederick ARC will hold its 9th annual hamfest on June 15, from 8 a.m. to 4 p.m., at the Frederick Fairgrounds, Frederick, Maryland. (Gates open for ex-

# SATELLITES

**USING THE A0-10 PREDICTIONS**

Apogee predictions for the month of June are provided for three sections of the United States: Washington, D.C.; Denver, Colorado; and Los Angeles, California. Times are in UTC and apogee in this case is mean anomaly 128 rounded to the nearest whole hour. Use the chart as a guide in aiming your antenna, then fine-tune the azimuth and elevation values to peak the satellite's beacon signal. If you require more accurate orbital predictions, contact AMSAT at PO Box 27, Washington DC 20044.

**AMSAT-OSCAR 10 APOGEE PREDICTIONS  
June 1986**

DAY	TIME	WASH		DENVER		LA	
		AZ	EL	AZ	EL	AZ	EL
1	1301	172	19	146	10	134	7
2	1220	163	18	138	6	128	2
3	1139	154	15	131	1		
4	1058	145	11				
5	1017	138	6				
6	0936	131	1				
8	1954					234	1
9	1913					228	6
10	1832			230	1	221	11
11	1751			223	5	213	16
12	1710			215	10	204	21
13	1629	230	1	207	14	195	24
14	1549	223	6	198	17	185	25
15	1508	215	11	188	18	174	25
16	1427	207	15	179	19	164	23
17	1346	198	18	169	18	155	21
18	1305	188	20	160	16	146	17
19	1224	178	21	151	14	138	12
20	1143	169	19	142	9	131	6
21	1102	159	17	135	5	125	0
22	1021	150	14	128	0		
23	0940	142	10				
24	0859	134	5				
25	0818	127	0				
27	1836					233	3
28	1755					226	9
29	1714			228	3	219	14
30	1633			221	8	211	19



hibitors at 8 p.m. on the 14th. Overnight security and parking provided.) Admission is \$3, tailgaters \$2 additional; exhibitor tables are \$10 for the first, \$5 for each additional table. YLs and children admitted free. For additional information, write Jim Kasunic KA3LPC, 9419 Highlander Court, Walkersville MD 21793.

**DUNELLEN NJ  
JUN 21**

The Raritan Valley Radio Club will hold its 15th annual hamfest on Saturday, June 21, beginning at 8 a.m., at Columbia Park, Dunellen, New Jersey. Admission is \$3; spouses and children are free. One selling space is \$5; \$10 for multiple spaces. Tables are not supplied. Talk-in on 146.025/.625 and 146.52. For more information, call Dave KA2TSM at (201)-763-4849 or Bill N2AZX at (201)-467-7342.

**ARGONNE LAB  
JUN 21**

The Argonne ARC will operate special-event station W9QVE from 11 a.m. to 4 p.m. CST on June 21 to commemorate the 40th anniversary of the establishment of the U.S. National Laboratory

System (Argonne was the first). Operation will be on 144.59/145.19 and the phone portion of the 20-meter General band. Send a QSL and an SASE to AARC, PO Box 275, Argonne IL 60439.

**MANCHESTER NH  
JUN 21**

The New Hampshire FM Association will sponsor an amateur radio/electronics flea market on Saturday, June 21, beginning at 9 a.m., at the Manchester Municipal Airport, Manchester, New Hampshire. The rain date is Sunday, June 22. Admission is \$1; \$5 for sellers—tables not provided. Talk-in on 146.52 FM. For more information, contact Pete Henriksen WA1RCF, 123 Woodlawn Circle, Portsmouth NH 03801; (603)-431-5432—or call Doug Aiken K1WPM at (603)-622-0831.

**TWIN VALLEY 100TH  
JUN 27-30**

Special-event station KE0DJ will be operated on June 27-30 to commemorate the centennial of Twin Valley, Minnesota. Operation will be primarily on 15, 20, and 40 phone, as well as available satellites. QSL with #10 SASE to KE0DJ, c/o Dale Cary WD0AKO,

1318 34th Avenue S. #301, Moorhead MN 56560.

**GRAND RAPIDS MI  
JUN 28**

The Independent Repeater Association will sponsor its annual IRA Hamfest, "The Amateur Extravaganza," on June 28, from 8 a.m. to 4 p.m., at the 44th Street Armory, Grand Rapids. Admission is \$3.50; tables free. Take U.S. 131 south of Grand Rapids to 44th Street and go west 1 mile. Talk-in on 147.765/.165. For table reservations and further information, write the Independent Repeater Association, 562 92nd Street, Byron Center MI 49315, or call Abe W8HVG at (616)-455-3915.

**LINCOLN BIRTHPLACE  
JUN 28-29**

The Lincoln Trail ARC will operate special-event station W4BEJ from the Abraham Lincoln Birthplace National Historic Site near Hodgenville, Kentucky, during Field Day, June 28-29. For a commemorative certificate, send a QSL and an SASE (Note: LTARC log will show only Field Day calls—be sure that you include that information) to LTARC,

PO Box 342, Vine Grove KY 40175.

**VANCOUVER 100TH/  
VARC 50TH  
JUN 28-29**

The Vancouver ARC is celebrating its home city's centennial and its own 50th anniversary by operating two Field Day stations on June 28-29. In cooperation with the Expo '86 Amateur Radio Committee, the club will operate station VE7 EXPO and station VC 100. Those who contact either station will receive a special QSL.

**ACB 50TH  
JUN 29-JUL 5**

The ACB Radio Amateurs, a special-interest affiliate of the American Council of the Blind, will operate special-event station KW4U from 0000 UTC on June 29 until 2400 UTC on July 5 from the Hilton Hotel in Nashville TN, the sight of the ACB's silver anniversary convention. Operation will be 80 through 10 meters: 30 kHz from the bottom of CW bands; 5 kHz from the bottom of phone bands ( $\pm$ QRM). For a commemorative certificate, send a QSL to John McCann K4WU, 2105 W. Illinois Street, Arlington VA 22205.

# FEEDBACK

In our continuing effort to present the best in amateur radio features and columns, we've decided to go directly to the source—you, the reader. Below, the articles and columns in this issue are assigned numbers. These numbers correspond to those on the "Feedback" card opposite this page. On the card, please check the box which honestly represents your opinion of each article or column.

"What's in it for me?" comes the cry from our faithful readers. Besides the knowledge that you're helping us find out what you like (and don't like), we'll draw one Feedback card each month and award the lucky winner a free one-year subscription (or extension) to 73.

To save some money on stamps, why not fill out the Reader Service card, the Product Report card, and the Feedback card and put them in an envelope. Toss in a damning or praising letter to the editor while you're at it. You can also enter your QSL in our QSL of the Month contest. All for the low, low price of 22 cents!

Feedback #	Title		
1	A Walk Through the VHF/UHF Spectrum	13	Contests
2	Hams in Space	14	Dealer Directory
3	Two to Ten	15	Fun!
4	Some Guys Make It . . .	16	Letters
5	Digital Simplex Repeaters	17	Looking West
6	Messing With Microwaves	18	Never Say Die
7	They Threw What Away?	19	New Products
8	Those Tantalizing Twos	20	NK6K > Packet
9	Computer Rotor Control	21	Propagation
10	Review: ICOM's IC-471A versus Kenwood's TS-811A	22	QRP
		23	QRX
11	Review: The MFJ-1270 TNC	24	RTTY Loop
12	Barter 'N' Buy	25	73 International



# ADVERTISERS

R.S.#		page
65	AEA	36
1	Advanced Computer Controls	11
2	All Electronics	109
*	Alinco Electronics, Inc.	103
3	Amateur Comm., Etc.	90
*	Amateur Electronic Supply	56, 57
4	Amidon Associates	45
74	Antique Electronic Supply	108
16	Astron Corp.	51
*	The Atlanta Hamfestival	32
7	BJX Supply Co.	47
53	Barker & Williamson	54
41	Barry Electronics	55
8	Bill Ashby & Son	81
90	Britt's 2-Way Radio	12
68	CES, Inc.	107
46	Charge-Rite	110
59	Communications Electronics	63
10	Communications Specialists	99
85	Comprad	81
11	Computer Trader	95
12	Connect Systems, Inc.	2
*	Dick Smith Electronics	47
15	Doppler Systems	81
87	ENCOMM, Inc.	9
88	ENCOMM, Inc.	105
158	Etron RF Enterprises	18
*	Engineering Consulting	71
58	Fox-Tango	45
17	GLB Electronics	62
72	Glen Martin Engineering	108
19	Hal-Tronix	54
20	Ham Radio Outlet	1
*	The Ham Station	32, 50
*	Hamtronics, NY	37
*	ICOM America, Inc.	Cov. II, 18
*	Indianapolis Hamfest	59
22	Jan Crystals	36
157	Jensen Tools	18
159	Kalglo	18
56	Kantronics	111
*	Kenwood	5, 6, 20, Cov. IV
*	The Laser Press	108
161	Larsen Antennas	18
152	MFJ Enterprises	24
24	MFJ Enterprises	14
89	MFJ Enterprises	15
25	Madison Electronic Supply	29
47	Maggiore Electronic Lab	19
153	Medford Specialized Services	18
26	Micro Control Specialties	107
70	Microlog Corp.	31
91	Mirage/KLM	16
80	Missouri Radio Center	112
84	Multi-Botics	62
155	Nemal Electronics	19
50	Nemal Electronics	93
154	Ovonic Thermo Electric Co.	18
28	P.C. Electronics	23
29	The PX Shack	95
44	Pac-Comm Packet Radio Systems, Inc.	93
30	QEP'S	108
31	Radio Amateur Callbook, Inc.	13
33	Radiokit	81
32	Radio Engineers	108
34	Ramsey Electronics	87
73		
	Subscriptions	33
	Sweepstakes	97
*	Silicon Solutions	25
160	Simpson	19
35	Spec-Com Journal	36
51	Spectrum Communications	13
77	TSG	108
*	Ten-Tec	101
60	Thomson Software	108
79	Vanguard Labs	90
38	W9INN Antennas	108
39	Western Electronics	90
40	Yaesu Electronics	Cov. III

\* Please correspond with this company directly.

## COMPACT 75 M SSB TRANSCEIVER



Dimensions 2" x 6" x 6"

Complete Kit  
**\$199.95**

plus \$3.00  
shipping and  
handling

### RECEIVER:

Frequency 3.8-4.0 MHz  
Sensitivity 0.5  $\mu$ V for 10 dB S/N  
Selectivity -6 dB @ 2.4 KHz  
AGC Range +60 dB in = +3 dB out  
Audio Output >350 mW into 8 ohms

### TRANSMITTER:

Frequency 3.8-4.0 MHz  
Output 30 watts into 50 ohms  
IMD -30 dB  
Harmonics 2<sup>nd</sup> -47 dB, 3<sup>rd</sup> -55 dB  
SWR Immunity 30:1 @ all phase angles  
ALC Amplified, fast response rate (quasi-processing)

### POWER REQUIREMENTS:

Voltage 28 Vdc regulated  
Current 2A transmit, 65 mA receive

Going Mobile, use  
12-24 Vdc Inverter.

1986-87  
CATALOG  
\$1.00



RADIO KIT  
BOX 411S  
Greenville, NH  
03048  
(603) 878-1033  
telex 887697

✓33

## DIRECTION FINDING?

- ★ Interference Location
- ★ Stuck Microphones
- ★ Cable TV Leaks
- ★ Security Monitoring



- ★ VHF and UHF Coverage
- ★ Computer Interface
- ★ Speech Synthesizer
- ★ 12 VDC Operation

**New Technology** (patent pending) converts any VHF or UHF FM receiver into an advanced Doppler shift radio direction finder. Simply plug into receiver's antenna and external speaker jacks. Uses four omnidirectional antennas. Low noise, high sensitivity for weak signal detection. Call or write for full details and prices.

**DOPPLER SYSTEMS, INC.** 5540 E. Charter Oak, (602) 998-1151  
Scottsdale, AZ 85254

✓15

## Comprad

### P/C Controlled Radio

Interface your commodore or Apple II PC and Kenwood's TS940, 811, 711 or 440 with COMPRAD Program all radio functions from your PC Keyboard Shortwave listeners: Station selections with one keystroke.

**Two disk package and manual \$49.95**

(price includes shipping)

Send money orders only to:

**MISIL • 50 Notre Dame Rd. • Bedford, MA • 01730**

**Available soon for IBM PC and Compatibles**

✓85

### PACKET RADIO

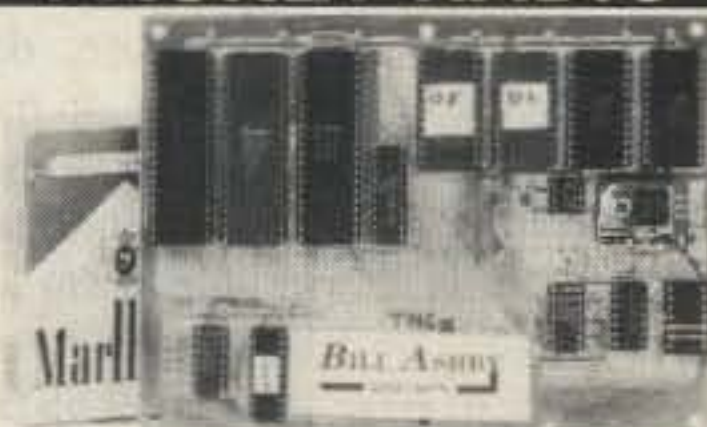

### ASCII—USA/AX.25 HDLC CONVERTER

USA/AX.25 is the AMRAD approved digital format STANDARD used on amateur packet radio networks.

PAC/NET board only \$80.00  
Assembled/Tested. No ICs. 90day warranty

Package of all ICs except 2-2716 EPROMs \$80.00

### PAC/NET SYSTEM

PAC/NET SYSTEM \$240.00  
System Tested 4.5 x 6" board complete with all ICs and programmed EPROMs personalized for each purchaser. Requires only single 8-10 volt 1/2 amp power. 1 year guarantee of hardware/software/AX.25 standard RS232 serial ASCII at any user baud rate. RS232 HDLC for 202 modem used for AFSK or direct to RF equipment for FSK.

Custom Systems Custom Programming

**BILL ASHBY**  
AND SON

**K2TKN—KA2OEG 201-658-3087  
BOX 332 PLUCKEMIN N.J. 07978**

✓8



# BARTER 'N' BUY

Individual (noncommercial) ..... 25¢ per word  
Commercial ..... 60¢ per word

Prepayment by check or money order is required with your ad. No discounts or commissions are available. Please make your payment to 73.

Advertising must pertain to amateur radio products or services. No special layouts or positions are possible. All advertising copy must be submitted typewritten (double-spaced) and must include full name and address. Copy limited to 100 words, maximum. Count only words in text. Address, free.

73 cannot verify advertising claims and cannot be held responsible for claims made by the advertiser. Liability will be limited to making any necessary corrections in the next available issue.

Copy must be received in Peterborough by the 5th of the second month preceding the cover date.

Make checks payable to 73 Magazine and send to: Hope Currier, 73 Magazine, WGE Center, Peterborough NH 03458-1194.

**MILITARY TECHNICAL MANUALS** for old and obsolete equipment. 60-page catalog, \$3.00. Military Technical Manual Service, 2266 Senasac Ave., Long Beach CA 90815. BNB045

**HAM RADIO REPAIR**, tube through solid state. Robert Hall Electronics, PO Box 8363, San Francisco CA 94128; (408)-729-8200. BNB219

**QSLs** to order. Variety of styles, colors, card stock. W4BPD QSLs, PO Drawer DX, Cordova SC 29039. BNB260

**THE DX'ERS MAGAZINE**. Up-to-date, informative, interesting. Compiled and edited by Gus Browning W4BPD, DXCC Honor Roll Certificate 2-4. Send for free sample and subscription information today. PO Drawer DX, Cordova SC 29039. BNB261

**INDIVIDUAL PHOTOFAC FOLDERS**. #1 to #1400, \$3 postpaid. Loeb, 414 Chestnut Lane, East Meadow NY 11554. BNB312

**IMRA**—International Mission Radio Association. Forty countries, 800 members. Assists missionaries with equipment loaned, week-day net. 14.280 MHz, 2:00-3:00 p.m. Eastern. Brother Bernard Frey, 1 Pryer Manor Road, Larchmont NY 10538. BNB326

**ELECTRON TUBES**: receiving, transmitting, microwave—all types available. Large inventory means next-day shipment in most cases. Daily Electronics, PO Box 5029, Compton CA 90224; (213)-774-1255. BNB330

**RADIO TRANSCRIPTION DISCS WANTED**. Any size, speed. W7FIZ, Box 724-WG, Redmond WA 98073-0724. BNB347

**CABLE CONVERTERS**. Lowest price. Dealer inquiries accepted. Quantity discounts. Free catalog. P.G. Video Corp., 61 Gatchell St., Dept. 73, Buffalo NY 14212. BNB349

**ELECTRON TUBES**—Radio and TV types. 80% off list price—huge inventory! Also, industrial types. Send for free catalog today or call toll-free (800)-221-5802. Box SC, Transletronics, Inc., 1365 39th St., Brooklyn NY 11218. BNB370

**CABLE TV CONVERTERS** and equipment. Plans and parts. Build or buy. For information, send SASE to C & D Electronics, PO Box 1402, Dept. 73, Hope AR 71801. BNB383

**QSL CARDS**: 100 for \$6.25 and 500 for \$20.00 postpaid—SASE for a sample: Ken Hand WB2EUF, PO Box 708, East Hampton NY 11937. BNB388

**SURPLUS AND MORE SURPLUS**. Thousands of items, free bargain-packed flyers. ETCO Electronics, Plattsburgh NY 12901. BNB399

**XEROX MEMORYWRITER**—parts, assemblies, boards, manuals. Free help with service problems. W6NTH, Box 250, Benton AR 72015; (501)-778-0920. BNB404

**HAM TRADER YELLOW SHEETS**, in our 24th year. Buy,

swap, sell ham-radio gear. Published twice a month. Ads quickly circulate—no long wait for results. SASE for sample copy. \$10.00 for one year (24 issues). PO Box 2057, Glen Ellyn IL 60138-2057. BNB412

**ROHN TOWERS**—Wholesale direct to you. 34% discount from the Rohn dealer price. All products available. Also, very low prices on Antenna Specialists antennas and Andrews Heliax. Write or call for catalog and price list. Hill Radio, 2503 G E Road, Bloomington IL 61701-1405; (309)-663-2141. BNB417

**DIGITAL AUTOMATIC DISPLAYS** for FT-101s, TS-520s, Collins, Swan, and all others. Six 1/2" digits. 5" wide by 1-1/4" high metal cabinet. Send \$1.00 for information and receive a \$25.00 discount. Be specific. Grand Systems, Dept. A, PO Box 3377, Blaine WA 98230. BNB423

**THE RADIO CLUB** of Junior High School 22 N.Y.C., Inc., is a non-profit organization incorporated under the laws of the State of New York with the goal of using the theme of Ham Radio to further and enhance the education of young people. Your equipment donation would be greatly appreciated. WB2JKJ via callbook or telephone (516)-674-4072, 24 hours, seven days a week. THANK YOU. BNB427

**QUALITY REPAIRS** at very affordable prices. \$25/hour. Skylab thanks everyone for their patronage. We have moved to a larger location where we can better serve you. Non-warranty repair on all HF Kenwood, Yaesu, and ICOM equipment. AMP Supply, Ameritron, Dentron, ICOM, Kenwood, and Yaesu amplifiers. Any Heathkit equipment, TV boards, and high-voltage supplies at 20% less than Heath. Most TV monitors, tuners, VHF/UHF, satellite, computers, drives, telephones, CBs. We do modifications and filter installations. 30-day warranty on parts and labor. We fix almost anything! Be sure to file our new address for later reference. Skylab, Inc., 5514 W. Lisbon Ave., Milwaukee WI 53210; (414)-87-12345, 24 hours. BNB428

**QSL CARDS**—Look good with top quality printing. Choose standard designs or fully customized cards. Better cards mean more returns to you. Free brochure, samples. Stamps appreciated. Chester

QSLs, 310 Commercial, Emporia KS 66801. BNB434

**KENWOOD 430S OWNERS!** Stop Scan stops the scan on busy channels. After they clear, scan continues automatically! Reviewed 73 2/85. \$19.95 (assembled \$29.95). Shipping \$2.50. JABCO, R1 Box 386, Alexandria IN 46001. BNB438

**NEW Spectrum Analyzer/Monitor Receiver kit** \$60. Send SASE for details. Science Workshop, Box 393, Dept. 73, Bethpage NY 11714. BNB440

**MARCO**—Medical Amateur Radio Council, Ltd. Operates daily and Sunday nets. Medically oriented amateurs (physicians, dentists, veterinarians, nurses, physio-therapists, lab technicians, etc.) invited to join. Presently over 550 members. For information, write MARCO, Box 73's, Acme PA 15610. BNB441

**ATTENTION Kenwood TS-430S, ICOM 745 and 751, Yaesu FT-757GX owners!** Modification for general-coverage transmit the right way. Send \$3 for each to W. Thomas, PO Box 96, Uniontown PA 15401. BNB445

**1986 "BLOSSOMLANDBLAST"** Sunday, October 5, 1986. Write "BLAST," PO Box 175, St. Joseph MI 49085. BNB446

**BRAND NAME 5.25" FLOPPY DISKS**. Ten disks in polypak: SS-DD, \$7.99; DSDD, \$8.99. Includes sleeves, ID labels, and tabs. Send check or money order to Micro Applications, Inc., 915 E. Sheridan, Des Moines IA 50316. Add \$1.50 for one to five polypaks, \$3 for five or more, COD orders add \$2; Iowa residents add 4% sales tax. BNB447

**YAESU OWNERS**—Hundreds of modifications and improvements for your rig. Select the best from 14 years of genuine top-rated Fox-Tango Newsletters by using our new Comprehensive Index. Only \$4 postpaid with Rebate Certificate creditable toward Newsletters purchases. Includes famous Fox-Tango Greensheet and Filter information for your rig (if specified). N4ML, FTC, Box 15944, W. Palm Beach FL 33416; (305)-683-9587. BNB448

**C-64 AND C-128 SOFTWARE**: Send SASE for list. PO Box 387, Chillicothe OH 45601. BNB449



**MORSE CODE.** Send Wordstar documents as Morse code over computer's internal speaker. SASE for details, \$7 for unprotected disk for IBM-PC and compatibles. AA4PG, 478 Cahaba Landings Road, Birmingham AL 35210. BNB450

**HEAR! HEAR! INTRODUCING WHIP-IT,** the new 1/4-wave whip

for your HT with the difference they can hear. So flexible you can tie it in a knot! Single-element design makes it almost indestructible—no sections to loosen or break. Gives you the edge you need to hit those distant repeaters! So WHIP-IT on for camping, emergencies, or just shooting the breeze. Available for 2m or 220 MHz. BNC only.

\$11.95 plus \$2 shipping. No CODs please. NRI Products, PO Box 11501, Reno NV 89510. BNB451

**WANTED, MILITARY/COMMERCIAL** Collins radio equipment. We need 618T, ARC-94, ARC-102, RT-712/ARC-105, ARC-114, ARC-115, ARC-116, ARC-159, ARC-164, ARC-186, ARN-118,

RT-1159A, 718F-1/2, 719A, MRC-95, HF-105, FRC-93, PRC-41, KWM-2A, 516F-2, PM-2, 312B-5, 30L-1 antenna couplers, 490T-1, 490T-2, 490T-9, 490S-1, CU-1658A/ARC, CU-1669/GRC. Top dollar paid or trade for new amateur gear. Write or phone Bill Slep, Slep Electronics Company, Highway 441, Otto NC 28763; (704)-524-7519. BNB452

# FUN!

John Edwards K12U  
PO Box 73  
Middle Village NY 11379

## THE SIXTH TIME AROUND

Is the Fun! Poll an institution or does its supervisor just belong in one?

Let's see—in ham radio three qualifications are required before something can be considered an institution. Most important, you have to be old. Well, I'm 31 and the poll is six. That's not old, it's just "getting there."

Next, ham institutions have to be serious. I guess we flunk there, too. After all, how can you take anything called a Fun! Poll seriously?

Finally, to be an amateur radio institution you have to be outdated. We can't qualify under that category either, since more people notice the poll and respond to it every year.

So there you have it: The Fun! Poll is definitely not an institution. That's this year's first conclusion.

As usual, we had a lot of fun tabulating the results. This year, computers helped us in a big way: two Apple II's and an Apple IIc, plus a 20-megabyte hard-disk drive enabled us to handle the calculations. That's a lot of computing power for a non-institution.

I'd also like to thank WB2LWJ for entering all of that data and downloading the responses from CompuServe, The Source, and MCI Mail.

The envelopes, please...

## ELEMENT 1 BACKGROUND

- 1) Sex:  
A) Male—98%  
B) Female—2%  
*Ham radio, like Mars in that old B-movie, needs women.*
- 2) Age:

- A) 15 or below—2%  
B) 16-21—0%  
C) 22-39—42%  
D) 40-59—40%  
E) 60 or above—16%

*The graying of amateur radio. The kids are gone!*

- 3) License class:  
A) Novice—4%  
B) Technician—10%  
C) General—8%  
D) Advanced—46%  
E) Extra—32%

*Fun! obviously attracts a very educated audience.*

- 4) Number of years licensed:  
A) 1 year or less—8%  
B) 1-5 years—16%  
C) 6-10 years—28%  
D) 11-20 years—8%  
E) 21 years and up—40%

*A veteran crowd, indeed.*

- 5) Do you have a new (post-March '78) call?  
A) Yes—56%  
B) No—44%

*Next year, we'll have to ask, "Do you have an old (pre-March '78) call?"*

- 6) How many hours a week do you devote to amateur radio?  
A) 0-1 hour—20%  
B) 2-5 hours—36%  
C) 6-10 hours—22%  
D) 11-20 hours—16%  
E) 21 hours or more—6%

*That's a fair amount of activity.*

- 7) Which HF band do you use most?  
A) 80-75 meters—30%  
B) 40 meters—18%  
C) 20 meters—26%  
D) 15 and/or 10 meters—12%  
E) Don't operate HF—14%

*Who says the low bands are obsolete?*

- 8) Which VHF/UHF band do you use most?  
A) 6 meters—2%  
B) 2 meters—64%  
C) 220 MHz—8%

- D) 420 MHz and/or up—6%  
E) Don't operate VHF/UHF—20%

*Hey, guys! Spread out!*

- 9) Which mode do you use most?  
A) SSB—44%  
B) CW—26%  
C) FM—24%  
D) RTTY—2%  
E) Other—4%  
*CW holds its own.*

- 10) How much money have you spent on amateur radio within the past year? (Include QSL expenses, magazine subscriptions, club dues, and other incidental expenses.)  
A) 0-\$250—42%  
B) \$251-\$500—20%  
C) \$501-\$1,000—18%  
D) \$1,001-\$2,500—12%  
E) \$2,501 and up—8%

*Compared to many other hobbies, that's not a heck of a lot of money spent.*

## ELEMENT 2 SOCIAL CHARACTERISTICS

- 11) On the whole, hams are:  
A) too young—0%  
B) too old—58%  
C) just the right age—42%  
*At least the age problem is getting some recognition.*

- 12) Do you like rock music?  
A) Yes—54%  
B) No—46%  
*Not Lawrence Welk? Not on 2 meters?*

- 13) Politically, how would you define yourself?  
A) Conservative—52%  
B) Middle-of-the-road—30%  
C) Liberal—18%  
*K7UGA must be happy.*

- 14) Should we get rid of the ARRL?  
A) Yes—10%  
B) No—90%  
*I guess that puts me in the minority. I'm for attacking Newington with a retty snitch.*

- 15) How old were you when you first became a ham?  
A) 15 or below—26%  
B) 16-21—28%

- C) 22-39—32%  
D) 40-59—12%  
E) 60 or above—2%

*See Question 2 and groan.*

- 16) Should the FCC increase the speeds on amateur CW examinations?

- A) Yes—6%  
B) No—94%

*How about increasing the speed on the written exam? Give those VEs a break.*

- 17) Do you own a home computer?  
A) Yes—74%  
B) No—26%

*I'd like to meet the hams who don't own one. Probably don't even use a digital display, heaven forbid.*

- 18) If you answered "yes" to question 17, which brand?  
A) Apple—20%  
B) IBM—14%  
C) Radio Shack—12%  
D) Commodore—34%  
E) Other—20%

*Imagine if these figures reflected the computer market as a whole. Golly.*

- 19) Do you think that home computing is siphoning people (including youngsters) away from amateur radio?

- A) Yes—62%  
B) No—38%

*Those kids have to be doing something.*

- 20) Are hams getting dumber?  
A) Yes—42%  
B) No—58%

*Could have fooled us.*

- 21) Do business interests deserve some of our virtually abandoned bands?

- A) Yes—10%  
B) No—90%

*Use it or lose it, I say.*

- 22) Should ham licenses have a minimum age requirement?

- A) Yes—12%  
B) No—88%

*We have a de facto one anyway, right?*

- 23) Should ham licenses have a maximum age requirement?



- A) Yes—4%
- B) No—96%

How about 100 years old as a limit, or would that eliminate too many hams? Only kidding, guys.

- 24) Should hams be subject to periodic retesting?
- A) Yes—30%
  - B) No—70%

Why not? Could be fun. Imagine the ARRL board of directors flunking.

### ELEMENT 3 OPERATING HABITS

25) If the users were restricted to data communication only (no phone or CW operation), would you be in favor of a no-code 220-MHz digital-class license?

- A) Yes—74%
- B) No—26%

What happened? A few years ago we would have been clobbered for even asking this question.

26) Would you be in favor of a no-code 220-MHz digital-class ticket if it permitted phone operation in addition to data transmission?

- A) Yes—52%
- B) No—48%

Ditto.

27) Have you ever used a personal computer in connection with your amateur radio activities?

- A) Yes—66%
- B) No—34%

Down 6 percent from last year.

28) Is it time to completely deregulate amateur radio by having the FCC turn over all responsibility for ham operation to the amateur community?

- A) Yes—16%
- B) No—84%

Moderation, moderation!

29) What do you think of people who view pay television services with MDS converters and satellite dishes that are not approved by broadcasters?

- A) They're skunks—2%

- B) They're within their rights—98%

As a dish owner, I agree.

30) Should we get rid of, or reduce in size, the CW subbands?

- A) Yes—28%
- B) No—72%

Let's rename them as "data bands."

31) Do you think DX nets have a place in ham radio?

- A) Yes—76%
- B) No—24%

A small place, I think.

32) Do you think nets in general have a place in ham radio?

- A) Yes—88%
- B) No—12%

As long as they're not DX nets.

33) The next time a ham operates from space, which band should he/she use?

- A) 2 meters—52%
- B) 220 MHz—14%
- C) 450 MHz—14%
- D) An even higher band—6%
- E) Shouldn't bother to operate—14%

How about 160 meters? They'd have to carry the antenna on another orbiter.

34) If, while tuning across a band, you heard a net called "Jammers International" in progress, would you:

- A) Jam it—2%
- B) Ignore it—48%
- C) Complain to the FCC or some other organization—18%
- D) Listen—26%
- E) Join it—6%

Hams are getting mellower in their old age.

35) If required, could you solidly copy CW at the speed at which you were licensed?

- A) Yes—62%
- B) No—38%

Sure, and all aspirins are alike.

36) If required, could you pass the FCC theory test for your license class?

- A) Yes—88%
- B) No—12%

But didn't Dick Bash go out of business?

37) Have you ever purposely operated in an amateur subband you weren't licensed to use?

- A) Yes—4%
- B) No—96%

Oops, the dial slipped.

38) Are you fluent in any computer language?

- A) Yes—66%
- B) No—34%

Of course everyone probably has his own definition of "fluent."

39) If you answered "yes" to Question 38, which language?

- A) Basic—50%
- B) Pascal—8%
- C) Assembler—10%
- D) Machine—10%
- E) Other—22%

Basic wins again, but the other languages are gaining strength.

40) Do you feel competent to write a short Basic program?

- A) Yes—72%
- B) No—28%

10 PRINT "Hello"

41) Do you feel competent to replace the finals in a transistor-type rig?

- A) Yes—92%
- B) No—8%

Without killing yourself? Gee.

42) Do you solder together your own coax connectors?

- A) Yes—100%
- B) No—0%

What? Nobody uses solderless connectors?

43) Do you own a TVRO (home Earth satellite) system?

- A) Yes—10%
- B) No—90%

And HBO sees a market here?

44) Do you operate a packet-radio system?

- A) Yes—12%
- B) No—88%

This will be a question to watch in the future.

45) What do you think of contesting?

- A) Great—10%
- B) Good—18%
- C) Okay—46%
- D) Don't like it—14%
- E) Despise it—12%

Sorry, WB2GFE.

46) What do you think of DXing?

- A) Great—26%
- B) Good—44%
- C) Okay—26%
- D) Don't like it—2%
- E) Despise it—2%

A general vote of approval.

47) What do you think of repeaters?

- A) Great—32%
- B) Good—44%
- C) Okay—18%
- D) Don't like them—2%
- E) Despise them—4%

But what do you think of the people on repeaters?

48) What do you think of traffic handling?

- A) Great—10%
- B) Good—48%
- C) Okay—26%
- D) Don't like it—10%
- E) Despise it—6%

What's not to like? I mean, some people think exercise is fun.

49) If you heard an emergency net in progress, would you immediately join in and offer your services?

- A) Yes—54%
- B) No—46%

Little gold stars to the respondents who said they would join in only if they had traffic to pass.

50) Have you ever secretly hoped for a minor disaster to strike your community just so you could demonstrate your radio skills?

- A) Yes—14%
- B) No—86%

Regardless of the numbers, I still think most hams really do hope for trouble.

## LOOKING WEST

Bill Pasternak WA6ITF  
28197 Robin Avenue  
Saugus CA 91350

### WA6ITF RETURNS

This column was originally written for publication in the January, 1982, issue of this magazine. The column was canceled by the deci-

sion to reformat 73, but I felt that I had an obligation to "... finish what I had started before going on." Next month, a look at what's happening today, with an emphasis on the emergence of regional band-planning super-councils.—WA6ITF.

I've often addressed the ques-

tion of band-plan standardization in this column, not just with regard to the FM relay mode, but for all types of operation. This is because it is my strong belief that only through such standardization can every mode, special interest, and amateur be assured of spectrum to "do his own thing" on our crowded VHF (and now UHF) bands.

Over the years, I have put forth ideas on how such standardization could be accomplished, presented complete conceptual band

plans, and what have you. It's interesting to note that some 15 years after the start of the VHF FM explosion only one of our amateur bands—220 to 225 MHz—has a band plan accepted on a national scale, including Southern California. As you are aware, the latter has been known to go its own way in most cases, caring little what the rest of the country is up to. Witness the decision back in '77 to use the "even-numbered" channel pairs in the 144.5–145.5-MHz repeater subband—every-



where else it's the "odd numbers" that are used. Some say that Southern California can't do anything right, but the hams of this area tend to consider themselves the true trend-setters; eventually "everyone else" will notice the error of his ways and come to this geographic locality's way of thinking.

In some cases it has happened. Inverted split-splits on 2 meters from 146 to 148 MHz were commonplace throughout half the nation until 20 kHz came along; the concept of inverting the tertiary channels was spawned by two well known Southern California hams, Burt Weiner K60QK and Bob Thornburg WB6JPI. This is common knowledge. At the time it also seemed to be a rather good alternative to the problems inherent with non-inverted 15-kHz tertiary channels. Like everything else in life, there was a trade-off involved. With non-inverted 15-kHz tertiaries, adjacent-channel repeaters can interfere with users. When you invert the 15-kHz channels, the user's radio sees a "30-kHz clear slot" for the most part, but now repeaters can interfere with other repeaters. This is because the output of Repeater A is only 15 kHz from the input to Repeater B. Obviously, where the terrain provides for geographic shielding and/or system separation, this is no problem. In cases where it doesn't, then some elaborate equipment is necessary to make the concept play. This may include such items as specially designed receivers with high dynamic range figures, suck-out traps and cavities, circulators, and the like. The system does work, as has been proven here and elsewhere for the better part of 12-1/2 years now, but at best, it's still a trade-off—in this case protecting the "user's radio" at the expense of overall repeater system performance.

Many years ago, an amateur in the Northeast named George Le Dioux K1TKJ came up with an even better solution. This was back in the late 1960s, FM's formative era. George suggested two changes that would have avoided the many pitfalls we've faced and had to find ways around. K1TKJ's idea was to put all two-meter repeaters on 20-kHz inter-system spacing, and utilize an input-to-output spacing of 1 MHz. Had this been done back in 1969, we would never

have faced the concept of 15-kHz tertiary splits. True, there wouldn't have been as many repeater pairs available, but overall technological system operation would have been vastly improved. But this was not to be the case. Le Dioux's ideas were ignored and the nation stayed with 30-kHz inter-system spacing and 600-kHz input-to-output separation. There were a number of reasons for this, the primary one being that at the time of the K1TKJ proposal, Technician-class operators were not permitted operation in the 147-148-MHz spectrum. With most radios being crystal-controlled in that era, 147.97 was considered the ex-officio top end of the "open repeater band."

Then came repeater deregulation. Technicians were granted operating privileges in the 147-MHz region. The doctrines of "Semi-Automatic" and "Fully Automatic" remote controls were established in D.C. and the big repeater rush was on. (It should be said that two Southern California amateurs were directly responsible for this first of many deregulatory moves with regard to repeater operation. They are Capt. Dick McKay K6VGP and Fred Deeg N6FD. Without their unceasing efforts on our behalf, the deregulatory process might never have come about.) Soon we were out of 30-kHz channels. The Northeast and then the entire eastern seaboard opted, ever reluctantly, to initiate the use of 15-kHz inter-system spacing. At that time little was known with regard to 15-kHz system spacing, so the decision was made to go "standard" right-side-up configuration.

The early days were hectic. The average ham transceiver of the day had been developed in the era of 60-kHz spacing; most could hack 30 kHz with little degradation in performance, but 15 kHz was another story. The same held true for a number of years through the mid 1970s. To this day I and a bunch of friends hold the somewhat dubious honor of having placed the first non-inverted 15-kHz tertiary machine in the nation into operation. Its callsign was WA2ZWP; it was located atop the Williamsburg Bank Building in Brooklyn, New York, on a frequency pair of 146.205 in, 146.805 out. No matter what we tried, it still wreaked havoc on our two neighboring systems

(.19/.79 and .25/.85). Not to the systems themselves, but to those using these two machines. Then again, they each only got it from "one side." Our users were caught smack dab between the other two systems, and it took a lot of research by our Technical Chairman, Dave Kuraner, into new filters to make most of our users' radios function on the system. In fact, Dave, Larry Levy, and I were the only three who could really make use of the system in the early days. We were the lucky ones. We were using converted Motorola and RCA land-mobile radios which had the needed selectivity. Most of the others were not that fortunate. Somehow, the WA2ZWP repeater survived for a few years. It led the way for others who were intrepid enough to copy our foolishness. Soon a de facto 15-kHz standard existed in the Northeast and spread elsewhere as areas ran out of 30-kHz channel pairs. It should also be noted that in spearheading the use of 15-kHz channel pairs, the Northeast was ahead of everyone else. It would be several years before the next major FM-oriented area would make the move, and when it did it would be in a different vein. Southern California elected to invert its tertiary channels as already mentioned, and most of the country west of the Continental Divide eventually followed suit as the need arose to implement utilization of 15-kHz channel pairs.

The ARRL gave its *official* blessing to either 15-kHz plan, but most of those placing repeaters into operation in a given area have kept with the norms established for that geographic region. Oh...there have been a few renegades here and there, but few problems have arisen and the status quo has been maintained. But many wondered if there was a better way. Most radios sold these days do operate fairly well on even, right-side-up 15-kHz channels, though in a 30-kHz or even an inverted 15-kHz environment, their overall operation seems greatly improved. I suspect that many of you reading this were not even around in the 30-kHz days. Very few, if any, are left from the 60-kHz era, so few are familiar with the way two meters sounded back then. I won't try to reconstruct the past other than to say that in the old days repeaters were fairly silent, with most FM being simplex in nature. How things have changed.

Is there an alternative to implementing 15-kHz tertiaries when you run out of the 30-kHz-split channel pairs? What about K1TKJ's old "Let's re-vamp to 20-kHz and 1-MHz input-to-output spacing"? Most amateurs felt that it was too late to go this route because of the investment in established hardware—both "system" and "user" hardware. At least one geographic locality seems to have decided to buck today's trend and has opted for something akin to the old K1TKJ concept. They have instituted the use of 20-kHz inter-system spacing, but have retained the standard 600-kHz input-to-output spacing. Actually, this is not so much an adaptation of K1TKJ's ideas as it is the adoption of the NARC 144.5-145.5-MHz band plan for the upper two MHz of the band. The area in question is the Pacific Northwest, and results are reported as being very positive. So much, in fact, that now the Canadian province of British Columbia has joined with Washington, Oregon, Utah, Montana, Texas, Arizona, New Mexico, Idaho, and eastern states like Alabama and Michigan to make this more than an experiment. Rather, things have reached the point where 20-kHz inter-system spacing on both the upper and lower repeater subbands on two meters must be considered a true regional band plan.

I am not saying that we should scrap years of commitment to 30-kHz and 15-kHz operation, but what has been accomplished in the Pacific Northwest is of definite note. They did not double the number of available channel pairs, as would have been the case had they opted for one of the 15-kHz plans, and they didn't have to fight any of the 15-kHz problems. Nor did anyone have to run out and buy a new radio, either. As pointed out in the British Columbia FM Communication Association newsletter, most amateurs with crystal-controlled radios had no problem swinging their crystals to the closest of the new 20-kHz pairs. As for the older 15-kHz-based synthesized sets, the BCFMA newsletter went on to explain that these radios could either be converted back to their original 20-kHz centers, since that was the original Japanese design concept to start with, or another "mix-down" to permit 5-kHz or 10-kHz incrementation could be added. Newer synthesized radios,



the article added, were already equipped for either 10-kHz incrementation with 5-kHz offset, or were incremented in 5-kHz steps. For those units, no mods were needed at all.

A few years ago there was but one band plan for two meters. It was known as the Modified Texas Plan and it sufficed for its day. It was based upon 30-kHz inter-system spacing and was the plan first modified in the Northeast to accept upright 15-kHz tertiaries, and then in the Southwest to accept inverted tertiaries. Because of politics, all of these plans have won the "Official Approval" of the League's Board of Directors. Had the ARRL approved only one, we would not be facing a new political dilemma, that of having to choose from three band plans. There is mounting political pressure for the national implementation of the Pacific Northwest band plan. And it's not all coming from the Pacific Northwest, either. This reporter feels that it may be a bit too late to find a "true national standard," much less get everyone to agree on its implementation and use. It could happen, but I, for one, have stopped holding my breath.

### The SCRRBA Report: Part III

We now begin the third and final installment of the SCRRBA report on the future of voluntary UHF coordination. While this report was primarily prepared for consumption in the Southern California area, it holds importance for all areas and all spectra where coordination is scarce. How to solve things? Here's one group's opinion:

### Keeping Current

One of the easiest ways in which the owner of a coordinated system can aid the Technical Committee is by remaining in close contact with us. Many coordinations were performed over five years ago. Having experienced no difficulties in the operation of their machines on the coordinated channels, the owners of these machines have not kept current with our Technical Committee. Since we are constantly referring to the file cabinets which contain the collected coordination records (which contain all paperwork received by the committee regarding each system), it becomes readily apparent how old some of these files are.

In the United States the aver-

age household changes living quarters about once every five years; in Southern California it may be more frequent. Any coordination file which has not been updated in the last five years is probably useless to the committee as a source of address and telephone information. We have an independent way of verifying this statement: Each time we mail out newsletters, we have approximately 20% returned by the Post Office marked "Addressee Unknown."

It is the responsibility of the operator of a coordinated system both to recognize the value of a UHF frequency pair in Southern California and to "protect his investment" by remaining in permanent contact with the Technical Committee. It only takes a few minutes to complete and mail a coordination update and it's an excellent "insurance policy." If you're not sure when you last updated your coordination, do it now. We can never have too much data.

### Avoid Wanderlust

Earlier we discussed the problems caused by "self-coordination" of new UHF systems within the array of existing repeaters and remote bases. The Technical Committee has also had problems, on a more or less continuing basis, with a different form of self-coordination performed by operators of presently functioning UHF systems: The movement of an existing system from one location where it was coordinated to a new location where it isn't coordinated.

The committee must emphasize that the coordination of a specific UHF pair for a particular individual or group is *only* for utilization at an exact land location for coverage of a specific geographic area. Coordination of a channel pair does not imply ownership with "rights" to transport the pair anywhere around Southern California. If it is necessary for the owner to move his system to a new land location, he must apply to the committee, in writing, in advance of the move, for recoordination of that system. The committee will determine whether the system can be operated at the new location without receiving interference from or creating interference with other co-channel and/or co-site systems. Please recall that the 70-cm band is not so heavily coordinated that a small change

in the operation of a single system has the potential for causing a major impact on the entire regional coordination array. It is not the intention of the committee to attempt to prevent coordinated systems from moving. If it is at all feasible for the system to operate from the proposed new location, an OK will be given quickly. Rather, it is the committee's desire to prevent unnecessary work and expense, both for itself and for the owners of the affected systems.

### Expect Company

Most Southern California UHF channel pairs between 440 and 450 MHz now support more than one system, and co-sharing of pairs will have to increase in the future. Long ago the committee learned an important lesson with regard to co-sharing of channel pairs: Everyone favors the practice... but only in principle. In its early days, the committee would contact the holder of a coordinated channel pair and request his approval for the co-sharing of his pair with another system, located far enough away geographically that mutual system interaction would be minimal. The initial response was almost always affirmative; later the complaints would start.

The committee learned that an approval for co-sharing should be interpreted as follows: "I am certainly agreeable to sharing the channel pair, as long as I can climb into my automobile and drive a minimum of 5 hours in any direction and still not hear the other system!" Therefore, we long ago stopped asking for advance approval.

SCRRBA will continue to coordinate co-channel systems using the best fit, on a geographical co-sharing basis, between a previously coordinated system and one of several completed applications for frequency coordination. A new system will be coordinated to co-share a pair with an existing system so that minimum practical overlap occurs between the users of each system. The Technical Committee will notify owners of existing systems that a specific new co-channel system has been coordinated.

In some instances there may be an occasional overlap in coverage, as mobiles from one group find themselves in specific locations which also put them within range of the other machine. This is to be expected. To prevent un-

necessary access, the committee recommends CTCSS protection for mountaintop repeaters. If necessary, full CTCSS systems can be used to protect against occasional reception of the other system's talkback.

### Toward The Future

The Technical Committee should make a full and complete report to the Southern California UHF community about the current state of the coordination process and explain how little flexibility the committee has in the performance of UHF frequency coordination (and why seemingly reasonable requests cannot be fulfilled). Moreover, it is the committee's hope that the community, after gaining this information, will act with the cohesiveness necessary to protect its considerable investment of time, money, and talent.

Southern California is recognized as the national leader in amateur UHF relay-system operation. Nowhere else in the country do systems exist which rival ours in complexity, sophistication, and length of service. Whether or not we can continue to operate our systems successfully in the future depends directly upon how we, individually and collectively, value and support the community's frequency-coordination program.

### Summation

What you have just read is the third part of a three-installment series on the future of voluntary relay-system coordination. It was gleaned from the June, 1981, issue of the SCRRBA newsletter. Parts 1 and 2 of this series appeared in the October and November, 1981, Looking West columns.

The entire series was condensed from a report to all Southern California UHF users from the Southern California Repeater Remote Base Association and was prepared by Gordon Schlessinger WA6LBV of the SCRRBA Technical Committee. While its initial audience was obvious, in retrospect I felt that anyone involved in putting up a repeater or helping get it coordinated could learn from what this particular group is accomplishing. Yes, it was written about the Southern California UHF repeater/remote, but there is something in it for all involved in repeaters or remotes, regardless of the band they operate on. ■



# RAMSEY

# THE FIRST NAME IN ELECTRONIC TEST GEAR

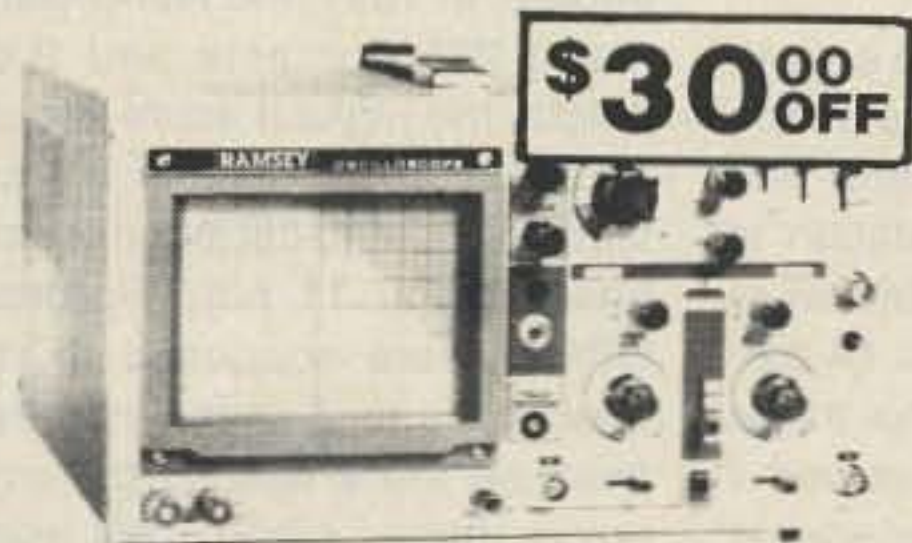

**\$30<sup>00</sup> OFF**

### Save \$30 on the RAMSEY 20MHz Dual Trace Oscilloscope

Unsurpassed quality at an unbeatable price, the Ramsey oscilloscope compares to others costing hundreds more. Features include a component testing circuit for resistor,

capacitor, digital circuit and diode testing • TV video sync filter • wide bandwidth & high sensitivity • internal graticule • front panel trace rotator • Z axis • high sensitivity x-y mode • regulated power supply • built-in calibrator • rock solid triggering

Was \$399.95 NOW ONLY **\$369<sup>95</sup>** high quality hook on probes included



### NEW RAMSEY 1200 VOM MULTITESTER

Check transistors, diodes and LEDs with this professional quality meter. Other features include, decibel scale • 20K volt metering system • 3 1/2" mirrored scale • polarity switch • 20 measuring ranges • safety probes • high impact plastic case

**\$19<sup>95</sup>** test leads and battery included



**NEW**

### RAMSEY D-4100 COMPACT DIGITAL MULTITESTER

Compact sized reliability and accuracy. This LCD digital multitester easily fits in your pocket, you can take it anywhere. It features full overload protection • 3 1/2 digit LCD readout • recessed input jacks • safety probes • diode check function • 2000 hours battery life

**\$22<sup>95</sup>** test leads and battery included

### NEW 35 MHz DUAL TRACE OSCILLOSCOPE



A heavy duty and accurate scope for service as well as production use. Features include • wide frequency bandwidth • optimal sensitivity • extremely bright display • delayed triggering sweep • hold off • ALT trigger • single sweep • TV sync • 5X magnification • XY or XYZ operation • HF/LF noise reduction

**3500 Dual Trace Oscilloscope \$499<sup>95</sup>** includes 2 high quality probes

**ALL OSCILLOSCOPES INCLUDE 2 PROBES**

### NEW 15 MHz DUAL TRACE PORTABLE OSCILLOSCOPE

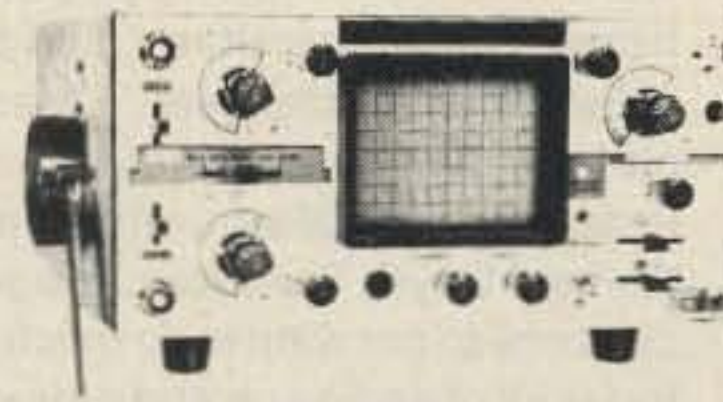

Ideal for field/bench applications, this scope can display up to 15 MHz signals. Internal battery pack allows up to 2 hours operation on a single charge. Features include • built-in battery charger • 5X horizontal magnification • high brightness CRT • front panel trace rotator • internal rechargeable battery pack

**2500 Portable Oscilloscope \$449<sup>95</sup>** includes 2 high quality probes

### MINI KITS—EASY TO ASSEMBLE, FUN TO USE BEGINNERS & PROS WILL HAVE A GREAT TIME WITH THESE KITS

#### FM MINI MIKE



A super high performance FM wireless mike kit! Transmits a stable signal up to 300 yards with exceptional audio quality by means of its built in electret mike. Kit includes case, mike, on-off switch, antenna, battery and super instructions. This is the finest unit available.

FM-3 Kit **\$14.95**  
FM-3 Wired and Tested **19.95**

#### Color Organ

See music come alive! 3 different lights flicker with music. One light each for, high, mid-range and lows. Each individually adjustable and drives up to 300 W. runs on 110VAC.

Complete kit, ML-1 **\$8.95**

#### Video Modulator Kit

Converts any TV to video monitor. Super stable, tunable over ch 4-6. Runs on 5-15V accepts sht. video signal. Best unit on the market! Complete kit, VD-1 **\$7.95**

#### Led Blinky Kit

A great attention getter which alternately flashes 2 jumbo LEDs. Use for name badges, buttons, warning panel lights, anything! Runs on 3 to 15 volts. Complete kit, BL-1 **\$2.95**

#### Super Sleuth

A super sensitive amplifier which will pick up a pin drop at 15 feet! Great for monitoring baby's room or as general purpose amplifier. Full 2W rms output, runs on 6 to 15 volts, uses 8-45 ohm speaker. Complete kit, BN-9 **\$5.95**

#### FM Wireless Mike Kit

Transmits up to 300' to any FM broadcast radio, uses any type of mike. Runs on 3 to 9V. Type FM-2 has added sensitive mike preamp stage.

FM-1 Kit **\$3.95** FM-2 Kit **\$4.95**

#### Whisper Light Kit

An interesting kit, small mike picks up sounds and converts them to light. The louder the sound, the brighter the light. Includes mike, controls up to 300 W. runs on 110 VAC. Complete kit, WL-1 **\$6.95**

#### Tone Decoder

A complete tone decoder on a single PC board. Features: 400-5000 Hz adjustable range via 20 turn pot, voltage regulation, 567 IC. Useful for touch-tone burst detection, FSK, etc. Can also be used as a stable tone encoder. Runs on 5 to 12 volts. Complete kit, TD-1 **\$5.95**

#### CPO-1

Runs on 3-12 Vdc. 1 wall out, 1 KHz good for CPO. Alarm, Audio Oscillator. Complete kit **\$2.95**

#### Universal Timer Kit

Provides the basic parts and PC board required to provide a source of precision timing and pulse generation. Uses 555 timer IC and includes a range of parts for most timing needs.

UT-5 Kit **\$5.95**

#### Mad Blaster Kit

Produces LOUD ear shattering and attention getting siren like sound. Can supply up to 15 watts of obnoxious audio. Runs on 6-15 VDC.

MB-1 Kit **\$4.95**

#### Siren Kit

Produces upward and downward wail characteristic of a police siren. 5 W peak audio output, runs on 3-15 volts, uses 3-45 ohm speaker. Complete kit, SM-3 **\$2.95**

#### 50 Hz Time Base

Runs on 5-15 VDC. Low current (25ma), 1 min. length accuracy TB-7 Kit **\$5.50**  
TB-7 Assy **\$9.95**

#### 30 Watt 2 mtr PWR AMP

Simple Class C power amp features 8 times power gain, 1 W in for 8 out, 2 W in for 15 out, 4 W in for 30 out. Max output of 35 W, incredible value, complete with all parts, less case and T-R relay.

PA-1, 30 W pwr amp kit **\$22<sup>95</sup>**  
TR-1, RF sensed T-R relay kit **6<sup>95</sup>**

#### Power Supply Kit

Complete triple regulated power supply provides variable 6 to 18 volts at 200 ma and -5 at 1 Amp. Excellent load regulation, good filtering and small size. Less transformers, requires 6 3V (a 1 A and 24 VCT). Complete kit, PS-3LT **\$6<sup>95</sup>**

#### CT-70 7 DIGIT 525 MHz COUNTER

Lab quality at a breakthrough price. Features • 3 frequency ranges each with pre amp • dual selectable gate times • gate activity indicator • 50mV @ 150 MHz typical sensitivity • wide frequency range • 1 ppm accuracy

**\$119<sup>95</sup>** wired includes AC adapter

CT-70 kit **\$99.95**  
BP-4 nicad pack **8.95**

#### CT-90 9 DIGIT 600 MHz COUNTER

The most versatile for less than \$300. Features 3 selectable gate times • 9 digits • gate indicator • display hold • 25mV @ 150 MHz typical sensitivity • 10 MHz timebase for WWV calibration • 1 ppm accuracy

**\$149<sup>95</sup>** wired includes AC adapter

CT-90 kit **\$129.95**  
OV-1 0.1 PPM oven timebase **59.95**  
BP-4 nicad pack **8.95**

#### CT-50 8 DIGIT 600 MHz COUNTER

**\$169<sup>95</sup>** wired

CT-50 kit **\$139.95**  
RA-1 receiver adapter kit **14.95**

#### CT-125 9 DIGIT 1.2 GHz COUNTER

**\$169<sup>95</sup>** wired includes AC adapter

BP-4 nicad **\$8.95**

#### DM-700 DIGITAL MULTIMETER

Professional quality at a hobbyist price. Features include 26 different ranges and 5 functions • 3 1/2 digit, 1/2 inch LED display • automatic decimal placement • automatic polarity

**\$119<sup>95</sup>** wired includes AC adapter

DM-700 kit **\$99.95**  
MP-1 probe set **4.95**

#### PR-2 COUNTER PREAMP

The PR-2 is ideal for measuring weak signals from 10 to 1,000 MHz • flat 25 db gain • BNC connectors • great for shifting RF • ideal receiver/TV preamp

**\$44<sup>95</sup>** wired includes AC adapter

PR-2 kit **\$34.95**

#### PS-2 AUDIO MULTIPLIER

The PS-2 is handy for high resolution audio resolution measurements, multiplies up in frequency • great for PL tone measurements • multiplies by 10 or 100 • 0.01 Hz resolution & built-in signal preamp/conditioner

**\$49<sup>95</sup>** wired

PR-2 kit **\$39.95**

#### PS-10B 1 GHz PRESCALER

Extends the range of your present counter to 1 GHz • 2 stage preamp • divide by 1000 circuitry • super sensitive (50 mV typical) • BNC connectors • 1 GHz in, 1 MHz out • drives any counter

**\$79<sup>95</sup>** wired includes AC adapter

- #### ACCESSORIES FOR RAMSEY COUNTERS
- Telescopic whip antenna—BNC plug **\$ 8.95**
  - High impedance probe, light loading **16.95**
  - Low pass probe, audio use **16.95**
  - Direct probe, general purpose use **13.95**
  - Tilt bail, for CT-70, 90, 125 **3.95**

PHONE ORDERS CALL **716-586-3950**  
TELEX 466735 RAMSEY CI

TERMS: • satisfaction guaranteed • examine for 10 days; if not pleased, return in original form for refund • add 6% for shipping and insurance to a maximum of \$10.00 • overseas add 15% for surface mail • COD add \$2.50 (COD in USA only) • orders under \$15.00 add \$1.50 • NY residents add 7% sales tax • 90 day parts warranty on all kits • 1 year parts & labor warranty on all wired units.

**RAMSEY ELECTRONICS, INC.**  
2575 Baird Rd.  
Penfield, N.Y. 14626





# QRP

William R. Stocking W0VM  
1030 Weidman Road  
Manchester MO 63011

## PLANNING FOR GOOD FIELD DAYS TO REMEMBER

"Fascinating, frustrating, or fun, Field Days are good tests of amateurs' engineering and operating ability." This was the opening sentence in an article in the June, 1969, issue of *73 Magazine* entitled "A Field Day to Remember." That article told how a group of inexperienced operators quickly planned, set up, and operated a makeshift Field Day station in the 1968 Field Day contest. It was fun and a good learning experience for those involved.

In the 17 years since then, the author of that article has participated in more than a dozen Field Day contests. In the last 10 years, he has functioned as the Field Day Coordinator for the Principia College Amateur Radio Club.

The purpose of this article is to present ideas and information gained from these experiences that could help other clubs have successful Field Day stations.

Many amateur operators consider the annual Field Day the most important amateur radio contest of the year. These operators might be called the "serious contesters." They want to work hard to make the best score possible. Each year they aim to make a better score than they did the previous year. Serious contesters are sometimes young high-speed ("hot shot") operators who can go 24 hours without sleep. Other seri-

ous contesters are older men (and sometimes women) who like to compete and can compete well in Field Day contests long after they are too old to compete in athletic sports such as football, basketball, or baseball.

Other operators are less competitive and think of Field Day as a weekend social event in which they can relax after a hard week's work and have fun with other hams. These operators could be called the "socializers." Many clubs have both serious contesters and socializers who come to Field Days. Too often, the socializers do not want to do much of the work of setting up and running a Field Day station. The serious contesters resent having to do nearly all the hard work, with little or no help from the socializers.

This article will present ideas which (hopefully) will satisfy the needs of both the serious contesters and the socializers.

If a Field Day station is powered by a gasoline engine driven ac generator, keeping the generator running for 24 hours is unpleasant work. The noise of the generator creates mental fatigue, which is not helpful to the operators.

Running a Class 1A battery-powered QRP Field Day station eliminates both the noise of the generator and the work of keeping it running. Furthermore, because of the QRP multiplier, it's easier to make a good score with a QRP Class 1A battery-powered station than with a higher powered generator-powered station. For the serious contesters, a QRP Class 1A

battery-powered station will provide a better score—with less work and without the tiresome noise of a generator.

## Here's Why

The Field Day rules give a multiplier of five for each contact made if the transmitter's rf output is 5 Watts or less and the station is powered by batteries. This makes it possible for QRP Class 1A battery-powered stations to make higher scores than more powerful stations using gasoline engine driven ac generators (see Table 1). A QRP Class 1A battery-powered station is ideal for a club (or other group of operators) that is relatively small (three to ten serious, competitive operators). A club may have only a small group of serious contesters, and a Class 1A battery-powered QRP station would be ideal for this group (see Table 2).

## How Our Group Got Started With QRP Field Days

Using power from a gasoline engine driven generator, the Principia College Amateur Radio Club did rather poorly in the 1980 Field Day contest. During the contest, a ham drove up the road from the station and tossed an antenna up into a tree. He put his little Heathkit HW-8 on a card table and connected it to the antenna, a telegraph key, and his car battery. Then he proceeded to make contacts. Many in the club were very impressed.

In discussing the club's lack of success in the 1980 contest, one member of the group made a

"radical suggestion": The club should use an HW-8 transceiver in the 1981 contest to do away with the noise and work of using a generator. The others in the club agreed. In 1981, the HW-8 station made 235 contacts and 2,650 points, the highest score the club had ever made. During the contest, W0VM and his logger started operating at 11 p.m. Saturday. Others were supposed to take over at 2 a.m. Sunday. However, because there was no generator noise, these "others" fell asleep and did not go to the station until 6 a.m. W0VM and his logger were having fun making 10 contacts per hour and so didn't mind the extra operating time.

## Planning a QRP Field Day

Soon after the end of a Field Day contest, members of the group can share ideas for making the next year's Field Day better. This planning can start as early as April—or even earlier, if experimenting with antennas is a part of this work. As soon as they are available, the Field Day paper forms (summary sheet, dupe sheets, etc.) should be obtained from the American Radio Relay League, 225 Main Street, Newington CT 06111. You can study the Field Day rules that appear in the May issue of *QST*. (It might be a good idea to have a few copies of the rules handy on Field Day.)

## The Field Day Site

It's important to obtain a good site for your Field Day station. The site should be on high ground and



Photo A. 1982's FD station in action.

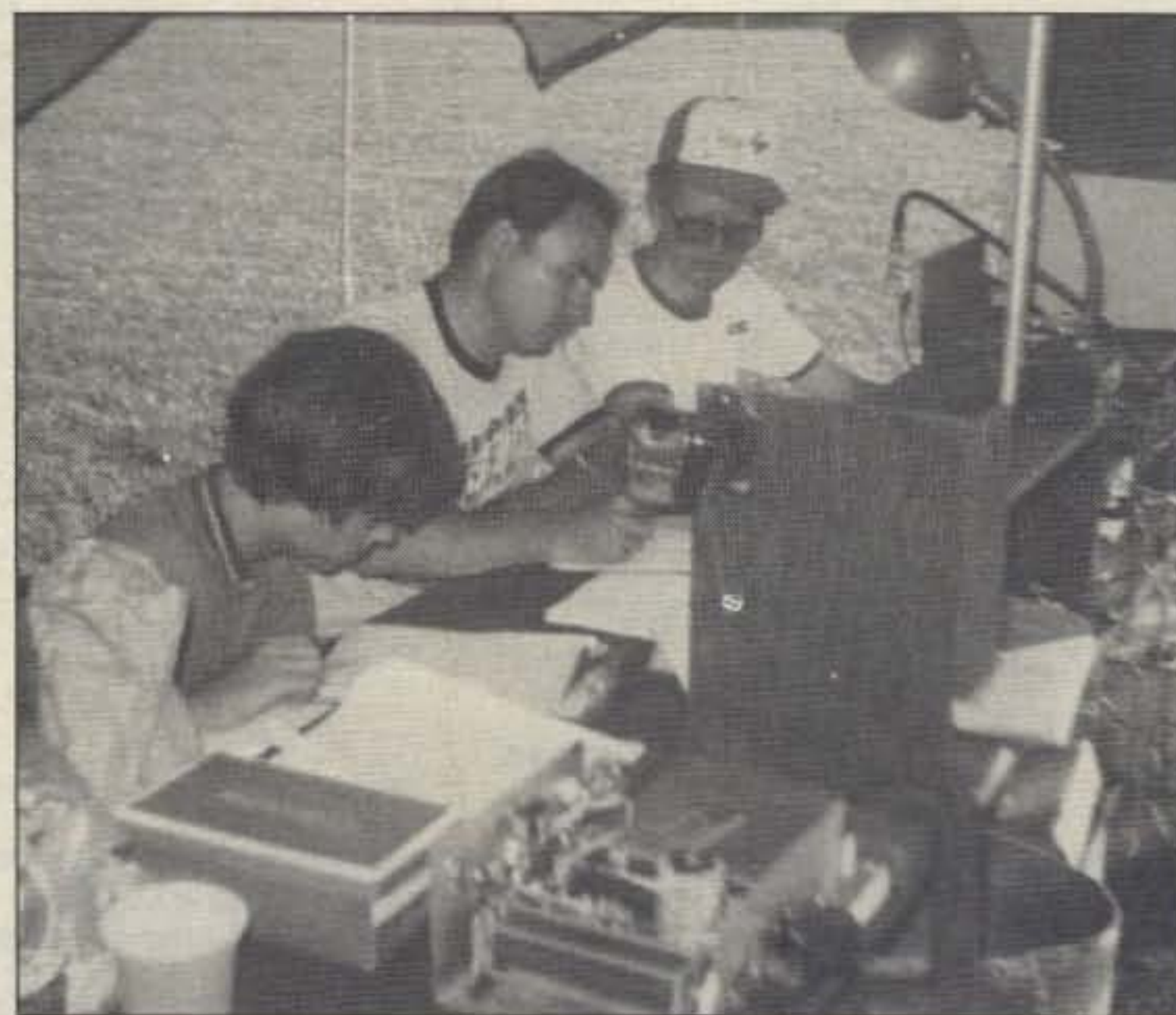

Photo B. The Principia College ARC operating 1A Battery: (l-r) KA0SAC, WB0VOE, K9BO.



Year	Battery-powered Station Scores	Ordinary Station Scores
1980	7015	4400
1981	7220	4828
1982	9585	5852
1983	7330	6152
1984	7900	5698
1985	9270	6544

Table 1. The scores of the top Class 1A QRP battery-powered stations compared with the top scores of the ordinary Class 1A stations for the years 1980-1985.

in the clear. Our group prefers a site with no trees or only a few trees around the edges. We have good temporary antenna supports and run the antennas north and south for good east and west coverage. Field Day stations can be located in public parks, on the grounds of schools, on farms, or on other private property. It's important to make arrangements early with the people who control the site. The site should have toilet and washroom facilities nearby. Picnic tables are also useful.

#### Shelter

The shelter for the station should be strong so that a storm cannot blow it down, as happened to our group in 1984. If you use an open canopy, set up a strong tent beside it into which you can move the station if a storm comes up. Trailers, campers, cottages, barns, and trucks can also house Field Day stations. For ease in operating, logging, and duping, the shelter should be big enough to include a large table with a shelf on it, which can hold antenna tuners, an SWR meter, and keyers.

Having a place nearby where Field Day contestants who are not operating can rest and sleep is most helpful. This place could be an extra tent or camper, or a nearby building. People can bring their own cots, sleeping bags, and blankets.

#### Bonus Points

The Field Day rules provide 100 bonus points for publicity: You must submit an article to a local newspaper for publication. (Radio or television publicity for the Field Day can sometimes be obtained.) A Field Day article should tell about the purposes of Field Day and about the setting up of emergency type stations all over the United States and southern Canada. Also include in the article the name of the club (or nonclub group), the location of the Field Day station, and the dates and

hours of the Field Day contest. Other information appropriate for the article is the type of station (Class 1A battery-operated in the case of a QRP station), names of the group's operators, and the fact that visitors are welcome.

Submit the Field Day article to the paper in late May or very early June so it will be printed in June before the Field Day weekend. It helps if you deliver the article in person to the editor of the paper, so you can emphasize the importance of the Field Day contest and explain that it's *the big amateur radio contest of the year!* Keep a copy of the article to send to the ARRL along with the summary sheet and other papers, in case the newspaper doesn't print the article. Proof that the article has been submitted will provide the 100 bonus points for publicity. If the article is printed, send a copy of it along with the other documents to the ARRL after the contest.

If you plan to make five contacts with "natural power" for an additional 100 bonus points, obtain a 12-volt motorcycle battery and a solar charger. (Perhaps you could borrow a solar charger from a college physics department.) Use the battery until it is fairly well discharged, then connect it to the solar charger and charge it on sunny days. At the slow charging rate of the solar charger (120 milliamps in full sun for the one our group used), it will take many hours to charge up the motorcycle battery. This charging might well start in the middle of May.

#### Power Supply

Two fully charged automobile batteries will run a transceiver with 5-Watt rf output for the full Field Day period. This includes running a 12-volt lamp during the night. (If the weather is cool, you can use a gasoline lamp, such as a Coleman lamp, for lighting, and its heat will be appreciated.)

1980	W5VBO	3
1981	W1MJ	11
1982	N4BP	3
1983	N4BP	3
1984	K9RS	7
1985	KP4FI	6

Table 2. The number of operators of the top Class 1A QRP battery-operated stations for 1980-1985.

#### Transceivers

The transceiver for the station should be one which has a single signal superheterodyne receiver. For best results, the receiver should have an i-f filter of 500 or fewer Hertz, plus an audio filter. A Ten-Tec Argosy transceiver used in its low power mode is an excellent Field Day transceiver. Although you can make contacts with transceivers with direct-conversion receivers, the fact that this type of receiver brings in each station at two places on the dial makes undesirable QRM. There's more than enough QRM during Field Day without adding to it by using a direct-conversion type of receiver! It should go without saying that it's desirable, if not necessary, to have a backup transceiver available.

#### Antennas

Having excellent antennas is of greatest importance for QRP Field Day stations. It's helpful for a station to have two antennas and the ability to instantly switch between them. If possible, the antennas should have gain as compared to a conventional half-wave dipole.

An allband tuned doublet or "center fed zepp" with 66 feet each side of the center is a good antenna for Field Day use. In 1983, using only this antenna, the Principia College Amateur Radio Club made 394 contacts in 24 hours with the 5-Watt rf output of a Ten-Tec Argosy transceiver. With its wires running north and south, the antenna was an unusually good half-wave dipole on 80 meters. On 40 meters, the antenna was "two half waves in phase" for a gain of 1.8 dB in the east and west directions (as compared to a dipole). On the 20- and 15-meter bands, the gain in the major lobes of the four-leafed-clover pattern was probably more than 2 dB. Because the antenna was in the form of an inverted vee with its center up 40 feet and the ends up 15-20 feet, the antenna sent well in all directions, on all bands.

If your station has two antennas, the second antenna should have much gain on the 20- and 15-meter bands. If the station is on the East Coast, a beam antenna aimed west would be the logical kind of antenna to use. For a West Coast station, a beam antenna aimed east would be appropriate. In the middle of the United States, you need a bi-directional beam. It isn't practical to rotate a beam on Field Day. This takes too much time, even if you could devise a 12-volt rotor or "armstrong" rotating system. Bi-directional beams are not hard to build and do work well. Vertically polarized bi-directional beams send out a wider beam than do horizontal beams, and this makes them good for Field Day use. An end fed, 20-meter, vertical W8JK, "end fire," bi-directional beam fed with tuned feeders works well on both 20 and 15 meters and has a gain of 4 dB as compared to a dipole (for both bands).

Each Field Day antenna system should have its own antenna tuner, and there must be a coax switch with which the operator can instantly switch the output of the transceiver from one antenna tuner to the other. All Field Day antennas should be fed with balanced tuned feeders so that the 5-Watt rf output of the transceiver will get into the antenna as effectively as possible. Ordinary vertical antennas (not vertically polarized beams) are not usually effective for use with the QRP Field Day station.

#### Field Day Operating QRP

Having a meeting of the operators, loggers, and dupers to discuss the rules, operating, logging, and duping procedures is helpful. To make the best score, it's a good idea to have the best operators do most of the operating. Other operators are usually glad to contribute by doing the logging and duping. It's also good to use call letters that are short, easy to send, and easy to read, preferably ending in a dah.



The following ideas will help a QRP station make contacts:

1. Answer CQs rather than call CQ.
2. Use a code speed that isn't too fast. The sending should be clear and accurate.
3. Conserve time by making the exchanges as brief as possible. Use a minimum of words. Sending de (your station's call) without sending the other station's call saves time.
4. Quick "tailgating" after a station has completed its exchange often results in a quickly made contact.
5. A computerized keyer programmed to send the exchange when a button is pushed is helpful.
6. Do not spend too much time trying to make a contact with a given station. If a contact is not made after three calls, move on and call another station.
7. Go to a less crowded part of a band if you cannot make contacts in a crowded part of the band.

#### Band Selection and Band Changing

Listening to the bands immediately before the contest starts will give an indication of which bands are open and active. (There will be many Field Day stations testing.) If the 15-meter band is open, you can make contacts there until the band dies or is "fished out." Twenty meters is also a good daytime band on which to start and is usually good well into the night. It's a good idea to spend most of the time on bands for which the antennas have the most gain. Forty meters is usually good both day and night. Eighty meters is strictly a nighttime band and, with a good antenna, will provide many contacts.

The station should stay on a band as long as it is making fre-

quent contacts. When the number of contacts per hour starts to decline, it's time to change to another band. Later in the contest, the station can go back to bands that were fished out earlier and may find many "new" stations to work. Using separate log sheets for each band helps in making out the summary sheet after the contest is over.

Having a good support group of people who are not operators is helpful. Wives and other family members of the operators can supply food and soft drinks. A Saturday evening pot luck supper in which the operators can take turns eating and operating adds to the enjoyment of Field Day. Operators can bring their own Saturday noon lunch, Sunday morning breakfast, and Sunday noon lunch.

#### Setting Up the Station

Some clubs like to set up their antennas on Friday evening. The rest of the station is set up on Saturday morning. This often takes more time than one would think. If the group starts at 9 a.m. Saturday, everything can be ready and tested by the starting time. You can use a good alarm clock (hand wound or battery operated) for logging. It's easier and less confusing to keep the log in local time, rather than to try to keep it in UTC.

A check list of everything needed will help to keep the group from forgetting anything. The Boy Scout motto "Be prepared" is a good one for Field Day. Being extra well prepared helps prevent Murphy's Law from shutting down the station.

#### Keeping the Socializers Happy

The socializers in a club are likely to be "phone hams"

("phone hams" in the eyes of the serious contesters), who have little interest in helping to run a QRP battery-operated CW station. To meet their needs, they can set up and operate another station with call letters different from those the station of the serious contesters uses. This station could be called the "fun station," and the station of the serious contesters the "contest station." The fun station should be located quite far, but not too far, from the contest station and powered by commercial power mains. Using commercial power eliminates the obnoxious noise of a generator and the unpleasant work of keeping the generator running.

In most cases, the QRP contest station would operate on CW and the fun station on the phone bands. The contest station would have the best possible antennas, while the fun station would use a coax-fed antenna with parallel elements or other devices that would make the antenna work on several frequency bands. (A "trap vertical" with radials lying on the ground could be used; it would be easy to put up and would not take up much space.)

The fun station should be managed in ways that would encourage visitors to become interested in amateur radio. The fun station operators should explain amateur radio to visitors and give them materials designed to get people interested in the amateur radio hobby. (Nearly all hams like to talk about their hobby to any people who will listen to them. Hi!)

Another good fun station activity would be to let visitors get behind the microphone and make contacts. The licensed operator in charge of the station should carefully supervise these contacts and be responsible for them. Visitors could also share in the logging

of contacts and marking of the dupe sheets. These activities, shared with visitors, would provide training in contest operating techniques.

The fun station should operate only on frequencies that will not interfere with the QRP contest station. Given a reasonable distance between the two stations and the fact that one station is on CW and the other station is on phone, interference between stations should not be a problem.

To arouse interest and stimulate activity, the operators of the fun station might be encouraged to be competitive enough to try to make as many contacts as the QRP station makes on CW. (It is assumed that the fun station will be a medium powered station.) If the fun station operators do not want to stay around all night, they could try to make as many contacts per hour as the contest station during the times when the fun station is on the air.

If possible, the fun station should use call letters that will naturally promote fun. One year the use of the call letters K9BO brought many humorous remarks from operators of stations worked. One of these was "Canine B.O., you must be a dirty dog." That year, it was singularly appropriate that K9BO made its last contact with station W0PU, operated by a female operator who gave the call letters as "Whiskey Zero Pink Underwear."

On the next Field Day, make both your serious contesters and your socializers happy by running two stations, each with its own call letters. May your fun station provide lots of fun and may your QRP Class 1A battery-operated contest station make the best score that your club ever had! ■

SEND 25¢ FOR OUR VERY COMPETITIVE PRICE SHEET



Amateur Communications Etc.

Hours:  
Mon-Fri 8:30 am-5:00 pm  
Sat-CST 9:00 am-2:00 pm

2317 Vance Jackson Rd  
San Antonio TX 78213  
(512) 734-7793

VISA

SYNTHESIZED SIGNAL GENERATOR

MADE IN USA



MODEL SG-100F \$429.95 delivered

- Covers 100 MHz to 199.999 MHz in 1 kHz steps with thumbwheel dial
- Accuracy +/- 1 part per 10 million at all frequencies
- Internal FM adjustable from 0 to 100 kHz at a 1 kHz rate
- External FM input accepts tones or voice
- Spurs and noise at least 60 dB below carrier
- Output adjustable from 5-500 mV at 50 Ohms
- Operates on 12 Vdc @ 1/2 Amp
- Available for immediate delivery • \$429.95 delivered
- Add-on accessories available to extend freq range, add infinite resolution, AM, and a precision 120 dB attenuator
- Call or write for details • Phone in your order as fast COD shipment.

79

VANGUARD LABS

196-23 Jamaica Ave., Hollis, NY 11423  
Phone: (718) 468-2720 Mon.-Thurs.

ALL BAND TRAP VERTICAL ANTENNAS!

FULL 1/4th WAVE - All Bands! Automatic Selection with proven Hi-Q Traps. 5 Models-ALL self supporting - Ground or roof mount. HI STRENGTH FIBERGLASS TUBING OVER - ALL. NO WOBBLY, LUMPY TRAPS - NO UNSIGHTLY CLAMPS needed - Size 1 1/4" all the way up - Traps hidden inside. You can use it in a 1 ft. sq. Backyard FOR APARTMENTS, MOBILE HOMES - CONDOS etc. where minimum space and neat appearance is MANDATORY! Instant "Drive In" ground mount (included). Use with or without radials (included) (All angle roof mount - Extra) COMPLETELY PRE-TUNED - NO ADJUSTMENTS NEEDED EVER! NO TUNER NEEDED FOR MOST TRANSCIVERS! Use - RG8U feedline, any length! 2000 Watt PEP, input power. Shipped - PREPAID IN USA. Assembles in 10 min. using only screwdriver. WEATHERPROOF!

No.-AVT80-10	5 Band	25'6"	\$199.95
No.-AVT40-10	4 Band	18'9"	\$139.95
No.-AVT20-10	3 Band	11'4"	\$109.95
No.-AVT80-10-3	6 Band	24'8"	\$229.95
No.-AVT40-10-3	5 Band	17'9"	\$159.95

SEND FULL PRICE FOR PP DEL IN USA (Canada is \$10.00 extra for postage, clerical, Customs ) or order using VISA, MASTER CARD or AMER-EXP. Ph 1-308-236-5333 9AM-6PM weekdays. We ship in 2-3 days. All Antennas Guaranteed for 1 year -10 day money back trial. Free Int.

WESTERN ELECTRONICS 39  
Dept. A7 Kearney Ne. 68847



# NEVER SAY DIE

from page 12

the air, you'll always be making a first impression on someone.

I have a fairly good vocabulary—the result of living with an upper middle class family which made a point of “looking it up” when anyone misused a word. Just as I dress to convey to others the real Wayne Green—I also am careful in my speech when meeting someone new. As I know them better I am more flexible in my dressing and my speech. I use dirty words sparingly, using them to communicate where needed for shock value—extreme emphasis.

The language used between a group on a 75m net who have been talking with each other nightly for months is going to be different from that used in first contacts. We should allow more latitude.

## What Can We Do?

Okay, let's address the situation head on. Let's say you hear some jerk going way beyond the bounds of decency in language. What should you do? Should you break in and arrogantly tell the sonofabitch off? Should you merely tune off the channel and sigh over what ham radio has come to? Should you try to jam the bastard? Note my use of emotion-stirring words as I talk about the people who are making you mad—mad when you just think about it! I suspect you agreed with my expressing my obvious distaste for these filthy, disgusting people with appropriate words.

My recommendation is to break in when you hear the bounds of propriety being overstepped—and I mean way overstepped, not just stretched a bit. Break in and tell the chap you find his language inappropriate for amateur radio. Be polite but firm. I guarantee he'll try to get you so mad you'll be inclined to sink to his level—so my suggestion is to make your statement and then tune the hell off the frequency before he can answer. Think about it. One thing your nervous system does not need is an attack on you—even over the air. It doesn't take very many such acrimonious events before you'll find yourself avoiding your ham rig. No, say your piece as unemotionally as you can and leave the

channel so you won't get burned by the fireworks.

You may think that your efforts to clean up the bands will be wasted. But look at it this way—tens of thousands of hams are reading this editorial. Maybe only a few hundred will have the guts to actually do something about the language on our bands, but by the time a bad language user has been reprimanded—and been unable to pick a fight over it, thus getting his jollies, he'll either start to clean up his act or will find himself hesitating to turn on his rig. If hamming isn't fun, we don't do it—so the idea is to make it less fun for the people who are making it less fun for us.

No, it is not necessary for you to give your call letters when you are helping to clean up our bands. And none of that sanctimonious crap (heh!) about it being illegal to transmit without giving your call. I don't see the rules helping us with bad language or bad operating, so don't wave rules at me. I use my call letters when I think they are needed, not to satisfy the FCC. The FCC could care less. They're getting out of the monitoring business anyway, so if we want our ham bands to be fun we damned well have to accept the responsibility for keeping them fun.

## The H&R Block

Non Illigiti Carborundum—don't let the bastards wear you down. Wear them down instead. Wear them down by hit-and-run tactics—what I call the H&R Block.

This technique is effective on the low bands—and to some degree on VHF. But when you run into foul language on your repeater you may need a more effective approach. Here, where your miscreant is nearby, you have a whole array of possibilities.

Just as I recommend every radio club have an I-Team—a group of three or so experienced amateurs who can keep their cool who go out and investigate every interference complaint against a local amateur—I also recommend clubs appoint a UFO-Team to handle perverse operators. UFO—Unofficial Friendly Operators.

The first step for the UFO-Team is to pay a friendly visit to a perpe-

trator and explain the club's view of his operating. If this doesn't work, a second visit with some tapes of his activities, perhaps accompanied by a somewhat larger representation from the club, might get the message across. Hard-core nasties may call for creative measures. Would tapes of his operating and a note to neighbors, his family, his employer, and so forth help create a more relaxed atmosphere?

When the crazies group for support, your approach might best be to work on each one as a separate case and ignore the group. Each then can individually feel the weight of your group disapproval, but without the support of his crazy group to back him up.

## Don't Be Officious

If you use your strength to swat a flea with a sledge, you'll lose your credibility. Hassling someone for minor indiscretions will waste your power. Save your muscle for the hard-core cases. You have to be careful in selecting a club UFO-Team. There is a tendency for the power-seekers to find these jobs. You'll soon find them with UFO-Team signs on their cars, flashing red lights, and a barrage of tape recorders in their shack as they tune the ham bands, eagerly seeking anything and everything to hassle.

## Feedback

If your club has some success with an I-Team or a UFO-Team, make sure someone writes it up so I can publish it in 73. We don't have to live with bad operators—we just have to retrain them. Let me hear your war stories—particularly those where you've won some battles.

## ATLANTA IN JULY?

The biggest hamfest in the Southeast is the Atlanta Ham Festival... this year July 19–20. There are only a few major hamfests where you'll see all of the major manufacturers showing off their newest gear—where you can corner them and get answers, where you can get your hands on just about every ham product made—and Atlanta is one.

Yep, I'm planning on being there and I'll be giving a performance—bring your seat belt and your tranquilizers.

Atlanta is always a joy to visit. It's really geared for visitors. They're working to rebuild Underground Atlanta, but in the meanwhile you don't want to miss the

refurbished Cyclorama—their updated zoo—and Stone Mountain, a nearby amusement park.

For you fat people (like me) there are great wonders. I seldom miss a pass at Aunt Fanny's Cabin. When I'm able to get someone to invite me out, I enjoy The Abbey—one of Atlanta's best (and most expensive) restaurants. Fatties will also go bananas over the buffet in the Marriott. There aren't many dessert buffets, but they've got one. Ice cream sundaes and banana splits, ice cream on pies, ice cream and cake... mmmmm. I hope they haven't changed that.

Jazz fans will enjoy Walter Mitty's, where you'll probably see the Trio-Kenwood gang tripping.

It's time you got serious about packet radio anyway, so check 'em all out at Atlanta.

Y'all come, y'hear?

## CAN WE REBUILD OUR LOST INFRASTRUCTURE

A brief industry meeting was held during Miami Hamboree last February. This was a follow-up on last year's meeting where it was decided to go ahead with a ham comic book project. The industry agreed to ante up \$10,000 for the project, which would be matched by an equal amount from the ARRL. The industry ante on this is still light.

Not much has happened yet on the project. It was discussed and agreed that it should continue as a test to see if this approach will result in some growth. There was no disagreement that amateur radio is in desperate need of growth—that without *something* to make it grow, we're looking at a dying hobby.

There's a tendency to put today's kids down—to blame the kids because they're not getting excited about amateur radio. I hear lots of excuses—well, hell, the kids are playing with computers these days—they're watching television. Bull. When I was a kid there were plenty of other things for kids to be interested in—has everyone forgotten that kids have always had plenty of things to do?

No, blaming the kids is a cop-out. The problem isn't the kids at all, it's plain and simple our own fault. I got interested in amateur radio about the time I entered high school—lo and behold, there was a school ham club, W2ANU. We got together a couple afternoons a week and talked hamming. We put our club station on the air and made contacts. We pored over



QST and Radio together. We visited each others' ham shacks.

We hams sat around arguing with each other twenty years ago when this whole infrastructure was destroyed by the League's "incentive licensing" proposal. Thousands of school radio clubs folded, right along with 85% of the ham stores around the country and 95% of the American manufacturers. That was a catastrophe we're still paying for.

Without the thousands of high school ham clubs to fan the starting flames of ham interest, this whole source of newcomers has almost totally dried up.

We didn't help this situation with our regular community ham clubs. In almost every instance these clubs became controlled by old-timers—old-timers who wanted to talk with old-timers, not kids. Kids are noisy. Kids ask a lot of dumb questions. Kids mean the club has to have a damned code class. Kids mean someone has to try and teach theory. Kids are impatient with the usual endless club bickering. Kids are impatient with long boring business meetings. Kids get fed up with committee reports and interminable arguments over trivia. So old-timers have run the kids out of most clubs. So we don't have any kids these days—surprise, surprise.

I'm wondering—even if a ham comic book does arouse some interest—so what? Where have the kids to turn for reinforcement? If my high school hadn't had a ham club, would I have had my interest in hamming fanned enough to get a ticket? Maybe. Probably not. I could easily have gotten involved with audio and hi-fi and drifted away from amateur radio. I had many friends who did just that.

It wasn't hamming itself which attracted me as much as it was having fun with other kids. I first listened—SWLing. Then I started building electronic gadgets and radios. Then I was guided by the school radio club members toward getting my own license. This was reinforced by daily contact with other similarly interested kids. From there I got on my roller skates and started visiting the nearby hams I heard on the air. I think I visited every active ham in Brooklyn.

The code put me off for a long time. Some of my friends got W2Ms. I'm sure I would have been licensed at least two years earlier if I'd stayed in the high school with the radio club (Eramus HS), but I changed to a small private school

with no ham club and lost the impetus. When I went off to college they had a ham club (W2SZ) and I almost immediately got licensed. This is what I see happening today—even when kids get excited about amateur radio, the excitement almost always blows over without the constant reinforcement of a school ham club.

So I'm not at all convinced that a ham comic book is going to do much for us in the long run. No, we not only need to make the fun of amateur radio known to kids, we have to rebuild the whole infrastructure which used to bring kids into the hobby. We need to get ham clubs back into the schools. We need to get every active community ham club dedicated to getting kids involved and seeing that their first tentative interest is fanned to a roaring flame—maybe even to a license. Avuncular old-timers like me aren't what kids need, they need peers—other kids to help them—to talk—to enthuse—to share excitement.

How in hell are we going to do all that? Well, it's not as hard as you may think. Yes, of course it can be done—done despite all the lame excuses about kids being attracted to computers these days. Sure they are—they have computer clubs in school—and they visit each others' homes and play with their computers. They talk about computers—read about 'em—they play games, they program and swap programs. They break the protection on programs and swap them. They get on the phone and break into bulletin boards—into banks—into military base computers. Talk about fun!

Amateur radio has every bit as much excitement as computers—and I've done the computers bit too. Computers are fun, no question, but they're no competition to working a rare DX contact—making a DX aurora contact on two meters—getting a new country via OSCAR—working a new state on 10 GHz from a mountain—operating in a DX contest—getting a good picture on an SSTV screen from a new country—visiting 9B1MM in Katmandu or 9M6MO in Kota Kinabalu in person—working South Africa with a 2m handie-talkie through a crossband repeater—getting a call on 20m from King Hussein—working Arthur Godfrey on safari in Africa and saying hello to an old friend of my father's who was with him.

I remember a 1946 night—after a college radio club meeting when

a bunch of us got into my old '41 Ford and drove to the top of Mt. Greylock in nearby Western Massachusetts. We had my SCR-522 and a 16-element beam on top of the car and had a ball. It was bitterly cold, so we set up the beam and turned it with a couple pieces of string running out the car window. Huddled around the 522 in the back seat, we worked dozens of stations—all the way to Boston!

Newspaper articles about our ham activities will help strike a spark of interest in kids, but without school ham clubs to follow up, it's a waste of time. Sure, we need PR in magazines, newspapers, on TV, radio... every medium. We need to demonstrate in shopping centers and malls. We need to provide communications for parades, rallies, and other community events. But most of this will be wasted if there isn't the follow up—the school clubs.

Okay, we need to rebuild the high school ham clubs. That'll get the kids in the 14–17 age bracket. Back before the ham dark ages—back in the 50s—ARRL studies showed that 50% of the new hams were either 14 or 15 years old. That's when it happens. I think we can start as early as ten these days, and I'm working on a fiendish plan for that. In the meanwhile let's go with what worked so well for 17 years after World War II—hooking the high school kids. Let's talk about getting high school ham clubs going again—rebuilding the infrastructure which we know worked so well.

It won't be as hard as you think. Better, it will be more exciting—and also more frustrating—than anything else you've done in amateur radio. Your first obstacle will be the resistance of the members of your own radio club. People in general and hams in particular tend to do everything they can *not* to change—often in the face of overwhelming evidence that change is not just necessary, but critically important. People in general and hams in particular are terribly lazy. They will go to incredible extremes not to do something. This is human nature and, contrary to most evidence, hams *are* human. Well, some are.

Let's not get into what hams are. Most of 'em are obviously crazy. Most are cheap bastards. I admit to both of those ham normalities, so I'm not throwing stones, just calling a spade a spade. I think, by almost any measure, any ham in the ham industry has to admit s/he is crazy. There's

no other rational explanation for such irrational profitless behavior.

My recommendation as to the easiest way to get ham clubs started in schools is to encourage our community ham clubs to get going on this as a club project. A small delegation from the club needs to talk with the school principal and explain the importance, to our country and to the kids, of getting them interested in a high-tech hobby such as amateur radio.

The next step is to start regular meetings—maybe once a week—preferably during school hours, if at all possible. Get the principal to allow a club meeting in lieu of a study hall. After-school clubs are often up against serious problems such as busing and sports conflicts. If you can't get a school period, then settle for after school.

The principal will quickly remember that a club has to have some sort of faculty advisor—and that means, particularly after school, overtime pay, which isn't in his budget. If your club can guarantee that it will supply an advisor, you may be able to handle this hurdle. The incipient hams will need someone to tell them about the glories of hamming—and perhaps organize theory and code courses. It's an opportunity to get the kids to come to the community club too—and even to visit local ham stations and maybe get fired up by talking with some DX.

If the principal isn't too interested, you may be able to work through a child or grandchild of a club member attending the school.

If you run into a particularly tough case you might point out that the lack of young radio amateurs has resulted in America falling far behind in engineers—with no growth in engineering graduates in over twenty years despite over a ten times growth in electronic sales. This is why Japan has been able, one by one, to take our consumer electronic industries away from us. Only by getting kids interested in high-tech careers will our country be able to reverse this destructive trend—and that means starting high school kids toward careers in electronics, communications, and computers. Every school in Japan has an active ham club.

Let me be blunt—I don't know for sure that we can pull this off, but if I wasn't pretty damned sure, I wouldn't waste my time trying. I don't have a record of failure—and I don't intend to break that record now. If you really believe I



# NEMAL ELECTRONICS

Your Authorized  
Distributor For



## INTRODUCTORY SALE!

Belden No.	Nemal No.	Description	Per 100 ft.	Per ft.
8214	1102B	RG8 /U Foam 96%	\$45.00	.50
8237	1100B	RG8/U Poly 96%	39.00	.44
8241	1500B	RG59/U Poly 96%	13.00	.15
8267	1130B	RG213/U Poly 96%	53.00	.59
9269	1600B	RG62A/U Poly 96%	15.00	.17
8216	1450B	RG174/U Poly 96%	12.00	.14
9913	1180	Low Loss 50 Ohm	46.00	.58

### OTHER QUALITY CABLES

Nemal No.	Description	Per 100 ft.	Per ft.
1110	RG8X 95% Shield (mini 8)	15.00	.17
1130	RG213/U Mil Spec. 96% Shield	34.00	.36
1140	RG214/U Mil Spec. - Silver	155.00	1.65
1705	RG142B/U Teflon - Silver	140.00	1.50
1310	RG217/U 5/8" 50 Ohm Dbl. Shld.	80.00	.85
1470	RG223/U Mil Spec. - Silver	80.00	.85

### ROTOR CABLE — 8 COND.

8C1822	2-18 Ga., 6-22 Ga.	19.00	.21
8C1620	2-16 Ga., 6-20 Ga. Heavy Duty	34.00	.36

### HARDLINE — 1/2"

FXA12	Smooth Alum. w/black jacket	79.00	.89
FLC12	Corrug'd. Copper (EQ. Helix LDF)	159.00	1.69

### CONNECTORS — MADE IN U.S.A.

NE720	Type N for Belden 9913	4.75	
PL259	Standard Plug for RG8, 213	.65	
PL259AM	Amphenol PL259	.89	
PL259TS	PL259 Teflon/Silver	1.59	
UG21D	Type N for RG8, 213, 214	3.00	
UG175	Adapter for RG58	.22	

Call or write for complete Price List

COD add \$2.00.

Shipping: Cable — \$3.00 per 100 ft.

Florida Residents add 5%.

Connectors — and 10%, \$3.00 minimum

Orders under \$20 Add \$2 Handling

Nemal's new 32-page Cable & Connector Selection Guide now available at no charge with orders of \$50 or more or at a cost of \$4.00 individually.

# NEMAL ELECTRONICS

12240 N.E. 14th Ave., Dept. S., Miami, FL 33161

Telephone (305) 893-3924

✓50

# PAC-COMM

GIVES YOU PACKET RADIO CHOICES



## PAC-COMM TNC-200

- Official TAPR TNC-2 design
- Top quality components
- Version 2 protocol
- Full duplex hardware HDLC
- Adaptable for HF packet
- 16K battery backed-up RAM
- 32K EPROM, software clock
- Multiconnect software
- Five labeled LEDs for status
- CMOS for low current drain
- NMOS for lower cost

- Assembled and Tested with Ref. Manual CMOS - \$219.95
- Full kit with Reference Man. and cabinet CMOS - 169.95
- Full kit with Reference Man. NO cabinet CMOS - 144.95
- Hard-to-find-parts kit and Assy Man. CMOS - 84.95
- Bare PC board and Assy Man. NMOS - 79.95
- Reference manual (100+ pages) 39.95
- Cabinet with end plates 9.95
- 29.95

Free UPS shipping in continental USA  
Florida addresses add 5%

Macintosh terminal software with menus, split screen, file transfers, auto routing, and more. MACPACKET / TNC200 \$69.95

ORDER TOLL FREE (24 hours) 800-835-2246 ext. 115

Intl TELEX 6502881526 WUI

(No COD) Information (call back) 813-689-3523



Discount 10% on orders of 5 or more kits



PAC-COMM PACKET RADIO SYSTEMS, INC.  
4040 W. Kennedy Blvd, Tampa, FL 33609

✓44

can't do this—if you're not going to support me—please let me know why. If you can think of anyone else in the entire world who you think can do this better than me, let me know—maybe we can get him to do it.

### R.I.P. POOR LRPC

One of the reasons I've been so concerned over the shortage of new hams has been my work with the FCC's Long Range Planning Committee. I was appointed to the committee when it was formed five years ago and, despite its meeting in Washington, I don't recall having missed more than one meeting in all that time.

The purpose of the committee was to tackle America's need for an emergency communications system which could be expected to survive even the most serious of emergencies... a nuclear attack. It became obvious early on that our commercial and military communications systems were totally inadequate for this need. The committee recognized that only amateur radio had the potential.

However, amateur radio had only the potential for this, not the actuality. The volume of communications which would be needed

should there be a nuclear attack is so far beyond the present capability of amateurs to handle that we are almost worthless right now. The millions of messages involved can't possibly be handled with our cumbersome, slow Morse-code traffic nets or even phone traffic nets. You know, it's estimated that 80% of us would be unable to pass a code retest if one were given.

Remember that any serious emergency wipes out telephones. Remember that most commercial communications services are on different frequencies and are therefore unable to intercommunicate. We've seen many times where only amateur repeater groups have been able to provide the interconnect between police, fire, ambulance, and other services.

The committee saw that any practical solution to the need would entail two major changes. First, we would have to get amateur radio into vigorous growth before we could expect to have enough hams to provide the needed service. Second, we'd have to get hams to develop technologies such as RTTY and packet radio far beyond where they are today

to achieve the message throughput needed. The committee also recognized that for an emergency communications system to be dependable it must be in everyday use.

The FCC commissioners appreciated the serious need for amateur growth, but the only move which seemed to have any real prospect for bringing about this growth was the no-code license. This had worked exceptionally well in Japan, bringing enthusiastic teenagers into amateur radio by the hundreds of thousands.

When the ARRL fought the FCC's proposed no-code license and defeated it, the FCC, with no other known options for producing new amateurs, gave up in disgust. They dumped the LRPC on FEMA, the Federal Emergency Management Authority, which, as I predicted, completely ignored it. FEMA never held one single LRPC meeting in two years. The FCC recently dusted off what was left of the LRPC and held what appeared to me a brief wake, pronouncing the committee a rousing success, complete with a nice plaque and an autographed photo of Ronny for retiring Defense Commissioner Mimi

Dawson. Mimi certainly gave it a fine try and did the best she could under the circumstances—a bravo to her.

Perhaps I should share the apparently common feeling that the situation is totally, completely hopeless, so why bother to waste time trying to fight it? Well, I don't think it is hopeless as far as getting amateur radio growing again. I even think, with 73 helping, we may be able to develop the high-speed automated digital message system we need. Heck, we already have the technology; all we need are the pioneers to work out the details and battle old-timer inertia to get it accepted. If we can get growth through kids, we'll have our pioneers.

But you tell me. Should I give up trying to fight amateur apathy, the ARRL, the FCC, and City Hall? Maybe you'd rather read about my misadventures on 20 meters. After all, the chances of a nuclear attack are almost zero anyway, what with the promised nuclear winter effect which would wipe out most of civilization. Amateur radio, as bumbling as it is, can usually cope fairly well with small localized emergencies such as earthquakes, floods, and vol-



canos—so why bother trying to develop more hams and a better communications system?

And, as far as getting amateur radio growing so America can generate engineers, technicians, and scientists so we can compete with Japan, perhaps it's time America got used to being a second-rate country—the way England has. Maybe we shouldn't bother to try and regain our former pride in our technology. It's so much easier to just let our kids enjoy drugs and television—to ignore their smoking cigarettes and spending their nights cruising. Recent statistics show the average American youngster spends an average of two and a half minutes alone with his father a day without the TV set on. Do we even care about our kids—about our country—or amateur radio? I see no evidence of anyone caring.

What do you think? I don't want to turn into a pest.

#### OUR HAM POPULATION

With a little over 400,000 licensed amateurs, we have a fairly strong hobby, eh? Of course we're seeing an increasing loss of newcomers, but the new ten-year licenses make it so the total number of licensed hams has stayed about the same.

What about concerns over the average ham age now reaching 56? How did that happen? I talked with an old-timer the other day who had an interesting perspective. He runs a ham store and he's observed that a surprisingly high percentage of the aging licensees are the wives and close friends of hams who were given or virtually given their licenses twenty-five years ago when that was popular. These Techs, now in their 40s and 50s, have never had enough interest to bother learning much about amateur radio, or to be particularly active. A more realistic guess at the even remotely active ham population might put it below 200,000.

The bright side: Most licensees who drop out each year are from the inactive half of the ledger. We're also losing an increasing number via Silent Keys, as the average age increases. Remember, the average life of men in the U.S. is around 72 years—which means, as I've pointed out before, by the time you're 72 half your friends will be dead and the other half dying.

We do have enough time left, however, to get busy and Elmer local school radio clubs so we can get amateur radio going again.

Yes, I've heard all about computers taking the kids away from amateur radio. Baloney. Kids have always had plenty of interesting things to do. If hamming is fun we can interest kids in it. But we do need the school radio clubs to fan that spark of interest and get 'em licensed.

These days, with packet radio growing so fast, we have even more to talk about to kids. Packet is a way for them to use their computers and do something really fun with them.

I hear whines about kids not having the money it takes for amateur radio equipment. Heck, if kids can support a \$100 a week cocaine habit, they should be able to put together a whopping ham station just by avoiding drugs. Any kid that really wants to can find after-school work and make money.

Speaking of money, what about the poor old-timers who are living in poverty on Social Security? I don't know about where you are but around here it's tough to find people for the available jobs. There's plenty of part-time work—and an unlimited number of ways for people to get into business for themselves.

So let's not be complacent, smugly assuring ourselves that we're 400,000 strong. Let's get to work rebuilding our hobby—getting youngsters. My goal for us is 1% of our population—yep, 2.5 million hams—over ten times as many as we really have today. If you get started with school radio clubs, I'll publish the simple construction projects and news of exciting new ham activities such as packet radio. Who knows, we may even get America back into high technology!

#### GOD WILL PROVIDE

A few years back... oh my, it was 1966, twenty years ago... I visited Robbie 5Z4ERR... he used to be VQ4ERR when Kenya was part of the British Empire... which was then known as Great Britain. I suspect the term today is generally used in irony. Anyway, Robbie, who had been writing for 73, suggested it would be nice of me to visit Kenya—and maybe go on a hunting safari.

I'd just read a book on how to go on an African Safari for \$690. I checked, and sure enough, I had \$690 burning a hole in my pocket. Should I start a new magazine or go on safari? Easy choice. I wrote an editorial in 73 asking if there were any hams interested in going

with me on safari. It turned out there were two, so we did it.

No, I'm not going to write a day-by-day account of the trip... at least not now. What I'm gradually getting around to has to do with Kenya at that time, just a few years after gaining independence. Robbie, a British chap, ran the largest drug store in Nairobi—and had the biggest signal out of Africa. Oh, we had a lot to talk about!

After the \$690 safari, which was most successful, thank you... while my trophies were being cured and shipped back... Robbie and I drove to the Serengeti game park for a few days. Robbie explained that one of the big gripes in Africa at the time was the attitude of the missionaries. The Europeans could see that what little they'd established in the way of civilization was unraveling, so they warned the missionaries to get out while the getting was good.

No, God Will Protect Us, they pioused. So then, when the blacks, caught up in *Uhuru*—freedom—started raping and killing, the cries of anguish arose—oh woe, please save us. Robbie was griping that then people had to endanger their lives to rescue these turkeys.

I tried to explain to Robbie that the inability to cope with an impending disaster is a human trait, not one isolated and perfected by missionaries. Oh, they saw the danger, but they just didn't believe it could happen to them. They really believed that God would somehow spare them, so they were very upset to discover that God helps those who help themselves—perhaps a new concept to them.

This came to mind as I thought about the similar reaction of businessmen. When the cash gets short they look around for temporary expediences, some of which can have devastating consequences. How many times have I called 73 advertisers to see what they're planning to run, only to be told they're short of money right now, so they're going to cut their advertising. None ever survive.

Yep, I know this seems self-serving—after all I'm selling advertising space, right? Yes, I am... but more important to you, the reader, and to the industry, what I'm selling is one of the most critical aspects of any business—communications with customers and potential customers. No customers, no business... so when

the connection to sales is cut, the business dies.

Most of the ads in 73 are run by small ham-owned companies. They're spending a bundle on ads in 73 in order to reach you, hoping desperately you'll buy their products. Few of them (any?) know much about advertising, so you'll see some terrible ads in amongst the few good ones. Rather than just skipping over the bum ads, you might take pity on a fellow ham and drop him a note explaining your reaction. Maybe he'll do better as a result.

Unless you're very unusual, the day is going to come when you and a ham friend or two get to talking about getting into the ham business. You'll have some gadget or some service and you'll want to give it a try. What could be more fun than being in business selling a ham product or service? Well, if you ask those who are in the business, you'll find there are many things far more rewarding—like jumping naked into a pit of hot tar.

Entrepreneurialism is a mental deviation which is generally more concentrated with only- or first-children, but can hit almost anyone. Hams seem particularly susceptible to this aberration, so watch out. One of these days you'll build some gadget which your ham friends will want. Will you make one for them? The next thing you know you're running small ads in 73. Then bigger ads. Then full pages. Then the sun spots fade away and so do sales. Instead of advertising smarter you start cutting ads... dum de dumm dumm.

When sales are good you don't worry about making your ads work better—about getting the most out of 'em. When the hard times come it's too late to do the learning you should have when you had the money. Pity.

I can hear my telephone ringing now—I'd like to get into the ham business—how can I find a product to sell? My first warning is not to try to sell to hams—a tight-fisted bunch of retired old men bent on making sure newcomers suffer just as much as they did to get their ham ticket. Well, most of 'em are that way, but we do have a few hams interested in new things—or else we wouldn't have several thousand packet-radio enthusiasts. Perhaps there's some hope yet.

My own formula for finding products to sell is to make an annual pilgrimage to where most of



# CTM

"...received my moneys worth with just one issue..."

—J. Trenbick

"...always stop to read CTM, even though most other magazines I receive (and write for) only get cursory examination..."

—Fred Blechman, K6UGT

U.S.A. .... \$15.00 for 1 year  
 Mexico, Canada ..... \$25.00  
 Foreign ..... \$35.00(land) - \$55.00(air)  
 (U.S. funds only)  
 Permanent (U.S. Subscription) ..... \$100.00  
 Sample Copy ..... \$3.50

**CHET LAMBERT, W4WDR**

1704 Sam Drive • Birmingham, AL 35235  
 (205) 854-0271

✓11

## THE FORMULA FOR TWO METER DX: MTT144/28R + MML144/200S = VUCCI!

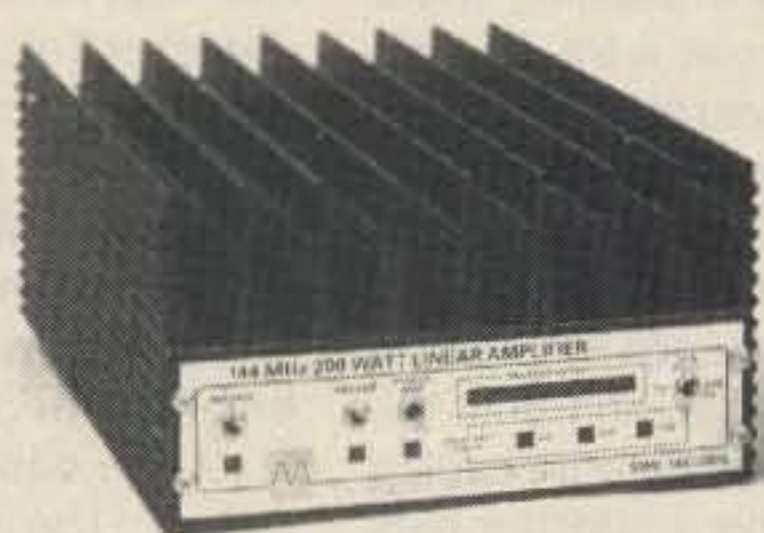

The MMT144/28R GaAsFET transverter and companion MML144/200S power amplifier give you ultimate flexibility on 144 Mhz. The MMT144/28R features ALC, 25 watts RF output, and built-in +600, -600 KHz offsets for FM repeater operation.

**MICROWAVE MODULES LTD.**



The MML144/200S offers three switched input drive sensitivity levels—3, 10 or 25 watts for a full 200 watts output! A low noise optimized GaAsFET preamp is included.

**THE "PX" SHACK**

52 Stonewyck Drive  
 Belle Mead, New Jersey 08502  
 (201) 874-6013



✓29

the new products are being invented and developed: Asia. I try not to miss the Japanese Consumer Electronic Show every October (there are generally a dozen or so hams on the fall show tour), plus CESs in Korea, Taiwan and Hong Kong. They're one after the other. I'm importing some great electronic gadgets from Asia that I've discovered on these trips. For instance, we're selling about 500 Apple disk drives a month and a couple thousand swivel bases for monitors with power switching and protection built in.

The entrepreneur will find inspiration almost anywhere. I'll bet I come up with a gangbusters idea at least once a month, with idea-ettes almost daily. Now that I've got my publishing and retailing businesses running fairly well, I'll be looking for coconspirators and investors to start more businesses.

You can bet that when cash flows glaciates, I'll be pumping out the PR and advertising, not cutting back on ads to save money. Every business runs into cash problems—it's part of the real world.

One piece of advice I give every firm consulting me: When things are going well it is time to invest in a good PR person and a writer. I know of many multi-million dollar firms which would be going strong today if they'd had such a team on hand when the going got rough. Many firms with excellent products and services went out of business for this lack.

Am I being a nudge about you're getting into business? I

guess I let my enthusiasm get away from me and write too much about it. I just get so darned fed up at hamfests hearing people plead poverty—poverty in the midst of plenty—plenty right there for those with the guts to go for it.

I wonder if there is any correlation between hams who try new things—who get involved with packet radio, who get enthused over OSCAR contacts, who get on 2m SSB—and being adventurous in life...in business? Seems to me there might be. Some hams get their Tech ticket and spend their declining years talking over a repeater—never really saying much. Some are into DXing, then into high-speed CW, then having a ball with slow scan. They never get bogged down for long.

One of the great charms of RTTY has always been the opportunity to talk with the more interesting and adventurous hams. The packet crowd is now saying the same thing. Plus, we seem to be able to communicate better in writing than we do on voice. These activities which take some extra effort are a fine filter to block out the boring turkeys. No, it isn't perfect, but it's good enough to keep most of us going on RTTY and packet well beyond our pioneering days.

Now, getting back to the God Will Protect Us syndrome—I see that same attitude—the same blindness to approaching catastrophe—on the part of our lower-intelligence old-timers. Here we have a hobby which depends totally on the use of incredibly valuable radio spectrum, a limited re-

source worth billions of dollars to commercial interests. We're an aging and shrinking group. We know that virtually all the technical advancements we used to contribute came from younger hams, yet we've allowed this resource to be almost wiped out. It's been a generation since we've done anything of value to warrant our use of our bands. Indeed, by keeping out the young experimenters we're now using only a few of our allocated bands at all. Will prayer save our hobby? Let's either get those prayer wheels going or get cracking on helping ourselves by getting school radio clubs going. Perhaps if we set all of our computers offering prayers 24-hours a day to save amateur radio from our own neglect, we might be able to relax and rag-chew without that guilt feeling. How about it you software chaps, have you a program which will take care of this for us?

### DO YOU WRITE?

I'm looking for some columnists to keep us up to date on what's going on in the dozen or so related hobbies we call amateur radio. We're covering some okay, but not enough. For instance, perhaps you're a true 160m fanatic—fine, you'll have a lot more activity on 160 if you let everyone know what's happening there and how much fun it is. We're interested in antennas, 160m equipment, contests, special events, band conditions, what DX is available on what frequencies, when, and so on.

If you're an 80m guru, we're interested in the same info—month-

ly. We're also interested in special activities such as RTTY, high-speed CW nets, and service nets. There's a lot going on on 80. Is there anyone who can tackle it?

Ditto the above for monthly reports on 40m, 20m, 15m, and 10m. In addition, if there's enough interest, we might have a separate 10m FM report. I don't know if there's enough activity on 6m to fill even a one-inch column, but if there is someone who lives and breathes six meters and can fill us in on what's happening there, let's hear from you.

There is so much doing on two meters I don't know how we could cover that. If there's someone with the guts to try, I'd like to hear what you propose. Trying to cover voice repeaters, RTTY repeaters, digipeaters, moonbounce, meteor scatter, SSB, CW, aurora...I don't think it can be done.

220 is easier—any volunteers to see what can be done about making 220 more popular? We need repeater lists, simplex channel data, contest information, equipment news, and so on. Perhaps we need a 220 contest?

430 is a busy band in many areas of the country, with some TV on the low end and a passel of repeaters higher up. Is much being done during contests? Simplex? Mountaintopping? Moonbounce? Spread spectrum? Is there a volunteer?

1250 MHz—volunteer? There's more and more ATV here, EME...and what about microwaves—like 10.5 GHz, 24 GHz, and so on? Is there a volunteer with enough interest to try



and get more activity on these bands? We need to know what's being done, what new equipment is available, how the bands do during VHF contests, and so on.

We need a column for SSTV. And how about high-speed CW—anyone into that who can tell us what's going on—where to listen—what equipment to use? EME... volunteer? We have OSCAR orbits, but how about news?

We have an estimated 150,000 American hams who are actually active in some way. Most of us are creatures of habit. We get stuck rag-chewing on 75 meters and tend to forget the fun of climbing a fire tower on top of a mountain in the middle of a well-below-freezing night to try for a 10.5-GHz contact with a new state. Some fun. So if you are having a ball with some aspect of amateur radio and would like to get more of us interested in your insanity, the best way to promote it is with a monthly column in 73, telling us what's going on, how to do it, and how much fun it is.

Even though I'm as habit-frozen as just about anyone, columns and articles on ham activities I haven't yet tried eventually get to me. Over the years I've been forced by magazine articles and columns to become an RTTY fanatic, worked more than my share of DX, have a big certificate collection, have done my bit with 75m DXing, was a pioneer on six meters, have the record for states worked on 10.5 GHz, had my own repeaters on several bands, operated SSTV from several countries, and so on. If you're enjoying ham radio, get more hams involved with your particular interest with a column.

If you'd like to give it a try, put together a sample column and send it to me so I can get an idea of what you can do. I'll pay modestly, but your main reward will be increased interest in your activity. I prefer to get both a disk and a printout so we won't have to retype your material. We're completely automated these days, so we plug your disk in, edit your stuff, then feed it right into the typesetting system.

I'll be judging your columns on how much you obviously know about your subject, how persuasive you are, and how much you'll be able to contribute without depending too much on material from readers. As a hard-core

stick-in-the-mud ham, one who tends to stay with what I'm doing unless dynamited into something else, I'll be looking to see if your column gets me to thinking about giving your interest a try. It won't hurt for you to include an outline of things you'd like to cover in future columns.

I got stuck for about a year talking to the same bunch of hams on 75m one time. It wasn't until the excitement of six meters opening to Europe during a sunspot high that I broke away. The enthusiastic articles and reports finally did it, getting me to convert an old FM radio to see what the fuss was about. WOW!

In order to keep columnists on their word processor keys, I want all of you to send me a Feedback card (page 80) every month telling me how you rate 'em. If they lose out in the ratings, I'll look for someone you'll like better. It's all too easy for columnists to run out of material and get dull. There isn't any excuse for dull in a bunch of hobbies like ours.

I don't know whether we'll get you going on high-speed CW, on EME, or what, but I'm going to do everything I can to get you off dead center. If you aren't an expert, at least contribute your news to the experts... and help me get as many hams subscribed to 73 as we can. Talk it up, okay? It's better than reciting your ham gear serial numbers.

### ASIAN TOUR

The Consumer Electronic Shows in Japan, Korea, Taiwan, and Hong Kong are back to back in October, making it possible to get to all four in a two-week Asian trip. It's a fast tour, with one-day travel and then two days in most countries, but it gives you a chance to both see these interesting countries and get to their electronic shows.

Compact disc fanatics will love the wide variety of CDs available in Japan and Hong Kong—thousands of CDs which aren't (and may never be) available here.

One of the nice aspects of this show tour is your freedom. If you want to go to the electronic shows, you'll have a bus and all the help you need. If not, there are sightseeing trips. Or you may want to go it alone. I've been going on the Commerce show tours for about eight years and find them invaluable for making contacts and keeping abreast of all electronic technologies.

The tour leaves the U.S. Octo-

ber 2nd from most any city you want, flying to Tokyo. You arrive the 3rd and are transferred to the New Takanawa Prince Hotel—a fine new hotel in the Shinagawa district of Tokyo. Several of us will be having dinner that first night just down the street in a great little (and surprisingly inexpensive) tempura restaurant.

The tour provides a first-class breakfast every morning—plus at least one banquet dinner per city visited. The breakfast is a fine time to meet your fellow tourers. The tour usually has between 150 and 250 people, including a dozen or more hams, so it takes a while to meet everyone.

The hotel is located right near the Shinagawa station, making it possible to get almost anywhere in Tokyo in minutes—such as Akihabara, where there are hundreds of electronics and parts stores. There's even a Baskin Robbins and a McDonalds across the street from the station, in case you get a yen for American fast food.

On the 6th we're off to Korea and the Seoul Hilton, which is near the famous Etweon shopping district. Between sightseeing (like the historical Korean Village), the electronics show and visiting electronics factories, there's plenty to do during your two days in Korea. We'll join the 73 Magazine DXpedition group here, where their tour begins.

Next stop is Taiwan on the 9th. If you didn't get a new suit in Seoul, you'll probably buy one here. By the way, though the yen has seriously escalated in price, currencies in Korea, Taiwan, and Hong Kong have held steady, so these are still first-rate shopping countries. Tailor-made suits are around \$150 here—shirts \$8. They can measure you the evening you arrive, make the first fitting the next morning, and have the finished suit for you that evening.

The Taiwan electronic show is always a big one, with hundreds of small businesses showing products of interest to importers. I've been importing a bunch of computer accessories from Taiwan, so I'll be looking for new ideas.

Yes, there's sightseeing, factory visits, an incredible place called Snake Alley—but most important for me—we'll be in Taiwan on October 10th—10-10, the biggest holiday of the year—so we'll be able to visit the huge stadium and watch the kids perform.

I'll have my 8mm video camera along this time and tape the whole production. You have to see the show those kids put on to believe it.

Then on to Hong Kong. Here, in addition to the fun of the city, you'll find your best shopping for cameras and electronics gadgets—plenty of record stores with wide CD selections—bargain portable CD players. If you bring along your 2m HT you can get a ticket here and operate on the seven repeaters.

There are side trips available to Macao XX, just an hour away by hydrofoil, or to Shenzhen City, for a peek into China BY.

After Hong Kong there are optional tour extensions—two days in Canton for the Canton Trade Fair, two days in Canton plus three in Beijing, where you can check out the Great Wall, the Ming Tombs, and perhaps get on the air from BY1PK, or two days in Singapore 9V1. If there's enough interest, I'll go on from Hong Kong with a small group for a short visit to the tiny countries of Sabah 9M6, Brunei V85, and Sarawak 9M8 on Borneo—an extra seven days—in case you'd like to see these fascinating, but seldom visited countries. I've been to all of them and they're well worth the trip.

How much does all this cost? The round trip economy fare from the West Coast, October 2–16th, to Japan, Korea, Taiwan, and Hong Kong, is \$2,639. It's a bit more if you want to travel Executive Class—and a bit extra from the East Coast, of course.

For a full schedule of dates, costs, and details, drop me a note and I'll get 'em to you.

If you've added 8mm video to your repertoire, be sure to bring your camera and plenty of tapes on the trip. I've visited these cities a dozen times or more over the last 25 years and they're still fascinating.

You need visas to visit most of these countries. These take time to get, so you can't wait until the last minute and suddenly decide I guess I'll go on the trip. The China add-on takes even longer, with July 31st being the deadline.

About two-thirds of the people on the tour are repeat customers, so Bob Chang, the chap who runs Commerce Tours and personally conducts the tours, is doing it right.

Write Wayne Green W2NSD/1, Asian Tour, WGE Center, Peterborough NH 03458. ■



**WIN!**

# 2m CLOUT

in 73's Powerhouse Sweepstakes!



## Grand Prize:

### Kenwood's 70-Watt TM-2570A 2m FM transceiver

Wouldn't you like to own the hottest 2m rig on the market? Kenwood's TM-2570A pumps out an amazing 70 Watts of rf from 142-149 MHz—all the power you need to hit everything that you can hear. You'll have 23 memories at your fingertips for instant recall of frequencies, repeater offsets, subaudible tones, and telephone numbers—the VS-1 Voice Synthesizer will keep you posted on what's where. Does the TM-2570A scan? You bet it does—memory scan and programmable band scan (with priority alert) are standard. You'll also get Kenwood's exclusive Digital Channel Link System, a CD-10 Call Sign Display, and a PS-50 20-Amp power supply for operating at home.

How can you win this top-of-the-line system? Just complete the attached entry card or the coupon below. No purchase is necessary.

**Be an instant winner!** Check the **YES** box on your entry card to start your subscription to **73** at our special introductory price—just \$19.97 for 12 months; you'll save 44% off the regular cover price!

#### OFFICIAL RULES (No Purchase Necessary)

1. On an official entry form or a 3" x 5" piece of paper, hand print your name, address, and zip code. Enter as often as you wish, but mail each entry separately to 73's Powerhouse Sweepstakes, Circulation Department, 70 Rte. 202 North, Peterborough, NH 03458. Entries must be received no later than July 31, 1986. The drawing will be held by August 30, 1986. All entries become the property of 73 Amateur Radio, which reserves the right to print the name and address of the winner.

2. Winner will be selected in a random drawing from among all entries received, under the supervision of the publisher of 73 Amateur Radio, whose decision will be final. Only one prize will be awarded in this Sweepstakes. Winner will be notified by mail and may be required to execute an affidavit of eligibility and release. Odds of winning will depend on number of entries received. The publisher of 73 Amateur Radio will arrange delivery of prize. Taxes are the responsibility of the winner. Any manufacturer's warranties will apply, but the publisher makes no warranties with regard to any prizes. Prize is not transferable. No substitution for prize.

3. Sweepstakes open to all residents of the U.S., its territories and possessions, who are at least 18 years old, except employees (and their families) of the publisher of 73 Amateur Radio, its affiliates, and its advertising and promotion agencies and Trio-Kenwood Communications. Void where prohibited or restricted by law.

4. For the winner's name, send a stamped, self-addressed envelope to 73 Amateur Radio, Circulation Department, 70 Rte. 202 North, Peterborough, NH 03458.

**YES!** Enter me in 73's Powerhouse Sweepstakes and start my subscription to 73 Amateur Radio for the term checked:

- One year for \$19.97
- Two years for \$34.95

Mail to:  
73's Powerhouse  
Sweepstakes  
Circulation Dept.  
70 Rte. 202 North  
Peterborough, NH  
03458

Check Enclosed      MC      VISA      AE  
Card# \_\_\_\_\_ Exp. Date \_\_\_\_\_

No, I do not wish to subscribe now, but please enter my name in the 73 Amateur Radio Sweepstakes.

Name \_\_\_\_\_ Call \_\_\_\_\_  
Address \_\_\_\_\_  
City \_\_\_\_\_ State \_\_\_\_\_ Zip \_\_\_\_\_

Offer valid only in the U.S., its territories and possessions. Please allow 4-8 weeks for delivery of first issue. 06SW86





## AUSTRALIA

J. E. Joyce VK3YJ  
44 Wren Street  
Altona 3018  
Victoria  
Australia

## VK6 INFORMATION

With the number of overseas visitors coming to the America's Cup Yacht Race in VK6 later this year, I have received several letters seeking information regarding amateur radio in VK6. Particularly needed was info on 2 metre and 70 cm repeater operation. I hope the following will assist these people in having an enjoyable stay in West Australia for the Cup.

Nearly all VHF-FM repeaters in Australia have a downwards shift of 600 KC [kHz] on transmit; e.g., Perth VK6RAP: receive on 146.700, transmit on 146.100. As not all repeaters are in operation at the same time, due to breakdowns or off-air being serviced (and as I am over 2,500 miles away on the other side of the continent), I cannot guarantee which ones will be working during your stay. However, here is a full list, to my knowledge, of VK6 repeater frequencies in Perth, for you to either program your sets, or bring the appropriate crystals:

RAP-146.700 (Voice)  
RTH-146.750 (Voice)  
RTH-146.800 (Voice)  
RPD-146.950 (Voice)  
REE-146.975 (Emergency)  
REE-147.000 (Emergency)  
RTY-147.050 (RTTY)  
RWC-147.100 (Voice)

There also is one 70 cm repeater operating in the Perth area on 438.525 MHz.

## PEOPLE TO CONTACT

If you wish to contact a radio club either when you arrive or beforehand, I would recommend the Perth Radio League of WA (Inc.), PO Box 106, Cannington, W.A. 6107, Australia.

As stated in previous articles, the best way to gain a reciprocal license in Australia is to apply upon arrival. In Perth the place to go is the Department of Communi-

cations, Caga Centre, 256 Adelaide Terrace, Perth 6000; Phone: 09-3255877 (within Australia).

**NOTE:** American Novice licenses are not recognized as valid for a reciprocal license within Australia.

The cost of a license, regardless of length of stay, is A\$23. [US\$1.00 about A\$1.40 as of April.] If you wish to apply for a license beforehand, please write to State Manager, Department of Communications, PO Box 6189, Hay Street East, Perth 6000, Australia. All that is required is either your original amateur license (or a certified copy) to show to our D.O.C. You will then be granted a similar grade license with a VK callsign for 12 months operation within Australia.

## RAOTC

In 1975, a small group of Australian amateur radio operators decided, mainly under the guidance of Bob Cunningham VK3ML, to form a Radio Amateurs' Old Timers Club, the main criterion being the holding of an amateur license for at least 25 years.

From this small beginning there are now over 750 members, with some members being classed as old old-timers, having held a license for over 50 years.

Between 1975 and 1985, club communication was via weekly on-air skeds and a newsletter. With the growing membership, it was felt an annual magazine was required to service its members. 1985 saw its inception with Max Hull VK3ZS its editor and Kevin Duff its co-editor.

The magazine itself is full of nostalgia, with listings of present members, plus later day silent keys; with the band conditions the way they are today, it is the only way some of the not-so-active old-timers get to know of a friend's passing.

The story below (by Lay VK3CF and Bill VK3CB) is typical of the magazine, and should bring back memories to some of the earlier days of amateur radio when experimentation was supreme.

## The Big Re-Broadcast

During the 1928-30 period in Melbourne, when a selected number of amateur stations had permission to have "fun and games"

on the broadcast band, there was much friendly rivalry between the boys to see who could come up with some novel programme to augment the playing of gramophone records.

One (big deal) for those days was to re-broadcast an overseas shortwave transmission or to introduce local "live" talent from Mum's front room, using it as a sound studio with a "Reiss" carbon microphone made from a marble block carved out by the local tombstone people plus pieces of mica and lots of carbon granules. I was Bill Sievers' (VK3CB) second op—and how Mum Sievers put up with us hanging chaff bags and hessian from the picture rail right around the room to reduce reverberation (yes! we knew something about acoustics even then) and pinching the four-inch wooden curtain rings from the spare room to make our multi-strand sausage-shaped zepp aerial, I'll never know.

An amusing highlight of those days happened to the late Bert Maddick VK3EF of Elwood. He had his talking cockatoo in the shack with him, and while transmitting, the bird let loose with profanity that would have done justice to a bullock driver at his best! However, Bert was let off the hook by the Postmaster-General's Department, but only after a severe reprimand. Enough said!

One of the best outside broadcasts (O/Bs) was put on by Arthur Forecast VK3AM who arranged with his second op, Headley Myers (the "Igranic" wireless man at Noyes Bros.), to receive the powerful American station KDKA, owned by the Western Electric & Manufacturing Company, from East Pittsburg, Pennsylvania, at his QTH and then, with special permission from the Department, send their programme down the telephone line to Arthur. This was technically and otherwise very good, and it created a lot of interest until one evening the local telephone exchange operator, being unaware of the Department's OK for this activity (so what's new?) heard music on the line and immediately put on the howler which caused Arthur's many listeners to imagine that their receivers were about to blow up!

The late Stan Gadsen VK3SW, Ivor Morgan VK3DH, and the Holst brothers, VK3BY, and many others were very active in those days, and last but by no means least, VK3CB and myself. I start-

ed out in the "OA prefix" days (prior to the VK prefix) as Bill's second op.

Not to be outdone by the aforementioned weekend amateur broadcasts, we let it be known one weekend that on the following Sunday night at 11 p.m. we would re-broadcast a programme from JOAK, Japan. This station could be heard on the BC band on a slightly higher frequency than 3LO when the latter closed down at 10:30 p.m., as did all the BC stations in those days.

Normally we could receive JOAK at good strength at East Richmond, but on the Saturday night prior to our much publicized "Big Re-Broadcast," my multi-tube receiver packed up and in no way could it be fixed up in time for the following night's "do." After the first wave of panic subsided, we dreamed up an idea to get us off the hook: in fact it was a stroke of genius! We announced on the Saturday that due to matters beyond our control, we could not relay the Japanese station but, as an alternative, we would do a re-broadcast from China and thus keep faith with our listeners who were patiently waiting for the overseas broadcast.

Bill and I now applied our true amateur talents! We had no idea at all of the existence of a Chinese broadcasting station, so we created one ourselves! Firstly, Bill managed to fit a switch which would reverse the direction of rotation of our gramophone motor while I arranged our Webster pickup arm to track from the inside out. We then drilled a new spindle hole about 3/4" off centre in an old 10" disc on which was recorded mainly voice. This was placed on the turntable using the off-centre position for the spindle and, after the big announcement of the "Big Re-Broadcast" from China, the thing was played off-centre, inside out, and back to front!! Talk about a Chinese broadcast; it was perfect! The secret of a nonexistent foreign broadcast has remained with us... until now!

I am grateful to VK3CF and VK3CB for the above story!

## WIA BADGES

For nearly half a century or more, the WIA has had the same lapel badge featuring Australia over a banner of the WIA, but with the ease of international travel, some of the members voiced a need for an international-type lapel badge, with the familiar diamond shape being mooted. This





# Catch of the day!

Have you been trawling the bounding main for a new product? We have just netted it—the TP-38 microprocessor controlled community repeater panel which provides the complete interface between the repeater receiver and transmitter. Scuttle individual tone cards, all 38 EIA standard CTCSS tones are included as well as time and hit accumulators, programmable timers, tone translation, and AC power supply at one low price of \$595.00. The TP-38 is packed like a can of sardines with features, as a matter of fact the only additional option is a DTMF module for \$59.95. This module allows complete offsite remote control of all TP-38 functions, including adding new customers or deleting poor paying ones, over the repeater receiver channel.

Other features include CMOS circuitry for low power consumption, non-volatile memory to retain programming if power loss occurs, immunity to falsing, programmable security code and much more. The TP-38 is backed by our legendary 1 year warranty and is shipped fresh daily. Why not set passage for the abundant waters of Communications Specialists and cast your nets for a TP-38 or other fine catch.



**\$595.00 each**  
**\$59.95 DTMF module**

**COMMUNICATIONS SPECIALISTS, INC.**  
 426 West Taft Avenue • Orange, CA 92665-4296  
 Local (714) 998-3021 • FAX (714) 974-3420  
 Entire U.S.A. 1-800-854-0547





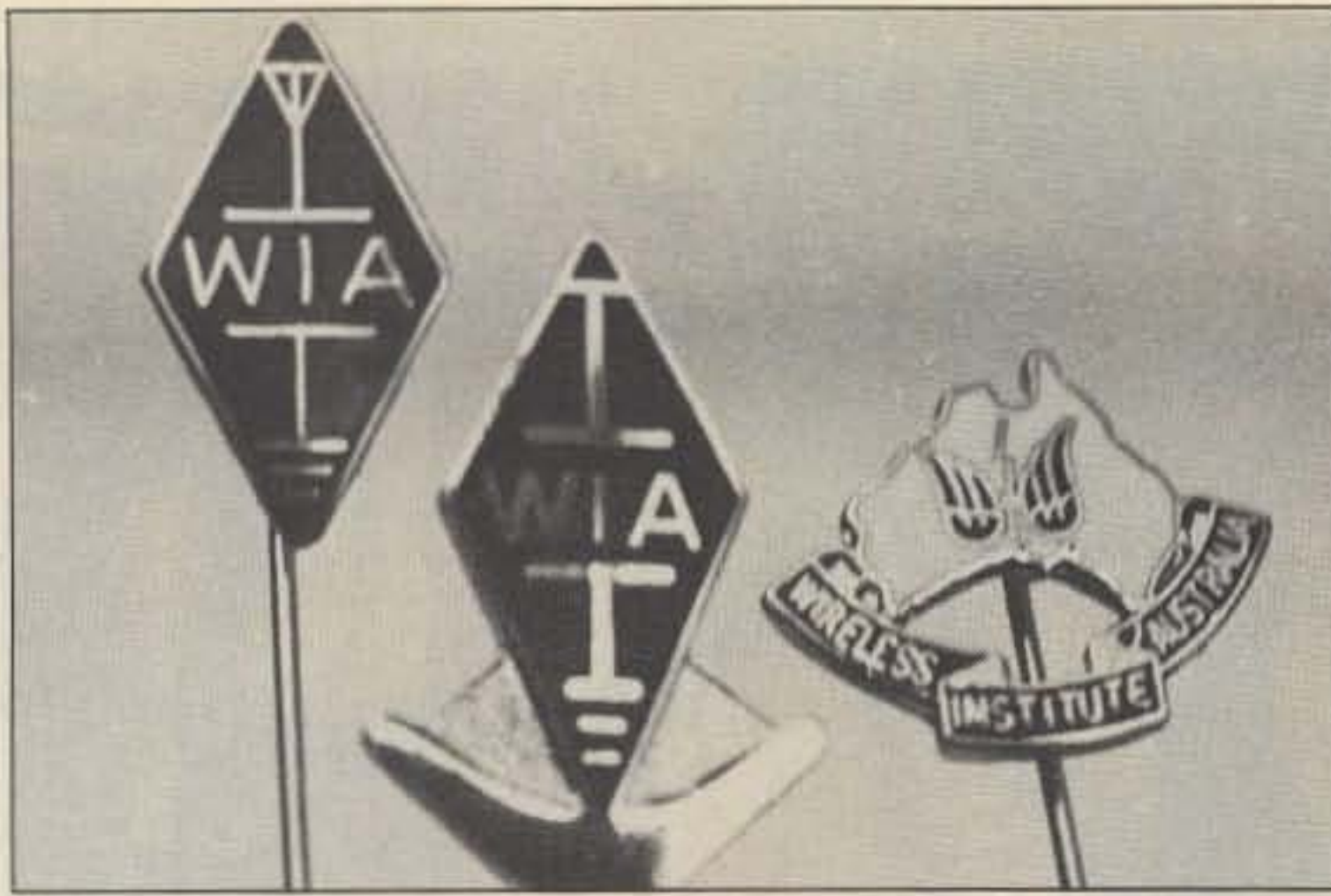

The Australian badges. L to R, new, newer, and old.

diamond-type badge was manufactured, with quite a few being bought by members.

This, of course, brought howls of indignation from some older members saying, "We are losing our National identity!" The arguments raged back and forth, with the result being that a third badge was made featuring the diamond shape plus a boomerang. The idea being that the diamond was for easy international recognition and the boomerang depicting Australia, with the added bonus that it was simple matter to have your callsign inscribed upon the boomerang; this badge would serve a three-fold purpose.

The arguments are still going strong with some members, as to which badge is the most representative of the Australian amateur. Photos of the three badges are included to help you form your own opinion!

#### SPICE UP YOUR QSO WITH PHRASE DROPPERS

Ever noticed how your QSO becomes a little light on technical conversation? Well, try a few of the combinations in Fig. 1 next time and no one will ever admit that they don't know what you are talking about! Select any three of

- |                 |                   |                |
|-----------------|-------------------|----------------|
| 0. integrated   | 0. muted          | 0. options     |
| 1. total        | 1. organizational | 1. flexibility |
| 2. systematized | 2. monitored      | 2. capability  |
| 3. parallel     | 3. reciprocal     | 3. mobility    |
| 4. functional   | 4. digital        | 4. programming |
| 5. responsive   | 5. reactive       | 5. concept     |
| 6. optional     | 6. transitional   | 6. time phase  |
| 7. synchronized | 7. incremental    | 7. projections |
| 8. compatible   | 8. overtone       | 8. hardware    |
| 9. balanced     | 9. emissional     | 9. consistency |

Fig. 1. An extract from the VK2 Westlakes Amateur Radio Club's Monthly Newsletter, April, 1982.

the phrases, such as 3, 7, and 9, which give "parallel incremental consistency." Maybe your transceiver just fits the bill.



#### BRAZIL

Carlos Vianne Carneiro PY1CC  
Rua Afonso Pena 49/701  
20270 Rio de Janeiro, RJ  
Brazil

#### WWSA CW 1986

Last year's changes in rules for the World Wide South American CW Contest brought very interesting consequences and results—a strong increase in participants being the immediate response. (See "Contests" in this issue.) Simplified purpose, contacts between stations in all countries, seems to be the best to everybody, considering we had almost double the radio amateurs from all parts in 1985.

As contest period annually is every second complete weekend of June, from 1500 UTC Saturday to 1500 UTC Sunday, this 1986 it starts June 14. Keep an eye on

that second and complete weekend! Bands are 1.8, 3.5, 7, 14, 21, 28 MHz, and crossband contacts are not valid.

Classifications—2-way CW mode, only for (1) single operator, single band or all bands, (2) multi-operator, single transmitter, all bands, (3) SWL. Call will be—CQ SA TEST.

Exchange—RST/QSO number starting from 001.

Points—Each QSO in same country 0 points (valid only as multiplier); in same continent, two points; in other continents, four points. Only for DX stations, QSO with South American stations, eight points!

Multipliers—all different countries (DXCC list) and different South American prefixes worked in each band.

Scoring—final score is the total QSO points multiplied by the sum of total multipliers from all bands.

Certificates will be granted to three top-scoring stations of each class in country, reasonable score provided. Results of South American entries will be listed separately from other continents.

A separate log for each worked band must be sent not later than August 31, 1986, and PSE follow standard international contest logging rules! Send to WWSA Contest Committee, PO Box 18003, Rio de Janeiro, RJ, Brazil 20772.

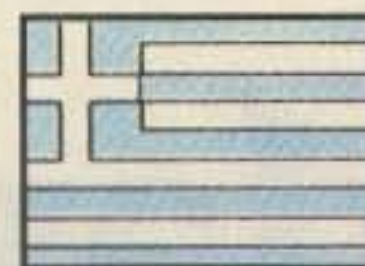

#### GREECE

Manos Darkadakis SV1IW  
Box 23051  
Athens 11210  
Greece

In one of my previous columns I had mention about a new repeater (R0) on top of Taigetos Mountain, and I promised to return to it with more details. The reason is this is the first Greek repeater under solar power and also under remote control. Of course this might look like a common situation for countries with a lot of amateur population, but for our country I shall call the event as unique.

The man behind this installation was John SV1KC, an excellent electronics engineer who has put all of his talent on writing the software but also designing and building the hardware for the control of the repeater.

The repeater's site is on a place

called Ag. Panteleimonas, 1640 meters above sea level in South Peloponese. Because of the high altitude, several parameters had to be met before everything was ready for the top.

Now what the hardware contained was a Yaesu receiver and transmitter, an RX-TX systems duplexer, a colinear heavy-duty antenna with four dipoles, three starved electrolyte batteries, and three photovoltaic panels from B.P. (British Petroleum). The repeater was designed with two power levels (2.8 and 8 W), and every two hours is giving telemetry with information about its status.

The full message is transmitted every two hours and looks like this: VVV CQ CQ DE SV3A ...CHRG...AH DICH...AH TEM IN...DEG TEM OUT ...DEG BAT CAP...AH AR.

CHRG gives charging current for the last two hours, DICH gives power consumption during the past two hours, TEM IN gives inside temperature, TEM OUT gives outside temperature, and finally BAT CAP gives battery capacity. Along with each transmission R0 sends a subcarrier of 72.8 Hz for monitoring service.

The receiver consumes only 14 mA squelched, and power output is dependent on the capacity of the batteries (more on this later). Both receiver and transmitter are using ovens for the crystal oscillator in order to keep temperature between 25–30 C. There is also a clever system into the receiver called "economizer" (Yaesu uses this in FT-209 handheld). With this system, the receiver if is not triggered for 10 seconds then goes to 9% duty cycle receive (90% off and 10% on) preventing spending energy for no reason.

I think that this is enough for the hard part of the repeater. In my next column I will look a little more inside SV3A's logic and will reveal all the power that a soft control can give to an ordinary repeater.



#### HONG KONG

P. J. Weaver VS6CT  
10A Bonaventure House  
91 Leighton Road  
Hong Kong

I am scheduled to leave here on May 12 for my triannual leave and will be visiting with friends in Cali-



# The **TITAN** final amplifier may be your final amplifier!



Model 425 TITAN  
Linear Power Amplifier

We have been accused of "over designing" the TITAN. And certainly, by cutting corners, it could be built at lower cost. But we think, in the long run, it will be an investment in reliability, flexibility, and the pure enjoyment of a permanent addition to your station — long after the price is forgotten.

Every component is chosen to work well below its rating. The power transformer is our own, using a Hypersil® tape wound core, generously designed for excellent regulation. Capacitors and inductors are also made in-house for close quality control.

The TITAN uses two 3CX800 tubes that will loaf along at 1,500 watts output. And, as they require lower plate voltage than older tubes, insulation breakdown is less likely.

We think we have included present and future needs. Things such as full break-in and operation on 160 meters and all authorized bands. A separate power supply makes station layout easy for most convenient operating. And if you use AMTOR, SSTV or RTTY, there is no problem with continuous operation.

The TITAN could easily be your final FINAL AMPLIFIER.

**FULL ONE YEAR**  
Warranty On All  
Ten-Tec Products

See your dealer or write

**TEN-TEC, INC.**  
SEVIERVILLE, TENNESSEE 37862

\*Commercial version available



ifornia, Oregon, and Illinois until June 15. Then I head for Miami and hope to join a 48' DeFever motor cruiser for a six-week cruise around the Bahamas and Exumas Islands. Subject to confirmation, I then hope to spend August in the U.S. Virgin Islands, perhaps operating as VS6CT/KP2, which will be bound to attract some attention! I will then be in the New York area for a week or two before going on to England in mid-September. I am due to return to start work here on October 15.

I had a most interesting five-day trip to Okinawa to visit the Western Pacific Search and Rescue Center. It was mainly a familiarization trip to learn how the other half operated, as we work very closely with that organization when there are any search-and-rescue operations going on in our region. Another seminar in Singapore in April is being put on by the International Maritime organization, but we will have to sing for our supper there. I am busy now preparing a paper to present, on how we do our search-and-rescue operations here, and the facilities we have. After Japan and Okinawa, Hong Kong is considered the most effective operation in the far east, and we have been asked to show other ASEAN country representatives how we do it.

Amateur radio in Hong Kong is making very big strides at this time. At the moment, we have over 300 licensees of whom over 70% have the Class B license—they have passed the technical exam but did not have to take code. They are permitted to operate on 30 MHz and above, and of course that includes satellite operation. They are a very keen bunch, and since we implemented this license (for which I was responsible for achieving), there has been great interest among the local Chinese. Thanks to this no-code licensing, which is the same as in the United Kingdom, with the same exam, we have had a big expansion in activity. By October I hope we will have four more repeaters to add to our present three, and a closed repeater for the English-speaking hams only. One of our major problems with the increased activity is that repeater chatter is all in Chinese, and as an English-speaker only, I can do a lot better if I don't have to listen to a repeater pouring out a language I don't understand.

Had great fun over the Chinese New Year holiday in February, doing one of my expeditions to

Macau. I made 2,700 contacts, well short of my average, but conditions were not the best, as was to be expected at the bottom of the current cycle. Expeditions to Macau are becoming more and more complicated, however. In the good old days, it was a matter of simply applying for a reciprocal license and getting on the air, either from an existing station which one had on loan or setting up in a hotel. The fee was US\$3.50. Now it is US\$17.50, plus US\$25 if you ask the Post Office to do all the forms for you, on the ubiquitous Portuguese "Blue Paper," which is used for all legal matters. The license is valid for only 30 days, and after setting up your station you have to have it inspected before you can operate. All this has happened just recently; and I don't think I'll bother with Macau again, at least not unless I can use an existing station.

My best to Wayne. It will be delightful to read his editorials again and I am delighted he is back at the helm of 73. I hope you will consider publishing short stories again from time to time. I have been amused by them in the past. Perhaps you could ask subscribers to contribute some which have a "ham flavor."



#### ISRAEL

*Ron Gang 4Z4MK  
Kibbutz Urim  
Negev M.P.O. 85530  
Israel*

An important precedent for amateur radio has been set in the Haifa City Court. Until recently, antenna lawsuits were troubles only to be read about in the American ham press, as far as Israeli amateurs were concerned. Now, after a short but tense court case, the hams here can breathe a sigh of relief, thanks to the refusal of Israel Lavie 4X4UF to bow to the pressure of his neighbours.

To supply necessary background, most Israelis do not live in detached houses, but dwell in apartment blocks which are the common property of the dwellers, each person owning his own apartment. The denizens elect a "house committee" which is responsible for the upkeep of the building, collects maintenance fees, and makes rules regarding the use of the common property.

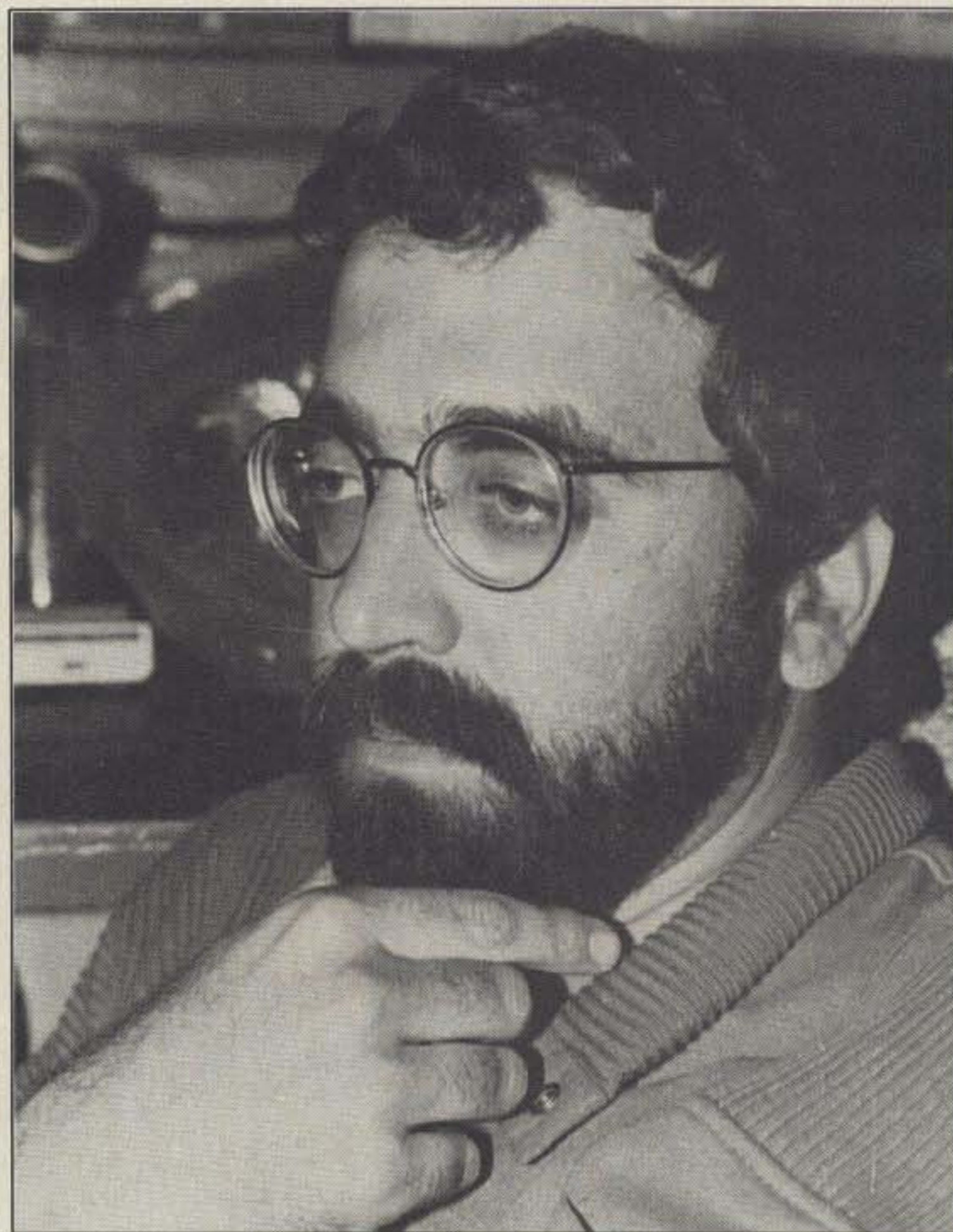

*Dov Gavish 4Z4DX.*

A few years ago, 4X4UF, a ham of more than twenty years seniority and known in the amateur community for his technical innovations and construction of miniaturized transceivers, moved from the Galilee town of Carmiel to the city of Haifa. Not a big DXer, he satisfied himself with a modest dipole antenna on his building's roof. I suspect that most of his operating anyway was on two meters while driving to and from work.

One bright day, the house committee of his building decided that the black coaxial cable coming down the side of the building to Israel's window from his dipole was an eyesore, and demanded that he remove it. Gritting his teeth, as it were, Israel complied, but in order to partly compensate himself he installed a small two-meter beam attached to the railing of his balcony facing out from the back of the building.

Ancient Hebrew proverb says, "You give them a finger and they take the whole hand." One day 4X4UF opens his mailbox and finds himself served with a summons to appear in the Haifa municipal court, charged with defacing the appearance of the building. In the meantime, he removes

the beam but photographs it for posterity.

Hiring a lawyer and accompanied by a few amateurs as witnesses, Israel appears in court and presents the photograph as evidence. The chief municipal building inspector says that to his recollection the antenna on the balcony was bigger, so the court adjourns so that the actual antenna in question could be examined.

In the course of the examination, it becomes clear that said antenna was not permanently attached to the building; it looks like that on these grounds Israel may get off the hook. However, in this case the right of the ham to his antenna will still be in question, and red-head 4X4UF, once challenged, does not back off.

There is no substitute for a smart lawyer, and, indeed, Israel's has been doing his homework. Checking the conditions of the license, the lawyer discovers that section 13 article 4 of the Israeli Amateur Radio License contains the following (which I have translated from the Hebrew):

"When there is, in the opinion of the Minister of Communications, a state of emergency, and the public welfare deems it neces-





# ALINCO ELECTRONICS INC.

P.O. Box 20009 • Reno, Nev. 89515 Phone (702)359-1414 • Telex 4993999 EGELECTR  
44 Glen Carran Circle • Sparks, Nev. 89431



**NOW ONLY  
\$289.95**

## ALM-203T List \$345.00 2m FM Handheld Transceiver

- 2 BAND HT  
BAND A 140-150 MHz  
BAND B 150-160 MHz (Receive Only)
- 10 channel memory
- Built In Sub Audible Tones
- Battery save function
- 3 watts output standard; 5 watts with 12 V adaptor
- Don't decide on a handheld until you have seen Alinco's newest!



**NOW ONLY  
\$289.95**

## ALR-206T LIST \$345.00

- 140-149.995 MHz covers MARS and CAP
- Programmable band scan
- Programmable non-standard repeater offset
- Unique Control Knob
- Completely Programmable From Microphone
- 25 Watt High - 5 Watt Low • 10 Channel Memory
- Built In Lithium Back Up Battery
- Up/Down Control On Microphone
- Built In Sub Audible Control
- Many Features, See Your Dealer



## Linear Amps

**LIST PRICES FROM \$69.95 to \$156.00**

- 2 m, 1 1/4 m and 70 cm micro Linear amplifiers
- 3 watts in provide 30 to 50 watts out to convert your HT to a high power mobile radio.
- Each amp includes a heavy duty heat sink, protection circuit and a low pass filter for a clean signal.
- Some models available with a 15 db gain GaAsFET receive preamp others with a 10 db gain FET receive preamp and one with an RF meter.



## Power Supplies

Affordable performance is the final output of these workhorses. These high efficiency, high output, regulated supplies each comes with automatic current limit and shut down protection. Choose from 4.5 to 55 amps of output. List Prices From \$69 to \$333.

**ALINCO ANNOUNCES THE PERFECT MATCH FOR MEDIUM SIZE ANTENNA SYSTEMS.  
THE NEW ALINCO TOWERS ARE IDEAL FOR MOUNTING:**

- Light-Weight Beams
- VHF UHF Antennas
- Oscar Antenna Systems
- Guy points when added support is required
- No rivets - all steel bolts
- Light-weight aluminum construction for easy installation and durability

- All towers have *four* legs for easy mounting. Along with ALINCO's unique dual wall construction for unparalleled strength
- Rotor mounts inside the ALINCO Tower with provisions for top mounted thrust bearing



model ETS 210  
List \$107.00



CONSTRUCTION OF LEGS

THRUST BEARING  
MODEL AAZ-7A  
\$36.00



ALINCO  
MODEL AAZ-7  
ROTATOR

ROTATOR  
MODEL AAZ-7 \$121.00



Contact your nearest dealer or Call Alinco for the location closest to you.



sary, the director [of the Ministry of Communications] will be authorized to take charge of the station, to supervise it or use it for the needs of the State, without payment, or to transfer it to whom he sees fit, or to order the owner of the license to operate the station according to his instruction. The duration of this clause will not expire with the cancellation, correction or change of the license."

Armed with this important yet generally overlooked section of the license, Israel's lawyer, taking a more offensive posture, asks the judge, how, in the time of national emergency, can a radio amateur comply with the terms of his license and be of service to his country if his station has been rendered ineffective by the lack of an antenna? Indeed, in such times, the ham station is not an individual's means of personal entertainment, but a vital resource determined by law to be put at the nation's disposal.

It should be pointed out that this case took place when the memory of the vital service provided by amateurs at the time of the Mexican earthquake disaster was still fresh in the public consciousness, and, coupled with a year of excellent media coverage, amateur radio in Israel was riding on high waves of popularity.

Upon hearing this argument, the judge was convinced and the case standing against 4X4UF was dismissed. The amateurs Israel had brought to court did not even have to testify, and similar charges that were standing against another Haifa amateur were dropped.

What is the significance of this court decision for the Israeli radio amateur? This case was fought in a municipal court, so although directly affecting only the city of Haifa, should the right of an amateur be contested in other courts, an important precedent has been set.

In Haifa, any licensed radio amateur can erect an antenna on the premises whose address appears on his station license. A transmitting antenna does not require a building permit, and the Haifa chief building inspector has said that should he receive any further complaints, he will first consult with officials of the Israel Amateur Radio Club before deciding whether action should be taken.

Compared to the costs of similar legal struggles abroad, this case was a bargain, with legal

fees costing \$500. The Israel Amateur Radio Club put up \$150 aid, and it is expected that Israel will receive enough donations so as not to feel any monetary pinch.

It is our hope that this will be the end of legal proceedings against ham antennas, and, naturally, a wish goes out from here that all amateurs worldwide will be able to defend their antenna rights with such relative ease.

At the time of writing Israel Lavie is not celebrating his victory with a monstrous multi-element tribander perched on his building's roof. However, his modest two-meter beam is no longer on the balcony railing but is on top of the building, and when he does manage to get on two meters, I'm told that his signal has never been better.

### A TOP DXER

#### 4Z4DX

One of the few Israeli amateurs to climb close to the pinnacle of the coveted DXCC honor roll is Dov Gavish 4Z4DX, who to date has confirmed 315 of the current 316 countries.

Brought up on amateur radio on Kibbutz Ramat David in the northern Jezreel Valley, Dov is the son of the late Israel Gavish 4X4VB, who passed away last year. With his wife, Anat, and two children, Dov today lives in Ramat HaSharon, ten miles north of Tel Aviv.

His back yard has turned into an antenna testing field, where it would seem that nothing less than a very thorough testing suffices. This is evidenced by having achieved on five bands, Worked All Zones (first in Israel), DXCC, and Worked All States—not a simple task from Israel. Other certificates earned are 160-meter DXCC, YL DXCC, Worked All German Countries, and 2500 U.S. counties certified in the County Award.

Inside his shack sit the Kenwood TS-930 and Drake TR4 plus the Robot slow-scan television outfit. The current antenna farm consists of a KLM 6-element tribander at 95 feet up, a 2-element 40-meter beam, and full-sized slopers and inverted vees for 80 and 160 meters. In the past he has tried different antennas for 80 and 40—delta loops, wire beams, slopers, and even a rhombic that he once stretched between four irrigation pipes on a once-vacant field adjoining his house.

Dov is also active in group activ-

ities, having found the club station 4Z4EX in Ramat HaSharon and organized the 4X6A multi-multi operation that took first Asia in the 1979 CQ World-Wide DX contest in SSB in which your faithful scribe had the honor to participate.

What's Dov's secret? If he has something special he isn't saying, but there's no doubt that the key is perseverance—listening on the bands with great concentration—good antennas, and a certain sixth sense that every serious DXer seems to develop.



NEW ZEALAND

D. J. (Des) Chapman ZL2VR  
459 Kennedy Road  
Napier  
New Zealand

### RECIPROCAL LICENSING

Over the past year or so I have had a few enquiries from amateurs who intend to visit New Zealand regarding our reciprocal licensing arrangements. For those who may be interested I shall outline them again, more fully than on the last occasion.

Countries with reciprocal agreements with the New Zealand Government include Sweden, Switzerland, French Republic, United States of America, and the Netherlands. In addition, countries with Commonwealth recognition include Australia, Canada, and the United Kingdom as well as a large number of Commonwealth and Pacific countries; countries with guest licenses include South Africa.

NZART, recognising the importance of this facet of our hobby, have appointed Russ Garlick ZL3AAA co-ordinator of the Reciprocal Licensing Bureau, and any enquiries regarding reciprocal licensing may be directed to him. He also keeps up with the information ZL amateurs need to know when they contemplate an overseas trip. The address for Russ is: Mr. R. A. Garlick ZL3AAA, 23 Lydia Street, Grey-mouth, New Zealand.

Here is a guide to the requirements for an application for a reciprocal license when visiting New Zealand:

1. Complete an application form in duplicate (obtainable from Russ or the Radio Regulatory Section,

Post Office Headquarters, Wellington, New Zealand).

2. Supply with the application a photocopy of your operator's certificate and a copy of your current receipt for annual fee paid.

3. A certificate to indicate the Morse speed at which the applicant is qualified.

4. If no evidence of Morse speed can be submitted, the applicant may sit for the examination in the normal way. (Remember, ZL VHF operation is with a non-Morse certificate, so if you only want 2m or 70cm operation, this condition is not important.)

5. A birth certificate or evidence of the date of birth, e.g., a copy of driver's license if date of birth is shown on it.

6. Applicant must submit a permanent postal address to where all correspondence can be sent (consulate, travel agent, etc.).

7. All applicants for a license must give at least two weeks notice before license application can be processed.

8. License applications can be made to the Radio Licensing Section, Post Office, of any of the 17 main cities or to Radio Regulatory Section, Post Office Headquarters, Wellington. It is recommended that you send your application to the Radio Licensing Section, Post Office Engineers Office, at your point of entry, or to Post Office Headquarters, Wellington.

9. Visiting amateurs will be allocated a callsign from the ZLØ series.

10. There is no charge for the service.

While on the subject of reciprocal licenses, I have nothing but praise for the FCC in the States and for the Department of Communications, Vancouver, Canada, for the prompt attention to my applications for reciprocal licenses to use on my visit to USA and Canada in May through to July this year. I made the usual applications for the licenses early in January, and one month later I had received both reciprocal licenses, well before my projected departure date.

We will have three weeks on a Friendship Force holiday at Kauai, Hawaii, Spokane, Washington, and the Seattle area, and after that period we will be proceeding on an independent couple of month's holidaying in Canada and the States. I shall be looking forward to many QSOs on 2m as we travel around with the 2m handheld, and also some HF QSOs on the HF bands while visit-





# ST-20T

## a SMART Radio... the INTELLIGENT Choice

	VHF FM TRANSCEIVER MODEL ST-20T	UHF FM TRANSCEIVER MODEL ST-40T
Suggested Retail	\$349.95	Coming 1st Quarter 1986
Frequency Range	142.000 to 150.995 MHz	440 MHz to 449.975 MHz
Type of Emission	F3	F3
Memory Channels	10 Channels	10 Channels
Antenna Impedance	50 ohms	50 ohms
Power Source	9.6V Nicd battery pack 9V Dry battery pack D.C. 8.4-16V	9.6V Nicd battery pack 9V Dry battery pack D.C. 8.4-16V
<b>Transmitter</b>		
RF Output Power	5.0 Watts (H), nominal at 12V 3.5 Watts (H), nominal at 10.5V 0.5 Watts (L), nominal at 10.5V	3.0 Watts (H), nominal at 10.5V 0.5 Watts (L), nominal at 10.5V
Modulation	Frequency modulation	Frequency modulation
Maximum Deviation	± 5 KHz	± 5 KHz
Transmit Spurious	- 60 dB	- 60 dB
Microphone	Electret Condenser Microphone	Electret Condenser Microphone
<b>Receiver</b>		
Receiving Methods	Double superheterodyne	Double superheterodyne
I.F.	1st 16.9MHz 2nd 455KHz	1st 21.4MHz 2nd 455KHz
Sensitivity	Less than - 0.25uV at 12dB SINAD	Less than - 0.25uV at 12 dB SINAD
Band Width	± 7.5 KHz at 6dB down	± 7.5 KHz at 6dB down
Selectivity	± 15 KHz at 60dB down	± 15 KHz at 60dB down
Audio Output Power	400mW at 8 ohm	400mW at 8 ohm

Note: See Accessory List for ST-200 for Compatible Accessories.

- TWO SEVEN-DIGIT AUTO DIAL MEMORIES • ONE HAND, ONE FINGER SIMPLIFIED KEYBOARD ENTRY OF INFORMATION • 142-150.995 OPERATION FOR M.A.R.S. AND OR C.A.P. • TEN MEMORY CHANNELS FOR 10 DIFFERENT REPEATER OPERATIONS PLUS 'SCANLOCK' FOR LOCKOUT OF ANY ONE CHANNEL OR MULTIPLE CHANNELS WITHOUT REPROGRAMMING • SANTEC'S MULTIPLE MODES OF SCANNING • 3.5—5 WATTS OUTPUT • DIRECT 12 V.D.C. OPERATION • SUB-AUDIBLE TONE COMPUTER CONTROLLED • MICROPROCESSOR CONTROLLED ENCODE/DECODE OPTION AVAILABLE • TIME OF DAY QUARTZ CLOCK • ANALOG METER MOUNTED FOR BEST D.F. ING • AUTOMATIC ENTRY OF STANDARD OFFSET FOR BAND WITH EACH NEW ENTRY • ANY CTCSS TONE IN ANY MEMORY CHANNEL • SLIDE ON/OFF BATTERY PACK COMPATIBILITY
- SANTEC/ENCOMM, INC.'S TWO YEAR EXTENDED SERVICE PERIOD AT NO EXTRA COST •



1506 CAPITAL AVENUE, PLANO, TEXAS 75074 PHONE - 214-423-0024 GIII FAX - 214-423-0081  
NATIONAL DISTRIBUTION FOR SANTEC - KDK - KENPRO - THL - WELZ PRODUCTS



ing at Port Coquitlam, near Vancouver, mid-May to mid-June, where through the courtesy of my host, Jack VE7CMD, I hope to have the use of his HF gear. Listen out for ZLVE7 portable about that time as I will be looking forward to QSOs with those who read this column.

I shall also be visiting amateur friends in Charleston, West Virginia, Buffalo and Amsterdam, New York, Peterborough, New Hampshire, Hartford, Connecticut, and Prince Edward Island, Canada, in the later part of June and early July.

Visiting amateur radio operators with whom you have already made contact is the fulfillment of the friendship begun on the air, and something I can well and worthily recommend to those who are able to travel overseas. I have had endless hours of pleasure from such experiences; in fact, this will be my third visit to Port Coquitlam in ten years, with many pleasant QSOs in between times.

#### IARU CONFERENCE "SHORTS"

All but four of the delegates took advantage of the visitors' license ZL0-series offer, and those who had sent license details in advance were given their ZL licenses and a supply of preprinted QSL cards on arrival.

There was an interesting sidelight to that too: All the Indonesian delegation joined NZART. When asked why, they said, "We have a ZL call, therefore we must join your society." Wouldn't this be a marvelous attitude to apply everywhere! It would make our amateur organizations much stronger numerically than we are now—with only about half the licensed amateurs being members of their national societies.

The ZM6ARU station and the Conference Award generated a lot of interest worldwide—in all, some 2500 cards, including 120 OSCAR-10 QSOs were dispatched through the bureau.

Bob Holt ZL1BBZ, the mini-bus driver for the ladies, took a week's leave to be amongst those lovely ladies—he ran up well over 2000 km during the period of the Conference chauffeuring the ladies around on their sight-seeing trips. The success of the ladies' programme was summed up by a delegate saying he did not have to worry about his wife during the day and she was too tired to want to go out at night!

#### SILENT KEY

Mrs. Myrtle England ZL4GR passed away on 31 January, 1986, just six days short of completing 56 years as a licensed amateur. "Myrt," as she was known on the air, was New Zealand's first licensed woman amateur radio operator, receiving her license on 6 February, 1930. She was honored at the 1980 NZART Conference when she was awarded WARO's (Womens' Amateur Radio Operators) first 50-year Certificate and elected an Honorary Life Member of that organization. Myrt was active in local and DX operating—she operated as a relay station during the Napier earthquake in 1931, a base station during snow-storm isolation, and a valuable aid in Search and Rescue over many years.

Myrt's friendly voice on the air has been stilled now, but she will long be remembered for her distinctive personality, her vitality and enthusiasm, and above all, her wit and humor which many shared with her at Association Conferences and other amateur gatherings.

#### REGION III AWARD

Eligible countries are those in Region III whose amateur radio societies are members of the IARU Region III Association. These are Australia, Brunei, Bangladesh, China (PRC), Fiji, French Polynesia (FO8 only), Hong Kong, India, Indonesia, Japan, Korea, Malaysia, New Zealand, Pakistan, Papua New Guinea, Philippines, Singapore, Solomon Islands, Sri Lanka, Thailand, Tonga, and Vanuatu.

Plus one country credit from U.S. Territories in the Pacific, from Guam, Northern Marianas, American Samoa, Wake Island, Baker Howland Group, as represented by ARRL; one country credit from Pitcairn Island (VR6), Chagos Arch (VQ9), represented by RSGB. (Current total of available "countries" is 24; requirements for award as from 1 January, 1986: Basic—7 areas; Silver endorsement—15 areas; Gold endorsement—20 areas.

These to be reviewed as considered necessary by the Custodian, Jock ZL2GX, who will recommend appropriately to the Region III Secretariat.

Applications to NZART Awards Manager, ZL2GX, 152 Lytton Road, Gisborne, New Zealand, with NZ\$1.00; if airmail postage

required, add another NZ\$1.00 extra. IRCs are acceptable.

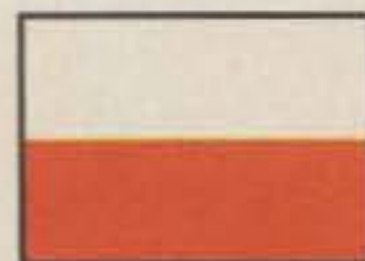

POLAND

Jerzy Szymczak  
78-200 Bialogard  
Buczka 2/3  
Poland

Many Polish scouts took part in the annual scout's jamboree on amateur bands. Participation in this fixture, serving for a consolidation of friendship among nations, will be rewarded with occasional diplomas issued by International Scouts Bureau in Geneva.

On July 20th and 21st, a meeting of members and friends of hams took place in Jaroslaw. 60 girls—radio amateurs—came to the meeting. An all-Polish Club of Women Radio Amateurs was formed. Zofia SP8LNO was elected the president and Maria SP8OBF the secretary of the "Club YLSP." The secretariat of the club announced that every 21st day of months is a women's-activity day. The club station uses the callsign SP0PYL.

On the occasion of International Telecommunication Day in May, occasional radio station SP0ITU worked on the amateur bands from 10 till 19 May last year. The radio station consisted of transceiver FT-101ZD of short-wave bands, transverter 144 MHz, radio-telephone FM306 on UHF, and antennas: dipole, inverted V, vertical 14AVQ for 7, 14, 21, 28 MHz bands. During 9 days of activity, 2821 QSOs of 92 countries and 28 WAZ zones were established. Most of the contacts were gained on the 20m band.

On October 5th and 6th last year a Convention of Radio Amateurs Railwaymen was held in Moszczenica. Dozens of hams took part in the convention under the slogan: "Railwaymen hams—boosters of technological education of society." The president of PRAA, Jerzy Rutkowski SP5JR, attending the convention, suggested a modification of the name to Polish Radio Amateur's Club Railwaymen. In consequence of a ballot, the first management of PRACR was set up. The function of the president of the club went to Henryk Paszkowski SP5HP, the vice-president, Ryszard Jablonowski SP9EES, and the secretary,

Mirosława Paszkowska SP5MHP.

The residence of the club is situated at Varsovian Communication Club "Kolejarz" Hoza 63/65 Warsaw. After the approving of the working programme, Adam Koziarski SP5AY, the author of the modification, gave a lecture on an adaptation of the radio-telephone FM-302 for a SW transceiver. An occasional radio station SP5PKP/7 began its activity on the eve of the Convention.

On the occasion of 40 anniversary of the end of the Second World War, PRAA instituted a diploma "Forty years anniversary of Victory and Peace". To win the diploma a radio amateur had to establish contacts with at least one of 38 ham veterans of the Second World War. The veterans' callsigns were "broken" with V (Victory). Mainly for good reasons, only 28 radio stations of veterans were active to 9 May 1985. Nevertheless, many Polish and foreign radio amateurs won the diplomas.



SPAIN

Domingo Gil Manrique EA5TX  
Delegation Local de U.R.E.  
Avd. La Mura 67  
12540 Villarreal (Castellon)  
Spain

The Spanish Radioamateurs Union (U.R.E.), through its local group in Villarreal, has established the TD-EA-CW Award, available to any ham or SWL with an official license granted by any IARU member country.

A two-way confirmed contact, direct, must be made with each of the nine EA districts over any period of time since January 1, 1976. CW only, over authorized amateur HF bands, and all must be made from the same DXCC country using the same callsign. Not valid: contacts through repeaters, satellites or similar means of communication, and mobile contacts.

Endorsement stickers: 5B (nine districts times 5 bands—45 contacts), and 160 (nine districts on the 160-meter band). Decisions of the Award Committee shall be final.

Send verified log and US\$3 or the equivalent in marks, pounds, or IRCs to the Awards Committee (TD-EA-CW) at the above address for the 5-color award on heavy paper, 46 x 34 cm. ■



## MAKE THE RIGHT CONNECTION

The CES phone patch is the **RIGHT CONNECTION** for your mobile radio-telephone system.



### Phone Patches

- Full Duplex
- Half Duplex
- VOX Simplex with EVD
- Sampling Simplex

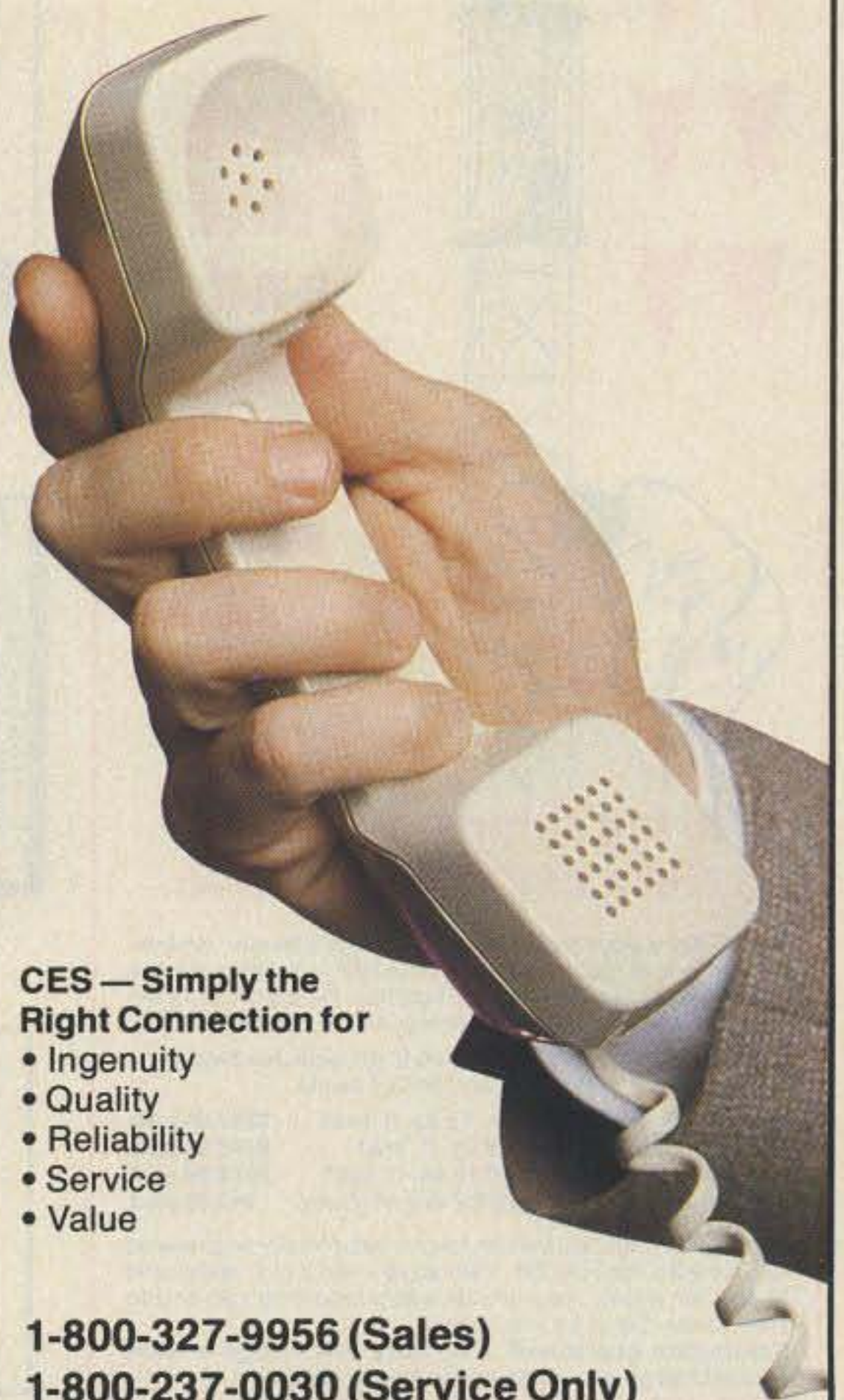

### CES — Simply the Right Connection for

- Ingenuity
- Quality
- Reliability
- Service
- Value

✓68  
**CES**

**Communications Electronics  
Specialties, Inc.**

P.O. Box 2930, Winter Park, Florida 32790  
Telephone: (305) 645-0474

**1-800-327-9956 (Sales)**  
**1-800-237-0030 (Service Only)**

*here is the next generation Repeater*

## MARK 4CR

The **only** repeaters and controllers with **REAL SPEECH!**

No other repeaters or controllers match Mark 4 in capability and features. That's why Mark 4 is the performance leader at amateur and commercial repeater sites around the world. Only Mark 4 gives you Message Master™ real speech • voice readout of received signal strength, deviation, and frequency error • 4-channel receiver voting • clock time announcements and function control • 7-helical filter receiver • extensive phone patch functions. Unlike others, Mark 4 even includes power supply and a handsome cabinet.

Call or write for specifications on the repeater, controller, and receiver winners.

Create messages just by talking. Speak any phrases or words in any languages or dialect and *your own voice* is stored instantly in solid-state memory. Perfect for emergency warnings, club news bulletins, and DX alerts. Create unique ID and tail messages, and the ultimate in a real speech user mailbox — only with a Mark 4.



**MICRO CONTROL SPECIALTIES**

Division of Kendecom Inc.  
23 Elm Park, Groveland, MA 01834 (617) 372-3442 ✓26





**SAVE  
TIME  
and  
MONEY  
with  
THE  
HAZER**

**Bring things down for  
safety and convenience.**

Never climb your tower again with this elevator system. Antennas and rotator mount on HAZER, complete system trams tower in verticle upright position. Safety lock system operates while raising or lowering. Never can fall.

Complete kit includes winch, 100 ft. of cable, hardware and instructions. For Rohn 20 and 25 G Towers.

Hazer 2 - Heavy duty alum. 12 sq. ft. load **\$297.00 ppd.**  
Hazer 3 - Standard alum. 8 sq. ft. load **\$213.00 ppd.**  
Hazer 4 - Heavy galv. steel 16 sq. ft. load **\$278.00 ppd.**  
Ball Thrust bearing TB-25 for any of above **\$42.50 ppd.**

Martin also mfgs. aluminum towers specifically engineered for use with the HAZER. Two sizes - M-13 (13" wide) and M-18 (18" wide). Also a truly self-supporting galvanized steel tower. Send for free details.

**Satisfaction guaranteed. Call today and charge to Visa, MasterCard or mail check or money order.**

**GLEN MARTIN ENGINEERING INC.**  
P.O. BOX 7 253  
Boonville, Mo. 65233  
816-882-2734



**—GEP's COAXIAL SALE—**  
BELDEN 9913 38.00/100 ft .39/ft. cut  
BELDEN 9258 RG-8X-\$160.00/1,000 ft—.17/ft cut  
**AMPHENOL Connectors & Adaptors**  
UG-21D N-type Male cable end 3.00  
\*\*UG-21D N-type Male cable end 4.50  
PL-259 UHF Plug silver plate 1.25  
UG-146/U N plug to UHF jack 7.50  
UG-83/U N jack to UHF plug 8.50  
UG-29A N-type barrel conn. 4.75  
\*\*Special fit for BELDEN 9913 cable.  
U.S. Geological Survey Maps—  
Complete N.J. Index in stock + plus +  
**COMPLETE STOCK, SAME DAY SHIPPING**  
110-4 Route 10, E. Hanover, N.J. 07936, 201/887-6424

**MULTI-BAND SLOPERS**  
ALSO: DIPOLES & LIMITED-SPACE ANTENNAS  
Outstanding performance of W9INN antennas is well known! Now enjoy multi-band BIG-SIGNAL reports! Automatic bandswitching • Very low SWR • Coax feed • 3kw power • Compact • FULLY ASSEMBLED to your specified center frequency each band • Easy to install • Very low profile • Complete instructions • Your personal check accepted

4-BAND SLOPER - 160, 80, 40, 30, or 20M	50 ft. long	\$ 48 ppd
3- " " " " " " " " " " " "	50 ft. "	\$ 43 "
2- " " " " " " " " " " " "	40 ft. "	\$ 35 "
3- " " NO-TRAP DIPOLE - 160, 80, 40M	113 ft. long	\$ 71 "
2- " " " " " " " " " " " "	85 ft. "	\$ 55 "
9-BAND SPACE-SAVER DIPOLE - 160 thru 10M*	46 ft. long	\$ 85 ppd

\* Requires wide-range tuner (80, 40, 20, 15M without tuner)  
SEND SASE for complete details of these and other unique antennas  
W9INN ANTENNAS 312-394-3414  
BOX 393-S MT. PROSPECT, IL 60056

**TUBES — OVER 2000 TYPES!  
DISCOUNT PRICES**

Parts, supplies, and literature for tube type radios, including early and hard-to-find tubes.

74 "New 20 page wholesale catalog available."  
**ANTIQUE ELECTRONIC SUPPLY**  
688 W. First St. • Tempe, Arizona 85281 • (602) 894-9503

**LSL QSL**  
**LASER PRINTED  
QSLs**  
Top Quality - Low prices  
Write for Information  
**THE LASER PRESS**  
P.O. BOX 876  
MOUNDSVILLE WV 26041

**PORTAQUADS**  
2-MTR & 220 MHz  
FOLDS INTO CASE CA. ADD  
SPECIFY BAND \$73.95 6% TAX  
**RADIO ENGINEERS**  
3941 MT. BRUNDAGE AVE.  
SAN DIEGO CA. 92111  
(619) 268-7988

**MASTER MORSE CODE IN 40% LESS TIME!**  
Method Eliminates the 10 - 13 WPM Plateau  
**ADOPTED BY THE U.S. MILITARY AS THE NEW TRAINING  
STANDARD**  
INSTRUCTION NOW OFFERED ON AUDIO TAPES or  
OUR NEW COMPUTER PROGRAM FOR THE COMMODORE  
64. Both methods teach the entire ALPHABET,  
NUMBERS, PUNCTUATION and SPECIAL CHARACTERS  
in 39 TRIALS at 20 WPM.  
Specify Audio Tapes (five cassettes),  
Floppy Disk or Computer Cassette.  
\$19.95 (IL. RES. include \$1 sales tax)  
77 TSG, P.O. BOX 3897, CARBONDALE, IL. 62902

**ATTENTION COMMODORE 64 USERS**  
Morse Code Translator now available for the Commodore 64. Code received through computer's cassette port is scrolled across the TV screen.

- Cassette port can connect to earphone output with one resistor.
- Keyboard code key for practice.
- Sound through TV speaker.
- 100% machine code - compact and fast.
- Up to 80wpm decode speed.
- Price: only \$3.00 plus self addressed stamped envelope for listing and instructions.

**THOMSON SOFTWARE**  
P.O. Box 1266  
Lombard, IL 60148

# HAM HELP

I'm looking for manuals for the following equipment: Topaz model 2LRA117SN anti-brown-out ac line regulator, Motorola model XT1034C/T1034C rf signal generator, Plessey model MRA101 Tellurometer, Motorola HT-200 low-band walkie-talkie, Supercall model 6080KM mobile telephone, and the following CB radios: Claricon Raider, JIL model 615CB, RCA model CRM-P3A-5, Radio Phone Mark VII, Lloyd models A-400 and A-410, Kraco KCB-2340, Pace 8015, Pony 40, Hy-Gain 9 model 2679A, Hy-Gain 7 model 3107, President John Q, Cobra 19 and 21 XLR, Johnson 123-SJ, Midland 13-884, Spitfire Mark II, Royce 1-648, Ross CB-1000, Fanon Convoy PLLF, Prominent PT-23, Pony model CD-705S, Beltek Rough Rider model W5396, Fanon Fanfare 330 Convoy (23 channels), Fanon Courier Classic III, and Beltek W-1326F.

I also need CB Photofacts; a service manual for a Pace Base

Command model P-5407 dummy load/wattmeter/swr meter; service manuals for Yaesu models FTC-2203, FTC-2205, and FTC-2640; back issues of *CB*, *S9*, *Canadian Transceiver*, and any others; NRI/McGraw Hill VCR servicing courses; and a service manual for a Hamlin MLD-1200-3.

**Rejean Mathieu VE2EUI**  
1897 3rd Avenue  
Val D'Or Quebec J9P 4N7

I am looking for a schematic and a manual for the Harvey Wells Bandmaster Senior model TBS-50C transmitter and power supply. I will pay for copying or will buy them—whichever you like.

**Charles E. Phillips WB8AGB**  
402 Wickshire Lane  
Durand MI 48429

Does W6RO aboard the Queen Mary QSL? I worked them in June, 1985, and so far, through mid-January, three cards, complete

with SASEs, have gone unanswered.

Also, I'm trying to locate a source for 36-mm vernier dials to replace those on a home-brew antenna tuner I bought. The vernier shafts extend 1/2" behind the panel, and the two mounting screw holes measure 1-1/4" center to center.

Last, but not least, where can I obtain a male plug for the user port on a Commodore 64 computer? It has a protective shell and a strain relief to prevent possible shorting of the contacts. The one included with my Kantronics Packet Communicator doesn't have the shell, and I'm worried about possibly shorting something out, damaging the computer and the TNC.

**Gary Payne KE6CZ**  
1347 E. Dakota  
Fresno CA 93704

I need NAVSHIPS 91713, 93241, and 93788 Volumes 2 and 3.

**C. T. Huth**  
229 Melmore St.  
Tiffin OH 44883

I need information on convert-

ing my Kenwood TS-180S with the WARC mod for 4.5-5.0-MHz MARS operation. I have already tried the fixed-crystal position with no luck. Any suggestions?

**Dave Whaley WB9SES**  
9 Quali Run  
L.I.T.H. IL 60102

Does anyone know of a short-wave facsimile program for the Commodore 64 that receives FAX weather maps?

**David Sakowich**  
15 Cove Street  
Chelmsford MA 01824

I need manuals and schematics for a 2-meter SBE SB-144 transceiver, and for a Sears 412-3573 2-meter transceiver.

**Don Norman AF8B**  
41991 Emerson Court  
Elyria OH 44035

I would like information about programs and interfaces for putting the IBM PC on RTTY, packet, FAX, and SSTV.

**Irene Pratt F6GAL**  
5 Bis, Rue Thirard  
94240 L Hay Les Roses  
France



**★ QUALITY PARTS ★ DISCOUNT PRICES ★ FAST SHIPPING!**

# ALL ELECTRONICS CORP.

SEND FOR  
**FREE**  
NEW 1986 CATALOG...  
48 PAGES!

### EDGE CONNECTORS

ALL ARE 1.56" SPACING.

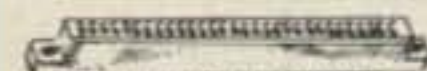

- 22/44 EDGE CONNECTOR  
PC. style \$2.00 each  
10 for \$18.00
- 22/44 EDGE CONNECTOR  
solder lug style \$2.50 each
- 28/56 EDGE CONNECTOR  
PC. style \$2.50 each  
10 for \$22.00
- 36/72 EDGE CONNECTOR  
PC. style \$3.00 each
- 43/86 EDGE CONNECTOR  
PC. style \$4.50 each

### TRANSISTORS

- 2N706 4 for \$1.00
- 2N2222A 3 for \$1.00
- PN2222A 4 for \$1.00
- 2N2904 3 for \$1.00
- 2N2904 3 for \$1.00
- 2N2905 3 for \$1.00
- MJ2955 \$1.50
- 2N3055 \$1.00
- PMD 10K40 \$1.00
- TIP 121 75¢
- TIP 125 75¢

### TRANSFORMERS

- 120 volt primaries
- 5.6 volts @ 750 ma. \$3.00
- 6 volts @ 150 ma. \$1.25
- 6.3 volt @ 600 ma. \$3.00
- 12 V.C.T. @ 200 ma. \$2.00
- 12 V.C.T. @ 400 ma. \$3.00
- 12 V.C.T. @ 1 amp \$4.00
- 12 V.C.T. @ 2 amp \$4.85
- 12 V.C.T. @ 4 amp \$7.00
- 18 volts @ 650 ma. \$3.50
- 24 V.C.T. @ 200 ma. \$2.50
- 24 V.C.T. @ 1 amp \$4.85
- 24 V.C.T. @ 2 amp \$6.75
- 24 V.C.T. @ 3 amp \$9.50
- 24 V.C.T. @ 4 amp \$11.00
- 36 V.C.T. @ 135 ma. \$3.00

### WALL TRANSFORMERS

- all plug directly into 120 vac outlet
- 4 VDC @ 70 ma. \$2.00
- 6 VDC @ 500 ma. \$3.50
- 6 VDC @ 750 ma. \$4.50
- 9 VDC @ 500 ma. \$5.00
- 12.5 VDC @ 265 ma. \$3.00
- 18 VAC @ 18 VA and 8.5 VAC @ 1.28 VA \$4.50
- 24 VAC @ 250 ma. \$3.00
- MULTI-VOLTAGE @ 500 ma. \$1.00
- 3, 4, 6, 7, 9 or 12 VDC \$7.50

### MINI-BOX

Pomona #2104.  
Heavy-duty black phenolic project box with cover and screws. 2 1/2" X 1 1/2" X 1 1/2".  
\$1.00 EACH

### FUSES

- 3AG (AGC) SIZE  
1, 1 1/2, 2, 2 1/2, 3, 4, 5, 6 AMP
- GMA SIZE  
1, 2, 3, 4, 5 AMP
- 5 of any ONE amperage 75¢



### SOUND AND VIDEO MODULATOR FOR T.I. COMPUTER

T.I. # UM1381-1. Designed for use with T.I. computers. Can be used with video sources. Built-in A/B switch. Channel 3 or 4 selection switch. Operate on 12 vdc. Hook-up diagram included.  
CAT# AVMOD WERE \$10.00 **REDUCED TO \$5.00 EACH**

### SLIM LINE COOLING FAN



Etri # 99XM182 low noise fan. Measures 3 1/4" square x 1" deep. 21 cfm, 23 db, 1700 rpm.  
**SPECIAL PRICE... \$12.50 each**

2K 10 TURN  
MULTI-TURN POT SPECTROL #MOD 534-7161  
\$5.00 EACH

### SOLID STATE BUZZER



Star #SMB-06L  
6 vdc  
TTL compatible.  
\$1.00 each  
10 for \$9.00

### ± 12 Vdc or 24Vdc POWER SUPPLY

DELTRON MODEL QD12/15-1.7  
Dual plus and minus 12Vdc open frame power supply. Can be used as 24Vdc @ 1.5 amp. INPUT: either 115 Vac or 230 Vac.  
Fully regulated computer grade supply.  
7" x 4 1/4" x 2 1/4"  
\$12.50 each 10 for \$110.00

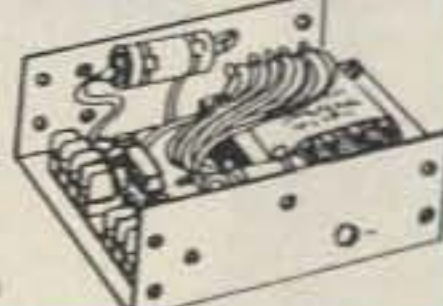

### SPECIALS

1 AMP 50 VOLT DIODES  
IN4001 TAPE AND REEL  
100 for \$4.50  
1000 for \$30.00

SOLDER TAIL I.C. SOCKETS  
24 PIN 10 for \$2.50  
100 for \$22.00  
1000 for \$200.00

### \*SPECIAL PRICE\* TRANSISTOR

plastic transistor  
PN3569 TO-92 N.P.N.  
100 for \$8.00  
1000 for \$60.00  
LARGE QUANTITIES AVAILABLE

### MICRO-CASSETTE MECHANISM

Micro-cassette tape transport for standard MC60 or MC45 micro-cassettes. 3 Vdc operation. Contains: drive motor, belt, head, capstan, pinch wheel and other components. 3 1/2" X 2 1/4" X 5/8"  
CAT# MCMEC \$3.00 each 10 for \$27.50



### COMPUTER GRADE CAPACITORS

- 2,000 mfd. 200 Vdc 1 3/4" x 5" high \$2.00
- 6,400 mfd. 60 Vdc 1 3/8" x 3 3/4" high \$2.50
- 9,700 mfd. 50 Vdc 1 3/8" x 4 1/2" high \$3.00
- 31,000 mfd. 15 Vdc 1 3/4" x 4" high \$2.50
- 50,000 mfd. 40 Vdc 3" x 5 3/4" high \$4.50
- 66,000 mfd. 15 Vdc 3" X 3 3/4" high \$3.00
- 60,000 mfd. 40 Vdc 3" x 5" high \$3.50
- 66,000 mfd. 15 Vdc 3" x 3 3/4" high \$3.00
- 86,000 mfd. 30 Vdc 3" x 5 1/4" high \$3.50
- 5,500 mfd. 30 Vdc 1 3/8" x 3 1/2" high \$1.00
- 5,900 mfd. 30 Vdc 1 3/8" x 2 1/4" high \$1.00
- 9,300 mfd. 50 Vdc 2" x 4 1/2" high \$1.00
- 18,000 mfd. 10 Vdc 1 3/8" x 2 5/8" high \$1.00
- 48,000 mfd. 10 Vdc 2 1/2" x 3 1/4" high \$1.00
- 100,000 mfd. 10 Vdc 2 1/2" x 6" high \$1.00
- 185,000 mfd. 6 Vdc 2 1/2" x 4 1/2" high \$1.00

### RELAYS

10 AMP SOLID STATE  
CONTROL: 3 - 32 vdc  
LOAD: 140 vac 10 amp  
SIZE: 2 1/2" x 1/4" x 1/4"  
\$9.50 EACH 10 FOR \$90.00

### ULTRA-MINIATURE 5 VDC RELAY

Fujitsu # FBR211NED005M20  
High sensitivity  
COIL: 120 ohms  
CONTACTS: 1 amp  
Mounts in 14 pin DIP socket  
\$1.25 each 10 for \$10.00

### MINIATURE 6 VDC RELAY

Aromat #RSD-6V  
Super Small S.P.D.T. relay  
Gold cobalt contacts rated  
1 amp @ 30 vdc. Highly sensitive, TTL direct drive possible. 120 ohm coil.  
Operate from 4.3 - 6 vdc.  
COIL: 120 ohms \$1.50 each  
1 1/16" x 1 1/16" x 1 1/16" 10 for \$13.50

### 13 VDC RELAY

CONTACTS: S.P.N.C.  
10 amp @ 120 vac  
Energize coil to open contact  
COIL: 13 vdc 650 ohms  
SPECIAL PRICE \$1.00 each

### 4PDT RELAY

14 pin KH style...  
3 amp contacts...  
USED but fully tested... \$1.70 each  
Specify coil voltage desired  
Either 24 vdc or 120 vac  
LARGE QUANTITIES AVAILABLE  
SOCKETS FOR KH RELAY 75¢ each

### RECHARGEABLE NI-CAD BATTERIES

- AAA SIZE 1.25V 500MAH \$1.85
- AA SIZE 1.25V 500MAH \$1.85
- AA with solder tab \$2.00
- C SIZE 1.2V 1200MAH \$3.50
- D SIZE 1.2V 1200MAH \$3.50

### UNIVERSAL CHARGER

Will charge 4-AA, C, D, or AAA ni-cads or one 9 volt ni-cad at one time...  
\$11.00 per charger

### 48 KEY ASSEMBLY FOR COMPUTER OR HOBBYIST

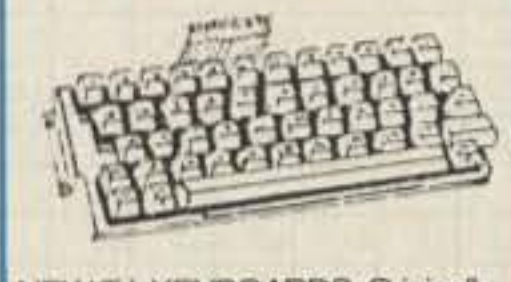

NEW T.I. KEYBOARDS. Originally used on computers, these keyboards contain 48 S.P.S.T. mechanical switches. Terminates to 15 pin connector. Frame 4" x 9"  
CAT # KP-48 \$6.50 each  
2 for \$11.00

### TI SWITCHING POWER SUPPLY

Compact, well-regulated switching power supply designed to power Texas Instruments computer equipment.  
INPUT: 14 - 25 vac @ 1 amp  
OUTPUT: + 12 vdc @ 350 ma.  
+ 5 vdc @ 1.2 amp  
- 5 vdc @ 200 ma.  
SIZE: 4 1/4" x 4 1/4" x 1 1/4" high \$5.00 each

### 13.8 VDC REGULATED POWER SUPPLY

These are solid state, fully regulated 13.8 vdc power supplies. Both feature 100% solid state construction, fuse protection, and L.E.D. power indicator. U.L. listed.  
2 amp constant, 4 amp surge \$18.00 each  
3 amp constant, 5 amp surge \$25.00 each

### D.C. CONVERTER

Designed to provide a steady ± 5 vdc @ 240 ma. from a battery supply of 3.5 to 6.25 volts.  
2 1/16" x 1 1/16" x 1 1/16"  
\$1.50 each

### TWIST-LOCK CONNECTOR

Same as Switchcraft #12CL5M.  
5 conductor in-line plug and chassis mount jack. Twist-lock style.  
\$2.50/SET

### 220 Vac COOLING FAN

ROTRON # MX77A3  
Muffin XL  
220 Vac  
4 1/8" square metal frame fan.  
CAT# CF-220 \$6.50 ea  
10 for \$60.00 / 100 for \$500.00  
QUANTITIES AVAILABLE

### 3 1/2" SPEAKER

8 ohm impedance, Full range speaker.  
8 oz magnet  
4" diagonal mounting centers.  
\$2.50 each 10 for \$20.00

### SPRING LEVER TERMINALS

Two color coded terminals on a sturdy 2 3/4" x 3 3/4" bakelite plate.  
Great for speaker enclosures or power supplies.  
75¢ EACH 10 for \$6.00

### LINE CORDS

- TWO WIRE  
6 18/2 SPT-1 flat 3 for \$1.00  
6 18/2 SPT-2 flat 2 for \$1.00  
6 16/2 SJT round \$1.25 each
- THREE WIRE  
6 18/3 flat \$1.50 each  
8 18/3 round \$2.00 each

### 7 CONDUCTOR RIBBON CABLE

Spectra-strip red marker strip, 28 ga. stranded wire.  
\$5.00 per 100' roll

### XENON FLASH TUBE

3/4" long X 1/8" dia. Flash tube designed for use in compact camera flash units. Ideal for experimentors.  
CAT# FLT-1 2 for \$1.00

### MINIATURE TOGGLE SWITCHES

ALL ARE RATED 5 AMPS @ 125 VAC

- S.P.D.T. (on-on) PC. style non-threaded bushing. 75¢ each 10 for \$7.00
- S.P.D.T. (on-on) Solder lug terminals. \$1.00 each 10 for \$9.00 100 for \$80.00
- S.P.D.T. (on-off-on) Solder lug terminals. \$1.00 each 10 for \$9.00 100 for \$80.00
- S.P.D.T. (on-on) PC. lugs threaded bushing. \$1.00 each 10 for \$9.00 100 for \$80.00
- D.P.D.T. (on-on) Solder lug terminals. \$2.00 each 10 for \$19.00 100 for \$180.00

### STANDARD JUMBO DIFFUSED T 1-3/4

- RED 10 for \$1.50 100 for \$13.00
- GREEN 10 for \$2.00 100 for \$17.00
- YELLOW 10 for \$2.00 100 for \$17.00

### FLASHER LED

5 volt operation red jumbo T 1 1/4 size \$1.00 each  
NEW GREEN FLASHER CAT# LED-4G \$1.00

### BI-POLAR LED HOLDERS

Two piece holder for jumbo LED 10 for 65¢ 100 for \$5.00

### CLEAR CLIPLITE LED HOLDER

Make LED a fancy indicator. Clear. 4 for \$1.00

### D.P.S.T. LIGHTED ROCKER SWITCH

115 vac lighted rocker, snap mounts in 3/4" x 1 1/4" hole. Orange lens. 16 amp contact.  
\$1.50

### MINI-PUSH BUTTON

S.P.S.T. momentary normally open 1/4" bushing. Red button. 35¢ each 10 for \$3.00

### SNAP ACTION SWITCH

Cherry elect. #E-21. N.O. or N.C. 0.1A contacts. Suitable for alarms and other low energy circuits. 1 1/4" lever.  
45¢ EACH 10 FOR \$4.20

### ROTARY ACTION MICRO

OMRON #C-5G3-C41  
Clockwise action micro used in coin operated mechanisms and low torque operations.  
RATED: 5 amps @ 125 Vac.  
\$1.25 each 10 for \$11.00  
LARGE QUANTITIES AVAILABLE

**ALL ELECTRONICS CORP.**  
LOS ANGELES, CA STORE  
905 S. Vermont Ave.  
213 380-8000  
VAN NUYS, CA STORE  
6228 Sepulveda Blvd.  
818 997-1806

MAIL ORDERS TO:  
P.O. BOX 20406  
Los Angeles, CA 90006  
TWX - 5101010163 ALL ELECTRONIC  
EASYLINK MBX - 62887748



TOLL FREE ORDERS ONLY  
1-800-826-5432  
(ORDER ONLY)  
(IN CALIFORNIA: 1-800-258-6666)  
ALASKA, HAWAII, OR INFORMATION  
(213) 380-8000 NO C.O.D.!

QUANTITIES LIMITED  
MINIMUM ORDER \$10.00  
USA: \$3.00 SHIPPING  
FOREIGN ORDERS:  
INCLUDING SUFFICIENT SHIPPING  
CALIF. RES. ADD 6 1/2%



New for  
**KENWOOD TH-21AT, 31AT, 41AT**  
 a *Fastcharger*

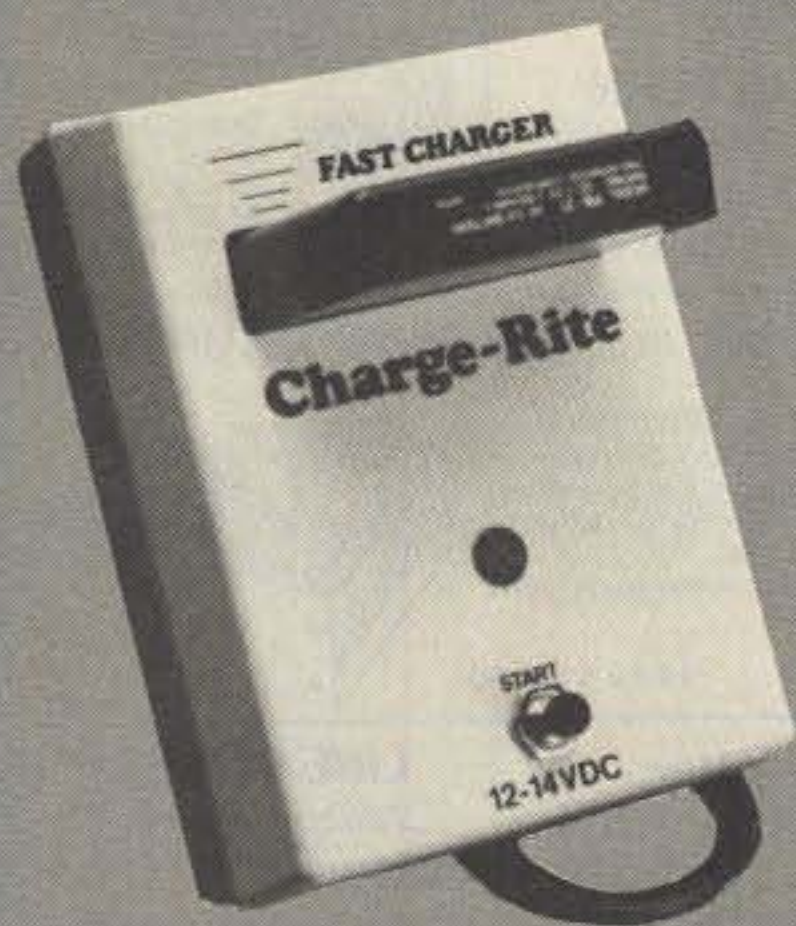

**SPECIAL SALE!**

~~\$54.95~~

Now **\$49.95**

Save \$15.00 when ordering charger with accessories kit.

+ \$3.00 shipping and handling  
 FL res. add 5% sales tax

**Features:**

- Charges in 15 minutes
- Automatic Voltage cut-off
- Battery doesn't heat-up
- 12v-14vdc input
- No memory
- Proven in daily use

Optional AC adapter with DC and mobile cords available ~~\$19.95~~ \$9.95

**Charge-Rite**

✓46

Call and talk with  
 Paul WB4WIG or  
 Dr. "S", WA4DRV

P.O. Box 4175, Vero Beach, FL 32964 (305) 476-8580

# PROPAGATION

Jim Gray W1XU

## EASTERN UNITED STATES TO:

	GMT:	00	02	04	06	08	10	12	14	16	18	20	22
ALASKA								20	20				
ARGENTINA									15	15	15	15	15
AUSTRALIA							40	20	20			15	15
CANAL ZONE	20	40	40	40	40			20	15	15	15	15	20
ENGLAND	40	40	40					20	20	20	20		
HAWAII		20				40	40	20	20				15
INDIA								20	20				
JAPAN								20	20				
MEXICO		40	40	40	40			20	15	15	15	15	
PHILIPPINES								20	20				
PUERTO RICO		40	40	40				20	15	15	15	15	
SOUTH AFRICA										15	15	15	
U. S. S. R.								20	20				
WEST COAST			80	80	40	40	40	40	20	20	20		

## CENTRAL UNITED STATES TO:

ALASKA	20	20							15				
ARGENTINA										15	15	15	15
AUSTRALIA	15	20				40	20	20					15
CANAL ZONE	20	20	40	40	40	40			15	15	15	15	20
ENGLAND		40	40						20	20	20	20	
HAWAII	15	20	20	20	40	40	40						15
INDIA									20	20			
JAPAN									20	20			
MEXICO	20	20	40	40	40	40			15	15	15	15	20
PHILIPPINES									20	20			
PUERTO RICO	20	20	40	40	40	40			15	15	15	15	20
SOUTH AFRICA											15	15	20
U. S. S. R.									20	20			

## WESTERN UNITED STATES TO:

ALASKA	20	20	20		40	40	40	40					15	
ARGENTINA	15	20		40	40	40							15	15
AUSTRALIA		15	20	20			40	40						
CANAL ZONE			20	20	20	20	20	20						15
ENGLAND										20	20			
HAWAII	15	20	20	40	40	40	40							15
INDIA		20	20											
JAPAN	20	20	20			40	40	40					20	20
MEXICO			20	20	20	20	20							15
PHILIPPINES	15						40			20				
PUERTO RICO			20	20	20	20	20	20						15
SOUTH AFRICA												15	15	
U. S. S. R.											20			
EAST COAST		80	80	40	40	40	40	20	20	20				

G=Good, F=Fair, P=Poor.

## JUNE

SUN	MON	TUE	WED	THU	FRI	SAT
1 G	2 G	3 G	4 G	5 G	6 G	7 G
8 G-F	9 F-P	10 P	11 P	12 P	13 P-F	14 F
15 F-P	16 P-F	17 F-G	18 F	19 F-G	20 G	21 G
22 G-F	23 F-P	24 P-F	25 F-G	26 G	27 G	28 G
29 G	30 G					

## DEALER DIRECTORY

### Fontana CA

Complete lines ICOM, DenTron, Ten-Tec, Mirage, Cubic, Lunar, over 4000 electronic products for hobbyist, technician, experimenter. Also CB radio, land-mobile. Fontana Electronics, 8628 Sierra Ave., Fontana CA 92335, 822-7710.

### San Jose CA

Bay Area's newest amateur radio store. New & used amateur radio sales & service. We feature Kenwood, ICOM, Azden, Yaesu, Ten-Tec, Santec & many more. Shaver Radio, Inc., 1775A S. Winchester Blvd., Campbell CA 95008, 370-6665.

### Littleton MA

The reliable ham store serving NE. Full line of ICOM & Kenwood, Drake, Daiwa, B&W accessories. Curtis & Trac keyers. Larsen, Hustler, Telex/Hy-Gain products. Mirage amps., Astron P.S., Alpha Delta protectors. ARRL & Kantronics instruction aids. Whistler radar detectors. Full line of coax fittings. TEL-COM Electronic Communications, 675 Great Rd. (Rt. 119), Littleton MA 01460, 486-3400/3040.

### Preston ID

Ross WB7BYZ has the largest stock of amateur gear in the Intermountain West and the best prices. Call me for all your ham needs. Ross Distributing, 78 So. State, Preston ID 83263, 852-0830.

### New Castle DE

Factory authorized dealer! Yaesu, ICOM, Ten-Tec, KDK, Kenwood, AEA, Kantronics, Santec. Full line of accessories. No sales tax in Delaware. One mile off I-95. Delaware Amateur Supply, 71 Meadow Road, New Castle DE 19720, 328-7728.

### Derry NH

Serving the ham community with new and used equipment. We stock and service most major lines: AEA, Astron, B&W, Cushcraft, Encomm, Hy-Gain, Hustler, ICOM, Kenwood, KLM, Larsen, Mirage, Mosley; books, rotors, cable and connectors. Business hours Mon.-Sat. 10-5, Thursday 10-9. Closed Sun./Holidays. Rivendell Electronics, 8 Londonderry Road, Derry, NH 03038, 434-5371.

### DEALERS

Your company name and message can contain up to 25 words for as little as \$150 yearly (prepaid), or \$15 per month (prepaid quarterly). No mention of mail-order business or area code permitted. Directory text and payment must reach us 60 days in advance of publication. For example, advertising for the September '86 issue must be in our hands by July 1st. Mail to 73 Amateur Radio, WGE Center, Peterborough, NH 03458. ATTN: Hope Currier.



# Work VHF or HF Packet On Any Computer With Kantronics Complete Packet Communicator

## KPC-2

From IBM to C-64, or any computer with an asynchronous serial port, you can now work packet on VHF or HF with one TNC, the KPC-2! Extra cost options are unnecessary. KPC-2 is packed full of features and backed by our full-time customer support departments. KPC-2 has totally new hardware and software, Kantronics designed. For more information contact Kantronics or a Kantronics dealer.

**Suggested Retail \$ 219.00**



### Features

- AX.25 Version 2.0 software
- Supports multiple connects, up to 26
- RS232 or TTL compatible (C-64 too!)
- HF modem included! (both U.S. and European tones)
- Carrier Detect, and software squelch operation
- FCC Part 15 Certified
- Kantronics industry standard extruded aluminum case
- Power supply and cabling included
- All EPROM software is Kantronics sourced and copyrighted

- 128K EPROM, 16K RAM — expandable to 32K, 4K EEPROM.
- Advanced software HDLC routines, eliminating costly out-of-date chips

### Customer Support

- Extensive dealer network
- In-house programmers/engineers
- In-house service representatives
- Periodic software updates (like 2.0!)

**Want more information on Packet?**

Contact us about our new **PACKET VIDEO**.

\$ 25.00 (shipping included), VHS or BETA format.

 **Kantronics**  
RF Data Communications Specialists

1202 E. 23 Street Lawrence, Kansas 66046 (913) 842-7745



# MISSOURI RADIO CENTER

102 N.W. Business Park Lane, Kansas City, MO 64150 816-741-8118

Call Toll Free — 9am - 6pm Mon. - Fri., 9am - 2pm Sat.  
In Missouri Call — 816-741-8118

# 1-800-821-7323

TRADE INS ACCEPTED  
MasterCard — VISA — COD Welcome

AEA  
ALINCO  
AMERITRON  
ASTRON  
AVANTI  
B & W  
BENCHER  
BUTTERNUT  
COMM SPEC  
CUSHCRAFT  
DAIWA

## KENWOOD



### TS940S "DX-celence"

- Programmable Scanning
- High Stability, Dual Digital VFO's
- 40 Channel Memory
- General Coverage Receiver

## KENWOOD

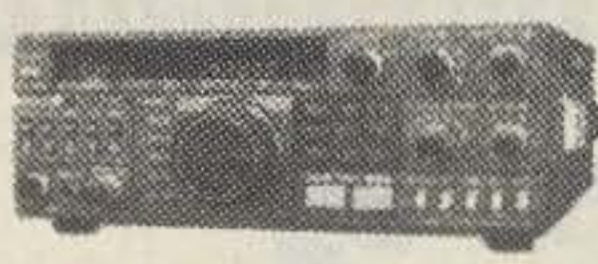

### TS-440S "DX-Citing"

- 100% Duty Cycle
- 100 Memories
- Direct Keyboard Entry
- Optional Built-in AT

On Sale Now, Call For Price!

## KENWOOD



### TM2570 "ALL NEW"

- First 70 Watt FM Mobile
- First With Memory & Auto Dialer
- 23 Channel Memory
- Front Panel Programmable CTCSS

## KENWOOD

### TR2600 "SPECIAL"

- 2.5 W/300 MW 2 Meter HT
- LCD Readout
- 10 Memories
- Band And Memory Scan



### TH-21AT "THE Smallest HT"

- Compact Pocket Size
- 1 Watt
- Optional 500mA Battery

## YAESU



### FT-757GX "CAT SYSTEM"

- All Mode Transceiver
- Dual VFO's
- Full Break-in CW
- 100% Duty Cycle

## YAESU

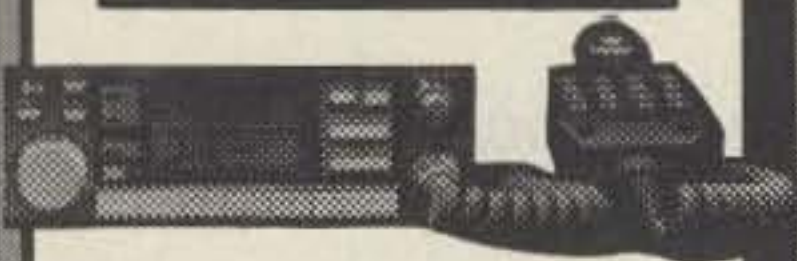

### FT-2700R "Yaesu gets you there"

- Duo-Band Full Duplex
- 25 Watt
- 144/430 MHz

## YAESU

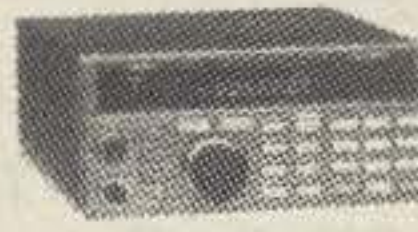

### FRG-9600

- 60 MHz-905 MHz Continuous
- 100 Memories
- Clock

## YAESU



### FT209RH "Powerful HT"

- 5 Watts
- 10 Memories
- LCD Readout
- Battery Saver

## ICOM



### IC-735 "NEW"

- HF Transceiver
- Ultra Compact Mobile
- Simplified Front Panel
- Continuously Adjustable output Power up to 100 Watts

## ICOM



### IC-751A "One Year Warranty"

- 100 KHz - 30 MHz
- FM Standard
- 32 Memories
- QSK (Nominal Speed 40 WPM)

## ICOM



### IC-27A "Call for Price"

- 25 Watts
- 32 PL Frequencies
- 9 Memories
- Scanning

## ICOM



### IC-2AT

- DTMF Pad
- 1.5 Watts
- Thumbwheel freq. selector

### IC-02AT

- DTMF Direct Keyboard Entry
- 3 Watts Standard
- 5 Watts Optional

## Kantronics

### PACKET COMMUNICATOR



- Fully Assembled
- One Year Warranty
- RS-232 Compatible Port

### AEA PK-64

- MBA - TOR\*
- AMTOR • Baudot
- ASCII • Morse
- 300 and 1200 Baud

## ALINCO



### ALR-206T "More For Your Money"

- Completely Programmable From Microphone
- 25 Watt

### ALM-203

- 5 Watt
- Subaudible Tone
- 10 Memories
- Built-in "S" meter



## ASTRON CORPORATION

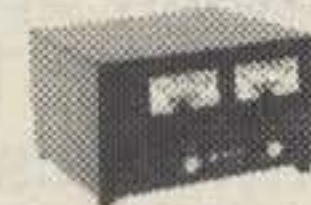

### Power Supply

- RS7A ..... \$48
- RS12A ..... \$68
- RS20A ..... \$88
- RS20M ..... \$105
- VS20M ..... \$125
- RS35A ..... \$133
- RS35M ..... \$149
- VS35M ..... \$165
- RS50A ..... \$189
- RS50M ..... \$215
- RM50A ..... \$219
- VS50M ..... \$229

## Antenna Sale

Hy-Gain On Sale Now	Ken Pro	KR400	\$139.00
Hustler 25% Off Mobile		KR500	179.00
Cushcraft		KR5400	299.00
KLM	Alinco	AAZ-7	89.00
Butternut HF6V	Columbia Cable		
HF2V	RG-8X		.15/ft.
AEA 144 Sr.	RG-8 Super Flex		.28/ft.
Avanti 151.3G	9913 Type		.39/ft.
	Rotor Cable		.18/ft.
Quatron	H.D. Rotor Cable		.31/ft.

CALL FOR BEST PRICES

## QUATRON

### AM-6000G - \$109.00



- 4 Band Graphic Equalizer
- Power Output Adjust
- VU Meter
- Compressor Amplifier
- Condensor Microphone

"Adaptable to Any Radio"

HUSTLER

HYGAIN

ICOM

J.I.L.

KANTRONICS

KOK





# Presenting two small cases for a lot of mobile power.

You won't find a 45-watt, 2-meter FM mobile rig that's built smaller than the Yaesu FT-270RH.

Nor will you find a dual-band FM mobile that offers the crossband full-duplex capability found in the 25-watt Yaesu FT-2700RH.

It shouldn't be surprising. We've been coming up with a lot of innovative concepts lately.

The FT-270RH measures just 2 x 6 x 7 inches. Conveniently fitting its high-power punch into many small spaces of your car. Places where other 45-watt mobiles just won't fit.

The FT-2700RH is small too. Smaller than other dual-banders. But with one big difference: a "DUP" button. Push it, and you're operating full duplex, 2 meters on one VFO, 440 MHz on the other. Each at 25 watts. So you can simultaneously

transmit and receive in true telephone style.

Once installed, you'll find the FT-270RH and the FT-2700RH equally simple to operate. Just turn the rig on, dial up a frequency, select offset or duplex split, and you're on the air.

Each rig gives you 10 memories for storing your favorite frequencies. Dual VFO capability. A clean, uncluttered LCD display for easy readout. Push-button jumps through the band in 1 MHz steps. Band scanning with programmable upper and lower limits. And priority channel operation.

You don't even have to take your eyes off the road to determine your operating frequency and memory channel. An optional voice synthesizer announces them both at the push of a button on the microphone. The FT-2700RH announces both your

2-meter and 440 MHz operating frequencies.

Also, tone encode and encode/decode capability is programmable from the front panel, using an optional plug-in board.

So when you need a lot of power in a compact mobile radio, discover Yaesu's FT-270RH and FT-2700RH. There's nothing else like them on the road.

**YAESU**

#### Yaesu USA

1720 Edwards Road, Cerritos, CA 90701  
(213) 404-2700

#### Yaesu Cincinnati Service Center

9070 Gold Park Drive, Hamilton, OH 45011  
(513) 874-3100

Prices and specifications subject to change without notice.

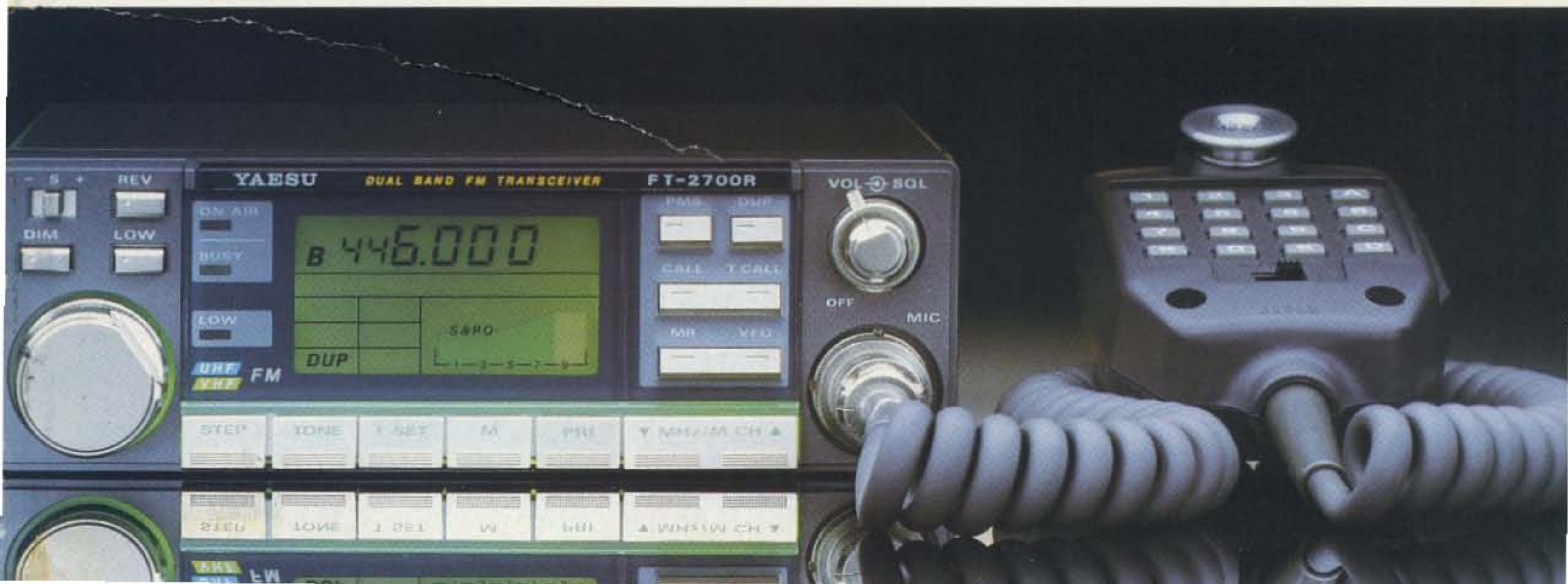



# KENWOOD

...pacesetter in Amateur radio

Just arrived!

## All-Mode Mobility!

### TR-751A

#### Compact 2-m all mode transceiver

It's the "New Sound" on the 2 meter band—Kenwood's TR-751A! Automatic mode selection, versatile scanning functions, illuminated multi-function LCD and status lights all contribute to the rig's ease-of-operation. All this and more in a compact package for VHF stations on-the-go!

• Automatic mode selection, plus LSB  
144.0 144.1 144.5 145.8 146.0 148.0 MHz

CW	USB	FM	USB	FM
----	-----	----	-----	----

- Optional front panel-selectable 38-tone CTCSS encoder
- Frequency range 142-149 MHz (modifiable to cover 141-151 MHz)
- High performance receiver with GaAs FET front end
- VS-1 voice synthesizer option

- 25 watts high/5 watts adjustable low
- Programmable scanning—memory, band, or mode scan with "COM" channel and priority alert
- 10 memory channels for frequency, mode, CTCSS tone, offset. Two channels for odd splits.
- All mode squelch, noise blanker, and RIT
- Easy-to-read analog S & RF meter

- Dual digital VFOs
- Semi break-in CW with side tone
- MC-48 16-key DTMF hand microphone included
- Frequency lock, offset, reverse switches
- Digital Channel Link (DCL) option

#### Optional accessories:

- CD-10 call sign display
- PS-430, PS-30 DC power supplies
- SW-100A/B SWR/power meter
- SW-200A/B SWR/power meter
- SWT-1 2-m antenna tuner
- TU-7 38-tone CTCSS encoder
- MU-1 modem unit for DCL system
- VS-1 voice synthesizer
- MB-10 extra mobile mount
- SP-40, SP-50 mobile speakers
- PG-2K extra DC cable
- PG-3A DC line noise filter
- MC-60A, MC-80, MC-85 deluxe base station mics.
- MC-42S UP/DOWN mic.
- MC-55 (8-pin) mobile mic.



Actual size front panel

### TR-9500

#### 70 CM SSB/CW/FM transceiver

- Covers 430-440 MHz, in steps of 100-Hz, 1-kHz, 5-kHz, 25-kHz or 1-MHz.
- CW-FM Hi—10 W, Low—1 W. SSB 10 W.
- Automatic band/memory scan. Search of selected 10-kHz segments on SSB/CW.
- 6 memory channels.



# KENWOOD

TRIO-KENWOOD COMMUNICATIONS  
1111 West Walnut Street  
Compton, California 90220

Complete service manuals are available for all Trio-Kenwood transceivers and most accessories. Specifications and prices are subject to change without notice or obligation. Specifications guaranteed for the 144-148 MHz Amateur band only.