

73 Amateur Radio Today

DECEMBER 2001
ISSUE #493
USA \$3.95
CANADA \$4.95

Raibeams:
RF Inferno?

Super
Wind Power
Project

Build:
• Battery Booster
• PS Tester

Island DXing:
• St. Mary's
• Cape Verde Is.

Crazy Builder's Tips
Inside VOMs

12
*****3-DIGIT 231
#00000109389WR6# JUL76 71
JACK SPEER 45
BUCKMASTER PUBLISHING P 4
6196 JEFFERSON HIGHWAY
MINERAL VA 23117-3425

Alinco's New HTs

Fun, Fantastic and Affordable!

Check out the new DJ-596 dual bander or the DJ-196/496 monoband units. No matter which you choose, you'll get a transceiver that's rugged, easy to program and built for years of dependable operation. You expect more value from Alinco and we deliver!



DJ-596T VHF/UHF Dual-band HT **NEW!**

Loaded with features! The breakthrough design supports optional digital voice communications and you can easily switch the unit between analog and digital modes!

- Full 4.5 watts output VHF/4w UHF
- Powerful NiMH battery
- 100 memories in any combination of VHF or UHF channels
- Direct frequency input from keypad
- Each memory capable of "odd split" operation.
- Alphanumeric channel labels
- CTCSS and DCS encode+decode plus tone bursts
- Full 2m and 440 band coverage
- Accepts 6 ~ 16 VDC direct input
- Three scan modes
- Illuminated keys and display
- Wide and narrow FM modes
- 10 autodial memories
- Theft alarm feature
- Optional EJ-40U Digital Voice Board!*

DJ-196T (2m) and DJ-496T (440 MHz)

These sturdy, full-featured monobanders are priced low and ready to go!

- 5 watts DJ-196 / 4 watts DJ-496
- Long-lasting NiMH battery
- 40 memory channels
- Keypad frequency input
- CTCSS and DCS encode+decode
- Alphanumeric display
- 13.8 VDC direct input
- Wide and narrow FM modes
- Illuminated keys and display
- Autodial memories
- S-meter
- DJ-196 TX 144 ~ 148MHz; RX 135 ~ 174 MHz
- DJ-496 TX 430 ~ 450 MHz RX 430 ~ 450 MHz



Great Accessories for Alinco and other radios!

Iron Horse antennas and accessories extend the use of your transceivers and scanners. BNC connections make it easy to take your HT mobile for BIG signals in and out!



IHC 19 car window mount
BNC connectors, window mount, sets up in just seconds!

IHMM270 Compact VHF/UHF Magnetic Mount Antenna

BNC connector, 9 feet of RG-174 cable and a powerful magnet. Less than 20 inches high, SWR less than 1.5:1 throughout either band. Max power: 50w/VHF; 25w UHF.

IHC 20 glass suction-cup mount

Extension BNC suction mount keeps your antenna inside but against the glass for a true "window on the world." For mobile or base use, includes 6 feet of RG-58U cable.



IHMM3 Magnetic Scanner Antenna

BNC connector, just 13.5 inches high. Powerful rare-earth magnet, 9 feet of RG-174 cable. Receives 100 ~ 1200 MHz, can transmit on 2m, 70cm and SMR frequencies.

www.ALINCO.com



Distributed in North America by ATOC Amateur Distributing LLC • 23 S. High St., Covington, OH 45318 • (937) 473-2840
Specifications subject to change without notice or obligation.

*Digital communications require at least two similarly equipped transceivers.

Digital mode is compatible with Alinco DR-135/235/435T mobile transceivers equipped with EJ-43U digital communications board.

Digital mode may not be legal in some countries. See FAQ on digital at www.alinco.com.

Products intended for use by properly licensed operators. Permits required for MARS/CAP use. Specifications subject to change without notice or obligation. All trademarks remain the property of their respective owners.

THE TEAM

DECEMBER 2001
ISSUE #493

El Supremo & Founder
Wayne Green W2NSD/1

Associate Publisher
F. I. Marion

Executive Editor
Jack Burnett

Managing Editor
Joyce Sawtelle

Technical Editor
Larry Antonuk WB9RRT

Contributing Culprits
Mike Bryce WB8VGE
Jim Gray II
Jack Heller KB7NO
Chuck Houghton WB6IGP
Andy MacAllister W5ACM
Joe Moell K0OV
Steve Nowak KE8YN/0
Dr. Rick Olsen N6NR

Advertising Sales
Evelyn Garrison WS7A
21704 S.E. 35th St.
Issaquah WA 98029
425-557-9611
Fax: 425-557-9612

Circulation
Frances Hyvarinen

Data Entry & Other Stuff
Norman Marion

Business Office
Editorial - Advertising - Circulation
Feedback - Product Reviews
73 Amateur Radio Today Magazine
70 Hancock Rd.
Peterborough NH 03458-1107
603-924-0058
Fax: 603-924-8613

Reprints: \$3 per article
Back issues: \$5 each

Printed in the USA

THE NEW! 73 Amateur Radio Today

TABLE OF CONTENTS

FEATURES

- 10 **Microwind to the Rescue! — WA8YKN**
Let the wind keep your emergency batteries charged.
- 17 **Subdivision Subterfuge — KD5IDU**
A Houston homeowner handles his hamming.
- 20 **IOTA — AS096 — VU2SBJ**
That's St. Mary's Island to you ...
- 23 **Bare Bones Battery Booster — N0GJ**
A good project — as long as you understand the dangers and limitations.
- 28 **VOM Primer — W2GOM/7**
This overview is helpful for beginners and old-timers alike.
- 30 **Travels with Henryk — Part 1 — SM0JHF**
SM0JHF shares some photos — and the fun of hamming.
- 32 **Ye Olde Fishpole Vertical — HL1/N8HI**
Some things never change — thankfully.
- 36 **The Builder's Dozen — AA2JZ**
Uncommon uses for common stuff.
- 37 **IC-706 Goes to Heil — W5RK**
How to mate your Icom rig with an old Heil headset.
- 38 **Helsinki or Buzz! — G3SWH**
No-frills tickets meant an instant junket to OH-land for this G3.
- 40 **Beginner's PS Tester — WB9YBM, N9BRL**
This variable active load will do the trick.

DEPARTMENTS

- 42 Above & Beyond — WB6IGP
49 Ad Index
64 Barter 'n' Buy
61 Calendar Events
46 The Digital Port — KB7NO
51 Hamsats — W5ACM
54 Homing In — K0OV
4 Never Say Die — W2NSD/1
48 New Products
53 On the Go — KE8YN/0
60 Propagation — Gray
45 QRP — WB8VGE
1 QRX
63 Radio Bookshop

E-Mail

design73@aol.com

Web Page

www.waynegrain.com

REVIEW

- 24 **RF Inferno — K7GCO**
Meet the new Raibeam antennas.

QRX . . .

More Hams Among Sept. 11 Missing

Bill Ruth W3HRD was a veteran of two wars and spent nearly 30 years as a social studies teacher. He has now been declared dead in the September 11th attack on the Pentagon.

According to the *Washington Post*, Ruth was a retired Army Chief Warrant Officer who lived in Mount Airy, Maryland. On the evening of Sept. 10th, he had presided over his first meeting as commander of his local Veterans of Foreign Wars post. The following day, he was at work in the Pentagon when a jetliner

Continued on page 6

Manuscripts: Contributions for possible publication are most welcome. We'll do the best we can to return anything you request, but we assume no responsibility for loss or damage. Payment for submitted articles will be made after publication. Please submit both a disk and a hard copy of your article [IBM (ok) or Mac (preferred) formats], carefully checked drawings and schematics, and the clearest, best focused and lighted photos you can manage. "How to write for 73" guidelines are available on request. US citizens, please include your Social Security number with submitted manuscripts so we can submit it to you know who.

73 Amateur Radio Today (ISSN 1052-2522) is published monthly by 73 Magazine, 70 Hancock Rd., Peterborough NH 03458-1107. The entire contents ©2001 by 73 Magazine. No part of this publication may be reproduced without written permission of the publisher, which is not all that difficult to get. The subscription rate is: one year \$24.97, two years \$44.97; Canada: one year \$34.21, two years \$57.75, including postage and 7% GST. Foreign postage: \$19 surface, \$42 airmail additional per year, payable in US funds on a US bank. Second class postage is paid at Peterborough, NH, and at additional mailing offices. Canadian second class mail registration #178101. Canadian GST registration #125393314. Microfilm edition: University Microfilm, Ann Arbor MI 48106. POSTMASTER: Send address changes to **73 Amateur Radio Today**, 70 Hancock Rd., Peterborough NH 03458-1107. 73 Amateur Radio Today is owned by Shabromat Way Ltd. of Hancock NH.



...POWER ON WITH ASTRON

SWITCHING POWER SUPPLIES...



MODEL SS-10TK



MODEL SS-12IF

SPECIAL FEATURES:

- HIGH EFFICIENCY SWITCHING TECHNOLOGY SPECIFICALLY FILTERED FOR USE WITH COMMUNICATIONS EQUIPMENT, FOR ALL FREQUENCIES INCLUDING HF
- HEAVY DUTY DESIGN
- LOW PROFILE, LIGHT WEIGHT PACKAGE
- EMI FILTER
- MEETS FCC CLASS B

PROTECTION FEATURES:

- CURRENT LIMITING
- OVERVOLTAGE PROTECTION
- FUSE PROTECTION
- OVER TEMPERATURE SHUTDOWN

SPECIFICATIONS:

INPUT VOLTAGE: 115 VAC 50/60HZ
OR 220 VAC 50/60HZ
SWITCH SELECTABLE
OUTPUT VOLTAGE: 13.8VDC

AVAILABLE WITH THE FOLLOWING APPROVALS: UL, CUL, CE, TUV.



MODEL SS-18

DESKTOP SWITCHING POWER SUPPLIES

MODEL	CONT. (Amps)	ICS	SIZE (inches)	Wt.(lbs.)
SS-10	7	10	1 1/2 x 6 x 9	3.2
SS-12	10	12	1 1/2 x 6 x 9	3.4
SS-18	15	18	1 1/2 x 6 x 9	3.6
SS-25	20	25	2 1/8 x 7 x 9 1/2	4.2
SS-30	25	30	3 1/4 x 7 x 9 1/2	5.0



MODEL SS-25M

DESKTOP SWITCHING POWER SUPPLIES WITH VOLT AND AMP METERS

MODEL	CONT. (Amps)	ICS	SIZE (inches)	Wt.(lbs.)
SS-25M*	20	25	2 1/8 x 7 x 9 1/2	4.2
SS-30M*	25	30	3 1/4 x 7 x 9 1/2	5.0



MODEL SRM-30

RACKMOUNT SWITCHING POWER SUPPLIES

MODEL	CONT. (Amps)	ICS	SIZE (inches)	Wt.(lbs.)
SRM-25	20	25	3 1/2 x 19 x 9 1/2	6.5
SRM-30	25	30	3 1/2 x 19 x 9 1/2	7.0

WITH SEPARATE VOLT & AMP METERS

MODEL	CONT. (Amps)	ICS	SIZE (inches)	Wt.(lbs.)
SRM-25M	20	25	3 1/2 x 19 x 9 1/2	6.5
SRM-30M	25	30	3 1/2 x 19 x 9 1/2	7.0

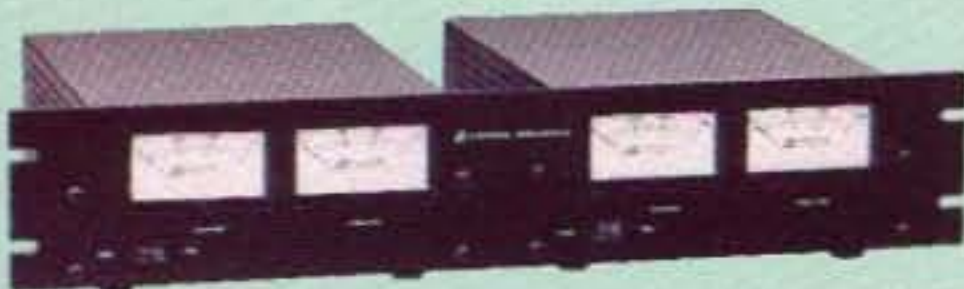

MODEL SRM-30M-2

2 ea SWITCHING POWER SUPPLIES ON ONE RACK PANEL

MODEL	CONT. (Amps)	ICS	SIZE (inches)	Wt.(lbs.)
SRM-25-2	20	25	3 1/2 x 19 x 9 1/2	10.5
SRM-30-2	25	30	3 1/2 x 19 x 9 1/2	11.0

WITH SEPARATE VOLT & AMP METERS

MODEL	CONT. (Amps)	ICS	SIZE (inches)	Wt.(lbs.)
SRM-25M-2	20	25	3 1/2 x 19 x 9 1/2	10.5
SRM-30M-2	25	30	3 1/2 x 19 x 9 1/2	11.0



MODEL SS-12SM/GTX



MODEL SS-10EFJ-98

CUSTOM POWER SUPPLIES FOR RADIOS BELOW

- EF JOHNSON AVENGER GX-MC41
- EF JOHNSON AVENGER GX-MC42
- EF JOHNSON GT-ML81
- EF JOHNSON GT-ML83
- EF JOHNSON 9800 SERIES
- GE MARC SERIES
- GE MONOGRAM SERIES & MAXON SM-4000 SERIES
- ICOM IC-F11020 & IC-F2020
- KENWOOD TK760, 762, 840, 860, 940, 941
- KENWOOD TK760H, 762H
- MOTOROLA LOW POWER SM50, SM120, & GTX
- MOTOROLA HIGH POWER SM50, SM120, & GTX
- MOTOROLA RADIUS & GM 300
- MOTOROLA RADIUS & GM 300
- MOTOROLA RADIUS & GM 300
- UNIDEN SMH1525, SMU4525
- VERTEX — FTL-1011, FT-1011, FT-2011, FT-7011

NEW SWITCHING MODELS

- SS-10GX, SS-12GX
- SS-18GX
- SS-12EFJ
- SS-18EFJ
- SS-10-EFJ-98, SS-12-EFJ-98, SS-18-EFJ-98
- SS-12MC
- SS-10MG, SS-12MG
- SS-101F, SS-121F
- SS-10TK
- SS-12TK OR SS-18TK
- SS-10SM/GTX
- SS-10SM/GTX, SS-12SM/GTX, SS-18SM/GTX
- SS-10RA
- SS-12RA
- SS-18RA
- SS-10SMU, SS-12SMU, SS-18SMU
- SS-10V, SS-12V, SS-18V



RAMSEY

GET THE CATALOG TODAY!
Over 100 NEW products!
www.ramseykits.com



SYNTHESIZED FM STEREO RADIO STATION

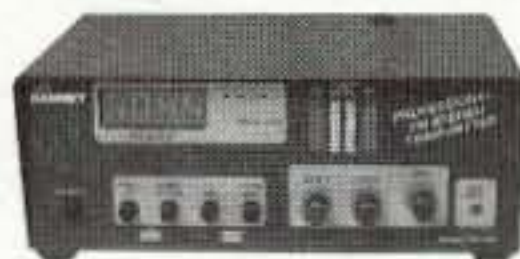

- Synthesized 88 to 108...no drift!
- Built in mixer - 2 line inputs and one microphone input!
- High power module available for export use
- Low pass filter for great audio

Our FM100 is used all over the world by serious hobbyists as well as churches, drive in theaters, and schools. The kit includes metal case, whip antenna and built-in 110 volt AC power supply.

FM100	Super-Pro FM Stereo Radio Station Kit	\$249.95
FM100WT	1 Watt, Wired Export Version	\$399.95

SYNTHESIZED FM STEREO TRANSMITTER



Professional quality rock stable synthesized transmitter. Dip switch settable for any frequency between 88-108 MHz. Strappable for high power output for export applications. Our most popular kit. Start your own radio station today with the FM25!

FM25	Synthesized FM Stereo Transmitter Kit	\$129.95
------	---------------------------------------	----------

FM STEREO TRANSMITTER



Great entry level FM broadcast kit. Thousands in use. Handy for sending music through house and yard, ideal for school projects too - you'll be amazed at the exceptional audio quality! Runs on 9V battery or 5 to 15 VDC. Add matching case and whip antenna set for great pro look.

FM10A	Tunable FM Stereo Transmitter Kit	\$34.95
CFM	Matching Case and Antenna Set	\$14.95
FMAC	12V DC Wall Plug Adapter	\$9.95

RF WIRELESS LINK MODULES

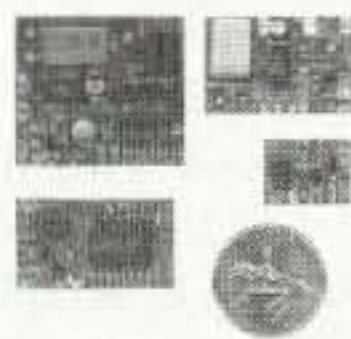

- SAW Resonators for high stability - NO Drift!
- Powerful +10 dbm output
- Range up to 600'
- 433 MHz license-free band
- Sensitive superhet receiver with RF LNA
- Stable over full 3-12 VDC range
- Optional on-board 12 bit encoder/decoder using Holtek HT12 series chips, Quarter not included!

RXD433	433 MHz Receiver/Decoder Mod., Assembled	\$26.95
TXE433	433 MHz Transmitter/Encoder Mod., Assembled	\$24.95
RX433	433 MHz Data Receiver Mod., Assembled	\$21.95
TX433	433 MHz Data Transmitter Mod., Assembled	\$19.95

THE CUBES! MINIATURE VIDEO TRANSMITTERS



Wireless crystal clear reception, yet smaller than a quarter! Transmits color or B&W with fantastic quality almost like a hard wire connection to any TV or VCR tuned to cable channel 59. Crystal controlled for no frequency drift with performance that equals law enforcement models that cost hundreds more! Basic 20mW unit goes up to 300' while the high

power version can virtually double that range! Fully assembled and tested, and ready to go. Powered by a standard 9V battery. Name that Quarter!

C2000	Video Cube, Factory Assembled & Tested	\$89.95
C2001	High Power Version, Assembled & Tested	\$129.95

INFRA-RED VIDEO CAMERA ILLUMINATOR



Lets video cameras "see in the dark". Invisible light source to us, but lots of light to CCD B&W cameras! Illuminates the area just like light, yet cannot be seen. Draws 180mA at 12 VDC. 110VAC power adapter available.

IR1	Infra-Red Camera Illuminator Kit	\$24.95
AC125	12VDC Power Supply	\$9.95

ELECTRONIC PROTOTYPING SOFTWARE



Priced for the hobbyist!

You can create and test AC and DC circuits minutes after installing this package on your PC. Start from scratch, or from the included library of pre-designed circuits. Drag and drop placement from a complete list of active and passive components. Test using a complete list of virtual instruments, Oscilloscope, voltmeter, ohmmeter, ammeter, and watt meter.

PLAB4	Electronic Prototype Software, Win95/98	\$49.95
-------	---	---------

ANALOG-DIGITAL PORTABLE LAB STATION



The COMPLETE analog-digital lab station in one. Includes function generator, clock output, power supplies, level switches, pulsers, pots, LEDs and a LARGE breadboarding area all in one! Includes a custom molded case as shown. Used through the world at universities, technical schools, and R&D labs. Available in "Learn as you Build" kit form or factory assembled and tested. A great buy either way!

ML200	Lab Station, Kit	\$155.95
ML200WT	Lab Station, Factory Assembled & Tested	\$225.95

CABLE WIZARD CABLE TRACER



Did you ever have to identify the "other end of that cable"? No more "ohming it out" with the Cable Wizard. Simply connect the wizard transmitter to one end of the cable and use the receiver to sniff out the other end. It's as simple as that! The transmitter sends a pulsating 2 KHz signal down the cable which is heard when the receiver is close to the cable. Works with any cable including coax, telephone pairs, ethernet and more. Equipped with an RJ45 for all telco connections and clip leads for single wire connections.

WCT20	Wireless Cable Tracer Kit	\$39.95
CWCT	Matching Case Set for Transmitter & Receiver	\$29.95
WCT20WT	Factory Assembled & Tested WCT20	\$99.95

SPEEDY PERSONAL SPEED RADAR GUN



This low cost microwave radar uses the same principle found in police units costing thousands more. This has been the number one Science Fair project for years. Direct digital readout in miles/hour, kilometers/hour, or feet/second. An earphone jack allows you to actually hear the Doppler frequency shift of moving objects. Our detailed manual not only guides you through construction, but covers the

how's and why's of speed radar theory. Learn while you build. Uses two 13 oz coffee cans for the antenna (not included, so start drinking!) and runs on 12 VDC.

SG7	Speedy Personal Speed Radar Kit	\$99.95
AC125	12VDC Power Supply	\$9.95

AND...OUR FAMOUS MINI-KITS



- These are easy to build kits that can be used either stand alone or as building blocks for more complex projects.
- | | | |
|------|------------------------------|---------|
| TS4 | Tickle-Stick Shocker | \$9.95 |
| BN9 | Super Snoop Amplifier Kit | \$8.95 |
| BL1 | LED Blinky Kit | \$3.95 |
| TD1 | Tone Encoder/Decoder Kit | \$6.95 |
| TT7 | Touch Tone Decoder Kit | \$29.95 |
| CPO3 | Code Practice Oscillator Kit | \$9.95 |
| UT5 | Universal Timer Kit | \$8.95 |

RAMSEY
 ELECTRONICS, INC.

793 Canning Parkway
 Victor, NY 14564
 716-924-4560
sales@ramseykits.com



Order Today! 800-446-2295
www.ramseykits.com

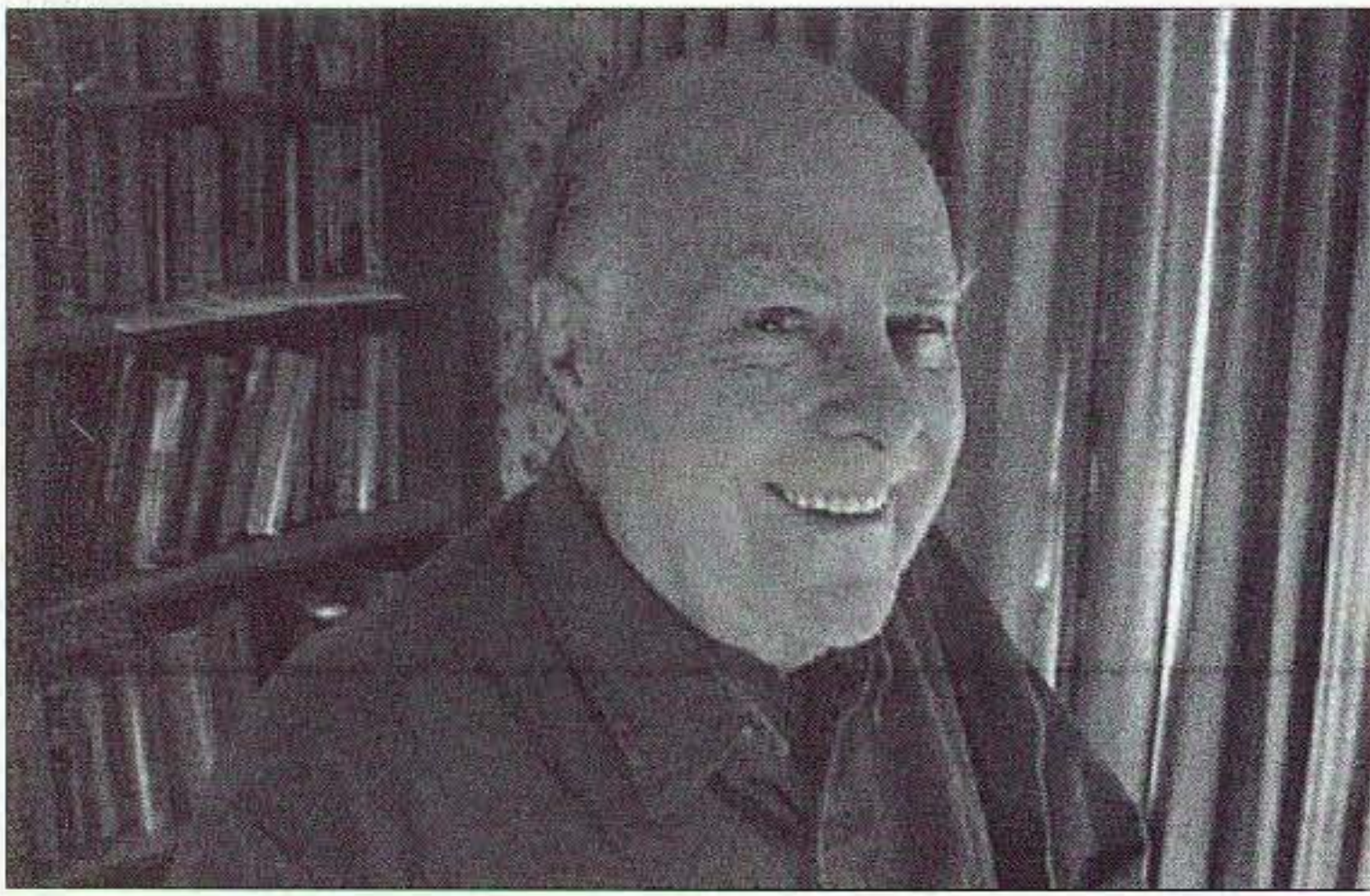

Surviving Bioterror

A couple of years ago, I was about the only one writing about the bioterrorism threat. Now it's the cover story of *Newsweek* and *Time*, and in feature articles in *Fortune*, etc. The World Trade Center attack finally woke the media into its usual pack action. But, how about you, are you awake yet?

Yes, the government has been asleep on this, too — despite a 1993 federal study reporting that 250 pounds of aerosolized anthrax sprayed over D.C. could kill up to three million people. The fact is that America is almost totally ill-prepared to deal with such an assault.

Bush's appointment of Tom Ridge as the antiterror czar, but then not giving him control over the counterterrorism budgets, gives him little real power. With dozens of federal bureaucracies, all fighting for more money, and doing their best not to communicate with other agencies, it's the usual D.C. mess. We have the State Department, Defense Department, Customs, FBI, CIA, NSA, DIA, CDC, NIH, FEMA, FDA, and on through the alphabet, all protecting their turf.

I hope you took time to watch the recent PBS series on the drug war. It demonstrated the incredibly stupid way Congress went about dealing with the drug problem and the mess it's made — plus hundreds of billions of our tax money that's been totally wasted — not to mention thousands of lives.

Alas, I suspect this may be a blueprint for the war on terrorism.

To start at the beginning: Anthrax seems like one of an enemy's most likely weapons. It's easy to make and freeze-dry into a powder. It's easy to disburse. By mail — pouff! — you're infected, from crop planes, a hot air balloon, a drone aircraft, spray cans, the Empire State Building observation deck, and so on.

Well, what about getting vaccinated against anthrax? Sure, once the company (Acambis) that's supposed to be making it gets the bugs out of their system. Once they're able to safely make the vaccine, the first few million doses will go to the military and then government employees.

Oh, yes, there's one more complication. The immunization requires six doses of vaccine given over 18 months, followed by yearly boosters. There's no word yet on the "acceptable losses" due to adverse reactions to the vaccine. We do know that many Gulf War veterans who got anthrax vaccinations had hellacious long term reactions to it. This does not inspire confidence in the whole immunization process. You'll have even less if you read Walene James' *Immunization, The Reality Behind the Myth* (see page 7 of my *Wisdom Guide*), or Harris Coulter's *Vaccination — Social Violence and Criminality — The Medical Assault on the American Brain*.

Now, the gritty-nitty — here's what you can — no, make that *must* — do.

Wise Up & Beat the Odds

NEVER SAY DIE

Wayne Green W2NSD/1

w2nsd@aol.com

www.waynegreen.com

Since telephones are usually the first service to fail in emergencies, and since our government has not established any national emergency communications alternative, it's going to be radio amateurs who will, as in all past serious emergencies, provide it.

- If you don't have a ham license, for heaven's sake get one — just memorize a few Q&As.

- Get a handie-talkie and get trained on emergency procedures over a local repeater.

- Join the local radio club and help them set up a van that will be able to permit all of the mobile radio services to intercommunicate. Like fire, police, doctors, hospitals, ambulances, sheriffs, the military, CB, CAP, FBI, Secret Service, and so on.

- Urge every inactive licensed ham in your area to get on the stick. Look 'em up on a *Callbook* ROM and call them.

- Keep a couple of gallons of silver colloid on hand, plus the ability to make a whole lot more. This is one of the most powerful antibiotics there is and it costs pennies to make. The anthrax death rate is around 90% for those without antibiotics, and within three days after the first symptoms of a fever and a cough appear.

- However, the best protection against any pathogen is a powerful immune system. Have you started rebuilding the damage you've been doing to yours yet?

The Silver Bullet

Shades of the Lone Ranger!

Well, our medical-pharmaceutical complex has done it to us again. I mean the over-use of antibiotics which has resulted in bacteria becoming resistant.

Researchers estimate that around half of antibiotic prescriptions are unnecessary. Then we put 70% of the antibiotics we produce into livestock — and eat the antibiotic-laced meat. All this encourages the weak microbes to become stronger. The result is that bacterial infections, including tuberculosis, pneumonia, and meningitis, which used to be easily handled with antibiotics, are becoming deadly.

Which leaves us with silver colloid, to which microbes have been unable to adapt.

With the increasing threat of biowarfare, it seems only prudent to have some silver colloid on hand. No prescription needed, and it's el cheapo to make, at a penny or two a gallon.

But, do your homework. Read *The Plague Makers* by Dr. Jeffrey Fisher (page 22 in my *Wisdom Guide*), and then *The Silver Micro-Bullet* by Dr. Paul Farber (page 18, *ibid.*). How do you make and use it? Read the Miller 73 article in the April 1997 issue. If you have been totally imprudent and don't have that issue, a reprint of the article is available for \$5 from Radio Bookshop—item #98, see page 63.

You can read more about the antibiotic resistance mess

Continued on page 8

Big Savings on Radio Scanners

Uniden® NEW!



Bearcat® 780XLT Trunk Tracker III
Mfg. suggested list price \$529.95
Less -\$190 Instant Rebate / Special \$339.95
500 Channels • 10 banks • CTCSS/DCS • S Meter
Size: 7^{5/8}" Wide x 6^{15/16}" Deep x 2^{13/16}" High
Frequency Coverage: 25.0000-512.0000 MHz., 806.000-823.9875MHz., 849.0125-868.9875 MHz., 894.0125-1300.000 MHz.

The Bearcat 780XLT has 500 channels and the widest frequency coverage of any Bearcat scanner ever. Packed with features such as Trunktracker III to cover EDACS, Motorola and EF Johnson systems, control channel only mode to allow you to automatically trunk certain systems by simply programming the control channel, S.A.M.E. weather alert, full-frequency display & backlit controls, built-in CTCSS/DCS to assign analog and digital subaudible tone codes to a specific frequency in memory, PC Control with RS232 port, Beep Alert, Record function, VFO control, menu-driven design, total channel control and much more. Our CEI package deal includes telescopic antenna, AC adapter, cigarette lighter cord, DC cord, mobile mounting bracket with screws, owner's manual, trunking frequency guide and one-year limited Uniden factory warranty. For maximum scanning enjoyment, order magnetic mount antenna part number ANTTMBNC for \$29.95; The BC780XLT comes with AC adapter, telescopic antenna, owner's manual and one year limited Uniden warranty. Not compatible with AGEIS, ASTRO or ESAS systems. For fastest delivery, order on-line at www.usascan.com.

Bearcat® 895XLT Trunk Tracker
Mfg. suggested list price \$499.95
Less -\$320 Instant Rebate / Special \$179.95
300 Channels • 10 banks • Built-in CTCSS • S Meter
Size: 10^{1/2}" Wide x 7^{1/2}" Deep x 3^{3/8}" High
Frequency Coverage: 29.000-54.000 MHz., 108.000-174 MHz., 216.000-512.000 MHz., 806.000-823.995 MHz., 849.0125-868.995 MHz., 894.0125-956.000 MHz.

The Bearcat 895XLT is superb for intercepting trunked communications transmissions with features like TurboScan™ to search VHF channels at 100 steps per second. This base and mobile scanner is also ideal for intelligence professionals because it has a Signal Strength Meter, RS232C Port to allow computer-control of your scanner via optional hardware and 30 trunking channel indicator annunciators to show you real-time trunking activity for an entire trunking system. Other features include Auto Store - Automatically stores all active frequencies within the specified bank(s). Auto Recording - Lets you record channel activity from the scanner onto a tape recorder. CTCSS Tone Board (Continuous Tone Control Squelch System) allows the squelch to be broken during scanning only when a correct CTCSS tone is received. For maximum scanning enjoyment, order the following optional accessories: PS001 Cigarette lighter power cord for temporary operation from your vehicle's cigarette lighter \$14.95; PS002 DC power cord - enables permanent operation from your vehicle's fuse box \$14.95; MB001 Mobile mounting bracket \$14.95; EX711 External speaker with mounting bracket & 10 feet of cable with plug attached \$19.95. The BC895XLT comes with AC adapter, telescopic antenna, owner's manual and one year limited Uniden warranty. Not compatible with AGEIS, ASTRO, EDACS, ESAS or LTR systems.



SCANNERS

Bearcat® 245XLT Trunk Tracker II
Mfg. suggested list price \$429.95/CEI price \$189.95
300 Channels • 10 banks • Trunk Scan and Scan Lists
Trunk Lockout • Trunk Delay • Cloning Capability
10 Priority Channels • Programmed Service Search
Size: 2^{1/2}" Wide x 1^{3/4}" Deep x 6" High
Frequency Coverage:
29.000-54.000 MHz., 108-174 MHz., 406-512 MHz., 806-823.995 MHz., 849.0125-868.995 MHz., 894.0125-956.000 MHz.

Our Bearcat TrunkTracker BC245XLT, is the world's first scanner designed to track Motorola Type I, Type II, Hybrid, SMARTNET, PRIVACY PLUS and EDACS® analog trunking systems on any band. Now, follow UHF High Band, UHF 800/900 MHz trunked public safety and public service systems just as if conventional two-way communications were used. Our scanner offers many new benefits such as Multi-Track - Track more than one trunking system at a time and scan conventional and trunked systems at the same time. 300 Channels - Program one frequency into each channel. 12 Bands, 10 Banks - Includes 12 bands, with Aircraft and 800 MHz. 10 banks with 30 channels each are useful for storing similar frequencies to maintain faster scanning cycles or for storing all the frequencies of a trunked system. Smart Scanner - Automatically program your BC245XLT with all the frequencies and trunking talk groups for your local area by accessing the Bearcat national database with your PC. If you do not have a PC simply use an external modem. Turbo Search - Increases the search speed to 300 steps per second when monitoring frequency bands with 5 KHz. steps. 10 Priority Channels - You can assign one priority channel in each bank. Assigning a priority channel allows you to keep track of activity on your most important channels while monitoring other channels for transmissions. Preprogrammed Service (SVC) Search - Allows you to toggle through preprogrammed police, fire/emergency, railroad, aircraft, marine, and weather frequencies. Unique Data Skip - Allows your scanner to skip unwanted data transmissions and reduces unwanted birdies. Memory Backup - If the battery completely discharges or if power is disconnected, the frequencies programmed in your scanner are retained in memory. Manual Channel Access - Go directly to any channel. LCD Back Light - An LCD light remains on for 15 seconds when the back light key is pressed. Autolight - Automatically turns the backlight on when your scanner stops on a transmission. Battery Save - In manual mode, the BC245XLT automatically reduces its power requirements to extend the battery's charge. Attenuator - Reduces the signal strength to help prevent signal overload. The BC245XLT also works as a conventional scanner. Now it's easy to continuously monitor many radio conversations even though the message is switching frequencies. The BC245XLT comes with AC adapter, one rechargeable long life ni-cad battery pack, belt clip, flexible rubber antenna, earphone, RS232C cable, Trunk Tracker frequency guide, owner's manual and one year limited Uniden warranty. Not compatible with AGEIS, ASTRO, ESAS or LTR systems. Hear more action on your radio scanner today. Order on-line at www.usascan.com for quick delivery.



More Radio Products

Save even more on radio scanners when purchased directly from CEI. Your CEI price after instant rebate is listed below:

Bearcat 895XLT 300 ch. Trunktracker I base/mobile scanner.....	\$179.95
Bearcat 780XLT 500 ch. Trunktracker III base/mobile.....	\$339.95
Bearcat 278CLT 100 ch. AM/FM/SAME WX alert scanner.....	\$159.95
Bearcat 245XLT 300 ch. Trunktracker II handheld scanner.....	\$189.95
Bearcat 248CLT 50 ch. base AM/FM/weather alert scanner.....	\$89.95
Bearcat Sportcat 200 alpha handheld sports scanner.....	\$169.95
Bearcat Sportcat 180B handheld sports scanner.....	\$149.95
Bearcat 80XLT 50 channel handheld scanner.....	\$99.95
Bearcat 60XLT 30 channel handheld scanner.....	\$74.95
Bearcat BC77 information mobile scanner.....	\$139.95
AOR AR8200 Mark II Wide Band handheld scanner.....	\$539.95
AOR AR16BQ Wide Band scanner with quick charger.....	\$209.95
ICOM ICR8500 wideband communications receiver.....	\$1,469.95
ICOM PCR1000 computer communications receiver.....	\$379.95
ICOM R10 handheld wideband communications receiver.....	\$279.95
Uniden WX100 Weather Alert with S.A.M.E. feature.....	\$49.95

AOR

AOR® AR8200 Mark IIB Radio Scanner
AOR8200 Mark IIB-A wideband handheld scanner/SPECIAL \$539.95
1,000 Channels • 20 banks • 50 Select Scan Channels
PASS channels: 50 per search bank + 50 for VFO search
Frequency step programmable in multiples of 50 Hz.
Size: 2^{1/2}" Wide x 1^{3/8}" Deep x 6^{1/8}" High

Frequency Coverage:
500 KHz to 823.995 MHz., 849.0125-868.995 MHz., 894.0125-2,040.000 MHz.
(Full coverage receivers available for export and FCC approved users.)



The AOR AR8200 Mark IIB is the ideal handheld radio scanner for communications professionals. It features all mode receive: WFM, NFM, SFM (Super Narrow FM), WAM, AM, NAM (wide, standard, narrow AM), USB, LSB & CW. Super narrow FM plus Wide and Narrow AM in addition to the standard modes. The AR8200 also has a versatile multi-function band scope with save trace facility, twin frequency readout with bar signal meter, battery save feature with battery low legend, separate controls for volume and squelch, arrow four way side rocker with separate main tuning dial, configurable keypad beep/illumination and LCD contrast, write protect and keypad lock, programmable scan and search including LINK, FREE, DELAY, AUDIO, LEVEL, MODE, computer socket fitted for control, clone and record, Flash-ROM no battery required memory, true carrier re-insertion in SSB modes, RF preselection of mid VHF bands, Detachable MW bar aerial. Tuning steps are programmable in multiples of 50 Hz in all modes, 8.33 KHz airband step correctly supported, Step-adjust, frequency offset, AFC, Noise limited & attenuator, Wide and Narrow AM in addition to the standard modes. For maximum scanning pleasure, you can add one of the following optional slot cards to this scanner: CT8200 CTCSS squelch & search decoder \$89.95; EM8200 External 4,000 channel backup memory, 160 search banks. \$69.95; RU8200 about 20 seconds chip based recording and playback \$69.95; TE8200 256 step tone eliminator \$59.95. In addition, two leads are available for use with the option socket. CC8200 PC control lead with CD Rom programming software \$109.95; CR8200 tape recording lead \$59.95. Includes 4 1,000 mAh AA ni-cad batteries, charger, cigar lead, whip aerial, MW bar antenna, belt hook, strap and one year limited AOR warranty. Enter your order now at <http://www.usascan.com>.

Buy with Confidence

Order on-line and get big savings

For over 32 years, millions of communications specialists and enthusiasts worldwide have trusted Communications Electronics for their mission critical communications needs. It's easy to order. For fastest delivery, order on-line at www.usascan.com. Mail orders to: Communications Electronics Inc., P.O. Box 1045, Ann Arbor, Michigan 48106 USA. Add \$20.00 per radio transceiver for UPS ground shipping, handling and insurance to the continental USA. Add \$13.00 shipping for all accessories and publications. For Canada, Puerto Rico, Hawaii, Alaska, Guam, P.O. Box or APO/FPO delivery, shipping charges are two times continental US rates. Michigan residents add sales tax. No COD's. Your satisfaction is guaranteed or return item in unused condition in original packaging within 61 days for refund, less shipping, handling and insurance charges. 10% surcharge for net 10 billing to qualified accounts. All sales are subject to availability, acceptance and verification. Prices, terms and specifications are subject to change without notice. We welcome your Discover, Visa, American Express, MasterCard, IMPAC or Eurocard. Call anytime 1-800-USA-SCAN or 800-872-7226 to order toll-free. Call 734-996-8888 if outside Canada or the USA. FAX anytime, dial 734-663-8888. Dealer and international inquiries invited. Order your radio scanners from Communications Electronics Inc. today at www.usascan.com.

**For credit card orders call
1-800-USA-SCAN**

e-mail: cei@usascan.com

www.usascan.com

PO Box 1045, Ann Arbor, Michigan 48106-1045 USA
For information call 734-996-8888 or FAX 734-663-8888
Price schedule effective March 2, 2001 AD #03020173 © 2001 Communications Electronics Inc.

**COMMUNICATIONS
ELECTRONICS INC.**
Emergency Operations Center

Visit WWW.USASCAN.COM • 1-800-USA-SCAN

continued from page 1

piloted by a suicide terrorist slammed into the building.

In addition to a lover of ham radio, Bill Ruth was described as an avid Redskins fan and a motorcyclist who enjoyed riding in Maryland's rolling hills. A Vietnam and Gulf War veteran, Ruth held a master's degree and taught for nearly three decades, most recently at John T. Baker Middle School in the town of Damascus, Maryland.

In addition, the *ARRL Letter* reports that missing are Rod Coppola KA2KET, 46, of NYC, who was the transmitter engineer on duty for Public Broadcasting station WNET, channel 13 at the time the attack occurred, Winston Grant KA2DRF, 59, of West Hempstead, NY, who was a computer technician with Empire Blue Cross/Blue Shield.

Neither man has been seen since the twin towers collapsed after being hit by hijacked jetliners on September 11th, bringing to seven the number of hams known to have been missing since that day.

Thanks to Daily DX, Washington Post, *ARRL*, and Henry Feinberg K2SSQ, via Newline, Bill Pasternak WA6ITF, editor.

Financial Assistance for Missing Engineers' Families

The Portland Chapter of the Society of Broadcast Engineers and the *ARRL* both report that a fund has been established to assist the families of broadcast engineers still missing at the collapsed World Trade Center. Checks can be sent to the Ennes Educational Foundation Trust, c/o The Society of Broadcast Engineers, Inc., 9247 N. Meridian St., Suite 305, Indianapolis, IN 46260. Please mark your envelope to the attention of the "Broadcast Engineer Relief Fund."

Thanks to *ARRL*, Portland SBE, courtesy of Newline, Bill Pasternak WA6ITF, editor.

Indiana Hams at Ground Zero

Ham radio operators from Indiana were among those who made the trek to New York City to aid in rescue efforts after the September 11th terrorist attack. Their job was communications.

Thirty-six hours after the first airplane crashed into the World Trade Center, Indiana's Task Force One was standing at the ground zero. Among the 62 members of this elite search and rescue team were two Indianapolis amateur radio operators.

Veteran firefighter Jim Curseaden KB9ZFF and Ed Elrod W9PTO made the 14-hour road trip to help with disaster efforts. Both men made

up the communications arm of this search and rescue team.

The moment they arrived, each man began setting up a UHF communications link from ground zero to their staging point several miles away at the Javits Convention Center. According to Jim Curseaden, getting UHF signals through the concrete canyon of New York City was a major challenge.

Ed Elrod said they first installed a repeater on a nearby building and directed a yagi antenna at the mountain of rubble. The Javits Convention Center posed another radio obstacle. Hand-held radios could not reach the repeater.

To fix this problem, Elrod wired a up a remote base on the roof of the convention center. This new link made it possible to communicate with the Indiana Search and Rescue personnel above and below the World Trade Center ruins.

Ed Elrod's most inspirational moment came during his second trip out of the devastation.

All week, hundreds of people had been lining the streets, cheering and showing signs of support. When heavy rains began dousing New York, the crowds disappeared. He said the contrast was amazing. The streets were nearly empty; except for one lonely figure standing in the rain. It was an elderly woman, holding a sign that read: "Thank You."

Thanks to Jack Parker WB1SH, via Newline, Bill Pasternak WA6ITF, editor.

CQ Contest Magazine SK; Ditto Hard-Copy Logs

CQ Contest, a magazine devoted to the art of amateur radio contesting ceased publication with its October, 2001, issue. *CQ Contest* had been published 10 times per year since 1996.

CQ Communications President and Publisher Dick Ross K2MGA said that the move was "a purely business decision" and that subscriptions to the specialty magazine would be fulfilled "on a dollar-for-dollar" basis with the company's flagship magazine, *CQ Amateur Radio*.

Writing in the final issue, *CQ Contest* Editor Bob Cox K3EST, explained that "good business economics" dictated that *CQ Communications* could no longer continue to publish *CQ Contest*. He thanked the readers for their "ideas, generosity, and loyalty." Cox also said he's working on developing an independent contest magazine on the World Wide Web, which would fulfill subscribers' terms if it is launched.

In a separate "Message from the Publisher," Ross explained that approximately \$750,000 has been invested in *CQ Contest* since its launch in 1996, with cumulative losses exceeding \$150,000. "As much as I love contesting," Ross said, "it no longer makes sense from a business standpoint to continue to subsidize *CQ Contest* ..."

In the meantime, following the events of Sept. 11, *CQ* has announced that all contest log submittals will henceforth be accepted in E-mail format only, and that there would be no guarantee that mailed entries would ever be opened.

Thanks to *CQ E-mailed press release*, published reports.

Ham Survivor at WTC

A cause to rejoice amidst the chaos is the case of an amateur who worked in the World Trade Center. Rob Nall WV0S reports that his friend, Herman Belderok, Jr., KB0EEB, managed to get out of his building just minutes before the structure collapsed. Thankfully, Herman survived unscathed.

Thanks to WV0S, via Newline, Bill Pasternak WA6ITF, editor.

Where Have All the Amateurs Gone?

Remember the old Kingston Trio folk tune, "Where Have All the Flowers Gone?" Well, it's now over a year since restructuring, and observers of the Amateur Radio service are asking where all the hams have gone. The answer is that they are on the move with the rest of society.

What growth ham radio is experiencing is following population shifts. That's according to W5YI VEC Administrator Fred Maia. According to statistics Maia recently published, about 682,000 people in the United States hold Amateur service licenses. Of these, just over 95,000 are Extra class, 87,000 are Advanced, 137,000 are Generals, and 320,000 are Technicians. Finally, 42,000 hams continue to hold onto their Novice class licenses.

Right now, more than half of all licensed hams in the US live in 10 of the 50 states. The states with the highest amateur populations are California, 102,000; Texas, with close to 42,000; and Florida, with almost 40,000. New York state is fourth with 32,275 hams.

The four states with the fewest hams are Wyoming, with 1,615; South Dakota, with 1,588; North Dakota, with 1562; and Delaware, with only 1389 hams.

But even these numbers are changing. Maia says that even though they have relatively small ham populations, Utah, Wyoming, Nevada, Idaho, Arizona, and New Mexico had triple the ham radio population growth of other states. Texas, along with Oklahoma and Colorado, had double the ham growth of other states.

And here's a twist. If you consider high population states with major cities like California, New York, and Illinois, they had no growth at all. In fact, Maia says some of those states actually suffered a net loss in the number of hams.

Why this is happening may have something to do with employment. Business trends are changing. Many high-tech companies wanting to reduce operating expenses are moving to less populated areas. Where the companies go, so do the job seekers, with many high-tech workers likely being hams.

Thanks to David Black KB4KCH, via Newslite, Bill Pasternak WA6ITF, editor.

More Hams Upgrading, But Little New Blood

A lot of hams are upgrading but there are few new people coming into the hobby. That was the bottom line as we passed the halfway point in the year 2001.

According to a person who should know, in the last four years the United States Amateur Radio Service has grown at a rate of only 2,000 additional hams annually. That's about three tenths of one percent per year and less than the United States Census Bureau's total projected percentage increase in the total population of the country.

The person presenting the facts is Fred Maia W5YI, who heads up the W5YI VEC and has been carefully evaluating trends in ham radio for over two decades. And what he has found is good reason for concern.

According to Maia, four years ago, the total Amateur census stood at 674,000. It now stands at 682,000. But, says Maia, an additional 30,000 amateurs are still listed in the FCC's database which includes those whose licenses have expired, but who fall within the government's 2-year renewal grace period. That's the time when you cannot operate a station but can renew without taking an exam.

Maia says that the FCC is now canceling about 1,500 licenses every month that are not renewed within that grace period. He suspects that many are silent keys.

The good news — if you can call it that — is that hams upgraded their licenses in unprecedented numbers. Maia believes that this was motivated by the FCC's restructuring of the United States Amateur Radio Service. With the reduction of the top Morse testing speed to 5 wpm, most Technician Plus, General, and Advanced class tickets upgraded simply because the 13 and 20 word per minute code exams were no longer required. As a result, and to the delight of equipment suppliers, tens of thousands of potential high frequency operators have been added to the all-band rolls. By license class that's 20,000 new Extra class and 27,000 added Generals.

But there is another side to the equation. As you might expect, the Novice, Technician Plus, and Advanced class — all of which have essentially been placed in limbo since restructuring — have seen comparable decreases in numbers. Advanced is down by about 15,000. The Tech Plus is down by 40,000 and there are 8,000 fewer Novices. The Tech Plus got a double-barrel hit since this license class is no longer being issued.

Instead, the database of Technician Plus and Technician class have been lumped together in the FCC's database. Existing Tech Plus license holders are having their tickets renewed as Technician even though they hold a 5 wpm code credit. This, says Maia, distorts the total of No-Code Technician class statistics since many Technician class holders do indeed hold Morse Code credit.

There is some good news. Statistics show that about 1,600 new code-free Technician class hams are licensed for the first time each month. That's close to 19,000 annually.

The first code-free Technician class tickets began appearing in the spring of 1991. It's now a decade later, and these licenses are just coming up for renewal. But, says Maia, it is very difficult to determine from the FCC's licensing records the percentages of eligible Technician and Technician Plus operators that are renewing their licenses.

According to Maia, whose VEC operation also handles license renewals — it appears as if many are not. Maia says that the Technician class has

Continued on page 62

Smartuners™ are the most popular tuners in the world. But don't just take our word for it...

SG-230

1.6-30 Mhz, 3 to 200 Watts

"Since installing the SG-230, it has operated flawlessly with excellent signal reports from all over the world. The low current drain is an additional plus."

Paul Poindexter - WA6RXM

"Just key the mike on ANY authorized frequency and the antenna will instantly tune."

Ronald Kane - K9MNI

"No more wasting time with a conventional tuner."

Edward O'Brien Jr.
KB2LUG

SG-231

1-60 Mhz, 3 to 100 Watts

"I routinely get good comments on the signal and audio."

Jon Haskell - KB9CML

"Within minutes I was up and running, talking world-wide from my sailboat."

Scott Brear - KG6QT

"I'll probably keep the Smartuner until it disintegrates."

Jerry Dixon - WA6QFC

"I never have any unwanted SWR."

Raymond Allard
W1RAA

SG-237

1.8-60 Mhz, 3 to 100W

"It's worth it's weight in gold to me! The SG-237 is perfect for any installation anywhere. The sky and your imagination is the only limit with what you can do with this coupler. The SG-237 has given me nothing but excellent performance and "all band" freedom with a very modest length of antenna wire."

Jason Hulet - W1WOW

SG-235

1.6-30 Mhz, 3 to 500 Watts

"I use it constantly for marine and ham frequencies with never a glitch. Operation is easy...just start transmitting."

Al Lee—WA4EWV

"It tunes to near 1:1 SWR."

Arnold Knadle—N1JX

"The next to greatest thing in my shack is the SG-235 Smartuner. The greatest is my callsign."

Haraldur Sigurosson—TF3A



See the entire Smartuner family and get FREE QSL CARDS at
www.sgcworld.com



Toll Free (800)259-7331 • Tel (425)746-6310 • Fax (425)746-6384 • Email: sgc@sgcworld.com

See you in Dayton! Booths 623, 624, 630, 631

NEVER SAY DIE

continued from page 4

in the May 2001 *Scientific American*.

Kontent Is King

If you'll peek over my shoulder into my crystal ball, which hasn't failed me yet, you'll get a good look at the future. Now, are you planning your life so as to take advantage of what's coming, or watching *Seinfeld* and *Frasier* reruns?

Yes, the rush of Internet dot-coms was premature. The Internet is still in the hand-cranked party line telephone stage of growth. The Web infrastructure is still rickety, with aged servers and telephone line choke points for most subscribers. We're heading toward a time when the world is fiber-opticked and a movie can be fast-forward downloaded in seconds. You want to read a book? Szzzt, and you've got it downloaded for a buck. No printing, no distributors or bookstore inventories. Hey, no book publisher — you've downloaded it from the author.

Who needs Sony Music or Warner Brothers when a musical group can sell direct to the end users via the Web? We'll download an hour of music in a couple of seconds and burn it into our own CD.

This is not a good time to make a long-term investment in any publishers or record companies. Just as Wal-Mart and the other discount chains have put most downtown stores out of business, we'll be seeing the Web doing major surgery on the whole merchandise distribution system.

In a few years (months?), I won't have to fight the fast-talking salesmen at the discount camera stores to buy the new digital camera — I'll get the lowest price from the manufacturer or the importer. Why should I drive an hour to Manchester or Nashua and deal with a sales clerk who knows almost nothing about the stuff he's selling when I can go to the Nikon site and get any info I want, and then

get the camera at a far lower price than Circuit City or Buy Right?

We're still going to need the giant companies for hardware — it's in the content that small businesses and entrepreneurs will be king.

Got you thinking yet?

Okay, if that didn't get your gray cells jumping, let me jam a thinking cap over that square protuberance above your shoulders.

Do you have any special interest that you know more about than 99% of the public? It can be your work or a hobby. If you don't, it's time to get a life. Step one is to get busy and outline a video presentation which will help that 99% learn more about your interest and why it's so interesting. Step two is to get a digital video camera and computer editing system and start producing the video. All you need is a camera and an iMac system. I got mine a year ago and the whole works then only cost \$2,500. Since then prices have, as usual for electronics and computers, dropped. Let me know what you find that works and I'll pass it along.

If you love to fly kites, well, get at it and show us how to do it and explain why it's so much fun and costs so little to enjoy. I'll pay a buck anytime to download something like that.

If you know how to make and fly ultralights, tell and show us. Or one of those flying parachutes!

We're heading into a world where content will be king and give you the Midas touch — if you are prepared.

For all its problems, e-commerce is already a \$34 billion business and growing at 35% a year. Compare this to the traditional retail growth of 4% to 5% per year! And this with the crude Web system we have to work with.

What customers want is the ability to shop via the Internet — to see a video showing them the benefits and features of a product, and to be able to answer their questions. I want to see what the latest ham rig can do for me — what all that

maze of knobs and buttons are for and how I'm going to have the time of my life twisting and pushing them.

And then, if I can't stand for one more day not having, I want it delivered pronto.

And there's the big catch. America's infrastructure is seriously outdated. We're not going to be ordering Webvan-like groceries which can't get through the traffic jams. Or stuff coming by air to airports that are overloaded. When I tried to fly to California to give a talk to a ham club I only got as far as Chicago before United Airlines gave up and sent me back to New Hampshire. I had to do my talk over the telephone.

Our roads are cracking and potholes proliferating, our bridges crumbling, and our airports are desperately in need of more runways. Harbors are silting up, landfills choking with old PCs, and our water is running dry. It's been 40 years since we've made a major infrastructure investment, and we're suffering because of it. The estimated cost? About \$1.5 trillion, the same as the recent tax cut. With an estimated \$20 trillion industry as the prize, it's time to give your politicians a hot foot. Try to get their minds off those fat envelopes of cash and vacation trips from lobbyists, and onto the voters.

In the meanwhile, are you getting ready to get a piece of the action? Hey, wake up, I'm talking to you.

The competitive market for creative music, books, films, art, and so on will, I predict, precipitate an explosion of creativity. The hold the music and book publishers have over these industries will blow away when they can no longer prevent prospective customers from knowing about new works. The big company control over distribution to book and music stores will blow away. No more bookstores or music stores.

One thing that is needed is a reliable source of information on what's good and what isn't. It was my providing this information via my *CD Review* magazine when CDs

were first introduced that helped CDs become the fastest growing consumer electronics industry in history. We mercilessly reviewed new CD releases and we polled our readers on how much they liked the sound, performance and the music on the CDs they'd bought. The result was a disaster for the major labels, with sales on independent labels going from 4% of the market to 16%, a loss of billions for the majors.

Someone ought to start a magazine and Web site for music and books available over the Web. It's a huge niche with the potential for making millions. You'd be able to download reviews and ratings for the top-rated music of any kind that interests you for a dime. Ditto books. Or spend \$20 for a year of *Merciless Music Reviews* magazine or *Merciless Book Reviews* magazine.

It costs about \$750,000 these days to get a new magazine up and running — anyone interested? Having started a couple dozen successful magazines, I know the ropes and will be glad to help.

Vaccines

I've written about vaccines several times. I've even included a review of Walene James's *Immunization — The Reality Behind the Myth* in my *Wisdom Guide* (p. 7). But the fact is that you are still allowing the medical/pharmaceutical industry to vaccinate your children and you're baring your arm (or rear) whenever a doctor says to. I know, it's too much trouble to do some reading and become informed — and Wayne's a nut about the medical industry anyway.

The June Acres U.S.A. had a most interesting article on vaccines. This monthly publication (\$27/yr.) is the best I've found to provide honest reporting on medical and food matters (call 800-355-5313 to subscribe). Where else would you find out about Linda Fisher being nominated for

Continued on page 62

LOW NOISE PREAMPS

LNY-() ECONOMY PREAMP ONLY \$29/w&t

- Miniature MOSFET Preamp.
- Low noise figure.
- Available for various bands from 28 to 450 MHz.



LNK-() PREAMP ONLY \$59/w&t

Low noise LNY-type preamp in alum case w/ BNC jacks.

LNP-() PRESELECTOR ONLY \$39/w&t

- Eliminate intermod!
- Sharp 3-section filter
- Low noise preamp
- Available for bands from 137 to 170 MHz.



R121 AVIATION RECEIVER



- Exciting new AM receiver for the 118-137 MHz aircraft band.
- Ideal for monitoring at airports.
- Allows pilot control of runway lighting.
- ELT monitor to detect and locate downed aircraft.

- Dip switch frequency selection.
- Superior sensitivity and selectivity.

R121 Receiver module wired/tested \$209
R121 Receiver in cabinet (see website)..... \$299

WEATHER FAX RECEIVER

Join the fun. Get striking images directly from the weather satellites!

A very sensitive wideband fm receiver optimized for NOAA APT & Russian Meteor weather fax on the 137MHz band.

Covers all 5 satellite channels. Scanner circuit & recorder control allow you to automatically capture signals as satellites pass overhead, even while away from home.

- R139 Receiver Kit less case \$159
- R139 Receiver Kit with case and ac power adapter. \$189
- R139 Receiver w/t in case with ac power adapter... \$239
- Internal PC demodulator board & imaging software... \$289
- Turnstile Antenna \$135



WEATHER ALERT RECEIVER



A sensitive and selective professional grade receiver to monitor critical NOAA weather broadcasts. Good reception even at distances of 70 miles or more with suitable antenna. No comparison with ordinary consumer radios!

Automatic mode provides storm watch, alerting you by unmuting receiver and providing an output to trip remote equipment when an alert tone is broadcast. Crystal controlled for accuracy; all 7 channels (162.40 to 162.55).

- RWX Rcvr kit, PCB only \$79
- RWX Rcvr kit with cabinet, speaker, & AC adapter \$99
- RWX Rcvr wired/tested in cabinet with speaker & adapter \$139

WWV RECEIVER

Get time & frequency checks without buying multiband hf rcvr. Hear solar activity reports affecting radio propagation.

Very sensitive and selective crystal controlled superhet, dedicated to listening to WWV on 10 MHz. Performance rivals the most expensive rcvrs.

- RWWV Rcvr kit, PCB only \$59
- RWWV Rcvr kit with cabt, spkr, & 12Vdc adapter \$89
- RWWV Rcvr w/t in cabt with spkr & adapter \$129



HIGH QUALITY VHF & UHF EXCITER & RECEIVER MODULES

FM EXCITERS:

Rated for continuous duty, 2W continuous duty output.

T301 Synthesized VHF

Exciter: for various bands 139-174MHz, 216-226 MHz. Dip switch freq. setting.

- Kit (ham bands only) (TCXO option \$40)..... \$109
- Wired/tested, incl TCXO..... \$189

T304 Synthesized UHF Exciter:

for various bands 400-470 MHz.

- Kit (440-450 ham band only) incl TCXO \$149
- Wired/tested \$189

CRYSTAL CONTROLLED:

- TA51: for 6M, 2M, 220 MHz kit \$99, w/t \$169
- TA451: for 420-475 MHz. kit \$99, w/t \$169
- TA901: for 902-928 MHz, (0.5W out)..... w/t \$169

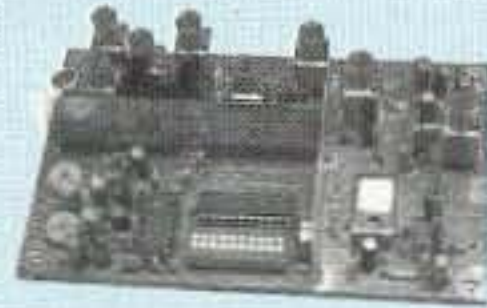

VHF & UHF POWER AMPLIFIERS:

Output levels from 10W to 100W Starting at \$99

FM RECEIVERS:

Very sensitive - 0.2µV. Superb selectivity, >100 dB down at ±12 kHz, best available anywhere, flutter-proof squelch.

R301 Synthesized VHF

Receiver: various bands 139-174MHz, 216-226 MHz.

- Kit (ham bands only) (TCXO option \$40) only \$139
- Wired/tested (incl TCXO) \$209

R304 Synthesized UHF Receiver:

various bands 400-470MHz.

- Kit (440-450 ham band only) (incl TCXO) \$179
- Wired/tested \$209

CRYSTAL CONTROLLED:

- R100 for 46-54, 72-76, 140-175, or 216-225 MHz. kit \$129, w/t \$189
- R144 Like R100, for 2M, with helical resonator in front end kit \$159, w/t \$219
- R451 for 420-475 MHz. kit \$129, w/t \$189
- R901 for 902-928MHz kit \$159, w/t \$219

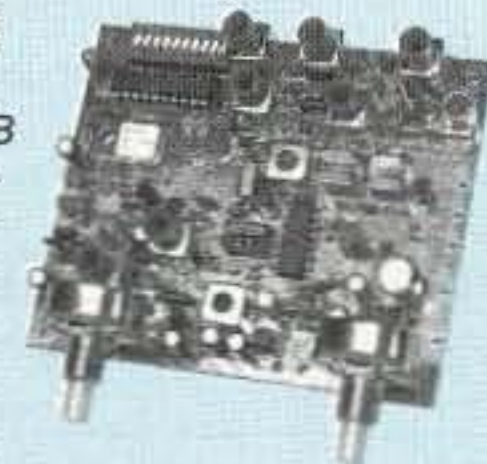

CTCSS TONE ENCODER/DECODER



Access all your favorite closed repeaters!

- Encodes all standard subaudible tones with crystal accuracy and convenient DIP switch selection.

- Decoder can be used to mute receive audio and is optimized for installation in repeaters to provide closed access. High pass filter gets rid of annoying rcvr buzz.

- TD-5 CTCSS Encoder/Decoder Kit \$39
- TD-5 CTCSS Encoder/Decoder Wired/tested \$59

TRANSMITTING & RECEIVING CONVERTERS

No need to spend thousands on new transceivers for each band!

- Convert vhf and uhf signals to & from 10M.
- Even if you don't have a 10M rig, you can pick up very good used xmtrs & rcvrs for next to nothing.
- Receiving converters (shown above) available for various segments of 6M, 2M, 220, and 432 MHz.
- Rcvg Conv Kits from \$49, wired/tested units only \$99.



- Transmitting converters for 2M, 432 MHz.
- Kits only \$89 vhf or \$99 uhf.
- Power amplifiers up to 50W.

Get more features for your dollar with our REP-200 REPEATER

A microprocessor-controlled repeater with full autopatch and many versatile dtmf remote control features at less than you might pay for a bare bones repeater or controller alone!



- kit still only \$1095
- factory assembled still only \$1295

50-54, 143-174, 213-233, 420-475 MHz.
(FCC type accepted for commercial service in 150 & 450 MHz bands.)

Digital Voice Recorder Option. Allows message up to 20 sec. to be remotely recorded off the air. Play back at user request by DTMF command, or as a periodic voice id, or both. Great for making club announcements! only \$100

REP-200C Economy Repeater. Real-voice ID, no dtmf or autopatch. Kit only \$795, w&t \$1195

REP-200N Repeater. Without controller so you can use your own. Kit only \$695, w&t \$995

You'll KICK Yourself If You Build a Repeater

Without Checking Out Our Website First!

Hamtronics has the most complete line of modules for making repeaters. In addition to exciters, pa's, and receivers, we offer the following controllers.

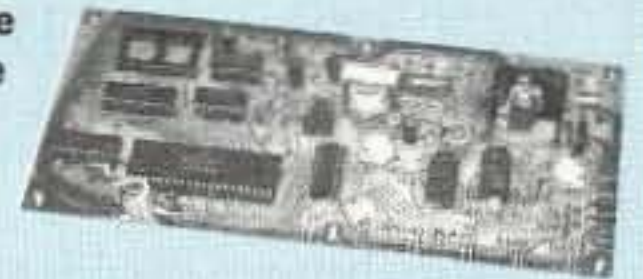

COR-3. Inexpensive, flexible COR module with timers, courtesy beep, audio mixer. only \$49/kit, \$79 w/t

CWID-2. Eprom-controlled ID'er. only \$54/kit, \$79 w/t

DVR-1. Record your own voice up to 20 sec. For voice id or playing club announcements. \$59/kit, \$99 w/t

COR-4. Complete COR and CWID all on one board. ID in eprom. Low power CMOS only \$99/kit, \$149 w/t

COR-6. COR with real-voice id. Low power CMOS, non-volatile memory. kit only \$99, w/t only \$149

COR-5. µP controller with autopatch, reverse ap, phone remote control, lots of DTMF control functions, all on one board, as used in REP-200 Repeater. \$379 w/t

AP-3. Repeater autopatch, reverse autopatch, phone line remote control. Use with TD-2. kit \$89

TD-2. Four-digit DTMF decoder/controller. Five latching on-off functions, toll call restrictor. kit \$79, w/t \$129

TD-4. DTMF controller as above except one on-off function and no toll call restrictor..... w/t \$89

HANDY FREQUENCY COUNTERS

Pocket sized, but lab quality! 3GHz bandwidth, 1ppm accuracy, very affordable. NiCd battery, ac adapter/charger, rugged black anodized aluminum case. Telescoping whip antenna and great sensitivity allow measurements even from a distance.

Three models with prices from \$99 to \$219. All go up to 3 GHz. Some go as low as 10 Hz with noise filters and other advanced features.

See our website for details.



Hamtronics, Inc.

65 Moul Rd; Hilton NY 14468-9535

Ph: 716-392-9430; Email: sales@hamtronics.com

See special offers and view or download complete catalog on our web site

hamtronics.com

Microwind to the Rescue!

Let the wind keep your emergency batteries charged.

Wind-powered generators have been around for a long time, but this unusual and efficient wind-powered generator is really something different.

Finishing a project always brings two things — a sense of accomplishment, and a pile of leftover parts. In this case, the project was a CNC-controlled drilling machine for fabricating circuit boards. Among the leftover parts were various pipe fittings, some scraps of angle iron and several hefty stepper motors.

I hadn't really decided what to do with the leftovers until I noticed the trash one of the neighbors had carried to the curb. On top of the pile was a rather beat-up box fan, and since it was very windy, the fan was spinning so fast I couldn't see the blades. Somewhere in the back of my head where new projects begin, a light went on. If

this thing spins so well in the wind, fitting it to one of the stepper motors could make a small wind generator. It could possibly generate enough "free energy" to help keep my emergency batteries charged, especially in stormy weather when there is an abundance of wind and the solar panels are not producing anything. I carried the fan home with me, took it apart and removed the plastic blade assembly from the motor.

The rest of the fan went back to the curb.

Most small wind generators use DC motors to produce direct current. The problem is that small DC motors run at very high RPM, and when used as a generator will not produce enough voltage to charge a battery until things are spinning much faster than a typical wind generator can safely turn.

Unlike a DC motor, a stepper motor has a permanent-magnet rotor inside a wire-wound field. When the field windings are energized, the rotor "steps" to the next pole, making the stepper useful for critical positioning tasks. However, when the shaft of a stepper motor is rotated, it becomes an alternator, producing AC current. Most precision steppers are designed with a step angle of less than two degrees, so there are LOTS of poles. Since the low-speed performance of an alternator increases with the number of poles, it follows that a stepper should work very well in a low-speed wind-driven configuration.

To test this assumption I selected one of the larger stepper motors and clamped the mounting flange in the vise. Checking the six leads with an ohmmeter, I discovered that there were



Photo A. The Microwind generator.

two separate windings, each with a center tap. I set the meter on AC VOLTS and connected it across one winding. To monitor the output frequency, I connected my old B&W frequency counter across the winding as well. Spinning the motor with a cordless electric drill produced over 40 volts at 375 Hz! With a center-tapped winding, this would be perfect for a simple full-wave rectifier. In addition, with another winding to generate a second phase, the output from a second rectifier could be connected in parallel with the first, increasing the output current.

Attaching the blades

The next step was to find a way to mount the fan blades to the motor. The stepper motor has a 5/16" shaft. The fan hub I had scrounged from the trash heap was designed to fit on a 5/16" flatted shaft, however it wouldn't mount directly on the motor since the blade hub would not clear the motor flange.

To solve this problem I took a 2" long piece of 3/4" diameter aluminum bar stock and drilled a 1/4" diameter hole straight through from one end to the other. From one end, I tapped the hole with a 5/16"-18 thread. Turning the piece around, I bored it halfway through with a 5/16" drill. On this end, I also drilled in from the side with a



Photo B. The emergency station: The Argonaut, HTs for 2 meters and CB, a scanner, 4" television, all-band receiver and 600-watt inverter, all powered from a 12-volt deep-cycle battery. The Microwind keeps it charged and ready!

#36 drill and tapped the hole for a #6-32 set screw to hold it onto the motor shaft.

I first mounted the extension to the motor shaft and tightened the set screw. I then drilled through the fan hub with the 5/16" drill, used a small round file to remove the flat side from the plastic bore and secured it to the extension with a 5/16" bolt and lock washer. Everything cleared, and it spun without any serious wobbles, so I took the motor/fan assembly outside and stood in the driveway facing the wind. I was pleased when, on the next gust, the fan started to spin ... I had a Microwind generator!

Mast and pivot bearing

Now that I had a way to mount the blades onto the motor, I needed to find a way to mount the assembly up in the air. Checking through the pile of left-over parts, I found a piece of 3/4" water pipe and a matching floor flange. I also had a few 3/4" pipe nipples 6" long, and some short pieces of 1/2" EMT electrical conduit.

I slid the conduit down into the 3/4" pipe until about 8" was sticking out the end. It was a loose fit, so I drove a couple of small nails into the gap to tighten it up. Since I have a small welder, I spot-welded the two pieces together. Then drove a 5/8" flat washer down over the conduit to rest on the pipe. (If you don't have a welder, steel-filled epoxy should work just

fine.) The pipe, conduit and washer would serve as both the mast and the pivot bearing so that the Microwind generator could yaw freely into the wind. I also cut a 1/2" wide ring off the end of the 3/4" pipe, which I drilled and tapped for a #6-32 set screw. This would become a retainer to prevent the generator from slipping off the end of the conduit. This is shown in detail in **Fig. 1.**

Mounting the stepper motor

I had a rail from an old bed frame I'd

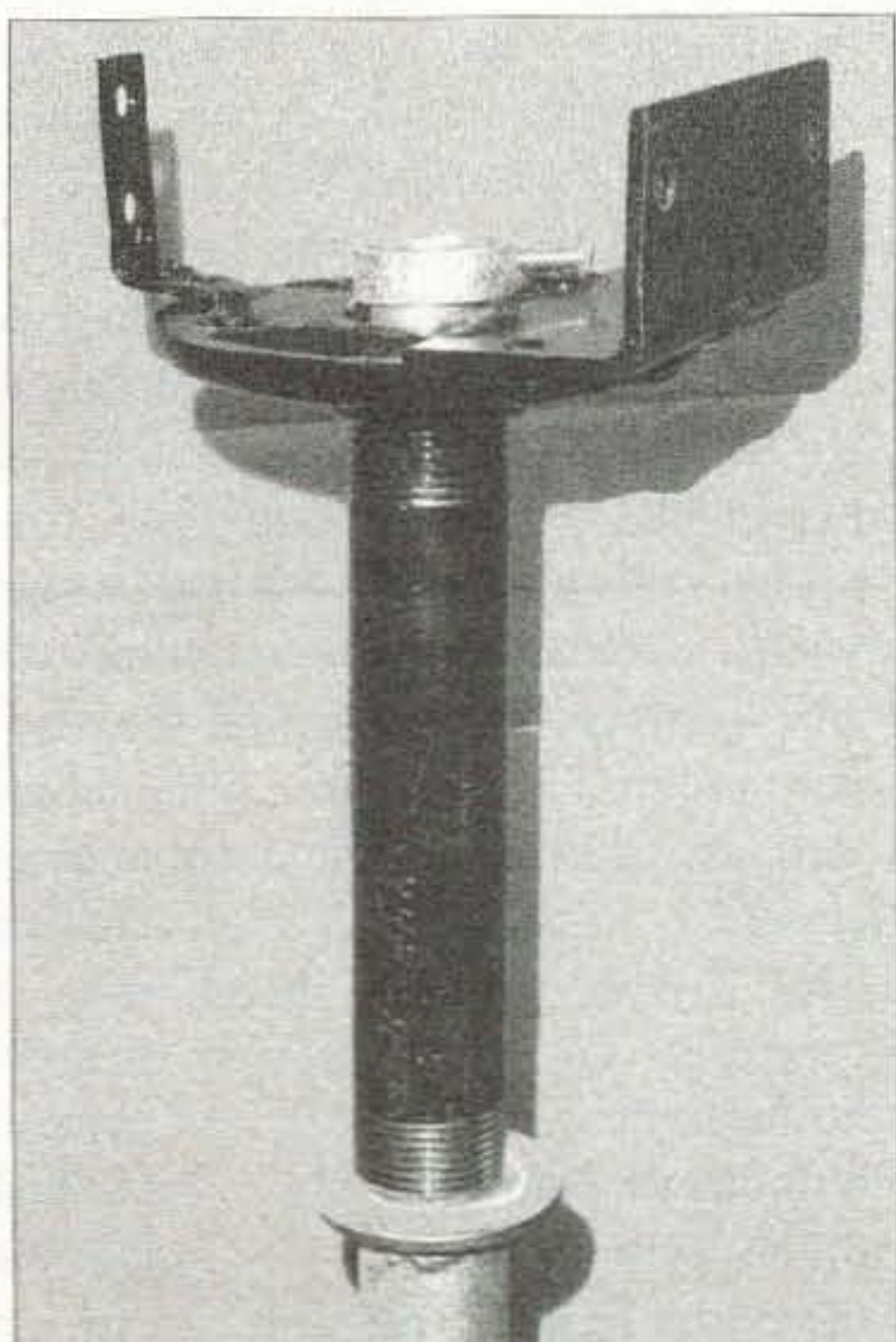

Photo C. The motor mount turns freely on the mast pivot.

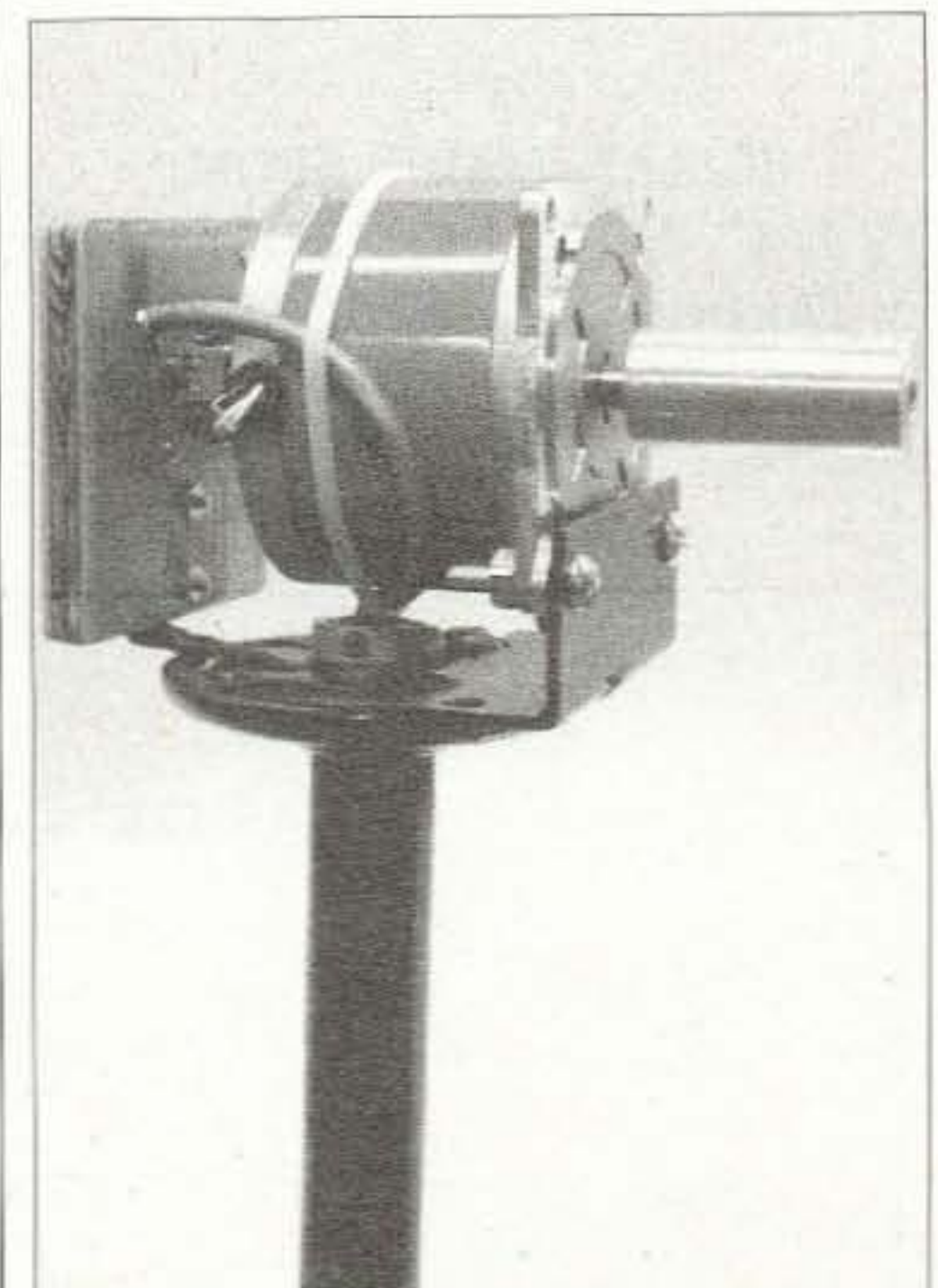

Photo D. Stepper motor and circuit board attached and wired. The cable passes down through the center of the mast.

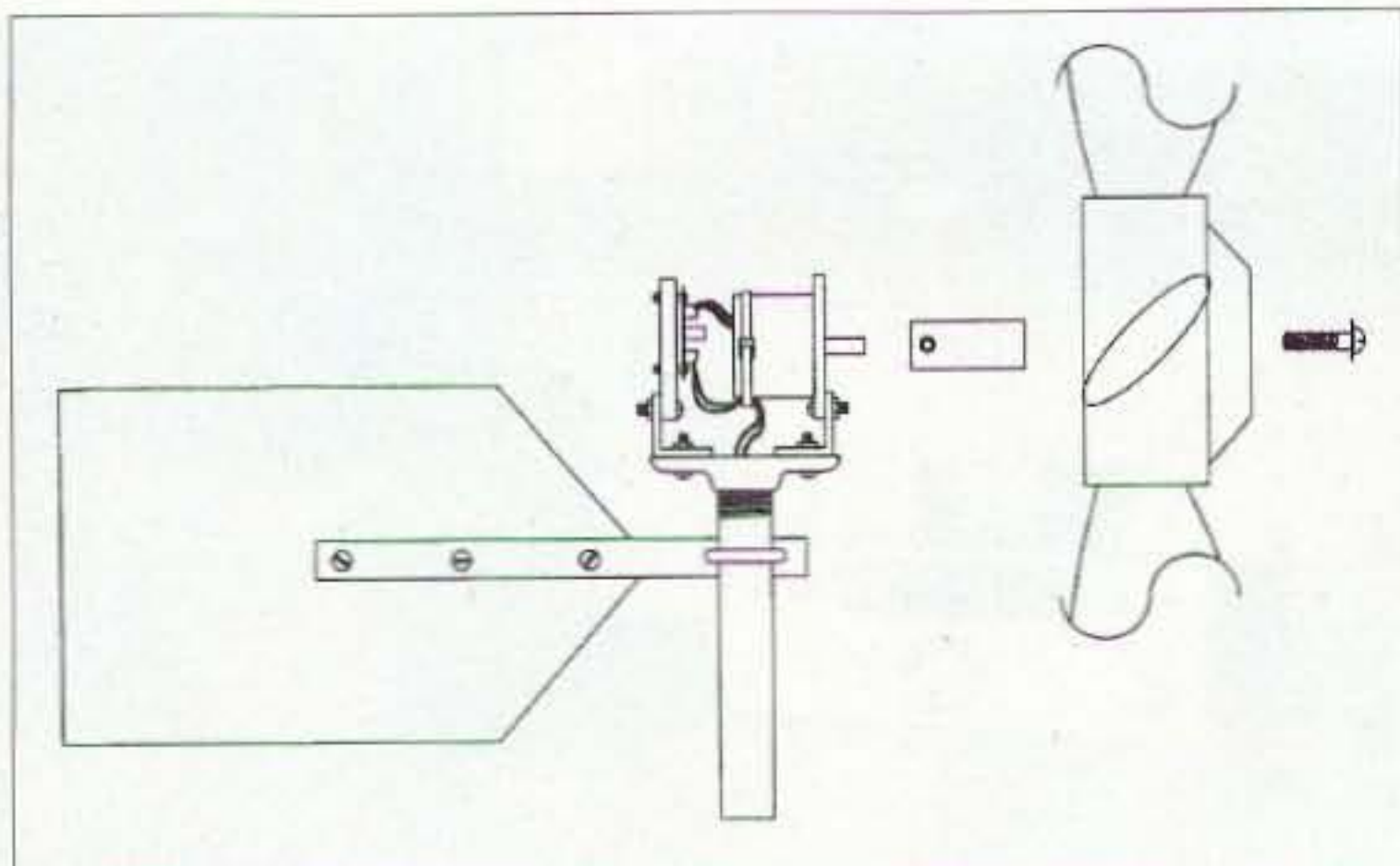

Fig. 1. Microwind generator assembly.

scrounged from the trash, and it was made from 2" wide angle iron. I cut a 4" long piece of this and drilled two 1/4" holes in it to fit the mounting flange of the stepper motor. It's important to keep the holes as close as possible to the edge of the angle iron, so that when it's mounted, the motor will be as high as possible.

I threaded the 6" pipe nipple into the 3/4" pipe flange. Turning the flange over so that the flat side was facing up, I clamped the angle iron motor mount to the flange with locking pliers and spot-welded them together. A pair of 1/4" bolts and nuts would work fine for this, but since I had the welder out anyway, welding it was quicker. While I was at it, I found a small right-angle corner bracket and welded it onto the

other side of the flange, facing in the opposite direction. This would provide a place to mount the small rectifier circuit board, making it possible to bring two wires down the mast instead of six.

Clamping the mast pipe into the vise, I slipped the generator head assembly over the conduit pivot post. The conduit was a bit long, hitting the motor, so I used a tubing cutter to trim the pivot until, with the end of the pipe nipple resting on the 5/8" washer, there was just barely enough conduit above the flange to mount the 1/2" wide retaining collar. I also carefully deburred the inside of the conduit so that there would be no sharp edges to cut the wires. Once I was sure that everything fit and would rotate freely without binding, I took it apart and painted the generator head assembly. When the paint was dry, I rubbed a thick coat of grease on the pivot and re-assembled everything. Bolting the stepper motor, shaft extension and fan blades onto the

other side of the flange, facing in the opposite direction. This would provide a place to mount the small rectifier circuit board, making it possible to bring two wires down the mast instead of six.

Putting it all together

"U" bolt and nuts. I cut a tail fin from a piece of plastic sign board and fastened it to the tail boom with #6-32 screws and nuts. Fig. 2 shows the assembly details for the Microwind generator.

Electrical circuit: two-phase AC to DC

With the mechanical assembly finished, the next step was the electrical hookup to get power out of the machine. Bringing two-phase AC down the mast is not practical, since it would require six wires. A much better idea is to install a two-phase rectifier at the stepper motor and bringing the DC output down using only two wires. Fig. 3 shows the circuit, which is actually two separate full-wave rectifiers with the outputs connected in parallel. I made a small circuit board to mount the rectifier diodes and terminal blocks to make the connection simple. Fig. 4 shows the component layout.

The circuit board was assembled, the flux cleaned from the soldered connections, and the board was heavily sprayed with clear urethane to seal it. (Put a piece of masking tape over the terminal blocks before you spray!)

The circuit board was then mounted on a 3-1/2" x 4" piece of plywood using small plastic standoff spacers and #4-40 screws and nuts. The plywood was also sealed with clear urethane. Once all the urethane was dry, I connected the wires from the stepper motor to the terminal block, and also used a piece of two-conductor cable about ten feet long to connect to the DC output block. Once everything was connected, the plywood with the circuit board attached was mounted on the small corner bracket behind the stepper motor. I fed the cable down through the center of the mast, and anchored it to the stepper motor with a large nylon wire tie, positioning it carefully so that it passed straight through the center of the 1/2" conduit without touching the edges. Note that this is why it's necessary to mount the motor as high as possible — to get room to pass the cable down through the mast.

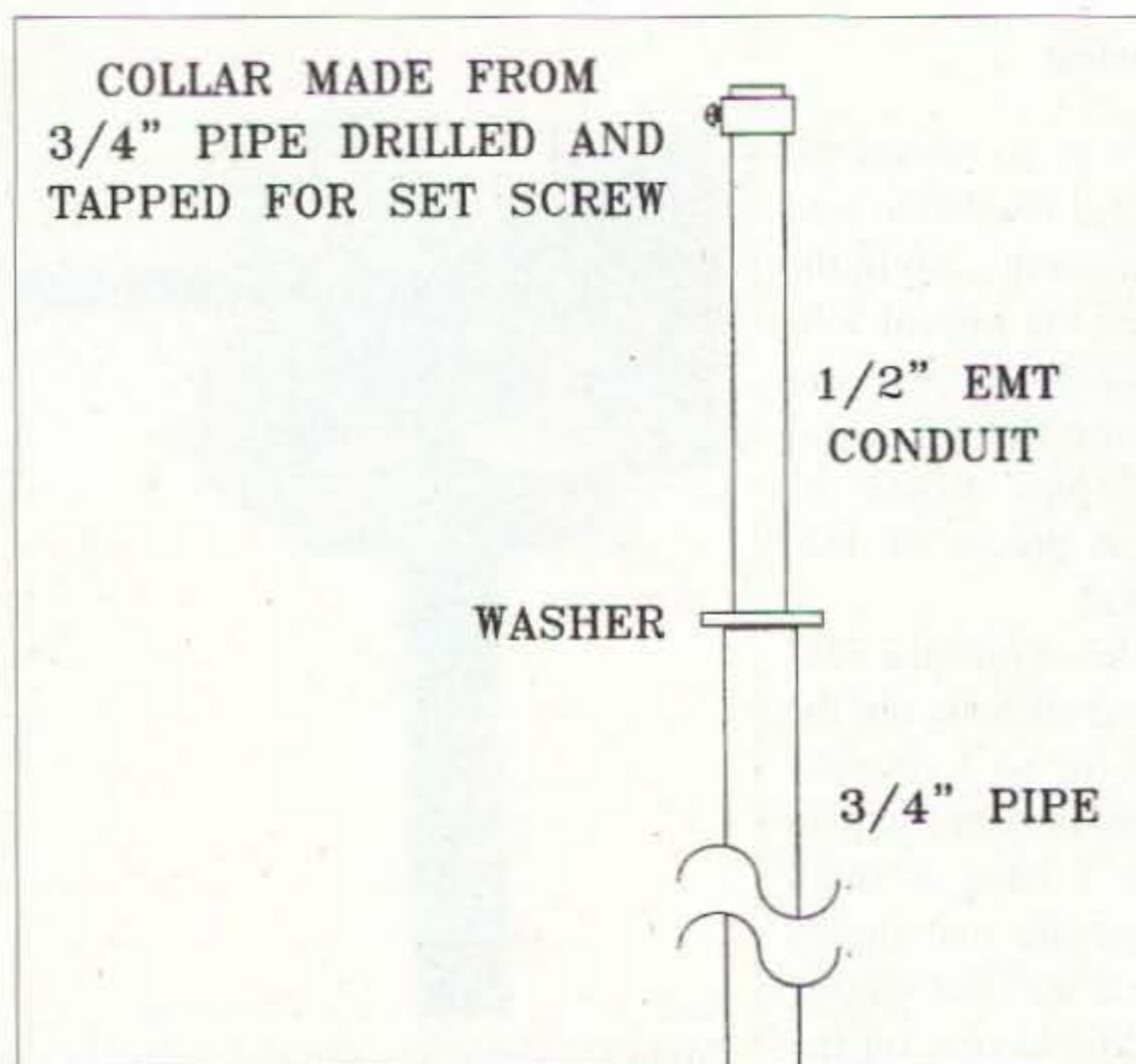

Fig. 2. Mast and pivot assembly made from pipe and conduit scraps.

head assembly, the Microwind generator was starting to take shape.

One thing lacking, however, was a tail to keep it pointed into the wind. Once again, scrounging the junk pile, I found a section of light steel slotted "U" channel intended to mount adjustable shelf brackets to the wall. I cut an 18" long piece and drilled two holes to clamp it to the generator head with a small

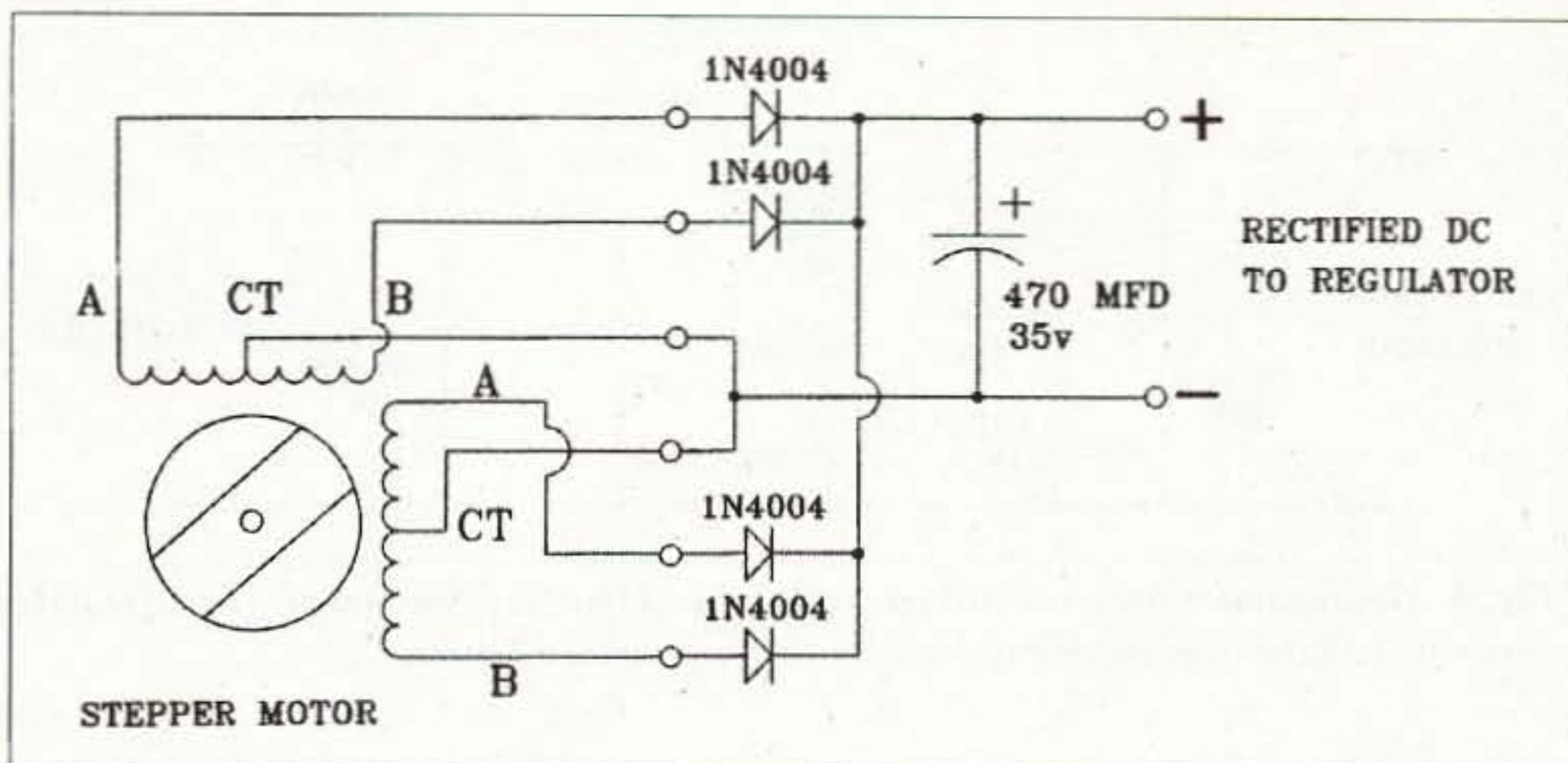

Fig. 3. Stepper motor generates two-phase AC, which is rectified and filtered before bringing the power down to the shack.

Bringing the power down to the ground

I've built several wind generators in sizes ranging from the Microwind up to machines with eight-foot rotors, and I have never needed to use slip rings and brushes at the top of the tower. To prevent wrapping the wires around the tower, I have always simply attached the wires at the top with a strain relief, and passed the wires down through the center of the mast. At the bottom of the mast, I let the wires hang straight down for twenty feet or so. The wires can't wrap around anything, and in the event that the wind does turn the generator a complete 360 degrees, all that happens is that a single twist is put into the pair of wires. I installed a plug at the bottom of the tower, so that should the wires ever accumulate more than a turn or two, it's a simple matter to unplug the wire, untwist it and plug it in again. This doesn't happen as often as you might think, since the wind tends to even out. My biggest machine was

up for a full year before we moved, and in that time I unplugged and untwisted the wire exactly once. This is hardly worth the added complexity of brushes and slip rings.

Once all the electrical connections were made and the circuit board was mounted, I sprayed another coat of urethane over everything, including the stepper motor. This would protect the connections, and also keep any water from seeping into the motor through the seams. I then cut a small piece of aluminum flashing and bent it into a "U"-shaped cover, which I attached to the plywood with two screws. This covered the motor and electrical connections to protect them from direct exposure to the weather.

Once the urethane was dry, I carried the Microwind generator up onto the shop roof and used a pair of large hose clamps to attach the pipe mast to the 4" vent that came up through the roof from the bathroom. I connected the end of the two-conductor cable to a

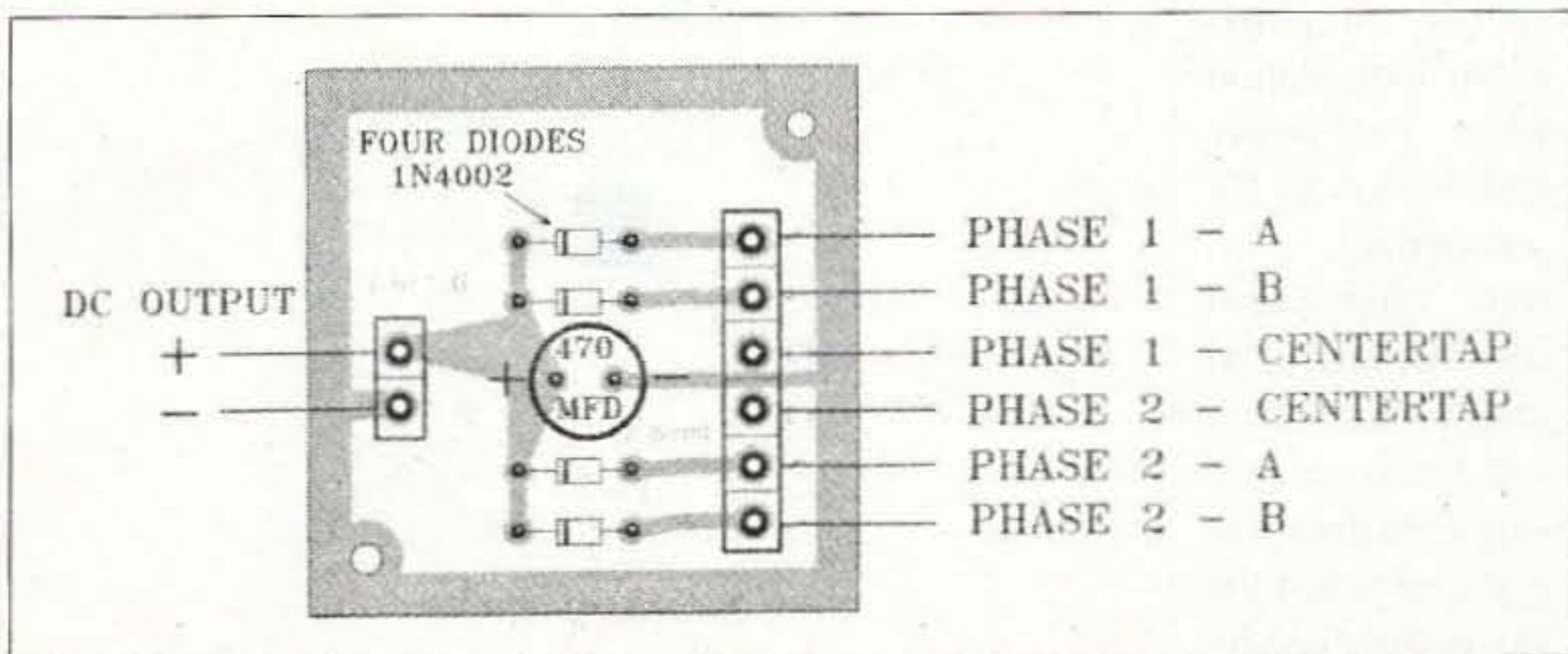

Fig. 4. Component layout for the rectifier circuit board.

ELECTRONIC MILITARY SURPLUS
FAIR RADIO SALES

40 Foot Mast Kit
 AB-155 Mast Kit, includes eight self-stacking 66" long x 1.6" diameter aluminum MS-44 mast sections to make 40 foot mast. Also 4 each guy ropes MX-381 (40'), MX-382 (31'), MX-383 (50'), one MX-516 rope, 5 each MX-378 guy rings, AB-154 swivel base, six GP-101 15" stakes, and HM-1 hammer; 70 lbs sh. Used Excellent, \$225.00 plus shipping.

Electron Tubes, JAN-BOXED unused:

4CX300A Eimac,	\$45.00	5998A Sylvania,	\$9.95
4D32 Raytheon,	\$28.00	6146W GE,	\$19.95
6AJ5 Tung-sol,	\$3.50	6336B Cetron,	\$30.00
811A Cetron,	\$25.00	6922 ECG,	\$3.50
955 Hytron,	\$3.50	7308 AmpereX,	\$3.50
1625 Nat. Union,	\$4.50	7360 ECG,	\$15.00

Allow money for shipping on merchandise.

WEBSITE: fairradio.com
 E-MAIL: fairradio@wcoil.com
 PHONE: 419-227-6573 - FAX: 419-227-1313
 1016 E. Eureka - Box 1105 Lima, OH 45802
 VISA, MASTERCARD, DISCOVER accepted
 Write for latest Catalog - Address Dept. 73

208-852-0830 rdc@rossdist.com
<http://rossdist.com>

Over 9010 HAM Items in Stock!

ICOM IC-V8 Under \$170.00

Check Out Our Specials! We're On The Web.
 ROSS DISTRIBUTING COMPANY All Prices Cash
 78 S. State Street, Preston, ID 83263 FOB Preston
 Hours Tue.-Fri. 9:30-12 / 2:30-6 • 9:30-4 Mon. Closed Sat & Sun

GORDON WEST
HAM TEST PREP TAPES
BOOKS SOFTWARE VIDEOS

Prepare for your ham test with "Gordo" WB6NOA as your personal instructor.

- THE NEW THEORY** on audio cassettes
 - No-Code Technician (4 tapes)\$19.95
 - General Class (4 tapes) \$19.95
 - Amateur Extra Class (4 tapes)\$19.95
- THE CODE** on audio cassettes
 - Learning CW (0-7wpm 6 tapes)\$29.95
 - Speed Builder (5-16wpm 6 tapes) .. \$29.95
 - Speed Builder (10-28wpm 6 tapes). \$29.95
- NEW STUDY MANUALS** by "Gordo"
 - No-Code Technician (Element 2) .. \$11.95
 - General Class (Element 3) \$12.95
 - Extra Class (Element 4) \$14.95
- PC SOFTWARE** with study manuals
 - No Code Technician (Element 2)\$34.95
 - Tech/Tech+/Gen. (+ Code, Windows)\$49.95
 - General Class (3+Code, Windows). \$34.95
 - Extra Class (4 + Code, Windows).. \$34.95
 - Ham Operator (Tech.-Extra + Code) \$59.95
 - Morse Software Only\$12.95
- VIDEO VHS** with study manual
 - No-Code Tech Video Course..... \$31.95

Add \$5.00 shipping 1st item, .50 each additional
 Priority Mail 2-3 day service available
 VISA, Mastercard, Discover, & AMEX Accepted

W5YI Group
 P.O. Box 565101 • Dallas TX 75356
1-800-669-9594
www.w5yi.org

ALL ELECTRONICS CORPORATION

C O R P O R A T I O N

SHOP OUR ONLINE STORE
www.allelectronics.com

Video / RF Modulator



Converts audio and video line level signals to RF which can be inputted to any television on channel 3 or 4. Channel 3-4 selector switch. Video, audio and power inputs are through a 7 foot cable terminated with a mini-DIN plug which generally needs to be cut off so connections can be made directly to conductors in cable. We supply a hook-up diagram. Requires a 4.5 - 6 Vdc, 50 mA power supply or wall adapter (not included). Large quantity available. **\$5.00 each**
CAT# MOD-6 **10 for \$4.50 each**

Assembly with 12 Vdc Motor, Gears and Pulleys

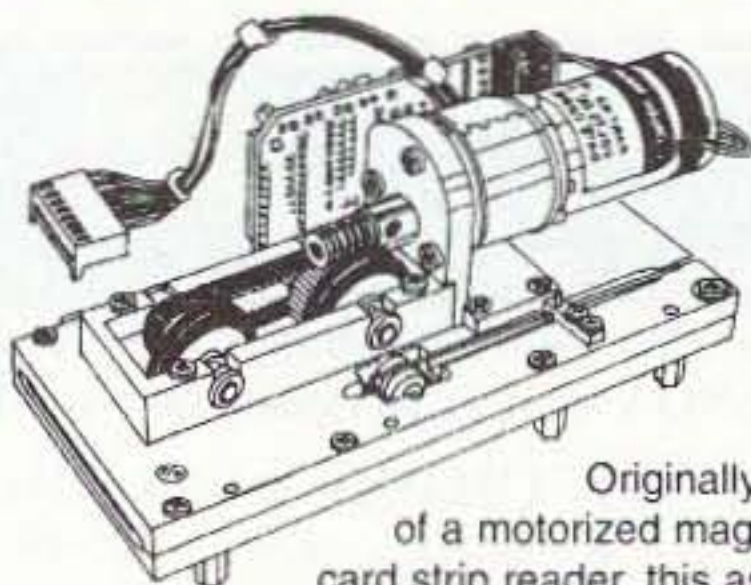

Originally part of a motorized magnetic card strip reader, this assembly is driven by one of our gear motors, either CAT# DCM-181U or DCM-182U. A worm gear turns a pair of cog pulleys linked by a cog belt. The rubber covered wheels pull a credit card past a magnetic head and two U-shaped optical sensors. Assembly includes motor, pulleys, belt, magnetic head and opto sensors. Mounted on an aluminum platform 6.25" x 2.75".

CAT # DCM-180 **\$17.95 each**

ORDER TOLL FREE
1-800-826-5432

CHARGE ORDERS to Visa, Mastercard, American Express or Discover

TERMS: NO MINIMUM ORDER. Shipping and handling for the 48 continental U.S.A. \$6.00 per order. All others including AK, HI, PR or Canada must pay full shipping. All orders delivered in CALIFORNIA must include local state sales tax. Quantities Limited. NO COD. Prices subject to change without notice.

CALL, WRITE FAX or E-MAIL for our FREE 96 Page CATALOG Outside the U.S.A. send \$3.00 postage.

MAIL ORDERS TO:
ALL ELECTRONICS CORPORATION
P.O. Box 567
Van Nuys, CA 91408
FAX (818)781-2653

e-mail allcorp@allcorp.com

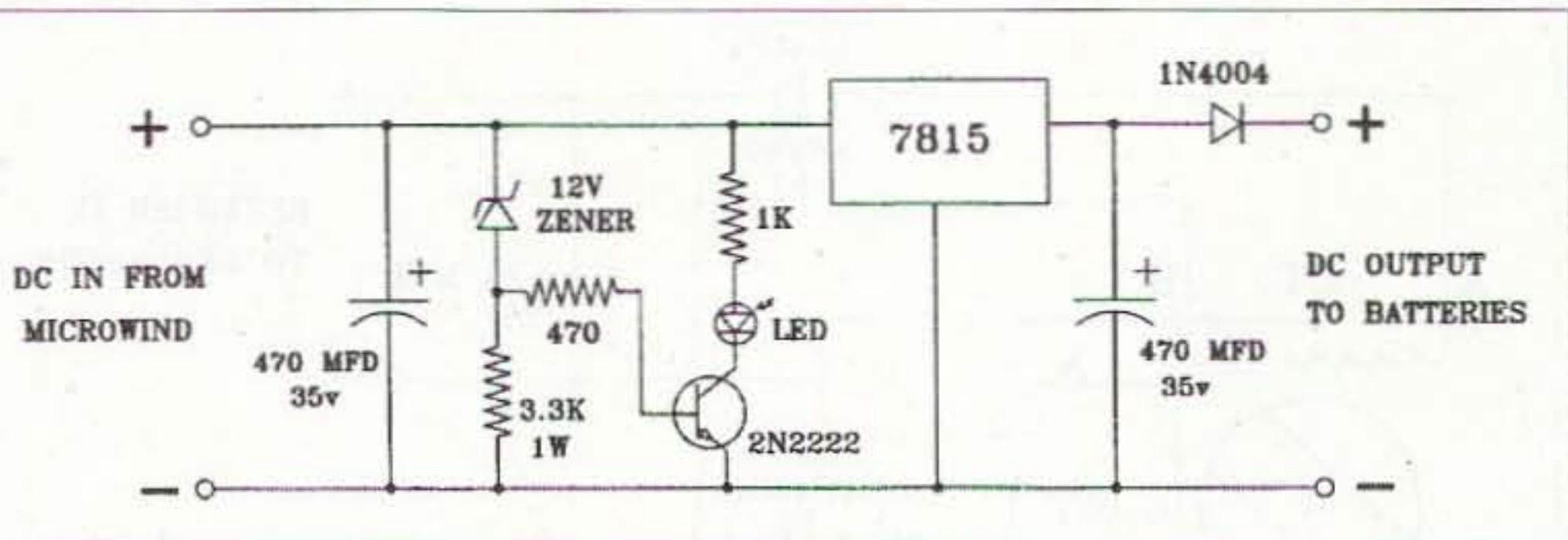

Fig. 5. The regulator prevents voltage peaks from damaging equipment. The LED lights when the voltage from the Microwind generator reaches 12 volts.

section cut from an old 100-foot extension cord, dropped it down the middle of the tower and brought the other end into the shop.

First tests: stormy weather!

The very next evening a strong weather front passed through our area, and as the temperature dropped, we also had some very strong, gusty winds. I hooked up a multi-meter in series with the positive lead and set it to measure current, then connected an analog 0-30 volt DC voltmeter across the line. For a load, I found a bullet-shaped 12-volt trailer clearance light and connected this to the line.

To my surprise, the Microwind generator picked up a strong gust and the trailer light started to glow brightly ... it was producing quite a bit of power in the gusts. I watched the meters through the evening, and at the strongest peaks I was able to measure over 20 volts at 750 milliamps. I measured 10 to 15 watts many times through the evening whenever the wind picked up.

Obviously, this is not enough to power your house, or even a good-sized light bulb, but it's plenty to trickle-charge a

car battery used to operate an emergency ham station when the power grid is down. By comparison, a 10 watt solar panel costs between \$100 and \$150, and it will not generate a single milliamp at night, or when the sky is darkened by storm clouds.

Regulator circuit

It is not a good idea to connect the Microwind generator directly to a battery used to power your emergency ham rig. Once the battery is fully charged, the voltage in wind gusts could reach 25 volts or more, which could be bad news for any electronic equipment connected to it. Fig. 5 shows a simple regulator circuit to clamp the voltage to 15 volts, a level that is safe for most electronics made to be powered from a 12-volt circuit. Also included in the circuit is an isolation diode to keep the 12-volt battery from discharging backwards through the circuit. This is always good practice, especially when you have other sources of charging current, such as a solar array. I also included a zener diode and a small transistor, which acts as a voltage-controlled switch. When the voltage crosses the 12-volt threshold, the LED will light, indicating that the charging level has been reached. The circuit board component layout is shown in Fig. 6. Both the two-phase rectifier and the regulator boards are identical in size. The foil patterns for the boards are shown in Fig. 7.

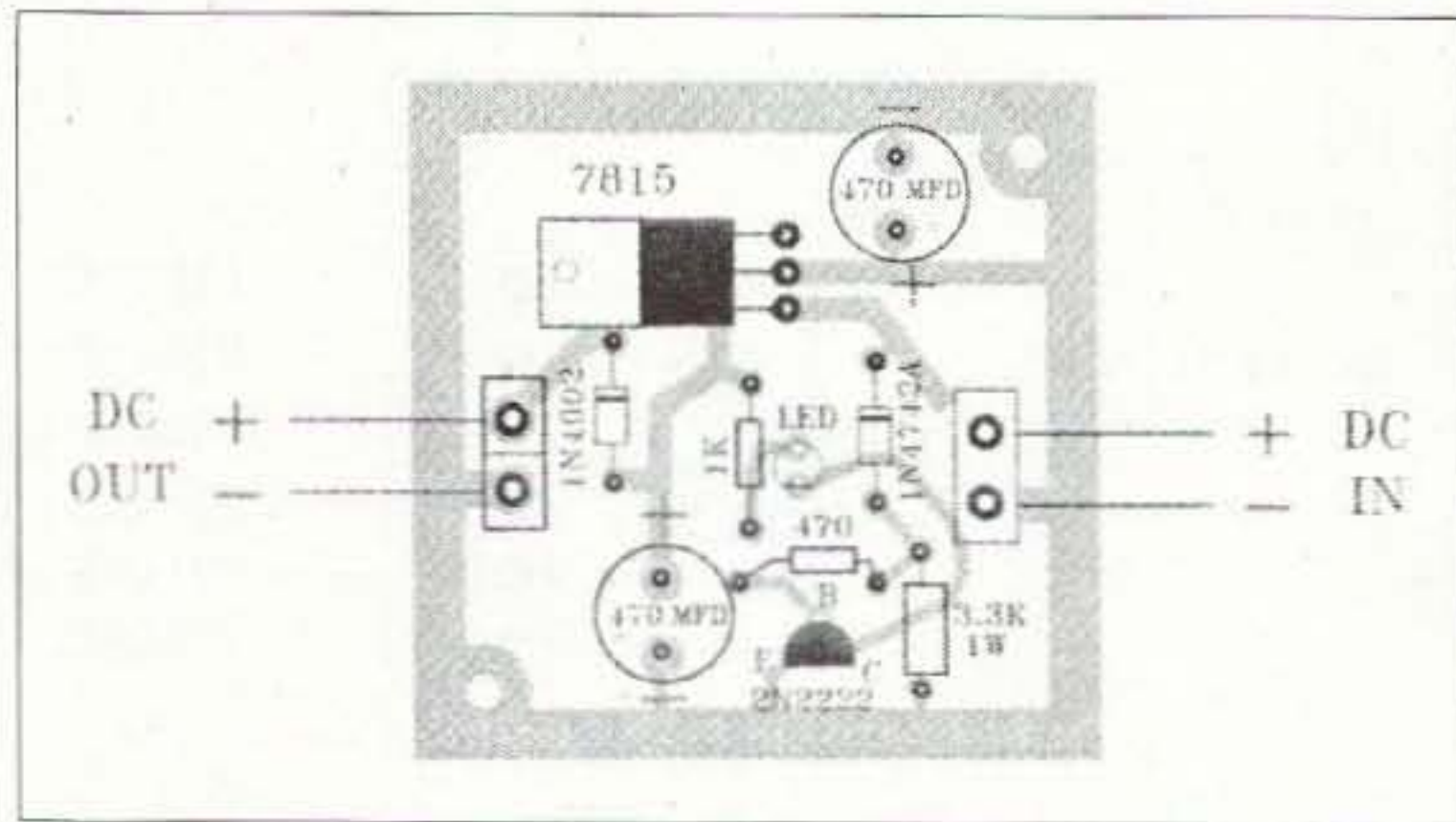

Fig. 6. Component layout for the regulator circuit board.

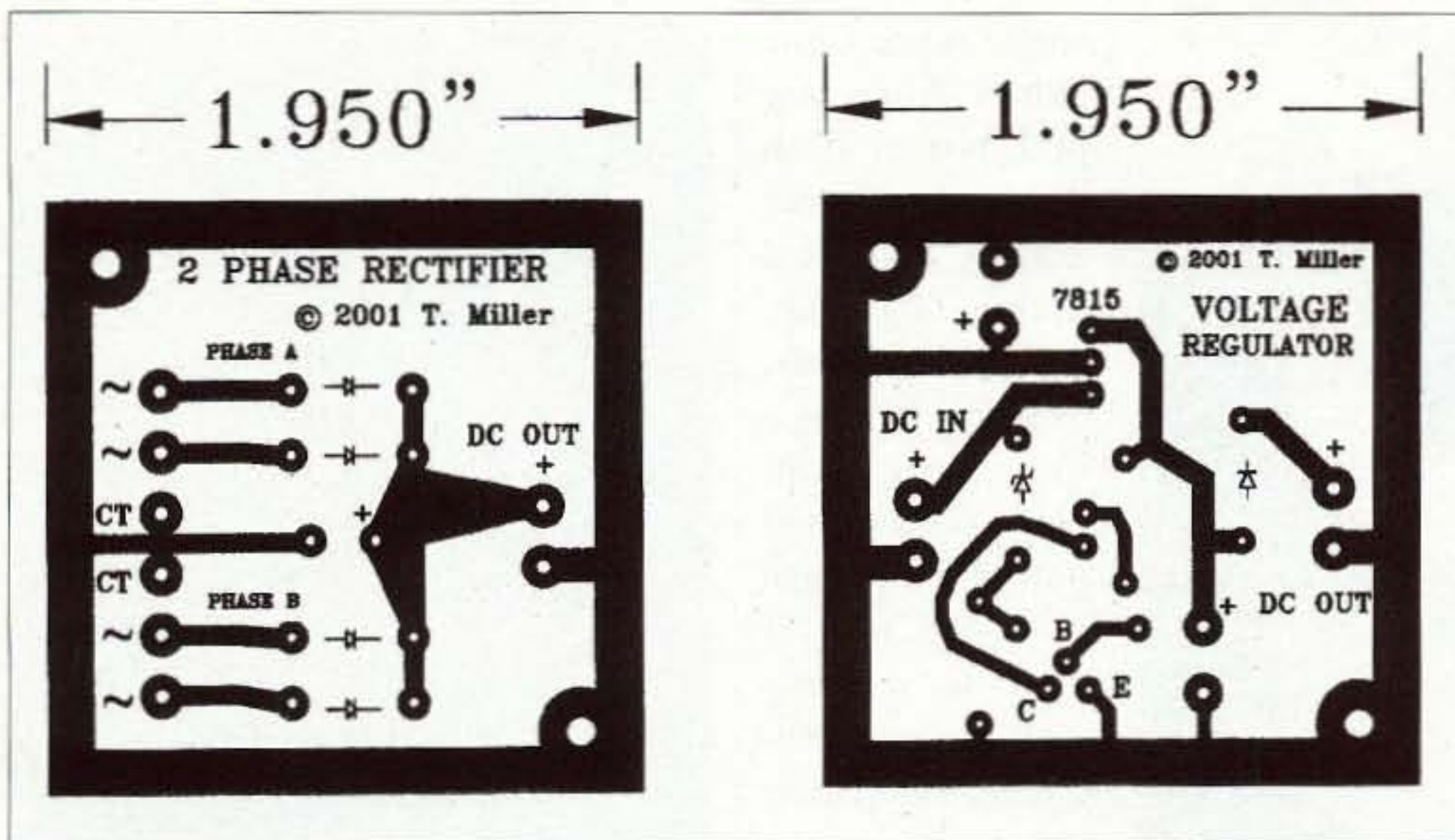

Fig. 7. Printed circuit board patterns for the rectifier and regulator.

More is better!

Since the Microwind project worked out well and I still had a few stepper motors left over, I located a few more junk fans and salvaged the blades. I now have three of these little machines spinning happily in the wind. One of the fans had a 1/2" shaft, so when I made the extension piece I chucked it in the lathe and turned one end down to 1/2" outside diameter after drilling, tapping and boring through the center. I filed a flat on it to fit into the fan

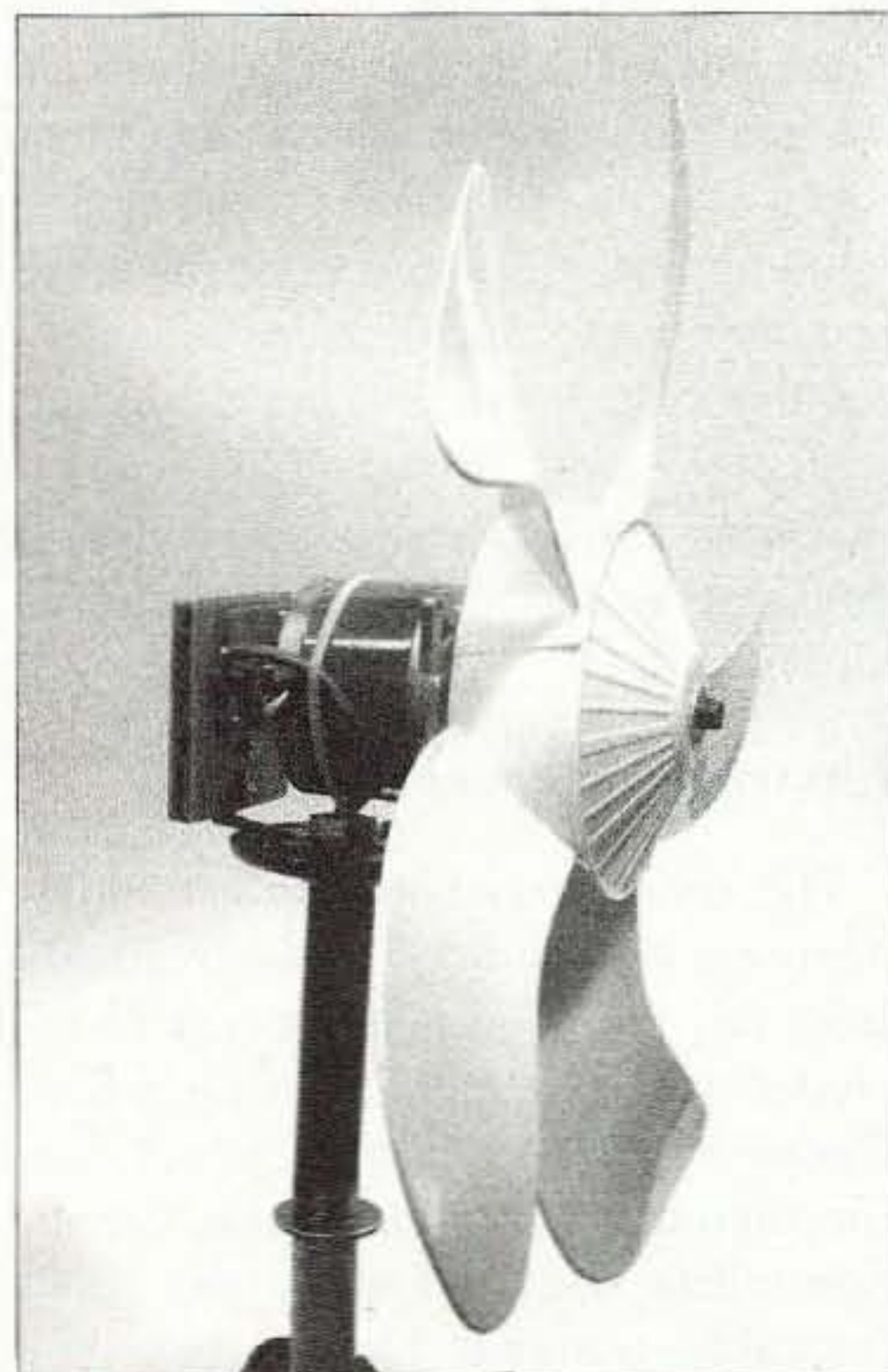

Photo E. The Microwind generator with blades attached. All it needs now is a tail to keep it pointed into the wind.

hub and secured it with the 5/16" bolt. This particular fan blade had a large flat center hub, which was not very streamlined. In order to cut the wind loading, I found a white plastic funnel that closely matched the diameter of the hub and mounted it with four small sheet metal screws.

The shop roof proved to be a less-than-ideal location for a wind generator. Located behind the house, the air swirled over the roof and down onto the shop in all sorts of eddies. The Microwind generator spent most of the time yawing back and forth, trying to track the shifting wind. I installed one of them on top of the 45-foot tower beside the shop, which is the proposed location for a large generator. This "next generation" wind machine will utilize an alternator made by adding neodymium magnets to the rotor of a single-phase AC induction motor. While I'm working on this project, the Microwind generator is giving me information on the wind speeds and directions I can expect when it's big brother arrives on the site. So far, it's showing a dramatic

difference between the high and low sites. A good rule of thumb is to locate any wind generator 12 to 15 feet above any nearby obstructions.

The Microwind generator is a fun project and provides a good, simple introduction to wind technology. It's also an unusual and practical application for surplus stepper motors. More experiments in this area could be interesting... the small plastic fan blades are not driving these steppers to the maximum, so it might be worthwhile to build larger, more efficient blades, possibly using a bicycle chain and sprockets to spin the stepper faster than the blades. There are also much larger stepper motors out there, and these do show up as surplus from time to time. In the past, I've worked with steppers that drew over six amps per winding. One of these could have some real potential for use as an alternator.

For the radio amateur, batteries are necessary to power the station in emergency conditions when the grid may be down. My emergency station is located in the basement, and consists of an elderly but functional Ten-Tec Argonaut, handie-talkies for 2 meters and CB, a scanner, a small television and a portable all-band receiver. All this is powered from a large marine battery, which also feeds a 600-watt inverter to provide 120 volts AC. A small relay brings the inverter on automatically when the power fails. Like many hams, I use a small solar panel to keep



Photo F. In a strong wind, the Microwind produced more power than expected!

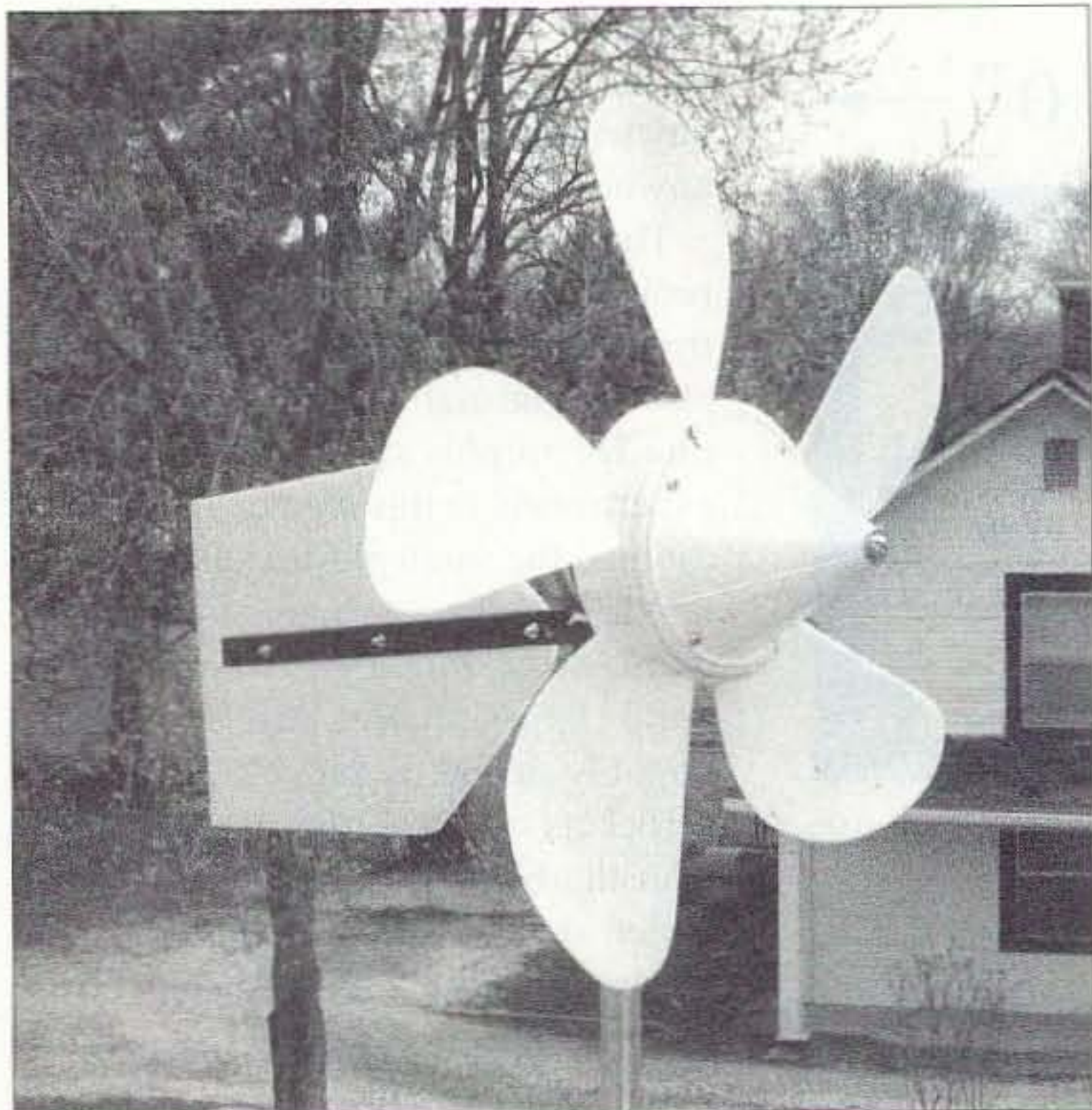

Photo G. This version sports a nose cone made from a plastic funnel.

the backup battery charged. The Microwind generator is now adding wind power to the system. Wind and solar complement each other ... when the weather socks in and there's very little solar power available, there is most often plenty of wind. Under those conditions, the Microwind generator really shines.

Sources

There is nothing sacred about the mechanical construction of the Microwind generator ... it evolved into the present configuration because every

single piece came either from my junk box or from the street corner during the local Spring Cleanup. All the materials, including the angle iron, pipe, conduit and assorted nuts and bolts can be found new at your local hardware store, but there's no reason not to adapt the design to utilize whatever materials you can find lying around.

The one piece that requires some fabrication is the blade adapter. This

can be made with hand tools if you're careful, since by drilling the piece straight through first, then boring it out halfway to fit the motor shaft, the two ends should be concentric. Still, if you have a friend with a small lathe, this can be done more easily and accurately.

Stepper motors

The heart of this project is the stepper motor. The leftovers I used were NEMA 34-frame steppers made by Sanyo. The original source for these no longer lists them, but I found a good supply when I visited Dean's

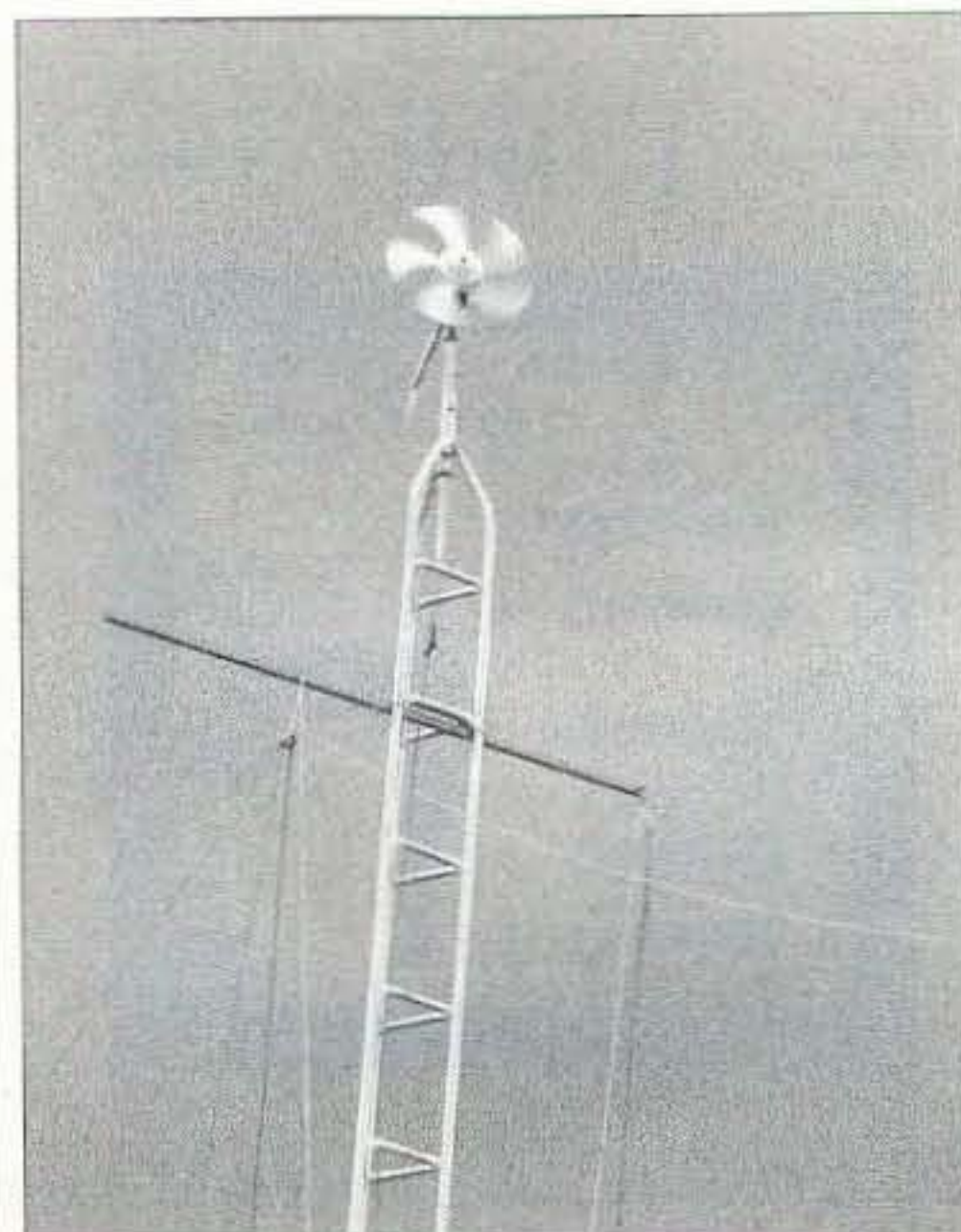

Photo H. High atop the tower, the Microwind generator charges the station batteries as storm clouds gather in the background. The tiny machine can survive and produce power in storms that would destroy a larger wind generator.

Hobby CNC Web site. Dean has the same Sanyo motor I used, both new and used for \$35 and \$25 respectively. Order directly from Dean's Web site [<http://plaza.v-wave.com/deanc/>] or write to him at Dean's Hobby CNC, 11222-131 St., Edmonton, AB, Canada T5M 1C3.

If you choose a different motor, be sure that it's a bipolar type. Larger, more powerful stepper motors are almost always bipolar, which means that there are two separate, center-tapped windings. Small steppers such as those used in printers and disk drives are often unipolar, having a single winding with many taps. These would require a different rectifier design, and would in any case be too small to be useful as alternators.

Electronic components

The rectifier and regulator components are very common items available from any electronics supplier. I've included part numbers from Digi-Key, Circuit Specialists and Radioshack.com for reference. For some reason, Circuit Specialists does not carry the small stackable terminal blocks, but they have the best prices for everything else

Qty.	Component	Digi-Key	Circuit Specialists	RadioShack.com
1	Transistor	PN2222-ND	PN2222	900-5369
1	Regulator	LM340-15-ND	7815	900-4504
5	Rectifier	1N4004GCT-ND	1N4004	900-2872
1	12V Zener	1N4742ACT-ND	1N4742A	900-3027
2	Capacitor	P5168-ND	CEM50-0470	900-1324
1	Red LED	LT1136-ND	L934HD	900-6088
1	470Ω Resistor	470XBK-ND	RB470	900-0371
1	1k Resistor	1.00KXBK-ND	RB1000	900-0379
1	3.3k Resistor	3.3KW-1-ND	RG3.3K	900-0702
6	Terminals	ED1609-ND	N/A	900-4110
1	Heat sink	HS105-ND	530-613	910-3263

Table 1. Parts list.

Continued on page 58

John R. Endsley, Jr. KD5IDU
5610 Cerritos Dr.
Houston TX 77035-2534
[kd5idu@msn.com]

Subdivision Subterfuge

Here's how a Houston homeowner handles his hamming.

Antenna challenge on a small or difficult lot got you down? Check out this photo essay for some handy pointers.

My solution is a manufactured vertical antenna that requires no radials, a home-brewed support, and an electrical discharge system to protect the antenna and my rig. Although not a problem in our subdivision, it could have "stealth" advantages where needed. As you can

see, the ability to swing the antenna down provides easy tuning and service.

The support is 10 feet, plus the antenna's 20 feet. Such an antenna is usually top-loaded and gives excellent DX and satellite operation. My antenna is an MFJ-1798 and is tuned for 75/80 to 2 meters, as specified by the

manufacturer. I have also found it to be effective on 160 meters as well. The counterpoise is located at the top. A top-quality SWR meter helps in getting good results.

The antenna is grounded by a heavy single-strand copper wire, and may be cut off during transmission by an AC

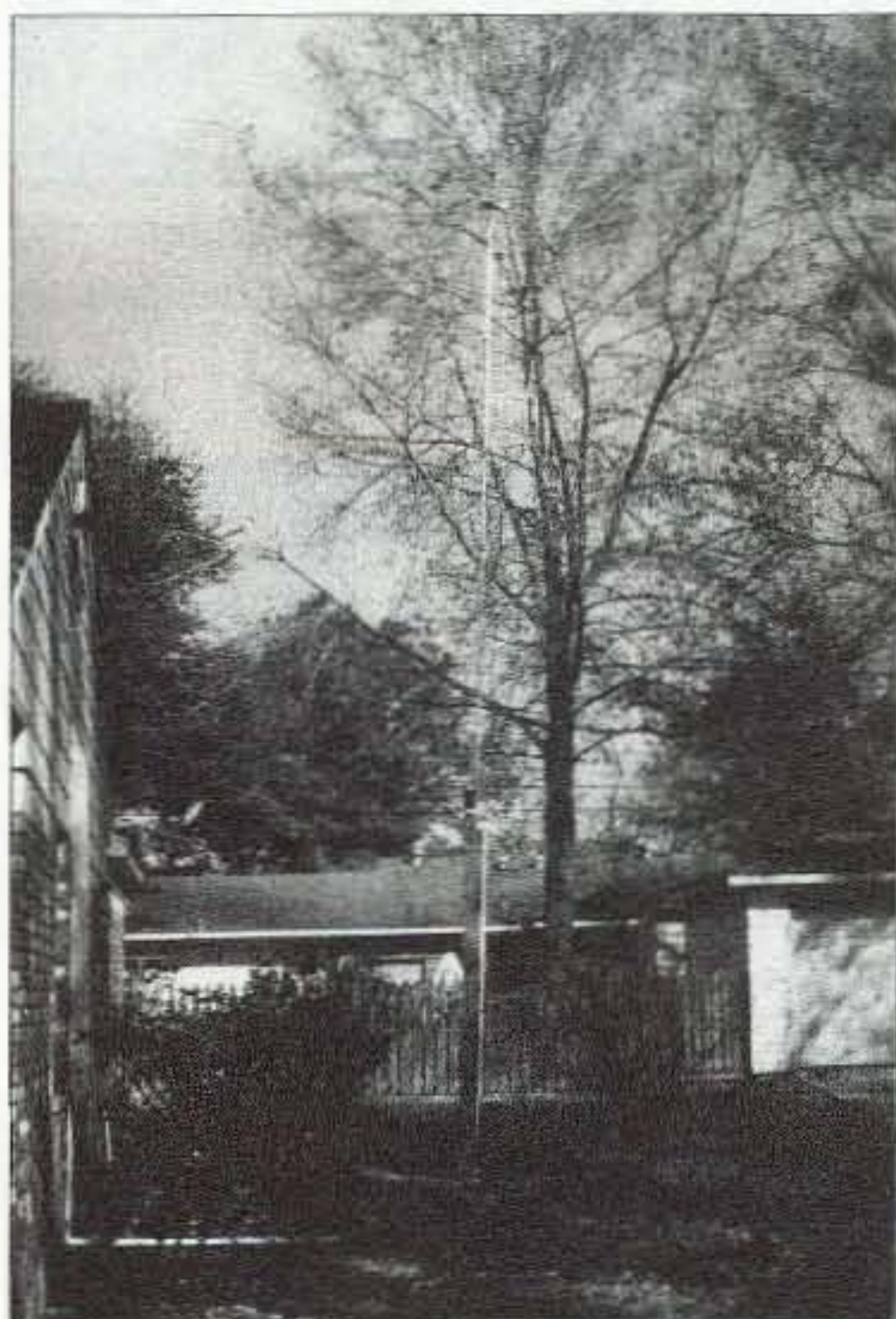

Photo A. The vertical antenna by our house.

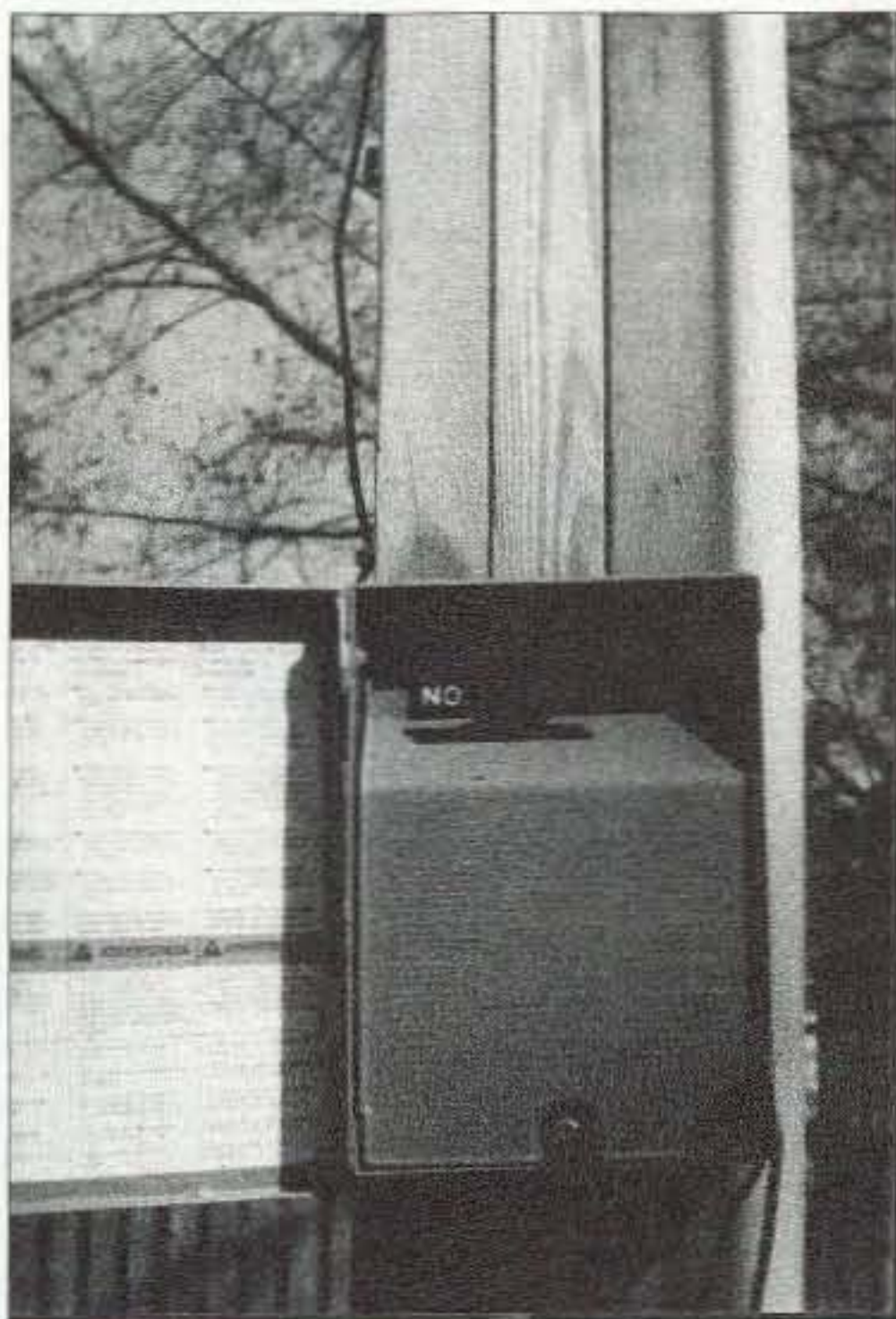

Photo B. This is the box which sets up broadcast or electrical discharge protection.



Photo C. My MFJ "Guardian Angel" surge protector.

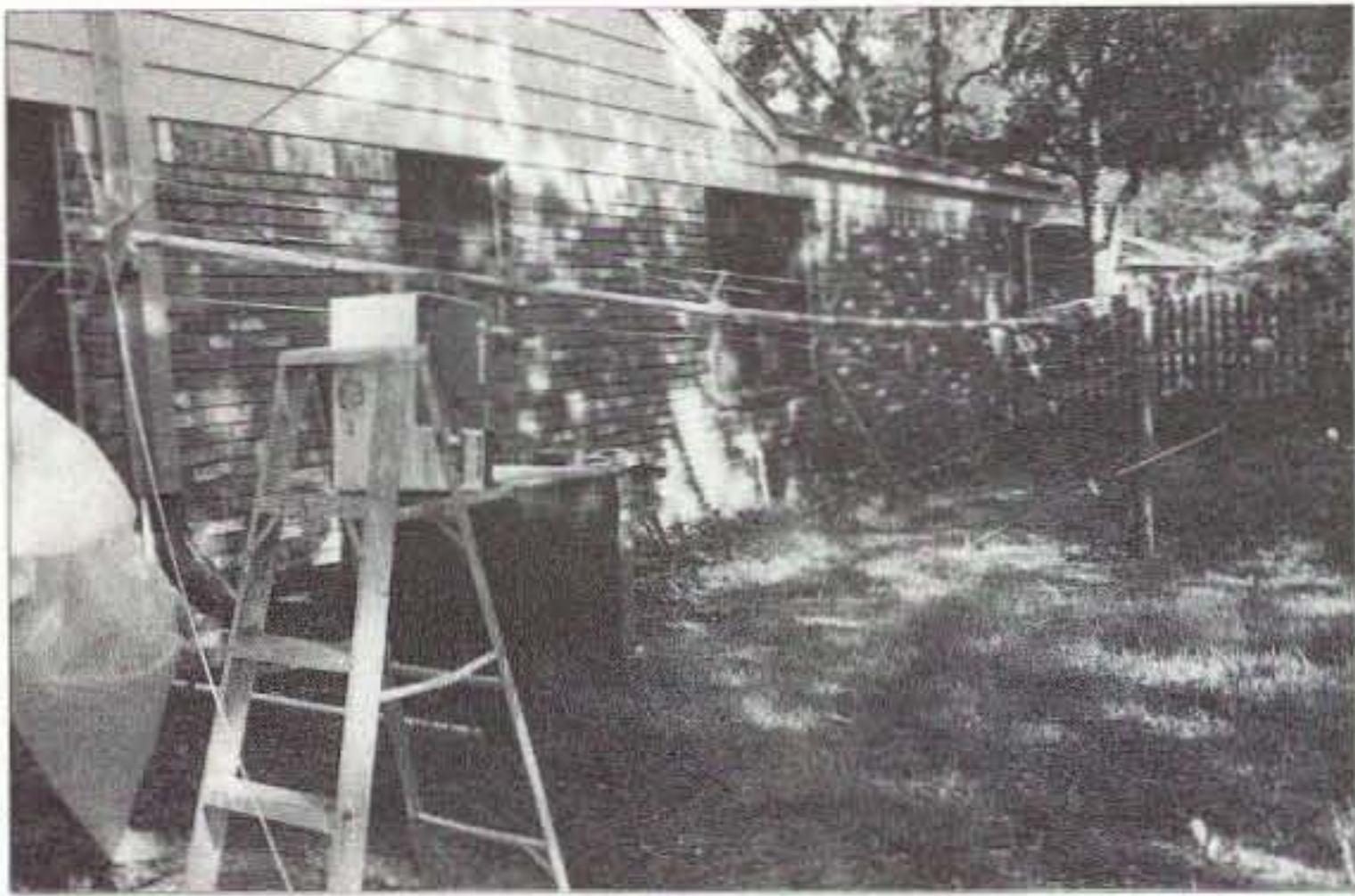

Photo D. Antenna swung down for service or installation.

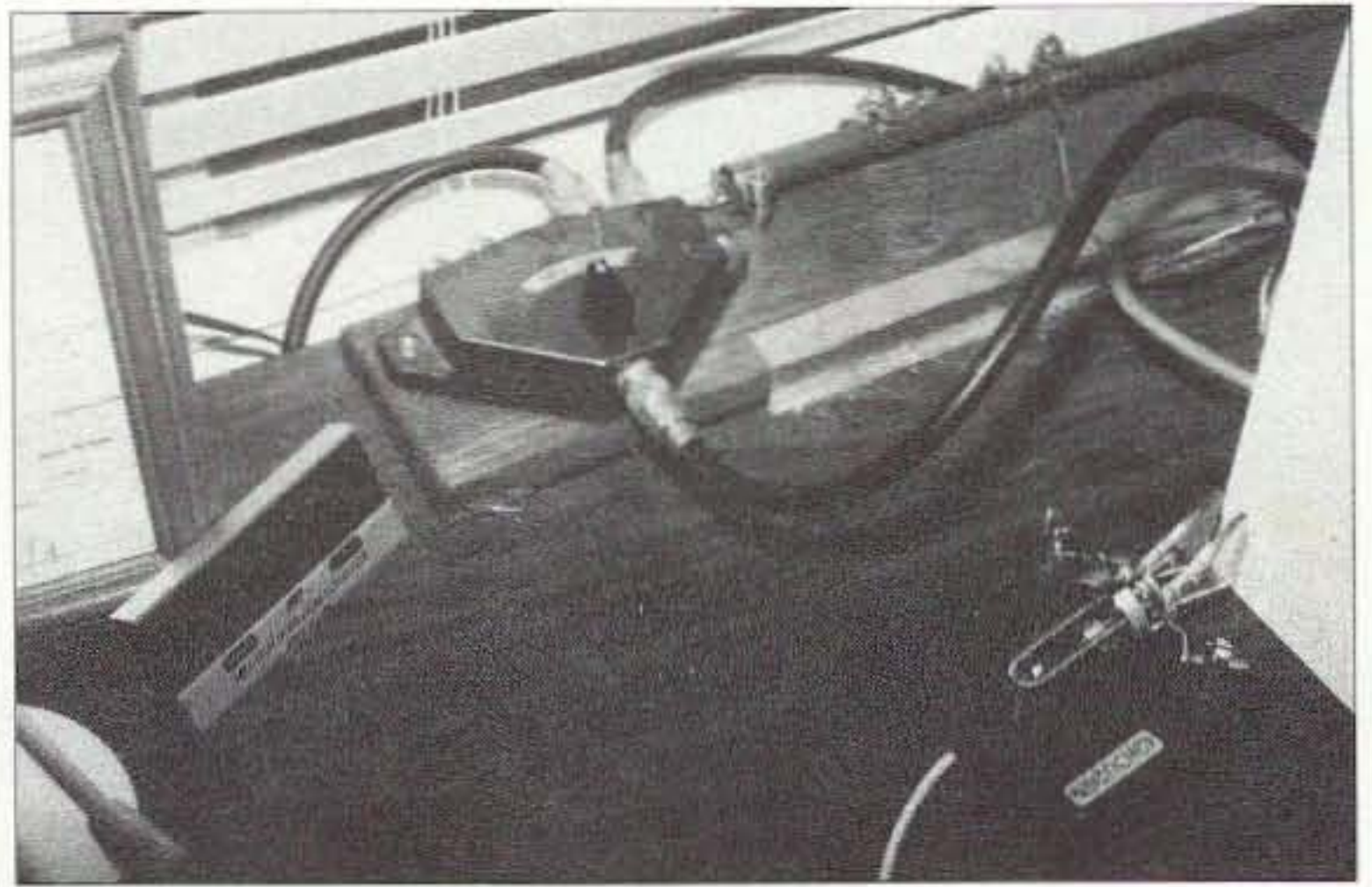

Photo E. Switch from the transceiver to the dummy load and the antenna.

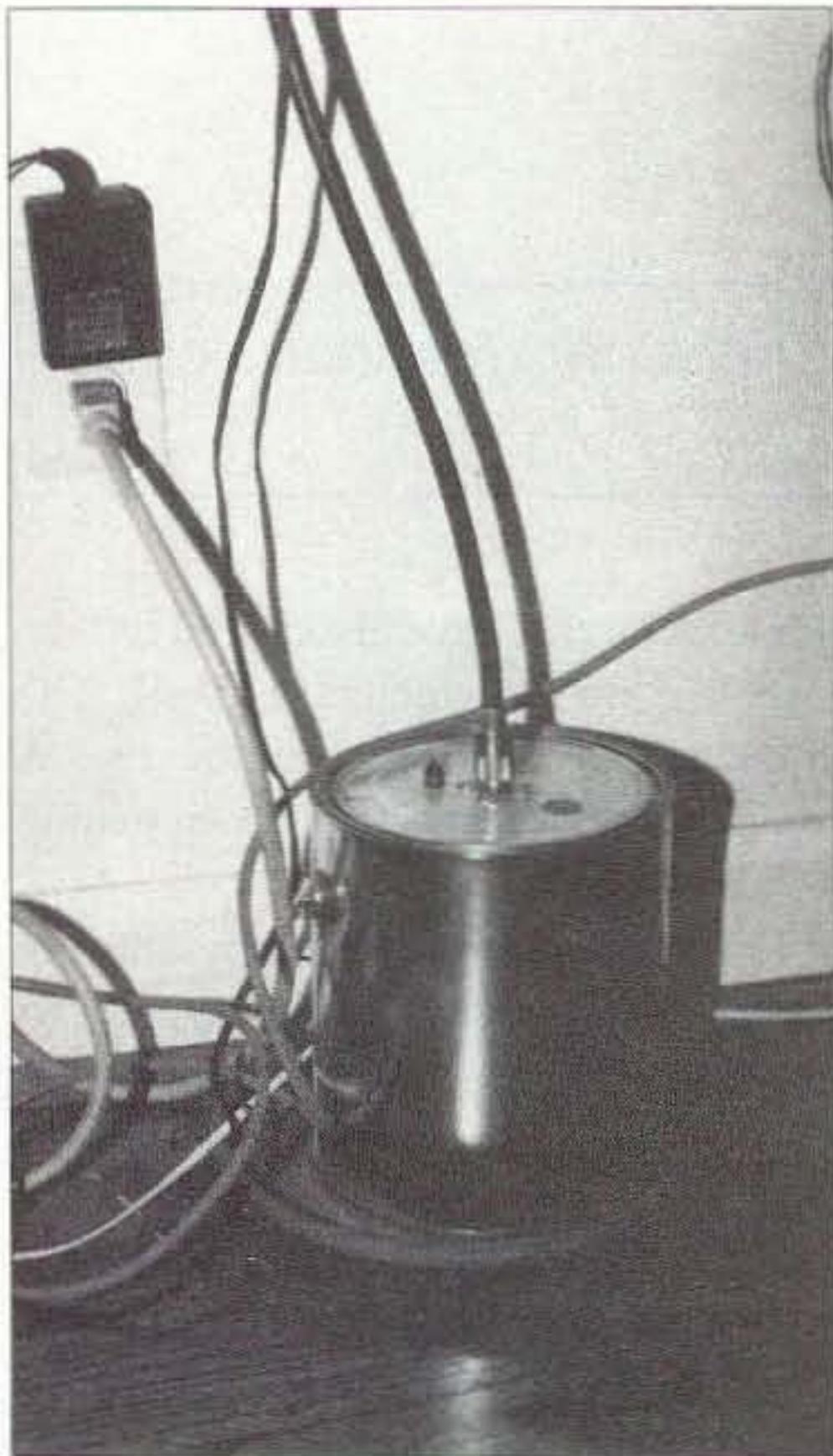

Photo F. Dummy load.



Photo G. Base of antenna showing balun and loading coil assembly.

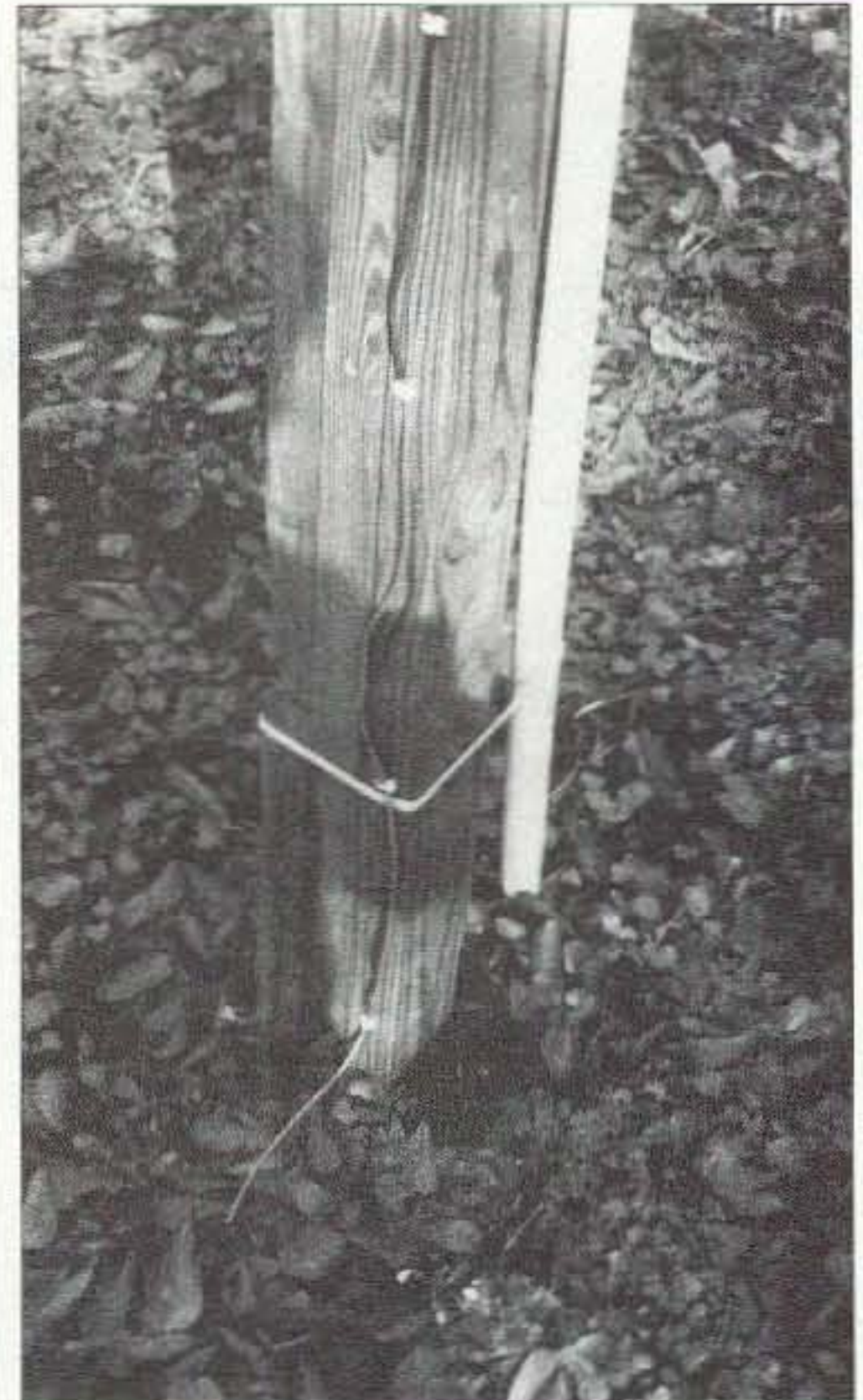

Photo H. Coax under ground from the antenna support to the entry to the house.

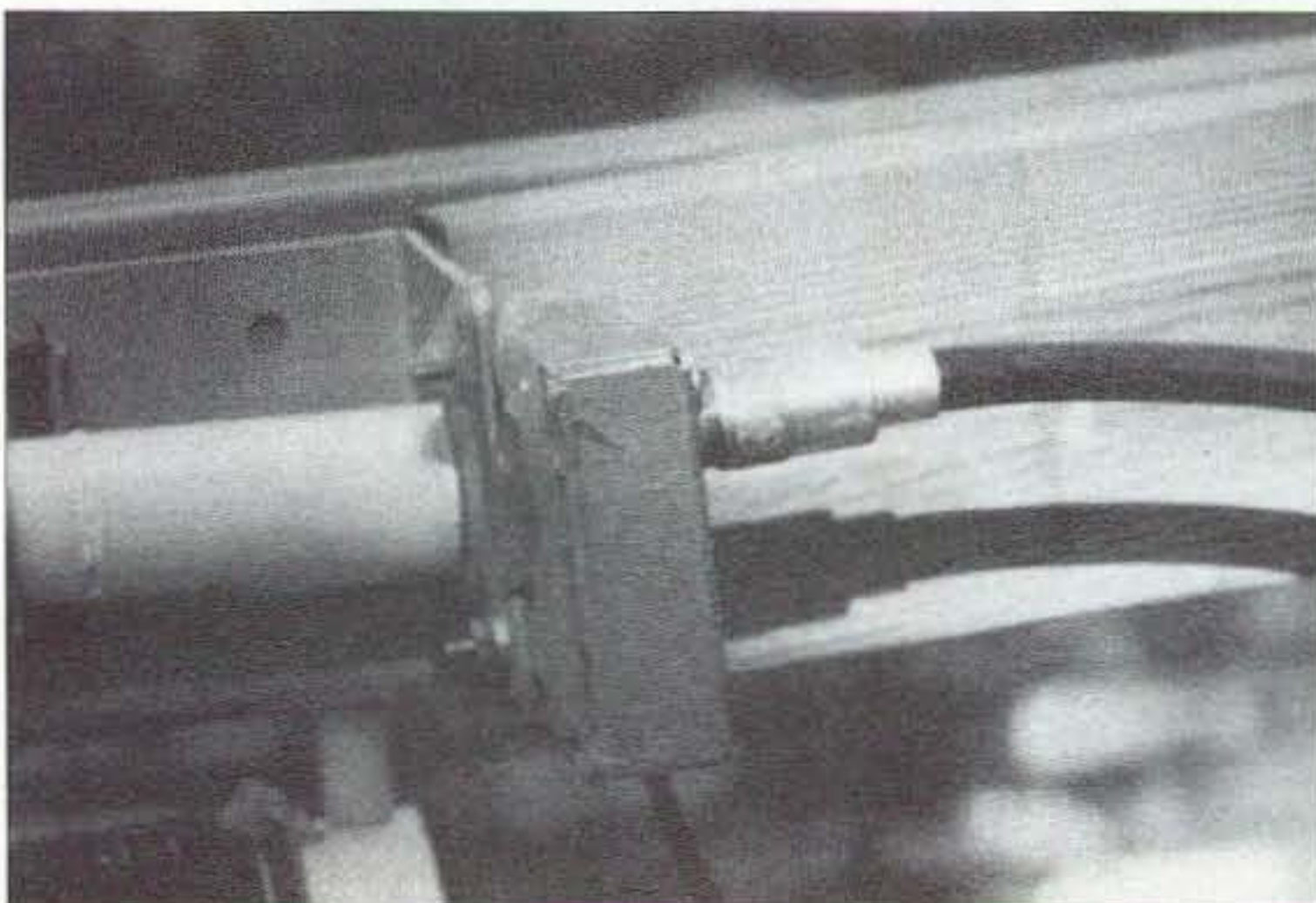

Photo I. Coax connected to antenna base.

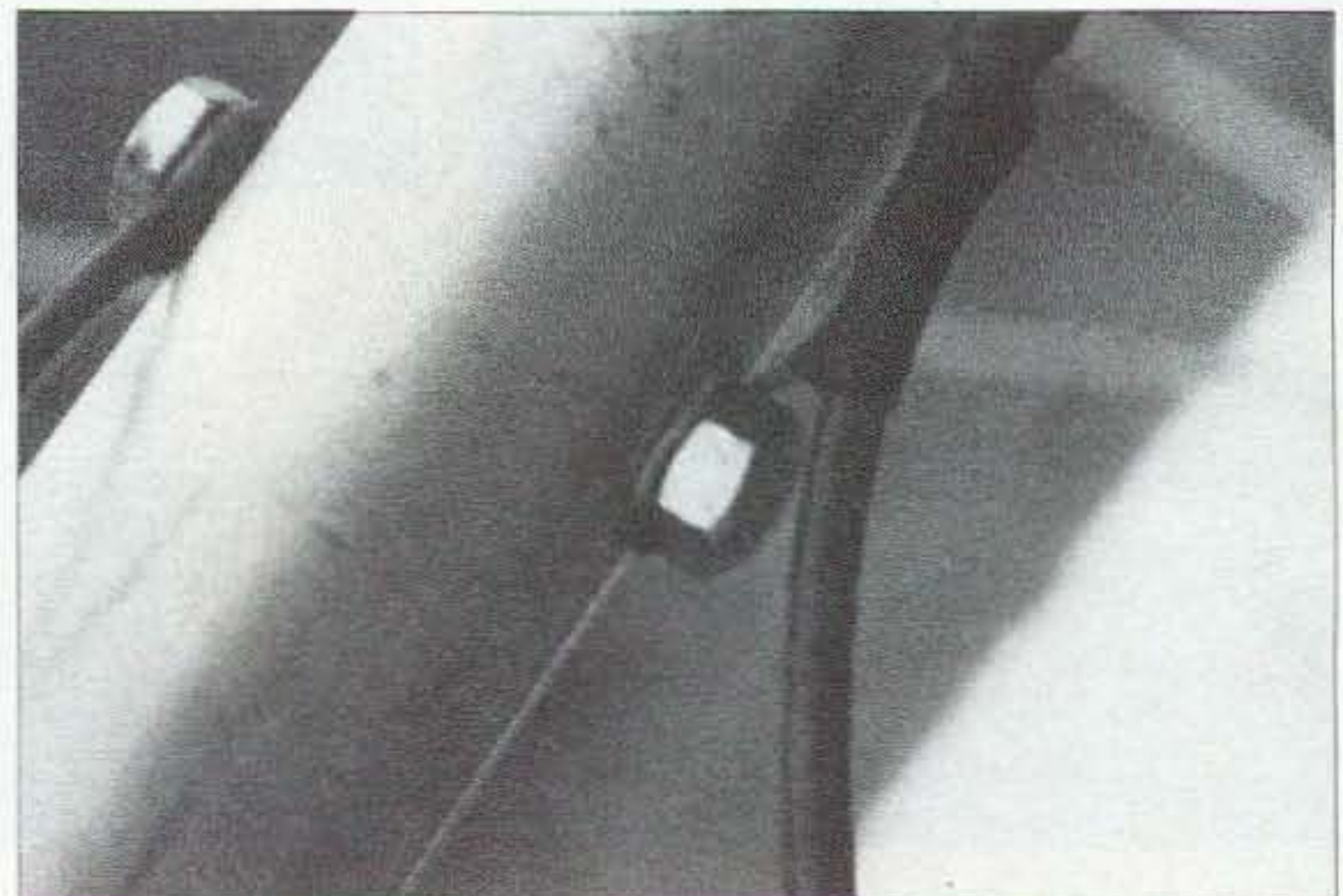

Photo J. Connection from antenna mast to ground.

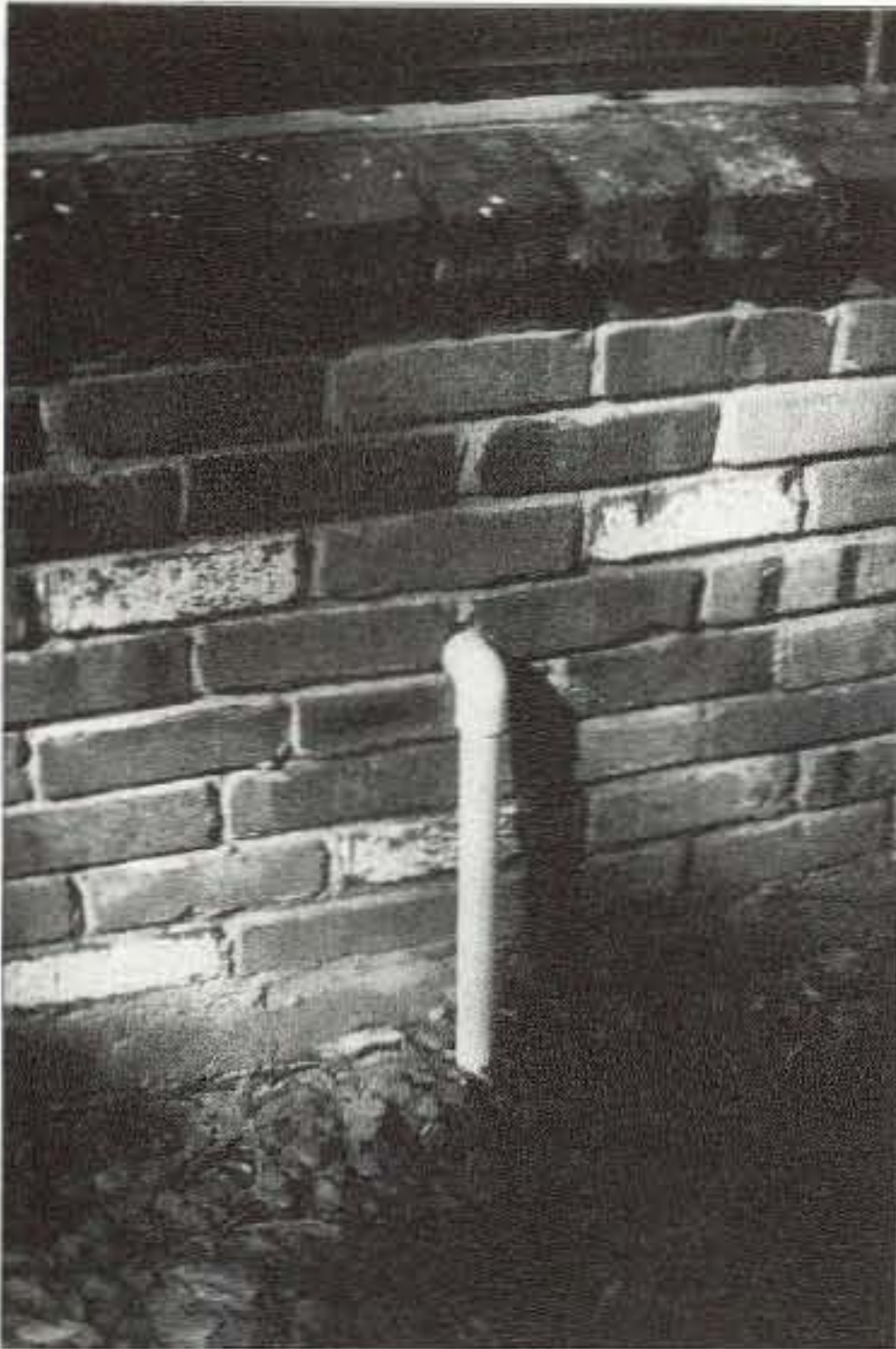

Photo K. Coax enters the house.

cutoff box. A shorting bar is in place where the fuse would be if it were being used with an AC unit. The station is protected by a

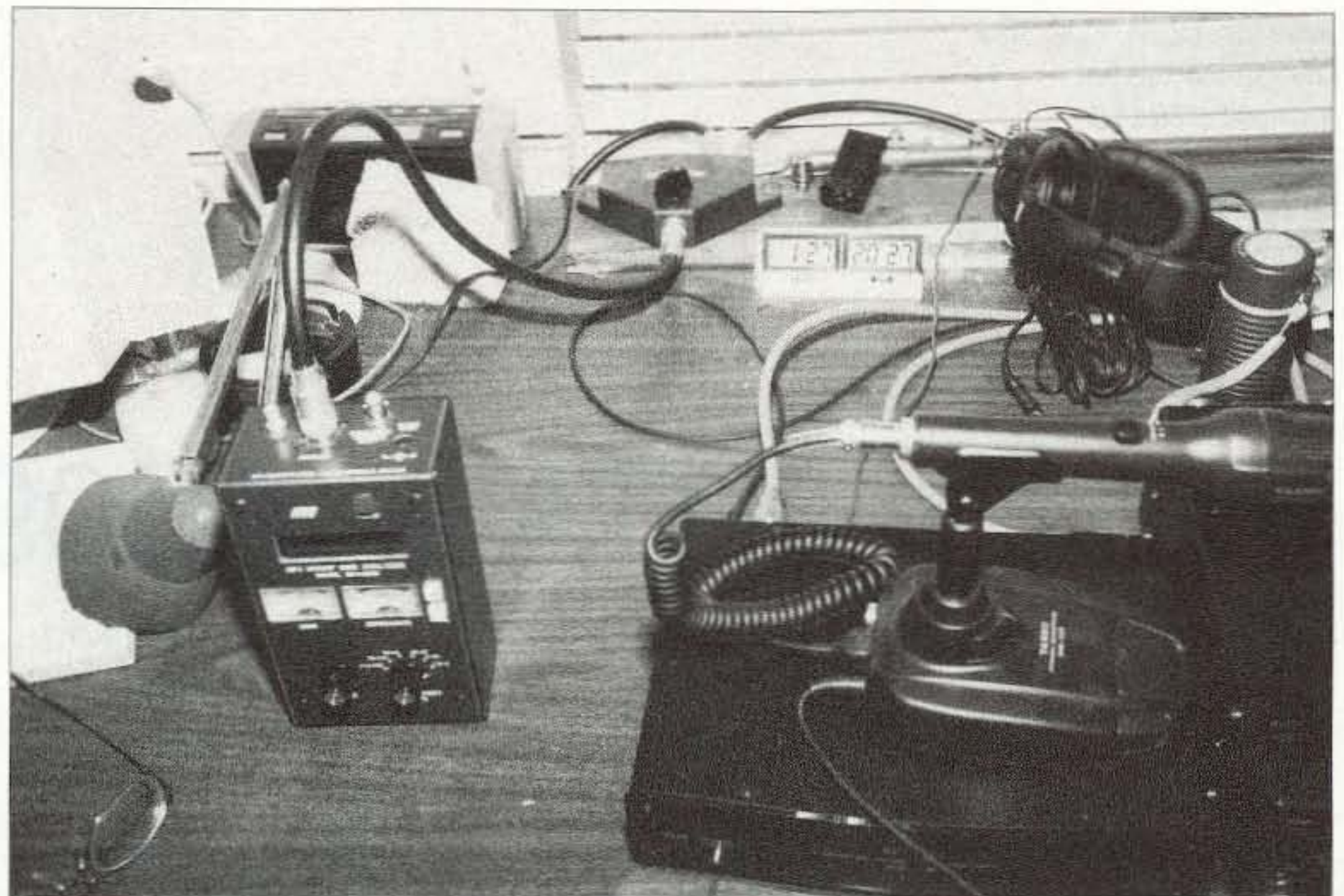

Photo L. KD5IDU's station setup.

discharge protector, available from dealers of Poly Phaser, MFJ, and others.

There are several verticals that can serve equally well. Check out 73 advertisers.

I plan to replace my home-brew support with a 25- to 37-foot crank-up tower when it becomes available later this year. **73**

ELMERS • VE's • INSTRUCTORS • CLUB GREETERS

Become A

HAM AMBASSADOR

The ham industry wants to support your efforts for ham radio growth with free instructor materials.



- Wall Maps • Log Books • Band Plan Charts
- Frequency Charts • Grid Square Guides
- Discounts on Licensing Materials
- Equipment Discount Program
- Gift Certificates

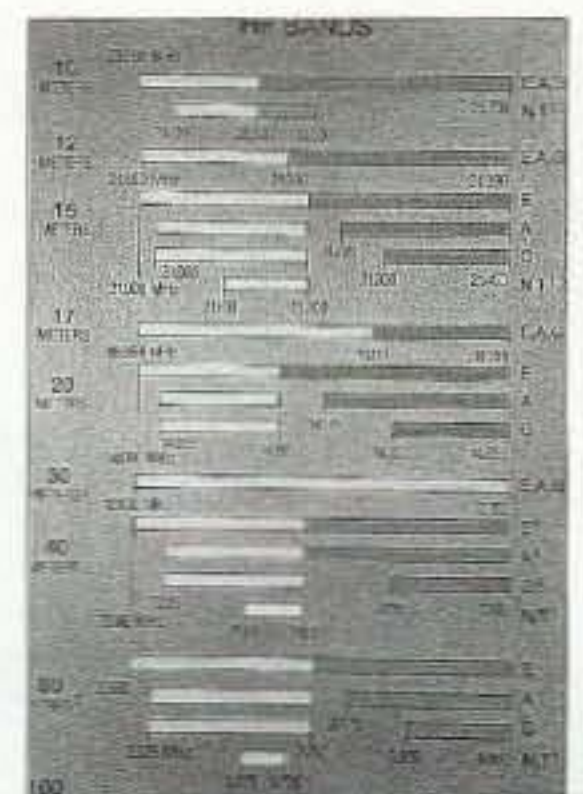

To request a detailed Ham Ambassador Introductory package, write to:
 Gordon West c/o 73 Magazine 70 Hancock Rd.,
 Peterborough, NH 03458. E-mail design73@aol.com

Srikanth Bhat VU2SBJ
37 Ananth Nagar
Manipal 576119
India
[vu2sbj@yahoo.com]
[http://www.vuiota.com]

IOTA — AS096

That's St. Mary's Island to you ...

St. Mary's Island (a constituent part of the AS096 group of isles) is about 3 km from the coast of Malpe in the Udupi district. The island is barren, without human inhabitants, shelter, or drinking water. About 400 meters by 150 meters in size, the small isle is often explored by tourists who visit it for a few hours, usually on weekends when few boats offer services from the Malpe coast.

The boat takes about 25 minutes from the Malpe coast to the island. Some boats cannot go all the way to the island, and tourists are transferred into a smaller boat that will go all the way. Some other types of boats move all the way from the coast to the island.

Overnight stay on the island is restricted by the police authorities of the district. Beginning at about 0530 UTC on Saturday, 5th May, 2001, the

IOTA (Islands on the Air) station was up almost continuously till about 0030 UTC on Monday, 7th May, 2001. With the ten operators who participated, this IOTA event operated four stations on phone and CW on various bands simultaneously.

Amidst a lot of weather uncertainties, the IOTA to AS096, The St. Mary's Island, was a grand success. The total count of logged QSOs crossed 3,500 in the less than 40 hours

of effective operating time. Logs are still being sorted out and more statistics will soon be available. It is our desire to QSL every QSO logged. A well-planned event by the Manipal and the Mangalore hams, the IOTA was the first of its kind for all operators who participated. Hoping WPC's approval will come in on time, which it eventually did, other coordinating efforts began just a few days prior to the scheduled date.

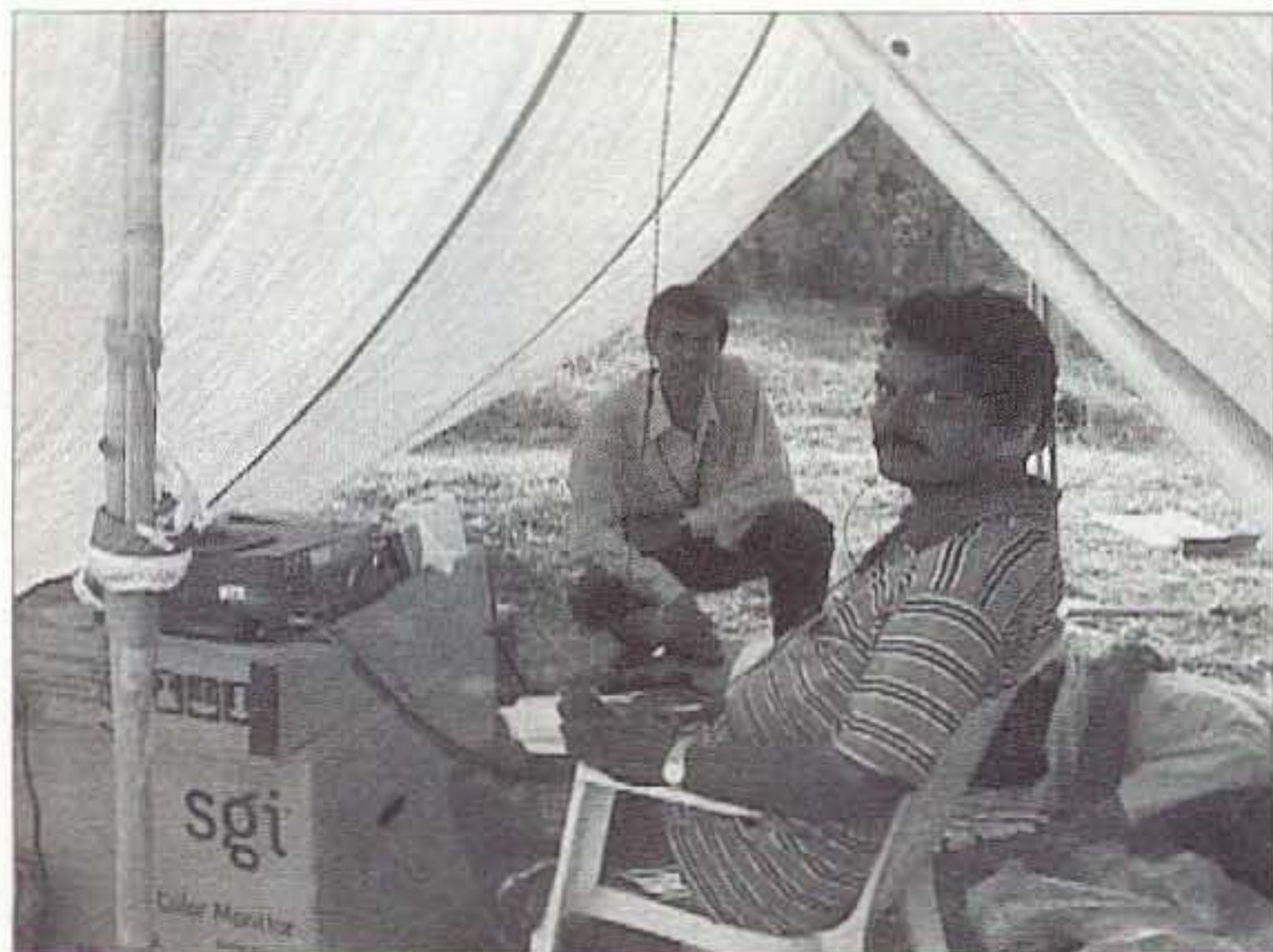

Photo A. OM Prakash VU2JIX, operating one of the stations on AS096. Mur VU2MTT in the background, watches while VU2SBJ takes a break lying on the floor. (Photo by VU2RDQ)



Photo B. A view of one of the four stations on AS096. VU2JIX operating while SWL Nidhi lies down. (Photo by VU2RDQ)

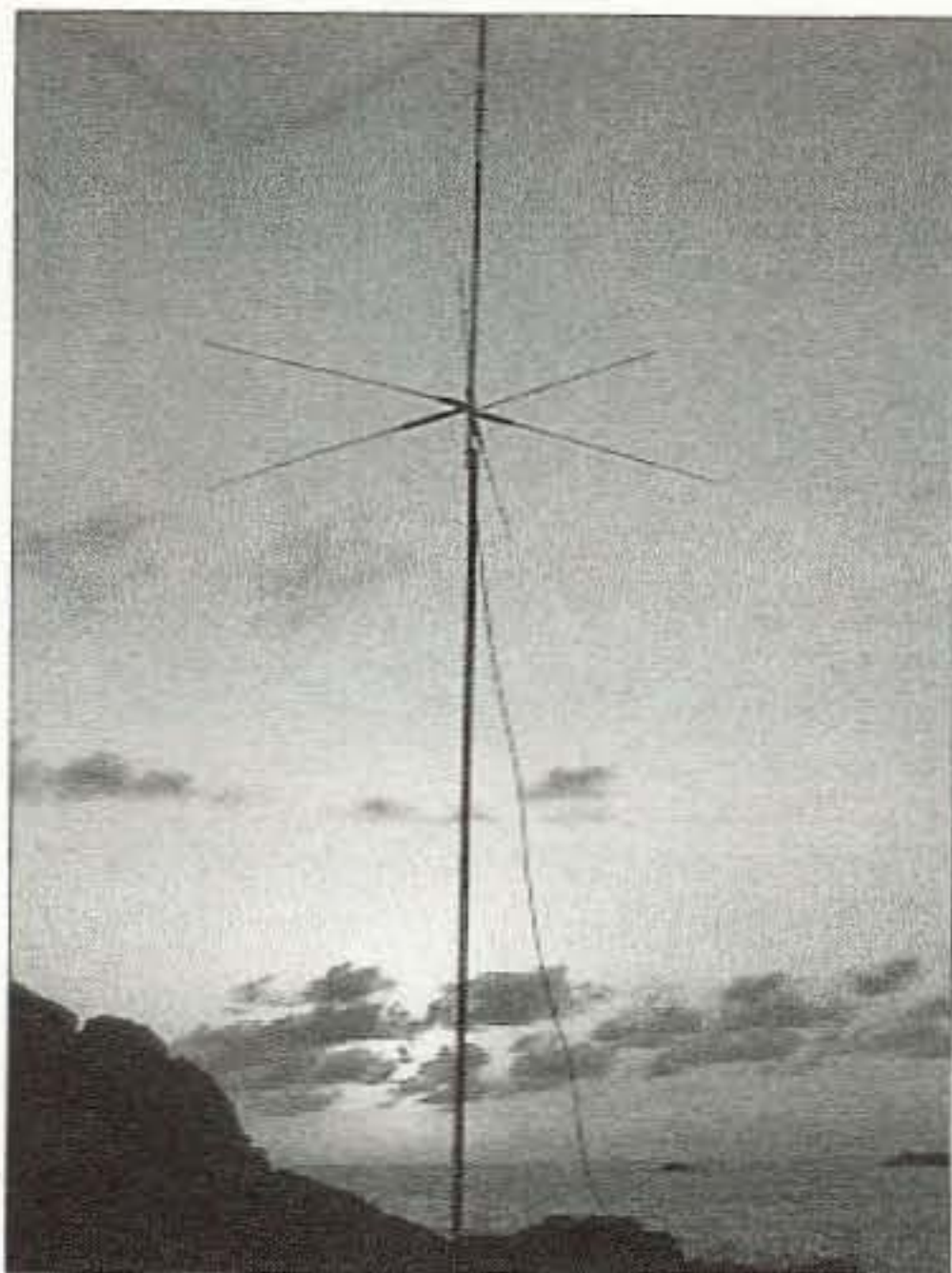

Photo C. A view of the Diamond CP6 vertical antenna during sunset in the background on AS096. (Photo by VU2RDQ)

The team that took part included Manikant VU2JRO, Bhat VU2NJJ, Sri VU2SBJ, Gopi VU2GPH, and VU2MHC (MIT Ham Club, Manipal) from Manipal; and Mur VU2MTT, Chets VU3DMP, Pai VU2PAI, Prakash VU2JIX, Rohit VU2RDQ, and Sukanya VU2RDJ from Mangalore.

SWL Laxminidhi from Manipal and two others from the Mangalore Coast Guard also accompanied the team.

These were the 4 stations we eventually set up.

STATION 1: HF

RIG: Kenwood TS 850 S
 ANT: 3-element 5-band yagi, Cushcraft MA5B (10/12/15/17/20) meters
 CABLE: RG-213
 MAST FOR ANT: 17 feet
 BATTERY: 180 Ah lead acid
 CHARGER: 35 VA solar panel
 SHELTER: Pre-erected bamboo frame with woven coconut leaves and tarpaulin.

OPERATORS: VU2PAI, VU2MTT, VU3DMP, VU2RDQ

N.B.: The camp kitchen was also in the same shelter — now you know why there were so many operators in one place! The camp kitchen was operated by VU2RDJ.

STATION 2: HF

RIG: Yaesu FT-757
 ANT1: 10m 3-el home-brew yagi

MAST1: 10 ft. GI pipe
 CABLE: RG-213
 ANT2: 15m 2-element home-brew yagi
 MAST2: 17 feet AL
 CABLE: RG-213
 TUNER: Home-brew
 BATTERY: 180 Ah lead acid
 CHARGER: 35 VA solar panel
 OPERATORS: VU3DMP, VU2MTT, VU2JIX, VU2RDQ
 SHELTER: Home-brew — tarpaulin tent with bamboo supports.

STATION 3: HF

RIG: Icom IC-751
 ANT1: Fritz 3-band (20/15/10) vertical antenna with mast in the water
 MAST: 12 feet aluminum
 CABLE1: RG-213
 ANT2: Home-brew G5RV allband horizontally supported on coconut trees
 CABLE2: RG-58
 TUNER: Home-brew
 BATTERY: 88 Ah lead acid
 CHARGER: 35 VA solar panel
 OPERATORS: VU2SBJ, VU2JRO, VU2NJJ, VU2GPH, VU2JIX, VU2MTT, VU2PAI, VU3DMP, VU2RDQ, VU2RDJ
 SHELTER: Home-brew — tarpaulin tent with bamboo supports.

STATION 4: HF

RIG: Icom IC-725
 ANT: Diamond CP6
 MAST: 17 ft. aluminum
 CABLE: RG 213
 BATTERY: 180 Ah lead acid
 CHARGER: 35 VA solar panel
 OPERATOR: VU2MTT
 SHELTER: Commercial dome tent

Logistics

This should give an idea of the enormous amount of luggage that was carried. The 6 lead acid batteries (2 extras) probably were the bulkiest items. A very useful sledge prepared by VU2RDQ was a boon to move the batteries. About 250 liters of drinking water, and another 50 liters for "other" purposes, came second in line in terms of bulk. Tarpaulins, bamboo staves for tents, aluminum masts, radio equipment, and antennas came in next. Due



Photo D. Unloading the stuff from the boat to the island. It took a good 40 minutes to get all the stuff out. (Photo by VU2RDQ)

to indications of rain, adequate water proofing for equipment (worth our life for most of us), utensils for cooking, and food were the other components of the luggage that was carried.

Rain and a flat tire delayed our start by about 60 minutes. Eventually, after a quick breakfast specially arranged by VU2NJJ at the wee hours of the morning at a hotel in Udupi, we reached Malpe and began unloading stuff from a mini truck and 3 other cars at about 7:45 a.m. (Saturday, 5th May).

It took about 30 minutes to load the boat, and a similar amount of time to unload after about 25 minutes of travel in the sea. It was drizzling and the sky was dark, so you can imagine the uncertainty in our minds. Fortunately, it was not windy. The boat people refuse to travel if it is windy.

After we landed on the island and unloaded all the stuff by using a human chain, it took us about 4 hours to get most of the things in place and to set up 2 stations on the island. Fortunately it stopped raining. (Later the temperature went up to as high as 42



Photo E. Setting up the Cushcraft MA5B for one of the stations. Seen in the picture are (left to right) VU2PAI, VU2JRO (face not seen), VU2NJJ, VU2MTT (on the chair), VU2JIX, SWL Nidhi. (Photo by VU2RDQ)



Photo F. A view of the AS096, St. Mary's Island. This picture was used on the QSL card, too. (Photo by VU2SBJ)

degrees C.) We were the only people on the island then.

The third and the fourth station came up subsequently. A very useful tip from K2KW encouraged us to install at least one vertical with the mast right in the sea water. You have got to see to believe how dramatically it improves the performance of the antenna. It was comparable to that of the other beams that were erected. For more details on

the special performance of verticals in salt water, visit [<http://www.k2kw.com/k5k/dxcomp.htm>].

The propagation condition from St. Mary's Island was moderate overall with solar flux showing 165 points on Saturday and 160 points on Sunday. The peak was showing a downtrend in the coming days.

Ten meters was good on 5th May during the 12:00Z to 15:00Z with a huge pileup,



Photo G. The entire AS096 team. Left to right: VU2MTT, VU2PAI, VU3DMP, VU2JIX, SWL Nidhi, VU2NIN, VU2SBJ, VU2GPH, VU2JRO, VU2RDJ, VU2RDQ. (Photo by self-timer)

usually from Europe. There were stations from N. America, S. America, JA, VKs coming through pretty well. The condition on 15 meters was exceptionally good and the pileup from Europe was tremendous during 17:00Z to 20:00Z. Also, some stations from N. America/S. America were strong on 15 meters. The 20/17/12 meter band was not encouraging on 5th May, but we could log maximum stations during the peak time on 12 meters on 6th May. 20 meters improved on 6th May with stations from Europe, N.

America, S. America coming through pretty well. 17 meters was quite moderate. We did our best to log maximum QSOs with optimum band propagation and minimum operating time.

We stopped operations early in the morning on the 7th (Monday). The specially hired boat was to pick us up at 7 a.m. It arrived dot on time. We were almost done with disassembling all the stations and the other stuff. It's amazing how much less time it takes to pull down a station as compared to setting it up! It took us less than 90 minutes to get all the stuff back to one place. We reached the shore of Malpe at about 9 a.m. A promisingly busy day at work for each of us looked certain. Nevertheless, it was worth every minute of the fun we had on AS096.

The small effort to publicize the IOTA event on the Web paid off well. Though the event was confirmed just a few days prior to the event after WPC's letters came in, the good response on the band made all efforts towards our maiden IOTA very worthwhile. 73

Subscriptions to 73 Magazine

Only \$24.97 — 1 year
\$44.97 — 2 years
\$65.00 — 3 years*

*best buy (54% off cover price!)

Call 800-274-7373

TRANSMITTER LOCATION

New fixed site direction finders provide 2 degree accuracy, and include software for triangulation from a central control site. Mobile versions also available covering 50MHz to 1 GHz

Doppler Systems Inc.
PO Box 2780 Carefree, AZ 85377
Tel: (480) 488-9755 Fax: (480) 488-1295
www.dopsys.com

European Marketing Director Denis Egan
PO Box 2, Seaton, Devon EX12 2YS England
Tel & Fax: 44 1297 62 56 90

Bare Bones Battery Booster

A good project — as long as you understand the dangers and limitations.

Back in the mid-1970s, I came across a circuit for a very simple constant current charger which was a capacitor in series with one side of the AC power line to a bridge rectifier with the output of the bridge going to the battery terminals. The capacitor value limited the AC current by its reactance value. I made mine to pass around 40 mA. I used it for several years without an isolation transformer. They are not cheap.

Recently I decided to change the design a little and not only make it safe but also give four different current outputs for batteries with different ampere-hour ratings. A ten percent charge rate is standard and will not damage a battery if left on charge for over 12 hours.

I had all the parts on hand in my junk box supply. There are just a few parts needed and it is a good project to do in your spare time. You can make your own layout and customize it to

your needs. One neat thing about this charger is that you can short the output leads and the current will still be limited. I used a surplus 0–150 mA meter mounted on the project box to show the actual current. You don't need the meter, but you should mount a couple of test lead jacks on the box to use your VOM current function to watch the current when trying different capacitors. Leave the output shorted while testing capacitors. After selection, you may replace the VOM with a jumper if

desired. Also, you may want to add a power switch and an indicator light.

The battery voltage under charge is not important as long as it is under 20 volts. The charging current is important. The charger output voltage drops to the battery level during charge unless the battery has an open cell, in which case no current will flow. Open circuit voltage is about 25 volts. Use Mylar capacitors with a voltage rating of at least 200 volts DC. Have fun. NØGJ.

73

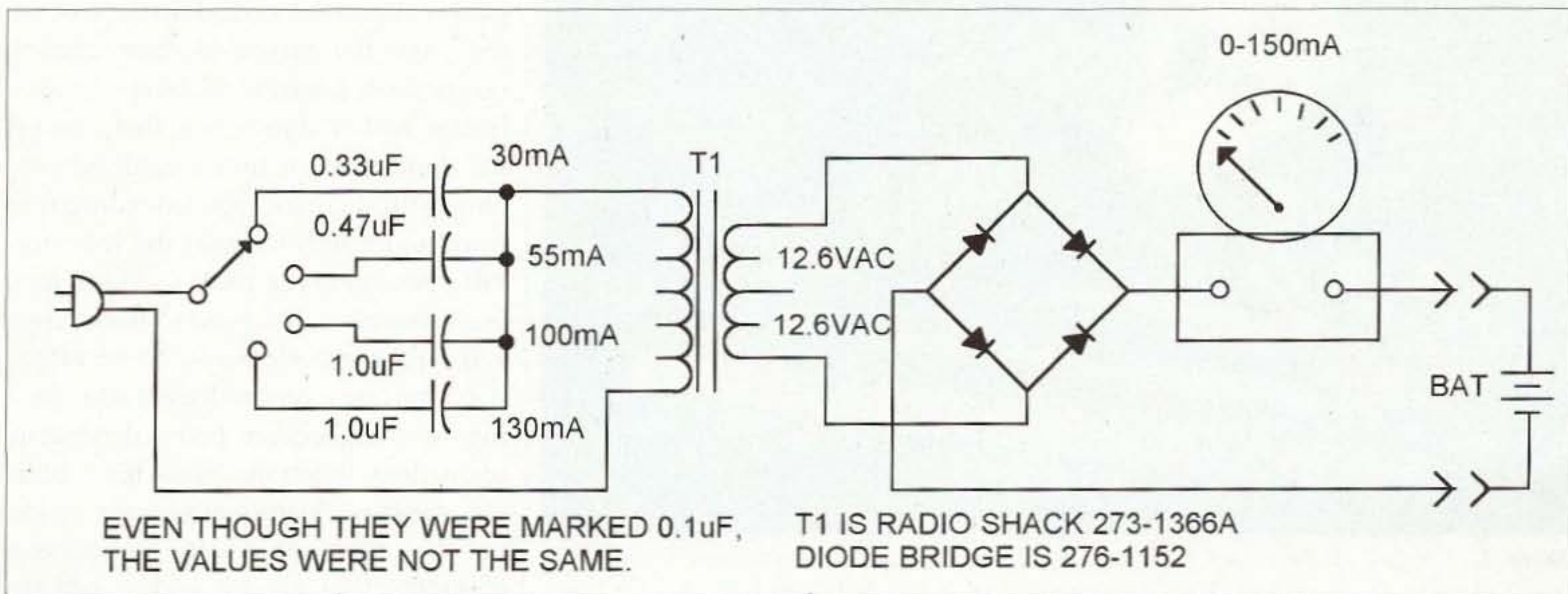

Fig. 1. Battery booster circuit.

RF Inferno

Meet the new Raibeam antennas.

It's the beam of the future and it can be on your tower today. This amazing new design is the development of Chuck Smith WA7RAI, who "just wanted to be competitive while DXing from a small city lot."

Dick Adcock W4GL was the earliest pioneer of this, in the late '40s, with a 3-element all-driven array that he advertised in *QST* for one month. Robert Martinez W6PU was a pioneer in 1980 with dual-driven quads, which he introduced to the amateur radio community via an article in the

December 1983 issue of *CQ*. He is still using this beam and it has no competition. Al Laun K3ZO followed up about a year later with an article in *CQ*, trying to prove W6PU wrong, and couldn't. K3ZO is a contest winner with his version. Antenna Mart has a version of this quad also. All driven

elements up to about three or four, and then "parasitic elements," appear to be the state-of-the-art. Even just two driven elements kick a lot of butt.

What makes this design so different? The typical yagi has a single dipole driven element (DE) that accepts power from the feedline. A dipole's free space pattern is donut-shaped with a gain of approximately 2.2 dBi as referenced to a theoretical isotropic source (this gain is expressed as dBi). Thus 2.2 dBi is generally accepted as a 0 dB reference for all antennas where their gain is expressed as dBd. In the case of the yagi, the driven element excites one or more parasitic elements, i.e., reflector and/or director(s), that change the donut pattern into a cardioid pattern, with its main lobe extending forward and a null towards the rear (the difference between these two extremes is expressed as the front to back ratio, F/B). Parasitic elements, to be effective, must be a certain length and spacing — the specifics being dependent upon their function. Yagis have been the standard beam antenna for years, but they must rely solely on parasitic elements that absorb and re-radiate RF energy, to affect and reinforce the



Photo A. The 2x2-element and 5-element Raibeams came neatly wrapped in one box. One 2-element is unwrapped. The bag of hardware and tools I added are shown. These were assembled and installed in one afternoon.

radiation of energy from the DE in the desired manner. Yagis (and quads), do a great job but all parasitic arrays of this type have limitations regarding maximum gain and best possible pattern, not to mention that their maximum gain and best F/B cannot occur simultaneously. The reflector and directors are "parasites on RF welfare," hence the name "parasitics."

A phased 2-element beam called the "ZL Special" was featured in a series of articles in the NZART (New Zealand Association of Radio Transmitters) publication, *Break In*, in the late 1940s. This beam was constructed using tubular folded dipole elements at a spacing of 0.125 wavelength, and despite numerous phasing line variations, it remained somewhat quirky and difficult to match to a feedline. Despite these difficulties, one of the versions worked quite well — actually, very well. I played with that myself in 1953. Obtaining the proper current distribution by employing a phasing line of the right length and impedance can be a very tricky procedure — and successful results have evaded many who tried. A Swiss ham later developed a somewhat successful plumber's delight version of it known as the "HB9CV."

In the 1980s, Chuck, after using and studying the ZL Special, began developing his own improvements which utilized closer-than-normal element spacing, increased phasing line delay, and a means to properly terminate the phase/delay line into each element. Since the impedance of both elements are fairly low due to their high degree of mutual coupling, the current flowing in them is quite high. Chuck soon developed a unique element bracket designed specifically to reduce high-current losses.

The Raibeam's driven element spacing is about 0.1 wavelength, which is much closer than the typical 0.125 wavelength or greater that is generally used with 180 degree phased elements. At this closer spacing, and higher degree of coupling, the driven elements can become — under certain sets of conditions — critically coupled, a state in which their currents become equal in

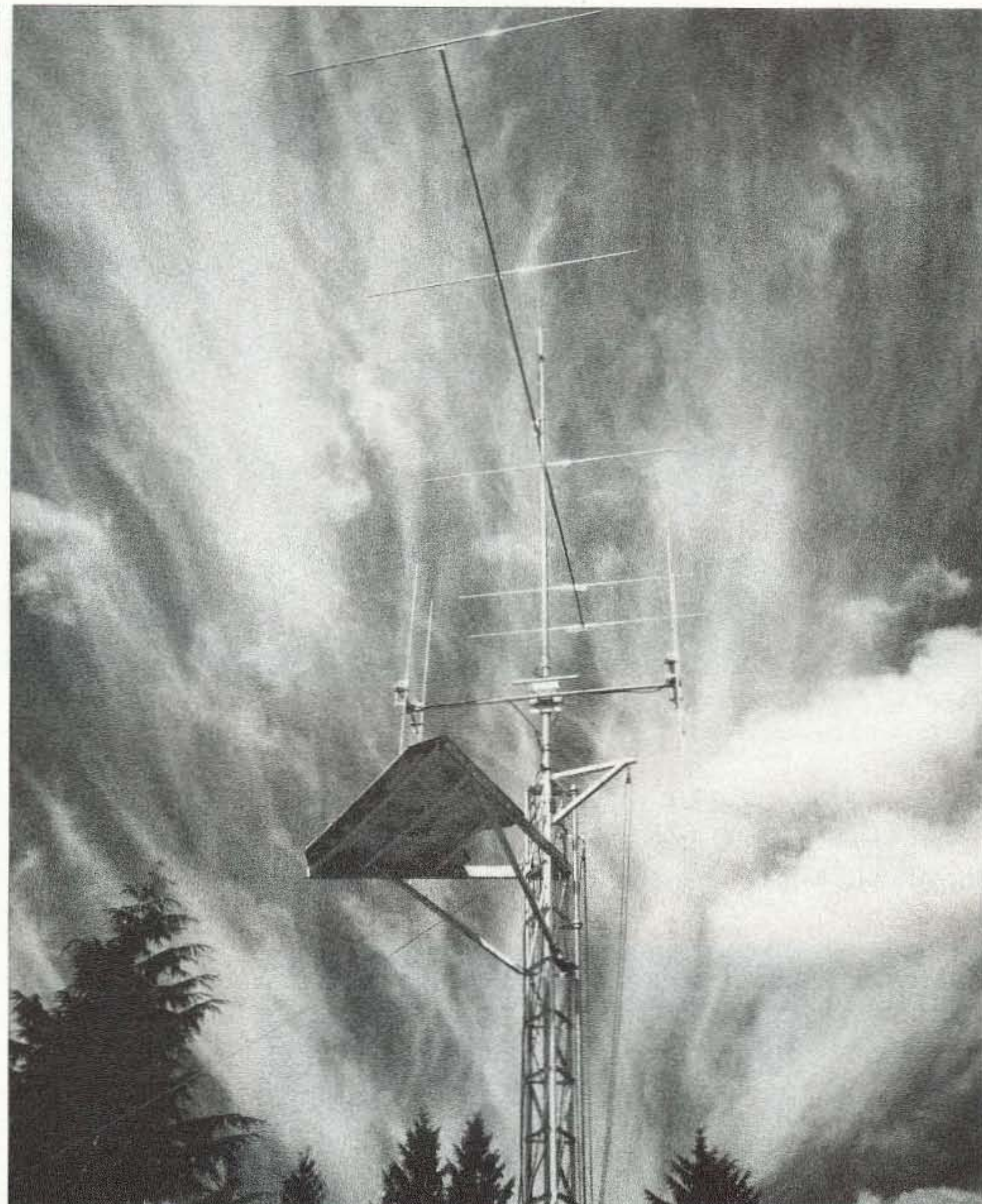

Photo B. The 6m 5-element Raibeam above the 2x2 phase-stacked vertically polarized Raibeams.

amplitude. Chuck has a patent on this unique design as it uses this critical coupling to an advantage, resulting in increased gain and a better overall pattern (excellent F/B).

Upon realizing that he had also developed an ideal "engine" for a reflectorless beam, Chuck soon married his design to parasitic directors. In 1995, he formed a company called Raibeam and then started selling mon-band beams for HF and 6m. It wasn't long before he discovered the best way to interlace the drivers, and thus his tri-band and dual-band beams were born. The 2-element tribander weighs 36 pounds and the dual-bander weighs 20 pounds. Raibeam has up to 4 elements on 20-10m. The 2 driven elements' "gain cell," as I call it, have an

RF running start with gain and F/B before directors are added for more gain and the F/B is retained. This is not so with a yagi DE, where its dipole vertical pattern is a circle with "0" gain.

After hearing a lot of good things about these beams, I decided to see for myself if there was anything to it. I should mention that I was also eager to experiment with stacking the 2-element ones. And, yes, I did pay full price for them, and on a retirement income as well.

All 3-6m beams came neatly wrapped in plastic wrap. After checking the packing lists for missing parts (there were none), their assembly was easy and straightforward. I was able to assemble all three beams in one afternoon. Their light weight allowed



Photo C. 2-element 6m Raibeam. Both elements are driven, have very good patterns, weigh just 3 pounds each.

me to install the beams all by myself in a very short time, although I do have the advantage of a very useful wooden

platform on the tower that allows me to do antenna work very quickly. Having close to 60 years of tower experience does tend to help — hi!



Photo D. 5-over 2-element 6m Raibeams with 1/2-wave vertical on top used as a listening antenna. These two beams can be selected individually or both together in phase. Various configurations are being tried to obtain different angles of radiation individually or phased together, or differences in polarization to create different angles of radiation to compensate for polarization shift.

There were no compromises in the quality of the materials and construction of all three beams despite their ease of assembly. I was impressed to see that an element tubing thickness of 0.058" was also used for the 0.625" diameter tips. The boom-to-element mounts are machined from thick aluminum flats that clamp on the boom, then secured with both a clamping bolt and pointed set screws. Each element sits in a finely milled saddle and is secured by two bolts. Tubing clamps are used at the telescoped tubing

joints (all hardware is stainless steel), and a thick aluminum mast-to-boom plate is included. Conductive grease is also supplied for the element joints to prevent corrosion, and for coating the threads of the stainless steel bolts, nuts, hose clamps, and U-bolts to prevent seizing. It's obvious that these beams were designed to take a lot of ice loading, very strong wind, and should be able to stay up for a long time without the need of maintenance.

The 5-element 6m beam is on a 23.5-ft. boom (1.125 wavelength), and from on-air tests, I have concluded that its pattern is sharper than the 7-element I once had with a 0.15 wavelength longer boom. That caught my immediate attention! I found it sometimes necessary to ask exactly where a local 6m station was located. If I were just 30 degrees off, I'd lose them in the noise. I use speeded up prop pitch motors as rotators to turn my beams, and the sudden signal strength change either way was dramatic. One station observed the sudden increase when I spun the beam on him and said "WOW! It was just like you'd suddenly moved down the street from me." With my previous 5-element 6m yagi — on a 16-ft. boom — I didn't have this effect at all. I can now hear differences in band noise as I rotate the beam, which I didn't hear before. It's not unusual to get 40–60 dB over S-9 reports in Seattle with just 100 W now.

The 2-element Raibeam weighs just 3 pounds and is on a 2.1-ft. boom, making them ideal for limited installations. I have both of the 2-element 6m beams vertically polarized, and stacked in phase on a horizontal fiberglass boom 10 feet below the 5-element horizontal beam. The short boom 2-element beams need only about 1/2-wave spacing for a 2.9 dB (maximum) additional stacking gain.

Vertically polarized beams will generally give a lower angle of radiation than a horizontal one at the same height, but I wanted to determine if the wide horizontal pattern, typical of 2-element beams, would perhaps be beneficial by filling the holes or areas not covered by the various lobe angles typical of a single horizontal antenna

that is several wavelengths above ground.

Another reason I wished to experiment with the 2x2 vertical array is that I have heard stations using horizontally stacked vertically polarized beams on 6m where the user claimed great success with them. Since they didn't have a horizontal reference beam, it couldn't be determined if a real advantage (or disadvantage) over a horizontally polarized beam at the same height did exist.

Another big advantage when switching to the vertically polarized beams is often the reduction of QSB due to polarization shift. You are at the mercy of it with only one polarization. This concept is applicable on 1.8-445 MHz and few use it — I sure do.

I have been able to run a few comparison tests, but so far, I've seen too few and no long openings to really come up with any real definitive data. Preliminary results suggest that the vertically polarized 2x2 array appears to have similar receive abilities when compared to the horizontal 5-element beam, but the horizontal 5-element beam was superior on transmit most of the time so far, more than the gain difference. Further tests may provide enough information to verify this phenomenon and perhaps find an explanation as to why this may be so. I will be using higher-gain beams vertically polarized.

In conclusion, the Raibeam's gain, F/B, and front-to-side ratios are very good. Maximum gain and F/B are never obtained simultaneously with yagis and quads, but there is ample evidence to suggest, that with the Raibeam's critically coupled driven elements, this is not only possible, it is more than likely the case. The 5-element 6m Raibeam has the best gain and F/B/Side of any antenna I've ever used in over 60 years of using beams. I found that with only 100 W I have a lot of "RF clout." If and when I didn't get a station on the first call, I would check and see if it was pointed at them, and in most cases, it wasn't.

When the band was open, there would be a lot of other local stations working the opening before and after me — which is normal. But what wasn't normal was when the band was about dead — I could still be working the weak stations, but no other local stations would be calling them. This happens routinely which implies that the other locals just aren't hearing them. Surprisingly, I have also worked scatter — over the Cascade Mountains into Yakima — KC7FFK. When a friend calls you on the phone to verify that you are really in contact with a station — and not faking it — it is a tip-off of very good antenna performance!

I can certainly believe Raibeam's claim of higher gain and lower noise reception. The matching arms are "DC shorts" across the feedpoints, which is not the case with a gamma and its series capacitor. There is nothing that will get a salty old antenna man more excited than a new design that has features and performance that the others don't!

I highly recommend this superb line of antennas [Raibeam, 5658 W. Alice, Glendale AZ 85302; 1 (800) 530-1913].

If you'd like to know more about them, check out their excellent Web site at [<http://www.raibeam.com>].

One photo shows the 6m 5-element Raibeam above the 2x2 phase-stacked vertically polarized Raibeams. I can select either or both in phase. On top is a 1/2-wave vertical antenna I use for monitoring the call frequencies of

50.110, 50.125 MHz, and beacon activity. A "monitoring antenna" is even more of a necessity using beams with very good F/B/Side on any band. In the near future, I plan on experimenting with stacked halos on top for monitoring also.

Get a Raibeam and create your own "bragging rights"! 73

Say you saw it in 73!

EVERY ISSUE OF
**73 Amateur
Radio Today**
on Microfiche!

The entire run of **73** from October 1960 through last year is now available. Over 800 fiche!

You can have access to the treasures of **73** without several hundred pounds of bulky back issues. Our 24x microfiche have 98 pages each and will fit in a card file on your desk.

We offer a battery operated hand held viewer for \$150, and a desk model for \$260. Libraries have these readers.

The collection of microfiche, is available as an entire set, (no partial sets) for \$325, plus \$10 shipping (USA). Annual updates available for \$10, plus \$3 shipping/handling. Satisfaction guaranteed or money back!



BUCKMASTER



6196 Jefferson Highway
Mineral, Virginia 23117 USA
540:894-5777 • 800:282-5628
Fax 540:894-9141
e-mail: info@buck.com

Quality communications
equipment since 1942.

WWW.RFfun.com



Universal Radio

6830 Americana Pkwy.
Reynoldsburg, OH 43068

◆ Orders: 800 431-3939

◆ Info: 614 866-4267

◆ Fax: 614 866-2339

VOM Primer

This overview is helpful for beginners and old-timers alike.

The VOM, volt-ohm-milliammeter, is the workhorse of the electronic workbench. How it works and why it works isn't important as long as it works. But the how and why are important if we are to know its limitations.

The galvanometer is the core of the instrument. It's the thing that indicates what's being measured. The galvanometer's operation depends on the forces applied to conductors in a magnetic field. In the usual form, a coil of wire with a pointer attached is suspended in a magnetic field and a current is established in the coil: The forces thus produced on the coil deflect it from its position of rest and the amount of deflection serves as a measure of the current in the coil. This is the operating principle of the d'Arsonval galvanometer (named after the French physicist, Arsene d'Arsonval) used in the measurement of small currents, as well as most voltmeters and ohmmeters.

Meters are rated by the current needed to produce their full scale deflection. For example, a 1 mA meter will have full scale deflection when the current in the meter is 1 mA; a 50 μ A meter will have full scale deflection when the current in the meter is 50 μ A.

The basic meter is a coil placed in the field of a permanent magnet. The coil is held at rest with a small spring and a needle is attached to the coil to sweep the needle across the meter face

to indicate the current in the coil. The coil is free to rotate in the magnetic field.

The magnetic field can be disturbed by nearby magnets or even magnetic material and affect the readings. Most meters, but not all, are shielded to isolate them from their surroundings.

There are many ways to abuse a meter: Mechanical shocks can dislodge the coil from its bearings. Strong overloads can bend the needle at the peg. Meters with bent needles are not uncommon. I have seen meters that have been overloaded until the coil's insulation has smoked. The faces are then tan with black numbers.

Most meters have a short across their terminals when they are not in use. The short across the meter damps out the effects of sudden movement of the meter. If the coil is moved with respect to the magnet, a current is induced in the coil and a counterforce is produced. The short is not intended to protect against stray voltages that might be encountered.

An unknown meter can be mechanically tested by rotating it in the plane of the meter face. If the needle moves, the coil (form) is in its bearings, and if

it returns to rest immediately, the coil is probably intact. Of course this kind of test doesn't tell anything about the electrical condition of the meter, only the mechanical.

Two characteristics of a basic meter are the resistance of the coil and the current required for full scale deflection. As you might guess, the resistance of the movement differs for different sensitivities. Typically the voltage across the coil is either 25 mV or 50 mV. Most 1 mA movements are about 25 or 30 ohms. More sensitive movements have a resistance in the range of 1,000 or 2,000 ohms. The current is the critical factor.

To make an ammeter requires a shunt across the basic meter. For this, the meter's resistance R_m must be known. If it is required to increase the full scale deflection from 1 mA to 10 mA, a 9 mA shunt must be placed across the meter. The voltage across the meter and across the shunt is $R_m \times I_s$. The current in the shunt is $R_m \times I_s / R_s$. The ratio of the shunt resistance to meter resistance is $R_s / R_m = I_s / I_m$. A 30-ohm R_m and a 1 mA movement needs a 3.333Ω shunt to increase the full scale deflection to 10 mA.

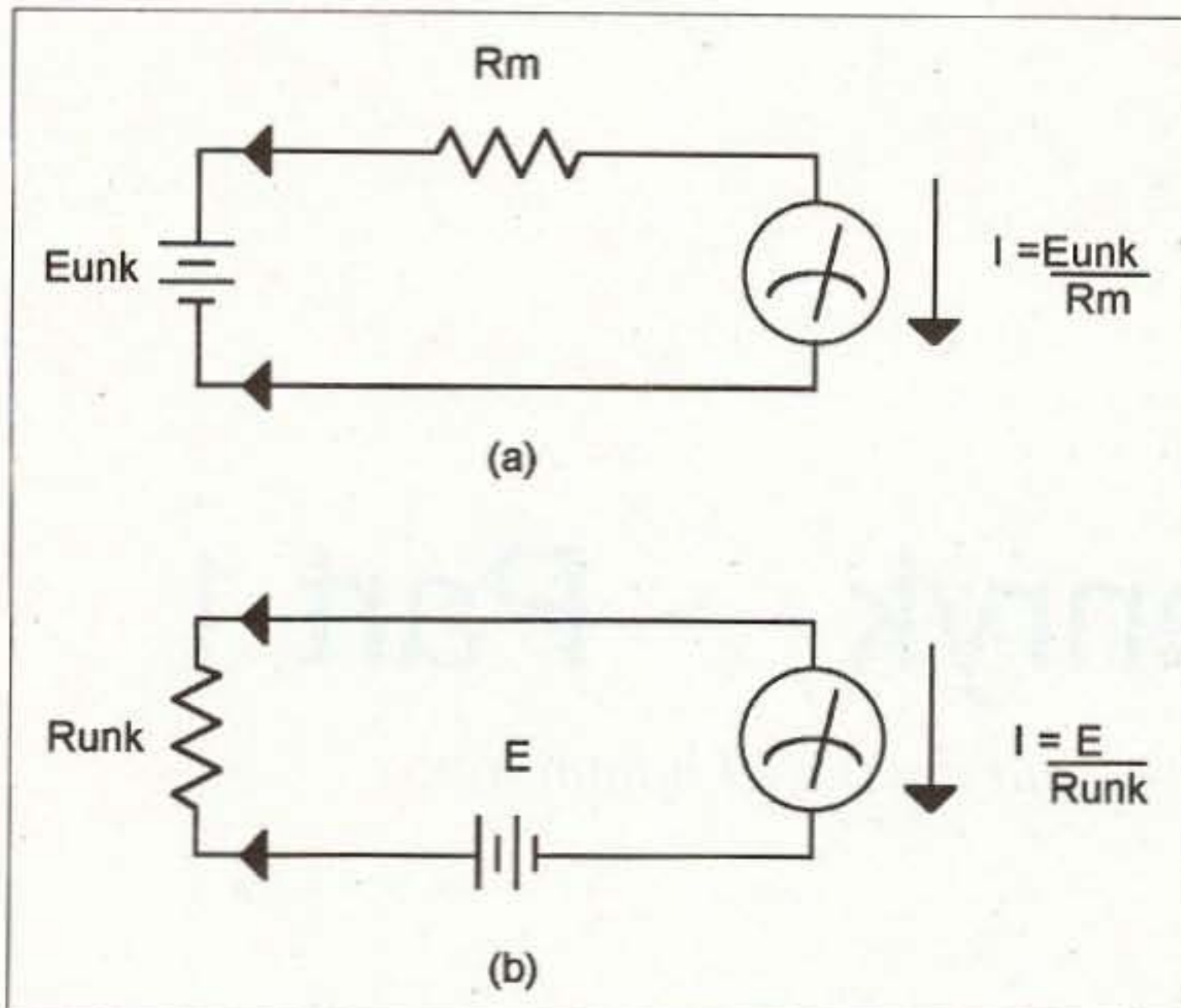

Fig. 1. (a) A current meter can measure voltage. (b) A current meter can measure resistance.

The unavoidable voltage drop across the meter is a limitation in very low current or very sensitive measurements. Usually we ignore the voltage drop across the current meter and ignore the few millivolts dropped across the meter. But the limitation should be recognized and evaluated for the particular case.

To make a voltmeter, a multiplier resistance is placed in series with the movement to limit the current. A multiplier resistance of 3k would limit the current from a 3-volt source to 1 mA. A multiplier resistance of 60k would limit the current from a 3-volt source to 50 μ A. The sensitivity of a voltmeter is often expressed in terms of ohms per volt.

The ohms per volt is just the reciprocal of the full scale meter current. A voltmeter with a 1 mA movement has a sensitivity of 1k ohms per volt and on a 3-volt scale loads the circuit under test with 3k. A 50 μ A movement has a sensitivity of 20k ohms per volt and a 3-volt scale loads the circuit with 60k. Most voltmeters indicate the ohms per volt on the face of the meter. We often ignore the loading imposed by the voltmeter, but the extra loading can upset a high impedance circuit. The meter's sensitivity indicates the loading that can be expected. For example, a 20k ohms per volt meter on the 100-volt scale loads the circuit with 2 megohms, but on the 3-volt scale the loading is 60k.

batteries are used in some instruments. The voltage is applied to the unknown resistor and the current measured. The unknown resistance is $E/I_{\text{indicated}}$.

Since the ohmmeter's battery voltage changes with use and time, a zeroing pot is included to set the full scale deflection. The pot is adjusted so the meter indicates full scale when the leads are shorted (the unknown resistance is zero).

Most VOMs also read AC volts. To

Continued on page 59

While the meter indicates current, the scale can be calibrated in anything from VUs to inches of water. So don't be put off by the scale; the meter works the same. It measures a current.

To make an ohmmeter requires a current meter and a known voltage of some sort; a single dry cell of 1.5 volts is fine for lower resistances, but 9-volt or even 30-volt

The Gordon West Study Guides

Examination Test Questions & Answers for General Class and Extra Class with explanations of the answers



General Class
\$12.95
Plus \$3.50 S&H



Extra Class
\$14.95
Plus \$3.50 S&H

Omega Sales

P.O. Box 376
Jaffrey, NH 03452
800-467-7237



Scrambling News

915 NW First Ave., Suite 2902, Miami FL, 33136
305-372-9427
www.scramblingnews.com

Pay TV and Satellite Descrambling 2002 - NEW! - satellite and cable. Includes latest information. \$19.95 plus \$1.75 shipping.
Hacking Digital Satellite Systems Video 2002 - New! - \$29.95 plus \$3.50 shipping.
Scrambling News Online - Online service for those interested in satellite television news. \$59.95/year. \$59.95/yr.
Pay TV and Satellite Descrambling Series CD-Rom - all 13 volumes over 300 pages, \$59.95 plus \$3.50 shipping.
Best Deal - Everything listed above for only \$99.95 plus \$3.50 shipping.

Logging As Easy As

1-2-3



1. Type The Callsign
2. Press Enter
3. Press F7

THAT'S HOW EASY IT IS!

Creative Services Software, Inc
503 West State Street, Suite 4
Muscle Shoals, AL 35661
256-381-6100

Log Windows 3.07
available from your
favorite dealer or
direct from CSS

\$69.95

<http://www.logwindows.com>



Henryk Kotowski SMØJHF
Sibeliusgängen 28 XI,
SE-16477 Kista, Sweden
[henryk.kotowski@chello.se]

Travels with Henryk — Part 1

SMØJHF shares some photos — and the fun of hamming.

The Cape Verde Islands, located off the coast of West Africa, are not very active on the air, but there are a few permanent hams there.

One is Carlos D44AC [d44ac@qsl.net], living on the island of Sao Vicente (IOTA AF 086), and the other is Angelo D44BS [d44bs@cvtelecom.cv], living on the island of Sao Tiago (IOTA AF 005). Both have rotary HF beams and can be heard well. Both will welcome visitors. I visited them



Photo A. Paul WA6PY (a.k.a. SMØPYP) enjoys moonbounce operation.

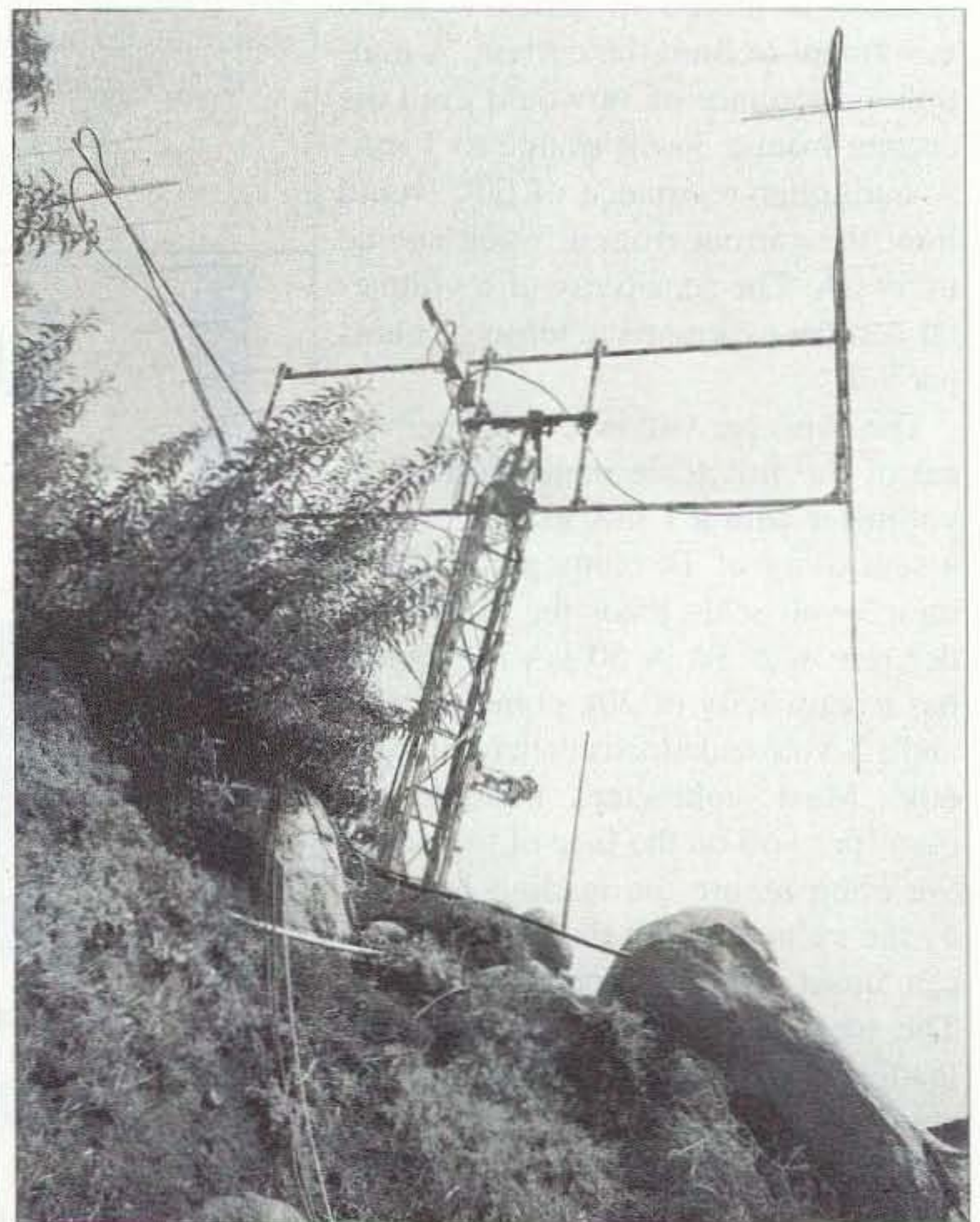

Photo B. WA6PY's antenna.

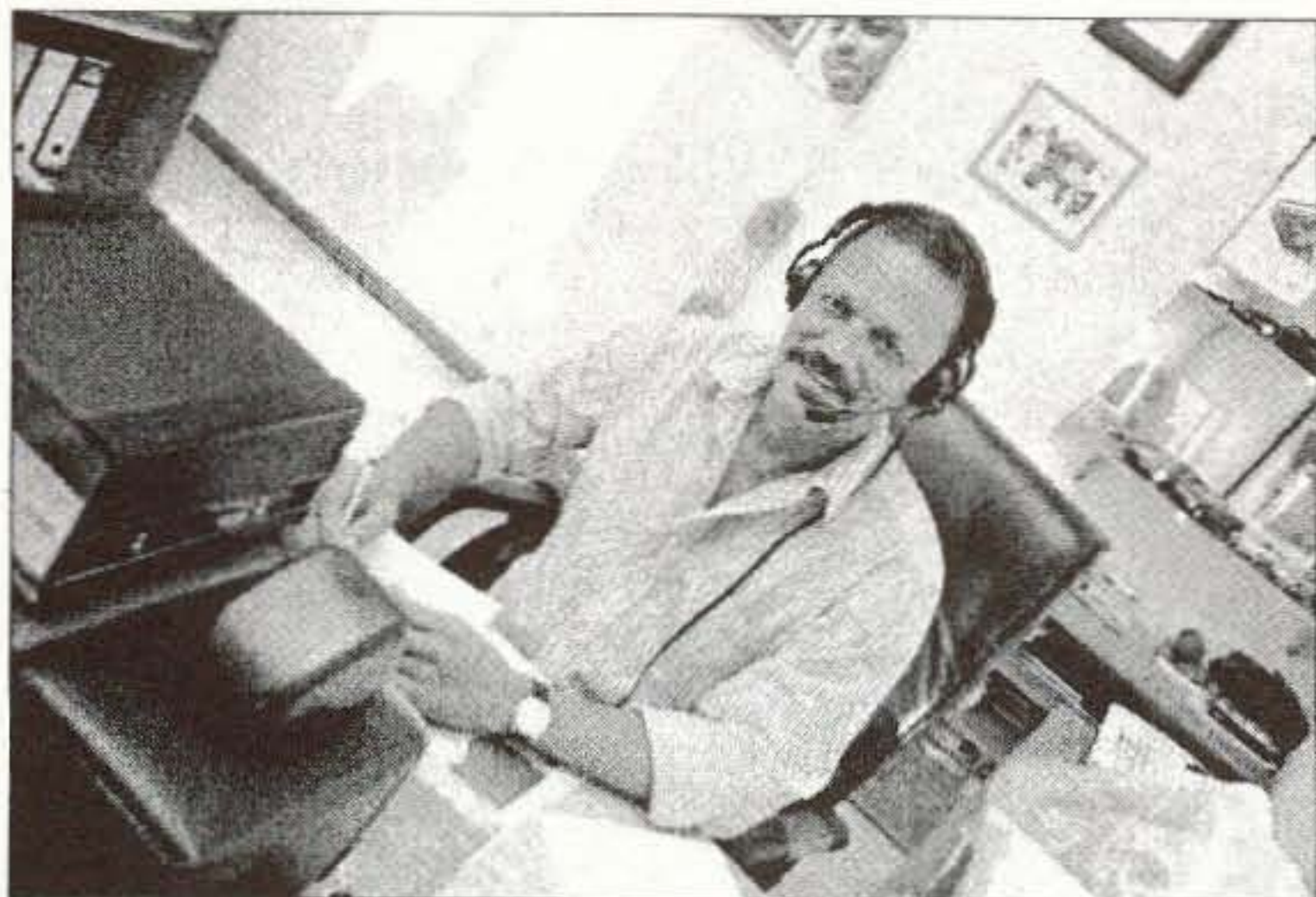

Photo C. Carlos D44AC of Sao Vicente.

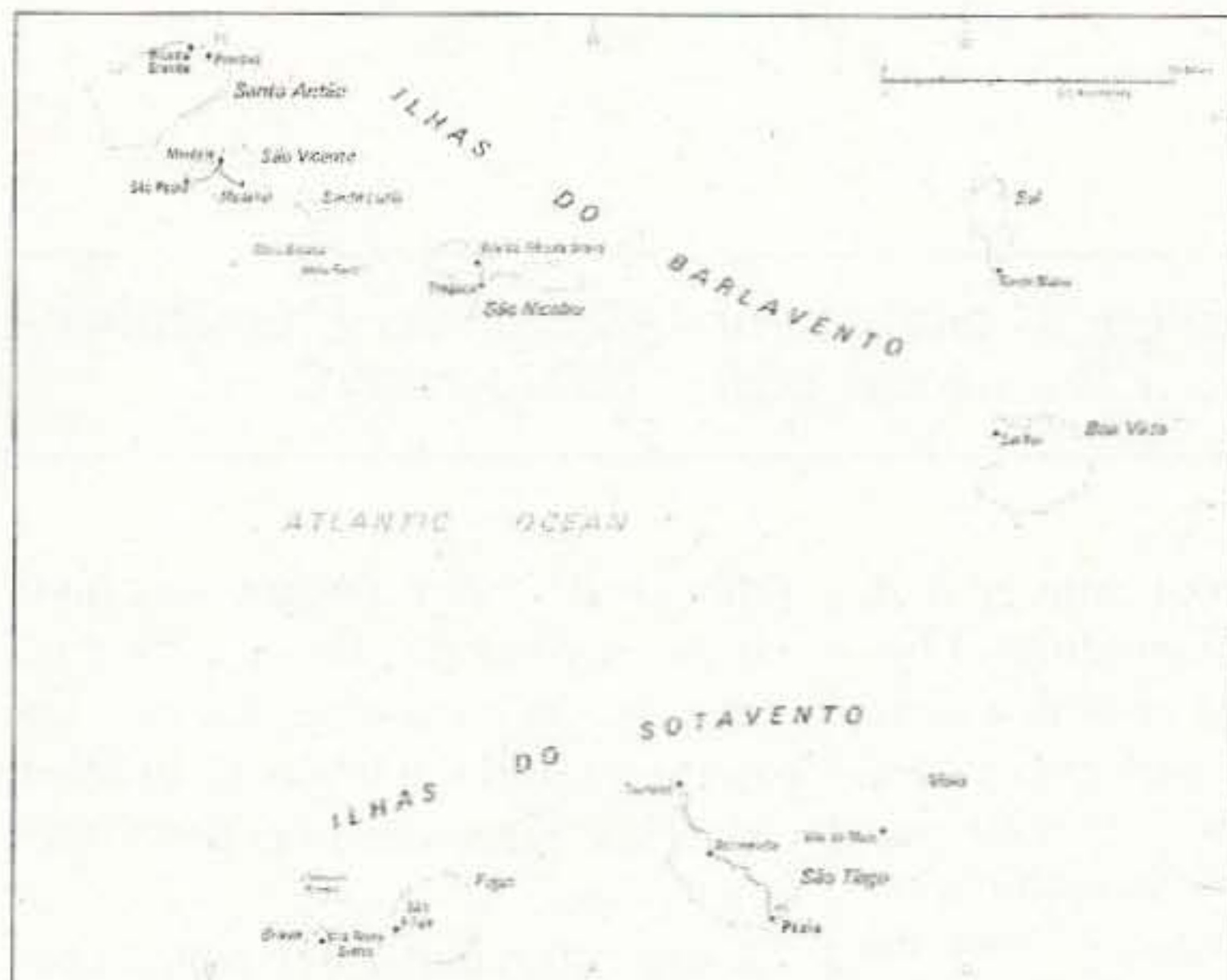

Photo D. Map of the Cape Verde Islands.



Photo E. Angelo D44BS on Sao Tiago.

last November, and even was on the air with my own callsign, D44CF [www.qsl.net/d44cf]. I plan to go to Cape Verde again this winter, as the climate is perfect, the music is enchanting, and the people are friendly. It is a peaceful place.



Photo F. Henryk D44CF operating during his November 2000 visit to the Cape Verde Islands.

Paul WA6PY, probably better known as SMØPYP, was very successful in EME contacts on several bands while living in Stockholm. Some five years ago he moved to San Diego in California and is back on the air with his new callsign. So far, his antennas are modest when compared with the large home-brew dish he had in Stockholm. Paul is busy, as his knowledge is in demand. He is planning moonbounce on 5.7 GHz and 24 GHz, apart from previous activities on 144 MHz, 1.3 GHz, 2.3 GHz, and 10 GHz from California. His E-mail address is [wa6py@qsl.net]. 73

CLEARLY HEAR THE DIFFERENCE



Dimensions: 5.5"x4.5"x2.5"

ClearSpeech™ Speaker

is a digital speaker that removes up to 95% of background noise from the receive side of any two-way radio communication. ClearSpeech™ Speaker is a high-tech, low cost solution that enhances the audio quality of car and truck, emergency vehicle, marine, mobile and base ham radio communications.

Put pleasure back in Ham Radio!

- Improves clarity and intelligibility of communications
- Continuous and adaptive removal of background noise
- Listen with less fatigue and greater concentration

\$149⁹⁵ (plus S&H) **30-DAY MONEY BACK GUARANTEE**



Also available is the ClearSpeech™ Base to use with your favorite base station or mobile speaker.
Dimensions: 3"x1"x5.5"

AM-COM, INC.

1-888-803-5823

www.amcominc.com

All major credit cards accepted

Am-Com, Inc., 100 Bierney Rd., Ste. C, Lakeside, MT 59922

Francis (Frank) Kelson HL1/N8HI
PSC 450 Box 826
APO AP 96206
USA
[qrpdx@korea.com]

Ye Olde Fishpole Vertical

Some things never change — thankfully.

Recently I have noticed the quest for portable antennas among our QRPers, and I remember the many times when I was in a situation where a sky wire couldn't be tolerated.

Over the years I have used small portable antennas, mini loops, helicoids, and hotel room window frames. All worked for me reasonably well, but I notice the trend these days is more for hiking into the hidden valleys, mountains, and personal Shangri-La's.

I've been an amateur radio operator for a number of years now, and I've experimented with helicoids, end fed dipoles, and Vertical Radiating Dipoles (VRD), which I have found

worked quite good from earth ground, but not from on top of buildings. I figured that I could come up with a small package that should perform reasonably well under the above conditions.

I knew that an antenna requires capacitance and inductance. From the formulas contained within the *ARRL Handbook* I also knew that it wouldn't take very much to accomplish an extremely small antenna whose weight would be ideal for backpacking. Experience gained by the use of fiberglass

components — fishing poles — for rotatable dipoles and two-element beams made me yank out my trusty old notebook, and peruse through the hundreds of schematics and antenna designs that I have.

Suddenly my attention was focused on a mini 20-meter two-element beam. It was quite efficient,

although the beam pattern was quite narrow, making the use of a rotator a necessity. Once the other station's signal was peaked up, it was no problem making a contact with 1 through 5 watts of RF power.

I also realized that I stumbled upon this design by first constructing one element and making it resonate to my frequency of choice, before making the other three elements. Armed with that data, it didn't take me but a few minutes to construct a vertical that could be collapsed down to a 28-inch package, and weighed in at just a few ounces.

This is one that could be used from a canoe or rowboat, held up by clamps, and with the radials running around the gunnels. Don't forget the Jolly Roger. Or from a hotel balcony, and — yes — from the fender of your vehicle if that is how you are backpacking. One that wouldn't attract the attention of the local Park Ranger, who more than likely will be thumbing through his handbook looking for a clause that mentions something about potential lightning hazards. You could even slip this antenna into a PVC tube with a mock wooden TV antenna at the top,



Photo A. Frank in the Sierra Nevadas, working DX with a simple portable vertical.

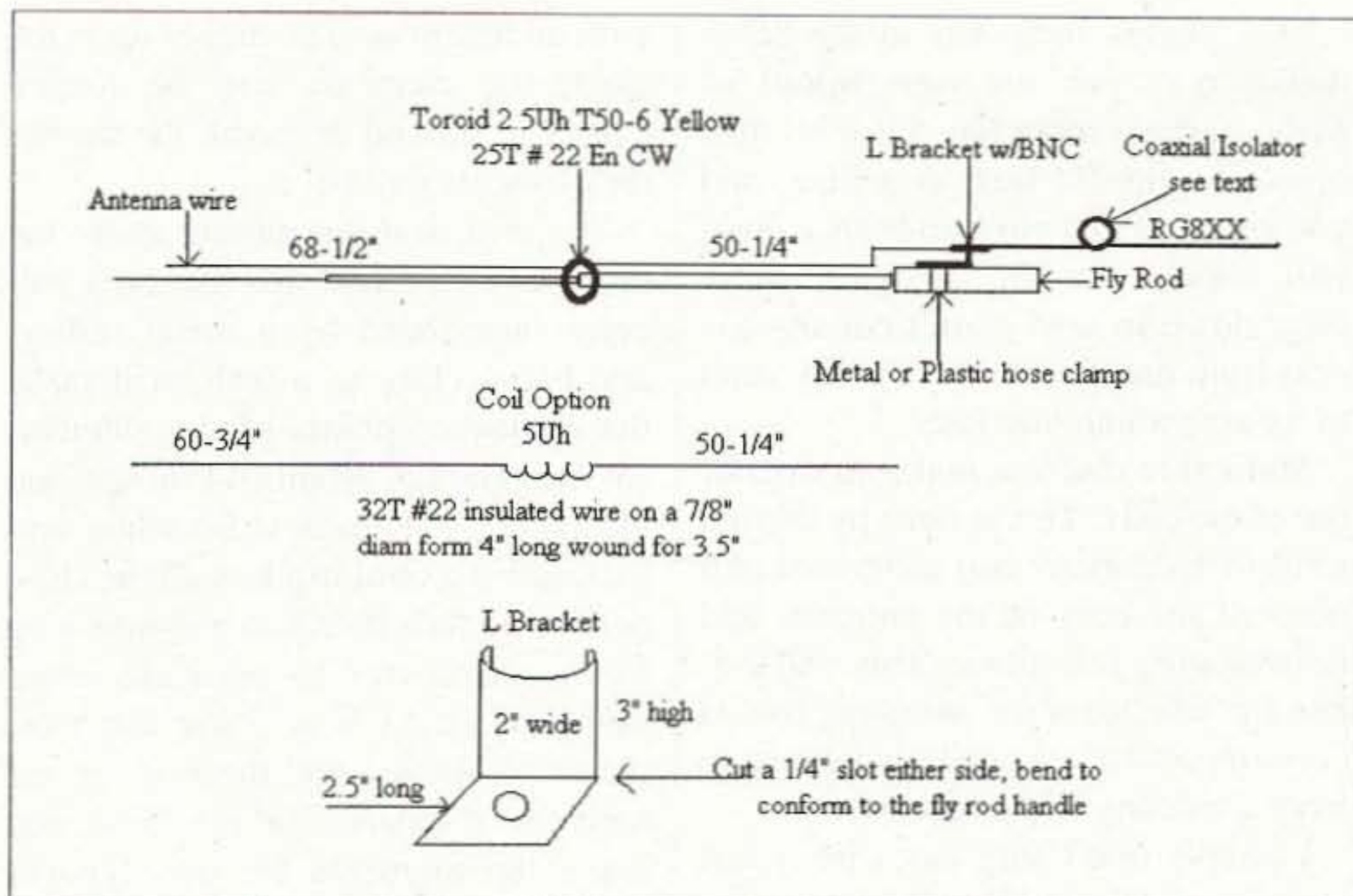

Fig. 1. Simple QRP vertical.

and use it as a vertical dipole. Don't forget to silver-paint the tiny UHF TV antenna.

The fly rod that I now have has been painted with camouflage green paint, and a good coat of varnish for a special application. It is now almost invisible in the bush.

The schematic shows that the antenna wire uses a fly rod to maintain its integrity. Simple fly rods that are 11 or 12 feet in length are rather cheap these days. Deviating from the norm of using air core coils, I used a simple ring core, which fits on the rod's frame rather nicely, and is quite small and easy to slide off for removal when you fold up the fly rod. When winding a ring core, make sure that you wind it

for only 80% of the ring; if that is not feasible, then you would have to go to the next larger core, or use a smaller-diameter wire. Right! If there are any doubts about these devices, please refer to Chapter 6 of the *ARRL Handbook* and scroll down for the area of interest.

I used the yellow core series since I have them on hand. Generally these are not ideal for wideband applications, but they are suitable for our needs in the area of from 2 to 50 MHz, with the 6 material being more temperature-stable.

If anything, I hope that this will stimulate your interest for further research and experimentation. There is no telling

Continued on page 34

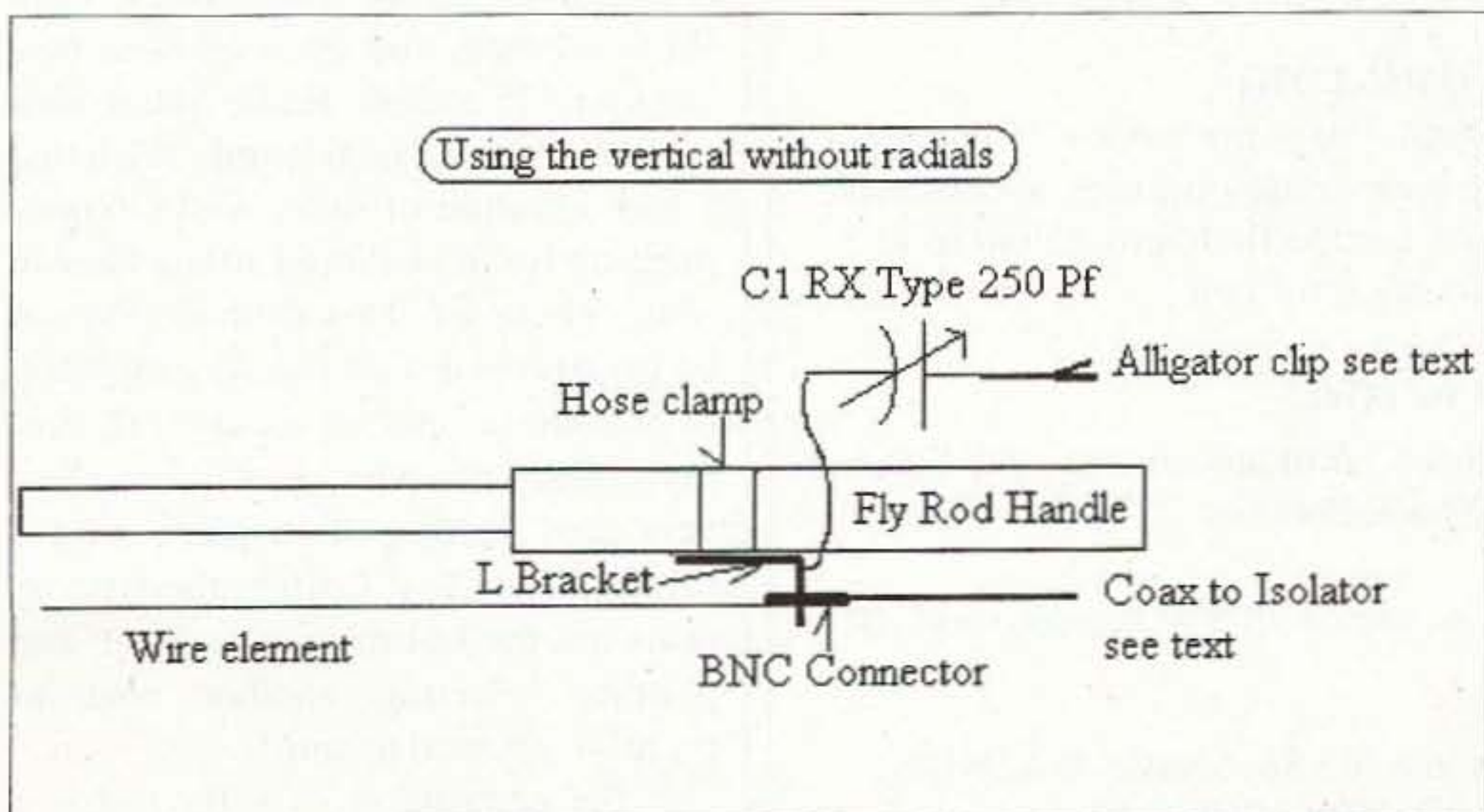

Fig. 2. Using QRP vertical without radials.

The New Pools!

Examination Test
Questions & Answers

The exact questions, multiple choices and answers for the Technician Class, General Class, and Extra Class operator's license.



Only
\$9.95
Plus \$3.50 S&H

Omega Sales

P.O. Box 376
Jaffrey, NH 03452
800-467-7237



LOW PROFILE HF ANTENNAS THAT REALLY WORK!

"Work the World Without Working Up the Neighborhood"

ISOTRON

BILAL COMPANY

Call for a FREE Catalog:

719/687-0650

137 Manchester Dr.
Florissant, CO 80816
www.rayfield.net/isotron

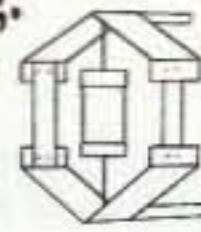

HamCall™ CD-ROM

U.S. & International - Over 1.63 million listings



We make a new HamCall every month! Clearly, the most current and complete CD-ROM available.

Latest Features

- Choose font and color of data display.
- Displays flag and map for each country.
- Shows CQ, ITU zone, and continent.
- History list shows each callsign entered.
- Print labels in a variety of formats.
- View & search interests of 39,000 hams.
- Search for club, military, vanity, silent keys, name, address, and more.

Over 1,631,000 U.S. and International listings, 128,000 e-mail addresses, 4,000 photos and QSL cards, 37,000 vanity calls, and 20,000 references to QSL managers.

Shows path distance & bearing.
Precise latitude/longitude for over 90% of addresses.
HamCall is \$50.00, included is 6 months free access to our HamCall Internet Service - request when ordering.

HamCall Mousepad, with morse code reference, 7.5" x 8", blue with yellow letters. \$5.00 + \$3 shipping.

\$5.00 shipping (\$8 Intl) per order. Your satisfaction guaranteed!



BUCKMASTER

6196 Jefferson Highway • Mineral, VA 23117 USA
e-mail: info@buck.com
540-894-5777 • 800-282-5628 • 540-894-9141 (fax)



Ye Olde Fishpole Vertical

continued from page 33

what you may come up with, and I will be looking forward to your articles.

An option for an airwound coil is also provided. You can accomplish this by using PVC pipe 4" long by 7/8" diameter. Close-wind 32 turns of #24 insulated audio wire for 3.5 inches, approximating 5 μ H; shim or glue into place. The coil wire and element wire in this case can be one continuous piece.

Constructing these antennas indoors is fine, but adjust them outdoors. Go out in the yard or to a city park, and prune for resonance. Make sure that you are not above a sewer pipe, or beneath power lines.

The lengths indicated in the schematics may put you well below 14 MHz, perhaps more like 13 or so. Just prune the tip 1/4 inch at a time, and you will find that your resonance point will simply pin the analyzer meter clear down to zero. Don't cut any excess from the fly rod — you may want to try something else later.

Make sure that you make an isolator out of the coax. This is done by curling a six-inch diameter coil composed of 6 turns at the base of the antenna, and tie-wrapping it in place. This will isolate the line from the antenna. This is very important, especially when using from a balcony or permanent site.

I usually don't snip any wire. I just curl it up into a small ball, and tape or rubber band it in place. Rule of thumb

with all antennas: The higher up in the clear, the elements will be longer. Closer to ground or metal, the shorter the elements will be.

You will find that tuning under the most severe conditions, like on a balcony surrounded by a metal railing, and being close to a wall, will make the resonance points of the elements shorter. The tip, around 44 inches, and the radial, 158 inches. So when embarking on a field trip less all the close density factors, then you will tune it up for resonance for its particular environment. That's why I say don't cut the elements, just roll them up, or just tune for resonance in the field, and leave the elements for that type of situation.

I mated the handle of the pole with a 3-foot piece of PVC pipe, and extended the radials out in GP fashion, using plastic tent stakes to hold them in place. Another alternative is to use a small camera tripod. I prefer to use a metal stake in the bottom of the PVC so that it can be forced into the earth, usually at about a 30-degree angle with the tip of the fly rod pointed in the direction of choice. It seems to me that an endfire is accomplished with these little antennas, that is, when the radials are placed 180 degrees from the tilt, and my first contact like this, as I recall, was a contact between Hawaii, and Seoul, Korea with only 5 watts.

On one model I used a car whip antenna for the tip element, but of course on a heavier model fly rod that permitted me to adjust the length of the whip for resonance, and even allowed tuning up to 15 meters. Radio Shack now has these in a 72-inch length. Wish that I had a couple of them while experimenting for my helicoid article back in May '94 for 73. This method also can be prearranged with the wire element, by marking a spot on the fly rod, simply coiling the wire up with two fingers, and holding it in place with a rubber band. Yes! Coiling the wire up nulls out the last resonance point, and permits selecting another resonant point — no need to snip!

If the acquisition of a fly rod is a problem, just tie a piece of fishing line

Amplifiers, ATU Down Converters & Hard to Find Parts

LINEAR AMPLIFIERS

HF Amplifiers
PC board and complete parts list for HF amplifiers described in the Motorola Application Notes and Engineering Bulletins:

AN779H (20W)	AN 758 (300W)
AN779L (20W)	AR313 (300W)
AN762 (140W)	EB27A (300W)
EB63 (140W)	EB104 (600W)
AR305 (600W)	AR347 (1000W)

2 Meter Amplifiers
(144-148 MHz)
(Kit or Wired and Tested)

35W - Model 335A,
\$79.95/\$109.95
75W - Model 875A,
\$119.95/\$159.95

HARD TO FIND PARTS

- RF Power Transistors
 - Broadband HF Transformers
 - Chip Caps - Kemet/ATC
 - Metallized Mica Caps - Unelco/Semco
 - ARCO/SPRAGUE Trimmer Capacitors
- We can get you virtually any RF transistor!
Call us for "strange" hard to find parts!
DIGITAL FREQUENCY READOUT
For older analog transceivers
TK-1 (Wired and Tested) \$149.95

ATU Down Converters

(Kit or Wired and Tested)
Model ATV-3 (420-450)
(GaAS - FET) \$49.95/\$69.95
Model ATV-4 (902-926)
(GaAS - FET) \$59.95/\$79.95

For detailed information and prices, call or write for our free catalog!

Phone
(937) 426-8600
FAX
(937) 429-3811

CCI Communication Concepts Inc.

508 Millstone Drive • Beavercreek, Ohio 45434-5840
e-mail: cci.dayton@pobox.com
www.communication-concepts.com

ADDITIONAL ITEMS

Heat Sink Material
Model 99 Heat Sink (6.5" x 12" x 1.6"), \$24
CHS-8 Copper Spreader (8" x 6" x 3/8"), \$24
Low Pass Filters (up to 300W)
for harmonics \$12.95
Specify 10M, 15M, 20M, 40M, 80M or 160M
HF Splitters and Combiners up to 2KW

Ham Mall

The world's largest internet store dedicated to Ham Radio!

www.HamMall.com

This is the internet store that has it all! Open 7 days per week - 24 hours per day. Browse through our catalog viewing pictures, descriptions, accessories, and our low prices. If you are looking for a hard to find item, Email us at Bill@HamMall.com, and we will try to locate it for you.

Check out all we offer!

Call Wall QSL Manager Listing News, Announcements and Specials
Ham-to-Ham Discussion Groups Ham Shack Photos

Visa/MasterCard accepted on line. Free shipping in continental US on all orders over \$100.

When in Seattle visit us at:

Radio Depot, Suite 176, 5963 Corson Ave., So. Seattle, WA 98108
Phone (206) 763-2936 Fax (206) 763-4172

on the tip, and hoist it up on a bush. Tilt the bottom end for a direction, and be sure that it is not so high as to permit the proper placement of the radials on the ground or on stakes.

Portable operations are mainly being at the right place at the right time, tenacity, and the ability to listen through the noise level for those elusive distance stations, which will bring you your fair share of the prize. My old logs are full of contacts with stations using weak signal applications and ham sticks, window frames, or a wire thrown out the window.

Using the vertical without radials

C1 is a receiver variable capacitor. Fig. 2. The one that I used was 250Pf, about 2 inches long by 1 1/4 inch wide. I mounted it within a pill bottle, then attached two short leads with alligator clips on them. One goes to the cap's hot side, and the other goes to the cap's ground side. The pill bottle containing the variable cap can be held in place with a plastic hose clamp.

The antenna is placed in it's area for operation. With the long radials, determine the tip end element of the fly rod for resonance. When resonance is accomplished disconnect the long radials, and connect the alligator clip from the ground side to the L bracket radial ground screw. Now connect the hot end of the cap with the clip to perhaps a radiator, balustrad, roof ladder, or even a vehicle ground.

Part	Description
Lightweight fly rod	At least 11 feet long
Toroidal core	Yellow, T50-6
Dual insulated audio cable	20 feet #24
Enamel wire	2 feet #22
Option air core coil	4" x 7/8" PVC
Connector	BNC or PL-259
Mini coax, part of balun	25 feet RG-8X
Angle bracket aluminum	Scrap. cut to schematic specs
Variable receiver-type capacitor	250 pF, see text
Knob	For capacitor
Alligator clips	2 each
Patience & tenacity	1 gallon

Table 1. Parts list.

You could start from scratch by just connecting C1 to a ground, and by reducing tip length, and C1 adjustment to obtain a resonance point, but the method in the paragraph above is much easier.

This will eliminate the lengthy radials on the apartment floor, or for any semi permanent location.

I used a 4 foot length of insulated wire to connect to a 20 foot spiral stairwell. Connect the rig end of the coax to an MFJ analyzer, then adjust C1 for a good healthy dip, then perhaps a slight adjustment of C1 when

Continued on page 59

- DIP switch programmable
- Miniature in size
- 37 EIA tones, 27 non-standard tones from 33.0 to 254.1 Hz included
- Reverse Burst built-in
- Easy 3 wire hookup

SS-64 CTCSS Encoder
.66" x 1.08" x .21"

SS-64 DIP Switch Programmable CTCSS Encoder \$28.95

- Fully enclosed CTCSS encoder
- All 32 EIA tones from 67.0 to 203.5 Hz included
- Perfect for mobile / base applications

TE-32
5.25" x 3.3" x 1.7"

TE-32 Multi-Tone CTCSS Encoder \$49.95

- 51 CTCSS Tones
- 106 DCS Codes
- Supports 157 Repeater Subscribers
- On-Line Computer Help
- Repeater CW ID
- Air Time Loading & Analysis Graphs
- Signalling Formats: CTCSS DCS & DTMF

TP-3200 Shared Repeater Tone Panel

TP-3200D Table Top Version \$269.95 each

TP-3200RM-A Single Rack Mount version \$279.95 each

TP-3200RM-B Triple Rack Mount version \$279.95 each

*Holds up to three TP-3200s

Call or write to receive our full Product Catalog or visit our Web site for complete information at:
<http://www.com-spec.com>

- Eight programmable, selectable messages
- Fully field programmable via included keypad
- Meets all FCC identification requirements

ID-8 Automatic Morse Code Identifier
1.85" x 1.12" x .35"

ID-8 Automatic Morse Station Identifier \$69.95



COMMUNICATIONS SPECIALISTS, INC.
426 WEST TAFT AVENUE • ORANGE, CA 92865-4296
(714) 998-3021 • FAX (714) 974-3420
Entire U.S.A. (800) 854-0547 • FAX (800) 850-0547
<http://www.com-spec.com>



World's best ham weather station*



Actual size: 6" x 2" x 1"

The ULTIMETER® 2000 tracks more than 100 values so you can monitor and record weather extremes in your area.

Instant access to: • current values • today's highs and lows • long term highs and lows • time/date for all highs/lows • rain totals† for today, yesterday, and long term • alarms, and much more. Easy to install.

• Connect data output directly to TNC for APRS weather station.

Features superbly accurate: • barometric pressure • 3-hr. pressure change • indoor/outdoor humidity† • dew point† • wind speed/direction • indoor and outdoor temperature • wind chill temperature • rainfall†.

Only \$379 plus shipping (†Optional sensors add'l.) Other ULTIMETER models starting at \$189.

*Even *WeatherWatch* magazine concludes "the best we have seen."

The Weather Picture®

An eyepopping add-on to your ULTIMETER

The most popular accessory for our precision weather systems, **The Weather Picture®** continuously displays all the vital weather data you've pre-selected from your ULTIMETER® Weather Station. Big red numerals are easy to read from across the room, day or night. Available in two sizes, in brushed aluminum, traditional oak, or solid teak.



Size shown: 15 1/2" x 11 1/2"

Call TOLL-FREE: **1-866-364-7338** FAX 407-892-8552

PEET BROS. COMPANY, Inc. 31 E. 17th Street, St. Cloud FL 34769

Our 26th Year © 2001 Peet Bros. Co.

Visit our Home Page to see and *actually* try our Weather Stations:
www.peetbros.com

The Builder's Dozen

Uncommon uses for common stuff.

During my tenure as a "ham operator/builder," I've been able to construct many projects, some of which would have required expensive shop tools, equipment, etc., which I don't have and haven't the resources to buy. By using the common objects surrounding all of us, we can usually "make do" without many devices and yet accomplish our desired goal.

Here are a "Builder's Dozen" I have used throughout the years. Have you ever tried any of them? Or, do you have any other ones to send me?

1. While shopping with my XYL, I came across "plastic shoe shipping rods," used to hold the shape of the shoes during shipment. These are about 10" long with a 2" bend on one end. One is in each shoe. Removing the bend portion leaves a long round rod, easily scored with a razor knife. Roll the rod along a flat surface while putting pressure on the knife. Snap the rod at the score. I use these as "spacers."

2. "A/B" boxes, used to shift data from one printer to another, make great project boxes. Some are plastic and are easily drilled and cut, while others are metal and require a new face and rear plate but are entirely usable for small projects. The price is usually very affordable at hamfests and flea markets.

3. Emery boards, used for trimming finger nails, are an excellent device for removing enamel coating from fine wire used to wind toroids and transformers. When the end of the emery board becomes too smooth to be effective, trim the end with shears and continue use.

4. Juice straws, from the little packages of "lunch box" style drinks, make an ideal "bobbin" for fine enamel-coated wire used to wind toroids and transformers. Cut the straw to about 2", and notch both ends to form a "vee" to hold the wire. Wind the wire on the length of the straw using the notches to hold the wire. Pass the entire "bobbin" through the toroid and unwind as necessary.

5. Coffee pot plastic. When I needed a source for clear or smoked plastic for a project face, I came across a broken coffee maker headed for the trash. The clear "water tank" provided a good source of tough, clear plastic which was easily cut to size, durable, and not scratched from use.

6. Speaker cloth to cover small units can be substituted with black felt (or your choice of color). Squares of felt can be purchased at the local sewing/cloth store for pennies.

7. Speaker grilles, the screen material used to cover the speaker hole, can be created from the bottom panel of VHS players, etc., that have ventilation holes stamped in them. Carefully measure and cut to size. Drill and paint to match the equipment.

8. Damaged paint on enclosures can be effectively covered using shelf contact paper. This product is sold in many stores in the housewares department, and comes in many colors including clear. Cut the product oversized, peel the protective backing and apply to the cabinet. Trim excess material for a finished appearance.

9. For a more permanent fix, use "metal tone" spray paint sold in most hardware stores. This paint dries with a "dimpled" texture and is great for covering a multitude of sins. It looks good too!

10. Need a "ground plane" of larger-than-normal size? Go to the craft store and purchase a roll of "Maid-o-Metal" copper tooling foil for about \$10. Using contact cement, a disposable brush, and a suitable backing material (I used an old legal-size clipboard), adhere the copper to the backing. Roll the copper on the backing (I used a recently emptied glass beverage bottle) to remove bubbles, etc. The foil roll is 36" by 12", so there's lots of material left over for future projects. This much cheaper than purchased circuit board stock of the same size.

Continued on page 59

IC-706 Goes to Heil

How to mate your Icom rig with an old Heil headset.

After winning an Icom 706 MKII at a recent hamfest, I decided now was the time to go mobile.

Mounting the rig in my Nissan Altima proved to be quite a problem. Car manufacturers certainly don't design the interior for mounting transceivers. After much frustration, and arguments with the XYL, the location was finalized. Now, mounting the antenna and running the coax and power leads caused a few headaches, but finally everything was in place.

A handheld mic doesn't lend itself very well to mobile operation, though. It's strictly a no-no as far as safety is concerned. I happened to have an old Heil headset — it would be ideal for operating VOX. However, since Icom uses electret microphone input, I had to figure out how to use my old headset.

After checking out the mic circuit, I decided to build a small preamp to drive the mic input. The voltage for the preamp is supplied from the mic connections of the Icom. It works so well that I decided to let others know how to use their Heil mics on the 706.

This circuit can be used with any other transceiver that uses the same type of input.

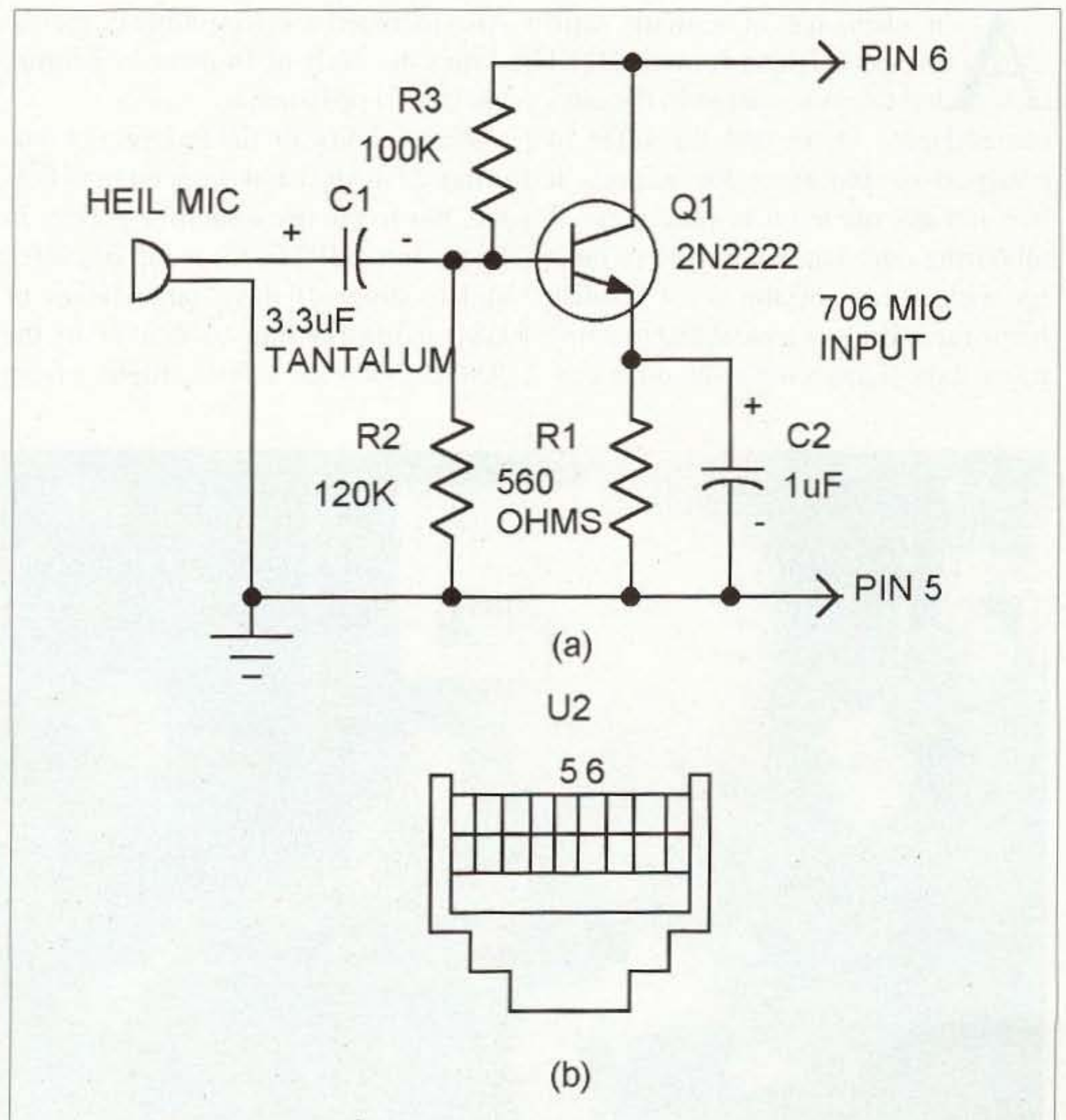

Fig. 1. (a) Preamp using NPN transistor and associated parts. (b) Rear view. 8-pin mic connector comes as an accessory.

Phil Whitchurch G3SWH
21 Dickensons Grove
Congresbury
Bristol
BS49 5HQ
United Kingdom

Helsinki or Buzz!

No-frills tickets meant an instant junket to OH-land for this G3.

For our Spring break this year, Jan and I decided to visit Helsinki. Part of the reason for the choice was that the "no frills" airline Buzz was offering two round-trip tickets for a total of £102, including taxes! The downside of this was that it meant flying from Stansted, which is about a 2.5-hour drive from home. This is the same as the flight time!

An exchange of E-mails with my good friend Jorma OH2KI led to a reservation in the city-center Helka Hotel and the offer of transport to and from the airport. It was not my intention to play radio at all during our visit, but maybe to meet up with a few of the local Finnish hams for a drink or a meal and to enjoy a few days sightseeing around the city.

Also included was a possible day's trip across the Gulf of Finland to Tallinn, the capital of Estonia.

We left home on the morning of Saturday 21st April and dropped in at Potters Bar to see my sometime partner in crime Jim G3RTE, for a cup of coffee and to drop off three large boxes of QSL cards for him to deliver to the RSGB bureau. The flight from

Stansted was a few minutes late, but Jorma was waiting for us at the Vantaa Airport arrivals gate. He then whisked us off to the Helka Hotel to deposit our luggage and then for a whistle stop tour of the city center, including a couple of much needed local beers.

Jorma was unable to join us for dinner that evening, so we found a restaurant and enjoyed an excellent bowl of mushroom soup followed by red deer en crouete, washed down with a bottle of good red wine.

Next morning, Jan wanted to go to visit the house of Gallen-Kallela, the national artist of Finland. This is situated some distance to the west of the city center, and Jorma didn't know how to get there by road, so we had to get advice from the hotel, who said "take the number 4 tram to the end of its route and then follow the signs for a couple of kilometers." Having once got hopelessly lost on the Paris Metro, I am always a bit suspicious of public transport systems in strange cities, but we found the number 4 tram route without any difficulty and paid our fare. It wasn't until we began to see on our right-hand side buildings that we had already passed on our left-hand



Photo A. Left to right: Jorma OH2KI; author Phil G3SWH; Jan, G3SWH's XYL; Hans OH2EA.

side that I realized that we had actually reached the end of the tram route and started the return journey. We hopped off smartly and began to look for the signs to the Gallen-Kallela Museum. Nothing! This was a residential district and there were very few passersby to ask — and those didn't speak English. Fortunately, it was a beautiful sunny day, although the residue of the previous day's snow on the ground made it cold. After a long walk following the many vaguely waved arms indicating "that direction," we eventually found the museum and collapsed in dire need of a cup of coffee.

After an hour or so looking around the museum, we followed the lakeshore back to the spot where we should have got off the tram, and found an ice cream stall doing a roaring trade. There's something particularly delicious about mango-flavored

ice cream! We then caught the tram back to the city center and a late lunch.

That evening, Jorma had arranged for us to meet up with Hans OH2EA and himself for a drink in the hotel bar. Hans is another ex-marine radio operator and we swapped many stories of our lives and experiences at sea. Unfortunately, Hans had a prior engagement and was not able to join us for dinner, so Jorma, Jan, and I went off to a very pleasant Chinese restaurant for a meal together, over which we discussed the possibility of a trip to Tallinn the following day. After dinner, we made a visit to the Nordic Jet Line ferry company's terminal and looked at the schedules. Our best option was to take a fast catamaran, which covered the 60-kilometer trip in one hour forty minutes and gave us six hours in Tallinn, before returning in the late afternoon. Strangely, the return fare increased if you wanted to stay longer!

Jorma then suddenly asked, "Do you know Vello ES1QD?" I replied, "I think I have worked him from just about every DX location where I have operated." Jorma immediately pulled out his mobile phone and called Vello, who readily agreed to meet us at the ferry terminal in Tallinn and show us around the city.

A taxi got us to the ferry terminal in good time. The weather was very cloudy and it was quite foggy during the voyage. Luckily, just before our arrival, the sun came out and it was another beautiful day. Vello was easily identifiable by the large "ES1QD" callsign

badge on his chest. He took us off to see the Kadriorg Palace, which is a few kilometers outside the city and was built in the early 18th century by the Russian tsar Peter the Great. Apparently Peter himself actually laid three bricks! Vello works as an engineer for the local state broadcasting authority and explained that he had to go to work for a short time, so he took us to meet his son Tomas and explained that Tomas would look after us in his absence. Both Tomas and Vello speak excellent English.

The old town of Tallinn is situated on a hill in the heart of the city and is medieval in origin with narrow, cobbled streets. Severely neglected during the time of the Soviet occupation, much good-quality restoration has been completed and the town is well on its way to becoming one of the architectural gems of Europe.

After a whistle stop tour of the town, Tomas took us to an excellent restaurant for lunch before we headed back towards the ferry terminal, where we were able to say our farewells to Vello before the trip back to Helsinki.

Neither Hans nor Jorma were able to join us for dinner again that evening, but we arranged for Jorma to pick us up at the hotel the following evening to take us back to the airport. We found an excellent steak house for dinner, where an Estonian student served us! It was then back to the hotel bar for a nightcap.

Our last day was spent walking around the city center just seeing the sights, including a 15-minute ferry trip to the Soumenlinna fortress, dating from 1748, and built on six islands in front of the city. Again, the weather was kind to us and although it was cold, only about 5 degrees C, it was sufficiently bright and sunny for us to sit in a pavement café and drink beer.

Jorma collected us in the late afternoon as arranged, and the trip home was completely uneventful. Even the M25 ran smoothly, although it did start to rain as we entered the Bristol area!



Photo B. The author with Vello ES1QD outside the Kadriorg Palace.

Beginner's PS Tester

This variable active load will do the trick.

You've just been told you've got a humming noise on your transmissions. Maybe you've even noticed a milder version of that on receive. Is your transceiver developing a problem, or is the filtering on your power supply failing? Here's an easy way to find out.

We're all familiar with the amplification capabilities of transistors: Turn it on a little by feeding the base junction, and

the collector turns on a lot. We use it every day in the amplifiers in our radios. Here, we're applying this concept to a more basic principle. By applying a

little voltage to the base through P1 in **Fig. 1**, the transistor starts to conduct. Instead of using the transistor's gain to amplify RF, though, we're using it to load an external power supply.

Before discussing actual operation, here are a few design considerations for our circuit. If we're going to test small to moderately sized power supplies, the 1-ampere transformer, rectifier, meter, and connectors available at Radio Shack will suffice. If you're going to test bigger supplies, then I recommend investigating heavier-duty components available through parts dealers like Digi-Key, Tri-State Electronics, Jameco, or Newark (my favorite four, but I'm sure that there are

Vendor	Fax	Telephone	Web Site	Address
Allied Electronics	Various	(800) 433-7500	alliedelec.com	7410 Pebble Dr., Ft. Worth TX 76118
DC Electronics	(602) 994-1707	(602) 945-7736	dckits.com	POB 3203, Scottsdale AZ 85271
Digi-Key Electronics	(218) 681-3380	(218) 681-6674	digi-key.com	701 Brooks Ave. S., Thief River Falls MN 56701
Jameco Electronics	(650) 592-2503	(800) 831-4242	jameco.com	1355 Shoreway Rd., Belmont CA 94002
Mouser Electronics	(817) 483-6899	(800) 346-6873	mouser.com	958 N. Main St., Mansfield TX 76063
Newark Electronics	(800) 718-1998	Various	newark.com	Various
Tri-State Electronics	(800) 255-0526	(847) 255-0600	Not specified	200 W. NW Highway, Mt. Prospect IL 60056

Table 1. Sources list.

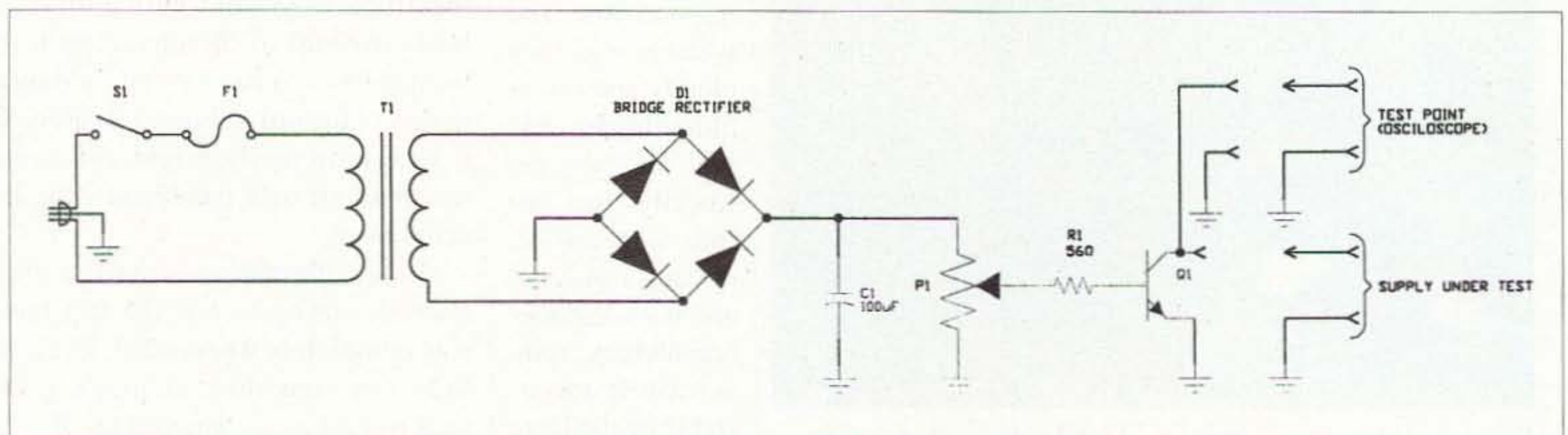

Fig. 1. Active load. Rolf E. Spies N9BRL had the original idea for this circuit, while son Klaus WB9YBM built the prototype.

others out there). Either way, though, the power transistor at Radio Shack (typically used for television sets, power supplies, and stereo equipment) will work. Be sure to heat-sink everything well—in this application, things will get warm!

I built my active load in a metal box — in this case, not to protect the inner

workings from stray RF (as is the concern of my other projects), but rather for safety. We're dealing with 110 volts, and a grounded metal box is still the best protection between my fingers OUTside the box and the voltages INSIDE the box! Also, as I said, in this application things will get warm. Metal enclosures can still not only

withstand but dissipate heat better than the other options out there.

In actual operation, always be sure to start the potentiometer in the position that will turn the transistor off. This will avoid unexpected surprises. Also, I included a second set of jacks, or test points, that I could hook an oscilloscope to. This will allow me to monitor the purity of the DC of the power supply being tested, as I slowly increase the conduction of the active load. If you don't have an oscilloscope available, don't despair! There is another way to test for hum, and that's with an audio amplifier similar to the one discussed on page 26 of the November 1999 issue of 73. Be sure your audio amplifier works properly (i.e., doesn't have hum of its own). Then, with a series capacitor in use (you don't want to feed DC into the input of your amplifier, so check to see if you need a series capacitor or if one is already built-in), hook up to the test points on the active load. Crank the volume on your audio amp, and if you don't hear a hum, your power supply is (at least close to) fine! 73

Part	Part Numbers					
	Digi-Key	Radio Shack	Tri-State	Allied Electronics	Jameco Electronics	DC Electronics
Transformer	HM520(12.6V 2.5A)	2731511B (12.6V 3A)	23V255 (12V 1A)	227-0103 (12V 4A)	29225 (12V 2A)	41FG010 (12.6V 1A)
	HM521 (12.6V 4A)	273-1352A (12.6V 1.2A)	23V415 (12V 2.0A)	227-0104 (12V 8A)	102120 (12V 4A)	41FG020 (12.6V 2A)
	HM522 (12.6V 6A)			2270144 (12V 16A)		41FG030 (12.6V 3A)
	HM523 (12.6V 8A)					
	HM524 (12.6V 10A)					
Meter	N/A	22-414 (500mA)	20-1118 (0-3A)	229-4110 (0-5A)	N/A	N/A
			20-1117 (0-10A)	229-4112 (0-10A)		
				229-4114 (0-20A) 229-4116 (0-30A)		
P1	Call	271-265 (25 ohm 3W)	P-20	Call	Call	Call
		271-1716 (50k 1/2W)				
Jacks	CBB104-ND	274-658	602	607-1132	N/A	N/A
Transistor	Call	276-2041	Call	Call	38324 (4A)	2N3715 (10A)
					40151 (8A)	2N3716 (10A)
					38308 (10A)	2N3055 (15A)
						2N3771 (3A) 2N3772 (3A)
Power cord	Q106-ND	61-2853	17534	None found	173809	LE-2
Power switch	CKN1004-ND	275-634	35-000	870-9118	76523	5W104
Case	See catalog	270-2530	W-2F	None suitable found	None suitable found	MW10
Screws, 6-32	H355-ND	64-3012	F-504	None found	42446	632-375
Nuts, 6-32	H220-ND	64-3018	F-559	None found	42420	6HN
Washers (lock)	H240-ND	64-3022	MW-412	None found	106868	62C
Ground lug	N/A	64-3030	M-1118-06	839-2381	N/A	7312
Bridge rectifier	Similar to Radio Shack — see catalog	276-3146 (4A) 276-1181 (6A) 276-1185 (25A)	Similar to Radio Shack — see catalog	Similar to Radio Shack — see catalog	Similar to Radio Shack — see catalog	Similar to Radio Shack — see catalog

Table 2. Parts list.

Subscriptions
to
73 Magazine

Only \$24.97 — 1 year
\$44.97 — 2 years
\$65.00 — 3 years*

*best buy (54% off cover price!)
Call 800-274-7373

Repeaters

6 & 2 m & 440 On your frequency
\$399.95 & \$499.95

Repeater Controllers

RC-1000V \$259.95 / RC-100 \$129.95

Micro Computer Concepts
8849 Gum Tree Ave
New Port Richey, FL 34653
727-376-6575 10 AM-10 PM
e-mail n9ee@akos.net
<http://mcc.stormfan.com>

The Channel Master 11.7 to 12.2 GHz LNB: Conversion to 10.368 GHz

This month, let's cover finding a gem in the swapmeet circles and making a silk purse out of this sow's ear. During one of these adventures at my local swapmeet, I noticed some very interesting shapes in a large box. On further inspection, they turned out to be microwave dish downconverters from a Channel Master satellite converter system.

Now, this box was not an apple crate, but rather a big box full of antenna feeds, converters, and shrouds of plastic that covered the converters. There seemed to be little interest in these items, as no one else even came over while I was digging in to verify just what treasures lay inside. This box was about the size of a small refrigerator cut in half, about 3 feet cubed. Digging into the material, I determined that there were quite a number of downconverters of several different types in this box. From all observation, it looked like these converters had been collected from service calls or were units removed from customers who were changing to other TV satellite or cable TV services.

Well, thinking about the possible use for these items brought many ideas into play. The first consideration is the price one has to pay to bring this decision into fruition. Does it warrant a single purchase for experimentation, or does a bulk-buy scenario take effect? The premise of this thinking is that if one costs several dollars, do they get cheaper in unit price if the whole box is bought?

A cheap per-unit cost certainly has benefits, especially if you can use all of the material. Also, you have to consider the testing to determine the good-to-bad ratio — how much proves to be good or whether all units are bad and junk.

These and many other thoughts go through your head prior to asking the price from the seller. Just don't ask, "What do you want for this goldmine of microwave material?" A simpler query would be "How much?" for one item. Get a feel for the range of price negotiations first before going over

the edge and paying too much for some untested devices. It's worth a try if you are interested in the lot of material and still being a part of the approved haggling at swapmeets. Haggling can be just as much fun as getting some treasure.

Well, in this instance I bought the whole box of plastic shrouds, converters, and antenna dish feeds for a modest to stiff price. At least it was a price I could walk away with knowing that if all items were defective, I would not take a bath in this deal. It's like playing poker: You have to pay to learn how to play the game. Just don't pay too much to learn how to play the game at swapmeets.

Going through the items at home, I removed the plastic shrouds and they became recycled material. The antenna dish feeds were cast aluminum. My grandchildren and I sorted out the aluminum from the plastic and I gave them the scrap metal price paid for the metal, 88 pounds of cast aluminum at 5 cents a pound. It was enough for each of them to get a Pokémon card set for their collection (my contribution), and a few dollars each for their piggy banks. A profitable event for the grandkids. I got the scrap removed and recovered the 11.7 to 12.2 GHz microwave downconverter, and we had a good time with something for all of us.

The materials recovered were the waveguide flange input connector and an "F" coax jack on the output. In actual operation, the converters are the units seen at the focus of a small microwave dish antenna, usually obscured by a plastic cover to give weather protection. What happens inside electronically is the same for all units, the only design differences being several RF

stages (ranging from 2 to 4), the number of elements in the RF filters, and how discretely the units are constructed. By that, I mean are they individual parts or a great big monolithic chip that is unconvertible to other applications?

Well, all the units I picked up were discrete. The circuitry inside was the same except for the number of stages, types of RF filters, and the mixer and IF types of the amplifiers.

The circuitry flow goes like this: The converter converts 11.7 to 12.2 GHz, a 500 MHz TV band of microwave from a satellite as received and amplified by the dish antenna, further amplified by the internal RF amplifier stages, and delivered to an internal mixer to convert down to an IF frequency of something in the 1 to 1.5 GHz frequency range. To allow great operation these amplifiers are constructed to have a very low noise figure, in the 0.8 to 1.4 dB range — to say the least, that is HOT! A great performer! This signal is now amplified some 30 dBd by the dish antenna, and another 50 to 60 dB to the IF output is then connected by a section of coax cable to the top of your TV set. The converter on top of your TV set converts the incoming 1 to 1.5 GHz input to standard TV channels for reception.

Now, with a basketful of converters, I found large gray ones, small black units, a small number of white plastic-covered units, and a large number of small beige units. All the different-colored units look alike except for physical size. The gray units were about 6 inches long and looked to be the oldest design type. The white plastic units were smaller and were sealed with a potting compound, making opening difficult. The black

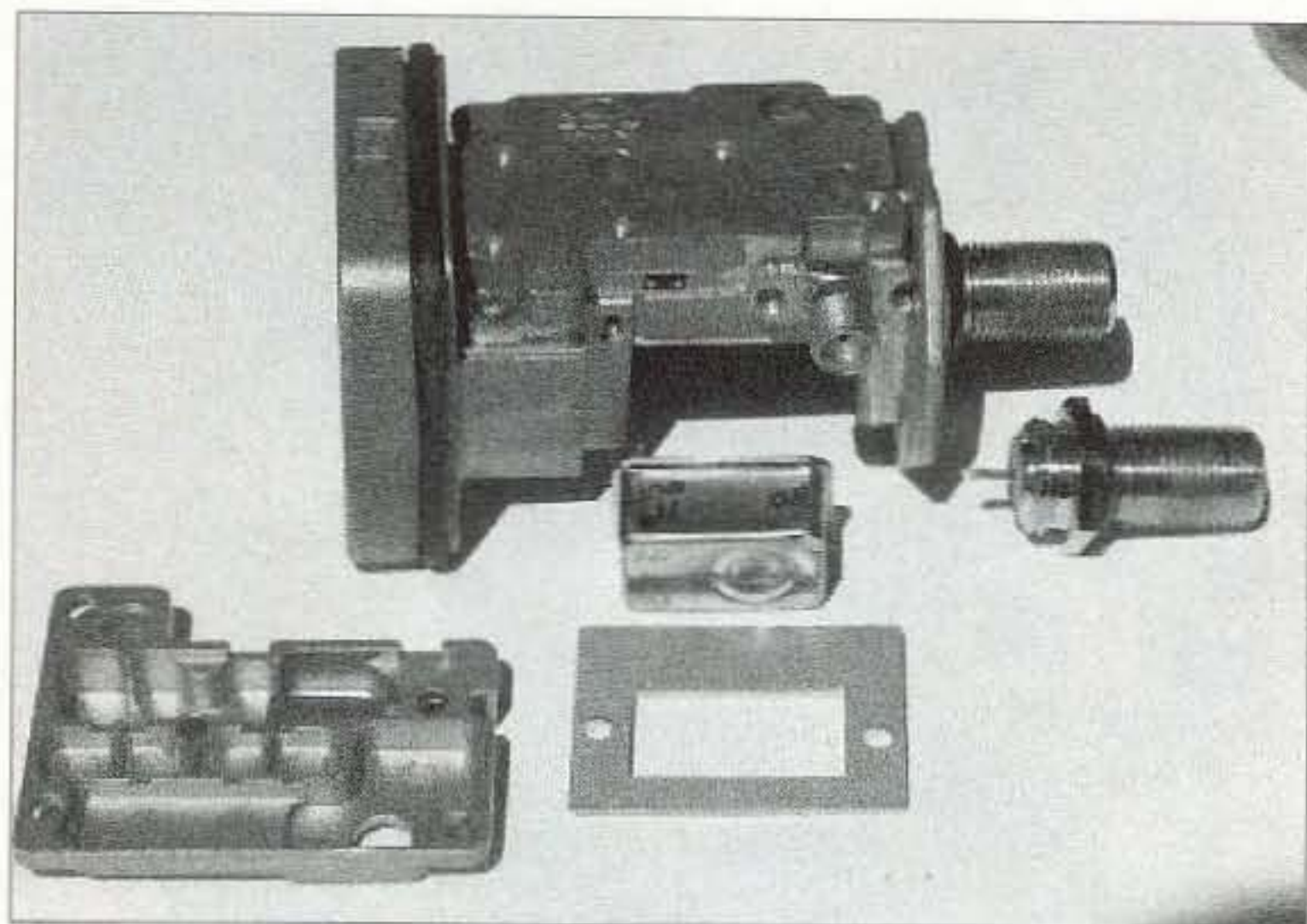

Photo A. The converter unit with the cover off. The RF housing plate is hollowed out, making small chambers for each part of the microwave circuitry to isolate parts of the circuit from other parts.

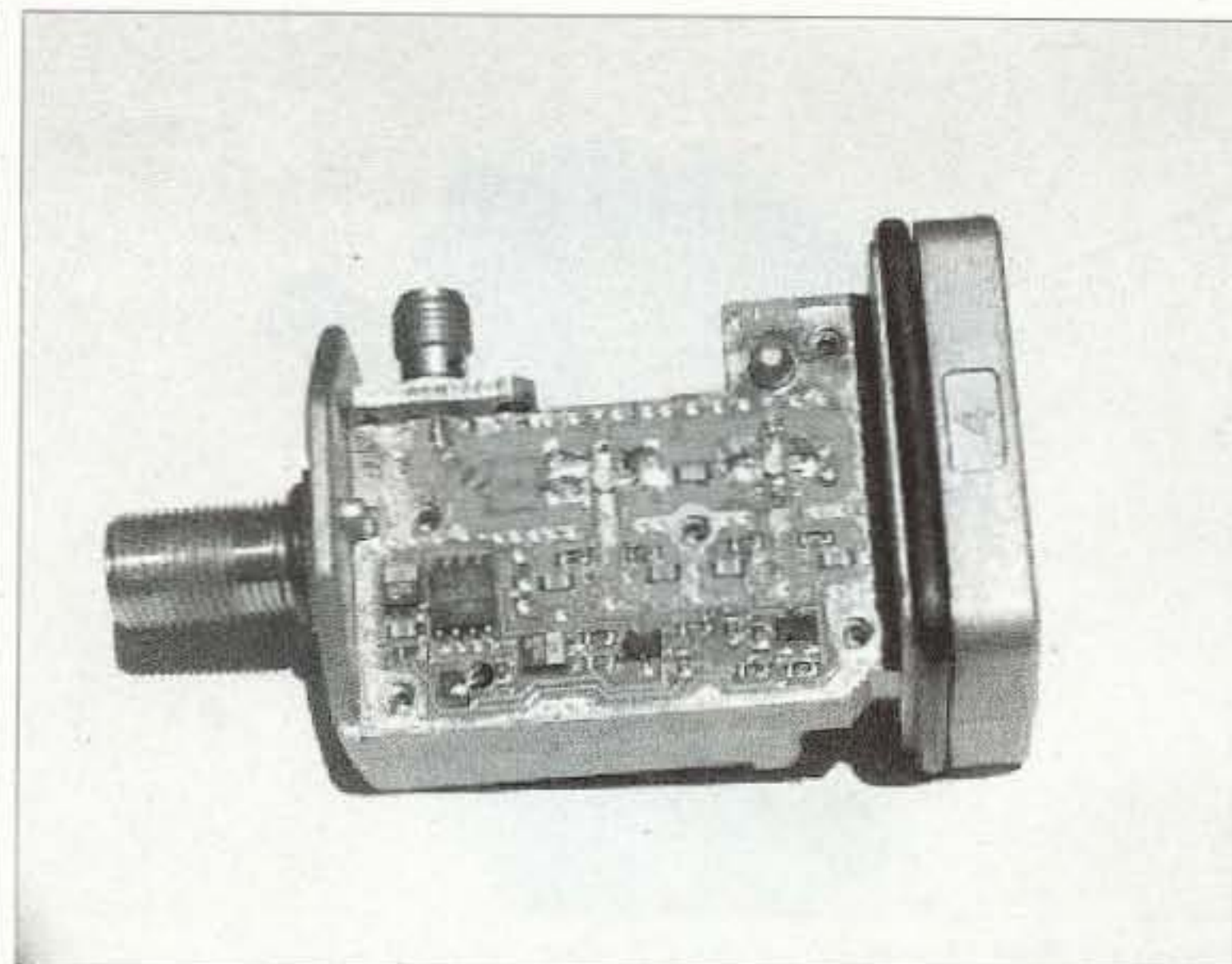

Photo B. SMA connection and RF board parts placement.

units were very high-tech internally and easy to open: Just remove the "F" connector nut on the rear of the unit and push against the "F" connector holding the case and the waveguide end, as it will pop out of the cover assembly. The beige units were opened last, and they proved to be the best of the batch: smallest in size, simple to open, and having very high-tech construction, with some very interesting circuitry yet to be discovered.

See **Photo A** for a photo of the unit opened. Depicted are the converter unit less cover, with the LO oscillator module and its cover hold-down plate, "F" connector, and a spare cover shield housing for the RF amplifier circuitry. As you can see, the RF housing plate is hollowed out, making small chambers for each part of the microwave circuitry to isolate one part of the circuit from another. This prevents what is called crosstalk from one part of a circuit to another, ensuring that the flow of amplification is as it should be and not a product of oscillations or feedback.

Now, what can be done to use these devices, as I am not going into satellite TV reception? Well, the base unit with some modification can be converted into a great low-noise dish feed amplifier for connection to a waveguide switch, or antenna directly. This would make full use of the RF LNA amplifier's low noise figure, allowing the RF amplifier to detect very weak signals in the 10 GHz amateur band after conversion. Benefits are low cost, easy modification, and low cost again, as if you mess up the conversion you can obtain another and give it a go again. With all the satellite systems being replaced and consumers upgrading systems everyday, there should be plenty of these units available at your local flea markets and swap meets.

The conversion and unit description

The LNB preamp input is a waveguide input, multistage minimum loss connection to the microwave antenna system. This allows for a very low noise front end as close as you can get to the antenna. This conversion from satellite LNB operation to amateur 10 GHz operation is quite easy. The benefits are many. First, the amplifier is pretested as a unit, with its internal DRO LO source mixing the 11.7 to 12.2 GHz down to the 1 to 1.5 GHz input to a converter located on your TV set for normal reception. These units operate with DC and IF (1 to 1.5 GHz) sharing the same coax from the LNB to this converter input. The voltage requirements are any voltage from +10 to about +24 volts. It normally shares the coax cable to the LNB coax center, positive and negative on the coax braid. There is diode polarity protection and a 7808 voltage regulator internal. Typical system noise figure is 0.8 to 1.2 dB.

Modification is quite easy. Remove the yellow cover by removing the type "F" connector nut. Slight pressure on the "F" connector will push out the LNB from the yellow case. On one side of the LNB there is a module that looks like a TTL crystal oscillator with a metal side cover held in place by two screws. Remove the two screws from the metal plate over the oscillator module. Then remove the five screws holding down the top cover over the microwave amp part of the LNB. Unsolder two pins connected to the PC board from the oscillator module, one on top and one on the underside of the LNB. This will remove the DRO microwave oscillator and mixer assembly. It is not required in the conversion. Notice that on the underside of the top

metal cover plate there are two arches where two top pins of the DRO connect to the upper PC board where the LNA circuitry resides.

At the spot where you unsoldered the DRO oscillator (on the beige unit, this module looks like a metal TTL oscillator 4-pin CHIP like metal can), on the top PC board RF circuitry, is where an SMA connector will be attached. At this point (SMA connector connection) and the output of the 2nd stage amplifier there is a filter that is DC-isolated from the last stage amplifier and the point where the SMA connector connects (same place where you unsoldered the DRO oscillator/mixer). Remove all of the filter elements except a center width of copper on the PC board, for a new trace same width as filter traces, Cut away a suitable opening in this line to insert a 1 to 2 pF microwave chip capacitor to provide DC isolation between the last amp stage and the output.

The SMA connector can be mounted on a metal plate the same size as the one removed that held the DRO oscillator in place originally. Use the same mounting screw holes to mount this plate and attach a 2-hole SMA connector, being very careful to be accurate in positioning the connector on the strip-line circuit board trace. Allow clearance for the top cover with its arch, which should give clearance for the SMA pin to go under the cover plate hole. If need be, file away additional clearance in the underside shield plate for the LNA's SMA connector clearance to prevent shorting to ground. Another method of mounting the SMA connector is to solder the center pin directly on the output trace and push up the 2-hole connector to the flat surface on the LNA body to get as close as possible to the



Photo C. Full side view of the Channel Master LNB.



Photo D. The shop.

housing side. Solder the center SMA pin on the output trace that connects to the 1-2 pF chip capacitor. See **Photo B** for SMA connection and RF board location parts placement information.

Now, solder the ground part of the SMA connector to the ground foil on the edge of the PC board. Do not oversolder, as you need clearance for the shield cover to fit allowing the arch to clear the SMA center pin and still provide rigid mounting for the SMA connector. It's not as rigid as the mounting plate scheme, but it's an alternative to use in your modification options. Last, remove the type "F" output connector and replace it with a feedthrough capacitor

of miniature size, and solder to the trace where the "F" connector was unsoldered. This will now be the new +12 volt DC power for the modified LNA. The waveguide input flange is WR-75 and will fit up to WR-90 waveguide switches by drilling out the four mounting holes through the back of the flange mount on the LNA and cutting away the outside edge to allow a screw to fit the pattern of the WR-90 flange. The 4 bolts will hold the mismatched waveguide fittings together with little trouble. It has been shown that as little as two screws will hold the LNA to a WR-90 waveguide fitting with great rigidity.

Here is a full side view of the Channel

Master LNB (**Photo C**) depicting the DRO removed along with a second top cover plate and DRO mounting plate and coax "F" connector. The "F" connector is removed and replaced with a feedthrough capacitor to bring DC only to the connection previously soldered to the "F" connector; mounting of the feedthrough cap is not critical. The DRO oscillator was removed in this picture, but where the top left pin of the DRO module is soldered to on the top LNA part of the PC board, it is replaced with the center pin of the SMA connector.

Fig. 1 is a short version of a reverse-engineered schematic of the beige downconverter. As you can see from the schematic, the DRO module we described was of great interest. It was discovered that not only was there an internal microwave DRO-type oscillator, but the RF mixer and IF preamplifier at 1 to 2 GHz range were also co-located inside this module as well. Quite high-tech to say the least. This fact made the conversion easy, as the remaining circuitry was the power supply and microwave RF circuits. These were the ideal remaining components, as the DRO, mixer, and IF were not needed in trying to make a great 10 GHz LNA for amateur microwave use. By the way, no conversion for frequency operation at the lower 10 GHz seemed to be needed — just the removal of the output filter and replacing it with a 1 to 2 pF microwave chip capacitor was required.

This mod was the result of several amateurs pooling efforts and making this project work. Ed W6OYJ, Pete W6DXJ, Kerry N6IZW, and I are all members of the San Diego Microwave Group. Recently, a quantity of these LNB amplifiers, along with several other types of slightly different

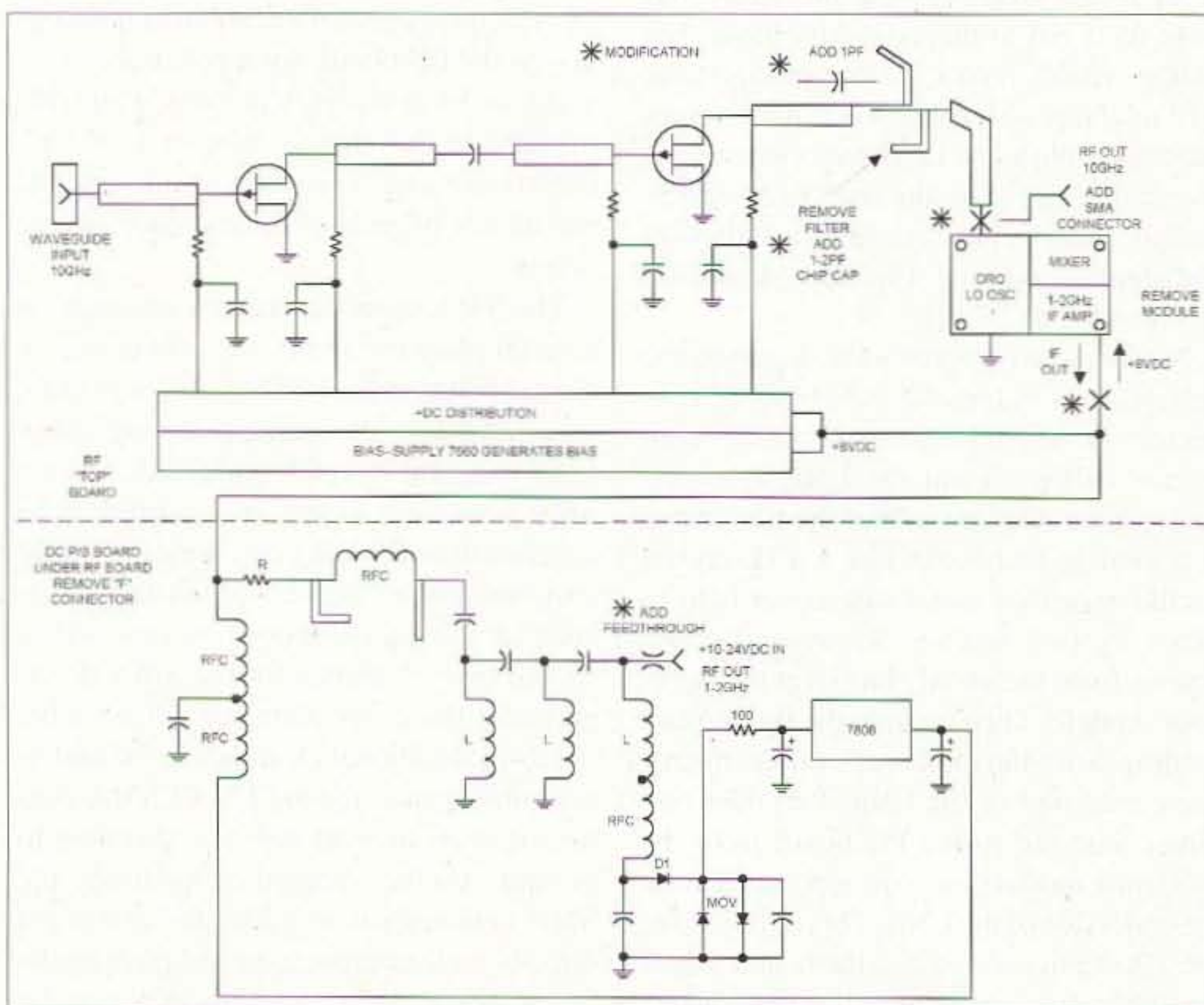

Fig. 1. A short version of a reverse-engineered schematic of the beige downconverter.

QRP-pourri

I had planned to have some receiver troubleshooting tips this month. But instead we will look at another project. I got started in getting the project done when working a keyer for Field Day. After a few months of Heathkit QRP radios, why not wrap things up with a look at the Heathkit HD-1410 keyer?

Of all the products Heathkit made, it seems kind of strange that they only made three versions of a CW keyer. The first was the rather funky HD-10 keyer. It had microswitches for the paddle contacts. It did not have a "fine" feel to the key. It did work, and Heath sold zillions of them. The HD-10 was designed primarily for the SB and HW tube-based gear that used grid-blocked keying.

The next keyer, the HD-1410, is a ripped off version of the Ten-Tec KR5 keyer. The electronics and key paddle are mounted in a slimline case.

The Heathkit HD-1410 iambic keyer is a very popular unit. Many of these are still in use today. Although the keying paddles are not by any means a Brown Brothers' key paddle, they're not too bad!

The HD-1410 features a built-in power supply and adjustable sidetone. The sidetone pitch is also adjustable, although you must open the case to access this control. The HD-1410 will operate on either 12 VDC or 110 VAC. What's nice about the 110 AC supply is the detectable power cord. If you want to use the HD-1410 during Field Day, you don't need to bring along the AC power cord.

The output is fully solid state. The HD-1410 will key either grid-block- or cathode-keyed transmitters. There's a jack for a straight key, too, although I don't know why you would use one with the keyer.

By pulling out the speed control, the HD-1410 will key the transmitter. That's a great feature for tuning the antenna tuner. There is a second knob on the front panel that controls the volume of the sidetone. And, like I said, a PC board-mounted trimmer controls sidetone pitch.

All of this is housed in a small wrap-around case that matches the "SB" line of

Heathkit equipment — in particular, the SB-104 and the HX-1681 transmitter, HR-1680 receiver. Heath did not change the color of the keyer to match the HW-9 or HW-99 transceivers. The HD-1410 continued with the Heathkit two-tone green paint job.

Since the HD-1410 is fully solid state, a good place to start looking for trouble is the power supply. If the HD-1410 works on an external battery but not on AC, check the 110 AC fuse and the power transformer. On the other hand, if the keyer seems dead, but the red power lamp comes on, check Q8 and D7. With a DVM, check the voltage on the collector of Q8. It should be at least 10 volts. The output, on the emitter should be at least 5 volts. If the emitter is over five volts, then Q8 is shorted. If the output on the emitter is zero, then suspect Q8 or D7. Diode D7 biases the driver transistor on. The TTL IC chips in the HD-1410 require +5 volts to operate. Too much or too low of voltage will cause the HD-1410 to fail.

A common problem is a shorted or open output transistor. You can easily check this by turning up the sidetone volume. If the sidetone follows the keying, then the keyer is working, but the output keying transistors have failed. Check Q5, Q6 and Q7. Also, check diodes D4 and D5. These parts fail if you try to key a transmitter the HD-1410 cannot handle.

I did mention that the HD-1410 would key a cathode-keyed radio. That's true, but you can't key an Elmac AF-67 with one. There are limits on the keying current the output keying transistors can handle.

To get the HD-1410 to key most solid state transmitters, remove D5 and R27 and replace these with jumper wires. This will allow the HD-1410 to pull the keying line to ground. You'll need to do this modification if

you want to use the HD-1410 with your Ten-Tec Argonaut transceiver.

I've found that IC3 can go bad and cause a string of either dots or dashes to be produced. Also check IC 5.

IC5 also drives the sidetone oscillator. Transistor Q3 takes the output from IC5 and drives the speaker.

After years of use, the paddles may need to be removed and cleaned. To remove the paddles, pull off the black plastic covers. Then, remove the speed and sidetone volume controls. Unsolder the wires from the pilot light. You can then pull down the front panel. There are a few screws holding the paddle assembly on the PC board. After removing the hardware, the paddles can be removed. Clean the contacts with a strip of typing paper. You can clean the contacts without taking the paddles apart or removing them from the case.

The Heathkit SA-5010 keyer

This keyer is a drastic departure from the HD-1410 keyer. The SA-5010 is a microprocessor-based electronic keyer. The SA-5010 will key either grid-block or pull the key line to ground. Again, there's a limit to how much current the output transistor will handle.

Housed in a two-piece plastic clamshell case that's really hard to reassemble, the SA-5010 came in two different paint jobs. You could get one to match the SB-104 line or one to match the HW-9.

The microprocessor was custom-made for Heath. Finding a replacement would be next to impossible. So, if the micro is cooked, you're cooked. However, I've never come across one with a bad CPU. Most of the time, the output switching transistors

Continued on page 59

Hams Make Good Use of High-Tech

This month, I want to touch on several areas that prove interesting on discovery. First, there are several new wrinkles in the MixW software. Those of you who are using the program and keeping up with the releases will think this is dated material because of the warp-speed development combined with the time lag due to publication schedule.

But for the rest of you, the following is going to sound much like way far-out tech. And that is exactly how it impressed me as I came across these developments.

New stuff in MixW 2

If you have looked around a bit, you have discovered software to roll-your-own QSL cards. I have a few of those very fine programs on the back burner of this computer and simply never devoted enough (any) time to them so I could send out modern cards that do not include the option of AM mode along with a few other thoughts from antiquity.

So, what would you think if you could simply select a QSO from your log, double-click a utility, and have a card ready to print? That is available in the Release 10 of MixW 2 that I am currently using. Absolutely amazed me.

I knew there was something of this nature available according to a few posts on the MixW reflector. I printed out the several pages of newsy items from the MixW download page and read the info on the card utility a few times. It was only about two short paragraphs and, for some reason, the brevity intimidated me. It just couldn't be this easy — had to be a catch.

But I took a deep breath and followed the simple directions which started with double-clicking the MixW QSL card test.doc which resides in the MixW folder. Being a .doc file means it will open in Microsoft Word. Not bad. I use the earliest version of Word for Windows which is Word 6 and was originally written for Windows 3.1, so this is a good test.

It works. The test document is a card already made up for UU9JDR as an example. Things didn't work at first because it is necessary to have MixW 2 up and running, but that is easy. The sample card is quite like the one in the screenshot this month, with different input, and is very easily duplicated with your own callsign and info.

The part that makes this so overwhelmingly simple is the process is just two steps. With MixW 2 and Word up and running, you first select the log entry for which you want the card printed. Second, using Explorer, go to your folder where MixW resides and double click the file MixW QSL card test.doc. That's it, nothing more. Your custom card assembles itself in the Word display.

Next, I printed a couple of cards for recent contacts and sent them out via E-mail as attached files. During the process, I realized there is a percentage of hams who will not be able to open these files because they will not have the correct software. I think most of the later WordPerfect software will open such files but I hate to send stuff that looks suspicious on the receiver's end.

The real point is it will be a simple project to print some of these and send them through the old fashioned mail system. As a matter of fact, by the time you read this, I would not be surprised if some of you have not already received a card like this from someone else. It looks like something that could really catch on.



KB7NO

Jack in Carson City, NV

To radio: **W9LR** Bill New Berlin, WI

Date	UTC	Band	Mode	RST
15-Aug-2001	03:15	14.1 MHz	BPSK31	599

Thanks for the nice QSO! 73! I use MixW version 2.0 RC10.

Fig. 1. Just a couple of clicks! This is s-o-o-o easy. Select the QSO from the MixW 2 log, double-click the file (see text) in the MixW folder and this prints on your Microsoft Word page. And it looks better than this if you simply print it to some card stock and mail it off. For some reason, the resolution went down the tube when I ran this into the clipboard and massaged it in the graphics program. But it does serve the purpose; you get a custom QSL print you will not be ashamed of and IT IS FREE. Always counts in my (pocket) book. If you are using the latest version of Word, the instructions say you can do a bit of customizing. The above print is as it comes from the box. This was the first experiment. Simply closed my eyes and shot from the hip.

Just as a further experiment, I did a lookup for a QSO in the MixW log that was earlier history and the card print system worked just fine from the info in the lookup result window. That makes certain situations easier to manage.

For instance, at this time MixW 2 does not allow a scroll feature in the log so you could select an entry directly for this card print process. I have seen a rumor that that feature may surface from the pile of things-to-do sometime soon. But that is not a hindrance to making these cards.

As I looked further into the minimal documentation I found field editing available if I were using the latest version of Word for Windows. This does not seem to be an absolute necessity, but perhaps the bundled software with the new computer has something in Microsoft Works that will lend a hand for a little tweaking.

How about an atlas?

Another feature that works extremely easily is the interface to the DxAtlas software which can be downloaded from [www.dxatlas.com]. If you go to the MixW Web site, you can download the file [Mix2DxAtlas1.zip]. With those two files you will be surprised how easily you can display a world map that gives you beam headings along with sunrise-sunset indicator and other useful information for your DX hunting.

Simply install the software per the instructions, then when you are running MixW2 and DxAtlas along with the Mix2DxAtlas utility, you simply double-click the callsign in the receive field as you make ready to make the contact and the DxAtlas program will display the location of the other station and when you point your cursor to the location the beam heading is calculated for you. Can't get any easier, plus, it is fun to do.

I shouldn't admit how some of these big-kid toys fascinate me. I can sit and see the calls on the monitor and, instead of trying to work them, I will start clicking on them so I can watch the programs strut their stuff. To be fair, I should mention DxAtlas is shareware and the demo copy is good for 30 days.

This kind of automation is making me entirely too lazy (and very addicted) for my own good. Here I have assembled a group of software on a simple old slow computer that works most every popular digital mode in use by active hams. Plus, it accesses my CD with ham addresses automatically, pops up previous contacts and now it simultaneously shows me where the other station is and how to head the antenna.



Fig. 2. DxAtlas in action. This is the flat world view of the world atlas. Also available is an azimuthal layout with your station located in the middle and the rest of the world revolving around you. Your choice — you can change it instantly back and forth. The overall size of the panel can be reduced to fit along side your MixW display or you can have them overlap. This view is shown over top and completely covering the MixW 2 display. If you do it this way, you can switch back and forth with the task bar buttons at the bottom. The KB7NO location is indicated by the antenna planted to the left of the W7 in the western U.S. When I double-clicked the PJ2 station in the receive pane in MixW, an antenna showed in the very northern part of South America. By moving the cursor to that point and clicking the mouse the program calculated beam headings and distances in the info box above the task bar. This was taken about 2 p.m. local time and you can spot the location of the sun by the bright (yellow) spot about 1,500 miles SW of the home QTH. You can see the sunrise-sunset indicator covering Europe, Africa, and most of Asia. There are several options for lookup on prefixes, countries, cities, etc., I did not wish to confuse the display with clutter. DxAtlas integrates nicely with MixW 2 with the patch shown by the button at the right of the task bar (Mix2Dx) that can be downloaded free. See text.

Then when I get all through with the contact, all that is necessary to produce a QSL card are a few simple clicks. A few more automated procedures and the station will be illegal; there won't be any need for a human at the controls. It will wake itself up in the middle of the night and start making contacts. Too much . . .

There is more. I haven't mentioned the automatic lookups you can effect with MixW via Internet databases. Mostly I have not mentioned this because I cannot demonstrate this on this limited old computer.

And there are another couple of items to make ham life more fun and less threatening that have to do with automatic antenna selection and heading. These are also covered in the material on the MixW Web site. And, due to lack of equipment in that category, I have not covered these subjects for you.

Upgrading the shack — again

But there is an area that I am trying to come up to speed. I think my wife was beginning to think I was about to break her new computer as I was having to rely more and more on it to test some of the new and improved software that keeps coming down the pike. So she caught me in a moment of weakness and insisted it was time to get a new computer.

I have it sitting on the floor just outside the door to the shack at this time. As soon as I get this article off in the mail that will be the next major shack project. I tried to get enough bells and whistles to be able to do all that might be deemed necessary for hookups and speed. More on that as I progress.

I did manage to purchase the largest monitor I could afford. It is still one size

Continued on page 50

NEW PRODUCTS

Alinco Introduces DJ-X3 Scanning Receiver— Compact Design Features “Hidden” Speaker

Alinco is announcing the release and FCC Type-acceptance of its new DJ-X3 scanning receiver, a compact unit that can receive from 100 kHz to 1.3 GHz in AM and wide or narrow FM modes. Announcement of the new unit was made by Craig Cota of ATOC Amateur Distributing, which distributes Alinco products to dealers in the USA and Canada.

- The DJ-X3 has a very distinctive design that places the speaker behind the display. Audio is heard from ports on either side of the display window. The compact unit easily fits in a shirt or jacket pocket. The DJ-X3 features 700 memory channels (10 banks of 70 channels), is powered by a rechargeable Ni-MH battery and also comes with a dry cell (3 X AA) battery pack. The triple conversion IF stage provides excellent reception.

The DJ-X3 can reproduce FM stereo when optional stereo headphones are connected to the unit. The operator also has four selectable antenna choices: an internal AM bar antenna, a short-wave bar antenna, the earphone cable may be used as an antenna, or the SMA whip antenna terminal can be activated. The unit is supplied with a removable whip antenna but an external antenna can also be connected to the SMA port. An attenuator function is available to reduce very strong signals. The receiver also has a “bug” detector, useful in searching for hidden transmitters.

- The DJ-X3 has three operating profiles, VFO, Preset AM, FM and TV frequencies and the Memory mode. The operator can make manual selections or scan in any of those modes. In the memory scan mode, the operator can choose one specified bank, certain banks can be linked for scanning or one can choose to scan all banks. There are 20 program and memory scan options.

- The DJ-X3 has three operating profiles, VFO, Preset AM, FM and TV frequencies and the Memory mode. The operator can make manual selections or scan in any of those modes. In the memory scan mode, the operator can choose one specified bank, certain banks can be linked for scanning or one can choose to scan all banks. There are 20 program and memory scan options.

- The DJ-X3 is capable of tuning in user-defined steps of 5, 6.25, 8.33, 10, 12.5, 15, 20, 25, 30, 50 and 100 kHz. The unit also has an AUTO step mode that selects the appropriate step for the band currently in use.

- The illuminated display is large and easy to read. In addition to frequency information, it will also show the operating mode, memory channel, battery strength, signal strength, and a number of other user-selected operating parameters. A charger, belt clip and strap are also included. The DJ-X3 can also “clone” to other DJ-X3 units, sharing its programmed parameters through a wire connection.

“The DJ-X3 is an exciting new addition to our growing line of receivers,” said Mr. Cota. “It is a great performer in a compact package. Along with the DJ-X2000, DJ-X2, and the DJ-X10, Alinco now offers the monitoring enthusiast a wide range of choices in receivers in different price ranges.”

The DJ-X3 is expected to be available in stores soon. MSRP is \$302.95. Accessories for the unit, such as extra battery packs, are also available. Dealers are free to set their own prices and often sell at prices below the MSRP.

Disclaimer: Specifications subject to change without notice or obligation.

For more information, contact Evelyn Garrison WS7A at (425) 557-9611.



Special Christmas Key

In celebration of the season, Morse Express has commissioned a special telegraph key which will double nicely as a Christmas tree ornament.

The Morse Express Christmas key is a fully operational miniature key, hand-machined from solid brass and plated in gold. It measures a tiny 1-3/4 in. by 15/16 in. at the base and weighs a mere 2 oz.

Designed by Marshall Emm N1FN, the Christmas key was a challenge for European key maker Llaves Telegraphicas Artisanas. All the usual adjustments (trunnion bearing tension, lever spring tension, and contact spacing) are available by means of gold-plated screws and matching lock nuts, and the indented

knob is very comfortable in use. All of the machining and assembly processes were done by hand.

The result, according to Emm, is “a pretty little key that will make an excellent Christmas tree decoration or stocking stuffer, but is also eminently usable for sending code. It’s the smallest key we sell, and one of the smallest we’ve ever seen, so it will be very handy for QRP portable operations. It will also add something special to Straight Key Night.”

The base of each key is engraved with the Morse Express logo and “Christmas 2001.” This is a limited edition of 200 keys, and each bears an engraved serial number on the base.

The Morse Express Christmas Key is \$49.95, plus s/h, and is available only from Morse Express. Photos and more information are available on the Morse Express Web site at [www.MorseX.com], where you will also find secure ordering facilities. Call (800) 238-8205 toll-free to order by phone, or (303) 752-3382 for more information.

PkTerm '99 Version 1.5 Now Out

Creative Services Software has now released version 1.5 of PkTerm '99, which supports the hot new digital mode PSK-31 as well as the AGW Packet Engine.

All of the features of PkTerm 1.5 except for one are available as a free update if you don't have the PK-232/PSK-31 hardware interface, or if you purchased PkTerm '99 after May 15, 2001. If you do own the interface, and purchased PkTerm '99 before May 15, then the update is \$29.95 for everything.

For further information, contact Creative Services Software, 503 West State St., Suite 4, Muscle Shoals AL 35661; (256) 381-6100; [www.cssincorp.com].

A GREAT gift idea for your ham friend(s)

is a subscription to 73 Magazine ... only \$24.97!
Call 800-274-7373 or write to 70 Hancock Rd.,
Peterborough NH 03458

There's still time to get a subscription for your favorite ham for Christmas. Just mention this ad when you call your order in, and we'll send you the latest issue to put under the tree!

ADVERTISERS' INDEX

R.S.#	page	R.S.#	page	R.S.#	page	R.S.#	page		
• Alinco	CV2	99	Communication Concepts	34	• Hamtronics, Inc.	9	• Radio Book Shop	48	
• Alinco	CV4	• Communications		42	Isotron	33	• Radio Book Shop	49	
• All Electronics Corp.	14	Electronics, Inc.	5	• Michigan Radio	49	• Radio Book Shop	58		
• Am-Com, Inc.	31	10	Communications	160	Micro Computer Concepts	41	• Radio Book Shop	63	
16	Astron Corporation	2	Specialists, Inc.	35	193	Morse Tutor Gold	57	• Radio Book Shop	64
• ATOC Amateur		• Creative Services		• Omega Sales	29	34	Ramsey Electronics	3	
Distributing LLC	CV2	Software, Inc.	29	• Omega Sales	33	254	Ross Distributing	13	
• ATOC Amateur		13	Doppler Systems	22	• Omega Sales	62	• Scrambling News	29	
Distributing LLC	CV4	• Fair Radio Sales	13	• Peet Bros.	35	• SGC	7		
• Bilal Company	33	193	GGTE	57	• Radio Book Shop	22	• Universal Radio	27	
168	Buckmaster Publishing	27	• Ham Ambassadors	19	• Radio Book Shop	27	• W5YI Group	13	
56	Buckmaster Publishing	33	• Ham Mall	34	• Radio Book Shop	41	• Yaesu	CV3	

When you buy products from these advertisers, please tell them that you saw their ads in 73.
 Subscribe to 73 right now...call 800-274-7373 (9-5 Monday-Friday EST).

WE SHIP WORLDWIDE
Michigan Radio
 SALES SERVICE

Local & Tech 1-810-771-4711, Service 1-810-771-4712, Fax Service 1-810-771-6546

OPEN
 TUES, WED, THUR 10-6
 FRI 11-8
 SAT 10-3
 CLOSED SUN & MON



Terms do not include shipping. Price and availability subject to change without notice. Most orders shipped same day. COD's welcome (\$5.50 & shipping).

26014 Groesbeck, Warren, MI 48089
1-800-TRU-HAMM (orders only)
 (800-878-4266)

Now on the World Wide Web

<http://michiganradio.com>

E-mail mirad@mich.com

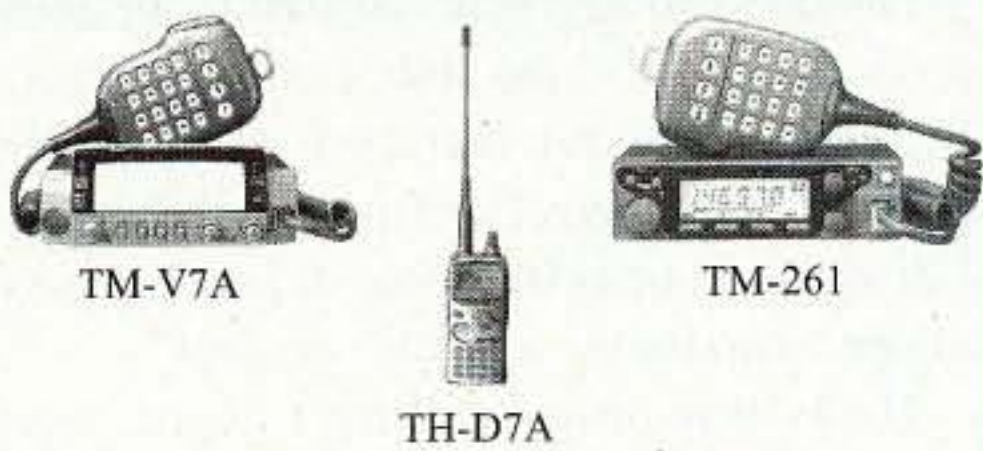

KENWOOD

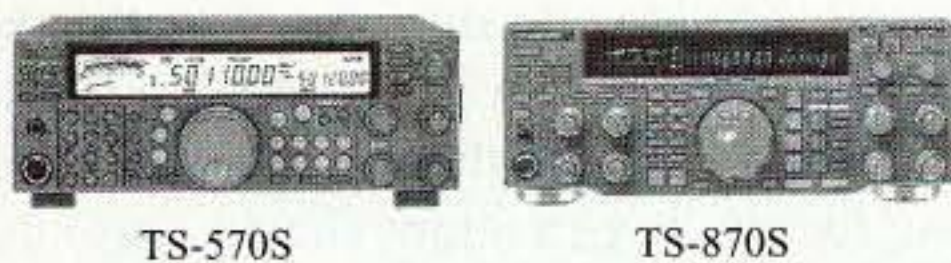
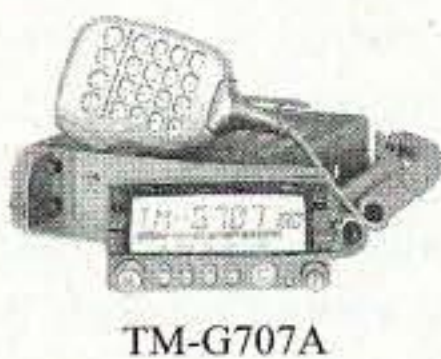

ICOM

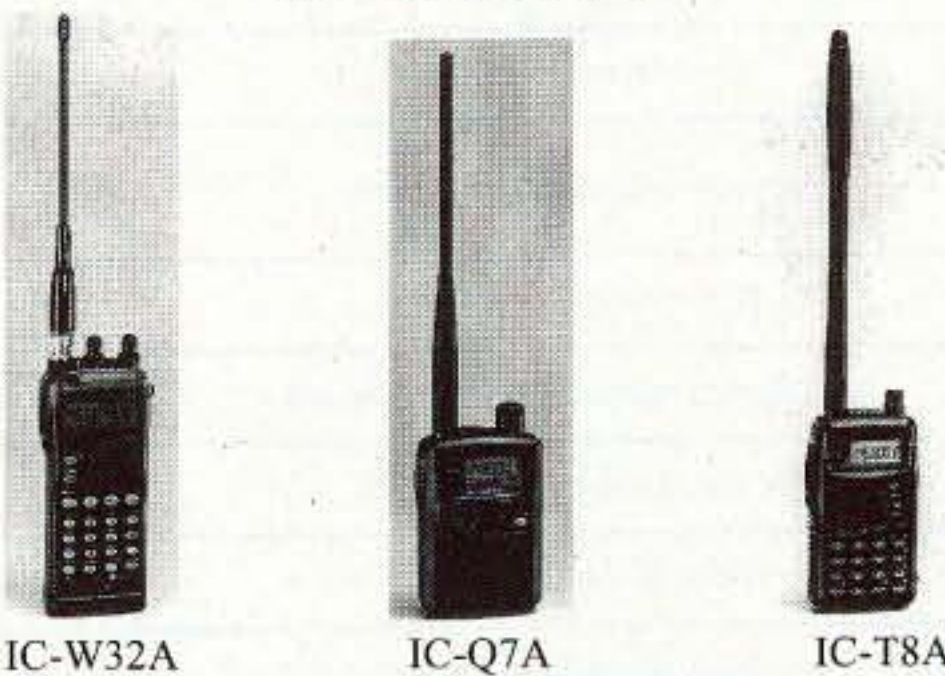

YAESU



Convert Excess Equipment to CASH • We buy good, clean, used equipment • Estate Sales

THE DIGITAL PORT

continued from page 47

down from the one that would have required a crow bar to get it through the door to the shack. There was a \$500 difference to go from 19 to 22 inches, so I only have to move one of the shelves to get it in here. Speaking of large, I doubt if the box the 19-inch monitor came in would have made it through the door without a squeeze.

By measurement, the available surface area on the 19-inch monitor is approximately 75 to 80 percent greater than the 15-inch. I think that will suffice to arrange the pictures for ease of viewing. Will let you know.

Just a little side note. Just a day or so after the purchase of the new machine, the XYL and I were passing a counter display in an office supply and I spotted one of those real treasures. Actually, the display

was covered with glass to keep strangers with grubby little paws from touching.

Inside the glass display case were a few honest-to-goodness fountain pens. We managed to get permission for me to hold one in my hand. They have changed the design a bit over the years. There is no exposed lever to aid in filling. The inside seemed empty and I asked where the bladder was.

Trying to either suppress a smirk or not let on she did not know what I meant, the girl behind the counter went and retrieved the innards of the mechanism from the back room and showed me a plastic cylinder with a twist mechanism on the end. Twist the knob with the pen immersed in the ink bottle and it draws ink into the cylinder.

The point of all this is that after the XYL became certain this was the find of the day and I should have one, she mentioned the fact that with such a fine writing instrument as this I might not really need that new computer after all. I told her the computer was still necessary, but the pen would become nearly indispensable if the printer failed. Plus, the pen has a lifetime warranty — the life of the owner, not the pen. Try to match that with the computer or the printer.

More on DxLabs

Last month's article is quickly becoming outdated as the work continues on the DxLabs projects. I did a bit of a no-no as I sent that article off. The time had gotten in very short supply due to technical difficulties with the previous Internet connection and getting the new setup going. Not very good excuses, but I notified Dave AA6YQ, after the mailing and included the text of the article he was not aware I was writing.

Needless to say, this resulted in an unintended surprise to the author of the fine software I wrote about. Dave was gracious and offered a few corrections and since that time I discovered he is involved in another great all-encompassing software project.

He is not only heading toward more modes than what the current PSK31 WinWarbler software offers, but is also about to embark on a project to expand past the Icom line of rig control. By the time this reaches print, you may be able to find support for the Yaesu rigs on the WinWarbler Web site and I can only guess how much more.

There are a lot of projects being initiated by the fertile minds of some of our leading ham oriented software folks. I really like what Dave has done and is doing. It would seem that doing all this work without asking for any pay in return should cause the

Source for:	Web address (URL):
Mix W Soundcard program for PSK31, RTTY, new modes, MTTY, FSK31, more	http://tav.kiev.ua/~nick/mixw2/www.nvbb.net/~jaffejim/mixwpage.htm
FREE MMHam site — MMTTY — MMSSTV	www.geocities.com/mmhamsoft/
FREE VK7AAB — SSTV-PAL — PSK-PAL	http://users.origin.net.au/~crac/
Much ham info w/SSTV downloads	www.conknet.com/~kb1hj/index.htm
TrueTTY — Sound card RTTY w/ PSK31	www.dxsoft.com/mitrtty.htm
Pasokon SSTV programs & hardware	www.ultranet.com/~sstv/lite.html
PSK31 — Free — and much PSK info	http://aintel.bi.edu.es/psk31.html
Interface for digital - rigs to computers	www.westmountainradio.com/RIGblaster.htm
Soundcard interface info — includes Alinco	www.packetradio.com/psk31.htm
Interface info for DIY digital hams	www.qsl.net/wm2u/interface.html
WinWarbler info and DXLab Suite	www.qsl.net/winwarbler/
MFSK-related tech info — how it works	www.qsl.net/z11bpu/
Throb — New — lots of info	www.lsear.freereserve.co.uk/www.btinternet.com/~g3vfp/
Download Logger, also Zakanaka	http://www.qsl.net/kc4elo/
PSKGNR — Front end for PSK31	www.al-williams.com/wd5gnr/pskgnr.htm
DigiPan — PSK31 — easy to use	http://members.home.com/hteller/digipan/
TAPR — Lots of info	www.tapr.org
TNC to radio wiring help	http://freeweb.pdq.net/medcall/ztx/
ChromaPIX and ChromaSound DSP software	www.siliconpixels.com
Creative Services S/W Multimode w/PSK	http://www.cssincorp.com/products.htm
Timewave DSP & AEA (prev.) products	www.timewave.com
Auto tuner and other kits	www.lidgelectronics.com
XPWare — TNC software with sample DL	www.goodnet.com/~gjohnson/
RCKRtty Windows program with free DL	http://www.rckrtty.de/
HF serial modem plans & RTTY & Pactor	http://home.att.net/~k7szl/
SV2AGW free Win95 programs	www.raag.org/index1.htm
Source for BayPac BP-2M & APRS	www.tigertronics.com/
Int'l Visual Communications Assn. — nonprofit org. dedicated to SSTV	www.mindspring.com/~sstv/
Hellschreiber & MT63 & MFSK16 (Stream)	http://iz8bly.sysonline.it
HamScope — multimode w/ MFSK16	http://users.mesatop.com/~ghansen/
YPLog shareware log — rig control — free demo	www.nucleus.com/~field/
WinLink 2000 System info	www.winlink.org/k4cjr/
Airmail — free program to use WinLink 2000	www.airmail2000.com/

Table 1. The Infamous Chart ... updated monthly.

Updates

If you missed last month's issue of 73, find a copy! The issue was packed with feature articles about the amateur-radio satellites. All of the authors involved are experts on many facets of space communications. The November 2001 issue will be a useful tool for satellite enthusiasts, and not just a one-month curiosity. Check it out!

New hamsats in orbit: On September 30th, four satellites were launched from the Kodiak Island launch complex in Alaska on a single Lockheed-Martin Athena-I rocket. The satellites included PCsat, SAPPHIRE, Starshine 3, and PicoSat. Three of the four satellites were designed to use VHF and UHF amateur-radio frequencies. The orbits are polar LEO (Low Earth Orbit) from 500 to 800 km.

PCsat

PCsat is the result of a U.S. Naval Academy project for students pursuing an aerospace major. The goal was to provide students with a hands-on experience in satellite design and operations. Funding was provided by the U.S. Naval Academy, and a grant from the Boeing Corporation. The launch was secured through the Department of Defense Space Test Program in cooperation with NASA. Even before the successful launch, the project had achieved its goal of designing and building a viable spacecraft. Bob Bruninga WB4APR provided an excellent article about the program and its operation in the November 73.

The mission of PCsat is to provide mobile and handheld digital communications for amateur-radio satellite operators using APRS (Automatic Position Reporting System). APRS has become more than just another use for packet radio. For many hams, packet has simply been a means to get on APRS. Those who have used APRS know that it is a lot more than a solution looking for a problem. It has become an easy and entertaining way to track the locations of friends, balloons, boats, planes, and just about anything that can carry a transceiver, TNC (Terminal Node Controller), and GPS (Global Positioning System) receiver. Now we have a satellite to relay this data to and

from remote locations, not to mention the short-message feature that allows users to send and receive brief communications along with latitude and longitude location data. Although Bob WB4APR had originally anticipated a two-week checkout after launch before the satellite would be released for general use, it only took a few days to test all systems and declare PCsat ready to go. For detailed and current satellite information see [<http://web.usna.navy.mil/~bruninga/pcsat.html>].

SAPPHIRE

SAPPHIRE is the first Satellite QUICK Research Testbed (SQUIRT) satellite and the second to fly. OPAL was the second satellite of the SQUIRT series, but the first to fly. The name SAPPHIRE stands for Stanford Audio-Phonic Photographic InfraRed Experiment. The SAPPHIRE project was started in 1994 and was ready for launch in 1998. But now, three years later, SAPPHIRE is finally in orbit. The satellite was developed by the Stanford Space Systems Development Laboratory to allow graduate students to gain experience in satellite design and construction.

SAPPHIRE carries three main experiments. The primary payload is a group of Tunneling Horizon Detectors. They are a new generation of infrared sensors that have been micromachined to fit in a chip and operate at room temperature. The digital camera experiment uses a Logitech digital camera called the Fotoman Plus. It can take and store 32 pictures in JPG format for transmission to ground stations. The third experiment is called Digitalker. It simply converts a text string to voice output for transmission via the 70cm FM transmitter. More information about SAPPHIRE can be found on the Internet at [[\[students.cec.wustl.edu/~sapphire/sysoverview.html\]\(http://students.cec.wustl.edu/~sapphire/sysoverview.html\)\].](http://</p></div><div data-bbox=)

Starshine 3

Project Starshine is a program developed by Gil Moore of Monument, Colorado, to encourage and involve younger students in satellites. Each Starshine satellite is covered with small round mirrors like a disco ball. Mirror kits are sent to school groups that wish to participate. The mirrors need to be ground, polished and returned for installation on the satellite. After launch the students learn about satellite orbits, and on appropriate passes, get a chance to see sunlight reflect from the satellite's mirrored surface. Starshine 3 is the third spacecraft in the series, but the second to achieve orbit. Starshine 2 is ready and waiting for launch on STS-108 later this year.

Starshine 3 is a 37-inch-diameter hollow

Satellite	Downlink	Uplink	
PCsat	145.825	435.250	1200 or 9600 baud AX.25 FM mobile
	145.825	145.825	1200 baud AX.25 APRS FM HT
	144.390		1200 baud AX.25 APRS special broadcast
SAPPHIRE	437.100	145.945	1200 baud AX.25 FM*
Starshine 3	145.825		9600 baud AX.25 FM data

*SAPPHIRE is also capable of synthesized voice downlink.

Table 1. New hamsat frequencies (MHz).



Photo A. PCsat, SAPPHIRE, and Starshine-3 all were on board the first orbital launch from Kodiak Island, Alaska. (NASA Photo)

aluminum sphere covered with 1,500 mirrors, 31 laser retroreflectors, and seven solar-cell clusters. There is also a 9600-baud packet telemetry system on 145.825 MHz to send back data about the system's power status and the satellite's spin rate. Data bursts are typically sent once or twice a minute via a 1.25-watt FM transmitter to a pair of quarter-wave monopole antennas. Later Starshine satellites will incorporate spin-up and spin-down systems. Hams are encouraged to collect telemetry from Starshine 3 and forward it via a radio data collection Web site [<http://www.epulation.com/starshine>]. The main mailing address is Project Starshine, 3855 Sierra Vista Road,

Monument CO 80132. More information about the past, current and future programs

can be found at [<http://www.azinet.com/starshine/>].

PicoSat

The final passenger on the flight was PicoSat. This small satellite was built by the same group that has provided so many UoSATS over the years, Surrey Satellite Technology, Ltd., at the University of Surrey in Guildford, England. The satellite was built under contract with the U.S. Air Force to test four experiments, including an RF beacon, GPS Ionospheric Sounding Payload, a Polymer Battery, and an Ultra-Quiet Stabilization Platform. There are no amateur-radio-frequency transmitters on board. Check [<http://www.sstl.co.uk>] for more on projects from the folks who brought you the highly popular UoSATS.

Athena

All of these satellites went to orbit on a Lockheed-Martin Athena-I booster from the commercial Kodiak launch complex on Kodiak Island off the south coast of Alaska. This was the third launch from the Alaska Aerospace Development Corporation's new 27-acre complex, but the first for an orbital mission dubbed Kodiak Star. The Athena-I is a three-stage rocket specifically designed for sending payloads that weigh 3,300 pounds (1,500 kg) or more to low orbits. The launcher for this flight was originally slated to carry the Vegetation Canopy Lidar satellite, but due to schedule slips, and the fact that the satellite has grown too large for an Athena-I, our hamsats and PicoSat got a ride.

The flight was broadcast via NASA-Select TV. During the wait for launch and various countdown holds, viewers got to see some of the beautiful sights on Kodiak Island, including wild horses milling around one of the tracking antennas, buffalo grazing nearby, flocks of birds, and even whales off the coast. The NASA broadcast also carried footage of the integration of the satellites and the launcher preparations. For details about the Kodiak Launch Complex, go to [<http://www.akaerospace.com>].

W3ADO-11>BEACON,SGATE:T#712,162,163,052,213,213,11111111,0011,1
KB7ADO-8>BEACON,W3ADO-1*:SYSTOP TEST NO users please. Wait till users authorized.
W3ADO-1>APRS3:Default LT3
W3ADO-1>BEACON,SGATE:T#713,159,066,139,044,213,11111110,0000,1
W3ADO-1>BEACON,SGATE:T#715,108,102,067,232,213,11111111,0010,1
W3ADO-1>APRS2:Default LT2
W3ADO-1>BEACON,SGATE:T#719,110,103,089,158,213,11111111,0010,1
W3ADO-1>BEACON,SGATE:US Naval Academy Prototype Comm. Sat. PCsat(A)

Table 2. A small sample of packet data received from PCsat on its first day in orbit.

How Do *You* Communicate?

Ham radio operators often think of themselves as great communicators, and in some ways we are excellent. In other ways, such as when talking to nonhams about the hobby, we may have difficulty in getting our message across.

There's a famous comedy sketch in which a character announces that he's a ham radio operator with "friends all over the world — all over the world. (pause) But none around here." We all laugh at the joke, because there is an element of truth to it. Some of us do better when in contact with another ham thousands of miles away than when talking with some people only a few feet away. Of course, it could be argued that the majority of our contacts are not really communication in the true sense of the word. If your average QSO consists of two callsigns and "five-nine," it cannot be compared to a true conversation. However, I believe that most of us are rag-chewers at heart and enjoy the communications aspect of the hobby as much as the technical side. One of the most important contacts we can ever make is with someone who might have an interest in the hobby. Unfortunately, while some hams are very skilled at this, some of us could use a little coaching.

We need to have a steady stream of new hams in the hobby or else we can bid a fond farewell to the hobby itself. Without a significant presence, we hams are going to lose our most important resource — our frequencies. The reality is such that being elite does not justify access to a rare commodity that is in high demand. A small number of hams who are highly skilled, technically expert, and dedicated to the hobby do not carry the clout of a large number of hams of whatever caliber. Whether we like it or not, that is a fact. Therefore, it is in our very own selfish best interests to sincerely invite in as many potential hams as we can.

There are a lot of people who could be interested in the hobby, if we effectively communicated its benefits. The problem is that many people don't know it even exists. Some are not aware of the hobby at all, while others think that this went out with

Morse Code and the big bands. Ham radio is one of the best-kept secrets around. We need to let people know ham radio exists and that they just might enjoy themselves.

Kids are naturals for ham radio today, just like when I was a kid. The difference is that they have a lot more options, and like most logical people are going to seek the path that provides the most benefit with the least investment. It's not a "dumbing down" as much as common sense. Why should anyone work twice as hard for the same outcome? If my goal is to talk to people all over the world, I can do that by ham radio or by the Internet. If I want to talk to friends at the other end of the amusement park, I can use a two-meter HT, a cell phone, or a Family Radio Service radio. Which is easier?

Rule Number One: Focus on the benefits of the hobby. With my interest in emergency

communications, I find it important that in a pinch, ham radio is the best chance to maintain communications. No other option exists in some situations. Other people have different benefits to focus on. Interested in space? Ham radio can communicate with the International Space Station and has its own satellites. Enjoy model rocketry or radio-controlled aircraft? Ham radio can be your telemetry or video downlink as well as your control frequency.

Rule Number Two: When speaking to someone about ham radio, don't try to impress them with your trials and tribulations. How many people do we scare off with our dissertation about the difficulty of the license exam? Do you truly believe that most folks who have a potential interest in the hobby wouldn't be able to pass the exam

Continued on page 62



Photo A. Kids today can be as attracted to ham radio as we were, but we have to compete with the Internet and other technology to catch their attention.

ARDF Championships, Part 1: Triumph in the Land of Enchantment

Just over a year ago, "Homing In" announced the search for a local radio club to host the first-ever national on-foot radio direction finding (RDF) championships in the USA. Ink on the last copy of the press run was barely dry when Albuquerque Amateur Radio Club (AARC) answered the call. Its members were eager to put on this historic event.

License plates in New Mexico proudly proclaim that it's the Land of Enchantment. From July 31 to August 4, it was the land of international-rules competitive RDF, also called foxhunting, foxtailing, radio-orienteering, and ARDF. Anyone, with or without a ham license, was welcome to enter the First USA ARDF Championships by paying the registration fee and traveling to Albuquerque.

Perhaps AARC's leaders didn't fully understand what they were signing up for, but

they were definitely up to the task. Following the suggestions in my site-search article,¹ they arranged for housing, local transportation, hunt venues, maps, medals, and the endless other details of a well-run radiosports event. I have much more to say about the fine people that made it a rousing success, but first let's focus on the competitors and how they fared.

A cross-section of America

We sought entrants from every part of the

country and with every ARDF skill level, from beginner to expert. In the end, ten states from coast to coast and border to border were represented. Although there was no formal teaming among the stateside hunters, some of them had trained together and put on local practice sessions for each other.

California sent the greatest number. The most experienced was Marvin Johnston KE6HTS from Santa Barbara. He had been on Team USA for the ARDF World Championships (WCs) in 1998 in Hungary² and

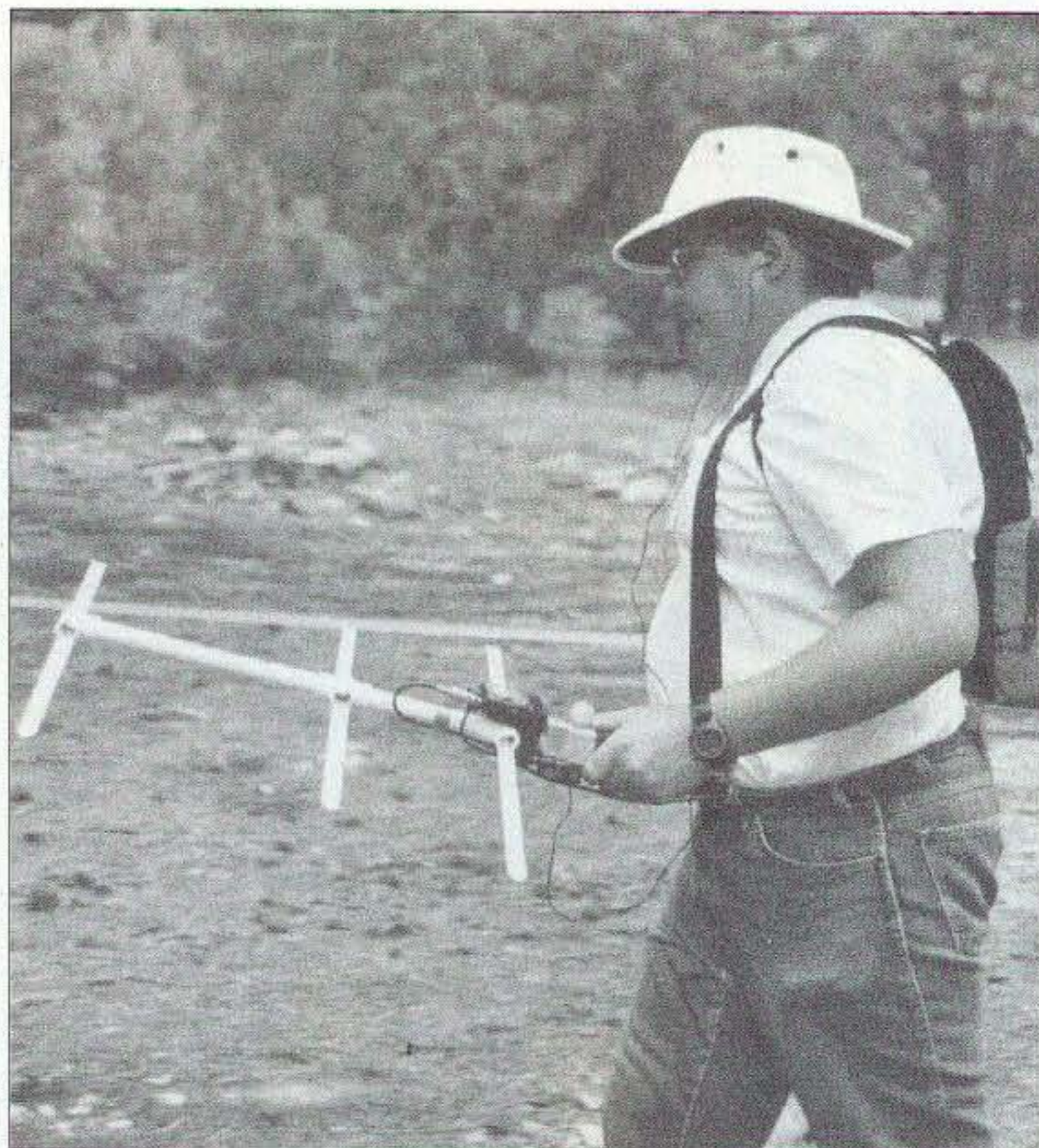

Photo A. Scott Moore KF6IKO of Santa Barbara is not having a good day on the 2m hunt, but he will go on to win a silver medal on 80m.

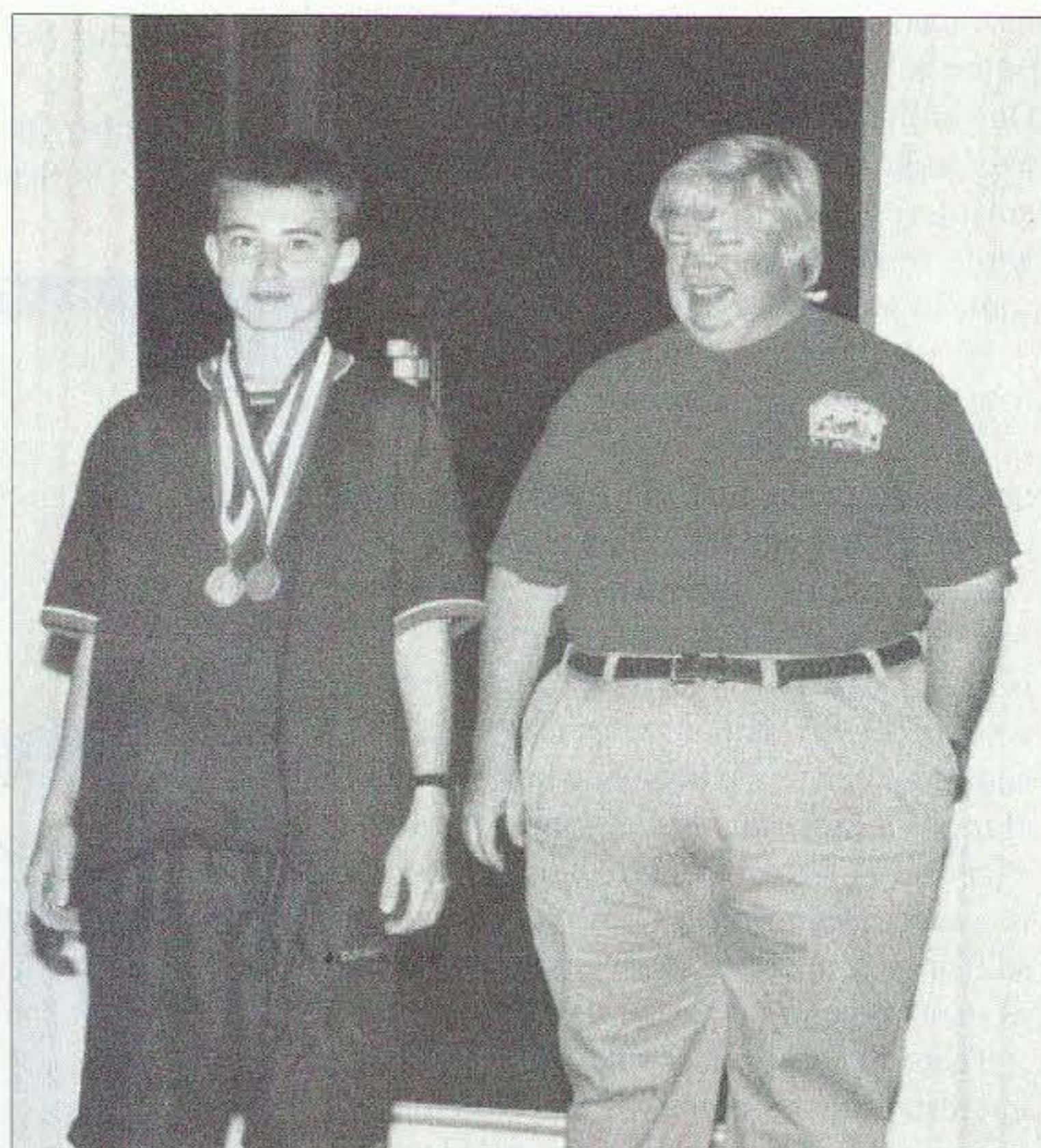

Photo B. Sixteen-year-old Jay Thompson W6JAY accepts gold medals for both 80m and 2m from AARC president Mike Eaton K5MJE.



Photo C. Wearing his skirted "Flying Nun" hat, Steve Shannonhouse from Georgia follows a wash toward the finish corridor.

2000 in China.³ A strong promoter of ARDF in his home town, KE6HTS encouraged two local newcomers, Scott Moore KF6IKO (**Photo A**) and Dave Jacobs K9KBX, to make the trip, and he helped them with training. Two other veterans of the China WCs were Jay Thompson W6JAY (**Photo B**) and his father Richard WA6NOL, who arrived by train from Santa Ana, California. Jay, who turned 16 just before the Albuquerque events, was this year's youngest competitor.

Scot Barth KA6UDZ and Rick Barrett KE6DKF are members of the San Gabriel

Valley Radio Club near Los Angeles. Although this was their first out-of-state event, they were experienced foxhunters, having already won trophies at on-foot hunts of ARRL Southwestern Division conventions and the West Coast VHF/UHF Conference.

The next-largest regional group came from the Peachtree State, where the Georgia Orienteering Club (GAOC) has been including radio-orienteering in its activities for a

couple of years under the leadership of Sam Smith N4MAP. Other GAOC members in Albuquerque were Kevin Haywood N4MGB, Steve Shannonhouse (**Photo C**), and Bill Farrell.

Traveling south from the Denver area were Larry Benko WØQE, Dave D'Epagnier KØQE, and Larry Noble NØNDM. Despite being newcomers, all were quick learners and good athletes. From the Cincinnati area came Dick Arnett WB4SUV (**Photo D**) and Bob Frey WA6EZV. Both had been to the China WCs and had trained hard for success in 2001.

Four localities with active ARDF programs were represented by "one-man teams." Dale Hunt WB6BYU of Yamhill, Oregon, was most experienced of the four, having competed at the WCs in Hungary, served on the International Jury at the WCs in China, and organized the 1999 International Amateur Radio Union (IARU) Region 2 Championships in Portland, near his home.⁴ Harley Leach KI7XF attended the China WCs and is putting on foxhunts at Montana State University in Bozeman, where he was professor of engineering for many years. Charles Scharlau NZØI represented the Piedmont area of North Carolina, where he has been promoting foxhunting since moving there from Seattle. Byon Garrabrant N6BG (**Photo E**) won foxhunting trophies in southern California in the mid-'90s and is now putting on events in Las Vegas, Nevada, following his recent move.

The remaining three stateside entrants learned ARDF by competing against champions in other countries. They were eager to teach and share their knowledge and

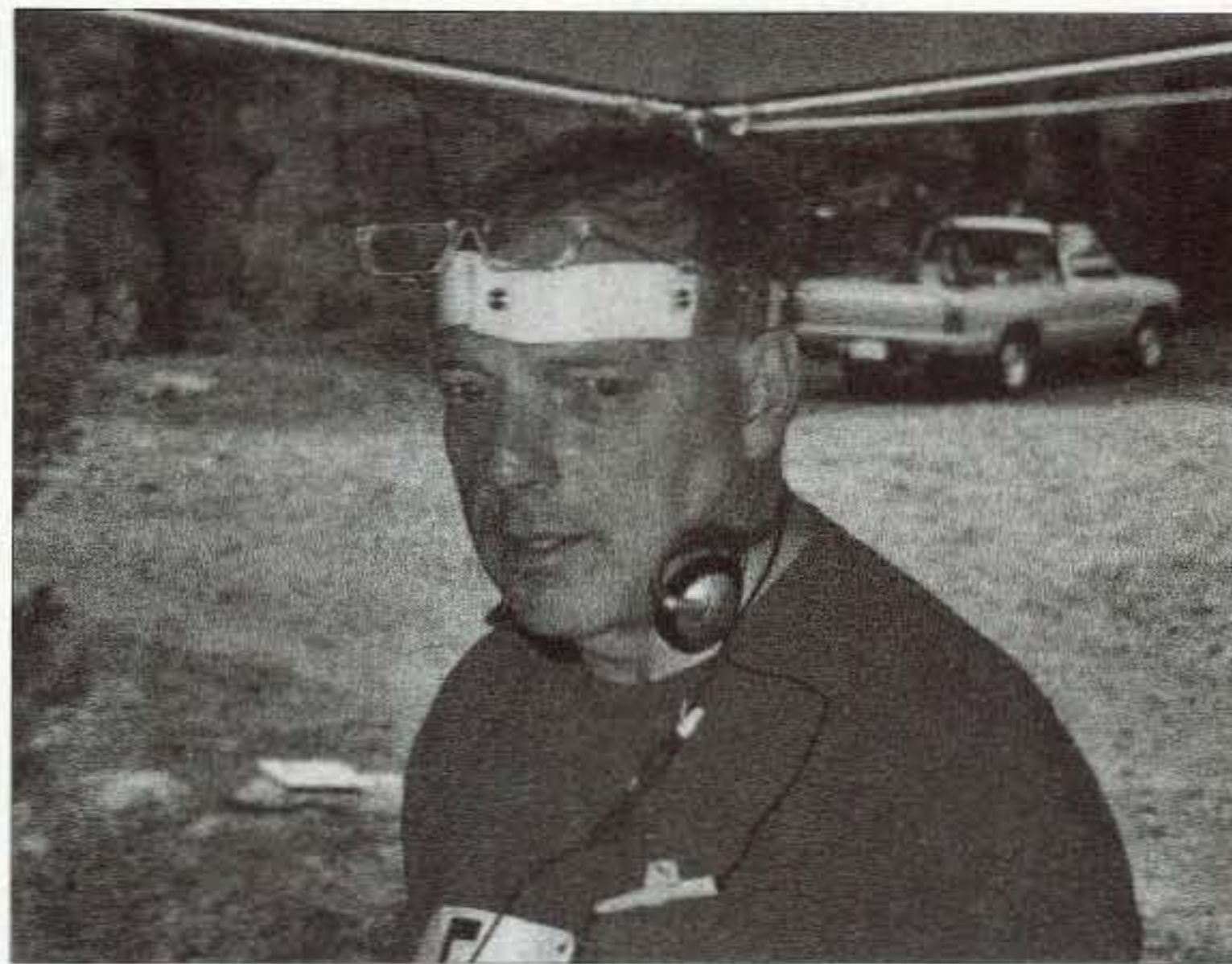

Photo D. Dick Arnett WB4SUV of Erlanger KY catches his breath after a gold medal-winning run. After losing his glasses on the championship course in China last year, he got a band to keep them firmly on his head this time.

experience. Gyuri Nagi HA3PA/KF6YKN (**Photo F**) and Csaba Tisztartó are Hungarian citizens with USA resident status, living on the east coast while in this country. Both competed on Team USA in the WCs of 1998 and 2000. Hiroshi "Yoh" Izuta JF1RPZ/KG6CEH was a national ARDF champion for 1987 and 1993 in his native Japan. He now resides in Sunnyvale, California.

It's traditional for foreign hams to compete in national championships as visitors,

Continued on page 56



Photo E. As photographers and timers stand at the ready, Byon Garrabrant N6BG of Las Vegas NV heads up the corridor to the 2m finish line.



Photo F. Gyuri Nagi HA3PA/KF6YKN, who trained in Hungary, had the best times of all in the USA-only standings.



Photo G. Marvin Johnston KE6HTS of Santa Barbara (right) put on a tri-tip beef barbecue after the practice session around Fenton Lake. Kevin Haywood N4MGB (left) of Georgia Orienteering Club captured a bronze medal three days later.

HOMING IN

continued from page 55

so the invitation went out to every country in the world with ARDF programs. Registrations came in from Australia, China, Mongolia, and Ukraine. They will be featured in an upcoming "Homing In."

Prepare for a monsoon

Early arrivers were treated to full-fledged practice sessions on both two- and eighty-meter bands, hosted by the four participants from Georgia Orienteering Club. This took place Monday, July 30, at Fenton Lake State Park, near Seven Springs. The site, at 7,740 feet above sea level, included a 25-acre lake

with a dam and downstream river, surrounded by steep hills and canyon walls that went up to the 8,400 feet elevation. According to Kevin Haywood N4MGB, "Each GAOC member took off in a different direction with one of the transmitters and walked up the slope as far as our lungs would carry us."

RDF was tricky at Fenton Lake, particularly on two meters as signals echoed and scattered off the canyon walls. The steep hills made the course physically difficult, not to mention the swarms of twin-engine mosquitos that nearly carried me away. I found out later that this was a backup location for the championships in case the primary location could not be used. It's good that didn't happen!

Afterwards, everyone enjoyed a Santa Barbara style tri-tip beef barbecue supper courtesy of Marvin Johnston KE6HTS, who had been marinating the tri-tips in a cooler for three days on the way to Albuquerque (**Photo G**). Others provided salads and fixings to complete the meal.

July and August is "monsoon season" in New Mexico. Warm moist air masses come in from the south, meet the mountains, and trigger thunderstorms almost every afternoon. This day was no exception, and after a couple of brief showers during the 80-meter hunt, a real gully-washer broke out just as the barbecue ended.

Next day, most of the competitors checked into dorm rooms at the University of New Mexico (UNM) campus near downtown Albuquerque. They ate there, too, at a facility that could hardly be called a "dorm cafeteria." It was actually a full-fledged food court with a variety of hot and cold selections for every meal, serving all you want to eat.



Photo H. This whimsical AARC logo was on the front of competitor and staff T-shirts.



Photo I. April Moell (right) sounds the horn to start Charles Scharlau NZ0I (left) and Scot Barth KA6UDZ on the 80m hunt. Scott drew #1 in the start lottery, putting him in the first starting position on 2m and the last on 80m.

Medal	2m winners	80m winners
M19, 4 foxes		
Gold	Jay Thompson W6JAY	Jay Thompson W6JAY
M21, 5 foxes		
Gold	Gyuri Nagi KF6YKN	Gyuri Nagi KF6YKN
Silver	Sam Smith N4MAP	Dave D'Epagnier KØQE
Bronze	Hiroshi Izuta KG6CEH	Richard Barrett KE6DKF
M40, 4 foxes		
Gold	Dale Hunt WB6BYU	Dale Hunt WB6BYU
Silver	Charles Scharlau NZØI	Scott Moore KF6IKO
Bronze	Kevin Haywood N4MGB	Charles Scharlau NZØI
M50, 4 foxes		
Gold	Dick Arnett WB4SUV	Dick Arnett WB4SUV
Silver	Larry Benko WØQE	Robert Frey WA6EZV
Bronze	Robert Frey WA6EZV	Larry Benko WØQE
M60, 3 foxes		
Gold	Harley Leach KI7XF	Harley Leach KI7XF

Table 1. USA-only standings and medal winners by category.

Wednesday, August 1, was a full day of organization, instruction, and practice on the campus. It began with the opening ceremonies, self-introductions, starting-order lottery, and a presentation from the U.S. Forest Service about its "Leave No Trace" program. Next, AARC's Event Chair, Jerry Boyd WB8WFK, thoroughly explained the rules. The most significant departure from standard IARU rules was an increase of the maximum allowable time on each hunt to three hours. This gave first-timers a greater chance of success. It also partially compensated for the high altitude and anticipated hot, dry weather.

AARC decided to use the new age/gender categories that had been proposed and debated by IARU officials in Europe and Asia, but had not yet been officially approved. The new categories for males, based on the competitors' ages on January 1, are M19 (19 and younger), M40 (40 and older), M50 (50 and older), M60 (60 and older), and M21 (intended for ages 20-39, but OK for any male). IARU also is considering four new divisions for females, but unfortunately no YLs entered these championships.

Sam Smith N4MAP of Georgia Orienteering Club then stepped up to cover all aspects of orienteering maps and forest navigation techniques, followed by Dale Hunt WB6BYU with a talk about ARDF course strategy. These presentations were primarily for the newcomers, some of whom had never participated in a full-course ARDF event and had no idea what terms like "cairn," "spur," and "reentrant" mean.

Everyone received a T-shirt with the event's unique "UFO" logo (blue for competitors, red for staff, see **Photo H**). Hydration backpacks and whistles were passed out to all, for health and safety in the forest. Competitors were told what to do in case they got hurt or lost, to summon help from the New Mexico Search and Rescue Team.

The rest of Wednesday afternoon was for training and equipment checkout, with plenty of 80m and 2m transmitters on the air throughout the UNM campus. Everyone wondered if the signal reflections and bearing aberrations caused by campus buildings were more severe than those they would encounter in the forest. After that, it was time for a hearty dinner and a good night's rest.

Where are we going?

Buses boarded promptly at 0800 Thursday. Rumors had been flying that the 2m hunt would be in the Sandia, San Pedro, or Sangre de Cristo Mountains, but instead the bus went 35 miles southeast of the city to Manzano Mountain State Park. It parked near the finish line, then AARC members drove a few hunters at a time down a narrow dirt road to the starting point, where the bus could not have gone. Scott Stevenson KC5VVB and his crew of volunteers were ready to send them off, two from different age divisions at a time, into the woods at five-minute intervals corresponding with the start of Fox #1 (MOE) transmissions (**Photo I**). While they waited, there was plenty of water and snacks.

After receiving their 11x17-inch maps just before start time, hunters discovered that the starting line was at the north end of the hunt area and the finish line was to the east. They would have to optimize their routes to find their required foxes along the way from start to finish.

IARU rules prohibit hunters from turning on their receivers until they are at the end of the start corridor, out of sight of the hunters still waiting to start. Some stayed at the end of the corridor for a full 5-fox transmission cycle, taking careful bearings on every required transmitter and plotting them on their maps. Others immediately ran off toward Fox #1.

The two-meter hunt area encompassed about 880 acres of forest, with ponderosa pine, pinon, and alligator juniper. Participants in last year's WCs in China agreed

WANT TO LEARN CODE?

Morse Tutor Gold from G.G.T.E. is the answer for beginners and experts alike.

*Get the software the ARRL sells and uses to create practice and test tapes; and **Morse Tutor Gold** is approved for VE exams at all levels.

*Since 1987, GGTE has guided nearly 25,000 hams and prospective hams around the world through proven structured lessons and a variety of character, word and conversational drills. Straight forward menus make the process simple and fun.

*This program features easy and speedy self-installation; random character drills with the characters you select; and you can create your own drills or import text files. You can type what you hear or copy by hand and see the results one line at a time. Pick the Farnsworth or the standard method; select the tone frequency most comfortable for you or select your code speed in tenths of a word per minute. For all DOS computers. You are always in command.

Certified by



Morse Tutor Gold uses your internal speaker or sound board. And, if you use a sound board **Morse Tutor Gold** supports volume control.

Sound Blaster and the Sound Blaster Compatibility Logo are trademarks of Creative Technology Ltd.



Available thru dealers, the ARRL, or send \$29.95 + \$5.00 S&H (CA residents add \$2.62 tax) to:
GGTE, 23801 Cassandra Bay,
Dana Point, CA 92629

that vegetation in Manzano Mountain Park was much less dense, making cross-country running easier, but not too easy. The weather was better this year, too. The direct sun was quite warm, but clouds increased as the hunt went on.

Altitude, which ranged from 7,250 to 7,840 feet, was the greatest running challenge for many hunters. The mosquitoes weren't out in force, but the forest floor had boulders in many places, making it important for hunters to mind their footing. The straight-line course length, from start to all five foxes and then to the finish, was just under five kilometers.

Mike Eaton K5MJE (AARC president) and another volunteer crew awaited the hunters as they ran through the corridor to the finish line. Boy Scouts at the entrance of the corridor used Family Radio Service (FRS) radios to alert the finish line staff and photographers when runners approached. The last finisher came in just as the afternoon's thunderstorm began soaking the finish shelter area. A special-event HF station (K5T) was ready, but no one wanted to operate it with lightning nearby.

The bus route was exactly the same on Friday for the 80-meter hunt, because that hunt ended in the same place. However, the start was 1.4 miles southwest of the two-meter start. The 80m hunt area was about the same size and directly south of the 2m zone. The starting line was at the western high point, so it was all downhill for the competitors if they chose the correct route.

As they picked up their 80m maps, every hunter was planning how to do better than the day before. For some, it was their first 80m hunt and they were using borrowed receivers. For others, it was an opportunity to try out their just-completed home-brew 80m ARDF sets.

Sure enough, everything went more smoothly, both for the organizers and the hunters. Almost every performance was better, even though the course length was 10 per cent longer than on two meters. The hunt was over before the afternoon rains came, except for one lost competitor that I'll tell you about next time.

The closing banquet on Friday evening, organized and presided over by Brian Milesosky N5ZGT, included an excellent Mexican food buffet, the traditional token gift exchange, speeches of thanks, raffle prizes, lots of photos, and, of course, the medals. Afterwards, it was time to go pack the suitcases for departure by train, plane, and highway the next morning.

The winners are ...

Experience in his native Hungary and at the last two ARDF WCs paid off for Gyuri Nagi HA3PA/KF6YKN, who had the best performance by a stateside competitor on both bands. Although he could have competed in M40 division, he chose M21, requiring him to find all five foxes. His time was under 54 minutes on 2m and under 50 minutes on 80m. Close behind him on 80m was newcomer Dave D'Epagnier KØQE with less than 63 minutes. On 2m, Sam Smith N4MAP was next with less than 68 minutes. All medalists in M21 had times under 99 minutes.

In M40 division, Dale Hunt WB6BYU cruised to a gold medal by finding his required four foxes in less than 83 minutes on both bands. Newcomer Charles Scharlau NZØI had excellent under-two-hour times on both bands. But the big surprise in M40 was Scott Moore KF6IKO, who found no 2m transmitters on Thursday and then went on to take silver on 80m by finding all four in less than 86 minutes.

In M50, the gold winner both days was Dick Arnett WB4SUV. He found his 4 foxes in less than 69 minutes on 2m and 82 minutes on 80m. The 2-day battle for runner-up was between Larry Benko WØQE and Bob Frey WA6EZV. Each went home with a silver and a bronze.

The youngest competitor (Jay Thompson W6JAY) and the oldest (Harley Leach KI7XF) were in categories by themselves. (Even though he was actually 59 at the time, Harley was in M60 because "division age" is the age on your birthday in the competition year.) Each had excellent performances and each took home gold medals. Harley found his required 3 foxes in less than an hour each day. The complete list of all medalists in the USA-only standings is in **Table 1**.

That's all for this month, but there's lots more to tell about the first USA ARDF Championships. Come back next month for more stories from New Mexico. The spotlight will be on the foreign visitors, the organizers, and the informal competition among the cities. Meanwhile, start planning on-foot or mobile transmitter hunts in your home town. I welcome your RDF stories and photos, which should be sent to the postal or E-mail addresses at the beginning of this article.

Footnotes

1. Moell, Joe, "Homing In: USA Foxhunting Championships 2001 — Let's Start Planning Now," *73 Magazine*, October 2000.

2. Moell, Joe, "Homing In: A Banner Year — More to Come," *73 Magazine*, January 1999.

3. Moell, Joe, "Homing In: A New Millennium for Foxhunting," *73 Magazine*, January 2001.

4. Moell, Joe, "Homing In: City of Roses — and Foxes," *73 Magazine*, October 1999. 73

Microwind to the Rescue!

continued from page 16

on the list. All three of these suppliers can be found on the Web, or you can order by phone. The contact information for these suppliers is:

DIGI-KEY

1-800-344-4539

[<http://www.digikey.com>]

CIRCUIT SPECIALISTS

1-800-528-1417

[<http://www.web-tronics.com/>]

RADIOSHACK.COM

1-800-442-7221

[<http://www.radioshack.com>]

While there's no reason why the circuits could not be built on small pieces of perfboard, the printed circuit boards make it simpler, avoiding any hand-wiring. I can provide a set of two bare circuit boards, etched and drilled, for \$5 plus \$1 for postage. Send check or money orders to:

THOMAS MILLER

216 East 10th Street

Ashland OH 44805

If there is enough interest, I will consider offering a kit of circuit boards, electronic components and the blade adapter. Keep an eye on my Web site [<http://www.bioelectrifier.com>] for updates and additional information on this and many other projects. 73

Back Issues

of

73 Magazine

Only \$5.00 Each!

Call 800-274-7373

VOM Primer

continued from page 29

read AC volts requires converting the AC into DC and then reading the DC in the usual way. A half-wave rectifier is used to convert the AC to DC. Half wave rectification produces a DC (average) voltage that is $0.3183 \times E_{\text{peak}}$. The meter face is marked to indicate the RMS voltage, which is $0.7071 \times E_{\text{peak}}$. The AC meter reads average and indicates RMS. Measuring complex wave shapes can lead to confusing readings unless the shape is known. If the AC frequency is very low, the meter will follow the voltage or current and not indicate the average.

Most meters are calibrated with 60 Hz. At low voltages, the forward voltage drop across the rectifier is significant, and a separate low AC voltage scale added to the meter.

Frequencies above high audio are not usually measured with a VOM because the capacitance of the meter's circuits is lossy or unpredictable and the equivalent multiplier is unknown.

To summarize the limitations of a VOM: The ideal current meter has zero resistance and drops no voltage. A real-world current meter has some resistance and drops a little voltage, usually on the order of 25 mV or 50 mV. The ideal voltmeter has an infinite resistance and does not load the circuit. A real-world voltmeter loads the circuit under test. The loading is a function of the voltage scale used and the sensitivity of the meter. The loading provided by a voltmeter is given as ohms per volt.

The AC voltmeter function reads the average of the AC and indicates RMS. The AC voltage is assumed to be a 60 Hz sinusoid. Voltages of audio frequencies can be read with unspecified accuracy. The circuit under test is still loaded by the meter.

The VOM is a most useful instrument. It is rugged but not bulletproof: They can be abused to the detriment of the meter. In fact, the VOM is probably the most used instrument on the bench, and no bench should be without one — despite its limitations. 73

Ye Olde Fishpole Vertical

continued from page 35

the coax is connected back on the rig.

If you don't have an antenna analyzer, you will have to go through the purgatory of reducing power and checking and rechecking the SWR.

I also obtained good results by using the metal frame of a door, and an air conditioner metal frame mount.

There will definitely be variations to the tuning, depending on the inherent density values surrounding your area of installation. In some cases a larger value capacitor may be required. My capacitor value turned out to be 125Pf under a variety of different applications. If the installation is to be permanent, then measure the cap's value and replace with a good fixed mica capacitor for a smaller foot print. Follow the simple rules in resonating an antenna, and I am sure that it will work quite as well for you as it has for me.

I am sure that this antenna will give you more ideas for other ventures, and I hope to be reading about them.

Although this antenna has been tested at 40 watts. I recommend that it be used for QRP only.

I used approximately 25 feet of mini RG-8X coax cable for my installations, but RG-58 could also be used. Although it has more capacitance per foot, I am sure that you could get it to resonate. Experiment! The MFJ SWR analyzer would be a great assist for the initial setup. Have fun! Get outdoors with your favorite hobby! 73

The Builder's Dozen

continued from page 36

11. Vernier gear drives can be created from VHS tape player deck gearing. Use heavy perfboard as a sandwich to hold the gearing. The plastic spacers described above can be cut to form the necessary corner spacers and bearings. While not a tight professional unit, it has been in service for several years now and works as it did when new.

12. Storage boxes, the ones sold at the craft store for storage of thread on small paper squares, make ideal units

for keeping resistors, caps, etc., sorted and ready for use. They're about 8" by 12" and are divided into compartments for easy sorting of parts. The price on these is about \$2, and sometimes they can be found on sale for half that. Mark the outside of the box with the contents for easy identification.

And there you have a "Builder's Dozen" of helpful hints for a more successful project. Keep building! There's no end to the pride and sense of accomplishment achieved when you create your own projects! 73

ABOVE & BEYOND

continued from page 44

configurations, were obtained; these will be made available to other amateurs. We make these devices available for those who cannot find units at their own local swap meets. The beige LNB, tested and ready to convert, is available for \$20 postpaid from the author. Please direct any question on this and any other items to Chuck WB6IGP at [clhough@pacbell.net]. 73

QRP

continued from page 45

either open up or short circuit. Lucky for us, they're just cheap bipolar transistors.

Opening the SA-5010 is easy: There are four screws holding the bottom plate on. The top and bottom halves come apart. On the bottom plate, a 7805 regulator is mounted with a connecting cable leading to the main PC board. This cable must be unplugged before the two halves can come apart. Once apart, there is one more cable that needs to be messed with. That's the one that goes to the keypad. There is another smaller PC board that holds the LED. This guy always seems to get in the way.

The keying transistors are mounted on the top right-hand side of the PC board. There you will also find the bridge rectifier made up of four diodes. These diodes provide the SA-5010 with the ability to operate on either AC or DC power. The SA-5010 is not polarity-sensitive either. These diodes will always select the proper polarity and send it the necessary circuits.

Putting the SA-5010 back together requires several more hands than most of us

Continued on page 61

DXers, Rejoice!

December should offer DXers some of the best conditions of the year, as daytime signal absorption and atmospheric noise both decline to seasonal minimums in the northern hemisphere. Activity on the sun is also expected to moderate somewhat, leaving plenty of opportunity to exchange "season's greetings" with stations worldwide.

As shown on the calendar, eighteen days should bring us at least Fair (F) propagation conditions — the best days being the 11th to 13th and 25th to 27th, when solar activity is projected to be very low. Of course, there will be some disturbed periods, and the whole week from the 2nd through 8th looks particularly dismal. Other "critical" dates are the 14th, 17th, 19th, 23rd, 28th, and 31st, so expect moderate flares, coronal mass ejections (CMEs), and associated high flux values on those days. As always, geomagnetic effects may follow some eruptions within 72 hours, so be sure to monitor WWV for any developments.

Last month, I mentioned that we would look at the methods and pitfalls of propagation forecasting. Unfortunately, due to various constraints, this discussion will have to wait until a future issue. However, to set you to pondering the first subject of my intended discourse, let me pose a question: What does the latitude of your station have to do with the propagation and quality of the HF signals that you send or receive?

Band-by-Band Summary

10-12 Meters

Worldwide openings will occur from sunrise to just after sunset. Europe, the Middle East, and Africa will be best before noon. Central and South America should remain open from midmorning through late afternoon, with some noontime fading. The Pacific and Asia should open from noon through early evening. Expect skip to be 1,000-2,000 miles.

December 2001						
SUN	MON	TUE	WED	THU	FRI	SAT
						1 G
2 F-P	3 P	4 P	5 F-P	6 F	7 F-P	8 F
9 F-G	10 F-G	11 G	12 VG	13 VG	14 P	15 F-G
16 F-G	17 F-P	18 F	19 F-P	20 F-G	21 F-G	22 G
23 F-P	24 F	25 G	26 VG	27 VG	28 F-P	29 F
30 F-G						

EASTERN UNITED STATES TO:												
GMT	00	02	04	06	08	10	12	14	16	18	20	22
Central America	15 (40)	20 (40)	20 (40)	(40)	(40)	(20-40)	(15-20)	10-20	10 (20)	10-17	10 (20)	(10) 20
South America	(15) 20	20 (40)	20 (40)	20 (40)	x	x	(15-20)	x	(10)	10 (15)	10 (20)	(10) 20
Western Europe	40	40	40	40	(40)	x	(10-20)	10 (20)	(10) 20	(15-20)	(20)	(20-40)
Southern Africa	(20-40)	(40)	x	x	x	x	x	(10-12)	10 (17)	(12) 17	(15-20)	20
Eastern Europe	(40)	(40)	x	x	(20)	x	(10-20)	(10) 20	(20)	x	x	x
Middle East	(40)	(40)	x	x	x	x	(10)	(10-15)	15 (20)	20	(20)	(20)
India/Pakistan	x	x	x	x	x	x	x	(15-20)	x	x	x	(20)
Far East/ Japan	(15) 20	20	(20)	(20)	x	x	(20)	x	x	x	x	(10-20)
Southeast Asia	(15-20)	x	x	x	x	x	x	(10-20)	(10-15)	x	x	x
Australia	(10-17)	(15-20)	x	x	(20)	(30-40)	(20-40)	(10) 20	(10-20)	x	(20)	(10-15)
Alaska	15-17	20-30	x	x	x	20-30	20-30	15-17	15-17	x	x	15-17
Hawaii	(10) 15	(20)	20	(20)	20 (40)	40	(20-40)	(20)	(15-20)	x	(10)	10 (15)
Western USA	(10) 40	(15) 40	20-40	(20) 40	40	40	40	(20-40)	(10-20)	10-20	10-20	10-20
CENTRAL UNITED STATES TO:												
Central America	(15) 20	20 (40)	(20) 40	(20) 40	(20) 40	40	(40)	(10) 20	10-20	10-15	10 (20)	15-20
South America	(15) 20	20	20 (40)	20 (40)	(20)	x	x	x	(10)	10	10 (20)	(10) 20
Western Europe	(40)	40	40	(40)	x	x	(20)	(15) 20	(10) 15	(15) 20	(20)	x
Southern Africa	20	(20)	x	x	x	x	x	x	(10-15)	(10) 15	15 (20)	20
Eastern Europe	x	(40)	x	x	x	x	x	(10) 20	(10-20)	x	x	x
Middle East	x	(40)	(20)	(20)	x	x	x	(10-15)	(10-15)	(20)	20	(20)
India/Pakistan	x	(15)	x	x	x	x	(20)	x	(15)	x	x	x
Far East/ Japan	x	x	(20)	20	(20-40)	(40)	(20)	20	(15-20)	x	15	(15)
Southeast Asia	x	x	x	x	(20)	(20)	20	(15-20)	(15)	x	(15)	x
Australia	(10) 15	15	(15-20)	20	20 (40)	20-40	20 (40)	(20)	x	x	x	(10-15)
Alaska	15-17	15-17	x	x	x	(40)	(40)	20	20	x	x	x
Hawaii	(10) 15	(15-20)	20	20	(40)	(20-40)	20 (40)	x	(15)	(15)	(15)	(10) 15
WESTERN UNITED STATES TO:												
Central America	(20-40)	40	40	40	(40)	x	(20)	(10) 20	10 (20)	10 (20)	(10) 20	(15) 20
South America	17 (40)	(20)	x	x	x	x	x	(15)	12 (20)	10-20	10-20	12 (40)
Western Europe	x	x	(40)	(20)	(20)	x	(20)	(10-20)	(10) 20	(20)	x	x
Southern Africa	(20)	x	x	x	x	x	x	x	(10)	(15)	15 (20)	(15) 20
Eastern Europe	x	x	x	x	x	x	x	x	x	x	x	x
Middle East	(20)	(40)	(20)	20	20	(20)	x	(15)	(10) 15	(10-15)	(20)	(20)
India/Pakistan	(15-20)	x	x	x	x	x	x	(20)	x	x	x	x
Far East/ Japan	(10) 20	(15-20)	x	x	(40)	40	(40)	x	x	x	(10-20)	10-20
Southeast Asia	(15)	(20)	x	x	x	x	x	(20)	(15) 20	(20)	(10-15)	10-15
Australia	(10-15)	(15-20)	x	x	x	(20-40)	(20-40)	20	(15-20)	15	(10-15)	10
Alaska	10-15	x	x	20-30	20-30	20-30	20-40	x	20	15	x	15-17
Hawaii	(15) 20	(15) 20	20	(20)	(40)	40	(20-40)	(15) 20	15 (20)	(10-15)	10 (15)	(10) 15
Eastern USA	(10) 40	(15) 40	20-40	(20) 40	40	40	(20-40)	(10-20)	10-20	10-20	10-20	10-20

Table 1. Band, time, country chart. Plain numerals indicate bands which should be workable on Fair to Good (F-G) and Good (G) days. Numbers in parentheses indicate bands usually workable on Good (G) days only. Dual numbers indicate that the intervening bands should also be usable. When one number appears in parentheses, that end of the range will probably be open on Good (G) days only.

CALENDAR EVENTS

Listings are free of charge as space permits. Please send us your Calendar Event two months in advance of the issue you want it to appear in. For example, if you want it to appear in the March issue, we should receive it by December 31. Provide a clear, concise summary of the essential details about your Calendar Event.

JAN 19

ST. JOSEPH, MO The 12th annual Northwest Missouri Winter Hamfest, co-sponsored by the Missouri Valley ARC and the Ray-Clay ARC, will be held 8 a.m.–3 p.m. at the Ramada Inn in St. Joseph MO. The motel is located at I-29 and Frederick Ave. (Exit 47 on I-29). Special room rates are offered for hamfest participants. Talk-in on 146.85 and 444.925. VE exams, major exhibitors and flea market all indoors. Free parking. Advance tickets \$2 each or 3 for \$5; at the door, \$3 each or 2 for \$5. Pre-registration requests received after January 6th will be held at the door. Swap tables \$10 each for the first two tables. Commercial

exhibitors are welcome, write for details: Northwest Missouri Winter Hamfest, c/o Neal WBOHNO or Carlene KAØIKS Makawski, 3704 Meadowoak Ln., St. Joseph MO 64503. E-mail [nem3238@ccp.com]; or tel. (816) 279-3406.

JAN 20

HAZEL PARK, MI The Hazel Park ARC's 36th Annual Swap & Shop will be held at the Hazel Park High School, 23400 Hughes St., Hazel Park MI, 8 a.m.–2 p.m. General admission is \$5 in advance or at the door. Plenty of free parking. Tables \$14. Reservations for tables must be received with a check. No reservations

by phone. Talk-in on 146.64(-), the DART rpt. For info about the swap, tickets, or table reservations, mail to HPARC, P.O. Box 368, Hazel Park MI 48030.

SPECIAL EVENTS, ETC.

DEC 14, 15

BETHLEHEM, IN The Clark County ARC will operate W9WWI 1500Z December 14th–2200Z December 15th, in celebration of the Christmas season. Operation will be on General 75, 40, and 20 meters. QSL with an SASE for a certificate to CCARC, 1805 E. 8th St., Jeffersonville IN 47130. 73

15–17 Meters

Openings can be found from sunrise to mid-evening on good days. The best times will generally be a bit after the peaks for 10 and 12 meters, but the bands should remain active until about 9 p.m. local. Skip will be shorter, though, at only 1,000 miles or so.

20 Meters

Around-the-clock activity can be found here. Expect peaks just after sunrise. From late afternoon to early evening, and just before midnight. Central and South America should be workable at all hours except sunrise. Skip will average 500–1,000 miles during the day and 1,500–2,000 miles at night.

30–40 Meters

These bands will usually be open between 7 p.m. and 7 a.m. local time. Europe and the Near East will be best before midnight while the Far East and the Pacific will be best after 12 a.m. The Americas should be open all night long. Expect short-skip to be from 1,000–2,000 miles.

80–160 Meters

December is a good month for these bands, given the long northern nights and few tropical disturbances. The greatest storm activity will occur in the South Pacific, so most

static will occur on paths across that area. The strongest signals are likely to be from Europe, Africa, and the Middle East between sunset and midnight. Short-skip will typically fall between 1,500 and 2,000 miles. Until next time, 73 and Happy Holidays! Jim Gray, [akdhc2pilot@yahoo.com]. 73

QRP

continued from page 59

are equipped with. Just plug the various circuit boards back into their jacks. Then squeeze the two halves together and, with a bit of luck, it will all fit. I've found that it takes about a half a dozen tries before you get everything back together like it should be.

HW-8 modifications

We're still looking for more modifications to the Heathkit QRP series. No matter how simple or complex, if you have a modification or a fix for a problem with any of the radios, please pass it on to me.

And, by the time this gets to print, I'll have uploaded PC board layout and circuits for the HD-1410 keyer on my Web site. Check them out at: [http://www.theheathkitshop.com]. 73

THE DIGITAL PORT

continued from page 50

development wheels to slow to a crawl. But the work keeps going and, if anything, the tempo increases. It takes a mighty amount of brainpower to continue to push forward on these diverse fronts as much as Dave does.

Ham bands are busy

As this is being written, it is one of the hottest August months I can recall. It hit the hundred mark just 30 miles down the road from here yesterday. I like to stay inside during that kind of weather. And I get lazy and like to play with the radio.

Usually, this time of year seems to lack for radio activity a bunch of the time, but this year is giving plenty of action. I am seeing plenty of foreign callsigns on the monitor. Sometimes they are not direct, but at least they are being worked by someone in a better spot for the propagation.

Other times, these signals are dropping in here just as well as they might in the early parts of Spring. I think some of this is because the popularity of the digital modes is keeping hams involved, and when that happens someone is on the air at the right time to take advantage of unpredictable openings.

What I am saying concerns activity. It

Continued on page 62

THE DIGITAL PORT

continued from page 61

doesn't have to be digital, or a certain band or mode. What matters is that there are enough stations on the air and listening to make some of those thrilling contacts to remote regions and faraway places.

That being said, we can get back to the fact that digital modes are causing a real stir in the ham ranks and a great percentage of the fun is to be had because of the new modes we discuss here. Keep it up, guys!

One final note. I just received my first Digital Port-related E-mail due to an article in the September issue. Now I know that the new E-mail address is out there and working. Always glad to hear from you folks in ham radio land.

If you have questions or comments about this column, E-mail me at [KB7NO@worldnet.att.net]. I will gladly share what I know or find a resource for you. For now, 73, Jack KB7NO. 73

ON THE GO

continued from page 53

with proper preparation? Also, don't take offense if people confuse ham radio with CB. Sure, there's a world of difference, but to many people, "Ten-four good buddy" doesn't sound significantly different than "Roger and thanks for the Cue-so."

Rule Number Three: Focus on the community that encompasses ham radio and how supportive it is. There are classes to help people prepare for their first exam or an upgrade. If you prefer to study alone,

there are "Elmers" who will be happy to answer a question or explain a concept. Maybe someone would enjoy being part of the Field Day group or the hamfest committee. Get two hams together at a restaurant on a regular basis and soon it'll be a small crowd enjoying the camaraderie.

Rule Number Four: Let people know how much ham radio helps out the neighborhood and the community. When people think of a disaster, they may automatically think of such organizations as the Red Cross or Salvation Army. These agencies depend upon hams to help them in their relief effort. If you live in an area that is subject to bad weather, you know how important SkyWarn is to the weather service. Hams' role in public service covers everything from the Christmas Parade to support at college football games.

Rule Number Five: It's a hobby. It's supposed to be fun. Most of us want to share the fun with others we like, so focus on how much fun you've had with the hobby. Focus on the fun you've had recently, not back in the good old days.

Now, don't just sit there: Go talk to somebody about how great a hobby this is! If you help someone become a ham, let me know. If you've been thinking of becoming a ham and this helps make up your mind, let me know that. I can't wait to hear from you. 73

QRX

continued from page 7

increased by about 20,000 since April 15th of 2000. At the same time, the total number of combined Technician and Technician Plus operators has

declined. Also, the number of Novice class license holders has been deteriorating steadily since 1991, when the No Code Technician became the entry level license of choice. There were 95,000 Novice license holders on February 1, 1991. Maia says that today there are only 42,000, a decrease of 60 percent.

On the surface, it would appear that there is a significant net loss of hams who held telegraphy skills, but Maia says that this too may be inaccurate, since many Technicians do indeed have their 5 wpm Morse

rating, as mentioned above. But they are now lumped in an FCC database that uses the term Technician to describe them all. In fact, this alone renders the term No Code Tech as being obsolete.

And here's the real kicker. Reducing the Morse testing speed to 5 wpm has not accounted for any significant numbers of new applicants for ham radio licenses. What it has done is to motivate existing hams to upgrade to get new privileges, but that's about it. The bottom line is that the number of amateurs in each license class has merely been rearranged.

Maia's conclusion? Amateur Radio is not growing in relation to the growth of the nation's population. He says that reduction of the Morse speed to 5 wpm and fewer license classes has had no discernible impact on growth in the United States Amateur Radio Service. Or at least none so far.

Thanks to David Black KB4KCH and the W5YI Report, via Newline, Bill Pasternak WA6ITF, editor. 73

NEVER SAY DIE

continued from page 8

the position of deputy administrator at the EPA? Linda, now an executive with Monsanto, had worked for the EPA for 10 years before heading Monsanto's Washington lobbying office. Back at the EPA in a top position, she'll be making biotech food decisions which can affect us all.

Anyway, here are some quotes from the vaccine article.

"The grandson of Congressman Daniel Burton, of Indiana, was vaccinated for nine different diseases in one day. Before the vaccines he had been a healthy child. Now he suffers from autism."

"Autism has an onset before 30 months of age. There has been a dramatic increase in this (psychiatric) disorder throughout the United States during the last six years. Statistics in Ohio show a 6,822 percent increase of this disease over that period of time. California has experienced a similar explosion in the number of new cases of autistic children. Nationally, we have had a 26 percent increase per year."

"Mercury is used as a preservative in many vaccines. With those nine vaccines, Congressman Burton's grandson was injected with 41 times the considered safe level of mercury in one day. Mercury poisoning alone has been linked to autism, other learning difficulties, and emotional disorders. Children under 2 years of age do not produce enough bile to remove the mercury, so it deposits in their brains, the kidneys, and in other vital organs. For many persons this heavy metal is never eliminated from the body."

Heard enough? 73

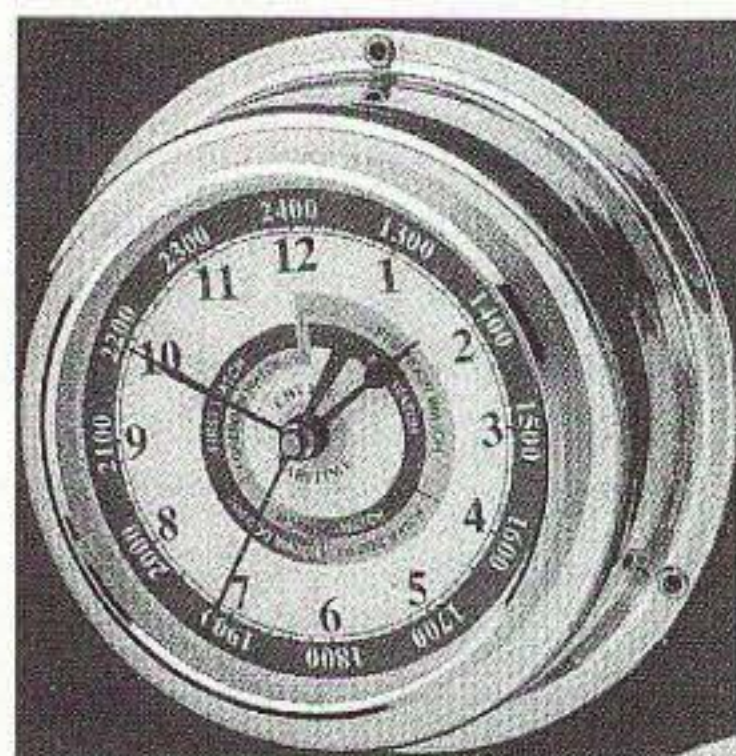

Beautifully hand-polished.
Stamped brass case and bezel.
Curved glass crystal.
Wall or bulkhead mounting.
Made so well they last from generation to generation!
Order this month and save \$20!

Chelsea Clock

Your price \$75

Clockmakers since 1897
The choice of The Coast
Guard Foundation.

Omega Sales

Quartz Clock

P.O. Box 376

4" Dial

Jaffrey NH 03452

1-800-467-7237

Wise Up!

Here are some of my books which can change your life (if you'll let 'em). If the idea of being healthy, wealthy and wise interests you, start reading. Yes, you can be all that, but only when you know the secrets which I've spent a lifetime uncovering.

.....Wayne

The Secret Guide to Health: Yes, there really is a secret to regaining your health and adding 30 to 60 years of healthy living to your life. The answer is simple, but it means making some serious lifestyle changes. Will you be skiing the slopes of Aspen with me when you're 90 or doddering around a nursing home? Or pushing up daisies? No, I'm not selling any health products, but I can help you cure yourself of cancer, heart trouble, or any other illness. Get this new, 2001 expanded edition (156p). \$10 (#05)

The Secret Guide to Wealth: Just as with health, you'll find that you have been brainwashed by "the system" into a pattern of life that will keep you from ever making much money and having the freedom to travel and do what you want. I explain how anyone can get a dream job with no college, no résumé, and even without any experience. I explain how you can get someone to happily pay you to learn what you need to know to start your own business. \$5 (#03)

The Secret Guide to Wisdom: This is a review of around a hundred books that will boggle your mind and help you change your life. No, I don't sell these books. They're on a wide range of subjects and will help to make you a very interesting person. Wait'll you see some of the gems you've missed reading. You'll have plenty of fascinating stuff to talk about on the air. \$5 (#02)

The Bioelectrifier Handbook: This explains how to build or buy (\$155) a little electrical gadget that can help clean your blood of any virus, microbe, parasite, fungus or yeast. The process was discovered by scientists at the Albert Einstein College of Medicine, quickly patented, and hushed up. It's curing AIDS, hepatitis C, and a bunch of other serious illnesses. It's working miracles! The circuit can be built for under \$20 from the instructions in the book. \$10 (#01)

My WWII Submarine Adventures: Yes, I spent from 1943-1945 on a submarine, right in the middle of the war with Japan. We almost got sunk several times, and twice I was in the right place at the right time to save the boat. What's it really like to be depth charged? And what's the daily life aboard a submarine like? How about

the Amelia Earhart inside story? If you're near Mobile, please visit the Drum. \$5 (#10)

Wayne's Caribbean Adventures: My super budget travel stories - where I visit the hams and scuba dive most of the islands of the Caribbean. You'll love the special Liat fare which let me visit 11 countries in 21 days, diving all but one of the islands, Guadeloupe, where the hams kept me too busy with parties. \$5 (#12)

Cold Fusion Overview: This is both a brief history of cold fusion, which I predict will be one of the largest industries in the world in the 21st century, plus a simple explanation of how and why it works. This new field is going to generate a whole new bunch of billionaires, just as the personal computer industry did. \$5 (#20)

Cold Fusion Journal: They laughed when I predicted the PC industry growth in 1975. PCs are now the third largest industry in the world. The cold fusion ground floor is still wide open, but then that might mean giving up watching ball games. Sample: \$10 (#22)

Julian Schwinger: A Nobel laureate's talk about cold fusion—confirming its validity. \$2 (#24)

Dowsing. Yes, dowsing really does work. I explain how and why it works, opening a huge new area for scientific research with profound effects for humanity. \$2 (#84)

Improving State Government: Here are 24 ways that state governments can cut expenses enormously, while providing far better service. I explain how any government bureau or department can be gotten to cut its expenses by at least 50% in three years and do it cooperatively and enthusiastically. I explain how, by applying a new technology, the state can make it possible to provide all needed services without having to levy any taxes at all! Read the book, run for your legislature, and let's get busy making this country work like its founders wanted it to. Don't leave this for "someone else" to do. \$5 (#30)

Mankind's Extinction Predictions: If any one of the experts who have written books predicting a soon-to-come catastrophe which will virtually wipe most of us out are right, we're in trouble. I explain the various disaster scenarios, like Nostradamus, who says the poles will soon shift (as they have several times in the past), wiping out 97% of mankind. Okay, so he's made a long string of past lucky guesses. The worst part of these predictions is the accuracy record of some of the experts - like Hapgood, Einstein, Snow, Noone, Felix, Strieber. \$5 (#31)

Moondoggle: After reading René's book, *NASA Mooned America*, I read everything I could find on our Moon landings. I watched the NASA videos, looked carefully at the photos, read the astronaut's biographies, and talked with readers who worked for

NASA. This book cites 45 good reasons I believe the whole Apollo program had to have been faked. \$5 (#32)

Classical Music Guide: A list of 100 CDs which will provide you with an outstanding collection of the finest classical music ever written. This is what you need to help you reduce stress. Classical music also raises youngster's IQs, helps plants grow faster, and will make you healthier. Just wait'll you hear some of Gotschalk's fabulous music! \$5 (#33)

The Radar Coverup: Is police radar dangerous? Ross Adey K6UL, a world authority, confirms the dangers of radio and magnetic fields, including our HTs and cell phones. \$3 (#34)

Three Gatto Talks: A prize-winning teacher explains what's wrong with American schools and why our kids are not being educated. Why are Swedish youngsters, who start school at 7 years of age, leaving our kids in the dust? Our kids are intentionally being dumbed down by our school system - the least effective and most expensive in the world. \$5 (#35)

Aspartame: a.k.a. NutraSweet, the stuff in diet drinks, etc., can cause all kinds of serious health problems. Multiple sclerosis, for one. Read all about it, two pamphlets for a buck. (#38)

\$1 Million Sales Video: The secret of how you can generate an extra million dollars in sales just by using PR. This will be one of the best investments you or your business will ever make. \$40 (#52)

Reprints of My Editorials from 73. Very few things in this world are as we've been taught, and as they appear. I blow the whistle on the scams around us, such as the health care, our school system, our money, the drug war, a college education, sugar, the food giants, our unhealthy food, fluorides, EMFs, NutraSweet, etc.

1996 Editorials: 120 pages, 100 choice editorials. \$10 (#72)

1997 Editorials: 148 fun-packed pages. 216 editorials. \$10 (#74)

1998 Editorials: 168 pages that'll give you lots of controversial things to talk about on the air. \$10 (#75)

1999 Editorials: 132 pages of ideas, book reviews, health, education, and

anything else I think you ought to know about. \$10 (#76)

2000 Editorials: 76 pages (thinner magazine as a result of our slowly dying hobby) \$5 (#77)

Silver Wire: With two 5-in. pieces of heavy pure silver wire + three 9V batteries you can make a thousand dollars worth of silver colloid. What do you do with it? It does what the antibiotics do, but germs can't adapt to it. Use it to get rid of germs on food, for skin fungus, warts, and even to drink. Read some books on the uses of silver colloid, it's like magic. \$15 (#80)

Silver Colloid Reprint. April 97 article on a silver colloid maker, history, and how to use the stuff. \$5 (#98)

Colloid Kit. Three 9V battery clips, 2 alligator clips & instructions. \$5 (#99)

Wayne's Bell Saver Kit. The cable and instructions enabling you to inexpensively tape Art Bell W6OBB's nightly 5-hr radio talk show. \$5 (#83)

73 Writer's Guide: It's easy, fun, can pad your résumé, and impress the hell out of your friends. \$0 (#78)

Cold Fusion Six-Pack: Six Cold Fusion Journal back issues to bring you up to speed. \$20 (#19)

NASA Mooned America: René makes an air-tight case that NASA faked the Moon landings. This book will convince even you. \$30 (#90)

Last Skeptic of Science: This is René's book where he debunks a bunch of accepted scientific beliefs - such as the ice ages, the Earth being a magnet, the Moon causing the tides, etc. \$30 (#91)

Dark Moon: 568 pages of carefully researched proof that the Apollo Moon landings were a hoax—a capping blow for René's skeptics. \$35 (#92)

Dark Moon Video: 222-minute exposé nailing NASA with their own photos. If you've watched the NASA films of the astronauts walking on the Moon you wondered at their weird gait. Wait'll you see it speeded up. It looks exactly like they're running on Earth! They catch NASA in dozens of giveaways that the photos and films had to have been faked. \$46 (#93)

Radio Bookshop

Box 416, Hancock NH 03449

Name _____ Call _____

Address _____

City-State-Zip _____

Use the numbers in the brackets or copy page and mark the books you want. Add \$3 s/h per total order in US (\$5 priority mail), \$6 Can, \$10 foreign.

Order total: US\$ _____ Phone (for CC orders) _____

MC/Visa for orders over \$10. # _____ Expire _____

www.waynegr.com • phone orders: 603-525-4747 • fax: 603-588-3205 • w2nsd@aol.com

- Yes! Put me down for a year of 73 for only \$25 (a steal). Canada US\$32. Foreign US\$44 by sea.
 I need some industrial strength stress reduction so send me your Adventures In Music CD catalog. Allow 4 weeks for delivery except foreign, though we try to get most orders shipped in a day or two.
Your e-mail address: _____

Barter 'n' Buy

Turn your old ham and computer gear into cash now. Sure, you can wait for a hamfest to try and dump it, but you know you'll get a far more realistic price if you have it out where 100,000 active ham potential buyers can see it, rather than the few hundred local hams who come by a flea market table. Check your attic, garage, cellar and closet shelves and get cash for your ham and computer gear before it's too old to sell. You know you're not going to use it again, so why leave it for your widow to throw out? That stuff isn't getting any younger!

The 73 Flea Market, Barter 'n' Buy, costs you peanuts (almost) — comes to 35 cents a word for individual (noncommercial!) ads and \$1.00 a word for commercial ads. Don't plan on telling a long story. Use abbreviations, cram it in. But be honest. There are plenty of hams who love to fix things, so if it doesn't work, say so.

Make your list, count the words, including your call, address and phone number. Include a check or your credit card number and expiration. If you're placing a commercial ad, include an additional phone number, separate from your ad.

This is a monthly magazine, not a daily newspaper, so figure a couple months before the action starts; then be prepared. If you get too many calls, you priced it low. If you don't get many calls, too high.

So get busy. Blow the dust off, check everything out, make sure it still works right and maybe you can help make a ham newcomer or retired old timer happy with that rig you're not using now. Or you might get busy on your computer and put together a list of small gear/parts to send to those interested?

Send your ads and payment to: **73 Magazine, Barter 'n' Buy, 70 Hancock Rd., Peterborough NH 03458 and get set for the phone calls.** The deadline for the February 2002 classified ad section is December 10, 2001.

220 MHz Award; see W9CYT on WWW.QRZ.COM for information. BNB645

K8CX HAM GALLERY [<http://hamgallery.com>]. BNB620

TELEGRAPH COLLECTOR'S PRICE GUIDE: 250 pictures/prices. \$12 postpaid. **ARTIFAX BOOKS**, Box 88, Maynard MA 01754. Telegraph Museum: [<http://wltip.com>]. BNB113

New miniature oscillator modules are now available ... all under \$20 ... plus our great reference book is still for sale. Write to **RMT Engineering**, 6863 Buffham Road, Seville OH 44273 or see our Web site at [www.ohio.net/~rtormet/index.html]. BNB640

RF TRANSISTORS TUBES 2SC2879, 2SC1971, 2SC1972, MRF247, MRF455, MB8719, 2SC1307, 2SC2029, MRF454, 2SC3133, 4CX250B, 12DQ6, 6KG6A, etc. **WESTGATE**, 1-800-213-4563. BNB6000

METHOD TO LEARN MORSE CODE FAST AND WITHOUT HANGUPS Johan N3RF. Send \$1.00 & SASE. **SVANHOLM RESEARCH LABORATORIES**, P.O. Box 81, Washington DC 20044 USA. BNB421

Cash for Collins: Buy any Collins Equipment. **Leo KJ6HI**. Tel./FAX (310) 670-6969. [radioleo@earthlink.net]. BNB425

Browse our Web site and check out the "Monthly Special." TDL Technology, Inc. [www.zianet.com/tdi]. BNB500

MAHLON LOOMIS, INVENTOR OF RADIO, by Thomas Appleby (copyright 1967). Second printing available from **JOHAN K.V. SVANHOLM N3RF**, SVANHOLM RESEARCH LABORATORIES, P.O. Box 81, Washington DC 20044. Please send \$25.00 donation with \$5.00 for S&H. BNB420

Ham Radio Repair, Quality workmanship. All Brands, Fast Service. **Affordable Electronics**, 7110 E. Thomas Rd., Scottsdale, AZ 85251. Call 480-970-0963, or E-mail [HAM_SERVICE@AOL.COM]. BNB427

SATELLITE TV — Large selection of items at reasonable prices. We specialize in Big Dish TVRO C & Ku Band equipment. Check us out at [www.daveswebshop.com]. BNB646

HEATHKIT COMPANY is selling photocopies of most Heathkit manuals. Only authorized source for copyright manuals. **Phone:** (616) 925-5899, 8-4 ET. BNB964

"MORSE CODE DECIPHERED" Simple, elegant, inexpensive, comprehensive, logical, easy! E-mail [judlind@earthlink.net]. BNB428

Electricity, Magnetism, Gravity, The Big Bang. New explanation of basic forces of nature in this 91-page book covering early scientific theories and exploring latest controversial conclusions on their relationship to a unified field theory. To order, send check or money order for \$16.95 to: American Science Innovations, P.O. Box 155, Clarington OH 43915. Web site for other products [http://www.asi_2000.com]. BNB100

COLLOIDAL SILVER GENERATOR! Why buy a "box of batteries" for hundreds of dollars? Current regulated, AC powered, fully assembled with #12 AWG silver electrodes, \$74.50. Same, but DC powered, \$54.50. Add \$2.50 shipping. **Thomas Miller**, 216 East 10th St., Ashland OH 44805. Web address [www.bioelectrifier.com]. BNB342

COLD FUSION! - FUEL CELL! - ELECTRIC BICYCLE! Each educational kit: (Basic - \$99.95, Deluxe - \$199.95, Information - \$9.95.) CATALOG - \$5.00. **ELECTRIC AUTOMOBILE BOOK** - \$19.95. **KAYLOR-KIT**, POB 1550ST, Boulder Creek CA 95006-1550. (831) 338-2300. BNB128

ANTENNA SCIENCE: Why do antennas radiate electromagnetic waves? Learn for yourself from this enlightening paper by **MAX RESEARCH**. Gain an understanding of the radiation mechanism of antennas! Written in a clear style for radio hobbyists, inquisitive amateurs and experimenters. \$4.95 ... ppd. Order from **MAX RESEARCH**, P.O. Box 1306, East Northport NY 11731. BNB426

DWM COMMUNICATIONS - Neat stuff! SASE brings catalog! POB 87-BB, Hanover MI 49241. BNB641

Exotic 2002 Caribbean Hamboree -- Join us in meeting with Caribbean hams, visiting interesting Georgetown, Guyana, operating from great DX location. March 29-31/02. For information contact KK4WW, 8R1WD or [www.public.usit.net/dlarsen]. BNB640

To place your ad in
73 Magazine
call
Evelyn Garrison
1-425-557-9611

UNITED STATES POSTAL SERVICE™ Statement of Ownership, Management, and Circulation (Required by 39 U.S.C. 3685)(1) Publication Title: 73 Amateur Radio Today (2) Publication No.: 1052-2522 (3) Filing Date: 10-01-01 (4) Issue Frequency: Monthly (5) No. of issues Published Annually: 12 (6) Annual Subscription Price: \$24.97 (7) Complete Mailing Address: 70 Hancock Road, Peterborough, Hillsborough Cty., NH 03458-1107 (8) Complete Address of Headquarters or General Business Office of Publisher (Not Printer): 70 Hancock Road, Peterborough, NH 03458-1107 (9) Full Names and Complete Mailing Addresses of Publisher, Editor, and Managing Editor: Wayne Green, 70 Hancock Road, Peterborough, NH 03458; Joyce Sawtelle, 70 Hancock Road, Peterborough, NH 03458 (10) Owner: Shabromat Way Ltd., P.O. Box 60, Hancock, NH 03449; Wayne Green, P.O. Box 60, Hancock, NH 03449 (11) Known Bondholders, Mortgagees, and Other Security Holders Owning or Holding 1 Percent or More of Total Amount of Bonds, Mortgages, or Other Securities: None (12) For completion by nonprofit organizations: (13) Publication Name: 73 Amateur Radio Today (14) Issue Date for Circulation Data Below: May 2001 (15) Extent and Nature of Circulation: Average No. Copies Each Issue During Preceding 12 Months: Actual No. Copies of Single Issue Published Nearest to Filing Date (a) Total No. Copies (Net Press Run) 11,994; 11,643 (b) Paid and/or requested Circulation - (1) Paid/Requested Outside-County Mail Subscriptions Stated on Form 3541. (Include advertiser's proof and exchange copies) 10,477; 10,001 (2) Paid In-County Subscriptions Stated on Form 3541 0; 0 (3) Sales Through Dealers and Carriers, Street Vendors, Counter Sales, and Other Non-USPS Paid Distribution 892; 840 (4) Other Classes Mailed Through the USPS 100; 100 (c) Total Paid and/or Requested Circulation [Sum of 15b(1), (2), (3), and (4)] 11,469; 10,941 (d) Free Distribution by Mail (Samples, Complimentary, and Other Free) (1) Outside-County as Stated on Form 3541 0; 0 (2) In-County as Stated on Form 3541 0; 0 (3) Other Classes Mailed Through the USPS 250; 250 (e) Free Distribution Outside the Mail (Carriers or Other Means) 0; 0 (f) Total Free Distribution (Sum of 15d and 15e) 250; 250 (g) Total Distribution (Sum of 15c and 15f) 11,719; 11,191 (h) Copies Not Distributed 275; 452 (i) Total (Sum of 15g and 15h) 11,994; 11,643 (j) Percent Paid and/or Requested Circulation (15c/15g x 100) 98%; 98% (16) This Statement of Ownership will be printed in the December '01 issue of this publication. (17) Signature and Title of Editor, Publisher, Business Manager, or Owner: Frances Hyvarinen, Business Manager Date: 10-24-01. I certify that all information furnished on this form is true and complete. I understand that anyone who furnishes false or misleading information on this form or who omits material or information requested on the form may be subject to criminal sanctions (including fines and imprisonment) and/or civil sanctions (including civil penalties).

Real Performance for the Real World!

Today's elite-class operators demand the best RF weaponry available. Yaesu's exciting new MARK-V FT-1000MP answers the call, with an expanded array of receiver filtering, 200 Watts of power output, and Class-A SSB operation capability for the cleanest signal on the band. Enhanced front-panel ergonomics on the front panel save you seconds in a pile-up or a contest "run," and Yaesu's HF design and manufacturing know-how ensures that no short-cuts have been taken in our effort to bring you the best HF transceiver money can buy. For more QSOs in your log, and more awards on your wall, there is only one choice: the MARK-V FT-1000MP from Yaesu!

I. Interlocked Digital Bandwidth Tracking System (IDBT)

II. Variable RF Front-End Filter (VRF)

III. 200 Watts of Transmitter Power Output

IV. Class-A SSB Operation

V. Multi-Function Shuttle Jog Tuning/Control Ring

Features

■ Frequency Coverage: (RX) 100 kHz-30 MHz; (TX) 160-10 m Amateur Bands ■ Dual In-band Receive w/Separate "S" Meters ■ Ten Pole Collins® Mechanical Filter Built-in ■ RX DSP Noise Reduction and CW Peaking Filter ■ High-speed Automatic Antenna Tuner ■ Two TX/RX Antenna Jacks plus RX-only Jack ■ TX Microphone Equalizer ■ RF Speech Processor ■ Direct Digital Synthesis ■ CW Spot and Two Key Jacks ■ Two Headphone Jacks (1/4" and 3.5 mm) ■ Low-Level Transverter RF Drive Jack ■ Separate FP-29 Power Supply (30 V/13.8 V DC Output)



HF 200 W All-Mode Transceiver

MARK-V FT-1000MP

For Elite-Class Amateur Radio Operators...

A NEW BREAKTHROUGH IN TRANSMITTED AUDIO QUALITY: THE YAESU MD-200A8X HIGH-FIDELITY DESKTOP MICROPHONE.

- New-Technology Polyethylene Terephthalate Film High-Fidelity Dynamic Microphone Element
- Vibration-Resistant Housing
- VSPC (Variable Side Pressure Control) Technique (Patent Pending)
- Ease of Operation through Ergonomic Design
- Provision for User-Supplied Additional Microphone Element

APPLICABLE TRANSCEIVERS

MARK-V FT-1000MP, FT-1000MP, FT-1000/1000D*, FT-990*, FT-920, FT-900, FT-847, FT-840*, FT-817

* The FT-1000/1000D/990/840 do not support the illumination of the TX LED during transmission.

VSPC (Variable Side Pressure Control)

Ultra-High-Fidelity Desktop Microphone

MD-200A8X

Expand Your DX Horizons With The FTV-1000 50 MHz Transverter!

- 50 MHz Transverter with 200 W PEP Power Output
- Class-A Bias Selection for Low TX IMD (PO: 50 W)
- High-Performance Receiver Front End
- Automatic, Effortless Operation with MARK-V FT-1000MP
- Upgrade to High Power with VL-1000 Linear Amplifier

Specifications

Frequency Range: 50-54 MHz
Antenna Impedance: 50 Ohms
Power Output: 200 Watts PEP
Spurious Emissions: At least 60 dB down
Power Source: DC 30 V and 13.8 V (supplied by FP-29 Power Supply of MARK-V)
Dimensions: 9.6" x 5.4" x 13" WHD (243.5 x 136.5 x 331 mm)

200 W 50 MHz Transverter

FTV-1000

For the latest Yaesu news, visit us on the Internet:
<http://www.vxstd.com>

Specifications subject to change without notice. Some accessories and/or options may be standard in certain areas. Frequency coverage may differ in some countries. Check with your local Yaesu Dealer for specific details.

YAESU
Choice of the World's top DX'ers™

Vertex Standard
US Headquarters
17210 Edwards Road,
Cerritos, CA 90703 (562)404-2700

Work the World With Alinco!

Base, mobile, portable or marine, Alinco HF transceivers open a world of possibilities at prices that are down to earth. Check out this great equipment and the low Alinco price at your favorite dealer!

DX-70TH HF + 6m

Mobile/Base/Portable

Rugged and versatile, DX-70 radios are recognized around the world as proven performers!



160m ~ 6m
Amateur Band TX
in all modes,
general coverage
RX 150 KHz ~ 30 MHz

and 50 ~ 54 MHz, 2 VFOs, 100 memories, removable face for remote mounting, speech compressor, SSB, CW and AM narrow filters, full, semi or automatic break-in, multi-function control, RIT, TXIT, easy split operation, RF gain, CTCSS for 10 and 6m repeaters. 100w output on both HF and 6m.

DX-77T HF Desktop Transceiver

It's the radio Amateurs asked us to build!



A super performer at a tiny price, the DX-77T has solid credentials and great reviews. 160 ~ 10m Amateur Band TX in all modes, general coverage RX 500 KHz ~ 30 MHz,

2 VFOs, internal keyer (6 ~ 50 wpm), 100 memories, 13.8 VDC input, optional computer control capability, CTCSS encoder (front panel programmable), RIT, easy split operation, speech compressor, selectable AGC, large front panel speaker. The value leader in HF desktop radios!

DM-330MV Communications Grade Switching Power Supply



Tiny, powerful, 30A continuous, 32A peak output, weighs less than 5 lbs! Variable output 5 ~ 15 VDC, memory output, rear panel high-current (30A) terminals, triple circuit protection, illuminated V/A meter, ultra-quiet with patent-pending noise-shift circuit. Front panel cigar (10A) and quick-connect (5A) terminals, ripple less than 15mV p-p. Perfect for travel, station or test bench use. There's no switching supply like it! **Also available: DM-340MV IC Regulated Power Supply.**

EDX-2 Automatic Wire Antenna Tuner



Quickly tune wire antenna (from 8 to 80 feet) for any band from 10 through 160 meters (minimum 40 foot wire antenna required for 160 meter use). Perfect for base, mobile or marine use. Plugs directly into Alinco DX-70 and DX-77 transceivers. You don't have to pay more for great performance!

Simple ■ Clean ■ Dependable



ALINCO

AMATEUR RADIO'S VALUE LEADERSM

Distributed in North America by ATOC Amateur Distributing LLC
23 S. High St., Covington, OH 45318 • (937) 473-2840 • www.alinco.com

Specifications subject to change without notice or obligation. Performance specifications only apply to Amateur Bands. Transceivers intended for use only by properly licensed Amateur Radio operators.