

ARRL's

\$19.95

# RF Amplifier Classics



Practical design and construction details from the pages of *QEX* and *QST*.



# JFLINT

## Contents

### HF/MF/VHF Amplifiers (1 to 54 MHz)

- An Easy-to-Build 25-Watt MF/HF Amplifier
- A Compact 1-kW 2-50 MHz Solid-State Linear Amplifier
- A Broadband HF Amplifier Using Low-Cost Power MOSFETs—Parts 1 and 2
- A 1.8 to 54 MHz 5-Watt Amplifier
- An Experimental Solid-State Kilowatt Linear Amplifier for 2 to 54 MHz
- An All-Band, 1500-Watt-Output 8877 Linear Amplifier—Parts 1 and 2
- High-Efficiency Class-E Power Amplifiers—Parts 1 and 2
- A 100-W MOSFET HF Amplifier
- The FARA HF Project

- Gary Breed, K9AY
- H.O. Granberg, K7ES/OH2ZE
- Mike Kossor, WA2EBY
- Zack Lau, KH6CP
- Joel Paladino, N6AMG
- Jerry Pittenger, K8RA
- David Rutledge, KN6EK, et al.
- William E. Sabin, WØIYH
- Jim Valdes, WA1GPO

### VHF/UHF Amplifiers

- A Compact “Brick” for 6 Meters
- A 300-W MOSFET Linear Amplifier for 50 MHz
- A No-Bandswitch, Dual-Band VHF Desktop Amplifier
- An 8-Watt, 2-Meter “Brickette”
- 903-MHz Linear Amplifiers—Parts 1 and 2
- 25-Watt Linear Amplifiers for 144 and 220 MHz
- A High-Power 2-Meter Amplifier Using the New 3CX800A7
- A Quick Powerhouse
- A Cathode-Driven Tetrode for 6 Meters
- A UHF Amplifier—from Scratch
- A Solid-State 6-Meter Linear Amplifier You Can Build
- Build a 6-Meter “Mini-Lini”
- A Grounded-Grid Kilowatt Amplifier for 432 MHz

- Pat Bunn, N4LTA
- Richard Frey, K4XU
- Paul Hewitt, WD7S
- Bob Larkin, W7PUA
- Dave Mascaro, WA3JUF
- Dave Mascaro, WA3JUF
- David Meacham, W6EMD
- Russ Miller, N7ART
- David Munyon, W7DVB
- John Reed, W6IOJ
- Tarmo Tammaru, WB2TMD
- Wilson Hoag, WA5OLT
- Stephen J. Powlishen, K1FO

### Microwave Amplifiers

- A Quarter-Kilowatt 23-cm Amplifier—Parts 1 and 2
- A 2-W 13-cm Amplifier
- 1296-MHz Solid-State Power Amplifiers

- E.R. “Chip” Angle, N6CA
- Zack Lau, KH6CP
- Al Ward, WB5LUA

### Amplifier Maintenance

- Amplifier Care and Maintenance

- Ward Silver, NØAX

# JFLINT

## Foreword

If antenna gain alone is not sufficient to bridge the path between two stations, the alternative is to increase RF power. Hams have been aware of this fact since the earliest days, and that is why RF power amplifier projects have always been popular.

In *RF Amplifier Classics* we have assembled a collection of articles published in *QST* magazine, and its sister technical journal, *QEX*. The collection spans the early 1980s through 2003 and includes many prominent authors. In those few instances where an author provided a design revision (or correction) after the article was published, that revision is *included* in the article as presented in this book.

See the latest issue of *QST* for other ARRL RF design-related publications, or visit our on-line bookstore at [www.arrl.org/catalog](http://www.arrl.org/catalog). Please take a few minutes to give us your comments and suggestions on this book. There's a handy Feedback Form for this purpose at the back, or you can send e-mail to [pubsfdbk@arrl.org](mailto:pubsfdbk@arrl.org).

Our thanks to the many authors whose work appears in this book. Without their willingness to share their knowledge with the amateur community, *RF Amplifier Classics* would not be possible.

Dave Sumner, K1ZZ  
Executive Vice President  
Newington, Connecticut  
August 2004

# An Easy-to-Build 25-Watt MF/HF Amplifier

Do you need a medium-power linear amplifier for SSB or CW? Congratulations—you just found it!

Here's a 25-W, 1.8- through 30-MHz, class-A linear power amplifier that's simplicity itself. What makes it simple is the use of a self-biased transistor module requiring few external components. To control harmonic output, a set of five-section low-pass filters is included. Power-supply requirements are +28 V at 2.5 A and -5 V at 200 mA.<sup>1</sup> With a gain of about 13 dB, a 1- to 1.4-W driving signal is all that's needed to deliver 25 W output. Gain is flat within  $\pm 0.75$  dB across the covered frequency range.

If 25W isn't enough for you, it's easy to directly apply the design information to build a 50-W amplifier—all you do is use a larger transistor module! Another step toward project simplicity is the availability of kits. Each kit contains all the major components for either a 25- or 50-W version.<sup>2</sup>

## Amplifier Design

When designing a power amplifier, the first step is to select the right transistor(s). Excellent bipolar-junction transistors (BJTs) and field-effect transistors (FETs) are available from well-known companies such as Motorola, M/A-COM PHI, SGS-Thomson, Philips, Mitsubishi and others. A number of smaller companies also make power transistors, usually for more-specialized applications. MicroWave Technology, Polyfet RF Devices, and Directed Energy may be company names unfamiliar to you, but they all make power transistors for MF and HF applications.

In this amplifier, I use the SLAM-0111 from MicroWave Technology.<sup>3</sup> I didn't choose it because of its gain, its efficiency, or even its price; I selected it because it's very easy to use. The device consists of two power JFETs (the particular specialty of MicroWave Technology), operating in push-pull. Since JFETs behave similarly to triode vacuum tubes, the company dubbed them *Solid State Triodes*. SLAM (Solid-state-triode Linear Amplifier Module) devices include thick-film bias resistors in

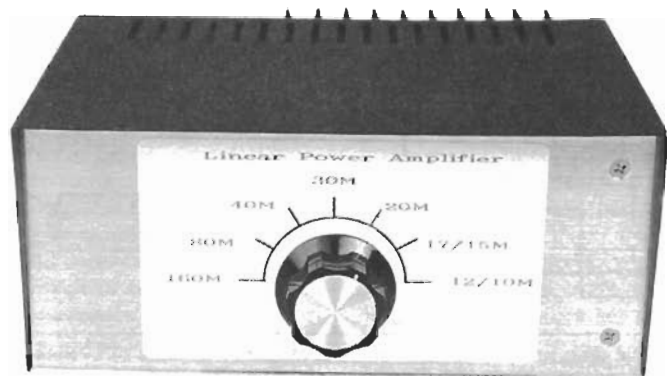

the package with the transistors. These resistors set the gate bias for class-A operation, and establish a 50- $\Omega$  input impedance. At the rated power and supply voltage, the push-pull output impedance is also 50  $\Omega$ !

With such convenient input and output impedances, matching the devices to a 50- $\Omega$  system merely requires 1:1 balun transformers at the input and output. Because the bias voltage is internally generated, the only other external circuitry required is a suitably bypassed and isolated 28-V power supply.

## Circuit Description

The amplifier schematic is shown in Fig 1. The balun driving the gates of the push-pull transistors is a conventional transformer. The primary and secondary windings are each three turns of #28 wire, wound on a two-hole ferrite balun core of 73 material ( $\mu_i = 2500$ ). These transformers are broadband enough to provide 1.8- to 30-MHz operation and offer dc isolation with no additional components. The input-transformer primary is center-tapped and bypassed to provide access to the gates for external dc bias (more on this later).

The output transformer is constructed in the same manner as the input transformer—it's just larger. Two ferrite beads

of 77 material ( $\mu_i = 2000$ ) make a two-hole core, with primary and secondary windings of three turns each, using #24 hookup wire. The primary (transistor side) is center-tapped and bypassed to provide dc voltage to the drains. Feeding dc through a center-tapped transformer eliminates the need for the usual bifilar RF choke seen in push-pull amplifiers—another reduction in the component count. Multiple bypass capacitor values (0.01, 0.1 and 10  $\mu$ F) are used to cover the MF/HF range. That's the basic amplifier block: two transformers, a SLAM device, and a few bypass capacitors!

## Class-A Operation Notes

By definition, transistors operating in class A conduct over the entire 360 degrees of the signal (that's all the time, of course). This operational mode assures that the transistor is always operating in the linear region of its input-to-output transfer characteristic. To do this, the device must be biased to handle the maximum signal at all times.

Obviously, this class of operation is pretty inefficient, since full current is drawn whenever the amplifier is on. A "perfect" transistor operating class A can only be 50-percent efficient, and real transistors

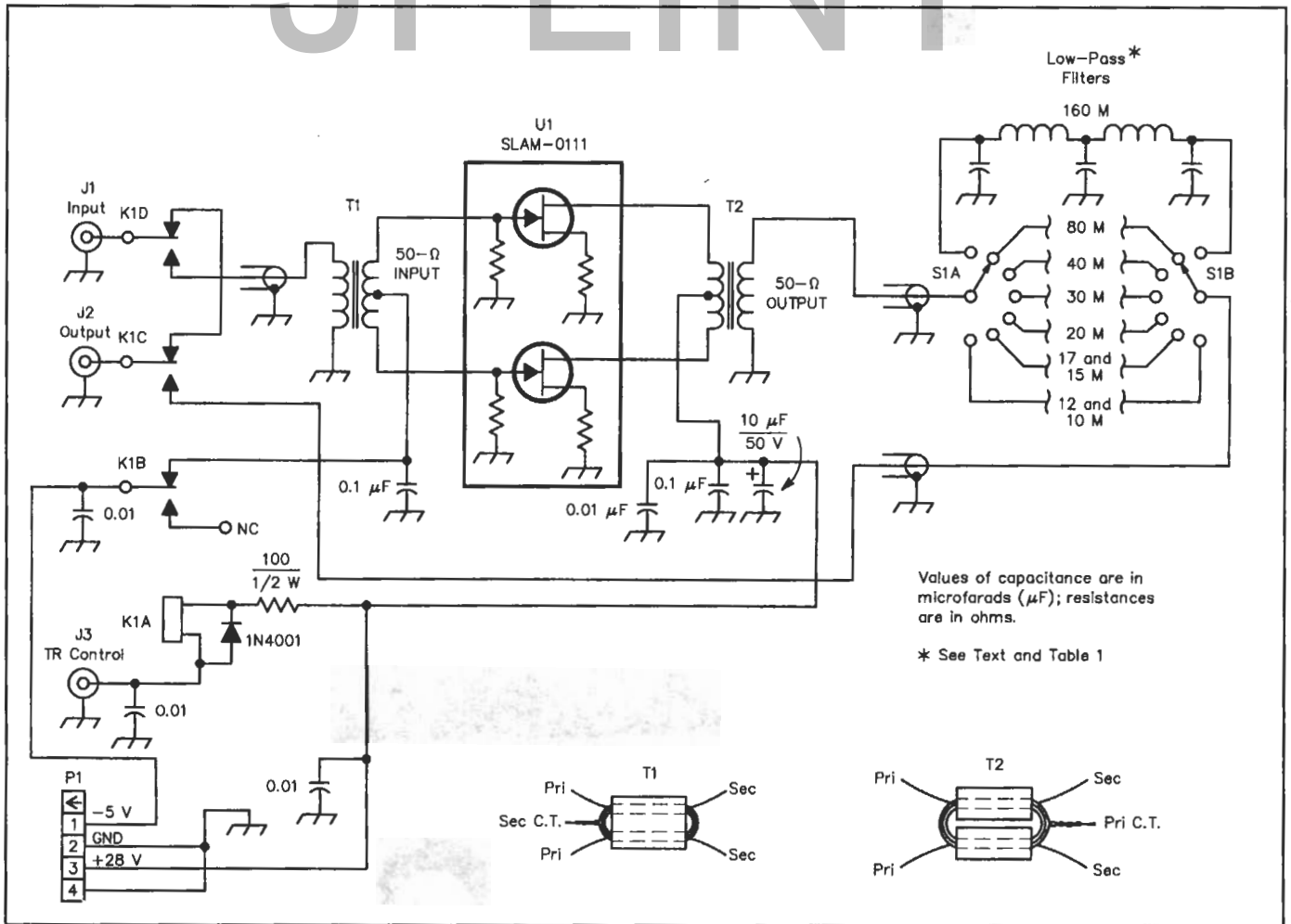

Fig 1—Schematic diagram of the 25-W class-A amplifier. Unless otherwise specified, resistors are 1/4-W, 5%-tolerance carbon-composition or film units. Equivalent parts can be substituted.

- J1—Panel-mount BNC socket.
- J2—SO-239 connector.
- J3—Phono jack.
- P1—4-pin male Jones plug.
- K1—3PDT relay with a 24-V dc coil. A surplus Potter & Brumfield KHP series 4-pole relay is shown in Fig 6; one pole is unused. (All Electronics catalog number 4PRLY-24N [\$4] or Ocean State Electronics R12-17D3-24 [\$10.90] are suitable. See the Part Suppliers List on pp 35-40 of *The 1994 ARRL Handbook* for addresses and telephone numbers. —Ed.)

- S1—2-pole, 7-position ceramic rotary switch. My switch is made from two surplus CRL 11-position switch wafers and an indexing assembly providing selectable stops. The wafers are spaced about 1 1/2 inches apart. CAL PA-200 series switch wafers and PA-300 series shaft and indexing assemblies are suitable (switches are available from Newark Electronics; tel 312-784-5100, fax 312-784-5100, ext 3107, to locate your nearest Newark distributor).
- T1—Primary: 3 turns #28 AWG; secondary, 3 turns #28 AWG, center-tapped. Core: Fair-Rite #2873002402 balun (Amidon BN 73-2402).

- T2—Primary, 3 turns #24, center-tapped; secondary, 3 turns #24. Core: two Fair-Rite #2677006301 beads (Amidon FB 77-6301).
- U1—SLAM-0111 ultralinear 25-W, class-A, self-biased power FET module or SLAM-0122, 50-W version (Microwave Technology, 4268 Solar Way, Fremont, CA 94538, tel 510-651-6700, fax 510-651-2208).
- Misc: RG-174 coax, enclosure (3 1/2 x 7/8 x 5 1/4 inches [HWD]), heat sink (3 x 4 1/8 x 1 3/8 inches [HWD]), PC-board material, knob, mounting hardware.

do no better than about 40 percent. This amplifier draws 2.5 A from a 28-V power supply for an input power of 70 W. When it is providing 25 W, it's 36-percent efficient. (When there is no input, it's 0-percent efficient!)

To help reduce the heat generated by an amplifier that requires 70 W, a negative bias can be applied to the gates when not transmitting. A bias of -5 V results in a 0.25-A standby drain current instead of the full 2.5 A. The internal bias resistors are about 50  $\Omega$  on each gate, and dissipate a maximum of 1 W. Under these biasing conditions, the resistors each dissipate 0.5 W. Don't try to cut off the transistors com-

pletely with greater bias voltage! You'll risk burning out the resistors.

Some may ask, "If class A is this power hungry, why use it?" In a word: linearity. If you want excellent linearity (which means minimum distortion caused by harmonics or intermodulation), class A is the way to go. For example, all small-signal amplifiers for receivers and low-level transmitter stages operate class A because they must handle signals without distortion. However, they operate at very low power, so power dissipation is rarely an issue. This power amplifier further minimizes distortion by using push-pull operation, which cancels even-order distortion products in

the output and makes the next part of the design easier than usual.

### Harmonic Filter Design

As mentioned previously, the amplifier uses several low-pass filters to cover the nine MF/HF amateur bands. Each filter was initially designed for a cutoff frequency 20 percent higher than the upper end of their respective 160, 80, 40, 30, 20, 15 and 10-meter ham bands. The 15-meter filter is also used for 17 meters, and the 10-meter filter for 12 meters.

With no filtering, even-order harmonics (2nd, 4th, etc) are more than 40 dB below the carrier, the result of good push-

**Table 1**  
**Filter Circuit and Comparison of Ideal and Final Component Values.**

Cutoff Freq. (MHz)	Ideal Filter Values			Actual Filter Values		
	C1, C5 (pF)	C3 (pF)	L2, L4 (μH)	C1, C5 (pF)	C3 (pF)	L2, L4 (μH)
2.40	1521	2620	4.55	1470	2880	4.41
4.80	761	1310	2.27	(1000 + 470) 830	(2200 + 680) 1430	(30 t on T-50-2) 2.37
8.76	417	718	1.25	(560 + 270) 430	(1000 + 430) 820	(22 t on T-50-2) 1.25
12.18	300	516	0.900	300	560	(16 t on T-50-2) 0.960
17.22	212	365	0.634	220	370	(14 t on T-50-2) 0.706
25.74	142	244	0.424	150	(270 + 100) 240	(12 t on T-50-6) 0.460
35.64	102	176	0.306	100	180	(10 t on T-50-6) (8 t on T-50-6) 0.314

In some cases it is necessary to parallel two smaller-value capacitors to obtain the proper values of capacitance for C1, C2 and C5. The inductors are wound on T-50-2 or T-50-6 cores. Inductors for the 160- and 80-meter filters are wound with #26 AWG wire in order to fit all turns on the cores; the other inductors are wound with #22 wire.

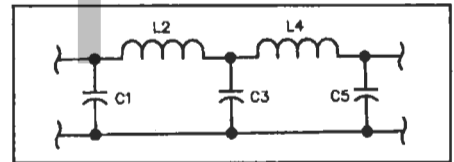

Fig 2—Schematic of the filter used for each band.

### Construction

I built my amplifier and low-pass filter modules on single-sided PC boards, using pads to mount the components. No holes are drilled (except for mounting screws) and all leads are attached by soldering them to the pads. The PC-board patterns for the amplifier and filters are available (see Note 2).

Fig 3 shows the amplifier-assembly parts. This assembly is mounted to a heat sink (see Figs 4 and 5) capable of dissipating more than 40 watts without excessive temperature rise. (This assumes a worst case of 50-percent transmitting time, and 7-watts dissipation in standby.) A cutout in the middle of the amplifier board allows placement of the SLAM device. The PC board leaves a conducting path around the ends of the SLAM to maintain a ground potential across the entire board. Four mechanical components make up the amplifier assembly. The first is a 0.1875-inch-thick aluminum base plate to which the SLAM is mounted. Next are two aluminum 0.1-inch-thick spacers, which are placed between the base plate and the circuit board. These spacers set the proper distance from the base plate to SLAM leads. The SLAM is installed through the top of the PC board, and its leads are soldered to the traces on top of the board.

pull balance using factory-matched transistors. The 3rd and 5th harmonics are more than 15 dB down. To reduce the 3rd harmonic to at least 50 dB below the carrier, a five-section Chebyshev filter with low passband ripple is an appropriate choice. This type of filter has a good SWR in the passband, and a smooth roll-off characteristic. The design process began by creating ideal designs using a public-domain filter design program.<sup>4</sup>

Ideal designs rarely correspond to standard capacitor or inductance values that can be realized with a discrete number of turns on common toroid cores. Using a circuit analysis program,<sup>5</sup> the ideal designs were analyzed to see the effects of such realworld limitations on harmonic rejection and SWR performance.

First, the ideal component values were entered into the program, and varied ±20 percent to see which ones had the greatest effect on performance. C1 and C5 (see Fig 2 and Table 1) were found to be least sensitive to variations, L2 and L4 were moder-

ately sensitive; varying C3 had the greatest effect on both passband and stopband performance. The ideal capacitor values were then replaced with standard capacitor values or—in some cases—parallel combinations of two common capacitor values. Inductors were given the nearest value available for coils wound on either T-50-2 or T-50-6 toroid cores. The final filter designs are the result of trade-offs between inductance, capacitance and filter performance. Table 1 shows the filter topology, along with a comparison of the original ideal filter component values and the values selected for the finished unit.

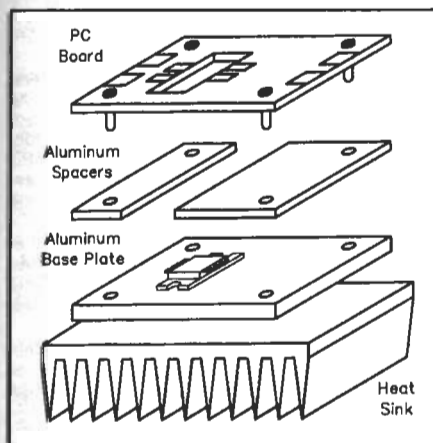

Fig 3—Mechanical assembly of the amplifier-module PC board, aluminum spacers and heat sink.

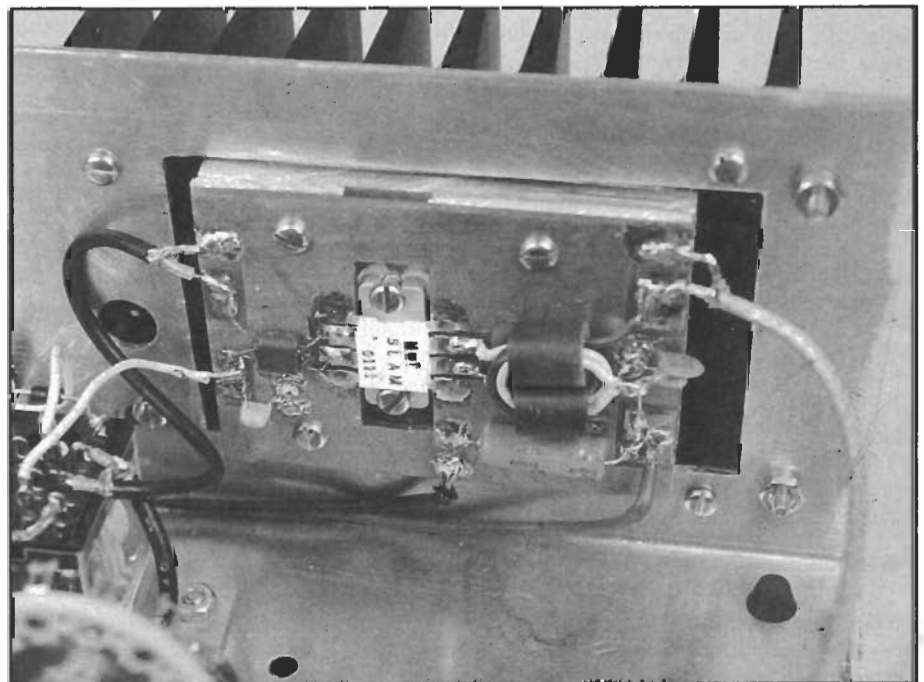

Fig 4—The assembled amplifier-module PC board in position and secured to the heat sink (see Fig 5, next page).

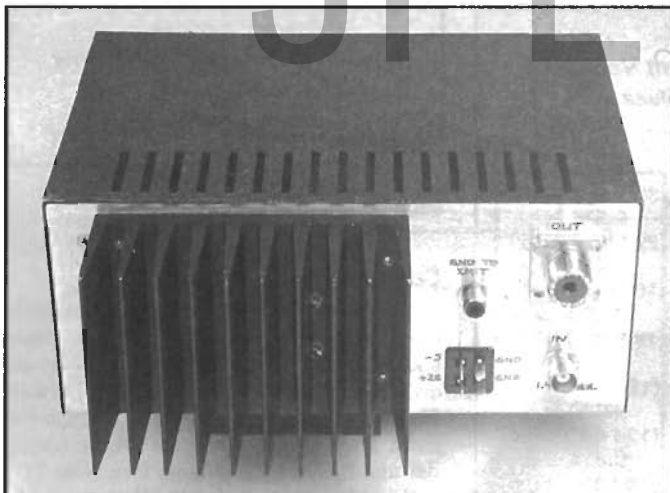

Fig 5—Rear view of the completed amplifier showing the hefty heat sink.

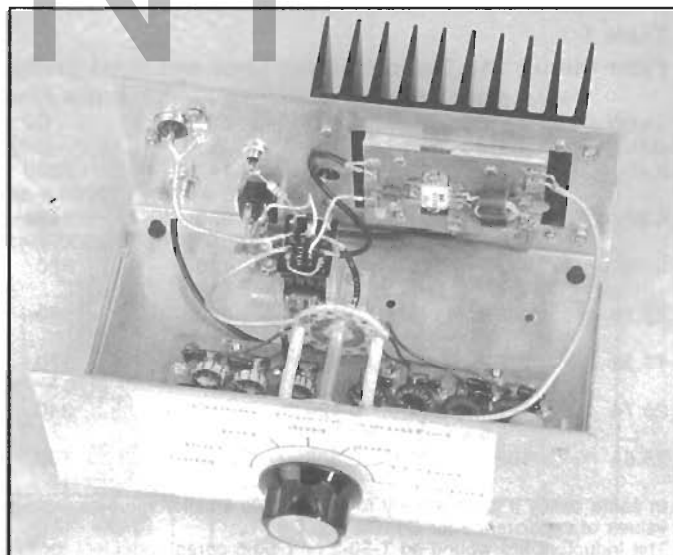

Fig 6—This interior view of the amplifier shows its simple and clean layout. The band switch is centered on the front panel. Immediately beneath the band switch is the filter assembly. Behind the switch and to the left is the TR relay, K1. A four-pin Jones plug power connector is mounted on the rear panel behind and to the left of the relay. On the bottom, near the outside lip of the rear panel, is J1. Above it is J2, with J3 to its right. Most of the rear panel—from its middle to the right lip—is occupied by the SLAM IC PC board and the aluminum spacers secured to the heat sink mounted on the rear panel's exterior. Rubber feet on the cabinet bottom help prevent scratching the supporting surface beneath and keep the amplifier from sliding. The band-switch knob center section is 1 1/8 inches in diameter; the skirt flares to a diameter of 1 1/2 inches.

Construction is easiest if the transformer connections to the SLAM are not soldered until after the SLAM is installed. This eliminates the possibility that the transformer connections will get in the way when you try to solder the SLAM into place. As with any power device, place a thin coating of thermal compound between the SLAM and the base plate, and between the base plate and the heat sink. Solder bypass capacitors directly to the transformer center tap and to the ground plane, with the minimum possible lead lengths.

The low-pass filter board is constructed one filter at a time. First, install the capacitor at the center (C3), then the inductors L2, L4), and finally the end capacitors (C1, C5). All inductors are wound with even spacing over three-quarters of the core circumference. Simply solder the capacitors to the pads and ground plane. Silver-mica capacitors were used in the prototype because they were on hand. Ceramic-disc capacitors with 200- to 500-V ratings will work equally well.

If the band switch is located close to the filter board (see Fig 6), short lengths of hookup wire can connect the filters to the switch wafers.

A spacious box houses the filter and amplifier assemblies, along with a TR relay that also switches the standby bias. Power and relay control leads are bypassed where they enter the enclosure.

Before final assembly, I gave the panels of the case a brushed look using a sanding block with oiled sandpaper. Band markings for the switch (see the title-page photo) are drawn on a large, adhesive-backed label attached to the front panel.

### Performance

Amplifier gain ranges from 12.5 to 14 dB between 1.8 and 30 MHz. The gain flatness is basically a function of the input and output transformers. (It's possible to make the amplifier gain flat within 1 dB from 1 MHz to 100 MHz using transmission-line

transformers and frequency compensation.) The required drive power for 25 watts output is 1.0 to 1.4 watts.

On-the-air performance is excellent. Besides low distortion in the SSB mode, a small advantage of linear amplification is a complete absence of rise and fall distortion of a CW waveform, which sometimes occurs in class-C amplifiers.

### Summary

This project shows how new RF products can make home construction of amateur equipment very easy. Home-brewers can benefit from a growing trend in RF product engineering: reducing development time by using "super components" that require few external components and little engineering time to design them into a product.

A secondary purpose of this project is to show how even simple software tools can be used to speed up design. The programs used to design the amplifier's low-pass filters are inexpensive, and accurate at frequencies in the MF/HF bands. In this case, they made it possible to examine tradeoffs among standard-value components for seven different filters, without having to build, measure and tweak each one.

The result is a linear power amplifier with good gain and performance. Its uncomplicated design leaves little room for error, and no fancy test equipment is needed to successfully build it. Projects

this easy can make an old-timer forget about the "simpler" days of vacuum tubes!

### Notes

<sup>1</sup>Power supplies are available from Marlin P. Jones & Assoc, mc, PO Box 12685, Lake Park, FL 33403-0685, tel 407-848-8236; fax 1-800-432-9937.

<sup>2</sup>Parts kits for this project are available from Crestone Engineering, PO Box 3702, Littleton, CO 80161, tel 303-770-4709. Each kit includes all electronic and mechanical components for the amplifier module and lowpass filter assembly, including circuit boards, heat sink and rotary band switch. Kits do not include an enclosure, connectors, or TR relay. A 25-W kit using the SLAM-0111 is \$115; a 50-W kit using the larger SLAM-0122 is \$190. Add \$6 per kit for shipping. Payment may be made by check, money order, VISA, MasterCard or American Express.

PC board patterns for the amplifier and filters are available free from the ARRL. Send your request to the Technical Department Secretary, ARRL, 225 Main St, Newington, CT 06111. With your request for the BREED AMPLIFIER PC-BOARD TEMPLATE, enclose a business-size envelope with one First-Class stamp.

<sup>3</sup>Microwave Technology, 4268 Solar Way, Fremont, CA 94538. Their products are distributed by Richardson Electronics, 40W267 Keslinger Road, LaFox, IL 60147, tel 708-208-2200.

<sup>4</sup>Mike Ellis, "A Comprehensive Filter Design Program," RF Design, July 1991. The program is available from the RF Design Software Service, PO Box 3702, Littleton, CO 80161-3702, tel 303-770-4709 (part #RFD0791, \$15 postpaid).

<sup>5</sup>NOVA, a shareware program by Robert Stanton, also available from the RE Design Software Service (part #RFD-0391, \$15 ppd).

# A Compact 1-kW 2-50 MHz Solid-State Linear Amplifier

Solid-state high-power linear amplifiers are becoming more and more popular in the field of ham radio as the prices of HF power transistors continue to fall. 250-W devices are now available for almost half the price they were selling for a few years ago. RF power FETs are still more expensive, but eventually their prices will also fall, although not as fast since they are still novelty items and the manufacturing yields are low due to ESD problems and requirement for cleaner facilities for wafer processing.

## General

It is much easier to design wideband power amplifiers with FETs than bipolar transistors mainly due to their higher input impedances at least up to VHF. Their input impedance also varies less with frequency than that of bipolar devices and changes in the output load line are reflected back to the input to a lesser degree because of the much lower value of feedback capacitance (collector to base vs drain to gate). Practically all RF power FETs on the market today are of the enhancement MOS type, meaning that positive voltage at the gate in respect to the source is required to turn the device on.

The 1-kW amplifier described here would be difficult, if not impossible, to design to cover four and a half octaves with comparable performance using inexpensive bipolar transistors. In addition, a series of power splitters and combiners would be required to reach high power levels. Biasing to class AB linear operation is also much simpler with FETs since the gate does not draw any dc current, whereas a current equal to  $I_C(\text{peak})/h_{FE}$  must be supplied to the base of a bipolar device. One example of this and the splitter-combiner complexity is presented in the Application Note AN-758 by Motorola, Inc.

This article features a state of the art extremely compact design using a pair of

FETs rated for 600 W of power output each. It would be capable of a power output of 1.2 kW as a push-pull circuit, but with the output matching employed, which is optimized at around 800 W, the unit starts saturating at around 1 kW at a 50-V dc supply, resulting in high IM distortion. Similarly at a 40-V supply, it would be usable up to 800 W. The type output matching transformer employed allows only integers as 1:4, 1:9, 1:16, etc. The 1:16 impedance ratio transformer would make the output matching optimized at 1400 W, which would result in a poor efficiency at 1200 W and lower power levels. The only way to compensate for this would be to adjust the supply voltage accordingly, in this case 45-46 V. However, the 1:16 ratio transformer of this type is physically much more difficult to fabricate than the lower ratio ones, and may not be available in the commercial market.

## The Bias Regulator

The gate bias regulator (IC1 in Fig 1) allows the main supply voltage to be varied or the use of an unregulated supply while keeping the gate bias voltages and the FET idle currents constant. Since the maximum operating voltage of the regulator IC is only 40 V, a Zener diode (D1) is employed to keep it at a safe level. The regulator supply terminals are separated from the main power supply permitting the use of a separate bias supply if desired. There is also an option for a thermistor connection to stabilize the idle currents against temperature changes. The thermistor should be in a physical contact preferably with a mounting flange of one of the FETs. The gate voltages are individually adjustable (R1, R2) making gate threshold voltage matching of the devices unnecessary. In case of a device failure, such as a drain-gate short, D2 and D3 block the full supply voltage from being fed back to destroy the regulator. R10, R11 and C3, C4 are merely AC

filters to protect the regulator from possibly strong RF fields. To set the idle currents, R1 and R2 must be adjusted to minimum. R3 is then adjusted for a regulator output voltage of about double the FET gate threshold voltages (IC1, pin 3). The current is monitored at the main supply voltage point while adjusting R1 for a desired idle current, typically 800 mA-1.0 A. R2 is then advanced until the current is doubled, resulting in equal idle currents for both devices. After this procedure, the settings of R1 through R3 should remain until one or both FETs must be replaced.

## The RF Path

The amplifier is designed to operate into the industry standard 50-ohm input and output interface. The impedance matching to the low impedance levels of the FETs is accomplished with broadband RF transformers. Both the input transformer (T1) and the output transformer (T2) are of the so-called conventional type in contrast to transmission line transformers.<sup>1,3,4</sup> Both employ only one turn in the low impedance winding. T2 is far more critical than T1 because it determines the efficiency and the high frequency end gain characteristics, plus it must be able to handle a large amount of RF power. For increased bandwidth characteristics, its low impedance, one turn winding consists of three parallel 10-ohm coaxial cables, resulting in a tight and controllable coupling between the primary and secondary. According to formulas given in Reference 2, approximately twice the present 4.7 cm<sup>2</sup> ferrite cross sectional area would be required in order for the core not to saturate with the calculated 127 gauss flux density. The saturation mainly occurs at the lowest frequencies, in this case at 2-3 MHz. Unfortunately most ferrite manufacturers do not give information on saturation flux densities that applies to applications such as this. However, it is known that high permeability ferrites, in



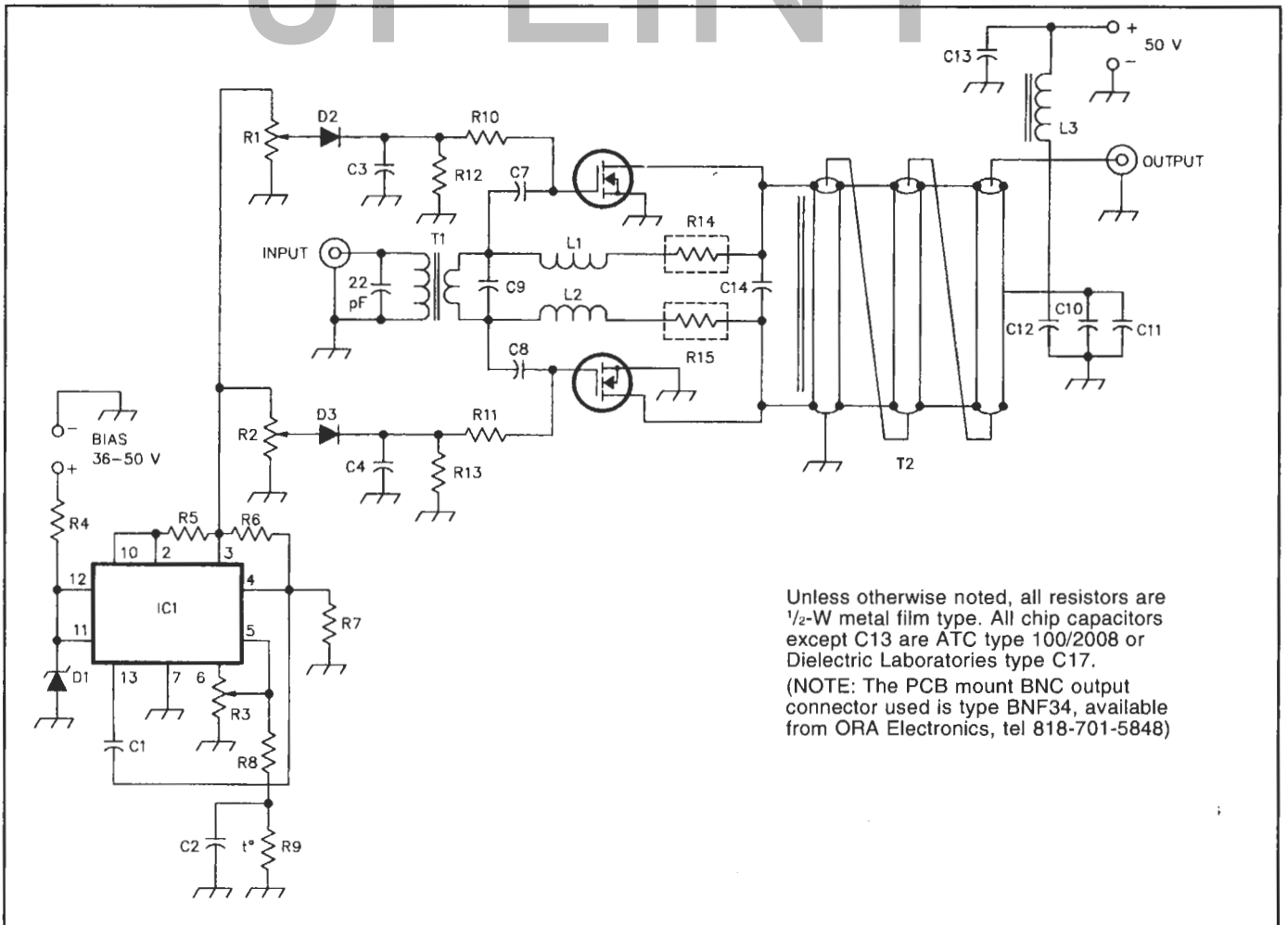

Unless otherwise noted, all resistors are 1/2-W metal film type. All chip capacitors except C13 are ATC type 100/2008 or Dielectric Laboratories type C17.  
 (NOTE: The PCB mount BNC output connector used is type BNF34, available from ORA Electronics, tel 818-701-5848)

Fig 1—Circuit Diagram—2 to 50 MHz Amplifier 2-50 MHz Amplifier Components List

- R1,R2—1 kΩ single-turn Trimpots
- R3—10 kΩ single-turn Trimpot
- R4—470 Ω, 2 watts
- R5—10 Ω
- R6,R12,R13—2 kΩ
- R7—10 Ω
- R8—Exact value depends on thermistor R9 used (typically 5-10 kΩ)
- R9—Thermistor, Keystone RL1 009-5820-97-D1 or equivalent
- R10,R11—100 Ω, 1 W carbon
- R14,R15—EMC Technology model 5308 or KDI Pyrofilm PPR 870-150-3 power resistors, 25 Ω
- D1—1 N5357A or equivalent
- D2,D3—1N4148 or equivalent
- IC1 —MC1723 (723) voltage regulator
- C1—1000-pF ceramic disc capacitor
- C2,C3,C4—0.1-μF ceramic disc capacitor

- C5—0.01-μF ceramic chip capacitor
- C6,C12—0.1-μF ceramic chip capacitor
- C7,C8—Two 2200-pF ceramic chip capacitors in parallel each
- C9—820-pF ceramic chip capacitor
- C10,C11—1000-pF ceramic chip capacitor
- C13—0.47-μF ceramic chip capacitor or two smaller values in parallel
- C14—Unencapsulated mica, 500 V. Two 1000-pF units in series, mounted under T2.
- L1,L2—15 μH, connecting wires to R14 and R15, 1.5 cm each #20 AWG
- L3—10 μH, 10 turns #12 AWG enameled wire on Fair-Rite Products Corp ferrite toroid #5961000401 or equivalent
- T1,T2—9:1 and 1:9 impedance ratio RF transformers, types RF800-3 and RF2067-3 R, respectively (RF Power Systems, 3038 E Corrine Dr, Phoenix, AZ 85032)

general, saturate easier than low permeability materials. Thus, the lowest permeability material should be selected that will satisfy the minimum inductive reactance requirement at the lowest frequency of operation. The formula to calculate this is  $NX_L = 2R_{S(L)}$ , where:  $X_L$ =inductive reactance for one turn,  $N$  = number of turns,  $R_{S(L)}$  = source or load impedance. Low permeability material is also less lossy at high frequencies, resulting in less heat generated in the transformer. T1, which must handle only 8-12 W of power, is made of higher permeability ferrite. This makes it

possible to make the unit physically small as well. In T1, the secondary consists of metal tubes (see Ref 1), where three turns of the primary wire is threaded through. Metal tubes are also used in T2, but only to hold the structure mechanically together.

At high-power levels generated with solid-state devices, which operate at relatively low voltages, the impedance levels automatically become low. This creates a problem for finding passive components, especially capacitors to handle the high RF currents involved. In vacuum tube circuits a similar problem exists, but in the form of

high voltages. In this design, C14 gets the roughest treatment. It must be able to carry RF currents in excess of 10 amperes at the higher frequencies, although the voltage across it is only 75 V rms. At first, several good quality ceramic chip capacitors were tried in parallel, but temperature excursions caused them to crack resulting in AF arcs that burned the circuit board in the area as well. Finally, two unencapsulated mica capacitors (brand names such as Unelco, Underwood, Standex, Elmenco and Semco) were soldered in series by attaching the terminal tabs together, making it a sym-

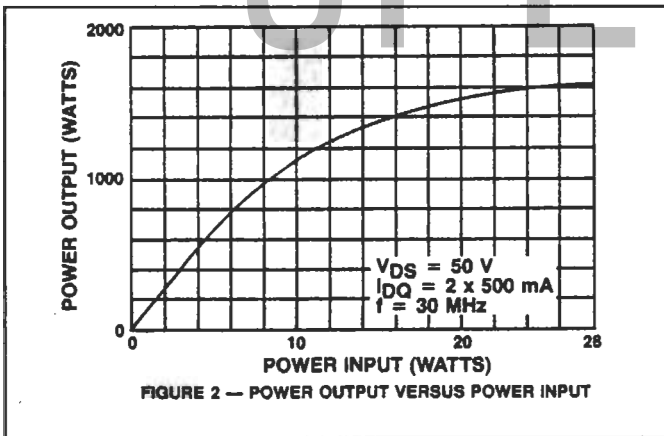

Fig 2

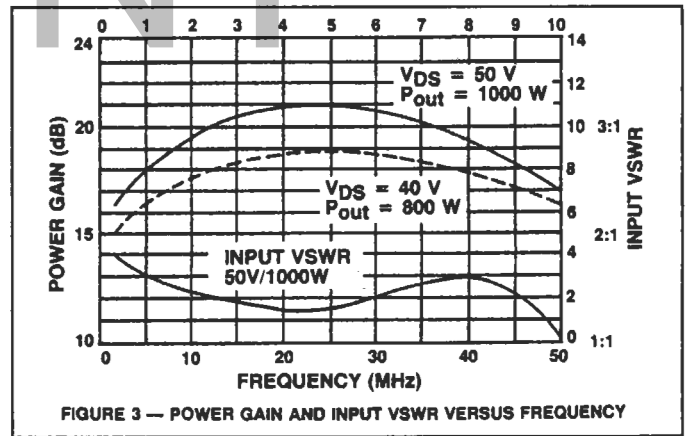

Fig 3

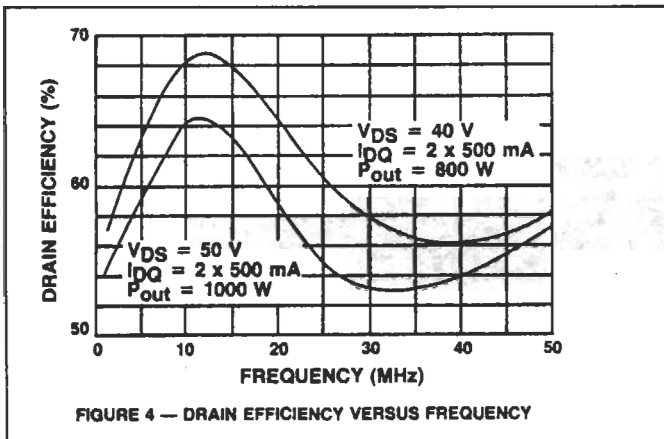

Fig 4

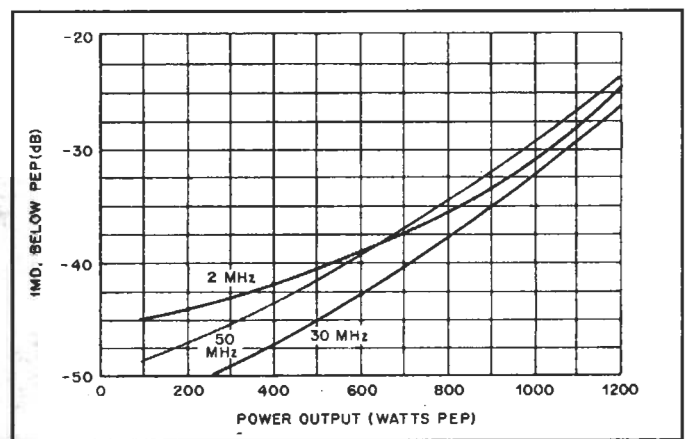

Fig 5

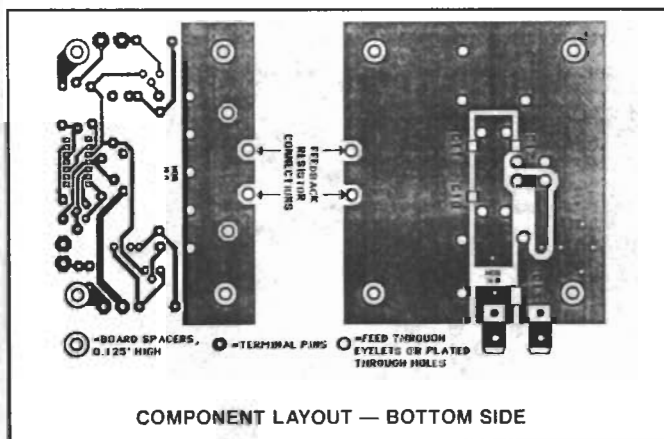

Fig 6

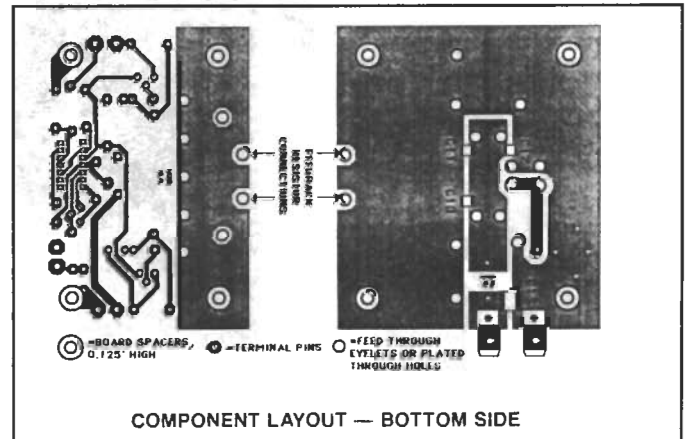

Fig 7

metrical structure. Since each is double the total value required and with double the number of plates, this increases the RF current carrying capability and provides a larger area to be soldered to the board metal foil to make the cooling more efficient. The low impedance winding terminals are then soldered to the tops of the capacitor metal casings, leaving the effective capacitance across the winding. For further fine tuning, an Arco (Elmenco) #469 or Sprague #GM-40900 compression mica trimmer can be soldered to the frontop terminals of the transformer. Slot openings in the metal foil

(Fig 7) located on each side of the output transformer, next to the drain terminals, were provided to increase the series inductance for certain highfrequency narrow-band applications. This tunes out some of the FET output capacitance, resulting in increased efficiency. At lower frequencies (below 80 MHz) however, they only add to the IR loss and should be shorted. The location of C9 is also critical and should be placed approximately as shown in Fig 7. This will affect the input VSWR at frequencies above 30 MHz.

Bypass capacitors C10 through C12 must

also be of good quality. The center tap of T2 should be free of AF if the circuit is balanced. This may not always be the case, in which case these capacitors will aid this function. L3 and C13 form an additional filter, ensuring that no RF energy is being fed back to the power supply. Switchmode power supplies especially are sensitive against RF and may actually get damaged from it.

Negative feedback is provided through the networks L1-R14 and L2-R15. Its purpose is to produce a relatively flat power gain versus frequency response. It also

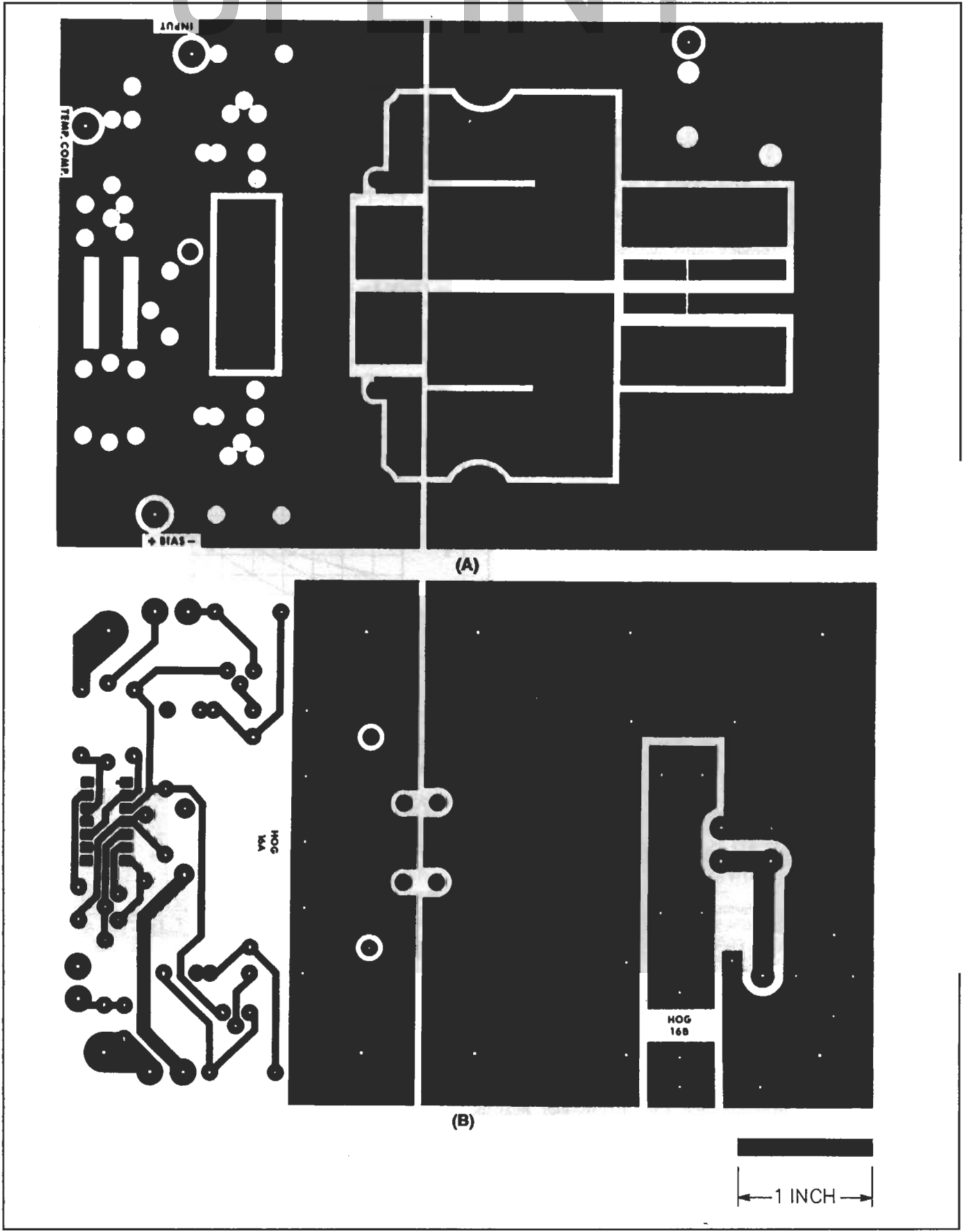

Figs 8A and 8B—Circuit Board—Top Side and Bottom Side

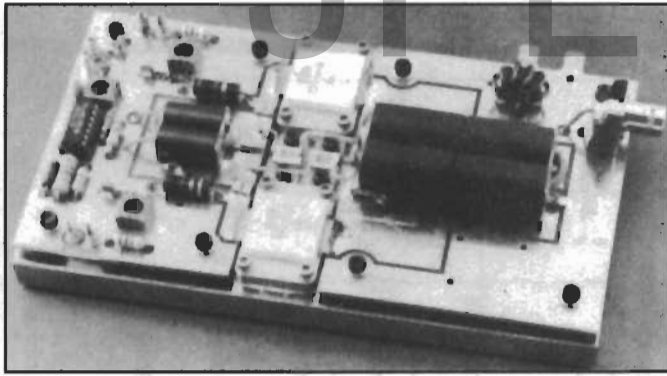

Fig 9—Amplifier mounted to the Heat Spreader.

improves the input return loss and helps to stabilize the amplifier at low frequencies, where the power gain would be 25-30 dB without it. The feedback is at its minimum at the high frequency end and at maximum at low frequencies, where most power is dissipated in R14 and R15. This power is roughly the difference in power input without the feedback between 2 and 50 MHz assuming a constant power output (in this case 25-30 W). A simple formula for calculating the feedback resistor values as well as their dissipation ratings is given in Reference 5. Reference 5 also includes information on physical construction of RF transformers such as used here.

### Thermal Aspects

Assuming a 50% worst case efficiency for the unit, each FET dissipates 500 W of heat in an area of 1 x 1.5 inch. It is imperative that the transistors are mounted on the surface of a material with low thermal resistance such as copper. This is called a heat spreader as it is then attached to a heat

sink made of material with poorer thermal resistance. It should extend about one inch beyond the edges of the FET mounting flanges at least on three sides. It is even more practical to make the heat spreader as large or larger than the amplifier itself. This would allow all circuit-board spacers to be an equal height of 0.125 inch. The thickness of the heat spreader should be a minimum of 0.375 inch. The heat spreader is then separately attached to the actual heat sink, which can be a 12-inch length of Wakefield Engineering type 4559 extrusion or equivalent<sup>6</sup>. Heat sink compound must be applied to all thermal interfaces and the recommended transistor mounting procedure should be followed, including the screw torque. Fig 9 shows the amplifier mounted to the heat spreader. Although the heat sink is not shown, one must be used for continuous operation and for test periods longer than a couple of minutes. For continuous operation, two 5-inch muffin fans under the heat sink will suffice. They will keep the device case temperature at

below 80°C, and the die temperature, which equals to device thermal resistance x power dissipation + case temperature =  $0.13 \times 500 + 80$ , at less than 145°C, which is well below the 200-degree maximum recommended value. We must realize that the 500-watt dissipation is only valid when the unit is operated into a 50-ohm load. Under mismatched conditions, depending on the phase angle, the dissipated power may be lower or higher than this value.

### Performance

Some of the amplifier performance characteristics are shown in Figs 2 through 5. Although at 30 MHz and above all harmonics are 25 dB or more below the fundamental, an output filter is required to comply with FCC regulations. However, it can be a simpler one than required for the low frequencies, where the third harmonic may be only attenuated 12-15 dB. In push-pull amplifiers, the even harmonics are not usually a problem since they are attenuated by the balanced operation of the circuit. Information on high power low-pass filters for applications as this can be found in Reference 7. These filters are automatically relay switched with BCD code available in most modern transceivers.

### References

- The circuit boards and other components for this design are available from Communication Concepts, Inc, 508 Millstone Drive, Xenia, OH 45385, tel 513-429-3811/220-9677.
- <sup>1</sup>Motorola, Inc, Semiconductor Sector Application Notes AN-749 and AN-i 035.
  - <sup>2</sup>Hilbers, A.H., "Design of HF Wideband Power Transformers," Amperex (Philips) Application Laboratory Report EC06907 and EC07213.
  - <sup>3</sup>Blocksome, Aoderick K., "Practical Wideband RF Power Transformers, Combiners and Splitters," *Proceedings of RF Expo*, February 1986.

# A Broadband HF Amplifier Using Low-Cost Power MOSFETs

*Part 1*—With only 1 W of drive, you'll get over 40 W out—from 160 through 10 meters!

Many articles have been written encouraging experimenters to use power MOSFETs to build HF RF amplifiers. That's because power MOSFETs—popular in the design of switching power supplies—cost as little as \$1 each, whereas RF MOSFET prices start at about \$35 each!

Over the years, I tucked away several of these articles, waiting for an opportunity to experiment with them. That opportunity came when I received a call from Al, W2OBJ. Al wanted a low-cost linear amplifier to use with his 5 W QRP transmitter when band conditions got poor. Ideally, the amplifier would generate at least 25 W on all the HF bands. Al's inquiry renewed my interest in the topic and provided the motivation I needed to get my project underway.

Al provided me with an extensive list of RF-amplifier construction articles that use power MOSFETs.<sup>1-8</sup> These articles provided useful information about MOSFETs and general guidelines for working with them, including biasing, parasitic-oscillation suppression, broadband impedance-matching techniques and typical amplifier performance data. It was clear from the performance data that Al's desire to get 25 W output from power MOSFETs on 1.8 to 30 MHz was going to be a challenge! The RF output power of most of the amplifiers described in the articles drops off to 10 W or less as frequency increases just to 14 MHz.

## An Idea Brews

After hundreds of hours of experimentation, I came up with a design that exceeds our original objective: One watt of input power produces over 40 W of output (after harmonic filtering) from 160 through 10 meters. To the basic amplifier, I added an RF-sensed TR relay and a set of low-pass filters designed to suppress harmonic out-

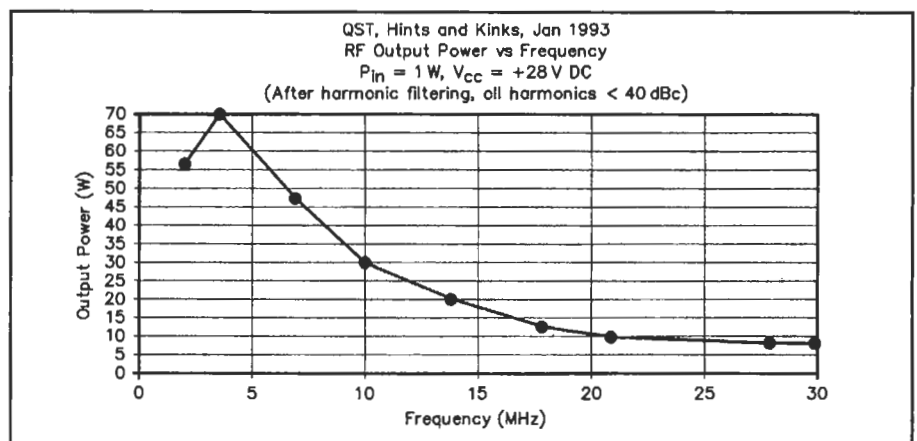
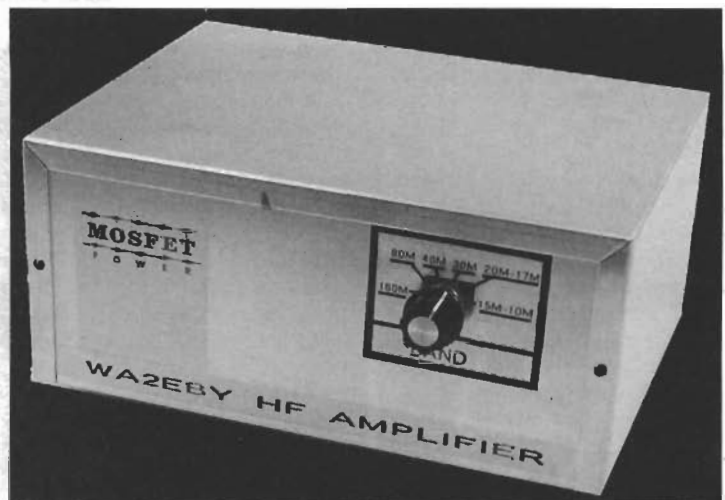
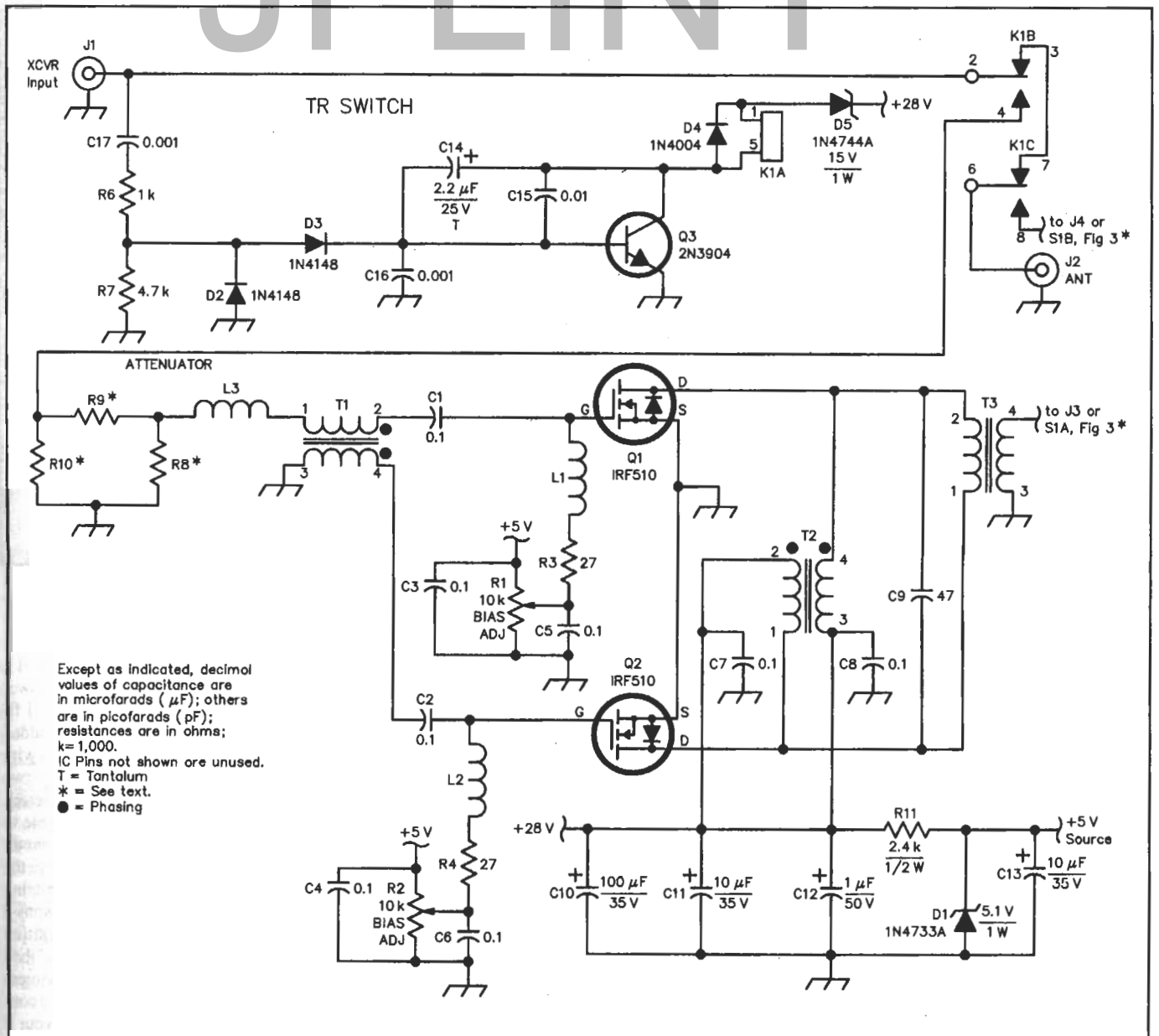

Figure 1—Jim Wyckoff, AA3X, "1 W In, 30 W out With Power MOSFETs at 80 M," Hints and Kinks, QST, Jan 1993, pp 50-51.



Except as indicated, decimal values of capacitance are in microfarads ( $\mu\text{F}$ ); others are in picofarads ( $\text{pF}$ ); resistances are in ohms; k=1,000. IC Pins not shown are unused. T = Tantalum \* = See text. ● = Phasing

Figure 2—Schematic of the MOSFET all-band HF amplifier. Unless otherwise specified, resistors are  $\frac{1}{4}$  W, 5% tolerance carbon-composition or film units. Equivalent parts can be substituted. Part numbers in parentheses are Mouser (Mouser Electronics, 968 N Main St, Mansfield, TX 76063; tel 800-346-6873, 817-483-4422, fax 817-483-0931; sales@mouser.com; <http://www.mouser.com>); see Note 9.

- C1-C8—0.1  $\mu\text{F}$  chip (140-CC502Z104M)
- C9—47 pF chip (140-CC502N470J)
- C10—100  $\mu\text{F}$ , 35 V (140-HTRL35V100)
- C11, C13—15  $\mu\text{F}$ , 35 V (140MLR35V10)
- C12—1  $\mu\text{F}$ , 50 V (140-MLRL50V1.0)
- C14—2.2  $\mu\text{F}$ , 35 V tantalum (581-2.2M35V)
- C15—0.01  $\mu\text{F}$  chip (140-CC502B103K)
- C16, C17—0.001  $\mu\text{F}$  chip (140-CC502B102K)
- D1—1N4733A, 5.1 V, 1 W Zener diode (583-1N4733A)
- D4—1N4004A(583-1N4004A)
- D2, D3—1N4148 (583-1N4148)
- D5—1N4744A, 15 V, 1 W Zener diode (583-1N4744A)
- J1, J2—SO-239 UHF connector (523-81-120)

- K1—12 V DPDT, 960  $\Omega$  coil, 12.5 mA (431-OVR-SH-212L)
- L1, L2—9 $\frac{1}{2}$  turns #24 enameled wire, closely wound 0.25-in. ID
- L3—3 $\frac{1}{2}$  turns #24 enameled wire, closely wound 0.190-in. ID
- Q1, Q2—IRF510 power MOSFET (570-IRF510)
- Q3—2N3904 (610-2N3904)
- R1, R2—10 k $\Omega$  trim pot (323-5000-10K)
- R3, R4—27  $\Omega$ ,  $\frac{1}{2}$  W (293-27)
- R6—1 k $\Omega$  chip (263-1K)
- R7—4.7 k $\Omega$  chip (263-4.7K)
- R8—130  $\Omega$ , 1 W (281-130); for 7 dB pad (5 W in, 1 W out)
- R9—43  $\Omega$ , 2 W (282-43); for 7 dB pad (5 W in, 1 W out)
- R10—130  $\Omega$ , 3 W (283-130); for 7 dB pad (5 W in, 1 W out)

- R8, R10—300  $\Omega$ ,  $\frac{1}{2}$  W (273-300); for 3 dB pad (2 W in, 1 W out)
- R9—18  $\Omega$ , 1 W (281-18); for 3 dB pad (2 W in, 1 W out)
- R11—2.4 k $\Omega$ ,  $\frac{1}{2}$  W (293-2.4K)
- T1—10 bifilar turns #24 enameled wire on an FT-50-43 core.
- T2—10 bifilar turns #22 enameled wire on two stacked FT-50-43 cores.
- T3—Pri 2 turns, sec 3 turns #20 Teflon-covered wire on BN-43-3312 balun core.
- Misc: Aluminum enclosure 3.5 $\times$ 8 $\times$ 6 inches (HWD) (537-TF-783), two TO-220 mounting kits (534-4724), heat-sink compound (577-1977), amplifier PC board (see Note 9), heat sink (AAVID [Mouser 532-244609B02]; see text), about two feet of RG-58 coax, #24 enameled wire and #20 Teflon-insulated wire.

put and comply with FCC requirements. The amplifier is built on double-sided PC board and requires *no tuning*. Another PC board contains the low-pass filters. Power-supply requirements are 28 V dc at 5 A, although the amplifier performs well at 13.8 V dc.

Several of these amplifiers have been built and exhibit similar performance. Al has been using his amplifier on each of the HF bands, logging well over 500 contacts in 18 months. Signal reports indicate a noticeable improvement in readability (about two S units on average) over his 5 W rig. No indications of in-stability, CW key clicks or distortion on SSB have been reported. To make it easy for you to duplicate this project, PC boards and parts kits are available, all at a cost of about \$100!<sup>9</sup>

### An Overview of MOSFETs

MOSFETs operate very differently from bipolar transistors. MOSFETs are voltage-controlled devices and exhibit a very high input impedance at dc, whereas bipolar transistors are current-controlled devices and have a relatively low input impedance. Biasing a MOSFET for linear operation only requires applying a fixed voltage to its gate via a resistor. With MOSFETs, no special bias or feedback circuitry is required to maintain the bias point over temperature as is required with bipolar transistors to prevent thermal runaway.<sup>10</sup> With MOSFETs, the gate-threshold voltage increases with increased drain current. This works to turn off the device, especially at elevated temperatures as transconductance decreases and  $R_{DS(on)}$  (static drain-to-source on resistance) increases. These built-in self-regulating actions prevent MOSFETs from being affected by thermal runaway. MOSFETs do not require negative feedback to suppress low-frequency gain as is often required with bipolar RF transistors. Bipolar transistor gain increases as frequency decreases. Very high gain at dc and low frequencies can cause unwanted, low-frequency oscillation to occur in bipolar transistor RF amplifiers unless negative feedback is employed to prevent it. Low-frequency oscillation can damage bipolar transistors by causing excess power dissipation, leading to thermal runaway.

### MOSFET Limitations

Of course, MOSFETs do have their limitations. The high gate impedance and the device structure make them susceptible to electrostatic discharge (ESD) damage. Some easily applied precautions prevent this: Use a soldering iron with grounded tip; use a wrist strap connected to ground through a 1 M $\Omega$  resistor to bleed off excess body charge while handling MOSFETs and do all work on an anti-static mat connected to ground via a 1 M $\Omega$  resistor.

The sensitivity of a MOSFET's gate to static and high-voltage spikes also makes it vulnerable to damage resulting from parasitic oscillation. This undesired self-oscillation could result in excessive gate-to-

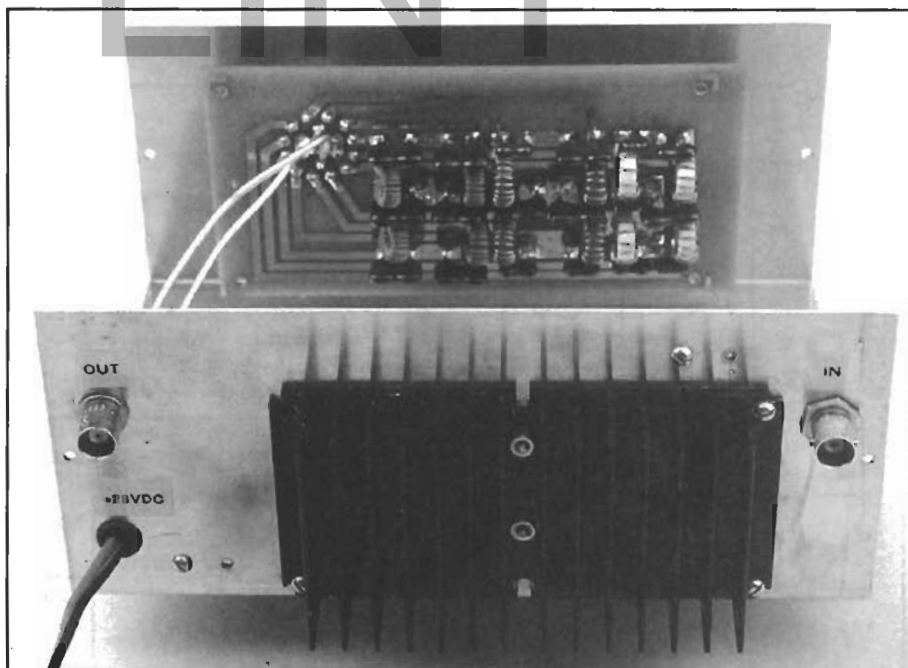

A rear panel view showing the heat sink.

source voltage that permanently damages the MOSFET's gate insulation. Another MOSFET limitation is gate capacitance. This parameter limits the frequency at which a MOSFET can operate effectively as an RF amplifier. I recommend reviewing the referents of Notes 1-3 if you are interested in more detailed information about MOSFETs.

### Power MOSFET RF Amplifiers

Of the several power MOSFET amplifiers I built to check their performance, the one providing the best performance is the push-pull design described by Jim Wyckoff, AA3X, in *QST* (see Note 3). I used IRF510 power MOSFETs rather than the IRF511s specified. The performance of this power MOSFET amplifier design is summarized in Figure 1; its basic design is very similar to another amplifier described in the referent of Note 4, written 10 years earlier. That amplifier uses a pair of more-expensive MRF138 MOSFETs designed specifically for RF applications.

As Figure 1 shows, the Hints and Kinks amplifier performance is excellent from 1.8 MHz to 7 MHz and far exceeds the published figure of 30 W output on 3.5 MHz. As frequency increases above 10 MHz, however, output drops off rapidly, falling below 10 W above 21 MHz. (These levels were measured after harmonic filtering.)

Although the amplifier is identified as stable, my first attempt at duplicating the amplifier resulted in oscillations that destroyed one of the IRF510s. I was puzzled by this. At first, I thought the problem was caused by my substitution of the slightly more robust IRF510 MOSFETs for the called-for IRF511s. That idea proved wrong when my second attempt to power up the amplifier with IRF511 MOSFETs

installed also resulted in a blown IRF511. (Thank goodness these are \$1 power MOSFETs, not \$35 RF MOSFETs!). I finally achieved good stability when I added a small amount of inductance in series with the MOSFET source to ground (just two turns of #24 wire, 0.125 inch diameter). With this added inductance, I was able to remove the ferrite beads from the circuit without any sign of instability. I believe the substitution of the IRF510 and minimizing source lead inductance are the reasons I obtained significantly higher RF output power and wider bandwidth than described in the referent of Note 3. This experiment underscores the need to observe *exact* construction techniques and physical layout if similar performance is to be expected. Even though I used PC board construction, I got significantly different results because my layout was not the same as the author's.

### Modifying the Design

Although the amplifier performed better than expected, its bandwidth was significantly less than desired. Considerable experimentation (and I do mean considerable!) resulted in the circuit shown in Figure 2. This amplifier consists of two power MOSFETs operating in push-pull and employs an RF-sensed TR relay.

During receive, TR relay K1 is deenergized. Signals from the antenna are connected to J2 and routed through K1 to a transceiver connected to J1. (This path loss is less than 0.3 dB from 1.8 MHz through 30 MHz.) In transmit, RF voltage from the transceiver is sampled by C17 and divided by R6 and R7. D2 and D3 rectify the RF voltage and charge C16. Q3 begins conducting when the detected RF voltage across C16 reaches approximately 0.7 V. This energizes K1, which then routes the transmitted RF signal from J1

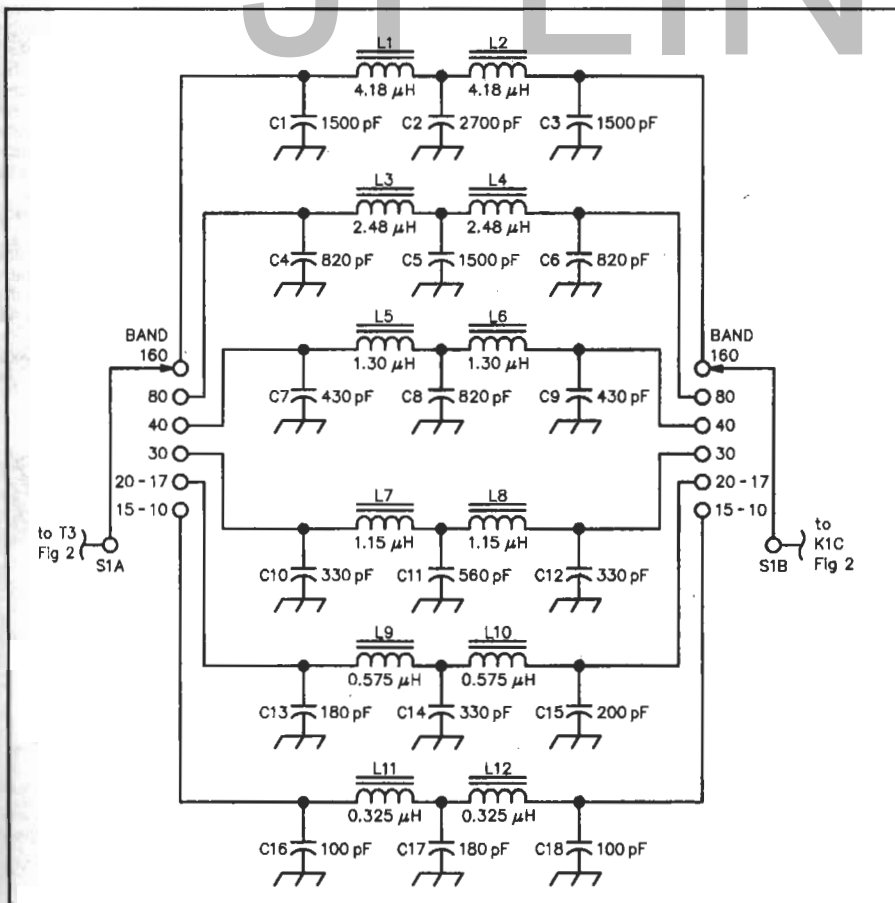

Figure 3—Low-pass filter schematic. In some cases, the actual filter component values differ from the calculated values of a standard 50  $\Omega$ -input filter. Such differences improve the impedance matching between the amplifier and the load. Capacitors are all dipped mica units.

- C1, C3, C5—1500 pF (5982-19-500V1500)
- C2—2700 pF (5982-19-500V2700)
- C4, C6, C8—820 pF (5982-19-500V820)
- C7, C9—430 pF (5982-15-500V430)
- C10, C12, C14—330 pF (5982-19-500V330)

- C11—560 pF (5982-19-500V560)
- C13, C17—180 pF (5982-15-500V180)
- C15—200 pF (5982-15-500V200)
- C16, C18—100 pF (5982-10-500V100)
- S1—2 pole, 6 position rotary (10YX026)
- Misc: low-pass filter PC board (see Note 9)

to the input of the amplifier and sends the output of the amplifier to the antenna at J2. RF-sensed relay response is very fast. No noticeable clipping of the first CW character has been reported.

I made provisions to include an RF attenuator (consisting of R8, R9 and R10) to enable adjusting the amplifier input power to 1 W. (The parts list contains resistor values to reduce the output of 2 or 5 W drivers to 1 W.) The 1 W signal is then applied to the primary of T1 via an input impedance-matching network consisting of L3. T1 is a 1:1 balun that splits the RF signal into two outputs 180 degrees out of phase. One of these signals is applied by C1 to Q1's gate. The other signal is routed via C2 to Q2's gate. The drains of Q1 and Q2 are connected to the primary of output transformer T3, where the two signals are recombined in phase to produce a single output. T3 also provides impedance transformation from the low output impedance of the MOSFETs to the 50  $\Omega$  antenna port. Dc power is provided to the drains of Q1 and Q2 by phase-reversal choke, T2. This is a very effective

method to provide power to Q1 and Q2 while presenting a high impedance to the RF signal over a broad range of frequencies. The drain chokes for Q1 and Q2 are wound on the same core, and the phase of one of the chokes (see the phasing-dot markings on T2) is reversed. C9 increases the bandwidth of impedance transformation provided by T3, especially at 21 MHz.

The 5 V bias supply voltage is derived from 28 V by Zener diode D1 and current-limiting resistor R11. Bypass capacitors C3, C4, C5, C6 and C13 remove RF voltages from the bias supply voltage. Gate bias for Q1 and Q2 is controlled independently. R1 adjusts Q1's gate-bias voltage via R3 and L1. R2 works similarly for Q2 via R4 and L2.

At low frequencies, the amplifier's input impedance is essentially equal to the series value of R3 and R4. L1 and L2 improve the input-impedance match at higher frequencies. The low value of series resistance provided by R3 and R4 also reduces the Q of impedance-matching inductors L1 and L2, which improves stability. Dc block-

ing capacitors C1 and C2 prevent loading the gate bias-supply voltage.

C14 keeps transistor Q3 conducting and K1 energized between SSB voice syllables or CW elements. Without C14, K1 would chatter in response to the SSB modulation envelope and fast keying. Increasing the value of C14 increases the time K1 remains energized during transmit. The reverse voltage generated by K1 when the relay is deenergized is clamped to a safe level by D4. D5 drops the 28 V supply to 13 V to power 12 V relay K1. D5 can be replaced with a jumper if K1 has a 28 V dc coil or if you intend to operate the amplifier with a 13.8 V dc supply.

### Harmonic Filtering

Although biased for class AB linear operation, this amplifier (like others of its type) exhibits some degree of nonlinearity, resulting in the generation of harmonics. This push-pull amplifier design cancels even-order harmonics (2f, 4f, 6f, etc) in the output transformer, T3. Odd-order harmonics are not canceled. Second-order harmonics generated by the amplifier are typically less than 30 dBc (30 dB below the carrier) whereas third-order harmonics are typically only 10 dBc. FCC regulations require all HF RF-amplifier harmonic output power to be at least 40 dBc at power levels between 50 to 500 W. To meet this requirement, it is common practice for HF amplifiers to use low-pass filters. Separate low-pass filters are needed for the 160, 80, 40 and 30 meter bands. The 20 and 17 meter bands can share the same low-pass filter. So, too, the 15, 12 and 10 meter bands can share a common low-pass filter; see Figure 3.

Switching among the six filters can be a messy wiring problem, especially on the higher-frequency bands where lead lengths should be kept short for optimum performance. This problem is solved by mounting all six low-pass filters on a PC board. A two-pole, six-position rotary switch (S1) mounted directly on the same PC board manages all filter interconnections. One pole of S1 connects the amplifier output to one of the six filter inputs, while S1's other pole simultaneously connects the corresponding filter's output to the TR relay, K1. Only two coaxial-cable connections are required between the RF amplifier and the low-pass filter board.

### Next Month

In Part 2, I'll wrap up with amplifier construction and adjustment, and discuss the amplifier's overall performance. See you then!

### Notes

- <sup>1</sup>Doug DeMaw, W1FB, "Power-FET Switches as RF Amplifiers," *QST*, Apr 1989, pp 30-33. See also Feedback, *QST*, May 1989, p 51.
- <sup>2</sup>Wes Hayward, W7ZOI, and Jeff Damm, WA7MLH, "Stable HEXFET RF Power Amplifiers," Technical Correspondence, *QST*, Nov 1989, pp 38-40; also see Feedback, *QST*, Mar 1990, p 41.
- <sup>3</sup>Jim Wyckoff, AA3X, "1 Watt In, 30 Watts Out with Power MOSFETs at 80 Meters," Hints and Kinks, *QST*, Jan 1993, pp 50-51.



<sup>4</sup>Doug DeMaw, W1FB, "Go Class B or C with Power MOSFETs," *QST*, March 1983, pp 25-29.

<sup>5</sup>Doug DeMaw, W1FB, "An Experimental VMOS Transmitter", *QST*, May 1979, pp 18-22.

<sup>6</sup>Wes Hayward, W7ZOI, "A VMOS FET Transmitter for 10-Meter CW," *QST*, May 1979, pp 27-30.

<sup>7</sup>Ed Oxner, ex-W9PRZ (SK), "Build a Broadband Ultralinear VMOS Amplifier," *QST*, May 1979, pp 23-26.

<sup>8</sup>Gary Breed, K9AY, "An Easy-to-Build 25-Watt MF/HF Amplifier," *QST*, Feb 1994, pp 31-34.

<sup>9</sup>Parts for this project are available in five modular kits. The following three kits are available from Mouser Electronics (Mouser Electronics, 958 N Main St, Mansfield, TX 76063; tel 800-346-6873, 817-483-4422, fax 817-483-0931; [sales@mouser.com](mailto:sales@mouser.com); [www.mouser.com](http://www.mouser.com)):

Amplifier components (Mouser P/N 371-HFAMP1) consisting of the amplifier PC board and all PC-board-mounted components (except for the ferrite cores). Price: \$35, plus shipping. Amplifier hardware kit (Mouser P/N 371-HFAMP2) consisting of the aluminum enclosure, two UHF connectors, two TO-220 mounting kits, AAVID heat sink and one container of heat sink compound. Price: \$30 plus shipping. Low-pass filter kit (Mouser P/N 371-HFAMP3) consisting of the low-pass filter PC board, rotary switch and all PC-board-mounted capacitors (inductor cores are *not* included). Price: \$35, plus shipping. Part-placement diagrams accompany the PC boards.

PC boards only are available from Mouser Electronics: HF amplifier board (#371-AMPPWB-2); filter PC board (#371-LPPWB-2). Price \$15 each, plus shipping.

The following two kits are available from

Amidon Inc (Amidon, Inc, 240 Briggs Ave, Costa Mesa, CA 92626; tel 1-800-898-1883, 714-850-4660, fax 714-850-1163): Amplifier ferrite kit (Amidon P/N HFAFC) containing the ferrite cores, balun core and magnet and Teflon wire to wind the transformers for the HF amplifier. Price: \$3.50 plus shipping. Low-pass filter cores kit (Amidon P/N HFFLT) containing all iron cores and wire for the low-pass filters. Price: \$4.50 plus ship.

<sup>10</sup>See Motorola Application Reports Q1/95, HB215, *Application Report AR346*.

Thermal runaway is a condition that occurs with bipolar transistors because bipolar transistors conduct more as temperature increases, the increased conduction causes an increase in temperature, which further increases conduction, etc. The cycle repeats until the bipolar transistor overheats and is permanently damaged.

# A Broadband HF Amplifier Using Low-Cost Power MOSFETs

## Part 2—Let's put the finishing touches on this all-band HF amplifier!

Last month,<sup>11</sup> I covered the history and development of this 40 W (average) amplifier. I'm sure you're anxious to get your amplifier finished and on the air, so let's get going!

### Amplifier Construction

The amplifier is constructed on a double-sided PC board with plated through holes to provide top-side ground connections. I used chip resistors and capacitors to simplify construction, but leaded capacitors may work if lead lengths are kept short. First, assemble all chip capacitors and resistors on the PC board. Tweezers help to handle chip components. Work with only one component value at a time (chip caps and resistors are very difficult to identify!). Chip capacitor and resistor mounting is simplified by tinning one side of the PC board trace with solder before positioning the capacitor or resistor. Touch the soldering iron tip to the capacitor or resistor to tack it in place. Finish mounting by soldering the opposite side of the

component. Don't apply too much heat to chip capacitors. The metalized contacts on the capacitor can be damaged or completely removed if too much heat is applied. Use a 15 to 20 W soldering iron and limit soldering time to five seconds.

Mount axial-leaded resistors, diodes and remaining capacitors next. To avoid damaging them, mount inductors and transformers last. L1 and L2 are wound on a 0.25-inch drill-bit shaft. By wrapping the wire around the shaft 10 times, you'll get 9½ turns. The last turn arcs only a half-turn before entering the PC board. L3 is wound on a 0.190-inch diameter drill bit with 3½ turns wound the same way as L1 and L2. Mounting K1 is simplified by first bending all its leads 90° outward so it lies flat

on the PC board. Use a wrist strap connected to ground through a 1 MΩ resistor to bleed off static body charge while handling MOSFETs, and do the work on an anti-static mat connected to ground via a 1 MΩ resistor. The gate input can be damaged by electrostatic discharge!

When winding T3, wind the primary first and add the secondary winding over the primary. Be sure to use Teflon-insulated wire for T3's windings; the high operating temperatures encountered will likely melt standard hook-up wire insulation.

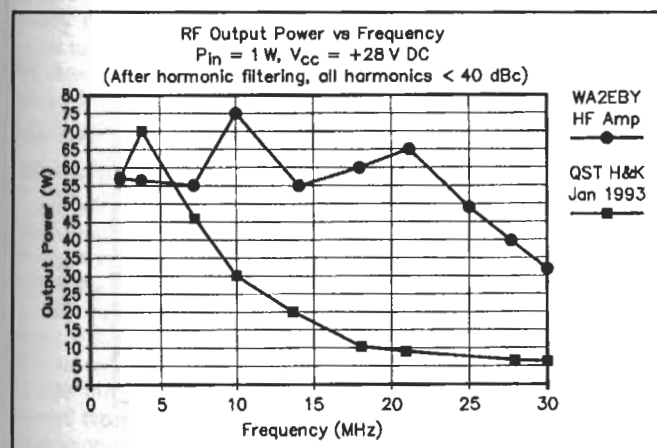
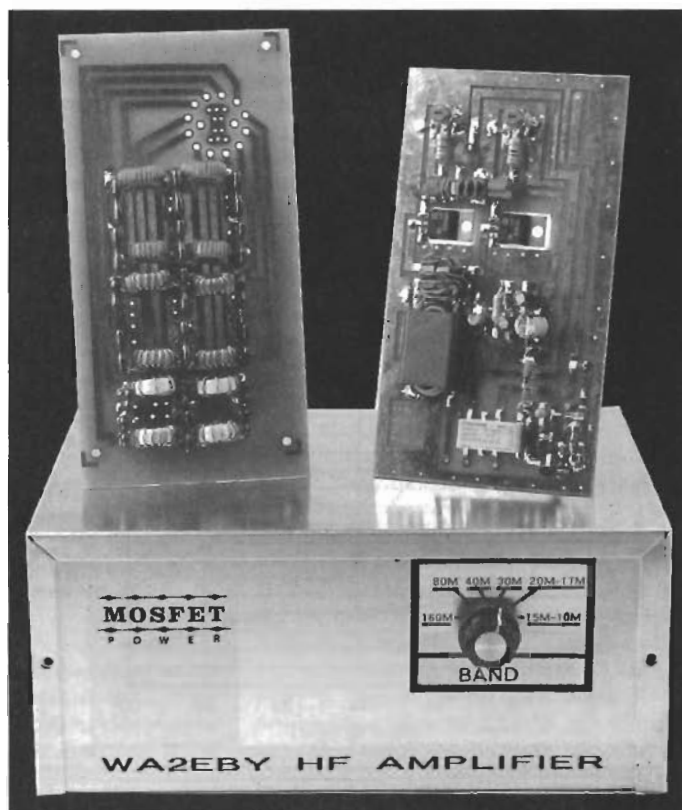

Figure 4—RF output power comparison of the Hint and Kink amplifier and this design.



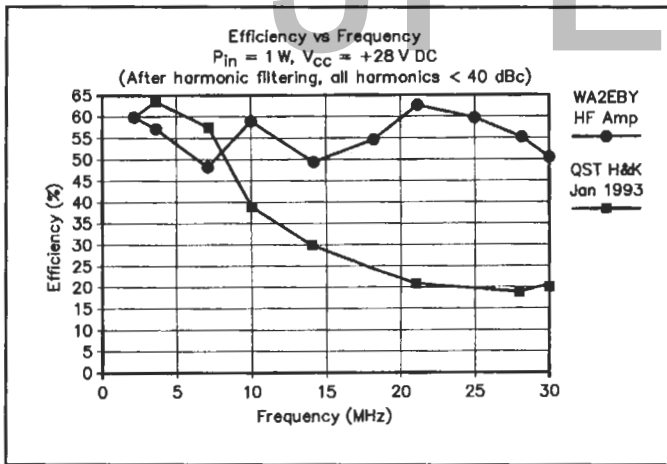

Figure 5—Efficiency comparison of the Hint and Kink amplifier and this one.

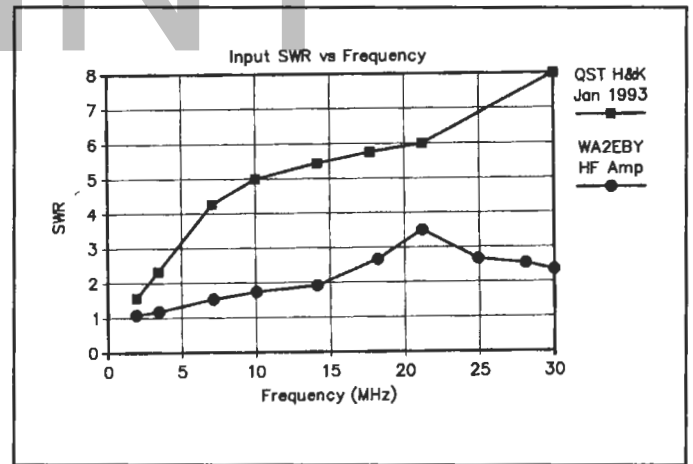

Figure 6—Input SWR comparison of the two amplifiers.

### Heat Sinking

Together, Q1 and Q2 dissipate up to 59 W. A suitable heat sink is required to prevent the transistors from overheating and damage. I used an AAVID 244609B02 heat sink originally designed for dc-to-dc power converters. The amplifier PC board and heat sink are attached to an aluminum enclosure by two #4-40 screws drilled through the PC board, enclosure and heat sink at diagonally opposite corners. A rectangular cutout in the enclosure allows Q1 and Q2 direct access to the heat sink. This is essential because of the large thermal impedance associated with the TO-220 package (more on this topic later). Mark the locations of the transistor-mounting-hole location in the center of the heat sink in between the cooling fins. Disassemble the heat sink to drill 0.115 inch holes for #4-40 mounting screws, or tap #4-40 mounting holes in the center of the heat-sink fins.

Use mica insulators and grommets when mounting Q1 and Q2 to prevent the #4-40 mounting screws from shorting the TO-220 package drain connections (tabs) to ground. Coat both sides of the mica insu-

lator with a *thin* layer of thermal compound to improve the thermal conduction between the transistor tab and the heat sink. Be sure to install the mica insulator on the heat sink *before* assembling the amplifier PC board to the enclosure and heat sink. The mica insulators are larger than the cut outs in the PC board, making it impossible to install them after the PC board is mounted.

### Low-Pass Filter Construction

Inductor winding information for the low-pass filters is provided in Table 1.

#### Single Band

A PC-board trace is available on the amplifier PC board next to amplifier output (J3) to allow the installation of a single-band low-pass filter between the terminals of J3 and K1's input, J4. This is handy if you intend to use the amplifier on one band only. The input inductor of the low-pass filter connects from J3 to the single PC trace adjacent to J3. The output inductor connects in series between the single PC trace to J4. The three filter capacitors connect from J3, J4

and the PC-board trace near J3 to ground. *This single trace is not used when multiple filters are required.* Remember to remove the single trace adjacent to J3 on the amplifier PC board before attaching the amplifier board between the RF connectors on the enclosure's rear panel.

#### Multiple-Band Filters

Using the amplifier on more than one band requires a different approach. A set of

**Table 1**  
Low-Pass Filter Inductor Winding Information

(Refer to Figure 3 in Part 1))

Inductor Number	No. of Turns	Core
L1, L2	30 turns	T-50-2
L3, L4	22 turns	T-50-2
L5, L6	16 turns	T-50-2
L7, L8	14 turns	T-50-2
L9, L10	11 turns	T-50-6
L11, L12	8 turns	T-50-6

Note: All inductors are wound with #22 enameled wire except for L1-L4, which are wound with #24 enameled wire.

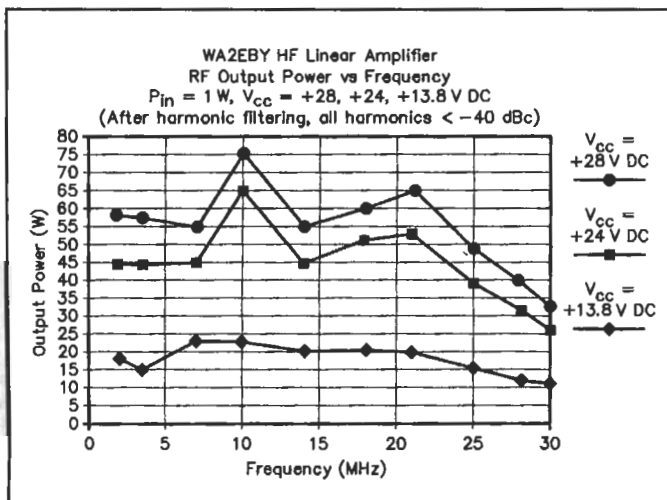

Figure 7—RF output power versus supply-voltage of this amplifier.

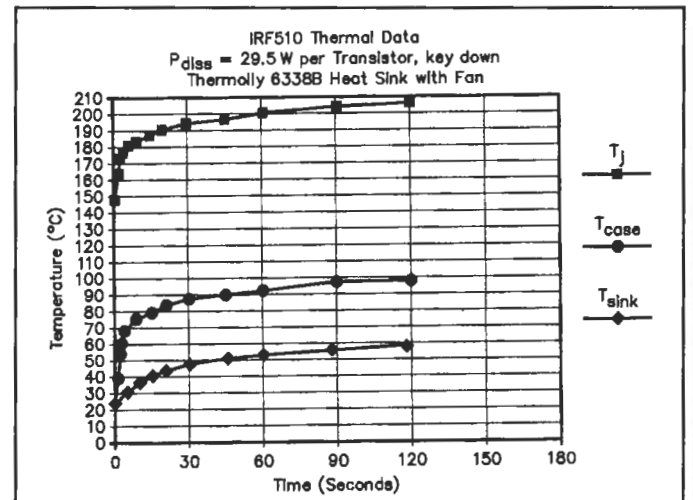

Figure 8—Thermal performance of the amplifier during key-down conditions.

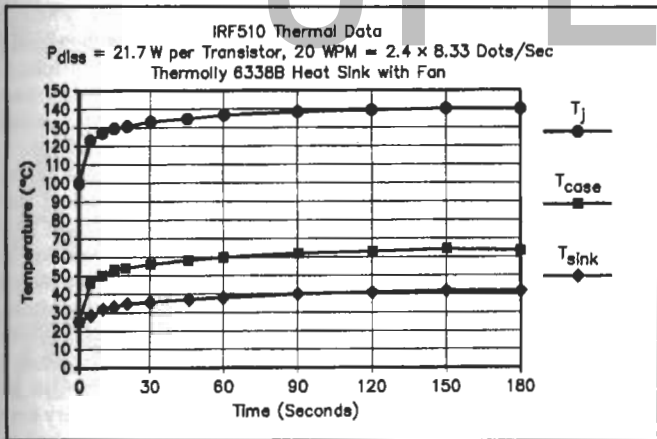

Figure 9—Thermal performance of the amplifier during simulated CW conditions.

six low-pass filters is built on a double-sided PC board with plated through holes to provide top-side ground connections. A PC-board mount, two-pole, six-position rotary switch does all low-pass filter selection. Silver-mica, leaded capacitors are used in all the filters. On 160 through 30 meters, T-50-2 toroids are used in the inductors. T-50-6 toroids are used for inductors on 20 through 10 meters. The number of turns wound on a toroid core are counted on the toroid's OD as the wire passes through the core center (*The ARRL Handbook*<sup>12</sup> provides complete details for winding toroids). Assemble one filter section at a time starting with the 160, 80, 40-meter filter, then the 30-meter filter. With the switch mounting position at your upper left, the filter input (C1) is near the top edge of the board and the filter output (C3) is near the bottom edge. *The last two filters are out of sequence*; the 15-10 meter filter comes *before* the 20-17 meter filter) and the inputs/outputs are reversed to simplify the PC-board layout. The input capacitors, C13 and C16, are mounted on the board *bottom edge*, and output capacitors, C15 and C18, are on the *top edge*.

Use care when assembling the rotary switch. All 14 terminals must fit through the PC board without damaging or bending the pins. Make sure there are no bent pins before you attempt assembly. Insert the rotary switch into the PC board. Do *not* press the rotary switch all the way into the PC-board holes flush with the ground plane! If you do, the top flange of the signal pins may short to the ground plane.

### Bias Adjustment

The biasing procedure is straightforward and requires only a multimeter to complete. First, set R1 and R2 fully counterclockwise, (0 V on the gates of Q1 and Q2). Terminate the RF input and outputs with a 50 Ω load. Next, connect the 28 V supply to the amplifier in series with a multimeter set to the 0-200 mA current range. Measure and record the idling current drawn by the 5 V bias supply. The value should be approximately 9.5 mA ( $28 - 5.1 \text{ V} / 2.4 \text{ k}\Omega = 9.5 \text{ mA}$ ). Set Q1's drain current to 10 mA

by adjusting R1 until the 28 V supply current increases by 10 mA above the idling current ( $9.5 + 10 = 19.5 \text{ mA}$ ). Next, adjust R2 for a Q2 drain current of 10 mA. This is accomplished by adjusting R2 until the 28 V supply current increases by an additional 10 mA (to 29.5 mA).

### Amplifier Performance

With a 28 V power supply and 1 W of drive, the RF output power of this amplifier exceeds 40 W from 1.8 MHz through 28 MHz. Peak performance occurs at 10 MHz, providing about 75 W after filtering! A performance comparison between this amplifier and my modified version of the Hint and Kink amplifier mentioned earlier is shown in Figure 4.

As shown in Figure 5, this amplifier achieves an efficiency of better than 50% over its frequency range, except at 7 MHz where the efficiency drops to 48%. In contrast, the Hint and Kink amplifier delivers greater efficiency between 1.8 and 7 MHz, but it drops rapidly to only 20% as frequency is increased.

Figure 6 compares the input SWR of the two amplifiers. The Hint and Kink amplifier's SWR is acceptable (< 2:1) only at 1.8 MHz. This amplifier is better, however it, too, exceeds 2:1 above 14 MHz. The input SWR of this amplifier can be improved to better than 2:1 on all bands by adding a 3 dB pad (R8-R10 of Figure 2) at the input and supplying 2 W to the pad input. This keeps the amplifier drive at 1 W.

Figure 7 graphs this amplifier's RF output power as a function of drain supply voltage. During this test, the amplifier RF drive level was kept constant at 1 W. As you can see, even when using a 13.8 V dc supply, the amplifier provides over 10 W output (a gain of more than 10 dB) from 1.8 to 30 MHz.

### Operation

The amplifier requires no tuning while operating on any HF amateur band. You must, however, *be sure to select the proper low-pass filter prior to transmitting*. If the wrong low-pass filter is selected, damage to the MOSFETs may result. Damage will

likely result if you attempt to operate the amplifier on a band with the low-pass filter selected for a lower frequency. For example, driving the amplifier with a 21 MHz signal while the 1.8 MHz low-pass filter is selected will likely destroy Q1 and/or Q2.

The amplifier can also be damaged by overheating. This limitation is imposed by the TO-220 packages in which Q1 and Q2 are housed. The thermal resistance from junction to case is a whopping 3.5°C/W. This huge value makes it virtually impossible to keep the junction temperature from exceeding the +150°C target for good reliability. Consider the following conditions: key down, 1 W input, 53 W output on 7 MHz (worst-case band for efficiency). The amplifier consumes  $28 \text{ V} \times 4 \text{ A} = 112 \text{ W}$ , of which 53 W are sent to the antenna, so 59 W ( $112 \text{ W} - 53 \text{ W} = 59 \text{ W}$ ) are dissipated in Q1 and Q2. Assuming equal current sharing between Q1 and Q2, each transistor dissipates 29.5 W. To keep the transistor junction temperature below +150°C requires preventing the transistor case temperature from exceeding 46.8°C ( $150 - [3.5 \times 29.5]$ ) while dissipating 29.5 W. Also, there is a temperature rise across the mica insulator between the transistor case and heat sink of 0.5°C/W. That makes the maximum allowable heat-sink temperature limited to  $46.8 - (0.5 \times 29.5) = 32^\circ\text{C}$ . In other words, the heat sink must dissipate 59 W (29.5 from each transistor) with only a 7°C rise above room temperature (25°C). Even if the junction temperatures were allowed to reach the absolute maximum of 175°C, the heat sink temperature must not exceed 57°C. Accomplishing this requires a heat sink with a thermal resistance of  $(57 - 25) / 59 = 0.54^\circ\text{C/W}$ . This is far less than the 1.9°C/W rating of the AAVID 244609B02 heat sink I used. The situation may seem bleak, but all is not lost. These calculations make it clear that the amplifier should not be used for AM, FM or any other continuous-carrier operation. The amplifier should be used only for CW and SSB operation where the duty cycle is significantly reduced.

Thermal performance of the amplifier is illustrated in Figure 8. Data was taken under dc operating conditions with power-dissipation levels set equal to conditions under RF operation. A RadioShack brushless 12 V dc fan (RS 273-243A) blows air across the heat sink. Key down, the maximum rated junction temperature is reached in as little as five seconds as illustrated in Figure 8. Prolonged key-down transmissions should be avoided for this reason.

Under intermittent CW conditions, the situation is very different. Transistor-case temperatures reached 66°C after operating four minutes under simulated CW conditions at 20 WPM (60 ms on, 60 ms off). The corresponding junction temperature is +141°C (based on an equivalent RMS power dissipation of 21.7 W per transistor). This keeps the junction temperature under the 150°C target (see Figure 9). One simple way to reduce power dissipation is

# FLINT

to reduce the power-supply voltage to 24 V. RF output power will decrease about 10 W from the maximum levels achieved with a 28 V supply.

From a thermal standpoint, the IRF510 power MOSFET is a poor choice for this RF amplifier application. Although I must say I am impressed with the robustness of these devices considering the times I spent testing them key down, five minutes at a time, without failure. Q1 and/or Q2 may need to be replaced after a year or so of operation because of the compromise in reliability. Considering their low cost, that is not a bad trade-off.

## Stability

High gain, broad bandwidth and close input/output signal routing (within the TR relay) all work against stability. With a good load (< 2:1 SWR) the amplifier is stable from 1.8 MHz through 39 MHz. Oscillation was observed when the transmitter frequency was increased to 40 MHz. The output load match also affects stability. Oscillation was observed on 27.5 MHz when the load SWR was 3:1. This should not be a problem since the frequency is outside the ham bands. I spent a great deal of time trying to make this design unconditionally stable even with loads exceeding 3:1 SWR without sacrificing output power (gain) at 28 MHz without success. I did identify some reasonable compromises.

One of the easiest ways to improve stability and the input SWR seen by the RF source is to add an RF attenuator (pad) at the amplifier input. An attenuator is absolutely required if the transmitter (driver) provides more than 1 W to the amplifier. R8, R9 and R10 form an RF attenuator that attenuates

the transmitter drive level, but does not attenuate received signals because it is only in the circuit when K1 is energized. To drive this amplifier with a 2-W-output transmitter requires use of a 3-dB pad. The pad improves the amplifier input SWR and the isolation between the amplifier's input and output. The drawback is that 1 W is wasted in the pad. Likewise, a 5-W driver requires use of a 7-dB pad, but 4 W are wasted in the pad. (Values for R8, R9 and R10 to make a 3-dB pad and a 7-dB pad are given in the parts list.) Installing a pad requires cutting the PC-board trace *under R9*, otherwise R9 would be shorted out by the trace. Make a small cut (0.1 inch wide) in the trace under R9 before soldering R9 in position. R8 and R10 have the same values, but may have different power ratings. Connect R10 between the RF input side of R9 and ground. Install R8 between the amplifier side of R9 and ground.

An impedance mismatch between the output of a 1-W-output driver and the amplifier input can be a source of instability. (Obviously, if the driving transmitter's output power is only 1 W, you can't use a pad as described earlier.) If you encounter stability problems, try these remedies: Place a resistor in parallel with L1 and L2 to decrease the Q of the amplifier matching network (try values between 50 and 220  $\Omega$ ). Try reducing the value of L3 or eliminating L3 entirely. Both of these modifications improve stability, but reduce the amplifier's output power above 21 MHz.

## Summary

This project demonstrates how inexpensive power MOSFETs can be used to build an all-band linear HF power amplifier. Fre-

quency of operation is extended beyond the limits of previous designs using the IRF510 and improved input-impedance matching. Long-term reliability is recognized as a compromise because of the poor thermal performance of the low-cost TO-220 package.

If you have been thinking about adding an amplifier to your QRP station, this project is a good way to experiment with amplifier design and is an excellent way to become familiar with surface-mount "chip" components. I made arrangements with Mouser Electronics and Amidon Inc to provide parts kits for this project at a discounted price (see the parts list in Part I). These parts kits make it very easy to get started and more economical to "homebrew" this project.

## Acknowledgments

I want to thank the following individuals associated with this project: Harry Randel, WD2AID, for his untiring support in capturing the schematic diagram and parts layout of this project; Al Roehm, W2OBJ, for his continued support and encouragement in developing, testing, editing and publishing this project; Larry Guttadore, WB2SPF, for building, testing and photographing the project; Dick Jansson, WD4FAB, for thermal-design suggestions; Adam O'Donnell, N3RCS, for his assistance building prototypes; and my wife, Laura, N2TDL, for her encouragement and support throughout this project.

## Notes

<sup>11</sup>Mike Kossor, "A Broadband HF Amplifier Using Low-Cost Power MOSFETs—Part 1," *QST*, Mar 1999, pp 40-43.

<sup>12</sup>R. Dean Straw, N6BV, *The 1999 ARRL Handbook for Radio Amateurs*, (Newington: ARRL), 76th ed, pp 25-23ff.

# A 1.8 to 54 MHz 5-Watt Amplifier

Need a rugged and stable amplifier for your multiband QRP rig? Not only has the design been optimized on a pricey computer program called *Touchstone* (by eesof) for unconditional stability, it has actually survived a variety of poor loads—it was used to sweep filters with 5 W of RF. The gain of the two stage amplifier was measured to be between 28 and 30 dB in the amateur bands, though there is another dB of gain around 37 MHz.

For ruggedness and ease of design, a Motorola MRF 137 was selected as the final transistor. While the MRF 138 may be more linear, insufficient design information was available to ensure a stable design. While some amateurs will balk at the high cost of these devices (\$24 in November 1991), such savings are easily lost if the cheaper device has a habit of blowing up. Also, one picks up a real clean SSB signal—the high-order IMD products are way down compared to typical bipolar amplifiers. For instance, the worst IMD on 3.5, 7, 14 and 28 MHz was -38 dB on 28 MHz, with the 5th order products 61 dB down (relative to PEP). The device was putting out 5-W PEP while being biased at 0.5 A (28-V supply).

Perhaps the biggest flaw is the power requirement—these FETs really like to see high voltages for best performance, and the MRF 137 is no exception. I biased the MRF 137 for 0.55 A and 28.2 V. It drew 0.6 A when putting out 4.6 W at 28 MHz. The driver runs off your normal 12-V supply.

The input amplifier shown in Fig 1a is pretty straightforward—a bipolar 2N5109 with the feedback networks adjusted to compensate the gain of the MRF 137. A series network of a 470- $\Omega$  resistor and a 12-pF capacitor was tacked between the collector and ground to ensure stability at all frequencies. The MRF 137 rolls off a few dB at 54 MHz, but the bipolar amplifier adequately compensates for this gain deficiency. The input return loss is better than 18 dB between 1.4 and 29.9 MHz, but degrades to 12 dB at 50 MHz. The input SWR was not tested with poor loads.

By itself, the MRF 137 amplifier stage

shown in Fig 1b (see next page) makes an excellent 16-dB gain block between 1 and 32 MHz, having less than 0.5 dB of gain variation. The transmission line transformer on the input seems to help the input return loss/SWR, keeping these numbers above 18/below 1.3 to 1 between 1 and 50 MHz. I suppose that putting another transmission line transformer on the output could be used to get a more powerful amplifier with less gain over a similar frequency range, but this variation has not been investigated.

The simplest circuit board I could think of was used—I cut two pads in a piece of double-sided circuit board for the gate and drain leads. Then I wrapped the edges of the board with copper tape and soldered it

down for good grounding. After making holes for the MRF 137 transistor and the mounting screws in the board and a spacer, made of 0.050-inch aluminum, I attached the spacer, the circuit board, and the MRF 137 to a heat sink tapped with 4-40 screw holes. Standard ground-plane construction was used to attach the other parts. The 2N5109 amplifier was built on its own ground plane—RF amplifiers work better if there isn't too much gain in one place. Three additional amplifiers were built by Mike Gruber, WA1SVF, for use in the lab. He noted that R8 had to be changed from 4.7 k $\Omega$  to 1 k $\Omega$  to bias the amplifiers at 0.5 amps. Apparently, the MRF 137s he used have a higher gate threshold voltage. Otherwise, performance was as expected.

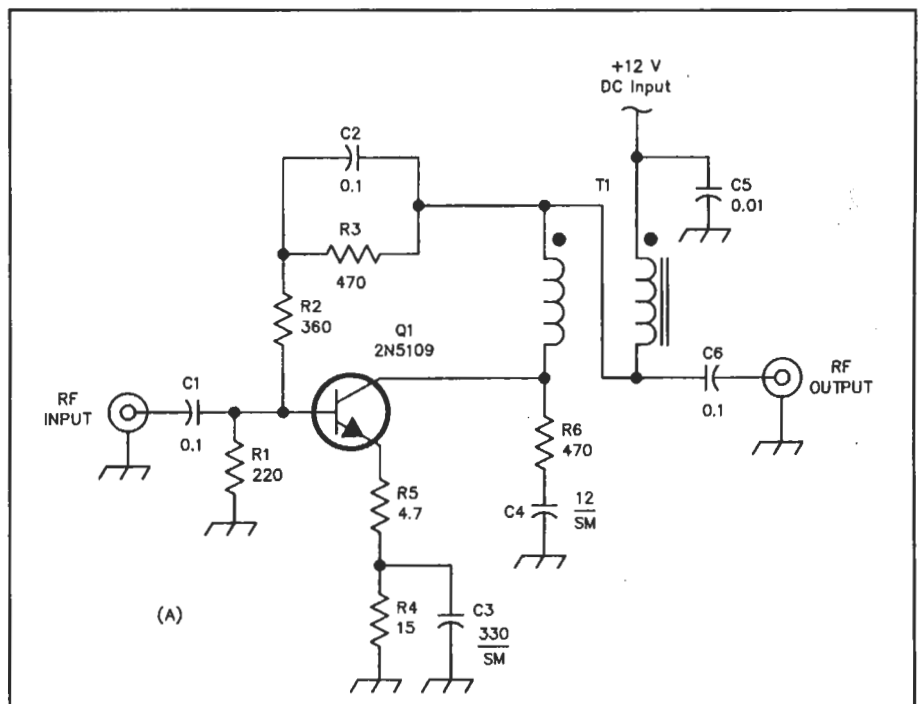

Fig 1a—Low-level amplifier designed to compensate for the gain rolloff from the power amplifier.

Q1—2N5109, 2.5-W heat-sinked RF transistor,  $f_T$  is 1200 MHz.

T1—15 turns bifilar #28 on FT-37-43 toroid core.

# JFLINT

Fig 1b—5-W TMOS power amplifier.

L1—26 turns no. 26 enameled wire on T-44-2 toroid, 3.9  $\mu$ h.

Q2—MRF 137 transistor.

R9—10-k $\Omega$  turn potentiometer for bias setting.

RFC1—21 turns of no. 26 enameled wire on FR-37-67 toriod.

T2—4 turns 25- $\Omega$  coax on FT-50-43 toroid core.

The 25- $\Omega$  coax is actually two 50- $\Omega$  coax run side-byside. The prototype used RG-196/U coax.

U1—78L05 5-V regulator.

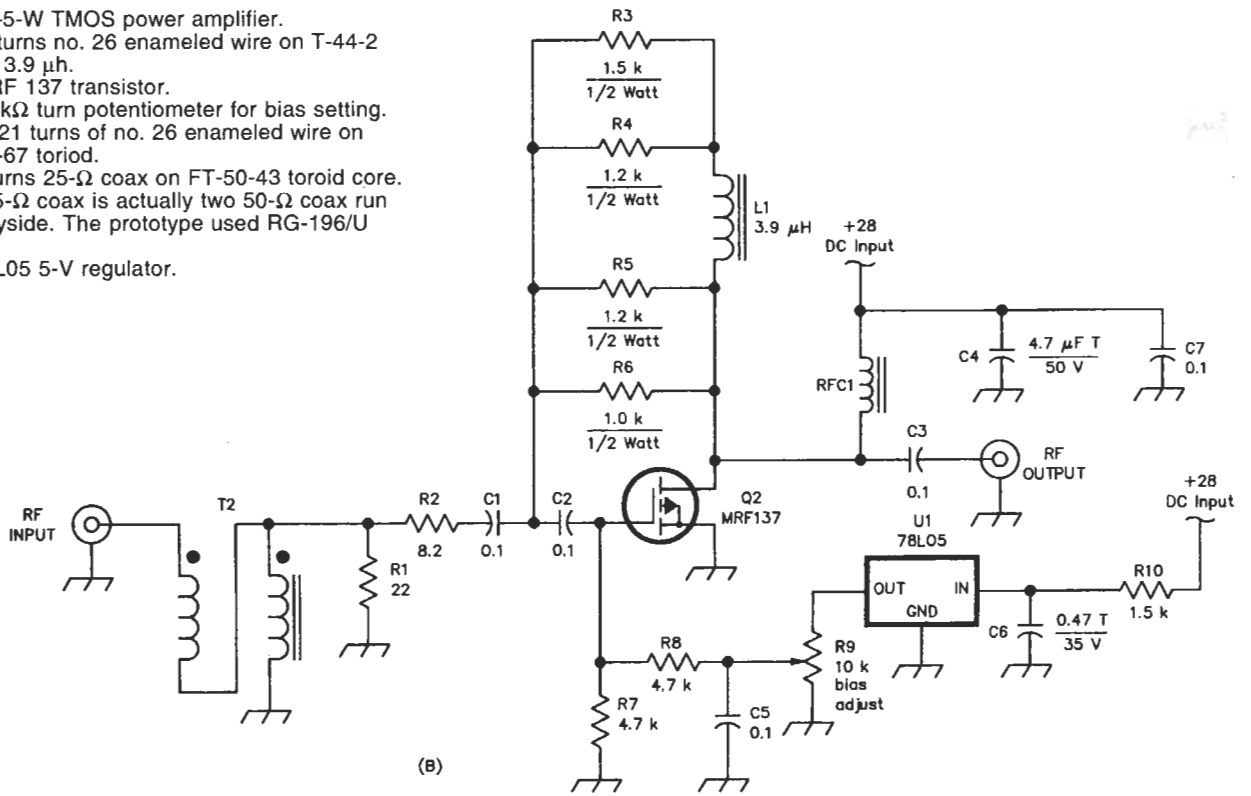

# An Experimental Solid-State Kilowatt Linear Amplifier for 2 to 54 MHz

Many kilowatt amplifiers could anchor a small boat, and don't cover 6 meters. Combined with its power supply, *this* kilowatt weighs less than 35 pounds.

This article describes progress toward achieving a well-defined goal: building the smallest possible MF/HF/VHF amplifier capable of at least 1000 watts output. Nicknamed the Solid State Kilowatt (SSKW), the project has its roots in an article by Helge Granberg of Motorola in October 1986 *RF Design*.<sup>1</sup> Two water-cooled amplifiers of that design, built by Mike Staal (K6MYC) of M2, had many problems. Some of them were device-related; others, power-supply related. (More about these issues later.) In February 1990 I rebuilt one of the water-cooled units using the old design and two new transistors. Optimized for 50 MHz, this amplifier could just reach the 1000-watt level. After using it for three weeks of South Pacific DXpeditioning, I decided to construct an air-cooled unit. I spent the spring, summer and fall of 1990 building the SSKW and getting it ready for another DXpedition in the fall.

## Circuit Description

Motorola's article reprint AR-347 describes the basic amplifier design. July 1990 QEX also carried an article about it.<sup>2</sup> Fig 1 shows the amplifier schematic. Briefly, the circuit consists of two MRF154 RF power MOSFETs in push-pull. Each of these transistors is capable of 600 watts output up to 100 MHz. The input and output transformers, 9:1 and 1:9, respectively, use cores of #67 ferrite material. The output transformer's 1:9 ratio is a compromise that is optimum at about 800 watts.

Incorporating the Motorola building block into a DXpedition-ready package required experimentation and problem-solving, as I described at the 1991 Central States VHF Conference.<sup>3</sup> Here's where the system stands today.

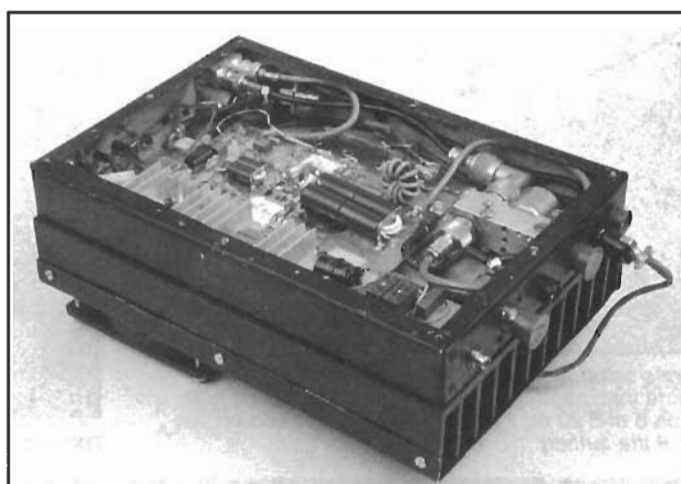

## TR Switching

The SSKW includes TR relays that bypass the Fig 1 circuitry in receive mode. I designed their control circuitry to eliminate the possibility of the high RF fields in the amplifier compartment causing relay falsing problems, and to simplify field repair by keeping parts count low. The relays are sequenced to allow the output relay to close before the amplifier puts out power. Because relays take a few milliseconds to operate, sequencing is necessary to keep the relay from hot-switching the amplifier output. (Hot-switching 1 kW will destroy a relay rapidly!)

This design has two small problems. For the short time it takes the amplifier's input relay to close on switching from receive to

transmit, the exciter operates without a load. This can be remedied by delaying the exciter keying. The other problem is the relay's closure time changes as the relay heats. This can be solved two ways: Use external electronics to do the delay, or temperature-compensate for the resistance change.

## SWR Protection

I haven't yet built SWR protection into the amplifier. In January 1983 QST, Helge Granberg described an SWR-protection circuit for a 2- to 30-MHz amplifier.<sup>4</sup> A phone conversation with Helge indicated that this circuit will work to 54 MHz, so it should suffice. How much mismatch the MRF154s can tolerate is unknown, however, so I don't



## 6-Meters: DXpeditioning with a Difference

Making the most of 6 meter DXpeditioning depends on knowing where and when to go. If you want to work Europe from the Canary Islands summertime is best because sporadic E propagation is best then if you want to work the US from EA8 go when fall shifts into winter to take advantage of east/west F2 layer propagation. It's always more exciting to go to a rare place but not necessarily more fun!

Once you've decided on a DXpedition site plan your travel on the assumption that you'll want to stay on site for at least two weeks. This gives you about a 50% better chance of having good openings within a given month.

Pay particular attention to the RF prospects of your accommodations. Ideally you'd be able to see ocean in all directions. If that's not possible all's not lost. A direct oceanic path isn't always the best propagation; may be better over the backscatter path. You'll want to get your antenna up as high as possible to minimize radiation angle and AFI. And consider EMI and NI possibilities carefully. Some areas of the world use NTSC channel 2; others, PAL on channel 1—right in the middle of the band! If your RF gets into a resort's CATV system you'll drive 60 televisions crazy rather than one or two.

Chapter 6 of *The ARRL Operating Manual* covers DXpedition power, health, licensing and logistical concerns in detail so see that book for more about those topics. I'll add one thing though: It helps to find a local ham with FAX capability as well as HF who can help you with questions on licensing and living accommodations.

This can take 80% of the surprises out of the expedition!



The author's setup at CN2JP, Rabat, Morocco. Efficiency counts more than neatness while you're busy making 900 contacts on 6 and 20 on 2-meter EME! (DXpedition photos courtesy of the author)

## Equipment

What I bring and use on 6-meter DXpeditions is based largely on the experiences of Jim Treybig, W6JKV, in his many years of 6 meter DXpeditioning. The core of the approach is pretty much this: Run as much power as permitted and bring as big an antenna as possible. There are practical limits to this, but let your ingenuity direct your thoughts. I consider 100 W as a minimum, 500 watts good and 1000 watts as optimum. High power lets you take advantage of scatter paths that simply won't work at 100 watts. It's very frustrating to hear a well equipped station that you cannot work!

### Which Antenna?

A DXpedition antenna must be compact, light and reproducible. The Yagi I use has six elements on a 30 foot boom. Optimized by Brian (K6STI) Beezley's Yagi optimization program YO it's fed with a T match and a half wave balun. Its boom folds down to two 40 inch sections, each 2 inches in diameter. Most of the element pieces fit inside the two 40-inch sections. The antenna is light enough to lift with one hand.

A rotatable antenna is *mandatory*. You'll need to turn your antenna to find the best direction of propagation. The antenna mast, 20 feet long overall, consists of 40 inch sections of 2-inch aluminum tubing joined with internal sleeves. The rotator is at the mast bottom and there's a slip ring at the mast top just below the Yagi (Having the rotator at the bottom makes putting the antenna up easier by minimizing weight at the upper end of the mast.)

I use Dacron rope for guying. How much rope should you

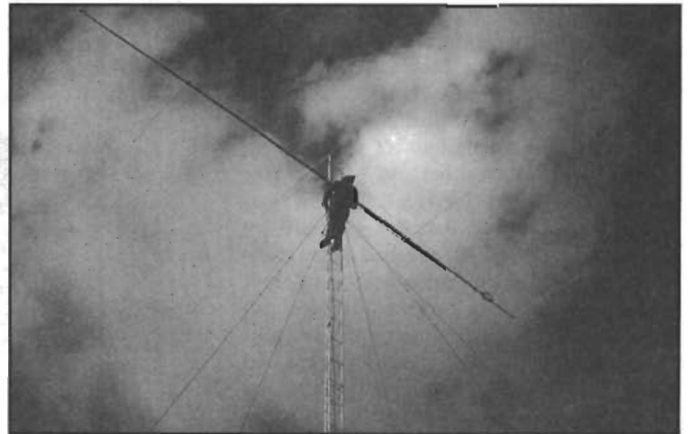

DXpeditioning would be no fun at all without antenna work!

want to use the SSKW to calibrate its own SWR-protection circuitry!

The amplifier's output can be reduced two ways: by turning down the exciter power via amplifier-generated ALC, or by reducing the amplifier bias. (These are enhancement-mode FETs, so positive bias is necessary to turn them on.) The ALC option is better because it does not affect the amplifier's linearity. A no-output-load condition must shut down the amplifier as quickly as possible.

### Overdrive Protection

Overdrive can destroy power MOSFETs instantly, so a drive limit control is essential. A threshold detector should be incorporated. The SSKW's input includes a 5-dB attenuator so 100-watt exciters can drive the amplifier without damaging it. If

the 5-dB pad fails to attenuate, or if the exciter puts out too much power, the amplifier must be shut down rapidly.

The amplifier must also be shut down if the transistors' flange temperature exceeds 40°C. Shutdown can be done two ways, depending on how the amplifier is used. The first way is to just turn down the bias, which changes the amplifier's linearity. The second way is to totally turn off the amplifier. This must be done gracefully so the amplifier does not shut down while producing full power. The following shutdown sequence is essential: (1) Turn down the bias; (2) open the input relay; and (3) open the output relay.

### Bias

The SSKW's bias circuitry is straightforward. R8's value must be tailored to the

particular MRF154s used. If the bias decreases too fast with rising temperature, increase the value of R8. The LM723's input voltage must never exceed 40 volts.

### Output Filtering

Filtering must be added to make the amplifier comply with FCC signal-purity regulations. The reactance of these filters away from their intended passbands must be taken into account. Absorptive low-pass filters should be considered. Such filters dissipate harmonic energy as heat rather than reflecting it back to the amplifier transistors.

### Packaging

I intended to make this amplifier as small and light as possible. Most of the amplifier's weight is its aluminum heat sink

take? Simple: Estimate what you need, multiply by 2.5 and you might make it! I usually bring two diameters,  $\frac{3}{16}$  and  $\frac{1}{8}$  inch.

### Radios

Bring at least two radios: one for HF liaison (usually at 10 meters) and another for 6 meters. I recommend maximizing redundancy by taking two radios that both cover 10 and 6. At least one of the 6-meter rigs should include an excellent noise blanker for power-line problems and motorbikes. It must also be able to drive a kilowatt amplifier to full output on 6. (I use one Kenwood TS-680S and one ICOM IC-575.) Receive coverage between 10 and 6 meters is another plus. Where it's allowed, listening to nonamateur services between 45 and 50 MHz can be very important in determining the direction of propagation.

### Additional Gear

Bring 12-volt supplies capable of operating at the line voltage and frequency at your DXpedition destination. The supplies should also be able to handle wide line-voltage variations around nominal. Carry two of them—one for each radio. I modify mine by adding line filtering and fusing. Parallel a standard receptacle of some kind with your supplies' rig plug or cable. Two-prong, polarized Jones plugs work well. You can use them on everything for quick setup and breakdown.

Bring a memory keyer for use as a beacon and in normal CW operation. Also consider taking a laptop computer. I now use a computer for logging, taking notes, calculating beam headings, and determining the footprint of the sun.

### Operating

Several operating subjects are of prime importance. Ten-meter liaison comes first. You must use 10 meters to get up-to-date propagation information and find out who's being heard. When you're feeling your way through a pile of stations, you can sometimes miss very rare propagation opportunities if you don't check 10 meters often.

Six-meter contact procedures come next. It's very difficult making everyone happy on 6 meters when you're the DX. You must set rules and stick to them. Pick a frequency and do your best to keep it when the band gets busy. Try to not work the same stations over and over again, especially during pileups. Your goal is to give as many people as possible a new country. Work each station as quickly as possible. Don't discuss names and grid squares—the time it takes just gives fewer people a chance to work you. Leave that info to the QSL cards! Which should you operate—phone or CW? The answer is "Probably both." CW penetrates weak conditions better than phone, and it gives more people at the edge of



DXpeditioning is also about meeting people. Here's Tarik Skiredj, CN8ST, and friends.

propagation a chance at working you. Then, when you go to phone, everyone who can will work you again. I favor CW DXpedition operation because of my experiences on the non-DX end.

Should you operate on a single frequency or split? Go to split when there's a massive opening and you're being QRMed by people calling you. This usually happens during intense backscatter openings. Hams on the 10-meter liaison frequency can tell you when QRM gets too heavy.

### Conclusion

Six-meter DXpeditioning is a blast. And the SSKW makes it even more fun: I can devote more weight to antennas!—N6AMG

and copper heat spreader. How much heat sinking is needed depends on the duty cycle required. I decided that a duty cycle of 50% or less was acceptable. The resulting weight for the package, 14 pounds, is very acceptable. The SSKW is 8 inches wide, 12 inches long and 5 inches high.

The key to making the package light was to use the smallest possible heat spreader. I decided to use enough  $\frac{1}{4}$ -inch-thick copper to surround each MRF154 with at least 1 inch of spreader. I machined the spreader flat and attached it to the heat sink, also machined flat. After attaching the copper to the aluminum, I resurfaced the copper again at the transistor contact points to insure flatness. I spread a thin layer of heat-sink compound between the copper and aluminum, and another layer between the copper and the transistors.

With two high-pressure, 24-volt fans blowing on the sink, the resultant duty cycle limit is a little less than 50%. These fans are in series across the amplifier's 50-volt supply. The small fan in the compartment is a 12-volt unit that just barely fits. (The compartment needs to be a little deeper.) A fan is necessary here, however, because compartment airflow dramatically keeps the output transformer's ferrite from getting hot.

A heat sink with more fins and a thicker base, but the same fin depth, would raise the duty-cycle limit. (The copper spreader should be made larger as well.) These changes would also make the amplifier heavier.

### Construction Techniques

A milling machine is required for

surfacing all of the amplifier's heat-conductive interfaces. Physical flatness is essential for maximum heat conductivity and to avoid warping the transistor cases. The Motorola bulletin specifies the torque of the screws on the MRF154s' flanges. Tightening these screws uniformly assures that the flanges won't warp during temperature cycling.

R14 and R15, the feedback resistors, are flange-mounted. Their beryllium copper leads cannot be flexed very many times before they break. (According to their manufacturer, that may be only once!) These two resistors just barely fit. So, make sure the two MRF154s are separated properly.

### Power Supply

To keep the amplifier small and light, I use a switching power supply. A Lambda

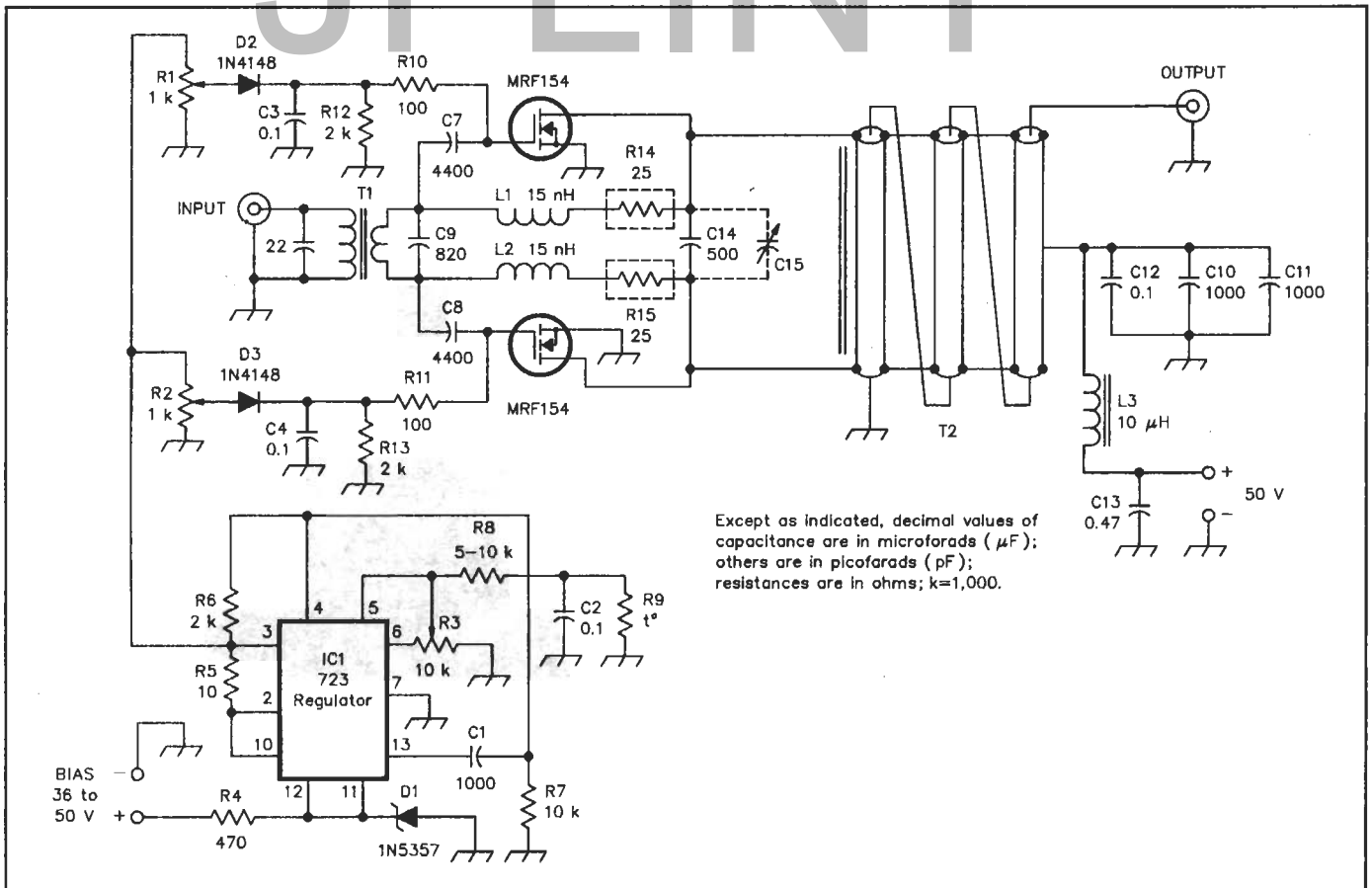

Fig 1—The basic SSKW circuit can produce at least 1 kW from 2 to 54 MHz. Duplicating this circuit requires additional information not given here. Output filtering is also necessary to ensure compliance with FCC emission-purity rules. See the text, Motorola Application Note AN-287, July 1990 *QEX* and the 1991 *Central States VHF Conference Proceedings* for details. The *Central States* write-up includes SSKW performance graphs and spectrograms in addition to a diagram of the amplifier's relay-control circuitry.

LFS-50-48 (net weight, 20 pounds) does the job, with good results. Sized at 15 inches long, 7.5 inches wide and 5 inches high, it can source 50 amperes at 50 volts. This power supply produces significant radio noise up to 30 MHz, most of it radiating from the supply's ac-line leads. I EMI-filtered the supply's leads with good success. (We need better, RF-quieter switching supplies!) Because linear supplies generate little or no RF EMI, they are superior to switching supplies for fixed-station use.

**Overshoot** is a regulated power supply characteristic that's particularly troublesome in switching supplies. **Overshoot** occurs when a regulator responds too slowly to keep its output voltage down in response to short-duration, high-current loading. In a 50-volt switching supply, and depending on the load, **overshoot transients** of more than 100 volts may result. I've seen overshoot destroy expensive transistors! The SSKW supply must be able to safely handle the variable power-supply demand that occurs

during SSB and CW transmission.

Power-supply RF sensitivity is another consideration. Some power supplies are sensitive to RF. Their output voltages may vary with the presence and amplitude of RF on their input and output leads. The SSKW's supply must be free of such effects.

### Hints and Kinks

Be careful when applying dc to the amplifier for the first time. Do not use a high-current supply for initial tests. Use a

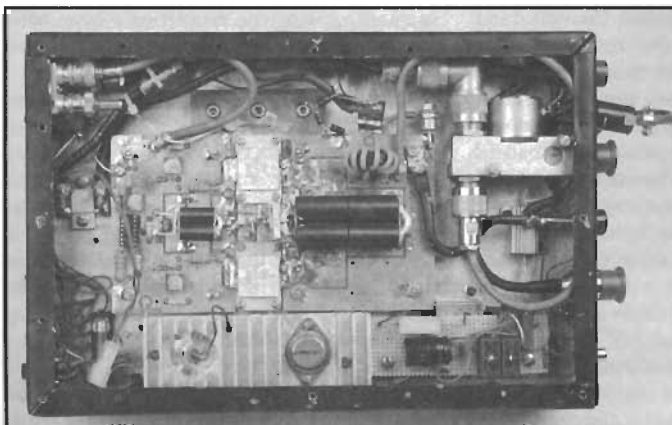

Two Motorola MRF154 RF power MOSFETS in push-pull make the SSKW perk. A 20-watt wxciter drives the amplifier to full output. (amplifier photos by Kirk Kleinschmidt, NTØZ)

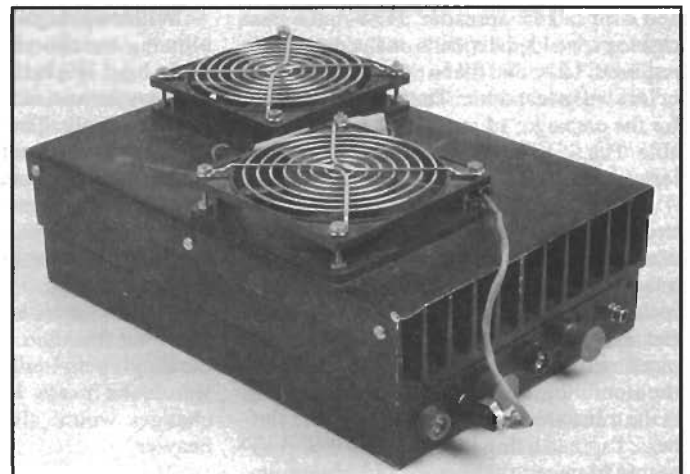

Without its two 24-volt fans, the SSKW's heat sink and spreader would have to be much larger.



What luggage weight the SSKW amplifier conserves can be put to other uses—2-meter moonbounce gear, for instance. Operating as CN2JP, the author completed 20 EME contacts—Morocco's first—in November 1991. On the same trip, the SSKW performed like a heavyweight through 900 contacts with 56 countries on 6 meters.

**Table 1**  
**SSKW Performance Versus Frequency**

Freq (MHz)	Drive Power (W)	Power Output (W)	$I_D$ (A)	Gain (dB)	Efficiency (%)	Input SWR	$V_{cc}$ (V)
2	24.5	1000	39.1	16.1	51.2	1.41	50
4	21.0	1000	33.4	16.8	59.9	1.39	50
8	17	1000	32.4	16.8	59.9	1.39	50
15	15.5	1000	32.3	17.7	61.9	1.36	50
30	19.5	1000	41.5	17.1	48.2	1.87	50
50	29	1000	39.7	15.4	50.4	1.51	50

current-limited, 3- or 4-ampere supply to check the regulator and set the bias. The amplifier should have a reverse polarity protection diode rated at a voltage appropriate to the supply.

Make sure that you have a 50-ohm load on the amplifier output. The bias circuitry may not act correctly if there is no load. Slowly increase drive. Watch the output power and the current drain to make sure they are in line with efficiency. If the input match is bad, check C7 and C8. If the amplifier does not achieve its efficiency capability, RF that doesn't make it to the load may try to leave via the dc input line. This can cause C12 to explode off of the underside of the board. Also, under normal operation, the single unit Motorola specifies for C12 can barely handle the RF current that passes through it. I recommend paralleling 100-volt, 0.05- or 0.1- $\mu$ F chip capacitors instead of using a single 0.1- $\mu$ F chip.<sup>5</sup> This problem is difficult to analyze because C12 is on the underside of the board.

As mentioned earlier, the SSKW's bias circuitry may have to be tailored to the particular MRF154s used. One thing not mentioned on the schematics is the addition of an Arco 365 variable capacitor (C15 in Fig 1) across C14 to cancel some of the

inductive reactance in the output transformer at 6 meters.

### Performance

With a 50-volt power supply, the SSKW can produce over 1.1 kW from 2 to 54 MHz. At this power level, the MOSFETs' drain current runs at around 40 amperes, depending on the operating frequency. Table 1 shows amplifier performance data taken at six different frequencies. The SSKW can produce up to 1.5 kW below 30 MHz.

Especially below 30 MHz, the SSKW's harmonic output rises with output power. It may be possible to use only four low-pass filters to cover the 2 to 54 MHz range if a second harmonic of -40 dB can be tolerated. Since the transistors operate in push-pull, the second harmonic is usually not a problem.

Without its 5-dB input pad and operating with a 50-volt supply, the amplifier exhibits an input SWR of less than 2:1 (referred to 50 ohms) throughout its frequency range. Only below 5 MHz does its input SWR exceed 1.6:1. Inserting the 5-dB pad adds 10 dB of return loss and keeps the input SWR below 1.3:1 through the amplifier's operating range. I have not yet measured the amplifier's two-tone, thirdorder IMD performance.

### Final Notes

For now, I can say that my goal of a compact, lightweight amplifier capable of at least 1 kW output is a reality. The SSKW has served me well in its intended DXpeditionary application. Nonetheless, the amplifier in its present form is still experimental. Before the SSKW could be acceptable for general use, output filtering and failureproof protection circuitry would have to be added. The next generation is on its way. The next project? Use the same 50-volt supply with power FETs capable of covering 144 to 432 MHz, and build it into a similar package!

### Acknowledgment

I thank Helge Granberg for spending considerable time answering questions about this project.

### Notes

- <sup>1</sup>H. Granberg, "New MOSFETs Simplify High Power RF Amplifier Design," RF Design, Oct 1986, pp 43-48, 50, 52.
- <sup>2</sup>H. Granberg, "A Compact 1-kW 2-50 MHz Solid-State Amplifier," QEX, Jul 1990, pp 3-8.
- <sup>3</sup>J. Paladino, "A Rapid Deployment Prototype Solid-State Kilowatt Linear Amplifier for 2 to 50 MHz Using MRF-154s," 1991 Central States VHF Conference Proceedings (Newington: ARRL, 1991), pp 61-70. Available from the ARRL Bookshelf as #3614.
- <sup>4</sup>H. Granberg, "MOSFET RF Power—An Update," Part 2, QST, Jan 1983, pp 30-33; also see Feedback, QST, Mar 1983, p 44. (Part 1 appeared in QST, Dec 1982, pp 13-16; also see Feedback, QST, Jan 1983, p 48.)
- <sup>5</sup>American Technical Ceramics (ATC) has some new chip caps (the 900 series) that have higher voltage and current ratings than the capacitor Motorola specifies. I have samples but have not tried them yet.

# An All-Band, 1500-Watt-Output 8877 Linear Amplifier

*Part 1*—This rock crusher, rated for continuous full-legal-limit output, can be built at home. It is, however, a major project requiring dedication and commitment.

This article is the result of a 10-month project to build a legal-limit linear amplifier. The amplifier uses the popular EIMAC 8877 (3CX1500A7) high-mu power triode that can provide a continuous RF output of 1500 W to the antenna.

In recent years, I have built several different linear amplifiers, and I must admit that this previous experience was necessary to obtain the results achieved with this project.<sup>1-4</sup> I hope that by sharing this experience, others will benefit from it. Any amplifier design depends on the various components used and individual preferences. Therefore, you may not want—or be able—to duplicate this amplifier exactly.

The comment I receive most often from the amateur fraternity is about the high cost to build an amplifier like this. The criticism is valid. This amplifier is not inexpensive to build. Plan to spend from \$1000 to \$1200 for the RF deck, and another \$500 to \$600 on the power supply. If you really think about it, though, these costs are a bargain when you consider the performance and quality of the final product and the cost of an equivalent commercial unit.

This article is presented in two parts. In this part, I will describe the RF deck and power supply in general terms. Schematic diagrams and parts considerations are included. Part 2 gives detailed instructions for constructing the two units and considerations for the final testing and operation.

## Preliminary Thoughts

### Finding Parts

Finding parts can be a big task. Even the most difficult parts to find, such as the vacuum variable capacitors, vacuum relays



**Table 1**  
**Recommended Tools**

- Drill press or drill fixture (with set of highspeed bits)
- Band saw capable of cutting 1/16-inch-thick metal
- Chassis punches (5/8 inch to 1 inch)
- Fly cutter, 2-inch radius
- Vise
- Set of taps
- Common handtools (screwdrivers, pliers, soldering iron and gun)
- Volt-ohmmeter
- Variable power supply (5-26 V, 1 A)
- Dip oscillator

and door-knob capacitors are available, however, and appear for sale in the ads (*QST* Ham-ads and the Yellow Sheets), or at hamfests and flea markets.<sup>5</sup> Probably the best source of parts is other hams who are actively building equipment. Go talk to these people and let them know what you are looking for. It's amazing how others will help, and even let you into their personal stores. There are people, like myself, who like to build amplifiers. Once you learn who these individuals are, keep in touch with them. They can help find the key parts.

Parts that are not available in the surplus market can be purchased new. This will be necessary for some parts, such as

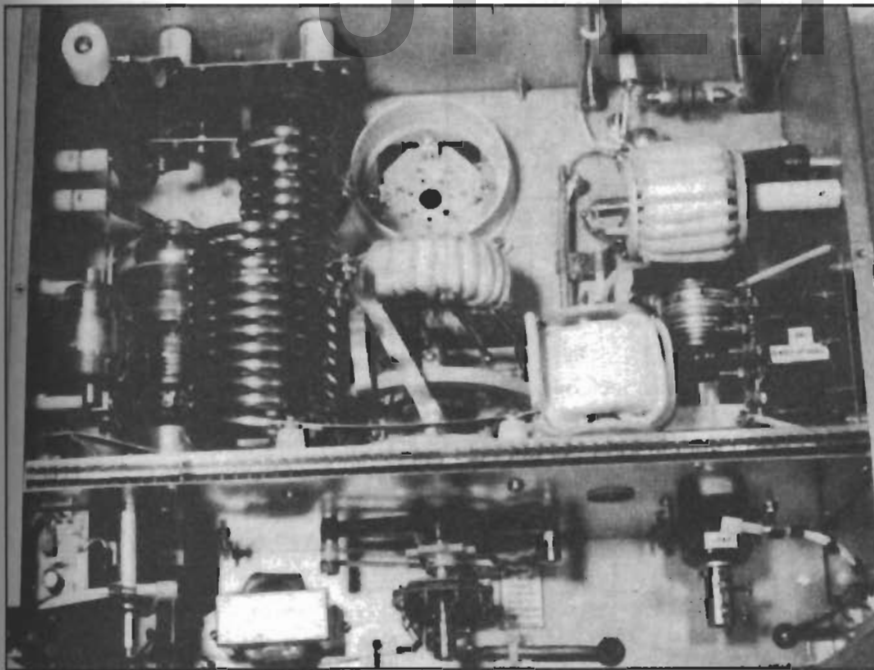

Fig 1—Top interior view of the 8877 linear amplifier RF deck.

cabinets, etc. Just remember that when you buy a new commercial amplifier, you pay the new price for every component.

#### Tools

A good assortment of hand tools, as well as some power tools, are necessary to complete this project. Table 1 shows the tools I recommend. In particular, I recommend that a drill press and band saw be available. You can do the job without all of the tools listed, but the job will be much more difficult.

#### Time

Time is probably the most valuable resource for most of us, and the one that may prove hardest to find. This project took well over 250 hours to complete. The key is to do each step right, and not hurry. Build the amplifier in a place where you can leave the project on the table and walk away. Plan each step and build in discrete modules. Work an hour or so whenever possible, and slowly, but surely, the modules will take shape. It is amazing how much you can accomplish using these small time segments. Also, great strides can be made on a Saturday or a Sunday. Commitment and consistency are the virtues required to finish the job.

#### RF Deck Circuit Description

The RF deck is designed to be a table-top unit (see title photo). The power supply is remotely controlled and can be located almost anywhere. The amplifier design is based on proven circuitry. Included are all circuits required to provide a clean signal as well as adequate protection devices for the metal-ceramic 8877 tube.

#### Control Circuitry

Fig 2 shows the schematic diagram for

the amplifier control circuitry and low-voltage power supply. The 117-V ac input from the high-voltage power supply enters the RF deck through a 5-conductor interconnecting control cable. Each control line is terminated in a pi-section filter as it enters the RF deck, to prevent RF from getting into the control cable and power supply. The pi-section filters are constructed as an independent module.

The amplifier is powered up by the FIL ON/OFF switch, S1. Engaging S1 turns on the blower, filament power and 26-V dc power supply. The current inrush to the tube is limited by R<sub>i</sub>, in series with the filament transformer primary. After approximately 1 second, K1 energizes and K1A shorts R<sub>i</sub> thus providing full filament voltage to the tube. The K1 delay is controlled by R2 and C1 across the relay coil. R3, in series with the other leg of the filament transformer primary, is adjusted to provide the proper filament voltage (4.85 V ac) to the tube under load.

The 8877 requires a 3-minute warmup period to reach proper operating temperature. A solid-state timing circuit, formed by Q1 and Q2, locks the amplifier out of operation until the warmup period has elapsed. When the 26 V dc comes on, C2 charges through the 500-kilohm time-delay adjust and 1.2-megohm resistors. Q1 and Q2 form a high-impedance Darlington circuit, and the emitter of Q2 follows the voltage rise on C2. The high-impedance Darlington circuit is required to prevent the capacitor charge from draining through the transistors. After approximately three minutes, the potential at the emitter of Q2 reaches 18 V at which point the 4PDT relay, K2, engages. K2A applies 26 V dc to the K2 relay coil, removing the relay current load from Q2. The voltage also turns

on the TIME pilot light located on the amplifier front panel to indicate that the warmup period is over. The same line also applies 26 V dc to S2B of the HV-ON push-button switch, which, when engaged, sends 26 V dc to the RF input/output relay circuits. K2B connects a 100-kilohm resistor across C2 to drain the charge from C2. This resets the 3-minute timer should the amplifier be turned off and immediately back on.

K2C and K2D are wired in parallel and apply 117 V ac to HV-ON switch S2A to energize the high-voltage power supply. The high-voltage power supply can't be turned on even if the HV-ON switch is engaged until after the 3-minute warmup period has ended. IN/OUT switch S3 allows the amplifier to be put in the standby mode with the amplifier turned on. Both HV-ON and IN/OUT front-panel push-button switches must be engaged to key the amplifier, thereby making it impossible to operate the amplifier without high voltage on the tube.

The amplifier is keyed by grounding the base of Q3 through the exciter TR-relay contact. A transistor is used to limit the current switched by the exciter VOX relay. This avoids a potential problem if the exciter VOX relay sparks on closure, which could damage the relay contacts. The "grid trip" break in the relay line causes the relays to drop out if the grid trip circuit actuates from too much grid current (approximately 120 mA). During normal operation, the grid trip break is shorted by a normally closed set of contacts on K3 (see Fig 3).

When the amplifier is keyed, the output RF relay must be closed before drive is applied to the tube—otherwise the tube will transmit for a brief period without a 50-ohm antenna load. This would not only be harmful to the tube, but also cause the grid-trip circuit to actuate. Therefore, a timing circuit, comprised of a 50-ohm resistor and 100-nF capacitor, is included across the RF input relay K4 to allow vacuum relay KS time to close. The capacitor value depends on the relay used. Do not make the delay too long, since during the delay time, the exciter does not have a proper 50-ohm load. Check the time delay by placing a low voltage across the relay contacts and monitoring the contact closure on a dual-trace scope. I used a delay of about 20 ms.

#### RF Amplifier Circuit Design

The RF amplifier circuit is shown in Fig 3. The amplifier uses a tuned input network to minimize distortion products and provide a proper impedance match between the exciter and the tube. The input network is remotely switched, using small DPDT relays, to connect the correct pi-section for the selected band. A homemade switch deck is mounted on the band-switch shaft, in front of the subpanel, to ground the 12-V dc line for the proper input relay as selected by the main band switch. On 160 meters, the switch also controls a solenoid relay to add a 160-pF capacitance in parallel with the TUNE vacuum variable capacitor.

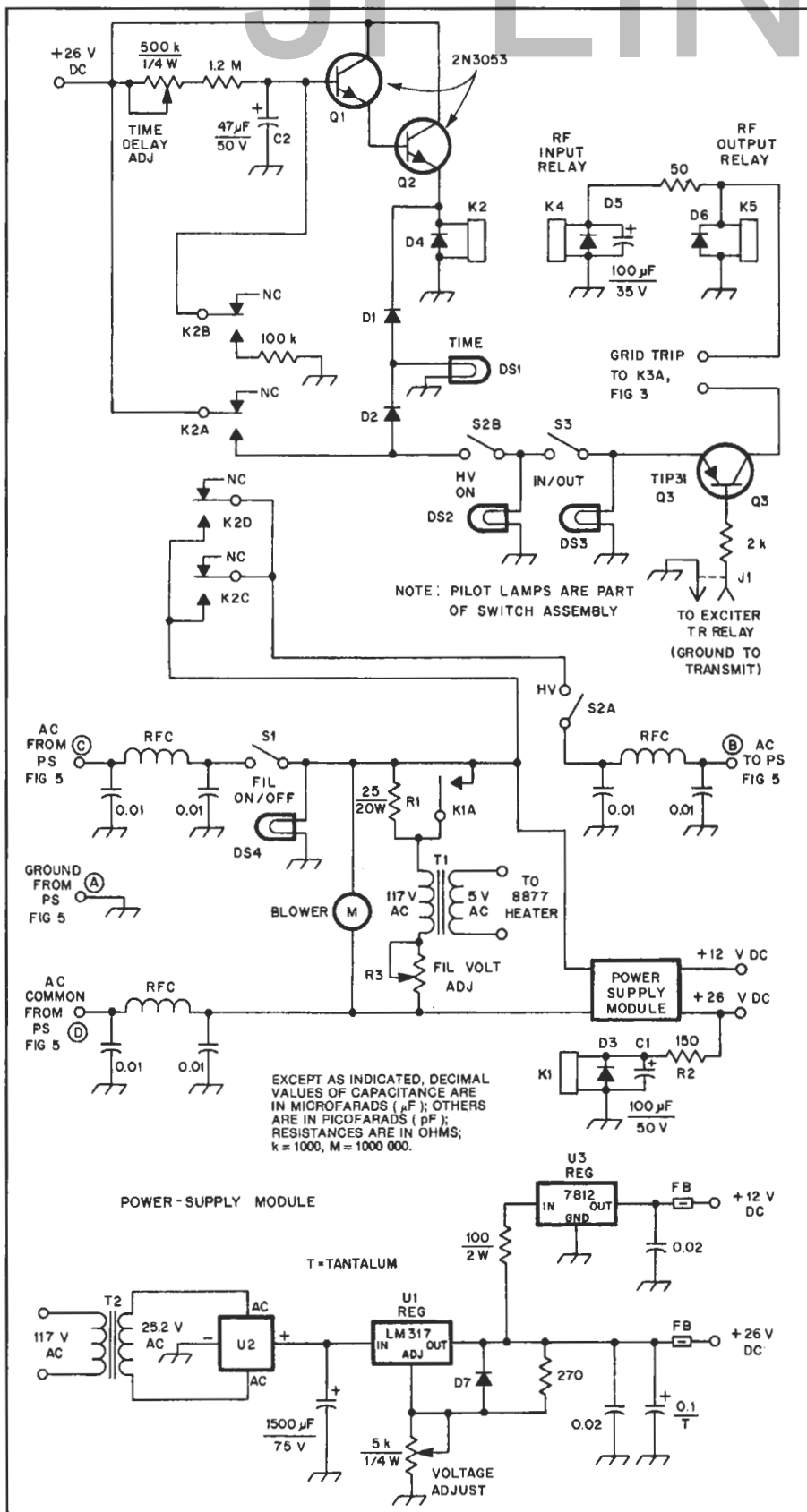

Fig 2—Amplifier control circuit and low-voltage power-supply schematic diagram. Part numbers shown in parentheses are Radio Shack.

- B—Blower, Dayton 4C004-i.
- D1-D6—Diode, 1 kV, 2.5 A.
- FB—Ferrite bead.
- K1-K4—4PDT 24-V dc relay, Potter & Brumfield KHU17D11.
- K5—SPDT vacuum relay, 26-V dc coil.
- Q1, Q2—2N3053 NPN transistor.
- Q3—TIP31 NPN transistor (276-2017).
- R1—25  $\Omega$ , 20 W.
- R2—150  $\Omega$ , 2 W.
- R3—25  $\Omega$ , 25 W variable.
- RFC—10 turns no. 14 enam wire on 1/4-in-diam ferrite rod.
- S1, S3—Alco 16TL5-11 SPST.
- S2—Alco 16TL5-22 DPDT.
- S4—Alco 16TZ pilot light.
- Ti—Filament transformer, 5.0 V ac, 10 A, Peter Dahl Co.
- T2—25.2 V ac, 1.0 A, Stancor P6469.
- U1—50-V, 4-A bridge rectifier.

tion. Although grid current flows through all paths from ground to the B – line, most of the grid current goes through R1. The current passing through R1 develops a voltage drop. For example, if 100 mA of grid current is drawn through R1, 1 volt is developed ( $E = IR = 0.100 \times 10$ ). This voltage is used to turn on the transistor switch, Q1. When Q1 turns on, the grid-trip relay, K3, energizes and opens the grid trip break in the RF relay control line to shut the amplifier down. R2 sets the current level at which Q1 turns on. The front-panel GRID TRIP lamp goes out if the trip circuit is activated. The switch is reset by pressing S3.

The plate tank circuit uses a pi-L configuration because this design provides approximately 20-dB better harmonic suppression than the conventional pi design. The TUNE and LOAD capacitors are vacuum variable types to minimize space requirements and also optimize performance on 12 and 10 meters where small capacitance values are needed to achieve an acceptable tank-circuit Q. The 10- to 40-meter tank coil is homemade from 1/4-inch copper tubing that is silver plated to minimize skin resistance. The 80-meter, 160-meter and L-coils are toroid designs to minimize space. Using a toroid for the L coil also helps isolate the L network from the rest of the tank circuit because of the toroid's self-shielding characteristics.

Metering circuits monitor plate and grid current, as well as filament voltage. Plate current is monitored by placing a meter in series with the B – line. Therefore, only a small dc voltage is across the meter. An additional position can be included on the FIL/GRID meter for plate voltage, but one is not shown in this design because a separate high-voltage meter is included in the power supply. It would be a good idea to include a high-voltage scale on the meter in case the RF deck is ever used with a different high-voltage supply. Grid current is monitored by measuring the voltage drop across R1. R3 is adjusted to give the cor-

An effective ALC circuit, adjustable from a front-panel control, is included to avoid overdriving the tube. This feature is essential in this amplifier because the drive requirement is only about 80 W for 1500-W output. The ALC circuit samples the RF drive level through a 27-pF mica capacitor

to generate a dc voltage that is fed back to the exciter for drive-power control.

The grid-trip-protection circuit shuts down the amplifier if grid current exceeds 120 mA. This protects the tube from tuning errors or other problems such as losing the antenna, or a tube flashover during opera-

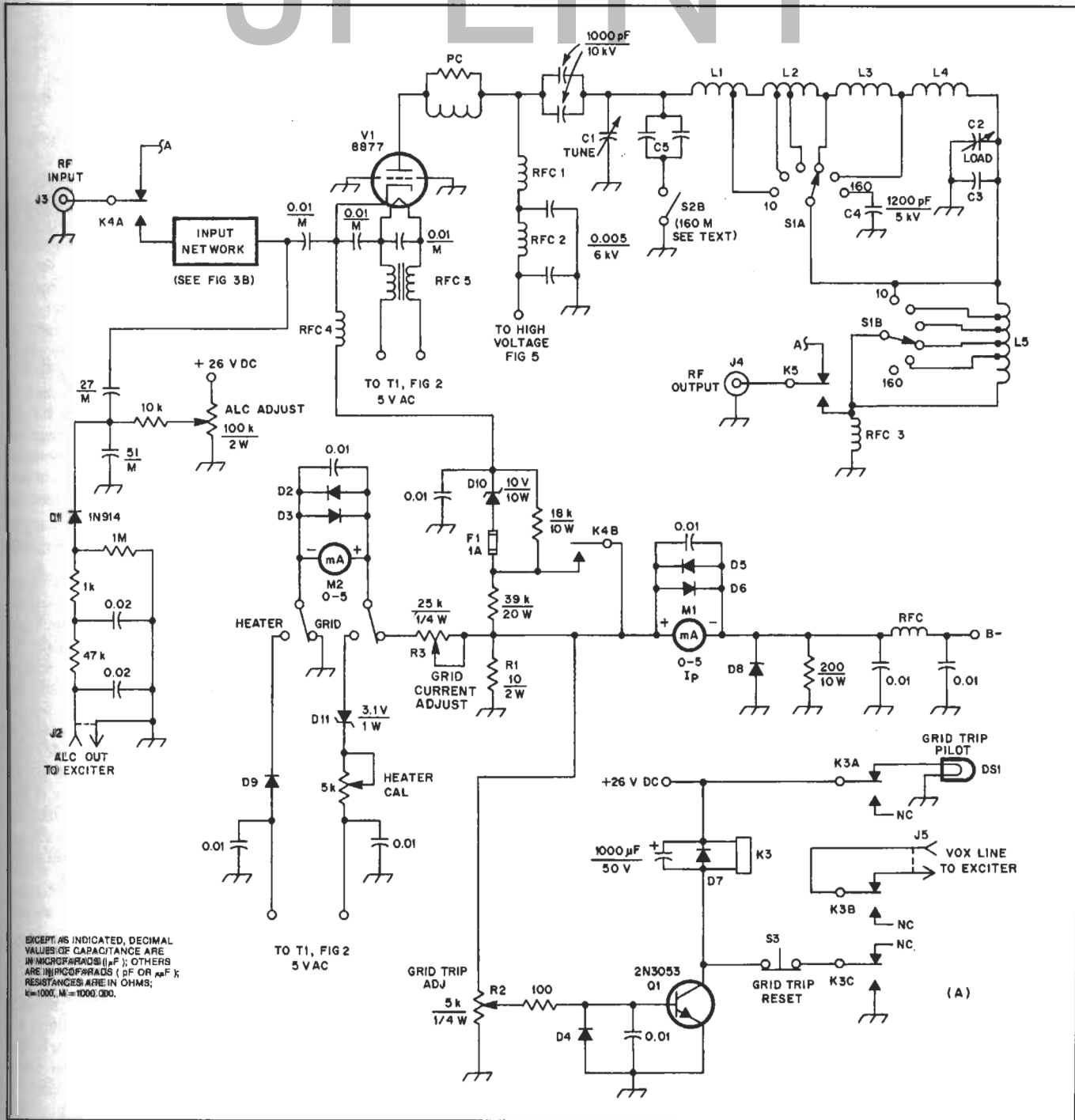

EXCEPT AS INDICATED, DECIMAL VALUES OF CAPACITANCE ARE IN MICROFARADS (μF); OTHERS ARE IN PICOFARADS (pF OR 10<sup>-12</sup> F); RESISTANCES ARE IN OHMS; k=1000, M=1000,000.

Fig 3—RF amplifier schematic diagram (see Part B on next page).

- C1—Vacuum variable capacitor, 375 pF, 10 kV.
- C2—Vacuum variable capacitor, 1000 pF, 10 kV.
- C3—Mica transmitting capacitor, 100 pF, 5 kV.
- C4—Mica transmitting capacitor, 3 × 400 pF, 5 kV.
- C5—Fixed vacuum capacitor, 2 × 80 pF, 20 kV.
- D1—Diode, 600 V, 1 A.
- D2-D9—Diode, 1 kV, 2.5 A, HEP 170.
- D10—Zener diode, 10 V, 1 W.
- D11—Zener diode, 3.1 V, 1 W.
- K1-K7—DPDT 12-V dc DIP relay (275-213).
- K8—SPST 12-V dc relay (275-241).
- RFC—10 turns no. 14 enam wire on 1/4-in-diam ferrite rod.
- RFC1—Plate choke, 2 A, Peter Dahl Co.
- RFC2—Air-wound coil, 15 turns, 1/2-in diam.

- RFC3—Choke, 1 mH, 800 mA.
- RFC4—110 turns no. 20 enam wire on 1/2-in diam fiber rod.
- RFC5—Filament choke, 18 bifilar turns no. 14 enam wire on 1/2-in-diam ferrite rod, 6 inches long.
- PC—Three 150-ohm, 2-W carbon resistors in parallel with 2-inch horseshoe loop of 1/2-inch silver-plated strap.
- L1-L5—See Table 2.
- M1, M2—Simpson Wide-Vue panel meter, 01253 bezel and 01165 lighting kit (See text).
- S1—9-position, 2-pole switch, Radio Switch model 88, 13-kV, 30-A.
- S2—Solenoid-controlled switch; see text.
- S3—SPST normally closed momentary switch, Alco 16TL-11 with 6T-2 red lens.



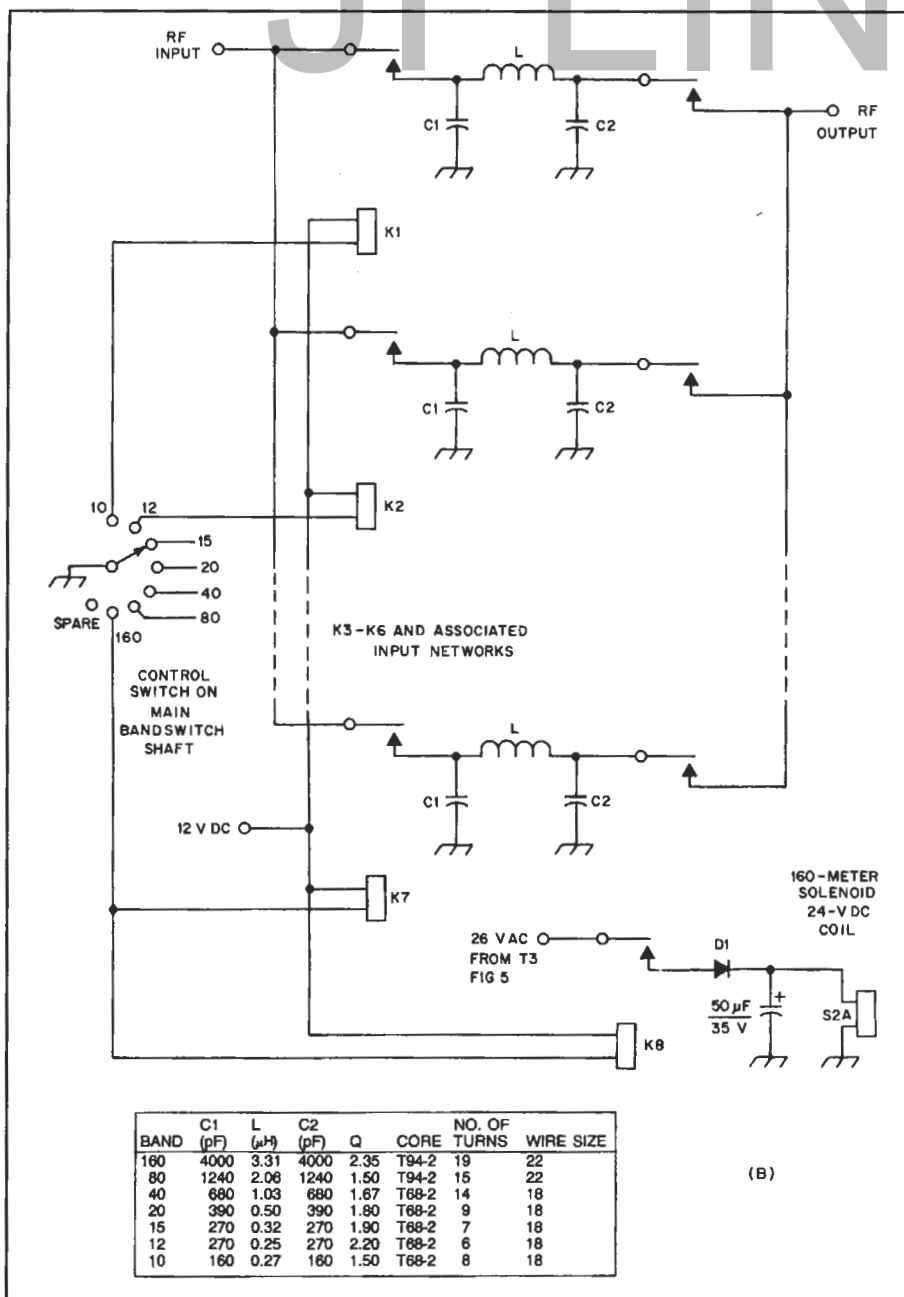

Fig 3B—see previous page.

rect gridcurrent meter reading. Filament voltage is measured by converting the ac voltage to dc and displaying the dc voltage on M2. The 3.1-V Zener diode expands the meter scale by not allowing conduction until the voltage reaches 3.1 V.

A vacuum relay is used for the amplifier output. The relay is small in size, quiet and capable of handling large RF currents.

### RF Deck Parts Selection

Finding all the parts for the RF deck is a major task. If you are planning to build an amplifier, begin collecting parts as soon as possible. It is the first step because the physical layout of the amplifier will depend on the components available. Don't try to exactly duplicate the components I used. For example, vacuum variable ca-

pacitors come in many different shapes and sizes, with different mounting provisions. Actually, the parts you find may be better than the parts used in my RF deck. As an example, a 1500-pF vacuum variable LOAD capacitor would be much better than the 1000-pF unit I used. Therefore, use whatever resources you have available to acquire the parts—but a word of caution! Do not compromise too much when gathering components. If you cannot find what you need on the surplus market, buy the parts new. It may cost a little more, but if the project is not done right, you will never be happy with the final result.

### Vacuum Variable Capacitors

Vacuum variable capacitors are often difficult to locate at reasonable prices. Plan

to spend about \$50 for the TUNE capacitor and \$75 to \$100 for the LOAD capacitor if vacuum capacitors are used. The TUNE capacitor should be at least 300 pF at 7 kV, and the LOAD capacitor should be at least 1000 pF at 3 kV.

An air variable capacitor can be used for the LOAD control, if desired. The minimum capacitance for the LOAD capacitor is 112 pF for 10 meters, which is not difficult to obtain with an air variable type. A rating of 1 kV, minimum, is recommended. However, it is a different story for the TUNE capacitor. The minimum required capacitance is 26 pF. The direct inter-electrode capacitance of the 8877 tube in grounded-grid service is 10 pF; therefore, the TUNE capacitor must have a minimum value of not more than 16 pF for 10 meters.

This is nearly impossible with a 300-pF air variable. In addition, the voltage requirements for the TUNE capacitor make any air variable rather large. For these reasons, a vacuum variable is recommended for the TUNE capacitor.

### Meters

Good-quality meters with bezels are essential for good appearance. The Simpson Wide-Vue® meters I used were purchased at a hamfest. The bezels were ordered directly from Simpson because they seldom appear on the surplus market. Actually, almost any meter movement can be used, so don't pass up a good meter just because it reads 50 V or 100 mA on the scale. Any meter with a movement from 100 µA to 5 mA can be used. This allows use of approximately 90% of the meters available on the surplus market. I will give instructions later for calibrating any meter to read whatever current or voltage is required.

### RF Band Switch

Good RF band switches are very difficult to locate. More problems are experienced with arcing band switches than with any other amplifier component. If the band switch selected has insufficient voltage insulation, it will arc to the wiper rotor on the high-impedance 10-meter position when operating on the lower-frequency bands. I obtained the band switch for my amplifier from Radio Switch Corp.<sup>6</sup> The model 88 switch is a 2-pole, 9-position unit with a 13-kV peak flashover/30-A contact rating. This switch will not arc! Its list price is currently \$107, and it is well worth the money!

### Miscellaneous Parts and Materials

Many of the small parts (capacitors, relays and resistors) can be purchased at Radio Shack. Their parts selection is good, and continues to increase. You can usually find a store around the corner in almost any city. Pioneer Electronics is also a good source for commercial-grade components.<sup>7</sup> Good-quality PC-board material can be found at almost any hamfest. Don't compromise here—use G10 glass-epoxy board. As for coils? Make them. Complete "how-to" instructions are given later.

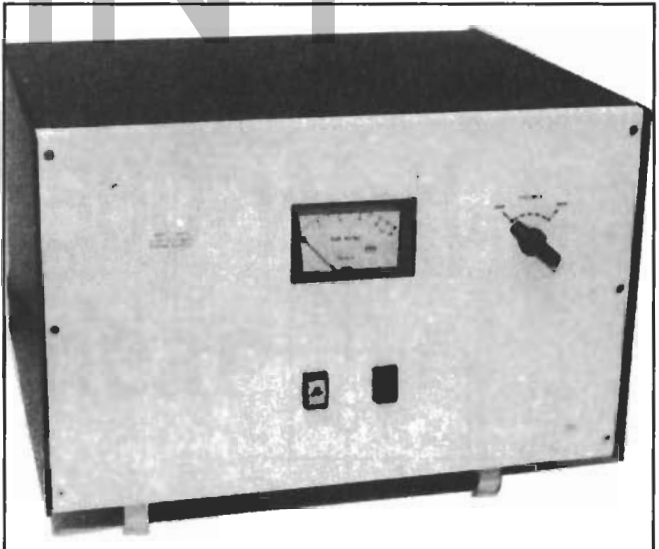
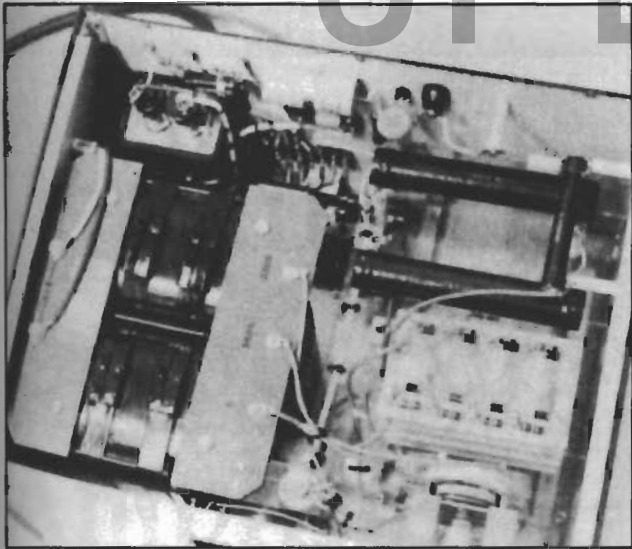

Fig 4—High-voltage power supply top interior view.

### High-Voltage Power-Supply Circuit Description

The key to continuous duty in a high-power linear amplifier is the power supply. It must be able to deliver the required voltage and current on a continuous basis. Power supplies are usually the limiting factor in commercial linear amplifiers.

**A WORD OF CAUTION IS IN ORDER.** *The power supply is a very dangerous piece of equipment! Give it proper respect. One mistake can be fatal. Use proper precautions in the construction and testing of this unit, and be careful to build a safe unit.*

I recommend that the power supply be built first. The construction is not complex and it can serve as a training ground for amplifier building techniques, particularly for the first-time builder.

### Power-Supply Design

The power supply is shown in Fig 4, and the schematic diagram is shown in Fig 5. The hypersil power transformer has a 234-V ac primary, and a 3300-V ac secondary that is tapped at 2600 V. This selection of two output voltages allows for a high- and lowpower capability. An alternative to this approach is to include a Variac® or Powerstat® autotransformer on the transformer primary.

The primary circuit of the power transformer includes a step-start circuit to protect the diode bank during the initial charge of C1, the 53- $\mu$ F filter capacitor, when the power supply is turned on. Two 50-ohm, 25-W resistors, one in each leg of the primary, are shorted by time-delayed relays approximately 3 to 4 seconds after application of power. The more current drawn through the resistors at start up, the more voltage drop realized and this, in turn, protects the diode bank. The delay is provided by the time constant of the 500-ohm resistor and 100- $\mu$ F capacitor. The relays must be dc types. Those I used have 90-V dc coils which allows power to be supplied from one 117-V leg of the pri-

mary. If 90-V relays can't be obtained, 24-V dc relays can be substituted. A 24-V dc power source must be provided if this is done.

The rectifier unit is a full-wave bridge with eight diodes in each leg. A 470-kilohm resistor and a 0.01- $\mu$ F, 1-kV capacitor are wired in parallel with each diode to equalize the voltage and protect the diodes from voltage spikes.

The power supply is controlled remotely from the RF deck. A test switch has been incorporated to allow the supply to be energized without the RF deck. A shorted Cinch-Jones plug must be inserted into a socket in the rear of the supply for test switch S1 to operate.

Two pilot lights are mounted on the front panel. One pilot light is on whenever 234 V ac is present in the supply. The other lights when the power supply is activated.

A high-voltage meter is included on the front panel. The metering is done across a 25-ohm, 5-W resistor in series with the bleeder resistor. This voltage divider keeps the total high voltage off the meter. A 50-ohm, 50-W resistor in series with the high-voltage B+ circuit protects the tube and power supply from any current surge resulting from a tube flashover or other cause. In addition, a 0.6-ohm, 1-W resistor in series with the B+ line acts as a fuse resistor. A large current surge will cause the resistor to explode—an inexpensive protection device should a problem occur.

### High-Voltage Power Supply Parts Selection

#### Transformer

It is important to find a good power transformer that can provide the proper operating voltages for the tube. Remember that some voltage drop will occur when current is drawn from the transformer. The voltage drop depends largely on the quality of the transformer (core and wire size), and can range from 200 V to over 1 kV. The transformer should have a 234-V ac pri-

mary. Transformers with 117-V primaries are usable only if two identical units can be wired in series to provide a 234-V primary. The secondaries can be wired in series or parallel, depending on the voltage requirements. Remember that the transformers must be identical.

The required transformer secondary voltage depends on the final voltage requirement of the tube and the power-supply circuitry. If a bridge rectifier is used, the power-supply high voltage will be about 1.4 times the secondary voltage. If a voltage doubler is used, the high voltage will be about 2.8 times the secondary voltage. A voltage doubler requires two filter capacitors, or more, so if a single oil-filled filter capacitor is to be used, the design can't be a voltage doubler. The *ARRL Handbook* contains circuits for both types of power supplies.<sup>8</sup>

The power-handling capability of a transformer can usually be estimated by its weight. As a rule, the heavier the transformer, the greater the power capability. The transformer for a 1500-W, continuous-duty amplifier will weigh 60-80 lb. The transformer used in this power supply was obtained from Peter Dahl Co.<sup>9</sup> The hypersil design provides a good ratio of power capability to size and weight. I have used several Peter Dahl transformer designs in the past and found them to be of excellent quality and reasonably priced.

#### Filter Capacitor

Enough filter capacitance is required to obtain good voltage regulation. What is enough? I have used as little as 18  $\mu$ F and as much as 100  $\mu$ F in power supplies. The required capacitance can be obtained with a single oil-filled capacitor or with a series string of computer-grade electrolytics. Either way, I recommend at least 25  $\mu$ F be used, with at least a 10% voltage safety factor. The filter capacitor used in this power supply is a single oil-filled unit rated at 53  $\mu$ F at 5kV dc. The capacitor was obtained

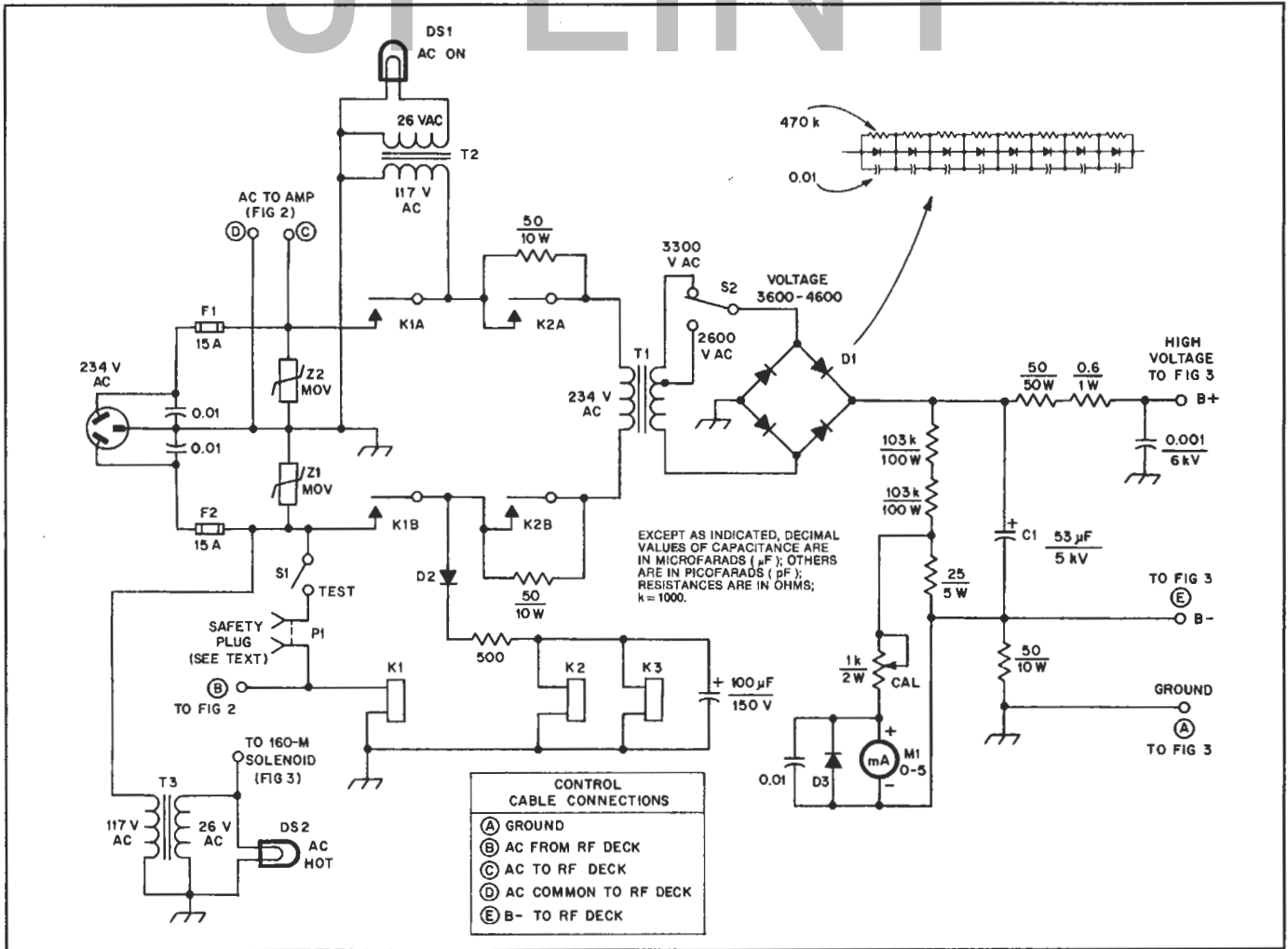

**Fig 5—High-voltage power supply schematic diagram.** Part numbers in parentheses are RadioShack.

C1—Oil-filled capacitor, 53  $\mu\text{F}$ , 5 kV, Peter Dahl Co.  
 D1—Diode bridge rectifier assembly, Peter Dahl Co, see text.  
 D2,D3—Diode, 1 kV, 2.5 A.  
 F1,F2—Fuse, 15 A.  
 K1—2PDT mercury plunger relay, Dayton 6X598-3.  
 K2,K3—SPDT relay, Potter Brumfield PRD1 DYO/9OVDC.  
 M1—High-voltage meter, 3 1/2-inch Simpson Wide-Vue, 01253 bezel and 01165 lighting kit.  
 Z1,Z2—MOV transient suppressor, 117 V ac (276-568)  
 P1—Two-pin Cinch-Jones socket and plug (274-201 and 274-202)  
 P2—Eight-pin Cinch-Jones connector.  
 S1—SPST switch (275-690)  
 S2—Modified 6PST switch, Fair Radio Sales.  
 T1—Power transformer, 2600/3300-V ac sec, Peter Dahl Co.  
 T2,T3—Transformer, 26 V ac, 300 mA (273-1386)  
 Miscellaneous  
 Pilot lamp—Alco 16TZ, 6T-4 (yellow) and 6T-2 (red) lenses.  
 Cabinet—CTS model MCLS 10-17-14 black and white, SPP 10-14 black side panels.

from Peter Dahl Co, and is physically very small for the voltage and capacitance rating.

### Diode Bridge Rectifier

The full-wave, diode-bridge rectifier is made up with 1000-PIV diodes rated at 3 A. The unit is a commercial module sold by Peter Dahl Co. Each diode string is built on a separate glass-epoxy board. The module is supplied with 1-inch angle brackets on each end, but because of space restraints, the angle was removed and the module was mounted in a vertical position using two Nylon bolts.

Should you decide to build the rectifier assembly, use good-quality diodes, such as HEP-170s or 1N5408s. Be sure to parallel each diode with a 470-kilohm resistor and a 0.01- $\mu\text{F}$ , 1-kV capacitor.

### High-Voltage Switch

The transformer has two taps on the sec-

ondary to provide a high- and low-voltage capability. The front-panel VOLTAGE 3600-4600 switch is fabricated from a 6-position, heavy-duty ceramic switch (Radio Switch Corp p/n 65). The switch detent and all but the second and fifth contacts are removed. New stops are fabricated from glass-epoxy board. Full high voltage appears across this switch, and therefore, it must be well insulated. The switch is mounted on two pieces of 3/4-inch Plexiglas® to provide 2-inch spacing from any chassis or panel ground. A fiber shaft protrudes from the switch through the front panel. To protect the contacts, this switch must never be actuated when the power supply is on.

### Construction Details

Next month, I will describe the unique construction details for building this high-power linear amplifier and power supply. In the meantime, should you be so inclined,

get out there and find the parts! Remember that you should build the power supply first, so concentrate on those components.

### Notes

- <sup>1</sup>J. L. Pittenger, "Modular Linear Amplifier for the High-Frequency Amateur Bands," *Ham Radio*, Jan 1981.
- <sup>2</sup>J. L. Pittenger, "A 3CX800A7 Linear Amplifier," *Ham Radio*, Aug 1984.
- <sup>3</sup>J. L. Pittenger, "3CX1200A7 10 to 80 Meter Amplifier," *Ham Radio*, Aug 1985.
- <sup>4</sup>W. I. Orr, ed, *Radio Handbook* (Indianapolis: H.W. Sams, 1975), 20th edition, Sect 22-4, "A Modern 3-1000Z Linear Amplifier for 80-10 Meters."
- <sup>5</sup>Ham Trader Yellow Sheets, PO Box 2057, Glen Ellyn, IL 60138-2057.
- <sup>6</sup>Radio Switch Corp, Rte 79, Marlboro, NJ 07746, tel 201-462-6100.
- <sup>7</sup>Pioneer Standard Industrial Electronics, 1900 Troy St, Dayton, OH 45404, tel 513-236-9900.
- <sup>8</sup>M. Wilson, ed, *The 1986 ARRL Handbook* (Newington: ARRL, 1985).
- <sup>9</sup>Peter Dahl Transformer Co, 4007 Fort Blvd, El Paso, TX 79930, tel 915-566-5365.

# An All-Band, 1500-Watt-Output 8877 Linear Amplifier

*Part 2*—Here's what you've been waiting for: detailed instructions for building a 1500-W RF deck and power supply.

Last month I described the circuitry and parts required for the 8877 linear amplifier and high-voltage power supply. This month I will cover the construction of both units. The power supply construction details are given first. Assuming that we have all the required parts in hand, we can determine the physical design of the power supply. To avoid costly mistakes, it is important to do adequate upfront planning before the first hole is drilled.

## Power Supply Construction

### Meter Selection and Labeling

Any meter with a movement from 100  $\mu$ A to 5 mA can be used for the high-voltage meter. This meter measures the voltage across the 25-ohm resistor at the bottom (B-) end of the bleeder string (see Fig 5 in Part 1). The more sensitive the meter, the higher the resistance setting of the variable 1-kilohm calibration resistor. The setting of the resistor is a simple Ohm's law problem. The maximum power-supply voltage on the meter scale causes a current equal to the meter-movement rating to flow through the meter, and thus give a full-scale reading. For example, the maximum scale on the meter in this supply is 5 kV dc. The meter has a 5-mA movement; therefore, if the supply is at 5 kV, 5 mA must flow through the calibration resistor and the meter for a fullscale reading. Looking at the complete bleeder string, the total resistance is the sum of the two 103-k $\Omega$  bleeder resistors plus the 25-ohm resistor, or 206,025 ohms. At 5 kV, approximately 24 mA (5000/206,025) flows through the string. The value of the calibration resistor, therefore, was selected to allow 5 mA through the meter and 19 mA through the 25-ohm re-

sistor. Using Ohm's law, the value of the resistor should be approximately 95 ohms (19 mA  $\times$  25 ohms/5 mA). The required wattage rating of the resistor is 0.23 W ( $I^2R$

= 0.005  $\times$  0.005  $\times$  95), and a 1-k $\Omega$ , 2-W potentiometer was used. The meter used originally had a 0-50 scale. The scale was changed to read 0 to 5 kV.

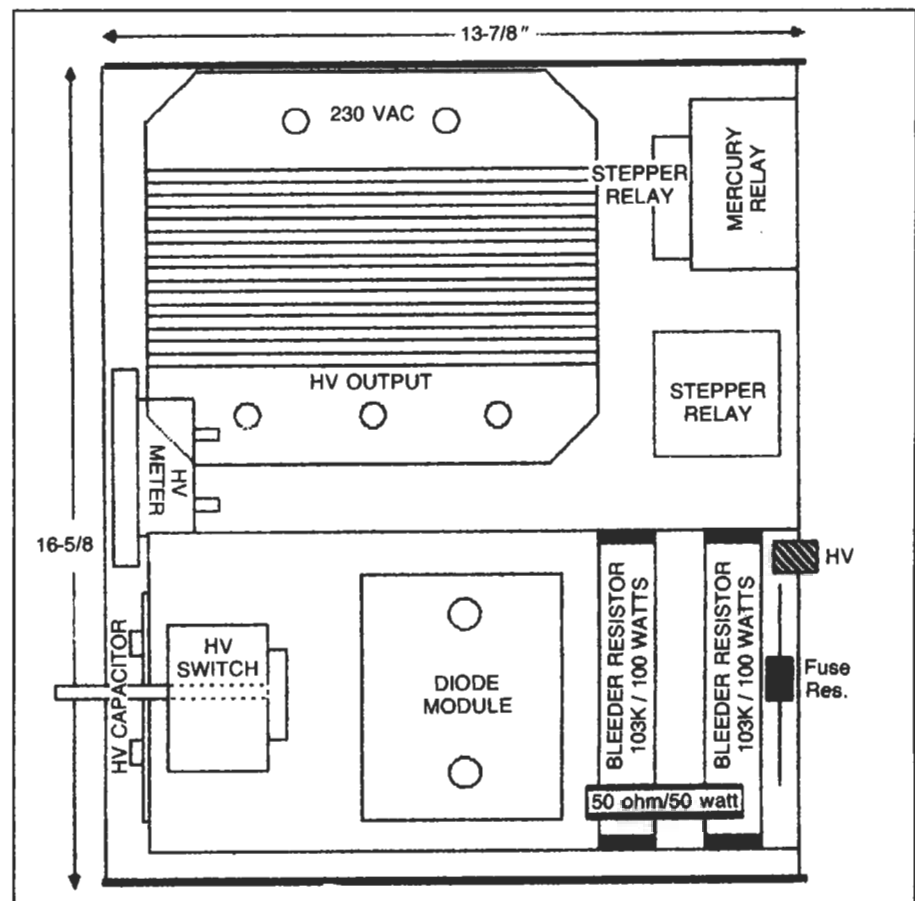

Fig 6—Typical computer-prepared layout drawing. Some component labels have been enlarged for legibility.

## Panel/Chassis Layout

I do all my layouts with an Apple® Macintosh computer. An example of this layout is shown in Fig 6. A manual method may be used, instead. Cut out a piece of poster board the size of the front panel or chassis, as well as all the major components. Shuffle the pieces until you get an acceptable layout. This may seem like a lot of extra work, but "one picture's worth 1000 words." You will save time in the long run by going through this procedure, and not have to correct errors that otherwise are certain to occur. The panel layout should be symmetrical. Align switches and center meters. Make sure that components are properly spaced to accommodate the physical size of the parts behind the panel.

The computer-generated or manual layouts serve as a guide during construction, but are by no means sacred. Once you start putting the parts in place, you probably will make minor changes. Go ahead and make the changes, but always update the documentation.

## Front-Panel Assembly

You probably will not be ready to cut metal until you are 3 to 4 months into the project. Do the front panel first, since the parts locations are fixed for symmetry. Parts behind the front panel can be moved to accommodate the front-panel design.

Cover the front panel with 3-inch-wide masking tape. The tape not only protects the panel from scratches, but also provides a way to lay out the panel with a pencil or pen. Before any holes are drilled, place all the major parts in their proper place in the cabinet to be sure that nothing obstructs the area behind the panel. Remember you have only one chance. Miss and it means a new panel, or cabinet!

Remove the front panel from the cabinet and center punch the panel where holes are to be drilled, as marked on the tape. Carefully drill a very small hole at each punch mark to serve as a guide, then cut the holes to final size. Holes up to approximately  $\frac{7}{16}$  inch can be drilled with either a hand drill or a drill press. Holes larger than  $\frac{7}{16}$  inch should be made with chassis punches. The meter hole is rectangular and is cut with a nibbler after drilling an access hole. Cut the meter hole about  $\frac{1}{32}$  inch smaller than needed and finish with a large file to straighten the edges. Be careful using the file—it is very easy to let the file slip out of the hole and make a big scratch in the panel. The meter hole doesn't have to be perfect since a meter bezel is used.

After the front-panel metal work is complete, carefully remove the masking tape. The front panel should be labeled before mounting the components. Labeling is done with dry-transfer lettering available from art stores or Radio Shack. Apply the labeling by laying the letter or figure on the panel in the proper position and rubbing over it with a soft pencil. The character will be transferred to the panel. If a mistake is made, the character can be removed with

masking or Scotch® tape. There is a mattefinish spray available to protect the lettering. I do not recommend using this spray. It will peel if bumped and does not work well.

The parts can now be mounted on the panel. The cabling to the front panel is connected through nylon multipin connectors (available from Radio Shack) to allow easy panel removal. The same technique is used in the RF deck.

## Rear-panel Assembly

Placement of parts on the rear panel is not as critical as on the front panel. Attention should still be paid to symmetry, however. I have found that it is best to mount rear-panel parts after the major parts have been mounted inside the cabinet. The rear panel is drilled and labeled in a manner similar to the front panel. The black rear panel requires white lettering. White lettering kits are available at art supply stores and some electronics suppliers.

Fig 7 shows the inside rear panel of the power supply. The control and power cables enter the rear panel and are routed directly to barrier strips. Each terminal is labeled for clarity. The rear panel is accessible by removing the front panel and the transformer. It sounds like a big job, but it can be accomplished in about 10 minutes. It is necessary to provide good strain relief for the cables. Immediately inside the rear panel, a piece of  $\frac{3}{4}$ -inch aluminum angle stock is mounted, to which each cable is clamped. Large rubber grommets are used in the holes for cable protection.

## Major Chassis Assembly

Power-supply components are extremely heavy and a good supporting structure is required. The  $\frac{1}{16}$ -inch-thick bottom cover supplied with the cabinet is replaced with a  $\frac{1}{4}$ -inch-thick base plate to provide an adequate foundation. The heavy plate is cut to size on a commercial metal shear. After the transformer, relays and filter capacitor are mounted, rubber-wheeled casters are bolted to the bottom so that the supply can be rolled, rather than carried from place to place.

The cabinet sides are formed by two removable panels. Parts can be mounted to the inner panel using countersunk screws and then covered with the  $\frac{1}{8}$ -inch painted cover plate to provide a professional appearance. A  $\frac{1}{4}$ -inch-thick sheet of Plexiglas® is mounted above the filter capacitor to support the high/low voltage switch, the diode bank and the bleeder resistors. The Plexiglas is supported by drilled and tapped holes for no. 6-32 countersunk screws in the rear and side panel. A post of  $\frac{1}{2}$ -inch aluminum bar stock supports the front-left corner of the Plexiglas.

The mercury-wetted power relay is mounted on the rear panel and must be positioned vertically. Mercury-wetted relays have a tendency to buzz if mounted on a solid surface. Use a rubber grommet to make a bushing in each mounting hole, or mount the relay on a rubber pad. The stepstart relays, K2 and K3, are also mounted on  $\frac{1}{4}$ -inch-thick rubber sheet to minimize noise.

Once the major components are mounted, wire them together, performing as much testing as possible along the way.

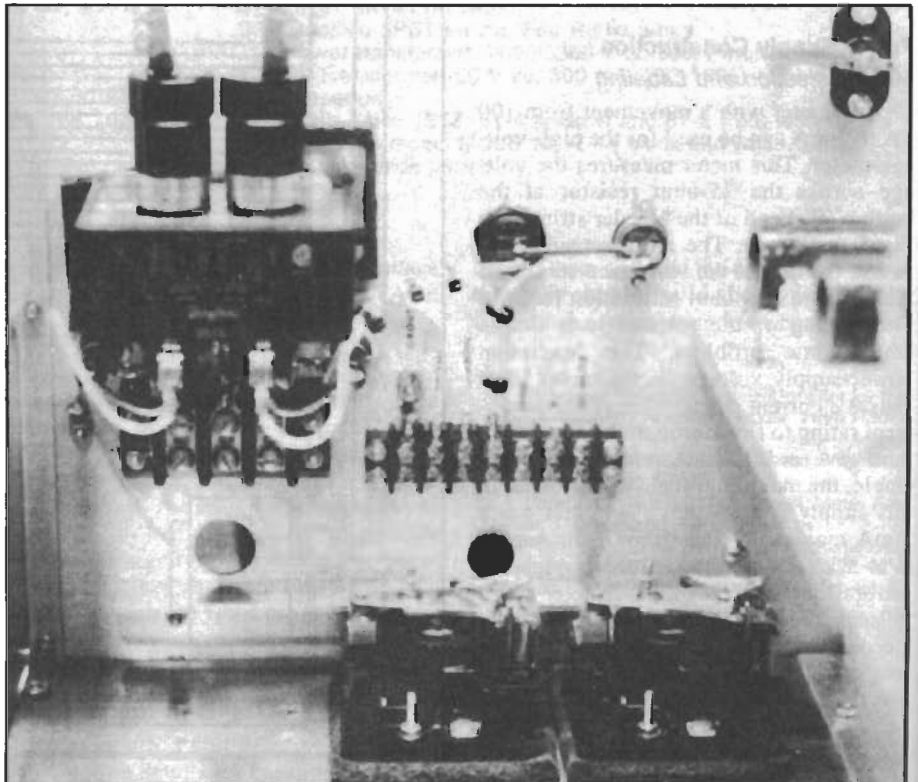

Fig 7—Interior view of rear panel. Note the mercury plunger relay mounting. Relays K2 and K3 are at the lower right.

# MACINTOSH

Front- and rear-panel components are mounted and wired before those that are mounted to the cabinet sides and base plate.

## Power-Supply Testing

When you are satisfied that the power supply has been correctly wired and carefully checked, go have a cup of coffee and come back later when your mind is fresh and check the wiring one more time. Remember that this power supply can be a lethal device. One wrong move could be fatal.

Final testing of the power supply is accomplished in three steps. Remove the wiring from the primary of the transformer and place a temporary line cord with a small variable autotransformer directly from a 117-V ac line to the primary. Turn the 117 V on and slowly run the variable autotransformer up. At 117 V, the power supply should be reading half-scale voltage. This test verifies that the diode bank and filter capacitor are correctly wired. Now is a good time to calibrate the front-panel meter. Using the variable auto-transformer, set the output voltage at a level that another VOM can measure accurately. For example, most VOMs can measure 1 kV. Adjust the calibration resistor so that the front-panel meter reads the same as the VOM.

The second test checks the primary 234-V ac circuitry. With the 234-V lines still disconnected from the primary, plug the power-supply line cord into a 234-V source. Remember that the shorted two-contact plug must be inserted into the rear-panel socket. Turn the power supply on with the test switch and listen for a 3- to 4-second time delay for the step-start relays. Check that 234 V appears across the two wires disconnected from the primary.

The final test is to try the entire power supply with 234 V applied to the primary. Check the high- and low-voltage indications on the front-panel meter.

## Power-Supply Performance

The design results in a husky supply that delivers about 4.6 kV and 3.8 kV (no load) on the high- and low-voltage positions, respectively. In either position the power supply drops less than 400 V under full load. This is the performance you need to achieve full-power capability and good linearity.

## RF Deck Construction

The physical design of the RF deck requires planning long before construction begins. Again, I used the Macintosh computer for my initial "paper design," but the same process can be done using paper and pencil. The important thing is to lay out the major components so that everything fits properly before starting to drill holes and cut metal. You must have all the major components in hand before doing the physical design, so you know what you have to work with.

Fig 8 shows the scaled Macintosh designs for the front, top and bottom views of

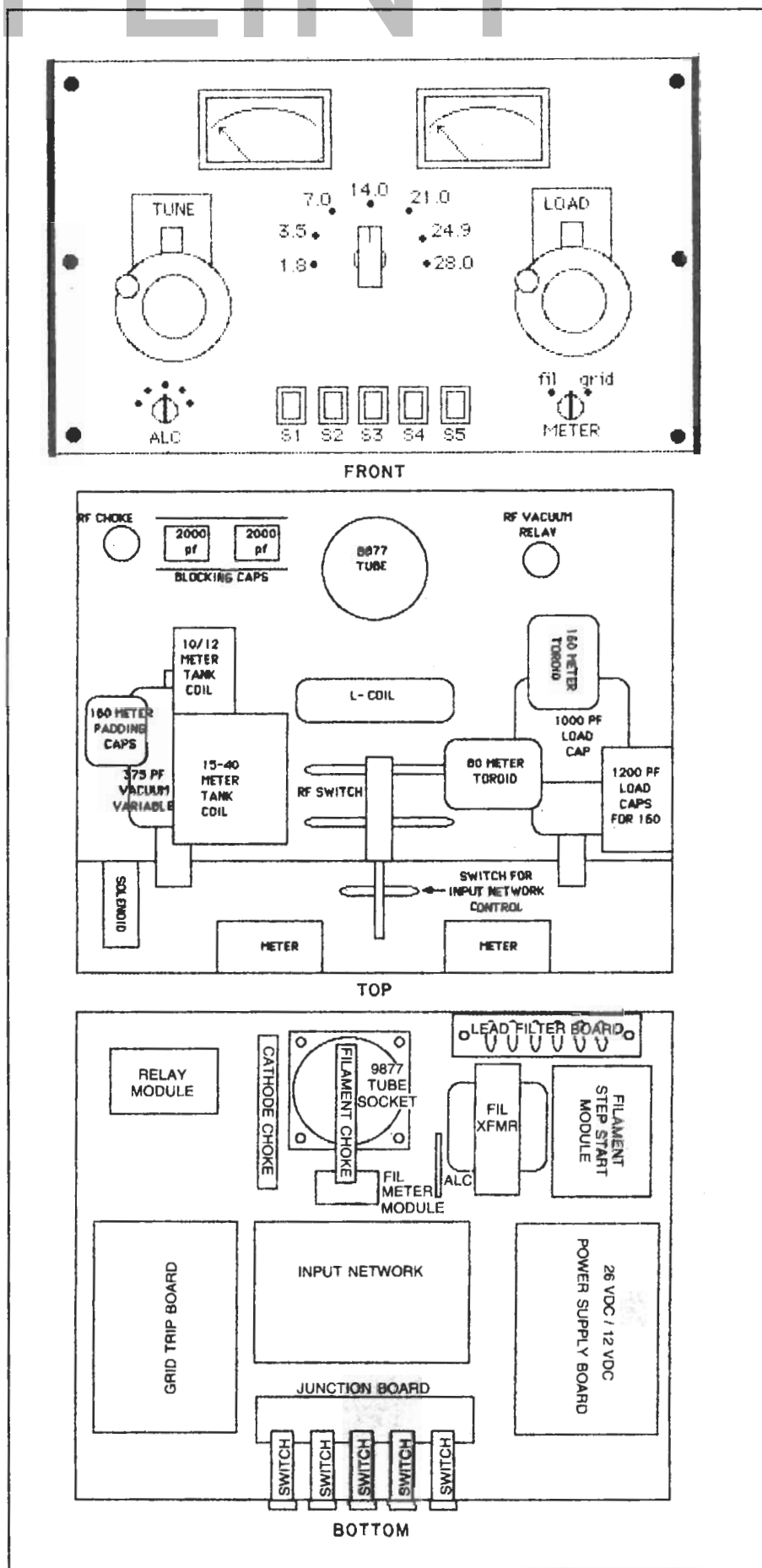

Fig 8—Scale layouts of the RF deck front, top and bottom views, as prepared on the Macintosh computer. Some component labels have been enlarged for legibility.

the amplifier. It is necessary to match the designs so that the front-panel controls end up at the right place on the panel. Everything must be drawn to scale to obtain the relative positions of the components. When designing the bottom and top layouts, only the major circuit boards and components like the grid trip, input network, low-voltage power supply, coils, capacitors and filament transformer are considered. The smaller components can be fitted in later. It is important that the unit be designed with maintainability in mind. Every component, large and small, must be accessible after the unit is completed. The amplifier was constructed in the following steps. Each major step is discussed in more detail later.

- Fabricate, build and test all printed circuit boards for the RF deck.
- Cut the holes in the front panel.
- Perform the major metal work on the subpanel and chassis plate.
- Mount the vacuum capacitors and band switch to the subpanel.
- Mount the PC boards, filament transformer and tube socket to the chassis plate.
- Wire and test the under-chassis control circuits.
- Fabricate and install the RF tank circuit.
- Label and calibrate meters.
- Complete the front panel and mate it to the chassis and cabinet.
- System test the amplifier with the power supply.

#### Printed-Circuit Board Fabrication

Making PC boards can be tedious, but with a little practice, good results can be obtained. Grouping interconnected circuits on the same PC board minimizes the cable harness between modules in the amplifier. In this design, nine PC board modules are required.

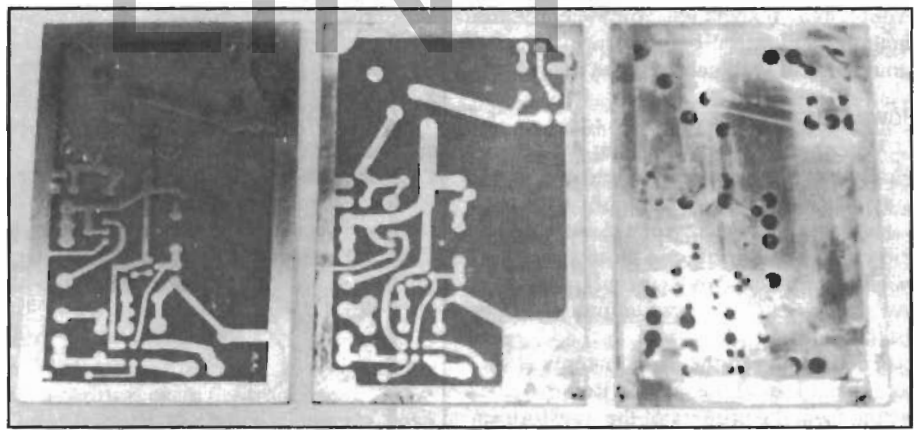

Fig 9—Things don't always work out. Three attempts were made to fabricate the grid-trip and bias PC board. The good board at left was subsequently damaged, requiring a fourth effort.

- |   | <i>Board Size</i>   |
|---|---|
| 1) Input network                                | 4" × 6"   |
| 2) Low-voltage power supply and timer circuit   | 4" × 6"   |
| 3) Grid-trip and bias circuit                   | 4" × 6"   |
| 4) Switch bank harness interface to front panel | 1" × 6"   |
| 5) Filament step-start circuit                  | 2 <sup>3</sup> / <sub>4</sub> " × 3 <sup>3</sup> / <sub>4</sub> " |
| 6) RF input/output relay timing circuit         | 2 <sup>3</sup> / <sub>4</sub> "                                   |
| 7) Line filters for control cable and blower    | 1 <sup>3</sup> / <sub>4</sub> " × 5 <sup>1</sup> / <sub>4</sub> " |
| 8) Filament-voltage-meter circuit               | 1 <sup>1</sup> / <sub>8</sub> " × 2"                              |
| 9) ALC circuit                                  | 1 <sup>3</sup> / <sub>4</sub> " × 2 <sup>1</sup> / <sub>4</sub> " |

All boards, except nos. 4, 7, 8 and 9, are mounted on 1/2-inch channel to the chassis plate. Therefore, the PC board layouts include a ground strip on the edges of each board to mount the boards to the channel.

The Macintosh computer, with a software package called "Draw," was used to lay out the circuit boards. The design of PC boards with the computer is beyond the

scope of this article. PC boards can also be laid out using pencil and paper. Once the design is laid out to scale, the layout must be transferred to the board. First wash the board with a mild detergent to remove all grease and dirt. Using tape and special dry transfers (Radio Shack p/n 276-1577), copy the design onto the board. The transfers are not exact, and the hand drawing only serves as a guide. Submerge the board into an etching solution to remove the exposed copper. I use ferric-chloride etchant. A flood lamp over the etching tray warms the solution and speeds the etching process. Agitate the solution occasionally. The final result should be a nicely etched board ready for drilling the holes for mounting parts. Believe me, however, it doesn't always go as planned.

Fig 9 shows three tries at making the grid-trip and bias board. Actually the third board, on the left, was damaged, and a fourth was necessary. However, once you get the hang of it, it usually goes well.

After etching the board, polish it with



Fig 10—In-process testing of the input-network PC board. Each coil was trimmed to produce a 1:1 SWR into a 50-ohm load. Note the power supply required to actuate relays.

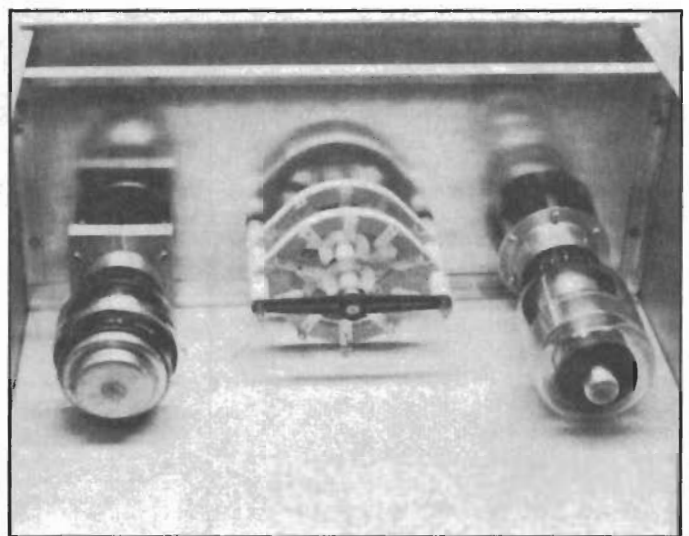

Fig 11—Subpanel installation in the cabinet. Note position of chassis plate, vacuum variable capacitors and band switch. Aluminum angle stock is used to mount the subpanel to the chassis plate and cabinet sides.

# FLINT

fine steel wool and drill the component mounting holes with a small drill. Use dry transfers to label the connections required to the board, before mounting parts. This will avoid wiring mistakes when the wiring harness is installed. Finally, mount and solder the components onto the board.

Test each board as much as possible before final assembly. For example, Fig 10 shows the input network being tested by hooking up coaxial cable and running 100 W through each section into a 50-ohm dummy load. The coils were adjusted at this time to give a flat 1:1 SWR. A power supply is needed to energize the relay for the pi-section being tuned.

### Front-panel Fabrication

Cover the front panel with masking tape to protect it from scratches, and mark the mounting positions of the components. Take your time with this step since it is hard to recover if an error is made. Mark the front panel where the holes are to be cut and carefully drill a small pilot hole followed by the correct hole size. The holes for the band switch, capacitor control shafts, ALC control and multimeter switch are  $\frac{3}{8}$ -inch diameter and can be made with a regular drill bit. The holes for the power switches are  $\frac{5}{8}$ -inch diameter and require a chassis punch. The meter-mounting holes are the most difficult to make. The rectangular cutouts are marked about  $\frac{1}{32}$ -inch smaller than required to protect against overcutting. Use a nibbler to cut the holes carefully, then file them to the exact size of the meter bezels. Be careful that the file doesn't slip and scratch the panel (disaster!). Using a large file will help avoid this tragedy.

I recommend doing all the front-panel metal work at one time to ensure proper component layout. When the metal work is complete, leave the masking tape on the panel for protection as it will be used as a template to locate the parts mounted behind the front panel.

### Chassis and Subpanel Metal Work

This amplifier design has very little metal work that requires more than a hacksaw and a file. The chassis plate was purchased with the cabinet. The only other panel, except for front and rear panels, is the subpanel that mounts perpendicular to the chassis plate, and 3 inches behind the front panel. The subpanel shields the meter compartment from RF and serves as a mounting support for the band switch, vacuum capacitors and 80-meter toroid coil.

The chassis is mounted  $3\frac{1}{2}$  inches from the bottom of the cabinet to allow room under the chassis plate for the filament transformer. Therefore, the subpanel is cut to  $6\frac{3}{4} \times 16\frac{1}{2}$  inches. Referring to Fig 11,  $\frac{1}{2}$ -inch aluminum angle is attached with screws to each edge of the subpanel to provide a mounting flange to the chassis plate and cabinet side walls. The top piece of angle stock provides a mounting surface for a piece of gold-plated finger stock that

seals the subpanel to the cabinet top plate.

Two large holes are required. A 3-inch-diameter hole is required in the chassis plate for the tube socket. A 5-inch-diameter hole is cut in the cabinet top plate and aligned directly above the tube socket to vent the air flowing from the tube and chimney. Use a large fly-cutter, available at most hardware stores. For safety, the fly-cutter should be used only on a drill press—never with a hand drill. Therefore, if you don't have a drill press, find a friend who has one. Before cutting the large holes, use 3-inch masking tape to cover the chassis plate and top panel to mark where the holes are to be drilled, and to protect the surfaces. For safety, clamp the panels onto a board and the base of the drill press before drilling.

Cut a piece of perforated aluminum stock to be slightly larger than the hole in the cabinet top panel. Clean the perforated metal well, and spray with paint to match the cabinet color. Fasten the perforated piece to the inside top panel with several small countersunk screws painted to match the cabinet.

### Mounting Vacuum Variable Capacitors and Band Switch

The vacuum variable capacitors and band switch are mounted to the subpanel, but their control shafts must be aligned with the front panel design. Allow enough slack in the positioning of these components to perform precise alignment with the front-panel holes when the front panel is installed. To mark the hole positions on the subpanel, slide the subpanel against the rear of the front panel while both the front panel and chassis plate are bolted into place in the cabinet. Cover the subpanel with masking tape and mark the exact centers of

the holes for the components. Drill the two holes in the subpanel for the vacuum variable capacitors with hole saws. Mount the vacuum variable capacitors and band switch on the subpanel.

### Mounting Major Components to the Chassis Plate

The major components (PC boards, filament transformer and tube socket) are mounted to the chassis plate as shown in Fig 12. The PC boards are first mounted to  $\frac{1}{2}$ -inch aluminum channel using sheet-metal screws for easy removal. Cover the bottom of the chassis plate with masking tape. Position and mark the PC boards, filament transformer and tube socket according to the planned physical layout. Drill the mounting holes in the chassis plate, then redrill the holes from the top with a countersink bit to allow flat-head countersunk screws to be used for mounting. This retains the flat surface on top of the chassis plate. With the  $\frac{1}{2}$ -inch channels on the PC boards, mark the hole positions on the bottom of each channel with a pencil, using the predrilled chassis-plate mounting holes as a template. Remove the channels from the PC boards, mount the channels on the chassis plate, and remount the PC boards on the channels.

### Under-Chassis Wiring

Complete the under-chassis wiring, according to the schematic diagram, using Teflon®-insulated wire. The nylon connectors near the front of the chassis connect to the front-panel power switches, the ALC potentiometer and the multimeter switch. This allows the front panel to be easily removed for rear-panel access. The small board in the front center of the chas-

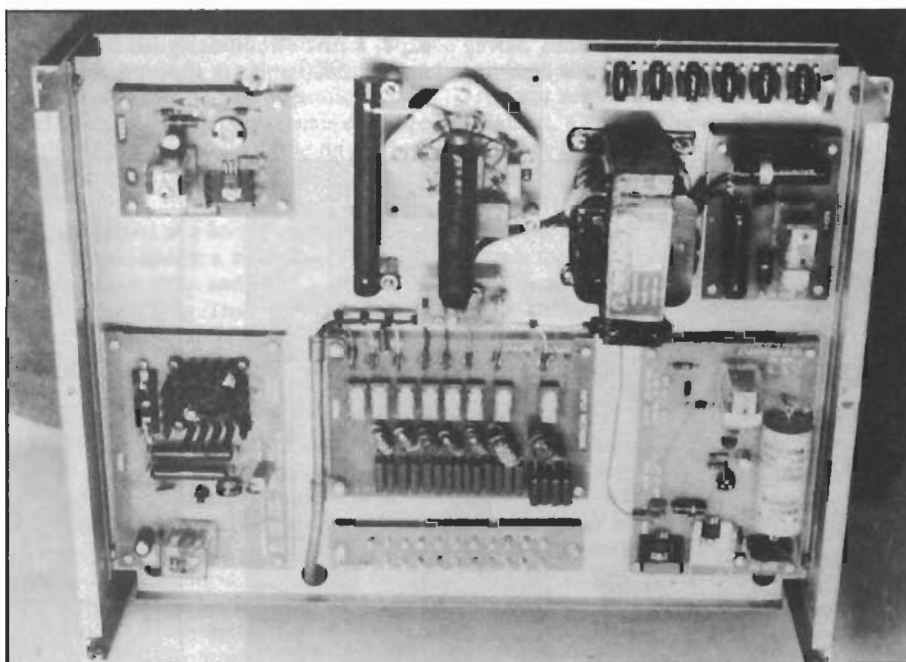

Fig 12—Bottom view of the RF deck showing placement of PC boards, transformer and tube socket.



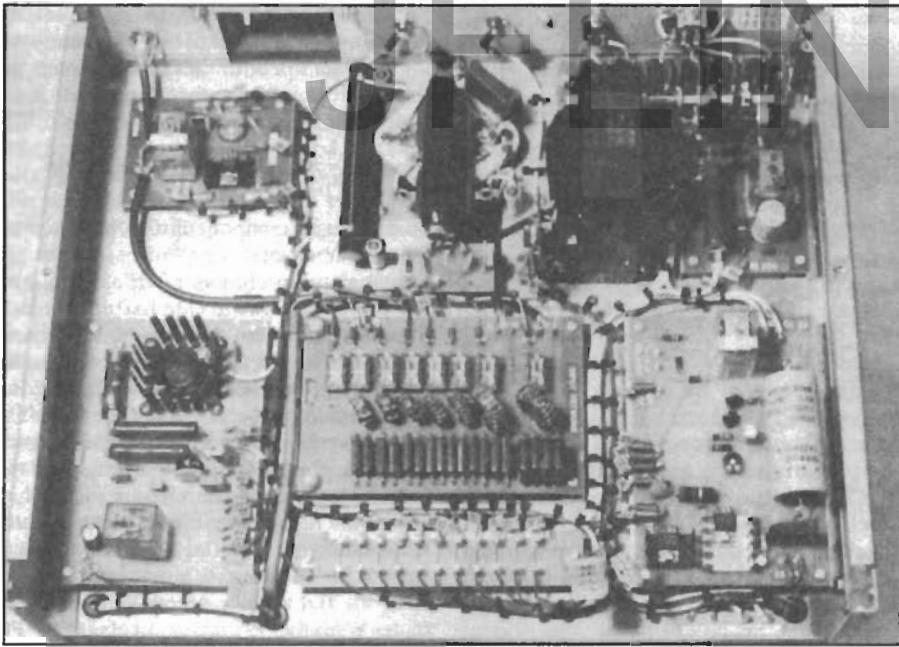

Fig 13—Bottom view of the RF deck showing harness wiring in place.

sis provides an easy way to mate the 12-pin nylon connector going to the power switches with the wiring harnesses under the chassis plate (see Fig 13). When making the PC boards, try to put all the connections to the board on one side. This allows access to the boards for maintenance without removing the wiring. Just unscrew the board from the channel and fold the board upward.

Each wire is labeled at each end with numbered tags, because the Teflon wire used is mostly the same color. A version of the schematic diagram was maintained with the wire numbers noted for easy wire tracing. The final wiring is cabled into harnesses with plastic cable ties. Don't be afraid to use plenty of ties, but at first only put a tie every inch or two. The ties will undoubtedly be cut several times during wiring to put in missing wires that are over-

looked. When all wiring is complete and tested, put a cable tie every 1/2 inch on the major harnesses.

#### Amplifier Tank Circuit

The plate tank-coil set is shown in Fig 14. Before making the coils, determine the tankcircuit parameters for the given tube plate impedance. The plate impedance can be determined from Eq 1.

$$\text{Plate impedance} = \frac{\text{plate voltage}}{1.57 \times \text{plate current}} \quad (\text{Eq 1})$$

Assuming the amplifier runs at 60% efficiency, the input power required for 1500-W output is approximately 2500 W. With 3200 V on the 8877 plate, plate current will be approximately 781 mA. From Eq 1, a tank circuit designed for approximately 2600 ohms is appropriate. A table

of pi-L network component values is contained in Hoff's article, and the values used in this amplifier are summarized in Table 2.<sup>10</sup>

The 80- and 160-meter coils are wound on an assembly of three T225-2 toroid cores taped together with Scotch no. 27 glass-cloth tape. Use plenty of tape to provide good voltage insulation from the cores. The 80-meter coil is wound with 11 turns of no. 10 wire covered with Teflon sleeving. The 160-meter coil is wound with 19 turns of no. 12 wire, also covered with Teflon sleeving. The cores of both coils are mounted from 1 to 2 inches from the mounting wall on ceramic insulators. Each coil is sandwiched between two pieces of fiberglass material held together by a ceramic standoff running through the middle of each toroid (see Fig 15). Wind all coils in the same direction (clockwise or counterclockwise), to avoid a "bucking" action between coils.

The 10- through 40-meter coil is made from 1/4-inch soft copper refrigerator tubing. Clean the tubing using fine steel wool (000) until the surface is smooth and bright. Use a piece of pipe with an OD equal to the desired coil ID and carefully wind the copper tubing around the pipe. After the smaller diameter part of the coil has been wound, change the pipe to a larger diameter, and wind the larger part of the coil. The inductance of the coil can be easily checked using a known fixed-mica capacitor with low internal inductance and a dip meter. After determining the resonant frequency, calculate the inductance using Eq 2.

$$\text{Inductance} = 1/(4 \pi f^2 C) \quad (\text{Eq 2})$$

Always wind the inductor with a few extra turns and then remove turns until the desired inductance is achieved. The induc-

<sup>10</sup>I.M. Hoff, "Pi Network Design for High Frequency Power Amplifiers," *Ham Radio*, Jun 1978.

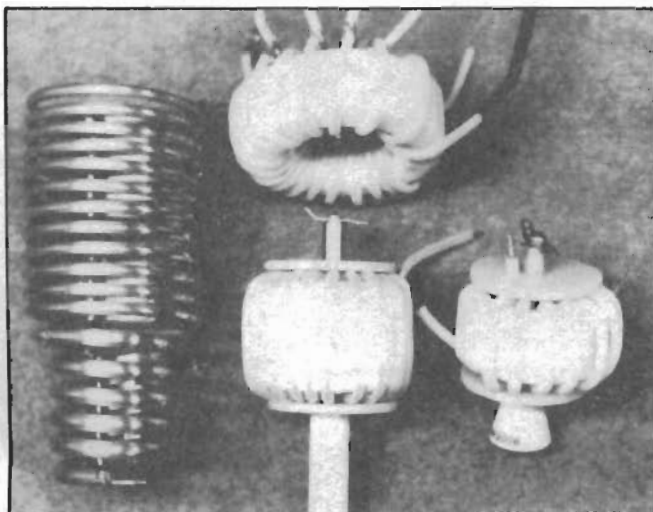
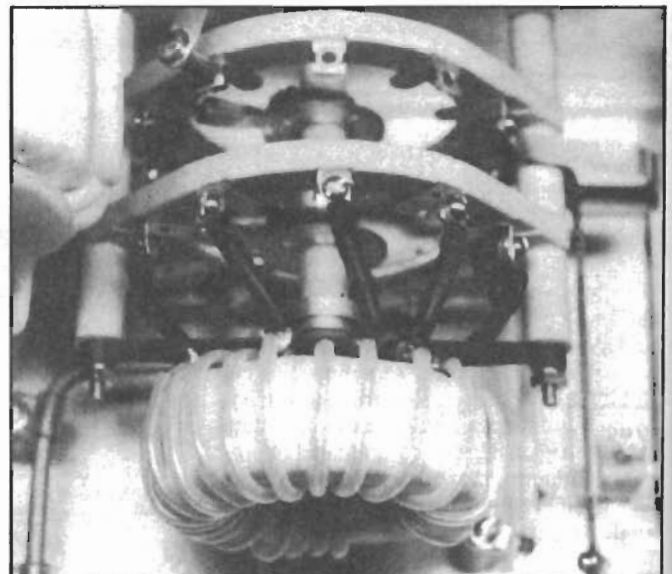

Fig 14—Plate tank coil set. Above: the various coils of the tank circuit. Right: the L toroid mounted on the rear of the band switch.



**Table 2**  
**Pi-L Network Design Parameters (See Fig 3, Part 1)**

Freq (MHz)	C1 (pF)	L1-L4 (μH)	C2 (pF)	L5 (μH)	Q
1.8	462	22.02	2121	8.90	13.1
3.5	244	10.99	1132	4.45	13.4
7.0	113	6.03	503	2.44	12.4
14.0	55	3.08	245	1.24	12.2
21.0	37	2.05	164	0.83	12.2
24.9	30	1.70	130	0.70	12.0
29.7	26	1.48	112	0.60	12.0

- L1, 10-12 meters—6 turns 1/4-inch silver-plated copper tubing, 2-inch outside diameter, 2 inches long. 10-m tap at 3 turns.
- L2, 15-40 meters—12 turns 1/4-inch silver-plated copper tubing, 3 1/4-inch outside diameter, 4 inches long. 15-m tap at 2 turns, 20-m tap at 4 turns, 40-m tap at 12 turns.
- L3, 80 meters—11 turns of no. 10 wire in Teflon sleeving over three T225A-2 iron-powder toroidal cores taped together with Scotch no. 27 glass-cloth electrical tape.
- L4, 160 meters—19 turns of no. 12 wire in Teflon sleeving over three T225A-2 toroidal cores taped together with Scotch no. 27 glass-cloth electrical tape.
- L5, L Coil—20 turns of no. 20 wire in Teflon sleeving over two T300-2 iron-powder toroidal cores taped together with Scotch no. 27 glass-cloth electrical tape. Tap as follows:

Band	10-12	15	20	40	80	160
Turn no.	2	3	4	6	10	20

tance measurement is only an approximate value because there is always stray inductance introduced by the interconnecting leads and the band switch.

The copper tubing is silver plated only after the ends are configured to match the mounting lugs in the amplifier. Silver plating is simple with the right materials. Go to a photographic lab and get a couple of gallons of used fixer solution. Fixer solution is not usable when it becomes saturated with silver. The labs usually sell the spent fixer for silver recovery, so you may have to pay for it. Clean the coil by giving it another brushing with steel wool, wash it thoroughly in a mild detergent and rinse it well before plating. Put the fixer solution in a large plastic container and submerge the coil in it. A bright silver plate will form within seconds. The silver plate is not very thick, but it is sufficient to keep the copper from tarnishing. The coil taps are small wrap-around clamps made from silver-plated 1/2-inch-wide copper strap. Plate about 2 inches of copper strap, then drill a hole in one end for a no. 8-32 screw. Using a short piece of 1/4-inch tubing as a jig, bend the end sharply around the tubing with a pair of duckbill pliers. Drill a second, matching hole, but squeeze the clamp in to provide a tight fit around the coil stock. Install the clamp with a flat washer on each side to provide a compression fit. The clamp should fit tightly. Don't solder the clamps until after the amplifier is tested. When the tap location is verified, heat the clamp and coil with a large solder gun and flow solder into the connection. After soldering the coil taps, spray the coil with a thin coat of clear plastic to retain the bright silver finish.

The L coil is wound on a pair of T300-2 toroid cores taped together with glass-cloth tape. The coil is mounted on the back

of the band switch and supported by the connections to the coil. The leads are not soldered to the band switch, but are held in place with no. 6-32 screws.

Other major considerations in the RF tank circuit are the TUNE and LOAD capacitors. The TUNE capacitor is a 375-pF vacuum variable. Table 2 shows that though this capacitor will easily cover 10 through 80 meters, it is too small for 160 meters. One solution is to use a 500-pF vacuum variable, but units in this size class are not readily available in the surplus market, and you probably don't want to buy a new one at approximately \$500. I solved the problem by switching in an additional 160-pF capacitor in parallel with the vacuum variable for 160 meters.

A 24-V dc solenoid, mounted on the subpanel, grounds a pair of 80-pF fixed vacuum capacitors. The solenoid is powered by a small 12-V relay that is energized by the 160-meter control line on the input network control switch. The grounding strap is made from a stiff piece of brass stock obtained at a hobby shop. A hinge is made by soldering a small piece of brass tubing to the strap and putting a solid rod through the tubing. The rod is supported on each end by a small piece of Plexiglas and allowed to pivot, thus forming a hinge. A piece of flexible braid is connected from the brass strap to ground for a good connection. The strap is held in the open position by a small spring pulling the strap back toward the subpanel. The contacts on the strap and the vacuum capacitors are from a 25-A power relay and soldered in place. A piece of 1/4-inch brass bar stock is used to mount the contact on the vacuum capacitor side and to absorb the shock from the closure. A rubber grommet on the brass strap, where the rod from the solenoid hits the strap, also absorbs some of the shock. This

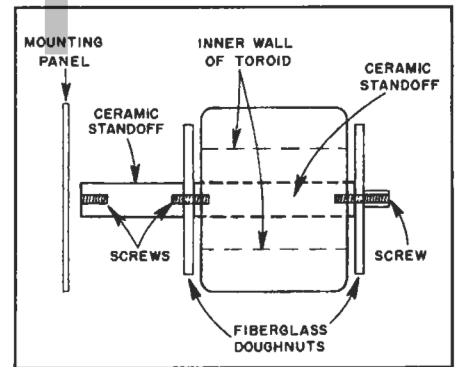

Fig 15—Mounting details of 80- and 160-meter toroids.

scheme works smoothly and once thought out, took about one evening to install.

The LOAD capacitor is a 1000-pF, 3-kV unit with a fixed 100-pF, 5-kV fixed mica transmitting capacitor in parallel. This provides a total of 1100 pF for 80 meters. On 160 meters, the band switch adds an additional 1200 pF in parallel to provide a total of 2300 pF. The 1200-pF capacitor consists of three 400-pF mica transmitting capacitors in parallel.

### Marking and Calibrating Meters

Any meter with a movement from 100 μA to 5 mA can be used for the front-panel meters. Use two identical meters, if possible, for esthetic reasons. In a very clean environment, begin by removing any internal meter shunts (on ammeters), or any series resistors inside the meter (on voltmeters) to obtain only the basic meter movement. Nothing else need be done for the multimeter, since the calibration resistors are a part of each metered circuit. A shunt resistor must be made for the plate-current meter. Wind about 2 feet of no. 22 enameled wire on a 2-W resistor of any value over 50 ohms, soldering the wire ends to the resistor terminals. Mount the resistor across the meter terminals to form a shunt. Connect the meter in series with another meter of known calibration and an adjustable power source. Trim the enameled wire 1 inch at a time until the meters read the same. If the meter being calibrated reads too low, the wire is too short. When the meters read the same, slip a piece of heat-shrink tubing over the resistor and seal the shunt.

Carefully remove the plastic face cover and the calibrated face plate from the meter. Do this in a clean environment because the magnet in the meter will attract metal shavings that could damage the movement. With a pencil eraser, rub off the original meter lettering, but not the analog scale tick marks. With small dry-transfer letters put the new numeric scale on the meter. Be careful not to bend the pointer when reassembling the meter.

### Mounting the Front Panel

Remove the masking tape from the

# 11J1NT

panel, and carefully label the front panel with dry-transfer lettering before mounting any components. Mount the meters, potentiometer and switches in place, and complete the wiring. Wire nylon connectors to the power switches, ALC control, multimeter switch and meters to mate with the connectors in the RF deck. This will result in a totally removable panel.

When mounting the front panel to the cabinet, give careful attention to aligning the vacuum-capacitor and band-switch shafts. Loosen the component mounting screws and mate the shafts, then retighten the screws. Continue the alignment process until the controls operate smoothly.

## Rear-Panel Assembly

Up to now, nothing has been done to the rear panel. Mount the panel and decide where the components should mount to obtain short connections. Lay the rear panel out in the same way as the front panel, and cut the necessary holes.

Mount the blower off the rear panel, located to allow good circulation of air up to the front of the under-chassis area and back to the tube socket. Positioning of the blower is not critical as long as air is not directly blown across the tube socket, which could cause backpressure.

Mount all components to the rear panel,

and mount and wire the panel to the RF deck. The rear panel is not easily removable like the front panel.

## Testing the Amplifier and Power Supply

Testing is the *big* moment and the climax of several months' work. First hook up the power-supply control cable and the ground cable. Leave the high-voltage cable off. Test the control circuits to ensure that the power supply can be turned on from the RF deck and the 3-minute time delay works. Make sure that the tube filaments are on. This isn't as easy as with a glass tube, which allows you to see the filaments glow. Let the tube run for about 10 minutes, then turn the power off. Immediately remove the tube and feel if the base is hot.

Test the amplifier first on 20 or 40 meters, since these bands use the midrange of the TUNE and LOAD capacitors. With high voltage applied to the tube, first key the amplifier with no input drive power. The resting idle current should be between 100 and 200 mA on the plate-current meter.

Now apply a little drive power to the tube. The plate current should rise. Move the 11JNE and LOAD controls until power output is indicated on a wattmeter. Increase the drive while adjusting the TUNE and LOAD controls to achieve about 20 mA

grid current and 650 to 700 mA of plate current, to realize 1500 W output. If the amplifier works properly on this band, proceed to the other bands and repeat the tests.

Efficiency should be at least 60% on all bands, except perhaps 10 and 12 meters, where efficiency may drop to 55%. If efficiency is poor, try moving the coil taps, but recognize that moving the taps also changes the Q of the coil. Decreasing the inductance and increasing the capacitance in the tank circuit will increase the Q. The amplifier may provide more power output over a larger frequency range with a lower tankcircuit Q, but harmonic suppression will also decrease and the amplifier could start generating interference or not meet FCC standards.

I must warn you one last time. *This device could kill you in one instant if you get tied into the high-voltage circuit. Put a good ground on both power supply and RF deck, and treat the equipment with proper respect!*

## Conclusion

I have spent many enjoyable hours operating with this amplifier/power supply combination, with nothing but good signal reports. It was an exhausting task, but now that it's finished, I'm glad I did it. Try building one and you'll see what I mean.

ci  
ne  
ne  
th  
an  
FC  
Th  
po  
an  
adj  
out  
Op  
B, a  
D a  
ope  
plet  
off.  
The  
1 Ω  
hund  
great

# High-Efficiency Class-E Power Amplifiers

**Part 1**—With 3 to 12 W of drive, you can push 300 to 500 W CW out of an \$11 transistor! The trick is to use Class E.

These 300 and 500-W 40-meter amplifiers evolved from a series of undergraduate student projects at Caltech. Our goal was to design an inexpensive amplifier that amateurs can easily duplicate.<sup>1</sup> The amplifiers use inexpensive, readily available power MOSFETs that can be driven by a QRP transceiver; in our case, the NorCal 40A. A block diagram of our setup is shown in Figure 1. The components of the station are shown in Figure 2.

Our 300-W amplifier uses an International Rectifier (IR) IRFP440; the 500-W amplifier employs an IRFP450. These transistors are widely used in switching power supplies, but we have not seen them previously reported for use as RF amplifiers. The MOSFETs have a maximum drain voltage of 500 V, with maximum RMS drain currents of 8.8 A for the IRFP440, and 14 A for the IRFP450. Both transistors are available from Digi-Key: The 440 costs \$8; the 450 costs \$11.

Class-E amplifiers are extremely efficient—about 90%. Because of the low loss, no cooling fan is required. No TR switch is needed; the received signal is piped through the amplifier itself. Even without an external filter, the amplifiers meet the FCC requirements for spurious emissions. They can be built and tuned up with an RF power meter, a multimeter, oscilloscope and a dummy load. Tune-up consists of adjusting an input coil for matching and an output coil to set the power level.

## Operational Classes

In addition to the well-known Class A, B, and C operational modes, there are Class D and E.<sup>2</sup> In Class D and E, the devices operate as switches, half the time completely on, and the other half completely off. But transistors are not perfect switches. The MOSFETs have a resistance of about 1  $\Omega$  when on, and a capacitance of several hundred picofarads when off. Losses are greatly reduced in switching amplifiers, but

there is a penalty: The output power no longer depends on the *drive power*, but rather on the *supply voltage*. This means that switching amplifiers are *not* linear amplifiers, and they are *not* suitable for SSB without additional limiting and modulating circuits. However, they are fine for CW, FSK and FM.

In a Class-D amplifier, a pair of transistors switch on and off, out of phase across an output transformer. Fred Raab, WA1WLW, recently developed a Class-D power amplifier that produces 250 W on 40 meters with an efficiency of 75%.<sup>3</sup> However, Class-D amplifiers are relatively complex. On the other hand, the Class-E circuit has significant advantages for the homebrewer because only one transistor, without gate bias or output transformer, is needed, and it can be driven by a low-power transceiver.

## The Class-E Amplifier

The Class-E amplifier was invented and

patented by Nathan Sokal, WA1HQC, and Alan Sokal, WA1HQB, in 1975.<sup>4</sup> It minimizes heat loss by having as little overlap as possible between voltage and current. Figure 3 shows an idealized Class-E circuit. As the switch opens and closes, the current alternately flows in the switch and in the load network. The switch voltage and current waveforms are shown in Figure 4. It may be easiest to understand the waveforms by starting at the beginning of the off-time interval. When the transistor turns off, the current flows into the resonant load network, and there is a transient voltage that rises and falls. With a properly de-

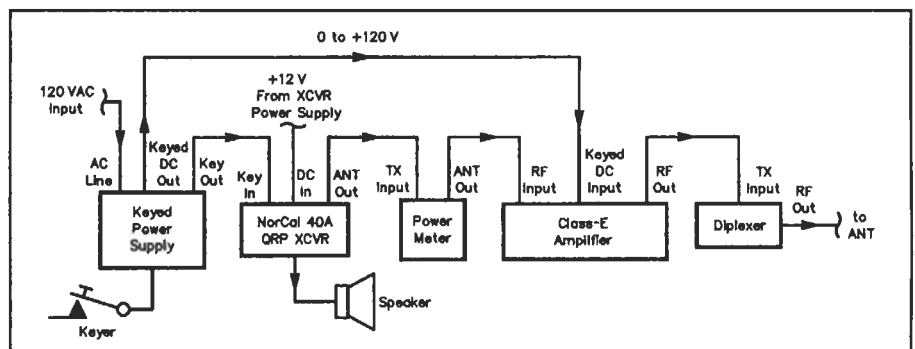
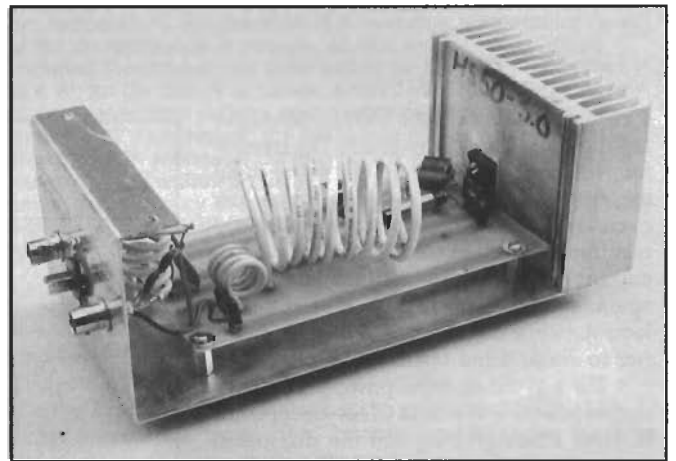

Figure 1—Block diagram of the Class-E amplifier station.



Figure 2—The components of the Class-E amplifier station. Clockwise from bottom left: the diplexer, amplifier, resonant speaker, NorCal 40A and keyed power supply. The latter houses the keyer and a pulse-stretching and shaping circuit.

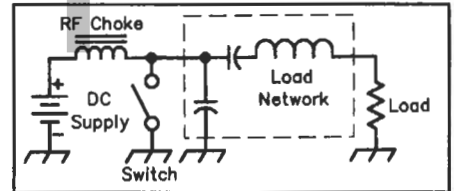

Figure 3—An idealized Class-E amplifier. The transistor is represented by a switch that opens and closes at RF.

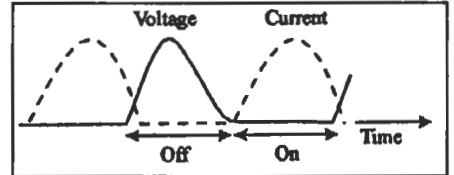

Figure 4—Class-E voltage and current waveforms. Class-E amplifiers reduce loss by keeping the overlap between voltage and current low.

signed load network, the voltage returns to zero smoothly with zero slope. The transistor switches on when both the voltage and the current are small, keeping losses low even if the switching is slow or slightly mistimed. Once the transistor turns on, the current rises smoothly until it switches off again, and the cycle repeats. The resonant load network does limit a Class-E amplifier to single-band operation.

For a given dc input power, the power output of a 90% efficient Class-E amplifier is three times greater, and the dissipated power is seven times smaller, than that of a 30% efficient Class-A amplifier. This means that for a given dissipated power, we can get 21 times more power from a Class-E amplifier.

### The Caltech Power Amplifiers

Both amplifiers have a common diagram (Figure 5) and PC board, but use components with different values. Several components are added to the basic Class-E circuit for matching and filtering. The MOSFET's gate impedance is rather low, and primarily capacitive, with a reactance of about 4 Ω. There is also a resistive component of about 2 Ω from parasitic series resistance in the gate itself, and the drain on resistance that is capacitively coupled to the gate. T1 reduces the 50-Ω impedance of the drive circuit to about 2 Ω to match the low resistance of the gate and sets the dc bias to 0 V. L1 is adjusted to cancel the gate capacitance; the input SWR is typically 1.5:1. C1 shunts L1 at high frequencies to reduce ringing in the VHF range. The 0-V gate bias ensures that the transistor is off when it is not driven, because this is far below the threshold voltage, which is about 4 V. We have never seen oscillations in these amplifiers.

C3 and L2 form a resonant network that produces the rising and falling voltage waveform needed for the Class-E ampli-

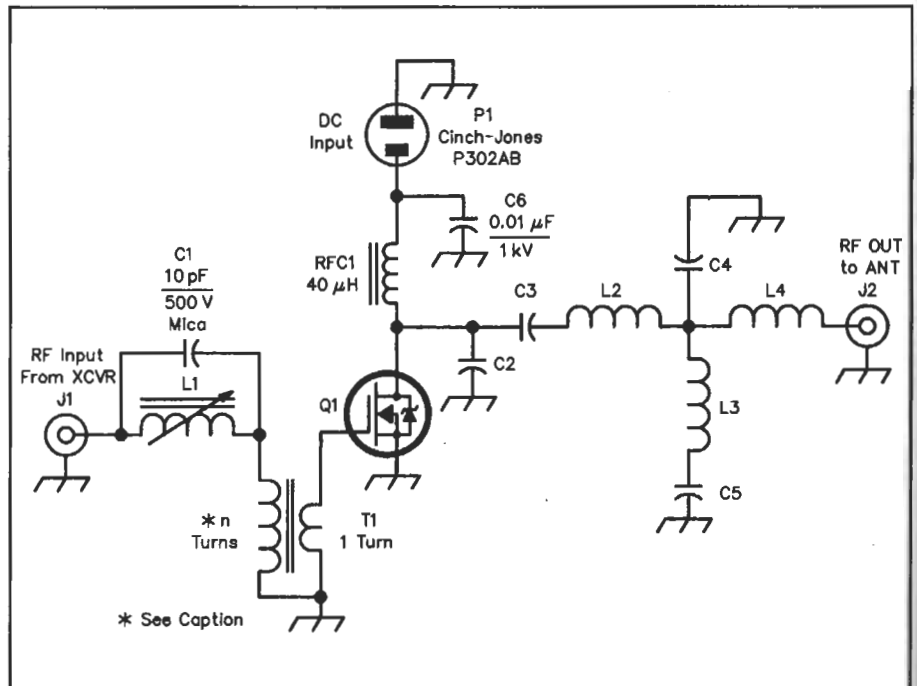

Figure 5—Circuit diagram and parts list for the amplifiers. Mica capacitors are available from Newark. L2, L3 and L4 are made with #10 THWN solid, insulated house wire sold in hardware stores. T1's core is an RF400-0, available from Communications Concepts (see Note 1 for supplier information). L1 is a Toko 10K (2.2 μH), available from Digi-Key. RFC1 is a J. W. Miller type 5240, available from Newark.

- C1—10 pF, 500 V mica
- C2—300 W, 270 pF; 500 W, 390 pF; (For C2 through C5, Cornell Dubilier mica capacitors, type CDV19, 1 kV, 5%)
- C3—300 W, 1500 pF; 500 W, 2000 pF
- C4—300 and 500 W, 100 pF
- C5—300 W, 680 pF; 500 W, 820 pF
- C6—0.01 μF, 1 kV ceramic disc
- J1, J2—BNC or SO-239 connectors
- L1—2.2 μH, Toko 10K; available from Digi-Key.
- L2—300 W, 9 turns; 500 W, 8 turns #10 THWN wound on 1 1/4-inch-OD plastic-pipe form; spread turns to fit holes in PC board.
- L3—300 W, 4 turns; 500 W, 3 turns #14 THWN wound closely spaced on a 1/2-inch-diam drill bit

- L4—300 W, 5 turns; 500 W, 5 turns #14 THWN wound on a 1/2-inch-diam drill bit form, turns spaced to occupy 1 inch
- P1—Cinch-Jones P302AB
- Q1—IRFP440 for 300-W amplifier; IRFP450 for 500-W amplifier; (use International Rectifier transistors only)
- RFC1—40 μH, 3 A
- T1—Pri: 300 W, 5 turns; 500 W 6 turns #26 stranded hook-up wire; wound on RF400-0 core, available from Communications Concepts
- Misc: Berquist K10-104 insulating pad (thermal resistance of 0.2-K/W, 6-kV breakdown rating); available from Digi-Key.

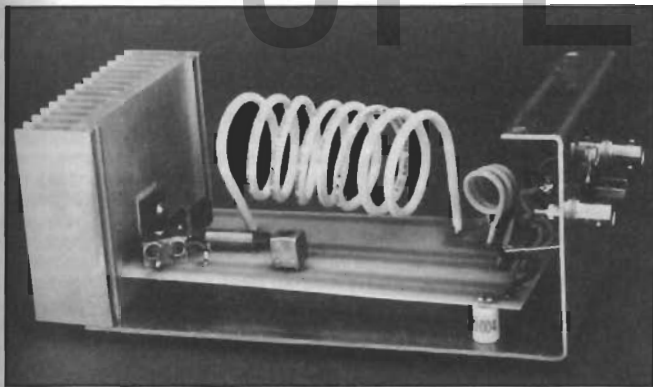

Figure 6—Inside the 500-W amplifier. The large coil is L2; L3 is the small coil. The circuit board is mounted on 1/2-inch standoffs. BNC connectors are used for the RF input and output. No harm is done if the RF input and output are accidentally interchanged.

fier. C5 and L3 act as a notch filter for the second harmonic. Without the notch filter, the second harmonic is typically between -25 and -30 dBc instead of the -40 dBc that the FCC requires on HF. In addition, C5 and L3 transform the 50- $\Omega$  antenna impedance to about 10  $\Omega$ , the appropriate load for a Class-E amplifier. RFC1 converts the 0 to 120-V dc input from the power supply to a current source, and C6 helps keep RF energy out of the power supply.

C4 and L4 form a low-pass filter to remove VHF harmonics. Without the filter, there are several harmonics at levels from -40 to -60 dBc in the frequency range from 130 to 210 MHz. With the filter, the VHF harmonics are reduced to the -70 to -80-dBc level.

### Amplifier Construction

The 500-W amplifier is shown in Figure 6 with its cover removed. The transistor is mounted on a 3 $\times$ 4 $\frac{1}{8}$ -inch heat sink with 1-inch fins (type HS50-3.0 from RF Parts, with a thermal resistance of 2 K/W with no fan) with a #6-32 bolt and nut. The transistor generates most of the heat (about 10% of the dc power) in the amplifier, so it must have good thermal contact to the heat sink. Because the transistor's case reaches high voltages, it must be electrically isolated from the heat sink. We use a Kapton pad manufactured by Berquist that has a thermal resistance of 0.2 K/W and a breakdown voltage of 6 kV. The heat-sink surface must be free of burrs, and the transistor should lie flat on the surface with minimal stress on the leads. If a torque screwdriver is available, International Rectifier recommends a mounting torque of 10 inch-pounds. The heat-sink baseplate is an aluminum L bracket bent from 0.050-inch-thick aluminum sheet. A U-shaped enclosure cover is made of 0.016-inch-thick aluminum sheet. A hole in the cover allows insertion of a plastic screwdriver for tuning L1.

Solder Q1 and C2 flush to the PC board to reduce VHF ringing on the gate signal. Good electrical contact is needed between Q1's source lead and the heat sink. Use a

#6-32 bolt and nut, with washer spacers so that the source lead does not bend. Scope-probe pigtailed soldered to Q1's gate and drain leads poke through holes in the baseplate. Rubber grommets in the holes prevent the pigtailed from shorting to the chassis.

L4, L3 and L2 are made by winding solid insulated wire on pipe and drill-bit forms. Orient the coils at right angles to each other to reduce coupling between them. L2 has a 7-MHz Q of 350; L3 and L4, a Q of about 170. For C2, C3 and C5, use only 1-kV mica capacitors—even 500-V capacitors fail spectacularly with a burst of flame. If a 1-kV, 100-pF capacitor is not available for C4, substitute a series-connected pair of 500-V, 200-pF mica capacitors. For best filtering, mount C4 and L4 directly on the center pin and ground lug of J2. Mount L4 with its axis vertical to reduce coupling to the other coils.

### The NorCal 40A Driver

For a driver, we use a NorCal 40A,<sup>5</sup> but its 2-W output is not enough to drive these amplifiers. Fortunately, the NorCal 40A can be modified to deliver greater power output.<sup>6</sup> We recommend 3 to 4 W drive for the 300-W amplifier, and 6 to 12 W for the 500-W amplifier. These drive levels give an efficiency in the 90% range (Figure 7). Drive levels lower than these give poor efficiency; higher drive levels increase the dissipated power without improving efficiency. Don't drive the 300-W amplifier with less than 2.3 W, and the 500-W amplifier with less than 5 W. At these low power levels, the transistor may not turn on fully at all supply voltages, subharmonic spuri-

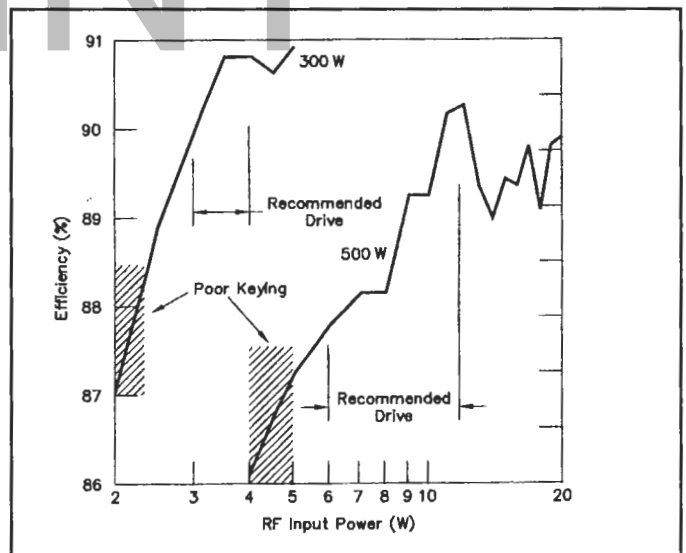

Figure 7—The measured efficiency plotted against RF input power. These measurements were taken with the heat sink at room temperature. In operation, the heat-sink temperature rises and the *on* resistance increases, so that the efficiency drops somewhat. Recommended drive power for the 300-W amplifier is 3 to 4 W; for the 500-W amplifier, 6 to 12 W. The dc input power was calculated from voltage and current measurements made with Fluke 87 multimeters; the RF output power was determined with a Bird 43P wattmeter using a 500-W element. Bird lists the accuracy of this wattmeter as  $\pm 25$  W, but we were able to improve the accuracy of the measurement to an estimated 1% by thermal calibration. RF input power was measured with a Diamond SX-200 wattmeter.

ous components may be generated, and the amplifier may not key properly.

The recommended drive powers produce peak gate voltages of between 15 and 20 V. International Rectifier specifies a maximum peak gate voltage of 20 V to avoid rupturing the gate. Although the drive levels are close to this limit, experience shows them to be quite safe. The 20-V limit is more appropriate for the low frequencies used in power supplies than for RF voltages. In controlled tests, we've pushed the 300-W amplifier to 60-V gate-voltage peaks, *three times* the manufacturer's voltage limit, without damage.

Next month, we'll discuss the keyed power supply, keying waveform shaper and tune-up. Join us!

### Notes

<sup>1</sup>A package of amplifier parts *only*, including PC board, components, connectors, heat sink and chassis is available at cost from Puff Distribution, Department of Electrical Engineering, MS 136-93, Caltech, Pasadena, CA 91125. Price: \$50 for US orders, \$60 for foreign orders. The price includes tax and shipping by surface mail. Make payment by check or money order only to "Caltech-Puff Distribution." Foreign checks must be drawn on a bank with a US branch office. Please provide your Amateur Radio call sign and specify which amplifier (the 300 or 500 W unit) you want. For more information, contact Dale Yee by e-mail at [yee@systems.caltech.edu](mailto:yee@systems.caltech.edu), fax 818-395-2137, or you can download an order form from: <http://www.systems.caltech.edu/EE/Faculty/rutledge/poweramp.html>. We do not offer power-supply components. Those parts are available from Communication Concepts, 508 Millstone Dr, Beavercreek, OH 45434-5840, tel 513-426-8600; Digi-Key, PO Box 677, Thief River Falls, MN 56701-0677, tel 800-344-4539, <http://www.digikey.com>;

# IFLINT

Newark Electronics, (many branches throughout the US; check your telephone book for a branch near you); main office: 4801 N Ravenswood Ave, Chicago, IL 06040-4496, tel 800-463-9275, 312-784-5100, fax 312-907-5217; RF Parts, 435 South Pacific St, San Marcos, CA 92069, tel 800-737-2787; Mouser Electronics, 2401 Hwy 287 N, Mansfield, TX 76062, tel 800-346-6873, 817-483-4422, fax: 817-483-0931 e-mail [sales@mouser.com](mailto:sales@mouser.com); <http://www.mouser.com>.

A template package is *not* available from the ARRL.

<sup>2</sup>Historically, amateurs have built high-power amplifiers with vacuum tubes rather than transistors to avoid complicated power-combining networks and many low-power transistors. See Dick Ehrhorn, W4ETO, "RF Power Amplifiers and Projects," *The 1996 ARRL Handbook*, Chapter 13. Exceptions to this are the elegant designs by Helge Granberg, K7ES/OH2ZE (SK). *RF Application Reports*, published by Motorola Inc, in 1995, contains over 20 Application Notes and Engineering Bulletins written by Helge Granberg on amplifiers with output powers of 20 to 1200 W. Communication Concepts sells the boards and com-

ponents for these amplifiers. *Radio Frequency Transistors*, by Norm Dye and Helge Granberg, published by Butterworth-Heinemann, Boston, 1993, is recommended reading. Joel Paladino, N6AMG, adapted one of Granberg's transistor amplifiers (see "An Experimental Solid-State Kilowatt Linear Amplifier for 2 to 54 MHz," *QST*, Sep 1992, pp 19-23). However, the power transistors alone cost \$900! This led us to look for a less-expensive way to make transistor power amplifiers.

<sup>3</sup>Fred Raab, WA1WLW, "Simple and Inexpensive High-Efficiency Power Amplifier," *Communications Quarterly*, Winter 1996, pp 57-63.

<sup>4</sup>Nathan Sokal, WA1HQC, and Alan Sokal, WA1HQB, "Class-E, A New Class of High-Efficiency Tuned, Single-Ended Switching Power Amplifiers," *IEEE Journal of Solid-State Circuits*, Vol SC-10, Jun 1975, pp 168-175. This paper by father and son is a classic in the radio engineering literature, and is still the basic reference for the Class-E amplifier.

<sup>5</sup>The NorCal 40A designed by Wayne Burdick, N6KR, is available in kit form for \$129 from Bob Dyer, KD6VIO, at Wilderness Radio, PO Box 734, Los Altos, CA 94023-0734, tel 415-

494-3806, <http://www.fix.net/jparker/wild.html>. The NorCal 40A Web address is: <http://www.fix.net/~jparker/norcal.html>.

<sup>6</sup>A number of NorCal 40 modifications were published in *QRPP*, the magazine of the Northern California QRP club that first made the NorCal 40 kit available. For information on subscriptions to *QRPP* and back issues, contact Jim Cates, 3241 Eastwood Rd, Sacramento, CA 95821. Wayne Burdick, N6KR, suggests increasing the supply voltage for more power. If you do this, increase the voltage rating of Zener diode D12 to accommodate a larger peak collector voltage. For 3 W output, we use an MRF237 at Q7, the PA. To further increase the power to 7 W, we reduced L7 from 18 turns to 11 turns, and L8 from 18 turns to 14 turns. We replaced C45 and C47 with 560-pF, 300-V mica capacitors, and C46 with a 1500-pF, 100-V mica capacitor. For other approaches to raising the output power, see Dave Meacham, W6EMD, "5 Watts from your NorCal 40A," *QRPP*, Mar 1995, pp 6-7, and Ron Manabe, KN6VO, "Increasing the Output Power of the NorCal 40," *QRPP*, Jun, 1994 pp 42-45. Ron reports an output power of 7 W.

# High-Efficiency Class-E Power Amplifiers

*Part 2*—Class-E operation permits low-cost MOSFETs to develop considerable power.

Last month<sup>7</sup> we talked about Class-E amplifier fundamentals and began construction of a 40-meter unit. Now we'll tackle the power supply, keyed-waveform shaper and develop some power.

## A Keyed Power Supply

Nonlinear Class-E operation sharpens the CW keying envelope, causing annoying key clicks. To prevent this, we key the power supply to shape the supply voltage. A separate 4×7×12-inch (HWD) enclosure houses the dc supplies, a stretcher circuit that delivers a stretched pulse to the driver and a shaper that produces the shaped pulse for the amplifier. Figure 8 shows how these circuits connect.

So that the RF drive does not end before the shaping pulse, the keying pulse to the NorCal 40A driver is stretched a few milliseconds. The stretcher (Figure 9) takes a keyer's CMOS logic signal and provides a buffered keying waveform to the shaper and a stretched keying waveform to the NorCal 40A driver. Dc supplies (Figure 10) provide 12 V dc to run the ICs and 0 to 120 V dc for the amplifier. A wave shaper (Figure 11) gives this 0 to 120 V dc supply voltage a controlled rise and fall time to avoid key clicks. Figure 12 shows the keyed power supply with its cover removed.

There are other advantages to using a keyed power supply to control the output power. The amplifier power dissipation is low at all supply voltage levels, so that loss is kept low throughout a keying pulse. Because the keyed power supply also acts as a solid-state TR switch, a relay is not needed. This is because the supply voltage is zero except during key down. (This feature works well with the NorCal 40A, because it, too, does not use a relay for switching.) At zero voltage, the drain-to-gate capacitance in a MOSFET is quite large, and the signal from the antenna is fed through the amplifier with a loss of only about 7 dB. The NorCal 40A receiver sensitivity is excellent,<sup>8</sup> and a 7 dB signal loss

does not hurt reception at all. A 7-dB loss degrades the MDS to -130 dBm, still far below typical 40-meter antenna noise levels of -90 to -110 dBm. On the positive side, with 7 dB attenuation, the receiver is less susceptible to intermodulation distortion from other signals in the 40 meter band.

In addition, the amplifier reduces AM broadcast signals by about 20 dB. The 7-dB loss does need to be made up at the audio end. For this, we mount a 2-inch-diameter speaker in a cardboard mailing tube cut to resonate at 650 Hz for CW reception. This gives a sound level that is quite adequate.<sup>9</sup>

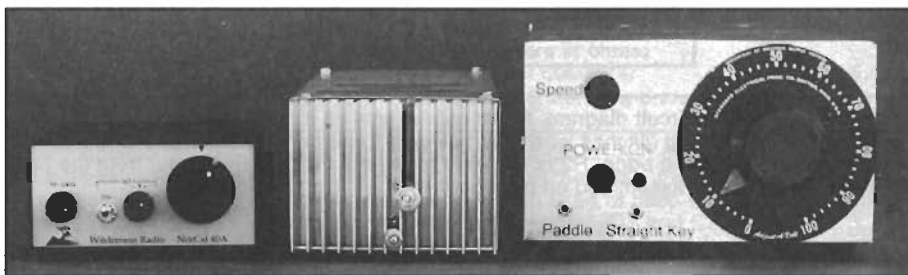

Transceiver, amplifier, and power supply for a 40-meter, 500-W station. The NorCal 40A transceiver driver is on the left, a 500-W amplifier is in the center and the power supply on the right. The amplifier's heat sink and transistor mounting screws are visible. The large dial controls the variable autotransformer, varying the RF output power.

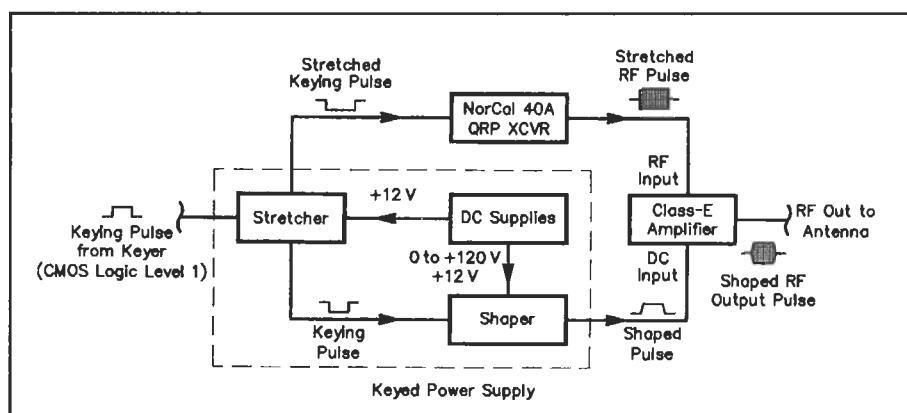

Figure 8—Block diagram showing the connections between the stretcher, dc supplies, shaper, NorCal 40A and the Class-E Amplifier. The stretcher, the dc supplies, and the shaper are in the keyed power supply. Power supply keying is done by a Curtis keyer IC (not shown) that provides a CMOS logic-level 1 during key down. The Curtis keyer IC and application note are available from MFJ Enterprises Inc, Box 494, Mississippi State, MS 39762, tel 800-647-1800, 601-323-5869, fax 601-323-6551; e-mail [mfg@mjenterprises.com](mailto:mfg@mjenterprises.com); <http://www.mjenterprises.com>. (Keyer circuits using Curtis ICs can be found in recent editions of *The ARRL Handbook*.—Ed.)



## The Diplexer

For greater reduction of spurious emissions, we recommend following the amplifier with a band-pass diplexer (see Figure 13) to terminate out-of-band spurious components in a 50 Ω load.<sup>10</sup> Our diplexer (in a 3.5×6×10-inch [HWD] box) uses the equivalents of a 100-pF series capacitor, an 1800-pF shunt capacitor and air-wound inductors. Stretch or compress L2 to achieve minimum SWR. The measured loss of 40-meter signals was extremely low, only 4%. Our experience shows that a diplexer can reduce all spurious components to more than -55 dBc.

## Tune-Up

Refer to Figure 3 in Part I. There are two amplifier coil adjustments. First, with the cover on and the dc input off, L1 is set for minimum input SWR with full RF input. Typically, the SWR can be reduced to 1.5:1. If it cannot be brought below 2:1, try adding or subtracting a turn from L1.

Output power is peaked by stretching or squeezing L2. Note: For safety, the amplifier's cover should always be attached when the RF drive is applied. The cover also significantly lowers the inductance of L2. Be sure to turn off the supply voltage

before you touch *any* amplifier parts! A high RF voltage will burn the skin. RF burns are deep and heal slowly. Having a keyed power supply helps here, because the amplifier supply voltage is zero except during key down.

Attach a dummy load and power meter to J2. With the RF input applied continuously, slowly increase the dc input voltage, while monitoring the gate and drain voltages using an oscilloscope with 10× high-impedance probes. (You should see waveforms similar to **those** in Figure 15, although the peak drain voltage should be about half of

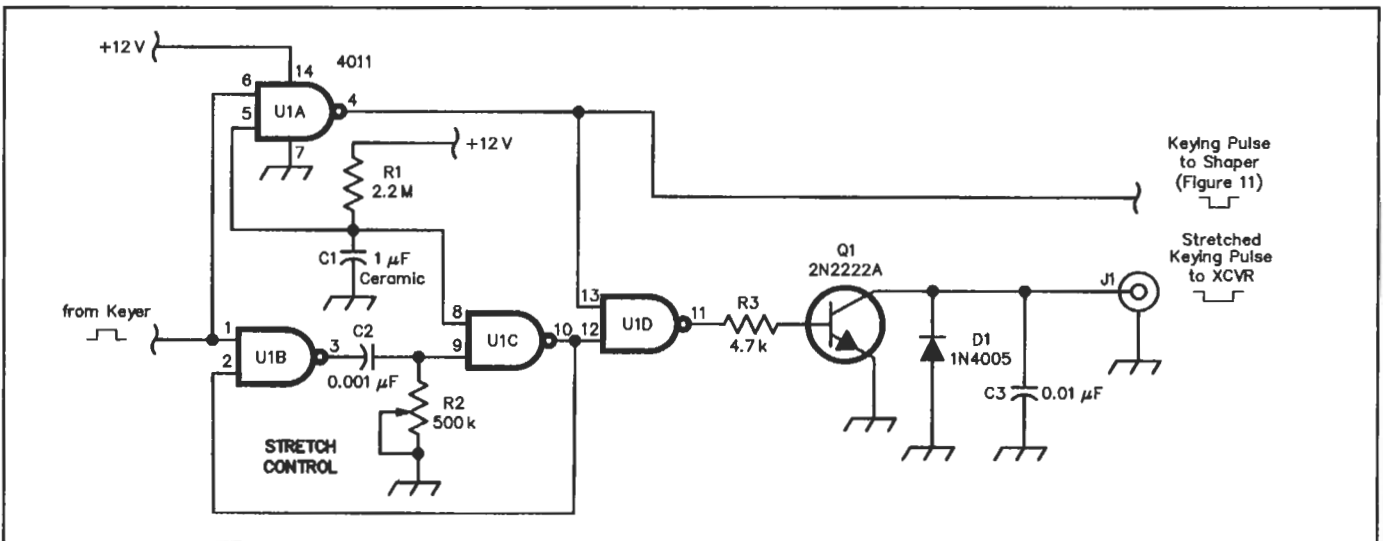

Figure 9—Stretcher circuit diagram. NAND gate A acts as a buffer and produces a keying pulse for the shaper. One input has an RC delay to prevent keying glitches when the power is turned on. Gates B and C are connected by an RC network that causes a pulse to be triggered on a falling edge. R2 is adjusted to ensure that the RF output from the NorCal 40A lasts longer than the shaping pulse. The components are assembled on perboard.

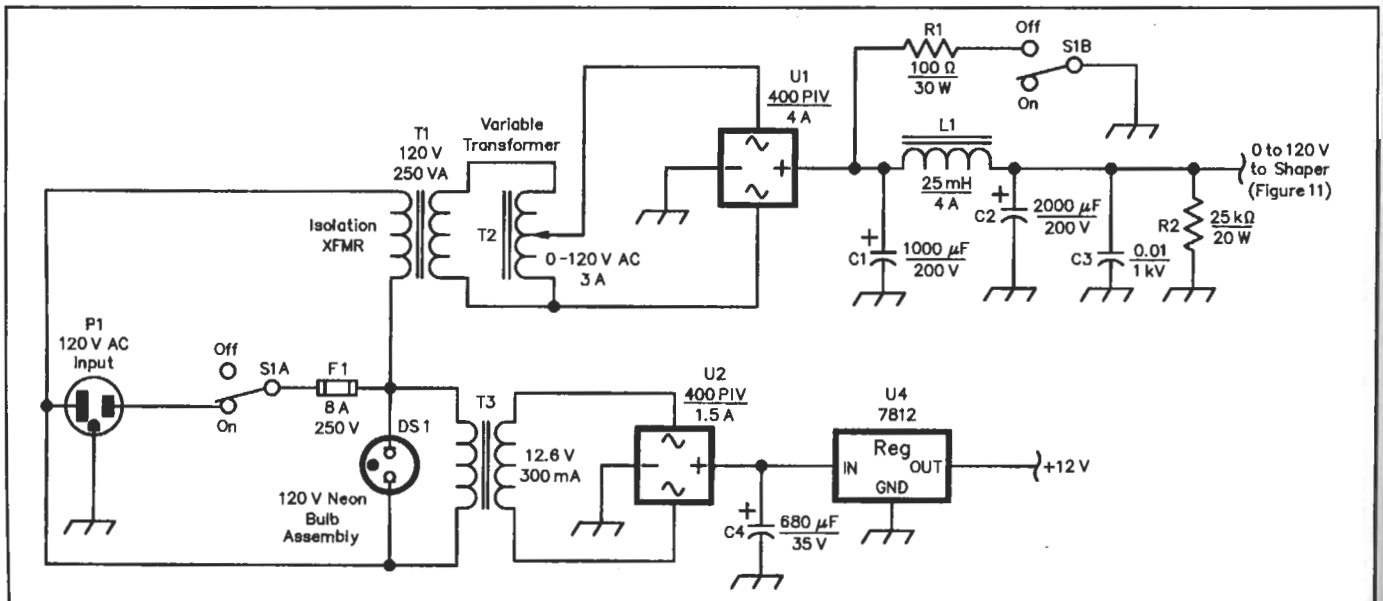

Figure 10—Dc supplies diagram. There are two isolated supplies: one with an unregulated 0 to 120-V output controlled by an autotransformer, and another with a +12-V regulated output. Two bleeder resistors help keep capacitor voltages at safe levels when the supply is turned off or its output reduced. The 4-A bridge rectifier is an RS404LR by Diodes, Inc, available from Digi-Key. The Panasonic 1000 and 2000-µF electrolytics in the filter are available from Digi-Key. The Stancor C-2686 25-mH choke is available from Newark. We scrounged the isolation transformer and variable autotransformer from old equipment. Look for them at swap meets, or purchase equivalents from Newark (Magnetek N55M 250-VA isolation transformer and the Staco 291 3-A variable autotransformer).

# FLINT

that in the figure.) The RF output should begin to rise. Increase the dc input until the forward RF output power is 25% of full power. Make sure the output SWR is 1.5:1 or less. Measure the dc input voltage, and adjust L2 to give 25% power at 60 V dc. Stretching L2 reduces its inductance and increases the output power, but usually lowers the amplifier's efficiency. Squeezing L2 reduces the output power and usually increases amplifier efficiency.

Increase the dc input voltage until the amplifier reaches maximum output power. The dc voltage should now be between 115 and 120 V, and the peak drain voltage

of the RF-stage MOSFET should be between 380 and 420 V. Larger peak drain voltages run the risk of transistor failures. Lower voltages may indicate an excessive drain current, which can lead to a failure. If the voltage is too high, stretch the coils a bit more. If the voltage is too low, squeeze the coils. Check the RF drive and input SWR again. You may find that they have changed somewhat and that readjustment is needed. Measure the dc supply current and voltage, and calculate the amplifier efficiency to ensure that it is 85% or above. Use a 0.001- $\mu$ F capacitor to bypass the voltmeter terminals because an RF voltage

there can cause a significant measurement error. (In addition, you should realize that RF power meters often have error factors as high as 10%.)

## Keyed-Waveform Shaping

The keying envelope is controlled by the three potentiometers in the shaper and stretcher circuits. R3 in the shaper circuit sets the rise time, R4 sets the fall time. R3 also helps control the power supply droop as the amplifier is keyed. R2 of Figure 9 determines the stretch in the pulse that keys the NorCal 40A, so that it does not stop transmitting before the end of the shaped

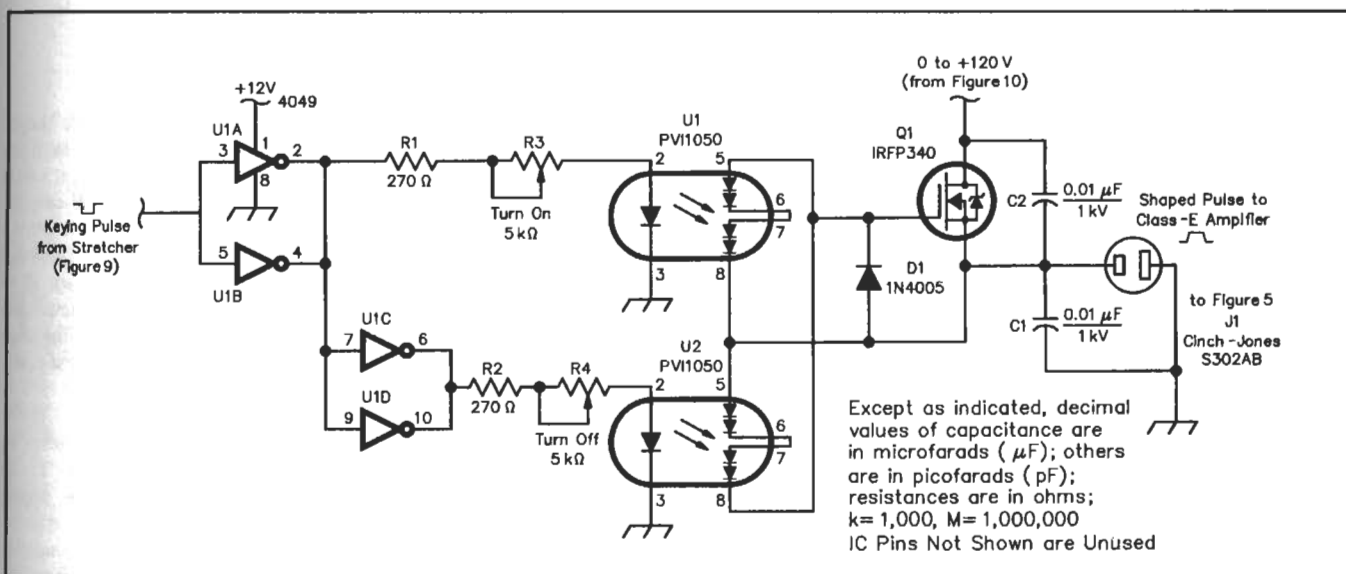

Figure 11—Shaper circuit diagram. A pair of optically isolated MOSFET drivers (type PVI1050) turn Q1 on and off to bring the supply voltage up and down. Keying waveform rise and fall times are adjusted by R3 and R4, which control the current to each MOSFET driver. The 270- $\Omega$  resistors limit the LED current to a safe level. The TURN-ON potentiometer is also used to keep the overshoot from the unregulated power supply to a reasonable level. D1 prevents Q1's gate voltage from drifting negative. C1 and C2 are RF bypasses. To keep the supply voltage from appearing across exposed contacts, a female socket is used at J1. All components are available from Digi-Key. Point-to-point wiring on perboard is used.



Figure 12—The keyed power supply with the cover removed, viewed from the side. T1 is mounted on the back plate, along with the fuse and connectors for the dc output, a keying line to the NorCal 40A and the ac line input. The TUNE switch keys the amplifier for testing. The variable autotransformer is on the left, mounted to the front panel. In the center foreground, mounted to the base plate, is L1, the 25-mH choke. Mylar sheets are taped to the perboards for electrical isolation. The large components are attached directly to the box. The IRFP340 is mounted on the bottom of the box using a Berquist K10-104 Kapton insulating pad, #6-32 screw and a torque of 10 inch-pounds. The other shaping circuit components are mounted on perboard. Layout is not critical.

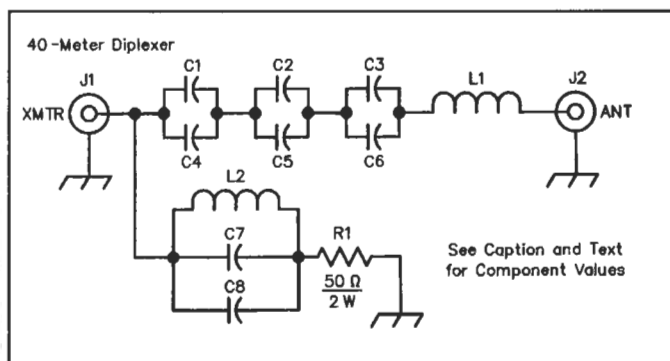

Figure 13—Schematic of our diplexer. It uses six 150 pF capacitors, two 910-pF capacitors and air-wound inductors made of  $\frac{3}{16}$ -inch-wide copper tape (see Note 1).  
 C1-C6—150 pF, 1 kV mica 5%-tolerance (Cornell Dubilier type CDV19; available from Newark Electronics, see Note 1)  
 C7, C8—910 pF (same type as above)  
 L1—24 turns of  $\frac{3}{16}$ -inch-wide copper tape,  $1\frac{3}{8}$  inch ID; see Note 1.  
 L2—4 turns of  $\frac{3}{16}$ -inch wide copper tape, 1 inch ID; see Note 1.  
 R1—50- $\Omega$ , 2-W (approx) termination, Jameco part number 71458; available from Jameco Electronics, 1355 Shoreway Rd, Belmont, CA 94002, tel 415-592-8097; fax 415-592-2503 and 415-595-2664)

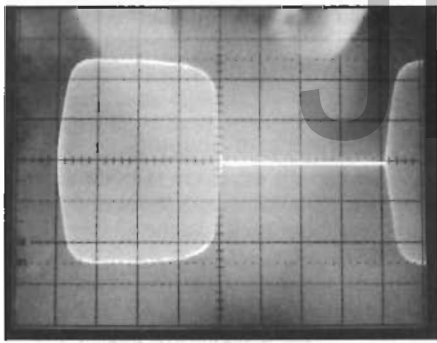

Figure 14—Keying waveform of the 500-W amplifier at 30 WPM. The horizontal axis is 10 ms per division. The rise and fall times are about 3 ms.

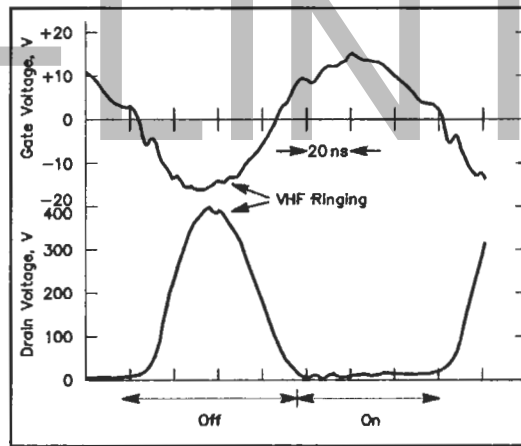

Figure 15—Drain waveform and ringing. Oscilloscope trace of the gate and drain voltages of the 300-W amplifier with 3 W drive. The dc supply voltage is 120 V; the input SWR is 1.6:1. Time scale is 20 ns per division; the transistor off and on times are shown. The transistor is off when the gate voltage is below the threshold, typically 4 V, and on when the gate voltage is several volts above the threshold. Peak gate voltage is 16 V, and the peak drain voltage is 400 V, safely within the manufacturer's ratings of 20 and 500 V, respectively.

pulse. We recommend using a keyer with adjustable weighting to offset the pulse stretching. The potentiometer settings interact somewhat, and there are variations at different sending speeds, so it is best to set them at the speed you commonly use. Adjust the controls for rise and fall times between 2 and 5 ms, and for a smooth keying envelope. Figure 14 shows keying at 30 WPM with rise and fall times of about 3 ms.

### VHF Ringing

In many Class-E amplifiers, ringing in the VHF range can be seen on the gate and drain waveforms (Figure 15). This ringing can be quite pronounced, with bumps several volts high on the gate or drain or both. The bumps disappear when the RF input is removed, and that is why we refer to this as *ringing* rather than *oscillation*. We have compared measured spectral plots with *PSPICE* simulations and believe that the waves are driven by the sudden turn-on and turn-off of the transistor, acting rather like the gong of a bell.

We notice two distinct time periods and frequency ranges for the ringing. During the time the transistor is on, the ringing frequency is about 80 MHz. This appears to be a resonance of the external drain capacitor combined with the internal inductance of the capacitor and the transistor and may indicate a mismatched load. The on-ringing is usually small if the load is matched so that the drain voltage comes smoothly to zero before the transistor turns on.

The ringing while the transistor is off covers a broad range of frequencies—from 130 to 210 MHz. If the output low-pass filter is removed, the ringing can be seen easily on a spectrum analyzer at levels between -40 and -60 dBc. The off-ringing appears to be caused by a resonance of the external drain capacitor and its internal inductance, together with the transistor's internal drain capacitance and its inductance. The internal drain capacitance varies greatly with the drain voltage, so that the frequency is modulated as the drain voltage rises and falls. The low-pass filter reduces these harmonics to the -70 to -80 dBc range.

### On the Air

The amplifiers meet the FCC requirements for spectral purity [confirmed in the ARRL Lab—*Ed.*]. NorCal 40A designer Wayne Burdick, N6KR, emphasizes that it is important to correctly tune the band-pass filter following the transmit mixer to minimize spurious emissions from the NorCal 40A.<sup>11</sup>

These amplifiers are excellent for chasing DX, schedules and "ragchews," particularly at this low point of the sunspot cycle. The amplifiers require no warm-up, no tune-up, and produce no fan or relay noise. We can vary the power from 1 W to full power via the variable autotransformer. The antenna SWR should be 1.5:1 or better because the amplifier is not protected against large mismatches. With a high SWR, the transistor will probably overheat. Check the dc voltage when the amplifier is delivering full power to the antenna to ensure that it remains between 115 V and 120 V. Readjust the coils if the voltage is too high or too low.

Our most common problem has been a poorly mounted PA transistor. If the transistor is not flat against the heat sink, heat transfer is poor and the transistor becomes quite hot; efficiency suffers (becoming usually less than 85%) and the amplifier may not reach full power. The output power may also drift downward, a sign that the transistor temperature is increasing and that the transistor is under stress.

Component temperature can be a good diagnostic tool. For the 500-W amplifier, our experience is that for CW QSOs longer than 30 minutes, the temperature of C3, C5 (Figure 5) and the heat sink rises to about 60°C. For the 300-W amplifier, the heat-sink temperature is about 50°C. This is hot to the touch, and it can be checked with a lab thermometer. The temperature will vary according to your operating style, and if the temperature is higher than you like, you can add a fan.

### The Future

We see room for improvements: protection against antenna mismatches and

employment of an inexpensive keyed *switching* power supply that is as light-weight as the amplifiers. Finally, it would be interesting to develop Class-E amplifiers for the other bands. We have built a 250-W amplifier for the 20 meter band that exhibits an efficiency of 88% with 10 W drive. We believe that Class-E amplifiers provide amateurs with good building challenges and operating fun at modest cost.

### Acknowledgments

This work began as senior theses by Joyce Wong and Meng-Chen Yu at Caltech, and many of their ideas appear here. John Davis was supported by a scholarship from the James Irvine Foundation and the Army Research Office. Eileen Lau, Kai-Wai Chiu, and Jeff Qin received Caltech Summer Undergraduate Research Fellowships funded by the ETO Corporation and the Caltech Gates Grubstake Fund. We appreciate the help from all the people at the ETO Corporation, particularly Dick Ehrhorn, WØID; Don Fowler, W1GRV; Tim Coutts; Chip Keen and Frank Myer. Mitsu Sakamoto, JA4FVE, of Kurashiki, Japan, sent us off-the-air recordings over the Internet. We would like to thank Wayne Burdick, N6KR; Wes Hayward, W7ZOI; and Bill Bridges, W6FA, for their advice.

### Notes

- <sup>7</sup>Eileen Lau, KE6VWU, et al, "High-Efficiency Class-E Amplifiers—Part 1," *QST*, May 1997, pp 39-42. The amplifier enclosures are 3 1/8x4 1/8x7 1/8 HWD.
- <sup>8</sup>Rick Lindquist, KX4V, "Low-Power Transceiver Kits You Can Build," Product Review, *QST*, Jun 1996, pp 45-50.
- <sup>9</sup>See J. B. and R. V. Heaton, "An Electro-Acoustic CW Filter," *QST*, Apr 1983, pp 35-36; Wally Millard, K4JVT, "A Resonant Speaker for CW," Hints and Kinks, *QST*, Dec 1987, p 43; and Richard Clemens, KB8OAB, "More on Resonant Speakers," Hints and Kinks, *QST*, Jan 1989, p 37.—*Ed.*
- <sup>10</sup>David Newkirk, WJ1Z (now W9VES), and Rick Karlquist, N6RK, "Mixers, Modulators, and Demodulators," *The 1996 ARRL Handbook*, Chapter 15, p 15.22.
- <sup>11</sup>Telephone conversation with Wayne Burdick. This tuning is done by carefully adjusting C50 to peak the output power.

# A 100-W MOSFET HF Amplifier

We had the power supply in Mar/Apr<sup>1</sup> and the diplexer filters in Jul/Aug,<sup>2</sup> here's the main event: a reliable FET power amplifier that needs only 10 dBm of drive to produce a pristine 100 W output.

The two-stage amplifier described in this article and shown in Fig 1 is intended for SSB/CW/Data operation on all nine HF amateur bands. An input ( $R_{in} \approx 50 \Omega$ ) of about 10 mW (+10 dBm) is amplified to 100 W (PEP or average), continuous duty, with a gain of 40–1.0 dB from 1.8 to 29.7 MHz. Third-order, two-tone intermodulation distortion (IMD) products are 35 to 40 dB below 100 W, and higher-order products are also within the high-quality range for amateur SSB equipment, as shown in Fig 2. The main goal for this amplifier is to operate as a driver, with low adjacent-channel interference, for a legal-limit 1500-W linear amplifier. At this power level, adjacent-channel reduction is especially important. And, of course, it is used in the barefoot mode as well.

The power supply (40 V at 8 A) for the push-pull, class-AB MRF150MP (matched-pair) MOSFET output stage was described previously (see Note 1). Six diplexer filters (see Note 2) also known as invulnerable filters provide more than adequate harmonic attenuation for all nine HF bands. They present a broadband load impedance to the MOSFETs that helps to assure freedom from regeneration and oscillation, and good IMD performance. A resistive load impedance between 45  $\Omega$  and 55  $\Omega$  is recommended for best performance.

The MRF 150 was chosen because it is designed for linear, class-AB SSB operation and because it has high gain (gm) at the 30-MHz end of the HF spectrum. A desirable feature of the MOSFET power transistor is its ability to achieve low values of the higher-order IMD products.<sup>3,4</sup> As mentioned previously, these products contribute to adjacent channel SSB interference. The first stage uses high-gain, class-A push-pull MRF426 (matched-pair) BJTs that require 13.5 V at about 1.0 A

from a separate supply. This supply is also the main supply for other system components. Matched pairs of both transistors are available for a small extra fee from at least two sources.<sup>5,6</sup> They are both listed in the current Motorola manual.<sup>7</sup>

One main idea for this amplifier is to operate it in a very low-stress manner that helps assure a low probability of failure for a very long time, which offsets the initial cost of the high-quality transistors. The MRF150 is a 50-V transistor operated at 40 V; the MRF426 is a 28-V transistor operated at 13.5 V. The required input level is low enough that most of the amplification at the signal frequency occurs in one gain block. Because of the good layout, circuit

design and decoupling, the 40-dB gain value does not result in any stability problems.

The balanced amplifier greatly reduces even-order harmonics—especially the second—prior to any output filtering, as shown in Fig 3 for a 7.0-MHz signal. It should be 40 dB or more below a 100-W CW signal for each amateur band. This reduction has been found reliable, once achieved. The lowlevel signal source that drives this amplifier must have at least 50 dB of second-harmonic attenuation, since this amplifier will not suppress that harmonic. This is easy to accomplish, but must be considered during the equipment system design (see Fig 9) and while bench-testing the amplifier as shown in Fig 4.

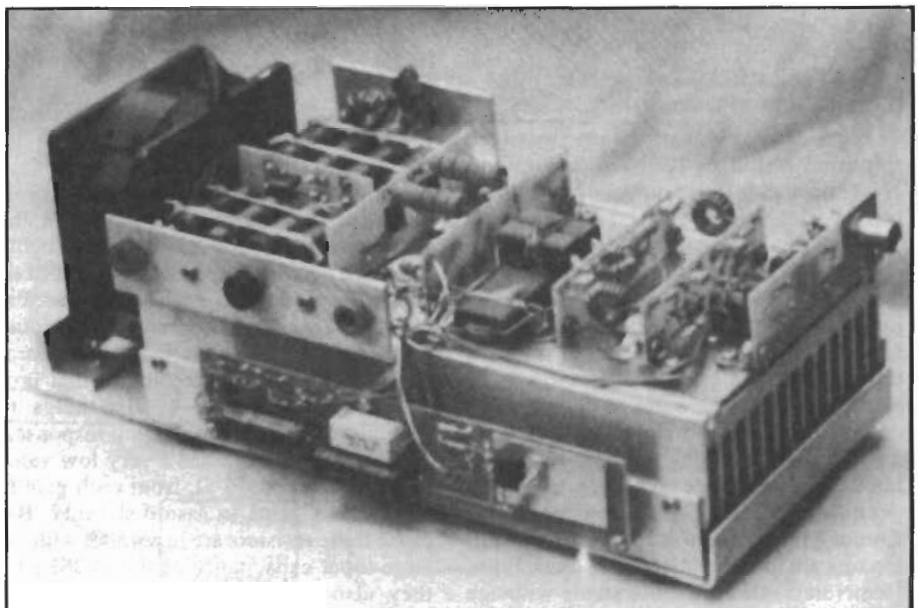

Fig 1—The 100-W broadband amplifier.

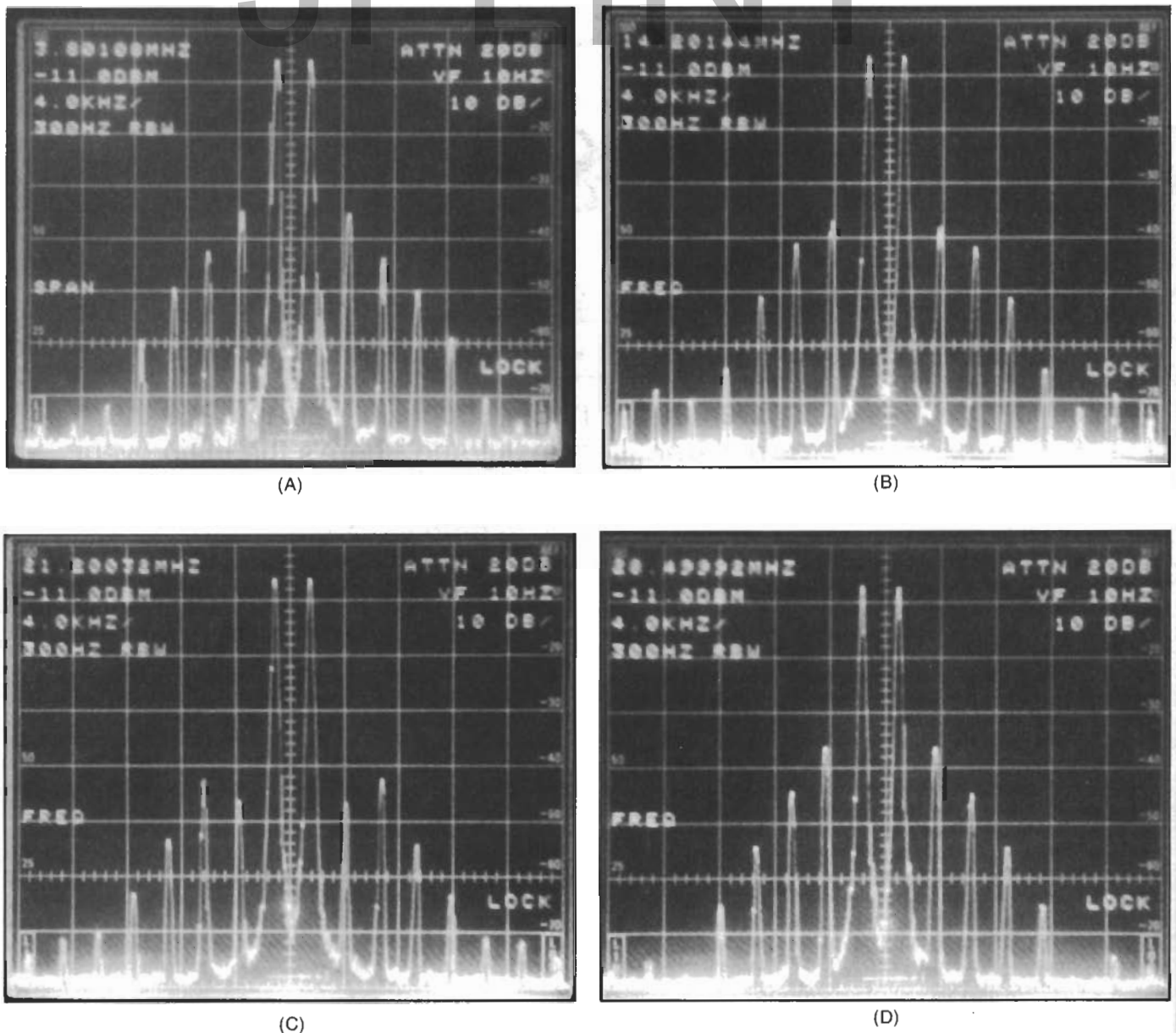

Fig 2—Two-tone IMD products: (A) 3.8 MHz, (B) 14.2 MHz, (C) 21.2 MHz, (D) 28.5 MHz.

### Circuit General Discussion

Fig 5 is the schematic of the two-stage amplifier. It utilizes 1:1 choke baluns and 1:4 (impedance) step-up and step-down transmission line (Guanella) transformers. The choke baluns significantly improve the balance of the input and output stages. Notice also that T2, T3 and T4 have floating center taps rather than bypasses to ground. This is recommended to improve the even-harmonic balance<sup>8</sup> (verified). T4 and T5 run slightly warm as compared to conventional transformers that get quite hot. The 5-W feedback resistors get warm, but their large surface area limits their temperature rise. They also receive cooling air from the fan. All power resistors in the RF circuits are the excellent metal-oxide types (see Note 5) that are quite stable with age and temperature, and have very low reactance at 30 MHz (measured). Metal-film

1% resistors are used in several critical locations.

The first stage has resistance and inductive loading from collector to collector. A powerful free-running oscillation in the first stage at about 32.5 MHz was being triggered occasionally at the moment of dc supply turn-on while a fairly large 28.0 to 29.7 MHz input was present. The loading reduces stage gain and suppresses the parasitic collector circuit resonance that produced the oscillation. It also helps to flatten the amplifier frequency response.

The second stage has a very low value of RF resistance, 15  $\Omega$ , from each gate to ground that helps to assure stability. Because these resistors are in parallel with the large input capacitance of the MOSFETs, they also help to flatten the frequency response. Both stages have negative feedback networks that further assure stability

and flatness of frequency response.

Two biasing networks are employed. The LM317 provides a highly regulated gate voltage for the second stage. The FET dissipation and linearity are very sensitive to this voltage; the bias voltage for SSB is fine-tuned for best signal purity using two-tone tests and a spectrum analyzer. Note the four 562-a resistors. If the LM317 fails short circuit, the voltage on the FET gates does not exceed 6.8 V, which will not damage the gates. The large drain current that results from this failure also does no damage because the 40-V power supply has current limiting and voltage fold-back that prevent harmful FET dissipation. The FETs are thus kept well within the safe-operating-area (SOAR) as defined in data sheets<sup>9</sup> (verified). It is important that each 56241 resistor from gate to ground be permanently attached directly between the gate and

# JELINT

source tabs of the FETs themselves so that the gates are never floating. Wrap the resistor leads around the tabs so that they cannot come loose. This avoids accidental static charges that might ruin them. On the other hand, it is better to tack and not wrap the base-collector and gate-drain signal leads so that they can be easily disconnected. We want to be able to test individual segments of the circuitry easily. In my experience, the MRF150 has proven to be a rugged transistor, much more so when operated conservatively and with the power-supply safeguards that I mentioned.

The LM317 provides about 5.8 V for the particular pair of FETs that I used. Individual pairs of FETs will probably require an adjustment of this voltage for idling current and for IMD products that resemble Fig 2. The adjustment procedure is described later. This bias value is set to emphasize the reduction of the higher-order products rather than third- and fifth-order products. These lower-order products do not contribute as much to adjacent channel interference; in fact, an SSB speech processor will make them worse anyway. The higher-order products need to be reduced and the MRF150 has this capability.

The 2N3906 PNP transistor is a bias-current source. The value of this current is determined by the 4.7-Ω resistor and the base-to-ground voltage of the 2N3906. The two 562-Ω resistors force equal base currents into the MRF426s. This helps to assure equal performance. The 0.47-Ω resistor is part of a negative-feedback bias loop. If collector current increases, the voltage across this resistor increases and this reduces the base current. Thermal runaway is avoided by this strategy because

the reduced base bias restricts the current increase to a small value. Because of the low dissipation of the MRF426s and the good heat sink, this method is very effective. These transistors are also well inside their SOAR requirements. This stage is very linear and contributes almost nothing to the overall IMD products. To verify this, it is necessary to turn off the drain voltage to the MRF150s and connect a spectrum analyzer across one of the 15-Ω resistors.

The diplexer filter method was decided upon after a lot of experimentation with other low-pass filter methods as a solution that is free of problems caused by complex

interactions between the filters and the output transistors. A special peculiar problem is discussed later. The MRF150 has high gain into the VHF region; the diplexers eliminated all problems associated with this fact. This approach is recommended as a simple way to assure correct operation for HF amateur-band operation of these high-frequency MOSFETs. I was able to get good enough operation with the more conventional low-pass filters, but this approach was by far the most satisfactory for an amateur-band amplifier, as confirmed by swept-frequency tests at all power levels into a 50-Ω load. More about complex loads later.

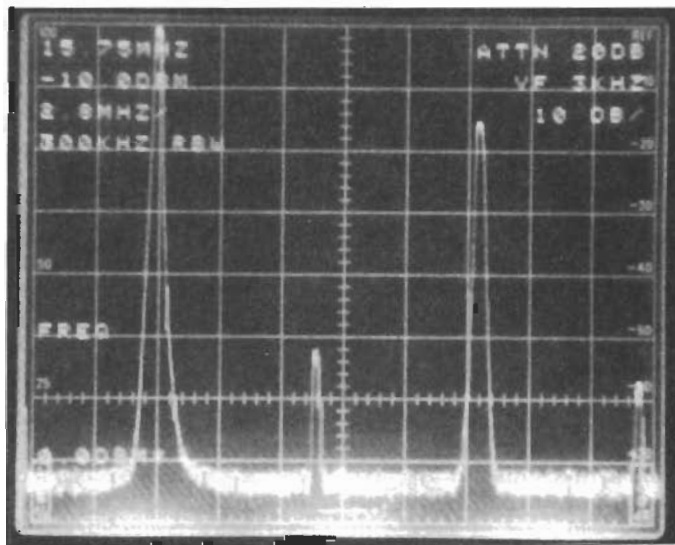

Fig 3—Wideband spectrum for a 7-MHz signal.

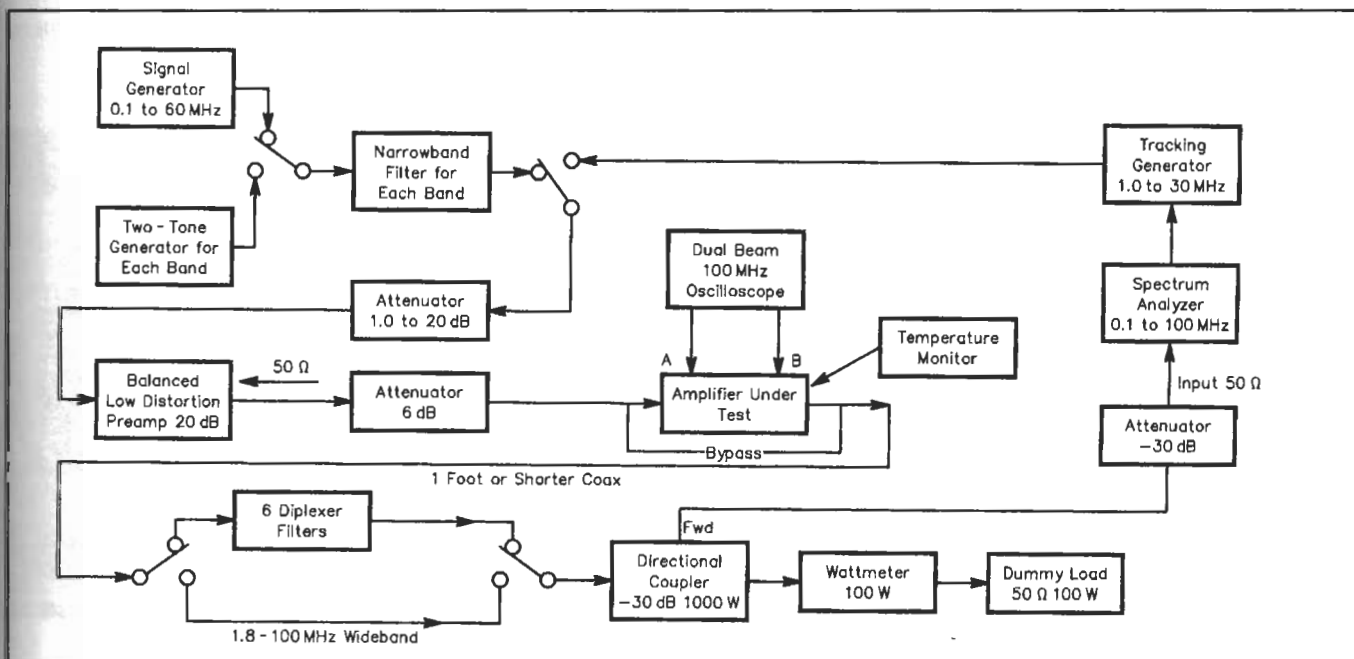
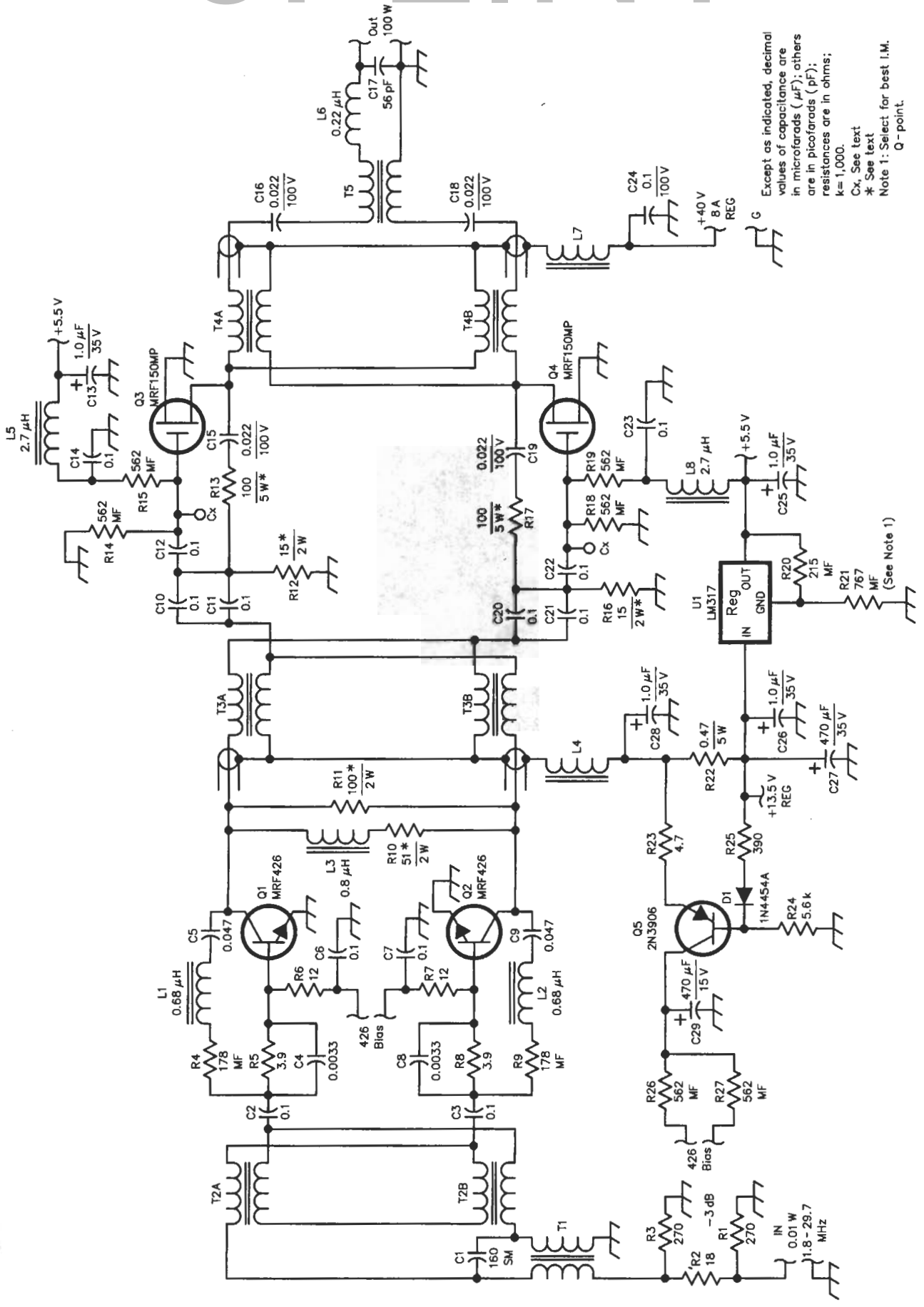

Fig 4—Block diagram for equipment setup, design and testing of the MOSFET amplifier.



Except as indicated, decimal values of capacitance are in microfarads (μF); others are in picofarads (pF); resistances are in ohms; k=1,000.  
 \* See text  
 Cx, See text  
 Note 1: Select for best I.M. Q-point.

Fig 5—(left) Schematic diagram of a two-stage, 100-W amplifier. Unless otherwise specified, use 1/4 W, 5%-tolerance carbon composition or film resistors. Resistors marked with an asterisk are metal-oxide units. MF indicates metal-film resistors. Both the MRF426 and MRF150 devices are matched pairs. All capacitors are 50 V, unless otherwise indicated.

### Frequency Compensation

The bipolar transistors have gain values that decrease as frequency increases. The MOSFETs have large capacitances that also affect frequency-response roll-off. It was a major exercise to design networks that flatten the response from 1.8 to 29.7 MHz. Fig 5 shows the approach. The idea is to compensate smoothly from input to output in such a way that neither of the two stages is over-driven at any frequency. The criterion for this is to check IMD products and harmonics during the design process, which involves approximate analysis (see the MOSFET Stage Simulation sidebar) and negative feedback.<sup>10</sup> Beyond about 32 MHz, the gain falls off fairly rapidly (but not too rapidly). This is also desirable.

When testing the frequency response using the test setup of Fig 4, it is necessary to measure the frequency response of the signal path from tracking generator to spectrum analyzer while bypassing the 100-W amplifier. This reference response is then compared with the response with the amplifier in the path, as shown in Fig 6. Note the vertical scale: 1.0 dB per division. For the most credible results and ease of measurement, it is very desirable that the impedance looking back from the input be 50  $\Omega$ .

### Signal Level Testing

We want to verify that the first stage is operating normally by measuring its RF

voltages at 4.0 MHz. The class-A first-stage input impedance is close to 50  $\Omega$ , and the input level is +10 dBm. Temporarily disconnect the signal leads to the gates of the FETs. The voltage at each output of T3 is about 1.35 V. Reconnect the gate signal leads. The final output over the entire range is then observed using the setup in Fig 4. A spectrum analyzer with tracking generator is very valuable for this. The accuracy of the wattmeter should be verified or calibrated by some means at both the 100-W and the 25-W levels (the power of each tone of a two-tone, 100-W PEP signal) in each amateur band.

If the second stage is working correctly, the output power is 100 W, or 71 V RMS across 50  $\Omega$ . These procedures assure that both stages are working properly and amplifying as intended. Because of the variations in the fabrication of the transistors,

the total gain can vary a decibel up or down despite the use of negative feedback in each stage. I suggest the 3-dB attenuator at the input not be modified for simplicity reasons.

The drain-to-drain load impedance of the class-AB output stage is 12.5  $\Omega$  and the CW output power is 100 W, so the drain-to-drain ac voltage is 35.4 V. Fig 7 shows the dual-trace scope waveforms (chop mode) on each drain, superimposed on the 40-V supply, and also the drain-to-drain waveform that is confined to the linear region. The third-harmonic content is visible. It is interesting to note that although these waveforms show considerable non-linearity, the fundamental component is quite linear with respect to the gate signal level. I also found that a 50-V dc supply created more heat, but at 100W, did not improve linearity enough to make it worthwhile. The 35.4 V ac also appears across the two series-connected 100- $\Omega$  feedback resis-

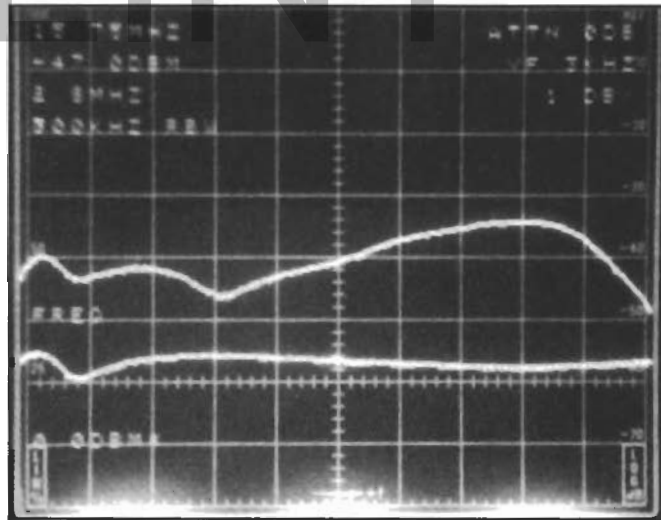
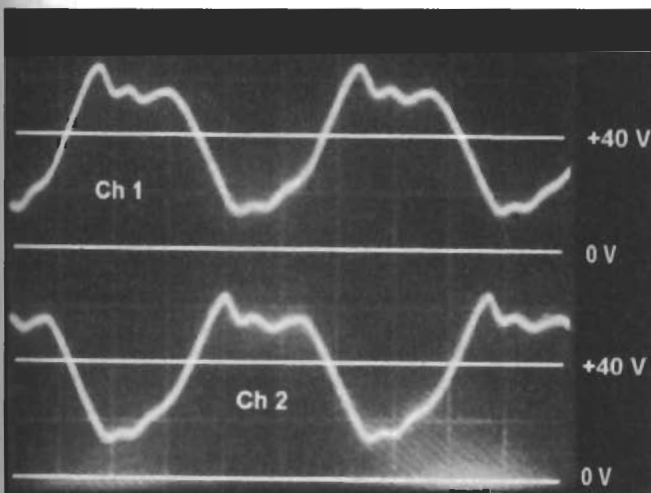
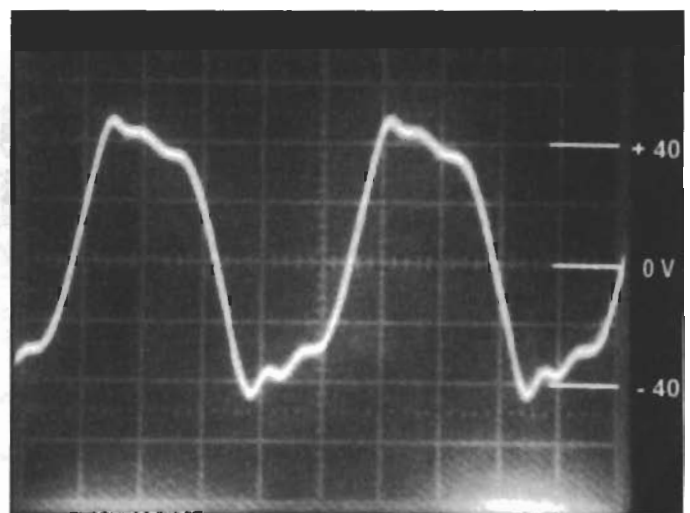

Fig 6—Gain variation, 1.8 MHz to 29.7 MHz, 1.0 dB per division vertical scale—The lower trace is a reference sweep that bypasses the 100-W amplifier—The response bump at low frequency is an artifact of the tracking generator.



(A)



(B)

Fig 7—(A) drain and (B) drain-to-drain oscilloscope waveforms.



tors; they dissipate about  $(35.42)/200 = 6.3$  W, or 3.2 W per resistor (64% of the 5 W rating).

A broadband, untuned power amplifier with flat frequency response and low distortion is not, by necessity, especially energy-efficient (ratio of RF output power to dc power). The output stage is less than 40% efficient for this reason. For SSB use, where the average power is not more than 25 W, even with speech processing, this is no problem at all. For continuous key-down at 100 W, the cooling fan is more than adequate.

Here is an important caution about using oscilloscope probes at the FET drains and the output connector: A 10:1 probe could be damaged (it happened to me) if used directly at this RF voltage level, especially at the upper end of the HF range. Use instead the homemade probe described previously (see Note 2) with a 50- $\Omega$  terminating resistor.

The quality of balance is checked by looking at the second harmonic on a spectrum analyzer using the setup in Fig 4 with the diplexer filters out of the signal path. At 100 W output, check the harmonics in each of the nine amateur bands. Capacitor  $C_x$  in Fig 5 is used (if needed) to improve the secondharmonic phase balance on the higher amateur bands. If the value is not well below 40 dBc, use  $C_x$  at one gate or the other to achieve 45 dBc. Extra pads are provided on the PC board for this capacitor. A value of between 22 pF and 56 pF should be adequate. Overkill is neither nec-

essary nor desirable: The output filters will do the rest. For each decibel of power output below 100 W, the second harmonic normally drops about two decibels.

### Construction Notes

Fig 1 shows how my version of the amplifier is constructed. A 0.125-inch (or 0.062-inch) double-clad PC board, 3.25  $\times$  8.0 inches, is firmly attached to the heat sink. I suggest using this compact size for best reproducibility. The heat sink shown may not be presently available from RF Parts (see Note 5), but I also purchased a Model 99 sink from CCI (see Note 6) that is 6.5 $\times$ 12 inches. This can be easily tailored to the appropriate size with a band saw that has a metal-cutting blade. Pieces of angle and sheet aluminum can then be creatively fashioned to accommodate the fan (RadioShack #273-242) and the PC board that contains the bias circuitry. The transistors are bolted directly to the heat sink (through cutouts in the PC board) using heat-sink compound and tapped (and carefully deburred) #4-40 holes. Careful mounting of the transistors is essential. The main PC board has small sections of copper removed underneath the base and collector tabs of the MRF426s and underneath the gate and drain tabs of the MRF150s, so that accidental grounding is avoided. Use a hobby knife to define the areas and a hot soldering iron to peel off the copper.

A bottom cover is advised, as shown, so that air is funneled through the heat-sink

fins efficiently. For a 100-W, continuous, single-tone output, the exhaust air temperature reaches 50°C. I used a RadioShack #22-174 multimeter with its temperature probe mounted inside the fins to monitor temperature during the design and testing phase.

The components are mounted on a set of seven small PC boards, six of which are mounted vertically (as shown) and bolted to the drilled-and-tapped heat sink through the PC board, using #4-40 screws and small angle brackets. I used stiff, right angle #6 solder lugs that worked out very nicely. The seven PC boards are cut from a single 4 $\times$ 6-inch two-sided PC board, shown in Fig 8. The bias circuit board has a ground plane; the others do not. This set of boards is available from FAR Circuits.<sup>11</sup>

I chose this method because it is easy, makes the amplifier more compact, reduces stray L and C that can degrade the wide-band frequency response and reduces stray couplings that can impair stability and harmonic balance. It also allows the ground plane to be one continuous surface, which is a plus factor. This approach worked out very well and I recommend it as a simple approach.

### Temperature Rise

The cooling fan is important. This amplifier, as designed, should have the fan running, and I have found that a simple and reliable way to keep everything safe. It has been tested at 100 W continuously, for sev-

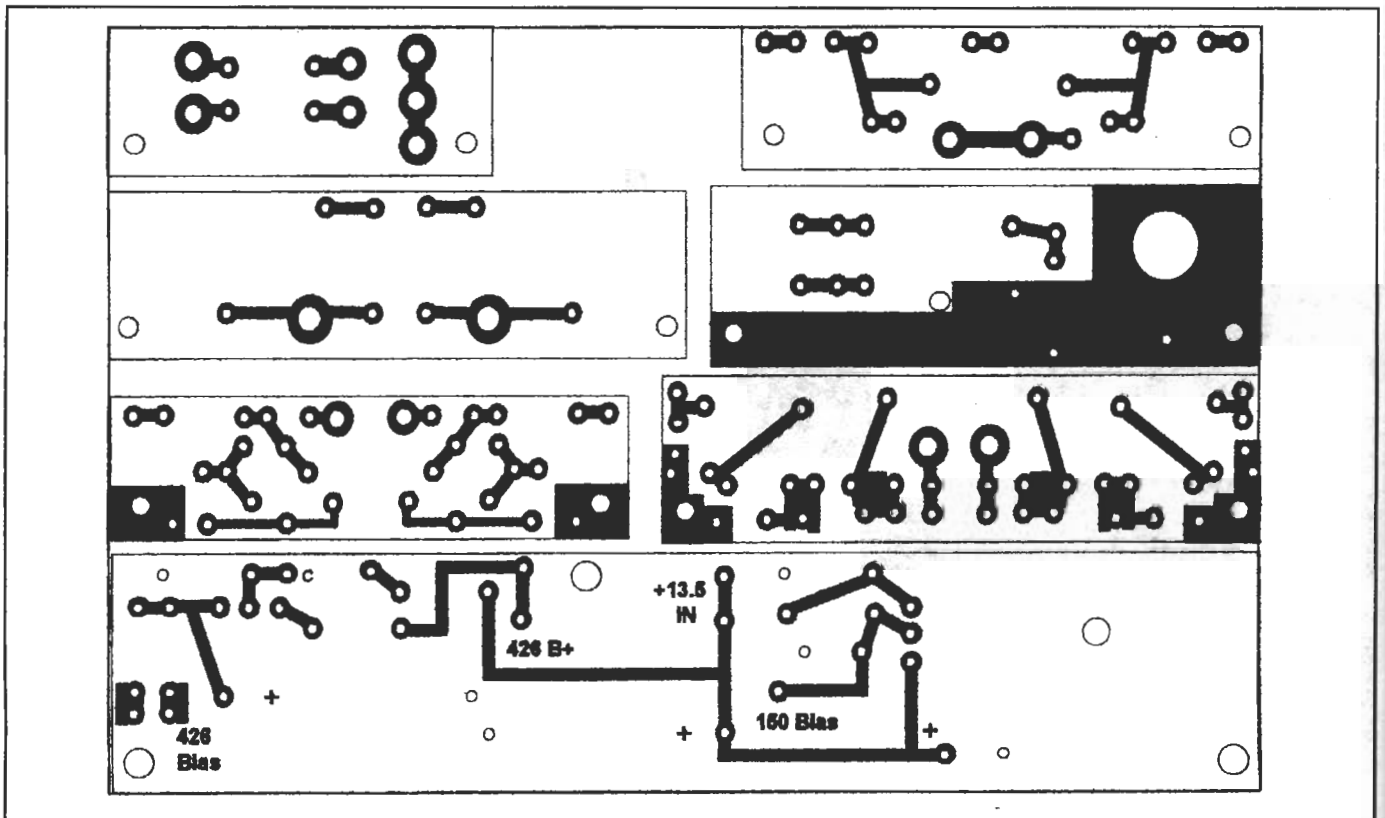

Fig 8—Etching pattern for a 4 $\times$ 6 inch (finished size) PC board that provides the seven individual boards.

## MOSFET Stage Simulation

A simplified analysis of the second MOSFET stage is presented (Fig A) to illustrate the effect of the resistive negative feedback of the 100- $\Omega$  resistors and the 40-pF gate-to-drain capacitance. The simulation diagram shows the voltage-controlled current sources with a  $G_m$  of 6.0 S, which is assumed constant over frequency. The gate-to-source capacitance is 360 pF and the drain-to-source capacitance is 200 pF. These numbers are from the MRF150 data sheets.

The frequency plot (Fig B) obtained from the ARRL Radio Designer program shows the gain, MS21 (dB), with (lower trace) and without (middle trace) the 100- $\Omega$  feedback resistors. The gain variation is reduced from about 6 dB to about 1.5 dB. In this simplified model (good enough for this illustration), the gain drop is caused by the capacitors, especially the 40-pF capacitor whose influence is greatly magnified by the Miller effect. If this 40-pF capacitance is eliminated from the simulation, the frequency response variation—even without the feedback resistors—is less than 1.0 dB, as seen on the upper trace.

If the power output at 15 MHz is to be held constant, the turns ratio of the output transformer and the value of the feedback resistors can be manipulated to achieve that end. The simulation shows that a turns ratio of  $1:\sqrt{2}$  and a resistor value of 120  $\Omega$  does this. The FET load impedance is now 25  $\Omega$  instead of 12.5  $\Omega$ . The increased voltage gain makes the Miller effect greater and increases the gain variation (lower trace) to 2.3 dB. The drain-to-drain voltage is now 50 V instead of 35 V, and this results in higher drain efficiency for the MOSFETs. However, the push-pull  $1:\sqrt{2}$ -turns-ratio transmission-line transformer is not as simple as the 1:2 that uses 25- $\Omega$  coax, and for me, that was the determining factor.

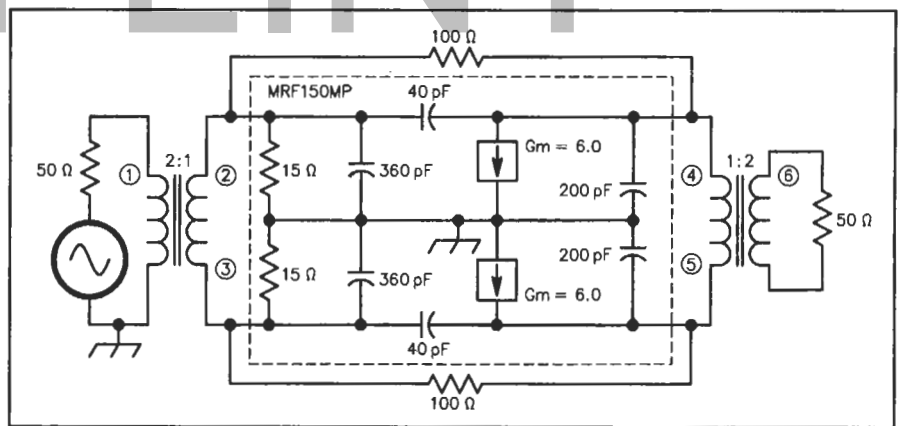

Fig A—A circuit used to analyze the PA output stage with ARD.

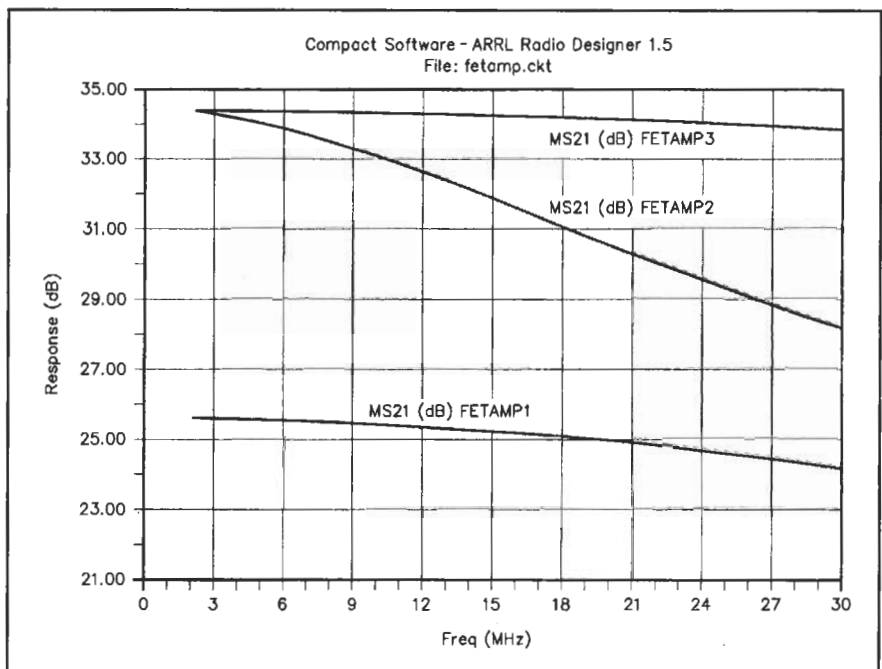

Fig B—The analysis results.

eral hours. The MOSFETs well separated on a good heat sink and with efficient airflow do not have a temperature-controlled gate-bias arrangement because I did not find it necessary at this power level. Because of the spread in threshold voltage of individual matched pairs, a one-time adjustment of gate bias is needed. The following simple procedure is used:

- Replace R21 with a resistor decade box set at 750  $\Omega$ .
- Place a 0-10 A meter in the +40-V line.
- With no signal input, switch on the amplifier and let the current reach its final value, which should reach about 1.5 A as the FETs warm up.
- Adjust the resistor value until DD is 1.5 A. After each adjustment, allow time for the FETs to reach a steady current value. This final value is not critical, but should be within 10%.
- Check the two-tone IMD at 100 W

PEP (50 W average) and make further small changes, if needed, to resemble the IMD patterns in Fig 2.

In this amplifier, we are able to use the self-limiting feature of the MOSFET. This approach would not be appropriate in higher-power, higher-temperature amplifiers because of thermal runaway possibilities, where the decrease with temperature rise of the gate threshold voltage exceeds the decrease of the dc transconductance.<sup>12,13</sup> If fan reliability is a concern, add a thermal cutout switch to the +40-V line.

### Load Impedance

Swept- and fixed-frequency tests at many signal levels and voltage values using various values of parallel conductance and capacitive/inductive susceptance did not reveal instability problems at SWR values less than 2:1. A tendency to oscillate in a peculiar manner occurred in the 20.0 to 29.7 MHz

range, but only with input signal applied (a driven oscillation) and certain values of drive level, supply voltages less than 30 V, SWR of 3:1 or more, and a certain range of shunt capacitance at the output of the amplifier itself or at the output of the 12/10 meter diplexer. The instability shows up as a Christmas tree pattern in which discrete, uniformly-spaced 2- to 4-MHz sidebands appear on the main carrier. It is due to a parametric effect<sup>14</sup> involving the voltage-variable capacitances of the MOSFET transistors that is somehow enhanced by the shunt test capacitance. Shunt inductance did not produce the problem. The amplitude modulation of the carrier by the low-frequency oscillation is clearly visible on an oscilloscope. The low-frequency oscillation itself can be seen on a spectrum analyzer. At SWR values less than 2:1 and drain voltages greater than 35 V (40 V is recommended), the safety margin is large. The 0.22- $\mu$ H,

56-pF network at the output greatly assisted with this problem. A coax cable from the PA to the diplexer assembly that is a foot or less duplicates my test setup. Under these conditions, there is no stability problem on any band caused by load-impedance values that my testing could identify. Actually, a resistive load between 45 Ω and 55 Ω is recommended for best SSB linearity, as mentioned previously. While driving a high-power linear amplifier to its rated two-tone SSB output, adjust its input impedance to 50 Ω resistive as closely as possible on each band, using a 50-Ω directional wattmeter. A broadband (untuned) solid-state driver amplifier such as this one requires such attention to load value for best results as compared to pi-network vacuum-tube PAs that can transform a fairly wide range of com-

plex load impedance values to the correct tube plate load resistance at resonance.

It is difficult to achieve stability in a broadband, transistor power amplifier. Having done so, it is still wise to operate into the correct 50-Ω load as closely as possible. The monitoring of forward and reflected power in Fig 9 is helpful for this and assures clean, stable and reliable operation. This circuitry will cut back the drive level to a value that protects the output stage from excessive drain current or gate drive. Incidentally, the first stage goes into saturation far below the level that would damage the MOSFETs.

response of the complete system from 1.8 to 29.7 MHz, the circuitry that drives this amplifier should also have a flat response and a 50-Ω output resistance—both easy to achieve. If it is not perfectly flat or not exactly 50 Ω, it may be necessary to slightly adjust the drive level on each band, which is not difficult. As mentioned before, the second-harmonic production of the circuitry preceding this amplifier must be of sufficiently low level (50 dBc) that balanced, push-pull operation is necessary. Narrow-band resonator filters are also very commonly used for amateur-band harmonic reduction in low-level exciter circuitry.<sup>15,16</sup>

The directional coupler detects excessive forward and reflected power. Both of these are displayed on a panel meter. The directional couplers forward port is also a

### System Design

Fig 9 suggests a system implementation of the amplifier. For the flattest frequency

### Parts List

- C1—160 pF SM
- C2, 3, 6, 7, 10-12, 14, 20-23—0.1 μF, 50-V CK05
- C4, 8—0.0033 μF, 50-V CK05
- C5, 9—0.047 μF, 50-V CK05
- C13, 25, 26, 28—1.0 μF, 35-V tantalum
- C15, 16, 18, 19—0.022 μF, 100-V CK05
- C17—56 pF SM
- C24—0.1 μF, 100-V CK05
- C27—470 μF, 35-V aluminum
- C29—470 μF, 15-V aluminum
- D1—1N4454A or equivalent
- L1, 2—0.68 μH, T50-2 core, 10 turns #26 AWG
- L3—0.80 μH, T50-2 core, 12 turns #26 AWG
- L4—BN-43-3312, 4 1/2 turns #22 hookup wire
- L5, 8—2.7 μH molded
- L6—0.22 μH, T50-2 core, 5 turns #26
- L7—2 FB-43-5621 cores, 1 1/2 turns #12 stranded
- Q1, 2—MRF426 matched pair
- Q3, 4—MRF150 matched pair
- Q5—2N3906 PNP
- R1, 3—270 Ω, 1/4 W, 5% tolerance
- R2—18 Ω, 1/4 W, 5% tolerance
- R4, 9—178 Ω, 1/8 W metal film, 1% tolerance
- R5, 8—3.9 Ω, 1/4 W, 5% tolerance

- R6, 7—12 Ω, 1/4 W, 5% tolerance
- R10—51 Ω, 2 W metal oxide
- R11—100 Ω, 2 W metal oxide
- R12, 16—51 Ω, 2 W metal oxide
- R13, 17—100 Ω, 5 W metal oxide
- R14, 15, 18, 19, 26, 27—562 Ω, 1/8 W metal film, 1% tolerance
- R20—215 Ω, 1/8 W metal film 1% tolerance
- R21—767 Ω, 1/8 W metal film 1% tolerance, test selected
- R22—0.47 Ω, 5W wire-wound
- R23—4.7 Ω, 1/4 W 5% tolerance
- R24—5.6 kΩ, 1/4 W, 5%
- R25—390 Ω, 1/4 W, 5%
- T1—BN-43-202, 2 1/2 turns #32 AWG, bifilar
- T2A, B—BN-43-202, 2 1/2 turns #32 AWG, bifilar
- T3A, B—BN-43-3312, 2 1/2 turns 25-Ω miniature coax\*
- T4A, B—(2) FB-43-5621, 1 1/2 turns 25-Ω miniature coax\*
- T5—(2) FB-43-5621, 2 1/2 turns 50-Ω miniature coax
- U1—LM317 adjustable voltage regulator

### Notes

- \*Microdot D260-4ii8-0000 available from Communication Concepts, Inc.
- All cores are available from Amidon.
- Closely matched transistor pairs are from RF Parts (see Note 5).

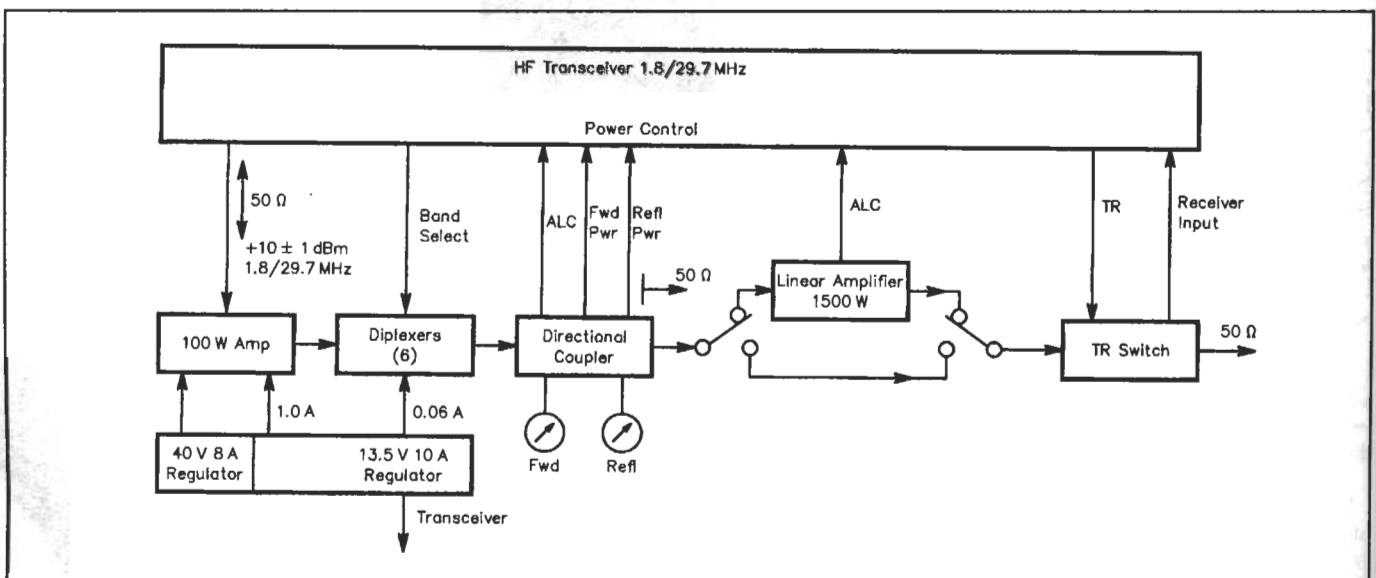

Fig 9—System implementation of the 100-W amplifier.

source of ALC voltage. These control voltages are fed back to the appropriate gain-controlled stages in the exciter. Gain control of the transistors in the 100-W amplifier is not recommended because changes in base or gate bias will degrade amplifier linearity, IMD products and possibly the flat frequency response. There are better ways to accomplish the gain-control task, such as preferably in a lowlevel IF amplifier. With respect to IMD, we are trying to control the odd-order curvature of the MOSFET transfer characteristic—especially for the higher-order products—by setting the gate-bias point. The bias value is found by looking at IMD on each amateur band and selecting the best compromise value. This was discussed previously in this article.

The diplexer filters are linked to the other band-switch circuitry so that the correct filter is always switched in. The TR relay is at the output of the diplexers. Do not hot-switch the diplexer filters because this might damage the inexpensive relays.

### Conclusion

In conjunction with the power supply (see Note 1) and the diplexer filters (see Note 2), the amplifier described here is a basic module for homebrew equipment that should satisfy the requirements for a 100-W power level, a 1.8 to 29.7 MHz bandwidth and a high-quality signal. It should run trouble-free for a very long time. The initial cost of the four transistors is about \$180, but they will last indefinitely if cared for properly. The ones that I use were abused considerably during the experimentation and continue to work perfectly. The

approach that I suggest is best implemented with diplexer filters and a preamplifier that has very low second-harmonic output and low IMD both easy to get at +10 dBm. The payoff for me is excellent performance and reliability, once the design was completed.

This project is suggested for the homebrew enthusiast who has at least some part-time access to lab-quality test equipment. Others who do not care to build may find the article, together with numerous other sources, interesting background information regarding MOSFET power-amplifier design and test methods.

Any attempt at building and testing this amplifier should also use the 40-V power supply in the referent of Note 1 or something similar. The automatic current limiting at 8 A, the automatic reduction of drain voltage, the short-circuit limiting to 4 A and the manual control down to 24 V help to protect the MOSFETs from mishaps that are bound to occur.

### Notes

- <sup>1</sup>W. Sabin, WØIYH, "Power Supply for a MOSFET Power Amplifier," *QEX*, Mar/Apr 1999, pp 50-54.
- <sup>2</sup>W. Sabin, WØIYH, "Diplexer Filters for an HF MOSFET Power Amplifier," *QEX*, Jul/Aug 1999, pp 20-26.
- <sup>3</sup>N. Dye and H. Granberg, *Radio Frequency Transistors* (New York: Butterworth-Heinemann, 1993), pp 42-43.
- <sup>4</sup>W. Sabin and E. Schoenike, *HF Radio Systems and Circuits* (Tucker, Georgia: Noble Publishing Co, 1998), Chapter 12, Solid State Power Amplifiers, by R. Blocksome. This chapter is highly recommended regarding solid-state SSB power amplifiers. This book is also ARRL Order No. 7253. ARRL publications are available from your local ARRL dealer or directly from the ARRL. Mail orders to Pub Sales Dept, ARRL, 225 Main St, Newington, CT 06111-1494. You can call us

toll-free at tel 888-277-5289; fax your order to 860-594-0303; or send e-mail to [pubsales@arrl.org](mailto:pubsales@arrl.org). Check out the full ARRL publications line on the World Wide Web at <http://www.arrl.org/catalog>.

<sup>5</sup>RF Parts Co, 4355 Pacific St, San Marcos, CA 92069; tel 760-744-0700, 800-737-2787 (orders only), fax 760-744-1943; [rfp@rfparts.com](mailto:rfp@rfparts.com), <http://www.rfparts.com/>.

<sup>6</sup>Communication Concepts, Inc. (CCI), 508 Millstone Dr, Beavercreek, OH 45434; tel 937-426-8600, fax 937-429-3811; [cci.dayton@pobox.com](mailto:cci.dayton@pobox.com), <http://www.communication-concepts.com/>; ask for a catalog.

<sup>7</sup>*Motorola Wireless Semiconductor Solutions, Device Data*, Rev 9, Vol. II; Motorola #DL110/D. The data book is available from RF Parts (see Note 5). (A Motorola Selector Guide is available at <http://www.motsp.com/books/sguides/pdf/sg46rev18.pdf>. There is a MRF150 page at [http://www.mot-sps.com/products/rf\\_and\\_if/rf\\_transistors/high\\_power/power\\_mosfets/mrf150.html](http://www.mot-sps.com/products/rf_and_if/rf_transistors/high_power/power_mosfets/mrf150.html). A MRF426 datasheet (MRF426/D) is available at <http://www.zettweb.com/CDROMs/cdrom013/pdf/mrf426rev0.pdf>, which is not a Motorola site—Ed.)

<sup>8</sup>Dye and Granberg, pp 113-115.

<sup>9</sup>*Motorola Wireless Semiconductor Solutions*; see pp 4.2-133 for the MRF151, similar to the MRF150. (See Note 7 for an MRF150 URL—Ed.)

<sup>10</sup>Dye and Granberg, Chapter 12.

<sup>11</sup>The set of boards costs \$12 plus shipping and handling. FAR Circuits, 18N640 Field Ct, Dundee, IL 60118-9269; tel 847-836-9148 (Voice mail), fax 847-836-9148 (same as voice mail); [farcir@ais.net](mailto:farcir@ais.net), <http://www.cl.ais.net/farcir/>.

<sup>12</sup>Dye and Granberg, Chapter 4.

<sup>13</sup>H. Granberg, *Wideband RF Power Amplifier, RF design*, Feb 1988; also *Motorola RF Application Reports*, AR313, p 424.

<sup>14</sup>Dye and Granberg, similar top 124, Fig 7.7.

<sup>15</sup>*The ARRL Handbook* (Newington, CT: 1995-2000 editions), ARRL Order No. 1832; pp 17.60-17.66 and Fig 17.69. See Note 4 for purchasing information.

<sup>16</sup>W. Sabin, WØIYH, "Designing Narrow Band-Pass Filters with a BASIC Program," *QST*, May 1983, pp 23-29.

# The FARA HF Project

Would you like an economical and relatively easy to build 30 W HF amplifier? For about \$130 worth of parts you can give that QRP rig an extra 12 dB of muscle!

One of the larger and more active radio clubs in the Cape Cod, Massachusetts area is the Falmouth Amateur Radio Association (FARA). Some of its members are affectionately referred to as the "hackers"—those who enjoy the construction phase of Amateur Radio. The renewed interest in low power (QRP) radios in the 2 to 5 W output range resulted in the desire for a 10 to 12 dB gain RF linear amplifier producing 30 to 40 W of output power. Commercial amplifiers capable of being driven with less than 50 W below 30 MHz are prohibited by FCC regulations.<sup>1</sup> As a radio amateur, you are permitted to construct one amplifier per year for your personal use. The amplifier described here is relatively easy to fabricate, given a basic knowledge of electronics and some familiarity with hand tools. This article describes in detail the construction of a 12 dB, nominal 30 W output, 1.8 to 30 MHz RF power amplifier. It is intended for 12 to 14.7 V dc operation, making it ideal for mobile use.

## Amplifier Description

The design of the amplifier is based upon common engineering practices. Ideas gathered from researching the handbooks published by the ARRL and The Radio Society of Great Britain (RSGB), as well as articles published in *QST* and other journals formed the basis of the design. This amplifier uses readily available components...many of the earlier designs were based on the Motorola MRF series of RF devices that are no longer available or are prohibitively expensive.

The amplifier is housed in a 5 × 7 × 2 inch aluminum box. It consists of two stacked circuit boards—an RF amplifier and a low-pass filter. The completed amplifier is shown in Figure 1. Figure 2 is the schematic diagram of the RF assembly together with the amplifier and low-pass filter parts list and Figure 3 is the low-pass filter schematic. The amplifier can be driven by 2 to 5 W at the RF input; an input attenuator consisting of R1, R2 and R3 must be selected (as noted in Figure 2) to ensure the proper drive level (2 W) for the

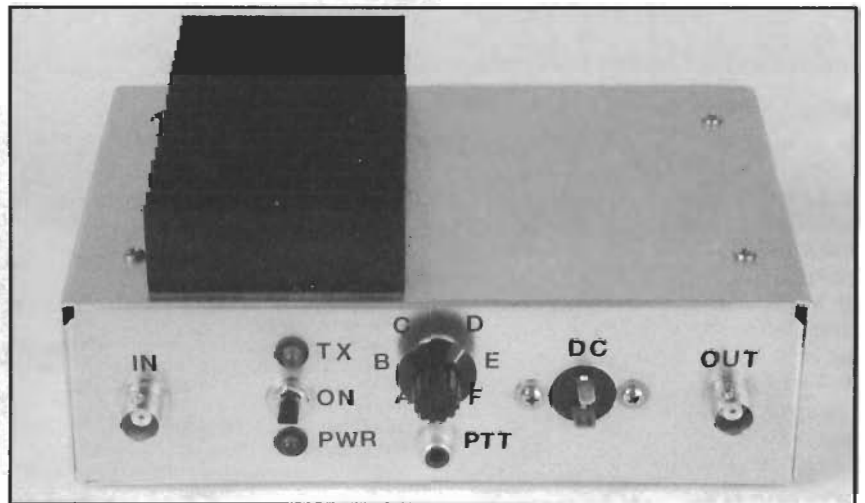

Figure 1—The completed 30 W amplifier. The band switch takes care of output low-pass filter switching.

push-pull (2SC2312C device types) class AB amplifier stage. T1 is wound on a small binocular core with a 4:1 ratio as detailed on the schematic. The low impedance secondary is a single turn center tapped; it carries the bias voltage to the output transistors. The bias voltage is derived from the LM317 regulator, which is operated as a switched current source. The LM317 is switched on when the internal PTT line is activated. Bias voltage is developed across the FES8J diode, which is in intimate thermal contact with the output transistors. The output transformer (T2) is also wound with a 4:1 ratio; it has a single-turn sense winding. The single-turn feedback winding provides some degree of negative feedback to flatten the gain and stabilize the input impedance over the HF frequency range. The RC network in the input base circuit establishes the overall gain. The 6.8 W series resistors determine the gain below 14 MHz, while the 4700 pF capacitors are effective above 14 MHz.

Figure 4 shows the output power versus frequency characteristics of the amplifier,

including the second and third harmonic response. All measurements were made with an IFR1600S Communications Service Monitor. In all cases, harmonics were greater than 40 dB down referenced to the fundamental frequency (−40 dBc), and the amplifier meets current FCC requirements for spectral purity.<sup>2</sup> Note that the gain starts to decrease above 21 MHz, rolling off from a nominal 30 W to 20 W at 29 MHz. On 10 meters this still represents 10 dB of gain, a worthwhile improvement. The dc voltage to the output transistors is decoupled by the pi network at the center-tapped primary of the output transformer, T2. This winding carries substantial current and should be wound with #18 Teflon covered wire. Any IR drop in the dc circuit will severely degrade the amplifier performance. TR switching is provided by relay K1. The PTT line can be operated manually (pulled to ground) or RF activated switching circuitry can be installed to eliminate the need for external keying controls. The value of C12 (3.3 μF) determines the SSB time constant for the RF activated switch.

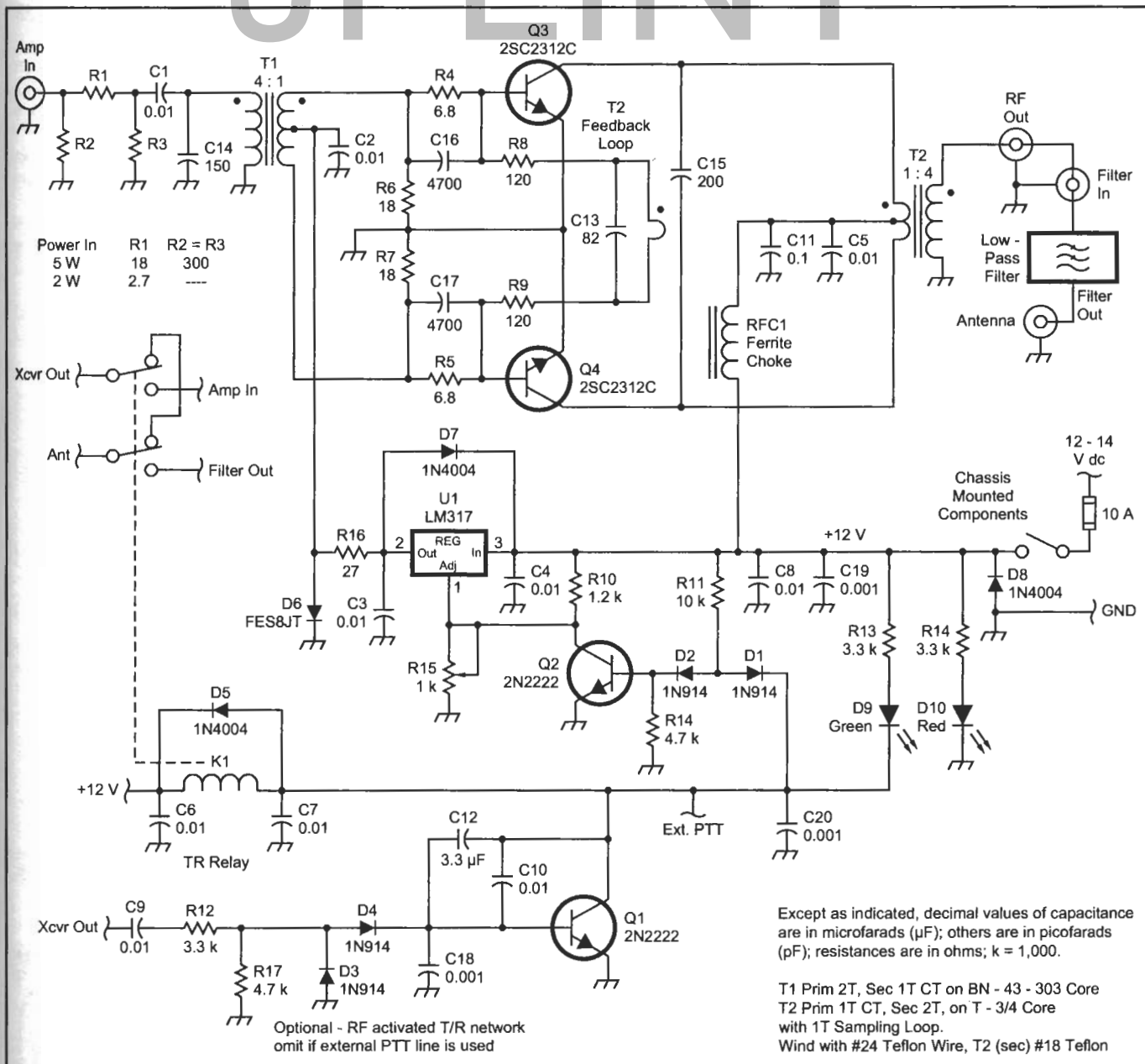

Figure 2—The RF amplifier schematic and parts list. (M) denotes Mouser Electronics, 1000 N Main St, Mansfield, TX 76063; tel 800-346-6873; [www.mouser.com](http://www.mouser.com). (RF) denotes RF Parts Co, 435 S Pacific St, San Marcos, CA 92069; tel 800-737-2787; [www.rfparts.com](http://www.rfparts.com). (A) denotes Amidon, 1240 Briggs Ave, Costa Mesa, CA 92626; tel 800-898-1883; [www.amidon-inductive.com](http://www.amidon-inductive.com). (F) denotes FAR Circuits, 18N640 Field Ct, Dundee, IL 60118; tel 847-836-9148; [www.farcircuits.net](http://www.farcircuits.net).

### RF Amplifier Board

C1-10—0.01  $\mu\text{F}$  capacitor,

(M) 140-100Z5-103Z.

C11—0.1  $\mu\text{F}$  capacitor,

(M) 80-CK06BX104K.

C12—3.3  $\mu\text{F}$  capacitor,

(M) 80-C340C335M5U.

C13—82 pF capacitor,

(M) 5982-15-500V82.

C14—150 pF capacitor,

(M) 5982-15-500V150.

C15—200 pF capacitor,

(M) 5982-15-500V200.

C16, 17—4700 pF capacitor,

(M) 140-50P5-472K-TB.

C18-20—0.001  $\mu\text{F}$  capacitor,

(M) 140-100Z5-102Z.

D1-D4—1N914 diode, (M) 610-1N914.

D5, D7, D8—1N4004 diode, (M) 583-1N4004.

D6—FES8JT diode, (M) 625-FES8JT.

D9—LED, green, with mount,

(M) 512-HLMP4719.

D10—LED, red, with mount,

(M) 512-HLMP4700.

K1—Relay, 12 V dc coil, DPDT,

(M) 551-MR-12USR.

Q1, Q2—Transistor, switching, 2N2222,

(M) 511-2N2222A.

Q3, Q4—Transistor, RF, 2SC2312C, (RF)

2SC2312C.

R1—300  $\Omega$ , 1 W, (M) 281-300.

R2, R3—18  $\Omega$ , 1 W, (M) 281-18.

R4, R5—6.8  $\Omega$ , 1/4 W, (M) 30BJ250-6.8.

R6, R7—18  $\Omega$ , 1/4 W, (M) 30BJ250-18.

R8, R9—120  $\Omega$ , 1/4 W, (M) 30BY250-120.

R10—1.2 k $\Omega$ , 1/4 W, (M) 30BJ250-1.2K.

R11—10 k $\Omega$ , 1/4 W, (M) 30BJ250-10K.

R12-14—3.3 k $\Omega$ , 1/4 W, (M) 30BJ250-3.3K.

R15—1 k $\Omega$ , potentiometer,

(M) 531-PTC10H-1K.

R16—27  $\Omega$ , 1 W, (M) 281-27.

R17—4.7 k $\Omega$ , 1/4 W, (M) 30BJ250-4.7K.

RFC1—RF choke, (RF) VK-200-3R.

T1—Transformer core, (A) BN-43-303.

T2—Transformer core, (RF) T-3/4 core.

U1—IC, LM317T, (M) 512-LM317T.

### Misc

2—TO-220 mounting kit, (M) 534-4724.

2—TO-220 thermal insulator pad,

(M) 526-NTETP0006.

PC board, FARA RF amplifier, (F).

**Low-Pass Filter Board**

(see Figure 3 for component delineation)

2—100 pF capacitor,

(M) 5982-15-500V100.

3—180 pF capacitor,

(M) 5982-15-500V180.

3—330 pF capacitor,

(M) 5982-15-500V330.

2—430 pF capacitor,

(M) 5982-15-500V430.

1—560 pF capacitor,

(M) 5982-15-500V560.

3—820 pF capacitor,

(M) 5982-15-500V820.

3—1500 pF capacitor,

(M) 5982-19-500V1500.

1—2700 pF capacitor,

(M) 5982-19-500V2700.

12—0.01  $\mu\text{F}$  capacitor,

(M) 140-100Z5-102Z.

[continued on next page]

[continuation of Figure 2]

- 12—Relay, 12 V dc coil, DPDT, (M) 655-T7NSD1-12.
- 1—Switch, 1 pole, 6 pos, (M) 10-YXX026.
- HF Filter Kit, (A) HFFLT. Contains the cores and wire necessary to build the low-pass filters.
- PC board, FARA LP Filter, (F).
- Chassis Parts**
- Chassis box, Bud, (M) 563-AC-402.
- Chassis cover, Bud, (M) 563-BPA-1589.
- Heat sink, (M) 532-244609B02.
- 4—4-40 hex-type standoff, (M) 534-2201.
- 9—4-40 x 1/4 pan head screw.
- 4—4-40 x 1/2 pan head screw.
- 6—4-40 flat washer.
- 9—4-40 lock washer.
- 2—4-40 nut.
- 2—8-32 x 1/4 pan head screw.
- 2—8-32 lock washer.
- 2—BNC socket, chassis mount, (M) 161-9323.
- RCA-type socket, female, chassis mount, (M) 161-1005.
- Switch, toggle, SPDT, (M) 10TC320.
- Jones-type socket, chassis mount, male, 2 pin, polarized, (M) 538-13023.

The low-pass filter assembly utilizes relays to select the proper filter network for the various frequency ranges. Relays were chosen to simplify the RF switching and to minimize cost. The six filters cover the nine amateur bands from 1.8 to 30 MHz; the frequency ranges and circuit constants are as noted on the LPF schematic diagram. The inductor cores and wire to wind the coils are available as a kit of parts from Amidon.<sup>3</sup> The L/C constants are the same as those recommended by WA2EBY for the MOSFET RF amplifier in *The ARRL Handbook*.<sup>4</sup> The filters are not used when the amplifier is off or when the PTT line is not activated—this permits multi-band listening and limited VHF use when a wide frequency transceiver is in use (like the Yaesu FT-817). There is no provision for ALC feedback, so caution must be exercised so as not to overdrive the amplifier.

### Construction Hints

Although no step-by-step instructions are provided, a few hints will ease the assembly process. The circuit boards pictured are the prototype assemblies; they are not solder-plated. However, the available circuit boards (from FAR Circuits) are plated but do not have plated through-holes, so through-holes must be pinned and soldered.<sup>5</sup> Detailed drawings of the PC boards, the parts layout, coil-winding data and chassis templates can be found at [www.arrl.org/files/qst-binaries/faraamp.zip](http://www.arrl.org/files/qst-binaries/faraamp.zip). Saul, K1BI, the FARA Webmaster has also set up a site for the project. It can be found at [www.falara.org/tektalk/tektalkfs.html](http://www.falara.org/tektalk/tektalkfs.html). The circuit boards as they appear before wiring can be seen in Figure 5.

Figure 3—The low pass filter (LPF) schematic.

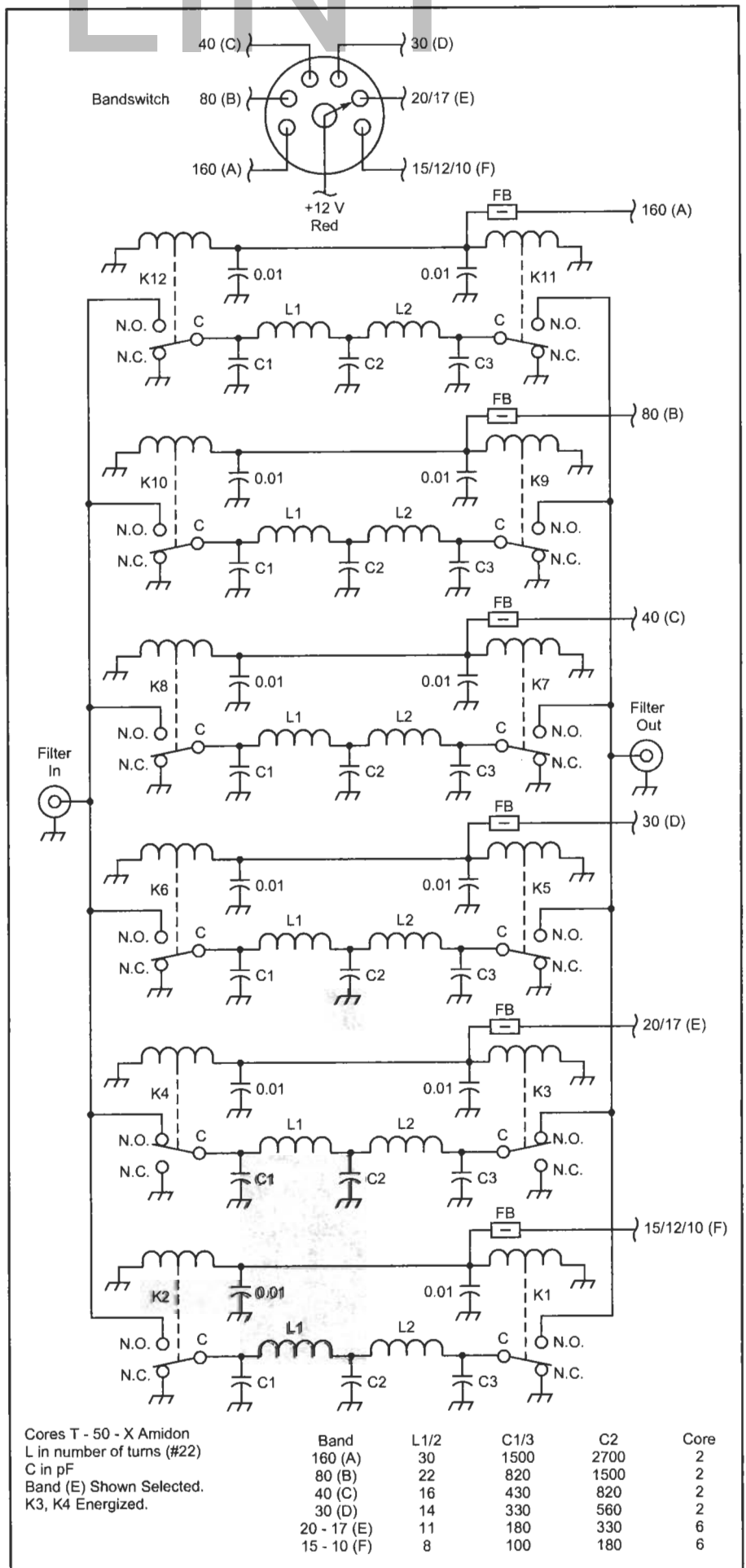

# JFLINT

## Circuit Board Preparation

- Given the large ground plane area, the boards must be clean or you will experience difficulty when soldering to the foil. Plated boards are best; they are easier to solder. Some solder flux may improve the solderability of the board, but be sure to use *only* rosin core solder and a *non-corrosive* flux.
- Carefully inspect all soldered connections for cold solder joints. Good soldering technique is crucial to the performance of the amplifier.
- Periodically, the flux should be removed from the board during the construction phase with a suitable chemical cleaner.

- There are a number of holes to be drilled and pinned on each board; these are noted on the parts placements diagrams. Wires should be inserted through the board, bent into the shape of a "Z," formed flat against the board, soldered and cut.
- The four corner holes on each board must be sized as a clearance hole for the 4-40 mounting hardware.
- Components should be mounted flush to the board—fixed capacitors should be mounted as close to the foil as possible.
- The large rectangular blocks on the RF board must be trimmed in order to mount the RF output transistors and the bias diode.

## RF Amplifier Circuit Board

A view of the completed RF board can be seen in Figure 6. The following suggestions pertain to the amplifier board.

- Wind the secondary winding on T2 and mount it to the circuit board first.
- The emitters of the 2SC2312s (Q3, Q4) are intended to be grounded through a hole on the pad. The following modification is advised—bend a thin brass or copper strap into a "U" shape and solder it on both sides of the board. This lowers the impedance to ground.
- Next, mount the smaller fixed components, the resistors and capacitors.
- The semiconductors and the relay mount last.
- Do not mount D6, Q3 and Q4 until the assembly is fixed in the chassis and positioned relative to the heat sink.

## Low-Pass Filter Circuit Board

This is a double-sided board; the reverse side is a ground plane with clearance etches for the various components. The LPF board can be seen in Figure 7. It may be necessary to form the capacitor leads slightly to conform to the hole spacing.

- Mount the filter components first, followed by the bypass capacitors and the jumper wires. Refer to the schematic for component values by frequency range.
- The relays mount last. Do not overheat their mounting pins when soldering.
- Do not mount the LPF assembly until the initial tune-up is completed. It is recommended that you pre-wire the band switch. It mounts between the two circuit boards when they are installed in the chas-

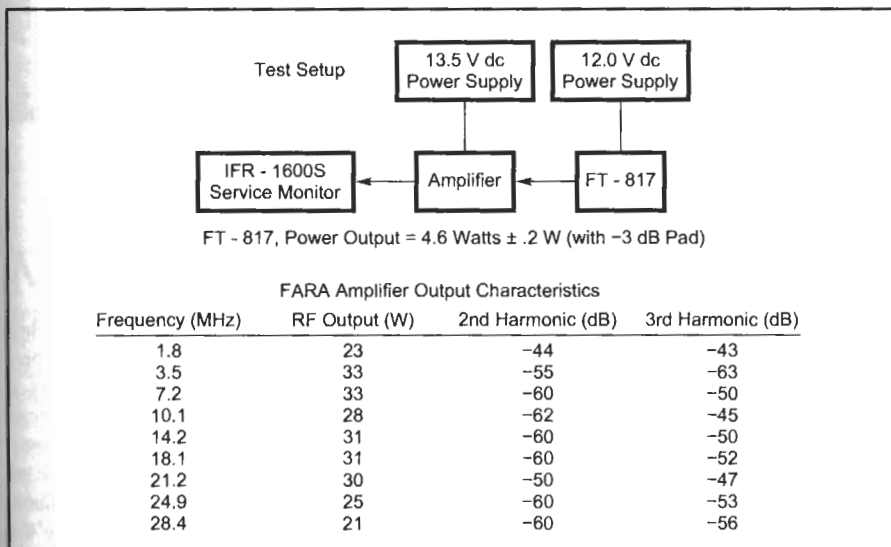

Figure 4—Amplifier output data, including second and third harmonic response.

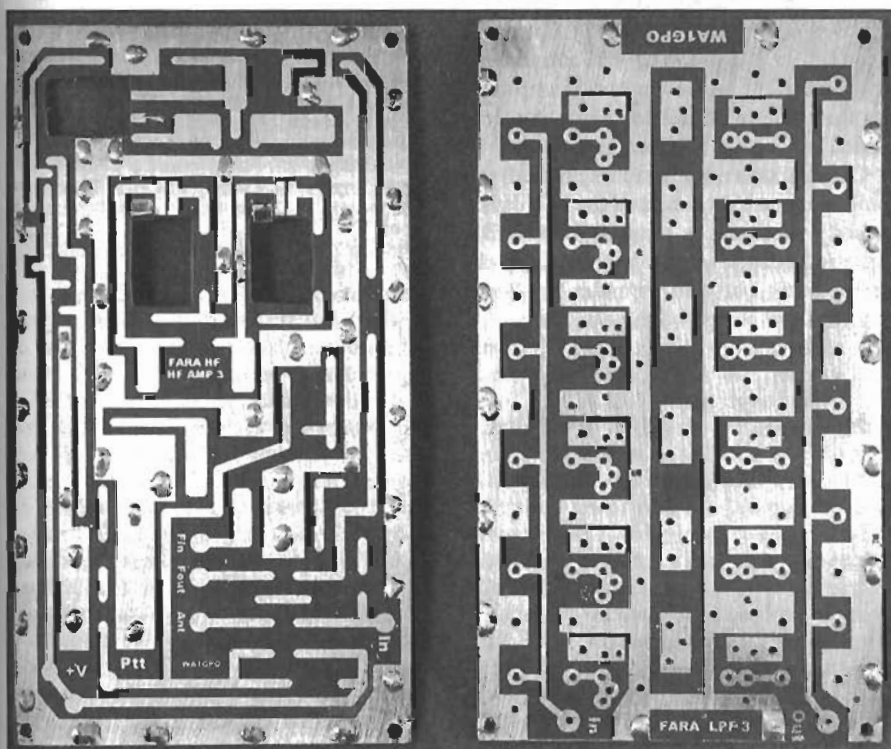

Figure 5—The circuit boards before wiring. The RF board is on the left and the LPF board is to the right. Note the pinned and soldered holes.

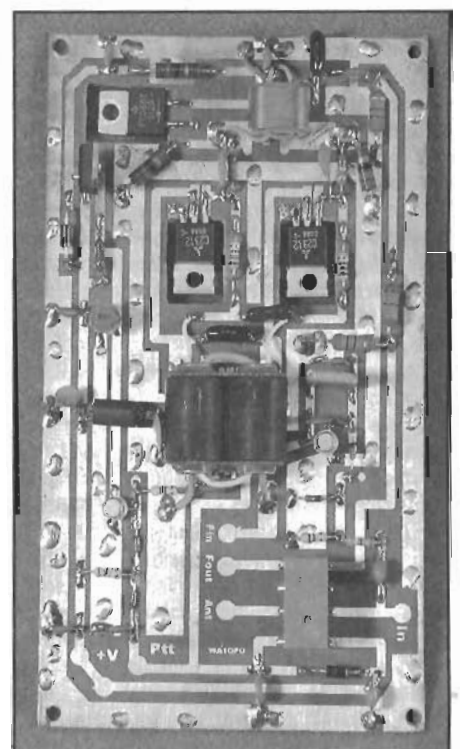

Figure 6—The completed RF assembly board.



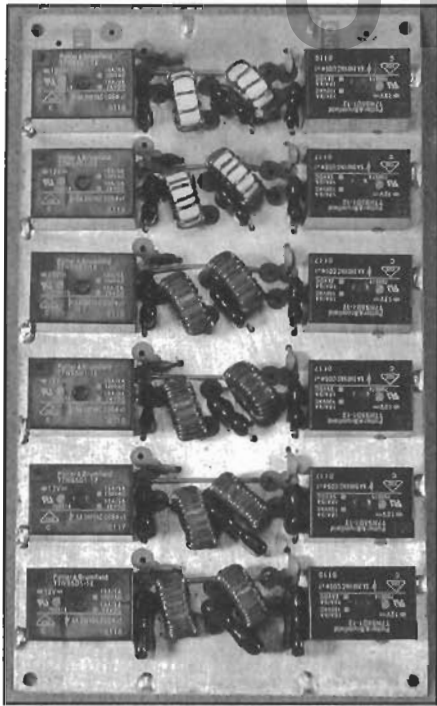

Figure 7—The completed LPF board. Note the relays that are used as filter switches—they are selected by the band switch.

sis and it is difficult to get to.

### Chassis, Panel and Heat Sink

Full size templates for the chassis and panel can be found on the Web site. Trim the templates to size and fold and tape them to the aluminum box and heat sink. It is important to center punch the holes and drill a small pilot hole at each location. Enlarge the holes to size according to the dimensions. Letter the panel with dry transfer lettering available at office supply stores. Spray on several light coats of clear lacquer to protect the lettering. Mount the heat sink and the panel components, but do not mount the bandswitch at this time. Mount the RF amplifier board using a couple of 4-40 flat washers as spacers between the chassis and the circuit board at each corner. Install the 4-40 standoffs to

hold the assembly in place. Mount D6, Q3 and Q4, using the TO-220 thermal pads and hardware to isolate the transistor mounting tab from the chassis. It is not necessary to isolate D6. Use RG-174 miniature coaxial cable for the internal RF connections.

### Tune-up and Testing

As this is a broadband design there is no tune-up; only the bias adjustment needs to be set. A 12 to 14 V dc current limited variable supply is recommended for initial adjustment and testing. Use a dummy load at the amplifier output. Drive levels refer to the attenuator output, if used.

- Connect a temporary jumper between the  $F_{in}$  and  $F_{out}$  pads on the RF board.
- Preset R15 (1 k $\Omega$  potentiometer) so that the wiper is at ground.
- Apply 12 V dc and ground the PTT line (the relay should pull in).
- Briefly drive the input with 1 W at 14 MHz and note the power output.
- Again apply 1 W and increase bias (R15) until the output increases about 15%.
- Increase drive to 2 W and note the power output (about 25 W).
- Increase voltage to 14.7 V dc; note the output with 2 W of drive (about 35 W).

Remove power; remove the temporary jumper; mount the band switch; connect and install the LPF board. Verify that the power output over the range of 1.8 to 29 MHz is as expected. A view inside the bottom of the amplifier, with the LPF board visible, is shown in Figure 8.

### Final Comments

The FCC has placed strict limitations on power amplifiers used below 30 MHz. Please review the appropriate FCC regulations before constructing this amplifier.<sup>6</sup> Kits offered for sale, even partial amplifier kits that require additional parts, are prohibited by current FCC regulations.<sup>7</sup>

Construction time, assuming that all the components are on hand and the boards are properly prepared, is about 4 hours. SSB operation results in the heat sink barely getting warm, and cooling under key-down

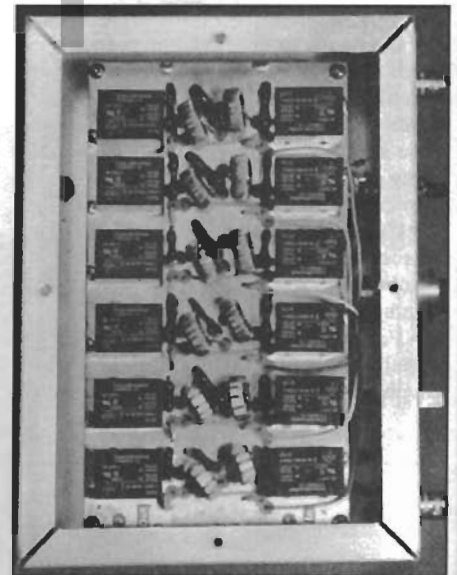

Figure 8—A bottom view inside the completed amplifier. The LPF board is mounted below the RF assembly.

conditions is more than adequate.

A project of this scope is more fun when others participate. Harry, W2RKB, provided the necessary prodding to get it started. He also fabricated the circuit boards and the filter assemblies for the prototype amplifiers. Dave Hosom assisted with the photographs. A generous thank you is extended to them both. Give the FARA amplifier a try... it's a practical and rewarding project!

### Notes

- <sup>1</sup>Federal Communications Commission, Sec 97.315.
- <sup>2</sup>See Note 1.
- <sup>3</sup>Amidon Associates, Inc, 240 Briggs Ave, Costa Mesa, CA 92626; 800-898-1883; [www.amidon-inductive.com](http://www.amidon-inductive.com).
- <sup>4</sup>The 2003 ARRL Handbook, pp 17.91-17.97.
- <sup>5</sup>FAR Circuits, 18N640 Field Court, Dundee, IL 60118; tel 847-836-9148; [www.farcircuits.net](http://www.farcircuits.net).
- <sup>6</sup>Federal Communications Commission, Sec 97.3 (19).
- <sup>7</sup>See Note 6.

# A Compact "Brick" for 6 Meters

Does your six-meter signal need some extra kick? This inexpensive amplifier bridges the gap from 10 to 100 watts.

Most transceivers available for the 6-meter band provide 10 W output. This power level provides satisfactory communications during good sporadic-E openings, but is not adequate for making long-haul contacts on meteor scatter or during F-layer openings. For the average station, an output level of 100 W seems to be a reasonable compromise between a 10-W exciter and a kilowatt amplifier. Unfortunately, 50-MHz amplifiers in this power class are not readily available.

I began operating on the 6-meter band a few years ago, near the lowest point in sunspot cycle 21. Sporadic E kept my interest high, and soon it became evident that I needed an amplifier. Being a builder at heart, I decided to "roll my own" and began to search the Amateur Radio literature for design examples. I found very few solid-state amplifiers, and only one in the 100-W class.<sup>1</sup>

I built the amplifier as specified, and I got good results. My 6-meter effectiveness made a quantum leap! One highlight was working Europe with a 12-foot-boom Yagi. The amplifier performed so well that several of my friends asked me to build them duplicates of it. With each revision, I tried to add design innovations, including on-board TR relays, a carrier-operated-relay (COR) circuit and transistor biasing, as well as low-pass filtering and more compact packaging. The product of these efforts is described in this article. At least 25 of these units have been constructed and are now in use. Several of these amplifiers have been used on DXpeditions, in beacon service, and as drivers for kilowatt-class amplifiers, and results have been excellent.

If you are looking for a low-cost 100-W amplifier, this proven design would make a nice addition to your 6-meter station. This circuit can also be adapted for use with an MRF140 FET, which produces over 160 W output with less than 10 W drive. See the sidebar for more details.



## Circuit Highlights

The amplifier circuit, shown in Fig 1, is a single-stage, 10-dB-gain, class-B design using the popular Motorola MRF492 transistor. The RF circuitry is based on a test circuit in Motorola's RF Device Data book.<sup>2</sup> Input and output impedance matching is done with low-Q lumped circuits rather than with broadband transformers. The amplifier's bandwidth is about 1.5 MHz, which covers the DX portion of the 6-meter band with plenty to spare. And, the output network has a secondary dip at about 53 MHz, allowing CW/SSB work and FM operation without the need to retune the amplifier. The narrowband nature of the matching networks helps reduce harmonics. A half-wave low-pass filter in the output circuit further reduces harmonic content to meet current FCC specifications (see Fig 2).

The COR circuit is based on a high-gain

operational amplifier that provides the sensitivity required for SSB operation. This circuit is much more effective than the Darlington-transistor COR circuits found in most commercial amplifiers. It works well with low-power SSB rigs that do not have easily accessible PTT lines, although a separate PTT input is also included.

The amplifier PC board<sup>3</sup> is mounted in a die-cast aluminum box (Hammond 1590R, Bud CU-247 or Jameco® part no. B5006) with an extruded-aluminum heat sink bolted to the bottom. (I used a 6-inch length of Wakefield no. 1527 heat sink. Any aluminum heat sink with similar dimensions should work fine.) The completed amplifier is operated inverted, with the removable lid serving as the bottom. The enclosure is painted flat black and labeled with white rub-on lettering. Stick-on rubber feet are attached at the corners of the bottom cover. The finished product



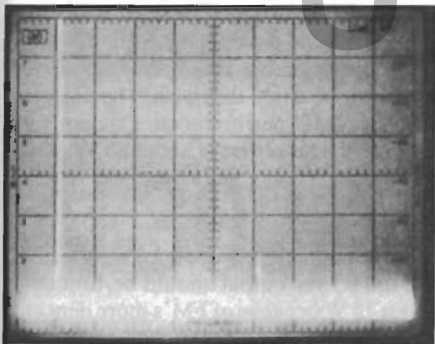

Fig 2—Worst-case spectral display of the 100-W 6-meter amplifier. Vertical divisions are each 10 dB; horizontal divisions are each 10 MHz. Output power was approximately 100 W at 50.2 MHz. All harmonics and spurious emissions are at least 60 dB below peak fundamental output when the amplifier is tuned as described in the text. The 100-W amplifier complies with current FCC specifications for spectral purity for equipment in this power-output class and frequency range. Better spectral purity can be obtained by using an external output filter (see the referent of note 1 for a suitable filter circuit).

board construction by mounting the parts that are soldered to traces on the other side of the board. This includes the COR parts and relays, the RG-174 jumper, and diode D1. Make sure that the diodes and Q2 are properly oriented.

The solder-side parts are surface-mounted. Keep lead lengths to a minimum (no more than 1/4 inch) on these parts. The

bypass capacitors should have the shortest possible leads, and should be surface-mounted on the PC board.

Wind the coils using 1/4- and 3/8-inch drill bits as temporary forms. Cut the coil leads to 1/4 inch, bend them 90°, scrape the insulation off the ends and solder the coils to the board. Some of the coils may need to be compressed or spread during tune-up to get maximum output power, so allow for this when mounting them. Use Fig 3 as a guide. Mount the mica trimmers by bending the solder tabs parallel to the board and surface-mounting them. (Some trimmers have extra tabs that may short to the PC board; I cut these off with side cutters to eliminate this risk.) When surface-mounting the larger components, a high-wattage soldering gun is useful, but be careful: The traces may separate from the PC board if excessive heat is used.

When the PC board is complete, temporarily place the MRF492 in its mounting hole in the PC board, making sure to orient the transistor properly (the beveled lead is the collector). Place the PC board inside the box assembly. Carefully mark the transistor-mounting holes and the single PC-board mounting hole on the enclosure, through the PC board. Remove the PC board from the case, then drill and tap these holes for no. 4-40 hardware. Mark and drill the heat sink using the enclosure as a guide.

Drill and tap four more no. 4-40 holes, near the corners of the case, through the case and into the heat sink. Apply heat-sink compound between the die-cast box

and the heat sink, then use no. 4-40 screws in these holes to secure the heat sink to the case.

Place the PC board into the case/heat-sink assembly again, and mark the location of the stud-mounted bias diode. Remove the board and drill and tap a 3/8-inch-deep no. 10-32 hole in the case/heat-sink assembly. The diode's threaded stud is more than 3/8 inch long, and should be carefully cut off (with a hacksaw) to 5/16 inch.

The rear of the PC board must be insulated from the box assembly, because many of the COR-circuit traces on the underside of the board are not at ground potential. I use 1/8-inch-thick double-sided foam tape to cover the solder-side traces and to support the board away from the case. Make sure the component leads are cut off closely at the rear of the PC board so that they don't punch through the foam tape and short to the box assembly. Mount the board inside the case, then screw the bias diode snugly into its mounting hole in the case/heat sink assembly.

Solder the MRF492 onto the board as the last step, after the transistor case has been mounted in the board and screwed into place. (This eliminates the possibility of cracking and ruining the \$15 device!) Be sure to use a liberal amount of silicone heat-sink compound between the transistor and the box.

Mount the front-panel LEDs, switches and the RF connectors of your choice to the box. Any suitable RF connectors can be used. The connectors are wired to the PC board with no. 18 tinned bus-wire jumpers. Make these as short as possible. I used no. 24 insulated hookup wire to connect the switches and LEDs to the PC board. Finally, mount the dc-power binding posts to the rear panel. These are wired to the PC board with no. 18 bus wire run through FT-43-801 ferrite beads.

### Initial Testing

After the switches, LEDs and connectors have been wired, carefully check all connections. Make certain that the jumper from the PC board to bias diode D2 is connected! If all looks good, connect the amplifier to a 13.8-V power supply capable of sourcing 1 A. (If you have one, a small, current-limited power supply is best for testing.) If your power supply does not have reliable current metering, a meter capable of measuring 0-500 mA should be placed in series with the positive supply lead.

With the amplifier turned off, turn on the power supply. The meter should indicate 0. Turn on the amplifier and note the total indicated current. It should be between 50 and 300 mA. If it is much greater than 300 mA, quickly turn off the power supply and look for problems.

If the current is within these limits, you can go about setting the operating bias. This involves changing the value of R1 until the collector current is between 75 and 175 mA. Note that this is not total circuit current, which includes the diode

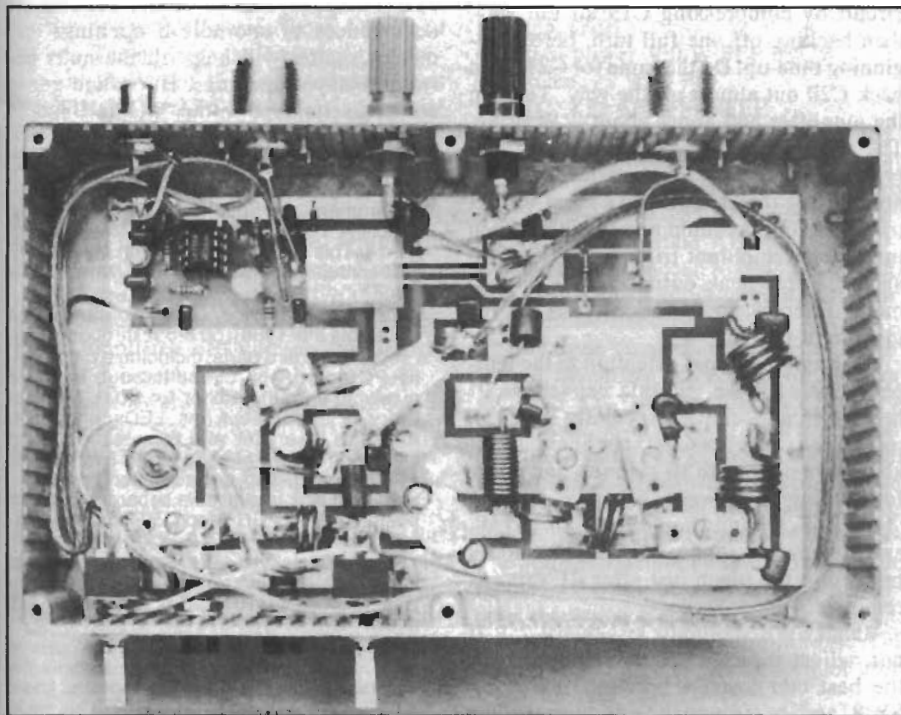

Fig 3—This inside view of the 100-W amplifier shows the circuit's simplicity. On the PC board, counterclockwise from upper left: the COR circuit; input-matching and bias networks, switches and indicators (lower left); MRF492 (lower center); collector choke and output network (lower right). The TA relays and connectors are at the upper center, and bias resistor R1 is just to the left of center.

## Using a MOSFET to Get More Power from the Basic MRF492 Amplifier Circuit

The MRF492 amplifier circuit described in the main text is easily modified for use with an MRF140 VMOS power FET, which has about 15 dB gain and over 160 W output—substantially more than the MRF492. Even the device cases are the same, so the changes required to operate this circuit with an MRF140 are quite straightforward. Specific details of the modifications required, including a schematic diagram, are available from the author for an SASE.

The main differences between the devices are that the MRF140, a MOSFET, needs different biasing and a higher supply potential (28 V) than the MRF492, and is more expensive (\$88 versus \$15 for the MRF492, at this writing). But if you have a 28-V supply and need more than 100 W or have a 5-W exciter, the change is probably worthwhile. The MRF140 is easily biased with a three-terminal regulator (an LM317T works well), and requires very few component changes other than those in the bias circuit. An additional capacitor and inductor are also required at the MRF140's gate.

Because the modified amplifier requires a 24- to 28-V supply, different TR relays must be used, or, alternatively, 12-V-coil relays can be wired in series. (The COR circuit needs no modification because the LM358 works fine at 28 V.)

Good heat sinking is more critical to amplifier performance at the higher power level, so I used a 3- × 5- inch slab of 1/8-inch-thick copper between the device and the case as a heat spreader. A larger heat sink and/or forced-air cooling are also desirable.—N4LTA

current and POWER LED current. The best way to measure collector current is to lift FB3 and insert a milliammeter in series with the collector-supply lead at that location. An alternative method is to use the following equation to approximate collector current:

$$I_C = I_{TOTAL} - [(V_{R1} \div R1) + (V_{CC} - 1) \div 1000]$$

where

$I_C$  = collector current in milliamperes  
 $V_{R1}$  = measured voltage across R1  
 $V_{CC}$  = measured supply voltage

This equation lets you calculate collector current by subtracting the current through R1 ( $V_{R1} \div R1$ ) and the current through the POWER LED ( $(V_{CC} - 1) \div 1000$ ) from the total supply current.

Using either method, substitute different resistors at R1 until the collector current falls into the 75- to 175-mA range. In almost every case, a 5-W resistor of 82, 91, 100, 110, 120 or 130  $\Omega$  will bring the current into that region. (I have never had to substitute more than three resistors to arrive in this bias-current range.) These 5-W resistors can be purchased for less than \$0.40 each, so, although a 200- $\Omega$ , 5-W wire-wound potentiometer could be used for R1, all six resistors can be purchased for far less. And, these days, high-wattage potentiometers are hard to find.

### Tune-Up

When the bias current has been set, the amplifier can be initially tuned. For this procedure, the amplifier should be connected to a power supply capable of delivering at least 15 A at 13.8 V. A power meter

capable of indicating at least 100 W at 50 MHz should be connected at the amplifier output, and the meter's output to a 50- $\Omega$  load. It is also desirable to measure input power from the exciter, as well as amplifier-input SWR, but these can be measured after initial tune-up if two meters aren't available.

Set the input-circuit trimmers (CS and C14) near midrange. Because the output circuit can be tuned several ways for the proper impedance transformation, it's important to preliminarily adjust the output circuit by compressing C13 all the way, then backing off one full turn, before beginning tune-up. Do the same for C21, then back C20 out almost all the way. Turn on the amplifier and apply about 2 W drive. The COR should sense the input RF and switch immediately into transmit. Using a nonmetallic tool, tune the two input-circuit trimmers for maximum power output, then tune the three output trimmers (C13, C20 and C21) for peak output. These adjustments interact, so continue tweaking for maximum power.

During tuning, pay attention to the temperatures of these variable capacitors. If heating is noticeable (especially in C13), reset these capacitors and start again. Limit key-down periods to 10 seconds, and allow for cooling in between. Increase drive to about 9 W. Output should be 95 to 105 W, and the output-tuning capacitors should be cool to the touch just after RF drive is removed.

Input SWR should be less than 1.2:1. If not, adjust the input-circuit trimmers for the best compromise between low input SWR and maximum power output. The amplifier is now ready for operation. Some MRF492s seem to be "hotter" (exhibit

more gain) than others; I have seen some devices produce 115 W easily and others strain to put out 95 W. On the air, the difference is so slight that it can't be detected. For best IMD performance, I recommend running the amplifier at about 85 W output on SSB.

### FM Operation

This amplifier also works well on FM, but the power output should be limited to about 75 W because of FM's more demanding duty cycle. As mentioned earlier, the amplifier's bandwidth characteristic is double-humped; if it's tuned up at 50.1 MHz, the second hump falls in the 53-MHz area, allowing for SSB and FM operation without retuning.

If the amplifier is to be used for beacon, CW or FM operation exclusively, I suggest you configure it for class-C operation. Efficiency in class-C operation is in the 72% range, versus 60% for class B. To configure the amplifier for class-C use, connect the inductor using FB2 (the multi-hole ferrite bead) from Q1's base to ground, and eliminate all of the other bias components, including D2. If you like, you can add a panel switch to change between class-C and class-B operation.

The amplifier should never be operated class C on SSB. Doing so results in severe distortion.

### Conclusion

I hope that you enjoy building this project, and will be motivated to try 50-MHz operation. As I write this, Japanese stations are being worked on the East Coast, and all continents are frequently heard. In the years to come, the regular occurrences of sporadic-E openings and meteor scatter will help fill the nulls between F-layer openings. Hurry and get in on the excitement on the "Magic Band"!

### Notes

<sup>1</sup>T. Tammaru, "A Solid-State 6-Meter Linear Amplifier You Can Build," *QST*, May 1982, pp 11-14. This circuit was based on an MRF492 test circuit in Motorola's *RF Device Data* book.

<sup>2</sup>Motorola *RF Device Data*, Fourth edition (Motorola Inc: 1986), pp 3-552 through 3-555.

<sup>3</sup>A set of PC-board parts, including a high-quality PC board with plated-through holes, is available from the author for \$100 (UPS delivery included). Switches, LEDs, enclosure, terminals, heat sink and connectors are not included. The PC board alone is available for \$17 postpaid, and a black anodized-aluminum heat sink is available separately for \$12 postpaid. (The ARRL and *QST* in no way warrant this offer.)

<sup>4</sup>Frontier Microwave, AD 1, Box 467, Ottsville, PA 18942, evening tel 215-795-2648; Down East Microwave, RR 1, Box 2310, Troy, ME 04987, tel 207-948-3741.

<sup>5</sup>Send a business-size SAE with return postage for 1 ounce with your request. Specify the information package for the 6-meter linear amplifier from October 1990 *QST*. This package includes full-size etching patterns for the front and rear sides of the amplifier PC board and a part-placement overlay.

# A 300-W MOSFET Linear Amplifier for 50 MHz

Everyone is looking to go QRO on 6 meters. Build this "almost a brick" to boost your signals from 15 to 300 W.

In an earlier article, I described a 50 MHz, 125 V, 250 W, class-C amplifier using ARF448AJB high-voltage MOSFET devices.<sup>1</sup> This paper describes an improved version of an amplifier that is capable of class-AB linear operation. The design changes required and the procedures involved are explained and demonstrated. Complete descriptions of the amplifier and its construction are presented, as well as the measured performance.

High-voltage, high-power MOSFETs have been shown to be very capable RF power amplifiers.<sup>2</sup> The metal-gate architecture of the ARF series from Advanced Power Technology has raised the frequency limits for this type of device to 100 MHz. The APT448A/B is typical of the series. It has a 68,000-square-mil die with a breakdown voltage rating,  $BV_{dss}$  of 450 V. The device is provided in the inexpensive TO-247 plastic package, and is available in common-source symmetric pairs. Like all MOSFETs, the gate threshold voltage,  $V_{th}$ , has a negative temperature coefficient. This makes operation as a linear amplifier difficult or impossible without compensation.

When forward biased with a constant gate voltage, the quiescent drain current rises as the temperature of the die increases. Operating at the typical drain voltage for these parts, about one third of the rated  $BV_{dss}$ , the power dissipation caused by the increasing  $i_d q$  results in "hot spotting" and subsequent thermal runaway. This is an unstable system. The dissipation increases so rapidly that the outside surface of the case does not follow internal junction temperature well. As a result, a bias-compensation scheme that uses temperature sensing cannot keep up with the  $V_{th}$  shift, and the device is destroyed.

The power dissipation within the die is a direct function of the operating voltage. By lowering the operating voltage, the thermal

loop gain can be reduced to a point where the gatethreshold shift can be compensated. Thermal stability can be achieved by sensing the case temperature. Linear operation thus becomes practical at 100 V and below. While this is less than 25% of the rated  $BV_{dss}$  and produces less gain, a very rugged and useful linear amplifier is the result.

## Amplifier Description

The following were the design goals for the amplifier:

- Frequency range 50 to 51 MHz
- Input SWR < 1.5:1
- Gain > 13dB
- Output power 300 W PEP or CW
- Efficiency > 50%
- IMD3 > 25 dB below PEP

A push-pull topology was chosen for best output power and minimum harmonic content. The previously reported class-C design used  $V_d = 125$  V. Since this is too high for reliable class-AB operation, 80 V was eventually chosen for this design. This is a compromise between gain, efficiency and thermal stability.

Since the gate input impedance is very low, it magnifies the effects of any stray inductance in the gate matching circuit. In a push-pull design, it is critical to maintain absolute symmetry between the two sides. This fact was demonstrated during the initial design work. One preliminary design had a slight asymmetry in the PCB artwork. The amplifier exhibited low efficiency, hot ferrite in the output transformer balun and poor distortion characteristics with asymmetrical IMD product amplitudes. This clearly demonstrates the benefit of symmetrically packaged devices.

A multiple-aperture ferrite bead was chosen for the input transformer. Brass tubing was used for the secondary, and the primary was wound inside the brass tubes to provide a very broadband balanced transformer design with minimum leakage reac-

tance. Several cores and construction methods were evaluated, and this well-tried design proved best.

The typical HF push-pull amplifier employs a bifilar choke to decouple the drain-voltage feed. As frequency and power increase, this feed method becomes less practical because the need to reduce the number of windings to offset the stray capacity and the need to prevent core saturation conflict. In this design, a powdered-iron toroid was chosen for the feed choke core. This proved far superior to any of the ferrite cores evaluated. It is inexpensive and easy to reproduce.

## Design

Three main areas must be addressed. The input matching must provide a balanced feed to a pair of low-impedance gates. The output must be matched to a suitable load impedance, and then transformed to a 50- $\Omega$  unbalanced load. The bias must be thermally compensated to track the negative temperature coefficient of the gate bias threshold.

The input is reasonably straightforward. Each gate input is  $0.2 + j0.5$ , as estimated from the data sheet. The push-pull topology puts these two impedances in series, which makes the matching less difficult. A Smith Chart<sup>3</sup> program makes the actual design easy. The program used here is *WinSmith*.<sup>4</sup> The two gate impedances are added in series, and a network synthesized to transform the resulting impedance up to 50  $\Omega$ . The Smith Chart program only works with single-ended circuits, so the center tap was added later. See Fig 1.

The input-transformer design was chosen for its simplicity and relative ease of construction. Of several attempts using different material permeabilities, multiple beads and different conductor types, this proved to be the best and most consistent performer. The core is a Fair-Rite<sup>5</sup> "multi-

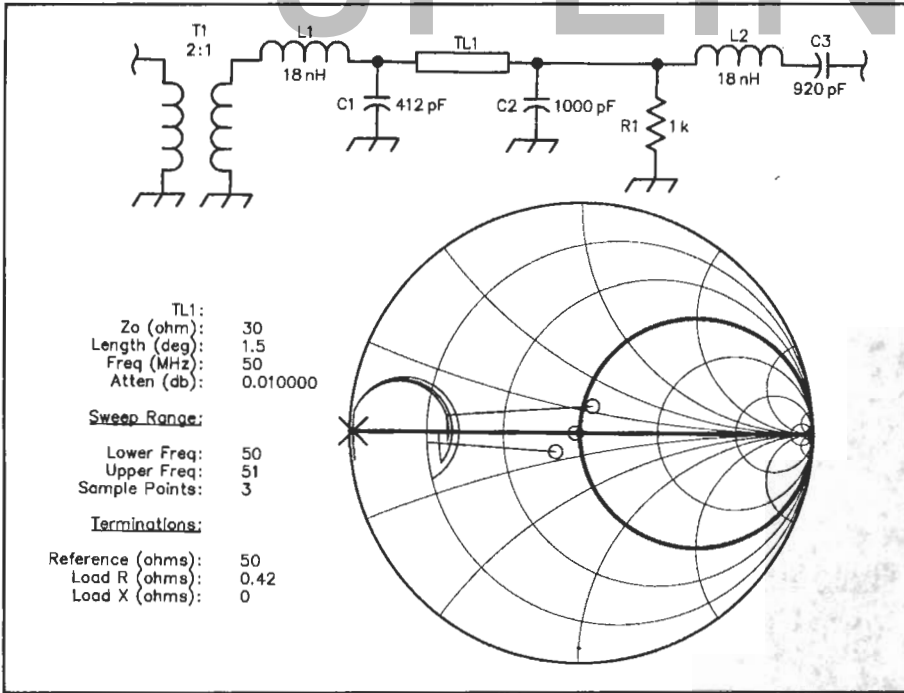

Fig 1—Input matching network and calculation.

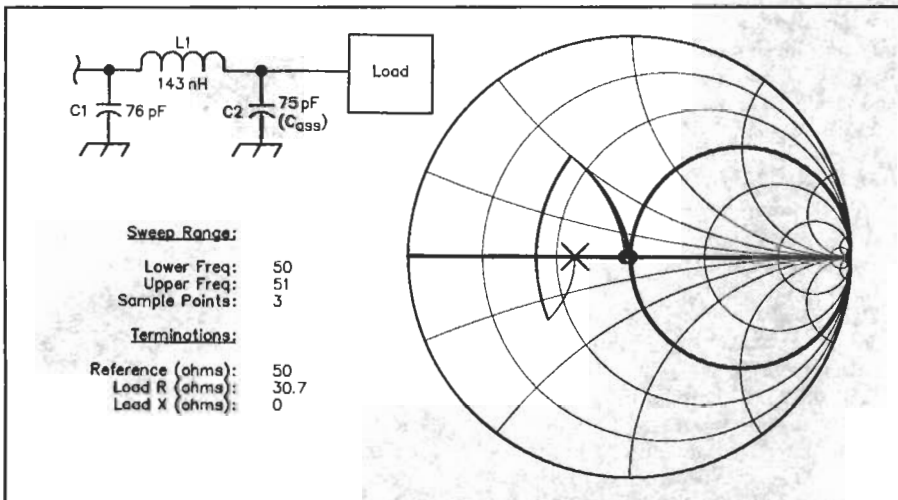

Fig 2—Output matching network and calculation.

aperture" core, part number 2843010402. The type-43 material has a  $\mu_r$  of 850. At 50 MHz, type-61 material ( $\mu_r$  of 125) would also be satisfactory. This transformer is essential to provide balanced drive to the gates of the MOSFETs. The secondary winding is  $\frac{3}{16}$ -inch brass tubing. Copper shim stock forms the connections to the brass tubing at each end of the transformer secondary. The two-turn primary is wound inside the tubing. This construction provides a very reproducible transformer with minimum leakage reactance and a very broad frequency response. It would be a suitable input transformer for a broadband amplifier covering 1 to 100 MHz.

The leakage reactance of the input transformer—referred to the secondary—is about 18 nH and is represented as L1 on the simplified input schematic in Fig 1. The gate load is represented by the "Load R." L2 and C3. Using all three parts of the gate impedance allows proper evaluation of the network bandwidth. A pi network consisting of C1, TL1 and C2 is used to step-up the gate load to the 12.5  $\Omega$  needed by the transformer and compensates for T1's leakage reactance. Notice that the net stray inductance of the gate is almost enough to effect a match with a single shunt capacitor. This has actually been done, but it was not easy to fit all the parts in the available space; so it was judged unacceptable here. To transform the network into the required balanced configuration, the series TL1 is split into two equal parts; the shunt capacitors remain the same, and a neutral center tap is provided at the transformer secondary.

Because of the high currents circulating in the input network, it is imperative that C2 be a larger-sized, class-1 dielectric (C0G or NP0) capacitor. It must be a leadless, surface-mount chip type, or the value will need to be adjusted. The input tuning capacitor, a 900 pF mica compression trimmer, is mounted directly to the end of the input transformer.

The output network is also straightforward. The proper load impedance for class

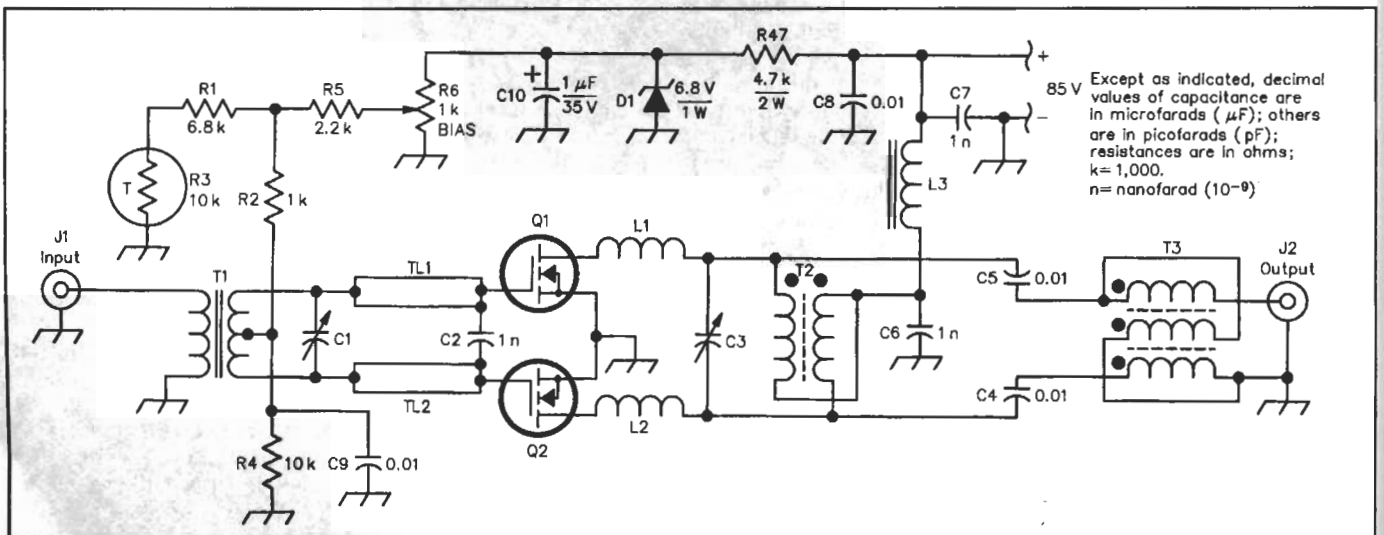

Fig 3—50 MHz amplifier schematic diagram.

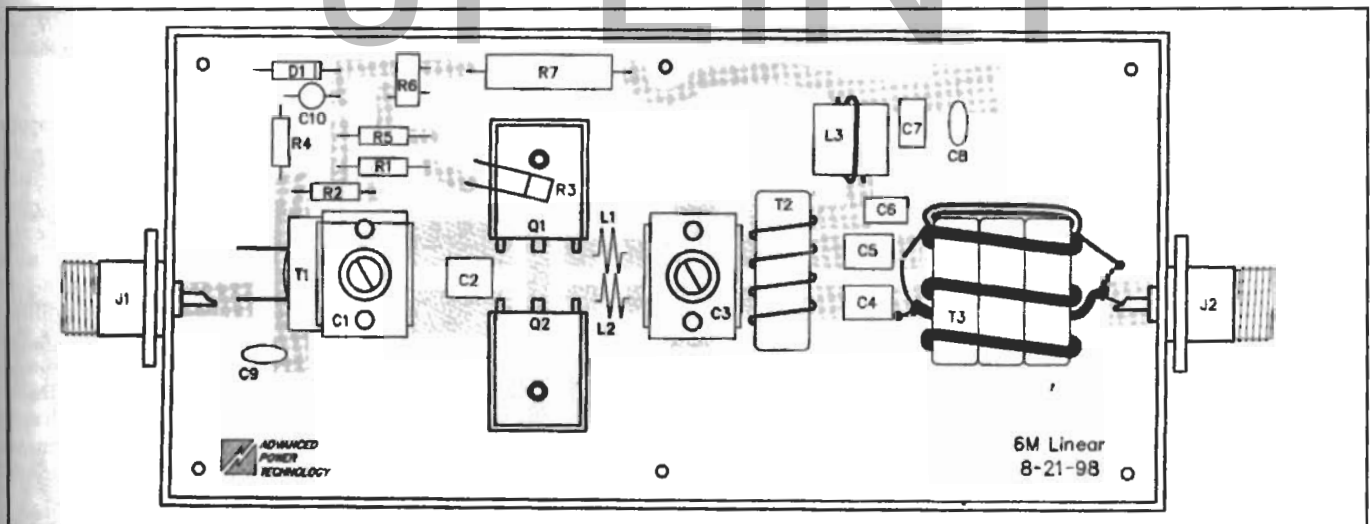

Fig 4—Amplifier parts layout.

AB is calculated from the formula:

$$R_L = \frac{0.98 V_{dd}^2}{2 P_o} \quad (\text{Eq 1})$$

This is the load for each device, and  $P_o$  is one half of the total in a push-pull circuit. It is shunted by the output capacitance,  $C_{oss}$ . As was done for the gate circuit, both output impedances are series-connected to represent the total output impedance. The result for both devices in push-pull is  $30.7 \Omega$  in parallel with  $75 \text{ pF}$ , half the output capacitance of a single device. Though the design goal was  $300 \text{ W PEP}$ , the amplifier was actually designed for a  $400 \text{ W}$  load line. This gives a good compromise between efficiency and linearity.

In a classical design, a suitable transformer would be used to set the load impedance, and either the output power or the operating voltage would be adjusted to fit the available turns ratio. Normally, in a low-voltage HF design, the output capacitance is ignored because it is shunted by a much smaller load resistance. At  $50 \text{ MHz}$ , the effects of the output capacitance must be compensated, so a slightly different approach was taken in this circuit.

WinSMITH was used again to design the output matching. See Fig 2. The output impedance of  $30 \Omega$  is rotated south by the effect of the shunt output capacitance, C2. Two options present themselves for compensation. Some additional shunt capacitance could be added to further reduce the equivalent series real part to  $12.5 \Omega$ , a series L used to resonate the resulting series C, then a 4:1 transformer used to go to  $50 \Omega$ . However, building a reproducible low-loss 4:1 balanced transformer was very difficult, and compensating its leakage reactance further complicates the design. The second option was used: The equivalent series output capacitance was resonated first, then more series inductance was added to rotate the load all the way up to the  $1/50\text{-mho}$  conductance circle. Finally, a shunt capacitor was used to resonate the

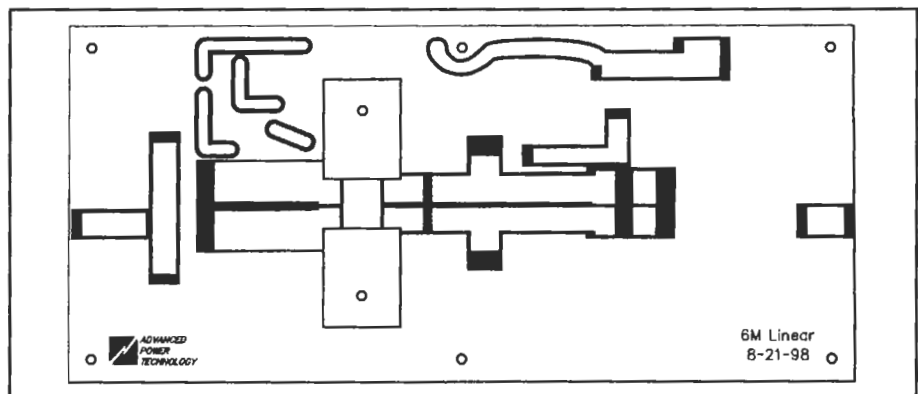

Fig 5—PCB artwork (not to scale, original size 3.35 (7.00 inches).

added  $X_L$ . The extra L and shunt C form an L-network, which transforms the  $20\text{-}\Omega$  equivalent series output impedance up to  $50 \Omega$ . This results in an easily duplicated design with a smooth, low-Q match.

The dc feed to the drains is provided through a shunt bifilar choke. At this frequency, most ferrite materials exhibit too much loss to be used at this impedance level. A powdered-iron core works famously here.

The balun-transformer function is provided by a simple coax and wire transformer. Two of the windings are provided by  $50\text{-}\Omega$  Teflon coax, and the third balancing winding by an additional single wire.

The bias network requires some explanation. Power MOSFETs have normal lot-to-lot variations in gate threshold voltage,  $V_{th}$ , forward transconductance,  $G_{fs}$ , and other parameters. A number of devices were checked for  $V_{th}$ , and they were all very close. They were all from the same die lot. The die lot number is marked on the package. For comparison, devices from another lot were checked and were uniformly a half a volt lower. Were this the case for the devices to be used in the amplifier, a dc block would need to be added to each side at the transformer, and the bias-feed network duplicated for each device. Since these devices were uniform, the additional compli-

cation of individual gate-bias adjustments was omitted in this design.

Because the gate-bias voltage required to maintain a particular value of idling drain current decreases as the temperature of the die increases, it is necessary to thermally compensate the gate-bias source, or the devices will "run away." A commonly available NTC resistor tracks the temperature of the case. (Refer to Fig 3.) This bias circuit has been in the literature for many years.<sup>6</sup> The ratio of R1 to R3 in part determines the degree of compensation. A smaller value of R1, or a larger value of R5, will increase the thermal sensitivity. A drop of thermally conductive glue keeps the thermistor in contact with the case. Proper operation is indicated when the set value of  $I_{dq}$  does not change after the heat sink gets hot from prolonged operation.

### Construction

Refer to Fig 4 for the parts layout. A photo master of the artwork is shown in Fig 5. The original size of the artwork is  $3.35 \times 7$  inches. The circuit board is 1-ounce-copper, double-sided  $1/16$ -inch G-10 PCB material. All four edges of the board and the three sides of the two rectangular cutouts for the transistors are wrapped with copper-foil tape that was soldered in place to



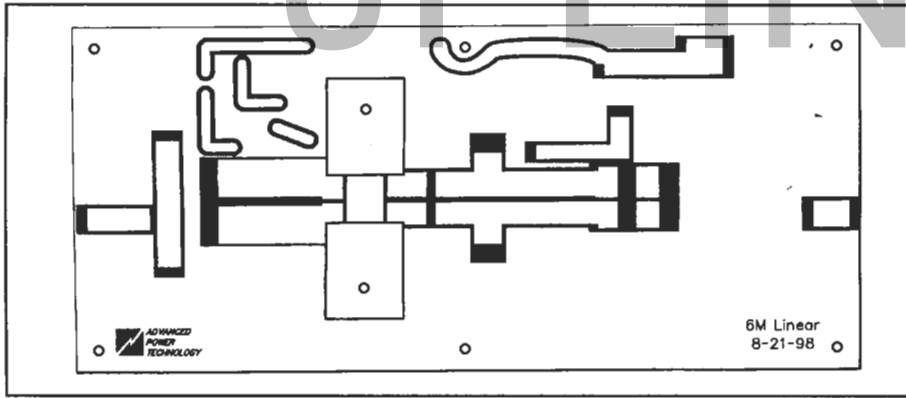

Fig 6—SSB IMD performance.

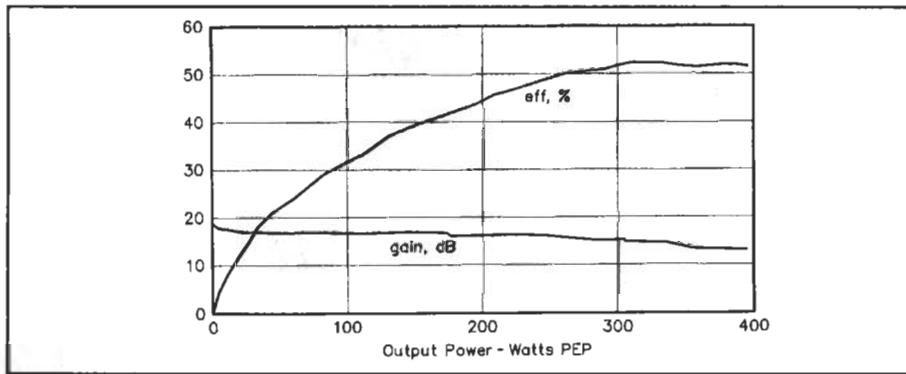

Fig 7—Amplifier efficiency and gain.

### Table 1—Amplifier Parts List

C10—1 $\mu$ F, 35 V electrolytic capacitor  
 C1—215-790 pF Arco<sup>®</sup> #469 mica compression trimmer  
 C2, C6, C7—1000 pF, 500 V NPO chip cap, KD9 #2020N102J501P  
 C3—20-180 pF Arco #463 mica compression trimmer  
 C4-C5, C8-C9—0.01  $\mu$ F, 500 V chip capacitor  
 D1—6.8 V, 1 W Zener diode  
 L1-L2—70 nH, 3t #18 AWG enameled wire 0.31-inch diameter 0.25-inch long  
 L3—2t #20 AWG on Fair-Rite #284301 0402 bead  $\mu_i = 850$   
 Q1—ARF448A  
 Q2—ARF448B  
 R3—10 k $\Omega$  NTC Fenwal<sup>10</sup> #140-103LAG-RB1  
 R6—1 k $\Omega$ , 0.5W 10-turn trimmer  
 T1—Primary 2t #20 PTFE, Secondary  $\frac{3}{16}$ -inch brass tube on Fair-Rite #2843010402 balun core  
 T2—6t bifilar #20 PTFE on Amidon #T-94-2 toroid  $\mu_i = 10$   
 T3—3t RG-316 coax, 3t #20 PTFE on three Fair-Rite #5961001801 toroids  $\mu_i = 125$   
 TL1, TL2—30- $\Omega$  printed line, 0.6 inches long

provide a low-impedance continuous ground plane. The two cutouts for the transistors and the six mounting holes are the only holes in the board. All of the parts are surface mounted, which permits the board to be mounted directly to the heat sink.

This amplifier was built on a 7-inch length of AAVID #60765 heat-sink extrusion.<sup>7</sup> It is 3.5 inches wide, 1.5 inches deep and has nine fins. With 50 CFM of air blown across it, the devices will easily maintain thermal stability in a 30°C environment. The heat sink is not big enough for anything but very intermittent use without a fan to assure adequate airflow across the fins. The input and output connectors are each secured by two #4-40 screws and

holes tapped into the base of the heat sink. A cover is recommended for safety; fairly high RF voltages are present.

### Power Supply

Power for the amplifier needs to be fairly well regulated, since any ripple will show in the output signal as undesired 120-Hz AM. For on-air testing at the author's home, a very simple power supply was constructed using a 500 W, 120 to 240 V isolation transformer to drive a full-wave, centertapped rectifier circuit with 50,000  $\mu$ F of filtering. Under SSB conditions, this is adequate. For CW, it needs some better regulation or the output power will sag over the length of a dash, and there will be some

detectable hum. A regulated supply capable of providing 80 V at 6 A is needed.

### Performance

This is the first-known, class-AB application of the ARF448 parts. Until now, the only other linear application is in a pulsed-mode linear amplifier for magnetic-resonance imaging. The SSB performance was encouraging because these devices were developed to serve the ISM plasma-generation market and no attention to linear performance was given in their design. The IMD performance with 200 mA of quiescent bias was better than expected. (See Fig 6.) The amplifier was tested with up to 0.5 A of  $I_{dq}$ . While the IMD performance improves somewhat at this level, the efficiency degrades significantly.

The gain and efficiency objectives have been met, as shown in Fig 7. The gain is 14.3 dB at 300 W PEP. The efficiency peaks at 51% at the same power. Under single-tone conditions, the drain efficiency is 61% at 250 W. The bandwidth of the amplifier is determined by the input network. The Smith-Chart plot of the input impedance shows the tracks for 50, 50.5 and 51 MHz. With the network adjusted for best match at 50.5 MHz, the SWR at the  $\pm 0.5$  MHz bandwidth points is 1.3:1. It would be difficult to increase this SWR bandwidth enough to cover the full 4 MHz of the amateur 6-m band without resorting to resistive loading, which would then reduce the available gain.

### Conclusion

This paper has presented a 50 MHz, 300-W PEP linear amplifier using plastic-packaged, high-voltage MOSFET transistors. This is the first-known implementation of a full-duty-cycle class-AB amplifier using these transistors. The design challenges, approaches to their solution and the resulting amplifier performance are shown. The parts, construction and mechanical layout all have been described in sufficient detail to permit duplication. The new line of plastic-packaged RF power transistors from APT offers designers a new cost-effective solution for efficient layout and performance.

### Notes

- <sup>1</sup>R. Frey, "A 50 MHz, 250 W Amplifier Using Push-Pull ARF448A/B," APT9702, Advanced Power Technology Inc.
- <sup>2</sup>R. Frey, "A Push-Pull 300 Watt Amplifier for 81.36 MHz," *Applied Microwaves and Wireless*, April 1998.
- <sup>3</sup>Smith Chart is a trademark and property of Analog Instruments Co, New Providence, New Jersey.
- <sup>4</sup>WinSMITH, copyright Eagleware Corp, 1995, available through Noble Publishing, Inc.
- <sup>5</sup>Fair-Rite Products Corp, PO Box J, One Commercial Row, Wallkill, NY 12589.
- <sup>6</sup>H. Granberg, "Wideband RF Power Amplifier," *RF Design*, February 1988.
- <sup>7</sup>AAVID Thermal Technologies Inc, Box 400, Laconia, NH 03247.
- <sup>8</sup>Arco Electronics, 5310 Derry Aye, Agoura Hills, CA 91301.
- <sup>9</sup>KD Components Inc, 2151 Challenger Way, Carson City, NV 89706.
- <sup>10</sup>Fenwal Electronics, Inc, 450 Fortune Blvd, Milford, MA 01757.

# A No-Bandswitch, Dual-Band VHF Desktop Amplifier

An old design idea together with new tubes yields legal-limit output on 6 and 2 meters from a small box.

Dual-band VHF amplifiers are by no means new in Amateur Radio. Several designs have appeared over the years, both commercial and homebrew.<sup>1,2</sup> The most recent commercial design was the Henry Tempo 6N2, now out of production for more than 20 years. There has never been a desktop capable of the new 1500-W PEP amateur power limit for both the 6- and 2-meter bands, until now. The amplifier I describe was designed primarily for meteor-scatter and weak-signal work, but the conservative design of the power supply and cooling system makes it well suited for EME (moonbounce) also. The amplifier uses a pair of Svetlana 3CX800A7s, operating in class AB2-push-pull on 2 meters and AB2-parallel on 6 meters. Features include: legal-limit output, no key-down time limit, no band switching, either-or operation, 50-60 W of drive for 1500 W PEP output on both bands, small size and light weight. In an effort to make this design easier to duplicate, off-the-shelf components and materials were used wherever possible. If you prefer not to "roll your own," Alpha Power should have a commercial version available soon.

## Output Tank Circuit and Construction Details

Since this was a new tank design, I decided to use a box-in-a-box approach for the layout to make adjusting and debugging much easier. This should also make duplication of the tank circuits much easier for those of you who wish to use a separate, outboard power supply. The tank compartment (See Figs 1, 2 and 7) starts with a 7x7x2-inch Bud chassis with two surplus

11-pin ceramic sockets<sup>3</sup> mounted three inches apart (center-to-center) and four inches from the rear of the chassis. The sockets are mounted 1/4 inch below the chassis in 2 1/2-inch-square holes with each socket oriented at 45° to the hole (Fig 3). This is similar to an Eimac 2216 socket for the 8877. The Eimac #1906 chimneys were used in the normal manner. This is probably the upper frequency limit for this

mounting scheme due to possible instability problems at UHF. One problem encountered while mounting the sockets this way is the small amount of tube exposed above the chimney to grasp for removal. This is easily solved by connecting several 1/4-inch-wide hose clamps together end to end, then clamping them to the anode cooler to serve as a temporary handle.

The front, top and sides of the tank com-

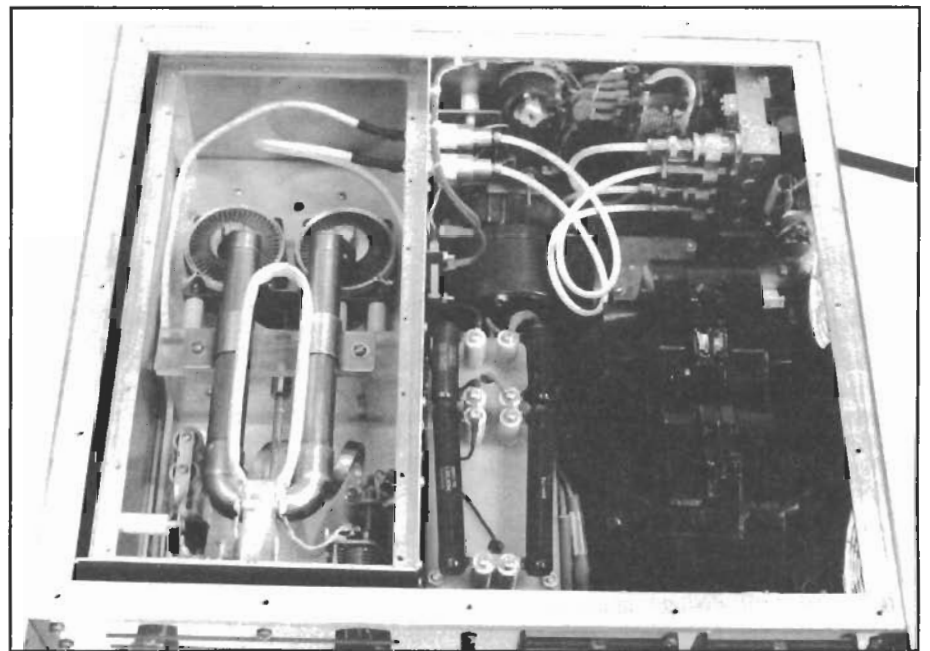

Fig 1—A top view of the amplifier. The plate transformer in the front right and high-voltage power assembly next to it occupy the majority of the control side with the blower, filament and control transformers sitting just behind. The tank compartment with the cover removed shows the plate line on its Plexiglas stand.

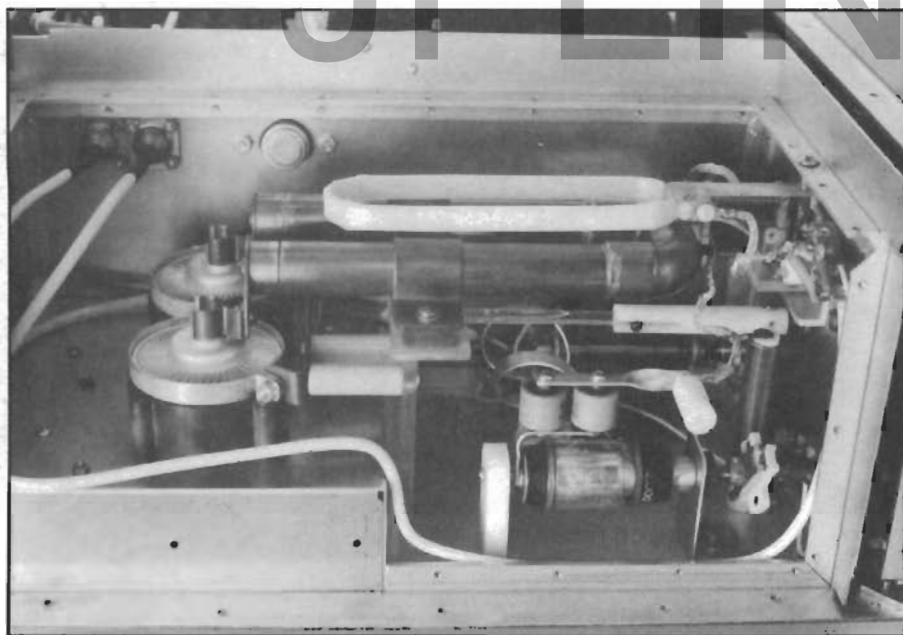

Fig 2—Side view of tank compartment. The 2-meter load capacitor on its ceramic standoffs mounted to the Plexiglas stand is in the center with the 6-meter tank coil just visible below the spline shaft assembly. The 6-meter tune capacitor on its L bracket is in the lower right front.

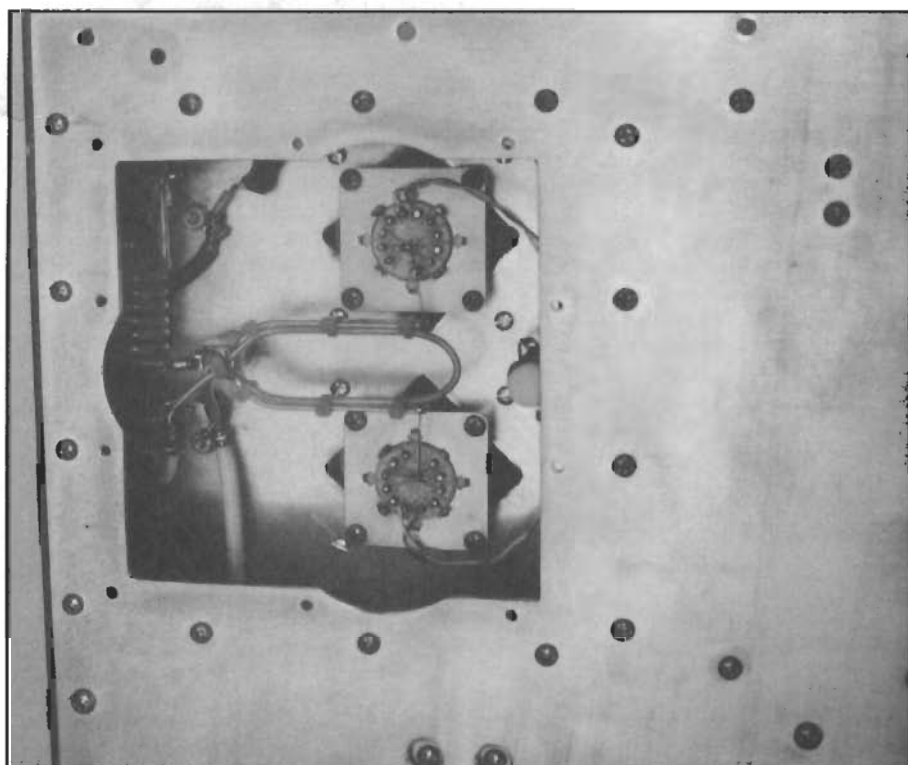

Fig 3—Bottom view of amplifier with cathode compartment cover removed. The filament choke is to the right with the 2-meter input network visible centered between the tube sockets. Both input tuning capacitors are mounted on the rear panel and one of the 6-meter input coils is just visible on the left. Note the use of coax for exciter lines to keep feedback paths minimized.

partment are all made from  $\frac{1}{16}$ -inch aluminum with  $\frac{1}{2} \times \frac{1}{2} \times \frac{1}{8}$ -inch aluminum angle brackets at all corners. The completed compartment measures  $7 \times 6\frac{1}{4} \times 14\frac{1}{2}$  inches (WHD). The front and right-side compartment panels extend to the top of the main cabinet cover to keep inlet and outlet air

separated. The compartment cover (not shown) has 176 0.2-inch holes above the tubes for cooling exhaust. When this box is attached to the floor of the main cabinet, it leaves a  $4 \times 7$ -inch hole at the back before the rear panel is attached. This opening serves as access for a dip meter when

checking the 2-meter tank resonance and tuning range.

The 2-meter tank circuit consists of a shorted  $\lambda/4$  balanced line section, tuned by a homebrew split-stator capacitor at the tube end of the line. Designing this type of tank circuit is made very pain-less with information and design exam-ples provided in references.<sup>4</sup> There are several advantages of using a push-pull tank circuit instead of a parallel arrangement at 144 MHz. In the push-pull arrangement,  $C_{out}$  and  $C_{in}$  of the tubes are in series, allowing a total  $C_{out}$  and  $C_{in}$  that is one quarter of that with the parallel arrangement. This allows lower values of loaded Q, resulting in higher efficiency and reduced compo-nent heating, minimizing thermal drift. The low value of  $C_{out}$  in this case allows the use of a  $\lambda/4$  line in place of a  $\lambda/2$  line, increasing bandwidth and decreasing size.

The line section, L2 of Fig 4, is made from  $\frac{3}{4}$ -inch type-K copper pipe; the shorted end is made from one standard 90° copper elbow and one "street" 90° copper elbow. The open ends of the line are closed with brass plugs of the same outside diameter as the pipe, with a portion machined to fit inside the pipe. Standard copper pipe caps could be substituted for these plugs. The total length of the line section is  $7\frac{3}{4}$  inches, from the ends to the inside of the shorted end. The plate-to-anode connections are made with  $\frac{1}{16}$ -inch copper plate fastened between copper fuse clips on the anode connectors and threaded holes in the ends of the brass plugs.

The line section is supported by a Plexiglas stand and held in place by two copper clamps. The stators of the 2-meter TUNE capacitor, C3, are supported by  $1\frac{1}{2}$ -inch ceramic standoffs attached to the Plexiglas stand (Fig 5). A  $\frac{3}{8} \times \frac{5}{8}$ -inch ear from each stator attaches to a  $\frac{3}{8}$ -inch-wide strap around each of the tubes' anode coolers. The rotor of C3 is a two-inch disk of  $\frac{1}{16}$ -inch copper, which is mounted to a piece of  $\frac{1}{4} \times 28$  brass all-thread rod. The threaded rod is held by a brass fitting (tapped for  $\frac{1}{4} \times 28$ ) that is attached to the Plexiglas stand. The threaded rod is coupled to a sliding spline shaft consisting of  $\frac{1}{4}$ -inch Plexiglas rod inside a  $\frac{1}{2}$ -inch piece of Teflon rod that has been drilled through the center. The Teflon tube is attached to a short piece of  $\frac{1}{4}$ -inch stainless-steel rod that exits the tank compartment through a  $\frac{1}{4}$ -inch panel bushing. This shaft is coupled to the turns counter with a synchronous gear belt (Fig 6). This shaft relocation via the gear belt serves only to improve the front-panel appearance; it may be omitted if desired.

The 2-meter tank circuit is coupled to the antenna by an adjustable reso-nant link. The link position is adjusted by a #10-24 screw through a threaded Plexiglas block, to which the link is attached (Fig 2). One end of the adjusting screw is supported by the top-cover angle bracket and the other end by a 2-inch-long piece of  $\frac{1}{2}$ -inch angle mounted to the front panel of the compart-

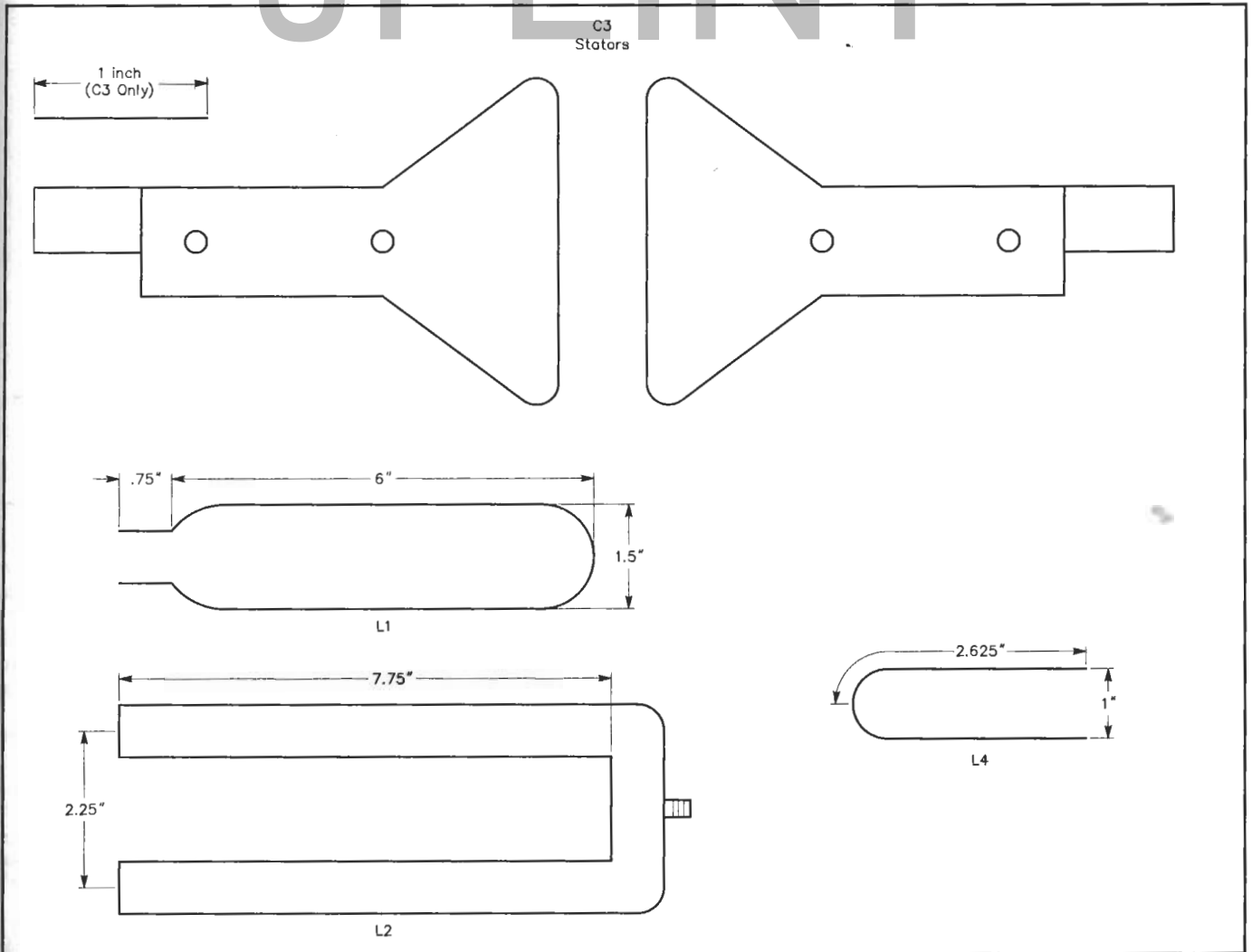

Fig 4—Details of 2-meter input and output tank indicators and the 2-meter TUNE capacitor stators.

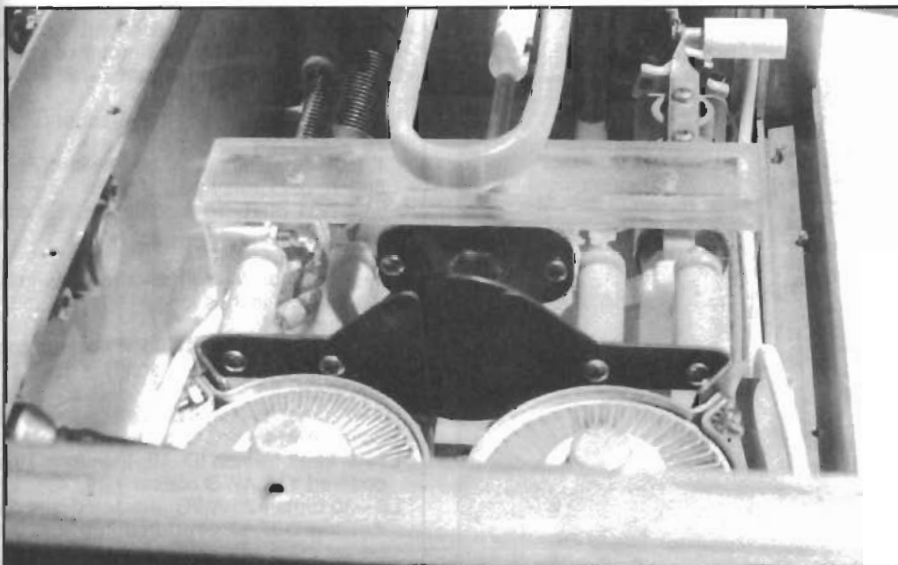

Fig 5—Rear view with the plate line removed showing the 2-meter TUNE capacitor.

ment. The link is made from  $\frac{1}{8} \times \frac{1}{16}$ -inch silver-plated copper strap, covered with a  $\frac{3}{8}$ -inch Teflon sleeve; it is attached to the Plexiglas block with four #10-32 nylon screws. Silver-plated coax braid attaches

the link to the 2-meter **LOAD** capacitor, C2, and the isolation relay, K3. The link-adjustment screw is accessed through  $\frac{3}{8}$ -inch hole in the main cabinet top cover during initial setup, then the hole is cov-

ered with a plastic plug.

As with all push-pull circuitry, the key to successful operation is symmetry. All stray capacitance must be divided equally between both sides of the line and tubes. Also, try to keep ferrous materials out of the tank compartment to prevent imbalance.

The 6-meter tank is a normal  $\pi$  network designed for a plate-load resistance of 1150 W with a loaded Q of approximately 22. The design parameters are shown in Table 1. The input of the  $\pi$  network is connected to the center of the shorted end of the balanced line section where a #10-32 brass stud has been soldered in place. This is the low-impedance point of the line section, and anything but a dead short can be attached here without affecting the performance of the line.<sup>5</sup> To verify that the physical center of the line is also the RF center, couple a dip meter to the line and tune for a dip around 144 MHz. Then without moving the dip meter (DM), touch the tip of a lead pencil at points along the line until you find the spot that has the least effect on the DM. This is the attachment point for the plate choke and the 6-meter tank.

To keep the loaded Q of the  $\pi$  network as low as possible, full 51-54 MHz opera-

**Table 1—Print out of operating parameters for the 6-meter input and output networks**

The values for the PI matching network were calculated with Elmer (W5FD) Wingfield's new formulas found in the more recent ARRL handbooks.			Conduction Angle	=	187.8	Degrees	
FREEWARE Courtesy of KD9JQ			Peak Grid Voltage	=	36.8	V	
Triode Amplifier Program Version 2.0			Zin @ Cathode	=	24.6	Ω	
For Grounded Grid Operation			Pin Drive (PEP)	=	41.0	W	
(2) USER Biased 3CX800A7 at 50.0 MHz Rated for FORCED AIR			P0 @ Plate (PEP)	=	1600.0	W	
DC Plate Volts	=	2150.0 V (2500 V Max)	P0 to Load (PEP)	=	1637.9	W	
Max Plate Voltage	=	2150.0 V	DC Power Input	=	2405.5	W	
Peak Plate Swing	=	1900.0 V	Efficiency	=	66.5	%	
Min Plate Voltage	=	250.0 V	Power Gain	=	16.0	dB	
Plate Current Peak	=	3.368 A	Cath to Grid Cap	=	52.00	pF	
Plate Current DC	=	1.119 A	Plate to Grid Cap	=	12.20	pF	
Grid Current DC	=	0.063 A	<b>T Match Input</b>			<b>Pi Match Output</b>	
Cath Current Peak	=	3.651 A	RS =	50.0 Ω		RP =	1154.8 Ω
Design Plate RL	=	1128.1 Ω	L2 =	0.521 μH		CI =	50.0 pF
RL for Matching	=	1154.8 Ω	CI =	44.924 pF		L1 =	0.2377 μH
Plate Dissipation	=	805.5 W (1600 W Max)	L1 =	0.422 μH		C2 =	232.0 pF
Grid Dissipation	=	3.2 W (8 W Max)	RFC =	0.195 μH		RL =	50.0 Ω
Cathode Bias	=	8.2 V	Zin =	22.6 -j9.9 Ω		QL =	22.0
			QL =	5.0			

tion was not attempted. The 6-meter TUNE capacitor, C1, operates very near its minimum capacitance because of strays and the C<sub>out</sub> of both tubes. These strays account for a large portion of the 6-meter tune capacitance, which causes the majority of the tank circulating current to flow through the blocking caps, C7-C8. I used parallel Centralab 858 "door-knobs" for the blocking capacitors and I haven't experienced any problems. Capacitors with larger current ratings (such as HT-57s) would be a better choice for longer duty cycles.

The 3-30 pF vacuum-variable capacitor is mounted to the floor of the tank compartment with an L-bracket bent from 1/16-inch aluminum. Use the bearing retainer nut to attach the capacitor to the bracket, but be sure to add shims to the bearing to make up for space lost by the thickness of the bracket, or backlash will

occur. The other end of the capacitor is supported by a #6-32 brass screw in the end of the capacitor that passes through a piece of Teflon bar stock mounted to the floor of the cabinet. A #6-32 hex nut holds the end of L3 and a piece of 3/8-inch strap (which supports C7 and C8) tight to the end of the vacuum cap. The other end of L3 is supported by a 1/2x1-inch Teflon standoff. Silver-plated braid ties this end to the 6-meter LOAD cap, which is mounted on the sidewall of the tank compartment.

**Setting the Output Tanks**

The 6-meter tank can be checked for tuning range with an SWR analyzer at the output connector. Connect a 1.1 kΩ, noninductive resistor from one of the tube anodes to ground to simulate the 1100-W plate-load resistance. You should be able to achieve a 1:1 match at both ends of the

desired tuning range. Some stretching or compression of L3 may be required to bring the tuning range to 50-51 MHz. Be sure the top cover of the tank compartment is in place, as the stray capacitance it introduces accounts for a portion of the tuning capacitance for 6-meters.

The 2-meter tank was set up entirely

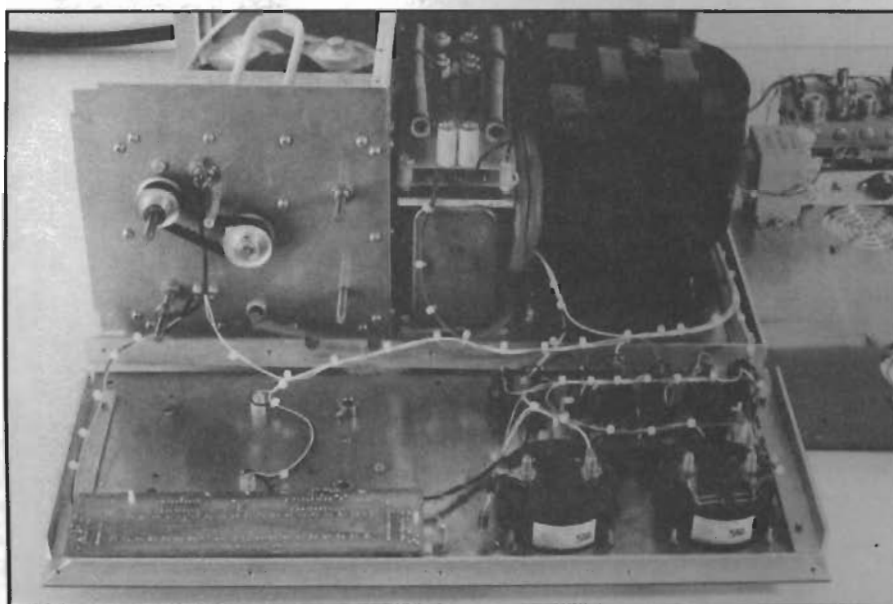

Fig 6—Front view of the amplifier with front panel folded down showing the location of high-voltage power-supply components at right and the gear-belt layout on the left. The bar-graph display PC board is visible in the lower left with the control board just beyond the two panel meters.

Fig 7—RF deck schematic. Unless otherwise specified, use 1/4 W, 5%-tolerance carbon composition or film resistors. See Table 3 for part-supplier contact information.

- C1—3-30 pF vacuum-variable capacitor
- C2—150 pF air-variable, 1400 V capacitor
- C3—Split-stator air-variable (see text and Fig 4)
- C4—325 pF air-variable, 1400 V capacitor
- C5, C6—4.3-75 pF APC-style air-variable trimmer capacitor
- C7, C8—1000 pF, 5 kV doorknob capacitor
- C9—2500 pF, 2.5 kV feedthrough capacitor
- D1—8.2 V, 50 W stud-mount Zener diode, 1N2806B
- K3—Jennings RJ1A SPDT vacuum relay, 26.5 V dc coil
- K4, K5—DowKey model 260B with "C" option, coax relay 26.5 V coil
- K6—SPDT relay, 10 A contacts, 24 V dc coil
- L1—See Fig 4
- L2—See Fig 4
- L3—2 turns of 3/8x1/16-inch strap, 1 1/2-inch diameter, 2 inches long
- L4—See Fig 4
- L5—8.5 inches of #14 Teflon covered copper wire with 6 inches tied tightly inside L4
- L6—7 turns, 1/2-inch IDx1 1/8-inch long Teflon covered #14 AWG copper wire
- L7—9 turns 1/2-inch IDx1 1/2-inch long Teflon covered #14 AWG copper wire
- L8—30 turns #26 AWG enameled wire on an Amidon T-37-17 powdered-iron core over center conductor of coax
- M1—0-2 A, 3.5-inch Simpson panel meter
- M2—0-100 mA, 3.5-inch Simpson panel meter
- RFC1—36 turns #18 AWG enameled wire, tight-wound on 1/2-inch-diameter Teflon rod
- RFC2, RFC3—Ohmite Z-50
- RFC4—Ohmite Z-144
- V1, V2—Svetlana 3CX800A7



with a dip meter inserted through the opening in the back of the compartment. Set the output link about  $\frac{1}{8}$ -inch from the top plane of the line; this is close to the final position and adds stray capacitance. To keep loaded Q low, try to set the line length so it doesn't take very much tune capacitance to resonate the line at 144 MHz. Start with a line section a little longer than shown and carefully trim it to resonance. Remember that 1 inch of line length equals approximately 10 MHz of tuning range! The tank should resonate at 144 MHz with about  $\frac{1}{4}$  inch of space between the plates of C3. When the desired tuning range is found, install a  $\frac{1}{4}$ ×28 lock nut on the threaded shaft of C3 to stop travel at the upper frequency limit. This will prevent accidental tuning of the tank to the third harmonic of 50 MHz, which could potentially damage the front end of a 2-meter exciter. Remember that the isolation of most coax relays is very poor at 144 MHz: It was only 35 dB with the DowKey 260B used here. For this reason, a Jennings RJ1A vacuum relay, K3, was added in series with the 2-meter transfer relay. The vacuum relay disconnects the 2-meter link from the coax and terminates the coax in a resistive load during 6-meter operation. Make sure the electrical length of the coax between the relays is more than  $\lambda/10$  and less than  $3\lambda/8$  at 144 MHz. With these safety measures in place, third-harmonic energy at the 2-meter input port was measured at -17 dBm during 1500-W 6-meter operation.

### Input Networks

The 2-meter input network consists of a single tuned-link, air-core transformer (Figs 3 and 4). This coupling method requires slightly more drive than a link-

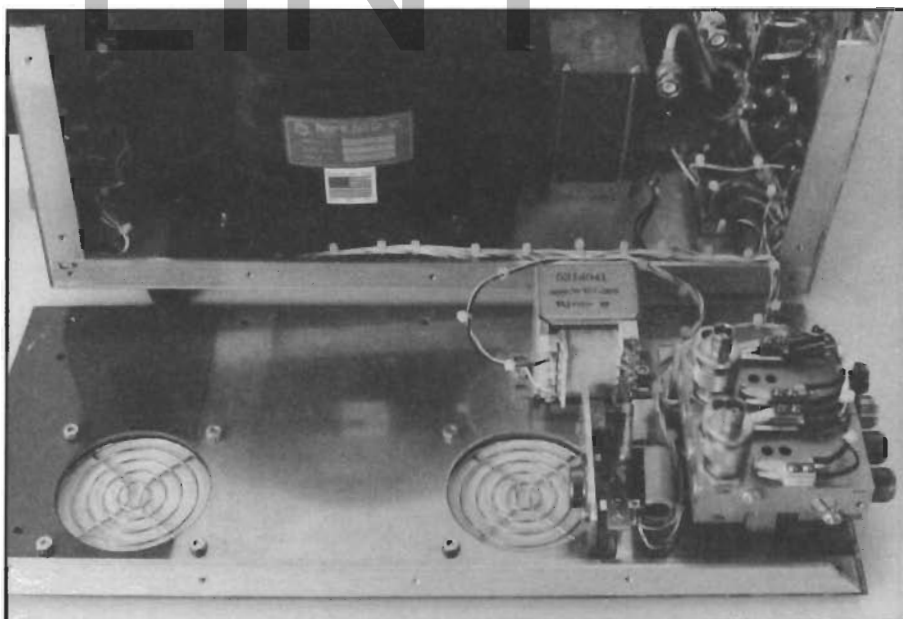

Fig 8—View of the right-hand side panel folded down showing the two transfer relays and the low-voltage power supply. The filament transformer is visible to the right of the plate transformer. Note the use of 80-mm fan covers for the cooling air inlets.

### Table 2—Operating parameters of the amplifier

Plate voltage no load, 2350 V
Plate voltage @ 1 A, 2150 V
Zero signal plate current, 35 mA
6-Meter drive, single tone, 49 W
6-Meter power output, 1420 W
6-Meter plate current, 980 mA
6-Meter grid current, 75 mA
Apparent efficiency, 67.4% (feed-through power not subtracted)
2-Meter drive, Single tone, 50 W
2-Meter power output, 1275 W
2-Meter plate current, 950 mA
2-Meter grid current, 68 mA
Apparent efficiency 62.4% (feed-through power not subtracted)

### Table 3—Parts suppliers

Fair Radio Sales Co, Inc  
1016 East Eureka St  
PO Box 1105  
Lima, OH 45804  
tel 419-227-6573, 419-223-2196  
fax 419-227-1313  
e-mail [fairradio@wcoil.com](mailto:fairradio@wcoil.com)  
URL <http://www.fairradio.com/>

Mouser Electronics  
2401 Hwy 287 N  
Mansfield, TX 76063  
tel 800-346-6873  
fax 817-483-0931  
e-mail [sales@mouser.com](mailto:sales@mouser.com)  
URL <http://www.mouser.com/>

Newark Electronics  
4801 N. Ravenswood Ave  
Chicago, IL 60640-4496  
tel 800-463-9275, 773-784-5100  
URL <http://www.newark.com/>

Peter W. Dahl Co, Inc  
5869 Waycross Ave  
El Paso, TX 79924  
tel 915-751-2300  
fax 915-751-0768  
e-mail [pwdco@pwdahl.com](mailto:pwdco@pwdahl.com)  
URL <http://www.pwdahl.com/>

RF Parts Co  
435 S Pacific St  
San Marcos, CA 92069  
tel 760-744-0700, 800-737-2787  
(orders only)  
fax 760-744-1943  
e-mail [rpf@rfparts.com](mailto:rpf@rfparts.com)  
URL <http://www.rfparts.com/>

Surplus Sales of Nebraska  
1502 Jones St  
Omaha, NE 68102-3112  
tel 402-346-4750, 800-244-4567  
(Orders only)  
fax 402-346-2939  
e-mail [grinnell@surplussales.com](mailto:grinnell@surplussales.com)  
URL <http://www.surplussales.com/>

Svetlana Electron Devices  
8200 S Memorial Pkwy  
Huntsville, AL 35802  
tel 256-882-1344, 800-239-6900  
fax 256-880-8077  
e-mail [sales@svetlana.com](mailto:sales@svetlana.com)  
URL <http://www.svetlana.com/>

# JFLINT

coupled, half-wavelength resonant line, but saves a lot of space. Two references<sup>6, 7</sup> give formulas and rules of thumb for designing this type of transformer, but it still required a lot of "cut and try" before suitable sizes for L4 and L5 were found. The loaded Q of the resonant input link is approximately 3.5 before the coupled-in resistance from the secondary modifies it. The degree of mutual coupling of air-core transformers is an elusive value that makes the final loaded Q difficult to calculate. The input tuning capacitor, C5, could be

changed to a 25-pF unit since the one used here turned out to be much larger than needed. Both sides of C5 are above chassis ground; it requires a nonmetallic screw-driver to adjust.

Six-meter drive and B- are applied to the center tap of L4, providing parallel cathode drive for 50-MHz operation. A common T network, with a loaded Q of five, matches the 50-W line to the 24.6-Ω input impedance of the parallel tubes. All the cathode pins of the sockets are tied together with buss wire in a star pattern.

One-inch-long bus-wire leads connect the ends of L4 to the center of the bus-wire stars on the sockets. Again, symmetry is all-important in balanced operation.

Both input networks were set up with an antenna analyzer and two 50-W carbon resistors to simulate the input load impedance. Tack-solder the resistors from cathode to ground on each socket with the shortest-possible leads. Short leads are very important on 2 meters because lead inductance and stray capacitance become quite significant. The resistors present

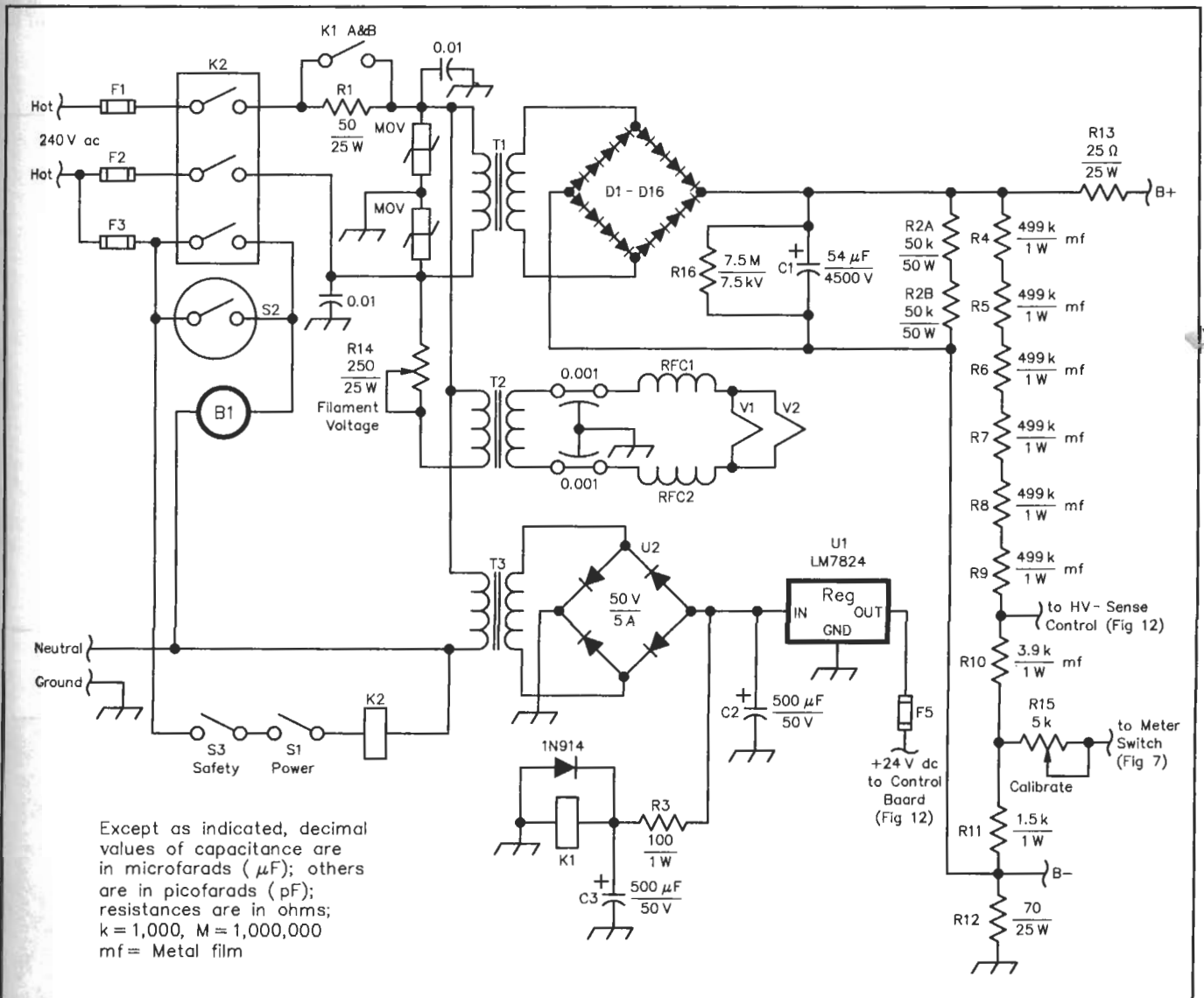

Fig 9—Power-supply schematic. Unless otherwise specified, use 1/4 W, 5%-tolerance carbon composition or film resistors. See Table 3 for part-supplier contact information.

- B1—Dayton #4C761 squirrel-cage blower
- C1—54  $\mu\text{F}$ , 4500 V oil-filled electrolytic capacitor
- C2, C3—500  $\mu\text{F}$ , 50 V electrolytic capacitor
- D1-D16—1N5409 1200 PIV, 3 A Silicon rectifiers, four diodes per string
- F1, F2—20 A, 250 V ceramic fast-blow fuse
- F3—3 A, 250 V fuse
- F5—2 A slow-blow fuse
- K1—DPST relay, 25 A contacts, 24 V dc coil
- K2—3PST relay, 25 A contacts, 120 V ac coil
- MOV—130 V metal oxide varistor, V130LA5

- R1—150  $\Omega$  25 W wire-wound resistor
- R2A, R2B—50 k $\Omega$  50 W wire-wound resistor
- R3—100  $\Omega$ , 1 W carbon resistor
- R4-R9—499 k $\Omega$ , 1 W metal film resistor
- R10—3.9 k $\Omega$ , 1 W metal film resistor
- R11—1.5 k $\Omega$ , 1 W metal film resistor
- R12—70  $\Omega$ , 25 W wire-wound resistor
- R13—25  $\Omega$ , 25 W wire-wound resistor
- R14—250  $\Omega$ , 25 W rheostat
- R15—5 k $\Omega$ , 10-turn potentiometer

- RFC1, RFC2—12 bifilar turns of #18 AWG enameled wire on 1/2-inch-diameter Teflon rod
- S1—SPST 5 A lighted panel switch
- S2—Temperature snap-disc control Grainger # 2E245
- S3—SPDT 5 A microswitch
- T1—Peter Dahl plate transformer: 240 V primary, 1800 V, 1 A CCS secondary
- T2—240 V primary, 16 V, 5 A secondary
- T3—120 V primary, 20 V, 2 A secondary
- U1—LM7824 TO-3 case
- U2—5 A, 50 V rectifier bridge



25 W to the parallel 6-meter network and 100 W to the 2-meter push-pull network. Connect the analyzer to the respective input ports and adjust each network for lowest SWR. Some adjustment of the 6-meter input coils (L6 and L7) may be required to achieve a 1:1 match. If the 2-meter network does not present a good match, some adjustment in length of L4 and L5 may be necessary. Again, the covers must be in place and tubes must be in their sockets when measuring the match. Both filament leads and the filament choke must be in their final positions because the cathode-to-filament capacitance affects input tuning at 144 MHz. Remember, this analyzer method only gets you close to the final tuning points; settings will be different under live conditions. Finally, don't forget to remove the temporary resistors from the cathode and tank circuits after the initial adjustments are done.

### AC Mains and Low-Voltage Power Supplies

Several protective measures are built into the amplifier to protect the tubes and the operator. The ac mains are brought into the amplifier with four-conductor cord to keep the neutral and ground separated per the NEC (Fig 9). Three fuses are used to keep the blower's ac source separate from the fused plate transformer. This was done so the blower's cool-down delay still functions after a high-voltage fault, which removes ac from the entire amplifier in dual-fuse designs. A thermal snap switch in the tank compartment keeps the blower running after shutdown or a high-voltage fault if the exhaust air has been above 110°F and is not yet below 90°. This only happens after several minutes of continuous operation. You may want to use a switch with slightly higher ratings (120°F on, 110°F off) if your shack is often warmer than the 90° off point used here. The 3CX800A7's filaments dissipate only 20 W each during cutoff and natural convection is more than enough to cool the tubes when shut off.

AC voltage for K2, the main control relay, is also taken from F3, the blower fuse, to make sure blower voltage is available before the amplifier can be powered up. A safety switch that closes when the top cover is in place supplies ac to S1, the main power switch. Power-supply inrush protection is provided by K1, which closes approximately one second after K2 and effectively removes R1 from the transformer primaries. The delay period is set by R3 and C3. There are two MOVs across the ac lines after the contacts of K2 and K1. Arcing at the relay contacts can and will produce voltage spikes and spike protection on the fuse side of K2 will not always save the high-voltage diode strings and other components. Filament voltage is adjusted at the primary of T2 by R14, a 250-Ω, 25-W rheostat. Filament voltage is measured at the filament choke via two leads brought to the back panel of the

amplifier. Purists may want to measure voltage at the filament pins, but the low filament-current demand of these tubes makes the voltage drop between the sockets and the choke negligible. The rheostat also provides passive filament-inrush protection.

The low-voltage supply—consisting of T3, U1 and U2—supplies regulated 24 V at 1 A. The bridge rectifier and 24-V regulator are mounted to a piece of 3/4×1-inch aluminum angle that is placed directly in the cooling-air inlet path (Fig 8).

### High-Voltage Power Supply

The high-voltage power supply consists of a Peter Dahl Hypersil plate transformer

and a full-wave bridge rectifier with capacitor input filter. The supply is capable of producing 2150 V at 1 A CCS. The entire supply is assembled as one piece, then installed on the floor of the main cabinet next to the plate transformer (Fig 6). The oil-filled filter capacitor is sandwiched between two 3×6 1/2-inch pieces of Plexiglas, in turn held together with four #10-24×5-inch-long flat-head screws. The rectifier strings and high-voltage-meter multiplier resistors are mounted to a 3×6 1/2-inch PC board supported by 1/4-inch spacers on the same four screws. A 3×6 1/2-inch piece of fiberglass board holding the two bleeder resistors, B+ current limiting resistor and B- float resistor tops off the

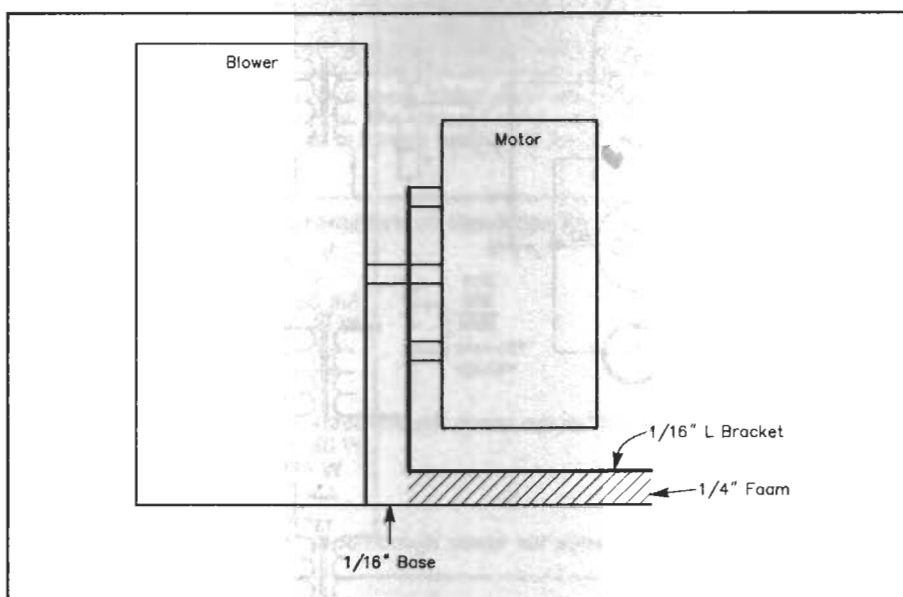

Fig 10—Layout of the blower modifications for sound reduction.

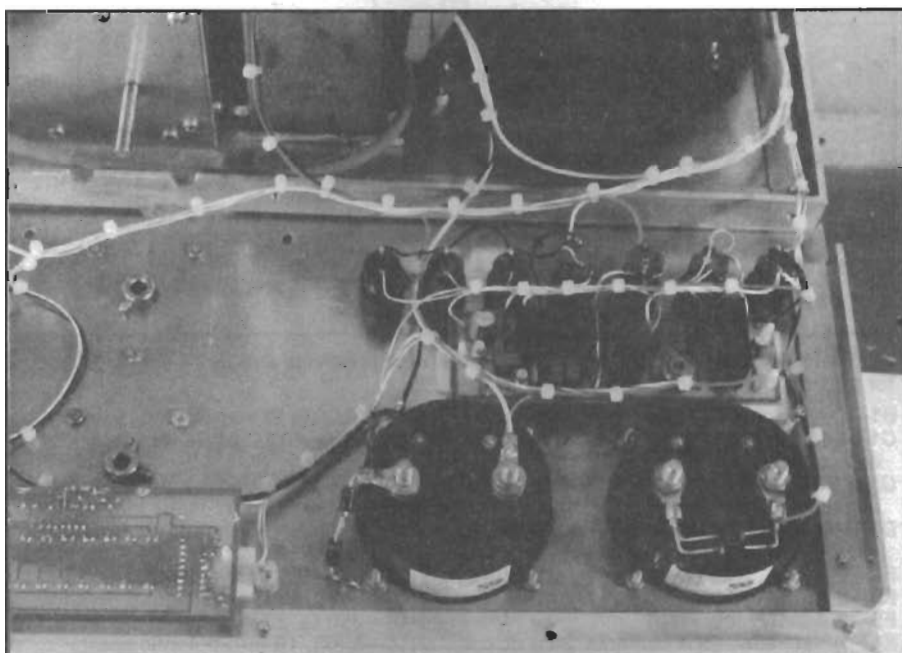

Fig 11—View of control board.



cage and mounted to an aluminum L bracket. The squirrel cage was mounted to a 4x4-inch piece of 1/16-inch aluminum that supports the L bracket through a piece of 1/4-inch foam (Fig 10). This sound-isolation method was borrowed from Alpha Power Inc, and it works very well.

### Control Board and Metering

The control PC board (Fig 11) is mounted on nylon standoffs (just below the panel meters and above the row of switches and panel lights). As with most indirectly heated, oxide-coated cathodes, a warm-up period is required; for the 3CX800A7, a minimum of three minutes is recommended. When the amplifier is turned on, regulated 24 V is applied to the warm-up

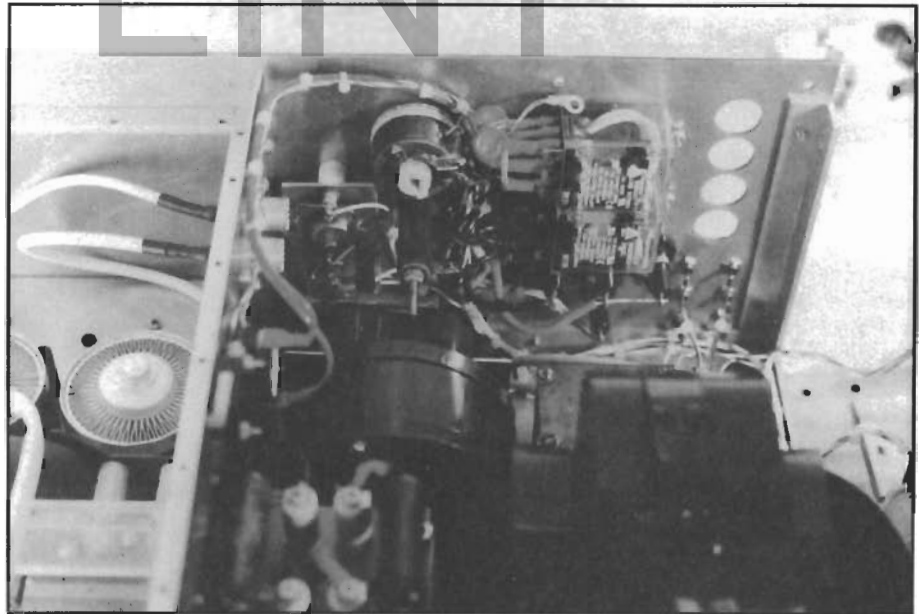

Fig 13—(right) View of panel showing K1 and K2. The bias heat sink and assembly is visible below the filament rheostat.

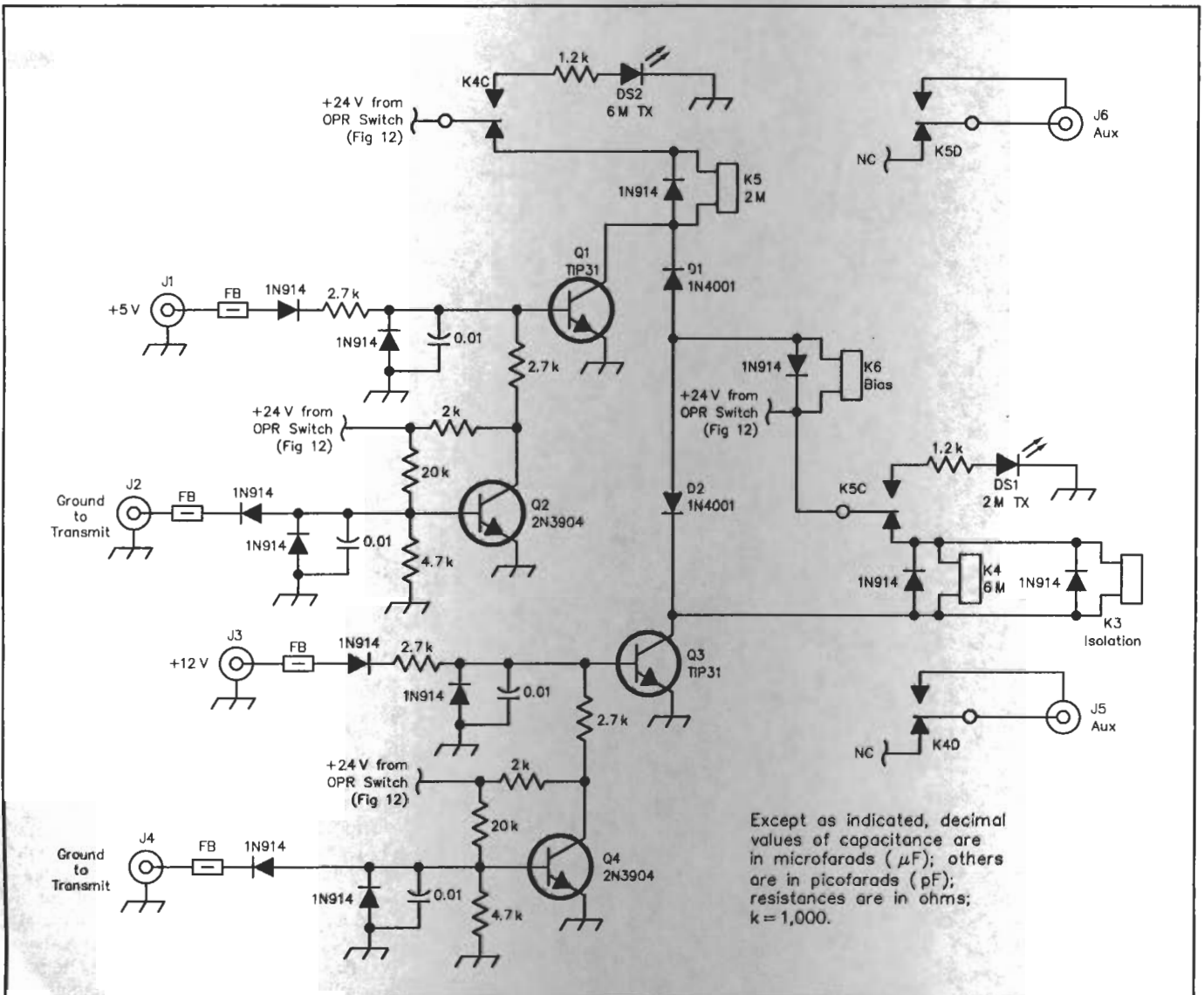

Fig 14—Schematic of the dual keying-circuit PC board. Unless otherwise specified, use 1/4 W, 5%-tolerance carbon composition or film resistors. See Table 3 for part-supplier contact information.

delay circuit consisting of Q1, R1 and C1 (Fig 12). When sufficient voltage appears at the base of Q1, relay K7 closes, with one set of contacts latching the relay on while the other set of contacts resets C1. If high-voltage is present, Q4 is switched on and K8 closes, lighting DS3 and supplying 24 V to the rest of the amp-lifier. Diode D1 was added between the field of K8 and the field of K7 to make sure K7 closes first. The proximity of the control board to the magnetic field of the plate transformer affects the timing of K7 slightly.

With the low grid-dissipation rating of these tubes, grid over-current protection is necessary. Grid current is measured as voltage drop across R1 of Fig 7, a 10-Ω, 25-W wire-wound resistor. R3 on the control board is set to fire K9 with Q3 at a grid current of 120 mA. One set of contacts latches the relay on; the other set interrupts the 24-V line to the OPR (operate) switch. Capacitor C2—across the field of K9—stops relay chatter on voice peaks. Lamp DS4 is part of the grid-reset switch S1, and it lights while K9 is energized. A second grid-current-sensing circuit, using Q2, is set to light DS7 on the front panel at 75 mA. This LED is used as a grid-current warning indicator and can be set at the grid-current level you prefer. The trip points of these two circuits and the grid-current meter reading are adjusted while the amplifier is disconnected from the ac supply.

To do so, connect a 24-V external supply to the 24-V bus of the amplifier after the timing circuit. Connect the positive lead of a variable-voltage dc supply to the ungrounded side of R1 of Fig 7 through an accurate dc milliammeter. Connect the external-supply negative lead to the chassis. With the grid-current panel meter disconnected, slowly increase the voltage of the bench supply until the milliammeter reaches the set points of 120 mA for grid trip and 75 mA for the warning LED. Adjust R3 and R2 (Fig 12), respectively, to set the trip points. After the trip points are set, reconnect the grid-current meter and adjust R4 (Fig 7) for a full-scale reading of 100 mA using the same method as for the trip points. This "cold" method of setting grid trip points is a lot safer for the tubes than removing B+ and then applying drive to induce grid current.

The panel meter, M2, serves as the high-voltage meter as well as the grid-current meter. The calibration of the high-voltage portion was "roughed in" with the amplifier off and all voltages removed. A 1.5-V dc supply was connected to the multiplier side of R15 on the high-voltage rectifier board, then R15 is adjusted for a full-scale reading on M2. This corresponds to a full-scale reading of 3000 V. Meter calibration was then checked with a high-voltage probe and an accurate DMM, after the amplifier was turned on.

Plate current is measured directly in the B-line of the high-voltage supply, which is held slightly above ground by R12 on the power-supply assembly. Both meters are

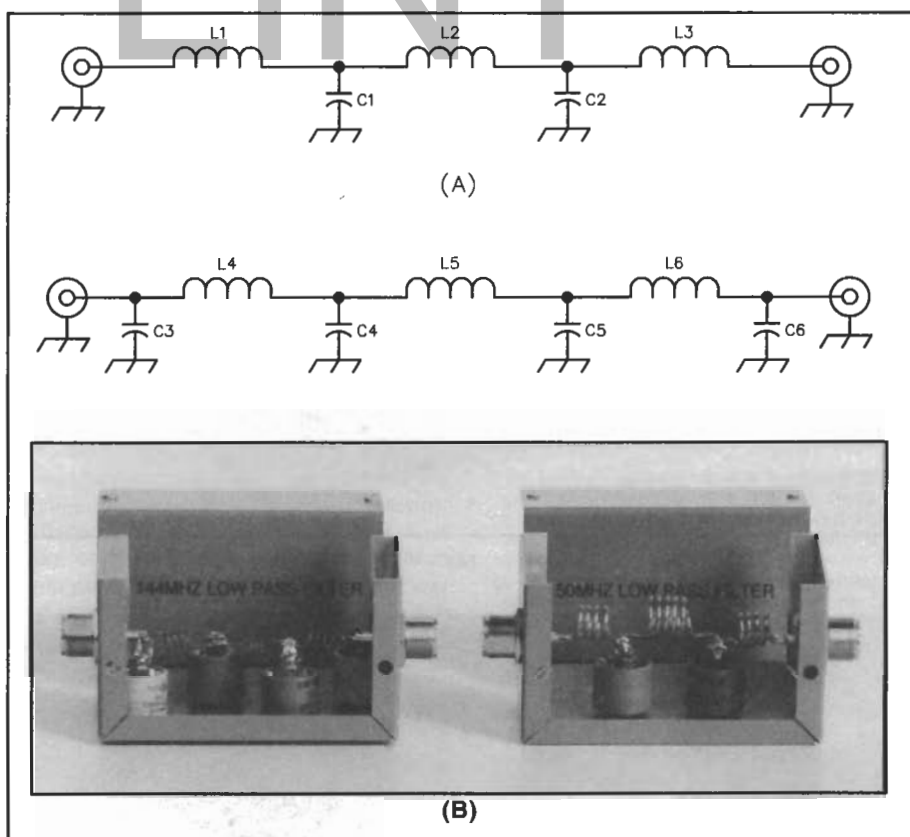

Fig 15—Details of the 2- and 6-meter low-pass filters. See Table 3 for part-supplier contact information.

#### 50 MHz

- C1, C2—50 pF doorknob capacitor
- L1, L3—4 turns #14 AWG copper, 5/16-inch ID×1/2-inch long
- L2—5 turns #14 AWG copper, 5/16-inch ID × 5/8-inch long

#### 144 MHz

- C3, C6—25 pF doorknob capacitor
- C4, C5—40 pF doorknob capacitor
- L4-L6—3.5 turns #16 AWG silver-plated copper wire, 1/4-inch ID×5/16-inch long

protected by 1N5408 diodes; two series-connected diodes on the B- bus keep it below approximately 1.4 V and two more are connected back-to-back from the multimeter to ground.

There are relative-output bar-graph displays for each band above the tune and load controls. These displays use two LM3914 bar-graph drivers per 20-segment display. A current-transformer pickup unit is used for 6 meters and a voltage-sensing pickup for 2 meters. The dual-bar-graph-display schematic can be found in Forrest Mims' book<sup>8</sup> and the 6- and 2-meter pickups are shown in Fig 7. The displays look appealing but turned out to be more trouble than they are worth, since I still use external wattmeters while I tune. The bar-graph displays' rapid response time would be better suited for plate- and grid-current meters.

#### Bias and Keying

Operating bias is developed across D1 of Fig 7, an 8.2-V, 50-W stud-mounted Zener diode. The Zener, along with K6, R2 and R3, is mounted on a 2×3-inch piece of 0.100-inch aluminum that serves as a heat sink (Fig 13). The entire assembly is mounted on two 1/2-inch Teflon stand-offs on the back panel of the cabinet. The 2-A cathode fuse is mounted on the back panel

alongside the ac-line fuses.

The keying PC board is mounted on the rear floor of the main cabinet (Fig 8). The PC board contains keying circuits for both 6 and 2 meters (Fig 14). Because they are identical, I'll only describe the operation of one.

At rest, Q2 is biased on, holding the base of Q1 low. Grounding J2 will take the base of Q2 low, turning it off. This allows voltage to appear at the base Q1, turning it on and energizing K5. Alternatively, applying +12 V to J1 will also turn Q1 on, keying the amplifier. Both keying inputs are logic-compatible. The bias relay is energized through D1 or D2, which comprise a two-input OR gate. Each transfer relay is a DowKey #260B with the "C" option, which is a pair of DPDT signaling switches. Each of the relays' supply voltages is routed through one of the opposite relay's normally closed signaling contacts. This mechanical EXCLUSIVE-OR gate keeps the amplifier from being simultaneously keyed on both bands. The normally open contacts are used to light transmit LEDs on the front panel; these are mounted between their respective tune and load controls to help eliminate confusion while tuning.

With this type of transfer relay, input and output relay sequencing is obviously



(A)

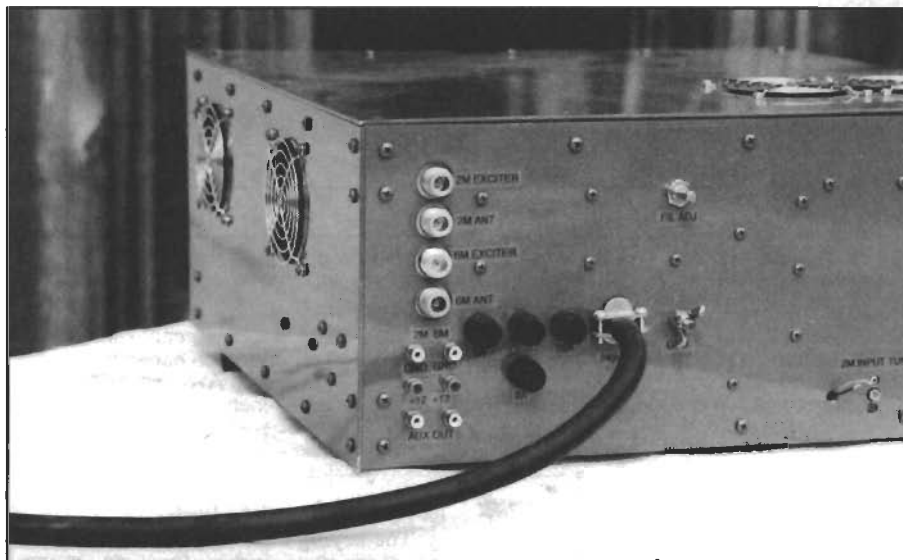

(B)

Fig 16—The completed amplifier ready for its ride to the mountain top. (A) Front view, (B) back panel.

not an option, and hot switching of the relays will result unless preventive measures are taken. One option is to key the amplifier and let it key the exciter. Each relay's spare set of signaling contacts was brought to the back panel for this possible use. Another option, which I employ, is to use an outboard keying sequencer. The sequencer takes care of my mast-mounted preamplifiers as well as the exciter-amplifier timing. A suitable sequencer can be found in the references.<sup>9</sup> When using separate exciters for each band, the spare set of signaling contacts can be used for audio muting of the unkeyed exciter while transmitting.

### General Construction Notes

The entire amplifier cabinet was built using common hand and power tools. All aluminum was cut with carbide saw blades in a radial arm saw and table saw. Blades with a 5° negative hook angle seem to work best for aluminum. The main amplifier cabi-

net measures 18×16×7½-inches (WDH). The plate transformer determined the cabinet height. The entire cabinet is built from 0.100-inch aluminum sheet and ¼×¾×⅛-inch aluminum angle stock. All outside corners are secured with #8-32 pan-head screws tapped into the angle stock. The area under the plate transformer and high-voltage supply assembly was beefed up with a second layer of 0.100-inch aluminum on the cabinet floor. A square hole cut in the cabinet floor provides access the cathode compartment; it is normally covered with a piece of ⅛-inch aluminum. All round holes were cut with chassis punches. The cabinet was painted with Dupont Chromaclear, which is a two-step (color coat/clear coat) automotive paint. After the base coat was applied over the primer, dry transfer lettering was applied to the front panel controls and Brothers P-touch labels were applied to the rear panel. Two coats of clear were applied over the base coat to finish the job.

All interior wiring was done with scrap Teflon-coated wire. The wiring harnesses were arranged so that all side panels can be removed and laid flat next to the chassis for ease of alignment and debugging. The internal coax runs were made with Teflon-dielectric coax to handle these high power levels, most other coax falls short, particularly at 144 MHz.

### Adjustment and Operation

Use an ohmmeter to check the ac paths and RF deck for possible shorts and wiring mistakes. Be sure to blow out the entire cabinet with compressed air to remove any hidden debris. Set the filament-voltage rheostat to maximum resistance. If you haven't already done so, apply 24 V from an external supply to the 24-V bus and check the timing, control and keying circuitry for proper operation. Connect the amplifier to a suitable ac mains supply and connect an accurate DMM to the filament-voltage test points. Connect a 2-meter exciter and dummy load. Turn on the main power switch and quickly set the filament voltage to 13.5 V, or slightly less. *Never* operate the filaments below the 12.9-V recommended minimum. Be sure to check the filament voltage again after 5 to 10 minutes to detect any thermal drift in the rheostat. Verify that the plate is at approximately 2375 V.

Both tank circuits should be set to the tuning values found during initial setup. After the three-minute delay has elapsed, key the amplifier with no drive and check for a cathode idling current of approximately 30-50 mA. Apply a little 144-MHz drive and tune C5 in the input circuit for minimum reflected power. The 2-meter output link should be preset approximately ½ inch above the top plane of the balanced line. Still with little drive, adjust the 2-meter tuning capacitor for maximum power output. Adjust the 2-meter load capacitor for peak output power and then leave it there until you are finished. Next, adjust link spacing as you would a load capacitor. Keep increasing the drive while increasing the link coupling for maximum power output, without exceeding grid-current limits and while also touching up the main tune capacitor, C3. Once the desired output power level is reached, check the link coupling by slowly decreasing the coupling until a slight decrease in output power is observed. Then increase the coupling slightly past the point where output power peaks and grid current is reduced to within operating limits. This should be very close to critical coupling, which will result in maximum efficiency. Go back and touch up the input network for minimum reflected power. The link is now set for operation and any further tuning adjustments can be made with C2 and C3.

Tune the 6-meter tank circuit the same way you would any other p network: by slowly increasing drive and tuning for maximum power output and best efficiency while touching up the input network for lowest reflected power. Then increase

loading until a 2% decrease in power output is observed.

With values of loaded Q below 30 in the output tanks, there is no way to keep harmonics below the 60-dB-down figure required by the FCC without outboard filtering. Harmonic filters are a very small price to pay for the higher efficiency, lower drive requirement and reduced thermal drift that the lower loaded Q provides. I've included descriptions of two suitable filters from the references;<sup>10,11</sup> they are very easy to build. The silver-mica capacitors originally in the filters have been replaced with surplus door-knob capacitors for better power-handling capability. With both filters installed all harmonics and spurious signals are more than 70 dB down from the fundamental.

### Final Thoughts

This amplifier was completed just before the summer E-skip season and was immediately put on the air. On-the-air signal reports were all good, and they compared well to the 8877 amplifier I normally use. Close in IMD testing was done with the help of NN7DX who is located nine miles away, over flat ground. Results showed no excessive signal bandwidth while our antennas were positioned to bring signals down to S-9 levels during I500-W output testing. The amplifier runs cool to the touch even after several hours.

The biggest problem encountered with the operation of the amplifier had to do with interfacing with certain exciters. Some of

the new multiband exciters provide multiple antenna ports that can be configured for HF, 6- and 2-meter outputs, but provide only one buffered keying line. The ICOM-746 is built this way, but it does provide two unbuffered keying lines: one for HF and 6 meters and one for VHF. The ICOM-706-series radios also provide two unbuffered lines but only two antenna ports. Both of these radios require some sort of external switching for the keying line—and the antenna line in the case of the '706—if this amplifier and an HF amplifier are both used. ICOM does provide band logic as a variable voltage at the radio's ACC plug. I've designed a simple decoder/buffer that uses this logic and the radio's internal power supply to automatically switch the keying line between HF, 6- and 2-meter amplifiers. The buffer will sink up to 3 A of relay current. It also selects from three separate ALC input lines for those of you that employ sequencers using the ALC line for transmit inhibit. The decoder is described in "Automatic Amplifier Selection for the ICOM IC-746, -736 and -706MKII Transceivers," *QST*, May 2000, pp 33-36. With the decoder in place, amplifier selection with an IC-746 becomes totally automatic when changing bands between HF, 6 and 2 meters. For the IC-706 series, an additional coaxial relay can switch one of the antenna ports between HF and 6 meters to allow automatic selection. The decoder also works with the ICOM IC-736, choosing between HF and 6 meters. Although not verified, I've been told that the Yaesu

FT-847 does have separate buffered keying lines for each of its four antenna ports, making interface to this amplifier easy. Performance figures for the amplifier are listed in Table 2 and the completed amplifier is shown in Fig I6. Enjoy!

### Acknowledgements

Thanks to Marv Gonsier, W6FR, and Roy Scanlon, NN7DX, for help in reviewing the text.

### Notes

- <sup>1</sup>C. M. Maer Jr, W0IC, "The Perseids Powerhouse," *QST*, Oct 1959, p 32.
- <sup>2</sup>R. M. Richardson, W4UCH, "A Kilowatt Amplifier for 6 and 2 Meters," *QST*, June 1973, p 16.
- <sup>3</sup>The surplus sockets have a built-in 0.005  $\mu$ f grid/screen bypass capacitor. RF Parts has a limited supply of these sockets. Substitutes include Johnson #124-0311-110 (with a grid collet) and Eimac SK1900.
- <sup>4</sup>G. R. Jessop, G6JP, *VHF/UHF Manual*, 4th edition, (Hertfordshire, England: Radio Society of Great Britain, 1983) Chapter 3.
- <sup>5</sup>E. P. Tilton, W1HDQ, *The Radio Amateur's VHF Manual*, (Newington: ARRL, 1972) p 77.
- <sup>6</sup>R. D. Straw, Ed., *The 1999 ARRL Handbook* (Newington: ARRL, 1998), pp 6-46 and 6-47.
- <sup>7</sup>R. Myers, W1FBY, *The 1975 ARRL Handbook* (Newington: ARRL, 1974), p 46.
- <sup>8</sup>F. M. Mims III, *The Forrest Mims Engineer's Notebook*, (San Diego, California: Hightext Publications Inc, 1992) p 107.
- <sup>9</sup>*The 1999 ARRL Handbook*, pp 22-53 through 22-56.
- <sup>10</sup>J. White, G3SEK, Editor, *The VHF/UHF DX Book*, Vol 1 First Edition (Buckingham, England: DIR Publishing, 1992) p 12-35.
- <sup>11</sup>R. Schetgen, KU7G, Ed. *The 1993 ARRL Handbook*, (Newington: ARRL, 1992) p 31-37, Fig 95.

# An 8-Watt, 2-Meter 'Brickette'

Put 20 mW into this little amplifier and get a 26-dB increase in transmitted power! Although the amplifier was designed initially for use with the DSP-10 transceiver, any 20-mW-output 2-meter exciter can enjoy the boost!

The DSP-10 transceiver<sup>1</sup> can be used with UHF/microwave transverters or as a very-QRP all-mode rig on 2-meters. The rig's 20-mW power output is sufficient for "barefoot" QSOs with locals, but that's hardly a big signal at any distance. Adding this little amplifier increases your fun quotient by raising the power level to 8 W, the high end of the QRP plateau. This brickette can also be used to drive an even higher-power, cascaded amplifier. Being a linear amplifier, it's suitable for use on all modes, including SSB, CW and FM.

The amplifier's front panel is quite simple, consisting of five monitoring LEDs. Knowing that everything is working correctly justifies the small amount of circuitry needed to operate these lights. The functions monitored include dc power on, transmit/receive status, power output, SWR and dc overvoltage. All amplifier control is done at the transceiver. Two RF cables connect to the transceiver output and receiver input, avoiding the need for an input relay in the amplifier.

This amplifier isn't limited to use with the DSP-10; any 2-meter transmitter that can deliver an output of 20 mW to drive the amplifier should work fine. In some cases, it might be desirable to use an input TR relay; there is sufficient room in the amplifier for adding one.

## Circuitry

At the heart of this amplifier is an integrated power-amplifier module, manufactured by Mitsubishi. Such modules are used in many commercially manufactured transceivers and using one here makes amplifier construction and alignment simple. Within the module are two cascaded linear-amplifier transistors, along with their associated

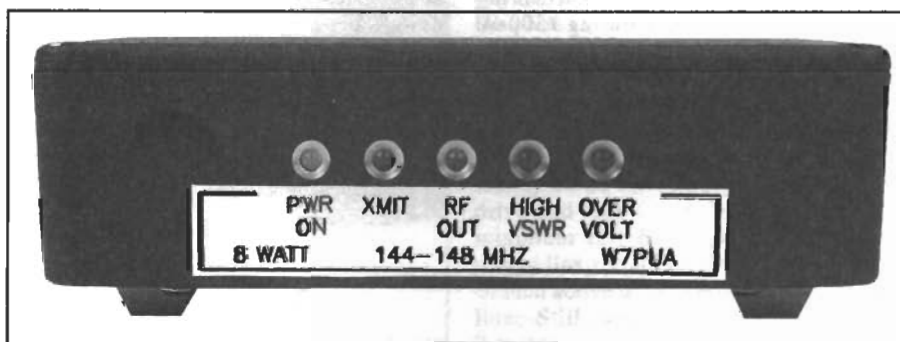

The five LEDs on the Brickette's front panel signal the amplifier's operating status. The power-output (RF OUT) and SWR (HIGH VSWR) LEDs vary in brightness depending on the forward and reflected power levels.

matching networks and biasing circuits for class AB operation. The module has 50- $\Omega$  input and output impedances. All we need to do is add a circuit to turn on the bias supply during transmit, install a low-pass filter for harmonic control and include an antenna-switching relay. To monitor amplifier operation, we tack on some simple circuitry.

Refer to the schematic in Figure 1. At the input pin of the RF module, U1, we apply 20 mW of drive. Blocking capacitors for the RF input and output ports are included within the module. Bypass capacitors on the three power leads are external, however. Ferrite beads, L6 to L8, prevent problems that might occur if RF gets on the power leads.

An L network consisting of L1 and C4 improves the impedance match to the module. Adding the network increases the output power by about 0.25 dB. Following the amplifier is a directional coupler (discussed

later). Next is a five-pole low-pass filter. For simplicity, it is configured with the same coil and capacitor types as are used in the directional coupler. This filter attenuates the second and higher-order harmonics.

Separate connectors are available on the DSP-10 for the transmitter output and the receiver input. This simplifies adding the antenna relay for the amplifier since no switching is required at the amplifier input. A miniature relay is adequate at the amplifier output. Providing an isolation of about 30 dB, the relay, along with the PIN attenuator that is part of the DSP-10, provides plenty of protection for the receiver.

A lumped-element directional coupler, consisting of L2, L3 and C5 to C10, delivers power samples of the forward and reflected output signals. This directional coupler works quite well, providing a coupling of about -28 dB and a directivity<sup>2</sup> of 20 dB, but only over a narrow (12-MHz)

bandwidth. For our application, this is adequate. Two diode detectors, built around D6 and D7, generate low-level dc signals that indicate the forward and reflected powers. These signals, in turn, are amplified by two sections of op amp U2. The resulting voltages are displayed on two LEDs, green for **RF OUT** (forward) power and red for **HIGH VSWR** (reflected) power. The LEDs serve as rough indicators of proper amplifier operation.

The **OVERVOLTAGE** indicator lights when the dc supply voltage exceeds 14.5 V, but does not automatically shut down the amplifier. The idea here is to supply a warning mechanism. When RF is not applied to the amplifier, it is quite resistant to supply overvoltage. As long as the supply overvoltage condition sets an alarm light, an observant operator will defer applying RF until the voltage is reduced.

Amplifier control is handled by the DSP-10. That transceiver has software-controlled relay sequencing, providing +5 V during transmit. Q2 and Q3 drive the antenna relay from this control. A ferrite bead, L11, and C24 keep RF at the antenna relay from getting back into the control circuits. D10 shunts the inductive kick from the deactivated relay coil. An LED, D2 (**XMIT**), across the relay displays the amplifier TR status.

Q4 provides an output that can control a follow-on amplifier. This output is an open-collector, ground-on-transmit type, compatible with many commercial and homebuilt amplifiers. For added driver-circuit protection, a reverse-voltage shunting diode, D11, is used.

### Building the Amplifier

You could build the amplifier on a scrap of PC board. In fact, my first version is built that way (see the sidebar). For many builders, however, a PC board<sup>1</sup> is a more convenient way to assemble the project and that is shown in the photos.

This PC board is double-sided, with plated through holes. The backside is a solid ground plane allowing the board to be fastened directly to the aluminum enclosure. Such construction works very well for RF boards because a low-inductance ground path can be maintained throughout, reducing any interactions between the various circuits. However, this mounting method does not allow component leads to extend beyond the bottom surface of the board. I dealt with this primarily by using surface-mount parts<sup>4</sup> and by carefully bending the component leads so they behave like surface-mount parts.

All of the chip resistors, chip capacitors, diodes, surface-mount ICs and ferrite-bead chips are soldered to their board pads conventionally. Install the amplifier module after the board is mounted in the box. The antenna relay, fuse clips and the variable resistor all have their leads bent away from their host. Avoid making any bends close to the component body; make the bends at a point about 1/16 inch away from the compo-

nent body. This approach eliminates mechanical stress on the lead attachment. These components end up about 1/16 inch above the board's top surface after they are soldered in place.

Figure 2 shows the construction of the four toroidal inductors, L2 through L5. Experience shows the inductor values are quite repeatable if the turns are always distributed in the same manner around the core. As the turns are pushed closer together, the inductance increases considerably. The matching-network coil, L1, is noncritical and it should be wound as shown in the part list and Figure 2; it should need little, if any, adjustment.

The LEDs all have long leads and are soldered to the board after bending the lead ends by about 1/8 inch. Be sure to keep track of the LEDs' longer (anode) leads: Those leads connect to the current-limiting resistors.

### Putting the Board in a Box

Once the PC board is assembled, use it as a template for marking the hole locations in the enclosure, a standard Hammond die-cast box. Mount the board flat against the box bottom using #4-40 hardware. Because there will likely be some mold marks and box-identification letters where the board and RF module lie, make the enclosure's inner-bottom surface reasonably flat; you can do this with 60-grit sandpaper. Bend the leads of the five LEDs to apply a slight forward pressure on the lights as they slide into the holes in the box front. That holds the LEDs in alignment without needing adhesive.

Take care when tightening the PA mod-

ule mounting screws to be sure that no pressure is applied to the ends of the module cover. The leads from the module need some trimming. They are above the board and need forming to get to the board level for soldering. Don't apply pressure at the edge of the module cover when doing this. You may need to hold each lead with needle-nose pliers to keep from damaging the case. It should be possible for the leads to reach the board surface within 1/8-inch of the cover.

Three short pieces of 50-Ω coax attach the board to J1, J2 and J3. Solder lugs under the jacks provide for ground connections at one end and PC-board pads take care of the other end of the coax.

Three leads run between connectors J4, J5 and J6 and the PC board. Each of these leads has a bypass capacitor (C28, C6 and C27, respectively) at the connector. Short, low-inductance leads are important on these capacitors. To help keep the RF signals inside the box, a small inductor wound on a ferrite core (L14, L15 and L16) is placed on each wire. Position these inductors close to their connectors. If #22 or #24 stranded hook-up wire with thin insulation is used, it's possible to wind the coils with the hook-up wire.

### Turning on the Amplifier

Now, to see it work! First, connect a 50-Ω noninductive dummy load to the amplifier output.<sup>5</sup> If you have a variable-voltage power supply to use for initial testing, slowly raise the dc supply voltage from 0 V to 13.8 V. Otherwise, you'll need to rely on the power-supply fuse as protection from any serious construction errors when apply-

### Did the Amplifier Always Look Finished?

No, it didn't. Some people may be able to put a finished amplifier on a PC board and have it work fine. I don't seem to be able to do that!

My first step in designing the amplifier was to search for suitable RF modules, mostly via the Internet. Once I selected the M57732L as having suitable power, gain and dc operating voltage, I drew a schematic in my notebook. Originally, the circuit had automatic shutdown for high SWR and full voltage regulation to deal with overvoltage. This looked too complex. It was necessary to cut off the drive to the amplifier, and the regulator had to be a low-dropout type (for these, the difference in voltage between the input and the output need be only a fraction of a volt). I couldn't find an integrated regulator that met my requirements and the thought of building one using op amps and transistors used more parts than I could justify.

I opted for simplification, putting alarm lights on for SWR and overvoltage and turned the automatic part over to the operator! A new schematic resulted, not unlike that of Figure 1. I went to the *ARRL Radio Designer*<sup>†</sup> and simulated the directional coupler and low-pass filter. A little playing around with the simulation showed that a single inductor value could be used for both subcircuits.

Next, I built the "breadboard" version using scraps of PC board. Testing showed that almost everything worked as expected. The **overvoltage** light did not have snap action, though. That was caused by using a resistor where the ferrite bead, L13, is now. I ran the input voltage temporarily up to 16 V and everything continued to function. Next, I left the amplifier running for an hour and nothing overheated. I checked the intermodulation products and harmonics and found them to be at satisfactory levels.

It was now time to layout the PC board. The experience of putting the breadboard together allowed a smarter final layout. The first version was on two boards and some of the connectors ended up on the front panel. This was all worked out for the final design.

—Bob Larkin, W7PUA

<sup>†</sup>ARRL order no. 6796. ARRL publications are available from your local dealer, or directly from the ARRL. See the ARRL Bookcase elsewhere in this issue, or check out the ARRL Web site at: <http://www.arrl.org/catalog/>.





Figure 1—Schematic of the 8-W amplifier. All resistors are 5% 1206 chips. These are available in small quantities from Mouser Electronics (Xicon). Unless otherwise noted all capacitors are either 1206 or 0805 chips (either size fits on the board). Capacitors less than 470 pF are NP0, while values from 470 pF and up are any general-purpose ceramic, such as X7R or Z5U. Component sources listed here are generally only a few of several that manufacture equivalent parts. If the amplifier is built without a pre-made PC board, change the chip components to leaded types. Component designations for the LEDs differ from QST style. Parts used in the amplifier are available from one or more of the following sources. Source abbreviations used in the parts list precede the company name: (DK) Digi-Key Corp, 701 Brooks Ave S, Thief River Falls, MN 56701; tel 800-344-4539, 218-681-6674; <http://www.digikey.com>; (ME) Mouser Electronics, 958 N Main, Mansfield, TX 76063; tel 800-346-6873, 817-483-4422; <http://www.mouser.com>; (RS) RadioShack—see your local distributor; <http://www.radioshack.com>; (RP) RF Parts, 435 South Pacific St, San Marcos, CA 92069; tel 800-737-2787, 760-744-0700; <http://www.rfparts.com>.

- C22—47  $\mu$ F, 16 V surface-mount electrolytic (DK PCE3033CT)
- C26, C27, C28—470 pF, 50 V, leaded ceramic (ME 140-50P2-471K)
- D1—Yellow T1 LED (DK 160-1079)
- D2, D3—Green T1 LED (DK 160-1080)
- D4, D5—Red T1 LED (DK 160-1078)
- D6, D7, D9, D10—BAR74 diode (DK BAR74ZXCT)
- D8—5-A, 50-V power rectifier, SMC package (DK S5ACDICT)
- D11—1-A, 100-V power rectifier, SMB package (DK S1BBDICT)
- K1—SPDT 12-V dc miniature relay, Omron G5V-1-DC12 (DK Z774)
- L1—2t, #20 or 22, 1/8-inch ID; see Figure 3.
- L2-L5—52 nH; 5 turns, #26 enameled wire on a T-25-17 toroid; see Figure 3.
- L6, L7, L9, L10, L11, L13—Ferrite SMT bead, 1206, 600  $\Omega$  at 100 MHz, Stewart HZ1206B601R (DK 240-1019-1)
- L8, L12—Ferrite SMT bead, 3 A, 1206, 100  $\Omega$  at 100 MHz, Stewart HI1206N101R (DK 240-1008-1)
- L14-L16—1.5  $\mu$ H, 5 turns #22 or #24 enameled wire on an FT-23-43 core; see text.
- F1—2-A, 5x20-mm fuse (DK F948) with two clips (DK F058)
- J1, J5, J6—Phono jacks (RS 274-346)
- J2, J3—BNC jack (RS 278-105)
- J4—5.5-mm OD, 2.1-mm ID power connector (RS 274-1563)
- Q1, Q3—FM3T3906 PNP transistor, SOT23 (DK FM3T3906CT)
- Q2, Q4—FM3T3904 NPN transistor, SOT23 (DK FM3T3904CT)
- R15—2 k $\Omega$  adjustable resistor, Bourns 3329H-1-202 (DK3329H-202)
- U1—RF amplifier module, Mitsubishi M57732L, (RP M57732L)
- U2—LM324AM dual op-amp (DK LM324AM)
- U3—78L05 5-V positive regulator, SO-8 package (DK LM78L05ACM)
- misc: PC board, enclosure 3.7x4.7 x1.3 inches, Hammond 1590BB (DK HM152), hardware.

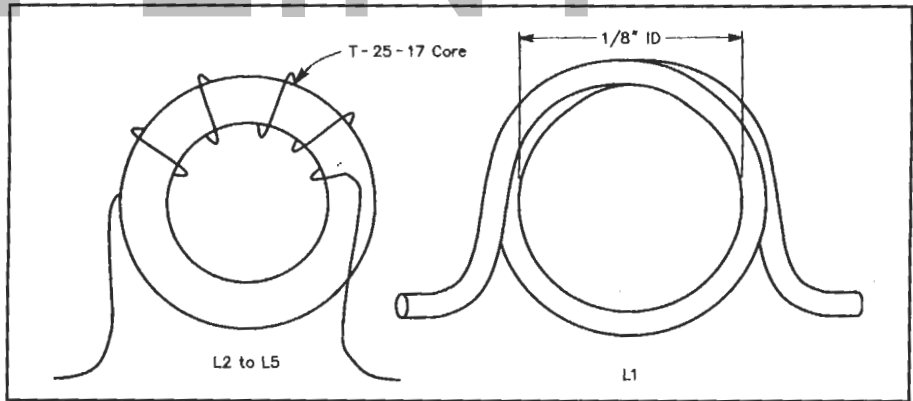

Figure 2—Coil details. Arrange the turns on the four toroids as shown here. L2 and L3 might need to have their turns spacing adjusted during tune-up.

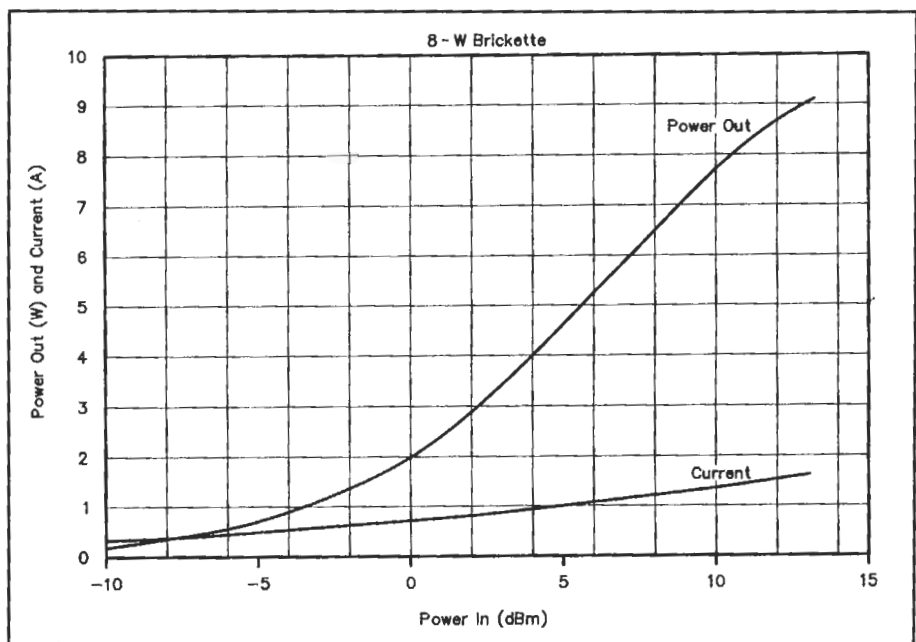

Figure 3—Measured power output and dc-supply current as a function of drive power. Notice that the output-power scale is not in decibels. This makes the output appear less compressed than it really is. The 1-dB compression point is at about 4 W.

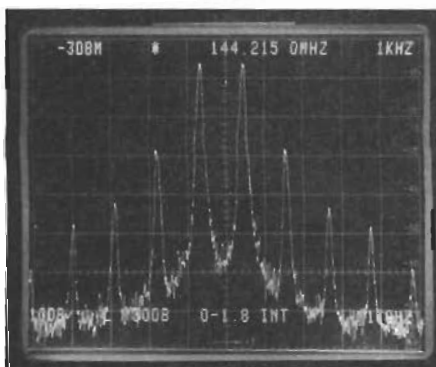
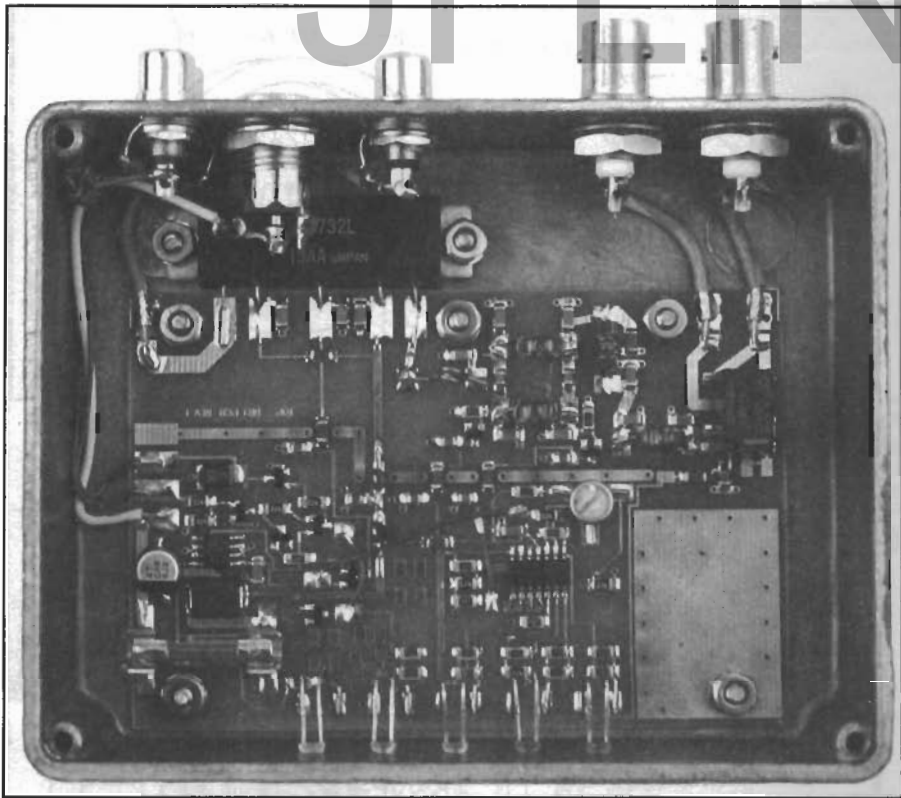

Figure 4—Measured intermodulation distortion with a PEP output of 8 W. Third-order products are down about 28 dB from peak power, fairly typical of this amplifier type. Perhaps more important is that the fifth and higher-order products continue to drop off as the order increases. These higher-order products are farther from the operating frequency and thus generally more disruptive to nearby stations. The current drawn during this two-tone test was 670 mA.

ing the full 13.8 V. At full voltage, the current drawn by the amplifier during receive should be about 10 mA. Next, set the **OVERVOLTAGE** alarm. Adjust the voltage at the wiper terminal of R15 to 4.68 V.<sup>6</sup> If you can vary the dc supply voltage, the **OVERVOLTAGE** LED should light at about 14.5 V.

When making the following adjustments, it is necessary to adjust the turns spacing on the toroidal inductors. For safety, *do this only when no RF drive is applied.*

Connect the TR control to the DSP-10 and connect J1, the amplifier's RF input, to the DSP-10 antenna connector. In CW mode, increase the DSP-10's RF power slowly until the **RF OUT** LED (D3) glows. Then adjust the turns spacing on L2 and L3 to extinguish the **HIGH VSWR** light (D4). This indicator is about 10 times more sensitive than the **RF OUT** LED, but it should be possible to extinguish the **HIGH VSWR** LED completely. Continue this adjustment process while increasing the drive power. You can measure the voltage at the output of the SWR op amp



Pretty outside and pretty inside, the Brickette's construction reflects a caring hand. At the top-left rear the RF-amplifier module can be seen fastened to the base of the enclosure, which serves as a heat sink for the module. The relay is at the upper-right and a kludge area is visible at the lower right behind the front panel.

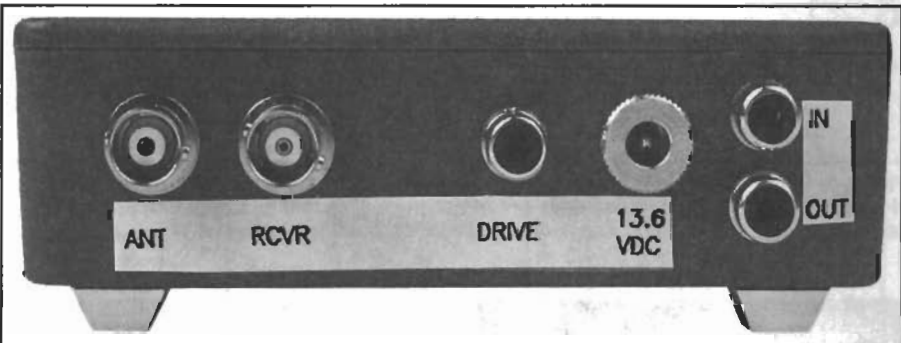

This rear-panel view of the 8-W Brickette shows compact but uncrowded I/O connectors clearly labeled.

(U2 pin 14) and continue to minimize this voltage, although the **VSWR** LED is not lit.

Optimize the amplifier matching by measuring the power output as indicated by the dc voltage at U2 pin 7 and adjusting L1's turn spacing (and perhaps changing the value of C4) for maximum output at high drive. Don't expect major changes with these adjustments as the amplifier is inherently quite well matched.

While in transmit, check that the bias voltage at pin 3 of U1 is about 4.9 V and that the idling current with no RF drive ap-

plied is about 140 mA.

### Performance

Figure 3 shows the power output and current level for various drive levels. The CW output is over 8 W for the two devices that I tested. When tested with a two-tone input signal and an output of 8 W PEP, the IMD level is down 28 dB for third-order products and 43 dB for fifth-order products (see Figure 4). The strongest harmonic is the second (at about 292 MHz) and this is 65 dB down from peak output, more than

enough to meet FCC 2002 requirements.<sup>7</sup>

### Concluding Thoughts

Several areas on the PC board have either a ground plane section or pads for mounting transistors, resistors and other components. These areas are available to you to use for modifications or additions to the amplifier (perhaps you have an application that needs an input TR relay or you need a different control circuit).

Now you're ready to get on the air with a medium-sized signal. You can increase power even further by cascading another amplifier. Or, use some of the signal processing in the DSP-10 to work deeper into the noise. QRP power levels have pushed the idea of "working smarter instead of harder."

### Notes

<sup>1</sup>Bob Larkin, W7PUA, "The DSP-10: An All-Mode 2-Meter Transceiver Using a DSP IF and PC-Controlled Front Panel," *QST*, —Part 1, Sept 1999, pp 33-41, —Part 2, Oct 1999, 34-40, —Part 3, Nov 1999, pp 42-45. Additional information on that project is available on the author's Web site, <http://www.proaxis.com/~boblar/dsp10.htm>. Any future information about this amplifier project will be placed at this Web site.

<sup>2</sup>The directivity of a coupler is the difference, in decibels, between the forward signal and the reflected signal, when the coupler is properly terminated in its designed load, in this case, 50 Ω. Couplers constructed from transmission lines have high directivity over a very wide frequency range. These lumped-element couplers are restricted in the frequency range where their isolation is high, but offer simplicity instead.

<sup>3</sup>Gerber files for making the PC board can be obtained from the author. Alternatively, unpopulated PC boards are available from Mashell Electric, PO Box 5, Eatonville, WA 98328. Price: \$20 each in the US, \$21 in Canada (air mail) and \$22.50 (air mail) elsewhere. These boards have plated through holes, a solder mask on the component side and a silk-screened legend. Check their Web site <http://members.aol.com/w7slb/w7slb.htm> for details.

<sup>4</sup>See Sam Ulbing, N4UAU, "Surface Mount Technology—You Can Work with It!", *QST*—Part 1, Apr 1999, pp 33-39; —Part 2, May 1999, pp 48-50; —Part 3, Jun 1999, pp 34-36; —Part 4, pp 38-41. Additional comments from Avery Davis, WB4RTP, can be found in the *QST* Technical Correspondence, Feb 2000, p 70. Surface-mount techniques are used for the DSP-10 transceiver. Some people were initially concerned about dealing with the tiny components, but after constructing the board, most builders felt that it went well.

<sup>5</sup>A satisfactory dummy load for 144 MHz can be constructed from four 200-Ω, 3-W metal-oxide resistors. Arrange them in parallel around a coax connector. Short leads are important. Do not use wire-wound resistors.

<sup>6</sup>The **OVERVOLTAGE** alarm triggers when the dc supply voltage is greater than 14.5 V. If an adjustable dc supply is available, you can set this directly. Alternatively, set the voltage at the wiper of R15 to  $0.360 \times (V - 0.6)$ , where V is the dc supply voltage.

<sup>7</sup>Larry Price, W4RA, and Paul Rinaldo, W4RI, "WARC97, An Amateur Radio Perspective," *QST*, Feb 1998, pp 31-34. By these rules, an 8-W 2-meter transmitter must suppress the harmonics by at least 52 dB. Greater amounts of suppression are required for higher power levels.

# 903-MHz Linear Amplifiers

*Part 1*—Looking for a gain block or two for your 903-MHz station? Here are *eleven* of them to cover just about any need you may have, from a simple receiving preamplifier to one with 23 dB gain and over 4 W output!

The 33-cm Amateur Radio band (902-928 MHz) is becoming well populated in many areas of the country. Propagation on 33 cm has traits similar to both 432 MHz and 1296 MHz, but has characteristics all its own at times, making it a very interesting band. It's pleasantly surprising what you can do with a few watts on 903 MHz with high-gain loop-Yagi antennas.

Articles have been published on transverters, amplifiers and receivers for 33 cm. I described a 759-MHz local oscillator<sup>1</sup> intended to be used with a 144-MHz IF for operation on 903 MHz. If you've built the transmit section of a transverter that gets you to the 10-mW level, or if you've purchased a commercial transverter such as Down East Microwave's low-power, no-tune unit,<sup>2</sup> you'll need to bring your transmitter power up to a usable level. Instead of showing a typical transmit-amplifier chain, many of which have been described in Amateur Radio literature, I will discuss eleven different gain blocks, for several different gains and power levels, in this two-part series.

I suggest that you build each amplifier in its own enclosure, rather than trying to build more than one amplifier in one box to eliminate connectors or reduce size. If you are building your own equipment, you probably aren't too concerned about size and compactness, and having separate enclosures makes for much easier tuning and troubleshooting. Many transistors used in 1296-MHz projects are suitable for use at 903 MHz; some even have more gain at 903.

Transistors with SD prefixes used in the following designs are manufactured by SGS-Thomson Microelectronics.<sup>3</sup> Some of these transistors don't operate at 12 V.

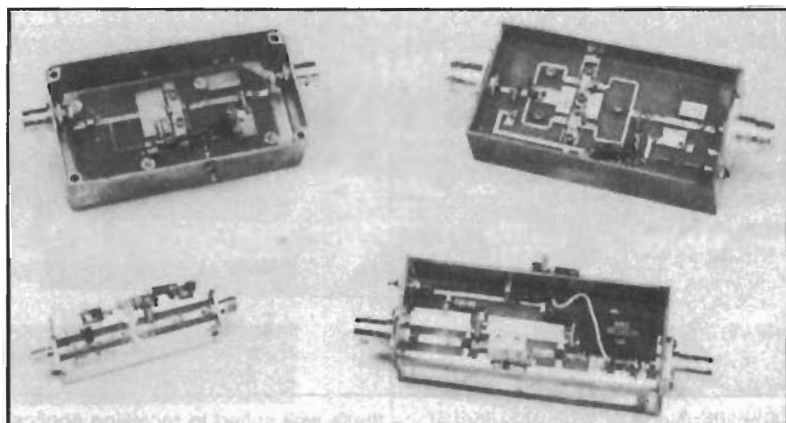

Again, in building your own equipment, this shouldn't be a major problem. Gains listed are averages for several different devices tried. All of the amplifiers can be driven harder than indicated—for CW or FM operation only—but should be used at or below their rated power output for SSB work. All the designs can be used at lower power output; they are all linear amplifiers.

## Construction

All of the amplifiers are built using similar techniques. Each design uses common 1/16-inch-thick, G-10, double-sided, fiberglass-epoxy PC board for the microstrip circuitry. The ground-plane side of each PC board is unetched.

The microstrip boards can be made using what I call the "X-ACTO®-etch" method. This involves using a piece of clear tape as the resist. (Four-inch-wide clear tape is available at stationery stores.) After drawing the pattern on the board with a pencil or fine-tipped marker, cover it on

both sides with clear tape and cut the pattern in the tape with an X-ACTO knife. Then, remove the tape from the areas to be etched and etch the boards in ferric chloride in a crock pot on low heat. Do this in a well-ventilated area! Etching takes about half an hour without agitation. The crock pot is a no-mess way to etch boards. Only an inch or so of ferric-chloride solution is needed. Of course, you can also use a photographic method to make boards, as I do for multiple or complicated boards.

After the PC board is etched, clean it with steel wool and drill holes at all dc- and RF-ground points using a no. 50 drill. No holes are needed for component leads, as all components are mounted on the microstrip side of each PC board. RF grounds must be located as close to the areas to be grounded as possible, to ensure low-inductance ground paths. There are at least two ways to do this. One is to install a rivet in each hole, flare it with an awl or ice pick, then flatten it by tapping with a small

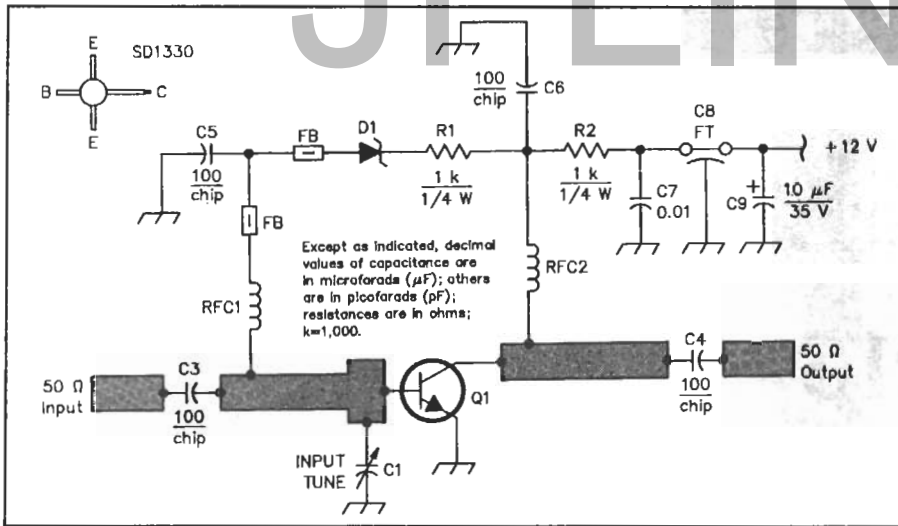

Fig 1—Schematic of the SD1330 receive preamplifier/low-level transmit stage. RFC1 and RFC2 consist of 8 turns of no. 24 enam wire closewound on a 0.1-inch-ID form (such as a 0.1-inch drill). D1 is a 9.1-V, 1/2-W Zener. C1, a 12.5-pF trimmer, is available from Mouser (part no. 24AA071).

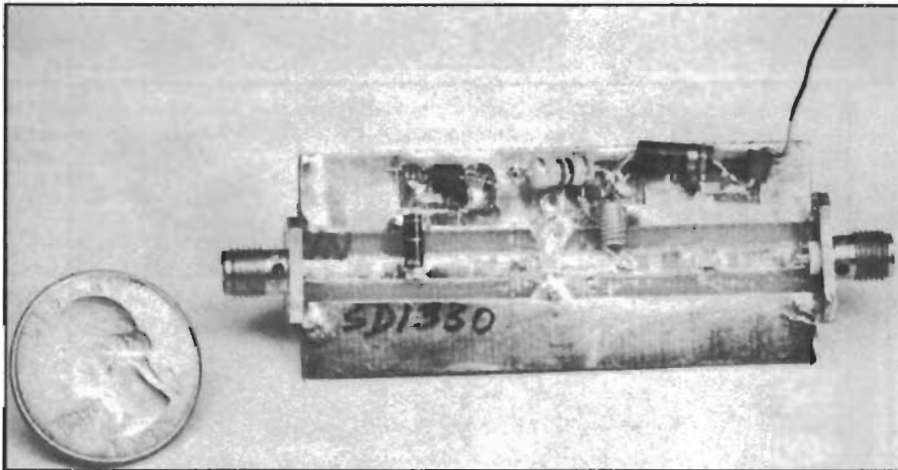
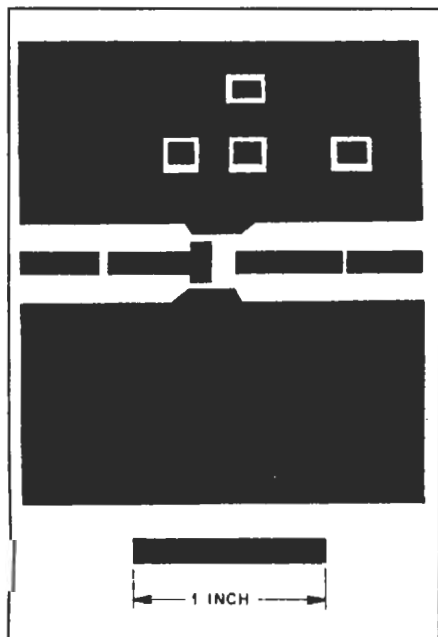

Fig 2—Amplifier No. 1, a 10-mW-output stage that's well suited to receiving applications, in prototype form.



hammer on an anvil or other hard surface. Then, solder the rivets on both sides of the PC board. Alternatively, pieces of bus wire can be used for grounding.

Because parts placement is quite straightforward, I haven't provided parts-placement drawings for all of the designs. The schematics and PC-board artwork should provide all the guidance you'll need to assemble the boards. I can help with any questions that you might have when building any of the amplifiers.

All of the amplifiers described, except those operating under the 300-mW level, require some heat sinking. A small brass sheet is sufficient for the studded parts, but a finned heat sink an inch or two square is needed for the flanged-device amplifiers.

Fig 3—Full-scale PC-board artwork for the 10-mW SD1330 amplifier. Black areas represent unetched copperfoil. All parts are mounted on the foil side of the board. Crop the finished boards as necessary.

Thermally conductive compound is required between the devices and their heat sinks. For studless devices, a small piece of brass shim stock soldered from the bottom of the device to the ground-plane side of the PC board should work fine.

An easy way to enclose an amplifier like those described is to make a housing using double-sided PC board or brass sheet for the four walls and bottom cover. The amplifier PC board makes the top cover. Input and output connectors (N, BNC or SMA) can be bolted or soldered to the end walls with their center pins soldered directly to the microstrip input/output lines in an end-launch configuration. When using PC-board material for housings, mount the side walls in such a way that the grounding is continuous from the connectors to the ground-plane side of the amplifier board.

Various die-cast aluminum boxes, such as Bud CU-123 and CU-124 and the Hammond 1590 series, also work great for enclosing these designs. Die-cast boxes usually provide sufficient heat sinking for amplifiers operating at less than 2 W output. Device studs or flanges should be attached directly to the boxes in these cases. All component leads must be kept as short as possible. This also applies to trimmer caps. Mount them flush to the PC board so that they act as capacitors—not as inductor/capacitor combinations. Use multiple rivets (or bus wires) to ground the trimmers.

### Components

Use ceramic chip capacitors for the dc blocks and high-frequency bypassing. Some of the larger-value bypass capacitors, like 0.001  $\mu$ F and 0.01  $\mu$ F, are available in chip form also. These epoxy types are good for all the designs described here. I use inexpensive chip caps from Mouser Electronics.<sup>4</sup> Chip caps and Johanson piston trimmers are available from Microwave Components of Michigan.<sup>5</sup> Transistors are available from RF Parts<sup>6</sup> and RF Gain, Ltd.<sup>7</sup> Components, rivets and PC boards are available from Frontier Microwave.<sup>8</sup>

### Tune-Up

In most of these amplifiers, the quiescent collector current ( $I_{cq}$ ) initially will have to be checked and set with no drive applied.

To check bias current, disconnect the cold end of the collector choke and insert a milliammeter in series with the choke. Adjust  $I_{cq}$  by changing the value of the collector-bias resistor or by changing the collector voltage. All amplifiers requiring 12 V can be powered directly from low-current, 12-V dc sources (a three-terminal, 12-V regulator, for example). Amplifiers running on 14-18 V dc or 21-23 V dc can be powered by an LM317T (or LM317K) adjustable regulator. Set the regulated voltage to a minimum, and adjust it upward from minimum while monitoring  $I_{cq}$ . Idling collector current can be adjusted to suit your gain and power-output requirements.

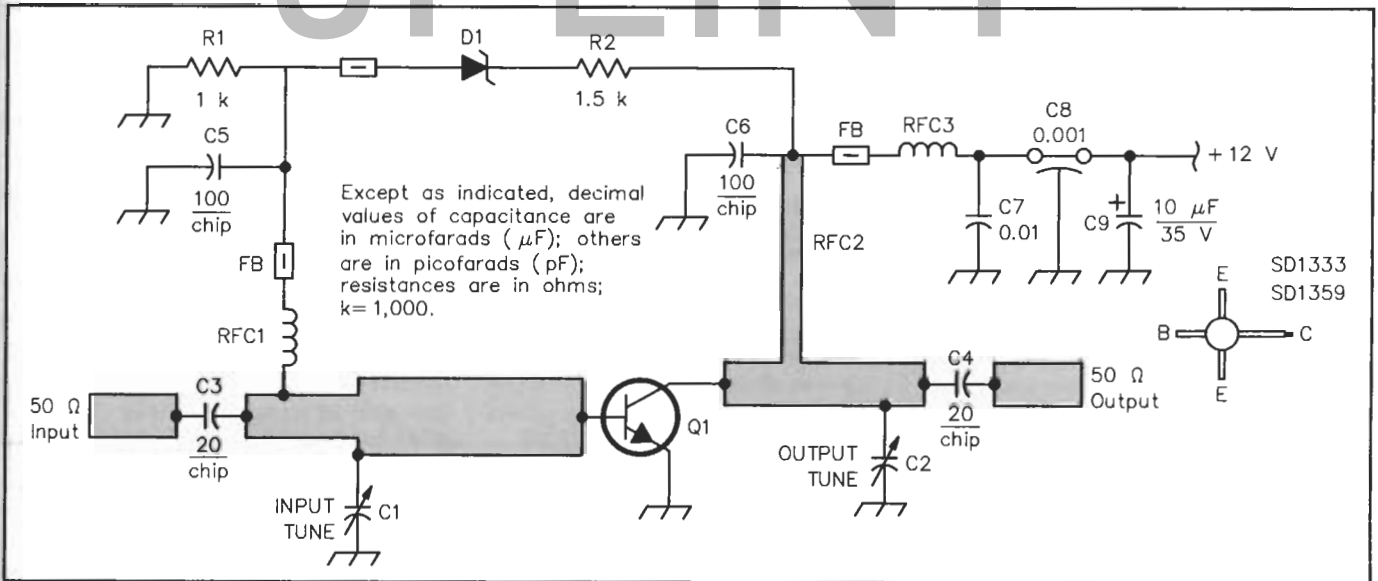

Fig 4—Schematic of the SD1333 and SD1359 amplifiers (Amplifiers No. 2 and No. 3). All components except Q1 are common to both designs (see text).

C1, C2—12.5-pF trimmer, Mouser no. 24AA071.

C7—0.01-μF disc ceramic.

RFC1, RFC3—8 turns of no. 24 enam wire, 0.1 inch ID, closewound.

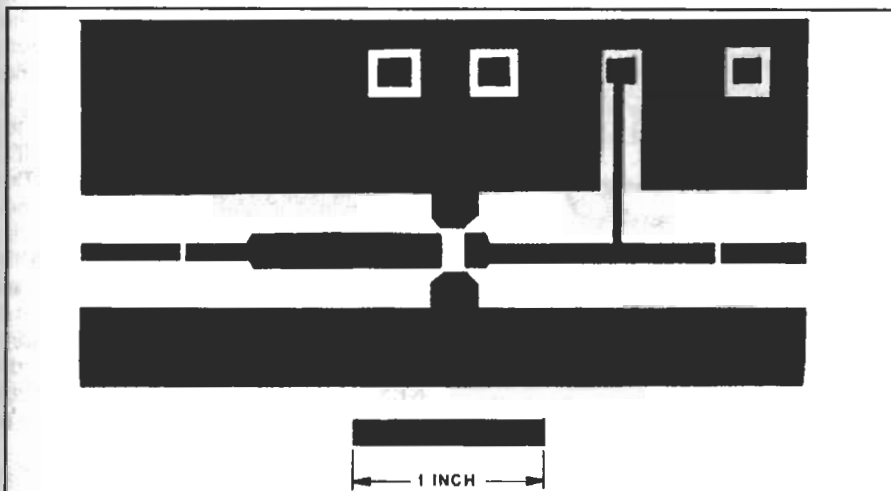

Fig 5—Full-scale PC-board network for the 100- and 250-mW amplifiers. Black areas represent unetched copper foil. All parts are mounted on the foil side of the board.

### Amplifier No. 1: A Receive Preamplifier or 10-mW-Output, 13-dB-Gain Transmit Stage

The amplifier shown in Figs 1 and 2 is a low-power stage using an SD1330, Motorola MRF901 or NEC NE64535. This stage is best suited to the receiving side of a transverter. With a noise figure (NF) of 2 dB, it makes a fine front end by itself. With a good, low-noise GaAsFET preamplifier in front of it, you'll have all the sensitivity you need in front of the receive mixer. For transmitting applications, where a low noise figure isn't important, an MMIC amplifier would be better because it is a lot easier to build for the same results.

The SD1330 amplifier is built on 0-10 double sided board; the artwork appears in

Fig 3. After etching the board, install rivets at the RF and dc grounds. To mount the device, drill a hole in the PC board the size of Q1's macro-X case. This allows all four leads to be soldered to the microstrip without bending them.

The idling current for this amplifier should be set to 5 mA or less for good noise figure. The idling current is kept constant for different transistors and over different voltages and temperatures by current-limiting resistors R1 and R2 and Zener diode D1. Tune the input trimmer for best NF or maximum gain if an NF-measurement setup isn't available.

### Amplifier No. 2: 10 mW In, 100 mW Out

The SD1333 transistor, a macro-X plas-

tic-packaged device used in this design, delivers 100-125 mW. This device is capable of a reasonable noise figure (2-3 dB) and good dynamic range, which allows it to be used as a second stage (following a GaAsFET preamplifier) in a receiving system. (Motorola's BFR96/MRF961/MRF962 also work well in this circuit; the BFR96 has slightly less gain.) Fig 4 shows the amplifier schematic and Fig 5 shows the full-scale artwork.

Zener-diode bias is used for simplicity and some temperature compensation. Set the quiescent current to 40-50 mA (not critical) by varying R1. A pot can be used initially, then the pot can be replaced by a fixed-value resistor. Or the collector voltage can be varied slightly.

After the rivets are installed in the PC board, drill a hole the diameter of Q1's molded package in the PC board. Mount the device in the board so its un bent leads are soldered directly to the microstrip board. Use the small variable capacitors to tune for maximum gain.

### Amplifier No. 3: 9 dB Gain, 250 mW Out

This unit is a slightly higher-power version of the previous amplifier, using an SD1359 or Motorola TRF559 plastic-packaged device. The artwork and schematic are identical to that of Amplifier No. 2. Idling current, 40-50 mA, can be optimized by adjusting the collector supply between 10 and 13 V to set the stage gain.

After the PC-board rivets are installed, drill a hole in the PC board to accept Q1. Mount the device in the board so its un bent leads are soldered directly to the microstrip board. Tuning is as discussed with Amplifier No. 2.

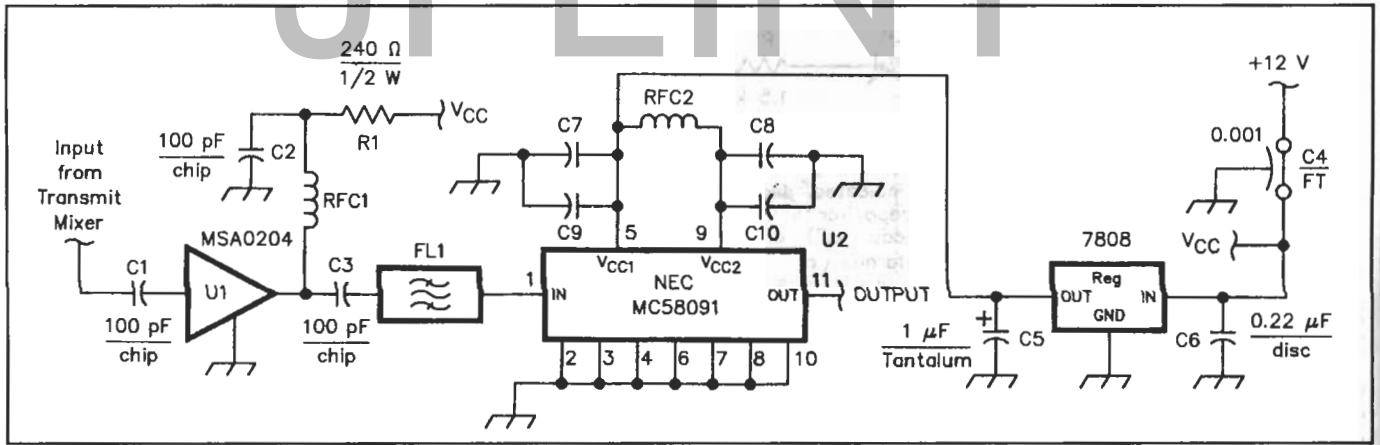

Fig 6—Schematic of the MSA 0204/MC5809L amplifier.

C7, C9—100-pF chip.  
C8, C10—0.01- $\mu$ F ceramic disc.

FL1—Two-stage Toko helical filter (Digi-Key no. TK23318).

RFC1—8 turns of no. 24 enam wire, 0.1 inch ID, closewound.  
RFC2—1- $\mu$ H molded choke.

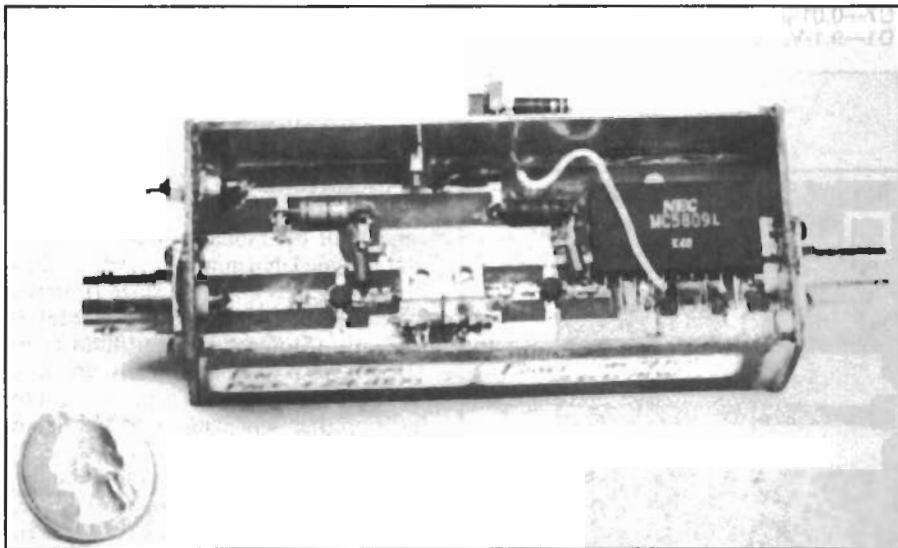

Fig 7—The 200-mW-output MSA 0204/MC5809L amplifier. In this prototype, I used MSA 0204 stages before and after the helical filter to provide additional gain. The biasing components (the 7808 and associated parts) are mounted on the outside of the enclosure for convenience.

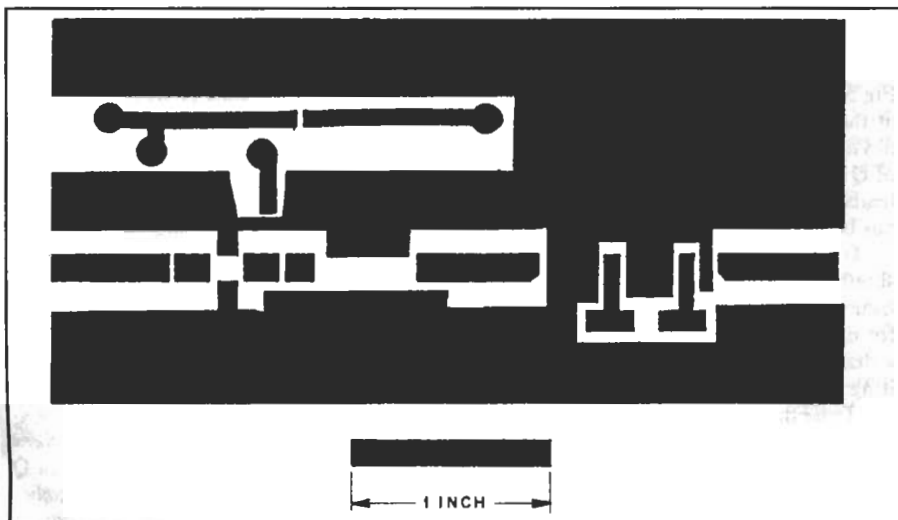

Fig 8—Full-scale PC-board artwork for the 200-mW amplifier. Black areas represent unetched copper foil.

### Amplifier No.4:0.8 mW In, 200 mW Out

The amplifier shown in Figs 6 and 7 is a high-gain unit that can be used to follow the output of your 903-MHz transmit mixer. An Avantek MSA 0204 or Mini-Circuits MAR-2 MMIC is used for the first stage, followed by a Toko two-stage helical filter.<sup>10</sup> (In the prototype amplifier shown in Fig 7, I used two MMIC stages, in addition to the helical filter, before the final stage.) The output stage is an NEC MC5809L thick-film hybrid module. This NEC hybrid module is one of four such units intended for hand-held cellular telephones operating in the 800- to 960-MHz range. The MC5809-series amplifiers are rated at 150 mW minimum power output at 7.5 V dc. Using a more readily available power source (a 7808 regulator), the NE5809s I tried were linear at over 200 mW output. These hybrid amps are easy to use and are stable into any load.

The full-scale PC-board artwork is shown in Fig 8. The helical filter is used between stages to clean up the transmitter signal by filtering out the local-oscillator and image frequencies, but isn't required for applications where such filtering is done in other stages. A three-stage Toko filter<sup>11</sup> will also fit on the board, and could be used for better filtering. The filter leads are bent to the side to allow soldering to the PCboard traces. See Fig 9 for parts placement.

This amplifier is easy to build and get working. Because both active stages and the filter are designed for 50  $\Omega$  in and out, the amplifier uses 50- $\Omega$  microstrip throughout. No trimmer capacitors are needed and no bias adjustments are necessary—just apply the dc voltages and the drive signal, and peak the helical filter for maximum power output at 903 MHz!

Because more gain is available from this design than I needed, I tried mixing two signals at the input of the first stage. Using a T connection at the input of the first stage,





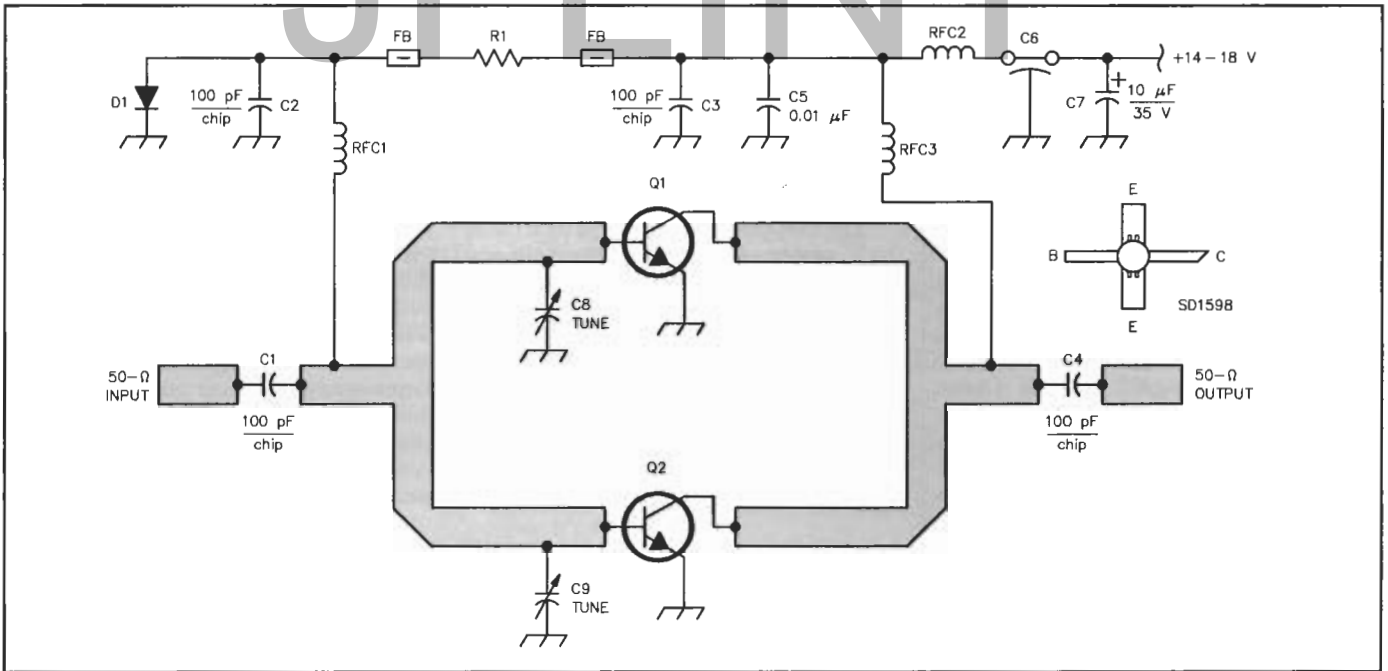

Fig 11—The 2x SD1598 amplifier. Glue D1 to Q2's ceramic body for thermal composition.

C8, C9—0.6- to 8-pF Johanson piston trimmer.  
D1—1N4001.

Q1, Q2—SD1598.  
R1—1.5-1.6 kΩ, 1/2 W

RFC1, RFC3—8 turns of no. 26 enam wire, closewound, 0.1 inch ID.

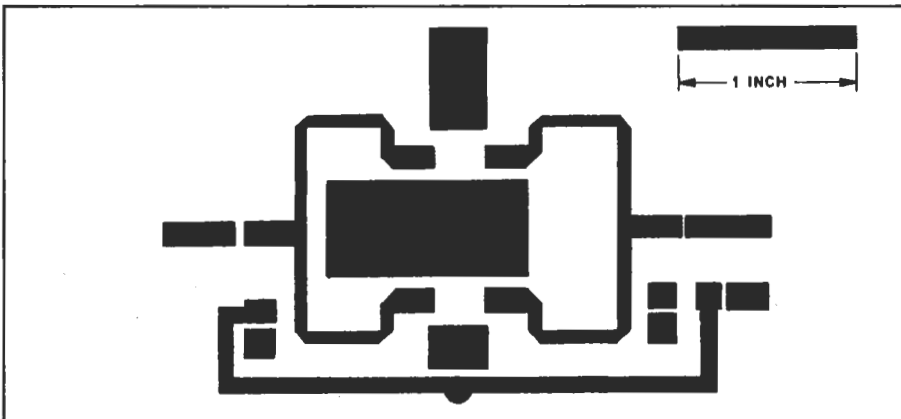

Fig 12—Full-scale PC-board artwork for the 2x SD1598 amplifier. Black areas represent unetched copper foil.

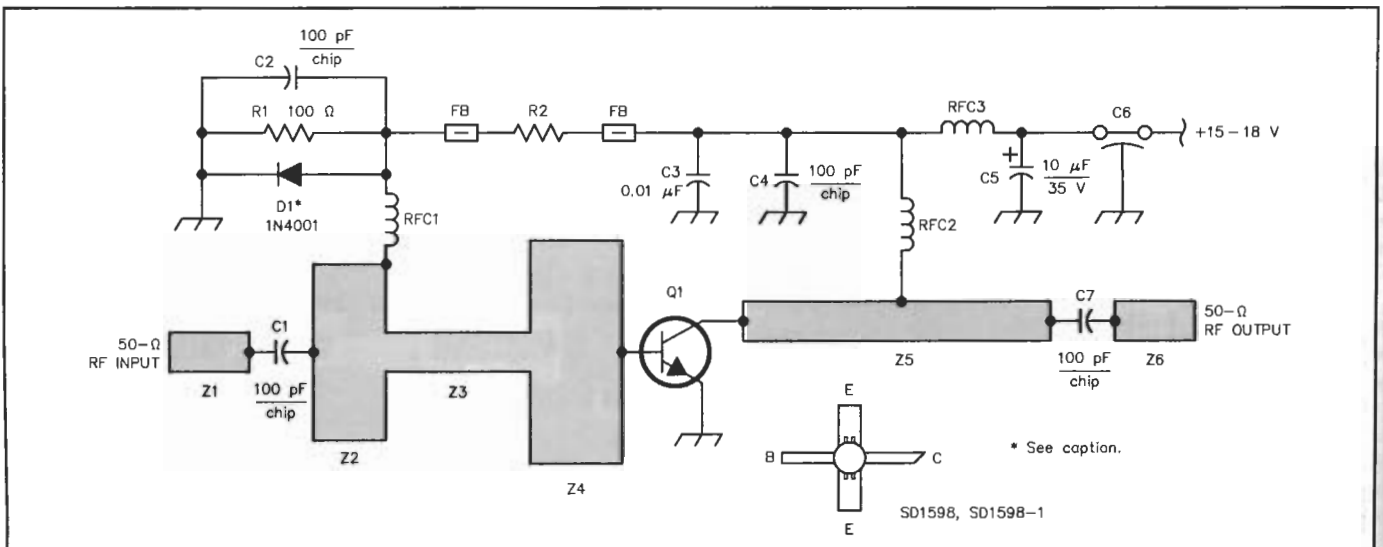

Fig 13—The 500-mW broadband amplifier. For power levels over 500 mW output, glue D1 to Q1's ceramic body for thermal compensation. RFC1 and RFC2 are implemented as PC-board traces.

Q1—SD1598 or SD1598-1.  
R2—1.5-1.6 kΩ, 1/2 W

RFC3—8 turns of no. 28 enam wire, closewound, 0.1 inch ID.

Z1-Z5—Microstriplines. See text and Fig 14.

No. 5 (Fig 10). If this amplifier is mounted in a die-cast box, no additional heat sinking is required; If not, a small heat sink should be attached to the stud of each device. Adjust C8 and C9 for maximum power output.

**Amplifier No.7: 12dB Gain, 500mW Out**

The amplifier shown in Fig 13 is a broadband design that's been around for about 6 years. Bill Olson, W3HQT, designed it as a 1296-MHz amplifier. (The 1296-MHz version differs in that it has a small piston trimmer on the output circuit, about an inch from Q1's ceramic cap.)

This amplifier is a very versatile design; it works from 900-1300 MHz and has a power gain of 10-13 dB over this range. I built two test amplifiers for this design: one for the studded transistor and one for the flanged version. Over a dozen different devices were tried in these test circuits, both at 903 MHz and at 1296 MHz. Classes A, AB, C and pulsed-class-C operation were all tried, and all worked well.

The studded SD1598 is used in this design. Full-scale artwork appears in Fig 14; Fig 15 shows parts placement. As with the other designs, rivets are used at all dc and RF grounds. After the rivets are soldered in place, drill a hole in the board for the device. Trim Q1's leads with scissors, then solder them directly to the microstriplines and ground foils. If the amplifier is to be mounted in a die-cast box, the box will provide sufficient heat sinking. If you use another mounting method, attach a small heat sink to Q1's stud.

Power output for SSB is 500 mW, and

Fig 14—Full-scale PC-board pattern for the broadband 500-mW SD1598 amplifier. Black areas represent unetched copper foil.

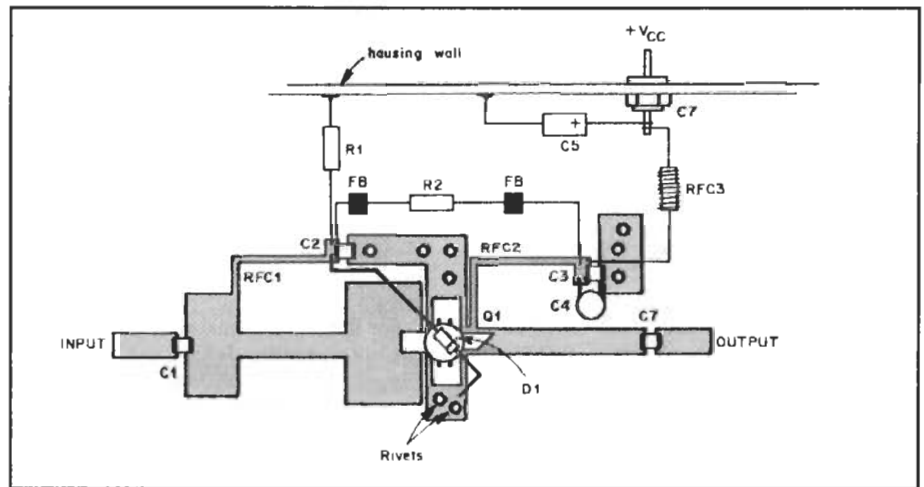
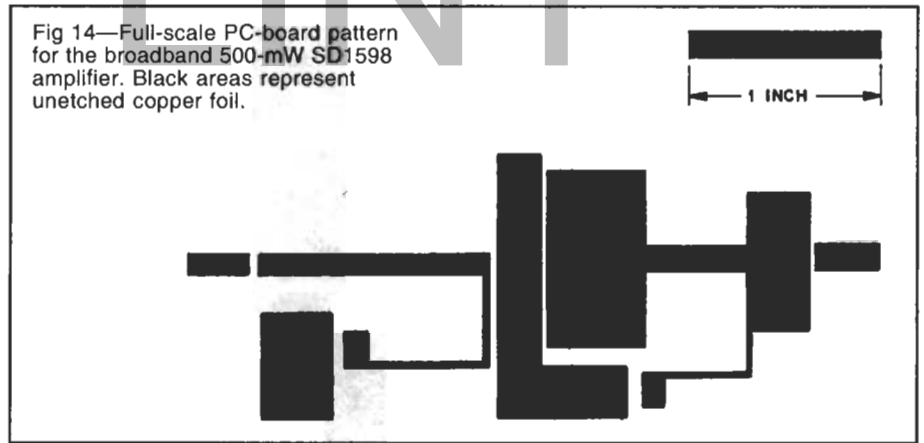

Fig 15—Parts-placement diagram for the broadband 500-mW SD1598 amplifier. The PC-board edges are not shown. All components are mounted on the foil side of the PC board (except those mounted to the enclosure).

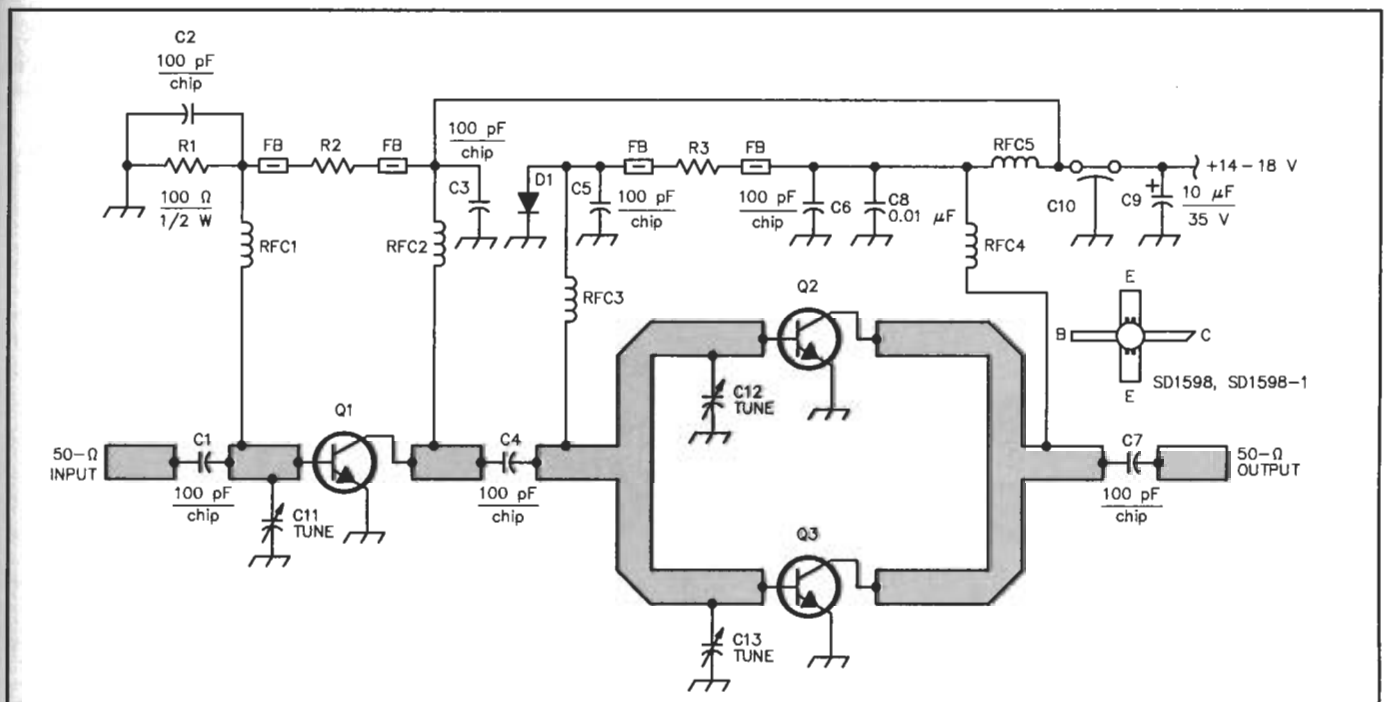

Fig 16—The two-stage, 1-W SD1598 amplifier. Glue D1 to Q2's ceramic body for thermal compensation.

C10—0.001-μF feedthrough.

C11, C13—0.6- to 8-pF Johanson piston trimmer.

Q1—SD1598 or SD1598-1.

Q2, Q3—SD1598.

R2, R3—1.5-1.6 kΩ, 1/2 W.

RFC1-RFC5—8 turns of no. 24 enam wire, closewound, 0.1 inch ID.

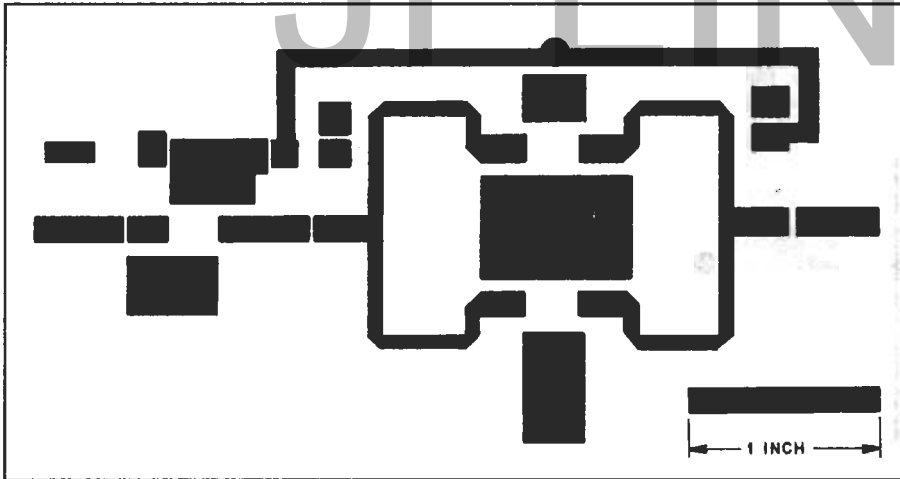

Fig 17—Full-scale PC-board pattern for the two-stage, 1-W SD1598 amplifier. Black areas represent unetched copper foil.

up to 1 W for CW and FM, depending on the device. In applications where the device will deliver over 500 mW, a 1N4001 (DI) diode can be glued to Q1 for thermal stabilization, as shown pictorially in Fig 15. Power gain at 1 W output is 7 dB or so. By varying R2, set Q1's  $I_{cq}$  for 30-50 mA for power levels up to 500 mW, and 15-20 mA for higher levels.

For low-level stages (up to 200mW out), you can use the SD1598-1 studless part in this circuit. Solder the studless device to the microstrip, then solder a piece of hobby brass to the device's gold-plated bottom area and to the ground plane. This provides enough heat sinking to dissipate a few hundred milliwatts.

At 903 MHz, no output trimmer capacitor is required. Some improvement in the output match can be achieved by trimming the width of the output line by a few thousandths of an inch with an X-ACTO knife.

#### Amplifier No. 8: 10 mW In, 1 W Out

A second 1-watt amplifier, this one using a pair of SD1598's driven by a single SD 1598, is shown in Fig 16. This design is similar to that of Amplifier No.6, with the addition of a driver stage. The artwork appears in Fig 17.

For the driver transistor, you can use an SD1598-1 studless device, as Q1 must provide only a hundred milliwatts or so. The driver is mounted in a hole in the PC board. A small piece of brass shim stock is soldered to the bottom of the device and to the ground-plane side of the PC board for heat sinking.

This amplifier runs on 14-18 V dc. The idling current for each device is around 30-50 mA. Again, the supply voltage can be provided by an LM317T regulator. Adjust R2 and R3 to individually set each device's idling current. Then, tune the amplifier by adjusting C11, C12 and C13 for maximum

output. Vary the supply voltage to optimize the required power output or gain.

The 2.4 × 4.4 × 1-inch Bud CU-124, or an equivalent die-cast box, is a suitable enclosure for this amplifier. Mount the connectors on the ends of the box, and place the amplifier PC board inside the box body, instead of on the inside of the cover. The box provides sufficient heat sinking for this amplifier.

Next month, I'll describe three more 903-MHz linear amplifiers, including two 4-W units.

#### Notes

- <sup>1</sup>D. Mascaro, "A 759-MHz Local Oscillator," *QEX*, May 1988, pp 12-15.
- <sup>2</sup>No-tune transverters, as well as antennas and microwave components, are available from Down East Microwave, Box 2310, RR 1, Troy, ME 04987, tel 207-948-3741. Catalog available.
- <sup>3</sup>The amplifiers in this article use transistors manufactured by SGS-Thomson Microelectronics, 211 Commerce Dr, Montgomeryville, PA 18936, tel 215-362-8500.
- <sup>4</sup>Mouser Electronics, 2401 Hwy 287 N, Mansfield, TX 76063, tel 817-483.4422. Catalog available.
- <sup>5</sup>Microwave Components of Michigan, 17141 Merriman, Romulus, MI 48174, evening tel 313-753-4581. Parts list available.
- <sup>6</sup>RF Parts, 1320 Grand Ave, San Marcos, CA 92069, tel 619-744-0728.
- <sup>7</sup>SGS-Thomson Microelectronics transistors are available through RF Gain Ltd, 100 Merrick Rd, Rockville Center, NY 11570, tel 800-645-2322. \$50 minimum order.
- <sup>8</sup>Frontier Microwave, RD 1, Box 467, Mink Rd, Ottsville, PA 18942, evening tel 215-795-2648.
- <sup>9</sup>D. Mascaro, "A Transverter Band-Switching Display and Universal Power Supply," *QEX*, Aug 1987, pp 8-14.
- <sup>10</sup>Available from Digi-Key Corp, 701 Brooks Ave South, PO Box 677, Thief River Falls, MN 56701-0677, tel 800-344-4539. Catalog available.
- <sup>11</sup>Toko filters and other components are available from Steve Kostro, N2CEI, Box 341A, RD 1, Frenchtown, NJ 08825, evening tel 201-996-3584. Parts list available.

# 903-MHz Linear Amplifiers

*Part 2*—Did you like the projects in Part 1? Here are three more amplifiers to suit your 903-MHz, 50-ohm gain-block needs.

In Part 1, I covered construction methods for building the 903-MHz linear amplifiers described in this twopart series. The amplifiers described this month cover a higher power range than those in Part 1, starting with a 2-W-output design, and finishing with a pair of 4-W output units (one with 13 dB gain, the other with 23 dB gain).

### Amplifier No. 9: 100 mW In, 2 W Out

The transistor used in this amplifier, an SD1853, is a class-A device in a "strip-pac" flanged package. The PC-board artwork is shown in Fig 18, and the schematic appears in Fig 19. The parts-placement

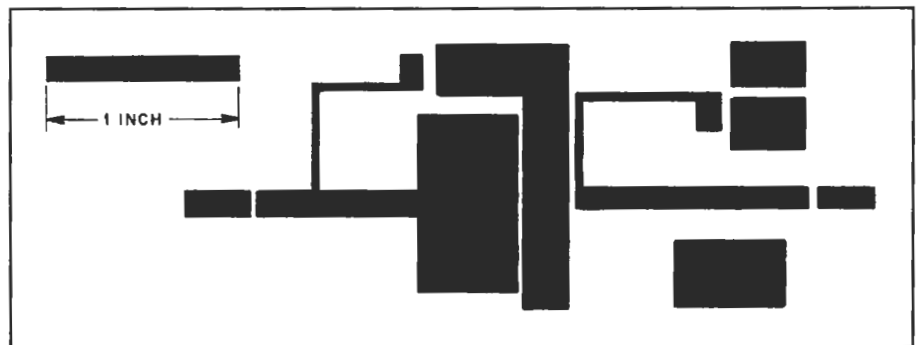

Fig 18—Full-scale PC-board pattern for the 2-W SD1853 amplifier. Black areas represent unetched copper foil.

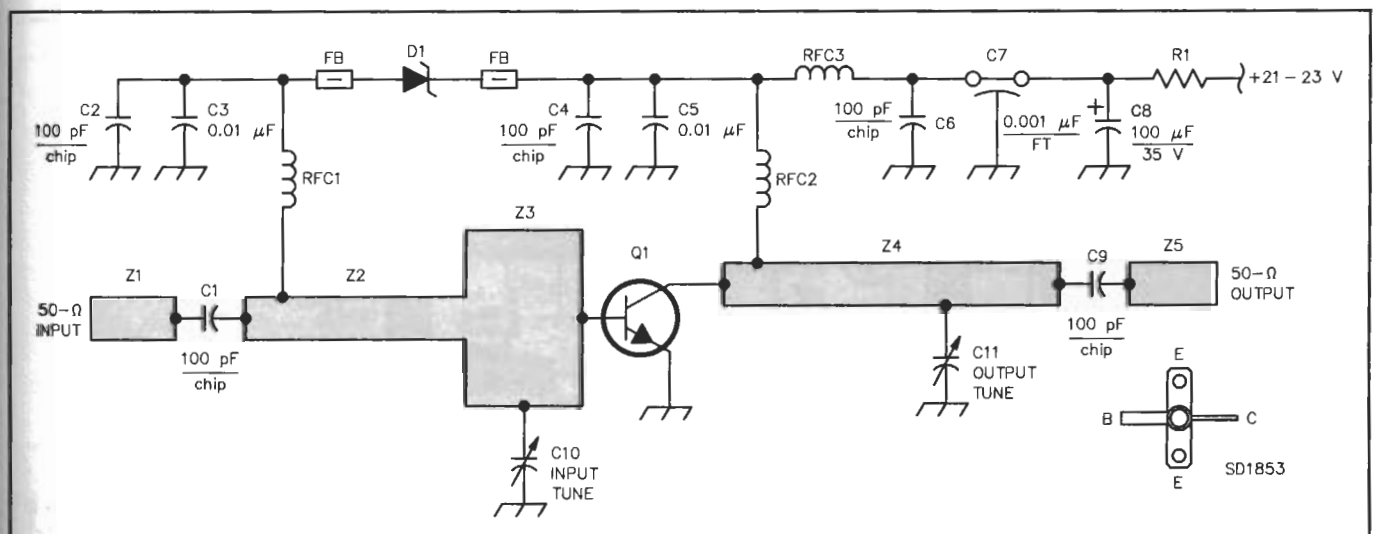

Fig 19—The 2-W SD1853 amplifier. RFC1 and RFC2 are implemented as PC-board traces.

C10, C11—0.3- to 3-pF Johanson piston trimmer.  
D1—1N4747A 20-V, 1-W Zener.

Q1—SD1853.  
R1—2-3  $\Omega$ , 1 W.  
RFC3—8 turns of no. 26 enam wire, closewound, 0.1" ID.

Z1-Z5—Microstriplines. See text and Fig 18.

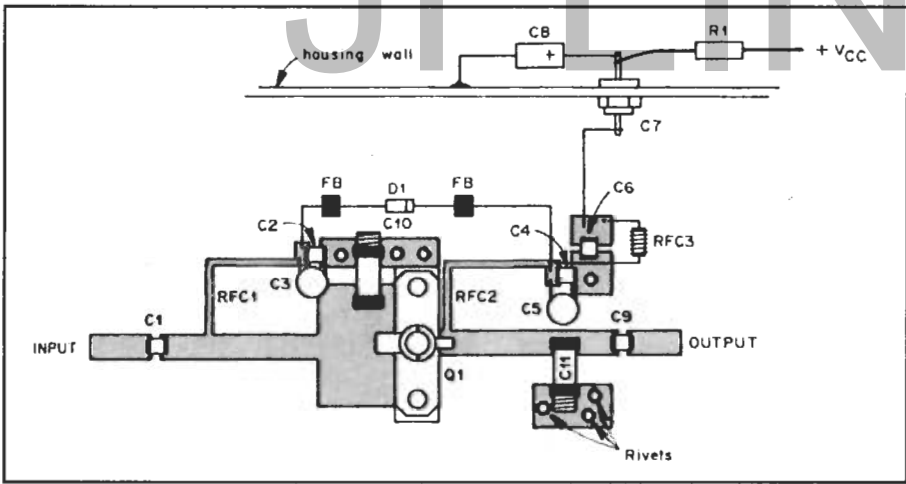

Fig 20—Parts-placement diagram for the 2-W SD1853 amplifier. The PC-board edges are not shown. All components are mounted on the trace side of the PC board (except those mounted to the enclosure).

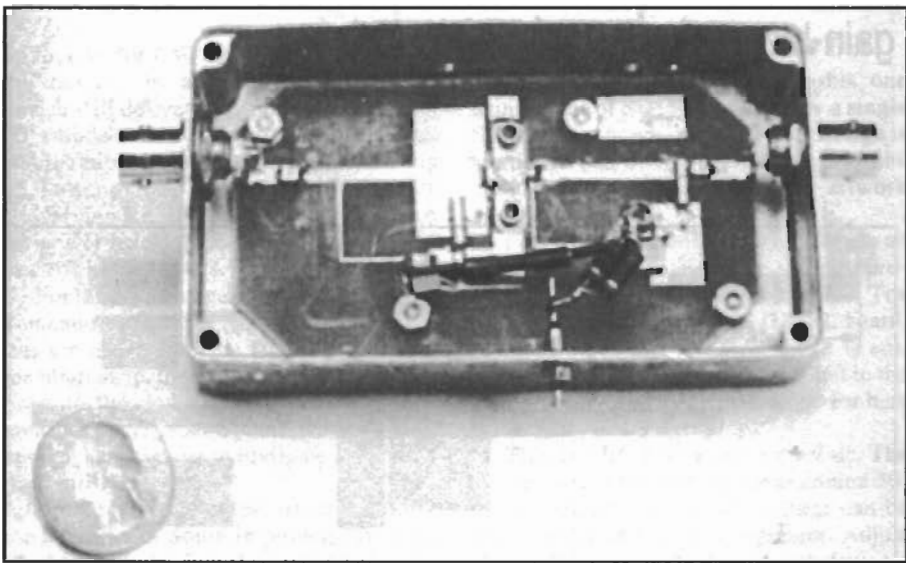

Fig 21—The prototype 2-W amplifier.

diagram is shown in Fig 20, and a photo of my prototype appears in Fig 21.

After the board is etched and rivets are installed, cut a hole and file its edges to accept Q1's flange. The SD1853 must be mounted to a heat sink. (A Bud CU-124 or equivalent die-cast box is adequate.) Use a piece of G-10 PC board between the amplifier board and the heat sink, to allow the device to be mounted flush to the microstrip. The device flange is the emitter, and a low-inductance ground connection is a must. Make this connection by using a piece of copper-foil tape soldered to the microstrip ground plane and placed between Q1's flange and the heat sink. Mount the transistor to the heat sink with no. 4-40 screws. Use heat-sink compound between Q1 and the heat sink.

An LM317T (or LM317K) adjustable regulator can be used to supply the voltage required by this amplifier. Use a 10-turn pot for the ADJUST control; smooth adjustment of the supply voltage to this amplifier is a must. Insert a milliammeter in series with current-limiting resistor R1, and slowly adjust the regulator output up from minimum until the idling current is 200-225 mA without RF drive applied. The exact supply voltage depends on the beta of

Fig 22 (below)—The 4-W, 2 x SD1853 amplifier.  
 C4-C6—0.3- to 3-pF Johanson piston trimmer.  
 D1—1N4747A 20-V, 1-W Zener.  
 Q1, Q2—Sd1853.  
 R1—2-3 Ω, 1 W.  
 RFC1, RFC2—8 turns of no. 26 enam wire, closewound, 0.1" ID.  
 Z1-Z5—Microstriplines. See text and Fig 23.

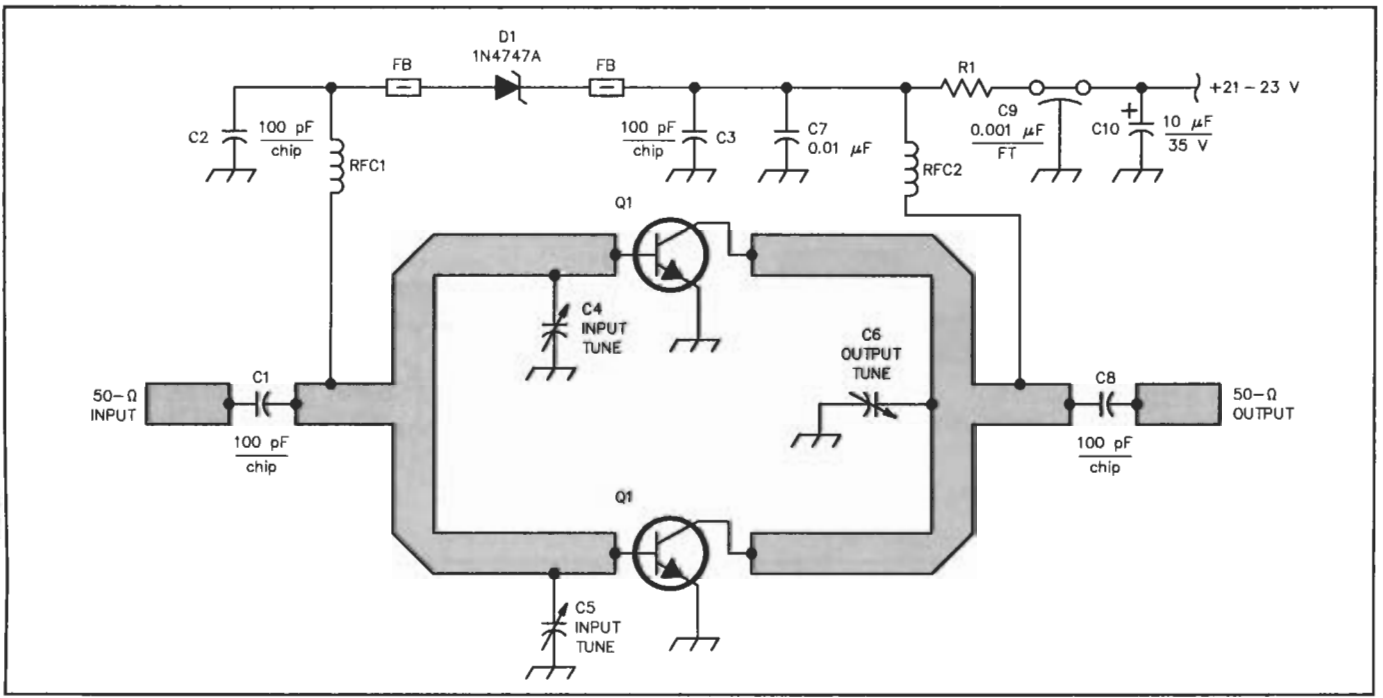



as that for Amplifier No. 8, is shown in Fig 17 (shown in Part 1). The board's driver-stage traces are by-passed with a brass strip in this amplifier. Fig 24 shows my prototype mounted in a PC-board enclosure. A single base-bias source, using a current-limiting resistor and Zener diode, feeds both devices. Total idling current, measured in series with R1, is 400-450 mA.

The same mounting arrangement used with the single-SD1853 amplifier (Amplifier No. 9) applies to this unit. The device flanges must have low-inductance ground connections. Mount the transistors to a heat sink about 2 x 3 inches with 1/2 inch or taller fins, as shown in Fig 25. Again, the supply voltage is switched on only during transmit. To tune this amplifier, adjust C4, C5 and C6 alternately for maximum output.

### Amplifier No. 11: 20 mW In, 4 W Out

A second 4-W amplifier, using a pair of

SD1853s driven by a single SD1598, is shown in Fig 26. The final stage is Amplifier No. 10, and the driver is the same as that used in Amplifier No. 8. The PC-board artwork is shown in Fig 17; the parts placement can be done using Figs 23 and 16 as guides.

The power-supply and bias adjustments are the same as those for the previously described amplifiers using these devices. Transistor mounting is also the same as before, but extra heat sinking is required with this unit because of the class of operation and the power output.

### Higher Power Output

Higher-power devices usable at 903 MHz are available from several manufacturers. NEC's NEL1320 (2SC3542) produces 18-20 W linear output at 903 MHz. These devices also work on the 1296-MHz band. These transistors, as well as single-

and dual-stage amplifiers based on them, are available from Down East Microwave (DEM). (The DEM two-stage 3318PA runs around 18 W output for about 1 W input),

SGS-Thomson Microelectronics also makes high-power devices for the 800- to 960-MHz range. For example, the SD1423 is a 4-W-in, 30-W-out class AB device, and the SD1660 is a class-AB transistor that runs a whopping 120 W output for about 35 W drive. Both of these devices run on 28 V dc.

### Summary

As I've shown in this two-part series, there's really nothing difficult about building your own 903-MHz equipment—from the local oscillator to the final amplifier. This ease of construction is a vast improvement over what it was just a few years ago—and the 903-MHz band's population has grown as a reflection of that. See you on the microwaves!



# 25-Watt Linear Amplifiers for 144 and 200 MHz

Do you need more punch from your hand-held or portable rig for 2 meters or 220 MHz? These little amplifiers can supply it!

Many hams have 2-meter and 220-MHz hand-held rigs and low-power portable SSB rigs these days. Unfortunately, many of these radios have limited usefulness because of their low power output. Also, as hand-held radios get smaller, so do the NiCd packs that power them—a few long-winded transmissions on high power and the battery is dead! The low-power mode is usually good only for short-range simplex operation, or repeater use when you're close to the repeater. High-capacity battery packs are available for most hand-held rigs, but using them takes away the size and weight advantage of today's smaller hand-held transceivers. Some rigs offer the option of removing the battery pack and plugging the unit directly into 12-V dc, which gives you a small, lightweight rig, but you're still stuck with relatively low power.

The solution to this problem is the addition of a linear amplifier. An amplifier after the hand-held transceiver or portable rig that can give you 25 to 30 W of output power (depending on the output of the driving rig) without imposing large weight, cost and current-drain constraints is a great addition to your VHF station. An amplifier also allows you to use the same low-powered rig in the house and in the car with high power output. You can mount an amplifier under the seat or in the trunk of your car, and minimize the possibility of theft by taking the radio with you when you leave the car.

## Amplifier Design

The amplifiers described in this article are capable of 25 to 30W of RF output for the drive power available from common handheld and portable rigs. The 2-meter and 220-MHz designs are so similar that we can describe them both in one discussion. The differences in the designs are covered in detail. Design, assembly, tun-

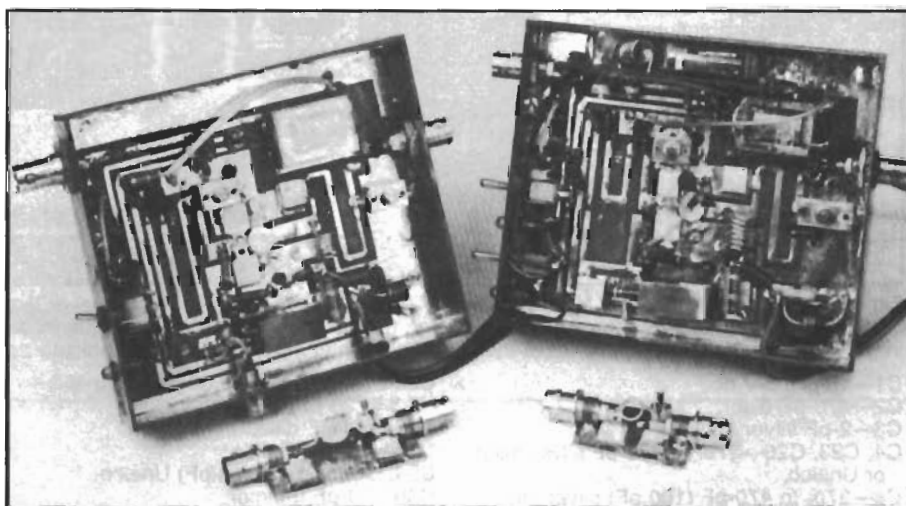

ing and use of the amplifiers is virtually identical for both versions. Both versions even use the same PC board! (Note that two different boards are shown in the lead photo—they were prototypes of the final board design.)

Receiving preamplifiers are included in both units. They, too, are quite similar, differing only in some component values.

This power amplifier uses a single SD1274 bipolar transistor manufactured by Thomson Components/Mostek Corp. The device is operated class AB for all-mode operation. Nominal dc power-supply voltage is 13.8. The amplifier will operate on any dc supply voltage between 12 and 14.5 (the typical automobile supply voltage range).

The main amplifier PC board is a microstripline design on standard 1/16-inch-thick, double-sided, G-10 fiberglass-epoxy board. Input and output tuning capacitors are provided for maximizing gain and power output in a given band segment. If

desired, the amplifiers can be tuned for broadband operation with only a slight reduction in power output across the operating frequency range.

The 2-meter and 220-MHz amplifiers are narrow-band designs. The 2-meter version gives 25 W output for 2 W of drive from 138 to 150 MHz, with a single tuning setting. When tuned for narrow-band operation, the amplifier gives about 20 W output for 1 W of drive. With the Kenwood TH-21AT on high power, my 2-meter amplifier puts out 25 W. On low power, I can adjust the amplifier for a maximum narrow-band gain, which gives about 7 to 8 W output. Efficiency is 50 to 60%, depending on tuning and power output.

The tuning range of the 220-MHz amplifier is 200 to 230 MHz. When tuned for narrow-band operation, the amplifier gives about 16 W output for 1 W of drive. Driving the amplifier with my ICOM IC-3AT on high power (about 1.5 W), the amplifier puts out 20 W. With the IC-3AT on low



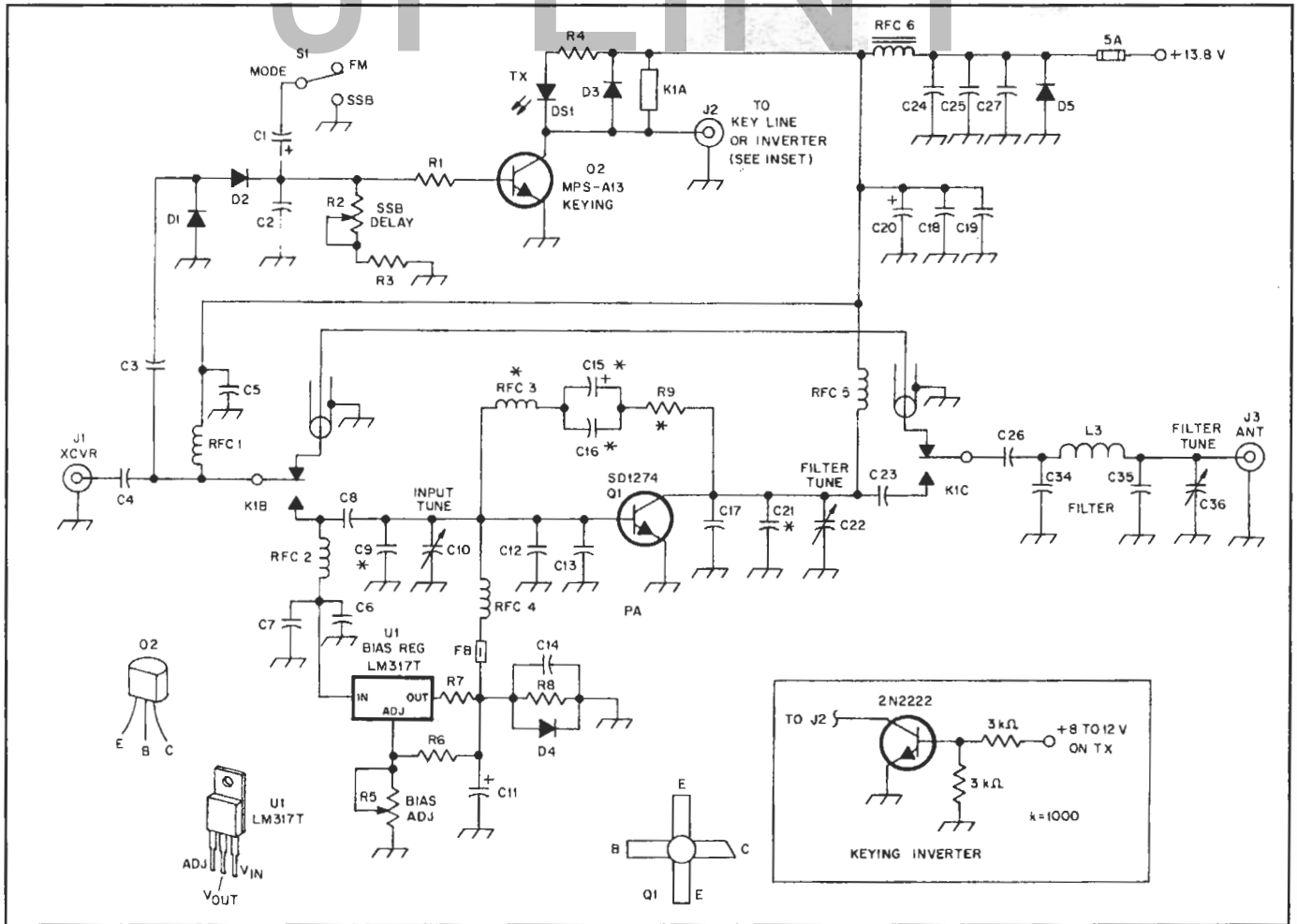

Fig 1—Schematic of the 25-W VHF amplifiers. The 5-A fuse is included in the power lead (external to the amplifier). Be extremely careful when mounting the power transistor—see text for precautions. In the parts list below, values for the 220-MHz version are given in parentheses where they differ from those in the 2-meter version. Asterisks indicate parts not used in the 220-MHz version.

- |  |   |   |
|--|---|---|
| <p>C1—15-<math>\mu</math>F, 6-V dc.<br/>         C2—470-pF disc.<br/>         C3—2-pF silver mica.<br/>         C4, C23, C26—270- to 470-pF silver mica or Unelco.<br/>         C8—270- to 470-pF (100 pF) silver mica or Unelco.<br/>         C5, C7, C14, C16, C19, C24—0.01-<math>\mu</math>F disc.<br/>         C6—0.22-<math>\mu</math>F disc.<br/>         C9—43-pF silver mica or Unelco.<br/>         C10—Arco 404—4 to 60 pF (Arco 403—4 to 40 pF).<br/>         C11, C15—1-<math>\mu</math>F, 15-V tantalum.<br/>         C12—180-pF (120-pF) Unelco.<br/>         C13, C18—220-pF Unelco.<br/>         C17—68-pF (51-pF) Unelco.<br/>         C20—10-<math>\mu</math>F, 35-V electrolytic.<br/>         C21*—33 pF silver mica or Unelco.</p> | <p>C22—Arco 404—4 to 60 pF (Arco 402—1.5 to 20 pF)<br/>         C25—0.1-<math>\mu</math>F disc.<br/>         C27—0.001-<math>\mu</math>F disc.<br/>         C34, C35—25-pF (18-pF) Unelco.<br/>         C36—10-pF trimmer.<br/>         D1, D2—1N4148 or 1N914.<br/>         D3, D4—1 N4001 or equiv.<br/>         D5—ECG 581 or equiv.<br/>         DS1—LED.<br/>         FB—Ferrite bead.<br/>         K1—Omron LZN203-UA-DC12 DPDT relay.<br/>         L3—3 turns (1 turn) no. 18, closewound, 0.2-in. (<math>\frac{1}{4}</math>-in.) ID.<br/>         Q1—Thomson/Mostek SD1 274.<br/>         Q2—MPS-A13 NPN Darlington.<br/>         R1, R4—1.5-k<math>\Omega</math>, <math>\frac{1}{4}</math> W.<br/>         R2—500-k<math>\Omega</math>, 10-turn potentiometer.</p> | <p>R3—10-k<math>\Omega</math>, <math>\frac{1}{4}</math> W.<br/>         R5—100-<math>\Omega</math> miniature potentiometer.<br/>         R6—270-<math>\Omega</math>, <math>\frac{1}{4}</math> W.<br/>         R7, R8—10-<math>\Omega</math>, <math>\frac{1}{2}</math> W.<br/>         R9*—15-<math>\Omega</math>, <math>\frac{1}{4}</math> W.<br/>         RFC1, RFC2, RFC4—0.47-<math>\mu</math>H molded choke.<br/>         RFC3*—0.15-<math>\mu</math>H molded choke.<br/>         RFC5—6 turns (5 turns) no. 16 enam, <math>\frac{1}{4}</math>-in. ID.<br/>         RFC6—VK200/4B ferrite choke.<br/>         S1—Miniature SPDT toggle.<br/>         U1—LM317T voltage regulator</p> <p><b>Miscellaneous</b><br/>         2 BNC or N connectors (see text).<br/>         4 <math>\times</math> 4 <math>\times</math> 1<math>\frac{1}{2}</math>-in. heat sink.<br/>         5-A fuse and in-line holder.<br/>         2 <math>\times</math> 1-in. scrap of thin sheet brass.</p> |
|--|---|---|

power (about 150 mW), I can tune the amplifier to give 4W output. Efficiency is about the same as the 2-meter version.

The saturated power output for both versions is more than 35 W in FM operation. The maximum FM power input is 4 W. Minimum power input for proper RF sensed keying operation is 100 mW.

### The Power-Amplifier Circuit

See Fig 1. K1 is similar to relays used in VCR RF circuits. I have switched up to

40 W at 2 meters and 35 W at 220 MHz with these relays. They present a good match to 50  $\Omega$ . The loss through the amplifiers (when not in use) resulting from these relays is less than 1 dB. This is typical for 2-meter and 220-MHz amplifiers.

In addition to switching the transmitted and received signals, the relays also switch the dc supply voltage. In the transmit mode, K1 switches 13.8 V dc to the input of the bias regulator, U1. The regulator IC and its associated resistors (R7, R8) and bias

diode (D5) supply a stiffer bias voltage to the base of Q1 than the more-common voltage-divider bias networks. This low-impedance bias source keeps the bias voltage constant over the range of RF drive levels. With a voltage-divider bias network, bias voltage can be upset by the base-emitter rectification (self bias) developed by the RF driving signal. In such a case, over-driving the amplifier causes the base bias to decrease, resulting in non-linear amplification. This effect is limited with the regulator-type bias

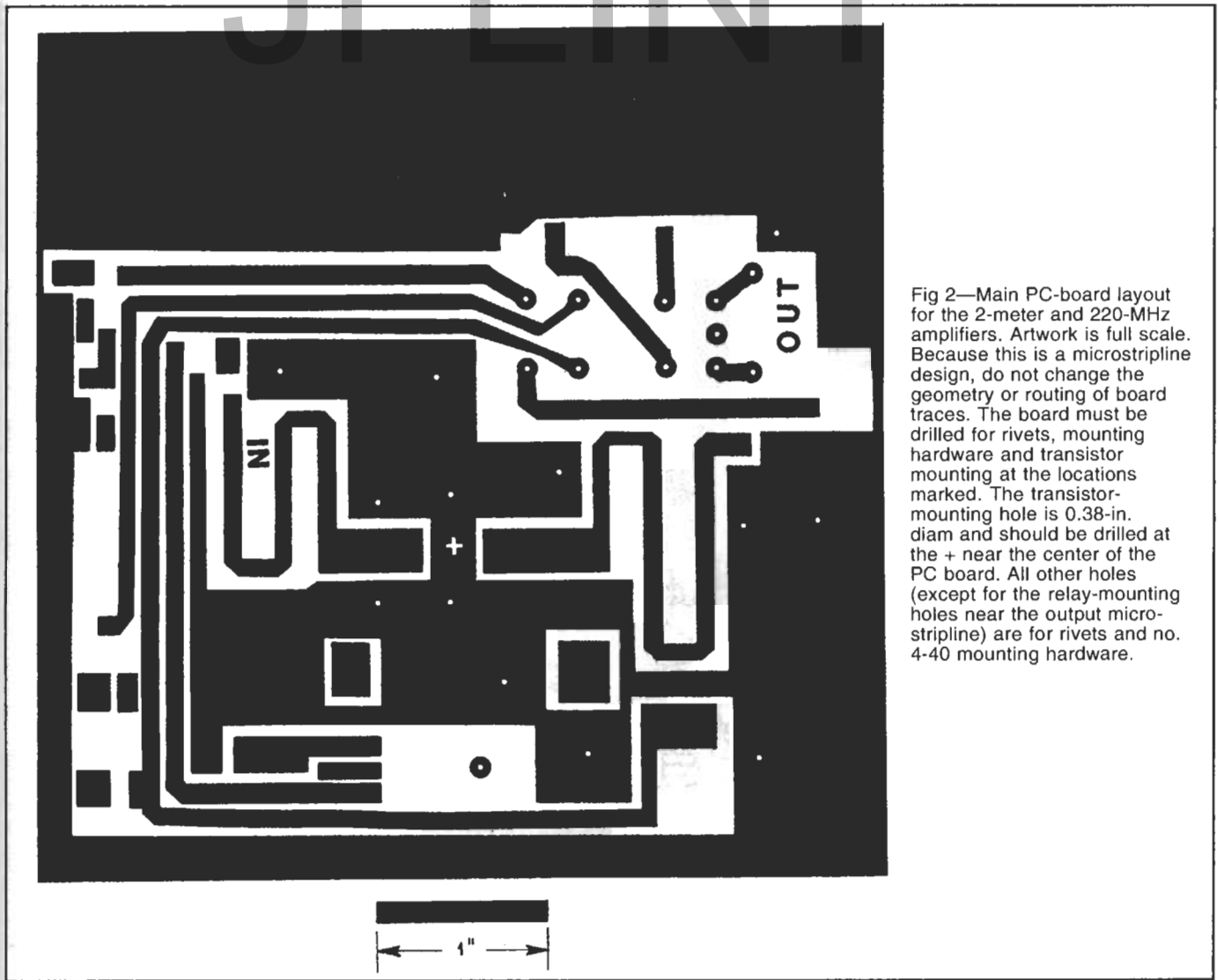

Fig 2—Main PC-board layout for the 2-meter and 220-MHz amplifiers. Artwork is full scale. Because this is a microstripline design, do not change the geometry or routing of board traces. The board must be drilled for rivets, mounting hardware and transistor mounting at the locations marked. The transistor-mounting hole is 0.38-in. diam and should be drilled at the + near the center of the PC board. All other holes (except for the relay-mounting holes near the output microstripline) are for rivets and no. 4-40 mounting hardware.

circuit used in these amplifiers.

TR switching is accomplished by an RF sensing circuit. A small amount of RF is sampled by C3 and rectified by D1 and D2, which turns on keying transistor Q2. Q2 pulls in K1, which switches the amplifier into the line.

When S1 is in the SSB position, a short drop-out delay is added in the RF-sensed-keying circuit to keep the amplifier keyed during brief pauses in speech. This delay is adjustable by varying R3. In the FM position, no delay is needed. S1 does not change the class of operation of Q1—it merely switches in the delay circuit.

The switching relays are wired so the amplifier can remain in-line at all times, with or without the supply voltage connected. Applying the supply voltage allows you to use the amplifier and preamp. Without the supply voltage connected, all transmitted and received signals pass through the amplifier.

The spectral output of these amplifiers is quite good, but to ensure clean signals, I've added filters to the output of each unit. Although there isn't much extra room for

the filter components inside the amplifier cabinet, you can mount them on the back side of the PC board or in another small enclosure. The filters, shown in the title photo, are very simple to build and tune.

### Construction

Each amplifier consists of two PC boards: the power-amplifier board and the preamp board (if used). After the PC boards are etched, holes are drilled with a no. 50 bit for installation of tinned grounding rivets at all RF and de grounds (see Fig 2).<sup>2</sup> Install the rivets on the board as follows: After inserting the rivets, flare the inserted end with an awl. Next, flatten the rivet by tapping it lightly with a hammer, using an anvil or other solid surface under the PC board as a support. Solder the rivets on both sides of the PC board. Alternatively, pieces of wire can be soldered through the board—but because the wires will not be flush with the board, mounting the heat sink may be difficult.

Drill the holes for Q1 and the board-mounting screws as indicated in Fig 2. No holes are needed for component mounting

because all parts are mounted on the trace side of the PC board. All the components except the preamp board are mounted next. (The preamp board is mounted after the amplifier has been tested, to prevent possible damage to the preamplifier.) Connect a piece of miniature 50-Ω Teflon® or RG-58 coaxial cable between K1 and the amplifier-input microstripline (see Fig 3).

After drilling or milling holes for Q1 in a suitable heat sink (see Fig 4), tap the mounting holes in the heat sink for no. 4-40 hardware, and mount the PC board to the heat sink. Trim the four leads of Q1 to about half their original length to make mounting easier.

Q1 can be mounted in one of several ways. The distance between the underside of the leads of Q1 and the heat-sink mounting area of Q1 is larger than the thickness of 1/16-in. G-10 board material. Because of this, the heat sink must be milled (see Fig 4), or small pieces of copper or brass must be soldered under each lead of Q1 to make up the difference in height. Alternatively, a second piece of G-10 material can be cut to the same size as the amplifier PC board

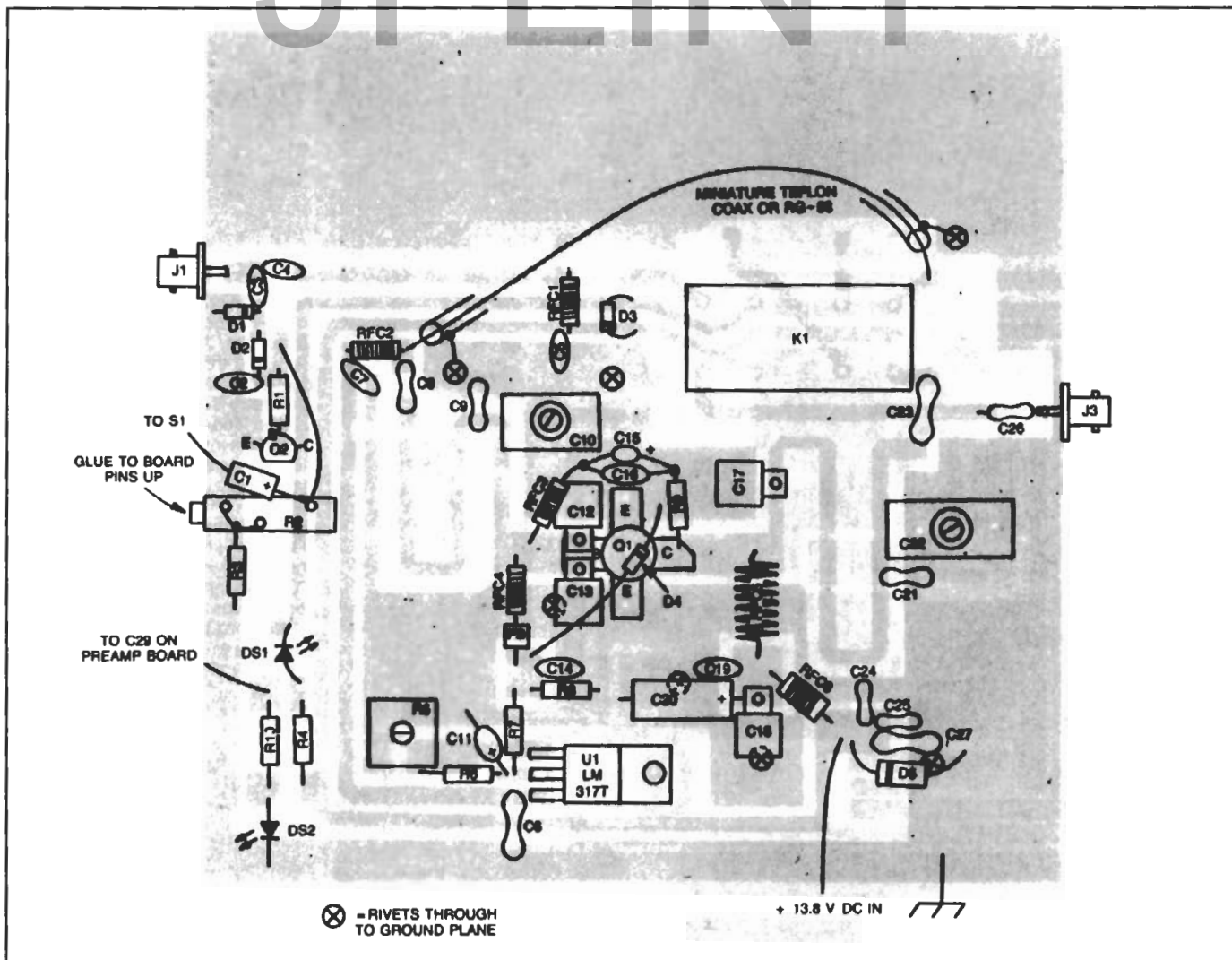

Fig 3—Parts-placement diagram for the VHF amplifiers. All parts are mounted on the foil-trace side of the PC board. The power transistor mounting stud passes through the board and into the heat sink. D5 is epoxied to the ceramic cap of Q1. R2 (10-turn potentiometer) is epoxied to the PC board as indicated, with the pins facing up.

and used as a spacer between the PC board and heat sink.

Be careful not to crack the body of Q1 where the leads of the device meet it—this can release beryllium-oxide (BeO) dust, which is lethal. The leads of the transistor can be bent down slightly to the PC board without affecting RF performance, but never force them in the opposite direction after the transistor has been tightened to the heat sink. Mount the transistor to the heat sink first, then solder its leads to the board, and not vice versa. Use thermally conductive compound between Q1's mounting surface and the heat sink.

Cut a piece of hobby-store sheet brass about as wide as the bias regulator IC and twice as long as the body of the device. This will be a heat sink for the bias regulator. When mounting the regulator IC, use thermally conductive compound between it and the brass sheet, and between the brass and the main PC board. After tightening the IC hardware to the PC board, bend the brass sheet in a U shape over the IC, leaving enough clearance for heat to escape between

the IC and the brass heat sink. This heatsink arrangement can be seen near the bottom center of each amplifier in the lead photograph.

### The Preamp Circuit

The high gain and low noise figure (NF) of a GaAsFET preamp are not necessary in amplifiers in this power class. I designed the preamp circuit (Fig 5) to use an inexpensive U310 FET. It has more than enough gain to overcome the losses of the amplifier switching circuits and the feed line to the amplifier. The preamp has more than 12 dB gain and noise figure of about 2 dB.

When S2 is closed, K2 closes, activating the preamplifier by applying the dc supply voltage to the drain circuit of Q3 and to the preamp ON LED, DS2. In the transmit mode, K1 switches off the supply voltage to K2, allowing K2 to drop out.

The preamp circuit is optional, and I didn't include it on the main amplifier PC board. If you're not going to build the preamp, solder foil-tape or wire jumpers between the two points on the main ampli-

fier PC board where the preamp connects during assembly.

### Building the Preamp

The schematic of the preamplifier circuit is shown in Fig 5. As mentioned earlier, although some component values differ between the 2-meter and 220-MHz versions, the two are essentially the same in all other respects. Components that have different values for the two versions are marked with asterisks on the schematic and the parts list. Unlike the main amplifier PC board, most preamp components are mounted through the board and soldered on the bottom side. The PC-board layout and parts-placement diagrams are shown in Figs 6 and 7, respectively.

As with most FET VHF preamplifiers, a shield is necessary between the input inductor and the active device. Solder a piece of scrap brass sheet to the ground foil between these circuit elements. (This preamp shield can be seen in the right-hand amplifier in the lead photo, just behind L1.)

After building the preamplifier, tune it

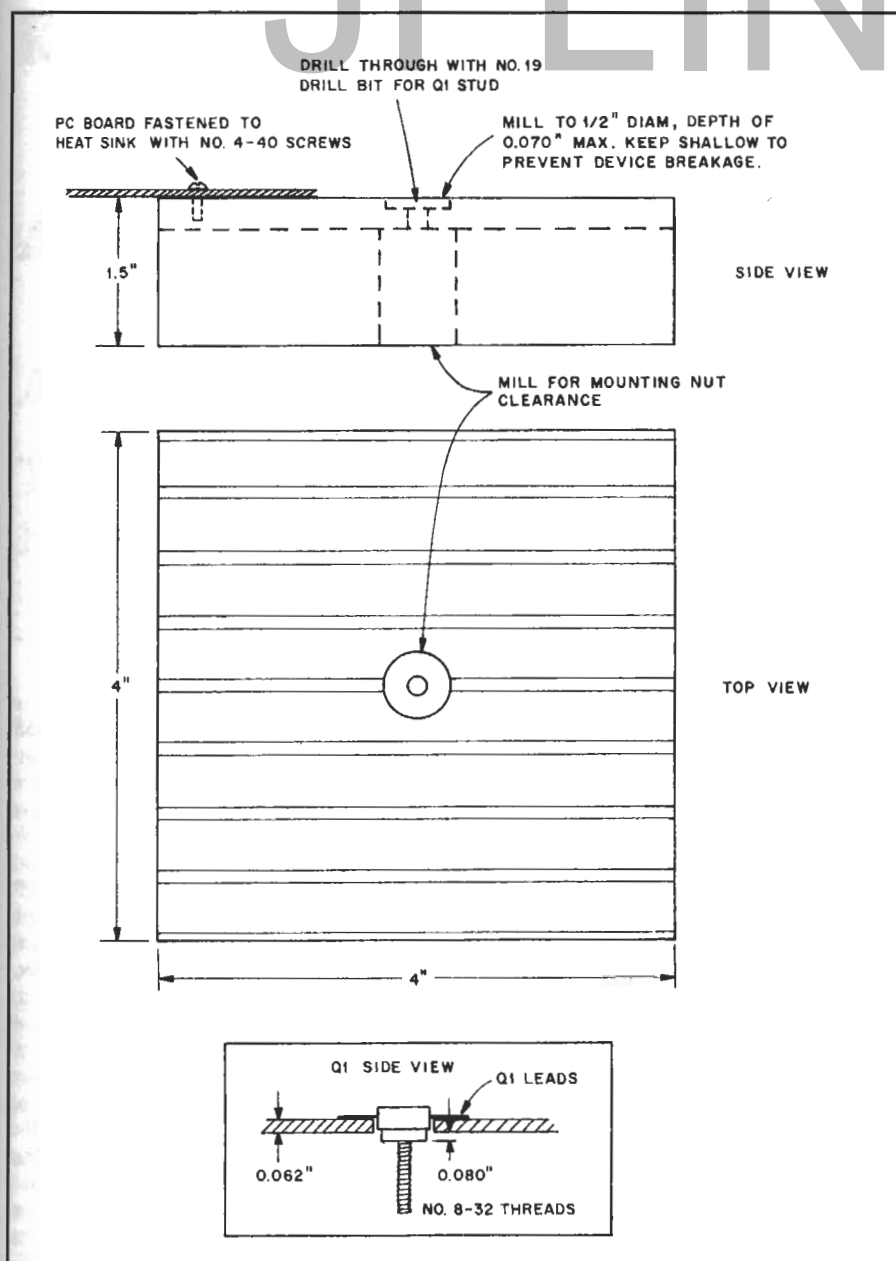

Fig 4—Heat-sink drilling dimensions for the VHF amplifiers. Overall heat-sink size isn't critical, but should be close to the dimensions shown. As an alternative to milling the heat sink to accept Q1, a piece of 1/16-in. double-sided PC-board material can be used as a shim. Be careful not to stress the transistor lead-to-body connections during mounting.

for maximum gain with a signal generator or an on-the-air signal. If one is available to you, use a noise-figure meter and tune the preamp for best NF.

### Building the Output Filters

I built the output filters for each amplifier on scraps of PC-board material. The construction is shown in the title photo. After building the filters, it's a good idea to use some silicone sealant on the coil (especially in the 2-meter filter) to hold the coil turns in place. Install the filter in a suitable enclosure, or in the amplifier cabinet.

To tune the filters, you'll need a receiver capable of receiving the second harmonic of the fundamental (288 MHz for the 2-meter filter, and 440 MHz for the 220-MHz filter), and a signal generator or an on-the-

air signal. Connect the filter between the antenna (or signal generator) and the receiver, and tune C36 for minimum second-harmonic signal level.

### Enclosures

I used the main amplifier PC board as the top cover for the unit (with the heat sink mounted on it). I made the sides and bottom cover of the enclosure from PC-board material. The side walls are soldered to the amplifier board, and the bottom cover is attached to the side walls with small brackets (also made of PC-board material) soldered to the bottom cover. Alternatively, the amplifier can be mounted in an aluminum enclosure.

Although I used BNC connectors for RF input and output, N connectors can also be

used. Make the connections from the input connector to the PC board with a piece of no. 16 wire or a 1/8-inch-wide strip of brass to the input microstripline. At the output, connect dc-blocking capacitor C26 between the microstripline and the antenna connector. Check the board for proper component placement and good solder joints, and get ready to tune up the amplifier!

### Amplifier Tune-Up

As with the amplifier-circuit design and description, the tune-up procedure is very similar for both. The only difference is the exciter you use. Here's how to tune either version.

Disconnect RFC4 from the base of Q1. Connect a voltmeter to the free end of RFC4. Apply 13.8 V dc to the amplifier supply voltage leads. Using the voltmeter, verify that R5 is mounted so that output of U1 increases with clockwise rotation of R5. Turn R5 fully counterclockwise (minimum U1 output voltage). Reconnect RFC4.

Set the quiescent (no-drive) current to Q1 as follows: Disconnect one end of RFC6 and connect an ammeter in series with it. Apply 13.8 V dc to the amplifier through a 5-A fuse. Turn the preamp off. Do not apply RF drive during this adjustment. Using a clip lead, ground the collector of Q2. This should actuate K1. Check the TX LED, DS1, for operation. (If K1 actuates and the TX LED does not light, the LED may be installed in reverse.) Slowly adjust R5 for an idling current (through RFC6) of 75 to 100 mA. The amplifier should be stable; instabilities are indicated by erratic variation of Q1's quiescent current as R5 is adjusted.

Disconnect the ground lead of Q2. Q1's collector current should drop to zero. If the collector current does not drop to zero, the amplifier is unstable. If all is well, remove the ammeter and reconnect RFC6. If the amplifier is unstable, check all bypass capacitors and solder connections.

Apply about 100 mW of drive to the amplifier and check that the COR and delay circuits work properly. Adjust C10 and C22 for maximum power output. Increase drive power and retune for maximum output. After final assembly, tune the amplifier for the desired frequency and power level.

### Final Assembly

The preamplifier board can now be installed on the main PC board. Mount the preamp on its edge (refer to the title photo and Fig 3) and solder the input and output microstriplines in place. Solder the ground foil of the preamp board to the ground foil of the main board in a few places to support the preamp board. Connect S2 and DS2 to the preamp board with hook-up wire (see Figs 5 and 6 for connection points). Apply power and check for proper operation of S2, K2 and DS2.

The enclosure can now be painted if you wish. Use masking tape to cover the connectors and heat sink. (Mount the LEDs and switches after painting.) You may want to

Fig 5—Schematic of the preamplifier circuit. K2 is identical to K1 on the main amplifier board. S2 and DS2 are mounted on the front panel of the amplifier. In the parts list below, values for 220-MHz version are given in parentheses where they differ from those of the 2-meter version.

- C28, C29, C33—0.01- $\mu$ F disc.
- C30—2-pF silver mica.
- C31, C32—20-pF trimmer.
- DS2—LED.
- D6—1 N4001.
- L1, L2—5 turns (4 turns) no. 16 enam, 0.3-in. ID.
- K2—Omron LZN2O3-UA-DC12 DPDT relay.
- Q3—U310 FET.
- R10—1.5-k $\Omega$ , 1/4 W.
- R11—91- $\Omega$ , 1/4 W.
- RFC7, RFC8—0.47- $\mu$ H molded choke.
- S2—Miniature SPDT toggle.

*Miscellaneous*  
1 x 1/2-in. strip of thin sheet brass

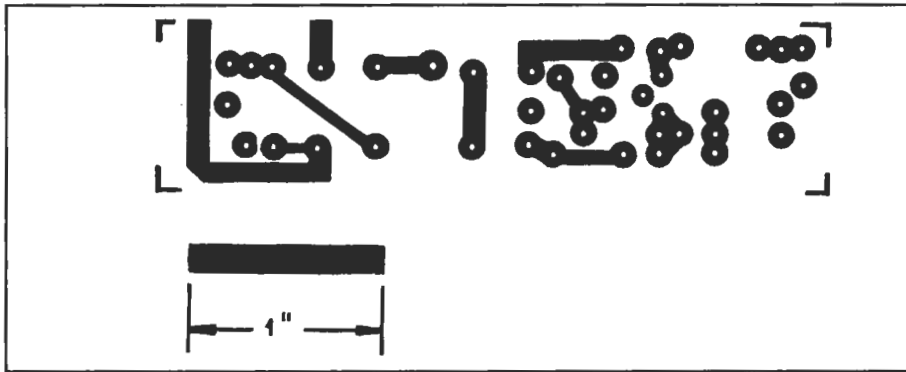
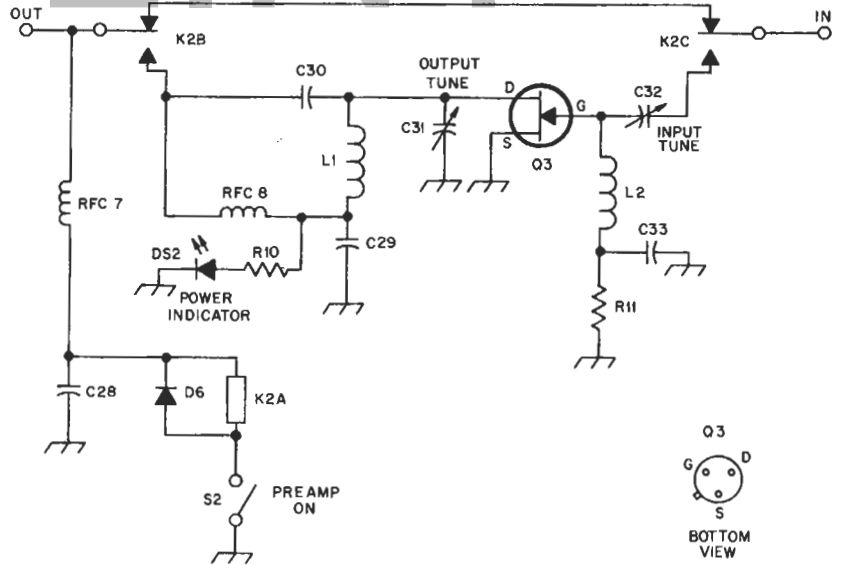

Fig 6—Full-size PC-board layout for the preamplifier circuit. Unlike the power-amplifier PC board, most of the preamplifier components are mounted on the non-trace side of the board.

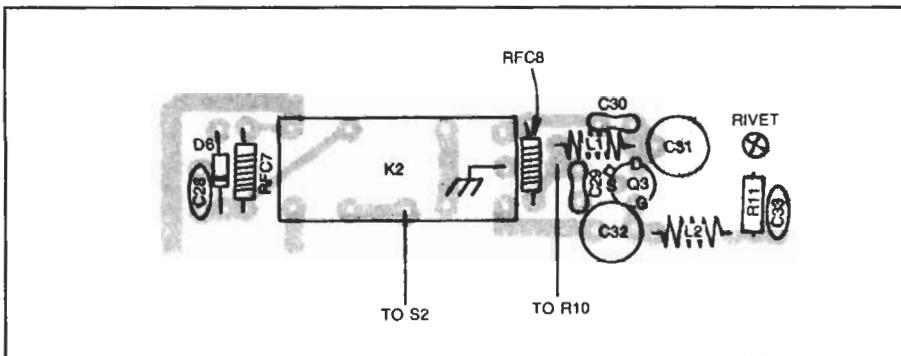

Fig 7—Parts-placement diagram for the VHF preamplifier. Mount all components on the unetched ground-plane side except for C30 and C31. Use a drill to clear the foil away from all mounting holes on the ground-plane side of the board (except for through-board ground connections). Solder all ground connections on both sides of the PC board (see text for rivet-installation instructions). Solder a brass-strip shield to the ground foil between L1 and Q3 on the component side of the PC board.

Limit the amplifier power output to 25 W during linear operation. All SSB amplifiers have a rated linear power output that should not be exceeded, even though the amplifier may be driven above that level. To keep your signal clean, do not overdrive any amplifier. For excitors with fixed power outputs that would overdrive the amplifier, use the loss of a length of RG-58, or a discrete attenuator, between the radio and the amplifier to prevent overdrive. The gain of the preamplifier (if used) will overcome the attenuator or cable loss during receiving.

When using any amplifier or transverter in the shack, it is a good practice to "hard key" it. Hard keying is simply forcing the amplifier or transverter into the transmit mode with a switch closure or an applied voltage. To do this, run a keying line from the exciter to the amplifier. (Ground the collector of Q2 to hard key these amplifiers.) I added a phono jack to the 220-MHz amplifier to facilitate hard keying. If a positive voltage is used for keying, a 2N2222 transistor inverter can be used between the transceiver and the collector of Q2 (see the inset in Fig 1).

### Summary

These amplifiers have served me well in the car and at home. After building one of these amplifiers, you'll probably find what I did: They're so handy to have around, and so easy to build, that you can't build just one!

### Notes

- 1Thomson Components/Mostek Corp, Semiconductor Division, Commerce Dr, Montgomeryville, PA 18966. Thomson transistors are available through RF Gain, Ltd, 100 Merrick Rd, Rockville Center, NY 11570, tel 516-536-8868 or 800-645-2322.
- 2The following parts are available from Frontier Microwave, RD 1 Box 467, Ottsville, PA 18942: 100+ tinned rivets: \$2; relays (K1, K2): 2 for \$8. Prices include shipping. The ARRL and QST in no way warrant this offer.

add stick-on rubber feet to the bottom cover to keep it from sliding around and being scratched.

### Amplifier Operation

The 2-meter amplifier works very well

with my Kenwood TH-21AT hand-held and ICOM IC-202S SSB/CW transceiver. I use one in my shack and one mobile—both at more than 25 W output. I drive the 220-MHz version of the amplifier with an ICOM IC-3AT (in its high-power mode).

# A High-Power 2-Meter Amplifier Using the New 3CX800A7

Tired of hearing exotic DX on 2 meters but not being able to work it? Build this amplifier, and you'll transform your pip-squeak signal into a real rockcrusher.

The 3CX800A7 triode recently announced by Varian EIMAC has a plate dissipation rating of 800 W and modest cooling requirements. Its oxide cathode gives high emission with only 20 W of heater power. With full ratings up to 350 MHz, this tube is a scaled-up version of the 8874 — a proven performer in amateur and commercial gear.

The amplifier described here is based on a design presented by Raymond F. Rinaudo, W6ZO, in January 1972 QST. Most of the changes in the new amplifier (Fig. 1) are designed to accommodate the larger size of the 3CX800A7 and its attendant higher capacitances and currents. A plate-current meter is not included because my station power supply is already well metered. However, there is room on the front panel of the amplifier for a plate-current meter if another builder wishes to add one. Other changes to Rinaudo's design are minor.

## Construction

The amplifier chassis is mounted on a standard 19-inch wide, 5/4-inch-high aluminum rack panel (Bud No. SFA-1833).<sup>1</sup> A 5 × 13 × 3-inch aluminum chassis (Bud No. AC-422) is spaced 1 3/4 inches behind the panel by two aluminum end brackets. A 3 1/2 × 4 1/2 × 1-inch aluminum chassis (Bud No. AC-1402) houses the input circuitry and is mounted on the larger chassis between it and the front panel. The right-hand end bracket has a large lip on the rear for mounting the heater transformer and connectors. Fig. 2 shows mechanical details of the chassis and end brackets. The cabinet chosen is a lightweight aluminum unit made by TenTec (No. 19-0525).

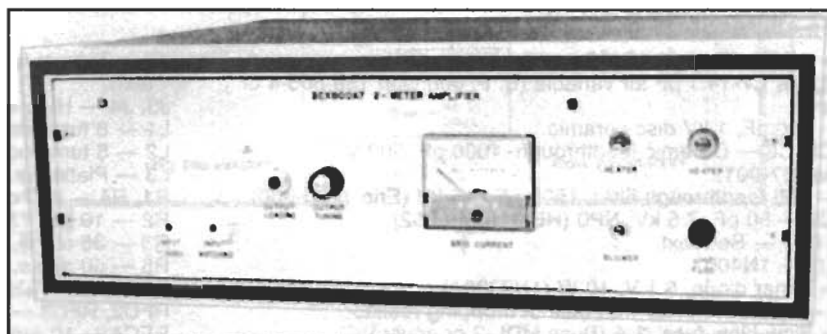

## Input Circuit

In the cathode-driven configuration, the input impedance of the 3CX800A7 appears as a nominal capacitance of 26.5 pF in parallel with a resistive component that varies with operating conditions but is typically about 49 ohms. The computerdesigned input circuit of this amplifier operates at a loaded Q of about 2.1. It can be set anywhere in the 2-meter band for a VSWR of less than 1.3:1. C1 and C2 are predominantly matching and tuning controls, respectively; there is some interaction between them, however. When the input is tuned at 144.5 MHz, the input VSWR will be less than 1.4:1 from 144 to 145 MHz.

The tube socket is an EIMAC SK-1900 or a Johnson part No. 124-311-100. Its center is mounted 2 inches from the end of the input box, adjacent to the mounting bracket. The tube pins and input circuit are cooled by a small amount of air admitted to the input box from the pressurized output box. Three holes, made with a no. 50 drill, provide adequate flow. These holes are spaced in a close triangle and are located

diagonally across from the variable capacitors. Air exhausts through the tuning holes. Fig. 3 shows details of the input circuitry.

The heater circuit includes two chokes, feedthrough capacitors, the filament transformer, a voltage-dropping resistor and a switch. The chokes are wound with a turn-to-turn spacing of about one-half the wire diameter. They are self-resonant (parallel resonant) just above the 2-meter band. Nominal heater voltage for the 3CX800A7 is 13.5 V. The closest available commercial transformer has a 14.0-V secondary, so R3 is used in the primary. Switching is set up so that the blower must be on before the heater can be activated. Conversely, this arrangement allows the blower to be left on after switching off the heater—a highly recommended practice.

Cathode bias is provided by a 5.1-V Zener diode, D3. R1 prevents the cathode voltage from soaring if the Zener fails. F2 will blow if excessive cathode current is drawn. R2 nearly cuts off plate current on receive. Because the grid is at dc ground, the negative supply lead must be kept above

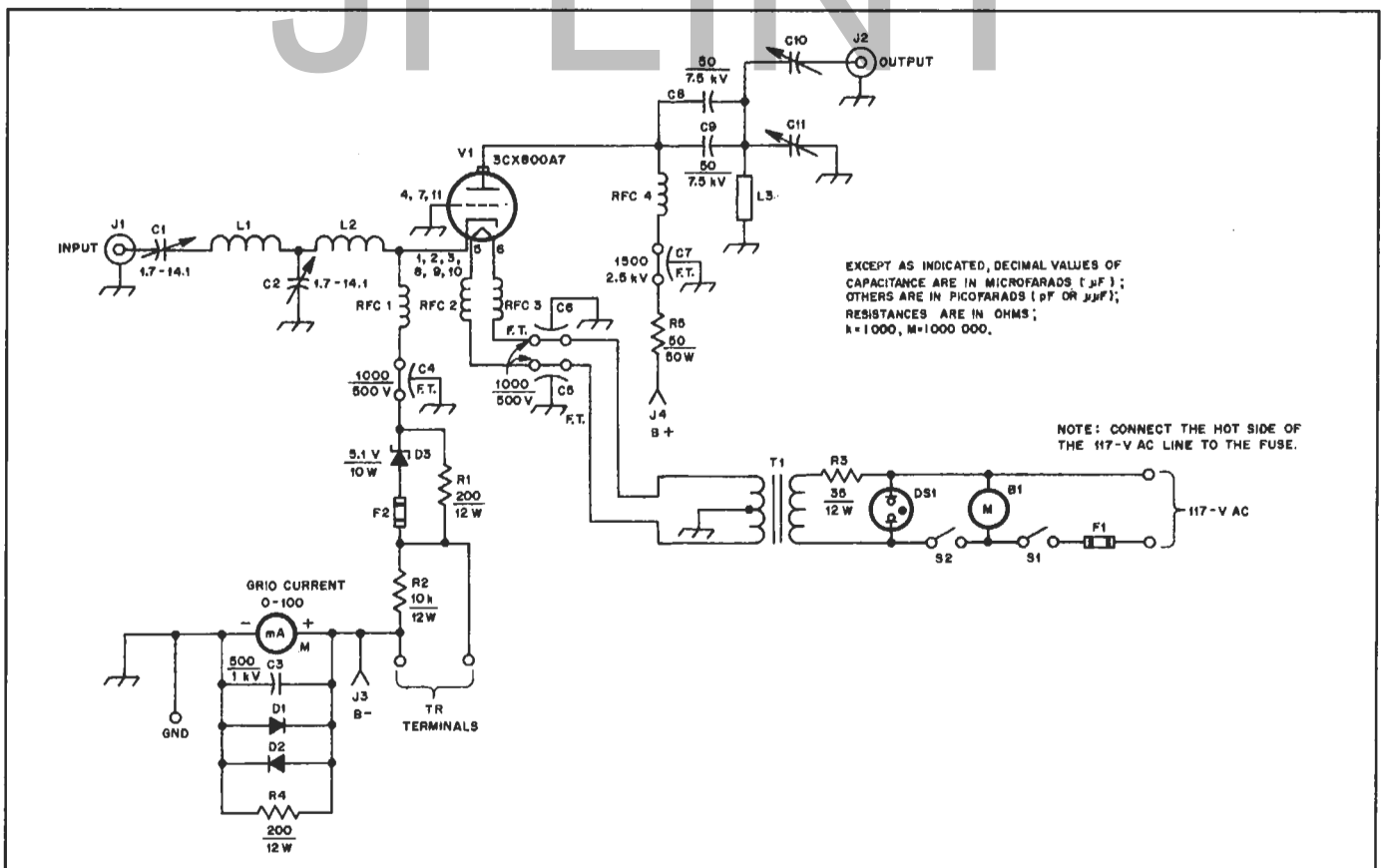

Fig. 1 — Schematic diagram of the 3CX800A7 amplifier.

- B1 — Blower (Dayton 4C012 or equiv.); see text.
- C1, C2 — 1.7-14.1 pF air variable (E. F. Johnson 189-505-4 or equiv.).
- C3 — 500 pF, 1 kV disc ceramic.
- C4, C5, C6 — Ceramic feedthrough, 1000 pF, 500 V (Erie 357-001).
- C7 — EMI feedthrough filter, 1500 pF, 2.5 kV (Erie 1280-060).
- C8, C9 — 50 pF, 7.5 kV, NPO (HEC HT-50 852).
- C10, C11 — See text.
- D1, D2 — 1N4001.
- D3 — Zener diode, 5.1 V, 10 W (1N3996A).
- DS1 — NE51 in holder with built-in dropping resistor.
- F1 — Slow-blow fuse, 2 A (Buss MDL-2 or equiv.).
- F2 — 1.5 A fuse (Buss AGC 1 $\frac{1}{2}$  or equiv.).
- J1 — BNC bulkhead feedthrough connector (UG-492 A/U).

- J2 — Type N female connector (part of C10 assembly — see text).
- J3, J4 — High-voltage connector (Millen 37001 or equiv.).
- L1 — 8 turns no. 16 tinned wire,  $\frac{3}{8}$ -in ID,  $1\frac{1}{16}$  in long.
- L2 — 6 turns no. 16 tinned wire,  $\frac{3}{8}$ -in ID,  $1\frac{1}{16}$  in long.
- L3 — Plate line,  $1\frac{5}{16}$  in wide,  $8\frac{3}{16}$  in long. See text and Fig. 4.
- R1, R4 — 200 ohms, 12 W.
- R2 — 10 k $\Omega$ , 12 W.
- R3 — 35 ohms, 12 W.
- R5 — 50 ohms, 50 W.
- RFC1 — 1.0  $\mu\text{H}$  choke, 300 mA (Miller 4602).
- RFC2, RFC3 — 11 turns no. 20 HF wire on  $\frac{3}{8}$ -in Noryl rod.
- RFC4 — 10 turns no. 16 tinned wire,  $\frac{1}{2}$ -in ID,  $1\frac{3}{16}$  in long.
- T1 — Filament transformer, 14.0-V, 2-A secondary (Triad F-215X or equiv.).

ground for grid-current metering by M1. R4 keeps the negative side of the plate supply from rising if M1, D1 and D2 all open up. D1, D2 and C3 protect the meter from transients and RF voltages.

### Output Circuit

The output tank circuit is a silver-plated quarter-wave strip line (Fig. 4) foreshortened by the tube, loading and tuning capacitances at, and near, its open end. It operates at a loaded Q of approximately 20. The silver-plated anode collet (Fig. 4) is made of 0.062-inch-thick brass sheet with Tech-Etch 134B finger stock soldered on the inside. It is supported by two Teflon® standoffs  $\frac{1}{2}$ -inch in diameter and 1 inch long. At the far end of the line, a silver-plated shorting block contacts the chassis and the strip line. This block (Fig. 4) is made from  $\frac{7}{16}$ -inch-thick brass  $1\frac{15}{16}$  inches wide and 1 inch high. EIMAC

CF-800 finger stock is screwed and then soldered on both top and bottom. The chassis and stripline are both slotted to allow  $\frac{3}{16}$  inch of shorting-block travel to set the tuning range of the capacitive-tuning paddle. A 1-inch-long Teflon standoff supports the center of the line.

The tuning (C11) and loading (C10) paddles are  $1\frac{3}{16}$ -inch-diameter discs made from silver-plated,  $\frac{1}{16}$ -inch-thick brass. They are spaced  $1\frac{3}{8}$  inches center-to-center. The output loading paddle is nearest the tube, and its center is  $1\frac{13}{16}$  inches from the tube cooler surface. Spacing between the paddle and line during operation is about 0.135 inch. The output tuning boss, EIMAC part No. 720362, is tapped for a  $\frac{1}{4}$ -28 threaded rod. The output loading control and output connector are two separate EIMAC assemblies combined into one unit. They are available from EIMAC as Support Assembly No. 720361 and Sliding Probe

Assembly No. 720407. For this amplifier, the outer conductor was lengthened to reach the front panel. The grid collet is also available from EIMAC as part No. 720359.

In addition to RFC4 and feedthrough capacitor C7, an energy-absorbing resistor (R5) is wired in series with the dc plate supply. This resistor will protect the tube and power supply in the event of a high-voltage arc. It provides necessary protection while dissipating only 12.5 W at 500-mA dc plate current.

### Cooling

The blower specified provides a measured 25 CFM airflow through the output box and tube cooler at 0.42 inch of water-column static pressure. This amount of cooling is sufficient for 800 W of plate dissipation at sea level with inlet air temperatures up to 35° C. It is adequate for the same dissipation at 5000 feet of altitude with

inlet-air temperatures up to 25° C.

Not evident from the photographs is the care taken to separate outgoing hot air from incoming cool air. This is accomplished by the addition of a simple dividing wall inside the cabinet running from the rear chassis cover of the output box to the rear of the cabinet. The material used is rigid fiberglass insulation — the kind you cut with a saw. It provides a measure of blower-noise suppression in addition to assuring cool inlet air.

Hot air leaving the anode cooler is directed to a homemade "honeycomb" RFI filter through a chimney made from rolled-up Teflon sheet. The filter is made of brass tubing and sheet with the honeycomb material soldered in place. See Fig. 5 for construction details. This filter acts as a waveguide-beyond-cutoff having high attenuation at 144 MHz.

The equation for calculating attenuation by this type of filter is

$$A_a = 32 D/d \quad (\text{Eq. 1})$$

where  $A_a$  = aperture attenuation (dB),  $D$  = length of pipe, and  $d$  = inside diameter of pipe. In this case, the "pipe" is each cell of the honeycomb. The basic material for the honeycomb is cadmium-plated brass heat-radiator core.<sup>2</sup> Each hexagonal-shaped cell has a width between flat sides (diameter) of 0.100 inch. The material is 1/2-inch thick. Plugging these values into the equation yields an  $A_a$  of 160 dB—more than enough! From a practical standpoint, it is usually sufficient to make cell length at least three times the nominal cell diameter.

### Tune-up

Initial work may be done with a dip meter, particularly on the output circuit. With the tube in place, but with no voltages applied, the shorting block on the end of the plate line should be set to give a paddle-tuning range that straddles the desired operating frequency. Bear in mind that when the tube is "hot," the resonant frequency will be somewhat lower than it is without electron flow.

The input-tuning capacitor can be dip-meter resonated with the matching capacitor set at one-half mesh for a start. Further work here must be done "hot" with a VSWR measuring device on the input.

Set the initial spacing between the output paddle and the plate line to 1/8-inch. Connect the output to a 50-ohm dummy load capable of handling at least 700W at 144 MHz through an accurate VHF wattmeter, such as a Bird model 43. Connect a driver capable of delivering about 20 W to the input through a VSWR-measuring device.

The heater of the 3CX800A7 should be run for at least three minutes before applying plate voltage. After the warm-up, short the TR terminals and apply about 1000 V to the plate. This should result in a small amount of idling plate current. Next, apply enough drive to produce a rise in plate current, and adjust the plate tuning for a peak

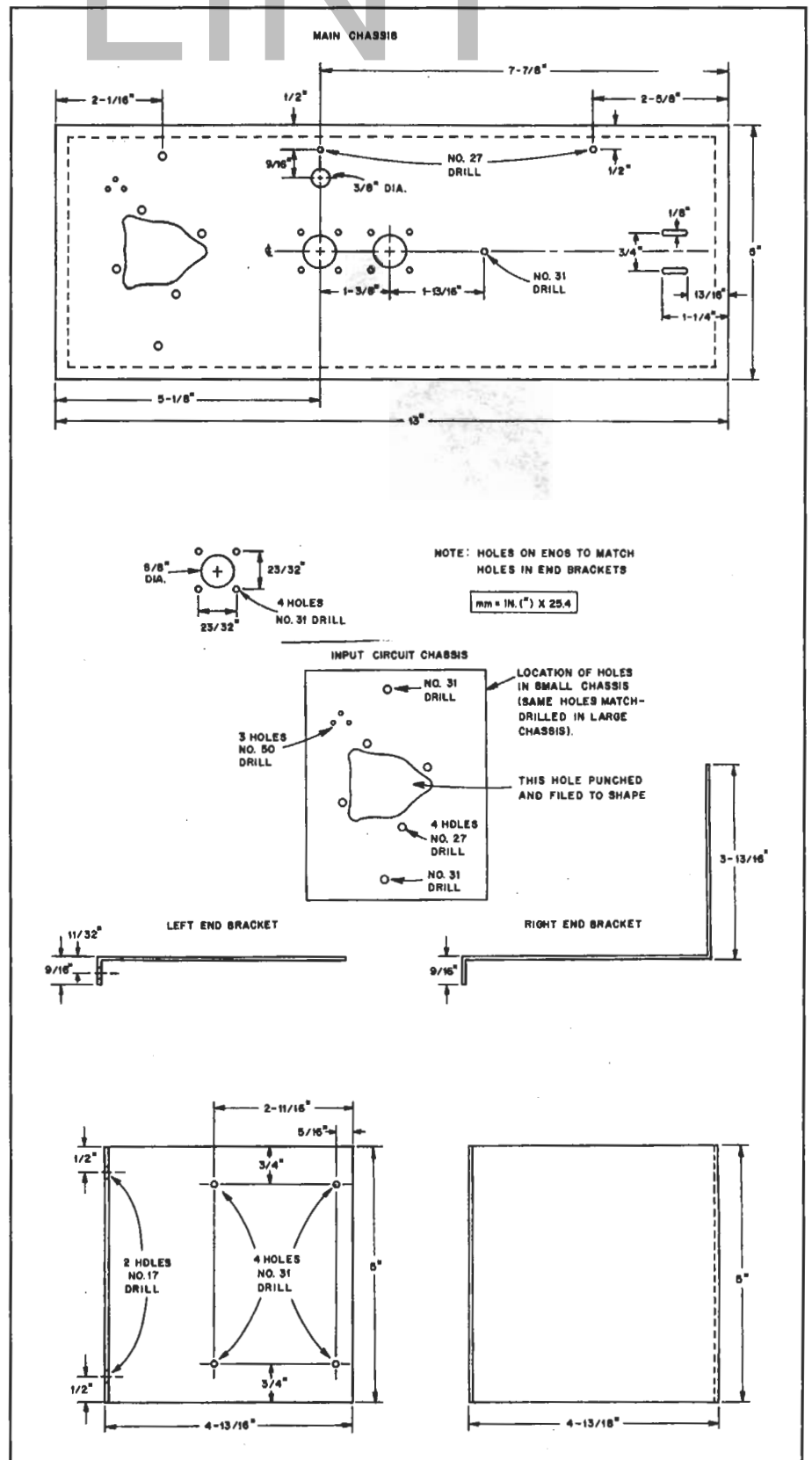

Fig 2—Mechanical details of the chassis and end brackets. The end brackets are made from 0.032-in aluminum, 5052 alloy or softer.

in output power. Now tune and match the input circuit for minimum input VSWR. Next, adjust the output loading paddle for maximum power output while keeping the plate current dipped with the plate tuning

paddle. Apply full plate voltage and higher drive power, and then repeat the output tuning and loading controls. Touch up the input tuning and matching, and the amplifier is ready for service.



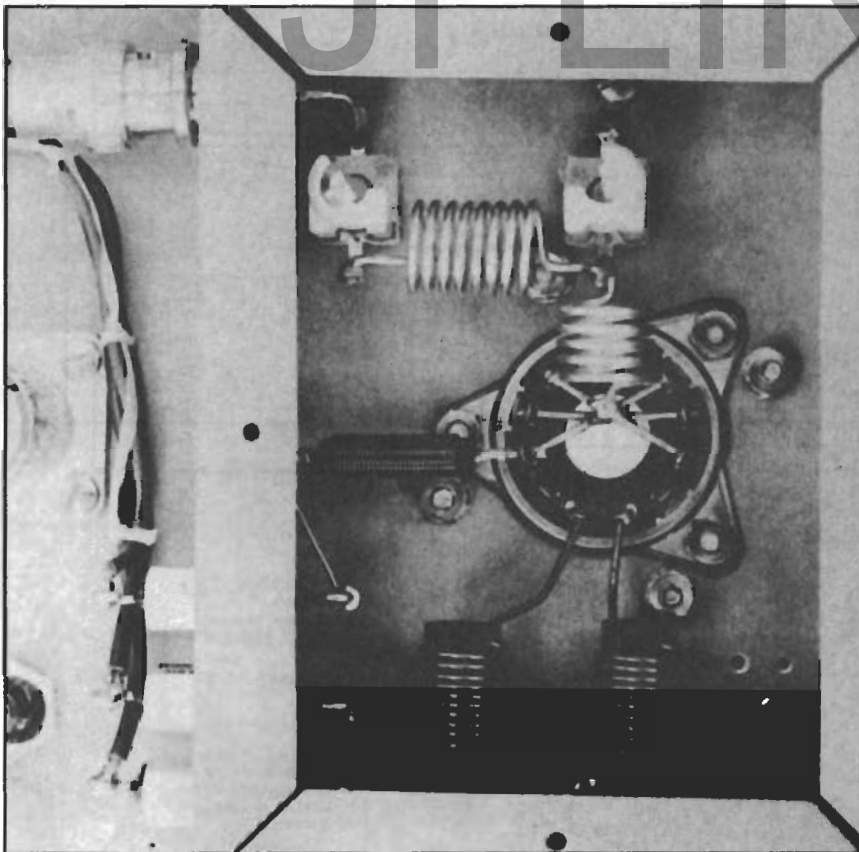

Fig 3—Close-up of the input circuitry and tube-socket wiring. Keep all leads as short as possible.

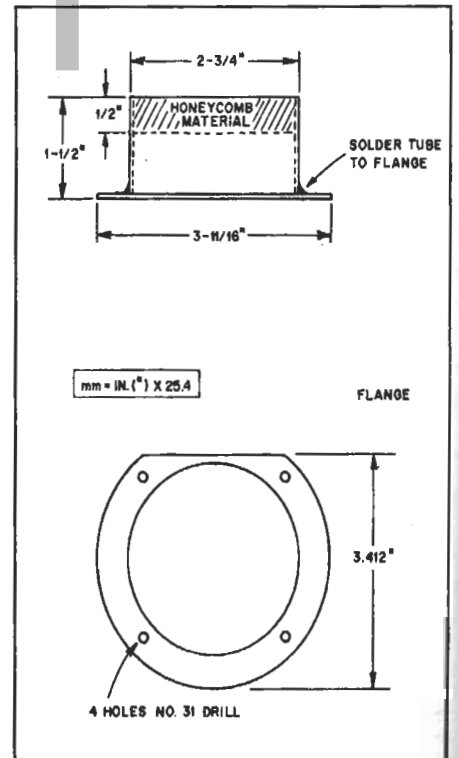

Fig 5—Mechanical details of the exhaust air RFI filter. The honeycomb material is soldered inside a 2<sup>3</sup>/<sub>4</sub>-in OD, 0.065-in wall brass tube. The flange, which bolts to the chassis, is made from 0.125-in-thick brass sheet.

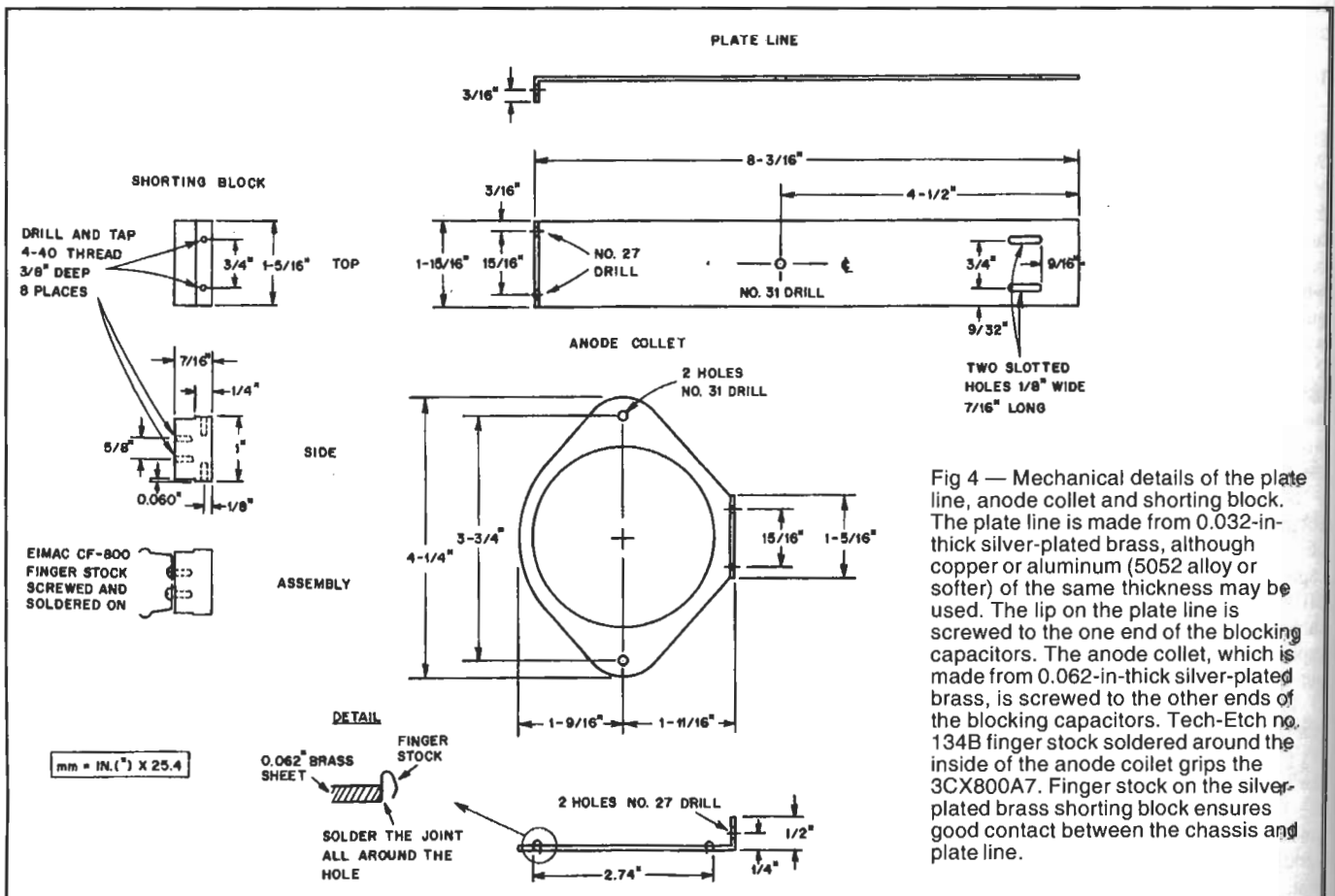

Fig 4—Mechanical details of the plate line, anode collet and shorting block. The plate line is made from 0.032-in-thick silver-plated brass, although copper or aluminum (5052 alloy or softer) of the same thickness may be used. The lip on the plate line is screwed to the one end of the blocking capacitors. The anode collet, which is made from 0.062-in-thick silver-plated brass, is screwed to the other ends of the blocking capacitors. Tech-Etch no. 134B finger stock soldered around the inside of the anode collet grips the 3CX800A7. Finger stock on the silver-plated brass shorting block ensures good contact between the chassis and plate line.

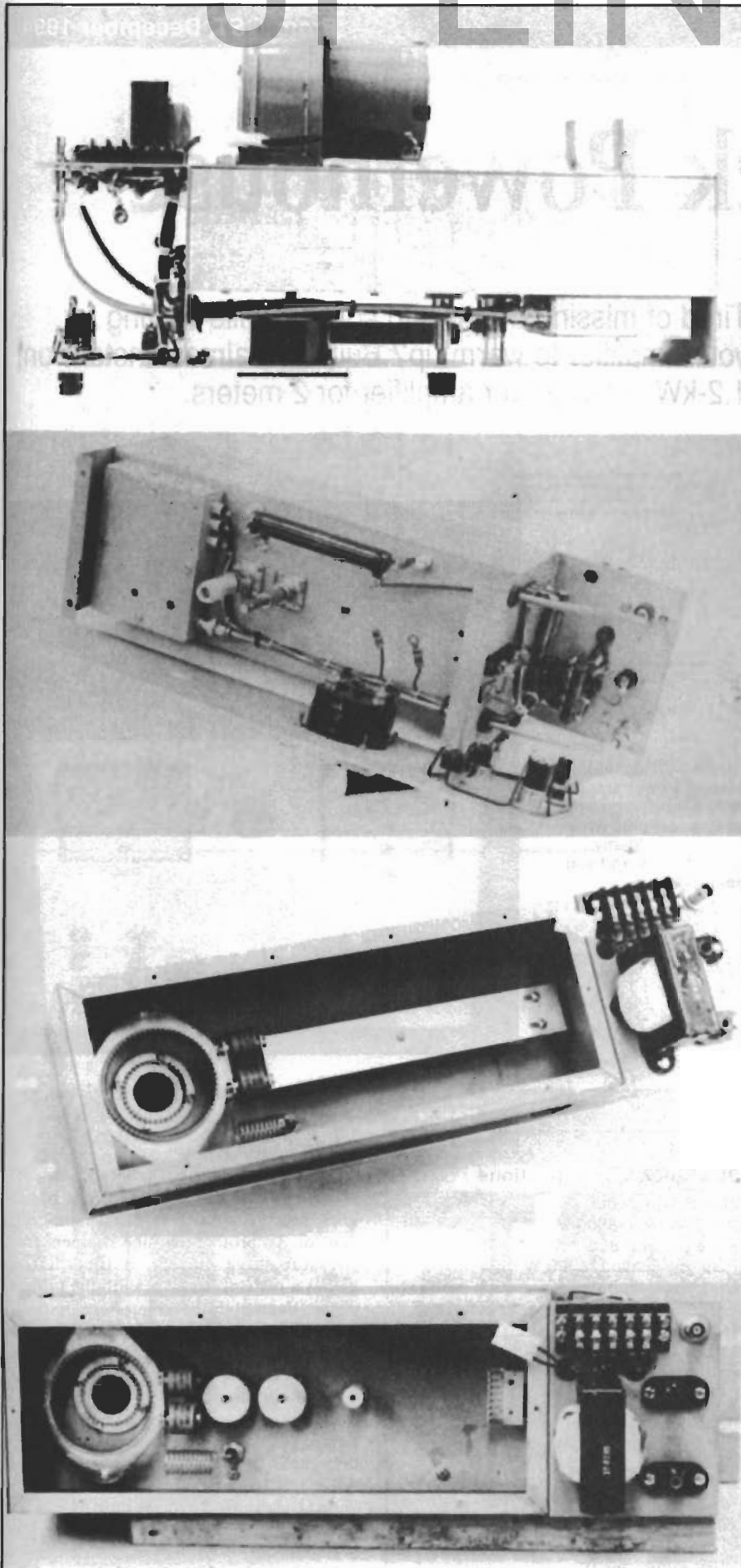

Fig 6—Various views of the completed 3CX800A7 amplifier.

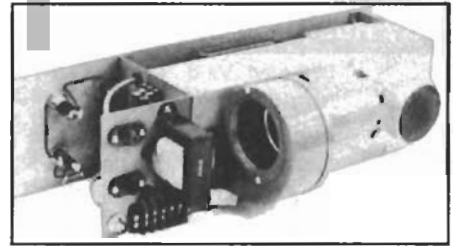

Fig 7—Rear view of the amplifier with the plate-compartment cover in place. Note the honeycomb RFI filter at the hot-air exhaust.

**Table 1**  
**Operating Conditions for the 3CX800A7 Amplifier**

Plate supply voltage	2200 V
Zero-signal plate current*	65 mA
Single-tone plate current	500 mA
Grid bias (Zener bias)	-5.1 V
Single-tone grid current*	40 mA
Driving power	18.5 W
Output power	707 W
Gain	15.8dB
Efficiency**	64%

\*Values may vary considerably from tube to tube.

\*\*Actual tube efficiency is about one percent higher because of power loss in the 50-ohm series resistor in the plate lead (R5).

A few words of caution are in order. Remember that the heater voltage must never be applied without the blower running, and that the heater must warm up at least three minutes before applying plate voltage. Never exceed 60-mA dc grid current, even during tune-up. Also, because of the relatively low grid dissipation of the 3CX800A7, RF drive must never be applied unless plate voltage is applied to the tube and a suitable load is connected to the output. Following these simple rules will substantially increase tube life and amplifier reliability.

### Typical Operating Conditions

With Zener-diode bias, the 3CX800A7 is best operated in Class AB2 for linear service. The data in Table 1 represent measured performance in linear service at 144 MHz. Complete data sheets are available from EIMAC. This amplifier is easily capable of conservative operation at 700-W output. Two of these tubes will run at the 1500-W output legal limit.

This amplifier uses straightforward construction techniques and is easily duplicated. Any builder will be rewarded with a great deal of satisfaction and a reliable amplifier.

### Notes

<sup>1</sup>mm = in x 25.4; m = ft x 0.3048.

<sup>2</sup>One source for the honeycomb radiator core material is Technit West Division, 320 North Nopal St., Santa Barbara, CA 93103.

# The Quick Powerhouse

Tired of missing a new grid square while waiting for your amplifier to warm up? Build this almost-instant-on, 1.2-kW linear power amplifier for 2 meters.

It's that typical, early summer afternoon, when, out of the blue comes co-channel interference to the low-band (channels 2 through 6) TV channels. Time to turn on the 2-meter receiver. Whoops! There's a sporadic-E opening, and stations are booming in from over 1000 miles away. Quickly, I hit the switches to warm up my linear amplifier. Time marches on, and now the amp is ready—only took 3 or 4 minutes. But that juicy, far-away clatter via sporadic E is gone! Woe is me!

Having had this happen more than once, I was delighted to find that Eimac was producing a new tube with an almost-instant-warm-up filament that functions well at 2 meters—the 3CX1200Z7.<sup>1</sup> The Z7 is different from the 3CX1200A7 by virtue of its external grid ring, redesigned anode assembly and a 6.3-V ac filament. One advantage to the 3CX1200Z7 is the wide range of plate voltages that can be used, from 2000 to 5500. This amplifier looks much like the easily duplicated W6PO design,<sup>2</sup> except for the plate collet and the addition of some control circuitry. The plate collet is adapted from the W6PO 222-MHz design.<sup>3</sup> The RF deck is a compact unit, designed for table-top use (Figure 1). Table 1 gives some data on the 3CX1200Z7; Table 2 lists CW operating performance for this amplifier.

## Input Circuit

The tuned-filament T network matches the 50- $\Omega$  drive source to the filament input impedance, providing a very low input SWR. Tuning is easy and docile. Grid bias is provided by an 8.2-V, 50-W Zener diode. Cutoff bias is provided by a 10-k $\Omega$ , 25-W resistor. A relay on the control board shorts out the cutoff-bias resistor, to place the amplifier in the TRANSMIT mode.

I didn't use a tube socket. Instead, I bolted the tube directly to the top plate of the subchassis, using the four holes (drilled to clear a #6 screw) in the grid flange. Connections to the heater pins are via drilled and slotted brass rods. The input circuit is contained within a 3½×6×7¼-inch (HWD) subchassis (Figure 3).

Figure 1—This table-top 2-meter power amplifier uses a quick-warm-up tube, a real plus when the band suddenly opens for DX and you want to join in.



**Table 1**  
**3CX1200Z7 Specifications**

Maximum Ratings	
Plate voltage:	5500 V
Plate current:	800 mA
Plate dissipation:	1200 W
Grid dissipation:	50 W

**Table 2**  
**CW Operating Data**

Plate voltage:	3200 V
Plate current (operating):	750 mA
Plate current (idling):	150 mA
Grid current:	165 mA
DC Power input:	2400 W
RF Power output:	1200 W
Plate dissipation:	1200 W
Efficiency:	50%
Drive power:	85 W
Input reflected power:	1 W

## Control Circuit

The control circuit (Figure 4) is a necessity. It provides grid overcurrent protection, keying control, and filament surge control. To protect the tube filament from stressful surge current, a timer circuit places a resistor in series with the primary of the filament transformer. After four seconds, the timer shorts the resistor, allowing full filament voltage to be applied. C2 and R4 establish the time delay.

Another timer inhibits keying for a total of 10 seconds, to give the internal tube temperatures a chance to stabilize. C1 and R3 determine the time constant of this timer. After 10 seconds, the amplifier can be keyed by grounding the keying line. When the amplifier is not keyed, it draws no plate current. When keyed, idle current is approximately 150 mA, and the amplifier only requires drive to produce output. A

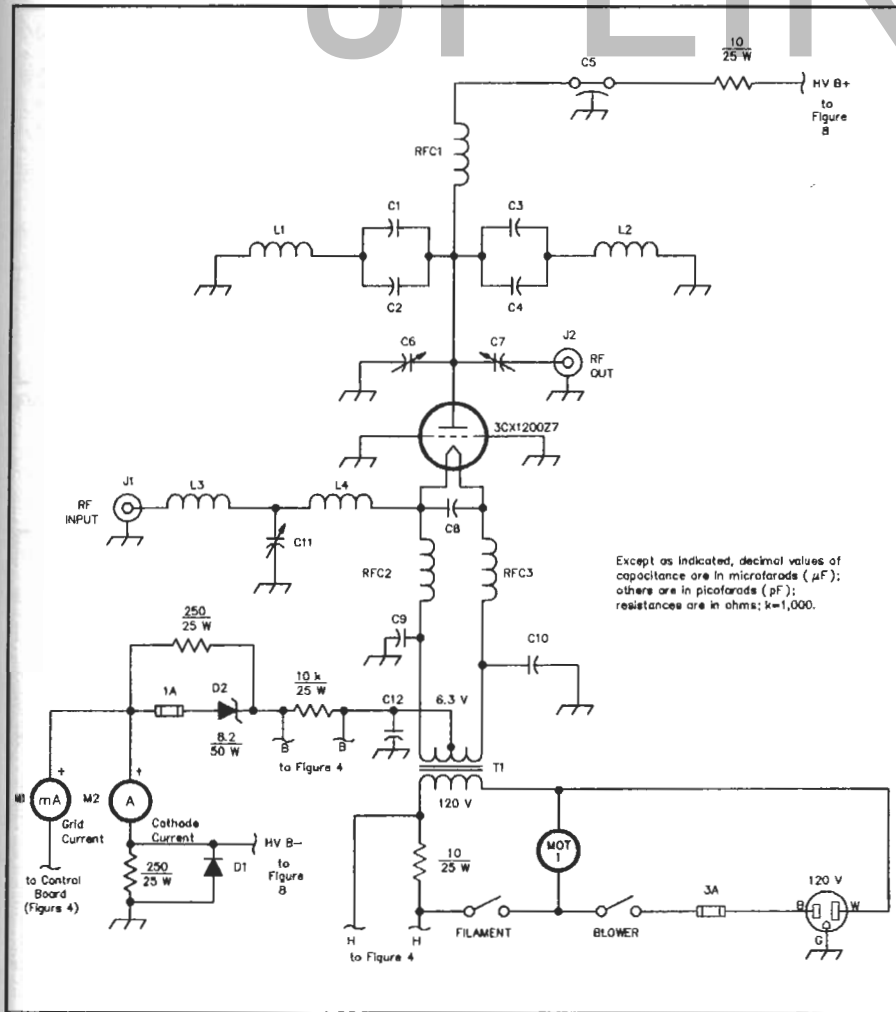

Figure 2—Schematic diagram of the 2-meter amplifier.

C1-C4—100 pF, 5 kV, type 850  
 C5—1000 pF, 5 kV  
 C6—Anode-tuning capacitor; see text and Figure 5 for details  
 C7—Output-loading capacitor; see text and Figure 7 for details  
 C8-C10—1000-pF silver mica, 500 V  
 C11—30-pF air variable  
 C12—0.01  $\mu\text{F}$ , 1 kV  
 D1—1000 PIV, 3-A diode, 1N5408 or equiv  
 D2—8.2-V, 50-W Zener diode, ECG 5249A  
 J1—Chassis-mount BNC connector  
 J2—Type-N connector fitted to output coupling assembly (see Figure 7)  
 L1, L2—Plate lines; see text and Figure 6 for details  
 L3—5 t no. 14,  $\frac{1}{2}$ -inch diameter, close wound  
 L4—3 t no. 14,  $\frac{5}{8}$ -inch diameter,  $\frac{1}{4}$ -inch spacing  
 RFC1—7 t no. 14,  $\frac{5}{8}$ -inch diameter,  $1\frac{3}{8}$  inch long  
 RFC2, RFC3—10 t no. 12,  $\frac{5}{8}$ -inch diameter, 2 inches long  
 T1—Filament transformer. Primary: 120 V; secondary: 6.3 V, 25 A, center tapped  
 Available from Avatar Magnetics (Ronald C. Williams, W9JVF, 240 Tamara Trail, Indianapolis, IN 46217, 317-783-1211); part number AV-539  
 M1—Grid milliammeter, 200 mA dc full scale  
 M2—Cathode ammeter, 2 A dc full scale  
 MOT1—140 free-air cfm, 120-V ac blower, Dayton 4C442 or equivalent.

Sources for some of the "hard to get parts" include:  
 Fair Radio Sales, 1016 E Eureka, Lima, OH 45802, tel 419-227-6573;  
 Surplus Sales of Nebraska, 1502 Jones Street, Omaha, NE 68102, tel 402-346-4750.

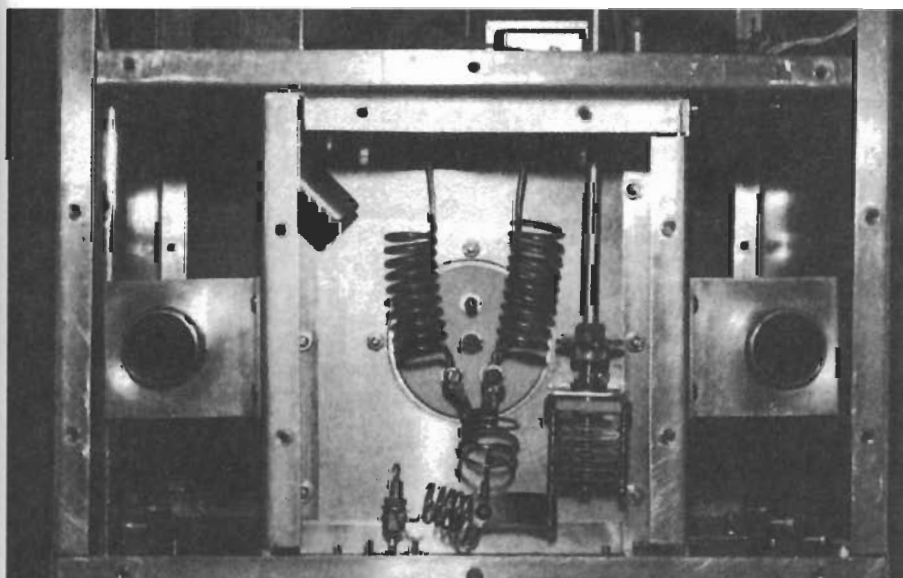

Figure 3—This view of the cathode-circuit compartment shows the input tuned circuit and filament chokes.

safety factor is built in: the keying circuit requires +12 V from the high-voltage supply. This feature ensures that high voltage is present before the amplifier is driven.

The grid overcurrent circuit should be set to trip if grid current reaches 200 mA. When it trips, the relay latches and the NORMAL LED extinguishes. Restoration requires you to press the RESET switch.

### Plate Circuit

Figure 5 shows an interior view of the plate compartment. The anode collet is patterned after the one used in the W6PO 222-MHz amplifier. The differences are small. A  $4 \times 2\frac{1}{4}$ -inch tuning capacitor plate and a  $2 \times 2$ -inch output coupling plate are centered on the collet. These parts are the same size and shape as those used on the 2-meter W6PO amplifier. The remaining difference is the diameter of the hole for the fingerstock. The hole diameter will be approximately  $3\frac{5}{8}$  inches.

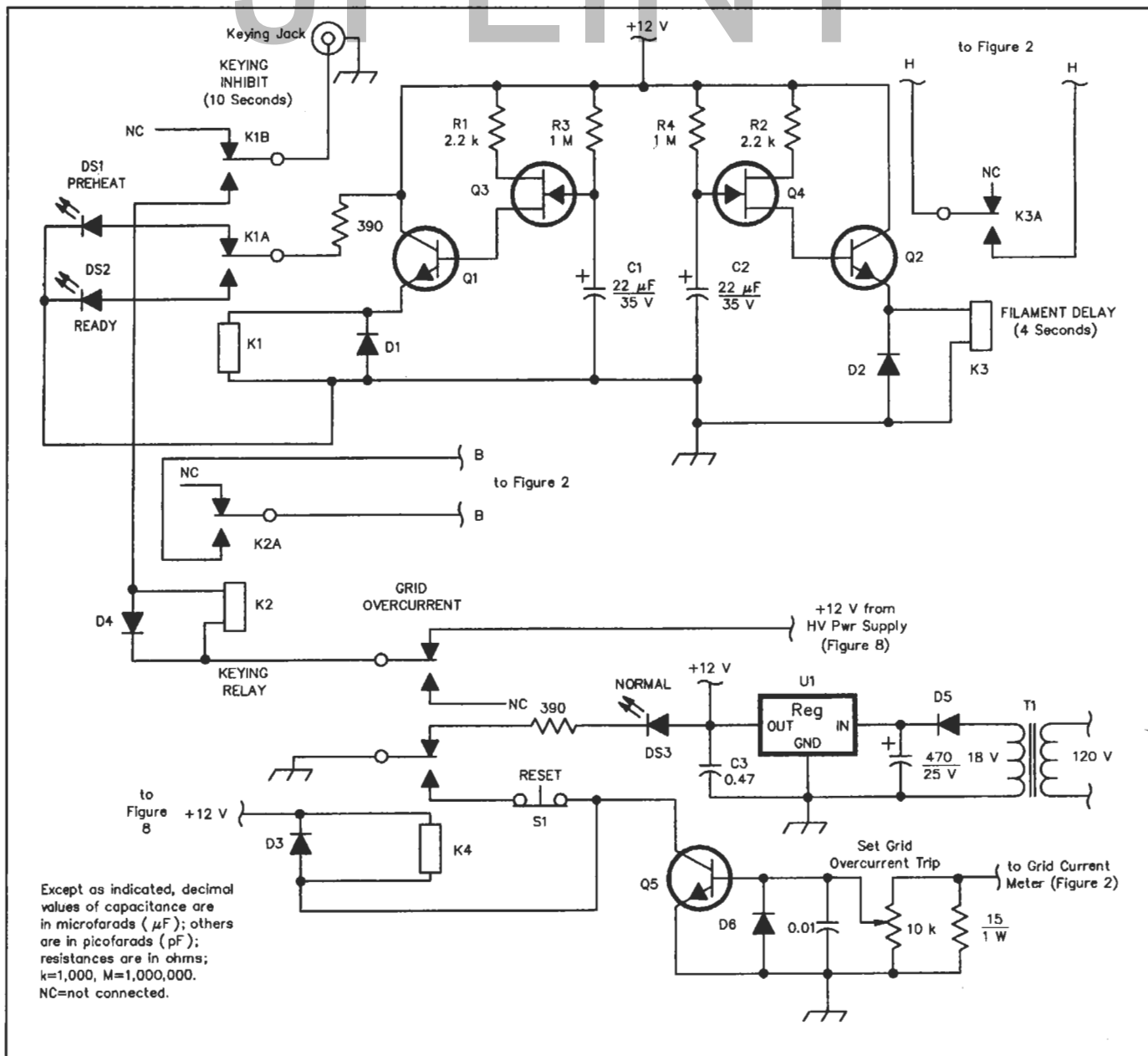

Figure 4—Schematic diagram of the amplifier-control circuits.

- C3—0.47- $\mu\text{F}$ , 25-V tantalum capacitor
- D1-D5—1N400i or equivalent
- D6—1N4007 or equivalent
- DS1—Yellow LED
- DS2—Green LED
- DS3—Red LED
- K1—Keying-inhibit relay, DPDT, 12-V dc coil, 1-A contact rating (RadioShack 275-249 or equivalent)
- K2—Amplifier keying relay, SPDT, 12-V dc coil, 2-A contact rating (RadioShack 275-248 or equivalent)
- K3—Filament delay relay, SPST, 12-V dc coil, 2-A contact rating (RadioShack 275-248 or equivalent)
- K4—Grid-overcurrent relay, DPDT, 12-V dc coil, 1-A contact rating (RadioShack 275-249 or equivalent)
- Q1, Q2, Q5—2N2222A or equivalent
- Q3—MPF102 or equivalent
- Q4—2N3819 or equivalent
- S1—Normally closed, momentary pushbutton switch (RadioShack 275-1549 or equivalent)
- T1—Power transformer, 120-V primary, 18-V, 1-A secondary
- U1—12 V regulator, 7812 or equivalent

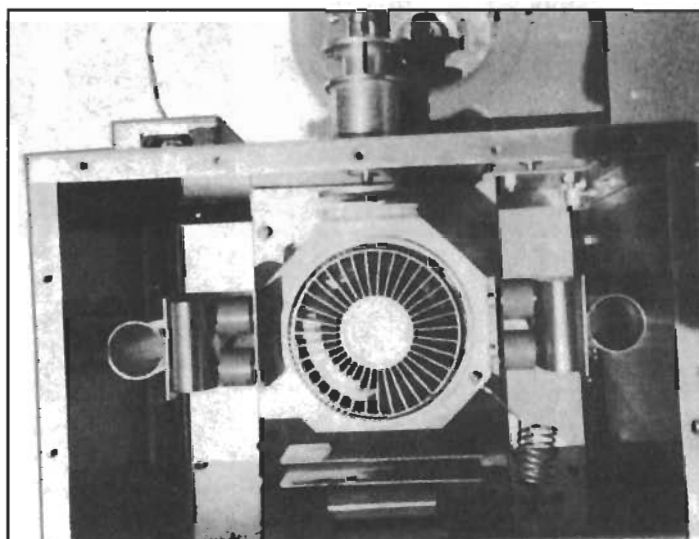

Figure 5—This top view of the plate compartment shows the plate-line arrangement, C1-C4 and the output coupling assembly.



Figure 6 is a drawing of the plate line and Figure 7 is a drawing of the output coupling assembly.

## Cooling

The amplifier requires an air exhaust through the top cover, as the plate compartment is pressurized. You can fashion a chimney from a 3 1/2-inch waste-water coupling (black PVC) and a piece of 1/32-inch-thick Teflon sheet. The PVC should extend down from the underside of the amplifier cover plate by 1 1/8 inches, with the Teflon sheet extending down 3/4 inch from the bottom of the PVC.

The base of the 3CX1200Z7 is cooled by using bleed air from the plate compartment, which is directed at the tube base, through a 7/8-inch tube set into the sub-chassis wall at a 45° angle.

The recommended blower will supply more than enough air for any temperature zone. A smaller blower is not recommended, as it is doubtful that the base area will be cooled adequately. The 3CX1200Z7 filament draws 25 A at 6.3 V! It alone generates a great deal of heat around the tube base seals and pins, so good air flow is critical.

## Construction

The amplifier is built into a 12×12×10-inch enclosure. A 12×10-inch partition is installed 7 1/4 inches from the rear panel. The area between the partition and the front panel contains the filament transformer, control board, meters, switches, Zener diode and miscellaneous small parts. Wiring between the front-panel area and the rear panel is through a 1/2-inch brass tube, located near the shorted end of the right-hand plate line.

High voltage is routed from an MHV jack on the rear panel, through a piece of RG-59, just under the shorted end of the left-hand plate line. The cable then passes through the partition to a high-voltage standoff insulator made from nylon. This insulator is fastened to the partition near the high-voltage feed-through capacitor. A 10-Ω, 25-W resistor is connected between the insulator and the feed-through capacitor.

The plate lines are connected to the dc-blocking capacitors on the plate collet with 1 3/4×2-inch phosphor-bronze strips. The bottom of the plate lines are attached to the sides of the subchassis, with the edge of the L-shaped mounting bracket flush with the bottom of the subchassis.

When preparing the subchassis top plate for the 3CX1200Z7, cut a 2 1/16-inch hole in the center of the plate. This hole size allows clearance between the tube enve-

Table 3

### Power Supply Specifications

High voltage: 3200 V  
Continuous current: 1.2 A  
Intermittent current: 2 A  
Step/Start delay: 2 seconds

lope and the top plate, without putting stress on the envelope in the vicinity of the grid flange seal.

Exercise care in placing the movable tuning plate and the movable output coupling disc, to ensure they cannot touch their fixed counterparts on the plate collet.

## Operation

When the amplifier is first turned on, it cannot be keyed until:

- 10 seconds has elapsed
- High voltage is available, as confirmed by presence of +12 V to the keying circuit

Connect the amplifier to a dummy load through an accurate power meter capable of indicating 1500 W full scale. Key the amplifier and check the idling plate current. With 3200-V plate voltage, it should be in the vicinity of 150 mA. Now, apply a small amount of drive and adjust the input tuning for maximum grid current. Adjust the output tuning until you see an indication of RF output. Increase drive and adjust the output coupling and tuning for the desired output. Do not overcouple the output; once desired output is reached, do not increase loading.

When you shut down the amplifier, leave the blower running for at least three minutes after you turn off the filament voltage. I found the 3CX1200Z7 to be an excellent tube. I tried it with excessive drive, plate-current saturation, excessive plate dissipation—all the abuse it's likely to encounter in amateur applications. I had no problems, but I don't recommend you repeat these tests!

## A Companion Power Supply

A good, solid-state high-voltage power supply is a necessity to ensure linearity in SSB operation. Specifications of the power supply I built are given in Table 3. Figure 8 is a schematic diagram of the supply. A power supply for a high-power linear amplifier should operate from a 240-V circuit, for best line regulation. I have specified a special, hydraulic/magnetic circuit breaker that doubles as the main power switch. I don't recommend you substitute a regular switch and fuses for this breaker, as

fuses won't operate quickly enough to protect the amplifier in case of an operating abnormality. The bleeder resistor dissipates about 100 W, so I included a small fan to remove the excess heat.

## Power Supply Construction

The power supply can be built into a 17×13×10-inch cabinet. The power transformer is quite heavy, so use 1/8-inch aluminum for the cabinet bottom, and reinforce it with aluminum angle for extra strength. The diode bridge consists of four legs, each containing five diodes.

## Power Supply Operation

When the front-panel breaker is turned on, the two, 25-Ω resistors in the primary circuit limit inrush current as the filter capacitor charges. After two seconds, K1 activates, shorting both resistors and allowing full line voltage to be applied to the transformer.

As with all high-voltage power supplies, you must be extremely careful! Before opening the cabinet, remove the ac-line plug from its receptacle, and confirm that the filter capacitor is discharged before working on the supply.

## Conclusion

This amplifier is a reliable and cost-effective way to generate a big 2-meter signal—almost as quickly as a solid-state amplifier.

To ensure that the output of my amplifier meets current spectral purity requirements, I use a high-power version of the half-wave output filter that appears as Figure 16 on page 39-10 of the 1993 and 1994 editions of *The ARRL Handbook*. Although I did not make spectral measurements of the output, I can run full output while my wife Mary Lou watches TV in a nearby room of our home.

Another suitable filter is the one that appears in the 1990 *ARRL Handbook* (Figure 150, on page 31-72) as part of the description of "A Legal-Limit 2-Meter Tetrode Amplifier."

## Notes

<sup>1</sup>Suggested retail price of the 3CX1200Z7 is \$625. You can obtain it from: Henry Radio, 2050 S Bundy Dr, Los Angeles, CA 90025, tel 310-820-1234; Richardson Electronics, 40 W 267 Keffinger Rd, La Fox, IL 60147, tel 708-208-2200; RF Parts, 435 South Pacific St, San Marcos, CA 92069, tel 619-744-0700.

<sup>2</sup>W. Orr, Editor, *Radio Handbook*, 23rd ed. (Indianapolis: Howard W. Sams and Co., 1987), pp 18-2 through 18-7.

<sup>3</sup>This project is also described in the *Radio Handbook*, pp 18-11 through 18-15.

# A Cathode-Driven Tetrode for 6 Meters

Stability, power, low cost: Is this what you're looking for in a 6-meter do-it-yourself project? If so, look what's here!

The advantages of grounded-grid amplifiers are numerous and have been proven over the years. They include: simplicity of design, good thirdorder IMD characteristics, inherent stability (generally without the need for neutralization) and noncritical tuning. The only requirement is abundant driving power. Usually, this is a small price to pay, unless the driver you intend to use is one of the many popular, low-power (10- to 25-W-output) VHF transceivers. Also, with the tremendous increase in the use of 100%-duty-cycle modes such as RTTY and SSTV, many of us would rather not operate our exciters at half to full bore while driving an amplifier. If you're willing to sacrifice only one of the aforementioned advantages—simplicity—the remaining attributes of grounded-grid operation can be made available at a considerable reduction in driving power.

## Enter the Tetrode

For many years, tetrodes (most often connected as triodes) have been used in grounded-grid circuits. But we have good reasons to consider the tetrode as a cathode-driven performer in its own right. First, the drive requirements are reduced. A 4-400A requires 40W of drive power for full output when triode connected. Only half that amount is needed to drive its class-AB1 counterpart. The second reason is cost. Tetrodes are still available as hamfest and surplus items at a fraction of their original cost. (Some of the newer triodes cost more than the exciters that drive them!)

But not all tetrodes can be triode connected. All of the external anode family of tubes, and a few others, have internal geometry that allows the control grid dissipation to be greatly exceeded if the tube is operated as a triode. Therefore, those tubes should be cathode driven only as tetrodes. The usual way to do this is to ground the

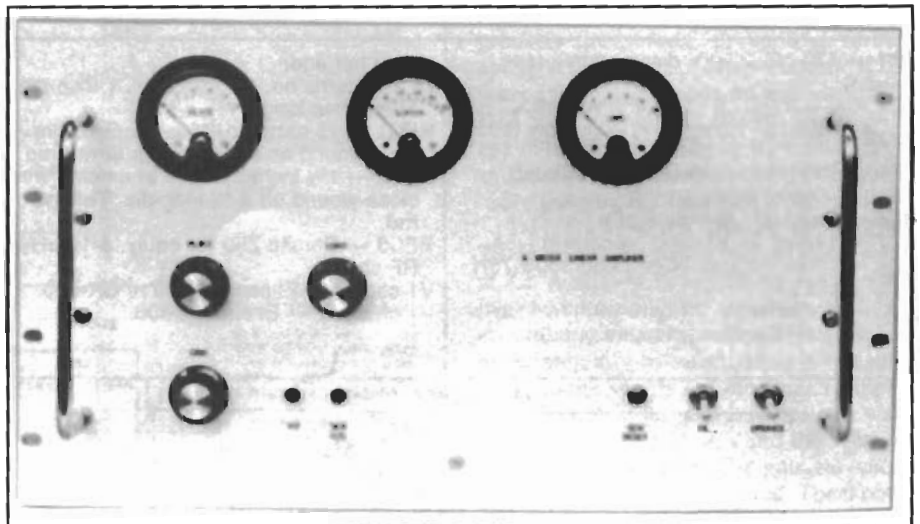

control and screen grids to RF with low-inductance bypass capacitors, and then place operating voltages on them. The cathode can be driven in a normal fashion, and the tube operated in any class consistent with linear service. Class-AB1 has the lowest drive requirements and is the easiest with which to work.

## Tetrode Vs. Triode

I concede that the addition of a screen element complicates the overall circuit, especially if the screen-circuit provisions are made properly. But, the circuit need be no more complex than that of its grid-driven equivalent. The cathode-driven tetrode requires grid bias and a well-regulated screen supply. Also, there is no correct way to load a tetrode without a meter to monitor the screen-grid current. This device is invaluable and should not be omitted for the sake of economy.

No discussion of the screen-grid circuit would be complete without some mention of an overcurrent-protection circuit. Several solutions have been offered in the past (including the use of no protection circuit!), and each has its disadvantages. Sensitive relays are expensive and their use can have an adverse effect on screen-voltage regulation. Current-limiting supplies do an excellent job of protecting the tube, but do not inform you when something is wrong. Since screen current is extremely sensitive to minor plate-voltage excursions and plateloading conditions, the builder has to be absolutely certain that these are correct, and that plate voltage is always present with screen voltage, if the screen-protection circuit is to be eliminated. The protection circuit is well worth the small cost involved. This amplifier incorporates an inexpensive and simple circuit that contains none of the disadvantages mentioned earlier.



## A Cathode-Driven 4CX250B

I became aware of the cathode-driven tetrode years ago while trying to get a 4-1000A to work on 50 MHz. The results were so good that, when it came time to build an amplifier for my new solid-state transverter, I decided that building a grid-driven amplifier would be a giant step backward.

The 4CX250B is an excellent tube for 6-meter use. This tube has a high plate-dissipation rating for its small physical size, has reasonable power-supply requirements, and requires approximately 10 W of drive in a cathode-driven, class-AB1 configuration. (If much more drive is available, an appropriate attenuator must precede the input circuit.) The only differences between this design and its grid-driven equivalent are the filament/cathode and control-grid circuits.

### Filament/Cathode Circuit

In Fig. 1, notice that the cathode and one of the filament connections are tied together. Normally, the isolation created by the physical separation of the two elements is sufficient to ensure stability, and a filament choke would not be required. I felt that this would not be the case on 50 MHz, and a call to Eimac confirmed it. At Bill Orr's recommendation, I tied the cathode and filament together, and fed the filament through a choke. The cathode impedance is approximately 120 ohms. In the interest of best linearity and minimum drive requirements, a tuned input circuit is used. The tank coil is tapped to present an input impedance of 50 ohms.

There are many sockets designed for use with this family of tubes. I recommend that you use one that incorporates a built-in screen bypass capacitor (1100 or 2700 pF); either one will do. A few of these types of sockets are so constructed that the four cathode pins are grounded internally; do not use one of these. An Eimac SK-600 or SK-620 socket is recommended. The four cathode pins (2, 4, 6, 8) and one of the filament pins (7) of the socket must be wired together to form one low-inductance connection. The easiest way to do this is to carefully bend pins 1 and 3 parallel to the chassis, and then strap together pins 2, 4, 6, 7 and 8. Make certain that this strap forms a complete circle around the socket. For strap material, I use some stretched and flattened shield braid removed from RG-58 coaxial cable. All connections made to the cathode, or the filament (pin 7), can be made anywhere along this ring. See Fig. 2 for details.

### Grid Circuit

The tube grid is accessed through the socket center connector and is bypassed to ground by C1. The capacitance of C1 is not as important as its physical size. C1 should be a high-voltage, disc-ceramic type (2 kV or more), whose body nearly spans the distance between the connection points. This provides for an absolute minimum lead

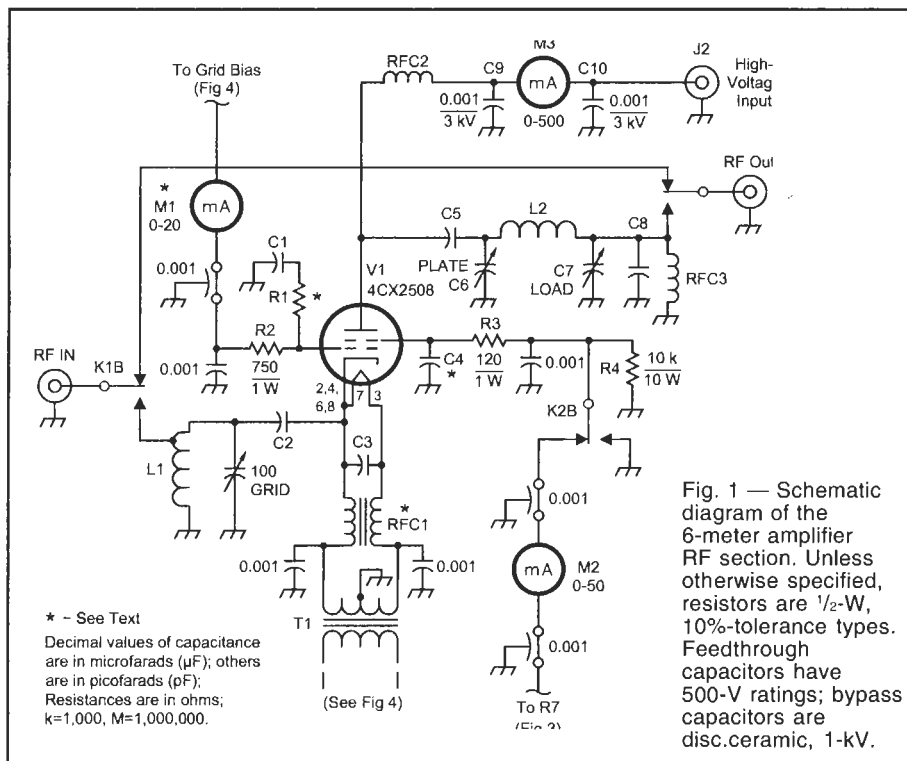

Fig. 1 — Schematic diagram of the 6-meter amplifier RF section. Unless otherwise specified, resistors are 1/2-W, 10%-tolerance types. Feedthrough capacitors have 500-V ratings; bypass capacitors are disc-ceramic, 1-kV.

- C1 — 470-pF, 2.5-kV disc-ceramic (see text).
- C2, C3 — 0.001- $\mu$ F, 500-V silver mica.
- C4 — Part of tube socket assembly (see text).
- C5 — 500-pF, 5-ky ceramic (Centralab 858S-500 or equiv.).
- C6 — See text (approx. 6 pF).
- C7 — 140-pF air variable, receiving type.
- C8 — 75-pF ceramic (Centralab 850S-75N or equiv.).
- L1 — 4 1/2 turns no. 14 bare wire, 1/2-inch-dia, 1 1/2 inches long, tapped one turn

- from hot end.
- L2 — 6 turns no. 10 bare wire, 1-inch-dia, 1 1/2 inches long.
- RFC1 — 15 turns no. 16 enameled wire closewound on a 1/2-inch-dia ferrite rod.
- RFC2 — 1 5/8 inches no. 22 enameled wire close-wound on a 3/8-inch-dia. Teflon® rod.
- RFC3 — Ohmite Z50 (or equiv. 5-10  $\mu$ H RF choke).
- V1 socket — Eimac SK-600 or SK-620.
- V1 chimney — Eimac SK-606.

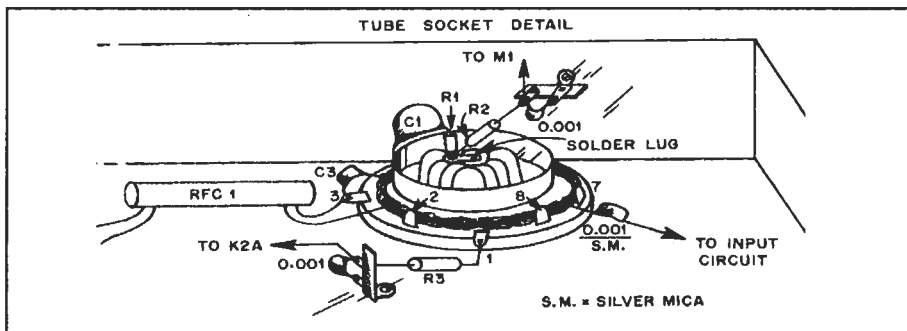

Fig 2—Tube socket detail. See text.

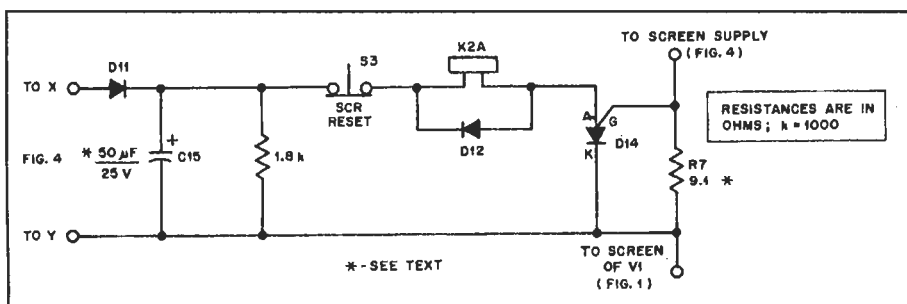

Fig 3—Screen overcurrent-protection circuit. Resistors are 1/2-W, 10%-tolerance types. D11, D12—1-kV, 2.5-A silicon diodes. D14—4-A, 200-V SCR (Jameco C106B1, ECG 5455 or equiv.). K2—DPDT 12-V dc relay, 1-A contacts (see text).



# JFLINT

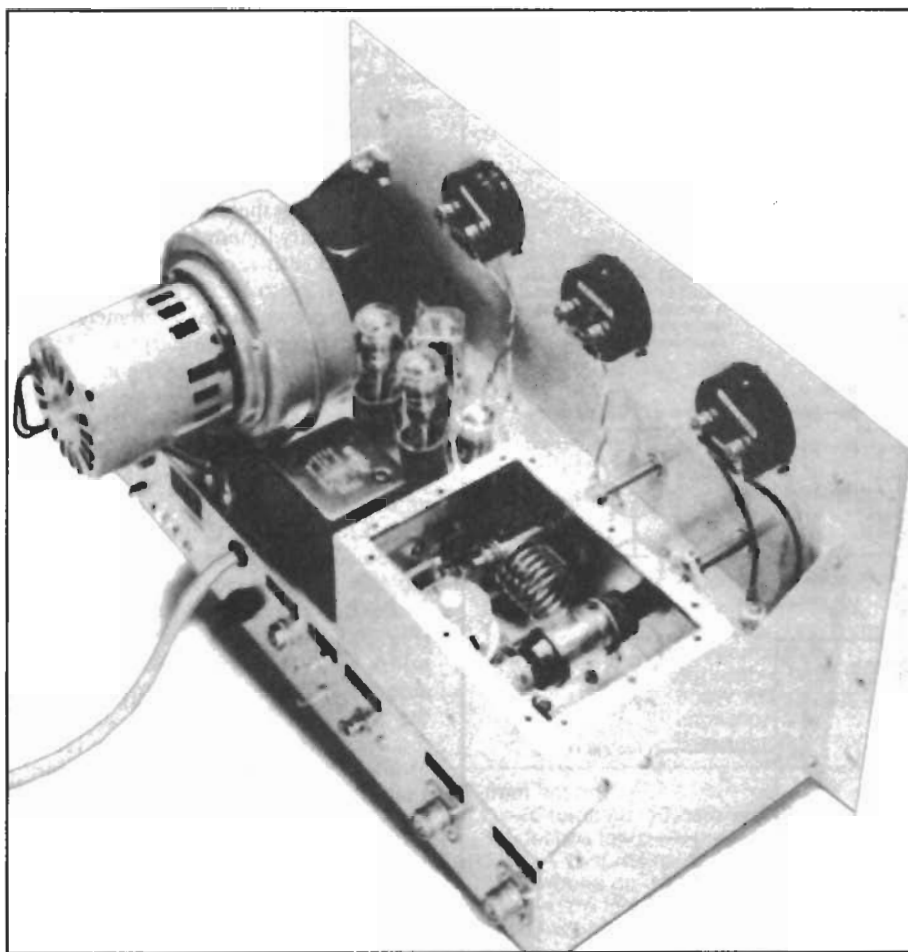

Fig 5—The final-amplifier-compartment cover has been removed for this photo.

as far away as possible from the RF leads. Most power-supply components are mounted on a fiberglass terminal board that is secured against the side of the chassis.

K3, D9, C11 and R5 (Fig. 4) constitute a time-delay circuit for filament inrush-current protection, and can be included if you feel that this is important. As it stands, the delay is approximately 1 second, which is more than ample. The 234-V ac relay is used on dc, and closes at about 70 V. The charging rate of C11 is controlled by its capacitance and the ohmic value of R5, and can be varied by changing their values.

Ideally, the input and output relays should be coaxial types; however, I used a single open-frame, 3PDT type and encountered no problems. The center pole is used for control (K1C), as that increases the isolation between the input and output circuits. In grid-driven amplifiers, I have never been able to use an open-frame relay for input and output switching. Because of the lower gain of this cathode-driven amplifier, I find no evidence of feedback or instability. Don't use plug-in type relays in their original form for K1. Remove the case, plug and connecting wires, and bolt the relay directly to the chassis. Use coaxial-cable braid to make the RF connections. The power supplies (Fig. 4) are of standard design. They may be replaced by any supplies yielding similar voltages, and

need not reside on the same chassis as the amplifier. The high-voltage supply should produce 2-kV dc under load. S1 turns on all supplies, including the external high-voltage supply. S2, the STANDBY/OPERATE switch, supplies power to K1, which allows the amplifier to be placed in operation; otherwise, the amplifier is simply bypassed.

If a 6.3-V ac filament transformer is used for T1, R6 will have to be included to drop the filament voltage to 6 V. The ohmic value of R6 will have to be determined experimentally. Use a resistor with the highest wattage rating practical for good voltage stability. With an accurate voltmeter, measure the filament voltage at the tube socket with the filament choke in place, as there will be a slight voltage drop across the choke. Nothing will cause a 4CX250B to "go south" quicker than high filament voltage, and that means anything in excess of 6 V.

The filament choke (RFC1) consists of 15 bifilar turns of no. 16 enameled wire wound on half of an Amidon 1/2-inch-diameter ferrite rod. The rod can be cut to a proper length by filing a small groove around its circumference, and then breaking it clean. Cover the rod with heat-shrink tubing or electrical tape before and after winding the choke. This will keep the rod and winding together, and make it self-supporting by its four leads.

The meters I used all have 0-1 mA

movements and homemade shunts. The original meter-face calibration marks were carefully erased, and new ones applied using dry-transfer labels. Most such labels are ideal for panel marking, but are a bit too large for meter-face use. Your local stationery store should have transfers with smaller-sized numbers. During amplifier operation, care should be taken to avoid accidental contact with the plate-voltage meter, as it has high voltage on it.

Most VHF amplifiers have a higher-than-necessary Q in the output circuit because of the use of high minimum-capacitance air-variable capacitors. This is acceptable providing the rest of the output components are heavy-duty types and can handle the higher circulating currents. (The small vacuum variable I used is admittedly first class, and it may not be used by many other builders.) Rather than using an air-variable capacitor, a homemade two-disc system is a preferred choice. If you can find a neutralizing capacitor with plates of 2-inch diameter or so, that would be ideal. If you must use an air-variable capacitor, use one with the least minimum capacitance; remove all unnecessary plates leaving just enough to do the job.

## Tune-Up

Before the tube is placed in the socket, close S1 and check that all of the operating voltages are correct. Ground the bottom end of the bias string at K1C, and check that the BIAS potentiometer range will supply -50 to -60 V; then set it at -55 V. J1 should be connected to the external-circuit control jack of your exciter so that it is grounded when your exciter is keyed. Open S1 and make certain all voltages have bled down, then install the tube. Close S1 and S2. After the tube warms up, with no drive applied, key the exciter and adjust the BIAS potentiometer so that the plate idling current is exactly 100 mA.

While the tube is idling, rotate all the tuning controls throughout their respective ranges. If there are no sudden plate-current increases, the amplifier is stable. With a small amount of drive applied, tune the GRID and PLATE controls for maximum output. Once you are satisfied that both of these controls will provide resonance, apply full drive and retune the plate to resonance. Increase loading slowly, retuning the PLATE control each time, until a screen current of 5 mA (the meter actually reads 20 mA) is indicated. Observe how sensitive the screen current is to the operation of the LOAD control, and that it is by far the best indicator of plate resonance. If grid current is indicated, you're over-driving the amplifier.

Adjust the drive level and the plate TUNE and LOAD controls so that the plate-current meter indicates 250 mA and the screen-current meter indicates 5 mA at resonance. Under these conditions, this amplifier develops a power output of about 310 W. With modulation, voice peaks should not exceed 150 mA on the plate-

# JFLINT

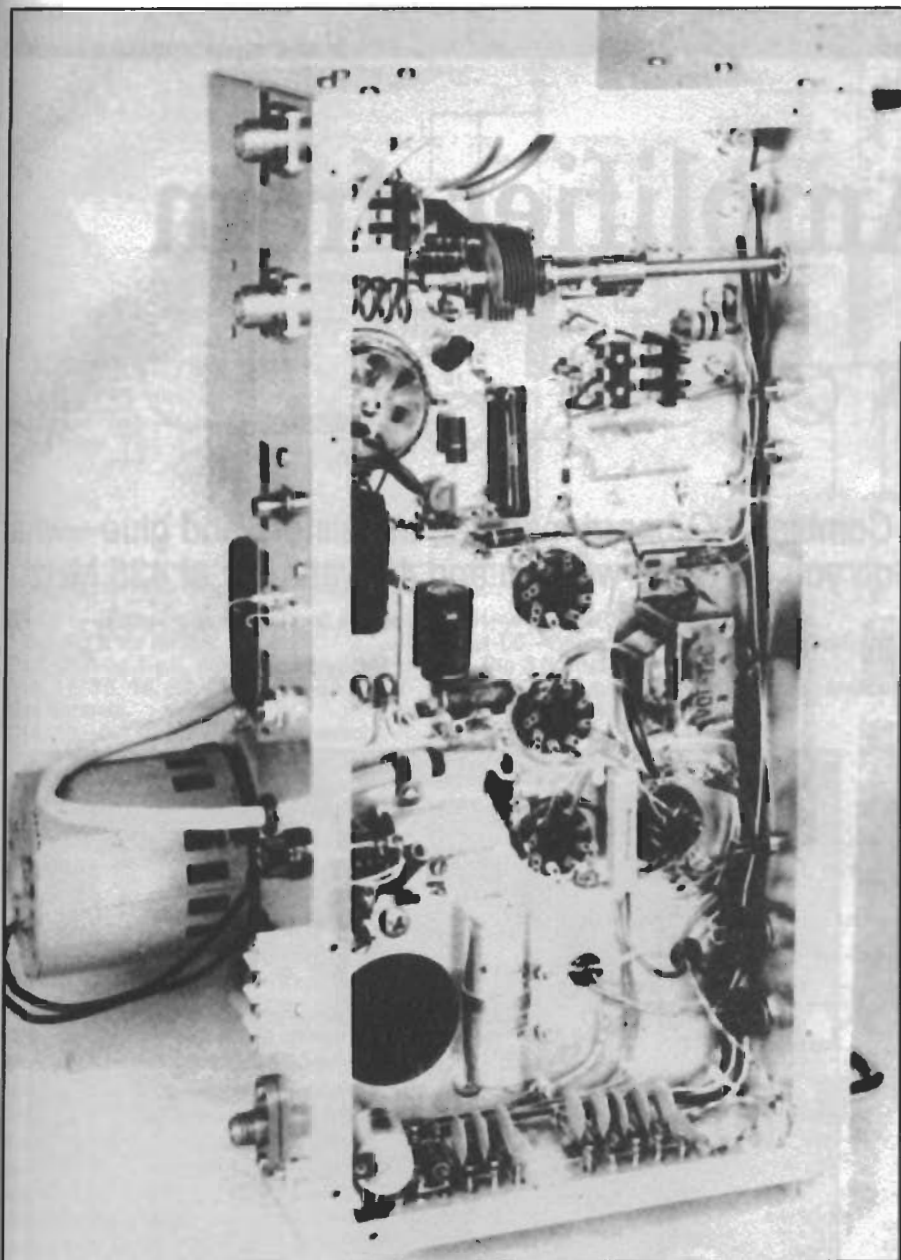

Fig 6—A bottom view of the 6-meter amplifier. The screen-protection circuit is mounted on the PC board to the right of the tube socket.

current meter, and a small amount of negative screen current is normal.

## Summary

This amplifier has been in operation now for over a year, and all reports of its operation have been complimentary. I hope that this amplifier will be duplicated by

many who had previously resigned themselves to grid-driven designs. Much of the material presented here is general enough to encourage interest in the cathode-driven tetrode as a viable alternative to the grounded-grid triode. I will be glad to answer all letters of inquiry regarding this amplifier; please include an s.a.s.e.

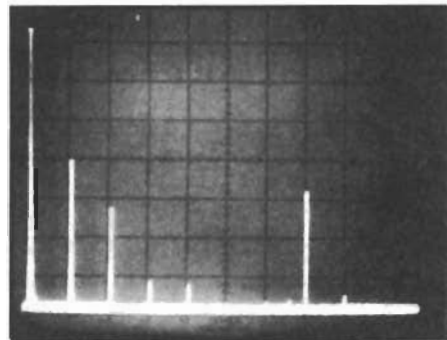

Fig 7—Spectral photo of the 6-meter amplifier without external filtering. Vertical divisions are each 10 dB; horizontal divisions are each 50 MHz. The fundamental (second pip from the left) has been notched approximately 40 dB by means of notch cavities to prevent analyzer overload. The seventh harmonic is approximately 48 dB below peak fundamental output.

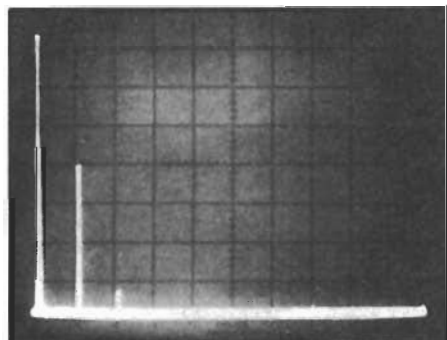

Fig 8—The addition of a simple filter (see Fig 9) at the amplifier output provides for excellent harmonic attenuation, and its use is recommended. All conditions are otherwise the same as those of Fig 7.

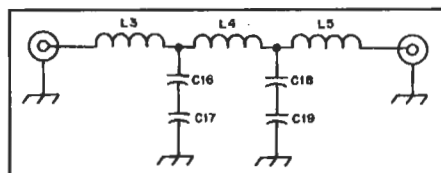

Fig 9—This simple harmonic-suppression filter, or one of similar characteristics, should be used at the output of the amplifier. The filter may be contained in a  $2\frac{1}{4} \times 2\frac{1}{4} \times 5$ -in (HWD) aluminum box.

C16-C19, incl.—110 pF, 1-kV silver-mica capacitors.

L3, L5—4 turns no. 14,  $\frac{5}{16}$ -in-ID,  $\frac{1}{2}$  in long.

L4—5 turns no. 14,  $\frac{7}{16}$ -in-ID,  $\frac{5}{8}$  in long.

## A UHF Amplifier—from Scratch

Combine PC-board material, transistors and glue—what do you get? Two watts in and 45 watts out at 435 MHz!

Most UHF RF equipment designs involve undefined reactance. For example, the self-inductance of a variable capacitor, or simply the method of attaching a 50-ohm cable to the circuit may constitute reactance that is critical to the operation of the circuit. The result is that complete success in duplicating a circuit is not likely unless the components and layout are exactly the same as in the original. This is nearly always a limiting factor for the do-it-yourselfer wanting to duplicate a project. This class-C UHF amplifier project uses homemade components that anyone can assemble. Tests show that their use has resulted in little or no compromise in the performance of the amplifier over a design using far more expensive commercial parts. My amplifier shows more than 45 W output with less than 2 W input at 435 MHz. The output stage efficiency is approximately 60%, and includes a double-tuned filter for improved spectral purity.

The key to this design is the glue-down stripline technique I have used in many other UHF projects.<sup>1</sup> This method permits easy modification of stripline parameters for optimizing circuitry. Striplines are cut from double-sided, glass-epoxy PC board having the same dimensions that you would choose using the etched-PC-board method. One side of the stripline is smeared with glue (Radio Shack all-purpose adhesive, 64-2307) and firmly pressed against the common base PC board. Parts can be soldered to the stripline immediately (without waiting for the glue to dry). No dc connection is required between the glue-line foils, and changes can be made within minutes by lifting the glue-down stripline with a knife and replacing it with one having altered dimensions. This project gives another example of how stripline parameters can be varied to optimize a circuit: homemade variable capacitors.

### Circuit Details

See Fig 1. The two-stage amplifier uses an MRF641 (driver) and an MRF646 (final).<sup>2</sup> They were chosen primarily because of their availability in the surplus market. These are controlled-Q devices with a combined minimum gain of 12.6 dB. Although the output stage is rated at 45 W, typical saturated output with a 13.6-V collector supply is about 60 W (including drive power).

The home-brew compression-type variable capacitors, shown in Fig 2, dictated the overall design. I made them as small as possible (to minimize selfinductance), but kept them large enough to provide the necessary capacitance. The nominal 5/8-inch-square compression plate results in a maximum capacitance of about 10 pF. The material used for the capacitor plates is 0.031-inch-thick Reynolds sheet alumi-

num, which is available at most hardware and home-supply stores. [Hobby store sheet brass works well in this application, is also commonly available, and is far easier to solder; it is a good alternative to aluminum—Ed.] The capacitor dielectric material is 2.7-mil polyethylene from a Dow Ziploc® heavy-duty freezer bag. Although I have tested this dielectric at a much higher voltage than it is subjected to in this application (at a high-impedance point in a vacuum-tube VHF amplifier), double thickness is used as a safeguard. The insulator between the adjustment screw and compression plate is made from plastic polymer. Most clear plastics used for miscellaneous household applications are of this type. I use plastic from a box used in packaging a tube of Grumbacher acrylic artists paint. Glass-epoxy insulation will work also, but at the higher-voltage

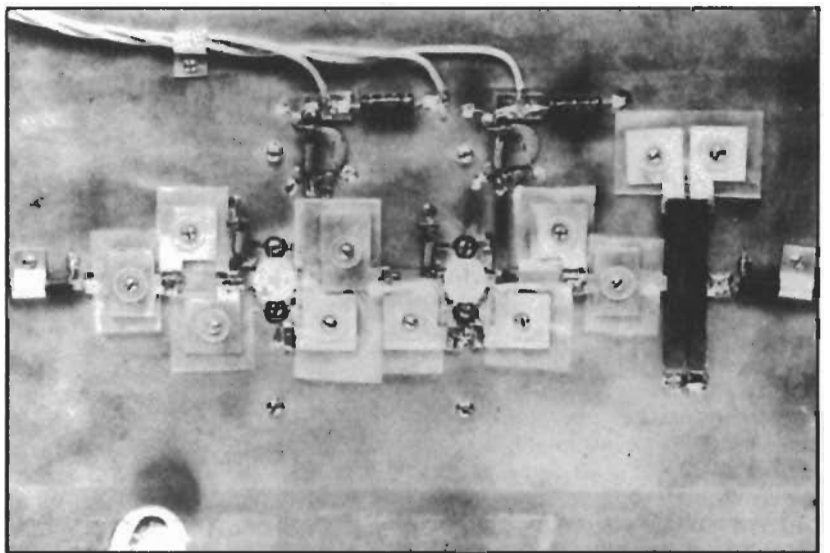

# JFLINT

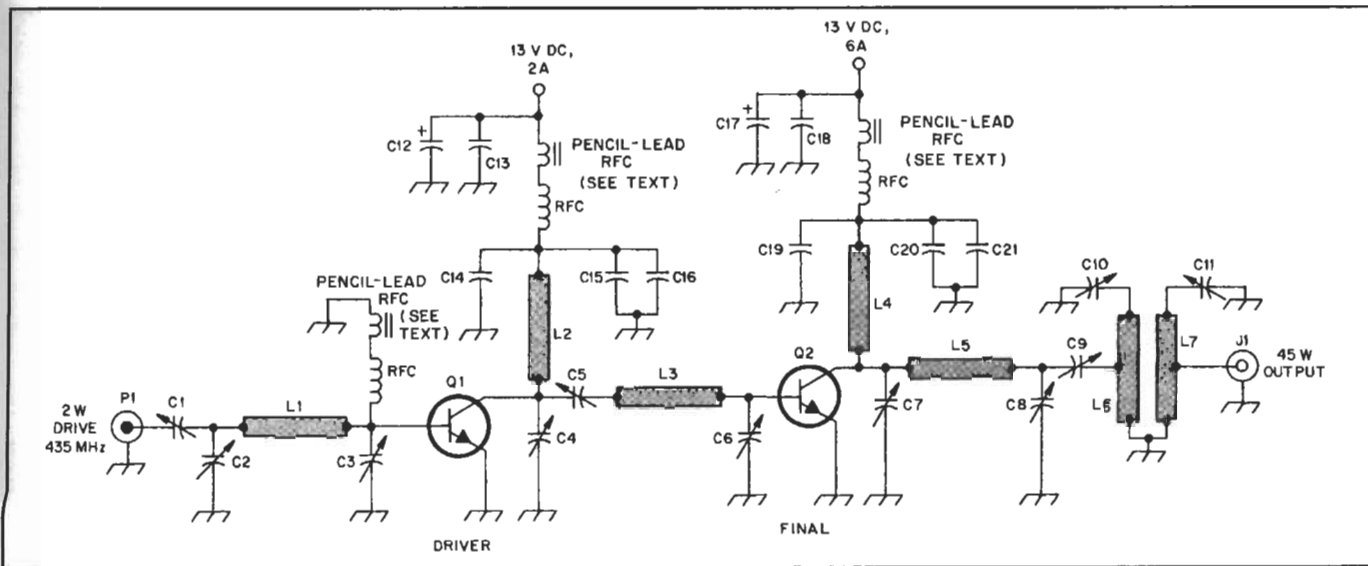

Fig 1—Schematic of the 435-MHz 45-W amplifier.

C1-C11—Homemade capacitors; see text and Fig 2 for details.  
 C12, C17—4.7- $\mu$ F, 35-V electrolytic.  
 C13, 15, 16, 18, 20, 21—0.001- $\mu$ F, 50-V disk ceramic.  
 C14, 19—0.1- $\mu$ F, 50-V disk ceramic.

J1—Female BNC connector.  
 L1-L5—Glue-down striplines; see text and Fig 3 for details.  
 L6, L7—Air-gap striplines; see text and Fig 4 for details.

P1—Male BNC connector.  
 Q1—MRF641.  
 Q2—MRF646.  
 RFC—10 turns, no. 26 enameled copper, air-wound,  $\frac{3}{16}$ -in diameter.

applications (especially at C10 and C11) there will be some loss and component heating.

Once I settled on the capacitor configuration, the input and output stripline characteristics were determined experimentally for optimum matching to Q1 and Q2. The related glue-down stripline and pad details are shown in Fig 3. The L2 L4  $\frac{1}{8}$ -inch-wide striplines act as RF chokes, making the inductance associated with the subsequent disc-ceramic capacitors uncritical. The pads include a number of the capacitor stators (C1, C4, C5, C6, C7 and C9). Foils which contact stator-adjustment screws are reamed out to approximately  $\frac{1}{8}$ -inch diameter to isolate the no. 2-56 screw from the stator. I did this with a large drill ( $\frac{3}{8}$ -inch). Screw contact with the bottom foil may also cause adjustment irregularities, so the foil was reamed appropriately. The stator plates must be completely deburred to prevent puncturing the plasticbag dielectric.

The amplifier output is coupled through C9 to a 1:1 inductively coupled, double-tuned filter. This 50-ohm filter consists of two striplines that are mounted parallel to each other and close together above the base PC board, as shown in Fig 4. Their close positioning establishes the necessary mutual coupling. Each line is tuned to resonance with a variable capacitor.

As indicated in Fig 1, dc-supply decoupling is identical for both stages. The 0.1- $\mu$ F disk capacitors eliminate a bothersome low-frequency instability mode. RF chokes following these capacitors include two-turn sections with pencil-lead cores to minimize the possibility of parasitics. The 4.7- $\mu$ F capacitors eliminate low-frequency power-supply instability problems.

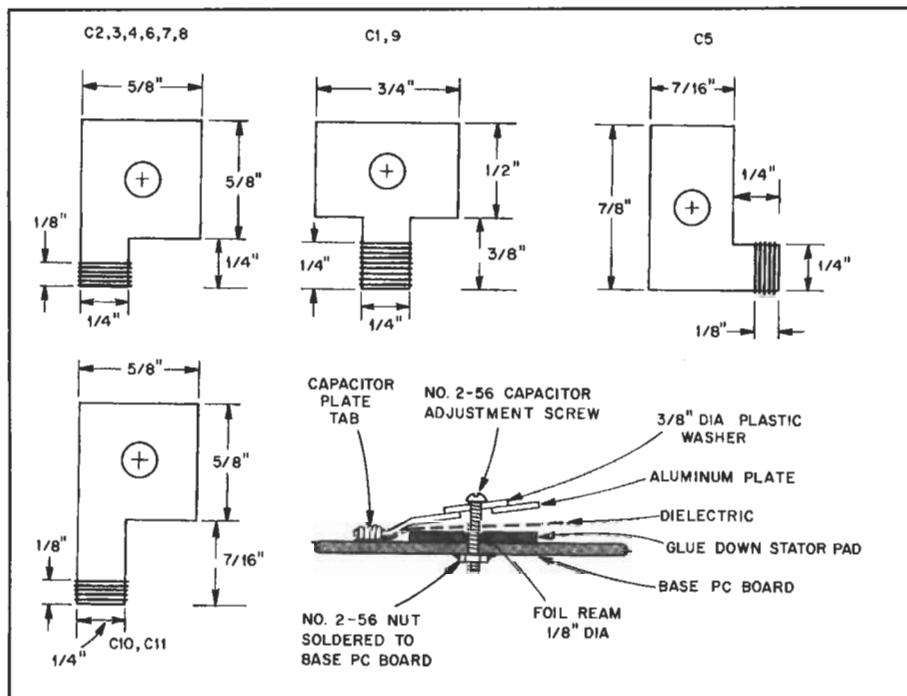

Fig 2—Variable-capacitor construction details. The "rotor" plates are made from 0.031-inch Reynolds aluminum sheet stock and polished with 320-grit sandpaper to ensure that no burrs are left that may puncture the dielectric material. Plate center holes are  $\frac{3}{16}$ -inch diameter. Connections are made to the capacitors by means of no. 26 tinned copper wire, tightly wrapped (and crimped in a vise) around the tab on the capacitor and soldered to the appropriate circuit board connection. Make these connections carefully to ensure good electrical contact. See text for details on the dielectric and washer materials.

## Assembly

The transistor-lead configurations are slightly modified to accommodate the glue-down striplines. Both the base and collector leads are bent up into an S shape so that the lead will overlap the stripline by

approximately  $\frac{1}{16}$  inch when the transistor and stripline are mounted flush with the base PC board. The leads are only 0.005-inch thick and can be bent easily with long-nose pliers. Care must be taken to minimize stress at the lead-ceramic junction.

# JFLINT

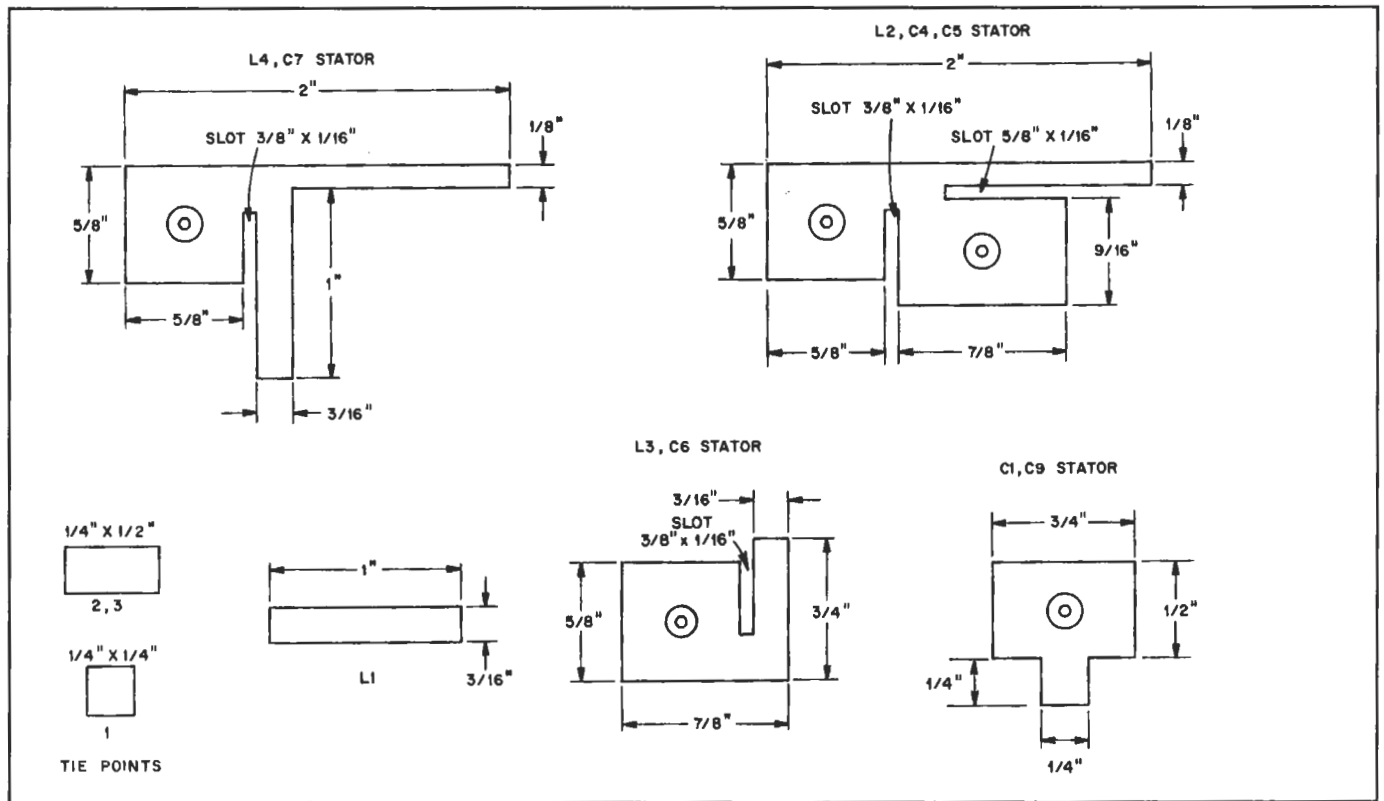

Fig 3—Glue-down stator pad construction details. Slots are cut with a hacksaw and then polished with a pattern file. The material is 0.062-inch-thick double-sided glass-epoxy circuit board material.<sup>6</sup> After cutting and filing, the pads must be polished with fine steel wool to remove any burrs.

tions. Also,  $\frac{3}{32}$  inch of each emitter lead must be cut off with scissors to allow room for the glue-down pads.

Details of the mounting arrangement are shown in Fig 5. My transistor mounting method was dictated by the dimensions of an old  $\frac{1}{8}$ -inch-thick aluminum panel (with many miscellaneous holes), which I pressed into service as a heat sink. First, I mounted each transistor on separate aluminum subbases. I then fastened the sub-bases to the heat sink. Thermally conductive compound is used between the transistors and the subbases and between the sub-bases and the heat sink. This arrangement permits removal of the heat sink without disturbing the transistor mountings when I need access to the bottom PC-board foil. Note that the base PC board cutout includes notches at the base and collector leads of the transistors to prevent shorting to the common foil.

Detailed assembly like that shown in Fig 6 is easy once the transistors are mounted. Simply smear glue on the pads and fit them into position. Start by positioning L1, followed by the C1 stator, then C1, C2 and C3. Drill holes in the base PC board for the no. 2-56 capacitor-adjustment screws as you go along. At the same time, solder the no. 2-56 nuts on the reverse side (using a screw to hold them in position). Bend the capacitor tabs to make certain the plates will be flush with the stator, inserting the capacitor dielectric as the final step. Make certain the dielectric has been pushed in between the capacitor plates as far as

possible (maximum safety margin), and use an awl to puncture the dielectric at the adjustment-screw position. The adjustment screw can then be easily started through the dielectric.

### Operation

UHF transistors are great devices, but

they can be damaged permanently with just one voltage transient. For example, an accidental short by a probe during a troubleshooting exercise, or the discharge of a probe capacitor at the transistor's base lead can be disastrous. Another common problem is instability that causes selfoscillation and excessive collector voltage (no insta-

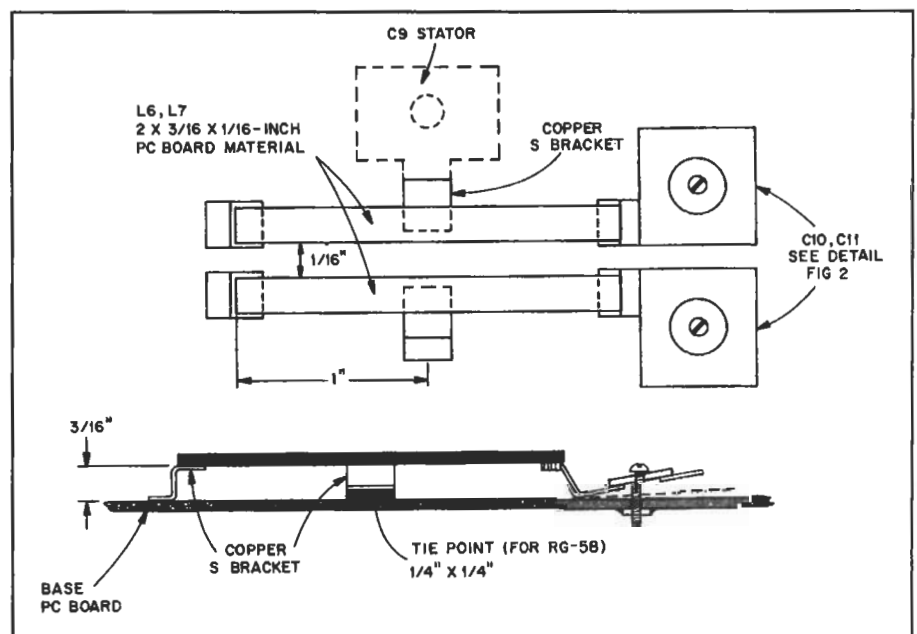

Fig 4—Construction details of the double-tuned output filter. The assembly is supported by copper brackets and parts of the variable capacitors.

# JFLINT

Motorola Application Note AN-548A.<sup>3</sup>

## Initial Tune-Up

The dummy load/power-measuring assembly and narrow-band peak detector pick-off assembly used in tune-up are the same as the ones that I used with my 15-W transmitter.<sup>4</sup> The dummy load consists of ten 1/2-W resistors connected in parallel and arranged in a circle to minimize self-inductance. Power measurements were made by calibrating dummy-load temperature rise with a dc input (ambient air-temperature conditions, no forced-air cooling). This information is then compared to the temperature rise of the dummy load resulting from the RF output of the amplifier. The "thermistor" used for measuring the temperature rise is a 1N34A (reading the reverse resistance).

Under key-down conditions during alignment, I place a blower at the chassis end to assist the limited heat-sink capabilities of the amplifier. Also, the dummy load requires forced-air cooling, as it becomes very hot in about two minutes under keydown conditions.

Miscellaneous lengths of RG-8/M and RG-58 were used as attenuators to increase power measurement capability of this system.<sup>5</sup> In testing the 45-W amplifier, I used a total cable attenuation of 6.4 dB. This increases the power-measurement capability by 4.4 times.

With a 5-V collector supply and 2 W of drive, first tune the input capacitors for maximum Q1 collector current, then tune the remaining capacitors for maximum power output. The output should be about 8 W. Increase the collector supply to 13 V; minor readjustment will probably be required. My final measurements showed an output of 48 W.

## Summary

This is a well-behaved amplifier. After completing an experimental version on the breadboard, I built a new assembly using the data in this article. Alignment of this final model was completed without any problems, and operation is flawless. The glue-down stripline technique is very reliable in this application, and is simple to use.

## Notes

- <sup>1</sup>J. Reed, "A Simple 435-MHz Transmitter," *QST*, May 1985, pp 14-18, 45.
- <sup>2</sup>These transistors are available from RF Parts Company, 1320-16 Grand Ave, San Marcos, CA 92069, tel 619-744-0728.
- <sup>3</sup>This note is reproduced in *Motorola RF Device Data* (fourth edition, first printing, 1986) on pages 6-61 through 6-65. This book is available from Motorola Literature Distribution, P0 Box 20912, Phoenix, AZ 85036, tel 602-994-6561. Cost is \$4.75 (plus 15 percent of the total for shipping).
- <sup>4</sup>See note 1.
- <sup>5</sup>My 435-MHz measurements indicated that the RG-8/M used has an attenuation of 9.0 dB per 100 feet (specified as 7.5 dB per 100 feet at 400 MHz); the RG-58 has 15.3 dB per 100 feet (specified as 12.0 dB per 100 feet at 400 MHz).
- <sup>6</sup>Available from John J. Meshna, Jr. Inc, 19 Allerton St, Lynn, MA 01904, tel 617-595-2275.

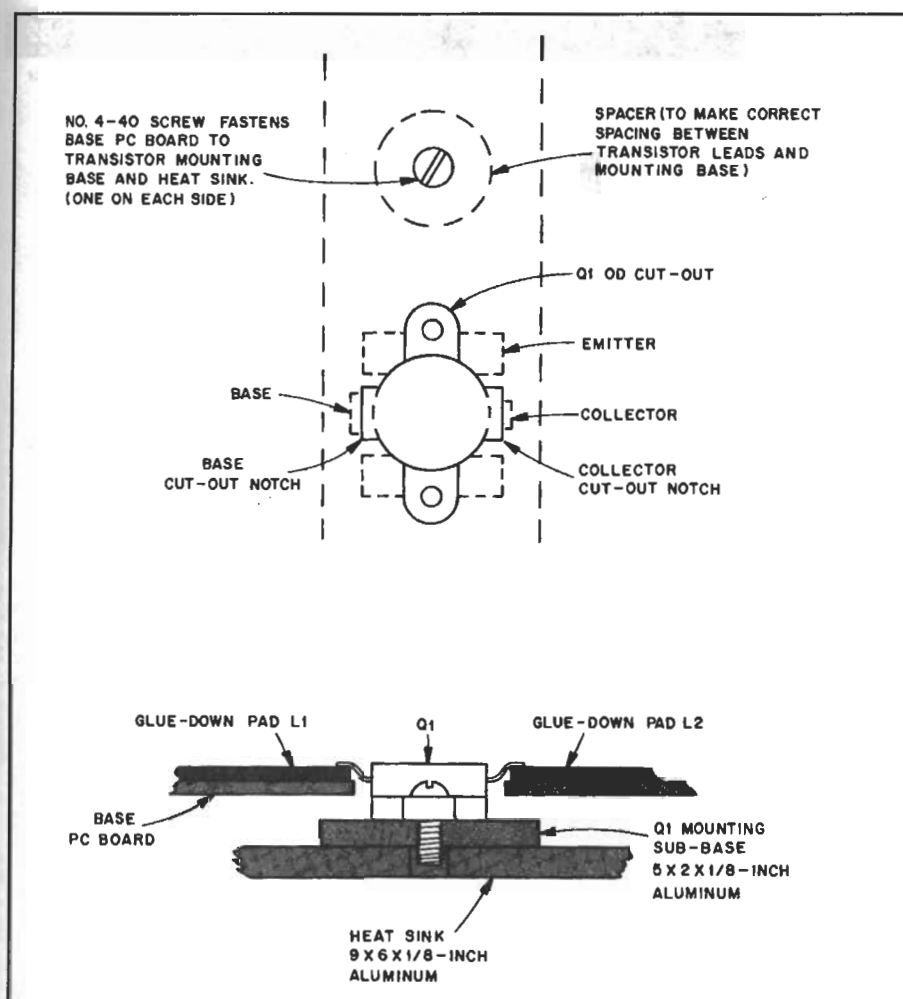

Fig 5—Pictorial of transistor mounting method. The same scheme is used for both the driver and final transistors.

bility modes are evident in the amplifier described here). These possible failure modes can be avoided by limiting the collector supply to 5 V (or less) during tune-up, as practically all instability modes will be evident at this lower potential (particularly if the input drive is varied over a wide range). Following alignment at 5 V, it is

surprising how little readjustment is required when the collector potential is increased to 13 V. (If you can't reduce your power supply voltage, you may want to use a 2N3055 as a pass transistor, driving it with an LM317T regulator [Radio Shack 276-2041 and 276-1778, respectively].) This low-voltage test procedure is mentioned in

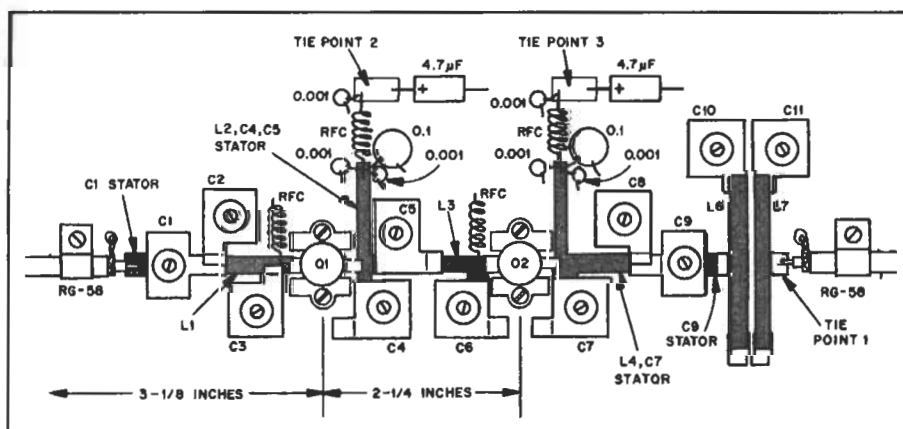

Fig 6—Circuit board layout of the completed amplifier. Begin construction by measuring the center-to-center distance from Q1 to Q2 and then mount the transistors, working away from them as you mount the other components. Use great care when mounting and soldering the transistors into the circuit to avoid damaging them. The PC board measures 9 1/2 in. x 6 in., and is made from double-sided, glass-epoxy material (Meshna PCB28—see note 1).



## A Solid-State 6-Meter Linear Amplifier You Can Build

Does your 6-meter signal need a little more punch? This amplifier will solve your problem—without breaking the bank!

The new breed of 8-to 10-W, solid-state vhf transceivers offer compactness and relative freedom from TVI. However, there are times when 10 W will not do the job. This amplifier can correct that situation. I used it during the September vhf QSO party and was able to work every station I heard, except one.

The transistor used in the amplifier is a Motorola MRF-492, which is designed for use as an fm amplifier in the "vhf low" public-service band. In this service, the nominal output is rated at 75 W with a 12.5-V collector supply. The manufacturer's data sheet shows a maximum output of 120 W at 16 V. Hence, in ssb service, I felt it would be safe to operate at the 100-W PEP level from a 13.5-V supply. Although no numbers are given, the MRF492 is claimed to have "load mismatch capability at high line and rf overdrive."<sup>1</sup>

### Circuit Description

The amplifier schematic diagram is shown in Fig. 1. Since I do not believe in "reinventing the wheel," the output matching network was taken directly from the Motorola data sheet. This network, incorporating L2 and L3 in the signal path, should provide excellent harmonic rejection. The network transforms the 50- $\Omega$  load impedance to the optimum transistor load of  $0.6 + j1.0 \Omega$ . Note that this unit, like most rf amplifiers, does not have a 50- $\Omega$  output impedance. We simply adjust the output network to obtain the rated power into a 50- $\Omega$  load. Fig. 2A is an amplifier output spectral display. While the harmonic suppression is good, additional filtering is required before using the unit on the air. A simple, 5-pole, lowpass filter was placed

at the amplifier output, and the resulting spectrum is shown in Fig. 2B. The low-pass filter circuit is given in Fig. 3.

Because the data sheet does not give values for input impedance in Class B service, the input circuit was derived basically by trial and error (the second version worked). The T matching network transforms the highly capacitive input impedance of approximately 1  $\Omega$  to a 50- $\Omega$  nonreactive load for the exciter.

In a Class B amplifier it is necessary to forward bias the base-emitter junction. There are basically two ways of doing this: the shunt diode method, and the emitter-follower method. The latter method undoubtedly results in lower inter-modulation products, but I have destroyed too many transistors using that method to try it with a \$20 device. Forward bias is achieved by using the shunt regulator diode D1. This diode must be connected to the same heat sink as the MRF492, Q1. The voltage across D1 is

adjusted to give a Q1 collector current of 100 mA with no drive applied. Do not attempt to set the bias point by measuring the base voltage of Q1 — use a milliammeter in the collector supply lead. I used an unmarked, surplus, 15-A rectifier diode for D1. Almost any diode will work, including power Zeners. I prefer a stud-mounted diode because it is easy to place in contact with the heat sink. Just be sure the polarity is such that the cathode is connected to the case. Several Motorola application notes specify a 1N4997 for this application. Unfortunately, this is a press-fit device. In any case, the heat sink must be grounded.

### Parts Procurement

All parts, with the possible exception of an adequate heat sink, are readily available. The MRF492 has recently been advertised by Westcom<sup>2</sup> and Semiconductor Surplus.<sup>3</sup> RFC1 is a Nytronics shielded ferrite choke, designed to reduce coupling

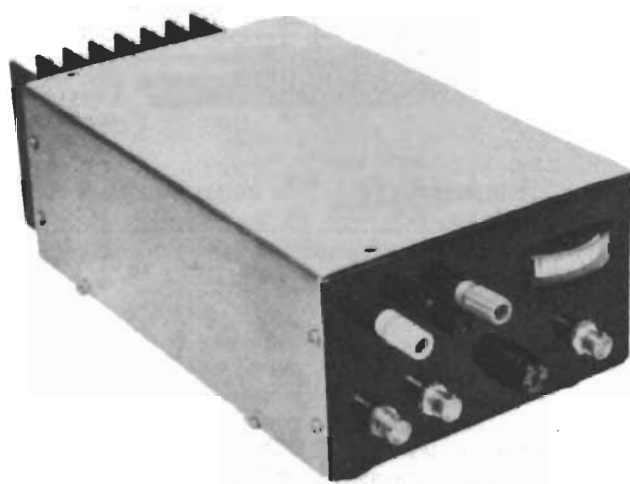

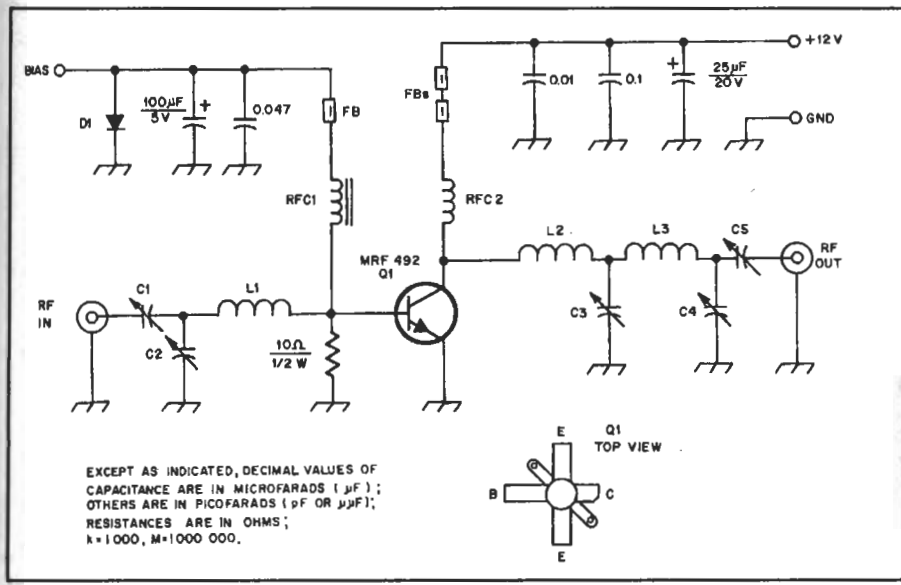
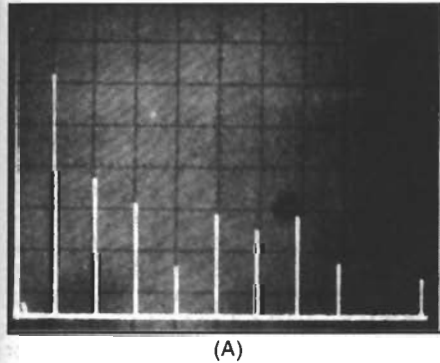

Fig. 1 — The schematic diagram of the amplifier circuit board. Decimal value capacitors are disc ceramic and polarized capacitors are electrolytic. Resistors are 10% carbon type.

- C1 — 9- to 180-pF mica compression trimmer, Arco 463 or equiv.
- C2, C4, C5 — 50- to 380-pF mica compression trimmer, Arco 465 or equiv.
- C3 — 80- to 480-pF mica compression trimmer, Arco 466 or equiv.
- D1 — 15-A, 50-V rectifier diode (see text).
- Fb — Ferrite bead, Radio Shack 273-1571 assortment or equiv.
- L1 — 2 t. of no. 14 bare copper wire,  $^{13}/_{32}$ -inch ID,  $^{3}/_{16}$ -inch long.

- L2 — Half loop of no. 14 bare copper wire,  $^{19}/_{32}$  inch high,  $^{13}/_{32}$  inch long (see photograph).
- L3 — 2 t. of no. 14 bare copper wire,  $^{13}/_{32}$ -inch ID,  $^{1}/_{4}$ -inch long.
- Q1 — Motorola rf power transistor, MRF492.
- RFC1 — 6.8  $\mu\text{H}$ , Nytronics SWD 6.8 or equiv. (see text).
- RFC2 — No. 16 enameled wire, close wound over full length of a 330- $\Omega$ , 2-W carbon resistor.



(A)

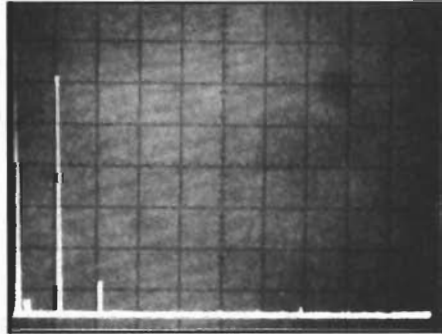

(B)

Fig. 2 — The amplifier output matching network provides some harmonic suppression (A). To further reduce harmonics, a simple low-pass filter should be used (B). With the filter, all harmonics and spurious signals are more than 60 dB below the carrier, thus meeting current FCC spurious emission requirements for commercial equipment. In these displays, the carrier level has been reduced by means of a notch filter to avoid analyzer overload. Vertical divisions are each 10 dB and the horizontal divisions are each 50 MHz. These measurements were made in the ARRL lab.

between the base and collector circuit. The J. W. Miller 9250-682 should be as good. A toroidal inductor of 1 to 10  $\mu\text{H}$  would also be suitable, since it is across an impedance of 1  $\Omega$ . Arco trimmers should be available from your local jobber. I used a surplus heat sink, measuring  $3\frac{1}{2} \times 4\frac{1}{2} \times 1\frac{3}{4}$  inches, which is quite adequate for ssb.<sup>4</sup> Anything much smaller will require a fan. Remember, it must be flat on one side. A replacement heat sink for any of the 80- to 100-W

2-meter amplifiers would be ideal.

### The Circuit Board

All the components shown in Fig. 1 mount on, or through, the circuit board (Fig. 4). Use double-sided glass epoxy board and cut away narrow channels to separate the various land (foil) areas. To form the channels, use a steel ruler and a sharp utility knife to cut through the foil. Next, pull a hot soldering iron along the

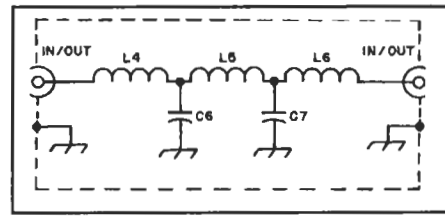

Fig. 3 — A simple low-pass filter for use with the 6-meter amplifier. The design information for this filter was taken from the 1982 ARRL *Radio Amateur's Handbook*. If the filter is mounted outside the amplifier cabinet, it should be enclosed in a metal box for shielding.

- C6, C7 — 82-pF, 1000-V silver-mica capacitor.
- L4, L6 — 4 t. of no. 14 enameled wire,  $^{3}/_{8}$ -inch ID,  $^{3}/_{4}$ -inch long with  $^{1}/_{8}$ -inch leads (approximately 0.1  $\mu\text{H}$ ).
- L5 — 6 t. of no. 14 enameled wire,  $^{3}/_{8}$ -inch ID,  $^{1}/_{2}$ -inch long with  $^{1}/_{8}$ -inch leads (approximately 0.2  $\mu\text{H}$ ).

strip of foil to be removed. You should see it curl up and away from the board. Start at one end, and pry up with the knife if it gets stuck. You will have to drill two holes, slightly more than  $^{1}/_{2}$  inch in diameter, through the board to provide clearance for Q1 and D1. Use a small round file to make the two clearance areas for the flanges of Q1. Connect the ground foils on the top and bottom of the board together by placing short lengths of wire through holes drilled in the board. Place the wires close to the transistor emitter tabs and near each corner of the board. Use pieces of the same type of wire you used to make the inductors, and drill the holes just large enough to pass the wire. Solder the wire on both sides.

### Assembly

Make sure you have all the parts on hand before you solder anything to the board. This will ensure that everything fits properly. To keep the inductors in place, I drilled holes through the board and stuck the ends of the wire into the holes. You will have to remove the foil from around these holes on the bottom of the board to keep from shorting the inductors to ground. A large drill bit works fine for this. Center the board on the heat sink, and drill the mounting holes for Q1 and D1. Although you may be able to use screws and nuts to attach Q1 and D1 (depending on the heat sink design), a better method is to tap the holes for the desired screw thread. Mount the board to the heat sink near the corners, shimming it with washers to the same depth as the Q1 mounting flange. Drop Q1 in from the top of the board. The tabs of Q1 should rest just above the top of the board when the flange is in contact with the heat sink. Do not put any upward pressure on the transistor tabs. Never cut or file an rf power transistor body — they contain beryllium oxide. It is highly toxic in powdered form and could be inhaled or absorbed through the skin.

Fasten Q1 to the heat sink before sol-

# JFLINT

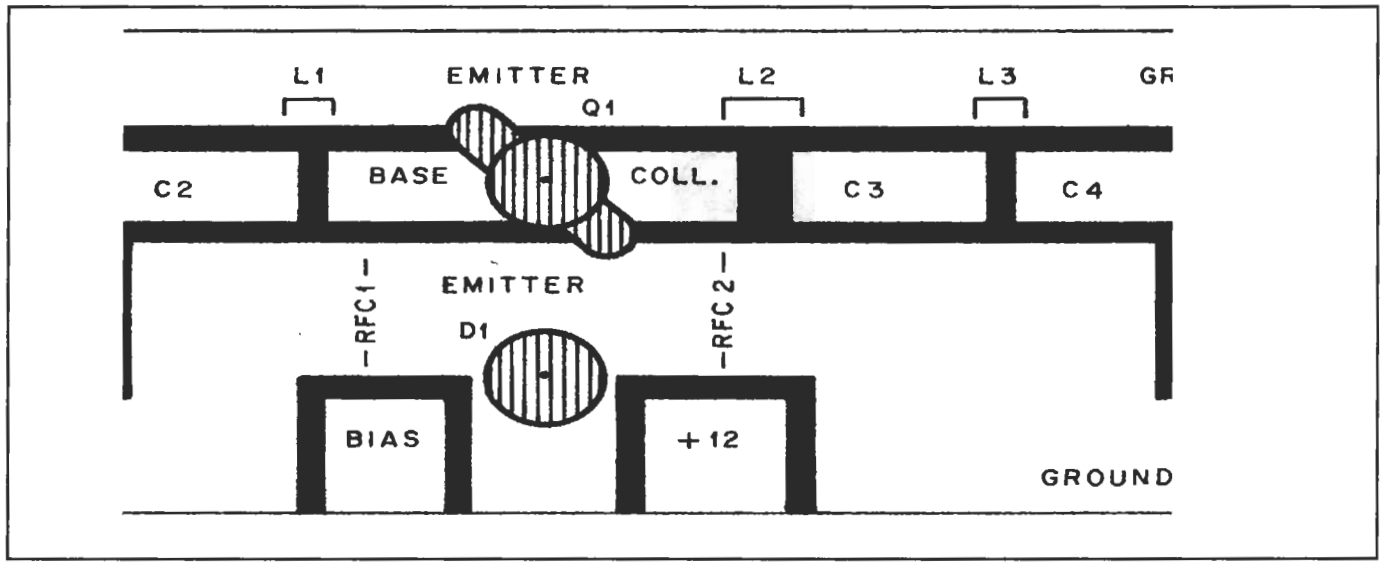

Fig 4—Full-scale circuit-board pattern and parts-placement guide for the 6-meter amplifier. Black represents those areas where copper has been removed by cutting or etching. The 10-ohm base resistor is connected between the base and ground foils, and is positioned next to RFC1.

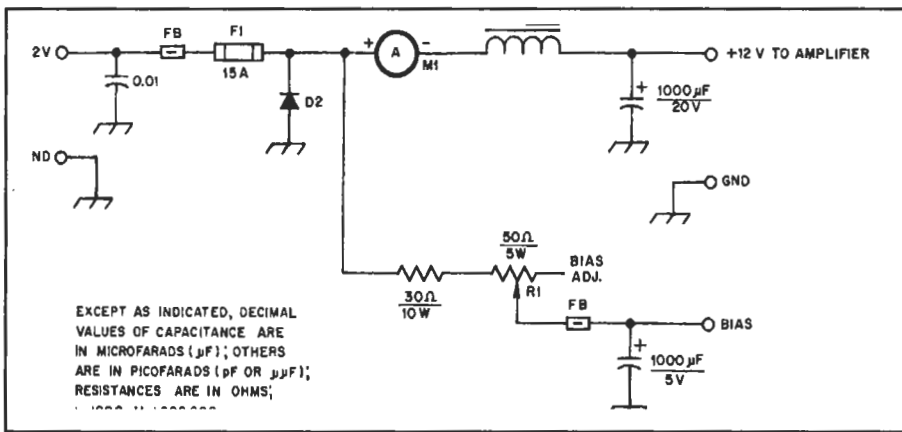

Fig 5—Schematic diagram of the bias-adjust circuit and other components not mounted on the circuit board. Decimal-value capacitors are disc ceramic, and polarized units are electrolytic type. Resistors are wire-wound type.

D2—20-A, 50-V rectifier diode.

RFC3—One turn of wire through a TV

balun core (part of Radio Shack 273-1571 assortment or equiv.).

dering it in place. Use thermal grease when mounting Q1 and D1. Be sure to solder the full length of the tabs to the board, right up to the body of the transistor. This is especially important for the emitter tabs, because nanohenrys of inductance here translate to decibels of gain loss.

Break off the little tabs on the sides of the mica compression trimmers. Bend the ends of the mounting terminals with pliers to aid in soldering the trimmers to the board. In doing this, be sure the adjusting screw will not touch the board when it is all the way down. C2, C3 and C4 should be oriented so that the screw is connected to the ground end of the capacitor. For C1 and C5 let the screw end be the 50- $\Omega$  side.

## Putting It All Together

I installed the circuit board and heat sink on the back wall of a  $3\frac{1}{2} \times 6 \times 10$ -inch Minibox. This is much larger than necessary, but does provide room for relays and

a receiving preamp for an eventual remote installation. I usually discard the top (plain U-shaped) half of these boxes and bend up a new piece that fits over the other half, instead of sliding into it.

Fig. 5 shows the biasing circuit and other chassis mounted parts. Control schemes for use with a transceiver are described by Kaplin<sup>5</sup> and Ridpath<sup>6</sup> (also see the ARRL *Radio Amateur's Handbook*). D2 does not have to be heat sunk. It only has to last long enough to blow the fuse in case the wrong supply polarity is inadvertently applied. On the other hand, the 50- $\Omega$  bias adjust control (R1) gets quite warm, and should be mounted to the enclosure. In wiring the bias circuit, attach one wire from R1 to D1 and another wire from D1 to the bias point on the circuit board; all other connections are made to the circuit board. If R1 were connected to the circuit board, with a strap going to D1, you would almost certainly damage the transistor if the strap to D1 broke.

## Alignment

It is necessary to set the bias before aligning the rf circuits. For an initial check, disconnect the wire between D1 and the circuit board (R1 is connected to D1). Apply power and measure the voltage across D1. It should be possible to lower it to 0.65 V, or less, by varying R1. Set R1 for the lowest voltage and connect the wire from D1 to the circuit board. Now reduce the resistance of R1 until the collector current is 100 mA. Be sure you are measuring collector current and not total supply current (you have about 300 mA flowing into D1).

For aligning the trimmers you will need, at least, an SWR indicator and a 50- $\Omega$  dummy load. You will, of course, not know how much power you are getting unless you also have a wattmeter. Connect the amplifier output to a dummy load and apply about 1 W of drive to the input through the SWR indicator. Adjust C1 and C2 for an SWR of 1:1. With CS snug, but not tight, adjust C3 and C4 for minimum collector current. With the SWR indicator or wattmeter connected between the output and the dummy load, adjust all the trimmers for maximum output. If more than one setting gives the same power, pick the one that corresponds to the lowest collector current. Slowly bring up the drive and keep readjusting all the trimmers. With 8 W of drive you should get an output of 100 W. The collector current will be approximately 15 A. Readjust the input for a 1:1 SWR at full power. This may, or may not coincide with maximum gain and you may have to compromise.

During testing you might consider using a harmonica to generate a multitone signal to reduce the average power dissipation (keep the speech processor off). If at any time the heat sink gets so hot you cannot hold your hand on it for five seconds, let it cool off. As a rough indication of power output, I found that at 100 W, a

# JFLINT

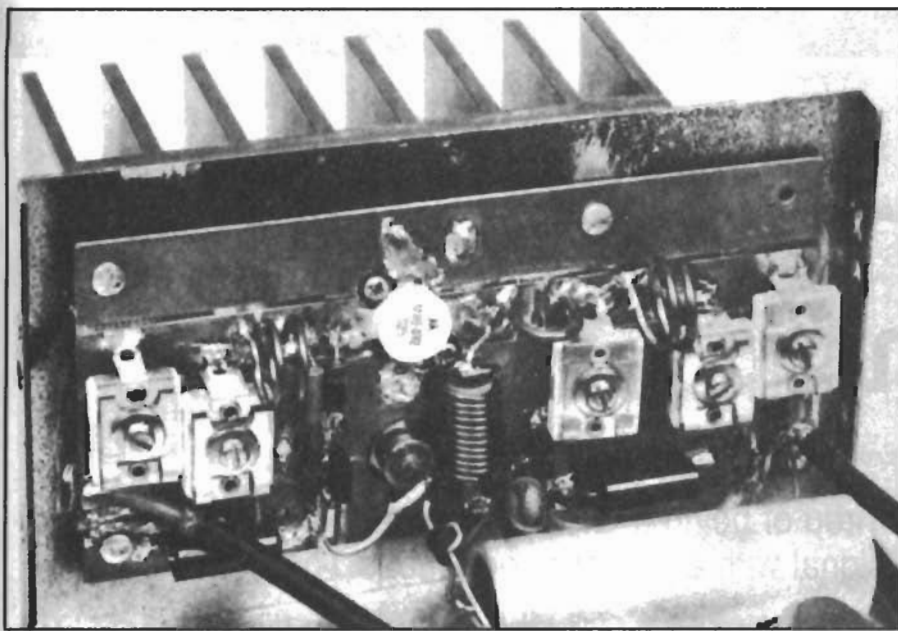

Interior view of the 6-meter amplifier showing the parts arrangement used by the author. The input matching network is at the right of the photo.

Drake DL 300 dummy load become too hot to hold after two minutes of key-down operation. To prevent rf burns, do not touch the dummy load while rf power is applied.

To maintain linearity, adjust the output circuits for 100 W, even if you are going to operate at 75 or 80 W. I evaluated the amplifier linearity by making two-tone IMD measurements with a spectrum analyzer. At a PEP output of 100 W, the third-order products were 25 dB below the PEP. At 80-W PEP they were down 30 dB. In over 100 contacts, I have not received any adverse comments on the signal quality.

#### Notes

<sup>1</sup>Motorola Inc., *Motorola Rf Data Manual*, 2nd ed. (Phoenix, AZ: Motorola Inc., 1980), p. 6-15.

<sup>2</sup>Westcom, 1320 Grand Ave., San Marcos, CA 92069.

<sup>3</sup>Semiconductor Surplus, 2822 N. 32nd St., No. 1, Phoenix, AZ 85008.

<sup>4</sup>mm = inches x 25.4.

<sup>5</sup>S. Kaplin, "Boots for QRP Rigs," *QST*, July 1981, pp. 15-20.

<sup>6</sup>J. Rldpath, "T-R Switching with PIN Diodes," *QST*, March 1981, pp. 19-21.

## Build A 6-Meter "Mini-Lini"

Tired of being a QRP station? Boost your low-level signal with a pair of sweep tubes.

Is low power enough for equality on 6 meters? Perhaps, but it has long been my contention that some stations are more equal than others! One of the great features of 6 meters is the ability to make contacts with just a few watts when the band is open. As solar activity begins to decline, band openings will be shorter and less frequent. This amplifier will add punch to your QRP signal.

The current offerings of solid-state 6-meter transceivers and transverters provide operating ease and good signal quality, but at the expense of rf power output. This, coupled with the paucity of linear amplifiers, resulting from the infamous amplifier ban, has caused an overall reduction in the average power output on 6 meters.

When I acquired my first solid-state rig (an IC-551) some time back, my tendency was to use its scan feature to locate a signal and then work the station with a 240-watt tube-type rig. A minor panic occurred when the tube rig "rolled over and died" midway through the '79-'80 F2 season. The Mini-Lini resulted from that panic.

### Design Approach

The amplifier was designed to be compatible with common power supplies, use a readily available tube, provide push-to-talk operation with the IC-551 and have approximately the same rf output as most tube-type transceivers. Fortunately, a design incorporating most of these features had been developed by Ed White, WA5RIA.<sup>1</sup> The major changes I made were in the methods of switching and bias adjustment. The tube used is the 6JB6, which is inexpensive, available and "happy" at 50 MHz. The biasing arrangement, an idea borrowed from Doug DeMaw,<sup>2,3</sup> allows the tubes to be matched for safe parallel operation. This amplifier provides about 50 watts of output when driven by a 10-watt exciter. More than one year of almost daily use has been trouble free and productive (42 states,

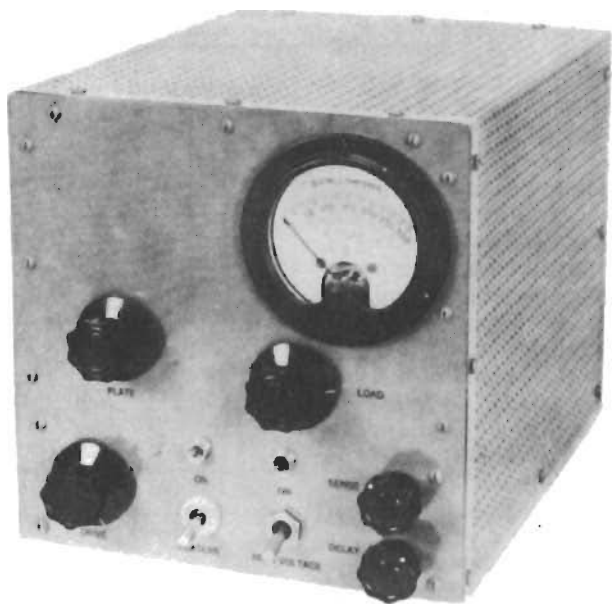

including KH6 and KL7, plus JA and several European).

### Circuit Details

The circuit is conventional and typical of many low-band amplifiers. The original design used a capacitive input, but I thought that the parallel-tuned input method shown in Fig. 1 would provide more output when used with other QRP drivers. This was proven in practice: The amplifier delivers about 20 watts of output when driven by an IC-502. The potential problem of operating unmatched tubes in parallel has been avoided by biasing each tube individually. Component values shown will allow coverage of the entire 6-meter band.

The output network will not reject harmonic energy, and the second harmonic, as measured in the ARRL lab, was less than 40 dB below the fundamental (Fig. 2). This works out to a healthy 5 mW at 100 MHz.

Most fm receivers in the neighborhood will detect this easily. FCC requirements for a commercial amplifier at this frequency are to have all spurious radiation at least 60 dB below the fundamental.

To meet this requirement (and to prevent a lot of RFI complaints) a 7-pole Chebyshev low-pass filter was built from data given in the 1982 *Radio Amateur's Handbook*, pages 6-11 and -12. Details of a filter with 0.01-dB of ripple and a 60-MHz cutoff frequency are given in Fig. 3. The coils can be wound on toroids, or be air-core types. Amidon T44-10 (or larger) cores should be adequate. The number of turns required will depend on core size or coil diameter, and can be calculated from data given on pages 2-12 and 2-30 of the *Handbook*. This filter reduced the second harmonic output to more than 65 dB below the fundamental (completely gone for all practical purposes). See Fig. 4.

# JFLINT

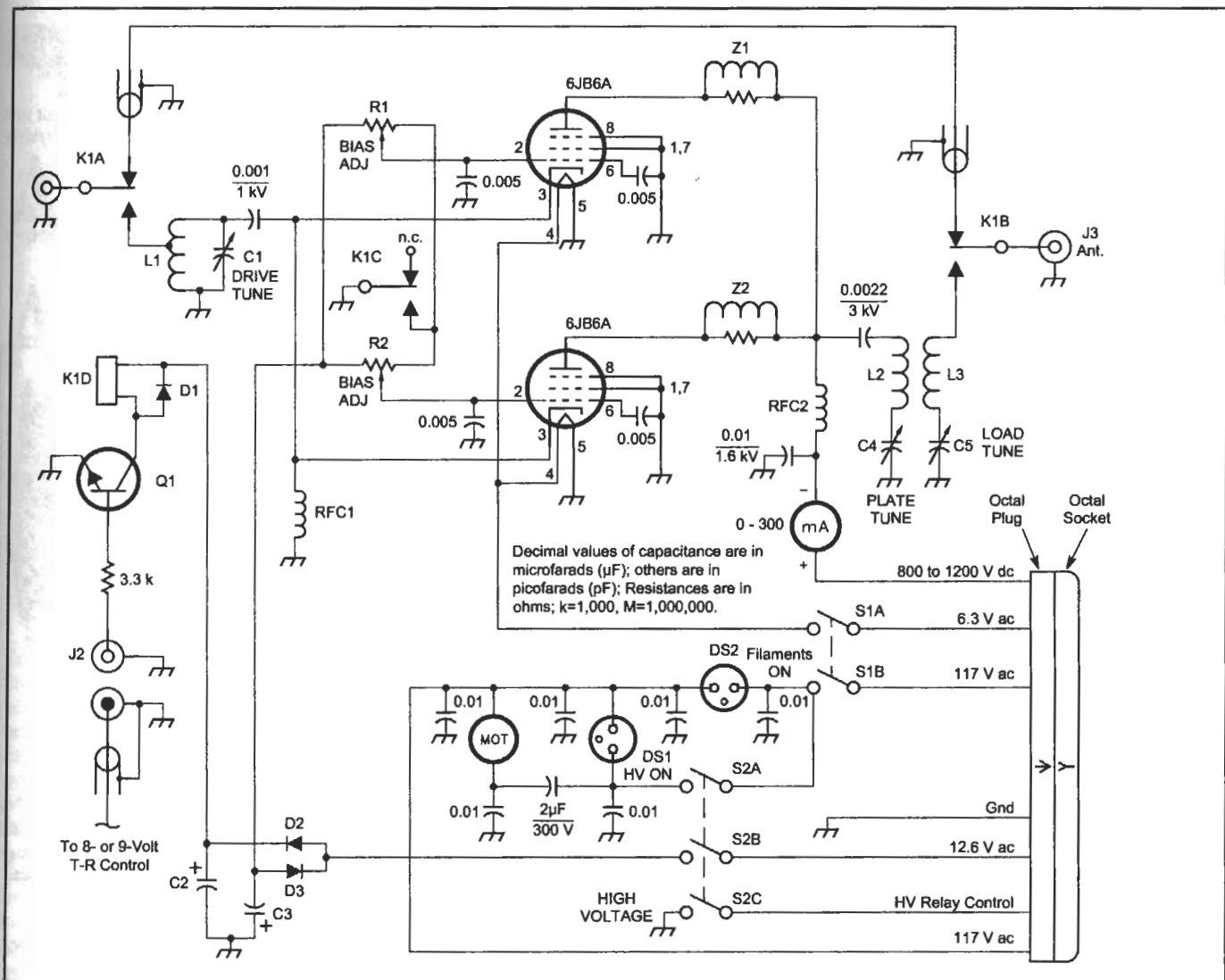

Fig. 1 — Schematic diagram of the 6-meter linear amplifier. The tube filaments can be wired in series, eliminating the need for a separate 6.3-V supply.

C1 — 50-pF miniature air variable, Cardwell 148-4 or equiv.  
 C2, C3 — 220-µF electrolytic, 50 V.  
 C4 — 25-pF air-variable, wide-spaced Hammarlund HF30X or equiv.  
 C5 — 100-pF air variable, Johnson 149-5 or equiv.  
 D1 — 1N914.  
 D2, D3 — 1 A, 50 V.  
 J1, J3 — SO-239.  
 J2 — Phono Jack.

K1 — 3pdt 12-V dc coil, rf type preferred, or KRP14DG.  
 L1 — 6 turns no. 14 enameled wire, 1/2-inch ID × 1-inch long, tapped at approximately 1 1/2 turns.  
 L2 — 5 turns no. 12 enameled wire, 1 1/2 inch ID × 2 1/2 inches long.  
 L3 — 2 turns no. 12 enameled wire, 1 1/2 inch ID × 1/2-inch long.  
 mA — 0-300 mA dc meter.  
 MOT — 117-V fan motor.

P1 — Chassis-mount octal plug.  
 Q1 — NPN power transistor, TIP31 or equivalent, (RS no. 276-2017).  
 R1, R2 — 10-kΩ, 2-W potentiometer.  
 RFC1 — 300-µH choke with ferrite bead on the ground lead.  
 RFC2 — 83 turns no. 28 enameled wire on a 1/2-inch diameter ceramic form. The coil is 2 inches long.  
 Z1, Z2 — 1 turn no. 16 enameled wire on 47-Ω, 2-W resistor.

## Construction

It should be possible to duplicate this amplifier for \$40 or less, depending on the status of your junkbox. Oddly enough, the tube sockets proved to be the most difficult component to locate, since they are not a common catalog item. The 6JB6 uses a 9-pin NOVAR socket, and the best source turned out to be a shop that specialized in TV replacement parts. Tuning capacitor C4 is a junkbox item of questionable parentage. Any spacing greater than about 0.060 inch (mm = inches × 25.4) should be okay. RADIOKIT of Greenville, New Hampshire would be a good source for all of the variable capacitors.

My amplifier is constructed on an 8 ×

10 × 2 1/2 inch chassis (BUD AC-1418) for a base, with 8 × 8-inch end panels. The panels were flanged with 1/2 × 1/2-inch aluminum channel for attachment of a can-metal cover for safety and TVI protection. Component placement is not critical, but all component leads should be as short as possible. The resulting layout was determined largely by some mid-project design changes aimed at making the unit compatible with a newly acquired IC-502. Visible on the lower-right front panel are potentiometers that were reserved for control of a planned rf-operated T-R relay.<sup>4</sup>

The tube sockets are modified slightly to ground the necessary tube elements. Copper washers, cut from flashing copper, fit inside

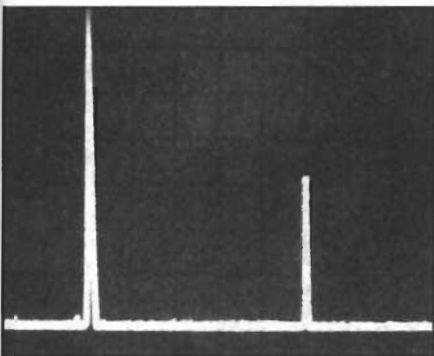

Fig 2—Spectral display of the amplifier output. Vertical divisions are each 10 dB, and horizontal divisions are each 10 MHz.

# JFLINT

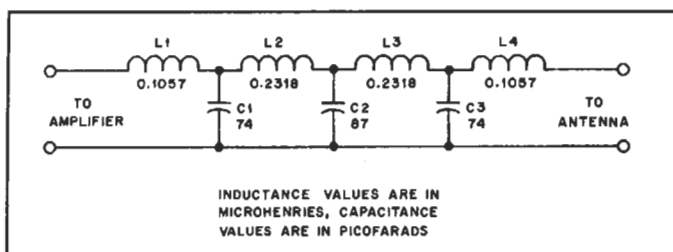

Fig 3—Schematic diagram of a 7-pole Chebyshev low-pass filter. Capacitors are silver-mica units, combined in parallel or series to obtain the design values. The text has information about winding the inductors.

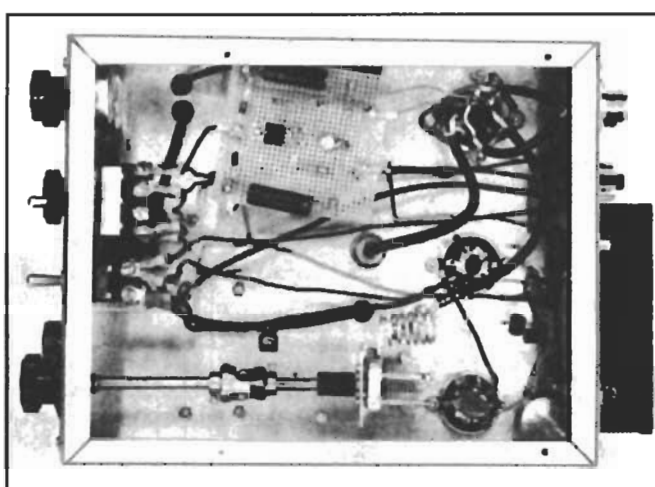

Fig 5—Bottom view of the amplifier chassis. Note the washers on the tube sockets, used to provide a ground connection for the appropriate pins.

the pins on the underside of the sockets. Pins 1, 4, 7, 8 and 9 are bent over and soldered to the washer. The washers are grounded to the chassis with short pieces of no. 14 wire on opposite sides of the socket. Pins 2 and 6 of both tubes are bypassed to ground by connecting 0.005- $\mu$ F disc-ceramic capacitors from these pins to the copper washers (Fig. 5). The control grids are raised above dc ground while providing a path for rf return. It also permits us to apply a dc bias to the control grid. This will establish the class of operation and cut the tubes off during receive, if desired.

Coils L1, L2 and L3 are wound with solid TW-insulated house wire from the local hardware store. I stripped the insulation from the wire before winding L1 and L2, but left it on L3 to prevent accidental contact with L2. The inside diameters shown are more the result of available cylindrical shapes than any electrical calculation. Coil spacing was adjusted, with the tubes in place, using a dip meter to ensure resonance at the proper frequency.

Heat-dissipating plate caps and a small fan provide cooling for the tubes. See Fig. 6. No thermal distress has been evident under any operating condition. The fan can be wired through S1 or S2, depending on whether cooling is desired during standby operation. Power connections to the fan should be isolated from the chassis.

A possible modification, shown on the

schematic diagram, involves the use of a 3pdt relay for K1. The ground legs of R1 and R2 can be wired through one of the normally open contacts. This lifts the potentiometers above ground in the receive mode, applying full bias voltage and cutting off the tubes.

The bias voltage source and relay driver are "hard wired" on a small piece of perf board. The signal for T-R switching is applied to J2. This +8-V signal is obtained from pin 6 of the IC-551 accessory socket. For use with other rigs, a 9-V battery, wired through a foot switch, works well. Current drain on this battery is low. An rf-operated T-R relay could be used in place of the directly keyed one described in this article. S2 disables the relay driver by removing the 12.6-V ac source in the standby position to permit straight-through operation.

### Tune-Up and Operation

Initial tune-up is simple and ordinary. Connect a dummy load and the power supply to the appropriate jacks. Any high-voltage power supply that has an output of 750- to 1200-V dc should be satisfactory. Turn on S1 and allow the heaters to warm up for a minute or more. Switch S2 to turn on the other voltages. Actuate K1 to ground the bias resistors, R1 and R2. Adjust R1 and R2 to obtain 15 mA of idling current for each tube (30 mA total).

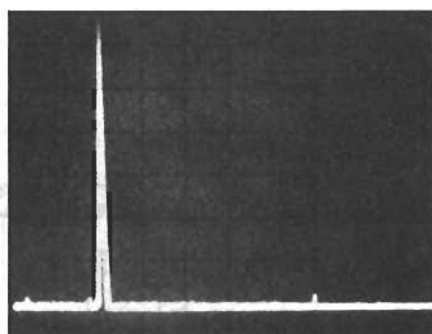

Fig 4—Spectral display of the amplifier output with a 7-pole Chebyshev filter. Vertical divisions are each 10 dB, and horizontal divisions are each 10 MHz.

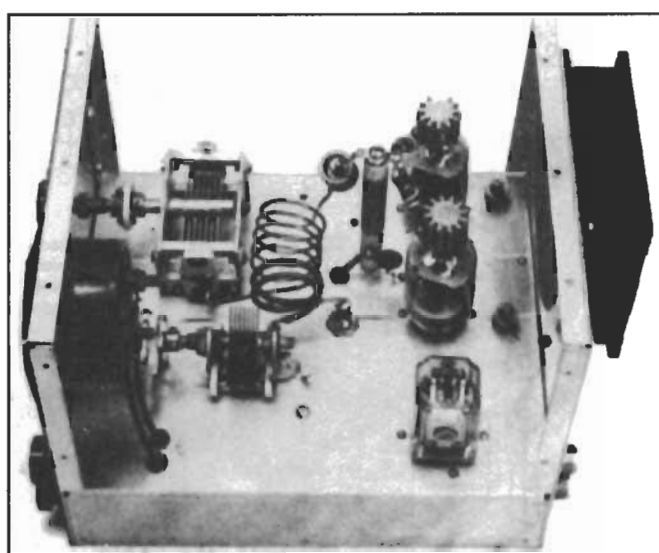

Fig 6—Top view of the Mini-Lini chassis. Large heat-dissipating plate caps and a fan help maintain cool operation of the tubes.

Connect the exciter to the amplifier through an SWR indicator. Actuate K1 and apply a small amount of drive. Adjust the position of the tap on L1 for minimum SWR. Be sure to remove all voltages each time you move the tap position!

Next, apply drive to the amplifier and adjust C1, C4 and C5 for maximum power output. For those lacking a wattmeter, an SWR indicator set in the FORWARD position can be used in the line between the amplifier and the dummy load.

### Conclusion

The Mini-Lini should be ideal for those looking for more output from their solid-state rigs. Typical operating parameters are 50 watts out for 10 watts of drive, with 1050-V dc on the plates. Reports of signal quality have been complimentary. Enhance your "equality" and come join the fun on 6! I would be happy to answer any questions about the amplifier — enclose an s.a.s.e., please.

### Notes

- <sup>1</sup>The design was taken from personal correspondence with Ed White, W4SRIA.
- <sup>2</sup>D. DeMaw, "Some Ground Rules for Sweep-Tube Linear-Amplifier Design," *QST*, July 1968, p. 30.
- <sup>3</sup>D. DeMaw, "Some Thoughts About TV Sweep Tubes," *QST*, Feb. 1980, p. 11.
- <sup>4</sup>D. DeMaw and J. Rusgrove, "An RF-Sensed Antenna Change-over Relay," *QST*, Aug. 1976, p. 21.





# JFLINT

By Stephen J. Powlshen, K1FO

From QST, October 1979

## A Grounded-Grid Kilowatt Amplifier for 432 MHz

Stable, linear operation for tropo or moonbounce DX... that's the end result of this project.

In the last few years I've built several high-power 432-MHz amplifiers that used tubes from the 4CX250 family. While they worked well in Class C, their performance when biased for linear operation left something to be desired. My previous experience with grounded-grid triode amplifiers on 2 meters was so good that I decided to try the same approach on 70 cm. An Eimac 8874 high-mu triode was selected for this design and a crude prototype was built in a few evenings. After the design was verified, the amplifier described in this article was built. It is stable, compact and delivers over 500 watts output while re-

quiring only a high-voltage supply and a source of about 25 watts of drive. The amplifier has been trouble free in over three years of heavy usage.

### Circuit Description

A schematic diagram of the 432-MHz kilowatt is given in Fig. 1. W1 is a half-wavelength stripline which is tuned and loaded by C6 and C7 respectively. Plate choke RFC4 is connected at the approximate electrical center of the plate line. C8 functions as the plate-bypass capacitor. The half-wavelength cathode line is comprised of W2, L2 and C2. L1 and C1 serve

to match the tube input impedance to the amplifier 50-ohm input. As the grid is grounded for dc as well as rf, D1 is used to develop operating bias at the cathode. R3 is switched in to supply near-cutoff bias during standby periods. M1 is used solely to monitor plate current in the high-voltage supply negative-return lead. M2 is switched to read grid current, high voltage and relative output. The latter function is by means of an external line sampler.<sup>1</sup> With the exception of the multimeter functions the metering and bias circuits are similar to those in a 220-MHz amplifier.<sup>2</sup>

Separate coaxial relays attached to the

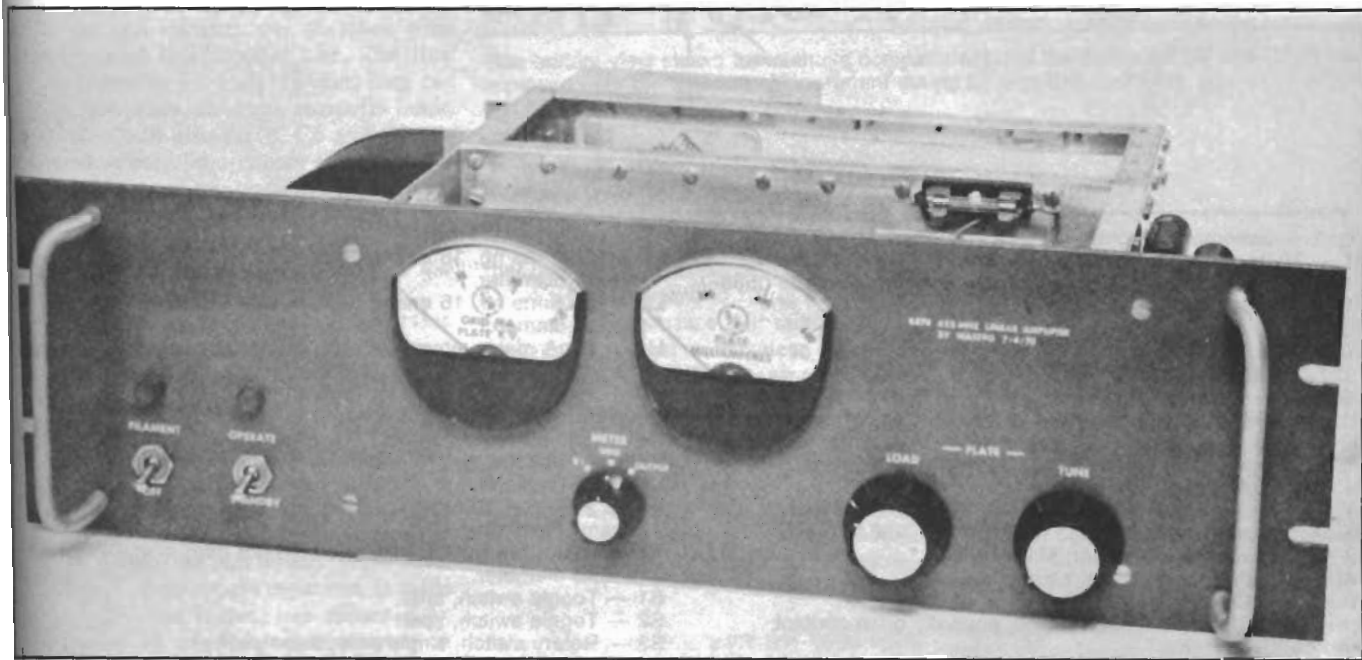

The high-power uhf amplifier. The toggle switches control filament power and standby/operate functions respectively. Multimeter function is selected with the switch located between the meters, while the plate tuning and loading controls are at the right. Modern knobs and homemade meter faces give the amplifier a commercial appearance.



## A Quarter-Kilowatt 23-cm Amplifier

Imagine, a linear amplifier with great efficiency and long-term stability that is super quiet and small in size. Sounds like HF? Not exactly...

To me, there is nothing more frustrating than having to dig through a construction article to find out exactly what performance you can expect from the finished product. So here it is:

- 1) Grounded-grid 7289/2C39 cavity amplifier, single tube.
- 2) Linear operation (what you put in, you get out, only more of it).
- 3) Covers 1240 to 1300 MHz.
- 4) Power gain ranges froth 12-20 dB depending on output power, input power, loading, anode voltage and grid bias voltage.
- 5) 50-ohm input and output — no stub tuner required.
- 6) Power output greater than 200W with about 12-W drive.

This is Part 1 of a two-part article. In this installment, I describe the design and construction of the RF deck. Part 2 describes power-supply construction, testing and operation.

This amplifier is a tried and proven design. Much development work has gone into this project. The amplifier works well, is reliable and can be duplicated. More than 50 of these amplifiers have been built to date. I have successfully worked many 1296-MHz EME (earth-moon-earth) stations with one of these amplifiers and a 384-element loop-Yagi array during the past year. Amplifiers of this design were used on both ends of the first California-to-Hawaii QSO on 1296 MHz. Another unit has logged more than 20,000 hours of continuous operation at the KH6HME beacon.

### General Design Approach

A cavity amplifier is similar to a conventional amplifier designed for lower frequencies. The tube anode excites a resonant circuit, and power is in turn coupled into a load, usually 50 ohms. Instead of using coils and capacitors, as at lower frequencies, the

cavity provides the resonant circuit necessary to tune the amplifier output.

The anode cavity of this amplifier is a squat cylinder. Cylinder height is set by mechanical tube requirements. The inside diameter of the cylinder sets the highest resonant frequency. Any capacitance added from the top to the bottom of the cavity will lower its resonant frequency, as will increasing the cavity diameter.

This amplifier uses 1/8-inch-thick copper plates for the cavity top and bottom, and a thick-wall aluminum ring, cut from tubing, for the walls.<sup>1</sup> This heavy construction virtually eliminates all resonant-frequency variations caused by thermal and mechanical changes.

Fig. 1 is a schematic diagram of the cavity amplifier. The circuit is simple. Filament voltage and cathode bias enter the RF deck through feed-through capacitors

(C4, C5) and RFC1 and 2. High voltage is fed to the anode through RFC3. C8, the anode bypass capacitor, is homemade from Teflon® dielectric sandwiched between a copper plate and the chassis.

The input pi network easily tunes the entire band at any power level. It is made from two Johanson piston trimmer capacitors and a "coil" made from copper wire. An input cavity is not necessary at 23 cm.

Output coupling is through a rotatable loop that serves as a variable loading control. This allows amplifier-tuning flexibility; it may be tuned for maximum gain or for maximum power. Light loading can produce stable power gains of up to 20 dB.

Amplifier tuning is accomplished with a homemade cylindrical coaxial capacitor with Teflon dielectric (C6). There are no moving metal parts to cause erratic performance. The Teflon rod/tube screws in and

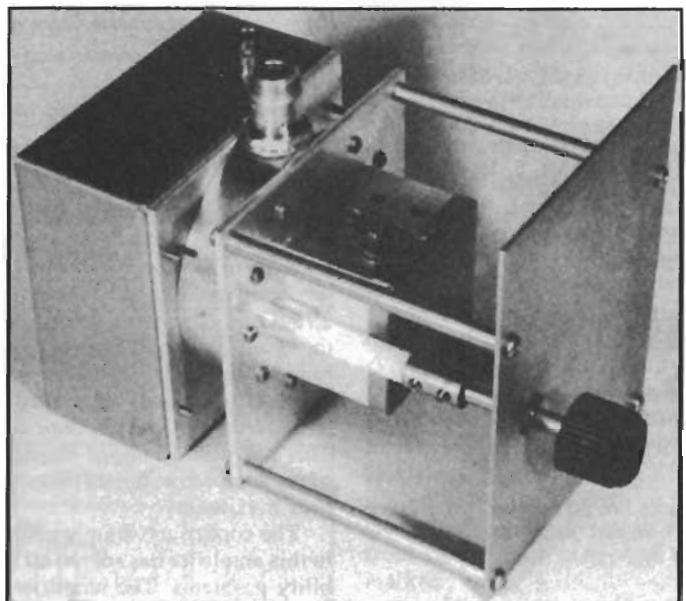

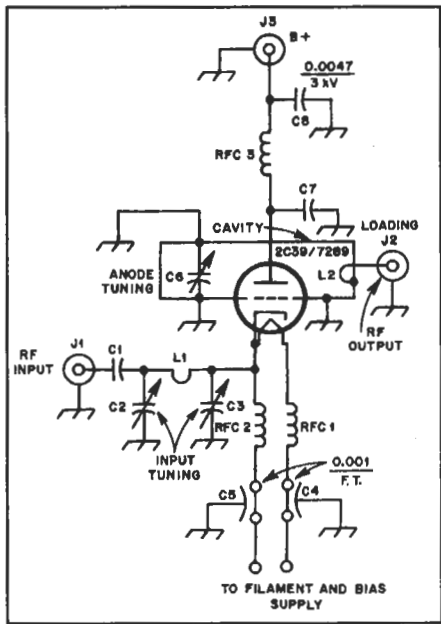

Fig. 1 — Schematic diagram of the 23-cm amplifier.

- C1 — 3-pF dipped mica capacitor.
- C2, C3 — 1- to 10-pF piston trimmer capacitor (Johanson no. 3957, 5201 or equiv.).
- C6 — Anode-tuning capacitor. See text and Fig. 11.
- C7 — Anode-bypass capacitor, 90 pF. Homemade from copper plate and Teflon sheet. See text and Figs. 5, 12 and 15.
- C8 — Disc ceramic, 0.0047- $\mu$ F, 3-kV capacitor.
- J1 — 5-mm SMA connector, chassis mount, female.
- J2 — Modified Type-N connector. See text and Fig. 7.
- J3 — Female chassis-mount BNC connector.
- L1 — Loop of no. 18 bus wire soldered between C2 and C3. See Fig. 15.
- L2 — Output-coupling loop. Part of output-connector assembly. See text and Fig. 7.
- RFC1, RFC2 — 5 turns no. 20 bus wire,  $\frac{3}{16}$ -inch ID.
- RFC3 — 3 turns no. 20 bus wire wound on a 20-ohm, 1-W carbon-composition resistor.

out of the coaxial capacitor, increasing or decreasing the capacitance by changing the amount of Teflon dielectric inside the cylinder. With the rod all the way in, the dielectric is all Teflon; with the rod all the way out, the dielectric is all air.

Teflon has a relative dielectric constant (relative to air = 1) of 2.05, which means that the value of the capacitor with the rod all the way in is twice the value of the capacitor with the rod all the way out. Full capacitance will pull the resonant frequency of the amplifier down to 1240 MHz. Use of only one tuning adjustment means the amplifier will have more gain because cavity shunt capacitance has been minimized.

### Thermal Considerations

The cavity walls are formed by a thick-wall aluminum ring, which is sandwiched between two thick copper plates. RF and

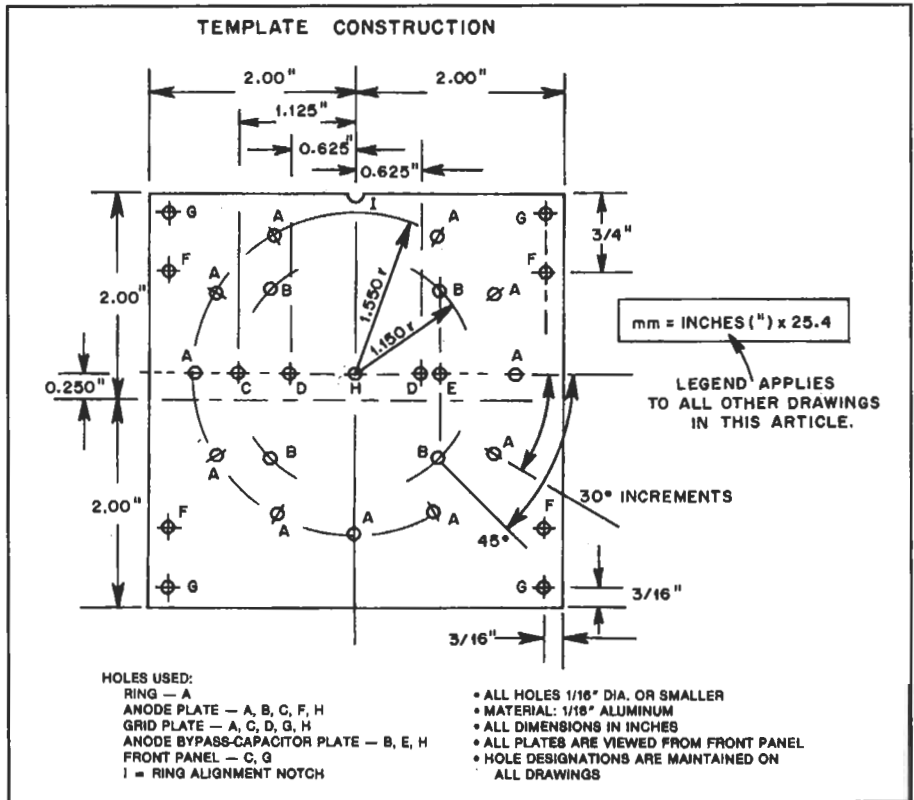

Fig 2—Complete dimensions for the aluminum template.

thermal properties of these two metals are reasonably close, whereas brass is rather poor in both respects. The 7289/2C39 tube used in this amplifier is being run at 2-2½ times its normal dissipation rating; therefore it's important to have a cavity that remains thermally stable.

Most previously described amplifiers have used sheet brass in their construction. This has usually meant constant retuning of resonance to maintain output power at or near maximum.

The copper and aluminum construction in this amplifier has solved all thermal stability problems. The amplifier can easily be run key down for over an hour at 200-W output without retuning. This, of course, is obtained only with a good tube and water cooling. A practical water cooling system will be described in Part 2 of this article.

Water cooling keeps the internal structure of the tube thermally stable. When air cooling is used for output levels of 100 to 150 W, output power fluctuations are a direct result of internal tube changes. These changes vary from tube to tube and must be tested for. In some cases, otherwise perfectly good RF tubes have had poor thermal stability. Such tubes can make good drivers at lower power levels.

### "Using Simple Hand Tools Will . . ."

Hand tools are great if you are skilled and patient. Most people want to hurry up and finish their new project. If that's you, then have a machine shop make all of the parts, leaving you only the final assembly. It should cost about \$200. The parts are not

difficult to fabricate, but the process is time consuming. If you have the time and patience to do it yourself, this amplifier can be very inexpensive.

### Gathering the Materials

All of the materials used in this amplifier are fairly common and should be available from suppliers in most metropolitan areas. Some suppliers have "short sale" racks, where they sell odd pieces cut off standard lengths or sheets at reduced prices. The parts for this project are small enough to be fashioned from cutoff stock, Surplus-metal houses have some great buys, so start there if one is nearby.

The key to successfully completing this project is careful layout work before cutting or drilling any parts. Invest in a can of marking dye, a sharp scribe, an accurate rule, vernier calipers and several center punches. These tools are available at any machinists' supply shop. The marking dye will make cutting and filing lines much easier to see. Measure all dimensions as carefully as you can and then recheck them before cutting. Mark with a sharp scribe because the sharper the scribe, the finer the marked line, and the finer the marked line, the closer your cut will be to where it should be. Remember—the accuracy of your drilled holes is only as good as your center-punching ability, so use a fine punch for the first mark and then a bigger one to enlarge the mark enough for drilling.

Access to a drill press is a must. It's extremely difficult to drill holes accurately with a hand drill. Although they are

not absolutely necessary, you should have access to a lathe or milling machine.

Other tools that will aid you with this project are a nibbling tool, a set of punches, a new set of files and some sharp drill bits. If you don't already have one, purchase a file card to clean metal shavings out of your files as you work. Clean, sharp files are faster and more accurate to work with. You'll also need an assortment of sandpaper for the final finish work.

## The Template Approach

I highly recommend fabrication of a single template for marking and drilling the anode plate, anode bypass capacitor, cavity ring, grid plate and front panel. The template shown in Fig. 2 has all of the holes for these parts. If you use the template, you'll only have to make the careful measurements once — after that, it's simple to mark and drill the rest of the parts.

The template approach offers several other advantages. A template makes it much easier to maintain accuracy between the anode plate, cavity ring, grid plate and front panel; these parts will fit perfectly because they were all drilled from the same master. The template approach also makes it possible to set up a small production line if you decide to build more than one of these amplifiers and combine them for higher power, or if a friend wants to build an amplifier along with you.

See Fig. 2 for complete template dimensions. Start with a piece of 1/16-inch-thick aluminum stock that is larger than you need and degrease it with soap and water. Dry it off and spray it with marking dye. Scribe a 4-inch square on the stock and cut the template to size. A shear will make this job much easier, but it can be cut with hand tools and filed to size.

Carefully measure and scribe all holes. Note that holes A and B are on the circumference of circles. Use a compass to scribe the circles, and then locate the holes. After you have marked and checked all holes, centerpunch and drill them. The holes should be drilled with a 1/16-inch or smaller bit. Recheck all measurements. If you goof, start again. The time you spend making the template as perfect as you can will save you much time and aggravation when you make and assemble the other parts.

When you finish the template, mark the front side for future reference. All plates made from the template are marked and drilled from the front side (as viewed from the front panel).

## Making the Copper Plates

Once you have completed the template, it will be easy to make the copper plates. The anode plate, grid plate and anode-bypass-capacitor plate are all made from 1/8-inch-thick copper. See Figs. 3, 4 and 5 for the dimensions of these pieces.

Measure and cut the three plates to the proper dimensions. Carefully break (deburr) all sharp edges to avoid small cuts to your fingers and hands.

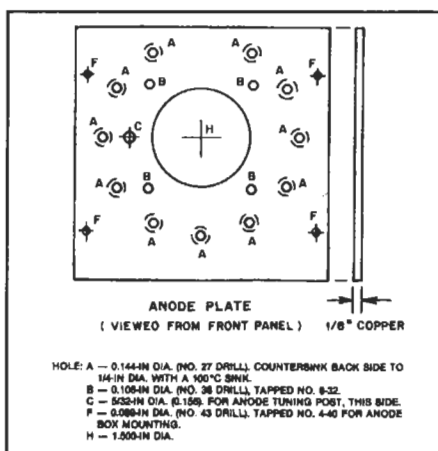

Fig 3—Drilling details for the anode plate. See Fig 2 for additional information on hole location.

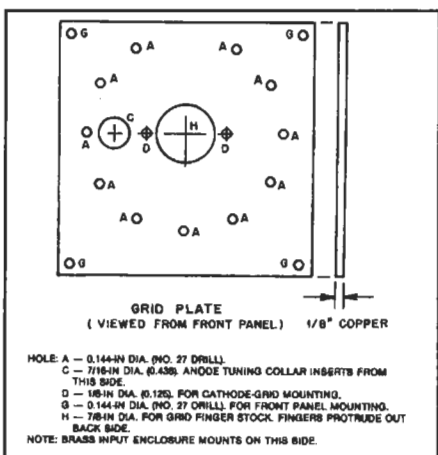

Fig 4—Drilling details for the grid plate. See Fig 2 for additional information on hole location.

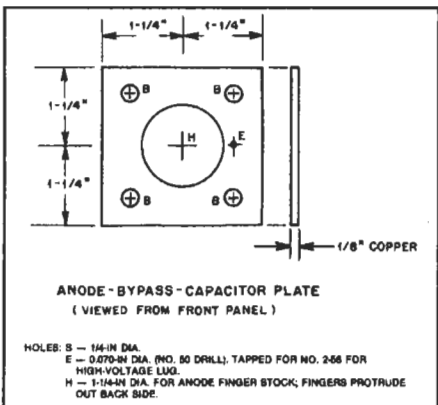

Fig 5—Drilling details for the anode bypass capacitor plate. See Fig 2 for additional information on hole location.

Clean the plates with alcohol and spray them with marking dye. Clamp the aluminum template to each plate, and carefully scribe the correct holes. Remember that all plates do not have the same holes. The anode plate uses holes A, B, C, F and H; the grid plate uses holes A, C, D, G and H. The anode-bypass-capacitor plate uses holes B,

E and H.

Use a small center punch to punch all holes lightly. If they then look accurate, enlarge them enough for drilling.

Copper isn't the easiest metal to work with. It's very stringy, and drilling it can be frustrating. You'll need the proper drill bits for best results. Special drills can be purchased, or you can use a grinder to carefully remove the sharp points on the outer edge of the cutting surface of each side of a standard drill bit. This will eliminate any tendency for the copper to grab. Practice on an old bit and be sure to grind it symmetrically. Modified drill bits can still be used on aluminum and other metals.

Always start with a smaller drill and work up to the final hole size. It's safer and more accurate. The larger holes can be cut with a flycutter, or you can drill a series of smaller holes around the inside of a larger hole and file to finish. Either way is fine. Use lots of cutting fluid to lubricate the drill bit, and wear safety glasses and an old shirt. Remember, some cutting fluids are not to be used on aluminum.

Start with a no.50 (0.070-inch) or smaller bit and drill pilot holes at each of your punched marks. The details for finishing each hole are listed in the drawings. Some holes are countersunk or tapped. Pay attention to the details, and take your time.

When you are through drilling, you must deburr each hole. Copper is soft, so it tends to rise up around the hole during drilling and deburring. Use a flat file for the initial cut, and then remove any remaining material with a countersink. File the copper plates flat again; a flush fit on both sides of the aluminum ring is important.

When all copper work is done, you should be able to stack the plates and see all pertinent holes align correctly. Enough tolerance is included in the dimensions to accommodate minor errors. After the holes are drilled, it can be difficult to tell which side of each plate is which, so mark the front side of each plate with a permanent marker.

## Machining the Ring

The aluminum ring that forms the cavity wall is cut (sliced) from a length of 3 1/2-inch OD tubing with a 3/8-inch wall thickness. See Fig. 6. The tubing ID is about 2 3/4 inches. The dimensions of the ring are the most critical in this amplifier. Tolerance of the ring thickness is  $\pm 0.005$  inch to maintain full band coverage.

The ring can be hacksawed or bandsawed out of the tubing, but take extreme care to be accurate. Cutting tubing straight isn't easy. Clamp the tubing to prevent rotating on the band saw. The final finish cut is best done on a lathe or milling machine, but careful filing will work.

Once the ring is the correct thickness, deburr the sharp edges and spray it with marking dye. Notice that the outside and inside diameters are not concentric. This is normal for large tubing. Lay the ring flat and find the thickest wall section. Scribe a

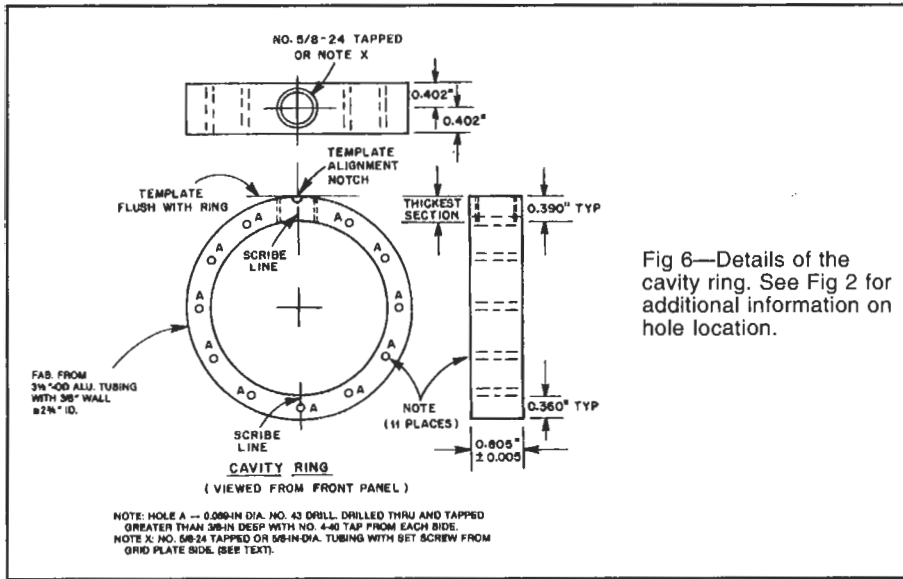

Fig 6—Details of the cavity ring. See Fig 2 for additional information on hole location.

pensive, but a tap and die for Type-N connectors are handy if you do much building.

If you don't have access to a lathe or a large tap, the second method is easier. Make the output connector coupling sleeve from 5/8-inch-OD brass or copper tubing, and drill the ring to just clear it. Then drill and tap the grid-plate side of the ring above the output connector to accept a setscrew. Also, drill a clearance hole in the grid plate for the setscrew. Use the setscrew to secure the output connector.

### Output Connector

A standard Type-N chassis-mount female connector (silver plated) is used for the output probe/connector. See Fig. 7. First, remove the flange with a hacksaw and file flush with the connector body. Next, make the output-coupling sleeve that is right for your application (threaded or unthreaded, depending on how you fabricated the ring). The sleeve will be the same length in either case. The output-coupling loop is fashioned from a piece of 0.032-inch-thick copper sheet that is 3/32 inches wide. Bend it to the dimensions shown in Fig. 7. We will solder the output connector together later.

### Grid Compartment

The grid compartment measures 2 inches square by 1 1/2 inches high. See Fig. 8. It is made from brass and can be sawed out of square tubing or bent from sheet. The cover can be made from any material.

I use two small PC boards (Fig. 9) for

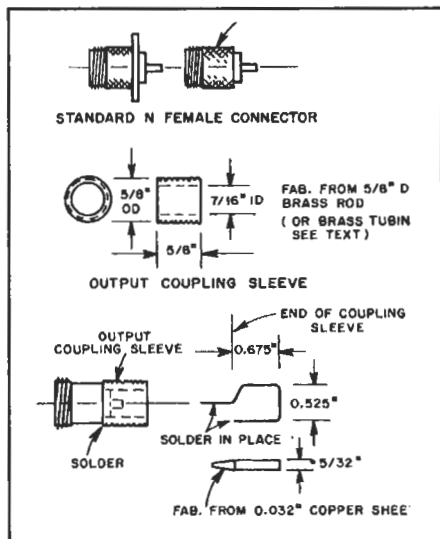

Fig 7—Output-probe/connector assembly details.

line across the wall at this point, across the center of the ring and across the wall on the other side. The scribed lines on each side of the ring will be used to align the template. The output connector will be placed at the thick wall section.

Carefully align notch I on the template with the line scribed on the thickest wall section on the ring. Clamp the template onto the ring. Mark each of the 11 holes labeled A on the template. After you mark the holes and remove the template, check alignment with the copper plates just in case. If everything lines up, center punch all eleven holes on one side of the ring only, and drill each hole completely through the ring. Use lots of cutting fluid. File the ring flat before and after deburring, taking care not to change the wall thickness. Tap each hole to accept no. 4-40 machine screws. Each hole will have to be tapped to a depth of at least 3/8 inch from both sides because

long taps don't exist. The inside of the ring doesn't need to be polished.

The hole for mounting the output connector can now be drilled. There are two ways to mount this connector, and either scheme works fine. Read ahead to the section on making the output connector for more information. The first method of mounting the connector involves tapping the ring with a no. 5/8-24 tap and using a lathe to cut matching threads on the output connector coupling sleeve. Large taps are ex-

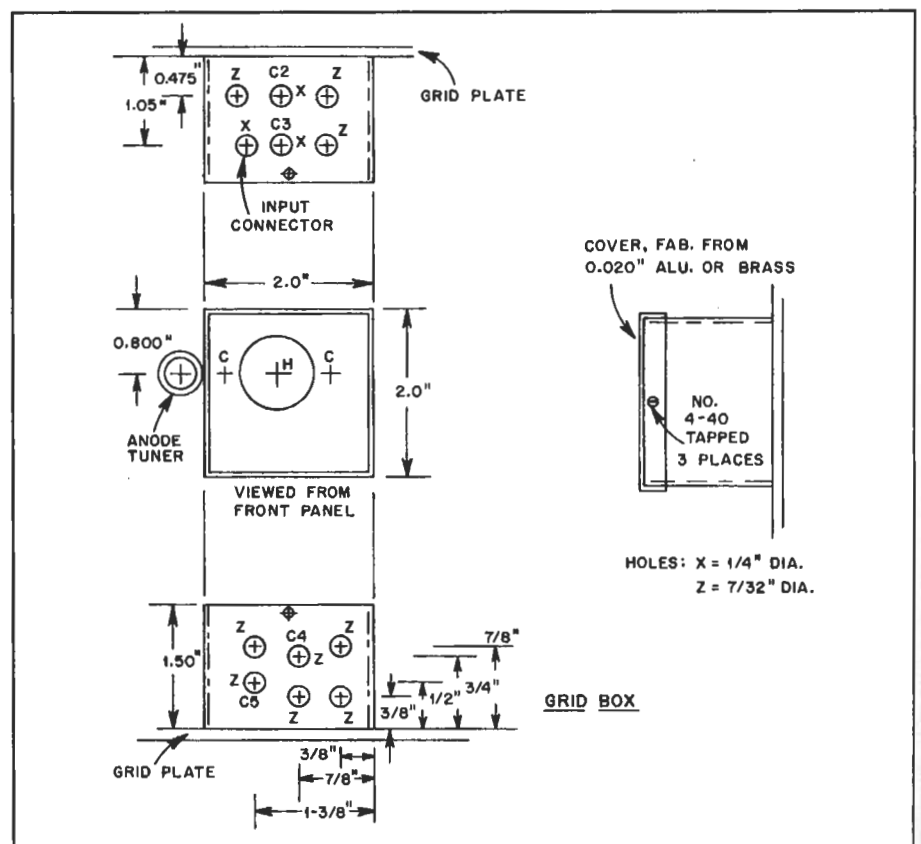

Fig 8—Input-compartment details.

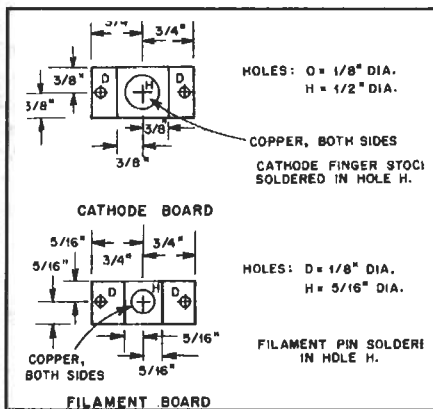

Fig 9—Cathode and filament PC-board details.

holding the finger stock that makes contact with the filament pin and cathode ring on the 2C39 tube. These boards are cut from 1/16-inch-thick, double-sided G-10 glass-epoxy stock. The copper pattern is identical for both sides of each piece. Mark and drill or file the holes first, and then cut the boards to size. Small boards are difficult to hold while drilling them. Mark each side of each board and score the copper foil with a sharp knife.

The unwanted copper can be removed easily by heating the foil with a soldering iron and lifting it off. Use a flat file to deburr the boards. Do not use a countersink because the copper foil must be as close to the holes as possible to facilitate soldering the finger stock in place.

The input connector that I use is a 5-mm SMA type. This is an excellent RF connector, especially for low-power UHF appli-

cations. I highly recommend use of an SMA, but any small screw-on connector will do. If you really feel you have to use a BNC then do so, but it's a lousy connector at frequencies above 200 MHz. Remember to move the connector hole to accommodate its larger size.

The input connector must be as close as possible to the first input capacitor. The lead length of the input dc blocking capacitor must be as short as possible. The 3-pF capacitor is series resonant at 1200 MHz only with short (1/16-inch or less) leads.

### Miscellaneous Bits and Pieces

There are still several small, but very important parts to fabricate. The front panel I use is shown in Fig. 10. It is made from a piece of 1/8-inch-thick aluminum sheet. Some builders may wish to mount the amplifier on a rack panel. Wash and dry your front-panel material and spray it with marking dye. Clamp it to the template and mark the holes. Check the hole alignment with the copper grid and anode plates. If all lines up correctly, center punch and drill the holes. The only front-panel control is for the anode tuning capacitor, which is adjusted by a 1/4-inch shaft protruding through a 3/8-inch panel bushing in hole C.

The anode tuning collar, shown in Fig. 11A, is made from a piece of 1/2-inch OD brass rod. This rod has a 3/8-inch hole drilled through its center, and it is turned down to 7/16-inch OD for half its length. The inside of the 1/2-inch-OD end is tapped to a depth of 1/4 inch to accept 3/8-24 threads. This collar will be inserted into hole C on the grid plate.

Fig. 11B also shows the anode tuning post. It is simply a length of 5/32-inch-OD

brass rod that inserts into hole C on the copper anode plate. This rod will form one plate of the anode tuning capacitor.

The anode tuner (Fig. 11C) is machined from a piece of 3/8-inch-OD Teflon rod. One end of the rod is drilled out with a no. 21 drill. The outer wall of this end is threaded with a no. 3/8-24 tap. This is the end that will thread into the anode tuning collar and slip over the anode tuning post. The other end is turned down to fit inside a 1/4-inch shaft coupler.

Fig. 12 shows the remaining parts. The tuning shaft (A) is made from a piece of 1/4-inch brass rod. A coupler (B) to connect the tuning shaft to the anode tuner may be purchased or made. This also applies to the front-panel spacers (C). The Teflon dielectric for the anode bypass capacitor (D) is made from 0.010-inch-thick Teflon sheet. Use the template to locate holes B and H. Teflon washers and inserts (F) are used to insulate the mounting hardware for the anode bypass capacitor from the chassis. The inserts are made from 1/4-inch-OD Teflon rod. The washers are made from Teflon sheet. Sharpen a piece of 3/8-inch aluminum tubing and chuck it up in a drill press. This tool will cut neat, round washers from the sheet.

The box that encloses the anode compartment (Fig. 13) is fabricated from a Bud AU-1083 utility cabinet. Clean the chassis and spray it with marking dye. Secure the template to the side of the enclosure that contacts the anode plate and scribe the holes labeled F. Make sure that these holes line up with the holes on the copper anode plate. If they do, center punch and drill them to size. If air cooling is used, the blower will mount to this box.

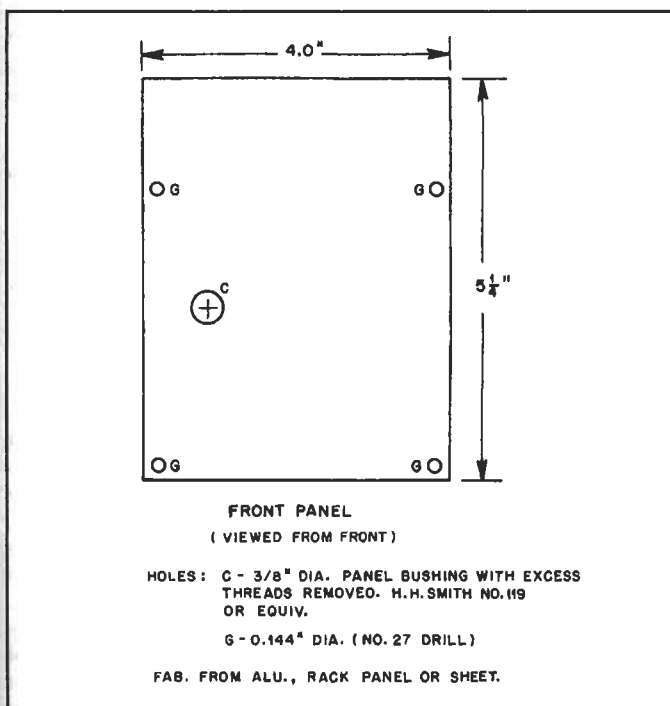

Fig 10—Front-panel details.

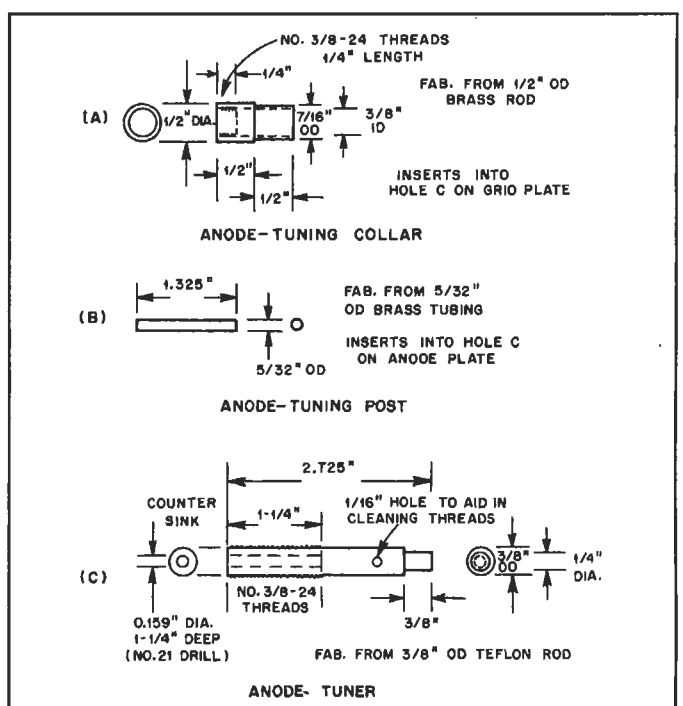

Fig 11—Anode-tuning capacitor details.

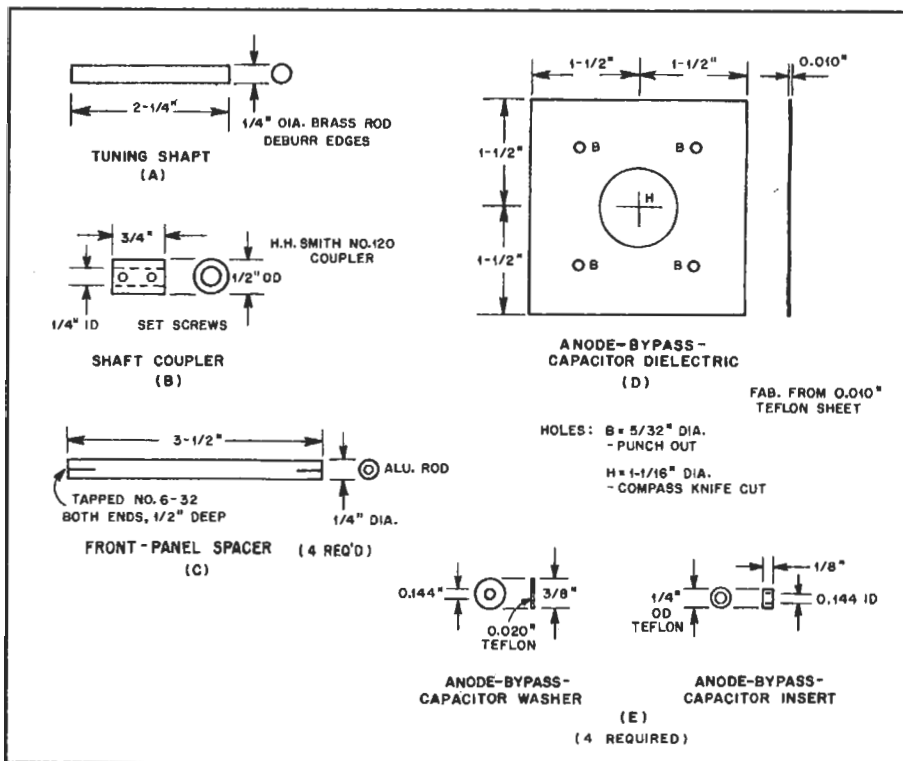

Fig 12—Miscellaneous parts necessary to complete the amplifier.

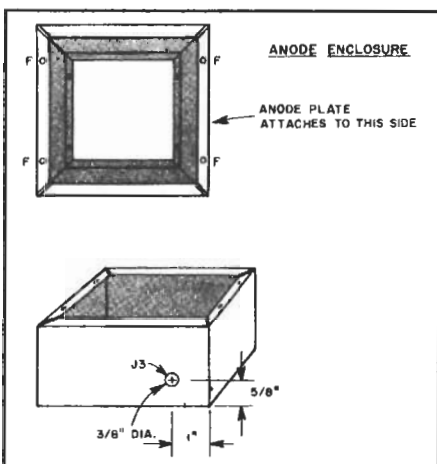

Fig 13—Anode-enclosure details.

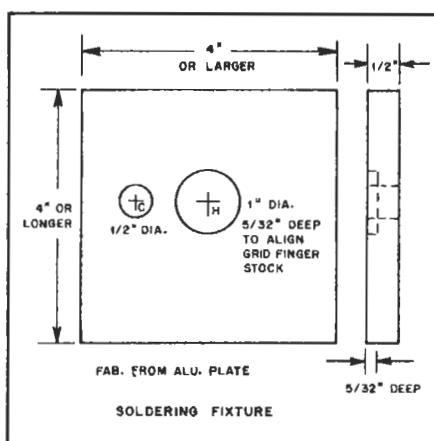

Fig 14—Dimensions of the soldering fixture. See Fig 2 for more information on hole location.

## Soldering the Subassemblies

Once all copper and brass parts are drilled and deburred, they should be cleaned with alcohol and Scotch-Brite<sup>®</sup>, a nonmetaffic pot cleaner, and washed in alcohol again. Set the pieces aside and avoid touching them. Fingerprints will inhibit soldering.

I have found that the best way to solder the heavy brass and copper parts is to first build the soldering fixture shown in Fig. 14. This soldering fixture, made from 1/2-inch-thick aluminum plate, will evenly heat the entire assembly to be soldered. Even heating will allow you to do a much better soldering job than you could otherwise.

The soldering fixture should be preheated on a stove or hot plate until bits of solder placed on its surface just melt. At this

point, reduce the heat slightly. Avoid excessive heat. If the copper parts placed on the fixture suddenly turn dark, it's too hot.

Solder the grid plate assembly first. You will need the copper grid plate, grid finger stock, anode tuning collar and brass input compartment.<sup>2</sup> Look at the drawings again to be sure that you know which parts go where. Insert the grid finger stock into hole H on the grid plate. As viewed from the front-panel side, the curved fingers will protrude out the back side, away from you. Apply liquid or paste flux and set the grid plate in the soldering fixture. The finger stock will fit in hole H in the fixture, allowing the grid plate to rest flush with the surface of the fixture. Next, apply flux to the anode tuning collar and insert it in hole C of the grid plate. Part of the tuning collar will

slip into hole C in the soldering fixture. Make sure the collar seats flush with the grid plate. The flux should start to bubble.

Carefully apply solder directly to the joints of the installed parts. The solder should melt almost immediately and flow bright and smooth. Next, place the square brass input compartment in place and apply flux. In a few seconds, it can be soldered by running solder around the joints, inside and outside. If you have trouble getting it to flow on both sides, merely tap the brass box aside (1/16 inch) and return it to its original position.

Now comes the hard part — getting the soldered assembly away from the heat without disturbing the alignment. A pair of forceps is recommended, but long pliers will do. Carefully lift the assembly off the soldering fixture and set on a cooling rack. Do this without moving any part. The cooling rack can be any two pieces of metal that will allow clearance for the protruding parts. You can expedite cooling by using an ordinary hair dryer in the "cool" position to gently blow air across the assembly.

While the grid assembly is cooling, assemble the output connector. See Fig. 7. Place the modified Type-N female connector, threaded end down, on the soldering fixture. Apply flux to the top and install the output coupling sleeve. Allow both parts to heat before applying solder. Carefully remove the soldered output connector from the fixture. When it has cooled, solder one end of the loop to the center pin of the N connector and the other to the output coupling sleeve.

Now place the anode plate on the soldering fixture and allow to heat. Apply flux to hole C. Insert the anode tuning post (5/32-inch-OD brass tube) and allow to heat; apply solder. Remove the parts and cool. Next, solder the finger stock in hole H on the anode bypass capacitor plate.<sup>3</sup>

This completes the work with the soldering fixture. Be sure to let it cool off before handling! Save the fixture for future construction; you never know when you might want it again.

The anode plate and the anode-bypass-capacitor plate must be filed and then sanded flat on their butt surfaces to assure that there are no solder bumps or sharp points to puncture the Teflon dielectric. This must be done after soldering. The Teflon sheet is adequate insulation for many times the anode potential of this amplifier, but only if the surfaces it separates are smooth!

Next, clean the cathode and filament PC boards. Install the fmgner stock in hole H of the cathode board. Apply flux to both sides of the board. Heat with a hot iron and apply solder around the circumference of hole H, soldering the finger stock on both sides of the board. Use the same technique to install the filament pin.<sup>4</sup>

After all parts have cooled, use a spray can of flux remover to clean them. Slight scrubbing with Scotch-Brite pot cleaner will finish them nicely. Congratulations: You have finished the pieces and are now



# JFLINT

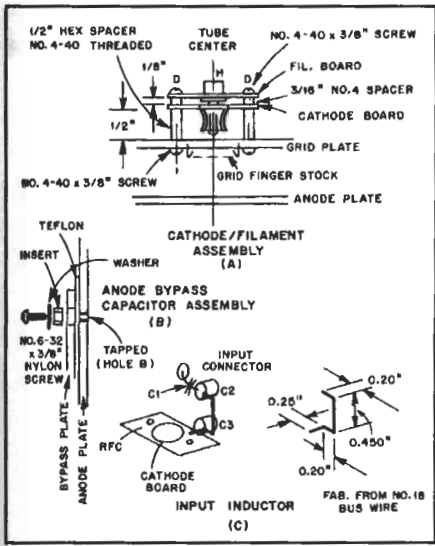

Fig 15—Assembly details for the filament and cathode boards (A), the anode-bypass capacitor (B) and the input pi network (C).

ready to bolt the amplifier together.

## Silver Plating

Over the years, many people have pushed silver plating as the only way to go. You may wish to silver plate the amplifier components before soldering them together, but I do not think it's necessary. I ran several tests to prove how much various types of plating affect performance of this amplifier. Remember that the RF skin conductivity of aluminum and copper is pretty good at 23 cm; they are much better than brass.

Four amplifiers were built for this test. They were plated as follows:

- 1) Nickel plated
- 2) Tin plated
- 3) Silver plated
- 4) Unplated

There was no difference in performance among the tin-plated, silver-plated and unplated versions. The nickel-plated amplifier exhibited 3-dB less gain.

In other words, it is not necessary to silver plate this amplifier; however, it does improve appearance by making the parts a similar color. Silver does tarnish, especially with fingerprints. The decision to plate or not to plate is up to you.

## Assembly

After fabrication of all parts, assembly is simple. Figs. 15 through 17 show assembly details. Loosely fasten the grid and anode plates to the ring. Mount the input connector and capacitors on the input compartment. Loosely install the cathode and filament boards and their respective spacers. See Fig. 15A.

Now insert a 7289/2C39 tube. This will center up all finger stock. Place the Teflon anode tuner in its collar on the grid plate and screw it most of the way in. Now tighten all of the screws. The 7289/2C39 tube should slide in and out snugly, and the anode tuner should screw in and out smoothly.

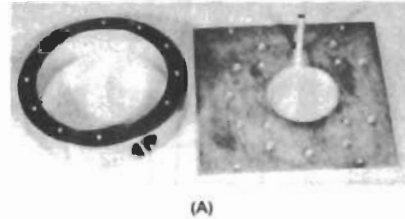

(A)

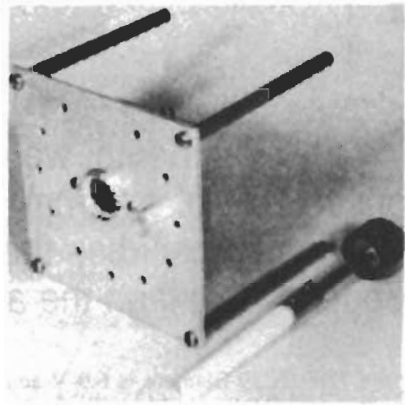

(B)

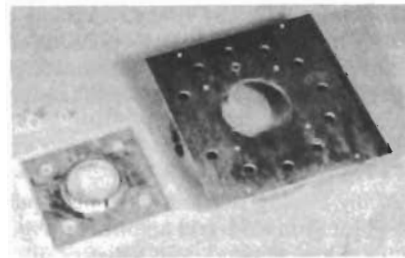

(C)

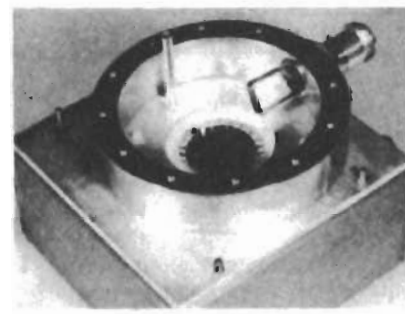

(D)

Fig. 16—The completed cavity ring and anode plate with anode tuning post soldered in place are shown at A. The photo at B shows the grid plate with finger stock, input compartment and anode tuning collar soldered in place. The completed anode tuner is at the right. C shows the cavity ring attached to the anode plate. The anode-bypass capacitor is ready for installation. At D, the interior of the cavity as seen from the grid plate side is visible. The output probe/connector assembly is installed. The anode bypass capacitor and anode enclosure have been installed on the anode plate.

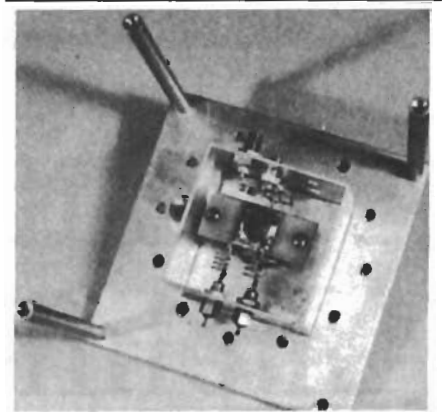

(A)

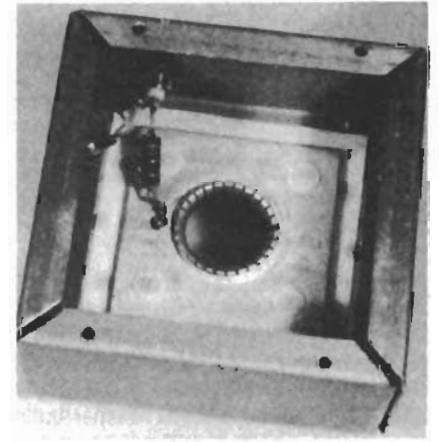

(B)

Fig 17—At A, the interior of the completed input compartment is visible. The photo at B shows the interior of the anode compartment with the anode bypass, RFC3, C8 and J3 installed.

The Teflon sheet and anode bypass capacitor plate can be installed now (Fig. 15B). Assemble the remaining input components, the filament feed-through capacitors and RFC5 (Fig. 15C). Screw the output probe into the cavity ring (or push in the probe and tighten the setscrew, depending on which method you chose). Install the high-voltage connector and other parts in the anode box. Mount the amplifier on the front panel and install the anode tuner shaft. This completes the assembly. Part 2 of this article will describe a complete power supply for the amplifier, a practical water cooling system, testing procedures, microwave radiation safety hazards, and amplifier tune-up and operation.

## Notes

<sup>1</sup>mm = in x 25.4.

<sup>2</sup>The finger stock for this project is manufactured by Instrument Specialties, P.O. Box A, Delaware Water Gap, PA 18237. Contact them for the name of the closest distributor. The part numbers for this amplifier are: anode bypass capacitor plate, no. 97-70A; grid plate, no. 97-74A; cathode board, no. 97-420A; filament board, no. 97-280A.

<sup>3</sup>See note 2.

<sup>4</sup>See note 2.

## A Quarter-Kilowatt 23-cm Amplifier

*Part 2*—Last month, we described the design and construction of a 23-cm cavity amplifier. This installment describes the rest of the components needed to put it on the air.

After you complete Construction of the cavity amplifier described in March QST, you are ready to assemble the rest of the components needed to put it on the air. This month, I will discuss the filament, bias and high-voltage supplies; a whisper-quiet, high-efficiency water-cooling system; testing and hookup; and, finally, tune-up and operation.

### Power Supplies

The filament and bias supplies for the cavity amplifier are shown schematically in Fig. 1. The manufacturer's specification

for the 7289/2C39 filament is 6.0-V ac at 1 A. I have found that the use of a standard 6.3-V ac, 1-A transformer only slightly increases the tube emission without much loss of tube life. The filament should be allowed to warm up before operating the amplifier, so the filament, bias and high-voltage supplies incorporate separate primary switches.

### Biasing

Many biasing schemes have been published for grounded-grid amplifiers. Fig. 1 shows a bias network that satisfies all of

the following operating requirements:

- 1) external bias supply referenced to ground
- 2) low-power components
- 3) variable bias to accommodate tube-to-tube variations
- 4) TR switchable with relay contact or transistor to ground
- 5) bias-supply protection in case of a defective or shorted tube.

U2 provides a variable bias-voltage source, adjustable by R1. The output of U2 drives the base of Q1, which is used to increase the current-handling capability of

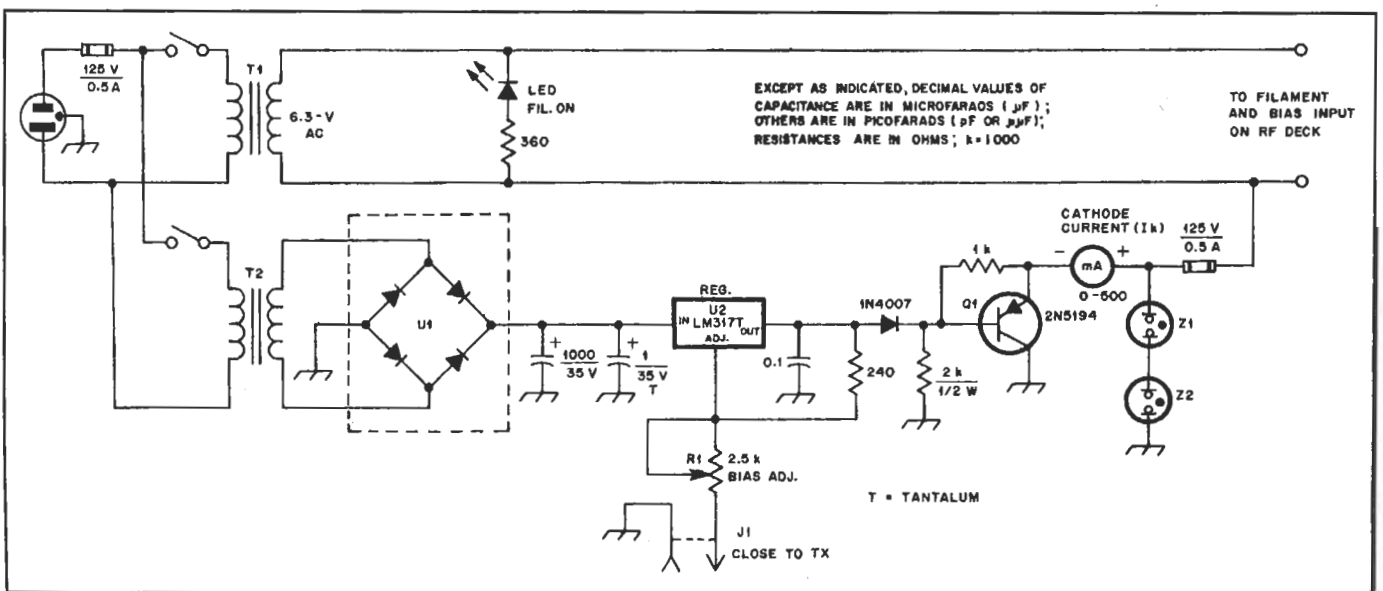

Fig 1—Schematic diagram of the cavity-amplifier filament and bias supplies. All resistors are 1/4-W carbon types unless otherwise noted.

J1—Female chassis-mount photo connector.  
T1—Filament transformer. primary, 117 V; secondary, 6.3 V at 1 A.  
T2—Power transformer. Primary, 117 V;

secondary, 24 to 28 V at 50 mA or greater.  
U1—Bridge rectifier, 50 PIV, 1 A.  
U2—Adjustable 3-terminal regulator

(LM317T or equiv.).  
Z1, Z2—20-V unipolar metal-oxide varistor (General Semiconductor SA20 or equiv.) or two 20-V, 1-W Zener diodes.

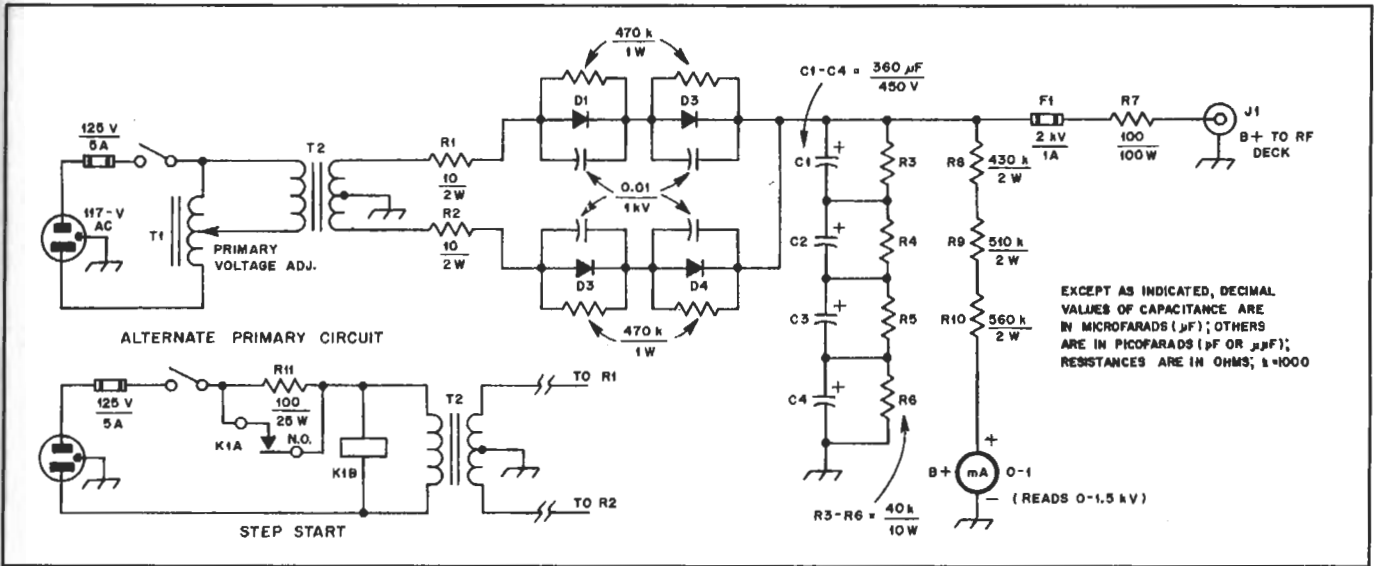

Fig 2—Schematic diagram of the amplifier high-voltage supply.

C1-C4—Electrolytic capacitor, 360  $\mu$ F, 450 V.  
 D1-D4—Silicon rectifier, 1000 PIV, 3 A.  
 F1—High-voltage fuse, 2 kV, 1 A.

J1—Chassis-mount female BNC or MHV connector.  
 R3-R6—Wirewound resistor, 40 k $\Omega$ , 11 W.  
 T1—Variable autotransformer, 500 VA.

T2—High-voltage transformer. Primary, 117 V; secondary, 900 to 1050 V at 500 mA.

the bias supply. Q1 must be mounted on a heat sink. J1 is connected to the station TR switching system so that R1 is grounded on transmit and disconnected on receive. The approximate range of the bias supply is 6 to 20 V. Z1 and Z2 provide protection for Q1 in case of a shorted tube. The amplifier can be run without Z1 and Z2 if you keep the anode voltage below 1100 V.

### High-Voltage Power Supply

A safe, reliable high-voltage power supply is described here. Of course, you can use any readily available HV supply; keep in mind, however, that the 7289/2C39 anode potential should never exceed 1400-V dc at full load and that the amplifier will withstand 1900-V dc at low cathode current and cut-off-bias conditions. For maximum power output, assuming adequate drive power is available, anode voltage under full load should be about 1200- to 1400-V dc.

Fig. 2 is a schematic diagram of the high-voltage supply. A power transformer (T2) that delivers 900- to 1050-V ac is ideal. The type of rectifier circuit used will depend on the type of transformer chosen. Each leg of the rectifier is made from two 1000-PIV, 3-A silicon diodes connected in series. Each diode is shunted with a 0.01- $\mu$ F capacitor to suppress transient voltage spikes, and a 470-k $\Omega$  equalizing resistor.

Filtering is accomplished with a string of four 360- $\mu$ F, 450-V electrolytic capacitors connected in series. R3-R6 equalize the voltage across each capacitor in the string and serve as bleeder resistors. Of course, a single oil-filled capacitor may be used here if available. Whatever type of filter you use, the total capacitance should be about 80  $\mu$ F at a voltage rating of at least 1500-V dc. This value allows adequate "droop" of the anode voltage under high-current loads to protect the amplifier in

case of RF overdrive or a defective tube.

### Protective Circuitry

Some type of start-up protection should be incorporated in the primary. Fully discharged filter capacitors look like a dead short at supply turn-on. Initial surge current (until the capacitors charge) may be high enough to destroy the rectifiers. R1 and R2 provide some surge-current limiting, but either of the two primary configurations shown in Fig. 2 should be used. T1, a variable autotransformer (Variac and Powerstat are two common trade names), is ideal. In addition to allowing you to bring the primary up slowly (and charging the capacitors gradually), it also allows full control of amplifier output power by varying anode voltage.

The second method, a "step-start" system, uses a resistor in the T2 primary to limit the turn-on surge current. When the capacitors have charged, K1 is energized, shorting out R11 and applying full voltage to the T2 primary.

F1 and R7 protect against high-voltage arc-overs or short circuits. If sustained overcurrent is drawn, F1 will open and remove B+ from the RF deck. Use a high-voltage fuse here; standard fuses may arc when blown and not interrupt the B+. R7 provides current limiting to protect the amplifier and power supply in case of a high-voltage arc.

### Safety

An HV meter should always be used to monitor the status of the power supply. The values for R8-R10 shown in Fig. 2 will give a 1500-V dc full-scale reading on a 0-1 mA meter. RG-58 or -59 coaxial cable should be used for the high-voltage interconnection between the power supply and the RF deck. Ground the shield at both ends for

safety and a good dc return.

Safety must be observed when working with all power supplies. These voltages are lethal! Always disconnect ac power and then discharge the filter capacitors before working on the power supply. Never guess or make assumptions about the status of a power supply. Assume it is hot.

### Metering

Cathode-current monitoring is all that's really necessary for observing amplifier dc performance. Cathode current ( $I_K$ ) is the sum of the plate ( $I_p$ ) and grid ( $I_G$ ) currents. Normally, when this amplifier is driven to 300- or 400-mA  $I_K$ , the grid current will be around 40 to 50 mA. The inclusion of a grid-current meter is not really necessary and only makes biasing and TR switching complicated.

### Cooling

Desired output power and the level of drive power available will dictate what type of cooling to use. For intermittent duty (SSB, CW) at output levels less than 50 W, air cooling is satisfactory. Any small blower may be easily mounted to the aluminum box surrounding the tube anode. For high-duty-cycle modes and/or output levels greater than 50 W, water cooling is highly recommended. Greater than twice the normal air-cooled output power can be obtained from a water-cooled tube, and water cooling is quiet.

### Tube Modification and Water Jacket

The first step is to remove the air radiator from the tube. The air radiator screws on, so it may simply be unscrewed without damage to the tube.

First, place a hose clamp around the tube anode. Secure the radiator fms in a vise and grip the hose clamp with a pair of large

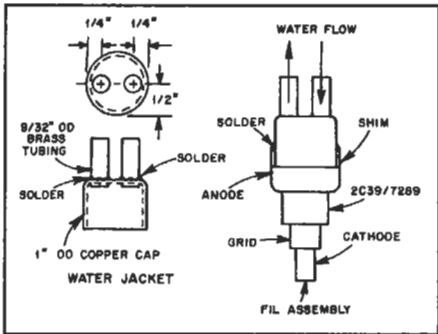

Fig 3—Details of the solder-on water jacket.

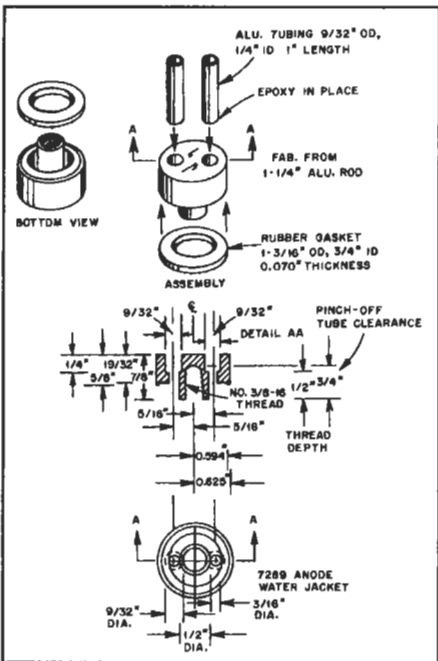

Fig 4—Details of the screw-on water jacket.

pliers. Gently unscrew the tube from the radiator. If the hose clamp slips slightly, tighten it.

Some 7289/2C39 tubes use an air radiator that is attached with setscrews. To remove the radiator, simply remove the setscrews and pull the radiator off.

The air radiator will be replaced with a water jacket that allows water to be circulated past the tube anode and through a radiator, where it is cooled and circulated past the tube anode again. I have successfully used two different types of water jackets; both are described here.

The water jacket shown in Fig. 3 will work with any type of 7289/2C39. It is fabricated from a 1-inch-OD copper tubing cap and two short pieces of 9/32-inch-OD brass tubing. The copper tubing cap should be available from a local hardware store or plumbing supply house. Brass tubing is available from many hobby stores and metal supply houses.

Mark and drill the copper cap so that the brass tubing is a snug fit. Thoroughly clean the parts until they shine. Push the tubing into the holes in the end cap and degrease

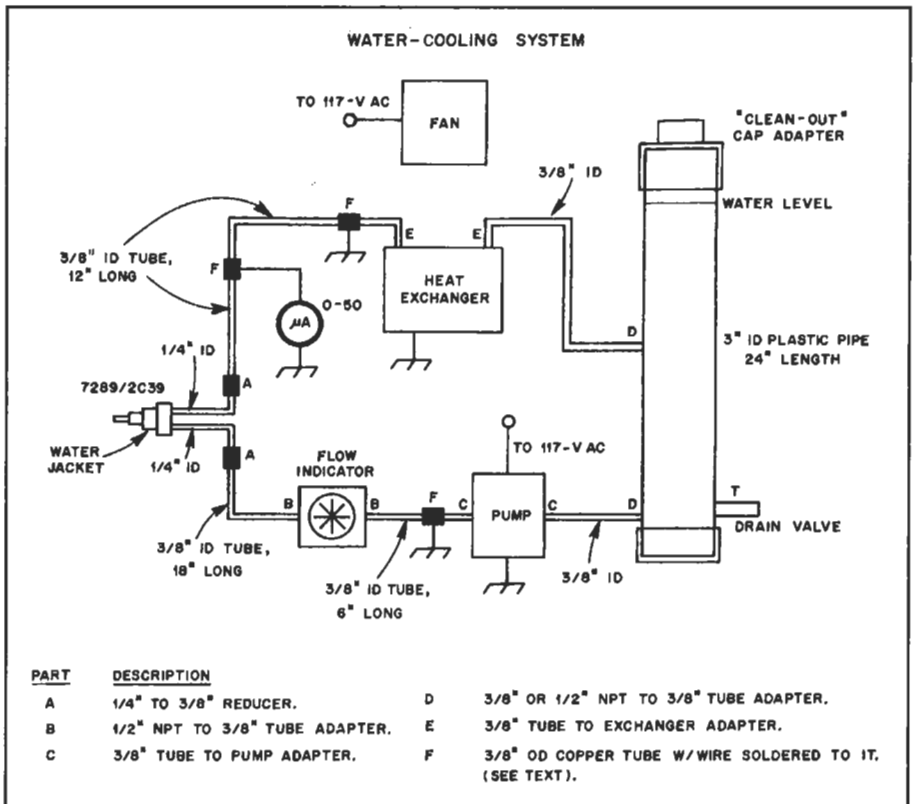

Fig 5—Details of the water-cooling system. Recommended pumps are: (1) Little Giant Pump Co. Model 1-42A or larger, available from most hardware stores; or (2) Calvert Engineering, Cal Pump Model 875S (160 gal/h), available from Calvert, 7051 Hayvenhurst Ave, Van Nuys, CA 91406, tel. 213-781-6029. The flow indicator (Model 15C; requires two 1/2-inch NPT adapters) is available from Proteus Industries, 240 Polaris Ave, Mountain View, CA 94043 tel. 415-964-4163.

the assembly with alcohol. Using plenty of flux, solder the seam around each section of tubing. Allow the jacket assembly to cool.

Meanwhile, thoroughly clean the 7289/2C39 anode to a bright finish. Check the water jacket for fit. In some cases, you'll have to use a 0.005- to 0.010-inch-thick copper shim to fill the gap between the copper cap and the tube anode. This shim helps eliminate pin holes in the solder.

Using plenty of flux, solder the water jacket to the tube anode. Solder it quickly with a hot, high-wattage iron. Allow the tube to cool in the air after soldering to avoid thermal shock and possible breakage. After the tube has cooled, use plenty of alcohol to remove all traces of flux from the tube and water jacket.

The second type of water jacket is shown in Fig. 4. This jacket will work only with 7289/2C39 tubes that have a screw-on air radiator. It is designed to thread onto the tube anode just like the air radiator did. This jacket is machined from a piece of 1 1/4-inch aluminum rod. The water inlet and outlet tubes are made from 9/32-inch-OD, 1/4-inch-ID aluminum tubing that is epoxied in place. A rubber gasket seals the jacket against leaks.

If you have access to a lathe, you should have no trouble duplicating the jacket. You could have one made up at a local machine

shop. Complete screw-on water jackets are also available from the author.

After you unscrew the air radiator from the 7289/2C39, check for and remove any burrs from the tube anode. The anode surface must be flat if the rubber gasket is to be effective. Screw the water jacket onto the tube. Tighten by hand only. Do not use any tools, or you could damage the tube or jacket! Do not use the water inlet and outlet tubes for leverage—they have thin walls and break easily.

### Water System

Fig. 5 depicts the complete water-cooling system. Recommended pumps and accessories that have proven reliable and effective are listed in the caption.

Any small pump, such as a fountain pump, that can deliver 160 to 200 gallons per hour can be used here. Most inexpensive pumps are not self-priming, which means that they won't pump water if they have air in the rotor. Although water can be forced through the pump for the initial prime, my system uses gravity priming. The water reservoir is a 2-foot length of 3-inch-OD plastic pipe that is available from hardware or plumbing stores. The outlet is at the bottom, and the inlet about halfway up the column. The inlet is located here to eliminate aeration that ionizes the water and reduces its effectiveness. The outlet

# JFLINT

## Microwave Radiation Safety

Intense RF radiation concentrated on body tissues can produce heat damage; the extent and penetration will depend on the radio frequency in use and on exposure duration. You should be aware of the approximate intensity of RF radiation of the transmitting equipment and antennas you come in contact with.

RF intensity is commonly expressed in milliwatts per square centimeter ( $\text{mW}/\text{cm}^2$ ), which is the power flowing away from a source through a unit sampling or interception area at some specified distance. Although the United States as yet has no federal RF protection standard, a useful interim guide is the 1982 standard of the American National Standards Institute (ANSI '82). The most stringent level in this standard is  $1 \text{ mW}/\text{cm}^2$  for frequencies between 30 and 300 MHz. Above 300 MHz, the protection level rises until it reaches  $5 \text{ mW}/\text{cm}^2$  at 1500 MHz. Beyond 1500 MHz, the recommended level remains at  $5 \text{ mW}/\text{cm}^2$ . These levels represent the average power density allowed over any six-minute period and are for the sum of all polarizations from a given source.

At 1296 MHz, where one wavelength ( $\lambda$ ) equals 23 cm, a thick resonant dipole feeding a calibrated power meter with matched coaxial cable (itself free of pickup) may be used to obtain an indication of power density. A reasonably lossless resonant dipole has an effective aperture of  $\lambda^2/8$ ; at 23 cm this is  $66 \text{ cm}^2$ . The power meter reading in milliwatts, divided by 66, is the indicated power density. For this to be a reliable indication, the dipole must be positioned far enough from the RF source to be in its far field. For a small source, the distance should be at least  $\lambda/2$ , and here that would be about 12 cm (4.5 inches). The dipole should be oriented for alignment with the dominant polarization. Note that the power meter must be capable of readings well below 1 mW.

This arrangement would be useful for checking leaks along the coaxial route that the high power (here 250 W) takes to a load, be it dummy load or antenna. Cable connectors may not be tightly secured, or they may be faulty. For equipment operating in the SHF region, waveguide flanges may not be clamped properly.

Direct measurement of electric field strength near an antenna (with a calibrated instrument, preferably one with the

indicating meter shielded and possibly positioned at the center of the sampling dipole) is another way to check for adequate protection. A field strength of 60 V per meter (V/m) corresponds to  $1 \text{ mW}/\text{cm}^2$ ; 134 V/m corresponds to  $5 \text{ mW}/\text{cm}^2$ . At a distance 60 cm (2 feet) from an isolated dipole fed with 26 watts, the field strength would be about 60 V/m. This is a far-field field strength for all frequencies where the half wavelength is less than 60 cm, or for frequencies above 250 MHz. For full 250 watts applied to the dipole, the 60 V/m level occurs at a distance of 1.8 meters (6 feet), and at this distance this holds for all frequencies above 80 MHz.

With SSB or CW keying, the fields during Amateur Radio operation are highly intermittent, and usually include considerable pauses or intervals for listening. These factors reduce the average power density over the six-minute averaging period.

Further information on RF safety and protection estimates can be found in Chapter 7 of *The Satellite Experimenter's Handbook*, published by the ARRL. The following rules of good practice for RF protection are recommended:

- Never operate an RF amplifier with equipment shielding removed.
- Never handle antennas with RF power applied.
- Never guess that RF levels are safe. Take the time to consult a reliable reference for an estimate, or measure levels carefully. Allow a "cushion" of about 6 dB (factor of four in power density). If possible, borrow an RF radiation monitor (after learning how to use it), or consult with a ham who is well informed on RF protection.
- Never look into an open end of a power waveguide; never point a powered directive antenna (a beam or a paraboloid, for example) toward people. Keep all VHF and UHF transmitting antennas as high as possible, distant from humans.
- Use good-quality, well-constructed coaxial cable and connectors to avoid RF leaks.
- Think RF and electrical safety first; test later!
- Watch QST for news on RF measurement techniques and progression, protection standards and proposed federal and state RE regulations.—David Davidson, W1GKM

directly feeds the pump. The pump and the reservoir outlet port should be mounted in the same plane. The pump should be oriented so that air bubbles will rise into the impeller output port and can be blown out once the pump starts running.

### Flow Indicator and Heat Exchanger

Water cooling is best described as "super quiet." There is no noisy fan to reassure you that the tube is receiving adequate cooling. If water flow is reduced or cut off during amplifier operation, tube damage is virtually assured.

Flow interlocks and switches to shut down the amplifier if water flow is reduced are hard to find and expensive. Flow indicators, however, are inexpensive and reliable. A flow indicator has a spoked rotor that turns as water passes through the unit. If the wheel is turning, there is water flow; if not, you have a problem. Changes in flow rate can be observed by watching for speed changes in the rotor. A small lamp illuminates the flow indicator, making it easy to see rotation. The flow indicator should be mounted where it can be seen from the operating position and monitored during operation.

Heat exchangers, or radiators, remove the heat from water as it passes through.

For this application, a small automobile transmission-oil cooler works great. Most auto-parts stores and speed shops have a good selection. Pick one that is similar in size and aspect ratio to a whisper fan (approximately  $4 \times 4 \times 1$  inches). Some come with mounting brackets. Look for a cooler with the input and output ports on the top so air bubbles will rise to the top and move on without becoming trapped. Trapped air degrades cooler performance.

If you use the amplifier for high-duty-cycle modes such as ATV or FM, or for long, slow-speed CW transmissions (EME, for example), you should use a small axial whisper fan to increase the effectiveness of the heat exchanger. A fan isn't necessary during normal operation, or even for sustained operation at moderate power levels, but I highly recommend one if you plan prolonged operation at maximum power. Locate the fan so the warm exhaust air won't heat up other equipment.

### Hoses and Fittings

Most hardware stores carry a complete line of brass fittings and adapters that can be used for this project. Brass, however, will eventually corrode and pollute the water supply. Plastic fittings are cheaper and don't corrode, but they are harder to find. Recre-

ational vehicle suppliers are my main source for these parts. They are used extensively in drinking water systems for mobile homes and travel trailers. Procure the fittings when you have the rest of the parts in hand, as there are many variables to consider.

You can use any relatively soft, thin-wall vinyl tubing for all water lines. The main runs are made from  $3/8$ -inch-ID hose, while  $1/4$ -inch-ID stock is used to connect to the 7289/2C39 water jacket. The  $1/4$ -inch-ID tubing fits snugly over the  $3/32$ -inch-OD inlet and outlet tubes on the water jacket, so no clamps are required. All other hose connections should be secured with stainless-steel clamps to prevent leaks. Any leaks mean air in the system and deterioration of cooling performance.

### Safety

The tube anode, and hence the water jacket and water, are in direct contact with the high-voltage supply, so some safety precautions must be observed. Approximately 12 to 18 inches of tubing should run between the 7289/2C39 jacket and any other component in the cooling system. This will allow enough resistance in the water to provide adequate current limiting, should the water contact any components that are grounded.

# JFLINT

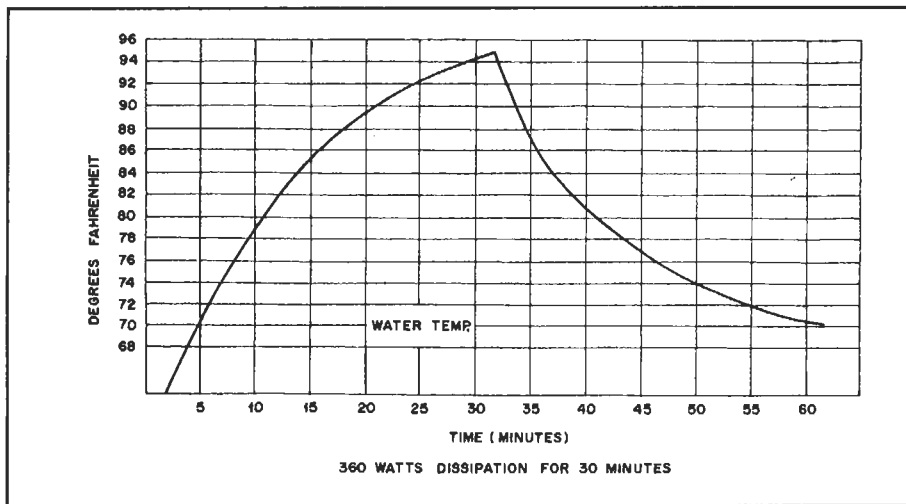

Fig 6—Performance graph of the water-cooling system.

It is best to ground the water supply at the pump. Do this by replacing a short section of the tubing that runs to the flow indicator with a piece of brass or copper tubing. Solder a wire to this metal tubing and connect the other end of the wire to your station ground. Use at least 24 inches of vinyl tubing between the anode cooling jacket and the ground point.

On the warm-water side of the 7289/2C39, run 12 inches of vinyl tubing to a small metal fitting or short section of metal tubing, and then another 12 inches of vinyl tubing to a grounded point (this can be at the heat exchanger). You can measure the water leakage current to ground by placing a microammeter between the metal fitting that connects the two vinyl hoses and ground. Leakage current should be less than 10  $\mu$ A with clean water and an anode potential of 1 kV. As the water ages, the leakage current will rise; when this happens, replace the water.

Grocery stores carry distilled water for use in steam irons. It may be deionized and not truly distilled, but it works fine for about four to six months in this application. Filters can be purchased from scientific supply houses, but they're not really worth buying because deionized water is so cheap.

Do not use tap water under any circumstances! When you turn on the water system for the first time, run a gallon of water through it for half an hour to wash out fabrication impurities. Replace with clean water before using the system to cool the amplifier.

Water was chosen because it's inexpensive, nontoxic, nonflammable and easy to clean up if you have a leak. Better liquid coolants are available, but they are toxic. Don't use them!

## Cooling Performance

I have used water-cooling systems for several years with no problems whatsoever. Fig. 6 is a graph of several transmit/receive cycles on a water-cooled, 500-W

output, 23-cm power amplifier. For this test, I used two of the amplifiers described in this article coupled with a pair of hybrid combiners. This particular cooling system used 1 gallon of water. Experiments indicate that, during extended operation, the water temperature rises only 30° to 35°F above ambient room temperature. Typically, the tube anode and water average 10° to 15°F above ambient during casual operating.

Flow rates in this system are typically  $\frac{1}{3}$  gallon per minute per tube, which is more than adequate. At this rate, more than 300 W of dissipation from a single inefficient 7289/2C39 were required to boil the water in the water jacket. The water should not be allowed to boil because this will heat the rubber gasket.

## Tubes

It is not really necessary to buy a new 7289/2C39. Used tubes can be found surplus for around \$1 to \$5 and, in many cases, will perform as well as a new tube. Most used tubes have been sitting around for several years, so it's a good idea to run them through the dishwasher to clean them up and then run the filaments for about 24 hours. This will restore operation in many cases.

If you buy a new tube, you should be aware that the 7289/2C39 is being run far in excess of its ratings in this amplifier. The manufacturer's warranty will not cover tubes run in this application.

Contrary to popular opinion, glass tubes will work. Physically, they are not as rugged as the ceramic version, but the glass-to-metal seal seems to provide better shelf life than the ceramic seal. The glass tubes make great driver tubes and will work fine for power levels up to 100-W output. Pulse tubes (7815, 7211) are not recommended because of their poor thermal stability at high power levels. Also, they generally are 30 to 40 MHz lower in resonant frequency in this amplifier compared to the 7289/2C39. Some 7289 tubes can be as much as 30 MHz lower in frequency. Minor length

adjustment of the anode-tuning post may be required to accommodate amplifier and tube differences.

## Tube Insertion

Extreme care must be exercised when inserting the 7289/2C39 tube. Never force the tube in place, as damage (bending) of the cathode finger stock may result. Observe the layout of the finger stock to get an idea of how the tube inserts. Carefully position the tube so it is straight as you gently push. It should slide in snugly without any solid resistance.

## Testing

After you have completed all of the parts for the amplifier, it's time to test everything before hooking it all together. Test the water-cooling system by turning it on and watching for steady water flow as indicated on the flow meter. The tube and water jacket can be removed from the cavity amplifier for this test.

Check all of the power-supply voltages first without connecting them to the RF deck. Then, without the tube in place, hook the bias and filament supplies to the cavity and check the voltages again at the tube finger-stock connections. Connect the high-voltage supply to the RF deck and bring the voltage up slowly with a variable autotransformer. Monitor the high voltage on the anode-bypass-capacitor plate, and look and listen for any possible arcing between the anode-bypass-capacitor plate and ground. Use extreme care when measuring and testing the high-voltage supply. If everything looks okay with the power supplies, shut them off and disconnect them.

You can make a safe, low-power test of the cavity resonance without applying any voltage. With the tube in place, insert a 2-inch-long coupling loop on the end of a piece of coaxial cable between the spring fingers of the anode down into the cavity. Connect the amplifier output probe/connector to a device capable of detecting low-level RF at 23 cm (for example, a spectrum analyzer or microwattmeter). Feed a signal from an L-band signal generator into cable attached to the wire coupling loop that you inserted into the cavity. Set the signal generator for various frequencies in the 23-cm band and tune the amplifier anode tuner. There will be sharp peak in output at cavity resonance.

This testing method can be used to determine cavity tuning range, anode-bypass capacitor effectiveness and resonance of various tube types for use in this amplifier. Any cavity amplifier can be tested completely without ever applying high voltage. The better your test equipment, the easier the amplifier is to test. If all dimensions were followed strictly, the amplifier will tune as designed.

## Amplifier Hookup

Installation and operation of this amplifier is relatively straightforward, but

# JFLINT

as with any amplifier, several precautions must be followed. If these are adhered to, the amplifier will provide years of reliable service.

The amplifier is designed to be operated in a 50-ohm system and should never be turned on without a good 50-ohm load connected to the output connector. Never operate it into an antenna that has not been tuned to 50 ohms!

Drive power to the amplifier should never exceed 15 W. Never apply drive power in excess of 1 W unless all operating voltages are present and the tube is biased on. Otherwise, the tube grid-dissipation rating will be exceeded and you will probably ruin it.

As in all TR-switched systems, some type of interlock or sequencing of transmit and receive functions should be incorporated. In most systems, the sequence for going into transmit is something like this: First, switch the antenna changeover relay from the receiver to the power amplifier. Next, bias the power amplifier on. Last, key the exciter and apply drive to the amplifier. To go to receive, unkey the exciter, remove operating bias from the amplifier and switch the antenna relay back to the receiver.

If the antenna relays are switched while the power amplifier is operating and putting out power, damage to the relay contacts and/or the amplifier is likely. If there is a momentary removal of the antenna while the power amplifier is biased on, oscillation may occur. This can damage the TR relay, the tube or even the receive preamplifier.

## Tune-up and Operation

This is it — the big moment when you will see your project come to life! Connect an accurate UHF power meter and a 50-ohm antenna or load to the amplifier output connector. A Bird Model 43 wattmeter with a 100- or 250-W, 400-1000 MHz slug will give reasonable accuracy, depending on the purity of the drive signal. Apply filament power and tube cooling, and allow 3 to 5 minutes for the filaments to warm up. Turn on bias supply (the amplifier will draw maximum current if the anode voltage is applied without bias). Apply 300 to 400 V to the anode. There should be no current flowing in the tube as indicated on the cathode-current meter. Ground J1 on the bias supply to apply transmit bias and observe cathode current. As R1, the bias control, is turned clockwise, quiescent idling current should increase. Set for about 25 mA.

Apply 1 W of RF drive power. Turn the

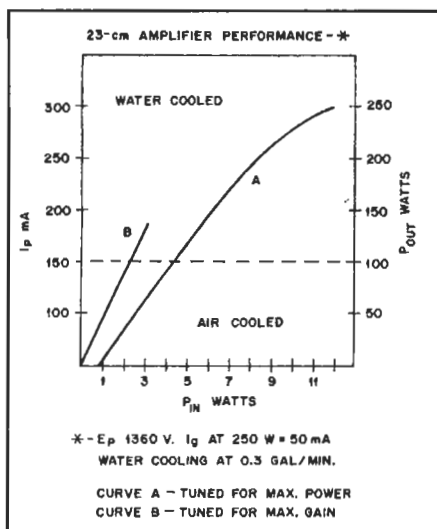

Fig 7—Performance of the cavity amplifier under different drive and plate-current conditions.

anode tuner while observing the RF output power meter and tune for maximum output. The output should go through a pronounced peak at cavity resonance. Adjust C2 and C3 on the input tuning network for maximum amplifier output. If possible, use a directional wattmeter between the driver and the amplifier input to check that best input SWR and maximum amplifier output occur at roughly the same setting.

Depending on the amount of drive power available, you may want to tune the amplifier for maximum power output or maximum gain. Fig. 7 shows what you can expect from different drive levels.

Once the amplifier is tuned for best input SWR and maximum output with 1 W of drive, anode voltage and drive power can be increased. Increase both in steps; be sure to keep the anode tuner peaked for maximum output power. When you get to the 100-W output level, very carefully readjust the input circuit for maximum output. The input capacitor closest to the cathode is critical and should need to be rotated less than 90 degrees maximum. Maximum output power will be roughly coincident with best input SWR.

Increase the drive power and keep the anode tuner peaked for maximum output. Increase the drive until you reach the desired output level, but do not exceed 400-mA I<sub>K</sub>! At 1400-V dc and 350-mA I<sub>K</sub>, output power with a good tube should be about 230 to 250 W. At lower anode voltages, I<sub>K</sub> will be higher for the same output

power. Higher anode voltages result in higher gain, lower drive levels, lower grid current and lower plate current for a given output power.

The anode tuner's tuning rate is approximately 5 MHz per turn. Clockwise rotation of the tuner lowers the resonant frequency of the cavity. This control will require readjustment as you make large frequency excursions within the 23-cm band (for example, if you go from 1296 weak-signal work to the 1269-MHz satellite segment). You should also check the input SWR if you move more than 15 MHz. Generally, amplifier tuning does not change much after initial setup. You should be able to turn it on and use it without re-tuning as it heats up. Slight adjustments may be necessary, however, depending on cooling, inherent thermal differences from tube to tube and duty cycle of the operating mode. Always keep the anode tuner peaked for maximum output, and check it from time to time, especially while you are first learning how the amplifier operates.

The output loading control is the output connector and probe assembly. Loading is changed by minor rotational adjustment of the N connector. First loosen the jam-nut (or setscrew) slightly. While observing output power and keeping the anode tuner peaked, rotate the loading control ±30 degrees maximum for greatest output power. This should be done only once and should not need repeating unless another tube is installed. Even then it may not be required.

## Conclusion

This cavity amplifier for the 23-cm band is capable of safe, reliable operation at output powers in excess of 200 W. More than 50 of these amplifiers are in operation, and you can build one, too. I would like to thank Mike Stahl, K6MYC, Bill Troetschel, K6UQH, William Jungwirth, AA6S, Lem Moeschler, W6KGS and Joseph Cadwallader, K6ZMW, for their help and encouragement during the development of this project.

## References

- Laakmann, "Cavity Amplifier for 1296 MHz," *QST*, Jan. 1968, pp. 17-22.
- Laakmann, "Kilowatt Amplifier for 1296 MHz," *Ham Radio*, Aug. 1968, pp. 8-17.
- "Power Amplifier for 23 cm," *VHF Communications*, April 1976, p. 222.
- "Power Amplifier for 24 cm," *VHF Communications*, March 1978, p. 175.
- Stefanski, "1270 MHz ATV Power Amplifier," *Ham Radio*, June 1977, pp. 67-73.
- Tech Report #6, Crawford Hill VHF Club, July 1971.
- Tech Report #13, Crawford Hill VHF Club, Dec. 1972.

## A 2-W, 13-cm Amplifier

This amplifier uses a resistively stabilized Hewlett Packard ATF-44101/AT-8 140 power GaAs FET running class A to provide 14 dB of gain and a 2-W output. It wasn't too difficult to choose the device—there aren't that many linear devices that cover the 2.3 GHz band at this power level. Unfortunately, it is fairly pricey; the circa 1990 price was around \$90. But since this transistor has been around a long time, it may be available surplus. Several hundred were sold at the bargain price of \$3 each about a year and a half ago. I bought a few—I should have bought more.

Even if you do buy your FETs at bargain prices, you still will want to ensure that they are biased safely. As has been pointed out many times in the literature, having the negative gate bias supply fail while the drain supply is applied may result in the destruction of the device. Thus, designers have devised elaborate protection schemes to shut off the drain supply if the gate supply fails.

Fig 1 shows a simpler power-supply circuit. The drain supply is controlled by an ordinary 723 voltage regulator with current limiting. The current limiting protects the device—instead of the expensive FET getting hot and self-destructing, the cheap TIP 30 power transistor gets warm. Doing this eliminates the need for complex shutdown circuits to handle a failed bias supply. While there are more modern regulator chips than the 723, they aren't significantly better for this application. In fact, some are "improved" to the point where they are tougher to use. For example, chips with better current-sensing circuits often require special low-value resistors. While you could use the copper wire table in the *ARRL Handbook* to make your own low-value resistors from wire, it makes more sense to me to use a 723 with standard, readily available parts.

The gate bias supply is produced by an NE555 timer running as an oscillator and driving a voltage inverter. An LM337 adjustable 3-terminal voltage regulator controls the gate supply. Now, you have to be a little careful using adjustable voltage regulators with bias supplies. While I haven't experienced this myself, it is entirely possible that a noisy potentiometer could momentarily present an open circuit between the wiper and the resistance ele-

ment. Conceivably, in some circuits, this could result in voltage spikes at the output of the voltage regulator as the voltage is adjusted. The cure for this is to wire the potentiometer so that it never presents an open circuit, even with an intermittent wiper, as I've done with R9 in Fig 1.

For some other GaAs FET circuits, it may be advantageous to use an active-bias supply which operates inside the feedback loop of the current limited supply. This allows the bias point to be unaffected by temperature variations. The current limiting acts as a failsafe, protecting the transistor if a more negative gate supply voltage is unable to turn off the transistor. I've successfully used this circuit when only a milliamp of bias current was needed. Due to the high current required by the gate circuit of the 2-W amplifier, I decided it was impractical to active-bias the FET in this application; the ICL7660 can't provide the needed current. But there are higher-current versions of this chip, for those who don't mind the price.

### RF Design

I found the AT-8 140 rather difficult to get unconditionally stable. I ended up plac-

ing a 10041 chip resistor from gate to ground, which resulted in pretty good stability, except around 2.3 GHz. Unfortunately, it doesn't appear possible to decouple this resistor without adversely affecting stability, so quite a bit of bias current is needed. Because of this, it is conceivable that you may find a FET that needs too much gate voltage for a typical 10041 chip resistor to handle. Whether this is the case with a particular FET depends on both the threshold voltage and the transconductance of the device. The threshold voltage can vary quite a bit, particularly in older devices, though the manufacturers have tightened up this specification in recent data books. Worst case would be a large negative threshold voltage and a high transconductance. Stacking chip resistors in parallel might be a solution, though this might also invite unwanted parallel resonance effects, similar to what is seen with paralleled capacitors.

While in-band stability is not too critical, since the source and load impedance matching is usually pretty good at the operating frequency, I used a series resistor in the gate decoupling line to make the amplifier unconditionally stable, according to

**Table 1—Measured Amplifier Performance**

Input to MGF 1801 driver (dBm)	Driver Output (dBm)	AT 8140 Output (dBm)	AT 8140 Gain (dB)
-7.0	5.7	19.8	14.1
0.0	12.5	26.6	14.1
3.0	15.5	29.7	14.2
4.0	16.5	30.8	14.3
5.0	17.5	31.7	14.2
6.0	18.4	32.6	14.2
7.0	19.2	33.3	14.1
8.0	20.3	33.9	13.6
9.0	21.2	34.1	13.1
10.0	22.1	34.6	12.5
13.0	24.2	34.9	10.7

The 1-dB compression point is at 34.1/33.2 dBm output.

Comparing measurements made using an HP8563E spectrum analyzer against those made with an HP 453B/8481A power meter, a signal that measures 4.7 dBm on the spectrum analyzer reads out as 3.8 dBm on the power meter. The values listed are from the spectrum analyzer, taking into account a 30.2-dB, 25-W Bird attenuator inserted between the amplifier and the analyzer.



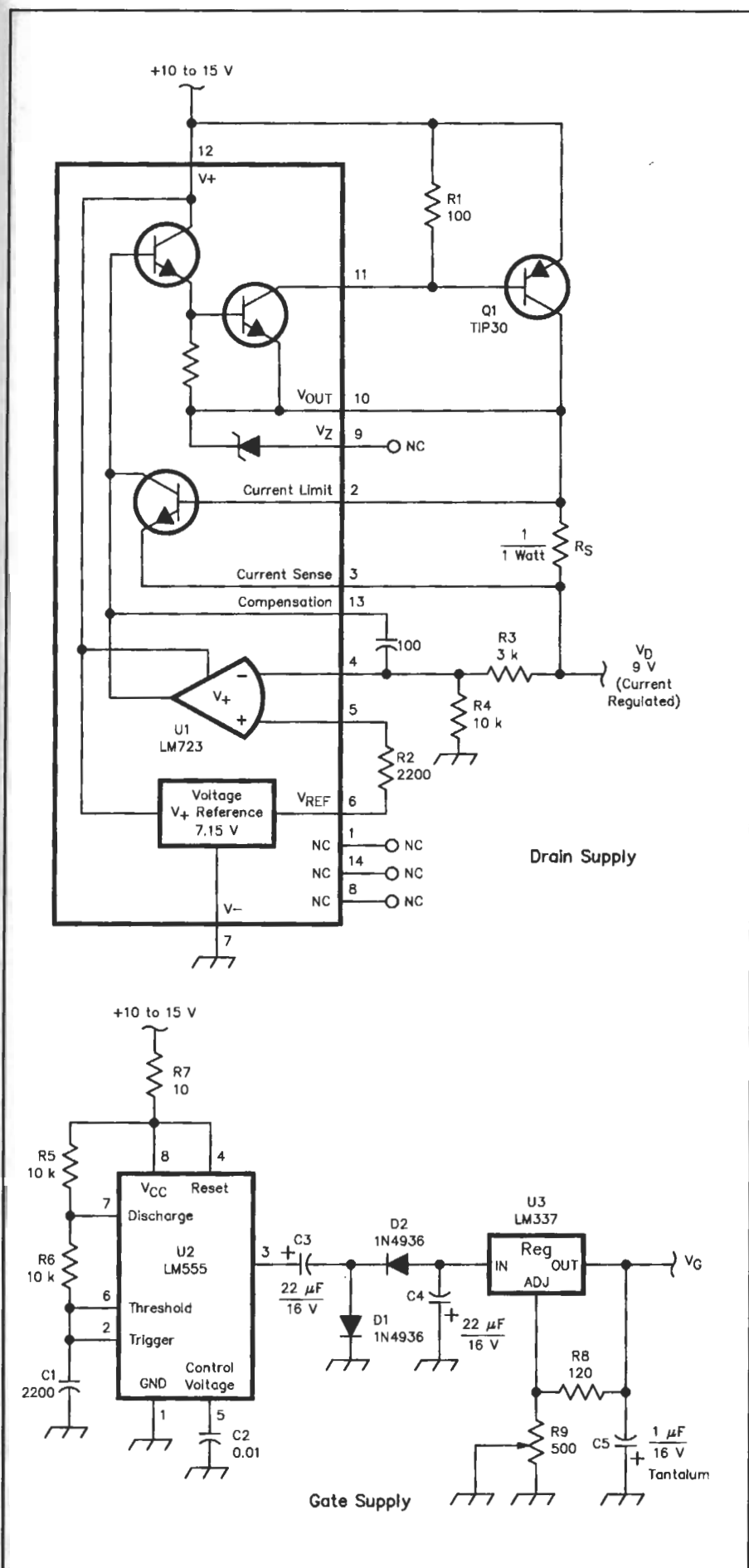

Fig 1—Power supply for the 2-W, 13-cm amplifier.

the computer model. This series resistor also improved the input match bandwidth, an important consideration if you don't want to tune the amplifier. Of course, improving the bandwidth with resistance also reduces the gain. The loss isn't too bad, however, seeing as this design is within a few dB of the maximum stable gain the data sheet specifies. The design was optimized with 150 Ω of series resistance, but I decided that such a high value was unwise. To accommodate such a high series resistance, it is entirely likely that the negative supply voltage would have to be more negative than the VGS limit. Then, if the 10041 resistor were to fail open-circuited, the supply could damage the gate of the transistor. For this reason, I chose to use a 5041 series resistor. I didn't reoptimize the design for 50 Ω of series resistance, since the likely improvement was small compared to the variations I've seen when optimizing the unit on the bench.

Finally, I discovered that additional gate circuit bypassing was required at audio frequencies to prevent the circuit from oscillating. This was done with a 1-μF capacitor that is not shown in the computer model. This frequency range wasn't covered by the model.

Several dB of additional saturated output power was obtained by modifying the output network with foil tabs. AT-8140s saturate at about 2.2 W output with around 200 mW of drive. An advantage to optimizing the circuit by modifying the 5041 striplines at the input and output of the amplifier is that the stability should not be adversely affected. But the board does have to be made larger to accommodate such tuning.

The original design was optimized using *Microwave Harmonica*, with the results shown in Table 2 and Fig 6. After I tweaked the output network to get maximum output power, I entered the changed circuit components into the computer and analyzed the circuit, resulting in the analysis shown in Table 3 and Fig 7. Table 1 shows the performance of the circuit in its final configuration.

### Construction Notes

To ground the drain bypass capacitor and the gate resistor, I cut slots in the board and connected the pads to the ground plane with 1-mil copper foil. Copper foil was also used to connect the gate bypass capacitor, although in this case I trimmed the board so that it wasn't necessary to cut a slot.

For high-quality grounding without lots of tiny screws, I decided to try using a heat spreader made out of 1-mil copper foil. I cut a hole in the circuit board for the FET and then carefully soldered the foil across the hole in the circuit board, taking care not to put any solder where it would interfere with heat-sinking action. I didn't want any air pockets, as they are extremely poor conductors of heat. Then, after attaching the board to a piece of 0.25-inch sheet aluminum with suitably tapped holes, I used a scribe to punch holes for the 0-80 screws to

# JFLINT

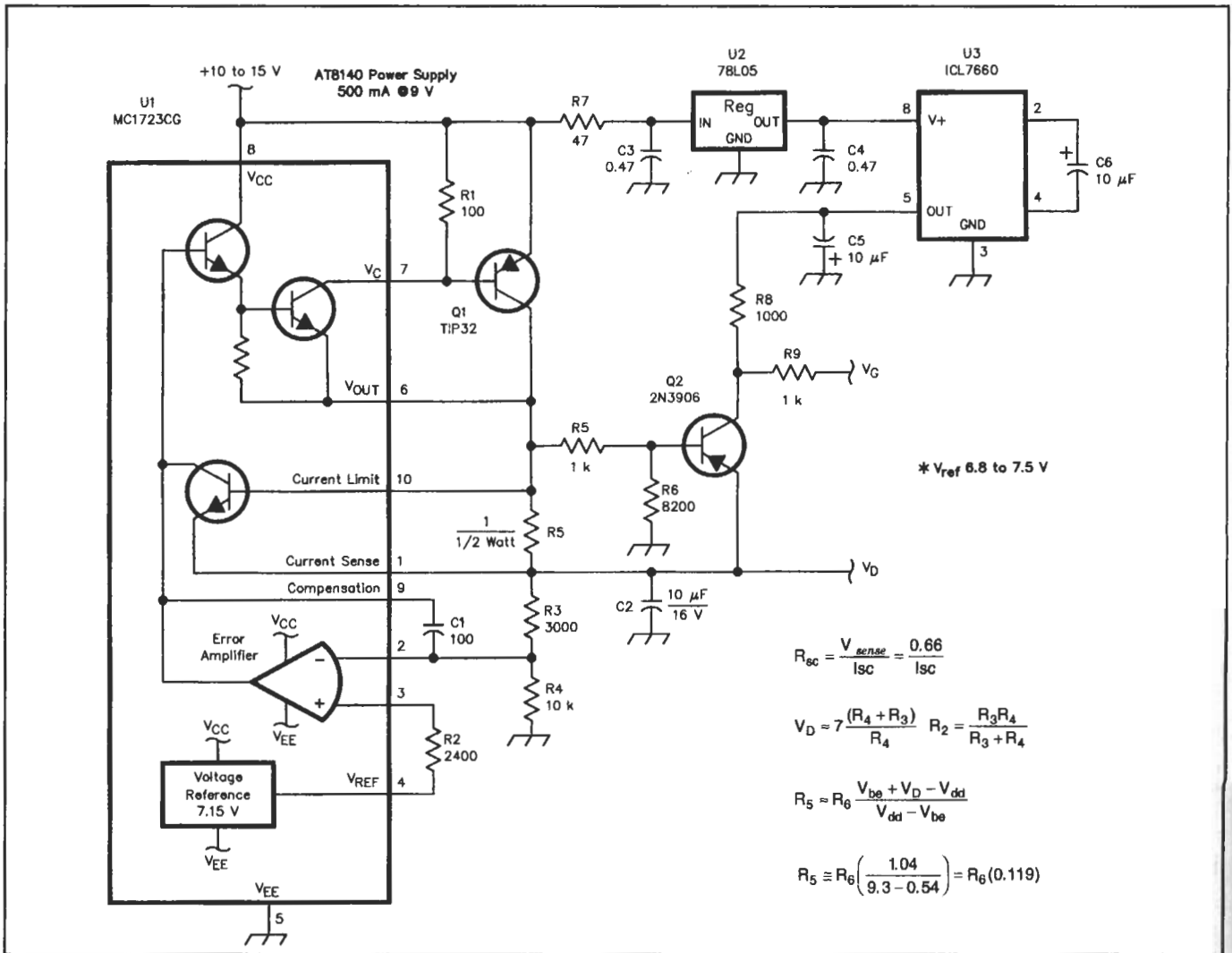

Fig 2—An active biasing circuit suitable for use with amplifiers that draw minimal gate current. Do not use this with the 2-W amplifier.

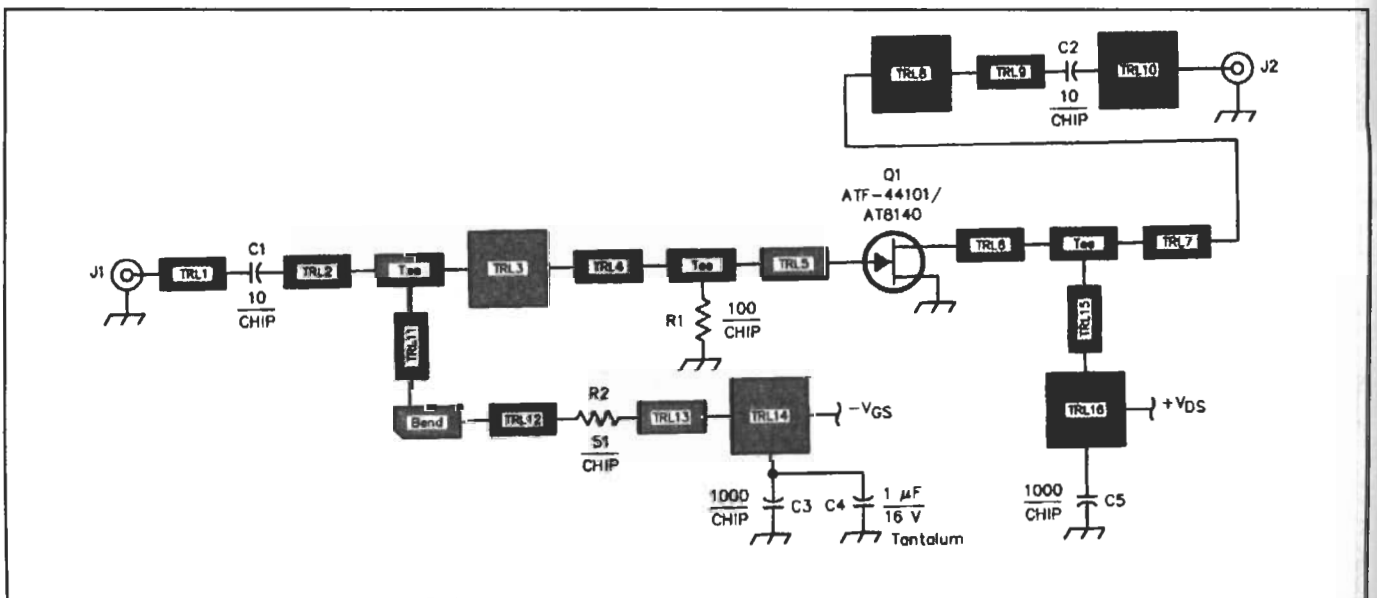

Fig 3—Schematic diagram for the 2-W amplifier.

C1, C2—10-pF, high-quality porcelain chip capacitors. I used 55-mil capacitors, although 100-mil capacitors should work just fine.  
C3, C5—1000-pF NP0 chip capacitors  
C4—1- $\mu$ F, 16-V tantalum capacitor.

J1, J2—SMA jacks.  
Q1—Hewlett Packard ATF-44101/AT-8410 medium power GaAs FET. This device must be properly heat-sinked.

The absolute maximum channel temperature is 175°C. The case-to-junction thermal resistance is 23°C/W.  
TRL1-16—Microstriplines etched on 0.031-inch-thick,  $\epsilon_r = 2.55$  Teflon circuit board.

# JFLINT

**Table 2—Microwave Harmonica Analysis (Original Circuit)**

MICROWAVE HARMONICA PC V5.5 File: \mh\2304\qexamp.ckt 22-DEC-93 17:54:54

Freq GHz	MS11 dB AMP	PS11 deg AMP	MS21 mag AMP	PS21 deg AMP	MS12 mag AMP	PS12 deg AMP	MS22 mag AMP	PS22 deg AMP	MS21 dB AMP	K AMP
1.000	-0.70	-167.5	2.084	19.3	0.017	-53.7	-6.01	-128.7	6.38	1.64
1.100	-0.57	-177.2	1.988	0.1	0.018	-71.2	-5.35	-139.0	5.97	1.43
1.200	-0.47	-173.3	1.941	-17.8	0.020	-87.3	-5.02	-148.2	5.76	1.27
1.300	-0.40	-164.0	1.945	-35.0	0.022	-102.6	-4.96	-156.6	5.78	1.17
1.400	-0.36	-154.7	1.999	-52.0	0.024	-117.7	-5.13	-164.3	6.01	1.09
1.500	-0.38	-145.2	2.110	-69.2	0.028	-132.9	-5.59	-171.4	6.48	1.05
1.600	-0.48	-135.2	2.288	-87.3	0.032	-148.9	-6.43	-177.6	7.19	1.02
1.700	-0.73	-124.6	2.542	-106.8	0.039	-166.3	-7.84	-178.8	8.10	1.01
1.800	-1.26	-113.0	2.872	-128.6	0.047	-174.0	-9.91	-177.3	9.16	1.01
1.900	-2.31	-101.1	3.240	-153.5	0.056	-151.3	-11.05	-156.6	10.21	1.01
2.000	-4.14	-90.9	3.547	-178.8	0.064	-125.8	-8.31	-138.3	11.00	1.02
2.100	-6.75	-87.5	3.682	-149.7	0.070	-98.9	-5.06	-141.0	11.32	1.04
2.200	-9.11	-95.3	3.655	-121.2	0.073	-72.6	-3.15	-153.0	11.26	1.06
2.300	-10.01	-108.4	3.587	-93.9	0.075	-47.6	-2.42	-167.3	11.09	1.07
2.304	-10.02	-108.9	3.585	-92.8	0.075	-46.6	-2.41	-167.9	11.09	1.08
2.400	-10.08	-120.9	3.503	-66.5	0.078	-22.4	-2.72	-177.8	11.08	1.09
2.500	-9.15	-137.4	3.638	-36.0	0.082	-5.9	-4.55	-162.9	11.22	1.11
3.000	-0.30	-98.5	0.945	-114.5	0.025	-146.5	-1.26	-164.2	-0.49	1.17
4.000	-0.74	-28.9	0.159	-140.2	0.006	-122.2	-0.11	-150.2	-15.96	1.91
5.000	-2.01	-15.1	0.071	-59.4	0.003	-55.4	-0.08	-123.6	-22.98	13.43
6.000	-0.78	-1.8	0.044	-120.4	0.003	-125.4	-0.07	-100.6	-27.20	9.68
7.000	-0.36	-60.0	0.158	-68.8	0.014	-86.8	-2.71	-123.5	-16.02	8.12
8.000	-0.77	-109.6	0.086	-76.3	0.010	-50.3	-0.74	-73.6	-21.26	14.53
9.000	-3.99	-178.3	0.030	-151.2	0.004	-174.8	-0.10	-53.3	-30.56	50.93
10.000	-1.70	-138.8	0.016	-5.4	0.003	-45.4	-0.10	-33.1	-36.06	75.19
11.000	-0.67	-163.8	0.024	-91.2	0.006	-46.2	-0.47	-12.8	-32.44	53.16
12.000	-0.95	-116.5	0.031	-106.0	0.010	-152.0	-0.48	-0.6	-30.15	33.01

**Table 3—Microwave Harmonica Analysis (Optimized for Output Power)**

MICROWAVE HARMONICA PC V5.5 File: b:qexamp.ckt 22-DEC-93 18:04:28

Freq GHz	MS11 dB AMP	PS11 deg AMP	MS21 mag AMP	PS21 deg AMP	MS12 mag AMP	PS12 deg AMP	MS22 mag AMP	PS22 deg AMP	MS21 dB AMP	K AMP
1.000	-0.72	-168.6	2.386	39.7	0.020	-33.3	-17.28	-86.0	7.55	1.63
1.100	-0.67	-178.3	2.331	20.4	0.022	-50.9	-15.61	-117.3	7.35	1.42
1.200	-0.64	-172.6	2.299	2.0	0.023	-67.5	-14.05	-142.9	7.23	1.27
1.300	-0.54	-163.7	2.294	-15.7	0.026	-83.3	-12.69	-165.0	7.21	1.17
1.400	-0.56	-155.0	2.314	-32.9	0.028	-98.6	-11.48	-175.0	7.29	1.09
1.500	-0.71	-146.5	2.365	-49.9	0.031	-113.6	-10.42	-156.4	7.48	1.05
1.600	-0.79	-137.8	2.453	-66.8	0.035	-128.4	-9.50	-138.6	7.79	1.02
1.700	-0.91	-128.9	2.588	-83.8	0.039	-143.3	-8.71	-121.3	8.26	1.01
1.800	-1.10	-119.4	2.786	-101.2	0.045	-158.5	-8.08	-103.9	8.90	1.01
1.900	-1.42	-108.8	3.071	-119.4	0.053	-174.6	-7.62	-85.7	9.75	1.01
2.000	-1.98	-96.3	3.482	-139.1	0.063	-167.9	-7.46	-65.7	10.84	1.02
2.100	-3.10	-80.3	4.065	-161.7	0.078	-147.5	-7.86	-41.8	12.18	1.04
2.200	-5.77	-57.1	4.815	-170.7	0.096	-122.2	-9.64	-9.1	13.65	1.05
2.300	-14.58	-10.6	5.418	-135.8	0.113	-89.5	-15.23	-52.9	14.68	1.07
2.304	-15.31	-6.6	5.428	-134.2	0.113	-88.0	-15.55	-57.2	14.69	1.07
2.400	-10.67	-157.1	5.138	-96.3	0.111	-52.3	-13.32	-174.5	14.22	1.09
2.500	-4.22	-165.0	4.086	-61.5	0.092	-19.6	-7.41	-119.7	12.23	1.11
3.000	-0.53	-96.9	1.222	-35.2	0.032	-67.2	-2.33	-21.6	1.74	1.17
4.000	-0.75	-29.2	0.494	-155.6	0.019	-173.6	-1.06	-79.0	-6.13	1.69
5.000	-1.99	-15.1	0.261	-93.6	0.013	-90.6	-1.04	-169.9	-11.67	11.23
6.000	-0.78	-1.9	0.137	-130.1	0.010	-135.1	-0.55	-116.4	-17.28	7.89
7.000	-0.39	-60.0	0.101	-160.7	0.009	-178.7	-0.92	-3.1	-19.91	8.22
8.000	-0.75	-109.9	0.196	-1.0	0.023	-25.0	-6.65	-66.0	-14.17	14.18
9.000	-4.01	-178.4	0.126	-132.4	0.018	-98.4	-1.60	-147.6	-18.01	39.98
10.000	-1.70	-138.8	0.076	-53.9	0.015	-93.9	-2.18	-130.1	-22.42	57.57
11.000	-0.66	-163.8	0.071	-60.9	0.017	-15.9	-9.01	-29.7	-22.92	50.28
12.000	-0.97	-116.5	0.092	-168.5	0.030	-145.5	-8.83	-160.9	-20.71	31.18

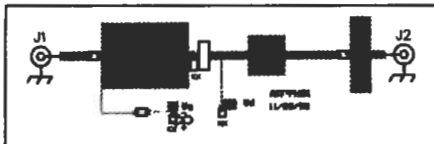

Fig 4—Parts placement diagram for the 2-W amplifier. Points labeled XX should be connected to the ground plane using copper foil.

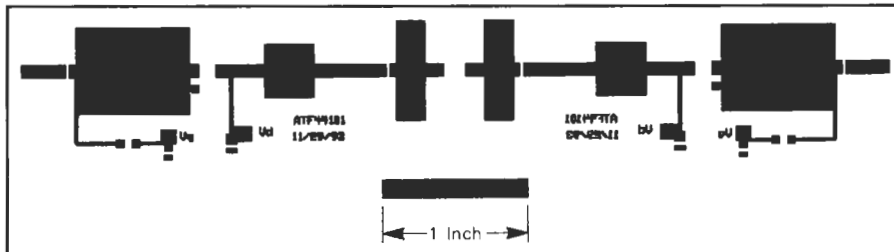

Fig 5—Etching pattern for the 2-W amplifier. Use 0.031-inch-thick,  $\epsilon_r = 2.55$  Teflon circuit board.

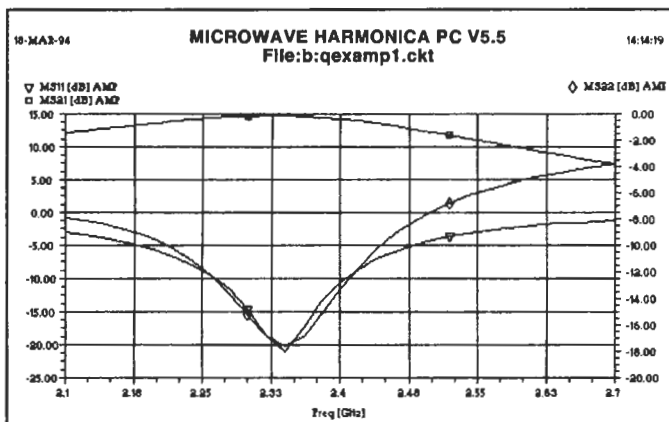

Fig 6—Microwave Harmonica analysis of the circuit's S parameters after computer optimization.

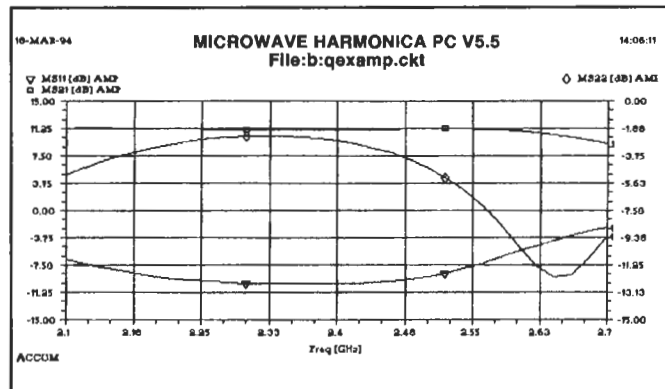

Fig 7—After the output network was optimized on the bench for maximum output power, Microwave Harmonica produced this analysis of the resulting circuit.

mount the FET. Ideally, clean holes would be punched into the copper, but I couldn't figure out a way to do that with the tools I have available. I used 0-80 screws, which are the largest screws I've found that will

fit in the mounting holes. While I've used smaller screws in the past, I prefer using the largest screws possible since taps generally get tougher to use as they get smaller. I built one amplifier using 0.125-inch thick

6061 aluminum, but found that to be too thin to easily make the tapped holes for attaching the connectors and brass strips, although the finished mounting plate was stiff enough.

## 1296-MHz Solid-State Power Amplifiers

Explore the DX possibilities of the 23-cm band with these modern amplifiers.

With the ever-increasing number of ready-to-go 1296-MHz transverters available on the market today, there is a great demand for a simple and economical way to generate higher power than the typical 0.5 to 1 W output these transverters provide. If 1 W or less is used to drive a typical 2C39/7289 stripline or cavity amplifier, the low output power is often disappointing. A tube-type amplifier run with 1 kV on the plate typically offers a gain of 10 dB. This means that, at best, you can expect 5- to 10-W output from your 1-W or less input.

A popular way of generating higher power is to cascade two tube-type amplifiers for 50- to 100-W output. Here I will show you an alternative: two solidstate amplifiers that can replace the tubetype driver amplifier and provide 10- to 20-W output—enough to drive a two-tube amplifier to full output.

The NEC NEL1306 and the NEL1320 1300-MHz power transistors are an economical solid-state approach to generating moderate power levels (10-20W) at 1269 and 1296 MHz. These amplifiers can be used for terrestrial or satellite work. When OSCAR 10 was designed, it was thought that 10 W into a modest gain antenna (20 dBi) would produce usable signals from the satellite. Unfortunately, there were some problems, and the sensitivity of AO-10 was not as originally expected for the Mode-L uplink. These amplifiers can, however, be used as a driver for a higher-powered tube amplifier for Mode-L service. If all goes according to plan with the launch of AMSAT-OSCAR Phase IIIC, 10 to 20 W with a 20-dBi gain antenna will produce acceptable downlink signals.

The NEL1306 is rated for 6-W output at 1296 MHz at the 1-dB compression point; the NEL 1320 is rated at 20 W. These devices offer several advantages for amateur experimenters. They were designed for collector voltages of 12- to 13.6-V dc,

making them ideal for portable and mobile operation. Although the price may seem high to someone familiar with HF parts, these devices are less expensive than most microwave power transistors. The NEL 1306 is in the \$26 price range, while the NEL1320 costs about \$42. California Eastern Laboratories makes these transistors available in single-lot quantities, so you don't have to be "in the business" to get your hands on them.<sup>1</sup>

The performance of the amplifiers I built and tested is shown in Table 1. The NEL1306 is a good buy. With 1.5-W input, 6- to 8-W output can be achieved. When the amplifier is tuned up at lower power levels, power gain can be as high as 10 dB. With 200-mW drive from my homemade transverter, an output power level of 2 W is attainable.<sup>2</sup>

Power gains as high as 17 dB are possible with a two-stage amplifier (an NEL1306 driving an NEL1320). With a mere 200 mW of drive, 10-W output is possible. When the pair of amplifiers is

driven with 1 W and tuned for maximum power output, the 1-dB compression point of 18 W will be achieved.

### Circuit Details

The basic design, shown schematically in Fig. 1, is an adaptation of a circuit described in the NEL1300 series data sheet. The design incorporates 30-ohm quarter-wavelength microstriplines on the input and output. C3, C4, C7 and C8, along with L1, form a pi network that matches the low input impedance of the device to 50 ohms. C5, C6, C9 and C10 and the 30-ohm transmission line (L2) form an output pi network that maximizes power transfer to 50 ohms. C10 is not always necessary, depending on variations among devices and circuit-board material.

I designed the amplifiers for 0.031-inch-thick, double-sided glass-epoxy circuit board. A 30-ohm line in this dielectric equates to a line width of 0.121 inch, which is equivalent to the width of the collector and base leads of the NEL1300 series

**Table 1**  
Typical Operating Conditions for the 1296-MHz Solid-State Power Amplifiers

Device	NE130681-12	NEL132081-12
$P_{out}$ (1-dB compression point)	7W	18W
Gain (1-dB compression point)	6 dB typ.	5 dB typ
Collector efficiency	40-50%	40-50%
Idling current	50 mA	150 mA
$I_C$ @ 1-dB compression point	1.1 A	3.0 A
$V_{CC}$	13.5 V	13.5 V
Power input	14.9 W	40.5 W

# JFLINT

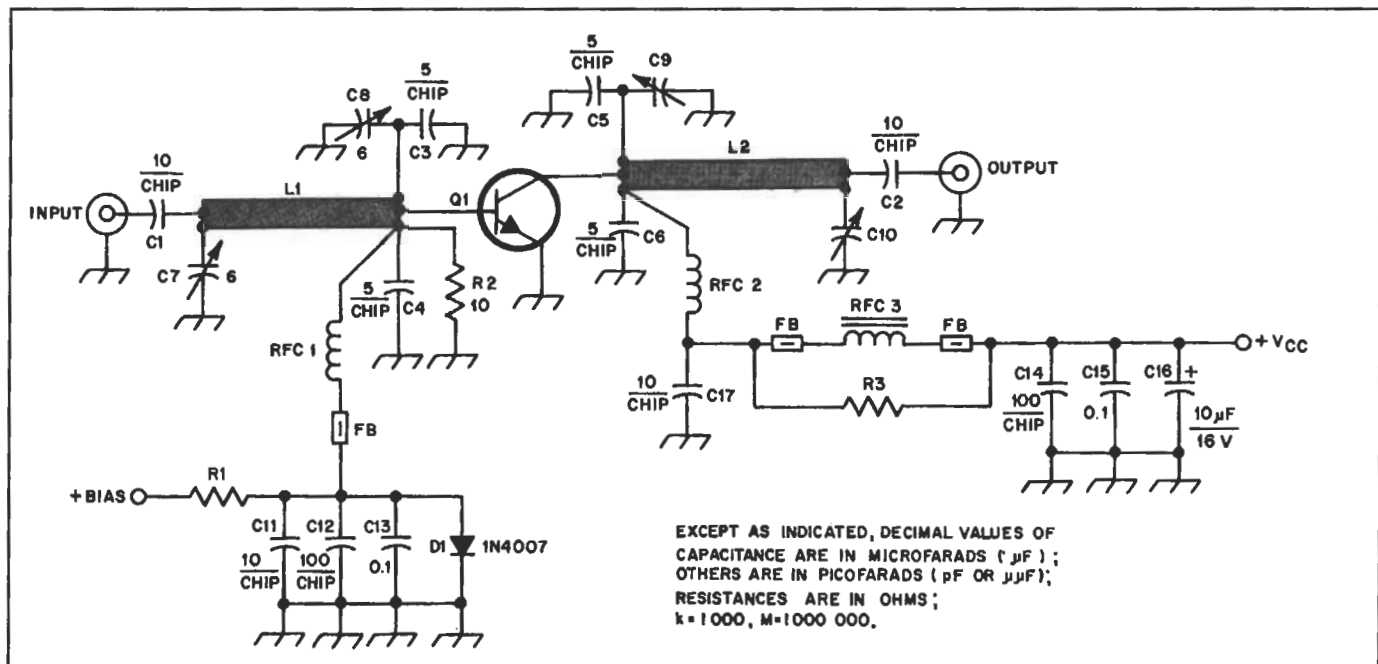

Fig. 1—Schematic diagram of the NEL1306 and NEL1320 1296-MHz solid-state power amplifiers. The schematic is identical for both versions. Component values are the same except as noted.

C1, C2, C11, C17—10-pF chip capacitor.  
 C3, C4, C5, C6—3.6- to 5.0-pF chip capacitor.  
 C7, C8—1.8- to 6.0-pF miniature trimmer capacitor (Mouser 24AA070 or equiv. See text).  
 C9, C10—Same as C7 and C8 for the NEL1306 amplifier. For the NEL1320 version, 0.8- to 10-pF piston trimmers are used (Johanson 5200 series or equiv.).

C12, C14—100-pF chip capacitor.  
 C13, C15—0.1- $\mu\text{F}$  disc ceramic capacitor.  
 C16—10- $\mu\text{F}$  electrolytic capacitor.  
 D1—1N4007 diode.  
 L1, L2—30-ohm microstripline,  $\frac{1}{4}$ -wavelength long (see text).  
 Q1—NEC NEL130681-12 (6 W) or NEL132081-12 (18 W) transistor.  
 R1—82- to 100- $\Omega$  resistor, 2-W minimum. Vary for specified idling current.

R2—10- $\Omega$ ,  $\frac{1}{4}$ -W carbon-composition resistor with "zero" lead length. See text.  
 R3—15- $\Omega$ , 1-W carbon-composition resistor.  
 RFC1—3t no. 24 wire, 0.125 inch ID, spaced 1 wire diam.  
 RFC2—1t no. 24 wire, 0.125 inch ID, spaced 1 wire diam.  
 RFC3—1- $\mu\text{H}$  RF choke; 18t no. 24 enam. close-spaced on a T50-10 toroid core.

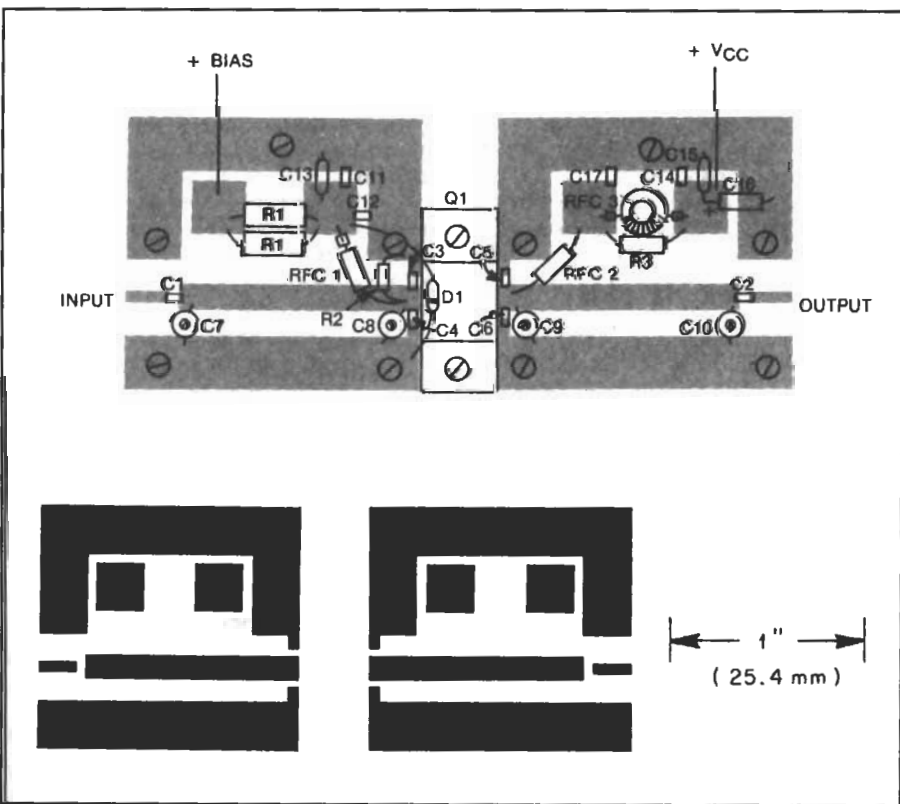

Fig 2—Parts-placement diagram and full-size etching pattern for the solid-state 1296-MHz power amplifiers. All components mount on the etched side of the board. The same PC boards are used for each version.

devices. This minimizes the discontinuity between L1, L2 and Q1.

Bias is provided by R1, R2 and D1. R1 can be optimized, if desired, to adjust the collector idling current.

I selected RFC1 and RFC2 by choosing the lowest possible reactance that will not affect power gain or output power. The RF chokes and the 10-pF bypass capacitors afford adequate decoupling at the frequency of operation. The values of RFC1 and RFC2 are purposely made different to avoid oscillations caused by bias-choke coupling.

After building several of these amplifiers, I noticed that the transistors sometimes generated low-frequency spurious signals. Although these signals were very low in amplitude and caused no problems, they were annoying. I found that I could eliminate them by keeping the high-frequency RF chokes in the collector circuit as small as possible and adding the parallel R3/RFC3 combination, as well as bypass capacitors C14, C15, C16. RFC3 must be capable of handling 1 A for the NEL1306 and 3 A for the NEL1320, so I made special RF chokes to withstand the current.

### Construction

Identical construction techniques are used for both amplifiers. Most of the components are mounted to the PC board, and

# JFLINT

the board and transistor are mounted to an aluminum base plate made from 1/4-inch-thick stock. PC-board layout is shown in Fig. 2. Two separate boards are used—one for the input side and one for the output—and they are mirror images of each other. The copper is retained on the bottom side and serves as a ground plane. The grounded areas on the top side must have a good connection to the bottom ground plane for low-inductance grounding of the transistor emitter leads, matching capacitors and bias circuitry. Etched PC boards and partial parts kits for this project are available from A & A Engineering.<sup>3</sup>

Several effective methods of connecting the top and bottom ground planes are summarized here.

1) Plated-through holes at the critical grounding areas mentioned earlier.

2) Use of pins or screws that penetrate through the circuit board into the aluminum base plate at the critical areas.

3) Use of "wrap-around" foils on all edges of the ground plane.

Plated-through holes are often used in the commercial and military electronic marketplace but are not so easily reproduced in the average builder's circuitboard shop. I've found that the best technique for the home builder is a combination of methods 2 and 3. First, wrap thin copper or brass foil around the board edges and then solder the foil to the top and bottom. Sometimes called "shim stock," thin sheet metal is often available from hobby shops or metal suppliers. Next, drill holes through the board and use no. 4-40 screws to tie the circuit board to the base plate at the critical areas shown in Fig. 2.

The transistor must be mounted so that its leads lie flat against the PC board. This poses a slight problem, since the transistor leads protrude from the device 0.165 inch above the bottom of the flange, and the PC boards are only 0.031 inch high. There are a couple of ways around this problem. They work equally well, so choose the method that is easiest for you.

If you have access to a machine shop, you can mill out a 0.240-inch-wide by 0.090-inch-deep slot in the aluminum base plate to clear the transistor flange. This is a simple task on a milling machine, and you can probably find a local machine shop that will do small jobs when business is slow. The other method is to mount the transistor to the base plate and use a piece of 0.090-inch-thick aluminum sheet to bring the input and output PC boards up to the right height. The 0.090-inch dimension allows a wrap-around foil and solder buildup of 0.040 inch, maximum.

I used 1-inch-long screws to secure the transistor to holes drilled and tapped in the aluminum base plate. The extra screw length that protrudes from the bottom of the base plate allows the use of an external heat sink, which is suggested if continuous operation is desired.

The clearance holes in the NEL1300 devices are for no. 4-40 hardware. I drilled

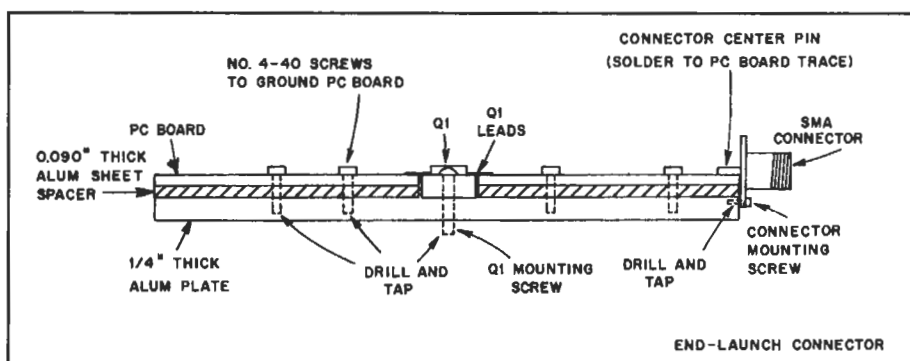

Fig 3—Construction details for the solid-state 1296-MHz power amplifiers. See text for additional information.

out the holes to accept no. 6-32 screws to make the assembly more rugged, although this may not be necessary. Be careful if you decide to drill out the holes to accept no. 6-32 hardware; the transistor flange is soft copper, and you could damage the device. Use a small vise to hold the transistor flange during the drilling operation.

Solder the components to pads on the board using surface-mounting techniques. Silver solder (2%) is recommended for the chip capacitors, but 5N63 will work fine. Use a 15-W iron and solder quickly to avoid burning the metallization off the capacitors.

The transistor leads should be soldered in place only after the circuit boards and transistor have been firmly bolted down to the base plate. This is necessary to minimize any buildup of stress in the transistor leads. Chip capacitors C3, C4, C5 and C6 should be soldered directly onto the leads of Q1 to ensure the shortest possible lead length. Keep D1 close to Q1. Thermal compound will enhance heat transfer to D1 to ensure minimal drift in idling current with temperature changes.

In the original design of these amplifiers, Johanson piston-trimmer capacitors (5200 series or equiv.) were used for C7, C8, C9 and C10. These capacitors are fairly large, and in some instances the coupling between the bodies of C8 and C9 was enough to cause an in-band oscillation. Smaller variable capacitors should be used if at all possible. I've used a 1.8- to 6.0-pF miniature ceramic trimmer capacitor, Mouser Electronics part number 24AA070, in the input and output networks of the NEL1306 amplifier and in the input network of the NEL1320 amplifier with no performance degradation.<sup>4</sup> I did use the Johanson piston trimmers in the output network of the NEL1320 amplifier because of the high RF currents involved.

The PC board makes use of end-launch SMA-type connectors. Fig. 3 illustrates this technique. Four-hole, flange-mount SMA connectors can be mounted to the edge of the base plate using two of the four mounting holes. Drill and tap the base plate for no. 2-56 hardware. Be careful—it's easy to accidentally cross-thread over-torque the no. 2-56 hardware.

An alternative approach is to mount the

amplifier in an aluminum die-cast box (Bud CU-124B or Hammond 1590B) and run miniature 50-ohm coaxial cable such as RG-174 from the amplifier board to the connector. The amplifiers shown in Figs. 4 and 5 use standard SMA connectors mounted to the walls of the metal box. BNC or Type-N connectors should work equally as well. When preparing each end of the coaxial cable, try to keep the pigtail leads as short as possible (1/8 inch or less); otherwise the mismatch will be difficult to tune out.

I compared the performance of an amplifier with end-launch connectors to that of another that used the approach just described. I could measure no difference in gain or 1-dB compression point.

Considerable effort was put forth to make sure the amplifiers are stable. The devices have fairly high gain at the frequency of operation, so layout and good construction practices are very important. Here are some construction hints that can help ensure amplifier performance and stability.

1) Use the smallest (physical) size variable capacitors that will still handle the RF current.

2) Use wrap-around ground foils as noted. Grounding screws are required at the critical RF-ground areas near the shunt variable capacitors, shunt bypass capacitors and Q1 emitters.

3) Connect braids from the coaxial-cable jumpers to the same ground as the shunt variable capacitors.

4) Use as little lead length as possible on R2—less than 1/8 inch.

5) In some instances when the large piston trimmers are used, a shield approximately 3/4 inch high mounted on top of Q1 and grounded via the mounting screws can improve isolation between C8 and C9.

## Tune-up and Operation

Measuring RF power at 1296 MHz can be difficult. I used a calibrated 20-dB directional coupler along with enough attenuator pads to allow power to be read with a Hewlett Packard HP430C power meter and an HP477B thermistor mount. Even better is the HP431 power meter with its associated HP478A thermistor mount (a newer version of the HP430C that does not

# JFLINT

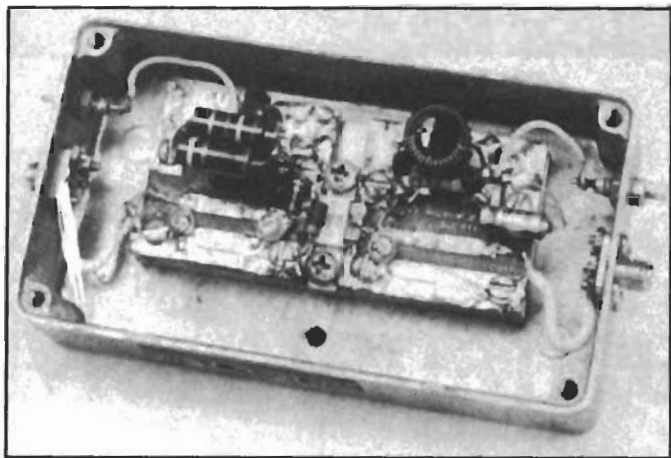

Fig 4—This NEL1306 amplifier was built inside a die-cast box. Miniature coaxial cable runs to the connectors.

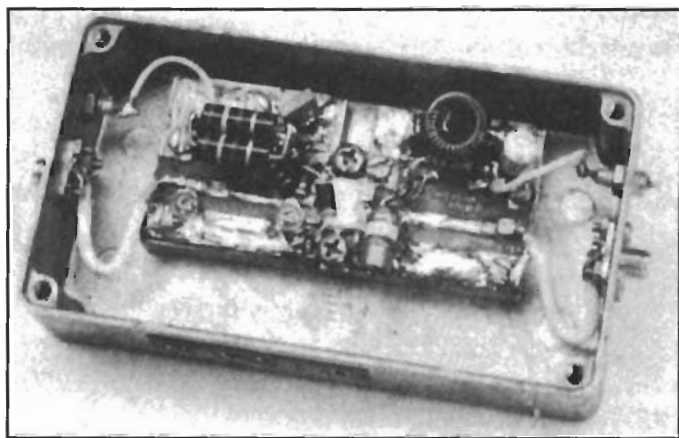

Fig 5—The NEL1320 amplifier is virtually identical to the NEL1306 version of Fig 4, except for the capacitors on the output strip line. C10 was not necessary on this version.

suffer from temperature-drift problems). Bird offers several low-power elements for the popular model 43 in this frequency range. Bird 400-1000 MHz elements are common, and they can be used with decreased accuracy.

Begin initial setup of each amplifier by terminating the input and output in good 50-ohm loads. I recommend that you use a fuse in the collector lead of Q1 to protect the device until you are sure everything is working normally. Start with all capacitors at minimum. Apply 12- to 13.5-V dc to the  $V_{CC}$  and bias terminals. The collector idling current should be as shown in Table 1. Vary the value of R1 for correct idling current.

For the NEL1306 amplifier, start out with 50 to 100 mW of drive. Adjust the output network for maximum power output and then peak the input network for maximum output power. Increase drive and repeak both matching networks for rated performance as shown in Table 1. Similarly, start out with approximately 1 W of drive for the NEL1320 and follow the same procedure. After a minute or two of operation at maximum power output,

remove RF drive power and check to see that the collector idling current has not increased more than 25% over the initial setting. Keeping D1 in close contact with Q1 will minimize drift in idling current with temperature changes.

If you're going to use transistor switching to apply dc to the power amplifier stages during transmit, consider the following technique. Apply 13.5-V dc to the  $V_{CC}$  terminal during receive and transmit. Use a series transistor switch to apply 13.5-V dc to the bias terminal during transmit. A power transistor capable of carrying only a few hundred milliamperes of bias current, as opposed to several amperes of collector current, will be required. More important, the voltage drop across the transistor switch in the  $V_{CC}$  line will be eliminated. This will ensure maximum power output of the NEL1300 devices by keeping  $V_{CC}$  at 13.5-V dc.

Switching the bias port off during receive is important for another reason. Normally during receive periods, the amplifier is left unterminated. Sometimes the input port is also left open. Depending on

the length of the unterminated 50-ohm cable on the amplifier ports, the unit may show signs of instability if it is drawing idling current.

Several amateurs in the Dallas area have duplicated these amplifiers with no problems. Other amplifiers of this design are in use in different parts of the country. The NEL1300 series amplifiers offer a simple and inexpensive means of generating medium power on 1296 MHz. You'll be amazed at what you can work with 18 W that you can't with 1 W.

I wish to thank everyone who offered technical advice, especially Wes Atchison, WASTKU, for helping with the construction and evaluation of the prototype amplifiers.

#### Notes

<sup>1</sup>NEC transistors are available from California Eastern Laboratories, 3260 Jay St., Santa Clara, CA 95050, tel. 408-988-3500.

<sup>2</sup>Complete construction details for this transverter may be found in Chapter 32 of the 1986 *ARRL Handbook*.

<sup>3</sup>A & A Engineering, 7970 Orchid Dr., Buena Park, CA 90620, tel. 714-521-4160.

<sup>4</sup>Mouser Electronics, 11433 Woodside Ave., Santee, CA 92071, tel. 619-449-2222.

By Ward Silver, N0AX

From QST, September 2003

## Amplifier Care and Maintenance

With few moving parts, your amplifier can be easy to overlook. Here are some ideas for taking care of amplifiers.

Amplifiers come in all shapes and sizes, large and small, light or heavy, tube or solid-state, VHF or HF. Regardless, they all need a little TLC from time to time. They can cost as much as top-of-the-line radios, so it's important that they get a little maintenance on a regular basis.

While this article focuses on amplifiers that use vacuum tubes, many of the ideas presented here can and should be applied to any amateur amplifier—HF or VHF/UHF. Solid-state amplifiers operate at lower voltages and generally have fewer points of failure, but they still need occasional maintenance.

### Safety First

It is important to review good safety practices.<sup>1</sup> Tube amplifiers use power supply voltages well in excess of 1 kV and the RF output at full throttle can be hundreds of volts, as well. Almost every voltage in an amplifier can be lethal! Take care of yourself and use caution!

- **Power Control**—Know and control the state of both ac line voltage and dc power supplies. Physically disconnect line cords and other power cables when you are not working on live equipment. Use a lock-out on circuit breakers. Double-check visually and with a meter to be absolutely sure power has been removed.

- **Interlocks**—Unless specifically instructed by the manufacturer's procedures to do so, never bypass or "rig" an interlock. This is rarely required except in troubleshooting and should only be done when absolutely necessary. Interlocks are there to protect you.

- **The One-Hand Rule**—Keep one hand in your pocket while making any measurements on live equipment. The hand in your pocket won't give current a chance to flow through you. It's also a good idea to wear shoes with insulating soles and work on dry surfaces. Current can be lethal even at mil-

liampere levels—don't tempt the laws of physics.

- **Patience**—Repairing an amplifier isn't a race. Take your time. Don't work on equipment when you're tired or frustrated. Wait several minutes after turning the amplifier off to open the cabinet—capacitors can take several minutes to discharge through their bleeder resistors.

- **A Chicken Stick**—Make this simple safety accessory shown in Figure 1 and use it whenever you work on equipment in which hazardous voltages have been present. The ground wire should be heavy duty (12 gauge minimum) due to the high peak currents (hundreds of amperes) present when discharging a capacitor or tripping a circuit breaker. When equipment is opened, touch the tip of the stick to every exposed component and connection that you might come in contact with. Assume nothing—accidental shorts and component failures can put voltage in places it shouldn't be.

- **The Buddy System and CPR**—It's always a good idea to use the buddy system

when working around any equipment that has the potential for causing serious injury. The buddy needn't be a ham, just anyone who can be nearby in case of trouble. Your buddy should know how to remove power and administer basic first aid. Since hams work around electrical equipment frequently, it would be a good idea to have your buddy or someone in the household know CPR, as well.<sup>2</sup>

### Cleanliness

The first rule of taking good care of an amplifier is cleanliness. I realize that 90 percent of ham shacks have just failed the first rule. Amplifiers need not be kept sparkling new, but their worst enemy is heat. Excess heat accelerates component aging and stresses those expensive tubes and transformers. There are two areas to keep clean—the inside and the outside.

Outside the amplifier, you need to prevent dust and obstructions from blocking the paths by which heat is removed. This means keeping all ventilation holes free of the ever-present dust bunnies, pet hair and

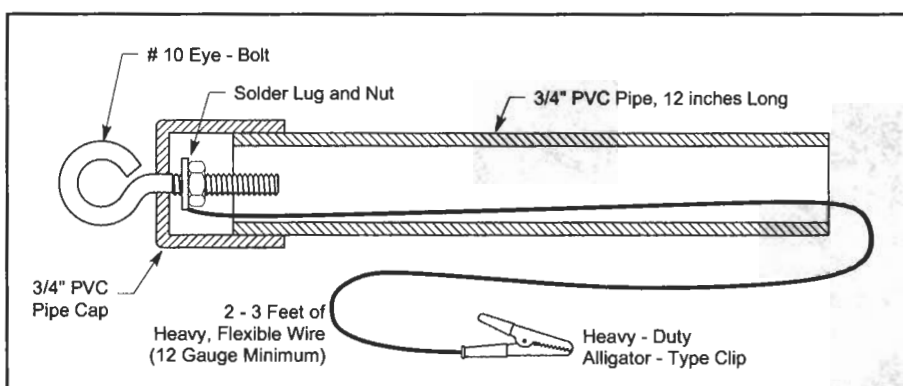

Figure 1—The "chicken stick" is a great way to ensure that everything inside the amplifier that should be discharged actually is. It can be a life saver.



insects. Fan intakes are particularly susceptible to inhaling all sorts of "goop." Get out the vacuum cleaner and clean not only the amplifier, but the surrounding areas. Don't even think about letting liquids anywhere near the amplifier. One spilled cup of coffee can cause hundreds of dollars of damage.

Keep papers or magazines off the amplifier—even if the cover is solid metal. Paper acts as an insulator and keeps heat from being radiated through the cover. Amplifier heat sinks must have free air circulation to be effective. There should be at least a couple of inches of free space surrounding an amplifier on its sides and top. If the manufacturer recommends a certain clearance, mounting orientation or air flow, follow those recommendations.

Just as the outside needs to be kept clean, so does the inside. High voltage (HV) circuits attract dust like crazy. The dust slows heat dissipation and will eventually build up to the point where it arcs or carbonizes. Our friend the vacuum cleaner should make another appearance to remove any dust or dirt. If you find insects (or worse) inside the amp, try to determine how they got in and plug that hole. Window screening works fine to allow airflow while keeping out visitors. While you're cleaning the inside, this is a great time to perform a visual inspection as described in the next section.

Vacuuming works best with an attachment commonly known as a "crevice cleaner." Figure 2 shows a crevice clean-

ing attachment being used with a small paintbrush to dislodge and remove dust. Don't use the vacuum cleaner brush attachment; they're designed for floors, not electronics. Some vacuums also have a blower mechanism, but these rarely have enough punch to clean as thoroughly as a brush. Besides, that dust you blow all over is going to wind up in some other equipment, so it's best to take it out of circulation, so to speak. The brush will root dust out of tight places and off components without damaging them or pulling on connecting wires.

If you can't get a brush or attachment close enough, a spray can of compressed air will usually dislodge dust and dirt. If you use a rag or towel to wipe down panels or large components, be sure not to leave threads or lint behind. Never use a solvent or spray cleaner to wash down components unless the manufacturer advises doing so—you might leave behind a residue or damage the component.

### Visual Inspection

Once the amplifier has been cleaned, it's time for a visual inspection. Remove any internal covers or access panels and...stop! Get out the chicken stick, clip its ground lead securely to the chassis and touch every exposed connection. Now, using a strong light and possibly a magnifier, look over the components and connections. Amplifiers have far fewer components than transceivers do, so it's quite feasible to look at every component and insulator. Look for cracks, signs of

arcing, carbon traces (thin black lines), discoloration, loose connections, melting of plastic, and anything else that doesn't "look right." This is a great time to be sure that mounting and grounding screws are tight. While you're in there, does anything smell burnt? The nose can quickly detect the odors of toasted transformer, cooked capacitor or roasted resistor. Learn the smells of healthy and not-so-healthy components.

Make a note of what you find, repair, or replace—even if it's absolutely nothing. If you don't keep a shack notebook, start one. A simple spiral notebook with notes about maintenance, wiring, color coding, antenna behavior and so forth can be a big time-saver.

### Electrical Components

An amplifier contains many heavy-duty HV and RF components. These can be expensive and hard to replace, so it's important that you take good care of them. Let's start with the power supply.

There are three basic parts to amplifier power supplies—the ac transformer and line devices, the rectifier/filter and the metering/regulation circuitry. Transformers need little maintenance except to be kept cool and be mounted securely. Line components such as switches, circuit breakers and fuses, if mechanically sound and adequately rated, are usually electrically okay, as well.

Rectifiers and the capacitors that filter the HV dc require occasional cleaning. Look for discoloration around components mounted on a printed circuit board (PCB) and make sure that all wire connections are secure. HV capacitors are generally electrolytic or oil and should show no signs of leakage, swelling or outgassing around terminals.

Located at the output of the filter, components that perform metering and regulation of voltage and current can be affected by heat or heavy dust. If there has been a failure of some other component in the amplifier—such as a tube—these circuits can be stressed severely. Resistors may survive substantial temporary overloads, but may show signs of overload, such as discoloration or swelling.

Amplifiers contain two types of relays—control and RF. Control relays switch ac and dc voltages and do not handle input or output RF energy. The usual problem encountered with control relays is oxidation or pitting of their contacts. A burnishing tool can be used to clean relay contacts. In a pinch a strip of ordinary paper can be pulled between contacts gently held closed. [Avoid the temptation to over-clean silver-plated relay and switch contacts, as the author points out later. It is easy to remove contact plating with excessive polishing and while silver-plated relay and switch contacts may appear to be dark in color, oxidized silver (black) is still a good conductor. Once the silver's gone, it's gone; contact erosion will then be pervasive.—Ed.] If visual inspection shows heavy pitting or

S. COHEN, N1SC; R. SCHETGEN, KU7G

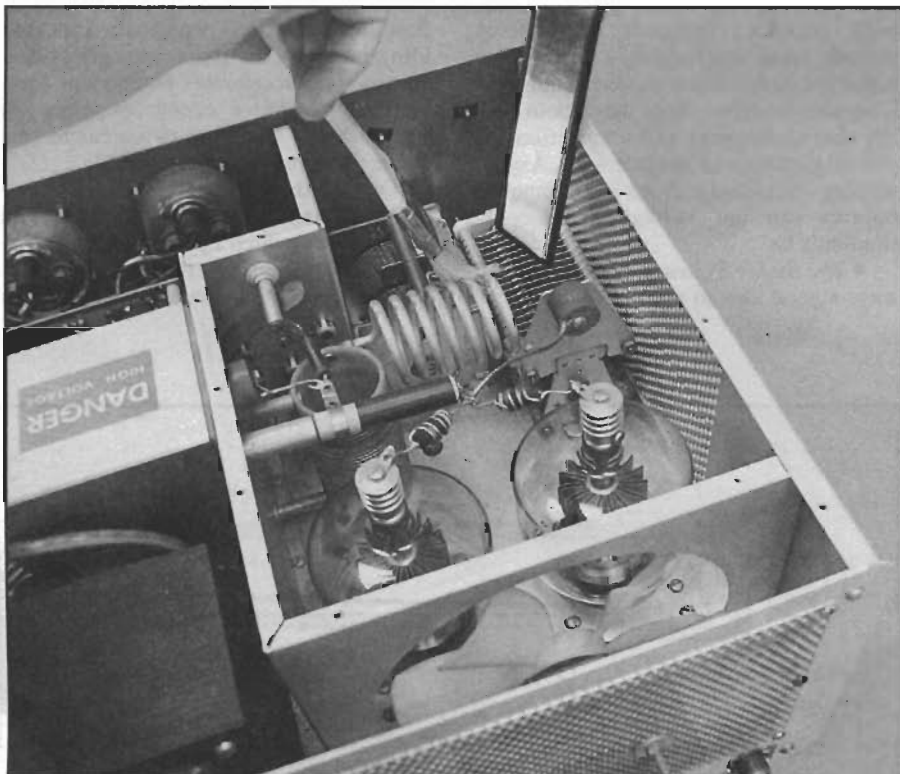

Figure 2—A small paintbrush and a vacuum cleaner crevice attachment make dust removal easy.

discoloration or resistance measurements show the relay to have intermittent contact quality, it is best replaced.

RF relays are used to perform transmit-  
receive (TR) switching and routing of RF  
signals through or around the amplifier cir-  
cuitry. Amplifiers designed for full break-  
in operation will usually use a high-speed  
vacuum TR relay. Vacuum relays are sealed  
and cannot be cleaned or maintained. When  
you replace RF relays, use a direct replace-  
ment part or one rated for RF service with  
the same characteristics as the original.

Cables and connectors are subjected to  
heavy heat and electrical loads in amplifi-  
ers. Plastics may become brittle and con-  
nections may oxidize. Cables should re-  
main flexible and not be crimped or  
pinched under clamps or tie-downs. It's a  
good idea to gently wiggle cables while  
watching the connections at each end for  
looseness or bending. Connectors can be  
unplugged and resealed once or twice to  
clear oxide on contact surfaces. Carefully  
inspect any connector that seems loose. Be  
especially careful with connectors and  
cables in amplifiers that have RF decks that  
are in separate enclosures from those of  
their power supplies. Those interconnects  
are susceptible to both mechanical and  
electrical stress and you don't want an en-  
ergized HV cable loose on the operating  
desk. Check both the soldered electrical  
integrity and the mechanical stability of  
those cables and make sure they are tightly  
fastened.

As with relays, switches found in am-  
plifiers are either control function orien-  
tated or RF routers. Adequately rated con-  
trol switches, if mechanically sound, are  
usually okay. Bandswitches are the most  
common RF switch—usually a rotary phe-  
nolic or ceramic type. A close visual in-  
spection should show no pitting or oxida-  
tion on the wiper (the part of the switch that  
rotates between contacts) or the individual  
contacts. Arcing or overheating will  
quickly destroy rotary switches. Figure 3  
is a photo of a heavy-duty band switch that  
has suffered severe damage from arcing.  
Slight oxidation is acceptable on silver-  
plated switches. Phosphor-bronze contacts  
can sometimes be cleaned with a light scrub  
from a pink pencil eraser, but plating can  
be easily removed, so use caution with this  
method and be sure to remove any eraser  
crumbs. Rotary switch contacts cannot be  
replaced easily although individual wafer  
sections may be replaced if an exact match-  
ing part can be obtained.

Amplifiers use all types of capacitors  
and resistors. When replacing them, be sure  
to use a part rated for the use to which it  
will be put. Voltage and power-handling  
ratings are particularly important, especially  
of those handling high RF currents. An RF  
tank capacitor replacement should be checked  
carefully for adequate RF voltage and cur-  
rent ratings, not just dc. HV resistors are  
generally long and thin to prevent arcing  
across their surfaces. Even if a smaller (and  
cheaper) resistor has an equivalent power

rating, resist the temptation to substitute it.  
In a pinch, a series string of resistors of the  
appropriate combined value can be used to  
replace one HV unit. Don't use carbon re-  
sistors for metering circuits, use metal or  
carbon film types. The carbon composition  
types are too unstable.

If you are repairing or maintaining an  
old amplifier and manufacturer-specific  
parts are no longer available, the ham com-  
munity has many sources for RF and HV  
components. Fair Radio Sales and Surplus  
Sales of Nebraska are familiar names.<sup>3</sup>  
Hamfests and Web sites such as [www.eham.net](http://www.eham.net)  
or [www.k1dwu.net/hamtrader](http://www.k1dwu.net/hamtrader)  
often have amplifier components for sale.  
You might consider buying another ampli-  
fier of the same type in non-working con-  
dition for parts use.

### Tubes

The single most expensive component  
in an amplifier is usually the vacuum tube  
that performs the amplification. Good  
maintenance of tubes starts with proper op-  
eration of the amplifier. Follow the man-  
ufacturer's instructions for input drive  
levels, duty cycles, tuning and output  
power level. Frequently check all metered  
voltages and current to be sure that the  
tubes are being operated properly and giv-  
ing you maximum lifetime. Penta Labs has  
an excellent Web page on maintaining  
power tubes.<sup>4</sup>

The internal mechanical structures of  
tubes generally do not deal well with me-  
chanical shock and vibration, so be gentle.  
The manufacturer may also specify how  
the amplifier is to be mounted, so read the  
operating manual.

Tubes generate a lot of heat, so it's im-  
portant that whatever cooling mechanism  
employed is kept at peak efficiency. Air-  
ways should be clean, including between  
the fins on metal tubes. All seals and chim-  
neys should fit securely and be kept clean.  
Wipe the envelope of glass tubes clean af-  
ter handling them—fingerprints should be  
removed to prevent baking them into the  
surface.

On metal tubes that use finger-stock  
contacts, be sure the contacts are clean and  
make good contact all the way around the  
tube. Partial contact or dirty finger stock  
can cause asymmetric current and heating  
inside the tube, resulting in warping of in-  
ternal grids and possibly causing harmon-  
ics or parasitics.

Plate cap connections and VHF parasitic  
suppressors should be secure and show no  
signs of heating. Overheated parasitic sup-  
pressors may indicate that the neutralization  
circuit is not adjusted properly. Inspect socket  
contacts and the tube pins to be sure all con-  
nections are secure, particularly high-current  
filament connections. Removing and insert-  
ing the tubes once or twice will clean the  
socket contacts.

Adjustments to the neutralizing net-  
work, which suppresses VHF oscillations  
by negative feedback from the plate to grid  
circuit, are rarely required except when you  
are replacing a tube or after you do major  
rewiring or repair of the RF components.  
The manufacturer will provide instructions  
on making these adjustments. If symptoms  
of VHF oscillations occur without chang-  
ing a tube, then perhaps the tube character-  
istics or associated components have  
changed. Parasitic oscillations in high-

H. WARD SILVER, N0AX

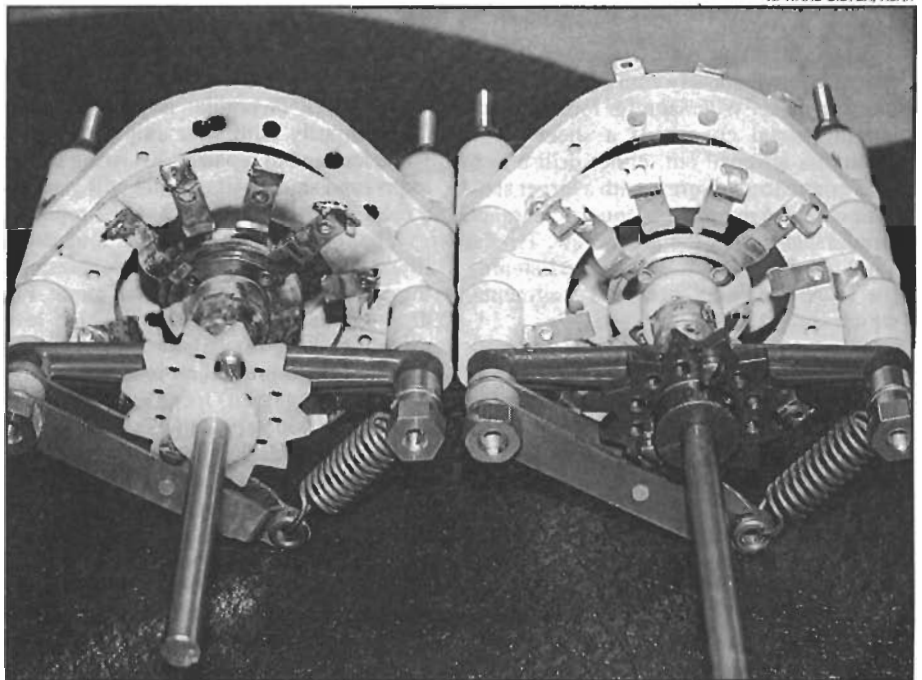

Figure 3—The band switch section on the left clearly shows the signs of destructive arcing.

power amplifiers can be strong enough to cause arcing damage. Perform a visual inspection prior to re-adjusting the neutralizing circuit.

Metering circuits rarely fail, but they play a key part in maintenance. By keeping a record of "normal" voltages and currents, you will have a valuable set of clues when things go wrong. This is perfect information for the shack notebook. Record tuning settings, drive levels, and tube voltages and currents on each band and with every antenna. When things change, you can refer back to the notebook instead of relying on memory.

### Mechanical

While the amplifier is primarily an electronic beast, it has a significant number of mechanical parts that affect its well-being. Thermal cycling and heat-related stresses can result in mechanical connections loosening over time or material failures.

Switch shafts, shaft couplings and panel bearings all need to be checked for tightness and proper alignment. All mounting hardware needs to be tight, particularly if it supplies a grounding path. Examine all panel-mounted components, particularly RF connectors, and be sure they're attached securely. BNC and UHF connectors that are mounted with a single nut in a round panel hole are notorious for loosening with repeated connect/disconnections.

Rubber and plastic parts are particularly stressed by heat. If there are any belts, gears or pulleys, make sure they're clean and that dust and lint are kept out of their lubricant. Loose or slipping belts should be replaced. Check O-rings, grommets and sleeves to be sure they are not brittle or cracked. If insulation sleeves or sheets are used, check to be sure they are covering what they're supposed to. Never discard them or replace them with improperly sized or rated materials.

Enclosures and internal shields should all be fastened securely with every required screw in place. Watch out for loosely overlapping metal covers. If a sheet metal screw has stripped out, either drill a new hole or replace the screw with a larger size, taking care to maintain adequate clearance around and behind the new screw. Tip the amplifier from side to side while listening for loose hardware or metal fragments, which should all be retrieved.

A great time to clean the front and back panels and get gummy finger deposits off before they cause permanent finish damage is during maintenance. If the amplifier is missing a foot on the cabinet or an internal shock mount, replace it. A clean unit with a complete cabinet will have a significantly higher resale value than a dirty, grubby one, so it's in your interest to keep the equipment looking its best.

### Shipping

When you are traveling with an amplifier or shipping it, some care in packing will prevent needless damage. Improper

packing can also result in difficulty in collecting on an insurance claim, should damage occur. The original shipping cartons are a good method of protecting the amplifier for storage and sale, but they were not made to hold up to frequent shipping. If you travel frequently, it is best to get a sturdy shipping case made for electronic equipment.<sup>5</sup>

Some amplifiers require the power transformer to be removed before shipping. Check your owner's manual or contact the manufacturer to find out. Failure to remove it before shipping can cause major structural damage to the amplifier's chassis and case.

Tubes should also be removed from their sockets for shipment. It may not be necessary to ship them separately if they can be packed in the amplifier's enclosure with adequate plastic foam packing material. If the manufacturer of the tube or amplifier recommends separate shipment, however, do it!

### Cleaning and Maintenance Plan

This discussion should have given you plenty to think about. It's easy to defer maintenance, but as with a vehicle, performance and lifetime are improved if a regular program is put into place. For amateur use, there is little need for maintenance more frequently than once per year. If there is a period of the year in which you are most active, put a note on the calendar about six weeks in advance to "open the hood," giving you time to obtain and replace any components.

Consider the maintenance requirements of your amplifier and what its manufacturer recommends. Sit down with your amplifier's manuals and make up a checklist of what major steps and tools are required. When maintenance time rolls around, you'll be prepared and be able to perform the job in the most efficient manner.

### Troubleshooting

A benefit of regular maintenance will be familiarity with your amplifier should you ever need to repair it. Knowing what it looks (and smells) like inside will give you a head start on effecting a quick repair.

The following discussion is intended to illustrate the general flow of a troubleshooting effort, not be a step-by-step guide. Figure 4 shows a moderately-high-level troubleshooting flow chart. Before starting on your own amplifier, review the amplifier manual's "Theory of Operation" section and familiarize yourself with the schematic. If there is a troubleshooting procedure in the manual, follow it, of course.

You might be surprised how many "amplifier is dead" problems turn out to be simply a lack of ac power. Before even opening the cabinet of an unresponsive amplifier, be sure that ac is really present at the wall socket and that the fuse or circuit breaker is really closed. Assuming that ac power is present, trace through any internal fuses, interlocks and relays all the way

through to the transformer primary terminals.

Hard failures in a high voltage power supply are rarely subtle, so it's usually clear if there is a problem and what components are involved. When you repair a power supply, take the opportunity to check all related components. If all defective components are not replaced, the failures may be repeated when the circuit is re-energized.

Rectifiers may fail open or shorted—test them using a DVM diode checker. An open rectifier will result in a drop in the HV output of 50 percent or more but will probably not overheat or destroy itself. A shorted rectifier failure is usually more dramatic and may cause additional rectifiers or filter capacitors to fail. If one rectifier in a string has failed, it may be a good idea to replace the entire string as the remaining rectifiers have been subjected to a higher-than-normal voltage.

High voltage filter capacitors usually fail shorted, although they will occasionally lose capacitance and show a rise in ESR (equivalent series resistance). Check the rectifiers and any metering components—they may have been damaged by the current surge caused by a shorted filter. Power transformer failures usually manifest themselves by insulation failures with consequent arcing of the windings. Either can result in the unmistakable aroma of overheated transformer. A failed transformer is generally not repairable.

Along with the HV plate supply, tetrode screen supplies occasionally fail, too. The usual cause is the regulation circuit that drops the voltage from the plate level. Operating without a screen supply can be damaging to a tube, so be sure to check the tube carefully after repairs.

If the power supply checks out okay and the tube's filaments are lit, check the resting or bias current. If it is excessive or very low, check all bias voltages and dc current paths to the tube, such as the plate choke, screen supply (for tetrodes) and grid or cathode circuits.

Having exhausted power supply and dc problems, you will then turn to the RF components or "RF deck." There is a natural tendency to forge ahead and swap in a known-good tube or tubes. Don't! Tubes are expensive and if the problem is elsewhere, you may damage the spares. Wait to swap tubes until you are sure that the tube is likely to be defective.

Check the input SWR to the amplifier. If it has changed (you did write down the normal SWR and drive levels, didn't you?) then you likely have a problem in the input circuitry or one or more tubes have failed. Perform a visual check of the input circuitry and the band switch, followed by an ohmmeter check of all input components.

If input SWR is normal and applying drive does not result in any change in plate current, you may have a defective tube, tube socket, or connection between the input circuits and the tube. Check the TR

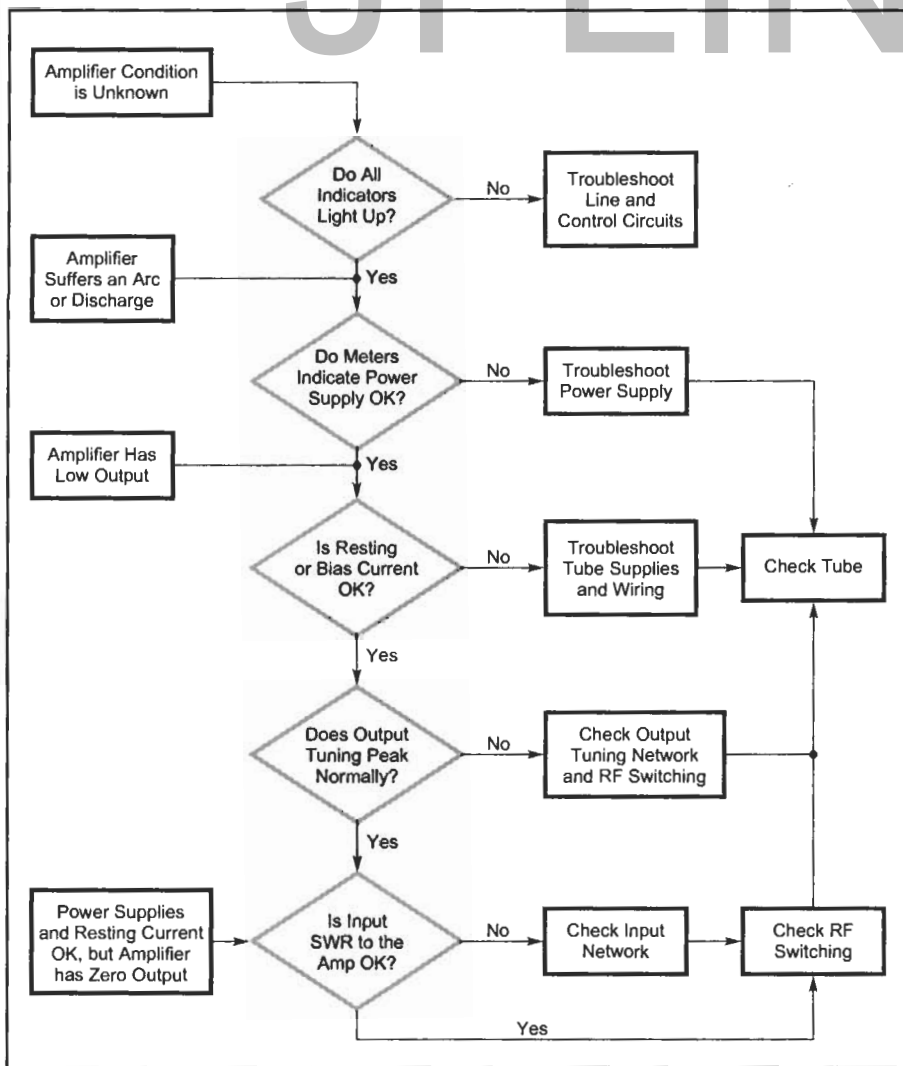

Figure 4—This moderate-level flow chart is a good way to identify amplifier problems quickly in lieu of a misplaced or nonexistent manufacturer's troubleshooting procedure.

control circuits and relay. If plate current changes, but not as much as normal, try adjusting the output tuning circuitry. If this has little or no effect, the tube may be de-

fective or a connection between the tube and output circuitry may have opened. If retuning has an effect, but at different settings than usual, the tube may be defective

or there may be a problem in the tuning circuitry. A visual inspection and an ohmmeter check are in order.

The key to finding the trouble with your amplifier is to be careful and methodical, and to avoid jumping to false conclusions or making random tests. The manufacturer's customer service department will likely be helpful if you are considerate and have taken careful notes detailing the trouble symptoms and any differences from normal operation. There may be helpful guidelines on the manufacturer's Web pages or from other Internet resources. Sometimes there is more than one problem—they work together to act like one very strange puzzle. Just remember that most problems are very simple and can be isolated by careful, step-by-step tests.

### Summary

Amplifiers have been part of ham radio for many years. They are simple, reliable pieces of equipment that respond well to basic care and common sense. Take the time to know your amp—inside and out. If you take care of it, it will reward you with reliable service and maximum tube lifetime.

### Notes

<sup>1</sup>Chapter 9 of the current *ARRL Handbook for Radio Communications* is an excellent source of safety information. Available from your local dealer or the ARRL Bookstore. Order no. 1921 (softcover), no. 1948 (hardcover). Telephone toll-free in the US 888-277-5289, or 860-594-0355, fax 860-594-0303; [www.arrl.org/shop/](http://www.arrl.org/shop/); [pubsales@arrl.org](mailto:pubsales@arrl.org).

<sup>2</sup>Instructions for CPR can be found at: [about-the-web.com/spiritworks/web/Kaiser/html/adult.htm](http://about-the-web.com/spiritworks/web/Kaiser/html/adult.htm).

<sup>3</sup>Two sources of HV and RF parts include Surplus Sales of Nebraska ([www.surplussales.com](http://www.surplussales.com)) and Fair Radio Sales ([www.fairradio.com](http://www.fairradio.com)). Others can be found at the ARRL Technical Information Service database ([www.arrl.org/tis/tisfind.html](http://www.arrl.org/tis/tisfind.html)).

<sup>4</sup>Penta Labs, "Tube Maintenance & Education" ([www.pentalaboratories.com/maintenance.asp](http://www.pentalaboratories.com/maintenance.asp)).

<sup>5</sup>Pelican ([www.pelican-shipping-cases.com](http://www.pelican-shipping-cases.com)) and Anvil ([www.anvil-site.com](http://www.anvil-site.com)) make excellent shipping cases suitable for carrying amplifiers and radio equipment.

# JFLINT

Build safe and reliable amplifiers. Produce loud and clean signals.

Planning to build an amplifier compares well to the work of a cook searching for a recipe and all the ingredients. Find the right design, and then locate the parts and components to begin building.

Shorten your discovery work with *ARRL's RF Amplifier Classics!* Use this book to find classic tube and solid-state designs at power levels from 5 W to 1.5 kW. Included are two-dozen amplifier projects and articles published in ARRL's popular journals between 1980 and 2003. There are amps for HF, MF, VHF and microwave. These are high quality works from respected authors such as Gary Breed, K9AY; Jerry Pittenger, K8RA; Bill Sabin, W0IYH; Al Ward, W5LUA; Dave Meacham, W6EMD and others.

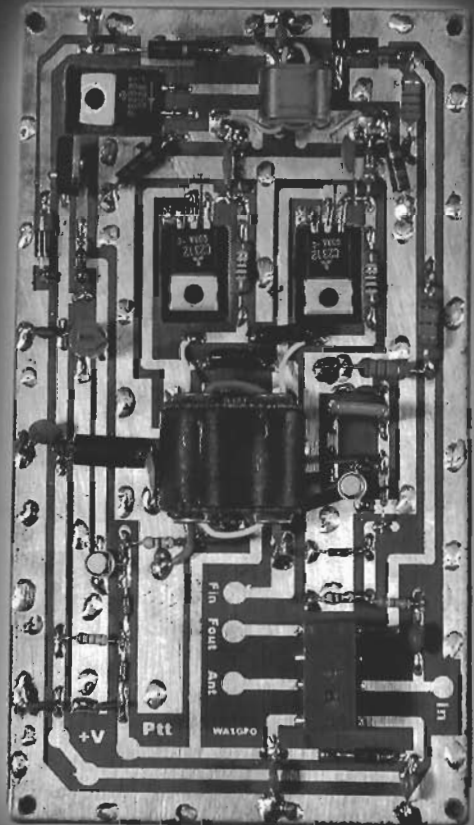

Turn dreams of constructing your first amp or next brick into reality!



**ARRL** The national association for  
**AMATEUR RADIO**

225 Main Street,  
Newington, CT 06111-1494 USA

**ARRLWeb: [www.arrl.org/](http://www.arrl.org/)**

ISBN 0-87259-931-0



ISBN 0-87259-931-0 ARRL Order No. 9310