

# Electromagnetic Interference (EMI)

## 28

### THE SCOPE OF THE PROBLEM

**A**s our lives become filled with technology, the likelihood of electronic interference increases. Every lamp dimmer, garage-door opener or other new technical “toy” contributes to the electrical noise around us. Many of these devices also “listen” to that growing noise and may react unpredictably to their electronic neighbors.

Sooner or later, nearly every Amateur Radio operator will have a problem with interference. Most cases of interference can be cured! The proper use of “diplomacy” skills and standard cures will usually solve the problem.

This chapter, by Ed Hare, W1RFI, is only an overview. *The ARRL RFI Book* contains detailed information on the causes of and cures for nearly every type of interference problem.<sup>1</sup>

### Pieces of the Problem

Every interference problem has two components — the equipment that is involved and the people who use it. A solution requires that we deal with both the equipment and the people effectively.

First, define the term “interference” without emotion. The ARRL recommends that the hams and their neighbors cooperate to find solutions. This view is shared by the FCC.

### Important Terms

**Bypass capacitor** — a capacitor used to provide a low-impedance radio-frequency path around a circuit element.

**Common-mode signals** — signals that are in phase on both (or several) conductors in a system.

**Conducted signals** — signals that travel by electron flow in a wire or other conductor.

**Decibel (dB)** — a logarithmic unit of relative power measurement that expresses the ratio of two power levels.

**Differential-mode signals** — Signals that arrive on two or more conductors such that there is a 180° phase difference between the signals on some of the conductors.

**Electromagnetic compatibility (EMC)** — the ability of electronic equipment to be operated without performance degradation from interference.

---

<sup>1</sup> ARRL Order no. 6834, available from ARRL Publication Sales or your local Amateur Radio equipment dealer.

**Electromagnetic interference (EMI)** — any electrical disturbance that interferes with the normal operation of electronic equipment.

**Emission** — electromagnetic energy propagated from a source by radiation.

**Filter** — a network of resistors, inductors and/or capacitors that offer little resistance to certain frequencies while blocking or attenuating other frequencies.

**Fundamental overload** — interference resulting from the fundamental signal of a radio transmitter.

**Ground** — a low-impedance electrical connection to the earth. Also, a common reference point in electronic circuits.

**Harmonics** — signals at exact multiples of the operating (or *fundamental*) frequency.

**High-pass filter** — a filter designed to pass all frequencies above a cutoff frequency, while rejecting frequencies below the cutoff frequency.

**Induction** — the transfer of electrical signals via magnetic coupling.

**Interference** — the unwanted interaction between electronic systems.

**Intermodulation** — the undesired mixing of two or more frequencies in a nonlinear device, which produces additional frequencies.

**Low-pass filter** — a filter designed to pass all frequencies below a cutoff frequency, while rejecting frequencies above the cutoff frequency.

**Noise** — any signal that interferes with the desired signal in electronic communications or systems.

**Nonlinear** — having an output that is not in linear proportion to the input.

**Notch filter** — a filter that rejects or suppresses a narrow band of frequencies within a wider band of frequencies.

**Passband** — the band of frequencies that a filter conducts with essentially no attenuation.

**Radiated emission** — radio-frequency energy that is coupled between two systems by electromagnetic fields.

**Radio-frequency interference (RFI)** — interference caused by a source of radio-frequency signals. This is a subclass of EMI.

**Spurious emission** — An emission, on frequencies outside the necessary bandwidth of a transmission, the level of which may be reduced without affecting the information being transmitted.

**Susceptibility** — the characteristic of electronic equipment that permits undesired responses when subjected to electromagnetic energy.

**TVI** — interference to television systems.

# Responsibility

When an interference problem occurs, we may ask “Who is to blame?” The ham and the neighbor often have different opinions. It is almost natural (but unproductive) to fix blame instead of the problem.

No amount of wishful thinking (or demands for the “other guy” to solve the problem) will result in a cure for interference. Each individual has a unique perspective on the situation, and a different degree of understanding of the personal and technical issues involved. On the other hand, each person has certain responsibilities to the other and should be prepared to address those responsibilities fairly.

## FCC Regulations

A radio operator is responsible for the proper operation of the radio station. This responsibility is spelled out clearly in Part 97 of the FCC regulations. If interference is caused by a spurious emission from your station, you *must* correct the problem there.

Fortunately, most cases of interference are *not* the fault of the transmitting station. Most interference problems involve some kind of electrical noise or fundamental overload.

## Personal Diplomacy

What happens when you first talk to your neighbor sets the tone for all that follows. Any technical solutions cannot help if you are not allowed in your neighbor’s house to explain them! If the interference is not caused by spurious emissions from your station, however, you should be a locator of solutions, not a provider of solutions.

Your neighbor will probably *not* understand all of the technical issues — at least not at first. Understand that, regardless of fault, an interference problem is annoying to your neighbor. Let your neighbor know that you want to help find a solution and that you want to begin by talking things over.

Talk about some of the more important technical issues, in nontechnical terms. Interference can be caused by unwanted signals from your transmitter. Assure your neighbor that you will check your station thoroughly and correct any problems. You should also discuss the possible susceptibility of consumer equipment. If you have a copy of the consumer pamphlet “What to Do If You Have an Electronic Interference Problem,” give it to your neighbor.<sup>2</sup>

Here is a good analogy: If you tune your TV to channel 3, and see channel 8 instead, would you blame channel 8? No. You might check another set to see if it has the same problem, or call channel 8 to see if the station has a problem. If channel 8 was operating properly, you would likely decide that your TV set is broken. Now, if you tune your TV to channel 3, and see your local shortwave radio station (quite possibly Amateur Radio), don’t blame the shortwave station without some investigation. In fact, many televisions respond to strong signals outside the television bands. They may be working as designed, but require added filters and/or shields to work properly near a strong, local RF signal.

Your neighbor will probably feel much better if you explain that you will help *find* a solution, even if the interference is *not* your fault. This offer can change your image from neighborhood villain to hero, especially if the interference is not caused by your station. (This is often the case.)

## PREPARE YOURSELF

### Learn About EMI

In order to troubleshoot and cure EMI, you need to learn more than just the basics. This is especially important when dealing with your neighbor. If you visit your neighbor’s house and try a

---

<sup>2</sup> The ARRL Technical Information Service has additional information available about EMI, a list of EMI-filter sources, EMI-resistant telephones, telephone-company contacts and a pamphlet that explains interference in nontechnical terms. See the [References](#) chapter for more information.

few dozen things that don't work (or make things worse), your neighbor may lose confidence in your ability to help cure the problem. If that happens, you may be asked to leave.

## **Local Help**

If you are not an expert (and even experts can use moral support), you should find some local help. Fortunately, such help is often available from your Section Technical Coordinator (TC). The TC knows of any local RFI committees, and may have valuable contacts in the local utility companies. Even an expert can benefit from a TC's help.

The easiest way to find your TC is through your ARRL Section Manager (SM). There is a list of ARRL Officers and SMs on page 12 of any recent *QST*. Contact your SM through the address or telephone number listed. He or she can quickly put you in contact with the best source of local help.

Even if you can't secure the help of a local expert, a second ham can be a valuable asset. Often a second party can help defuse any hostility. It is also helpful to have someone to operate your station while you and your neighbor run through troubleshooting steps and try various cures.

## **Prepare Your Home**

The first step toward curing an interference problem is to make sure your own signal is clean. You must eliminate all interference in your own house to be sure you are not causing the interference! This is also a valuable troubleshooting tool: If you know your station is clean, you have cut the size of the problem in half! If the FCC ever gets involved, you can demonstrate that you are not interfering with your own equipment.

Apply EMI cures to your own consumer electronics equipment. When your neighbor sees your equipment working well, it demonstrates that filters work and cause no harm.

To clean up your station, clean up the mess! A rat's nest of wires, unsoldered connections and so on in your station can contribute to EMI. To help build a better relationship, you may want to show your station to your neighbor. A clean station looks professional; it inspires confidence in your ability to solve the EMI problem.

Install a transmit filter (low-pass or band-pass) and a reasonable station ground. (If the FCC becomes involved, they will ask you about both items.) Show your neighbor that you have installed the necessary filter on your transmitter and explain that if there is still interference, it is necessary to try filters on the neighbor's equipment, too.

Operating practices and station-design considerations can affect EMI. Don't overdrive a transmitter or amplifier; that can increase its harmonic output. You can take steps to reduce the strength of your signal at the victim equipment. This might include reducing transmit power. Locate the antenna as far as possible from susceptible equipment or its wiring (ac line, telephone, cable TV). Antenna orientation may be important. For example, if your HF dipole at 30 ft is coupling into the neighbor's overhead cable-TV drop, that coupling could be reduced 20 dB by changing to a vertical antenna — even more by orienting the antenna so that the drop is off its end. Try different modes; CW or FM usually do not generate nearly as much telephone interference as AM or SSB, for example.

## **Call Your Neighbor**

Now that you have learned more about EMI, located some local help (we'll assume it's the TC) and done all of your homework, make contact with your neighbor. First, arrange an appointment convenient for you, the TC and your neighbor. After you introduce the TC, allow him or her to explain the issues to your neighbor. Your TC will be able to answer most questions, but be prepared to assist with support and additional information as required.

Invite the neighbor to visit your station. Show your neighbor some of the things you do with your radio equipment. Point out any test equipment you use to keep your station in good working order. Of course, you want to show the filters you have installed on your transmitter.

Next, have the TC operate your station on several different bands. Show your neighbor that your home electronics equipment is working properly while your station is in operation. Point out the filters you have installed to correct any susceptibility problems.

At this point, tell your neighbor that the next step is to try some of these cures on his or her equipment. This is a good time to emphasize that the problem is probably not your fault, but that you and the TC will try to help find a solution anyway.

**Table 28.1** is a list of the things needed to troubleshoot and solve most EMI problems. Decide ahead of time which of these items are needed and take them with you.

## At Your Neighbor's Home

You and the TC should now visit the neighbor's home. Inspect the equipment installation and ask when the interference occurs, what equipment is involved and what frequencies or channels are affected. The answers are valuable clues. Next, either you or the TC should operate your station while the other observes the effects. Try all bands and modes that you use. Ask the neighbor to demonstrate the problem.

The tests may show that your station isn't involved at all. You may immediately recognize electrical noise or some kind of equipment malfunction. If so, explain your findings to the neighbor and suggest that he or she contact appropriate service personnel.

---

### Table 28.1 EMI Survival Kit

#### Literature:

- *The ARRL Handbook*
- *The ARRL RFI Book*
- "What To Do If You Have an Electronic Interference Problem" (the consumer pamphlet)
- ARRL EMI and RFI information; see the [References](#) chapter.

#### Filters:

- (2) 300- $\Omega$  high-pass filter (different brands recommended)
- (2) 75- $\Omega$  high-pass filter (different brands recommended)
- (2) Commercially available common-mode chokes
- (12) Assorted ferrite cores: 43, 63 and 75 material, FT-140 and FT-240 size
- (3) Telephone RFI filters (different brands recommended)
- (2) Brute-force ac line filters
- (6) 0.01- $\mu$ F ceramic capacitors
- (6) 0.001- $\mu$ F ceramic capacitors
- (2) Speaker-lead filters

#### Miscellaneous:

- Hand tools, assorted screwdrivers, wire cutters, pliers
- Hookup wire
- Electrical tape
- Soldering iron and solder (use with caution!)
- Assorted lengths 75- $\Omega$  coaxial cable with connectors
- Spare F connectors, male
- F-connector female-female "barrel"
- Alligator clips
- Notebook and pencil
- Portable multimeter

### **Warning: Performing Repairs**

You are the best judge of a local situation, but the ARRL strongly recommends that you do not work on your neighbor's equipment. The minute you take the back off a TV or open up a telephone, you may become liable for problems. Internal modifications to your neighbor's equipment may cure the interference problem, but months later, when that 25-year-old clunker gives up the ghost, you may be held to blame. In some states, it is *illegal* for you to do *any* work on electronic equipment other than your own. — *Ed Hare, W1RFI, ARRL Laboratory Supervisor*

# EMC Fundamentals

Knowledge is one of the most valuable tools for solving EMI problems. A successful EMI cure usually requires familiarity with the relevant technology and troubleshooting procedures.

## SOURCE-PATH-VICTIM

All cases of EMI involve a *source* of electromagnetic energy, a device that responds to this electromagnetic energy (*victim*) and a transmission path that allows energy to flow from the source to the victim. Sources include radio transmitters, receiver local oscillators, computing devices, electrical noise, lightning and other natural sources.

There are three ways that EMI can travel from the source to the victim: radiation, conduction and induction. Radiated EMI propagates by electromagnetic radiation from the source, through space to the victim. A conducted signal travels over wires connected to the source and the victim. Induction occurs when two circuits are magnetically coupled. Most EMI occurs via conduction, or some combination of radiation and conduction. For example, a signal is radiated by the source and picked up by a conductor attached to the victim (or directly by the victim's circuitry) and is then conducted into the victim. EMI from induction is rare.

## DIFFERENTIAL VS COMMON-MODE

It is important to understand the differences between differential-mode and common-mode conducted signals (see **Fig 28.1**). Each of these conduction modes requires different EMI cures. Differential-mode cures, (the typical high-pass filter, for example) do not attenuate common-mode signals. On the other hand, a typical common-mode choke does not affect interference resulting from a differential-mode signal.

Differential-mode currents usually have two easily identified conductors. In a two-wire transmission line, for example, the signal leaves the generator on one line and returns on the other. When the two conductors are in close proximity, they form a transmission line and there is a 180° phase difference between their respective signals. It's relatively simple to build a filter that passes desired signals and shunts unwanted signals to the return line. Most *desired* signals, such as the TV signal inside a coaxial cable are differential-mode signals.

In a common-mode circuit, many wires of a multiwire system act as if they were a single wire. The result can be a good antenna, either as a radiator or as a receptor of unwanted energy. The return path is usually earth ground. Since the source and return conductors are usually well separated, there is no reliable phase difference between the conductors and no convenient place to shunt un-

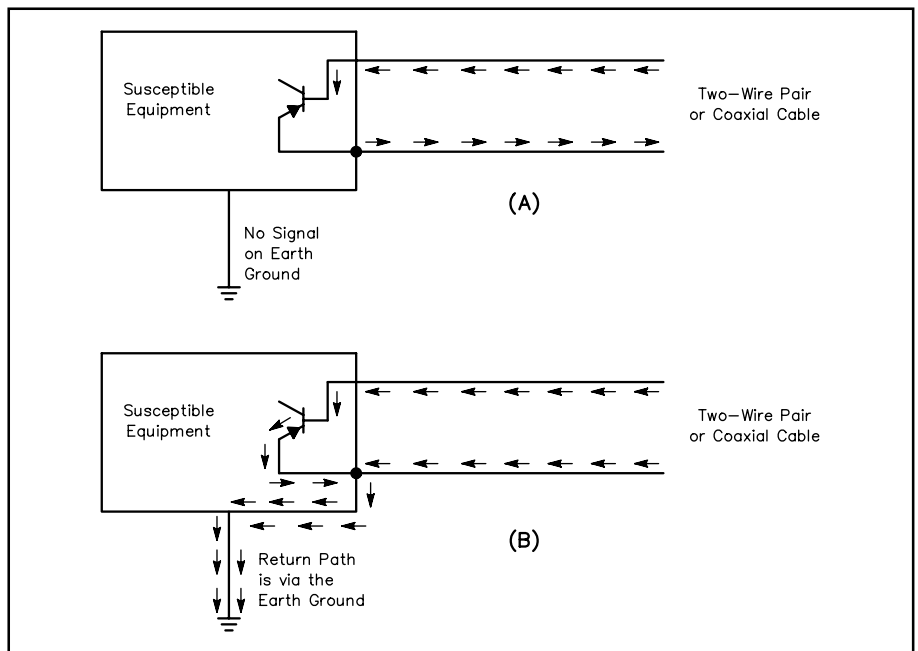

**Fig 28.1** — A shows a differential-mode, while B shows a common-mode signal. The two kinds of signals are described in the text.

wanted signals. Toroid chokes are the answer to common-mode interference. (The following explanation applies to rod cores as well as toroids, but since rod cores may couple into nearby circuits, use them only as a last resort.)

Toroids work differently, but equally well, with coaxial cable and paired conductors. A common-mode signal on a coaxial cable is usually a signal that is present on the *outside* of the cable *shield*. When we wrap the cable around a ferrite-toroid core the choke appears as a reactance in series with the outside of the shield, but it has no effect on signals inside the cable because their field is (ideally) confined inside the shield. With paired conductors such as zip-cord, signals with opposite phase set up magnetic fluxes of opposite phase in the core. These “differential” fluxes cancel each other, and there is no net reactance for the differential signal. To common-mode signals, however, the choke appears as a reactance in series with the line.

Toroid chokes work less well with single-conductor leads. Because there is no return current to set up a canceling flux, the choke appears as a reactance in series with *both* the desired and undesired signals.

## SOURCES OF EMI

The basic causes of EMI can be grouped into several categories:

- Fundamental overload effects
- External noise
- Spurious emissions from a transmitter
- Intermodulation distortion or other external spurious signals

As an EMI troubleshooter, you must determine which of these are involved in your interference problem. Once you do, it is easy to select the necessary cure.

### Fundamental Overload

Most cases of interference are caused by fundamental overload. The world is filled with RF signals. Properly designed equipment should be able to select the desired signal, while rejecting all others. Unfortunately, because of design deficiencies such as inadequate shields or filters, some equipment is unable to reject strong out-of-band signals.

A strong fundamental signal can enter equipment in several different ways. Most commonly, it is conducted into the equipment by wires connected to it. Possible conductors include antennas and feed lines, interconnecting cables, power lines and ground wires. TV antennas and feed lines, telephone or speaker wiring and ac power leads are the most common points of entry.

The effect of an interfering signal is directly related to its strength. The strength of a radiated signal diminishes with the square of the distance from the source: When the distance from the source doubles, the strength of the electromagnetic field decreases to one-fourth of its strength at the original distance from the source. This characteristic can often be used to help solve EMI cases. You can often make a significant improvement by moving the victim equipment and the antenna farther away from each other.

### External Noise

Most cases of interference reported to the FCC involve some sort of external noise source. The most common of these noise sources are electrical. External “noise” can also come from transmitters or from unlicensed RF sources such as computers, video games, electronic mice repellents and the like.

Electrical noise is fairly easy to identify by looking at the picture of a susceptible TV or listening on an HF receiver. A photo of electrical noise on a TV screen is shown in the [TVI section](#) of this chapter. On a receiver, it usually sounds like a buzz, sometimes changing in intensity as the arc or spark sputters a bit. If you determine the problem to be caused by external noise, it must be cured at the source. Refer to the [Electrical Noise section](#) of this chapter and the ARRL RFI book.

## Spurious Emissions

All transmitters generate some (hopefully few) RF signals that are outside their allocated frequency bands. These out-of-band signals are called spurious emissions, or *spurs*. Spurious emissions can be discrete signals or wideband noise. Harmonics, the most common spurious emissions, are signals at exact multiples of the operating (or *fundamental*) frequency. Other discrete spurious signals are usually caused by the superheterodyne mixing process used in most modern transmitters. Fig 28.2 shows the spectral output of a transmitter, including harmonics and mixing products.

Transmitters may also produce broadband noise and/or “parasitic” oscillations. (Parasitic oscillations are discussed in the [Amplifiers](#) chapter.) If these unwanted signals cause interference to another radio service, FCC regulations require the owner to correct the problem.

### Troubleshooting EMI

Most EMI cases are complex. They involve a source, a path and a victim. Each of these main components has a number of variables: Is the problem caused by harmonics, fundamental overload, conducted emissions, radiated emissions or a combination of all of these factors? Should it be fixed with a low-pass filter, high-pass filter, common-mode chokes or ac-line filter? How about shielding, isolation transformers, a different ground or antenna configuration?

By the time you finish with these questions, the possibilities could number in the millions. You probably will not see your exact problem and cure listed in this book or any other. You must diagnose the problem!

Troubleshooting an EMI problem is a three-step process, and all three steps are equally important:

- Identify the problem
- Diagnose the problem
- Cure the problem.

### IDENTIFY THE PROBLEM

**Is It Really EMI?** — Before trying to solve a suspected case of EMI, verify that the symptoms actually result from external causes. A variety of equipment malfunctions or external noise can look like interference. “Your” EMI problem might be caused by another ham or a radio transmitter of another radio service, such as a local CB or police transmitter.

**Is It Your Station?** — If it appears that your station is involved, operate your station on each band, mode and power level that you use. Note all conditions that produce interference. If no transmissions produce the problem, your station *may* not be the cause. (Although some contributing factor may have been

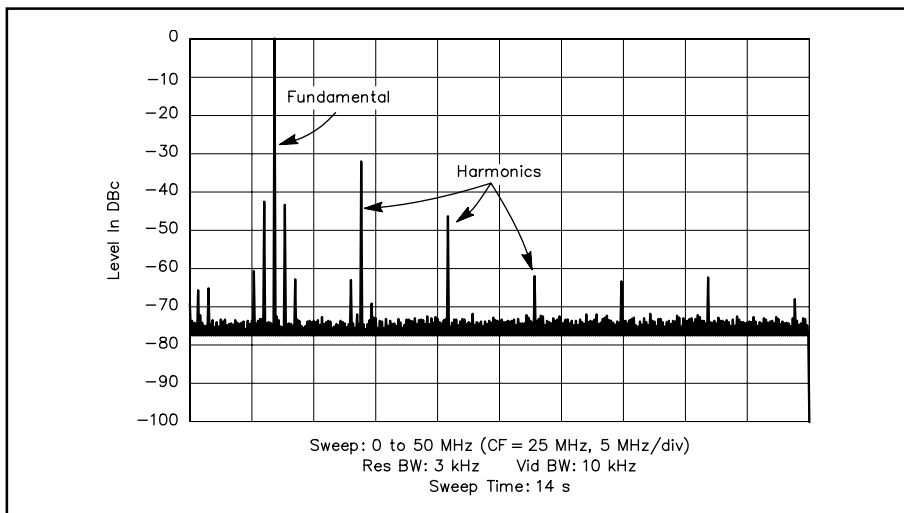

**Fig 28.2 — The spectral output of a typical amateur transmitter. The fundamental is at 7 MHz. There are visible harmonics at 14, 21 and 28 MHz. Unlabeled lines are nonharmonic spurious emissions. This transmitter complies with the stringent FCC spectral-purity regulations regarding amateur transmitters with less than 5 W of RF output.**



missing in the test.) Have your neighbor keep notes of when and how the interference appears: what time of day, what station, what other appliances were in use, what was the weather? You should do the same whenever you operate. If you can readily reproduce the problem with your station, you can start to troubleshoot the problem.

## **DIAGNOSE THE PROBLEM**

***Look Around*** — Aside from the brain, eyes are a troubleshooter's best tool. Look around. Installation defects contribute to many EMI problems. Look for loose connections, shield breaks in a cable-TV installation or corroded contacts in a telephone installation. Fix these first.

Problems that occur only on harmonics of the fundamental signal usually indicate the transmitter. Harmonics can also be generated in nearby semiconductors, such as an unpowered VHF receiver left connected to an antenna, or a corroded connection in a tower guy wire. Harmonics can also be generated in the front-end components of the TV or radio experiencing interference.

Is the wiring connected to the victim equipment resonant on one or more amateur bands? If so, a common-mode choke placed at the middle of the wiring may be an easy cure.

These are only a few of the questions you might need to ask. Any information you gain about the systems involved will help find the EMI cause and cure.

# Cures

**At Your Station** — Make sure that your own station and consumer equipment are clean. This cuts the size of the problem in half! Once this is done, you won't need to diagnose or troubleshoot your station later. Also, any cures successful at your house may work at your neighbor's as well. If you do have problems in your own house, refer first to the [Transmitter section](#) of this chapter, or continue through the troubleshooting steps and specific cures and take care of your own problem first.

**Simplify the Problem** — Don't tackle a complex system — such as a telephone system in which there are two lines running to 14 rooms — all at once. You could spend the rest of your life running in circles and never find the true cause of the problem.

There's a better way. In our hypothetical telephone system, first locate the telephone jack closest to the telephone service entrance. Disconnect the lines to more remote jacks and connect one EMI-resistant telephone at the remaining jack. If the interference remains, try cures until the problem is solved, then start adding lines and equipment back one at a time, fixing the problems as you go along. If you are lucky, you will solve all of the problems in one pass. If not, at least you can point to one piece of equipment as the source of the problem.

**Multiple Causes** — Many EMI problems have multiple causes. These are usually the ones that give new EMI troubleshooters the most trouble. If, for example, a TVI problem is caused by harmonics from the transmitter, an arc in the transmitting antenna, an overloaded TV preamp, differential-mode fundamental overload generating harmonics in the TV tuner, induced and conducted RF in the ac-power system and a common-mode signal picked up on the shield of the TV's coaxial feed line, you would never find a cure by trying only one at a time!

In this case, the solution requires that you apply all of the cures at the same time. When troubleshooting, if you try a cure, leave it in place. When you finally try a cure that really works, start removing the "temporary" attempts one at a time. If the interference returns, you know that there were multiple causes.

## OVERVIEW OF TECHNIQUES

### Shields

Shields are used to set boundaries for radiated energy. Thin conductive films, copper braid and sheet metal are the most common shield materials. Maximum shield effectiveness usually requires solid sheet metal that completely encloses the source or susceptible circuitry or equipment. Small discontinuities, such as holes or seams, decrease shield effectiveness.

### Filters

A major means of separating signals relies on their frequency differences. Filters offer little opposition to certain frequencies while blocking others. Filters vary in attenuation characteristics, frequency characteristics and power-handling capabilities. The names given to various filters are based on their uses.

**Low-pass filters** pass frequencies below some cutoff frequency, while attenuating frequencies above that cutoff frequency. A typical low-pass filter curve is shown in **Fig 28.3**. A schematic is shown in **Fig 28.4**. These filters are difficult to construct properly so you should buy one. Many retail Amateur Radio stores that advertise in *QST* stock low-pass filters.

**High-pass filters** pass frequencies above some cutoff frequency while attenuating frequencies below that cutoff frequency. A typi-

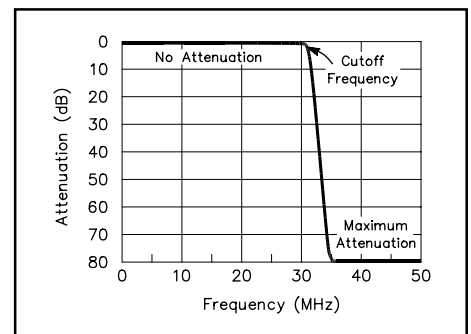

**Fig 28.3** — An example of a low-pass filter response curve.

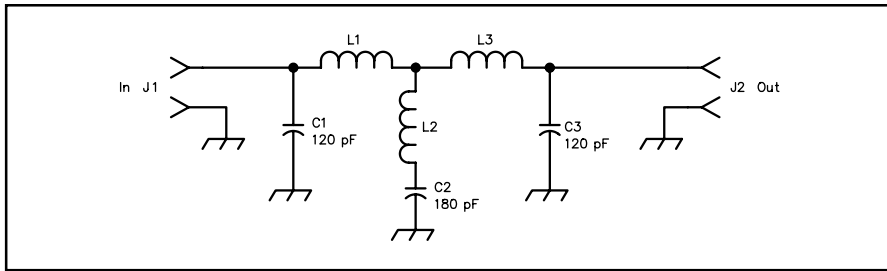

**Fig 28.4** — A low-pass filter for amateur transmitting use. Complete construction information appears in the Transmitters chapter of the ARRL RFI book.

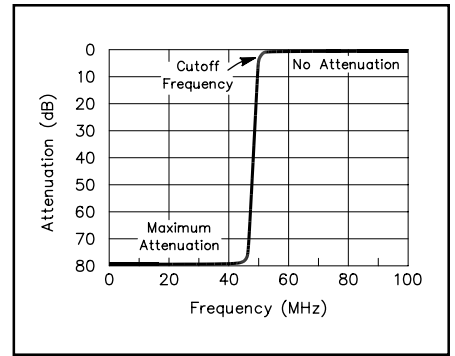

**Fig 28.5** — An example of a high-pass filter response curve.

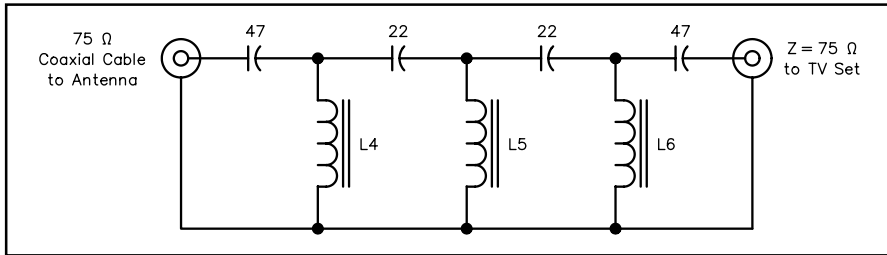

**Fig 28.6** — A differential-mode high-pass filter for 75- $\Omega$  coax. It rejects HF signals picked up by a TV antenna or that leak into a cable-TV system. It is ineffective against common-mode signals. All capacitors are high-stability, low-loss, NP0 ceramic discs. Values are in pF. The inductors are all #24 enameled wire on T-44-0 toroid cores. L4 and L6 are each 12 turns (0.157  $\mu$ H). L5 is 11 turns (0.135  $\mu$ H).

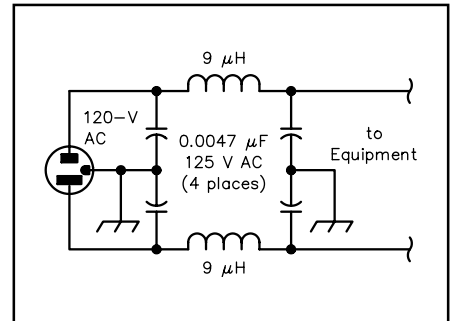

**Fig 28.7** — A “brute-force” ac-line filter.

cal high-pass filter curve is shown in **Fig 28.5**. **Fig 28.6** shows a schematic of a typical high-pass filter. Again, it is best to buy one of the commercially available filters.

**Bypass capacitors** can be used to cure EMI problems. A bypass capacitor is usually placed between a signal or power lead and circuit ground. It provides a low-impedance path to ground for RF signals. Bypass capacitors for HF signals are usually 0.01  $\mu$ F, while VHF bypass capacitors are usually 0.001  $\mu$ F.

**AC-line filters**, sometimes called “brute-force” filters, are used to filter RF energy from power lines. A schematic is shown in **Fig 28.7**. Use ac-rated components as specified. We *strongly* recommend UL-listed, commercially made ac-line filters; the ac-power lines are no place for home-brew experimentation.

## Common-Mode Chokes

Common-mode chokes may be the best-kept secret in Amateur Radio. The differential-mode filters described earlier are *not* effective against common-mode signals. To eliminate common-mode signals properly, you need common-mode chokes. They may help nearly any interference problem, from cable TV to telephones to audio interference caused by RF picked up on speaker leads.

Common-mode chokes usually have ferrite core materials. These materials are well suited to attenuate common-mode currents. Several kinds of common-mode chokes are shown in **Fig 28.8**.



**Fig 28.8** — Several styles of common-mode chokes.

## **Warning: Surplus Toroidal Cores**

Don't use an unknown core or an old TV yoke core to make a common-mode choke. Such cores may not be suitable for the frequency you want to remove. If you try one of these "unknowns" and it *doesn't* work, you may incorrectly conclude that a common-mode choke won't help. Perhaps the correct material would have done the job.

Ferrite beads are also used for EMI control, both as common-mode chokes and low-pass filters. It takes quite a few beads to be effective at the lower end of the HF range, though. It is usually better to form a common-mode choke by wrapping about 10 to 20 turns of wire or coaxial cable around an FT-140 (1.4-inch OD) or FT-240 (2.4-inch OD) core of the correct material. Mix 43 is a good material for most of the HF and VHF ranges. — *Ed Hare, W1RFI, ARRL Laboratory Supervisor*

The optimum size and ferrite material are determined by the application and frequency. For example, an ac cord with a plug attached cannot be easily wrapped on a small ferrite core. The characteristics of ferrite materials vary with frequency, as shown by the graph in **Fig 28.9**.

## **Grounds**

An electrical ground is not a huge sink that somehow swallows noise and unwanted signals. Ground is a *circuit* concept,

whether the circuit is small, like a radio receiver, or large, like the propagation path between a transmitter and cable-TV installation. Ground forms a universal reference point between circuits.

This chapter deals with the EMC aspects of grounding. While grounding is not a cure-all for EMI problems, ground is an important safety component of any electronics installation. It is part of the lightning protection system in your station and a critical safety component of your house wiring. Any changes made to a grounding system must not compromise these important safety considerations. Refer to the **Safety** chapter for important information about grounding.

Many amateur stations have several grounds: a safety ground that is part of the ac-wiring system, another at the antenna for lightning protection and perhaps another at the station for EMI control. These grounds can interact with each other in ways that are difficult to predict.

## **Ground Loops**

All of these station grounds can form a large ground loop. This loop can act as a large loop antenna, with increased susceptibility to lightning or EMI problems. **Fig 28.10** shows a ground loop and a proper single-point ground system.

## **When is Ground not a Ground?**

In many stations, it is impossible to get a good RF connection to earth ground. Most practical installations require several feet of wire between the station ground connection and an outside ground rod.

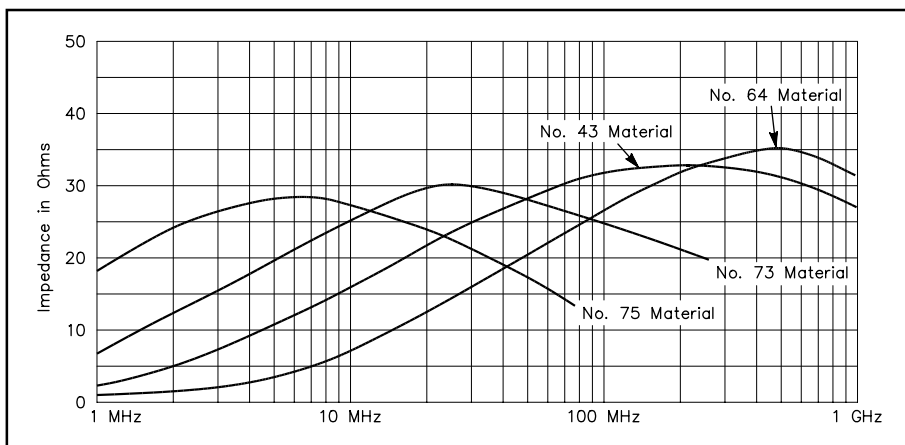

**Fig 28.9 — Impedance vs frequency plots for “101” size ferrite beads.**

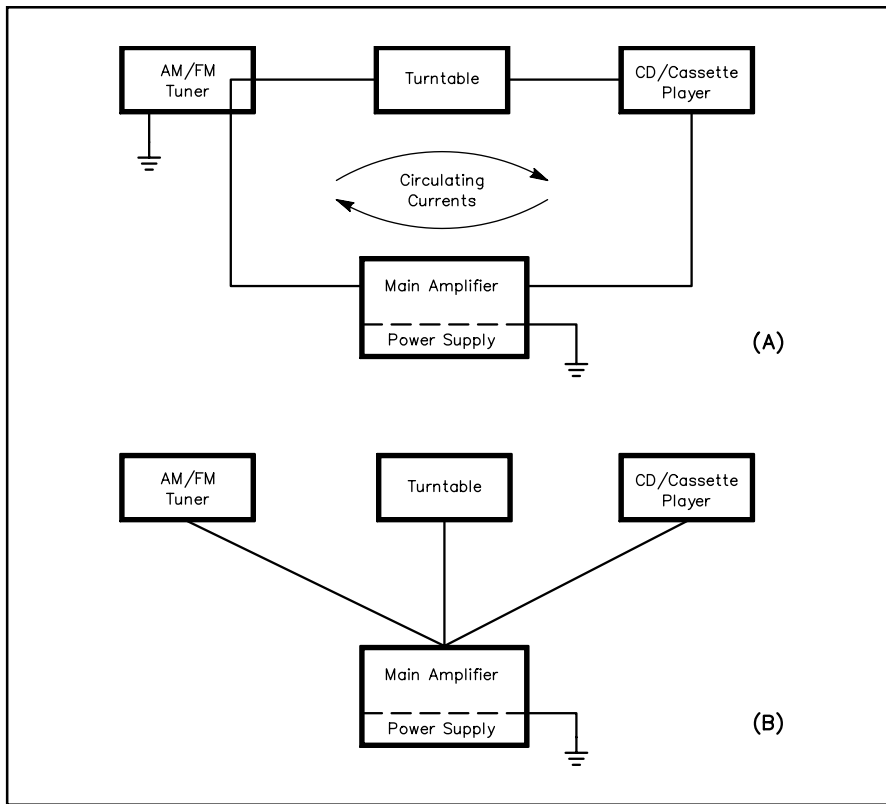

**Fig 28.10** — A shows a stereo system grounded as an undesirable “ground loop.” B is the proper way to ground a multiple-component system.

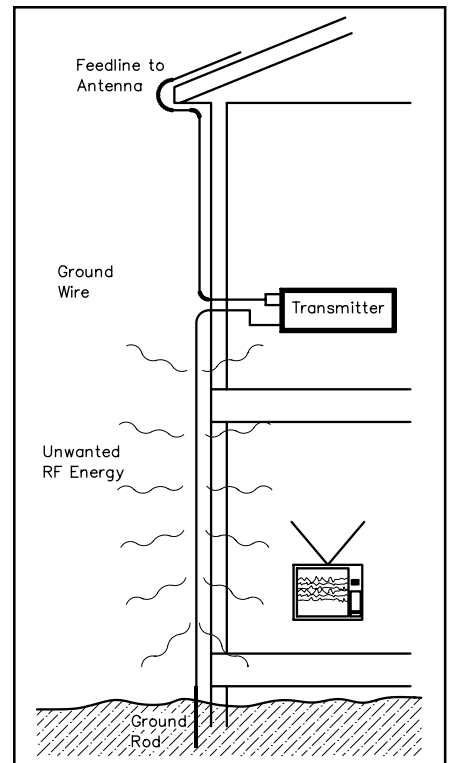

**Fig 28.11** — When a transmitter is located on an upper floor, the ground lead may act as an antenna for VHF/UHF energy. Such stations may be better off without a normal ground.

Many troublesome harmonics are in the VHF range. At VHF, a ground wire length can be several wavelengths long — a very effective long-wire antenna! Any VHF signals that are put on a long ground wire will be radiated. This is usually not the intended result of grounding.

Take a look at the station shown in **Fig 28.11**. In this case, the ground wire could very easily contribute to an interference problem in the downstairs TV set.

While a station ground may cure some transmitter EMI problems — either by putting the transmitter chassis at a low-impedance reference point or by rearranging the problem so the “hot spots” are farther away from susceptible equipment — it is not the cure-all that some literature has suggested. A ground is easy to install, and it may reduce stray fundamental or harmonic currents on your antenna lead; it is worth a try.

## SPECIFIC CURES

Now that you have learned some EMI fundamentals, you can work on technical solutions. A systematic approach will identify the problem and suggest a cure. Armed with your EMI knowledge, a kit of filters and tools, your local TC and a determination to solve the problem, it is time to diagnose the problem.

Most EMI problems can be solved by the application of standard cures. If you try these cures and they work, you may not need to troubleshoot the problem at all. Perhaps if you can install a low-pass filter on your transmitter or a common-mode choke on a TV, the problem will be solved.

Here are some specific cures for different interference problems. You should also get a copy of the ARRL RFI book. It’s comprehensive and picks up where this chapter leaves off. Here are several standard cures.

## Transmitters

We start with transmitters not because most interference comes from transmitters, but because your station transmitter is under your direct control. Many of the troubleshooting steps in other parts of this chapter assume that your transmitter is “clean” (free of unwanted RF output).

**Controlling Spurious Emissions**—Start by looking for patterns in the interference. If the interference is only on frequencies that are multiples of your operating frequency, you clearly have interference from harmonics. (Although these harmonics may *not* come from your station!)

If HF-transmitter spurs are interfering with a VHF service, a low-pass filter on the transmitter will usually cure the problem. Install it after the amplifier (if used) and *before* the antenna tuner. (A second filter between the transmitter and amplifier may occasionally help as well.) Install a low-pass filter as your first step in any interference problem that involves another radio service.

Interference from nonharmonic spurious emissions is extremely rare in commercially built radios. Any such problem indicates a malfunction that should be repaired.

## Television Interference (TVI)

For a TV signal to look good, it must have about a 45 to 50 dB signal-to-noise ratio. This requires a good signal at the TV antenna-input connector. This brings up an important point: to have a good signal, you must be in a good signal area. The FCC does not protect fringe-area reception.

TVI, or interference to any radio service, can be caused by one of several things:

- Spurious signals within the TV channel coming from your transmitter or station.
- The TV set may be overloaded by your transmitter’s fundamental signal.
- Signals within the TV channel from some source other than your station, such as electrical noise, an overloaded mast-mounted TV preamplifier or a transmitter in another service.
- The TV set might be defective or misadjusted, making it look like there is an interference problem.

All of these potential problems are made more severe because the TV set is hooked up to *two* antenna systems: (1) the incoming antenna and its feed line and (2) the ac power lines. These two “long-wire” antennas can couple *a lot* of fundamental or harmonic energy into the TV set! The TVI Troubleshooting Flowchart in the [References](#) chapter is a good starting point.

### *Fundamental Overload*

A television set can be overloaded by a strong, local RF signal. This happens because the manufacturer did not install the necessary filters and shields to protect the TV set from other signals present on the air. These design deficiencies can sometimes be corrected externally.

Start by determining if the interference is affecting the video, the sound or both. If it is present only on the sound, it is probably a case of audio rectification. (See the [Stereo](#) section of this chapter.) If it is present on the video, or both, it could be getting into the video circuitry or affecting either the tuner or IF circuitry.

The first line of defense for an antenna-connected TV is a high-pass filter. Install a high-pass filter directly on the back of the TV set. You may also have a problem with common-mode interference. The second line of defense is a common-mode choke on the antenna feed line — try this first in a cable-television installation. These two filters can probably cure most cases of TVI!

**Fig 28.12** shows a “bulletproof” installation. If this doesn’t cure the problem, the TV circuitry is picking up your signal directly. In that case, don’t try to fix it yourself — it is a problem for the TV manufacturer.

**VHF Transmitters** — A VHF transmitter can interfere with over-the-air TV reception. Most TV tuners are not very selective and a strong VHF signal can overload the tuner easily. In this case, a VHF notch or stop-band filter at the TV can help by reducing the VHF fundamental signal that gets to the TV

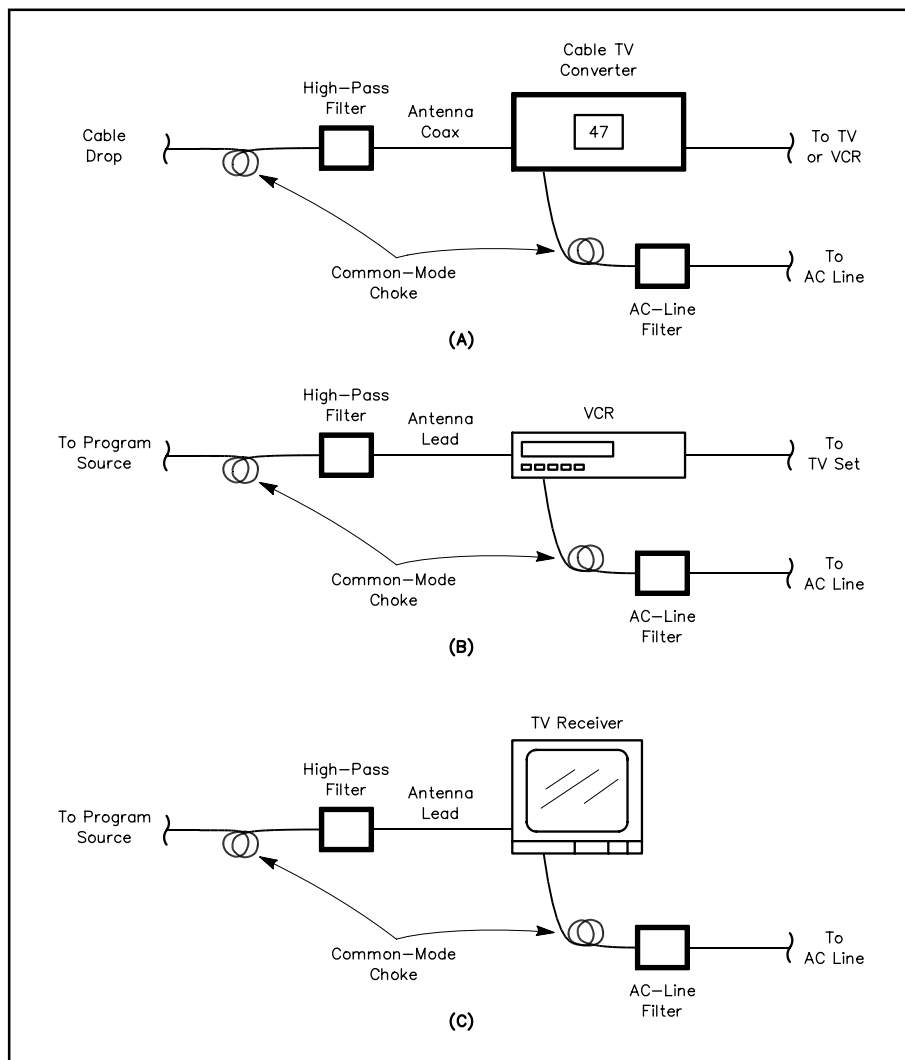

**Fig 28.12 — This sort of installation should cure any kind of conducted TVI. It will not cure direct-pickup or spurious-emission problems.**

cured there. So, if the problem occurs only when you transmit, go back and check your station. Refer to the section on [Transmitters](#). You must first find out if the transmitter has any spurs.

If your transmitter and station check “clean,” then you must look elsewhere. The most likely cause is TV susceptibility — fundamental overload. This is usually manifest by interference to all channels, or at least all VHF channels. If the problem is fundamental overload, see that section [earlier in this chapter](#). If not, read on.

### Electrical Noise

Electrical noise is fairly easy to identify by looking at the picture or listening on an HF receiver. Electrical noise on a TV screen is shown in [Fig 28.13](#). On a receiver, it usually sounds like a buzz, sometimes changing in intensity as the arc or spark sputters a bit. If you have a problem with electrical noise, go to the [Electrical Noise section](#).

### Cable TV

Cable TV has been a blessing and a curse for Amateur Radio

tuner. Star Circuits is one company that sells tunable notch filters.<sup>3</sup>

The Electronic Industries Association (EIA) can help you contact equipment manufacturers. Contact them directly for assistance in locating help. (Their address is in the [References](#) chapter Address List.)

### Spurious Emissions

Start by analyzing which TV channels are affected. The TV Channel Chart in the [References](#) chapter shows the relationship of the ham allocations and their harmonics to over-the-air and cable channels. Each channel is 6-MHz wide. If the interference is only on channels that are multiples of your operating frequency, you clearly have interference from harmonics. (It is not certain that these harmonics are coming from your station, however.)

You are responsible for spurious signals produced by your station. If your station is generating any interfering spurious signals, the problem must be

<sup>3</sup>Star Circuits Model: 23H tunes 6 m, Model: 1822 tunes 2 m and Model: 46FM tunes the FM broadcast band. Their address is in the [References](#) chapter Address List.



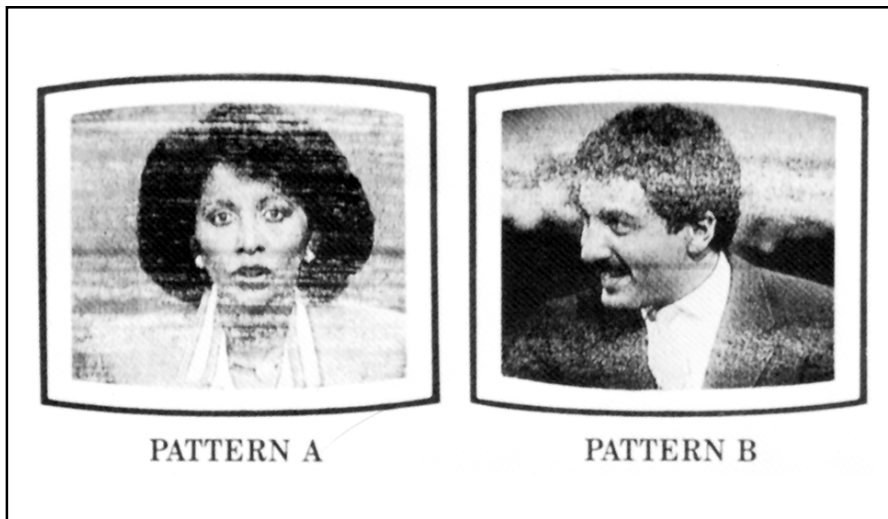

**Fig 28.13** — Two examples of TVs experiencing electrical noise.

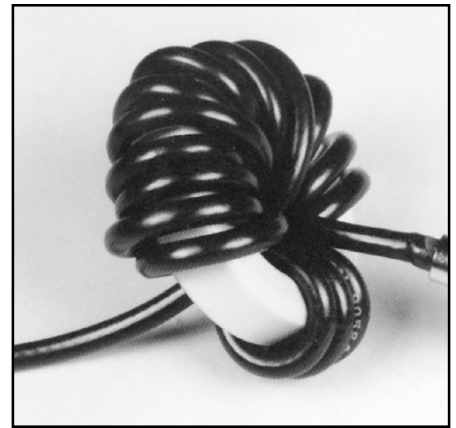

**Fig 28.14** — Several turns of coax on a ferrite core eliminate HF and VHF signals from the outside of a coaxial cable.

TVI problems. On the plus side, the cable delivers a strong, consistent signal to the TV receiver. It is also (in theory) a shielded system, so an external signal can't get in and cause trouble. On the minus side, the cable forms a large, long-wire antenna that can pick up lots of external signals on its shield (in the common mode). Many TVs and VCRs and even some cable set-top converters are easily overloaded by such common-mode signals.

Leakage into a cable-TV system is called ingress. Leakage out is called egress. If the cable isn't leaking, there should be no external signals getting inside the cable. So, an in-line filter such as a high-pass filter is not usually necessary. For a cable-connected TV, the first line of defense is a common-mode choke. Only in rare cases is a high-pass filter necessary. It is important to remember this, because if your neighbor has several TVs connected to cable and you suggest the wrong filter (at \$15 each), you may have a personal diplomacy problem of a whole new dimension. **Fig 28.14** shows a common-mode choke.

**Fig 28.12** shows a bulletproof installation for cable TV. (The high-pass filter is usually not needed.) If all of the cures shown have been tried, the interference probably results from direct pickup inside the TV. In this case, contact the TV manufacturer through the EIA.

Interference to cable-TV installations from VHF transmitters is a special case. Cable TV uses frequencies allocated to over-the-air services, such as Amateur Radio. When the cable shielding is less than perfect, interference can result.

The TV Channel Chart in the [References](#) chapter shows which cable channels coincide with ham bands. If, for example, you have interference to cable channel 18 from amateur 2-m operation, suspect cable ingress. Contact the cable company; it may be their responsibility to locate and correct the problem. The cable company is not responsible, however, for leakage occurring in customer-owned, cable-ready equipment that is tuned to the same frequency as the over-the-air signal. If there is interference to a cable-TV installation, the cable company should be able to demonstrate interference-free reception when using a cable-company supplied set-top converter.

### **TV Preamplifiers**

Some television owners use a preamplifier — sometimes when it's not needed. Preamplifiers are only needed in weak-signal areas, and they often cause more trouble than they prevent. They are subject to the same overload problems as TVs, and their location on the antenna mast usually makes it difficult to install the appropriate cures. You may need to install a high-pass or notch filter at the *input* of the



preamplifier, as well as a common-mode choke on the input, output and power-supply wiring (if separate) to effect a complete cure.

## VCRs

A VCR usually contains a television tuner, or has a TV channel output, so it is subject to all of the interference problems of a TV receiver. It is also hooked up to an antenna or cable system and the ac-line wiring. The video baseband signal extends from 30 Hz to 3.5 MHz, with color information centered around 3.5 MHz and the FM sound subcarrier at 4.5 MHz. The entire video baseband is frequency modulated onto the tape at frequencies up to 10 MHz. It is no wonder that some VCRs are quite susceptible to EMI.

Many cases of VCR EMI can be cured. Start by proving that the VCR is the susceptible device. Temporarily disconnect the VCR from the television. If there is no interference to the TV, then the VCR is the most likely culprit.

You need to find out how the interfering signal is getting into the VCR. Temporarily disconnect the antenna or cable feed line from the VCR. If the interference goes away, then the antenna line is involved. In this case, you can probably fix the problem with a common-mode choke or high-pass filter.

Fig 28.12 shows a bulletproof VCR installation. If you have tried all of the cures shown and still have a problem, the VCR is probably subject to direct pickup. In this case, contact the manufacturer through the EIA.

## Nonradio Devices

Interference to nonradio devices is not the fault of the transmitter. (A portion of the *FCC Interference Handbook*, 1990 Edition, is shown in Fig 28.15.<sup>4</sup>) In essence, the FCC views nonradio devices that pick up nearby radio signals as improperly functioning; contact the manufacturer and return the equipment. The FCC does not require that nonradio devices include EMI protection and they don't offer legal protection to users of these devices that are susceptible to interference.

---

<sup>4</sup>The *FCC Interference to Home Electronic Entertainment Equipment Handbook* is available at the FCC web site, <http://www.fcc.gov/cib/Publications/tvibook.html>, or from the US Government Printing Office. See the [References](#) chapter for their address and telephone number.

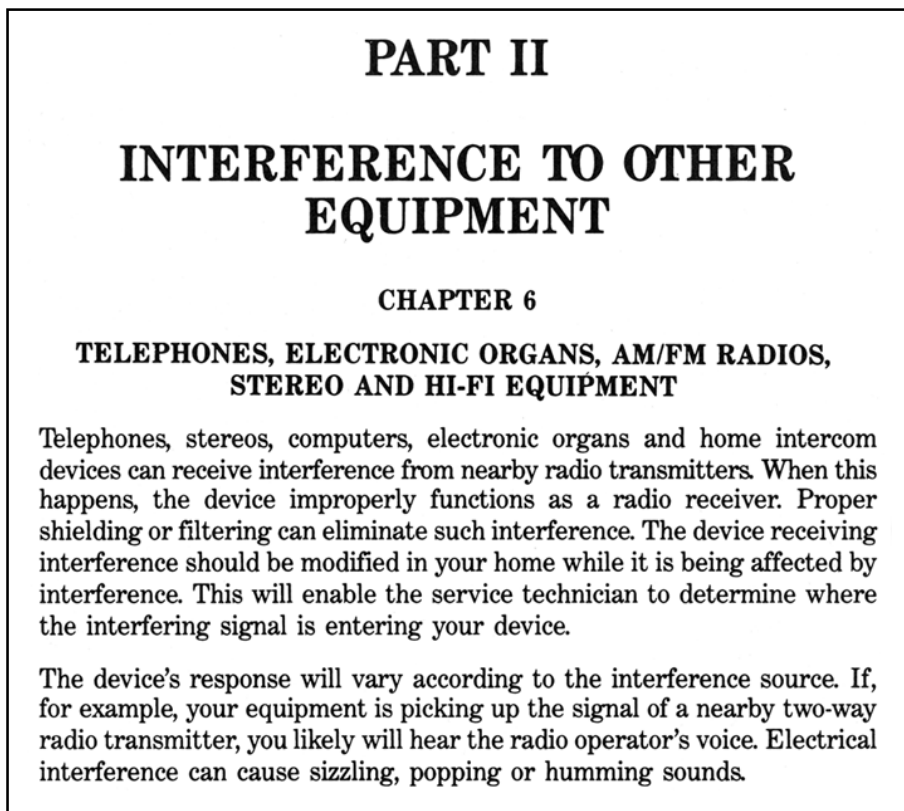

Fig 28.15 — Part of page 18 from *FCC Interference Handbook* (1990 edition) explains the facts and places responsibility for interference to nonradio equipment.

## **Telephones**

Telephones have probably become the number one interference problem of Amateur Radio. However, most cases of telephone interference can be cured by correcting any installation defects and installing telephone EMI filters where needed.

Telephones can improperly function as radio receivers. There are devices inside many telephones that act like diodes. When such a telephone is connected to the telephone wiring (a large antenna), an AM radio receiver can be formed. When a nearby transmitter goes on the air, these telephones can be affected.

Troubleshooting techniques were discussed earlier in the chapter. The suggestion to simplify the problem applies especially to telephone interference. Disconnect all telephones except one, right at the service entrance if possible, and start troubleshooting the problem there.

If any one device, or bad connection in the phone system, detects RF and puts the detected signal back onto the phone line as audio, that audio cannot be removed with filters. Once the RF has been detected and turned into audio, it cannot be filtered out because the interference is at the same frequency as the desired audio signal. To effect a cure, you must locate the detection point and correct the problem there.

The telephone company lightning arrestor may be defective. Defective arrestors can act like diodes, rectifying any nearby RF energy. Telephone-line amplifiers or other electronic equipment may also be at fault. Leave the telephone company equipment to the experts, however. There are important safety issues that are the sole responsibility of the telephone company.

Inspect the installation. Years of exposure in damp basements, walls or crawl spaces may have caused deterioration. Be suspicious of anything that is corroded or discolored. In many cases, homeowners have installed their own telephone wiring, often using substandard wiring. If you find sections of telephone wiring made from nonstandard cable, replace it with standard twisted-pair wire. Radio Shack, among others, sells several kinds of telephone wire.

Next, evaluate each of the telephone instruments. If you find a susceptible telephone, install a telephone EMI filter on that telephone. Several *QST* advertisers sell small, attractive telephone EMI filters.

If you determine that you have interference only when you operate on one particular ham band, the telephone wiring is probably resonant on that band. If possible, install a few strategically placed in-line telephone EMI filters to break up the resonance.

**Telephone Accessories** — Answering machines, fax machines and some alarm systems are also prone to interference problems. All of the troubleshooting techniques and cures that apply to telephones also apply to these telephone devices. In addition, many of these devices connect to the ac mains. Try a common-mode choke and/or ac-line filter on the power cord (which may be an ac cordset, a small transformer or power supply).

**Cordless Telephones** — A cordless telephone is an unlicensed *radio* device that is manufactured and used under Part 15 of the FCC regulations. The FCC does not intend Part 15 devices to be protected from interference. These devices usually have receivers with very wide front-end filters, which make them very susceptible to interference. A label on the telephone or a paragraph in the owner's manual should explain that the telephone must not cause interference to other services and must tolerate any interference caused to it.

It's worthwhile to try a telephone filter on the base unit and properly filter its ac line cord. (You might get lucky!) The best source of help is the manufacturer, but they may point out that the Part 15 device is not protected from interference. These kinds of problems are difficult to fix after the fact. The necessary engineering should be done when the device is designed.

## **Other Audio Devices**

Other audio devices, such as stereos, intercoms and public-address systems can also pick up and detect strong nearby transmitters. The FCC considers these nonradio devices and does not protect them from

licensed radio transmitters that may interfere with their operation. See Fig 28.15 for the FCC's point of view.

Use the standard troubleshooting techniques discussed earlier in this chapter to isolate problems. In a multicomponent stereo system (as in Fig 28.16), for example, you must determine what combination of components is involved with the problem. First, disconnect all auxiliary components to determine if there is a problem with the main receiver/amplifier. (Long speaker/interconnect cables are prime suspects.)

**Stereos** — If the problem remains with the main amplifier isolated, determine if the interference level is affected by the volume control. If so, the interference is getting into the circuit *before* the volume control, usually through accessory wiring. If the volume control has no effect on the level of the interfering sound, the interference is getting in *after* the control, usually through speaker wires.

*Speaker wires* are often resonant on the HF bands. In addition, they are often connected directly to the output transistors, where RF can be detected. Most amplifier designs use a negative feedback loop to improve fidelity. This loop can conduct the detected RF signal back to the high-gain stages of the amplifier. The combination of all of these factors makes the speaker leads the usual indirect cause of interference to audio amplifiers.

There is a simple test that will help determine if the interfering signal is being coupled into the amplifier by the speaker leads. Temporarily disconnect the speaker leads from the amplifier, and plug in a test set of headphones with short leads. If there is no interference with the headphones, filtering the speaker leads will cure the problem.

The best way to eliminate RF signals from speaker leads is with common-mode chokes. Fig 28.17 shows how to wrap speaker wires around an FT-140-43 ferrite core to cure speaker-lead EMI. Use the correct core material for the job. See the information about [common-mode chokes](#) earlier in this chapter.

Another way to cure speaker-lead interference is with an LC filter as shown in Fig 28.18. Sources for similar filters are listed in the ARRL Technical Information Service (TIS) EMI and RFI packages; see the [References](#) chapter.

*Interconnect cables* can couple interfering signals into an am-

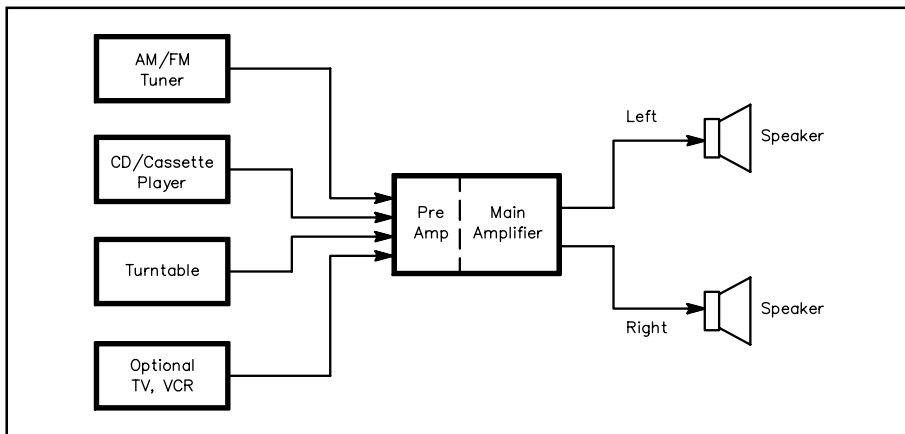

Fig 28.16 — A typical modern stereo system.

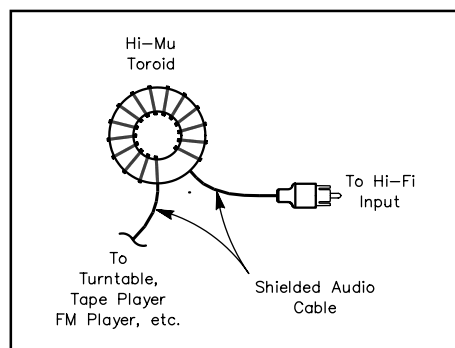

Fig 28.17 — This is how to make a speaker-lead common-mode choke. Be sure to use the correct ferrite material.

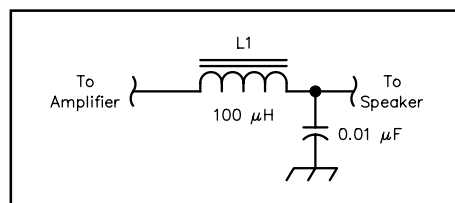

Fig 28.18 — An LC filter for speaker leads.

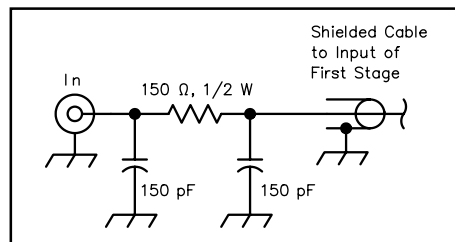

Fig 28.19 — A filter for use at the input of audio equipment. The components should be installed inside of the chassis at the connector by a qualified technician.

### **Warning: Bypassing Speaker Leads**

Older amateur literature might tell you to put a 0.01- $\mu$ F capacitor across the speaker terminals to cure speaker-lead interference. *Don't do this!* Some modern solid-state amplifiers can break into a destructive, full-power, sometimes ultrasonic oscillation if they are connected to a highly capacitive load. If you do this to your neighbor's amplifier, you will have a whole new kind of personal diplomacy problem! — *Ed Hare, W1RFI, ARRL Laboratory Supervisor*

plifier or accessories. The easiest cure here is also a common-mode choke. However, it may also be necessary to add a differential-mode filter to the input of the amplifier or accessory. **Fig 28.19** shows a home-brew version of such a filter.

**Intercoms and Public-Address Systems** — All of these problems also apply to intercoms, public-address (PA) systems and similar devices. These systems usually have long speaker leads or interconnect cables that can pick up a lot of RF energy from a nearby transmitter. The cures discussed above do apply to these systems, but you may also need to contact the manufacturer to see if they have any additional, specific information.



The Sounds of  
Amateur Radio

Listen to a CW transmission interfering with reception of an AM broadcast.

### **Computers and Other Unlicensed RF Sources**

Computers and microprocessors can be sources, or victims, of interference. These devices contain oscillators that can, and do, radiate RF energy. In addition, the internal functions of a computer generate different frequencies, based on the various data rates as software is executed. All of these signals are digital in nature — with fast rise and fall times that are rich in harmonics.

Don't just think "computer" when thinking of computer systems. Many household appliances contain microprocessors: digital clocks, video games, calculators and more.

Computing devices are covered under Part 15 of the FCC regulations as unintentional emitters. The FCC has set up absolute radiation limits for these devices. FCC regulations state that the operator or owner of Part 15 devices must take whatever steps are necessary to reduce or eliminate any interference they cause to a licensed radio service. This means that if your neighbor's video game interferes with your radio, the neighbor is responsible for correcting the problem. (Of course, your neighbor may appreciate your help in locating a solution!)

The FCC has set up two levels of type acceptance for computing devices. Class A is for computers used in a commercial environment. FCC Class B requirements are more stringent — for computers used in residential environments. If you buy a computer or peripheral, be sure that it is Class B certified or it will probably generate interference to your amateur station or home-electronics equipment.

If you find that your computer system is interfering with your radio (not uncommon in this digital-radio age), start by simplifying the problem. Temporarily switch off as many peripherals as possible and disconnect their cables from the back of the computer. If possible, use just the computer, keyboard and monitor. This test may indicate one or more peripherals as the source of the interference.

When seeking cures, first ensure that all interconnection cables are shielded. Replace any unshielded cables with well shielded ones; this often significantly reduces RF noise from computer systems. The second line of defense is the common-mode choke, made from a ferrite toroid. The toroids should be installed as close to the computer and/or peripheral device as practical. **Fig 28.20** shows the location of common-mode chokes in a complete computer system where both the computer and peripherals are noisy.

In some cases, a switching power supply may be a source of interference. A common-mode choke and/or ac-line filter may cure this problem. In extreme cases of computer interference you may need to

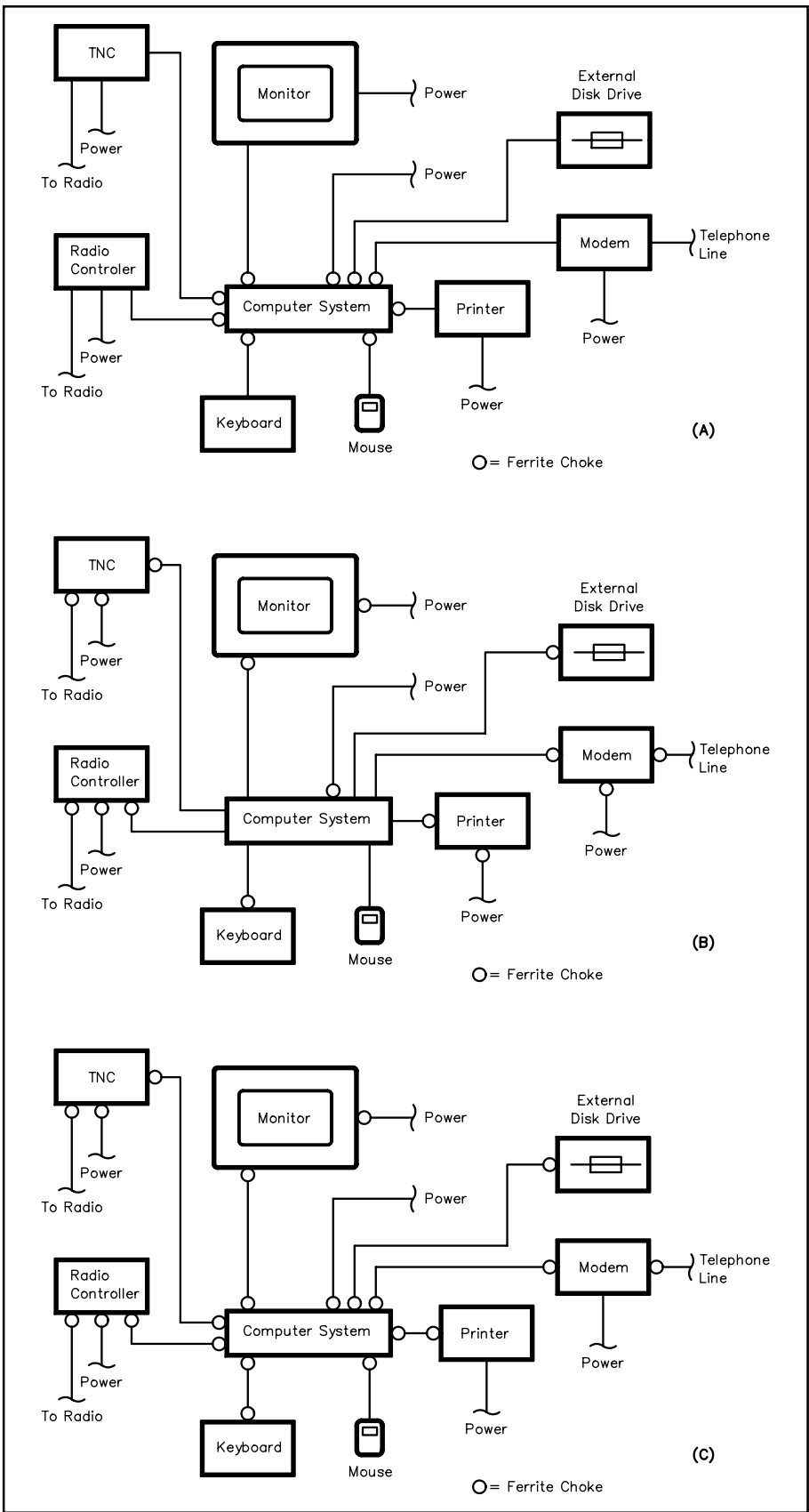

**Fig 28.20 — Where to locate ferrites in a computer system. At A, the computer is noisy, but the peripherals are quiet. At B, the computer is quiet, but external devices are noisy. At C, both the computer and externals are noisy.**

improve the shielding of the computer. Refer to the ARRL RFI book for more information about how to do this. Don't forget that some peripherals (such as modems) are connected to the phone line, so you may need to treat them like telephones.

### Automobiles

As automobiles have become more technologically sophisticated, questions about the compatibility of automobiles and amateur transmitters have increased in number and scope. The use of microprocessors in autos makes them computer systems on wheels, subject to all of the same problems as any other computer. Installation of ham equipment can cause problems, ranging from nuisances like a dome light coming on every time you transmit to serious ones such as damage to the vehicle electronic control module (ECM).

Only qualified service personnel should work on automotive EMC problems. Many critical safety systems on modern cars should not be handled by amateurs. Even professionals can meet with mixed results. The ARRL (TIS) contacted each of the automobile manufacturers and asked about their EMC policies, service bulletins and best contacts to resolve EMI problems. About 20% of the companies never answered, and answers from the rest ranged from good to poor. One company even said that the answers to those questions were "proprietary."

Some of the companies *do*

have reasonable EMC policies, but these policies often fall apart at the dealer level. The ARRL has reports of problems with nearly every auto manufacturer. Check with your dealer before you install a transceiver in a car. The dealer can direct you to any service bulletins or information that is applicable to your model. If you are not satisfied with the dealer's response, contact the regional or factory customer service representatives.

The ARRL TIS maintains a file on each manufacturer, as well as a list of contact people that can help. The TIS can also supply a reprint of the General Motors installation guidelines.<sup>5</sup> For additional information about automotive EMC, refer to the Automobiles chapter in the ARRL RFI book.

### **Electrical Noise**

Many electrical appliances and power lines can generate electrical noise. On a receiver, electrical noise usually sounds like a rough buzz, heard across a wide frequency range. The buzz will either have a strong 60- or 120-Hz component, or its pitch will vary with the speed of a motor that generates the noise. The appearance of electrical noise on a television set is shown in the [TVI section](#) of this chapter. This kind of noise can come from power lines, electrical motors or switches, to name just a few. Here is one quick diagnostic trick — if electrical noise seems to come and go with the weather, the source is probably outside, usually on the power lines. If electrical noise varies with the time of day, it is usually related to what people are doing, so look to your own, or your neighbors', house and lifestyle. The ARRL RFI book describes techniques for locating RFI sources.

Filters usually cure electrical noise. At its source, the noise can usually be filtered with a differential-mode filter. A differential-mode filter can be as simple as a 0.01- $\mu$ F ac-rated capacitor, such as Panasonic part ECQ-U2A103MN, or it can be a pi-section filter like that shown in [Fig 28.7](#).

For removing signals that arrive via power lines, a common-mode choke is usually the best defense. Wrap about 10 turns of the ac-power cord around an FT-240-43 ferrite core; do this as close as possible to the device you are trying to protect.

Electrical noise can also indicate a dangerous electrical condition that needs to be corrected. The ARRL has recorded several cases where defective or arcing doorbell transformers caused widespread neighborhood electrical interference. This subject is well covered in the *Interference Handbook* or *The ARRL RFI Book*.<sup>6</sup>

**Power Lines** — Electrical noise can also come from power lines. Diagnosis and repair of power-line problems *must* be left to professionals. It is even dangerous to tap poles with a hammer as a diagnostic tool; broken insulators can fall and possibly strike people or passing cars. If you have a problem with power-line noise, contact the utility company for help. Most electric utility companies have qualified, knowledgeable personnel to correct EMI problems.

### **In Conclusion**

Remember that EMI problems can be cured. With the proper technical knowledge and interpersonal skills, you can deal effectively with the people and hardware that make up any EMI problem.

---

<sup>5</sup>The ARRL "EMI/RFI — GM Installations Guidelines" is a reprint of the General Motors booklet. Send a 9 × 12-inch SASE with three units of First-Class postage and a specific request for the "EMI/RFI GM Installation Guidelines" to TIS at ARRL HQ.

---

<sup>6</sup>*Interference Handbook*, ARRL Order no. 6015. *The ARRL RFI Book*, ARRL Order no. 6834. Both are available from ARRL Publication Sales or your local Amateur Radio equipment dealer.