

Activities

2

One of the best things about this hobby we call Amateur Radio is its *flexibility*. In other words, Amateur Radio can be whatever *you* want it to be. Whether you are looking for relaxation, excitement, or a way to stretch your mental (and physical) horizons, Amateur Radio can provide it. This chapter was written by Larry Kollar, KC4WZK. Let's take a brief tour through the following topic areas:

Awards — the individual and competitive pursuits that make up the tradition we call “paper chasing.”

Contests — the challenge of on-the-air competition.

Nets — both traffic nets, where amateurs pass messages on behalf of hams and nonhams, and the casual nets, where groups of people with common interests often meet on the air to swap equipment, anecdotes and information.

Ragchewing — meeting new friends on the air.

Amateur Radio Education — Educating current and future hams brings in new blood (and revitalizes old blood!); educating our neighbors about ham radio is good for public relations and awareness.

ARRL Field Organization — Amateur Radio in general, and the ARRL in particular, depend on the volunteer spirit. As part of the Field Organization, you can exercise your administrative, speaking and diplomatic skills in service of the amateur community.

Emergency Communications — When disaster strikes, hams often have the only reliable means to communicate with the outside world. Practice and preparation are key to fulfilling this mission.

DF (Direction Finding) — If you've ever wanted to know where a transmitter (hidden or otherwise) is located, you'll find DFing is an enjoyable and useful skill.

Satellite Operation — You may be surprised to learn that hams have their own communications satellites! Satellite operation can be great fun and a technical challenge for those who want to operate on the “final frontier.”

Repeaters — Using and operating repeaters is one of the most popular activities for both new and old hams.

Image Communications — Although it's fun to talk to other amateurs, it's even more fun to *see* them.

Digital Communications — Use your computer to communicate with stations around your town or around the world.

VHF, UHF and Microwave Weak-Signal Operating — Explore the challenging, quirky and surprising world above 50 MHz.

EME (Earth-Moon-Earth), Meteor Scatter and Aurora — Making contacts by bouncing your signals off the moon, the fiery trails of meteors and auroras.

AWARDS

Winning awards, or “paper chasing,” is a time-honored amateur tradition. For those who enjoy individual pursuits or friendly competition, the ARRL and other organizations offer awards ranging from the coveted to the humorous.

DX Awards

The two most popular DX awards are DXCC (DX Century Club), sponsored by the ARRL and WAC (Worked All Continents), sponsored by the International Amateur Radio Union (IARU). The WAC award is quite simple: all you have to do is work one station on each of six continents. The DXCC is more challenging: you must work at least one station in each of 100 countries! QSL cards from each continent or country are required as proof of contact.

How-to's of DXCC — Direct QSLs and DX Bureaus

Since DX stations are often inundated with QSL cards (and QSL requests) from US hams, it is financially impossible for most of them to pay for the return postage. Hams have hit upon several ways to lighten the load on popular DX stations.

The fastest, but most expensive, way to get QSL cards is the *direct* approach. You send your QSL card, with one or two International Reply Coupons—IRCs—(or one or two dollars) and a self-addressed airmail envelope to the DX station. International Reply Coupons are available from your local post office and can be used nearly anywhere in the world for return postage. Some DX hams prefer that you send one or two “green stamps” (dollar bills) because they can be used to defray posting, printing and other expenses. However, it is illegal in some countries to possess foreign currency. If you’re not sure, ask the DX station or check DX bulletins available on packet radio and BBSs.

Many DX hams have recruited *QSL managers*, hams who handle the QSL chores of one or more DX stations. QSL managers are convenient for everyone. The DX station need only send batches of blank cards and a copy of the logs; hams wanting that station’s card need only send a First Class stamp for US return postage and can expect a prompt reply. (In the case of QSL managers located outside the United States, you must still send IRCs [or dollars] and a self-addressed return envelope.)

The easiest (and slowest) way to send and receive large batches of QSL cards is through the incoming and outgoing QSL bureaus. The outgoing bureau is available to ARRL members. The incoming bureaus are available to all amateurs. Bureau instructions and addresses are printed periodically in *QST*; they appear in the *ARRL Operating Manual*, and they are available from ARRL Headquarters for an SASE.

DXpeditions

What does the avid DXer who has worked them all (or almost all of them) do for an encore? Answer: *become* the DX! DXpeditions journey to countries with few or no hams, often making thousands of contacts in the space of a few days.

In 1991, Albania opened its borders and legalized Amateur Radio for the first time in many years. To train the first new generation of Albanian hams and to relieve the pileups that were sure to happen, a contingent of European and American hams organized a DXpedition to Albania. The DXpedition made over 10,000 contacts and changed Albania from one of the rarest and most-desired countries to an “easy one.”



One of the most prized awards in Amateur Radio: the DX Century Club.

DX Nets

The beginning DXer can get a good jump on DXCC by frequenting DX nets. On DX nets, a net control station keeps track of which DX stations have checked into the net. He or she then allows a small group of operators (usually 10) to check in and work one of the DX stations. This permits weaker stations to be heard instead of being buried in a pileup. Since the net control station does not tolerate net members making contacts out-of-turn, beginning operators have a better chance of snagging a new country. Nets and frequencies on which they operate vary. For the latest information on DX nets, check with local DXers and DX bulletins.

Efficient DX Operation

The best DXers will tell you the best equipment you have is “the equipment between your ears.” Good operators can make contacts with modest power. The details of efficient DX operating cannot be covered in such a brief space. The ARRL sells two publications that are excellent references for new DX enthusiasts: *The Complete DXer* and *The DXCC Companion*.

WAS (Worked All States)

The WAS certificate is awarded to amateurs who have QSL cards from at least one operator in each of the 50 United States. Chasing WAS is often a casual affair, although there are also nets dedicated to operators who are looking for particular states.

Endorsements

The initial DXCC or WAS award does not mean the end. There are over 300 DXCC countries. As you reach certain levels in your country count, you qualify for endorsements. Endorsements arrive in the form of stickers that you attach to your DXCC certificate.

Both WAS and DXCC offer endorsements for single-band or single-mode operation. For example, if you work all 50 United States on the 15-m band, your certificate has an endorsement for 15 m. The most difficult endorsement is the 5-band (5B) endorsement. Rare indeed is the operator who can display a 5BDXCC certificate!

Other Awards

The ARRL and other organizations offer a variety of awards for both serious and fun achievements. You can qualify for some awards, like the ARRL’s RCC (Rag Chewers’ Club, for long contacts), on your very first contact! Other awards are sponsored by local clubs.

The ARRL Friendship Award is available to any ARRL member who can prove contact with 26 stations whose call signs end with each of the 26 letters of the alphabet. (For example, N1MZA, K0ORB, W3ABC...K1ZZ.) Any frequency or mode qualifies. Most consider the Friendship Award to be the next step up from the Rag Chewers’ Club. It’s more difficult to earn, but just as much fun.

One of the most coveted awards is the A-1 Operator Club. Qualifying for this award is as simple as cultivating spotless operating habits and always operating by the [Amateur’s Code](#) (found near the front of this *Handbook*). To receive this award, you must be recommended by two A-1 members.

CONTESTS

Some people enjoy the thrill of competition, and Amateur Radio provides challenges at all levels in

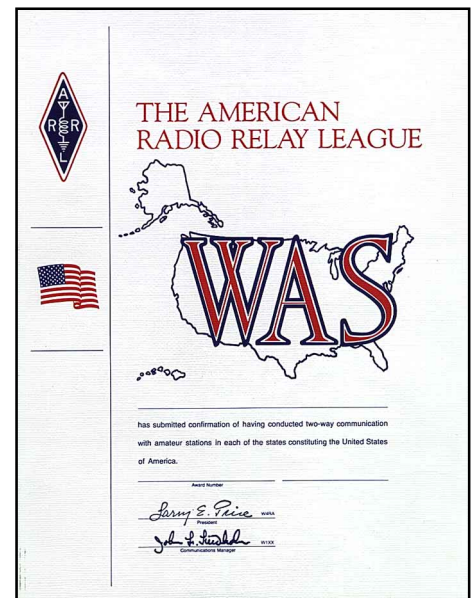

Work one station in each of the 50 states and you’re eligible for the ARRL’s Worked All States (WAS) award.

the form of operating contests. Besides the competitive outlet, contests have provided many hams with a means to hone their operating skills under less-than-optimum conditions. On the VHF and higher bands, contests are one way to stimulate activity on little-used segments of the amateur spectrum.

This section briefly discusses a few ARRL-sponsored contests. The Contest Corral section of *QST* provides up-to-date information on these and other contests. The ARRL also publishes the *National Contest Journal (NCJ)*, which is good reading for any serious (or semi-serious) contester.

Field Day

Every year on the fourth full weekend in June, thousands of hams take to the hills, forests, campsites and parking lots to participate in Field Day. The object of Field Day is not only to make contacts, but to make contacts under conditions that simulate the aftermath of a disaster. Most stations are set up outdoors and use emergency power sources.

Many clubs and individuals have built elaborate Field Day equipment, and that is all to the best—if a real disaster were to strike, those stations could be set up quickly, wherever needed, and need not depend on potentially unreliable commercial power!

Other Contests

Other popular contests include:

QSO Parties. These are fairly relaxed contests—good for beginners. There are many state QSO parties, and others for special interests, such as the QRP ARCI Spring QSO Party.

Sweepstakes. This is a high-energy contest that brings thousands of operators out of the woodwork each year.

Various DX contests. DX contests offer good opportunities for amateurs to pursue their DXCC award contacts. A good operator can work over 100 countries in a weekend!

VHF, UHF and microwave contests. These contests are designed to stimulate activity on the weak-signal portions of our highest-frequency bands. The ARRL VHF/UHF contests are held during the spring and fall. There is also a contest for 10-GHz operators, and another one for EME (moonbounce) enthusiasts.

Each issue of *QST* lists the contests to be held during the next two months.

NETS

A net is simply a group of hams who meet on a particular frequency at a particular time. Nets come in three classes: public service, traffic and special interest.

Public Service/Traffic Nets

Public service and traffic nets are part of a tradition that dates back almost to the dawn of Amateur Radio. The ARRL, in fact, was formed to coordinate and promote the formation of traffic nets. In those early days, nets were needed to communicate over distances longer than a few miles. (Thus the word “Relay” in “American Radio Relay League.”)

Public service and traffic nets benefit hams and nonhams alike. Any noncommercial message—birthday and holiday greetings, personal information or a friendly hello—may be sent anywhere in the US and to foreign countries that have third-party agreements with the United States. Many missionaries in South America, for example, keep in touch with stateside families and sponsors via Amateur Radio.



Elaine Larson, KD6DUT, takes a turn at logging as Fred Martin, KI6YN, works the paddles during the Conejo Valley Amateur Radio Club's Field Day operation.

Keeping a Logbook

At one time, keeping a log of your contacts was an FCC requirement. The FCC has dropped this requirement in recent years, but many amateurs, both new and old, still keep logs.

Why Keep a Log?

If keeping a log is optional, why do it? Some of the more important reasons for keeping a log include:

Legal protection—If you can show a complete log of your activity, it can help you deal with interference complaints. Good recordkeeping can help you protect yourself if you are ever accused of intentional interference, or have a problem with unauthorized use of your call sign.

Awards tracking—A log helps you keep track of contacts required for DXCC, WAS, or other awards. Keeping a log lets you quickly see how well you are progressing toward your goal.

An operating diary—A logbook is a good place for recording general information about your station. You may be able to tell just how well that new antenna is working compared to the old one by comparing recent QSOs with older contacts. The logbook is also a logical place to record new acquisitions (complete with serial numbers in case your gear is ever stolen). You can also record other events, such as the names and calls of visiting operators, license upgrades, or contests, in your log.

Paper and Computer Logs

Many hams, even those with computers, choose to keep their logs on paper. Paper logs still offer several advantages (such as flexibility) and do not require power. Paper logs also survive hard-drive crashes!

Preprinted logsheets are available, or you can create your own. Computers with word processing and publishing software let you create customized logsheets in no time.

On the other hand, computer logs offer many advantages to the serious contester or DXer. For example, the computer can search a log and instantly tell you whether you need a particular station for DXCC. Contesters use computer logs in place of *dupe sheets* to weed out duplicate contacts before they happen, saving valuable time. Computer logs can also tell you at a glance how far along you are toward certain awards.

Computer logging programs are available from commercial vendors. Some programs may be available as shareware (you can download it from a BBS and pay for the program if you like the way it works). If you can program your computer, you can also create your own custom logging program—and then give it to your friends or even sell it!

The ARRL National Traffic System (NTS) oversees many of the existing traffic nets. Most nets are local or regional. They use many modes, from slow-speed CW nets in the Novice HF bands, to FM repeater nets on 2 m.

Since the amateur packet-radio network now covers much of the US and the world, many messages travel over packet links. Amateurs use the packet radio network not only for personal or third-party traffic, but for lively conferences, discussions and for trading equipment.

HF and Repeater Nets

HF nets usually cover a region, although some span the entire country. This has obvious advantages for amateurs sending traffic over long distances. Repeater nets usually cover only a local area, but some linked repeater nets can cover several states.

Both types of nets work together to speed traffic to its destination. For example, think of the HF nets as a “trunk” or highway that carries traffic quickly and reliably toward its *approximate* destination. From there, the local and regional nets take over and pass the traffic directly to the city or town. Finally, a local amateur delivers the message to the recipient.

Routine traffic handling keeps the National Traffic System (NTS) prepared for emergencies. In the wake of Hurricane Andrew in 1992, hams carried thousands of messages in and out of the stricken south

Florida region. The work that hams do during crisis situations ensures good relations with neighbors and local governments.

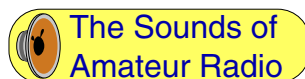

Listen to traffic being passed over the Nutmeg Net on 2-meter FM.

Other Nets

Many nets exist for hams with common interests inside and outside of Amateur Radio. Some examples include computers, owners of Collins radio equipment, religious groups and scattered friends and families. Most nets meet on the 80- and 20-m phone bands, where propagation is fairly predictable and there are no shortwave broadcast stations to dodge.

RAGCHEWING

Ragchewing is the fine art of the long contact. Old friends often get together on the air to catch up on current events. Family members use ham radio to keep in touch. And, of course, new acquaintances get to know each other!

In many cases, friends scattered across the country get together to create ragchewing nets. These nets are very informal and may not make much sense to the outsider listening in. The “serious” ragchewer’s shack decoration is not complete without the Rag Chewers’ Club (RCC) certificate. The RCC, the Friendship Award and other certificates are discussed earlier in this chapter.

AMATEUR RADIO EDUCATION

Elmering (helping new and prospective operators) is a traditional amateur activity. Much of an amateurs’ educational efforts go toward licensing (original and upgrading), but there are other opportunities for education, including public relations.

License Classes

Anyone can set up license classes. Many Amateur Radio clubs hold periodic classes, usually for the Novice and Technician elements with CW practice sessions. The ARRL supports Registered Amateur Radio Instructors, but registration is not necessary to conduct a class.

If you are looking for a class to attend, and do not have an “Elmer” to answer your questions, write ARRL Field & Educational Services for a list and schedule of classes in your area. If you want to become an instructor, you can request the same list of classes from Field & Educational Services—most classes will welcome another helping hand.

Volunteer Examiners (VEs)

To become a VE, you must hold a General or higher amateur license and be certified by one of the VE Coordinators (VECs). The ARRL supports the largest VE program in the nation; other

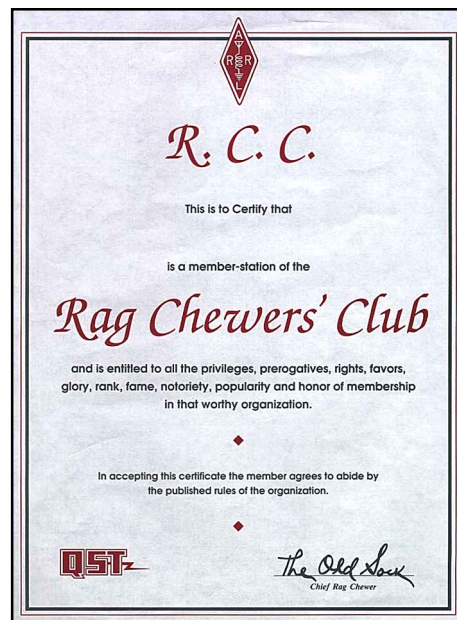

The Rag Chewers’ Club award is one of the easiest to earn. You probably qualify already!



Dave Hanson, KB0EVM (r), is congratulated by Volunteer Examiner (VE) Len Buonaiuto, KE2LE, after passing his exam. (photo courtesy of KE2LE)



Dry run just before the shuttle pass. Keilah Meuser is practicing with others looking on.

organizations run VE programs on a national or regional basis. General and Advanced licensees on a VE team must be supervised by at least one Extra Class licensee.

School Presentations

Amateur Radio complements any school program. Schoolchildren suddenly find that Amateur Radio gives them a chance to apply their studies immediately. The math and science used in Amateur Radio applies equally to the classroom. Even geography takes on a new meaning when a student works a new country!

Unfortunately, many schools do not have an active Amateur Radio presence—and that is why local volunteers are important. An HF or satellite station, or even a 2-m hand-held transceiver tuned to the local repeater, can prove an exciting and educational experience for both the volunteer and the students.

Thanks to NASA's SAREX (Space Amateur Radio Experiment) program, amateurs all over the nation have put schoolchildren in direct contact with shuttle astronauts. Who knows how many future scientists received their inspiration while sitting behind an amateur's microphone?

ARRL FIELD ORGANIZATION

ARRL members elect the Board of Directors and the Section Managers. Each Section Manager appoints volunteers to posts that promote Amateur Radio within that Section. (The United States is divided into 15 ARRL *Divisions*. These Divisions are further broken down into 69 *Sections*.) A few of the posts include:

Assistant Section Managers—ASMs are appointed as necessary by the SM to assist the SM in responding to membership needs within the Section.

Official Observers (OO) / Amateur Auxiliary—Official Observers are authorized by the FCC to monitor the amateur bands for rules discrepancies or violations. The Amateur Auxiliary is administered by Section Managers and OO Coordinators, with support from ARRL Headquarters.

Technical Coordinators (TC) and Technical Specialists (TS)—Technical Coordinators and Technical Specialists assist hams with technical questions and interference problems. They also represent the ARRL at technical symposiums, serve on cable TV advisory committees and advise municipal governments on technical matters.

EMERGENCY COMMUNICATIONS

The FCC Rules list emergency communications as one of the purposes of the Amateur Radio Service—and in reality, the ability to provide emergency communications justifies Amateur Radio's existence. The FCC has recognized Amateur Radio as being among the most reliable means of medium- and long-distance communication in disaster areas.



Chuck, NI5I (left), and Rick, WB5TJV, were two of the many hams who provided communications in the wake of a devastating earthquake in Mexico City. (photos courtesy of WB5TJV)

Amateur Radio operators have a long tradition of operating from backup power sources. Through events such as Field Day, hams have cultivated the ability to set up communication posts wherever they are needed. Moreover, Amateur Radio can provide computer networks (with over-the-air links where needed) and provide other services such as video (ATV) and store-and-forward satellite links that no other service can deploy on a wide scale. One can argue, therefore, that widespread technology makes Amateur Radio even more crucial in a disaster situation.

If you are interested in participating in this important public service, you should contact your local EC (Emergency Coordinator). Plan to participate in preparedness nets and a yearly SET (Simulated Emergency Test).

ARES AND RACES

The Amateur Radio Emergency Service (ARES) and the Radio Amateur Civil Emergency Service (RACES) are the umbrella organizations of Amateur Radio emergency communications. The ARES is sponsored by ARRL (although ARRL membership is not required for ARES participation) and handles many different kinds of public-service activities. On the other hand, RACES is administered by the Federal Emergency Management Agency (FEMA) and operates only for civil preparedness and in times of civil emergency. RACES is activated at the request of a state or federal official.

Amateurs serious about emergency communication should carry dual RACES/ ARES membership. RACES rules now make it possible for ARES and RACES to use the same frequencies, so that an ARES group also enrolled in RACES can work in either organization as required by the situation.

MILITARY AFFILIATE RADIO SERVICE (MARS)

MARS is administered by the US armed forces, and exists for the purpose of transmitting communications between those serving in the armed forces and their families. This service has existed in one form or another since 1925.

There are three branches of MARS: Army MARS, Navy/Marine Corps MARS and Air Force MARS. Each branch has its own requirements for membership, although all three branches require members to hold a valid US Amateur Radio license and to be 18 years of age or older (amateurs from 14 to 18 years of age may join with the signature of a parent or legal guardian).¹

MARS operation takes place on frequencies adjoining the amateur bands and usually consists of nets. Nets are usually scheduled to handle traffic or to handle administrative tasks. Various MARS branches may also maintain repeaters or packet systems.

MARS demonstrated its importance during the 1991 Desert Storm conflict, when MARS members handled thousands of messages between the forces on the front lines and their friends and families at home. While MARS usually handles routine traffic, the organization is set up to handle official and emergency traffic if needed.

DIRECTION FINDING (DF)

If you've ever wanted to learn a skill that's both fun *and* useful, then you'll enjoy direction finding, or DFing. DFing is the art of locating a signal or noise source by tracking it with portable receivers and directional antennas. Direction finding is not only fun, it has a practical side as well. Hams have been instrumental in hunting down signals from aircraft ELTs (emergency locator transmitters), saving lives and property in the process.

We will just scratch the surface of DF activities in this section. There is much more in the [Repeaters, Satellites, EME and DF](#) chapter.

Fox Hunting

Fox hunting, also called *T-hunting* or sometimes *bunny hunting*, is ham radio's answer to hide-and-

seek. One player is designated the fox; he or she hides a transmitter and the other player attempts to find it. Rules change from place to place, but the fox must generally locate the transmitter within certain boundaries and transmit at specific intervals.

Fox hunts vary around the world. American fox hunts often employ teams of fox hunters cruising in their cars over a wide area. European and other fox hunters employ a smaller area and conduct fox hunts on foot. *Radiosport* competitions are usually European style.

Locating Interference

Imagine trying to check into your favorite repeater or HF net one day, only to find reception totally destroyed by noise or a rogue signal. If you can track down the interference, then you can figure out how to eliminate it.

Finding interference sources, accidental or otherwise, has both direct and indirect benefits. Touch lamps are a notorious noise source, especially on 80 m. If you can find one, the owner is legally obligated to eliminate the interference. Even better, if you can show your neighbors that something other than your station is interfering with their TV reception, you might gain an ally next time you petition the local government to let you have a higher tower!



Dave Pingree, N1NAS, hunts down a transmitter on 2-m FM. (photo by Kirk Kleinschmidt, NT0Z)

SATELLITE OPERATION

Amateur Radio has maintained a presence in space since 1961, with the launch of OSCAR 1 (OSCAR is an acronym for *Orbiting Satellite Carrying Amateur Radio*). Since then, amateurs have launched over two dozen satellites, with over a dozen still in orbit today.

Amateurs have pioneered several developments in the satellite industry, including low-orbit communication “birds” and *PACSATs*—orbiting packet bulletin board systems.

What Does It Take?

When someone mentions satellite operation, many people conjure up an image of large dishes and incredibly complex equipment. Actually, you can probably work several OSCARs with the equipment you have in your shack right now!

The entire collection of OSCARs—and their operating modes—can be broken down into three basic types:

Voice/CW (Analog)

Analog satellites range from the low-orbit RS (Radio Sputnik) birds built and launched from Russia, to the high-orbit Phase 3 satellites, AO-10 and the soon-to-be-launched Phase 3D. Operating on analog satellites is much like operating on HF—you’ll find lots of SSB and CW contacts, with some RTTY and even SSTV signals thrown in.

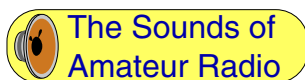

W0SL listening to his own signal “echoing” through the OSCAR 10 satellite.

Packet (Digital)

Most of the digital satellites are orbiting packet mailboxes with some extra features. Many digital satellites carry one or more video cameras. These cameras snap pictures of Earth and space and make them available

for downloading. Because most digital satellites are in low orbits, some clever software has been designed to allow ground stations to download images (or other data files) by monitoring a few orbital passes.

Several digital satellites carry an experiment called RUDAK, a versatile system that allows experimentation with packet, analog and crossband FM modes. The Fujisats from Japan also carry sophisticated systems that allow these birds to switch from analog to digital operation.

SAREX and *MIR*

The American and Russian space programs both recognize the value of Amateur Radio in space. The space shuttles often carry a mission called SAREX (*Space Amateur Radio Experiment*) that allows hams to make packet or voice contacts with the astronauts onboard. SAREX gives many school children the opportunity to talk to the astronauts and ask questions about their work.

The Russian *MIR* space station carries a permanent packet and FM station on board. *MIR* can occasionally be heard with a very strong signal, even on 2-m hand-held radios, and some hams have made contacts with mobile rigs.

Both of these orbiting amateur stations have proven their worth time and again. Their educational value is immense, and in case of normal communication failure Amateur Radio equipment provides a ready backup.



Dick Esneault, W4IJC, a member of the original Project OSCAR team, looks over a model of the Phase 3D satellite. The body of the actual satellite will be well over 7 feet wide. This advanced Amateur Radio satellite is scheduled for launch in 2000. (photo courtesy AMSAT-NA)

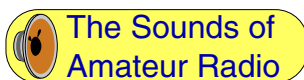

Listen to KO4GA making contact with the space shuttle Columbia.

REPEATERS

Many amateurs make their first contacts on repeaters. Repeaters carry the vast majority of VHF/UHF traffic, making local mobile communication possible for many hams.

Hams in different regions have different opinions on repeater usage. In some areas, hams use repeaters only for brief contacts, while those in other areas encourage socializing and ragchewing. All repeater users give priority to mobile emergency communications.

The best way to learn the customs of a particular repeater is to listen for a while before transmitting. This avoids the misunderstandings and embarrassment that can occur when a newcomer jumps in. For example, in some repeater systems it is assumed that the word "break" indicates an urgent or emergency situation. Other systems recognize "break" as a simple request to join or interrupt a conversation in progress. Neither usage is more "correct," but you can imagine what might happen to a traveling ham who was unaware of the local customs!

Most repeaters are *open*, meaning that any amateur may use the repeater. Other repeaters are *closed*, meaning that usage is restricted

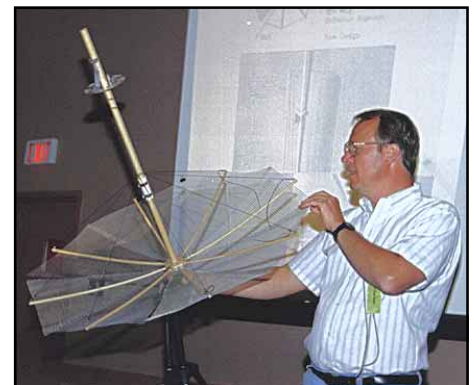

Assembling a 2.4-GHz Mode-S downlink dish is easier than you think. Ed Krome, KA9LNV, put together this portable home-brew dish in less than 15 minutes. It's made of wood dowels, wire mesh and Dacron string. The helical feed and reflector plate are mounted at the focal point. (photo by WB8IMY)

to members. Many repeaters have an *autopatch* capability that allows amateurs to make telephone calls. However, most autopatches are closed, even on otherwise open repeaters. The *ARRL Repeater Directory* shows repeater locations, frequencies, capabilities and whether the repeater is open or closed.

Most repeaters are maintained by clubs and other local organizations. If you use a particular repeater frequently, you should join and support the repeater organization. Some hams set up their own repeaters as a service to the community.

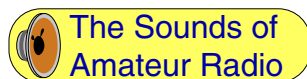

Listen to the automated voice identification (ID) from the W1KKF FM repeater.

IMAGE COMMUNICATIONS

Several communications modes allow amateurs to exchange still or moving images over the air. Advances in technology in the last few years have brought the price of image transmission equipment within reach of the average ham's budget. This has caused a surge of interest in image communication.

ATV

Amateur TV is full-motion video over the air. (It is sometimes referred to as *fast scan*, or *FSTV*.) ATV signals use the same format as broadcast (and cable) TV. Watching an ATV transmission is the same as watching your own television. With ATV, however, you can turn a small space in your home into your own television studio. Amateur communication takes on an exciting, new dimension when you can actually *see* the person you're communicating with!

The costs of ATV equipment have declined steadily over the years. The popularity of the camcorder has also played a significant role. (The family camcorder can do double duty as a station camera!) It is now possible to assemble a versatile station for well under \$1000. Amateur groups in many areas have set up ATV repeaters, allowing lower-powered stations to communicate over a fairly wide area. If you're fortunate enough to live within range of an ATV repeater, you won't need complicated antenna arrays or high power.

If you can erect high-gain directional antennas for your ATV station, you can try your hand at DXing. When the bands are open, it's not uncommon to enjoy conversations with stations several hundred miles away. In addition to your directional antennas, you must run moderate power levels to work ATV DX. Most DXers use at least 50 W or more.

Since this is a wide-bandwidth mode, operation is limited to the UHF bands (70 cm and higher). The *ARRL Repeater Directory* and the *ARRL Operating Manual* list band plans. The *Repeater Directory* includes lists of ATV repeaters. The [Modulation Sources](#) chapter provides details on setting up an ATV station with dedicated or converted video gear.

SSTV

SSTV, or slow-scan TV, is a narrow-bandwidth image mode. Instead of full-motion video at roughly 24 frames per second, SSTV pictures are transmitted at 8, 16 or 32 seconds per frame. In the beginning, SSTV was strictly a black-and-white mode. The influx of computers (and digital interfaces) have spawned color SSTV modes. Since SSTV is a narrow-band mode, it is popular on HF. Some experimenters run an SSTV net on OSCAR 13 as well.

An SSTV signal is generated by breaking an image into individual *pixels*, or dots. Each color or shade

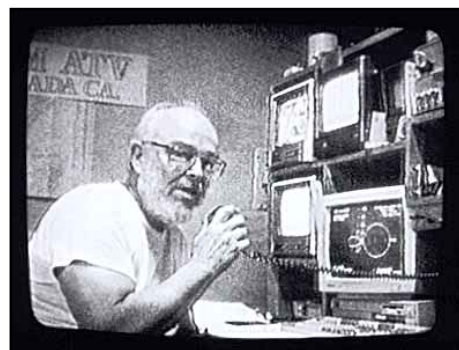

Give him the specifications and Sam, K6LVM, can show you the radiation pattern of your antenna—via ATV! (photo by Tom O'Hara, W6ORG)

is represented by a different audio tone. This tone is fed into the audio input of an SSB transmitter, converting the tones into RF. On the receive end, the audio tones are regenerated and fed into a dedicated SSTV converter or into a simple computer interface to regenerate the picture. For more information about SSTV, see the [Modulation Sources](#) chapter.



An SSTV image as seen on a standard TV set using a digital scan converter.



The Sounds of
Amateur Radio

Listen to an SSTV transmission.

Fax

Fax, or *facsimile* transmission, is one of the original image communication modes. Fax was once unavailable to amateurs due to FCC regulations, but is now a legal communication mode on most HF and higher bands.

Amateur Radio fax works much like old analog fax systems: an image is scanned from paper and converted into a series of tones representing white or black portions of a page. Amateurs are working on standards for the use of digital fax machines over radio as well.

Uses for amateur fax are as limitless as your imagination. Suppose you were having trouble with the design of your new home-brewed widget. You could fax a copy of the schematic to a sympathetic ham, who could mark in some changes and fax it back to you. And how about faxing QSL cards? No hunting for stamps or waiting for the mail to arrive!

DIGITAL COMMUNICATIONS

Digital communications predate the personal computer by many years. In fact, some amateurs consider CW to be a digital mode in which the amateur's mind handles the encoding and decoding of information. For the purposes of this *Handbook*, however, we consider digital modes to be those traditionally encoded and decoded by mechanical or electronic means. Common digital modes in use today include RTTY, AMTOR, PACTOR, G-TOR and packet radio.

As personal computers continue decreasing in price and increasing in power, many have found their way into ham shacks. Amateurs' computers perform tasks as mundane as keeping station logs and as exciting as controlling a worldwide data network!

Packet

Packet radio is one of the fastest-growing modes of operation within the amateur community. Packet radio's strongest suits include networking and unattended operation. Do you need to give some information to an absent friend? Send an electronic mail message (or *e-mail* in networking parlance). Is your friend out of range of your 2-meter packet radio? Send your message through the packet network.

In packet radio, transmitted data is broken into "packets" of data by a *TNC* (terminal node controller). Before sending these packets over the air, the TNC calculates each packet's checksum and makes sure the frequency is clear. On the receive end, a TNC checks packets for accuracy and re-



Dave Patterson, WB8ISZ, checks into his local packet bulletin board as his cat Sam looks on. (photo by WB8IMY)

requests retransmission of bad packets to ensure error-free communication.

Packet radio works best on frequencies that are relatively uncrowded. On busy frequencies (or LANs), it is possible for two stations to begin transmitting at once, garbling both packets (this is called a *collision*). Another common problem is the *hidden transmitter*, which happens when one of two stations (that are out of range of each other) is in contact with a third station within range of *both* (see **Fig 2.1**). Collisions can easily occur at the third station since neither of the other two stations can hear each other and thus may transmit simultaneously.

Thousands of packet radio stations have formed a worldwide network, one that parallels (and overlaps in some places) the massive Internet. Services available on the packet radio network include global e-mail, callbook servers, “white pages” servers (that provide network addresses of amateurs on the network) and gateways to (and from) the Internet. Other services, available in various locations, include libraries of program and text files, databases of equipment modifications, gateways to packet frequencies on HF and packet satellites.

Most amateur networkers use VHF or UHF radios to access the packet network. Many amateurs, however, can be found using packet on HF and the packet satellites. Both HF and satellites see a great deal of internode network traffic as well.

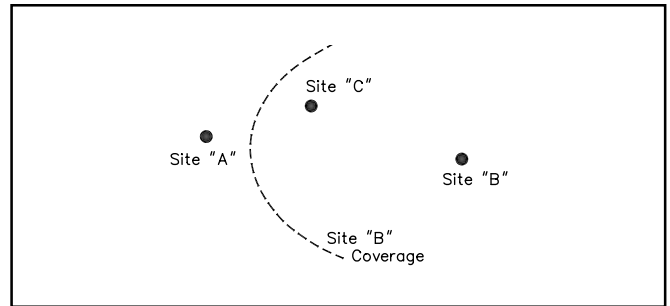
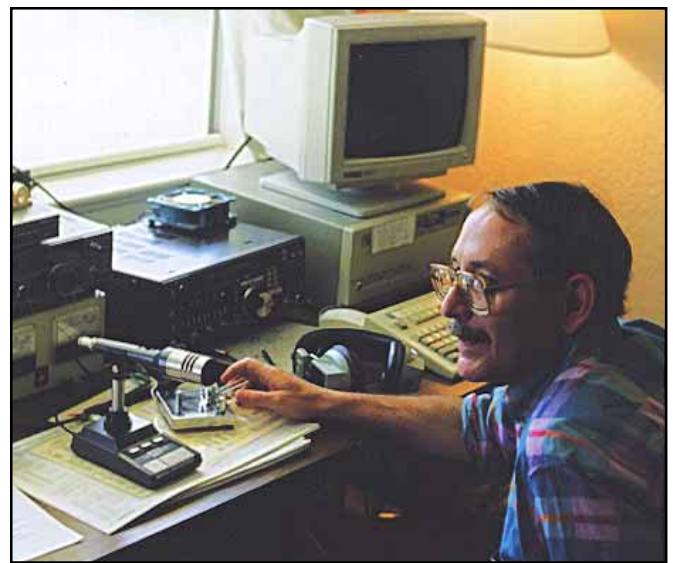



Fig 2.1—The “hidden transmitter” problem. Site B has established contact with site C, but cannot hear site A. However, site C can hear *both stations*. If site B transmits while site A is transmitting, or vice versa, a packet collision occurs.



John Shew, N4QQ (at a portable station set up by KG5OG) makes an EME CW contact with VE3ONT. (photo by WB8IMY)

	The Sounds of Amateur Radio	Listen to a packet radio transmission on HF.
---	--	---

AMTOR/PACTOR/G-TOR

AMTOR (*Amateur Teleprinting Over Radio*) is an “RF-hardened” digital mode. It is based on the SITOR mode (used in marine communications) and is an error-correcting mode.

A transmitting station using AMTOR sends three characters then waits for a response from the receiving station. (This produces the “cricket” sound unique to AMTOR.) The receiving station sends an ACK (send the next three characters) or a NAK (repeat the last three characters). This exchange of ACKs and NAKs ensures that only error-free text arrives at the receiving station.

Actually, there is much more than this to AMTOR; there are several submodes for calling CQ, or for reliable sending to multiple receivers.

PACTOR is a packet-like mode based on AMTOR, but with slightly longer packets and AX.25 compatibility. Unlike standard packet radio, PACTOR does not allow frequency sharing. PACTOR is much faster than AMTOR while still retaining AMTOR’s ability to communicate through moderate noise or interference without errors. In addition, PACTOR uses the complete ASCII character set (with upper- and lower-case letters) and can easily handle binary data transfers. The latest version of PACTOR is PACTOR II.

QSLing

A QSL card (or just “QSL”) is an Amateur Radio tradition. QSL cards are nearly as old as Amateur Radio itself, and the practice has spread so that SWLs can get cards from commercial shortwave and AM broadcast stations.

Most amateurs have printed QSL cards. QSL card printers usually have several standard layouts that you can choose from. Some offer customized designs at extra cost. If you are just starting out, or anticipate changing your call sign (just think, you could get a call like “KC4WZK”), you may want to purchase a pack of “generic” QSL cards available from many ham stores and mail-order outlets.

Filling Out Your Cards

QSL cards must have certain information for them to be usable for award qualification. At a minimum, the card must have:

- Your call sign, street address, city, state or province and country. This information should be preprinted on one side of your QSL card.
- The call of the station worked.
- The date and time (in UTC) of the contact.
- The signal report.
- The band and mode used for the contact.

Awards for VHF and UHF operations may also require the grid locator (or “grid square”) in which your station is located. If you have no plans to operate VHF and UHF, you can omit the grid square (you can always write it in later if required).

Many hams provide additional information on their QSL cards such as the equipment and antennas used during the contact, power levels, former calls and friendly comments.

Sending and Receiving Domestic QSLs

Most QSL cards can be sent as post cards within the United States, usually saving some postage costs. Back when postage was cheap, you could send out 100 post cards for a few dollars and domestic stations would send QSLs as a matter of course. Nowadays, if you really need a particular QSL, it is best to send a self-addressed stamped envelope along with your card.

QSLing for DX stations is somewhat more involved and is discussed elsewhere in this chapter.

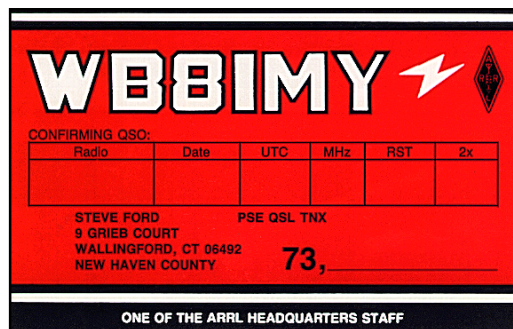

WB8IMY’s QSL is a properly formatted card. Notice how all of the information is on one side of the card.

G-TOR uses several compression, checking and correction techniques along with automatic repeat requests. These techniques speed data transfer on the HF bands over that possible with AMTOR or PACTOR. The “G” in G-TOR stands for “Golay,” a kind of forward-error-correction coding.

RTTY

RTTY is the original data communication mode, and it remains in use today. While RTTY does not support the features of the newer data modes, such as frequency sharing or error correction, RTTY is better suited for “roundtable” QSOs with several stations.

RTTY was originally designed for use with mechanical teleprinters, predating personal computers by several decades. Amateurs first put RTTY on the air using surplus teletypewriters (TTYs) and homebrewed vacuum-tube-based interfaces. Today, of course, RTTY uses computers or dedicated controllers, many of which also support other digital modes such as CW, PACTOR, AMTOR and packet.

CLOVER

CLOVER is a relatively new digital communications mode. It utilizes a four-tone modulation

system and digital signal processing (DSP) to pass data on the HF bands at a rate much faster than AMTOR or even PACTOR. In addition, CLOVER's signal bandwidth is relatively narrow (500 Hz at -50 dB). When two CLOVER stations are linked, they share information concerning signal conditions and power output levels. As a result, CLOVER has the remarkable ability to adjust output power *automatically* to maintain a stable communication pathway. For example, if the signal begins to deteriorate at the receiving station, the transmitting station is "aware" of this fact and increases power until conditions improve. Under excellent conditions, power is adjusted *down*—sometimes to as little as a few watts!

The complete CLOVER system is contained on a card that plugs into the expansion slot of an IBM-PC or compatible computer (80286 microprocessor or better). An SSB transceiver is also required. The transceiver must be very stable because CLOVER cannot tolerate more than approximately 15 Hz of drift after the link is established. As this *Handbook* went to press, CLOVER was primarily used as a means to move high-volume digital traffic (messages and files) on the HF bands.

MICROWAVE AND VHF/UHF WEAK-SIGNAL OPERATING

Hams use many modes and techniques to extend the range of line-of-sight signals. Those who explore the potential of VHF/UHF communications are often known as *weak-signal* operators. Weak-signal enthusiasts probe the limits of propagation. Their goal is to discover just how far they can communicate.

They use directional antennas (beams or parabolic dishes) and very sensitive receivers. In some instances, they employ considerable output power, too. As a result of their efforts, distance records are broken almost yearly! On 2 m, for example, conversations between stations hundreds and even thousands of miles apart are not uncommon. The distances decrease as frequencies increase, but communications have spanned several hundred miles even at microwave frequencies.

EME, Meteor Scatter and Aurora

EME (Earth-Moon-Earth) communication, also known as "moonbounce," continues to fascinate many amateurs. The concept is simple: use the moon as a passive reflector for VHF and UHF signals. With a total path length of about 500,000 miles, EME is the ultimate DX.

Amateur involvement in moonbounce grew out of experiments by the military after World War II. While the first amateur signals reflected from the moon were received in 1953, it took until 1960 for the first two-way amateur EME contacts to take place. Using surplus parabolic dish antennas and high-power klystron amplifiers, the Eimac Radio Club, W6HB, and the Rhododendron Swamp VHF Society, W1BU, achieved the first EME QSO in July 1960 on 1296 MHz. Since then, EME activity has proliferated onto most VHF and higher amateur bands.

Advances in low-noise semiconductors and Yagi arrays in the 1970s and 1980s have put EME within the grasp of most serious VHF and UHF operators. Further advances in technology will bring forth sophisticated receivers with digital signal processing (DSP) that may make EME affordable to most amateurs.

EME activity is primarily a CW mode. However, improvements in station equipment now allow the best-equipped stations to make SSB contacts under the right conditions. Regardless of the transmission mode, successful EME operating requires:

- Power output as close to the legal limit as possible.
- A good-sized antenna array. Arrays of 8, 16, or more Yagis are common on the VHF frequencies, while large parabolic dish antennas are common on UHF and microwave frequencies.
- Accurate azimuth and elevation.
- Minimal transmission line losses.
- The best possible receiving equipment, generally a receiver with a low system noise figure and a low-noise preamplifier mounted at the antenna.

Where's the Action?

Hams enthusiastically adopted (and adapted) personal computers very early on. Many of the modes described in this chapter—RTTY, FAX, SSTV and others—no longer require the use of specific hardware terminals. Instead, combined with a small interface unit, they consist of software and home PCs. Now hams can operate many modes with just the press of a few keys on the PC's keyboard.

Often, the interface consists of just one IC, one or two transistors, and a handful of resistors, capacitors and diodes. It is connected between the serial or parallel port of the PC and the microphone and speaker jacks of a rig. A little software tweaking (usually just by selecting menu items) and you have instant FAX, SSTV or whatever the mode selected.

Then came the Internet. Hams quickly seized upon it to exchange information, make EME skeds, and distribute newsletters and software. It wasn't long before a few tied their rigs to their computers, and with the *chat channels* of the Internet, allowed hams from around the world to use their rigs.

A popular new activity, combining repeaters and the Internet, uses software called *IPhone*. All it takes is a PC with the *IPhone* software, a VOX interface and a VHF or UHF rig set to the local repeater (see **Fig A**). Hams from anywhere in the world can use their computers to talk through their local repeater. When two or more repeaters are linked you can be driving down the street, using your 2-meter repeater, in contact with another ham across the country using her 440 repeater (**Fig B**). Without some other means of positive verification of identities, a control operator must be present for each repeater, to ensure the repeaters are used properly.—*N111*

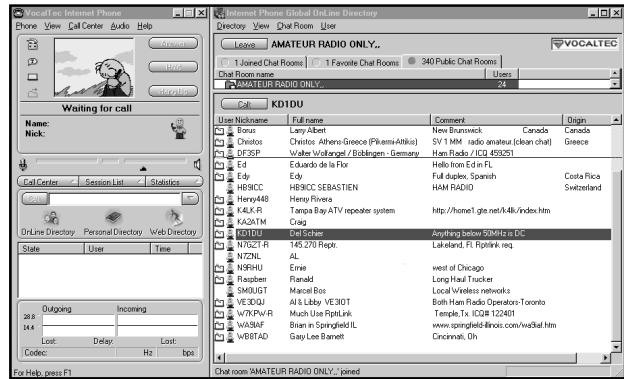

Fig A—Log in on *IPhone*, and this is what you might see. The call letters ending with *-R* are repeaters. *GIF file courtesy of Del (Anything Below 50 MHz is DC) Schier, KD1DU*

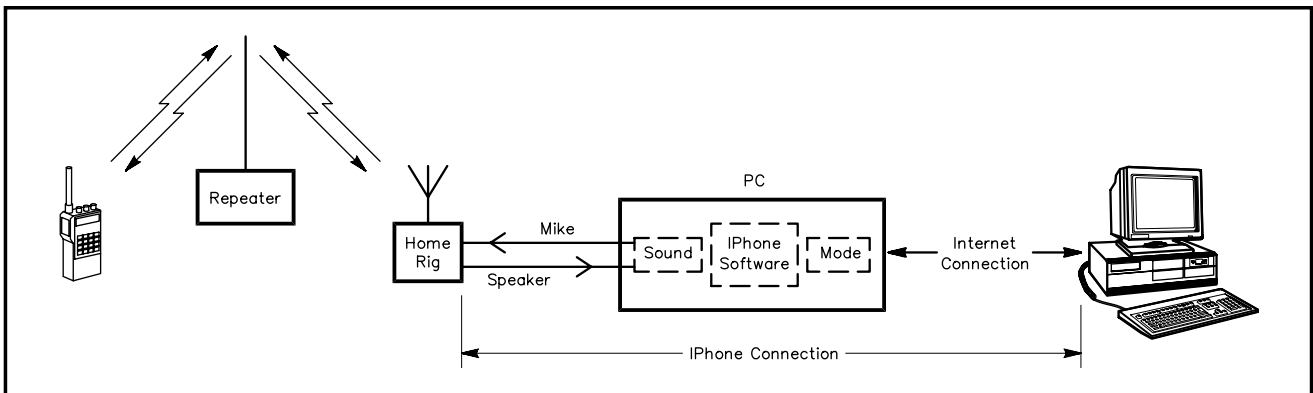

Fig B—End-to-end, this is how it works. If the PC on the right were also connected to a VHF or UHF rig, the range of two HTs would go from local to global!

The ARRL sponsors EME contests to stimulate activity. Given the marginal nature of most EME contacts, EME contests designate a “liaison frequency” on HF where EME participants can schedule contacts. Contest weekends give smaller stations the opportunity to make many contacts with stations of all sizes. See the [Repeaters, Satellites, EME and DF](#) chapter for more about EME.

Meteor Scatter

As a meteor enters the Earth’s atmosphere, it vaporizes into an ionized trail of matter. Such trails are often strong enough to reflect VHF radio signals for several seconds. During meteor showers, the ionized region becomes large enough (and lasts long enough) to sustain short QSOs.

Amateurs experimenting with meteor scatter propagation use high power (100 W or more) and beam antennas with an elevation rotor (to point the beam upward at the incoming meteors). Most contacts are made using CW, as voice modes experience distortion and fading. Reflected CW signals often have a rough note.

The *ARRL UHF/Microwave Experimenter’s Handbook* contains detailed information about the techniques and equipment used for meteor scatter.

Auroral Propagation

During intense solar storms, the Earth’s magnetic field around the poles can become heavily charged with ions. In higher latitudes, this often produces a spectacular phenomenon called the *aurora borealis* (or northern lights) in the Northern Hemisphere and the *aurora australis* (or southern lights) in the Southern Hemisphere. The ionization is often intense enough to reflect VHF radio signals. Many amateurs experiment with aurora contacts on 10 and 2 m. Aurora contacts are often possible even when the aurora is not visible.

Equipment used to make aurora contacts is similar to that used for meteor-scatter contacts: high power, directional antennas and CW. Antenna pointing is less critical, however, since the antenna need only be aimed at the aurora curtain. Reflected CW signals often have a rough buzzsaw-like note and can also be Doppler-shifted.

The *ARRL UHF/Microwave Experimenter’s Handbook* contains detailed information about the techniques and equipment used for auroral propagation.

1 You can find more information online about the three branches of the Military Affiliate Radio Service at their respective web sites. See the [References](#) chapter Address List.