

# RF Power Amplifiers and Projects

## 13

**T**his chapter describes the design and construction of power RF amplifiers for use in an Amateur Radio station. Dick Ehrhorn, W4ETO, contributed materially to this section.

An amplifier may be required to develop as much as 1500 W of RF output power, the legal maximum in the United States. The voltages and currents needed to perform this feat are much higher than those found in other amateur equipment—the voltage and current levels are potentially lethal, in fact.

Every component in an RF power amplifier must be carefully selected to endure these high electrical stress levels without failing. Large amounts of heat are produced in the amplifier and must be dissipated safely. Generation of spurious signals must be minimized, not only for legal reasons, but also to preserve good neighborhood relationships. Every one of these challenges must be overcome to produce a loud, clean signal from a safe and reliable amplifier.

# Types of Power Amplifiers

Power amplifiers are categorized by their power level, intended frequencies of operation, device type, class of operation and circuit configuration. Within each of these categories there almost always are two or more options available. Choosing the most appropriate set of options from all those available is the fundamental concept of design.

## SOLID STATE VERSUS VACUUM TUBES

With the exception of high-power amplifiers, nearly all items of amateur equipment manufactured commercially today use solid-state (semiconductor) devices exclusively. Semiconductor diodes, transistors and integrated circuits (ICs) offer several advantages in designing and fabricating equipment:

- Compact design—Even with their heat sinks, solid-state devices are smaller than functionally equivalent tubes, allowing smaller packages.
- “No-tune-up” operation—By their nature, transistors and ICs lend themselves to low impedance, broadband operation. Fixed-tuned filters made with readily available components can be used to suppress harmonics and other spurious signals. Bandswitching of such filters is easily accomplished when necessary; it often is done using solid-state switches. Tube amplifiers, on the other hand, usually must be retuned on each band, and even for significant frequency movement within a band.
- Long life—Transistors and other semiconductor devices have extremely long lives if properly used and cooled. When employed in properly designed equipment, they should last for the entire useful life of the equipment—commonly 100,000 hours or more. Vacuum tubes wear out as their filaments (and sometimes other parts) deteriorate with time in normal operation; the useful life of a typical vacuum tube may be on the order of 10,000 to 20,000 hours.
- Manufacturing ease—Most solid-state devices are ideally suited for printed-circuit-board fabrication. The low voltages and low impedances that typify transistor and IC circuitry work very well on printed circuits (some circuits use the circuit board traces themselves as circuit elements); the high impedances found with vacuum tubes do not. The IC or transistor’s physical size and shape also lends itself well to printed circuits and the devices usually can be soldered right to the board.

These advantages in fabrication mean reduced manufacturing costs. Based on all these facts, it might seem that there would be no place for vacuum tubes in a solid state world. Transistors and ICs do have significant limitations, however, especially in a practical sense. Individual RF power transistors available today cannot develop more than approximately 150 W output; this figure has not changed much in the past two decades.

Individual present-day transistors cannot generally handle the combination of current and voltage needed, nor can they safely dispose of the amount of heat dissipated, for RF amplification to higher power levels. So pairs of transistors, or even pairs of pairs, are usually employed in practical power amplifier designs, even at the 100-W level. Beyond the 300-W output level, somewhat exotic (at least for most radio amateurs) techniques of power combination from multiple amplifiers ordinarily must be used. Although this is commonly done in commercial equipment, it is an expensive proposition.

It also is far easier to ensure safe cooling of vacuum tubes, which operate satisfactorily at surface temperatures as high as 150-200°C and may be cooled by simply blowing sufficient ambient air past or through their relative large cooling surfaces. The very small cooling surfaces of power transistors should be held to 75-100°C to avoid drastically shortening their life expectancy. Thus, assuming worst-case 50°C ambient air temperature, the large cooling surface of a vacuum tube can be allowed to rise 100-150°C above ambient, while the small surface of a transistor must not be allowed to rise more than about

50°C. Moreover, power tubes are considerably more likely than transistors to survive, without significant damage, the rare instance of severe overheating.

Furthermore, RF power transistors are much less tolerant of electrical abuse than are most vacuum tubes. An overvoltage spike lasting only microseconds can—and is likely to—destroy transistors costing \$75 to \$150 each. A comparable spike is unlikely to have any effect on a tube. So the important message is this: designing with expensive RF power transistors demands using extreme caution to ensure that adequate thermal and electrical protection is provided. It is an area best left to knowledgeable designers.

Even if one ignores the challenge of the RF portions of a high-power transistor amplifier, there is the dc power supply to consider. A solid-state amplifier capable of delivering 1 kW of RF output might require regulated (and transient-free) 50 V at more than 40 A. Developing that much current is a challenging and expensive task. These limitations considered, solid-state amplifiers have significant practical advantages up to a couple of hundred watts output. Beyond that point, and certainly at the kilowatt level, the vacuum tube still reigns for amateur constructors because of its cost-effectiveness and ease of equipment design.

## CLASSES OF OPERATION

The class of operation of an amplifier stage is defined by its conduction angle, the angular portion of each RF drive cycle, in degrees, during which plate current (or collector or drain current in the case of transistors) flows. This, in turn, determines the amplifier's gain, efficiency, linearity and input and output impedances.

- **Class A:** The conduction angle is 360°. DC bias and RF drive level are set so that the device is not driven to output current cutoff at any point in the driving-voltage cycle, so some device output current flows throughout the complete 360° of the cycle (see **Fig 13.1A**). Output voltage is generated by the variation of output current flowing through the load resistance. Maximum linearity and gain are achieved in a Class A amplifier, but the efficiency of the stage is low. Maximum theoretical efficiency is 50%, but 25 to 30% is more common in practice.
- **Class AB:** The conduction angle is greater than 180° but less than 360° (see Fig 13.1B). In other words, dc bias and drive level are adjusted so device output current flows during appreciably more than half the drive cycle, but less than the whole drive cycle. Efficiency is much better than Class A, typically reaching 50-60% at peak output power. Class AB linearity and gain are not as good as that achieved in Class A, but are very acceptable for even the most rigorous high-power SSB applications in Amateur Radio.

Class AB vacuum tube amplifiers are further defined as class AB1 or AB2. In class AB1, the grid is not driven positive so no grid current flows. Virtually no drive power is required, and gain is quite high, typically 15-20 dB. The load on the driving stage is relatively constant throughout the RF cycle. Efficiency typically exceeds 50% at maximum output.

In Class AB2, the grid is driven positive on peaks and some grid current flows. Efficiency commonly reaches 60%, at the expense of greater demands placed on the driving stage and slightly reduced linearity. Gain commonly reaches 15 dB.

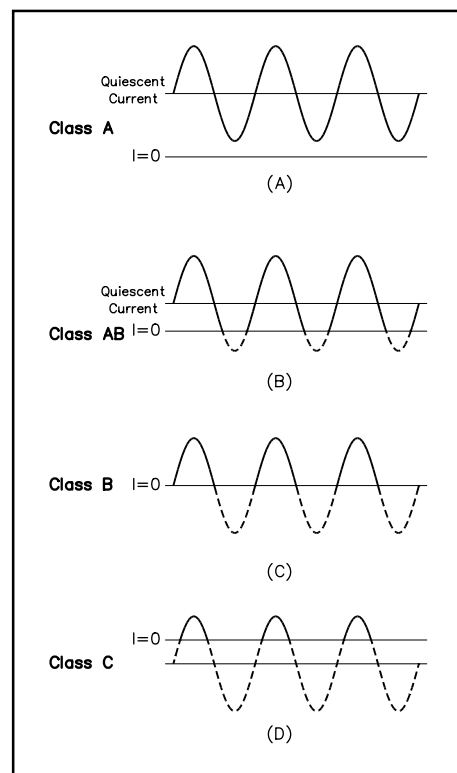

**Fig 13.1—Amplifying device output current for various classes of operation. All assume a sinusoidal drive signal.**

- Class B: Conduction angle =  $180^\circ$ . Bias and RF drive are set so that the device is just cut off with no signal applied (see Fig 13.1C), and device output current flows during one half of the drive cycle. Efficiency commonly reaches as high as 65%, with fully acceptable linearity.
- Class C: The conduction angle is much less than  $180^\circ$ —typically  $90^\circ$ . DC bias is adjusted so that the device is cut off when no drive signal is applied. Output current flows only during positive crests in the drive cycle (see Fig 13.1D), so it consists of pulses at the drive frequency. Efficiency is relatively high—up to 80%—but linearity is extremely poor. Thus Class C amplifiers are not suitable for amplification of amplitude-modulated signals such as SSB or AM, but are quite satisfactory for use in on-off keyed stages or with frequency or phase modulation. Gain is lower than for the previous classes of operation, typically 10-13 dB.
- Classes D through H use various switched mode techniques and are not commonly found in amateur service. Their prime virtue is high efficiency, and they are used in a wide range of specialized audio and RF applications to reduce power-supply requirements and dissipated heat. These classes of RF amplifiers require fairly sophisticated design and adjustment techniques, particularly at high-power levels. The additional complexity and cost could rarely if ever be justified for amateur service.

Class of operation is independent of device type and circuit configuration (see [Analog Signal](#) chapter). The active amplifying device and the circuit itself must be uniquely applied for each operating class, but amplifier linearity and efficiency are determined by the class of operation. Clever amplifier design cannot improve on these fundamental limits. Poor design and implementation, though, can certainly prevent an amplifier from approaching its potential in efficiency and linearity.

## MODELING THE ACTIVE DEVICE

It is very useful to have a model for the active devices used in a real-world RF power amplifier. Although the actual active device used in an amplifier might be a vacuum tube, a transistor or an FET, each model has certain common characteristics.

See Fig 13.2A, where a vacuum tube is modeled as a current generator in parallel with a *dynamic plate resistance*  $R_p$  and a *load resistance*  $R_L$ . In this simplified model, any residual reactances (such as the inductance of connecting leads and the output capacity of the tube) are not specifically shown. The control-grid voltage in a vacuum tube controls the stream of electrons moving between the cathode and the plate. An important measure for a tube is its *transconductance*, which is the change in plate current caused by a change in grid-cathode voltage. The plate current is:

$$i_p = g_m \times e_g \quad (1)$$

where

$i_p$  = plate current

$g_m$  = transconductance (also called mutual conductance) of tube  
 $= \Delta i_p / \Delta e_g$

$e_g$  = grid RF voltage.

The concept of dynamic plate resistance is sometimes misunderstood. It is a measure of how the plate current changes with a change in plate voltage, given a constant grid voltage. The con-

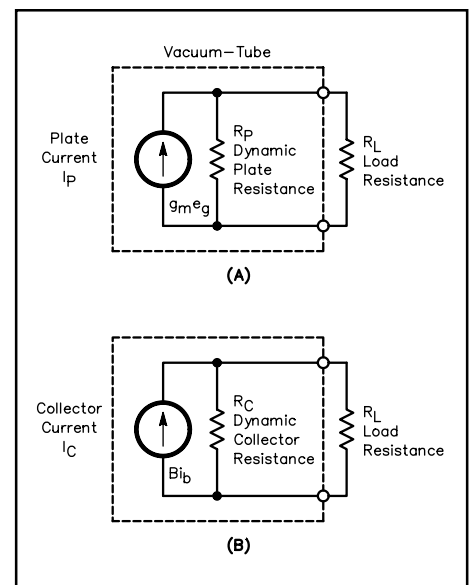

**Fig 13.2—At A, the current-generator model for a vacuum-tube amplifier operating linearly. Typical values for  $R_p$  and  $R_L$  for small-signal vacuum tubes are 100 k $\Omega$  and 5 k $\Omega$  respectively. The plate current  $I_p$  is equal to the product of the tube transconductance  $g_m$  times the grid voltage. At B, the current-generator model for a transistor. Typical values for  $R_C$  and  $R_L$  are on the same order as those for a small-signal vacuum tube.**

trol-grid voltage is by far the major determinant of the plate current in a triode. In a tetrode or pentode vacuum tube, the screen grid “screens” the plate current even further from the effect of changes in the plate voltage. For small-signal operation (where the plate voltage does not swing below the screen voltage) the plate current in a pentode or tetrode changes remarkably little when the plate voltage is changed. Thus the dynamic plate resistance is very high in a tetrode or pentode that is operating linearly, and only somewhat less for a triode. The plate current delivered into the load resistance  $R_L$  creates RF power.

An FET operates much like the vacuum-tube model. Obviously, there is no vacuum inside the case of an FET, and the FET electrodes are called gate, drain and source instead of grid, plate and cathode, but the current-generator model is just as viable for an FET as for a vacuum tube.

In a transistor, the base current controls the flows of electrons (or holes) in the collector circuit. See Fig 13.2B. A transistor operating in a linear fashion resembles the operation of a tetrode or pentode vacuum tube since the equivalent collector dynamic output resistance is also high. This is so because the collector current is not affected greatly by the collector voltage—it is mainly determined by the base current. The collector current in the current-generator model for a transistor is:

$$i_c = \beta \times i_b \quad (2)$$

where

$i_c$  = collector current

$\beta$  = current gain of transistor

$i_b$  = base current.

## IMPEDANCE TRANSFORMATION —“MATCHING NETWORKS”

Over the years, some confusion in the amateur ranks has resulted from imprecise use of the terms *matching* and *matching network*. The term “matching” was first used in the technical literature in connection with transmission lines. When a matching network such as a *Transmatch* is tuned properly, it “matches” (that is, makes equal) a particular load impedance to the fixed characteristic impedance of the transmission line used at the Transmatch input.

In this chapter, we are concerned with using active devices to generate useful RF power. For a given active device, RF power is generated most efficiently, and with the least distortion for a linear amplifier, when it delivers RF current into an *optimum value of load resistance*. For an amplifier, the output network transforms the load impedance (such as an antenna) into an optimum value of load resistance for the active device. In part to differentiate active power amplifiers from passive transmission lines, we prefer to call such a transforming network an *output network*, rather than a matching network.

### Output Networks and Class AB, B, and C Amplifiers

In Class AB, B and C amplifiers, we select a load resistance that will keep the tube or transistor from dissipating too much power or, in the case of Class AB or B amplifiers, to achieve the desired linearity.

In these classes of amplifiers, the device output current is zero for large parts of the RF cycle. Because of this, the effective source resistance is no longer the simple dynamic plate resistance of a Class A amplifier. In fact, the value of  $R_p$  varies with the drive level. This means that, since the load resistance (of an antenna, for example) is constant, the efficiency of the amplifier also varies with the drive level.

It may at first appear contradictory that Class AB and B amplifiers use nonlinear devices but achieve “linear” operation nevertheless. The explanation is that the peak amplitude of device output current faithfully follows that of the drive voltage, even though its waveform does not. In tuned amplifiers, the flywheel effect of the resonant output network restores the missing part of each RF input cycle, as well as its sinusoidal waveform. In broadband transistor amplifiers, balanced push-pull circuitry commonly is used to restore the missing RF cycles, and low-pass filters on the output remove harmonics and thereby

restore the sinusoidal RF waveform. The result in both cases is linear amplification of the input signal—by the clever application of nonlinear devices.

The usual practice in RF power amplifier design is to select an optimum load resistance that will provide the highest power output consistent with required linearity, while staying within the amplifying device's ratings. The optimum load resistance is determined by the amplifying device's current transfer characteristics and the amplifier's class of operation. For a transistor amplifier, the optimum load resistance is approximately:

$$R_L = \frac{V_{CC}^2}{2P_O} \quad (6)$$

where

$R_L$  = the load resistance

$V_{CC}$  = the collector dc voltage

$P_O$  = the amplifier power output in watts.

Vacuum tubes have complex current transfer characteristics, and each class of operation produces different RMS values of RF current through the load impedance. The optimum load resistance for vacuum-tube amplifiers can be approximated by the ratio of the dc plate voltage to the dc plate current at maximum signal, divided by a constant appropriate to each class of operation. The load resistance, in turn, determines the maximum power output and efficiency the amplifier can provide. The optimum tube load resistance is

$$R_L = \frac{V_P}{K \times I_P} \quad (7)$$

where

$R_L$  = the appropriate load resistance, in ohms

$V_P$  = the dc plate potential, in V

$I_P$  = the dc plate current, in A

$K$  = a constant that approximates the RMS current to dc current ratio appropriate for each class. For the different classes of operation:

Class A,  $K \approx 1.3$

Class AB,  $K \approx 1.5 - 1.7$

Class B,  $K \approx 1.57 - 1.8$

Class C,  $K \approx 2$ .

Graphical or computer-based analytical methods may be used to calculate more precisely the optimum plate load resistance for specific tubes and operating conditions, but the above “rules of thumb” generally provide satisfactory results for design.

The ultimate load for an RF power amplifier usually is a transmission line connected to an antenna or the input of another amplifier. It usually isn't practical, or even possible, to modify either of these load impedances to the optimum value needed for high-efficiency operation. An output network is thus used to transform the real load impedance to the optimum load resistance for the amplifying device. Two basic types of output networks are found in RF power amplifiers: tank circuits and transformers.

## TANK CIRCUITS

Parallel-resonant circuits and their equivalents have the ability to store energy. Capacitors store electrical energy in the electric field between their plates; inductors store energy in the magnetic field induced by the coil winding. These circuits are referred to as *tank circuits*, since they act as storage “tanks” for RF energy.

The energy stored in the individual tank circuit components varies with time. Consider for example the tank circuit shown in **Fig 13.4**. Assuming that  $R$  is zero, the tank circuit dissipates no power. Therefore, no power need be supplied by the source; hence no line current  $I_{LINE}$  flows. Only circulating current  $I_{CIRC}$  flows, and it is exactly the same through both  $L$  and  $C$  at any instant. Similarly, the voltage across  $L$  and  $C$  is always exactly the same. At some point the capacitor is fully charged, and the current through both the capacitor and inductor is zero. So the inductor has no magnetic field and therefore no energy stored in its field. All the energy in the tank is stored in the capacitor's electric field.

At this instant, the capacitor starts to discharge through the inductor. The current flowing in the inductor creates a magnetic field, and energy transferred from the capacitor is stored in the inductor's magnetic field. Still assuming there is no loss in the tank circuit, the increase in energy stored in the inductor's magnetic field is exactly equal to the decrease in energy stored in the capacitor's electric field. The total energy stored in the tank circuit stays constant; some is stored in the inductor, some in the capacitor. Current flow into the inductor is a function of both time and of the voltage applied by the capacitor, which decreases with time as it discharges into the inductor. Eventually, the capacitor's charge is totally depleted and all the tank circuit's energy is stored in the magnetic field of the inductor. At this instant, current flow through  $L$  and  $C$  is maximum and the voltage across the terminals of both  $L$  and  $C$  is zero.

Since energy no longer is being transferred to the inductor, its magnetic field begins to collapse and becomes a source of current, still flowing in the same direction as when the inductor was being driven by the capacitor. When the inductor becomes a current source, the voltage across its terminals reverses and it begins to recharge the capacitor, with opposite polarity from its previous condition. Eventually, all energy stored in the inductor's magnetic field is depleted as current decreases to zero. The capacitor is fully charged, and all the energy is then stored in the capacitor's electric field. The exchange of energy from capacitor to inductor and back to capacitor is then repeated, but with opposite voltage polarities and direction of current flow from the previous exchange. It can be shown mathematically that the "alternating" current and voltage produced by this process are sinusoidal in waveform, with a frequency of

$$f = \frac{1}{2\pi\sqrt{LC}} \quad (8)$$

which of course is the resonant frequency of the tank circuit. In the absence of a load or any losses to dissipate tank energy, the tank circuit current would oscillate forever.

In a typical tank circuit such as shown in Fig 13.4, the values for  $L$  and  $C$  are chosen so that the reactance ( $X_L$ ) of  $L$  is equal to the reactance ( $X_C$ ) of  $C$  at the frequency of the signal generated by the ac voltage source. If  $R$  is zero (since  $X_L$  is equal to  $X_C$ ), the line current  $I_{LINE}$  measured by  $M1$  is close to zero. However, the circulating current in the loop made up of  $L$ ,  $R$  and  $C$  is definitely not zero. Examine what would happen if the circuit were suddenly broken at points  $A$  and  $B$ . The circuit is now made up of  $L$ ,  $C$  and  $R$ , all in series.  $X_L$  is equal to  $X_C$ , so the circuit is resonant. If some voltage is applied between points  $A$  and  $B$ , the magnitude of circulating current is limited only by resistance  $R$ . If  $R$  were equal to zero, the circulating current would be infinite!

### The Flywheel Effect

A tank circuit can be likened to a flywheel—a mechanical device for storing energy. The energy in a flywheel is stored in the angular momentum of the wheel.

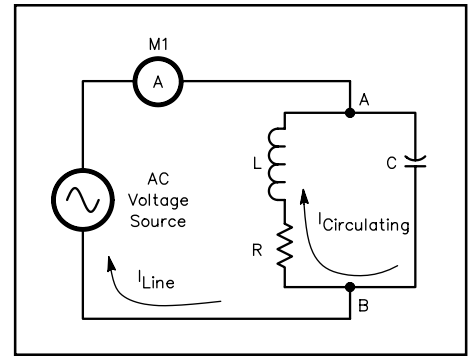

**Fig 13.4—There are two currents in a tank circuit: the line current ( $I_{LINE}$ ) and the circulating current ( $I_{CIRC}$ ). The circulating current is dependent on tank  $Q$ .**

As soon as a load of some sort is attached, the wheel starts to slow or even stop. Some of the energy stored in the spinning flywheel is now transferred to the load. In order to keep the flywheel turning at a constant speed, the energy drained by the load must be replenished. Energy has to be added to the flywheel from some external source. If sufficient energy is added to the flywheel, it maintains its constant rotational speed.

In the real world, of course, flywheels and tank circuits suffer from the same fate; system losses dissipate some of the stored energy without performing any useful work. Air resistance and bearing friction slow the flywheel. In a tank circuit, resistive losses drain energy.

### Tank Circuit Q

In order to quantify the ability of a tank circuit to store energy, a quality factor,  $Q$ , is defined.  $Q$  is the ratio of energy stored in a system during one complete RF cycle to energy lost.

$$Q = 2\pi \frac{W_S}{W_L} \quad (9)$$

where

$W_S$  = is the energy stored

$W_L$  = the energy lost to heat and the load.

By algebraic substitution and appropriate integration, the  $Q$  for a tank circuit can be expressed as

$$Q = \frac{X}{R} \quad (10)$$

where

$X$  = the reactance of either the inductor or the capacitor

$R$  = the series resistance.

Since both circulating current and  $Q$  are proportional to  $1/R$ , circulating current is therefore proportional to  $Q$ . The tank circulating current is equal to the line current multiplied by  $Q$ . If the line current is 100 mA and the tank  $Q$  is 10, then the circulating current through the tank is 1 A. (This implies, according to Ohm's Law, that the voltage potentials across the components in a tank circuit also are proportional to  $Q$ .)

When there is no load connected to the tank, the only resistances contributing to  $R$  are the losses in the tank circuit. The *unloaded*  $Q_{Loss}$  ( $Q_U$ ) in that case is:

$$Q_U = \frac{X}{R_{Loss}} \quad (11)$$

where

$X$  = the reactance of either the inductor or capacitor

$R_{Loss}$  = the effective series loss resistance in the circuit.

A load connected to a tank circuit has exactly the same effect on tank operation as circuit losses. Both consume energy. It just happens that energy consumed by circuit losses becomes heat rather than useful output. When energy is coupled out of the tank circuit into a load, the *loaded*  $Q$  ( $Q_L$ ) is:

$$Q_L = \frac{X}{R_{Loss} + R_{Load}} \quad (12)$$

where  $R_{Load}$  is the load resistance. Energy dissipated in  $R_{Loss}$  is wasted as heat. Ideally, all the tank circuit energy should be delivered to  $R_{Load}$ . This implies that  $R_{Loss}$  should be as small as practical, to yield the highest reasonable value of unloaded  $Q$ .



## Tank Circuit Efficiency

The efficiency of a tank circuit is the ratio of power delivered to the load resistance ( $R_{Load}$ ) to the total power dissipated by losses ( $R_{Load}$  and  $R_{Loss}$ ) in the tank circuit. Within the tank circuit,  $R_{Load}$  and  $R_{Loss}$  are effectively in series, and the circulating current flows through both. The power dissipated by each is therefore proportional to its resistance. The loaded tank efficiency can therefore be defined as

$$\text{Tank Efficiency} = \frac{R_{Load}}{R_{Load} + R_{Loss}} \times 100 \quad (13)$$

where efficiency is stated as a percentage. By algebraic substitution, the loaded tank efficiency can also be expressed as

$$\text{Tank Efficiency} = \left( 1 - \frac{Q_L}{Q_U} \right) \times 100 \quad (14)$$

where

$Q_L$  = the tank circuit loaded Q

$Q_U$  = the unloaded Q of the tank circuit.

It follows then that tank efficiency can be maximized by keeping  $Q_L$  low, which keeps the circulating current low and the  $I^2R$  losses down.  $Q_U$  should be maximized for best efficiency; this means keeping the circuit losses low.

The selectivity provided by a tank circuit helps suppress harmonic currents generated by the amplifier. The amount of harmonic suppression is dependent upon circuit loaded  $Q_L$ , so a dilemma exists for the amplifier designer. A low  $Q_L$  is desirable for best tank efficiency, but yields poorer harmonic suppression. High  $Q_L$  keeps amplifier harmonic levels lower at the expense of some tank efficiency. At HF, a compromise value of  $Q_L$  can usually be chosen such that tank efficiency remains high and harmonic suppression is also reasonable. At higher frequencies, tank  $Q_L$  is not always readily controllable, due to unavoidable stray reactances in the circuit. However, unloaded  $Q_U$  can always be maximized, regardless of frequency, by keeping circuit losses low.

## Tank Output Circuits

Tank circuit output networks need not take the form of a capacitor connected in parallel with an inductor. A number of equivalent circuits can be used to match the impedances normally encountered in a power amplifier. Most are operationally more flexible than a parallel-resonant tank. Each has its advantages and disadvantages for specific applications, but the final choice usually is based on practical construction considerations and the component values needed to implement a particular network. Some networks may require unreasonably high or low inductance or capacitance values. In that case, use another network, or a different value of  $Q_L$ . Several different networks may be investigated before an acceptable final design is reached.

The impedances of RF components and amplifying devices frequently are given in terms of a parallel combination of a resistance and a reactance, although it is often easier to use a series R-X combination to design networks. Fortunately, there is a series impedance equivalent to every parallel impedance and vice versa. The equivalent circuits, and equations for conversion from one to the other, are given in [Fig 13.7](#). In order to use most readily available design equations for computing matching networks, the parallel impedance must first be converted to its equivalent series form.

The  $Q_L$  of a parallel impedance can be derived from the series form as well. Substitution of the usual formula for calculating  $Q_L$  into the equations from [Fig 13.7](#) gives

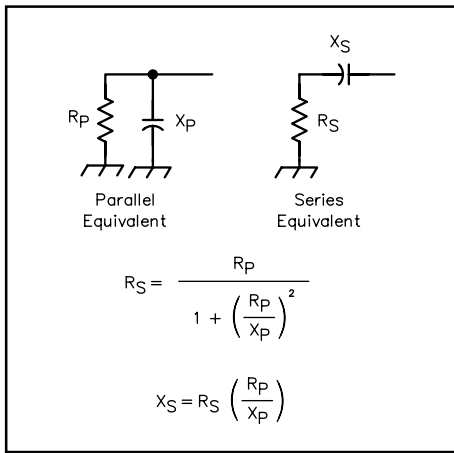

**Fig 13.7—Parallel and series equivalent circuits and the formulas used for conversion.**

$$Q_L = \frac{R_P}{X_P} \quad (15)$$

where

$R_P$  = the parallel equivalent resistance

$X_P$  = the parallel equivalent reactance.

Several impedance-matching networks are shown in the **Receivers** chapter. A low-pass T network and two low-pass L networks are possible matching networks. Both types of matching networks provide good harmonic suppression. The pi network is also commonly used for amplifier matching. Harmonic suppression of a pi network is a function of the impedance transformation ratio and the  $Q_L$  of the circuit. Second-harmonic attenuation is approximately 35 dB for a load impedance of 2000  $\Omega$  in a pi network with a  $Q_L$  of 10. The third harmonic is typically 10 dB lower and the fourth approxi-

mately 7 dB below that. A typical pi network as used in the output circuit of a tube amplifier is shown in **Fig 13.8**.

You can calculate Pi-network matching-circuit values using the following equations. These equations are from Elmer (W5FD) Wingfield's August 1983 *QST* article, "New and Improved Formulas for the Design of Pi and Pi-L Networks," and Feedback in January 1984 *QST*. (See the **Bibliography** at the end of this chapter.) **Table 13.1** shows some data from a computer program Wingfield wrote to calculate these values. This program (*PI-CMIN.EXE*) and a similar program to calculate Pi-L network values (*PI-LCMIN.EXE*) are available from ARRLWeb (see [page vii](#)), along with several other useful Wingfield programs. The programs are for IBM PC and compatible computers. A more complete set of tables is also available from ARRL as a template package. See the **References** chapter for ordering information.

The computer programs take into account the minimum practical capacitance ( $C_{min}$ ) you can expect to achieve with your circuit, based on your knowledge of the tube output capacitance, stray circuit capacitance, the minimum capacitance of the variable tuning capacitors and a reasonable amount of capacitance for tuning. (Start with a minimum capacitance of about 35 pF for vacuum variable capacitors and about 45 to 50 pF for air variable capacitors.) If the following equations lead to a capacitor value less than the minimum capacitance you expect to achieve, use the minimum value to recalculate the other quantities as shown in **Q<sub>1</sub> Based Pi-Network Equations**. This will result in a final circuit operating Q value that is larger than the selected value. (Wingfield uses  $Q_0$  to represent this output Q, which is the same as  $Q_L$  referred to earlier in this chapter. We will use  $Q_0$  in the equations.) The program output includes this new calculated  $Q_0$  value.

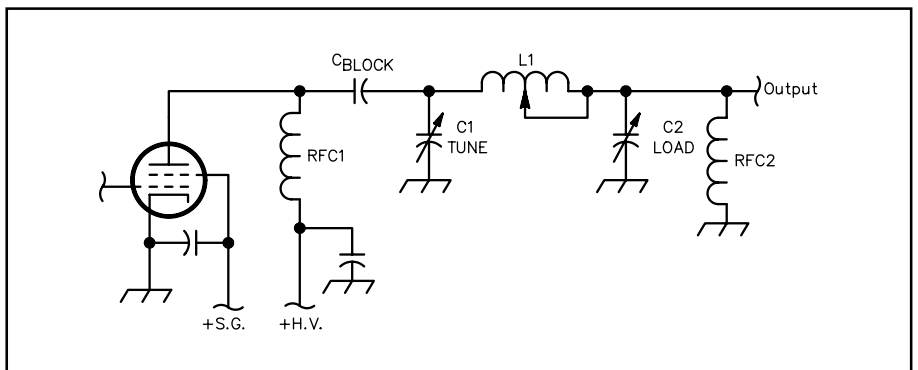

**Fig 13.8—A pi matching network used at the output of a tetrode power amplifier. RFC2 is used for protective purposes in the event  $C_{BLOCK}$  fails.**

**Table 13.1**  
**Pi-Network Values for Various Plate Impedances**  
**(Sample Output from PI-CMIN.EXE by W5FD)**  
**C in pF and L in  $\mu$ H**  
**PI-Net Values**  
**R2=50  $\Omega$ , Q<sub>0</sub> = 12, C(min) = 35 pF**

Band	C1	C2	L	
<i>R1=1500 ohms</i>				
160	580	2718	13.9	
80	294	1378	7.0	
40	154	721	3.7	
30	109	511	2.7	
20	78	364	1.86	Q <sub>0</sub> =12.0
17	61	285	1.45	Q <sub>0</sub> =12.0
15	52	243	1.24	Q <sub>0</sub> =12.0
12	44	207	1.06	Q <sub>0</sub> =12.0
10	38	179	0.91	Q <sub>0</sub> =12.0
<i>R1=1600 ohms</i>				
160	547	2619	14.6	
80	278	1328	7.4	
40	145	695	3.9	
30	103	492	2.8	
20	73	351	1.96	Q <sub>0</sub> =12.0
17	57	274	1.53	Q <sub>0</sub> =12.0
15	49	234	1.31	Q <sub>0</sub> =12.0
12	42	199	1.11	Q <sub>0</sub> =12.0
10	36	172	0.96	Q <sub>0</sub> =12.0
<i>R1=1700 ohms</i>				
160	518	2527	15.4	
80	263	1281	7.8	
40	137	671	4.1	
30	97	475	2.9	
20	69	338	2.06	Q <sub>0</sub> =12.0
17	54	265	1.61	Q <sub>0</sub> =12.0
15	46	226	1.38	Q <sub>0</sub> =12.0
12	39	192	1.17	Q <sub>0</sub> =12.0
10	35	173	0.99	Q <sub>0</sub> =12.3
<i>R1=1800 ohms</i>				
160	491	2441	16.1	
80	249	1238	8.2	
40	130	648	4.3	
30	92	459	3.0	
20	66	327	2.16	Q <sub>0</sub> =12.0
17	51	256	1.69	Q <sub>0</sub> =12.0
15	44	218	1.44	Q <sub>0</sub> =12.0
12	37	186	1.23	Q <sub>0</sub> =12.0
10	35	180	0.99	Q <sub>0</sub> =13.0
<i>R1=1900 ohms</i>				
160	468	2360	16.9	
80	237	1197	8.6	
40	124	626	4.5	
30	88	443	3.2	
20	63	316	2.26	Q <sub>0</sub> =12.0
17	49	247	1.77	Q <sub>0</sub> =12.0
15	42	211	1.51	Q <sub>0</sub> =12.0
12	36	180	1.29	Q <sub>0</sub> =12.0
10	35	186	0.99	Q <sub>0</sub> =13.7

Band	C1	C2	L	
<i>R1=2000 ohms</i>				
160	446	2284	17.6	
80	226	1158	8.9	
40	118	606	4.7	
30	84	429	3.3	
20	60	306	2.36	Q <sub>0</sub> =12.0
17	47	239	1.85	Q <sub>0</sub> =12.0
15	40	204	1.58	Q <sub>0</sub> =12.0
12	35	184	1.29	Q <sub>0</sub> =12.5
10	35	193	0.98	Q <sub>0</sub> =14.4
<i>R1=2100 ohms</i>				
160	427	2213	18.4	
80	216	1122	9.3	
40	113	587	4.9	
30	80	416	3.5	
20	57	296	2.46	Q <sub>0</sub> =12.0
17	45	232	1.92	Q <sub>0</sub> =12.0
15	38	198	1.64	Q <sub>0</sub> =12.0
12	35	189	1.30	Q <sub>0</sub> =13.0
10	35	199	0.98	Q <sub>0</sub> =15.1
<i>R1=2200 ohms</i>				
160	409	2145	19.1	
80	207	1088	9.7	
40	109	569	5.1	
30	77	403	3.6	
20	55	287	2.56	Q <sub>0</sub> =12.0
17	45	232	2.00	Q <sub>0</sub> =12.0
15	37	192	1.71	Q <sub>0</sub> =12.0
12	35	197	1.29	Q <sub>0</sub> =13.7
10	35	205	0.98	Q <sub>0</sub> =15.8
<i>R1=2300 ohms</i>				
160	392	2081	19.8	
80	199	1055	10.1	
40	104	552	5.3	
30	74	391	3.7	
20	53	279	2.65	Q <sub>0</sub> =12.0
17	41	218	2.08	Q <sub>0</sub> =12.0
15	35	186	1.77	Q <sub>0</sub> =12.0
12	35	210	1.30	Q <sub>0</sub> =12.0
10	35	211	0.98	Q <sub>0</sub> =16.5
<i>R1=2400 ohms</i>				
160	377	2020	20.5	
80	191	1024	10.4	
40	100	536	5.5	
30	71	379	3.9	
20	51	270	2.75	Q <sub>0</sub> =12.0
17	40	212	2.15	Q <sub>0</sub> =12.0
15	35	192	1.78	Q <sub>0</sub> =12.5
12	35	207	1.30	Q <sub>0</sub> =14.8
10	35	216	0.98	Q <sub>0</sub> =17.2
<i>R1=2500 ohms</i>				
160	363	1961	21.3	
80	184	994	10.8	
40	96	520	5.6	
30	68	368	4.0	
20	49	262	2.85	Q <sub>0</sub> =12.0
17	38	205	2.23	Q <sub>0</sub> =12.0
15	35	198	1.78	Q <sub>0</sub> =13.0
12	35	215	1.29	Q <sub>0</sub> =15.5
10	35	222	0.98	Q <sub>0</sub> =17.9

### Pi-Network Equations at $C_{Min}$

Wingfield's equations are a great improvement because they solve for the desired component values in terms of  $Q_0$ , the desired output  $Q$ . When the overall circuit capacitance  $C_{Min}$  at the plate is too great (common at higher frequencies), the normal equations do not work. Use the following procedure for this case.

$$Q_1 = \frac{R_1}{X_{CMin}} \quad (A)$$

where  $X_{CMin}$  is the reactance at minimum capacitance at the plate, including strays, such as the plate output capacitance and the minimum capacitance of variable  $C_1$ .

$$X_{C2} = \frac{\sqrt{R_1 \times R_2}}{\sqrt{Q_1^2 + 1 - \frac{R_1}{R_2}}} \quad (B)$$

$$Q_2 = \frac{R_2}{X_{C2}} \quad (C)$$

$$X_L = \frac{Q_1^2 + 1}{Q_1^2} X_{CMin} + \frac{Q_2^2}{Q_2^2 + 1} X_{C2} \quad (D)$$

$$Q_0 = Q_1 + Q_2 \quad (E)$$

Use the following equations to calculate specific component values for a Pi-network matching circuit. Select the desired circuit operating  $Q$ ,  $Q_0$ , to satisfy these relationships, depending on whether the load resistance is higher or lower than the transformed resistance presented to the plate:

$$Q_0^2 > \frac{R_1}{R_2} - 1 \text{ and } Q_0^2 > \frac{R_2}{R_1} - 1 \quad (16)$$

where:

$R_1$  is the input resistance to be matched, in ohms

$R_2$  is the load (output) resistance to be matched, in ohms.

Calculate the value of the input  $Q$ ,  $Q_1$ :

$$Q_1 = \frac{R_1 Q_0 - \sqrt{R_1 R_2 Q_0^2 - (R_1 - R_2)^2}}{R_1 - R_2} \quad (17)$$

We will work through an example as the equations are presented. Let's select  $Q_0 = 12$ ,  $R_1 = 1500 \Omega$  and  $R_2 = 50 \Omega$ .

$$Q_1 = \frac{1500 \times 12 - \sqrt{1500 \times 50 \times 12^2 - (1500 - 50)^2}}{1500 - 50}$$

$$Q_1 = \frac{1.80 \times 10^4 - \sqrt{8.6975 \times 10^6}}{1450} = 10.38$$

Next calculate the value of the output  $Q$ ,  $Q_2$ :

$$Q_2 = Q_0 - Q_1 \quad (18)$$

$$Q_2 = 12 - 10.38 = 1.62$$

Now calculate the reactance of the input capacitor, output capacitor and inductor.

$$X_{C1} = \frac{R_1}{Q_1} \quad (19)$$

$$X_{C1} = \frac{1500}{10.38} = 144.5 \Omega$$

$$X_{C2} = \frac{R_2}{Q_2} \quad (20)$$

$$X_{C2} = \frac{50}{1.62} = 30.86 \Omega$$

$$X_L = \frac{R_1 Q_0}{Q_1^2 + 1} \quad (21)$$

$$X_L = \frac{1500 \times 12}{10.38^2 + 1} = \frac{1.80 \times 10^4}{108.74} = 165.5 \Omega$$

Finally, calculate the component values:

$$C_1 = \frac{1}{2\pi f X_{C1}} \quad (22)$$

where  $f$  is in Hz and  $X_{C1}$  is in ohms.

For our example, let's find the component values at 3.75 MHz.

$$C_1 = \frac{1}{2\pi \cdot 3.75 \times 10^6 \times 144.5} = 294 \text{ pF}$$

$$C_2 = \frac{1}{2\pi f X_{C2}} \quad (23)$$

$$C_2 = \frac{1}{2\pi \cdot 3.75 \times 10^6 \times 30.86} = 1375 \text{ pF}$$

$$L = \frac{X_L}{2\pi f} \quad (24)$$

$$L = \frac{165.5}{2\pi \cdot 3.75 \times 10^6} = 7.02 \mu\text{H}$$

As an alternate method, after selecting the values for  $Q_0$ ,  $R_1$  and  $R_2$ , you can use the following equations:

$$X_L = \frac{Q_0(R_1 + R_2) + 2\sqrt{R_1 R_2(Q_0^2 + 4) - (R_1 + R_2)^2}}{Q_0^2 + 4} \quad (25)$$

$$X_L = \frac{12(1500 + 50) + 2\sqrt{1500 \times 50(12^2 + 4) - (1500 + 50)^2}}{12^2 + 4}$$

$$X_L = \frac{1.86 \times 10^4 + 2\sqrt{1.11 \times 10^7 - 2.4025 \times 10^6}}{148} = 165.5 \Omega$$

$$Q_1 = \sqrt{\frac{Q_0 R_1}{X_L} - 1} \quad (26)$$

$$Q_1 = \sqrt{\frac{12 \times 1500}{165.5} - 1} = 10.38$$

$$Q_2 = Q_0 - Q_1$$

or

$$Q_2 = \sqrt{\frac{Q_0 R_2}{X_L} - 1} \quad (27)$$

$$Q_2 = \sqrt{\frac{12 \times 50}{165.5} - 1} = 1.62$$

Use equations 19 and 20 to calculate the reactances of capacitors  $C_1$  and  $C_2$ . Equations 22, 23 and 24 give the capacitance and inductance values for the pi network.

The pi-L network is a combination of a pi network followed by an L network. The pi network transforms the load resistance to an intermediate impedance level called the image impedance. Typically, the image impedance is chosen to be between 300 and 700  $\Omega$ . The L section then transforms from the image impedance down to 50  $\Omega$ . The output capacitor of the pi network is combined with the input capacitor for the L network, as shown in **Fig 13.9**. The pi-L configuration attenuates harmonics better than a pi network. Second harmonic level for a pi-L network with a  $Q_L$  of 10 is approximately 52 dB below the fundamental. The third harmonic is attenuated 65 dB and the fourth harmonic approximately 75 dB.

The following equations help you calculate pi-L matching-network values. Select an image resistance value ( $R_m$ ) that the L network will supply as a load for the pi network. This value must be between the desired pi-L network input resistance ( $R_1$ ) and the output load resistance ( $R_2$ ). For example, you can use the value given:

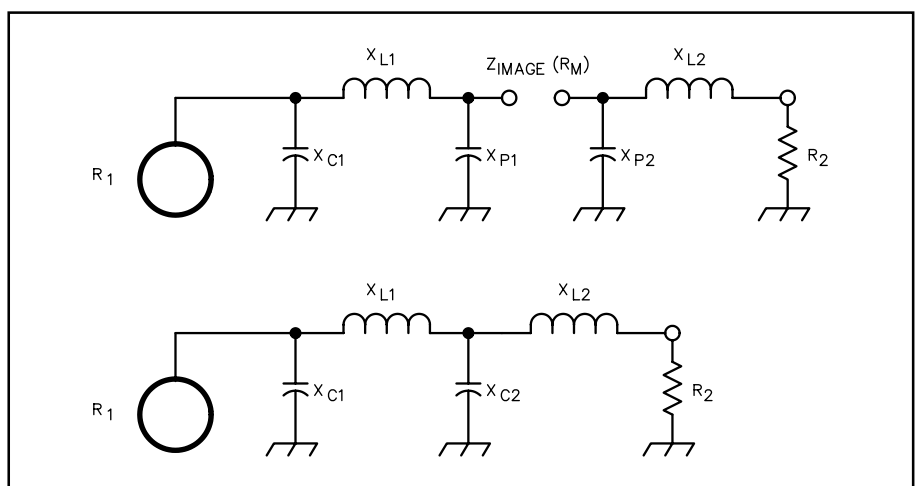

**Fig 13.9**—The pi-L network uses a pi network to transform the input impedances ( $R_1$ ) to the image impedance ( $Z_{IMAGE}$ ). An L network transforms  $Z_{IMAGE}$  to  $R_2$ .

$$R_m = \sqrt{R_1 R_2} \quad (28)$$

The computer program, PI-LCMIN. EXE, uses 300  $\Omega$  for  $R_m$  in its calculations. Changing the image resistance results in a different network solution. Use this equation to compute the L network Q value,  $Q_L$ :

$$Q_L = \sqrt{\frac{R_m}{R_2} - 1} \quad (29)$$

We will work through an example, using  $R_1 = 1500 \Omega$ ,  $R_2 = 50 \Omega$  and the desired pi-L network output Q,  $Q_0 = 12$ .

$$Q_L = \sqrt{\frac{300}{50} - 1} = 2.24$$

Use equations 30 and 31 to calculate the L-network reactances.

$$X_{L2} = Q_L R_2 \quad (30)$$

$$X_{L2} = 2.24 \times 50 = 112 \Omega \quad (31)$$

$$X_{P2} = \frac{R_m}{Q_L} \quad (32)$$

Next calculate the desired Q of the pi-network section ( $Q_{0\pi}$ ).

$$Q_{0\pi} = Q_0 - Q_L \quad (33)$$

$$Q_{0\pi} = 12 - 2.24 = 9.76$$

Use equations 17 through 21 or 25 through 29 to calculate the pi-network reactances,  $X_{C1}$ ,  $X_{L1}$  and  $X_{P1}$  as shown in Fig 13.9. Be sure to use the value specified for  $R_m$  as  $R_2$  in these calculations. Also use the value just calculated for  $Q_{0\pi}$  as  $Q_0$ . Notice that  $X_{P1}$  is  $X_{C2}$  in equation 23.

$$Q_1 = \frac{R_1 Q_{0\pi} - \sqrt{R_1 R_m Q_{0\pi}^2 - (R_1 - R_m)^2}}{R_1 - R_m}$$

$$Q_1 = \frac{1500 \times 9.76 - \sqrt{1500 \times 300 \times 9.76^2 - (1500 - 300)^2}}{1500 - 300}$$

$$Q_1 = \frac{1.464 \times 10^4 - \sqrt{4.287 \times 10^7 - 1.44 \times 10^6}}{1200} = 6.84$$

$$Q_2 = Q_{0\pi} - Q_1 = 9.76 - 6.84 = 2.92$$

$$X_{C1} = \frac{R_1}{Q_1} = \frac{1500}{6.84} = 219.3 \Omega$$

$$X_{P1} = \frac{R_m}{Q_2} = \frac{300}{2.92} = 102.7 \Omega$$

$$X_{L1} = \frac{R_1 Q_{0\pi}}{Q_1^2 + 1} = \frac{1500 \times 9.76}{6.84^2 + 1} = 306.3 \Omega$$

Combine the two parallel capacitors,  $X_{P1}$  and  $X_{P2}$  to find the Pi-L network  $X_{C2}$  value.

$$X_{C2} = \frac{X_{P1} X_{P2}}{X_{P1} + X_{P2}}$$

$$X_{C2} = \frac{102.7 \times 134}{102.7 + 134} = 58.3 \Omega$$

Finally, calculate the capacitance and inductance values using equations 22 through 24. **Table 13.2** shows some data from Wingfield's program, *PI-LCMIN*. For the sample calculation shown here, we choose a frequency of 3.75 MHz.

$$C_1 = \frac{1}{2\pi f X_{C1}} = \frac{1}{2\pi \times 3.75 \times 10^6 \times 219.3}$$

$$C_1 = 193.5 \text{ pF}$$

$$C_2 = \frac{1}{2\pi f X_{C2}} = \frac{1}{2\pi \times 3.75 \times 10^6 \times 58.3}$$

$$C_2 = 730 \text{ pF}$$

$$L_1 = \frac{X_{L1}}{2\pi f} = \frac{306.3}{2\pi \times 3.75 \times 10^6} = 13.0 \mu\text{H}$$

$$L_2 = \frac{X_{L2}}{2\pi f} = \frac{112}{2\pi \times 3.75 \times 10^6} = 4.75 \mu\text{H}$$

The values for L and C in Tables 13.1 and 13.2 are based on purely resistive load impedances and assume ideal capacitors and inductors. Any other circuit reactances will modify these values.

Stray circuit reactances, including tube capacitances and capacitor stray inductances, should be included as part of the matching network. It is not uncommon for such reactances to render the use of certain matching circuits impractical, because they require either unacceptable loaded Q values or unrealistic component values. If all matching network alternatives are investigated and found unworkable, some compromise solution must be found.

Above 30 MHz, transistor and tube reactances tend to dominate circuit impedances. At the lower impedances found in transistor circuits, the standard networks can be applied so long as suitable components are used. Above 50 MHz, capacitors often exhibit values far different from their marked values because of stray internal reactances and lead inductance, and this requires compensation. Tuned circuits are frequently fabricated in the form of strip lines or other transmission lines in order to circumvent the problem of building "pure" inductances and capacitances. The choice of components is often more significant than the type of network used.

The high impedances encountered in VHF tube-amplifier plate circuits are not easily matched with typical networks. Tube output capacitance is usually so large that most matching networks are unsuitable. The usual practice is to resonate the tube output capacitance with a low-loss inductance connected in series or parallel. The result can be a very high Q tank circuit. Component losses must be kept to an absolute minimum in order to achieve reasonable tank efficiency. Output impedance transformation is usually performed by a link inductively coupled to the tank circuit or by a parallel transformation of the output resistance using a series capacitor.

## Transformers

Broadband transformers are often used in matching to the input impedance or optimum load impedance in a power amplifier. Multioctave power amplifier performance can be achieved by appropriate



**Table 13.2**

**Pi-L Network Values for Various Plate Impedances  
(Sample Output from PI-LCMIN.EXE by W5FD)**

**C in pF and L in  $\mu$ H**

**Pi-L Network Values**

**Rm = 300  $\Omega$ , Q<sub>0</sub> = 12, R2 = 50  $\Omega$**

**C<sub>(Min)</sub> = 35 pF**

**Band C1 C2 L1 L2**

*R1=1500 ohms*

160	382	1443	25.7	9.38	
80	194	732	13.0	4.76	
40	102	383	6.83	2.49	
30	72	270	4.82	1.76	
20	51	193	3.44	1.26	Q <sub>0</sub> =12.0
17	40	151	2.69	0.98	Q <sub>0</sub> =12.0
15	35	131	2.25	0.84	Q <sub>0</sub> =12.2
12	35	123	1.64	0.71	Q <sub>0</sub> =14.0
10	35	118	1.24	0.62	Q <sub>0</sub> =15.9

*R1=1600 ohms*

160	362	1423	26.9	9.38	
80	184	722	13.6	4.76	
40	96	378	7.13	2.49	
30	68	267	5.04	1.76	
20	48	190	3.60	1.26	Q <sub>0</sub> =12.0
17	38	149	2.81	0.98	Q <sub>0</sub> =12.0
15	35	134	2.23	0.84	Q <sub>0</sub> =12.8
12	35	126	1.63	0.71	Q <sub>0</sub> =14.7
10	35	120	1.23	0.62	Q <sub>0</sub> =16.7

*R1=1700 ohms*

160	344	1404	28.0	9.38	
80	175	712	14.2	4.76	
40	92	373	7.44	2.49	
30	65	263	5.25	1.76	
20	46	188	3.75	1.26	Q <sub>0</sub> =12.0
17	36	147	2.94	0.98	Q <sub>0</sub> =12.0
15	35	136	2.22	0.84	Q <sub>0</sub> =13.4
12	35	129	1.62	0.71	Q <sub>0</sub> =15.4
10	35	123	1.22	0.62	Q <sub>0</sub> =17.5

*R1=1800 ohms*

160	328	1387	29.2	9.38	
80	166	703	14.8	4.76	
40	87	368	7.74	2.49	
30	61	260	5.47	1.76	
20	44	186	3.90	1.26	Q <sub>0</sub> =12.0
17	35	147	3.01	0.98	Q <sub>0</sub> =12.2
15	35	139	2.21	0.84	Q <sub>0</sub> =13.9
12	35	131	1.61	0.71	Q <sub>0</sub> =16.0
10	35	125	1.21	0.62	Q <sub>0</sub> =18.2

*R1=1900 ohms*

160	313	1371	30.3	9.38	
80	159	695	15.4	4.76	
40	83	364	8.04	2.49	
30	59	257	5.68	1.76	
20	42	184	4.06	1.26	Q <sub>0</sub> =12.0
17	35	149	2.99	0.98	Q <sub>0</sub> =12.7
15	35	141	2.20	0.84	Q <sub>0</sub> =14.5
12	35	133	1.60	0.71	Q <sub>0</sub> =16.7
10	35	128	1.20	0.62	Q <sub>0</sub> =19.0

**Band C1 C2 L1 L2**

*R1=2000 ohms*

160	300	1356	31.4	9.38	
80	152	687	15.9	4.76	
40	80	360	8.34	2.49	
30	56	254	5.89	1.76	
20	40	181	4.20	1.26	Q <sub>0</sub> =12.0
17	35	152	2.97	0.98	Q <sub>0</sub> =13.2
15	35	143	2.18	0.84	Q <sub>0</sub> =15.1
12	35	136	1.59	0.71	Q <sub>0</sub> =17.4
10	35	130	1.19	0.62	Q <sub>0</sub> =19.7

*R1=2100 ohms*

160	288	1341	32.5	9.38	
80	146	680	16.5	4.76	
40	76	356	8.63	2.49	
30	54	251	6.09	1.76	
20	39	180	4.35	1.26	Q <sub>0</sub> =12.0
17	35	154	2.97	0.98	Q <sub>0</sub> =13.6
15	35	146	2.17	0.84	Q <sub>0</sub> =15.6
12	35	138	1.58	0.71	Q <sub>0</sub> =18.0
10	35	132	1.19	0.62	Q <sub>0</sub> =20.5

*R1=2200 ohms*

160	277	1327	33.6	9.38	
80	140	673	17.0	4.76	
40	73	352	8.92	2.49	
30	52	249	6.30	1.76	
20	37	178	4.50	1.26	Q <sub>0</sub> =12.0
17	35	156	2.95	0.98	Q <sub>0</sub> =14.1
15	35	148	2.16	0.84	Q <sub>0</sub> =16.2
12	35	140	1.57	0.71	Q <sub>0</sub> =18.7
10	35	134	1.18	0.62	Q <sub>0</sub> =21.3

*R1=2300 ohms*

160	266	1315	34.7	9.38	
80	135	667	17.6	4.76	
40	71	349	9.21	2.49	
30	50	246	6.50	1.76	
20	36	176	4.65	1.26	Q <sub>0</sub> =12.0
17	35	158	2.93	0.98	Q <sub>0</sub> =14.6
15	35	150	2.15	0.84	Q <sub>0</sub> =16.7
12	35	142	1.57	0.71	Q <sub>0</sub> =19.3
10	35	137	1.17	0.62	Q <sub>0</sub> =22.0

*R1=2400 ohms*

160	257	1302	35.8	9.38	
80	130	660	18.2	4.76	
40	68	346	9.50	2.49	
30	48	244	6.71	1.76	
20	35	176	4.71	1.26	Q <sub>0</sub> =12.2
17	35	161	2.92	0.98	Q <sub>0</sub> =15.0
15	35	152	2.13	0.84	Q <sub>0</sub> =17.3
12	35	145	1.56	0.71	Q <sub>0</sub> =20.0
10	35	139	1.17	0.62	Q <sub>0</sub> =22.8

*R1=2500 ohms*

160	248	1291	36.9	9.38	
80	126	654	18.7	4.76	
40	66	343	9.79	2.49	
30	46	242	6.91	1.76	
20	35	178	4.70	1.26	Q <sub>0</sub> =12.6
17	35	163	2.91	0.98	Q <sub>0</sub> =15.5
15	35	154	2.13	0.84	Q <sub>0</sub> =17.8
12	35	147	1.55	0.71	Q <sub>0</sub> =20.6
10	35	141	1.16	0.62	Q <sub>0</sub> =23.5

application of these transformers. The input and output transformers are two of the most critical components in a broadband amplifier. Amplifier efficiency, gain flatness, input SWR, and even linearity all are affected by transformer design and application. There are two basic RF transformer types, as described elsewhere in this *Handbook*: the conventional transformer and the transmission-line transformer.

The conventional transformer is wound much the same way as a power transformer. Primary and secondary windings are wound around a high-permeability core, usually made from a ferrite or powdered-iron material. Coupling between the secondary and primary is made as tight as possible to minimize leakage inductance. At low frequencies, the coupling between windings is predominantly magnetic. As the frequency rises, core permeability decreases and leakage inductance increases; transformer losses increase as well.

Typical examples of conventional transformers are shown in **Fig 13.10**. In Fig 13.10A, the primary windings consist of brass or copper tubes inserted into ferrite sleeves. The tubes are shorted together at one end by a piece of copper-clad circuit board material. The secondary winding is threaded through the tubes. Since the low-impedance winding is only a single turn, the transformation ratio is limited to the squares of integers; for example, 1, 4, 9, 16, and so on. The lowest effective transformer frequency is determined by the inductance of the one-turn winding. It should have a reactance, at the lowest frequency of intended operation, at least four times greater than the impedance it is connected to.

The coupling coefficient between the two windings is a function of the primary tube diameter and its length, and the diameters and insulation thickness of the wire used in the high-impedance winding. High impedance ratios, greater than 36:1, should use large-diameter secondary windings. Miniature coaxial cable (using only the braid as the conductor) works well. Another use for coaxial cable braid is illustrated in Fig 13.10B. Instead of using tubing for the primary winding, the secondary winding is threaded through copper braid. Performance of the two units is almost identical.

The cores used must be large enough so the core material will not saturate at the power level applied to the transformer. Core saturation can cause permanent changes to the core permeability, as well as overheating. Transformer nonlinearity also develops at core saturation. Harmonics and other distortion products are produced, clearly an undesirable situation. Multiple cores can be used to increase the power capabilities of the transformer.

Transmission-line transformers are similar to conventional transformers, but can be used over wider frequency ranges. In a conventional transformer, high-frequency performance deterioration is caused primarily by leakage inductance, which rises with frequency. In a transmission-line transformer, the windings are arranged so there is tight capacitive coupling between the two. A high coupling coefficient is maintained up to considerably higher frequencies than with conventional transformers.

## Output Filtering

Amplifier output filtering is sometimes necessary to meet spurious signal requirements. Broadband amplifiers, by definition, provide little if any inherent suppression of harmonic energy. Even amplifiers using output tank circuits often require further

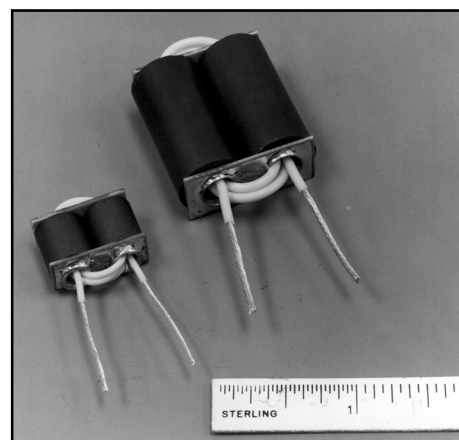

(A)

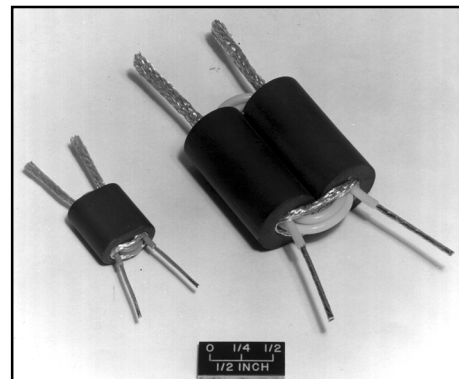

(B)

**Fig 13.10—The two methods of constructing the transformers outlined in the text. At A, the one-turn loop is made from brass tubing; at B, a piece of coaxial cable braid is used for the loop.**

attenuation of undesired harmonics. High-level signals from one transmitter, particularly at multiple transmitter sites, can be intercepted by an antenna connected to another transmitter, conducted down the feed line and mixed in a power amplifier, causing spurious outputs. For example, an HF transceiver signal radiated from a triband beam may be picked up by a VHF FM antenna on the same mast. The signal saturates the low-power FM transceiver output stage, even with power off, and is reradiated by the VHF antenna. Proper use of filters can reduce such spurious energy considerably.

The filter used will depend on the application and the level of attenuation needed. Band-pass filters attenuate spurious signals above and below the passband for which they are designed. Low-pass filters attenuate only signals above the cutoff frequency, while high-pass filters reduce energy below the design cutoff frequency.

The **Filters** chapter includes detailed information about designing suitable filters. Tables of component values in the **References** chapter allow you to select a particular design and scale the values for different frequencies and impedance ranges as needed.

## TRANSMITTING DEVICE RATINGS

### Plate Dissipation

The ultimate factor limiting the power-handling capability of a tube often (but not always) is its maximum plate dissipation rating. This is the measure of how many watts of heat the tube can safely dissipate, if it is cooled properly, without exceeding critical temperatures. Excessive temperature can damage or destroy internal tube components or vacuum seals, resulting in tube failure. The same tube may have different voltage, current and power ratings depending on the conditions under which it is operated, but its safe temperature ratings must not be exceeded in any case! Important cooling considerations are discussed in more detail in the **Amplifier Cooling** section of this chapter.

The efficiency of a power amplifier may range from approximately 25% to 75%, depending on its operating class, adjustment, and circuit losses. The efficiency indicates how much of the dc power supplied to the stage is converted to useful RF output power; the rest is dissipated as heat, mostly by the plate. By knowing the plate-dissipation limit of the tube and the efficiency expected from the class of operation selected, the maximum power input and output levels can be determined. The maximum safe power output is

$$P_{\text{OUT}} = \frac{P_{\text{D}} N_{\text{P}}}{100 - N_{\text{P}}} \quad (34)$$

where

- $P_{\text{OUT}}$  = the power output in W
- $P_{\text{D}}$  = the plate dissipation in W
- $N_{\text{P}}$  = the efficiency (10% = 10).

The dc input power would simply be

$$P_{\text{IN}} = \frac{100 P_{\text{D}}}{100 - N_{\text{P}}} \quad (35)$$

Almost all vacuum-tube power amplifiers in amateur service today operate as linear amplifiers (Class AB or B) with efficiencies of approximately 50% to 65%. That means that a useful power output of approximately 1 to 2.0 times the plate dissipation generally can be achieved. This requires, of course, that the tube is cooled enough to realize its maximum plate dissipation rating and that no other tube rating, such as maximum plate current or grid dissipation, is exceeded.

Type of modulation and duty cycle also influence how much output power can be achieved for a given tube

dissipation. Some types of operation are less efficient than others, meaning that the tube must dissipate more heat. Some forms of modulation, such as CW or SSB, are intermittent in nature, causing less average heating than modulation formats such as RTTY in which there is continuous transmission. Power-tube manufacturers use two different rating systems to allow for the variations in service. CCS (Continuous Commercial Service) is the more conservative rating and is used for specifying tubes that are in constant use at full power. The second rating system is based on intermittent, low-duty-cycle operation, and is known as ICAS (Intermittent Commercial and Amateur Service). ICAS ratings are normally used by commercial manufacturers and individual amateurs who wish to obtain maximum power output consistent with reasonable tube life in CW and SSB service. CCS ratings should be used for FM, RTTY and SSTV applications. (Plate power transformers for amateur service are also rated in CCS and ICAS terms.)

## Maximum Ratings

Tube manufacturers publish sets of maximum values for the tubes they produce. No maximum rated value should ever be exceeded. As an example, a tube might have a maximum plate-voltage rating of 2500 V, a maximum plate-current rating of 500 mA, and a maximum plate dissipation rating of 350 W. Although the plate voltage and current ratings might seem to imply a safe power input of  $2500 \text{ V} \times 500 \text{ mA} = 1250 \text{ W}$ , this is true only if the dissipation rating will not be exceeded. If the tube is used in class AB2 with an expected efficiency of 60%, the maximum safe dc power input is

$$P_{\text{IN}} = \frac{100 P_{\text{D}}}{100 - \eta_{\text{D}}} = \frac{100 \times 350}{100 - 60} = 875 \text{ W}$$

In this case, any combination of plate voltage and current whose product does not exceed 875 W (and which allows the tube to achieve the expected 60% efficiency) is acceptable. A good compromise might be 2000 V and 437 mA:  $2000 \times 0.437 = 874 \text{ W}$  input. If the maximum plate voltage of 2500 is used, then the plate current should be limited to 350 mA (not 500 mA) to stay within the maximum plate dissipation rating of 350 W.

## TRANSISTOR POWER DISSIPATION

RF power-amplifier transistors are limited in power-handling capability by the amount of heat the device can safely dissipate. Power dissipation for a transistor is abbreviated  $P_{\text{D}}$ . The maximum rating is based on maintaining a case temperature of  $25^{\circ}\text{C}$  ( $77^{\circ}\text{F}$ ), which is seldom possible if a conventional air-cooled heat sink is used in an ambient air temperature of  $70^{\circ}\text{F}$  or higher. For higher temperatures, the device must be derated (in terms of milliwatts or watts per degree C) as specified by the manufacturer for that particular device. The efficiency considerations described earlier in reference to plate dissipation apply here also. A rule of thumb for selecting a transistor suitable for a given RF power output level is to choose one that has a maximum dissipation (with the heat sink actually to be used) of twice the desired output power.

## MAXIMUM TRANSISTOR RATINGS

Transistor data sheets specify the maximum operating voltage for several conditions. Of particular interest is the  $V_{\text{CEO}}$  specification (collector to emitter voltage, with the base open). In RF amplifier service the collector to emitter voltage can rise to twice the dc supply potential. Thus, if a 12-V supply is used, the transistor should have a  $V_{\text{CEO}}$  of 24 V or greater to preclude damage.

The maximum collector current is also specified by the manufacturer. This specification is actually limited by the current-carrying capabilities of the internal bonding wires. Of course, the collector current must stay below the level that generates heat higher than the allowable device power dissipation. Many transistors are also rated for the load mismatch they can safely withstand. A typical specification might be for a transistor to tolerate a 30:1 SWR at all phase angles.

Transistor manufacturers publish data sheets that describe all the appropriate device ratings. Typical operating results are also given in these data sheets. In addition, many manufacturers publish application notes illustrating the use of their devices in practical circuits. Construction details are usually given. Perhaps owing to the popularity of Amateur Radio among electrical engineers, many of the notes describe applications especially suited to the Amateur Service. Specifications for some of the more popular RF power transistors are found in the [Component Data](#) chapter.

## PASSIVE COMPONENT RATINGS

### Output Tank Capacitor Ratings

The tank capacitor in a high-power amplifier should be chosen with sufficient spacing between plates to preclude high-voltage breakdown. The peak RF voltage present across a properly loaded tank circuit, without modulation, may be taken conservatively as being equal to the dc plate or collector voltage. If the dc supply voltage also appears across the tank capacitor, this must be added to the peak RF voltage, making the total peak voltage twice the dc supply voltage. At the higher voltages, it is usually desirable to design the tank circuit so that the dc supply voltages do not appear across the tank capacitor, thereby allowing the use of a smaller capacitor with less plate spacing. Capacitor manufacturers usually rate their products in terms of the peak voltage between plates. Typical plate spacings are given in **Table 13.3**.

Output tank capacitors should be mounted as close to the tube as temperature considerations will permit, to make possible the shortest path with the lowest possible inductive reactance from plate to cathode. Especially at the higher frequencies, where minimum circuit capacitance becomes important, the capacitor should be mounted with its stator plates well spaced from the chassis or other shielding. In circuits in which the rotor must be insulated from ground, the capacitor should be mounted on ceramic insulators of a size commensurate with the plate voltage involved and—most important of all, from the viewpoint of safety to the operator—a well-insulated coupling should be used between the capacitor shaft and the knob. The section of the shaft attached to the control knob should be well grounded. This can be done conveniently by means of a metal shaft bushing at the panel.

### Tank Coils

Tank coils should be mounted at least half their diameter away from shielding or other large metal surfaces, such as blower housings, to prevent a marked loss in Q. Except perhaps at 24 and 28 MHz, it is not essential that the coil be mounted extremely close to the tank capacitor. Leads up to 6 or 8 inches are permissible. It is more important to keep the tank capacitor, as well as other components, out of the immediate field of the coil.

The principal practical considerations in designing a tank coil usually are to select a conductor size and coil shape that will fit into available space and handle the required power without excessive heating. Excessive power loss as such is not necessarily the worst hazard in using too-small a conductor: it is not uncommon for the heat generated to actually unsolder joints in the tank circuit and lead to physical damage or failure. For this reason it's extremely important, especially at power levels above a few hundred watts, to ensure that all electrical joints in the tank circuit are secured me-

---

**Table 13.3**  
**Typical Tank-Capacitor Plate Spacings**

<i>Spacing Inches</i>	<i>Peak Voltage</i>	<i>Spacing Inches</i>	<i>Peak Voltage</i>	<i>Spacing Inches</i>	<i>Peak Voltage</i>
0.015	1000	0.07	3000	0.175	7000
0.02	1200	0.08	3500	0.25	9000
0.03	1500	0.125	4500	0.35	11000
0.05	2000	0.15	6000	0.5	13000

---

mechanically as well as soldered. **Table 13.4** shows recommended conductor sizes for amplifier tank coils, assuming loaded tank circuit  $Q_s$  of 15 or less on the 24 and 30 MHz bands and 8 to 12 on the lower frequency bands.

In the case of input circuits for screen-grid tubes where driving power is quite small, loss is relatively unimportant and almost any physically convenient wire size and coil shape is adequate.

The conductor sizes in Table 13.4 are based on experience in continuous-duty amateur CW, SSB, and RTTY service and assume that the coils are located in a reasonably well ventilated enclosure. If the tank area is not well ventilated and/or if significant tube heat is transferred to the coils, it is good practice to increase AWG wire sizes by two (for example, change from AWG 12 to AWG 10) and tubing sizes by  $1/16$  inch.

Larger conductors than required for current handling are often used to maximize unloaded  $Q$ , particularly at higher frequencies. Where skin depth effects increase losses, the greater surface area of large diameter conductors can be beneficial. Small-diameter copper tubing, up to  $3/8$  inch outer diameter, can be used successfully for tank coils up through the lower VHF range. Copper tubing in sizes suitable for constructing high-power coils is generally available in 50 ft rolls from plumbing and refrigeration equipment suppliers. Silver plating the tubing further reduces losses. This is especially true as the tubing ages and oxidizes. Silver oxide is a much better conductor than copper oxides, so silver-plated tank coils maintain their low-loss characteristics even after years of use.

At VHF and above, tank circuit inductances do not necessarily resemble the familiar coil. The inductances required to resonate tank circuits of reasonable  $Q$  at these higher frequencies are small enough that only strip lines or sections of transmission line are practical. Since these are constructed from sheet metal or large-diameter tubing, current-handling capabilities normally are not a relevant factor.

## RF Chokes

The characteristics of any RF choke vary with frequency. At low frequencies the choke presents a nearly pure inductance. At some higher frequency it takes on high impedance characteristics resembling those of a parallel-resonant circuit. At a still higher frequency it goes through a series-resonant condition, where the impedance is lowest—generally much too low to perform satisfactorily as a shunt-feed plate choke. As frequency increases further, the pattern of alternating parallel and series resonances repeats. Between resonances, the choke will show widely varying amounts of inductive or capacitive reactance.

In series-feed circuits, these characteristics are of relatively small importance because the RF voltage across the choke is negligible. In a shunt-feed circuit such as is used in most high-power amplifiers, however, the choke is directly in parallel with the tank circuit, and is subject to the full tank RF voltage. If the choke does not present a sufficiently high impedance, enough power will be absorbed by the choke to burn it out. To avoid this, the choke must have a sufficiently high reactance to be effective at the lowest frequency (*at least* equal to the plate load resistance), and yet have no series resonances near any of the higher frequency bands. A resonant-choke failure in a high-power amplifier can be very dramatic and damaging!

Thus any choke intended for shunt-feed use should be carefully investigated with a dip meter. The choke must be shorted end-to-end with a direct, heavy braid or strap. Because nearby metallic objects affect the resonances, it should be mounted in its intended position, but disconnected from the rest of

**Table 13.4**  
**Copper Conductor Sizes for Transmitting Coils for Tube Transmitters**

<i>Power Output (Watts)</i>	<i>Band (MHz)</i>	<i>Minimum Conductor Size</i>
1500	1.8-3.5	10
	7-14	8 or $1/8$ "
	18-28	6 or $3/16$ "
500	1.8-3.5	12
	7-14	10
	18-28	8 or $1/8$ "
150	1.8-3.5	16
	7-14	12
	18-28	10

\*Whole numbers are AWG; fractions of inches are tubing ODs.

the circuit. A dip meter coupled an inch or two away from one end of the choke nearly always will show a deep, sharp dip at the lowest series-resonant frequency and shallower dips at higher series resonances.

Any choke to be used in an amplifier for the 1.8 to 28 MHz bands requires careful (or at least lucky!) design to perform well on *all* amateur bands within that range. Most simply put, the challenge is to achieve sufficient inductance that the choke doesn't "cancel" a large part of tuning capacitance on 1.8 MHz. At the same time, try to position all its series resonances where they can do no harm. In general, close wind enough #20 to #24 magnet wire to provide about 135  $\mu\text{H}$  inductance on a  $3/4$  to 1-inch diameter cylindrical form of ceramic, Teflon, or fiberglass. This gives a reactance of 1500  $\Omega$  at 1.8 MHz and yet yields a first series resonance in the vicinity of 25 MHz. Before the advent of the 24.9 MHz band this worked fine. But trying to "squeeze" the resonance into the narrow gaps between the 21, 24, and/or 28 MHz bands is quite risky unless sophisticated instrumentation is available. If the number of turns on the choke is selected to place its first series resonance at 23.2 MHz, midway between 21.45 and 24.89 MHz, the choke impedance will typically be high enough for satisfactory operation on the 21, 24 and 28 MHz bands. The choke's first series resonance should be measured very carefully as described above using a dip meter and calibrated receiver or RF impedance bridge, with the choke mounted in place on the chassis.

Investigations with a vector impedance meter have shown that "trick" designs, such as using several shorter windings spaced along the form, show little if any improvement in choke resonance characteristics. Some commercial amplifiers circumvent the problem by bandswitching the RF choke. Using a larger diameter (1 to 1.5 inch) form does move the first series resonance somewhat higher for a given value of basic inductance. Beyond that, it is probably easiest for an all-band amplifier to add or subtract enough turns to move the first resonance to about 35 MHz and settle for a little less than optimum reactance on 1.8 MHz.

## Blocking Capacitors

A series capacitor is usually used at the input of the amplifier output circuit. Its purpose is to block dc from appearing on matching circuit components or the antenna. As mentioned in the section on tank capacitors, output-circuit voltage requirements are considerably reduced when only RF voltage is present.

To provide a margin of safety, the voltage rating for a blocking capacitor should be at least 25 to 50% greater than the dc voltage applied. A large safety margin is desirable, since blocking capacitor failure can bring catastrophic results.

To avoid affecting the amplifier's tuning and matching characteristics, the blocking capacitor should have a low impedance at all operating frequencies. Its reactance at the lowest operating frequency should be not more than about 5% of the plate load resistance.

The capacitor also must be capable of handling, without overheating or significantly changing value, the substantial RF current that flows through it. This current usually is greatest at the highest frequency of operation where tube output capacitance constitutes a significant part of the total tank capacitance. A significant portion of circulating tank current therefore flows through the blocking capacitor. As a conservative and very rough rule of thumb, the maximum RF current in the blocking capacitor (at 28 MHz) is

$$I_{\text{CBlock}} \approx I_p + 0.15 \times C_{\text{OUT}} \times V_{\text{dc}} \quad (36)$$

where

$I_{\text{CBlock}}$  = maximum RMS current through blocking capacitor, in A

$C_{\text{OUT}}$  = output capacitance of the output tubes, in pF

$V_{\text{dc}}$  = dc plate voltage, in kV

$I_p$  = dc plate current at full output, in A.

Transmitting capacitors are rated by their manufacturers in terms of their RF current-carrying capacity at various frequencies. Below a couple hundred watts at the high frequencies, ordinary disc ceramic capacitors of suitable voltage rating work well in high-impedance tube amplifier output circuits. Some larger disk capacitors rated at 5 to 8 kV also work well for higher power levels at HF; for example, two inexpensive Centralab type DD-602 discs (0.002  $\mu\text{F}$ , 6 kV) in parallel have proved to be a reliable blocking capacitor for 1.5-kW amplifiers operating at plate voltages to about 2.5 kV. At very high power and voltage levels and at VHF, ceramic “doorknob” transmitting capacitors are needed for their low losses and high current handling capabilities. So-called “TV doorknobs” may break down at high RF current levels and should be avoided.

The very high values of  $Q_L$  found in many VHF and UHF tube-type amplifier tank circuits often require custom fabrication of the blocking capacitor. This can usually be accommodated through the use of a Teflon “sandwich” capacitor. Here, the blocking capacitor is formed from two parallel plates separated by a thin layer of Teflon. This capacitor often is part of the tank circuit itself, forming a very low-loss blocking capacitor. Teflon is rated for a minimum breakdown voltage of 2000 V per mil of thickness, so voltage breakdown should not be a factor in any practically realized circuit. The capacitance formed from such a Teflon sandwich can be calculated from the information presented elsewhere in this *Handbook* (use a dielectric constant of 2.1 for Teflon). In order to prevent any potential irregularities caused by dielectric thickness variations (including air gaps), Dow-Corning DC-4 silicone grease should be evenly applied to both sides of the Teflon dielectric. This grease has properties similar to Teflon, and will fill in any surface irregularities that might cause problems.

The very low impedances found in transistorized amplifiers present special problems. In order to achieve the desired low blocking-capacitor impedance, large-value capacitors are required. Special ceramic chips and mica capacitors are available that meet the requirements for high capacitance, large current carrying capability and low associated inductance. These capacitors are more costly than standard disk-ceramic or silver-mica units, but their level of performance easily justifies their price. Most of these special-purpose capacitors are either leadless or come with wide straps instead of normal wire leads. Disc-ceramic and other wire-lead capacitors are generally not suitable for transistor power-amplifier service.

## **SOURCES OF OPERATING VOLTAGES**

### **Tube Filament or Heater Voltage**

The heater voltage for the indirectly heated cathode-tubes found in low-power classifications may vary 10% above or below rating without seriously reducing the life of the tube. A power vacuum tube can use either a directly heated filament or an indirectly heated cathode. The filament voltage for either type should be held within 5% of rated voltage. Because of internal tube heating at UHF and higher, the manufacturers’ filament voltage rating often is reduced at these higher frequencies. The derated filament voltages should be followed carefully to maximize tube life. Series dropping resistors may be required in the filament circuit to attain the correct voltage. The voltage should be measured at the filament pins of the tube socket while the amplifier is running. The filament choke and interconnecting wiring all have voltage drops associated with them. The high current drawn by a power-tube heater circuit causes substantial voltage drops to occur across even small resistances. Also, make sure that the plate power drawn from the power line does not cause the filament voltage to drop below the proper value when plate power is applied.

Thoriated filaments lose emission when the tube is overloaded appreciably. If the overload has not been too prolonged, emission sometimes may be restored by operating the filament at rated voltage, with all other voltages removed, for a period of 30 to 60 minutes. Alternatively, you might try operating the tube at 20% above rated filament voltage for five to ten minutes.



## Vacuum-Tube Plate Voltage

DC plate voltage for the operation of RF amplifiers is most often obtained from a transformer-rectifier-filter system (see the **Power Supplies** chapter) designed to deliver the required plate voltage at the required current. It is not unusual for a power tube to arc over internally (generally from the plate to the screen or control grid) once or twice, especially soon after it is first placed into service. The flashover by itself is not normally dangerous to the tube, provided that instantaneous maximum plate current to the tube is held to a safe value and the high-voltage plate supply is shut off very quickly.

A good protective measure against this is the inclusion of a high-wattage power resistor in series with the plate high-voltage circuit. The value of the resistor, in ohms, should be approximately 10 to 15 times the no-load plate voltage in kV. This will limit peak fault current to 67 to 100 A. The series resistor should be rated for 25 or 50 W power dissipation; vitreous enamel coated wire-wound resistors of the common Ohmite or Clarostat types have been found to be capable of handling repeated momentary fault-current surges without damage. Aluminum-cased resistors such as some made by Dale are not recommended for this application. Each resistor also must be large enough to safely handle the maximum value of normal plate current; the wattage rating required may be calculated from  $P = I^2R$ . If the total filter capacitance exceeds 25  $\mu\text{F}$ , it is a good idea to use 50-W resistors in any case. Even at high plate-current levels, the addition of the resistors does little to affect the dynamic regulation of the plate supply.

Since tube (or other high-voltage circuit) arcs are not necessarily self-extinguishing, a fast-acting plate overcurrent relay or primary circuit breaker also is recommended to quickly shut off ac power to the HV supply when an arc begins. Using this protective system, a mild HV flashover may go undetected, while a more severe one will remove ac power from the HV supply. (The cooling blower should remain energized, however, since the tube may be hot when the HV is removed due to an arc.) If effective protection is not provided, however, a “normal” flashover, even in a new tube, is likely to damage or destroy the tube, and also frequently destroys the rectifiers in the power supply as well as the plate RF choke. A power tube that flashes over more than about 3 to 5 times in a period of several months likely is defective and will have to be replaced before long.

## Grid Bias

The grid bias for a linear amplifier should be highly filtered and well regulated. Any ripple or other voltage change in the bias circuit modulates the amplifier. This causes hum and/or distortion to appear on the signal. Since most linear amplifiers draw only small amounts of grid current, these bias-supply requirements are not difficult to achieve.

Fixed bias for class AB1 tetrode and pentode amplifiers is usually obtained from a variable-voltage regulated supply. Voltage adjustment allows setting bias level to give the desired resting plate current. **Fig 13.11A** shows a simple Zener-diode-regulated bias supply.

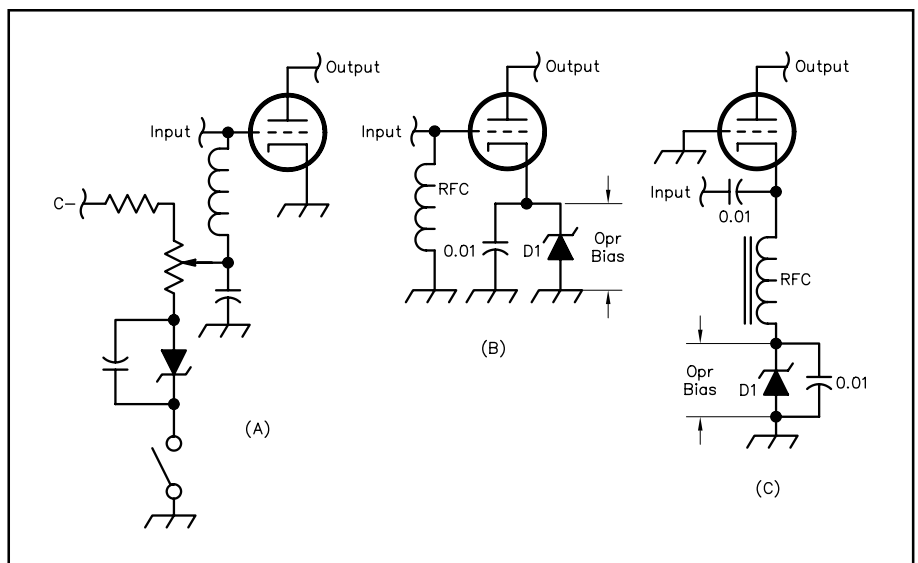

**Fig 13.11**—Various techniques for providing operating bias with tube amplifiers.

The dropping resistor is chosen to allow approximately 10 mA of Zener current. Bias is then reasonably well regulated for all drive conditions up to 2 or 3 mA of grid current. The potentiometer allows bias to be adjusted between Zener and approximately 10 V higher. This range is usually adequate to allow for variations in the characteristics of different tubes. Under standby conditions, when it is desirable to cut off the tube entirely, the Zener ground return is interrupted so the full bias supply voltage is applied to the grid.

In Fig 13.11B and C, bias is obtained from the voltage drop across a Zener diode in the cathode (or filament center-tap) lead. Operating bias is obtained by the voltage drop across D1 as a result of plate (and screen) current flow. The diode voltage drop effectively raises the cathode potential relative to the grid. The grid is therefore negative with respect to the cathode by the Zener voltage of the diode. The Zener-diode wattage rating should be twice the product of the maximum cathode current times the rated zener voltage. Therefore, a tube requiring 15 V of bias with a maximum cathode current of 100 mA would dissipate 1.5 W in the Zener diode. To allow a suitable safety factor, the diode rating should be 3 W or more. The circuit of Fig 13.11C illustrates how D1 would be used with a cathode driven (grounded grid) amplifier as opposed to the grid driven example at B.

In all cases, the Zener diode should be bypassed by a 0.01- $\mu$ F capacitor of suitable voltage. Current flow through any type of diode generates shot noise. If not bypassed, this noise would modulate the amplified signal, causing distortion in the amplifier output.

### Screen Voltage For Tubes

Power tetrode screen current varies widely with both excitation and loading. The current may be either positive or negative, depending on tube characteristics and amplifier operating conditions. In a linear amplifier, the screen voltage should be well regulated for all values of screen current. The power output from a tetrode is very sensitive to screen voltage, and any dynamic change in the screen potential can cause distorted output. Zener diodes are commonly used for screen regulation.

Fig 13.12 shows a typical example of a regulated screen supply for a power tetrode amplifier. The voltage from a fixed dc supply is dropped to the Zener stack voltage by the current-limiting resistor. A screen bleeder resistor is connected in parallel with the zener stack to allow for the negative screen current developed under certain tube operating conditions. Bleeder current is chosen to be roughly 10 to 20 mA greater than the expected maximum negative screen current, so that screen voltage is regulated for all values of current between maximum negative screen current and maximum positive screen current. For external-anode tubes in the 4CX250 family, a typical screen bleeder current value would be 20 mA. For the 4CX1000 family, a screen-bleeder current of 70 mA is required.

Screen voltage should never be applied to a tetrode unless plate voltage and load also are applied; otherwise the screen tends to act like an anode and will draw excessive current. Supplying the screen through a series dropping resistor from the plate supply affords a measure of protection, since the screen voltage only appears when there is plate voltage. Alternatively, a fuse can be placed between the regulator and the bleeder resistor. The fuse should not be installed between the bleeder resistor and the tube, because the tube should never be operated without a load on the screen. Without a load, the screen potential tends to rise to the anode voltage. Any screen bypass capacitors or other associated circuits are likely be damaged by this high voltage.

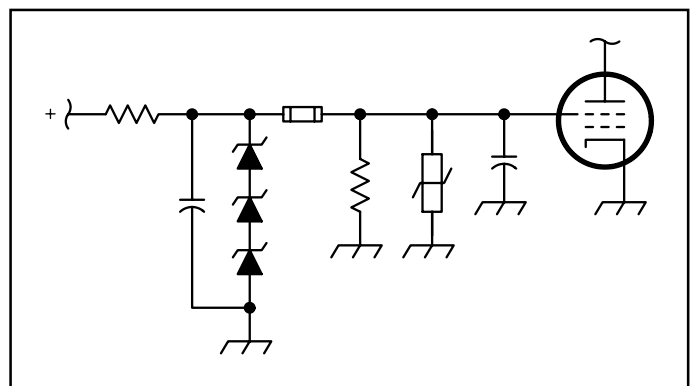

Fig 13.12—A Zener-regulated screen supply for use with a tetrode. Protection is provided by a fuse and a varistor.

In Fig 13.12, a varistor is connected from screen to ground. If, because of some circuit failure, the screen voltage should rise substantially above its nominal level, the varistor will conduct and clamp the screen voltage to a low level. If necessary to protect the varistor or screen dropping resistors, a fuse or overcurrent relay may be used to shut off the screen supply so that power is interrupted before any damage occurs. The varistor voltage should be approximately 30 to 50% higher than normal screen voltage.

## Transistor Biasing

Solid-state power amplifiers generally operate in Class C or AB. When some bias is desired during Class C operation (Fig 13.13A), a resistance of the appropriate value can be placed in the emitter return as shown. Most transistors will operate in Class C without adding bias externally, but in some instances the amplifier efficiency can be improved by means of emitter bias. Reverse bias supplied to the base of the Class C transistor should be avoided because it will lead to internal breakdown of the device during peak drive periods. The damage is frequently a cumulative phenomenon, leading to gradual destruction of the transistor junction.

A simple method for Class AB biasing is shown in Fig 13.13B. D1 is a silicon diode that acts as a bias clamp at approximately 0.7 V. This forward bias establishes linear-amplification conditions. That value of bias is not always optimum for a specified transistor in terms of IMD. Variable bias of the type illustrated in Fig 13.13C permits the designer sufficient flexibility to position the operating point for best linearity. The diode clamp or the reference sensor for another type of regulator is usually thermally bonded to the power transistor or its heat sink. The bias level then tracks the thermal characteristics of the output transistor. Since a transistor's current transfer characteristics are a function of temperature, thermal tracking of the bias is necessary to maintain device linearity and, in the case of bipolar devices, to prevent thermal runaway and the subsequent destruction of the transistor.

## AMPLIFIER COOLING

### Tube Cooling

Vacuum tubes must be operated within the temperature range specified by the manufacturer if long tube life is to be achieved. Tubes having glass envelopes and rated at up to 25-W plate dissipation may be used without forced-air cooling if the design allows a reasonable amount of convection cooling. If a perforated metal enclosure is used, and a ring of  $\frac{1}{4}$  to  $\frac{3}{8}$ -inch-diameter holes is placed around the tube socket, normal convective air flow can be relied on to remove excess heat at room temperatures.

For tubes with greater plate dissipation ratings, and even for very small tubes operated

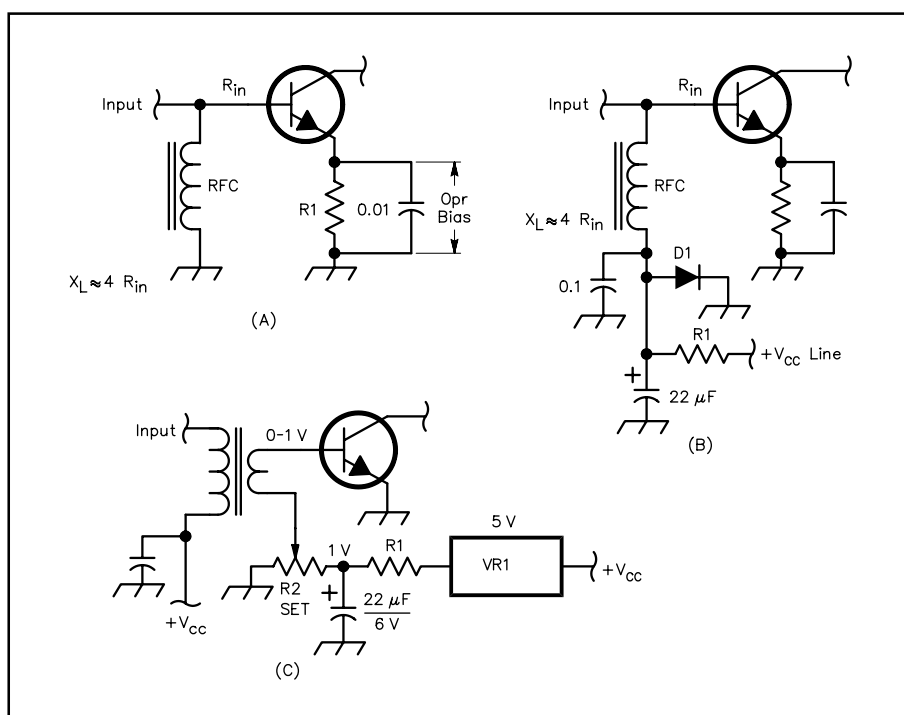

Fig 13.13—Biasing methods for use with transistor amplifiers.

close to maximum rated dissipation, forced-air cooling with a fan or blower is needed. Most manufacturers rate tube cooling requirements for continuous-duty operation. Their literature will indicate the required volume of air flow, in cubic feet per minute (CFM), at some particular back pressure. Often this data is given for several different values of plate dissipation, ambient air temperature and even altitude above sea level.

One extremely important consideration is often overlooked by power-amplifier designers and users alike: a tube's plate dissipation rating is only its maximum *potential* capability. The power that it can *actually* dissipate safely depends directly on the cooling provided. The actual power capability of virtually all tubes used in high-power amplifiers for amateur service depends on the volume of air forced through the tube's cooling structure.

This requirement usually is given in terms of cubic feet of air per minute, (CFM), delivered into a "back pressure" representing the resistance of the tube cooler to air flow, stated in inches of water. Both the CFM of air flow required and the pressure needed to force it through the cooling system are determined by ambient air temperature and altitude (air density), as well as by the amount of heat to be dissipated. The cooling fan or blower must be capable of delivering the specified air flow into the corresponding back pressure. As a result of basic air flow and heat transfer principles, the volume of air flow required through the tube cooler increases considerably faster than the plate dissipation, and back pressure increases even faster than air flow. In addition, blower air output decreases with increasing back pressure until, at the blower's so-called "cutoff pressure," actual air delivery is zero. Larger and/or faster-rotating blowers are required to deliver larger volumes of air at higher back pressure.

Values of CFM and back pressure required to realize maximum rated plate dissipation for some of the more popular tubes, sockets and chimneys (with 25°C ambient air and at sea level) are given in **Table 13.5**. Back pressure is specified in inches of water and can be measured easily in an operational air system as indicated in **Figs 13.14** and **13.15**. The pressure differential between the air passage and

**Table 13.5**  
**Specifications of Some Popular Tubes, Sockets and Chimneys**

<i>Tube</i>	<i>CFM</i>	<i>Back Pressure (inches)</i>	<i>Socket</i>	<i>Chimney</i>
3-500Z	13	0.13	SK-400, SK-410	SK-416
3CX800A7	19	0.50	SK-1900	SK-1906
3CX1200A7	31	0.45	SK-410	SK-436
3CX1200Z7	42	0.30	SK-410	—
3CX1500/8877	35	0.41	SK-2200, SK-2210	SK-2216
4-400A/8438	14	0.25	SK-400, SK-410	SK-406
4-1000A/8166	20	0.60	SK-500, SK-510	SK-506
4CX250R/7850	6.4	0.59	SK-600, SK-600A, SK602A, SK-610, SK-610A SK-611, SK-612, SK-620, SK-620A, SK-621, SK-630	SK-626
4CX400/8874	8.6	0.37	SK1900	SK606
4CX400A	8	0.20	SK2A	—
4CX800A	20	0.50	SK1A	—
4CX1000A/8168	25	0.20	SK-800B, SK-810B, SK-890B	SK-806
4CX1500B/8660	34	0.60	SK-800B, SK-1900	SK-806
4CX1600B	36	0.40	SK3A	CH-1600B

These values are for sea-level elevation. For locations well above sea level (5000 ft/1500 m, for example), add an additional 20% to the figure listed.

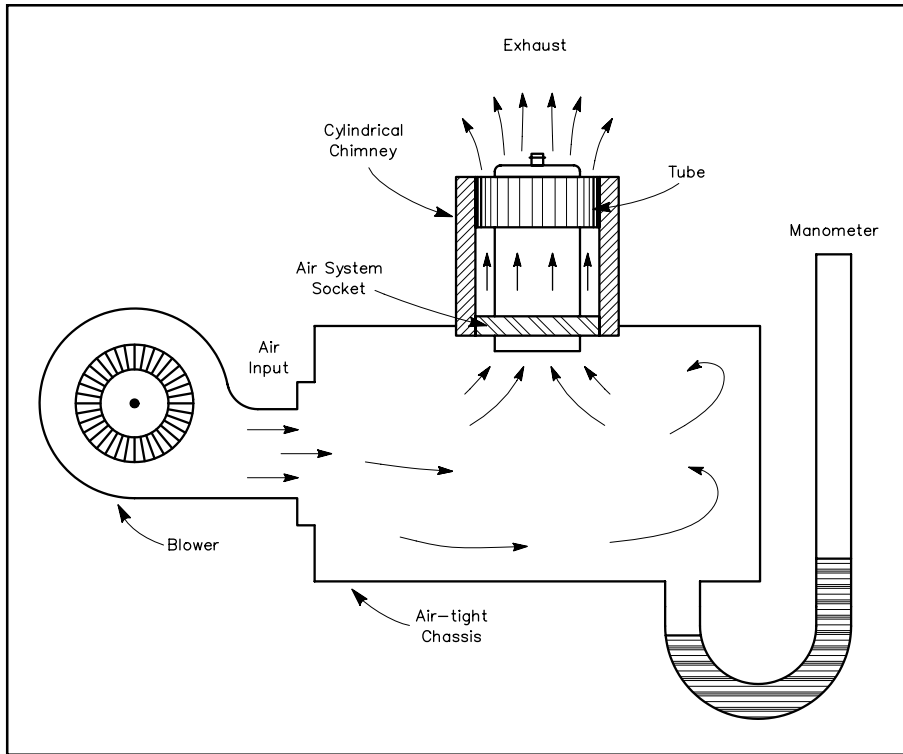

**Fig 13.14—Air is forced into the chassis by the blower and exits through the tube socket. The manometer is used to measure system back pressure, which is an important factor in determining the proper size blower.**

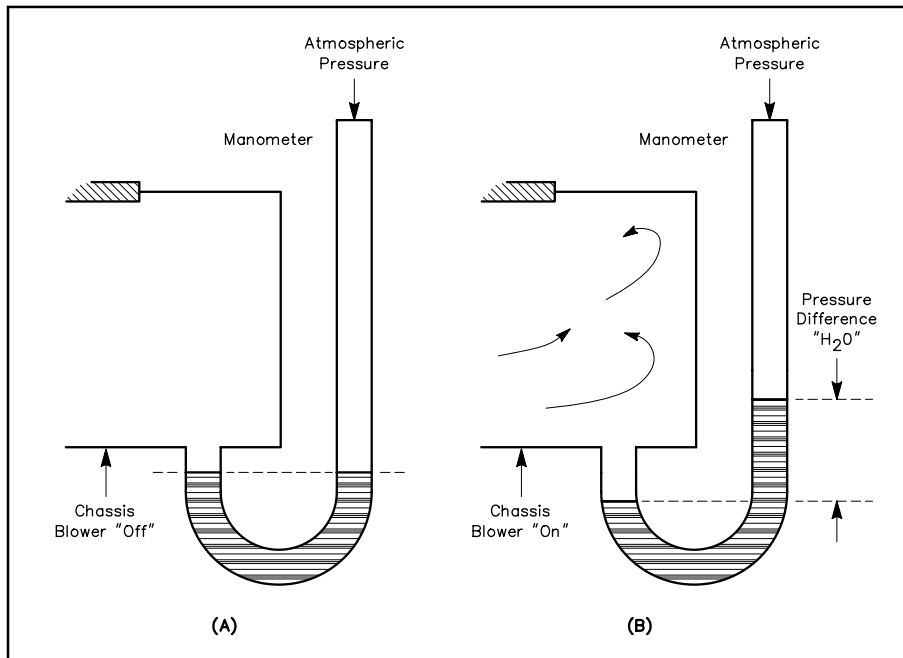

**Fig 13.15—At A the blower is “off” and the water will seek its own level in the manometer. At B the blower is “on” and the amount of back pressure in terms of inches of water can be measured as indicated.**

atmospheric pressure is measured with a device called a manometer. A manometer is nothing more than a piece of clear tubing, open at both ends and fashioned in the shape of a “U.” The manometer is temporarily connected to the chassis and is removed after the measurements are completed. As shown in the diagrams, a small amount of water is placed in the tube. At Fig 13.15A the blower is “off” and the water seeks its own level, because the air pressure (ordinary atmospheric pressure) is the same at both ends of the manometer tube. At B, the blower is “on” (socket, tube and chimney in place) and the pressure difference, in terms of inches of water, is measured. For most applications a standard ruler used for measurement will yield sufficiently accurate results.

**Table 13.6** gives the performance specifications for a few of the many Dayton blowers which are available through Grainger catalog outlets in all 50 states. Other blowers having wheel diameters, widths and rotational speeds similar to any in Table 13.6 likely will have similar flow and back-pressure characteristics. If in doubt about specifications, consult the manufacturer. Tube temperature under actual operating conditions is the ultimate criterion for cooling adequacy and may be determined using special crayons or lacquers which melt and change appearance at specific temperatures. The setup of Fig 13.15, however, nearly always gives sufficiently accurate information.

As an example, consider the cooling design of a linear amplifier to use one 3CX800A7 tube, to operate near sea level with the air temperature not above 25°C. The tube, running 1150-W dc input, easily delivers 750-W continuous output, resulting in 400 W plate dissipation ( $P_{DIS} = P_{IN} - P_{OUT}$ ). According to the manufacturer’s data, adequate tube cooling at 400 W  $P_D$  requires at least 6 CFM of air at 0.09 inches of water back pressure. Referring to Table 13.6, a Dayton no. 2C782 will do the job with a good margin of safety.

If the same single tube were to be operated at 2.3 kW dc input to deliver 1.5 kW output (substantially exceeding its maximum electrical ratings!),  $P_{IN}$  would be about 2300 W and  $P_D \approx 800$  W. The minimum cooling air required would be about 19 CFM at 0.5 inches of water pressure—doubling  $P_{DIS}$ , more than tripling the CFM of air flow required and increasing back pressure requirements on the blower by a factor of 5.5!

However, two 3CX800A7 tubes are needed to deliver 1.5 kW of continuous maximum legal output power in any case. Each tube will operate under the same conditions as in the single-tube example above, dissipating 400-W. The total cooling air requirement for the two tubes is therefore 12 CFM at about 0.09 inches of water, only two-thirds as much air volume and one-fifth the back pressure required by a single tube. While this may seem surprising, the reason lies in the previously mentioned fact that both the airflow required by a tube and the resultant back pressure increase much more rapidly than  $P_D$  of the tube. Blower air delivery capability, conversely, decreases as back pressure is increased. Thus a Dayton 2C782 blower can cool two 3CX800A7 tubes dissipating 800 W total, but a much larger (and probably noisier) no. 4C440 would be required to handle the same power with a single tube.

**Table 13.6**  
**Blower Performance Specifications**

<i>Wheel Dia</i>	<i>Wheel Width</i>	<i>RPM</i>	<i>Free Air CFM</i>	<i>CFM for Back Pressure (inches)</i>					<i>Cutoff</i>	<i>Stock No.</i>
				<i>0.1</i>	<i>0.2</i>	<i>0.3</i>	<i>0.4</i>	<i>0.5</i>		
2"	1"	3160	15	13	4	—	—	—	0.22	2C782
3"	1 <sup>15</sup> / <sub>32</sub> "	3340	54	48	43	36	25	17	0.67	4C012
3"	1 <sup>7</sup> / <sub>8</sub> "	3030	60	57	54	49	39	23	0.60	4C440
3"	1 <sup>7</sup> / <sub>8</sub> "	2880	76	70	63	56	45	8	0.55	4C004
3 <sup>13</sup> / <sub>16</sub> "	1 <sup>7</sup> / <sub>8</sub> "	2870	100	98	95	90	85	80	0.80	4C443
3 <sup>13</sup> / <sub>16</sub> "	2 <sup>1</sup> / <sub>2</sub> "	3160	148	141	135	129	121	114	1.04	4C005

In summary, three very important considerations to remember are these:

- A tube's actual safe plate dissipation capability is *totally dependent* on the amount of cooling air forced through its cooling system. Any air-cooled power tube's maximum plate dissipation rating is meaningless unless the specified amount of cooling air is supplied.
- Two tubes will always safely dissipate a given power with a significantly smaller (and quieter) blower than is required to dissipate the same power with a single tube of the same type. A corollary is that a given blower can virtually always dissipate more power when cooling two tubes than when cooling a single tube of the same type.
- Blowers vary greatly in their ability to deliver air against back pressure so blower selection should not be taken lightly.

A common method for directing the flow of air around a tube involves the use of a pressurized chassis. This system is shown in Fig 13.14. A blower attached to the chassis forces air around the tube base, often through holes in its socket. A chimney is used to guide air leaving the base area around the tube envelope or anode cooler, preventing it from dispersing and concentrating the flow for maximum cooling.

A less conventional approach that offers a significant advantage in certain situations is shown in Fig 13.16. Here the anode compartment is pressurized by the blower. A special chimney is installed between the anode heat exchanger and an exhaust hole in the compartment cover. When the blower pressurizes the anode compartment, there are two parallel paths for air flow: through the anode and its chimney, and through the air system socket. Dissipation, and hence cooling air required, generally is much greater for the anode than for the tube base. Because high-volume anode airflow need not be forced through restrictive air channels in the base area, back pressure may be very significantly reduced with certain tubes and sockets. Only airflow actually needed is bled through the base area. Blower back pressure requirements may sometimes be reduced by nearly half through this approach.

Table 13.5 also contains the part numbers for air-system sockets and chimneys available for use with the tubes that are listed. The builder should investigate which of the sockets listed for the 4CX250R, 4CX300A, 4CX1000A and 4CX1500A best fit the circuit needs. Some of the sockets have certain tube elements grounded internally through the socket. Others have elements bypassed to ground through capacitors that are integral parts of the sockets.

Depending on one's design philosophy and tube sources, some compromises in the cooling system may be appropriate. For example, if glass tubes are available inexpensively as broadcast pulls, a shorter life span may be acceptable. In such a case, an increase of convenience and a reduction in cost, noise, and complexity can be had by using a pair of "muffin" fans. One fan may be used for the filament seals and one for the anode seal, dispensing with a blower and air-system socket and chimney. The air flow with this scheme is not as uniform as with the use of a chimney. The tube envelope mounted in a cross flow has flow stagnation points and low heat transfer in certain regions of the envelope. These points become hotter than the rest of the envelope. The use of multiple fans to disturb the cross air flow can significantly reduce this problem. Many amateurs have used this cooling method successfully in low-duty-cycle CW and SSB operation but it is not recommended for AM, SSTV or RTTY service. The true test of the effectiveness of a forced air cooling system is the amount of heat carried away from the tube by the air stream. The power dissipated can be calculated from the air flow temperatures. The dissipated power is

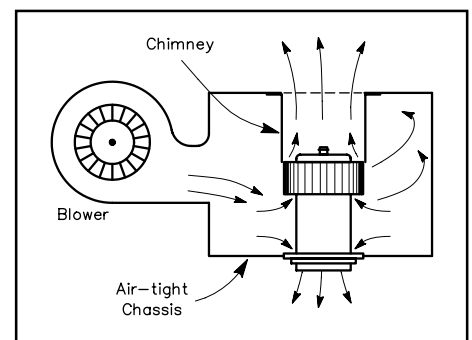

**Fig 13.16—Anode compartment pressurization may be more efficient than grid compartment pressurization. Hot air exits upwards through the tube anode and through the chimney. Cool air also goes down through the tube socket to cool tube's pins and the socket itself.**

$$P_D = 169 Q_A \left[ \frac{T_2}{T_1} - 1 \right] \quad (37)$$

where

$P_D$  = the dissipated power, in W

$Q_A$  = the air flow, in CFM (cubic feet per minute)

$T_1$  = the inlet air temperature, kelvins (normally quite close to room temperature)

$T_2$  = the amplifier exhaust temperature, kelvins.

The exhaust temperature can be measured with a cooking thermometer at the air outlet. The thermometer should not be placed inside the anode compartment because of the high voltage present.

## Transistor Cooling

Transistors used in power amplifiers dissipate significant amounts of power, and the heat so generated must be effectively removed to maintain acceptable device temperatures. Some bipolar power transistors have the collector connected directly to the case of the device, as the collector creates most of the heat generated when the transistor is in operation. Others have the emitter connected to the case. However, if operated close to maximum rated dissipation, even the larger case designs cannot normally conduct heat away fast enough to keep the operating temperature of the device within the safe area—the maximum temperature that a device can stand without damage. Safe area is usually specified in a device data sheet, often in graphical form. Germanium power transistors theoretically may be operated at internal temperatures up to 100°C, while silicon devices may be run at up to 200°C. However, to assure long device lifetimes much lower case temperatures—not greater than 50° to 75°C for germanium and 75° to 100°C for silicon—are highly desirable. Leakage currents in germanium devices can be very high at elevated temperatures; thus, silicon transistors are preferred for most power applications.

A properly chosen heat sink often is essential to help keep the transistor junction temperature in the safe area. For low-power applications a simple clip-on heat sink will suffice, while for 100 W or higher input power a massive cast-aluminum finned radiator usually is necessary. The appropriate size heat sink can be calculated based on the thermal resistance between the transistor case and ambient air temperature. The first step is to calculate the total power dissipated by the transistor:

$$P_D = P_{DC} + P_{RF_{in}} - P_{RF_{out}} \quad (38)$$

where

$P_D$  = the total power dissipated by the transistor in W

$P_{DC}$  = the dc power into the transistor, in W

$P_{RF_{in}}$  = the RF (drive) power into the transistor in W

$P_{RF_{out}}$  = the RF output power from the transistor in W.

The value of  $P_D$  is then used to obtain the  $q_{CA}$  value from

$$\theta_{CA} = (T_C - T_A)/P_D \quad (39)$$

where

$\theta_{CA}$  = the thermal resistance of the device case to ambient

$T_C$  = the device case temperature in °C

$T_A$  = the ambient temperature (room temperature) in °C.

A suitable heat sink, capable of transferring all of the heat generated by the transistor to the ambient



air, can then be chosen from the manufacturer's specifications for  $\theta_{CA}$ . A well-designed heat-sink system minimizes thermal path lengths and maximizes their cross-sectional areas. The contact area between the transistor and heat sink should have very low thermal resistance. The heat sink's mounting surface must be flat and the transistor firmly attached to the heat sink so intimate contact—without gaps or air voids—is made between the two. The use of silicone-based heat sink compounds can provide considerable improvement in thermal transfer. The thermal resistance of such grease is considerably lower than that of air, but not nearly as good as that of copper or aluminum. The quantity of grease should be kept to an absolute minimum. Only enough should be used to fill in any small air gaps between the transistor and heat sink mating surfaces. The maximum temperature rise in the transistor junction may easily be calculated by using the equation

$$T_J = (\theta_{JC} + \theta_{CA}) P_D + T_A \quad (40)$$

where

$T_J$  = the transistor junction temperature in °C

$\theta_{JC}$  = the manufacturer's published thermal resistance of the transistor

$\theta_{CA}$  = the thermal resistance of the device case to ambient

$P_D$  = the power dissipated by the transistor

$T_A$  = the ambient temperature in °C.

The value of  $T_J$  should be kept well below the manufacturer's recommended maximum to prevent premature transistor failure. Measured values of the ambient temperature and the device case temperature can be used in the preceding formulas to calculate junction temperature. The [Real World Components](#) chapter contains a more detailed discussion of transistor cooling.

# Design Guidelines and Examples

Most of the problems facing an amplifier designer are not theoretical, but have to do with real-world component limitations. The **Real World Components** chapter discusses the differences between ideal and real components

A simplified equivalent schematic of an amplifying device is shown in **Fig 13.17A**. The input is represented by a series (parasitic) inductance feeding a resistance in parallel with a capacitance. The output consists of a current generator in parallel with a resistance and capacitance, followed by a series inductance. This is a reasonably accurate description of both transistors and vacuum tubes, regardless of circuit configuration (as demonstrated in Figs 13.17B and C). Both input and output impedances have a resistive component in parallel with a reactive component. Each also has a series inductive reactance, which represents connecting leads within the device. These inductances, unlike the other components of input and output impedance, often are not characterized in manufacturers' device specifications.

The amplifier input and output matching networks must transform the complex impedances of the amplifying device to the source and load impedances (often 50-Ω transmission lines). Impedances associated with other parts of the amplifier circuit, such as a dc-supply choke, must also be considered in designing the matching networks. The matching networks and other circuit components are influenced by each other's presence, and these mutual effects must be given due consideration.

Perhaps the best way to clarify the considerations that enter into designing various types of RF power amplifiers is through example. The following examples illustrate common problems associated with power-amplifier design. They are not intended as detailed construction plans, but only demonstrate typical approaches useful in designing similar projects.

## DESIGN EXAMPLE 1: A HIGH-POWER VACUUM TUBE HF AMPLIFIER

Most popular HF transceivers produce approximately 100-W output. The EIMAC 8877 can deliver 1500-W output for approximately 60 W of drive when used in a grounded grid circuit. Grounded-grid operation is usually the easiest tube amplifier circuit to implement. Its input impedance is relatively low, often close to 50 Ω. Input/output shielding provided by the grid and negative feedback inherent in the grounded-grid circuit configuration reduce the likelihood of amplifier instability and provide excellent linearity without critical adjustments. Fewer supply voltages are needed in this configuration compared to others: often just high-voltage dc for the plate and low-voltage ac for the filament.

The first step in the amplifier design process is to verify that the tube is actually capable of producing the desired results while remaining within manufacturer's ratings. The plate dissipation expected during normal operation of the amplifier is computed first. Since the amplifier will be used for SSB, a class of operation producing linear amplification must be used. Class AB2 provides a very good compromise between linearity and good efficiency, with effective efficiency typically exceeding 60%. Given that efficiency, an input power of 2500 W is needed to produce the desired 1500-W output. Operated under these conditions, the tube

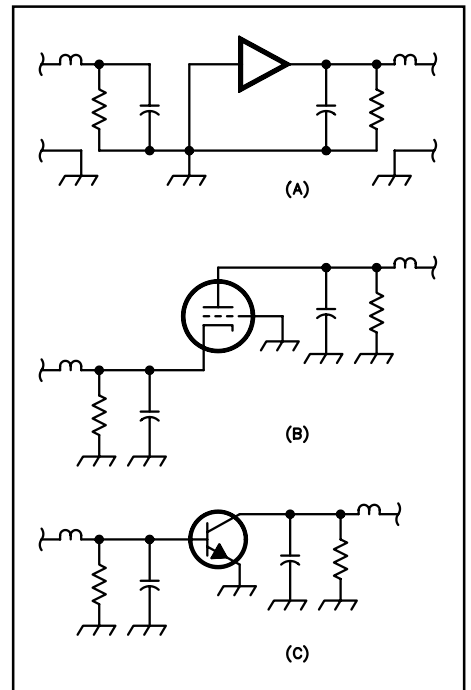

**Fig 13.17—The electrical equivalents for power amplifiers. At A, the input is represented by a series stray inductance, then a resistor in parallel with a capacitor. The output is a current source in parallel with a resistor and capacitor, followed by a series stray inductance. These effects are applied to tubes and transistors in B and C.**

will dissipates about 1000 W—well within the manufacturer’s specifications, provided adequate cooling airflow is supplied.

The grid in modern high- $\mu$  triodes is a relatively delicate structure, closely spaced from the cathode and carefully aligned to achieve high gain and excellent linearity. To avoid shortening tube life or even destruction of the tube, the specified maximum grid dissipation must not be exceeded for more than a few milliseconds under any conditions. For a given power output, the use of higher plate voltages tends to result in lower grid dissipation. It is important to use a plate voltage which is high enough to result in safe grid current levels at maximum output. In addition to maximum ratings, manufacturers’ data sheets often provide one or more sets of “typical operation” parameters. This makes it even easier for the builder to achieve optimum results.

The 8877, operating at 3500 V, can produce 2075 W of RF output with excellent linearity and 64 W of drive. Operating at 2700 V it can deliver 1085 W with 40 W of drive. To some extent, the ease and cost of constructing a high-power amplifier, as well as its ultimate reliability, are enhanced by using the lowest plate voltage which will yield completely satisfactory performance. Interpolating between the two sets of typical operating conditions suggests that the 8877 can comfortably deliver 1.5 kW output with a 3100-V plate supply and 50 to 55 W of drive. Achieving 2500-W input power at this plate voltage requires 800 mA of plate current—well within the 8877’s maximum rating of 1.0 A.

The next step in the design process is to calculate the optimum plate load resistance at this plate voltage and current for Class AB2 operation and design an appropriate output matching network. From the earlier equations,  $R_L$  is calculated to be 2200  $\Omega$ .

Several different output networks might be used to transform the nominal 50- $\Omega$  resistance of the actual load to the 2200- $\Omega$  load resistance required by the 8877, but experience shows that pi and pi-L networks are most practical. Each can provide reasonable harmonic attenuation, is relatively easy to build mechanically and uses readily available components. The pi-L gives significantly greater harmonic attenuation than the pi and usually is the better choice—at least in areas where there is any potential for TVI or crossband interference. In a multiband amplifier, the extra cost of using a pi-L network is the “L” inductor and its associated bandswitch section.

To simplify and avoid confusion with terminology previously used in the pi and pi-L network design tables, in the remainder of this chapter  $Q_{IN}$  is the loaded Q of the amplifier’s input matching tank,  $Q_{OUT}$  is the loaded Q of the output pi-L tank,  $Q_{PI}$  is the loaded Q of the output pi section only, and  $Q_L$  is the loaded Q of the output L section only.

The input impedance of a grounded-grid 8877 is typically on the order of 50 to 55  $\Omega$ , shunted by input capacitance of about 38 pF. While this average impedance is close enough to 50  $\Omega$  to provide negligible input SWR, the instantaneous value varies greatly over the drive cycle—that is, it is nonlinear. This nonlinear impedance is reflected back as a nonlinear load impedance at the exciter output, resulting in increased intermodulation distortion, reduced output power, and often meaningless exciter SWR meter indications. In addition, the tube’s parallel input capacitance, as well as parasitic circuit reactances, often are significant enough at 28 MHz to create significant SWR. A tank circuit at the amplifier input can solve both of these problems by tuning out the stray reactances and stabilizing (linearizing) the tube input impedance through its flywheel effect. The input tank should have a loaded Q (called  $Q_{Lin}$  in this discussion) of at least two for good results. Increasing  $Q_{Lin}$  to as much as five results in a further small improvement in linearity and distortion, but at the cost of a narrower operating bandwidth. Even a  $Q_{Lin}$  of 1.0 to 1.5 yields significant improvement over an untuned input. A pi network commonly is used for input matching at HF.

**Fig 13.18** illustrates these input and output networks applied in the amplifier circuit. The schematic shows the major components in the amplifier RF section, but with band-switching and cathode dc-return circuits omitted for clarity. C1 and C2 and L1 form the input pi network. C3 is a blocking capacitor to isolate the exciter from the cathode dc potential. Note that when the tube’s average input resistance is

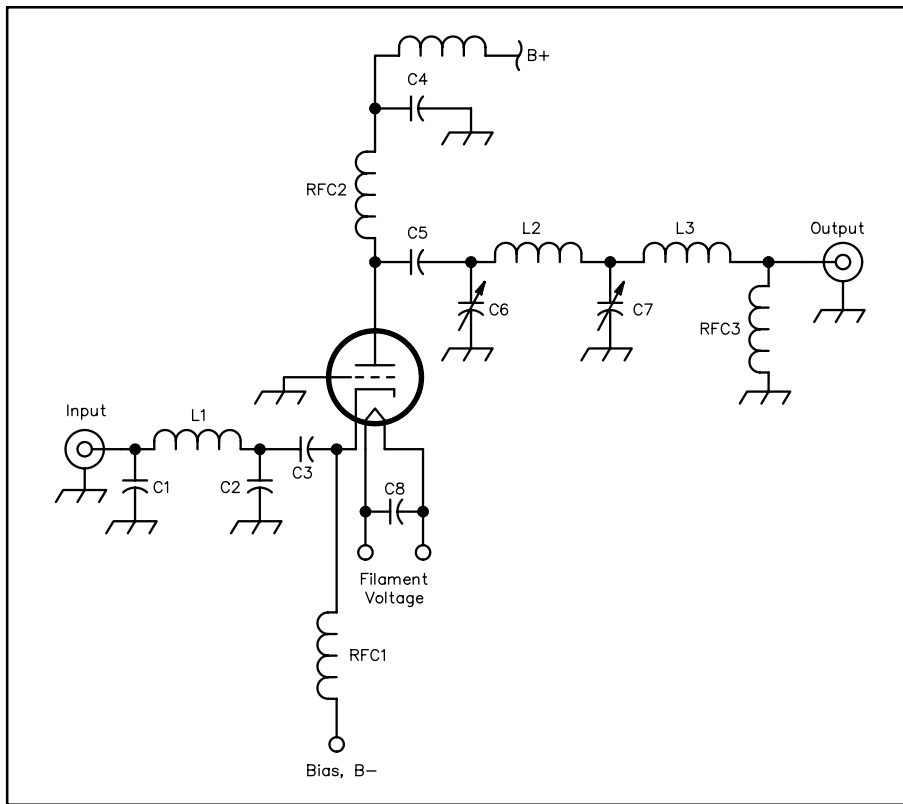

**Fig 13.18—A simplified schematic of a grounded-grid amplifier using a pi network input and pi-L network output.**

close to  $50\ \Omega$ , as in the case of the 8877, a simple parallel-resonant tank often can successfully perform the tuning and flywheel functions, since no impedance transformation is necessary. In this case it is important to minimize stray lead inductance between the tank and tube to avoid undesired impedance transformation.

The filament or “heater” in indirectly heated tubes such as the 8877 must be very close to the cathode to heat the cathode efficiently. A capacitance of several picofarads exists between the two. Particularly at very high frequencies, where these few picofarads represent a relatively low reactance, RF drive intended for the cathode can be capacitively coupled to the lossy filament and dissipated as heat.

To avoid this, above about 50 MHz, the filament must be kept at a high RF impedance above ground. The high impedance (represented by choke RFC1 in Fig 13.18) minimizes RF current flow in the filament circuit so that RF dissipated in the filament becomes negligible. The choke’s low-frequency resistance should be kept to a minimum to lessen voltage drops in the high-current filament circuit.

The choke most commonly used in this application is a pair of heavy-gauge insulated wires, bifilar-wound over a ferrite rod. The ferrite core raises the inductive reactance throughout the HF region so that a minimum of wire is needed, keeping filament-circuit voltage drops low. The bifilar winding technique assures that both filament terminals are at the same RF potential.

Below 30 MHz, the use of such a choke seldom is necessary or beneficial, but actually can introduce another potential problem. Common values of cathode-to-heater capacitance and heater-choke inductance often are series resonant in the 1.8 to 29.7 MHz HF range. A capacitance of 5 pF and an inductance of 50  $\mu\text{H}$ , for example, resonate at 10.0 MHz; the actual components are just as likely to resonate near 7 or 14 MHz. At resonance, the circuit constitutes a relatively low impedance shunt from cathode to ground, which affects input impedance and sucks out drive signal. An unintended resonance like this near any operating frequency usually increases input SWR and decreases gain on that one particular band. While aggravating, the problem rarely completely disables or damages the amplifier, and so is seldom pursued or identified.

Fortunately, the entire problem is easily avoided—below 30 MHz the heater choke can be deleted. At VHF-UHF, or wherever a heater isolation choke is used for any reason, the resonance can be moved below the lowest operating frequency by connecting a sufficiently large capacitance (about 1000 pF) between the tube cathode and one side of the heater. It is good practice also to connect a similar capacitor between the heater terminals. It also would be good practice in designing other VHF/UHF amplifiers,

such as those using 3CX800A7 tubes, unless the builder can insure that the actual series resonance is well outside of the operating frequency range.

Plate voltage is supplied to the tube through RFC2. C5 is the plate blocking capacitor. The output pi-L network consists of tuning capacitor C6, loading capacitor C7, pi coil L2, and L coil L3. RFC3 is a high-inductance RF choke placed at the output for safety purposes. Its value, usually 100  $\mu\text{H}$  to 2 mH, is high enough so that it appears as an open circuit across the output connector for RF. However, should the plate blocking capacitor fail and allow high voltage onto the output matching network, RFC3 would short the dc to ground and blow the power-supply fuse or breaker. This prevents dangerous high voltage from appearing on the feed line or antenna. It also prevents electrostatic charge—from the antenna or from blocking capacitor leakage—from building up on the tank capacitors and causing periodic dc discharge arcs to ground. If such a dc discharge occurs while the amplifier is transmitting, it can trigger a potentially damaging RF arc.

Our next step is designing the input matching network. As stated earlier, tube input impedance varies moderately with plate voltage and load resistance as well as bias, but is approximately 50 to 55- $\Omega$  paralleled by  $C_{\text{IN}}$  of 38 pF, including stray capacitance. A simple parallel-resonant tank of  $Q_{\text{IN}} = 2$  to 3 can provide an input SWR not exceeding 1.5:1, provided all wiring from RF input connector to tank to cathode is heavy and short. On each band a  $Q_{\text{IN}}$  between 2 to 3 requires an  $X_{\text{Ctot}} = X_{\text{Lin}}$  between 25 and 17  $\Omega$ .

A more nearly perfect match, with greater tolerance for layout and wiring variations, may be achieved by using the pi input tank as shown in Fig 13.18. Design of this input matching circuit is straightforward. Component values are computed using a  $Q_{\text{IN}}$  between 2 or 3. Higher  $Q_{\text{IN}}$  values reduce the network's bandwidth, perhaps even requiring a front-panel tuning control for the wider amateur bands. The purpose of this input network is to present the desired input impedance to the exciter, not to add selectivity. As with a parallel tank, the value of the capacitor at the tube end of the pi network should be reduced by 38 pF; stray capacity plus tube  $C_{\text{IN}}$  is effectively in parallel with the input pi network's output.

The output pi-L network must transform the nominal 50- $\Omega$  amplifier load to a pure resistance of 2200  $\Omega$ . We previously calculated that the 8877 tube's plate must see 2200  $\Omega$  for optimum performance. In practice, real antenna loads are seldom purely resistive or exactly 50  $\Omega$ ; they often exhibit SWRs of 2:1 or greater on some frequencies. It's desirable that the amplifier output network be able to transform any complex load impedance corresponding to an SWR up to about 2:1 into a resistance of 2200  $\Omega$ . The network also must compensate for tube  $C_{\text{OUT}}$  and other stray plate-circuit reactances, such as those of interconnecting leads and the plate RF choke. These reactances, shown in Fig 13.19, must be taken into account when designing the matching networks. Because the values of most stray reactances are not accurately known, the most satisfactory approach is to estimate them, and then allow sufficient flexibility in the matching network to accommodate modest errors.

Fig 13.19 shows the principal reactances in the amplifier circuit.  $C_{\text{OUT}}$  is the actual tube output capacitance of 10 pF plus the stray capacitance between its anode and the enclosure metal-

work. This stray C varies with layout; we will approximate it as 5 pF, so  $C_{\text{OUT}}$  is roughly 15 pF.  $L_{\text{OUT}}$  is the stray inductance of leads from the tube plate to the tuning capacitor (internal to the tube as well as external circuit wiring). External-anode tubes like the 8877

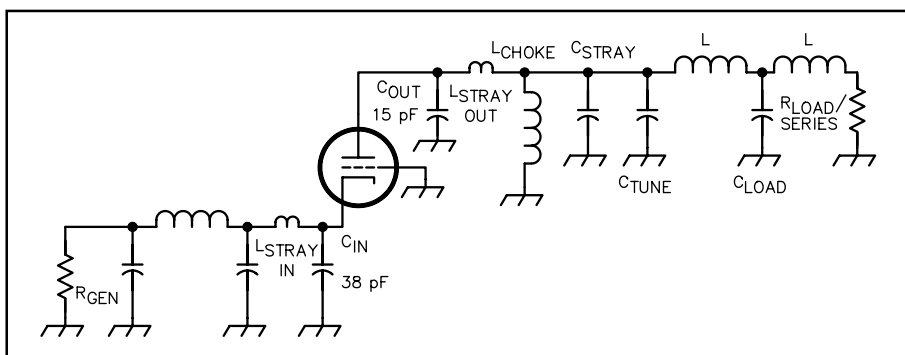

Fig 13.19—The effective reactances for the amplifier in Fig 13.18.

have essentially no internal plate leads, so  $L_{OUT}$  is almost entirely external. It seldom exceeds about  $0.3\ \mu\text{H}$  and is not very significant below 30 MHz.  $L_{CHOKE}$  is the reactance presented by the plate choke, which usually is significant only below 7 MHz.  $C_{STRAY}$  represents the combined stray capacitances to ground of the tuning capacitor stator and of interconnecting RF plate circuit leads. In a well constructed, carefully thought out power amplifier,  $C_{STRAY}$  can be estimated to be approximately 10 pF. Remaining components  $C_{TUNE}$ ,  $C_{LOAD}$ , and the two tuning inductors, form the pi-L network proper.

The tables presented earlier in this chapter greatly simplify the task of selecting output circuit values. Both the pi and pi-L design tables are calculated for a  $Q_{OUT}$  value of 12. A pi network loaded Q much lower than 10 does not provide adequate harmonic suppression; a value much higher than 15 increases matching network losses caused by high circulating currents. For pi networks, a  $Q_{OUT}$  of 12 is a good compromise between harmonic suppression and circuit losses. In practice, it often is most realistic and practical with both pi and pi-L output networks to accept somewhat higher  $Q_{OUT}$  values on the highest HF frequencies—perhaps as large as 18 or even 20 at 28 MHz. When using a pi-L on the 1.8 and 3.5 MHz bands, it often is desirable to choose a moderately lower  $Q_{OUT}$ , perhaps 8 to 10, to permit using a more reasonably-sized plate tuning capacitor.

Nominal pi-L network component values for 2200- $\Omega$  plate impedance can be taken directly from [Table 13.2](#). These values can then be adjusted to allow for circuit reactances outside the pi-L proper. First, low-frequency component values should be examined. At 3.5 MHz, total tuning capacitance  $C_1$  value from [Table 13.2](#) is 140 pF. From [Fig 13.19](#) we know that three other stray reactances are directly in parallel with  $C_{TUNE}$  (assuming that  $L_{OUT}$  is negligible at the operating frequency, as it should be). The tube's internal and external plate capacitance to ground,  $C_{OUT}$ , is about 15 pF. Strays in the RF circuit,  $C_{STRAY}$ , are roughly 10 pF.

The impedance of the plate choke,  $X_{CHOKE}$ , is also in parallel with  $C_{TUNE}$ . Plate chokes with self-resonance characteristics suitable for use in amateur HF amplifiers typically have inductances of about  $90\ \mu\text{H}$ . At 3.5 MHz this is an inductive reactance of  $+1979\ \Omega$ . This appears in parallel with the tuning capacitance, effectively canceling an equal value of capacitive reactance. At 3.5 MHz, an  $X_C$  of  $1979\ \Omega$  corresponds to 23 pF of capacitance—the amount by which tuning capacitor  $C_{TUNE}$  must be increased at 3.5 MHz to compensate for the effect of the plate choke.

The pi-L network requires an effective capacitance of 140 pF at its input at 3.5 MHz. Subtracting the 25 pF provided by  $C_{OUT}$  and  $C_{STRAY}$  and adding the 23 pF canceled by  $X_{CHOKE}$ , the actual value of  $C_{TUNE}$  must be  $140 - 25 + 23 = 138\ \text{pF}$ . It is good practice to provide at least 10% extra capacitance range to allow matching loads having SWRs up to 2:1. So, if 3.5 MHz is the lower frequency limit of the amplifier, a variable tuning capacitor with a maximum value of at least 150 to 160 pF should be used.

Component values for the high end of the amplifier frequency range also must be examined, for this is where the most losses will occur. At 29.7 MHz, the values in [Table 13.2](#) are chosen to accommodate a minimum pi-L input capacitance of 35 pF, yielding  $Q_{OUT} = 21.3$ . Since  $C_{OUT}$  and  $C_{STRAY}$  contribute 25 pF,  $C_{TUNE}$  must have a minimum value no greater than 10 pF. A problem exists, because this value is not readily achievable with a 150 to 160 pF air variable capacitor suitable for operation with a 3100 V plate supply. Such a capacitor typically has a minimum capacitance of 25 to 30 pF. Usually, little or nothing can be done to reduce the tube's  $C_{OUT}$  or the circuit  $C_{STRAY}$ , and in fact the estimates of these may even be a little low. If 1.8 MHz capability is desired, the maximum tuning capacitance will be at least 200 to 250 pF, making the minimum-capacitance problem at 29.7 MHz even more severe.

There are three potential solutions to this dilemma. We could accept the actual minimum value of pi-L input capacitance, around 50 to 55 pF, realizing that this will raise the pi-L network's loaded Q to about 32. This results in very large values of circulating tank current. To avoid damage to tank components—particularly the bandswitch and pi inductor—by heat due to  $I^2R$  losses, it will be necessary to either use oversize components or reduce power on the highest-frequency bands. Neither option is appealing.

A second potential solution is to reduce the minimum capacitance provided by  $C_{TUNE}$ . We could use

a vacuum variable capacitor with a 300-pF maximum and a 5-pF minimum capacity. These are rated at 5 to 15 kV, and are readily available. This reduces the minimum effective circuit capacitance to 30 pF, allowing use of the pi-L table values for  $Q_{OUT} = 12$  on all bands from 1.8 through 29.7 MHz. While brand new vacuum variables are quite expensive, suitable models are widely available in the surplus and used markets for prices not much higher than the cost of a new air variable. A most important caveat in purchasing a vacuum capacitor is to ensure that its vacuum seal is intact and that it is not damaged in any way. The best way to accomplish this is to “hi-pot” test the capacitor throughout its range, using a dc or peak ac test voltage of 1.5 to 2 times the amplifier plate supply voltage. For all-band amplifiers using plate voltages in excess of about 2500 V, the initial expense and effort of securing and using a vacuum variable input tuning capacitor often is well repaid in efficient and reliable operation of the amplifier.

A third possibility is the use of an additional inductance connected in series between the tube and the tuning capacitor. In conjunction with  $C_{OUT}$  of the tube, the added inductor acts as an L network to transform the impedance at the input of the pi-L network up to the 2200- $\Omega$  load resistance needed by the tube. This is shown in Fig 13.20A. Since the impedance at the input of the main pi-L matching network is reduced, the loaded  $Q_{OUT}$  for the total capacitance actually in the circuit is lower. With lower  $Q_{OUT}$ , the circulating RF currents are lower, and thus tank losses are lower.

$C_{OUT}$  in Fig 13.20 is the output capacitance of the tube, including stray C from the anode to metal enclosure.  $X_L$  is the additional series inductance to be added. As determined previously, the impedance seen by the tube anode must be a 2200  $\Omega$  resistance for best linearity and efficiency, and we have estimated  $C_{OUT}$  of the tube as 15 pF. If the network consisting of  $C_{OUT}$  and  $X_L$  is terminated at A by 2200- $\Omega$ , we can calculate the equivalent impedance at point B, the input to the pi-L network, for various values of series  $X_L$ . The pi-L network must then transform the nominal 50- $\Omega$  load at the transmitter output to this equivalent impedance.

We work backwards from the plate of the tube towards the  $C_{TUNE}$  capacitor. First, calculate the series-equivalent impedance of the parallel combination of the desired 2200- $\Omega$  plate load and the tube  $X_{OUT}$  (15 pF at 29.7 MHz =  $-j357 \Omega$ ). The series-equivalent impedance of this parallel combination is  $56.5 - j348 \Omega$ , as shown in Fig 13.20B. Now suppose we use a 0.5  $\mu$ H inductor, having an impedance of  $93 \Omega + j93 \Omega$  at 29.7 MHz, as the series inductance  $X_L$ . The resulting series-equivalent impedance is  $56.5 - j348 + j93$ , or  $56.5 - j255 \Omega$ . Converting back to the parallel equivalent gives the network of Fig 13.20C: 1205  $\Omega$  resistance in parallel with  $-j267 \Omega$ , or 20 pF at 29.7 MHz. The pi-L tuning network must now transform the 50- $\Omega$  load to a resistive load of 1205  $\Omega$  at B, and absorb the shunt capacity of 20 pF.

Using the pi-L network formulas in this chapter for  $R1 = 1205$

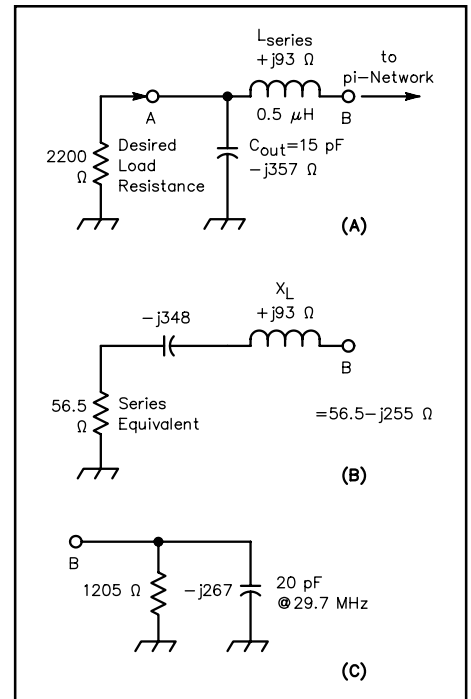

**Fig 13.20—The effect of adding a small series inductance in vacuum tube output circuit. At A, a 0.5  $\mu$ H coil  $L_{SERIES}$  is connected between anode and the output pi network, and this represents a reactance of  $+j93 \Omega$  at 29.7 MHz. The 15 pF output capacity ( $C_{OUT}$ ) of the tube has a reactance of  $-j357 \Omega$  at 29.7 MHz. At B, the equivalent series network for the parallel 2200- $\Omega$  desired load resistance and the  $-j357 \Omega$   $C_{OUT}$  is  $56.5 \Omega$  in series with  $-j348 \Omega$ . At C, this series-equivalent is combined with the series  $+j93 \Omega$   $X_{SERIES}$  and converted back to the parallel equivalent, netting an equivalent parallel network of 1205  $\Omega$  shunted by a 20 pF capacitor. The pi tuning network must transform the load impedance (usually 50  $\Omega$ ) into the equivalent parallel combination and absorb the 20-pF parallel component. The series inductor has less effect as the operating frequency is lowered from 29.7 MHz.**

and  $Q_{OUT} = 15$  at 29.7 MHz yields a required total capacitive reactance of  $1205/15 = 80.3 \Omega$ , which is 66.7 pF at 29.7 MHz. Note that for the same loaded  $Q_{OUT}$  for a 2200- $\Omega$  load line, the capacitive reactance is  $2200/15 = 146.7 \Omega$ , which is 36.5 pF. When the 20 pF of transformed input capacity is subtracted from the 66.7 pF total needed, the amount of capacity is 46.7 pF. If the minimum capacity in  $C_{TUNE}$  is 25 pF and the stray capacity is 10 pF, then there is a margin of  $46.7 - 35 = 10.7$  pF beyond the minimum capacity for handling SWRs greater than 1:1 at the load.

The series inductor should be a high-Q coil wound from copper tubing to keep losses low. This inductor has a decreasing, yet significant effect, on progressively lower frequencies. A similar calculation to the above should be made on each band to determine the transformed equivalent plate impedance, before referring to [Table 13.2](#). The impedance-transformation effect of the additional inductor decreases rapidly with decreasing frequency. Below 21 MHz, it usually may be ignored and pi-L network values taken directly from the pi-L tables for  $R1 = 2200 \Omega$ .

The nominal 90- $\mu$ H plate choke remains in parallel with  $C_{TUNE}$ . It is rarely possible to calculate the impedance of a real HF plate choke at frequencies higher than about 5 MHz because of self-resonances. However, as mentioned previously, the choke's reactance should be sufficiently high that the tables are useful if the choke's first series-resonance is at 23.2 MHz.

This amplifier is made operational on multiple bands by changing the values of inductance at L2 and L3 for different bands. The usual practice is to use inductors for the lowest operating frequency, and short out part of each inductor with a switch, as necessary, to provide the inductance needed for each individual band. Wiring to the switch and the switch itself add stray inductance and capacitance to the circuit. To minimize these effects at the higher frequencies, the unswitched 10-m L2 should be placed closest to the high-impedance end of the network at C6. Stray capacitance associated with the switch then is effectively in parallel with C7, where the impedance level is around 300  $\Omega$ . The effects of stray capacitance are relatively insignificant at this low impedance level. This configuration also minimizes the peak RF voltage that the switch insulation must withstand.

Pi and L coil tap positions that yield desired values of inductance may be determined with fairly good accuracy by using a dip meter and a small mica capacitor of 5% tolerance. The pi and L coils and bandswitch should be mounted in the amplifier and their common point connected only to the bandswitch rotors. Starting at the highest-frequency switch position, lightly tack solder a short length of copper braid or strap to the pi or L switch stator terminal for that band. Using the shortest leads possible, tack a 50 to 100 pF, 5% dipped mica capacitor between the braid and a trial tap position on the appropriate coil. Lightly couple the dip meter and find the resonant frequency. The inductance then may be calculated from the equation

$$L = \frac{1,000,000}{C(2\pi f)^2} \quad (41)$$

where

L = inductance in  $\mu$ H

C = capacitor value in pF

f = resonant frequency in MHz.

As each tap is located, it should be securely wired with strap or braid and the process repeated for successively lower bands.

The impedance match in both the input and output networks can be checked without applying dc voltage, once the amplifier is built. In operation, the tube input and output resistances are the result of current flow through the tube. Without filament power applied, these resistances are effectively infinite but  $C_{IN}$  and  $C_{OUT}$  are still present because they are passive physical properties of the tube. The tube input resistance can be simulated by an ordinary 5%  $1/4$ -W to 2-W composition or film resistor (don't use



wirewound, though; they are more inductive than resistive at RF). A resistor value within 10% of the tube input resistance, connected in parallel with the tube input, presents approximately the same termination resistance to the matching network as the tube does in operation.

With the input termination resistor temporarily soldered in place using very short leads, input matching network performance can be determined by means of a noise bridge or an SWR meter that does not put out more RF power than the temporary termination resistor is capable of dissipating. Any good self- or dipper-powered bridge or analyzer should be satisfactory. Connect the bridge to the amplifier input and adjust the matching network, as necessary, for lowest SWR. Be sure to remove the terminating resistor before powering up the amplifier!

The output matching network can be evaluated in exactly the same fashion, even though the plate load resistance is not an actual resistance in the tube like the input resistance. According to the reciprocity principle, if the impedance presented at the output of the plate matching network is 50- $\Omega$  resistive when the network input is terminated with  $R_L$ , then the tube plate will “see” a resistive load equal to  $R_L$  at the input when the output is terminated in a 50- $\Omega$  resistance (and vice versa). In this case, a suitable 2200- $\Omega$  resistor should be connected as directly as possible from the tube plate to chassis. If the distance is more than a couple of inches, braid should be used to minimize stray inductance. The bridge is connected to the amplifier output. If coil taps have been already established as described previously, it is a simple matter to evaluate the output network by adjusting the tune and load capacitors, band by band, to show a perfect 50- $\Omega$  match on the SWR bridge.

When these tests are complete, the amplifier is ready to be tested for parasitic oscillations in preparation for full-power operation. Refer to [Amplifier Stabilization](#), later in this chapter.

## DESIGN EXAMPLE 2: A MEDIUM-POWER 144-MHZ AMPLIFIER

For several decades the 4CX250 family of power tetrodes has been used successfully up through 500 MHz. They are relatively inexpensive, produce high gain and lend themselves to relatively simple amplifier designs. In amateur service at VHF, the 4CX250 is an attractive choice for an amplifier. Most VHF exciters used now by amateurs are solid state and often develop 10 W or less output. The drive requirement for the 4CX250 in grounded cathode, Class AB operation ranges between 2 and 8 W for full power output, depending on frequency. At 144 MHz, manufacturer’s specifications suggest an available output power of over 300 W. This is clearly a substantial improvement over 10 W, so a 4CX250B will be used in this amplifier.

The first design step is the same as in the previous example: verify that the proposed tube will perform as desired while staying within the manufacturer’s ratings. Again assuming a basic amplifier efficiency of 60% for Class AB operation, 300 W of output requires a plate input power of 500 W. Tube dissipation is rated at 250 W, so plate dissipation is not a problem, as the tube will only be dissipating 200 W in this amplifier. If the recommended maximum plate potential of 2000 V is used, the plate current for 500-W input will be 250 mA, which is within the manufacturer’s ratings. The plate load resistance can now be calculated. Using the same formula as before, the value is determined to be 5333  $\Omega$ .

The next step is to investigate the output circuit. The manufacturer’s specification for  $C_{OUT}$  is 4.7 pF. The inevitable circuit strays, along with the tuning capacitor, add to the circuit capacitance. A carefully built amplifier might only have 7 pF of stray capacitance, and a specially made tuning capacitor can be fabricated to have a midrange value of 3 pF. The total circuit capacitance adds up to about 15 pF. At 144 MHz this represents a capacitive reactance of only 74  $\Omega$ . The  $Q_L$  of a tank circuit with this reactance with a plate load resistance of 5333  $\Omega$  is  $5333/74 = 72$ . A pi output matching network would be totally impractical, because the L required would be extremely small and circuit losses would be prohibitive. The simplest solution is to connect an inductor in parallel with the circuit capacitance to form a parallel-resonant tank circuit.

To keep tank circuit losses low with such a high  $Q_L$ , an inductor with very high unloaded Q must be used. The lowest-loss inductors are formed from transmission line sections. These can take the form of

either coaxial lines or strip lines. Both have their advantages and disadvantages, but the strip line is so much easier to fabricate that it is almost exclusively used in VHF tank circuits today.

The reactance of a terminated transmission line section is a function of both its characteristic impedance and its length (see the [Transmission Lines](#) chapter). The reactance of a line terminated in a short circuit is

$$X_{IN} = Z_0 \tan \ell \quad (42)$$

where

$X_{IN}$  = is the circuit reactance

$Z_0$  = the line's characteristic impedance

$\ell$  = the transmission line length in degrees.

For lines shorter than a quarter wavelength ( $90^\circ$ ) the circuit reactance is inductive. In order to resonate with the tank circuit capacitive reactance, the transmission line reactance must be the same value, but inductive. Examination of the formula for transmission-line circuit reactance suggests that a wide range of lengths can yield the same inductive reactance, as long as the line  $Z_0$  is appropriately scaled. Based on circuit Q considerations, the best bandwidth for a tank circuit results when the ratio of  $Z_0$  to  $X_{IN}$  is between one and two. This implies that transmission line lengths between  $26.5^\circ$  and  $45^\circ$  give the best bandwidth. Between these two limits, and with some adjustment of  $Z_0$ , practical transmission lines can be designed. A transmission line length of  $35^\circ$  is 8 inches long at 144 MHz, a workable dimension mechanically. Substitution of this value into the transmission-line equation gives a  $Z_0$  of  $105 \Omega$ .

The width of the strip line and its placement relative to the ground planes determine the line impedance. Other stray capacitances such as mounting standoffs also affect the impedance. Accurate calculation of the line impedance for most physical configurations requires extensive application of Maxwell's equations and is beyond the scope of this book. The specialized case in which the strip line is parallel to and located halfway between two ground planes has been documented in *Reference Data for Radio Engineers* (see [Bibliography](#)). According to charts presented in that book, a  $105\text{-}\Omega$  strip line impedance is obtained by placing a line with a width of approximately 0.4 times the ground plane separation halfway between the ground planes. Assuming the use of a standard 3-inch-deep chassis for the plate compartment, this yields a strip-line width of 1.2 inches. A strip line 1.2 inches wide located 1.5 inches above the chassis floor and grounded at one end has an inductive reactance of  $74 \Omega$  at 144 MHz.

The resulting amplifier schematic diagram is shown in **Fig 13.21**. L2 is the strip-line inductance just described. C3 is the tuning capacitor, made from two parallel brass plates whose spacing is adjustable. One plate is connected directly to the strip line while the other is connected to ground through a wide, low-inductance strap. C2 is the plate blocking capacitor. This can be either a ceramic doorknob capacitor such as the Centralab 850 series or a homemade "Teflon sandwich." Both are equally effective at 144 MHz.

Impedance matching from the plate resistance down to  $50 \Omega$  can be either through an inductive link or through capacitive reactance matching.

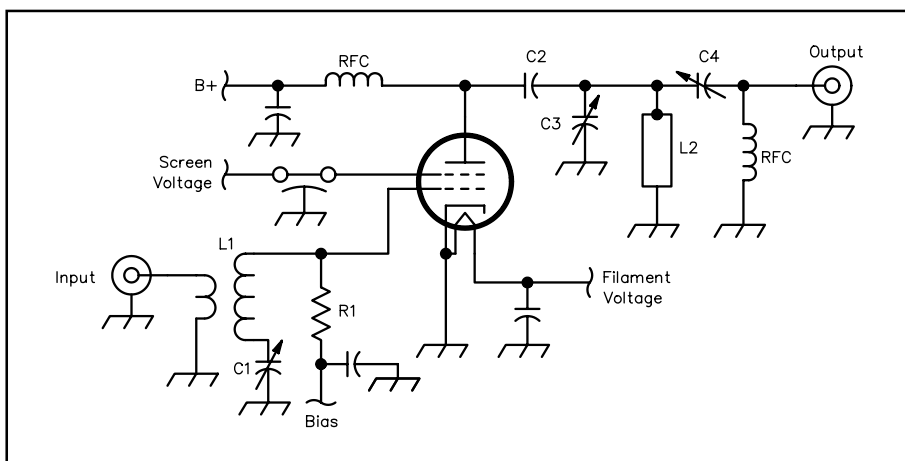

**Fig 13.21**—Simplified schematic for a VHF power amplifier using a power tetrode. The output circuit is a parallel-tuned tank circuit with series capacitive-reactance output matching.

Mechanically, the capacitive approach is simpler to implement. **Fig 13.22** shows the development of reactance matching through a series capacitor ( $C_4$  in **Fig 13.21**). By using the parallel equivalent of the capacitor in series with the 50- $\Omega$  load, the load resistance can be transformed to the 5333- $\Omega$  plate resistance. Substitution of the known values into the parallel-to-series equivalence formulas reveals that a 2.15 pF capacitor at  $C_4$  matches the 50- $\Omega$  load to the plate resistance. The resulting parallel equivalent for the load is 5333  $\Omega$  in parallel with 2.13 pF. The 2.13-pF capacitor is effectively in parallel with the tank circuit.

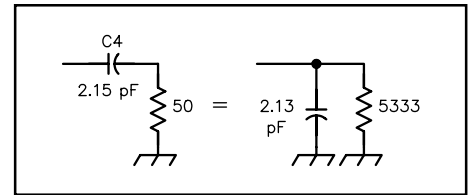

**Fig 13.22—Series reactance matching as applied to the amplifier in **Fig 13.21**.**

A new plate line length must now be calculated to allow for the additional capacitance. The equivalent circuit diagram containing all the various reactances is shown in **Fig 13.23**. The total circuit capacitance is now just over 17 pF, which is a reactance of 64  $\Omega$ . Keeping the strip-line width and thus its impedance constant at 105  $\Omega$  dictates a new resonant line length of 31°. This calculates to be 7.14 inches for 144 MHz.

The alternative coupling scheme is through the use of an inductive link. The link can be either tuned or untuned. The length of the link can be estimated based on the amplifier output impedance, in this case, 50  $\Omega$ . For an untuned link, the inductive reactance of the link itself should be approximately equal to the output impedance, 50  $\Omega$ . For a tuned link, the length depends on the link loaded  $Q$ ,  $Q_L$ . The link  $Q_L$  should generally be greater than two, but usually less than five. For a  $Q_L$  of three this implies a capacitive reactance of 150  $\Omega$ , which at 144 MHz is just over 7 pF. The self-inductance of the link should of course be such that its impedance at 144 MHz is 150  $\Omega$  (0.166  $\mu$ H). Adjustment of the link placement determines the transformation ratio of the circuit line. Some fine adjustment of this parameter can be made through adjustment of the link series tuning capacitor. Placement of the link relative to the plate inductor is an empirical process.

The input circuit is shown in **Figs 13.21** and **13.23**.  $C_{IN}$  is specified to be 18.5 pF for the 4CX250. This is only  $-j60 \Omega$  at 2 m, so the pi network again is unsuitable. Since a surplus of drive is available with a 10-W exciter, circuit losses at the amplifier input are not as important as at the output. An old-fashioned “split stator” tuned input can be used.  $L_1$  in **Fig 13.21** is series tuned by  $C_{IN}$  and  $C_1$ . The two capacitors are effectively in series (through the ground return). A 20-pF variable at  $C_1$  set to 18.5 pF gives an effective circuit capacitance of 9.25 pF. This will resonate at 144 MHz with an inductance of 0.13  $\mu$ H at  $L_1$ .  $L_1$  can be wound on a toroid core for mechanical convenience. The 50- $\Omega$  input impedance is then matched by link coupling to the toroid. The grid impedance is primarily determined by the value for  $R_1$ , the grid bias feed resistor.

### DESIGN EXAMPLE 3: A BROADBAND HF SOLID-STATE AMPLIFIER

Linear power amplifier design using transistors at HF is a fundamentally simple process, although a good understanding of application techniques is important to insure that the devices are effectively protected against damage or destruction due to parasitic self-oscillations, power transients, load mismatch and/or overdrive.

An appropriate transistor meeting the desired performance specifications is selected on the basis of dissipation and power output. Transistor manufacturers greatly simplify the design by specifying each type of power transistor according to its frequency range and power output.

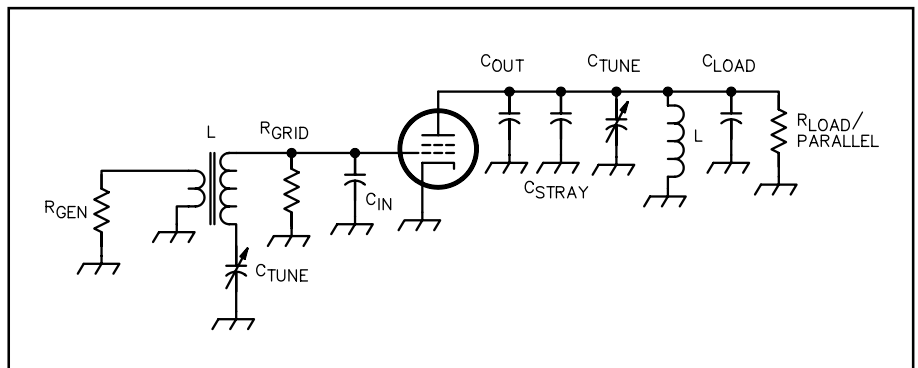

**Fig 13.23—The reactances and resistances for the amplifier in **Fig 13.21**.**

The amplifier designer need only provide suitable impedance matching to the device input and output, along with appropriate dc bias currents to the transistor.

The Motorola MRF464 is an RF power transistor capable of 80 W PEP output with low distortion. Its usable frequency range extends through 30 MHz. At a collector potential of 28 V, a collector efficiency of 40% is possible. **Fig 13.24** shows the schematic diagram of a 2 to 30-MHz broadband linear amplifier using the MRF464. The input impedance of the transistor is specified by

the manufacturer to be  $1.4 - j0.30 \Omega$  at 30 MHz and decreases to  $9.0 - j5.40 \Omega$  at 2 MHz. Transformers T1 and T2 match the 50- $\Omega$  amplifier input impedance to the median value of the transistor input impedance. They are both 4:1 step-down ratio transmission-line transformers. A single 16:1 transformer could be used in place of T1 and T2, but 16:1 transformers are more difficult to fabricate for broadband service.

The specified transistor output resistance is approximately 6  $\Omega$  (in parallel with a corresponding output capacitance) across the frequency range. T3 is a ferrite-loaded conventional transformer with a step-up ratio of approximately 8:1. This matches the transistor output to 50  $\Omega$ .

The amplifier has a falling gain characteristic with rising frequency. To flatten out gain across the frequency range, negative feedback could be applied. However, most power transistors have highly reactive input impedances and large phase errors would occur in the feedback loop. Instability could potentially occur.

A better solution is to use an input correction network. This network is used as a frequency-selective attenuator for amplifier drive. At 30 MHz, where transistor gain is least, the input power loss is designed to be minimal (less than 2 dB). The loss increases at lower frequencies to compensate for the increased transistor gain. The MRF464 has approximately 12 dB more gain at 1.8 MHz than at 30 MHz; the compensation network is designed to have 12 dB loss at 1.8 MHz. A properly designed compensation network will result in an overall gain flatness of approximately 1 dB.

## AMPLIFIER STABILIZATION

### Stable Operating Conditions

Purity of emissions and the useful life (or even survival) of the active devices in a tube or transistor circuit depend heavily on stability during operation. Oscillations can occur at the operating frequency or far from it, because of undesired positive feedback in the amplifier. Unchecked, these oscillations pollute the RF spectrum and can lead to tube or transistor over-dissipation and subsequent failure. Each type of oscillation has its own cause and its own cure.

In a linear amplifier, the input and output circuits operate on the same frequency. Unless the coupling between these two circuits is kept to a small enough value, sufficient energy from the output may be coupled in phase back to the input to cause the amplifier to oscillate. Care should

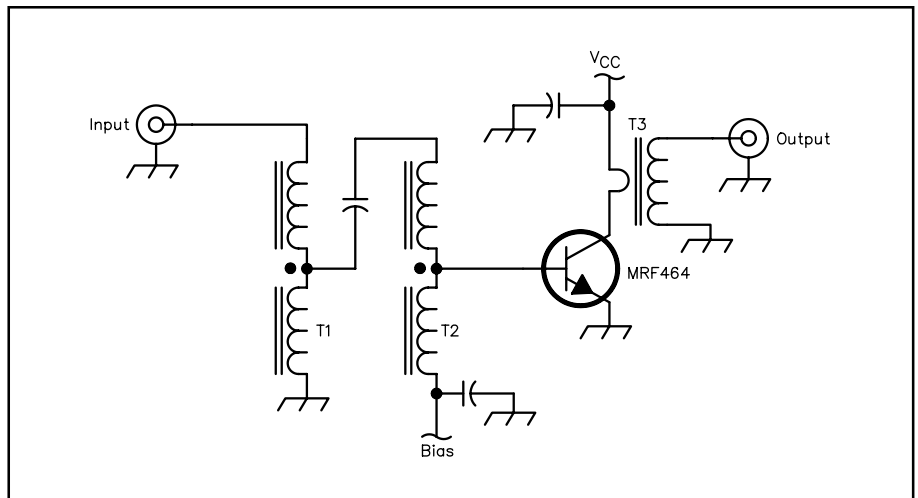

**Fig 13.24—A simplified schematic of a broadband HF transistorized power amplifier. T1 and T2 are 4:1 broadband transformers to match the low input impedance of the transistor.**

be used in arranging components and wiring of the two circuits so that there will be negligible opportunity for coupling external to the tube or transistor itself. A high degree of shielding between input and output circuits usually is required. All RF leads should be kept as short as possible and particular attention should be paid to the RF return paths from input and output tank circuits to emitter or cathode.

In general, the best arrangement using a tube is one in which the input and output circuits are on opposite sides of the chassis. Individual shielded compartments for the input and output circuitry add to the isolation. Transistor circuits are somewhat more forgiving, since all the impedances are relatively low. However, the high currents found on most amplifier circuit boards can easily couple into unintended circuits. Proper layout, the use of double-sided circuit board (with one side used as a ground plane and low-inductance ground return), and heavy doses of bypassing on the dc supply lines often are sufficient to prevent many solid-state amplifiers from oscillating.

### VHF and UHF Parasitic Oscillations

RF power amplifier circuits contain parasitic reactances that have the potential to cause so-called parasitic oscillations at frequencies far above the normal operating frequency. Nearly all vacuum-tube amplifiers designed for operation in the 1.8 to 29.7 MHz frequency range exhibit tendencies to oscillate somewhere in the VHF-UHF range—generally between about 75 and 250 MHz depending on the type and size of tube. A typical parasitic resonant circuit is highlighted by bold lines in **Fig 13.25**.

Stray inductance between the tube plate and the output tuning capacitor forms a high-Q resonant circuit with the tube's  $C_{OUT}$ .  $C_{OUT}$  normally is much smaller (higher  $X_C$ ) than any of the other circuit capacitances shown. The tube's  $C_{IN}$  and the tuning capacitor  $C_{TUNE}$  essentially act as bypass capacitors, while the various chokes and tank inductances shown have high reactances at VHF. Thus the values of these components have little influence on the parasitic resonant frequency.

Oscillation is possible because the VHF resonant circuit is an inherently high-Q parallel-resonant tank that is not coupled to the external load. The load resistance at the plate is very high, and thus the voltage gain at the parasitic frequency can be quite high, leading to oscillation.

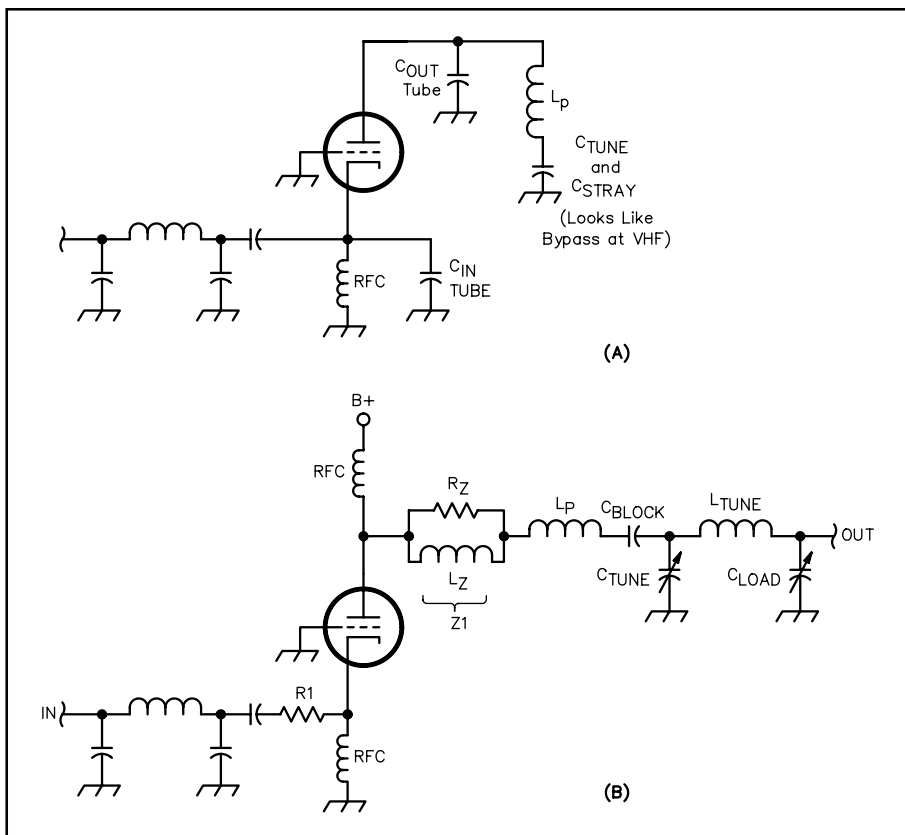

**Fig 13.25—At A, typical VHF/UHF parasitic resonance in plate circuit. The HF tuning inductor in the pi network looks like an RF choke at VHF/UHF. The tube's output capacity and series stray inductance combine with the pi-network tuning capacity and stray circuit capacity to create a VHF/UHF pi network, presenting a very high impedance to the plate, increasing its gain at VHF/UHF. At B,  $Z_1$  lowers the Q and therefore gain at parasitic frequency.**

The parasitic frequency,  $f_r$ , is approximately:

$$f_r = \frac{1000}{2\pi\sqrt{L_P C_{OUT}}} \quad (43)$$

where

$f_r$  = parasitic resonant frequency in MHz

$L_P$  = total stray inductance between tube plate and ground via the plate tuning capacitor (including tube internal plate lead) in  $\mu\text{H}$

$C_{OUT}$  = tube output capacitance in pF.

In a well-designed HF amplifier,  $L_P$  might be in the area of 0.2  $\mu\text{H}$  and  $C_{OUT}$  for an 8877 is about 10 pF. Using these figures, the equation above yields a potential parasitic resonant frequency of

$$f_r = \frac{1000}{2\pi\sqrt{0.2 \times 10}} = 112.5 \text{ MHz}$$

For a smaller tube, such as the 3CX800A7 with  $C_{OUT}$  of 6 pF,  $f_r = 145$  MHz. Circuit details affect  $f_r$  somewhat, but these results do in fact correspond closely to actual parasitic oscillations experienced with these tube types. VHF-UHF parasitic oscillations can be prevented (*not* just minimized!) by reducing the loaded Q of the parasitic resonant circuit so that gain at its resonant frequency is insufficient to support oscillation. This is possible with any common tube, and it is especially easy with modern external-anode tubes like the 8877, 3CX800A7, and 4CX800A.

Z1 of Fig 13.25B is a parasitic suppressor. Its purpose is to add loss to the parasitic circuit and reduce its Q enough to prevent oscillation. This must be accomplished without significantly affecting normal operation.  $L_z$  should be just large enough to constitute a significant part of the total parasitic tank inductance (originally represented by  $L_P$ ), and located right at the tube plate terminal(s). If  $L_z$  is made quite lossy, it will reduce the Q of the parasitic circuit as desired.

The inductance and construction of  $L_z$  depend substantially on the type of tube used. Popular glass tubes like the 3-500Z and 4-1000A have internal plate leads made of wire. This significantly increases  $L_P$  when compared to external-anode tubes. Consequently,  $L_z$  for these large glass tubes usually must be larger in order to constitute an adequate portion of the total value of  $L_P$ . Typically a coil of 3 to 5 turns of #10 wire, 0.25 to 0.5 inches in diameter and about 0.5 to 1 inches long is sufficient. For the 8877 and similar tubes it usually is convenient to form a “horseshoe” in the strap used to make the plate connection. A “U” about 1 inch wide and 0.75 to 1 inch deep usually is sufficient. In either case,  $L_z$  carries the full operating-frequency plate current; at the higher frequencies this often includes a substantial amount of circulating tank current, and  $L_z$  must be husky enough to handle it without overheating even at 29 MHz.

Regardless of the form of  $L_z$ , loss may be introduced as required by shunting  $L_z$  with one or more suitable noninductive resistors. In high-power amplifiers, two composition or metal film resistors, each 100  $\Omega$ , 2 W, connected in parallel across  $L_z$  usually are adequate. For amplifiers up to perhaps 500 W a single 47- $\Omega$ , 2-W resistor may suffice. The resistance and power capability required to prevent VHF/UHF parasitic oscillations, while not overheating as a result of normal plate circuit current flow, depend on circuit parameters. Operating-frequency voltage drop across  $L_z$  is greatest at higher frequencies, so it is important to use the minimum necessary value of  $L_z$  in order to minimize power dissipation in  $R_z$ .

The parasitic suppressors described above very often will work without modification, but in some cases it will be necessary to experiment with both  $L_z$  and  $R_z$  to find a suitable combination. Some designers use nichrome or other resistance wire for  $L_z$ , but there is no credible evidence of any fundamental difference in performance as a result. Amplifier manufacturer W4ETO has never seen an HF amplifier using modern tubes that could not be made completely free of VHF parasitics by using one of the simple parasitic suppressor constructions described above.

In exceptionally difficult cases, particularly when using glass tetrodes or pentodes, additional parasitic suppression may be attained by connecting a low value resistor (about 10 to 15  $\Omega$ ) in series with the tube input, near the tube socket. This is illustrated by R1 of Fig 13.25B. If the tube has a relatively low input impedance, as is typical of grounded-grid amplifiers and some grounded-cathode tubes with large  $C_{IN}$ , R1 may dissipate a significant portion of the total drive power.

### Testing Tube Amplifiers for VHF-UHF Parasitic Oscillations

Every high-power amplifier should be tested before being placed in service, to insure that it is free of parasitic oscillations. For this test, nothing is connected to either the RF input or output terminals, and the bandswitch is first set to the lowest-frequency range. If the input is tuned and can be bandswitched separately, it should be set to the highest-frequency band. The amplifier control system should provide monitoring for both grid current and plate current, as well as a relay, circuit breaker, or fast-acting fuse to quickly shut off high voltage in the event of excessive plate current. To further protect the tube grid, it is a good idea to temporarily insert in series with the grid current return line a resistor of approximately 1000  $\Omega$  to prevent grid current from soaring in the event a vigorous parasitic oscillation breaks out during initial testing.

Apply filament and bias voltages to the amplifier, leaving plate voltage off and/or cutoff bias applied until any specified tube warmup time has elapsed. Then apply the lowest available plate voltage and switch the amplifier to transmit. Some idling plate current should flow. If it does not, it may be necessary to increase plate voltage to normal or to reduce bias so that at least 100 mA or so does flow. Grid current should be zero. Vary the plate tuning capacitor slowly from maximum capacitance to minimum, watching closely for any grid current or change in plate current, either of which would indicate a parasitic oscillation. If a tunable input network is used, its capacitor (the one closest to the tube if a pi circuit) should be varied from one extreme to the other in small increments, tuning the output plate capacitor at each step to search for signs of oscillation. If at any time either the grid or plate current increases to a large value, shut off plate voltage immediately to avoid damage! If moderate grid current or changes in plate current are observed, the frequency of oscillation can be determined by loosely coupling an RF absorption meter or a spectrum analyzer to the plate area. It will then be necessary to experiment with parasitic suppression measures until no signs of oscillation can be detected under any conditions. This process should be repeated using each bandswitch position.

When no sign of oscillation can be found, increase the plate voltage to its normal operating value and calculate plate dissipation (idling plate current times plate voltage). If dissipation is at least half of, but not more than, its maximum safe value, repeat the previous tests.



**Fig 13.26—Suppression methods for VHF and UHF parasitics in solid-state amplifiers.**

If plate dissipation is much less than half of maximum safe value, it is desirable (but not absolutely essential) to reduce bias until it is. If no sign of oscillation is detected, the temporary grid resistor should be removed and the amplifier is ready for normal operation.

## Parasitic Oscillations in Solid-State Amplifiers

In low-power solid-state amplifiers, parasitic oscillations can be prevented by using a small amount of resistance in series with the base or collector lead, as shown in **Fig 13.26A**. The value of R1 or R2 typically should be between 10 and 22  $\Omega$ . The use of both resistors is seldom necessary, but an empirical determination must be made. R1 or R2 should be located as close to the transistor as practical.

At power levels in excess of approximately 0.5 W, the technique of parasitic suppression shown in **Fig 13.26B** is effective. The voltage drop across a resistor would be prohibitive at the higher power levels, so one or more ferrite beads placed over connecting leads can be substituted (Z1 and Z2). A bead permeability of 125 presents a high impedance at VHF and above without affecting HF performance. The beads need not be used at both circuit locations. Generally, the terminal carrying the least current is the best place for these suppression devices. This suggests that the resistor or ferrite beads should be connected in the base lead of the transistor.

C3 of **Fig 13.27** can be added to some power amplifiers to dampen VHF/UHF parasitic oscillations. The capacitor should be low in reactance at VHF and UHF, but must present a high reactance at the operating frequency. The exact value selected will depend upon the collector impedance. A reasonable estimate is to use an  $X_C$  of 10 times the collector impedance at the operating frequency. Silver-mica or ceramic chip capacitors are suggested for this application. An additional advantage is the resultant bypassing action for VHF and UHF harmonic energy in the collector circuit. C3 should be placed as close to the collector terminal as possible, using short leads.

The effects of C3 in a broadband amplifier are relatively insignificant at the operating frequency. However, when a narrow-band collector network is used, the added capacitance of C3 must be absorbed into the network design in the same manner as the  $C_{OUT}$  of the transistor.

## Low-Frequency Parasitic Oscillations

Bipolar transistors exhibit a rising gain characteristic as the operating frequency is lowered. To preclude low-frequency instabilities because of the high gain, shunt and degenerative feedback are often used. In the regions where low-frequency self-oscillations are most likely to occur, the feedback increases by nature of the feedback network, reducing the amplifier gain. In the circuit of **Fig 13.27**, C1 and R3 provide negative feedback, which increases progressively as the frequency is lowered. The network has a small effect at the desired operating frequency but has a pronounced effect at the lower frequencies. The values for C1 and R3 are usually chosen experimentally. C1 will usually be between 220 pF and 0.0015  $\mu$ F for HF-band amplifiers while R3 may be a value from 51 to 5600  $\Omega$ .

R2 of **Fig 13.27** develops emitter degeneration at low frequencies. The bypass capacitor, C2, is chosen for adequate RF bypassing at the intended operating frequency. The impedance

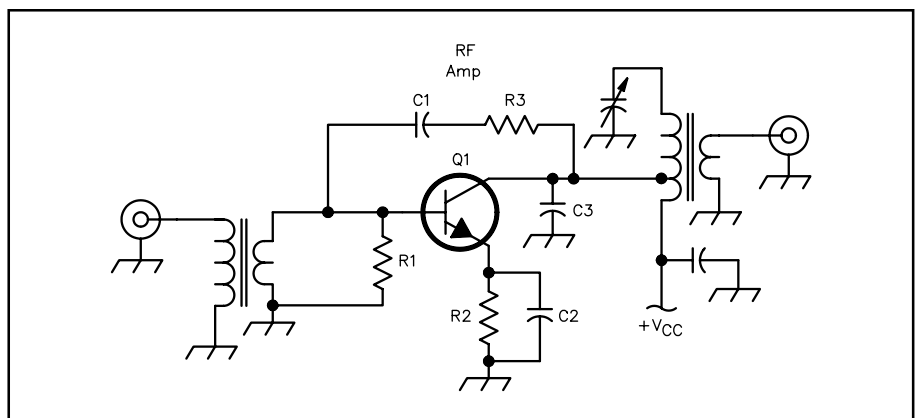

**Fig 13.27**—Illustration of shunt feedback in a transistor amplifier. C1 and R3 make up the feedback network.



of  $C_2$  rises progressively as the frequency is lowered, thereby increasing the degenerative feedback caused by  $R_2$ . This lowers the amplifier gain.  $R_2$  in a power stage is seldom greater than  $10\ \Omega$ , and may be as low as  $1\ \Omega$ . It is important to consider that under some operating and layout conditions  $R_2$  can cause instability. This form of feedback should be used only in those circuits in which unconditional stability can be achieved.

$R_1$  of Fig 13.27 is useful in swamping the input of an amplifier. This reduces the chance for low-frequency self oscillations, but has an effect on amplifier performance in the desired operating range. Values from  $3$  to  $27\ \Omega$  are typical. When connected in shunt with the normally low base impedance of a power amplifier, the resistors lower the effective device input impedance slightly.  $R_1$  should be located as close to the transistor base terminal as possible, and the connecting leads must be kept short to minimize stray reactances. The use of two resistors in parallel reduces the amount of inductive reactance introduced compared to a single resistor.

Although the same concepts can be applied to tube-type amplifiers, the possibility of self-oscillations at frequencies lower than VHF is significantly lower than in solid-state amplifiers. Tube amplifiers will usually operate stably as long as the input-to-output isolation is greater than the stage gain. Proper shielding and dc-power-lead bypassing essentially eliminate feedback paths, except for those through the tube itself.

On rare occasions tube-type amplifiers will oscillate at frequencies in the range of about  $50$  to  $500\ \text{kHz}$ . This is most likely with high-gain tetrodes using shunt feed of dc voltages to both grid and plate through RF chokes. If the resonant frequency of the grid RF choke and its associated coupling capacitor occurs close to that of the plate choke and its blocking capacitor, conditions may support a tuned-plate tuned-grid oscillation. For example, using typical values of  $1\ \text{mH}$  and  $1000\ \text{pF}$ , the expected parasitic frequency would be around  $160\ \text{kHz}$ .

Make sure that there is no low-impedance, low-frequency return path to ground through inductors in the input matching networks in series with the low impedances reflected by a transceiver output transformer. Usually, oscillation can be prevented by changing choke or capacitor values to insure that the input resonant frequency is much lower than that of the output.

## Amplifier Neutralization

Depending on stage gain and interelectrode capacitances, sufficient positive feedback may occur to cause oscillation at the operating frequency. This should not occur in well-designed grounded-grid amplifiers, nor with tetrode or pentodes operating at gains up to about  $15\ \text{dB}$  as is current practice at HF where  $50$  to  $100\ \text{W}$  of drive is almost always available. If triodes are grid-driven, however, and under certain other circumstances, neutralization may be necessary because of output energy capacitively coupled back to the input as shown in Fig 13.28. Neutralization involves coupling a small amount of output energy back to the amplifier input out of phase, to cancel the unwanted in-phase (positive) feedback. A typical circuit is given in Fig 13.29.  $L_2$  provides a  $180^\circ$  phase reversal because it is center

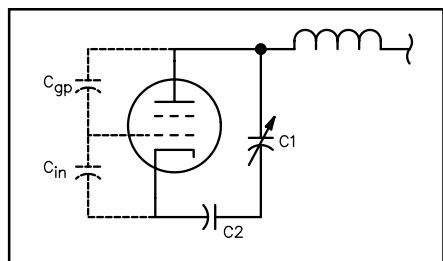

**Fig 13.28**—The equivalent feedback path due to the internal capacitance of the tube grid-plate structure in a power amplifier. Also see Fig 13.30.

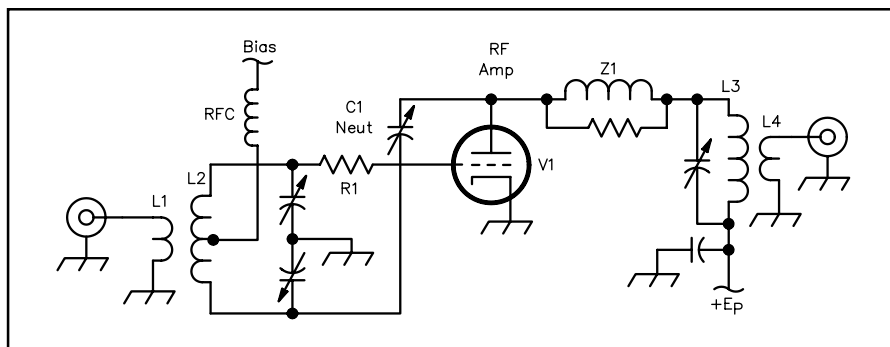

**Fig 13.29**—Example of neutralization of a single-ended RF amplifier.

tapped. C1 is connected between the plate and the lower half of the grid tank. C1 is then adjusted so that the energy coupled from the tube output through the neutralization circuit is equal in amplitude and exactly 180° out of phase with the energy coupled from the output back through the tube. The two signals then cancel and oscillation is impossible.

The easiest way to adjust a neutralization circuit is to connect a low-level RF source to the amplifier output tuned to the amplifier operating frequency. A sensitive RF detector like a receiver is then connected to the amplifier input. The amplifier must be turned off for this test. The amplifier tuning and loading controls, as well as any input network adjustments are then peaked for maximum indication on the RF detector connected at the input. C1 is then adjusted for minimum response on the detector. This null indicates that the neutralization circuit is canceling energy coupled from the amplifier output to its input through tube, transistor, or circuit capacitances.

### Screen-Grid Tube Stabilization

The plate-to-grid capacitance in a screen-grid tube is reduced to a fraction of a picofarad by the interposed grounded screen. Nevertheless, the power gain of these tubes may be so great in some circuits that only a very small amount of feedback is necessary to start oscillation. To assure a stable tetrode amplifier, it is usually necessary to load the grid circuit, or to use a neutralizing circuit.

### Grid Loading

The need for a neutralizing circuit may often be avoided by loading the grid circuit to reduce stage gain, provided that the driving stage has some power capacity to spare. Loading by tapping the grid down on the grid tank coil, or by placing a “swamping” resistor from grid to cathode, is effective to stabilize an amplifier. Either measure reduces the gain of the amplifier, lessening the possibility of oscillation. If a swamping resistor is connected between grid and cathode with very short leads, it may help reduce any tendency toward VHF-UHF parasitic oscillations as well. In a class AB1 amplifier, which draws no grid current, a swamping resistor can be used to replace the bias supply choke if parallel feed is used.

Often, reducing stage gain to the value required by available drive power is sufficient to assure stability. If this is not practical or effective, the bridge neutralizing system for screen-grid tubes shown in **Fig 13.30** may be used. C1 is the neutralizing capacitor. The value of C1 should be chosen so that at some adjustment of C1,

$$\frac{C1}{C3} = \frac{C_{gp}}{C_{IN}} \quad (44)$$

where

$C_{gp}$  = tube grid-plate capacitance

$C_{IN}$  = tube input capacitance.

The grid-to-cathode capacitance must include all strays directly across the tube capacitance, including the capacitance of the tuning capacitor.

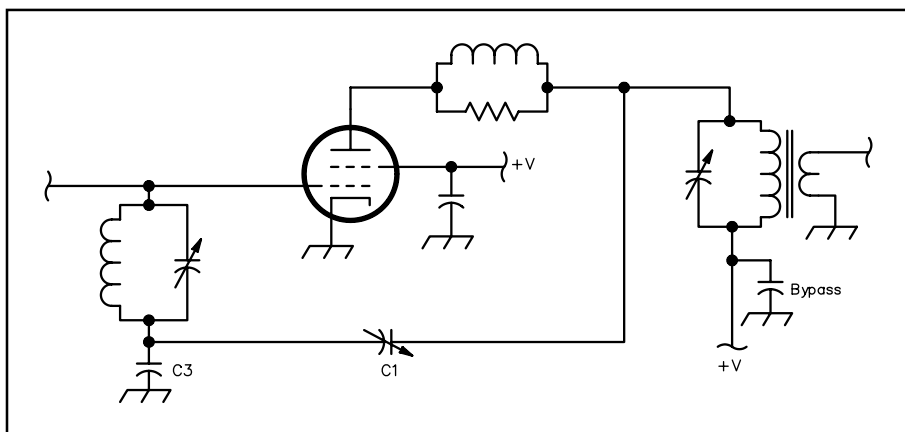

**Fig 13.30—A neutralization circuit uses C1 to cancel the effect of the tube internal capacitance.**

## THE SUNNYVALE/SAINT PETERSBURG KILOWATT-PLUS

This article describes a modern 1500-W output linear amplifier for the amateur HF bands. It uses a relatively recent arrival on the transmitting tube scene in the US, a 4CX1600B power tetrode made by Svetlana in Saint Petersburg, Russia. The amplifier was designed and constructed by George T. Daughters, K6GT, who lives in Sunnyvale, California—hence the name “Sunnyvale/Saint Petersburg” for this project. **Fig 13.31** shows the completed amplifier and the power supply cabinet.

Power tetrodes such as the 4CX1600B feature higher power gain than do the power triodes (such as the 3-500Z or 8877) often used in linear amplifiers. The increased power gain gives the designer additional flexibility, at the expense of a somewhat more complex dc supply design. This amplifier operates in the grounded-cathode configuration, with a 50- $\Omega$  resistor from control grid to ground. This provides a good load for the transceiver driving the amplifier, promotes amplifier stability and also eliminates the need for switched-input tuned circuits. The advantages of such a *passive-grid*, grounded-cathode design outweigh the cost and complication of the screen-grid supply needed by the tetrode tube.

The Svetlana 4CX1600B is designed with a “striped-cathode,” where emission takes place mainly in the spaces between parallel control-grid wires. This reduces the number of electrons intercepted by the control grid under normal drive conditions. (The Eimac 4CX1500B is also designed this way.) However, the linearity of such a high-gain tetrode falls off rapidly if the control grid is allowed to draw any current at all. Even a small positive voltage at the control grid can cause a large current to flow in the grid.

Note that the control grid in this type of high-gain tetrode is only rated at 2 W dissipation. (The first versions of the data sheet for the 4CX1600B specified the grid dissipation as 100 *milliwatts*!) By comparison, the control grid dissipation of the venerable, but much lower-gain, 4-1000A tetrode is 25 W. Any circumstance where measurable control grid current flows in the 4CX1600B will result in nonlinear operation, resulting not only in splatter, but also in possible damage to the control grid. It is thus important to provide some sort of *grid current prevention* scheme or, at the very least, a *grid current warning* alarm, for an amplifier using the 4CX1600B.

The grid of the 4CX1600B in this amplifier is tapped down on the input resistor. With 100 W of drive, the grid voltage cannot swing positive enough to result in significant grid current. Deliberate cathode degeneration (negative feedback) is also used to help prevent grid-current flow. This is accomplished by placing a noninductive resistor between the cathode and ground. In addition, a sensitive grid-current meter is provided, reading 1.3 mA at full-scale deflection. Finally, a simple, yet sensitive, grid-current-activated warning is also included in this design, using a red LED on the front panel as a warning lamp.

In receive, a 100  $\Omega$  resistor is switched into the screen grid circuit to chassis ground. This removes the screen voltage and keeps the tube cut off to avoid the generation of any shot noise. In transmit, a 17.5-k $\Omega$ , 15-W resistor to ground is switched into the screen grid circuit to keep a



(A)

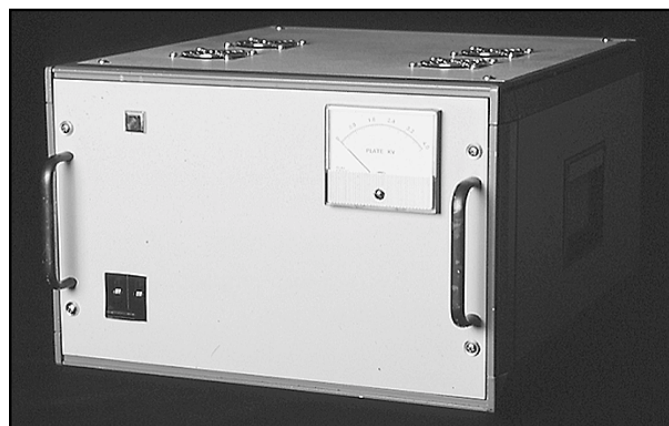

(B)

**Fig 13.31**—At A, photo of Sunnyvale/Saint Petersburg Kilowatt-Plus amplifier RF Deck. At B, the Power Supply cabinet.

constant load of 20 mA on the series regulator. This allows the regulator to function properly with up to  $-20$  mA of screen current. (Negative screen current is a condition common to these types of power tetrodes under some load conditions.) The 20-mA constant load is indicated on the screen-current meter as “zero,” so that the meter reads actual screen current from  $-20$  to  $+80$  mA.

## BUILDING IT

The heart of the amplifier consists of the RF deck, the control and metering circuitry and the cooling system. These are all mounted in a surplus 19-inch rack-mount cabinet of the sort picked up at surplus stores and hamfests. The power supply is built into another cabinet.

**Fig 13.32** shows the schematic diagram of the RF deck. The 4CX1600B is mounted in the Svetlana SK-3A socket, modified as described below (to allow the cathode to operate above ground potential for negative feedback). Svetlana’s CH-1600B chimney routes the cooling airflow through the anode cooling fins. An additional CH-1600B acts as a chimney extension, discharging the air through the top of the RF deck’s cabinet. The cooling fan is a squirrel-cage blower. According to the 4CX1600B data sheet at 1600 W of plate dissipation, the blower should deliver at least 36 cfm (cubic feet per minute) of cooling air at an ambient temperature of  $25^{\circ}\text{C}$ , at a back pressure of 0.4 inches of water.

The low-cost filament transformer specified in **Fig 13.32** produces 13.5 V ac (with nominal mains voltage), so two  $0.1\text{-}\Omega$ , 5-W resistors were added to drop the voltage at the filament terminals of the 4CX1600B to the 12.6 V ac recommended by the tube manufacturer.

The input grid resistor is  $51.6\ \Omega$ , with a dissipation capability exceeding 100 W. It consists of three Caddock MP850 resistors—two  $71.2\text{-}\Omega$  resistors in parallel, in series with  $15\ \Omega$ , all mounted on a surplus heat sink ( $5.0 \times 5.5 \times 0.75$  inch or  $12.7 \times 14.0 \times 2.0$  cm). This passive grid resistor is mounted below the chassis, near the SK-3A socket, and has its own small cooling “biscuit” fan. While the air below the chassis is pressurized by the main blower to provide cooling of the tube, the auxiliary fan cools the input resistors and keeps the air stirred up to prevent any stagnant hot air below the chassis.

The grid of the 4CX1600B is tapped at the  $35.6\text{-}\Omega$  point of the input resistive divider. As a further aid to stability, a  $10\text{-}\Omega$ , 2-W composition resistor is placed in series with the control-grid lead. This arrangement results in an input SWR of 1.0:1 at 1.9 MHz, increasing to just over 1.6:1 at 29.6 MHz, mainly due to the reactance of the 86 pF input capacitance of the 4CX1600B. No frequency compensation was deemed necessary. The cathode resistor is made up of four  $16\text{-}\Omega$ , 3-W noninductive metal-oxide film resistors from the cathode terminal ring on the socket to each of the four socket mounting screws.

The plate tank circuit components include a heavy-duty bandswitch, a silver-plated inductor for the high bands, powdered iron toroidal inductors for the low bands and a plate choke wound on a Delrin form. These components are those used in a Command Technologies HF-2500 amplifier but other suitable components could be utilized. (As it is currently configured, the plate tank cannot be tuned to 30 meters. Operation at full power on this band would require another position on the bandswitch and another tap on the tank coil or compromises on other bands. These are options which the author considered to be unnecessary and undesirable, since US hams have a power limit of 200 W on 30 meters.)

The anode connector is a Svetlana AC-2, and the plate parasitic choke is two turns of tinned copper strap ( $0.032$ -inch thick  $\times$   $0.188$ -inches wide, or  $0.8\ \text{mm} \times 4.8\ \text{mm}$ ) over three  $91\text{-}\Omega$ , 2-W composition resistors in parallel. (Any value from 47 to  $100\ \Omega$  will be satisfactory.) The antenna change-over relay has a 115 V ac coil ( $12\ \text{V}$  dc would be fine also). The author’s relay had wide, gold-plated contacts.

## CONTROL CIRCUITRY

The control circuitry is shown in **Fig 13.32**. The amplifier is turned on with the main switch/breaker on the power-supply cabinet. When the switch is thrown, all voltages are ready (after the step-start delay in the plate supply). The 4CX1600B filament begins to heat; the cooling fans go on; the time delay starts and anode voltage is applied to the 4CX1600B. After the mandatory three minutes for filament warmup,

**Fig 13.32—Schematic diagram of the RF Deck of the 4CX1600B linear amplifier. Resistors are 1/2 W unless noted. Capacitors are disc ceramic unless noted and those marked with a + are electrolytic. See the Address List in the [References](#) chapter.**

- B1—Squirrel-cage blower capable of 36 cfm at 0.4 inches of water back pressure (Dayton 4C753 or similar).**
- B2—“Biscuit” blower, 12 V dc, 130 mA (Rotron BD12A3 or similar) mounted inside the pressurized RF deck to aid cooling the input grid resistor R1.**
- BT1—9 V transistor radio battery.**
- C1, C2—0.02 μF, 500 V disc ceramic.**
- C3, C4, C5, C6—0.05 μF, 50 V disc ceramic.**
- C7—Screen bypass capacitor (0.02 μF, 1 kV disc ceramic at the screen terminal on the socket in parallel with the internal bypass capacitor, which is part of the Svetlana SK-3A socket).**
- C8—0.05 μF, 1 kV disc ceramic.**
- C9, C10—parallel 2500 pF, 10 kV ceramic doorknob, Newark #46F5253.**
- C11, C12—2500 pF, 10 kV ceramic doorknob, Newark #46F5253.**
- C13—Plate tuning capacitor; front section is 30-150 pF; rear section is 25-90 pF (Command Technologies P/N 73-2-100-41).**
- C14, C17—500 pF, 5 kV ceramic doorknob.**
- C15—200 pF, 5 kV ceramic doorknob.**
- C16—Plate loading capacitor, 35-700 pF (Command Technologies P/N 73-1-45-65).**
- D1—1N4001.**
- DS1, DS2, DS3—Indicator lamps (green: 120 V ac; amber: 12 V; and red: 12 V).**
- DS4—Jumbo red LED.**
- FL1—IEC 110 V ac connector with 6 A line filter.**
- FT—0.001 μF, 1000 V feedthrough capacitors.**
- FB, C<sub>B</sub>—RF decoupling components used in multiple places; ferrite beads FB-43-1801 and 0.01 μF, 1 kV disc-ceramic capacitors.**
- K1—110 V ac DPDT antenna changeover relay.**
- K2—115 V ac 3-minute time delay (Macromatic SS-6262-KK).**
- K3—12 V dc relay, DPST.**
- L1—Plate tank inductor; 1/4-inch diameter, silver-plated copper tubing, 6 turns with inside diameter of 1 1/4 inches, followed by 4 1/2 turns with inside diameter of 1 3/4 inches. Tap for 10 (and 12) meters is 4 turns from small-diameter end; tap for 15 (and 17) meters is 2 turns further down. All of L1 is used for 20 meters.**
- L2—Toroid coil; 5 turns #10 PTFE wire (40 inches long, overall) on two T-225-8 cores.**
- L3—Toroid coil; 6 groups of 3 each #10 PTFE wires (150 inches long, overall) on three T-225-28 cores.**
- M1—200 μA meter movement, internal resistance 2000 Ω.**
- P1—IEC power cable to J1 on [Fig 13.34](#).**
- Q1 to Q6—2N3904 or similar (Silicon, general purpose, NPN).**
- Q5—2N3015 or similar (Silicon, low V<sub>ce</sub> (Sat), NPN).**
- R1—15 Ω, Caddock MP-850, mounted on heat sink with R3 and R4.**
- R2—10 Ω, 2 W composition.**
- R3, R4—71.2 Ω Caddock MP-850, mounted on heat sink with R1.**
- R5, R13—6.2 kΩ, 1 W. (R5 is part of the cathode current meter multiplier, as is R13. Their values were chosen to provide 1.3 A full-scale reading on the meter used.)**
- R6—4 Ω, 12 W (4 each 16 Ω, 3 W, noninductive metal-oxide-film, in parallel on 4CX1600B tube socket).**
- R7—20 M Ω, 3 W (Caddock MX430).**
- R8—120 k Ω, 1 W composition.**
- R11, R12—Filament dropping resistors; 0.1 Ω, 5 W.**
- R16—Screen bleeder; 17.5 kΩ, 15 W (two 25 kΩ, 5 W in parallel, in series with 5 kΩ, 5 W).**
- RFC—1 mH RF choke.**
- RFC1—Plate choke, 91 turns #26 enamel on 1-inch diameter × 3.75 inch delrin form (Command Technologies P/N RFC-1).**
- T1—Broadband 2:1 transformer; 13 bifilar turns #12 PTFE (120 inches, overall) on three FT-240-61 cores. Note that plate tank inductors, bandswitch, plate RF choke, and toroidal RF transformer are part of Command Technologies HF-2500 plate tank circuit.**
- T2—Filament transformer, 12.6 V ac (center-tapped), 6A (Triad F-182).**
- V1—Svetlana 4CX1600B power tetrode in modified Svetlana SK-3A socket. The anode connector is a Svetlana AC-2, and the chimney and the chimney extension are each a Svetlana CH-1600B.**
- Z1—Parasitic suppressor; two turns of tinned copper strap (0.032-inch thick × 0.313-inch wide) over three 91 Ω, 2 W composition resistors in parallel.**

[[Schematic](#) on next page.]

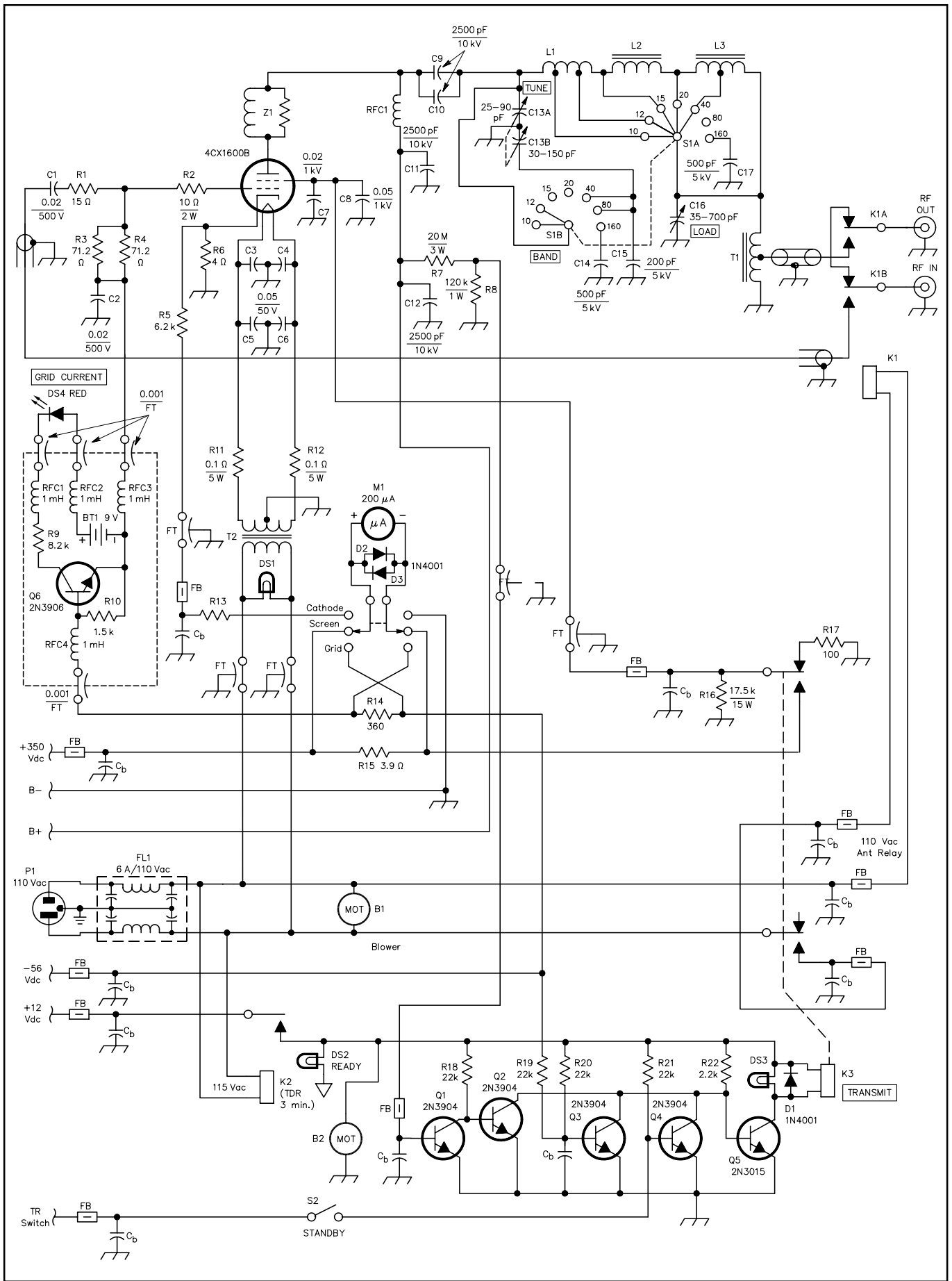

the +12 V dc control voltage is enabled by the time-delay relay. At this time, the control circuitry (consisting of transistors Q1 to Q5) determines whether screen voltage can be applied to the 4CX1600B and whether to activate the antenna changeover relay. Q5 is the main switch activating T/R relay K2 whenever 12 V is available (that is, after the 3-minute warmup period). Screen voltage will thus be supplied to the tube only when all of the following conditions are met:

1. The anode voltage for the 4CX1600B is available. This is sensed in the RF deck by the resistive divider R7/R8 shown in [Fig 13.32](#). If the HV sense line is low, then Q1 and Q2 hold the base of Q5 at a low level.
2. The negative control-grid bias is present. If this voltage is near zero, transistor Q3 is saturated, and again Q5 is turned off.
3. The T/R switch from the exciter has pulled the base of Q4 low, allowing its collector to rise.

## THE POWER SUPPLY

*Remember that almost every voltage inside a power supply for a high-power linear amplifier is lethal! Turn it off, unplug it, and short it out before you touch anything! Always apply the “one hand in the pocket” principle when working on anything above 24 V!*

The high-voltage power supply uses a Peter W. Dahl ARRL-002 transformer, weighing 46 pounds. As shown in [Fig 13.34](#), a simple *step-start circuit* using K1 and K2 limits the current surge charging the filter capacitors when power is first applied. The transformer’s output is rectified by a bridge of K2AW’s Silicon Alley 10-kV diode arrays, and the filter capacitor is made up of a string of ten 470  $\mu$ F, 400-V electrolytic capacitors. These were removed from a laser power supply board, which was available at a local surplus store (Alltronics, Santa Clara, CA) for \$14.95. The voltage is divided equally across the capacitor string by 25-k $\Omega$ , 25-W resistors that also serve as the power supply bleeder. (This divider

**Fig 13.34—Schematic diagram of the high-voltage plate and regulated screen supply for the 4CX1600B linear amplifier. K1, K2 and associated circuitry provide a “step-start” characteristic to limit the power-on surge of charging current for the filter capacitors. Resistors are 1/2 W unless noted. Capacitors are disc ceramic unless noted and those marked with a + are electrolytic. Addresses for parts suppliers are given in the [References](#) chapter.**

B1—Muffin fan (Rotron SU2A1 or similar).  
 C1 to C10—Filter capacitors; 470  $\mu$ F, 400 V electrolytic.  
 C11—600  $\mu$ F, 50 V electrolytic.  
 C12—0.01  $\mu$ F, 6 kV disc ceramic.  
 C13—220  $\mu$ F, 450 V electrolytic.  
 C14, C22—0.01  $\mu$ F, 600 V disc ceramic.  
 C15, C16—3300  $\mu$ F, 16 V electrolytic.  
 C17, C18, C19—0.01  $\mu$ F, 50 V disc ceramic.  
 C20, C21—100  $\mu$ F, 63 V electrolytic.  
 CB1—2  $\times$  20 A, 240 V ac circuit breaker.  
 D1 to D4—K2AW’s HV-10 rectifier diodes.  
 D5—1N4002.  
 D6—Zener diodes, three 1N4764A and one 1N5369B to total approximately 350 V dc.  
 D7, D8—1N5402.  
 D9, D10—1N4002.  
 D11—Zener diode, 1N5363B (30 V, 5 W).  
 D12—Zener diode, 1N5369B (51 V, 5 W).  
 DS1—120 V ac indicator lamp (red).  
 FL1—240 V ac/20 A EMI filter.  
 J1—110 V ac, 15 A receptacle for plug P1 on [Fig 13.32](#).

K1—120 V ac DPDT relay; both poles of 240 V ac/15 A contacts in parallel.  
 K2—24 V dc relay; 120 V ac/5 A contacts.  
 M1—200  $\mu$ A meter movement.  
 Q1—MPSU010.  
 Q2—2N2222.  
 R1 to R10—Bleeder resistors; 25 k $\Omega$ , 10 W.  
 R11—20  $\Omega$ , 25 W.  
 R12—20 M $\Omega$ , 3 W (Caddock MX430).  
 R13—3.9 k $\Omega$ , 3 W.  
 R14—50  $\Omega$ , 50 W mounted on standoff insulators.  
 R15—300  $\Omega$ , 3 W.  
 R18—160 k $\Omega$ , 2 W composition.  
 R19, R20—100  $\Omega$ , 2 W composition.  
 R21, R22—10 k $\Omega$ , 1 W composition.  
 R24—5 k $\Omega$  potentiometer; sets control grid bias for desired no-signal cathode current.  
 T1—Plate transformer (Peter W. Dahl No. ARRL-002).  
 T2—Power transformer, 120 V / 275 V at 0.06 A, 6.3 V at 2 A, 35 V at 0.15 A.  
 U1—600 V, 1 A rectifier bridge.  
 U2—7812, +12 V IC voltage regulator.

[[Schematic](#) on next page.]

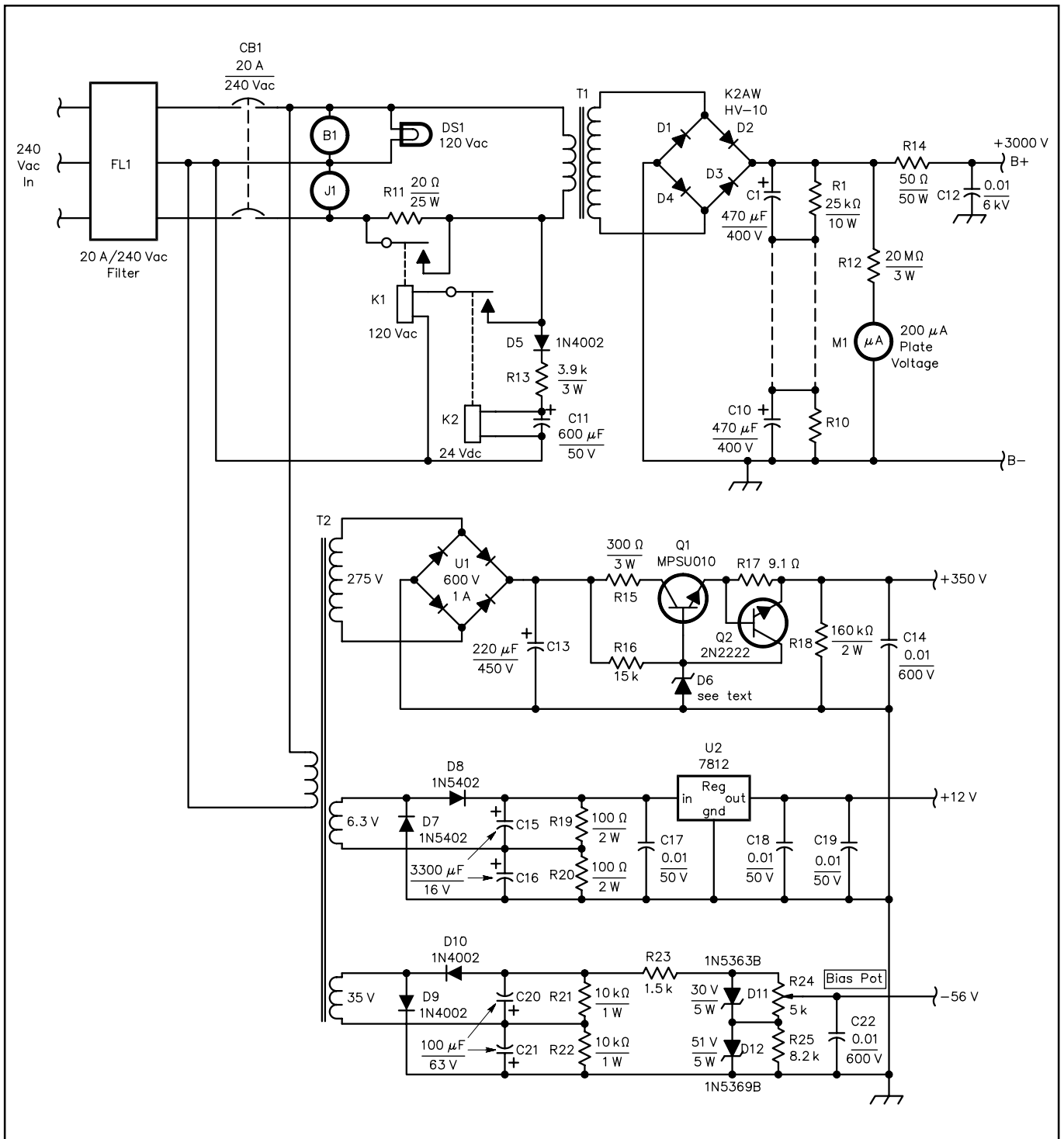



results in a considerably higher bleeder current than the typical 100 k $\Omega$  resistors often seen. The result is a stiffer power supply, but more heat is generated.)

The author's junk box produced a transformer with output windings of 275 V ac at 60 mA, 6.3 V ac at 2 A, and 35 V ac at 150 mA. These windings were dedicated to a regulated 350-V screen supply, a regulated 12-V dc supply for relay and indicator lamps (using a full-wave doubler and a three-terminal IC regulator), and the control-grid bias supply. The circuitry for these supplies is very straightforward. These supplies were built in the same cabinet as the plate high-voltage supply.

All power supplies are cooled by a muffin fan on the rear panel of the cabinet. Although the fan probably isn't necessary, cool components are sure to last longer. The major source of heat in this cabinet is the bleeder-resistor chain, which dissipates about 36 W when the plate voltage is 3000 V. High voltage is monitored with a 200  $\mu$ A surplus meter movement through a Caddock MX430 20 M $\Omega$  multiplier resistor.

All power to the RF deck is supplied from the power supply cabinet. There is a standard IEC 120-V ac cable for the 4CX1600B filament transformer and the antenna changeover relay, an auxiliary power cable and a high-voltage line for the anode voltage. The shielded auxiliary power cable carries the screen and control-grid bias voltages and the 12-V dc and the ground. The high-voltage line is a 40-kV #18 wire obtained from a local surplus store, with Millen 37001 connectors at each end.

In this design it is possible to plug in and turn on the HV supply without any connection to the RF deck. If you should forget to connect the ground wire and only connect the HV cable by itself, then a potentially *unsafe* condition exists, with high voltage on the RF deck chassis with respect to the power supply chassis. You can avoid this in several ways: Use a special high-voltage cable/connector that incorporates a chassis ground connection together with the HV lead. Or you could use an interlock system, with an additional high-current relay in the 240 V ac line that is activated only when an interlock cable is connected. (The interlock cable would contain a direct inter-chassis ground connection.) Finally, a simple but effective approach is to bundle the HV cable with the other inter-cabinet cables, with a distinctive bright warning label to remind the operator to make sure all connections are made between the power supply and the RF deck.

Because no control-grid current flows, the control-grid bias voltage (nominally  $-56$  V) is provided by a simple half-wave voltage doubler, with low-power zener diodes and a potentiometer to allow grid bias adjustment for the desired no-signal cathode current. The common practice of using a zener diode in the cathode circuit to provide operating bias was rejected because of the need for actual resistance between the cathode and ground for negative feedback.

The screen supply provides a dc voltage of 350 V by means of a series electronic regulator. The regulator has a current-limiting feature, where the output voltage falls if the screen draws more than 60 mA. This prevents the screen grid dissipation from exceeding its maximum rating of 20 W.

## MODIFYING THE SK-3A SOCKET

Because the stock Svetlana socket has the cathode tied directly to chassis ground (through the socket's mounting plate) and because an internal bypass capacitor for the screen grid is placed between the screen grid and the cathode, you must modify the socket for this application. You will need four insulating shoulder washers (Teflon or other insulating material), made for 4-40 screws.

1. Drill out the four rivets holding the screen ring to the screen contactors at the very top of the socket.
2. At the bottom of the socket, remove the four nuts from the machine screws holding the socket assembly together.
3. Disassemble the socket:

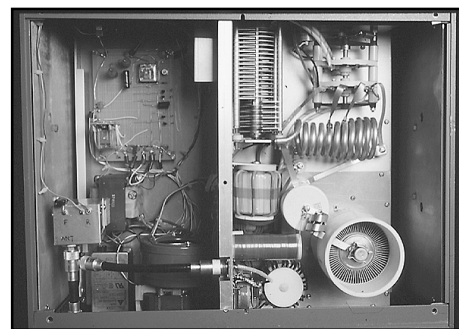

**Fig 13.35—**Inside view of RF deck. Tank components are from a Command Technologies HF-2500 amplifier.

- a) First remove the cathode contact ring. Be sure to mark its position relative to the underlying bakelite layer.
  - b) Remove the bakelite socket layer, which has the factory markings and serial number, also marking its position relative to the socket mounting plate. (This is the 0.060-inch [1.5-mm] silver-plated brass plate.)
  - c) Carefully remove the screen contactor assembly, freeing the contactor “ears” by springing them outward. Don’t drop the screen capacitor! It is the ceramic annulus with silver plating on each side and it is very brittle.
  - d) Finish removing the spring plate, the capacitor and the other spring plate, if they didn’t already come out with the screen contactor assembly in step (c) above.
  - e) Remove the mounting plate assembly, marking its position relative to the remaining socket assembly.
4. Drill out the four holes in the mounting plate assembly using a #14 drill (0.180 inches). These are the second set of holes in from the outer edge, through which the socket assembly screws pass. (The screws should still be in the top layer of the socket, with heater, grid, and cathode contactors.)
  5. Put the new Teflon shoulder washers on the screws. When the socket is reassembled, the cathode will be isolated from the main mounting plate and the screen bypass capacitor.
  6. Replace the capacitor assembly in the following order: spring, capacitor and spring. Now replace the screen contactor assembly and the bakelite bottom section, taking care to align this section with your previous mark. Carefully guide the socket solder tabs through the bakelite bottom without bending them.
  7. Cut the outer tabs off the cathode ring contact. After all of this work, you don’t want this ring (the cathode terminal) to be grounded when you mount the socket in the chassis! Place the modified cathode contact ring over the screws.
  8. Replace the washers and nuts on the socket assembly machine screws and tighten each a little at a time, until the assembly is snug.

This completes the socket conversion. The screen ring on the 4CX1600B is contacted exactly as before. The internal screen bypass capacitor still appears between the screen grid and ground (through the socket mounting plate). The heater, control grid, and screen contacts function exactly as in the original.

The cathode annulus on the 4CX1600B is contacted exactly as before, but the electrical connection for the cathode is now isolated from the chassis. The cathode contact on the socket is now made through the thin cathode ring on the bottom of the socket. (The ring is silver-plated and easily soldered, convenient for an application like the present one, which requires multiple contacts.)

## METERING

The author obtained some attractive meters with 200  $\mu$ A movements from a local surplus store. The internal resis-

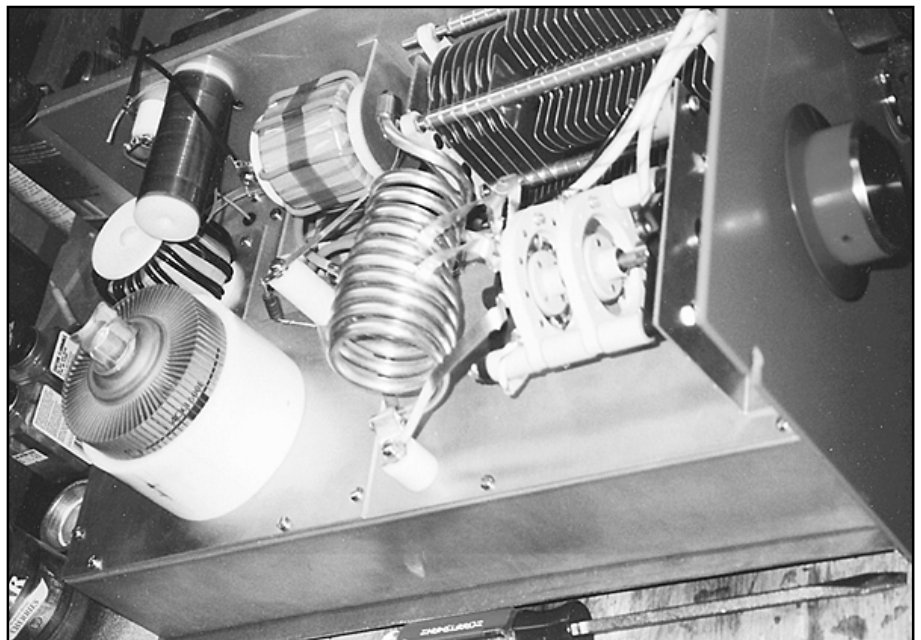

**Fig 13.36—Another view of RF deck during construction.**

tance was 2000  $\Omega$ . One meter became a voltmeter on the anode power supply (0 to 4 kV); one became a triple-purpose multimeter to measure anode current (0 to 1.3A), screen-grid current (–20 to +80 mA), and control-grid current (0 to 1.3 mA). The third meter, not shown in the schematic, indicates forward (0 to 1500 W) and reflected power (0 to 150 W) at the output connector. After dc calibration against a digital multimeter, he carefully removed the cover and face of each movement and attached a homemade laser-printed scale.

## GRID CURRENT WARNING

The circuitry for the grid-current warning indicator light is very simple and is shown in Fig 13.32 also. When control-grid current flows, it develops a voltage across R10. This causes the collector current of Q6 to light a red LED indicator brightly when grid current is about 1.0 mA. (Although the battery is always connected to the circuit of transistor Q6, the current drain due to collector-emitter leakage current is negligible, so battery life should be very long. If you don't like the floating 9-V battery, a small dc power supply could be included or a small "wall-wart" type of dc supply could be built right into the cabinet. It must, however, be capable of floating at the grid potential, about 60 V away from chassis ground potential.)

When the grid-current warning LED flickers on voice peaks, it's time to back off the transceiver's RF output control to reduce the drive. In CW mode, many transceivers will put out a high-power spike on initial key closure, even when the RF output control is set to quite low values. If this happens with your transceiver, the warning blink from the LED will alert you to the problem. The circuitry for the grid-current warning indicator is built into a small aluminum minibox that uses feedthrough capacitors and RF chokes to eliminate stray RF.

## RESULTS

The zero-signal plate current is about 280 mA, resulting in a zero-signal plate dissipation of about 900 W. At full 1.5 kW output on 40 meters, the plate current is about 0.8 A and the anode dissipation is less than 1000 W. (Until the TR switch is activated, the screen voltage is zero and the tube is effectively cut off, so there is no plate dissipation except during transmit periods.) After a heavy period of operating the amplifier, let the fan run for a few minutes in standby mode to cool the tube before turning the amplifier off.

Performance figures for the amplifier are presented in Table 13.7.

**Table 13.7**  
**4CX1600B, Class AB1, Passive Grid-Driven Service**

	<i>Zero Signal</i>	<i>Maximum Signal</i>
Plate Voltage	3200 V	3040 V
Control Grid Bias Voltage	–56 V	–56 V
Screen Grid Voltage	350 V	350 V
DC Plate Current	280 mA	800 mA
Approx. Plate Load	—	2400 $\Omega$
Drive Power	0 W	66 W
Power Output	0 W	1500 W
Intermodulation Distortion Products		
3rd order	—	–35 dB
5th order	—	–43 dB
7th order	—	–47 dB

## A 6-METER KILOWATT AMPLIFIER USING THE SVETLANA 4CX1600B

The Svetlana 4CX1600B tube has attracted a lot of attention lately because of its potent capabilities and relatively low cost. Because of its high gain and its large anode dissipation capabilities, the tube has relatively large input and output capacitances—85 pF at the input and 12 pF at the output. Stray capacitance of about 10 pF must be added in as well. On bands lower than 50 MHz, these capacitances can be dealt with satisfactorily with a broadband 50- $\Omega$  input resistor and conventional output tuning circuitry.

See the article by George Daughters, K6GT, “[The Sunnyvale/Saint Petersburg Kilowatt-Plus](#)” earlier in this chapter for details on suitable control and power-supply circuitry. This 6-meter amplifier uses the same basic design as K6GT’s, except for modified input and output circuits in the RF deck. See **Fig 13.37**, a photograph of the front panel of the 6-meter amplifier.

On the 50-MHz band the tube’s high input capacitance must be tuned out. Author Dick Stevens, W1QWJ, used a T network so that the input impedance looks like a non-reactive 50  $\Omega$  to the transceiver. To keep the output tuning network’s loaded Q low enough for efficient power generation, he used a 1.5 to 46 pF Jennings CHV1-45-5S vacuum-variable capacitor, in a Pi-L configuration to keep harmonics low. You should use a quarter-wave shorted coaxial stub in parallel with the output RF connector to make absolutely sure that the second harmonic is reduced well below the FCC specification limits.

To guarantee stability, the author had to make sure the screen grid was kept as close as possible to RF ground. This allows the screen to do its job “screening”—this minimizes the capacitance between the control grid and the anode. He used the Svetlana SK-3A socket, which includes a built-in screen bypass capacitor, and augmented that with a 50-MHz series-tuned circuit to ground. In addition, to prevent VHF parasitics, he used a parasitic suppressor in the anode circuit.

Unlike the K6GT HF amplifier, this 6-meter amplifier uses no cathode degeneration. W1QWJ wanted maximum stable power gain, with less drive power needed on 6 meters. He left the SK-3A socket in stock form, with the cathode directly grounded. This amplifier requires about 25 W of drive power to produce full output.

**Fig 13.38** is a schematic of the RF deck built by W1QWJ. The control and power supply circuitry are basically the same as that used in **Fig 13.32** and **Fig 13.34** in the K6GT HF amplifier, except that plate current is monitored with a meter in series with the B– lead, since the cathode in this amplifier is grounded directly. The K6GT power supply is modified by inserting a 250- $\Omega$ , 25-W power resistor to ground in place of the direct ground connection. See **Fig 13.39**. In **Fig 13.38**, C1 blocks grid-bias dc voltage from appearing at the transceiver, while L1, L2 and C2 make up the T-network that tunes out the input capacitance of V1. R1 is a non-reactive 50- $\Omega$  50-W resistor.

C6 is the built-in screen bypass capacitor in the SK-3A socket, while L3 and C7 make up the series-tuned screen bypass circuit. RFC3 is a safety choke, in case blocking capacitor C12 should break down and short, which would otherwise place high voltage at the output connector.

### CONSTRUCTION

Like the K6GT amplifier, this W1QWJ amplifier is constructed in two parts: an RF deck and a power supply. Two aluminum chassis boxes bolted together and mounted to a front panel are used to make the RF deck.



**Fig 13.37**—Photo of the front panel of W1QWJ’s 6-meter 4CX1600B amplifier.

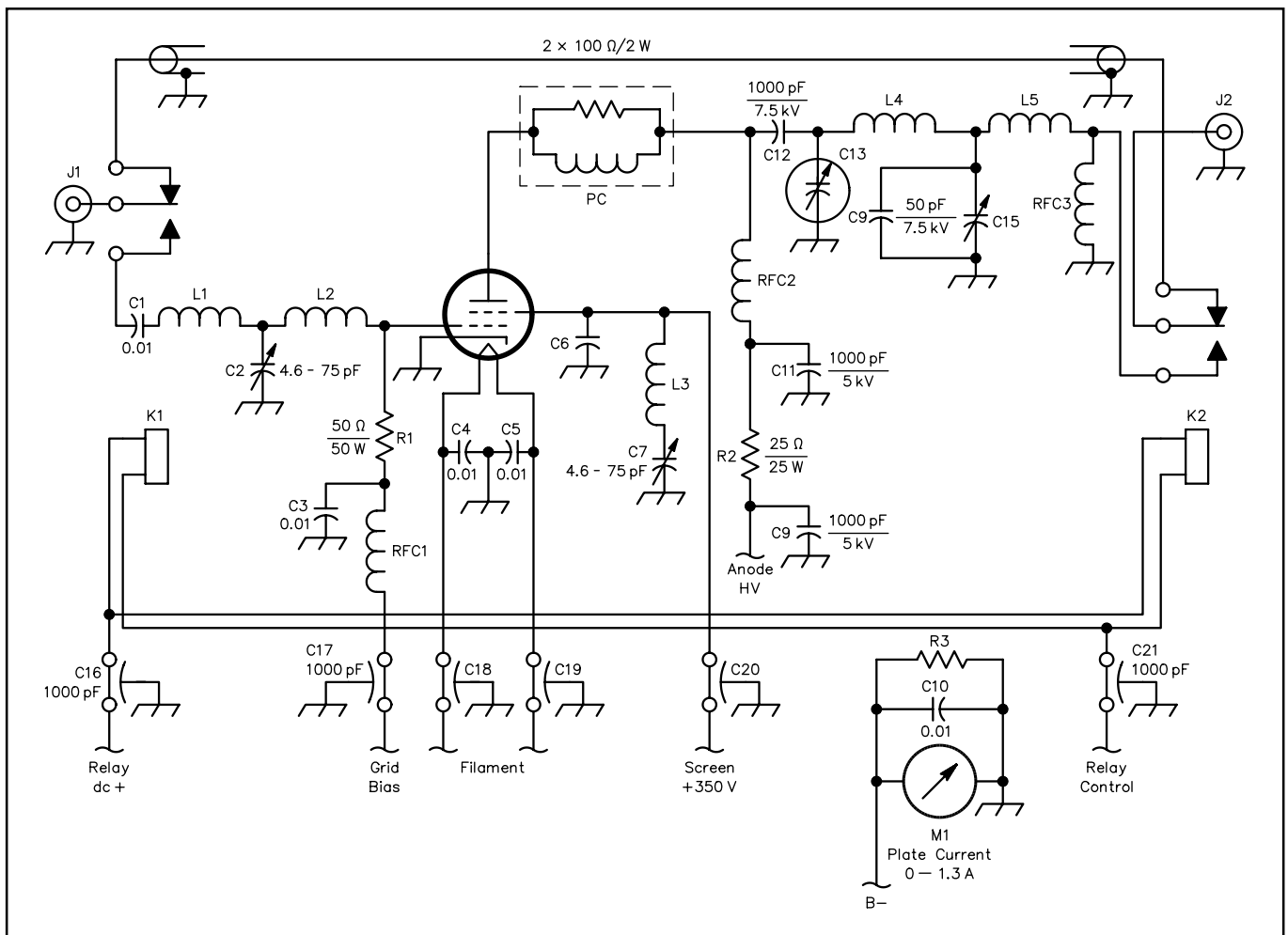

**Fig 13.38—Schematic for the RF deck for the 6-meter 4CX1600B amplifier. Capacitors are disc ceramic unless noted. Addresses for parts suppliers are given in the [References](#) chapter.**

**C2, C7—4.6-75 pF, 500-V air-variable trimmer capacitor, APC style.**

**C6—Screen bypass capacitor, built into SK-3A socket.**

**C13—1-45 pF, 5 kV, Jennings CHV1-45-5S vacuum-variable capacitor.**

**C14—50 pF, 7.5 kV, NPO ceramic doorknob capacitor.**

**C15—4-102 pF, 1100V, HFA-100A type air-variable capacitor.**

**C16, 17, 18, 19, 20, 21—1000 pF, 1 kV feedthrough capacitors.**

**L1—11 turns, #16,  $\frac{3}{8}$ -inch diameter, 1-inch long.**

**L2—9 turns #16,  $\frac{3}{8}$ -inch diameter, close-wound.**

**L3—8 turns #16,  $\frac{3}{8}$ -inch diameter,  $\frac{7}{8}$ -inch long.**

**L4— $\frac{1}{4}$ -inch copper tubing, 4 $\frac{1}{2}$  turns, 1 $\frac{1}{4}$  inches diameter, 4 $\frac{3}{4}$  inches long.**

**L5—5 turns #14,  $\frac{1}{2}$  inch diameter, 1 $\frac{3}{8}$  inches long.**

**M1—0-1.3 A meter, with homemade shunt resistor, R3, across 0-10 mA movement meter.**

**PC—Parasitic suppressor, 2 turns #14,  $\frac{1}{2}$  inch diameter, shunted by two 100- $\Omega$ , 2-W carbon composition resistors in parallel.**

**RFC1—10  $\mu$ H, grid-bias choke.**

**RFC2—Plate choke, 40 turns #20,  $\frac{1}{2}$  inch diameter, close-wound.**

**RFC3—Safety choke, 20 turns #20,  $\frac{3}{8}$  inch diameter.**

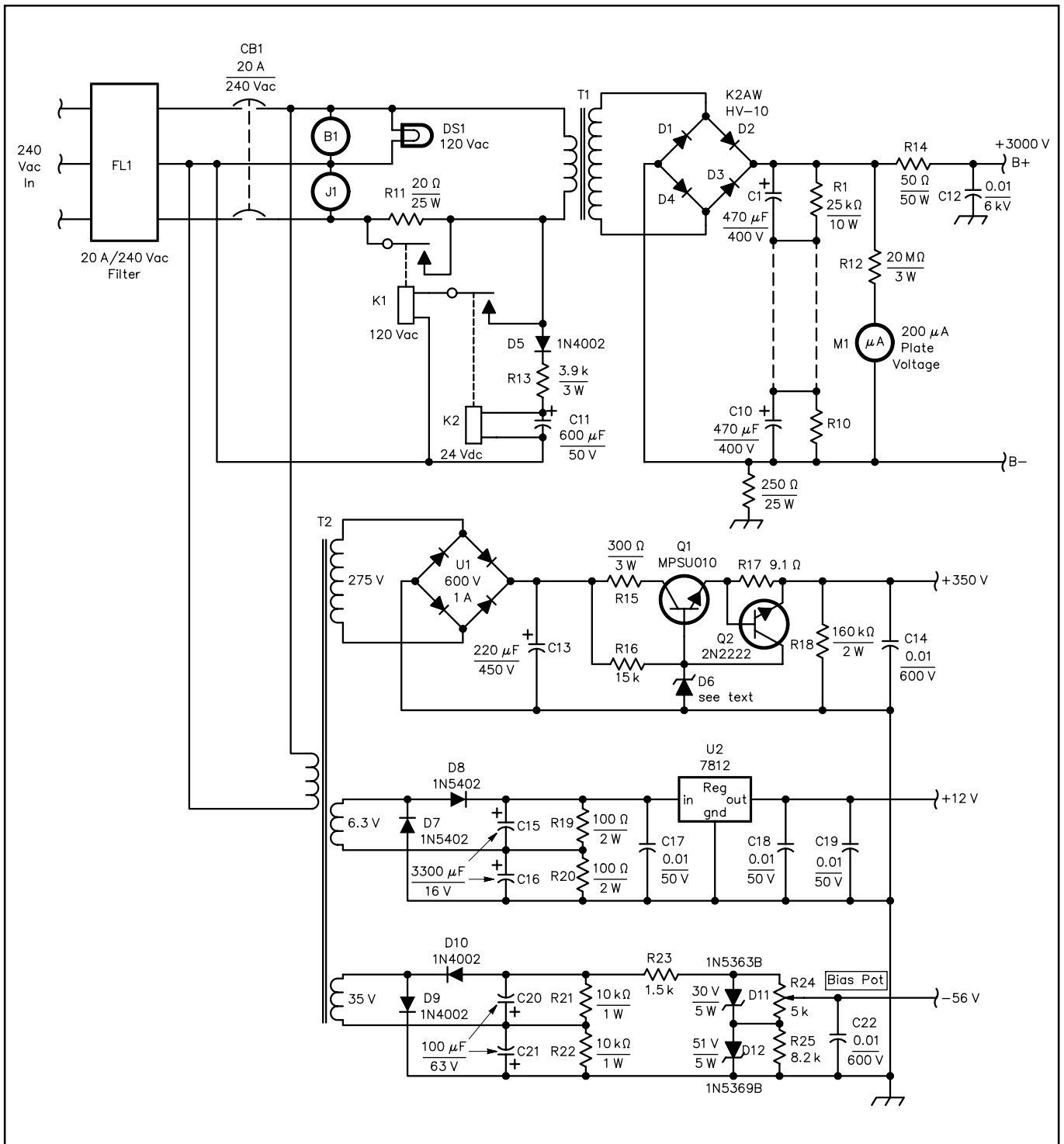

**Fig 13.39—**Partial schematic of K6GT HV power supply (see Fig 13.34), showing modification with 250-Ω, 25-W power resistor to ground on B- line, allowing for metering of the plate current in the amplifier.

**Fig 13.40** shows the 4CX1600B tube and the 6-meter output tank circuit. **Fig 13.41** shows the underside of the RF deck, with the input circuitry shown in more detail in **Fig 13.42**. The 50- $\Omega$ , 50-W noninductive power resistor is shown at the bottom of Fig 13.42. Note that the tuning adjustment for the input circuit is accessed from the rear of the RF deck.

## AMPLIFIER ADJUSTMENT

The tune-up adjustments can be done without power applied to the amplifier and with the top and bottom covers removed. You can use readily available test instruments: an MFJ-259 SWR Analyzer and a VTVM with RF probe.

1. Activate the antenna change-over relay, either mechanically or by applying control voltage to it. Connect a 2700- $\Omega$ ,  $\frac{1}{2}$ -W carbon composition resistor from anode to ground using short leads. Connect the SWR analyzer, tuned to 50 MHz, to the output connector. Adjust plate tuning and loading controls for a 1:1 SWR. You are using the **Pi-L** network in reverse this way.
2. Now, connect the MFJ-259 to the input connector and adjust the input **T**-network for a 1:1 SWR. Some spreading of the turns of the inductor may be required.
3. Disconnect the **Pi-L** output network from the tube's anode, leaving the 2700- $\Omega$  carbon composition resistor from the anode still connected. Connect the RF probe of the VTVM to the anode and run your exciter at low power into the amplifier's input connector. Tune the screen series-tuned bypass circuit for a distinct dip on the VTVM. The dip will be sharp and the VTVM reading should go to zero.
4. Now, disconnect the 2700- $\Omega$  carbon resistor from the anode and replace the covers. Connect the power supply and control circuitry. When you apply power to the amplifier, you should find that only a slight tweaking of the output controls will be needed for final adjustment.

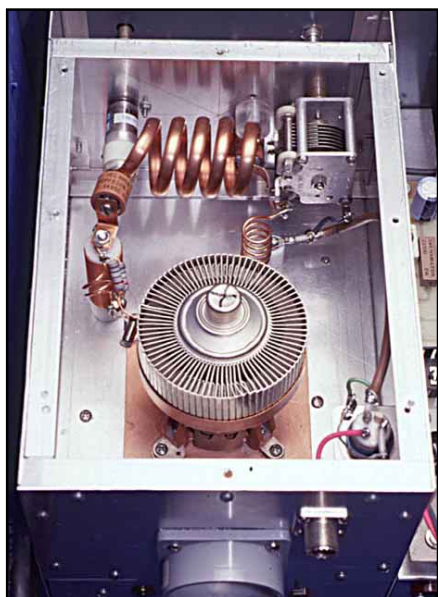

**Fig 13.40**—Close-up photo of the anode tank circuit for 6-meter kW amplifier. The air-cooling chimney has been removed in this photo.

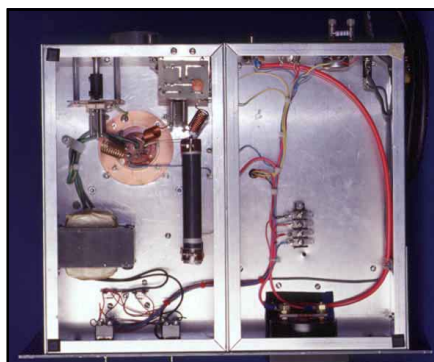

**Fig 13.41**—Underneath the 6-meter kW amplifier RF deck, showing on the left the tube socket and input circuitry.

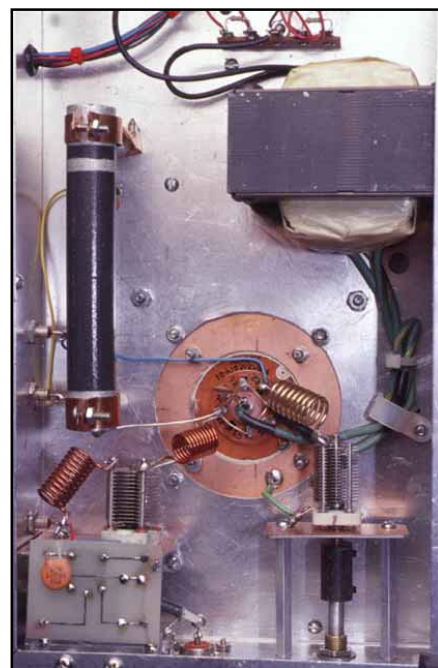

**Fig 13.42**—Close-up photo of the input circuitry for the 6-meter kW amplifier. Input tuning capacitor C2 is adjusted from the rear panel during operation, if necessary. The series-tuning capacitor C7 used to thoroughly ground the screen for RF is shown at the lower right. It is adjusted through a normally plugged hole in the rear panel during initial adjustment only.

## A 144-MHz AMPLIFIER USING THE 3CX1200Z7

This 2-m, 1-kW amplifier uses the EIMAC 3CX1200Z7 triode. The original article by Russ Miller, N7ART, appeared in December 1994 *QST*. The tube requires a warmup of about 10 s after applying filament voltage—no more waiting for three agonizingly long minutes until an amplifier can go on-line!

The 3CX1200Z7 is different from the earlier 3CX1200A7 by virtue of its external grid ring, redesigned anode assembly and a 6.3-V ac filament. One advantage to the 3CX1200Z7 is the wide range of plate voltages that can be used, from 2000 to 5500 V. This amplifier looks much like the easily duplicated W6PO design. The RF deck is a compact unit, designed for table-top use (See Fig 13.44 and schematic in Fig 13.45).

Table 13.9 gives some data on the 3CX1200Z7 and Table 13.10 lists CW operating performance for this amplifier.

### Input Circuit

Tuning is easy and docile. Grid bias is provided by an 8.2-V, 50-W Zener diode. Cutoff bias is provided by a 10-k $\Omega$ , 25-W resistor. A relay on the control board shorts out the cutoff-bias resistor, to place the amplifier in the TRANSMIT mode.

The author didn't use a tube socket. Instead, he bolted the tube directly to the top plate of the subchassis, using the four holes (drilled to clear a #6 screw) in the grid flange. Connections to the heater pins are via drilled and slotted brass rods. The input circuit is contained within a 3 $\frac{1}{2}$   $\times$  6  $\times$  7 $\frac{1}{4}$ -inch (HWD) subchassis (Fig 13.46).

### Control Circuit

The control circuit (Fig 13.47) is a necessity. It provides grid



Fig 13.44—This table-top 2-m power amplifier uses a quick-warm-up tube, a real plus when the band suddenly opens for DX and you want to join in.

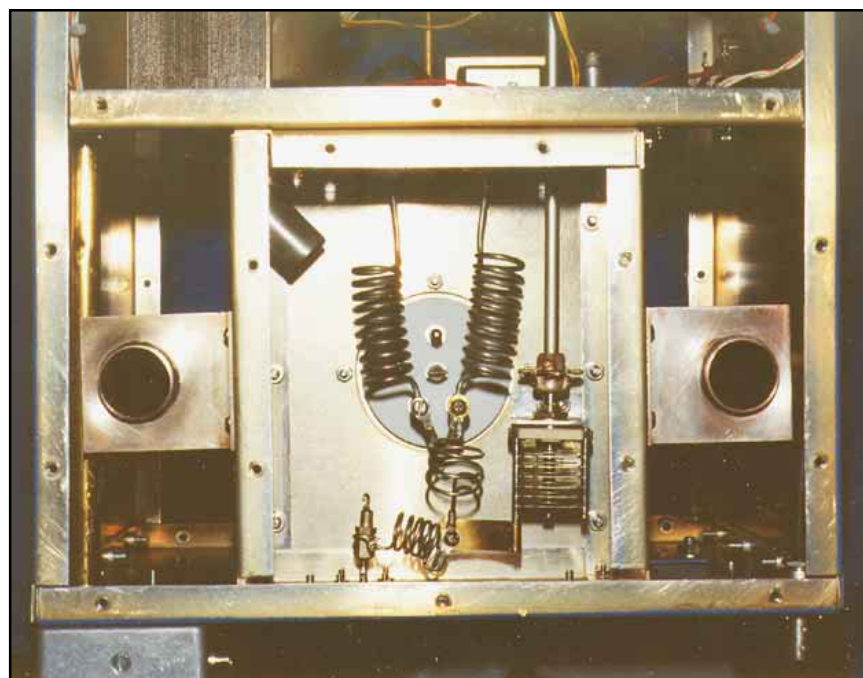

Fig 13.46—This view of the cathode-circuit compartment shows the input tuned circuit and filament chokes.

Table 13.9  
3CX1200Z7 Specifications

#### Maximum Ratings

Plate voltage: 5500 V  
Plate current: 800 mA  
Plate dissipation: 1200 W  
Grid dissipation: 50 W

Table 13.10  
CW Operating Data

Plate voltage: 3200 V  
Plate current (operating): 750 mA  
Plate current (idling): 150 mA  
Grid current: 165 mA  
DC Power input: 2400 W  
RF Power output: 1200 W  
Plate dissipation: 1200 W  
Efficiency: 50%  
Drive power: 85 W  
Input reflected power: 1 W





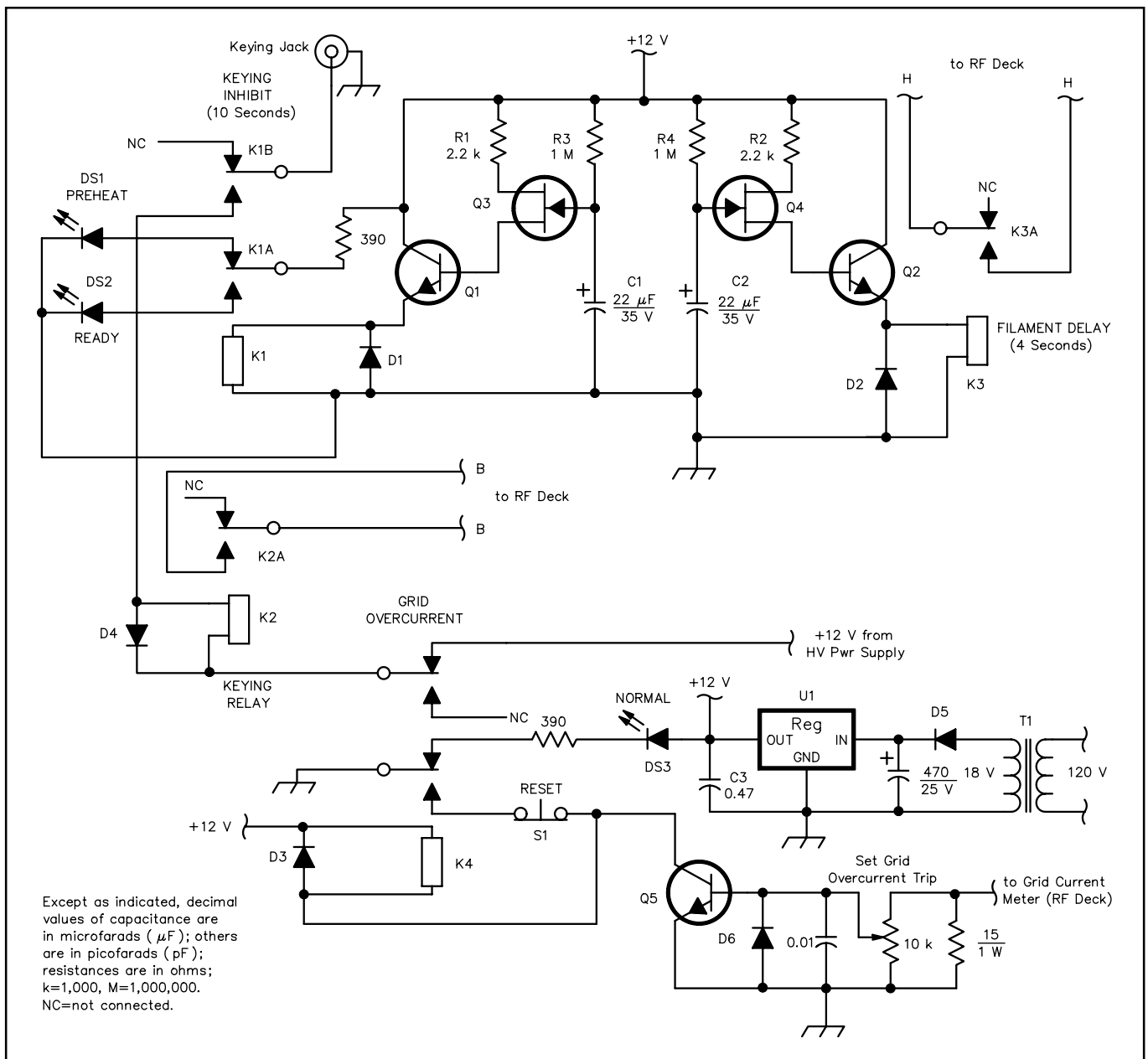

Fig 13.47—Schematic diagram of the amplifier-control circuits.

C3—0.47- $\mu\text{F}$ , 25-V tantalum capacitor.

D1-D5—1N4001 or equiv.

D6—1N4007 or equiv.

DS1—Yellow LED.

DS2—Green LED.

DS3—Red LED.

K1—Keying-inhibit relay, DPDT, 12-V dc coil, 1-A contact rating (Radio Shack 275-249 or equiv).

K2—Amplifier keying relay, SPDT, 12-V dc coil, 2-A contact rating (Radio Shack 275-248 or equiv).

K3—Filament delay relay, SPST, 12-V dc coil, 2-A contact rating (Radio Shack 275-248 or equiv).

K4—Grid-overcurrent relay, DPDT, 12-V dc coil, 1-A contact rating (Radio Shack 275-249 or equiv).

Q1, Q2, Q5—2N2222A or equiv.

Q3—MPF102 or equiv.

Q4—2N3819 or equiv.

S1—Normally closed, momentary pushbutton switch (Radio Shack 275-1549 or equiv).

T1—Power transformer, 120-V primary, 18-V, 1-A secondary.

U1—+12 V regulator, 7812 or equiv.

overcurrent protection, keying control and filament surge control. To protect the tube filament from stressful surge current, a timer circuit places a resistor in series with the primary of the filament transformer. After four seconds, the timer shorts the resistor, allowing full filament voltage to be applied. C2 and R4 establish the time delay.

Another timer inhibits keying for a total of 10 s, to give the internal tube temperatures a chance to stabilize. C1 and R3 determine the time constant of this timer. After 10 s, the amplifier can be keyed by grounding the keying line. When the amplifier is not keyed, it draws no plate current. When keyed, idle current is approximately 150 mA, and the amplifier only requires RF drive to produce output. A safety factor is built in: the keying circuit requires +12 V from the high-voltage supply. This feature ensures that high voltage is present before the amplifier is driven.

The grid overcurrent circuit should be set to trip if grid current reaches 200 mA. When it trips, the relay latches and the NORMAL LED extinguishes. Restoration requires the operator to press the RESET switch.

### Plate Circuit

Fig 13.48 shows an interior view of the plate compartment. A  $4 \times 2\frac{1}{4}$ -inch tuning capacitor plate and a  $2 \times 2$ -inch output coupling plate are centered on the anode collet. See Fig 13.49. Sufficient clearance in the collet hole for the 3CX1200Z7 anode must be left for the fingerstock. The hole diameter will be approximately  $3\frac{5}{8}$  inches. Fig 13.50 is a drawing of the plate line, Fig 13.51 is a drawing of the plate tuning capacitor assembly, and Fig 13.52 shows the output coupling assembly.

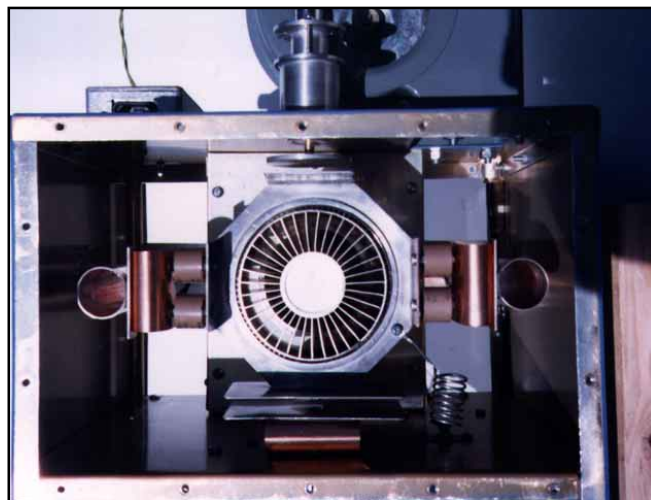

Fig 13.48—This top view of the plate compartment shows the plate-line arrangement, C1-C4 and the output coupling assembly.

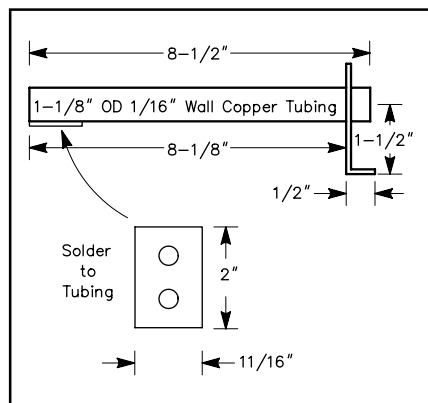

Fig 13.50—Plate line details.

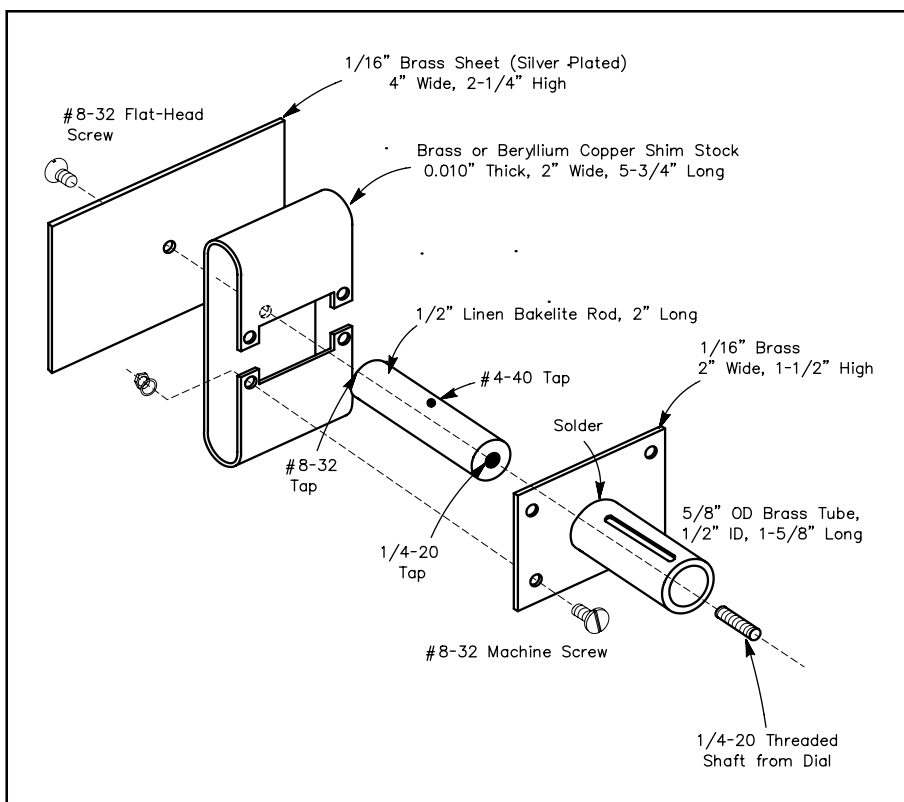
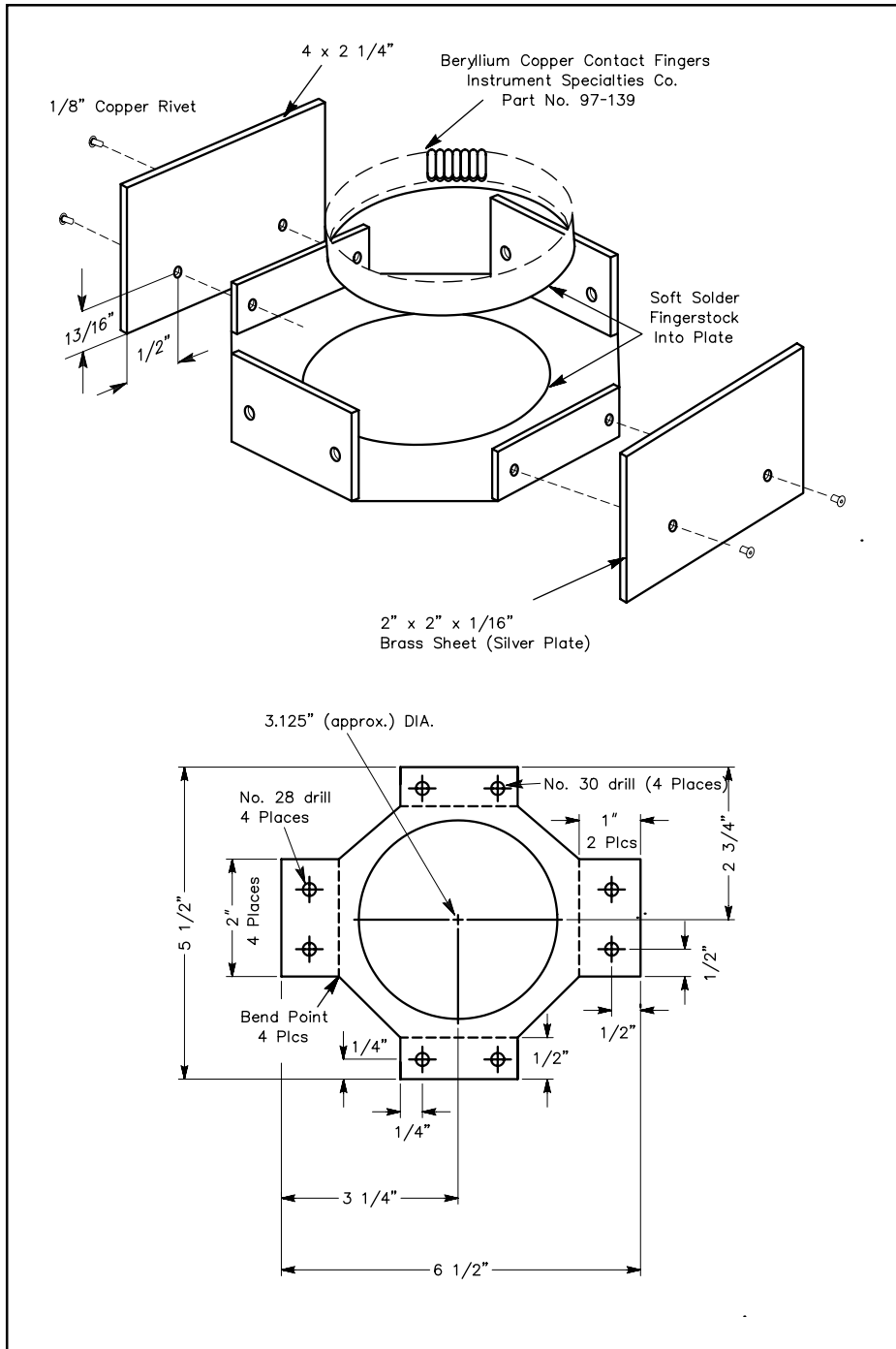
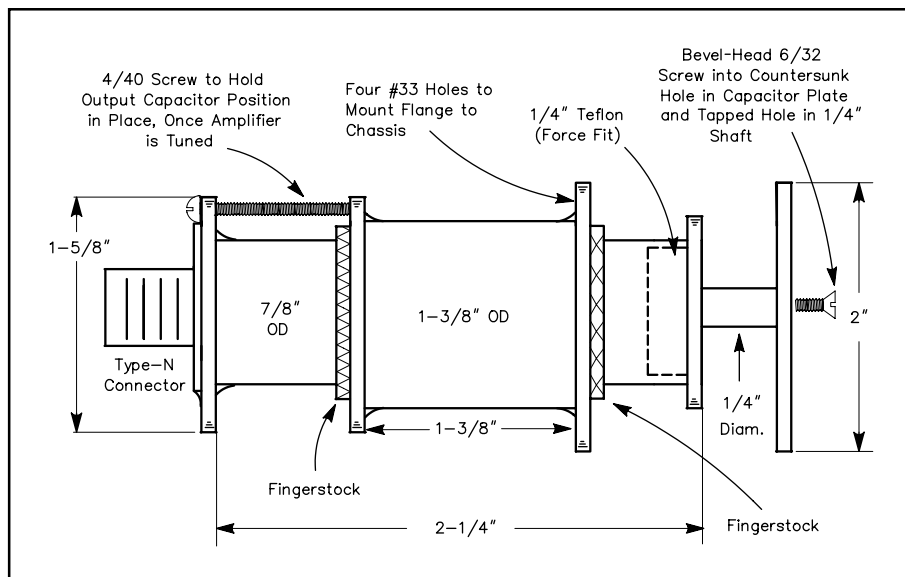

Fig 13.51—Plate tuning capacitor details.



**Fig 13.49—Anode collet details.**



**Fig 13.52—Details of the output coupling assembly.**

## Cooling

The amplifier requires an air exhaust through the top cover, as the plate compartment is pressurized. Fashion a chimney from a 3<sup>1</sup>/<sub>2</sub>-inch waste-water coupling (black PVC) and a piece of 1/32-inch-thick Teflon sheet. The PVC should extend down from the underside of the amplifier cover plate by 1<sup>1</sup>/<sub>8</sub> inches, with the Teflon sheet extending down 3/4 inch from the bottom of the PVC.

The base of the 3CX1200Z7 is cooled using bleed air from the plate compartment. This is directed at the tube base,

through a 7/8-inch tube set into the subchassis wall at a 45° angle. The recommended blower will supply more than enough air for any temperature zone. A smaller blower is not recommended, as it is doubtful that the base area will be cooled adequately. The 3CX1200Z7 filament draws 25 A at 6.3 V! It alone generates a great deal of heat around the tube base seals and pins, so good air flow is critical.

## Construction

The amplifier is built into a 12×12×10-inch enclosure. A 12×10-inch partition is installed 7<sup>1</sup>/<sub>4</sub> inches from the rear panel. The area between the partition and the front panel contains the filament transformer, control board, meters, switches, Zener diode and miscellaneous small parts. Wiring between the front-panel area and the rear panel is through a 1/2-inch brass tube, located near the shorted end of the right-hand plate line.

High voltage is routed from an MHV jack on the rear panel, through a piece of solid-dielectric RG-59 (*not* foam dielectric!), just under the shorted end of the left-hand plate line. The cable then passes through the partition to a high-voltage standoff insulator made from nylon. This insulator is fastened to the partition near the high-voltage feedthrough capacitor. A 10-Ω, 25-W resistor is connected between the insulator and the feedthrough capacitor.

The plate lines are connected to the dc-blocking capacitors on the plate collet with 1<sup>3</sup>/<sub>4</sub> × 2-inch phosphor-bronze strips. The bottom of the plate lines are attached to the sides of the subchassis, with the edge of the L-shaped mounting bracket flush with the bottom of the subchassis.

When preparing the subchassis top plate for the 3CX1200Z7, cut a 2<sup>11</sup>/<sub>16</sub>-inch hole in the center of the plate. This hole size allows clearance between the tube envelope and the top plate, without putting stress on the envelope in the vicinity of the grid flange seal.

Exercise care in placing the movable tuning plate and the movable output coupling disc, to ensure they cannot touch their fixed counterparts on the plate collet.

## Operation

When the amplifier is first turned on, it cannot be keyed until:

- 10 s has elapsed
- High voltage is available, as confirmed by presence of +12 V to the keying circuit

Connect the amplifier to a dummy load through an accurate power meter capable of indicating 1500 W full scale. Key the amplifier and check the idling plate current. With 3200-V plate voltage, it should be in the vicinity of 150 mA. Now, apply a small amount of drive and adjust the input tuning for maximum grid current. Adjust the output tuning until you see an indication of RF output. Increase drive and adjust the output coupling and tuning for the desired output. Do not overcouple the output; once desired output is reached, do not increase loading. Insert the hold-down screw to secure the output coupling capacitor from moving. One setting is adequate for tuning across the 2-m band if the SWR on the transmission line is reasonably low.

When you shut down the amplifier, leave the blower running for at least three minutes after you turn off the filament voltage. The 3CX1200Z7 is an excellent tube. The author tried it with excessive drive, plate-current saturation, excessive plate dissipation—all the abuse it’s likely to encounter in amateur applications. There were no problems, but that doesn’t mean you should repeat these torture tests!

## A Companion Power Supply

A good, solid-state high-voltage power supply is a necessity to ensure linearity in SSB operation. Specifications of the power supply are given in **Table 13.11**. The schematic and parts list for the author’s power supply are in the [Power Supplies and Projects](#) chapter.

## Conclusion

This amplifier is a reliable and cost-effective way to generate a big 2-m signal—almost as quickly as a solid-state amplifier. To ensure that the output of the amplifier meets current spectral purity requirements, a high-power output filter, as shown in **Fig 13.53**, should be used. The author reports that he can run full output while his wife watches TV in a nearby room.

**Table 13.11**

### Power Supply Specifications

High voltage: 3200 V  
 Continuous current: 1.2 A  
 Intermittent current: 2 A  
 Step/Start delay: 2 s

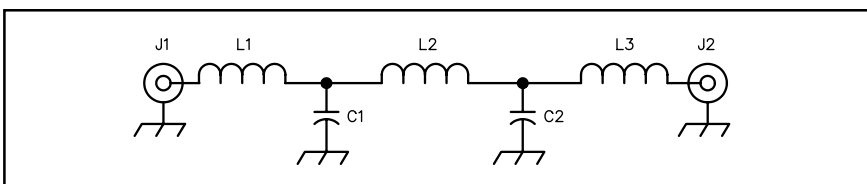

**Fig 13.53—Schematic diagram of output harmonic filter.**

**C1, C2—27-pF Centralab 850 series ceramic transmitting capacitor.**  
**J1, J2—Female chassis-mount N connector (UG-58 or equiv).**  
**L1, L3—2 t #14 wire, 0.3125 inch ID, 0.375 inch long.**  
**L2—3 t #14 wire, 0.3125 inch ID, 0.4375 inch long.**

## A 2-M BRICK AMP FOR HANDHELDS

Perhaps you've been looking for a fun weekend project and need a bit more output from your HT while operating mobile. This Brick Amp project may be exactly what you're looking for—construction is easy and all the parts are readily available. The following was contributed by ARRL Laboratory Engineer, Mike Gruber, W1MG.

The Brick Amp is easily driven at the low-output power setting of most handhelds. The same design is used for either a 25 or a 50 W version—only the amplifier module is changed. See **Fig 13.54** for a view of what's inside a typical module, alongside the finished amplifier.

The low-power 25 W Brick Amp complies with the bioeffects guidelines set forth in the **Safety** chapter. The full 50 W version can be built when more output is required. (Note: The bioeffects guidelines recommend that field-strength measurements be made in mobile installations of greater than 25 W output. Be sure to consult the **Safety** chapter before building the 50 W version.)

### Circuit Details

The heart of this project is a Toshiba amplifier module. The S-AV7 is used for the 25 W output, while the mechanically identical S-AV17 is used in the 50 W version. Both modules are biased as class-C amplifiers, keeping their efficiency up and making them ideally suited for FM or CW use. Since they are not linear, however, they are not useful for other modes, such as SSB or AM.

From a builder's standpoint, these modules keep the parts count down to a minimum and construction simple. All you need to add for circuitry is input drive attenuation, if required, transmit/receive switching, an output filter and the usual dc filter and decoupling components. Beginners and seasoned veterans alike will no doubt appreciate this Brick Amp's simplicity!

### DC Filtering and Decoupling

See the schematic diagram in **Fig 13.55**. C1 through C6 and chokes L1-L2 provide dc filtering and decoupling. D5 provides reverse-polarity protection, by blowing F1 should the +13.8 V line be wrongly connected.

### The Input and Output Circuitry

The Brick Amp's input circuitry consists of a resistive T-

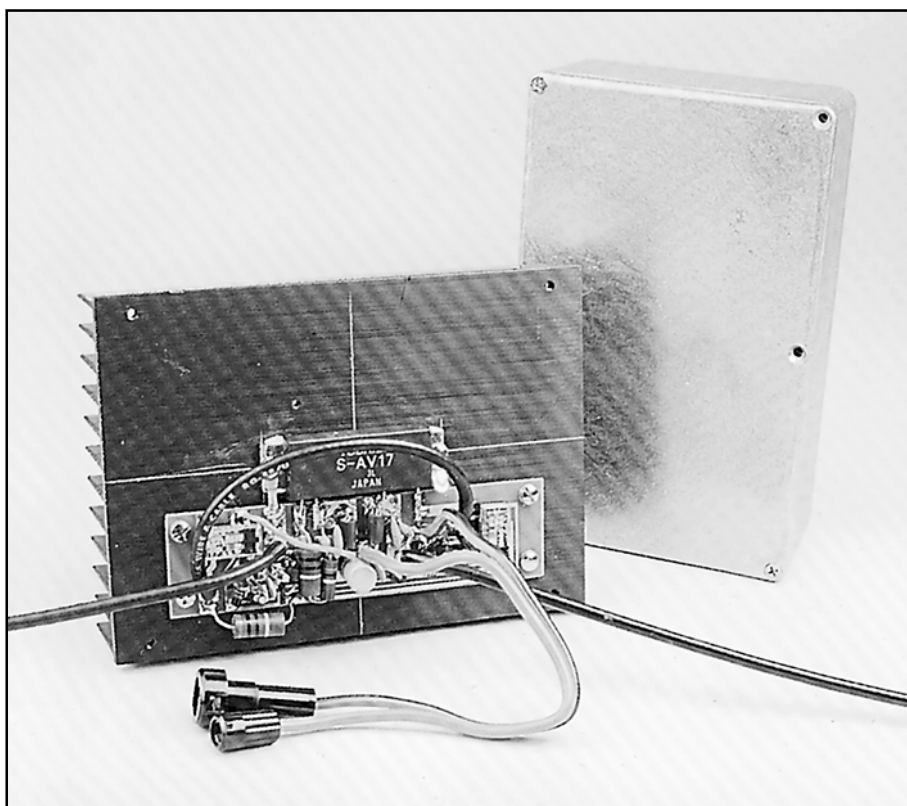

(A)

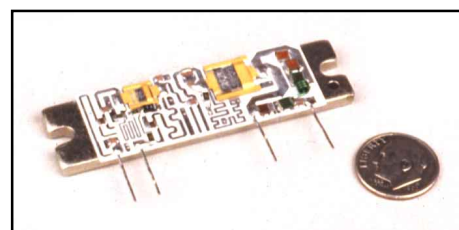

(B)

**Fig 13.54**—At A, photo of 2-m Brick Amp assembly and at B, a 25 W power module with cover removed.

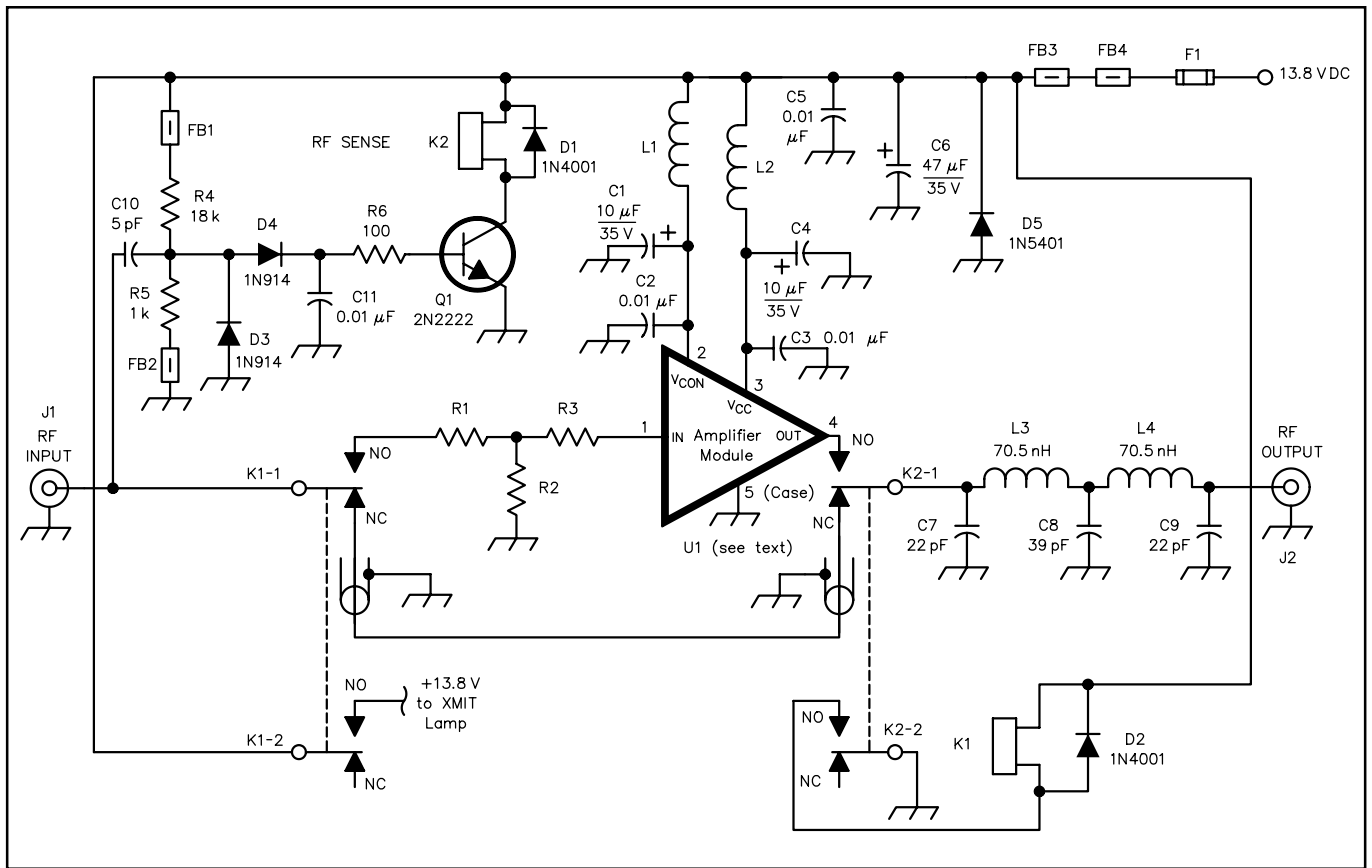

Fig 13.55—Schematic and parts list. Supplier contact information appears in the [References](#) chapter [Address List](#).

Case—Hammond cat. no. 1590D.

Heat sink—5 x 7 inches, RF Parts.

C1, C4—1.0  $\mu\text{F}$ , 35 V dipped tantalum (RS 272-1434).

C2, C3, C5, C11—0.01  $\mu\text{F}$ , 500 V ceramic disc (RS 272-131).

C6—47  $\mu\text{F}$ , 25 V electrolytic (RS 272-1027).

C7, C9—22 pF, DM-15 dipped mica.

C8—39 pF, DM-15 dipped mica.

C10—5 pF, DM-15 dipped mica.

D1, D2—1N4001 diode.

D3, D4—1N914 diode.

D5—1N5401 diode.

F1—10 A for 25 W, 15 A for 50 W.

K1, K2—221D012 relay, RF Parts.

FB1, FB2, FB3, FB4—56590-65/3B Ferroxcube, Communications Concepts Inc (CCI).

L1, L2—VK200-20/4B Ferroxcube ferrite choke, CCI.

L3, L4—70.5 nH, 7 t #20 AWG, 0.125 inch ID, 0.33 inch long, 0.10 inch leads.

Q1—2N2222.

R1, R2, R3—see [Table 13.12](#).

S1—20 A at 12 V.

U1—Power module, Toshiba S-AV7 (25 W) or S-AV17 (50 W).

DS1, DS2—Pilot and transmit indicator lamps, 13.8 V.

J1, J2—connectors, BNC or UHF as desired.

Coax—RG-8X, 2 ft.



pad formed by R1, R2 and R3. The pad attenuates the HT's output to the input level required by the module. Select the proper pad values based upon the HT output and the amplifier module selected. Refer to **Table 13.12** for pad resistor values for typical HT output levels.

Reduced drive power results in less than full rated output power, while excessive drive can result in exceeding the limits of the module. Proper T-pad selection is essential for full rated output power without exceeding design limits. Be sure to use only noninductive resistors, such as carbon or metal oxide, with the specified power ratings for the T pad.

**CAUTION:** Some HTs can generate a momentary high power output pulse when keyed in the low power mode, especially when first keyed. Such a spike could exceed the amplifier module specified input limits if a low-power T-pad is selected. Observe the HT output on an oscilloscope or check with its manufacturer to make sure it doesn't exhibit this characteristic.

The output circuitry is a low-pass filter consisting of C7, C8, C9, L3 and L4. **Fig 13.56** shows the filtered output to be better than -60 dBc, the FCC requirement for spectral purity for a transmitter at this frequency and power class.

### The TR Switching Circuit

While in the receive mode, signals from the antenna are applied to the receiver through the normally closed relay contacts of K2-1 and K1-1. The low-pass filter used in transmit remains in the circuit for receive. This is a useful feature, since many HTs are prone to overload from strong out-of-band signals, such as from nearby UHF-TV transmitters. Further, harmonics generated by the TR switching circuit are suppressed to better than 60 dBc in the bypass mode. When the HT is keyed, RF is

**Table 13.12**  
**T-Pad Values**

**25 W Module, S-AV7**

HT Power (W)	Attenuation (dB)	R1,R3 (Ω)	R2 (Ω)
0.5	1	2.9	430
0.8	2	5.6	220
1.0	4	12	100
1.5	6	16	68
2.0	7	18	56
2.5	8	22	47
3.0	9	24	39
4.0	10	27	36
5.0	11	56/56*	62/62*

**50 W Module, S-AV17**

0.5	4	12	100
0.8	6	16	68
1.0	7	20	56
1.5	9	24	39
2.0	10	27	36
2.5	11	27	30
3.0	12	30	27
4.0	13	33	24
5.0	14	62/62*	43/43*

**Note:** For power inputs up to and including 4.0 W, use 2 W resistors for R1 and R3, 1/2 W resistors for R2. All resistors are carbon composition or metal oxide.  
\* Use parallel connected resistors: 2 W for R1 and R3; 1 W for R2.

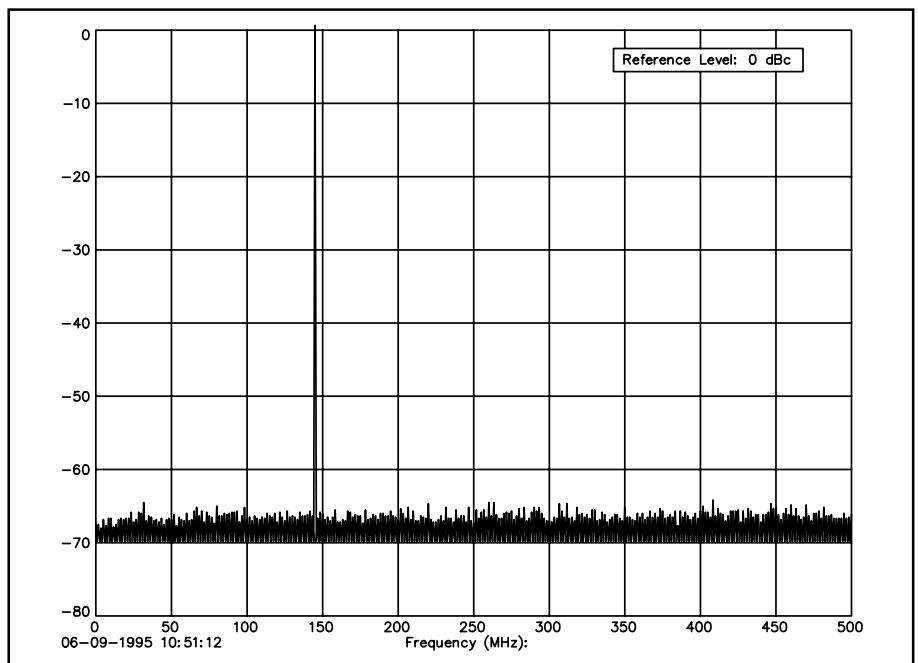

**Fig 13.56—Plot of output spectrum for 25 W Brick Amp showing that it meets current FCC specifications for output purity, with second harmonic reduced by more than 60 dB.**

applied to voltage doubler D3 and D4. The junction of D3 and D4 is biased to approximately 0.5 V by R4 and R5 to facilitate diode turn-on at low RF levels. Once transistor Q1 is turned on, K2 is energized. The K2-2 contacts then energize K1 by applying +13.8 V to its coil. The K1-2 relay contacts provide power for an optional transmit light. This two-relay system provides two features not possible with a single relay:

1. Improved isolation between the input and output relay contacts. Coupling between these contacts is sufficiently small to prevent the amplifier from oscillating. (Initial experiments in the Lab with a single two-pole relay resulted in an excellent 2-m oscillator.)
2. “Hot switching” the output relay is eliminated. Since K2 is activated first, RF cannot appear across the K1 output relay contacts until K2 is already closed. Contact bounce with output power applied is thus eliminated, resulting in improved switching reliability and enhanced contact life.

This sequence is reversed when switching from transmit to receive. Once the RF is removed, Q1 is cut off and relay K2 is deenergized. Diodes D1 and D2 protect against voltage spikes created by the relay coils as their magnetic fields collapse upon deactivation. K1 is returned to the receive mode by the opening of the K2-2 contacts.

## Construction Details

A surface-mount circuit board was selected for the Brick Amp, with traces on the top of the board and ground plane on the underside. Components connected to RF ground (such as the output filter capacitors C7, C8 and C9), have their ground leads soldered on both top and bottom sides to provide good RF ground continuity. Otherwise, component leads are soldered directly to top-side PC traces. The PC board is mounted above the heat sink surface, using metal #6 flat washers as spacers. The amplifier module pins and their associated PC board pads are in close vertical alignment, eliminating excessive bending of the pins at solder time.

The heat sink and case were selected on the basis of availability, ruggedness and heat dissipation ability. The heat sink may be overkill, especially for the 25 W version. It is, however, readily available and adequate for the task, even in a hot car on a summer day after a long-winded transmission (such as the author has been known to make on occasion). If you intend to mount the Brick Amp in a car trunk, the sharp edges of a heat sink could be hazardous to its other contents. Be sure to give your mounting options careful consideration before making your final decision.

The case is die-cast aluminum, strong enough to withstand the most severe abuse in a car trunk, or any other mounting spot you may select. If you are budget minded and have a big junk box, here is where cost saving substitutions may be made. The only critical aspects of the heat sink is that it present a flat surface upon which to mount the module, large enough to mount the PC board, and that it meet the heat dissipating requirements for the conditions in which you intend to use the Brick Amp.

**CAUTION:** Before considering a heat sink, make sure that the module lies perfectly flat against the sink’s mounting surface. Attempts to mount a module on a surface that is not flat can cause permanent damage to the module!

Begin construction by mounting the module at the center of the heat sink. Using the module as a template, drill two holes with a #36 drill bit. Remove any burrs around the holes with an oversized drill, and thread them both with a #6 tap. Clean the holes and heat sink mounting surface with a rag. Lightly rub 400 to 600 grit emery cloth (or fine steel wool) across the module and heat sink surfaces. It is not necessary to remove the black finish from the aluminum of the heat sink shown in [Fig 13.54](#). Clean both surfaces and screw holes with a suitable solvent, such as denatured alcohol or flux remover, to remove any dirt, grease or oil. Wipe the exposed surfaces with a clean cloth and let dry.

Apply a very thin coat of thermal conducting grease to module and heat-sink mating surfaces. Place two #6 mounting screws through two flat washers and two #6 solder lugs (with internal lock teeth) pointing toward the PC board, through the mounting flanges on each side of the module. Alternately

increase the torque on each screw until full torque is achieved and wipe off excess thermal compound with a rag. Be careful not to bend the module leads during this process.

Next, slide the board in place, line up the pins with the correct pads, center the board and mark the four mounting holes onto the heat sink. Drill holes with a #36 bit and tap them for #6 screws. Deburr and clean with solvent as before. Next, solder jumper wires through the 6 holes so indicated. Bend as shown in the inset to the layout in **Fig 13.57**, and solder the wire on the top and bottom of the PC board. These connections tie the underside ground plane foil on the board to ground. Install the components with ground connection through their holes now.

Mount the board to the heat sink using #6 screws and two washers as spacers. Make sure that the soldered wires do not touch the heat sink as torque is applied to the screws. More washers may be added as necessary to prevent the solder connections from touching the heat sink, but you must use an equal amount for each screw. Solder the module pins to the appropriate PC board pads, but be sure to leave sufficient free pin length to account for flexing from temperature changes and vibration.

Solder the ground lug at the input side of the module to ground on top of the PCB. Solder a short piece of braid from the underside of the PCB to the ground lug at the output side of the module.

Carefully bend the pins on each of the relays outward. Pliers may be used to accomplish this, or you may wish to try gently pressing all four lead tips against a hard surface. It is not necessary that they be at right angles to the relay, but they must be sufficiently bent to permit surface mount soldering. Avoid any unnecessary reworking or bending of these pins. Before soldering the relays onto the board, make certain they are oriented correctly. Carefully line up each relay pin with its pad and solder it in place.

Continue soldering the components on the board as shown in Fig 13.57. L3 and L4 can both be wound on the shank of a 1/8 inch drill bit. Other construction data for these coils is given in the parts list. Finally, install the coax and +12 V dc jumpers.

Fuse the Brick Amp with either a ready-made cable having an in-line fuse pair, or a fuse holder in the

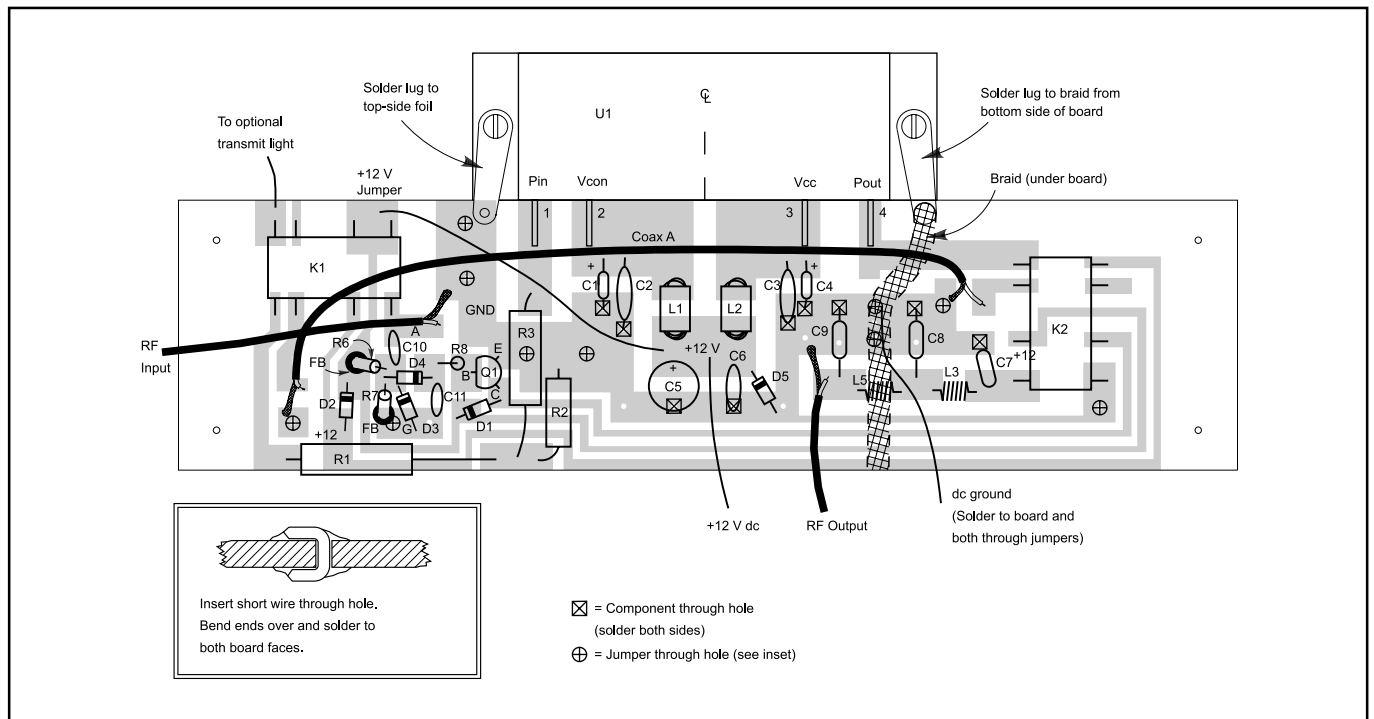

**Fig 13.57—Part-placement diagram for the 2-m brick. Inset shows how leads for through-hole jumpers are bent over on top and bottom of PC board to provide good continuity for RF ground currents.**

case. Temporarily connect the dc power cable (with fuses installed) to the proper PC board pads and test the Brick Amp for operation and function.

Assuming the Brick Amp works correctly, install its case. Cut a square hole in the case large enough to accommodate the PC board and module. Position the hole so that the heat sink will be centered on the case. Mark and drill and tap (#6) holes for four mounting screws.

Install one or both of the optional lights, if desired. Make holes for both input and output connectors, dc power cable and on/off switch. (NOTE: A BNC for the input, and a UHF connector for the output facilitates coax connection to the HT and prevents accidental input/output cable reversal.) Tailor the input/output connectors and cabinet layout to suit your requirements. Install the heat sink and other components in the cabinet. Be sure to install the ferrite beads before soldering the wires and cables!

A PC-board template is in Chapter 30, [References](#).

## BIBLIOGRAPHY

- Belcher, "RF Matching Techniques, Design and Example," *QST*, October 1972, pp 24-30.
- Feynman, *Lectures on Physics, Vol. 1*, Addison-Wesley Publishing Co, 1977.
- Goodman, "My Feed Line Tunes My Antenna," *QST*, April 1977, pp 40-42.
- Granberg, "Build This Solid-State Titan," *QST*, June 1977, pp 27-31 (Part 1); *QST*, July 1977, pp 27-29 (Part 2). Granberg, "One KW-Solid-State Style," *QST*, April 1976, pp 11-14 (Part 1); *QST*, May 1976, pp 28-30 (Part 2).
- Hejhall, "Broadband Solid-State Power Amplifiers for SSB Service," *QST*, March 1972, pp 36-43.
- Johnson and Artigo, "Fundamentals of Solid-State Power-Amplifier Design," *QST*, September 1972, pp 29-36 (Part 1); *QST*, November 1972, pp 16-20 (Part 2); *QST*, April 1973, pp 28-34 (Part 3).
- Johnson, "Heat Losses in Power Transformers," *QST*, May 1973, pp 31-34.
- Knadle, "A Strip-line Kilowatt Amplifier 432 MHz," *QST*, April 1972, pp 49-55.
- Meade, "A High-Performance 50-MHz Amplifier," *QST*, September 1975, pp 34-38.
- Meade, "A 2-KW PEP Amplifier for 144 MHz," *QST*, December 1973, pp 34-38.
- Measures, "Improved Parasitic Suppression for Modern Amplifier Tubes," *QST*, October 1988, pp 36-38, 66, 89.
- Measures, "Parasitics Revisited," *QST*, September 1990, pp 15-18, October 1990, pp 32-35.
- Olsen, "Designing Solid-State RF Power Circuits," *QST*, August 1977, pp 28-32 (Part 1); *QST*, September 1977, pp 15-18 (Part 2); *QST*, October 1977, pp 22-24 (Part 3).
- Orr, *Radio Handbook*, 22nd Ed, Howard W. Sams & Co, Inc, 1981.
- Potter and Fich, *Theory of Networks and Lines*, Prentice-Hall, Inc, 1963.
- Reference Data for Radio Engineers*, ITT, Howard & Sams Co, Inc.
- RF Data Manual*, Motorola, Inc, 1982.
- Simpson, *Introductory Electronics for Scientists and Engineers*, Allyn and Bacon, Inc, 1975.
- Solid State Power Circuits*, RCA Designer's Handbook, 1972.
- Terman, *Electronic and Radio Engineering*, McGraw-Hill Book Company, Inc. This book provides a lucid explanation of vacuum-tube amplifier design, explaining the current and voltage-source models very well.
- White, "Thermal Design of Transistor Circuits," *QST*, April 1972, pp 30-34.
- Wingfield, "New and Improved Formulas for the Design of Pi and Pi-L Networks," *QST*, August 1983, pp 23-29. (Feedback, *QST*, January 1984, p 49.)
- Wingfield, "A Note on Pi-L Networks," *QEX*, December 1983, pp 5-9.