

Component Data

24

None of us has the time or space to collect all the literature available on the many different commercially available manufactured components. Even if we did, the task of keeping track of new and obsolete devices would surely be formidable. Fortunately, amateurs tend to use a limited number of component types. This chapter, by Douglas Heacock, AA0MS, provides information on the components most often used by the Amateur Radio experimenter.

COMPONENT VALUES

Throughout this *Handbook*, composition resistors and small-value capacitors are specified in terms of a system of “preferred values.” This system allows manufacturers to supply these components in a standard set of values, which, when considered along with component tolerances, satisfy the vast majority of circuit requirements.

The preferred values are based on a roughly logarithmic scale of numbers between 1 and 10. One decade of these values for three common tolerance ratings is shown in **Table 24.1**.

The Table represents the two significant digits in a resistor or capacitor value. Multiply these numbers by multiples of ten to get other standard values. For example, 22 pF, 2.2 μ F, 220 μ F, and 2200 μ F are all standard capacitance values, available in all three tolerances. Standard resistor values include 3.9 Ω , 390 Ω , 39000 Ω and 3.9 M Ω in $\pm 5\%$ and $\pm 10\%$ tolerances. All standard resistance values, from less than 1 Ω to about 5 M Ω are based on this table.

Each value is greater than the next smaller value by a multiplier factor that depends on the tolerance. For $\pm 5\%$ devices, each value is approximately 1.1 times the next lower one. For $\pm 10\%$ devices, the multiplier is 1.21, and for $\pm 20\%$ devices, the multiplier is 1.47. The resultant values are rounded to make up the series.

Table 24.1
Standard Values for Resistors and Capacitors

$\pm 5\%$	$\pm 10\%$	$\pm 20\%$
1.0	1.0	1.0
1.1		
1.2	1.2	
1.3		
1.5	1.5	1.5
1.6		
1.8	1.8	
2.0		
2.2	2.2	2.2
2.4		
2.7	2.7	
3.0		
3.3	3.3	3.3
3.6		
3.9	3.9	
4.3		
4.7	4.7	4.7
5.1		
5.6	5.6	
6.2		
6.8	6.8	6.8
7.5		
8.2	8.2	
9.1		
10.0	10.0	10.0

Tolerance refers to a range of acceptable values above and below the specified component value. For example, a 4700-Ω resistor rated for ±20% tolerance can have an actual value anywhere between 3760 Ω and 5640 Ω. You may always substitute a closer-tolerance device for one with a wider tolerance. For projects in this *Handbook*, assume a 10% tolerance if none is specified.

COMPONENT MARKINGS

The values, tolerances or types of most small components are typically marked with a color code or an alphanumeric code according to standards agreed upon by component manufacturers. The Electronic Industries Association (EIA) is a US agency that sets standards for electronic components, testing procedures, performance and device markings. The EIA cooperates with other standards agencies such as the International Electrotechnical Commission (IEC), a world-wide standards agency. You can often find published EIA standards in the engineering library of a college or university.

The standard EIA color code is used to identify a variety of electronic components. Most resistors are marked with color bands according to the code, shown in **Table 24.2**. Some types of capacitors and inductors are also marked using this color code.

Resistor Markings

Carbon-composition, carbon-film, and metal-film resistors are typically manufactured in roughly cylindrical cases with axial leads. They are marked with color bands as shown in **Fig 24.1A**. The first two bands represent the two significant digits of the component value, the third band represents the multiplier, and the fourth band (if there is one) represents the tolerance. Some units are marked with a fifth band that represents the percentage of resistance change per 1000 hours of operation: brown = 1%; red = 0.1%; orange = 0.01%; and yellow = 0.001%. Precision resistors (EIA Std RS-279, Fig 24.1B) and some mil-spec (MIL STD-1285A) resistors also use five color bands. On precision resistors,

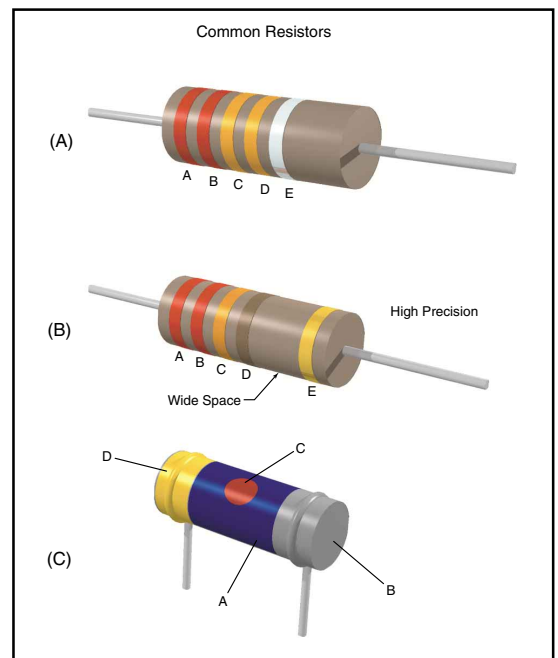

Fig 24.1—Color coding and body size for fixed resistors. The color code is given in Table 24.2. The colored areas have the following significance.
A—First significant figure of resistance in ohms.
B—Second significant figure.
C—Decimal multiplier.
D—Resistance tolerance in percent. If no color is shown the tolerance is ±20%.
E—Relative percent change in value per 1000 hours of operation; Brown, 1%; Red 0.1%; Orange 0.01%; Yellow 0.001%.

Table 24.2
Resistor-Capacitor Color Codes

Color	Significant Figure	Decimal Multiplier	Tolerance (%)	Voltage Rating*
Black	0	1	-	-
Brown	1	10	1*	100
Red	2	100	2*	200
Orange	3	1,000	3*	300
Yellow	4	10,000	4*	400
Green	5	100,000	5*	500
Blue	6	1,000,000	6*	600
Violet	7	10,000,000	7*	700
Gray	8	100,000,000	8*	800
White	9	1,000,000,000	9*	900
Gold	-	0.1	5	1000
Silver	-	0.01	10	2000
No color	-	-	20	500

*Applies to capacitors only

the first *three* bands are used for significant figures and the space between the fourth and fifth bands is wider than the others, to identify the tolerance band. On the military resistors, the fifth band indicates reliability information such as failure rate.

For example, if a resistor of the type shown in Fig 24.1A is marked with A = red; B = red; C = orange; D = no color, the significant figures are 2 and 2, the multiplier is 1000, and the tolerance is $\pm 20\%$. The device is a 22,000- Ω , $\pm 20\%$ unit.

Some resistors are made with radial leads (Fig 24.1C) and are marked with a color code in a slightly different scheme. For example, a resistor as shown in Fig 24.1C is marked as follows: A (body) = blue; B (end) = gray; C (dot) = red; D (end) = gold. The significant figures are 6 and 8, the multiplier is 100, and the tolerance is $\pm 5\%$; 6800 Ω with $\pm 5\%$ tolerance.

Resistor Power Ratings

Carbon-composition and metal-film resistors are available in standard power ratings of $1/10$, $1/8$, $1/4$, $1/2$, 1 and 2 W. The $1/10$ - and $1/8$ -W sizes are relatively expensive and difficult to purchase in small quantities. They are used only where miniaturization is essential. The $1/4$, $1/2$, 1, and 2-W composition resistor packages are drawn to scale in Fig 24.2. Metal-film resistors are typically slightly smaller than carbon-composition units of the same power rating. Film resistors can usually be identified by a glossy enamel coating and an hourglass profile. Carbon-film and metal-film are the most commonly available resistors today, having largely replaced the less-stable carbon-composition resistors.

Capacitor Markings

A variety of systems for capacitor markings are in use. Some use color bands, some use combinations of numbers and letters. Capacitors may be marked with their value, tolerance, temperature characteristics, voltage ratings or some subset of these specifications. Fig 24.3 shows several popular capacitor marking systems.

In addition to the value, ceramic disk capacitors may be marked with an alphanumeric code signifying temperature characteristics. Table 24.3 explains the EIA code for ceramic-disk capacitor temperature characteristics. The code is made up of one character from each column in the table. For example, a capacitor marked Z5U is suitable for use between +10 and +85°C, with a maximum change in capacitance of -56% or $+22\%$.

Capacitors with highly predictable temperature coefficients of capacitance are sometimes used in

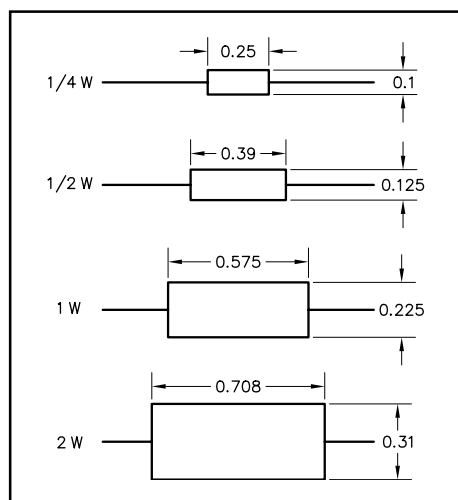

Fig 24.2—Typical carbon-composition resistor sizes.

Table 24.3

EIA Temperature Characteristic Codes for Ceramic Disc Capacitors

Minimum temperature	Maximum temperature	Maximum capacitance change over temperature range
X -55°C	2 $+45^{\circ}\text{C}$	A $\pm 1.0\%$
Y -30°C	4 $+65^{\circ}\text{C}$	B $\pm 1.5\%$
Z $+10^{\circ}\text{C}$	5 $+85^{\circ}\text{C}$	C $\pm 2.2\%$
	6 $+105^{\circ}\text{C}$	D $\pm 3.3\%$
	7 $+125^{\circ}\text{C}$	E $\pm 4.7\%$
		F $\pm 7.5\%$
		P $\pm 10\%$
		R $\pm 15\%$
		S $\pm 22\%$
		T -33% , $+22\%$
		U -56% , $+22\%$
		V -82% , $+22\%$

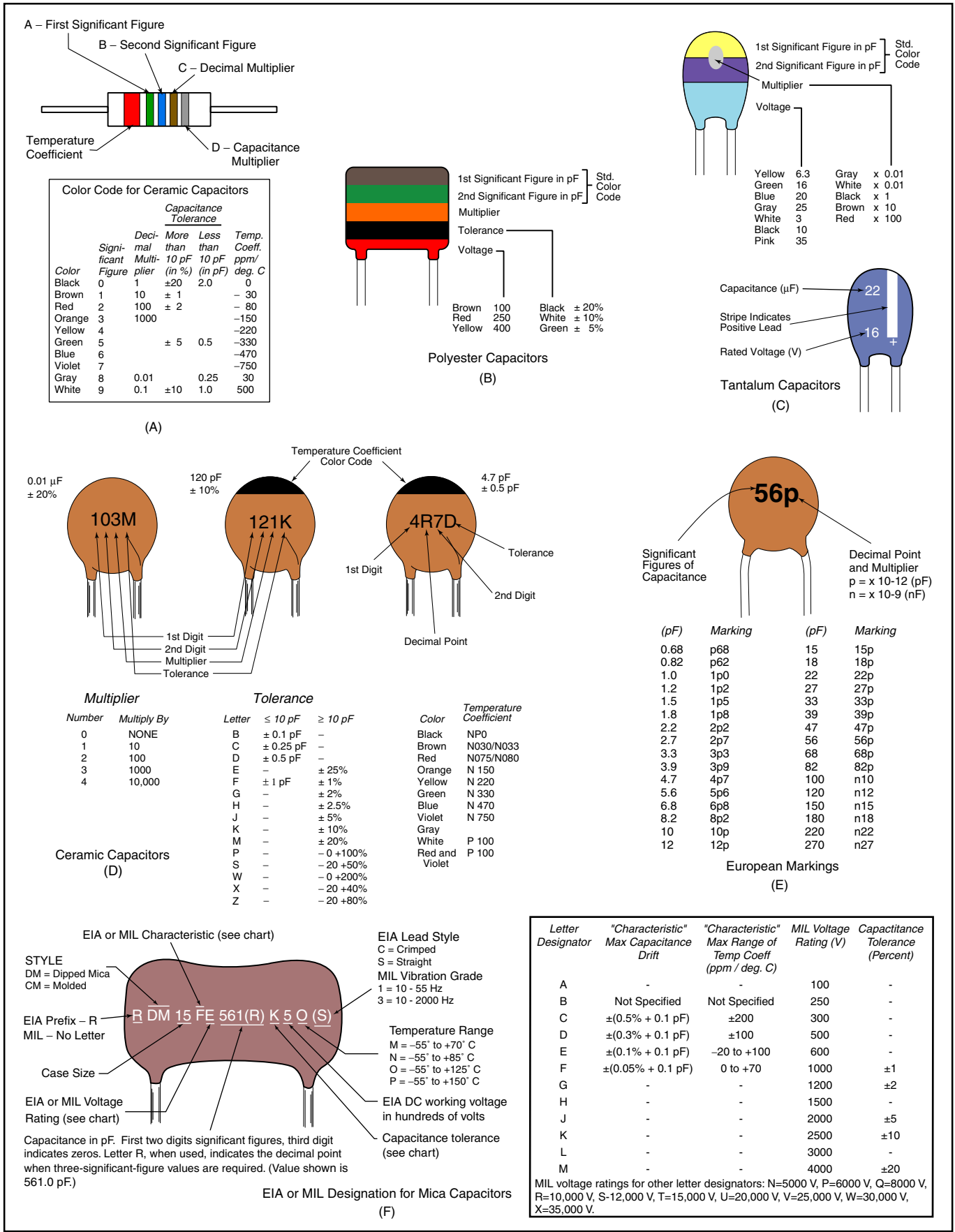

Fig 24.3—Capacitors can be identified by color codes and markings. Shown here are identifying markings found on many common capacitor types.

oscillators that must be frequency stable with temperature. If an application called for a temperature coefficient of -750 ppm/ $^{\circ}\text{C}$ (N750), a capacitor marked U2J would be suitable. The older industry code for these ratings is being replaced with the EIA code shown in **Table 24.4**. NP0 (that is, N-P-zero) means “negative, positive, zero;” it is a characteristic often specified for RF circuits requiring temperature stability, such as VFOs. A capacitor of the proper value marked C0G is a suitable replacement for an NP0 unit.

Some capacitors, such as dipped silver-mica units, have a letter designating the capacitance tolerance. These letters are deciphered in **Table 24.5**.

Surface-Mount Resistor and Capacitor Markings

Many different types of electronic components, both active and passive, are now available in surface-mount packages. These are commonly-known as chip resistors and capacitors. The very small size of these components leaves little space for marking with conventional codes, so brief alphanumeric codes are used to convey the most information in the smallest possible space.

Surface-mount resistors are typically marked with a three- or four-digit value code and a character indicating tolerance. The nominal resistance, expressed in ohms, is identified by three digits for 2% (and greater) tolerance devices. The first two digits represent the significant figures; the last digit specifies the multiplier as the exponent of ten. (It may be easier to remember the multiplier as the number of zeros you must add to the significant figures.) For values less than 100 Ω , the letter R is substituted for one of the significant digits and represents a decimal point. Here are some examples:

<i>Resistor Code</i>	<i>Value</i>
101	10 and 1 zero = 100 Ω
224	22 and 4 zeros = 220,000 Ω
1R0	1.0 and no zeros = 1 Ω
22R	22.0 and no zeros = 22 Ω
R10	0.1 and no zeros = 0.1 Ω

If the tolerance of the unit is narrower than $\pm 2\%$, the code used is a four-digit code where the first three digits are the significant figures and the last is the multiplier. The letter R is used in the same way to represent a decimal point. For example, 1001 indicates a 1000- Ω unit, and 22R0 indicates a 22- Ω unit.

The tolerance rating for a surface-mount resistor is expressed with a single character at the end of the numeric value code, according to **Table 24.6**.

Surface-mount capacitors are marked with a two-character code consisting of a letter indicating the significant digits (see **Table 24.7**) and a number indicating the multiplier (see **Table 24.8**). The code represents the capacitance in picofarads. For example, a chip capacitor marked “A4” would have a capacitance of 10,000 pF, or 0.01 μF . A unit marked “N1” would be a 33-pF capacitor. If there is sufficient space on the device package, a tolerance code may be included (see **Fig 24.3D** for tolerance

Table 24.4
EIA Capacitor Temperature-Coefficient Codes

<i>Industry</i>	<i>EIA</i>	<i>Industry</i>	<i>EIA</i>
NP0	C0G	N330	S2H
N033	S1G	N470	U2J
N075	U1G	N1500	P3K
N150	P2G	N2200	R3L
N220	R2G		

Table 24.5
EIA Capacitor Tolerance Codes

<i>Code</i>	<i>Tolerance</i>
C	$\pm 1/4$ pF
D	$\pm 1/2$ pF
F	± 1 pF or $\pm 1\%$
G	± 2 pF or $\pm 2\%$
J	$\pm 5\%$
K	$\pm 10\%$
L	$\pm 15\%$
M	$\pm 20\%$
N	$\pm 30\%$
P or GMV*	-0%, +100%
W	-20%, +40%
Y	-20%, +50%
Z	-20%, +80%

*GMV = guaranteed minimum value.

Table 24.6
SMT Resistor Tolerance Codes

<i>Letter</i>	<i>Tolerance</i>
D	$\pm 0.5\%$
F	$\pm 1.0\%$
G	$\pm 2.0\%$
J	$\pm 5.0\%$

Table 24.7**SMT Capacitor Significant Figures Code**

Character	Significant Figures	Character	Significant Figures
A	1.0	T	5.1
B	1.1	U	5.6
C	1.2	V	6.2
D	1.3	W	6.8
E	1.5	X	7.5
F	1.6	Y	8.2
G	1.8	Z	9.1
H	2.0	a	2.5
J	2.2	b	3.5
K	2.4	d	4.0
L	2.7	e	4.5
M	3.0	f	5.0
N	3.3	m	6.0
P	3.6	n	7.0
Q	3.9	t	8.0
R	4.3	y	9.0
S	4.7		

codes). Surface-mount capacitors can be very small; you may need a magnifying glass to read the markings.

INDUCTORS AND CORE MATERIALS

Inductors, both fixed and variable, are available in a wide variety of types and packages, and many offer few clues as to their values. Some coils and chokes are marked with the EIA color code shown in [Table 24.2](#). See [Fig 24.4](#) for another marking system for tubular encapsulated RF chokes.

Most powdered-iron toroid cores that we amateurs use are manufactured by Micrometals, who uses paint to identify the material used in the core. The Micrometals color code is part of [Table 24.9](#). [Table 24.10](#) gives the physical characteristics of powdered-iron toroids. Ferrite cores are not typically painted, so identification is more difficult. See [Table 24.11](#) for information about ferrite cores.

TRANSFORMERS

Many transformers, including power transformers, IF transformers and audio transformers, are made to be installed on PC boards, and have terminals designed for that purpose. Some transformers are manufactured with wire leads that are color-coded to identify each connection. When colored wire leads are present, the color codes in [Tables 24.12](#), [24.13](#) and [24.14](#) usually apply.

In addition, many miniature IF transformers are tuned with slugs that are color-coded to signify their application. [Table 24.15](#) lists application vs slug color.

SEMICONDUCTORS

Most semiconductor devices are clearly marked with the part number and in some cases, a manufacturer's date code as well. Identification of semiconductors can be difficult, however, when the parts are "house-marked" (marked with codes used by an equipment manufacturer instead of the stan-

Table 24.8**SMT Capacitor Multiplier Codes**

Numeric Character	Decimal Multiplier
0	1
1	10
2	100
3	1,000
4	10,000
5	100,000
6	1,000,000
7	10,000,000
8	100,000,000
9	0.1

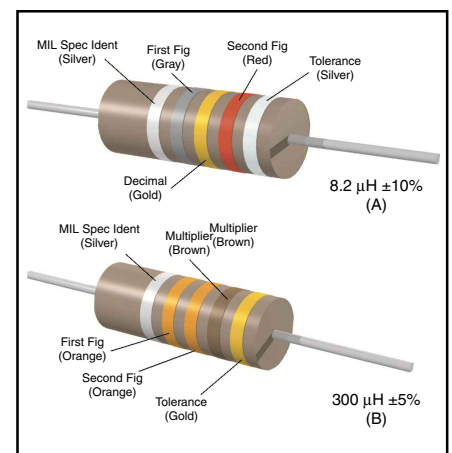

Fig 24.4—Color coding for tubular encapsulated RF chokes. At A, an example of the coding for an 8.2- μ H choke is given. At B, the color bands for a 330- μ H inductor are illustrated. The color code is given in [Table 24.2](#).

Table 24.9**Powdered-Iron Toroid Cores: Magnetic Properties****Inductance and Turns Formula**

The turns required for a given inductance or inductance for a given number of turns can be calculated from:

$$N = 100 \sqrt{\frac{L}{A_L}} \qquad L = A_L \left(\frac{N^2}{10,000} \right)$$

where N = number of turns; L = desired inductance (μH); A_L = inductance index (μH per 100 turns).*

A_L Values

Size	<i>Mix</i>										
	26**	3	15	1	2	7	6	10	12	17	0
T-12	na	60	50	48	20	18	17	12	7.5	7.5	3.0
T-16	145	61	55	44	22	na	19	13	8.0	8.0	3.0
T-20	180	76	65	52	27	24	22	16	10.0	10.0	3.5
T-25	235	100	85	70	34	29	27	19	12.0	12.0	4.5
T-30	325	140	93	85	43	37	36	25	16.0	16.0	6.0
T-37	275	120	90	80	40	32	30	25	15.0	15.0	4.9
T-44	360	180	160	105	52	46	42	33	18.5	18.5	6.5
T-50	320	175	135	100	49	43	40	31	18.0	18.0	6.4
T-68	420	195	180	115	57	52	47	32	21.0	21.0	7.5
T-80	450	180	170	115	55	50	45	32	22.0	22.0	8.5
T-94	590	248	200	160	84	na	70	58	32.0	na	10.6
T-106	900	450	345	325	135	133	116	na	na	na	19.0
T-130	785	350	250	200	110	103	96	na	na	na	15.0
T-157	870	420	360	320	140	na	115	na	na	na	na
T-184	1640	720	na	500	240	na	195	na	na	na	na
T-200	895	425	na	250	120	105	100	na	na	na	na

* The units of A_L (μH per 100 turns) are an industry standard; however, to get a correct result use A_L only in the formula above.

** Mix-26 is similar to the older Mix-41, but can provide an extended frequency range.

Magnetic Properties Iron Powder Cores

Mix	Color	Material	μ	Temp stability (ppm/°C)	f (MHz)	Notes
26	Yellow/white	Hydrogen reduced	75	825	dc - 1	Used for EMI filters and dc chokes
3	Gray	Carbonyl HP	35	370	0.05 - 0.50	Excellent stability, good Q for lower frequencies
15	Red/white	Carbonyl GS6	25	190	0.10 - 2	Excellent stability, good Q
1	Blue	Carbonyl C	20	280	0.50 - 5	Similar to Mix-3, but better stability
2	Red	Carbonyl E	10	95	2 - 30	High Q material
7	White	Carbonyl TH	9	30	3 - 35	Similar to Mix-2 and Mix-6, but better temperature stability
6	Yellow	Carbonyl SF	8	35	10 - 50	Very good Q and temp. stability for 20-50 MHz
10	Black	Powdered iron W	6	150	30 - 100	Good Q and stability for 40 - 100 MHz
12	Green/white	Synthetic oxide	4	170	50 - 200	Good Q, moderate temperature stability
17	Blue/yellow	Carbonyl	4	50	40 - 180	Similar to Mix-12, better temperature stability, Q drops about 10% above 50 MHz, 20% above 100 MHz
0	Tan	phenolic	1	0	100 - 300	Inductance may vary greatly with winding technique

Courtesy of Amidon Assoc and Micrometals

Note: Color codes hold only for cores manufactured by Micrometals, which makes the cores sold by most Amateur Radio distributors.

Table 24.10**Powdered-Iron Toroid Cores: Dimensions***Red E Cores—500 kHz to 30 MHz ($\mu = 10$)*

No.	OD (in)	ID (in)	H (in)
T-200-2	2.00	1.25	0.55
T-94-2	0.94	0.56	0.31
T-80-2	0.80	0.50	0.25
T-68-2	0.68	0.37	0.19
T-50-2	0.50	0.30	0.19
T-37-2	0.37	0.21	0.12
T-25-2	0.25	0.12	0.09
T-12-2	0.125	0.06	0.05

Black W Cores—30 MHz to 200 MHz ($\mu=7$)

No.	OD (In)	ID (In)	H (In)
T-50-10	0.50	0.30	0.19
T-37-10	0.37	0.21	0.12
T-25-10	0.25	0.12	0.09
T-12-10	0.125	0.06	0.05

Yellow SF Cores—10 MHz to 90 MHz ($\mu=8$)

No.	OD (In)	ID (In)	H (In)
T-94-6	0.94	0.56	0.31
T-80-6	0.80	0.50	0.25
T-68-6	0.68	0.37	0.19
T-50-6	0.50	0.30	0.19
T-26-6	0.25	0.12	0.09
T-12-6	0.125	0.06	0.05

Number of Turns vs Wire Size and Core Size

Approximate maximum number of turns—single layer wound—enameled wire.

Wire Size	T-200	T-130	T-106	T-94	T-80	T-68	T-50	T-37	T-25	T-12
10	33	20	12	12	10	6	4	1		
12	43	25	16	16	14	9	6	3		
14	54	32	21	21	18	13	8	5	1	
16	69	41	28	28	24	17	13	7	2	
18	88	53	37	37	32	23	18	10	4	1
20	111	67	47	47	41	29	23	14	6	1
22	140	86	60	60	53	38	30	19	9	2
24	177	109	77	77	67	49	39	25	13	4
26	223	137	97	97	85	63	50	33	17	7
28	281	173	123	123	108	80	64	42	23	9
30	355	217	154	154	136	101	81	54	29	13
32	439	272	194	194	171	127	103	68	38	17
34	557	346	247	247	218	162	132	88	49	23
36	683	424	304	304	268	199	162	108	62	30
38	875	544	389	389	344	256	209	140	80	39
40	1103	687	492	492	434	324	264	178	102	51

Actual number of turns may differ from above figures according to winding techniques, especially when using the larger size wires. Chart prepared by Michel J. Gordon, Jr., WB9FHC

Courtesy of Amidon Assoc.

Table 24.11

Ferrite Toroids: A_L Chart (mH per 1000, turns) Enameled Wire

Core Size	63/67-Mix $\mu = 40$	61-Mix $\mu = 125$	43-Mix $\mu = 850$	77 (72) Mix $\mu = 2000$	J (75) Mix $\mu = 5000$
FT-23	7.9	24.8	188.0	396	980
FT-37	19.7	55.3	420.0	884	2196
FT-50	22.0	68.0	523.0	1100	2715
FT-82	22.4	73.3	557.0	1170	NA
FT-114	25.4	79.3	603.0	1270	3170

Number turns = $1000 \sqrt{\text{desired L (mH)} \div A_L \text{ value (above)}}$

Ferrite Magnetic Properties

Property	Unit	63/67-Mix	61-Mix	43-Mix	77 (72) Mix	J (75)-Mix
Initial perm (μ_i)		40	125	850	2000	5000
Maximum perm.		125	450	3000	6000	8000
Saturation flux density @ 10 oer	Gauss	1850	2350	2750	4600	3900
Residual flux density	Gauss	750	1200	1200	1150	1250
Curie temp.	$^{\circ}\text{C}$	450	350	130	200	140
Vol. resistivity	ohm/cm	1×10^8	1×10^8	1×10^5	1×10^2	5×10^2
Resonant circuit frequency	MHz	15-25	0.2-10	0.01-1	0.001-1	0.001-1
Specific gravity		4.7	4.7	4.5	4.8	4.8
Loss factor	$\frac{1}{\mu_i Q}$	110×10^{-6} @25 MHz	32×10^{-6} @2.5 MHz	120×10^{-6} @1 MHz	4.5×10^{-6} @0.1 MHz	15×10^{-6} @0.1 MHz
Coercive force	Oer	2.40	1.60	0.30	0.22	0.16
Temp. Coef. of initial perm.	$\% / ^{\circ}\text{C}$ (20-70 $^{\circ}\text{C}$)	0.10	0.15	1.0	0.60	0.90

Ferrite Toroids—Physical Properties

Core Size	OD	ID	Height	A_e	l_e	V_e	A_S	A_W
FT-23	0.230	0.120	0.060	0.00330	0.529	0.00174	0.1264	0.01121
FT-37	0.375	0.187	0.125	0.01175	0.846	0.00994	0.3860	0.02750
FT-50	0.500	0.281	0.188	0.02060	1.190	0.02450	0.7300	0.06200
FT-82	0.825	0.520	0.250	0.03810	2.070	0.07890	1.7000	0.21200
FT-114	1.142	0.750	0.295	0.05810	2.920	0.16950	2.9200	0.43900

OD—Outer diameter (inches)
 ID—Inner diameter (inches)
 Hgt—Height (inches)
 A_W —Total window area (in)²

A_e —Effective magnetic cross-sectional area (in)²
 l_e —Effective magnetic path length (inches)
 V_e —Effective magnetic volume (in)³
 A_S —Surface area exposed for cooling (in)²

Courtesy of Amidon Assoc.

Table 24.12**Power-Transformer Wiring Color Codes**

Non-tapped primary leads:	Black
Tapped primary leads:	Common: Black
	Tap: Black/yellow striped
	Finish: Black/red striped
High-voltage plate winding:	Red
Center tap:	Red/yellow striped
Rectifier filament winding:	Yellow
Center tap:	Yellow/blue striped
Filament winding 1:	Green
Center tap:	Green/yellow striped
Filament winding 2:	Brown
Center tap:	Brown/yellow striped
Filament winding 3:	Slate
Center tap:	Slate/yellow striped

Table 24.13**IF Transformer Wiring Color Codes**

Plate lead:	Blue
B+ lead:	Red
Grid (or diode) lead:	Green
Grid (or diode) return:	Black

Note: If the secondary of the IF transformer is center-tapped, the second diode plate lead is green-and-black striped, and black is used for the center-tap lead.

Table 24.14**IF Transformer Slug Color Codes**

Frequency	Application	Slug color
455 kHz	1st IF	Yellow
	2nd IF	White
	3rd IF	Black
	Osc tuning	Red
10.7 MHz	1st IF	Green
	2nd or 3rd IF	Orange, Brown or Black

Table 24.15**Audio Transformer Wiring Color Codes**

Plate lead of primary	Blue
B+ lead (plain or center-tapped)	Red
Plate (start) lead on center-tapped primaries	Brown (or blue if polarity is not important)
Grid (finish) lead to secondary	Green
Grid return (plain or center tapped)	Black
Grid (start) lead on center tapped secondaries	Yellow (or green if polarity not important)

Note: These markings also apply to line-to-grid and tube-to-line transformers.

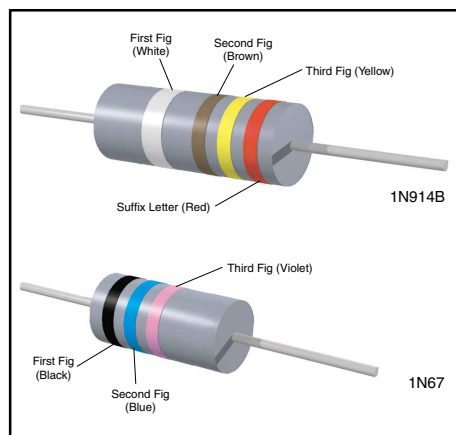

Fig 24.5—Color coding for semiconductor diodes. At A, the cathode is identified by the double-width first band. At B, the bands are grouped toward the cathode. Two-figure designations are signified by a black first band. The color code is given in Table 24.2. The suffix-letter code is A—Brown, B—red, C—orange, D—yellow, E—green, F—blue. The 1N prefix is understood.

standard part numbers). In such cases, it is often possible to find the standard equivalent or a suitable replacement by using one of the semiconductor cross-reference directories available from various replacement-parts distributors. If you look up the house number and find the recommended replacement part, you can often find other standard parts that are replaced by that same part.

Diodes

Most diodes are marked with a part number and some means of identifying which lead is the cathode. Some diodes are marked with a color-band code (see Fig 24.5). Important diode parameters include maximum forward current, maximum peak inverse voltage (PIV) and the power-handling capacity.

Transistors

Some important parameters for transistor selection are voltage

and current limits, power-handling capability, beta or gain characteristics and useful frequency range. The case style may also be an issue; some transistors are available in several different case styles.

Integrated Circuits

Integrated circuits (ICs) come in a variety of packages, including transistor-like metal cans, dual and single in-line packages (DIPs and SIPs), flat-packs and surface-mount packages. Most are marked with a part number and a four-digit manufacturer's date code indicating the year (first two digits) and week (last two digits) that the component was made. ICs are frequently house-marked, and the cross-reference directories mentioned above can be helpful in identification and replacement.

Another very useful reference tool for working with ICs is *IC Master*, a master selection guide that organizes ICs by type, function and certain key parameters. A part number index is included, along with application notes and manufacturer's information for tens of thousands of IC devices. Some of the data from *IC Master* is also available on computer disks.

IC part numbers usually contain a few digits that identify the circuit die or function and several other letters and/or digits that identify the production process, manufacturer and package. For example, a '4066 IC contains four independent SPST switches. Harris (CD74HC4066, CD4066B and CD4066BE), National (MM74HC4066, CD4066BC and CD4066BM) and Panasonic (MN74HC4066 and MN4066B) all make similar devices (as do many other manufacturers) with slight differences. Among the numbers listed, "CD" (CMOS Digital), "MM" (MOS Monolithic), and "MN" indicate CMOS parts. "74" indicates a commercial quality product (for applications from 0°C to 70°C), which is pin compatible with the 74/54 TTL families. "HC" means high-speed CMOS family, which is as fast as the LS TTL family. The "B" suffix, as is CD4066B, indicates a buffered output. This is only a small example of the conventions used in IC part numbers. For more information look at data books from the various manufacturers. Base diagrams for many common ICs appear in *The ARRL Electronics Data Book*.

When choosing ICs that are not exact replacements, several operating needs and performance aspects should be considered. First, the replacement power requirements must be met: Some ICs require 5 V dc, others 12 V and some need both positive and negative supplies. Current requirements vary among the various IC families, so be sure that sufficient current is available from the power supply. If a replacement IC uses much more current than the device it replaces, a heat sink or blower may be needed to keep it cool.

Next consider how the replacement interacts with its neighboring components. Input capacitance and "fanout" are critical factors in digital circuits. Increased input capacitance may overload the driving circuits. Overload slows circuit operation, which may prevent lines from reaching the "high" condition. Fanout tells how many inputs a device can drive. The fanout of a replacement should be equal to, or greater than, that required in the circuit. Operating speed and propagation delay are also significant. Choose a replacement IC that operates at or above the circuit clock speed. (Although increased speed can increase EMI and cause other problems.) Some circuits may not function if the propagation delay varies much from the specified part. Look at the [Digital](#) chapter for details of how these operating characteristics relate to circuit performance.

Analog ICs have similar characteristics. Input and output capacities are often defined as how much current an analog IC can "sink" (accept at an input) or "source" (pass to a load). A replacement should be able to source or sink at least as much current as the device it replaces. Analog speed is sometimes listed as bandwidth (as in discrete-component circuits) or slew rate (common in op amps). Each of these quantities should meet or exceed that of the replaced component.

Some ICs are available in different operating temperature ranges. Op amps, for example, are commonly available in three standard ranges:

- Commercial 0°C to 70°C
- Industrial -25°C to 85°C
- Military -55°C to 125°C

In some cases, part numbers reflect the temperature ratings. For example, an LM301A op amp is rated for the commercial temperature range; an LM201A op amp for the industrial range and an LM101A for the military range.

When necessary, you can add interface circuits or buffer amplifiers that improve the input and output capabilities of replacement ICs, but auxiliary circuits cannot improve basic device ratings, such as speed or bandwidth.

An excellent source of information on many common ICs is *The ARRL Electronics Data Book*, which contains detailed data for digital ICs (CMOS and TTL), op amps and other analog ICs.

OTHER SOURCES OF COMPONENT DATA

There are many sources you can consult for detailed component data. Many manufacturers publish data books for the components they make. Many distributors will include data sheets for parts you order if you ask for them. Parts catalogs themselves are often good sources of component data. The following list is representative of some of the data resources available from manufacturers and distributors.

Motorola Small-Signal Transistor Data

Motorola RF Device Data

Motorola Linear and Interface ICs

Signetics: General Purpose/Linear ICs

NTE Technical Manual and Cross Reference

TCE SK Replacement Technical Manual and Cross Reference

National Semiconductor:

Discrete Semiconductor Products Databook

CMOS Logic Databook

Linear Applications Handbook

Linear Application-Specific ICs Databook

Operational Amplifiers Databook

Copper Wire Specifications

Bare and Enamel-Coated Wire

Wire Size (AWG)	Diam (Mils)	Area (CM ²)	Enamel Wire Coating Turns / Linear inch ²			Feet per Pound Bare	Ohms per 1000 ft 25° C	Current Carrying Capacity Continuous Duty ³			Nearest British SWG No.
			Single	Heavy	Triple			at 700 CM per Amp ⁴	Open air	Conduit or bundles	
1	289.3	83694.49				3.948	0.1239	119.564			1
2	257.6	66357.76				4.978	0.1563	94.797			2
3	229.4	52624.36				6.277	0.1971	75.178			4
4	204.3	41738.49				7.918	0.2485	59.626			5
5	181.9	33087.61				9.98	0.3134	47.268			6
6	162.0	26244.00				12.59	0.3952	37.491			7
7	144.3	20822.49				15.87	0.4981	29.746			8
8	128.5	16512.25				20.01	0.6281	23.589			9
9	114.4	13087.36				25.24	0.7925	18.696			11
10	101.9	10383.61				31.82	0.9987	14.834			12
11	90.7	8226.49				40.16	1.2610	11.752			13
12	80.8	6528.64				50.61	1.5880	9.327			13
13	72.0	5184.00				63.73	2.0010	7.406			15
14	64.1	4108.81	15.2	14.8	14.5	80.39	2.5240	5.870	32	17	15
15	57.1	3260.41	17.0	16.6	16.2	101.32	3.1810	4.658			16
16	50.8	2580.64	19.1	18.6	18.1	128	4.0180	3.687	22	13	17
17	45.3	2052.09	21.4	20.7	20.2	161	5.0540	2.932			18
18	40.3	1624.09	23.9	23.2	22.5	203.5	6.3860	2.320	16	10	19
19	35.9	1288.81	26.8	25.9	25.1	256.4	8.0460	1.841			20
20	32.0	1024.00	29.9	28.9	27.9	322.7	10.1280	1.463	11	7.5	21
21	28.5	812.25	33.6	32.4	31.3	406.7	12.7700	1.160			22
22	25.3	640.09	37.6	36.2	34.7	516.3	16.2000	0.914		5	22
23	22.6	510.76	42.0	40.3	38.6	646.8	20.3000	0.730			24
24	20.1	404.01	46.9	45.0	42.9	817.7	25.6700	0.577			24
25	17.9	320.41	52.6	50.3	47.8	1031	32.3700	0.458			26
26	15.9	252.81	58.8	56.2	53.2	1307	41.0200	0.361			27
27	14.2	201.64	65.8	62.5	59.2	1639	51.4400	0.288			28
28	12.6	158.76	73.5	69.4	65.8	2081	65.3100	0.227			29
29	11.3	127.69	82.0	76.9	72.5	2587	81.2100	0.182			31
30	10.0	100.00	91.7	86.2	80.6	3306	103.7100	0.143			33
31	8.9	79.21	103.1	95.2		4170	130.9000	0.113			34
32	8.0	64.00	113.6	105.3		5163	162.0000	0.091			35
33	7.1	50.41	128.2	117.6		6553	205.7000	0.072			36
34	6.3	39.69	142.9	133.3		8326	261.3000	0.057			37
35	5.6	31.36	161.3	149.3		10537	330.7000	0.045			38
36	5.0	25.00	178.6	166.7		13212	414.8000	0.036			39
37	4.5	20.25	200.0	181.8		16319	512.1000	0.029			40
38	4.0	16.00	222.2	204.1		20644	648.2000	0.023			
39	3.5	12.25	256.4	232.6		26969	846.6000	0.018			
40	3.1	9.61	285.7	263.2		34364	1079.2000	0.014			
41	2.8	7.84	322.6	294.1		42123	1323.0000	0.011			
42	2.5	6.25	357.1	333.3		52854	1659.0000	0.009			
43	2.2	4.84	400.0	370.4		68259	2143.0000	0.007			
44	2.0	4.00	454.5	400.0		82645	2593.0000	0.006			
45	1.8	3.10	526.3	465.1		106600	3348.0000	0.004			
46	1.6	2.46	588.2	512.8		134000	4207.0000	0.004			

Continued on [next page](#).

Teflon Coated, Stranded Wire

Continued from [previous page](#).
(As supplied by Belden Wire and Cable)

Turns per Linear inch² UL Style No.

Size	Strands ⁵	1180	1213	1371
16	19×29	11.2		
18	19×30	12.7		
20	7×28	14.7	17.2	
20	19×32	14.7	17.2	
22	19×34	16.7	20.0	23.8
22	7×30	16.7	20.0	23.8
24	19×36	18.5	22.7	27.8
24	7×32		22.7	27.8
26	7×34		25.6	32.3
28	7×36		28.6	37.0
30	7×38		31.3	41.7
32	7×40			47.6

Notes

- ¹ A circular mil (CM) is a unit of area equal to that of a one-mil-diameter circle ($\pi/4$ square mils). The CM area of a wire is the square of the mil diameter.
- ² Figures given are approximate only; insulation thickness varies with manufacturer.
- ³ Maximum wire temperature of 212°F (100°C) with a maximum ambient temperature of 13°F (57°C) as specified by the manufacturer. The *National Electrical Code* or local building codes may differ.
- ⁴ 700 CM per ampere is a satisfactory design figure for small transformers, but values from 500 to 1000 CM are commonly used. The *National Electrical Code* or local building codes may differ.
- ⁵ Stranded wire construction is given as “count” × “strand size” (AWG).

Color Code for Hookup Wire

Wire Color	Type of Circuit
Black	Grounds, grounded elements and returns
Brown	Heaters or filaments, off ground
Red	Power Supply B plus
Orange	Screen grids and base 2 of transistors
Yellow	Cathodes and transistor emitters
Green	Control grids, diode plates, and base 1 of transistors
Blue	Plates and transistor collectors
Violet	Power supply, minus leads
Gray	Ac power line leads
White	Bias supply, B or C minus, AGC

Note: Wires with tracers are coded in the same manner as solid-color wires, allowing additional circuit identification over solid-color wiring. The body of the wire is white and the color band spirals around the wire lead. When more than one color band is used, the widest band represents the first color.

Aluminum Alloy Characteristics

Common Alloy Numbers

Type	Characteristic
2024	Good formability, high strength
5052	Excellent surface finish, excellent corrosion resistance, normally not heat treatable for high strength
6061	Good machinability, good weldability, can be brittle at high temps
7075	Good formability, high strength

General Uses

Type	Uses
2024-T3	Chassis boxes, antennas, anything that will be bent or flexed repeatedly
7075-T3	
6061-T6	Mounting plates, welded assemblies or machined parts

Common Tempers

Type	Characteristics
T0	Special soft condition
T3	Hard
T6	Very hard, possibly brittle
TXXX	Three digit tempers—usually specialized high-strength heat treatments, similar to T6

Crystal Holders

Note: Solder Seal, Cold Weld, and Resistance Weld sealing methods are commonly available.
All dimensions are in inches

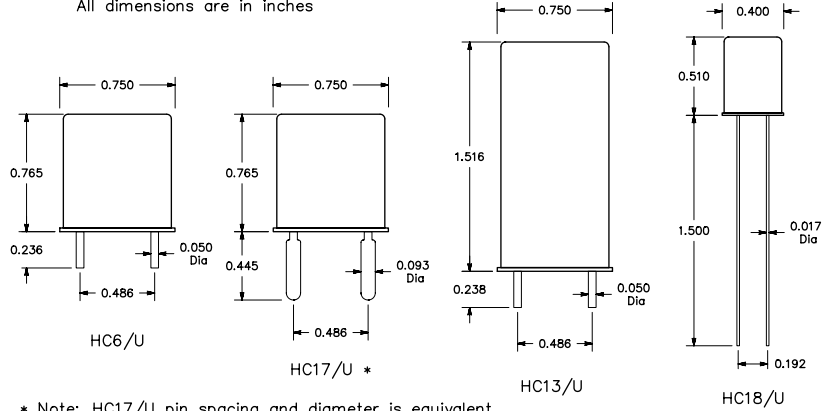

* Note: HC17/U pin spacing and diameter is equivalent to the older FT-243 (32 pF) holder.

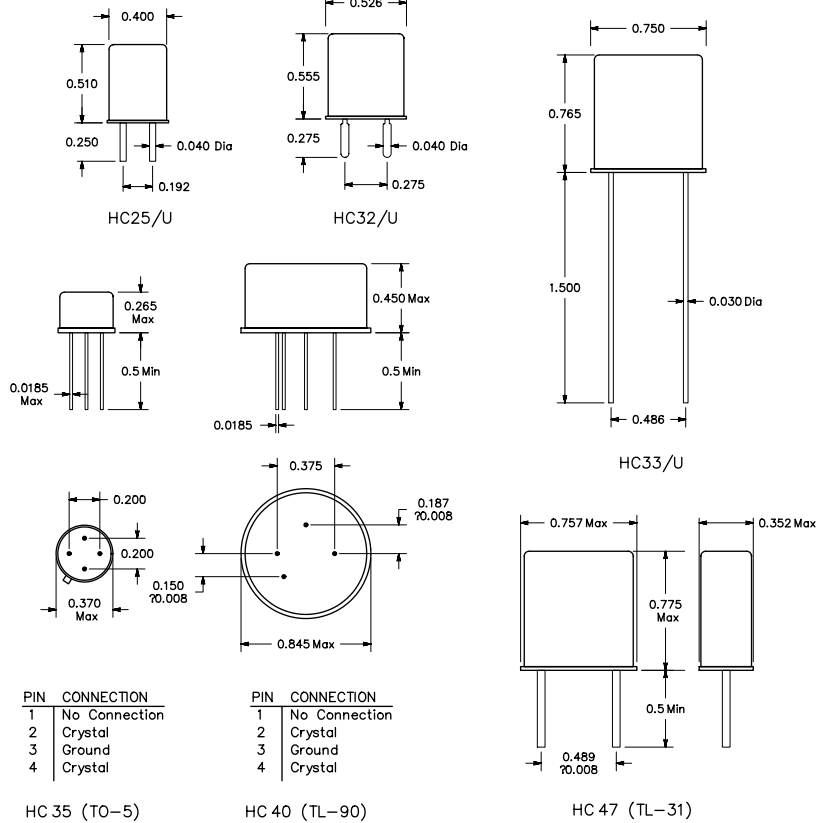

* Note: HC17/U pin spacing and diameter is equivalent to the older FT-243 (32 pF) holder.

Miniature Lamp Guide



**Bulbs are described by a letter indicating shape and a number that is an approximation of diameter expressed in eighths of an inch. For example S-8 is "S" shape, 8 eighths or 1 inch in diameter.

BULB STYLES

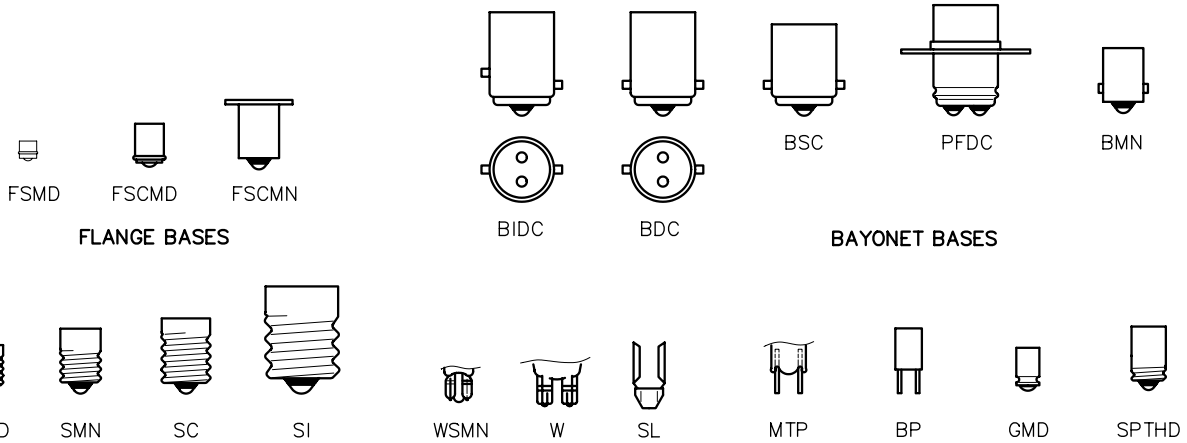

Lamp Base Legend

BDC Bayonet, dual-contact
 BMD Bayonet, indexed dual-contact
 BMN Bayonet, miniature
 BP Bipin
 BSC Bayonet, single-contact
 FSCMN Flanged, single-contact, miniature

FSCMD Flanged, midget single-contact
 FSMD Flanged, submidget
 GMD Midget grooved
 MTP Miniature two-pin
 PFDC Prefocused dual-contact
 SL Slide (various sizes)
 SC Screw, candelabra

SI Screw, intermediate
 SMD Screw, midget
 SMN Screw, miniature
 SPTHD Screw, special thread
 W Wedge
 WSMN Wedge, subminiature
 WT Wire terminal

$t_k = 1000$

Type	Bulb	Base	V	A	Life†	Type	Bulb	Base	V	A	Life†
PR2	B-3½	FSCMN	2.38	0.500	15	159	T-3¼	W	6.30	0.150	5K
PR3	B-3½	FSCMN	3.57	0.500	15	161	T-3¼	W	14.00	0.190	4K
PR4	B-3½	FSCMN	2.33	0.270	10	168	T-3¼	W	14.00	0.350	1.5K
PR6	B-3½	FSCMN	2.47	0.300	30	219	G-3½	BMN	6.30	0.250	5K
PR7	B-3½	FSCMN	3.70	0.300	30	222	TL-3	SMN	2.25	0.250	0.5
PR12	B-3½	FSCMN	5.95	0.500	15	239	T-3¼	BMN	6.30	0.360	5K
PR13	B-3½	FSCMN	4.75	0.500	15	240	T-3¼	BMN	6.30	0.360	5K
10	G-3½	MTP	2.50	0.500	3K	259	T-3¼	W	6.30	0.250	5K
12	G-3½	MTP	6.30	0.150	5K	268	T-1¼	FSCMD	2.50	0.350	10K
13	G-3½	SMN	3.70	0.300	15	305	S-8	BSC	28.00	0.510	300
14	G-3½	SMN	2.47	0.300	15	307	S-8	BSC	28.00	0.670	300
19	G-3½	MTP	14.40	0.100	1K	308	S-8	BDC	28.00	0.670	300
27	G-4½	SMN	4.90	0.300	30	313	T-3¼	BMN	28.00	0.170	500
37	T-1¼	WSMN	14.00	0.090	1.5K	323	T-1¼	SPTHD	3.00	0.190	350
40	T-3¼	SMN	6.30	0.150	3K	327	T-1¼	FSCMD	28.00	0.040	4K
43	T-3¼	BMN	2.50	0.500	3K	327AS15	T-1¼	FSCMD	28.00	0.040	4K
44	T-3¼	BMN	6.30	0.250	3K	328	T-1¼	FSCMD	6.00	0.200	1K
45	T-3¼	BMN	3.20	0.350	3K	330	T-1¼	FSCMD	14.00	0.080	1.5K
46	T-3¼	SMN	6.30	0.250	3K	331	T-1¼	FSCMD	1.35	0.060	3K
47	T-3¼	BMN	6.30	0.150	3K	334	T-1¼	GMD	28.00	0.040	4K
48	T-3¼	SMN	2.00	0.060	1K	335	T-1¼	SMD	28.00	0.040	4K
49	T-3¼	BMN	2.00	0.060	1K	336	T-1¼	GMD	14.00	0.080	1.5K
50	G-3½	SMN	7.50	0.220	1K	337	T-1¼	GMD	6.00	0.200	1K
51	G-3½	BMN	7.50	0.220	1K	338	T-1¼	FSCMD	2.70	0.060	6K
52	G-3½	SMN	14.40	0.100	1K	342	T-1¼	SMD	6.00	0.040	10K
53	G-3½	BMN	14.40	0.120	1K	344	T-1¼	FSCMD	10.00	0.014	50K
55	G-4½	BMN	7.00	0.410	500	345	T-1¼	FSCMD	6.00	0.040	10K
57	G-4½	BMN	14.00	0.240	500	346	T-1¼	GMD	18.00	0.040	10K
63	G-6	BSC	7.00	0.630	1K	349	T-1¼	FSCMD	6.30	0.200	5K
73	T-1¼	WSMN	14.00	0.080	15K	370	T-1¼	FSCMD	18.00	0.040	10K
74	T-1¼	WSMN	14.00	0.100	500	373	T-1¼	SMD	14.00	0.080	1.5K
82	G-6	BDC	6.50	1.020	500	375	T-1¼	FSCMD	3.00	0.015	10K
85	T-1¼	WSMN	28.00	0.040	7K	376	T-1¼	FSCMD	28.00	0.060	25K
86	T-1¼	WSMN	6.30	0.200	20K	380	T-1¼	FSCMD	6.30	0.040	20K
88	S-8	BDC	6.80	1.910	300	381	T-1¼	FSCMD	6.30	0.200	20K
93	S-8	BSC	12.80	1.040	700	382	T-1¼	FSCMD	14.00	0.080	15K
112	TL-3	SMN	1.20	0.220	5	385	T-1¼	FSCMD	28.00	0.040	10K
130	G-3½	BMN	6.30	0.150	5K	386	T-1¼	GMD	14.00	0.080	15K
131	G-3½	SMN	1.30	0.100	50	387	T-1¼	FSCMD	28.00	0.040	7K
158	T-3¼	W	14.00	0.240	500	388	T-1¼	GMD	28.00	0.040	7K

Continued on next page.

Miniature Lamp Guide

Continued from [previous page](#).

Type	Bulb	Base	V	A	Life†	Type	Bulb	Base	V	A	Life†
397	T-1¾	GMD	10.00	0.040	5K	1892	T-3¼	BMN	14.40	0.120	1K
398	T-1¾	GMD	6.30	0.200	5K	1893	T-3¼	BMN	14.00	0.330	7.5K
399	T-1¾	SMD	28.00	0.040	7K	1895	G-4½	BMN	14.00	0.270	2K
502	G-4½	SMN	5.10	0.150	100	2102	T-1¾	WT	18.00	0.040	10K
555	T-3¼	W	6.30	0.250	3K	2107	T-1¾	WT	10.00	0.040	5K
656	T-3¼	W	28.00	0.060	2.5K	2158	T-1¾	WT	3.00	0.015	10K
680AS15	T-1	WT	5.00	0.060	60K	2162	T-1¾	WT	14.00	0.100	10K
682AS15	T-1	FSMD	5.00	0.060	60K	2169	T-1¾	WT	2.50	0.350	20K
683AS15	T-1	WT	5.00	0.060	25K	2180	T-1¾	WT	6.30	0.040	20K
685AS15	T-1	FSMD	5.00	0.060	25K	2181	T-1¾	WT	6.30	0.200	20K
715AS15	T-1	WT	5.00	0.115	40K	2182	T-1¾	WT	14.00	0.080	40K
715AS25	T-1	WT	5.00	0.115	40K	2187	T-1¾	WT	28.00	0.040	7K
718AS25	T-1	FSMD	5.00	0.115	40K	2304	T-1¾	BP	3.00	0.300	1.5K
755	T-3¼	BMN	6.30	0.150	20K	2307	T-1¾	BP	6.30	0.200	5K
756	T-3¼	BMN	14.00	0.080	15K	2314	T-1¾	BP	28.00	0.050	1K
757	T-3¼	BMN	28.00	0.080	7.5K	2316	T-1¾	BP	18.00	0.040	10K
1034	S-8	BIDC	14.00	0.590	5K	2324	T-1¾	BP	28.00	0.040	4K
1073	S-8	BSC	12.80	1.800	200	2335	T-1¾	BP	14.00	0.080	15K
1130	S-8	BDC	6.40	2.630	200	2337	T-1¾	BP	6.30	0.200	20K
1133	RP-11	BSC	6.20	3.910	200	2342	T-1¾	BP	28.00	0.040	25K
1141	S-8	BSC	12.80	1.440	1K	3149	T-1¾	BP	5.00	0.060	5K
1143	RP-11	BSC	12.50	1.980	400	6803AS25	T-¾	WT	5.00	0.060	60K
1184	RP-11	BDC	5.50	6.250	100	6833AS15	T-¾	WT	5.00	0.060	25K
1251	G-6	BSC	28.00	0.230	2K	6838	T-1	WT	28.00	0.024	4K
1445	G-3½	BMN	14.40	0.130	2K	6839	T-1	FSMD	28.00	0.024	4K
1487	T-3¼	SMN	14.00	0.200	3K	7001	T-1¾	BP	24.00	0.050	2K
1488	T-3¼	BMN	14.00	0.150	200	7003	T-1¾	BP	24.00	0.050	2K
1490	T-3¼	BMN	3.20	0.160	3K	7153AS15	T-¾	WT	5.00	0.115	40K
1493	S-8	BDC	6.50	2.750	100	7265	T-1	BP	5.00	0.060	5K
1619	S-8	BSC	6.70	1.900	500	7327	T-1¾	BP	28.00	0.040	4K
1630	S-8	PFDC	6.50	2.750	100	7328	T-1¾	BP	6.00	0.200	1K
1691	S-8	BSC	28.00	0.610	1K	7330	T-1¾	BP	14.00	0.080	1.5K
1705	T-1¾	WT	14.00	0.080	1.5K	7344	T-1¾	BP	10.00	0.014	50K
1728	T-1¾	WT	1.35	0.060	3K	7349	T-1¾	BP	6.30	0.200	5K
1730	T-1¾	WT	6.00	0.040	20K	7361	T-1¾	BP	5.00	0.060	25K
1738	T-1¾	WT	2.70	0.060	6K	7362	T-1¾	BP	5.00	0.115	40K
1762	T-1¾	WT	28.00	0.040	4K	7367	T-1¾	BP	10.00	0.040	5K
1764	T-1¾	WT	28.00	0.040	4K	7370	T-1¾	BP	18.00	0.040	10K
1767	T-1¾	SMD	2.50	0.200	500	7371	T-1¾	BP	12.00	0.040	10K
1768	T-1¾	SMD	6.00	0.200	1K	7373	T-1¾	BP	14.00	0.100	10K
1775	T-1¾	SMD	6.30	0.075	1K	7374	T-1¾	BP	28.00	0.040	10K
1813	T-3¼	BMN	14.40	0.100	1K	7375	T-1¾	BP	3.00	0.015	10K
1815	T-3¼	BMN	14.00	0.200	3K	7376	T-1¾	BP	28.00	0.065	10K
1816	T-3¼	BMN	13.00	0.330	1K	7377	T-1¾	BP	6.30	0.075	1K
1818	T-3¼	BMN	24.00	0.170	250	7380	T-1¾	BP	6.30	0.040	30K
1819	T-3¼	BMN	28.00	0.040	2.5K	7381	T-1¾	BP	6.30	0.200	20K
1820	T-3¼	BMN	28.00	0.100	1K	7382	T-1¾	BP	14.00	0.080	15K
1821	T-3¼	SMN	28.00	0.170	500	7387	T-1¾	BP	28.00	0.040	7K
1822	T-3¼	BMN	36.00	0.100	1K	7410	T-1¾	BP	14.00	0.080	15K
1828	T-3¼	BMN	37.50	0.050	3K	7839	T-1	BP	28.00	0.025	4K
1829	T-3¼	BMN	28.00	0.070	1K	7876	T-1¾	BP	28.00	0.060	25K
1835	T-3¼	BMN	55.00	0.050	5K	7931	T-1¾	BP	1.35	0.060	3K
1847	T-3¼	BMN	6.30	0.150	5K	7945	T-1¾	BP	6.00	0.040	20K
1850	T-3¼	BMN	5.00	0.090	1.5K	7968	T-1¾	BP	2.50	0.200	500
1864	T-3¼	BMN	28.00	0.170	1.5K	8099	T-1	BP	18.00	0.020	16K
1866	T-3¼	BMN	6.30	0.250	5K	8362	T-1¾	SMD	14.00	0.080	15K
1869	T-1¾	WT	10.00	0.014	50K	8369	T-1¾	SMD	28.00	0.065	10K
1891	T-3¼	BMN	14.00	0.240	500						

STANDARD LINE-VOLTAGE LAMPS

Type	V	W	Bulb	Base
10C7DC	115-125	10	C-7	BDC
3S6	120, 125	3	S-6	SC
6S6	30, 48, 115, 120, 125, 130, 135, 145, 155	6	S-6	SC
6S6/R	115-125	6	S-6 (red)	SC
6S6/W	115-125	6	S-6 (white)	SC
6T4½	120, 130	6	T-4½	SC
7C7	115-125	7	C-7	SC
7C7/W	115-125	7	C-7 (white)	SC
10C7	115-125	10	C-7	SC
10S6	120	10	S-6	SC
10S6/10	220, 230, 250	10	S-6	SC
6S6DC	30, 120, 125, 145	6	S-6	BDC
10S6/10DC	230, 250	10	S-6	BDC
40S11 N	115-125	40	S-11	SI
120MB	120	3	T-2½	BMN
120MB/6	120	6	T-2½	BMN
120PSB	120	3	T-2	SL
120PS	120	3	T-2	WT
120PS/6	120	6	T-2½	WT

INDICATOR LAMPS

Each has a T-2 bulb and a slide base.

Type	V	A	Life †
6PSB	6.00	0.140	20K
12PSB	12.00	0.170	12K
24PSB	24.00	0.073	10K
28PSB	28.00	0.040	5K
48PSB	48.00	0.050	10K
60PSB	60.00	0.050	7.5K
120PSB	120.00	0.025	7.5K

NEON GLOW LAMPS

Operating circuit voltage 105-125.

Type	Breakdown Voltage		Bulb	Base	W	External Resistance†
	AC	DC				
NE-2	65	90	T-2	WT	1/12	150K
NE-2A	65	90	T-2	WT	1/15	100K
NE-2D	65	90	T-2	FSCMD	1/12	100K
NE-2E	65	90	T-2	WT	1/12	100K
NE-2H	95	135	T-2	WT	1/4	30K
NE-2J	95	135	T-2	FSCMD	1/4	30K
NE-2V	65	90	T-2	WT	1/12	100K
NE-45	65	90	T-4 1/2	SC	1/4	NONE
NE-51	65	90	T-3 1/4	BMN	1/25	220K
NE-51H	95	135	T-3 1/4	BMN	1/7	47K
NE-84	95	135	T-2	SL	1/4	30K
NE-120PSB	95	95	T-2	SL	1/4	NONE

Metal-Oxide Varistor (MOV) Transient Suppressors

Listed by voltage.

Type No.	ECG/NTE ^{††} no.	V_{acRMS}	Maximum Applied Voltage V_{acPeak}	Maximum Energy (Joules)	Maximum Peak Current (A)	Maximum Power (W)	Maximum Varistor Voltage (V)
V180ZA1	1V115	115	163	1.5	500	0.2	285
V180ZA10	2V115	115	163	10.0	2000	0.45	290
V130PA10A		130	184	10.0	4000	8.0	350
V130PA20A		130	184	20.0	4000	15.0	350
V130LA1	1V130	130	184	1.0	400	0.24	360
V130LA2	1V130	130	184	2.0	400	0.24	360
V130LA10A	2V130	130	184	10.0	2000	0.5	340
V130LA20A	524V13	130	184	20.0	4000	0.85	340
V150PA10A		150	212	10.0	4000	8.0	410
V150PA20A		150	212	20.0	4000	15.0	410
V150LA1	1V150	150	212	1.0	400	0.24	420
V150LA2	1V150	150	212	2.0	400	0.24	420
V150LA10A	524V15	150	212	10.0	2000	0.5	390
V150LA20A	524V15	150	212	20.0	4000	0.85	390
V250PA10A		250	354	10.0	4000	0.85	670
V250PA20A		250	354	20.0	4000	7.0	670
V250PA40A		250	354	40.0	4000	13.0	670
V250LA2	1V250	250	354	2.0	400	0.28	690
V250LA4	1V250	250	354	4.0	400	0.28	690
V250LA15A	2V250	250	354	15.0	2000	0.6	640
V250LA20A	2V250	250	354	20.0	2000	0.6	640
V250LA40A	524V25	250	354	40.0	4000	0.9	640

^{††} ECG and NTE numbers for these parts are identical, except for the prefix. Add the “ECG” or “NTE” prefix to the numbers shown for the complete part number.

Voltage-Variable Capacitance Diodes†

Listed numerically by device

Device	CT Nominal Capacitance pF			Case Style	Device	CT Nominal Capacitance pF			Case Style
	$\pm 10\%$ @ $V_R = 4.0\text{ V}$ $f = 1.0\text{ MHz}$	Capacitance Ratio 4-60 V Min.	Q @ 4.0 V 50 MHz Min.			$\pm 10\%$ @ $V_R = 4.0\text{ V}$ $f = 1.0\text{ MHz}$	Capacitance Ratio 4-60 V Min.	Q @ 4.0 V 50 MHz Min.	
1N5441A	6.8	2.5	450		1N5471A	39	2.9	450	
1N5442A	8.2	2.5	450		1N5472A	47	2.9	400	
1N5443A	10	2.6	400	DO-7	1N5473A	56	2.9	300	DO-7
1N5444A	12	2.6	400		1N5474A	68	2.9	250	
1N5445A	15	2.6	450		1N5475A	82	2.9	225	
1N5446A	18	2.6	350		1N5476A	100	2.9	200	
1N5447A	20	2.6	350		MV2101	6.8	2.5	450	
1N5448A	22	2.6	350	DO-7	MV2102	8.2	2.5	450	
1N5449A	27	2.6	350		MV2103	10	2.0	400	TO-92
1N5450A	33	2.6	350		MV2104	12	2.5	400	
1N5451A	39	2.6	300		MV2105	15	2.5	400	
1N5452A	47	2.6	250		MV2106	18	2.5	350	
1N5453A	56	2.6	200	DO-7	MV2107	22	2.5	350	
1N5454A	68	2.7	175		MV2108	27	2.5	300	TO-92
1N5455A	82	2.7	175		MV2109	33	2.5	200	
1N5456A	100	2.7	175		MV2110	39	2.5	150	
1N5461A	6.8	2.7	600		MV2111	47	2.5	150	
1N5462A	8.2	2.8	600		MV2112	56	2.6	150	
1N5463A	10	2.8	550	DO-7	MV2113	68	2.6	150	TO-92
1N5464A	12	2.8	550		MV2114	82	2.6	100	
1N5465A	15	2.8	550		MV2115	100	2.6	100	
1N5466A	18	2.8	500						
1N5467A	20	2.9	500						
1N5468A	22	2.9	500	DO-7					
1N5469A	27	2.9	500						
1N5470A	33	2.9	500						

† For package shape, size and pin-connection information, see manufacturers' data sheets. Many retail suppliers offer data sheets to buyers free of charge on request. Data books are available from many manufacturers and retailers.

Zener Diodes

Volts	Power (Watts)								
	0.25	0.4	0.5	1.0	1.5	5.0	10.0	50.0	
1.8	1N4614								
2.0	1N4615								
2.2	1N4616								
2.4	1N4617	1N4370,A	1N4370,A 1N5221,B 1N5985,B 1N5222B						
2.5									
2.6	1N702,A								
2.7	1N4618	1N4371,A	1N4371,A 1N5223,B 1N5839, 1N5986 1N5224B						
2.8									
3.0	1N4619	1N4372,A	1N4372 1N5225,B 1N5987						
3.3	1N4620	1N746,A 1N764,A 1N5518	1N746,A 1N5226,B 1N5988	1N3821 1N4728,A	1N5913	1N5333,B			
3.6	1N4621	1N747,A 1N5519	1N747A 1N5227,B 1N5989	1N3822 1N4729,A	1N5914	1N5334,B			
3.9	1N4622	1N748,A 1N5520	1N748A 1N5228,B 1N5844, 1N5990	1N3823 1N4730,A	1N5915	1N5335,B	1N3993A	1N4549,B 1N4557,B	
4.1	1N704,A								
4.3	1N4623	1N749,A 1N5521	1N749,A 1N5229,B 1N5845 1N5991	1N3824 1N4731,A	1N5916	1N5336,B	1N3994,A	1N4550,B 1N4558,B	
4.7	1N4624	1N750,A 1N5522	1N750A 1N5230,B 1N5846, 1N5992	1N3825 1N4732,A	1N5917	1N5337,B	1N3995,A	1N4551,B 1N4559,B	
5.1	1N4625 1N4689	1N751,A 1N5523	1N751,A, 1N5231,B 1N5847 1N5993	1N3826 1N4733	1N5918	1N5338,B	1N3996,A	1N4552,B 1N4560,B	
5.6	1N708A 1N4626	1N752,A 1N5524	1N752,A 1N5232,B 1N5848, 1N5994	1N3827 1N4734,A	1N5919	1N5339,B	1N3997,A	1N4553,B 1N4561,B	
5.8	1N706A	1N762							
6.0			1N5233B 1N5849			1N5340,B			
6.2	1N709,1N4627 MZ605, MZ610 MZ620, MZ640 1N4565-84,A	1N753,A 1N821,3,5,7,9;A	1N753,A 1N5234,B, 1N5850 1N5995	1N3828,A 1N4735,A	1N5920	1N5341,B	1N3998,A	1N4554,B 1N4562,B	
6.4	1N4565-84,A								
6.8	1N4099	1N754,A 1N957,B 1N5526	1N754,A 1N757,B 1N5235,B 1N5851 1N5996	1N3016,B 1N3829 1N4736,A	1N3785 1N5921	1N5342,B	1N2970,B 1N3999,A	1N2804B 1N3305B 1N4555, 1N4563	
7.5	1N4100	1N755,A 1N958,B 1N5527	1N755A, 1N958,B 1N5236,B 1N5852 1N5997	1N3017,A,B 1N3830 1N4737,A	1N3786 1N5922	1N5343,B	1N2971,B 1N4000,A	1N2805,B 1N3306,B 1N4556, 1N4564	
8.0	1N707A								
8.2	1N712A 1N4101	1N756,A 1N959,B 1N5528	1N756,A 1N959,B 1N5237,B 1N5853 1N5998	1N3018,B 1N4738,A	1N3787 1N5923	1N5344,B	1N2972,B	1N2806,B 1N3307,B	
8.4		1N3154-57,A	1N3154,A 1N3155-57 1N5238,B 1N5854						
8.5	1N4775-84,A								
8.7	1N4102					1N5345,B			
8.8		1N764							
9.0		1N764A	1N935-9;A,B						
9.1	1N4103	1N757,A 1N960,B 1N5529	1N757,A, 1N960,B 1N5239,B, 1N5855 1N5999	1N3019,B 1N4739,A	1N3788 1N5924	1N5346,B	1N2973,B	1N2807,B 1N3308,B	
10.0	1N4104	1N758,A 1N961,B 1N5530,B	1N758,A, 1N961,B 1N5240,B, 1N5856 1N6000	1N3020,B 1N4740,A	1N3789 1N5925	1N5347,B	1N2974,B	1N2808,B 1N3309,A,B	
11.0	1N715,A 1N4105	1N962,B 1N5531	1N962,B 1N5241,B 1N5857, 1N6001 1N941-4;A,B	1N3021,B 1N4741,A	1N3790 1N5926	1N5348,B	1N2975,B	1N2809,B 1N3310,B	
11.7	1N716,A 1N4106								
12.0		1N759,A 1N963,B 1N5532	1N759,A, 1N963,B, 1N5242,B, 1N5858 1N6002	1N3022,B 1N4742,A	1N3791 1N5927	1N5349,B	1N2976,B	1N2810,B 1N3311,B	
13.0	1N4107	1N964,B 1N5533	1N964,B 1N5243,B, 1N5859 1N6003	1N3023,B 1N4743,A	1N3792 1N5928	1N5350,B	1N2977,B	1N2811,B 1N3312,B	

Continued on [next page](#).

Zener Diodes

Continued from [previous page](#).

Volts	Power (Watts)							
	0.25	0.4	0.5	1.0	1.5	5.0	10.0	50.0
14.0	1N4108	1N5534	1N5244B 1N5860			1N5351,B	1N2978,B	1N2812,B 1N3313,B
15.0	1N4109	1N965,B 1N5535	1N965,B 1N5245,B, 1N5861, 1N6004	1N3024,B 1N4744A	1N3793 1N5929	1N5352,B	1N2979,A,B	1N2813,A,B 1N3314,B
16.0	1N4110	1N966,B 1N5536	1N966,B, 1N5246,B 1N5862, 1N6005	1N3025,B 1N4745,A	1N3794 1N5930	1N5353,B	1N2980,B	1N2814,B 1N3315,B
17.0	1N4111	1N5537	1N5247,B 1N5863			1N5354,B	1N2981B	1N2815,B 1N3316,B
18.0	1N4112	1N967,B 1N5538	1N967,B 1N5248,B	1N3026,B 1N4746,A	1N3795 1N5931	1N5355,B	1N2982,B	1N2816,B 1N3317,B
19.0	1N4113	1N5539	1N5864, 1N6006 1N5249,B 1N5865			1N5356,B	1N2983,B	1N2817,B 1N3318,B
20.0	1N4114	1N968,B 1N5540	1N968,B 1N5250,B 1N5866, 1N6007	1N3027,B 1N4747,A	1N3796 1N5932,A,B	1N5357,B	1N2984,B	1N2818,B 1N3319,B
22.0	1N4115	1N969,B 1N5541	1N969,B 1N5241,B 1N5867, 1N6008	1N3028,B 1N4748,A	1N3797 1N5933	1N5358,B	1N2985,B	1N2819,B 1N3320,A,B
24.0	1N4116	1N5542 1N9701B	1N970,B 1N5252,B, 1N586 1N6009	1N3029,B 1N4749,A	1N3798 1N5934	1N5359,B	1N2986,B	1N2820,B 1N3321,B
25.0	1N4117	1N5543	1N5253,B 1N5869			1N5360,B	1N2987B	1N2821,B 1N3322,B
27.0	1N4118	1N971,B	1N971 1N5254,B, 1N5870, 1N6010	1N3030,B 1N4750,A	1N3799 1N5935	1N5361,B	1N2988,B	1N2822B 1N3323,B
28.0	1N4119	1N5544	1N5255,B 1N5871			1N5362,B		
30.0	1N4120	1N972,B 1N5545	1N972,B 1N5256,B, 1N5872, 1N6011	1N3031,B 1N4751,A	1N3800 1N5936	1N5363,B	1N2989,B	1N2823,B 1N3324,B
33.0	1N4121	1N973,B 1N5546	1N973,B 1N5257,B 1N5873 1N6012	1N3032,B 1N4752,A	1N3801 1N5937	1N5364,B	1N2990,A,B	1N2824,B 1N3325,B
36.0	1N4122	1N974,B	1N974,B 1N5258,B 1N5874, 1N6013	1N3033,B 1N4753,A	1N3802 1N5938	1N5365,B	1N2991,B	1N2825,B 1N3326,B
39.0	1N4123	1N975,B	1N975,B, 1N5259,B 1N5875, 1N6014	1N3034,B 1N4754,A	1N3803 1N5939	1N5366,B	1N2992,B	1N2826,B 1N3327,B
43.0	1N4124	1N976,B	1N976,B 1N5260,B, 1N5876, 1N6015	1N3035,B 1N4755,A	1N3804 1N5940	1N5367,B	1N2993,A,B	1N2827,B 1N3328,B
45.0							1N2994B	1N2828B 1N3329B
47.0	1N4125	1N977,B	1N977,B, 1N5261,B 1N5877, 1N6016	1N3036,B 1N4756,A	1N3805 1N5941	1N5368,B	1N2996,B	1N2829,B 1N3330,B 1N2830B 1N3331B
51.0	1N4126	1N978,B	1N978,B, 1N5262,A,B 1N5878, 1N6017	1N3037,B 1N4757,A	1N3806 1N5942	1N5369,B	1N2997,B	1N2831,B 1N3332,B 1N3333
52.0							1N2998B	1N3333
56.0	1N4127	1N979,B	1N979 1N5263,B 1N6018	1N3038,B 1N4758,A	1N3807 1N5943	1N5370,B	1N2999,B	1N2822,B 1N3334,B
60.0	1N4128		1N5264,A,B			1N5371,B		
62.0	1N4129	1N980,B	1N980 1N5265,A,B 1N6019	1N3039,B 1N4759,A	1N3808 1N5944	1N5372,B	1N3000,B	1N2833,B 1N3335,B
68.0	1N4130	1N981,B	1N981,B 1N5266,A,B 1N6020	1N3040,A,B 1N4760,A	1N3809 1N5945	1N5373,B	1N3001,B	1N2834,B 1N3336,B
75.0	1N4131	1N982,B	1N982 1N5267,A,B 1N6021	1N3041,B 1N4761,A	1N3810 1N5946	1N5374,B	1N3002,B	1N2835,B 1N3337,B
82.0	1N4132	1N983,B	1N983 1N5268,A,B 1N6022	1N3042,B 1N4762,A	1N3811 1N5947	1N5375,B	1N3003,B	1N2836,B 1N3338,B
87.0	1N4133		1N5269,B			1N5376,B		
91.0	1N4134	1N984,B	1N984 1N5270,B 1N6023	1N3043,B 1N4763,A	1N3812 1N5948	1N5377,B	1N3004,B	1N2837,B 1N3339,B
100.0	1N4135	1N985	1N985,B 1N5271,B 1N6024	1N3044,A,B 1N4764,A	1N3813 1N5949	1N5378,B	1N3005,B	1N2838,B 1N3340,B
105.0							1N3006B	1N2839,B 1N3341,B
110.0		1N986	1N986 1N5272,B 1N6025	1N3045,B 1M110ZS10	1N3814 1N5950	1N5379,B	1N3007A,B	1N2840,B 1N3342,B

Continued on [next page](#).

Zener Diodes

Continued from [previous page](#).

Volts	Power (Watts)							
	0.25	0.4	0.5	1.0	1.5	5.0	10.0	50.0
120.0		1N987	1N987,B 1N5273,B 1N6026	1N3046,B 1M120ZS10	1N3815 1N5951	1N5380,B	1N3008A,B	1N2841,B 1N3343,B
130.0		1N988	1N988,B 1N5274,B 1N6027	1N3047,B 1M130ZS10	1N3816 1N5952	1N5381,B	1N3009,B	1N2842,B 1N3344,B
140.0		1N989	1N5275,B			1N5382B	1N3010B	1N3345B
150.0		1N990	1N989 1N5276,B 1N6028	1N3048,B 1M150ZS10	1N3817 1N5953	1N5383,B	1N3011,B	1N2843,B 1N3346,B
160.0		1N991	1N990 1N5277,B 1N6029	1N3049,B 1M160ZS10	1N3818 1N5954	1N5384,B	1N3012A,B	1N2844,B 1N3347,B
170.0		1N992	1N5278,B	1M170ZS10		1N5385,B		
175.0							1N3013B	1N3348B
180.0			1N991,B 1N5279,B 1N6030	1N3050,A,B 1M180ZS10	1N3819 1N5955	1N5386,B	1N3014,B	1N2845,B 1N3349,B
190.0			1N5280,B			1N5387,B		
200.0			1N992 1N5281,B 1N6031	1N3051,B 1M200ZS10	1N3820 1N5956	1N5388B	1N3015,B	1N2846,B 1N3350,B

Semiconductor Diode Specifications†

Listed numerically by device

Device	Type	Material	Peak Inverse Voltage, PIV (V)	Average Rectified Current Forward (Reverse) $I_O(A)(I_R(A))$	Peak Surge Current, I_{FSM} 1 s @ 25°C (A)	Average Forward Voltage, V_F (V)
1N34	Signal	Ge	60	8.5 m (15.0 μ)		1.0
1N34A	Signal	Ge	60	5.0 m (30.0 μ)		1.0
1N67A	Signal	Ge	100	4.0 m (5.0 μ)		1.0
1N191	Signal	Ge	90	5.0 m		1.0
1N270	Signal	Ge	80	0.2 (100 μ)		1.0
1N914	Fast Switch	Si	75	75.0 m (25.0 n)	0.5	1.0
1N1183	RFR	Si	50	40 (5 m)	800	1.1
1N1184	RFR	Si	100	40 (5 m)	800	1.1
1N2071	RFR	Si	600	0.75 (10.0 μ)		0.6
1N3666	Signal	Ge	80	0.2 (25.0 μ)		1.0
1N4001	RFR	Si	50	1.0 (0.03 m)		1.1
1N4002	RFR	Si	100	1.0 (0.03 m)		1.1
1N4003	RFR	Si	200	1.0 (0.03 m)		1.1
1N4004	RFR	Si	400	1.0 (0.03 m)		1.1
1N4005	RFR	Si	600	1.0 (0.03 m)		1.1
1N4006	RFR	Si	800	1.0 (0.03 m)		1.1
1N4007	RFR	Si	1000	1.0 (0.03 m)		1.1
1N4148	Signal	Si	75	10.0 m (25.0 n)		1.0
1N4149	Signal	Si	75	10.0 m (25.0 n)		1.0
1N4152	Fast Switch	Si	40	20.0 m (0.05 μ)		0.8
1N4445	Signal	Si	100	0.1 (50.0 n)		1.0
1N5400	RFR	Si	50	3.0 (500 μ)	200	
1N5401	RFR	Si	100	3.0 (500 μ)	200	
1N5402	RFR	Si	200	3.0 (500 μ)	200	
1N5403	RFR	Si	300	3.0 (500 μ)	200	
1N5404	RFR	Si	400	3.0 (500 μ)	200	
1N5405	RFR	Si	500	3.0 (500 μ)	200	
1N5406	RFR	Si	600	3.0 (500 μ)	200	
1N5408	RFR	Si	1000	3.0 (500 μ)	200	
1N5711	Schottky	Si	70	1 m (200 n)	15 m	0.41 @ 1 mA
1N5767	Signal	Si		0.1 (1.0 μ)		1.0
1N5817	Schottky	Si	20	1.0 (1 m)	25	0.75
1N5819	Schottky	Si	40	1.0 (1 m)	25	0.9
1N5821	Schottky	Si	30	3.0		
ECG5863	RFR	Si	600	6	150	0.9
1N6263	Schottky	Si	70	15 m	50 m	0.41 @ 1 mA
5082-2835	Schottky	Si	8	1 m (100 n)	10 m	0.34 @ 1 mA

Si = Silicon; Ge = Germanium; RFR = rectifier, fast recovery.

† For package shape, size and pin-connection information see manufacturers' data sheets. Many retail suppliers offer data sheets to buyers free of charge on request. Data books are available from many manufacturers and retailers.

European Semiconductor Numbering System (PRO Electron Code)

BFR90

<i>First Letter (Material)</i>	<i>Second Letter (Type)</i>	<i>Third, Fourth, Fifth Character (Serial Code)</i>
A Germanium	A Low-power diode, voltage-variable capacitor	Y## Industrial service (no letter "Z"). ## is a W## registration number from 10 to 99.
B Silicon	B Varicap	100 - Device for consumer or 999 entertainment use.
C Compound materials such as cadmium sulfide or gallium arsenide used in semiconductor devices (Energy gap band of 1.3 or more electron-volts)	C Small-signal audio transistor	
D Materials with an energy gap band of less than 0.6 electron-volts such as indium antimonide	D Audio power transistor	
R Radiation detectors, photoconductive cells, hall-effect generators and so on	E Tunnel diode	
	F Small-signal RF transistor	
	G Miscellaneous	
	H Field probe	
	K Hall generator	
	L RF-power transistor	
	M Hall modulators and multipliers	
	P Photodiode, phototransistor, photoconductive cell (LDR), radiation device	
	R Low-power controlled rectifier	
	S Low-power switching transistor	
	T Breakdown devices, high-power controlled rectifier, Schottky diode, Thyristor, pnpn diodes	
	U High-power switching transistor	
	X Multiplier diode	
	Y High-power rectifier (diode)	
	Z Zener diode	

Japanese Semiconductor Nomenclature

All transistors manufactured in Japan are registered with the Electronic Industries Association of Japan (EIAJ). In addition, the Japan industrial Standard JIS-C-7012 provides type numbers for transistors and thyristors.

Each transistor type number contains five elements.

i	ii	iii	iv	v
2	S	C	82D	A

Figure Letter Letter Figure Letter

- i) Kind of device, indicating number of effective electrical connections minus one.
 - ii) For a semiconductor registered with the EIAJ this letter is always an S.
 - iii) This letter designates polarity and application, as follows:

Letter	Polarity and Application
A	PNP transistor, high frequency
B	PNP transistor, low frequency
C	NPN transistor, high frequency
D	NPN transistor, low frequency
E	P-gate thyristor
G	N-gate thyristor
H	N-base unijunction transistor
J	P-channel FET
K	N-channel FET
M	Bi-directional triode thyristor
 - iv) These figures designate the order of application for EIAJ registration, starting with 11.
 - v) This letter indicates the level of improvement. An improvement device may be used in place of a previous-generation device, but not necessarily the other way around.
-

Suggested Small-Signal FETs

Device No.	Type	Max Diss (mW)	Max V_{DS} (V) ³	$V_{GS(off)}$ (V) ³	Min gfs (μ S)	Input C (pF)	Max ID (mA) ¹	f_{max} (MHz)	Noise Figure (typ)	Case	Base	Mfr ²	Applications
2N4416	N-JFET	300	30	-6	4500	4	-15	450	400 MHz 4 dB	TO-72	1	S, M	VHF/UHF amp, mix, osc
2N5484	N-JFET	310	25	-3	2500	5	30	200	200 MHz 4 dB	TO-92	2	M	VHF/UHF amp, mix, osc
2N5485	N-JFET	310	25	-4	3500	5	30	400	400 MHz 4 dB	TO-92	2	S	VHF/UHF amp, mix, osc
2N5486	N-JFET	360	25	-2	5500	5	15	400	400 MHz 4 dB	TO-92	2	M	VHF/UHF amp, mix, osc
3N200 NTE222 SK3065	N-dual-gate MOSFET	330	20	-6	10,000	4-8.5	50	500	400 MHz 4.5 dB	TO-72	3	R	VHF/UHF amp, mix, osc
3N202 NTE454 SK3991	N-dual-gate MOSFET	360	25	-5	8000	6	50	200	200 MHz 4.5 dB	TO-72	3	S	VHF amp, mixer
MPF102 ECG451 SK9164	N-JFET	310	25	-8	2000	4.5	20	200	400 MHz 4 dB	TO-92	2	N, M	HF/VHF amp, mix, osc
MPF106 2N5484	N-JFET	310	25	-6	2500	5	30	400	200 MHz 4 dB	TO-92	2	N, M	HF/VHF/UHF amp, mix, osc
40673 NTE222 SK3050	N-dual-gate MOSFET	330	20	-4	12,000	6	50	400	200 MHz 6 dB	TO-72	3	R	HF/VHF/UHF amp, mix, osc
U304	P-JFET	350	-30	+10		27	-50	—	—	TO-18	4	S	analog switch chopper
U310	N-JFET	500 300	30 30	-6	10,000	2.5	60	450	450 MHz 3.2 dB	TO-52	5	S	common-gate VHF/UHF amp,
U350	N-JFET Quad	1W	25	-6	9000	5	60	100	100 MHz 7 dB	TO-99	6	S	matched JFET doubly bal mix
U431	N-JFET Dual	300	25	-6	10,000	5	30	100	$\frac{10nV}{\sqrt{Hz}}$	TO-99	7	S	matched JFET cascode amp and bal mix
2N5670	N-JFET	350	25	8	3000	7	20	400	100 MHz 2.5 dB	TO-92	2	M	VHF/UHF osc, mix, front-end amp
2N5668	N-JFET	350	25	4	1500	7	5	400	100 MHz 2.5 dB	TO-92	2	M	VHF/UHF osc, mix, front-end amp
2N5669	N-JFET	350	25	6	2000	7	10	400	100 MHz 2.5 dB	TO-92	2	M	VHF/UHF osc, mix, front-end amp
J308	N-JFET	350	25	6.5	8000	7.5	60	1000	100 MHz 1.5 dB	TO-92	2	M	VHF/UHF osc, mix, front-end amp
J309	N-JFET	350	25	4	10,000	7.5	30	1000	100 MHz 1.5 dB	TO-92	2	M	VHF/UHF osc, mix, front-end amp
J310	N-JFET	350	25	6.5	8000	7.5	60	1000	100 MHz 1.5 dB	TO-92	2	M	VHF/UHF osc, mix, front-end amp
NE32684A	HJ-FET	165	2.0	-0.8	45,000	—	30	20 GHz	12 GHz 0.5 dB	84A		NE	Low-noise amp

Notes:

¹ 25°C.

² M = Motorola; N = National Semiconductor; NE=NEC; R = RCA; S = Siliconix.

³ For package shape, size and pin-connection information, see manufacturers' data sheets. Many retail suppliers offer data sheets to buyers free of charge on request. Data books are available from many manufacturers and retailers.

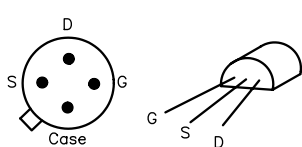

(1)

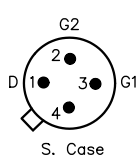

(3)

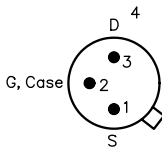

(4)

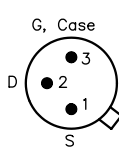

(5)

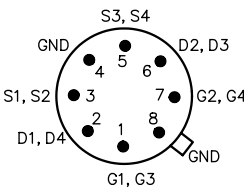

(6)

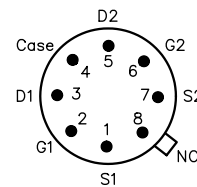

(7)

Low-Noise Transistors

Device	NF (dB)	F (MHz)	f_T (GHz)	I_C (mA)	Gain (dB)	F (MHz)	$V_{(BR)CEO}$ (V)	I_C (mA)	P_T (mW)	Case
MRF904	1.5	450	4	15	16	450	15	30	200	TO-206AF
MRF571	1.5	1000	8	50	12	1000	10	70	1000	Macro-X
MRF2369	1.5	1000	6	40	12	1000	15	70	750	Macro-X
MPS911	1.7	500	7	30	16.5	500	12	40	625	TO-226AA
MRF581A	1.8	500	5	75	15.5	500	15	200	2500	Macro-X
BFR91	1.9	500	5	30	16	500	12	35	180	Macro-T
BFR96	2	500	4.5	50	14.5	500	15	100	500	Macro-T
MPS571	2	500	6	50	14	500	10	80	625	TO-226AA
MRF581	2	500	5	75	15.5	500	18	200	2500	Macro-X
MRF901	2	1000	4.5	15	12	1000	15	30	375	Macro-X
MRF941	2.1	2000	8	15	12.5	2000	10	15	400	Macro-X
MRF951	2.1	2000	7.5	30	12.5	2000	10	100	1000	Macro-X
BFR90	2.4	500	5	14	18	500	15	30	180	Macro-T
MPS901	2.4	900	4.5	15	12	900	15	30	300	TO-226AA
MRF1001A	2.5	300	3	90	13.5	300	20	200	3000	TO-205AD
2N5031	2.5	450	1.6	5	14	450	10	20	200	TO-206AF
MRF4239A	2.5	500	5	90	14	500	12	400	3000	TO-205AD
BFW92A	2.7	500	4.5	10	16	500	15	35	180	Macro-T
MRF521*	2.8	1000	4.2	-50	11	1000	-10	-70	750	Macro-X
2N5109	3	200	1.5	50	11	216	20	400	2500	TO-205AD
2N4957*	3	450	1.6	-2	12	450	-30	-30	200	TO-206AF
MM4049*	3	500	5	-20	11.5	500	-10	-30	200	TO-206AF
2N5943	3.4	200	1.5	50	11.4	200	30	400	3500	TO-205AD
MRF586	4	500	1.5	90	9	500	17	200	2500	TO-205AD
2N5179	4.5	200	1.4	10	15	200	12	50	200	TO-206AF
2N2857	4.5	450	1.6	8	12.5	450	15	40	200	TO-206AF
2N6304	4.5	450	1.8	10	15	450	15	50	200	TO-206AF
MPS536*	4.5	500	5	-20	4.5	500	-10	-30	625	TO-226AA
MRF536*	4.5	1000	6	-20	10	1000	-10	-30	300	Macro-X

* denotes a PNP device

Complimentary devices

NPN	PNP
2N2857	2N4957
MRF904	MM4049
MRF571	MRF521

For package shape, size and pin-connection information, see manufacturers' data sheets. Many retail suppliers offer data sheets to buyers free of charge on request. Data books are available from many manufacturers and retailers.

VHF and UHF Class-A Transistors

The devices listed below are recommended for class-A linear applications, and include medium-power parts that are useful at frequencies from 100 MHz to 2 GHz.

<i>Device</i>	<i>Frequency (MHz)</i>	<i>V_{CC} (V)</i>	<i>P_O @ 1 dB Compression (W)</i>	<i>Small Signal Gain/Frequency (MHz)</i>	<i>Bias Point (V_{dc}/A)</i>	<i>Package</i>
MRA1000-3.5L	1000	19	3.5	10/1000	19/0.6	145A-09/1
MRA1000-7L	1000	19	7	9/1000	19/1.2	145A-09/1
MRA1000-14L	1000	19	14	8/1000	19/2.4	145A-09/1
MRF1029	1000	25	1.5	8/1000	25/0.2	244-04/1
MRF1030	1000	25	3	7.5/1000	25/0.4	244-04/1
MRF1031	1000	25	4.5	7/1000	25/0.6	244-04/1
MRF1032	1000	25	6	6.5/1000	25/0.85	244-04/1
MRF3094	2000	20	0.5	10.5/2000	20/0.12	328A-03/1
MRF3104	2000	20	0.5	10.5/2000	20/0.12	305A-01/1
MRF3095	2000	20	0.8	9/2000	20/0.12	328A-03/1
MRF3105	2000	20	0.8	9/2000	20/0.12	305A-01/1
MRF3096	2000	20	1.6	9/2000	20/0.24	328A-03/1
MRF3106	2000	20	1.6	9/2000	20/0.24	305A-01/1
MRF2000-5L	2000	20	5	7/2000	19/0.6	360A-01/1

For package shape, size and pin-connection information, see manufacturers' data sheets. Many retail suppliers offer data sheets to buyers free of charge on request. Data books are available from many manufacturers and retailers.

Monolithic Amplifiers (50 Ω)

Mini-Circuits Labs MMICs

Device	Freq Range (MHz)	Gain (dB) at 1000 MHz	Output Level 1 dB Comp (dBm)	NF (dB)	I_{max} (mA)	P_{max} (mW)
MAR-1	dc - 1000	15.5	+1.5	5.5	40	200
MAR-2	dc - 2000	12.0	+4.5	6.5	60	325
MAR-3	dc - 2000	12.0	+10.0	6.0	70	400
MAR-4	dc - 1000	8.0	+12.5	6.5	85	500
MAR-6	dc - 2000	16.0	+2.0	3.0	50	200
MAR-7	dc - 2000	12.5	+5.5	5.0	60	275
MAR-8	dc - 1000	22.5	+12.5	3.3	65	500
RAM-1	dc - 1000	15.5	+1.5	5.5	40	200
RAM-2	dc - 2000	11.8	+4.5	6.5	60	325
RAM-3	dc - 2000	12.0	+10.0	6.0	80	425
RAM-4	dc - 1000	8.0	+12.5	6.5	100	540
RAM-6	dc - 2000	16.0	+2.0	2.8	50	200
RAM-7	dc - 2000	12.5	+5.5	4.5	60	275
RAM-8	dc - 1000	23.0	+12.5	3.0	65	420
MAV-1	dc - 1000	15.0	+1.5	5.5	40	200
MAV-2	dc - 1500	11.0	+4.5	6.5	60	325
MAV-3	dc - 1500	11.0	+10.0	6.0	70	400
MAV-4	dc - 1000	7.5	+11.5	7.0	85	500
MAV-11	dc - 1000	10.5	+17.5	3.6	80	550

RAM-x, case VV105; MAR-x, case BBB123; MAV-x, case AF190[†]

Avantek MMICs

Device	Freq Range (MHz)	Typical Gain (dB)	Output Level 1 dB Comp (dBm)	NF (dB)	I_{max} (mA)	P_{max} (mW)
MSA-01xx	dc - 1300	18.5	1.5	5.5	40	200
MSA-02xx	dc - 2800	12.5	4.5	6.5	60	325
MSA-03xx	dc - 2800	12.5	10	6.0	80	425
MSA-04xx	dc - 4000	8.3	11.5	7.0	85	500
MSA-05xx	dc- 2800	7.0	19.0	6.5	135	1.5
MSA-06xx	dc - 800	19.5	2.0	3.0	50	200
MSA-07xx	dc - 2500	13.0	5.5	4.5	50	175
MSA-08xx	dc - 6000	32.5	12.5	3.0	65	500
MSA-09xx	dc - 6000	7.2	10.5	6.2	65	500
MSA-11xx	50 - 1300	12.0	17.5	3.6	80	550

Each listing represents a series of devices in different cases. Performance varies somewhat with the case (for example, the frequency range is often 30% less for a plastic package, as compared to that with a ceramic package).[†]

Continued on [next page](#).

Monolithic Amplifiers (50 Ω)

Continued from [previous page](#).

Hewlett-Packard MMIC†

Device	Freq Range (GHz)	Typical Gain (dB)	Output Level 1 dB Comp (dBm)	NF (dB)	I_{max} (mA)
MGA-86576	1.5-8	15.4	3.8	2.1	22

Motorola Hybrid Amplifiers (50 Ω)

Device	Freq Range (MHz)	Gain (dB) min/typ	Supply Voltage (V)	Output Level, 1 dB Comp (dBm)	NF at 250 MHz (dB)
MWA110	0.1 - 400	13/14	2.9	-2.5	4
MWA120	0.1 - 400	13/14	5	+8.2	5.5
MWA130	0.1 - 400	13/14	5.5	+18	7
MWA131	0.1 - 400	13/14	5.5	+20	5
MWA210	0.1 - 600	9/10	1.75	+1.5	6
MWA220	0.1 - 600	9/10	3.2	+10.5	6.5
MWA230	0.1 - 600	9/10	4.4	+18.5	7.5
MWA310	0.1 - 1000	7/8	1.6	+3.5	6.5
MWA320	0.1 - 1000	7/8	2.9	+11.5	6.7
MWA330	0.1 - 1000	na/6.2	4	+15.2	9

MWAxxx case 31A-03/2†

† For package shape, size and pin-connection information, see manufacturers' data sheets. Many retail suppliers offer data sheets to buyers free of charge on request. Data books are available from many manufacturers and retailers.

General Purpose Transistors†

Listed numerically by device

Device	Type	V_{CEO}	V_{CBO}	V_{EBO}	I_C	P_D	Minimum DC Current Gain		Current-Gain Bandwidth Product f_T^* (MHz)	Noise Figure NF Maximum (dB)
		Maximum Collector Emitter Voltage (V)	Maximum Emitter Base Voltage (V)	Maximum Emitter Base Voltage (V)			Maximum Collector Current (mA)	Maximum Device Dissipation (W)		
2N918	NPN	15	30	3.0	50	0.200	20 (3 mA)	—	600	6.0
2N2102	NPN	65	120	7.0	1000	1.0	20	40	60	6.0
2N2218	NPN	30	60	5.0	800	0.8	20	40	250	
2N2218A	NPN	40	75	6.0	800	0.8	20	40	250	
2N2219	NPN	30	60	5.0	800	3.0	35	100	250	
2N2219A	NPN	40	75	6.0	800	3.0	35	100	300	4.0
2N2222	NPN	30	60	5.0	800	1.2	35	100	250	
2N2222A	NPN	40	75	6.0	800	1.2	35	100	200	4.0
2N2905	PNP	40	60	5.0	600	0.6	35	—	200	
2N2905A	PNP	60	60	5.0	600	0.6	75	100	200	
2N2907	PNP	40	60	5.0	600	0.400	35	—	200	
2N2907A	PNP	60	60	5.0	600	0.400	75	100	200	
2N3053	NPN	40	60	5.0	700	5.0	—	50	100	
2N3053A	NPN	60	80	5.0	700	5.0	—	50	100	
2N3563	NPN	15	30	2.0	50	0.600	20	—	800	
2N3904	NPN	40	60	6.0	200	0.625	40	—	300	5.0
2N3906	PNP	40	40	5.0	200	1.5	60	—	250	4.0
2N4037	PNP	40	60	7.0	1000	5.0	—	50		
2N4123	NPN	30	40	5.0	200	0.35	—	25(50 mA)	250	6.0
2N4124	NPN	25	30	5.0	200	0.350	120 (2 mA)	60(50 mA)	300	5.0
2N4125	PNP	30	30	4.0	200	0.625	50 (2 mA)	25(50 mA)	200	5.0
2N4126	PNP	25	25	4.0	200	0.625	120 (2 mA)	60(50 mA)	250	4.0
2N4401	NPN	40	60	6.0	600	0.625	20	100	250	
2N4403	PNP	40	40	5.0	600	0.625	30	100	200	
2N5320	NPN	75	100	7.0	2000	10.0	—	30(1 A)		
2N5415	PNP	200	200	4.0	1000	10.0	—	30(50 mA)	15	
MM4003	PNP	250	250	4.0	500	1.0	20 (10 mA)	—		
MPSA55	PNP	60	60	4.0	500	0.625	—	50 (0.1 A)	50	
MPS6531	NPN	40	60	5.0	600	0.625	60 (10 mA)	90 (0.1 A)		
MPS6547	NPN	25	35	3.0	50	0.625	20 (2 mA)	—	600	

* Test conditions: $I_C = 20$ mA dc; $V_{CE} = 20$ V; $f = 100$ MHz

RF Power Amplifier Modules

Listed by frequency

<i>Device</i>	<i>Supply (V)</i>	<i>Frequency Range (MHz)</i>	<i>Output Power (W)</i>	<i>Power Gain (dB)</i>	<i>Package†</i>	<i>Mfr/ Notes</i>
M57735	17	50-54	14	21	H3C	MI; SSB mobile
M57719N	17	142-163	14	18.4	H2	MI; FM mobile
S-AV17	16	144-148	60	21.7	5-53L	T, FM mobile
S-AV7	16	144-148	28	21.4	5-53H	T, FM mobile
MHW607-1	7.5	136-150	7	38.4	301K-02/3	MO; class C
BGY35	12.5	132-156	18	20.8	SOT132B	P
M67712	17	220-225	25	20	H3B	MI; SSB mobile
M57774	17	220-225	25	20	H2	MI; FM mobile
MHW720-1	12.5	400-440	20	21	700-04/1	MO; class C
MHW720-2	12.5	440-470	20	21	700-04/1	MO; class C
M57789	17	890-915	12	33.8	H3B	MI
MHW912	12.5	880-915	12	40.8	301R-01/1	MO; class AB
MHW820-3	12.5	870-950	18	17.1	301G-03/1	MO; class C

Manufacturer codes: MO = Motorola; MI = Mitsubishi; P = Philips; T = Toshiba.

† For package shape, size and pin-connection information, see manufacturers' data sheets. Many retail suppliers offer data sheets to buyers free of charge on request. Data books are available from many manufacturers and retailers.

General Purpose Silicon Power Transistors

*TO-220 case**

<i>NPN</i>	<i>PNP</i>	I_C Max (A)	V_{CEO} Max (V)	h_{FE} Min	F_T (MHz)	Power Dissipation (W)
D44C8		4	60	100/220	50	30
	D45C8	-4	-60	40/120	50	30
TIP29		1	40	15/75	3	30
	TIP30A	1	40	15/75	3	30
TIP29A		1	60	15/75	3	30
	TIP30A	1	60	15/75	3	30
TIP29B		1	80	15/75	3	30
TIP29C		1	100	15/75	3	30
	TIP30C	1	100	15/75	3	30
TIP47		1	250	30/150	10	40
TIP48		1	300	30/150	10	40
TIP49		1	350	30/150	10	40
TIP50		1	400	30/150	10	40
TIP110		2	60	500	> 5	50
	TIP115	2	-60	500	> 5	50
TIP116		2	80	500	25	50
TIP31		3	40	25	3	40
	TIP32	3	40	25	3	40
TIP31A		3	60	25	3	40
	TIP32A	3	60	25	3	40
TIP31B		3	80	25	3	40
	TIP32B	3	80	25	3	40
TIP31C		3	100	25	3	40
	TIP32C	3	100	25	3	40
2N6124		4	45	25/100	2.5	40
2N6122		4	60	25/100	2.5	40
MJE13004		4	300	6/30	4	60
TIP120		5	60	1000	> 5	65
	TIP125	5	-60	1000	> 10	65
TIP42		6	40	15/75	3	65
TIP41A		6	60	15/75	3	65
TIP41B		6	80	15/75	3	65
2N6290		7	50	30/150	4	40
	2N6109	7	50	30/150	4	40
2N6292		7	70	30/150	4	40
	2N6107	7	70	30/150	4	40
MJE3055T		10	60	20/70	—	75
	MJE2955T	10	60	20/70	—	57
TIP140		10	60	500	> 5	125
	TIP145	10	-60	500	> 10	125

Continued on [next page](#).

General Purpose Silicon Power Transistors

Continued from [previous page](#).

TO-204 case (TO-3)*

NPN	PNP	I_c Max (A)	V_{CE0} Max (V)	h_{FE} Min	F_T (MHz)	Power Dissipation (W)
2N6486		15	40	20/150	5	75
2N6488		15	80	20/150	5	75
2N6545		8	400	7/35	6	125
2N3789		10	60	15	4	150
2N3715		10	60	30	4	150
	2N3791	10	60	30	4	150
2N5875		10	60	20/100	4	150
2N3790		10	80	15	4	150
2N3716		10	80	30	4	150
	2N3792	10	80	30	4	150
2N3055		15	60	20/70	2.5	115
	MJ2955	15	60	20/70	2.5	115
2N3055A		15	60	20/70	0.8	115
2N5881		15	60	20/100	4	160
2N5880		15	80	20/100	4	160
2N6249		15	200	10/50	2.5	175
2N6250		15	275	8/50	2.5	175
2N6546		15	300	6/30	6-24	175
2N6251		15	350	6/50	2.5	175
2N5630		16	120	20/80	1	200
2N3773		16	140	15/60	4	200
2N5039		20	75	20/100	60	140
2N5303		20	80	15/60	2	200
2N6284		20	100	750/18K	—	160
	2N6287	20	100	750/18K	—	160
MJ15003		20	140	25/150	2	250
	MJ15004	20	140	25/150	2	250
2N5885		25	60	—	4	200
2N5886		25	80	20/100	4	200
	2N5884	25	80	20/100	4	200
MJ15024		25	250	15/60	5	250
2N3771		30	40	—	2	150
2N5301		30	40	15/60	2	200
2N5302		30	60	15/60	2	200
	2N4399	30	60	15/60	2	200
MJ802		30	100	25/100	2	200
	MJ4502	30	100	25/100	2	200

■ = Complimentary pairs

* For package shape, size and pin-connection information, see manufacturers' data sheets. Many retail suppliers offer data sheets to buyers free of charge on request. Data books are available from many manufacturers and retailers.

RF Power Transistors

Device	Output Power (W)	Input Power (W)	Gain (dB)	Typ Supply Voltage (V)	Case [†]	Mfr
<i>1.5 to 30 MHz, HF SSB/CW</i>						
2SC2086	0.3		13	12	TO-92	MI
BLV10	1		18	12	SOT123	PH
BLV11	2		18	12	SOT123	PH
MRF476	3	0.1	15	12.5-13.6	221A-04/1	MO
BLW87	6		18	12	SOT123	PH
2SC2166	6		13.8	12	TO-220	MI
BLW83	10		20	26	SOT123	PH
MRF475	12	1.2	10	12.5-13.6	221A-04/1	MO
MRF433	12.5	0.125	20	12.5-13.6	211-07/1	MO
2SC3133	13		14	12	TO-220	MI
MRF485	15	1.5	10	28	221A-04/1	MO
2SC1969	16		12	12	TO-220	MI
BLW50F	16		19.5	45	SOT123	PH
MRF406	20	1.25	12	12.5-13.6	221-07/1	MO
SD1285	20	0.65	15	12.5	M113	SG
MRF426	25	0.16	22	28	211-07/1	MO
MRF427	25	0.4	18	50	211-11/1	MO
MRF477	40	1.25	15	12.5-13.6	211-11/1	MO
MRF466	40	1.25	15	28	211-07/1	MO
BLW96	50		19	40	SOT121	PH
2SC3241	75		12.3	12.5	T-45E	MI
SD1405	75	3.8	13	12.5	M174	SG
2SC2097	75		12.3	13.5	T-40E	MI
MRF464	80	2.53	10	28	211-11/1	MO
MRF421	100	10	10	12.5-13.6	211-11/1	MO
SD1487	100	7.9	11	12.5	M174	SG
2SC2904	100		11.5	12.5	T-40E	MI
SD1729	130	8.2	12	28	M174	SG
MRF422	150	15	10	28	211-11/1	MO
MRF428	150	7.5	13	50	211-11/1	MO
SD1726	150	6	14	50	M174	SG
PT9790	150	4.8	15	50	211-11/1	MO
MRF448	250	15.7	12	50	211-11/1	MO
MRF430	600	60	10	50	368-02/1	MO
<i>50 MHz</i>						
MRF475	4	0.4	10	12.5-13.6	221A-04/1	MO
MRF497	40	4	10	12.5-13.6	221A-04/2	MO
SD1446	70	7	10	12.5	M113	SG
MRF492	70	5.6	11	12.5-13.6	211-11/1	MO
SD1405	100	20	7	12.5	M174	SG
<i>VHF to 175 MHz</i>						
2N4427	0.7		8	7.5	TO-39	PH
2N3866	1		10	28	TO-39	PH
BFQ42	1.5		8.4	7.5	TO-39	PH
2SC2056	1.6		9	7.2	T-41	MI
2N3553	2.5	0.25	10	28	79-04/1	MO
BFQ43	3		9.4	7.5	TO-39	PH
SD1012	4	0.25	12	12.5	M135	SG
2SC2627	5		13	12.5	T-40	MI
2N5641	7	1	8.4	28	144B-05/1	MO
MRF340	8	0.4	13	28	221A-04/2	MO
BLW29	9		7.4	7.5	SOT120	PH
SD1143	10	1	10	12.5	M135	SG

Continued on [next page](#).

RF Power Transistors

Continued from [previous page](#).

<i>Device</i>	<i>Output Power (W)</i>	<i>Input Power (W)</i>	<i>Gain (dB)</i>	<i>Typ Supply Voltage (V)</i>	<i>Case†</i>	<i>Mfr</i>
2SC1729	14		10	13.5	T-31E	MI
SD1014-02	15	3.5	6.3	12.5	M135	SG
BLV11	15		8	13.5	SOT123	PH
2N5642	20	3	8.2	28	145A-09/1	MO
MRF342	24	1.9	11	28	221A-04/2	MO
BLW87	25		6	13.5	SOT123	PH
2SC1946	28		6.7	13.5	T-31E	MI
MRF314	30	3	10	28	211-07/1	MO
SD1018	40	14	4.5	12.5	M135	SG
2N5643	40	6.9	7.6	28	145A-09/1	MO
BLW40	40		10	12.5	SOT120	PH
MRF315	45	5.7	9	28	211-07/1	MO
PT9733	50	10	7	28	145A-09/1	MO
MRF344	60	15	6	28	221A-04/2	MO
2SC2694	70		6.7	12.5	T-40	MI
BLV75/12	75		6.5	12.5	SOT119	PH
MRF316	80	8	10	28	316-01/1	MO
SD1477	100	25	6	12.5	M111	SG
BLW78	100		6	28	SOT121	PH
MRF317	100	12.5	9	28	316-01/1	MO
TP9386	150	15	10	28	316-01/1	MO
<i>220 MHz</i>						
MRF207	1	0.15	8.2	12.5	79-04/1	MO
2N5109	2.5		11	12	TO-205AD	MO
MRF227	3	0.13	13.5	12.5	79-05/5	MO
MRF208	10	1	10	12.5	145A-09/1	MO
MRF226	13	1.6	9	12.5	145A-09/1	MO
2SC2133	30		8.2	28	T-40E	MI
2SC2134	60		7	28	T-40E	MI
2SC2609	100		6	28	T-40E	MI
<i>UHF to 512 MHz</i>						
2N4427	0.4		10	12.5	TO-39	PH
2SC3019	0.5		14	12.5	T-43	MI
MRF581	0.6	0.03	13	12.5	317-01/2	MO
2SC908	1		4	12.5	TO-39	MI
2N3866	1		10	28	TO-39	PH
2SC2131	1.4		6.7	13.5	TO-39	MI
BLX65E	2		9	12.5	TO-39	PH
BLW89	2		12	28	SOT122	PH
MRF586	2.5		16.5	15	79-04	MO
MRF630	3	0.33	9.5	12.5	79-05/5	MO
2SC3020	3	0.3	10	12.5	T-31E	MI
BLW80	4		8	12.5	SOT122	PH
BLW90	4		11	12.5	SOT122	PH
MRF652	5	0.5	10	12.5	244-04/1	MO
MRF587	5		16.5	15	244A-01/1	MO
2SC3021	7	1.2	7.6	12.5	T-31E	MI
BLW81	10		6	12.5	SOT122	PH
MRF653	10	2	7	12.5	244-04/1	MO
BLW91	10		9	28	SOT122	PH
MRF654	15	2.5	7.8	12.5	244-04/1	MO
2SC3022	18	6	4.7	12.5	T-31E	MI
BLU20/12	20		6.5	12.5	SOT119	PH
BLX94A	25		6	28	SOT48/2	PH

Continued on [next page](#).

RF Power Transistors

Continued from [previous page](#).

<i>Device</i>	<i>Output Power (W)</i>	<i>Input Power (W)</i>	<i>Gain (dB)</i>	<i>Typ Supply Voltage (V)</i>	<i>Case†</i>	<i>Mfr</i>
2SC2695	28		4.9	13.5	T-31E	MI
BLU30/12	30		6	12.5	SOT119	PH
BLU45/12	45		4.8	12.5	SOT119	PH
2SC2905	45		4.8	12.5	T-40E	MI
MRF650	50	15.8	5	12.5	316-01/1	MO
TP5051	50	6	9	24	333A-02/2	MO
BLU60/12	60		4.4	12.5	SOT119	PH
2SC3102	60	20	4.8	12.5	T-41E	MI
BLU60/28	60		7	28	SOT119	PH
MRF658	65	25	4.15	12.5	316-01/1	MO
MRF338	80	15	7.3	28	333-04/1	MO
SD1464	100	28.2	5.5	28	M168	SG

UHF to 960 MHz

MRF581	0.6	0.06	10	12.5	317-01/2	MO
MRF8372	0.75	0.11	8	12.5	751-04/1	MO
MRF557	1.5	0.23	8	12.5	317D-02/2	MO
BLV99	2		9	24	SOT172	PH
SD1420	2.1	0.27	9	24	M122	SG
MRF839	3	0.46	8	12.5	305A-01/1	MO
MRF896	3	0.3	10	24	305-01/1	MO
MRF891	5	0.63	9	24	319-06/2	MO
2SC2932	6		7.8	12.5	T-31B	MI
SD1398	6	0.6	10	24	M142	SG
2SC2933	14	3	6.7	12.5	T-31B	MI
SD1400-03	14	1.6	9.5	24	M118	SG
MRF873	15	3	7	12.5	319-06/2	MO
SD1495-03	30	6	7	24	M142	SG
SD1424	30	5.3	7.5	24	M156	SG
MRF897	30	3	10	24	395B-01/1	MO
MRF847	45	16	4.5	12.5	319-06/1	MO
BLV101A	50		8.5	26	SOT273	PH
SD1496-03	55	10	7.4	24	M142	SG
MRF898	60	12	7	24	333A-02/1	MO
MRF880	90	12.7	8.5	26	375A-01/1	MO
MRF899	150	24	8	26	375A-01/1	MO

Manufacturer codes: MI = Mitsubishi; MO = Motorola; PH = Philips; SG = SGE/Thomson

† For package shape, size and pin-connection information, see manufacturers' data sheets. Many retail suppliers offer data sheets to buyers free of charge on request. Data books are available from many manufacturers and retailers.

Power FETs

<i>Device</i>	<i>Type</i>	<i>VDSS min (V)</i>	<i>RDS(on) max (W)</i>	<i>ID max (A)</i>	<i>PD max (W)</i>	<i>Case†</i>	<i>Mfr</i>
BS250P	P-channel	45	14	0.23	0.7	E-line	Z
IRFZ30	N-channel	50	0.050	30	75	TO-220	IR
MTP50N05E	N-channel	50	0.028	25	150	TO-220AB	M
IRFZ42	N-channel	50	0.035	50	150	TO-220	IR
2N7000	N-channel	60	5	0.20	0.4	E-line	Z
VN10LP	N-channel	60	7.5	0.27	0.625	E-line	Z
VN10KM	N-channel	60	5	0.3	1	TO-237	S
ZVN2106B	N-channel	60	2	1.2	5	TO-39	Z
IRF511	N-channel	60	0.6	2.5	20	TO-220AB	M
MTP2955E	P-channel	60	0.3	6	25	TO-220AB	M
IRF531	N-channel	60	0.180	14	75	TO-220AB	M
MTP23P06	P-channel	60	0.12	11.5	125	TO-220AB	M
IRFZ44	N-channel	60	0.028	50	150	TO-220	IR
IRF531	N-channel	80	0.160	14	79	TO-220	IR
ZVP3310A	P-channel	100	20	0.14	0.625	E-line	Z
ZVN2110B	N-channel	100	4	0.85	5	TO-39	Z
ZVP3310B	P-channel	100	20	0.3	5	TO-39	Z
IRF510	N-channel	100	0.6	2	20	TO-220AB	M
IRF520	N-channel	100	0.27	5	40	TO-220AB	M
IRF150	N-channel	100	0.055	40	150	TO-204AE	M
IRFP150	N-channel	100	0.055	40	180	TO-247	IR
ZVP1320A	P-channel	200	80	0.02	0.625	E-line	Z
ZVN0120B	N-channel	200	16	0.42	5	TO-39	Z
ZVP1320B	P-channel	200	80	0.1	5	TO-39	Z
IRF620	N-channel	200	0.800	5	40	TO-220AB	M
MTP6P20E	P-channel	200	1	3	75	TO-220AB	M
IRF220	N-channel	200	0.400	8	75	TO-220AB	M
IRF640	N-channel	200	0.18	10	125	TO-220AB	M

Manufacturers: IR = International Rectifier; M = Motorola; S = Siliconix; Z = Zetex.

† For package shape, size and pin-connection information, see manufacturers' data sheets. Many retail suppliers offer data sheets to buyers free of charge on request. Data books are available from many manufacturers and retailers.

Logic IC Families

Type	Propagation Delay for $C_L = 50 \text{ pF}$ (ns)		Max Clock Frequency (MHz)	Power Dissipation (CL = 0) @ 1 MHz (mW/gate)	Output Current @ 0.5 V max (mA)	Input Current (Max mA)	Threshold Voltage (V)	Supply Voltage (V)		
	Typ	Max						Min	Typ	Max
CMOS										
74AC	3	5.1	125	0.5	24	0	V+/2	2	5 or 3.3	6
74ACT	3	5.1	125	0.5	24	0	1.4	4.5	5	5.5
74HC	9	18	30	0.5	8	0	V+/2	2	5	6
74HCT	9	18	30	0.5	8	0	1.4	4.5	5	5.5
4000B/74C (10 V)	30	60	5	1.2	1.3	0	V+/2	3	5 - 15	18
4000B/74C (5V)	50	90	2	3.3	0.5	0	V+/2	3	5 - 15	18
TTL										
74AS	2	4.5	105	8	20	0.5	1.5	4.5	5	5.5
74F	3.5	5	100	5.4	20	0.6	1.6	4.75	5	5.25
74ALS	4	11	34	1.3	8	0.1	1.4	4.5	5	5.5
74LS	10	15	25	2	8	0.4	1.1	4.75	5	5.25
ECL										
ECL III	1.0	1.5	500	60	—	—	-1.3	-5.19	-5.2	-5.21
ECL 100K	0.75	1.0	350	40	—	—	-1.32	-4.2	-4.5	-5.2
ECL100KH	1.0	1.5	250	25	—	—	-1.29	-4.9	-5.2	-5.5
ECL 10K	2.0	2.9	125	25	—	—	-1.3	-5.19	-5.2	-5.21
GaAs										
10G	0.3	0.32	2700	125	—	—	-1.3	-3.3	-3.4	-3.5
10G	0.3	0.32	2700	125	—	—	-1.3	-5.1	-5.2	-5.5

Source: Horowitz (W1HFA) and Hill, *The Art of Electronics—2nd edition*, page 570. © Cambridge University Press 1980, 1989. Reprinted with the permission of Cambridge University Press.

Three-Terminal Voltage Regulators

Listed numerically by device

<i>Device</i>	<i>Description</i>	<i>Package</i>	<i>Voltage</i>	<i>Current (Amps)</i>
317	Adj Pos	TO-205	+1.2 to +37	0.5
317	Adj Pos	TO-204,TO-220	+1.2 to +37	1.5
317L	Low Current Adj Pos	TO-205,TO-92	+1.2 to +37	0.1
317M	Med Current Adj Pos	TO-220	+1.2 to +37	0.5
338	Adj Pos	TO-3	+1.2 to +32	5.0
350	High Current Adj Pos	TO-204,TO-220	+1.2 to +33	3.0
337	Adj Neg	TO-205	-1.2 to -37	0.5
337	Adj Neg	TO-204,TO-220	-1.2 to -37	1.5
337M	Med Current Adj Neg	TO-220	-1.2 to -37	0.5
309		TO-205	+5	0.2
309		TO-204	+5	1.0
323		TO-204,TO-220	+5	3.0
140-XX	Fixed Pos	TO-204,TO-220	Note 1	1.0
340-XX		TO-204,TO-220		1.0
78XX		TO-204,TO-220		1.0
78LXX		TO-205,TO-92		0.1
78MXX		TO-220		0.5
78TXX		TO-204		3.0
79XX	Fixed Neg	TO-204,TO-220	Note 1	1.0
79LXX		TO-205,TO-92		0.1
79MXX		TO-220		0.5

Note 1—XX indicates the regulated voltage; this value may be anywhere from 1.2 V to 35 V. A 7815 is a positive 15-V regulator, and a 7924 is a negative 24-V regulator.

The regulator package may be denoted by an additional suffix, according to the following:

<i>Package</i>	<i>Suffix</i>
TO-204 (TO-3)	K
TO-220	T
TO-205 (TO-39)	H, G
TO-92	P, Z

For example, a 7812K is a positive 12-V regulator in a TO-204 package. An LM340T-5 is a positive 5-V regulator in a TO-220 package. In addition, different manufacturers use different prefixes. An LM7805 is equivalent to a μ A7805 or MC7805.

Continued on [next page](#).

Three-Terminal Voltage Regulators

Continued from [previous page](#).

K Suffix Metal TO-204 Package

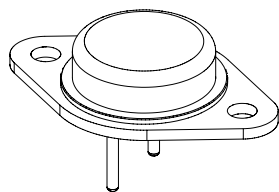

Pins 1 and 2 Electrically Isolated from Case. Case is Third Electrical Connection.

BOTTOM VIEW

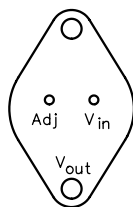

Case is Output
317
350

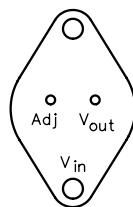

Case is Input
337

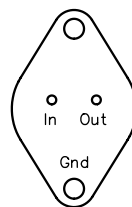

Case is Ground
140 k-XX
340 k-XX
309
7800 Series
78T00 Series

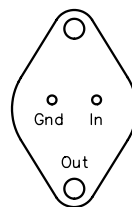

Case is Input
7900 Series

T Suffix TO-220 Package

Center Lead is Connected to the Heat Sink

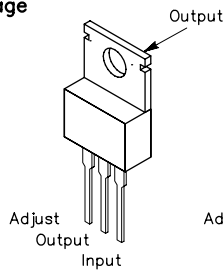

317
350

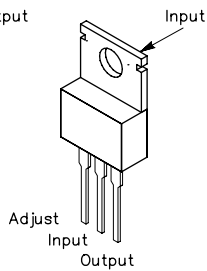

337
337M

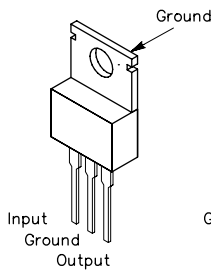

7800 Series
78T00 Series
78M00 Series
140T-XX
340T-XX

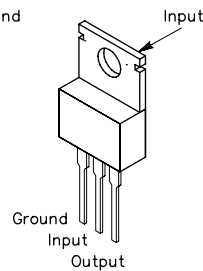

7900 Series
79M00 Series

H, G Suffix TO-205 Package

BOTTOM VIEW

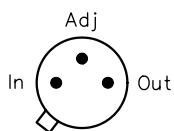
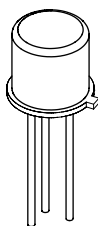

Case is Output
317
317L

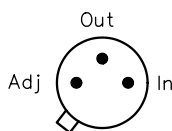

Case is Input
337

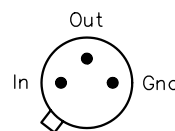

Case is Ground
78L00 Series
78M00 Series

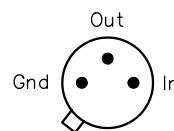

Case is Input
79L00 Series
79M00 Series

P, Z Suffix TO-92 Package

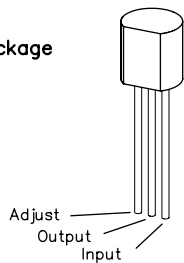

317L

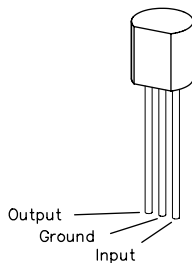

78L00 Series

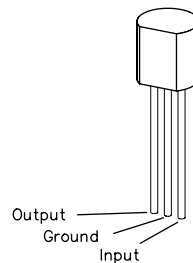

79L00 Series

Op Amp ICs

Listed by device number

Device	Type	Freq Comp	Max Supply* (V)	Min Input Resistance (M Ω)	Max Offset Voltage (mV)	Min dc Open-Loop Gain (dB)	Min Output Current (mA)	Min Small-Signal Bandwidth (MHz)	Min Slew Rate (V/ μ s)	Notes
101A	Bipolar	ext	44	1.5	3.0	79	15	1.0	0.5	General purpose
108	Bipolar	ext	40	30	2.0	100	5	1.0		
124	Bipolar	int	32		5.0	100	5	1.0		Quad op amp, low power
148	Bipolar	int	44	0.8	5.0	90	10	1.0	0.5	Quad 741
158	Bipolar	int	32		5.0	100	5	1.0		Dual op amp, low power
301	Bipolar	ext	36	0.5	7.5	88	5	1.0	10	Bandwidth extendable with external components
324	Bipolar	int	32		7.0	100	10	1.0		Quad op amp, single supply
347	BiFET	ext	36	10 ⁶	5.0	100	30	4	13	Quad, high speed
351	BiFET	ext	36	10 ⁶	5.0	100	20	4	13	
353	BiFET	ext	36	10 ⁶	5.0	100	15	4	13	
355	BiFET	ext	44	10 ⁶	10.0	100	25	2.5	5	
355B	BiFET	ext	44	10 ⁶	5.0	100	25	2.5	5	
356A	BiFET	ext	36	10 ⁶	2.0	100	25	4.5	12	
356B	BiFET	ext	44	10 ⁶	5.0	100	25	5.0	12	
357	BiFET	ext	36	10 ⁶	10.0	100	25	20.0	50	
357B	BiFET	ext	36	10 ⁶	5.0	100	25	20.0	30	
358	Bipolar	int	32		7.0	100	10	1.0		Dual op amp, single supply
411	BiFET	ext	36	10 ⁶	2.0	100	20	4.0	15	Low offset, low drift
709	Bipolar	ext	36	0.05	7.5	84	5	0.3	0.15	
741	Bipolar	int	36	0.3	6.0	88	5	0.4	0.2	
741S	Bipolar	int	36	0.3	6.0	86	5	1.0	3	Improved 741 for AF
1436	Bipolar	int	68	10	5.0	100	17	1.0	2.0	High-voltage
1437	Bipolar	ext	36	0.050	7.5	90		1.0	0.25	Matched, dual 1709
1439	Bipolar	ext	36	0.100	7.5	100		1.0	34	
1456	Bipolar	int	44	3.0	10.0	100	9.0	1.0	2.5	Dual 1741
1458	Bipolar	int	36	0.3	6.0	100	20.0	0.5	3.0	
1458S	Bipolar	int	36	0.3	6.0	86	5.0	0.5	3.0	Improved 1458 for AF
1709	Bipolar	ext	36	0.040	6.0	80	10.0	1.0		
1741	Bipolar	int	36	0.3	5.0	100	20.0	1.0	0.5	
1747	Bipolar	int	44	0.3	5.0	100	25.0	1.0	0.5	Dual 1741

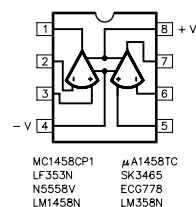
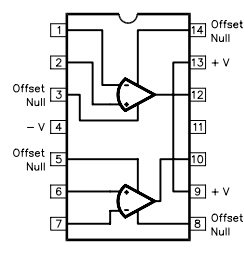
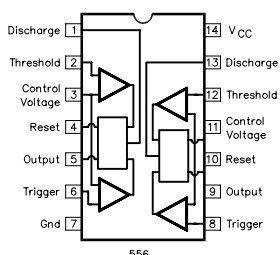
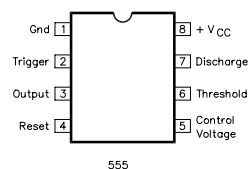
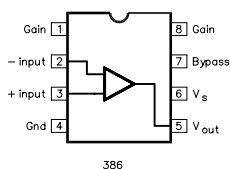

Top View

Continued on [next page](#).

Op Amp ICs

Continued from [previous page](#).

Listed by device number

Device	Type	Freq Comp	Max Supply* (V)	Min Input Resistance (MΩ)	Max Offset Voltage (mV)	Min dc Open-Loop Gain (dB)	Min Output Current (mA)	Min Small-Signal Bandwidth (MHz)	Min Slew Rate (V/μs)	Notes
1748	Bipolar	ext	44	0.3	6.0	100	25.0	1.0	0.8	Noncompensated 1741
1776	Bipolar	int	36	50	5.0	110	5.0		0.35	Micro power, programmable Strobable output
3140	BiFET	int	36	1.5 × 10 ⁶	2.0	86	1	3.7	9	Quad, low power
3403	Bipolar	int	36	0.3	10.0	80		1.0	0.6	Dual op amp and dual comparator
3405	Bipolar	ext	36		10.0	86	10	1.0	0.6	Dual, low power
3458	Bipolar	int	36	0.3	10.0	86	10	1.0	0.6	Quad, Norton single supply
3476	Bipolar	int	36	5.0	6.0	92	12		0.8	Dual, wideband
3900	Bipolar	int	32	1.0		65	0.5	4.0	0.5	Quad 1741
4558	Bipolar	int	44	0.3	5.0	88	10	2.5	1.0	Low noise, can swing 20V P-P across 600
4741	Bipolar	int	44	0.3	5.0	94	20	1.0	0.5	Equivalent to 1456
5534	Bipolar	int	44	0.030	5.0	100	38	10.0	13	Dual, equivalent to 1458
5556	Bipolar	int	36	1.0	12.0	88	5.0	0.5	1	JFET input
5558	Bipolar	int	36	0.15	10.0	84	4.0	0.5	0.3	Ultra-low noise, high speed
34001	BiFET	int	44	10 ⁶	2.0	94		4.0	13	
AD745	BiFET	int	±18	10 ⁴	0.5	63	20	20	12.5	

LT1001 Precision op amp, low offset voltage (15 μV max), low drift (0.6 μV/°C max), low noise (0.3 μVp-p)

LT1007 Extremely low noise (0.06 μVp-p), very high gain (20 × 10⁶ into 2 kΩ load)

LT1360 High speed, very high slew rate (800 V/μs), 50 MHz gain bandwidth, ±2.5 V to ±15 V supply range

NE5514	Bipolar	int	±16	100	1		10	3	0.6	
NE5532	Bipolar	int	±20	0.03	4	47	10	10	9	Low noise
OP-27A	Bipolar	ext	44	1.5	0.025	115		5.0	1.7	Ultra-low noise, high speed
OP-37A	Bipolar	ext	44	1.5	0.025	115		45.0	11.0	
TL-071	BiFET	int	36	10 ⁶	6.0	91		4.0	13.0	Low noise
TL-081	BiFET	int	36	10 ⁶	6.0	88		4.0	8.0	
TL-082	BiFET	int	36	10 ⁶	15.0	99		4.0	8.0	Low noise
TL-084	BiFET	int	36	10 ⁶	15.0	88		4.0	8.0	Quad, high-performance AF
TLC27M2	CMOS	int	18	10 ⁶	10	44		0.6	0.6	Low noise
TLC27M4	CMOS	int	18	10 ⁶	10	44		0.6	0.6	Low noise

*From -V to +V terminals

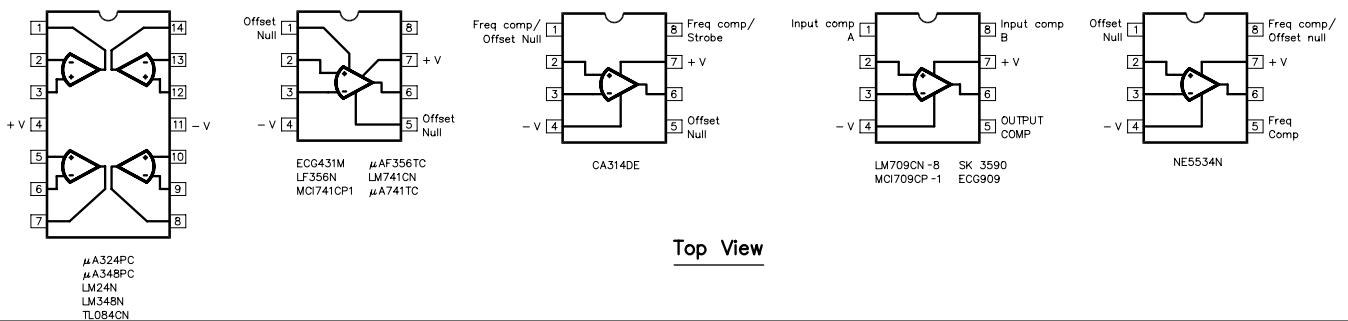

Top View

Triode Transmitting Tubes

Type	Maximum Ratings				Cathode (V)	Capacitances (pF)			Base Diagram	Service Class ¹	Typical Operation					
	Power Diss. (W)	Plate (V)	Plate (mA)	Grid dc (mA)		C _{in}	C _{cp}	C _{out}			Plate (V)	Grid (V)	Plate (mA)	Grid dc (mA)	Input (W)	P to P Load (kΩ)
5675	5	165	30	8	6.3	0.135	2.3	1.3	0.09	CG0	120	-8	25	4	—	0.05
2C40	6.5	500	25	—	6.3	0.75	2.1	1.3	0.05	CT	250	-5	20	0.3	—	0.075
5893	8.0	400	40	13	6.0	0.33	2.5	1.75	0.07	CT	350	-33	35	13	2.4	6.5
2C43	12	500	40	—	6.3	0.9	2.9	1.7	0.05	CP	300	-45	30	12	2.0	6.5
811-A	65	1500	175	50	6.3	4.0	5.9	5.6	0.7	CTO	470	—	38 ⁷	—	—	9 ²
812-A	65	1500	175	35	6.3	4.0	5.4	5.5	0.77	CT	1500	-70	173	40	7.1	200
3CX100A5 ⁶	100	1000	125 ⁵	50	6.0	1.05	7.0	2.15	0.035	CP	1250	-120	140	45	10.0	135
	70	600	100 ⁵	—	6.0	1.1	6.5	1.95	0.03	B ²	1250	0	27/175	28	12	165
2C39	100	1000	60	40	6.3	1.1	6.5	1.95	0.03	AB ₁	1250	0	27/175	13	3.0	155
AX9900	135	2500	200	40	6.3	5.4	5.8	5.5	0.1	CT	1500	-120	173	30	6.5	190
572B	160	2750	275	—	6.3	4.0	—	—	—	CP	1250	-115	140	35	7.6	130
T160L	200	2200	250	—	6.3	3.2	19.5	7.0	0.03	B ²	1500	-48	283/10	270 ⁴	5.0	13.2
8873	300	2200	250	—	6.3	3.2	19.5	7.0	0.03	AGG	800	-20	80	30	6	27
8875	300	2200	250	—	6.3	3.2	19.5	7.0	0.03	CP	600	-15	75	40	6	18
833A	350	3300	500	100	10	10	12.3	6.3	8.5	G1C	600	-35	60	40	5.0	20
	450 ⁶	4000 ⁶	—	—	10	10	12.3	6.3	8.5	CTO	900	-40	90	30	—	40
8874	400	2200	350	—	6.3	4.0	—	—	—	CP	600	-150	100 ⁵	50	—	—
3-400Z	400	3000	400	—	5	14.5	7.4	4.1	0.07	CT	2500	-200	200	40	16	—
3-500Z	500	4000	400	—	5	14.5	7.4	4.1	0.07	CP	2000	-225	127	40	16	—
3-600Z	600	4000	425	—	5	15.0	7.8	4.6	0.08	B ²	2500	-90	80/330	350 ⁴	14 ²	15.68
										CT	1650	-70	165	32	6	205
										B/GG ²	2400	-2.0	90/500	—	100	600
										AB ₂	2000	—	22/500	98 ³	27 ³	505
										AB ₂	2000	—	22/500	98 ³	27 ³	505
										CTO	2250	-125	445	85	23	780
										CP	3000	-160	335	70	20	800
										CP	2500	-300	335	75	30	635
										B ₂	3000	-240	335	70	26	800
										B ₂	3000	-70	100/750	400 ⁴	20 ⁴	1650
										AB ₂	2000	—	22/500	98 ³	27 ³	505
										B/GG	3000	0	100/333	120	32	655
										B/GG	3000	—	370	115	30	5
										CT	3500	-75	300	115	22	850
										B/GG	3000	—	400	118	33	810
										B/GG	3500	—	400	110	35	950
3CX800A7	800	2250	600	60	13.5	1.5	26	—	6.1	AB ₂ G ₂	2200	-8.2	500	36	16	750
3-1000Z	1000	3000	800	—	7.5	21.3	17	6.9	0.12	B/GG	3000	0	180/670	300	65	1360
3CX1200A7	1200	5000	800	—	7.5	21.0	20	12	0.2	AB ₂ G ₂	3600	-10	700	230	85	1500
8877	1500	4000	1000	—	250	5.0	42	10	0.1	AB ₂	2500	-6.2	1000	—	57	1520

¹KEY TO CLASS-OF-SERVICE ABBREVIATIONS
 A₁ = Class-A₁ AF modulator.
 AB₁ = Class-AB₁ push-pull AF modulator.
 AB₂ = Class-AB₂ push-pull AF modulator.
 B = Class-B push-pull AF modulator.
 CM = Frequency multiplier.
 CP = Class-C plate-modulated telephone.
 CT = Class-C CW.
 CTG = Class-C amplifier-oscillator.
 AB₂GG = Grounded-grid class AB₂ amplifier.
 BGG = Grounded-grid class B amp. (single tone)
 GGO = Grounded-grid oscillator.
 G1C = Grid-isolation circuit.
 GMA = Grid-modulated amplifier.
²Values are for two tubes in push-pull.
³Maximum signal value.
⁴Peak AF grid-to-grid volts.
⁵Maximum cathode current in mA.
⁶Forced-air cooling required.
⁷Key-down CW.

Continued on next page.

Triode Transmitting Tubes

Continued from [previous page](#).

Type	Maximum Ratings				Cathode				Capacitance (pF)				Typical Operation									
	Plate Diss (W)	Plate (V)	Screen Diss (W)	Screen (V)	Freq (MHz)	(A)	(V)	C _{IN}	C _{GP}	C _{OUT}	Base	Serv	Plate (V)	Screen (V)	Sup P (V)	Grid (V)	Plate (mA)	Screen (mA)	Grid (mA)	P _m (W)	P-to-P Load (kΩ)	P _{out} (W)
6146	25	750	3	250	60	6.3	1.25	13	0.24	8.5	7CK	CT	500	170	—	-66	135	9	2.5	0.2	—	48
6146A													750	160	—	-62	120	11	3.1	0.2	—	70
8032												CT ⁶	400	190	—	-54	150	10.4	2.2	3.0	—	35
6883	25	750	3	250	60	12.6	0.585	13	0.24	8.5	7CK	CP	400	150	—	-87	112	7.8	3.4	0.4	—	32
													600	150	—	-87	112	7.8	3.4	0.4	—	52
6159B	25	750	3	250	60	26.5	0.3	13	0.24	8.5	7CK	AB ₂ ⁹	600	190	—	-48	28/270	1.2/20	2 ⁴	0.3	5	113
807												AB ⁸	750	165	—	-46	22/240	0.3/20	2.6 ⁵	0.4	7.4	131
807W	30	750	3.5	300	60	6.3	0.9	12	0.2	7	5AW	CP	600	275	—	-90	100	6.5	4	0.4	—	42.5
5933												AB ₁	750	300	—	-35	15/70	3/8	7.5 ³	0	—	72
1625	30	750	3.5	300	60	12.6	0.45	12	0.2	7	5AZ	B ⁷	750	200	—	0	15/240	—	5.5 ³	5.3 ²	6.65	120
6146B												CT	750	200	—	-77	160	10	2.7	0.3	—	85
8298A	35	750	3	250	60	6.3	1.125	13	0.22	8.5	7CK	CP	600	175	—	-92	140	9.5	3.4	0.5	—	62
												AB ₁	750	200	—	-48	25/125	6.3	—	—	3.5	61
												CT10	1250	300	0	-75	180	35	12	1.7	—	170
													2250	400	0	-155	220	40	15	4	—	375
813 ⁷	125	2500	20	800	30		5	16.3	0.25	14	5BA	AB ₁	2500	750	0	-95	25/145	27 ²	0	0	—	245
												AB ₂ ⁸	2000	750	0	-90	40/315	1.5/58	230 ³	0.1 ²	16	455
													2500	750	0	-95	35/360	1.2/55	235 ³	0.35 ²	17	650
4-400A	400 ⁴	4000	35	600	110	5	14.5	12.5	0.12	4.7	5BK	CT/CP	4000	300	—	-170	20	22.5	10	10	—	720
												GG	2500	0	—	0	80/270 ⁹	55 ⁹	100 ⁹	38 ⁹	4.0	325
4CX400A	400	2500	8	400	500	6.3	3.2	24	.08	7	See Note 11	AB ₁	2500	750	—	-130	95/317	0/14	0	0	—	425
												AB ₂	2200	325	—	-30	100/270	22	2	9	—	405
												AB ₂	2500	400	—	-35	100/400	18	1	13	—	610

Type	Maximum Ratings				Cathode				Capacitance (pF)				Typical Operation									
	Plate Diss (W)	Plate (V)	Screen Diss (W)	Screen (V)	Freq (MHz)	(A)	(V)	C _{IN}	C _{GP}	C _{OUT}	Base	Serv	Plate (V)	Screen (V)	Sup P (V)	Grid (V)	Plate (mA)	Screen (mA)	Grid (mA)	P _m (W)	P-to-P Load (kΩ)	P _{out} (W)
4CX800A	800	2500	15	350	150	12.6	3.6	51	.9	11	See Note 12	AB ₂	2200	350	—	-56	160/530	24	1	32	—	750
												GD	2200	300	—	-57	100/590	20	2	41	—	750
												CT	3000	500	—	-150	700	146	38	11	—	1430
8166	1000	6000	75	1000	—	7.5	21	27.2	0.24	7.6	—	CP	3000	500	—	-200	600	145	36	12	—	1390
4-1000A												AB ₂	4000	500	—	-60	300/1200	0/95	—	11	7	3000
												GG	3000	0	—	0	100/700 ⁹	105 ⁹	170 ⁹	130 ⁹	2.5	1475
													2000	325	—	-55	500/2000	-4/60	—	—	2.8	2160
4CX1000A	1000	3000	12	400	400	6	12.5	35	0.005	12	—	AB ⁸	2500	325	—	-55	500/2000	-4/60	—	—	3.1	2920
													3000	325	—	-55	500/1800	-4/60	—	—	3.85	3360
													2400	350	—	-53	500/1100	20	2	28	—	1600
4CX1600B	1600	3300	20	350	250	12.6	4.4	86	0.15	12	See Note 13	AB ₂	2400	350	—	-70	200/870	48	2	83 ¹⁰	—	1500
													3200	240	—	-57	200/740	21	1	33	—	1600

¹ SERVICE CLASS ABBREVIATIONS:
 AB₂GD = AB₂ linear with 50-Ω passive grid driver circuit.
 B = Class-B push-pull at modulator.
 CM = Frequency multiplier.
 CP = Class-C plate-modulated phone.
 CT = Class-C telegraph.
 CTO = Class-C amplifier-oscillator.
 GG = Grounded-grid (grid and screen connected together).

² Maximum signal value.
³ Peak grid-to-grid volts.
⁴ Forced-air cooling required.
⁵ Two tubes triode connected, G2 to G1 through 20kΩ input to G2.
⁶ Typical operation at 175 MHz.

⁷ ±1.5 V.
⁸ Values are for two tubes.
⁹ Single tone.
¹⁰ 24-Ω cathode resistance.
¹¹ Base same as 4CX250B, Socket is Russian SK2A.
¹² Socket is Russian SK1A.
¹³ Socket is Russian SK3A.

TV Deflection Tubes

Type	Plate Dissipation Watts	Screen Dissipation Watts	Transconductance Micromhos	Capacitances			Base	RF Operation (Up to 30 MHz)										
				Heater (6.3V) Amperes	C _{in} pF	C _{gp} pF		C _{out} pF	Class of Service	Plate Voltage	Screen Voltage	Grid Voltage	Plate Current mA	Screen Current mA	Grid Current mA	Approx. Driving Power Watts	Approx. Output Power Watts	
6DQ5	24	3.2	10.5k	2.5	23	0.5	11	8JC										
6DQ6B	18	3.6	7.3k	1.2	15	0.5	7	6AM	C	400	200	-40	100	12	1.5	0.1	25	
6FH6	17	3.6	6k	1.2	33	0.4	8	6AM										
6GC6	17.5	4.5	6.6k	1.2	15	0.55	7	8JX										
6GJ5	17.5	3.5	7.1k	1.2	15	0.26	6.5	9NM	C	500	200	-75	180	15	5	0.43	63	
									AB ₁	500	200	-43	85	4		35		
6HF5	28	5.5	11.3k	2.25	24	0.56	10	12FB	C	500	140	-85	232	12.5	8	0.76	77	
									AB ₁	500	140	-46	133	4.5		58		
6JB6	17.5	3.5	7.1k	1.2	15	0.2	6	9QL	C	500	200	-75	180	13.3	5	0.43	63	
									AB ₁	500	200	-42	85	4.2		35		
6JE6C	30	5	10.5k	2.5	24.3		14.5	9QL	C	500	125	-85	222	17	8	0.82	76	
									AB ₁	500	125	-44	110	3.9		47		
6JG6A	17	3.5	10k	1.6	22	0.7	9	9QU	C	450	150	-80	202	20	8	0.75	63	
									AB ₁	450	150	-35	98	4.5		38		
6JM6	17.5	3.5	7.3k	1.2	16	0.6	7	12FJ	C	500	200	-75	190	13.7	4	0.32	61	
									AB ₁	500	200	-42	85	4.4		37		
6JN6	17.5	3.5	7.3k	1.2	16	0.34	7	12FK										
6JS6C	30	5.5		2.25	24	0.7	10	12FY										
6KD6	33	5	14k	2.85	40	0.8	16	12GW	GG	800	0	-11	150			12.5	82	
6LB6	30	5	13.4k	2.25	33	0.4	18	12GJ										
6LG6	28	5	11.5k	2	25	0.8	13	12HL										
6LQ6	30	5	9.6k	2.5	22	0.46	11	9QL										
6MH6	38.5	7	14k	2.65	40	1.0	20	12GW										

Note: For AB₁ operation, input data is average 2-tone value. Output power is PEP.

EIA Vacuum-Tube Base Diagrams

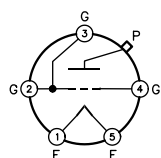
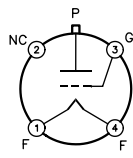
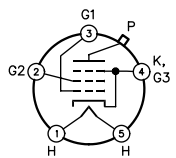

FIG 3



3G



5AW

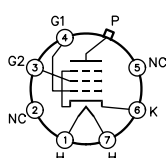

5AZ

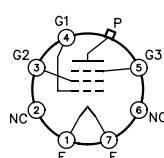

5BA

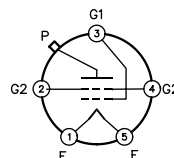

5BK

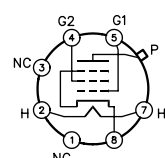

6AM

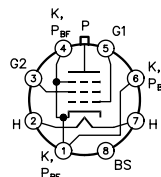

7CK

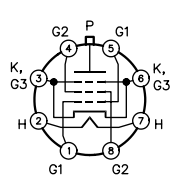

8JC

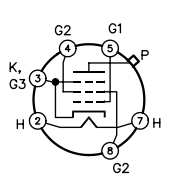

8JX

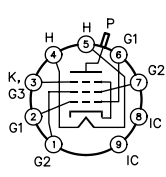

9NM

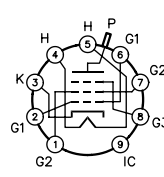

9QL

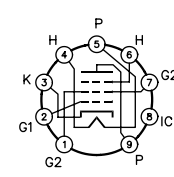

9QU

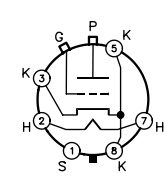
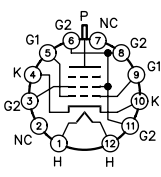
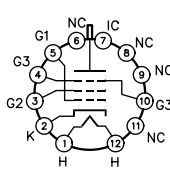

FIG 11



12FB



12FJ

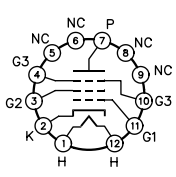

12FK

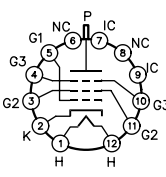

12FY

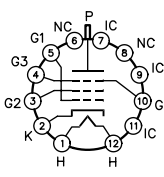

12GJ

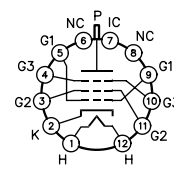

12GW

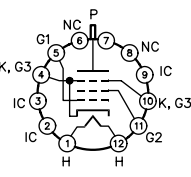

12HL

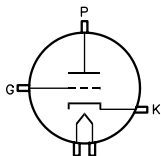

FIG 21

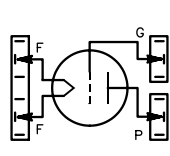

FIG 41

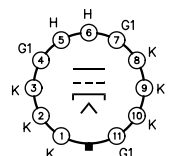

FIG 87

Base diagrams correspond to the codes in "Base" columns of the tube-data tables. Bottom views are shown throughout. Base connections are abbreviated as follows:

- | | |
|--------------------------|-------------------------------|
| BS - Base sleeve | NC - No connection |
| F - Filament | P - Plate |
| G - Grid | P _{BF} - Beam plates |
| H - Heater | S - Shell |
| IC - Internal connection | K - Cathode |

Alphabetical subscripts (D = diode, P = pentode, T = triode and HX = hexode) indicate structures in multistroke tubes. Subscript CT indicates filament or heater center tap.

Generally, when pin 1 of a metal-envelope tube (except all triodes) is shown connected to the envelope, pin 1 of a glass-envelope counterpart (suffix G or GT) is connected to an internal shield.

Properties of Common Thermoplastics

Polyvinyl Chloride (PVC)

Advantages:

- can be compounded with plasticizers, fillers, stabilizers, lubricants and impact modifiers to produce a wide range of physical properties
- can be pigmented to almost any color
- Rigid PVC has good corrosion and stain resistance, thermal & electrical insulation, and weatherability

Disadvantages:

- base resin can be attacked by aromatic solvents, ketones, aldehydes, naphthalenes, and some chloride, acetate, and acrylate esters
- should not be used above 140°

Applications:

- conduit
- conduit boxes
- electrical fittings
- housings
- pipe
- wire and cable insulation

Polystyrene

Advantages:

- low cost
- moderate strength
- electrical properties only slightly affected by temperature and humidity
- sparkling clarity
- impact strength is increased by blending with rubbers, such as polybutadiene

Disadvantages:

- brittle
- low heat resistance

Applications:

- capacitors
- light shields
- knobs

Polyphenylene Sulfide (PPS)

Advantages:

- excellent dimensional stability
- strong
- high-temperature stability
- chemical resistant
- Inherently completely flame retardant
- completely transparent to microwave radiation.

Applications:

R3-R5 have various glass-fiber levels that are suitable for applications demanding high mechanical and impact strength as well as good dielectric properties.

R8 and R10 are suitable for high arc-resistance applications

R9-901 is suitable for encapsulation of electronic devices

Polypropylene

Advantages:

- low density
- good balance of thermal, chemical, and electrical properties
- moderate strength (increases significantly with glass-fiber reinforcement)

Disadvantages:

- Electrical properties affected to varying degrees by temperature (as temperature goes up, dielectric strength increases and volume resistivity decreases.)
- Inherently unstable in presence of oxidative and UV radiation

Applications:

- Automotive battery cases
- blower housings
- fan blades
- fuse housings
- insulators
- lamp housings
- supports for current-carrying electrical components.
- TV yokes

Polyethylene (PE)

Advantages: Low Density PE

- Good toughness
- excellent chemical resistance
- excellent electrical properties
- low coefficient of friction
- near zero moisture absorption
- easy to process
- relatively low heat resistance

Disadvantage

- susceptible to environmental and some chemical stress cracking
- wetting agents (such as detergents) accelerate stress cracking

Advantages: High Density PE

- Same as above, plus increased rigidity and tensile strength

Advantages: Ultra-High Molecular Weight PE

- outstanding abrasion resistance
- low coefficient of friction
- high impact strength
- excellent chemical resistance
- material does not break in impact strength tests using standard notched specimens

Applications:

- bearings
- components requiring maximum abrasion resistance, impact strength, and low coefficient of friction

Phenolic

Advantages:

- low cost
- superior heat resistance
- high heat-deflection temperatures
- good electrical properties
- good flame resistance
- excellent moldability
- excellent dimensional stability
- good water and chemical resistance

Applications:

- commutators and housings for small motors
- heavy duty electrical components
- rotary-switch wafers
- insulating spacers

Nylon

Advantages

- excellent fatigue resistance
- low coefficient of friction
- toughness a function of degree of crystallinity
- resists many fuels and chemicals
- good creep- and cold-flow resistance as compared to less rigid thermoplastics
- resists repeated impacts

Disadvantages:

- all nylons absorb moisture
- nylons that have not been compounded with a UV stabilizer are sensitive to UV light, and thus not suitable for extended outdoor use

Applications

- bearings
- housing and tubing
- rope
- wire coatings
- wire connectors
- wear plates

Continued on [next page](#).

Properties of Common Thermoplastics

Continued from [previous page](#).

ASTM or UL test	NYLONS (DRY, AS MOLDED)					PHENOLICS					POLYETHYLENE				
	Type					Type of compound					Low density	Medium density	High density	Ultrahigh molecular weight	
	6/6	6	6/12	11	Castable	General purpose	impact	Non-bleeding	Electrical	Heat resistant					Special purpose*
PHYSICAL															
D792	1.14	1.13	1.06	1.04	1.15-1.17	1.35-1.46	1.36-1.41	1.37-1.38	1.36-1.75	1.41-1.84	1.37-1.75	0.910-0.925	0.926-0.940	0.941-0.965	0.928-0.941
D792	24.2	24.5	25.9	26.6	23.8							30.4-29.9	29.9-29.4	29.4-28.7	29.4
D570	1.2	1.6	0.25	0.4	0.9	0.6-0.7	0.6-0.9	0.8-0.9	0.05-0.20	0.30-0.35	0.20-0.40	<0.01	<0.01	<0.01	<0.01
MECHANICAL															
D638	12,000	11,800	8,800	8,500	11,000-14,000	6,500-7,000	6,000-7,000	6,000-7,000	5,000-7,000	5,000-6,000	7,000-9,000	600-2,300	1,200-3,500	3,100-5,500	4,000-6,000
D638	60	200	150	120	10-50	11-13	12	10	17-25	14	10	90-800	50-600	20-1,000	200-500
D638	4.2	3.8	2.9	1.8	3.5-4.5	70-95 (E)	82 (E)	82 (E)	75-88 (E)	94 (E)	76 (E)	0.14-0.38	0.25-0.55	0.6-1.8	0.20-1.10
D785	121 (R)	119 (R)	114 (R)	—	112-120 (R)	70-95 (E)	82 (E)	10-12	12-25	11-23	10-19	10 (F)	15 (F)	65 (F)	55 (F)
D790	4.1	3.9	2.9	1.5	—	11-14	12-25	10-12	12-25	11-23	10-19	0.08-0.60	0.60-1.15	1.0-2.0	1.0-1.7
D256	1.0	0.8	1.0	3.3	0.9	0.30-0.35	0.6-1.05	0.28	0.28-0.45	0.26	0.50	No break	0.5-16	0.5-20	No break
THERMAL															
C177	1.7	1.7	1.5	—	1.7	7.1†	7.9†	—	16.0†	—	8.8†	8.0†	8.0-10.0†	11.0-12.4†	11.0†
D696	4.0	4.5	5.0	5.1	5.0	3.95	3.56	4.40	2.60	2.80	3.60	5.6-12.2	7.8-8.9	6.1-7.2	7.8
D648	194	152	194	118	300-425	275-360	270-500	370	310-400	330-360	360-430	90-105	105-120	110-130	118
UL 94	455	365	356	154	400-425	V-1	HB	—	V-0	V-0	HB	100-121	120-165	140-190	170
ELECTRICAL															
D149	600	400	400	425	500-600*	350	350-400	200	400	170	175	460-700	460-650	450-500	900*
D150	3.9	3.7	4.0	3.3	3.7	5.2-5.3	5.2-5.4	—	4.9-6.5	11.7	7.8	2.25-2.35	2.30-2.35	2.30-2.35	—
D150	0.02	0.02	0.02	0.03	0.02	0.04-0.05	0.04-0.06	—	0.025-0.10	0.15	0.12	0.0002	0.0002	0.0003	0.0002
D267	10 ¹⁵	10 ¹⁵	10 ¹⁵	2 × 10 ¹⁵	—	10 ¹¹ -10 ¹²	10 ¹¹ -10 ¹²	10 ¹²	10 ¹¹ -10 ¹³	10 ¹²	10 ¹¹	10 ¹⁵	10 ¹⁵	10 ¹⁵	10 ¹⁸
D485	116	—	121	—	—	100	50	—	184	181	—	135-160	200-235	—	—
OPTICAL															
D542	—	—	—	—	—	—	—	—	—	—	—	1.51	1.52	1.54	—
D1003	—	—	—	—	—	—	—	—	—	—	—	4-50	4-50	10-50	—

*kV/cm.
 *Chemical-resistant compound, 1/8-in. thick specimens.
 *0.040 in. thick specimen
 †(10⁻⁵ cal/cm²·sec·°C)

Continued on [next page](#).

Coaxial Cable End Connectors

UHF Connectors

Military No.	Style	Cable RG- or Description
PL-259	Str (m)	8, 9, 11, 13, 63, 87, 149, 213, 214, 216, 225
UG-111	Str (m)	59, 62, 71, 140, 210
SO-239	Pnl (f)	Std, mica/phenolic insulation
UG-266	Blkhd (f)	Rear mount, pressurized, copolymer of styrene ins.

Adapters

PL-258	Str (f/f)	Polystyrene ins.
UG-224,363	Blkhd (f/f)	Polystyrene ins.
UG-646	Ang (f/m)	Polystyrene ins.
M-359A	Ang (m/f)	Polystyrene ins.
M-358	T (f/m/f)	Polystyrene ins.

Reducers

UG-175		55, 58, 141, 142 (except 55A)
UG-176		59, 62, 71, 140, 210

Family Characteristics:

All are nonweatherproof and have a nonconstant impedance. Frequency range: 0-500 MHz. Maximum voltage rating: 500 V (peak).

N Connectors

Military No.	Style	Cable RG-	Notes
UG-21	Str (m)	8, 9, 213, 214	50 Ω
UG-94A	Str (m)	11, 13, 149, 216	70 Ω
UG-536	Str (m)	58, 141, 142	50 Ω
UG-603	Str (m)	59, 62, 71, 140, 210	50 Ω
UG-23, B-E	Str (f)	8, 9, 87, 213, 214, 225	50 Ω
UG-602	Str (f)	59, 62, 71, 140, 210	—
UG-228B, D, E	Pnl (f)	8, 9, 87, 213, 214, 225	—
UG-1052	Pnl (f)	58, 141, 142	50 Ω
UG-593	Pnl (f)	59, 62, 71, 140, 210	50 Ω
UG-160A, B, D	Blkhd (f)	8, 9, 87, 213, 214, 225	50 Ω
UG-556	Blkhd (f)	58, 141, 142	50 Ω
UG-58, A	Pnl (f)		50 Ω
UG-997A	Ang (f)		50 Ω ¹¹ / ₁₆ "

Pnl mount (f) with clearance above panel

M39012/04-	Blkhd (f)	Front mount hermetically sealed
UG-680	Blkhd (f)	Front mount pressurized

Continued on [next page](#).

Coaxial Cable End Connectors

Continued from [previous page](#).

N Adapters

Military No.	Style	Notes
UG-29,A,B	Str (f/f)	50 Ω , TFE ins.
UG-57A,B	Str (m/m)	50 Ω , TFE ins.
UG-27A,B	Ang (f/m)	Mitre body
UG-212A	Ang (f/m)	Mitre body
UG-107A	T (f/m/f)	—
UG-28A	T (f/f/f)	—
UG-107B	T (f/m/f)	—

Family Characteristics:

N connectors with gaskets are weatherproof. RF leakage: -90 dB min @ 3 GHz. Temperature limits: TFE: -67° to 390° F (-55° to 199° C). Insertion loss 0.15 dB max @ 10 GHz. Copolymer of styrene: -67° to 185° F (-55° to 85° C). Frequency range: 0-11 GHz. Maximum voltage rating: 1500 V P-P. Dielectric withstanding voltage 2500 V RMS. SWR (MIL-C-39012 cable connectors) 1.3 max 0-11 GHz.

BNC Connectors

Military No.	Style	Cable RG-	Notes
UG-88C	Str (m)	55, 58, 141, 142, 223, 400	
UG-959	Str (m)	8, 9	
UG-260,A	Str (m)	59, 62, 71, 140, 210	Rexolite ins.
UG-262	Pnl (f)	59, 62, 71, 140, 210	Rexolite ins.
UG-262A	Pnl (f)	59, 62, 71, 140, 210	nwx, Rexolite ins.
UG-291	Pnl (f)	55, 58, 141, 142, 223, 400	
UG-291A	Pnl (f)	55, 58, 141, 142, 223, 400	nwx
UG-624	Blkhd (f)	59, 62, 71, 140, 210	Front mount Rexolite ins.
UG-1094A	Blkhd		Standard
UG-625B	Receptacle		
UG-625			

BNC Adapters

Military No.	Style	Notes
UG-491,A	Str (m/m)	
UG-491B	Str (m/m)	Beryllium, outer contact
UG-914	Str (f/f)	
UG-306	Ang (f/m)	
UG-306A,B	Ang (f/m)	Beryllium outer contact
UG-414,A	Pnl (f/f)	# 3-56 tapped flange holes
UG-306	Ang (f/m)	
UG-306A,B	Ang (f/m)	Beryllium outer contact
UG-274	T (f/m/f)	
UG-274A,B	T (f/m/f)	Beryllium outer contact

Family Characteristics:

Z = 50 Ω . Frequency range: 0-4 GHz w/low reflection; usable to 11 GHz. Voltage rating: 500 V P-P. Dielectric withstanding voltage 500 V RMS. SWR: 1.3 max 0-4 GHz. RF leakage -55 dB min @ 3 GHz. Insertion loss: 0.2 dB max @ 3 GHz. Temperature limits: TFE: -67° to 390° F (-55° to 199° C); Rexolite insulators: -67° to 185° F (-55° to 85° C). "Nwx" = not weatherproof.

Continued on [next page](#).

Coaxial Cable End Connectors

Continued from [previous page](#).

HN Connectors

<i>Military No.</i>	<i>Style</i>	<i>Cable RG-</i>	<i>Notes</i>
UG-59A	Str (m)	8, 9, 213, 214	
UG-1214	Str (f)	8, 9, 87, 213, 214, 225	Captivated contact
UG-60A	Str (f)	8, 9, 213, 214	Copolymer of styrene ins.
UG-1215	Pnl (f)	8, 9, 87, 213, 214, 225	Captivated contact
UG-560	Pnl (f)		
UG-496	Pnl (f)		
UG-212C	Ang (f/m)		Beryllium outer contact

Family Characteristics:

Connector Styles: Str = straight; Pnl = panel; Ang = Angle; Blkhd = bulkhead. $Z = 50 \Omega$. Frequency range = 0-4 GHz. Maximum voltage rating = 1500 V P-P. Dielectric withstanding voltage = 5000 V RMS SWR = 1.3. All HN series are weatherproof. Temperature limits: TFE: -67° to 390°F (-55° to 199°C); copolymer of styrene: -67° to 185°F (-55° to 85°C).

Cross-Family Adapters

<i>Families</i>	<i>Description</i>	<i>Military No.</i>
HN to BNC	HN-m/BNC-f	UG-309
N to BNC	N-m/BNC-f	UG-201,A
	N-f/BNC-m	UG-349,A
	N-m/BNC-m	UG-1034
N to UHF	N-m/UHF-f	UG-146
	N-f/UHF-m	UG-83,B
	N-m/UHF-m	UG-318
UHF to BNC	UHF-m/BNC-f	UG-273
	UHF-f/BNC-m	UG-255
