

# Chapter 3

## Safety

This chapter was written by James N. Woods, W7PUP, and includes additional contributors as well. This chapter will focus on how to avoid potential hazards as we explore Amateur Radio and its many facets. We need to learn as much as possible about what could *go wrong* so we can avoid factors that might result in accidents. Amateur Radio activities are not inherently hazardous, but like many things in modern life, it pays to be informed. Stated another way, while we long to be creative and innovative, there is still the need to act responsibly. Safety begins with our attitude. Make it a habit to plan work carefully. Don't be the one to say, "I didn't think it could happen to me."

Having a good attitude about safety is not enough, however. We must be knowledgeable about common safety guidelines and follow them faithfully. Safety guidelines cannot possibly cover all situations, but if we approach each task with a measure of common sense, we should be able to work safely.

This chapter will address some of the most popular ham radio activities: building and erecting antennas, constructing radio equipment, and the testing and troubleshooting of our radios. Safety as-

sociated with emergency disaster operations are covered best by the agencies and organizations affected.

Although the RF, ac and dc voltages in most amateur stations pose a potentially grave threat to life and limb, common sense and knowledge of good safety practices will help us avoid accidents. Building and operating an Amateur Radio station can be, and is for almost all amateurs, a perfectly safe pastime. Carelessness can lead to severe injury, or even death, however. The ideas presented here are only guidelines; it would be impossible to cover all safety precautions. *Remember: There is no substitute for common sense.*

Fires in well-designed electronic equipment are not common but are known to occur. Proper use of a suitable fire extinguisher can make the difference between a small fire with limited damage and loss of an entire home. Make sure you know the limitations of your extinguisher and the importance of reporting the fire to your local fire department immediately.

Several types of extinguishers are suitable for electrical fires. The multipurpose dry chemical or "ABC" type units are relatively inexpensive and contain a solid powder that is nonconductive. Avoid buying the

smallest size; a 5-pound capacity will meet most requirements in the home. ABC extinguishers are also the best choice for kitchen fires (the most common location of home fires). One disadvantage of this type is the residue left behind that might cause corrosion in electrical connectors. Another type of fire extinguisher suitable for energized electrical equipment is the carbon dioxide unit. CO<sub>2</sub> extinguishers require the user to be much closer to the fire, are heavy and difficult to handle, and are relatively expensive. For obvious reasons, water extinguishers are not suitable for fires in or near electronic equipment.

Involve your family in Amateur Radio. Having other people close by is always beneficial in the event that you need immediate assistance. Take the valuable step of showing family members how to turn off the electrical power to your equipment safely. Additionally, cardiopulmonary resuscitation (CPR) training can save lives in the event of electrical shock. Classes are offered in most communities. Take the time to plan with your family members exactly what action should be taken in the event of an emergency, such as electrical shock, equipment fire or power outage. Practice your plan!

## Antenna and Tower Safety

Since antennas are generally outdoors, they are affected by such potentially hazardous weather as wind, ice and lightning. Learning about the potential hazards of towers and antennas and how to do antenna work safely will pay dividends.

ARRL Technical Advisor Paul Krugh, N2NS, reminds us to remember that putting up a tower has a set of responsibilities associated with it. *Any heavy, large and permanent structure that fails or collapses can potentially hurt or even kill somebody.*

The complete installation *must* comply with all applicable structural and building codes. Professional engineers design towers to withstand code loadings — that is, dead weight, wind and ice loadings that are applicable to the environment at your particular location. The latest revision of the EIA-222 standard is the document from which professional engineers work to ensure that their tower designs are structurally safe. For further information, contact the Electronic Industries Alliance

(EIA) in Arlington, CA.

To ensure structural safety and integrity, you must demonstrate that your tower has been designed by a qualified engineer to withstand EIA-222 loadings at your specific geographic area. Further, the tower, foundation, guys and anchors must be installed (and maintained) according to any drawings, instructions and specifications supplied by the professional engineer. Remember: A properly designed, installed and maintained tower should be

as safe as a building or a bridge!

It is not feasible to discuss each type of antenna and tower in detail, so this section will include only highlights. For a full understanding of the specific hardware you will be working with, consult the manufacturer or supplier. You should discuss your antenna plans with a qualified engineer. The ARRL Volunteer Consulting Engineer program can steer you to a knowledgeable engineer.

In addition, your town or city will probably require that you obtain a building permit to erect a tower or antenna. This is their way to help ensure that the installation follows good practices and that the installation is safe. Wise amateurs realize that an independent review of drawings and site inspections are beneficial and can result in fewer problems in the future.

Towers must have a properly engineered support, both for the tower sections themselves as well as guy wire attachments. Sometimes towers are braced to buildings for added support. The Antenna Supports chapter of *The ARRL Antenna Book* covers this subject in greater detail. Towers are available commercially in both guyed and self-supporting styles, and constructed of both steel and aluminum materials. Masts may be wood or metal. One popular and inexpensive mast used to support small antennas is the tubular mast often sold for TV antenna use. These come in telescoping sections, in heights from 20 to 50 ft.

Aluminum extension ladders are sometimes used for temporary antenna supports, such as at Field Day sites. One problem with this approach is the difficulty in holding down the bottom section while “walking up” the ladder. Do *not* try to erect this type of support alone.

Trees are sometimes pressed into service for holding one end of a wire antenna. When using slingshots or arrows to string up the antenna, be sure no one is in range before you launch.

### FACTORS TO CONSIDER WHEN SELECTING A TOWER

- Towers have design load limitations. Make very sure the tower you consider has the capacity to safely handle the antenna(s) you intend to install in the kind of environment that is applicable to your QTH.
- The antenna must be located in such a position that *it cannot possibly tangle with power lines, both during normal operation or if the structure should fall.*
- Sufficient yard space must be available to position a guyed tower properly. A rule of thumb is that the guy anchors should be between 60% and 80% of the tower height in distance from the base

of the tower.

- Provisions must be made to keep children from climbing the support.
- Always write to the manufacturer of the tower before purchasing and ask for installation specifications, including guying data.
- Soil conditions at the tower site should be investigated. The footings need to be designed around actual soil conditions, particularly on a rocky site.

### TOWER TIPS

- Beware of used towers. Have them professionally inspected and contact the manufacturer for installation criteria.
- Always follow manufacturer’s instructions, using only parts that are designed for the model you have.
- Never rush into projects. Consult the most experienced amateurs in your community for assistance, especially if you are new to tower installation.
- Check with your local building officials.
- Liability may be increased with a tower installation. Check with your insurer to ensure your coverage is adequate.
- Consider your neighbors about any hazards your antennas may present to them.
- Don’t let your installation become an “attractive nuisance.” Take steps to install barriers so your tower cannot easily be climbed by others, particularly adventurous children.
- Use only the highest quality materials in your system.
- Make sure you have all the tools needed before starting. Some specialized tools (such as a gin pole) may be required.
- Never erect an antenna, tower or rotor during an electrical storm or rainstorm, or when lightning is a possibility.
- The assembly crew as well as those climbing the tower during erection must wear hard hats and use appropriate personal protective equipment including gloves, boots, climbing belt or harness. Don’t forget that lifelines are needed when the belt is unattached from the tower while moving.
- Be careful not to over-stress the tower when it is being assembled. The tower manufacturer can offer suggestions that will avoid jeopardizing the tower.
- Install guy wires using the proper tools. Care should be exercised especially when handling loose, un-terminated, and sharp guy wire ends! Avoid wrapping guy wire around your hands to pull it into place, and instead use sufficient length to easily attach it to the anchors. Use tower-rated turnbuckles or similar devices to adjust tension evenly around the tower.
- Assign someone in the erection crew to monitor the use of safety equipment.

- After the tower is installed, keep the installation safe. Inspection and maintenance recommended by the tower’s manufacturer should be carefully followed.
- If making attachments to houses or installations on roofs, have a qualified person determine that the method is adequate and the loading conditions are satisfactory.
- Avoid metal ladders if there are any utility lines in the vicinity. Assume that any line is energized — including cable television and telephone lines.

### POWER LINES

Hundreds of people have been killed or seriously injured when attempting to install or dismantle antennas. In virtually all cases, the victim was aware of the hazards, including the potential for serious electrical shock, but did not take the necessary steps to eliminate the risks. Never install antennas, towers and masts near power lines. How far away is considered safe? Towers and masts should be installed twice the height of the installation away from power lines. Every electrical wire must be considered dangerous. If the installation should contact power lines, you or those around you could be killed! If you have any questions about power lines, contact your electrical utility, city inspector or a qualified professional.

If, for some reason your tower or antenna structure begins to fall, get away from it immediately! If it contacts energized lines, it can become a lethal hazard if you are touching any part of the conductive structure. If a coworker becomes energized, **do not touch the person!** The safest practice is to keep all others clear of the area, call 911, and just wait for the power company and rescue team to arrive and assist the victim. At some greater risk, a well-insulated pole such as fiberglass or PVC pipe — as long as possible for safety — can be utilized in an attempt to dislodge the live wire or collapsed metal structure from the victim (with moisture, etc., wood can be a *poor insulator* — especially at high voltages!). If the victim can be well cleared of the hazard and is not breathing, immediately start CPR procedures and seek emergency assistance. **Remember, use caution and understand that during such an accident, the live conductor or live antenna structure can further move (lurch) suddenly and without warning. One accident is bad enough — there is no need to have two victims! It is best to just seek qualified emergency help if you are unsure of the situation-specific hazards.**

Further information about tower safety appears in *The ARRL Antenna Book*.

# Electrical Wiring Around the Shack

The standard power available from commercial mains in the United States for residential service is 120/240-V ac. The “primary” voltages that feed transformers in our neighborhoods may range from 2000 to about 10,000 V. Generally, the responsibility for maintaining the power distribution system belongs to a utility company, electric cooperative or city. The “ownership” of conductors usually transfers from the electric utility supplier to the homeowner where the power connects to the meter or weatherhead. If you are unsure where the division of responsibility falls in your community, a call to your electrical utility will provide the answer. **Fig 3.1** shows the typical division of responsibility between the utility company and the homeowner.

There are two facets to success with electrical power: safety and performance. Since we are not professionals, we need to pursue safety first and consult professionals for alternative solutions if performance is unacceptable.

## STATION CONCERNS

The primary electrical power supplied to your radio equipment should be controlled by one master switch so that it is easy to kill the power in an emergency. One convenient means is a switched outlet strip, as used for computer equipment. The strip should be listed by a nationally recognized testing laboratory such as Underwriters Lab and incorporate a circuit breaker. See “What Does UL Listing Mean?” and “How Safe are Outlet Strips?” for warnings about poor quality products. It is poor practice to “daisy-chain” several power strips. If you need more outlets than are available on a strip, have additional convenience outlets installed.

Before adding equipment to your home, be sure that it does not overload the circuit. National and local codes set permissible branch capacities according to a rather complex process. Here’s a safe rule of thumb: consider adding a new circuit if the total load is more than 80% of the circuit breaker or fuse rating. (This assumes that the fuse or breaker is correct. If you have any doubts, have an electrician check it.)

## Do It Yourself Wiring?

Amateurs sometimes “rewire” parts of their homes to accommodate their hobby. Most local codes *do* allow for modification of wiring (by building owners), so long as the electrical codes are met. Generally, the building owner must obtain an electrical permit before beginning changes or additions to permanent wiring. Some

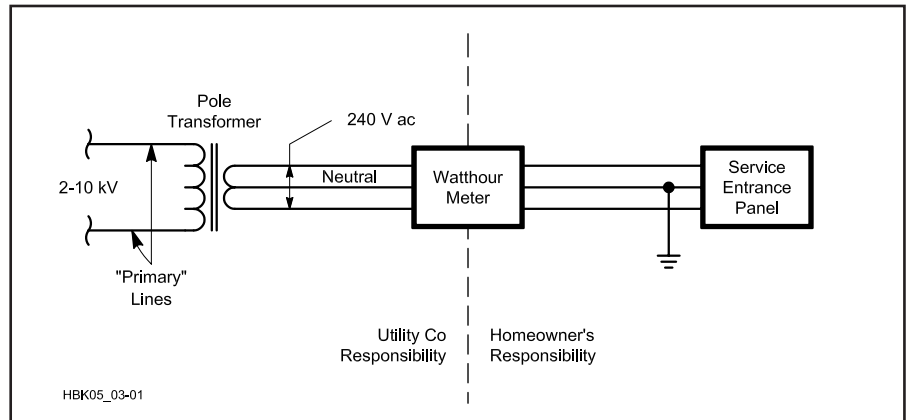

**Fig 3.1** — Typical division of responsibility for maintenance of electrical power conductors and equipment. The meter is supplied by the utility company.

## What Does UL Listing Mean?

**CAUTION:** Listing *does not* mean what most consumers expect it to mean! More often than not the listing *does not* relate to the performance of the listed product. The listing simply indicates that a sample of the device meets certain manufacturers’ construction criteria. Similar devices from the same or different manufacturers may differ significantly in overall construction and performance even though all are investigated and listed against the same UL product category

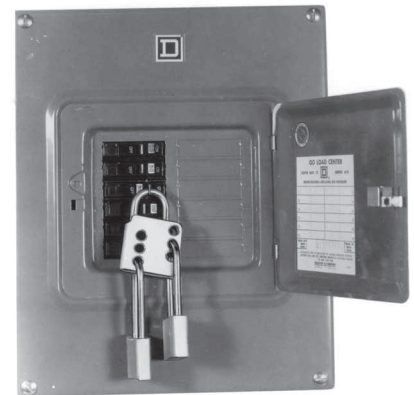

**Fig 3.2** — If the switch box feeding power to your shack is equipped with a lock-out hole, use it. With a lock through the hole on the box, the power cannot be accidentally turned back on. (Photo courtesy of American ED-CO)

jobs may require drawings of planned work. Often the permit fee pays for an inspector to review the work. Considering the risk of injury or fire if critical mistakes are left uncorrected, a permit and inspection are well worth the effort. *Don’t take chances* — seek assistance from the building officials or an experienced electrician if you have *any* questions or doubts about proper wiring techniques.

*Ordinary 120-V circuits are the most common source of fatal electrical accidents.* Never use bare wire for exposed circuits or open-chassis construction with exposed connections! Remember that high-current, low-voltage power sources can be just as dangerous as high-voltage sources.

*Never work on electrical wiring with the conductors energized!* Switch off the circuit breaker or remove the fuse and take

positive steps to ensure that others do not restore the power while you are working. (**Fig 3.2** illustrates one way to ensure that power will be off until you want it turned on.) Check the circuit with an ac voltmeter to be sure that it is “dead” *each time you begin work*. Before restoring power, check your work with an ohm meter: There should be good continuity between the neutral conductor (white wire, “silver” screw) and the grounding conductor (green or bare wire, green screw). An ohmmeter should indicate a closed circuit between the conductors.

There should be no continuity between the hot conductor (black wire, “brass” screw) and the grounding conductor or the neutral conductor. An ohmmeter should indicate an *open* circuit between the hot wire and either of the other two conductors.

A commercially available plug-in tester

is the best way to test regular three-wire receptacles.

## NATIONAL ELECTRICAL CODE

Fortunately, much has been learned about how to harness electrical energy safely. This collective experience has been codified into the *National Electrical Code*, or *NEC*. The *Code* details safety requirements for many kinds of electrical installations. Compliance with the *NEC* provides an installation that is *essentially* free from hazard, but not necessarily efficient, convenient or adequate for good service (paraphrased from *NEC* Article 90-1a and b). For example, the *NEC* requirements discussed here are *not* adequate for lightning protection and high transient voltage events. Look at “Lightning/Transient Protection” for more information. While the *NEC* is national in nature and sees wide application, it is not universal.

Local building authorities set the codes for their area of jurisdiction. They often incorporate the *NEC* in some form, while considering local issues. For example, Washington State specifically exempts telephone, telegraph, radio and television wires and equipment from conformance to electrical codes, rules and regulations. However, some local jurisdictions (city, county and so on) do impose a higher level of installation criteria, including some of the requirements exempted by the state.

Code interpretation is a complex subject, and untrained individuals should steer clear of the *NEC* itself. The *NEC* is not written to be understood by do-it-yourselfers. Therefore, the best sources of information about code compliance and acceptable practices are local building officials, engineers and practicing electricians. With that said, let’s look at a few *NEC* requirements for radio installations.

**Antenna conductors** — Transmitting antennas using hard-drawn copper wire: #14 for unsupported spans less than 150 ft, and #10 for longer spans. Copper-clad steel, bronze or other high-strength conductors must be #14 for spans less than 150 ft and #12 for longer spans. Open-wire transmission line conductors must be at least as large as those specified for antennas.

**Lead-ins** — There are several *NEC* requirements for antenna lead-in conductors. For transmitting stations, their size must be equal to or greater than that of the antenna. Lead-ins attached to buildings must be firmly mounted at least 3 inches clear of the surface of the building on non-absorbent insulators. Lead-in conductors must enter through rigid, noncombustible, nonabsorbent insulating tubes or bush-

ings, through an opening provided for the purpose that provides a clearance of at least 2 inches; or through a drilled windowpane. All lead-in conductors to transmitting equipment must be arranged so that accidental contact is difficult.

**Lightning arrestors** — Transmitting stations are required to have a means of draining static charges from the antenna system. An antenna discharge unit (lightning arrestor) must be installed on each lead-in conductor that is not protected by a permanently and effectively grounded metallic shield, unless the antenna itself is permanently and effectively grounded. (The code exception for shielded lead-ins does *not* apply to coax, but to shields such as thin-wall conduit. Coaxial braid is neither “adequate” nor “effectively grounded” for lightning protection purposes.) An acceptable alternative

to lightning arrestor installation is a switch (capable of withstanding many kilovolts) that connects the lead-in to ground when the transmitter is not in use.

## Ground Conductors

Grounding conductors may be made from copper, aluminum, copper-clad steel, bronze or similar erosion-resistant materials. Insulation is not required. [Lightning and high-voltage transient events may require much larger conductors. —Ed.] The “protective grounding conductor” (main conductor running to the ground rod) must be as large as the antenna lead-in, but not smaller than #10. The “operating grounding conductor” (to bond equipment chassis together) must be at least #14. There is a “unified” grounding electrode requirement — it is necessary to bond *all* ground

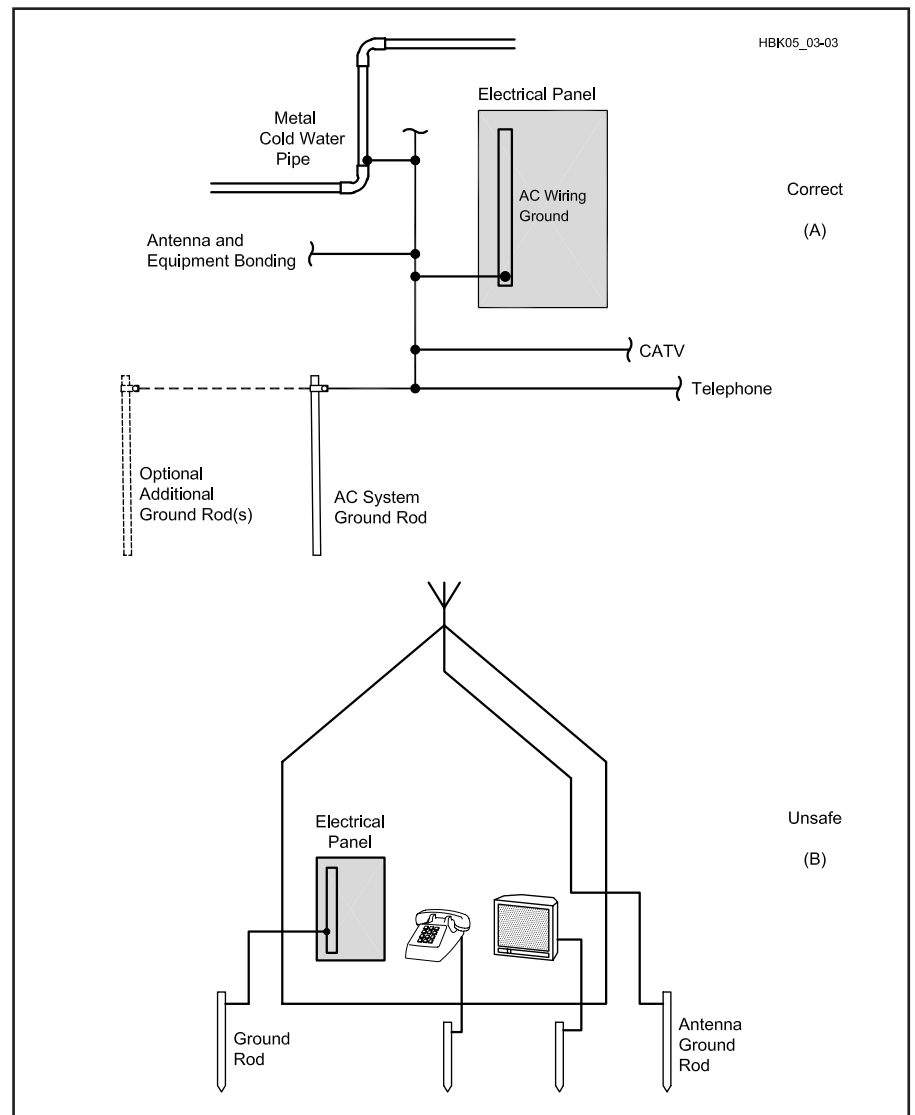

**Fig 3.3 — At A, proper bonding of all grounds to electrical service panel. Installation shown at B is unsafe — the separate grounds are not bonded. This could result in a serious accident or electrical fire.**

rods to the electric service entrance ground. All utilities, antennas and any separate grounding rods used must be bonded together. Fig 3.3 shows correct (A) and incorrect (B) ways to bond ground rods. Fig 3.4 demonstrates the importance of correctly bonding ground rods. (Note: The

NEC requirements do not address effective RF grounds. See the **EMI/Direction Finding** chapter of this book for information about RF grounding practices.)

Additionally, the *Code* covers some information on safety inside the station. All conductors inside the building must be

at least 4 inches away from conductors of any lighting or signaling circuit except when they are separated from other conductors by conduit or insulator. Transmitters must be enclosed in metal cabinets, and the cabinets must be grounded. All metal handles and controls accessible by the operator must be grounded. Access doors must be fitted with interlocks that will automatically disconnect all voltages above 350 when the door is opened.

### How Safe are Outlet Strips?

**CAUTION:** The switch in outlet strips is generally *not* rated for repetitive *load break* duty. Early failure and fire hazard may result from using these devices to switch loads. Misapplications are common (another bit of bad technique that has evolved from the use of personal computers), and manufacturers are all too willing to accommodate the market with marginal products that are “cheap.”

Nonindicating and poorly designed surge protection also add to the safety hazard of using power strips. Marginally rated MOVs often fail in a manner that could cause a fire hazard, especially in outlet strips that have nonmetallic enclosures.

A lockable disconnect switch or circuit breaker, as shown in Fig 3.2, is a better and safer station master switch.

### Ground-Fault Circuit Interrupters

GFCIs are devices that can be used with common 120-V circuits to reduce the chance of electrocution when the path of current flow leaves the branch circuit (say, through a person’s body to another branch or ground). The *NEC* requires GFCI outlets in all wet or potentially wet locations, such as: bathrooms, kitchens, and any outdoor outlet with ground-level access, garages and unfinished basements. Any area with bare concrete floors or concrete masonry walls should be GFCI equipped. GFCIs are available as portable units, duplex outlets and as individual circuit breakers. Some early units may have been sensitive to RF radiation but this problem appears to have been solved. Ham radio shacks in potentially wet areas (basements, out buildings) should be GFCI equipped. Fig 3.5 is a simplified diagram of a GFCI.

### LIGHTNING/TRANSIENT PROTECTION

Nearly everyone recognizes the need to protect themselves from lightning. From miles away, the sight and sound of lightning boldly illustrates its destructive potential. Many people don’t realize that destructive transients from lightning and other events can reach electronic equipment from many sources, such as outside antennas, power, telephone and cable TV installations. Many hams don’t realize that the standard protection scheme of several decades, a ground rod and simple “lightning arrester” is *not* adequate.

Lightning and transient high-voltage protection follows a familiar communications scenario: identify the unwanted signal, isolate it and dissipate it. The difference here is that the unwanted signal is many megavolts at possibly 200,000 A. What can we do?

Hams *cannot* expect to design or install effective lightning protection systems, but reasonably complete protection from lightning is available in systems designed by lightning protection professionals. Hams *can* easily follow some general guidelines that will protect their stations against high-voltage events that are induced by nearby lightning strikes or that

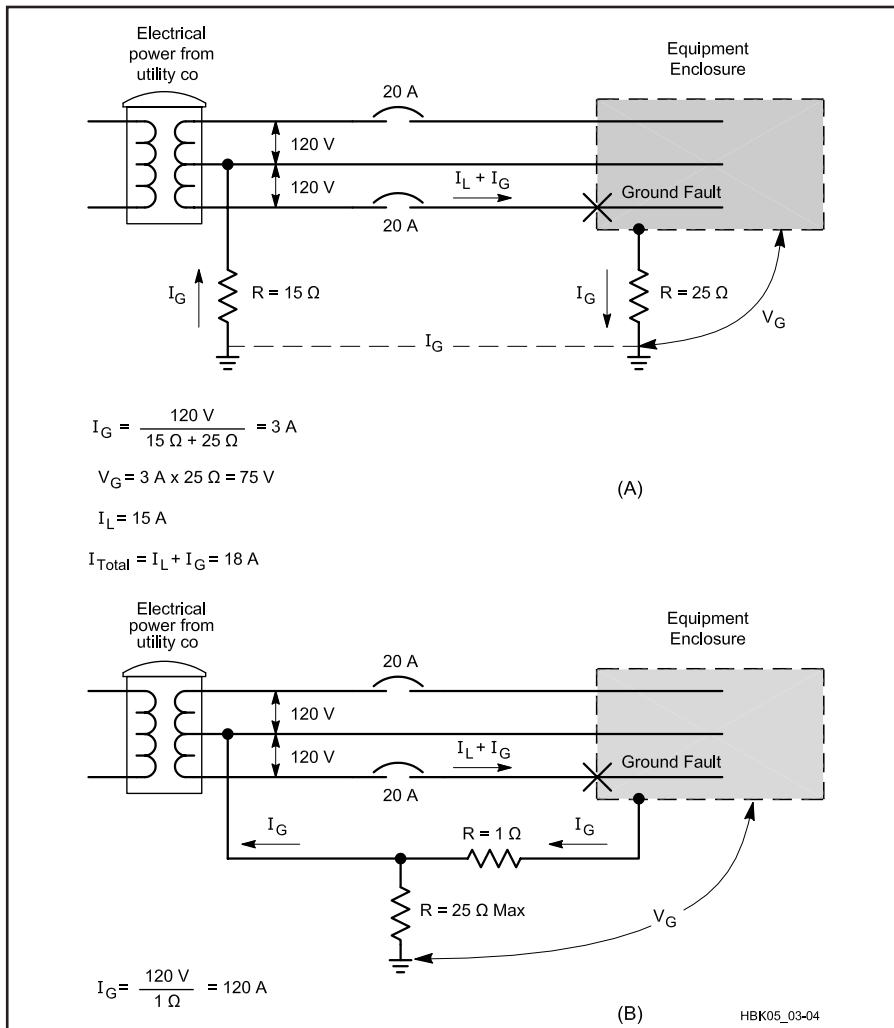

**Fig 3.4** — These drawings show the importance of properly bonded ground rods. In the system shown in A, the 20-A breaker will not trip. In the system in B, the 20-A circuit breaker trips instantly. There is an equipment internal short to ground — the ground rod is properly bonded back to the power system ground. Of course, the main protection should be in a circuit ground wire in the equipment power cord itself!

arrive via utility lines. Let's talk about where to find professionals first, and then consider construction guidelines.

### Professional Help

Start with your local government. Find out what building codes apply in your area

and have someone explain the regulations about antenna installation and safety. For more help, look in your telephone yellow pages for professional engineers, lightning protection suppliers and contractors.

Companies that sell lightning-protection products may offer considerable help

to apply their products to specific installations. One such source is PolyPhaser Corporation. Look under "Ground References," later in this chapter, for a partial list of PolyPhaser's publications.

### Construction Guidelines

**Ground rods** — Ground rods should be either solid copper, copper-clad steel, hot-dipped galvanized steel or stainless steel. They should be at least 8 ft long by 1/2 inch in diameter (5/8 inch diameter for iron or steel).

**Bonding Conductors** — Copper strapping (or *flashing*) comes in a number of sizes; use 1 1/2 inches wide and 0.051 inches thick as a *minimum* for ground connections. Copper strap is a better lightning and RF ground than wire because straps have less inductance than wires. On the other hand, straps are more expensive than wire and more difficult to find.

Use bare copper for buried ground wires. (There are some exceptions; seek an expert's advice if your soil is corrosive.) Exposed runs above ground that are subject to physical damage may require additional protection (a conduit) to meet code requirements. Wire size depends on the application, but never use anything smaller than #6 AWG for bonding conductors. Local lightning-protection experts or building inspectors can recommend sizes for each application.

### Tower and Antennas

Because a tower is usually the highest metal object on the property, it is the most likely strike target. Proper tower grounding is essential to lightning protection. The goal is to establish short multiple paths to the Earth so that the strike energy is divided and dissipated.

Connect each tower leg and each fan of metal guy wires to a separate ground rod. Space rods at least 6 ft apart. Bond the leg ground rods together with a #6 AWG or larger copper bonding conductor (form a ring around the tower base, see **Fig 3.6**). Connect a continuous bonding conductor between the tower ring ground and the entrance panel. Make all connections with fittings approved for grounding applications. **Do not use solder for these connections.** Solder will be destroyed in the heat of a lightning strike.

Unless the tower is also a shunt-fed antenna, use grounded metal guys. For crank-up or telescoping towers, connect the sections with strap jumpers. Because galvanized steel (which has a zinc coating) reacts with copper when combined with moisture, use stainless steel hardware between the galvanized metal and the copper grounding materials.

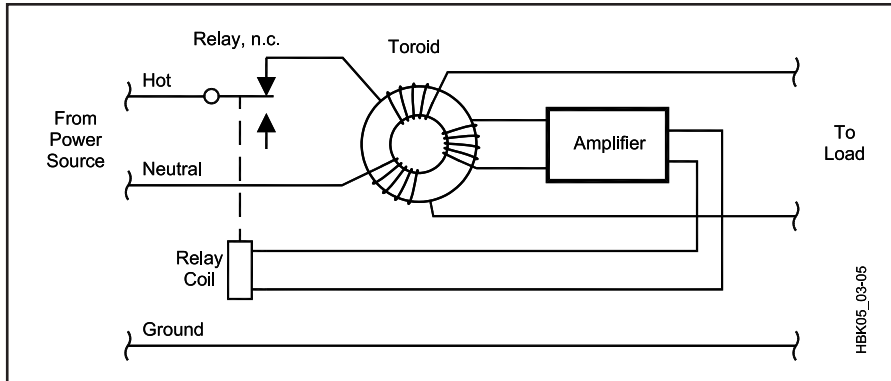

**Fig 3.5** — Simplified diagram of a 120-V ac ground fault circuit interrupter (GFCI). When a stray current flows from the load (or outlet) side to ground, the toroidal current becomes unbalanced allowing detection, amplification and relay actuation to immediately cut off power to the load (and to the stray path!) GFCI units require a manual reset after tripping. GFCI's are required in wet locations (near kitchen sinks, in garages, in outdoor circuits and for construction work.) They are available as portable units or combined with over-current circuit breakers for installation in entrance panels.

### About the National Electrical Code

#### **Exactly how does the National Electrical Code become a requirement? How is it enforced?**

Cities and other political subdivisions have the responsibility to act for the public safety and welfare. To address safety and fire hazards in buildings, regulations are adopted by local laws and ordinances usually including some form of permit and accompanying inspections. Because the technology for the development of general construction, mechanical and electrical codes is beyond most city building departments, model codes are incorporated by reference. There are several general building code models used in the US: Uniform, BOCA and Southern Building Codes are those most commonly adopted. For electrical issues, the *National Electrical Code* is in effect in virtually every community. City building officials will serve as "the authority having jurisdiction" and interpret the provisions of the *Code* as they apply it to specific cases.

Building codes differ from planning or zoning regulations: Building codes are directed only at safety, fire and health issues. Zoning regulations often are aimed at preservation of property values and aesthetics.

The *NEC* is part of a series of reference codes published by the National Fire Protection Association, a nonprofit organization. Published codes are regularly kept up-to-date and are developed by a series of technical committees whose makeup represents a wide consensus of opinion. The *NEC* is updated every three years.

#### **Do I have to update my electrical wiring as code requirements are updated or changed?**

Generally, no. Codes are typically applied for new construction and for renovating existing structures. Room additions, for example, might not directly trigger upgrades in the existing service panel unless the panel was determined to be inadequate. However, the wiring of the new addition would be expected to meet current codes. Prudent homeowners, however, may want to add safety features for their own value. Many homeowners, for example, have added GFCI protection to bathroom and outdoor convenience outlets.

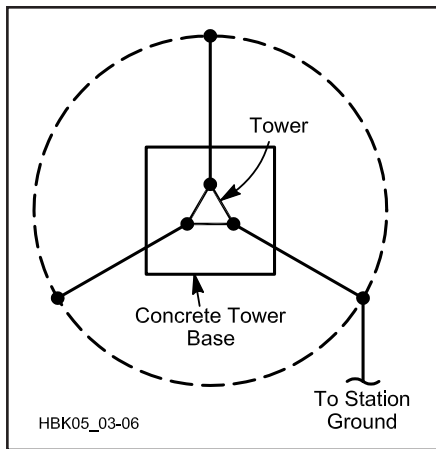

**Fig 3.6 — Schematic of a properly grounded tower. A bonding conductor connects each tower leg to a ground rod and a buried (1 ft deep) bare, tinned copper ring (dashed line), which is also connected to the station ground and then to the ac safety ground. Locate ground rods on the ring, as close as possible to their respective tower legs. All connectors should be compatible with the tower and conductor materials to prevent corrosion. See text for conductor sizes and details of lightning and voltage transient protection.**

To prevent strike energy from entering a shack via the feed line, ground the feed line *outside* the home. Ground the coax shield *to the tower* at the antenna and the base to keep the tower and line at the same potential. Several companies offer grounding blocks that make this job easy.

All grounding media at the home must be bonded together. This includes lightning-protection conductors, electrical service, telephone, antenna system grounds and underground metal pipes. Any ground rods used for lightning protection or entrance-panel grounding must be spaced at least 6 ft from each other and the electrical service or other utility grounds and then bonded to the ac system ground as required by the *NEC*.

### A Radio Entrance Panel

We want to control the flow of the energy in a strike. Eliminate any possible paths for surges to enter the building. This involves routing the feed lines, rotator control cables, and so on at least 6 ft away from other nearby grounded metal objects.

Every conductor that enters the structure should have its own surge suppressor including antenna system control lines at the Radio Entrance Panel and other services where they connect to the ac system ground. They are available from a number of manufacturers, including ICE and PolyPhaser.

Both balanced line and coax arrestors should be mounted to a secure ground connection on the *outside* of the building. The easiest way to do this is to install a large metal enclosure as a bulkhead and ground block. This bulkhead serves as the last line of lightning defense, so it's critical that it be installed properly. You can home-brew a bulkhead panel from 1/8-inch copper sheet, bent into a box shape. Position the bulkhead on the building exterior, 4 to 6 inches (minimum) away from nearby combustible materials. Install a separate ground rod for this panel and connect it to the bulkhead with a short, direct connection. Bond this ground rod to the rest of the ground system. Mount all protective devices, switches and relay disconnects on the outside face wall of the bulkhead.

### Lightning Arrestors

Feed line lightning arrestors are available for both coax cable and balanced line. Most of the balanced line arrestors use a simple spark gap arrangement, but a balanced line *impulse* suppressor is available from Industrial Communication Engineers, Ltd (ICE), Indianapolis, IN.

**Coaxial Cable Arrestors** — DC blocking arrestors have a fixed frequency range. They present a high-impedance to lightning (less than 1 MHz) while offering a low impedance to RF.

DC continuity arrestors (gas tubes and spark gaps) can be used over a wider frequency range than those that block dc. Where the coax carries supply voltages to remote devices (such as a mast-mounted preamp or remote coax switch), dc-continuous arrestors *must* be used.

### GROUNDS

As hams we are concerned with three kinds of ground, which are easily confused because we call each of them "ground." The first is the power line ground, which is required by building codes to ensure the safety of life and property surrounding electrical systems. The *NEC* requires that all grounds be *bonded* together; this is a very important safety feature as well as an *NEC* requirement. Ground systems to prevent shock hazards are generally referred to as the *dc ground* by amateurs, although *safety ground* is a more appropriate term.

The previous section discussed some of the features of a lightning protection grounding system. Additional information on lightning, surge and EMI grounding can be found in *The ARRL Antenna Book*. The *National Electrical Code* requires lightning protection ground rods to be separate from the power line safety grounding electrodes. As discussed later,

### Suppliers of Lightning Protection Equipment

For current vendor contact information, use your favorite Internet search tool.

- Alpha Delta Communications: Coax lightning arrestors, coax switches with surge protectors.
- The Wireman: copper wire up to #4 AWG, 2-inch flat copper strap, 8-ft copper clad ground rods and 1 × 1/4-inch buss bar.
- Industrial Communication Engineers, Ltd (ICE): Coax lightning arrestors.
- PolyPhaser Corporation: Many lightning protection products for feed lines, towers, equipment, and so on.
- Rohn: Copper strap and other tower grounding products.
- Zero Surge Inc: Power line surge protector.

however, all grounding systems must eventually be bonded together.

An effective safety ground system is necessary for every amateur station. It provides a common reference potential for all parts of the ac system and reduces the possibility of electrical shock by ensuring that all exposed conductors remain at that (low) potential. Three-wire electrical systems effectively ground our equipment for dc and low frequencies. Unfortunately, an effective ground conductor at 60 Hz (5,000,000 m wavelength) may be an excellent antenna for a 20 m signal.

When stray RF causes interference or other problems, we need another kind of ground — a low-impedance path for RF to reach the earth or some other "ground" that dissipates, rather than radiates, the RF energy. Let's call this an *RF ground*.

In most stations, dc ground and RF ground are provided by the same system. If you install ground rods, however, bond them to each other and to the safety ground at the electrical service entrance. In older houses, water lines are sometimes used for the service entrance panel ground. It is a good idea to check that the pipes are electrically continuous from the panel to earth. (Consider that Teflon tape is often used to seal pipe joints in modern repairs.)

For decades, amateurs have been advised to bond all equipment cabinets to an RF ground located near the station. That's a good idea, but it's not easily achieved. "Near" in this use is 10 ft or less for HF operation, even less for higher frequencies. At some stations, it is very difficult to

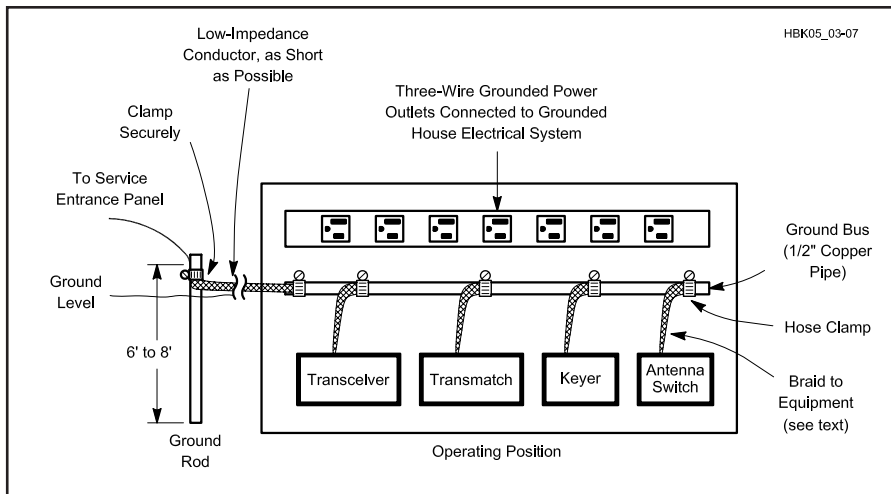

**Fig 3.7 — An effective station ground bonds the chassis of all equipment together with low-impedance conductors and ties into a good earth ground. Note that the ground bus is in turn bonded to the service entrance panel. This connection should be made by a licensed electrician with #6 AWG (minimum size) copper wire.**

produce an effective RF ground. When levels of unwanted RF are low, an RF ground may not be needed. (See the **EMI/Direction Finding** chapter for more about RF grounds and interference.) Some think that RF grounds should be isolated from the safety ground system — *that is not true!* All grounds, including safety, RF, lightning protection and commercial communications, must be bonded together in order to protect life and property.

The first step in building an RF ground system is to bond together the chassis of all equipment in your station. Choose conductors large enough to provide a low-impedance path. The *NEC* requires that grounding conductors be as large as the largest conductor in the primary power circuit (#14 for a 15-A circuit, #12 for 20 A). Copper strap, sold as “flashing copper,” is excellent for this application. Coax braid is a popular choice; but it is not a good ground conductor unless tinned, and then it’s no longer very flexible. It is best to use commercially made copper braid ground strap that is tinned and ampacity rated — wider straps make better RF grounds. Avoid solid conductors; they tend to break.

Grounding straps can be run from equipment chassis to equipment chassis, but a more convenient approach is illustrated in **Fig 3.7**. In this installation, a 1/2-inch-diameter copper water pipe runs the entire

length of the operating bench. A wide copper ground braid runs from each piece of equipment to a stainless-steel clamp on the pipe.

After the equipment is bonded to a common ground bus, the ground bus must be wired to a good earth ground. This run should be made with a heavy conductor (copper braid is a good choice again) and should be as short and direct as possible. The earth ground usually takes one of two forms.

In most cases, the best approach is to drive one or more ground rods into the earth at the point where the conductor from the station ground bus leaves the house. The best ground rods to use are those available from an electrical supply house. These rods are generally 8 ft long and made from steel with a heavy copper plating. Do not depend on shorter, thinly plated rods sold by some home electronics suppliers, as they can quickly rust and soon become worthless.

Once the ground rod is installed, clamp the conductor from the station ground bus to it with a clamp that can be tightened securely and will not rust. Copper-plated clamps made specially for this purpose (and matching the rods) are available from electrical supply houses. Multiple ground rods reduce the electrical resistance and improve the effectiveness of the ground system.

Building cold water supply systems were used as station grounds in years past. Connection was made via a low-impedance conductor from the station ground bus to a convenient cold water pipe, preferably somewhere near the point where the main water supply enters the house. (Hot water lines are unsuitable for grounding conductors.) Increased use of plastic plumbing both inside and outside houses is reducing the availability of this option. If you do use the cold water line, ensure that it has a good electrical connection to the earth and attach it *outside* the structure to reduce EMI. As with ground rods, ensure that the water line is also bonded to the service entrance panel.

For some installations, especially those located above the first floor, a conventional ground system such as that just described will make a fine dc ground but will not provide the necessary low-impedance path to ground for RF. The length of the conductor between the ground bus and the ultimate ground point becomes a problem. For example, the ground wire may be about 1/4 wavelength (or an odd multiple of 1/4 wavelength) long on some amateur band. A 1/4-wavelength wire acts as an impedance inverter from one end to the other. Since the grounded end is at a very low impedance, the equipment end will be at a high impedance. The likely result is RF hot spots around the station while the transmitter is in operation. In this case, this ground system may be worse (from an RF viewpoint) than no ground at all.

## Ground References

- Federal Information Processing Standards (FIPS) publication 94: *Guideline on Electrical Power for ADP Installations*. FIPS are available from the National Technical Information Service.
- IAEI: *Soares’ Book on Grounding*, available from International Association of Electrical Inspectors (IAEI).
- IEEE Std 1100: *Powering and Grounding Sensitive Electronics Equipment*.
- PolyPhaser: *The Grounds for Lightning and EMP Protection*. PolyPhaser’s quarterly newsletter, *Striking News*, contains articles on Amateur Radio station lightning protection in the February and May 1994 issues. Complimentary copies of these issues are available from PolyPhaser.



## AN EARTH-CONTINUITY TESTER

This project was first published by the Radio Society of Great Britain (RSGB) and is reproduced here by permission. This simple ground continuity tester determines the quality of the ground (earth) connection in an Amateur Radio station installation. In the context of this discussion, the terms *ground* and *earth* are synonymous.

When using mains-powered electrical equipment, a good-quality protective earth system is very important for safety. Good earth connections are additionally important for radio operation, both for protection against lightning strikes and also for the greater effectiveness of antennas that use earth as one half of a dipole. In situations where the earth path is a *functional* earth as opposed to a *protective* earth, a simple low-voltage, low-current continuity tester or resistance meter is usually sufficient for checking earthing resistance, but for a proper test of a protective earth a high-current tester is needed, as shown in Fig 3.8. This is because a deteriorating earth connection in the form of a stranded wire where many of the strands are broken will still show a low resistance to a low-current tester but, in a fault situation when the earth path needs to pass a high current to ground and thus trigger a protective device, the high current causes the remaining strands to *burn out*, i.e., go open-circuit, before the protective device has time to operate. The protection is then nonexistent!

### SAFETY STANDARDS

Recognizing this situation, the British and European safety standards for electrical safety, for example BS EN 60335-1 for

household equipment, demand that the resistance of the protective earth path between an exposed metal part and the protective earth pin is less than  $0.1 \Omega$ .

The equipment needed for checking to this standard is specialized and expensive, but this simple project provides a low-cost alternative that will check resistance at 2-3 A if good-quality batteries are used. To simplify use, the circuit gives a pass/fail indication instead of a resistance value.

### WHEATSTONE BRIDGE

The circuit can be considered in three parts; TEST, DETECTOR and OUTPUT INDICATOR. See the diagram in Fig 3.9 and the components list in Table 3.1. The TEST part of the circuit is based on a Wheatstone bridge, where the earth resistance path forms one of the resistance arms. See Fig 3.10 for the principle behind a Wheatstone bridge. As a consequence of the values of resistance chosen (the test leads are assumed to have a resistance of  $0.1 \Omega$ ), if the earth resistance is less than  $0.1 \Omega$ , the voltage between the midpoints of the two halves of the Wheatstone bridge will be positive, and if it is less than  $0.1 \Omega$ , it will be negative. This is fed to the detector part of the circuit. The DETECTOR is an op-amp wired as a comparator. Connected in this way, it has such a high gain that its output is roughly equal to either the positive or negative supply rail voltage, depending on whether the PD between its non-inverting and inverting inputs is positive or negative. It doesn't matter whether the PD is large or small — the output will always be at either extreme. This means there will always be a definite pass or fail indication from the

detector, no matter how large or small the output from the Wheatstone bridge. This is important, as it means correct operation of the circuit doesn't depend on the voltage of the high-current battery, particularly as it is a chemical type whose output voltage can fall dramatically when a high current is being drawn. The pass/fail voltage  $V_{pf}$  from the detector then passes to the output indicator circuit.

Table 3.1

#### Components List

##### Resistors

R1, 2  $0.1 \Omega$ , 2.5 W

R3, 4  $10k \Omega$

R6, 7  $24k \Omega$

R5, 8  $150 \Omega$

R9, 10  $330 \Omega$

All resistors metal oxide  $0.4 \text{ W } 1\%$ , except R1 & R2

##### Semiconductors

U1 LM324

D1, 2 TLY114A yellow, or TLR114A red and TLG114A green

Q1 BC179 (general-purpose npn)

Q2 BC109C (general-purpose npn)

##### Additional items

B1  $1 \times \text{AA Duracell}$

B2 PP3, 9V

S1 Double pole, momentary on, or push-to-make

S2 SPST

Battery clips/holders

Stripboard

Plastic case\*

$2 \times 4\text{mm}$  plugs & sockets\*

$2 \times$  alligator clips

\*Only required if you are building the project in a case.

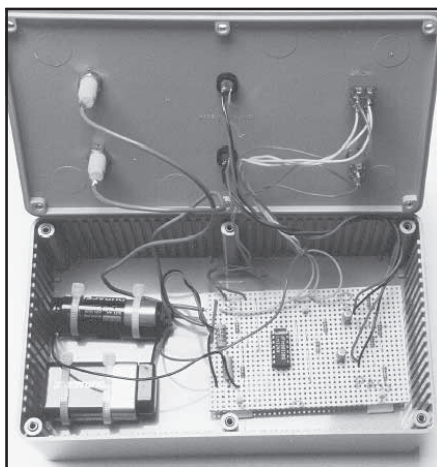

Fig 3.8 — Inside a completed tester. Note that in an enclosed project, the LEDs are brought out to the front panel.

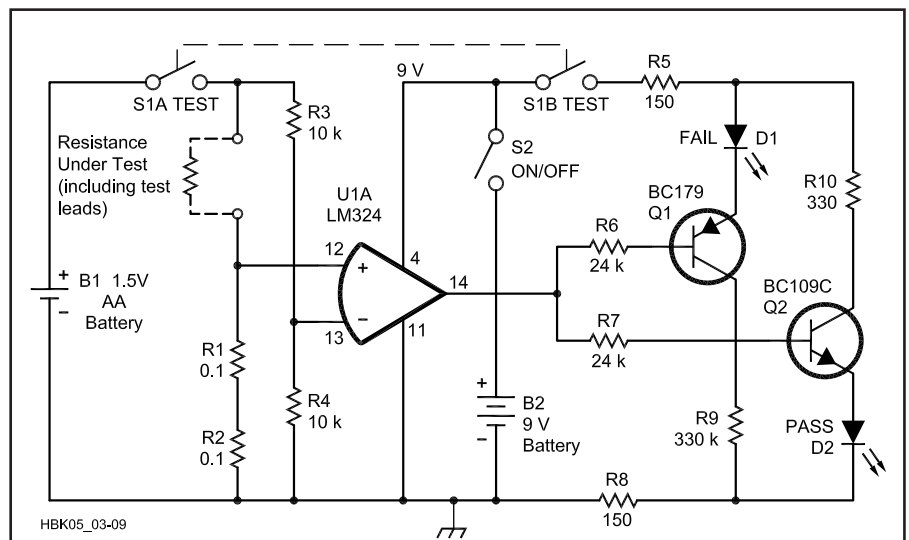
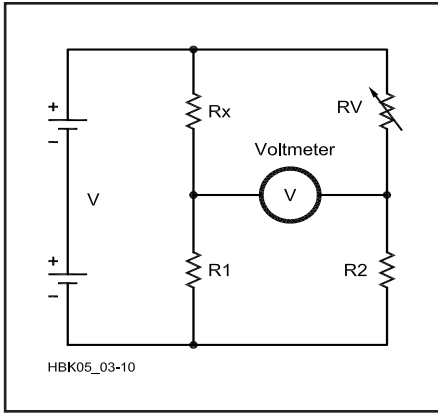
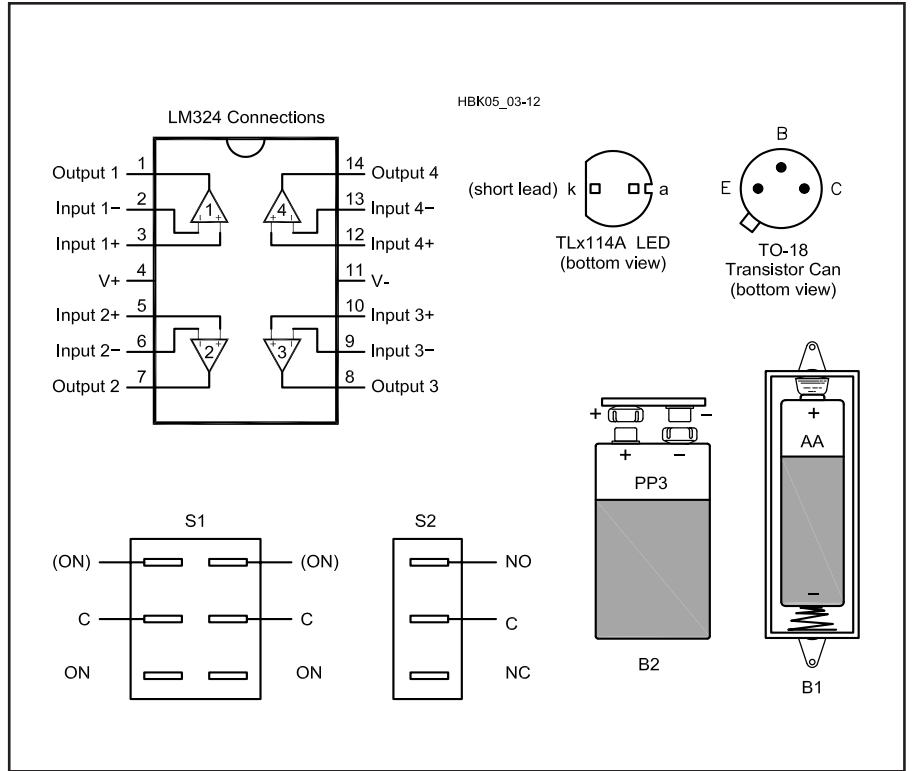

Fig 3.9 — Circuit diagram of the earth-continuity tester.



**Fig 3.10** — In a conventional Wheatstone bridge circuit, the value of an unknown resistance ( $R_x$ ) is determined by adjusting a variable resistor ( $R_V$ ) with a calibrated scale until the reading on the voltmeter is zero. At that point  $(R_x/R_1) = (R_V/R_2)$  so the value of  $R_x$  is then given by  $R_x = (R_1 \times R_V)/R_2$ . The advantage of this method is that, at the balance point, no current flows through the voltmeter, so the resistance of it doesn't affect the measurement. This is a sensitive method for detecting small changes in resistance, as a small change causes a large meter reading.



**Fig 3.12** — Orientation (and pin-outs) of the batteries, U1, LEDs and transistors.

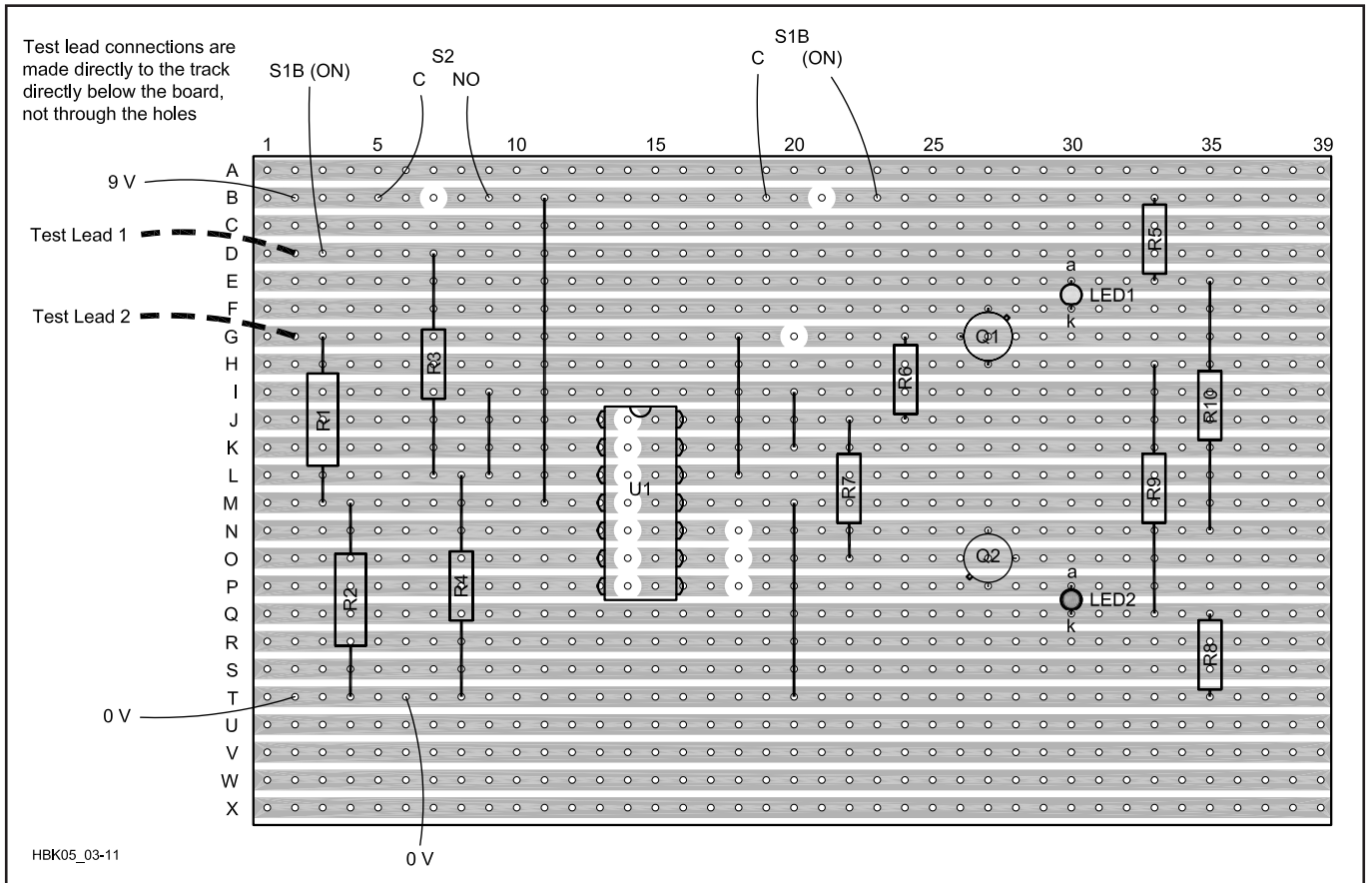

**Fig 3.11** — Layout of the circuit on stripboard.

The OUTPUT INDICATOR circuit consists of two LEDs, driven by transistors to provide sufficient current, which indicate either a pass or a fail for an earth path resistance of less than or more than 0.1  $\Omega$ . Q2 is an npn transistor that switches on when its input is high, while Q1 is a pnp type that switches on when its input is low. A separate supply voltage is needed for the op-amp and LED circuit, since the test battery voltage will drop under a heavy load current.

Because the output of the op-amp does not swing completely to the positive and negative supply rails, measures need to be taken to ensure that the LED driver transistors switch off correctly.

### Construction

A suitable stripboard layout is shown in Fig 3.11, and Fig 3.12 shows how to identify and orientate several of the components. Use thick wire for the test leads!

### How To Use It

Using flying leads with suitable connectors, eg, alligator clips, connect the circuit to each end of the earth path to be tested. This would usually be the mains plug earth pin and any metal part meant to be earthed. Then press the test button. Release the test switch as soon as a pass/fail indicator lights (certainly within 5 to 10 seconds, to lengthen battery life and prevent possible overheating of R1 and R2).

### Safety Notice

The project described here may be used to test the resistance of appliance earth connections, but it is *not* intended to conform to any *legal* requirements for the testing of electrical safety. The RSGB, ARRL and the author accept no responsibility for any accident or injury caused by its use. *Never* use on mains equipment plugged into the mains —

the connection to the mains plug earth pin mentioned in the previous paragraph implies that the plug is free. — *Ed*

### STATION POWER

Amateur Radio stations generally require a 120-V ac power source. (In residential systems voltages from 110 V through 125 V are considered equivalent, as are those from 220 V through 250 V.) 120-V ac is converted to the proper ac or dc levels required for the station equipment. Power supplies should accommodate the measured voltage range at each station. (The measured voltage usually varies by hour, day, season and location.) Power supply theory is covered in the **Power Supplies** chapter. If your station is located in a room with electrical outlets, you're in luck. If your station is located in the basement, an attic or other area without a convenient 120-V source, you may need to have a new line run to your operating position.

Stations with high-power amplifiers should have a 240-V ac power source in addition to the 120-V supply. Some amplifiers may be powered from 120 V, but they require current levels that may exceed the limits of standard house wiring. For safety, and for the best possible voltage regulation in the equipment, it is advisable to install a separate 240 or 120-V line with an appropriate current rating if you use an amplifier.

The usual line running to baseboard outlets is rated at 15 A, although 20-A outlets may be installed in newer houses. This may or may not be enough current to power your station. To determine how much current your station requires, check the ratings for each piece of gear. Usually, the manufacturer will specify the required current at 120 V; if the power consumption is rated in watts, divide that rating by

120 V to get amperes. If the total current required for your station is near 12 ( $0.8 \times 15 = 12$  A), you need to install another circuit. Keep in mind that other rooms may be powered from the same branch of the electrical system, so the power consumption of any equipment connected to other outlets on the branch must be taken into account. Whenever possible, power your station from a separate, heavy-duty line run directly to the distribution panel through a disconnect switch or circuit breaker that can be locked in the off position.

If you decide to install a separate heavy-duty 120-V line or a 240-V line, consult the power company for local requirements. In some areas, a licensed electrician must perform this work. Others may require a special building permit. Even if you are allowed to do the work yourself, it might need inspection by a licensed electrician. Go through the system and get the necessary permits and inspections! Faulty wiring can destroy your possessions and take away your loved ones. Many fire insurance policies are void if there is unapproved wiring in the structure.

If you decide to do the job yourself, work closely with local building officials. Most home-improvement centers sell books to guide do-it-yourself wiring projects. If you have any doubts about doing the work yourself, get a licensed electrician to do the installation.

### Three-Wire 120-V Power Cords

Most metal-cased electrical tools and appliances are equipped with three-conductor power cords. Two of the conductors carry power to the device, while the third conductor is connected to the case or frame. Fig 3.13 shows two commonly used connectors.

When both plug and receptacle are prop-

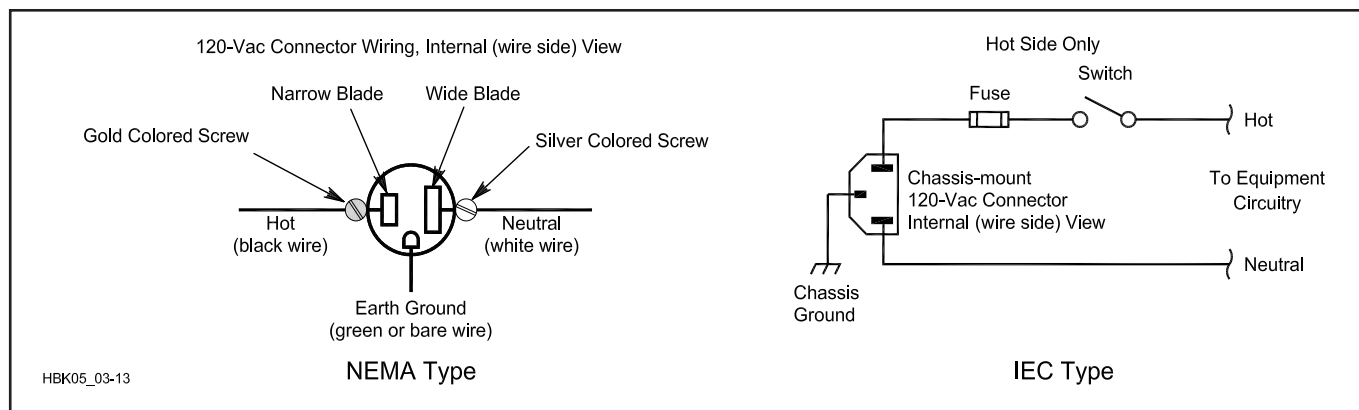

Fig 3.13 — 120-V ac chassis connector wiring.

## FCC RF-Exposure Regulations

FCC regulations control the amount of RF exposure that can result from your station's operation (§§97.13, 97.503, 1.1307 (b)(c)(d), 1.1310 and 2.1093). The regulations set limits on the maximum permissible exposure (MPE) allowed from operation of transmitters in all radio services. They also require that certain types of stations be evaluated to determine if they are in compliance with the MPEs specified in the rules. The FCC has also required that five questions on RF environmental safety practices be added to Novice, Technician and General license examinations.

These rules went into effect on January 1, 1998 for new stations or stations that file a 610 application with the FCC. Other existing stations have until September 1, 2000 to be in compliance with the rules.

### THE RULES

#### Maximum Permissible Exposure (MPE)

All radio stations regulated by the FCC must comply with the requirements for MPEs, even QRP stations running only a few watts or less. The MPEs vary with frequency, as shown in **Table A**. MPE limits are specified in maximum electric and magnetic fields for frequencies below 30 MHz, in power density for frequencies above 300 MHz and all three ways for frequencies from 30 to 300 MHz. For compliance purposes, all of these limits must be considered *separately*. If any one is exceeded, the station is not in compliance.

The regulations control human exposure to RF fields, not the strength of RF fields. There is no limit to how strong a field can be as long as no one is being exposed to it, although FCC regulations require that amateurs use

the minimum necessary power at all times (§97.311 [a]).

### Environments

The FCC has defined two exposure environments — *controlled* and *uncontrolled*. A controlled environment is one in which the people who are being exposed are aware of that exposure and can take steps to minimize that exposure, if appropriate. In an uncontrolled environment, the people being exposed are not normally aware of the exposure. The uncontrolled environment limits are more stringent than the controlled environment limits.

Although the controlled environment is usually intended as an occupational environment, the FCC has determined that it generally applies to amateur operators and members of their immediate households. In most cases, controlled-environment limits can be applied to your home and property to which you can control physical access. The uncontrolled environment is intended for areas that are accessible by the general public, such as your neighbors' properties.

The MPE levels are based on average exposure. An averaging time of 6 minutes is used for controlled exposure; an averaging period of 30 minutes is used for uncontrolled exposure.

### Station Evaluations

The FCC requires that certain amateur stations be evaluated for compliance with the MPEs. Although an amateur can have someone else do the evaluation, it

**Table A — (From §1.1310) Limits for Maximum Permissible Exposure (MPE)**

(A) Limits for Occupational/Controlled Exposure

Frequency Range (MHz)	Electric Field Strength (V/m)	Magnetic Field Strength (A/m)	Power Density (mW/cm <sup>2</sup> )	Averaging Time (minutes)
0.3-3.0	614	1.63	(100)*	6
3.0-30	1842/f	4.89/f	(900/f <sup>2</sup> )*	6
30-300	61.4	0.163	1.0	6
300-1500	—	—	f/300	6
1500-100,000	—	—	5	6

f = frequency in MHz

\* = Plane-wave equivalent power density (see Note 1).

(B) Limits for General Population/Uncontrolled Exposure

Frequency Range (MHz)	Electric Field Strength (V/m)	Magnetic Field Strength (A/m)	Power Density (mW/cm <sup>2</sup> )	Averaging Time (minutes)
0.3-1.34	614	1.63	(100)*	30
1.34-30	824/f	2.19/f	(180/f <sup>2</sup> )*	30
30-300	27.5	0.073	0.2	30
300-1500	—	—	f/1500	30
1500-100,000	—	—	1.0	30

f = frequency in MHz

\* = Plane-wave equivalent power density (see Note 1).

Note 1: This means the equivalent far-field strength that would have the E or H-field component calculated or measured. It does not apply well in the near field of an antenna. The equivalent far-field power density can be found in the near or far field regions from the relationships:  $P_d = |E_{total}|^2 / 3770 \text{ mW/cm}^2$  or from  $P_d = H_{total}^2 \times 37.7 \text{ mW/cm}^2$ .

is not difficult for hams to evaluate their own stations. The ARRL book *RF Exposure and You* contains extensive information about the regulations and a large chapter of tables that show compliance distances for specific antennas and power levels. Generally, hams will use these tables to evaluate their stations. Some of these tables have been included in the FCC's information — *OET Bulletin 65* and its *Supplement B*. If hams choose, however, they can do more extensive calculations, use a computer to model their antenna and exposure, or make actual measurements.

### Categorical Exemptions

Some types of amateur stations do not need to be evaluated, but these stations must still comply with the MPE limits. The station licensee remains responsible for ensuring that the station meets these requirements.

The FCC has exempted these stations from the evaluation requirement because their output power, operating mode and frequency are such that they are presumed to be in compliance with the rules.

Stations using power equal to or less than the levels in **Table B** do not have to be evaluated. For the 100-W HF ham station, for example, an evaluation would be required *only* on 12 and 10 meters.

Hand-held radios and vehicle-mounted mobile radios that operate using a push-to-talk (PTT) button are also categorically exempt from performing the routine evaluation. Repeater stations that use less than 500 W ERP or those with antennas not mounted on buildings, if the antenna is at least 10 meters off the ground, also do not need to be evaluated.

### Correcting Problems

Most hams are already in compliance with the MPE requirements. Some amateurs, especially those using indoor antennas or high-power, high-duty-cycle modes such as a RTTY bulletin station and specialized stations for moonbounce operations and the like may need to make adjustments to their station or operation to be in compliance.

The FCC permits amateurs considerable flexibility in complying with these regulations. As an example, hams can adjust their operating frequency, mode or power to comply with the MPE limits. They can also adjust their operating habits or control the direction their antenna is pointing.

**Table B — Power Thresholds for Routine Evaluation of Amateur Radio Stations**

Wavelength Band	Evaluation Required if Power* (watts) Exceeds:
	<b>MF</b>
160 m	500
	<b>HF</b>
80 m	500
75 m	500
40 m	500
30 m	425
20 m	225
17 m	125
15 m	100
12 m	75
10 m	50
<b>VHF (all bands)</b>	50
	<b>UHF</b>
70 cm	70
33 cm	150
23 cm	200
13 cm	250
<b>SHF (all bands)</b>	250
<b>EHF (all bands)</b>	250

**Repeater stations (all bands)** *non-building-mounted antennas:* height above ground level to lowest point of antenna < 10 m *and* power > 500 W ERP *building-mounted antennas:* power > 500 W ERP

\*Transmitter power = Peak-envelope power input to antenna. For repeater stations **only**, power exclusion based on ERP (effective radiated power).

### More Information

This discussion offers only an overview of this topic; additional information can be found in *RF Exposure and You* and on *ARRLWeb* at [www.arrl.org/news/rfsafety/](http://www.arrl.org/news/rfsafety/). *ARRLWeb* has links to the FCC Web site, with *OET Bulletin 65* and *Supplement B* and links to software that hams can use to evaluate their stations.

erly wired, the three-contact polarized plug connects the equipment to the system ground. This grounds the chassis or frame of the appliance and prevents the possibility of electrical shock to the user. Most commercially manufactured test equipment and ac-operated amateur equipment is supplied with these three-wire cords. Unfortunately, the ground wire is sometimes improperly installed. Before

connecting any new equipment, check for continuity from case to ground pin with an ohmmeter. If there is no continuity, have the equipment repaired before use. Use such equipment only with properly installed three-wire outlets. If your house does not have such outlets, consult with an electrician or local building officials to learn about safe alternatives.

Equipment with plastic cases is often

“double insulated” and fed with a two-wire cord. Such equipment is safe because both conductors are completely insulated from the user. Nonetheless, there is still a hazard if, say, a double insulated drill were used to drill an improperly grounded case of a transmitter that was still plugged in. Remember, all insulation is prey to age, damage and wear that may erode its initial protection.

# Safe Homebrewing

Since Amateur Radio began, building equipment in home workshops has been a major part of an amateur's activity. In fact, in the early days, building equipment with your hands was the *only* option available. While times and interests change, home construction of radio equipment and related accessories remains very popular and enjoyable. Building your own gear need not be hazardous if you become familiar with the hazards, learn how to perform the necessary functions and follow some basic safe practices including the ones listed below.

*Consider your State of Mind...* when working on projects or troubleshooting (especially where high voltage is present). Some activities require a lot of concentration. As we grow older, this may be a challenge for some of us. Put another way, if we aren't able to be highly alert, we should put off doing hazardous work until we are better able to focus on the hazards.

*Read instructions carefully...and follow them.* The manufacturers of tools are the most knowledgeable about how to use their products safely. Tap their knowledge by carefully reading all operating instructions and warnings. Avoiding injuries with power tools requires safe tool design as well as proper operation by the user. Keep the instructions in a place where you can refer to them in the future.

*Keep your tools in good condition.* Al-

ways take care of your investment. Store tools in a way to prevent damage or use by untrained persons (young children, for example). Keep the cutting edges of saws, chisels and drill bits sharp. Protect metal surfaces from corrosion. Frequently inspect the cords and plugs of electrical equipment and make any necessary repairs. If you find that your power cord is becoming frayed, do not delay its repair. Often the best solution is to buy a replacement cord with a molded connector already attached.

*Protect yourself.* Use of drills, saws, grinders and other wood- or metal-working equipment can release small fragments that could cause serious eye damage. Always wear safety glasses or goggles when doing work that might present a flying object hazard. If you use hammers, wirecutters, chisels and other hand tools, you will also need the protection that safety eyewear offers. Dress appropriately — loose clothing (or even hair) can be caught in exposed rotating equipment such as drill presses.

*Take your time.* If you hurry, not only will you make more mistakes and possibly spoil the appearance of your new equipment, you won't have time to think things through. Always plan ahead. Do not work with shop tools if you can't concentrate on what you are doing.

*Know what to do in an emergency.* Despite your best efforts to be careful, acci-

dents may still occur from time to time. Ensure that everyone in your household knows basic first aid procedures and understands how to summon help in an emergency. They should also know where to find and how to safely shut down electrical power in your shack and shop. Keep your shop neat and orderly, with everything in its place. Do not store an excessive amount of flammable materials. Keep clutter off the floor so no one will trip or lose their footing. Exemplary housekeeping is contagious — set a good example for everyone!

*Soldering.* Soldering requires a certain degree of practice and, of course, the right tools. What potential hazards are involved?

- Since the solder used for virtually all electronic components is a lead-tin alloy, the first thing in most people's mind is lead, a well-known health hazard. There are two primary ways lead might enter our bodies when soldering: we could breathe lead fumes into our lungs or we could ingest (swallow) lead or lead-contaminated food. Inhalation of lead fumes is extremely unlikely because the temperatures ordinarily used in electronic soldering are far below those needed to vaporize lead. But since lead is soft and we may tend to handle it with our fingers, contaminating our food is a real possibility. For this reason, wash your hands carefully after any soldering (or touching of solder connections).
- Generally, solder used for electronic components contains a flux, often a rosin material. When heated the flux flows freely and emits a vapor in the form of a light gray smoke-like plume. This flux vapor, which often contains aldehydes, is a strong irritant and can cause potentially serious problems to persons who may have respiratory sensitivity conditions including those who suffer from asthma. In most cases it is relatively easy to use a small fan to move the flux vapor away from your eyes and face. Open a window, if there is one, to provide additional air exchange. In extreme cases use an organic vapor cartridge respirator.
- Although it is fairly obvious, be careful when soldering not to burn yourself. A soldering iron stand is helpful.
- Solvents are often used to remove excess flux after the parts have cooled to room temperature. Minimize skin contact with solvents by wearing molded gloves that are resistant to the solvent.

## RF Burns!

There's a lot of talk about hazards of RF radiation, but most people don't think about RF burns. Happily, most ham shacks offer little exposure to RF current. Transmitters are enclosed, coaxial cable is the most common feed line, and antennas are located well out of reach.

Some people have experienced a mild tingling on their lips while operating with a metal microphone — a gentle reminder of "RF in the shack." When first licensed in 1963, I learned a stronger lesson. Lightbulbs were often used as dummy loads then: they give a nice visual indication of output power, but provide a poor load for the transmitter (not 50  $\Omega$ ). Also, you can work a lot of people on such a "dummy" antenna. (Don't try this with a modern solid-state transmitter; the mismatch could be fatal to the radio!)

While tuning my Viking Adventurer one day, I bumped the lit bulb and it fell off the table. I prevented a broken lightbulb by catching it — with my finger across the cable ends that were soldered to the bulb. 50-W of RF went through my finger tip and cauterized a path about  $\frac{3}{16} \times \frac{1}{8}$  inch. It was an extremely painful burn; I would rather have broken the bulb. To avoid RF burns, insulate or enclose any exposed RF conductors and keep your antennas out of reach. Ground mounted vertical antennas that carry more than a few watts should be enclosed by an insulator such as a PVC pipe slipped over the radiator or an 8-ft-high fence around the antenna base.

— Bob Schetgen, KU7G, QEX Managing Editor

# RF Radiation and Electromagnetic Field Safety

Amateur Radio is basically a safe activity. In recent years, however, there has been considerable discussion and concern about the possible hazards of electromagnetic radiation (EMR), including both RF energy and power-frequency (50-60 Hz) electromagnetic (EM) fields. FCC regulations set limits on the maximum permissible exposure (MPE) allowed from the operation of radio transmitters. These regulations do not take the place of RF-safety practices, however. This section deals with the topic of RF safety.

This section was prepared by members of the ARRL RF Safety Committee and coordinated by Dr. Robert E. Gold, WBØKIZ. It summarizes what is now known and offers safety precautions based on the research to date.

All life on Earth has adapted to survive in an environment of weak, natural, low-frequency electromagnetic fields (in addition to the Earth's static geomagnetic field). Natural low-frequency EM fields come from two main sources: the sun, and thunderstorm activity. But in the last 100 years, man-made fields at much higher intensities and with a very different spectral distribution have altered this natural EM background in ways that are not yet fully understood. Researchers continue to look at the effects of RF exposure over a wide range of frequencies and levels.

Both RF and 60-Hz fields are classified as *nonionizing radiation*, because the frequency is too low for there to be enough photon energy to ionize atoms. (*Ionizing radiation*, such as X-rays, gamma rays and even some ultraviolet radiation has enough energy to knock electrons loose from their atoms. When this happens, positive and negative ions are formed.) Still, at sufficiently high power densities, EMR poses certain health hazards. It has been known since the early days of radio that RF energy can cause injuries by heating body tissue. (Anyone who has ever touched an improperly grounded radio chassis or energized antenna and received an *RF burn* will agree that this type of injury can be quite painful.) In extreme cases, RF-induced heating in the eye can result in cataract formation, and can even cause blindness. Excessive RF heating of the reproductive organs can cause sterility. Other health problems also can result from RF heating. These heat-related health hazards are called *thermal effects*. A microwave oven is a positive application of this thermal effect.

There also have been observations of changes in physiological function in the presence of RF energy levels that are too

low to cause heating. These functions return to normal when the field is removed. Although research is ongoing, no harmful health consequences have been linked to these changes.

In addition to the ongoing research, much else has been done to address this issue. For example, FCC regulations set limits on exposure from radio transmitters. The Institute of Electrical and Electronics Engineers, the American National Standards Institute and the National Council for Radiation Protection and Measurement, among others, have recommended voluntary guidelines to limit human exposure to RF energy. The ARRL has established the RF Safety Committee, consisting of concerned medical doctors and scientists, serving voluntarily to monitor scientific research in the fields and to recommend safe practices for radio amateurs.

## THERMAL EFFECTS OF RF ENERGY

Body tissues that are subjected to *very high* levels of RF energy may suffer serious heat damage. These effects depend on the frequency of the energy, the power density of the RF field that strikes the body and factors such as the polarization of the wave.

At frequencies near the body's natural resonant frequency, RF energy is absorbed more efficiently, and an increase in heating occurs. In adults, this frequency usually is about 35 MHz if the person is grounded, and about 70 MHz if insulated from the ground. Individual body parts may be resonant at different frequencies. The adult head, for example, is resonant around 400 MHz, while a baby's smaller head resonates near 700 MHz. Body size thus determines the frequency at which most RF energy is absorbed. As the frequency is moved farther from resonance, less RF heating generally occurs. *Specific absorption rate (SAR)* is a term that describes the rate at which RF energy is absorbed in tissue.

Maximum permissible exposure (MPE) limits are based on whole-body SAR values, with additional safety factors included as part of the standards and regulations. This helps explain why these safe exposure limits vary with frequency. The MPE limits define the maximum electric and magnetic field strengths or the plane-wave equivalent power densities associated with these fields, that a person may be exposed to without harmful effect — and with an acceptable safety factor. The regulations assume that a person exposed to a specified (safe) MPE level also

will experience a safe SAR.

Nevertheless, thermal effects of RF energy should not be a major concern for most radio amateurs, because of the power levels we normally use and the intermittent nature of most amateur transmissions. Amateurs spend more time listening than transmitting, and many amateur transmissions such as CW and SSB use low-duty-cycle modes. (With FM or RTTY, though, the RF is present continuously at its maximum level during each transmission.) In any event, it is rare for radio amateurs to be subjected to RF fields strong enough to produce thermal effects, unless they are close to an energized antenna or unshielded power amplifier. Specific suggestions for avoiding excessive exposure are offered later in this chapter.

## ATHERMAL EFFECTS OF EMR

Research about possible health effects resulting from exposure to the lower level energy fields, the athermal effects, has been of two basic types: epidemiological research and laboratory research.

Scientists conduct laboratory research into biological mechanisms by which EMR may affect animals including humans. Epidemiologists look at the health patterns of large groups of people using statistical methods. These epidemiological studies have been inconclusive. By their basic design, these studies do not demonstrate cause and effect, nor do they postulate mechanisms of disease. Instead, epidemiologists look for associations between an environmental factor and an observed pattern of illness. For example, in the earliest research on malaria, epidemiologists observed the association between populations with high prevalence of the disease and the proximity of mosquito infested swamplands. It was left to the biological and medical scientists to isolate the organism causing malaria in the blood of those with the disease, and identify the same organisms in the mosquito population.

In the case of athermal effects, some studies have identified a weak association between exposure to EMF at home or at work and various malignant conditions including leukemia and brain cancer. A larger number of equally well-designed and performed studies, however, have found no association. A risk ratio of between 1.5 and 2.0 has been observed in positive studies (the number of observed cases of malignancy being 1.5 to 2.0 times the "expected" number in the population). Epidemiologists generally regard a risk ratio of 4.0 or greater to be indicative of a strong association between the cause and

effect under study. For example, men who smoke one pack of cigarettes per day increase their risk for lung cancer tenfold compared to nonsmokers, and two packs per day increases the risk to more than 25 times the nonsmokers' risk.

Epidemiological research by itself is rarely conclusive, however. Epidemiology only identifies health patterns in groups — it does not ordinarily determine their cause. And there are often confounding factors: Most of us are exposed to many different environmental hazards that may affect our health in various ways. Moreover, not all studies of persons likely to be exposed to high levels of EMR have yielded the same results.

There also has been considerable laboratory research about the biological effects of EMR in recent years. For example, some separate studies have indicated that even fairly low levels of EMR might alter the human body's circadian rhythms, affect the manner in which T lymphocytes function in the immune system and alter the nature of the electrical and chemical signals communicated through the cell membrane and between cells, among other things. Although these studies are intriguing, they do not demonstrate any effect of these low-level fields on the overall organism.

Much of this research has focused on low-frequency magnetic fields, or on RF fields that are keyed, pulsed or modulated at a low audio frequency (often below 100 Hz). Several studies suggested that humans and animals could adapt to the presence of a steady RF carrier more readily than to an intermittent, keyed or modulated energy source.

The results of studies in this area, plus speculations concerning the effect of various types of modulation, were and have remained somewhat controversial. None of the research to date has demonstrated that low-level EMR causes adverse health effects.

Given the fact that there is a great deal of ongoing research to examine the health consequences of exposure to EMF, the American Physical Society (a national group of highly respected scientists) issued a statement in May 1995 based on its review of available data pertaining to the possible connections of cancer to 60-Hz EMF exposure. This report is exhaustive and should be reviewed by anyone with a serious interest in the field. Among its general conclusions were the following:

1. The scientific literature and the reports of reviews by other panels show no consistent, significant link between cancer and power line fields.

2. No plausible biophysical mecha-

nisms for the systematic initiation or promotion of cancer by these extremely weak 60-Hz fields have been identified.

3. While it is impossible to prove that no deleterious health effects occur from exposure to any environmental factor, it is necessary to demonstrate a consistent, significant, and causal relationship before one can conclude that such effects do occur.

In a report dated October 31, 1996, a committee of the National Research Council of the National Academy of Sciences has concluded that no clear, convincing evidence exists to show that residential exposures to electric and magnetic fields (EMFs) are a threat to human health.

A National Cancer Institute epidemiological study of residential exposure to magnetic fields and acute lymphoblastic leukemia in children was published in the *New England Journal of Medicine* in July 1997. The exhaustive, seven-year study concludes that if there is any link at all, it is far too weak to be concerned about.

Readers may want to follow this topic as further studies are reported. Amateurs should be aware that exposure to RF and ELF (60 Hz) electromagnetic fields at all power levels and frequencies has not been fully studied under all circumstances. "Prudent avoidance" of any avoidable EMR is always a good idea. Prudent avoidance doesn't mean that amateurs should be fearful of using their equipment. Most amateur operations are well within the MPE limits. If any risk does exist, it will almost surely fall well down on the list of causes that may be harmful to your health (on the other end of the list from your automobile). It does mean, however, that hams should be aware of the potential for exposure from their stations, and take whatever reasonable steps they can take to minimize their own exposure and the exposure of those around them.

### Safe Exposure Levels

How much EM energy is safe? Scientists and regulators have devoted a great deal of effort to deciding upon safe RF-exposure limits. This is a very complex problem, involving difficult public health and economic considerations. The recommended safe levels have been revised downward several times over the years — and not all scientific bodies agree on this question even today. An Institute of Electrical and Electronics Engineers (IEEE) standard for recommended EM exposure limits was published in 1991 (see Bibliography). It replaced a 1982 American National Standards Institute (ANSI) standard. In the new standard, most of the permitted exposure levels were revised downward (made more stringent), to better

reflect the current research. The new IEEE standard was adopted by ANSI in 1992.

The IEEE standard recommends frequency-dependent and time-dependent maximum permissible exposure levels. Unlike earlier versions of the standard, the 1991 standard recommends different RF exposure limits in *controlled environments* (that is, where energy levels can be accurately determined and everyone on the premises is aware of the presence of EM fields) and in *uncontrolled environments* (where energy levels are not known or where people may not be aware of the presence of EM fields). FCC regulations also include controlled/occupational and uncontrolled/general population exposure environments.

The graph in **Fig 3.14** depicts the 1991 IEEE standard. It is necessarily a complex graph, because the standards differ not only for controlled and uncontrolled environments but also for electric (E) fields and magnetic (H) fields. Basically, the lowest E-field exposure limits occur at frequencies between 30 and 300 MHz. The lowest H-field exposure levels occur at 100-300 MHz. The ANSI standard sets the maximum E-field limits between 30 and 300 MHz at a power density of 1 mW/cm<sup>2</sup> (61.4 V/m) in controlled environments — but at one-fifth that level (0.2 mW/cm<sup>2</sup> or 27.5 V/m) in uncontrolled environments. The H-field limit drops to 1 mW/cm<sup>2</sup> (0.163 A/m) at 100-300 MHz in controlled environments and 0.2 mW/cm<sup>2</sup> (0.0728 A/m) in uncontrolled environments. Higher power densities are permitted at frequencies below 30 MHz (below 100 MHz for H fields) and above 300 MHz, based on the concept that the body will not be resonant at those frequencies and will therefore absorb less energy.

In general, the 1991 IEEE standard requires averaging the power level over time periods ranging from 6 to 30 minutes for power-density calculations, depending on the frequency and other variables. The ANSI exposure limits for uncontrolled environments are lower than those for controlled environments, but to compensate for that the standard allows exposure levels in those environments to be averaged over much longer time periods (generally 30 minutes). This long averaging time means that an intermittently operating RF source (such as an Amateur Radio transmitter) will show a much lower power density than a continuous-duty station — for a given power level and antenna configuration.

Time averaging is based on the concept that the human body can withstand a greater rate of body heating (and thus, a higher level of RF energy) for a short



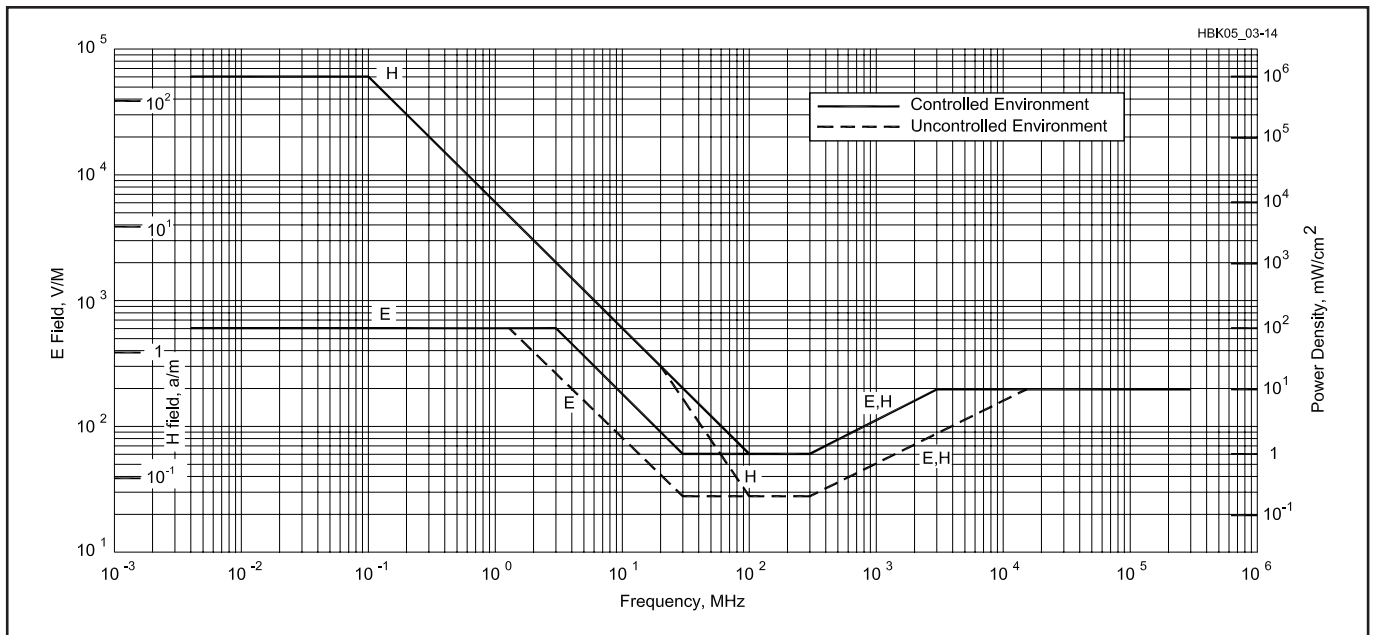

**Fig 3.14 — 1991 RF protection guidelines for body exposure of humans. It is known officially as the “IEEE Standard for Safety Levels with Respect to Human Exposure to Radio Frequency Electromagnetic Fields, 3 kHz to 300 GHz.”**

time than for a longer period. Time averaging may not be appropriate, however, when considering nonthermal effects of RF energy.

The IEEE standard excludes any transmitter with an output below 7 W because such low-power transmitters would not be able to produce significant whole-body heating. (Recent studies show that hand-held transceivers often produce power densities in excess of the IEEE standard within the head.)

There is disagreement within the scientific community about these RF exposure guidelines. The IEEE standard is still intended primarily to deal with thermal effects, not exposure to energy at lower levels. A small but significant number of researchers now believe athermal effects also should be taken into consideration. Several European countries and localities in the United States have adopted stricter standards than the recently updated IEEE standard.

Another national body in the United States, the National Council for Radiation Protection and Measurement (NCRP), also has adopted recommended exposure guidelines. NCRP urges a limit of 0.2 mW/cm<sup>2</sup> for nonoccupational exposure in the 30-300 MHz range. The NCRP guideline differs from IEEE in two notable ways: It takes into account the effects of modulation on an RF carrier, and it does not exempt transmitters with outputs below 7 W.

The FCC MPE regulations are based on parts of the 1992 IEEE/ANSI standard and

recommendations of the National Council for Radiation Protection and Measurement (NCRP). The MPE limits under the regulations are slightly different than the IEEE/ANSI limits. Note that the MPE levels apply to the FCC rules put into effect for radio amateurs on January 1, 1998. These MPE requirements do not reflect and include all the assumptions and exclusions of the IEEE/ANSI standard.

### Cardiac Pacemakers and RF Safety

It is a widely held belief that cardiac pacemakers may be adversely affected in their function by exposure to electromagnetic fields. Amateurs with pacemakers may ask whether their operating might endanger themselves or visitors to their shacks who have a pacemaker. Because of this, and similar concerns regarding other sources of electromagnetic fields, pacemaker manufacturers apply design methods that for the most part shield the pacemaker circuitry from even relatively high EM field strengths.

It is recommended that any amateur who has a pacemaker, or is being considered for one, discuss this matter with his or her physician. The physician will probably put the amateur into contact with the technical representative of the pacemaker manufacturer. These representatives are generally excellent resources, and may have data from laboratory or “in the field” studies with specific model pacemakers.

One study examined the function of a

modern (dual chamber) pacemaker in and around an Amateur Radio station. The pacemaker generator has circuits that receive and process electrical signals produced by the heart, and also generate electrical signals that stimulate (pace) the heart. In one series of experiments, the pacemaker was connected to a heart simulator. The system was placed on top of the cabinet of a 1-kW HF linear amplifier during SSB and CW operation. In another test, the system was placed in close proximity to several 1 to 5-W 2-meter hand-held transceivers. The test pacemaker was connected to the heart simulator in a third test, and then placed on the ground 9 meters below and 5 meters in front of a three-element Yagi HF antenna. No interference with pacemaker function was observed in these experiments.

Although the possibility of interference cannot be entirely ruled out by these few observations, these tests represent more severe exposure to EM fields than would ordinarily be encountered by an amateur — with an average amount of common sense. Of course prudence dictates that amateurs with pacemakers, who use hand-held VHF transceivers, keep the antenna as far as possible from the site of the implanted pacemaker generator. They also should use the lowest transmitter output required for adequate communication. For high power HF transmission, the antenna should be as far as possible from the operating position, and all equipment should be properly grounded.

## LOW-FREQUENCY FIELDS

Although the FCC doesn't regulate 60-Hz fields, some recent concern about EMR has focused on low-frequency energy rather than RF. Amateur Radio equipment can be a significant source of low-frequency magnetic fields, although there are many other sources of this kind of energy in the typical home. Magnetic fields can be measured relatively accurately with inexpensive 60-Hz meters that are made by several manufacturers.

**Table 3.2** shows typical magnetic field intensities of Amateur Radio equipment and various household items. Because these fields dissipate rapidly with distance, "prudent avoidance" would mean staying perhaps 12 to 18 inches away from most Amateur Radio equipment (and 24 inches from power supplies with 1-kW RF amplifiers).

## DETERMINING RF POWER DENSITY

Unfortunately, determining the power density of the RF fields generated by an amateur station is not as simple as measuring low-frequency magnetic fields. Although sophisticated instruments can be used to measure RF power densities quite accurately, they are costly and require frequent recalibration. Most amateurs don't have access to such equipment, and the inexpensive field-strength meters that we do have are not suitable for measuring RF power density.

**Table 3.3** shows a sampling of measurements made at Amateur Radio stations by the Federal Communications Commission and the Environmental Protection Agency in 1990. As this table indicates, a good antenna well removed from inhabited areas poses no hazard under any of the IEEE/ANSI guidelines. However, the FCC/EPA survey also indicates that amateurs must be careful about using indoor or attic-mounted antennas, mobile antennas, low directional arrays or any other antenna that is close to inhabited areas, especially when moderate to high power is used.

Ideally, before using any antenna that is in close proximity to an inhabited area, you should measure the RF power density. If that is not feasible, the next best option is make the installation as safe as possible by observing the safety suggestions listed in **Table 3.4**.

It also is possible, of course, to calculate the probable power density near an antenna using simple equations. Such calculations have many pitfalls. For one, most of the situations where the power density would be high enough to be of concern are in the near field. In the near field, ground interactions and other variables produce power densities that cannot

be determined by simple arithmetic. In the far field, conditions become easier to predict with simple calculations.

The boundary between the near field and the far field depends on the wavelength of the transmitted signal and the physical size and configuration of the antenna. The boundary between the near field and the far field of an antenna can be as much as several wavelengths from the antenna.

Computer antenna-modeling programs are another approach you can use. *MININEC* or other codes derived from *NEC* (Numerical Electromagnetics Code) are suitable for estimating RF magnetic and electric fields around amateur antenna systems.

These models have limitations. Ground interactions must be considered in estimating near-field power densities, and the "correct ground" must be modeled. Computer modeling is generally not sophisticated enough to predict "hot spots" in the near field — places where the field intensity may be far higher than would be ex-

pected, due to reflections from nearby objects. In addition, "nearby objects" often change or vary with weather or the season, so the model so laboriously crafted may not be representative of the actual situation, by the time it is running on the computer.

Intensely elevated but localized fields often can be detected by professional measuring instruments. These "hot spots" are often found near wiring in the shack, and metal objects such as antenna masts or equipment cabinets. But even with the best instrumentation, these measurements also may be misleading in the near field.

One need not make precise measurements or model the exact antenna system, however, to develop some idea of the relative fields around an antenna. Computer modeling using close approximations of the geometry and power input of the antenna will generally suffice. Those who are familiar with *MININEC* can estimate their power densities by computer modeling, and those who have access to profes-

**Table 3.2**

### Typical 60-Hz Magnetic Fields Near Amateur Radio Equipment and AC-Powered Household Appliances

Values are in milligauss.

Item	Field	Distance
Electric blanket	30-90	Surface
Microwave oven	10-100	Surface
	1-10	12"
IBM personal computer	5-10	Atop monitor
	0-1	15" from screen
Electric drill	500-2000	At handle
Hair dryer	200-2000	At handle
HF transceiver	10-100	Atop cabinet
	1-5	15" from front
1-kW RF amplifier	80-1000	Atop cabinet
	1-25	15" from front

(Source: measurements made by members of the ARRL RF Safety Committee)

**Table 3.3**

### Typical RF Field Strengths Near Amateur Radio Antennas

A sampling of values as measured by the Federal Communications Commission and Environmental Protection Agency, 1990

Antenna Type	Freq (MHz)	Power (W)	E Field (V/m)	Location
Dipole in attic	14.15	100	7-100	In home
Discone in attic	146.5	250	10-27	In home
Half sloper	21.5	1000	50	1 m from base
Dipole at 7-13 ft	7.14	120	8-150	1-2 m from earth
Vertical	3.8	800	180	0.5 m from base
5-element Yagi at 60 ft	21.2	1000	10-20	In shack
			14	12 m from base
3-element Yagi at 25 ft	28.5	425	8-12	12 m from base
Inverted V at 22-46 ft	7.23	1400	5-27	Below antenna
Vertical on roof	14.11	140	6-9	In house
			35-100	At antenna tuner
Whip on auto roof	146.5	100	22-75	2 m antenna
			15-30	In vehicle
			90	Rear seat
5-element Yagi at 20 ft	50.1	500	37-50	10 m antenna

---

**Table 3.4****RF Awareness Guidelines**

*These guidelines were developed by the ARRL RF Safety Committee, based on the FCC/EPA measurements of Table 3.2 and other data.*

- Although antennas on towers (well away from people) pose no exposure problem, make certain that the RF radiation is confined to the antennas' radiating elements themselves. Provide a single, good station ground (earth), and eliminate radiation from transmission lines. Use good coaxial cable or other feed line properly. Avoid serious imbalance in your antenna system and feed line. For high-powered installations, avoid end-fed antennas that come directly into the transmitter area near the operator.
  - No person should ever be near any transmitting antenna while it is in use. This is especially true for mobile or ground-mounted vertical antennas. Avoid transmitting with more than 25 W in a VHF mobile installation unless it is possible to first measure the RF fields inside the vehicle. At the 1-kW level, both HF and VHF directional antennas should be at least 35 ft above inhabited areas. Avoid using indoor and attic-mounted antennas if at all possible. If open-wire feeders are used, ensure that it is not possible for people (or animals) to come into accidental contact with the feed line.
  - Don't operate high-power amplifiers with the covers removed, especially at VHF/UHF.
  - In the UHF/SHF region, never look into the open end of an activated length of waveguide or microwave feed-horn antenna or point it toward anyone. (If you do, you may be exposing your eyes to more than the maximum permissible exposure level of RF radiation.) Never point a high-gain, narrow-bandwidth antenna (a paraboloid, for instance) toward people. Use caution in aiming an EME (moonbounce) array toward the horizon; EME arrays may deliver an effective radiated power of 250,000 W or more.
  - With hand-held transceivers, keep the antenna away from your head and use the lowest power possible to maintain communications. Use a separate microphone and hold the rig as far away from you as possible. This will reduce your exposure to the RF energy.
  - Don't work on antennas that have RF power applied.
  - Don't stand or sit close to a power supply or linear amplifier when the ac power is turned on. Stay at least 24 inches away from power transformers, electrical fans and other sources of high-level 60-Hz magnetic fields.
- 

sional power-density meters can make useful measurements.

While our primary concern is ordinarily the intensity of the signal radiated by an antenna, we also should remember that there are other potential energy sources to be considered. You also can be exposed to RF radiation directly from a power amplifier if it is operated without proper shielding. Transmission lines also may radiate a significant amount of energy under some conditions. Poor microwave waveguide joints or improperly assembled connectors are another source of incidental radiation.

**FURTHER RF EXPOSURE SUGGESTIONS**

Potential exposure situations should be taken seriously. Based on the FCC/EPA measurements and other data, the "RF awareness" guidelines of Table 3.4 were developed by the ARRL RF Safety Committee. A longer version of these guidelines, along with a complete list of references, appeared in a *QST* article by Ivan Shulman, MD, WC2S ("Is Amateur Radio Hazardous to Our Health?" *QST*, Oct 1989, pp 31-34).

In addition, the ARRL has published a book, *RF Exposure and You*, that is helping hams comply with the FCC's RF-exposure regulations. The ARRL also maintains an RF-exposure news page on its Web site. See [www.arrrl.org/news/rfsafety](http://www.arrrl.org/news/rfsafety). This site contains reprints of selected *QST* articles on RF exposure and links to the FCC and other useful sites.

## Other Hazards in the Ham Shack

### CHEMICALS

We can't seem to live without the use of chemicals, even in the electronics age. A number of substances are used everyday by amateurs without causing ill effects. A sensible approach is to become knowledgeable of the hazards associated with the chemicals we use in our shack and then treat them with respect.

A few key suggestions:

- Read the information that accompanies the chemical and follow the manufacturer's recommended safety practices. If you would like more information than is printed on the label, ask for a material safety data sheet.
- Store chemicals properly away from sunlight and sources of heat. Provide security so they won't fall off the shelf. Secure them so that children and un-

trained persons will not gain access.

- Always keep containers labeled so there is no confusion about the contents. Use the container in which the chemical was purchased.
- Handle chemicals carefully to avoid spills.
- Clean up any spills or leaks promptly but don't overexpose yourself in the process. Never dispose of chemicals in household sinks or drains. Instead, contact your local waste plant operator or fire department to determine the proper disposal procedures for your area. Many communities have household hazardous waste collection programs. Of course, the best solution is to only buy the amount of chemical that you will need, and use it all if possible. Always label any waste chemicals, especially if they are no longer in their

original containers. Oil-filled capacitors and transformers were once commonly filled with oil containing PCB's. Never dispose of any such items that may contain PCB's in landfills.

- Always use recommended personal protective equipment (such as gloves, face shield, splash goggles and aprons).
- If corrosives (acids or caustics) are splashed on you *immediately* rinse with cold water for a minimum of 15 minutes to flush the skin thoroughly. If splashed in the eyes, direct a gentle stream of cold water into the eyes for at least 15 minutes. Gently lift the eyelids so trapped liquids can be flushed completely. Start flushing before removing contaminated clothing. Seek professional medical assistance. It is unwise to work alone since people splashed with chemicals need

- the calm influence of another person.
- Food and chemicals don't mix. Keep food, drinks and cigarettes *away* from areas where chemicals are used and don't bring your chemicals to places where you eat.

**Table 3.5** summarizes the uses and hazards of chemicals used in the ham shack. It includes preventive measures that can minimize risk.

## ERGONOMICS

Ergonomics is a term that loosely means

“fitting the work to the person.” If tools and equipment are designed about what people can accommodate, the results will be much more satisfactory. For example, in the 1930s research was done in telephone equipment manufacturing plants because use of long-nosed pliers for wiring switchboards required considerable force at the end of the hand's range of motion. A simple tool redesign resolved this issue. Considerable attention has been focused on ergonomics in recent years because we have come to realize that long

periods of time spent in unnatural positions can lead to repetitive-motion illness. Much of this attention has been focused on people whose job tasks have required them to operate video display terminals (VDTs). While most Amateur Radio operators do not devote as much time to their hobby as they might in a full-time job, it does make sense to consider comfort and flexibility when choosing furniture and arranging it in the shack or workshop. Adjustable height chairs are available with air cylinders to serve as a shock absorber.

**Table 3.5**  
**Properties and Hazards of Chemicals often used in the Shack or Workshop**

<i>Generic Chemical Name</i>	<i>Purpose or Use</i>	<i>Hazards</i>	<i>Ways to Minimize Risks</i>
Lead-tin solder	Bonding electrical components	<ul style="list-style-type: none"> <li>• Lead exposure (mostly from hand contact)</li> <li>• Flux exposure (inhalation)</li> </ul>	<ul style="list-style-type: none"> <li>• Always wash hands after soldering or touching solder.</li> <li>• Use good ventilation.</li> </ul>
Isopropyl alcohol	Flux remover	<ul style="list-style-type: none"> <li>• Dermatitis (skin rash)</li> <li>• Vapor inhalation</li> <li>• Fire hazard</li> </ul>	<ul style="list-style-type: none"> <li>• Wear molded gloves suitable for solvents.</li> <li>• Use good ventilation and avoid aerosol generation.</li> <li>• Use good ventilation, limit use to small amounts, keep ignition sources away, dispose of rags only in tightly sealed metal cans.</li> </ul>
Freons	Circuit cooling and general solvent	<ul style="list-style-type: none"> <li>• Vapor inhalation</li> <li>• Dermatitis</li> </ul>	<ul style="list-style-type: none"> <li>• Use adequate ventilation.</li> <li>• Wear molded gloves suitable for solvents.</li> </ul>
Phenols and methylene chloride	Enameled wire/	<ul style="list-style-type: none"> <li>• Strong skin corrosive paint stripper</li> </ul>	<ul style="list-style-type: none"> <li>• Avoid skin contact; wear suitable molded gloves; use adequate ventilation.</li> </ul>
Beryllium oxide	Ceramic insulator which can conduct heat well	<ul style="list-style-type: none"> <li>• Toxic when in fine dust form and inhaled</li> </ul>	<ul style="list-style-type: none"> <li>• Avoid grinding, sawing or reducing to dust form.</li> </ul>
Beryllium metal	Lightweight metal, alloyed with copper.	<ul style="list-style-type: none"> <li>• Same as beryllium oxide</li> </ul>	<ul style="list-style-type: none"> <li>• Avoid grinding, sawing, welding, or often reducing to dust. Contact supplier for special procedures.</li> </ul>
Various paints	Finishing	<ul style="list-style-type: none"> <li>• Exposures to solvents</li> <li>• Exposures to sensitizers (especially urethane paint)</li> <li>• Exposure to toxic metals (lead, cadmium, chrome, and so on) in pigments</li> <li>• Fire hazard (especially when spray painting)</li> </ul>	<ul style="list-style-type: none"> <li>• Adequate ventilation; use respirator when spraying.</li> <li>• Adequate ventilation and use respirator. Contact supplier for more info.</li> <li>• Adequate ventilation and use respirator. Contact supplier for more info.</li> <li>• Adequate ventilation; control of residues; eliminate ignition sources.</li> </ul>
Ferric chloride	Printed circuit board etchant	<ul style="list-style-type: none"> <li>• Skin and eye contact</li> </ul>	<ul style="list-style-type: none"> <li>• Use suitable containers; wear splash goggles and molded gloves suitable for acids.</li> </ul>
Ammonium persulphate and mercuric chloride	Printed circuit board etchants	<ul style="list-style-type: none"> <li>• Skin and eye contact</li> </ul>	<ul style="list-style-type: none"> <li>• Use suitable containers; wear splash goggles and molded gloves suitable for acids.</li> </ul>
Epoxy resins	General purpose cement or paint	<ul style="list-style-type: none"> <li>• Dermatitis and possible sensitizer</li> </ul>	<ul style="list-style-type: none"> <li>• Avoid skin contact. Mix only amount needed.</li> </ul>
Sulfuric acid	Electrolyte in lead-acid batteries	<ul style="list-style-type: none"> <li>• Strong corrosive when on skin or eyes.</li> <li>• Will release hydrogen when charging (fire, explosion hazard).</li> </ul>	<ul style="list-style-type: none"> <li>• Always wear splash goggles and molded plastic gloves (PVC) when handling. Keep ignition sources away from battery when charging. Provide adequate ventilation.</li> </ul>

Footrests might come in handy if the chair is so high that your feet cannot support your lower leg weight. The height of tables and keyboards often is not adjustable.

Placement of VDT screens should take into consideration the reflected light coming from windows. It is always wise to build into your sitting sessions time to walk around and stimulate blood circulation. Your muscles are less likely to stiffen, while the flexibility in your joints can be enhanced by moving around.

Selection of hand tools is another area where there are choices to make that may affect how comfortable you will be while working in your shack. Look for screwdrivers with pliable grips. Take into account how heavy things are before picking them up — your back will thank you.

## ENERGIZED CIRCUITS

Working with energized circuits can be very hazardous since our senses cannot directly detect dangerous voltages. The first thing we should ask ourselves when faced with troubleshooting, aligning or other “live” procedures is, “Is there a way to reduce the hazard of electrical shock?” Here are some ways of doing just that.

1. If at all possible, troubleshoot with an ohmmeter. With a reliable schematic diagram and careful consideration of how various circuit conditions may reflect resistance readings, it will often be unnecessary to do live testing.

2. Keep a fair distance from energized circuits. What is considered “good practice” in terms of distance? The *National Electrical Code* specifies minimum working space about electric equipment in Sections 110-16 and 110-34, depending on the voltage level. The principle here is that a person doing live work needs adequate space so they are not forced to be dangerously close to energized equipment.

3. If you need to measure the voltage of a circuit, install the voltmeter with the power safely off, back up, and only then energize the circuit. Remove the power before disconnecting the meter.

4. If you are building equipment that has hinged or easily removable covers that could expose someone to an energized circuit, install interlock switches that safely remove power in the event that the enclosure was opened with the power still on. Interlock switches are generally not used if tools are required to open the enclosure.

5. Never assume that a circuit is at zero potential even if the power is switched off and the power cable disconnected. Capacitors can retain a charge for a considerable period of time. Bleeder resistors should be installed, but don't assume they have bled

## High-Voltage Hazards

### What happens when someone receives an electrical shock?

Electrocutions (fatal electric shocks) usually are caused by the heart ceasing to beat in its normal rhythm. This condition, called ventricular fibrillation, causes the heart muscles to quiver and stop working in a coordinated pattern, in turn preventing the heart from pumping blood.

The current flow that results in ventricular fibrillation varies between individuals but may be in the range of 100 mA to 500 mA. At higher current levels the heart may have less tendency to fibrillate but serious damage would be expected. Studies have shown 60-Hz alternating current to be more hazardous than dc currents. Emphasis is placed on application of cardiopulmonary resuscitation (CPR), as this technique can provide mechanical flow of some blood until paramedics can “restart” the heart's normal beating pattern. Defibrillators actually apply a carefully controlled dc voltage to “shock” the heart back into a normal heartbeat. It doesn't always work but it's the best procedure available.

### What are the most important factors associated with severe shocks?

You may have heard that the current that flows through the body is the most important factor, and this is generally true. The path that current takes through the body affects the outcome to a large degree. While simple application of Ohm's Law tells us that the higher the voltage applied with a fixed resistance, the greater the current that will flow. Most electrical shocks involve skin contact. Skin, with its layer of dead cells and often fatty tissues, is a fair insulator. Nonetheless, as voltage increases the skin will reach a point where it breaks down. Then the lowered resistance of deeper tissues allows a greater current to flow. This is why electrical codes refer to the term “high voltage” as a voltage above 600 V.

### How little a voltage can be lethal?

This depends entirely on the resistance of the two contact points in the circuit, the internal resistance of the body, and the path the current travels through the body. Historically, reports of fatal shocks suggest that as little as 24 V *could* be fatal under extremely adverse conditions. To add some perspective, one standard used to prevent serious electrical shock in hospital operating rooms limits leakage flow from electronic instruments to only 50  $\mu$ A due to the use of electrical devices and related conductors inside the patient's body.

off the voltage. Instead, after power is removed and disconnected use a “shorting stick” to ground all exposed conductors and ensure that voltage is not present. Avoid using screwdrivers, as this brings the amateur too close to the circuit and could ruin the screwdriver's blade.

6. If you must hold a probe to take a measurement, always keep one hand in your pocket. As mentioned in the sidebar on the effects of high voltages, the worst path current could take through your body is from hand to hand since the flow would pass through the chest cavity.

7. Make sure someone is in the room with you and that they know how to remove the power safely. If they grab you with the power still on they will be shocked as well.

8. Test equipment probes and their leads must be in very good condition and rated for the conditions they will encounter.

9. Be wary of the hazards of “floating” (ungrounded) test equipment. A number of options are available to avoid this

hazard. Contact your test equipment manufacturer for suggested procedures.

10. Ground-fault circuit interrupters can offer additional protection for stray currents that flow through the ground on 120-V circuits. Know their limitations. They cannot offer protection for the plate supply voltages in linear amplifiers, for example.

11. Older radio equipment containing ac/dc power supplies have their own hazards. If working on these live, use an isolation transformer, as the chassis may be connected directly to the hot or neutral power conductor.

12. Be aware of electrolytic capacitors that might fail if used outside their intended applications.

13. Replace fuses only with those having proper ratings.

## SUMMARY

The ideas presented in this chapter are intended to reinforce the concept that

ham radio, like many other activities in modern life, does have certain risks. But by understanding the hazards and how to deal effectively with them, the risk can be minimized. Common-sense measures can go a long way to help us prevent accidents. Traditionally, amateurs are inventors, and experimenting is a major part of our nature. But reckless chance-taking is never wise, especially when our health and well-being is involved. A healthy attitude toward doing things the

right way will help us meet our goals and expectations.

#### **BIBLIOGRAPHY**

Source material and more extended discussion of topics covered in this chapter can be found in the references given below. *Lightning Protection Code*, NFPA 780, National Fire Protection Association, Quincy, MA, 1992. *National Electrical Code*, NFPA 70, National Fire Protection Association,

Quincy, MA, 1993. *National Electrical Code* and *NEC* are registered trademarks of the National Fire Protection Association, Inc, Quincy, MA 02269.

R. P. Haviland, "Amateur Use of Telescoping Masts," *QST*, May 1994, pp 41-45. For more information about soldering hazards, symptoms, and protection, see "Making Soldering Safer," by Bryan P. Bergeron, MD, NU1N (Mar 1991 *QST*, pp 28-30) and "More on Safer Soldering," by Gary E. Myers, K9CZB (Aug 1991 *QST*, p 42).