

Chapter 4

Electrical Fundamentals

DC Circuits and Resistance Glossary

Alternating current — A flow of charged particles through a conductor, first in one direction, then in the other direction.

Ampere — A measure of flow of charged particles per unit time. One ampere represents one coulomb of charge flowing past a point in one second.

Atom — The smallest particle of matter that makes up an element. Consists of protons and neutrons in the central area called the nucleus, with electrons surrounding this central region.

Coulomb — A unit of measure of a

quantity of electrically charged particles. One coulomb is equal to 6.25×10^{18} electrons.

Direct current — A flow of charged particles through a conductor in one direction only.

EMF — Electromotive Force is the term used to define the force of attraction between two points of different charge potential. Also called voltage.

Energy — Capability of doing work. It is usually measured in electrical terms as the number of watts of power consumed during a specific period of time, such as

watt-seconds or kilowatt-hours.

Joule — Measure of a quantity of energy. One joule is defined as one newton (a measure of force) acting over a distance of one meter.

Ohm — Unit of resistance. One ohm is defined as the resistance that will allow one ampere of current when one volt of EMF is impressed across the resistance.

Power — Power is the rate at which work is done. One watt of power is equal to one volt of EMF, causing a current of one ampere through a resistor.

Volt — A measure of electromotive force.

Introduction

The DC Circuits and Resistance section of this chapter was written by Roger Taylor, K9ALD.

The atom is the primary building block of the universe. The main parts of the atom include protons, electrons and neutrons. Protons have a positive electrical charge, electrons a negative charge and neutrons have no electrical charge. All atoms are electrically neutral, so they have the same number of electrons as protons. If an atom loses electrons, so it has more protons than electrons, it has a net positive charge. If an atom gains electrons, so it has more electrons than protons, it has a negative charge. Particles with a positive or negative charge are called ions. Free electrons are also called ions, because they have a negative charge.

When there are a surplus number of positive ions in one location and a surplus

number of negative ions (or electrons) in another location, there is an attractive force between the two collections of particles. That force tries to pull the collections together. This attraction is called electromotive force, or EMF.

If there is no path (conductor) to allow electric charge to flow between the two locations, the charges cannot move together and neutralize one another. If a conductor is provided, then electric current (usually electrons) will flow through the conductor.

Electrons move from the negative to the positive side of the voltage, or EMF source. *Conventional current* has the opposite direction, from positive to negative. This comes from an arbitrary decision made by Benjamin Franklin in the 18th century. The conventional current direction is important in establishing the

proper polarity sign for many electronics calculations. Conventional current is used in much of the technical literature. The arrows in semiconductor schematic symbols point in the direction of conventional current, for example.

To measure the quantities of charge, current and force, certain definitions have been adopted. Charge is measured in *coulombs*. One coulomb is equal to 6.25×10^{18} electrons (or protons). Charge flow is measured in *amperes*. One ampere represents one coulomb of charge flowing past a point in one second. Electromotive force is measured in *volts*. One volt is defined as the potential force (electrical) between two points for which one ampere of current will do one *joule* (measure of energy) of work flowing from one point to another. (A joule of work per second represents a power of one watt.)

Voltage can be generated in a variety of ways. Chemicals with certain characteristics can be combined to form a battery. Mechanical motion such as friction (static electricity, lightning) and rotating conductors in a magnetic field (generators) can also produce voltage.

Any conductor between points at different voltages will allow current to pass between the points. No conductor is perfect or lossless, however, at least not at normal temperatures. Charged particles such as electrons resist being moved and it requires energy to move them. The amount of resistance to current is measured in *ohms*.

OHM'S LAW

One ohm is defined as the amount of resistance that allows one ampere of current to flow between two points that have a potential difference of one volt. Thus, we get Ohm's Law, which is:

$$R = \frac{E}{I} \quad (1)$$

where:

- R = resistance in ohms,
- E = potential or EMF in volts and
- I = current in amperes.

Transposing the equation gives the other common expressions of Ohm's Law as:

$$E = I \times R \quad (2)$$

and

$$I = \frac{E}{R} \quad (3)$$

All three forms of the equation are used often in radio work. You must remember that the quantities are in volts, ohms and amperes; other units cannot be used in the equations without first being converted. For example, if the current is in milliamperes you must first change it to the equivalent fraction of an ampere before substituting the value into the equations.

The following examples illustrate the use of Ohm's Law. The current through a 20000- Ω resistance is 150 mA. See **Fig 4.1**. What is the voltage? To find voltage, use equation 2 ($E = I \times R$). Convert the current from milliamperes to amperes. Divide by 1000 mA / A (or multiply by 10^{-3} A / mA) to make this conversion. (Notice the conversion factor of 1000 does not limit the number of significant figures in the calculated answer.)

$$I = \frac{150 \text{ mA}}{1000 \frac{\text{mA}}{\text{A}}} = 0.150 \text{ A}$$

Then:

$$E = 0.150 \text{ A} \times 20000 \Omega = 3000 \text{ V}$$

When 150 V is applied to a circuit, the current is measured at 2.5 A. What is the resistance of the circuit? In this case R is the unknown, so we will use equation 1:

$$R = \frac{E}{I} = \frac{150 \text{ V}}{2.5 \text{ A}} = 60 \Omega$$

No conversion was necessary because the voltage and current were given in volts and amperes.

How much current will flow if 250 V is applied to a 5000- Ω resistor? Since I is unknown,

$$I = \frac{E}{R} = \frac{250 \text{ V}}{5000 \Omega} = 0.05 \text{ A}$$

It is more convenient to express the current in mA, and $0.05 \text{ A} \times 1000 \text{ mA} / \text{A} = 50 \text{ mA}$.

RESISTANCE AND CONDUCTANCE

Suppose we have two conductors of the same size and shape, but of different materials. The amount of current that will flow when a given EMF is applied will vary with the resistance of the material. The lower the resistance, the greater the current for a given EMF. The *resistivity* of a material is the resistance, in ohms, of a cube of the material measuring one centimeter on each edge. One of the best conductors is copper, and in making resistance calculations it is frequently convenient to compare the resistance of the material under consideration with that of a copper conductor of the same size and shape. **Table 4.1** gives the ratio of the resistivity of various conductors to the resistivity of copper.

The longer the physical path, the higher the resistance of that conductor. For direct current and low-frequency alternating currents (up to a few thousand hertz) the resistance is inversely proportional to the cross-sectional area of the path the current must travel; that is, given two conductors of the same material and having the same length, but differing in cross-sectional area, the one with the larger area will have the lower resistance.

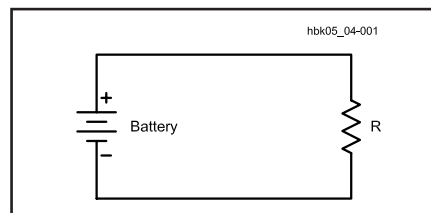

Fig 4.1 — A simple circuit consisting of a battery and a resistor.

Table 4.1

Relative Resistivity of Metals

Material	Resistivity Compared to Copper
Aluminum (pure)	1.60
Brass	3.7-4.90
Cadmium	4.40
Chromium	1.80
Copper (hard-drawn)	1.03
Copper (annealed)	1.00
Gold	1.40
Iron (pure)	5.68
Lead	12.80
Nickel	5.10
Phosphor bronze	2.8-5.40
Silver	0.94
Steel	7.6-12.70
Tin	6.70
Zinc	3.40

tional area, the one with the larger area will have the lower resistance.

RESISTANCE OF WIRES

The problem of determining the resistance of a round wire of given diameter and length—or its converse, finding a suitable size and length of wire to provide a desired amount of resistance—can easily be solved with the help of the copper wire table given in the **Component Data and References** chapter. This table gives the resistance, in ohms per 1000 ft, of each standard wire size. For example, suppose you need a resistance of 3.5 Ω , and some #28 wire is on hand. The wire table in the **Component Data and References** chapter shows that #28 wire has a resistance of 66.17 Ω / 1000 ft. Since the desired resistance is 3.5 Ω , the required wire length is:

$$\text{Length} = \frac{R_{\text{DESIRED}}}{\frac{R_{\text{WIRE}}}{1000 \text{ ft}}} = \frac{3.5 \Omega}{\frac{66.17 \Omega}{1000 \text{ ft}}} = \frac{3.5 \Omega \times 1000 \text{ ft}}{66.17 \Omega} = 53 \text{ ft} \quad (4)$$

As another example, suppose that the resistance of wire in a circuit must not exceed 0.05 Ω and that the length of wire required for making the connections totals 14 ft. Then:

$$\frac{R_{\text{WIRE}}}{1000 \text{ ft}} < \frac{R_{\text{MAXIMUM}}}{\text{Length}} = \frac{0.05 \Omega}{14.0 \text{ ft}} \quad (5)$$

$$= 3.57 \times 10^{-3} \frac{\Omega}{\text{ft}} \times \frac{1000 \text{ ft}}{1000 \text{ ft}}$$

$$\frac{R_{\text{WIRE}}}{1000 \text{ ft}} < \frac{3.57 \Omega}{1000 \text{ ft}}$$

Find the value of $R_{\text{WIRE}} / 1000 \text{ ft}$ that is less than the calculated value. The wire table shows that #15 is the smallest size

having a resistance less than this value. (The resistance of #15 wire is given as $3.1810 \Omega / 1000 \text{ ft.}$) Select any wire size larger than this for the connections in your circuit, to ensure that the total wire resistance will be less than 0.05Ω .

When the wire in question is not made of copper, the resistance values in the wire table should be multiplied by the ratios shown in Table 4.1 to obtain the resulting resistance. If the wire in the first example were made from nickel instead of copper, the length required for 3.5Ω would be:

$$\text{Length} = \frac{R_{\text{DESIRED}}}{\frac{R_{\text{WIRE}}}{1000 \text{ ft}}} \quad (6)$$

$$= \frac{3.5 \Omega}{\frac{66.17 \Omega}{1000 \text{ ft}} \times 5.1}$$

$$= \frac{3.5 \Omega \times 1000 \text{ ft}}{66.17 \Omega \times 5.1}$$

$$\text{Length} = \frac{3500 \text{ ft}}{337.5} = 10.37 \text{ ft}$$

TEMPERATURE EFFECTS

The resistance of a conductor changes with its temperature. The resistance of practically every metallic conductor increases with increasing temperature. Carbon, however, acts in the opposite way; its resistance decreases when its temperature rises. It is seldom necessary to consider temperature in making resistance calculations for amateur work. The temperature effect is important when it is necessary to maintain a constant resistance under all conditions, however. Special materials that have little or no change in resistance over a wide temperature range are used in that case.

RESISTORS

A package of material exhibiting a certain amount of resistance, made up into a single unit is called a resistor. Different resistors having the same resistance value may be considerably different in physical size and construction (see Fig 4.2). Cur-

Fig 4.2 — Examples of various resistors. At the top left is a small 10-W wirewound resistor. A single in-line package (SIP) of resistors is at the top right. At the top center is a small PC-board-mount variable resistor. A tiny surface-mount (chip) resistor is also shown at the top. Below the variable resistor is a 1-W carbon composition resistor and then a ½-W composition unit. The dog-bone-shaped resistors at the bottom are ½-W and ¼-W film resistors. The ¼-inch-ruled graph paper background provides a size comparison. The inset photo shows the chip resistor with a penny for size comparison.

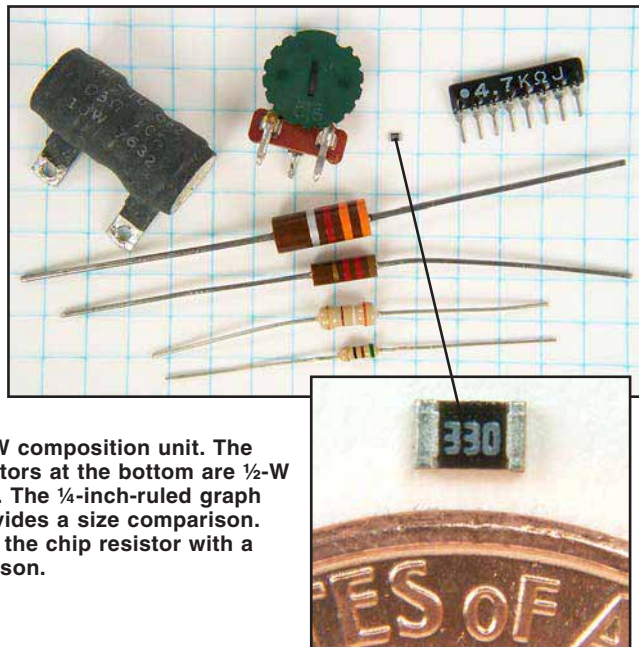

rent through a resistance causes the conductor to become heated; the higher the resistance and the larger the current, the greater the amount of heat developed. Resistors intended for carrying large currents must be physically large so the heat can be radiated quickly to the surrounding air. If the resistor does not dissipate the heat quickly, it may get hot enough to melt or burn.

The amount of heat a resistor can safely dissipate depends on the material, surface area and design. Typical carbon resistors used in amateur electronics ($1/8$ to 2-W resistors) depend primarily on the surface area of the case, with some heat also being carried off through the connecting leads. Wirewound resistors are usually used for higher power levels. Some have finned cases for better convection cooling and/or metal cases for better conductive cooling.

In some circuits, the resistor value may be critical. In this case, precision resistors are used. These are typically wirewound, or carbon-film devices whose values are carefully controlled during manufacture.

In addition, special material or construction techniques may be used to provide temperature compensation, so the value does not change (or changes in a precise manner) as the resistor temperature changes. There is more information about the electrical characteristics of real resistors in the **Real-World Component Characteristics** chapter.

CONDUCTANCE

The reciprocal of resistance ($1/R$) is *conductance*. It is usually represented by the symbol G. A circuit having high conductance has low resistance, and vice versa. In radio work, the term is used chiefly in connection with electron-tube and field-effect transistor characteristics. The unit of conductance is the siemens, abbreviated S. A resistance of 1Ω has a conductance of 1 S, a resistance of 1000Ω has a conductance of 0.001 S, and so on. A unit frequently used in connection with electron devices is the μS or one millionth of a siemens. It is the conductance of a $1\text{-M}\Omega$ resistance.

Series and Parallel Resistances

Very few actual electric circuits are as simple as Fig 4.1. Commonly, resistances are found connected in a variety of ways. The two fundamental methods of connecting resistances are shown in Fig 4.3. In part A, the current flows from the source of EMF (in the direction shown by the ar-

row) down through the first resistance, R1, then through the second, R2 and then back to the source. These resistors are connected in series. The current everywhere in the circuit has the same value.

In part B, the current flows to the common connection point at the top of the two

resistors and then divides, one part of it flowing through R1 and the other through R2. At the lower connection point these two currents again combine; the total is the same as the current into the upper common connection. In this case, the two resistors are connected in parallel.

RESISTORS IN PARALLEL

In a circuit with resistances in parallel, the total resistance is less than that of the lowest resistance value present. This is because the total current is always greater than the current in any individual resistor. The formula for finding the total resistance of resistances in parallel is:

$$R = \frac{1}{\frac{1}{R_1} + \frac{1}{R_2} + \frac{1}{R_3} + \frac{1}{R_4} + \dots} \quad (7)$$

where the dots indicate that any number of resistors can be combined by the same method. For only two resistances in parallel (a very common case) the formula becomes:

$$R = \frac{R_1 \times R_2}{R_1 + R_2} \quad (8)$$

Example: If a 500-Ω resistor is connected in parallel with one of 1200 Ω, what is the total resistance?

$$R = \frac{R_1 \times R_2}{R_1 + R_2} = \frac{500 \Omega \times 1200 \Omega}{500 \Omega + 1200 \Omega}$$

$$R = \frac{600000 \Omega^2}{1700 \Omega} = 353 \Omega$$

KIRCHHOFF'S FIRST LAW (KIRCHHOFF'S CURRENT LAW)

Suppose three resistors (5.00 kΩ, 20.0 kΩ and 8.00 kΩ) are connected in parallel as shown in Fig 4.4. The same EMF, 250 V, is applied to all three resistors. The current in each can be found from

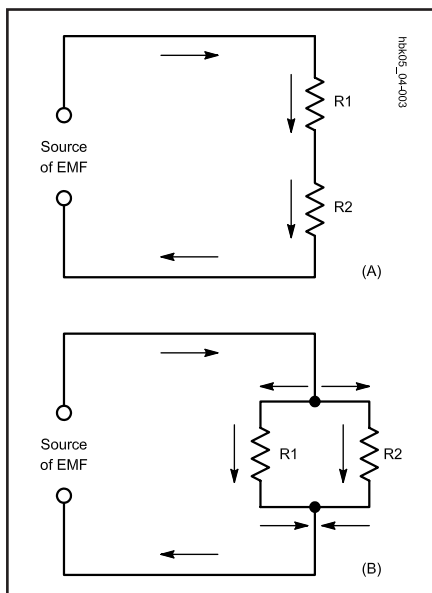

Fig 4.3 — Resistors connected in series at A, and in parallel at B.

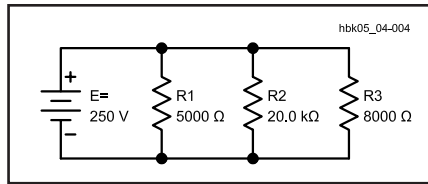

Fig 4.4 — An example of resistors in parallel. See text for calculations.

Ohm's Law, as shown below. The current through R1 is I1, I2 is the current through R2 and I3 is the current through R3.

For convenience, we can use resistance in kΩ, which gives current in milliamperes.

$$I_1 = \frac{E}{R_1} = \frac{250 \text{ V}}{5.00 \text{ k}\Omega} = 50.0 \text{ mA}$$

$$I_2 = \frac{E}{R_2} = \frac{250 \text{ V}}{20.0 \text{ k}\Omega} = 12.5 \text{ mA}$$

$$I_3 = \frac{E}{R_3} = \frac{250 \text{ V}}{8.00 \text{ k}\Omega} = 31.2 \text{ mA}$$

Notice that the branch currents are inversely proportional to the resistances. The 20000-Ω resistor has a value four times larger than the 5000-Ω resistor, and has a current one quarter as large. If a resistor has a value twice as large as another, it will have half as much current through it when they are connected in parallel.

The total circuit current is:

$$I_{\text{TOTAL}} = I_1 + I_2 + I_3 \quad (9)$$

$$I_{\text{TOTAL}} = 50.0 \text{ mA} + 12.5 \text{ mA} + 31.2 \text{ mA}$$

$$I_{\text{TOTAL}} = 93.7 \text{ mA}$$

This example illustrates Kirchhoff's Current Law: The current flowing into a node or branching point is equal to the sum of the individual currents leaving the node or branching point. The total resistance of the circuit is therefore:

$$R = \frac{E}{I} = \frac{250 \text{ V}}{93.7 \text{ mA}} = 2.67 \text{ k}\Omega$$

You can verify this calculation by combining the three resistor values in parallel, using equation 7.

RESISTORS IN SERIES

When a circuit has a number of resistances connected in series, the total resistance of the circuit is the sum of the individual resistances. If these are numbered R1, R2, R3 and so on, then:

$$R_{\text{TOTAL}} = R_1 + R_2 + R_3 + R_4 \dots \quad (10)$$

where the dots indicate that as many resistors as necessary may be added.

Example: Suppose that three resistors are

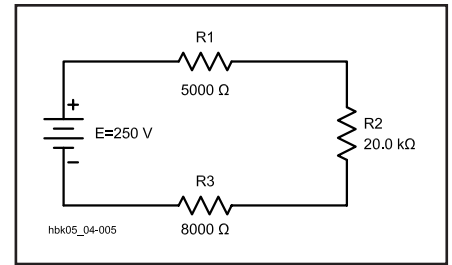

Fig 4.5 — An example of resistors in series. See text for calculations.

connected to a source of EMF as shown in Fig 4.5. The EMF is 250 V, R1 is 5.00 kΩ, R2 is 20.0 kΩ and R3 is 8.00 kΩ. The total resistance is then

$$R_{\text{TOTAL}} = R_1 + R_2 + R_3$$

$$R = 5.00 \text{ k}\Omega + 20.0 \text{ k}\Omega + 8.00 \text{ k}\Omega$$

$$R = 33.0 \text{ k}\Omega.$$

The current in the circuit is then

$$I = \frac{E}{R} = \frac{250 \text{ V}}{33.0 \text{ k}\Omega} = 7.58 \text{ mA}$$

(We need not carry calculations beyond three significant figures; often, two will suffice because the accuracy of measurements is seldom better than a few percent.)

KIRCHHOFF'S SECOND LAW (KIRCHHOFF'S VOLTAGE LAW)

Ohm's Law applies in any portion of a circuit as well as to the circuit as a whole. Although the current is the same in all three of the resistances in the example of Fig 4.5, the total voltage divides between them. The voltage appearing across each resistor (the voltage drop) can be found from Ohm's Law.

Example: If the voltage across R1 is called E1, that across R2 is called E2 and that across R3 is called E3, then

$$E = IR_1 = 0.00758 \text{ A} \times 5000 \Omega = 37.9 \text{ V}$$

$$E = IR_2 = 0.00758 \text{ A} \times 20000 \Omega = 152 \text{ V}$$

$$E = IR_3 = 0.00758 \text{ A} \times 8000 \Omega = 60.6 \text{ V}$$

Notice here that the voltage drop across each resistor is directly proportional to the resistance. The 20000-Ω resistor value is four times larger than the 5000-Ω resistor, and the voltage drop across the 20000-Ω resistor is four times larger. A resistor that has a value twice as large as another will have twice the voltage drop across it when they are connected in series.

Kirchhoff's Voltage Law accurately describes the situation in the circuit: The sum of the voltages in a closed current loop is zero. The resistors are power sinks, while the battery is a power source. It is common to assign a + sign to power sources and a

– sign to power sinks. This means the voltages across the resistors have the opposite sign from the battery voltage. Adding all the voltages yields zero. In the case of a single voltage source, algebraic manipulation implies that the sum of the individual voltage drops in the circuit must be equal to the applied voltage.

$$E_{TOTAL} = E1 + E2 + E3 \quad (11)$$

$$E_{TOTAL} = 37.9 \text{ V} + 152 \text{ V} + 60.6 \text{ V}$$

$$E_{TOTAL} = 250 \text{ V}$$

(Remember the significant figures rule for addition.)

In problems such as this, when the current is small enough to be expressed in milliamperes, considerable time and trouble can be saved if the resistance is expressed in kilohms rather than in ohms. When the resistance in kilohms is substituted directly in Ohm's Law, the current will be milliamperes, if the EMF is in volts.

RESISTORS IN SERIES-PARALLEL

A circuit may have resistances both in parallel and in series, as shown in Fig 4.6A. The method for analyzing such a circuit is as follows: Consider R2 and R3 to be the equivalent of a single resistor, R_{EQ} whose value is equal to R2 and R3 in parallel.

$$R_{EQ} = \frac{R2 \times R3}{R2 + R3} = \frac{20000 \Omega \times 8000 \Omega}{20000 \Omega + 8000 \Omega}$$

$$= \frac{1.60 \times 10^8 \Omega^2}{28000 \Omega}$$

$$R_{EQ} = 5710 \Omega = 5.71 \text{ k}\Omega$$

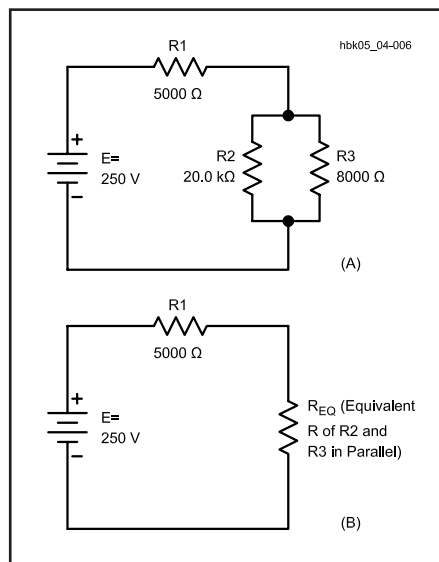

Fig 4.6 — At A, an example of resistors in series-parallel. The equivalent circuit is shown at B. See text for calculations.

This resistance in series with R1 forms a simple series circuit, as shown in Fig 4.6B. The total resistance in the circuit is:

$$R_{TOTAL} = R1 + R_{EQ} = 5.00 \text{ k}\Omega + 5.71 \text{ k}\Omega$$

$$R_{TOTAL} = 10.71 \text{ k}\Omega$$

The current is:

$$I = \frac{E}{R} = \frac{250 \text{ V}}{10.71 \text{ k}\Omega} = 23.3 \text{ mA}$$

The voltage drops across R1 and R_{EQ} are:

$$E1 = I \times R1 = 23.3 \text{ mA} \times 5.00 \text{ k}\Omega = 117 \text{ V}$$

$$E2 = I \times R_{EQ} = 23.3 \text{ mA} \times 5.71 \text{ k}\Omega = 133 \text{ V}$$

with sufficient accuracy. These two voltage drops total 250 V, as described by Kirchhoff's Current Law. E2 appears across both R2 and R3 so,

$$I2 = \frac{E2}{R2} = \frac{133 \text{ V}}{20.0 \text{ k}\Omega} = 6.65 \text{ mA}$$

$$I3 = \frac{E3}{R3} = \frac{133 \text{ V}}{8.00 \text{ k}\Omega} = 16.6 \text{ mA}$$

where:

I2 = current through R2 and

I3 = current through R3.

The sum of I2 and I3 is equal to 23.3 mA, conforming to Kirchhoff's Voltage Law.

THEVENIN'S THEOREM

Thevenin's Theorem is a useful tool for simplifying electrical networks. Thevenin's Theorem states that any two-terminal network of resistors and voltage or current sources can be replaced by a single voltage source and a series resistor. Such a transformation can simplify the calculation of current through a parallel branch. Thevenin's Theorem can be readily applied to the circuit of Fig 4.6A, to find the current through R3.

In this example, R1 and R2 form a voltage divider circuit, with R3 as the load (Fig 4.7A). The current drawn by the load (R3) is simply the voltage across R3, divided by its resistance. Unfortunately, the value of R2 affects the voltage across R3, just as the presence of R3 affects the potential appearing across R2. Some means of separating the two is needed; hence the Thevenin-equivalent circuit.

The voltage of the Thevenin-equivalent battery is the open-circuit voltage, measured when there is no current from either terminal A or B. Without a load connected between A and B, the total current through the circuit is (from Ohm's Law):

$$I = \frac{E}{R1 + R2} \quad (12)$$

and the voltage between terminals A and B (E_{AB}) is:

$$E_{AB} = I \times R2 \quad (13)$$

By substituting the first equation into the second, we can find a simplified expression for E_{AB}:

$$E_{AB} = \frac{R2}{R1 + R2} \times E \quad (14)$$

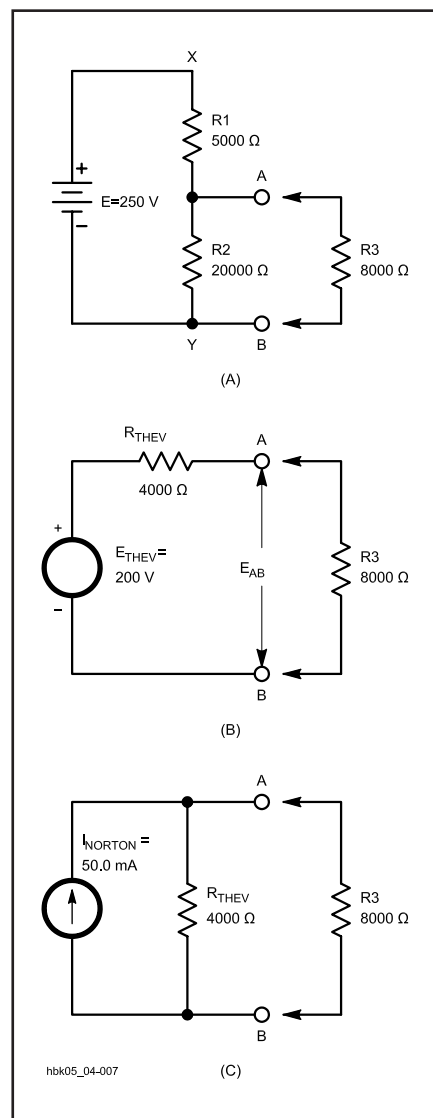

Fig 4.7 — Equivalent circuits for the circuit shown in Fig 4.6. A shows the load resistor (R3) looking into the circuit. B shows the Thevenin-equivalent circuit, with a resistor and a voltage source in series. C shows the Norton-equivalent circuit, with a resistor and current source in parallel.

Using the values in our example, this becomes:

$$E_{AB} = \frac{20.0 \text{ k}\Omega}{25.0 \text{ k}\Omega} \times 250 \text{ V} = 200 \text{ V}$$

when nothing is connected to terminals A or B. With no current drawn, E is equal to E_{AB} .

The Thevenin-equivalent resistance is the total resistance between terminals A and B. The ideal voltage source, by definition, has zero internal resistance. Assuming the battery to be a close approximation of an ideal source, put a short between points X and Y in the circuit of Fig 4.7A. R1 and R2 are then effectively placed in parallel, as viewed from terminals A and B. The Thevenin-equivalent resistance is then:

$$R_{THEV} = \frac{R1 \times R2}{R1 + R2} \quad (15)$$

$$R_{THEV} = \frac{5000 \Omega \times 20000 \Omega}{5000 \Omega + 20000 \Omega}$$

$$R_{THEV} = \frac{1.00 \times 10^8 \Omega^2}{25000 \Omega} = 4000 \Omega$$

This gives the Thevenin-equivalent circuit as shown in Fig 4.7B. The circuits of Figures 4.7A and 4.7B are equivalent as far as R3 is concerned.

Once R3 is connected to terminals A and

B, there will be current through R_{THEV} , causing a voltage drop across R_{THEV} and reducing E_{AB} . The current through R3 is equal to

$$I3 = \frac{E_{THEV}}{R_{TOTAL}} = \frac{E_{THEV}}{R_{THEV} + R3} \quad (16)$$

Substituting the values from our example:

$$I3 = \frac{200 \text{ V}}{4000 \Omega + 8000 \Omega} = 16.7 \text{ mA}$$

This agrees with the value calculated earlier.

NORTON'S THEOREM

Norton's Theorem is another tool for analyzing electrical networks. Norton's Theorem states that any two-terminal network of resistors and current or voltage sources can be replaced by a single current source and a parallel resistor. Norton's Theorem is to current sources what Thevenin's Theorem is to voltage sources. In fact, the Thevenin resistance calculated previously is also used as the Norton equivalent resistance.

The circuit just analyzed by means of Thevenin's Theorem can be analyzed just as easily by Norton's Theorem. The equivalent Norton circuit is shown in Fig 4.7C. The current I_{SC} of the equivalent current source is the short-circuit current

through terminals A and B. In the case of the voltage divider shown in Fig 4.7A, the short-circuit current is:

$$I_{SC} = \frac{E}{R1} \quad (17)$$

Substituting the values from our example, we have:

$$I_{SC} = \frac{E}{R1} = \frac{250 \text{ V}}{5000 \Omega} = 50.0 \text{ mA}$$

The resulting Norton-equivalent circuit consists of a 50.0-mA current source placed in parallel with a 4000- Ω resistor. When R3 is connected to terminals A and B, one-third of the supply current flows through R3 and the remainder through R_{THEV} . This gives a current through R3 of 16.7 mA, again agreeing with previous conclusions.

A Norton-equivalent circuit can be transformed into a Thevenin-equivalent circuit and vice versa. The equivalent resistor stays the same in both cases; it is placed in series with the voltage source in the case of a Thevenin-equivalent circuit and in parallel with the current source in the case of a Norton-equivalent circuit. The voltage for a Thevenin-equivalent source is equal to the no-load voltage appearing across the resistor in the Norton-equivalent circuit. The current for a Norton-equivalent source is equal to the short-circuit current provided by the Thevenin source.

Power and Energy

Regardless of how voltage is generated, energy must be supplied if current is drawn from the voltage source. The energy supplied may be in the form of chemical energy or mechanical energy. This energy is measured in joules. One joule is defined from classical physics as the amount of energy or work done when a force of one newton (a measure of force) is applied to an object that is moved one meter in the direction of the force.

Power is another important concept. In the USA, power is often measured in horsepower in mechanical systems. We use the metric power unit of watts in electrical systems, however. In metric countries, mechanical power is usually expressed in watts also. One watt is defined as the use (or generation) of one joule of energy per second. One watt is also defined as one volt of potential pushing one ampere of current through a resistance. Thus,

$$P = I \times E \quad (18)$$

where:

P = power in watts

I = current in amperes

E = EMF in volts.

When current flows through a resistance, the electrical energy is turned into heat. Common fractional and multiple units for power are the milliwatt (one thousandth of a watt) and the kilowatt (1000 W).

Example: The plate voltage on a transmitting vacuum tube is 2000 V and the plate current is 350 mA. (The current must be changed to amperes before substitution in the formula, and so is 0.350 A.) Then:

$$P = I \times E = 2000 \text{ V} \times 0.350 \text{ A} = 700 \text{ W}$$

By substituting the Ohm's Law equivalent for E and I, the following formulas are obtained for power:

$$P = \frac{E^2}{R} \quad (19)$$

and

$$P = I^2 \times R \quad (20)$$

These formulas are useful in power calculations when the resistance and either the current or voltage (but not both) are known.

Example: How much power will be converted to heat in a 4000- Ω resistor if the potential applied to it is 200 V? From equation 19,

$$P = \frac{E^2}{R} = \frac{40000 \text{ V}^2}{4000 \Omega} = 10.0 \text{ W}$$

As another example, suppose a current

of 20 mA flows through a 300-Ω resistor. Then:

$$P = I^2 \times R = 0.020^2 \text{ A}^2 \times 300 \Omega$$

$$P = 0.00040 \text{ A}^2 \times 300 \Omega$$

$$P = 0.12 \text{ W}$$

Note that the current was changed from milliamperes to amperes before substitution in the formula.

Electrical power in a resistance is turned into heat. The greater the power, the more rapidly the heat is generated. Resistors for radio work are made in many sizes, the smallest being rated to dissipate (or carry safely) about $\frac{1}{16}$ W. The largest resistors commonly used in amateur equipment will dissipate about 100 W. Large resistors, such as those used in dummy-load antennas, are often cooled with oil to increase their power-handling capability.

If you want to express power in horsepower instead of watts, the following relationship holds:

$$1 \text{ horsepower} = 746 \text{ W} \quad (21)$$

This formula assumes lossless transformation; practical efficiency is taken up shortly. This formula is especially useful if you are working with a system that converts electrical energy into mechanical energy, and vice versa, since mechanical power is often expressed in horsepower, in the US.

This discussion relates to direct current in resistive circuits. See the **AC Theory and Reactive Components** section of this chapter for a discussion about power in ac circuits, including reactive circuits.

GENERALIZED DEFINITION OF RESISTANCE

Electrical energy is not always turned into heat. The energy used in running a motor, for example, is converted to mechanical motion. The energy supplied to a radio transmitter is largely converted into radio waves. Energy applied to a loudspeaker is changed into sound waves. In each case, the energy is converted to other forms and can be completely accounted for. None of the energy *just disappears!* This is a statement of the Law of Conservation of Energy. When a device converts energy from one form to another, we often say it *dissipates* the energy, or power. (Power is energy divided by time.) Of course the device doesn't really "use up" the energy, or make it disappear, it just converts it to another form. Proper operation of electrical devices often requires that the power must be supplied at a specific ratio of voltage to current. These fea-

The Ohm's Law and Power Circle

During the first semester of my *Electrical Power Technology* program, one of the first challenges issued by our dedicated instructor—Roger Crier—to his new freshman students was to identify and develop 12 equations or formulas that could be used to determine voltage, current, resistance and power. Ohm's Law is expressed as

$$R = \frac{E}{I}$$

and it provided three of these equation forms while the basic equation relating power to current and voltage ($P = I \times E$) accounted for another three. With six known equations, it was just a matter of applying mathematical substitution for his students to develop the remaining six. Together, these 12 equations compose the

circle or *wheel* of voltage (E), current (I), resistance (R) and power (P) shown in **Fig A**. Just as Roger's previous students had learned at the Worcester Industrial Technical Institute (Worcester, Massachusetts), our Class of '82 now held the basic electrical formulas needed to proceed in our studies or professions. As can be seen in Fig A, we can determine any one of these four electrical quantities by knowing the value of any two others. You may want to keep this page bookmarked for your reference. You'll probably be using many of these formulas as the years go by—this has certainly been my experience—*Dana G. Reed, W1LC, ARRL Handbook Editor*

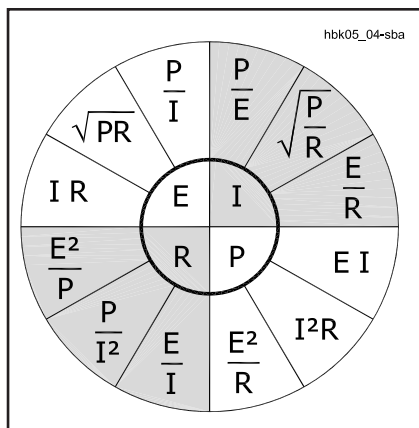

Fig A—Electrical formulas.

tures are characteristics of resistance, so it can be said that any device that "dissipates power" has a definite value of resistance.

This concept of resistance as something that absorbs power at a definite voltage-to-current ratio is very useful; it permits substituting a simple resistance for the load or power-consuming part of the device receiving power, often with considerable simplification of calculations. Of course, every electrical device has some resistance of its own in the more narrow sense, so a part of the energy supplied to it is converted to heat in that resistance even though the major part of the energy may be converted to another form.

EFFICIENCY

In devices such as motors and vacuum tubes, the objective is to convert the supplied energy (or power) into some form other than heat. Therefore, power converted to heat is considered to be a loss, because it is not useful power. The efficiency of a device is the useful power output (in its converted form) divided by the power input to the device. In a vacuum-tube transmitter, for example, the objective is to convert power from a dc source into ac power at some radio frequency. The ratio of the RF power output to the dc input is the efficiency of the tube. That is:

$$\text{Eff} = \frac{P_O}{P_I} \quad (22)$$

where:

Eff = efficiency (as a decimal)

P_O = power output (W)

P_I = power input (W).

Example: If the dc input to the tube is 100 W, and the RF power output is 60 W, the efficiency is:

$$\text{Eff} = \frac{P_O}{P_I} = \frac{60 \text{ W}}{100 \text{ W}} = 0.6$$

Efficiency is usually expressed as a percentage — that is, it tells what percent of the input power will be available as useful output. To calculate percent efficiency, just multiply the value from equation 22 by 100%. The efficiency in the example above is 60%.

Suppose a mobile transmitter has an RF power output of 100 W with 52% efficiency at 13.8 V. The vehicle's alternator system charges the battery at a 5.0-A rate at this voltage. Assuming an alternator efficiency of 68%, how much horsepower must the engine produce to operate the transmitter and charge the battery? Solution: To charge the battery, the alternator

must produce $13.8 \text{ V} \times 5.0 \text{ A} = 69 \text{ W}$. The transmitter dc input power is $100 \text{ W} / 0.52 = 190 \text{ W}$. Therefore, the total electrical power required from the alternator is $190 + 69 = 260 \text{ W}$. The engine load then is:

$$P_1 = \frac{P_O}{\text{Eff}} = \frac{260 \text{ W}}{0.68} = 380 \text{ W}$$

We can convert this to horsepower using the formula given earlier to convert between horsepower and watts:

$$380 \text{ W} \times \frac{1 \text{ horsepower}}{746 \text{ W}} = 0.51 \text{ horsepower}$$

ENERGY

When you buy electricity from a power company, you pay for electrical energy, not power. What you pay for is the *work*

that electricity does for you, not the rate at which that work is done. Work is equal to power multiplied by time. The common unit for measuring electrical energy is the watt-hour, which means that a power of 1 W has been used for one hour. That is:

$$\text{W hr} = P T$$

where:

W hr = energy in watt-hours

P = power in watts

T = time in hours.

Actually, the watt-hour is a fairly small energy unit, so the power company bills you for kilowatt-hours of energy used. Another energy unit that is sometimes useful is the watt-second (joule).

Energy units are seldom used in amateur practice, but it is obvious that a small amount of power used for a long time can

eventually result in a power bill that is just as large as if a large amount of power had been used for a very short time.

One practical application of energy units is to estimate how long a radio (such as a hand-held unit) will operate from a certain battery. For example, suppose a fully charged battery stores 900 mA hr of energy, and a radio draws 30 mA on receive. You might guess that the radio will receive 30 hrs with this battery, assuming 100% efficiency. You shouldn't expect to get the full 900 mA hr out of the battery, and you will probably spend some of the time transmitting, which will also reduce the time the battery will last. The **Real-World Component Characteristics** and **Power Supplies** chapters include additional information about batteries and their charge/discharge cycles.

Circuits and Components

SERIES AND PARALLEL CIRCUITS

Passive components (resistors for dc circuits) can be used to make voltage and current dividers and limiters to obtain a desired value. For instance, in **Fig 4.8A**, two resistors are connected in series to provide a voltage divider. As long as the device connected at point A has a much higher resistance than the resistors in the divider, the voltage will be approximately the ratio of the resistances. Thus, if $E = 10 \text{ V}$, $R_1 = 5 \Omega$ and $R_2 = 5 \Omega$, the voltage at point A will be 5 V measured on a high-impedance voltmeter. A good rule of thumb is that the load at point A should be at least ten times the value of the highest resistor in the divider to get reasonably close to the voltage you want. As the load resistance gets closer to the value of the divider, the current drawn by the load affects the division and causes changes from the desired value. If you need precise voltage division from fixed resistors and know the value of the load resistance, you can use Kirchhoff's Laws and Thevenin's Theorem (explained earlier) to calculate exact values.

Similarly, resistors can be used, as shown in **Fig 4.8B**, to make current dividers. Suppose you had two LEDs (light emitting diodes) and wanted one to glow twice as brightly as the other. You could use one resistor with twice the value of the other for the dimmer LED. Thus, approximately two-thirds of the current would flow through one LED and one-third through the other (neglecting any effect of the 0.7-V drop across the diode).

Resistors can also be used to limit the current through a device from a fixed voltage source. A typical example is shown in **Fig 4.8C**. Here a high-voltage source feeds a battery in a battery charger. This is typical of nickel cadmium chargers. The high resistor value limits the current that can possibly flow through the battery to a value that is low enough so it will not damage the battery.

SWITCHES

Switches are used to start or stop a signal (current) flowing in a particular circuit. Most switches are mechanical devices, although the same effect may be achieved with solid-state devices. Relays are switches that are controlled by another electrical signal rather than manual or mechanical means.

Switches come in many different forms and a wide variety of ratings. The most important ratings are the voltage and current handling capabilities. The voltage rating usually includes both the breakdown rating and the interrupt rating. Normally, the interrupt rating is the lower value, and therefore the one given on (for) the switch. The current rating includes both the current carrying capacity and the interrupt capability.

Most power switches are rated for alternating current use. Because ac voltage goes through zero with each cycle, switches can successfully interrupt much more alternating current than direct current without arcing. A switch that has a 10-A ac current rating may arc and dam-

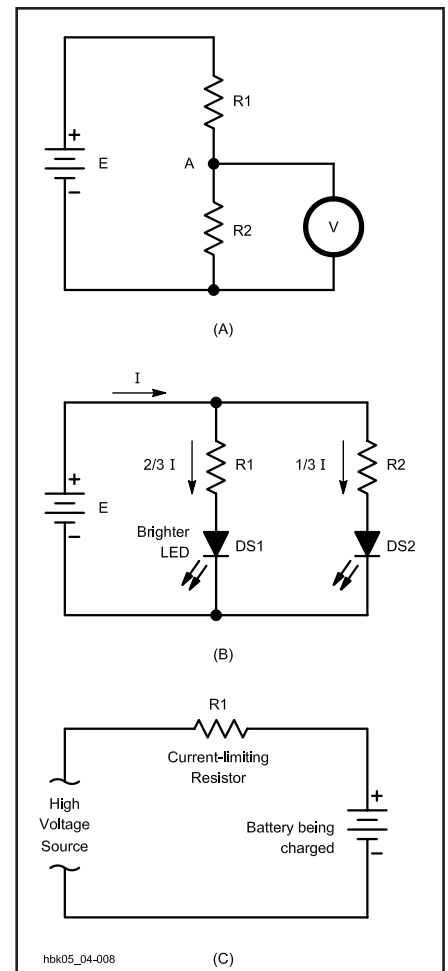

Fig 4.8 — This circuit shows a resistive voltage divider at A, a resistive current divider at B, and a current-limiting resistor at C.

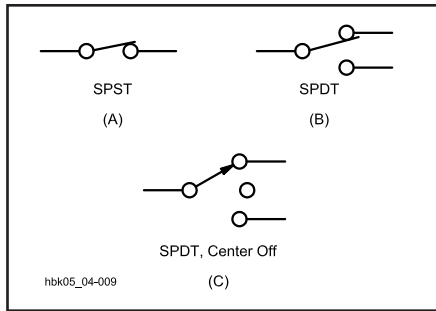

Fig 4.9 — Schematic diagrams of various types of switches. A is an SPST, B is an SPDT, and C is an SPDT switch with a center-off position.

age the contacts if used to turn off more than an ampere or two of dc.

Switches are normally designated by the number of *poles* (circuits controlled) and *positions* (circuit path choices). The simplest switch is the on-off switch, which is a single-pole, single-throw (SPST) switch as shown in **Fig 4.9A**. The off position does not direct the current to another circuit. The next step would be to change the current path to another path. This would be a single-pole, double-throw (SPDT) switch as shown in **Fig 4.9B**. Adding an off position would give a single-pole, double-throw, center-off switch as shown in **Fig 4.9C**.

Several such switches can be “ganged” to the same mechanical activator to provide double pole, triple pole or even more, separate control paths all activated at once. Switches can be activated in a variety of ways. The most common methods include lever, push button and rotary switches. Samples of these are shown in **Fig 4.10**. Most switches stay in the position set, but some are spring loaded so they only stay in the desired position while held there. These are called momentary switches.

Switches typically found in the home are usually rated for 125 V ac and 15 to 20 A. Switches in cars are usually rated for 12 V dc and several amperes. The breakdown voltage rating of a switch, which is usually higher than the interrupt rating, primarily depends on the insulating material surrounding the contacts and the separation between the contacts. Plastic or phenolic material normally provides both structural support and insulation. Ceramic material may be used to provide better insulation, particularly in rotary (wafer) switches.

The current carrying capacity of the switch depends on the contact material and size and on the pressure between the contacts. It is primarily determined from the

allowable contact temperature rise. On larger ac switches, or most dc switches, the interrupt capability may be lower than the current carrying value.

Rotary/wafer switches can provide very complex switching patterns. Several poles (separate circuits) can be included on each wafer. Many wafers may be stacked on the same shaft. Not only may many different circuits be controlled at once, but by wiring different poles/positions on different wafers together, a high degree of circuit switching logic can be developed. Such switches can select different paths as they are turned and can also “short” together successive contacts to connect numbers of components or paths. They can also be designed to either break one contact before making another, or to short two contacts together before disconnecting the first one (make before break) to eliminate arcing or perform certain logic functions.

In choosing a switch for a particular task, consideration should be given to function, voltage and current ratings, ease of use, availability and cost. If a switch is to be operated frequently, a slightly higher cost for a better-quality switch is usually less costly over the long run. If signal noise or contact corrosion is a potential problem, (usually in low-current signal applications) it is best to get gold plated contacts. Gold does not oxidize or corrode, thus providing surer contact, which can be particularly important at very low signal levels. Gold plating will not hold up under high-current-interrupt applications, however.

FUSES

Fuses self-destruct to protect circuit wiring or equipment. The fuse element that melts is a carefully shaped piece of soft metal, usually mounted in a cartridge of some kind. The element is designed to safely carry a given amount of current and to melt at a current value that is a certain

percentage over the rated value. The melting value depends on the type of material, the shape of the element and the heat dissipation capability of the cartridge and holder, among other factors. Some fuses (Slo-blo) are designed to carry an overload for a short period of time. They typically are used in motor starting and power-supply circuits that have a large inrush current when first started. Other fuses are designed to blow very quickly to protect delicate instruments and solid-state circuits. A replacement fuse should have the same current rating and the same characteristics as the fuse it replaces. **Fig 4.11** shows a variety of fuse types and sizes.

The most important fuse rating is the nominal current rating that it will safely carry. Next most important are the timing characteristics, or how quickly it opens under a given current overload. A fuse also has a voltage rating, both a value in volts and whether it is expected to be used in ac or dc circuits. While you should never substitute a fuse with a higher current rating than the one it replaces, you can use a fuse with a higher voltage rating. There is no danger in replacing a 12-V, 2-A fuse with a 250-V, 2-A unit.

Fuses fail for several reasons. The most obvious reason is that a problem develops in the circuit, which causes too much current to flow. In this case, the circuit problem needs to be fixed. A fuse may just fail eventually, particularly when cycled on and off near its current rating. A kind of metal fatigue sets in, and eventually the fuse goes. A fuse can also blow because of a momentary power surge, or even turning something on and off several times quickly when there is a large inrush current. In these cases it is only necessary to replace the fuse with the same type and value. Never substitute a fuse with a larger current rating. You may cause permanent

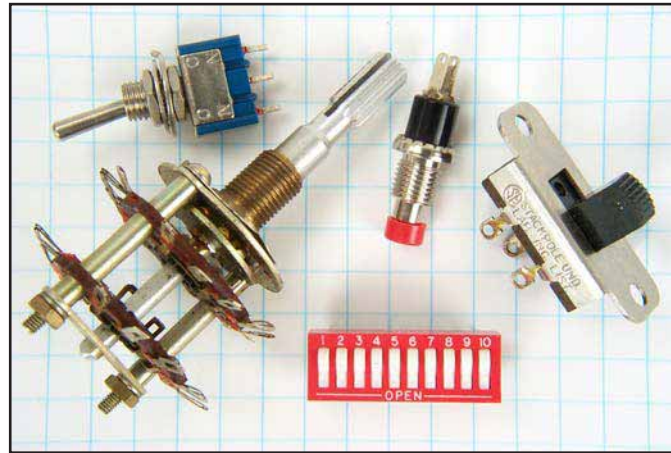

Fig 4.10 — This photo shows examples of various styles of switches. The ¼-inch-ruled graph paper background provides for size comparison.

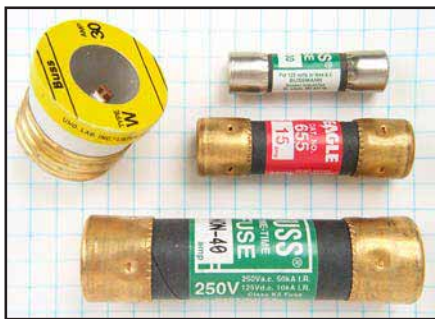

Fig 4.11 — These photos show examples of various styles of fuses. The ¼-inch-ruled graph paper background provides a size comparison.

damage (maybe even a fire) to the wiring or circuit elements if/when there is an internal problem in the equipment.

RELAYS

Relays are switches that are driven by an electrical signal, usually through a magnetic coil. An armature that moves when current is applied pushes the switch contacts together, or pulls them apart. Many such contacts can be connected to the same armature, allowing many circuits to be controlled by a single signal. Usually, relays have only two positions (opening some contacts and closing others) although there are special cases.

Like switches, relays have specific voltage and current ratings for the contacts. These may be far different from the voltage and current of the coil that drives the relay. That means a small signal voltage might control very large values of voltage and/or current. Relay contacts (and housings) may be designed for ac, dc or RF signals. The control voltages are usually 12 V dc or 125 V ac for most amateur

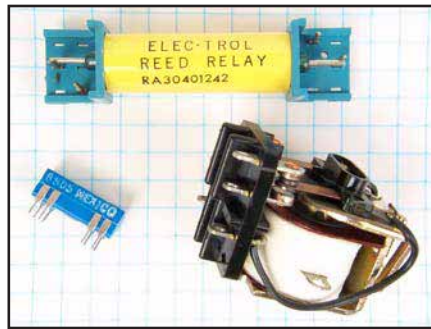

(A)

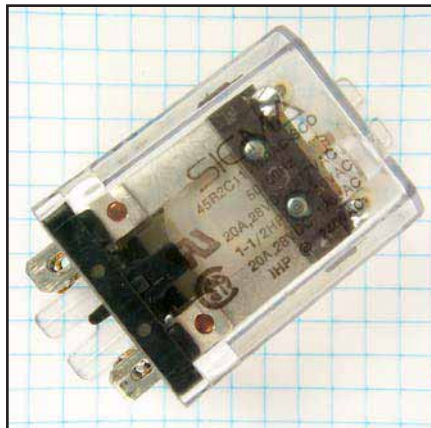

(B)

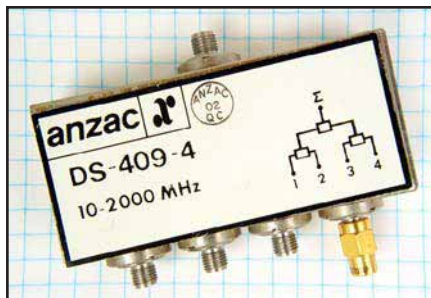

(C)

Fig 4.12 — These photos show examples of various styles and sizes of relays. Photo A shows a large reed relay, and a small reed relay in a package the size of a DIP IC. The contacts and coil can clearly be seen in the open-frame relay. Photo B shows a relay inside a plastic case. Photo C shows a four-position relay with SMA coaxial connectors. The ¼-inch-ruled graph paper background provides a size comparison.

applications, but the coils may be designed to be “current sensing” and operate when the current through the coil exceeds a specific value. **Fig 4.12** shows some typical relays found in amateur equipment. Relays with 24- and 28-V coils are also common.

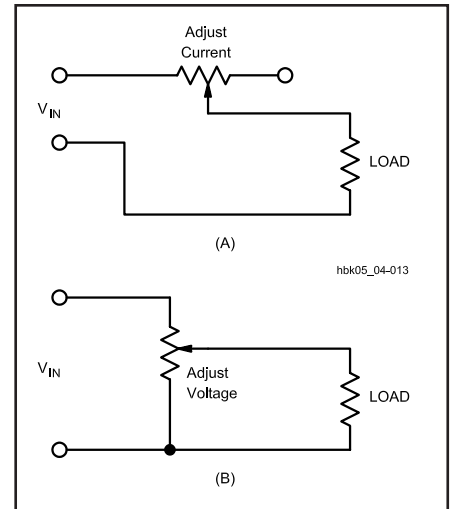

Fig 4.13 — Various uses of potentiometers.

Coaxial relays are specially designed to handle RF signals and to maintain a characteristic impedance to match certain values of coaxial-cable impedance. They typically are used to switch an antenna between a receiver and transmitter or between a linear amplifier and a transceiver.

POTENTIOMETERS

Potentiometer is a big name for a variable resistor. They are commonly used as volume controls on radios, televisions and stereos. A typical potentiometer is a circular pattern of resistive material, usually a carbon compound, that has a wiper on a shaft moving across the material. For higher power applications, the resistive material may be wire, wound around a core. As the wiper moves along the material, more resistance is introduced between the wiper and one of the fixed contacts on the material. A potentiometer may be used primarily to control current, voltage or resistance in a circuit. **Fig 4.13** shows several circuits to demonstrate various uses. **Fig 4.14** shows several different types of potentiometers.

Typical specifications for a potentiometer include maximum resistance, power dissipation, voltage and current ratings, number of turns (or degrees) the shaft can rotate, type and size of shaft, mounting arrangements and resistance “taper.”

Not all potentiometers have a *linear* taper. That is, the resistance may not be the same for a given number of degrees of shaft rotation along different portions of the resistive material. A typical use of a potentiometer with a nonlinear taper is as

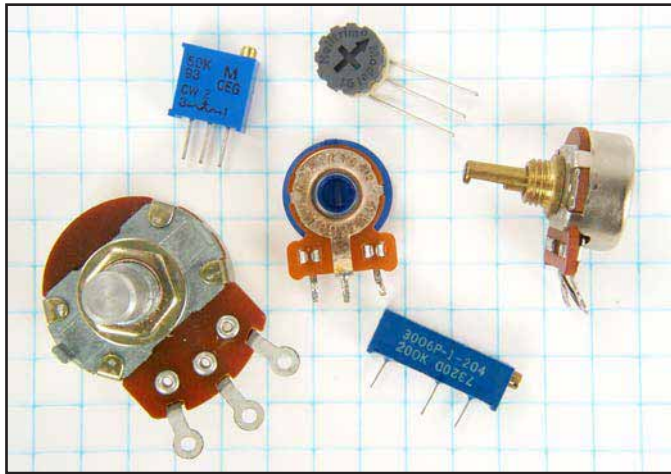

Fig 4.14 — This photo shows examples of different styles of potentiometers. The ¼ -inch-ruled graph paper background provides a size comparison.

a volume control. Since the human ear has a logarithmic response to sound, a volume control may actually change the volume (resistance) much more near one end of the potentiometer than the other (for a given amount of rotation) so that the “perceived” change in volume is about the same for a similar change in the control. This is commonly called an “audio taper” as the change in resistance per degree of rotation attempts to match the response of the human ear. The taper can be designed to match almost any desired control function for a given application. Linear and audio tapers are the most common.

AC Theory and Reactance Glossary

Admittance (Y) — The reciprocal of impedance, measured in siemens (S).

Capacitance (C) — The ability to store electrical energy in an electrostatic field, measured in farads (F). A device with capacitance is a capacitor.

Conductance (G) — The reciprocal of resistance, measured in siemens (S).

Current (I) — The rate of electron flow through a conductor, measured in amperes (A).

Flux density (B) — The number of magnetic-force lines per unit area, measured in gauss.

Frequency (f) — The rate of change of an ac voltage or current, measured in cycles per second, or hertz (Hz).

Impedance (Z) — The complex combination of resistance and reactance, measured in ohms (Ω).

Inductance (L) — The ability to store electrical energy in a magnetic field, measured in henrys (H). A device, such as a coil, with inductance is an inductor.

Peak (voltage or current) — The maximum value relative to zero that an ac voltage or current attains during any cycle.

Peak-to-peak (voltage or current) — The value of the total swing of an ac voltage or current from its peak negative value to its peak positive value, ordinarily twice

the value of the peak voltage or current.

Period (T) — The duration of one ac voltage or current cycle, measured in seconds (s).

Permeability (μ) — The ratio of the magnetic flux density of an iron, ferrite, or similar core in an electromagnet compared to the magnetic flux density of an air core, when the current through the electromagnet is held constant.

Power (P) — The rate of electrical-energy use, measured in watts (W).

Q (quality factor) — The ratio of energy stored in a reactive component (capacitor or inductor) to the energy dissipated, equal to the reactance divided by the resistance.

Reactance (X) — Opposition to alternating current by storage in an electrical field (by a capacitor) or in a magnetic field (by an inductor), measured in ohms (Ω).

Resistance (R) — Opposition to current by conversion into other forms of energy, such as heat, measured in ohms (Ω).

Resonance — Ordinarily, the condition in an ac circuit containing both capacitive and inductive reactance in which the reactances are equal.

RMS (voltage or current) — Literally, “root mean square,” the square root of the

average of the squares of the instantaneous values for one cycle of a waveform. A dc voltage or current that will produce the same heating effect as the waveform. For a sine wave, the RMS value is equal to 0.707 times the peak value of ac voltage or current.

Susceptance (B) — The reciprocal of reactance, measured in siemens (S).

Time constant (τ) — The time required for the voltage in an RC circuit or the current in an RL circuit to rise from zero to approximately 63.2% of its maximum value or to fall from its maximum value 63.2% toward zero.

Toroid — Literally, any donut-shaped solid; most commonly referring to ferrite or powdered-iron cores supporting inductors and transformers.

Transducer — Any device that converts one form of energy to another; for example an antenna, which converts electrical energy to electromagnetic energy or a speaker, which converts electrical energy to sonic energy.

Transformer — A device consisting of at least two coupled inductors capable of transferring energy through mutual inductance.

Voltage (E) — Electromotive force or electrical pressure, measured in volts (V).

AC Theory and Reactive Components

AC IN CIRCUITS

A circuit is a complete conductive route for electrons to follow from a source, through a load and back to the source. If the source permits the electrons to flow in only one direction, the current is *dc* or *direct current*. If the source permits the current periodically to change direction, the current is *ac* or *alternating current*. **Fig 4.15** illustrates the two types of circuits. Drawing A shows the source as a battery, a typical dc source. Drawing B shows a more abstract source symbol to indicate ac. In an ac circuit, not only does the current change direction periodically; the voltage also periodically reverses. The rate of reversal may range from a few times per second to many billions per second.

Graphs of current or voltage, such as Fig 4.15, begin with a horizontal axis that represents time. The vertical axis represents the amplitude of the current or the voltage, whichever is graphed. Distance above the zero line means a greater positive amplitude; distance below the zero line means a greater negative amplitude. Positive and negative simply designate the opposing directions in which current may flow in an

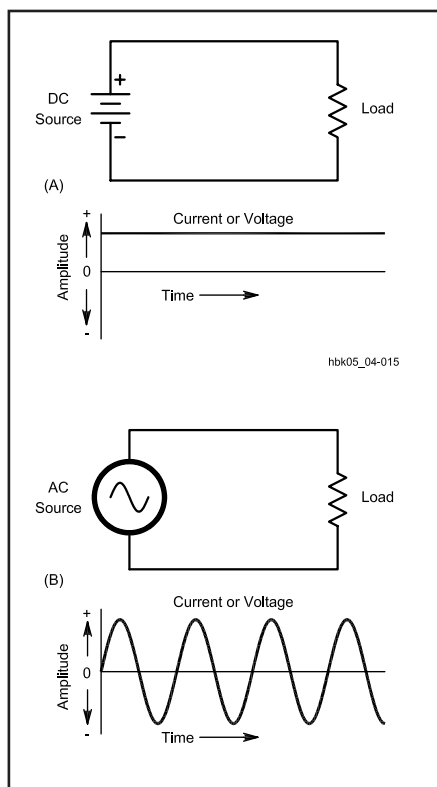

Fig 4.15 — Basic circuits for direct and alternating currents. With each circuit is a graph of the current, constant for the dc circuit, but periodically changing direction in the ac circuit.

alternating current circuit or the opposing directions of force of an ac voltage.

If the current and voltage never change direction, then from one perspective, we have a dc circuit, even if the level of dc constantly changes. **Fig 4.16** shows a current that is always positive with respect to 0. It varies periodically in amplitude, however. Whatever the shape of the variations, the current can be called *pulsating dc*. If the current periodically reaches 0, it can be called *intermittent dc*. From another perspective, we may look at intermittent and pulsating dc as a combination of an ac and a dc current. Special circuits can separate the two currents into ac and dc com-

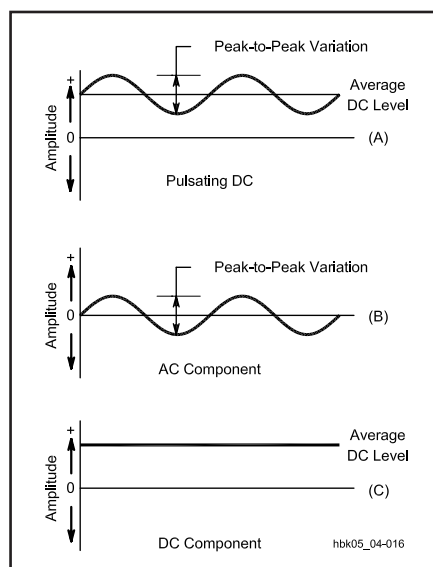

Fig 4.16 — A pulsating dc current (A) and its resolution into an ac component (B) and a dc component (C).

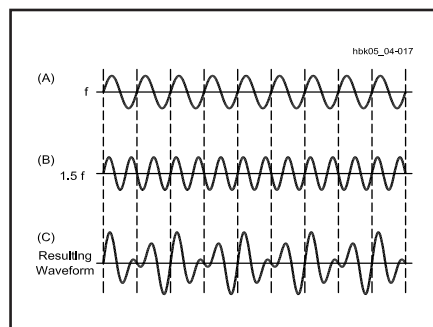

Fig 4.17 — Two ac waveforms of similar frequencies ($f_1 = 1.5 f_2$) and amplitudes form a composite wave. Note the points where the positive peaks of the two waves combine to create high composite peaks: this is the phenomenon of beats. The beat note frequency is $1.5f - f = 0.5f$ and is visible in the drawing.

ponents for separate analysis or use. There are also circuits that combine ac and dc currents and voltages for many purposes.

We can combine ac and dc voltages and currents. Different ac voltages and currents also form combinations. Such combinations will result in complex waveforms. A *waveform* is the pattern of amplitudes reached by the voltage or current as measured over time. **Fig 4.17** shows two ac waveforms fairly close in frequency, and their resultant combination. **Fig 4.18** shows two ac waveforms dissimilar in both frequency and wavelength, along with the resultant combined waveform. Note the similarities (and the differences) between the resultant waveform in Fig 4.18 and the combined ac-dc waveform in Fig 4.16.

Alternating currents may take on many useful wave shapes. **Fig 4.19** shows a few that are commonly used in practical circuits and in test equipment. The square

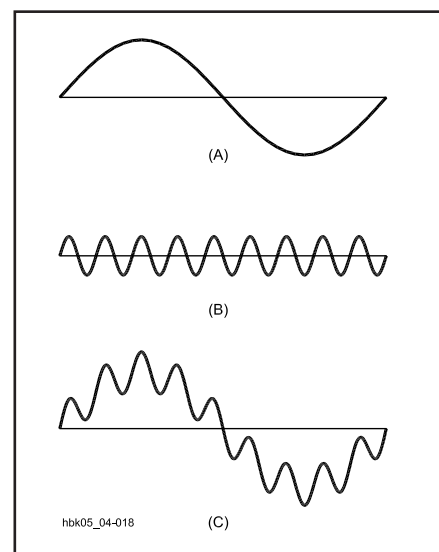

Fig 4.18 — Two ac waveforms of widely different frequencies and amplitudes form a composite wave in which one wave appears to ride upon the other.

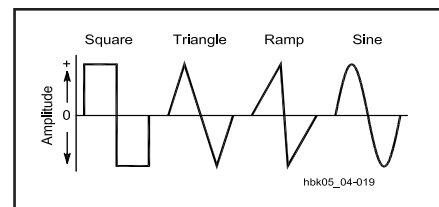

Fig 4.19 — Some common ac waveforms: square, triangle, ramp and sine.

wave is vital to digital electronics. The triangular and ramp waves — sometimes called “sawtooth” waves — are especially useful in timing circuits. The sine wave is both mathematically and practically the foundation of all other forms of ac; the other forms can usually be reduced to (and even constructed from) a particular collection of sine waves.

There are numerous ways to generate alternating currents: with an ac power generator (an *alternator*), with a transducer (for example, a microphone) or with an electronic circuit (for example, an RF oscillator). The basis of the sine wave is circular motion, which underlies the most usual methods of generating alternating current. The circular motion of the ac generator may be physical or mechanical, as in an alternator. Currents in the resonant circuit of an oscillator may also produce sine waves without mechanical motion.

Fig 4.20 demonstrates the relationship of the current (and voltage) amplitude to relative positions of a circular rotation through one complete revolution of 360°. Note that the current is zero at point 1. It rises to its maximum value at a point 90° from point 1, which is point 3. At a point 180° from point 1, which is point 4, the current level falls back to zero. Then the current begins to rise again. The direction of the current after point 4 and prior to its return to point 1, however, is opposite the direction of current from point 1 to point 4. Point 2 illustrates one of the innumerable intermediate values of current throughout the cycle.

Tracing the rise and fall of current over a linear time line produces the curve accompanying the circle in Fig 4.20. The curve is *sinusoidal* or a *sine wave*. The amplitude of the current varies as the sine of the angle made by the circular movement with respect to the zero point. The sine of 90° is 1, and 90° is also the point of maximum current (along with 270°). The sine of 45° (point 2) is 0.707, and the value of current at the 45° point of rotation is

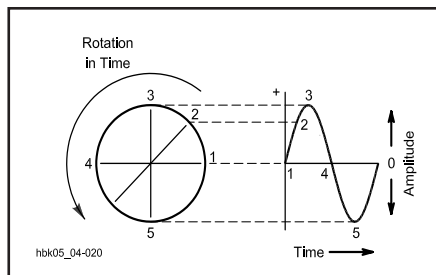

Fig 4.20 — The relationship of circular motion and the resultant graph of ac current or voltage. The curve is sinusoidal, a sine wave.

0.707 times the maximum current. Similar considerations apply to the variation of ac voltage over time.

FREQUENCY AND PERIOD

With a continuously rotating generator, alternating current will pass through many equal cycles over time. Select an arbitrary point on any one cycle and use it as a marker. For this example, the positive peak will work as an unambiguous marker. The number of times per second that the current (or voltage) reaches this positive peak in any one second is called the *frequency* of the ac. In other words, frequency expresses the *rate* at which current (or voltage) cycles occur. The unit of frequency is *cycles per second*, or *hertz*—abbreviated Hz (after the 19th century radio-phenomena pioneer, Heinrich Hertz).

The length of any cycle in units of time is the *period* of the cycle, as measured from and to equivalent points on succeeding cycles. Mathematically, the period is simply the inverse of the frequency. That is,

$$\text{Frequency (f) in Hz} = \frac{1}{\text{Period (T) in seconds}} \quad (23)$$

and

$$\text{Period (T) in seconds} = \frac{1}{\text{Frequency (f) in Hz}} \quad (24)$$

Example: What is the period of a 400-hertz ac current?

$$T = \frac{1}{f} = \frac{1}{400 \text{ Hz}} = 0.00250 \text{ s} = 2.5 \text{ ms}$$

The frequency of alternating currents used in Amateur Radio circuits varies from a few hertz, or cycles per second, to thousands of millions of hertz. Likewise, the period of alternating currents amateurs use ranges from significant fractions of a second down to nanoseconds or smaller. In order to express units of frequency, time and almost everything else in electronics compactly, a standard system of prefixes is used. In magnitudes of 1000 or 10³, frequency is measurable in hertz, in kilohertz (1000 hertz or kHz), in megahertz (1 million hertz or MHz), gigahertz (1 billion hertz or GHz) and even in tera-hertz (1 trillion hertz or THz). For units smaller than one, as in the measurement of period, the basic unit seconds can become milliseconds (1 thousandth of a second or ms), microseconds (1 millionth of a second or μs), nanoseconds (1 billionth of a second or ns) and picoseconds (1 trillionth of a second or ps).

The uses of ac in Amateur Radio cir-

cuits are many and varied. Most can be cataloged by reference to ac frequency ranges used in circuits. For example, ac power used in the home, office and factory is ordinarily 60 Hz in the United States and Canada. In Great Britain and much of Europe, ac power is 50 Hz. For special purposes, ac power has been generated up to about 400 Hz.

Sonic and ultrasonic applications of ac run from about 20 Hz up to several MHz. Audio work makes use of the lower end of the sonic spectrum, with communications audio focusing on the range from about 300 to 3000 Hz. High-fidelity audio uses ac circuits capable of handling 20 Hz to at least 20 kHz. Ultrasonics — used in medicine and industry — makes use of ac circuits above 20 kHz.

Amateur Radio circuits include both power- and sonic-frequency-range circuits. Radio communication and other electronics work, however, require ac circuits capable of operation with frequencies up to the gigahertz range. Some of the applications include signal sources for transmitters (and for circuits inside receivers); industrial induction heating; diathermy; microwaves for cooking, radar and communication; remote control of appliances, lighting, model planes and boats and other equipment; and radio direction finding and guidance.

AC IN CIRCUITS AND TRANSDUCED ENERGY

Alternating currents are often loosely classified as audio frequency (AF) and radio frequency (RF). Although these designations are handy, they actually represent something other than the electrical energy of ac circuits: They designate special forms of energy that we find useful.

Audio or *sonic* energy is the energy imparted by the mechanical movement of a medium, which can be air, metal, water or even the human body. Sound that humans can hear normally requires the movement of air between 20 Hz and 20 kHz, although the human ear loses its ability to detect the extremes of this range as we age. Some animals, such as elephants, can apparently detect air vibrations well below 20 Hz, while others, such as dogs and cats, can detect air vibrations well above 20 kHz.

Electrical circuits do not directly produce air vibrations. Sound production requires a *transducer*, a device to transform one form of energy into another form of energy; in this case electrical energy into sonic energy. The speaker and the microphone are the most common audio transducers. There are numerous ultrasonic transducers for various applications.

Likewise, converting electrical energy

into radio signals also requires a transducer, usually called an *antenna*. In contrast to RF alternating currents in circuits, RF *energy* is a form of electromagnetic energy. The frequencies of electromagnetic energy run from 3 kHz to above 10^{12} GHz. They include radio, infrared, visible light, ultraviolet and a number of energy forms of greatest interest to physicists and astronomers. **Table 4.2** provides a brief glimpse at the total spectrum of electromagnetic energy.

All electromagnetic energy has one thing in common: it travels, or *propagates*, at the speed of light. This speed is approximately 300000000 (or 3.00×10^8) meters per second in a vacuum. Electromagnetic-energy waves have a length uniquely associated with each possible frequency. The wavelength (λ) is simply the speed of propagation divided by the frequency (f) in hertz.

$$f \text{ (Hz)} = \frac{3.00 \times 10^8 \left(\frac{\text{m}}{\text{s}} \right)}{\lambda \text{ (m)}} \quad (25)$$

and

$$\lambda \text{ (m)} = \frac{3.00 \times 10^8 \left(\frac{\text{m}}{\text{s}} \right)}{f \text{ (Hz)}} \quad (26)$$

Example: What is the frequency of an 80.0-m RF wave?

$$f \text{ (Hz)} = \frac{3.00 \times 10^8 \left(\frac{\text{m}}{\text{s}} \right)}{\lambda \text{ (m)}}$$

$$= \frac{3.00 \times 10^8 \left(\frac{\text{m}}{\text{s}} \right)}{80.0 \text{ m}}$$

$$f \text{ (Hz)} = 3.75 \times 10^6 \text{ Hz}$$

We could use a similar equation to calculate the wavelength of a sound wave in air, but we would have to use the speed of sound instead of the speed of light in the numerator of the equation. The speed of propagation of the mechanical movement of air that we call sound varies considerably with air temperature and altitude. The speed of sound at sea level is about 331 m/s at 0°C and 344 m/s at 20°C.

To calculate the frequency of an electromagnetic wave directly in kilohertz, change the speed constant to 300,000 (3.00×10^5) km/s.

$$f \text{ (kHz)} = \frac{3.00 \times 10^5 \left(\frac{\text{km}}{\text{s}} \right)}{\lambda \text{ (m)}} \quad (27)$$

and

$$\lambda \text{ (m)} = \frac{3.00 \times 10^5 \left(\frac{\text{km}}{\text{s}} \right)}{f \text{ (kHz)}} \quad (28)$$

For frequencies in megahertz, use:

$$f \text{ (MHz)} = \frac{300 \left(\frac{\text{Mm}}{\text{s}} \right)}{\lambda \text{ (m)}} \quad (29)$$

and

$$\lambda \text{ (m)} = \frac{300 \left(\frac{\text{Mm}}{\text{s}} \right)}{f \text{ (MHz)}} \quad (30)$$

You would normally just drop the units that go with the speed of light constant to make the equation look simpler.

Example: What is the wavelength of an RF wave whose frequency is 4.0 MHz?

$$\lambda \text{ (m)} = \frac{300}{f \text{ (MHz)}} = \frac{300}{4.0 \text{ MHz}} = 75 \text{ m}$$

At higher frequencies, circuit elements act like transducers. This property can be put to use, but it can also cause problems for some circuit operations. Therefore, wavelength calculations are of some importance in designing ac circuits for those frequencies.

Within the part of the electromagnetic-

energy spectrum of most interest to radio applications, frequencies have been classified into groups and given names. **Table 4.3** provides a reference list of these classifications. To a significant degree, the frequencies within each group exhibit similar properties. For example, HF or high frequencies, from 3 to 30 MHz, all exhibit *skip* or ionospheric refraction that permits regular long-range radio communications. This property also applies occasionally both to MF (medium frequencies) and to VHF (very high frequencies).

Despite the close relationship between RF electromagnetic energy and RF ac circuits, it remains important to distinguish the two. To the ac circuit producing or amplifying a 15-kHz alternating current, the ultimate transformation and use of the electrical energy may make no difference to the circuit's operation. By choosing the right transducer, one can produce either an audio tone or a radio signal — or both. Such was the accidental fate of many horizontal oscillators and amplifiers in early television sets; they found ways to vibrate parts audibly and to radiate electromagnetic energy.

PHASE

When tracing a sine-wave curve of an ac voltage or current, the horizontal axis represents time. We call this the *time domain* of the sine wave. Events to the right take place later; events to the left occur earlier. Although time is measurable in parts of a second, it is more convenient

Table 4.2
Key Regions of the Electromagnetic Energy Spectrum

Region Name	Frequency Range
Radio frequencies	3.0×10^3 Hz to 3.0×10^{11} Hz
Infrared	3.0×10^{11} Hz to 4.3×10^{14} Hz
Visible light	4.3×10^{14} Hz to 1.0×10^{15} Hz
Ultraviolet	1.0×10^{15} Hz to 6.0×10^{16} Hz
X-rays	6.0×10^{16} Hz to 3.0×10^{19} Hz
Gamma rays	3.0×10^{19} Hz to 5.0×10^{20} Hz
Cosmic rays	5.0×10^{20} Hz to 8.0×10^{21} Hz

Table 4.3
Classification of the Radio Frequency Spectrum

Abbreviation	Classification	Frequency Range
VLF	Very low frequencies	3 to 30 kHz
LF	Low frequencies	30 to 300 kHz
MF	Medium frequencies	300 to 3000 kHz
HF	High frequencies	3 to 30 MHz
VHF	Very high frequencies	30 to 300 MHz
UHF	Ultrahigh frequencies	300 to 3000 MHz
SHF	Superhigh frequencies	3 to 30 GHz
EHF	Extremely high frequencies	30 to 300 GHz

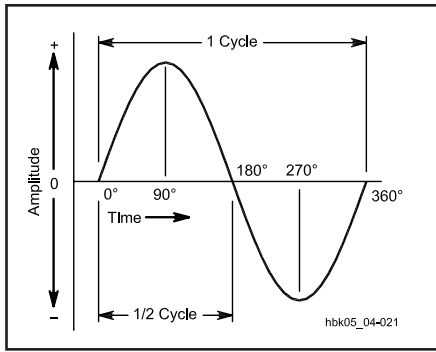

Fig 4.21 — An ac cycle is divided into 360° that are used as a measure of time or phase.

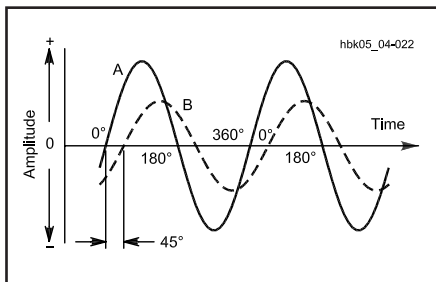

Fig 4.22 — When two waves of the same frequency start their cycles at slightly different times, the time difference or phase difference is measured in degrees. In this drawing, wave B starts 45° (one-eighth cycle) later than wave A, and so lags 45° behind A.

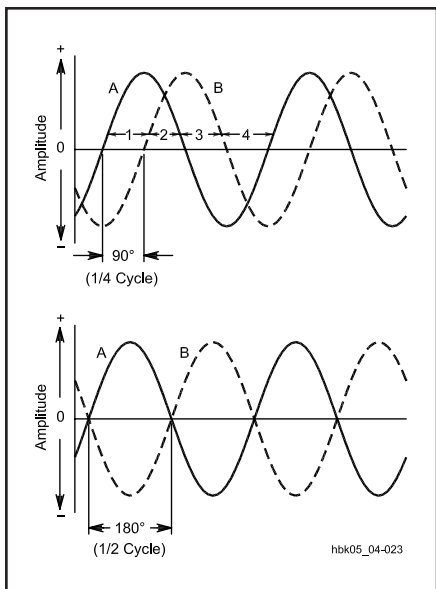

Fig 4.23 — Two important special cases of phase difference: In the upper drawing, the phase difference between A and B is 90°; in the lower drawing, the phase difference is 180°.

to treat each cycle as a complete time unit that we divide into 360°. The conventional starting point for counting degrees is the zero point as the voltage or current begins the positive half cycle. The essential elements of an ac cycle appear in **Fig 4.21**.

The advantage of treating the ac cycle in this way is that many calculations and measurements can be taken and recorded in a manner that is independent of frequency. The positive peak voltage or current occurs at 90° along the cycle. Relative to the starting point, 90° is the *phase* of the ac at that point. Thus, a complete description of an ac voltage or current involves reference to three properties: frequency, amplitude and phase.

Phase relationships also permit the comparison of two ac voltages or currents at the same frequency, as **Fig 4.22** demonstrates. Since B crosses the zero point in the positive direction after A has already done so, there is a *phase difference* between the two waves. In the example, B lags A by 45°, or A leads B by 45°. If A and B occur in the same circuit, their composite waveform will also be a sine wave at an intermediate phase angle relative to each. Adding any number of sine waves of the same frequency always results in a sine wave at that frequency.

Fig 4.22 might equally apply to a voltage and a current measured in the same ac circuit. Either A or B might represent the voltage; that is, in some instances voltage will lead the current and in others voltage will lag the current.

Two important special cases appear in **Fig 4.23**. In Part A, line B lags 90° behind line A. Its cycle begins exactly one quarter cycle later than the A cycle. When one wave is passing through zero, the other just

reaches its maximum value.

In Part B, lines A and B are 180° *out of phase*. In this case, it does not matter which one is considered to lead or lag. Line B is always positive while line A is negative, and vice versa. If the two waveforms are of two voltages or two currents in the same circuit and if they have the same amplitude, they will cancel each other completely.

MEASURING AC VOLTAGE, CURRENT AND POWER

Measuring the voltage or current in a dc circuit is straightforward, as **Fig 4.24A** demonstrates. Since the current flows in only one direction, for a resistive load, the voltage and current have constant values until the circuit components change.

Fig 4.24B illustrates a perplexing problem encountered when measuring voltages and currents in ac circuits. The current and voltage continuously change direction and value. Which values are meaningful? In fact, several values of constant sine-wave voltage and current in ac circuits are important to differing applications and concerns.

Instantaneous Voltage and Current

Fig 4.25 shows a sine wave of some arbitrary frequency and amplitude with respect to either voltage or current. The instantaneous voltage (or current) at point A on the curve is a function of three factors: the maximum value of voltage (or current) along the curve (point B), the frequency of the wave, and the time elapsed in seconds or fractions of a second. Thus,

$$E_{\text{inst}} = E_{\text{max}} \sin (2\pi ft) \theta \quad (31)$$

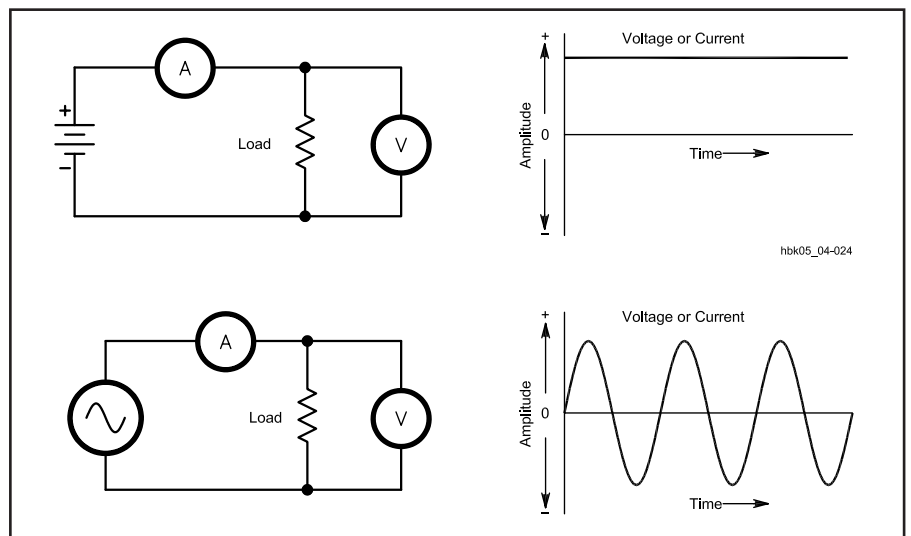

Fig 4.24 — Voltage and current measurements in dc and ac circuits.

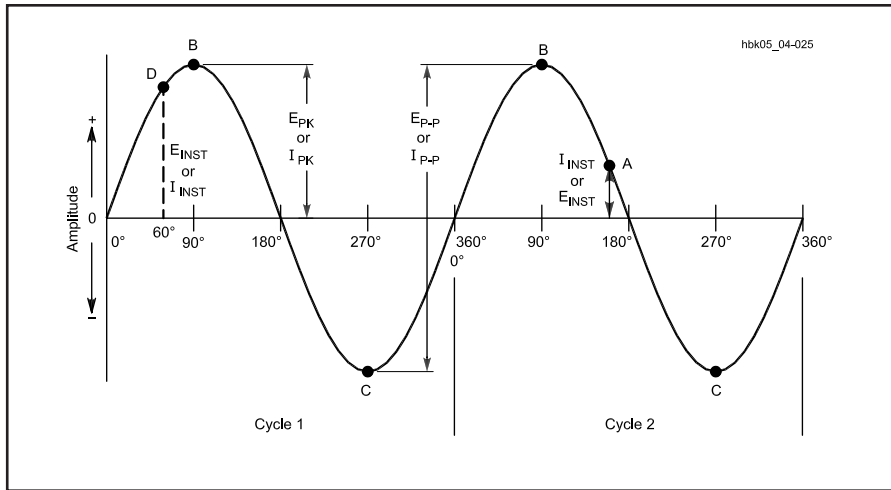

Fig 4.25 — Two cycles of a sine wave to illustrate instantaneous, peak, and peak-to-peak ac voltage and current values.

Considering just one sine wave, independent of frequency, the instantaneous value of voltage (or current) becomes

$$E_{inst} = E_{max} \sin \theta \quad (32)$$

where θ is the angle in degrees through which the voltage has moved over time after the beginning of the cycle.

Example: What is the instantaneous value of voltage at point D in Fig 4.25, if the maximum voltage value is 120 V and the angular travel is 60.0° ?

$$\begin{aligned} E_{inst} &= 120 \text{ V} \times \sin 60.0^\circ \\ &= 120 \times 0.866 = 104 \text{ V} \end{aligned}$$

Peak and Peak-to-Peak Voltage and Current

The most important instantaneous voltages and currents are the maximum or peak values reached on each positive and negative half cycle of the sine wave. In Fig 4.25, points B and C represent the positive and negative peaks of voltage or current. Peak (pk) values are especially important with respect to component ratings, which the voltage or current in a circuit must not exceed without danger of component failure.

The peak power in an ac circuit is simply the product of the peak voltage and the peak current, or

$$P_{pk} = E_{pk} \times I_{pk} \quad (33)$$

The span from points B to C in Fig 4.25 represents the largest voltage or current swing of the sine wave. Designated the *peak-to-peak* (P-P) voltage (or current), this span is equal to twice the peak value of the voltage (or current). Thus,

$$E_{P-P} = 2E_{pk} \quad (34)$$

Amplifying devices often specify their input limits in terms of peak-to-peak voltages. Operational amplifiers, which have almost unlimited gain potential, often require input-level limiting to prevent the output signals from distorting if they exceed the peak-to-peak output rating of the devices.

RMS Voltages and Currents

The *root mean square* or *RMS* values of voltage and current are the most common values encountered in electronics. Sometimes called the *effective* values of ac voltage and current, they are based upon equating the values of ac and dc power required to heat a resistive element to exactly the same temperature. The peak ac power required for this condition is twice the dc power needed. Therefore, the aver-

age ac power equivalent to a corresponding average dc power is half the peak ac power.

$$P_{ave} = \frac{P_{pk}}{2} \quad (35)$$

Since a circuit with a constant resistance is linear — that is, raising or lowering the voltage will raise or lower the current proportionally — the voltage and current values needed to arrive at average ac power are related to their peak values by the factor.

$$E_{RMS} = \frac{E_{pk}}{\sqrt{2}} = \frac{E_{pk}}{1.414} = E_{pk} \times 0.707 \quad (36)$$

$$I_{RMS} = \frac{I_{pk}}{\sqrt{2}} = \frac{I_{pk}}{1.414} = I_{pk} \times 0.707 \quad (37)$$

In the time domain of a sine wave, the RMS values of voltage and current occur at the 45° , 135° , 225° and 315° points along the cycle shown in Fig 4.26. (The sine of 45° is approximately 0.707.) The absolute instantaneous value of voltage or current is greater than the RMS value for half the cycle and less than the RMS value for half the cycle.

The RMS values of voltage and current get their name from the means used to derive their value relative to peak voltage and current. Square the individual values of all the instantaneous values of voltage or current in a single cycle of ac. Take the average of these squares and then find the square root of the average. This *root mean square* procedure produces the RMS value of voltage or current.

If the RMS voltage is the peak voltage divided by the $\sqrt{2}$, then the peak voltage must be the RMS voltage multiplied by

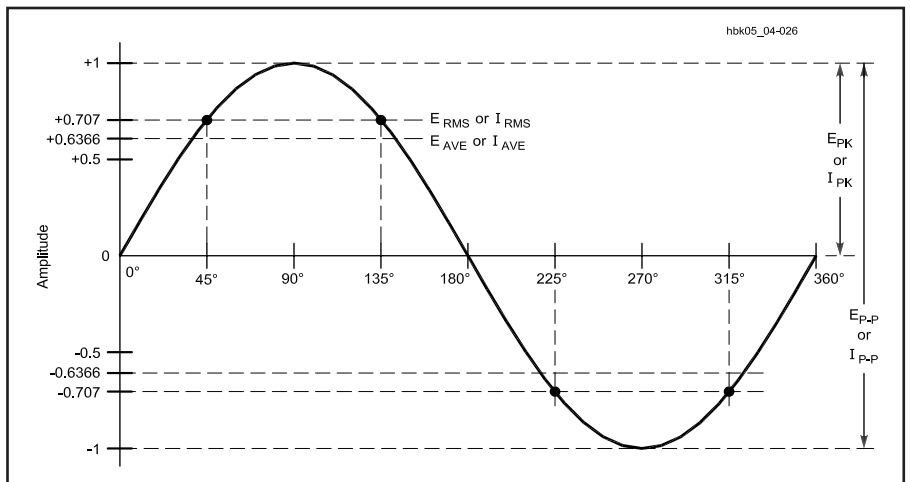

Fig 4.26 — The relationships between RMS, average, peak, and peak-to-peak values of ac voltage and current.

Table 4.4**Conversion Factors for AC Voltage or Current**

From	To	Multiply By
Peak	Peak-to-Peak	2
Peak-to-Peak	Peak	0.5
Peak	RMS	$1 / \sqrt{2}$ or 0.707
RMS	Peak	$\sqrt{2}$ or 1.414
Peak-to-Peak	RMS	$1 / (2 \times \sqrt{2})$ or 0.35355
RMS	Peak-to-Peak	$2 \times \sqrt{2}$ or 2.828
Peak	Average	$2 / \pi$ or 0.6366
Average	Peak	$\pi / 2$ or 1.5708
RMS	Average	$(2 \times \sqrt{2}) / \pi$ or 0.90
Average	RMS	$\pi / (2 \times \sqrt{2})$ or 1.11

Note: These conversion factors apply only to continuous pure sine waves.

the $\sqrt{2}$, or

$$E_{pk} = E_{RMS} \times 1.414 \quad (38)$$

$$I_{pk} = I_{RMS} \times 1.414 \quad (39)$$

Since circuit specifications will most commonly list only RMS voltage and current values, these relationships are important in finding the peak voltages or currents that will stress components.

Example: What is the peak voltage on a capacitor if the RMS voltage of a sinusoidal waveform signal across it is 300 V ac?

$$E_{pk} = 300 \text{ V} \times 1.414 = 424 \text{ V}$$

The capacitor must be able to withstand this higher voltage, plus a safety margin. The capacitor must also be rated for ac use. A capacitor rated for 1 kV dc may explode if used in this application. In power supplies that convert ac to dc and use capacitive input filters, the output voltage will approach the peak value of the ac voltage rather than the RMS value.

Example: What is the peak voltage and the peak-to-peak voltage at the usual household ac outlet, if the RMS voltage is 120 V?

$$E_{pk} = 120 \text{ V} \times 1.414 = 170 \text{ V}$$

$$E_{p-p} = 2 \times 170 \text{ V} = 340 \text{ V}$$

Unless otherwise specified, unlabeled ac voltage and current values found in most electronics literature are normally RMS values.

Average Values of Voltage and Current

Certain kinds of circuits respond to the *average* value of an ac waveform. Among these circuits are electrodynamic meter movements and power supplies that convert ac to dc and use heavily inductive (“choke”) input filters, both of which use the pulsating dc output of a full-wave rectifier. The average value of each ac half cycle is the *mean* of all the instantaneous values in that half cycle. Related to the peak values of voltage and current, average values are $2 / \pi$ (or 0.6366) times the peak value.

$$E_{ave} = 0.6366 E_{pk} \quad (40)$$

$$I_{ave} = 0.6366 I_{pk} \quad (41)$$

For convenience, **Table 4.4** summarizes the relationships between all of the common ac values. All of these relationships apply only to pure sine waves.

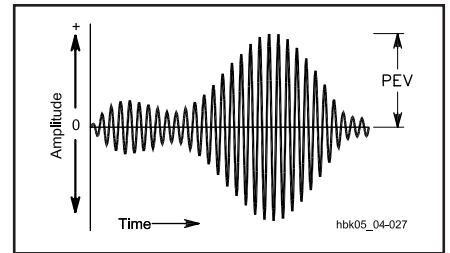

Fig 4.27 — The peak envelope voltage (PEV) for a composite waveform.

Complex Waves and Peak-Envelope Values

Complex waves, as shown earlier in Fig 4.18, differ from pure sine waves. The amplitude of the peak voltage may vary significantly from one cycle to the next. Therefore, other amplitude measures are required, especially for accurate measurement of voltage and power with single sideband (SSB) waveforms. **Fig 4.27** illustrates a multitone composite waveform with an RF ac waveform as the basis.

The RF ac waveform has a frequency many times that of the audio-frequency ac waveform with which it is usually combined in SSB operations. Therefore, the resultant waveform appears as an amplitude envelope superimposed upon the RF waveform. The *peak envelope voltage* (PEV), then, is the maximum or peak value of voltage achieved.

Peak envelope voltage permits the calculation of *peak envelope power* (PEP). The Federal Communications Commission (FCC) uses the concept of peak envelope power to set the maximum power standards for amateur transmitters. PEP is the *average* power supplied to the antenna transmission line by a transmitter during one RF cycle at the crest of the modulation envelope, taken under normal operating conditions. Since calculation of PEP requires the average power of the cycle, multiply the PEV by 0.707 to obtain the RMS value. Then calculate power by using the square of the voltage divided by the load resistance.

$$PEP = \frac{(PEV \times 0.707)^2}{R} \quad (42)$$

Capacitance and Capacitors

Without the ability to store electrical energy, radio would not be possible. One may build and hold an electrical charge in an *electrostatic field*. This phenomenon is called *capacitance*, and the devices that exhibit capacitance are called *capacitors*. See Chapter 6 for more information on practical capacitor applications and problems. **Fig 4.28** shows several schematic symbols for capacitors. Part A shows a fixed capacitor; one that has a single value of capacitance. Part B shows variable capacitors; these are adjustable over a range of values. Ordinarily, the straight line in each symbol connects to a positive voltage, while the curved line goes to a negative voltage or to ground. Some capacitor designs require rigorous adherence to polarity markings; other designs are symmetrical and non-polarized.

CHARGE AND ELECTROSTATIC ENERGY STORAGE

Suppose two flat metal plates are placed close to each other (but not touching) and are connected to a battery through a switch, as illustrated in **Fig 4.29A**. At the instant the switch is closed, electrons are attracted from the upper plate to the positive terminal of the battery, and the same number are repelled into the lower plate from the negative battery terminal. Enough electrons move into one plate and out of the other to make the voltage between the plates the same as the battery voltage.

If the switch is opened after the plates have been charged in this way, the top plate is left with a deficiency of electrons and the bottom plate with an excess. Since there is no current path between the two, the plates remain charged despite the fact that the battery no longer is connected. The charge remains due to the electrostatic field between the plates. The large number of opposite charges exert an attractive force across the small distance between plates, as illustrated in **Fig 4.29B**.

If a wire is touched between the two plates (short-circuiting them), the excess electrons on the bottom plate flow through the wire to the upper plate, restoring electrical neutrality. The plates are discharged.

These two plates represent an electrical capacitor, a device possessing the property of storing electrical energy in the electric field between its plates. During the time the electrons are moving — that is, while the capacitor is being charged or discharged — a current flows in the circuit even though the circuit apparently is broken by the gap between the capacitor

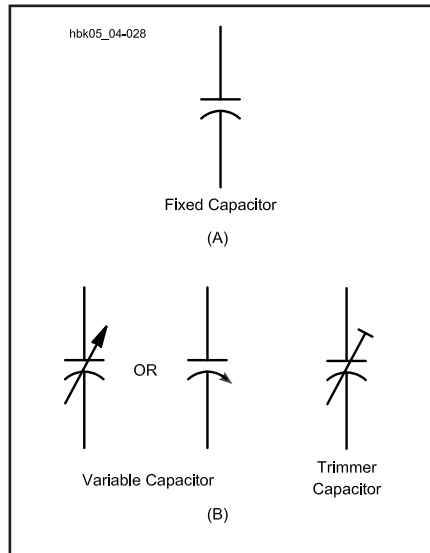

Fig 4.28 — Schematic symbol for a fixed capacitor is shown at A. The symbols for a variable capacitor are shown at B.

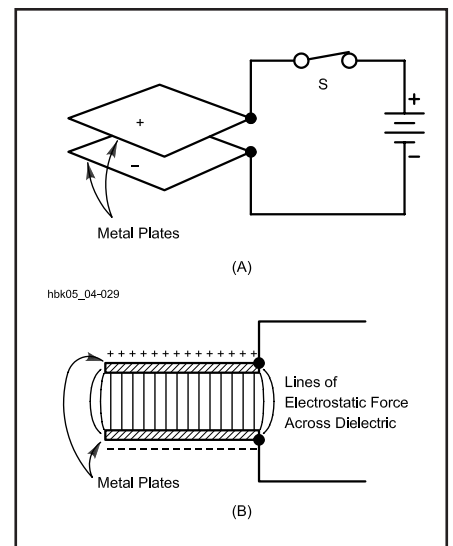

Fig 4.29 — A simple capacitor showing the basic charging arrangement at A, and the retention of the charge due to the electrostatic field at B.

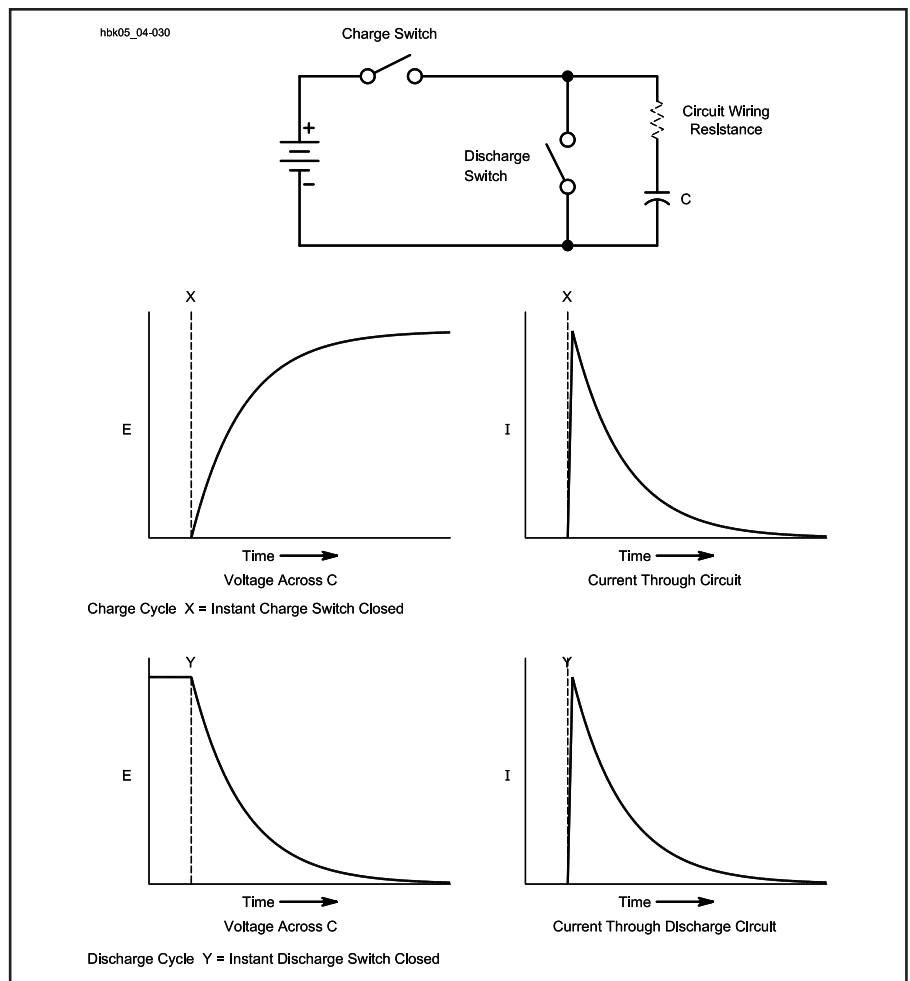

Fig 4.30 — The flow of current during the charge and discharge of a capacitor. The charge graphs assume that the charge switch is closed and the discharge switch is open. The discharge graphs assume just the opposite.

plates. The current flows only during the time of charge and discharge, however, and this time is usually very short. There can be no continuous flow of direct current through a capacitor.

Fig 4.30 demonstrates the voltage and current in the circuit, first, at the moment the switch is closed to charge the capacitor and, second, at the moment the shorting switch is closed to discharge the unit. Note that the periods of charge and discharge are very short, but that they are not zero. This finite charging and discharging time can be lengthened and will prove useful later in timing circuits.

Although dc cannot pass through a capacitor, alternating current can. As fast as one plate is charged positively by the positive excursion of the alternating current, the other plate is being charged negatively. Positive charges flowing into one plate causes a current to flow out of the other plate during one half of the cycle, resulting in a negative charge on that plate. The reverse occurs during the second half of the cycle.

The charge or quantity of electricity that can be held on the capacitor plates is proportional to the applied voltage and to the capacitance of the capacitor:

$$Q = CE \quad (43)$$

where:

- Q = charge in coulombs,
- C = capacitance in farads, and
- E = electrical potential in volts.

The energy stored in a capacitor is also a function of electrical potential and capacitance:

$$W = \frac{E^2 C}{2} \quad (44)$$

where:

- W = energy in joules (watt-seconds),
- E = electrical potential in volts (some texts use V instead of E), and
- C = capacitance in farads.

The numerator of this expression can be derived easily from the definitions for charge, capacitance, current, power and energy. The denominator is not so obvious, however. It arises because the voltage across a capacitor is not constant, but is a function of time. The average voltage over the time interval determines the energy stored. The time dependence of the capacitor voltage is a very useful property; see the section on time constants.

UNITS OF CAPACITANCE AND CAPACITOR CONSTRUCTION

A capacitor consists, fundamentally, of two plates separated by an insulator or

Table 4.5

Relative Dielectric Constants of Common Capacitor Dielectric Materials

Material	Dielectric Constant (k)	(O)rganic or (I)norganic
Vacuum	1 (by definition)	
Air	1.0006	
Ruby mica	6.5 - 8.7	
Glass (flint)	10	
Barium titanate (class I)	5 - 450	
Barium titanate (class II)	200 - 12000	
Kraft paper	≈ 2.6	O
Mineral Oil	≈ 2.23	O
Castor Oil	≈ 4.7	O
Halowax	≈ 5.2	O
Chlorinated diphenyl	≈ 5.3	O
Polyisobutylene	≈ 2.2	O
Polytetrafluoroethylene	≈ 2.1	O
Polyethylene terephthalate	≈ 3	O
Polystyrene	≈ 2.6	O
Polycarbonate	≈ 3.1	O
Aluminum oxide	≈ 8.4	
Tantalum pentoxide	≈ 28	
Niobium oxide	≈ 40	
Titanium dioxide	≈ 80	

(Adapted from: Charles A. Harper, *Handbook of Components for Electronics*, p 8-7.)

dielectric. The *larger* the plate area and the *smaller* the spacing between the plates, the *greater* the capacitance. The capacitance also depends on the kind of insulating material between the plates; it is smallest with air insulation or a vacuum. Substituting other insulating materials for air may greatly increase the capacitance.

The ratio of the capacitance with a material other than a vacuum or air between the plates to the capacitance of the same capacitor with air insulation is called the dielectric constant, or K, of that particular insulating material. The dielectric constants of a number of materials commonly used as dielectrics in capacitors are given in **Table 4.5**. For example, if a sheet of polystyrene is substituted for air between the plates of a capacitor, the capacitance will be 2.6 times greater.

The basic unit of capacitance, the ability to store electrical energy in an electrostatic field, is the farad. This unit is generally too large for practical radio work, however. Capacitance is usually measured in microfarads (abbreviated μF), nanofarads (abbreviated nF) or picofarads (pF). The microfarad is one millionth of a farad (10^{-6} F), the nanofarad is one thousandth of a microfarad (10^{-9} F) and the picofarad is one millionth of a microfarad (10^{-12} F).

In practice, capacitors often have more than two plates, the alternate plates being connected to form two sets, as shown in **Fig 4.31**. This practice makes it possible to

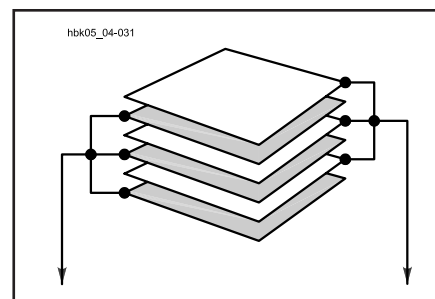

Fig 4.31 — A multiple-plate capacitor. Alternate plates are connected to each other.

obtain a fairly large capacitance in a small space, since several plates of smaller individual area can be stacked to form the equivalent of a single large plate of the same total area. Also, all plates except the two on the ends are exposed to plates of the other group on both sides, and so are twice as effective in increasing the capacitance.

The formula for calculating capacitance from these physical properties is:

$$C = \frac{0.2248 K A (n - 1)}{d} \quad (45)$$

where:

- C = capacitance in pF,
- K = dielectric constant of material between plates,
- A = area of one side of one plate in square inches,

d = separation of plate surfaces in inches, and
 n = number of plates.

If the area (A) is in square centimeters and the separation (d) is in centimeters, then the formula for capacitance becomes

$$C = \frac{0.0885 K A (n - 1)}{d} \quad (46)$$

If the plates in one group do not have the same area as the plates in the other, use the area of the smaller plates.

Example: What is the capacitance of 2 copper plates, each 1.50 square inches in area, separated by a distance of 0.00500 inch, if the dielectric is air?

$$C = \frac{0.2248 K A (n - 1)}{d}$$

$$C = \frac{0.2248 \times 1 \times 1.50 (2 - 1)}{0.00500}$$

$$C = 67.4 \text{ pF}$$

KINDS OF CAPACITORS AND THEIR USES

The capacitors used in radio work differ considerably in physical size, construction and capacitance. Representative kinds are shown in Fig 4.32. In variable capacitors, which are almost always constructed with air for the dielectric, one set of plates is made movable with respect to the other set so the capacitance can be varied. Fixed capacitors — those having a single, nonadjustable value of capacitance — can also be made with metal plates and with air as the dielectric.

Fixed capacitors are usually constructed from plates of metal foil with a thin solid or liquid dielectric sandwiched between, so a relatively large capacitance can be obtained in a small unit. The solid dielectrics commonly used are mica, paper and special ceramics. An example of a liquid dielectric is mineral oil. Electrolytic capacitors use aluminum-foil plates with a semiliquid conducting chemical compound between them. The actual dielectric is a very thin film of insulating material that forms on one set of plates through electrochemical action when a dc voltage is applied to the capacitor. The capacitance obtained with a given plate area in an electrolytic capacitor is very

large compared to capacitors having other dielectrics, because the film is so thin — much less than any thickness practical with a solid dielectric.

The use of electrolytic and oil-filled capacitors is confined to power-supply filtering and audio-bypass applications because their dielectrics have high losses at higher frequencies. Mica and ceramic capacitors are used throughout the frequency range from audio to several hundred megahertz.

New dielectric materials appear from time to time and represent improvements in capacitor performance. Silvered-mica capacitors, formed by spraying thin coats of silver on each side of the mica insulating sheet, improved the stability of mica capacitors in circuits sensitive to temperature changes. Polystyrene and other synthetic dielectrics, along with tantalum electrolytics, have permitted the size of capacitors to shrink per unit of capacitance.

VOLTAGE RATINGS AND BREAKDOWN

When high voltage is applied to the plates of a capacitor, considerable force is exerted on the electrons and nuclei of the dielectric. The dielectric is an insulator; its electrons do not become detached from

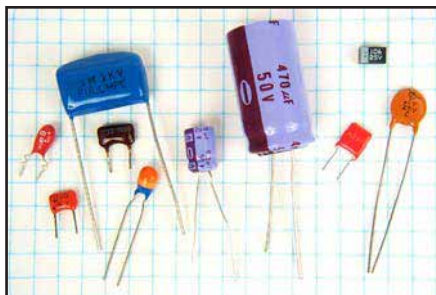

(A)



(B)

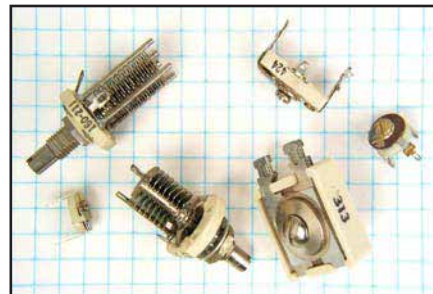

(C)

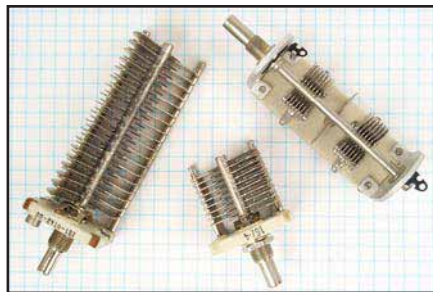

(D)



(E)

Fig 4.32 — Fixed-value capacitors are shown in parts A and B. Aluminum electrolytic capacitors are pictured near the center of photo A. The small tear-drop units to the left of center are tantalum electrolytic capacitors. The rectangular units are silvered-mica, polystyrene film and monolithic ceramic. At the right edge is a disc-ceramic capacitor and near the top right corner is a surface-mount capacitor. B shows a large “computer-grade” electrolytic. These have very low equivalent series resistance (ESR) and are often used as filter capacitors in switch-mode power supplies, and in series-strings for high-voltage supplies of RF power amplifiers. Parts C and D show a variety of variable capacitors, including air variable capacitors and mica compression units. Part E shows a vacuum variable capacitor such as is sometimes used in high-power amplifier circuits. The 1/4-inch-ruled graph paper backgrounds provide size comparisons.

atoms the way they do in conductors. If the force is great enough, however, the dielectric will break down. Failed dielectrics usually puncture and offer a low-resistance current path between the two plates.

The *breakdown voltage* a dielectric can withstand depends on the chemical composition and thickness of the dielectric. Breakdown voltage is not directly proportional to the thickness; doubling the thickness does not quite double the breakdown voltage. Gas dielectrics also break down, as evidenced by a spark or arc between the plates. Spark voltages are generally given with the units *kilovolts per centimeter*. For air, the spark voltage or V_s may range from more than 120 kV/cm for gaps as narrow as 0.006 cm down to 28 kV/cm for gaps as wide as 10 cm. In addition, a large number of variables enter into the actual breakdown voltage in a real situation. Among the variables are the electrode shape, the gap distance, the air pressure or density, the voltage, impurities in the air (or any other dielectric material) and the nature of the external circuit (with air, for instance, the humidity affects conduction on the surface of the capacitor plate).

Dielectric breakdown occurs at a lower voltage between pointed or sharp-edged surfaces than between rounded and polished surfaces. Consequently, the breakdown voltage between metal plates of any given spacing in air can be increased by buffing the edges of the plates. With most gas dielectrics such as air, once the voltage is removed, the arc ceases and the capacitor is ready for use again. If the plates are damaged so they are no longer smooth and polished, they may have to be polished or the capacitor replaced. In contrast, solid dielectrics are permanently damaged by dielectric breakdown, and often will totally short out and melt or explode.

A thick dielectric must be used to withstand high voltages. Since the capacitance is inversely proportional to dielectric thickness (plate spacing) for a given plate area, a high-voltage capacitor must have more plate area than a low-voltage one of the same capacitance. High-voltage, high-capacitance capacitors are therefore physically large.

Dielectric strength is specified in terms of a dielectric withstanding voltage (DWV), given in volts per mil (0.001 inch) at a specified temperature. Taking into account the design temperature range of a capacitor and a safety margin, manufacturers specify *dc working voltage* (dcwv) to express the maximum safe limits of dc voltage across a capacitor to prevent dielectric breakdown.

It is not safe to connect capacitors across an ac power line unless they are rated for such use. Capacitors with dc ratings may short the line. Several manufacturers make capacitors specifically rated for use across the ac power line.

For use with other ac signals, the peak value of ac voltage should not exceed the dc working voltage, unless otherwise specified in component ratings. In other words, the RMS value of ac should be 0.707 times the dcwv value or lower. With many types of capacitors, further derating is required as the operating frequency increases. An additional safety margin is good practice.

Any two surfaces having different electrical potentials, and which are close enough to exhibit a significant electrostatic field, constitute a capacitor. The arrangement of circuit components and leads sometimes results in the creation of unintended capacitors. This is called *stray capacitance*: It often results in the passage of signals in ways that disrupt the normal operation of a circuit. Good design minimizes stray capacitance.

Stray capacitance may have a greater affect in a high-impedance circuit because the capacitive reactance may be a greater percentage of the circuit impedance. Also, because stray capacitance often appears in parallel with the circuit, the stray capacitor may bypass more of the desired signal at higher frequencies. Stray capacitance can often adversely affect sensitive circuits.

For further information about the physical and electrical characteristics of various types of capacitors in actual use, see the **Real-World Component Characteristics** chapter.

CAPACITORS IN SERIES AND PARALLEL

When a number of capacitors are connected in parallel, as in **Fig 4.33A**, the total capacitance of the group is equal to the sum of the individual capacitances:

$$C_{\text{total}} = C_1 + C_2 + C_3 + C_4 + \dots + C_n \quad (47)$$

When two or more capacitors are connected in series, as in **Fig 4.33B**, the total capacitance is less than that of the smallest capacitor in the group. The rule for finding the capacitance of a number of series-connected capacitors is the same as that for finding the resistance of a number of parallel-connected resistors.

$$C_{\text{total}} = \frac{1}{\frac{1}{C_1} + \frac{1}{C_2} + \frac{1}{C_3} + \dots + \frac{1}{C_n}} \quad (48)$$

For only two capacitors in series, the

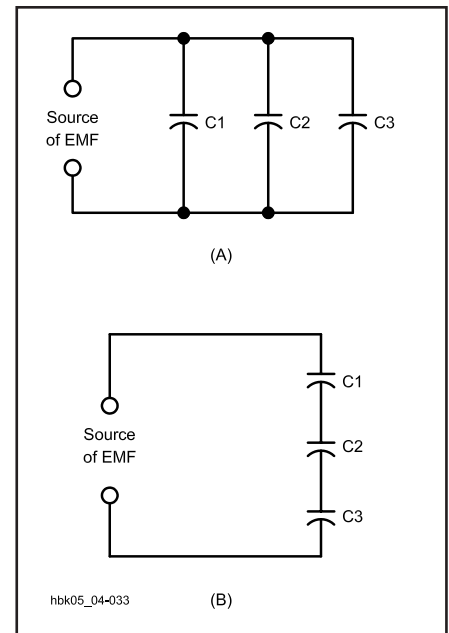

Fig 4.33 — Capacitors in parallel are shown at A, and in series at B.

formula becomes:

$$C_{\text{total}} = \frac{C_1 \times C_2}{C_1 + C_2} \quad (49)$$

The same units must be used throughout; that is, all capacitances must be expressed in either μF , nF or pF. Different units cannot be used in the same equation.

Capacitors are usually connected in parallel to obtain a larger total capacitance than is available in one unit. The largest voltage that can be applied safely to a parallel-connected group of capacitors is the voltage that can be applied safely to the one having the lowest voltage rating.

When capacitors are connected in series, the applied voltage is divided between them according to Kirchhoff's Voltage Law. The situation is much the same as when resistors are in series and there is a

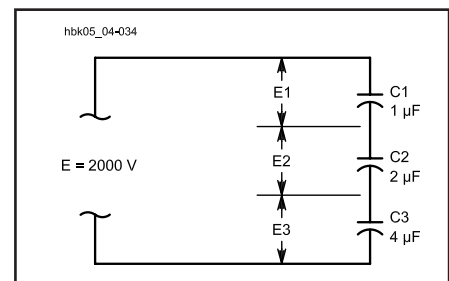

Fig 4.34 — An example of capacitors connected in series. The text shows how to find the voltage drops, E1 through E3.

voltage drop across each. The voltage that appears across each series-connected capacitor is inversely proportional to its capacitance, as compared with the capacitance of the whole group. (This assumes ideal capacitors.)

Example: Three capacitors having capacitances of 1, 2 and 4 μF , respectively, are connected in series as shown in Fig 4.34. The voltage across the entire series is 2000 V. What is the total capacitance? (Since this is a calculation using theoretical values to illustrate a technique, we will not follow the rules of significant figures for the calculations.)

$$C_{\text{total}} = \frac{1}{\frac{1}{C_1} + \frac{1}{C_2} + \frac{1}{C_3}}$$

$$= \frac{1}{\frac{1}{1\mu\text{F}} + \frac{1}{2\mu\text{F}} + \frac{1}{4\mu\text{F}}}$$

$$C_{\text{total}} = \frac{1}{\frac{7}{4\mu\text{F}}} = \frac{4\mu\text{F}}{7} = 0.5714\mu\text{F}$$

The voltage across each capacitor is proportional to the total capacitance divided by the capacitance of the capacitor in question. So the voltage across C1 is:

$$E_1 = \frac{0.5714\mu\text{F}}{1\mu\text{F}} \times 2000\text{ V} = 1143\text{ V}$$

Similarly, the voltages across C2 and C3 are:

$$E_2 = \frac{0.5714\mu\text{F}}{2\mu\text{F}} \times 2000\text{ V} = 571\text{ V}$$

and

$$E_3 = \frac{0.5714\mu\text{F}}{4\mu\text{F}} \times 2000\text{ V} = 286\text{ V}$$

The sum of these three voltages equals 2000 V, the applied voltage.

Capacitors may be connected in series to enable the group to withstand a larger voltage than any individual capacitor is rated to withstand. The trade-off is a decrease in the total capacitance. As shown by the previous example, the applied voltage does not divide equally between the capacitors except when all the capacitances are precisely the same. Use care to ensure that the voltage rating of any capacitor in the group is not exceeded. If you use capacitors in series to withstand a higher voltage, you should also connect an "equalizing resistor" across each capacitor. Use resistors with about 100 Ω per volt of supply voltage, and be sure they have sufficient power-handling capability for

the circuit. With real capacitors, the leakage resistance of the capacitors may have more effect on the voltage division than does the capacitance. A capacitor with a high parallel resistance will have the highest voltage across it. Adding equalizing resistors reduces this effect.

RC TIME CONSTANT

Connecting a dc voltage source directly to the terminals of a capacitor charges the capacitor to the full source voltage almost instantaneously. Any resistance added to the circuit as in Fig 4.35A limits the current, lengthening the time required for the voltage between the capacitor plates to build up to the source-voltage value. During this charging period, the current flowing from the source into the capacitor gradually decreases from its initial value. The increasing voltage stored in the capacitor's electric field offers increasing opposition to the steady source voltage.

While it is being charged, the voltage between the capacitor terminals is an exponential function of time, and is given by:

$$V(t) = E \left(1 - e^{-\frac{t}{RC}} \right) \quad (50)$$

where:

- V(t) = capacitor voltage in volts at time t;
- E = potential of charging source in volts;
- t = time in seconds after initiation of charging current;
- e = natural logarithmic base = 2.718;
- R = circuit resistance in ohms; and
- C = capacitance in farads.

Theoretically, the charging process is never really finished, but eventually the charging current drops to an unmeasurable value. For many purposes, it is convenient to let $t = RC$. Under this condition, the above equation becomes:

$$V(RC) = E(1 - e^{-1}) \approx 0.632 E \quad (51)$$

The product of R in ohms times C in

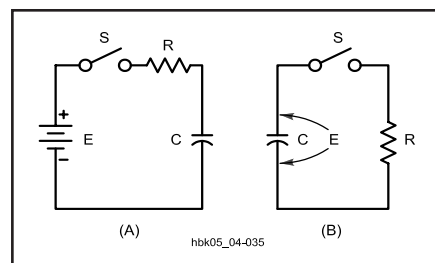

Fig 4.35 — An illustration of the time constant in an RC circuit.

farads is called the *time constant* of the circuit and is the time in seconds required to charge the capacitor to 63.2% of the supply voltage. (The lower-case Greek letter tau $[\tau]$ is often used to represent the time constant in electronics circuits.) After two time constants ($t = 2\tau$) the capacitor charges another 63.2% of the difference between the capacitor voltage at one time constant and the supply voltage, for a total charge of 86.5%. After three time constants the capacitor reaches 95% of the supply voltage, and so on, as illustrated in the curve of Fig 4.36A. After 5 RC time periods, a capacitor is considered fully charged, having reached 99.24% of the source voltage.

If a charged capacitor is discharged through a resistor, as indicated in Fig 4.35B, the same time constant applies for the decay of the capacitor voltage. A direct short circuit applied between the capacitor terminals would discharge the capacitor almost instantly. The resistor, R, limits the current, so the capacitor voltage decreases only as rapidly as the capacitor can discharge itself through R. A capacitor discharging through a resistance

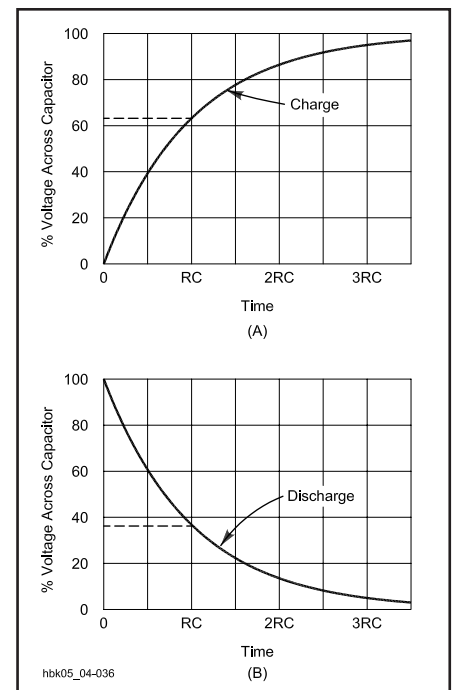

Fig 4.36 — At A, the curve shows how the voltage across a capacitor rises, with time, when charged through a resistor. The curve at B shows the way in which the voltage decreases across a capacitor when discharging through the same resistance. For practical purposes, a capacitor may be considered charged or discharged after 5 RC periods.

exhibits the same time-constant characteristics (calculated in the same way as above) as a charging capacitor. The voltage, as a function of time while the capacitor is being discharged, is given by:

$$V(t) = E \left[e^{-\frac{t}{RC}} \right] \quad (52)$$

where t = time in seconds after initiation of discharge.

Again, by letting $t = RC$, the time constant of a discharging capacitor represents a decrease in the voltage across the capacitor of about 63.2%. After 5 time-constant periods, the capacitor is considered fully discharged, since the voltage has dropped to less than 1% of the full-charge voltage.

Time constant calculations have many uses in radio work. The following examples are all derived from practical-circuit applications.

Example 1: A 100- μF capacitor in a high-voltage power supply is shunted by a 100-k Ω resistor. What is the minimum time before the capacitor may be considered fully discharged? Since full discharge is approximately 5 RC periods,

$$\begin{aligned} t &= 5 \times RC = 5 \times 100 \times 10^3 \Omega \times 100 \times 10^{-6} \text{ F} \\ &= 50000 \times 10^{-3} \text{ seconds} \\ t &= 50.0 \text{ s} \end{aligned}$$

Note: Although waiting almost a minute for the capacitor to discharge seems safe in this high-voltage circuit, never rely solely on capacitor-discharging resistors (often called *bleeder resistors*). Be certain the power source is removed and the capacitors are totally discharged before touching any circuit components.

Example 2: Smooth CW keying without clicks requires approximately 5 ms (0.005 s) of delay in both the make and break edges of the waveform, relative to full charging and discharging of a capacitor in the circuit. What typical values might a builder choose for an RC delay circuit in a keyed voltage line? Since full charge and discharge require 5 RC periods,

$$RC = \frac{t}{5} = \frac{0.005 \text{ s}}{5} = 0.001 \text{ s}$$

Any combination of resistor and capacitor whose values, when multiplied together, equal 0.001 would do the job. A typical capacitor might be 0.05 μF . In that case, the necessary resistor would be:

$$\begin{aligned} R &= \frac{0.001 \text{ s}}{0.05 \times 10^{-6} \text{ F}} \\ &= 0.02 \times 10^6 \Omega = 20000 \Omega = 20 \text{ k}\Omega \end{aligned}$$

In practice, a builder would likely either experiment with values or use a variable resistor. The final value would be selected after monitoring the waveform on an oscilloscope.

Example 3: Many modern integrated circuit (IC) devices use RC circuits to control their timing. To match their internal circuitry, they may use a specified threshold voltage as the trigger level. For example, a certain IC uses a trigger level of 0.667 of the supply voltage. What value of capacitor and resistor would be required for a 4.5-second timing period?

First we will solve equation 50 for the time constant, RC. The threshold voltage is 0.667 times the supply voltage, so we use this value for $V(t)$.

$$\begin{aligned} V(t) &= E \left[1 - e^{-\frac{t}{RC}} \right] \\ 0.667 E &= E \left[1 - e^{-\frac{t}{RC}} \right] \\ e^{-\frac{t}{RC}} &= 1 - 0.667 \\ \ln \left[e^{-\frac{t}{RC}} \right] &= \ln(0.333) \\ -\frac{t}{RC} &= -1.10 \end{aligned}$$

We want to find a capacitor and resistor combination that will produce a 4.5 s

timing period, so we substitute that value for t .

$$RC = \frac{4.5 \text{ s}}{1.10}$$

If we select a value of 10 μF , we can solve for R.

$$R = \frac{4.1 \text{ s}}{10 \times 10^{-6} \text{ F}} = 0.41 \times 10^6 \Omega = 410 \text{ k}\Omega$$

A 1% tolerance resistor and capacitor will give good precision. You could also use a variable resistor and an accurate method to measure the time to set the circuit to a 4.5 s period.

As the examples suggest, RC circuits have numerous applications in electronics. The number of applications is growing steadily, especially with the introduction of integrated circuits controlled by part or all of a capacitor charge or discharge cycle.

ALTERNATING CURRENT IN CAPACITANCE

Everything said about capacitance and capacitors in a dc circuit applies to capacitance in an ac circuit with one major exception. Whereas a capacitor in a dc circuit will appear as an open circuit except for the brief charge and discharge periods, the same capacitor in an ac circuit will both pass and limit current. A capacitor in an ac circuit does not handle electrical energy like a resistor, however. Instead of converting the energy to heat and dissipating it, capacitors store electrical energy and return it to the circuit.

In **Fig 4.37** a sine-wave ac voltage having a maximum value of 100 is applied to a ca-

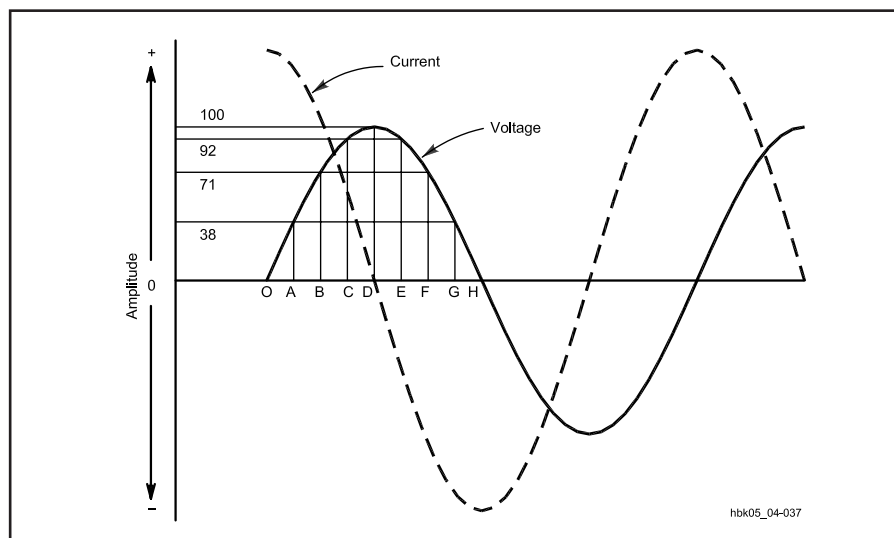

Fig 4.37 — Voltage and current phase relationships when an alternating current is applied to a capacitor.

capacitor. In the period OA, the applied voltage increases from 0 to 38; at the end of this period the capacitor is charged to that voltage. In interval AB the voltage increases to 71; that is, 33 V additional. During this interval a smaller quantity of charge has been added than in OA, because the voltage rise during interval AB is smaller. Consequently the average current during interval AB is smaller than during OA. In the third interval, BC, the voltage rises from 71 to 92, an increase of 21 V. This is less than the voltage increase during AB, so the quantity of electricity added is less; in other words, the average current during interval BC is still smaller. In the fourth interval, CD, the voltage increases only 8 V; the charge added is smaller than in any preceding interval and therefore the current also is smaller.

By dividing the first quarter cycle into a very large number of intervals, it could be shown that the current charging the capacitor has the shape of a sine wave, just as the applied voltage does. The current is largest at the beginning of the cycle and becomes zero at the maximum value of the voltage, so there is a phase difference of 90° between the voltage and the current. During the first quarter cycle the current is flowing in the normal direction through the circuit, since the capacitor is being charged. Hence the current is positive, as indicated by the dashed line in Fig 4.37.

In the second quarter cycle — that is, in the time from D to H — the voltage applied to the capacitor decreases. During this time the capacitor loses its charge. Applying the same reasoning, it is evident that the current is small in interval DE and continues to increase during each succeeding interval. The current is flowing against the applied voltage, however, because the capacitor is discharging into the circuit. The current flows in the negative direction during this quarter cycle.

The third and fourth quarter cycles repeat the events of the first and second, respectively, with this difference: the polarity of the applied voltage has reversed, and the current changes to correspond. In other words, an alternating current flows in the circuit because of the alternate charging and discharging of the capacitance. As shown in Fig 4.37, the current starts its cycle 90° before the voltage, so the current in a capacitor *leads* the applied voltage by 90°. You might find it helpful to remember the word “ICE” as a mnemonic because the current (I) in a capacitor (C) comes before voltage (E). We can also turn this statement around, to say the voltage in a capacitor *lags* the current by 90°.

CAPACITIVE REACTANCE

The quantity of electric charge that can be placed on a capacitor is proportional to

the applied voltage and the capacitance. This amount of charge moves back and forth in the circuit once each cycle; hence, the rate of movement of charge (the current) is proportional to voltage, capacitance and frequency. When the effects of capacitance and frequency are considered together, they form a quantity that plays a part similar to that of resistance in Ohm’s Law. This quantity is called *reactance*. The unit for reactance is the ohm, just as in the case of resistance. The formula for calculating the reactance of a capacitor at a given frequency is:

$$X_C = \frac{1}{2\pi f C} \quad (53)$$

where:

- X_C = capacitive reactance in ohms,
- f = frequency in hertz,
- C = capacitance in farads
- $\pi = 3.1416$

Note: In many references and texts, the symbol ω is used to represent $2\pi f$. In such references, equation 53 would read

$$X_C = \frac{1}{\omega C}$$

Although the unit of reactance is the ohm, there is no power dissipated in reactance. The energy stored in the capacitor during one portion of the cycle is simply returned to the circuit in the next.

The fundamental units for frequency and capacitance (hertz and farads) are too cumbersome for practical use in radio circuits. If the capacitance is specified in microfarads (μF) and the frequency is in megahertz (MHz), however, the reactance calculated from the previous formula retains the unit ohms.

Example: What is the reactance of a capacitor of 470 pF (0.000470 μF) at a frequency of 7.15 MHz?

$$\begin{aligned} X_C &= \frac{1}{2\pi f C} \\ &= \frac{1}{2\pi \times 7.15 \text{ MHz} \times 0.000470 \mu\text{F}} \\ &= \frac{1\Omega}{0.0211} = 47.4 \Omega \end{aligned}$$

Example: What is the reactance of the same capacitor, 470 pF (0.000470 μF), at a frequency of 14.29 MHz?

$$\begin{aligned} X_C &= \frac{1}{2\pi f C} \\ &= \frac{1}{2\pi \times 14.29 \text{ MHz} \times 0.000470 \mu\text{F}} \\ &= \frac{1\Omega}{0.0422} = 23.7 \Omega \end{aligned}$$

The rate of change of voltage in a sine wave increases directly with the frequency. Therefore, the current into the capacitor also increases directly with frequency. Since, for a given voltage, an increase in current is equivalent to a decrease in reactance, the reactance of any capacitor decreases proportionally as the frequency increases. Fig 4.38 traces the decrease in reactance of an arbitrary-value capacitor with respect to increasing frequency. The only limitation on the application of the graph is the physical make-up of the capacitor, which may favor low-frequency uses or high-frequency applications.

Among other things, reactance is a measure of the ability of a capacitor to limit the flow of ac in a circuit. For some purposes it is important to know the ability of a capacitor to pass current. This ability is called *susceptance*, and it corresponds to conductance in resistive circuit elements. In an ideal capacitor with no resistive losses — that is, no energy lost as heat — susceptance is simply the reciprocal of reactance. Hence,

$$B = \frac{1}{X_C} \quad (54)$$

where:

- X_C is the reactance, and
- B is the susceptance.

The unit of susceptance (and conductance and admittance) is the *siemens* (abbreviated S). In literature only a few years old, the term *mho* is also sometimes given as the unit of susceptance (as well as of conductance and admittance). The role of reactance and susceptance in current and other Ohm’s Law calculations will appear in a later section of this chapter.

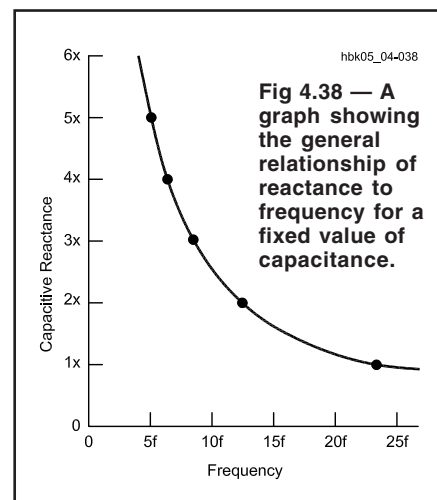

Inductance and Inductors

A second way to store electrical energy is in a *magnetic field*. This phenomenon is called *inductance*, and the devices that exhibit inductance are called *inductors*. Inductance depends upon some basic underlying magnetic properties. See Chapter 6 for more information on practical inductor applications and problems.

MAGNETISM

Magnetic Fields, Flux and Flux Density

Magnetic fields are closed fields that surround a magnet, as illustrated in **Fig 4.39**. The field consists of lines of magnetic force or *flux*. It exhibits polarity, which is conventionally indicated as north-seeking and south-seeking poles, or *north* and *south poles* for short. Magnetic flux is measured in the SI unit of the weber, which is a volt second ($\text{Wb} = \text{Vs}$). In the *centimeter gram second (cgs)*

metric system units, we measure magnetic flux in maxwells ($1\text{Mx} = 10^{-8} \text{Wb}$).

The field intensity, known as the *flux density*, decreases with the square of the distance from the source. Flux density (B) is represented in gauss (G), where one gauss is equivalent to one line of force per square centimeter of area across the field ($G = \text{Mx} / \text{cm}^2$). The gauss is a *cgs* unit. In SI units, flux density is represented by the tesla (T), which is one weber per square meter ($T = \text{Wb}/\text{m}^2$).

Magnetic fields exist around two types of materials. First, certain ferromagnetic materials contain molecules aligned so as to produce a magnetic field. Lodestone, Alnico and other materials with high *retentivity* form *permanent magnets* because they retain their magnetic properties for long periods. Other materials, such as soft iron, yield temporary magnets that lose their magnetic properties rapidly.

The second type of magnetic material is an electrical conductor with a current through it. As shown in **Fig 4.40**, moving electrons are surrounded by a closed magnetic field lying in planes perpendicular to their motion. The needle of a compass placed near a wire carrying direct current will be deflected by the magnetic field around the wire. This phenomenon is one aspect of a two-way relationship: a moving magnetic field whose lines cut across a wire will induce an electrical current in the wire, and an electrical current will produce a magnetic field.

If the wire is coiled into a solenoid, the magnetic field greatly intensifies as the individual flux lines add together. **Fig 4.41** illustrates the principle by showing a coil section. Note that the resulting *electro-*

magnet has magnetic properties identical in principle to those of a permanent magnet, including poles and lines of force or flux. The strength of the magnetic field depends on several factors: the number of turns of the coil, the magnetic properties of the materials surrounding the coil (both inside and out), the length of the magnetic path and the amplitude of the current.

The magnetizing or *magnetomotive force* that produces a flux or total magnetic field is measured in gilberts (Gb). The force in gilberts equals 0.4π (approximately 1.257) times the number of turns in the coil times the current in amperes. (The SI unit of magnetomotive force is the ampere turn, abbreviated A, just like the ampere.) The magnetic field strength, H , measured in oersteds (Oe) produced by any particular magnetomotive force (measured in gilberts) is given by:

$$H = \frac{0.4\pi NI}{\ell} \quad (55)$$

where:

H = magnetic field strength in oersteds,

N = number of turns,

I = dc current in amperes,

$\pi = 3.1416$, and

ℓ = mean magnetic path length in centimeters.

The gilbert and oersted are *cgs* units. These are given here because most amateur calculations will use these units. You may also see the preferred SI units in some literature. The SI unit of magnetic field strength is the ampere (turn) per meter.

A force is required to produce a given magnetic field strength. This implies that there is a resistance, called *reluctance*, to be overcome.

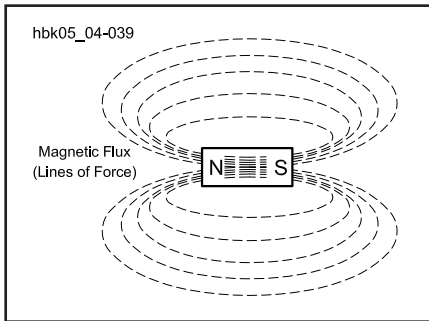

Fig 4.39 — The magnetic field and poles of a permanent magnet. The magnetic field direction is from the north to the south pole.

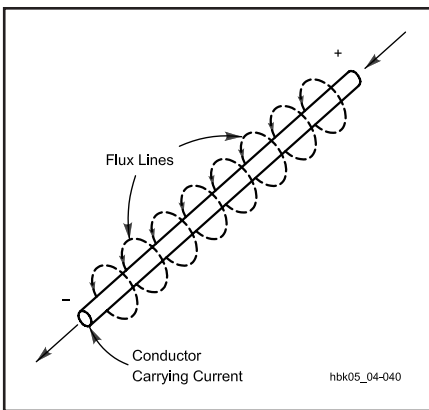

Fig 4.40 — The magnetic field around a conductor carrying an electrical current. If the thumb of your right hand points in the direction of the conventional current (plus to minus), your fingers curl in the direction of the magnetic field around the wire.

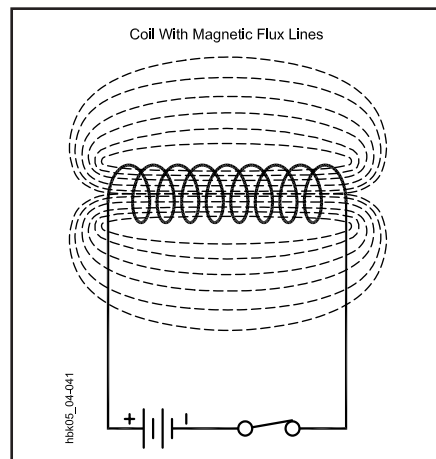

Fig 4.41 — Cross section of an inductor showing its flux lines and overall magnetic field.

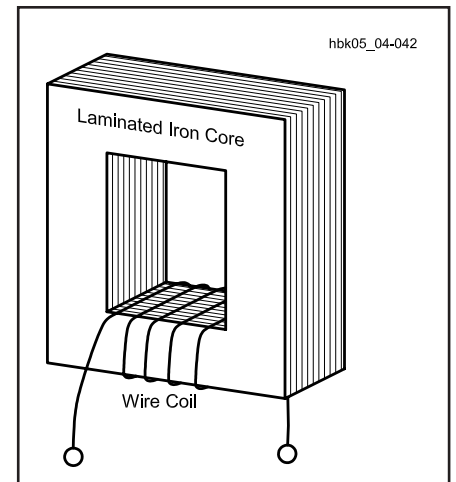

Fig 4.42 — A coil of wire wound around a laminated iron core.

Table 4.6
Properties of Some High-Permeability Materials

Material	Approximate Percent Composition					Maximum Permeability
	Fe	Ni	Co	Mo	Other	
Iron	99.91	—	—	—	—	5000
Purified Iron	99.95	—	—	—	—	180000
4% silicon-iron	96	—	—	—	4 Si	7000
45 Permalloy	54.7	45	—	—	0.3 Mn	25000
Hipernik	50	50	—	—	—	70000
78 Permalloy	21.2	78.5	—	—	0.3 Mn	100000
4-79 Permalloy	16.7	79	—	—	0.3 Mn	100000
Supermalloy	15.7	79	—	5	0.3 Mn	800000
Permendur	49.7	—	50	—	0.3 Mn	5000
2V Permendur	49	—	49	—	2 V	4500
Hiperco	64	—	34	—	2 Cr	10000
2-81 Permalloy*	17	81	—	2	—	130
Carbonyl iron*	99.9	—	—	—	—	132
Ferroxcube III**	(MnFe ₂ O ₄ + ZnFe ₂ O ₄)			—	1500	—

Note: all materials in sheet form except * (insulated powder) and ** (sintered powder). (Reference: L. Ridenour, ed., *Modern Physics for the Engineer*, p 119.)

Core Properties: Permeability, Saturation, Reluctance, Hysteresis

The nature of the material within the coil of an electromagnet, where the lines of force are most concentrated, has the greatest effect upon the magnetic field established by the coil. All materials are compared to air. The ratio of flux density produced by a given material compared to the flux density produce by an air core is the *permeability* of the material. Suppose the coil in Fig 4.42 is wound on an iron core having a cross-sectional area of 2 square inches. When a certain current is sent through the coil, it is found that there are 80000 lines of force in the core. Since the area is 2 square inches, the magnetic flux density is 40000 lines per square inch. Now suppose that the iron core is removed and the same current is maintained in the coil. Also suppose the flux density without the iron core is found to be 50 lines per square inch. The ratio of these flux densities, iron core to air, is 40000 / 50 or 800, the core's permeability.

Permeabilities as high as 10⁶ have been attained. The three most common types of materials used in magnetic cores are these:

A. stacks of laminated steel sheets (for power and audio applications);

B. various ferrite compounds (for cores shaped as rods, toroids, beads and numerous other forms); and

C. powdered iron (shaped as slugs, toroids and other forms for RF inductors).

Brass has a permeability less than 1. A brass core inserted into a coil will decrease the inductance compared to an air core.

The permeability of silicon-steel power-transformer cores approaches 5000 in

high-quality units. Powdered-iron cores used in RF tuned circuits range in permeability from 3 to about 35, while ferrites of nickel-zinc and manganese-zinc range from 20 to 15000. **Table 4.6** lists some common magnetic materials, their composition and their permeabilities. Core materials are often frequency sensitive, exhibiting excessive losses outside the frequency band of intended use.

As a measure of the ease with which a magnetic field may be established in a material as compared with air, permeability (μ) corresponds roughly to electrical conductivity. Permeability is given as:

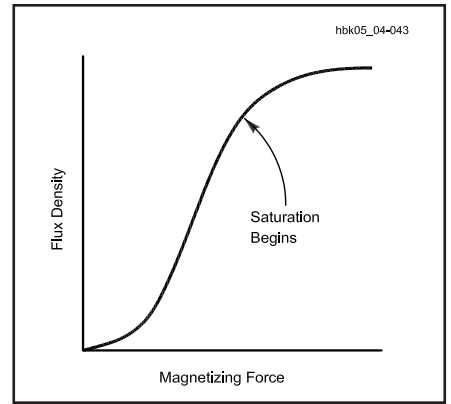

Fig 4.43 — A typical permeability curve for a magnetic core, showing the point where saturation begins.

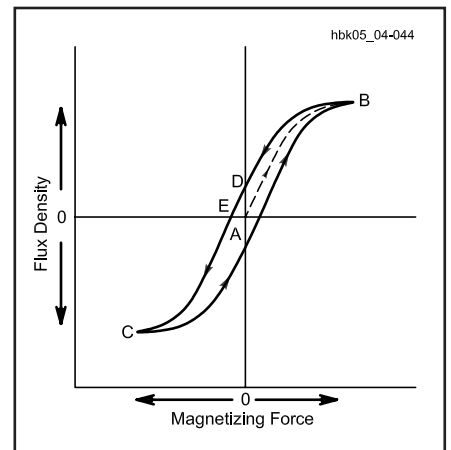

Fig 4.44 — A typical hysteresis curve for a magnetic core, showing the additional energy needed to overcome residual flux.

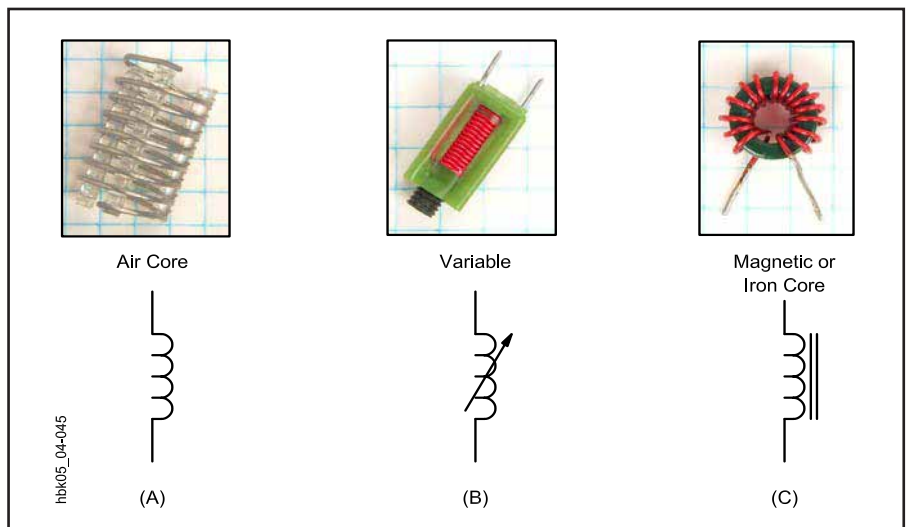

Fig 4.45 — Photos and schematic symbols for representative inductors. A, an air-core inductor; B, a variable inductor with a nonmagnetic slug and C, an inductor with a toroidal magnetic core. The 1/4-inch-ruled graph paper background provides a size comparison.

$$\mu = \frac{B}{H} \quad (56)$$

where:

B is the flux density in gauss, and

H is the magnetic field strength in oersts.

Unlike electrical conductivity, which is independent of other electrical parameters, the permeability of a magnetic material varies with the flux density. At low flux densities (or with an air core), increasing the current through the coil will cause a proportionate increase in flux. But at very high flux densities, increasing the current beyond a certain point may cause no appreciable change in the flux. At this point, the core is said to be *saturated*. Saturation causes a rapid decrease in permeability, because it decreases the ratio of flux lines to those obtainable with the same current using an air core. **Fig 4.43** displays a typical permeability curve, showing the region of saturation. The saturation point varies with the makeup of different magnetic materials. Air and other nonmagnetic materials do not saturate and have a permeability of one. *Reluctance*, which is the reciprocal of permeability and corresponds roughly to resistance in an electrical circuit, is also one for air and other nonmagnetic cores.

The retentivity of magnetic core materials creates another potential set of losses caused by *hysteresis*. **Fig 4.44** illustrates the change of flux density (B) with a changing magnetizing force (H). From starting point A, with no residual flux, the flux reaches point B at the maximum magnetizing force. As the force decreases, so too does the flux, but it does not reach zero simultaneously with the force at point D. As the force continues in the opposite direction, it brings the flux density to point C. As the force decreases to zero, the flux once more lags behind. In effect, a reverse force is necessary to overcome the residual magnetism retained by the core material, a *coercive force*. The result is a power loss to the magnetic circuit, which appears as heat in the core material. Air cores are immune to hysteresis effects and losses.

INDUCTANCE AND DIRECT CURRENT

In an electrical circuit, any element having a magnetic field is called an *inductor*. **Fig 4.45** shows schematic-diagram symbols and photographs of a few representative inductors: an air-core inductor, a slug-tuned variable inductor with a nonmagnetic core and an inductor with a magnetic (iron) core.

The transfer of energy to the magnetic field of an inductor represents work per-

formed by the source of the voltage. Power is required for doing work, and since power is equal to current multiplied by voltage, there must be a voltage drop in the circuit while energy is being stored in the field. This voltage drop, exclusive of any voltage drop caused by resistance in the circuit, is the result of an opposing voltage induced in the circuit while the field is building up to its final value. Once the field becomes constant, the *induced voltage* or back-voltage disappears, because no further energy is being stored. The induced voltage opposes the voltage of the source and tends to prevent the current from rising rapidly when the circuit is closed. **Fig 4.46A** illustrates the situation of energizing an inductor or magnetic circuit, showing the relative amplitudes of induced voltage and the delayed rise in current to its full value.

The amplitude of the induced voltage is proportional to the rate at which the current changes (and consequently, the rate at which the magnetic field changes) and to a constant associated with the circuit itself: the *inductance* (or *self-inductance*) of the circuit. Inductance depends on the physical configuration of the inductor.

Coiling a conductor increases its inductance. In effect, the growing (or shrinking) magnetic field of each turn produces magnetic lines of force that — in their expansion (or contraction) — cut across the other turns of the coil, inducing a voltage in every other turn. The mutuality of the effect multiplies the ability of the coiled conductor to store electrical energy.

A coil of many turns will have more inductance than one of few turns, if both coils are otherwise physically similar. Furthermore, if an inductor is placed around a magnetic core, its inductance will increase in proportion to the permeability of that core, if the circuit current is below the point at which the core saturates.

The polarity of an induced voltage is always such as to oppose any change in the circuit current. This means that when the current in the circuit is increasing, work is being done against the induced voltage by storing energy in the magnetic field. Likewise, if the current in the circuit tends to decrease, the stored energy of the field returns to the circuit, and adds to the energy being supplied by the voltage source. Inductors try to maintain a

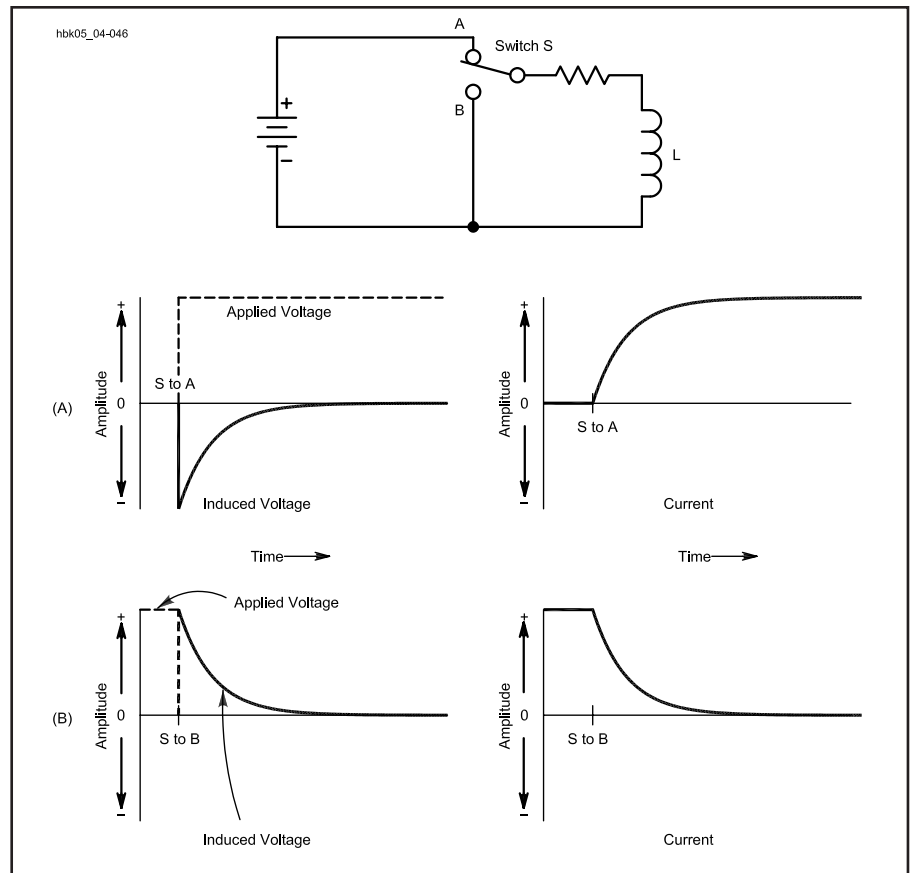

Fig 4.46 — Inductive circuit showing and graphing the generation of induced voltage and the rise of current in an inductor at A, and the decay of current as power is removed and the coil shorted at B.

constant current through the circuit. This phenomenon tends to keep the current flowing even though the applied voltage may be decreasing or be removed entirely. Fig 4.46B illustrates the decreasing but continuing flow of current caused by the induced voltage after the source voltage is removed from the circuit.

The energy stored in the magnetic field of an inductor is given by the formula:

$$W = \frac{I^2 L}{2} \quad (57)$$

where:

- W = energy in joules,
- I = current in amperes, and
- L = inductance in henrys.

This formula corresponds to the energy-storage formula for capacitors: energy storage is a function of current squared over time. As with capacitors, the time dependence of inductor current is a significant property; see the section on time constants.

The basic unit of inductance is the *henry* (abbreviated H), which equals an induced voltage of one volt when the inducing current is varying at a rate of one ampere per second. In various aspects of radio work, inductors may take values ranging from a fraction of a nanohenry (nH) through millihenrys (mH) up to about 20 H.

MUTUAL INDUCTANCE AND MAGNETIC COUPLING

Mutual Inductance

When two coils are arranged with their axes on the same line, as shown in Fig 4.47, current sent through coil 1 creates a magnetic field that cuts coil 2. Consequently, a voltage will be induced in coil 2 whenever the field strength of coil 1 is changing. This induced voltage is similar to the voltage of self-induction, but since it appears in the second coil because of

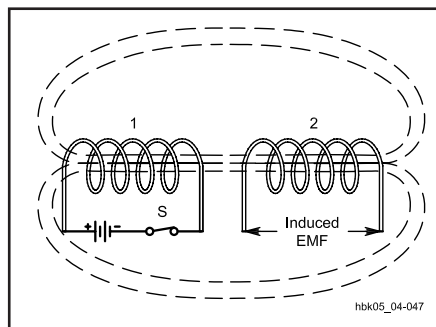

Fig 4.47 — Mutual inductance: When S is closed, current flows through coil number 1, setting up a magnetic field that induces a voltage in the turns of coil number 2.

current flowing in the first, it is a mutual effect and results from the *mutual inductance* between the two coils.

When all the flux set up by one coil cuts all the turns of the other coil, the mutual inductance has its maximum possible value. If only a small part of the flux set up by one coil cuts the turns of the other, the mutual inductance is relatively small. Two coils having mutual inductance are said to be *coupled*.

The ratio of actual mutual inductance to the maximum possible value that could theoretically be obtained with two given coils is called the *coefficient of coupling* between the coils. It is frequently expressed as a percentage. Coils that have nearly the maximum possible mutual inductance (coefficient = 1 or 100%) are said to be closely, or tightly, coupled. If the mutual inductance is relatively small the coils are said to be loosely coupled. The degree of coupling depends upon the physical spacing between the coils and how they are placed with respect to each other. Maximum coupling exists when they have a common axis and are as close together as possible (for example, one wound over the other). The coupling is least when the coils are far apart or are placed so their axes are at right angles.

The maximum possible coefficient of coupling is closely approached when the two coils are wound on a closed iron core. The coefficient with air-core coils may run as high as 0.6 or 0.7 if one coil is wound over the other, but will be much less if the two coils are separated. Although unity coupling is suggested by Fig 4.47, such coupling is possible only when the coils are wound on a closed magnetic core.

Unwanted Couplings: Spikes, Lightning and Other Pulses

Every conductor passing current has a magnetic field associated with it — and therefore inductance — even though the conductor is not formed into a coil. The inductance of a short length of straight wire is small, but it may not be negligible. If the current through it changes rapidly, the induced voltage may be appreciable. This is the case in even a few inches of wire with an alternating current having a frequency on the order of 100 MHz or higher. At much lower frequencies or at dc, the inductance of the same wire might be ignored because the induced voltage would seemingly be negligible.

There are many phenomena, however, both natural and man-made, which create sufficiently strong magnetic fields to induce voltages into straight wires. Many of them are brief but intense pulses of energy that act like the turning on of the

switch in a circuit containing self-inductance. Because the fields created grow to very high levels rapidly, they cut across wires leading into and out of — and wires wholly within — electronic equipment, inducing unwanted voltages by mutual coupling.

Short-duration, high-level voltage spikes occur on ac and dc power lines. Because the field intensity is great, these spikes may induce voltages upon conducting elements in sensitive circuits, disrupting them and even injuring components. Lightning in the vicinity of the equipment can induce voltages on power lines and other conductive paths (even ground conductors) that lead to the equipment location. Lightning that seems a safe distance away can induce large spikes on power lines that ultimately lead to the equipment. Closer at hand, heavy equipment with electrical motors can induce significant spikes into power lines within the equipment location. Even though the power lines are straight, the powerful magnetic field of a spike source can induce damaging voltages on equipment left “plugged in” during electrical storms or during the operation of heavy equipment that inadequately filters its spikes.

Parallel-wire cables linking elements of electronic equipment consist of long wires in close proximity to each other. Signal pulses can couple both magnetically and capacitively from one wire to another. Since the magnetic field of a changing current decreases as the square of distance, separating the signal-carrying lines diminishes inductive coupling. Placing a grounded wire between signal-carrying lines reduces capacitive coupling. Unless they are well-shielded and filtered, however, the lines are still susceptible to the inductive coupling of pulses from other sources.

INDUCTORS IN RADIO WORK

Various facets of radio work make use of inductors ranging from the tiny up to the massive. Small values of inductance, as illustrated by Fig 4.48A, serve mostly in RF circuits. They may be self-supporting air-core or air-wound coils or the winding may be supported by nonmagnetic strips or a form. Phenolic, certain plastics and ceramics are the most common coil forms for air-core inductors. These inductors range in value from a few hundred μH for medium- and high-frequency circuits down to tenths of a μH for VHF and UHF work. The smallest values of inductance in radio work result from component leads. For VHF work and higher frequencies, component lead length is often critical. Circuits may fail

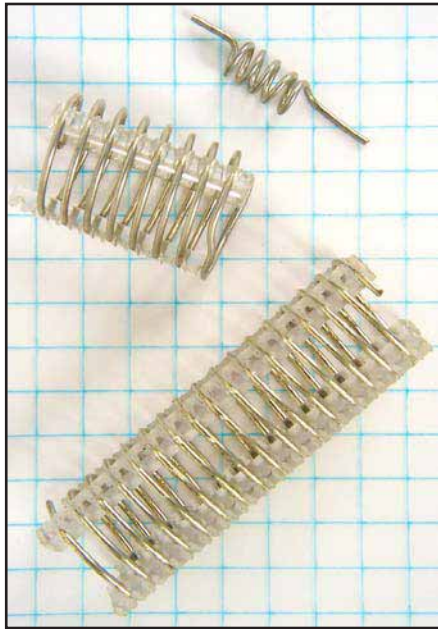

(A)



(B)

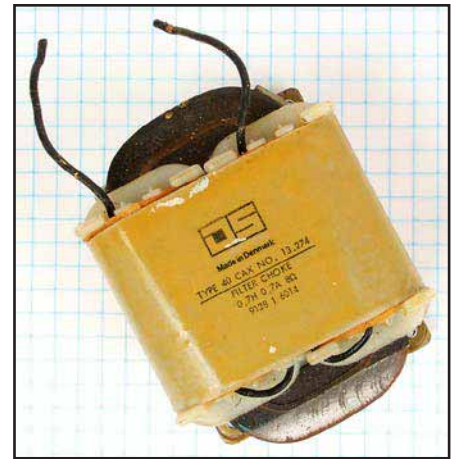

(C)

Fig 4.48 — Part A shows small-value air-wound inductors. Part B shows some inductors with values in the range of a few millihenrys and C shows a large inductor such as might be used in audio circuits or as power-supply chokes. The 1/4-inch-ruled graph paper background provides a size comparison.

to operate properly because leads are a little too short or too long.

It is possible to make these solenoid coils variable by inserting a slug in the center of the coil. (Slug-tuned coils normally have a ceramic, plastic or phenolic insulating form between the conductive slug and the coil winding.) If the slug material is magnetic, such as powdered iron, the inductance increases as the slug is centered along the length of the coil. If the slug is brass or some other conductive but nonmagnetic material, centering the slug will reduce the coil's inductance. This effect stems from the fact that brass has low electrical resistance and acts as an effective short-circuited one-turn secondary for the coil. (See more on transformer effects later in this chapter.)

An alternative to air-core inductors for RF work are toroidal coils wound on cores composed of powdered iron mixed with a binder to hold the material together. The availability of many types and sizes of powdered-iron cores has made these inductors popular for low-power fixed-value service. The toroidal shape concentrates the inductor's field tightly about the coil, eliminating the need in many cases for other forms of shielding to limit the interaction of the inductor's magnetic field with the fields of other inductors.

Fig 4.48B shows samples of inductors in the millihenry range. Among these inductors are multisection RF chokes designed to keep RF currents from passing beyond them to other parts of circuits.

Low-frequency radio work may also use inductors in this range of values, sometimes wound with *litz* wire. Litz wire is a special version of stranded wire, with each strand insulated from the others. For audio filters, toroidal coils with values below 100 mH are useful. Resembling powdered-iron-core RF toroids, these coils are wound on ferrite or molybdenum-permalloy cores having much higher permeabilities.

Audio and power-supply inductors appear in Fig 4.48C. Lower values of these

iron-core coils, in the range of a few henrys, are useful as audio-frequency chokes. Larger values up to about 20 H may be found in power supplies, as choke filters, to suppress 120-Hz ripple. Although some of these inductors are open frame, most have iron covers to confine the powerful magnetic fields they produce.

INDUCTANCES IN SERIES AND PARALLEL

When two or more inductors are connected in series (Fig 4.49A), the total

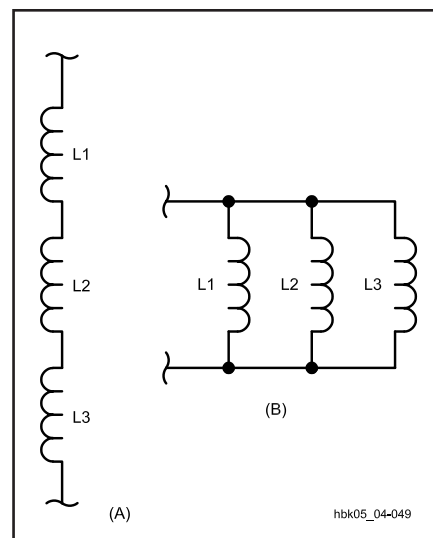

Fig 4.49 — Part A shows inductances in series, and Part B shows inductances in parallel.

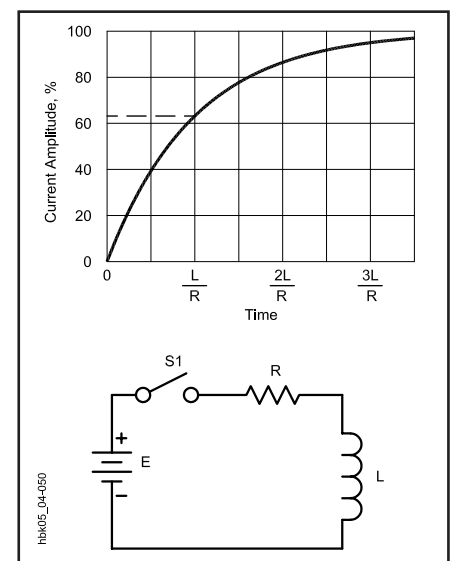

Fig 4.50 — Time constant of an RL circuit being energized.

inductance is equal to the sum of the individual inductances, provided that the coils are sufficiently separated so that coils are not in the magnetic field of one another. That is:

$$L_{\text{total}} = L_1 + L_2 + L_3 \dots + L_n \quad (58)$$

If inductors are connected in parallel (Fig 4.49B), and if the coils are separated sufficiently, the total inductance is given by:

$$L_{\text{total}} = \frac{1}{\frac{1}{L_1} + \frac{1}{L_2} + \frac{1}{L_3} + \dots + \frac{1}{L_n}} \quad (59)$$

For only two inductors in parallel, the formula becomes:

$$L_{\text{total}} = \frac{L_1 \times L_2}{L_1 + L_2} \quad (60)$$

Thus, the rules for combining inductances in series and parallel are the same as those for resistances, assuming that the coils are far enough apart so that each is unaffected by another's magnetic field. When this is not so, the formulas given above will not yield correct results.

RL TIME CONSTANT

A comparable situation to an RC circuit exists when resistance and inductance are connected in series. In Fig 4.50, first consider L to have no resistance and also consider that R is zero. Closing S1 sends a current through the circuit. The instantaneous transition from no current to a finite value, however small, represents a rapid change in current, and a reverse voltage is developed by the self-inductance of L. The value of reverse voltage is almost equal and opposite to the applied voltage. The resulting initial current is very small.

The reverse voltage depends on the change in the value of the current and would cease to offer opposition if the current did not continue to increase. With no resistance in the circuit (which, by Ohm's Law, would lead to an infinitely large current), the current would increase forever, always growing just fast enough to keep the self-induced voltage equal to the applied voltage.

When resistance in the circuit limits the current, Ohm's Law defines the value that the current can reach. The reverse voltage generated in L must only equal the difference between E and the drop across R, because the difference is the voltage actually applied to L. This difference becomes smaller as the current approaches the final Ohm's Law value. Theoretically, the reverse voltage never quite disappears, and so the current never quite reaches the Ohm's Law value. In practical terms, the

differences become unmeasurable after a time.

The current at any time after the switch in Fig 4.50 has been closed, can be found from:

$$I(t) = \frac{E \left[1 - e^{-\frac{tR}{L}} \right]}{R} \quad (61)$$

where:

I(t) = current in amperes at time t,
 E = power supply potential in volts,
 t = time in seconds after initiation of current,
 e = natural logarithmic base = 2.718,
 R = circuit resistance in ohms, and
 L = inductance in henrys.

The time in seconds required for the current to build up to 63.2% of the maximum value is called the time constant, and is equal to L/R , where L is in henrys and R is in ohms. After each time interval equal to this constant, the circuit conducts an additional 63.2% of the remaining current. This behavior is graphed in Fig 4.50. As is the case with capacitors, after 5 time constants the current is considered to have reached its maximum value. As with capacitors, we often use the lower-case Greek tau (τ) to represent the time constant.

Example: If a circuit has an inductor of 5.0 mH in series with a resistor of 10 Ω , how long will it take for the current in the circuit to reach full value after power is applied? Since achieving maximum current takes approximately five time constants,

$$t = 5L/R = (5 \times 5.0 \times 10^{-3} \text{ H}) / 10 \Omega \\ = 2.5 \times 10^{-3} \text{ seconds or } 2.5 \text{ ms}$$

Note that if the inductance is increased to 5.0 H, the required time increases by a factor of 1000 to 2.5 seconds. Since the circuit resistance didn't change, the final current is the same for both cases in this example. Increasing inductance increases the time required to reach full current.

Zero resistance would prevent the circuit from ever achieving full current. All inductive circuits have some resistance, however, if only the resistance of the wire making up the inductor.

An inductor cannot be discharged in the simple circuit of Fig 4.50 because the magnetic field collapses as soon as the current ceases. Opening S1 does not leave the inductor charged in the way that a capacitor would remain charged. The energy stored in the magnetic field returns

instantly to the circuit when S1 is opened. The rapid collapse of the field causes a very large voltage to be induced in the coil. Usually the induced voltage is many times larger than the applied voltage, because the induced voltage is proportional to the rate at which the field changes. The common result of opening the switch in such a circuit is that a spark or arc forms at the switch contacts during the instant the switch opens. When the inductance is large and the current in the circuit is high, large amounts of energy are released in a very short time. It is not at all unusual for the switch contacts to burn or melt under such circumstances. The spark or arc at the opened switch can be reduced or suppressed by connecting a suitable capacitor and resistor in series across the contacts. Such an RC combination is called a *snubber network*.

Transistor switches connected to and controlling coils, such as relay solenoids, also require protection. In most cases, a small power diode connected in reverse across the relay coil will prevent field-collapse currents from harming the transistor.

If the excitation is removed without breaking the circuit, as theoretically diagrammed in Fig 4.51, the current will decay according to the formula:

$$I(t) = \frac{E}{R} \left[e^{-\frac{tR}{L}} \right] \quad (62)$$

where t = time in seconds after removal of

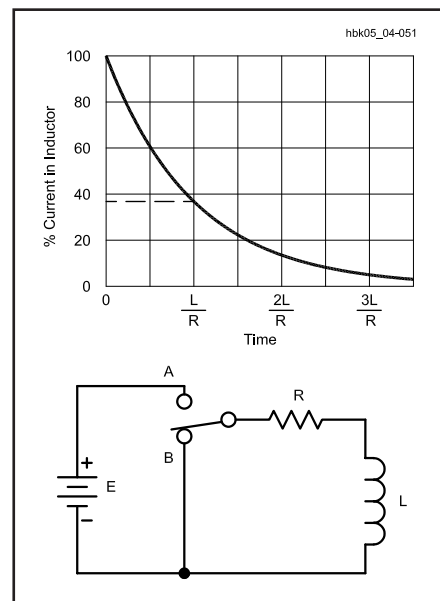

Fig 4.51 — Time constant of an RL circuit being deenergized. This is a theoretical model only, since a mechanical switch cannot change state instantaneously.

the source voltage.

After one time constant the current will lose 63.2% of its steady-state value. (It will decay to 36.8% of the steady-state value.) The graph in Fig 4.51 shows the current-decay waveform to be identical to the voltage-discharge waveform of a capacitor. Be careful about applying the terms *charge* and *discharge* to an inductive circuit, however. These terms refer to energy storage in an electric field. An inductor stores energy in a magnetic field.

ALTERNATING CURRENT IN INDUCTORS

When an alternating voltage is applied to an ideal inductance (one with no resistance — all practical inductors have some resistance), the current is 90° out of phase with the applied voltage. In this case the current *lags* 90° behind the voltage, the opposite of the capacitor current-voltage relationship, as shown in Fig 4.52. (Here again, we can also say the voltage across an inductor *leads* the current by 90° .)

If you have difficulty remembering the phase relationships between voltage and current with inductors and capacitors, you may find it helpful to think of the phrase, “ELI the ICE man.” This will remind you that voltage across an inductor leads the current through it, because the E comes before the I, with an L between them, as you read from left to right. (The letter L represents inductance.) It will also help you remember the capacitor conditions because I comes before E with a C between them.

Interpreting Fig 4.52 begins with understanding that the primary cause for current

lag in an inductor is the reverse voltage generated in the inductance. The amplitude of the reverse voltage is proportional to the rate at which the current changes. In time segment OA, when the applied voltage is at its positive maximum, the reverse or induced voltage is also maximum, allowing the least current to flow. The rate at which the current is changing is the highest, a 38% change in the time period OA. In the segment AB, the current changes by only 33%, yielding a reduced level of induced voltage, which is in step with the decrease in the applied voltage. The process continues in time segments BC and CD, the latter producing only an 8% rise in current as the applied and induced voltage approach zero.

In segment DE, the applied voltage changes direction. The induced voltage also changes direction, which returns current to the circuit from storage in the magnetic field. The direction of this current is now opposite to the applied voltage, which sustains the current in the positive direction. As the applied voltage continues to increase negatively, the current — although positive — decreases in value, reaching zero as the applied voltage reaches its negative maximum. The negative half-cycle continues just as did the positive half-cycle.

Compare Fig 4.52 with Fig 4.37. Whereas in a pure capacitive circuit, the current *leads* the voltage by 90° , in a pure inductive circuit, the current *lags* the voltage by 90° . These phenomena are especially important in circuits that combine inductors and capacitors.

INDUCTIVE REACTANCE

The amplitude of alternating current in an inductor is inversely proportional to the applied frequency. Since the reverse voltage is directly proportional to inductance for a given rate of current change, the current is inversely proportional to inductance for a given applied voltage and frequency.

The combined effect of inductance and frequency is called inductive reactance, which — like capacitive reactance — is expressed in ohms. The formula for inductive reactance is:

$$X_L = 2\pi f L \quad (63)$$

where:

X_L = inductive reactance,

f = frequency in hertz,

L = inductance in henrys, and

$\pi = 3.1416$.

(If $\omega = 2\pi f$, then $X_L = \omega L$.)

Example: What is the reactance of a coil having an inductance of 8.00 H at a frequency of 120 Hz?

$$\begin{aligned} X_L &= 2\pi f L \\ &= 6.2832 \times 120 \text{ Hz} \times 8.00 \text{ H} \\ &= 6030 \Omega \end{aligned}$$

In RF circuits the inductance values are usually small and the frequencies are large. When the inductance is expressed in millihenrys and the frequency in kilohertz, the conversion factors for the two units cancel, and the formula for reactance may be used without first converting to fundamental units. Similarly, no conversion is necessary if the inductance is expressed in microhenrys and the frequency in megahertz.

Example: What is the reactance of a 15.0-microhenry coil at a frequency of 14.0 MHz?

$$\begin{aligned} X_L &= 2\pi f L \\ &= 6.2832 \times 14.0 \text{ MHz} \times 15.0 \mu\text{H} \\ &= 1320 \Omega \end{aligned}$$

The resistance of the wire used to wind the coil has no effect on the reactance, but simply acts as a separate resistor connected in series with the coil.

Example: What is the reactance of the same coil at a frequency of 7.0 MHz?

$$\begin{aligned} X_L &= 2\pi f L \\ &= 6.2832 \times 7.0 \text{ MHz} \times 15.0 \mu\text{H} \\ &= 660 \Omega \end{aligned}$$

Comparing the two examples suggests correctly that inductive reactance varies directly with frequency. The rate of change of the current varies directly with the frequency, and this rate of change also

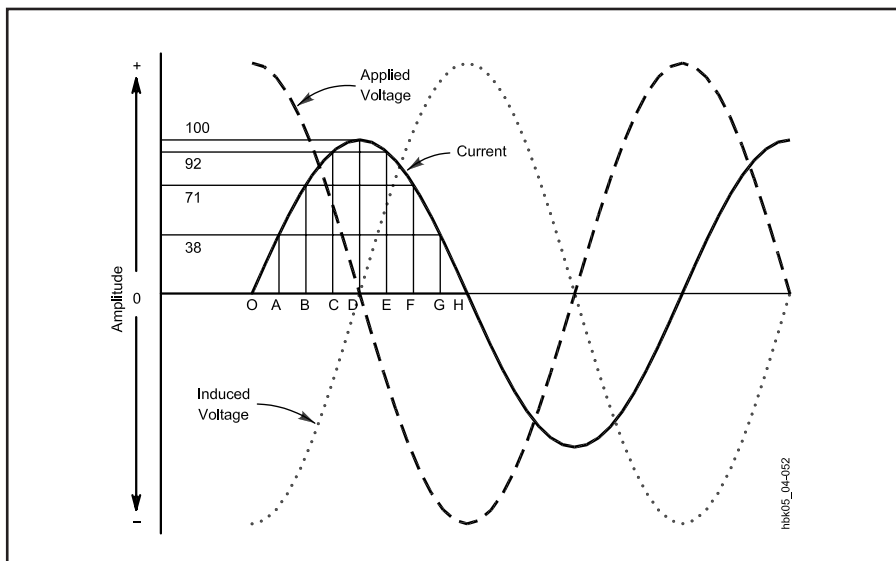

Fig 4.52 — Phase relationships between voltage and current when an alternating current is applied to an inductance.

determines the amplitude of the induced or reverse voltage. Hence, the opposition to the flow of current increases proportionally to frequency. This opposition is called *inductive reactance*. The direct relationship between frequency and reactance in inductors, combined with the inverse relationship between reactance and frequency in the case of capacitors, will be of fundamental importance in

creating resonant circuits.

As a measure of the ability of an inductor to limit the flow of ac in a circuit, inductive reactance is similar to capacitive reactance in having a corresponding *susceptance*, or ability to pass ac current in a circuit. In an ideal inductor with no resistive losses — that is, no energy lost as heat — susceptance is simply the reciprocal of reactance.

$$B = \frac{1}{X_L} \quad (64)$$

where:

X_L = reactance, and
 B = susceptance.

The unit of susceptance for both inductors and capacitors is the *siemens*, abbreviated S.

Quality Factor, or Q of Components

Components that store energy, like capacitors and inductors, may be compared in terms of quality or Q. The Q of any such component is the ratio of its ability to store energy to the sum total of all energy losses within the component. In practical terms, this ratio reduces to the formula:

$$Q = \frac{X}{R} \quad (65)$$

where:

Q = figure of merit or quality (no units),
 $X = X_L$ (inductive reactance) for inductors and X_C (capacitive reactance) for capacitors (in ohms), and

R = the sum of all resistances associated with the energy losses in the component (in ohms).

The Q of capacitors is ordinarily high.

Good quality ceramic capacitors and mica capacitors may have Q values of 1200 or more. Small ceramic trimmer capacitors may have Q values too small to ignore in some applications. Microwave capacitors can have poor Q values; 10 or less at 10 GHz and higher frequencies.

Inductors are subject to many types of electrical energy losses, however, such as wire resistance, core losses and skin effect. All electrical conductors have some resistance through which electrical energy is lost as heat. Moreover, inductor wire must be sized to handle the anticipated current through the coil. Wire conductors suffer additional ac losses because alternating current tends to flow on the conductor surface. As the frequency increases, the current is confined to a thinner layer of the

conductor surface. This property is called *skin effect*. If the inductor's core is a conductive material, such as iron, ferrite, or brass, the core will introduce additional losses of energy. The specific details of these losses are discussed in connection with each type of core material.

The sum of all core losses may be depicted by showing a resistor in series with the inductor (as in Figs 4.50 and 4.51), although there is no separate component represented by the resistor symbol. As a result of inherent energy losses, inductor Q rarely, if ever, approaches capacitor Q in a circuit where both components work together. Although many circuits call for the highest Q inductor obtainable, other circuits may call for a specific Q, even a very low one.

AC Component Summary

Component	Resistor	Capacitor	Inductor
Basic Unit	ohm (Ω)	farad (F)	henry (H)
Units Commonly Used		microfarads (μF) picofarads (pF)	millihenrys (mH) microhenrys (μH)
Quantity Stored (Does not want to change in circuit)	(None)	Voltage	Current
Combining components in series	$R_1 + R_2$	$C_1 \times C_2 / C_1 + C_2$	$L_1 + L_2$
Combining components in parallel	$R_1 \times R_2 / R_1 + R_2$	$C_1 + C_2$	$L_1 \times L_2 / L_1 + L_2$
Time constant	(None)	RC	L/R
Voltage-Current Phase	In phase	Current leads voltage Voltage lags current	Voltage leads current Current lags voltage
Resistance or Reactance	Resistance	$X_C = 1 / 2\pi fC$	$X_L = 2\pi fL$
Change with increasing frequency	No	Reactance decreases	Reactance increases
Q of circuit	Not defined	X_C / R	X_L / R

Calculating Practical Inductors

Although builders and experimenters rarely construct their own capacitors, inductor fabrication is common. In fact, it is often necessary, since commercially available units may be unavailable or expensive. Even if available, they may consist of coil stock to be trimmed to the

required value. Core materials and wire for winding both solenoid and toroidal inductors are readily available. The following information includes fundamental formulas and design examples for calculating practical inductors, along with additional data on the theoretical limits in

the use of some materials.

AIR-CORE INDUCTORS

Many circuits require air-core inductors using just one layer of wire. The approximate inductance of a single-layer air-core coil may be calculated from the

simplified formula:

$$L (\mu\text{H}) = \frac{d^2 n^2}{18d + 40\ell} \quad (66)$$

where:

- L = inductance in microhenrys,
- d = coil diameter in inches (from wire center to wire center),
- ℓ = coil length in inches, and
- n = number of turns.

The notation is explained in **Fig 4.53**. This formula is a close approximation for coils having a length equal to or greater

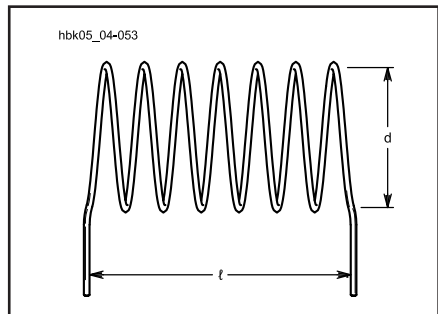

Fig 4.53 — Coil dimensions used in the inductance formula for air-core inductors.

than 0.4 d. (Note: Inductance varies as the square of the turns. If the number of turns is doubled, the inductance is quadrupled. This relationship is inherent in the equation, but is often overlooked. For example, if you want to double the inductance, put on additional turns equal to 1.4 times the original number of turns, or 40% more turns.)

Example: What is the inductance of a coil if the coil has 48 turns wound at 32 turns per inch and a diameter of $3/4$ inch? In this case, $d = 0.75$, $\ell = 48/32 = 1.5$ and $n = 48$.

$$L = \frac{0.75^2 \times 48^2}{(18 \times 0.75) + (40 \times 1.5)}$$

$$= \frac{1300}{74} = 18 \mu\text{H}$$

To calculate the number of turns of a single-layer coil for a required value of inductance, the formula becomes:

$$n = \frac{\sqrt{L(18d + 40\ell)}}{d} \quad (67)$$

Example: Suppose an inductance of $10.0 \mu\text{H}$ is required. The form on which the coil is to be wound has a diameter of

one inch and is long enough to accommodate a coil of $1\ 1/4$ inches. Then $d = 1.00$ inch, $\ell = 1.25$ inches and $L = 10.0$. Substituting:

$$n = \frac{\sqrt{10.0[(18 \times 1.00) + (40 \times 1.25)]}}{1}$$

$$= \sqrt{680} = 26.1 \text{ turns}$$

A 26-turn coil would be close enough in practical work. Since the coil will be 1.25 inches long, the number of turns per inch will be $26.1 / 1.25 = 20.9$. Consulting the wire table in the **Component Data and References** chapter, we find that #17 enameled wire (or anything smaller) can be used. The proper inductance is obtained by winding the required number of turns on the form and then adjusting the spacing between the turns to make a uniformly spaced coil 1.25 inches long.

Most inductance formulas lose accuracy when applied to small coils (such as are used in VHF work and in low-pass filters built for reducing harmonic interference to televisions) because the conductor thickness is no longer negligible in comparison with the size of the coil. **Fig 4.54** shows the measured inductance of VHF coils and may be used as a basis for circuit design. Two curves are given; curve A is for coils wound to an inside diameter of $1/2$ inch; curve B is for coils of $3/4$ -inch inside diameter. In both curves, the wire size is #12, and the winding pitch is eight turns to the inch ($1/8$ -inch center-to-center turn spacing). The inductance values given include leads $1/2$ -inch long.

Machine-wound coils with the preset diameters and turns per inch are available in many radio stores, under the trade names of B&W Miniductor, Airdux and Polycoil. The **Component Data and References** chapter provides information on using such coil stock to simplify the process of designing high-quality inductors for most HF applications. Forming a wire into a solenoid increases its inductance, and also introduces distributed capacitance. Since each turn is at a slightly different ac potential, each pair of turns effectively forms a parasitic capacitor. See the **Real-World Component Characteristics** chapter for information on the effects of these complications to the "ideal" inductors under discussion in this chapter. Moreover, the Q of air-core inductors is, in part, a function of the coil shape, specifically its ratio of length to diameter. Q tends to be highest when these dimensions are nearly equal. With wire properly sized to the current carried by the coil, and with high-caliber construction, air-core inductors can achieve Qs as high as 400 are possible.

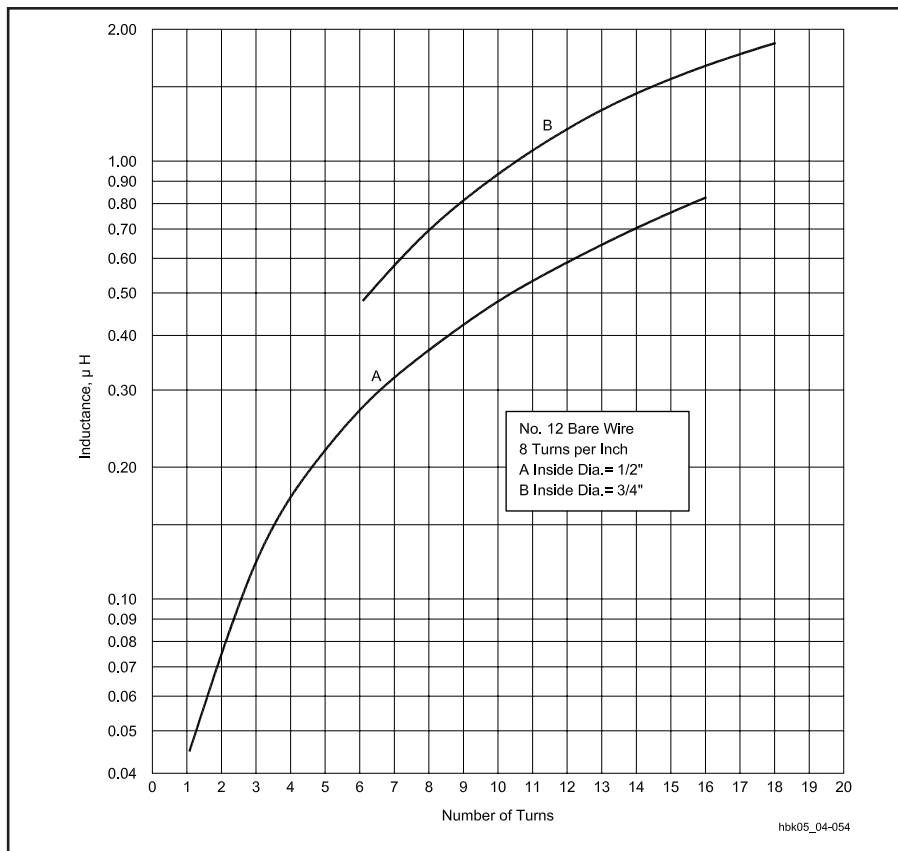

Fig 4.54 — Measured inductance of coils wound with #12 bare wire, eight turns to the inch. The values include half-inch leads.

STRAIGHT-WIRE INDUCTANCE

At low frequencies the inductance of a straight, round, nonmagnetic wire in free space is given by:

$$L = 0.00508 b \left\{ \ln \left(\frac{2b}{a} \right) - 0.75 \right\} \quad (68)$$

where:

- L = inductance in μH ,
- a = wire radius in inches,
- b = wire length in inches, and
- ln = natural logarithm = $2.303 \times$ common logarithm (base 10).

If the dimensions are expressed in milli-

meters instead of inches, the equation may still be used, except replace the 0.00508 value with 0.0002.

Skin effect reduces the inductance at VHF and above. As the frequency approaches infinity, the 0.75 constant within the brackets approaches unity. As a practical matter, skin effect will not reduce the inductance by more than a few percent.

Example: What is the inductance of a wire that is 0.1575 inch in diameter and 3.9370 inches long? For the calculations, a = 0.0787 inch (radius) and b = 3.9370 inch.

$$\begin{aligned} L &= 0.00508 b \left\{ \ln \left(\frac{2b}{a} \right) - 0.75 \right\} \\ &= 0.00508 (3.9370) \times \\ &\quad \left\{ \ln \left(\frac{2 \times 3.9370}{0.0787} \right) - 0.75 \right\} \end{aligned}$$

$$\begin{aligned} L &= 0.0200 [\ln (100) - 0.75] \\ &= 0.0200 (4.60 - 0.75) \\ &= 0.0200 \times 3.85 = 0.077 \mu\text{H} \end{aligned}$$

Fig 4.55 is a graph of the inductance for wires of various radii as a function of length.

A VHF or UHF tank circuit can be fabricated from a wire parallel to a ground plane, with one end grounded. A formula for the inductance of such an arrangement is given in **Fig 4.56**.

Example: What is the inductance of a wire 3.9370 inches long and 0.0787 inch in radius, suspended 1.5748 inch above a ground plane? (The inductance is measured between the free end and the ground plane, and the formula includes the inductance of the 1.5748-inch grounding link.) To demonstrate the use of the formula in Fig 4.56, begin by evaluating these quantities:

$$\begin{aligned} b + \sqrt{b^2 + a^2} &= 3.9370 + \sqrt{3.9370^2 + 0.0787^2} \\ &= 3.9370 + 3.94 = 7.88 \end{aligned}$$

$$\begin{aligned} b + \sqrt{b^2 + 4(h^2)} &= 3.9370 + \sqrt{3.9370^2 + 4(1.5748^2)} \\ &= 3.9370 + \sqrt{15.500 + 4(2.4800)} \\ &= 3.9370 + \sqrt{15.500 + 9.9200} \\ &= 3.9370 + 5.0418 = 8.9788 \end{aligned}$$

$$\frac{2h}{a} = \frac{2 \times 1.5748}{0.0787} = 40.0$$

$$\frac{b}{4} = \frac{3.9370}{4} = 0.98425$$

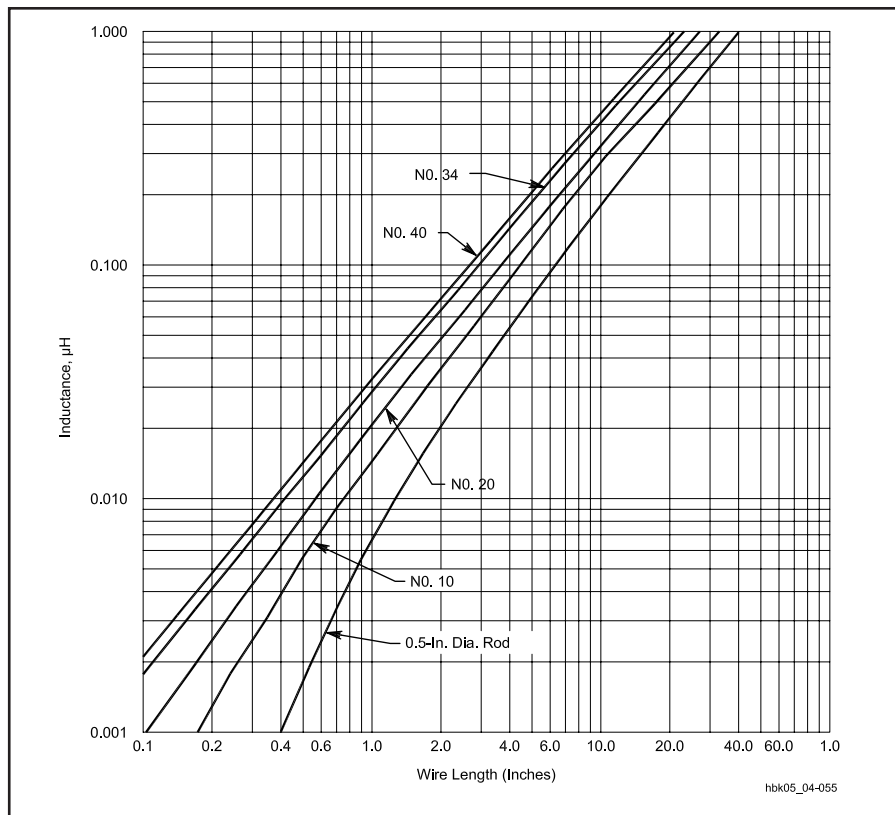

Fig 4.55 — Inductance of various conductor sizes as straight wires.

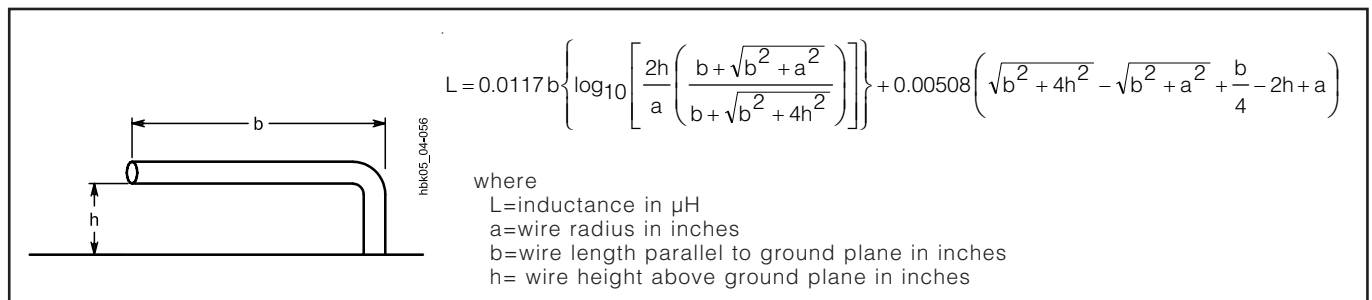
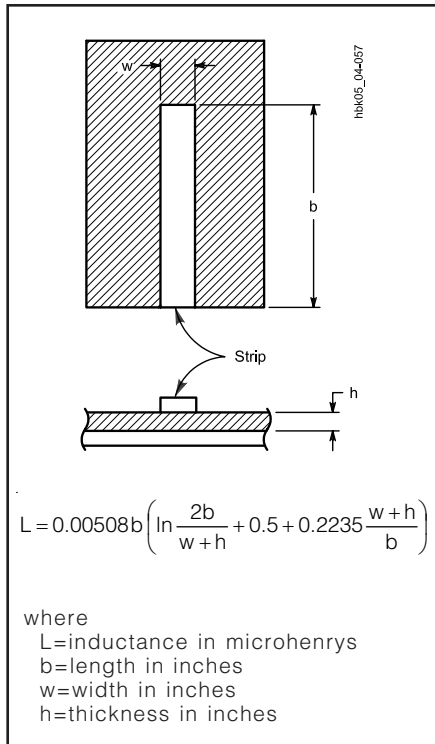

Fig 4.56 — Equation for determining the inductance of a wire parallel to a ground plane, with one end grounded. If the dimensions are in millimeters, the numerical coefficients become 0.0004605 for the first term and 0.0002 for the second term.



$$L = 0.00508b \left(\ln \frac{2b}{w+h} + 0.5 + 0.2235 \frac{w+h}{b} \right)$$

where
 L=inductance in microhenrys
 b=length in inches
 w=width in inches
 h=thickness in inches

Fig 4.57 — Equation for determining the inductance of a flat strip inductor.

Substituting these values into the formula yields:

$$L = 0.0117 \times 3.9370 \left\{ \log_{10} \left[40.0 \times \left(\frac{7.88}{8.9788} \right) \right] \right\} + 0.00508 \times (5.0418 - 3.94 + 0.98425 - 3.1496 + 0.0787)$$

$$L = 0.0662 \mu\text{H}$$

Another conductor configuration that is frequently used is a flat strip over a ground plane. This arrangement has lower skin-effect loss at high frequencies than round wire because it has a higher surface-area to volume ratio. The inductance of such a strip can be found from the formula in **Fig 4.57**. For a large collection of formulas useful in constructing air-core inductors of many configurations, see the “Circuit Elements” section in Terman’s *Radio Engineers’ Handbook* or the “Transmission Media” chapter of *The ARRL UHF/Microwave Experimenter’s Manual*.

IRON-CORE INDUCTORS

If the permeability of an iron core in an inductor is 800, then the inductance of any given air-wound coil is increased 800 times by inserting the iron core. The inductance will be proportional to the magnetic flux through the coil, other things being equal. The inductance of an iron-core inductor is highly dependent on

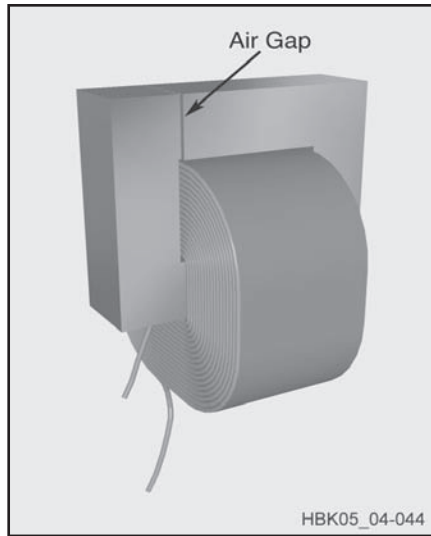

Fig 4.58 — Typical construction of an iron-core inductor. The small air gap prevents magnetic saturation of the iron and thus maintains the inductance at high currents.

the current flowing in the coil, in contrast to an air-core coil, where the inductance is independent of current because air does not saturate.

Iron-core coils such as the one sketched in **Fig 4.58** are used chiefly in power-supply equipment. They usually have direct current flowing through the winding, and any variation in inductance with current is usually undesirable. Inductance variations may be overcome by keeping the flux density below the saturation point of the iron. Opening the core so there is a small air gap, indicated by the dashed lines in **Fig 4.58**, will achieve this goal. The reluctance or magnetic resistance introduced by such a gap is very large compared with that of the iron, even though the gap is only a small fraction of an inch. Therefore, the gap — rather than the iron — controls the flux density. Air gaps in iron cores reduce the inductance, but they hold the value practically constant regardless of the current magnitude.

When alternating current flows through a coil wound on an iron core, a voltage is induced. Since iron is a conductor, a current also flows in the core. Such currents are called *eddy currents*. Eddy currents represent lost power because they flow through the resistance of the iron and generate heat. Losses caused by eddy currents can be reduced by laminating the core (cutting the core into thin strips). These strips or laminations are then insulated from each other by painting them with some insulating material such as varnish or shellac. These losses add to hysteresis

losses, which are also significant in iron-core inductors.

Eddy-current and hysteresis losses in iron increase rapidly as the frequency of the alternating current increases. For this reason, ordinary iron cores can be used only at power-line and audio frequencies — up to approximately 15000 Hz. Even then, a very good grade of iron or steel is necessary for the core to perform well at the higher audio frequencies. Laminated iron cores become completely useless at radio frequencies.

SLUG-TUNED INDUCTORS

For RF work, the losses in iron cores can be reduced to a more useful level by grinding the iron into a powder and then mixing it with a “binder” of insulating material in such a way that the individual iron particles are insulated from each other. Using this approach, cores can be made that function satisfactorily even into the VHF range.

Because a large part of the magnetic path is through a nonmagnetic material (the “binder”), the permeability of the iron is low compared with the values obtained at power-line frequencies. The core is usually shaped in the form of a slug or cylinder for fit inside the insulating form on which the coil is wound. Despite the fact that the major portion of the magnetic path for the flux is in air, the slug is quite effective in increasing the coil inductance. By pushing (or screwing) the slug in and out of the coil, the inductance can be varied over a considerable range.

POWDERED-IRON TOROIDAL INDUCTORS

For fixed-value inductors intended for use at HF and VHF, the powdered-iron toroidal core has become almost the standard core and material in low power circuits. **Fig 4.59** shows the general outlines of a toroidal coil on a magnetic core. Manufacturers offer a wide variety of core materials, or mixes, to provide units that will perform over a desired frequency range with a reasonable permeability. Initial permeabilities for powdered-iron cores fall in the range of 3 to 35 for various mixes. In addition, core sizes are available in the range of 0.125-inch outside diameter (OD) up to 1.06-inch OD, with larger sizes to 5-inch OD available in certain mixes. The range of sizes permits the builder to construct single-layer inductors for almost any value using wire sized to meet the circuit current demands. While powdered-iron toroids are often painted various colors, you must know the manufacturer to identify the mix. There seems to be no set standard between manufac-

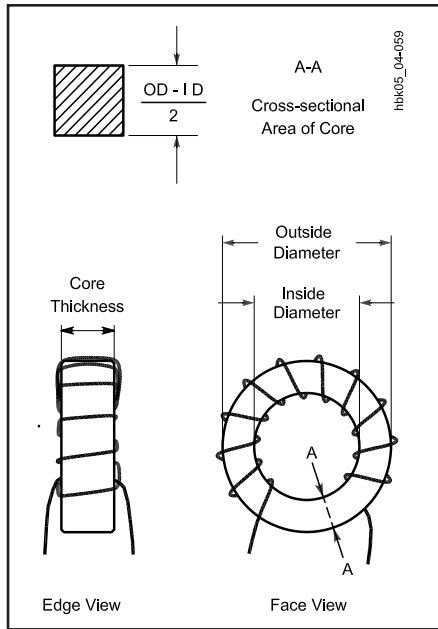

Fig 4.59 — A typical toroidal inductor wound on a powdered-iron or ferrite core. Some key physical dimensions are noted. Equally important are the core material, its permeability, its intended range of operating frequencies, and its A_L value. This is an 11-turn toroid.

turers. Iron-powder toroids usually have rounded edges.

The use of powdered iron in a binder reduces core losses usually associated with iron, while the permeability of the core permits a reduction in the wire length and associated resistance in forming a coil of a given inductance. Therefore, powdered-iron-core toroidal inductors can achieve Q_s well above 100, often approaching or exceeding 200 within the frequency range specified for a given core. Moreover, these coils are considered self-shielding since most of the flux lines are within the core, a fact that simplifies circuit design and construction.

Each powdered-iron core has a value of A_L determined and published by the core manufacturer. For powdered-iron cores, A_L represents the *inductance index*, that is, the inductance in μH per 100 turns of wire on the core, arranged in a single layer. The builder must select a core size capable of holding the calculated number of turns, of the required wire size, for the desired inductance. Otherwise, the coil calculation is straightforward. To calculate the inductance of a powdered-iron toroidal coil, when the number of turns and the core material are known, use the formula:

$$L = \frac{A_L \times N^2}{10000} \quad (69)$$

where:

L = the inductance in μH ,

A_L = the inductance index in μH per 100 turns, and

N = the number of turns.

Example: What is the inductance of a 60-turn coil on a core with an A_L of 55? This A_L value was selected from manufacturer's information about a 0.8-inch OD core with an initial permeability of 10. This particular core is intended for use in the range of 2 to 30 MHz. See the **Component Data and References** chapter for more detailed data on the range of available cores.

$$L = \frac{A_L \times N^2}{10000} = \frac{55 \times 60^2}{10000} \\ = \frac{198000}{10000} = 19.8 \mu\text{H}$$

To calculate the number of turns needed for a particular inductance, use the formula:

$$N = 100 \sqrt{\frac{L}{A_L}} \quad (70)$$

Example: How many turns are needed for a 12.0- μH coil if the A_L for the selected core is 49?

$$N = 100 \sqrt{\frac{L}{A_L}} = 100 \sqrt{\frac{12.0}{49}} \\ = 100 \sqrt{0.245} = 100 \times 0.495 = 49.5 \text{ turns}$$

If the value is critical, experimenting with 49-turn and 50-turn coils is in order, especially since core characteristics may vary slightly from batch to batch. Count turns by each pass of the wire through the center of the core. (A straight wire through a toroidal core amounts to a one-turn coil.) Fine adjustment of the inductance may be possible by spreading or squeezing inductor turns.

The power-handling ability of toroidal cores depends on many variables, which include the cross-sectional area through the core, the core material, the numbers of turns in the coil, the applied voltage and the operating frequency. Although powdered-iron cores can withstand dc flux densities up to 5000 gauss without saturating, ac flux densities from sine waves above certain limits can overheat cores. Manufacturers provide guideline limits for ac flux densities to avoid overheating. The limits range from 150 gauss at 1 MHz

to 30 gauss at 28 MHz, although the curve is not linear. To calculate the maximum anticipated flux density for a particular coil, use the formula:

$$B_{\text{max}} = \frac{E_{\text{RMS}} \times 10^8}{4.44 \times A_c \times N \times f} \quad (71)$$

where:

B_{max} = the maximum flux density in gauss,

E_{RMS} = the voltage across the coil,

A_c = the cross-sectional area of the core in square centimeters,

N = the number of turns in the coil, and

f = the operating frequency in Hz.

Example: What is the maximum ac flux density for a coil of 15 turns if the frequency is 7.0 MHz, the RMS voltage is 25 V and the cross-sectional area of the core is 0.133 cm^2 ?

$$B_{\text{max}} = \frac{E_{\text{RMS}} \times 10^8}{4.44 \times A_c \times N \times f} \\ = \frac{25 \times 10^8}{4.44 \times 0.133 \times 15 \times 7.0 \times 10^6} \\ = \frac{25 \times 10^8}{62 \times 10^6} = 40 \text{ gauss}$$

Since the recommended limit for cores operated at 7 MHz is 57 gauss, this coil is well within guidelines.

FERRITE TOROIDAL INDUCTORS

Although nearly identical in general appearance to powdered-iron cores, ferrite cores differ in a number of important characteristics. They are often unpainted, unlike powdered-iron toroids. Ferrite toroids often have sharp edges, while powdered-iron toroids usually have rounded edges. Composed of nickel-zinc ferrites for lower permeability ranges and of manganese-zinc ferrites for higher permeabilities, these cores span the permeability range from 20 to above 10000. Nickel-zinc cores with permeabilities from 20 to 800 are useful in high-Q applications, but function more commonly in amateur applications as RF chokes. They are also useful in wide-band transformers (discussed later in this chapter).

Because of their higher permeabilities, the formulas for calculating inductance and turns require slight modification. Manufacturers list ferrite A_L values in mH per 1000 turns. Thus, to calculate inductance, the formula is

$$L = \frac{A_L \times N^2}{1000000} \quad (72)$$

where:

L = the inductance in mH,

A_L = the inductance index in mH per 1000 turns, and

N = the number of turns.

Example: What is the inductance of a 60-turn coil on a core with an A_L of 523? (See the **Component Data and References** chapter for more detailed data on the range of available cores.)

$$L = \frac{A_L \times N^2}{1000000} = \frac{523 \times 60^2}{1000000}$$

$$= \frac{1.88 \times 10^6}{1 \times 10^6} = 1.88 \text{ mH}$$

To calculate the number of turns needed for a particular inductance, use the formula:

$$N = 1000 \sqrt{\frac{L}{A_L}} \quad (73)$$

Example: How many turns are needed for a 1.2-mH coil if the A_L for the selected core is 150?

$$N = 1000 \sqrt{\frac{L}{A_L}} = 1000 \sqrt{\frac{1.2}{150}}$$

$$= 1000 \sqrt{0.008} = 1000 \times 0.089 = 89 \text{ turns}$$

For inductors carrying both dc and ac currents, the upper saturation limit for most ferrites is a flux density of 2000 gauss, with power calculations identical to those used for powdered-iron cores. For detailed information on available cores and their characteristics, see *Iron-Powder and Ferrite Coil Forms*, a combination catalog and information book from Amidon Associates, Inc.

Ohm's Law for Reactance

Only ac circuits containing capacitance or inductance (or both) have reactance. Despite the fact that the voltage in such circuits is 90° out of phase with the current, circuit reactance does limit current in a manner that corresponds to resistance. Therefore, the Ohm's Law equations relating voltage, current and resistance apply to purely reactive circuits:

$$E = IX \quad (74)$$

$$I = \frac{E}{X} \quad (75)$$

$$X = \frac{E}{I} \quad (76)$$

where:

E = ac voltage in RMS,

I = ac current in amperes, and

X = inductive or capacitive reactance.

Example: What is the voltage across a capacitor of 200 pF at 7.15 MHz, if the current through the capacitor is 50 mA?

Since the reactance of the capacitor is a function of both frequency and capacitance, first calculate the reactance:

$$X_C = \frac{1}{2\pi f C}$$

$$= \frac{1}{2 \times 3.1416 \times 7.15 \times 10^6 \text{ Hz} \times 200 \times 10^{-12} \text{ F}}$$

$$= \frac{10^6 \Omega}{8980} \quad 111 \Omega$$

Next, use Ohm's Law:

$$E = I \times X_C = 0.050 \text{ A} \times 111 \Omega = 5.6 \text{ V}$$

Example: What is the current through an 8.00-H inductor at 120 Hz, if 420 V is applied?

$$X_L = 2\pi f L = 2 \times 3.1416 \times 120 \text{ Hz} \times 8.00 \text{ H} = 6030 \Omega$$

Fig 4.60 charts the reactances of capacitors from 1 pF to 100 μF, and the reactances of inductors from 0.1 μH to 10 H, for frequencies between 100 Hz and 100 MHz. Approximate values of reactance can be read or interpolated from the chart. The formulas will produce more exact values, however.

Although both inductive and capacitive reactance limit current, the two types of reactance differ. With capacitive reactance, the current *leads* the voltage by 90°, whereas with inductive reactance, the current *lags* the voltage by 90°. The convention for charting the two types of reactance appears in **Fig 4.61**. On this graph, inductive reactance is plotted along the +90° vertical line, while capacitive reactance is plotted along the -90° vertical line. This convention of assigning a positive value to inductive reactance and a negative value to capacitive reactance results from the mathematics involved in impedance calculations.

REACTANCES IN SERIES AND PARALLEL

If a circuit contains two reactances of the same type, whether in series or in parallel, the resultant reactance can be deter-

mined by applying the same rules as for resistances in series and in parallel. Series reactance is given by the formula

$$X_{\text{total}} = X_1 + X_2 + X_3 + \dots + X_n \quad (77)$$

Example: Two noninteracting inductances are in series. Each has a value of 4.0 μH, and the operating frequency is 3.8 MHz. What is the resulting reactance?

The reactance of each inductor is:

$$X_L = 2\pi f L = 2 \times 3.1416 \times 3.8 \times 10^6 \text{ Hz} \times 4 \times 10^{-6} \text{ H} = 96 \Omega$$

$$X_{\text{total}} = X_1 + X_2 = 96 \Omega + 96 \Omega = 192 \Omega$$

We might also calculate the total reactance by first adding the inductances:

$$L_{\text{total}} = L_1 + L_2 = 4.0 \mu\text{H} + 4.0 \mu\text{H} = 8.0 \mu\text{H}$$

$$X_{\text{total}} = 2\pi f L = 2 \times 3.1416 \times 3.8 \times 10^6 \text{ Hz} \times 8.0 \times 10^{-6} \text{ H}$$

$$X_{\text{total}} = 191 \Omega$$

(The fact that the last digit differs by one illustrates the uncertainty of the calculation caused by the uncertainty of the measured values in the problem, and differences caused by rounding off the calculated values. This also shows why it is important to follow the rules for significant figures.)

Example: Two noninteracting capacitors are in series. One has a value of 10.0 pF, the other of 20.0 pF. What is the resulting reactance in a circuit operating at 28.0 MHz?

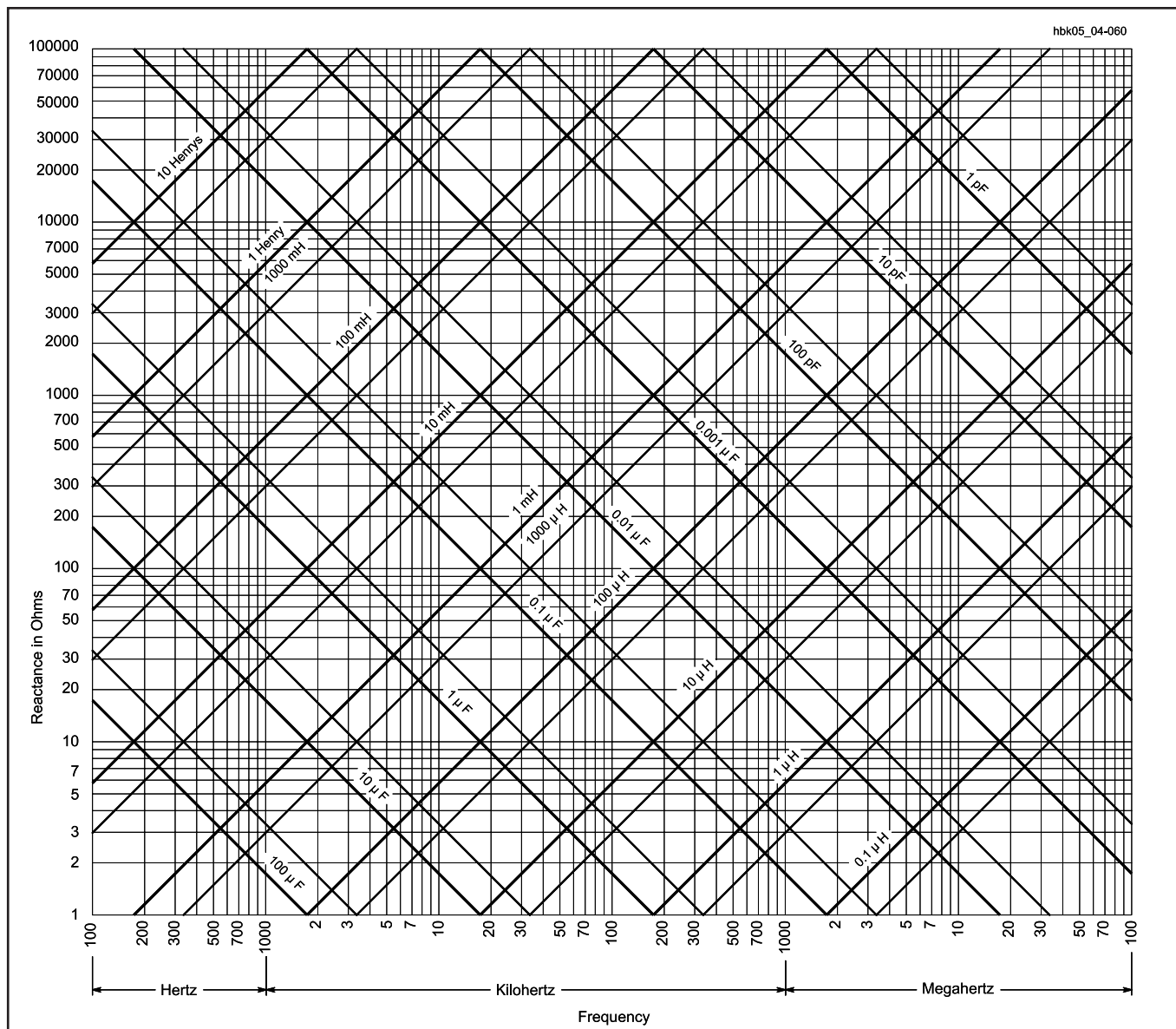

Fig 4.60 — Inductive and capacitive reactance vs frequency. Heavy lines represent multiples of 10, intermediate lines multiples of 5. For example, the light line between 10 μH and 100 μH represents 50 μH ; the light line between 0.1 μF and 1 μF represents 0.5 μF , and so on. Other values can be extrapolated from the chart. For example, the reactance of 10 H at 60 Hz can be found by taking the reactance of 10 H at 600 Hz and dividing by 10 for the 10 times decrease in frequency.

$$X_{C1} = \frac{1}{2\pi f C}$$

$$= \frac{1}{2 \times 3.1416 \times 28.0 \times 10^6 \text{ Hz} \times 10.0 \times 10^{-12} \text{ F}}$$

$$= \frac{10^6 \Omega}{1760} = 568 \Omega$$

$$X_{C2} = \frac{1}{2\pi f C}$$

$$= \frac{1}{2 \times 3.1416 \times 28.0 \times 10^6 \text{ Hz} \times 20.0 \times 10^{-12} \text{ F}}$$

$$= \frac{10^6 \Omega}{3520} = 284 \Omega$$

$$X_{\text{total}} = X_{C1} + X_{C2} = 568 \Omega + 284 \Omega = 852 \Omega$$

Alternatively, for series capacitors, the total capacitance is $6.67 \times 10^{-12} \text{ F}$ or 6.67 pF. Then:

$$X_{\text{total}} = \frac{1}{2\pi f C}$$

$$= \frac{1}{2 \times 3.1416 \times 28.0 \times 10^6 \text{ Hz} \times 6.67 \times 10^{-12} \text{ F}}$$

$$= \frac{10^6 \Omega}{1170} = 855 \Omega$$

(Within the uncertainty of the measured values and the rounding of values in the calculations, this is the same result as we obtained with the first method.)

This example serves to remind us that *series capacitance* is not calculated in the manner used by other series resistance and inductance, but *series capacitive reactance* does follow the simple addition formula.

For reactances of the same type in parallel, the general formula is:

$$X_{\text{total}} = \frac{1}{\frac{1}{X_1} + \frac{1}{X_2} + \frac{1}{X_3} + \dots + \frac{1}{X_n}} \quad (78)$$

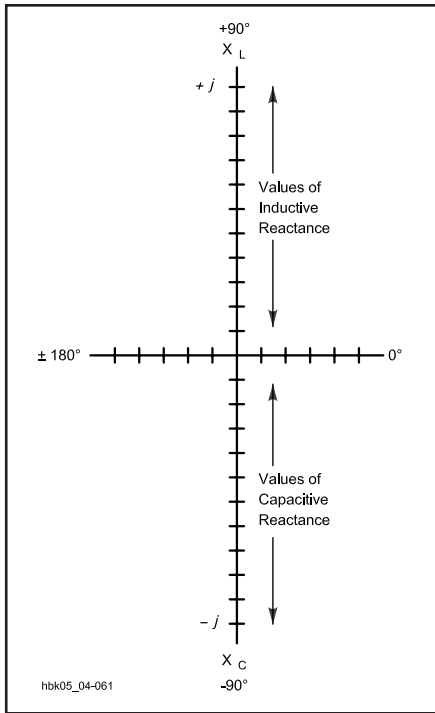

Fig 4.61 — The conventional method of plotting reactances on the vertical axis of a graph, using the upward or “plus” direction for inductive reactance and the downward or “minus” direction for capacitive reactance. The horizontal axis will be used for resistance in later examples.

or, for exactly two reactances in parallel

$$X_{\text{total}} = \frac{X_1 \times X_2}{X_1 + X_2} \quad (79)$$

Example: Place the capacitors in the last example (10.0 pF and 20.0 pF) in parallel in the 28.0 MHz circuit. What is the resultant reactance?

$$\begin{aligned} X_{\text{total}} &= \frac{X_1 \times X_2}{X_1 + X_2} \\ &= \frac{568 \Omega \times 284 \Omega}{568 \Omega + 284 \Omega} = 189 \Omega \end{aligned}$$

Alternatively, two capacitors in parallel add their capacitances.

$$C_{\text{total}} = C_1 + C_2 = 10.0 \text{ pF} + 20.0 \text{ pF} = 30 \text{ pF}$$

$$\begin{aligned} X_C &= \frac{1}{2 \pi f C} \\ &= \frac{1}{2 \times 3.1416 \times 28.0 \times 10^6 \text{ Hz} \times 30 \times 10^{-12} \text{ F}} \\ &= \frac{10^6 \Omega}{5280} = 189 \Omega \end{aligned}$$

Example: Place the series inductors above (4.0 μH each) in parallel in a 3.8-MHz circuit. What is the resultant reactance?

$$\begin{aligned} X_{\text{total}} &= \frac{X_{L1} \times X_{L2}}{X_{L1} + X_{L2}} \\ &= \frac{96 \Omega \times 96 \Omega}{96 \Omega + 96 \Omega} = 48 \Omega \end{aligned}$$

Of course, equal reactances (or resistances) in parallel yield a reactance that is the value of one of them divided by the number (n) of equal reactances, or:

$$X_{\text{total}} = \frac{X}{n} = \frac{96 \Omega}{2} = 48 \Omega$$

All of these calculations apply only to reactances of the same type; that is, all capacitive or all inductive. Mixing types of reactances requires a different approach.

UNLIKE REACTANCES IN SERIES

When combining unlike reactances — that is, combinations of inductive and capacitive reactance — in series, it is necessary to take into account that the voltage-to-current phase relationships differ for the different types of reactance. **Fig 4.62** shows a series circuit with both types of reactance. Since the reactances are in series, the current must be the same in both. The voltage across each circuit element differs in phase, however. The voltage E_L leads the current by 90°, and the voltage E_C lags the current by 90°. Therefore, E_L and E_C have opposite polarities and cancel each other in whole or in part. The dotted line in **Fig 4.62** approximates the resulting voltage E , which is the *difference* between E_L and E_C .

Since, for a constant current, the reactance is directly proportional to the voltage, the net reactance must be the difference between the inductive and the capacitive reactances, or:

$$X_{\text{total}} = X_L - X_C \quad (80)$$

For this and subsequent calculations in which there is a mixture of inductive and capacitive reactance, use the absolute value of each reactance. The convention of recording inductive reactances as positive and capacitive reactances as negative is built into the mathematical operators in the formulas.

Example: Using **Fig 4.62** as a visual aid, let $X_C = 20.0 \Omega$ and $X_L = 80.0 \Omega$. What is the resulting reactance?

$$\begin{aligned} X_{\text{total}} &= X_L - X_C \\ &= 80.0 \Omega - 20.0 \Omega = +60.0 \Omega \end{aligned}$$

Since the result is a positive value, reactance is inductive. Had the result been a negative number, the reactance would have been capacitive.

When reactance types are mixed in a series circuit, the resulting reactance is always smaller than the larger of the two reactances. Likewise, the resulting voltage across the series combination of reactances is always smaller than the larger of the two voltages across individual reactances.

Every series circuit of mixed reactance types with more than two circuit elements can be reduced to the type of circuit covered here. If the circuit has more than one capacitor or more than one inductor in the overall series string, first use the formulas given earlier to determine the total series inductance alone and the total series capacitance alone (or their respective reactances). Then combine the resulting single capacitive reactance and single inductive reactance as shown in this section.

UNLIKE REACTANCES IN PARALLEL

The situation of parallel reactances of mixed type appears in **Fig 4.63**. Since the elements are in parallel, the voltage is common to both reactive components. The current through the capacitor, I_C , leads the voltage by 90°, and the current through the inductor, I_L , lags the voltage by 90°. The two currents are 180° out of phase and thus cancel each other in whole or in part. The total current is the difference between the individual currents, as indicated by the dotted line in **Fig 4.63**.

Since reactance is the ratio of voltage to current, the total reactance in the circuit is:

$$X_{\text{total}} = \frac{E}{I_L - I_C} \quad (81)$$

In the drawing, I_C is larger than I_L , and the resulting differential current retains the phase of I_C . Therefore, the overall reactance, X_{total} , is capacitive in this case. The total reactance of the circuit will be larger than the larger of the individual reactances, because the total current is smaller than the larger of the two individual currents.

In parallel circuits of this type, reactance and current are inversely proportional to each other for a constant voltage. Therefore, to calculate the total reactance directly from the individual reactances, use the formula:

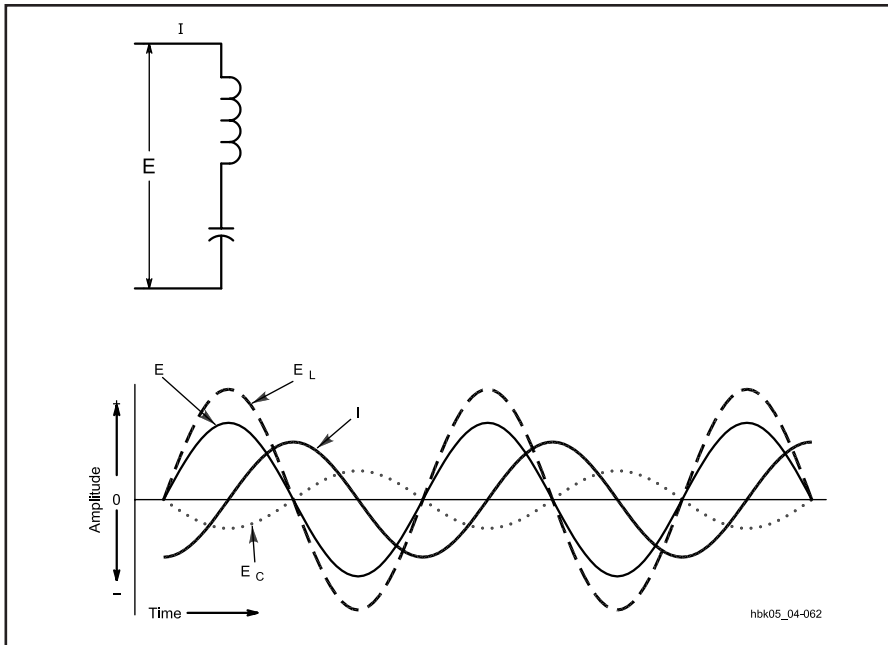

Fig 4.62 — A series circuit containing both inductive and capacitive components, together with representative voltage and current relationships.

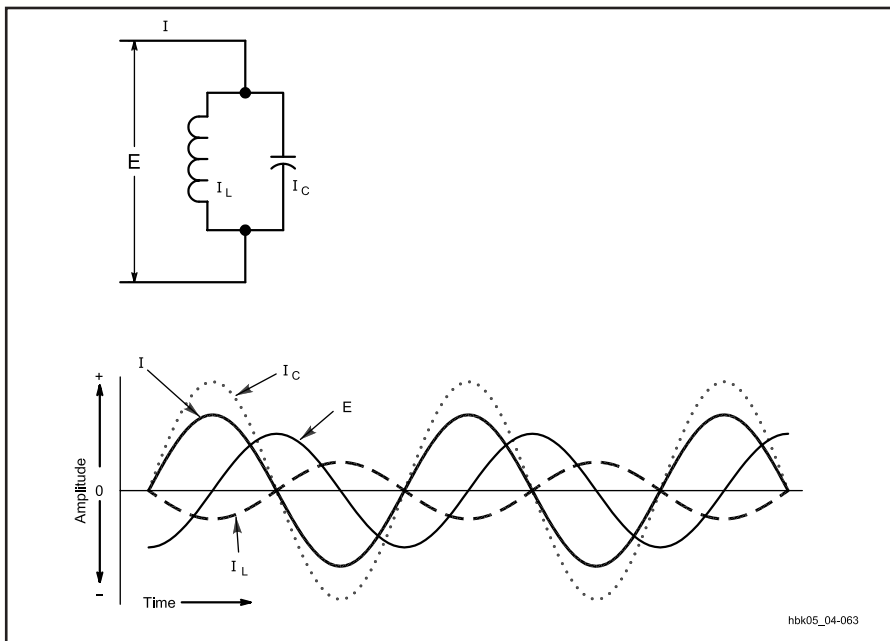

Fig 4.63 — A parallel circuit containing both inductive and capacitive components, together with representative voltage and current relationships.

$$X_{\text{total}} = \frac{-X_L \times X_C}{X_L - X_C} \quad (82)$$

As with the series formula for mixed reactances, use the absolute values of the reactances, since the minus signs in the formula take into account the convention of treating capacitive reactances as nega-

tive numbers. If the solution yields a negative number, the resulting reactance is capacitive, and if the solution is positive, then the reactance is inductive.

Example: Using Fig 4.63 as a visual aid, place a capacitive reactance of 10.0Ω in parallel with an inductive reactance of 40.0Ω . What is the resulting reactance?

$$\begin{aligned} X_{\text{total}} &= \frac{-X_L \times X_C}{X_L - X_C} \\ &= \frac{-40.0 \Omega \times 10.0 \Omega}{40.0 \Omega - 10.0 \Omega} \\ &= \frac{-400 \Omega}{30.0 \Omega} = -13.3 \Omega \end{aligned}$$

The reactance is capacitive, as indicated by the negative solution. Moreover, the resultant reactance is always smaller than the larger of the two individual reactances.

As with the case of series reactances, if each leg of a parallel circuit contains more than one reactance, first simplify each leg to a single reactance. If the reactances are of the same type in each leg, the series reactance formulas for reactances of the same type will apply. If the reactances are of different types, then use the formulas shown above for mixed series reactances to simplify the leg to a single value and type of reactance.

APPROACHING RESONANCE

When two unlike reactances have the same numerical value, any series or parallel circuit in which they occur is said to be *resonant*. For any given inductance or capacitance, it is theoretically possible to find a value of the opposite reactance type to produce a resonant circuit for any desired frequency.

When a series circuit like the one shown in Fig 4.62 is resonant, the voltages E_C and E_L are equal and cancel; their sum is zero. Since the reactance of the circuit is proportional to the sum of these voltages, the total reactance also goes to zero. Theoretically, the current, as shown in Fig 4.64, can rise without limit. In fact, it is limited only by power losses in the components and other resistances that would be in a real circuit of this type. As the frequency of operation moves slightly off resonance, the reactance climbs rapidly and then begins to level off. Similarly, the current drops rapidly off resonance and then levels.

In a parallel-resonant circuit of the type in Fig 4.63, the current I_L and I_C are equal and cancel to zero. Since the reactance is inversely proportional to the current, as the current approaches zero, the reactance rises without limit. As with series circuits, component power losses and other resistances in the circuit limit the current drop to some point above zero. Fig 4.65 shows the theoretical current curve near and at resonance for a purely reactive parallel-resonant circuit. Note that in both Fig 4.64 and Fig 4.65, the departure of current from the resonance value is close to, but not quite, symmetrical above and below the

resonant frequency.

Example: What is the reactance of a series L-C circuit consisting of a 56.04-pF capacitor and an 8.967- μ H inductor at 7.00, 7.10 and 7.20 MHz? Using the formulas from earlier in this chapter, we calculate a table of values:

Frequency (MHz)	X_L (Ω)	X_C (Ω)	X_{total} (Ω)
7.000	394.4	405.7	-11.3
7.100	400.0	400.0	0
7.200	405.7	394.4	11.3

The exercise shows the manner in which the reactance rises rapidly as the frequency moves above and below resonance. Note that in a series-resonant circuit, the reactance at frequencies below resonance is capacitive, and above resonance, it is inductive. Fig 4.66 displays this fact graphically. In a parallel-resonant circuit, where the reactance increases without limit at resonance, the opposite condition exists: above resonance, the reactance is capacitive and below resonance it is inductive, as shown in Fig 4.67. Of course, all graphs and calculations in this section are theoretical and presume a purely reactive circuit. Real circuits are never purely reactive; they contain some resistance that modifies their performance considerably. Real resonant circuits will be discussed later in this chapter.

REACTIVE POWER

Although purely reactive circuits, whether simple or complex, show a mea-

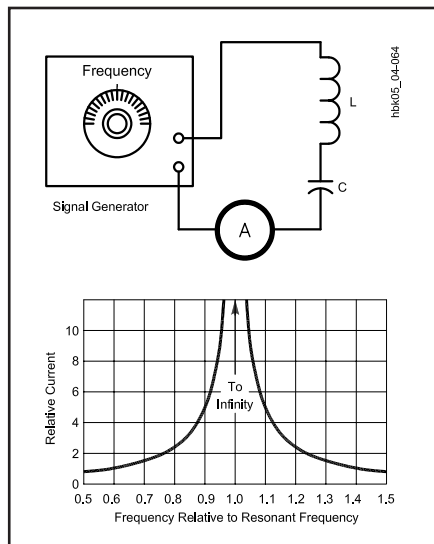

Fig 4.64 — The relative generator current with a fixed voltage in a series circuit containing inductive and capacitive reactances as the frequency approaches and departs from resonance.

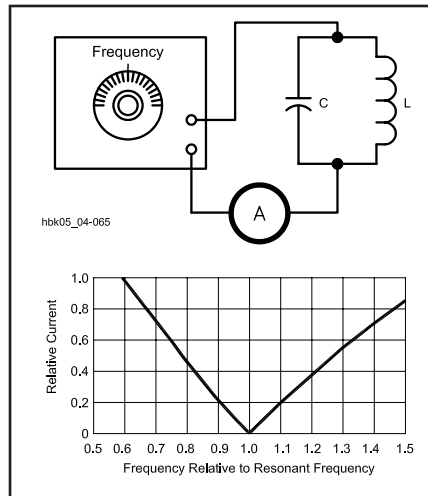

Fig 4.65 — The relative generator current with a fixed voltage in a parallel circuit containing inductive and capacitive reactances as the frequency approaches and departs from resonance. (The circulating current through the parallel inductor and capacitor is a maximum at resonance.)

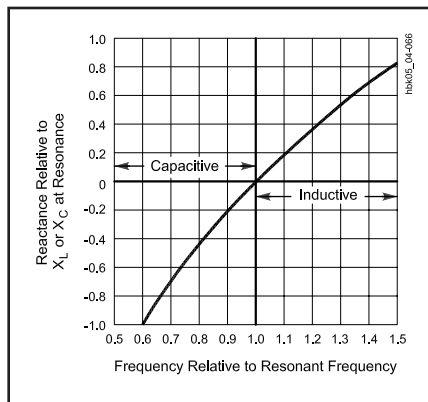

Fig 4.66 — The transition from capacitive to inductive reactance in a series-resonant circuit as the frequency passes resonance.

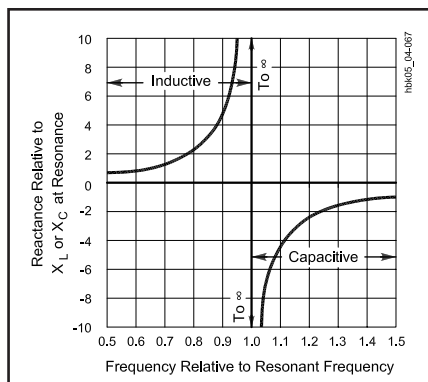

Fig 4.67 — The transition from inductive to capacitive reactance in a parallel-resonant circuit as the frequency passes resonance.

surable ac voltage and current, we cannot simply multiply the two together to arrive at power. Power is the rate at which energy is consumed by a circuit, and purely reactive circuits do not consume power. The charge placed on a capacitor during part of an ac cycle is returned to the circuit during the next part of a cycle. Likewise, the energy stored in the magnetic field of an inductor returns to the circuit as the field collapses later in the ac cycle. A reactive circuit simply cycles and recycles energy into and out of the reactive components. If a purely reactive circuit were possible in reality, it would consume no power at all.

In reactive circuits, circulation of energy accounts for seemingly odd phenomena. For example, in a series circuit with capacitance and inductance, the voltages across the components may exceed the supply voltage. That condition can exist because, while energy is being stored by the inductor, the capacitor is returning energy to the circuit from its previously charged state, and vice versa. In a parallel circuit with inductive and capacitive branches, the current circulating through the components may exceed the current drawn from the source. Again, the phenomenon occurs because the inductor's collapsing field supplies current to the capacitor, and the discharging capacitor provides current to the inductor.

To distinguish between the non-dissipated power in a purely reactive circuit and the dissipated power of a resistive circuit, the unit of reactive power is called the *volt-ampere reactive*, or VAR. The term watt is not used; sometimes reactive power is called wattless power. Formulas similar to those for resistive power are used to calculate VAR:

$$\text{VAR} = I \times E \quad (83)$$

$$\text{VAR} = I^2 \times X \quad (84)$$

$$\text{VAR} = \frac{E^2}{X} \quad (85)$$

These formulas have only limited use in radio work.

REACTANCE AND COMPLEX WAVEFORMS

All of the formulas and relationships shown in this section apply to alternating current in the form of regular sine waves. Complex wave shapes complicate the reactive situation considerably. A complex or nonsinusoidal wave can be resolved into a fundamental frequency and a series of harmonic frequencies whose amplitudes depend on the original wave shape. When such a complex wave — or collection of

sine waves — is applied to a reactive circuit, the current through the circuit will not have the same wave shape as the applied voltage. The difference results because the reactance of an inductor and capacitor depend in part on the applied frequency.

For the second-harmonic component of the complex wave, the reactance of the inductor is twice and the reactance of the capacitor is half their respective values at the fundamental frequency. A third-harmonic component produces inductive reactances that are triple and capacitive reactances that are one-third those at the fundamental frequency. Thus, the overall circuit reactance is different for each harmonic component.

The frequency sensitivity of a reactive circuit to various components of a com-

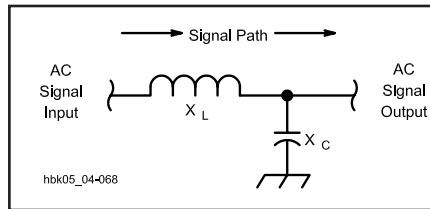

Fig 4.68 — A signal path with a series inductor and a shunt capacitor. The circuit presents different reactances to an ac signal and to its harmonics.

plex wave shape creates both difficulties and opportunities. On the one hand, calculating the circuit reactance in the presence of highly variable as well as complex waveforms, such as speech, is difficult at

best. On the other hand, the frequency sensitivity of reactive components and circuits lays the foundation for filtering, that is, for separating signals of different frequencies and passing them into different circuits. For example, suppose a coil is in the series path of a signal and a capacitor is connected from the signal line to ground, as represented in Fig 4.68. The reactance of the coil to the second harmonic of the signal will be twice that at the fundamental frequency and oppose more effectively the flow of harmonic current. Likewise, the reactance of the capacitor to the harmonic will be half that to the fundamental, allowing the harmonic an easier current path away from the signal line toward ground. See the **RF and AF Filters** chapter for detailed information on filter theory and construction.

Impedance

When a circuit contains both resistance and reactance, the combined opposition to current is called *impedance*. Symbolized by the letter Z , impedance is a more general term than either resistance or reactance. Frequently, the term is used even for circuits containing only resistance or reactance. Qualifications such as “resistive impedance” are sometimes added to indicate that a circuit has only resistance, however.

The reactance and resistance comprising an impedance may be connected either in series or in parallel, as shown in Fig 4.69. In these circuits, the reactance is shown as a box to indicate that it may be either inductive or capacitive. In the series circuit at A, the current is the same in both elements, with (generally) different voltages appearing across the resistance and reactance. In the parallel circuit at B, the same voltage is applied to both elements, but different currents may flow in the two branches.

In a resistance, the current is in phase with the applied voltage, while in a reactance it is 90° out of phase with the voltage. Thus, the phase relationship between current and voltage in the circuit as a whole may be anything between zero and 90° , depending on the relative amounts of resistance and reactance.

As shown in Fig 4.61 in the preceding

section, reactance is graphed on the vertical (Y) axis to record the phase difference between the voltage and the current. Fig 4.70 adds resistance to the graph. Since the voltage is in phase with the current, resistance is recorded on the horizontal axis, using the positive or right side of the scale.

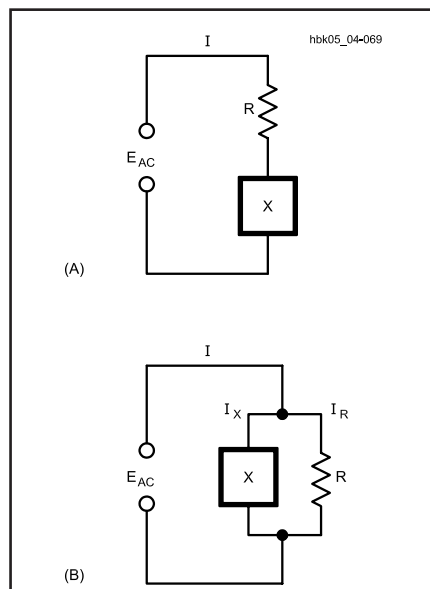

Fig 4.69 — Series and parallel circuits containing resistance and reactance.

CALCULATING Z FROM R AND X IN SERIES CIRCUITS

Impedance is the complex combination of resistance and reactance. Since there is a 90° phase difference between resistance and reactance (whether inductive or capacitive), simply adding the two values will not yield what actually happens in a

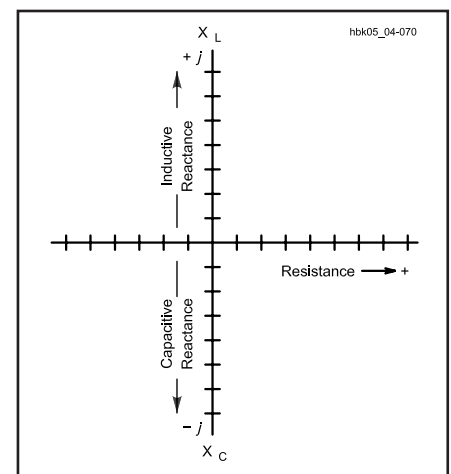

Fig 4.70 — The conventional method of charting impedances on a graph, using the vertical axis for reactance (the upward or “plus” direction for inductive reactance and the downward or “minus” direction for capacitive reactance), and using the horizontal axis for resistance.

circuit. Therefore, expressions like “ $Z = R \pm X$ ” can be misleading, because they suggest simple addition. As a result, impedance is often expressed “ $Z = R \pm jX$.”

In pure mathematics, “ i ” indicates an imaginary number. Because i represents current in electronics, we use the letter “ j ” for the same mathematical operator, although there is nothing imaginary about what it represents in electronics. With respect to resistance and reactance, the letter j is normally assigned to those figures on the vertical scale, 90° out of phase with the horizontal scale. The actual function of j is to indicate that calculating impedance from resistance and reactance requires *vector addition*. In vector addition, the result of combining two values at a 90° phase difference results in a new quantity for the combination, and also in a new combined phase angle relative to the base line.

Consider Fig 4.71, a series circuit consisting of an inductive reactance and a resistance. As given, the inductive reactance is 100Ω and the resistance is 50Ω . Using *rectangular coordinates*, the impedance becomes

$$Z = R + jX \quad (86)$$

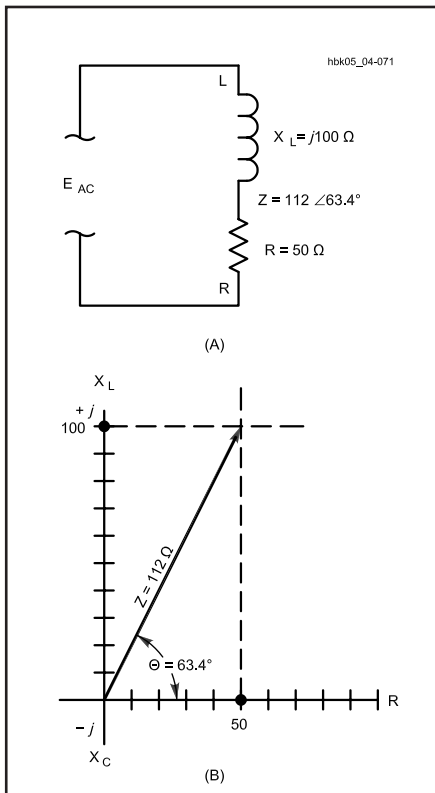

Fig 4.71 — A series circuit consisting of an inductive reactance of 100Ω and a resistance of 50Ω . At B, the graph plots the resistance, reactance, and impedance.

where:

Z = the impedance in ohms,
 R = the resistance in ohms, and
 X = the reactance in ohms.

In the present example,

$$Z = 50 + j100 \Omega$$

As the graph shows, the combined opposition to current (or impedance) is represented by a line triangulating the two given values. The graph will provide an estimate of the value. A more exact way to calculate the resultant impedance involves the formula for right triangles, where the square of the hypotenuse equals the sum of the squares of the two sides. Since impedance is the hypotenuse:

$$Z = \sqrt{R^2 + X^2} \quad (87)$$

In this example:

$$\begin{aligned} Z &= \sqrt{(50 \Omega)^2 + (100 \Omega)^2} \\ &= \sqrt{2500 \Omega^2 + 10000 \Omega^2} \\ &= \sqrt{12500 \Omega^2} = 112 \Omega \end{aligned}$$

The impedance that results from combining 50Ω of resistance with 100Ω of inductive reactance is 112Ω . The phase angle of the resultant is neither 0° nor $+90^\circ$. Instead, it lies somewhere between the two. Let θ be the angle between the horizontal axis and the line representing the impedance. From trigonometry, the tangent of the angle is the side opposite the angle divided by the side adjacent to the angle, or

$$\tan \theta = \frac{X}{R} \quad (88)$$

where:

X = the reactance, and
 R = the resistance.

Find the angle by taking the inverse tangent, or arctan:

$$\theta = \arctan \frac{X}{R} \quad (89)$$

In the example shown in Fig 6.57,

$$\theta = \arctan \frac{100 \Omega}{50 \Omega} = \arctan 2.0 = 63.4^\circ$$

Combining the resultant impedance with the angle provides the impedance in *polar coordinate* form:

$$Z \angle \theta \quad (90)$$

Using the information just calculated, the impedance is:

$$Z = 112 \Omega \angle 63.4^\circ$$

The expressions $R \pm jX$ and $Z \angle \theta$ both provide the same information, but in two different forms. The procedure just given permits conversion from rectangular coordinates into polar coordinates. The reverse procedure is also important. Fig 4.72 shows an impedance composed of a capacitive reactance and a resistance. Since capacitive reactance appears as a negative value, the impedance will be at a negative phase angle, in this case, 12.0Ω at a phase angle of -42.0° or $Z = 12.0 \Omega \angle -42.0^\circ$.

Think of the impedance as forming a triangle with the values of X and R from the rectangular coordinates. The reactance axis forms the side opposite the angle θ .

$$\sin \theta = \frac{\text{side opposite}}{\text{hypotenuse}} = \frac{X}{Z} \quad (91)$$

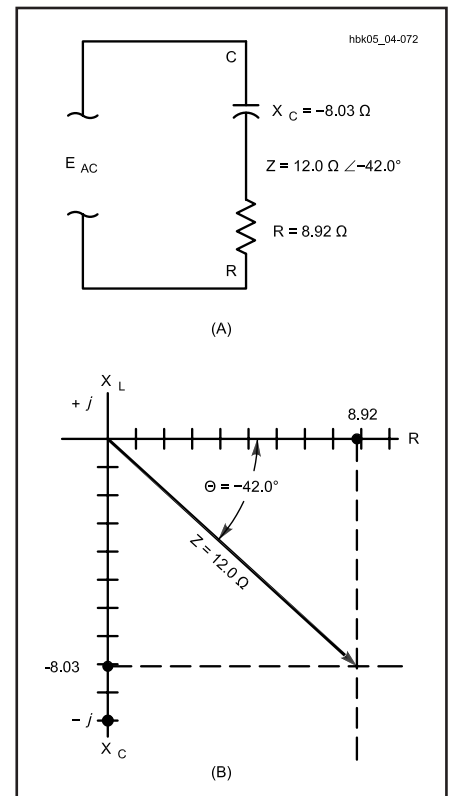

Fig 4.72 — A series circuit consisting of a capacitive reactance and a resistance: the impedance is given as 12.0Ω at a phase angle θ of -42 degrees. At B, the graph plots the resistance, reactance, and impedance.

Solving this equation for reactance, we have:

$$X = Z \times \sin \theta \text{ (ohms)} \quad (92)$$

Likewise, the resistance forms the side adjacent to the angle.

$$\cos \theta = \frac{\text{side adjacent}}{\text{hypotenuse}} = \frac{R}{Z}$$

Solving for resistance, we have:

$$R = Z \times \cos \theta \text{ (ohms)} \quad (93)$$

Then from our example:

$$\begin{aligned} X &= 12.0 \Omega \times \sin(-42^\circ) \\ &= 12.0 \Omega \times -0.669 = -8.03 \Omega \\ R &= 12.0 \Omega \times \cos(-42.0^\circ) \\ &= 12.0 \Omega \times 0.743 = 8.92 \Omega \end{aligned}$$

Since X is a negative value, it plots on the lower vertical axis, as shown in Fig 4.72, indicating capacitive reactance. In rectangular form, $Z = 8.92 \Omega - j8.03 \Omega$.

In performing impedance and related calculations with complex circuits, rectangular coordinates are most useful when formulas require the addition or subtraction of values. Polar notation is most useful for multiplying and dividing complex numbers.

All of the examples shown so far in this section have presumed values of reactance that contribute to the circuit impedance. Reactance is a function of frequency, however, and many impedance calculations may begin with a value of capacitance or inductance and an operating frequency. In terms of these values, the series impedance formula (Eq 87) becomes two formulas:

$$Z = \sqrt{R^2 + (2\pi f L)^2} \quad (94)$$

$$Z = \sqrt{R^2 + \left(\frac{1}{2\pi f C}\right)^2} \quad (95)$$

Example: What is the impedance of a circuit like Fig 4.71 with a resistance of 100Ω and a $7.00\text{-}\mu\text{H}$ inductor operating at a frequency of 7.00 MHz ? Using equation 94,

$$\begin{aligned} Z &= \sqrt{R^2 + (2\pi f L)^2} \\ &= \sqrt{(100\Omega)^2 + (2\pi \times 7.00 \times 10^{-6} \text{ H} \times 7.00 \times 10^6 \text{ Hz})^2} \\ Z &= \sqrt{10,000 \Omega^2 + (308 \Omega)^2} \end{aligned}$$

$$= \sqrt{10,000 \Omega^2 + 94,900 \Omega^2}$$

$$= \sqrt{104900 \Omega^2} = 323.9 \Omega$$

Since 308Ω is the value of inductive reactance of the $7.00\text{-}\mu\text{H}$ coil at 7.00 MHz , the phase angle calculation proceeds as given in the earlier example (equation 89):

$$\begin{aligned} \theta &= \arctan \frac{X}{R} = \arctan \left(\frac{308.0 \Omega}{100.0 \Omega} \right) \\ &= \arctan(3.08) = 72.0^\circ \end{aligned}$$

Since the reactance is inductive, the phase angle is positive.

CALCULATING Z FROM R AND X IN PARALLEL CIRCUITS

In a parallel circuit containing reactance and resistance, such as shown in Fig 4.73, calculation of the resultant impedance from the values of R and X does not proceed by direct triangulation. The general formula for such parallel circuits is:

$$Z = \frac{RX}{\sqrt{R^2 + X^2}} \quad (96)$$

where the formula uses the absolute (unsigned) reactance value. The phase angle for the parallel circuit is given by:

$$\theta = \arctan \left(\frac{R}{X} \right) \quad (97)$$

If the parallel reactance is capacitive, then θ is a negative angle, and if the parallel reactance is inductive, then θ is a positive angle.

Example: An inductor with a reactance of 30.0Ω is in parallel with a resistor of 40.0Ω . What is the resulting impedance and phase angle?

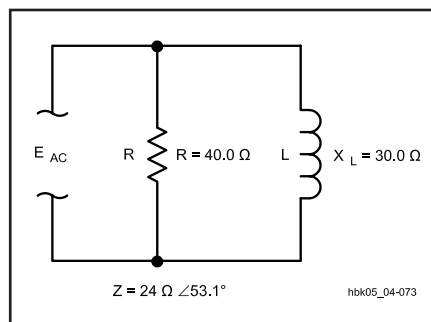

Fig 4.73 — A parallel circuit containing an inductive reactance of 30.0Ω and a resistor of 40.0Ω . No graph is given, since parallel impedances do not triangulate in the simple way of series impedances.

$$\begin{aligned} Z &= \frac{RX}{\sqrt{R^2 + X^2}} = \frac{30.0 \Omega \times 40.0 \Omega}{\sqrt{(30.0 \Omega)^2 + (40.0 \Omega)^2}} \\ &= \frac{1200 \Omega^2}{\sqrt{900 \Omega^2 + 1600 \Omega^2}} = \frac{1200 \Omega^2}{\sqrt{2500 \Omega^2}} \end{aligned}$$

$$Z = \frac{1200 \Omega^2}{50.0 \Omega} = 24.0 \Omega$$

$$\theta = \arctan \left(\frac{R}{X} \right) = \arctan \left(\frac{40.0 \Omega}{30.0 \Omega} \right)$$

$$\theta = \arctan(1.33) = 53.1^\circ$$

Since the parallel reactance is inductive, the resultant angle is positive.

Example: A capacitor with a reactance of 16.0Ω is in parallel with a resistor of 12.0Ω . What is the resulting impedance and phase angle?

$$\begin{aligned} Z &= \frac{RX}{\sqrt{R^2 + X^2}} = \frac{16.0 \Omega \times 12.0 \Omega}{\sqrt{(16.0 \Omega)^2 + (12.0 \Omega)^2}} \\ &= \frac{192 \Omega^2}{\sqrt{256 \Omega^2 + 144 \Omega^2}} = \frac{192 \Omega^2}{\sqrt{400 \Omega^2}} \end{aligned}$$

$$Z = \frac{192 \Omega^2}{20.0 \Omega} = 9.60 \Omega$$

$$\theta = \arctan \left(\frac{R}{X} \right) = \arctan \left(\frac{12.0 \Omega}{16.0 \Omega} \right)$$

$$\theta = \arctan(0.750) = -36.9^\circ$$

Because the parallel reactance is capacitive, the resultant phase angle is negative.

ADMITTANCE

Just as the inverse of resistance is conductance (G) and the inverse of reactance is susceptance (B), so too impedance has an inverse: admittance (Y), measured in siemens (S). Thus,

$$Y = \frac{1}{Z} \quad (98)$$

Since resistance, reactance and impedance are inversely proportional to the current ($Z = E / I$), conductance, susceptance and admittance are directly proportional to current. That is,

$$Y = \frac{1}{E} \quad (99)$$

One handy use for admittance is in simplifying parallel circuit impedance calculations. A parallel combination of reactance and resistance reduces to a vector addition of susceptance and con-

ductance, if admittance is the desired outcome. In other words, for parallel circuits:

$$Y = \sqrt{G^2 + B^2} \quad (100)$$

where:

- Y = admittance,
- G = conductance or $1/R$, and
- B = susceptance or $1/X$.

Example: An inductor with a reactance of 30.0Ω is in parallel with a resistor of 40.0Ω . What is the resulting impedance and phase angle? The susceptance is $1/30.0 \Omega = 0.0333 \text{ S}$ and the conductance is $1/40.0 \Omega = 0.0250 \text{ S}$.

$$\begin{aligned} Y &= \sqrt{(0.0333 \text{ S})^2 + (0.0250 \text{ S})^2} \\ &= \sqrt{0.00173 \text{ S}^2} = 0.0417 \text{ S} \\ Z &= \frac{1}{Y} = \frac{1}{0.0417 \text{ S}} = 24.0 \Omega \end{aligned}$$

The phase angle in terms of conductance and susceptance is:

$$\theta = \arctan\left(\frac{B}{G}\right) \quad (101)$$

In this example,

$$\theta = \arctan\left(\frac{0.0333 \text{ S}}{0.0250 \text{ S}}\right) = \arctan(1.33) = 53.1^\circ$$

Again, since the reactive component is inductive, the phase angle is positive. For a capacitively reactive parallel circuit, the phase angle would have been negative. Compare these results with the direct calculation earlier in the section.

Conversion from resistance, reactance and impedance to conductance, susceptance and admittance is perhaps most useful in complex-parallel-circuit calculations. Many advanced facets of active-circuit analysis will demand familiarity both with the concepts and with the calculation strategies introduced here, however.

More than Two Elements in Series or Parallel

When a circuit contains several resistances or several reactances in series, simplify the circuit before attempting to calculate the impedance. Resistances in series add, just as in a purely resistive circuit. Series reactances of the same kind — that is, all capacitive or all inductive — also add, just as in a purely reactive circuit. The goal is to produce a single value of resistance and a single value of reactance for the impedance calculation.

Fig 4.74 illustrates a more difficult case in which a circuit contains two different reactive elements in series, along with a

further series resistance. The series combination of X_C and X_L reduce to a single value using the same rules of combination discussed in the section on purely reactive components. As Fig 4.74B demonstrates, the resultant reactance is the difference between the two series reactances.

For parallel circuits with multiple resistances or multiple reactances of the same type, use the rules of parallel combination to reduce the resistive and reactive components to single elements. Where two or more reactive components of different types appear in the same circuit, they can be combined using formulas shown earlier for pure reactances. As Fig 4.75 suggests, however, they can also be combined as susceptances. Parallel susceptances of different types add, with attention to their differing signs. The resulting single susceptance can then be combined with the conductance to arrive at the overall circuit admittance. The inverse of the admittance is the final circuit impedance.

Equivalent Series and Parallel Circuits

The two circuits shown in Fig 4.69 are equivalent if the same current flows when a given voltage of the same frequency is applied, and if the phase angle between voltage and current is the same in both cases. It is possible, in fact, to transform any given series circuit into an equivalent parallel circuit, and vice versa.

A series RX circuit can be converted into its parallel equivalent by means of the formulas:

$$R_P = \frac{R_S^2 + X_S^2}{R_S} \quad (102)$$

$$X_P = \frac{R_S^2 + X_S^2}{X_S} \quad (103)$$

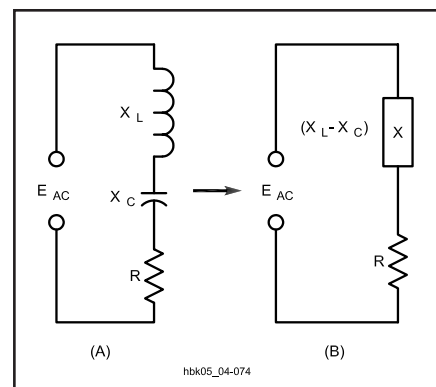

Fig 4.74 — A series impedance containing mixed capacitive and inductive reactances can be reduced to a single reactance plus resistance by combining the reactances algebraically.

where the subscripts P and S represent the parallel- and series-equivalent values, respectively. If the parallel values are known, the equivalent series circuit can be found from:

$$R_S = \frac{R_P X_P^2}{R_P^2 + X_P^2} \quad (104)$$

and

$$X_S = \frac{R_P^2 X_P}{R_P^2 + X_P^2} \quad (105)$$

Example: Let the series circuit in Fig 4.69 have a series reactance of -50.0Ω (indicating a capacitive reactance) and a resistance of 50.0Ω . What are the values of the equivalent parallel circuit?

$$\begin{aligned} R_P &= \frac{R_S^2 + X_S^2}{R_S} = \frac{(50.0 \Omega)^2 + (-50.0 \Omega)^2}{50.0 \Omega} \\ &= \frac{2500 \Omega^2 + 2500 \Omega^2}{50.0 \Omega} = \frac{5000 \Omega^2}{50.0 \Omega} = 100 \Omega \end{aligned}$$

$$\begin{aligned} X_P &= \frac{R_S^2 + X_S^2}{X_S} = \frac{(50.0 \Omega)^2 + (-50.0 \Omega)^2}{-50.0 \Omega} \\ &= \frac{2500 \Omega^2 + 2500 \Omega^2}{-50.0 \Omega} = \frac{5000 \Omega^2}{-50.0 \Omega} \\ &= -100 \Omega \end{aligned}$$

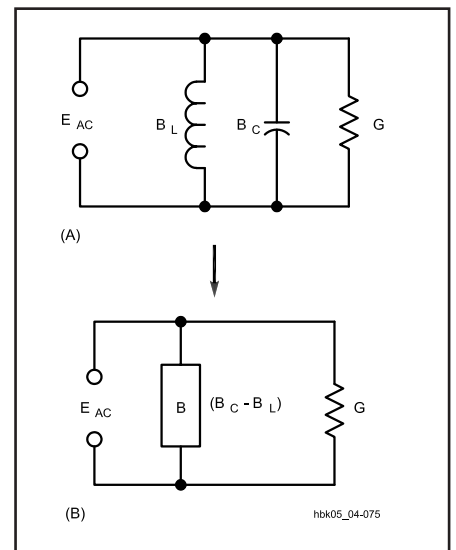

Fig 4.75 — A parallel impedance containing mixed capacitive and inductive reactances can be reduced to a single reactance plus resistance using formulas shown earlier in the chapter. By converting reactances to susceptances, as shown in A, you can combine the susceptances algebraically into a single susceptance, as shown in B.

The parallel circuit in Fig 4.69 calls for a capacitive reactance of 100Ω and a resistance of 100Ω to be equivalent to the series circuit.

OHM'S LAW FOR IMPEDANCE

Ohm's Law applies to circuits containing impedance just as readily as to circuits having resistance or reactance only. The formulas are:

$$E = IZ \quad (106)$$

$$I = \frac{E}{Z} \quad (107)$$

$$Z = \frac{E}{I} \quad (108)$$

where:

- E = voltage in volts,
- I = current in amperes, and
- Z = impedance in ohms.

Fig 4.76 shows a simple circuit consisting of a resistance of 75.0Ω and a reactance of 100Ω in series. From the series-impedance formula previously given, the impedance is

$$\begin{aligned} Z &= \sqrt{R^2 + X_L^2} = \sqrt{(75.0 \Omega)^2 + (100 \Omega)^2} \\ &= \sqrt{5630 \Omega^2 + 10000 \Omega^2} = \sqrt{15600 \Omega^2} \\ &= 125 \Omega \end{aligned}$$

If the applied voltage is 250 V, then

$$I = \frac{E}{Z} = \frac{250 \text{ V}}{125 \Omega} = 2.00 \text{ A}$$

This current flows through both the resistance and reactance, so the voltage drops are:

$$E_R = IR = 2.00 \text{ A} \times 75.0 \Omega = 150 \text{ V}$$

$$E_{X_L} = IX_L = 2.00 \text{ A} \times 100 \Omega = 200 \text{ V}$$

The simple arithmetical sum of these

two drops, 350 V, is greater than the applied voltage because the two voltages are 90° out of phase. Their actual resultant, when phase is taken into account, is:

$$\begin{aligned} E &= \sqrt{(150 \text{ V})^2 + (200 \text{ V})^2} \\ &= \sqrt{22500 \text{ V}^2 + 40000 \text{ V}^2} = \sqrt{62500 \text{ V}^2} \\ &= 250 \text{ V} \end{aligned}$$

POWER FACTOR

In the circuit of Fig 4.76, an applied voltage of 250 V results in a current of 2.00 A, giving an apparent power of $250 \text{ V} \times 2.00 \text{ A} = 500 \text{ W}$. Only the resistance actually consumes power, however. The power in the resistance is:

$$P = I^2 R = (2.00 \text{ A})^2 \times 75.0 \Omega = 300 \text{ W}$$

The ratio of the consumed power to the apparent power is called the power factor of the circuit.

$$\text{PF} = \frac{P_{\text{consumed}}}{P_{\text{apparent}}} = \frac{R}{Z} \quad (109)$$

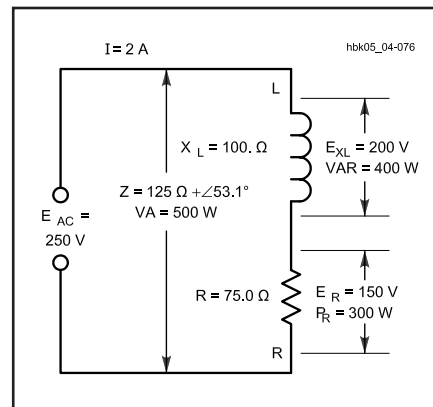

Fig 4.76 — A series circuit consisting of an inductive reactance of 100Ω and a resistance of 75.0Ω . Also shown is the applied voltage, voltage drops across the circuit elements, and the current.

In this example the power factor would be $300 \text{ W} / 500 \text{ W} = 0.600$. Power factor is frequently expressed as a percentage; in this case, 60%. An equivalent definition of power factor is:

$$\text{PF} = \cos \theta$$

where θ is the phase angle. Since the phase angle equals:

$$\begin{aligned} \theta &= \arctan \left(\frac{X}{R} \right) = \arctan \left(\frac{100 \Omega}{75.0 \Omega} \right) \\ &= \arctan (1.33) = 53.1^\circ \end{aligned}$$

Then the power factor is:

$$\text{PF} = \cos 53.1^\circ = 0.600$$

as the earlier calculation confirms.

Real, or dissipated, power is measured in watts. Apparent power, to distinguish it from real power, is measured in volt-amperes (VA). It is simply the product of the voltage across and the current through an overall impedance. It has no direct relationship to the power actually dissipated unless the power factor of the circuit is known. The power factor of a purely resistive circuit is 100% or 1, while the power factor of a pure reactance is zero. In this illustration, the reactive power is:

$$\text{VAR} = I^2 X_L = (2.00 \text{ A})^2 \times 100 \Omega = 400 \text{ VA}$$

Since power factor is always rendered as a positive number, the value must be followed by the words "leading" or "lagging" to identify the phase of the voltage with respect to the current. Specifying the numerical power factor is not always sufficient. For example, many dc-to-ac power inverters can safely operate loads having a large net reactance of one sign but only a small reactance of the opposite sign. Hence, the final calculation of the power factor in this example yields the value 0.600, leading.

Resonant Circuits

A circuit containing both an inductor and a capacitor — and therefore, both inductive and capacitive reactance — is often called a *tuned circuit*. There is a particular frequency at which the inductive and capacitive reactances are the same, that is, $X_L = X_C$. For most purposes, this is the *resonant frequency* of the circuit. (Special considerations apply to parallel circuits; they will emerge in the section devoted to such circuits.) At the resonant frequency — or at resonance, for short:

$$X_L = 2\pi f L = X_C = \frac{1}{2\pi f C}$$

By solving for f , we can find the resonant frequency of any combination of inductor and capacitor from the formula:

$$f = \frac{1}{2\pi\sqrt{LC}} \quad (110)$$

where:

- f = frequency in hertz (Hz),
- L = inductance in henrys (H),
- C = capacitance in farads (F), and
- $\pi = 3.1416$.

For most high-frequency (HF) radio work, smaller units of inductance and capacitance and larger units of frequency are more convenient. The basic formula becomes:

$$f = \frac{10^3}{2\pi\sqrt{LC}} \quad (111)$$

where:

- f = frequency in megahertz (MHz),
- L = inductance in microhenrys (μH),
- C = capacitance in picofarads (pF), and
- $\pi = 3.1416$.

Example: What is the resonant frequency of a circuit containing an inductor of $5.0 \mu\text{H}$ and a capacitor of 35 pF ?

$$f = \frac{10^3}{2\pi\sqrt{LC}} = \frac{10^3}{6.2832 \times \sqrt{5.0 \times 35}} \\ = \frac{10^3}{83} = 12 \text{ MHz}$$

To find the matching component (inductor or capacitor) when the frequency and one component is known (capacitor or inductor) for general HF work, use the formula:

$$f^2 = \frac{1}{4\pi^2 LC} \quad (112)$$

where F , L and C are in basic units. For HF

work in terms of MHz, μH and pF, the basic relationship rearranges to these handy formulas:

$$L = \frac{25330}{f^2 C} \quad (113)$$

$$C = \frac{25330}{f^2 L} \quad (114)$$

where:

- f = frequency in MHz,
- L = inductance in μH , and
- C = capacitance in pF.

Example: What value of capacitance is needed to create a resonant circuit at 21.1 MHz , if the inductor is $2.00 \mu\text{H}$?

$$C = \frac{25330}{f^2 L} = \frac{25330}{(21.1^2 \times 2.00)} \\ = \frac{25330}{890} = 28.5 \text{ pF}$$

For most radio work, these formulas will permit calculations of frequency and component values well within the limits of component tolerances. Resonant circuits have other properties of importance, in addition to the resonant frequency, however. These include impedance, voltage drop across components in series-resonant circuits, circulating current in parallel-resonant circuits, and bandwidth. These properties determine such factors as the selectivity of a tuned circuit and the component ratings for circuits handling considerable power. Although the basic determination of the tuned-circuit resonant frequency ignored any resistance in the circuit, that resistance will play a vital role in the circuit's other characteristics.

SERIES-RESONANT CIRCUITS

Fig 4.77 presents a basic schematic diagram of a *series-resonant circuit*. Although most schematic diagrams of radio circuits would show only the inductor and the capacitor, resistance is always present in such circuits. The most notable resistance is associated with losses in the inductor at HF; resistive losses in the capacitor are low enough at those frequencies to be ignored. The current meter shown in the circuit is a reminder that in series circuits, the same current flows through all elements.

At resonance, the reactance of the capacitor cancels the reactance of the inductor. The voltage and current are in phase with each other, and the impedance

of the circuit is determined solely by the resistance. The actual current through the circuit at resonance, and for frequencies near resonance, is determined by the formula:

$$I = \frac{E}{Z} = \frac{E}{\sqrt{R^2 + \left[2\pi f L - \frac{1}{2\pi f C}\right]^2}} \quad (115)$$

where all values are in basic units.

At resonance, the reactive factor in the formula is zero. As the frequency is shifted above or below the resonant frequency without altering component values, however, the reactive factor becomes significant, and the value of the current becomes smaller than at resonance. At frequencies far from resonance, the reactive components become dominant, and the resistance no longer significantly affects the current amplitude.

The exact curve created by recording the current as the frequency changes depends on the ratio of reactance to resistance. When the reactance of either the coil or capacitor is of the same order of magnitude as the resistance, the current decreases rather slowly as the frequency is moved in either direction away from resonance. Such a curve is said to be *broad*. Conversely, when the reactance is considerably larger than the resistance, the current decreases rapidly as the frequency moves away from resonance, and the circuit is said to be *sharp*. A sharp circuit will respond a great deal more readily to the resonant frequency than to frequencies quite close to resonance; a broad circuit will respond almost equally well to a

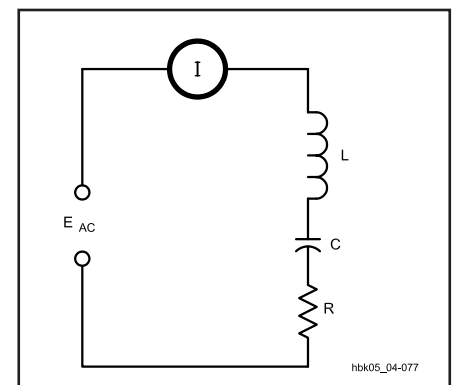

Fig 4.77 — A series circuit containing L , C , and R is resonant at the applied frequency when the reactance of C is equal to the reactance of L . The I in the circle is the schematic symbol for an ammeter.

group or band of frequencies centered around the resonant frequency.

Both types of resonance curves are useful. A sharp circuit gives good selectivity — the ability to respond strongly (in terms of current amplitude) at one desired frequency and to discriminate against others. A broad circuit is used when the apparatus must give about the same response over a band of frequencies, rather than at a single frequency alone.

Fig 4.78 presents a family of curves, showing the decrease in current as the frequency deviates from resonance. In each case, the reactance is assumed to be 1000 Ω. The maximum current, shown as a relative value on the graph, occurs with the lowest resistance, while the lowest peak current occurs with the highest resistance. Equally important, the rate at which the current decreases from its maximum value also changes with the ratio of reactance to resistance. It decreases most rapidly when the ratio is high and most slowly when the ratio is low.

Q

As noted in earlier sections of this chapter, the ratio of reactance or stored energy to resistance or consumed energy is Q. Since both terms of the ratio are measured in ohms, Q has no units and is variously known as the *quality factor*, the *figure of merit* or the *multiplying factor*. Since the resistive losses of the coil dominate the energy consumption in HF series-resonant

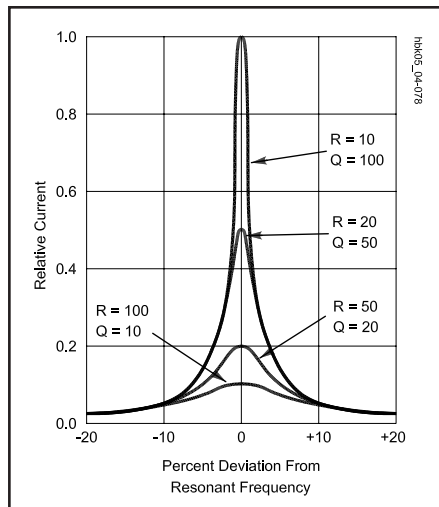

Fig 4.78 — Current in series-resonant circuits with various values of series resistance and Q. The current values are relative to an arbitrary maximum of 1.0. The reactance for all curves is 1000 Ω. Note that the current is hardly affected by the resistance in the circuit at frequencies more than 10% away from the resonant frequency.

circuits, the inductor Q largely determines the resonant-circuit Q. Since this value of Q is independent of any external load to which the circuit might transfer power, it is called the *unloaded Q* or Q_U of the circuit.

Example: What is the unloaded Q of a series-resonant circuit with a loss resistance of 5 Ω and inductive and capacitive components having a reactance of 500 Ω each? With a reactance of 50 Ω each?

$$Q_{U1} = \frac{X1}{R} = \frac{500\Omega}{5\Omega} = 100$$

$$Q_{U2} = \frac{X2}{R} = \frac{50\Omega}{5\Omega} = 10$$

Bandwidth

Fig 4.79 is an alternative way of drawing the family of curves that relate current to frequency for a series-resonant circuit. By assuming that the peak current of each curve is the same, the rate of change of current for various values of Q_U and the associated ratios of reactance to resistance are more easily compared. From the curves, it is evident that the lower Q_U circuits pass frequencies over a greater *bandwidth* of frequencies than the circuits with a higher Q_U . For the purpose of comparing tuned circuits, bandwidth is often defined as the frequency spread between the two frequencies at which the current amplitude decreases to 0.707 (or $1/\sqrt{2}$) times the

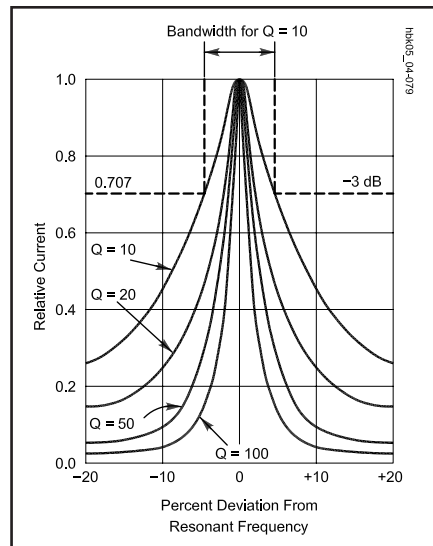

Fig 4.79 — Current in series-resonant circuits having different values of Q_U . The current at resonance is set at the same level for all curves in order to show the rate of change of decrease in current for each value of Q_U . The half-power points are shown to indicate relative bandwidth of the response for each curve. The bandwidth is indicated for a circuit with a Q_U of 10.

maximum value. Since the power consumed by the resistance, R, is proportional to the square of the current, the power at these points is half the maximum power at resonance, assuming that R is constant for the calculations. The half-power, or -3 dB, points are marked on Fig 4.79.

For Q values of 10 or greater, the curves shown in Fig 4.79 are approximately symmetrical. On this assumption, bandwidth (BW) can be easily calculated:

$$BW = \frac{f}{Q_U} \quad (116)$$

where BW and f are in the same units, that is, in Hz, kHz or MHz.

Example: What is the bandwidth of a series-resonant circuit operating at 14 MHz with a Q_U of 100?

$$BW = \frac{f}{Q_U} = \frac{14\text{ MHz}}{100} = 0.14\text{ MHz} = 140\text{ kHz}$$

The relationship between Q_U , f and BW provides a means of determining the value of circuit Q when inductor losses may be difficult to measure. By constructing the series-resonant circuit and measuring the current as the frequency varies above and below resonance, the half-power points can be determined. Then:

$$Q_U = \frac{f}{BW} \quad (117)$$

Example: What is the Q_U of a series-resonant circuit operating at 3.75 MHz, if the bandwidth is 375 kHz?

$$Q_U = \frac{f}{BW} = \frac{3.75\text{ MHz}}{0.375\text{ MHz}} = 10.0$$

Table 4.7 provides some simple formulas for estimating the maximum current and phase angle for various bandwidths, if both f and Q_U are known.

Voltage Drop Across Components

The voltage drop across the coil and across the capacitor in a series-resonant circuit are each proportional to the reactance of the component for a given current (since $E = I X$). These voltages may be many times the source voltage for a high-Q circuit. In fact, at resonance, the voltage drop is:

$$E_X = Q_U E \quad (118)$$

where:

E_X = the voltage across the reactive component,

Q_U = the circuit unloaded Q, and
E = the source voltage.

Table 4.7

The Selectivity of Resonant Circuits

Approximate percentage of current at resonance ¹ or of impedance at resonance ²	Bandwidth (between half-power or -3 dB points on response curve)	Series circuit current phase angle (degrees)
95	f / 3Q	18.5
90	f / 2Q	26.5
70.7	f / Q	45
44.7	2f / Q	63.5
24.2	4f / Q	76
12.4	8f / Q	83

¹For a series resonant circuit
²For a parallel resonant circuit

(Note that the voltage drop across the inductor is the vector sum of the voltages across the resistance and the reactance; however, for Qs greater than 10, the error created by using equation 96 is not ordinarily significant.) Since the calculated value of E_x is the RMS voltage, the peak voltage will be higher by a factor of 1.414. Antenna couplers and other high-Q circuits handling significant power may experience arcing from high values of E_x, even though the source voltage to the circuit is well within component ratings.

Capacitor Losses

Although capacitor energy losses tend to be insignificant compared to inductor losses up to about 30 MHz, the losses may affect circuit Q in the VHF range. Leakage resistance, principally in the solid dielectric that forms the insulating support for the capacitor plates, is not exactly like the wire resistance losses in a coil. Instead of forming a series resistance, capacitor leakage usually forms a parallel resistance with the capacitive reactance. If the leakage resistance of a capacitor is significant enough to affect the Q of a series-resonant circuit, the parallel resistance must be converted to an equivalent series resistance before adding it to the inductor's resistance.

$$R_s = \frac{X_C^2}{R_p} = \frac{1}{R_p \times (2\pi f C)^2} \quad (119)$$

Example: A 10.0 pF capacitor has a leakage resistance of 10000 Ω at 50.0 MHz. What is the equivalent series resistance?

$$R_s = \frac{1}{R_p \times (2\pi f C)^2}$$

$$= \frac{1}{1.00 \times 10^4 \times (6.283 \times 50.0 \times 10^6 \times 10.0 \times 10^{-12})^2}$$

$$R_s = \frac{1}{1.00 \times 10^4 \times 9.87 \times 10^{-6}}$$

$$= \frac{1}{0.0987} = 10.1 \Omega$$

In calculating the impedance, current and bandwidth for a series-resonant circuit in which this capacitor might be used, the series-equivalent resistance of the unit is added to the loss resistance of the coil. Since inductor losses tend to increase with frequency because of skin effect, the combined losses in the capacitor and the

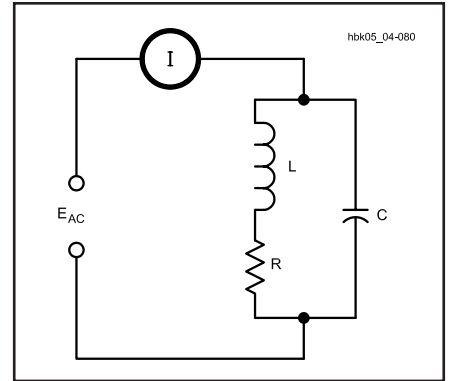

Fig 4.80 — A typical parallel-resonant circuit, with the resistance shown in series with the inductive leg of the circuit. Below a Q_U of 10, resonance definitions may lead to three separate frequencies which converge at higher Q_U levels. See text.

inductor can seriously reduce circuit Q, without special component- and circuit-construction techniques.

PARALLEL-RESONANT CIRCUITS

Although series-resonant circuits are common, the vast majority of resonant circuits used in radio work are *parallel-resonant circuits*. **Fig 4.80** represents a typical

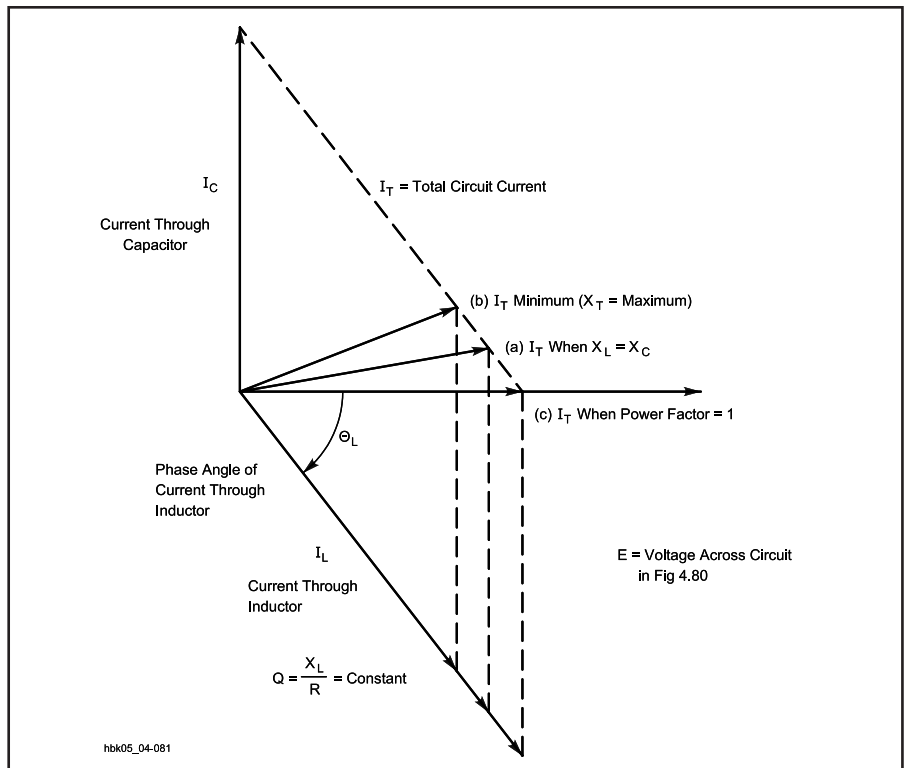

Fig 4.81 — Resonant conditions for a low-Q_U parallel circuit. Resonance may be defined as (a) X_L = X_C, (b) minimum current flow and maximum impedance or (c) voltage and current in phase with each other. With the circuit of Fig 4.80 and a Q_U of less than 10, these three definitions may represent three distinct frequencies.

HF parallel-resonant circuit. As is the case for series-resonant circuits, the inductor is the chief source of resistive losses, and these losses appear in series with the coil. Because current through parallel-resonant circuits is lowest at resonance, and impedance is highest, they are sometimes called *antiresonant* circuits. Likewise, the names *acceptor* and *rejector* are occasionally applied to series- and parallel-resonant circuits, respectively.

Because the conditions in the two legs of the parallel circuit in Fig 4.80 are not the same — the resistance is in only one of the legs — all of the conditions by which series resonance is determined do not occur simultaneously in a parallel-resonant circuit. Fig 4.81 graphically illustrates the situation by showing the currents through the two components. When the inductive and capacitive reactances are identical, the condition defined for series resonance is met as shown in line (A). The impedance of the inductive leg is composed of both X_L and R , which yields an impedance that is greater than X_C and that is not 180° out of phase with X_C . The resultant current is greater than its minimum possible value and not in phase with the voltage.

By altering the value of the inductor slightly (and holding the Q constant), a new frequency can be obtained at which the current reaches its minimum. When parallel circuits are tuned using a current meter as an indicator, this point (B) is ordinarily used as an indication of resonance. The current “dip” indicates a condition of maximum impedance and is sometimes called the *antiresonant* point or *maximum impedance resonance* to distinguish it from the condition where $X_C = X_L$. Maximum impedance is achieved by vector addition of X_C , X_L and R , however, and the result is a current somewhat out of phase with the voltage.

Point (C) on the curve represents the *unity-power-factor* resonant point. Adjusting the inductor value and hence its reactance (while holding Q constant) produces a new resonant frequency at which the resultant current is in phase with the voltage. The inductor’s new value of reactance is the value required for a parallel-equivalent inductor and its parallel-equivalent resistor (calculated according to the formulas in the last section) to just cancel the capacitive reactance. The value of the parallel-equivalent inductor is always smaller than the actual inductor in series with the resistor and has a proportionally smaller reactance. (The parallel-equivalent resistor, conversely, will always be larger than the coil-loss resistor shown in series with the inductor.) The result is a resonant frequency slightly dif-

ferent from the one for minimum current and the one for $X_L = X_C$.

The points shown in the graph in Fig 4.82 represent only one of many possible situations, and the relative positions of the three resonant points do not hold for all possible cases. Moreover, specific circuit designs can draw some of the resonant points together, for example, compensating for the resistance of the coil by retuning the capacitor. The differences among these resonances are significant for circuit Q s below 10, where the inductor’s series resistance is a significant percentage of the reactance. Above a Q of 10, the three points converge to within a percent of the frequency and can be ignored for practical calculations. Tuning for minimum current will not introduce a sufficiently large phase angle between voltage and current to create circuit difficulties.

Parallel Circuits of Moderate to High Q

The resonant frequencies defined above converge in parallel-resonant circuits with Q s higher than about 10. Therefore, a single set of formulas will sufficiently approximate circuit performance for accurate predictions. Indeed, above a Q of 10, the performance of a parallel circuit appears in many ways to be simply the inverse of the performance of a series-resonant circuit using the same components.

Accurate analysis of a parallel-resonant circuit requires the substitution of a parallel-equivalent resistor for the actual inductor-loss series resistor, as shown in Fig 4.82. Sometimes called the *dynamic resistance* of the parallel-resonant circuit, the parallel-equivalent resistor value will increase with circuit Q , that is, as the series resistance value decreases. To calculate

the approximate parallel-equivalent resistance, use the formula:

$$R_P = \frac{X_L^2}{R_S} = \frac{(2\pi f L)^2}{R_S} = Q_U X_L \quad (120)$$

Example: What is the parallel-equivalent resistance for a coil with an inductive reactance of 350Ω and a series resistance of 5.0Ω at resonance?

$$\begin{aligned} R_P &= \frac{X_L^2}{R_S} = \frac{(350 \Omega)^2}{5.0 \Omega} \\ &= \frac{122,500 \Omega^2}{5.0 \Omega} = 24,500 \Omega \end{aligned}$$

Since the coil Q_U remains the inductor’s reactance divided by its series resistance, the coil Q_U is 70. Multiplying Q_U by the reactance also provides the approximate parallel-equivalent resistance of the coil series resistance.

At resonance, where $X_L = X_C$, R_P defines the impedance of the parallel-resonant circuit. The reactances just equal each other, leaving the voltage and current in phase with each other. In other words, the circuit shows only the parallel resistance. Therefore, equation 120 can be rewritten as:

$$Z = \frac{X_L^2}{R_S} = \frac{(2\pi f L)^2}{R_S} = Q_U X_L \quad (121)$$

In this example, the circuit impedance at resonance is $24,500 \Omega$.

At frequencies below resonance the current through the inductor is larger than that through the capacitor, because the reactance of the coil is smaller and that of the capacitor is larger than at resonance. There is only partial cancellation of the two reactive currents, and the line current therefore is larger than the current taken by the resistance alone. At frequencies above resonance the situation is reversed and more current flows through the capacitor than through the inductor, so the line current again increases. The current at resonance, being determined wholly by R_P , will be small if R_P is large, and large if R_P is small. Fig 4.83 illustrates the relative current flows through a parallel-tuned circuit as the frequency is moved from below resonance to above resonance. The base line represents the minimum current level for the particular circuit. The actual current at any frequency off resonance is simply the vector sum of the currents through the parallel equivalent resistance and through the reactive components.

To obtain the impedance of a parallel-tuned circuit either at or off the resonant

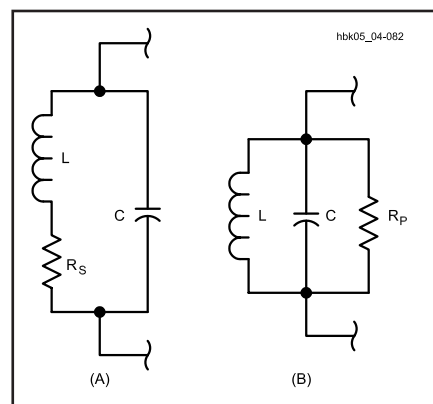

Fig 4.82 — Series and parallel equivalents when both circuits are resonant. The series resistance, R_S in A, is replaced by the parallel resistance, R_P in B, and vice versa. $R_P = X_L^2 / R_S$.

frequency, apply the general formula:

$$Z = \frac{Z_C Z_L}{Z_S} \quad (122)$$

where:

Z = overall circuit impedance

Z_C = impedance of the capacitive leg (usually, the reactance of the capacitor),

Z_L = impedance of the inductive leg (the vector sum of the coil's reactance and resistance), and

Z_S = series impedance of the capacitor-inductor combination as derived from the denominator of equation 115.

After using vector calculations to obtain Z_L and Z_S , converting all the values to polar form — as described earlier in this chapter — will ease the final calculation. Of course, each impedance may be derived from the resistance and the application of the basic reactance formulas on the values of the inductor and capacitor at the frequency of interest.

Since the current rises off resonance, the parallel-resonant-circuit impedance must fall. It also becomes complex, resulting in an ever greater phase difference between the voltage and the current. The rate at

which the impedance falls is a function of Q_U . **Fig 4.84** presents a family of curves showing the impedance drop from resonance for circuit Q_s ranging from 10 to 100. The curve family for parallel-circuit impedance is essentially the same as the curve family for series-circuit current.

As with series tuned circuits, the higher the Q of a parallel-tuned circuit, the sharper the response peak. Likewise, the lower the Q , the wider the band of frequencies to which the circuit responds. Using the half-power (–3 dB) points as a comparative measure of circuit performance, equations 116 and 117 apply equally to parallel-tuned circuits. That is, $BW = f / Q_U$ and $Q_U = f / BW$, where the resonant frequency and the bandwidth are in the same units. As a handy reminder, **Table 4.8** summarizes the performance of parallel-resonant circuits at high and low Q_s and above and below resonant frequency.

It is possible to use either series or parallel-resonant circuits do the same work in many circuits, thus giving the designer considerable flexibility. **Fig 4.85** illustrates this general principle by showing a series-resonant circuit in the signal path and a parallel-resonant circuit shunted from the signal path to ground. Assume both circuits

are resonant at the same frequency, f , and have the same Q . The series tuned circuit at A has its lowest impedance at f , permitting the maximum possible current to flow along the signal path. At all other frequencies, the impedance is greater and the current at those frequencies is less. The circuit passes the desired signal and tends to impede signals at undesired frequencies. The parallel circuit at B provides the highest impedance at resonance, f , making the signal path the lowest impedance path for the signal. At frequencies off resonance, the

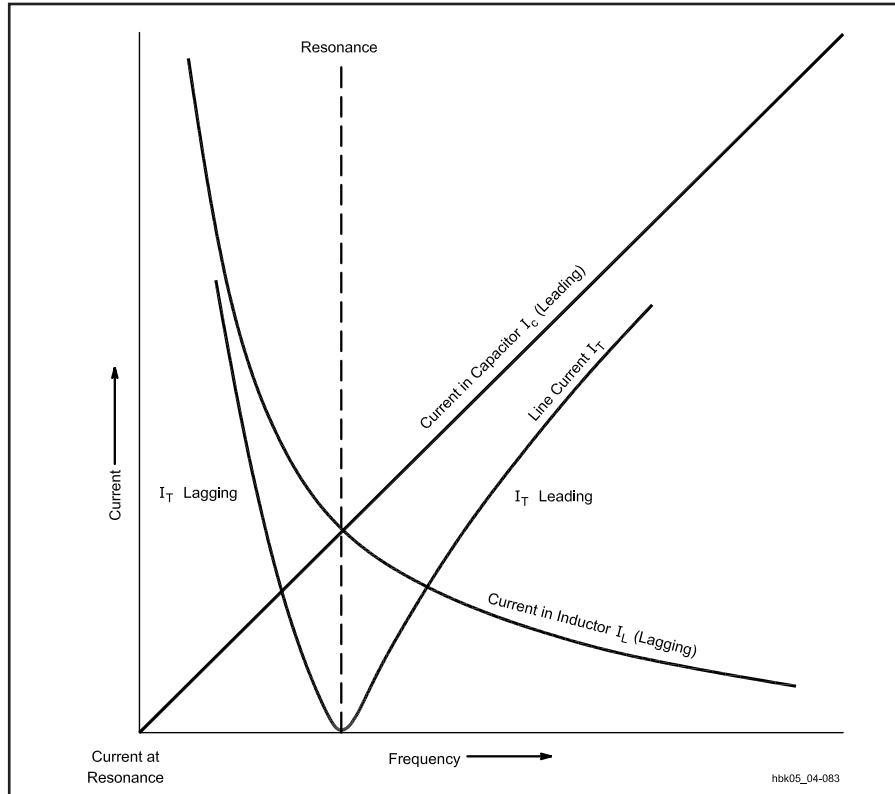

Fig 4.83 — The currents in a parallel-resonant circuit as the frequency moves through resonance. Below resonance, the current lags the voltage; above resonance the current leads the voltage. The base line represents the current level at resonance, which depends on the impedance of the circuit at that frequency.

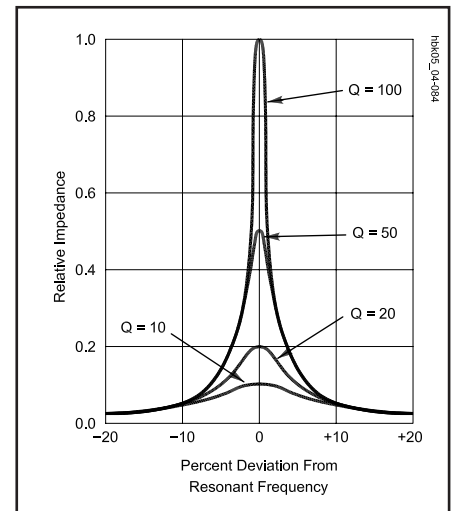

Fig 4.84 — Relative impedance of parallel-resonant circuits with different values of Q_U . The curves are similar to the series-resonant circuit current level curves of Fig 4.78. The effect of Q_U on impedance is most pronounced within 10% of the resonance frequency.

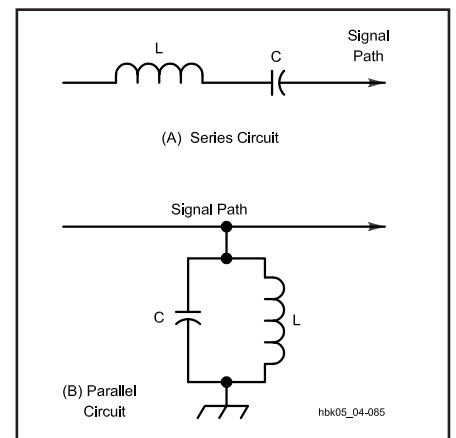

Fig 4.85 — Series- and parallel-resonant circuits configured to perform the same theoretical task: passing signals in a narrow band of frequencies along the signal path. A real design example would consider many other factors.

Table 4.8

The Performance of Parallel-Resonant Circuits

A. High and Low Q Circuits (in relative terms)

Characteristic	High Q Circuit	Low Q Circuit
Selectivity	high	low
Bandwidth	narrow	wide
Impedance	high	low
Line current	low	high
Circulating current	high	low

B. Off-Resonance Performance for Constant Values of Inductance and Capacitance

Characteristic	Above Resonance	Below Resonance
Inductive reactance	increases	decreases
Capacitive reactance	decreases	increases
Circuit resistance	unchanged*	unchanged*
Circuit impedance	decreases	decreases
Line current	increases	increases
Circulating current	decreases	decreases
Circuit behavior	capacitive	inductive

*This is true for frequencies near resonance. At distant frequencies, skin effect may alter the resistive losses of the inductor.

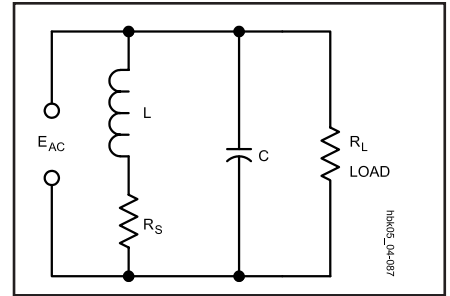

Fig 4.87 — A loaded parallel-resonant circuit, showing both the inductor-loss resistance and the load, R_L . If smaller than the inductor resistance, R_L will control the loaded Q of the circuit (Q_L).

cies below 30 MHz, most of this resistance is in the coil. Within limits, increasing the number of turns in the coil increases the reactance faster than it raises the resistance, so coils for circuits in which the Q must be high are made with relatively large inductances for the frequency.

When the circuit delivers energy to a load (as in the case of the resonant circuits used in transmitters), the energy consumed in the circuit itself is usually negligible compared with that consumed by the load. The equivalent of such a circuit is shown in **Fig 4.87**, where the parallel resistor, R_L , represents the load to which power is delivered. If the power dissipated in the load is at least 10 times as great as the power lost in the inductor and capacitor, the parallel impedance of the resonant circuit itself will be so high compared with the resistance of the load that for all practical purposes the impedance of the combined circuit is equal to the load impedance. Under these conditions, the load resistance replaces the circuit impedance in calculating Q. The Q of a parallel-resonant circuit loaded by a resistive impedance is:

$$Q_L = \frac{R_L}{X} \tag{124}$$

where:

Q_L = circuit loaded Q,

R_L = parallel load resistance in ohms,

and

X = reactance in ohms of either the inductor or the capacitor.

Example: A resistive load of 3000 Ω is connected across a resonant circuit in which the inductive and capacitive reactances are each 250 Ω . What is the circuit Q?

$$Q_L = \frac{R_L}{X} = \frac{3000 \Omega}{250 \Omega} = 12$$

The effective Q of a circuit loaded by a parallel resistance increases when the reactances are decreased. A circuit loaded with a relatively low resistance (a few

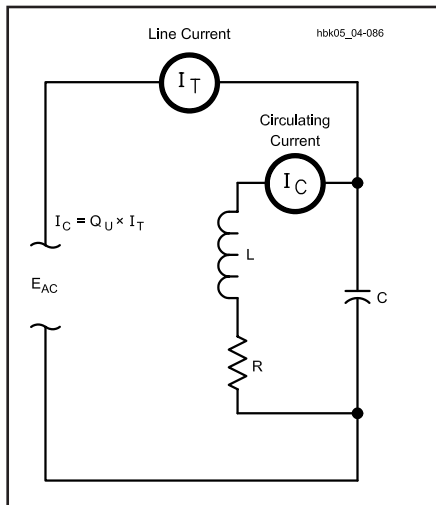

Fig 4.86 — A parallel-resonant circuit redrawn to illustrate both the line current and the circulating current.

parallel-resonant circuit presents a lower impedance, thus presenting signals with a path to ground and away from the signal path. In theory, the effects will be the same relative to a signal current on the signal path. In actual circuit design exercises, of course, many other variables will enter the design picture to make one circuit preferable to the other.

Circulating Current

In a parallel-resonant circuit, the source voltage is the same for all the circuit elements. The current in each element, however, is a function of the element's

reactance. **Fig 4.86** redraws the parallel-tuned circuit to indicate the line current and the current circulating between the coil and the capacitor. The current drawn from the source may be low, because the overall circuit impedance is high. The current through the individual elements may be high, however, because there is little resistive loss as the current circulates through the inductor and capacitor. For parallel-resonant circuits with an unloaded Q of 10 or greater, this *circulating current* is approximately:

$$I_C = Q_U I_T \tag{123}$$

where:

I_C = circulating current in A, mA or μ A,

Q_U = unloaded circuit Q, and

I_T = line current in the same units as I_C .

Example: A parallel-resonant circuit permits an ac or RF line current of 30 mA and has a Q of 100. What is the circulating current through the elements?

$$I_X = Q_U I = 100 \times 30 \text{ mA} = 3000 \text{ mA} = 3 \text{ A}$$

Circulating currents in high-Q parallel-tuned circuits can reach a level that causes component heating and power loss. Therefore, components should be rated for the anticipated circulating currents, and not just the line current.

The Q of Loaded Circuits

In many resonant-circuit applications, the only power lost is that dissipated in the resistance of the circuit itself. At frequen-

thousand ohms) must have low-reactance elements (large capacitance and small inductance) to have reasonably high Q. Many power-handling circuits, such as the output networks of transmitters, are designed by first choosing a loaded Q for the circuit and then determining component values. See the **RF Power Amplifiers** chapter for more details.

Parallel load resistors are sometimes added to parallel-resonant circuits to lower the circuit Q and increase the circuit bandwidth. By using a high-Q circuit and adding a parallel resistor, designers can tailor the circuit response to their needs. Since the parallel resistor consumes power, such techniques ordinarily apply to receiver and similar low-power circuits, however.

Example: Specifications call for a parallel-resonant circuit with a bandwidth of 400 kHz at 14.0 MHz. The circuit at hand has a Q_U of 70.0 and its components have reactances of 350 Ω each. What is the parallel load resistor that will increase the bandwidth to the specified value? The bandwidth of the existing circuit is:

$$\begin{aligned} BW &= \frac{f}{Q_U} = \frac{14.0 \text{ MHz}}{70.0} = 0.200 \text{ MHz} \\ &= 200 \text{ kHz} \end{aligned}$$

The desired bandwidth, 400 kHz, requires a circuit with a Q of:

$$Q = \frac{f}{BW} = \frac{14.0 \text{ MHz}}{0.400 \text{ MHz}} = 35.0$$

Since the desired Q is half the original value, halving the resonant impedance or parallel-resistance value of the circuit is in order. The present impedance of the circuit is:

$$Z = Q_U X_L = 70.0 \times 350 \Omega = 24500 \Omega$$

The desired impedance is:

$$\begin{aligned} Z &= Q_U X_L = 35.0 \times 350 \Omega \\ &= 12250 \Omega = 12.25 \text{ k}\Omega \end{aligned}$$

or half the present impedance.

A parallel resistor of 24500 Ω , or the nearest lower value (to guarantee sufficient bandwidth), will produce the required reduction in Q and bandwidth increase. Although this example simplifies the situation encountered in real design cases by ignoring such factors as the shape of the band-pass curve, it illustrates the interaction of the ingredients that determine the performance of parallel-resonant circuits.

Impedance Transformation

An important application of the parallel-resonant circuit is as an impedance matching device in the output circuit of an RF power amplifier. There is an optimum value of load resistance for each type of tube or transistor and each set of required operating conditions. The resistance of the load to which the active device delivers power may be considerably lower than the value required for proper device operation, or the load impedance may be considerably higher than the amplifier output impedance.

To transform the actual load resistance to the desired value, the load may be tapped across part of the coil, as shown in **Fig 4.88**. This is equivalent to connecting

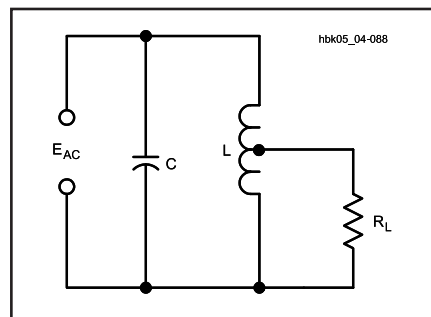

Fig 4.88 — A parallel-resonant circuit with a tapped coil to effect an impedance match. Although the impedance presented by the entire circuit is very high, the impedance “seen” by the load, R_L , is lower.

a higher value of load resistance across the whole circuit, and is similar in principle to impedance transformation with an iron-core transformer (described in the next section of this chapter). In high-frequency resonant circuits, the impedance ratio does not vary exactly as the square of the turns ratio, because all the magnetic flux lines do not cut every turn of the coil. A desired impedance ratio usually must be obtained by experimental adjustment.

When the load resistance has a very low value (say below 100 Ω) it may be connected in series in the resonant circuit (R_S in Fig 4.82A, for example), in which case it is transformed to an equivalent parallel impedance as previously described. If the Q is at least 10, the equivalent parallel impedance is:

$$Z_R = \frac{X^2}{R_L} \quad (125)$$

where:

Z_R = resistive parallel impedance at resonance,

X = reactance (in ohms) of either the coil or the capacitor, and

R_L = load resistance inserted in series.

If the Q is lower than 10, the reactance will have to be adjusted somewhat — for the reasons given in the discussion of low-Q circuits — to obtain a resistive impedance of the desired value.

Networks like the one in Fig 4.88 have some serious disadvantages for some applications. For instance, the common connection between the input and the output provides no dc isolation. Also, the common ground is sometimes troublesome with regard to ground-loop currents. Consequently, a network with only mutual magnetic coupling is often preferable. With the advent of ferrites, constructing impedance transformers that are both broadband and permit operation well up into the VHF portion of the spectrum has become relatively easy. The basic principles of broadband impedance transformers appear in the following section.

Transformers

When the ac source current flows through every turn of an inductor, the generation of a counter-voltage and the storage of energy during each half cycle is said to be by virtue of *self-inductance*. If another inductor — not connected to the source of the original current — is positioned so the expanding and contracting magnetic field of the first inductor cuts across its turns, a current will be induced into the second coil. A load such as a resistor may be connected across the second coil to consume the energy transferred magnetically from the first inductor. This phenomenon is called *mutual inductance*.

Two inductors positioned so that the magnetic field of one (the *primary* inductor) induces a current in the other (the *secondary* inductor) are *coupled*. **Fig 4.89** illustrates a pair of coupled inductors, showing an ac energy source connected to one and a load connected to the other. If the coils are wound tightly on an iron core so that nearly all the lines of force or magnetic flux from the first coil link with the turns of the second coil, the pair is said to be *tightly coupled*. Coils with air cores separated by a distance would be *loosely coupled*. The signal source for the primary inductor may be household ac power lines, audio or other waveforms at lower frequencies, or RF currents. The load may be a device needing power, a speaker converting electrical energy into sonic energy, an antenna using RF energy for communications or a particular circuit set up to process a signal from a preceding circuit. The uses of magnetically coupled energy in electronics are innumerable.

Mutual inductance (M) between coils is measured in henrys. Two coils have a mutual inductance of 1 H under the following conditions: as the primary inductor current changes at a rate of 1 A/s, the voltage across the secondary inductor is 1 V. The level of mutual inductance varies with many factors: the size and shape of the inductors, their relative positions and distance from each other, and the perme-

ability of the inductor core material and of the space between them.

If the self-inductance values of two coils are known, it is possible to derive the mutual inductance by way of a simple experiment schematically represented in **Fig 4.90**. Without altering the physical setting or position of two coils, measure the inductance of the series-connected coils with their windings complementing each other and again with their windings opposing each other. Since, for the two coils, $L_C = L_1 + L_2 + 2M$, in the complementary case, and $L_O = L_1 + L_2 - 2M$ for the opposing case,

$$M = \frac{L_C - L_O}{4} \quad (126)$$

The ratio of magnetic flux set up by the secondary coil to the flux set up by the primary coil is a measure of the extent to which two coils are coupled, compared to the maximum possible coupling between

them. This ratio is the *coefficient of coupling* (k) and is always less than 1. If k were to equal 1, the two coils would have the maximum possible mutual coupling. Thus:

$$M = k\sqrt{L_1 L_2} \quad (127)$$

where:

- M = mutual inductance in henrys,
- L_1 and L_2 = individual coupled inductors, each in henrys, and
- k = the coefficient of coupling.

Using the experiment above, it is possible to solve equation 127 for k with reasonable accuracy.

Any two coils having mutual inductance comprise a *transformer* having a *primary winding* or inductor and a *secondary winding* or inductor. **Fig 4.91** provides a pictorial representation of a typical iron-core transformer, along with the schematic symbols for both iron-core and air-core

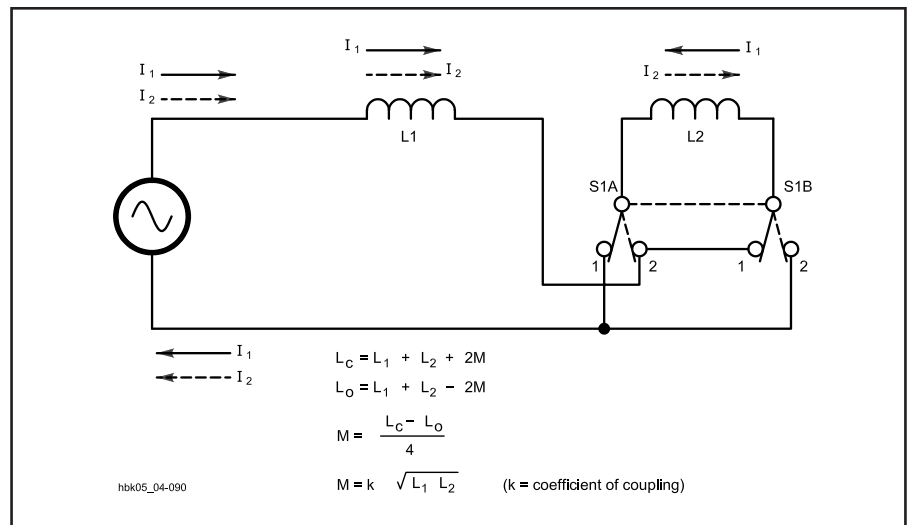

Fig 4.90 — An experimental setup for determining mutual inductance. Measure the inductance with the switch in each position and use the formula in the text to determine the mutual inductance.

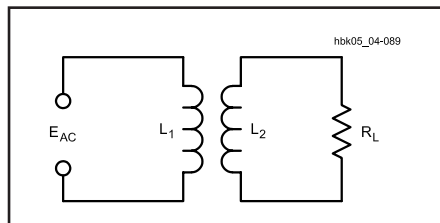

Fig 4.89 — A basic transformer: two inductors — one connected to an ac energy source, the other to a load — with coupled magnetic fields.

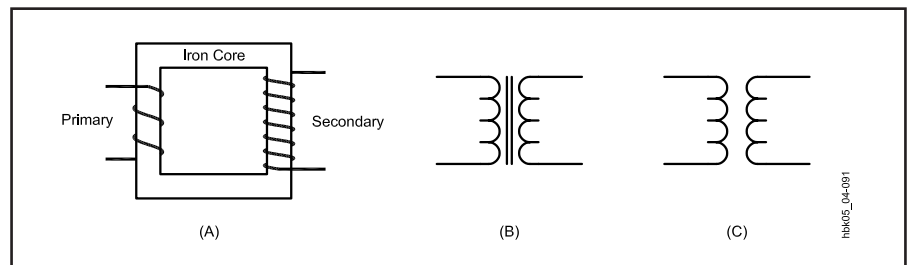

Fig 4.91 — A transformer. A is a pictorial diagram. Power is transferred from the primary coil to the secondary by means of the magnetic field. B is a schematic diagram of an iron-core transformer, and C is an air-core transformer.

transformers. Conventionally, the term *transformer* is most commonly applied to coupled inductors having a magnetic core material, while coupled air-wound inductors are not called by that name. They are still transformers, however.

We normally think of transformers as ac devices, since mutual inductance only occurs when magnetic fields are expanding or contracting. A transformer connected to a dc source will exhibit mutual inductance only at the instants of closing and opening the primary circuit, or on the rising and falling edges of dc pulses, because only then does the primary winding have a changing field. The principle uses of transformers are three: to physically isolate the primary circuit from the secondary circuit, to transform voltages and currents from one level to another, and to transform circuit impedances from one level to another. These functions are not mutually exclusive and have many variations.

IRON-CORE TRANSFORMERS

The primary and secondary coils of a transformer may be wound on a core of magnetic material. The permeability of the magnetic material increases the inductance of the coils so a relatively small number of turns may be used to induce a given voltage value with a small current. A closed core having a continuous magnetic path, such as that shown in Fig 4.91, also tends to ensure that practically all of the field set up by the current in the primary coil will cut the turns of the secondary coil. For power transformers and impedance-matching transformers used in audio work, cores of iron strips are most common and generally very efficient.

The following principles presume a coefficient of coupling (k) of 1, that is, a perfect transformer. The value $k = 1$ indicates that all the turns of both coils link with all the magnetic flux lines, so that the voltage induced per turn is the same with both coils. This condition makes the induced voltage independent of the inductance of the primary and secondary inductors. Iron-core transformers for low frequencies most closely approach this ideal condition. Fig 4.92 illustrates the conditions for transformer action.

Voltage Ratio

For a given varying magnetic field, the voltage induced in a coil within the field is proportional to the number of turns in the coil. When the two coils of a transformer are in the same field (which is the case when both are wound on the same closed core), it follows that the induced voltages will be proportional to the num-

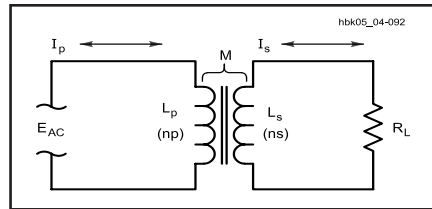

Fig 4.92 — The conditions for transformer action: two coils that exhibit mutual inductance, an ac power source, and a load. The magnetic field set up by the energy in the primary circuit transfers energy to the secondary for use by the load, resulting in a secondary voltage and current.

ber of turns in each coil. In the primary, the induced voltage practically equals, and opposes, the applied voltage, as described earlier. Hence:

$$E_S = E_P \left(\frac{N_S}{N_P} \right) \quad (128)$$

where:

- E_S = secondary voltage,
- E_P = primary applied voltage,
- N_S = number of turns on secondary, and
- N_P = number of turns on primary.

Example: A transformer has a primary of 400 turns and a secondary of 2800 turns, and a voltage of 120 V is applied to the primary. What voltage appears across the secondary winding?

$$E_S = 120 \text{ V} \left(\frac{2800}{400} \right) = 120 \text{ V} \times 7 = 840 \text{ V}$$

(Notice that the number of turns is taken as a known value rather than a measured quantity, so they do not limit the significant figures in the calculation.) Also, if 840 V is applied to the 2800-turn winding (which then becomes the primary), the output voltage from the 400-turn winding will be 120 V.

Either winding of a transformer can be used as the primary, provided the winding has enough turns (enough inductance) to induce a voltage equal to the applied voltage without requiring an excessive current. The windings must also have insulation with a voltage rating sufficient for the voltage present.

Current or Ampere-Turns Ratio

The current in the primary when no current is taken from the secondary is called the *magnetizing current* of the transformer. An ideal transformer, with no internal losses, would consume no power, since the current through the primary in-

ductor would be 90° out of phase with the voltage. In any properly designed transformer, the power consumed by the transformer when the secondary is open (not delivering power) is only the amount necessary to overcome the losses in the iron core and in the resistance of the wire with which the primary is wound.

When power is taken from the secondary winding by a load, the secondary current sets up a magnetic field that opposes the field set up by the primary current. For the induced voltage in the primary to equal the applied voltage, the original field must be maintained. The primary must draw enough additional current to set up a field exactly equal and opposite to the field set up by the secondary current.

In practical transformer calculations it may be assumed that the entire primary current is caused by the secondary load. This is justifiable because the magnetizing current should be very small in comparison with the primary load current at rated power output.

If the magnetic fields set up by the primary and secondary currents are to be equal, the primary current multiplied by the primary turns must equal the secondary current multiplied by the secondary turns.

$$I_P = I_S \left(\frac{N_S}{N_P} \right) \quad (129)$$

where:

- I_P = primary current,
- I_S = secondary current,
- N_P = number of turns on primary, and
- N_S = number of turns on secondary.

Example: Suppose the secondary of the transformer in the previous example is delivering a current of 0.20 A to a load. What will be the primary current?

$$I_P = 0.20 \text{ A} \times \left(\frac{2800}{400} \right) = 0.20 \text{ A} \times 7 = 1.4 \text{ A}$$

Although the secondary voltage is higher than the primary voltage, the secondary current is lower than the primary current, and by the same ratio. The secondary current in an ideal transformer is 180° out of phase with the primary current, since the field in the secondary just offsets the field in the primary. The phase relationship between the currents in the windings holds true no matter what the phase difference between the current and the voltage of the secondary. In fact, the phase difference, if any, between voltage and current in the secondary winding will be reflected back to the primary as an identical phase difference.

Power Ratio

A transformer cannot create power; it can only transfer it and change the voltage level. Hence, the power taken from the secondary cannot exceed that taken by the primary from the applied voltage source. There is always some power loss in the resistance of the coils and in the iron core, so in all practical cases the power taken from the source will exceed that taken from the secondary.

$$P_O = n P_I \quad (130)$$

where:

P_O = power output from secondary,
 P_I = power input to primary, and
 n = efficiency factor.

The efficiency, n , is always less than 1. It is usually expressed as a percentage: if n is 0.65, for instance, the efficiency is 65%.

Example: A transformer has an efficiency of 85.0% at its full-load output of 150 W. What is the power input to the primary at full secondary load?

$$P_I = \frac{P_O}{n} = \frac{150 \text{ W}}{0.850} = 176 \text{ W}$$

A transformer is usually designed to have the highest efficiency at the power output for which it is rated. The efficiency decreases with either lower or higher outputs. On the other hand, the losses in the transformer are relatively small at low output but increase as more power is taken. The amount of power that the transformer can handle is determined by its own losses, because these losses heat the wire and core. There is a limit to the temperature rise that can be tolerated, because too high a temperature can either melt the wire or cause the insulation to break down. A transformer can be operated at reduced output, even though the efficiency is low, because the actual loss will be low under such conditions. The full-load efficiency of small power transformers such as are used in radio receivers and transmitters usually lies between about 60 and 90%, depending on the size and design.

IMPEDANCE RATIO

In an ideal transformer — one without losses or leakage reactance — the following relationship is true:

$$Z_P = Z_S \left(\frac{N_P}{N_S} \right)^2 \quad (131)$$

where:

Z_P = impedance looking into the primary terminals from the power source,

Z_S = impedance of load connected to secondary, and
 N_P, N_S = turns ratio, primary to secondary.

A load of any given impedance connected to the transformer secondary will be transformed to a different value looking into the primary from the power source. The impedance transformation is proportional to the square of the primary-to-secondary turns ratio.

Example: A transformer has a primary-to-secondary turns ratio of 0.6 (the primary has six-tenths as many turns as the secondary) and a load of 3000 Ω is connected to the secondary. What is the impedance at the primary of the transformer?

$$Z_P = 3000 \Omega \times (0.6)^2 = 3000 \Omega \times 0.36$$

$$Z_P = 1080 \Omega$$

By choosing the proper turns ratio, the impedance of a fixed load can be transformed to any desired value, within practical limits. If transformer losses can be neglected, the transformed (reflected) impedance has the same phase angle as the actual load impedance. Thus, if the load is a pure resistance, the load presented by the primary to the power source will also be a pure resistance. If the load impedance is complex, that is, if the load current and voltage are out of phase with each other, then the primary voltage and current will show the same phase angle.

Many devices or circuits require a specific value of load resistance (or impedance) for optimum operation. The impedance of the actual load that is to dissipate the power may differ widely from the impedance of the source device or circuit, so a transformer is used to change the actual load into an impedance of the desired value. This is called impedance matching.

$$\frac{N_P}{N_S} = \sqrt{\frac{Z_P}{Z_S}} \quad (132)$$

where:

N_P / N_S = required turns ratio, primary to secondary,
 Z_P = primary impedance required, and
 Z_S = impedance of load connected to secondary.

Example: A transistor audio amplifier requires a load of 150 Ω for optimum performance, and is to be connected to a loudspeaker having an impedance of 4.0 Ω . What is the turns ratio, primary to secondary, required in the coupling transformer?

$$\frac{N_P}{N_S} = \sqrt{\frac{Z_P}{Z_S}} = \frac{N_P}{N_S} \sqrt{\frac{150 \Omega}{4.0 \Omega}} = \sqrt{38} = 6.2$$

The primary therefore must have 6.2 times as many turns as the secondary.

These relationships may be used in practical work even though they are based on an ideal transformer. Aside from the normal design requirements of reasonably low internal losses and low leakage reactance, the only other requirement is that the primary have enough inductance to operate with low magnetizing current at the voltage applied to the primary.

The primary terminal impedance of an iron-core transformer is determined wholly by the load connected to the secondary and by the turns ratio. If the characteristics of the transformer have an appreciable effect on the impedance presented to the power source, the transformer is either poorly designed or is not suited to the voltage and frequency at which it is being used. Most transformers will operate quite well at voltages from slightly above to well below the design figure.

Transformer Losses

In practice, none of the formulas given so far provides truly exact results, although they afford reasonable approximations. Transformers in reality are not simply two coupled inductors, but a network of resistances and reactances, most of which appear in **Fig 4.93**. Since only the terminals numbered 1 through 4 are accessible to the user, transformer ratings and specifications take into account the additional losses created by these complexities.

In a practical transformer not all of the magnetic flux is common to both windings, although in well designed transformers the amount of flux that cuts one coil and not the other is only a small percentage of the total flux. This *leakage flux* causes a voltage of self-induction. Consequently, there are small amounts of leakage inductance associated with both windings of the transformer. Leakage inductance acts in exactly the same way as an equivalent amount of ordinary inductance inserted in series with the circuit. It has, therefore, a certain reactance, depending on the amount of leakage inductance and the frequency. This reactance is called *leakage reactance*, shown as X_{L1} and X_{L2} in **Fig 4.93**.

Current flowing through the leakage reactance causes a voltage drop. This voltage drop increases with increasing current; hence, it increases as more power is taken from the secondary. Thus, the greater the secondary current, the smaller the secondary terminal voltage becomes.

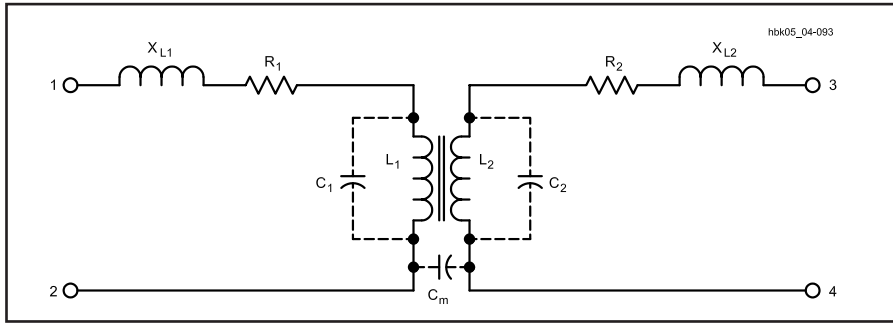

Fig 4.93 — A transformer as a network of resistances, inductances and capacitances. Only L1 and L2 contribute to the transfer of energy.

The resistances of the transformer windings, R_1 and R_2 , also cause voltage drops when there is current. Although these voltage drops are not in phase with those caused by leakage reactance, together they result in a lower secondary voltage under load than is indicated by the transformer turns ratio.

Thus, the voltage regulation in a real transformer is not perfect. At ac line frequencies (50 or 60 Hz), the voltage at the secondary, with a reasonably well-designed transformer, should not drop more than about 10% from open-circuit conditions to full load. The voltage drop may be considerably more than this in a transformer operating at voice and music frequencies, because the leakage reactance increases directly with the frequency.

In addition to wire resistances and leakage reactances, certain stray capacitances occur in transformers. An electric field exists between any two points having a different voltage. When current flows through a coil, each turn has a slightly different voltage than its adjacent turns, creating a capacitance between turns. This *distributed capacitance* appears in Fig 4.93 as C_1 and C_2 . Another capacitance, C_M , appears between the two windings for the same reason. Moreover, transformer windings can exhibit capacitance relative to nearby metal, for example, the chassis, the shield and even the core.

Although these stray capacitances are of little concern with power and audio transformers, they become important as the frequency increases. In transformers for RF use, the stray capacitance can resonate with either the leakage reactance or, at lower frequencies, with the winding reactances, L_1 or L_2 , especially under very light or zero loads. In the frequency region around resonance, transformers no longer exhibit the properties formulated above or the impedance properties to be described below.

Iron-core transformers also experience losses within the core itself. *Hysteresis*

losses include the energy required to overcome the retentivity of the core's magnetic material. Circulating currents through the core's resistance are *eddy currents*, which form part of the total core losses. These losses, which add to the required magnetizing current, are equivalent to adding a resistance in parallel with L_1 in Fig 4.93.

Core Construction

Audio and power transformers usually employ one or another grade of silicon steel as the core material. With permeabilities of 5000 or greater, these cores saturate at flux densities approaching 10^5 lines per square inch of cross section. The cores consist of thin insulated laminations to break up potential eddy current paths.

Each core layer consists of an E and an I piece butted together, as represented in Fig 4.94. The butt point leaves a small gap. Since the pieces in adjacent layers have a continuous magnetic path, however, the flux density per unit of applied magnetic force is increased and flux leakage reduced.

Two core shapes are in common use, as shown in Fig 4.95. In the shell type, both windings are placed on the inner leg, while in the core type the primary and secondary windings may be placed on separate legs, if desired. This is sometimes done when it is necessary to minimize capacitive effects between the primary and secondary, or when one of the windings must operate at very high voltage.

The number of turns required in the primary for a given applied voltage is determined by the size, shape and type of core material used, as well as the frequency. The number of turns required is inversely proportional to the cross-sectional area of the core. As a rough indication, windings of small power transformers frequently have about six to eight turns per volt on a core of 1-square-inch cross section and have a magnetic path 10 or 12 inches in length. A longer path or smaller cross sec-

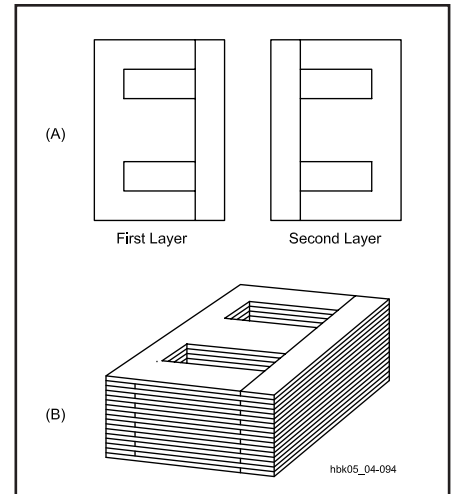

Fig 4.94 — A typical transformer iron core. The E and I pieces alternate direction in successive layers to improve the magnetic path while attenuating eddy currents in the core.

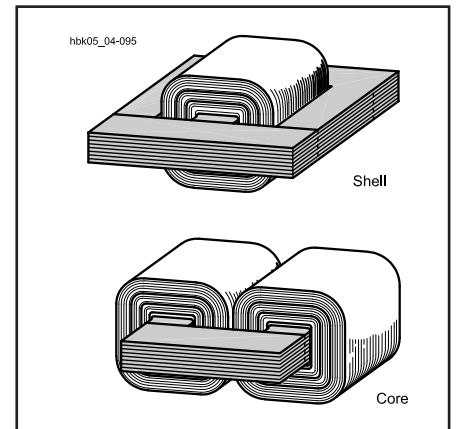

Fig 4.95 — Two common transformer constructions: shell and core.

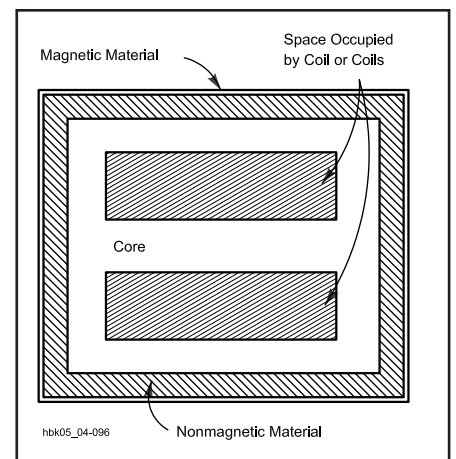

Fig 4.96 — A shielded transformer: the core plus an outer shield of magnetic material contain nearly all of the magnetic field.

tion requires more turns per volt, and vice versa.

In most transformers the coils are wound in layers, with a thin sheet of treated-paper insulation between each layer. Thicker insulation is used between adjacent coils and between the first coil and the core.

Shielding

Because magnetic lines of force are continuous and closed upon themselves, shielding requires a path for the lines of force of the leakage flux. The high-permeability of iron cores tends to concentrate the field, but additional shielding is often needed. As depicted in Fig 4.96, enclosing the transformer in a good magnetic material can restrict virtually all of the magnetic field in the outer case. The

nonmagnetic material between the case and the core creates a region of high reluctance, attenuating the field before it reaches the case.

AUTOTRANSFORMERS

The transformer principle can be used with only one winding instead of two, as shown in Fig 4.97A. The principles that relate voltage, current and impedance to the turns ratio also apply equally well. A one-winding transformer is called an *autotransformer*. The current in the common section (A) of the winding is the difference between the line (primary) and the load (secondary) currents, since these currents are out of phase. Hence, if the line and load currents are nearly equal, the common section of the winding may be wound with comparatively small wire. The line and load currents will be equal only when the primary (line) and secondary (load) voltages are not very different.

Autotransformers are used chiefly for boosting or reducing the power-line voltage by relatively small amounts. Fig 4.97B illustrates the principle schematically with a switched, stepped autotransformer. Continuously variable autotransformers are commercially available under a variety of trade names; Variac and Powerstat are typical examples.

Technically, tapped air-core inductors, such as the one in the network in Fig 4.88 at the close of the discussion of resonant circuits, are also autotransformers. The voltage from the tap to the bottom of the coil is less than the voltage across the entire coil. Likewise, the impedance of the tapped part of the winding is less than the impedance of the entire winding. Because leakage reactances are great and the co-efficient of coupling is quite low, the relationships true of a perfect transformer grow quite unreliable in predicting the exact values. For this reason, tapped inductors are rarely referred to as transformers. The stepped-down situation in Fig 4.88 is better approximated — at or close to resonance — by the formula

$$R_P = \frac{R_L X_{COM}^2}{X_L} \quad (133)$$

where:

R_P = tuned-circuit parallel-resonant impedance,

R_L = load resistance tapped across part of the coil,

X_{COM} = reactance of the portion of the coil common to both the resonant circuit and the load tap, and

X_L = reactance of the entire coil.

The result is approximate and applies only

to circuits with a Q of 10 or greater.

AIR-CORE RF TRANSFORMERS

Air-core transformers often function as mutually coupled inductors for RF applications. They consist of a primary winding and a secondary winding in close proximity. Leakage reactances are ordinarily high, however, and the coefficient of coupling between the primary and secondary windings is low. Consequently, unlike transformers having a magnetic core, the turns ratio does not have as much significance. Instead, the voltage induced in the secondary depends on the mutual inductance.

Nonresonant RF Transformers

In a very basic transformer circuit operating at radio frequencies, such as in Fig 4.98A, the source voltage is applied to L1. R_S is the series resistance inherent in the source. By virtue of the mutual inductance, M, a voltage is induced in L2. A current flows in the secondary circuit through the reactance of L2 and the load resistance of R_L . Let X_{L2} be the reactance of L2 independent of L1, that is, independent of the effects of mutual inductance. The impedance of the secondary circuit is then:

$$Z_S = \sqrt{R_L^2 + R_{L2}^2} \quad (134)$$

where:

Z_S = the impedance of the secondary circuit in ohms,

R_L = the load resistance in ohms, and

X_{L2} = the reactance of the secondary inductance in ohms.

The effect of Z_S upon the primary circuit is the same as a coupled impedance in series with L1. Fig 4.98B displays the coupled impedance (Z_P) in a dashed enclosure to indicate that it is not a new physical component. It has the same absolute value of phase angle as in the secondary impedance, but the sign of the reactance is reversed; it appears as a capacitive reactance. The value of Z_P is:

$$Z_P = \frac{(2\pi f M)^2}{Z_S} \quad (135)$$

where:

Z_P = the impedance introduced into the primary,

Z_S = the impedance of the secondary circuit in ohms, and

$2\pi f M$ = the mutual reactance between the reactances of the primary and secondary coils (also designated as X_M).

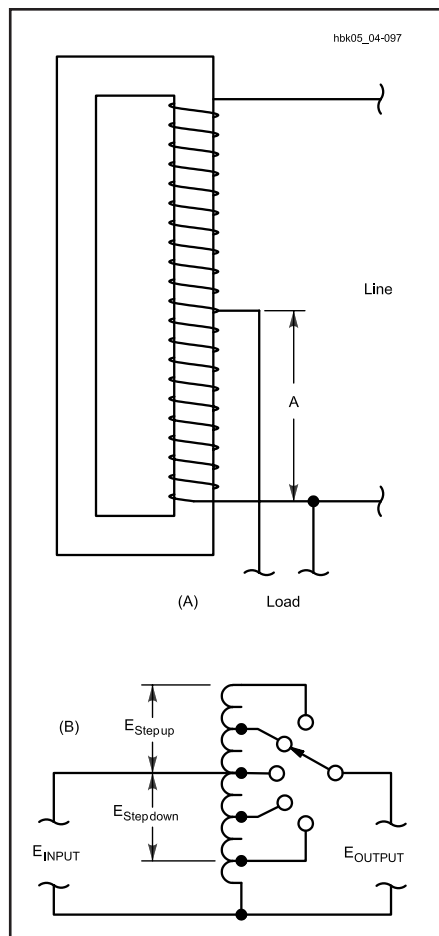

Fig 4.97 — The autotransformer is based on the transformer, but uses only one winding. The pictorial diagram at A shows the typical construction of an autotransformer. The schematic diagram at B demonstrates the use of an autotransformer to step up or step down ac voltage, usually to compensate for excessive or deficient line voltage.

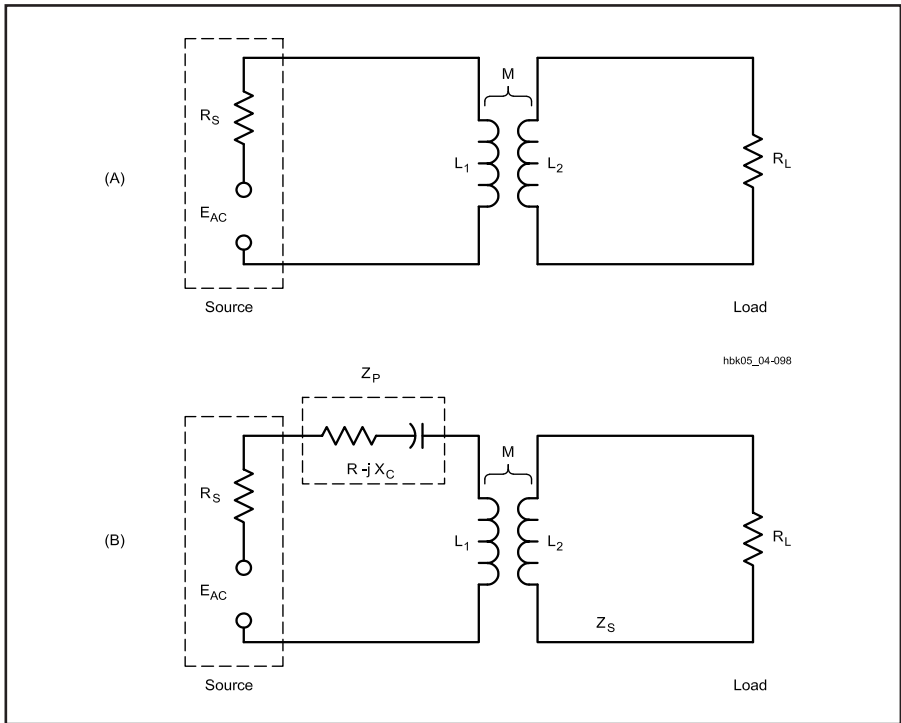

Fig 4.98 — The coupling of a complex impedance back into the primary circuit of a transformer composed of nonresonant air-core inductors.

Resonant RF Transformers

The use of at least one resonant circuit in place of a pair of simple reactances eliminates the reactance from the transformed impedance in the primary. For loaded or operating Qs of at least 10, the resistances of individual components is negligible. **Fig 4.99** represents just one of many configurations in which at least one of the inductors is in a resonant circuit. The reactance coupled into the primary circuit is cancelled if the circuit is tuned to resonance while the load is connected. If the reactance of the load capacitance, C_L is at least 10 times any stray capacitance in the circuit, as is the case for low imped-

ance loads, the value of resistance coupled to the primary is

$$R1 = \frac{X_M^2 R_L}{X_2^2 + R_L^2} \tag{136}$$

where:

- R1 = series resistance coupled into the primary circuit,
- X_M = mutual reactance,
- R_L = load resistance, and
- X_2 = reactance of the secondary inductance.

The parallel impedance of the resonant circuit is just R1 transformed from a

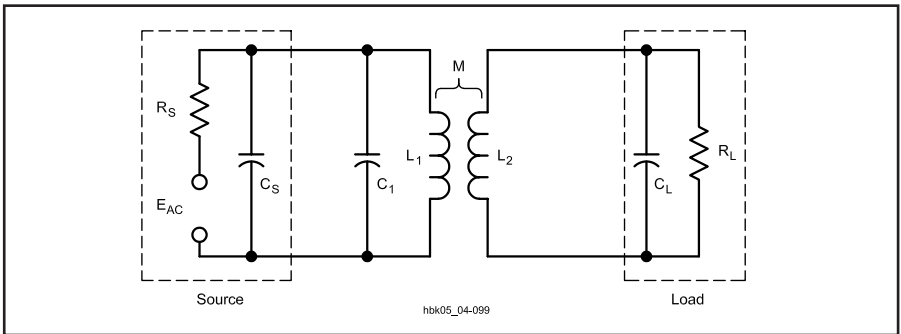

Fig 4.99 — An air-core transformer circuit consisting of a resonant primary circuit and an untuned secondary. R_S and C_S are functions of the source, while R_L and C_L are functions of the load circuit.

series to a parallel value by the usual formula, $R_p = X^2 / R1$.

The higher the loaded or operating Q of the circuit, the smaller the mutual inductance required for the same power transfer. If both the primary and secondary circuits consist of resonant circuits, they can be more loosely coupled than with a single tuned circuit for the same power transfer. At the usual loaded Q of 10 or greater, these circuits are quite selective, and consequently narrowband.

Although coupling networks have to a large measure replaced RF transformer coupling that uses air-core transformers, these circuits are still useful in antenna tuning units and other circuits. For RF work, powdered-iron toroidal cores have generally replaced air-core inductors for almost all applications except where the circuit handles very high power or the coil must be very temperature stable. Slug-tuned solenoid coils for low-power circuits offer the ability to tune the circuit precisely to resonance. For either type of core, reasonably accurate calculation of impedance transformation is possible. It is often easier to experiment to find the correct values for maximum power transfer, however. For further information on coupled circuits, see the section on Tuned (Resonant) Networks in the **Receivers and Transmitters**, chapter.

BROADBAND FERRITE RF TRANSFORMERS

The design concepts and general theory of ideal transformers presented earlier in this chapter apply also to transformers wound on ferromagnetic-core materials (ferrite and powdered iron). As is the case with stacked cores made of laminations in the classic I and E shapes, the core material has a specific permeability factor that determines the inductance of the windings versus the number of wire turns used.

Toroidal cores are useful from a few hundred hertz well into the UHF spectrum. The principal advantage of this type of core is the self-shielding characteristic. Another feature is the compactness of a transformer or inductor. Therefore, toroidal-core transformers are excellent for use not only in dc-to-dc converters, where tape-wound steel cores are employed, but at frequencies up to at least 1000 MHz with the selection of the proper core material for the range of operating frequencies. Toroidal cores are available from micro-miniature sizes up to several inches in diameter. The latter can be used, as one example, to build a 20-kW balun for use in antenna systems.

One of the most common ferromagnetic transformers used in Amateur Radio work

is the *conventional broadband transformer*. Broadband transformers with losses of less than 1 dB are employed in circuits that must have a uniform response over a substantial frequency range, such as a 2- to 30-MHz broadband amplifier. In applications of this sort, the reactance of the windings should be at least four times the impedance that the winding is designed to look into at the lowest design frequency.

Example: What should be the winding reactances of a transformer that has a 300-Ω primary and a 50-Ω secondary load? Relative to the 50-Ω secondary load:

$$X_S = 4 Z_S = 4 \times 50 \Omega = 200 \Omega$$

The primary winding reactance (XP) is:

$$X_P = 4 Z_P = 4 \times 300 \Omega = 1200 \Omega$$

The core-material permeability plays a vital role in designing a good broadband transformer. The effective permeability of the core must be high enough to provide ample winding reactance at the low end of the operating range. As the operating frequency is increased, the effects of the core tend to disappear until there are scarcely any core effects at the upper limit of the operating range. The limiting factors for high frequency response are distributed capacity and leakage inductance due to uncoupled flux. A high-permeability core minimizes the number of turns needed for a given reactance and therefore also minimizes the distributed capacitance at high frequencies.

Ferrite cores with a permeability of 850 are common choices for transformers used between 2 and 30 MHz. Lower frequency ranges, for example, 1 kHz to 1 MHz, may require cores with permeabilities up to 2000. Permeabilities from 40 to 125 are useful for VHF transformers. Conventional broadband transformers require resistive loads. Loads with reactive components should use appropriate networks to cancel the reactance.

Conventional transformers are wound in the same manner as a power transformer. Each winding is made from a separate length of wire, with one winding placed over the previous one with suitable insulation between. Unlike some transmission-line transformer designs, conventional broadband transformers provide dc isolation between the primary and secondary circuits. The high voltages encountered in high-impedance-ratio step-up transformers may require that the core be wrapped with glass electrical tape before adding the windings (as an additional protection from arcing and voltage break-

down), especially with ferrite cores that tend to have rougher edges. In addition, high voltage applications should also use wire with high-voltage insulation and a high temperature rating.

Fig 4.100 illustrates one method of transformer construction using a single toroid as the core. The primary of a step-down impedance transformer is wound to occupy the entire core, with the secondary wound over the primary. The first step in planning the winding is to select a core of the desired permeability. Convert the required reactances determined earlier into inductance values for the lowest frequency of use. To find the number of turns for each winding, use the A_L value for the selected core and equation 73 from the section on ferrite toroidal inductors earlier in this chapter. Be certain the core can handle the power by calculating the maximum flux using equation 71, given earlier in the chapter, and comparing the result with the manufacturer's guidelines.

Example: Design a small broadband transformer having an impedance ratio of 16:1 for a frequency range of 2.0 to 20.0 MHz to match the output of a small-signal stage (impedance $\approx 500 \Omega$) to the input (impedance $\approx 32 \Omega$) of an amplifier.

1. Since the impedance of the smaller winding should be at least 4 times the lower impedance to be matched at the lowest frequency, $X_S = 4 \times 32 \Omega = 128 \Omega$.

2. The inductance of the secondary winding should be

$$L_S = X_S / 2 \pi f = 128 / (6.2832 \times 2.0 \times 10^6 \text{ Hz}) = 0.0101 \text{ mH}$$

3. Select a suitable core. For this low-power application, a $\frac{3}{8}$ -inch ferrite core with permeability of 850 is suitable. The core has an value of 420. Calculate the number of turns for the secondary.

$$N_S = 1000 \sqrt{\frac{L}{A_L}} = 1000 \sqrt{\frac{0.010}{420}}$$

4. A 5-turn secondary winding should suffice. The primary winding derives from the impedance ratio:

$$NP = N_S \sqrt{\frac{Z_P}{Z_S}} = 5 \sqrt{\frac{16}{1}} = 5 \times 4 = 20 \text{ turns}$$

This low power application will not approach the maximum flux density limits for the core, and #28 enamel wire should both fit the core and handle the currents involved.

A second style of broadband transformer construction appears in **Fig 4.101**.

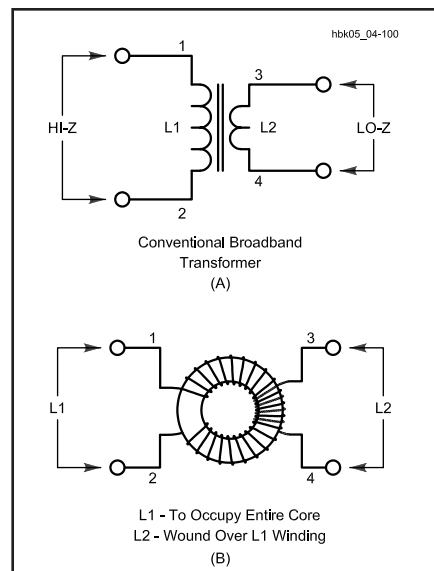

Fig 4.100 — Schematic and pictorial representation of a conventional broadband transformer wound on a ferrite toroidal core. The secondary winding (L2) is wound over the primary winding (L1).

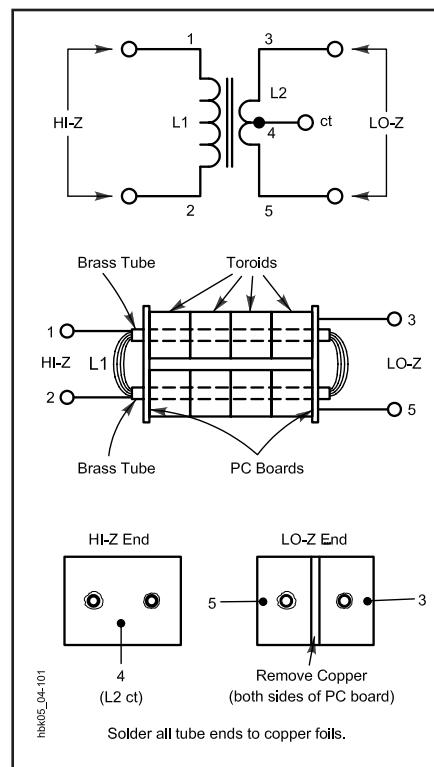

Fig 4.101 — Schematic and pictorial representation of a “binocular” style of conventional broadband transformer. This style is used frequently at the input and output ports of transistor RF amplifiers. It consists of two rows of high-permeability toroidal cores, with the winding passed through the center holes of the resulting stacks.

The key elements in this transformer are the stacks of ferrite cores aligned with tubes soldered to pc-board end plates. This style of transformer is suited to high power applications, for example, at the input and output ports of transistor RF power amplifiers. Low-power versions of this transformer can be wound on “binocular” cores having pairs of parallel holes through them.

For further information on conventional transformer matching using ferromagnetic materials, see the Matching Networks section in the **RF Power Amplifiers** chapter. Refer to the **Component Data and References** chapter for more detailed information on available ferrite cores. A standard reference on conventional broadband transformers using ferro-magnetic materials is *Ferromagnetic Core Design and Applications Handbook* by Doug DeMaw, W1FB, published by Prentice Hall.

TRANSMISSION-LINE TRANSFORMERS

Conventional transformers use flux linkages to deliver energy to the output circuit. *Transmission line transformers* use transmission line modes of energy transfer between the input and the output terminals of the devices. Although toroidal versions of these transformers physically resemble toroidal conventional broadband transformers, the principles of operation differ significantly. Stray inductances and intertwining capacitances form part of the characteristic impedance of the transmission line, largely eliminating resonances that limit high frequency response. The limiting factors for transmission line transformers include line length, deviations in the constructed line from the design value of characteristic impedance, and parasitic capacitances and inductances that are independent of the characteristic impedance of the line.

The losses in conventional transformers depend on current and include wire, eddy-current and hysteresis losses. In contrast, transmission line transformers exhibit voltage-dependent losses, which make higher impedances and higher VSWR values limiting factors in design. Within design limits, the cancellation of flux in the cores of transmission line transformers permits very high efficiencies across their passbands. Losses may be lower than 0.1 dB with the proper core choice.

Transmission-line transformers can be configured for several modes of operation, but the chief amateur use is in *baluns* (*balanced-to-unbalanced transformers*) and *unununs* (*unbalanced-to-unbalanced transformers*). The basic principle behind a balun appears in **Fig 4.102**, a representation of the classic Guanella 1:1 balun. The input and output impedances are the same, but the output is balanced about a real or virtual center point (terminal 5). If the characteristic impedance of the transmission line forming the inductors with numbered terminals equals the load impedance, then E_2 will equal E_1 . With respect to terminal 5, the voltage at terminal 4 is $E_1 / 2$, while the voltage at terminal 2 is $-E_1 / 2$, resulting in a balanced output.

The small losses in properly designed baluns of this order stem from the potential gradient that exists along the length of transmission line forming the transformer. The value of this potential is $-E_1 / 2$, and it forms a dielectric loss that can't be eliminated. Although the loss is very small in well-constructed 1:1 baluns at low impedances, the losses climb as impedances climb (as in 4:1 baluns) and as the VSWR climbs. Both conditions yield higher voltage gradients.

The inductors in the transmission-line transformer are equivalent to — and may be — coiled transmission line with a char-

acteristic impedance equal to the load. They form a choke isolating the input from the output and attenuating undesirable currents, such as antenna current, from the remainder of the transmission line to the energy source. The result is a *current* or *choke* balun. Such baluns may take many forms: coiled transmission line, ferrite beads placed over a length of transmission line, windings on linear ferrite cores or windings on ferrite toroids.

Reconfiguring the windings of Fig 4.102 can alter the transformer operation. For example, if terminal 2 is connected to terminal 3, a positive potential gradient appears across the lengths of line, resulting in a terminal 4 potential of $2 E_1$ with respect to ground. If the load is disconnected from terminal 2 and reconnected to ground, $2 E_1$ appears across the load — instead of $\pm E_1 / 2$. The product of this experiment is a 4:1 impedance ratio, forming an unun. The bootstrapping effect of the new connection is applicable to many other design configurations involving multiple windings to achieve custom impedance ratios from 1:1 up to 9:1.

Balun and unun construction for the impedances of most concern to amateurs requires careful selection of the feed line used to wind the balun. Building transmission line transformers on ferrite toroids may require careful attention to wire size and spacing to approximate a 50- Ω line. Wrapping wire with polyimide tape (one or two coatings, depending upon the wire size) and then glass taping the wires together periodically produces a reasonable 50- Ω transmission line. Ferrite cores in the permeability range of 125 to 250 are generally optimal for transformer windings, with 1.25-inch cores suitable to 300- Ω power levels and 2.4-inch cores usable to the 5 kW level. Special designs may alter the power-handling capabilities of the core sizes. For the 1:1 balun shown in Fig 4.102, 10 bifilar turns (#16 wire for the smaller core and #12 wire for the larger, both Thermaleze wire) yields a transformer operable from 160 to 10 m.

Transmission-line transformers have their most obvious application to antennas, since they isolate the antenna currents from the feed line, especially where a coaxial feed line is not exactly perpendicular to the antenna. The balun prevents antenna currents from flowing on the outer surface of the coax shielding, back to the transmitting equipment. Such currents would distort the antenna radiation pattern. Appropriately designed baluns can also transform impedance values at the same time. For example, one might use a 4:1 balun to match a 12.5- Ω Yagi antenna impedance to a 50- Ω feed line. A 4:1 balun

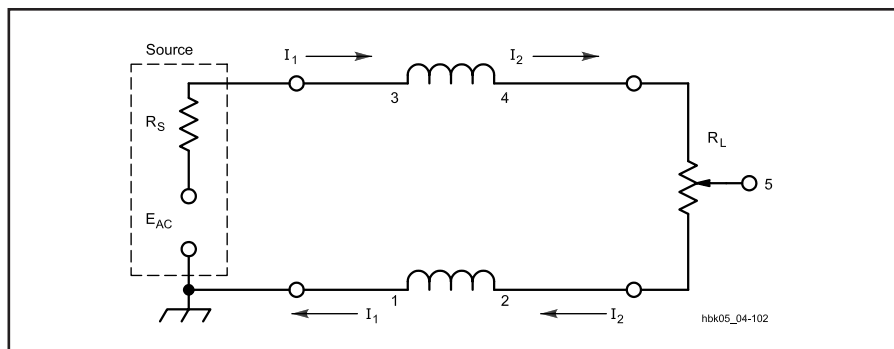

Fig 4.102 — Schematic representation of the basic Guanella “choke” balun or 1:1 transmission line transformer. The inductors are a length of two-wire transmission line. R_S is the source impedance and R_L is the load impedance.

might also be used to match a $75\text{-}\Omega$ TV antenna to $300\text{-}\Omega$ feed line.

Interstage coupling within solid-state transmitters represents another potential for transmission-line transformers. Broadband coupling between low-impedance, but mismatched stages can benefit from

the low losses of transmission-line transformers. Depending upon the losses that can be tolerated and the bandwidth needed, it is often a matter of designer choice between a transmission-line transformer and a conventional broadband transformer as the coupling device.

For further information on transmission-line transformers and their applications, see the **RF Power Amplifiers** chapter. Another reference on the subject is *Transmission Line Transformers*, by Jerry Sevick, W2FMI, published by Noble Publishing.