

Chapter 8

Circuit Construction

Home construction of electronics projects can be a fun part of Amateur Radio. Some folks have said that hams don't build things nowadays; this just isn't so! An ARRL survey shows that 53% of active hams build some electronic projects. When you go to any ham flea market, you see row after row of dealers selling electronic components; people are leaving those tables with bags of parts. They must be doing something with them.

Even experienced constructors will find valuable tips in this chapter. It discusses tools and their uses, electronic construction techniques, tells how to turn a schematic into a working circuit and then summarizes common mechanical construction practices. This chapter was written by Ed Hare, W1RFI, and includes material contributions from Bruce Hale, KB1MW, Ian White, G3SEK, and Chuck Adams, K7QO.

SHOP SAFETY

All the fun of building a project will be gone if you get hurt. To make sure this doesn't happen, let's first review some safety rules.

- Read the manual! The manual tells all you need to know about the operation and safety features of the equipment you are using.
- Do not work when you are tired. You will be more likely to make a mistake or forget an important safety rule.
- Never disable any safety feature of any tool. If you do, sooner or later someone will make the mistake the safety feature was designed to prevent.
- Never fool around in the shop. Practical jokes and horseplay are in bad taste at social events; in a shop they are downright dangerous. A work area is a dangerous place at all times; even hand tools can hurt someone if they are misused.
- Keep your shop neat and organized. A

messy shop is a dangerous shop. A knife left laying in a drawer can cut someone looking for another tool; a hammer left on top of a shelf can fall down at the worst possible moment; a sharp tool left on a chair can be a dangerous surprise for the weary constructor who sits down.

- Wear the proper safety equipment. Wear eye-protection goggles when working with chemicals or tools. Use earplugs or earphones when working near noise. If you are working with dangerous chemicals, wear the proper protective clothing.
- Make sure your shop is well ventilated. Paint, solvents, cleaners or other chemicals can create dangerous fumes. If you feel dizzy, get into fresh air immediately, and seek medical help if you do not recover quickly.
- Get medical help when necessary. Every workshop should contain a good first-aid kit. Keep an eye-wash kit near any dangerous chemicals or power tools that can create chips. If you become injured, apply first aid and then seek medical help if you are not sure that you are okay. Even a small burn or scratch on your eye can develop into a serious problem.
- Respect power tools. Power tools are not forgiving. A drill can go through your hand a lot easier than metal. A power saw can remove a finger with ease. Keep away from the business end of power tools. Tuck in your shirt, roll up your sleeves and remove your tie before using any power tool. If you have long hair, tie it back so it can't become entangled in power equipment.
- Don't work alone. Have someone nearby who can help if you get into trouble when working with dangerous equipment, chemicals or voltages.
- Think! Pay attention to what you are doing. No list of safety rules can cover

all possibilities. Safety is always your responsibility. You must think about what you are doing, how it relates to the tools and the specific situation at hand.

TOOLS AND THEIR USES

All electronic construction makes use of tools, from mechanical tools for chassis fabrication to the soldering tools used for circuit assembly. A good understanding of tools and their uses will enable you to perform most construction tasks.

While sophisticated and expensive tools often work better or more quickly than simple hand tools, with proper use, simple hand tools can turn out a fine piece of equipment. **Table 8.1** lists tools indispensable for construction of electronic equipment. These tools can be used to perform nearly any construction task. Add tools to your collection from time to time, as finances permit.

Sources of Tools

Radio-supply houses, mail-order stores and most hardware stores carry the tools required to build or service Amateur Radio equipment. Bargains are available at ham flea markets or local neighborhood sales, but beware! Some flea-market bargains are really shoddy imports that won't work very well or last very long. Some used tools are offered for sale because the owner is not happy with their performance.

There is no substitute for quality! A high-quality tool, while a bit more expensive, will last a lifetime. Poor quality tools don't last long and often do a poor job even when brand new. You don't need to buy machinist-grade tools, but stay away from cheap tools; they are not the bargains they might appear to be.

Care of Tools

The proper care of tools is more than a matter of pride. Tools that have not been cared for properly will not last long or

Table 8.1**Recommended Tools and Materials****Simple Hand Tools****Screwdrivers**

Slotted, 3-inch, 1/8-inch blade
 Slotted, 8-inch, 1/8-inch blade
 Slotted, 3-inch, 3/16-inch blade
 Slotted, stubby, 1/4-inch blade
 Slotted, 4-inch, 1/4-inch blade
 Slotted, 6-inch, 5/16-inch blade
 Phillips, 2 1/2-inch, #0 (pocket clip)
 Phillips, 3-inch, #1
 Phillips, stubby, #2
 Phillips, 4-inch, #2
 Phillips, 4-inch, #2
 Long-shank screwdriver with holding clip on blade
 Jeweler's set
 Right-angle, slotted and Phillips

Pliers, Sockets and Wrenches

Long-nose pliers, 6- and 4-inch
 Diagonal cutters, 6- and 4-inch
 Channel-lock pliers, 6-inch
 Slip-joint pliers
 Locking pliers (Vise Grip or equivalent)
 Socket nut-driver set, 1/16- to 1/2-inch
 Set of socket wrenches for hex nuts
 Allen (hex) wrench set
 Wrench set
 Adjustable wrenches, 6- and 10-inch
 Tweezers, regular and reverse-action
 Retrieval tool/parts holder, flexible claw
 Retrieval tool, magnetic

Cutting and Grinding Tools

File set consisting of flat, round, half-round, and triangular. Large and miniature types recommended
 Burnishing tool
 Wire strippers
 Wire crimper
 Hemostat, straight
 Scissors
 Tin shears, 10-inch
 Hacksaw and blades
 Hand nibbling tool (for chassis-hole cutting)
 Scratch awl or scribe (for marking metal)
 Heavy-duty jackknife
 Knife blade set (X-ACTO or equivalent)
 Machine-screw taps, #4-40 through #10-32 thread
 Socket punches, 1/2 in, 5/8 in, 3/4 in, 1 1/8 in, 1 1/4 in, and 1 1/2 in
 Tapered reamer, T-handle, 1/2-inch maximum width
 Deburring tool

Miscellaneous Hand Tools

Combination square, 12-inch, for layout work
 Hammer, ball-peen, 12-oz head
 Hammer, tack
 Bench vise, 4-inch jaws or larger
 Center punch
 Plastic alignment tools
 Mirror, inspection
 Flashlight, penlight and standard
 Magnifying glass
 Ruler or tape measure

Dental pick
 Calipers
 Brush, wire
 Brush, soft
 Small paintbrush
 IC-puller tool

Hand-Powered Tools

Hand drill, 1/4-inch chuck or larger
 High-speed drill bits, #60 through 3/8-inch diameter

Power Tools

Motor-driven emery wheel for grinding
 Electric drill, hand-held
 Drill press
 Miniature electric motor tool (Dremel or equivalent) and accessory drill press

Soldering Tools and Supplies

Soldering pencil, 30-W, 1/8-inch tip
 Soldering iron, 200-W, 5/8-inch tip
 Solder, 60/40, resin core
 Soldering gun, with assorted tips
 Desoldering tool
 Desoldering wick

Safety

Safety glasses
 Hearing protector, earphones or earplugs
 Fire extinguisher
 First-aid kit

Useful Materials

Medium-weight machine oil
 Contact cleaner, liquid or spray can
 Duco modeling cement or equivalent
 Electrical tape, vinyl plastic
 Sandpaper, assorted
 Emery cloth
 Steel wool, assorted
 Cleaning pad, Scotchbrite or equivalent
 Cleaners and degreasers
 Contact lubricant
 Sheet aluminum, solid and perforated, 16- or 18-gauge, for brackets and shielding.
 Aluminum angle stock, 1/2 x 1/2-inch x 1/4-inch-diameter round brass or aluminum rod (for shaft extensions)
 Machine screws: Round-head and flat head, with nuts to fit. Most useful sizes: 4-40, 6-32 and 8-32, in lengths from 1/4-inch to 1 1/2 inches. (Nickel-plated steel is satisfactory except in strong RF fields, where brass should be used.)
 Bakelite, Lucite, polystyrene and copper-clad PC-board scraps.
 Soldering lugs, panel bearings, rubber grommets, terminal-lug wiring strips, varnished-cambric insulating tubing, heat-shrinkable tubing
 Shielded and unshielded wire
 Tinned bare wire, #22, #14 and #12
 Enameled wire, #20 through #30

work well. Dull or broken tools can be safety hazards. Tools that are in good condition do the work for you; tools that are misused or dull are difficult to use.

Store tools in a dry place. Tools do not fit in with most living-room decors, so they are often relegated to the basement or garage. Unfortunately, many basements or garages are not good places to store tools; dampness and dust are not good for tools. If your tools are stored in a damp place, use a dehumidifier. Sometimes you can minimize rust by keeping your tools lightly oiled, but this is a second-best solution. If you oil your tools, they may not rust, but you will end up covered in oil every time you use them. Wax or silicone spray is a better alternative.

Store tools neatly. A messy toolbox, with tools strewn about haphazardly, can be more than an inconvenience. You may waste a lot of time looking for the right tool and sharp edges can be dulled or nicked by tools banging into each other in the bottom of the box. As the old adage says, every tool should have a place, and every tool should be in its place. If you must search the workbench, garage, attic and car to find the right screwdriver, you'll spend more time looking for tools than building projects.

Sharpening

Many cutting tools can be sharpened. Send a tool that has been seriously dulled to a professional sharpening service. These services can sharpen saw blades, some files, drill bits and most cutting blades. Touch up the edge of cutting tools with a whetstone to extend the time between sharpenings.

Sharpen drill bits frequently to minimize the amount of material that must be removed each time. Frequent sharpening also makes it easier to maintain the critical surface angles required for best cutting with least wear. Most inexpensive drill-bit sharpeners available for shop use do a poor job, either from the poor quality of the sharpening tool or inexperience of the operator. Also, drills should be sharpened at different angles for different applications. Commercial sharpening services do a much better job.

Intended Purpose

Don't use tools for anything other than their intended purpose! If you use a pair of wire cutters to cut sheet metal, pliers as a vise or a screwdriver as a pry bar, you ruin a good tool. Although an experienced constructor can improvise with tools, most take pride in not abusing them.

Tool Descriptions and Uses

Specific applications for tools are discussed throughout this chapter. Hand tools are used for so many different applications that they are discussed first, followed by some tips for proper use of power tools.

Soldering Iron

Soldering is used in nearly every phase of electronic construction so you'll need soldering tools. A soldering tool must be hot enough to do the job and lightweight enough for agility and comfort. A 100-W soldering gun is overkill for printed-circuit work, for example. A temperature-controlled iron works well, although the cost is not justified for occasional projects. Get an iron with a small conical or chisel tip.

You may need an assortment of soldering irons to do a wide variety of soldering tasks. They range in size from a small 25-W iron for delicate printed-circuit work to larger 100 to 300-W sizes used to solder large surfaces. Several manufacturers also sell soldering guns. Small "pencil" butane torches are also available, with optional soldering-iron tips. A small butane torch is available from the Solder-It Company. This company also sells a soldering kit that contains paste solders (in syringes) for electronics, pot metal and plumbing.

Keep soldering tools in good condition by keeping the tips well tinned with solder. Do not run them at full temperature for long periods when not in use. After each period of use, remove the tip and clean off any scale that may have accumulated. Clean an oxidized tip by dipping the hot tip in sal ammoniac (ammonium chloride) and then wiping it clean with a rag. Sal ammoniac is somewhat corrosive, so if you don't wipe the tip thoroughly, it can contaminate electronic soldering.

If a copper tip becomes pitted, file it smooth and bright and then tin it immediately with solder. Modern soldering iron tips are nickel or iron clad and should not be filed.

The secret of good soldering is to use the right amount of heat. Many people who have not soldered before use too little heat, dabbing at the joint to be soldered and making little solder blobs that cause unintended short circuits.

Solders have different melting points, depending on the ratio of tin to lead. Tin melts at 450°F and lead at 621°F. Solder made from 63% tin and 37% lead melts at 361°F, the lowest melting point for a tin and lead mixture. Called 63-37 (or eutectic), this type of solder also provides the most rapid solid-to-liquid transition and

the best stress resistance.

Solders made with different lead/tin ratios have a plastic state at some temperatures. If the solder is deformed while it is in the plastic state, the deformation remains when the solder freezes into the solid state. Any stress or motion applied to "plastic solder" causes a poor solder joint.

60-40 solder has the best wetting qualities. Wetting is the ability to spread rapidly and bond materials uniformly. 60-40 solder also has a low melting point. These factors make it the most commonly used solder in electronics.

Some connections that carry high current can't be made with ordinary tin-lead solder because the heat generated by the current would melt the solder. Automotive starter brushes and transmitter tank circuits are two examples. Silver-bearing solders have higher melting points, and so prevent this problem. High-temperature silver alloys become liquid in the 1100°F to 1200°F range, and a silver-manganese (85-15) alloy requires almost 1800°F.

Because silver dissolves easily in tin, tin bearing solders can leach silver plating from components. This problem can be greatly reduced by partially saturating the tin in the solder with silver or by eliminating the tin. Tin-silver or tin-lead-silver alloys become liquid at temperatures from 430°F for 96.5-3.5 (tin-silver), to 588°F for 1.0-97.5-1.5 (tin-lead-silver). A 15.0-80.0-5.0 alloy of lead-indium-silver melts at 314°F.

Never use acid-core solder for electrical work. It should be used only for plumbing or chassis work. For circuit construction, only use fluxes or solder-flux combinations that are labeled for electronic soldering.

The resin or the acid is a *flux*. Flux removes oxide by suspending it in solution and floating it to the top. Flux is not a cleaning agent! Always clean the work before soldering. Flux is not a part of a soldered connection—it merely aids the soldering process. After soldering, remove any remaining flux. Resin flux can be removed with isopropyl or denatured alcohol. A cotton swab is a good tool for applying the alcohol and scrubbing the excess flux away. Commercial flux-removal sprays are available at most electronic-part distributors.

The two key factors in quality soldering are time and temperature. Generally, rapid heating is desired, although most unsuccessful solder jobs fail because insufficient heat has been applied. Be careful; if heat is applied too long, the components or PC board can be damaged, the flux may be used up and surface oxidation can become a problem. The soldering-iron tip

should be hot enough to readily melt the solder without burning, charring or discoloring components, PC boards or wires. Usually, a tip temperature about 100°F above the solder melting point is about right for mounting components on PC boards. Also, use solder that is sized appropriately for the job. As the cross section of the solder decreases, so does the amount of heat required to melt it. Diameters from 0.025 to 0.040 inches are good for nearly all circuit wiring.

Here's how to make a good solder joint. This description assumes that solder with a flux core is used to solder a typical PC board connection such as an IC pin.

- Prepare the joint. Clean all conductors thoroughly with fine steel wool or a plastic scrubbing pad. Do the circuit board at the beginning of assembly and individual parts such as resistors and capacitors immediately before soldering. Some parts (such as ICs and surface-mount components) cannot be easily cleaned; don't worry unless they're exceptionally dirty.
- Prepare the tool. It should be hot enough to melt solder applied to its tip quickly (half a second when dry, instantly when wet with solder). Apply a little solder directly to the tip so that the surface is shiny. This process is called "tinning" the tool. The solder coating helps conduct heat from the tip to the joint.
- Place the tip in contact with one side of the joint. If you can place the tip on the underside of the joint, do so. With the tool below the joint, convection helps transfer heat to the joint.
- Place the solder against the joint directly opposite the soldering tool. It should melt within a second for normal PC connections, within two seconds for most other connections. If it takes longer to melt, there is not enough heat for the job at hand.
- Keep the tool against the joint until the solder flows freely throughout the joint. When it flows freely, solder tends to form concave shapes between the conductors. With insufficient heat solder does not flow freely; it forms convex shapes—blobs. Once solder shape changes from convex to concave, remove the tool from the joint.
- Let the joint cool without movement at room temperature. It usually takes no more than a few seconds. If the joint is moved before it is cool, it may take on a dull, satin look that is characteristic of a "cold" solder joint. Reheat cold joints until the solder flows freely and hold them still until cool.
- When the iron is set aside, or if it loses its shiny appearance, wipe away any dirt

with a wet cloth or sponge. If it remains dull after cleaning, tin it again.

Overheating a transistor or diode while soldering can cause permanent damage. Use a small heat sink when you solder transistors, diodes or components with plastic parts that can melt. Grip the component lead with a pair of pliers up close to the unit so that the heat is conducted away (be careful—it is easy to damage delicate component leads). A small alligator clip also makes a good heat sink.

Mechanical stress can damage components, too. Mount components so there is no appreciable mechanical strain on the leads.

Soldering to the pins of coil forms or male cable plugs can be difficult. Use a suitable small twist drill to clean the inside of the pin and then tin it with resin-core solder. While it is still liquid, clear the surplus solder from each pin with a whipping motion or by blowing through the pin from the inside of the form or plug. Watch out for flying hot solder! Next, file the nickel plate from the pin tip. Then insert the wire and solder it. After soldering, remove excess solder with a file, if necessary.

When soldering to the pins of plastic coil forms, hold the pin to be soldered with a pair of heavy pliers to form a heat sink. Do not allow the pin to overheat; it will loosen and become misaligned.

In order to remove components, you need to learn the art of desoldering—removing solder from components and PC boards so they can be separated easily. Use commercially made wicking material (braid) to soak up excess solder from a joint. Another useful tool is an air-suction solder remover. Another method is to heat the joint and “flick” the wet solder off. (Watch out for solder splashes!)

Soldering equipment gets *hot!* Be careful. Treat a soldering burn as you would any other. Handling lead or breathing soldering fumes is also hazardous. Observe these precautions to protect yourself and others:

- Properly ventilate the work area. If you can smell fumes, you are breathing them.
- Wash your hands after soldering, especially before handling food.
- Minimize direct contact with flux and flux solvents.

For more information about soldering hazards and the ways to make soldering safer, see “Making Soldering Safer,” by Brian P. Bergeron, MD, NU1N (Mar 1991 *QST*, pp 28-30) and “More on Safer Soldering,” by Gary E. Meyers, K9CZB (Aug 1991 *QST*, p 42).

Screwdrivers

For construction or repair, you need to have an assortment of screwdrivers. Each blade size is designed to fit a specific range of screw-head sizes. Using the wrong size blade usually damages the blade, the screw head or both. You may also need stubby sizes to fit into tight spaces. Right-angle screwdrivers are inexpensive and can get into tight spaces that can’t otherwise be reached.

Electric screwdrivers are relatively inexpensive. If you have a lot of screws to fasten, they can save a lot of time and effort. They come with a wide assortment of screwdriver and nut-driver bits. An electric drill can also function as an electric screwdriver, although it may be heavy and over-powered for some applications.

Keep screwdriver blades in good condition. If a blade becomes broken or worn out, replace the screwdriver. A screwdriver only costs a few dollars; do not use one that is not in perfect condition. Save old screwdrivers to use as pry bars and levers, but use only good ones on screws. Filing a worn blade seldom gives good results.

Pliers and Locking-Grip Pliers

Pliers and locking-grip pliers are used to hold or bend things. They are not wrenches! If pliers are used to remove a nut or bolt, the nut or the pliers is usually damaged. Pliers are not intended for heavy-duty applications. Use a metal brake to bend heavy metal; use a vise to hold a heavy component. To remove a nut, use a wrench or nut driver. There is one exception to this rule of thumb: To remove a nut that is stripped too badly for a wrench, use a pair of pliers, locking-grip pliers, or a diagonal cutter to bite into the nut and turn it a bit. If you do this, use an old tool or one dedicated to just this purpose; this technique is not good for the tool. If the pliers’ jaws or teeth become worn, replace the tool.

Wire Cutters

Wire cutters are primarily used to cut wires or component leads. The choice of diagonal blades (sometimes called “dikes”) or end-nip blades depends on the application. Diagonal blades are most often used to cut wires, while the end-nip blades are useful to cut off the ends of components that have been soldered into a printed-circuit board. Some delicate components can be damaged by cutting their leads with dikes. Scissors designed to cut wire can be used.

Wire strippers are handy, but you can

usually strip wires using a diagonal cutter or a knife. This is not the only use for a knife, so keep an assortment handy.

Do not use wire cutters or strippers on anything other than wire! If you use a cutter to trim a protruding screw head, or cut

Table 8.2
Numbered Drill Sizes

No.	Diameter (Mils)	Will Clear Screw	Drilled for Tapping from Steel or Brass
1	228.0	12-24	—
2	221.0	—	—
3	213.0	—	14-24
4	209.0	12-20	—
5	205.0	—	—
6	204.0	—	—
7	201.0	—	—
8	199.0	—	—
9	196.0	—	—
10	193.5	—	—
11	191.0	10-24 10-32	—
12	189.0	—	—
13	185.0	—	—
14	182.0	—	—
15	180.0	—	—
16	177.0	—	12-24
17	173.0	—	—
18	169.5	—	—
19	166.0	8-32	12-20
20	161.0	—	—
21	159.0	—	10-32
22	157.0	—	—
23	154.0	—	—
24	152.0	—	—
25	149.5	—	10-24
26	147.0	—	—
27	144.0	—	—
28	140.0	6-32	—
29	136.0	—	8-32
30	128.5	—	—
31	120.0	—	—
32	116.0	—	—
33	113.0	4-40	—
34	111.0	—	—
35	110.0	—	—
36	106.5	—	6-32
37	104.0	—	—
38	101.5	—	—
39	99.5	3-48	—
40	98.0	—	—
41	96.0	—	—
42	93.5	—	—
43	89.0	—	4-40
44	86.0	2-56	—
45	82.0	—	—
46	81.0	—	—
47	78.5	—	3-48
48	76.0	—	—
49	73.0	—	—
50	70.0	—	2-56
51	67.0	—	—
52	63.5	—	—
53	59.5	—	—
54	55.0	—	—

a hardened-steel spring, you will usually damage the blades.

Files

Files are used for a wide range of tasks. In addition to enlarging holes and slots, they are used to remove burrs, shape metal, wood or plastic and clean some surfaces in preparation for soldering. Files are especially prone to damage from rust and moisture. Keep them in a dry place. The cutting edge of the blades can also become clogged with the material you are removing. Use file brushes (also called file cards) to keep files clean. Most files cannot be sharpened easily, so when the teeth become worn, the file must be replaced. A worn file is sometimes worse than no file at all. At best, a worn file requires more effort.

Drill Bits

Drill bits are made from carbon steel, high-speed steel or carbide. Carbon steel is more common and is usually supplied unless a specific request is made for high-speed bits. Carbon-steel drill bits cost less than high-speed or carbide types; they are sufficient for most equipment construction work. Carbide drill bits last much longer under heavy use. One disadvantage of carbide bits is that they are brittle and break easily, especially if you are using a hand-held power drill.

Twist drills are available in a number of sizes. Those listed in bold type in **Table 8.2** are the most commonly used in construction of amateur equipment. You may not use all of the drills in a standard set, but it is nice to have a complete set on hand. You should also buy several spares of the more common sizes. Although Table 8.2 lists drills down to #54, the series extends to number #80.

Specialized Tools

Most constructors know how to use common tools, such as screwdrivers, wrenches and hammers. Let's discuss other tools that are not so common.

A hand nibbling tool is shown in **Fig 8.1**. Use this tool to remove small "nibbles" of metal. It is easy to use; posi-

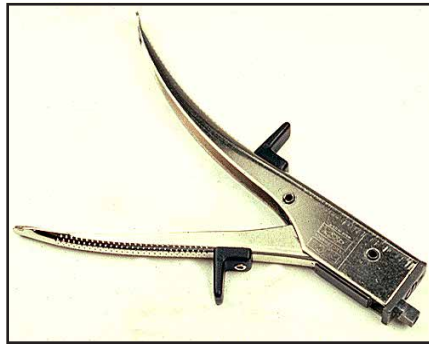

Fig 8.1—A nibbling tool is used to remove small sections of sheet metal.



Fig 8.2—A deburring tool is used to remove the burrs left after drilling a hole.

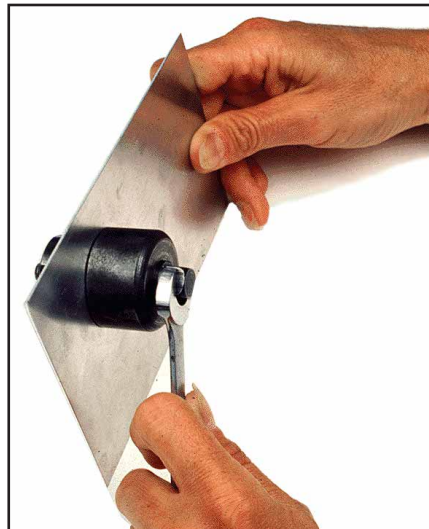

Fig 8.3—A socket punch is used to easily punch a hole in sheet metal.

tion the tool where you want to remove metal and squeeze the handle. The tool takes a small bite out of the metal. When you use a nibbler, be careful that you don't remove too much metal, clip the edge of a component mounted to the sheet metal or grab a wire that is routed near the edge of a chassis. Fixing a broken wire is easy, but something to avoid if possible. It is easy to remove metal but nearly impossible to put it back. Do it right the first time!

Deburring Tool

A deburring tool is just the thing to remove the sharp edges left on a hole after most drilling or punching operations. See **Fig 8.2**. Position the tool over the hole as shown and rotate it around the hole edge to remove burrs or rough edges. As an alternative, select a drill bit that is somewhat larger than the hole, position it over the hole, and spin it lightly to remove the burr.

Socket Punches

Greenlee is the most widely known of the socket-punch manufacturers. Most socket punches are round, but they do come in other shapes. To use one, drill a pilot hole large enough to clear the bolt that runs through the punch. Then, mount the punch as shown in **Fig 8.3**, with the cutter on one side of the sheet metal and the socket on the other. Tighten the nut with a wrench until the cutter cuts all the way through the sheet metal.

Useful Shop Materials

Small stocks of various materials are used when constructing electronics equipment. Most of these are available from hardware or radio-supply stores. A representative list is shown at the end of Table 8.1.

Small parts, such as machine screws, nuts, washers and soldering lugs can be economically purchased in large quantities (it doesn't pay to buy more than a lifetime supply). For items you don't use often, many radio-supply stores or hardware stores sell small quantities and assortments.

A DELUXE SOLDERING STATION

The simple tool shown in Figs 8.4 through 8.6 can enhance the usefulness and life of a soldering iron as well as make electronic assembly more convenient. It includes a protective heat sink and a tip-cleaning sponge rigidly attached to a sturdy base for efficient one-handed operation.

Soldering-iron tips and heating elements last longer if operated at a reduced temperature when not being used. Temperature reduction is accomplished by half-wave rectification of the applied ac. D1 conducts during only one-half of the ac cycle. With current flowing only in one direction, only one electrode of the neon bulb glows. Closing S1 short-circuits the diode and applies full power to the soldering iron, igniting both bulb electrodes brightly.

The base for the unit is a $2 \times 6 \times 4$ -inch (HWD) aluminum chassis (Bud AC-431 or equivalent). A 30- or 40-W soldering iron fits neatly on the chassis top. The holder has two mounting holes in each foot. A sponge tray nests between the feet and the case. In this model, a sardine tin is used for the sponge tray.

The tray and iron holder are secured to

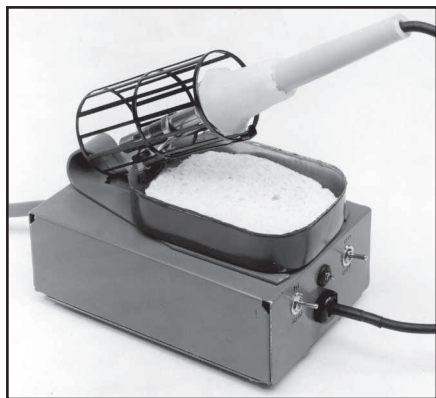

Fig 8.4—A compact assembly of commonly available items, this soldering station makes soldering easier. Miniature toggle switches are used because they are easy to operate.

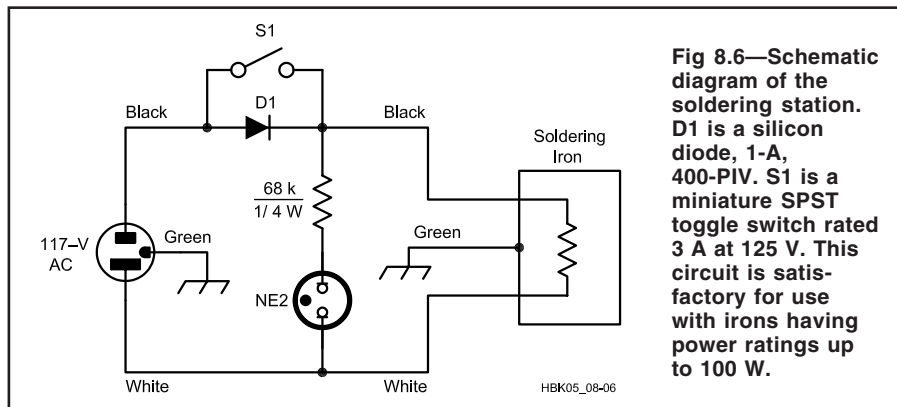

Fig 8.6—Schematic diagram of the soldering station. D1 is a silicon diode, 1-A, 400-PIV. S1 is a miniature SPST toggle switch rated 3 A at 125 V. This circuit is satisfactory for use with irons having power ratings up to 100 W.

the chassis by $6-32 \times \frac{1}{2}$ -inch pan-head machine screws and nuts, with flat washers under the screw heads (sponge tray) and lock washers under the nuts (chassis

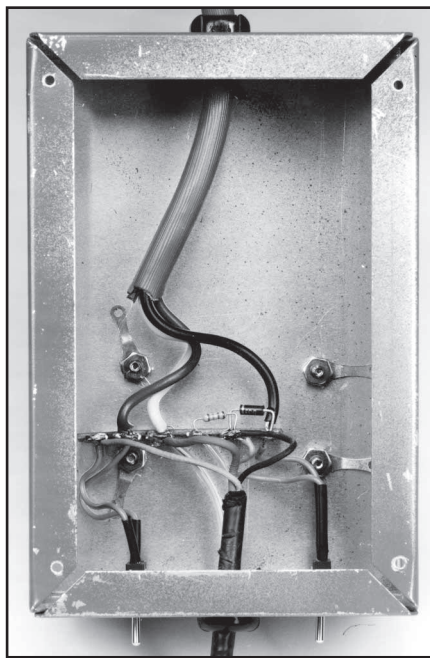

Fig 8.5—View of the soldering-station chassis underside with the bottom plate removed. #24 hookup wire is adequate for all connections. Make sure no possibility of a short circuit exists.

underside). One of these nuts fastens a six-lug tie point strip to the chassis bottom. Use the soldering-iron holder base as a template for drilling the chassis and sponge tray. The floor of the sponge tray must be sealed around the screw heads to prevent moisture from leaking into the electrical components below the chassis. RTV compound was used for this purpose in the unit pictured.

Notice that the soldering iron and the soldering station use separate ac line cords. This ensures that the cord of the soldering iron will be long enough to do useful work. Bushings are used to anchor both cords. If these aren't available, grommets and cable clamps work well. Knotting the cords inside the chassis is a simple technique that normally provides adequate strain relief.

The underchassis assembly is shown in Fig 8.5. The neon bulb is installed in a $\frac{3}{16}$ -inch-ID grommet. The leads are insulated with spaghetti insulation or heat-shrink tubing to prevent short circuits. If you mount the bulb in a fixture or socket, use a clear lens to ensure that the electrodes are distinctly visible. Install a cover on the bottom of the chassis to prevent accidental contact with the live ac wiring. Stick-on rubber feet prevent the bottom of the unit from scratching your work surface.

SOLDERING-IRON TEMPERATURE CONTROL

A temperature control gives greater flexibility than the simple control just described. An incandescent-light dimmer can be used to control the working temperature of the tip. **Fig 8.7** shows a temperature control built into an electrical box. A dimmer and a duplex outlet are mounted in the box; the wiring diagram is shown in **Fig 8.8**. Only one of the two ac outlets is controlled by the dimmer. A jumper on the duplex outlet connects the hot terminals of both outlets together. This jumper must be removed. The hot terminal is narrower than the neutral one and its connecting screw is usually brass. Neutral terminals remain interconnected.

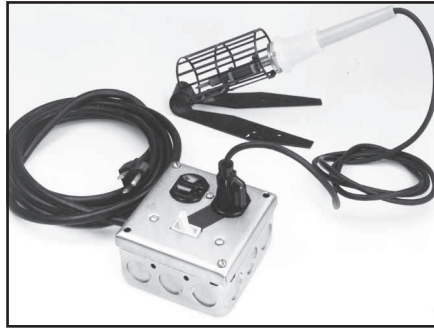

Fig 8.7—An incandescent-light dimmer controls soldering-iron tip temperature. Only one of the duplex outlets is connected through the dimmer.

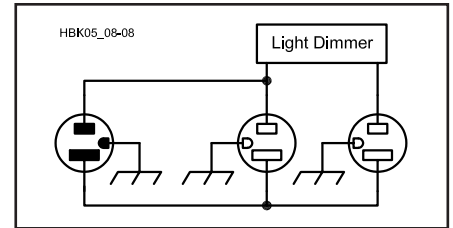

Fig 8.8—Schematic diagram of the soldering-iron temperature control.

The dimmer shown in Fig 8.7 can be purchased at any hardware or electrical-supply store. The knob is capable of fine control of the soldering temperature.

Electronic Circuits

Most of the construction projects undertaken by the average amateur involve electronic circuitry. The circuit is the “heart” of most amateur equipment. It might seem obvious, but in order for you to build it, the circuit must work! Don’t always assume that a “cookbook” circuit that appears in an applications note or electronics magazine is flawless. These are sometimes design examples that have not always been thoroughly debugged. Many home-construction projects are “one-time” deals; the author has put one together and it worked. In some cases, component tolerances or minor layout changes might make it difficult to get a second unit working.

Protecting Components

You need to take steps to protect the electronic and mechanical components you use in circuit construction. Some components can be damaged by rough handling. Dropping a $\frac{1}{4}$ -W resistor causes no harm, but dropping a vacuum tube or other delicate subassemblies usually causes damage.

Some components are easily damaged by heat. Some of the chemicals used to clean electronic components (such as flux removers, degreasers or control-lubrication sprays) can damage plastic. Check them for safety before you use them.

Electrostatic Discharge

Some components, especially high-impedance components such as FETs and CMOS gates, can be damaged by electrostatic discharge (ESD). Protect these parts from static charges. Most people are familiar with the static charge that builds up

when one walks across a carpet then touches a metal object; the resultant spark can be quite lively. Walking across a carpet on a dry day can generate 35 kV! A worker sitting at a bench can generate voltages up to 6 kV, depending on conditions, such as when relative humidity is less than 20%.

You don’t need this much voltage to damage a sensitive electronic component; damage can occur with as little as 30 V. The damage is not always catastrophic. A MOSFET can become noisy, or lose gain; an IC can suffer damage that causes early failure. To prevent this kind of damage, you need to take some precautions.

The energy from a spark can travel inside a piece of equipment to effect internal components. Protection of sensitive electronic components involves the prevention of static build-up together with the removal of any existing charges by dissipating any energy that does build up.

Several techniques can be used to minimize static build-up. First, remove any carpet in your work areas. You can replace it with special antistatic carpet, but this is expensive. It’s less expensive to treat the carpet with antistatic spray, which is available from Chemtronics, GC Thorsen and other lines carried by electronics wholesalers.

Even the choice of clothing you wear can affect the amount of ESD. Polyester has a much greater ESD potential than cotton.

Many builders who have their workbench on a concrete floor use a rubber mat to minimize the risk of electric shocks from the ac line. Unfortunately, the rubber mat increases the risk of ESD. An antistatic rubber mat can serve both purposes.

Many components are shipped in anti-static packaging. Leave components in their conductive packaging. Other components, notably MOSFETs, are shipped with a small metal ring that temporarily shorts all of the leads together. Leave this ring in place until the device is fully installed in the circuit.

These precautions help reduce the build-up of electrostatic charges. Other techniques offer a slow discharge path for the charges or keep the components and the operator handling them at the same ground potential.

One of the best techniques is to connect the operator and the devices being handled to earth ground, or a common reference point. It is not a good idea to directly ground an operator working on electronic equipment, though; the risk of shock is too great. If the operator is grounded through a high-value resistor, ESD protection is still offered but there is no risk of shock.

The operator is usually grounded through a conductive wrist strap. 3M makes a grounding wrist band. This wrist band is equipped with a snap-on ground lead. A 1-M Ω resistor is built into the snap of the strap to protect the user should a live circuit be contacted. Build a similar resistor into any homemade ground strap.

The devices and equipment being handled are also grounded, by working on a charge-dissipating mat that is connected to ground. The mat should be an insulator that has been impregnated with a resistance material. Suitable mats and wrist straps are made by 3M, GC Electronics and others; they are available from most electronics supply houses. **Fig 8.9** shows a typical ESD-safe work station.

The work area should also be grounded, directly or through a conductive mat. Use a soldering iron with a grounded tip to solder sensitive components. Most irons that have three-wire power cords are properly grounded. When soldering static-sensitive devices, use two or three jumpers to ground you, the work and the iron. If the iron does not have a ground wire in the power cord, clip a jumper from the metal part of the iron near the handle to the metal box that houses the temperature control. Another jumper connects the box to the work. Finally, a jumper goes from the box to an elastic wrist band for static grounding.

Use antistatic bags to transport susceptible components or equipment. Keep your workbench free of objects such as paper, plastic and other static-generating items. Use conductive containers with a dissipative surface coating for equipment storage.

All of the antistatic products described above are available from Newark Electronics and other suppliers.

Electronics Construction Techniques

Several different point-to-point wiring techniques or printed-circuit boards (PC boards) can be used to construct electronic circuits. Most circuit projects use a combination of techniques. The selection of techniques depends on many different factors and builder preferences.

The simple audio amplifier shown in Fig 8.10 will be built using various point-to-point or PC-board techniques. This shows how the different construction methods are applied to a typical circuit.

Point-to-Point Techniques

Point-to-point techniques include all circuit construction techniques that rely on tie points and wiring, or component leads, to build a circuit. This is the technique used in most home-brew construction projects. It is sometimes used in commercial construction, such as old vacuum-tube receivers and modern tube amplifiers.

Point-to-point is also used to connect the “off-board” components used in a printed-circuit project. It can be used to interconnect the various modules and printed-circuit boards used in more complex electronic systems. Most pieces of electronic equipment have at least some point-to-point wiring.

Ground-Plane Construction

A point-to-point construction technique that uses the leads of the components as tie points for electrical connections is known as “ground-plane construction,” “dead-bug” or

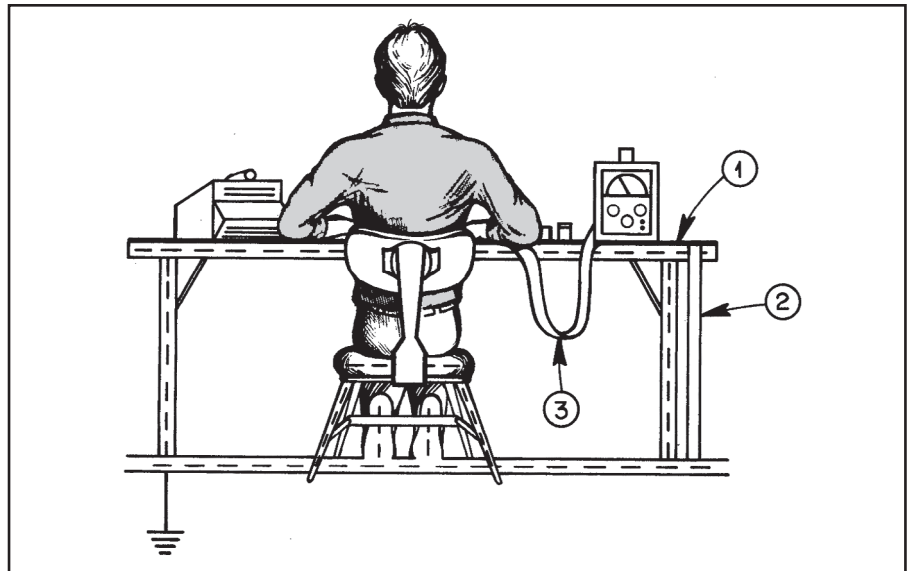

Fig 8.9—A work station that has been set up to minimize ESD features (1) a grounded dissipative work mat and (2) a wrist strap that (3) grounds the worker through high resistance.

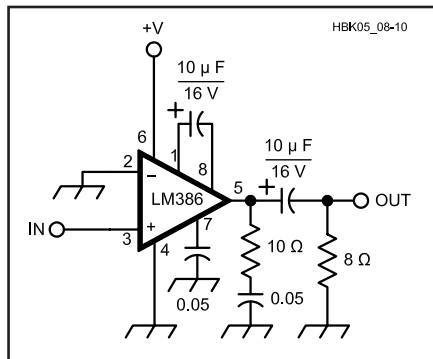

Fig 8.10—Schematic diagram of the audio amplifier used as a design example of various construction techniques.

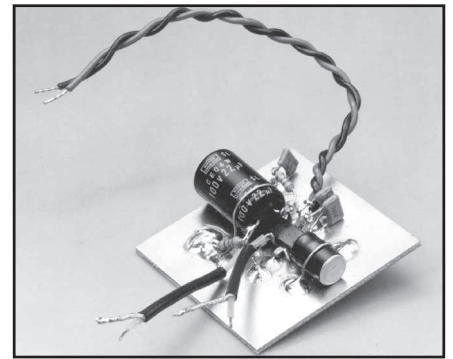

Fig 8.11—The example audio amplifier of Fig 8.10 built using ground-plane construction.

“ugly construction.” (The term “ugly construction” was coined by Wes Hayward, W7ZOI.) “Dead-bug construction” gets its name from the appearance of an IC with its leads sticking up in the air. In most cases, this technique uses copper-clad circuit-board material as a foundation and ground plane on which to build a circuit using point-to-point wiring, so in this chapter it is called “ground-plane construction.” An example is shown in Fig 8.11.

Ground-plane construction is quick and simple: You build the circuit on an unetched piece of copper-clad circuit board. Wherever a component connects to ground, you solder it to the copper board. Ungrounded connections between components are made point-to-point. Once you learn how to build with a ground-plane board, you can grab a piece of circuit board and start building any time you see an interesting circuit.

A PC board has strict size limits; the components must fit in the space allotted. Ground-plane construction is more flexible; it allows you to use the parts on hand. The circuit can be changed easily—a big help when you are experimenting. The greatest virtue of ground-plane construction is that it is fast.

Ground-plane construction is something like model building, connecting parts using solder almost—but not exactly—like glue. In ground-plane construction you build the circuit directly from the schematic, so it can help you get familiar with a circuit and how it works. You can build subsections of a large circuit on small ground-plane modules and string them together into a larger design.

Circuit connections are made directly, minimizing component lead length. Short lead lengths and a low-impedance ground conductor help prevent circuit instability.

There is usually less intercomponent capacitive coupling than would be found between PC-board traces, so it is often better than PC-board construction for RF, high-gain or sensitive circuits.

Use circuit components to support other circuit components. Start by mounting one component onto the ground plane, building from there. There is really only one two-handed technique to mount a component to the ground plane. Bend one of the component leads at a 90° angle, and then trim off the excess. Solder a blob of solder to the board surface, perhaps about 0.1 inch in diameter, leaving a small dome of solder. Using one hand, hold the component in place on top of the soldered spot and reheat the component and the solder. It should flow nicely, soldering the component securely. Remove the iron tip and hold the component perfectly still until the solder cools. You can then make connections to the first part.

Connections should be mechanically secure before soldering. Bend a small hook in the lead of a component, then “crimp” it to the next component(s). Do not rely only on the solder connections to provide mechanical strength; sooner or later one of these connections will fail, resulting in a dead circuit.

In most cases, each circuit has enough grounded components to support all of the components in the circuit. This is not always possible, however. In some circuits, high-value resistors can be used as standoff insulators. One resistor lead is soldered to the copper ground plane; the other lead is used as a circuit connection point. You can use 1/4- or 1/2-W resistors in values from 1 to 10 MΩ. Such high-value resistors permit almost no current to flow, and in low-impedance circuits they act more like insulators than resistors. As a rule of thumb, resistors used as standoff insulators should have a value that is at least 10 times the circuit impedance at that circuit point.

Fig 8.12A shows how to use the standoff technique to wire the circuit shown at Fig 8.12C. Fig 8.12B shows how the resistor leads are bent before the standoff component is soldered to the ground plane. Components E1 through E5 are resistors that are used as standoff insulators. They do not appear in the schematic diagram. The base circuitry at Q1 of Fig 8.12A has been stretched out to reduce clutter in the drawing. In a practical circuit, all of the signal leads should be kept as short as possible. E4 would, therefore, be placed much closer to Q1 than the drawing indicates.

No standoff posts are required near R1 and R2 of Fig 8.12. These two resistors serve two purposes: They are not only the normal circuit resistances, but function as standoff posts as well. Follow this prac-

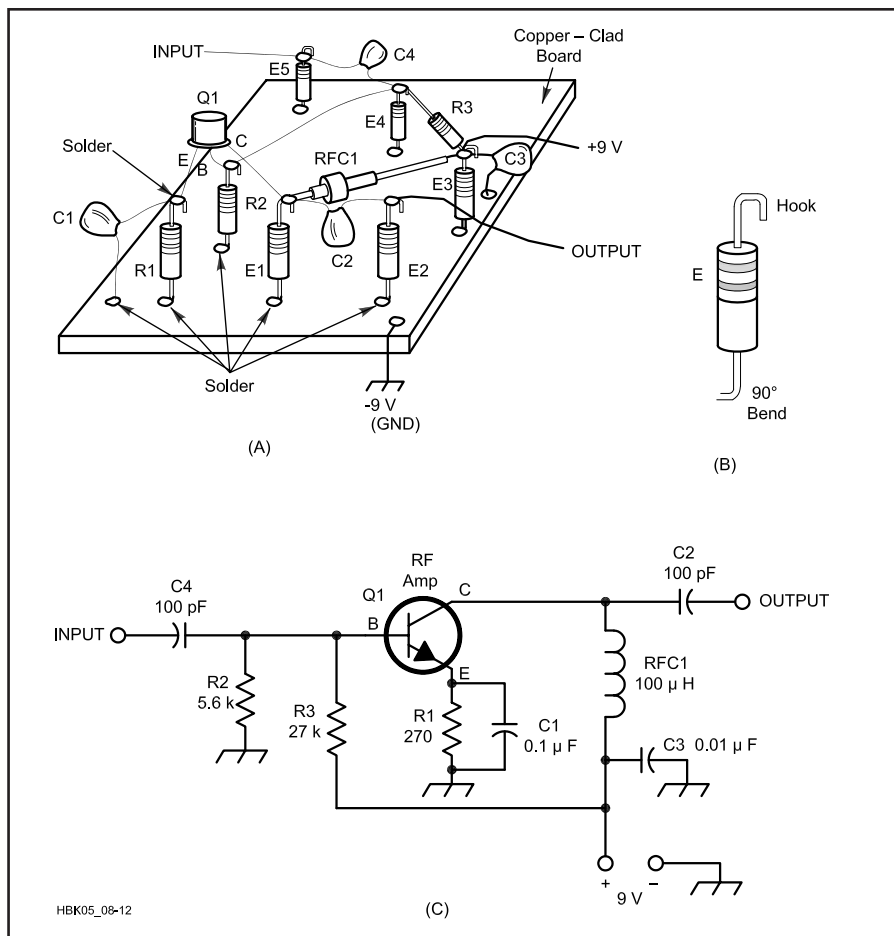

Fig 8.12—Pictorial view of a circuit board that uses ground-plane construction is shown at A. A close-up view of one of the standoff resistors is shown at B. Note how the leads are bent. The schematic diagram at C shows the circuit displayed at A.

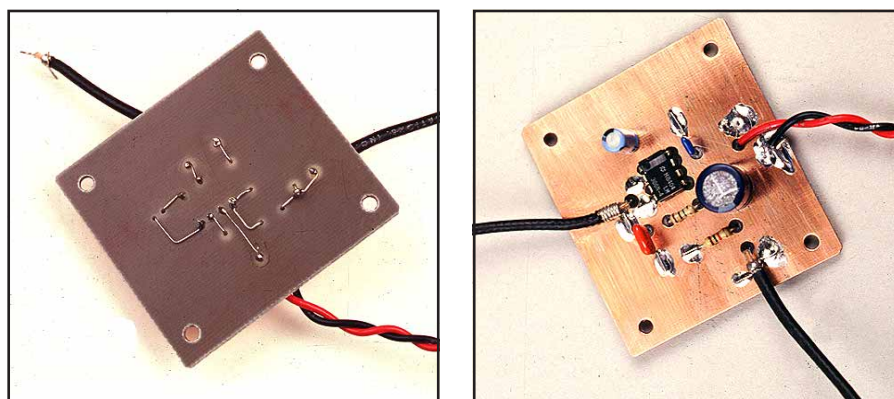

Fig 8.13—The audio amplifier built using wired-traces construction.

tice wherever a capacitor or resistor can be employed in the dual role.

Wired Traces—the Lazy PC Board

If you already have a PC-board design, but don't want to copy the entire circuit—or you don't want to make a double-sided PC board—then the easiest construction technique is to use a bare board (or

perfboard) and hard-wire the traces.

Drill the necessary holes in a piece of single-sided board, remove the copper ground plane from around the holes, and then wire up the back using component leads and bits of wire instead of etched traces (Fig 8.13).

To transfer an existing board layout, make a 1:1 photocopy and tape it to your

piece of PC board. Prick through the holes with an automatic (one-handed) center punch or by firm pressure with a sharp scribe, remove the photocopy and drill all the holes. Holes for ground leads are optional—you generally get a better RF ground by bending the component lead flat to the board and soldering it down. Remove the copper around the rest of the holes by pressing a drill bit lightly against the hole and twisting it between your fingers. A drill press can also be used, but either way, don't remove too much board material. Then wire up the circuit beneath the board. The results look very neat and tidy—from the top, at least!

Circuits that contain components originally designed for PC-board mounting are good candidates for this technique. Wired traces would also be suitable for circuits involving multipin RF ICs, double-balanced mixers and similar components. To bypass the pins of these components to ground, connect a miniature ceramic capacitor on the bottom of the board directly from the bypassed pin to the ground plane.

A wired-trace board is fairly sturdy, even though many of the components are only held in by their bent leads and blobs of solder. A drop of cyanoacrylate “super glue” can hold down any larger components, components with fragile leads or wires that might move.

Perforated Construction Board

A simple approach to circuit building uses a perforated board (perfboard). Perfboard is available with many different hole patterns. Choose the one that suits your needs. Perfboard is usually unclad, although it is made with pads that facilitate soldering.

Circuit construction on perforated board is easy. Start by placing the components loosely on the board and moving them around until a satisfactory layout is obtained. Most of the construction techniques described in this chapter can be applied to perfboard. The audio amplifier of Fig 8.10 is shown constructed with this technique in Fig 8.14.

Perfboard and accessories are widely available. Accessories include mounting hardware and a variety of connection terminals for solder and solderless construction.

Terminal and Wire

A perfboard is usually used for this technique (Fig 8.15). Push terminals are inserted into the hole in a perfboard. Components can then be easily soldered to the terminals. As an alternative, drill holes into a bare or copper-clad board wherever they are needed. The compo-

nents are usually mounted on one side of the board and wires are soldered to the bottom of the board, acting as wired PC-board “traces.” If a component has a reasonably rigid lead to which you can attach other components, use that instead of a push terminal, a modification of the ground-plane construction technique.

If you are using a bare board to provide a ground plane, drill holes for your terminals with a high-speed PC-board drill and drill press. Mark the position of the hole with a center punch to prevent the drill from skidding. The hole should provide a snug fit for the push terminal.

Mount RF components on top of the

board, keeping the dc components and much of the interconnecting wiring underneath. Make dc feed-through connections with terminals having bypass capacitors on top of the board. Use small solder-in feedthrough capacitors for more critical applications.

Solderless Prototype Board

One construction alternative that works well for audio and digital circuits is the solderless prototype board (proto-board), shown in Fig 8.16. It is usually not suitable for RF circuits.

A proto-board has rows of holes with spring-loaded metal strips inside the board. Circuit components and hookup wire are inserted into the holes, making contact with the metal strips. Components that are inserted into the same row are connected together. Component and interconnection changes are easy to make.

Proto-boards have some minor disadvantages. The boards are not good for building RF circuits; the metal strips add too much stray capacitance to the circuit.

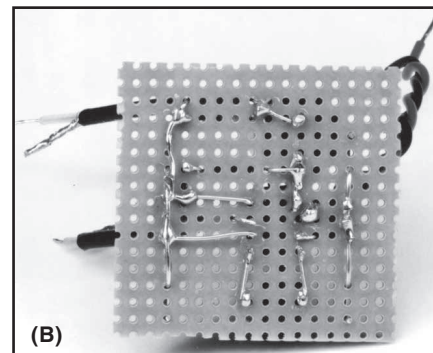
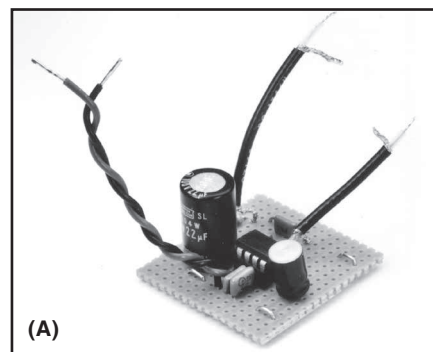

Fig 8.14—The audio amplifier built on perforated board. Top view at A; bottom view at B.

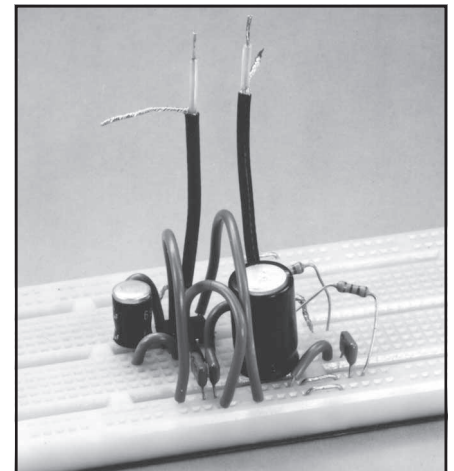

Fig 8.16—The audio amplifier built on a solderless prototyping board.

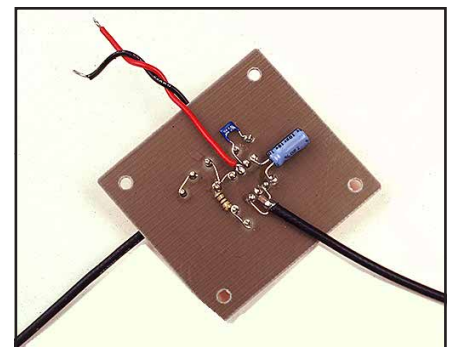
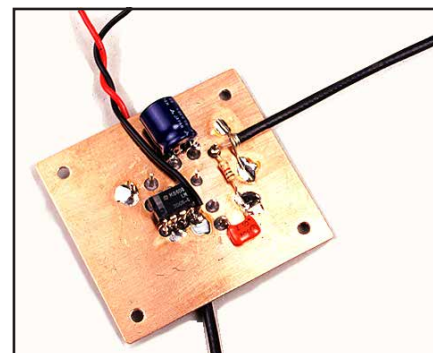

Fig 8.15—The audio amplifier built using terminal-and-wire construction.

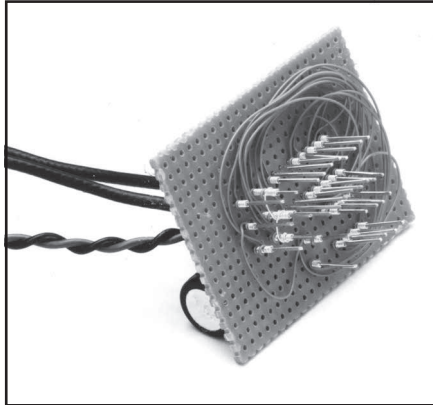
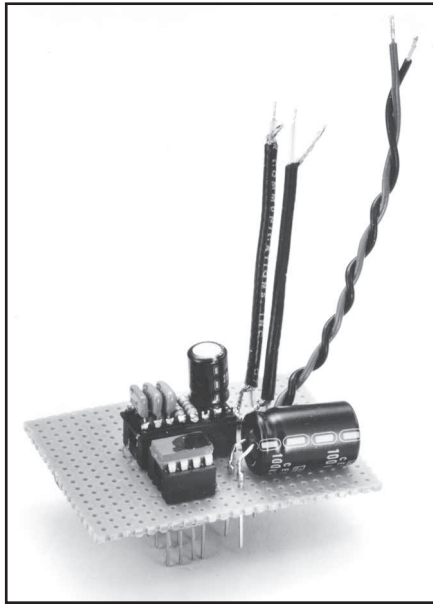

Fig 8.17—The audio amplifier built using wire-wrap techniques.

Large component leads can deform the metal strips.

Wire Wrap

Wire-wrap techniques can be used to quickly construct a circuit without solder. Low- and medium-speed digital circuits are often assembled on a wire-wrap board. The technique is not limited to digital circuits, however. **Fig 8.17** shows the audio amplifier built using wire wrap. Circuit changes are easy to make, yet the method is suitable for permanent assemblies.

Wire wrap is done by wrapping a wire around a small square post to make each connection. A wrapping tool resembles a thick pencil. Electric wire-wrap guns are convenient when many connections must be made. The wire is almost always #30 wire with thin insulation. Two wire-wrap methods are used: the standard and the modified wrap (**Fig 8.18**). The modified wrap is more secure. The wrap-post termi-

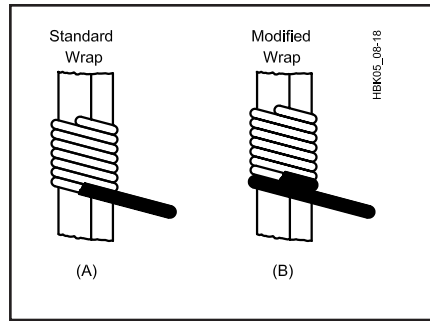

Fig 8.18—Wire-wrap connections. Standard wrap is shown at A; modified wrap at B.

nals are square (wire wrap works only on posts with sharp corners). They should be long enough for at least two connections. **Fig 8.18** and **Fig 8.19** show proper and improper wire-wrap techniques. Mount small components on an IC header plug. Insert the header into a wire-wrap IC socket as shown in **Fig 8.17**. The large capacitor in that figure has its leads soldered directly to wire-wrap posts.

Surface Mounting

Surface mounting is not new—it was an established ground-plane and professional technique for years before its appearance in consumer and amateur electronics. This technique is particularly suitable for PC-board construction, although it can be applied to many other construction techniques. Surface-mounted components take up very little space on a PC board.

Modern automated manufacturing techniques and surface-mount technology have evolved together; most modern ICs are being made specifically for this technique. Chip resistors and capacitors are common in UHF and microwave designs. Chip devices have low stray inductance and capacitance, making them excellent components to use in this frequency range. Other components, such as transistors and diode arrays are also available in this space-saving format.

Surface-mount techniques are not limited to “surface-mount” ICs, however. This technique can be used to mount standard resistors, capacitors or ICs. See the sidebar “Surface Mount Construction Techniques.”

Removing SMT Components

The surface-mount ICs used in commercial equipment are not easy for experimenters to replace. They have tiny pins designed for precision PC boards. Sooner or later, you may need to replace one, though. If you do, don’t try to get the old IC out in one piece! This will damage the

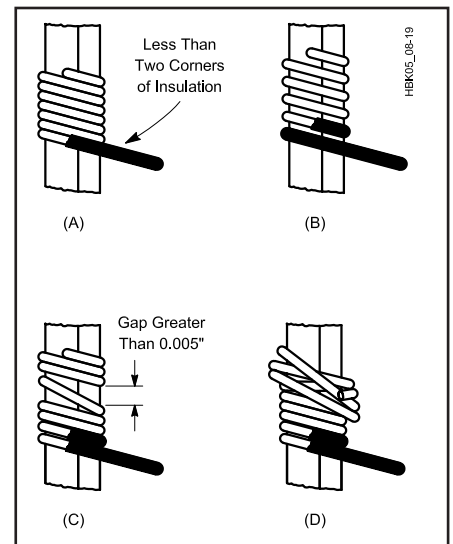

Fig 8.19—Improper wire-wrap connections. Insufficient insulation for modified wrap is shown at A; a spiral wrap at B, where there is too much space between turns; an open wrap at C, where one or more turns are improperly spaced and an overwrap at D, where the turns overlap on one or more turns.

IC beyond use anyway, and will probably damage the PC board in the process.

Although it requires a delicate touch and small tools, it’s possible to change a surface mount IC at home. To remove the old one, use small, sharp wire cutters to cut the IC pins flush with the IC. This usually leaves just enough old pin to grab with a tiny pair of needle-nose pliers or a hemostat. Heat the soldered connection with a small iron and use the pliers to gently pull the pin from the PC board. Solder in the new component using the techniques discussed in the sidebar.

Printed-Circuit Boards

Many builders prefer the neatness and miniaturization made possible by the use of etched printed-circuit boards (PC boards). Once designed, a PC board is easily duplicated, making PC boards ideal for group projects. To make a PC board, resist material is applied to a copper-clad bare PC board, which is then immersed into an acid etching bath to remove selected areas of copper. In a finished board, the conductive copper is formed into a pattern of conductors or “traces” that form the actual wiring of the circuit.

PC Board Stock

PC board stock consists of a sheet made from insulating material, usually glass epoxy or phenolic, coated with conduc-

Surface Mount Construction Techniques

“Oh no, this project uses SMT parts!” Some homebrewers recoil at the thought of assembling a kit that uses surface mount technology (SMT) components. They fear the parts are too small to see, handle, solder or debug when assembled. I had these same concerns until I tried it and found that it wasn’t so difficult when using the right tools. Further, I discovered some benefits of using SMT parts that made my QRP projects smaller, lighter and more portable for optimized field use.

I’ve chosen two quite different projects to illustrate some successful SMT assembly techniques. One is a small DDS signal generator “daughtercard” kit that comes with an assortment of SMT capacitors, resistors and inductors, and an SOIC integrated circuit. The other example circuit is a small one-stage audio amplifier built “Manhattan-style”! Yes, you *can* homebrew using SMT parts—results can sometimes be even better than when using conventional leaded parts.

But first, here is some component history and what you need to do to get your work area ready for constructing an SMT project.

What is an SMT component?

Resistors and capacitors with axial or radial leads have been most common over the years. Same too for integrated circuits arranged in dual in-line package (DIP) format with rows of leads separated by a generous 0.3 inch or so. This open-leaded component and easily accessed IC pins made for easy circuit board assembly back in the Heathkit days. Although these types of components are still available today, parts miniaturization has brought about more compact and less expensive products. Discrete components packaging has shrunk to 0.12×0.06 inches, as shown in the ‘1206’ capacitor in **Fig A** compared to a penny. Even smaller packages are common today, requiring much less pc board area for the same equivalent circuits. Integrated circuit packaging has also been miniaturized to create 10×5 mm SOIC packages with lead separations of 0.025 inches. You need some extra skills beyond what was necessary when assembling that Heath SB-104 transceiver back in 1974!

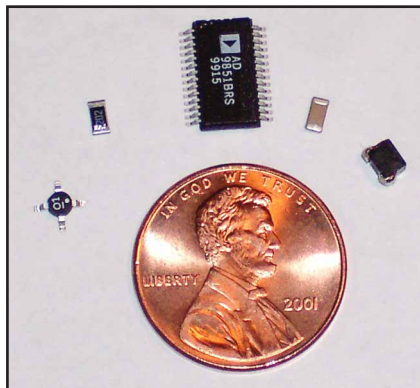

Fig A—SMT components are small. Clockwise from left: MMIC RF amp, 1206 resistor, SOIC integrated circuit, 1206 capacitor and ferrite inductor.



Fig B—A magnifying visor is great for close-up work on a circuit board. These headsets are often available for less than \$10 at hamfests and some even come with superbright LEDs mounted on the side to illuminate the components being soldered.

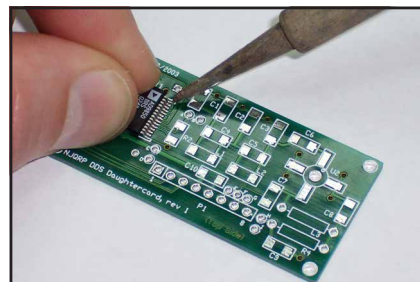

Fig C—This DDS Daughtercard has all interconnections on the top side. Connections to the ground plane on the backside of the board are made by the use of “vias,” wires through the PC board. Pin 28 of the SMT IC is shown being tack-soldered to hold it to the board, keeping all other pins carefully aligned on their pads. Then the other pins are carefully soldered, starting with pin 14 (opposite pin 28). Finally, pin 28 is reheated to ensure a good connection there. If you bridge solder across adjacent pads or pins, use solder wick or a vacuum solder sucker to draw off the excess solder.

Preparing for the job

The key to success with any construction project is selecting and using the proper tools. A magnifying lamp is essential for well-lighted, close-up work on the components. **Fig B** shows a convenient magnifying visor. Tweezers or fine-tipped pliers allow you to grab the small chip components with dexterity. Thinner solder (0.015 inches) than you might normally use is preferred because it melts more quickly and leaves a smaller amount of solder on the component lead. Use of a super fine-tipped soldering iron make soldering the leads of these small parts straightforward and easy. A clean work surface is of paramount importance because SMT components have a tendency to fly away even when held with the utmost care by tweezers—you’ll have the best chance of recovering your wayward part if your table is clear. When the inevitable happens, you’ll have lots of trouble finding it if the part falls onto a rug. It’s best to have your work area in a non-carpeted room, for this reason as well as to protect static-sensitive parts.

Assembling SMT parts on a PC board

The first project example is the **DDS Daughtercard**—a small module that generates precision RF signals for a variety of projects. This kit has become immensely popular in homebrew circles and is supplied with the chip components contained in color-coded packaging that makes an easy job of identifying the little parts, a nice touch by a kit supplier.

Fig C shows the DDS PC board, a typical layout for SMT components. All traces are on one side, since the component leads are not “through-hole.” The little square pads are the places where the 1206 package-style chips will eventually be soldered.

The trick to soldering surface-mount devices to PC boards is to (a) pre-solder (“tin”) one of the pads on the board where the component will ultimately go by placing a small blob of solder there; (b) carefully hold the component in place with small needle-nose pliers or sharp tweezers on the tinned pad; (c) reheat the tinned pad and component to reflow the solder onto the component lead, thus temporarily holding the component in place; and (d) solder the other end of the component to its pad. Finally, check all connections to

make sure there are no bridges or shorts. **Fig D** illustrates how to use this technique. **Fig E** shows the completed DDS board.

Homebrewing with SMT parts

The second project example is the **K8IQY Audio Amp**—a discrete component audio amplifier that is constructed “Manhattan-style.” You glue little pads to the board wherever you need to attach component leads or wires. See **Fig F**.

Instead of using little squares or dots of pcb material for pads, you might decide to create isolated connection points by cutting an “island” in the copper using an end mill. No matter how the pads are created, SMT components may be easily soldered from pad-to-pad, or from pad-to-ground plane to build up the circuit. **Fig G** shows the completed board, combining SMT and

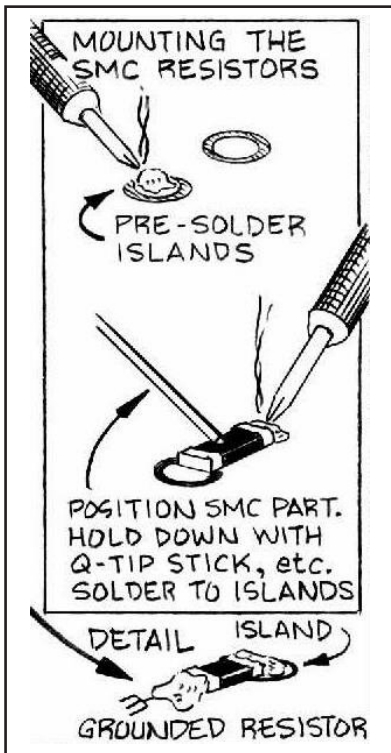

Fig D—Attaching an SMT part. Things are a lot easier attaching capacitors, resistors and other discrete components compared to multi-pin ICs. Carefully hold the component in place and properly aligned using needle-nose pliers or tweezers and then solder one end of the component. Then reheat the joint while gently pushing down on the component with the pliers or a Q-tip stick to ensure it is lying flat on the board. Finally, solder the other side of the component.

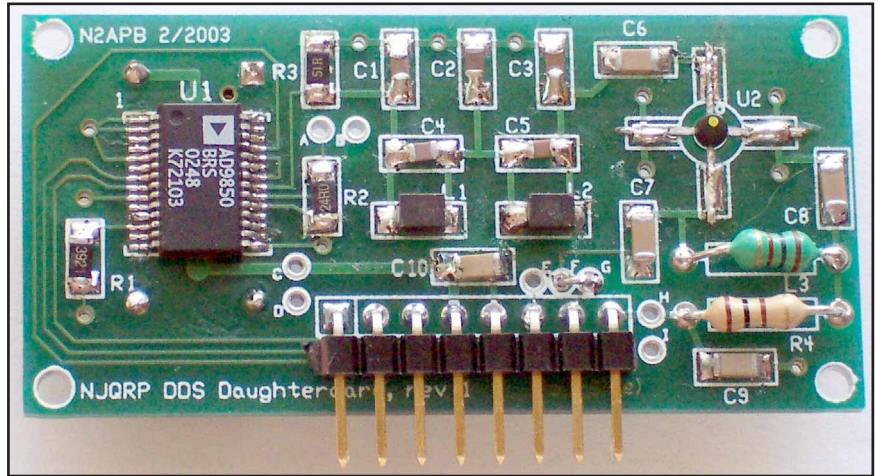

Fig E—The fully-populated DDS Daughtercard PC board contains a mix of SMT and through-hole parts, showing how both packaging technologies can be used together.



Fig F—SMT resistors soldered to base board of the Audio Amp in the beginning stages of assembly.

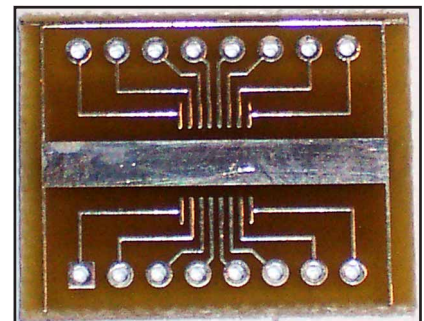

Fig H—Surface mount ICs can be mounted to general-purpose carrier boards, then attached as a submodule with wires to the base board of the homebrew project.

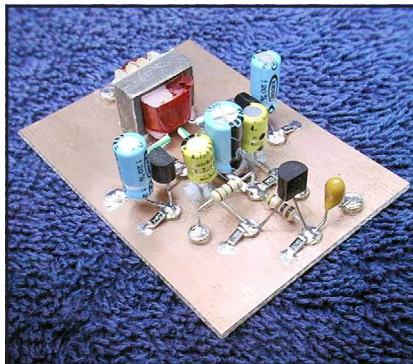

Fig G—The completed homebrew Audio Amp assembly shows simple, effective use of SMT components used together with conventional leaded components when constructed “Manhattan-style.”

leaded components.

Homebrewing with SOIC-packaged integrated circuits is a little trickier and typically requires the use of an “SOIC carrier board” such as the one shown in **Fig H**, onto which you solder your surface mount integrated circuit. You

can then wire the carrier board onto your homebrew project, copper-clad base board or whatever you’re using to hold your other circuit components.

So start melting solder!

The techniques are easy, the SMT components are actually cheaper than conventional through-hole leaded components and you’ll have a smaller, more portable project when you’re done. Go for it!—*George Heron, N2APB.*

References

Full details on the DDS Daughtercard, the K8IQY Islander Audio Amp, and the Islander Pad Cutter may be found online at www.njqr.org/dds, www.njqr.org/islanderamp, and www.njqr.org/islanderpadcutter, respectively. Also see: www.arri.org/tis/info/surface.html.

tive copper. Copper-clad stock is manufactured with phenolic, FR-4 fiberglass and Teflon base materials in thicknesses up to 1/8 inch. The copper thickness varies. It is usually plated from 1 to 2 oz per square foot of bare stock.

Resists

Resist is a material that is applied to a PC board to prevent the acid etchant from eating away the copper on those areas of the board that are to be used as conductors. There are several different types of resist materials, both commercial and home brew. When resist is applied to those areas of the board that are to remain as copper traces, it “resists” the acid action of the etchant.

The PC board stock must be clean before any resist is applied. This is discussed later in the chapter. After you have applied resist, by whatever means, protect the board by handling it only at its edges. Do not let it get scraped. Etch the board as soon as possible, to minimize the likelihood of oxidation, moisture or oils contaminating the resist or bare board.

Tape

To make a single PC board, Scotch, adhesive or masking tape, securely applied, makes a good resist. (Don’t use drafting tape; its glue may be too weak to hold in the etching bath.) Apply the tape to the entire board, transfer the circuit pattern by means of carbon paper, then cut out and remove the sections of tape where the copper is to be etched away. An X-Acto hobby knife is excellent for this purpose.

Resist Pens

Several electronics suppliers sell resist pens. Use a resist pen to draw PC-board artwork directly onto a bare board. Commercially available resist pens work well. Several types of permanent markers also function as resist, especially the “Sharpie” brand. They come in fine-point and regular sizes; keep two of each on hand.

Paint

Some paints are good resists. Exterior enamel works well. Nail polish is also good, although it tends to dry quickly so you must work fast. Paint the pattern onto the copper surface of the board to be etched. Use an artist’s brush to duplicate the PC board pattern onto bare PC-board stock. Tape a piece of carbon paper to the PC-board stock. Tape the PC-board pattern to the carbon paper. Trace over the original layout with a ballpoint pen. The carbon paper transfers the outline of the pattern onto the bare board. Fill in the outline with the resist paint. After paint

has been applied, allow it to dry thoroughly before etching.

Rub-On Transfer

Several companies (Kepron Circuit Systems, DATAK Corp, GC Electronics) produce rub-on transfer material that can also be used as resist. Patterns are made with various width traces and for most components, including ICs. As the name implies, the pad or trace is positioned on the bare board and rubbed to adhere to the board.

Etchant

Etchant is an acid solution that is designed to remove the unwanted copper areas on PC-board stock, leaving other areas to function as conductors. Almost any strong acid bath can serve as an etchant, but some acids are too strong to be safe for general use. Two different etchants are commonly used to fabricate prototype PC boards: ammonium persulfate and ferric chloride. The latter is the more common of the two.

Ferric chloride etchant is usually sold ready-mixed. It is made from one part ferric chloride crystals and two parts water, by volume. No catalyst is required.

Etchant solutions become exhausted as they are used. Keep a supply on hand. Dispose of the used solution safely; follow the instructions of your local environmental protection authority.

Most etchants work better if they are hot. A board that takes 45 minutes to etch at room temperature will take only a few minutes if the etchant is hot. Use a heat lamp to warm the etchant to the desired temperature. A darkroom thermometer is handy for monitoring the temperature of the bath.

Be careful! Do not heat your etchant above the recommended temperature, typically 160°F. If it gets too hot, it will probably damage the resist. Hot or boiling etchant is also a safety hazard.

Insert the board to be etched into the solution and agitate it continuously to keep fresh chemicals near the board surface. This speeds up the etching process. Normally, the circuit board should be placed in the bath with the copper side facing up.

After the etching process is completed, remove the board from the tray and wash it thoroughly with water. Use medium-grade steel wool to rub off the resist.

WARNING: Use a glass or other non-reactive container to hold etching chemicals. Most etchants will react with a metal container. Etchant is caustic and can burn eyes or skin easily. Use rubber gloves and wear old clothing, or a lab smock, when working with any chemicals. If you get

some on your skin, wash it with soap and cold water. Wear safety goggles (the kind that fit snugly on your face) when working with any dangerous chemicals. Read the safety labels and follow them carefully. If you get etchant in your eyes, wash immediately with large amounts of cool water and seek immediate medical help. Even a small chemical burn on your eye can develop into a serious problem.

Planning and Layout

A PC board can be a real convenience. If you want to build a project and a ready-made PC board is available, you can assemble the project quickly and expect it to work. This is true because someone else has done most of the real work involved—designing the PC board layout and fixing any “bugs” caused by intertrace capacitive coupling, ground loops and similar problems. In most cases, if a ready-made board is not available, ground-plane construction is a lot less work than designing, debugging and then making a PC board.

A later section of this chapter explains how to turn a schematic into a working circuit. It is not as simple as laying out the PC board just like the circuit is drawn on the schematic. Read that section before you design a PC board.

Rough Layout

Start by drawing a rough scale pictorial diagram of the layout. Draw the interconnecting leads to represent the traces that are needed on the board. Rearrange the layout as necessary to find an arrangement that completes all of the circuit traces with a minimum number of jumper-wire connections. In some cases, however, it is not possible to complete a design without at least a few jumpers.

Layout

After you have completed a rough layout, redraw the physical layout on a grid. Graph paper works well for this. Most IC pins are on 0.1-inch centers. Use graph paper that has 10 lines per inch to draw artwork at 1:1 and estimate the distance halfway between lines for 0.05-inch spacing. Drafting templates are helpful in the layout stage. Local drafting-supply stores should be able to supply them. The templates usually come in either full-scale or twice normal size.

To lay out a double-sided board, ensure that the lines on both sides of the paper line up (hold the paper up to the light). You can then use each side of the paper for each side of the board.

When using graph paper for a PC-board layout, include bolt holes, notches for wires and other mechanical consider-

ations. Fit the circuit into and around these, maintaining clearance between parts.

Most modern components have leads on 0.1-inch centers. The rows of dual-inline-package (DIP) IC pins are spaced 0.3 or 0.4 inch. Measure the spacing for other components. Transfer the dimensions to the graph paper. It is useful to draw a schematic symbol of the component onto the layout.

Most IC specification sheets show a top view of the pin locations. If you are designing the “foil” side of a PC board, be sure to invert the pin out.

Draw the traces and pads the way they will look. Using dots and lines is confusing. It’s okay to connect more than one lead per pad, or run a lead through a pad, although using more than two creates a complicated layout. In that case, there may be problems with solder bridges that form short circuits. Traces can run under some components; it is possible to put two or three traces between 0.4-inch centers for a 1/4-W resistor, for example.

Leave power-supply and other dc paths for last. These can usually run just about anywhere, and jumper wires are fine for these noncritical paths.

Do not use traces less than 0.010 inch (10 mil) wide. If 1-oz stock is used, a 10-mil trace can safely carry up to 500 mA. To carry higher current, increase the width of the traces in proportion. (A trace should be 0.200 inch to carry 10 A, for example.) Allow 0.1 inch between traces for each kilovolt in the circuit.

When doing a double-sided board, use pads on both sides of the board to connect traces through the board. Home-brew PC boards do not use plated-through holes (a manufacturing technique that has copper and tin plating inside all of the holes to form electrical connections). Use a through hole and solder the associated component to both sides of the board. Make other through-hole connections with a small piece of bus wire providing the connection through the board; solder it on both sides. This serves the same purpose as the plated-through holes found in commercially manufactured boards.

After you have planned the physical design of the board, decide the best way to complete the design. For one or two simple boards, draw the design directly onto the board, using a resist pen, paint or rub-on resist materials. To transfer the design to the PC board, draw light, accurate pencil lines at 0.1- or 0.05-inch centers on the PC board. Draw both horizontal and vertical lines, forming a grid. You only need lines on one side. For single-sided boards, use this grid to transfer the layout directly onto

the board surface. To make drilling easier, use a center punch to punch the centers of holes accurately. Do this before applying the resist so the grid is visible.

When drawing a pad with plenty of room around it, use a pad about 0.05 to 0.1 inch in diameter. For ICs, or other close quarters, make the pad as small as 0.03 inch or so. A “ring” that is too narrow invites soldering problems; the copper may delaminate from the heat. Pads need not be round. It’s okay to shave one or more edges if necessary, to allow a trace to pass nearby.

Draw the traces next. A drafting triangle can help. It should be spaced about 0.1 inch above the table, to avoid smudging the artwork. Use a 9-inch or larger triangle, with a rubber grommet taped to each corner (to hold it off the table). Select a sturdy triangle that doesn’t bend easily.

Align the triangle with the grid lines by eye and make straight, even traces similar to the layout drawing. The triangle can help with angled lines, too. Practice on a few pieces of scrap board.

Make sure that the resist adheres well to the PC board. Most problems can be seen by eye; there can be weak areas or bare spots. If necessary, touch up problems with additional resist. If the board is not clean the resist will not adhere properly. If necessary, remove the resist, clean the board and start from the beginning.

Discard troublesome pens. Resist pens dry out quickly. Keep a few on hand, switch back and forth and put the cap back on each for a bit to give the pen a chance to recover.

Once all of the artwork on the board is drawn, check it against the original artwork. It is easy to leave out a trace. It is not easy to put copper back after a board is etched. In a pinch, replace the missing trace with a small wire.

Applied resist takes about an hour to dry at room temperature. Fifteen minutes in a 200°F oven is also adequate.

Special techniques are used to make double-sided PC boards. See the section on double-sided boards for a description.

Making a PC Board

Several techniques can be used to make PC boards. They usually start with a PC-board “pattern” or artwork. All of the techniques have one thing in common: this pattern needs to be transferred to the copper surface of the PC board. Unwanted copper is then removed by chemical or mechanical means.

Most variations in PC-board manufacturing technique involve differences in resist or etchant materials or techniques.

Cut the Board to Size

No matter what technique you use, you should determine the required size of the PC board, and then cut the board to size. Trimming off excess PC-board material can be difficult after the components are installed.

Board Preparation

The bare (unetched) PC-board stock should be clean and dry before any resist is applied. (This is not necessary if you are using stock that has been treated with presensitized photoresist.) Wear rubber gloves when working with the stock to avoid getting fingerprints on the copper surface. Clean the board with soap and water, and then scrub the board with #000 steel wool. Rinse the board thoroughly then dry it with a clean, lint-free cloth. Keep the board clean and free of fingerprints or foreign substances throughout the entire manufacturing process.

No-Etch PC Boards

The simplest way to make PC boards is to mechanically remove the unwanted copper. Use a grinding tool, such as the Moto-Tool manufactured by the Dremel Company (available at most hardware or hobby stores). Another technique is to score the copper with a strong, sharp knife, then remove unwanted copper by heating it with a soldering iron and lifting it off with a knife while it is still hot. This technique requires some practice and is not very accurate. It often fails with thin traces, so use it only for simple designs.

Photographic Process

Many magazine articles feature printed-circuit layouts. Some of these patterns are difficult to duplicate accurately by hand. A photographic process is the most efficient way to transfer a layout from a magazine page to a circuit board.

The resist ink, tape or dry-transfer processes can be time consuming and tedious for very complex circuit boards. As an alternative, consider the photo process. Not only does the accuracy improve, you need not trace the circuit pattern yourself!

A copper board coated with a light-sensitive chemical is at the heart of the photographic process. In a sense, this board becomes your photographic film.

Make a contact print of the desired pattern by transferring the printed-circuit artwork to special copy film. This film is attached to the copper side of the board and both are exposed to intense light. The areas of the board that are exposed to the light—those areas not shielded by the black portions of the artwork—undergo a chemical



Fig 8.20—PC-board materials are available from several sources. This kit is from RadioShack.

change. This creates a transparent image of the artwork on the copper surface.

Develop the PC board, using techniques and chemicals specified by the manufacturer. After the board is developed, etch it to remove the copper from all areas of the board that were exposed to the light. The result is a PC board that looks like it was made in a factory.

Kepro sells materials and supplies for all types of PC-board manufacturing. RadioShack also sells PC-board materials. See **Fig 8.20**. If you're looking for printed-circuit board kits, chemicals, tools and other materials, contact Ocean State Electronics. They carry products by Kepro and the Meadowlake Corporation.

Iron-On Resist

One company that makes an iron-on resist is the Meadowlake Corporation. Their products make an artwork positive using a standard photocopier. A clothes iron transfers the printed resist pattern to the bare PC board.

Some experimenters have reported satisfactory results using standard photocopier paper or the output from a laser printer. Apparently the toner makes a reasonable resist. Note that the artwork for this method must be reversed with respect to a normal etching pattern because the print must be placed with the toner against the copper.

To transfer the resist pattern onto the board, place the pattern on the board (image side toward the copper), and then firmly press a hot iron onto the entire surface. Use plenty of heat and even pressure. This melts the resist, which then sticks to the bare PC board. This is not a perfect process; there will probably be bad areas on the resist. The amount of heat, the cleanliness of the bare board and the "skill" of the operator may affect the outcome.

The key to making high quality boards with the photocopy techniques is to be good at retouching the transferred resist.

Double-Sided PC Boards—by Hand!

Forget those nightmares about expensive photoresists that didn't work; forget that business of fifty bucks a board! You don't need computer-aided design to make a double-sided PC board just improve on the basics, and keep it simple. Anyone can make low-cost double-sided boards with traces down to 0.020 inch, with perfect front-to-back hole registration.

To make a double-sided board, drill the holes before applying the resist artwork; that is the only way to assure good front-to-back registration. The artwork on both sides can then be properly positioned to the holes. PC-board drilling was discussed earlier in the text.

After you have drilled the board, clean its surface thoroughly. After that, wear clean rubber or cotton gloves to keep it clean. One fingerprint can really mess up the application of resist or the etchant.

Tape the board to your work surface, making sure it can't move around. Transfer the artwork from your layout grid to the PC board, drawing by hand with a resist pen.

Allot enough time to finish at least one side of the artwork in one sitting. Start with the pads. To make a handy pad-drawing tool, press the tip of a regular-size Sharpie into one of the drilled PC-board holes. This "smushes" the tip into the shape of the hole, leaving a flat shoulder to draw the pad. See **Fig A**. The diameter of the pad is determined by how hard the pen is pressed; pressing too hard forms a pad that is way too large for most applications. Practice on scrap board first. Use this modified pen to fill in all the holes and draw the pads at the same time. Use an unmodified resist pen to draw all of the traces and to touch up any voids or weak areas in the pads. For the rest of the drawing, the procedure described for single-sided boards applies to double-sided boards, too.

After the resist is applied to the first side, carefully draw the second side. Inspect the board thoroughly; you may have scratched or smudged the first side while you were drawing the second.

Etching a double-sided board is not much different than etching a single-sided board, except that you must ensure that the etchant is able to reach both sides of the board. If you dunk the board in and out of the etchant solution, both sides are exposed to the etchant. If you use a tray, put some spacers on the bottom and rest the board on the spacers. (The spacers must be put on the board edges, not where you want to actually etch.) This ensures that etchant gets to both sides. If you use this method, turn the board over once or twice during the process.—*Dave Reynolds, KE7QF*

Or Photo-Etched

You can also make double-sided boards at home without drawing the layout by hand. This procedure can't produce results to match the finest professionally made double-sided boards, but it can make boards that are good enough for many moderately complex projects.

Start with the same sort of artwork used for single-sided boards, but leave a margin for taping at one edge. It is critical that the patterns for the two sides are accurately sized. The chief limiting factor in this technique is the requirement that matching pads on the two sides are positioned correctly. Not only must the two sides match each other, but they must also be the correct size for the parts in the project. Slight reproduction errors can accumulate to major problems in the length of a 40-pin DIP IC. One good tool to achieve this requirement is a photocopy machine that can make reductions and enlargements in 1% steps. Perform a few experiments to arrive at settings that yield accurately sized patterns.

Choose two holes at opposite corners of the etching patterns. Tape one of the two patterns to one side of the PC board. Choose some small wire and a drill bit that closely matches the wire diameter. For example, #20 enameled wire is a close match for a #62 or a #65 drill, depending on the thickness of the wire's enamel coating. Drill through the pattern and the board at the two chosen holes. Drill the chosen holes through the second pattern. Place two pieces of the wire through the PC board and slide the second pattern down these wire "pins" to locate the pattern on the board. Tape the second pattern in position and remove the pins. From this point on, expose and process each side of the board as if it were a single-sided board, but take care when exposing each side to keep the reverse side protected from light.—*Bob Schetgen, KU7G*



Fig A—Make a permanent marker into a specialized PC-board drawing tool. Simply press the marker point into a drilled hole to form a modified point as shown. More pressure produces a wider shoulder that makes larger pads on the PC board.

Fortunately, the problems are usually easy to retouch, if you have a bit of patience. A resist pen does a good job of reinforcing any spotty areas in large areas of copper.

Double-Sided PC Boards

All of the examples used to describe the above techniques were single-sided PC boards, with traces on one side of the board and either a bare board or a ground plane on the other side. PC boards can also have patterns etched onto both sides, or even have multiple layers. Most home-construction projects use single-sided boards, although some kit builders supply double-sided boards. Multilayer boards are rare in ham construction. One method for making double-sided boards is described in the sidebar, “Double-Sided PC Boards—by Hand!”

Tin Plating

Most commercial PC boards are tin plated, to make them easier to solder. Commercial tin-plating techniques require electroplating equipment not readily available to the home constructor. Immersion tin plating solutions can deposit a thin layer of tin onto a copper PC board. Using them is easy; put some of the solution into a plastic container and immerse the board in the solution for a few minutes. The chemical action of the tin-plating solution replaces some of the copper on the board with tin. The result looks nearly as good as a commercially made board. Agitate the board or solution from time to time. When the tinning is complete, take the board out of the solution and rinse it for five minutes under running water. If you don't remove all of the residue, solder may not adhere well to the surface. Kepro sells immersion tin plating solution.

Drilling a PC Board

After you make a PC board using one of the above techniques, you need to drill holes in the board for the components. Use a drill press, or at least improvise one. Boards can be drilled entirely “free hand” with a hand-held drill but the potential for error is great. A drill press or a small Moto-Tool in an accessory drill press makes the job a lot easier. A single-sided board should be drilled after it is etched; the easiest way to do a double-sided board is to do it before the resist is applied.

To drill in straight lines, build a small movable guide for the drill press so you can slide one edge of the board against it and line up all of the holes on one grid line at a time. See Fig 8.21. This is similar to the “rip fence” set up by most woodworkers to cut accurately and repeatably with a table saw.

The drill-bit sizes available in hardware stores are too big for PC boards. You can use high-speed steel bits, but glass epoxy stock tends to dull these after a few hundred holes. (When your drill bit becomes worn, it makes a little “hill” around each drilled hole, as the worn bit pushes and pulls the copper rather than drilling it.) A PC-board drill bit, available from many electronic suppliers, will last for thousands of holes! If you are doing a lot of boards, it is clearly worth the investment.

Small drill bits are usually ordered by number. Here are some useful numbers and their sizes:

Number	Diameter
68	0.0310"
65	0.0350"
62	0.0380"
60	0.0400"

Use high RPM and light pressure to make good holes. Count the holes on both the board and your layout drawing to ensure that none are missed. Use a larger-size drill bit, lightly spun between your fingers, to remove any burrs. Don't use too much pressure; remove only the burr.

“READY-MADE” PC BOARDS

Utility PC Boards

“Utility” PC boards are an alternative to custom-designed etched PC boards. They offer the flexibility of perforated board construction and the mechanical and electrical advantages of etched circuit connection pads. Utility PC boards can be used to build anything from simple passive filter circuits to computers.

Circuits can be built on boards on which the copper cladding has been divided into connection pads. Power supply voltages can be distributed on bus strips. Boards like those shown in Fig 8.22 are commercially available.

An audio amplifier constructed on a utility PC board is shown in Fig 8.23. Component leads are inserted into the board and soldered to the etched pads. Wire jumpers connect the pads together to complete the circuit.

Utility boards with one or more etched plugs for use in computer-bus, interface and general purpose applications are widely available. Connectors, mounting hardware and other accessories are also available. Check with your parts supplier for details.

PC-Board Assembly Techniques

Once you have etched and drilled a PC board you are ready to use it in a project. Several tools come in handy: needle-nose pliers, diagonal cutters, pocket knife, wire strippers, clip leads and soldering iron.

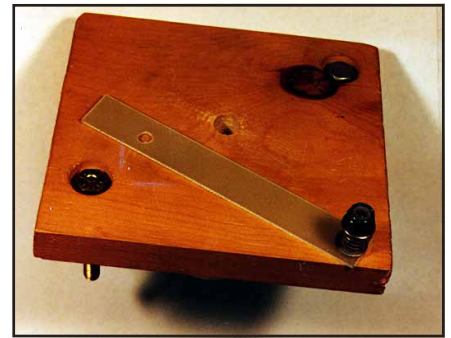
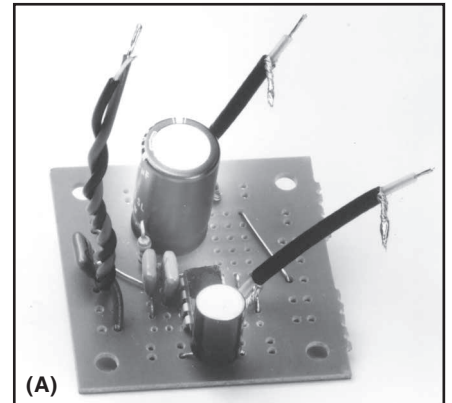

Fig 8.21—This home-built drill fence makes it easy to drill PC-board holes in straight rows.



Fig 8.22—Utility PC boards like these are available from many suppliers.



(A)

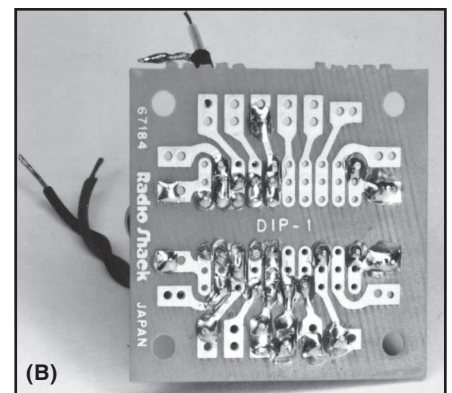

(B)

Fig 8.23—The audio amplifier built on a multipurpose PC breadboard. Top view at A; bottom view at B.

Cleanliness

Make sure your PC board and component leads are clean. Clean the entire PC board before assembly; clean each component before you install it. Corrosion looks dark instead of bright and shiny. Don't use sandpaper to clean your board. Use a piece of fine steel wool or a Scotchbrite cleaning pad to clean component leads or PC board before you solder them together.

Installing Components

In a construction project that uses a PC board, most of the components are installed on the board. Installing components is easy—stick the components in the right board holes, solder the leads, and cut off the extra lead length. Most construction projects have a parts-placement diagram that shows you where each component is installed.

Getting the components in the right holes is called “stuffing” the circuit board. Inserting and soldering one component at a time takes too long. Some people like to put the components in all at once, and then turn the board over and solder all the leads. If you bend the leads a bit (about 20°) from the bottom side after you push them through the board, the components are not likely to fall out when you turn the board over.

Start with the shortest components—horizontally mounted diodes and resistors. Larger components sometimes cover smaller components, so these smaller parts must be installed first. Use adhesive tape to temporarily hold difficult components in place while you solder.

PC-Board Soldering

To solder components to a PC board, bend the leads at a slight angle; apply the soldering iron to one side of the lead, and flow the solder in from the other side of the lead. See Fig 8.24. Too little heat causes a bad or

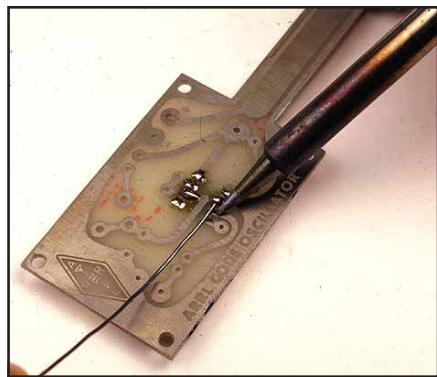

Fig 8.24—This is how to solder a component to a PC board. Make sure that the component is flush with the board on the other side.

“cold” solder joint; too much heat can damage the PC board. Practice a bit on some spare copper stock before you tackle your first PC board project. After the connection is soldered properly, clip the lead flush with the solder.

Special Concerns

Make sure you have the components in the right holes before you solder them. Components that have polarity, such as diodes, ICs and some capacitors must be oriented as shown on the parts-placement diagram.

FROM SCHEMATIC TO WORKING CIRCUIT

Some people don't know how to turn a schematic into a working circuit. One thing is usually true—you can't build it the way it looks on the schematic. Many design and layout considerations that apply in the real world of practical electronics don't appear on a schematic.

PC Boards—Always the Best Choice?

PC boards are everywhere—in all kinds of consumer electronics, in most of your Amateur Radio equipment. They are also used in most kits and construction projects. A newcomer to electronics might think that there is some unwritten law against building equipment in any other way!

The misconception that everything needs to be built on a printed-circuit board is often a stumbling block to easy project construction. In fact, a PC board is probably the worst choice for a one-time project. In actuality, a moderately complex project (like a QRP transmitter) can be built in much less time using other techniques. The additional design, layout and manufacturing is usually much more work than it would take to build the project by hand.

So why does everyone use PC boards? The most important reason is that they are reproducible. They allow many units to be mass-produced with exactly the same layout, reducing the time and work of conventional wiring and minimizing the possibilities of wiring errors. If you can buy a ready-made PC board or kit for your project, it can save a lot of construction time.

Using a PC board usually makes project construction easier by minimizing the risk of wiring errors or other construction blunders. Inexperienced constructors usually feel more confident when construction has been simplified to the assembly of components onto a PC board. One of the best ways to get started with home construction (to some the best part of Amateur Radio) is to start by assembling a few kits using PC

boards. Contact information for kit manufacturers can be found on *ARRLWeb* (www.arrl.org/cgi-bin/tisfind?pattern=amateur+radio+kit).

One-Time Projects

Kits are fun, but another facet of electronics construction is building and developing your own circuits, starting from circuit diagrams. For one-time construction, PC boards are really not necessary. It takes time to lay out, drill and etch a PC board. Alterations are difficult to make if you change your ideas or make a mistake. Most important, PC boards aren't always the best technique for building RF circuits.

Layout

A circuit diagram is a poor guide toward a proper layout. Circuit diagrams are drawn to look attractive on paper. They follow drafting conventions that have very little to do with the way the circuit works. On a schematic, ground and supply voltage symbols are scattered all over the place. The first rule of RF layout is—*do not wire RF circuits as they are drawn!* How a circuit works in practice depends on the layout. Poor layout can ruin the performance of even a well-designed circuit.

How to Design a Good Circuit Layout

The easiest way to explain good layout practices is to take you through an example. Fig 8.25 is the circuit diagram of a two-stage receiver IF amplifier using dual-gate MOSFETs. It is only a design example, so the values are only typical. To analyze which things are important to the layout of this circuit, ask these questions:

- Which are the RF components, and which are only involved with LF or dc?
- Which components are in the main RF signal path?
- Which components are in the ground return paths?

Use the answers to these questions to plan the layout. The RF components that are in the main RF signal path are usually the most critical. The AF or dc components can usually be placed anywhere. The components in the ground return path should be positioned so they are easily connected to the circuit ground. Answer the questions, apply the answers to the layout, and then follow these guidelines:

- Avoid laying out circuits so their inputs and outputs are close together. If a stage's output is too near a previous stage's input, the output signal can feed-back into the input and cause problems.
- Keep component leads as short as prac-

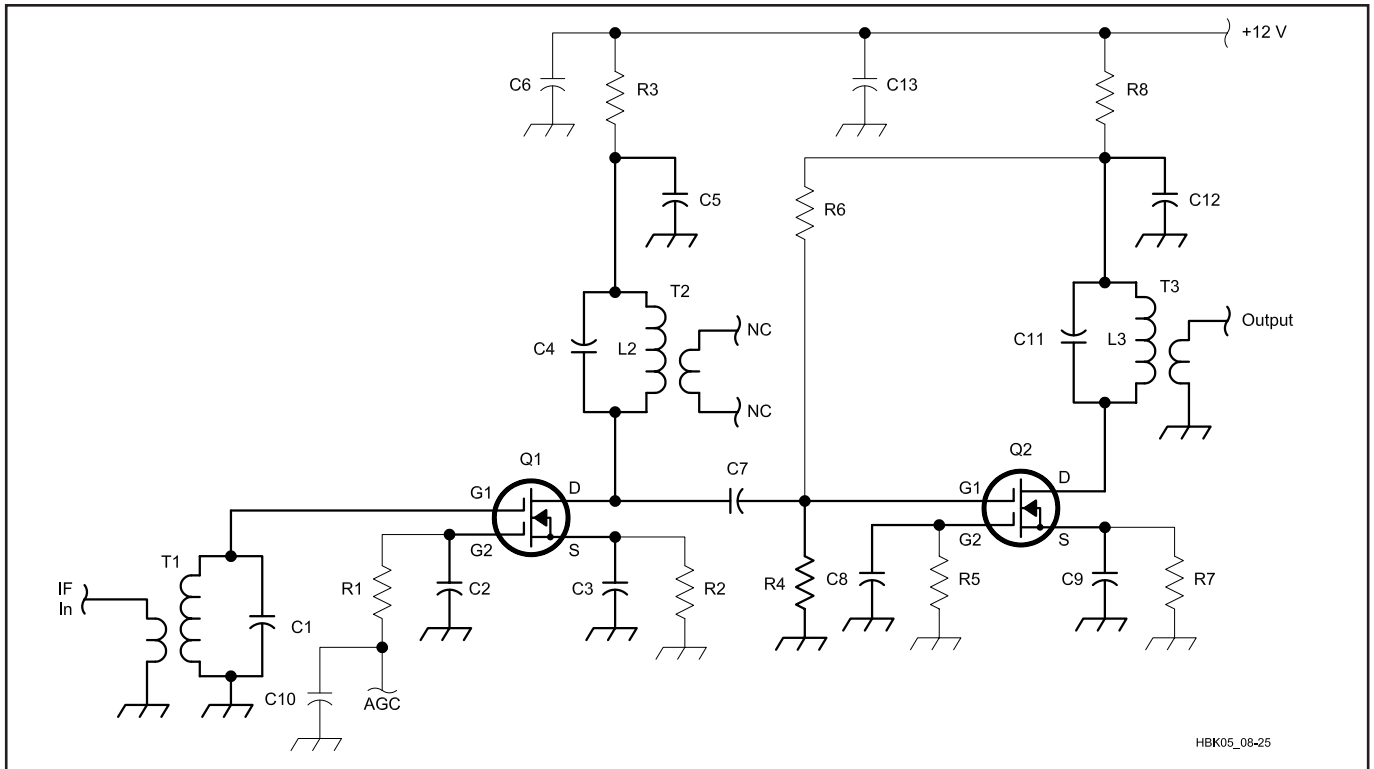

Fig 8.25—The IF amplifier used in the design example. C1, C4 and C11 are not specified because they are internal to the IF transformers.

tical. This doesn't necessarily mean as short as possible—just consider lead length as part of your design.

- Remember that metal transistor cases conduct, and that a transistor's metal case is usually connected to one of its leads. Prevent cases from touching ground or other components, unless called for in the design.

In our design example, the RF components are shown in heavy lines, though not all of these components are in the main RF signal path. The RF signal path consists of T1/C1, Q1, T2/C4, C7, Q2, T3/C11. These need to be positioned in almost a straight line, to avoid feedback from output to input. They form the backbone of the layout, as shown in **Fig 8.26A**.

The question about ground paths requires some further thought—what is really meant by “ground” and “ground-return paths”? Some points in the circuit need to be kept at RF ground potential. The best RF ground potential on a PC board is a copper ground plane covering one entire side. Points in the circuit that cannot be connected directly to ground for dc reasons must be bypassed (“decoupled”) to ground by capacitors that provide ground-return paths for RF.

In Fig 8.26, the components in the ground-return paths are the RF bypass capacitors C2, C3, C5, C8, C9 and C12.

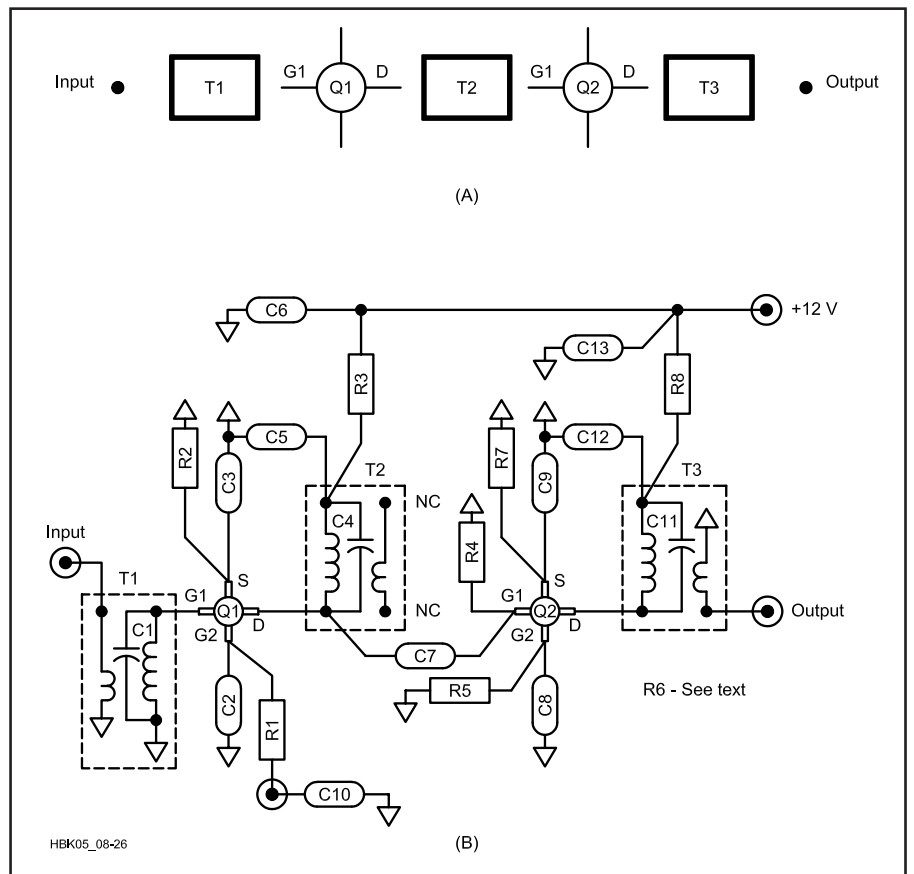

Fig 8.26—Layout sketches. The preliminary line-up is shown in A; the final layout in B.

R4 is primarily a dc biasing component, but it is also a ground return for RF so its location is important. The values of RF bypass capacitors are chosen to have a low reactance at the frequency in use; typical values would be 0.1 μF at LF, 0.01 μF at HF, and 0.001 μF or less at VHF. Not all capacitors are suitable for RF decoupling; the most common are disc ceramic capacitors. RF decoupling capacitors should always have short leads.

Almost every RF circuit has an input, an output and a common ground connection. Many circuits also have additional ground connections, both at the input side and at the output side. Maintain a low-impedance path between input and output ground connections. The input ground connections for Q1 are the grounded ends of C1 and the two windings of T1. (The two ends of an IF transformer winding are generally not interchangeable; one is designated as the “hot” end, and the other must be connected or bypassed to RF ground.) The capacitor that resonates with the adjustable coil is often mounted inside the can of the IF transformer, leaving only two component leads to be grounded as shown in Fig 8.26B.

The RF ground for Q1 is its source connection via C3. Since Q1 is in a plastic package that can be mounted in any orientation, you can make the common ground either above or below the signal path in Fig 8.26B. Although the circuit diagram shows the source at the bottom. The practical circuit works much better with the source at the top, because of the connections to T2.

It’s a good idea to locate the hot end of the main winding close to the drain lead of the transistor package, so the other end is toward the top of Fig 8.26B. If the source of Q1 is also toward the top of the layout, there is a common ground point for C3 (the source bypass capacitor) and the output bypass capacitor C5. Gate 2 of Q1 can safely be bypassed toward the bottom of the layout.

C7 couples the signal from the output of Q1 to the input of Q2. The source of Q2 should be bypassed toward the top of the layout, in exactly the same way as the source of Q1. R4 is not critical, but it should be connected on the same side as the other components. Note how the pinout of T3 has placed the output connection as far as possible from the input. With this layout for the signal path and the critical RF components, the circuit has an excellent chance of working properly.

DC Components

The rest of the components carry dc, so their layout is much less critical. Even so, try to keep everything well separated from

the main RF signal path. One good choice is to put the 12-V connections along the top of the layout, and the AGC connection at the bottom. The source bias resistors R2 and R7 can be placed alongside C3 and C9. The gate-2 bias resistors for Q2, R5 and R6 are not RF components so their locations aren’t too critical. R7 has to cross the signal path in order to reach C12, however, and the best way to avoid signal pickup would be to mount R7 on the opposite side of the copper ground plane from the signal wiring. Generally speaking, $1/8$ -W or $1/4$ -W metal-film or carbon-film resistors are best for low-level RF circuits.

Actually, it is not quite accurate to say that resistors such as R3 and R8 are not “RF” components. They provide a high impedance to RF in the positive supply lead. Because of R8, for example, the RF signal in T2 is conducted to ground through C5 rather than ending up on the 12-V line, possibly causing unwanted RF feedback. Just to be sure, C6 bypasses R3 and C13 serves the same function for R8. Note that the gate-2 bias resistor R6 is connected to C12 rather than directly to the 12-V supply, to take advantage of the extra decoupling provided by R8 and C13.

If you build something, you want it to work the first time, so don’t cut corners! Some commercial PC boards take liberties with layout, bypassing and decoupling. Don’t assume that you can do the same. Don’t try to eliminate “extra” decoupling components such as R3, C6, R8 and C13, even though they might not all be absolutely necessary. If other people’s designs have left them out, put them in again. In the long run it’s far easier to take a little more time and use a few extra components, to build in some insurance that your circuit will work. For a one-time project, the few extra parts won’t hurt your pocket too badly; they may save untold hours in debugging time.

A real capacitor does not work well over a large frequency range. A 10- μF electrolytic capacitor cannot be used to bypass or decouple RF signals. A 0.1- μF capacitor will not bypass UHF or microwave signals. Choose component values to fit the range. The upper frequency limit is limited by the series inductance, L_s . In fact, at frequencies higher than the frequency at which the capacitor and its series inductance form a resonant circuit, the capacitor actually functions as an inductor. This is why it is a common practice to use two capacitors in parallel for bypassing, as shown in Fig 8.27. At first glance, this might appear to be unnecessary. However, the self-resonant frequency of C1 is usually 1 MHz or less; it cannot supply any bypassing above that frequency. How-

ever, C2 is able to bypass signals up into the lower VHF range.

Let’s summarize how we got from Fig 8.24 to Fig 8.26B:

- Lay out the signal path in a straight line.
- By experimenting with the placement and orientation of the components in the RF signal path, group the RF ground connections for each stage close together, without mixing up the input and output grounds.
- Place the non-RF components well clear of the signal path, freely using decoupling components for extra measure.

Practical Construction Hints

Now it’s time to actually construct a project. The layout concepts discussed earlier can be applied to nearly any construction technique. Although you’ll eventually learn from your own experience, the following guidelines give a good start:

- Divide the unit into modules built into separate shielded enclosures—RF, IF, VFO, for example. Modular construction improves RF stability, and makes the individual modules easier to build and test. It also means that you can make major changes without rebuilding the whole unit. RF signals between the modules can usually be connected using small coaxial cable.
- Use a full copper ground plane. This is your largest single assurance of RF stability and good performance.
- Keep inputs and outputs well separated for each stage, and for the whole unit. If possible, lay out all stages in a straight line. If an RF signal path doubles back or recrosses itself it usually results in instability.
- Keep the stages at different frequencies well-separated to minimize interstage coupling and spurious signals.
- Use interstage shields where necessary, but don’t rely on them to cure a bad layout.
- Make all connections to the ground plane short and direct. Locate the common ground for each stage between the input and the output ground. Single-point grounding may work for a single stage, but it is rarely effective in a complex RF system.
- Locate frequency-determining components away from heat sources and mount them so as to maximize mechanical strength.
- Avoid unwanted coupling between tuned circuits. Use shielded inductors or toroids rather than open coils. Keep the RF high-voltage points close to the ground plane. Orient air-wound coils at right angles to minimize mutual coupling.

- Use lots of extra RF bypassing, especially on dc supply lines.
- Try to keep RF and dc wiring on opposite sides of the board, so the dc wiring is well away from RF fields.
- Compact designs are convenient, but don't overdo it! If the guidelines cited above mean that a unit needs to be bigger, make it bigger.

Combination Techniques

You can use a mixture of construction techniques on the same board and in most cases you probably should. Even though you choose one style for most of the wiring, there will probably be places where other techniques would be better. If so, do whatever is best for that part of the circuit. The resulting hybrid may not be pretty (these techniques aren't called "ugly construction" for nothing), but it will work!

Mount dual-in-line package (DIP) ICs in an array of drilled holes, then connect them using wired traces as described earlier. It is okay to mount some of the components using a ground-plane method, push pins or even wire wrap. On any one board, you may use a combination of these techniques, drilling holes for some ICs, or gluing others upside down, then surface mounting some of the pins, and other techniques to connect the rest. These combination techniques are often found in a project that combines audio, RF and digital circuitry.

A Final Check

No matter what construction technique is chosen, do a final check before applying power to the circuit! Things do go wrong, and a careful inspection minimizes the risk of a project beginning and ending its life as a puff of smoke! Check wiring carefully. Make a photocopy of the schematic and mark each lead on the schematic with a red X when you've verified that it's connected to the right spot in the circuit.

Inspect solder connections. A bad solder joint is much easier to find before the PC board is mounted to a chassis. Look for any damage caused to the PC board by soldering. Look for solder "bridges" between adjacent circuit-board traces. Solder bridges (Fig 8.28) occur when solder accidentally connects two or more conductors that are supposed to be isolated. It is often difficult to distinguish a solder bridge from a conductive trace on a tin-plated board. If you find a bridge, remelt it and the adjacent trace or traces to allow the solder's surface tension to absorb it. Double check that each component is installed in the proper holes on the board and that the orientation is correct. Make sure that no component leads or transistor

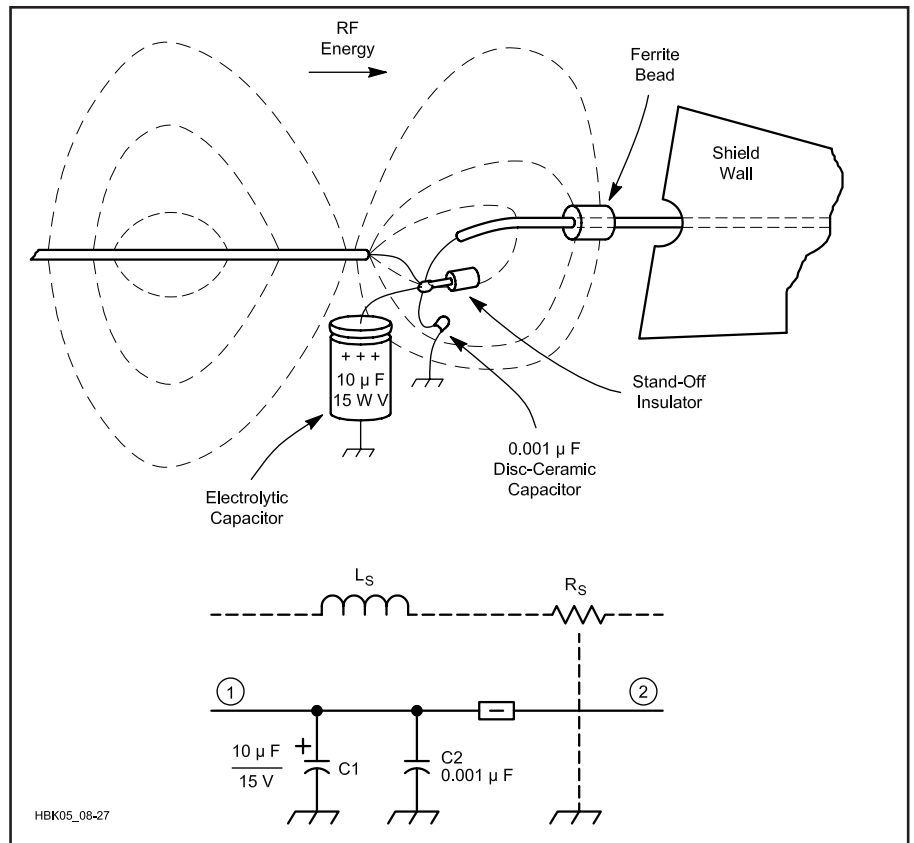

Fig 8.27—Two capacitors in parallel afford better bypassing across a wide frequency range.

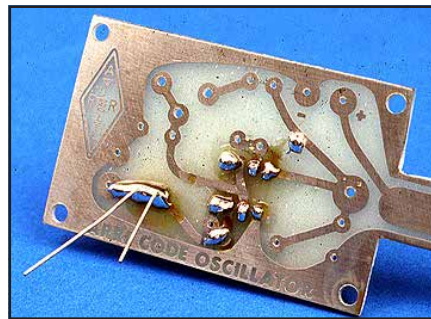

Fig 8.28—A solder bridge has formed a short circuit between PC board traces.

tabs are touching other components or PC board connections. Check the circuit voltages before installing ICs in their sockets. Ensure that the ICs are oriented properly and installed in the correct sockets.

OTHER CONSTRUCTION TECHNIQUES

Wiring

Select the wire used in connecting amateur equipment by considering: the maximum current it must carry, the voltage its insulation must withstand and its use.

To minimize EMI, the power wiring of

all transmitters should use shielded wire. Receiver and audio circuits may also require the use of shielded wire at some points for stability or the elimination of hum. Coaxial cable is recommended for all 50-Ω circuits. Use it for short runs of high-impedance audio wiring.

When choosing wire, consider how much current it will carry. Stranded wire is usually preferred over solid wire because stranded wire better withstands the inevitable bending that is part of building and troubleshooting a circuit. Solid wire is more rigid than stranded wire; use it where mechanical rigidity is needed or desired.

Wire with typical plastic insulation is good for voltages up to about 500 V. Use Teflon-insulated or other high-voltage wire for higher voltages. Teflon insulation does not melt when a soldering iron is applied. This makes it particularly helpful in tight places or large wiring harnesses. Although Teflon-insulated wire is more expensive, it is often available from industrial surplus houses. Inexpensive wire strippers make the removal of insulation from hookup wire an easy job. Solid wire is often used to wire HF circuits. Bare soft-drawn tinned wire, #22 to #12 (depending on mechanical requirements) is suitable. Avoid kinks by stretching a piece 10 or

15 ft long and then cutting it into short, convenient lengths. Run RF wiring directly from point to point with a minimum of sharp bends and keep the wire well-spaced from the chassis or other grounded metal surfaces. Where the wiring must pass through the chassis or a partition, cut a clearance hole and line it with a rubber grommet. If insulation is necessary, slip

spaghetti insulation or heat-shrink tubing over the wire. For power-supply leads, bring the wire through the chassis via a feed-through capacitor.

In transmitters where the peak voltage does not exceed 500 V, shielded wire is satisfactory for power circuits. Shielded wire is not readily available for higher voltages—use point-to-point wiring in-

stead. In the case of filament circuits carrying heavy current, it is necessary to use #10 or #12 bare or enameled wire. Slip the bare wire through spaghetti then cover it with copper braid pulled tightly over the spaghetti. Slide the shielding back over the insulation and flow solder into the end of the braid; the braid will stay in place, making it unnecessary to cut it back or

Microwave Construction Techniques

Microwave construction is becoming more popular, but at these frequencies the size of physical component leads and PC-board traces cannot be neglected. Microwave construction techniques either minimize these stray values or make them part of the circuit design.

Microwave construction does not always require tight tolerances and precision construction. A fair amount of error can often be tolerated if you are willing to tune your circuits, as you do at MF/HF. This usually requires the use of variable components that can be expensive and tricky to adjust.

Proper design and construction techniques, using high precision, can result in a “no-tune” microwave design. To build one of these no-tune projects, all you need do is buy the parts and install them on the board. The circuit tuning has been precisely controlled by the board and component dimensions so the project should work.

One tuning technique you can use with a microwave design, if you have the suitable test equipment, is to use bits of copper foil or EMI shielding tape as “stubs” to tune circuits. Solder these small bits of conductor into place at various points in the circuit to make reactances that can actually tune a circuit. After their position has been determined as part of the design, tuning is accomplished by removing or adding small amounts of conductor, or slightly changing the placement of the tuning stub. The size of the foil needed depends on your ability to determine changes in circuit performance, as well as the frequency of operation and the circuit board parameters. A precision setup that lets you see tiny changes allows you to use very small pieces of foil to get the best tuning possible.

From a mechanical accuracy point of view, the most tolerant type of construction is waveguide construction. Tuning is usually accomplished via one or more screws threaded into the waveguide. It becomes unwieldy to use waveguide on the amateur bands below 10 GHz because the dimensions get too large.

At 24 GHz and above, even waveguide becomes small and difficult to work with. At these frequencies, most readily available coax connectors work unreliably, so these higher bands are really a challenge. Special SMA connectors are available for use at 24 GHz.

Modular construction is a useful technique for microwave circuits. Often, circuits are tested by hooking their inputs and output to known 50- Ω sources and loads. Modules are typically kept small to prevent the chassis and PC board from acting as a waveguide, providing a feedback path between the input and output of a circuit, resulting in instability.

At microwave frequencies, the mechanical aspects and physical size of circuits become very much a part of the design. A few millimeters of conductor has significant reactance at these frequencies. This even affects VHF and HF designs! The traces and conductors used in an HF or

VHF design resonate on microwave frequencies. If a high-performance FET has lots of gain in this region, a VHF preamplifier might also function as a 10-GHz oscillator if the circuit stray reactances were just right (or wrong!). You can prevent this by using shields between the input and output or by adding microwave absorptive material to the lid of the shielded module. (SHF Microwave sells absorptive materials.)

It is important to copy microwave circuits exactly, unless you really know what you are doing. “Improvements,” such as better shielding or grounding can sometimes cause poor performance. It isn’t usually attractive to substitute components, particularly with the active devices. It may look possible to substitute different grades of the same wafer, such as the ATF13135 and the ATF13335, but these are really the same transistor with different performance measurements. While two transistors may have exactly the same gain and noise figure at the desired operating frequency, often the impedances needed to maintain stability at other frequencies are be different. Thus, the “substitute” may oscillate, while the proper transistor would work just fine.

You can often substitute MMICs (monolithic microwave integrated circuits) for one another because they are designed to be stable and operate with the same input and output impedances (50 Ω).

The size of components used at microwaves can be critical—in some cases, a chip resistor 80 mils across is not a good substitute for one 60 mils across. Hopefully, the author of a construction project tells you which dimensions are critical, but you can’t always count on this; the author may not know. It’s not unusual for a person to spend years building just one prototype, so it’s not surprising that the author might not have built a dozen different samples to try possible substitutions.

When using glass-epoxy PC board at microwave frequencies, the crucial board parameter is the thickness of the dielectric. It can vary quite a bit, in excess of 10%. This is not surprising; digital and lower-frequency analog circuits work just fine if the board is a little thinner or thicker than usual. Some of the board types used in microwave-circuit construction are a generic Teflon PC board, Duroid 5870 and 5880. These boards are available from Microwave Components of Michigan.

Proper connectors are a necessary expense at microwaves. At 10 GHz, the use of the proper connectors is essential for repeatable performance. Do not hook up microwave circuits with coax and pigtailed. It might work but it probably can’t be duplicated. SMA connectors are common because they are small and work well. SMA jacks are sometimes soldered in place, although 2-56 hardware is more common.—Zack Lau, W1VT, ARRL Laboratory Engineer

secure it in place. Clean the braid first so solder will take with a minimum of heat.

For receivers, RF wiring follows the methods described above. At RF, most of the current flows on the surface of the wire (a phenomenon called “skin effect”). Hollow tubing is just as good a conductor at RF as solid wire.

High-Voltage Techniques

High-voltage wiring requires special care. You need to use wire rated for the voltage it is carrying. Most standard hookup wire is inadequate. High-voltage wire is usually insulated with Teflon or special multilayer plastic. Some coaxial cable is rated at up to 3700 V.

Air is a great insulator, but high voltage can break down its resistance and form an arc. You need to leave ample room between any circuit carrying voltage and any nearby conductors. At dc, leave a gap of at least 0.1 inch per kilovolt. The actual breakdown voltage of air varies with the frequency of the signal, humidity and the shape of the conductors.

High voltage is also prone to corona discharge, a bleeding off of charge, primarily from sharp edges. For this reason, all connections need to be soldered, leaving only rounded surfaces on the soldered connection. It takes a little practice to get a “ball” of solder on each joint, but for voltages above 5 kV it is important.

Be careful working near high-voltage circuits! Most high-voltage power supplies can deliver a lethal shock.

Cable Lacing and Routing

Where power or control leads run together for more than a few inches, they present a better appearance when bound together in a single cable. Both plastic and waxed-linen lacing cords are available. You can also use a variety of plastic devices to bundle wires into cables and to clamp or secure them in place. Check with your local electronic parts supplier for items that are in stock.

To give a commercial look to the wiring of any unit, route any dc leads and shielded signal leads along the edge of the chassis. If this isn't possible, the cabled leads should then run parallel to an edge of the chassis. Further, the generous use of the tie points mounted parallel to an edge of the chassis, for the support of one or both ends of a resistor or fixed capacitor, adds to the appearance of the finished unit. In a similar manner, arrange the small components so that they are parallel to the panel or sides of the chassis.

Tie Points

When power leads have several

branches in the chassis, it is convenient to use fiber-insulated multiple tie points as anchors for junction points. Strips of this kind are also useful as insulated supports for resistors, RF chokes and capacitors. Hold exposed points of high-voltage wiring to a minimum; otherwise, make them inaccessible to accidental contact.

Winding Coils

Winding coils seems so simple, yet many new constructors run into difficulty. Understanding the techniques prevents some of the frustration or construction errors associated with coil winding.

Close-wound coils are readily wound on the specified form by anchoring one end of the length of wire (in a vise or to a doorknob) and the other end to the coil form. Straighten any kinks in the wire and then pull to keep the wire under slight tension. Wind the coil to the required number of turns while walking toward the anchor, always maintaining a slight tension on the wire.

To space-wind the coil, wind the coil simultaneously with a suitable spacing medium (heavy thread, string or wire) in the manner described above. When the winding is complete, secure the end of the coil to the coil-form terminal and then carefully unwind the spacing material. If the coil is wound under suitable tension, the spacing material can be easily removed without disturbing the winding. Finish space-wound coils by judicious applications of Duco cement to hold the turns in place.

The “cold” end of a coil is the end at (or close to) chassis or ground potential. Wind coupling links on the cold end of a coil to minimize capacitive coupling.

Winding Toroidal Inductors

Toroidal inductors and transformers are specified for many projects in this *Handbook*. The advantages of these cores include compactness and a self-shielding property. **Figs 8.29** and **8.30** illustrate the proper way to wind and count turns on a toroidal core.

The task of winding a toroidal core, when more than just a few turns are required, can be greatly simplified by the use of a homemade bobbin upon which the wire is first wound. A simple yet effective bobbin can be fashioned from a wooden popsicle stick. Cut a “V” notch at each end and first wind the wire coil on the popsicle stick lengthwise through the notches. Once this is done, the wound bobbin can be easily passed through the toroid's inside diameter. While firmly grasping one of the wire ends against the toroidal core, the bobbin can be moved up, around, and through the toroidal core repeatedly until the wire has been completely transferred

from the bobbin. The choice of bobbin used is somewhat dependent on the inside diameter of the toroid, the wire size, and the number of turns required.

When you wind a toroid inductor, count each pass of the wire through the toroid center as a turn. You can count the number of turns by counting the number of times the wire passes through the center of the core. See Fig 8.30A.

Multiwire Windings

A bifilar winding is one that has two identical lengths of wire, which when

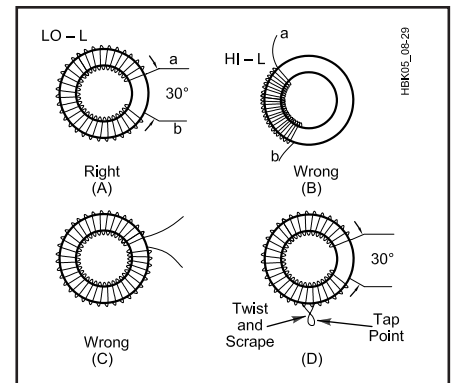

Fig 8.29—The maximum-Q method for winding a single-layer toroid is shown at A. A 30° gap is best. Methods at B and C have greater distributed capacitance. D shows how to place a tap on a toroidal coil winding.

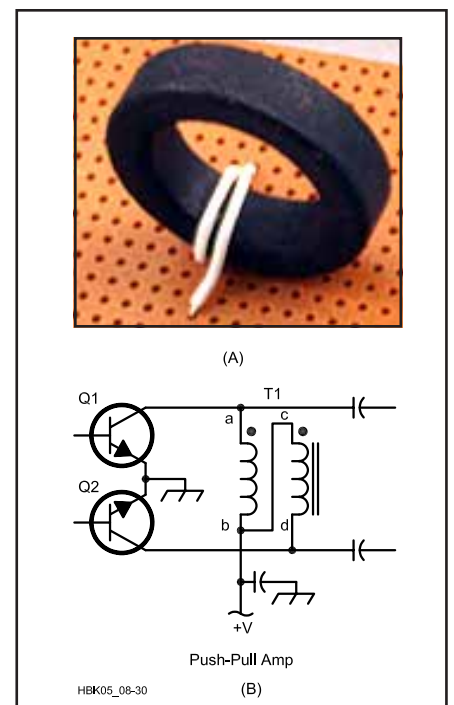

Fig 8.30—A shows a toroidal core with two turns of wire (see text). Large black dots, like those at T1 in B, indicate winding polarity (see text).

placed on the core result in the same number of turns for each wire. The two wires are wound on the core side by side at the same time, just as if a single winding were being applied. An easier and more popular method is to twist the two wires (8 to 15 turns per inch is adequate), then wind the twisted pair on the core. The wires can be twisted handily by placing one end of each in a bench vise. Tighten the remaining

ends in the chuck of a small hand drill and turn the drill to twist the pair.

A trifilar winding has three wires, and a quadrifilar winding has four. The procedure for preparation and winding is otherwise the same as for a bifilar winding. **Fig 8.31** shows a bifilar toroid in schematic and pictorial form. The wires have been twisted together prior to placing them on the core. It is helpful, though by no

means essential, to use wires of different color when multifilar-winding a core. It is more difficult to identify multiple windings on a core after it has been wound. Various colors of enamel insulation are available, but it is not easy for amateurs to find this wire locally or in small-quantity lots. This problem can be solved by taking lengths of wire (enameled magnet wire), cleaning the ends to remove dirt and

How to Buy Parts for Electronics Projects

The number one question received by the ARRL Technical Information Service starts out "Where can I buy..." It seems that one of the most perplexing problems faced by the would-be constructor is where to get parts. Sometimes you are lucky—the circuit author has made a kit available. But not every project has a ready-made kit. If you would like to expand your construction horizons, you can learn to be your own "purchasing manager." That means searching out parts sources and dealing with them in person.

In reality, it is not all that difficult to find most parts. Unfortunately, though, the days of the local electronic parts supplier seem to be gone. This is not surprising. Years ago an electronics supplier had to stock a relatively small number of electronic components—resistors, capacitors, tube sockets, a few relays and variable resistors. Technology has increased the number of components by a few orders of magnitude. Nowadays, the number of integrated circuits alone is enough to fill a multivolume book. No single electronics supplier could possibly stock them all. It has become a mail-order world; the electronics world is no exception.

Although it is no longer always possible to purchase all of your electronic needs from a local electronics supplier, the good news is that you don't have to! For a few dollars, mail-order companies are willing to supply whatever you need. You only need do two things to obtain nearly any electronic component—make a phone call and write a check.

Become an electronic catalog collector. Electronic suppliers also advertise in magazines that cater to ham-radio and electronics enthusiasts. If you are lucky, you may have a local source of electronics parts. Look in the Yellow Pages under "Electronic Equipment Suppliers" to find the local outlets. RadioShack is one local source found nearly everywhere. They carry an assortment of the more common electronic parts. You'll probably need to order from more than one mail-order company. (It's almost a corollary to Murphy's Law: No matter how wide a selection you find in one mail-order catalog, there's always at least one part you must buy somewhere else!)

While you're waiting for your catalogs, look at the parts list for the project you want to build. Unfortunately, you can't just photocopy the list and send it off to a mail-order company with a note that says "please send me these parts." You need to convert the part list into a part-order list that shows the order number and quantity required of each component. This may require a similar list for each parts supplier where one supplier does not have all the parts.

Check the type, tolerance, power rating and other key characteristics of the parts. Group the parts by those parameters before grouping them by value. If all of the circuit's components are already grouped by value on the parts list, you can just count the number of each value. Each time you add parts to the order list, check them off the published parts list. Sometimes the parts list does not

include common components like resistors and capacitors. If this is the case, make a copy of the schematic and check off the parts as you build your shopping list.

Although you'll probably be able to order exactly the right number of each part for a project, buy a few extras of some parts for your junk box. It's always good to have a few extra parts on hand; you may break a component lead during assembly, or damage a solid-state component with too much heat or by wiring it in backwards. If you don't have extras, you'll need to order another part. Even if you don't need the extras for this project, they may come in handy, and you'll be encouraged to build another project! Pick up an extra toroid or two as well.

Now's the time to decide whether you're going to build your project with ground-plane construction or PC board. If you need a PC-board, FAR Circuits and others have them for many ARRL book and QST projects. If you're going to use ground-plane construction, buy a good-sized piece of single-sided copper-clad board—glass-epoxy board if you can. Phenolic board is inferior because it is brittle and deteriorates rapidly with soldering heat.

Don't forget an enclosure for your project. This is often overlooked in parts lists for most projects, because different builders like different enclosures. Make sure there's room in the box for all of the components used in your project. Some people like to cram projects in the smallest possible box, but miniaturization can be extremely frustrating if you're not good at it.

There are almost always a few items you can't get from one company and most have minimum orders. You may need to distribute your order between two or more companies to meet minimum-order requirements. Some companies put out beautiful catalogs, but their minimum order is \$25 or they charge \$5 for shipping if you place a small order.

If you order enough parts, you'll soon find out which companies you like to deal with and which have slow service. It is frustrating to receive most of an order, then wait months for the parts that are on back-order. If you don't want the company to back-order your parts, write clearly on the order form, "Do not back-order parts." They will then ship the parts they have and leave you to order the rest from somewhere else.

If you are in a hurry, call the company to inquire about the availability of the parts in your order. Some companies take credit-card orders over the telephone. Some companies hold orders a few weeks to allow personal checks to clear.

If you are familiar with the catalogs and policies of electronic-component suppliers, you will find that getting parts is not difficult. Concentrate on the fun part—building the circuit and getting it working.—Bruce Hale, KB1MW

grease, then spray painting them. Ordinary aerosol-can spray enamel works fine. Spray lacquer is not as satisfactory because it is brittle when dry and tends to flake off the wire.

The winding sense of a multifilar toroidal transformer is important in most circuits. Fig 8.30B illustrates this principle. The black dots (called phasing dots) at the top of the T1 windings indicate polarity. That is, points a and c are both start or finish ends of their respective windings. In this example, points a and d are of opposite phase (180° phase difference) to provide push-pull voltage output from Q1 and Q2.

After you wind a coil, scrape the insulation off the wire before you solder it into the circuit.

MECHANICAL FABRICATION

Buy or Build a Chassis?

Most projects end up in some sort of an enclosure, and most hams choose to purchase a ready-made chassis for small projects, but some projects require a custom enclosure. Even a ready-made chassis may require a fabricated sheet-metal shield or bracket, so it's good to learn something about sheet-metal and metal-fabrication techniques.

Most often, you can buy a suitable enclosure. These are sold by RadioShack and most electronics distributors.

Select an enclosure that has plenty of room. A removable cover or front panel can make any future troubleshooting or modifications easy. A project enclosure should be strong enough to hold all of the components without bending or sagging; it should also be strong enough to stand up to expected use and abuse.

Cutting and Bending Sheet Metal

Enclosures, mounting brackets and shields are usually made of sheet metal. Most sheet metal is sold in large sheets, 4 to 8 ft or larger. It must be cut to the size needed.

Most sheet metal is thin enough to cut with metal shears or a hacksaw. A jigsaw or bandsaw makes the task easier. If you use any kind of saw, select a blade that has teeth fine enough so that at least two teeth are in contact with the metal at all times.

If a metal sheet is too large to cut conveniently with a hacksaw, it can be scored and broken. Make scratches as deep as possible along the line of the cut on both sides of the sheet. Then, clamp it in a vise and work it back and forth until the sheet breaks at the line. Do not bend it too far before the break begins to weaken, or the edge of the sheet might bend. A pair of flat bars, slightly longer than the sheet being

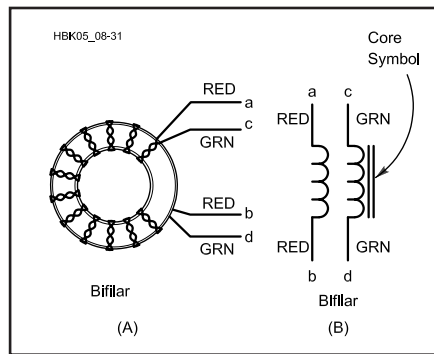

Fig 8.31—Schematic and pictorial presentation of a bifilar-wound toroidal transformer.

bent, make it easier to hold a sheet firmly in a vise. Use "C" clamps to keep the bars from spreading at the ends.

Smooth rough edges with a file or by sanding with a large piece of emery cloth or sandpaper wrapped around a flat block.

Finishing Aluminum

Give aluminum chassis, panels and parts a sheen finish by treating them in a caustic bath. Use a plastic container to hold the solution. Ordinary household lye can be dissolved in water to make a bath solution. Follow the directions on the container. A strong solution will do the job more rapidly.

Stir the solution with a stick of wood until the lye crystals are completely dissolved. If the lye solution gets on your skin, wash with plenty of water. If you get any in your eyes, immediately rinse with plenty of clean, room-temperature water and seek medical help. It can also damage your clothing, so wear something old. Prepare sufficient solution to cover the piece completely. When the aluminum is immersed, a very pronounced bubbling takes place. Provide ventilation to disperse the escaping gas. A half hour to two hours in the bath is sufficient, depending on the strength of the solution and the desired surface characteristics.

Chassis Working

With a few essential tools and proper procedure, building radio gear on a metal chassis is a relatively simple matter. Aluminum is better than steel, not only because it is a superior shielding material, but also because it is much easier to work and provides good chassis contact when used with secure fasteners.

Spend sufficient time planning a project to save trouble and energy later. The actual construction is much simpler when all details are worked out beforehand. Here we discuss a large chassis-and-cabinet

project, such as a high-power amplifier. The techniques are applicable to small projects as well.

Cover the top of the chassis with a piece of wrapping paper or graph paper. Fold the edges down over the sides of the chassis and fasten them with adhesive tape. Place the front panel against the chassis front and draw a line there to indicate the chassis top edge.

Assemble the parts to be mounted on the chassis top and move them about to find a satisfactory arrangement. Consider that some will be mounted underneath the chassis and ensure that the two groups of components won't interfere with each other.

Place controls with shafts that extend through the cabinet first, and arrange them so that the knobs will form the desired pattern on the panel. Position the shafts perpendicular to the front chassis edge. Locate any partition shields and panel brackets next, then sockets and any other parts. Mark the mounting-hole centers of each part accurately on the paper. Watch out for capacitors with off-center shafts that do not line up with the mounting holes. Do not forget to mark the centers of socket holes and holes for wiring leads. Make the large center hole for a socket *before* the small mounting holes. Then use the socket itself as a template to mark the centers of the mounting holes. With all chassis holes marked, center-punch and drill each hole.

Next, mount on the chassis the capacitors and any other parts with shafts extending to the panel. Fasten the front panel to the chassis temporarily. Use a machinist's square to extend the line (vertical axis) of any control shaft to the chassis front and mark the location on the front panel at the chassis line. If the layout is complex, label each mark with an identifier. Also mark the back of the front panel with the locations of any holes in the chassis front that must go through the front panel. Remove the front panel.

PC-Board Materials

Much tedious sheet-metal work can be eliminated by fabricating chassis and enclosures from copper-clad printed-circuit board material. While it is manufactured in large sheets for industrial use, some hobby electronics stores and surplus outlets market usable scraps at reasonable prices. PC-board stock cuts easily with a small hacksaw. The nonmetallic base material isn't malleable, so it can't be bent. Corners are easily formed by holding two pieces at right angles and soldering the seam. This technique makes excellent RF-tight enclosures. If mechanical rigidity is required of a large copper-clad surface,

solder stiffening ribs at right angles to the sheet.

Fig 8.32 shows the use of PC-board stock to make a project enclosure. This enclosure was made by cutting the pieces to size, then soldering them together. Start by laying the bottom piece on a workbench, then placing one of the sides in place at right angles. Tack-solder the second piece in two or three places, then start at one end and run a bead of solder down the entire seam. Use plenty of solder and plenty of heat. Continue with the rest of the pieces until all but the top cover is in place.

In most cases, it is better to drill all needed holes in advance. It can sometimes be difficult to drill holes after the enclosure is soldered together.

You can use this technique to build enclosures, subassemblies or shields. This technique is easy with practice; hone your skills on a few scrap pieces of PC-board stock.

Drilling Techniques

Before drilling holes in metal with a hand drill, indent the hole centers with a center punch. This prevents the drill bit from “walking” away from the center when starting the hole. Predrill holes greater than 1/2-inch in diameter with a smaller bit that is large enough to contain the flat spot at the large bit’s tip. When the metal being drilled is thinner than the depth of the drill-bit tip, back up the metal with a wood block to smooth the drilling process.

The chuck on the common hand drill is limited to 3/8-inch bits. Some bits are much larger, with a 3/8-inch shank. If necessary, enlarge holes with a reamer or round file. For very large or odd-shaped holes, drill a series of closely spaced small holes just inside of the desired opening. Cut the metal remaining between the holes with a cold chisel and file or grind the hole to its finished shape. A nibbling tool also works well for such holes.

Use socket-hole punches to make socket holes and other large holes in an aluminum chassis. Drill a guide hole for the punch center bolt, assemble the punch with the bolt through the guide hole and

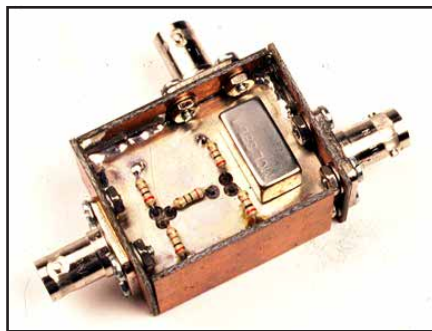

Fig 8.32—A box made entirely from PC-board stock.

tighten the bolt to cut the desired hole. Oil the threads of the bolt occasionally.

Cut large circular holes in steel panels or chassis with an adjustable circle cutter (“flycutter”). Occasionally apply machine oil to the cutting groove to speed the job. Test the cutter’s diameter setting by cutting a block of wood or scrap material first.

Remove burrs or rough edges that result from drilling or cutting with a burr-remover, round or half-round file, a sharp knife or chisel. Keep an old chisel sharpened and available for this purpose.

Rectangular Holes

Square or rectangular holes can be cut with a nibbling tool or a row of small holes as previously described. Large openings can be cut easily using socket-hole punches.

Construction Notes

If a control shaft must be extended or insulated, a flexible shaft coupling with adequate insulation should be used. Satisfactory support for the shaft extension, as well as electrical contact for safety, can be provided by means of a metal panel bushing made for the purpose. These can be obtained singly for use with existing shafts, or they can be bought with a captive extension shaft included. In either case the panel bushing gives a solid feel to the control. The use of fiber washers between ceramic insulation and metal brackets, screws or nuts will prevent the ceramic parts from breaking.

Painting

Painting is an art, but, like most arts, successful techniques are based on skills that can be learned. The surfaces to be painted must be clean to ensure that the paint will adhere properly. In most cases, you can wash the item to be painted with soap, water and a mild scrub brush, then rinse thoroughly. When it is dry, it is ready for painting. Avoid touching it with your bare hands after it has been cleaned. Your skin oils will interfere with paint adhesion. Wear rubber or clean cotton gloves.

Sheet metal can be prepared for painting by abrading the surface with medium-grade sandpaper, making certain the strokes are applied in the same direction (not circular or random). This process will create tiny grooves on the otherwise smooth surface. As a result, paint or lacquer will adhere well. On aluminum, one or two coats of zinc chromate primer applied before the finish paint will ensure good adhesion.

Keep work areas clean and the air free of dust. Any loose dirt or dust particles will probably find their way onto a freshly painted project. Even water-based paints produce some fumes, so properly ventilate work areas.

Select a paint suitable to the task. Some paints are best for metal, others for wood and so on. Some dry quickly, with no fumes; others dry slowly and need to be thoroughly ventilated. You may want to select a rust-preventative paint for metal surfaces that might be subjected to high moisture or salts.

Most metal surfaces are painted with some sort of spray, either from a spray gun or from spray cans of paint. Either way, follow the manufacturer’s instructions for a high-quality job.

SUMMARY

If you’re like most amateurs, once you’ve got the building bug, you won’t let your soldering iron stay cold for long. Starting is the hardest part. Now, the next time you think about adding another project to your station, you’ll know where to start.