

# Power Supplies

## Glossary

**Bipolar Transistor** — A term used to denote the common two junction transistor types (NPN, PNP) as opposed to the field effect families of devices (JFET, MOSFET and so on).

**Bleeder** — A resistive load across the output or filter of a power supply, intended to quickly discharge stored energy once the supply is turned off.

**C-Rate** — The charging rate for a battery, expressed as a ratio of the battery's ampere-hour rating.

**Circular Mils** — A convenient way of expressing the cross-sectional area of a round conductor. The area of the conductor in circular mils is found by squaring its diameter in mils (thousandths of an inch), rather than squaring its radius and multiplying by pi. For example, the diameter of 10-gauge wire is 101.9 mils (0.1019 inch). Its cross-sectional area is 10380 CM, or 0.008155 square inches.

**Core Saturation (Magnetic)** — That condition whereby the magnetic flux in a transformer or inductor core is more than the core can handle. If the flux is forced beyond this point, the permeability of the core will decrease, and it will approach the permeability of air.

**Crowbar** — A last-ditch protection circuit included in many power supplies to protect the load equipment against failure of the regulator in the supply. The crowbar senses an overvoltage condition on the supply's output and fires a shorting device (usually an SCR) to directly short-circuit the supply's output and protect the load. This causes very high currents in the power supply, which blow the supply's input-line fuse.

**Darlington Transistor** — A package

of two transistors in one case, with the collectors tied together, and the emitter of one transistor connected to the base of the other. The effective current gain of the pair is approximately the product of the individual gains of the two devices.

**DC-DC Converter** — A circuit for changing the voltage of a dc source to ac, transforming it to another level, and then rectifying the output to produce direct current.

**Fast Recovery Rectifier** — A specially doped rectifier diode designed to minimize the time necessary to halt conduction when the diode is switched from a forward-biased state to a reverse-biased state.

**Foldback Current Limiting** — A special type of current limiting used in linear power supplies, which reduces the current through the supply's regulator to a low value under short circuited load conditions in order to protect the series pass transistor from excessive power dissipation and possible destruction.

**Ground Fault (Circuit) Interrupter (GFI or GFCI)** — A safety device installed between the household power mains and equipment where there is a danger of personnel touching an earth ground while operating the equipment. The GFI senses any current flowing directly to ground and immediately switches off all power to the equipment to minimize electrical shock. GFIs are now standard equipment in bathroom and outdoor receptacles.

**Input-Output Differential** — The voltage drop appearing across the series pass transistor in a linear voltage regulator. This term is usually stated as a mini-

mum value, which is that voltage necessary to allow the regulator to function and conduct current. A typical figure for this drop in most three-terminal regulator ICs is about 2.5 V. In other words, a regulator that is to provide 12.5 V dc will need a source voltage of at least 15.0 V at all times to maintain regulation.

**Inverter** — A circuit for producing ac power from a dc source.

**Peak Inverse Voltage** — The maximum reverse-biased voltage that a semiconductor is rated to handle safely. Exceeding the peak inverse rating can result in junction breakdown and device destruction.

**Power Conditioner** — Another term for a power supply.

**Regulator** — A device (such as a Zener diode) or circuitry in a power supply for maintaining a constant output voltage over a range of load currents and input voltages.

**Resonant Converter** — A form of dc-dc converter characterized by the series pass switch turning on into an effective series-resonant load. This allows a zero current condition at turn-on and turn-off. The resonant converter normally operates at frequencies between 100 kHz and 500 kHz and is very compact in size for its power handling ability.

**Ripple** — The residual ac left after rectification, filtration and regulation of the input power.

**RMS** — Root of the Mean of the Squares. Refers to the effective value of an alternating voltage or current, corresponding to the dc voltage or current that would cause the same heating effect.

**Secondary Breakdown** — A runaway failure condition in a transistor, occurring at higher collector-emitter voltages, where hot spots occur due to (and promoting) localization of the collector current at that region of the chip.

**Series Pass Transistor, or Pass Transistor** — The transistor(s) that controls the passage of power between the unregulated dc source and the load in a regulator. In a linear regulator, the series pass transistor acts as a controlled resistor to drop the voltage to that needed by the load. In a switch-mode regulator, the series pass transistor switches between its ON and OFF states.

**SOAR (Safe Operating Area)** — The range of permissible collector current and

collector-emitter voltage combinations where a transistor may be safely operated without danger of device failure.

**Spike** — An extremely short perturbation on a power line, usually lasting less than a few microseconds.

**Surge** — A moderate-duration perturbation on a power line, usually lasting for hundreds of milliseconds to several seconds.

**Transient** — A short perturbation on a power line, usually lasting for microseconds to tens of milliseconds.

**Varistor** — A surge suppression device used to absorb transients and spikes occurring on the power lines, thereby protecting electronic equipment plugged into that line. Frequently, the term MOV

(Metal Oxide Varistor) is used instead.

**Volt-Amperes** — The product obtained by multiplying the current times the voltage in an ac circuit without regard for the phase angle between the two. This is also known as the *apparent power* delivered to the load as opposed to the actual or *real power* absorbed by the load, expressed in watts.

**Voltage Multiplier** — A type of rectifier circuit that is arranged so as to charge a capacitor or capacitors on one half-cycle of the ac input voltage waveform, and then to connect these capacitors in series with the rectified line or other charged capacitors on the alternate half-cycle. The voltage doubler and tripler are commonly used forms of the voltage multiplier.

## Alternating-Current Power

Ken Stuart, W3VVN, wrote the text for the theory portion of this chapter.

In most residences, three wires are brought in from the outside electrical-service mains to the house distribution panel. In this three-wire system, one wire is neutral and should be at earth ground. The voltage between the other two wires is 60-Hz alternating current with a potential difference of approximately 240 V RMS. Half of this voltage appears between each of these wires and the neutral, as indicated in Fig 17.1A. In systems of this type, the 120-V household loads are divided at the breaker panel as evenly as possible between the two sides of the power mains. Heavy appliances such as electric stoves, water heaters, central air conditioners and so forth, are designed for 240-V operation and are connected across the two ungrounded wires.

Both ungrounded wires should be fused. A fuse or switch should never be used in the neutral wire, however. Opening the neutral wire does not disconnect the equipment from an active or “hot” line, creating a potential shock hazard between that line and earth ground.

Another word of caution should be given at this point. Since one side of the ac line is grounded to earth, all communications equipment should be reliably connected to the ac-line ground through a heavy ground braid or bus wire of #14 or heavier-gauge wire. This wire must be a separate conductor. You must not use the power-wiring neutral conductor for this safety ground. (A properly wired 120-V outlet with a ground terminal uses one wire for the ac *hot* connection, one wire for the

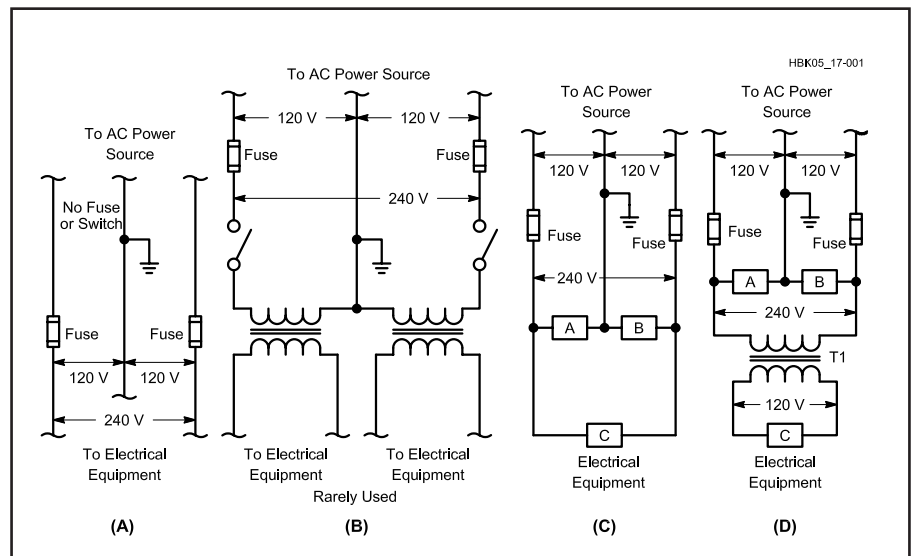

**17.1 — Three-wire power-line circuits.** At A, normal three-wire termination. No fuse should be used in the grounded (neutral) line. The ground symbol is the power company’s ground, not yours! Do *not* connect *anything*, including the equipment chassis, to the power neutral wire. At B, the “hot” lines each have a switch, but a switch in the neutral line would not remove voltage from either side of the line and should never be used. At C, connections for both 120 and 240-V transformers. At D, operating a 120-V plate transformer from the 240-V line to avoid light blinking. T1 is a 2:1 step-down transformer.

ac *neutral* connection and a third wire for the safety *ground* connection.) This not only places the chassis of the equipment at earth ground for minimal RF energy on the chassis, but also provides a measure of safety for the operator in the event of accidental short or leakage of one side of the ac line to the chassis.

Remember, the antenna system is al-

most always bypassed to the chassis via an RF choke or tuning circuit, which could make the antenna electrically “live” with respect to the earth ground and create a potentially lethal shock hazard. A Ground Fault Circuit Interrupter (GFCI or GFI) is also desirable for safety reasons, and should be a part of the shack’s electrical power wiring.

## FUSES AND CIRCUIT BREAKERS

All transformer primary circuits should be fused properly, and multiple secondary outputs should also be individually fused. To determine the approximate current rating of the fuse or circuit breaker to be used, multiply each current being drawn by the load or appliance, in amperes, by the voltage at which the current is being drawn. In the case of linear regulated power supplies, this voltage has to be the voltage appearing at the output of the rectifiers before being applied to the regulator stage. Include the current taken by bleeder resistors and voltage dividers. Also include filament power if the transformer is supplying filaments. The National Electrical Code also specifies maximum fuse ratings based on the wire sizes used in the transformer and connections.

After multiplying the various voltages and currents, add the individual products. This will be the total power drawn from the line by the supply. Then divide this power by the line voltage and add 10 or 20%. Use a fuse or circuit breaker with the nearest larger current rating. Remember that the charging of filter capacitors can take large surges of current when the supply is turned on. If turn on is a problem, use slow-blow fuses, which allow for high initial surge currents.

For low-power semiconductor circuits, use fast-blow fuses. As the name implies, such fuses open very quickly once the current exceeds the fuse rating by more than 10%.

## ELECTRICAL POWER CONDITIONING

We often use the term “power supply” to denote a piece of equipment that will process the electrical power from a source, such as the ac power mains, by manipulating it so the device output will be acceptable to other equipment that we want to power. The common form of the power supply is the familiar direct-current power supply, which will power a transmitter, receiver or other of a wide variety of electronic devices.

In the strictest terms, however, the power supply is not actually a source, or “supply” of power, but is actually a processor of already existing energy. Therefore, the old term of “power supply” is becoming obsolete, and a new term has arisen to refer to the technology of the processing of electrical power: “power conditioning.” By contrast, the term “power supply” is now used to refer to devices for chemical to electrical energy conversion (batteries) or mechanical to electrical conversion (generators). Other varieties include thermoelectric genera-

tors (TEGs) and radioactive thermoelectric generators (RTGs).

In this chapter, we shall examine the traditional forms of power conditioning, which consists of the following component parts in various combinations: transformer, rectifier, filter and regulator. We will also look briefly at true power supplies as we examine battery technology and emergency power generation.

## POWER TRANSFORMERS

Numerous factors are considered in order to match a transformer to its intended use. Some of these parameters are listed below:

1. Output voltage and current (volt-ampere rating)
2. Power source voltage and frequency
3. Ambient temperature
4. Duty cycle and temperature rise of the transformer at rated load
5. Mechanical shape and mounting

### Volt-Ampere Rating

In alternating-current equipment, the term “volt-ampere” is often used rather than the term “watt.” This is because ac components must handle reactive power as well as real power. If this is confusing, consider a capacitor connected directly across the secondary of a transformer. The capacitor appears as a reactance that permits current to flow, just as if the load were a resistor. The current is at a 90° phase angle, however. If we assume a perfect capacitor, there will be no heating of the capacitor, so no real power (watts) will be delivered by the transformer. The transformer must still be capable of supplying the voltage, and be able to handle the current required by the reactive load. The current in the transformer windings will heat the windings as a result of the  $I^2R$  losses in the winding resistances. The product of the voltage and current is referred to as “volt-amperes”, since “watts” is reserved for the real, or dissipated, power in the load. The volt-ampere rating will always be equal to, or greater than, the power actually being drawn by the load.

The number of volt-amperes (VA) delivered by a transformer depends not only upon the dc load requirements, but also upon the type of dc output filter used (capacitor or choke input), and the type of rectifier used (full-wave center tap or full-wave bridge). With a capacitive-input filter, the heating effect in the secondary is higher because of the high peak-to-average current ratio. The volt-amperes handled by the transformer may be several times the power delivered to the load. The primary winding volt-amperes will be

somewhat higher because of transformer losses.

## Source Voltage and Frequency

A transformer operates by producing a magnetic field in its core and windings. The intensity of this field varies directly with the instantaneous voltage applied to the transformer primary winding. These variations, coupled to the secondary windings, produce the desired output voltage. Since the transformer appears to the source as an inductance in parallel with the (equivalent) load, the primary will appear as a short circuit if dc is applied to it. The unloaded inductance of the primary must be high enough so as not to draw an excess amount of input current at the design line frequency (normally 60 Hz). This is achieved by providing sufficient turns on the primary and enough magnetic core material so that the core does not saturate during each half-cycle.

The magnetic field strength produced in the core is usually referred to as the *flux density*. It is set to some percentage of the maximum flux density that the core can stand without saturating, since at saturation the core becomes ineffective and causes the inductance of the primary to plummet to a very low level and input current to rise rapidly. This causes high primary currents and extreme heating in the primary windings. For this reason, transformers and other electromagnetic equipment designed for 60-Hz systems must not be used on 50-Hz power systems unless specifically designed to handle the lower frequency.

### How to Evaluate an Unmarked Power Transformer

Many hams that regularly visit hamfests eventually end up with a junk box filled with used and unmarked transformers. After years of use, transformer labels or markings on the coil wrappings may come off or be obscured. There is a good possibility that the transformer is still useable. The problem is to determine what voltages and currents the transformer can supply. First consider the possibility that you may have an audio transformer or other impedance-matching device rather than a power transformer. If you aren't sure, don't connect it to ac power!

If the transformer has color-coded leads, you are in luck. There is a standard for transformer lead color-coding, as is given in the **Component Data and References** chapter. Where two colors are listed, the first one is the main color of the insulation; the second is the color of the stripe.

Check the transformer windings with an ohmmeter to determine that there are no

shorted (or open) windings. The primary winding usually has a resistance higher than a filament winding and lower than a high-voltage winding.

A convenient way to test the transformer is to rig a pair of test leads to an electrical plug with a 25-W household light bulb in series to limit current to safe (for the transformer) levels. See Fig 17.2. Use an isolation transformer, and be sure to insulate all connections before you plug into the ac mains. Switch off the power while making or changing any connections. Connect the test leads to each winding separately. **BE CAREFUL! YOU ARE DEALING WITH HAZARDOUS VOLTAGES!** The filament/heater windings will cause the bulb to light to full brilliance. The high-voltage winding will cause the bulb to be extremely dim or to show no light at all, and the primary winding will probably cause a small glow.

When you are connected to what you think is the primary winding, measure the voltages at the low-voltage windings with an ac voltmeter. If you find voltages close to 6-V ac and 5-V ac, you know that you have found the primary. Label the primary and low voltage windings.

Even with the light bulb, a transformer can be damaged by connecting ac mains power to a low-voltage or filament winding. In such a case the insulation could break down in a high-voltage winding.

Connect the voltmeter to the high-voltage windings. Remember that the old TV transformers will typically put out as much as 800 V or so across the winding, so make sure that your meter can withstand these potentials without damage. Divide 6.3 by

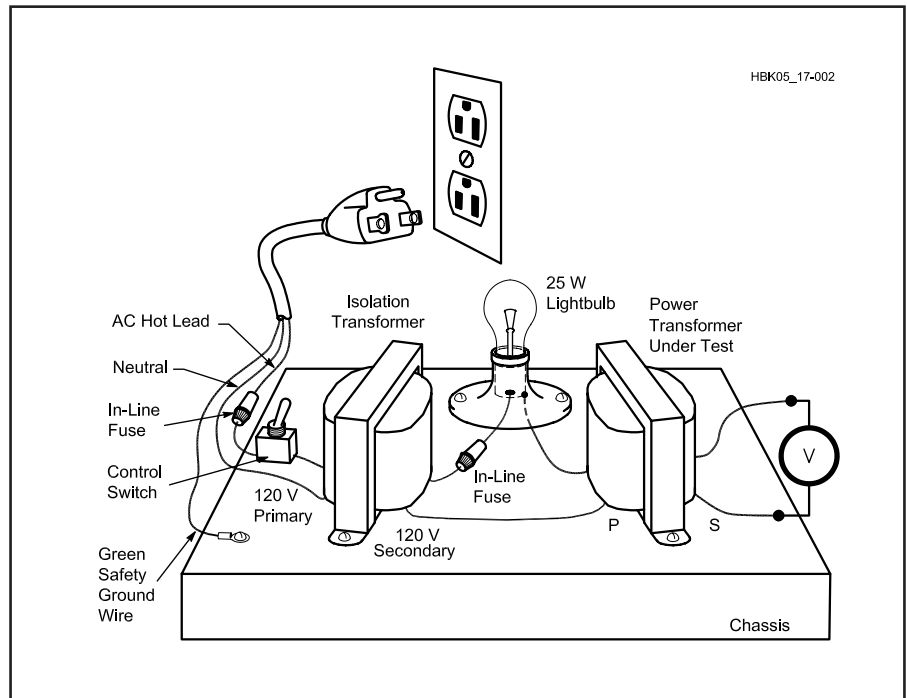

**Fig 17.2 — Use a test fixture like this to test unknown transformers. Don't omit the isolation transformer, and be sure to insulate all connections before you plug into the ac mains.**

the voltage you measured across the 6.3-V winding in this test setup. This gives a multiplier that you can use to determine the actual no-load voltage rating of the high-voltage secondary. Simply multiply the ac voltage measured across the winding by the multiplier.

The current rating of the windings can

be determined by loading each winding with the primary connected directly (no bulb) to the ac line. Using power resistors, increase loading on each winding until its voltage drops by about 10% from the no-load figure. The current drawn by the resistors is the approximate winding load-current rating.

## Rectifier Types

### VACUUM TUBE

Once the mainstay of the rectifier field, the vacuum-tube rectifier has largely been supplanted by the silicon diode, but it may be found in vintage receivers still in use. Vacuum-tube rectifiers were characterized by high forward voltage drops and inherently poor regulation, but they were immune to ac line transients that can destroy other rectifier types.

### MERCURY VAPOR

The mercury-vapor rectifier was an improvement over the vacuum tube recti-

fier in that the electron stream from cathode to plate would ionize the vaporized mercury in the tube and greatly reduce the forward voltage drop. Since ionized mercury is a much better conductor of current than a vacuum, these tubes can carry relatively high currents. As a result, they were popular in transmitters and RF power amplifiers.

Mercury rectifiers had to be treated with special care, however. When power was initially applied, the tube filament had to be turned on first to vaporize condensed mercury before the high-voltage ac could

be applied to the plate. This could take from one to two minutes. Also, if the tube was handled or the equipment transported, filament power would have to be applied for about a half hour to vaporize any mercury droplets that might have been shaken onto tube insulating surfaces. Mercury vapor rectifiers have mostly been replaced by silicon diodes.

### SELENIUM

The selenium rectifier was the first of the solid-state rectifiers to find its way into commercial electronic equipment. Offer-



ing a relatively low forward voltage drop, selenium rectifiers found their way into the plate supplies of test equipment and accessories, which needed only a few tens of milliamperes of current at about a hundred volts, such as grid-dip meters, VTVMs and so forth.

Selenium rectifiers had a relatively low reverse resistance and were therefore inefficient. Voltage breakdown per rectifying junction was only about 20 V.

## GERMANIUM

Germanium diodes were the first of the solid-state semiconductor rectifiers. They have an extremely low forward voltage drop. Germanium diodes are relatively temperature sensitive, however. They can be easily destroyed by overheating during soldering, for instance. Also, they have some degree of back resistance, which varies with temperature.

Germanium diodes are used for special applications where the very low forward drop is needed, such as signal diodes used for detectors and ring modulators.

## SILICON

Silicon diodes are the main choice today for virtually all rectifier applications.

They are characterized by extremely high reverse resistance, forward drops of usually a volt or less and operation at high temperatures.

## FAST RECOVERY

DC-DC converters regularly operate at 25 kHz and higher frequencies. Switch-mode regulators also operate in these same frequency ranges. When the switching transistors in these devices switch, voltage transitions take place within time periods usually much less than one microsecond, and the new FET switching transistors cause transitions that are often less than 100 ns.

When the transitions in these circuits occur, the previously conducting diodes see a reversal of current direction. This change tends to reverse bias those diodes, and thereby put them into an open-circuit condition. Unfortunately, solid-state rectifiers cannot be made to cease conduction instantaneously. As a result, when the opposing diodes in a bridge rectifier or full-wave rectifier become conductive at the time the converter switches states, the diodes being turned off will actually conduct in the reverse direction for a brief time, and effectively short circuit the con-

verter for several microseconds. This puts excessive strain on the switching transistors and creates high current spikes, leading to electromagnetic interference. As the switching frequency of the converter or regulator increases, more of these transitions happen each second, and more power is lost due to this diode cross-conduction.

Semiconductor manufacturers have recognized this as a problem for some time. Many companies have product lines of specially doped diodes designed to minimize this storage time. These diodes are called fast-recovery rectifiers and are commonly used in high-frequency dc-dc converters and regulators. Diodes are available that can recover in about 50 ns and less, as compared to standard-recovery diodes that can take several microseconds to cease conduction in the reverse direction.

Amateurs building their own switching power supplies and dc-dc converters will find greatly improved performance with the use of these diodes in their output rectifiers. Fast-recovery rectifiers are not needed for 60-Hz rectification because the source voltage is a sine wave (no fast transitions) and the input frequency is too slow for transitions to be of significance.

# Rectifier Circuits

## HALF-WAVE RECTIFIER

Fig 17.3 shows a simple half-wave rectifier circuit. A rectifier (in this case a semiconductor diode) conducts current in one direction but not the other. During one half of the ac cycle, the rectifier conducts and there is current through the rectifier to the load (indicated by the solid line in Fig 17.3B). During the other half cycle, the rectifier is reverse biased and there is no current (indicated by the broken line in Fig 17.3B) to the load. As shown, the output is in the form of pulsed dc, and current always flows in the same direction. A filter can be used to smooth out these variations and provide a higher average dc voltage from the circuit. This idea will be covered in the section on filtration further on in this chapter.

The average output voltage — the voltage read by a dc voltmeter — with this circuit (no filter connected) is  $0.45 \times E_{RMS}$  of the ac voltage delivered by the transformer secondary. Because the frequency of the pulses is low (one pulse per cycle), considerable filtering is required to pro-

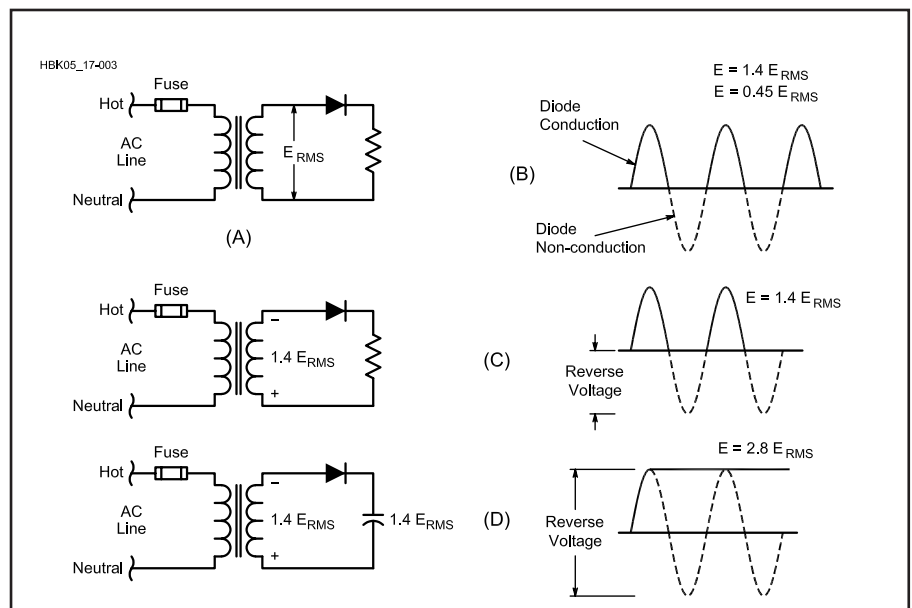

**Fig 17.3 — Half-wave rectifier circuit. A illustrates the basic circuit, and B displays the diode conduction and nonconduction periods. The peak-inverse voltage impressed across the diode is shown at C and D, with a simple resistor load at C and a capacitor load at D.  $E_{PIV}$  is  $1.4 E_{RMS}$  for the resistor load and  $2.8 E_{RMS}$  for the capacitor load.**

vide adequately smooth dc output. For this reason the circuit is usually limited to applications where the required current is small, as in a transmitter bias supply.

The peak inverse voltage (PIV), the voltage that the rectifier must withstand when it isn't conducting, varies with the load. With a resistive load, it is the peak ac voltage ( $1.4 \times E_{RMS}$ ); with a capacitor filter and a load drawing little or no current, it can rise to  $2.8 \times E_{RMS}$ . The reason for this is shown in parts C and D of Fig 17.3.

With a resistive load as shown at C, the voltage applied to the diode is that voltage on the lower side of the zero-axis line, or  $1.4 \times E_{RMS}$ . A capacitor connected to the circuit (shown at D) will store the peak positive voltage when the diode conducts on the positive pulse. If the circuit is not supplying any current, the voltage across the capacitor will remain at that same level. The peak inverse voltage impressed across the diode is now the sum of the voltage stored in the capacitor plus the

peak negative swing of voltage from the transformer secondary. In this case the PIV is  $2.8 \times E_{RMS}$ .

### FULL-WAVE CENTER-TAP RECTIFIER

A commonly used rectifier circuit is shown in Fig 17.4. Essentially an arrangement in which the outputs of two half-wave rectifiers are combined, it makes use of both halves of the ac cycle. A transformer with a center-tapped secondary is required with the circuit.

The average output voltage is  $0.9 \times E_{RMS}$  of half the transformer secondary; this is the maximum that can be obtained with a suitable choke-input filter. The peak output voltage is  $1.4 \times E_{RMS}$  of half the transformer secondary; this is the maximum voltage that can be obtained from a capacitor-input filter.

As can be seen in Fig 17.4C, the PIV impressed on each diode is independent of the type of load at the output. This is because the peak inverse voltage condition occurs when diode A conducts and diode B does not conduct. The positive and negative voltage peaks occur at precisely the same time, a condition different from that in the half-wave circuit. As the cathodes of diodes A and B reach a positive peak ( $1.4 E_{RMS}$ ), the anode of diode B is at a negative peak, also  $1.4 E_{RMS}$ , but in the opposite direction. The total peak inverse voltage is therefore  $2.8 E_{RMS}$ .

Fig 17.4B shows that the frequency of the output pulses is twice that of the half-wave rectifier. Comparatively less filtering is required. Since the rectifiers work alternately, each handles half of the load current. The current rating of each rectifier need be only half the total current drawn from the supply.

### FULL-WAVE BRIDGE RECTIFIER

Another commonly used rectifier circuit is illustrated in Fig 17.5. In this arrangement, two rectifiers operate in series on each half of the cycle, one rectifier being in the lead to the load, the other being the return lead. As shown in Fig 17.5A and B, when the top lead of the transformer secondary is positive with respect to the bottom lead, diodes A and C will conduct while diodes B and D are reverse biased. On the next half cycle, when the top lead of the transformer is negative with respect to the bottom, diodes B and D will conduct while diodes A and C are reverse biased.

The output wave shape is the same as that from the simple full-wave center-tap rectifier circuit. The average dc output voltage into a resistive load or choke-input filter is 0.9 times the RMS voltage delivered by the transformer secondary;

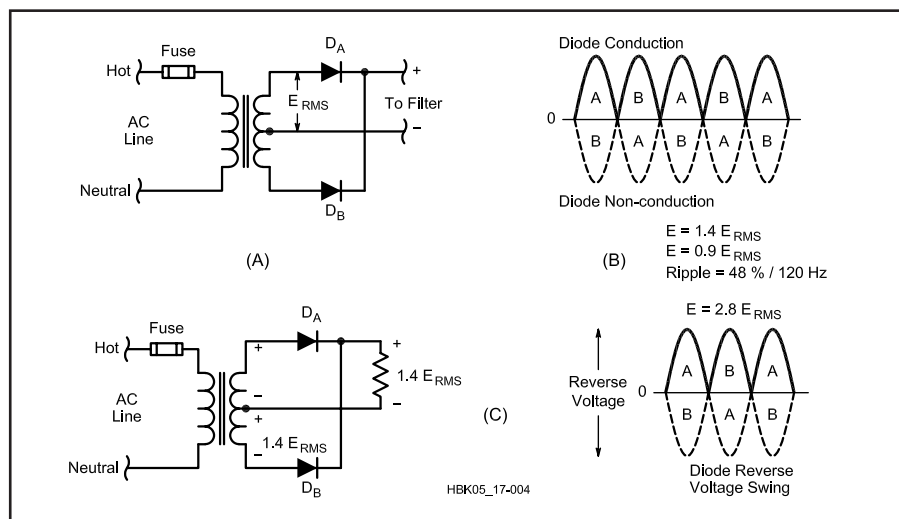

Fig 17.4 — Full-wave center-tap rectifier circuit. A illustrates the basic circuit. Diode conduction is shown at B with diodes A and B alternately conducting. The peak-inverse voltage for each diode is  $2.8 E_{RMS}$  as depicted at C.

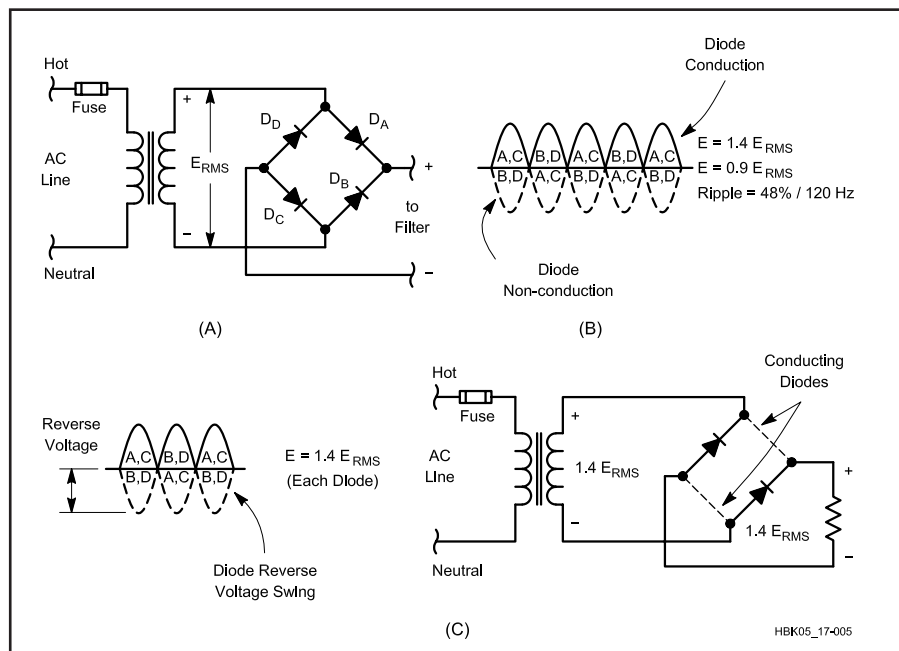

Fig 17.5 — Full-wave bridge rectifier circuit. The basic circuit is illustrated at A. Diode conduction and nonconduction times are shown at B. Diodes A and C conduct on one half of the input cycle, while diodes B and D conduct on the other. C displays the peak inverse voltage for one half cycle. Since this circuit reverse-biases two diodes essentially in parallel,  $1.4 E_{RMS}$  is applied across each diode.

with a capacitor filter and a light load, the maximum output voltage is 1.4 times the secondary RMS voltage.

Fig 17.5C shows the inverse voltage to be  $1.4 E_{RMS}$  for each diode. When an alternate pair of diodes (such as  $D_A$  and  $D_C$ ) is conducting, the other diodes are essentially connected in parallel in a reverse-biased direction. The reverse stress is then  $1.4 E_{RMS}$ . Each pair of diodes conducts on alternate half cycles, with the full load current through each diode during its conducting half cycle. Since each diode is not conducting during the other half cycle the average current is one half the total load current drawn from the supply.

## PROS AND CONS OF THE RECTIFIER CIRCUITS

Comparing the full-wave center-tap rectifier circuit and the full-wave bridge-rectifier circuit, we can see that both circuits have almost the same rectifier requirement, since the center tap has half the number of rectifiers as the bridge. These rectifiers have twice the inverse voltage rating requirement of the bridge diodes, however. The diode current ratings are identical for the two circuits. The bridge makes better use of the transformer's secondary than the center-tap rectifier, since the transformer's full winding supplies power during both half cycles, while each half of the center-tap circuit's secondary provides power only during its positive half-cycle. This is usually referred to as the *transformer utilization factor*, which is unity for the bridge configuration and 0.5 for the full-wave, center-tapped circuit.

The bridge rectifier often takes second place to the full-wave center tap rectifier in high-current low-voltage applications. This is because the two forward-conducting series-diode voltage drops in the bridge introduce a volt or more of additional loss, and thus more heat to be dissipated, than does the single diode drop of the full-wave rectifier.

The half-wave configuration is rarely used in 60-Hz rectification for other than bias supplies. It does see considerable use, however, in high-frequency switching power supplies in what are called *forward converter* and *flyback converter* topologies.

## VOLTAGE MULTIPLIERS

Other rectification circuits of interest are the so-called *voltage multipliers*. These circuits function by the process of charging one or more capacitors on one half cycle of the ac waveform, and then connecting that capacitor or capacitors in series with the opposite polarity of the ac

waveform on the alternate half cycle. With full-wave multipliers, this charging occurs during both half-cycles.

Voltage multipliers, particularly doublers, find considerable use in high-voltage supplies. When a doubler is employed, the secondary winding of the power transformer need only be half the voltage that would be required for a bridge rectifier. This reduces voltage stress in the windings and decreases the transformer insulation requirements. It also reduces the chance of corona in the windings, prolonging the life of the transformer. This is not without cost, however, because the transformer-secondary current rating has to be correspondingly doubled.

## Half-Wave Doubler

Fig 17.6 shows the circuit of a half-wave voltage doubler. Parts B, C and D illustrate the circuit operation. For clarity, assume the transformer voltage polarity at the moment the circuit is activated is that shown at B. During the first negative half cycle,  $D_A$  conducts ( $D_B$  is in a nonconductive state), charging C1 to the peak rectified voltage ( $1.4 E_{RMS}$ ). C1 is charged with the polarity shown at B. During the positive half cycle of the secondary voltage,  $D_A$  is cut off and  $D_B$  conducts, charging capacitor C2. The amount of voltage delivered to C2 is the sum of the transformer peak secondary voltage plus the voltage stored in C1 ( $1.4 E_{RMS}$ ). On the next negative half cycle,  $D_B$  is non-conducting and C2 will discharge into the load. If no load is connected across C2, the capacitors will remain charged — C1 to

$1.4 E_{RMS}$  and C2 to  $2.8 E_{RMS}$ . When a load is connected to the circuit output, the voltage across C2 drops during the negative half cycle and is recharged up to  $2.8 E_{RMS}$  during the positive half cycle.

The output waveform across C2 resembles that of a half-wave rectifier circuit because C2 is pulsed once every cycle. Fig 17.6D illustrates the levels to which the two capacitors are charged throughout the cycle. In actual operation, the capacitors will not discharge all the way to zero as shown.

## Full-Wave Doubler

Fig 17.7 shows the circuit of a full-wave voltage doubler. The circuit operation can best be understood by following Parts B, C and D. During the positive half cycle of the transformer secondary voltage, as shown at B,  $D_A$  conducts charging capacitor C1 to  $1.4 E_{RMS}$ .  $D_B$  is not conducting at this time.

During the negative half cycle, as shown at C,  $D_B$  conducts, charging capacitor C2 to  $1.4 E_{RMS}$ , while  $D_A$  is non-conducting. The output voltage is the sum of the two capacitor voltages, which will be  $2.8 E_{RMS}$  under no-load conditions. Fig 17.7D illustrates that each capacitor alternately receives a charge once per cycle. The effective filter capacitance is that of C1 and C2 in series, which is less than the capacitance of either C1 or C2 alone.

Resistors R1 and R2 in Fig 17.7A are used to limit the surge current through the rectifiers. Their values are based on the transformer voltage and the rectifier surge-current rating, since at the instant

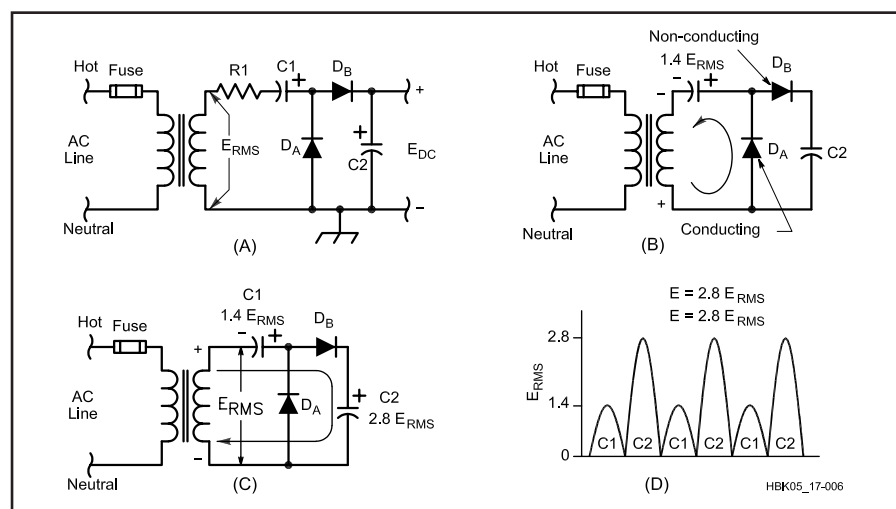
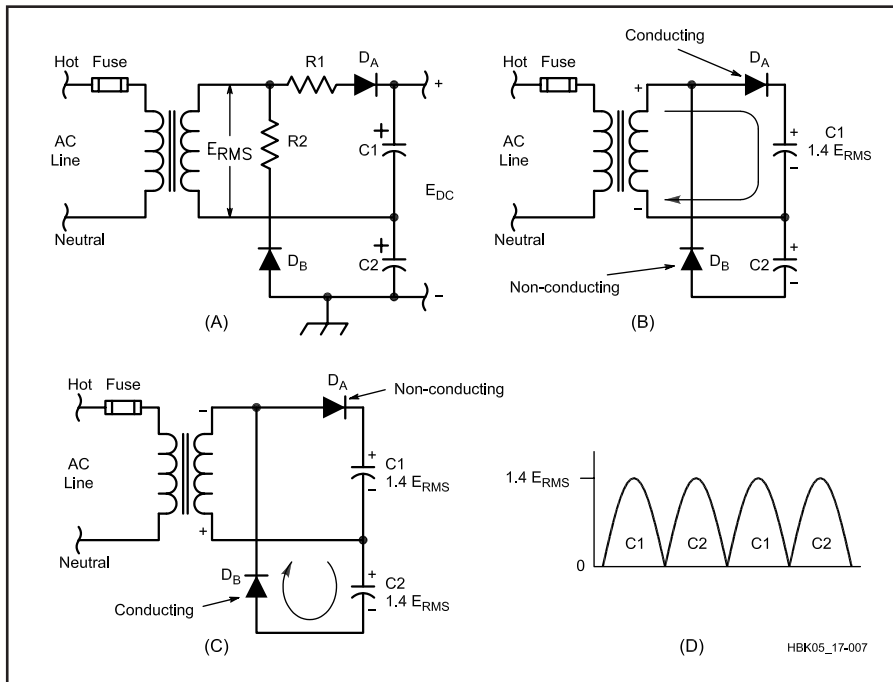
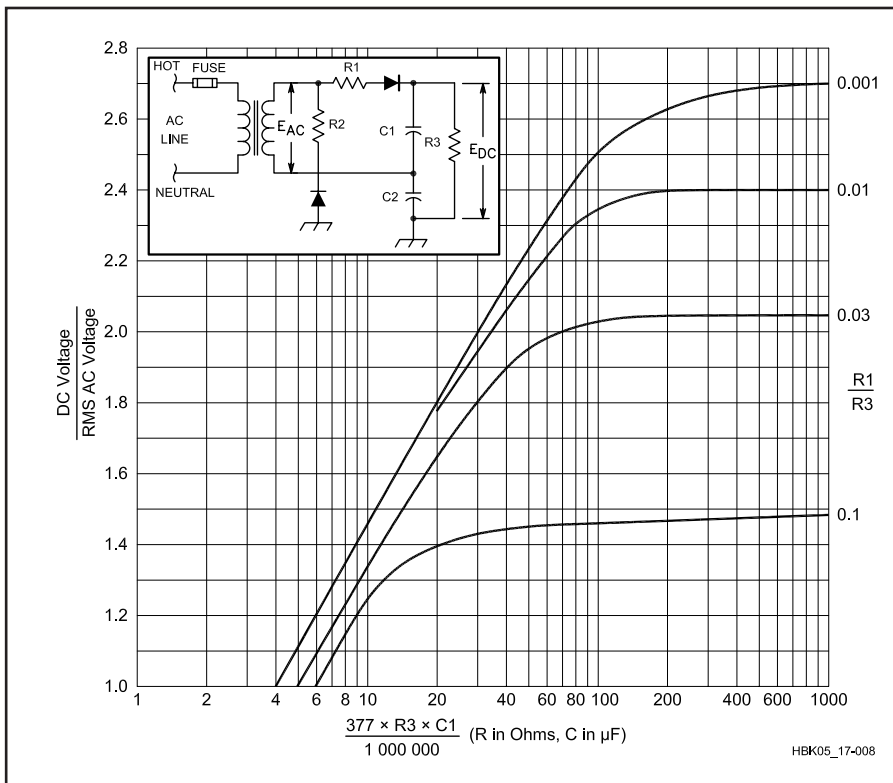

Fig 17.6 — Part A shows a half-wave voltage-doubler circuit. B displays how the first half cycle of input voltage charges C1. During the next half cycle (shown at C), capacitor C2 charges with the transformer secondary voltage plus that voltage stored in C1 from the previous half cycle. The arrows in parts B and C indicate the conventional current. D illustrates the levels to which each capacitor charges over several cycles.



**Fig 17.7** — Part A shows a full-wave voltage-doubler circuit. One-half cycle is shown at B and the next half cycle is shown at C. Each capacitor receives a charge during every input-voltage cycle. D illustrates how each capacitor is charged alternately.



**Fig 17.8** — DC output voltages from a full-wave voltage-doubler circuit as a function of the filter capacitances and load resistance. For the ratio  $R1 / R3$  and for the  $R3 \times C1$  product, resistance is in ohms and capacitance is in microfarads. Equal resistance values for  $R1$  and  $R2$ , and equal capacitance values for  $C1$  and  $C2$  are assumed. These curves are adapted from those published by Otto H. Schade in "Analysis of Rectifier Operation," *Proceedings of the I. R. E.*, July 1943.

the power supply is turned on, the filter capacitors look like a short-circuited load. Provided the limiting resistors can withstand the surge current, their current-handling capacity is based on the maximum load current from the supply. Output voltages approaching twice the peak voltage of the transformer can be obtained with the voltage doubling circuit shown in Fig 17.7. **Fig 17.8** shows how the voltage depends upon the ratio of the series resistance to the load resistance, and the load resistance times the filter capacitance. The peak inverse voltage across each diode is  $2.8 E_{RMS}$ .

### Tripler and Quadrupler

**Fig 17.9A** shows a voltage-tripling circuit. On one half of the ac cycle,  $C1$  and  $C3$  are charged to the source voltage through  $D1$ ,  $D2$  and  $D3$ . On the opposite half of the cycle,  $D2$  conducts and  $C2$  is charged to twice the source voltage, because it sees the transformer plus the charge in  $C1$  as its source ( $D1$  is cut off during this half cycle). At the same time,  $D3$  conducts, and with the transformer and the charge in  $C2$  as the source,  $C3$  is charged to three times the transformer voltage.

The voltage-quadrupling circuit of **Fig 17.9B** works in similar fashion. In either of the circuits of **Fig 17.9**, the output voltage will approach an exact multiple of the peak ac voltage when the output

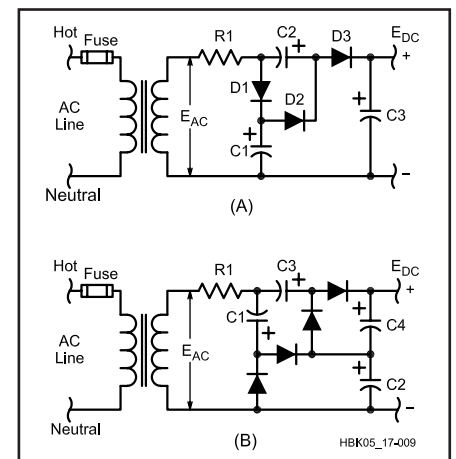

**Fig 17.9** — Voltage-multiplying circuits with one side of the transformer secondary used as a common connection. A shows a voltage tripler and B shows a voltage quadrupler. Capacitances are typically 20 to 50  $\mu F$ , depending on the output current demand. Capacitor dc ratings are related to  $E_{PEAK}$  ( $1.4 E_{RMS}$ ):  
 $C1$  — Greater than  $E_{PEAK}$   
 $C2$  — Greater than  $2 E_{PEAK}$   
 $C3$  — Greater than  $3 E_{PEAK}$   
 $C4$  — Greater than  $2 E_{PEAK}$



current drain is low and the capacitance values are high.

## RECTIFIER RATINGS VERSUS OPERATING STRESS

Power supplies designed for amateur equipment use silicon rectifiers almost exclusively. These rectifiers are available in a wide range of voltage and current ratings. In peak inverse voltage (PIV) ratings of 600 or less, silicon rectifiers carry current ratings as high as 400 A. At 1000 PIV, the current ratings may be several amperes. It is possible to stack several units in series for higher voltages. Stacks are available commercially that will handle peak inverse voltages up to 10 kV at a load current of 1 A or more.

## RECTIFIER STRINGS OR STACKS

### Diodes in Series

When the PIV rating of a single diode is not sufficient for the application, similar diodes may be used in series. (Two 500 PIV diodes in series will withstand 1000 PIV and so on.) There used to be a general recommendation to place a resistor across each diode in the string to equalize the PIV drops. With modern diodes, this practice is no longer necessary.

Modern silicon rectifier diodes are constructed to have an avalanche characteristic. Simply put, this means that the diffusion process is controlled so the diode will exhibit a Zener characteristic in the reverse biased direction before destructive breakdown of the junction can occur. This provides a measure of safety for diodes in series. A diode will go into Zener conduction before it self destructs. If other diodes in the chain have not reached their avalanche voltages, the current through the avalanched diode will be limited to the leakage current in the other diodes. This should normally be very low. For this reason, shunting resistors are generally not needed across diodes in series rectifier strings. In fact, shunt resistors can

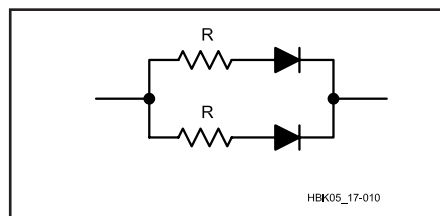

**Fig 17.10** — Diodes can be connected in parallel to increase the current-handling capability of the circuit. Each diode should have a series current-equalizing resistor, with a value selected to provide a few tenths of a volt drop at the expected current.

actually create problems because they can produce a low-impedance source of damaging current to any diode that may have reached avalanche potential.

### Diodes in Parallel

Diodes can be placed in parallel to increase current-handling capability. Equalizing resistors should be added as shown in **Fig 17.10**. Without the resistors, one diode may take most of the current. The resistors should be selected to have several tenths of a volt drop at the expected peak current.

## RECTIFIER PROTECTION

The important specifications of a silicon diode are:

1. PIV, the peak inverse voltage.
2.  $I_0$ , the average dc current rating.
3.  $I_{REP}$  — the peak repetitive forward current.
4.  $I_{SURGE}$ , a non-repetitive peak half-sine wave of 8.3 ms duration (one-half cycle of 60-Hz line frequency).
5. Switching speed.
6. Power dissipation and thermal resistance.

The first two specifications appear in most catalogs.  $I_{REP}$  and  $I_{SURGE}$  often are not specified in catalogs, but they are very important. Because the rectifier never allows current to flow more than half the

time, when it does conduct it has to pass at least twice the average direct current. With a capacitor-input filter, the rectifier conducts much less than half the time, so that when it does conduct, it may pass as much as 10 to 20 times the average dc current, under certain conditions. This is shown in **Fig 17.11**. Part A shows a simple half-wave rectifier with a resistive load. The waveform to the right of the drawing shows the output voltage along with the diode current. Parts B and C show conditions for circuits with “low” capacitance and “high” capacitance to filter the output.

After the capacitor is charged to the peak-rectified voltage, a period of diode non-conduction elapses while the output voltage discharges through the load. As the voltage begins to rise on the next positive pulse, a point is reached where the rectified voltage equals the stored voltage in the capacitor. As the voltage rises beyond that point, the diode begins to supply current. The diode will continue to conduct until the waveform reaches the crest, as shown. Since the diode has only that short time in which to charge the capacitor with enough energy to provide power to the load for the non-conducting balance of the cycle, the current will be high. The larger the capacitor for a given load, the shorter the diode conduction time and the higher the peak repetitive current ( $I_{REP}$ ).

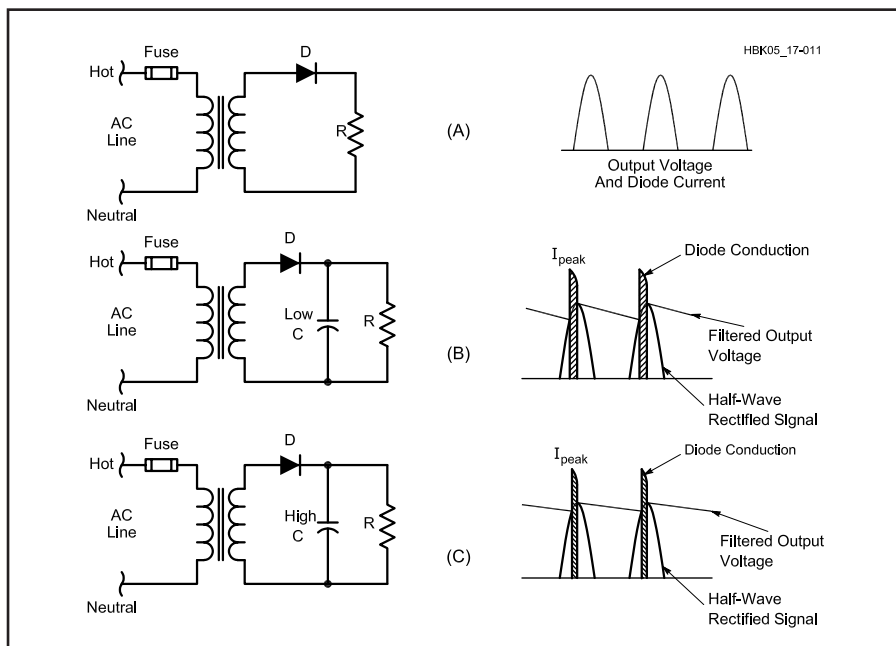

**Fig 17.11** — The circuit shown at A is a simple half-wave rectifier with a resistive load. The waveform shown to the right is the output voltage and current. B illustrates how the diode current is modified by the addition of a capacitor filter. The diode conducts only when the rectified voltage is greater than the voltage stored in the capacitor. Since this time is usually only a short portion of a cycle, the peak current will be quite high. C shows an even higher peak current. This is caused by the larger capacitor, which effectively shortens the diode conduction period.

## Current Inrush

When the supply is first turned on, the discharged input capacitor looks like a dead short, and the rectifier passes a very heavy current. This current transient is called  $I_{\text{SURGE}}$ . The maximum surge current rating for a diode is usually specified for a duration of one-half cycle (at 60 Hz), or about 8.3 ms. Some form of surge protection is usually necessary to protect the diodes until the input capacitor becomes nearly charged, unless the diodes used have a very high surge-current rating (several hundred amperes). If a manufacturer's data sheet is not available, an educated guess about a diode's capability can be made by using these rules of thumb for silicon diodes commonly used in Amateur Radio power supplies:

Rule 1. The maximum  $I_{\text{REP}}$  rating can be assumed to be approximately four times the maximum  $I_0$  rating.

Rule 2. The maximum  $I_{\text{SURGE}}$  rating can be assumed to be approximately 12 times the maximum  $I_0$  rating. (This figure should provide a reasonable safety factor. Silicon rectifiers with 750-mA dc ratings, for example, seldom have 1-cycle surge ratings of less than 15 A; some are rated up to 35 A or more.) From this you can see that the rectifier should be selected on the basis of  $I_{\text{SURGE}}$  and not on  $I_0$  ratings.

Although you can sometimes rely on the dc resistance of the transformer secondary to provide ample surge-current limiting, this is seldom true in high-voltage power supplies. Series resistors are often installed between the secondary and the rectifier strings or in the transformer's primary circuit, but these can be a deterrent to good voltage regulation.

## Voltage Spikes

Vacuum-tube rectifiers had little problem with voltage spikes on the incoming power lines — the possibility of an internal arc was of little consequence, since the heat produced was of very short duration and had little effect on the massive plate and cathode structures. Unfortunately, such is not the case with silicon diodes.

Silicon diodes, because of their forward voltage drop of about one volt, create very little heat with high forward currents and therefore have tiny junction areas. Conduction in the reverse direction, however, can cause junction temperatures to rise

extremely rapidly with the resultant melting of the silicon and migration of the dopants into the rectifying junction. Destruction of the semiconductor junction is the end result.

To protect semiconductor rectifiers, special surge-absorption devices are available for connection across the incoming ac bus or transformer secondary. These devices operate in a fashion similar to a Zener diode, by conducting heavily when a specific voltage level is reached. Unlike Zener diodes, however, they have the ability to absorb very high transient energy levels without damage. With the clamping level set well above the normal operating voltage range for the rectifiers, these devices normally appear as open circuits and have no effect on the power-supply circuits. When a voltage transient occurs, however, these protection devices clamp the spike and thereby prevent destruction of the rectifiers.

Transient protectors are available in three basic varieties:

1. Silicon Zener diodes — large junction Zeners specifically made for this purpose and available as single junction for dc (unipolar) and back-to-back junctions for ac (bipolar). These silicon protectors are available under the trade name of TransZorb from General Semiconductor Corporation and are also made by other manufacturers. They have the best transient suppressing characteristics of the three varieties mentioned here, but are expensive and have the least energy absorbing capability per dollar of the group.

2. Varistors — made of a composition metal-oxide material that breaks down at a certain voltage. Metal-oxide varistors, also known as MOVs, are cheap and easily obtained, but have a higher internal resistance, which allows a greater increase of clamped voltage than the Zener variety. Varistors can also degrade with successive transients within their rated power handling limits (this is not usually a problem in the ham shack where transients are few and replacement of the varistor is easily accomplished).

Varistors usually become short circuited when they fail. Large energy dissipation can result in device explosion. Therefore, it is a good idea to include a fuse that limits the short-circuit current through the varistor, and to protect people

and circuitry from debris.

3. Gas tube — similar in construction to the familiar neon bulb, but designed to limit conducting voltage rise under high transient currents. Gas tubes can usually withstand the highest transient energy levels of the group. Gas tubes suffer from an ionization time problem, however. A high voltage across the tube will not immediately cause conduction. The time required for the gas to ionize and clamp the spike is inversely proportional to the level of applied voltage in excess of the device ionization voltage. As a result, the gas tube will let a little of the transient through to the equipment before it activates.

In installations where reliable equipment operation is critical, the local power is poor and transients are a major problem, the usual practice is to use a combination of protectors. Such systems consist of a varistor or Zener protector, combined with a gas-tube device. Operationally, the solid-state device clamps the surge immediately, with the beefy gas tube firing shortly thereafter to take most of the surge from the solid-state device.

## Heat

The junction of a diode is quite small; hence, it must operate at a high current density. The heat-handling capability is, therefore, quite small. Normally, this is not a prime consideration in high-voltage, low-current supplies. Use of high-current rectifiers at or near their maximum ratings (usually 2-A or larger stud-mount rectifiers) requires some form of heat sinking. Frequently, mounting the rectifier on the main chassis — directly, or with thin mica insulating washers — will suffice. If insulated from the chassis, a thin layer of silicone grease should be used between the diode and the insulator, and between the insulator and the chassis, to assure good heat conduction. Large, high-current rectifiers often require special heat sinks to maintain a safe operating temperature. Forced-air cooling is sometimes used as a further aid. Safe case temperatures are usually given in the manufacturer's data sheets and should be observed if the maximum capabilities of the diode are to be realized. See the thermal design section in the **Real-World Component Characteristics** chapter for more information.

# Filtration

The pulsating dc waves from the rectifiers are not sufficiently constant in amplitude to prevent hum corresponding to the pulsations. Filters are required between the rectifier and the load to smooth out the pulsations into an essentially constant dc voltage. The design of the filter depends to a large extent on the dc voltage output, the voltage regulation of the power supply and the maximum load current rating of the rectifier. Power-supply filters are low-pass devices using series inductors and shunt capacitors.

## LOAD RESISTANCE

In discussing the performance of power-supply filters, it is sometimes convenient to express the load connected to the output terminals of the supply in terms of resistance. The load resistance is equal to the output voltage divided by the total current drawn, including the current drawn by the bleeder resistor.

## VOLTAGE REGULATION

The output voltage of a power supply always decreases as more current is drawn, not only because of increased voltage drops in the transformer and filter chokes, but also because the output voltage at light loads tends to soar to the peak value of the transformer voltage as a result of charging the first capacitor. Proper filter design can eliminate the soaring effect. The change in output voltage with load is called voltage regulation, and is expressed as a percentage.

$$\text{Percent Regulation} = \frac{(E1 - E2)}{E2} \times 100\% \quad (1)$$

where:

- E1 = the no-load voltage
- E2 = the full-load voltage.

A steady load, such as that represented by a receiver, speech amplifier or unkeyed stages of a transmitter, does not require good (low) regulation as long as the proper voltage is obtained under load conditions. The filter capacitors must have a voltage rating safe for the highest value to which the voltage will soar when the external load is removed.

A power supply will show more (higher) regulation with long-term changes in load resistance than with short temporary changes. The regulation with long-term changes is often called the static regulation, to distinguish it from the dynamic regulation (short temporary load changes). A load that varies at a syllabic or keyed rate, as represented by some audio and RF

amplifiers, usually requires good dynamic regulation (15% or less) if distortion products are to be held to a low level. The dynamic regulation of a power supply can be improved by increasing the value of the output capacitor.

When essentially constant voltage regardless of current variation is required (for stabilizing an oscillator, for example), special voltage regulating circuits described later in this chapter are used.

## BLEEDER RESISTOR

A bleeder resistor is a resistance connected across the output terminals of the power supply. Its functions are to discharge the filter capacitors as a safety measure when the power is turned off and to improve voltage regulation by providing a minimum load resistance. When voltage regulation is not of importance, the resistance may be as high as 100-W per volt of power supply output voltage. The resistance value to be used for voltage-regulating purposes is discussed in later sections. From the consideration of safety, the power rating of the resistor should be as conservative as possible, since a burned-out bleeder resistor is dangerous!

## RIPPLE FREQUENCY AND VOLTAGE

Pulsations at the output of the rectifier can be considered to be the result of an alternating current superimposed on a steady direct current. From this viewpoint, the filter may be considered to consist of shunt capacitors that short circuit the ac component while not interfering with the flow of the dc component. Series chokes will readily pass dc but will impede the flow of the ac component.

The alternating component is called

ripple. The effectiveness of the filter can be expressed in terms of percent ripple, which is the ratio of the RMS value of the ripple to the dc value in terms of percentage.

$$\text{Percent Ripple (RMS)} = \frac{E1}{E2} \times 100\% \quad (2)$$

where:

- E1 = the RMS value of ripple voltage
- E2 = the steady dc voltage.

Any frequency multiplier or amplifier supply in a CW transmitter should have less than 5% ripple. A linear amplifier can tolerate about 3% ripple on the plate voltage. Bias supplies for linear amplifiers should have less than 1% ripple. VFOs, speech amplifiers and receivers may require a ripple no greater than to 0.01%.

Ripple frequency refers to the frequency of the pulsations in the rectifier output waveform — the number of pulsations per second. The ripple frequency of half-wave rectifiers is the same as the line-supply frequency — 60 Hz with a 60-Hz supply. Since the output pulses are doubled with a full-wave rectifier, the ripple frequency is doubled — to 120 Hz with a 60-Hz supply.

The amount of filtering (values of inductance and capacitance) required to give adequate smoothing depends on the ripple frequency. More filtering is required as the ripple frequency is reduced.

## CAPACITOR-INPUT FILTERS

Capacitor-input filter systems are shown in Fig 17.12. Disregarding voltage drops in the chokes, all have the same characteristics except with respect to ripple. Better ripple reduction will be obtained when LC sections are added as shown in Fig 17.12B and C.

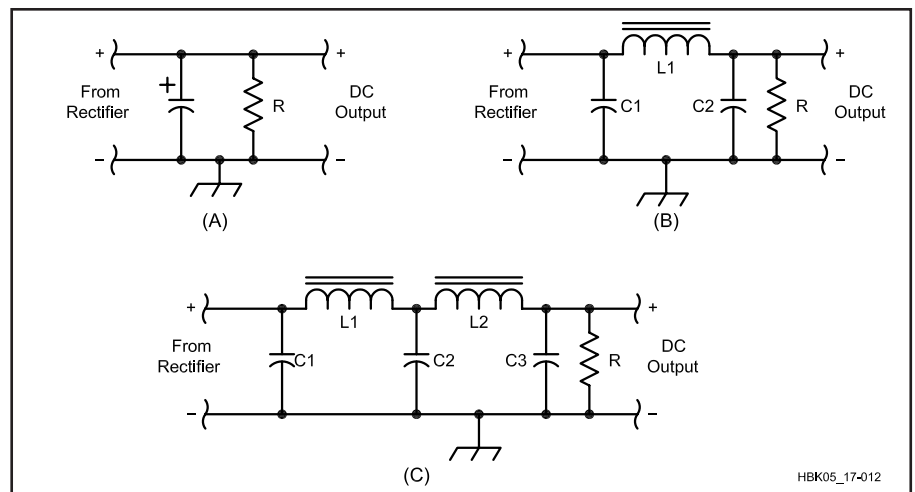

Fig 17.12 — Capacitor-input filter circuits. At A is a simple capacitor filter. B and C are single- and double-section filters, respectively.

## Input Versus Output Voltage

The average output voltage of a capacitor-input filter is generally poorly regulated with load-current variations. This is because the rectifier diodes conduct for only a small portion of the ac cycle to charge the filter capacitor to the peak value of the ac waveform. When the instantaneous voltage of the ac passes its peak, the diode ceases to conduct. This forces the capacitor to support the load current until the ac voltage on the opposing diode in the bridge or full wave rectifier is high enough to pick up the load and recharge the capacitor. For this reason, the diode currents are usually quite high.

Since the cyclic peak voltage of the capacitor-filter output is determined by the peak of the input ac waveform, the minimum voltage and, therefore, the ripple amplitude, is determined by the amount of voltage discharge, or “droop,” occurring in the capacitor while it is discharging and supporting the load. Obviously, the higher the load current, the proportionately greater the discharge, and therefore the lower the average output.

Although not exactly accurate, an easy way to determine the peak-to-peak ripple for a certain capacitor and load is to assume a constant load current. We can calculate the droop in the capacitor by using the relationship:

$$C \times E = I \times t \quad (3)$$

where:

C = the capacitance in microfarads,

E = the voltage droop, or peak-to-peak ripple voltage,

I = the load current in milliamperes and

t = the length of time per cycle when the rectifiers are not conducting, and the filter capacitor must support the load current. For 60-Hz, full-wave rectifiers, t is about 7.5 ms.

As an example, let’s assume that we need to determine the peak to peak ripple voltage at the dc output of a full-wave rectifier/filter combination that produces 13.8 V dc and supplies a transceiver drawing 2.0 A. The filter capacitor in the power supply is 5000  $\mu$ F. Using the above relationship:

$$C \times E = I \times t$$

$$5000 \mu\text{F} \times E = 2000 \text{ mA} \times 7.5 \text{ ms}$$

$$E = \frac{2000 \text{ mA} \times 7.5 \text{ ms}}{5000 \mu\text{F}} = 3 \text{ V P-P}$$

Obviously, this is too much ripple. A capacitor value of about 20000  $\mu$ F would be better suited for this application. If a linear regulator is used after this rectifier/filter combination, however, and the source voltage raised to produce a dc voltage of about 20 V, the 5000- $\mu$ F capacitor with its 3-V peak-to-peak ripple would work well, since the regulator would remove the ripple content before the output

power was applied to the transceiver.

## CHOKE-INPUT FILTERS

Choke-input filters have become less popular than they once were, because of the high surge current capability of silicon rectifiers. Choke-input filters provide the benefits of greatly improved output voltage stability over varying loads and low peak-current surges in the rectifiers. On the negative side, however, the choke is bulky and heavy, and the output voltage is lower than that of a capacitor-input filter.

As long as the inductance of the choke is large enough to maintain a continuous current over the complete cycle of the input ac waveform, the filter output voltage will be the average value of the rectified output. The average dc value of a full-wave rectified sine wave is 0.637 times its peak voltage. Since the RMS value is 0.707 times the peak, the output of the choke input filter will be (0.637 / 0.707), or 0.90 times the RMS ac voltage. For light loads, however, there may not be enough energy stored in the choke during the input waveform crest to allow continuous current over the full cycle. When this happens, the filter output voltage will rise as the filter assumes more and more of the characteristics of a capacitor-input filter.

Choke-input filters see extensive use in the energy-storage networks of switch-mode regulators.

## Regulation

The output of a rectifier/filter system may be usable for some electronic equipment, but for today’s transceivers and accessories, further measures may be necessary to provide power sufficiently clean and stable for their needs. Voltage regulators are often used to provide this additional level of conditioning.

Rectifier/filter circuits by themselves are unable to protect the equipment from the problems associated with input-power-line fluctuations, load-current variations and residual ripple voltages. Regulators can eliminate these problems, but not without costs in circuit complexity and power-conversion efficiency.

### ZENER DIODES

A Zener diode (named after American physicist Dr. Clarence Zener) can be used to maintain the voltage applied to a circuit at a practically constant value, regardless of the voltage regulation of the power supply or variations in load current. The typical cir-

cuit is shown in **Fig 17.13**. Note that the cathode side of the diode is connected to the positive side of the supply. The electrical characteristics of a Zener diode under conditions of forward and reverse voltage are given in the **Real-World Component**

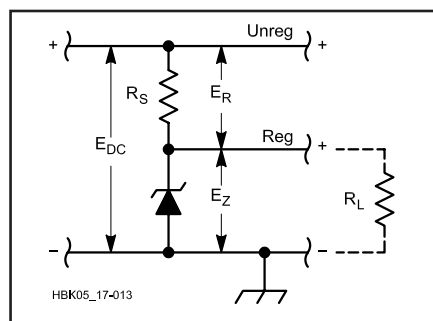

**Fig 17.13 — Zener-diode voltage regulation. The voltage from a negative supply may be regulated by reversing the power-supply connections and the diode polarity.**

**Characteristics** chapter.

Zener diodes are available in a wide variety of voltages and power ratings. The voltages range from less than two to a few hundred, while the power ratings (power the diode can dissipate) run from less than 0.25 W to 50 W. The ability of the Zener diode to stabilize a voltage depends on the diode’s conducting impedance. This can be as low as 1  $\Omega$  or less in a low-voltage, high-power diode or as high as 1000  $\Omega$  in a high-voltage, low-power diode.

### LINEAR REGULATORS

Linear regulators come in two varieties: *series* and *shunt*. The shunt regulator is simply an electronic (also called “active”) version of the Zener diode. For the most part, the active shunt regulator is rarely used since the series regulator is a superior choice for most applications. **Fig 17.14B** shows a shunt regulator.

The series regulator consists of a stable voltage reference, which is usually estab-



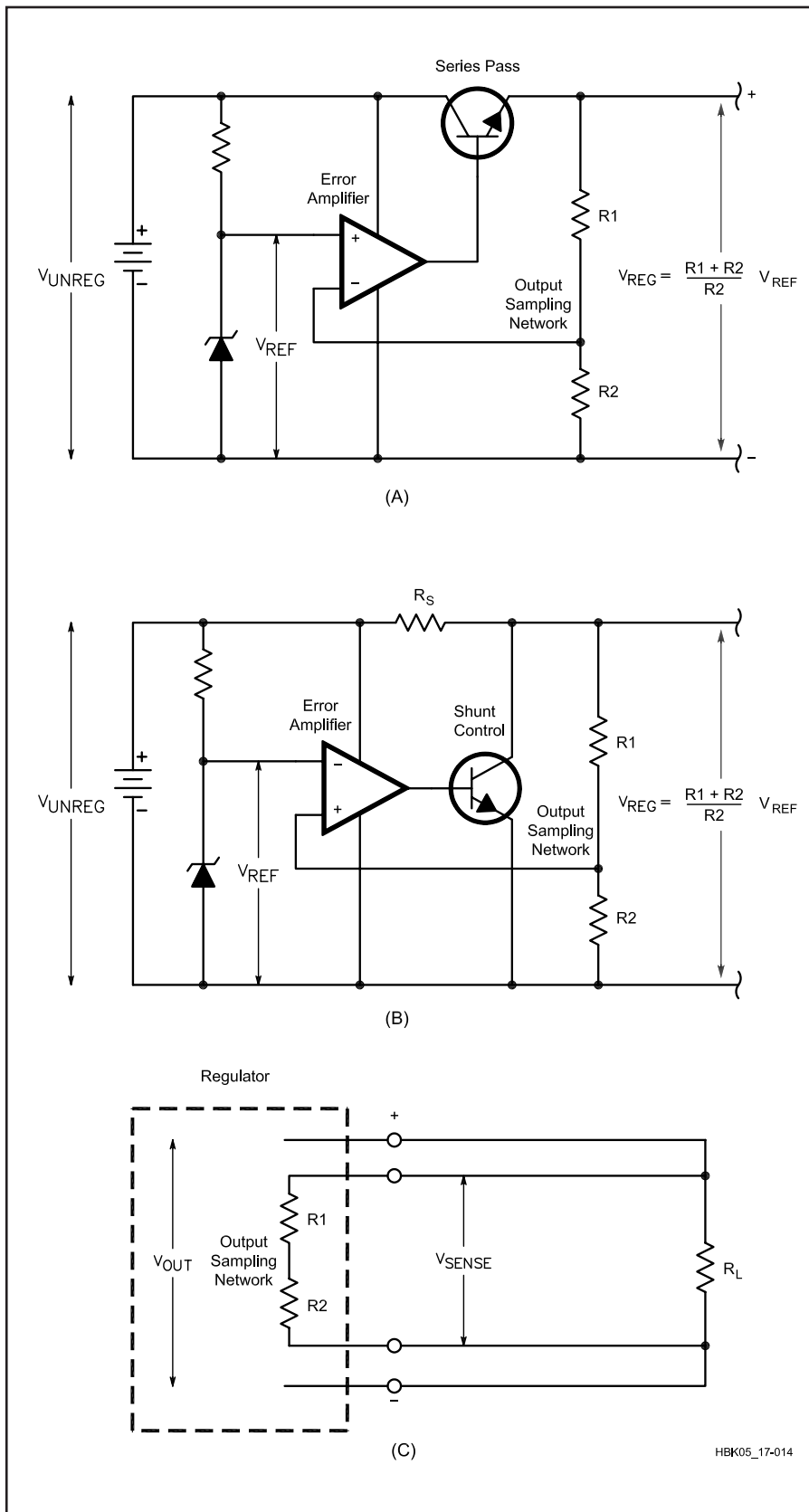

**Fig 17.14 — Linear electronic voltage-regulator circuits.** In these diagrams, batteries represent the unregulated input-voltage source. A transformer, rectifier and filter would serve this function in most applications. Part A shows a series regulator and Part B shows a shunt regulator. Part C shows how remote sensing overcomes poor load regulation caused by the  $I R$  drop in the connecting wires by bringing them inside the feedback loop.

lished by a Zener diode, a transistor in series with the power source and the load (called a *series pass transistor*), and an error amplifier. In critical applications a temperature-compensated reference diode would be used instead of the Zener diode. (See Fig 17.14A.)

The output voltage is sampled by the error amplifier, which compares the output (usually scaled down by a voltage divider) to the reference. If the scaled-down output voltage becomes higher than the reference voltage, the error amplifier reduces the drive current to the pass transistor, thereby allowing the output voltage to drop slightly. Conversely, if the load pulls the output voltage below the desired value, the amplifier drives the pass transistor into increased conduction.

The “stiffness” or tightness of regulation of a linear regulator depends on the gain of the error amplifier and the ratio of the output scaling resistors. In any regulator, the output is cleanest and regulation stiffest at the point where the sampling network or error amplifier is connected. If heavy load current is drawn through long leads, the voltage drop can degrade the regulation at the load. To combat this effect, the feedback connection to the error amplifier can be made directly to the load. This technique, called *remote sensing*, moves the point of best regulation to the load by bringing the connecting leads inside the feedback loop. This is shown in Fig 17.14C.

### Input Versus Output Voltage

In a series regulator, the pass-transistor power dissipation is directly proportional to the load current and input/output voltage differential. The series pass element can be located in either leg of the supply. Either NPN or PNP devices can be used, depending on the ground polarity of the unregulated input.

The differential between the input and output voltages is a design tradeoff. If the input voltage from the rectifiers and filter is only slightly higher than the required output voltage, there will be minimal voltage drop across the series pass transistor resulting in minimal thermal dissipation and high power-supply efficiency. The supply will have less capability to provide regulated power in the event of power line brownout and other reduced line voltage conditions, however. Conversely, a higher input voltage will provide operation over a wider range of input voltage, but at the expense of increased heat dissipation.

### Pass Transistors

#### *Darlington Pairs*

A simple Zener-diode reference or IC op-amp error amplifier may not be able to

source enough current to a pass transistor that must conduct heavy load current. The Darlington configuration of **Fig 17.15A** multiplies the pass-transistor beta, thereby extending the control range of the error amplifier. If the Darlington arrangement is implemented with discrete transistors, resistors across the base-emitter junctions may be necessary to prevent collector-to-base leakage currents in Q1 from being amplified and turning on the transistor pair. These resistors are contained in the envelope of a monolithic Darlington device.

When a single pass transistor is not available to handle the current required from a regulator, the current-handling capability may be increased by connecting two or more pass transistors in parallel. The circuit of Fig 17.15B shows the method of connecting these pass transistors. The resistances in the emitter leads of each transistor are necessary to equalize the currents.

### Transistor Ratings

When bipolar (NPN, PNP) power transistors are used in applications in which they are called upon to handle power on a continuous basis, rather than switching, there are four parameters that must be examined to see if any maximum limits are being exceeded. Operation of the transistor outside these limits can easily result in device failure. Unfortunately, not many hams (nor, sometimes, equipment manufacturers) are aware of all these parameters. Yet, for a transistor to provide reliable operation, the circuit designer must be sure not to allow his power supply or amplifier to cause overstress.

The four limits are maximum collector current ( $I_C$ ), maximum collector-emitter voltage ( $V_{CEO}$ ), maximum power and second breakdown ( $I_{SB}$ ). All four of these parameters are graphically shown on the transistor's data sheet on what is known as a Safe Operating Area (SOAR) graph. (See **Fig 17.16**.) The first three of these limits are usually also listed prominently with the other device information, but it is often the fourth parameter that is responsible for the "sudden death" of the power transistor after an extended operating period.

The maximum current limit of the transistor ( $I_C$  MAX) is usually the current limit for fusing of the bond wire connected to the emitter, rather than anything pertaining to the transistor chip itself. When this limit is exceeded, the bond wire can melt and open circuit the emitter. On the operating curve, this limit is shown as a horizontal line extending out from the Y-axis (zero volts between collector and emitter) and ending at the voltage point where the constant power limit begins.

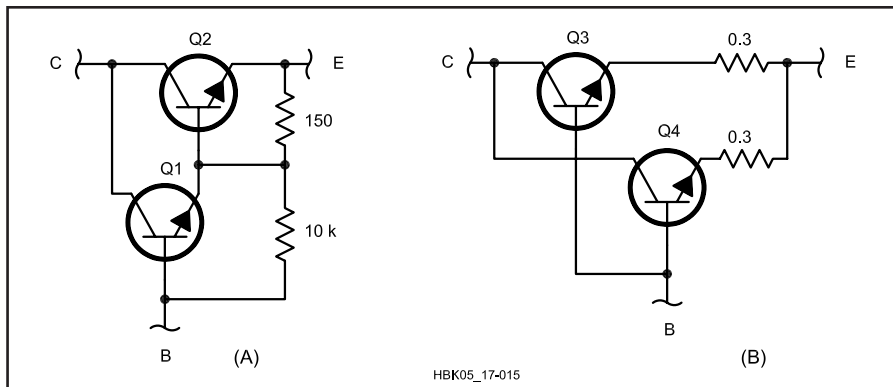

**Fig 17.15** — At A, a Darlington-connected transistor pair for use as the pass element in a series-regulating circuit. At B, the method of connecting two or more transistors in parallel for high-current output. Resistances are in ohms. The circuit at A may be used for load currents from 100 mA to 5 A, and the one at B may be used for currents from 6 A to 10 A.

**Q1** — Motorola MJE 340 or equivalent

**Q2 - Q4** — Power transistor such as 2N3055 or 2N3772

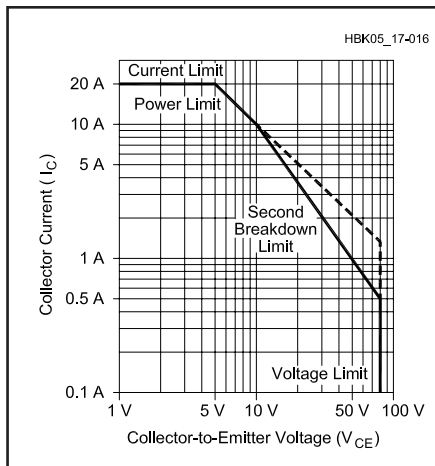

**Fig 17.16** — Typical graph of the Safe Operating Area (SOAR) of a transistor. See text for details. Safe operating conditions for specific devices may be quite different from those shown here.

The maximum collector-emitter voltage limit of the transistor ( $V_{CE}$  MAX) is the point at which the transistor can no longer stand off the voltage between collector and emitter.

With increasing collector-emitter voltage drop at maximum collector current, a point is reached where the power in the transistor will cause the junction temperature to rise to a level where the device leakage current rapidly increases and begins to dominate. In this region, the product of the voltage drop and the current would be constant and represent the maximum power ( $P_T$ ) rating for the transistor; that is,

as the voltage drop continues to increase, the collector current must decrease to maintain the power dissipation at a constant value.

With most of the higher voltage rated transistors, a point is reached on the constant power portion of the curve whereby, with further increased voltage drop, the maximum power rating is *not* constant, but decreases as the collector to emitter voltage increases. This decrease in power handling capability continues until the maximum voltage limit is reached.

This special region is known as the forward bias second breakdown (FBSB) area. Reduction in the transistor's power handling capability is caused by localized heating in certain small areas of the transistor junction ("hot spots"), rather than a uniform distribution of power dissipation over the entire surface of the device.

The region of operating conditions contained within these curves is called the Safe Operating Area, or SOAR. If the transistor is always operated within these limits, it should provide reliable and continuous service for a long time.

### MOSFET Transistors

The bipolar junction transistor (BJT) is rapidly being replaced by the MOSFET transistor in new power supply designs due to the latter's ease of drive. Just as the BJT comes in both NPN and PNP varieties, the MOSFET is available in N-channel and P-channel types, with the N-channel being the more popular of the two. The N-channel MOSFET is equivalent to the NPN bipolar, and the P-channel is equivalent to the PNP.

There are some considerations that should be observed when using a MOSFET as a linear regulator series pass transistor. Several volts of gate drive are needed in order to start conduction of the device, as opposed to less than one volt for the BJT. MOSFETs are inherently very-high-frequency devices, and will readily oscillate with stray-circuit capacitances. In order to prevent oscillation in the transistor and surrounding circuits, it is common practice to insert a small resistor of about 100 ohms directly in series with the gate of the series-pass transistor to reduce the gate circuit Q.

### Overcurrent Protection

Damage to a pass transistor can occur when the load current exceeds the safe amount. **Fig 17.17A** illustrates a simple current-limiter circuit that will protect Q1. All of the load current is routed through R1. A voltage difference will exist across R1; the value will depend on the exact load current at a given time. When the load current exceeds a predetermined safe value, the voltage drop across R1 will forward-bias Q2 and cause it to conduct. Because Q2 is a silicon transistor, the voltage drop across R1 must exceed 0.6 V to turn Q2 on. This being the case, R1 is chosen for a value that provides a drop of 0.6 V when the maximum safe-load current is drawn. In this instance, the drop will be 0.6 V when  $I_L$  reaches 0.5 A. R2 protects the base-emitter junction of Q2 from current spikes, or from destruction in the event Q1 fails under short-circuit conditions.

When Q2 turns on, some of the current through  $R_S$  flows through Q2, thereby depriving Q1 of some of its base current. This action, depending upon the amount of Q1 base current at a precise moment, cuts off Q1 conduction to some degree, thus limiting the current through it.

### Foldback Current Limiting

Under short-circuit conditions, a constant-current-type current limiter must still withstand the full source voltage and limited short-circuit current simultaneously, which can impose a very high-power dissipation or second-breakdown stress on the series pass transistor. For example, a 12-V regulator with current limiting set for 10 A and having a source of 16 V will have a dissipation of 40 W  $[(16\text{ V} - 12\text{ V}) \times 10\text{ A}]$  at the point of current limiting (knee). But its dissipation will rise to 160 W under short-circuit conditions  $(16\text{ V} \times 10\text{ amps})$ .

A modification of the limiter circuit can cause the regulated-output current to decrease with decreasing load resistance

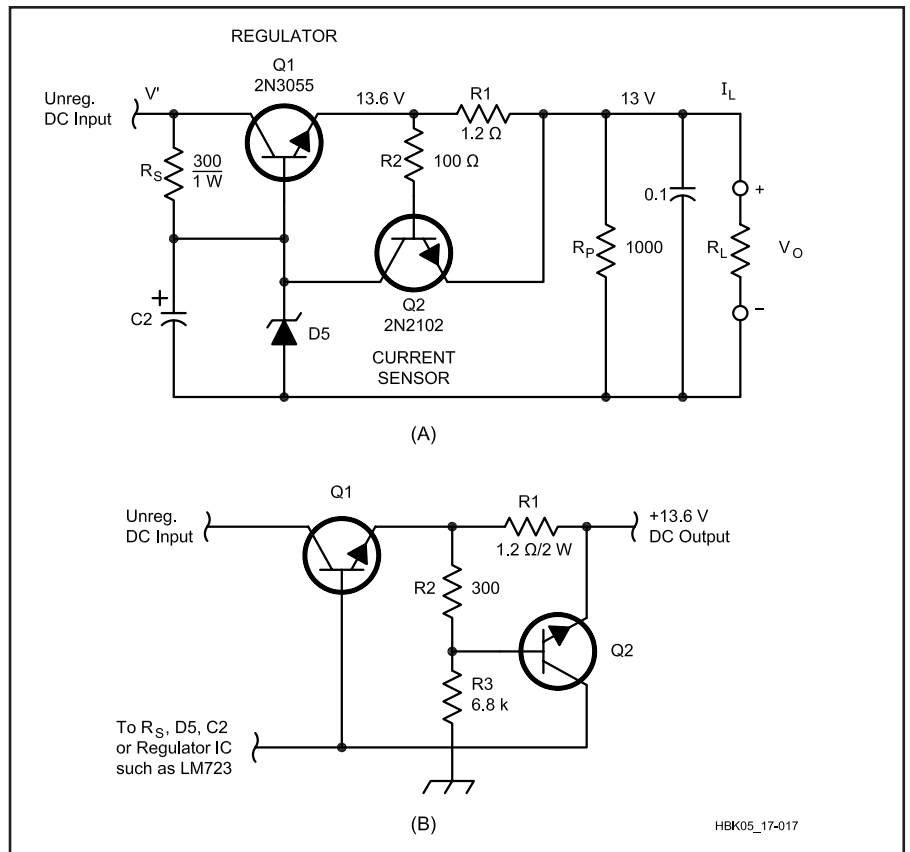
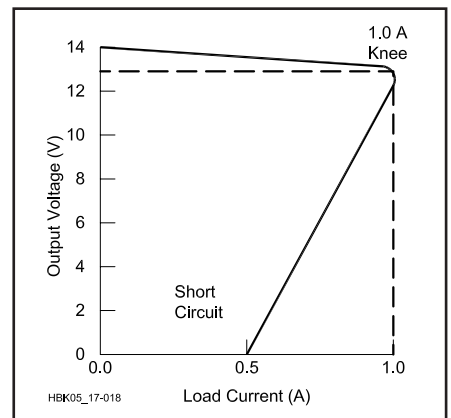

**Fig 17.17** — Overload protection for a regulated supply can be implemented by addition of a current-overload-protective circuit, as shown at A. At B, the circuit has been modified to employ current-foldback limiting.

after the over-current knee. With the output shorted, the output current is only a fraction of the knee-current value, which protects the series-pass transistor from excessive dissipation and possible failure. Using the previous example of the 12-V, 10-A regulator, if the short-circuit current is designed to be 3 A (the knee is still 10 A), the transistor dissipation with a short circuit will be only  $16\text{ V} \times 3\text{ A} = 48\text{ W}$ .

**Fig 17.17B** shows how the current-limiter example given in the previous section would be modified to incorporate foldback limiting. The divider string formed by R2 and R3 provides a negative bias to the base of Q2, which prevents Q2 from turning on until this bias is overcome by the drop in R1 caused by load current. Since this hold-off bias decreases as the output voltage drops, Q2 becomes more sensitive to current through R1 with decreasing output voltage. See **Fig 17.18**.

The circuit is designed by first calculating the value of R1 for short-circuit current. For example, if 0.5 A is chosen, the value for R1 is simply  $0.6\text{ V} / 0.5\text{ A} = 1.2\ \Omega$  (with the output shorted, the amount of hold-off bias supplied by R2 and R3 is very small and can be neglected). The knee



**Fig 17.18** — The 1-A regulator shown in **Fig 17.17B** will fold back to 0.5 A under short-circuit conditions. See text.

current is then chosen. For this example, the selected value will be 1.0 A. The divider string is then proportioned to provide a base voltage at the knee that is just sufficient to turn on Q2 (a value of 13.6 V for 13.0 V output). With 1.0 A flowing through R1, the voltage across the divider will be 14.2 V. The voltage dropped by R2

must then be  $14.2\text{ V} - 13.6\text{ V}$ , or  $0.6\text{ V}$ . Choosing a divider current of  $2\text{ mA}$ , the value of  $R_2$  is then  $0.6\text{ V} / 0.002\text{ A} = 300\ \Omega$ .  $R_3$  is calculated to be  $13.6\text{ V} / 0.002\text{ A} = 6800\ \Omega$ .

### “Crowbar” Circuits

Electronic components *do* fail from time to time. In a regulated power supply, the only component standing between an elevated dc source voltage and your rig is one transistor, or a group of transistors wired in parallel. If the transistor, or one of the transistors in the group, happens to short internally, your rig could suffer lots of damage.

To safeguard the rig or other load equipment against possible overvoltage, some power-supply manufacturers include a circuit known as a crowbar. This circuit usually consists of a silicon-controlled rectifier (SCR) connected directly across the output of the power supply, with a voltage-sensing trigger circuit tied to its gate. In the event the output voltage exceeds the trigger set point, the SCR will fire, and the output is short circuited. The resulting high current in the power supply (shorted output in series with a series pass transistor failed short) will blow the power supply’s line fuses. This is both a protection for the supply as well as an indicator that something has malfunctioned internally. For these reasons, never replace blown fuses with ones that have a higher current rating.

### IC VOLTAGE REGULATORS

The modern trend in regulators is toward the use of three-terminal devices commonly referred to as *three-terminal regulators*. Inside each regulator is a voltage reference, a high-gain error amplifier, temperature-compensated voltage sensing resistors and a pass element. Many currently available units have thermal shutdown, overvoltage protection and current foldback, making them virtually destruction-proof.

Three-terminal regulators (a connection for unregulated dc input, regulated dc output and ground) are available in a wide range of voltage and current ratings. It is easy to see why regulators of this sort are so popular when you consider the low price and the number of individual components they can replace. The regulators are available in several different package styles, depending on current ratings. Low-current ( $100\text{ mA}$ ) devices frequently use the plastic TO-92 and DIP-style cases. TO-220 packages are popular in the  $1.5\text{-A}$  range, and TO-3 cases house the larger  $3\text{-A}$  and  $5\text{-A}$  devices.

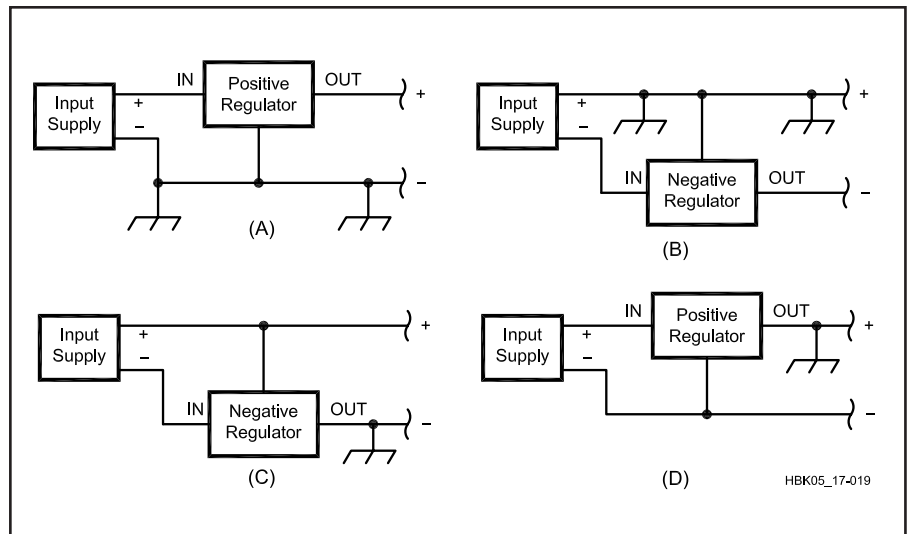

**Fig 17.19** — Parts A and B illustrate the conventional manner in which three-terminal regulators are used. Parts C and D show how one polarity regulator can be used to regulate the opposite-polarity voltage.

Three-terminal regulators are available as positive or negative types. In most cases, a positive regulator is used to regulate a positive voltage and a negative regulator a negative voltage. Depending on the system ground requirements, however, each regulator type may be used to regulate the “opposite” voltage.

**Fig 17.19A** and B illustrate how the regulators are used in the conventional mode. Several regulators can be used with a common-input supply to deliver several voltages with a common ground. Negative regulators may be used in the same manner. If no other common supplies operate from the input supply to the regulator, the circuits of Fig 17.19C and D may be used to regulate positive voltages with a negative regulator and vice versa. In these configurations the input supply is floated; neither side of the input is tied to the system ground.

Manufacturers have adopted a system of family numbers to classify three-terminal regulators in terms of supply polarity, output current and regulated voltage. For example, National uses the number LM7805C to describe a positive 5-V, 1.5-A regulator; the comparable unit from Texas Instruments is a UA7805KC. LM7812C describes a 12-V regulator of similar characteristics. LM7905C denotes a negative 5-V, 1.5-A device. There are many such families with widely varied ratings available from manufacturers. Fixed-voltage regulators are available with output ratings in most common values between 5 and 28 V. Other families

include devices that can be adjusted from 1.25 to 50 V.

### Regulator Specifications

When choosing a three-terminal regulator for a given application, the most important specifications to consider are device output voltage, output current, input-to-output differential voltage, line regulation, load regulation and power dissipation. Output voltage and current requirements are determined by the load with which the supply will ultimately be used.

Input-to-output differential voltage is one of the most important three-terminal regulator specifications to consider when designing a supply. The differential value (the difference between the voltage applied to the input terminal and the voltage on the output terminal) must be within a specified range. The minimum differential value, usually about  $2.5\text{ V}$ , is called the dropout voltage. If the differential value is less than the dropout voltage, no regulation will take place. At the other end of the scale, maximum input-output differential voltage is generally about  $40\text{ V}$ . If this differential value is exceeded, device failure may occur.

Increases in either output current or differential voltage produce proportional increases in device power consumption. By employing a safety feature called current foldback, some manufacturers ensure that maximum dissipation will never be exceeded in normal operation. **Fig 17.20** shows the relationship between output current, input-output differential and cur-



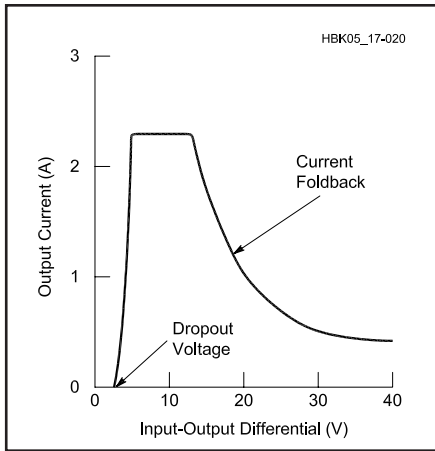

**Fig 17.20 — Effects of input-output differential voltage on three-terminal regulator current.**

rent limiting for a three-terminal regulator nominally rated for 1.5-A output current. Maximum output current is available with differential voltages ranging from about 2.5 V (dropout voltage) to 12 V. Above 12 V, the output current decreases, limiting the device dissipation to a safe value. If the output terminals are accidentally short circuited, the input-output differential will rise, causing current foldback, and thus preventing the power-supply components from being overstressed. This protective feature makes three-terminal regulators particularly attractive in simple power supplies.

When designing a power supply around a particular three-terminal regulator, input-output voltage characteristics of the regulator should play a major role in selecting the transformer-secondary and filter-capacitor component values. The unregulated voltage applied to the input of the three-terminal device should be higher than the dropout voltage, yet low enough that the regulator does not go into current limiting caused by an excessive differential voltage. If, for example, the regulated output voltage of the device shown in Fig 17.20 was 12, then unregulated input voltages of between 14.5 and 24 would be acceptable if maximum output current is desired.

In use, all but the lowest current regulators generally require an adequate external heat sink because they may be called on to dissipate a fair amount of power. Also, because the regulator chip contains a high-gain error amplifier, bypassing of the input and output leads is essential for stable operation.

Most manufacturers recommend bypassing the input and output directly at the leads where they protrude through the heat sink. Solid tantalum capacitors are usu-

ally recommended because of their good high-frequency capabilities.

External capacitors used with IC regulators may discharge through the IC junctions under certain circuit conditions, and high-current discharges can harm ICs. Look at the regulator data sheet to see whether protection diodes are needed, what diodes to use and how to place them in any particular application.

In addition to fixed-output-voltage ICs, high-current, adjustable voltage regulators are available. These ICs require little more than an external potentiometer for an adjustable output range from 5 to 24 V at up to 5 A. The unit price on these items is only a few dollars, making them ideal for test-bench power supplies. A very popular low current, adjustable output voltage three terminal regulator, the LM317, is shown in Fig 17.21. It develops a steady 1.25-V reference,  $V_{REF}$ , between the output and adjustment terminals. By installing  $R_1$  between these terminals, a constant current,  $I_1$ , is developed, governed by the equation:

$$I_1 = \frac{V_{REF}}{R_1} \quad (4)$$

Both  $I_1$  and a 100- $\mu$ A error current,  $I_2$ , flow through  $R_2$ , resulting in output voltage  $V_O$ .  $V_O$  can be calculated using the equation:

$$V_O = V_{REF} \left( 1 + \frac{R_2}{R_1} \right) + I_2 \times R_2 \quad (5)$$

Any voltage between 1.2 and 37 V may be obtained with a 40-V input by changing the ratio of  $R_2$  to  $R_1$ . At lower output voltages, however, the available current will be limited by the power dissipation of the regulator.

Fig 17.22 shows one of many flexible applications for the LM317. By adding only one resistor with the regulator, the voltage regulator can be changed into a constant-current source capable of charging NiCd batteries, for example. Design equations are given in the figure. The same precautions should be taken with adjustable regulators as with the fixed-voltage units. Proper heat sinking and lead bypassing are essential for proper circuit operation.

### Increasing Regulator Output Current

When the maximum output current from an IC voltage regulator is insufficient to operate the load, discrete power transistors may be connected to increase the current capability. Fig 17.23 shows two methods for boosting the output current of a positive regulator, although the same techniques can be applied to negative regulators.

In A, an NPN transistor is connected as an emitter follower, multiplying the output current capacity by the transistor beta. The shortcoming of this approach is that the base-emitter junction is not inside the feed-back loop. The result is that the output voltage is reduced by the base-emitter

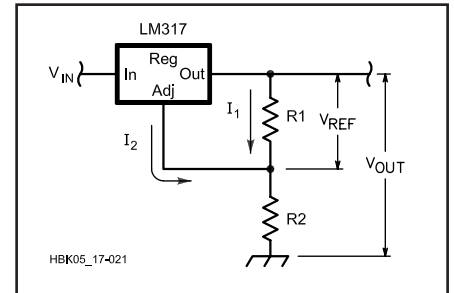

**Fig 17.21 — By varying the ratio of  $R_2$  to  $R_1$  in this simple LM317 schematic diagram, a wide range of output voltages is possible. See text for details.**

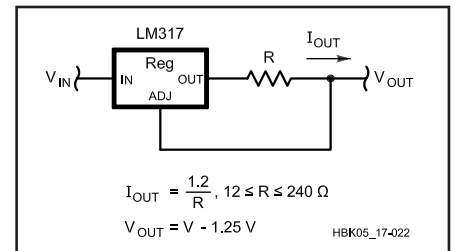

**Fig 17.22 — The basic LM317 voltage regulator is converted into a constant-current source by adding only one resistor.**

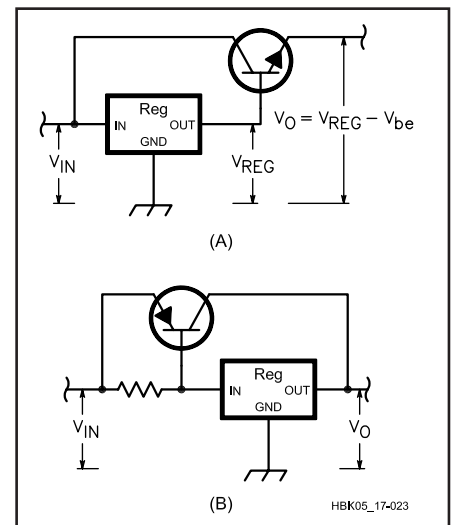

**Fig 17.23 — Two methods for boosting the output-current capacity of an IC voltage regulator. Part A shows an NPN emitter follower and B shows a PNP “wrap-around” configuration. Operation of these circuits is explained in the text.**

drop, and the load regulation is degraded by variations in this drop.

The circuit at B has a PNP transistor “wrapped around” the regulator. The regulator draws current through the base-emitter junction, causing the transistor to conduct. The IC output voltage is unchanged by the transistor because the collector is connected directly to the IC output (sense point). Any increase in output voltage is detected by the IC regulator, which shuts off its internal-pass transistor, and this stops the boost-transistor base current.

### HIGH-PRECISION SERIES REGULATOR LOOP DESIGN

This regulator-loop-design material was contributed by William E. Sabin, WØIYH. (A similar discussion appears in May 1991 *QEX*, pp 3-9.) The discussion here concerns some of the important factors in the design and testing of a series-regulator feedback loop. These techniques were used to design “A Series Regulated 4.5- to 25-V 2.5-A Power Supply,” which appears later in this chapter. The values and measurements discussed here are from that circuit. **Fig 17.24** is a simplified ver-

sion of that supply, which is adequate for this discussion.

The series regulator is a good example of a feedback-control system. Open-loop gain and bandwidth, the phase and gain margins and the transient response are important factors. The goal of the design is to maximize the regulator closed-loop performance. One approach is to use a high value of open-loop gain and establish the open-loop frequency response in two ways: (1) an RC low-pass filter consisting of C6, R2, R3,  $\frac{1}{2} R_e$  and the output resistances of Q1 and Q2; and (2) a single small capacitor (C4) at the regulator IC. Note that the voltage drop across R2 and R3 is applied to pins 2 and 3 of the LM723 regulator IC, which are used for current limiting. R2 sets the current limit value, and R2’s value affects the RC filter.

### Test Circuits

Fig 17.24 shows three test circuits. One is an adjustable Load-Test Circuit that can be modulated linearly (almost) by: (1) a sine or triangle wave from a function generator with a dc-offset adjustment (so that the waveform always has positive polarity), or (2) by a bidirectional square

wave. This circuit is used to test the loop response to various load fluctuations. It has proved to be very informative, as discussed later.

The second test circuit (Loop Gain Tester) is inserted into the regulator loop, so that a test signal can be injected into the loop in order to measure the open-loop gain and frequency response. Notice that the loop is closed through the feedback path of R4, R<sub>b</sub> and R<sub>a</sub> at dc and very low frequencies (less than 0.5 Hz), and the dc-output voltage is reasonably well regulated (which is essential to loop testing). By observing the magnitude (and rate of change) of the frequency response, it is possible to deduce information about phase shift. With this information available, the gain and phase margins (and therefore the regulation, stability, transient response and output impedance) of the closed-loop regulator can be estimated.

The third test circuit is a two-stage op amp preamplifier and oscilloscope. It is used to measure very small signals in the 0.1-Hz to 400-kHz range.

### Open-Loop Tests

The test signal applied to points A and

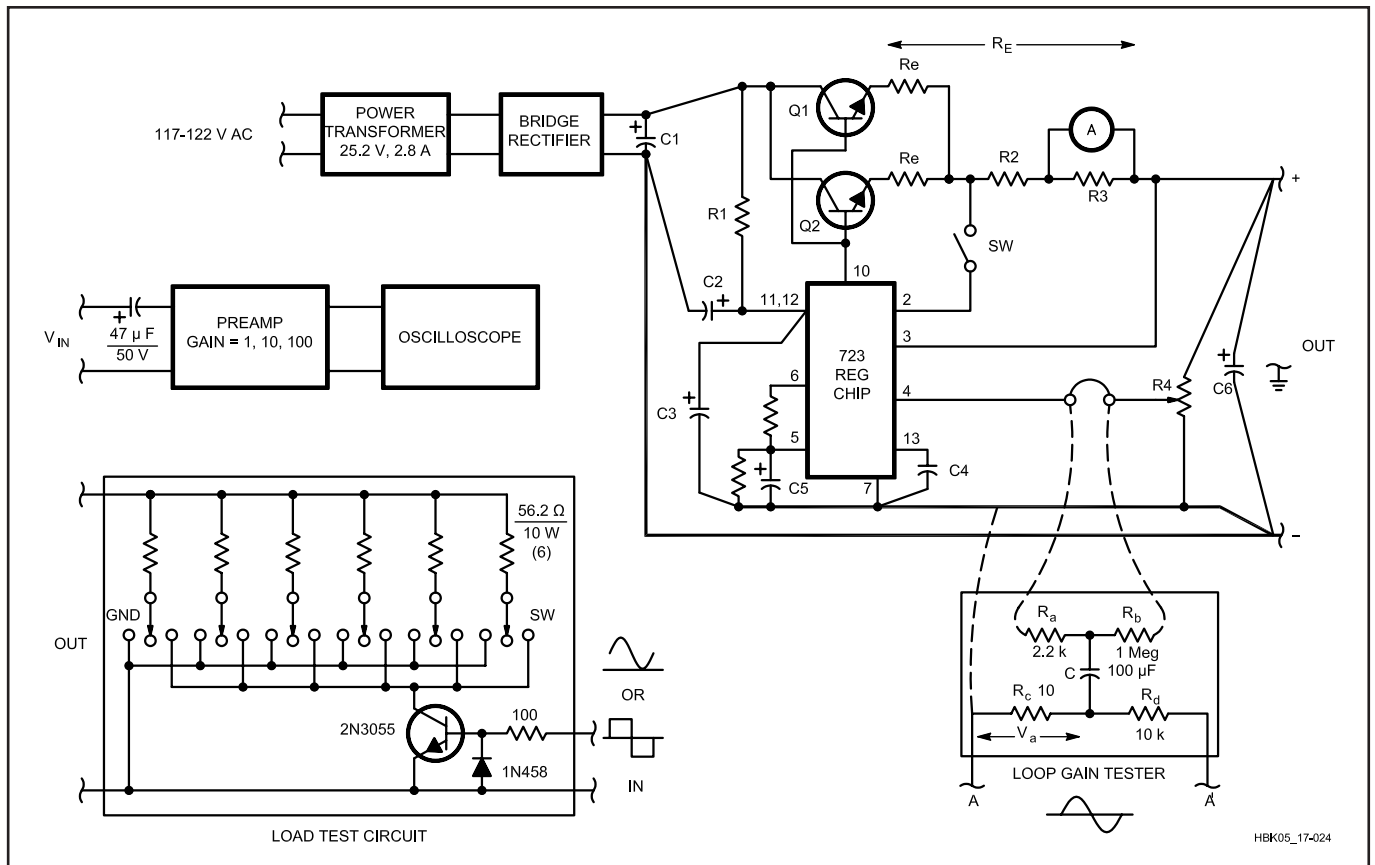

**Fig 17.24** — A simplified voltage-regulator feedback loop. The Loop-Gain Tester, Load Tester, Load-Test Circuit and oscilloscope circuits are used to test open-loop response and gain. The heavy lines indicate critical low-impedance circuit paths.

A' is reduced 60 dB by a voltage divider:  $R_d$  and  $R_c$ . (The voltage division converts convenient input voltages, which we can measure with ordinary equipment, to microvolt levels in the loop.) Capacitor C couples  $V_a$ , the voltage across  $R_c$ , to the '723 through  $R_a$ .  $R_a$  is roughly the resistance that the '723 sees in normal operation. The test signal is amplified by at most 74 dB on its way (clockwise around the loop and through the regulator) to the right-hand end of  $R_b$ . It is then attenuated 100 dB by  $R_b$  and  $R_c$ . This means that the "leak-through" back to the '723 input is much smaller than the  $V_a$  that we started with, if the frequency is 2 Hz or greater. At dc (and very low frequencies) the regulator functions somewhat normally. Above 2 Hz, then, the magnitude of the open-loop gain at the test frequency is very nearly the ratio  $|V_{out}| / |V_a|$ .

The first benefit of this test circuit was that it isolated an instability in the '723. The oscillation, at several hundred kHz, was cured by adding C4 (33 pF) and C3 (100  $\mu$ F / 50 V with very short leads). Normally, one would suspect an oscillation to involve the overall loop, but this was not the case. This kind of instability is common in feedback control systems: Everything appears to function (usually not to full specification), but an embedded element is not stable.

### Open-Loop Frequency Response

Referring to Fig 17.24, the open-loop gain is the product of three factors. The test signal is:

1. Voltage amplified by the regulator IC (about 74 dB for the '723) on its way (clockwise) to the emitters of Q1 and Q2.
  2. Low-pass filtered by C6 and  $R_E$  (the combination of  $\frac{1}{2} R_c + R2 + R3$ ).
  3. Divided by potentiometer R4.
- For the 2.5-A supply, the greatest open-

loop gain values are 59 dB at 25 V output and 74 dB at 4.5 V.

Fig 17.25 shows the open-loop frequency response to the top of R4 when  $R_E$  is set for a 2.5-A current limit. At very low frequencies, the drop-off is due to the gradual closure of the feedback loop, as mentioned above. At higher frequencies, the roll off results from the combined effects of C4 and C6; it occurs at a 6-dB-per-octave rate (within the errors of instrumentation). The cutoff frequency is about 280 Hz, which is:

$$f_{co} = \frac{1}{2 \times \pi \times R_E \times C6} \quad (6)$$

where:

$$\begin{aligned} f_{co} &= \text{cutoff frequency in Hz} \\ R_E &= 0.57 \Omega \\ C6 &= 1000 \mu\text{F} \end{aligned}$$

For comparison, a reference curve (6 dB per octave at the high and low ends) is superimposed. At about 1.2 kHz or so, the reactance of C6 is roughly equal to its equivalent series resistance (ESR), which is about 0.13  $\Omega$  for a small 1000- $\mu$ F aluminum-electrolytic capacitor. Beyond this frequency the impedance of C6 does not diminish, and C4 takes over (thereby maintaining the 6-dB-per-octave roll-off rate). Careful measurements and computer simulations of the regulator loop verified that C4 and C6 do, in fact, collaborate quite well in this manner.

This characteristic is the desired effect. At 120 Hz (the major ripple frequency) the loop gain is maximum, so the regulator loop works hard to suppress output ripple. At higher frequencies, the roll-off rate implies a loop phase shift in the neighborhood of 90°, which assures closed-loop stability and good transient response. Closed-loop transient response tests (using a square-wave signal injected into

the Load Test Circuit) verify the absence of ringing or large overshoot.

When  $R_E$  is increased to limit at smaller currents, the cutoff frequency decreases. In the example supply, the 0.5-A and 0.1-A range cutoff frequencies are 58 Hz and 12 Hz, respectively, and the roll-off rate remains 6 dB per octave as before. Hence, the loop gain at 120 Hz is reduced. The ripple voltage across C1, however, is also greatly reduced at lighter load currents. In the end, output ripple remains very low.

### Closed-Loop Response

The closed-loop gain of the regulator is:

$$G_{CL} = 20 \log \left( \frac{V_{out}}{V_{ref}} \right) \quad (7)$$

where:

$$\begin{aligned} G_{CL} &= \text{closed-loop gain, in dB} \\ V_{out} &= \text{output voltage} \\ V_{ref} &= \text{reference voltage.} \end{aligned}$$

Here,  $V_{out}$  is 4.5 V, minimum (25.0 V, maximum) and  $V_{ref}$  is 4.5 V. Fig 17.25 shows the locations of the minimum and maximum gain values and also the corresponding closed-loop bandwidths. By locating the 280-Hz cutoff frequency fairly close to the 120-Hz ripple frequency, the closed-loop bandwidth is minimized, which is desirable in a voltage regulator.

Another important regulator parameter is closed-loop output impedance. Fig 17.26 shows a computer simulation of this parameter. Mathematical analysis and actual measurements using the Load Test Circuit with a sine-wave test signal corroborate the simulations quite well. Two results are shown. For curve A, the C6 component (of Fig 17.24) is removed from the circuit, and C4 is increased so that the 280-Hz cutoff frequency is maintained, as

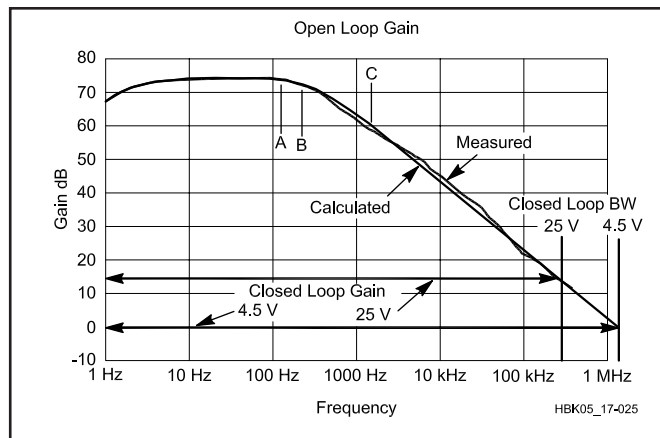

Fig 17.25 — The open-loop frequency-response curves of the voltage-regulator feedback loop. Point A is 120 Hz; point B is 280 Hz; point C is 1.2 kHz (above 1.2 kHz, C6 is no longer effective).

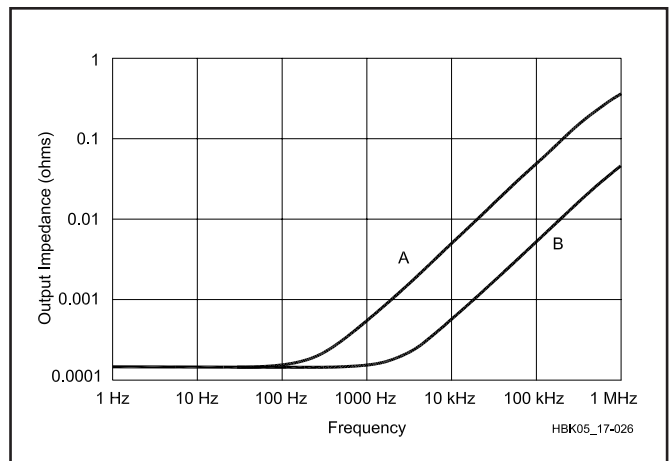

Fig 17.26 — Output impedance magnitude for the voltage-regulator feedback loop.

we discussed before. At low frequencies, the output impedance should be  $R_E$  ( $0.57 \Omega$ ) divided by the open-loop voltage gain (5000 maximum), about  $0.11 \text{ m}\Omega$ . Above 280 Hz, though, the output impedance increases rapidly because the open-loop gain is decreasing. It will eventually reach the value of  $R_E$ .

For curve B, the original values of C6 and C4 are used, and the output impedance remains low up to about 1.2 kHz. It then increases, but remains much lower than curve A. This happens because C4 is smaller than in curve A and

C4 mainly determines the frequency characteristic. In other words, the impedance of C6 (its reactance plus its ESR) is in parallel with the relatively small output impedance of a high-gain feedback amplifier. Therefore, C4 is much less influential in determining the power-supply output impedance. This situation gradually changes as frequency increases.

This discussion shows that the output-impedance characteristic of the power supply is reduced at frequencies that are significant in certain applications. Furthermore, it can be reduced by feedback to

levels that are impossible with practical capacitors. To take advantage of this lower impedance, the regulator must be located extremely close to the load (remote sensing is another possibility).

When extremely tight regulation and low-output impedance are important, the leads to the load must be very short, heavy straps. Multiple loads should be connected in parallel directly at the binding posts: A “daisy-chain” connection scheme does not assure equal regulation for each load; it counteracts precision regulation.

## High-Voltage Techniques

The construction of high-voltage supplies poses special considerations in addition to the normal design and construction practices used for lower-voltage supplies. In general, the constructor needs to remember that physical spacing between leads, connections, parts and the chassis must be sufficient to prevent arcing. Also, the series connection of components such as capacitor and resistor strings needs to be done with consideration for voltage stresses in the components.

### CAPACITORS

Capacitors will usually need to be connected in series strings to form an equivalent capacitor with the capability to withstand the applied voltage. When this is done, equal-value bypassing resistors need to be connected across each capacitor in the string in order to distribute the voltage equally across the capacitors. The *equalizing resistors* should have a value low enough to equalize differences in capacitor leakage resistance between the capacitors, while high enough not to dissipate excessive power. Also, capacitor bodies need to be insulated from the chassis and from each other by mounting them on insulating panels, thereby preventing arcing to the chassis or other capacitors in the string.

For high voltages, oil-filled paper-dielectric capacitors are superior to elec-

trolytics because they have lower internal impedance at high frequencies, lower leakage resistance and are available with higher working voltages. These capacitors are available in values of several microfarads and have working voltage ratings of thousands of volts. Avoid older oil-filled capacitors. They may contain polychlorinated biphenyls (PCBs), a known cancer-causing agent. Newer capacitors have eliminated PCBs and have a notice on the case to that effect.

### BLEEDER RESISTORS

Bleeder resistors should be given careful consideration. These resistors provide protection against shock when the power supply is turned off and dangerous wiring is exposed. A general rule is that the bleeder should be designed to reduce the output voltage to 30 V or less within 2 seconds of turning off the power supply. Take care to ensure that the maximum voltage rating of the resistor is not exceeded. The bleeder will consist of several resistors in series. One additional recommendation is that two separate bleeder strings be used, to provide safety in the event one of the strings fails.

### METERING TECHNIQUES

Special considerations should be observed for metering of high-voltage supplies, such as the plate supplies for linear

amplifiers. This is to provide safety to both personnel and also to the meters themselves.

To monitor the current, it is customary to place the ammeter in the supply return (ground) line. This ensures that both meter terminals are close to ground potential, as compared to the hazard created by placing the meter in the positive output line — in which case the voltage on each meter terminal would be near the full high-voltage potential. Also, there is the strong possibility that an arc could occur between the wiring and coils inside the meter and the chassis of the amplifier or power supply itself. This hazardous potential cannot exist with the meter in the negative leg. Another good safety practice is to place a low-voltage Zener diode across the terminals of the ammeter. This will bypass the meter in the event of an internal open circuit in the meter.

For metering of high voltage, the builder should remember that resistors to be used in multiplier strings have voltage-breakdown ratings. Usually, several resistors need to be used in series to reduce voltage stress across each resistor. A basic rule of thumb is that resistors should be limited to a maximum of 200 V, unless rated otherwise. Therefore, for a 2000-V power supply, the voltmeter would have a string of 10 resistors connected in series to distribute the voltage equally.

## Batteries and Charging

The availability of solid-state equipment makes it practical to use battery power under portable or emergency conditions. Hand-held transceivers and instruments are obvious applications, but even fairly powerful transceivers (100 W or so output) may be practical users of battery

power (for example, emergency power for the home station for ARES operation).

Lower-power equipment can be powered from two types of batteries. The “primary” battery is intended for one-time use and is then discarded; the “storage” (or “secondary”) battery may be recharged

many times.

A battery is a group of chemical cells, usually series-connected to give some desired multiple of the cell voltage. Each assortment of chemicals used in the cell gives a particular nominal voltage. This must be taken into account to make up a



particular battery voltage. For example, four 1.5-V carbon-zinc cells make a 6-V battery and six 2-V lead-acid cells make a 12-V battery. The **Electrical Fundamentals** chapter has more information about energy storage in batteries. In addition, the **Real-World Component Characteristics** chapter has information about battery capacity and charge/discharge rates.

## PRIMARY BATTERIES

One of the most common primary-cell types is the alkaline cell, in which chemical oxidation occurs during discharge. When there is no current, the oxidation essentially stops until current is required. A slight amount of chemical action does continue, however, so stored batteries eventually will degrade to the point where the battery will no longer supply the desired current. The time taken for degradation without battery use is called *shelf life*.

The alkaline battery has a nominal voltage of 1.5 V. Larger cells are capable of producing more milliampere hours and less voltage drop than smaller cells. Heavy-duty and industrial batteries usually have a longer shelf life.

Lithium primary batteries have a nominal voltage of about 3 V per cell and by far the best capacity, discharge, shelf-life and temperature characteristics. Their disadvantages are high cost and the fact that they cannot be readily replaced by other types in an emergency.

The lithium-thionyl-chloride battery is a primary cell, and should not be recharged under any circumstances. The charging process vents hydrogen, and a catastrophic hydrogen explosion can result. Even accidental charging caused by wiring errors or a short circuit should be avoided.

Silver oxide (1.5 V) and mercury (1.4 V) batteries are very good where nearly constant voltage is desired at low currents for long time periods. Their main use (in sub-miniature versions) is in hearing aids, though they may be found in other mass-produced devices such as household smoke alarms.

## SECONDARY OR RECHARGEABLE BATTERIES

Many of the chemical reactions in primary batteries are theoretically reversible if current is passed through the battery in the reverse direction.

Primary batteries should not be recharged for two reasons: It may be dangerous because of heat generated within sealed cells, and even in cases where there may be some success, both the charge and life are limited. One type of alkaline battery is rechargeable, and is so marked.

## Nickel Cadmium

The most common type of small rechargeable battery is the nickel-cadmium (NiCd), with a nominal voltage of 1.2 V per cell. Carefully used, these are capable of 500 or more charge and discharge cycles. For best life, the NiCd battery must not be fully discharged. Where there is more than one cell in the battery, the most-discharged cell may suffer polarity reversal, resulting in a short circuit, or seal rupture. All storage batteries have discharge limits, and NiCd types should not be discharged to less than 1.0 V per cell. There is a popular belief that it is necessary to completely discharge NiCd cells in order to recharge them to full capacity. Called the “memory effect,” professional engineers have proved this to be a myth.

Nickel-cadmium cells are not limited to “D” cells and smaller sizes. They also are available in larger varieties ranging to mammoth 1000 Ah units having carrying handles on the sides and caps on the top for adding water, similar to lead-acid types. These large cells are sold to the aircraft industry for jet-engine starting, and to the railroads for starting locomotive diesel engines. They also are used extensively for uninterruptible power supplies. Although expensive, they have very long life. Surplus cells are often available through surplus electronics dealers, and these cells often have close to their full rated capacity.

Advantages for the ham in these vented-cell batteries lie in the availability of high discharge current to the point of full discharge. Also, cell reversal is not the problem that it is in the sealed cell, since water lost through gas evolution can easily be replaced. Simply remove the cap and add distilled water. By the way, tap water should never be added to either nickel-cadmium or lead-acid cells, since dissolved minerals in the water can hasten self discharge and interfere with the electrochemical process.

## Lead Acid

The most widely used high-capacity rechargeable battery is the lead-acid type. In automotive service, the battery is usually expected to discharge partially at a very high rate, and then to be recharged promptly while the alternator is also carrying the electrical load. If the conventional auto battery is allowed to discharge fully from its nominal 2 V per cell to 1.75 V per cell, fewer than 50 charge and discharge cycles may be expected, with reduced storage capacity.

The most attractive battery for extended high-power electronic applications is the so-called “deep-cycle” battery, which is

intended for such uses as powering electric fishing motors and the accessories in recreational vehicles. Size 24 and 27 batteries furnish a nominal 12 V and are about the size of small and medium automotive batteries. These batteries may furnish between 1000 and 1200 W-hr per charge at room temperature. When properly cared for, they may be expected to last more than 200 cycles. They often have lifting handles and screw terminals, as well as the conventional truncated-cone automotive terminals. They may also be fitted with accessories, such as plastic carrying cases, with or without built-in chargers.

Lead-acid batteries are also available with gelled electrolyte. Commonly called *gel cells*, these may be mounted in any position if sealed, but some vented types are position sensitive.

Lead-acid batteries with liquid electrolyte usually fall into one of three classes — conventional, with filling holes and vents to permit the addition of distilled water lost from evaporation or during high-rate charge or discharge; maintenance-free, from which gas may escape but water cannot be added; and sealed. Generally, the deep-cycle batteries have filling holes and vents.

## Nickel Metal Hydride

This battery type is quite similar to the NiCd, but the Cadmium electrode is replaced by one made from a porous metal alloy that traps hydrogen; therefore the name of metal hydride. Many of the basic characteristics of these cells are similar to NiCds. For example, the voltage is very nearly the same, they can be slow-charged from a constant current source, and they can safely be deep cycled. There are also some important differences: The most attractive feature is a much higher capacity for the same cell size — often nearly twice as much as the NiCd types! The typical size AA NiMH cell has a capacity between 1000 and 1300 mAh, compared to the 600 to 830 mAh for the same size NiCd. Another advantage of these cells is a complete freedom from memory effect. We can also find comfort in the fact that NiMH cells do not contain any dangerous substances, while both NiCd and lead-acid cells do contain quantities of toxic heavy metals.

The internal resistance of NiMH cells is somewhat higher than that of NiCd cells, resulting in reduced performance at very high discharge current. This can cause slightly reduced power output from an HT powered by a NiMH pack, but the effect is barely noticeable, and the higher capacity and resulting longer run time far outweigh this. At least one manufacturer warns that

the self-discharge of NiMH cells is higher than for NiCd, but again, in practice this can hardly be noticed. The fast-charge process is different for NiMH batteries. A fast charger designed for NiCd will not correctly charge NiMH batteries. But many commercial fast chargers are designed for both types of batteries. NiMH batteries outperform NiCd batteries whenever high capacity is desired, while NiCd batteries still have advantages when delivering very high peak currents.

At the time of this writing, many cell phones and portable computers use NiMH batteries, and several manufacturers offer NiMH packs for Amateur Radio applications. Standard-sized NiMH cells are widely available from the major electronic parts suppliers.

### Lithium-Ion Cells

The lithium-ion cell is another possible alternative to NiCd cells. It features, for the same energy storage, about one third the weight and one half the volume of a NiCd. It also has a lower self-discharge rate. Typically, at room temperature, a NiCd cell will lose from 0.5 to 2% of its charge per day. The Lithium-ion cell will lose less than 0.5% per day and even this loss rate decreases after about 10% of the charge has been lost. At higher temperatures the difference is even greater. The result is that Lithium-ion cells are a much better choice for standby operation where frequent recharge is not available.

One major difference between NiCd and Li-ion cells is the cell voltage. The nominal voltage for a NiCd cell is about 1.2 V. For the Li-ion cell it is 3.6 V with a maximum cell charging voltage of 4 V. You cannot substitute Li-ion cells directly for NiCd cells. You will need one Li-ion cell for three NiCd cells. Chargers intended for NiCd batteries must not be used with Li-ion batteries, and vice versa.

## PROS AND CONS

### Chemical Hazards of Each Battery Type

In addition to the precautions given above, the following precautions are recommended. (Always follow the manufacturer's advice.)

Gas escaping from storage batteries may be explosive. Keep flames or lighted tobacco products away.

Dry-charged storage batteries should be given electrolyte and allowed to soak for at least half an hour. They should then be charged at about a 15 A rate for 15 minutes or so. The capacity of the battery will build up slightly for the first few cycles of charge and discharge, and then have fairly

constant capacity for many cycles. Slow capacity decrease may then be noticed.

No battery should be subjected to unnecessary heat, vibration or physical shock. The battery should be kept clean. Frequent inspection for leaks is a good idea. Electrolyte that has leaked or sprayed from the battery should be cleaned from all surfaces. The electrolyte is chemically active and electrically conductive, and may ruin electrical equipment. Acid may be neutralized with sodium bicarbonate (baking soda), and alkalis may be neutralized with a weak acid such as vinegar. Both neutralizers will dissolve in water, and should be quickly washed off. Do not let any of the neutralizer enter the battery.

Keep a record of the battery use, and include the last output voltage and (for lead-acid storage batteries) the hydrometer reading. This allows prediction of useful charge remaining, and the recharging or procuring of extra batteries, thus minimizing failure of battery power during an excursion or emergency.

### Internal Resistance

Cell internal resistance is very important to handheld-transceiver users. This is because the internal resistance is in series with the battery's output and therefore reduces the available battery voltage at the high discharge currents demanded by the transmitter. The result is reduced transmitter output power and power wasted in the cell itself by internal heating. Because of cell-construction techniques and battery chemistry, certain types of cells typically have lower internal resistance than others.

The NiCd cell is the undisputed king of cell types for high discharge current capability. Also, the NiCd maintains this low internal resistance throughout its discharge curve, because the specific gravity of its potassium-hydroxide electrolyte does not change.

Next in line is probably the alkaline primary cell. When these cells are used with handheld transceivers, it is not uncommon to have lower output power, and often to have the low battery indicator come on, even with fresh cells.

The lead-acid cell, which is finding popularity in belt-hung battery packs, is pretty close to the alkaline cell for internal resistance, but this is only at full charge. Unlike the NiCd, the electrolyte in the lead-acid cell enters into the chemical reaction. During discharge, the specific gravity of the electrolyte gradually drops as it approaches water, and the conductivity decreases. Therefore, as the lead-acid cell approaches a discharged state, the internal resistance increases. For the belt

pack, larger cells are used (approximately 2 Ah) and the internal resistance is consequently reduced.

The worst cell of all is the common carbon-zinc flashlight cell. With the transmit current demand levels of handheld radios, these cells are pretty much useless.

## BATTERY CAPACITY

The common rating of battery capacity is ampere hours (Ah), the product of current drain and time. The symbol "C" is commonly used; C/10, for example, would be the current available for 10 hours continuously. The value of C changes with the discharge rate and might be 110 at 2 A but only 80 at 20 A. Fig 17.27 gives capacity-to-discharge rates for two standard-size lead-acid batteries. Capacity may vary from 35 mAh for some of the small hearing-aid batteries to more than 100 Ah for a size 28 deep-cycle storage battery.

Sealed primary cells usually benefit from intermittent (rather than continuous) use. The resting period allows completion of chemical reactions needed to dispose of by-products of the discharge.

The output voltage of all batteries drops as they discharge. "Discharged" condition for a 12-V lead-acid battery, for instance, should not be less than 10.5 volts. It is also good to keep a running record of hydrometer readings, but the conventional readings of 1.265 charged and 1.100 discharged apply only to a long, low-rate discharge. Heavy loads may discharge the battery with little reduction in the hydrometer reading.

Batteries that become cold have less of their charge available, and some attempt to keep a battery warm before use is worthwhile. A battery may lose 70% or more of its capacity at cold extremes, but it will recover with warmth. All batteries have

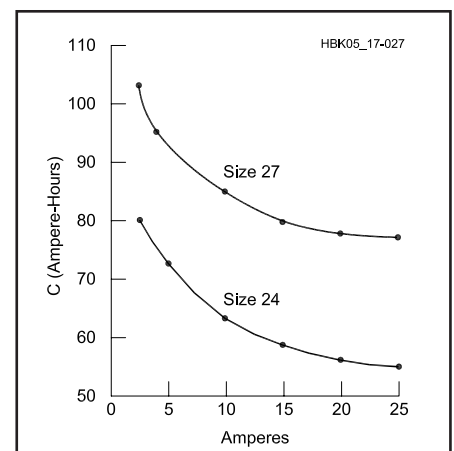

Fig 17.27 — Output capacity as a function of discharge rate for two sizes of lead-acid batteries.

some tendency to freeze, but those with full charges are less susceptible. A fully charged lead-acid battery is safe to  $-30^{\circ}\text{F}$  ( $-34^{\circ}\text{C}$ ) or colder. Storage batteries may be warmed somewhat by charging. Blowtorches or other flame should never be used to heat any type of battery.

A practical discharge limit occurs when the load will no longer operate satisfactorily on the lower output voltage near the “discharged” point. Much gear intended for “mobile” use may be designed for an average of 13.6 V and a peak of perhaps 15 V, but will not operate well below 12 V. For full use of battery charge, the gear should operate well (if not at full power) on as little as 10.5 V with a nominal 12 to 13.6-V rating.

Somewhat the same condition may be seen in the replacement of carbon-zinc cells by NiCd storage cells. Eight carbon-zinc cells will give 12 V, while 10 of the same size NiCd cells are required for the same voltage. If a 10-cell battery holder is used, the equipment should be designed for 15 V in case the carbon-zinc units are plugged in.

### Discharge Planning

Transceivers usually drain a battery at two or three rates: one for receiving, one for transmit standby and one for key-down or average voice transmit. Considering just the first and last of these (assuming the transmit standby is equal to receive), average two-way communication would require the low rate  $\frac{3}{4}$  of the time and the high rate  $\frac{1}{4}$  of the time. The ratio may vary somewhat with voice. The user may calculate the percentage of battery charge used in an hour by the combination (sum) of rates. If, for example, 20% of the battery capacity is used in an hour, the battery will provide five hours of communications per charge. In most actual traffic and DX-chasing situations the time spent listening should be much greater than that spent transmitting.

### Charging/Discharging Requirements

The rated full charge of a battery, C, is expressed in ampere-hours. No battery is perfect, so more charge than this must be offered to the battery for a full-charge. If, for instance, the charge rate is 0.1 C (the 10-hour rate), 12 or more hours may be needed for the charge.

Basically NiCd batteries differ from the lead-acid types in the methods of charging. It is important to note these differ-

ences, since improper charging can drastically shorten the life of a battery. NiCd cells have a flat voltage-versus-charge characteristic until full charge is reached; at this point the charge voltage rises abruptly. With further charging, the electrolyte begins to break down and oxygen gas is generated at the positive (nickel) electrode and hydrogen at the negative (cadmium) electrode.

Since the cell should be made capable of accepting an overcharge, battery manufacturers typically prevent the generation of hydrogen by increasing the capacity of the cadmium electrode. This allows the oxygen formed at the positive electrode to reach the metallic cadmium of the negative electrode and reoxidize it. During overcharge, therefore, the cell is in equilibrium. The positive electrode is fully charged and the negative electrode less than fully charged, so oxygen evolution and recombination “wastes” the charging power being supplied.

In order to ensure that all cells in a NiCd battery reach a fully-charged condition, NiCd batteries should be charged by a constant current at about a 0.1-C current level. This level is about 50 mA for the AA-size cells used in most hand-held radios. This is the optimum rate for most NiCds since 0.1 C is high enough to provide a full charge, yet it is low enough to prevent over-charge damage and provide good charge efficiency.

Although fast-charge-rate (3 to 5 hours typically) chargers are available for hand-held transceivers, they should be used with care. The current delivered by these units is capable of causing the generation of large quantities of oxygen in a fully charged cell. If the generation rate is greater than the oxygen recombination rate, pressure will build in the cell, forcing the vent to open and the oxygen to escape. This can eventually cause drying of the electrolyte, and then cell failure. The cell temperature can also rise, which can shorten cell life. To prevent overcharge from occurring, fast-rate chargers should have automatic charge-limiting circuitry that will switch or taper the charging current to a safe rate as the battery reaches a fully-charged state.

Gelled-electrolyte lead-acid batteries provide 2.4 V/cell when fully charged. Damage results, however, if they are overcharged. (Avoid constant-current or trickle charging unless battery voltage is monitored and charging is terminated when a full charge is reached.) Voltage-

limited charging is best for these batteries. A proper charger maintains a safe charge-current level until 2.3 V/cell is reached (13.8 V for a 12-V battery). Then, the charge current is tapered off until 2.4 V/cell is reached. Once charged, the battery may be safely maintained at the “float” level, 2.3 V/cell. Thus, a 12-V gel-cell battery can be “floated” across a regulated 13.8-V system as a battery backup in the event of power failure.

Deep-cycle lead-acid cells are best charged at a slow rate, while automotive and some NiCd types may safely be given quick charges. This depends on the amount of heat generated within each cell, and cell venting to prevent pressure build-up. Some batteries have built-in temperature sensing, used to stop or reduce charging before the heat rise becomes a danger. Quick and fast charges do not usually allow gas recombination, so some of the battery water will escape in the form of gas. If the water level falls below a certain point, acid hydrometer readings are no longer reliable. If the water level falls to plate level, permanent battery damage may result.

Overcharging NiCds in moderation causes little loss of battery life. Continuous overcharge, however, may generate a voltage depression when the cells are later discharged. For best results, charging of NiCd cells should be terminated after 15 hours at the slow rate. Better yet, circuitry may be included in the charger to stop charging, or reduce the current to about 0.02 C when the 1.43-V-per-cell terminal voltage is reached. For lead-acid batteries, a timer may be used to run the charger to make up for the recorded discharge, plus perhaps 20%. Some chargers will switch over automatically to an acceptable standby charge.

### Solar Charging Systems

Price and availability make solar panels an attractive way to maintain the charge on your batteries. Relatively small, low-power solar arrays provide a convenient way to charge a NiCd or sealed-lead-acid battery for emergency and portable operation. This is especially popular with QRP operators. You should always connect some type of charge controller between the battery and the solar array. This will prevent overcharging the battery, and the possible resulting battery damage. The Micro M+ described in the projects section of this chapter is a suitable charge controller.



# Emergency Operations

## CARE AND FEEDING OF GENERATORS

For long-term-emergency operation, a generator is a must, as anyone who has operated field day can attest to. The generator will provide power as long as the fuel supply holds out. Proper care is necessary to keep the generator operating reliably, however.

When the generator runs out of fuel, the operator may be tempted to rush over with the gasoline can and begin refueling. This is very hazardous, since the engine's manifold and muffler are at temperatures that can ignite spilled gasoline. The operator should wait a few minutes to allow hot surfaces to cool sufficiently to ensure safety. For these periods when the generator is shut down, plan on having battery

power available to support station operation until the generator can be brought back on line.

Check the level of the engine's lubricating oil from time to time. If the oil sump becomes empty, the engine can seize, putting the station out of operation and necessitating costly engine repairs.

Remember that the engine will produce carbon monoxide gas while it is running. The generator should never be run indoors, and should be placed away from open windows and doors to keep exhaust fumes from coming inside.

## INVERTERS

For battery-powered operation of alternating-current loads, inverters are available. An inverter is a dc-to-ac converter,

switching at 60 Hz to provide 120-V ac to the loads.

Inverters come in varying degrees of sophistication. The simplest, as mentioned above, produces a square-wave output. This is no problem for lighting and other loads that don't care about the input waveform. Lots of equipment using motors will work poorly or not at all when supplied with square wave power. Therefore, many higher-power inverters use waveform shaping to approximate a sine-wave output. The simplest of these methods is a resonant inductor and capacitor filter. Higher-power units employ pulse-width modulation of the converter switches to create a sinusoidal output waveform.

# Power-Supply Projects

Construction of a power supply can be one of the most rewarding projects undertaken by a radio amateur. Whether it's a charger for the NiCds in a VHF handheld transceiver, a low-voltage, high-current monster for a new 100-W solid-state transceiver, or a high-voltage supply for a new linear amplifier, a power supply is basic to all of the radio equipment we operate and enjoy. Final testing and adjustment of most power-supply projects requires only a voltmeter, and perhaps an oscilloscope — tools commonly available to most amateurs.

General construction techniques that may be helpful in building the projects in this chapter are outlined in the **Circuit Construction** chapter. Other chapters in this *Handbook* contain basic information about the components that make up power supplies.

Safety must always be carefully considered during design and construction of any power supply. Power supplies contain potentially lethal voltages, and care must be taken to guard against accidental exposure. For example, electrical tape, insulated tubing (spaghetti) or heat-shrink tubing is recommended for covering exposed wires, component leads, component solder terminals and tie-down points. Whenever possible, connectors used to mate the power supply to the outside world should be of an insulated type designed to prevent accidental contact.

Connectors and wire should be checked for voltage and current ratings. Always

use wire with an insulation rating higher than the working voltages in the power supply. Special high-voltage wire is available for use in B+ supplies. The **Component Data and References** chapter contains a table showing the current-carrying capability of various wire sizes. Scrimping on wire and connectors to save money could result in flashover, meltdown or fire.

All fuses and switches should be placed in the hot leg(s) only. The neutral leg should not be interrupted. Use of a three-wire (grounded) power connection will greatly reduce the chance of accidental shock. The proper wiring color code for 120-V circuits is: black — hot; white — neutral; and green — ground. For 240-V circuits, the second hot lead generally uses a red wire.

## POWER-SUPPLY PRIMARY CIRCUIT CONNECTOR STANDARD

The International Commission on Rules for the Approval of Electrical Equipment (CEE) standard for power-supply primary-circuit connectors for use with detachable cable assemblies is the CEE-22 (see **Fig 17.28**). The CEE-22 has been recognized by the ARRL and standards agencies of many countries. Rated for up to 250 V, 6 A at 65°C, the CEE-22 is the most commonly used three-wire (grounded), chassis-mount primary circuit connector for electronic equipment in North America and Europe. It is often used in Japan and Australia as well.

When building a power supply requir-

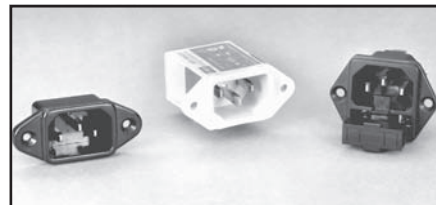

**Fig 17.28** — CEE-22 connectors are available with built-in line filters and fuse holders.

ing 6 A or less for the primary supply, a builder would do well to consider using a CEE-22 connector and an appropriate cable assembly, rather than a permanently installed line cord. Use of a detachable line cord makes replacement easy in case of damage. CEE-22 compatible cable assemblies are available with a wide variety of power plugs including most types used overseas.

Some manufacturers even supply the CEE-22 connector with a built-in line filter. These connector/filter combinations are especially useful in supplies that are operated in RF fields. They are also useful in digital equipment to minimize conducted interference to the power lines.

CEE-22 connectors are available in many styles for chassis or PC-board mounting. Some have screw terminals; others have solder terminals. Some styles even contain built-in fuse holders.



## A SERIES-REGULATED 4.5- TO 25-V, 2.5-A POWER SUPPLY

For home-laboratory requirements, a series-regulator supply is simpler and less expensive than a switching power supply. Series-regulated supplies are also free of electrical switching noise, which is a problem with some switching supplies. During tests of sensitive low-level circuitry, the power supply output should be pure dc; it should not contribute to problems in the circuit under test.

The power supply in Fig 17.29 was designed and built by William E. Sabin, WØIYH. See “High-Precision Series Regulator Loop Design,” earlier in this chapter, for a discussion of the design, analysis and tests of the feedback control loop used in this power supply.

### FEATURES

This supply was designed to meet the following objectives:

- Continuously variable output voltage from 4.5 to 25.0 V.
- Tight load voltage regulation, better than 0.03%, for load currents from 0 to 2.0 A, 0.1% to 2.5 A; 0.01% into a 2.0-A load for ac-line voltages from 117 to 122 V.
- Excellent response to load fluctuations and transients (low output impedance).
- Very low ac ripple, less than 2  $\mu$ V RMS with a 2.0-A load.
- Very low random noise, less than 2  $\mu$ V RMS from 0.1 Hz to 500 kHz.
- Use an off-the-shelf transformer and other easily obtainable parts.
- Load currents up to 2.5 A, continuous duty.
- Switch selectable current limiting, at 0.1, 0.5 or 2.5 A, to protect delicate circuits under test.

### THE CIRCUIT

Fig 17.30 is a schematic of the power-supply circuit. An LM723 regulator was selected because it's simple, and its reference voltage is available (pin 6) for filtering. Reference noise (typical of zener diodes) is reduced to a very low level via C5, as suggested in the data sheet for the LM723. The current-limiting circuitry is also accessible (at pins 2 and 3). It senses the voltage drop across R2 and R3.

The combination of R2 and R3 sets the current limit at  $0.62 / (R2 + R3)$  A. R3 (R3a and R3b together) forms an 0.11- $\Omega$ , 4-W resistor, which acts as a shunt for the digital meter that measures load current. R8 provides meter adjustment without affecting R3 significantly. S3 selects from three values of R2 to set current limits at approximately 0.1, 0.5 or 2.5 A.

C1 has a large value to reduce output ripple voltage. Smaller values would increase ripple and require a higher trans-former voltage to prevent regulator drop out. Other voltage drops between the Q1/Q2 emitters and the output terminal are mini-mized to assure that a standard 25.2-V trans-former can do the job. The R1-C2 combination reduces ac ripple at the LM723 by a factor of 25; this eliminates the need for an extremely large value of C1.

The circuitry of Q3, R10, C7 and D1 prevents the voltage on pins 11 and 12 of U2 from exceeding the 40-V maximum rating of the LM723 (especially with light loads and high line voltage). C7 eliminates a very small ac ripple at the dc output. As load current increases, the voltage at C1 decreases and Q3 is saturated.

When R4 is adjusted to reduce output voltage, U2 and Q1/Q2 are switched off until C6 discharges to the lower voltage. This causes the emitter-base junctions of Q1 and Q2 to break down (at about 2.0 V) so that C6 could discharge through R5. D2 provides an alternate path and prevents this breakdown. R5 provides a minimum load for U2.

The foldback circuit is interesting: Q4, D4 and R13 provide a constant current through, and therefore a constant voltage drop across, R16. This voltage makes the current limiting (pins 2 and 3 of U2) work properly over the entire 4.5- to 25.0-V range. As the current limiting action pulls the voltage at the top of R16 below about 4.0 V, D3 quickly stops conducting, the voltage across R16 approaches zero and the load current is limited at about 1.9 A. This limits Q1/Q2 and T1 dissipation and provides short-circuit protection. This is a regenerative positive feedback process. R14 sets the current at which foldback begins, 2.6 A. There is further discussion of foldback circuitry earlier in this chapter.

An inexpensive Heath SM-2300-A auto ranging DMM (mounted on the front panel) displays the supply output levels. The dedicated DMM can display very small output changes. S2 selects either voltage or current (divided by ten) for display. (The DMM is left in its voltage range for both measurements.) The voltage across R3 is 0.11 times

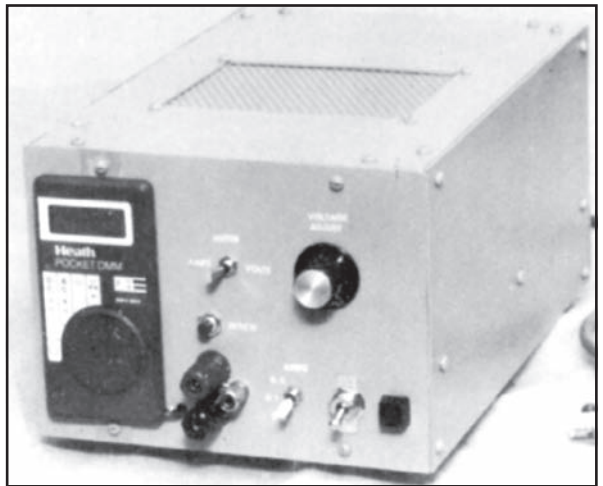

Fig 17.29 — An exterior view of the 2.5-A power supply. The DMM is mounted on the control panel as the output meter.

the load current. R8 provides the required ammeter adjustment without significantly affecting R3. The meter shows 0.2 for 2 A. Ordinary wire-wound resistors are adequate for R3 because they do not heat significantly at 2.5 A.

R9 sets the reference voltage on pin 5 of U2 at 4.5 V to establish the minimum output voltage. R11 sets the 25.0-V upper limit. A three-wire line cord assures that the supply chassis is always tied to the ac-line ground, for safety reasons. The dc output is not referenced to chassis ground, and performance is independent of the ac-ground connection. If the load current is very small, it may take a long time for C6 to discharge when the power is switched off; a press of S4 quickly discharges the capacitors (through R15) after turnoff. The mechanical construction emphasizes heat removal, so a cooling fan is not needed.

### CONSTRUCTION

Several areas are critical to good performance. Pay particular attention to these:

- Wire C1 with short, heavy leads to present a minimum impedance to ac ripple. Also, connect C1 directly to the negative binding post with a heavy lead. This provides a low inductance path for load-current fluctuations and keeps them off the PC-board ground plane.
- Connect C2 directly to the negative lead of C1.
- Connect C6 directly across the binding posts.
- Connect R4 to R11 with a low-impedance lead and connect R11 directly to the PC board ground plane.

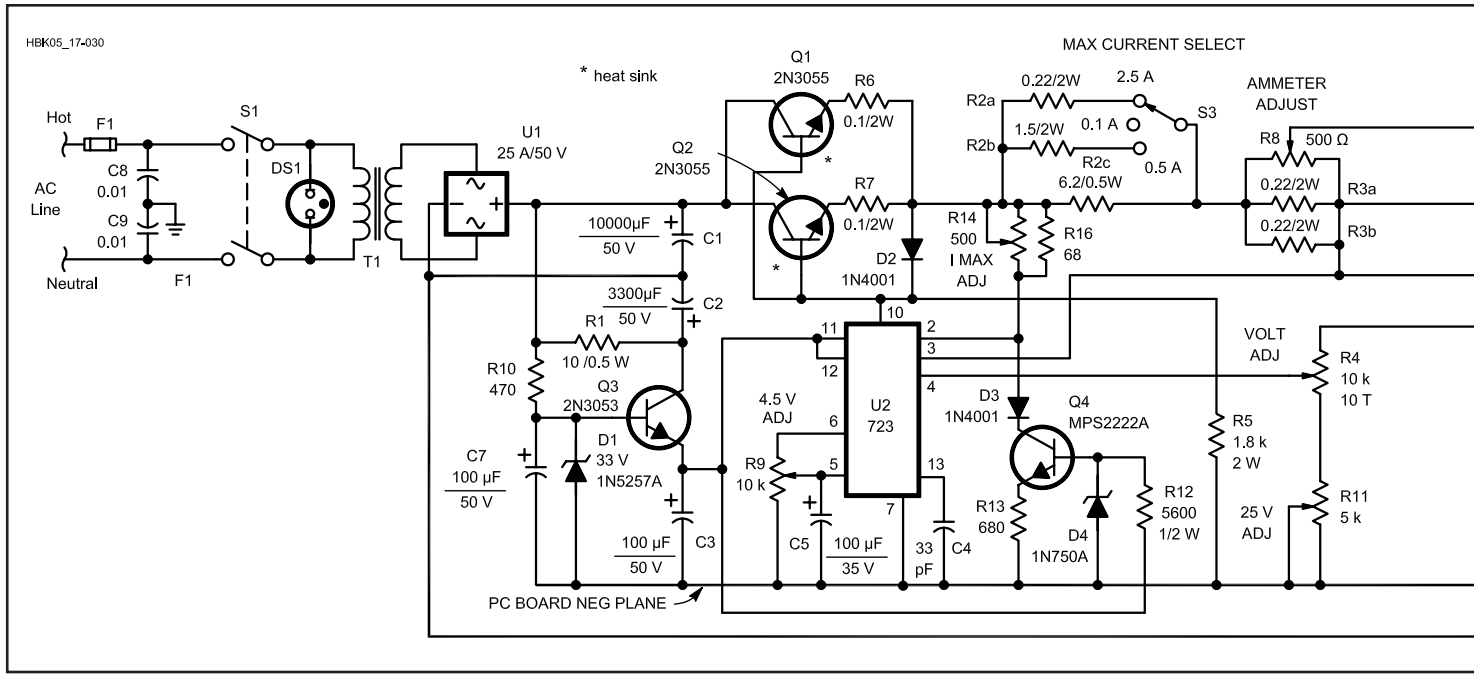
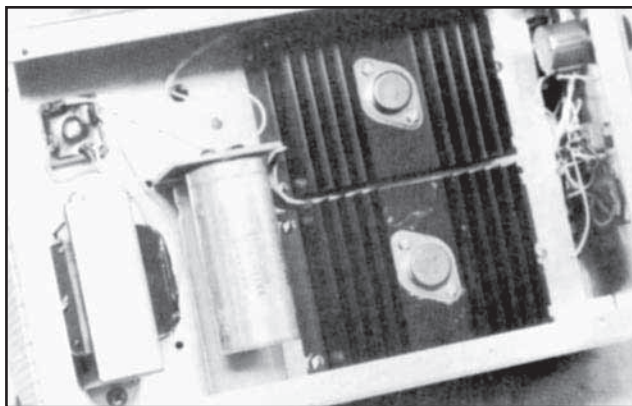

Fig 17.30 — Schematic of the 4.5 to 25-V, 2.5-A regulated dc power supply. Heavy lines indicate critical low-impedance conductors; use short conductors with large surface areas. “RS” signifies a RadioShack part number; “CDE” is a Cornell Dubilier Electric part.

- C1 — 10000  $\mu$ F, 50 V (CDE 10000-50-AC, or equiv)
- C2 — 3300  $\mu$ F, 50 V (CDE 3300-50-M, or equiv)
- C3, C7 — 100  $\mu$ F, 50 V (RS 272-1044, or equiv)
- C4 — 33 pF, 50 V
- C5 — 100  $\mu$ F, 35 V (RS 272-1028, or equiv)
- C6 — 1000  $\mu$ F, 35 V (RS 272-1032, or equiv)
- C8, C9 — 0.01  $\mu$ F, ac-rated capacitor.
- D1 — 1N5257A 33-V Zener diode.
- D2, D3 — 1N4001 (RS 276-1101, or equiv)
- D4 — 1N750A
- DS1 — Neon lamp, 120-V ac (RS 272-704, or equiv)
- F1 — 1.5 A slow-blow (RS 270-1284, or equiv)

- M1 — DMM (Heath SM-2300-A, or equiv)
- P1 — Three-wire power cord and plug
- Q1, Q2 — 2N3055 (RS 276-2041, or equiv)
- Q3 — 2N3053 (RS 276-2030, or equiv).
- Q4 — MPS2222A (RS 276-2009, or equiv)
- R1 — 10  $\Omega$ , 0.5 W
- R2a — 0.22  $\Omega$ , 2 W
- R2b — 1.5  $\Omega$ , 2 W
- R2c — 6.2  $\Omega$ , 5%, 0.5 W
- R3 — 0.15  $\Omega$ , 2 W
- R4 — 10 k $\Omega$ , 10-turn potentiometer (Bourns 3540S, or equiv)
- R5 — 1.8 k $\Omega$ , 2 W
- R6, R7 — 0.1  $\Omega$ , 2 W
- R8, R14 — 500  $\Omega$  potentiometer (RS 271-226, or equiv)
- R9 — 10 k $\Omega$  potentiometer.

- R10 — 470  $\Omega$ , 0.25 W
- R11 — 5 k $\Omega$  potentiometer
- R12 — 5.6 k $\Omega$ , 0.5 W
- R13 — 680  $\Omega$ , 0.25 W
- R16 — 68  $\Omega$  0.25 W
- S1, S2 — DPDT (RS 275-652, or equiv).
- S3 — SPDT (center off) (RS 275-654, or equiv)
- S4 — Normally open, momentary-contact, push-button switch (RS 275-1547, or equiv)
- T1 — 120-V primary, 25.2-V, 2.8-A secondary (Stancor P-8388, or equiv)
- U1 — Rectifier bridge, 25 A, 50 V (RS 276-1185, or equiv)
- U2 — LM723 regulator (RS 27-1740, or equiv)
- Heat sink — Wakefield 403A, or equiv (two required).



(A)

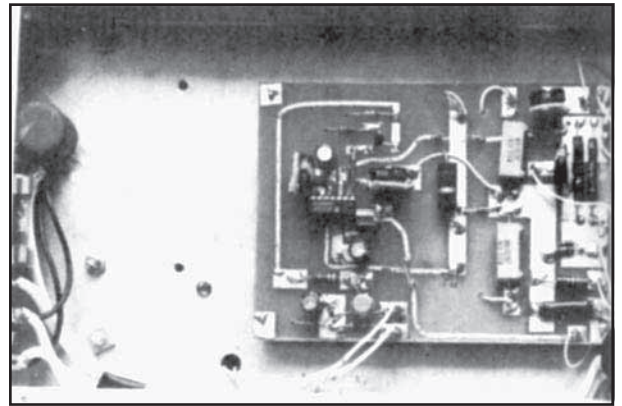

(B)

Fig 17.31 — A shows a top view of the open power-supply chassis. The 1/8-inch plate holding C1 is visible at the left edge of the heat sinks. B shows a bottom view. Notice that the components are mounted on the etched side of the board. The circuit pattern is simple enough for freehand layout. The front panel is at right in both views.

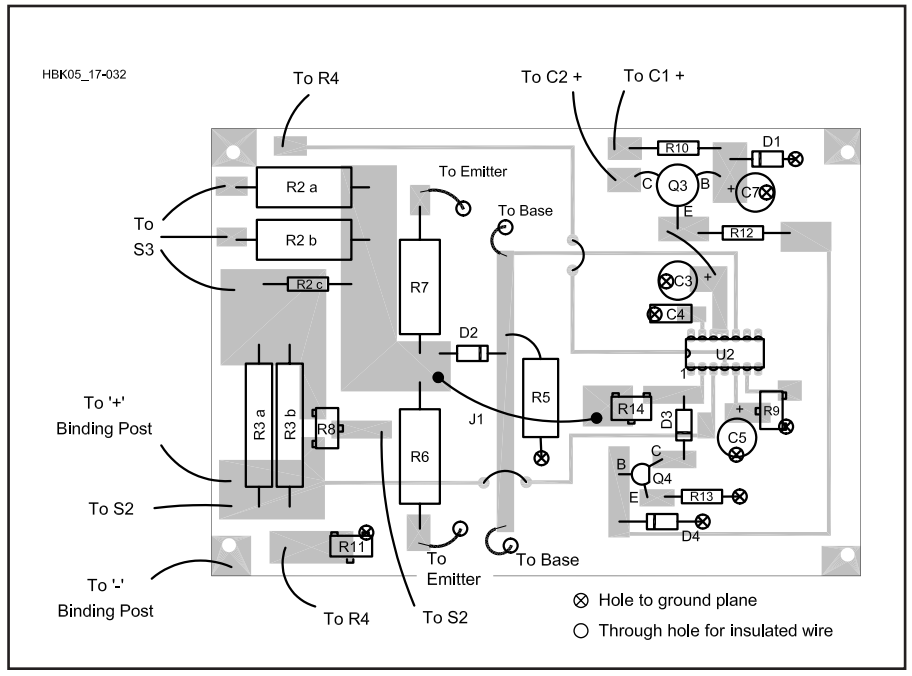
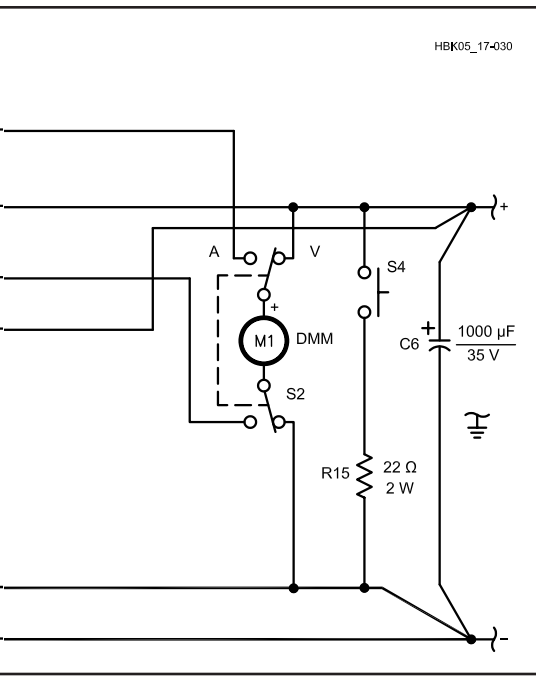

**Fig 17.32** — A parts-placement diagram for the 2.5-A power supply. The component side is shown, and the etching is on the component side. Cross hairs indicate holes through the board. Component leads that terminate at cross hairs are grounded on the far side of the board. The emitter and base leads of Q1 and Q2 do not connect to the ground plane. Use insulated wire to pass through the PC board and holes in the chassis to the transistors on the heat sinks. Wire Jumper J1 is soldered to the pad surfaces without drilling holes. If you do drill holes for the jumper be sure to remove the ground plane around the holes on the non-component side. A full-size etching pattern is in the **Templates** section of the **Handbook CD-ROM**.

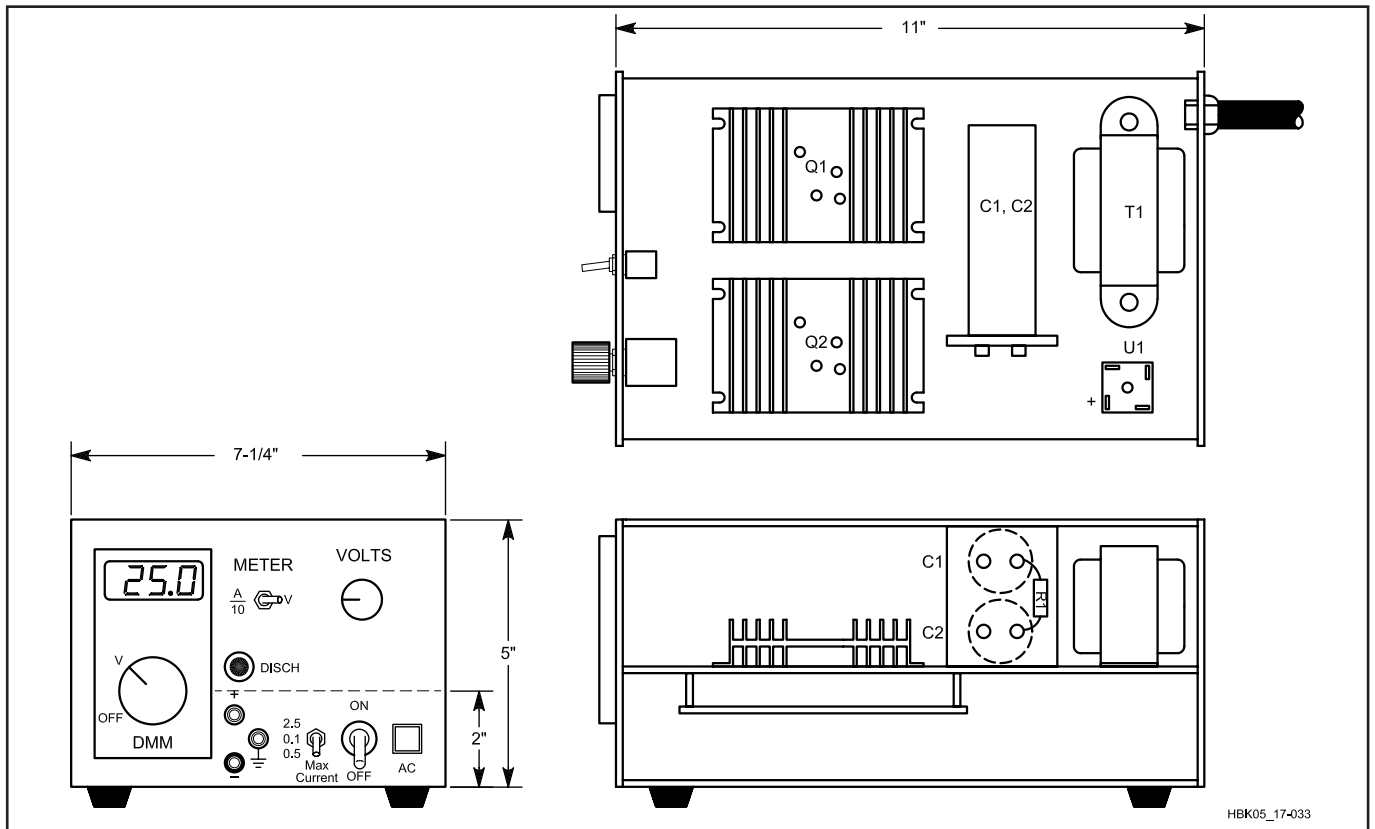

**Fig 17.33** — This three-view drawing shows the panel layout and locations of major power-supply components.

- Connect the regulator PC board ground plane to the negative binding post at a single point.
- Use heavy-duty binding posts to reduce a small but significant voltage drop (from the rear to the front) at the front panel.

**Fig 17.31** shows the general construction and **Fig 17.32** shows the front-panel layout. The cabinet and chassis surface are 1/16-inch aluminum plates connected by aluminum angle stock, drilled and tapped for #6-32 screws. Ventilation screens at the top and rear provide an excellent chimney effect. The chassis plate is tightly joined to the side plates for good heat transfer. Construction of the cabinet shown is somewhat labor intensive; it involves a lot of metal work. Any enclosure of similar size with good ventilation is suitable. For example, a 7 × 11 × 2 -inch chassis with a bottom cover and rubber feet, a 7½ × 6-inch front panel and a U-shaped perforated metal cover would serve well.

Q1 and Q2 each have a Wakefield 403A heat sink. The sinks were selected according to the thermal design discussion in the **Real-World Component Characteristics** chapter. The worst-case 2N3055 junction temperature was calculated to be 145°C, based on a measured case temperature of 95°C and dissipation of 32 W (each) for Q1 and Q2. This temperature is a little higher than recommended, but it's acceptable for intermittent lab use.

The DMM is epoxied to a narrow aluminum strip, which is then screwed to the front panel. This allows easy removal to replace the DMM battery.

**Fig 17.31B** shows the supply underside. The PC board is mounted on standoff insulators and positioned so that the posi-

tive and negative outputs are close to the binding posts.

**Fig 17.33** is a parts-placement diagram for the regulator board. A full-size etching pattern is included in the **Templates** section of the CD-ROM included with this *Handbook*. All components and wiring are on the etched side of the board (with the help of a few jumper wires). The other side is entirely ground plane. The components are surface mounted by bending a section of each lead and soldering it to the surface of the appropriate copper pad. The socket for U2 is mounted by bending the pins out 90° and soldering pins 11 and 12 to the pad for C3. Some leads pass through holes (marked with cross hairs in **Fig 17.33**) in the PC board and solder to the ground plane. The emitter and base leads of Q1 and Q2 are isolated from ground; use insulated-wire to pass from the PC-board pads through holes in the PC board and chassis to the transistors.

**Fig 17.32** shows the placement of major parts in front, top and side views. Silastic and pieces of Kraft paper cover any exposed 120-V wiring.

C1, C2 and R1 are mounted on a 1/8-in thick plastic board as shown in **Fig 17.32**. In the supply shown, it's a piece of 1/8-in PC board with wide traces. A piece of angle stock mounts the board to the chassis.

The main voltage control, R4, is a 10-turn potentiometer, for ease of adjustment. C8 and C9 are ceramic capacitors rated for ac-line use. Once the supply is complete, double check all wiring and connections.

## ADJUSTMENTS

Several adjustments are needed: the dedicated AMMETER ADJUST (R8), the foldback limit (R 14, I MAX ADJ), the lower

(R9, 4.5 VOLT ADJ) and upper (R11, 25 V ADJ) voltage limits. First, obtain an accurate external ammeter and a test load that can draw at least 3 A at 12 V or so (automobile sealed beam headlights work well). Series connect the load and external meter to the supply binding posts. Set S3 to the 2.5-A range; set R4 for minimum output; set S2 to A and switch on the power. Advance R4 until the ammeter reads 2.0 A, and adjust R8 until the panel meter also reads 0.200. Next, increase R4 until the current slightly exceeds 2.6 A, and adjust R14 so that current begins to decrease (foldback). Switch off the supply and remove the external meter and load.

Adjust the voltage limits with no load connected and S2 set to v. Switch on the supply, set R4 for minimum voltage and adjust R9 until the meter reads 4.5. Increase R4 to maximum voltage and adjust R11 so that the meter reads 25. The supply is ready for use.

## PERFORMANCE AND USE

The example supply met the design goals: When the line voltage was varied from 117 to 122 V (with a 25-V dc 2.0-A load), the output voltage varied less than 0.01%. When the dc load was varied from 0 to 2.0 A, the output voltage changed less than 0.03%.

When extremely tight regulation and low output impedance are important, the leads to the load must be very short, heavy straps. Multiple loads should be parallel-connected directly at the binding posts. A “Daisy chain” connection scheme does not assure equal regulation for each load; it counteracts the precision regulation of this supply.

## A 13.8-V, 40-A SWITCHING POWER SUPPLY

Switching power supplies (“switchers,” as they are often called) offer very attractive features — small size, low weight, high efficiency and low heat dissipation. Although some early switchers produced objectionable amounts of RF noise, nowadays you can build very quiet switchers using proper design techniques and careful EMI filtering. This power supply produces 13.8 V, regulated to better than 1%, at a continuous load current up to 40 A and with an efficiency of 88%. No minimum load is required and the ripple on the output is about 20 mV.

The supply produces no detectable RF noise at any frequency higher than the main switching frequency of 50 kHz. The author, Manfred Mornhinweg, XQ2FOD,



**Fig 17.34** — Photo of the completed 13.8-V, 40-A switching supply built by WR1B.

checked this with a wire looped around his supply, tuning his TS-450 from 30 kHz to 40 MHz. The completed supply weighs only 2.8 kg (6.2 pounds)! **Fig 17.34** shows the unit built by HQ staffer Larry Wolfgang, WR1B, for the ARRL Lab.

## LINEAR VERSUS SWITCHING SUPPLIES

A typical linear regulated power supply is simple and uses few parts — but several of these parts are big, heavy and expensive. The efficiency is usually only around 50%, producing *lots* of heat that must be removed by a big heat sink and often fans.

In this switching power supply, the line voltage is directly rectified and filtered at



300 V dc, which feeds a power oscillator operating at 25 kHz. This relatively high frequency allows the use of a small, lightweight and low-cost transformer. The output is then rectified and filtered. The control circuit steers the power oscillator so that it delivers just the right amount of energy needed; little energy is wasted.

While MOSFETs can switch faster, bipolar switching devices have lower conduction losses. Since very fast switching was undesirable because of RF noise, the author used bipolar transistors. These tend to be *too* slow, however, if the driving current is heavier than necessary. If the transistors must switch at varying current levels, the drive to them must also be varied. This is called *proportional driving* and is used in this project.

The switching topology used is called a *half-bridge forward* converter design (also known as a *single-ended push pull* converter — *Ed.*). The converter is controlled using pulse-width modulation, using the generic 3524 IC.

## CIRCUIT DESCRIPTION

Refer to the schematic diagram in **Fig 17.35**. Line voltage enters through P1, a connector that includes EMI filtering. It then goes through fuse F1, a 2-pole power switch and an additional common-mode noise filter (C1, L1, C2). Two NTC (negative temperature coefficient) resistors limit the inrush current. Each exhibits a resistance of about 2.5  $\Omega$  when cold and then loses most of its resistance as it heats up. A rectifier delivers the power to C3A and C3B, big electrolytic capacitors working at the 300-V dc level. The power oscillator is formed by Q1, Q2, the components near them, and the feedback and control transformer T3. T2 and associated components act as a primary-current sensor.

T1 is the power transformer, delivering a 20-V square wave to the Schottky rectifiers (D6 through D9). A toroidal inductor L2 and six low equivalent-series-resistance (ESR) electrolytic capacitors form the main filter, while L3, C23 and C24 are there for additional ripple reduction. The 13.8 V is delivered to the output through a string of ferrite beads with RF decoupling capacitors mounted directly on the output terminals.

The control circuit IC U1 is powered from an auxiliary rectifier D17. U1 senses the output voltage and the current level and controls the power oscillator through Q3 and Q4. C37, C35 and R23 are used to implement a full PID (*proportional-integral-derivative*) response in the control loop.

A quad operational amplifier U2 controls the cooling fan according to the average current level and also drives the

voltage indicating tricolor LED, which glows green if the voltage is okay, orange if the voltage is too low and red if it is too high.

## MORE DESIGN DETAILS

When the unit is powered up, the operating voltage builds up on C3A and C3B, and R2 and R6 bias the two power transistors Q1 and Q2 into their active zones. They start conducting a few mA, but for only a short time, because the positive feedback introduced by T3 quickly throws the system out of balance. One of the two transistors receives an increased base current from T3, while the other one sees its base drive reduced. It takes just a fraction of a microsecond for one of the transistors to become saturated and the other cut off. Which transistor will start first is unpredictable, but for this analysis let's suppose it is Q1. Because the control circuit is not yet powered, Q3 and Q4 are off at startup.

T1 sees about 150 V ac across its primary, producing about 20 V ac on the secondary. Schottky rectifiers D6 through D9 rectify this, so L2 sees 20 V across it. The current in L2 will start rising and this is reflected back to the primary side of T1. The primary current passes through the one-turn winding of T3, forcing one-eighth as much current to flow into the base of Q1, the transistor assumed to be conducting at this moment. After some time, the ferrite core of T3 will saturate, causing the base drive of Q1 to decrease sharply. Q1 will stop and Q2 will start conducting. Now the flux in T3's core decreases, crosses zero and increases in the other direction until it saturates the core again, shutting Q2 off and turning Q1 back on. Meanwhile, the current in L2 continues to build up and the filter capacitors C17 through C22 are charged.

For safe startup, it is essential that T3 saturates completely before T1 starts to do so. If this were not the case, the transistors would have to switch under a very high and potentially destructive current. The power supply will oscillate freely for only a few cycles, because D17 is already charging C32 and C33, powering up the control circuit so that it takes over the control of the power oscillator. Note that the self-oscillation frequency must be lower than the operating frequency for the feedback loop to be able to control things properly.

Q3 and Q4, together with D13 and D14, can place a short on T3's control winding. This holds the voltage across that transformer close to zero, regardless of any current that may be flowing in the windings. When U1 wishes to switch Q1 on, it simply switches pin 12 to ground, switch-

ing off Q4 and ending the short circuit on T3. Through R14 and D12, about 15 mA flow into the control winding center tap, returning to ground via Q3. This puts about 50 mA into the base of Q1, which quickly switches on. Now the heavy collector current (up to 8 A at full load) adds up to the total current flowing in T3 and puts enough drive into Q1 to keep it saturated at that heavy current. Note that by this method the strong drive current for the power transistors comes from the collector current through T3 so the control circuit does not have to provide any substantial driving power.

If U1 now determines that Q1 has been conducting long enough, it simply switches off pin 12. Q4 starts conducting again, shorting out T3. The current in T3 is dumped into Q4, which may have to take up to 300 mA. The voltage on T3 falls and Q1 switches off. Some time later, U1 grounds pin 13, starting the conduction cycle for Q2.

U1 uses two input signals to decide what to do with its outputs. One is a sample of the output voltage, taken through R25 and nearby components, while the other is a current sample taken through the primary of T2. This current transformer produces 200 times less current from its secondary than what goes through its one-turn primary. At full load, about 40 mA goes into R12, producing a maximum voltage drop of about 7 V. This is rectified and half of it is taken at the center tap, divided down by R13 and VR1 and smoothed by C31. When VR1 is properly adjusted, there will be 200 mV at pin 4 of U1 with the power supply running at full load.

A second amplifier inside U1 is used for current limiting. Its inputs are at pins 4 and 5. This amplifier is ground-referenced and has an internal offset of 200 mV. The amplifier will pull down the main error amplifier's output if the difference between pin 4 and pin 5 reaches 200 mV.

U1 also contains an internal oscillator, whose frequency is set by R24 and C36 to approximately 50 kHz. The sawtooth output of this oscillator is connected to an internal comparator, which has its other input internally connected to the output of the error amplifier. The output of the comparator is a square wave whose duty cycle depends on the dc voltage at the output of the error amplifier.

During operation at medium to high loads, the duty cycle is about 70%. At the cathodes of the Schottky rectifiers you will see a square wave that stays at about 20 V for some 14  $\mu$ s, and then goes slightly below ground level for 6  $\mu$ s. L2, which has its output end at a constant 13.8 V, will therefore see about 6 V for 14  $\mu$ s, followed



Fig 17.35 — Schematic diagram and parts list for the 13.8-V, 40-A switching power supply.

- C1, 2 — 0.1  $\mu\text{F}$ , 250 V ac polypropylene, Digi-Key P4610ND  
 C3A, C3B — 1500  $\mu\text{F}$ , 200 V electrolytic  
 C4 to C11 — 0.47  $\mu\text{F}$ , 400 V polypropylene, Digi-Key P3496ND  
 C12, C13 — 1  $\mu\text{F}$ , 50 V ceramic multilayer  
 C14 — 0.0033  $\mu\text{F}$ , 1.6 kV polypropylene  
 C15, C16 — 0.01  $\mu\text{F}$ , 250 V ac polypropylene  
 C17 to C22 — 1000  $\mu\text{F}$ , 25 V low-impedance (low-ESR) electrolytic  
 C23, C24 — 2200  $\mu\text{F}$ , 16 V low-impedance (low-ESR) electrolytic  
 C25 to C30 — 0.1  $\mu\text{F}$ , 50 V ceramic  
 C31 — 0.47  $\mu\text{F}$ , 50 V ceramic multilayer  
 C35 — 0.033  $\mu\text{F}$ , 50 V polyester  
 C36 — 0.0047  $\mu\text{F}$ , 50 V polyester  
 C37 — 0.33  $\mu\text{F}$ , 50 V polyester or ceramic multilayer  
 D1 — Rectifier bridge, 1 kV, 12 A, GBPC1210 or similar  
 D2, D4, D17 — Ultrafast diode, 1 kV, 1 A. UF4007 or similar. Lower voltage (down to 100 V) is acceptable. The ARRL Lab used UF1007 diodes, Digi-Key UF1007DICT-ND  
 D3, D5 — Ultrafast diode 1 kV, 3 A. UF5408 or similar, from Techsonic  
 D6 to D9 — Dual Schottky diode, 100 V, 30 A total. PBYR30100CT or similar. Single diode would also be suitable. ARRL Lab used International Rectifier 30CPQ100, Digi-Key 30CPQ100-ND  
 D10 to D16, D18 — 1N4148 switching diode  
 F1, F2 — Fuse, 10 A for 120-V ac operation; 5 A for 240-V ac operation  
 FB1, FB2 — Amidon FB-73-801 ferrite bead, slipped over wire. Available from Bytemark  
 FB3 to FB14 — Amidon FB-73-2401 ferrite beads, slipped six each over the two 13.8 V dc output cables. Available from Bytemark  
 L1 — Common mode choke, approximately 2 mH each winding, 6 A. Author used junk box specimen. We used a Magnatek CMT908-V1 choke (Digi-Key part 10543-ND) in the supply built in the ARRL Lab  
 L2 — 20  $\mu\text{H}$ , 60 A choke. 16 turns on Amidon T-200-26 toroid, wound with ten #16 enameled wires in parallel  
 L3 — 5  $\mu\text{H}$  (uncritical), 60 A choke. 10 turns on ferrite solenoid, 10 mm diameter, 50 mm long. Wound with two #12 wires in parallel. Amidon #33-050-200 used in ARRL Lab  
 LED1—Dual LED, green-red, common cathode, Digi-Key LU204615-ND (pin 1 is red; pin 3 is green)  
 M1 — 12 V, 5 W brushless dc fan, approximately 120  $\times$  120  $\times$  25 mm, Digi-Key P9753-ND is 120  $\times$  120  $\times$  38 mm and 5.5 W  
 NTC1, NTC2 — Inrush current limiter, 2.5  $\Omega$  cold resistance, Digi-Key KC003L-ND  
 P1 — Male ac connector with integrated EMI filter, 250 V ac, 10 A, Newark 97F8256  
 Q1, Q2 — High voltage switching transistor, BUH1215 or similar. Motorola MJW16010 was used in ARRL Lab; Newark 08TMJW16012  
 Q3, Q4 — BC639-16 transistor, available from Newark. Must resist 100 V and 0.5 A  
 Q5 — BD683 Darlington transistor, from Techsonic. The back of the transistor should be facing the outside of the board  
 R1, R5 — 10  $\Omega$ , 5 W, low inductance preferred. For the supply built in the ARRL Lab, we used three 30  $\Omega$ , 2 W film resistors wired in parallel  
 R9 — 47  $\Omega$ , 5 W, low inductance preferred. For the supply built in the ARRL Lab, we used three 150  $\Omega$ , 2 W film resistors wired in parallel  
 R10, R11 — 1.8  $\Omega$ , 2 W, low inductance preferred  
 S1 — 2-pole power switch, 250 V ac, 10 A  
 S2 — 120/240 V ac power selector slide switch, 250 V ac, 10 A. A locking tab made of aluminum locks the switch in either 240 or 120-V position  
 T1 — Primary 15 turns, secondary 2+2 turns. Wound with copper foil and mylar sheet. Uses four Amidon EA-77-625 ferrite E-cores (8 halves). Equivalents include Thompson GER42x21x15A, Phillips 768E608, TDK EE42/42/15  
 T2 — Secondary is 100+100 turns #36 enamel wire. Primary is one turn #14 plastic insulated cable, wound on secondary. Wound on Amidon EE24-25-B bobbin. Uses an Amidon EA-77-250 core. Equivalents are Thompson GER25x10x6, Phillips 812E25Q, TDK EE25/19  
 T3 — Control winding is 26+26 turns #28 enamel wire. Base windings are 8 turns #20 each. Collector winding is one turn #14 plastic insulated wire. Bobbin and core same as T2  
 U1 — Pulse-width modulator IC, LM3524, SG3524, UC3524 or similar  
 U2 — Quad single-supply operational amplifier, LM324 or similar  
 U3 — 5 V voltage reference, LM336Z-5.0 or similar  
 VR1 to VR3 — 1 k $\Omega$  PCB-mounted trimpot, Digi-Key #3309P-102-ND  
 Cabinet — Hammond Manufacturing, PN 1426Y-B, 12  $\times$  6  $\times$  5.5 inches, and internal case mounting rails, Hammond Manufacturing 1448R12, used in ARRL Lab

by  $-14$  V for the rest of the time. Given its inductance of about 20  $\mu\text{H}$ , the current in L2 will increase by about 4 A during each conduction cycle and decrease by that same amount during rest time. As long as the current drawn from the power supply is more than 2 A, the current in L2 will never cease completely. For example, if the current is 20 A on average, the current in L2 will vary between about 18 and 22 A. As the ripple current stays basically constant while operating at up to the maximum current of the power supply, filter capacitors C17 to C22 are never exposed to more than about 1.5 A RMS total ripple current, assuring that they have a long lifetime. This is an advantage over some other types of switching power supplies, where the ripple current is much higher, forcing the designer to use more expensive capacitors or to accept reduced lifetime in these components.

If the load is less than about 2 A, the current flow in L2 is no longer continuous. The duty cycle of the power transistors starts to drop, until at zero load the duty cycle almost becomes zero too.

C37 serves several purposes. For higher frequencies it couples the first filter stage (L2 and C17 through C22) to the error amplifier, while for lower frequencies (and at dc) the output of the supply is sampled. This is necessary because each filter stage introduces 180° of phase shift at the higher frequencies. After two stages the phase shift goes through a full 360°, making it impossible to stabilize the control loop without additional circuitry. But for dc, sampling the output is desirable to compensate for the voltage drop in L3. C37 gives the error amplifier a nice PID response, together with R23 and C35. This affords the best possible transient behavior with unconditional stability. In addition, C37 provides some measure of soft starting, so the voltage does not overshoot too much when first switching on the power supply.

R34 and C38 average out the current level over a period of about 2 minutes. U2C amplifies the resulting voltage by an amount that can be adjusted. U2D acts as a Schmidt trigger to switch the fan cleanly on and off when the current average crosses the trigger level set by VR3. R39 limits the speed of the fan to a rather low value that is more than enough to keep the power supply cool. At this low speed the fan produces almost no noise and it will probably last longer than its owner.

### Snubbers and EMI Filters

No transformer is perfect. Each winding has some inductance that is not magnetically coupled to the others. There is



also the magnetizing current, which can be a considerable part of the total current in small transformers. At the end of a conduction cycle, a strong current flows in T1. After switching the power transistors off, some means must be provided to discharge the energy stored in the magnetic field of the core and in the leakage inductances. D3 and D5 are included for this purpose. They recover most of this energy and dump it back into C3. Another portion flows through the Schottky diodes into L2, but this cannot be more than the current flowing in L2 at the moment of switchoff.

A problem arises if the magnetizing current is bigger than the actual load current, a situation that can occur during startup. Also it must be taken into account that diodes, even fast ones, take some time to switch, and the transformer cannot wait to start dumping its energy. So some absorbing RC networks have to be included. These are commonly called *snubbers*. R9 and C14 form the primary snubber, absorbing energy during the switching of D3, D5, Q1 and Q2. On the secondary side of T1, R10, C15, R11 and C16 protect the Schottky rectifiers from inductive spikes.

Some RF noise is generated and it must be cleaned up. Between C3 and the power oscillator, two Type-73 ferrite beads FB1 and FB2 perform a critical noise-absorbing task. On the output side, L2 already absorbs most of the noise. It is wound on a high-permeability iron-powder toroid that is very lossy in the HF range. The main filter capacitors have low equivalent-series-resistances for good filtering.

L3 is another noise absorber. To minimize capacitive coupling, a ferrite solenoid was used instead of a toroid so that the input windings are well separated from the output ones. The ferrite used starts absorbing at HF, so this coil not only blocks but also absorbs RF energy. Finally, the output leads are passed through a dozen 73-material ferrite beads. The filtering is completed by bypass capacitors on the output leads to the cabinet. Note that the ground on the printed circuit board is floating to reduce stray HF currents on the enclosure.

### Running on 240/120 V ac

The author lives in a country where the mains supply is 220 V at 50 Hz. This supply will accept input voltages between about 95 to 250 V ac, using S2 to switch from 240 to 120 V ac operation. For 120-V ac operation the fuse F1 should be rated at 10 A, 5 A for 240 V ac operation.

### THE PCB

The exact size of the pc board is 120 × 272 mm (4.72 × 10.71 inches). It must be

made from good quality, single-sided glass epoxy board — don't try to use a cheaper grade of board. The heavy components would stress it too much and the copper adhesion is not good enough for the heavy soldering required. A circuit board is available from FAR Circuits.

### BUILDING THE MAGNETIC COMPONENTS

The biggest challenge for most home

builders will be the magnetic components. To keep things simple, Amidon cores were used. The only exceptions are L1 and L3, which were made from materials found in the author's junk box. Both of these inductors are not critical, and suitable Amidon part numbers are included in the parts list.

T1, the main power transformer, is the heart of this circuit. T1 was built using a tape-winding technique, stacking four

### Parts Substitution

Don't be afraid to substitute parts when you can't find the exact one specified. Here is some information for hard-to-find parts:

D1: Any rectifier bridge that can handle 8 A at 240 V ac (or 12 A at 120 V ac), with enough headroom for spikes, will do the job. Try to find one that fits the PCB or modify the board accordingly. You may also use single diodes, but mount them close to the board to get suitable heatsinking through their terminals.

D2, D4, D17: Any ultrafast diode rated for at least 100 V and 1 A is suitable. The author used the UF4007, which is an ultrafast equivalent to the 1N4007 (1 kV, 1 A). *Do not* use 1N4007 diodes! They are not fast enough for this job. You need a switching speed in the 50-ns class.

D3, D5: You can use any ultrafast diode rated for 600 V, 3 A or higher. The UF5408 is rated at 1 kV, somewhat of an overkill here. Again, *do not* use the low speed 1N5408.

D6, D7, D8, D9: PBYR30100CT dual Schottky diodes were used. A good replacement is any single or dual Schottky rectifier rated at least at 100 V and 30 A total current, that comes in a TO-218 or similar package. If you use single diodes, you may have to bend the pins to fit the board properly. These 100-V Schottky diodes have been widely available only for a few years, although they are becoming more common.

Q1, Q2: BUH1215 transistors were used, which can work at a higher voltage than actually necessary in this circuit. If you need to replace them, look for any NPN power switching transistors that have a  $V_{CEO}$  of at least 400 V,  $I_C$  of at least 15 A, an  $h_{FE}$  of at least 12 at 8 A, and come in a TO-218 or similar package. The power transistors *must* maintain their beta up to at least 8 A; otherwise they will cut short the conduction cycles when the load increases. Motorola MJW16010 transistors are a suitable alternative.

Some power switching transistors have a reverse protection diode and a base-to-emitter resistor built in. Beware of these! The resistor would not allow this power supply to start. If in doubt, take a multimeter and measure the resistance between base and emitter. If you get the same low resistance (typically 50  $\Omega$ ) in *both* senses, the transistor is unsuitable for this project. If you get a diode behavior, the transistor is okay.

Q3, Q4: Instead of the BC639-16 you can use any small TO-92 cased NPN transistor that has a  $V_{CEO}$  rating of 100 V and an  $I_C$  of 1 A. Be careful with the pinout, because not all TO-92 transistors use the same pinout. You may have to bend the leads to fit the printed circuit board.

Q5: Instead of the BD683 you can use any small NPN Darlington transistor that has an  $I_C$  of at least 1 A.

U3: If you have trouble finding the LM336Z-5.0 voltage reference, you have several options. You may use a reference at another voltage (2.5 V is typical) and modify the values of R27 to R30 accordingly. Or you may replace U3 with a 3-terminal regulator like the 7805, modifying the circuit as necessary. Finally, you could completely eliminate U3 and R31 and use the 5V reference provided by U1 at pin 16. In this case you would lose the voltage indicator's independence from U1. Note that using a simple zener diode instead of U3 is not suitable because zeners are not stable enough for this application.

If you cannot find low-ESR electrolytic capacitors, simply use normal capacitors. The circuit is designed to place a low ripple current on these capacitors, so standard components can be used. The noise at the output will be slightly higher, however.



pairs of ferrite E cores to obtain the necessary magnetic capabilities. Comments from WR1B as he constructed the transformers and inductors are included in the construction details below.

### Making T1

Because four cores are stacked there is no factory-made bobbin available for this transformer, so the author made a paper bobbin. He wound the transformer using 0.1-mm thick copper strips interleaved with Mylar sheets, because a thick wire needed for the heavy current would be impossible to bend around the sharp corners of the bobbin. Instead of using a lot of thin wires in parallel, it is better to use copper strips. The whole assembly is sealed in epoxy resin, with the magnetic cores also glued in place with epoxy.

Cut a piece of hardwood to serve as a form when making the bobbin. As the center legs of the four stacked cores measure  $62 \times 12$  mm ( $2.44 \times 0.47$  inches), the wood block must be 63 mm (2.48 inches) wide and 12.5 mm (0.49 inches) thick, to allow for some play. The length of the block should be around 100 mm (4 inches). The height of the bobbin will be 28 mm (1.10 inches), so make your block long enough to hold it with the bobbin in place with room for holding onto it. The author used a belt sander to trim his wood block to the exact dimensions. Try to be precise — if the bobbin is too big you will waste valuable winding space, running the risk of not being able to fit the windings. If the bobbin comes out too small your finished winding assembly may not fit the ferrite cores, making it unusable.

Now wrap the wood block with one layer of plastic film, such as that used in the kitchen to preserve food. This material allows you to remove the bobbin from the wood block easily. Cut a strip of strong packing paper, 28 mm (1.10 inches) wide and about 1 m (39.4 inches) long. A brown-paper grocery bag is a good source of suitable paper. Mix some 5-minute epoxy glue (the author used the type sold in airplane modeling shops, which comes in good sized bottles) and apply a layer of epoxy to the paper strip. Now wind 6 layers of the paper strip very tightly around the plastic-wrapped wood block. Wrap another sheet of plastic film around your work and press it between two wooden blocks held together with strong rubber bands or wood clamps so the long sides of the bobbin are flat and smooth against the wood. Now place the bobbin assembly in an oven for about 15 minutes at  $50^{\circ}\text{C}$  ( $122^{\circ}\text{F}$ ). The epoxy sets much more quickly and becomes somewhat stronger at that temperature.

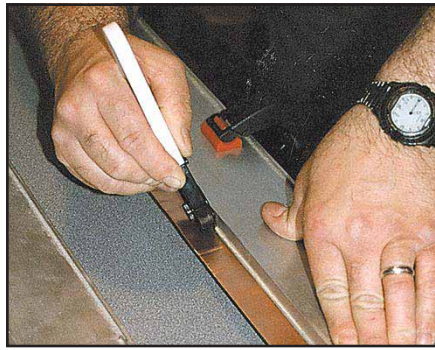

**Fig 17.36** — Larry Wolfgang, WR1B, using a 4-foot straightedge designed as a guide for hand-held circular saws to clamp the copper-foil tape to a board on a tabletop. After carefully measuring to ensure a uniform 22-mm width, he cut the foil tape using a Fiskars rotary cutter. Be careful to keep the cutter wheel against the straightedge for the entire length. Move the tape in 4-foot intervals to cut the entire length. (Photo by Dan Wolfgang.)

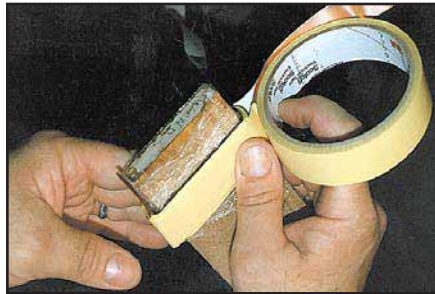

**Fig 17.37** — Winding the foil tape tightly on the epoxy-coated-paper bobbin on the wooden block. The Mylar tape is unrolled and positioned over the foil layer as you wind. (Photo by Dan Wolfgang.)

[Comments from Larry Wolfgang, WR1B: The paper I used for my T1 bobbin was cut from a 36-inch-wide length of Kraft paper. This had been used to wrap some paper my wife had purchased at an art-supply store. It was about as heavy as the paper used for grocery bags. I used 30-minute epoxy for this step, providing a bit more “working time” than 5-minute epoxy allows. It takes *lots* of epoxy, because so much soaks into the paper. My epoxy was the kind with the double plunger, and equal amounts come out of both tubes as you push in the plunger. Wear rubber or plastic gloves to protect your hands. I squeezed out an amount that made a puddle of resin and a puddle of hardener each about  $1\frac{1}{2}$  inches across and  $\frac{1}{8}$  inch or so deep. This was not enough, and I had to mix more. I used a spring clamp to hold the paper to my workbench and then held the paper in one hand while spreading

epoxy with a heavy toothpick. I coated the entire length and then wrapped my plastic-covered wooden block. My electronic-controlled gas oven only allows me to set the temperature as low as  $170^{\circ}\text{F}$ , so I had to watch the temperature and shut the oven off as the temp rose to about  $150^{\circ}\text{F}$ , then let it cool down. I ran it twice this way to “cure” the 30-minute epoxy I used for the bobbin. — WR1B]

Now you will need some 0.1 mm (0.004 inches = 4 mils) thick copper tape, and some Mylar sheet of a similar thickness. Cut the copper in strips 22 mm (0.87 inches) wide, and the Mylar in strips 28 mm (1.10 inches) wide. (The Wireman has suitable copper foil available.) If you can make long strips, say 2 m (6.56 feet), this is an advantage. Otherwise, you will have to solder individual copper strips together. In total, you will need about 7 m (23 feet) of copper tape and slightly less Mylar tape. [I made 7 meters of “double-thickness” tape, using two 3-mil thick, sticky-backed copper tapes that we had in the ARRL Lab. After making the 15-turn winding, I cut the leftovers in four equal lengths to make the “four-layer tape” used in the secondary. There was less than a foot of left-over tape after the transformer was completed. The Mylar tape I used was made by 3M and was 2-mil thick and 1-inch wide with adhesive backing. This thickness is sufficient for the voltages involved, provided that care is taken so that the Mylar isn’t punctured by accident. If, like the author, you cut strips from a sheet of copper, you should file down the edges to remove burrs. See Fig 17.36. — WR1B]

Once the epoxy has had ample time to harden and has cooled, remove the rubber bands, the outer wood blocks, and the outer plastic wrapping (don’t worry if it doesn’t come off completely). Do not remove the plastic wrapping that separates the bobbin from the wood. The wrapped wooden core and epoxy-paper bobbin sub-assembly is now complete.

With a 60 mm (2.36 inch) length of #12 bare copper wire, wrap the end of one of your copper strips around the wire, so that the wire protrudes out from one side of the copper loop. Use a big soldering iron to flow some solder into the junction. Try to avoid getting solder on the outside, because this could later puncture the Mylar insulation. [I scraped the adhesive from the back of the sticky-backed tape where I soldered the wire. Otherwise, the solder won’t stick to the back of the copper, and the layers may not have good conductivity between them. — WR1B]

Now place the copper wire on one of the narrow sides of the bobbin, so that the copper strip is centered on the width of the bobbin, leaving 3 mm (0.12 inches) room

on each side. Seal the start of the copper strip to the bobbin with some thin adhesive tape. See **Fig 17.37**.

Position the start of a Mylar strip so that it covers all the copper and is centered on the bobbin, and then tape it in place. Wind 15 turns of this copper-Mylar sandwich as tightly as possible, keeping the Mylar aligned with the bobbin sides and the copper nicely centered. Don't lose your grip, or the whole thing will spring apart! If the copper strip is not long enough, fix everything with strong rubber bands or a clamp, and solder another copper strip to the end of the first one, allowing 2 mm of overlap. Before doing this, cut the first copper sheet so that the joint will be on one of the narrow sides of the bobbin, because here you have space, while the wide sides will have to fit inside the ferrite core's window. If the Mylar strip runs out, just use adhesive tape to add another strip. Make the overlap 5 mm to avoid risk of creepage between the sheets and also try to locate the joint on one of the narrow sides of the bobbin. See **Fig 17.38**.

When the 15 turns are complete, cut the copper strip so that the second terminal will be on the same narrow side of the bobbin as the first terminal. Solder the second terminal (another 60 mm piece of bare copper wire) to the strip, position it and wind three or four layers of Mylar to make the insulation safe between the primary and secondary. [I started my primary winding with the bulge of the wire on the corner, so that I was immediately winding along the wide side. When I finished the 15 turns, I positioned the end wire so it is on the narrow side, just beyond the corner of the long side. This way, the two bulges meet at the middle, but don't cross each other. — *WRIB*]

If you think this is a messy business, you are right. But it's fun too! The secondary is just a little bit messier: It is wound with a five-layer sandwich — four layers of copper and the Mylar topping layer. But it's only four turns total, so take a deep breath and do it. Solder the four copper strips together around a piece of #12 copper wire. Don't be overly worried if the outcome is not very clean; the author's was quite a mess too, yet it worked well on the first try. Just be sure you don't create sharp edges or pointed solder mounds, because these may damage the insulation. See **Fig 17.38** for details.

Now position the start of your secondary conductor so the terminal wire will come out on the same side as those of the primary, but on the other narrow side of the coil assembly. The goal is to end up with a transformer with its primary leads on one extreme and the secondary on the

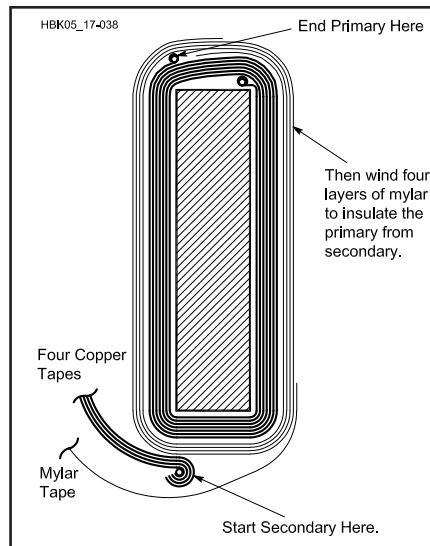

**Fig 17.38 — Primary 15 turns on bobbin, with start of 4-turn, center-tapped secondary winding.**

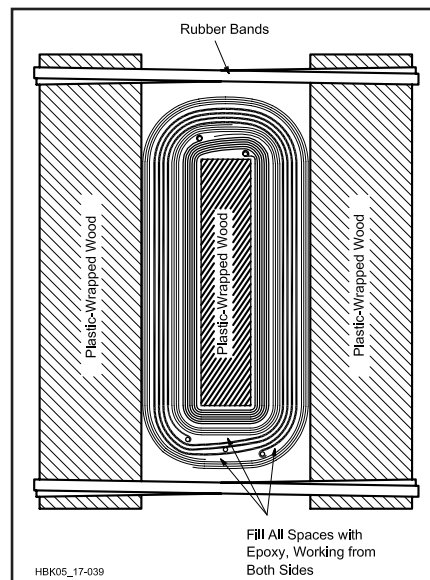

**Fig 17.39 — Clamping the T1 assembly and filling with epoxy.**

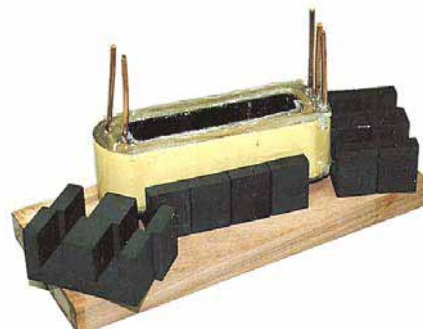

**Fig 17.40 — Photo showing how the core halves must fit into the completed transformer after it is removed from the wooden block. You will have to file off the rough edges of epoxy to allow the cores to meet properly. The top E-cores have not been inserted into the bobbin yet. (Photo by Larry Wolfgang.)**

other, and that will also fit the printed circuit board nicely. Wind two turns, solder the center tap wire between the four copper strips, wind the other two turns, solder the last terminal wire, and then wind a finishing layer of Mylar and fix it in place with adhesive tape. This finishes the worst part of making T1.

What you have now is a springy, messy coil assembly that will fall apart if you let it go. You have to seal it, but this is easy to do. Temporarily hold things together with some stout rubber bands. Wrap the two wooden blocks, the same blocks you used to press together the bobbin, in plastic film. Place them against the sides of the coil assembly, and apply hard pressure, using a clamp or a lot of rubber bands, so that the long sides of the coil straighten out completely and any slack is displaced to the narrow sides. Now mix a fair quantity of epoxy glue, place the coil assembly so that the pins face up, and let the epoxy run into the coil. Continue supplying epoxy until it starts to set. If it drips out from the other side, no problem. (Just don't do this work over your best carpet!) When the epoxy doesn't flow any longer, turn the coil assembly over, mix a new batch of epoxy and fill the other side completely, forming a smooth surface. As the lower side is now sealed, the epoxy will not flow out there. When this epoxy has set, turn the assembly over again, mix some more epoxy and apply it to form a smooth surface there. The idea is to replace all the air between the copper and Mylar sheets with epoxy, and especially to fill the room left by the copper strip, which is narrower than the Mylar. This filling is necessary both for mechanical and for electric safety reasons. See **Fig 17.39**. [My wooden "screw clamps" worked well for applying strong even pressure to the sides. I don't think rubber bands would apply enough pressure to minimize the air space inside the transformer. — *WRIB*]

Now place the assembly in the oven again. Let the epoxy harden completely, then remove the coil from the oven, remove the clamp, rubber bands, wooden blocks, wooden core and all remains of plastic film. You will be surprised how your messy and springy assembly changed into a very robust, hard and strong coil. Now test-fit the ferrite cores. See **Fig 17.40**. Determine if they can be installed easily, so that each pair of facing E-cores comes together in intimate contact, without pressing on the winding. If everything is right, the winding should have some play room in the assembled core. But it is easy to get too much epoxy on the coil. If this happens, work the epoxy down with a file so that it doesn't disturb the ferrite. The



ferrite core *must* close properly, otherwise you risk power transistor failure.

When the sides fit, prepare some more epoxy, apply a very thin layer to all contact faces of the ferrite cores and mount them onto the coil assembly. You can hold them in place with adhesive tape until the epoxy sets. Again, use the oven to speed up the hardening. The last thing you have to do is bend the copper wires into the proper shape to fit the printed circuit board holes. Be sure that on the secondary winding the center tap is actually in the center position. The polarity of the other pins doesn't matter. This completes the manufacture of T1. All the other transformers and coils are just child's play after making T1!

### Making T2

The current sense transformer T2 has a lot of turns but they needn't be wound nicely side-by-side. You can use a winding machine with a turns counter, or you can just wind T2 by hand. Get some #36 or other thin enameled wire, solder the end to one of the outer pins of the EE24-25-B bobbin, and wind 100 turns. Don't worry if your winding is criss-crossed and ugly, and don't feel guilty if you lose count and wind a few turns more or less. As long as you don't overdo it, it will just affect the position of VR1 when you adjust the completed power supply later. Solder the wire to the center pin on the same side, then wind another 100 turns in the same sense. Solder to the other outer pin on the same bobbin side, and apply one or two layers of Mylar to protect the thin wire.

With #14 plastic insulated wire, wind one single turn over the Mylar, and solder the two ends to the two outer pins of the other side of the bobbin. It doesn't matter which end goes to which side. Install the EA77-250 core with a small amount of epoxy cement, and T2 is finished. [I used #14 AWG house wire here. The insulation made it a bit tight for the core, but it fit. — WR1B]

### Making T3

T3 is made using the same kind of bobbin and core as T2. Wind 26 turns of #28 enameled wire. The 26 turns should fit nicely in a single layer. Study the schematic diagram to see how the windings connect to the bobbin pins. Bring the wire back to the starting side over the last half turn, for connection to the center-tap pin. Wind one layer of Mylar sheet, then put on the next 26 turns. Again, bring the wire back to the starting side over the last half turn for connection to the bobbin pin.

Wind 3 layers of Mylar tape, to insulate the primary and secondary properly. Wind 8 turns of #20 wire, and solder the ends to the bobbin pins. Look at the printed circuit board drawing to determine which wire is soldered to which pin. Wind a single layer of Mylar, then wind the other 8-turn winding over the first one. This will leave a space at one side of the bobbin big enough to take the single turn of #14 plastic insulated wire. This completes the assembly. See Fig 17.41 for a cross-sectional view of the windings. Now glue the core in place with epoxy cement and T3 is finished.

### Making L2

L2 is wound on an Amidon T-200-26

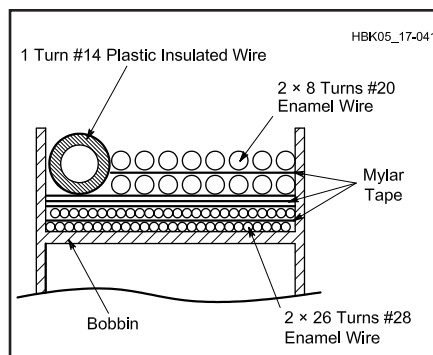

Fig 17.41 — Cross-sectional view of T3 (not to scale), showing distribution of windings.

iron powder toroid core. As it is too difficult to bend thick wire through a toroid, and tape winding it is not practical either, the author chose to make this coil with 10 pieces of #16 enameled wire in parallel.

Cut the wires to about 1.5 m (59 inches) in length and lightly twist them together. Then insert the bundle into the core, and starting from the middle of the wire bundle, wind 8 turns, using half of the core's circumference. Now wind another 7 turns, starting from the middle toward the other end of the wire bundle. The 16th turn is the one you made when you inserted the wire bundle into the core to start.

### Making L3

To make L3 you must first find a suitable rod. I used a part of an old ferrite antenna rod about 10 mm in diameter (0.39 inches) and 50 mm long (1.97 inches). (An Amidon number 33-050-200 rod is just the right size.) Wind 10 bifilar turns of #12 enameled wire. This wire is quite stiff, but it is still no problem to handle. You should wind the coil on a 12 mm (15/32 inches) drill bit, allow it to spring open and place it on the ferrite core. Otherwise you could crack the ferrite trying to wind directly on it. A tapered "drift punch" helps to open the turns just enough to fit the core. Fix the core to the winding with some epoxy. Bend the wires so that all four of them point down with the core pointing straight up. That's the position in which L3 is mounted on the PCB.

### PUTTING IT TOGETHER

Install and solder all parts except for Q1, Q2, and D6 to D9. Before installing D1, fashion a simple heatsink from a 30 × 80 mm (1.18 × 3.15 inches) piece of 1 mm (0.039 inches) thick aluminum sheet, bent into U shape. Drill a hole and screw the rectifier bridge onto the heatsink together with a lock washer. Then solder D1 to the board.

The author made his own enclosure, using two 3-mm (0.12 inches) aluminum

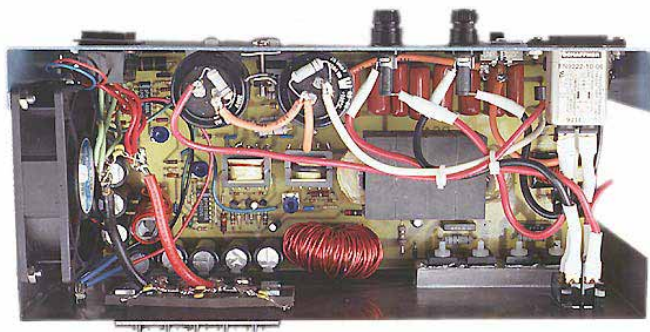

Fig 17.42 — Photo of top of PCB mounted in cabinet.

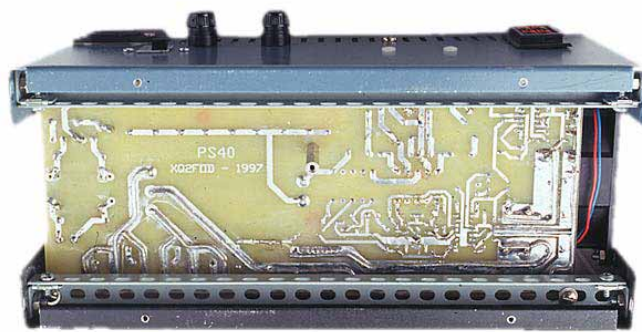

Fig 17.43 — Photo of bottom of PCB mounted in cabinet.

plates, measuring 300 × 120 mm (11.81 × 4.72 inches) for the front and rear walls. They are screwed to the fan, the PCB and to a 120-mm (4.72-inch) long spreader tube of 6-mm (0.24-inch) diameter, so that these parts become integral to the structure. The connections between the PCB, aluminum plates and fan were made with small pieces of 10 × 10 mm (0.39 × 0.39 inches) aluminum angle stock. The assembly is surprisingly rigid.

The top and bottom covers were made from 1 mm (0.04 inch) aluminum sheet and measure 126 × 300 mm (4.96 × 11.81 inches). The bottom cover has a hole for the PCB's center mount. The side covers were cut from wire mesh to allow unrestricted airflow, and measure 122 × 126 mm (4.80 × 4.96 inches). The panels are held together with 10 × 10 mm (0.39 × 0.39 inches) aluminum angle stock, running along all edges and held with small sheet-metal screws. These covers are not installed until the power supply is complete, tested and adjusted.

All the panels were painted flat black on the outside, which looks nice together with the anodized aluminum angle stock. The edges and insides were kept free of paint, in order to get proper electrical contact between the panels for good shielding.

The version made by WR1B (see **Fig 17.42** and **Fig 17.43**) used a Hammond Manufacturing ventilated, low-profile instrument case, catalog number 1426Y-B. This is a rugged case that also looks very nice. Larry mounted the circuit board inside the case using a pair of steel mounting rails, also from Hammond, catalog number 1448R12.

The components external to the PCB (P1, SW1, C3, the LED and the output screw terminal block) are mounted to the front and rear panels. Q1 and Q2 are mounted to the rear panel, using M3 Nylon screws and 3 mm (0.12-inch) thick ceramic insulators. These thick insulators were used not only for safety reasons but also because they reduce the capacitive coupling of the transistors to the enclosure. Do not use metal screws with plastic washers, because this approach does not give enough safety margin to operate at the input line voltage. [The author's junk-box ceramic insulators proved difficult to duplicate for the supply we built in the ARRL Lab. Equivalent new parts would have nearly doubled the cost of the supply! Instead, for good heat-transfer properties, we used thin rubber insulators manufactured by Wakefield Engineering as PN 175-6-250-P, available from Newark Electronics as PN 46F7884. Individual alu-

minum spacers milled from aluminum blocks were used between Q1, Q2 and the Schottky diodes and the metal chassis. Care must be taken to make sure the surfaces of the spacers are parallel and free of burrs to ensure low thermal resistance.]

The Schottky diodes are mounted using the same kind of insulators and screws, but there is a heat spreader made from 6-mm (0.24-inch) aluminum plate between those insulators and the case. All surfaces requiring thermal contact are covered with heat-transfer compound before assembly. When installing the diodes and transistors, first do all the mechanical assembly, and then solder the pins. Otherwise you could stress them too much while fastening the screws.

All wire connections are made next, and the output filter is assembled by sliding the ferrite beads over the output cables and soldering the bypass capacitors C25 through C30. Be sure to use thick wire for the output. A 40-A, continuous-duty current is no joke.

The tracks on the PCB cannot be trusted to carry 40 A without some help. Use a big soldering iron (100 to 150 W) to solder lengths of #12 bare copper wire cut and bent to fit the shape of all the high-current paths. To prevent any failures due to vibration from the fan, place some drops of hot-melt glue anywhere a wire is connected to the board. Hot-melt glue is also excellent for fixing anything that would otherwise rattle, like ferrite beads.

### Testing and Adjusting

Make sure you do a thorough visual check. Set the three potentiometers to mid position. Check that there is no continuity between the ac input and ground, between the ac input and the dc output, or between the dc output and chassis ground.

Connect a variable voltage supply (you need 12 to 15 V for the tests) to the output leads, without plugging the switcher into the ac line. You should see the LED light up. Change the voltage fed into your project to see how the LED changes color. If you have a dual-channel oscilloscope, connect its two channels to the base-emitter junctions of the power transistors. [Since you are not connected to the ac power line, you will not be grounding it through the oscilloscope's ground leads connected to the emitter leads. — *Ed.*] With the external voltage at about 12 V, you should see small pulses. As you increase the voltage, the pulses will suddenly disappear. You can pre-adjust VR2 by setting your lab power supply to exactly 13.8 V and then setting VR2 to where

the pulses just disappear.

Now it's time to start up the switcher. Remove your lab supply and the oscilloscope leads, and connect the supply to the ac line in series with a 60-W light bulb. This will avoid most or all damage if something is really wrong. Connect a voltmeter to the output and switch on your supply. If everything is right, the bulb will light up, then slowly dim while the power supply starts up and delivers about 13.8 V.

Now, connect a load of about 2 A to the output — a car brake-light bulb makes a good load. At 2-A output, the bulb in the ac line will probably glow, with 13.8-V dc at the output. If everything is okay so far, now comes the big moment. Remove the series bulb from the ac circuit. Startup of the supply should be fast and you can now connect a heavier load to it. With a load of 2 to 10 A connected (the value is uncritical, given the good regulation of this supply), adjust VR2 so that you have exactly 13.8 V at the output.

Next adjust the current shutdown point. For this you need a load that can handle 40 A. You could make one by connecting a lot of car headlamps in parallel or you could use some resistance wire to build a big power resistor. The author made a 13.8-V, 550-W heater for his supply. Connect the load and adjust VR1 so that the output voltage is just at the limit of shutting down.

The last adjustment is for the fan trigger point. Connect a 65-W car headlamp or similar load that consumes about 5 A. Let the supply run for several minutes, then move VR3 to the point where the fan switches on. Now check out the trigger function by changing the load several times between about 2 and 10 A. The fan should switch off and on between 30 to 60 seconds after each load change. You may have to readjust VR3 until you get the fan to switch on at no more than 7-A continuous load and switch off at about 4 A.

### And If It Doesn't Work?

If you used substitute parts for the magnetic cores and made a bad choice, the results could be dramatic. If either T1 or L2 saturates, the power transistors could burn out before the fuse has a chance to open. The protective light bulb in the ac line will avoid damage in this case, so by all means use that bulb for initial testing!

Another possible error is reversing the phase of a winding in T3. If you get one of the 8-turn windings reversed, the results will be explosive unless you have the light bulb in series. If you reverse the 1-turn winding, the power supply will simply not start.



## 28-V, HIGH-CURRENT POWER SUPPLY

Many modern high-power transistors used in RF power amplifiers require 28-V dc collector supplies, rather than the traditional 12-V supply. By going to 28 V (or even 50 V), designers significantly reduce the current required for an amplifier in the 100-W or higher output class. The power supply shown in Fig 17.44 through Fig 17.48 is conservatively rated for 28 V at 10 A (enough for a 150-W output amplifier) — continuous duty! It was designed with simplicity and readily-available components in mind. Mark Wilson,

K1RO, built this project in the ARRL lab.

### CIRCUIT DETAILS

The schematic diagram of the 28-V supply is shown in Fig 17.45. T1 was designed by Avatar Magnetics specifically for this project. The primary requires 120-V ac, but a dual-primary (120/240 V) version is available. The secondary is rated for 32 V at 15 A, continuous duty. The primary is bypassed by two 0.01- $\mu$ F capacitors and protected from line transients by an MOV. U1 is a 25-A bridge module available



Fig 17.44 — The front panel of the 28-V power supply sports only a power switch, pilot lamp and binding posts for the voltage output. There is room for a voltmeter, should another builder desire one.

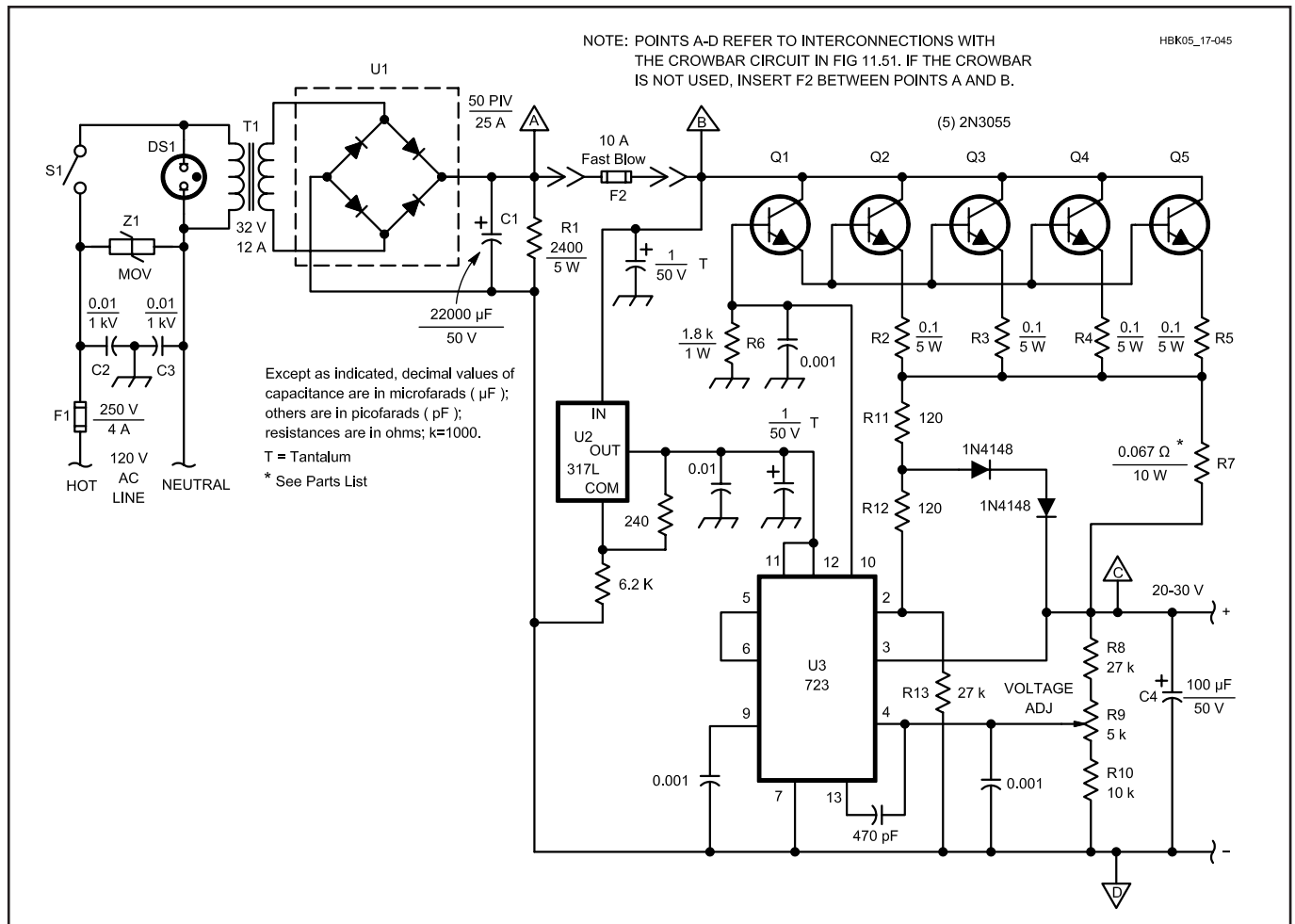
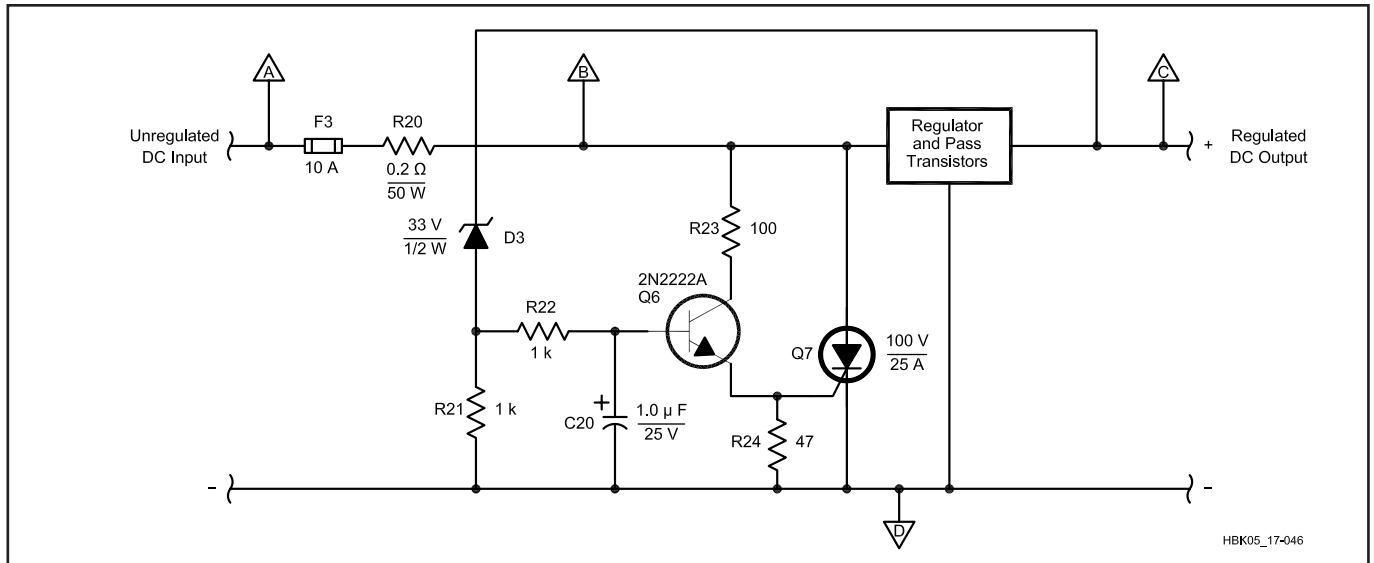

Fig 17.45 — Schematic diagram of the 28-V, high-current power supply. Resistors are  $\frac{1}{4}$ -W, 5% types unless otherwise noted. Capacitors are disc ceramic unless noted; capacitors marked with polarity are electrolytic. Parts numbers given in parentheses that are preceded by the letters RS are RadioShack catalog numbers.

C1 — Electrolytic capacitor, 22000  $\mu$ F, 50 V (Mallory CGS223U050X4C or equiv., available from Mouser Electronics)  
C2, C3 — AC-rated bypass capacitors.  
C4 — Electrolytic capacitor, 100  $\mu$ F, 50 V  
DS1 — Pilot lamp, 120-V ac (RS 272-705)  
Q1-Q5 — NPN power transistor, 2N3055 or equiv. (RS 276-2041)

R2-R5 — Power resistor, 0.1  $\Omega$ , 5 W (or greater), 5% tolerance  
R7 — Power resistor, 0.067  $\Omega$ , 10 W (or greater), made from three 0.2- $\Omega$ , 5-W resistors in parallel  
T1 — Power transformer. Primary, 120-V ac; secondary, 32 V, 15 A. (Avatar Magnetics AV-430 or equiv. Dual primary version is part #AV-431. Available from Avatar Magnetics.)

U1 — Bridge rectifier, 50 PIV, 25 A (RS 276-1185)  
U2 — Three-terminal adjustable voltage regulator, 100 mA (LM-317L or equiv.). See text  
U3 — 723-type adjustable voltage regulator IC, 14-pin DIP package (LM-723, MC1723, etc. RS 276-1740)  
Z1 — 130-V MOV (RS 276-570)



**Fig 17.46 — Schematic diagram of the overvoltage protection circuit. Resistors are ¼-W, 5% carbon types unless noted.**  
**D3 — 33 V, ½-W Zener (NTE 5036A or equiv.)**  
**Q6 — NPN Transistor (2N2222A or equiv.)**  
**Q7 — 100 V, 25A SCR (NTE 5522 or equiv.)**

from RadioShack or a number of other suppliers. It requires a heat sink in this application. Filter capacitor C1 is a computer-grade 22,000- $\mu\text{F}$  electrolytic. Bleeder resistor R1 is included for safety because of the high value of C1; bleeder current is about 12 mA.

There is a tradeoff between the transformer secondary voltage and the filter-capacitor value. To maintain regulation, the minimum supply voltage to the regulator circuitry must remain above approximately 31 V. Ripple voltage must be taken into account. If the voltage on the bus drops below 31 V in ripple valleys, regulation may be lost.

In this supply, the transformer secondary voltage was chosen to allow use of a commonly available filter value. The builder found that 50-V electrolytic capacitors of up to about 25,000  $\mu\text{F}$  were common and the prices reasonable; few dealers stocked capacitors above that value, and the prices increased dramatically. If you have a larger filter capacitor, you can use a transformer with a lower secondary voltage; similarly, if you have a transformer in the 28- to 35-V range, you can calculate the size of the filter capacitor required. Equation 3, earlier in this chapter in the Filtration section, shows how to calculate ripple for different filter-capacitor and load-current values.

The regulator circuitry takes advantage of commonly available parts. The heart of the circuit is U3, a 723 voltage regulator IC. The values of R8, R9 and R10 were chosen to allow the output voltage to be varied from 20 to 30 V. The 723 has a maximum input voltage rating of 40 V,

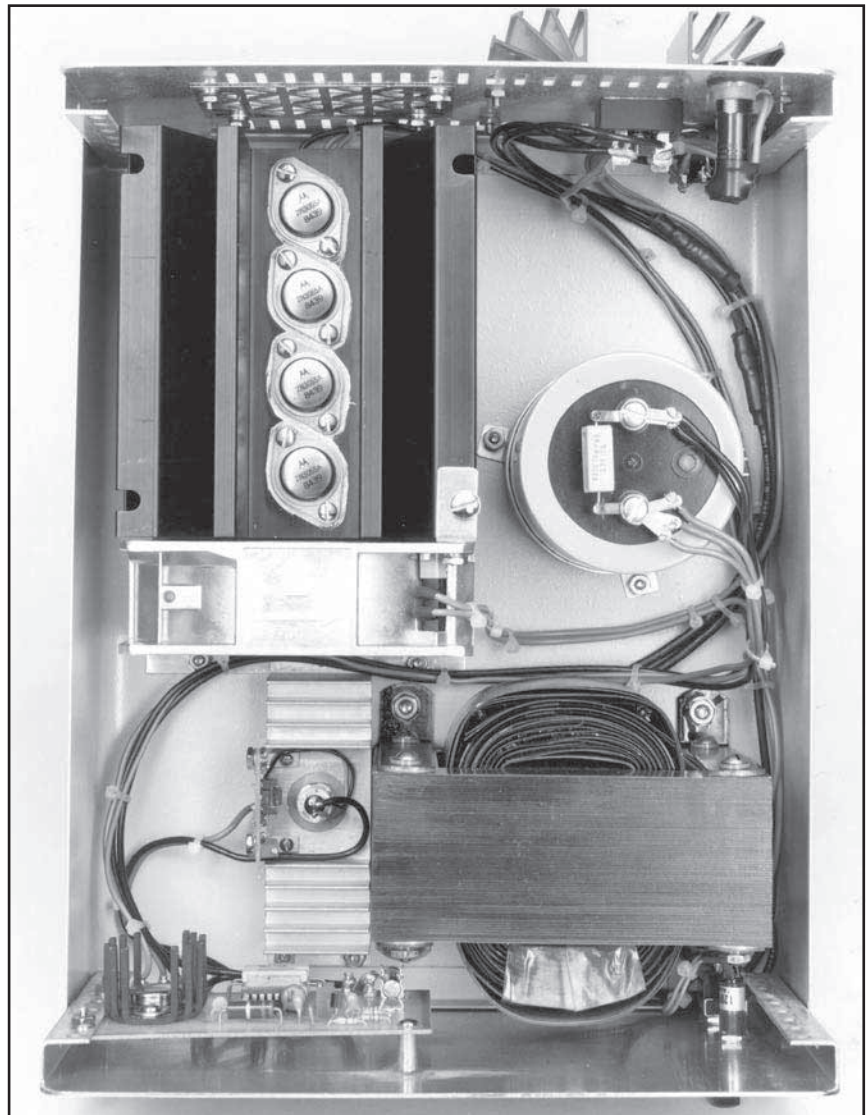

**Fig 17.47 — Interior of the 28-V, high-current power supply. The cooling fan is necessary only if the pass transistors and heat sink are mounted inside the cabinet. See text.**

somewhat lower than the filtered bus voltage. U2 is an adjustable 3-terminal regulator; it is set to provide approximately 35 V to power U3. U3 drives the base of Q1, which in turn drives pass transistors Q2-Q5. This arrangement was selected to take advantage of common components. At first glance, the number of pass transistors seems high for a 10-A supply. Input voltage is high enough that the pass transistors must dissipate about 120 W (worst case), so thermal considerations dictate the use of four transistors. See the **Real-World Component Characteristics** chapter for a complete discussion of thermal design. If you use a transformer with a significantly different secondary potential, refer to the thermal-design tutorial to verify the size heat sink required for safe operation.

R9 is used to adjust supply output voltage. Since this supply was designed primarily for 28-V applications, R9 is a “set and forget” control mounted internally. A 25-turn potentiometer is used here to allow precise voltage adjustment. Another builder may wish to mount this control, and perhaps a voltmeter, on the front panel to easily vary the output voltage.

The 723 features current foldback if the load draws excessive current. Foldback current, set by R7, is approximately 14 A, so F2 should blow if a problem occurs. The output terminals, however, may be shorted indefinitely without damage to any power-supply components.

If the regulator circuitry should fail, or if a pass transistor should short, the unregulated supply voltage will appear at the output terminals. Most 28-V RF transistors would fail with 40-plus volts on the collector, so a prospective builder might wish to incorporate the overvoltage protection circuit shown in Fig 17.46 in the power supply. This circuit is optional. It connects across the output terminals and may be added or deleted with no effect on the rest of the supply. If you choose to use the “crowbar,” make the interconnections as shown. Note that R20 and F3 of Fig 17.46 are added between points A and B of Fig 17.45. If the crowbar is not used, connect F2 between points A and B of Fig 17.45.

The crowbar circuit functions as follows: The Zener-hold off diode (D3) blocks the positive regulated voltage from appearing at the base of Q6 until its avalanche voltage is exceeded. In the case of the device selected, this voltage level is 33 V, which provides for small overshoots that might occur with sudden removal of the output load (switching off a load, for instance).

In the event the output voltage exceeds 33 V, D3 will conduct, and forward bias Q6 through R22 and C20, which eliminates short duration transients and noise.

When Q6 is biased on, trigger current flows through R23 and Q6 into the gate of SCR Q7, turning it on and shorting the raw dc source, forcing F3 to blow. Since some SCRs have a tendency to turn themselves on at high temperature, resistor R24 shunts any internal leakage current to ground.

## CONSTRUCTION

Fig 17.47 shows the interior of the 28-V supply. It is built in a Hammond 1401K enclosure. All parts mount inside the box. The regulator components are mounted on a small PC board attached to the rear of the front panel. See Fig 17.48. Most of the parts were purchased at local electronics stores or from major national suppliers. Many parts, such as the heat sink, pass transistors, 0.1-Ω power resistors and filter capacitor can be obtained from scrap computer power supplies found at flea markets.

Q2-Q5 are mounted on a Wakefield model 441K heat sink. The transistors are mounted to the heat sink with insulating washers and thermal heat-sink compound to aid heat transfer. RadioShack TO-3 sockets make electrical connections easier. The heat-sink surface under the transistors must be absolutely smooth. Carefully deburr all holes after drilling and lightly sand the edges with fine emery cloth.

A five-inch fan circulates air past the heat sink inside the cabinet. Forced-air cooling is necessary only because the heat sink is mounted inside the cabinet. If the heat sink was mounted on the rear panel with the fins vertical, natural convection

would provide adequate cooling and no fan would be required.

U1 is mounted to the inside of the rear panel with heat-sink compound. Its heat sink is bolted to the outside of the rear panel to take advantage of convection cooling.

U2 may prove difficult to find. The 317L is a 100-mA version of the popular 317-series 1.5-A adjustable regulator. The 317L is packaged in a TO-92 case, while the normal 317 is usually packaged in a larger TO-220 case. Many electronics suppliers sell them, and RCA SK7644 or Sylvania ECG1900 direct replacements are available from many local electronics shops. If you can't find a 317L, you can use a regular 317 (available from RadioShack, among others).

R7 is made from two 0.1-Ω, 5-W resistors connected in parallel. These resistors get warm under sustained operation, so they are mounted approximately 1/16 inch above the circuit board to allow air to circulate and to prevent the PC board from becoming discolored. Similarly, R6 gets warm to the touch, so it is mounted away from the board to allow air to circulate. Q1 becomes slightly warm during sustained operation, so it is mounted to a small TO-3 PC board heat sink.

Not obvious from the photograph is the use of a single-point ground to avoid ground-loop problems. The PC-board ground connection and the minus lead of the supply are tied directly to the minus terminal of C1, rather than to a chassis ground.

The crowbar circuit is mounted on a small heat sink near the output terminals. Q7 is a

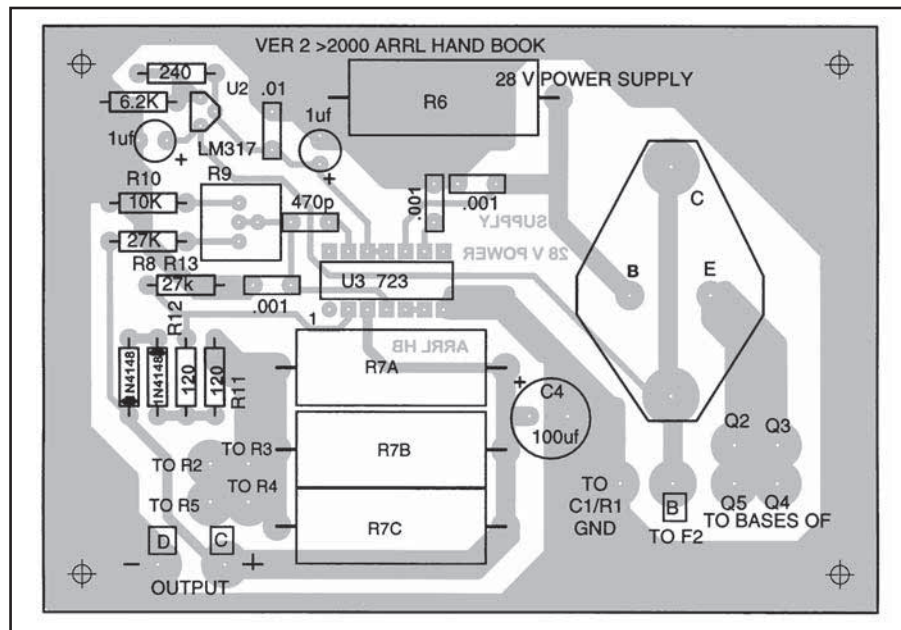

Fig 17.48 — Parts placement diagram for the 28-V power supply. A full-size etching pattern is in the **Templates** section of the *Handbook* CD-ROM.



stud-mount SCR and is insulated from the heat sink. The other components are mounted on a small circuit board attached to the heat sink with angle brackets.

Although the output current is not extremely high, #14 or #12 wire should be used for all high-current runs, including the wiring between C1 and the collectors of Q2-Q5; between R2-R5 and R7; between F2 and the positive output terminal; and between C1 and the negative output terminal. Similar wire should be

used between the output terminals and the load.

## TESTING

First, connect T1, U1 and C1 and verify that the no-load voltage is approximately 44 V dc. Then, connect unregulated voltage to the PC board and pass transistors. Leave the gate lead of Q6 disconnected from pin 8 of U4 at this time. You should be able to adjust the output voltage between approximately 20 and 30 V. Set the output to 28 V.

Next, short the output terminals to verify that the current foldback is working. Voltage should return to 28 when the shorting wire is disconnected. This completes testing and setup.

The supply shown in the photographs dropped approximately 0.1 V between no load and a 12-A resistive load. During testing in the ARRL lab, this supply was run for four hours continuously with a 12-A resistive load on several occasions, without any difficulty.

## A COMMERCIAL-QUALITY, HIGH-VOLTAGE POWER SUPPLY

This two-level, high-voltage power supply was designed and built by ARRL *Handbook* Editor Dana G. Reed, W1LC. It was designed primarily for use with an RF power amplifier using a triode in class AB<sub>2</sub> grounded-grid operation. The supply is rated at a continuous output current of

1.5 A, and will easily handle intermittent peak currents of 2 A. The 12-V control circuitry, and the low-tap setting of the plate transformer secondary, can both be used with the N7ART 2-meter amplifier. See the **RF Power Amplifiers** chapter for details.

The step-start circuit is straightforward and ensures that the rectifier diodes are current-limited when the power supply is first turned on. A 6-kV meter is used to monitor high-voltage output.

Fig 17.49 is a schematic diagram of the bi-level supply. An ideal power supply for

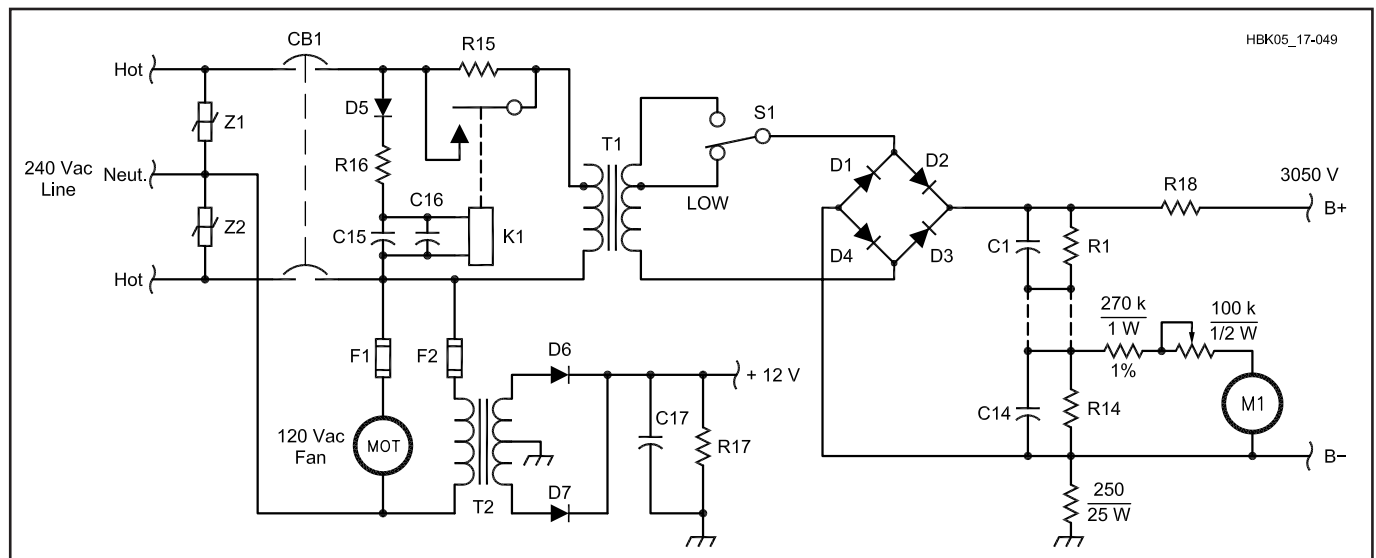

Fig 17.49 — Schematic diagram of the 3050-V/5400-V high-voltage power supply.

- C1 to C14 — Electrolytic capacitor, 800  $\mu$ F, 450 V (Mallory CGS801T450V4L or equiv.)
- C15-C16 — Electrolytic capacitor, 4700  $\mu$ F, 50 V
- C17 — Electrolytic capacitor, 1000  $\mu$ F, 50 V
- CB1 — 20-A hydraulic/magnetic circuit breaker (Potter and Brumfield W68X2Q12-20 or equiv). 40-A version required for commercial applications/service (Potter and Brumfield W92X112-40)
- D1-D4 — Commercial diode block assembly: K2AW HV14-1, from K2AW's Silicon Alley
- D5 — 1000-PIV, 3-A diode, 1N5408 or equiv
- D6-D7 — 200-PIV, 3-A diode, 1N5402 or equiv
- F1-F2 — Fuse, 0.5 A, 250 V (Littelfuse® 313 Series, 3AG Glass Body or equiv)

- K1 — DPDT power relay, 24-V dc coil; both poles of 240-V ac/25-A contacts in parallel (Potter & Brumfield PRD-11DY0-24 or equiv)
- M1 — High-voltage meter, 6-kV dc full scale. (Important: Use a 1-mA or smaller meter movement to minimize parallel-resistive loading at R14. Also, select series meter-resistor and adjustment-potentiometer values to calibrate your specific meter. Values shown are for a 1-mA meter movement.)
- MOT1 — Cooling fan, 119mm, 110-120-V ac, 30-60 CFM, (EBM 4800Z or equiv)
- R1 to R14 — Bleeder resistor, 100 k $\Omega$ , 3 W, Metal Oxide Film (MOF)
- R15 — Power resistor, 50  $\Omega$ , 100 W
- R16 — Power resistor, 1.2 k $\Omega$ , 25 W
- R17 — Power resistor, 30  $\Omega$ , 25 W
- R18 — Power resistor, 20  $\Omega$ , 50 W

- S1 — Ceramic rotary, 2-pos. tap-select switch (optional). Voltage rating between tap positions should be at least 2.5 kV. Mount switch on insulated or ungrounded material such as a metal plate on standoff insulators, or an insulating plate, and use only a *non-conductive* or otherwise *electrically-isolated* shaft through the front panel for safety
- T1 — High-voltage plate transformer, 220/230-V primary, 2000/3500-V, 1.5-A CCS JK secondary. (Peter W. Dahl Company, Inc., Hipersil C-Core.) Primary 220-V tap fed with nominal 240-V ac line voltage to obtain modest increase in specified secondary voltage levels
- T2 — Power transformer, 120-V Pri., 18-VCT, 2-A Sec. (Hi-Q Magnetics; Mouser 41FJ020)
- Z1-Z2 — 130-V MOV (AVX VE24M00131K or equiv)



a high-power linear amplifier should operate from a 240-V circuit, for best line regulation. A special, hydraulic/magnetic circuit breaker also serves as the disconnect for the plate transformer primary. Don't substitute a standard circuit breaker, switch or fuses for this breaker; fuses won't operate quickly enough to protect the amplifier or power supply in case of an operating abnormality. The bleeder resistors are each 100 k $\Omega$ , 3 W and of stable MOF design. These resistors are wired across each of the 14 capacitors to equalize voltage drops in the series-connected bank. This choice of bleeder resistor value provides a lighter load (less than 25 watts total under high-tap output) and benefits mainly the capacitor-bank filter by yielding much less heat as a result. A reason-

able, but longer bleed-down time to fully discharge the capacitors results — about nine minutes after power is removed. A small fan is included to remove any excess heat from the power supply cabinet during operation.

### POWER SUPPLY CONSTRUCTION

The power supply can be built into a 23 1/2 × 10 3/4 × 16-inch cabinet. The plate transformer is quite heavy at 67 lbs, so use 1/8-inch aluminum for the cabinet bottom and reinforce it with aluminum angle for extra strength and stability. The capacitor bank will be sized for the specific capacitors used. This project employed 3/8-inch thick polycarbonate for reasonable mechanical stability and excellent high-voltage isolation. The full-wave bridge consists of four com-

mercial diode block assemblies.

### POWER SUPPLY OPERATION

When the front-panel breaker is turned on, a single 50- $\Omega$ , 100-W power resistor limits primary inrush current to a conservative value as the capacitor bank charges. After approximately two seconds, step-start relay K1 actuates, shorting the 50- $\Omega$  resistor and allowing full line voltage to be applied to the plate transformer. No-load output voltages under low- and high-tap settings as configured and shown in Fig 17.49 are 3050 V and 5400 V, respectively. Full-load levels are somewhat lower, approximately 2800 V and 4900 V. If a tap-select switch is used as described in the schematic parts list, it should only be switched when the supply is off.

## THE MICRO M+

The Micro M+ is an ideal photovoltaic (PV) controller for use at home or in the field. It's an easy-to-build, one-evening project even a beginner can master. This project was designed by Mike Bryce, WB8VGE. An earlier charge controller called the "Micro M" proved to be a very popular project.<sup>1</sup>

Hams really do like to operate their rigs from solar power. Many have found solar power to be very addictive. I had dozens of requests for information on how to increase the current capacity of the original "Micro M" controller. The Micro M would handle up to 2 A of current. I wanted to improve the performance of the Micro M while I was at it. Because the Micro M switched the negative lead of the solar panel on and off, that lead had to be insulated from the system ground. While that's not a problem with portable use, it may cause trouble with a home station where all the grounds should be connected. Here's what I wanted to do:

- Reduce the standby current at night
- Increase current handling capacity to 4 A
- Change the charging scheme to high (positive) side switching
- Improve the charging algorithm
- Keep the size as small as possible, but large enough to easily construct.

I called the end result the Micro M+. You can assemble one in about an hour. Everything mounts on one double-sided PC board. It's small enough to mount inside your rig yet large enough so you won't misplace it! You can stuff four of them in your shirt pocket! And, you need not worry about RFI being generated by the Micro M+. It's completely silent and

makes absolutely no RFI!

The Micro M+ will handle up to 4 A of current from a solar panel. That's equal to a 75-W solar panel.<sup>2</sup> I've reduced the standby current to less than one milliamp. I've also introduced a new charging algorithm to the Micro M+. All the current switching is done on the positive side. Now, you can connect the photovoltaic array, battery and load grounds together.

A complete kit of parts is available as well as just the PC board.<sup>3</sup> The Micro M+ is easy to build, making it a perfect first time project.

### HOW IT WORKS

Fig 17.50 shows the complete Micro

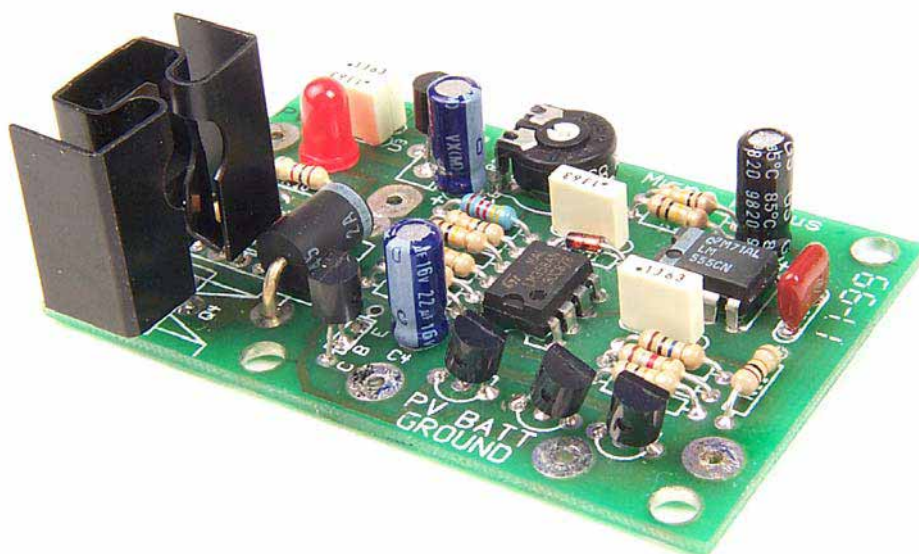
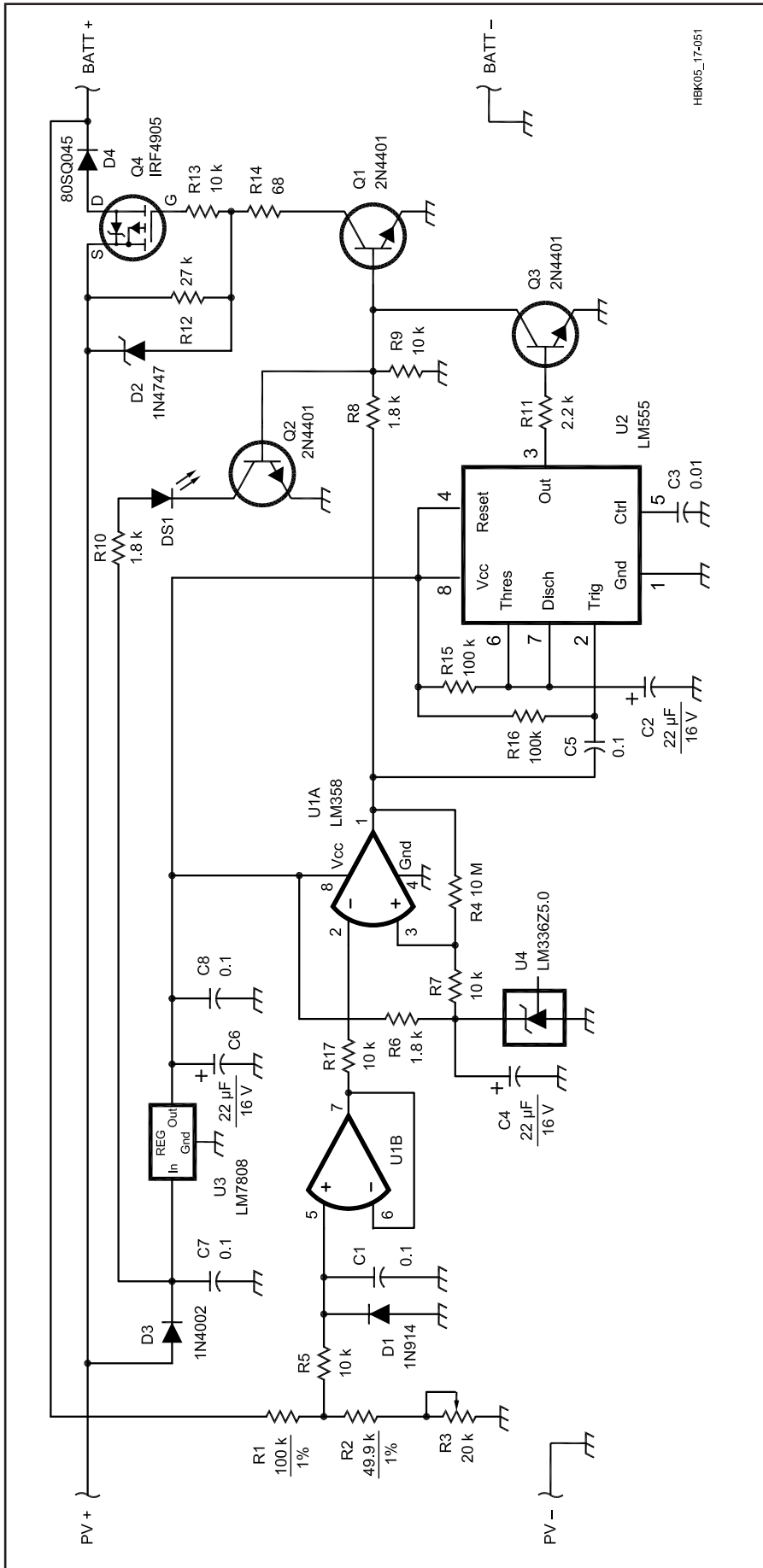

Fig 17.50 — This photo shows the Micro M+ charge controller circuit board. Leads solder to the board and connect to a solar panel and to the battery being charged.

M+. Fig 17.51 shows the schematic diagram. Let's begin with the current handling part of the Micro M+. Current from the solar panel is controlled by a power MOSFET. Instead of using a common N-channel MOSFET, however, the Micro M+ uses an International Rectifier IRF4905 P-channel MOSFET. This P-channel FET has a current rating of 64 A with an RDS<sub>on</sub> of 0.02  $\Omega$ . It comes in a TO-220 case. Current from the solar panel is routed directly to the MOSFET source lead.

N-channel power MOSFETs have very low RDS<sub>on</sub> and even lower prices. To switch current on and off in a high-side application, though, the gate of an N-channel MOSFET must be at least 10 V higher



HBK05\_17-051

than the rail it is switching. In a typical 12-V system, the gate voltage must be at least 22 V to ensure the MOSFET is turned completely on. If the gate voltage is less than that required to fully enhance the MOSFET, it will be almost on and somewhat off (the MOSFET is operating in its linear region). Hence, the device will likely be destroyed at high current levels.

Normally, to produce this higher gate voltage, some sort of oscillator is used to charge a capacitor via a voltage doubler. This charge pump generates harmonics that may ride on the dc flowing into the battery under charge. Normally, this would not cause any problem, and in most cases, a filter or two on the dc bus will eliminate most of the harmonics generated. Even the best filter won't get rid of all the harmonics, however. To compound the problem, long wire runs to and from the solar panels and batteries act like antennas.

The P-channel MOSFET eliminates the need for a charge pump altogether. To turn on a P-channel MOSFET, all we have to do is pull the gate lead to ground! Since the Micro M+ does not have a charge pump, it generates NO RFI!

Now, you may be wondering if the P-channel MOSFET is so great, why have you not seen them in applications like this before? The answer is twofold. First, the  $R_{DS(on)}$  of a P-channel MOSFET has always been much higher than its N-channel cousin. Several years ago, a P-channel

**Fig 17.51 — The schematic diagram of the Micro M+ charge controller.**

- C1, C5, C7, C8 — 0.1  $\mu$ F
- C2, C4, C6 — 22  $\mu$ F, 16 V electrolytic
- C3 — 0.01  $\mu$ F
- D1 — 1N914, small signal silicon switching diode
- D2 — 1N4747, 20-V, 1-W Zener
- D3 — 1N4002, silicon rectifier diode
- D4 — 80SQ045, 45-V, 8A Schottky diode
- DS1 — LED, junkbox variety
- Q1, Q2, Q3 — 2N4401 NPN small-signal transistor (2N2222 or 2N3904 will also work.)
- Q4 — IRF4905 P channel MOSFET in TO-220 case. You will also need a small clip-on heat sink for this case.
- R1 — 100 k $\Omega$ , 1%
- R2 — 49.9 k $\Omega$ , 1%
- R3 — 20 k $\Omega$  trimmer
- U1 — LM358AN, Dual op-amp
- U2 — LM555AN timer
- U3 — LM78L08, 8-V regulator
- U4 — LM336Z-5.0, 5.0-V Zener diode in TO-92 case. The adjust terminal allows control of the temperature coefficient and voltage over a range. The adjust terminal is not used for the Micro M+.

MOSFET with an  $R_{DS(on)}$  of  $0.12\ \Omega$  was considered very low. At that time an N-channel MOSFET had an  $R_{DS(on)}$  of  $0.009\ \Omega$ . Suppose you want to control 10 A of current from your solar panel. Using the N-channel MOSFET above we find the MOSFET will dissipate less than a watt of power. On the other hand, the P-channel MOSFET will dissipate 12 W of power! Current generated by our solar panels is way too precious (and expensive) to have 12 W go up as heat from the charge controller.

The second factor was price. The P-channel MOSFET I described above would have easily sold for \$19 each. The N-channel device would have been a few dollars.

More recently, the  $R_{DS(on)}$  of a typical P-channel MOSFET has fallen to  $0.028\ \Omega$ . The price, while still a bit expensive, has dropped to about \$8 each.

With the P channel MOSFET controlling the current, diode D4 — a 80SQ045 Schottky — prevents battery current from flowing into the solar panel at night. This diode also provides reverse polarity protection to the battery in the event you connect the solar panel backwards. This protects the expensive P channel MOSFET.

Zener diode D2, a 1N4747, protects the gate from damage due to spikes on the solar panel line. Resistor R12 pulls the gate up, ensuring the power MOSFET is off when it is supposed to be.

### THE MICRO M+ LIKES TO SLEEP

The Micro M+ never draws current from the battery. The solar panel provides all the power the Micro M+ needs, which means the Micro M+ goes to sleep at night. When the sun rises, the Micro M+ will start up again. As soon as the solar panel is producing enough current and voltage to start charging the battery, the Micro M+ will pass current into the battery.

To reduce the amount of stand-by current, diode D3 passes current from the solar panel to U3, the voltage regulator. U3, an LM78L08 regulator, provides a steady +8 V to the Micro M+ controller. Bypass capacitors, C6, C7 and C8 are used to keep everything happy. As long as there is power being produced by the solar panel, the Micro M+ will be awake. At sun down, the Micro M+ will go to sleep. Sleep current is on the order of less than 1 mA!

### BATTERY SENSING

The battery terminal voltage is divided down to a more usable level by resistors, R1, R2 and R3. Resistor R3, a 20 k $\Omega$  trimmer, sets the state-of-charge for the Micro M+. A filter consisting of R5 and C1 helps keep the input clean from noise picked up

by the wires to and from the solar panel. Diode D1 protects the op-amp input in case the battery sense line was connected backwards.

An LM358 dual op-amp is used in the Micro M+. One section (U1B) buffers the divided battery voltage before passing it along to the voltage comparator, U1A. Here the battery sense voltage is compared to the reference voltage supplied by U4. U4 is an LM336Z-5.0 precision diode. To prevent U1A from oscillating, a 10-M $\Omega$  resistor is used to eliminate any hysteresis.

As long as the voltage of the battery under charge is below the reference point, the output of U1A will be high. This saturates transistors Q1 and Q2. Q2 conducts and lights LED DS1, the CHARGING LED. Q1, also fully saturated, pulls the gate of the P channel MOSFET to ground. This effectively turns on the FET, and current flows from the solar panel into the battery via D4.

As the battery begins to take up the charge, its terminal voltage will increase. When the battery reaches the state-of-charge set point, the output of U1A goes low. With Q1 and Q2 now off, the P channel MOSFET is turned off, stopping all current into the battery. With Q2 off, the CHARGING LED goes dark.

Since we have eliminated any hysteresis in U1A, as soon as the current stops, the output of U1A pops back up high again. Why? Because the battery terminal voltage will fall back down as the charging current is removed. If left like this, the Micro M+ would sit and oscillate at the state-of-charge set point.

To prevent that from happening, the output of U1A is monitored by U2, an LM555 timer chip. As soon as the output of U1A goes low, this low trips U2. The output of U2 goes high, fully saturating transistor Q3. With Q3 turned on, it pulls the base of Q1 and Q2 low. Since both Q1 and Q2 are now deprived of base current, they remain off.

With the values shown for R15 and C2, charging current is stopped for about four seconds after the state-of-charge has been reached.

After the four second delay, Q1 and Q2 are allowed to have base drive from U1A. This lights up the charging LED and allows Q4 to pass current once more to the battery.

As soon as the battery hits the state-of-charge once more, the process is repeated. As the battery becomes fully charged, the “on” time will shorten up while the “off” time will always remain the same four seconds. In effect, a pulse of current will be sent to the battery that will shorten over

time. I call this charging algorithm “Pulse Time Modulation.”

As a side benefit of the pulse time modulation, the Micro M+ won't go nuts if you put a large solar panel onto a small battery. The charging algorithm will always keep the off time at four seconds allowing the battery time to rest before being hit by higher current than normal for its capacity.

### BUILDING YOUR OWN MICRO M+

There's nothing special about the circuit. The use of a PC board makes the assembly of the Micro M+ quick and easy. It also makes it much easier if you need to troubleshoot the circuit. The entire circuit can be built on a piece of perf board.

The power MOSFET must be protected against static discharges. A dash of common sense and standard MOSFET handling procedures will work best. Don't handle the MOSFET until you need to install it in the circuit. A wrist strap is a good idea to prevent static damage. Once installed in the PC board, the device is quite robust.

A small clip-on heat sink is used for the power MOSFET. If you desire, the MOSFET could be mounted to a metal chassis. If you do this, make sure you electrically insulate the MOSFET tab from the chassis.

If you plan to use the Micro M+ outside, then consider soldering the IC directly onto the board. I've found that cheap solder-plated IC sockets corrode. If you want to use an IC socket, use one with gold plated contacts.

Feel free to substitute part values. There's nothing really critical. I do suggest you stick with 1% resistors for both R1 and R2. This isn't so important for their closer tolerance but for the 50-PPM temperature compensation they have. You can use standard off-the-shelf parts for either or both R1 and R2, but the entire circuit should then be located in an environment with a stable temperature.

### ADJUSTMENTS

You'll need a good digital voltmeter and a variable power supply. Set the power supply to 14.3 V. Connect the Micro M+ battery negative lead to the power supply negative lead. Connect the Micro M+ PV positive and battery positive leads to the power supply positive lead. The charging LED should be on. If not, adjust trimmer R3 until it comes on. Check for +8 V at the VCC pins of the LM358 and the LM555. You should also see +5 V from the LM336Z5.0 diode.

Quickly move the trimmer from one end of its travel to the other. At one point the



LED will go dark. This is the switch point. To verify that the “off pulse” is working, as soon as the LED goes dark quickly reverse the direction of the trimmer. The LED should remain off for several seconds and then come back on. If everything seems to be working, it’s time to set the state-of-charge trimmer.

Now, slowly adjust the trimmer until the LED goes dark. You might want to try this adjustment more than once as the closer you get the comparator to switch at exactly 14.3 V, the more accurate the Micro M+ will be. Here’s a hint I’ve learned after adjusting hundreds of Micro M+ controllers. Set the power supply to slightly above the cut-off voltage that you want. If you want 14.3 V, then set the supply to 14.5 V. I’ve found that in the time it takes to react to the LED going dark, you overshoot the cut-off point. Setting the supply higher takes this into account and usually you can get the trimmer set to exactly what you need in one try. That’s all you need to do. Disconnect the supply from the Micro M+ and you’re ready for the solar panel.

#### ODDS AND ENDS

The 14.3-V terminal voltage will be

correct for just about all sealed and flooded-cell lead-acid batteries. You can change the state-of-charge set point if you want to recharge NiCds or captive sealed lead-acid batteries.

Keep the current from the solar panel within reason for the size of the battery you’re going to be using. If you have a 7-amp hour battery, then don’t use a 75-W solar panel. You’ll get much better results and smoother operation with a smaller panel.

The tab of the power MOSFET is electrically hot. If you plan on using the Micro M+ without a protective case, make sure you insulate the tab from the heatsink. A misplaced wire touching the heatsink could cause real damage to both the Micro M+ and your equipment. A small plastic box from RadioShack works great.

#### MORE CURRENT?

Well yes, you can get the Micro M+ to handle more current. You must increase the capacity of the blocking diode and mount the power MOSFET on a larger heat sink. I’ve used an MBR2025 diode and a large heatsink for the MOSFET and can easily control 12 A of current.

#### BATTERY CHARGING WITHOUT A SOLAR PANEL?

Yes, it’s possible. The trick is to use a power supply for which you can limit the output current. A discharged lead-acid battery will draw all the current it can from the charging source. In a solar panel setup, if the panel produces 3 A, that’s all it will do. With an ac-powered supply, the current can be excessive. To use the Micro M+ with an ac-powered supply, set the voltage to 15.5 V. Then limit the current to 2 or 3 A.

No matter if you’re camping in the outback, or storing photons just in case of an emergency, the Micro M+ will provide your battery with the fullest charge. The Micro M+ is simple to use and completely silent. Just like the sun!

#### Notes

- <sup>1</sup>The Micro M, September 1996 *QST*, p 41.
- <sup>2</sup>A 75-W module produces 4.4 A at 17 V. The Micro M+ can easily handle the extra 400 ma.
- <sup>3</sup>A complete kit of parts is available from Sunlight Energy Systems, also known as The Heathkit Shop. Visa, MC accepted. [www.theheathkitshop.com](http://www.theheathkitshop.com).

## THE UPS — A UNIVERSAL POWER SUPPLY

If you have spent much time around personal computers, you have probably heard of the uninterruptible power supply (UPS). This supply is designed to provide a continuous source of power for a computer in the event of an ac power-line failure. The UPS plugs into the ac house current and the computer plugs into the UPS. Under normal operating conditions, the UPS passes the 120-V house current to the computer. Surge protection and ac power conditioning circuitry is included in the UPS, protecting your computer from voltage spikes and other electrical conditions that could cause damage.

A UPS contains a battery and dc-to-ac inverter circuitry. The battery-charging circuitry in the UPS will maintain the battery at a full charge during normal operation. If the ac power goes off for any reason, the inverter automatically turns on to maintain the 120-V ac supply. You can continue working on the computer, either until the UPS battery discharges or until the ac power comes back on. At the very least, this will give you time to save files and shut down your computer normally.

This project is adapted from the January 1999 *QST* Technical Correspondence column, page 64, by Robert Whitaker, KI5PG. It describes how you can modify a

UPS to supply 120 V ac and 12 V dc for a wide variety of ham-shack applications.

#### WHAT TO LOOK FOR, WHERE TO FIND IT

Computer salvage dealers, computer shows and hamfests are good places to

shop for a used UPS. Try calling the service department of some computer dealers and computer-repair services to find out what they have on hand.<sup>1</sup> You may pick up one or more older supplies that were taken in trade or with failed batteries, for much less than you would pay for a new

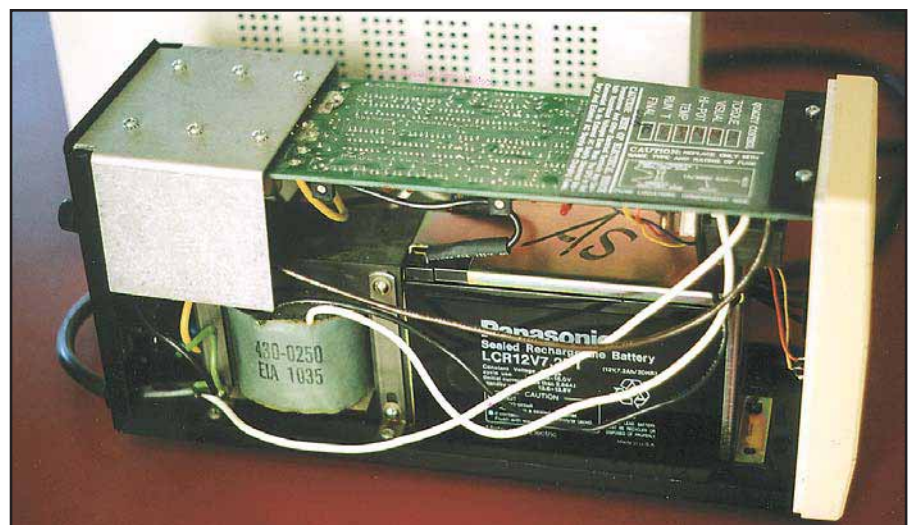

Fig 17.52 — UPS with cover removed to show internal layout. All UPS’s have ac-line conditioning components, a battery, and a dc-to-ac inverter.



UPS. Computer users often throw these supplies away when the battery fails, even though many of the supplies have user-replaceable batteries!

Look for a UPS that can be forced into the inverting mode without the need to disconnect it from an active ac line. Most medium-sized units have an on/off switch and a test/alarm disable switch. Some American Power Conversion (APC)<sup>2</sup> UPS's have secondary DIP switches labeled TEST and ALARM DISABLE. On these models, the unit switches to the inverter mode while connected to ac power when you switch the unit on and press the ALARM DISABLE button.

Higher grade UPS's, such as the APC Back-UPS Pro series have a single on/off power pushbutton. These models can usually be forced into the inverter mode by pressing and holding the pushbutton for a few seconds.

Most medium or small UPS's use a single 12-V gel cell. Larger supplies may use two 6-V batteries in series. Some use two 12-V batteries to form a 24-V system. You will want a UPS with a 12-V system for maximum utility. A 12-V system can be easily configured to work with an external deep-discharge or marine battery. Fig 17.52 shows a small UPS with the cover removed.

## MODIFYING A UPS

If you have a UPS with a battery that will no longer hold a charge, you can either replace the battery or simply use your Universal Power Supply with an external battery. Remember that used batteries are considered hazardous materials, and must be taken to a recycling center or otherwise disposed of properly. Used or new batteries for these supplies are usually not too expensive. Check with battery suppliers like E. H. Yost & Company, W & W Manufacturing and B. G. Micro.

With the battery removed, test the charging circuit by plugging the UPS into a 120-V ac outlet and checking the voltage at the battery leads. With a 12-V system, the charging voltage should be around 13.85 V.

To attach an external battery to the UPS, simply bring the battery-lead connections outside the case. Fig 17.53 shows how you can add a set of terminal posts on the back



**Fig 17.53** — This rear-panel view of a converted UPS shows a pair of binding posts for the 12 V dc connections and a fuse holder for the 12 V output. **Carefully position and drill the mounting holes for the binding posts and fuse holder, so that you don't damage existing parts. Ensure that the placement of these parts will not interfere with any existing components. A Unibit or KWIK STEPPER is ideal for cutting through the 1/8-inch thick steel rear panel. (See "Tool Tips," Technical Correspondence, QST, Dec 1998, p 63.)**

panel. You should also install a chassis-mounted fuse holder in series with the positive terminal post. A 15- or 20-A fuse should be sufficient to provide adequate current with a margin of safety against short circuiting the output.

Many UPS's have a DIP switch, one section of which disables the power-failure alarm. If your supply doesn't have such a switch, you may want to permanently disable the alarm by unsoldering the alarm lead or cutting a PC board trace.

Keep extra fuses handy by taping spares to the inside or outside of the case. Be sure to include extra fuses for the 120-V, ac-input and 12-V, dc-output lines. Don't let a careless mistake and a blown fuse deprive you of power when you need it most!

## USING YOUR UPS

An uninterruptible power supply converted to a universal power supply has many uses:

- Portable 120-V, ac-power source using the internal battery.
- Portable 12-V, dc-power source using the internal battery.
- 120-V, ac-power source with dc for the inverter taken from an external 12-V, dc-automotive or deep-cycle battery.
- Base station 12-V, dc-power supply and 120-V, ac-backup supply.
- Battery charger (12 V) using 120-V, ac-line input.

The UPS is intended for medium power output for short-term use. Don't expect the internal battery-driven inverter or the battery alone to power your 100-W HF rig for a week. You can expect to power a VHF/UHF-mobile radio at medium power for a day or more during an emergency. If you are using an HT, you can probably operate it on high power for a week or more.

Adding a heavy gel-cell or deep-cycle marine battery in parallel with — or independently from — the internal back-up battery will prolong the power-delivery cycle. Be sure that you don't draw more power than your UPS's rated output. If you must draw power at or near the rated power output, use a fan to force air inside the case to help get rid of the heat.

## HOW LONG WILL IT LAST?

A test may help you estimate how long you can expect to use the UPS's battery-driven inverter with a given load. Connect a lamp with a 60-W light bulb, which will draw 0.5 A at 120 V. Two lamps in parallel will draw 1 A. (Just plug in two lamps to the ac output of your supply.) Use a voltmeter to record the battery voltage at the beginning of the test and every 5 to 15 minutes. Plot your data on a graph, with time along the horizontal (X) axis and the battery voltage along the vertical (Y) axis.

## Notes

<sup>1</sup>ATCI Consultants is one possible source for used uninterruptible power supplies.

[www.dallas.net/~atci](http://www.dallas.net/~atci)

<sup>2</sup>American Power Conversion manufactures a variety of supplies and also offers repair and battery-replacement services.

[www.apcc.com](http://www.apcc.com)

## A PORTABLE POWER SUPPLY

This project was developed and the text written by Tony Jarvis, G6TTL. It originally appeared in the May, 1997 issue of *RadCom*, the monthly publication of the Radio Society of Great Britain (RSGB).

When time permits, I enjoy participating in the Backpacker series of RSGB contests,<sup>1</sup> operating in the 3-W category. The power supply I use for these outings is described here and shown in Fig 17.54. It is ideal for the purpose and can also be used as a simple, uninterruptible power supply (UPS) for the shack.

### DESIGN CRITERIA

- A weight maximum of 10 lb (4.5 kg)
- Able to be carried in a small backpack
- Able to be plugged into the nearest power outlet to be recharged
- When at home, to run in 'float-charge mode' to operate low-current equipment
- To be of reasonable cost
- To use readily available components

At a Rainham Rally, I found several sealed, lead-acid cells rated at a nominal 12 V and 7-Ah capacity. They weighed in at a little over 2.2 kg (5 lb) — just what I needed! To prevent gassing, care must be exercised to not overcharge sealed cells, which requires a charge voltage limit of 13.8 V at the terminals. Thus, a stabilized supply is essential.

### THE CIRCUIT

The float charger is hardly original; it

was adapted from an excellent series of articles by John Case.<sup>2</sup> One major consideration was the need to over-engineer it, as I would leave it plugged in and switched on almost continuously.

Fig 17.55 shows the circuit diagram. Many of the components were salvaged from redundant equipment or the junk box; however, the critical components — transformer, pass transistor, reservoir capaci-

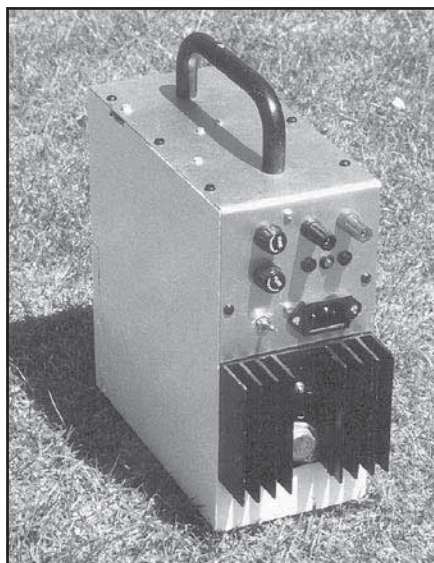

Fig 17.54 — The completed power supply.

Table 17.1

### Components List

#### Resistors

R1	1.2 k $\Omega$
R2	1.5 k $\Omega$
R3	2.7 k $\Omega$
R4	0.5 $\Omega$ , 2W
R5	8.2 k $\Omega$
R6	7.5 k $\Omega$
R7	820 $\Omega$
R8	500 $\Omega$ linear preset potentiometer
R9	1 k $\Omega$ linear preset potentiometer
VDR1	V275LA40A

All resistors 1/2-W, metal film, 5% tolerance, unless otherwise specified.

#### Capacitors

C1	10,000 $\mu$ F, 40 V electrolytic
C2	4.7 $\mu$ F, 40 V electrolytic
C3	500 pf ceramic

#### Semiconductors

D1	Red LED
D2	Yellow LED
D3	Green LED
D4	MR752 (or similar)
D5	50 PIV, 25A
U1	LM723
Q1	2N3055

#### Additional items

F1	1A fuse and holder
F2	3A fuse and holder
S1	DPST toggle
T1	Power transformer with 2 ea, 15V @ 0.75A secondaries
	7Ah sealed lead-acid battery
	IEC socket
	Matrix board
	Screw terminals, insulated
	Case to suit

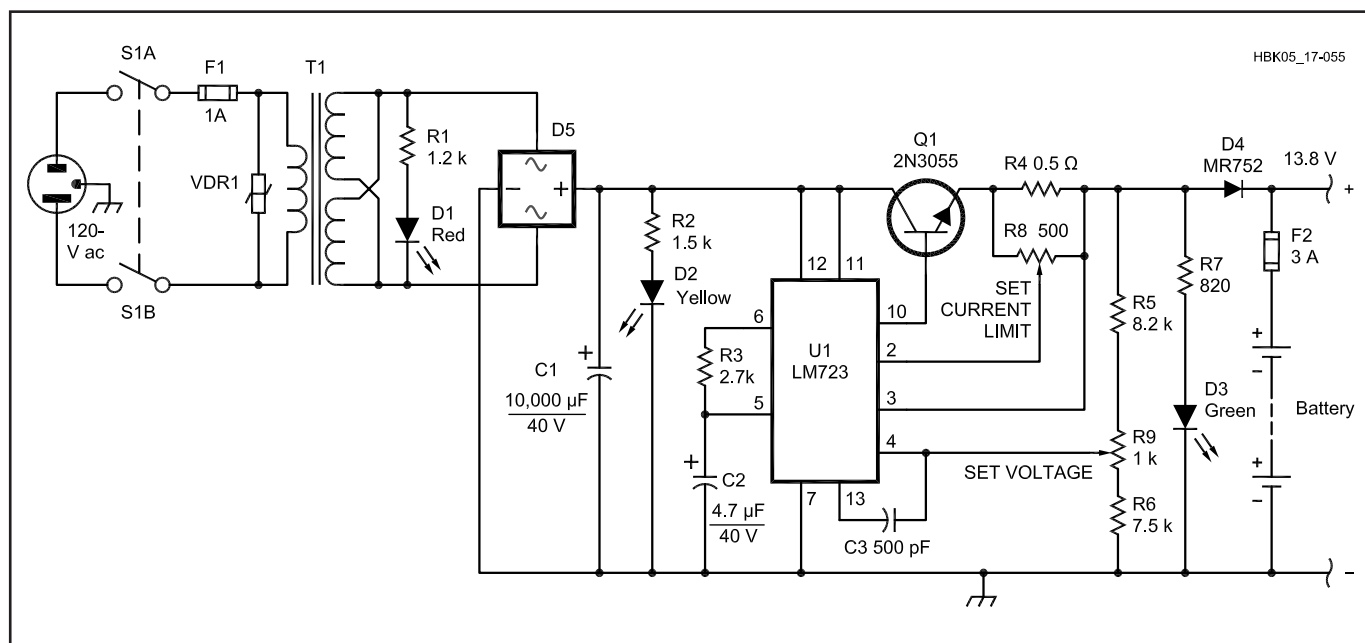

Fig 17.55 — Schematic diagram. The portable power supply works by float-charging a sealed lead-acid battery to provide an uninterruptible supply.

tor and regulator chip — were all purchased new.

There are many options available for layout; mine were dictated by the size and shape of the heatsink. In my case, the box that holds it all is made from half-inch plywood, with the major components mounted on an L-shaped aluminum plate that forms the front and part of one side. A voltage-dependent resistor (varistor) is located across the primary of the transformer, and an over-current control is provided to limit the current to 1.5A.

A heavy-duty diode, D4, is incorporated in the feed to the battery, and LEDs are placed at strategic points as a confidence

feature and for ease of fault-finding. The voltage controller, an LM723, is mounted, along with its components, on a small piece of matrix board, the remaining components being wired point-to-point using substantial cable for the heavy-current paths. Setup is quite straightforward — connect everything together to a fully charged battery, connect a voltmeter to the battery's terminals, turn-on and adjust the output to 13.8V as measured at the battery terminals. Set the current limit to 1.5A, which in practice is rarely exceeded.

## RESULTS

Does it meet the criteria set forth previ-

ously? That is for you to decide:

- Weight — 11 lb.
- Size — approximately 10 × 10 × 4 inches, including heatsink and handle.
- Cost — about \$40.
- Capacity — enough for a full backpacking session.

Even when left on continuously, the temperature of the portable power pack hardly rises above room temperature.

## Notes

<sup>1</sup>Backpacking — Summertime Delights, G6TTL, *RadCom*, May, 1997.

<sup>2</sup>Power Supplies on a Shoestring, GW4HWR, *RadCom*, July and August 1986.