

Transmission Lines

RF power is rarely generated right where it will be used. A transmitter and the antenna it feeds are a good example. To radiate effectively, the antenna should be high above the ground and should be kept clear of trees, buildings and other objects that might absorb energy.

The transmitter, however, is most conveniently installed indoors, where it is out of the weather and is readily accessible. A *transmission line* is used to convey RF energy from the transmitter to the antenna. A transmission line should transport the RF from the source to its destination with as little loss as possible. This chapter was written by Dean Straw, N6BV.

There are three main types of transmission lines used by radio amateurs: coaxial lines, open-wire lines and waveguides. The most common type is the *coaxial* line, usually called *coax*. See Fig 21.1A. Coax is made up of a center conductor, which may be either stranded or solid wire, surrounded by a concentric outer conductor. The outer conductor may be braided shield wire or a metallic sheath. A flexible aluminum foil is employed in some coaxes to improve shielding over that obtainable from a woven shield braid. If the outer conductor is made of solid aluminum or copper, the coax is referred to as *Hardline*.

The second type of transmission line utilizes parallel conductors side by side, rather than the concentric ones used in coax. Typical examples of such *open-wire* lines are 300- Ω TV ribbon line and 450- Ω ladder line. See Fig 21.1B. Although open-wire lines are enjoying a sort of renaissance in recent years due to their inherently lower losses in simple multi-band antenna systems, coaxial cables are far more prevalent, because they are much more convenient to use.

The third major type of transmission line is the *waveguide*. While open-wire and coaxial lines are used from power-line frequencies to well into the microwave

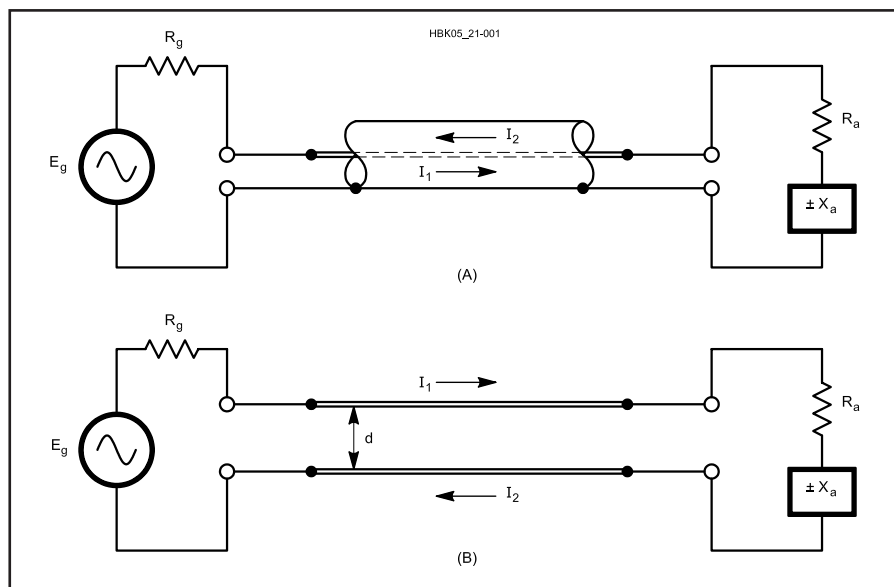

Fig 21.1—In A, coaxial cable transmission line connecting signal generator having source resistance R_g to reactive load $R_a \pm jX_a$, where X_a is either a capacitive (–) or inductive (+) reactance. Velocity factor (VF) and characteristic impedance (Z_0) are properties of the line, as discussed in the text. B shows open-wire balanced transmission line.

region, waveguides are used at microwave frequencies only. Waveguides will be covered at the end of this chapter.

TRANSMISSION LINE BASICS

In either coaxial or open-wire line, currents flowing in each of the two conductors travel in opposite directions. If the physical spacing between the two parallel conductors in an open-wire line is small in terms of wavelength, the phase difference between the currents will be very close to 180°. If the two currents also have equal amplitudes, the field generated by each conductor will cancel that generated by the other, and the line will not radiate energy, even if it is many wavelengths long.

The equality of amplitude and 180°

phase difference of the currents in each conductor in an open-wire line determine the degree of radiation cancellation. If the currents are for some reason unequal, or if the phase difference is not 180°, the line will radiate energy. How such imbalances occur and to what degree they can cause problems will be covered in more detail later.

In contrast to an open-wire line, the outer conductor in a coaxial line acts as a shield, confining RF energy within the line. Because of *skin effect* (see the **Real-World Component Characteristics** chapter in this *Handbook*), current flowing in the outer conductor of a coax does so mainly on the inner surface of the outer conductor. The fields generated by the

Table 21.1

Nominal Characteristics of Commonly Used Transmission Lines

RG or Type	Part Number	Nom. Z_0 Ω	VF %	Cap. pF/ft	Cent. Cond. AWG	Diel. Type	Shield Type	Jacket OD Matl	inches (RMS)	Max V	Matched Loss (dB/100)			
											1 MHz	10	100	1000
RG-6	Belden 1694A	75	82	16.2	#18 Solid BC	FPE	FC	P1	0.275	600	0.2	.7	1.8	5.9
RG-6	Belden 8215	75	66	20.5	#21 Solid CCS	PE	D	PE	0.332	2700	0.4	0.8	2.7	9.8
RG-8	Belden 7810A	50	86	23.0	#10 Solid BC	FPE	FC	PE	0.405	600	0.1	0.4	1.2	4.0
RG-8	TMS LMR400	50	85	23.9	#10 Solid CCA	FPE	FC	PE	0.405	600	0.1	0.4	1.3	4.1
RG-8	Belden 9913	50	84	24.6	#10 Solid BC	ASPE	FC	P1	0.405	600	0.1	0.4	1.3	4.5
RG-8	CXP1318FX	50	84	24.0	#10 Flex BC	FPE	FC	P2N	0.405	600	0.1	0.4	1.3	4.5
RG-8	Belden 9913F7	50	83	24.6	#11 Flex BC	FPE	FC	P1	0.405	600	0.2	0.6	1.5	4.8
RG-8	Belden 9914	50	82	24.8	#10 Solid BC	FPE	FC	P1	0.405	600	0.2	0.5	1.5	4.8
RG-8	TMS LMR400UF	50	85	23.9	#10 Flex BC	FPE	FC	PE	0.405	600	0.1	0.4	1.4	4.9
RG-8	DRF-BF	50	84	24.5	#9.5 Flex BC	FPE	FC	PE	0.405	600	0.1	0.5	1.6	5.2
RG-8	WM CQ106	50	84	24.5	#9.5 Flex BC	FPE	FC	P2N	0.405	600	0.2	0.6	1.8	5.3
RG-8	CXP008	50	78	26.0	#13 Flex BC	FPE	S	P1	0.405	600	0.1	0.5	1.8	7.1
RG-8	Belden 8237	52	66	29.5	#13 Flex BC	PE	S	P1	0.405	3700	0.2	0.6	1.9	7.4
RG-8X	Belden 7808A	50	86	23.5	#15 Solid BC	FPE	FC	PE	0.240	600	0.2	0.7	2.3	7.4
RG-8X	TMS LMR240	50	84	24.2	#15 Solid BC	FPE	FC	PE	0.242	300	0.2	0.8	2.5	8.0
RG-8X	WM CQ118	50	82	25.0	#16 Flex BC	FPE	FC	P2N	0.242	300	0.3	0.9	2.8	8.4
RG-8X	TMS LMR240UF	50	84	24.2	#15 Flex BC	FPE	FC	PE	0.242	300	0.2	0.8	2.8	9.6
RG-8X	Belden 9258	50	82	24.8	#16 Flex BC	FPE	S	P1	0.242	600	0.3	0.9	3.1	11.2
RG-8X	CXP08XB	50	80	25.3	#16 Flex BC	FPE	S	P1	0.242	300	0.3	0.9	3.1	14.0
RG-9	Belden 8242	51	66	30.0	#13 Flex SPC	PE	SCBC	P2N	0.420	5000	0.2	0.6	2.1	8.2
RG-11	Belden 8213	75	84	16.1	#14 Solid BC	FPE	S	PE	0.405	600	0.2	0.4	1.3	5.2
RG-11	Belden 8238	75	66	20.5	#18 Flex TC	PE	S	P1	0.405	600	0.2	0.7	2.0	7.1
RG-58	Belden 7807A	50	85	23.7	#18 Solid BC	FPE	FC	PE	0.195	300	0.3	1.0	3.0	9.7
RG-58	TMS LMR200	50	83	24.5	#17 Solid BC	FPE	FC	PE	0.195	300	0.3	1.0	3.2	10.5
RG-58	WM CQ124	52	66	28.5	#20 Solid BC	PE	S	PE	0.195	1400	0.4	1.3	4.3	14.3
RG-58	Belden 8240	52	66	28.5	#20 Solid BC	PE	S	P1	0.193	1900	0.3	1.1	3.8	14.5
RG-58A	Belden 8219	53	73	26.5	#20 Flex TC	FPE	S	P1	0.195	300	0.4	1.3	4.5	18.1
RG-58C	Belden 8262	50	66	30.8	#20 Flex TC	PE	S	P2N	0.195	1400	0.4	1.4	4.9	21.5
RG-58A	Belden 8259	50	66	30.8	#20 Flex TC	PE	S	P1	0.192	1900	0.4	1.5	5.4	22.8
RG-59	Belden 1426A	75	83	16.3	#20 Solid BC	FPE	S	P1	0.242	300	0.3	0.9	2.6	8.5
RG-59	CXP 0815	75	82	16.2	#20 Solid BC	FPE	S	P1	0.232	300	0.5	0.9	2.2	9.1
RG-59	Belden 8212	75	78	17.3	#20 Solid CCS	FPE	S	P1	0.242	300	0.6	1.0	3.0	10.9
RG-59	Belden 8241	75	66	20.4	#23 Solid CCS	PE	S	P1	0.242	1700	0.6	1.1	3.4	12.0
RG-62A	Belden 9269	93	84	13.5	#22 Solid CCS	ASPE	S	P1	0.240	750	0.3	0.9	2.7	8.7
RG-62B	Belden 8255	93	84	13.5	#24 Flex CCS	ASPE	S	P2N	0.242	750	0.3	0.9	2.9	11.0
RG-63B	Belden 9857	125	84	9.7	#22 Solid CCS	ASPE	S	P2N	0.405	750	0.2	0.5	1.5	5.8
RG-142	CXP 183242	50	69.5	29.4	#19 Solid SCCS	TFE	D	FEP	0.195	1900	0.3	1.1	3.8	12.8
RG-142B	Belden 83242	50	69.5	29.0	#19 Solid SCCS	TFE	D	TFE	0.195	1400	0.3	1.1	3.9	13.5
RG-174	Belden 7805R	50	73.5	26.2	#25 Solid BC	FPE	FC	P1	0.110	300	0.6	2.0	6.5	21.3
RG-174	Belden 8216	50	66	30.8	#26 Flex CCS	PE	S	P1	0.110	1100	1.9	3.3	8.4	34.0
RG-213	Belden 8267	50	66	30.8	#13 Flex BC	PE	S	P2N	0.405	3700	0.2	0.6	1.9	8.0
RG-213	CXP213	50	66	30.8	#13 Flex BC	PE	S	P2N	0.405	600	0.2	0.6	2.0	8.2
RG-214	Belden 8268	50	66	30.8	#13 Flex SPC	PE	D	P2N	0.425	3700	0.2	0.6	1.9	8.0
RG-216	Belden 9850	75	66	20.5	#18 Flex TC	PE	D	P2N	0.425	3700	0.2	0.7	2.0	7.1
RG-217	WM CQ217F	50	66	30.8	#10 Flex BC	PE	D	PE	0.545	7000	0.1	0.4	1.4	5.2
RG-217	M17/78-RG217	50	66	30.8	#10 Solid BC	PE	D	P2N	0.545	7000	0.1	0.4	1.4	5.2
RG-218	M17/79-RG218	50	66	29.5	#4.5 Solid BC	PE	S	P2N	0.870	11000	0.1	0.2	0.8	3.4
RG-223	Belden 9273	50	66	30.8	#19 Solid SPC	PE	D	P2N	0.212	1400	0.4	1.2	4.1	14.5
RG-303	Belden 84303	50	69.5	29.0	#18 Solid SCCS	TFE	S	TFE	0.170	1400	0.3	1.1	3.9	13.5
RG-316	CXP T1316	50	69.5	29.4	#26 Flex BC	TFE	S	FEP	0.098	1200	1.2	2.7	8.0	26.1
RG-316	Belden 84316	50	69.5	29.0	#26 Flex SCCS	TFE	S	FEP	0.096	900	1.2	2.7	8.3	29.0
RG-393	M17/127-RG393	50	69.5	29.4	#12 Flex SPC	TFE	D	FEP	0.390	5000	0.2	0.5	1.7	6.1
RG-400	M17/128-RG400	50	69.5	29.4	#20 Flex SPC	TFE	D	FEP	0.195	1400	0.4	1.1	3.9	13.2
LMR500	TMS LMR500UF	50	85	23.9	#7 Flex BC	FPE	FC	PE	0.500	2500	0.1	0.4	1.2	4.0
LMR500	TMS LMR500	50	85	23.9	#7 Solid CCA	FPE	FC	PE	0.500	2500	0.1	0.3	0.9	3.3
LMR600	TMS LMR600	50	86	23.4	#5.5 Solid CCA	FPE	FC	PE	0.590	4000	0.1	0.2	0.8	2.7
LMR600	TMS LMR600UF	50	86	23.4	#5.5 Flex BC	FPE	FC	PE	0.590	4000	0.1	0.2	0.8	2.7
LMR1200	TMS LMR1200	50	88	23.1	#0 Copper Tube	FPE	FC	PE	1.200	4500	0.04	0.1	0.4	1.3
Hardline														
1/2"	CATV Hardline	50	81	25.0	#5.5 BC	FPE	SM	none	0.500	2500	0.05	0.2	0.8	3.2
1/2"	CATV Hardline	75	81	16.7	#11.5 BC	FPE	SM	none	0.500	2500	0.1	0.2	0.8	3.2
7/8"	CATV Hardline	50	81	25.0	#1 BC	FPE	SM	none	0.875	4000	0.03	0.1	0.6	2.9
7/8"	CATV Hardline	75	81	16.7	#5.5 BC	FPE	SM	none	0.875	4000	0.03	0.1	0.6	2.9
LDF4-50A	Heliac -1/2"	50	88	25.9	#5 Solid BC	FPE	CC	PE	0.630	1400	0.05	0.2	0.6	2.4
LDF5-50A	Heliac -7/8"	50	88	25.9	0.355" BC	FPE	CC	PE	1.090	2100	0.03	0.10	0.4	1.3
LDF6-50A	Heliac -1 1/4"	50	88	25.9	0.516" BC	FPE	CC	PE	1.550	3200	0.02	0.08	0.3	1.1
Parallel Lines														
TV Twinlead (Belden 9085)		300	80	4.5	#22 Flex CCS	PE	none	P1	0.400	**	0.1	0.3	1.4	5.9
Twinlead (Belden 8225)		300	80	4.4	#20 Flex BC	PE	none	P1	0.400	8000	0.1	0.2	1.1	4.8
Generic Window Line		405	91	2.5	#18 Solid CCS	PE	none	P1	1.000	10000	0.02	0.08	0.3	1.1
WM CQ 554		420	91	2.7	#14 Flex CCS	PE	none	P1	1.000	10000	0.02	0.08	0.3	1.1
WM CQ 552		440	91	2.5	#16 Flex CCS	PE	none	P1	1.000	10000	0.02	0.08	0.3	1.1
WM CQ 553		450	91	2.5	#18 Flex CCS	PE	none	P1	1.000	10000	0.02	0.08	0.3	1.1
WM CQ 551		450	91	2.5	#18 Solid CCS	PE	none	P1	1.000	10000	0.02	0.08	0.3	1.1
Open-Wire Line		600	92	1.1	#12 BC	none	none	none	**	12000	0.02	0.06	0.2	0.7

Approximate Power Handling Capability (1:1 SWR, 40°C Ambient):

	1.8 MHz	7	14	30	50	150	220	450	1 GHz
RG-58 Style	1350	700	500	350	250	150	120	100	50
RG-59 Style	2300	1100	800	550	400	250	200	130	90
RG-8X Style	1830	840	560	360	270	145	115	80	50
RG-8/213 Style	5900	3000	2000	1500	1000	600	500	350	250
RG-217 Style	20000	9200	6100	3900	2900	1500	1200	800	500
LDF4-50A	38000	18000	13000	8200	6200	3400	2800	1900	1200
LDF5-50A	67000	32000	22000	14000	11000	5900	4800	3200	2100
LMR500	18000	9200	6500	4400	3400	1900	1600	1100	700
LMR1200	52000	26000	19000	13000	10000	5500	4500	3000	2000

Legend:

**	Not Available or varies	N	Non-Contaminating
ASPE	Air Spaced Polyethylene	P1	PVC, Class 1
BC	Bare Copper	P2	PVC, Class 2
CC	Corrugated Copper	PE	Polyethylene
CCA	Copper Cover Aluminum	S	Single Braided Shield
CCS	Copper Covered Steel	SC	Silver Coated Braid
CXP	Cable X-Perts, Inc.	SCCS	Silver Plated Copper Coated Steel
D	Double Copper Braids	SM	Smooth Aluminum
DRF	Davis RF	SPC	Silver Plated Copper
FC	Foil + Tinned Copper Braid	TC	Tinned Copper
FEP	Teflon @ Type IX	TFE	Teflon@
Flex	Flexible Stranded Wire	TMS	Times Microwave Systems
FPE	Foamed Polyethylene	UF	Ultra Flex
Heliax	Andrew Corp Heliax	WM	Wireman

currents flowing on the outer surface of the inner conductor and on the inner surface of the outer conductor cancel each other out, just as they do in open-wire line.

In a real (non-ideal) transmission line, the energy actually travels somewhat slower than the speed of light (typically from 65 to 97% of light speed), depending primarily on the dielectric properties of the insulating materials used in the construction of the line. The fraction of the speed of propagation in a transmission line compared to the speed of light in free space is called the *velocity factor* (VF) of the line. The velocity factor causes the line's *electrical* wavelength to be shorter than the wavelength in free space. Eq 1 describes the physical length of an electrical wavelength of transmission line.

$$\lambda = \frac{983.6}{f} \times VF \quad (1)$$

where

- λ = wavelength, in ft
- f = frequency in MHz
- VF = velocity factor.

Each transmission line has a characteristic velocity factor, related to the specific properties of its insulating materials. The velocity factor must be taken into account when cutting a transmission line to a spe-

cific electrical length. **Table 21.1** shows various velocity factors for the transmission lines commonly used by amateurs. For example, if RG-8A, which has a velocity factor of 0.66, were used to make a quarter-wavelength line at 3.5 MHz, the length would be $(0.66 \times 983.6/3.5)/4 = 46.4$ ft long, instead of the free-space length of 70.3 ft. Open-wire line has a velocity factor of 0.97, close to unity, because it lacks a substantial amount of solid insulating material. Conversely, molded 300- Ω TV line has a velocity factor of 0.80 to 0.82 because it does use solid insulation between the conductors.

A perfectly lossless transmission line may be represented by a whole series of small inductors and capacitors connected in an infinitely long line, as shown in **Fig 21.2**. (We first consider this special case because we need not consider how the line is terminated at its end, since there is no end.)

Each inductor in Fig 21.2 represents the inductance of a very short section of one wire and each capacitor represents the capacitance between two such short sections. The inductance and capacitance values per unit of line depend on the size of the conductors and the spacing between them. The smaller the spacing between the two conductors and the greater their diameter, the higher the capacitance and the

lower the inductance. Each series inductor acts to limit the rate at which current can charge the following shunt capacitor, and in so doing establishes a very important property of a transmission line: its *surge impedance*, more commonly known as its *characteristic impedance*. This is usually abbreviated as Z_0 , and is approximately equal to $\sqrt{L/C}$, where L and C are the inductance and capacitance per unit length of line.

The characteristic impedance of an air-insulated parallel-conductor line, neglecting the effect of the insulating spacers, is given by

$$Z_0 = 276 \log_{10} \frac{2S}{d} \quad (2)$$

where

- Z_0 = characteristic impedance
- S = center-to-center distance between conductors
- d = diameter of conductor (in same units as S).

The characteristic impedance of an air-insulated coaxial line is given by

$$Z_0 = 138 \log_{10} \left(\frac{b}{a} \right) \quad (3)$$

where

- Z_0 = characteristic impedance
- b = inside diameter of outer conductors
- a = outside diameter of inner conductor (in same units as b).

It does not matter what units are used for S, d, a or b, so long as they are the same units. A line with closely spaced, large conductors will have a low characteristic impedance, while one with widely spaced, small conductors will have a relatively high characteristic impedance. Practical open-wire lines exhibit characteristic impedances ranging from about 200 to 800 Ω , while coax cables have Z_0 values between 25 to 100 Ω .

All practical transmission lines exhibit some power loss. These losses occur in the resistance that is inherent in the conductors that make up the line, and from leakage currents flowing in the dielectric material between the conductors. We'll next consider what happens when a real transmission line, which is not infinitely long, is terminated in real load impedances.

Matched Lines

Real transmission lines do not extend to infinity, but have a definite length. In use they are connected to, or *terminate* in, a load, as illustrated in **Fig 21.3A**. If the load is a pure resistance whose value equals the characteristic impedance of the line, the line is said to be *matched*. To current traveling along the line, such a load at the end

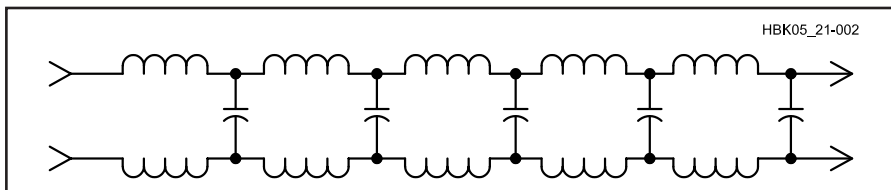

Fig 21.2—Equivalent of an infinitely long lossless transmission line using lumped circuit constants.

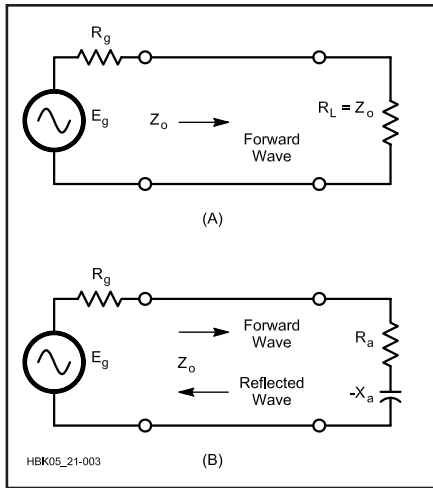

Fig 21.3—At A the coaxial transmission line is terminated with resistance equal to its Z_0 . All power is absorbed in the load. At B, coaxial line is shown terminated in an impedance consisting of a resistance and a capacitive reactance. This is a mismatched line, and a reflected wave will be returned back down the line toward the generator. The reflected wave reacts with the forward wave to produce a standing wave on the line. The amount of reflection depends on the difference between the load impedance and the characteristic impedance of the transmission line.

of the line acts as though it were still more transmission line of the same characteristic impedance. In a matched transmission line, energy travels outward along the line from the source until it reaches the load, where it is completely absorbed.

Mismatched Lines

Assume now that the line in Fig 21.3B is terminated in an impedance Z_a which is not equal to Z_0 of the transmission line. The line is now a *mismatched* line. RF energy reaching the end of a mismatched line will not be fully absorbed by the load impedance. Instead, part of the energy will be reflected back toward the source. The amount of reflected versus absorbed energy depends on the degree of mismatch between the characteristic impedance of the line and the load impedance connected to its end.

The reason why energy is reflected at a discontinuity of impedance on a transmission line can best be understood by examining some limiting cases. First, consider the rather extreme case where the line is shorted at its end. Energy flowing to the load will encounter the short at the end, and the voltage at that point will go to zero, while the current will rise to a maximum. Since the current can't develop any power

in a dead short, it will all be reflected back toward the source generator.

If the short at the end of the line is replaced with an open circuit, the opposite will happen. Here the voltage will rise to maximum, and the current will by definition go to zero. The phase will reverse, and all energy will be reflected back towards the source. By the way, if this sounds to you like what happens at the end of a half-wave dipole antenna, you are quite correct. However, in the case of an antenna, energy traveling along the antenna is lost by radiation on purpose, whereas a good transmission line will lose little energy to radiation because of field cancellation between the two conductors.

For load impedances falling between the extremes of short- and open-circuit, the phase and amplitude of the reflected wave will vary. The amount of energy reflected and the amount of energy absorbed in the load will depend on the difference between the characteristic impedance of the line and the impedance of the load at its end.

Now, what actually happens to the energy reflected back down the line? This energy will encounter another impedance discontinuity, this time at the generator. Reflected energy flows back and forth between the mismatches at the source and load. After a few such journeys, the reflected wave diminishes to nothing, partly as a result of finite losses in the line, but mainly because of absorption at the load. In fact, if the load is an antenna, such absorption at the load is desirable, since the energy is actually radiated by the antenna.

If a continuous RF voltage is applied to the terminals of a transmission line, the voltage at any point along the line will consist of a vector sum of voltages, the composite of waves traveling toward the load and waves traveling back toward the source generator. The sum of the waves traveling toward the load is called the *forward* or *incident* wave, while the sum of the waves traveling toward the generator is called the *reflected* wave.

Reflection Coefficient and SWR

In a mismatched transmission line, the ratio of the voltage in the reflected wave at any one point on the line to the voltage in the forward wave at that same point is defined as the *voltage reflection coefficient*. This has the same value as the current reflection coefficient. The reflection coefficient is a complex quantity (that is, having both amplitude and phase) and is generally designated by the Greek letter ρ (rho), or sometimes in the professional literature as Γ (Gamma). The relationship

Reflections on the Smith Chart

Although most radio amateurs have seen the Smith Chart, it is often regarded with trepidation. It is supposed to be complicated and subtle. However, the chart is extremely useful in circuit analysis, especially when transmission lines are involved. The Smith Chart is not limited to transmission-line and antenna problems.

The basis for the chart is Eq 4 in the main text relating reflection coefficient to a terminating impedance. Eq 4 is repeated here:

$$\rho = \frac{Z - Z_0}{Z + Z_0} \quad (1)$$

where Z_0 is the characteristic impedance of the chart, and $Z = R + jX$ is a complex terminating impedance. Z might be the feed-point impedance of an antenna connected to a Z_0 transmission line.

It is useful to define a normalized impedance $z = Z/Z_0$. The normalized resistance and reactance become $r = R/Z_0$ and $x = X/Z_0$. Inserting these into Eq 1 yields:

$$\rho = \frac{z - 1}{z + 1} \quad (2)$$

where r and z are both complex, each having a magnitude and a phase when expressed in polar coordinates, or a real and an imaginary part in XY coordinates.

Eq 1 and 2 have some interesting

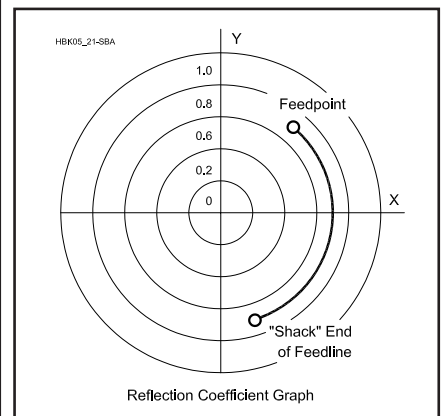

Fig A—Plot of polar reflection coefficient. Circles represent contours of constant ρ . The starting “feed point” value, 0.5 at $+45^\circ$, represents an antenna impedance of $69.1 + j65.1 \Omega$ with $Z_0 = 50 \Omega$. The arc represents a 15-ft section of 50- Ω , VF 0.66 transmission line at 7 MHz, yielding a shack ρ of 0.5 at -71.3° . The shack z is calculated as $40.3 - j50.9 \Omega$.

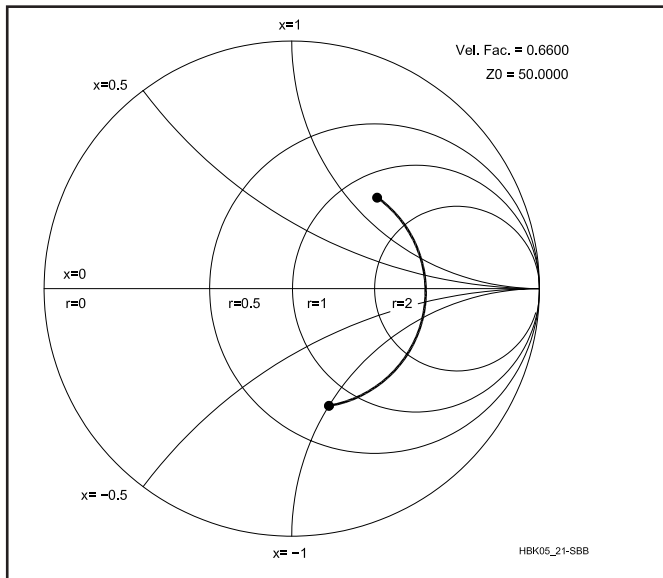

Fig B—This plot shows a Smith Chart. The circles now represent contours of constant normalized resistance or reactance. Note the arc with the markers: This illustrates the same antenna and line used in the previous figure. The plot is the same on the two charts; only the scale details have changed.

and useful properties, characteristics that make them physically significant:

- Even though the components of z (and Z) may take on values that are very large, the reflection coefficient ρ , is restricted to always having a magnitude between zero and one if z has a real part, r , that is positive.
- If all possible values for e are examined and plotted in polar coordinates, they will lie within a circle with a radius of one. This is termed *the unit circle*. A plot is shown in **Fig A**.
- An impedance that is perfectly matched to Z_0 , the characteristic value for the chart, will produce a ρ at the center of the unit circle.
- Real Z values, ones that have no reactance, “map” onto a horizontal line that divides the top from the bottom of the unit circle. By convention, a polar variable with an angle of zero is on the x axis, to the right of the origin.
- Impedances with a reactive part produce ρ values away from the dividing line. Inductive impedances with the imaginary part greater than zero appear in the upper half of the chart, while capacitive impedances appear in the lower half.
- Perhaps the most interesting and exciting property of the reflection coefficient is the way it describes the impedance-transforming properties of a transmission line, presented in closed mathematical form in the main text as Eq 11.

Neglecting loss effects, a transmission line of electrical length θ will transform a normalized impedance represented by ρ to another with the same magnitude and a new angle that differs from the original by -2θ . This rotation is clockwise.

Clearly, the reflection coefficient is more than an intermediate step in a mathematical development. It is a useful, alternative description of complex impedance. However, our interest is still focused on impedance; we want to know, for example, what the final z is after transformation with a transmission line. This is the problem that Phillip Smith solved in creating the Smith Chart. Smith observed that the unit circle, a graph of reflection coefficient, could be labeled with lines representing *normalized impedance*. A Smith Chart is shown in **Fig B**. All of the lines on the chart are complete or partial circles representing a line of constant normalized resistance and reactance.

How might we use the Smith Chart? A classic application relates antenna feed-point impedance to the impedance seen at the end of the “shack” end of the line. Assume that the antenna impedance is known, $Z_a = R_a + jX_a$. This complex value is converted to normalized impedance by dividing R_a and X_a by Z_0 to yield $r_a +$

jx_a , and is plotted on the chart. A compass is then used to draw an arc of a circle centered at the origin of the chart. The arc starts at the normalized antenna impedance and proceeds in a clockwise direction for $2\theta^\circ$, where θ is the electrical degrees, derived from the physical length and velocity factor of the transmission line. The end of the arc represents the normalized impedance at the end of the line in the shack; it is denormalized by multiplying the real and imaginary parts by Z_0 .

Antenna feed-point Z can also be inferred from an impedance measurement at the shack end of the line. A similar procedure is followed. The only difference is that rotation is now in a counterclockwise direction. The Smith Chart is much more powerful than depicted in this brief summary. A detailed treatment is given by Phillip H. Smith in his classic book: *Electronic Applications of the Smith Chart* (McGraw-Hill, 1969). I also recommend his article “Transmission Line Calculator” in Jan 1939 *Electronics*. Joseph White presented a wonderful summary of the chart in a short but outstanding paper: “The Smith Chart: An Endangered Species?” Nov 1979 *Microwave Journal*. *WinSMITH 2.0* is available from ARRL for \$80. The impedance matching tutorial is included.—*Wes Hayward, W7ZOI*

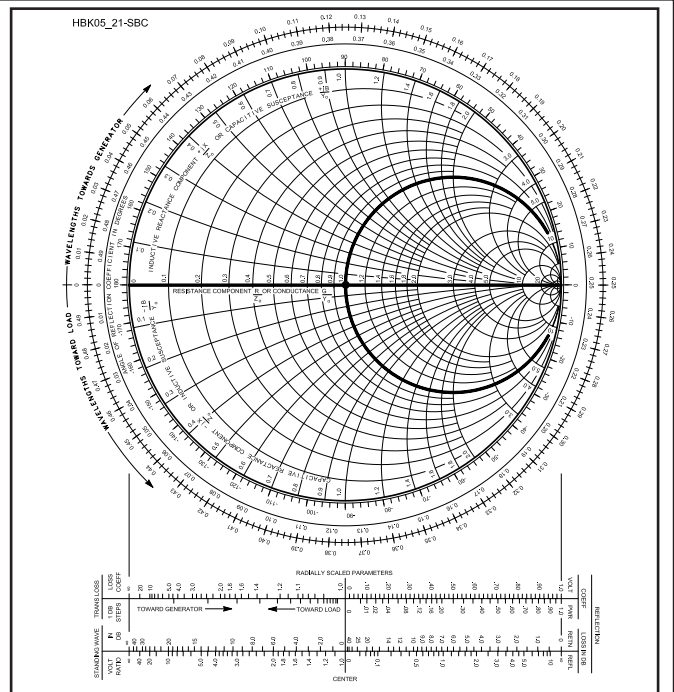

Fig C—The Smith Chart shown in Fig B was computer generated with *winSMITH 2.0*. A much more detailed plot is presented here; this is the chart form used by Smith, suitable for graphic applications. This chart is used with the permission of Analog Instruments.

between R_a (the load resistance), X_a (the load reactance), Z_0 (the line characteristic impedance, whose real part is R_0 and whose reactive part is X_0) and the complex reflection coefficient ρ is

$$\rho = \frac{Z_a - Z_0}{Z_a + Z_0} = \frac{(R_1 \pm jX_a) - (R_0 \pm jX_0)}{(R_1 \pm jX_a) + (R_0 \pm jX_0)} \quad (4)$$

For most transmission lines the characteristic impedance Z_0 is almost completely resistive, meaning that $Z_0 = R_0$ and $X_0 \cong 0$. The magnitude of the complex reflection coefficient in Eq 4 then simplifies to:

$$|\rho| = \sqrt{\frac{(R_a - R_0)^2 + X_a^2}{(R_a + R_0)^2 + X_a^2}} \quad (5)$$

For example, if the characteristic impedance of a coaxial line is 50Ω and the load impedance is 120Ω in series with a capacitive reactance of -90Ω , the magnitude of the reflection coefficient is

$$|\rho| = \sqrt{\frac{(120 - 50)^2 + (-90)^2}{(120 + 50)^2 + (-90)^2}} = 0.593$$

Note that if R_a in Eq 4 is equal to R_0 and X_a is 0, the reflection coefficient, ρ , is 0. This represents a matched condition, where all the energy in the incident wave is transferred to the load. On the other hand, if R_a is 0, meaning that the load has no real resistive part, the reflection coefficient is 1.0, regardless of the value of R_0 . This means that all the forward power is reflected since the load is completely reactive. The concept of reflection is often shown in terms of the *return loss*, which is 20 log the reciprocal of the reflection coefficient, in dB. In the example above, the return loss is 4.5 dB.

If there are no reflections from the load, the voltage distribution along the line is constant or *flat*. A line operating under these conditions is called either a *matched* or a *flat* line. If reflections do exist, a voltage *standing-wave* pattern will result from the interaction of the forward and reflected waves along the line. For a lossless transmission line, the ratio of the maximum peak voltage anywhere on the line to the minimum value anywhere on the line (which must be at least $1/4 \lambda$) is defined as the *voltage standing-wave ratio*, or VSWR. Reflections from the load also produce a standing-wave pattern of currents flowing in the line. The ratio of maximum to minimum current, or ISWR, is

identical to the VSWR in a given line.

In amateur literature, the abbreviation SWR is commonly used for standing-wave ratio, as the results are identical when taken from proper measurements of either current or voltage. Since SWR is a ratio of maximum to minimum, it can never be less than one-to-one. In other words, a perfectly flat line has an SWR of 1:1. The SWR is related to the magnitude of the complex reflection coefficient by

$$\text{SWR} = \frac{1 + |\rho|}{1 - |\rho|} \quad (6)$$

and conversely the reflection coefficient magnitude may be defined from a measurement of SWR as

$$|\rho| = \frac{\text{SWR} - 1}{\text{SWR} + 1} \quad (7)$$

The definitions in Eq 6 and 7 are valid for any line length and for lines which are lossy, not just lossless lines longer than $1/4 \lambda$ at the frequency in use. Very often the load impedance is not exactly known, since an antenna usually terminates a transmission line, and the antenna impedance may be influenced by a host of factors, including its height above ground, end effects from insulators, and the effects of nearby conductors. We may also express the reflection coefficient in terms of forward and reflected power, quantities which can be easily measured using a directional RF wattmeter. The reflection coefficient may be computed as

$$|\rho| = \sqrt{\frac{P_r}{P_f}} \quad (8)$$

where

P_r = power in the reflected wave
 P_f = power in the forward wave.

If a line is not matched (SWR > 1:1) the difference between the forward and reflected powers measured at any point on the line is the net power going toward the load from that point. The forward power measured with a directional wattmeter (often referred to as a reflected power meter or *reflectometer*) on a mismatched line will thus always appear greater than the forward power measured on a flat line with a 1:1 SWR.

Losses in Transmission Lines

A real transmission line exhibits a certain amount of loss, caused by the resistance of the conductors used in the line and by dielectric losses in the line's insulators. The *matched-line loss* for a particular type and length of transmission line,

operated at a particular frequency, is the loss when the line is terminated in a resistance equal to its characteristic impedance. The loss in a line is lowest when it is operated as a matched line.

Line losses increase when SWR is greater than 1:1. Each time energy flows from the generator toward the load, or is reflected at the load and travels back toward the generator, a certain amount will be lost along the line. The net effect of standing waves on a transmission line is to increase the average value of current and voltage, compared to the matched-line case. An increase in current raises I^2R (ohmic) losses in the conductors, and an increase in RF voltage increases E^2/R losses in the dielectric. Line loss rises with frequency, since the conductor resistance is related to skin effect, and also because dielectric losses rise with frequency.

Matched-line loss is stated in decibels per hundred feet at a particular frequency. **Fig 21.4** shows the matched-line loss per hundred feet versus frequency for a number of common types of lines, both coaxial and open-wire balanced types. For example, RG-213 coax cable has a matched-line loss of 2.5 dB/100 ft at 100 MHz. Thus, 45 ft of this cable feeding a 50- Ω load at 100 MHz would have a loss of

$$\begin{aligned} \text{Matched line loss} &= \frac{2.5 \text{ dB}}{100 \text{ ft}} \times 45 \text{ ft} \\ &= 1.13 \text{ dB} \end{aligned}$$

If a line is not matched, standing waves will cause additional loss beyond the inherent matched-line loss for that line. On lines which are inherently lossy, the total line loss (the sum of matched-line loss and additional loss due to SWR) can be surprisingly high for high values of SWR.

Total Mismatched-Line Loss (dB)

$$= 10 \log \left[\frac{a^2 - |\rho|^2}{a(1 - |\rho|^2)} \right] \quad (9)$$

where

$a = 10^{\text{ML}/10}$ = matched-line ratio

$$|\rho| = \frac{\text{SWR} - 1}{\text{SWR} + 1}$$

ML = matched-line loss in dB
 SWR = SWR measured at load

Because of losses in a transmission line, the measured SWR at the input of the line is less than the SWR measured at the load end of the line.

$$\text{SWR at input} = \frac{a + |\rho|}{a - |\rho|} \quad (10)$$

For example, RG-8A solid-dielectric coax cable exhibits a matched-line loss per 100 ft at 28 MHz of 1.18 dB. A 250-ft length of this cable has a matched-line loss of 2.95 dB. Assume that we measure the SWR at the load as 6:1.

$$a = 10^{2.95/10} = 1.972$$

$$|\rho| = \frac{6.0 - 1}{6.0 + 1} = 0.714$$

$$\text{Total Loss} = 10 \log \frac{1.972^2 - 0.714^2}{1.972^2 (1 - 0.714^2)}$$

$$= 5.4 \text{ dB}$$

$$\text{SWR}_{\text{in}} = \frac{1.972 + 0.714}{1.972 - 0.714} = 2.1$$

The additional loss due to the 6:1 SWR at 28 MHz is 5.4 – 3.0 = 2.4 dB. The SWR at the input of the 250-ft line is only 2.1:1, because line loss has masked the true extent

of the SWR (6:1) at the load end of the line.

The losses become larger if coax with a larger matched-line loss is used under the same conditions. For example, RG58A coaxial cable is about one-half the diameter of RG8A, and it has a matched-line loss of 2.5 dB/100 ft at 28 MHz. A 250-ft length of RG58A has a total matched-line loss of 6.3 dB. With a 6:1 SWR at the load, the additional loss due to SWR is 3.0 dB, for a total loss of 9.3 dB. The additional cable loss due to the mismatch reduces the SWR at the input of the line to 1.4:1. An unsuspecting operator measuring the SWR at his transmitter might well believe that everything is just fine, when in truth only about 12% of the transmitter power is getting to the antenna! Be suspicious of very low SWR readings for an antenna fed with a long length of coaxial cable, especially if the SWR remains low across a wide frequency range. Most antennas have narrow SWR bandwidths, and the SWR *should* change across a band.

On the other hand, if expensive 3/4-inch

diameter 50-Ω Hardline cable is used at 28 MHz, the matched-line loss is only 0.28 dB/100 ft. For 250 ft of Hardline the matched-line loss is 0.7 dB, and the additional loss due to a 6:1 SWR is 1.1 dB. The total loss is 1.8 dB. See **Table 21.2** for a summary of the losses for 250 ft of the three types of coax as a function of frequency for matched line and 6:1 SWR conditions.

At the upper end of the HF spectrum, when the transmitter and antenna are separated by a long transmission line the use of bargain coax may prove to be a very poor cost-saving strategy. A 7.5 dB linear amplifier, to offset the loss in RG58A compared to Hardline, would cost a great deal more than higher-quality coax. Furthermore, no *transmitter* amplifier can boost *receiver* sensitivity—loss in the line has the same effect as putting an attenuator in front of the receiver.

At the low end of the HF spectrum, say 3.5 MHz, the amount of loss in common coax lines is less of a problem for the range

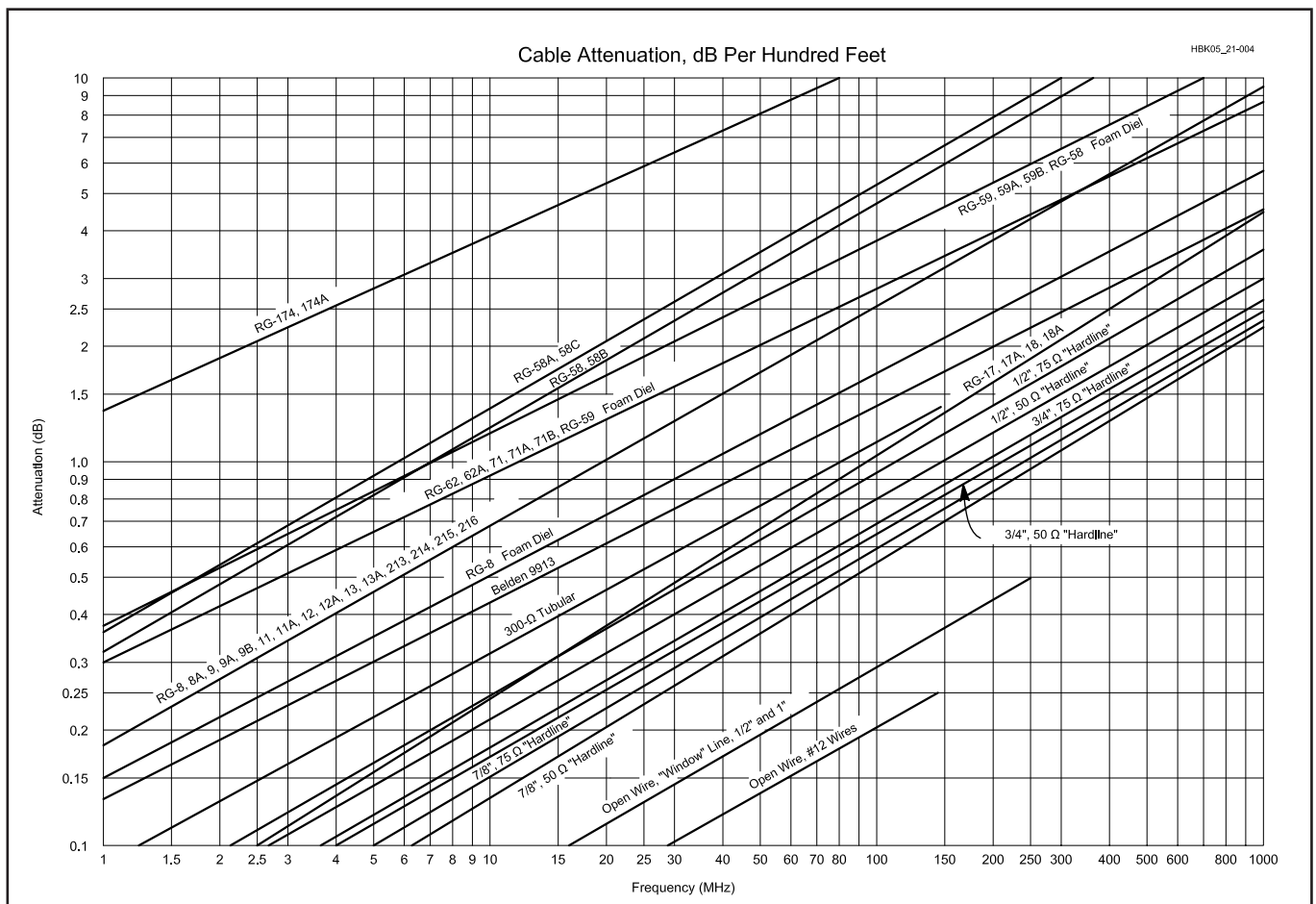

Fig 21.4—This graph displays the matched-line attenuation in decibels per 100 ft for many popular transmission lines. The vertical axis represents attenuation and the horizontal axis frequency. Note that these loss figures are only accurate for properly matched transmission lines.

of SWR values typical on this band. For example, consider an 80-m dipole cut for the middle of the band at 3.75 MHz. It exhibits an SWR of about 6:1 at the 3.5 and 4.0 MHz ends of the band. At 3.5 MHz, 250 ft of RG58A small-diameter coax has an additional loss of 2.1 dB for this SWR, giving a total line loss of 4.0 dB. If larger-diameter RG8A coax is used instead, the additional loss due to SWR is 1.3 dB, for a total loss of 2.2 dB. This is an acceptable level of loss for most 80-m operators.

However, the loss situation gets dramatically worse as the frequency increases into the VHF and UHF regions. At 146 MHz, the total loss in 250 ft of RG-58A with a 6:1 SWR at the load is 16.5 dB, 10.8 dB for RG-8A, and 4.2 dB for 3/4-inch 50-Ω Hardline. At VHF and UHF, a low SWR is essential to keep line losses low, even for the best coaxial cable. The length of transmission line must be kept as short as practical at these frequencies.

The effect of SWR on line loss is shown graphically in Fig 21.5. The horizontal axis is the attenuation, in decibels, of the line when perfectly matched. The vertical axis gives the additional attenuation due to SWR. If long coaxial-cable transmission lines are necessary, the matched loss of the coax used should be kept as low as possible, meaning that the highest-quality, largest-diameter cable should be used.

Choosing a Transmission Line

It is no accident that coaxial cable became as popular as it has since it was first widely used during World War II. Coax is mechanically much easier to use than open-wire line. Because of the excellent shielding afforded by its outer shield, coax can be run up a metal tower leg, taped together with numerous other cables, with virtually no interaction or crosstalk between the cables. At the top of a tower, coax can be used with a rotatable Yagi or quad antenna without worrying about shorting or twisting the conductors, which might happen with an open-wire line. Class 2 PVC non-contaminating outer

jackets are designed for long-life outdoor installations. Class 1 PVC outer jackets are not recommended for outdoor installations. Coax can be buried underground, especially if it is run in plastic piping (with suitable drain holes) so that ground water and soil chemicals cannot easily deteriorate the cable. A cable with an outer jacket of polyethylene (PE) rather than polyvinyl chloride (PVC) is recommended for direct-bury installations.

Open-wire line must be carefully spaced away from nearby conductors, by at least several times the spacing between its conductors, to minimize possible electrical imbalances between the two parallel conductors. Such imbalances lead to line radiation and extra losses. One popular type of open-wire line is called *ladder line* because the insulators used to separate the two parallel, uninsulated conductors of the line resemble the steps of a ladder. Long lengths of ladder line can twist together in the wind and short out if not properly supported.

Despite the mechanical difficulties associated with open-wire line, there are some compelling reasons for its use, especially in simple multiband antenna systems. Every antenna system, no matter what its physical form, exhibits a definite value of impedance at the point where the transmission line is connected. Although the input impedance of an antenna system is seldom known exactly, it is often possible to make a close estimate of its value, especially since sophisticated computer-modeling programs have become available to the radio amateur. As an example, Table 21.3 lists the computed characteristics versus frequency for a multiband, 100-ft long center-fed dipole, placed 50 ft above average ground having a dielectric constant of 13 and a conductivity of 10 mS/m.

These values were computed using a complex program called *NEC-2* (Numerical Electromagnetic Code), which incorporates a sophisticated Sommerfeld/Norton ground-modeling algorithm for

antennas close to real earth. A nonresonant 100-ft length was chosen as an illustration of a practical size that many radio amateurs could fit into their backyards, although nothing in particular recommends this antenna over other forms. It is merely used as an example.

Examine Table 21.3 carefully in the following discussion. Columns three and four show the SWR on a 50-Ω RG-8A coaxial transmission line directly connected to the antenna, followed by the total loss in 100 ft of this cable. The impedance for this nonresonant, 100-ft long antenna varies over a very wide range for the nine operating frequencies. The SWR on a 50-Ω coax connected directly to this antenna would be *extremely* high on some frequencies, particularly at 1.8 MHz,

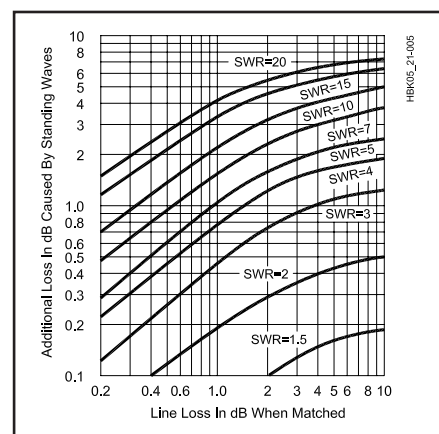

Fig 21.5—Increase in line loss because of standing waves (SWR measured at the load). To determine the total loss in decibels in a line having an SWR greater than 1, first determine the matched-line loss for the particular type of line, length and frequency, on the assumption that the line is perfectly matched (from Fig 21.4). For example, Belden 9913 has a matched-line loss of 0.49 dB/100 ft at 14 MHz. Locate 0.49 dB on the horizontal axis. For an SWR of 5:1, move up to the curve corresponding to this SWR. The increase in loss due to SWR is 0.65 dB beyond the matched line loss.

Table 21.2
Matched-Line Loss for 250 ft of Three Common Coaxial Cables

Comparisons of line losses versus frequency for 250-ft lengths of three different coax cable types: small-diameter RG58A, medium-diameter RG8A, and 3/4-inch OD 50-Ω Hardline. At VHF, the losses for the small-diameter cable are very large, while they are moderate at 3.5 MHz.

<i>Xmsn</i> Line	3.5 MHz Matched- Line Loss, dB	3.5 MHz Loss, 6:1 SWR, dB	28 MHz Matched- Line Loss, dB	28 MHz Loss, 6:1 SWR, dB	146 MHz Matched- Line Loss, dB	146 MHz Loss 6:1 SWR, dB
RG-58A	1.9	4.0	6.3	9.3	16.5	21.6
RG-8A	0.9	2.2	3.0	5.4	7.8	10.8
3/4" 50-Ω Hardline	0.2	0.5	0.7	1.8	2.1	4.2

where the antenna is highly capacitive because it is very short of resonance. The loss for an SWR of 1818:1 in 100 ft of RG-8A at 1.8 MHz is a staggering 25.9 dB.

Contrast this to the loss in 100 ft of 450-Ω open-wire line. Here, the loss at 1.8 MHz is 12.1 dB. While 12.1 dB of loss is not particularly desirable, it is almost 14 dB better than the coax! Note that the RG-8A coax exhibits a good deal of loss on almost all the bands due to mismatch. Only on 14 MHz does the loss drop down to 1.9 dB, where the antenna is just past $\frac{3}{2}\lambda$ resonance. From 3.8 to 28.4 MHz the open-wire line has a maximum loss of only 0.9 dB.

Columns six and seven in Table 21.3 list the maximum RMS voltage for 1500 W of RF power on the 50-Ω coax and on the 450-Ω open-wire line. The maximum RMS voltage for 1500 W on the open-wire line is extremely high, at 7640 V at 1.8 MHz. The voltage for a 100-W transmitter would be reduced by a ratio of $\sqrt{1500/100} = 3.87:1$. This is 1974 V, still high enough to cause arcing in many antenna tuners.

In general, such a nonresonant antenna is a proven, practical multiband radiator when fed with 450-Ω open-wire ladder line connected to an antenna tuner, although a longer antenna would be preferable for more efficient 160-m operation, even with open-wire line. The tuner and the line itself must be capable of handling the high RF voltages and currents involved for high-power operation. On the other hand, if such a multiband antenna is fed directly with coaxial cable, the losses on most frequencies are prohibitive. Coax is most suitable for antennas whose resonant

feed-point impedances are close to the characteristic impedance of the feed line.

The Transmission Line as Impedance Transformer

If the complex mechanics of reflections, SWR and line losses are put aside momentarily, a transmission line can very simply be considered as an impedance transformer. A certain value of load impedance, consisting of a resistance and reactance, at the end of the line is transformed into another value of impedance at the input of the line. The amount of transformation is determined by the electrical length of the line, its characteristic impedance, and by the losses inherent in the line. The input impedance of a real, lossy transmission line is computed using the following equation

$$Z_{in} = Z_0 \times \frac{Z_L \cosh(\eta\ell) + Z_0 \sinh(\eta\ell)}{Z_L \sinh(\eta\ell) + Z_0 \cosh(\eta\ell)} \quad (11)$$

where

Z_{in} = complex impedance at input of line
= $R_{in} \pm j X_{in}$

Z_L = complex load impedance at end of line = $R_a \pm j X_a$

Z_0 = characteristic impedance of line = $R_0 \pm j X_0$

η = complex loss coefficient = $a + j b$

α = matched line loss attenuation

constant, in nepers/unit length

(1 neper = 8.688 dB; most cables are rated in dB/100 ft)

β = phase constant of line in radians/unit length (related to physical length of line by the fact that 2π

radians = 1 wavelength, and by Eq 1)
 ℓ = electrical length of line in same units of length measurement as a or above.

Solving this equation manually is tedious, since it incorporates hyperbolic cosines and sines of the complex loss coefficient, but it may be solved using a traditional paper Smith Chart or a computer program. *The ARRL Antenna Book* has a chapter detailing the use of the Smith Chart. *MicroSmith* is a sophisticated graphical Smith Chart program written for the IBM PC, and is available through the ARRL. *TLA* (Transmission Line) is another ARRL program that performs this transformation, but without Smith Chart graphics. *TLA.EXE* is on the CD-ROM accompanying this book.

Lines as Stubs

The impedance-transformation properties of a transmission line are useful in a number of applications. If the terminating resistance is zero (that is, a short) at the end of a low-loss transmission line which is less than $\frac{1}{4}\lambda$, the input impedance consists of a reactance, which is given by a simplification of Eq 11.

$$X_{in} \cong Z_0 \tan \ell \quad (12)$$

If the line termination is an open circuit, the input reactance is given by

$$X_{in} = Z_0 \cot \ell \quad (13)$$

The input of a short (less than $\frac{1}{4}\lambda$) length of line with a short circuit as a terminating load appears as an inductance, while an open-circuited line appears as a

Table 21.3

Modeled Data for a 100-ft Flat-Top Antenna

100-ft long, 50-ft high, center-fed dipole over average ground, using coaxial or open-wire transmission lines. Antenna impedance computed using *NEC2* computer program, with ground relative permittivity of 13, ground conductivity of 5 mS/m and Sommerfeld/Norton ground model. Note the extremely reactive impedance levels at many frequencies, but especially at 1.8 MHz. If this antenna is fed directly with RG-8A coax, the losses are unacceptably large on 160 m, and undesirably high on most other bands also. The RF voltage at 3.8 MHz for high-power operation with open-wire line is extremely high also, and would probably result in arcing either on the line itself, or more likely in the Transmatch. Each transmission line is 100 ft long.

Frequency (MHz)	Antenna Impedance (Ohms)	SWR RG-8A Coax	Loss 100 ft RG-8A Coax	Loss 100 ft 450-Ω Line	Max Volt. RG-8A 1500 W	Max Volt. 450-Ω Line 1500 W
1.8 MHz	4.5 - j 1673	1818:1	25.9 dB	12.1 dB	1640	7640
3.8 MHz	38.9 - j 362	63:1	5.7 dB	0.9 dB	1181	3188
7.1 MHz	481 + j 964	49:1	5.8 dB	0.3 dB	981	1964
10.1 MHz	2584 - j 3292	134:1	10.4 dB	0.9 dB	967	2869
14.1 MHz	85.3 - j 123.3	6.0:1	1.9 dB	0.5 dB	530	1863
18.1 MHz	2097 + j 1552	65:1	9.0 dB	0.6 dB	780	2073
21.1 MHz	345 - j 1073	73:1	9.8 dB	0.8 dB	757	2306
24.9 MHz	202 + j 367	18:1	5.2 dB	0.4 dB	630	1563
28.4 MHz	2493 - j 1375	65:1	10.1 dB	0.7 dB	690	2051

capacitance. This is a useful property of a transmission line, since it can be used as a low-loss inductor or capacitor in matching networks. Such lines are often referred to as *stubs*.

A line that is an electrical quarter wavelength is a special kind of a stub. When a quarter-wave line is short circuited at its load end, it presents an open circuit at its input. Conversely, a quarter-wave line with an open circuit at its load end presents a short circuit at its input. Such a line inverts the sense of a short or an open circuit at the frequency for which the line is a quarter-wave long. This is also true for frequencies that are odd multiples of the quarter-wave frequency. However, for frequencies where the length of the line is a half wavelength, or integer multiples thereof, the line will duplicate the termination at its end.

For example, if a shorted line is cut to be a quarter wavelength at 7.1 MHz, the impedance looking into the input of the cable will be an open circuit. The line will have no effect if placed in parallel with a transmitter's output terminal. However, at twice the frequency, 14.2 MHz, that same line is now a half wavelength, and the line looks like a short circuit. The line, often dubbed a *quarter-wave stub* in this application, will act as a trap for not only the second harmonic, but also for higher even-order harmonics, such as the fourth or sixth harmonics.

Quarter-wave stubs made of good-quality coax, such as RG-213, offer a convenient way to lower transmitter harmonic levels. Despite the fact that the exact amount of harmonic attenuation depends on the impedance (often unknown) into which they are working at the harmonic frequency, a quarter-wave stub will typically yield 20 to 25 dB of attenuation of the second harmonic when placed directly at the output of a transmitter feeding common amateur antennas. Because different manufacturing runs of coax will have slightly different velocity factors, a quarter-wave stub is usually cut a little longer than calculated, and then carefully pruned by snipping off short pieces, while monitoring the response at the fundamental frequency, using a grid-dip meter or an SWR indicator. Because the end of the coax is an open circuit while pieces are being snipped away, the input of a quarter-wave line will show a short circuit exactly at the fundamental frequency. Once the coax has been pruned to frequency, a short jumper is soldered across the end, and the response at the second harmonic frequency is measured.

We will examine further applications of quarter-wave transmission lines later in the next section.

Matching the Antenna to the Line

When transmission lines are used with a transmitter, the most common load is an antenna. When a transmission line is connected between an antenna and a receiver, the receiver input circuit is the load, not the antenna, because the power taken from a passing wave is delivered to the receiver.

Whatever the application, the conditions existing at the load, and *only* the load, determine the reflection coefficient, and hence the standing-wave ratio, on the line. If the load is purely resistive and equal to the characteristic impedance of the line, there will be no standing waves. If the load is not purely resistive, or is not equal to the line Z_0 , there will be standing waves. No adjustments can be made at the input end of the line to change the SWR at the load. Neither is the SWR affected by changing the line length, except as previously described when the SWR at the input of a lossy line is masked by the attenuation of the line.

Only in a few special cases is the antenna impedance the exact value needed to match a practical transmission line. In all other cases, it is necessary either to operate with a mismatch and accept the SWR that results, or else to bring about a match between the line and the antenna.

Technical literature sometimes uses the term *conjugate match* to describe the condition where the reactance seen looking toward the load from any point on the line is the complex conjugate of the impedance seen looking toward the source. A conjugate match is necessary to achieve the maximum power gain possible from a small-signal amplifier. For example, if a small-signal amplifier at 14.2 MHz has an output impedance of $25.8 + j 11.0 \Omega$, then the maximum power possible will be generated from that amplifier when the output load is $25.8 - j 11.0 \Omega$. The amplifier and load system is resonant because the $\pm 11.0\text{-}\Omega$ reactances cancel.

Now, assume that 100 ft of 50- Ω RG-213 coax at 14.2 MHz just happens to be terminated in an impedance of $115 - j 25 \Omega$. Eq 11 calculates that the impedance looking into the input of the line is $25.8 - j 11.0 \Omega$. If this transmission line is connected directly to the small-signal amplifier above, then a conjugate match is created, and the amplifier generates the maximum possible amount of power it can generate.

However, if the impedance at the output of the amplifier is not $25.8 - j 11.0 \Omega$, then a matching network is needed between the amplifier and its load for maximum power gain. For example, if 50 ft of RG-213 is terminated in a $72 - j 34 \Omega$ antenna impedance, the impedance at the line

input becomes $35.9 - j 21.6 \Omega$. A matching network is designed to transform $35.9 - j 21.6 \Omega$ to $25.8 - j 11.0 \Omega$, so that once again a conjugate match is created for the small-signal amplifier.

Now, let us consider what happens with amplifiers where the power level is higher than the milliwatt level of small-signal amplifiers. Most modern transmitters are designed to work into a 50- Ω load. Most will reduce power automatically if the load is not 50 Ω —this protects them against damage and ensures linear operation without distortion.

Many amateurs use an *antenna tuner* between their transmitter and the transmission line feeding the antenna. The antenna tuner's function is to transform the impedance, whatever it is, at the shack-end of the transmission line into the 50 Ω required by their transmitter. Note that the SWR on the transmission line between the antenna and the output of the antenna tuner is rarely exactly 1:1, even though the SWR on the short length of line between the tuner and the transmitter is 1:1.

Therefore, some loss is unavoidable: additional loss due to the SWR on the line, and loss in the antenna tuner itself. However, most amateur antenna installations use antennas that are reasonably close to resonance, making these types of losses small enough to be acceptable.

Despite the inconvenience, if the antenna tuner could be placed at the antenna rather than at the transmitter output, it can transform the $72 - j 34 \Omega$ antenna impedance to a nonreactive 50 Ω . Then the line SWR is 1:1.

Impedance matching networks can take a variety of physical forms, depending on the circumstances.

Matching the Antenna to the Line, at the Antenna

This section describes methods by which a network can be installed at the antenna itself to provide matching to a transmission line. Having the matching system up at the antenna rather than down in the shack at the end of a long transmission line does seem intuitively desirable, but it is not always very practical, especially in multiband antennas.

If a highly reactive antenna can be tuned to resonance, even without special efforts to make the resistive portion equal to the line's characteristic impedance, the resulting SWR is often low enough to minimize additional line loss due to SWR. For example, the multiband 100-ft long dipole in Table 21.3 has an antenna impedance of $4.5 - j 1673 \Omega$ at 1.8 MHz. Assume that the antenna reactance is tuned out with a network consisting of two symmetrical

inductors whose reactance is +836.5 Ω each, with a Q of 200. The inductors are made up of 73.95 μH coils in series with inherent loss resistances of $836.5/200 = 4.2 \Omega$. The total series resistance is thus $4.5 + 2 \times (4.2) = 12.9 \Omega$, and the antenna reactance and inductor reactance cancel out. See Fig 21.6.

If this tuned system is fed with 50- Ω coaxial cable, the SWR is $50/12.9 = 3.88:1$, and the loss in 100 ft of RG-8A cable would be 0.47 dB. The radiation efficiency is $4.5/12.9 = 34.9\%$. Expressed another way, there is 4.57 dB of loss. Adding the 0.47 dB of loss in the line yields an overall system loss of 5.04 dB. Compare this to the loss of 17.1 dB if the RG-8A coax is used to feed the antenna directly, without any matching at the antenna. The use of a moderately high-Q resonator has yielded almost 12 dB of “gain” (that is, less loss) compared to the nonresonator case. The drawback of course is that the antenna is now resonated on only one frequency, but it certainly is a lot more efficient on that one frequency.

The Quarter-Wave Transformer or “Q” Section

The range of impedances presented to the transmission line is usually relatively small on a typical amateur antenna, such as a dipole or a Yagi when it is operated close to resonance. In such antenna systems, the impedance-transforming properties of a quarter-wave section of transmission line are often utilized to match the transmission line at the antenna.

One example of this technique is an array of stacked Yagis on a single tower. Each antenna is resonant and is fed in parallel with the other Yagis, using equal lengths of coax to each antenna. A stacked array is used to produce not only gain, but also a wide vertical elevation pattern, suitable for coverage of a broad geographic area. (See *The ARRL Antenna Book* for details about Yagi stacking.) The feed-point impedance of two 50- Ω Yagis fed with equal lengths of feed line connected in parallel is 25 Ω ($50/2 \Omega$); three in parallel yield 16.7 Ω ; four in parallel yield 12.5 Ω . The nominal SWR for a stack of four Yagis is 4:1 ($50/12.5$). This level of SWR does not cause excessive line loss, provided that low-loss coax feed line is used. However, many station designers want to be able to select, using relays, any individual antenna in the array, without having the load seen by the transmitter change. (Perhaps they might wish to turn one antenna in the stack in a different direction and use it by itself.) If the load changes, the amplifier must be retuned, an inconvenience at best.

See Fig 21.7. If the antenna impedance and the characteristic impedance of a feed line to be matched are known, the characteristic impedance needed for a quarter-wave matching section of low-loss cable is expressed by another simplification of Eq 11.

$$Z = \sqrt{Z_1 Z_0} \quad (14)$$

where

Z = characteristic impedance needed for matching section

Z_1 = antenna impedance

Z_0 = characteristic impedance of the line to which it is to be matched.

Example: To match a 50- Ω line to a Yagi stack consisting of two antennas fed in parallel to produce a 25- Ω load, the quarter-wave matching section would require a characteristic impedance of

$$Z = \sqrt{50 \times 25} = 35.4 \Omega$$

A transmission line with a characteristic impedance of 35 Ω could be closely approximated by connecting two equal lengths of 75- Ω cable (such as RG-11A) in parallel to yield the equivalent of a 37.5- Ω cable. Three Yagis fed in parallel would require a quarter-wave transformer made using a cable having a characteristic impedance of

$$\sqrt{16.7 \times 50} = 28.9 \Omega$$

This is approximated by using a quarter-wave section of 50- Ω cable in parallel

with a quarter-wave section of 75- Ω cable, yielding a net impedance of 30 Ω , quite close enough to the desired 28.9 Ω . Four Yagis fed in parallel would require a quarter-wave transformer made up using cable with a characteristic impedance of 25 Ω , easily created by using two 50- Ω cables in parallel.

T- and Gamma-Match Sections

Many types of antennas exhibit a feed-point impedance lower than the 50- Ω characteristic impedance of commonly available coax cable. Both the so-called *T-Match* and the *Gamma-Match* are used extensively on Yagi and quad beam antennas to increase the antenna feed impedance to 50 Ω .

The method of matching shown in Fig 21.8 is based on the fact that the impedance between any two points equidistant from the center along a resonant antenna is resistive, and has a value that depends on the spacing between the two points. It is therefore possible to choose a pair of points between which the impedance will have the right value to match a transmission line. In practice, the line cannot be connected directly at these points because the distance between them is much greater than the conductor spacing of a practical transmission line. The T arrangement in Fig 21.8A overcomes this difficulty by using a second conductor paralleling the antenna to form a matching section to which the line may be connected.

The T is particularly well suited to use with parallel-conductor feed line. The

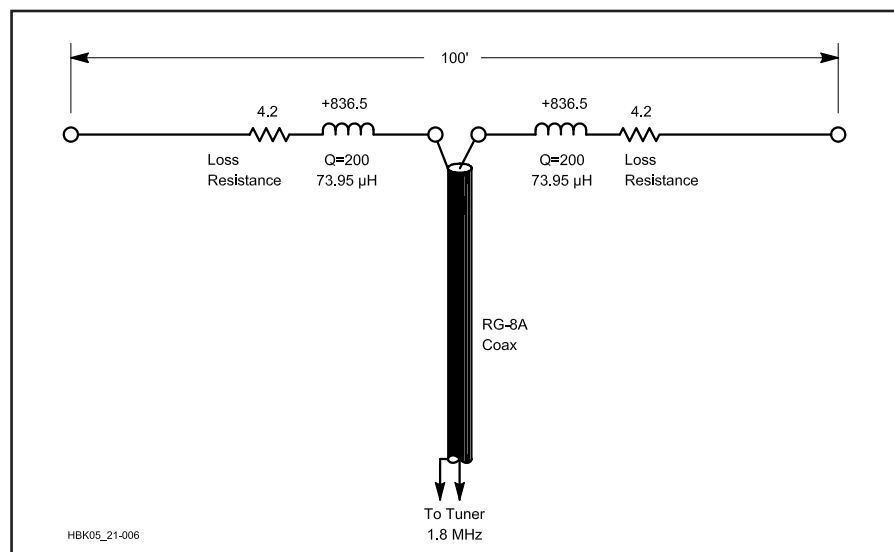

Fig 21.6—The efficiency of the dipole in Table 21.3 can be improved at 1.8 MHz with a pair of inductors inserted symmetrically at the feed point. Each inductor is assumed to have a Q of 200. By resonating the dipole in this fashion the system efficiency, when fed with RG8A coax, is almost 12 dB better than using this same antenna without the resonator. The disadvantage is that the formerly multiband antenna can only be used on a single band.

operation of this system is somewhat complex. Each T conductor (Y in the drawing) forms a short section of transmission line with the antenna conductor opposite it. Each of these transmission-line sections can be considered to be terminated in the impedance that exists at the point of connection to the antenna. Thus, the part of the antenna between the two points carries a transmission-line current in addition to the normal antenna current. The two transmission-line matching sections are in series, as seen by the main transmission line.

If the antenna by itself is resonant at the operating frequency, its impedance will be purely resistive. In this case the matching-section lines are terminated in a resistive load. As transmission-line sections, however, these matching sections are terminated in a short, and are shorter than a quarter wavelength. Thus their input impedance, the impedance seen by the main transmission line looking into the matching-section terminals, will be inductive as well as resistive. The reactive component of the input impedance must be tuned out before a proper match can be obtained.

One way to do this is to detune the antenna just enough, by shortening its length, to cause capacitive reactance to appear at the input terminals of the matching section, thus canceling the reactance introduced. Another method, which is considerably easier to adjust, is to insert a variable capacitor in series with each matching section where it connects to the transmission line, as shown in the chapter

on **Antennas**. The capacitors must be protected from the weather.

When the series-capacitor method of reactance compensation is used, the antenna should be the proper length for resonance at the operating frequency. Trial positions of the matching-section taps are then taken, each time adjusting the capacitor for minimum SWR, until the lowest possible SWR has been achieved. The unbalanced (gamma) arrangement in Fig 21.8B is similar in principle to the T, but is adapted for use with single coax line. The method of adjustment is the same.

The Hairpin Match

In beam antennas such as Yagis or quads, which utilize parasitic directors and reflectors to achieve directive gain, the mutual impedance between the parasitic and the driven elements lowers the resistive component of the driven-element impedance, typically to a value between 10 and 30 Ω . If the driven element is purposely cut slightly shorter than its half-wave resonant length, it will exhibit a capacitive reactance at its feed point. A shunt inductor as shown in Fig 21.9 placed across the feed-point center in-sulator can be used to transform the antenna resistance to match the characteristic impedance of the transmission line, while canceling out the capacitive reactance simultaneously. The antenna's capacitive reactance and the hairpin-shaped shunt inductor form an L network.

For mechanical convenience, the shunt inductor is often constructed using heavy-

gauge aluminum wire bent in the shape of a hairpin. The center of the hairpin, the end farthest from the driven element, is grounded to the boom, since this point in a balanced feed system is equidistant from the antenna feed terminals. This gives some protection against static buildup and a certain measure of lightning protection.

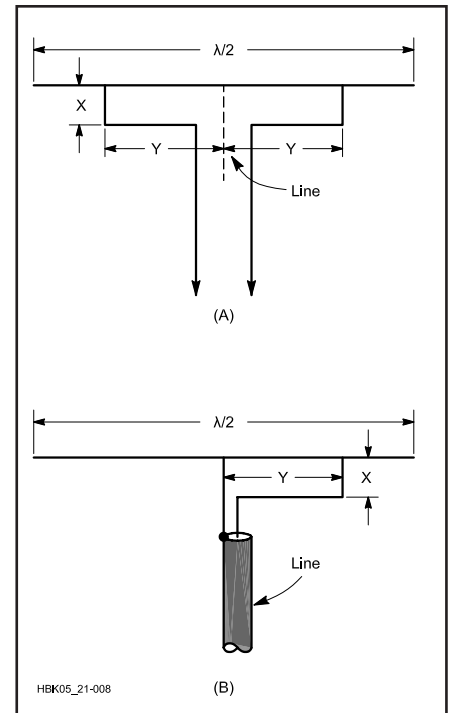

Fig 21.8—The T match (A) and gamma match (B).

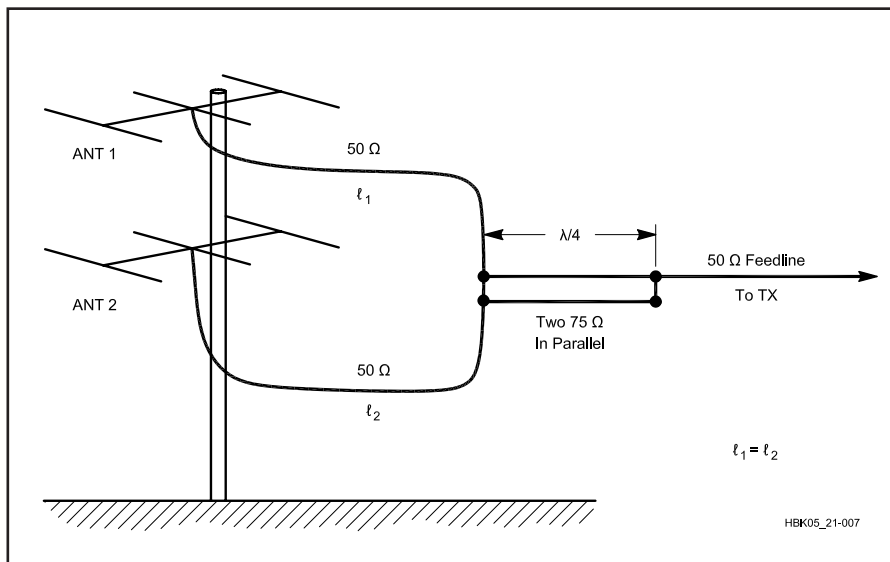

Fig 21.7—Array of two stacked Yagis, illustrating use of quarter-wave matching sections. At the junction of the two equal lengths of $50\text{-}\Omega$ feed line the impedance is 25Ω . This is transformed back to 50Ω by the two paralleled $75\text{-}\Omega$, quarter-wave lines, which together make a net characteristic impedance of 37.5Ω . This is close to the 35.4Ω value computed by the formula.

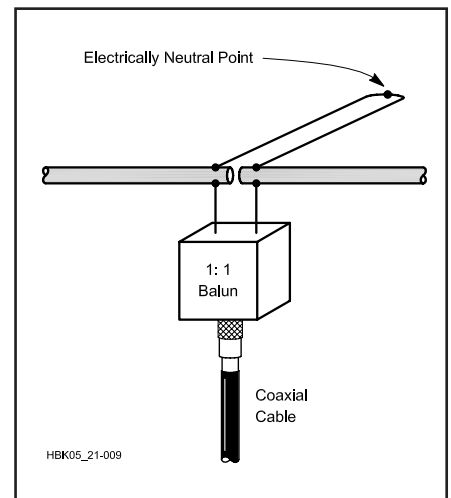

Fig 21.9—Hairpin match, sometimes called the Beta match. The "hairpin" is a shunt inductor, which together with the series capacitive reactance of an electrically short driven element forms an L network. This L network transforms the antenna resistive component to 50Ω .

The disadvantage of the hairpin match is that it does require that the driven element be split and insulated at its center. The length of the driven element and the value of shunt inductance can be varied in the hairpin match to bring the SWR down to exactly 1:1 at a desired frequency in the band. This can also be achieved with the T or gamma matches previously described.

Matching the Line to the Transmitter

So far we have been concerned mainly with the measures needed to achieve acceptable amounts of loss and a low SWR when real coax lines are connected to real antennas. Not only is feed-line loss minimized when the SWR is kept within reasonable bounds, but also the transmitter is able to deliver its rated output power, at its rated level of distortion, when it sees the load resistance it was designed to feed.

Most modern amateur transmitters use broadband, untuned solid-state final amplifiers designed to work into a 50-Ω load. Such a transmitter very often utilizes built-in protection circuitry, which automatically reduces output power if the SWR rises to more than about 2:1. Protective circuits are needed because many solid-state devices will willingly and almost instantly destroy themselves attempting to deliver power into low-impedance loads. Solid-state devices are a lot less forgiving than vacuum tube amplifiers, which can survive momentary overloads without being destroyed instantly. Pi networks used in vacuum-tube amplifiers typically have the ability to match a surprisingly wide range of impedances on a transmission line. See the **RF Power Amplifiers** chapter in this *Handbook*.

Besides the rather limited option of using only inherently low-SWR antennas to ensure that the transmitter sees the load for which it was designed, we radio amateurs have another alternative. We can use an *antenna tuner*. The function of an

antenna tuner is to transform the impedance at the input end of the transmission line, whatever it may be, to the 50 Ω needed to keep the transmitter loaded properly. Do not forget: A tuner does not alter the SWR on the transmission line going to the antenna; it only keeps the transmitter looking into the load for which it was designed. Indeed, some solid-state transmitters incorporate (usually at extra cost) automatically tuned *antenna couplers* (another name for antenna tuner), so that they too can cope with practical antennas and transmission lines that are not perfectly flat. The range of impedances that can be matched is typically rather limited, however, especially at lower frequencies.

Over the years, radio amateurs have derived a number of circuits for use as tuners. At one time, when open-wire transmission line was more widely used, link-coupled tuned circuits were in vogue. See **Fig 21.10**. With the increasing popularity of coaxial cable used as feed lines, other circuits have become more prevalent. The most common form of antenna tuner in recent years is some variation of a T configuration, as shown in **Fig 21.11A**.

The T network can be visualized as being two L networks back to front, where the common element has been conceptually broken down into two inductors in parallel. See Fig 21.11B. The L network connected to the load transforms the output impedance $R_a \pm jX_a$ into its parallel equivalent

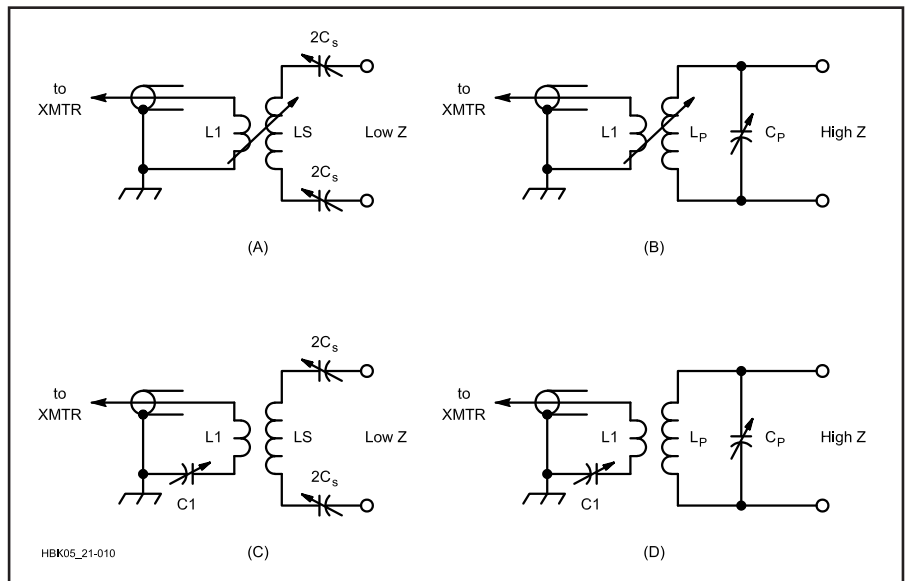

Fig 21.10—Simple antenna tuners for coupling a transmitter to a balanced line presenting a load different from the transmitter's design load impedance, usually 50 Ω. A and B, respectively, are series and parallel tuned circuits using variable inductive coupling between coils. C and D are similar but use fixed inductive coupling and a variable series capacitor, C1. A series tuned circuit works well with a low-impedance load; the parallel circuit is better with high impedance loads (several hundred ohms or more).

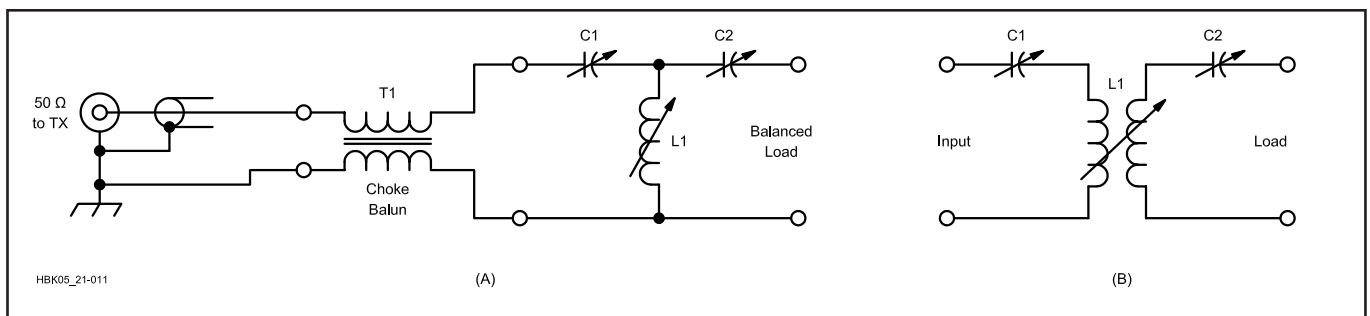

Fig 21.11—Antenna tuner network in T configuration. This network has become popular because it has the capability of matching a wide range of impedances. At A, the balun transformer at the input of the antenna tuner preserves balance when feeding a balanced transmission line. At B, the T configuration is shown as two L networks back to back.

lent by means of the series output capacitor C2. The first L network then transforms the parallel equivalent back into the series equivalent and resonates the reactance with the input series capacitor C1.

Note that the equivalent parallel resistance R_p across the shunt inductor can be a very large value for highly reactive loads, meaning that the voltage developed at this point can be very high. For example, assume that the load impedance at 3.8 MHz presented to the antenna tuner is $Z_a = 20 - j 1000$. If C2 is 300 pF, then the equivalent parallel resistance across L1 is 66,326 Ω . If 1500 W appears across this parallel resistance, a peak voltage of 14,106 V is produced, a very substantial level indeed. Highly reactive loads can produce very high voltages across components in a tuner.

The ARRL computer program *TLA* calculates and shows graphically the antenna-tuner values for operator selected antenna impedances transformed through lengths of various types of practical transmission lines. The **Station Layout and Accessories** chapter includes antenna tuner projects, and *The ARRL Antenna Book* contains detailed information on tuner design and construction.

Myths About SWR

This is a good point to stop and mention that there are some enduring and quite misleading myths in Amateur Radio concerning SWR.

- Despite some claims to the contrary, a high SWR *does not by itself* cause RFI, or TVI or telephone interference. While it is true that an antenna located close to such devices can cause overload and interference, the SWR on the feed line to that antenna has nothing to do with it, providing of course that the tuner, feed line or connectors are not arcing. The antenna is merely doing its job, which is to radiate. The transmission line is doing its job, which is to convey power from the transmitter to the radiator.
- A second myth, often stated in the same breath as the first one above, is that a high SWR will cause excessive radiation from a transmission line. SWR has nothing to do with excessive radiation from a line. *Imbalances* in open-wire lines cause radiation, but such imbalances are not related to SWR. This subject will be covered more in the section on baluns.
- A third and perhaps even more prevalent myth is that you can't "get out" if the SWR on your transmission line is higher than 1.5:1, or 2:1 or some other such arbitrary figure. On the HF bands,

if you use reasonable lengths of good coaxial cable (or even better yet, open-wire line), the truth is that you need not be overly concerned if the SWR at the load is kept below about 6:1. This sounds pretty radical to some amateurs who have heard horror story after horror story about SWR. The fact is that if you can load up your transmitter without any arcing inside, or if you use a tuner to make sure your transmitter is operating into its rated load resistance, you can enjoy a very effective station, using antennas with feed lines having high values of SWR on them. For example, a 450- Ω open-wire line connected to the multiband dipole shown in Table 21.3 would have a 19:1 SWR on it at 3.8 MHz. Yet time and again this antenna has proven to be a great performer at many installations.

Fortunately or unfortunately, SWR is one of the few antenna and transmission-line parameters easily measured by the average radio amateur. Ease of measurement does not mean that a low SWR should become an end in itself! The hours spent pruning an antenna so that the SWR is reduced from 1.5:1 down to 1.3:1 could

be used in far more rewarding ways—making contacts, for example, or studying transmission-line theory.

Loads and Balancing Devices

Center-fed dipoles and loops are *balanced*, meaning that they are electrically symmetrical with respect to the feed point. A balanced antenna should be fed by a balanced feeder system to preserve this electrical symmetry with respect to ground, thereby avoiding difficulties with unbalanced currents on the line and undesirable radiation from the transmission line itself. Line radiation can be prevented by a number of devices which detune or *decouple* the line for currents radiated by the antenna back onto the line that feeds it, greatly reducing the amplitude of such so-called *antenna currents*.

Many amateurs use center-fed dipoles or Yagis, fed with unbalanced coaxial line. Some method should be used for connecting the line to the antenna without upsetting the symmetry of the antenna itself. This requires a circuit that will isolate the balanced load from the unbalanced line, while still providing efficient power transfer. Devices for doing this are

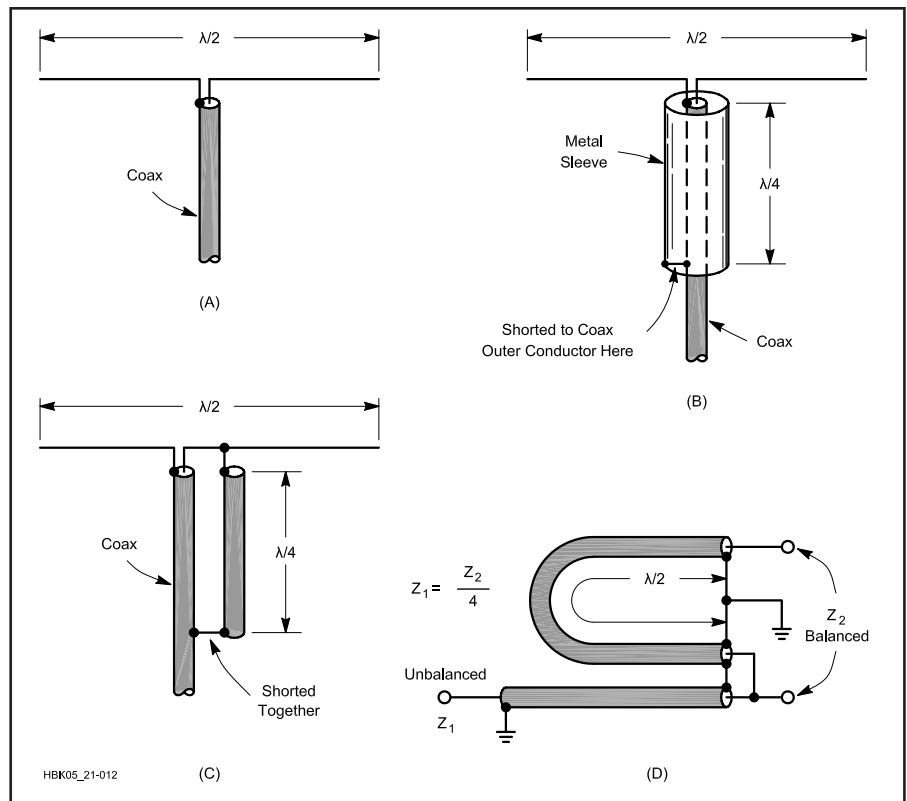

Fig 21.12—Quarter-wave baluns. Radiator with coaxial feed (A) and methods of preventing unbalanced currents from flowing on the outside of the transmission line (B and C). The $\frac{1}{2}\lambda$ -phasing section shown at D is used for coupling to an unbalanced circuit when a 4:1 impedance ratio is desired or can be accepted.

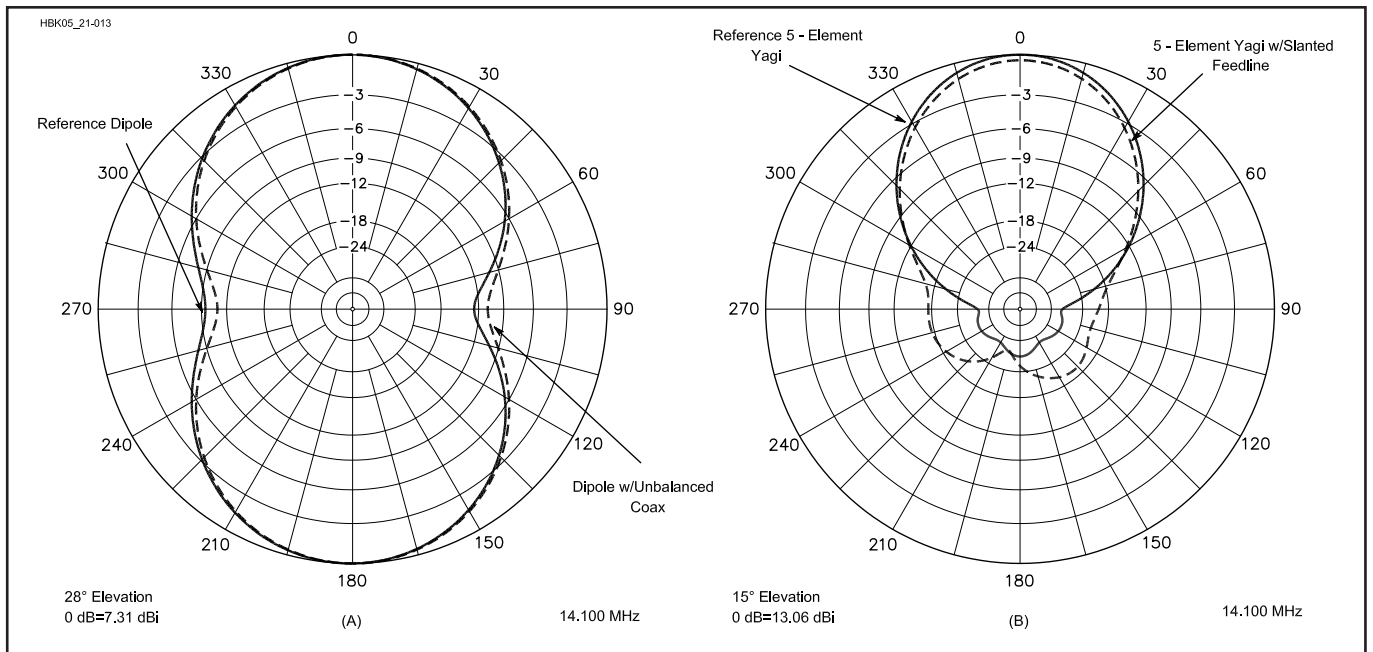

Fig 21.13—At A, computer-generated azimuthal responses for two $\lambda/2$ dipoles placed 0.71λ high over typical ground. The solid line is for a dipole with no feed line. The dashed line is for an antenna with its feed line slanted 45° down to ground. Current induced on the outer braid of the $1\text{-}\lambda$ -long coax by its asymmetry with respect to the antenna causes the pattern distortion. At B, azimuthal response for two 5-element 20-meter Yagis placed 0.71λ over average ground. Again, the solid line is for a Yagi without a feed line and the dashed line is for an antenna with a 45° slanted, $1\text{-}\lambda$ long feed line. The distortion in the radiated pattern is now clearly more serious than for a simple dipole. A balun is needed at the feed point, and most likely $1/4\text{-}\lambda$ way down the feed line from the feed point, to suppress the common-mode currents and restore the pattern.

called *baluns* (a contraction for “balanced to unbalanced”). A balanced antenna fed with balanced line, such as two-wire ladder line, will maintain its inherent balance, so long as external causes of unbalance are avoided. However, even they will require some sort of balun at the transmitter, since modern transmitters have unbalanced (coax) outputs.

If a balanced antenna is fed at the center through a coaxial line without a balun, as indicated in **Fig 21.12A**, the inherent symmetry and balance is upset because one side of the radiator is connected to the shield while the other is connected to the inner conductor. On the side connected to the shield, current can be diverted from flowing into the antenna, and instead can flow down over the outside of the coaxial shield. The field thus set up cannot be canceled by the field from the inner conductor because the fields inside the cable cannot escape through the shielding of the outer conductor. Hence currents flowing on the outside of the line will be responsible for some radiation from the line.

This is a good point to say that striving for perfect balance in a line and antenna system is not always absolutely mandatory. For example, if a nonresonant center fed dipole is fed with open-wire line and a

tuner for multiband operation, the most desirable radiation pattern for general-purpose communication is actually an omnidirectional pattern. A certain amount of feed-line radiation might actually help fill in otherwise undesirable nulls in the azimuthal pattern of the antenna itself. Furthermore, the radiation pattern of a coaxial-fed dipole that is only a few tenths of a wavelength off the ground (50 ft high on the 80-m band, for example) is not very directional anyway, because of its severe interaction with the ground.

Purists may cry out in dismay, but there are many thousands of coaxial-fed dipoles in daily use worldwide that perform very effectively without the benefit of a balun. See **Fig 21.13A** for a worst-case comparison between a dipole with and without a balun at its feed point. This is with a $1\text{-}\lambda$ long feed line slanted downward 45° under one side of the antenna. *Common-mode currents* are radiated and conducted onto the braid of the feed line, which in turn radiates. The amount of pattern distortion is not particularly severe for a dipole. It is debatable whether the bother and expense of installing a balun for such an antenna is worthwhile.

However, some form of balun should be used to preserve the pattern of an antenna

that is purposely designed to be highly directional, such as a Yagi or a quad. **Fig 21.13B** shows the distortion that can result from common-mode currents conducted and radiated back onto the feed line for a 5-element Yagi. This antenna has purposely been designed for an excellent pattern but the common-mode currents seriously distort the rearward pattern and reduce the forward gain as well. A balun is highly desirable in this case.

Quarter-Wave Baluns

Fig 21.12B shows a balun arrangement known as a *bazooka*, which uses a sleeve over the transmission line. The sleeve, together with the outside portion of the outer coax conductor, forms a shorted quarter-wave line section. The impedance looking into the open end of such a section is very high, so the end of the outer conductor of the coaxial line is effectively isolated from the part of the line below the sleeve. The length is an electrical quarter wave, and because of the velocity factor may be physically shorter if the insulation between the sleeve and the line is not air. The bazooka has no effect on antenna impedance at the frequency where the quarter-wave sleeve is resonant. However, the sleeve adds inductive shunt reactance

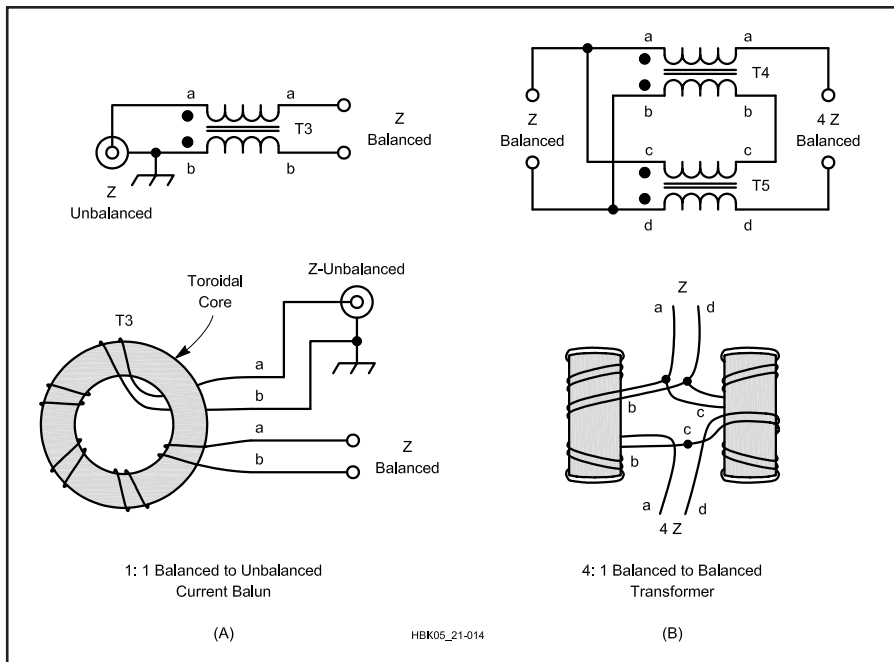

Fig 21.14—Broadband baluns. (A) 1:1 current balun and (B) 4:1 current transformer wound on two cores, which are separated. Use 12 bifilar turns of #14 enameled wire wound on FT240-43 cores for A and B. Distribute bifilar turns evenly around core.

Table 21.4

Effective Choke (Current Baluns)

Wind the indicated length of coaxial feed line into a coil (like a coil of rope) and secure with electrical tape. The balun is most effective when the coil is near the antenna. Lengths are not critical.

Single Band (Very Effective)

Freq, MHz	RG-213, RG-8	RG-58
3.5	22 ft, 8 turns	20 ft, 6-8 turns
7	22 ft, 10 turns	15 ft, 6 turns
10	12 ft, 10 turns	10 ft, 7 turns
14	10 ft, 4 turns	8 ft, 8 turns
21	8 ft, 6-8 turns	6 ft, 8 turns
28	6 ft, 6-8 turns	4 ft, 6-8 turns

Multiple Band

Freq, MHz	RG-8, 58, 59, 8X, 213
3.5-30	10 ft, 7 turns
3.5-10	18 ft, 9-10 turns
14-30	8 ft, 6-7 turns

at frequencies lower, and capacitive shunt reactance at frequencies higher than the quarter-wave-resonant frequency. The bazooka is mostly used at VHF, where its physical size does not present a major problem. On HF a quarter-wavelength rigid sleeve becomes considerably more challenging to construct, especially for a rotary antenna such as a Yagi.

Another method that gives an equivalent effect is shown at Fig 21.12C. Since the voltages at the antenna terminals are equal and opposite (with reference to

ground), equal and opposite currents flow on the surfaces of the line and second conductor. Beyond the shorting point, in the direction of the transmitter, these currents combine to cancel out. The balancing section acts like an open circuit to the antenna, since it is a quarter-wave parallel-conductor line shorted at the far end, and thus has no effect on normal antenna operation. This is not essential to the line balancing function of the device, however, and baluns of this type are sometimes made shorter than a quarter wavelength to

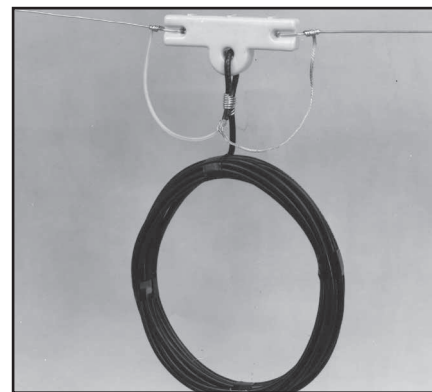

Fig 21.15—RF choke formed by coiling the feed line at the point of connection to the antenna. The inductance of the choke isolates the antenna from the remainder of the feed line.

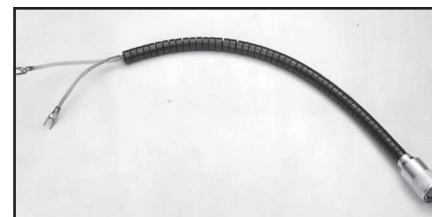

Fig 21.16—W2DU bead balun consisting of 50 FB-73-2401 ferrite beads over a length of RG-303 coax. See text for details.

provide a shunt inductive reactance required in certain matching systems (such as the hairpin match).

Fig 21.12D shows a third balun, in which equal and opposite voltages, balanced to ground, are taken from the inner conductors of the main transmission line and half-wave phasing section. Since the voltages at the balanced end are in series while the voltages at the unbalanced end are in parallel, there is a 4:1 step-down in impedance from the balanced to the unbalanced side. This arrangement is useful for coupling between a 300-Ω balanced line and a 75-Ω unbalanced coaxial line.

Broadband Baluns

At HF and even at VHF, broadband baluns are generally used nowadays. Examples of broadband baluns are shown in Fig 21.14.

Choke or current baluns force equal and opposite currents to flow. The result is that currents radiated back onto the transmission line by the antenna are effectively reduced, or “choked off,” even if the antenna is not perfectly balanced. If winding inductive reactance becomes marginal at lower frequencies, the balun’s ability to

eliminate antenna currents is reduced, but (for the 1:1 balun) no winding impedance appears across the line.

If radiated current on the line is a problem, perhaps because the feed line must be run in parallel with the antenna for some portion of its length, additional choke baluns can be placed at approximately $\frac{1}{4}\lambda$ intervals along the line. Choke baluns are particularly useful for feeding asymmetrical antennas with unbalanced coax line.

Broadband Balun Construction

Either type of broadband balun can be constructed using a variety of techniques. Construction of choke (current) baluns is described here. The objective is to obtain a high impedance for currents that tend to flow on the line. Values from a few hundred to over a thousand ohms of inductive reactance are readily achieved. These baluns work best with antennas having resonant feed-point impedances less than $100\ \Omega$ or so ($400\ \Omega$ for 4:1 baluns). This is because the winding inductive reactance must be high relative to the antenna impedance for effective operation. A rule of thumb is that the inductive reactance should be four times higher than the antenna impedance. High impedances are difficult to achieve over a wide frequency range. Any sort of transformer operated at impedances for which it was not designed can fail, sometimes spectacularly.

The simplest construction method for a 1:1 balun for coaxial line is simply to wind a portion of the line into a coil. See **Fig 21.15**. This type of choke balun is simple, cheap and effective. Currents on the outside of the line encounter the coil's impedance, while currents on the inside are unaffected. A flat coil (like a coil of rope) shows a broad resonance that easily covers three octaves, making it reasonably effective over the entire HF range. If particular problems are encountered on a single band, a coil that is resonant at that band may be added. The coils shown in **Table 21.4** were constructed to have a high impedance at the indicated frequencies, as measured with an impedance meter. Many other geometries can also be effective. This construction technique is not effective with open-wire or twin-lead line because of coupling between adjacent turns. A 4:1 choke balun is shown in **Fig 21.14B**.

Ferrite-core baluns can provide a high impedance over the entire HF range. They may be wound either with two conductors in bifilar fashion, or with a single coaxial cable. Rod or toroidal cores may be used (**Fig 21.14A**). Current on the shield of a choke balun is the "antenna current" on

the line—If the balun is effective, this current is small. Baluns used for high-power operation should be tested by checking for temperature rise before use. If the core overheats, add turns or use a larger or lower-loss core. It also would be wise to investigate the imbalance causing such high line antenna currents.

Type 72, 73 or 77 ferrite gives the greatest impedance over the HF range. Type 43 ferrite has lower loss, but somewhat less impedance. Core saturation is not a problem with these ferrites at HF, since they overheat due to loss at flux levels well below saturation. The loss occurs because there is insufficient inductive reactance, especially at lower frequencies. Ten to twelve turns on a toroidal core or 10 to 15 turns on a rod are typical for the HF range. Winding impedance increases approximately as the square of the number of turns.

Another type of choke balun that is very effective was originated by M. Walter Maxwell, W2DU. A number of ferrite toroids are strung, like beads on a string, directly onto the coax where it is connected to the antenna. The "bead" choke balun in **Fig 21.16** consists of 50 FB-73-2401 ferrite beads slipped over a 1-ft length of Teflon-insulation RG-303 coax. The beads fit nicely over the insulating jacket of the coax and occupy a total length of $9\frac{1}{2}$ inches. Twelve FB-77-1024 or equivalent beads will come close to doing the same job using RG-8A or RG-213 coax. Type-73 material is recommended for 1.8 to 30 MHz use, but type-77 material may be substituted; use type-43 material for 30 to 250 MHz.

The cores present a high impedance to any RF current that would otherwise flow on the outside of the shield. The total

impedance is in approximate proportion to the stacked length of the cores. The impedance stays fairly constant over a wide range of frequencies. Again, 70-series ferrites are a good choice for the HF range; use type-43 if heating is a problem or increase the number of beads. Type-43 or -61 is the best choice for the VHF range. Cores of various materials can be used in combination, permitting construction of baluns effective over a very wide frequency range, such as from 2 to 250 MHz.

WAVEGUIDES

A waveguide is a hollow conducting tube, through which microwave energy is transmitted in the form of electromagnetic waves. The tube does not carry a current in the same sense that the wires of a two-conductor line do. Instead, it is a boundary that confines the waves to the enclosed space. Skin effect on the inside walls of the waveguide confines electromagnetic energy inside the guide, in much the same manner that the shield of a coaxial cable confines energy within the coax. Microwave energy is injected at one end (either through capacitive or inductive coupling or by radiation) and is received at the other end. The waveguide merely confines the energy of the fields, which are propagated through it to the receiving end by means of reflections off its inner walls.

Evolution of a Waveguide

Suppose an open-wire line is used to carry UHF energy from a generator to a load. If the line has any appreciable length, it must be well insulated from the supports to avoid high losses. Since high-quality insulators are difficult to make for microwave frequencies, it is logical to support the transmission line with quarter-wave

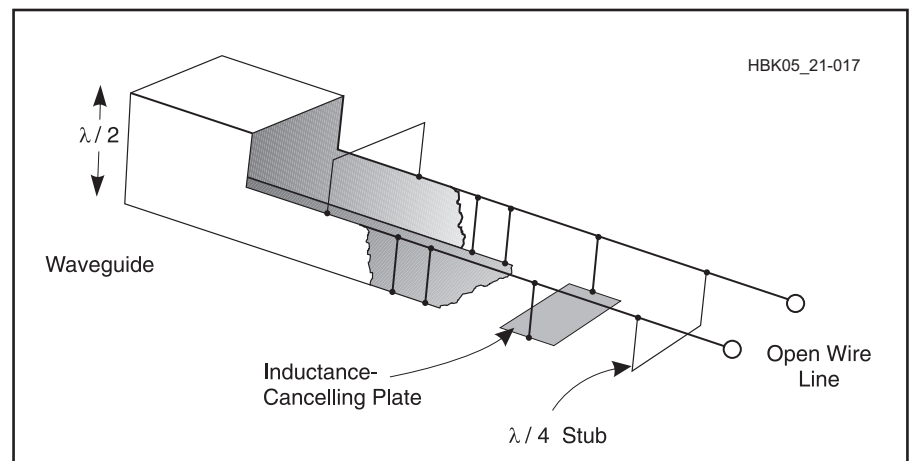

Fig 21.17—At its cutoff frequency a rectangular waveguide can be analyzed as a parallel two-conductor transmission line supported from top and bottom by an infinite number of quarter-wavelength stubs.

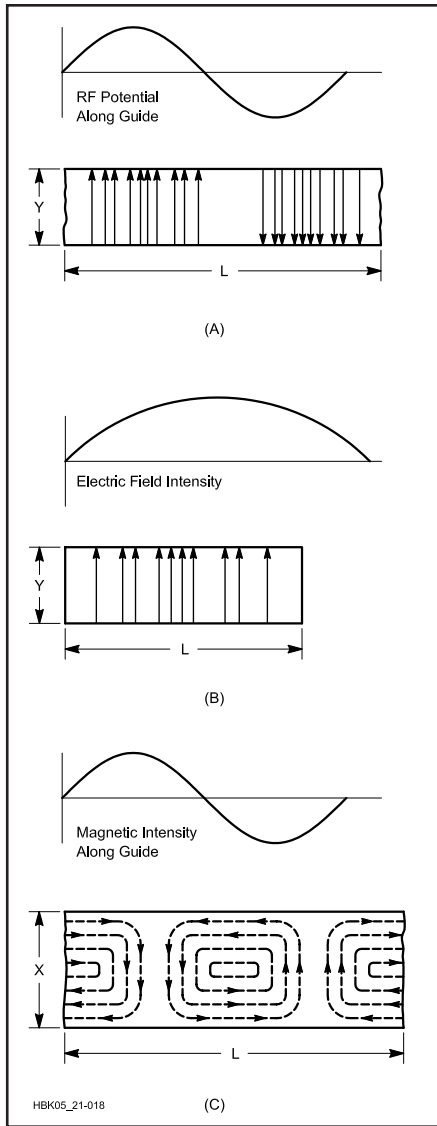

Fig 21.18—Field distribution in a rectangular waveguide. The $TE_{1,0}$ mode of propagation is depicted.

length stubs, shorted at the far end. The open end of such a stub presents an infinite impedance to the transmission line, provided that the shorted stub is non-reactive. However, the shorting link has finite length and, therefore, some inductance. This inductance can be nullified by making the RF current flow on the surface of a plate rather than through a thin wire. If the plate is large enough, it will prevent the magnetic lines of force from encircling the RF current.

An infinite number of these quarter-wave stubs may be connected in parallel without affecting the standing waves of voltage and current. The transmission line may be supported from the top as well as the bottom, and when infinitely many supports are added, they form the walls of

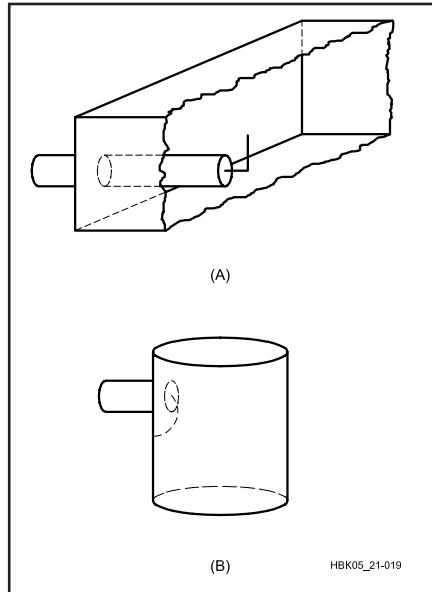

Fig 21.19—Coupling to waveguide and resonators. The probe at A is an extension of the inner conductor of coax line. At B an extension of the coax inner conductor is grounded to the waveguide to form a coupling loop.

a waveguide at its cutoff frequency. Fig 21.17 illustrates how a rectangular waveguide evolves from a two-wire parallel transmission line. This simplified analysis also shows why the cutoff dimension is a half wavelength.

While the operation of waveguides is usually described in terms of fields, current does flow on the inside walls, just as fields exist between the current-carrying conductors of a two-wire transmission line. At the waveguide cutoff frequency, the current is concentrated in the center of the walls, and disperses toward the floor and ceiling as the frequency increases.

Analysis of waveguide operation is based on the assumption that the guide material is a perfect conductor of electricity. Typical distributions of electric and magnetic fields in a rectangular guide are shown in Fig 21.18. The intensity of the electric field is greatest (as indicated by

closer spacing of the lines of force in Fig 21.18B) at the center along the X dimension and diminishes to zero at the end walls. Zero field intensity is a necessary condition at the end walls, since the existence of any electric field parallel to any wall at the surface would cause an infinite current to flow in a perfect conductor, an impossible situation.

Modes of Propagation

Fig 21.18 represents a relatively simple distribution of the electric and magnetic fields. An infinite number of ways exist in which the fields can arrange themselves in a guide, as long as there is no upper limit to the frequency to be transmitted. Each field configuration is called a *mode*. All modes may be separated into two general groups. One group, designated *TM* (transverse magnetic), has the magnetic field entirely crosswise to the direction of propagation, but has a component of electric field in the propagation direction. The other type, designated *TE* (transverse electric) has the electric field entirely crosswise to the direction of propagation, but has a component of magnetic field in the direction of propagation. TM waves are sometimes called E waves, and TE waves are sometimes called H waves. The TM and TE designations are preferred, however.

The particular mode of transmission is identified by the group letters followed by subscript numbers; for example $TE_{1,1}$, $TM_{1,1}$ and so on. The number of possible modes increases with frequency for a given size of guide. There is only one possible mode (called the *dominant mode*) for the lowest frequency that can be transmitted. The dominant mode is the one normally used in practical work.

Waveguide Dimensions

In rectangular guides the critical dimension (shown as X in Fig 21.18C) must be more than one-half wavelength at the lowest frequency to be transmitted. In practice, the Y dimension is usually made about equal to $1/2$ X to avoid the possibility of operation at other than the dominant mode. Cross-sectional shapes other than

Table 21.5
Wavelength Formulas for Waveguide

	Rectangular	Circular
Cut-off wavelength	2X	3.41R
Longest wavelength transmitted with little attenuation	1.6X	3.2R
Shortest wavelength before next mode becomes possible	1.1X	2.8R

rectangles can be used; the most important is the circular pipe.

Table 21.5 gives dominant-mode wavelength formulas for rectangular and circular guides. X is the width of a rectangular guide, and R is the radius of a circular guide.

Coupling to Waveguides

Energy may be introduced into or extracted from a waveguide or resonator by means of either the electric or magnetic field. The energy transfer frequently takes place through a coaxial line. Two methods for coupling are shown in **Fig 21.21**. The probe at A is simply a short extension of the inner conductor of the feed coaxial line, oriented so that it is parallel to the electric lines of force. The loop shown at B is arranged to enclose some of the magnetic lines of force. The point at which maximum coupling will be obtained depends on the particular mode of propagation in the guide or cavity; the coupling

will be maximum when the coupling device is in the most intense field.

Coupling can be varied by rotating the probe or loop through 90°. When the probe is perpendicular to the electric lines the coupling will be minimum; similarly, when the plane of the loop is parallel to the magnetic lines, the coupling will be minimum. See *The ARRL Antenna Book* for more information on waveguides.

BIBLIOGRAPHY

J. Devoldere, *ON4UN's Low Band DXing*, 3rd Edition (Newington: ARRL, 1999).
W. Everitt, *Communication Engineering*, 2nd Edition (New York: McGraw-Hill, 1937).
H. Friis, and S. Schelkunoff, *Antennas: Theory and Practice* (New York: John Wiley and Sons, 1952).
M. Maxwell, *Reflections: Transmission Lines and Antennas* (Newington: ARRL, 1990) [out of print].
F. Regier, "Series-Section Transmission

Line Impedance Matching," *QST*, Jul 1978, pp 14-16.

A. Roehm, W2OBJ, "Some Additional Aspects of the Balun Problem," *The ARRL Antenna Compendium Vol 2*, p 172.
W. Sabin, WØIYH, "Computer Modeling of Coax Cable Circuits," *QEX*, Aug 1996 pp 3-10.
P. Smith, "Transmission Line Calculator," *Electronics*, Jan 1939.
P. Smith, *Electronic Applications of the Smith Chart* (McGraw-Hill, 1969).
W.D. Stewart, Jr, N7WS, "Balanced Transmission Lines in Current Amateur Practice," *The ARRL Antenna Compendium Vol 6* (Newington: ARRL, 1999).
R. D. Straw, N6BV, Ed., *The ARRL Antenna Book*, 20th Edition (Newington: ARRL, 2003).
F. Witt, "Baluns in the Real (and Complex) World," *The ARRL Antenna Compendium Vol 5* (Newington: ARRL, 1996).