

Chapter 26

Troubleshooting and Repair

Traditionally, the radio amateur has maintained a working knowledge of electronic equipment. This knowledge, and the ability to make repairs with whatever resources are available, keeps amateur stations operating when all other communications fail. This troubleshooting ability is not only a tradition; it is fundamental to the existence of the service.

This chapter, by Ed Hare, W1RFI, tells you what to do when you are faced with equipment failure or a circuit that doesn't work. It will help you ask and answer the right questions: "Should I fix it or send it back to the dealer for repair? What do I need to know to be able to fix it myself? Where do I start? What kind of test equipment do I need?" The best answers to these questions will depend on the type of test equipment you have available, the availability of a schematic or service manual and the depth of your own electronic and troubleshooting experience.

Not everyone is an electronics wizard; your set may end up at the repair shop in spite of your best efforts. The theory you learned for the FCC examinations and the information in this *Handbook* can help you decide if you can fix it yourself. If the problem is something simple (and most are), why not avoid the effort of shipping the radio to the manufacturer? It is gratifying to save time and money, but, even better, the experience and confidence you gain by fixing it yourself may prove even more valuable.

Although some say troubleshooting is as much art as it is science, the repair of electronic gear is not magic. It is more like detective work. A knowledge of complex math is not required. However, you must have, or develop, the ability to read a sche-

matic diagram and to visualize signal flow through the circuit.

SAFETY FIRST

Always! Death is permanent. A review of safety must be the first thing discussed in a troubleshooting chapter. Some of the voltages found in amateur equipment can be fatal! Only 50 mA flowing through the body is painful; 100 to 500 mA is usually fatal. Under certain conditions, as little as 24 V can kill.

Make sure you are 100% familiar with all safety rules and the dangerous conditions that might exist in the equipment you are servicing. Remember, if the equipment is not working properly, dangerous conditions may exist where you don't expect them. Treat every component as potentially "live."

Some older equipment uses "ac/dc" circuitry. In this circuit, one side of the chassis is connected directly to the ac line. This is an electric shock waiting to happen.

A list of safety rules can be found in **Table 26.1**. You should also read the **Safety** chapter of this *Handbook* before you proceed.

GETTING HELP

Other hams may be able to help you with your troubleshooting and repair problems, either with a manual or technical help. Check with your local club or repeater group. You may get lucky and find a troubleshooting "wizard." (On the other hand, you may get some advice that is downright dangerous, so be selective.) You can also place a classified ad in one of the ham magazines, perhaps when you are looking for a rare manual.

Your fellow hams in the ARRL Field organization may also help. Technical

Coordinators (TCs) and Technical Specialists (TSs) are volunteers who are willing to help hams with technical questions. For the name and address of a local TC or TS, contact your Section Manager (listed in the front of any recent issue of *QST*).

THEORY

To fix electronic equipment, you need to understand the system and circuits you are troubleshooting. A working knowledge of electronic theory, circuitry and components is an important part of the process. If necessary, review the electronic and circuit theory explained in the other chapters of this book. When you are troubleshooting, you are looking for the unexpected. Knowing how circuits are supposed to work will help you to look for things that are out of place.

TEST EQUIPMENT

Many of the steps involved in troubleshooting efficiently require the use of test equipment. We cannot see electrons flow. However, electrons do affect various devices in our equipment, with results we can measure.

Some people think they need expensive test instruments to repair their own equipment. This is not so! In fact, you probably already own the most important instruments. Some others may be purchased inexpensively, rented, borrowed or built at home. The test equipment available to you may limit the kind of repairs you can do, but you will be surprised at the kinds of repair work you can do with simple test equipment.

Senses

Although they are not "test equipment"

Table 26.1**Safety Rules**

1. Keep one hand in your pocket when working on live circuits or checking to see that capacitors are discharged.
2. Include a conveniently located ground-fault current interrupter (GFCI) circuit breaker in the workbench wiring.
3. Use only grounded plugs and receptacles.
4. Use a GFCI protected circuit when working outdoors, on a concrete or dirt floor, in wet areas, or near fixtures or appliances connected to water lines, or within six feet of any exposed grounded building feature.
5. Use a fused, power limiting isolation transformer when working on ac/dc devices.
6. Switch off the power, *disconnect equipment from the power source, ground the output of the internal dc power supply*, and discharge capacitors when making circuit changes.
7. Do not subject electrolytic capacitors to excessive voltage, ac voltage or reverse voltage.
8. Test leads should be well insulated.
9. Do not work alone!
10. Wear safety glasses for protection against sparks and metal fragments.
11. Always use a safety harness when working above ground level.
12. Wear shoes with nonslip soles that will support your feet when climbing.
13. Wear rubber-sole shoes or use a rubber mat when standing on the ground or on a concrete floor.
14. Wear a hard hat when someone is working above you.
15. Be careful with tools that may cause short circuits.
16. Replace fuses only with those having proper ratings.

in the classic sense, your own senses will tell you as much about the equipment you are trying to fix as the most-expensive spectrum analyzer. We each have some of these natural “test instruments.”

Eyes — Use them constantly. Look for evidence of heat and arcing, burned components, broken connections or wires, poor solder joints or other obvious visual problems.

Ears — Severe audio distortion can be detected by ear. The “snaps” and “pops” of arcing or the sizzling of a burning component may help you track down circuit faults. An experienced troubleshooter can diagnose some circuit problems by the sound they make. For example, a bad audio-output IC sounds slightly different than a defective speaker.

Nose — Your nose can tell you a lot. With experience, the smells of ozone, an overheating transformer and a burned carbon-composition resistor each become unique and distinctive.

Finger — Carefully use your fingers to measure low heat levels in components. Small-signal transistors can be fairly warm to the touch; anything hotter can indicate a circuit problem. (Be careful; some high-power devices or resistors can get downright hot during normal operation.)

Brain — More troubleshooting prob-

lems have been solved with a VOM and a brain than with the most expensive spectrum analyzer. You must use your brain to analyze data collected by other instruments.

“Internal” Equipment

Some “test equipment” is included in the equipment you repair. Nearly all receivers include a speaker. An S meter is usually connected ahead of the audio chain. If the S meter shows signals, it indicates that the RF and IF circuitry is probably functioning. Analyze what the unit is doing and see if it gives you a clue.

Some older receivers include a crystal frequency calibrator. The calibrator signal, which is rich in harmonics, is injected in the RF chain close to the antenna jack and may be used for signal tracing and alignment.

Bench Equipment

Here is a summary of test instruments and their applications. Some items serve several purposes and may substitute for others on the list. The list does not cover all equipment available, only the most common and useful instruments. The theory and operation of much of this test equipment is discussed in more detail in the **Test Procedures** chapter.

Multimeters — The multimeter is the

most often used piece of test equipment. This group includes vacuum-tube voltmeters (VTVMs), volt-ohm-milliammeters (VOMs), field-effect transistor VOMs (FETVOMs) and digital multimeters (DMMs). Multimeters are used to read bias voltages, circuit resistance and signal level (with an appropriate probe). They can test resistors, capacitors (within certain limitations), diodes and transistors.

DMMs have become quite inexpensive. Their high input impedance, accuracy and flexibility are well worth the cost. Many of them contain other test equipment as well, such as capacitance meters, frequency counters, transistor testers and even digital thermometers. Some DMMs are affected by RF, so most technicians keep an analog-display VOM on hand for use near RF equipment.

When buying an analog meter, look for one with an input impedance of 20 k Ω /V or better. Reasonably priced models are available with 30 k Ω /V (\$35) and 50 k Ω /V (\$40). The 10 M Ω or better input impedance of DMMs, FETVOMs, VTVMs and other electronic voltmeters makes them the preferred instruments for voltage measurements.

Test leads — Keep an assortment of wires with insulated, soldered alligator clips. Commercially made leads have a high failure rate because they use small wire that is not soldered to the clips; it is best to make your own.

Open wire leads (Fig 26.1A) are good for dc measurements, but they can pick up unwanted RF energy. This problem is reduced somewhat if the leads are twisted together (Fig 26.1B). A coaxial cable lead is much better, but its inherent capacitance can affect RF measurements.

The most common probe is the low-capacitance ($\times 10$) probe shown in Fig 26.1C. This probe isolates the oscilloscope from the circuit under test, preventing the ‘scope’s input and test-probe capacitance from affecting the circuit and changing the reading. A network in the probe serves as a 10:1 divider and compensates for frequency distortion in the cable and test instrument.

Demodulator probes (see the **Test Procedures** chapter and the schematic shown in Fig 26.1D) are used to demodulate or detect RF signals, converting modulated RF signals to audio that can be heard in a signal tracer or seen on a low-bandwidth ‘scope.

You can make a probe for inductive coupling as shown in Fig 26.1E. Connect a two- or three-turn loop across the center conductor and shield before sealing the end. The inductive pick up is useful for coupling to high-current points.

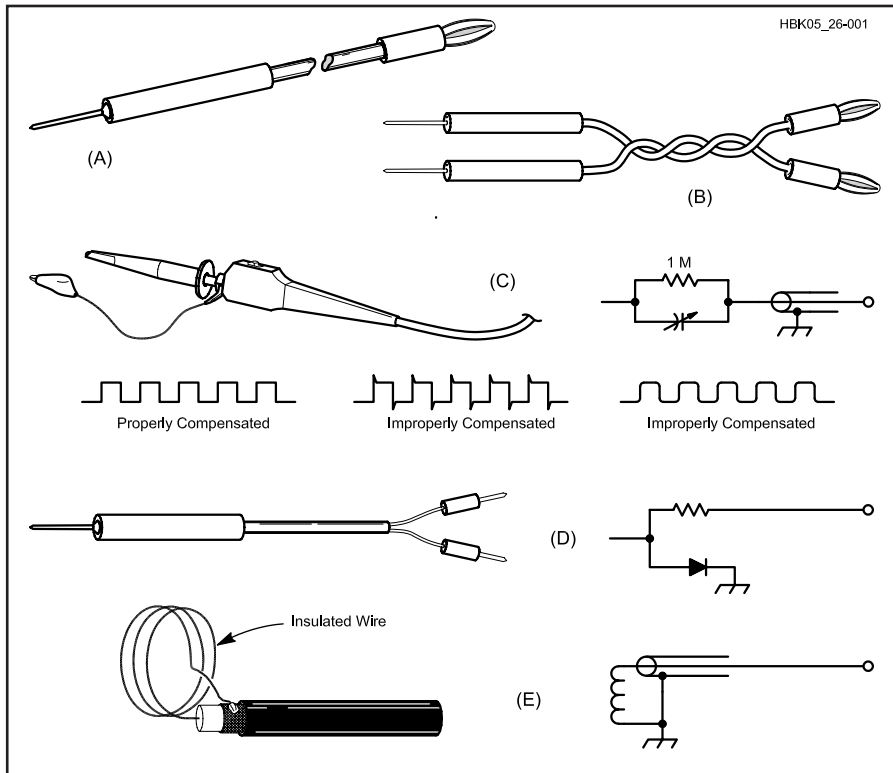

Fig 26.1—An array of test probes for use with various test instruments.

RF power and SWR meters — Every shack should have one. It is used to measure forward and reflected RF power. A standing-wave ratio (SWR) meter can be the first indicator of antenna trouble. It can also be used between an exciter and power amplifier to spot an impedance mismatch.

Simple meters indicate relative power SWR and are fine for Transmatch adjustment and line monitoring. However, if you want to make accurate measurements, a calibrated wattmeter with a directional coupler is required.

Dummy load — A “dummy” or “phantom” load is a necessity in any shack. Do not put a signal on the air while repairing equipment. Defective equipment can generate signals that interfere with other hams or other radio services. A dummy load also provides a known, matched load (usually 50 Ω) for use during adjustments.

When buying a dummy load, avoid used, oil-cooled dummy loads unless you can be sure that the oil does not contain PCBs. This biologically hazardous compound was common in transformer oil until a few years ago.

Dummy loads in the shack are often required to dissipate a transmitter’s or linear amplifier’s full power output, i.e., up to 1500 W, at least for a short time. They are also used in lower power applications—typically smaller sized and rated, and can also be used as impedance standards or as terminations for low-power

computer or communications lines.

Dip meter — This device is often called a transistor dip meter or a grid-dip oscillator from vacuum-tube days.

Most dip meters can also serve as an absorption frequency meter. In this mode, measurements are read at the current peak, rather than the dip. Some meters have a connection for headphones. The operator can usually hear signals that do not register on the meter. Because the dip meter is an oscillator, it can be used as a signal generator in certain cases where high accuracy or stability are not required.

When purchasing a dip meter, look for one that is mechanically and electrically stable. The coils should be in good condition. A headphone connection is helpful. Battery operated models are easier to use for antenna measurements. Dip meters are not nearly as common as they once were.¹

Oscilloscope — The oscilloscope, or ‘scope, is the second most often used piece of test equipment, although a lot of repairs can be accomplished without one. The trace of a ‘scope can give us a lot of information about a signal at a glance.

The simplest way to display a waveform is to connect the vertical amplifier of the ‘scope to a point in the circuit through a simple test lead. When viewing RF, use a low-capacitance probe that has been adjusted to match the ‘scope. Select the vertical gain and time-base (horizontal scale,

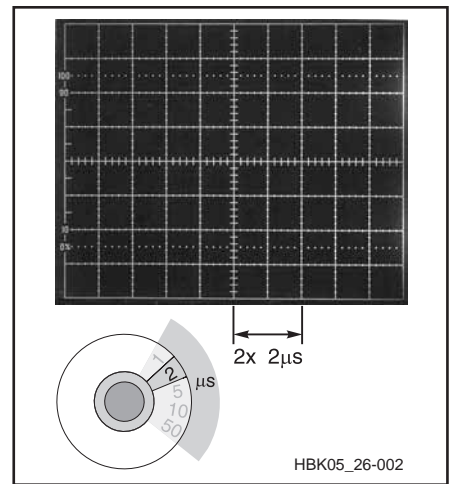

Fig 26.2—An oscilloscope display showing the relationship between time-base setting and graticule lines.

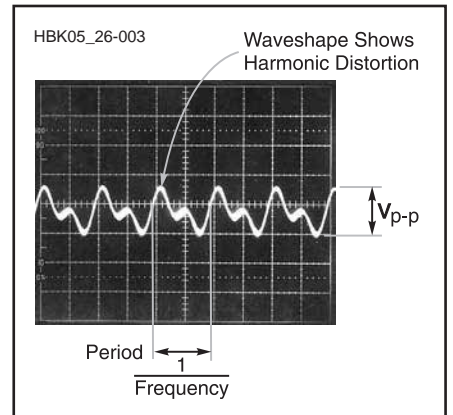

Fig 26.3—Information available from a typical oscilloscope display of a waveform.

Fig 26.2) for the most useful displayed waveform.

A ‘scope waveform shows voltage (if calibrated), approximate period (frequency is the reciprocal of the period) and a rough idea of signal purity (see Fig 26.3). If the ‘scope has dual-trace capability (meaning it can display two signals at once), a second waveform may be displayed and compared to the first. When the two signals are taken from the input and output of a stage, stage linearity and phase shift can be checked (see Fig 26.4).

An important specification of an oscilloscope is its amplifier bandwidth. This tells us the frequency at which amplifier response has dropped 3 dB. The instrument will display higher frequencies, but its accuracy at higher frequencies is not known. Even well below its rated bandwidth a ‘scope is not capable of much more than about 5% accuracy. This is adequate

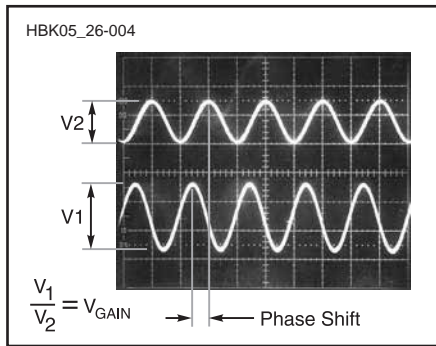

Fig 26.4—A dual-trace oscilloscope display of amplifier input and output waveforms.

for most amateur applications.

An oscilloscope will show gross distortions of audio and RF waveforms, but it cannot be used to verify that a transmitter meets FCC regulations for harmonics and spurious emissions. Harmonics that are down only 20 dB from the fundamental would be illegal in most cases, but they would not change the oscilloscope waveform enough to be seen.

When buying a 'scope, get the greatest bandwidth you can afford. Old Hewlett-Packard or Tektronix 'scopes are usually quite good for amateur use.

Signal generator — Although signal generators have many uses, in troubleshooting they are most often used for signal injection (more about this later) and alignment.

An AF/RF signal-injector schematic is shown in Fig 26.5. If frequency accuracy is needed, the crystal-controlled signal source of Fig 26.6 can be used. The AF/RF circuit provides usable harmonics up to 30 MHz, while the crystal controlled oscillator will function with crystals from 1 to 15 MHz. These two projects are not meant to compete with standard signal generators, but they are adequate for signal injection.² A better generator is required for receiver alignment or for receiver quality testing.

When buying a generator, look for one that can generate a sine wave signal. A good signal generator is double or triple shielded against leakage. Fixed-frequency audio should be available for modulation of the RF signal and for injection into audio stages. The most versatile generators can generate amplitude and frequency modulated signals.

Good generators have stable frequency controls with no backlash. They also have multiposition switches to control signal level. A switch marked in dBm is a good indication that you have located a high-quality test instrument. The output jack should be a coaxial connector (usually a

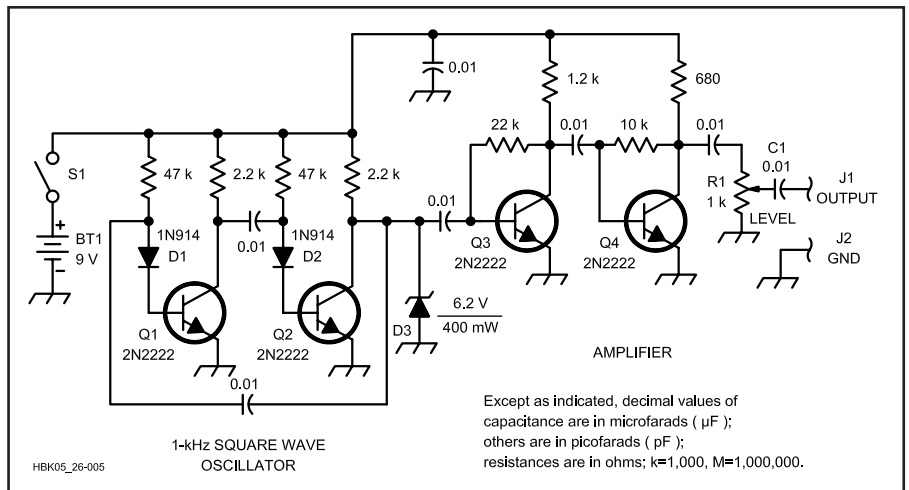

Fig 26.5—Schematic of the AF/RF signal injector. All resistors are 1/4-W, 5% carbon units, and all capacitors are disc ceramic.

- BT1** — 9-V battery.
- D1, D2** — Silicon switching diode, 1N914 or equiv.
- D3** — 6.2-V, 400-mW Zener diode.
- J1, J2** — Banana jack.
- Q1-Q4** — General-purpose silicon NPN transistors, 2N2222 or similar.
- R1** — 1-kΩ panel-mount control.
- S1** — SPST toggle switch.

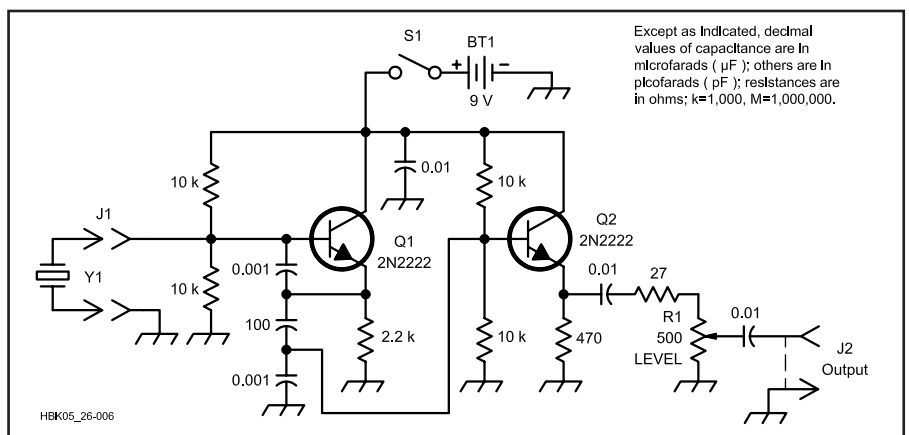

Fig 26.6 — Schematic of the crystal-controlled signal source. All resistors are 1/4-W, 5% carbon units, and all capacitors are disc ceramic. A full-size etching pattern and parts-placement diagram can be found on the Templates Section of the Handbook CD-ROM.

- BT1** — 9-V transistor radio battery.
- J1** — Crystal socket to match the crystal type used.
- J2** — RCA phono jack or equivalent.
- Q1, Q2** — General-purpose silicon NPN transistors, 2N2222 or similar.
- R1** — 500-Ω panel-mount control.
- S1** — SPST toggle switch.
- Y1** — 1 to 15-MHz crystal.

BNC or N), not the kind used for microphone connections.

Some older, high-quality units are common. Look for World War II surplus units of the URM series, Boonton, GenRad, Hewlett-Packard, Tektronix, Measurements Inc or other well-known brand names. Some home-built signal generators may be quite good, but make sure to check construction techniques, level control and shielding quality.

Signal tracer — Signals can be traced with a voltmeter and an RF probe, a dip

meter with headphones or an oscilloscope, but there are some devices made especially for signal tracing. A signal tracer is primarily a high-gain audio amplifier. It may have a built-in RF detector, or rely on an external RF probe. Most convert the traced signal to audio through a speaker.

The tracer must function as a receiver and detector for each frequency range in the test circuit. A high-impedance tracer input is necessary to prevent circuit loading.

A general-coverage receiver can be used to trace RF or IF signals, if the receiver covers the necessary frequency range. Most receivers, however, have a low-impedance input that severely loads the test circuit. To minimize loading, use a capacitive probe or loop pickup. When the probe is held near the circuit, signals will be picked up and carried to the receiver. It may also pick up stray RF, so make sure you are listening to the correct signal by switching the circuit under test on and off while listening.

Tube tester — Vacuum-tube testers used to be found in nearly every drug or department store. They are scarce now because tubes are no longer used in modern consumer or (most) amateur equipment. Older tube gear is found in many ham shacks or flea markets, though. There are many aficionados of vintage gear who enjoy working with old vacuum-tube equipment.

Most simple tube testers measure the cathode emission of a vacuum tube. Each grid is shorted to the plate through a switch and the current is observed while the tube operates as a diode. By opening the switches from each grid to the plate (one at a time), we can check for opens and shorts. If the plate current does not drop slightly as a switch is opened, the element connected to that switch is either open or shorted to another element. (We cannot tell an open from a short with this test.) The emission tester does not necessarily indicate the ability of a tube to amplify.

Other tube testers measure tube gain (transconductance). Some transconductance testers read plate current with a fixed bias network. Others use an ac signal to drive the tube while measuring plate current.

Most tube testers also check interelement leakage. Contamination inside the tube envelope may result in current leakage between elements. The paths can have high resistance, and may be caused by gas or deposits inside the tube. Tube testers use a moderate voltage to check for leakage. Leakage can also be checked with an ohmmeter using the $\times 1\text{M}$ range, depending on the actual spacing of tube elements.

Transistor tester — Transistor testers are similar to transconductance tube testers. Device current is measured while the device is conducting or while an ac signal is applied at the control terminal. Commercial surplus units are often seen at ham flea markets. Some DMMs being sold today also include a built-in, simple transistor tester.

Most transistor failures appear as either an open or shorted junction. Opens and

shorts can be found easily with an ohmmeter; a special tester is not required.

Transistor gain characteristics vary widely, however, even between units with the same device number. Testers can be used to measure the gain of a transistor. A tester that uses dc signals measures only transistor dc alpha and beta. Testers that apply an ac signal show the ac alpha or beta. Better testers also test for leakage.

In addition to telling you whether a transistor is good or bad, a transistor tester can help you decide if a particular transistor has sufficient gain for use as a replacement. It may also help when matched transistors are required. The final test is the repair circuit.

Frequency meter — Most frequency counters are digital units, often able to show frequency to a 1-Hz resolution. Some older “analog” counters are sometimes found surplus, but a low-cost digital counter will out-perform even the best of these old “classics.”

Power supplies — A well-equipped test bench should include a means of varying the ac-line voltage, a variable-voltage regulated dc supply and an isolation transformer.

AC-line voltage varies slightly with load. An autotransformer with a movable tap lets you boost or reduce the line voltage slightly. This is helpful to test circuit functions with supply-voltage variations.

As mentioned earlier, ac/dc radios must be isolated from the ac line during testing and repair. Keep an isolation transformer handy if you want to work on table-model broadcast radios or television sets (check for other ac/dc equipment, too. Even some old phonographs or Amateur Radio transceivers used this dangerous circuit design).

A good multivoltage supply will help with nearly any analog or digital troubleshooting project. Many electronics distributors stock bench power supplies. A variable-voltage dc supply may be used to power various small items under repair or provide a variable bias supply for testing active devices. Construction details for a laboratory power supply appear in the **Power Supplies** chapter.

If you want to work on vacuum-tube gear, the maximum voltage available from the dc supply should be high enough to serve as a plate or a bias supply for common tubes (about 300 to 400 V ought to do it).

Accessories — There are a few small items that may be used in troubleshooting. You may want to keep them handy.

Many circuit problems are sensitive to temperature. A piece of equipment may work well when first turned on (cold) but

fail as it warms up. In this case, a cold source will help you find the intermittent connection. When you cool the bad component, the circuit will suddenly start working again (or stop working). Cooling sprays are available from most parts suppliers.

A heat source helps locate components that fail only when hot. A small incandescent lamp can be mounted in a large piece of sleeve insulation to produce localized heat for test purposes.

A heat source is usually used in conjunction with a cold source. If you have a circuit that stops working when it warms up, heat the circuit until it fails, then cool the components one by one. When the circuit starts working again, the last component sprayed was the bad one.

A stethoscope (with the pickup removed — see Fig 26.7) or a long piece of sleeve insulation can be used to listen for arcing or sizzling in a circuit.

WHERE TO BEGIN

New Construction

In most repair work, the technician is aided by the knowledge that the circuit once worked. It is only necessary to find the faulty part(s) and replace it. This is not so with newly constructed equipment. Repair of equipment with no working history is a special, and difficult, case. You

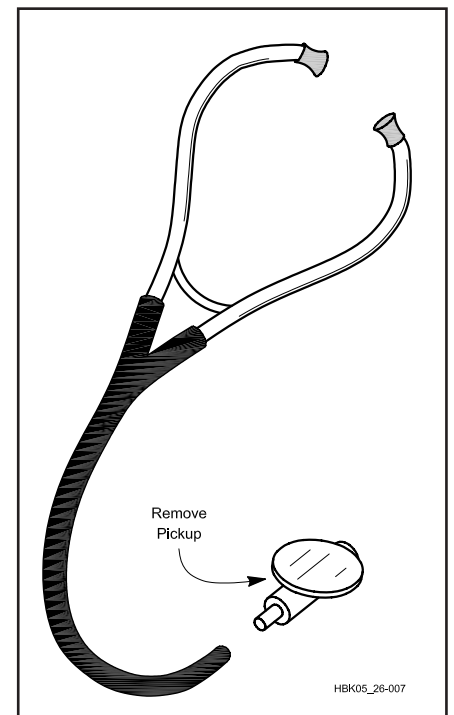

Fig 26.7 — A stethoscope, with the pickup removed, is used to listen for arcing in crowded circuits.

may be dealing with a defective component, construction error or even a faulty design. Carefully checking for these defects can save you hours.

All Equipment

Check the Obvious

Try the easy things first. If you are able to solve the problem by replacing a fuse or reconnecting a loose cable, you might be able to avoid a lot of effort. Many experienced technicians have spent hours troubleshooting a piece of equipment only to learn the hard way that the on/off switch was “off” or that they were not using the equipment properly.

Read the manual! Your equipment may be working as designed. Many electronic “problems” are caused by a switch that is set in the wrong position, or a unit that is being asked to do something it was not designed to do. Before you open up your equipment for major surgery, make sure you are using it correctly.

Next, make sure the equipment is plugged in, that the ac outlet does indeed have power, that the equipment is switched “on” and that all of the fuses are good. If the equipment uses batteries or an external power supply, make sure these are working.

Check that all wires, cables and accessories are working and plugged in to the right connectors or jacks. In a “system,” it is often difficult to be sure which component or subsystem is bad. Your transmitter may not work on SSB because the transmitter is bad, but it could also be a bad microphone.

Connector faults are more common than component troubles. Consider poor connections as prime suspects in your troubleshooting detective work. Do a thorough inspection of the connections. Is the antenna connected? How about the speaker, fuses and TR switch? Are transistors and ICs firmly seated in their sockets? Are all interconnection cables sound and securely connected? Many of these problems are obvious to the eye, so look around carefully.

Simplify the Problem

If the broken equipment is part of a system, you need to find out exactly which part of the system is bad. For example, if your amateur station is not putting out any RF, you need to determine if it is a microphone problem, a transmitter problem, an amplifier problem or a problem somewhere in your station wiring. If you are trying to diagnose a bad channel on your home modular stereo system, it could be anything from a bad cable to a bad amplifier to a bad speaker.

Simplify the system as much as possible. To troubleshoot the “no-RF” problem, temporarily eliminate the amplifier from the station configuration. To diagnose the stereo system, start troubleshooting by checking just the amplifier with a set of known good headphones. Simplifying the problem will often isolate the bad component quickly.

Documentation

Once you have determined that a piece of equipment is indeed broken, you need to do some preparation before you diagnose and fix it. First, locate a schematic diagram and service manual. It is possible to troubleshoot without a service manual, but a schematic is almost indispensable.

The original equipment manufacturer is the best source of a manual or schematic. However, many old manufacturers have gone out of business. Several sources of equipment manuals can be located by a web search.

If all else fails, you can sometimes reverse engineer a simple circuit by tracing wiring paths and identifying components to draw your own schematic. If you have access to the databooks for the active devices used in the circuit, the pin-out diagrams and applications notes will sometimes be enough to help you understand and troubleshoot the circuit.

Define Problems

To begin troubleshooting, define the problem accurately. Ask yourself these questions:

1. What functions of the equipment do not work as they should; what does not work at all?
2. What kind of performance can you realistically expect?
3. Has the trouble occurred in the past? (Keep a record of troubles and maintenance in the owner’s manual or log book.)

Write the answers to the questions. The information will help with your work, and may help service personnel if their advice or professional service is required.

Take It Apart

All of the preparation work has been done. It is time to really dig in. You usually will have to start by taking the equipment apart. This is the part that can trap the unwary technician. Most experienced service technicians can tell you the tale of the equipment they took apart and were unable to easily put back together. Don’t let it happen to you.

Take lots of notes about the way you take it apart. Take notes about each component you remove. Write down the order in which you do things, color codes, part

placements, cable routings, hardware notes and anything else you think you might need to be able to reassemble the equipment weeks from now when the back-ordered part comes in.

Put all of the screws in one place. A plastic jar with a lid works well; if you drop it the plastic is not apt to break and the lid will keep all the parts from flying around the work area (you will never find them all). It may pay to have a separate labeled container for each subsystem.

Look Around

Many service problems are visible, if you look for them carefully. Many a technician has spent hours tracking down a failure, only to find a bad solder joint or burned component that would have been spotted in careful inspection of the printed-circuit board. Start troubleshooting by carefully inspecting the equipment.

It is time consuming, but you really need to look at every connector, every wire, every solder joint and every component. A connector may have loosened, resulting in an open circuit. You may spot broken wires or see a bad solder joint. Flexing the printed-circuit board or tugging on components a bit while looking at their solder joints will often locate a defective solder job. Look for scorched components.

Make sure all of the screws securing the printed-circuit board are tight and making good electrical contact. (Do not tighten the adjusting screws, however! You will ruin the alignment.) See if you can find evidence of previous repair jobs; these may not have been done properly. Make sure that each IC is firmly seated in its socket. Look for pins folded underneath the IC rather than making contact with the socket. If you are troubleshooting a newly constructed circuit, make sure each part is of the correct value or type number and is installed correctly.

If your careful inspection doesn’t reveal anything, it is time to apply power to the unit under test and continue the process. Observe all safety precautions while troubleshooting equipment. There are voltages inside some equipment that can kill you. If you are not qualified to work safely with the voltages and conditions inside of the equipment, do not proceed. See Table 26.1 and the **Safety** chapter.

Other Senses

With power applied to the unit, listen for arcs and look and smell for smoke. If no problems are apparent, you will have to start testing the various parts of the circuit.

VARIOUS APPROACHES

There are two fundamental approaches to troubleshooting: the systematic

approach and the instinctive approach. The systematic approach uses a defined process to analyze and isolate the problem. An instinctive approach relies on troubleshooting experience to guide you in selecting which circuits to test and which tests to perform. The systematic approach is usually chosen by beginning troubleshooters.

At the Block Level

The block diagram is a road map. It shows the signal paths for each circuit function. These paths may run together, cross occasionally or not at all. Those blocks that are not in the paths of faulty functions can be eliminated as suspects. Sometimes the symptoms point to a single block, and no further search is necessary.

In cases where more than one block is suspect, several approaches may be used. Each requires testing a block or stage. Signal injection, signal tracing, instinct or combination of all techniques may be used to diagnose and test electronic equipment.

Systematic Approaches

The instinctive approach works well for those with years of troubleshooting experience. Those of us who are new to this game need some guidance. A systematic approach is a disciplined procedure that allows us to tackle problems in unfamiliar equipment with a reasonable hope of success.

There are two common systematic approaches to troubleshooting at the block level. The first is signal tracing; the second is signal injection. The two techniques are very similar. Differences in test equipment and the circuit under test determine which method is best in a given situation. They can often be combined.

Power Supplies

You may be able to save quite a bit of time if you test the power supply first. All of the other circuits may be dead if the power supply is not working. Power supply diagnosis is discussed in detail later in this chapter.

Signal Tracing

In signal tracing, start at the beginning of a circuit or system and follow the signal through to the end. When you find the signal at the input to a specific stage, but not at the output, you have located the defective stage. You can then measure voltages and perform other tests on that stage to locate the specific failure. This is much faster than testing every component in the unit to determine which is bad.

It is sometimes possible to use over-the-air signals in signal tracing, in a receiver

for example. However, if a good signal generator is available, it is best to use it as the signal source. A modulated signal source is best.

Signal tracing is suitable for most types of troubleshooting of receivers and analog amplifiers. Signal tracing is the best way to check transmitters because all of the necessary signals are present in the transmitter by design. Most signal generators cannot supply the wide range of signal levels required to test a transmitter.

Equipment

A voltmeter, with an RF probe, is the most common instrument used for signal tracing. Low-level signals cannot be measured accurately with this instrument. Signals that do not exceed the junction drop of the diode in the probe will not register at all, but the presence, or absence, of larger signals can be observed.

A dedicated signal tracer can also be used. It is essentially an audio amplifier. An experienced technician can usually judge the level and distortion of the signal by ear. You cannot use a dedicated signal tracer to follow a signal that is not amplitude modulated (single sideband is a form of AM). Signal tracing is not suitable for tracing CW signals, FM signals or oscillators. To trace these, you will have to use a voltmeter and RF probe or an oscilloscope.

An oscilloscope is the most versatile signal tracer. It offers high input impedance, variable sensitivity, and a constant display of the traced waveform. If the oscilloscope has sufficient bandwidth, RF signals can be observed directly. Alternatively, a demodulator probe can be used to show demodulated RF signals on a low-bandwidth 'scope. Dual-trace scopes can simultaneously display the waveforms, including their phase relationship, present at the input and output of a circuit.

Procedure

First, make sure that the circuit under test and test instruments are isolated from the ac line by transformers. Set the signal source to an appropriate level and frequency for the unit you are testing. For a receiver, a signal of about 100 μV should be plenty. For other circuits, use the schematic, an analysis of circuit function and your own good judgment to set the signal level.

In signal tracing, start at the beginning and work toward the end of the signal path. Switch on power to the test circuit and connect the signal-source output to the test-circuit input. Place the tracer probe at the circuit input and ensure that you can hear the test signal. Observe the characteristics of the signal if you are using a

'scope (see Fig 26.8). Compare the detected signal to the source signal during tracing.

Move the tracer probe to the output of the next stage and observe the signal. Signal level should increase in amplifier stages and may decrease slightly in other stages. The signal will not be present at the output of a "dead" stage.

Low-impedance test points may not provide sufficient signal to drive a high-impedance signal tracer, so tracer sensitivity is important. Also, in some circuits the output level appears low where there is an impedance change from input to output of a stage (see Fig 26.9). For example, the circuit in Fig 26.9 is a common-collector current amplifier with a high input impedance and low output impedance. The voltages at TP1 and TP2 are approximately equal and in phase.

There are two signals — the test signal and the local oscillator signal — present in a mixer stage. Loss of either one will result in no output from the mixer stage. Switch the signal source on and off repeatedly to make sure that the tracer reading varies (it need not disappear) with source switching.

Signal Injection

Like signal tracing, signal injection is particularly suited to some situations. Signal injection is a good choice for receiver troubleshooting because the receiver already has a detector as part of the design. It is suitable for either high- or low-impedance circuits and can be used with vacuum tubes, transistors or ICs.

Equipment

If you are testing equipment that does not include a suitable detector as part of the circuit, some form of signal detector is required. Any of the instruments used for signal tracing are adequate.

Most of the time, your signal injector will be a signal generator. There are other injectors available, some of which are square-wave audio oscillators rich in RF harmonics (see Fig 26.5). These are usually built into a pen-sized case with a test probe at the end. These "pocket" injectors do have their limits because you can't vary their output level or determine their frequency. They are still useful, though, because most circuit failures are caused by a stage that is completely dead.

Consider the signal level at the test point when choosing an instrument. The signal source used for injection must be able to supply appropriate frequencies and levels for each stage to be tested. For example, a typical superheterodyne receiver requires AF, IF and RF signals that vary from 6 V

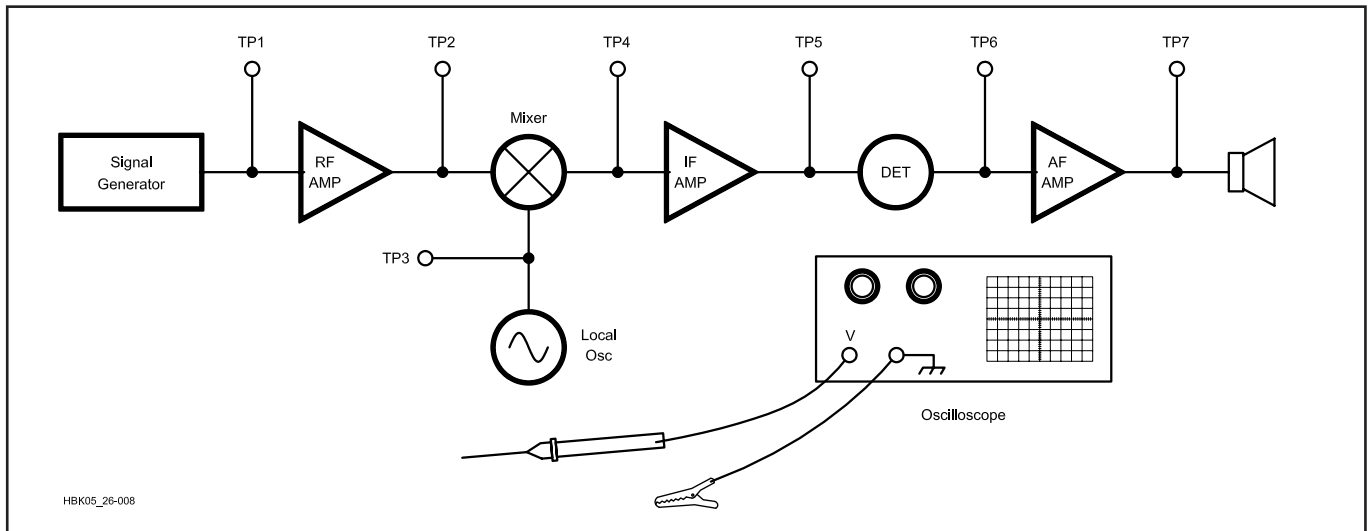

Fig 26.8 — Signal tracing in a simple receiver.

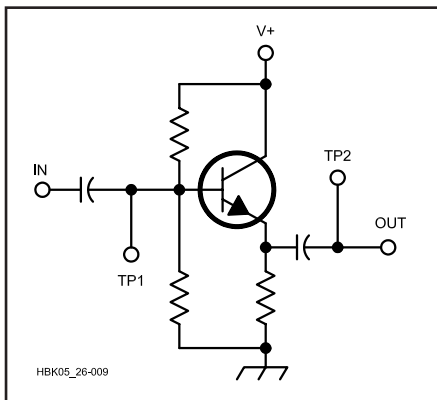

Fig 26.9 — The effect of circuit impedance on an oscilloscope display. Although the circuit functions as a current amplifier, the change in impedance from TP1 to TP2 results in the traces described. This is a common-collector amplifier.

at AF, to 0.2 mV at RF. Each conversion stage used in a receiver requires another IF from the signal source.

Procedure

If an external detector is required, set it to the proper level and connect it to the test circuit. Set the signal source for AF, and inject a signal directly into the signal detector to test operation of the injector and detector. Move the signal source to the input of the preceding stage, and observe the signal. Continue moving the signal source to the inputs of successive stages.

When you inject the signal source to the input of the defective stage, there will be no output. Prevent stage overload by

reducing the level of the injected signal as testing progresses through the circuit. Use suitable frequencies for each tested stage.

Make a rough check of stage gain by injecting a signal at the input and output of an amplifier stage. You can then compare how much louder the signal is when injected at the input. This test may mislead you if there is a radical difference in impedance from stage input to output. Understand the circuit operation before testing.

Mixer stages present a special problem because they have two inputs, rather than one. A lack of output signal from a mixer can be caused by either a faulty mixer or a faulty local oscillator (LO). Check oscillator operation with a 'scope or absorption wavemeter, or by listening on another receiver. If none of these instruments are available, inject the frequency of the LO at the LO output. If a dead oscillator is the only problem, this should restore operation.

If the oscillator is operating, but off frequency, a multitude of spurious responses will appear. A simple signal injector that produces many frequencies simultaneously is not suitable for this test. Use a well-shielded signal generator set to an appropriate level at the LO frequency.

Divide and Conquer

Under certain conditions, the block search may be speeded by testing at the middle of successively smaller circuit sections. Each test limits the fault to one half of the remaining circuit (see Fig 26.10). Let's say the receiver has 14 stages and the fault is in stage 12. This approach requires only four tests to locate the faulty stage, a substantial saving of time.

This "divide and conquer" tactic cannot be used in equipment that splits the signal path between the input and the output. Test readings taken inside feedback loops are misleading unless you understand the circuit and the waveform to be expected at each point in the test circuit. It is best to consider all stages within a feedback loop as a single block during the block search.

Both signal tracing and signal injection procedures may be speeded by taking some diagnostic short cuts. Rather than check each stage sequentially, check a point halfway through the system. As an example:

An HF receiver is not working. There is absolutely no response from the speaker. First, substitute a suitable speaker — still no sound. Next, check the power supply — no problem there. No clues indicate any particular stage. Signal tracing or injection must provide the answer.

Get out the signal generator and switch it on. Set the generator for a low-level RF signal, switch the signal off and connect the output to the receiver. Switch the signal on again and place a high-impedance signal-tracer probe at the antenna connection. Instantly, the tracer emits a strong audio note. Good; the test equipment is functioning.

Move the probe to the input of the receiver detector. As the tracer probe touches the circuit the familiar note sounds. Next, set the tracer for audio and place the probe halfway through the audio chain. It is silent! Move the probe halfway back to the detector, and the note appears once again. Yet, no signal is present at the output of the stage. You now know that the defect is somewhere between the two

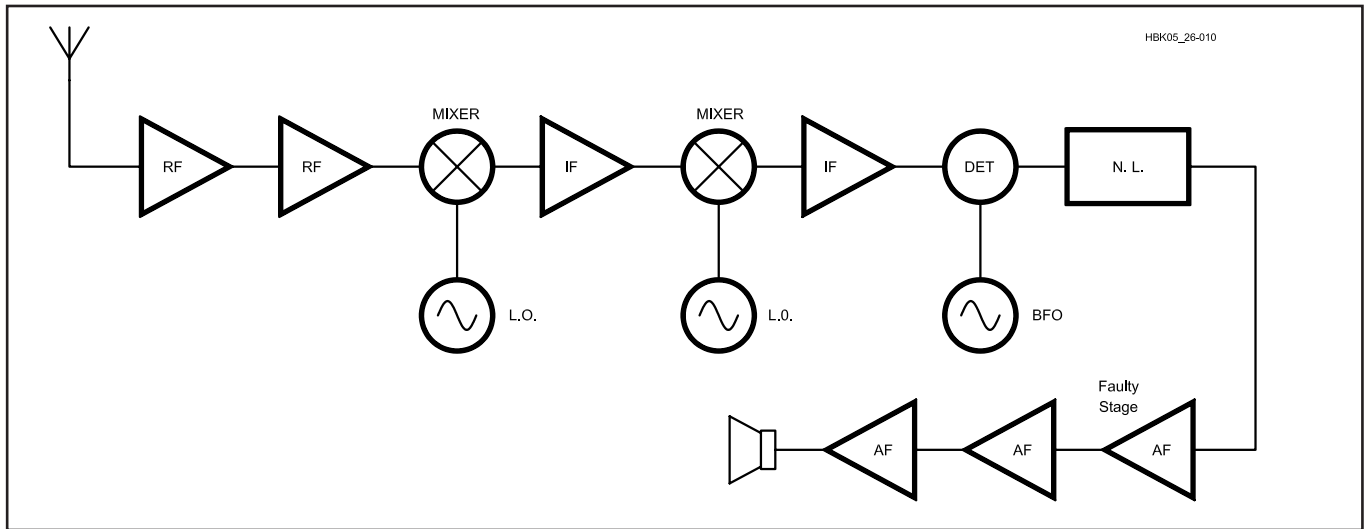

Fig 26.10 — The 14-stage receiver diagnosed by the “divide and conquer” technique.

points tested. In this case, the third audio stage is faulty.

The Instinctive Approach

In an “instinctive” approach to troubleshooting, you rely on your judgment and experience to decide where to start testing, what and how to test. When you immediately check power supply voltages, or the ac fuse on a unit that is completely nonfunctional, that is an example of an instinctive approach. If you are faced with a receiver that has distorted audio and immediately start testing the speaker and audio output stage, or if you immediately start checking the filter and bypass capacitors in an audio stage that is oscillating or “motorboating” you are troubleshooting on instinct.

Most of our discussion on the instinctive approach is really a collection of tips and guidelines. Read them to build your troubleshooting skills.

The check for connector problems mentioned at the beginning of this section is a good idea. Experience has shown connector faults to be so common that they should be checked even before a systematic approach begins.

When instinct is based on experience, searching by instinct may be the fastest procedure. If your instinct is correct, repair time and effort may be reduced substantially. As experience and confidence grow, the merits of the instinctive approach grow with them. However, inexperienced technicians who choose this approach are at the mercy of chance.

TESTING WITHIN A STAGE

Once you have followed all of the troubleshooting procedures and have iso-

lated your problem to a single defective stage or circuit, a few simple measurements and tests will usually pinpoint one or more specific components that need adjustment or replacement.

First, check the parts in the circuit against the schematic diagram to be sure that they are reasonably close to the design values, especially in a newly built circuit. Even in a commercial piece of equipment, someone may have incorrectly changed them during attempted repairs. A wrong-value part is quite likely in new construction, such as a home-brew project.

Voltage Levels

Check the circuit voltages. If the voltage levels are printed on the schematic, this is easy. If not, analyze the circuit and make some calculations to see what the circuit voltages should be. Remember, however, that the printed or calculated voltages are nominal; measured voltages may vary from the calculations.

When making measurements, remember the following points:

- Make measurements at device leads, not at circuit-board traces or socket lugs.
- Use small test probes to prevent accidental shorts.
- Never connect or disconnect power to solid-state circuits with the switch on. Consider the effect of the meter on measured voltages. A 20-k Ω /V meter may load down a high-impedance circuit and change the voltage.

Voltages may give you a clue to what is wrong with the circuit. If not, check the active device. If you can check the active

device in the circuit, do so. If not, remove it and test it, or substitute a known good device. After connections, most circuit failures are caused directly or indirectly by a bad active device. The experienced troubleshooter usually tests or substitutes these first.

Analyze the other components and determine the best way to test each. There is additional information about electronic components in the electronic-theory chapters and in the **Component Data and References** chapter.

There are two voltage levels in most circuits (V+ and ground, for example). Most component failures (opens and shorts) will shift dc voltages near one of these levels.

Typical failures that show up as incorrect dc voltages include: open coupling transformers; shorted capacitors; open, shorted or overheated resistors and open or shorted semiconductors.

Noise

A slight hiss is normal in all electronic circuits. This noise is produced whenever current flows through a conductor that is warmer than absolute zero. Noise is compounded and amplified by succeeding stages. Repair is necessary only when noise threatens to obscure normally clear signals.

Semiconductors can produce hiss in two ways. The first is normal — an even white noise that is much quieter than the desired signal. Faulty devices frequently produce excessive noise. The noise from a faulty device is usually erratic, with pops and crashes that are sometimes louder than the desired signal. In an analog circuit, the end result of noise is usually sound. In a con-

trol or digital circuit, noise causes erratic operation: unexpected switching and so on.

Noise problems usually increase with temperature, so localized heat may help you find the source. Noise from any component may be sensitive to mechanical vibration. Tapping various components with an insulated screwdriver may quickly isolate a bad part. Noise can also be traced with an oscilloscope or signal tracer.

Nearly any component or connection can be a source of noise. Defective components are the most common cause of crackling noises. Defective connections are a common cause of loud, popping noises.

Check connections at cables, sockets and switches. Look for dirty variable-capacitor wipers and potentiometers. Mica trimmer capacitors often sound like lightning when arcing occurs. Test them by installing a series 0.01- μ F capacitor. If the noise disappears, replace the trimmer.

Potentiometers are particularly prone to noise problems when used in dc circuits. Clean them with spray cleaner and rotate the shaft several times.

Rotary switches may be tested by jumpering the contacts with a clip lead. Loose contacts may sometimes be repaired, either by cleaning, carefully rebending the switch contacts or gluing loose switch parts to the switch deck. Operate variable components through their range while observing the noise level at the circuit output.

Oscillations

Oscillations occur whenever there is sufficient positive feedback in a circuit that has gain. (This can even include digital devices.) Oscillation may occur at any frequency from a low-frequency audio buzz (often called “motorboating”) well up into the RF region.

Unwanted oscillations are usually the result of changes in the active device (increased junction or interelectrode capacitance), failure of an oscillation suppressing component (open decoupling or bypass capacitors or neutralizing components) or new feedback paths (improper lead dress or dirt on the chassis or components). It can also be caused by improper design, especially in home-brew circuits. A shift in bias or drive levels may aggravate oscillation problems.

Oscillations that occur in audio stages do not change as the radio is tuned because the operating frequency, and therefore the component impedances, do not change. However, RF and IF oscillations usually vary in amplitude as operating frequency is changed.

Oscillation stops when the positive

feedback is removed. Locating and replacing the defective (or missing) bypass capacitor may effect an improvement. The defective oscillating stage can be found more reliably with a signal tracer or oscilloscope.

Amplitude Distortion

Amplitude distortion is the product of nonlinear operation. The resultant waveform contains not only the input signal, but new signals at other frequencies as well. All of the frequencies combine to produce the distorted waveform. Distortion in a transmitter gives rise to splatter, harmonics and interference.

Fig 26.11 shows some typical cases of distortion. Clipping (also called flat-topping) is the consequence of excessive drive. The corners on the waveform show that harmonics are present. (A square wave contains the fundamental and all odd harmonics.) These odd harmonics would be heard well away from the operating fre-

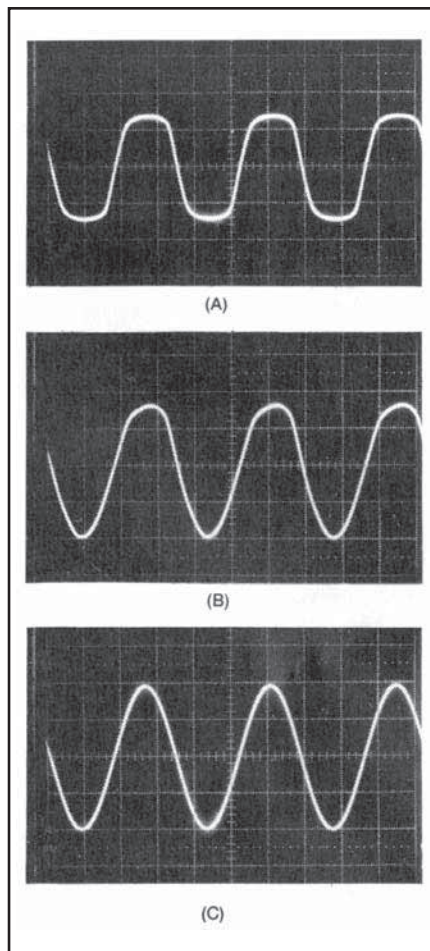

Fig 26.11 — Examples of distorted waveforms. The result of clipping is shown in A. Nonlinear amplification is shown in B. A pure sine wave is shown in C for comparison.

quency, possibly outside of amateur bands. Key clicks are similar to clipping.

Harmonic distortion produces radiation at frequencies far removed from the fundamental; it is a major cause of electromagnetic interference (EMI). Harmonics are generated in nearly every amplifier. When they occur in a transmitter, they are usually caused by insufficient transmitter filtering (either by design, or because of filter component failure).

Incorrect bias brings about unequal amplification of the positive and negative wave sections. The resultant waveform is rich in harmonics.

Frequency Distortion

If a “broadband” amplifier, such as an audio amplifier, doesn’t amplify all frequencies equally, there is frequency distortion. In many cases, this “frequency distortion” is deliberate, as in a transmitter microphone amplifier that has been designed to pass only frequencies from 200 to 2000 Hz. In most cases, the amateur’s ability to detect and measure distortion is limited by available test equipment.

Distortion Measurement

A distortion meter is used to measure distortion of AF signals. A spectrum analyzer is the best piece of test gear to measure distortion of RF signals. If a distortion meter is not available, an estimation of AF distortion can sometimes be made with a function generator (sine and square waves) and an oscilloscope.

To estimate the amount of frequency distortion in an audio amplifier, set the generator for a square wave and look at it on the ‘scope. (Use a low-capacitance probe.) The wave should show square corners and a flat top. Next, inject a square wave at the amplifier input and again look at the input wave on the ‘scope. Any new distortion is a result of the test circuit loading the generator output. (If the wave shape is severely distorted, the test is not valid.) Now, move the test probe to the test circuit output and look at the waveform. Refer to Fig 26.12 to evaluate square-wave distortion and its cause.

The above applies only to audio amplifiers without frequency tailoring. In RF gear, the transmitter may have a very narrow audio passband, so inserting a square wave into the microphone input may result in an output that is difficult to interpret. The frequency of the square wave will have a significant effect.

Anything that changes the proper bias of an amplifier can cause distortion. This includes failures in the bias components, leaky transistors or vacuum tubes with interelectrode shorts. These conditions

Look for the Obvious

The best example of how looking for the obvious can save a lot of repair time comes from my days as the manager of an electronics service shop. We had hired a young engineering graduate to work for us part time. He was the proud holder of a First-Class FCC Radiotelephone license (the predecessor to today's General Radiotelephone license). He was a likable sort, but, well . . . the chip on his young shoulder was a bit hard to take sometimes.

One day, I had asked him to repair a "tube-type" FM tuner. He had been poking around without success: hooking up a voltmeter, oscilloscope and signal generator, pretty much in that order. Finally, in total exasperation, he pronounced that the unit was beyond economical repair and suggested that I return it to the customer unfixed. The particular customer was a "regular," so I wanted to be sure of the diagnosis before I sent the tuner back. I told the tech I wanted to take a look at it before we wrote it off.

He started to expound loudly that there was no way that I, a lowly technician (even though I was also his boss) could find a problem that he, an engineering graduate and holder of a First Class . . . you get the idea. I did remind him gently that I was the boss, and he, realizing that I had him there, stepped aside, mumbling something about my suiting myself. He stepped back to gloat when I couldn't find it either.

I began by giving the tuner a thorough visual inspection. I looked it over carefully from stem to stern, while listening to our young apprentice proclaiming with certainty that one cannot fix electronic equipment by merely looking at it. I didn't see anything obviously wrong, so I decided to move wires and components around, looking for a bad solder joint or broken component. Of course, I had to listen to him telling me that one cannot possibly find bad components by touch. Unfortunately for our loud friend, he couldn't have been more wrong.

I grabbed hold of a ceramic bypass capacitor to give it a little wiggle, and much to my surprise it was hot enough to cause some real pain. I kept my composure; it was an opportunity for a good learning experience. Ceramic capacitors don't get very hot unless they are either shorted or very leaky. I kept silent and never let on that my finger "probe" had indeed located the bad part. I set the tuner down, sighed a bit, and then looked him right in the eye when I pointed to the capacitor and said "Change that part!"

They probably heard his bellowing in the next county! He went on and on about how there was just no way in the world that I could tell a good part from a bad part by just looking and touching things. He alternated between accusing me of pulling his leg and guessing, then back to just plain bellowing again. After letting this "source of great noise" run his course, I offered the ultimate shop challenge — I bet him a can of soda pop.

The traditional shop challenge did the trick. He smugly grabbed a replacement part from the bin and got out his soldering iron. In a matter of seconds (a new shop record, I believe) the capacitor was installed. He hooked the tuner up to a test amplifier and turned them on. After a couple of seconds, he smugly turned to me and started an "I told ya' so!" Just then, the last tube warmed up and the sounds of our local rock station blasted out of the speaker. He stopped in mid "told-ya" and stared at the tuner in disbelief. The tempo and pitch of his voice jumped by an order of magnitude as he asked me how I managed to fix the tuner without using even an ohmmeter to test a fuse. It was weeks before I told him — the soda pop tasted especially good.

The moral of the story is clear; sophisticated test equipment and procedures are useful in troubleshooting, but they are no substitute for the experience of a veteran troubleshooter. — *Ed Hare, W1RFI, ARRL Laboratory Supervisor*

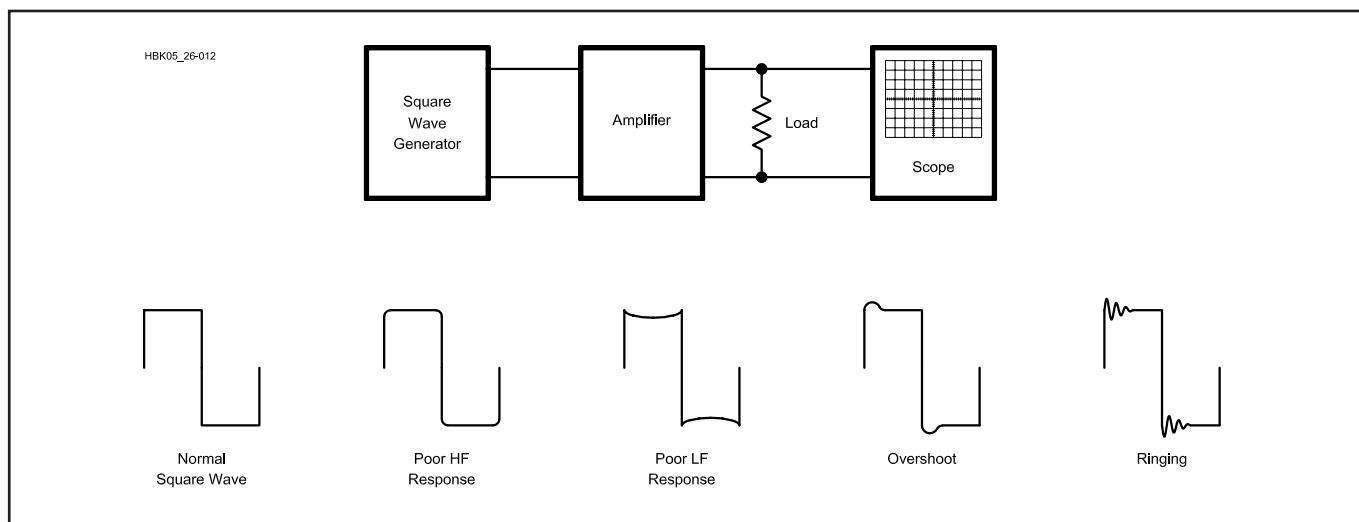

Fig 26.12 — Square-wave distortion and probable causes.

may mimic AGC trouble. Improper bias often results from an overheated or open resistor. Heat can cause resistor values to permanently increase. Leaky, or shorted capacitors and RF feedback can also produce distortion by disturbing bias levels. Distortion is also caused by circuit imbalance in Class AB or B amplifiers.

Oscillations in an IF amplifier may produce distortion. They cause constant, full AGC action, or generate spurious signals that mix with the desired signal. IF oscillations are usually evident on the S meter, which will show a strong signal even with the antenna disconnected.

Alignment

Alignment is rarely the cause of an electronics problem. As an example, suppose an AM receiver suddenly begins producing weak and distorted audio. An inexperienced person frequently suspects poor alignment as a common problem. Even though the manufacturer's instructions and the proper equipment are not available, our "friend" (this would never be one of US!) begins "adjusting" the transformer cores. Before long, the set is hopelessly misaligned. Now our misguided ham must send the radio to a shop for an alignment that was not needed before repairs were attempted.

Alignment does not shift suddenly. A normal signal tracing procedure would have shown that the signal was good up to the audio-output IC, but badly distorted after that. The defective IC that caused the problem would have been easily found and quickly replaced.

Contamination

Contamination is another common service problem. Cold soda pop spilled into a hot piece of electronics is an extreme example (but one that does actually happen).

Conductive contaminants range from water to metal filings. Most can be removed by a thorough cleaning. Any of the residue-free cleaners can be used, but remember that the cleaner may also be conductive. Do not apply power to the circuit until the area is completely dry.

Keep cleaners away from variable-capacitor plates, transformers and parts that may be harmed by the chemical. The most common conductive contaminant is solder, either from a printed-circuit board "solder bridge" or a loose piece of solder deciding to surface at the most inconvenient time.

Solder "Bridges"

In a typical PC-board solder bridge, the solder that is used to solder one component has formed a short circuit to another

PC-board trace or component. Unfortunately, they are common in both new construction and repair work. Look carefully for them after you have completed any soldering, especially on a PC-board. It is even possible that a solder bridge may exist in equipment you have owned for a long time, unnoticed until it suddenly decided to become a short circuit.

Related items are loose solder blobs, loose hardware or small pieces of component leads that can show up in the most awkward and troublesome places.

Arcing

Arcing is a serious sign of trouble. It may also be a real fire hazard. Arc sites are usually easy to find because an arc that generates visible light or noticeable sound also pits and discolors conductors.

Arcing is caused by component failure, dampness, dirt or lead dress. If the dampness is temporary, dry the area thoroughly and resume operation. Dirt may be cleaned from the chassis with a residue-free cleaner. Arrange leads so high-voltage conductors are isolated. Keep them away from sharp corners and screw points.

Arcing occurs in capacitors when the working voltage is exceeded. Air-dielectric variable capacitors can sustain occasional arcs without damage, but arcing indicates operation beyond circuit limits. Transmatches working beyond their ability may suffer from arcing. A failure or high SWR in an antenna circuit may also cause transmitter arcing.

Replacing Parts

If you have located a defective component within a stage, you need to replace it. When replacing socket mounted components, be sure to align the replacement part correctly. Make sure that the pins of the device are properly inserted into the socket.

Some special tools can make it easier to remove soldered parts. A chisel-shaped soldering tip helps pry leads from printed-circuit boards or terminals. A desoldering iron or bulb forms a suction to remove excess solder, making it easier to remove the component. Spring-loaded desoldering pumps are more convenient than bulbs. Desoldering wick draws solder away from a joint when pressed against the joint with a hot soldering iron.

In all cases, remember that soldering tools and melted solder can be hot and dangerous! Wear protective goggles and clothing when soldering. A full course in first aid is beyond the scope of this chapter, but if you burn your fingers, run the burn immediately under cold water and seek first aid or medical attention. Always

seek medical attention if you burn your eyes; even a small burn can develop into serious trouble.

TYPICAL SYMPTOMS AND FAULTS

Power Supplies

Many equipment failures are caused by power-supply trouble. Fortunately, most power-supply problems are easy to find and repair (see **Fig 26.13**). First, use a voltmeter to measure output. Loss of output voltage is usually caused by an open circuit. (A short circuit draws excessive current that opens the fuse, thus becoming an open circuit.)

Most fuse failures are caused by a shorted diode in the power supply or a shorted power device (RF or AF) in the failed equipment. More rarely, one of the filter capacitors can short. If the fuse has opened, turn off the power, replace the fuse and measure the load-circuit dc resistance. The measured resistance should be consistent with the power-supply ratings. A short or open load circuit indicates a problem.

If the measured resistance is too low, check the load circuit with an ohmmeter to locate the trouble. (Nominal circuit resistances are included in some equipment manuals.) If the load circuit resistance is normal, suspect a defective regulator IC or problem in the rest of the unit. Electrolytic capacitors fail with long (two years) disuse; the electrolytic layer may be reformed as explained later in this chapter.

IC regulators can oscillate, sometimes causing failure. The small-value capacitors on the input, output or adjustment pins of the regulator prevent oscillations. Check or replace these capacitors whenever a regulator has failed.

AC ripple (hum) is usually caused by low-value filter capacitors in the power supply. Less likely, hum can also be caused by excessive load, a regulation problem or RF feedback in the power supply. Look for a defective filter capacitor (usually open or low-value), defective regulator or shorted filter choke. In older equipment, the defective filter capacitor will often have visible leaking electrolyte: Look for corrosion residue at the capacitor leads. In new construction projects make sure RF energy is not getting into the power supply.

Here's an easy filter-capacitor test: Temporarily connect a replacement capacitor (about the same value and working voltage) across the suspect capacitor. If the hum goes away, replace the bad component permanently.

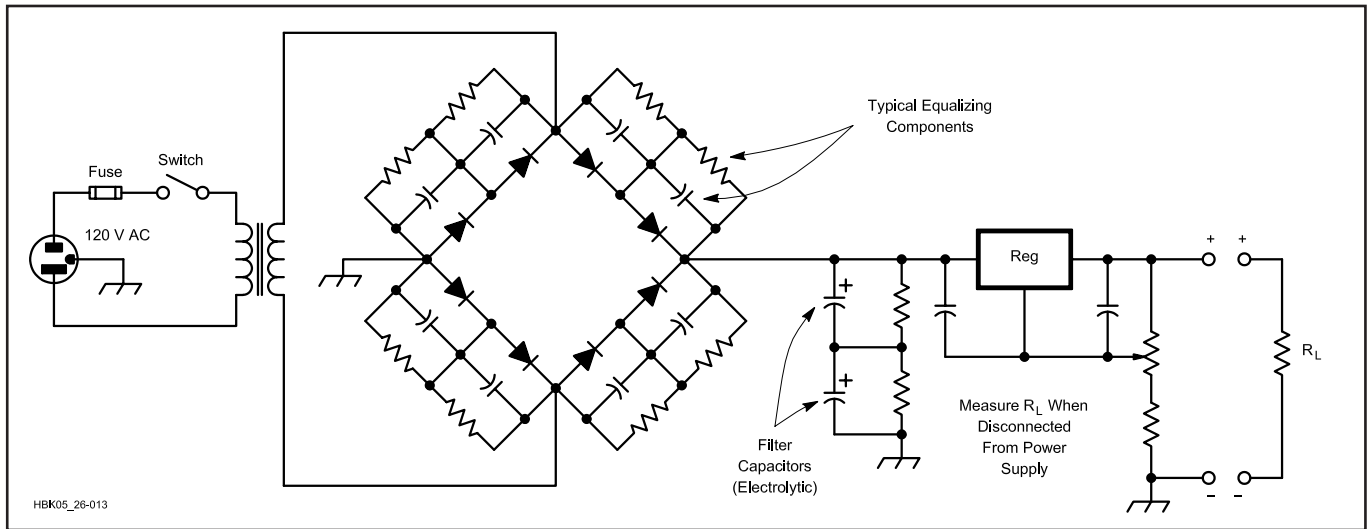

Fig 26.13 — Schematic of a typical power supply showing the components mentioned in the text.

Once the faulty component is found, inspect the surrounding circuit and consider what may have caused the problem. Sometimes one bad component can cause another to fail. For example, a shorted filter capacitor increases current flow and burns out a rectifier diode. While the defective diode is easy to find, the capacitor may show no visible damage.

Switching Power Supplies

Switching power supplies are quite different than conventional supplies. In a “switcher,” a switching transistor is used to change dc voltage levels. They usually have AF oscillators and complex feedback paths. Any component failure in the rectifiers, switch, feedback path or load usually results in a completely dead supply. Every part is suspect. While active device failure is still the number one suspect, it pays to carefully test all components if a diagnosis cannot be made with traditional techniques.

Some equipment, notably TVs and monitors, derive some of the power-supply voltages from the proper operation of other parts of the circuit. In the case of a TV or monitor, voltages are often derived by adding secondary low-voltage windings to the flyback transformer and rectifying the resultant ac voltage (usually about 15 kHz). These voltages will be missing if there is any problem with the circuit from which they are derived.

Amplifiers

Amplifiers are the most common circuits in electronics. The output of an ideal amplifier would match the input signal in every respect except magnitude: No distortion or noise would be added. Real amplifiers always add noise and distortion.

Gain

Gain is the measure of amplification. Gain is usually expressed in decibels (dB) over a specified frequency range, known as the bandwidth or passband of the amplifier. When an amplifier is used to provide a stable load for the preceding stage, or as an impedance transformer, there may be little or no voltage gain.

Amplifier failure usually results in a loss of gain or excessive distortion at the amplifier output. In either case, check external connections first. Is there power to the stage? Has the fuse opened? Check the speaker and leads in audio output stages, the microphone and push-to-talk (PTT) line in transmitter audio sections. Excess voltage, excess current or thermal runaway can cause sudden failure of semiconductors. The failure may appear as either a short, or open, circuit of one or more PN junctions.

Thermal runaway occurs most often in bipolar transistor circuits. If degenerative feedback (the emitter resistor reduces base-emitter voltage as conduction increases) is insufficient, thermal runaway will allow excessive current flow and device failure. Check transistors by substitution, if possible.

Faulty coupling components can reduce amplifier output. Look for component failures that would increase series, or decrease shunt, impedance in the coupling network. Coupling faults can be located by signal tracing or parts substitution. Other passive component defects reduce amplifier output by shifting bias or causing active-device failure. These failures are evident when the dc operating voltages are measured.

In a receiver, a fault in the AGC loop

may force a transistor into cutoff or saturation. Open the AGC line to the device and substitute a variable voltage for the AGC signal. If amplifier action varies with voltage, suspect the AGC-circuit components; otherwise, suspect the amplifier.

In an operating amplifier, check carefully for oscillations or noise. Oscillations are most likely to start with maximum gain and the amplifier input shorted. Any noise that is induced by 60-Hz sources can be heard, or seen with a 'scope synchronized to the ac line.

Unwanted amplifier RF oscillations should be cured with changes of lead dress or circuit components. Separate input leads from output leads; use coaxial cable to carry RF between stages; neutralize interelement or junction capacitance. Ferrite beads on the control element of the active device often stop unwanted oscillations.

Low-frequency oscillations (“motor-boating”) indicate poor stage isolation or inadequate power-supply filtering. Try a better lead-dress arrangement and/or check the capacitance of the decoupling network (see Fig 26.14). Use larger capacitors at the power-supply leads; increase the number of capacitors or use separate decoupling capacitors at each stage. Coupling capacitors that are too low in value can also cause poor low-frequency response. Poor response to high frequencies is usually caused by circuit design.

Amplifiers vs Switches

To help you hone your skills, let’s analyze a few simple circuits. There is often a big difference in the performance of similar-looking circuits. Consider the differences between a common-emitter amplifier and a common-emitter switch circuit.

Common-Emitter Amplifier

Fig 26.15 is a schematic of a common-emitter transistor amplifier. The emitter, base and collector leads are labeled e, b and c, respectively. Important dc voltages are measured at these points and designated V_e , V_b and V_c . Similarly, the important currents are I_e , I_b and I_c . $V+$ indicates the supply voltage.

First, analyze the voltages and signal levels in this circuit. The “junction drop,” is the potential measured across a semiconductor junction that is conducting. It is typically 0.6 V for silicon and 0.2 V for germanium transistors.

This is a Class-A linear circuit. In Class-A circuits, the transistor is always conducting some current. R1 and R2 form a voltage divider that supplies dc bias (V_b) for the transistor. Normally, V_e is equal to V_b less the emitter-base junction drop. R4 provides degenerative dc bias, while C3 provides a low-impedance path for the signal. From this information, normal operating voltages can be estimated.

The bias and voltages will be set up so that the transistor collector voltage, V_c , is somewhere between $V+$ and ground potential. A good rule of thumb is that V_c should be about one-half of $V+$, although this can vary quite a bit, depending on component tolerances. The emitter voltage is usually a small percentage of V_c , say about 10%.

Any circuit failure that changes I_c (ranging from a shorted transistor or a failure in the bias circuit) changes V_c and V_e as well. An increase of I_c lowers V_c and raises V_e . If the transistor shorts from collector to emitter, V_c drops to about 1.2 V, as determined by the voltage divider formed by R3 and R4.

You would see nearly the same effect if the transistor were biased into saturation by collector-to-base leakage, a reduction in R1's value or an increase in R2's value. All of these circuit failures have the same effect. In some cases, a short in C1 or C2 could cause the same symptoms.

To properly diagnose the specific cause of low V_c , consider and test all of these parts. It is even more complex; an increase in R3's value would also decrease V_c . There would be one valuable clue, however; if R3 increased in value, I_c would not increase; V_e would also be low.

Anything that decreases I_c increases V_c . If the transistor failed “open,” R1 increased in value, R2 were shorted to ground or R4 opened, then V_c would be high.

Common-Emitter Switch

A common-emitter transistor switching

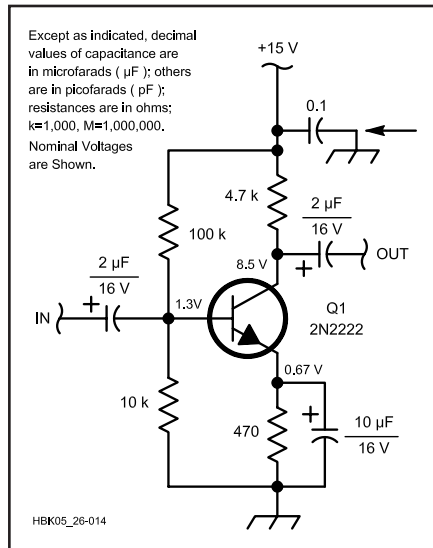

Fig 26.14 — The decoupling capacitor in this circuit is designated with an arrow.

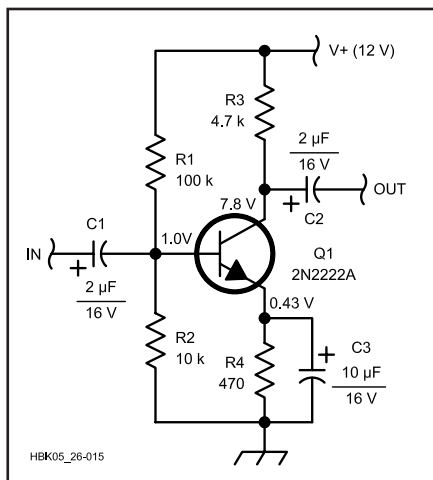

Fig 26.15 — A typical common-emitter audio amplifier.

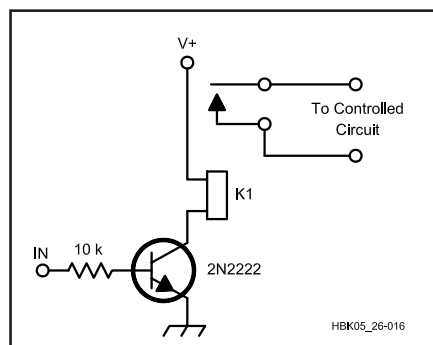

Fig 26.16 — A typical common-emitter switching amplifier.

circuit is shown in **Fig 26.16**. This circuit functions differently than the circuit shown in Fig 26.15. A linear amplifier is designed so that the output signal is a faithful reproduction of the input signal. Its input and output may have any value from $V+$ to ground.

The switching circuit of Fig 26.16, however, is similar to a “digital” circuit. The active device is either on or off, 1 or 0, just like digital logic. Its input signal level should either be 0 V or positive enough to switch the transistor on fully (saturate). Its output state should be either full off (with no current flowing through the relay), or full on (with the relay energized). A voltmeter placed on the collector will show either approximately +12 V or 0 V, depending on the input.

Understanding this difference in operation is crucial to troubleshooting the two circuits. If V_c were +12 V in the circuit in Fig 26.15, it would indicate a circuit failure. A V_c of +12 V in the switching circuit, is normal when V_b is 0 V. (If V_b measured 0.8 V or higher, V_c should be low and the relay energized.)

DC Coupled Amplifiers

In dc coupled amplifiers, the transistors are directly connected together without coupling capacitors. They comprise a unique troubleshooting case. Most often, when one device fails, it destroys one or more other semiconductors in the circuit. If you don't find all of the bad parts, the remaining defective parts can cause the installed replacements to fail immediately. To reliably troubleshoot a dc coupled circuit, you must test every semiconductor in the circuit and replace them all at once.

Oscillators

In many circuits, a failure of the oscillator will result in complete circuit failure. A transmitter will not transmit, and a superheterodyne receiver will not receive if you have an internal oscillator failure. (These symptoms do not always mean oscillator failure, however.)

Whenever there is weakening or complete loss of signal from a radio, check oscillator operation and frequency. There are several methods:

- Use a receiver with a coaxial probe to listen for the oscillator signal.
- A dip meter can be used to check oscillators. In the absorptive mode, tune the dip meter to within ± 15 kHz of the oscillator, couple it to the circuit, and listen for a beat note in the dip-meter headphones.
- Look at the oscillator waveform on a 'scope. The operating frequency can't

be determined with great accuracy, but you can see if the oscillator is working at all. Use a low capacitance (10×) probe for oscillator observations.

- Tube oscillators usually have negative grid bias when oscillating. Use a high-impedance voltmeter to measure grid bias. The bias also changes slightly with frequency.
- Emitter current varies slightly with frequency in transistor oscillators. Use a sensitive, high-impedance voltmeter across the emitter resistor to observe the current level. (You can use Ohm's Law to calculate the current value.)

Many modern oscillators are phase-locked loops (PLLs). A PLL is a marriage of an analog oscillator and digital control circuitry. Read the Digital Circuitry section in this chapter and the **Oscillators and Synthesizers** chapter of this book in order to learn PLL repair techniques.

To test for a failed oscillator tuned with inductors and capacitors, use a dip meter in the active mode. Set the dip meter to the oscillator frequency and couple it to the oscillator output circuit. If the oscillator is dead, the dip-meter signal will take its place and temporarily restore some semblance of normal operation. Tune the dip meter very slowly, or you may pass stations so quickly that they sound like "birdies."

Stability

We are spoiled; modern amateur equipment is very stable. Drift of several kilohertz per hour was once normal. You may want to modify old equipment for more stability, but drift that is consistent with the equipment design is not a defect. (This applies to new equipment as well as old.) It is normal for some digital displays to flash back and forth between two values for the least-significant digit.

Drift is caused by variations in the oscillator. Poor voltage regulation and heat are the most common culprits. Check regulation with a voltmeter (use one that is not affected by RF). Voltage regulators are usually part of the oscillator circuit. Check them by substitution.

Chirp is a form of rapid drift that is usually caused by excessive oscillator loading or poor power-supply regulation. The most common cause of chirp is poor design. If chirp appears suddenly in a working circuit, look for component or design defects in the oscillator or its buffer amplifiers. (For example, a shorted coupling capacitor increases loading drastically.) Also check lead dress, tubes and switches for new feedback paths (feedback defeats buffer action).

Frequency instability may also result

from defects in feedback components. Too much feedback may produce spurious signals, while too little makes oscillator start-up unreliable.

Sudden frequency changes are frequently the result of physical variations. Loose components or connections are probable causes. Check for arcing or dirt on printed-circuit boards, trimmers and variable capacitors, loose switch contacts, bad solder joints or loose connectors.

Frequency Accuracy

Dial tracking errors may be associated with oscillator operation. Misadjustments in the frequency-determining components make dial accuracy worse at the ends of the dial. Tracking errors that are constant everywhere in the passband can be caused by misalignment or by slippage in the dial drive mechanism or indicator. This is usually cured by calibration of a simple mechanical adjustment.

In LC oscillators, tracking at the high-frequency end of the dial is controlled by trimmer capacitors. A trimmer is a variable capacitor connected in parallel with the main tuning capacitor (see Fig 26.17). The trimmer represents a higher percentage of the total capacitance at the high end of the tuning range. It has relatively little effect on tuning characteristics at the low-frequency end of the dial.

Low-end tracking is adjusted by a padder capacitor. A padder is a variable capacitor that is connected in series with the main tuning capacitor. Padder capacitance has a greater effect at the low-frequency end of the dial. The padder capacitor is often eliminated to save money. In that case, the low-frequency tracking is adjusted by the main tuning coil.

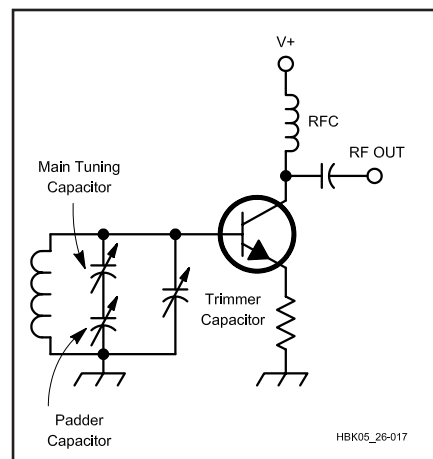

Fig 26.17 — A partial schematic of a simple oscillator showing the locations of the trimmer and padder capacitors.

Control Circuitry

Semiconductors have made it practical to use diodes for switching, running only a dc lead to the switching point. This eliminates problems caused by long analog leads in the circuit. Semiconductor switching usually reduces the cost and complexity of switching components. Switching speed is increased; contact corrosion and breakage are eliminated. In exchange, troubleshooting is complicated by additional components such as voltage regulators and decoupling capacitors (see Fig 26.18). The technician must consider many more components and symptoms when working with diode and transistor switched circuits.

Mechanical switches are relatively rugged. They can withstand substantial voltage and current surges. The environment does not drastically affect them, and there is usually visible damage when they fail. Semiconductor switching offers inexpensive, high-speed operation. When subjected to excess voltage or current, however, most transistors and diodes silently expire. Occasionally, if the troubleshooter is lucky, one sends up a smoke signal to mark its passing.

Temperature changes semiconductor characteristics. A normally adequate control signal may not be effective when transistor beta is lowered by a cold environment. Heat may cause a control voltage regulator to produce an improper control signal.

A control signal is actually a bias for the semiconductor switch. Forward biased diodes and transistors act as closed switches; reverse biased components simulate open switches. If the control (bias) signal is not strong enough to completely saturate the semiconductor, conduction may not continue through a full ac cycle. Severe distortion can be the result.

When dc control leads provide unwanted feedback paths, switching transistors may become modulators or mixers. Additionally, any reverse biased semiconductor junction is a potential source of white noise.

Microprocessor Control

Nearly every new transceiver is controlled by a miniature computer. Entire books have been written about microprocessor (μP) control. Many of the techniques are discussed in the Digital Circuitry section. Many microprocessor related problems end up back at the factory for service; however, the surface mounted components are just too difficult for most hams to replace. For successful repair of microprocessor controlled circuits, you should have the knowledge and

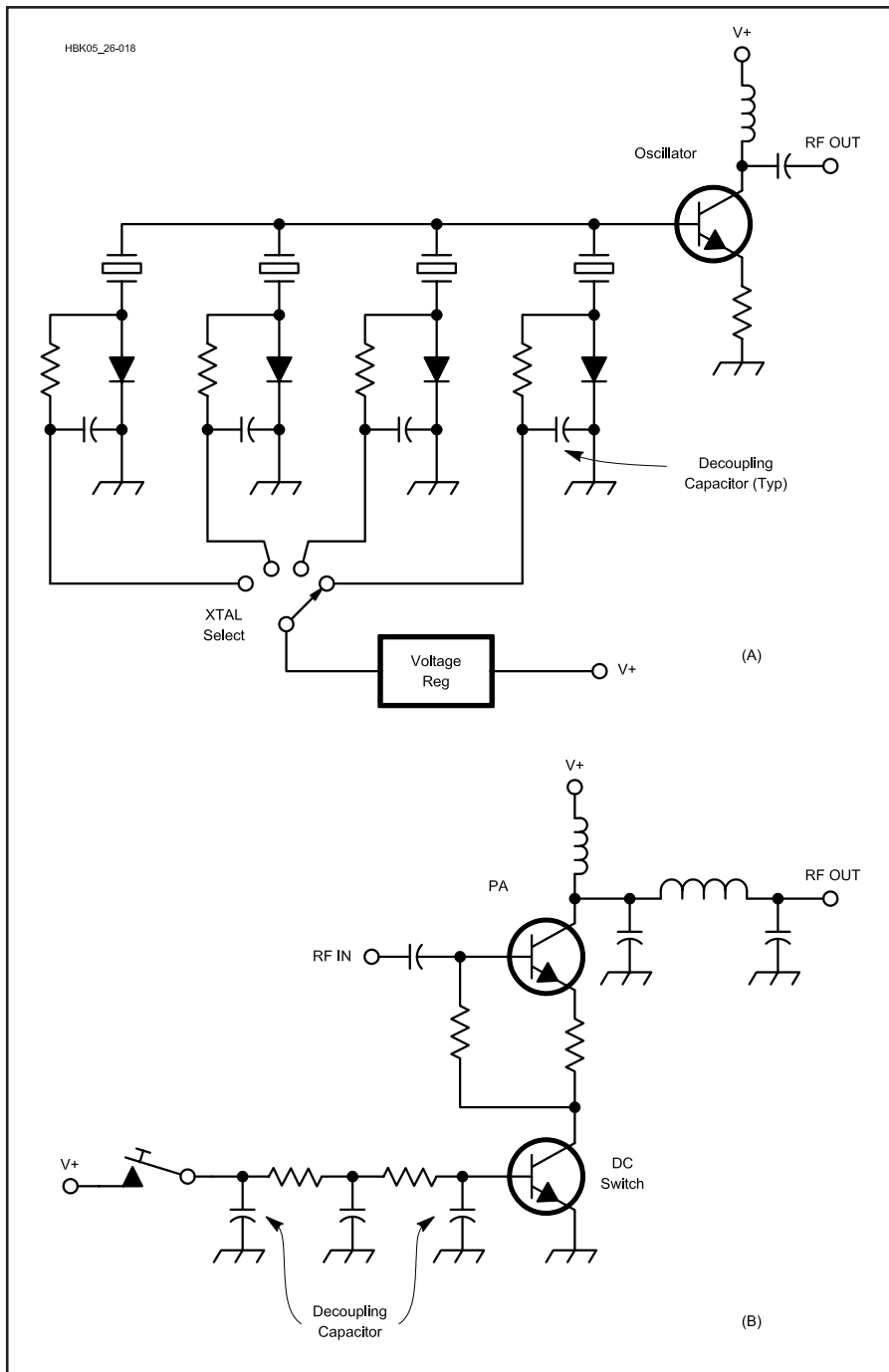

Fig 26.18 — Diode switching selects oscillator crystals at A. A transistor switch is used to key a power amplifier at B.

test equipment necessary for computer repair. Familiarity with machine-language programming may also be desirable.

Digital Circuitry

The digital revolution has hit most ham shacks and amateur equipment. Microprocessors have brought automation to everything from desk clocks to ham transceivers and computer controlled EME antenna arrays. Although every aspect of their operation may be resolved to a simple 1 or

0, or tristate (an infinite impedance or open circuit), the symptoms of their failure are far more complicated. As with other equipment:

- Observe the operating characteristics.
- Study the block diagram and the schematic.
- Test.
- Replace defective parts.

Problems in digital circuits have two elementary causes. First, the circuit may

give false counts because of electrical noise at the input. Second, the gates may lock in one state.

False counts from noise are especially likely in a ham shack. (A 15- to 20- μ s voltage spike can trigger a TTL flip-flop.) Amateur Radio equipment often switches heavy loads; the attendant transients can follow the ac line or radiate directly to nearby digital equipment. Oscillation in the digital circuit can also produce false counts.

How these false counts affect a circuit is dependent on the design. A station clock may run fast, but a microprocessor controlled transceiver may “decide” that it is only a receiver. It might even be difficult to determine that there is a problem without a logic analyzer or a multitrace oscilloscope and a thorough understanding of circuit operation.

Begin by removing the suspect equipment from RF fields. If the symptoms stop when there is no RF energy around, you need to shield the equipment from RF.

In the mid '90s, microprocessors in general use ran clock speeds up to a few hundred megahertz. (They are increasing all the time.) It may be impossible to filter RF signals from the lines when the RF is near the clock frequency. In these cases, the best approach is to shield the digital circuit and all lines running to it.

If digital circuitry interferes with other nearby equipment, it may be radiating spurious signals. These signals can interfere with your Amateur Radio operation or other services. Digital circuitry can also be subject to interference from strong RF fields. Erratic operation or a complete “lock up” is often the result. *The ARRL RFI Book* has a chapter on computer and digital interference. That chapter discusses interference to and from digital devices and circuits.

Logic Levels

To troubleshoot a digital circuit, check for the correct voltages at the pins of each chip. The correct voltages may not always be known, but you should be able to identify the power pins (V_{cc} and ground).

The voltages on the other pins should be either a logic high, a logic low, or tristate (more on this later). In most working digital circuitry the logic levels are constantly changing, often at RF rates. A dc voltmeter may not give reliable readings. An oscilloscope or logic analyzer is usually needed to troubleshoot digital circuitry.

Most digital circuit failures are caused by a failed logic IC. In clocked circuits, listen for the clock signal with a coax probe and a suitable receiver. If the signal is found at the clock chip, trace it to each of the other ICs to be sure that the clock

system is intact. Some digital circuits use VHF clock speeds; an oscilloscope must have a bandwidth of at least twice the clock speed to be useful. If you have a suitable scope, check the pulse timing and duration against circuit specifications.

As in most circuits, failures are catastrophic. It is unlikely that an AND gate will suddenly start functioning like an OR gate. It is more likely that the gate will have a signal at its input, and no signal at the output. In a failed device, the output pin will have a steady voltage. In some cases, the voltage is steady because one of the input signals is missing. Look carefully at what is going into a digital IC to determine what should be coming out. Keep manufacturers' data books handy. These data books describe the proper functioning of most digital devices.

Tristate Devices

Many digital devices are designed with a third logic state, commonly called tristate. In this state, the output of the device acts as if it weren't there at all. Many such devices can be connected to a common "bus," with the devices that are active at any given time selected by software or hardware control signals. A computer's data and address busses are good examples of this. If any one device on the bus fails by locking itself on in a 0 or 1 logic state, the entire bus becomes nonfunctional. These tristate devices can be locked "on" by inherent failure or a failure of the signal that controls them.

Simple Gate Tests

Logic gates, flip-flops and counters can be tested (see Fig 26.19) by triggering them manually, with a power supply (4 to 5 V is a safe level). Diodes may be checked with an ohmmeter. Testing of more complicated ICs requires the use of a logic analyzer, multitrace scope or a dedicated IC tester.

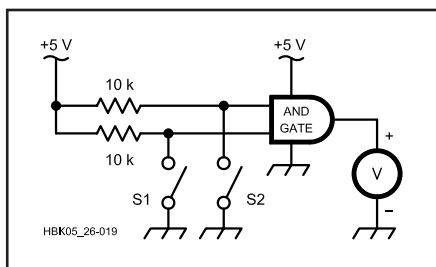

Fig 26.19 — This simple digital circuit can be tested with a few components. In this case, an AND gate is tested. Open and close S1 and S2 while comparing the voltmeter reading with a truth table for the device.

TROUBLESHOOTING HINTS

Receivers

A receiver can be diagnosed using any of the methods described earlier, but if there is not even a faint sound from the speaker, signal injection is not a good technique. If you lack troubleshooting experience, avoid following instinctive hunches. That leaves signal tracing as the best method.

The important characteristics of a receiver are selectivity, sensitivity, stability and fidelity. Receiver malfunctions ordinarily affect one or more of these areas.

Selectivity

Tuned transformers or the components used in filter circuits may develop a shorted turn, capacitors can fail and alignment is required occasionally. Such defects are accompanied by a loss of sensitivity. Except in cases of catastrophic failure (where either the filter passes all signals, or none), it is difficult to spot a loss of selectivity. Bandwidth and insertion-loss measurements are necessary to judge filter performance.

Sensitivity

A gradual loss of sensitivity results from gradual degradation of an active device or long-term changes in component values. Sudden partial sensitivity changes are usually the result of a component failure, usually in the RF or IF stages. Complete and sudden loss of sensitivity is caused by an open circuit anywhere in the signal path or by a "dead" oscillator.

Receiver Stability

The stability of a receiver depends on its oscillators. See the Oscillators section elsewhere in this chapter.

Distortion

Receiver distortion may be the effect of poor connections or faulty components in the signal path. AGC circuits produce many receiver defects that appear as distortion or insensitivity.

AGC

AGC failure usually causes distortion that affects only strong signals. All stages operate at maximum gain when the AGC influence is removed. An S meter can help diagnose AGC failure because it is operated by the AGC loop.

An open AGC bypass capacitor causes feedback through the loop. This often results in a receiver "squeal" (oscillation). Changes in the loop time constant affect tuning. If stations consistently blast, or are too weak for a brief time when first tuned

in, the time constant is too fast. An excessively slow time constant makes tuning difficult, and stations fade after tuning. If the AGC is functioning, but the "timing" seems wrong, check the large-value capacitors found in the AGC circuit — they usually set the AGC time constants. If the AGC is not functioning, check the AGC-detector circuit. There is often an AGC voltage that is used to control several stages. A failure in any one stage could affect the entire loop.

Detector Problems

Detector trouble usually appears as complete loss or distortion of the received signal. AM, SSB and CW signals may be weak and unintelligible. FM signals will sound distorted. Look for an open circuit in the detector near the detector diodes. If tests of the detector parts indicate no trouble, look for a poor connection in the power-supply or ground lead. A BFO that is "dead" or off frequency prevents SSB and CW reception. In modern rigs, the BFO frequency is either crystal controlled, or derived from the PLL.

Receiver Alignment

Unfortunately, IF transformers are as enticing to the neophyte technician as a carburetor is to a shade-tree mechanic. In truth, radio alignment (and for that matter, carburetor repair) is seldom required. Circuit alignment may be justified under the following conditions:

- The set is very old and has not been adjusted in many years.
- The circuit has been subject to abusive treatment or environment.
- There is obvious misalignment from a previous repair.
- Tuned-circuit components or crystals have been replaced.
- An inexperienced technician attempted alignment without proper equipment. ("But all the screws in those little metal cans were loose!")
- There is a malfunction, but all other circuit conditions are normal. (Faulty transformers can be located because they will not tune.)

Even if one of the above conditions is met, do not attempt alignment unless you have the proper equipment. Receiver alignment should progress from the detector to the antenna terminals. When working on an FM receiver, align the detector first, then the IF and limiter stages and finally the RF amplifier and local oscillator stages. For an AM receiver, align the IF stages first, then the RF amplifier and oscillator stages.

Both AM and FM receivers can be aligned in much the same manner. Always

follow the manufacturer's recommended alignment procedure. If one is not available, follow these guidelines:

1. Set the receiver RF gain to maximum, BFO control to zero or center (if applicable to your receiver) and tune to the high end of the receiver passband.
2. Disable the AGC.
3. Set the signal source to the center of the IF passband, with no modulation and minimum signal level.
4. Connect the signal source to the input of the IF section.
5. Connect a voltmeter to the IF output as shown in **Fig 26.20**.
6. Adjust the signal-source level for a slight indication on the voltmeter.
7. Peak each IF transformer in order, from the meter to the signal source. The adjustments interact; repeat steps 6 and 7 until adjustment brings no noticeable improvement.
8. Remove the signal source from the IF-section input, reduce the level to minimum, set the frequency to that shown on the receiver dial and connect the source to the antenna terminals. If necessary, tune around for the signal — if the local oscillator is not tracking, it may be off.
9. Adjust the signal level to give a slight reading on the voltmeter.
10. Adjust the trimmer capacitor of the RF amplifier for a peak reading of the test signal. (Verify that you are reading the correct signal by switching the source on and off.)

11. Reset the signal source and the receiver tuning for the low end of the passband.

12. Adjust the local-oscillator padder for peak reading.

13. Steps 8 through 11 interact, so repeat them until the results are as good as you can get them.

Transmitters

Many potential transmitter faults are discussed in several different places in this chapter. There are, however, a few techniques used to ensure stable operation of RF amplifiers in transmitters that are not covered elsewhere.

High-power RF amplifiers often use parasitic chokes to prevent instability. Older parasitic chokes usually consist of a 51- to 100- Ω noninductive resistor with a coil wound around the body and connected to the leads. It is used to prevent VHF and UHF oscillations in a vacuum-tube amplifier. The suppressor is placed in the plate lead, close to the plate connection.

In recent years, problems with this style of suppressor have been discovered. Look at the **RF Power Amplifiers** chapter for information about suppressing parasitics.

Parasitic chokes often fail from excessive current flow. In these cases, the resistor is charred. Occasionally, physical shock or corrosion produces an open circuit in the coil. Test for continuity with an ohmmeter.

Transistor amplifiers are protected

against parasitic oscillations by low-value resistors or ferrite beads in the base or collector leads. Resistors are used only at low power levels (about 0.5 W), and both methods work best when applied to the base lead. Negative feedback is used to prevent oscillations at lower frequencies. An open component in the feedback loop may cause low-frequency oscillation, especially in broadband amplifiers.

Keying

The simplest form of modulation is on/off keying. Although it may seem that there cannot be much trouble with such an elementary form of modulation, two very important transmitter faults are the result of keying problems.

Key clicks are produced by fast rise and decay times of the keying waveform. Most transmitters include components in the keying circuitry to prevent clicks. When clicks are experienced, check the keying filter components first, then the succeeding stages. An improperly biased power amplifier, or a Class C amplifier that is not keyed, may produce key clicks even though the keying waveform earlier in the circuit is correct. Clicks caused by a linear amplifier may be a sign of low-frequency parasitic oscillations. If they occur in an amplifier, suspect insufficient power-supply decoupling. Check the power-supply filter capacitors and all bypass capacitors.

The other modulation problem associated with on/off keying is called back-

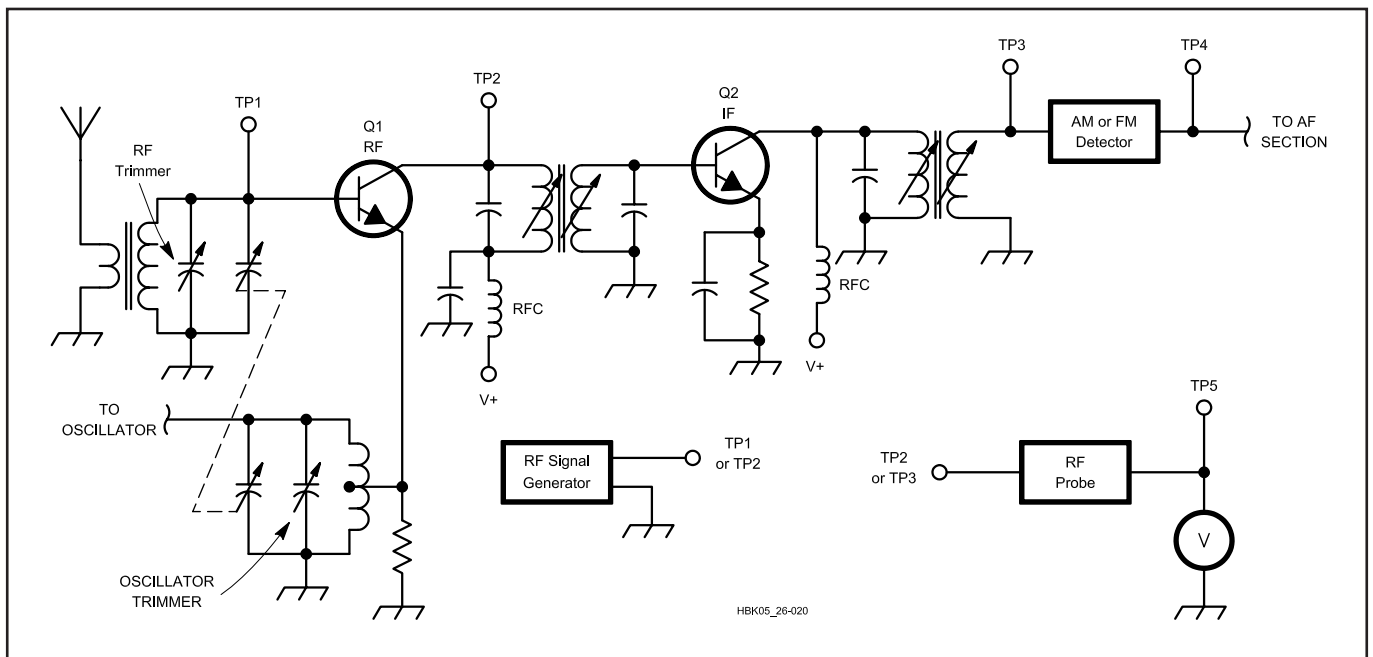

Fig 26.20 — Typical receiver alignment test points. To align the entire radio, connect a dc voltmeter at TP4. Inject an IF signal at TP2 and adjust the IF transformers. Move the signal generator to TP1 and inject an RF signal for alignment of the RF amplifier and oscillator stages. To align a single stage, place the generator at the input and an RF voltmeter (or demodulator probe and dc voltmeter) at the output: TP1/TP2 for RF, TP2/TP3 for IF.

wave. Backwave is a condition in which the signal is heard, at a reduced level, even when the key is up. This occurs when the oscillator signal feeds through a keyed amplifier. This usually indicates a design flaw, although in some cases a component failure or improper keyed-stage neutralization may be to blame.

Low Output Power

Some transmitters automatically reduce power in the TUNE mode. Check the owner's manual to see if the condition is normal. Check the control settings. Transmitters that use broadband amplifiers require so little effort from the operator that control settings are seldom noticed. The CARRIER (OR DRIVE) control may have been bumped. Remember to adjust tuned amplifiers after a significant change in operating frequency (usually 50 to 100 kHz). Most modern transmitters are designed to reduce power if there is high (say 2:1) SWR. Check these obvious external problems before you tear apart your rig.

Power transistors may fail if the SWR protection circuit malfunctions. Such failures occur at the "weak link" in the amplifier chain: It is possible for the drivers to fail without damaging the finals. An open circuit in the "reflected" side of the sensing circuit leaves the transistors unprotected, a short "shuts them down."

Low power output in a transmitter may also spring from a misadjusted carrier oscillator or a defective SWR protection circuit. If the carrier oscillator is set to a frequency well outside the transmitter passband, there may be no measurable output. Output power will increase steadily as the frequency is moved into the passband.

Transceivers

Switching

Elaborate switching schemes are used in transceivers for signal control. Many transceiver malfunctions can be attributed to relay or switching problems. Suspect the switching controls when:

- The S meter is inoperative, but the unit otherwise functions. (This could also be a bad S meter.)
- There is arcing in the tank circuit. (This could also be caused by a bad antenna system.)
- Plate current is high during reception.
- There is excessive broadband PA noise in the receiver.

Since transceiver circuits are shared, stage defects frequently affect both the transmit and receive modes, although the symptoms may change with mode. Oscillator problems usually affect both transmit and receive modes, but different oscilla-

tors, or frequencies, may be used for different emissions. Check the block diagram.

For example, one particular transceiver uses a single carrier oscillator with three different crystals (see **Fig 26.21**). One crystal sets the carrier frequency for CW, AM and FSK transmit. Another sets USB transmit and USB/CW receive, and a third sets LSB transmit and LSB/FSK receive. This radio showed a strange symptom. After several hours of CW operation, the receiver produced only a light hiss on USB and CW. Reception was good in other modes, and the power meter showed full output during CW transmission. An examination of the block diagram and schematic showed that only one of the crystals (and seven support components) was capable of causing the problem.

VOX

Voice operated transmit (VOX) controls are another potential trouble area. If there is difficulty in switching to transmit in the VOX mode, check the VOX-SENSITIVITY and ANTI-VOX control settings. Next, see if the PTT and manual (MOX) transmitter controls work. If the PTT and MOX controls function, examine the VOX control diodes and amplifiers. Test the switches, control lines and control voltage if the transmitter does not respond to other TR controls.

VOX SENSITIVITY and ANTI-VOX settings should also be checked if the transmitter switches on in response to received audio. Suspect the ANTI-VOX circuitry next. Unacceptable VOX timing results from a poor VOX-delay adjustment, or a bad resistor or capacitor in the timing circuit or VOX amplifiers.

Alignment

The mixing scheme of the modern SSB transceiver is complicated. The signal passes through many mixers, oscillators and filters. Satisfactory SSB communication requires accurate adjustment of each stage. Do not attempt any alignment without a copy of the manufacturer's instructions and the necessary test equipment.

Troubleshooting Charts

Tables 26.2, 26.3, 26.4 and 26.5 list some common problems and possible cures. These tables are not all-inclusive. They are a collection of hints and shortcuts that may save you some troubleshooting time. If you don't find your problem listed, continue with systematic troubleshooting.

COMPONENTS

Once you locate a defective part, it is time to select a replacement. This is not

always an easy task. Each electronic component has a function. This section acquaints you with the functions, failure modes and test procedures of resistors, capacitors, inductors and other components. Test the components implicated by symptoms and stage-level testing. In most cases, a particular faulty component will be located by these tests. If a faulty component is not indicated, check the circuit adjustments. As a last resort, use a shotgun approach — replace all parts in the problem area with components that are known to be good.

Check the Circuit

Before you install a replacement component of any type, you should be sure that another circuit defect didn't cause the failure. Check the circuit voltages carefully before installing any new component. Check the potential on each trace to the bad component. The old part may have "died" as a result of a lethal voltage. Measure twice — repair once! (With apologies to the old carpenter.) Of course, circuit performance is the final test of any substitution.

Fuses

Most of the time, when a fuse fails, it is for a reason — usually a short circuit in the load. A fuse that has failed because of a short circuit usually shows the evidence of high current: a blackened interior with little blobs of fuse element everywhere. Fuses can also fail by fracturing the element at either end. This kind of failure is not visible by looking at the fuse. Check even "good" fuses with an ohmmeter. You may save hours of troubleshooting.

For safety reasons, always use *exact* replacement fuses. Check the current and voltage ratings. The fuse timing (fast, normal or slow blow) must be the same as the original. Never attempt to force a fuse that is not the right size into a fuse holder. The substitution of a bar, wire or penny for a fuse invites a "smoke party."

Wires

Wires seldom fail unless abused. Short circuits can be caused by physical damage to insulation or by conductive contamination. Damaged insulation is usually apparent during a close visual inspection of the conductor or connector. Look carefully where conductors come close to corners or sharp objects. Repair worn insulation by replacing the wire or securing an insulating sleeve (spaghetti) or heat-shrink tubing over the worn area.

When wires fail, the failure is usually caused by stress and flexing. Nearly everyone has broken a wire by bending it back

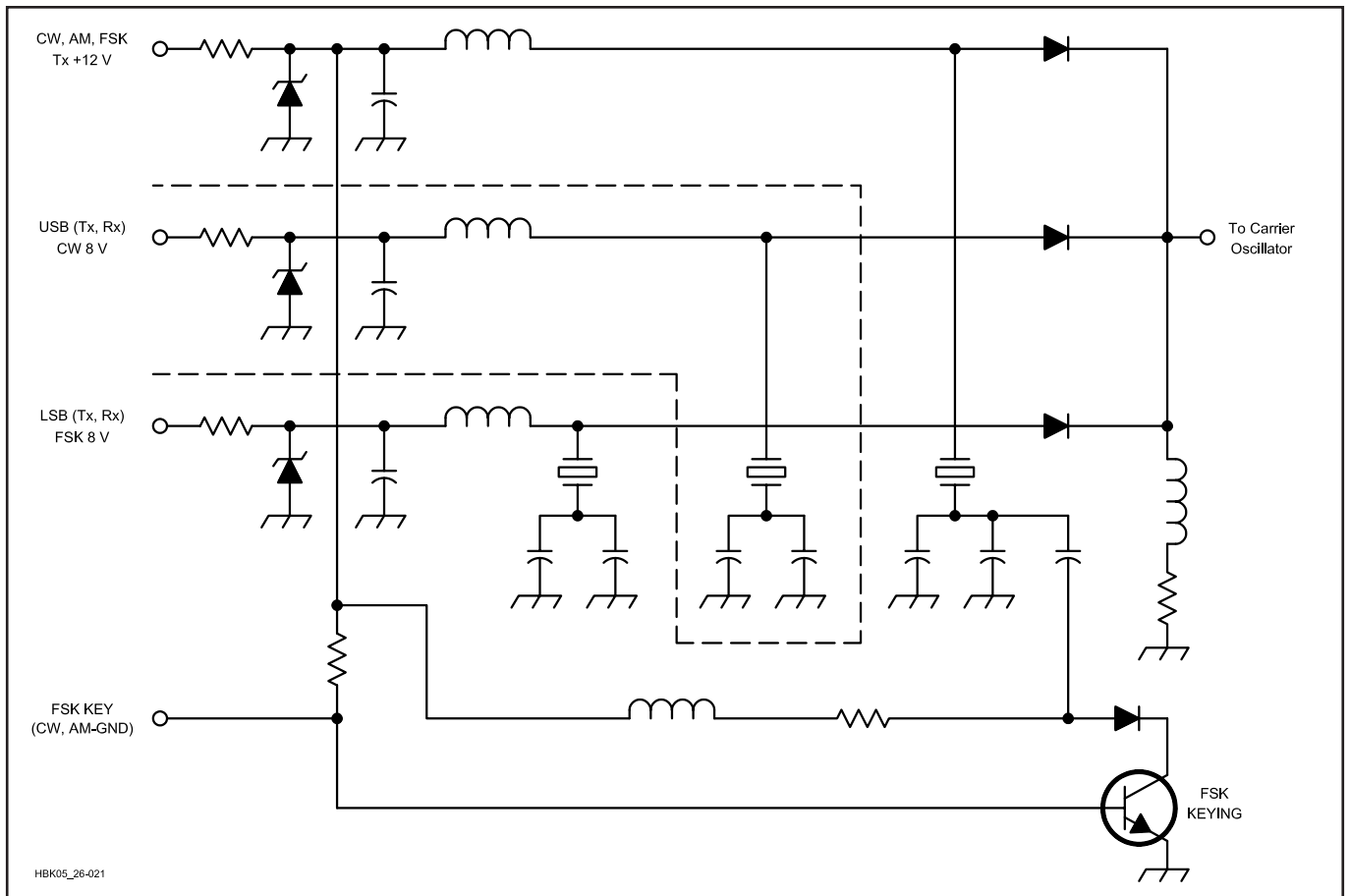

Fig 26.21 — Partial schematic of a transceiver oscillator. The symptoms described in the text are caused by one or more components inside the dashed lines or a faulty USB/CW control signal.

and forth, and broken wires are usually easy to detect. Look for sharp bends or bulges in the insulation.

When replacing conductors, use the same material and size, if possible. Substitute only wire of greater cross-sectional area (smaller gauge number) or material of greater conductivity. Insulated wire should be rated at the same, or higher, temperature and voltage as the wire it replaces.

Connectors

Connection faults are one of the most common failures in electronic equipment. This can range from something as simple as the ac-line cord coming out of the wall, to a connector having been put on the wrong socket, to a defective IC socket. Connectors that are plugged and unplugged frequently can wear out, becoming intermittent or noisy. Check connectors carefully when troubleshooting.

Connector failure can be hard to detect. Most connectors maintain contact as a result of spring tension that forces two

conductors together. As the parts age, they become brittle and lose tension. Any connection may deteriorate because of non-conductive corrosion at the contacts. Solder helps prevent this problem but even soldered joints suffer from corrosion when exposed to weather.

The dissipated power in a defective connector usually increases. Signs of excess heat are sometimes seen near poor connections in circuits that carry moderate current. Check for short and open circuits with an ohmmeter or continuity tester. Clean those connections that fail as a result of contamination.

Occasionally, corroded connectors may be repaired by cleaning, but replacement of the conductor/connector is usually required. Solder all connections that may be subject to harsh environments and protect them with acrylic enamel, RTV compound or a similar coating.

Choose replacement connectors with consideration of voltage and current ratings. Use connectors with symmetrical pin

arrangements only where correct insertion will not result in a safety hazard or circuit damage.

Resistors

Resistors usually fail by becoming an open circuit. More rarely they change value. This is usually caused by excess heat. Such heat may come from external sources or from power dissipated within the resistor. Sufficient heat burns the resistor until it becomes an open circuit.

Resistors can also fracture and become an open circuit as a result of physical shock. Contamination of a high-value resistor (100 kΩ or more) can cause a change in value through leakage. This contamination can occur on the resistor body, mounts or printed-circuit board. Resistors that have changed value should be replaced. Leakage is cured by cleaning the resistor body and surrounding area.

In addition to the problems of fixed-value resistors, potentiometers and rheostats can develop noise problems,

Table 26.2**Symptoms and Their Causes for All Electronic Equipment**

<i>Symptom</i>	<i>Cause</i>
Power Supplies	
No output voltage	Open circuit (usually a fuse or transformer winding)
Hum or ripple	Faulty regulator, capacitor or rectifier, low-frequency oscillation
Amplifiers	
Low gain	Transistor, coupling capacitors, emitter-bypass capacitor, AGC component, alignment
Noise	Transistors, coupling capacitors, resistors
Oscillations	Dirt on variable capacitor or chassis, shorted op-amp input
Untuned (oscillations do not change with frequency)	Audio stages
Tuned	RF, IF and mixer stages
Squeal	Open AGC-bypass capacitor
Static-like crashes	Arcing trimmer capacitors, poor connections
Static in FM receiver	Faulty limiter stage, open capacitor in ratio detector, weak RF stage, weak incoming signal
Intermittent noise	All components and connections, band-switch contacts, potentiometers (especially in dc circuits), trimmer capacitors, poor antenna connections
Distortion (constant)	Oscillation, overload, faulty AGC, leaky transistor, open lead in tab-mount transistor, dirty potentiometer, leaky coupling capacitor, open bypass capacitors, imbalance in tuned FM detector, IF oscillations, RF feedback (cables)
Distortion (strong signals only)	Open AGC line, open AGC diode
Frequency change	Physical or electrical variations, dirty or faulty variable capacitor, broken switch, loose compartment parts, poor voltage regulation, oscillator tuning (trouble when switching bands)
No Signals	
All bands	Dead VFO or heterodyne oscillator, PLL won't lock
One band only	Defective crystal, oscillator out of tune, band switch
No function control	Faulty switch, poor connection, defective switching diode or circuit
Improper Dial Tracking	
Constant error across dial	Dial drive
Error grows worse along dial	Circuit adjustment

Table 26.3**Transmitter Problems**

<i>Symptom</i>	<i>Cause</i>
Key clicks	Keying filter, distortion in stages after keying
Modulation Problems	
Loss of modulation	Broken cable (microphone, PTT, power), open circuit in audio chain, defective modulator
Distortion on transmit	Defective microphone, RF feedback from lead dress, modulator imbalance, bypass capacitor, improper bias, excessive drive
Arcing	Dampness, dirt, improper lead dress
Low output	Incorrect control settings, improper carrier shift (CW signal outside of passband) audio oscillator failure, transistor or tube failure, SWR protection circuit
Antenna Problems	
Poor SWR	Damaged antenna element, matching network, feed line, balun failure (see below), resonant conductor near antenna, poor connection at antenna
Balun failure	Excessive SWR, weather or cold-flow damage in coil choke, broken wire
RFI	Arcing or poor connections anywhere in antenna system or nearby conductors

especially in dc circuits. Dirt often causes intermittent contact between the wiper and resistive element. To cure the problem, spray electronic contact cleaner into the control, through holes in the case, and rotate the shaft a few times.

The resistive element in wire-wound potentiometers eventually wears and

breaks from the sliding action of the wiper. In this case, the control needs to be replaced.

Replacement resistors should be of the same value, tolerance, type and power rating as the original. The value should stay within tolerance. Replacement resistors may be of a different type than the

original, if the characteristics of the replacement are consistent with circuit requirements.

Substitute resistors can usually have a greater power rating than the original, except in high-power emitter circuits where the resistor also acts as a fuse or in cases where the larger size presents a problem.

Table 26.4**Receiver Problems**

<i>Symptom</i>	<i>Cause</i>
Low sensitivity Signals and calibrator heard weakly (low S-meter readings) (strong S-meter readings)	Semiconductor contamination, weak tube, alignment RF chain AF chain, detector
No signals or calibrator heard, only hissing	RF oscillators
Distortion	
On strong signals only	AGC fault
AGC fault	Active device cut off or saturated
Difficult tuning	AGC fault
Inability to receive	Detector fault
AM weak and distorted	Poor detector, power or ground connection
CW/SSB unintelligible	BFO off frequency or dead
FM distorted	Open detector diode

Table 26.5**Transceiver Problems**

<i>Symptom</i>	<i>Cause</i>
Inoperative S meter PA noise in receiver Excessive current on receive Arcing in PA	Faulty relay
Reduced signal strength on transmit and receive	IF failure
Poor VOX operation Poor VOX timing	VOX amplifiers and diodes Adjustment, component failure in VOX timing circuits or amplifiers
VOX consistently tripped by receiver audio	AntiVOX circuits or adjustment

Variable resistors should be replaced with the same kind (carbon or wire wound) and taper (linear, log, reverse log and so on) as the original. Keep the same, or better tolerance and pay attention to the power rating.

In all cases, mount high-temperature resistors away from heat-sensitive components. Keep carbon resistors away from heat sources. This will extend their life and ensure minimum resistance variations.

Capacitors

Capacitors usually fail by shorting, opening or becoming electrically (or physically) leaky. They rarely change value. Capacitor failure is usually caused by excess current, voltage, temperature or age. Leakage can be external to the capacitor (contamination on the capacitor body or circuit) or internal to the capacitor.

Tests

The easiest way to test capacitors is out of circuit with an ohmmeter. In this test, the resistance of the meter forms a timing

circuit with the capacitor to be checked. Capacitors from 0.01 μF to a few hundred μF can be tested with common ohmmeters. Set the meter to its highest range and connect the test leads across the discharged capacitor. When the leads are connected, current begins to flow. The capacitor passes current easily when discharged, but less easily as the charge builds. This shows on the meter as a low resistance that builds, over time, toward infinity.

The speed of the resistance build-up corresponds to capacitance. Small capacitance values approach infinite resistance almost instantly. A 0.01- μF capacitor checked with an 11-M Ω FETVOM would increase from zero to a two-thirds scale reading in 0.11 s, while a 1- μF unit would require 11 s to reach the same reading. If the tested capacitor does not reach infinity within five times the period taken to reach the two-thirds point, it has excess leakage. If the meter reads infinite resistance immediately, the capacitor is open. (Aluminum electrolytics normally exhibit high-leakage readings.)

Fig 26.22 shows a circuit that may be used to test capacitors. To use this circuit, make sure that the power supply is off, set S1 to CHARGE and S2 to TEST, then connect the capacitor to the circuit. Switch on the power supply and allow the capacitor to charge until the voltmeter reading stabilizes. Next, switch S1 to TEST and watch the meter for a few seconds. If the capacitor is good, the meter will show no potential. Any appreciable voltage indicates excess leakage. After testing, set S1 to CHARGE, switch off the power supply, and press the DISCHARGE button until the meter shows 0 V, then remove the capacitor from the test circuit.

Capacitance can also be measured with a capacitance meter, an RX bridge or a dip meter. Some DMMs (digital multimeters) measure capacitance. Capacitance measurements made with DMMs and dedicated capacitance meters are much more accurate than those made with RX bridges or dip meters. To determine capacitance with a dip meter, a parallel-resonant circuit should be constructed using the capacitor of unknown value and an inductor of known value. The formula for resonance is discussed in the **Electrical Fundamentals** chapter of this book.

It is best to keep a collection of known components that have been measured on accurate L or C meters. Alternatively, a “standard” value can be obtained by ordering 1 or 2% components from an electronics supplier. A 10%-tolerance component can be used as a standard; however, the results will only be known to within 10%. The accuracy of tests made with any of these alternatives depends on the accuracy of the “standard” value component. Further information on this technique appears in Bartlett’s article, “Calculating Component Values,” in Nov 1978 *QST*.

Cleaning

The only variety of common capacitor that can be repaired is the air-dielectric variable capacitor. Electrical connection to the moving plates is made through a spring-wiper arrangement (see **Fig 26.23**). Dirt normally builds on the contact area, and they need occasional cleaning. Before cleaning the wiper/contact, use gentle air pressure and a soft brush to remove all dust and dirt from the capacitor plates. Apply some electronic contact cleaning fluid. Rotate the shaft quickly several times to work in the fluid and establish contact. Use the cleaning fluid sparingly, and keep it off the plates except at the contact point.

Replacements

Replacement capacitors should match the original in value, tolerance, dielectric, working voltage and temperature coefficient.

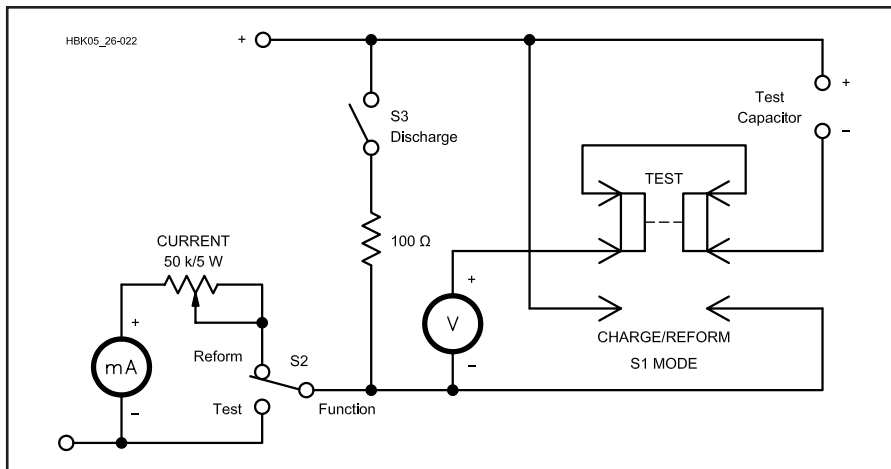

Fig 26.22 — A fixture for testing capacitors and reforming the dielectric of electrolytic capacitors. Use 12 V for testing the capacitor. Use the capacitor working voltage for dielectric reformation.

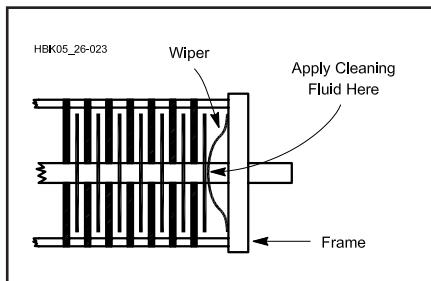

Fig 26.23 — Partial view of an air-dielectric variable capacitor. If the capacitor is noisy or erratic in operation, apply electronic cleaning fluid where the wiper contacts the rotor plates.

cient. Use only ac-rated capacitors for line service. If exact replacements are not available, substitutes may vary from the original part in the following respects: Bypass capacitors may vary from one to three times the capacitance of the original. Coupling capacitors may vary from one half to twice the value of the original. Capacitance values in tuned circuits (especially filters) must be exact. (Even then, any replacement will probably require circuit realignment.)

If the same kind of capacitor is not available, use one with better dielectric characteristics. Do not substitute polarized capacitors for nonpolarized parts. Capacitors with a higher working voltage may be used, although the capacitance of an electrolytic capacitor used significantly below its working voltage will usually increase with time.

The characteristics of each type of capacitor are discussed in the **Real-World**

Component Characteristics chapter. Consider these characteristics if you're not using an exact replacement capacitor.

Inductors and Transformers

The most common inductor or transformer failure is a broken conductor. More rarely, a short circuit can occur across one or more turns of a coil. In an inductor, this changes the value. In a transformer, the turns ratio and resultant output voltage changes. In high-power circuits, excessive inductor current can generate enough heat to melt plastics used as coil forms.

Inductors may be checked for open circuit failure with an ohmmeter. In a good inductor, dc resistance rarely exceeds a few ohms. Shorted turn and other changes in inductance show only during alignment or inductance measurement.

The procedure for measurement of inductance with a dip meter is the same as that given for capacitance measurement, except that a capacitor of known value is used in the resonant circuit.

Replacement inductors must have the same inductance as the original, but that is only the first requirement. They must also carry the same current, withstand the same voltage and present nearly the same Q as the original part. Given the original as a pattern, the amateur can duplicate these qualities for many inductors. Note that inductors with ferrite or iron-powder cores are frequency sensitive, so the replacement must have the same core material.

If the coil is of simple construction, with the form and core undamaged, carefully count and write down the number of turns and their placement on the form. Also note how the coil leads are arranged and connected to the circuit. Then determine the

wire size and insulation used. Wire diameter, insulation and turn spacing are critical to the current and voltage ratings of an inductor. (There is little hope of matching coil characteristics unless the wire is duplicated exactly in the new part.) Next, remove the old winding—be careful not to damage the form—and apply a new winding in its place. Be sure to dress all coil leads and connections in exactly the same manner as the original. Apply Q dope to hold the finished winding in place.

Follow the same procedure in cases where the form or core is damaged, except that a suitable replacement form or core (same dimensions and permeability) must be found.

Ready-made inductors may be used as replacements if the characteristics of the original and the replacement are known and compatible. Unfortunately, many inductors are poorly marked. If so, some comparisons, measurements and circuit analysis are usually necessary.

When selecting a replacement inductor, you can usually eliminate parts that bear no physical resemblance to the original part. This may seem odd, but the Q of an inductor depends on its physical dimensions and the permeability of the core material. Inductors of the same value, but of vastly different size or shape, will likely have a great difference in Q. The Q of the new inductor can be checked by installing it in the circuit, aligning the stage and performing the manufacturer's passband tests. Although this practice is all right in a pinch, it does not yield an accurate Q measurement. Methods to measure Q appear in the **Test Procedures** chapter.

Once the replacement inductor is found, install it in the circuit. Duplicate the placement, orientation and wiring of the original. Ground-lead length and arrangement should not be changed. Isolation and magnetic shielding can be improved by replacing solenoid inductors with toroids. If you do, however, it is likely that many circuit adjustments will be needed to compensate for reduced coupling and mutual inductance. Alignment is usually required whenever a tuned-circuit component is replaced.

A transformer consists of two inductors that are magnetically coupled. Transformers are used to change voltage and current levels (this changes impedance also). Failure usually occurs as an open circuit or short circuit of one or more windings.

Amateur testing of power transformers is limited to ohmmeter tests for open circuits and voltmeter checks of secondary voltage. Make sure that the power-line voltage is correct, then check the secondary voltage against that specified. There should be less than 10% difference

between open-circuit and full-load secondary voltage.

Replacement transformers must match the original in voltage, volt-ampere (VA), duty cycle and operating-frequency ratings. They must also be compatible in size. (All transformer windings should be insulated for the full power-supply voltage.)

Relays

Although relays have been replaced by semiconductor switching in low-power circuits, they are still used extensively in high-power Amateur Radio equipment. Relay action may become sluggish. AC relays can buzz (with adjustment becoming impossible). A binding armature or weak springs can cause intermittent switching. Excessive use or hot switching ruins contacts and shortens relay life.

You can test relays with a voltmeter by jumpering across contacts with a test lead (power on, in circuit) or with an ohmmeter (out of circuit). Look for erratic readings across the contacts, open or short circuits at contacts or an open circuit at the coil.

Most failures of simple relays can be repaired by a thorough cleaning. Clean the contacts and mechanical parts with a residue-free cleaner. Keep it away from the coil and plastic parts that may be damaged. Dry the contacts with lint-free paper, such as a business card; then burnish them with a smooth steel blade. Do not use a file to clean contacts.

Replacement relays should match or exceed the original specifications for voltage, current, switching time and stray impedance (impedance is significant in RF circuits only). Many relays used in transceivers are specially made for the manufacturer. Substitutes may not be available from any other source.

Before replacing a multicontact relay, make a drawing of the relay, its position, the leads and their routings through the surrounding parts. This drawing allows you to complete the installation properly, even if you are distracted in the middle of the operation.

Semiconductors

Diodes

The primary function of a diode is to pass current in one direction only. They can be easily tested with an ohmmeter.

Signal or switching diodes — The most common diode in electronics equipment, they are used to convert ac to dc, to detect RF signals or to take the place of relays to switch ac or dc signals within a circuit. Signal diodes usually fail open, although shorted diodes are not rare. They can easily be tested with an ohmmeter.

Power-rectifier diodes — Most equipment contains a power supply, so power-rectifier diodes are the second-most common diodes in electronic circuitry. They usually fail shorted, blowing the power-supply fuse.

Other diodes — Zener diodes are made with a predictable reverse-breakdown voltage and used as voltage regulators. Varactor diodes are specially made for use as voltage controlled variable capacitors. (Any semiconductor diode may be used as a voltage-variable capacitance, but the value will not be as predictable as that of a varactor.) A Diac is a special-purpose diode that passes only pulses of current in each direction.

Diode tests — There are several basic tests for most diodes. First, is it a diode? Does it conduct in one direction and block current flow in the other? An ohmmeter is suitable for this test in most cases. An ohmmeter will read high resistance in one direction, low resistance in the other. Make sure the meter uses a voltage of more than 0.7 V and less than 1.5 V to measure resistance. Use a good diode to determine the meter polarity.

Diodes should be tested out of circuit. Disconnect one lead of the diode from the circuit, then measure the forward and reverse resistance. Diode quality is shown by the ratio of reverse to forward resistance. A ratio of 100:1 or greater is common for signal diodes. The ratio may go as low as 10:1 for old power diodes.

The first test is a forward-resistance test. Set the meter to read $\times 100$ and connect the test probes across the diode. When the negative terminal of the ohmmeter battery is connected to the cathode, the meter will typically show about 200 to 300 Ω (forward resistance) for a good silicon diode, 200 to 400 Ω for a good germanium diode. The exact value varies quite a bit from one meter to the next.

Next, test the reverse resistance. Reverse the lead polarity and set the meter to $\times 1M$ (times one million, or the highest scale available on the meter) to measure diode reverse resistance. Good diodes should show 100 to 1000 $M\Omega$ for silicon and 100 $k\Omega$ to 1 $M\Omega$ for germanium. When you are done, mark the meter lead polarity for future reference.

This procedure measures the junction resistances at low voltage. It is not useful to test Zener diodes. A good Zener diode will not conduct in the reverse direction at voltages below its rating.

We can also test diodes by measuring the voltage drop across the diode junction while the diode is conducting. (A test circuit is shown in **Fig 26.24**.) To test, connect the diode, adjust the supply voltage

until the current through the diode matches the manufacturer's specification and compare the junction drop to that specified. Silicon junctions usually show about 0.6 V, while germanium is typically 0.2 V. Junction voltage-drop increases with current flow. This test can be used to match diodes with respect to forward resistance at a given current level.

A final simple diode test measures leakage current. Place the diode in the circuit described above, but with reverse polarity. Set the specified reverse voltage and read the leakage current on a milliammeter. (The currents and voltages measured in the junction voltage-drop and leakage tests vary by several orders of magnitude.)

The most important specification of a Zener diode is the Zener (or avalanche) voltage. The Zener-voltage test also uses the circuit of **Fig 26.24**. Connect the diode in reverse. Set the voltage to minimum, then gradually increase it. You should read low current in the reverse mode, until the Zener point is reached. Once the device begins to conduct in the reverse direction, the current should increase dramatically. The voltage shown on the voltmeter is the Zener point of the diode. If a Zener diode has become leaky, it might show in the leakage-current measurement, but substitution is the only dependable test.

Replacement diodes — When a diode fails, check associated components as well. Replacement rectifier diodes should have the same current and peak inverse voltage (PIV) as the original. Series diode combinations are often used in high-voltage rectifiers, with resistor and capacitor networks to distribute the voltage equally among the diodes.

Switching diodes may be replaced with diodes that have equal or greater current ratings and a PIV greater than twice the peak-to-peak voltage encountered in the circuit. Switching time requirements are not critical except in RF, logic and some keying circuits. Logic circuits may require exact replacements to assure compatible switching speeds and load characteristics. RF switching diodes used near resonant circuits must have exact replacements as the diode resistance and capacitance will affect the tuned circuit.

Voltage, current and capacitance characteristics must be considered when replacing varactor diodes. Once again, exact replacements are best. Zener diodes should be replaced with parts having the same Zener voltage and equal or better current, power, impedance and tolerance specifications. Check the associated current-limiting resistor when replacing a Zener diode.

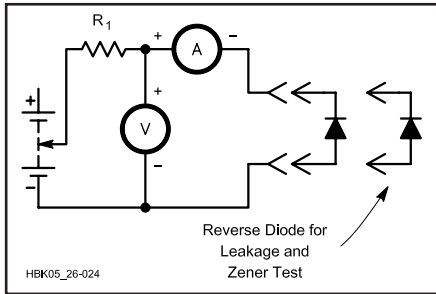

Fig 26.24 — A diode conduction, leakage and Zener-point test fixture. The ammeter should read mA for conduction and Zener point, μA for leakage tests.

Bipolar Transistors

Transistors are primarily used to switch or amplify signals. Transistor failures occur as an open junction, a shorted junction, excess leakage or a change in amplification performance.

Most transistor failure is catastrophic. A transistor that has no leakage and amplifies at dc or audio frequencies will usually perform well over its design range. For this reason, transistor tests need not be performed at the planned operating frequency. Tests are made at dc or a low frequency (usually 1000 Hz). The circuit under repair is the best test of a potential replacement part. Swapping in a replacement transistor in a failed circuit will often result in a cure.

A simple and reliable bipolar-transistor test can be performed with the transistor in a circuit and the power on. It requires a test lead, a 10-k Ω resistor and a voltmeter. Connect the voltmeter across the emitter/collector leads and read the voltage. Then use the test lead to connect the base and emitter (**Fig 26.25A**). Under these conditions, conduction of a good transistor will be cut off and the meter should show nearly the entire supply voltage across the emitter/collector leads. Next, remove the clip lead and connect the 10-k Ω resistor from the base to the collector. This should bias the transistor into conduction and the emitter/collector voltage should drop (**Fig 26.25B**). (This test indicates transistor response to changes in bias voltage.)

Transistors can be tested (out of circuit) with an ohmmeter in the same manner as diodes. Look up the device characteristics before testing and consider the consequences of the ohmmeter-transistor circuit. Limit junction current to 1 to 5 mA for small-signal transistors. Transistor destruction or inaccurate measurements may result from careless testing.

Use the $\times 100 \Omega$ and $\times 1000\text{-}\Omega$ ranges

for small-signal transistors. For high-power transistors use the $\times 1 \Omega$ and $\times 10\text{-}\Omega$ ranges. The reverse-to-forward resistance ratio for good transistors may vary from 30:1 to better than 1000:1.

Germanium transistors sometimes show high leakage when tested with an ohmmeter. Bipolar transistor leakage may be specified from the collector to the base, emitter to base or emitter to collector (with the junction reverse biased in all cases). The specification may be identified as I_{cbo} , I_{bo} , collector cutoff current or collector leakage for the base-collector junction, I_{ebo} , and so on for other junctions.³ Leakage current increases with junction temperature.

A suitable test fixture for base-collector leakage measurements is shown in **Fig 26.26**. Make the required connections and set the voltage as stated in the transistor specifications and compare the measured leakage current with that specified. Small-signal germanium transistors exhibit I_{cbo} and I_{ebo} leakage currents of about 15 μA . Leakage increases to 90 μA or more in high-power components. Leakage currents for silicon transistors are seldom more than 1 μA . Leakage current tends to double for every 10 $^{\circ}\text{C}$ increase above 25 $^{\circ}\text{C}$.

Breakdown-voltage tests actually measure leakage at a specified voltage, rather than true breakdown voltage. Breakdown voltage is known as BV_{cbo} , BV_{ces} or BV_{ceo} . Use the same test fixture shown for leakage tests, adjust the power supply until the specified leakage current flows, and compare the junction voltage against that specified.

A circuit to measure dc current gain is shown in **Fig 26.27**. Transistor gain can range from 10 to over 1000 because it is not usually well controlled during manufacture. Gain of the active device is not critical in a well-designed transistor circuit.

The test conditions for transistor testing are specified by the manufacturer. When testing, do not exceed the voltage, current (especially in the base circuit) or dissipated-power rating of the transistor. Make sure that the load resistor is capable of dissipating the power generated in the test.

While these simple test circuits will identify most transistor problems, RF devices should be tested at RF. Most component manufacturers include a test-circuit schematic on the data sheet. The test circuit is usually an RF amplifier that operates near the high end of the device frequency range.

Semiconductor failure is sometimes the result of environmental conditions. Open junctions, excess leakage (except with

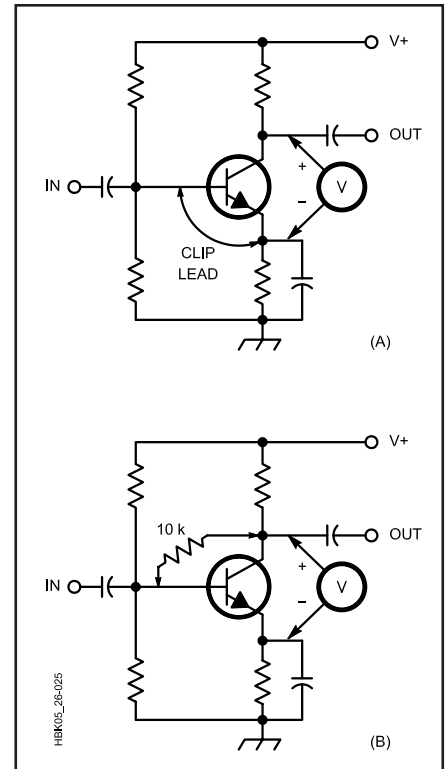

Fig 26.25 — An in-circuit semiconductor test with a clip lead, resistor and voltmeter. The meter should read V+ at (A). During test (B) the meter should show a decrease in voltage, ranging from a slight variation down to a few millivolts. It will typically cut the voltage to about half of its initial value.

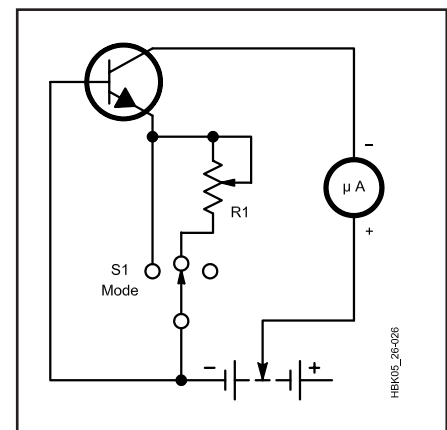

Fig 26.26 — A test circuit for measuring collector-base leakage with the emitter shorted to ground, open or connected to ground through a variable resistance, depending on the setting of S1. See the transistor manufacturer's instructions for test conditions and the setting of R1 (if used). Reverse battery polarity for PNP transistors.

germanium transistors) and changes in amplification performance result from overload or excessive current. Electrostatic discharge can destroy a semiconductor in microseconds. Shorted junctions are caused by voltage spikes. Check surrounding parts for the cause of the transistor's demise, and correct the problem before installing a replacement.

JFETs

Junction FETs can be tested with an ohmmeter in much the same way as bipolar transistors (see text and Fig 26.28). Reverse leakage should be several megohms or more. Forward resistance should be 500 to 1000 Ω .

MOSFETs

MOS (metal-oxide semiconductor) layers are extremely fragile. Normal body static is enough to damage them. Even "gate protected" (a diode is placed across the MOS layer to clamp voltage) MOSFETs may be destroyed by a few volts of static electricity.

Make sure the power is off, capacitors discharged and the leads of a MOSFET are shorted together before installing or removing it from a circuit. Use a voltmeter to be sure the chassis is near ground potential, then touch the chassis before and during MOSFET installation and removal. This assures that there is no difference of potential between your body, the chassis and the MOSFET leads. Ground the soldering-iron tip with a clip lead when soldering MOS devices. The FET source should be the first lead connected to and the last disconnected from a circuit. The insulating layers in MOSFETs prevent testing with an ohmmeter. Substitution is the only practical means for amateur testing of MOSFETs.

FET Considerations

Replacement FETs should be of the same kind as the original part: JFET or MOSFET, P-channel or N-channel, enhancement or depletion. Consider the breakdown voltage required by the circuit. The breakdown voltage should be at least two to four times the power-supply and signal voltages in amplifiers. Allow for transients of ten times the line voltage in power supplies. Breakdown voltages are usually specified as $V_{(BR)GSS}$ or $V_{(BR)GDO}$.

The gate-voltage specification gives the gate voltage required to cut off or initiate channel current (depending on the mode of operation). Gate voltages are usually listed as $V_{GS(OFF)}$, V_p (pinch off), V_{TH} (threshold) or $I_{D(ON)}$ or I_{TH} .

Dual-gate MOSFET characteristics are more complicated because of the interac-

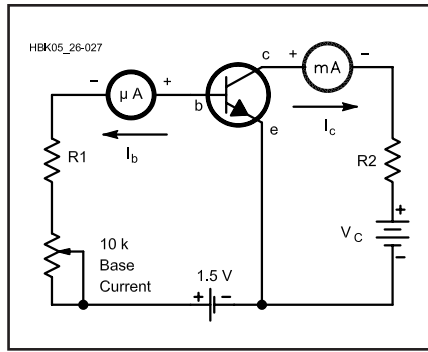

Fig 26.27 — A test circuit for measuring transistor beta. Values for R1 and R2 are dependent on the current range of the transistor tested. Reverse the battery polarity for PNP transistors.

tion of the two gates. Cutoff voltage, breakdown voltage and gate leakage are the important traits of each gate.

Integrated Circuits

The basics of integrated circuits are covered in earlier chapters of this book. Amateurs seldom have the sophisticated equipment required to test ICs. Even a multitrace 'scope can view only their simplest functions. We must be content to check every other possible cause, and only then assume that the problem lies with an IC. Experienced troubleshooters will tell you that — most of the time anyway — if a defective circuit uses an IC, it is the IC that is bad.

Linear ICs — There are two major classes of ICs: linear and digital. Linear ICs are best replaced with identical units. Original equipment manufacturers are the best source of a replacement; they are the only source with a reason to stockpile obsolete or custom-made items. If substitution of an IC is unavoidable, first try the cross-reference guides published by several distributors. You can also look in manufacturers' databooks and compare pinouts and other specifications.

Digital ICs — It is usually not a good idea to substitute digital devices. While it may be okay to substitute an AB74LS00YZ from manufacturer "A" with a CD74LS00WX from a different manufacturer, you will usually not be able to replace an LS (low-power Schottky) device with an S (Schottky), C (CMOS) or any of a number of other families. The different families all have different speed, current-consumption, input and output characteristics. You would have to analyze the circuit to determine if you could substitute one type for another.

Semiconductor Substitution

In all cases try to obtain exact replacement semiconductors. Specifications vary slightly from one manufacturer to the next. Cross-reference equivalents are useful, but not infallible. Before using an equivalent, check the specifications against those for the original part. When choosing a replacement, consider:

- Is it silicon or germanium?
- Is it a PNP or an NPN?
- What are the operating frequency and input/output capacitance?
- How much power does it dissipate (often less than $V_{max} \times I_{max}$)?
- Will it fit the original mount?
- Are there unusual circuit demands (low noise and so on)?
- What is the frequency of operation?

Remember that cross-reference equivalents are not guaranteed to work in every

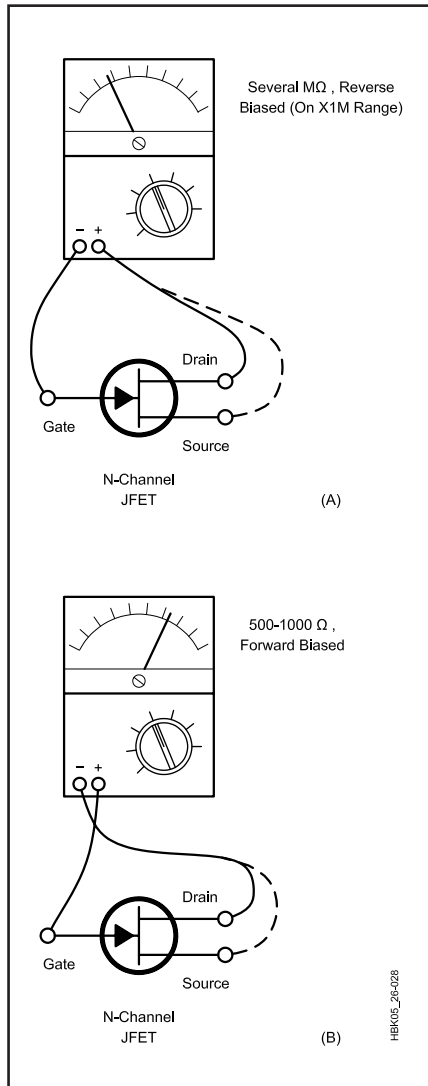

Fig 26.28 — Ohmmeter tests of a JFET. The junction is reverse biased at A and forward biased at B.

application. There may be cases where two dissimilar devices have the same part number, so it pays to compare the listed replacement specifications with the intended use. If “the book” says to use a diode in place of an RF transistor, it isn’t going to work! Derate power specifications, as recommended by the manufacturer, for high-temperature operation.

Tubes

The most common tube failures in amateur service are caused by cathode depletion and gas contamination. Whenever a tube is operated, the coating on the cathode loses some of its ability to produce electrons. It is time to replace the tube when electron production (cathode current, I_c) falls to 50 - 60% of that exhibited by a new tube.

Gas contamination in a tube can often be identified easily because there may be a greenish or whitish-purple glow between the elements during operation. (A faint deep-purple glow is normal in most tubes.) The gas reduces tube resistance and leads to runaway plate current evidenced by a red glow from the anode, interelectrode arcing or a blown power-supply fuse. Less common tube failures include an open filament, broken envelope and interelectrode shorts.

The best test of a tube is to substitute a new one. Another alternative is a tube tester; these are now rare. You can also do some limited tests with an ohmmeter. Tube tests should be made out of circuit so circuit resistance does not confuse the results.

Use an ohmmeter to check for an open filament (remove the tube from the circuit first). A broken envelope is visually obvious, although a cracked envelope may appear as a gassy tube. Interelectrode shorts are evident during voltage checks on the operating stage. Any two elements that show the same voltage are probably shorted. (Remember that some interelectrode shorts, such as the cathode-suppressor grid, are normal.)

Generally, a tube may be replaced with another that has the same type number. Compare the data sheets of similar tubes to assess their compatibility. Consider the base configuration and pinout, interelectrode capacitances (a small variation is okay except for tubes in oscillator service), dissipated power ratings of the plate and screen grid and current limitations (both peak and average). For example, the 6146A may be replaced with a 6146B (heavy duty), but not vice versa.

In some cases, minor type-number differences signify differences in filament voltages, or even base styles, so check all

specifications before making a replacement. (Even tubes of the same model number, prefix and suffix vary slightly, in some respects, from one supplier to the next.)

AFTER THE REPAIRS

Once you have completed your troubleshooting and repairs, it is time to put the equipment back together. Take a little extra time to make sure you have done everything correctly.

All Units

Give the entire unit a complete visual inspection. Look for any loose ends left over from your troubleshooting procedures — you may have left a few components temporarily soldered in place or overlooked some other repair error. Look for cold solder joints and signs of damage incurred during the repair. Double check the position, leads and polarity of components that were removed or replaced.

Make sure that all ICs are properly oriented in their sockets and all of the pins are properly inserted in the IC socket or printed-circuit board holes. Test fuse continuity with an ohmmeter and verify that the current rating matches the circuit specification.

Look at the position of all of the wires and components. Make sure that wires and cables will be clear of hot components, screw points and other sharp edges. Make certain that the wires and components will not be in the way when covers are installed and the unit is put back together.

Separate the leads that carry dc, RF, input and output as much as possible. Plug-in circuit boards should be firmly seated with screws tightened and lock washers installed if so specified. Shields and ground straps should be installed just as they were on the original.

For Transmitters Only

Since the signal produced by an HF transmitter can be heard the world over, a thorough check is necessary after any service has been performed. Do not exceed the transmitter duty cycle while testing. Limit transmissions to 10 to 20 seconds unless otherwise specified by the owner’s manual.

1. Set all controls as specified in the operation manual, or at midscale.
2. Connect a dummy load and a power meter to the transmitter output.
3. Set the drive or carrier control for low output.
4. Switch the power on.
5. Transmit and quickly set the final-amplifier bias to specifications.
6. In narrowband equipment, slowly tune the output network through reso-

nance. The current dip should be smooth and repeatable. It should occur simultaneously with the maximum power output. Any sudden jumps or wiggles of the current meter indicate that the amplifier is unstable. Adjust the neutralization circuit (according to the manufacturer’s instructions) if one is present or check for oscillation. An amplifier usually requires neutralization whenever active devices, components or lead dress (that affect the output/input capacitance) are changed.

7. Check to see that the output power is consistent with the amplifier class used in the PA (efficiency should be about 25% for Class A, 50 to 60% for Class AB or B, and 70 to 75% for Class C).

8. Repeat steps 4 through 6 for each band of operation from lowest to highest frequency.

9. Check the carrier balance (in SSB transmitters only) and adjust for minimum power output with maximum RF drive and no microphone gain.

10. Adjust the VOX controls.

11. Measure the passband and distortion levels if equipment (wideband scope or spectrum analyzer) is available.

Other Repaired Circuits

After the preliminary checks, set the circuit controls per the manufacturer’s specifications (or to midrange if specifications are not available) and switch the power on. Watch and smell for smoke, and listen for odd sounds such as arcing or hum. Operate the circuit for a few minutes, consistent with allowable duty cycle. Verify that all operating controls function properly.

Check for intermittent connections by subjecting the circuit to heat, cold and slight flexure. Also, tap or jiggle the chassis lightly with an alignment tool or other insulator.

If the equipment is meant for mobile or portable service, operate it through an appropriate temperature range. Many mobile radios do not work on cold mornings, or on hot afternoons, because a temperature-dependent intermittent was not found during repairs.

Button It Up

After you are convinced that you have repaired the circuit properly, put it all back together. If you followed the advice in this book, you have all the screws and assorted doodads in a secure container. Look at the notes you took while taking it apart; put it back together in the reverse order. Don’t forget to reconnect all internal connections, such as ac-power, speaker or antenna leads.

Once the case is closed, and all appears

well, don't neglect the final, important step — make sure it still works. Many an experienced technician has forgotten this important step, only to discover that some minor error, such as a forgotten antenna connector, has left the equipment non-functional.

PROFESSIONAL REPAIRS

This chapter does not tell you how to perform all repairs. Repairs that deal with very complex and temperamental circuits, or that require sophisticated test equipment, should be passed on to a professional.

The factory authorized service personnel have a lot of experience. What seems like a servicing nightmare to you is old hat to them. There is no one better qualified to service your equipment than the factory.

If the manufacturer is no longer in business, check with your local dealer or look in the classified ads in electronics and Amateur Radio magazines. You can usually find one or more companies that service "all makes and models." Your local TV shop might be willing to tackle a repair, especially if you have located a schematic.

If you are going to ship your equipment somewhere for repair, notify the repair center first. Get authorization for shipping and an identification name or number for the package.

Packing It Up

You can always blame shipping damage on the shipper, but it is a lot easier for all concerned if you package your equipment properly for shipping in the first place. Firmly secure all heavy components, either by tying them down or blocking them off with shipping foam. Large vacuum tubes should be wrapped in packing material or shipped separately. Make sure that all circuit boards and parts are firmly attached.

Use a box within a box for shipping. (See Fig 26.29.) Place the equipment and some packing material inside a box and seal it with tape. Place that box inside another that is at least six inches larger in each dimension. Fill the gap with packing material, seal, address and mark the outer box. Choose a good freight carrier and insure the package.

Don't forget to enclose a statement of the trouble, a short history of operation

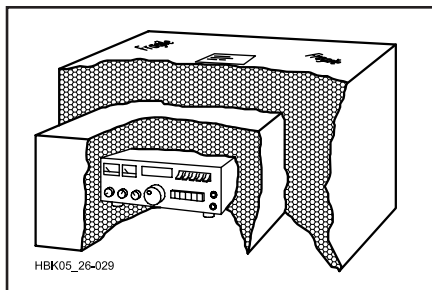

Fig 26.29 — Ship equipment packed securely in a box within a box.

and any test results that may help the service technician. Include a good description of the things you have tried. Be honest! At current repair rates you want to tell the technician everything to help ensure an efficient repair.

Even if you ended up sending it back to the factory, you can feel good about your experience. You learned a lot by trying, and you have sent it back knowing that it really did require the services of a "pro." Each time you troubleshoot and repair a piece of electronic circuitry, you learn something new. The down side is that you may develop a reputation as a real electronics whiz. You may find yourself spending a lot of time at club meetings offering advice, or getting invited over to a lot of shacks for a late-evening pizza snack. There are worse fates.

References

- J. Bartlett, "Calculating Component Values," *QST*, Nov 1978.
- J. Carr, *How to Troubleshoot and Repair Amateur Radio Equipment*, Blue Ridge Summit, PA: TAB Books Inc, 1980.
- D. DeMaw, "Understanding Coils and Measuring their Inductance," *QST*, Oct 1983.
- H. Gibson, *Test Equipment for the Radio Amateur*, London, England: Radio Society of Great Britain, 1974.
- C. Gilmore, *Understanding and Using Modern Electronic Servicing Test Equipment*, TAB Books, Inc, 1976.
- F. Glass, *Owner Repair of Amateur Radio Equipment*, Los Gatos, CA: RQ Service Center, 1978.
- R. Goodman, *Practical Troubleshooting with the Modern Oscilloscope*, TAB

Books, Inc, 1979.

- A. Haas, *Oscilloscope Techniques*, New York: Gernsback Library, Inc, 1958.
- C. Hallmark, *Understanding and Using the Oscilloscope*, TAB Books, Inc, 1973.
- A. Helfrick, *Amateur Radio Equipment Fundamentals*, Englewood Cliffs, NJ: Prentice-Hall Inc, 1982.
- K. Henney, and C. Walsh, *Electronic Components Handbook*, New York: McGraw-Hill Book Company, 1957.
- L. Klein, and K. Gilmore, *It's Easy to Use Electronic Test Equipment*, New York: John R. Rider Publisher, Inc (A division of Hayden Publishing Company), 1962.
- J. Lenk, *Handbook of Electronic Test Procedures*, Prentice-Hall Inc, 1982.
- G. Loveday, and A. Seidman, *Troubleshooting Solid-State Circuits*, New York: John Wiley and Sons, 1981.
- A. Margolis, *Modern Radio Repair Techniques*, TAB Books Inc, 1971.
- H. Neben, "An Ohmmeter with a Linear Scale," *QST*, Nov 1982.
- H. Neben, "A Simple Capacitance Meter You Can Build," *QST*, Jan 1983.
- F. Noble, "A Simple LC Meter," *QST*, Feb 1983.
- J. Priedigkeit, "Measuring Inductance and Capacitance with a Reflection-Coefficient Bridge," *QST*, May 1982.
- H. Sartori, "Solid Tubes — A New Life for Old Designs," *QST*, Apr 1977; "Questions on Solid Tubes Answered," Technical Correspondence, *QST*, Sep 1977.
- B. Wedlock, and J. Roberge, *Electronic Components and Measurements*, Prentice-Hall Inc, 1969.
- "Some Basics of Equipment Servicing," series, *QST*, Dec 1981-Mar 1982; Feedback May 1982.

Notes

- ¹The ARRL has prepared a list of dip-meter sources. These are available on the **CD-ROM** included with this *Handbook*.
- ²More information about the signal injector and signal sources appears in "Some Basics of Equipment Servicing," February 1982 *QST* (Feedback, May 1982).
- ³The term "I_{cb0}" means "Current from collector to base with emitter open." The subscript notation indicates the status of the three device terminals. The terminals measured are listed first, with the remaining terminal listed as "s" (shorted) or "o" (open).