

Build a Linear 2 Meter 80 W All Mode Amplifier

This solid state amplifier will give your low power VHF transceiver or transverter just the boost you need.



James Klitzing, W6PQL

There are many different 2 meter low power rigs in use, ranging from handheld transceivers for FM to older multimode transceivers and even the newer all purpose types such as the Yaesu FT-817 or the Elecraft 2 meter transverters. Low power (QRP) operation can be fun, but if you're like me, you have the occasional need for a bit more power.

If you have a couple of afternoons to spend on a project, you can build this 80 W multimode amplifier with ease. It's easy because it uses one of the newer Toshiba modules as the heart of the amplifier. The Toshiba S-AV36 provides direct 50 Ω input and output impedances with gain galore — so much gain that less than 50 mW can drive it to full output in any mode. This design will work with any exciter providing 1 to 10 W drive, through the use of a built in attenuator.

My original intent in making this was to have an amplifier capable of boosting an older 10 W multimode radio up to 80 or 100 W. I wanted to keep it low in cost and simple (no preamp or power meters), yet capable of fixed station or mobile operation in any mode and operation from the usual nominal 12 V dc power supply. In this way, the supply that powers a 100 W HF transceiver can likely power the amplifier as well.

After absorbing the specs in the data sheet, it was clear to me that this module could be driven by almost any low power rig; thinking about it a bit more, and keeping in mind the low cost and simplicity requirements, a few more useful features came to mind, such as:

- An output low-pass filter to comply with FCC regulations for harmonic and spurious suppression.
- A low loss antenna relay.

- An RF-sensing TR switch for remote operation, as well as a hard key option.
- TR sequencing to protect the S-AV36 module and prevent hot switching of the antenna relay.
- Indicator LEDs and control switches.
- Reverse polarity protection.

The inside of the final project is shown in Figure 1. Note the simplicity.

The devil is in the details for the designer, though, and it did take a little planning, but the end result was a small PC board made at home using common hobby tools. Add a few interconnecting wires, heat sink, connectors, switches, a couple of sheet metal parts for the enclosure, and that's about it. A schematic and parts list is provided in Figure 2. The

input and output power of the amplifier with the built in attenuator for a 10 W exciter shown in Figure 2 is provided in Table 1. This also shows the current required at 13.8 V dc.

Designing the Amplifier

The S-AV36 module is pretty easy to use; aside from RF IN and RF OUT, there are two power connections; one is for BIAS (this turns the module on and off), and the other for main DC POWER, 13.5 V nominal at up to 15 A. Since the input power required to drive it is only about 50 mW, the first thing to do is design an input attenuator to match the output of the driver to the S-AV36. The resistive attenuator (R7, R8 and R9) can adapt the attenuator to drive levels ranging from 1 to 10 W as shown in Table 2. There are some strange values there, but these are not terribly critical,

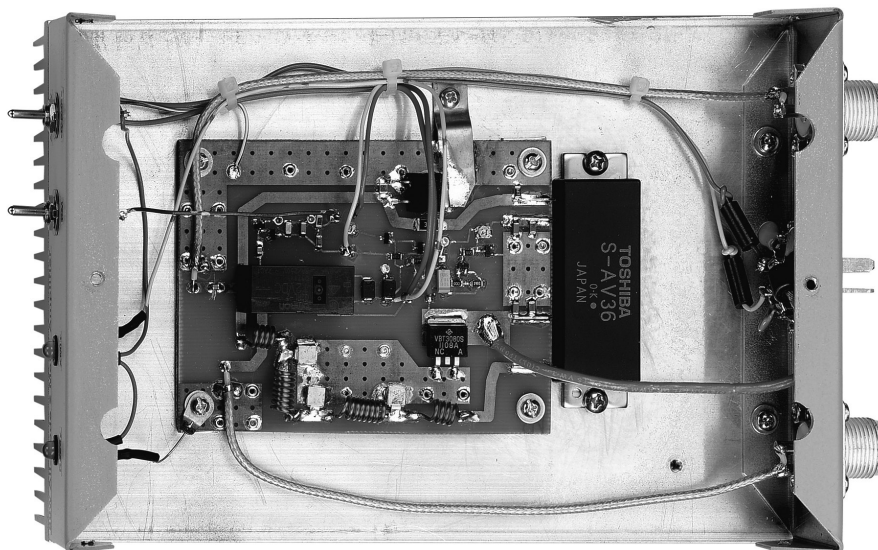

Figure 1 — Inside of the compact amplifier showing the simplicity of the final design. The amplifier module is the black rectangle connected to the right edge of the PC board.

you just have to get within a few ohms to get the job done. For example, a 23 dB attenuator is needed for a 10 W radio. The resistors chosen were those readily available from major distributors, so 58 Ω became 56, and 351 became 360 (close enough). L5 is not really necessary. Its purpose is to compensate for the stray capacitance of R7 at 2 meters (a 35 W tab-mounted resistor). The input SWR was acceptable without it, but it does make the input match almost perfect.

The Low-Pass Filter

Now that the input is taken care of, let's deal with the output. The data sheet says the second harmonic will only be down about 25 dB, and the third about 30. Not good enough for the FCC, so we need an output filter that will put us in good graces with at least 60 dB total suppression. For that 25 dB second harmonic, we need another 35 dB.

The filter shown (L1-L4, C12-C14 in Figure 2) is a standard pi type, Chebyshev filter of seven poles. The design provides the required suppression with very little insertion loss at the operating frequency.

The Antenna Relay and Switching Controls

In the spirit of keeping costs low, a PCB mount type of DPDT general purpose relay was chosen for TR and bypass switching. At less than \$5 in cost, the contacts are rated at 8 A. At 2 meters, a bit of reactance is introduced by this part, but compensated for by a small capacitor (C15) in series with its input.

The best way to tell the amplifier to switch on is to use a control line back to the driving radio (PTT). If this is unavailable or inconvenient, the amplifier has an RF sensing circuit that samples a bit of drive from the input connector to provide the transmit trigger.

In another little twist; switching from receive to transmit should be sequenced for two reasons; first, the S-AV36 is tough, but no self-

respecting amplifier module likes seeing an open circuit while those lazy relay contacts are moving, even if it only takes 20 ms to happen. It's not good for the module, and just plain rude. For this reason, the module has to be kept off while the relay contacts are settling. The other reason is to protect the relay contacts from that 80 to 100 W the amplifier will generate before they finally settle; it tends to shorten the life of the relay.

C4, D1 and D2 sample the input while C5, C6, R1 and R2 provide filtering and some timing, depending on the position of S1. In SSB mode, the circuit provides a delay on switching to RECEIVE similar to VOX, providing a second or so of delay. In FM mode, the switch back to RECEIVE is much quicker, as the delay is not necessary for FM operation. The circuit is sensitive, and will trigger with less than 1/2 W drive.

Q1 is the switch that operates the relay. When the relay is turned on by Q1, it also turns on Q2 (the bias switch) after a short delay. This delay is provided by C9 and R4, and is about 50 ms in duration, allowing those relay contacts to settle before the module becomes active.

When switching back to RECEIVE, the bias to the module is cut off before the relay contacts open. This fast cutoff is timed by C9 and R5, and is only about 5 ms in duration.

Another noteworthy component is D6, the reverse-polarity protection diode. This diode's purpose is to blow the in-line fuse in the power cord if you accidentally connect the power cord backwards (come on, we've all done it).

The extra contacts on power connector J3, Pins 3 and 4, provide a means to disable the RF sensing and connect PTT directly to the driver should the RF sensing be deemed unnecessary. If just Pin 4 of J3 is grounded by a PTT line, the amplifier will be switched by the PTT, but all the delays will apply. If Pin 3 is grounded the amplifier will follow the PTT with only the delays designed to protect against hot switching, as described above.

Building the Amplifier

Here are the recommended steps, in sequence, for constructing the amplifier:

- Mark the heat sink for drilling by using the PC board as a template. You can also position the Toshiba module and mark its two mounting holes; leave a small gap of 2 to 3 mm between the module body and the board for strain relief.
- Drill and tap the module mounting

holes for #6-32 screws, and the PCB holes for 4-40 screws.

Install all the PC board components except for the module. The relay should be installed last, and because the pins will protrude through the bottom of the board, they should be cut off flush with the board after soldering.

While I used a PC board and surface mount components, there is no reason leaded components could not be substituted. The PC board is still recommended because the etched transmission lines going in and out of the TR the relay will provide minimum loss on receive — important since any loss adds directly to the receive noise figure.

- Make the enclosure parts and two aluminum spacers as shown in the fabrication drawings available on the *QST* in Depth web page.¹

- A PC board is available from the author, or can be made from the artwork on the *QST* in Depth web page. Mount the board to the heat sink with four 4-40 screws. The two aluminum spacers must be positioned under the board on either end to elevate the board to a convenient height for the module and keep the back side PCB connections at the relay pins from shorting against the heat sink.

- Some minor tuning of the low-pass filter coils can be made at this time. Connect a dummy load to the output of the board, and a transmitter and SWR meter to the trace at the input of the filter where the module will connect. Apply 12 V across the relay coil to close the relay, and spread or compress L1-L4 for lowest SWR reading. If this is inconvenient to do, the filter can be adjusted after the amplifier is fully constructed, adjusting for max power at about 50 W output. It's best to do it now, though, and you'll probably find that

¹www.arrl.org/qst-in-depth

**Table 1
Output Power and Current
Required with Resting
Current at 8 A**

Drive Power (W)	Output Power (W)	Current (A) at 13.5 V
1	12	8.2
2	29	9.0
3	44	9.5
4	53	10.0
5	66	11.0
6	74	11.5
7	80	12.0
8	85	12.5
9	89	12.8
10	92	13.0

**Table 2
Values of R7, R8 and R9 for
Different Drive Levels**

Drive Power (W)	Attenuation (dB)	R7, R9 (Ω)	R8 (Ω)
1	13.0	79	106
2	16.0	69	154
3	17.8	65	191
4	19.0	63	220
5	20.0	61	248
6	20.8	60	272
7	21.5	59	295
8	22.0	59	313
9	22.6	58	335
10	23.0	58	351

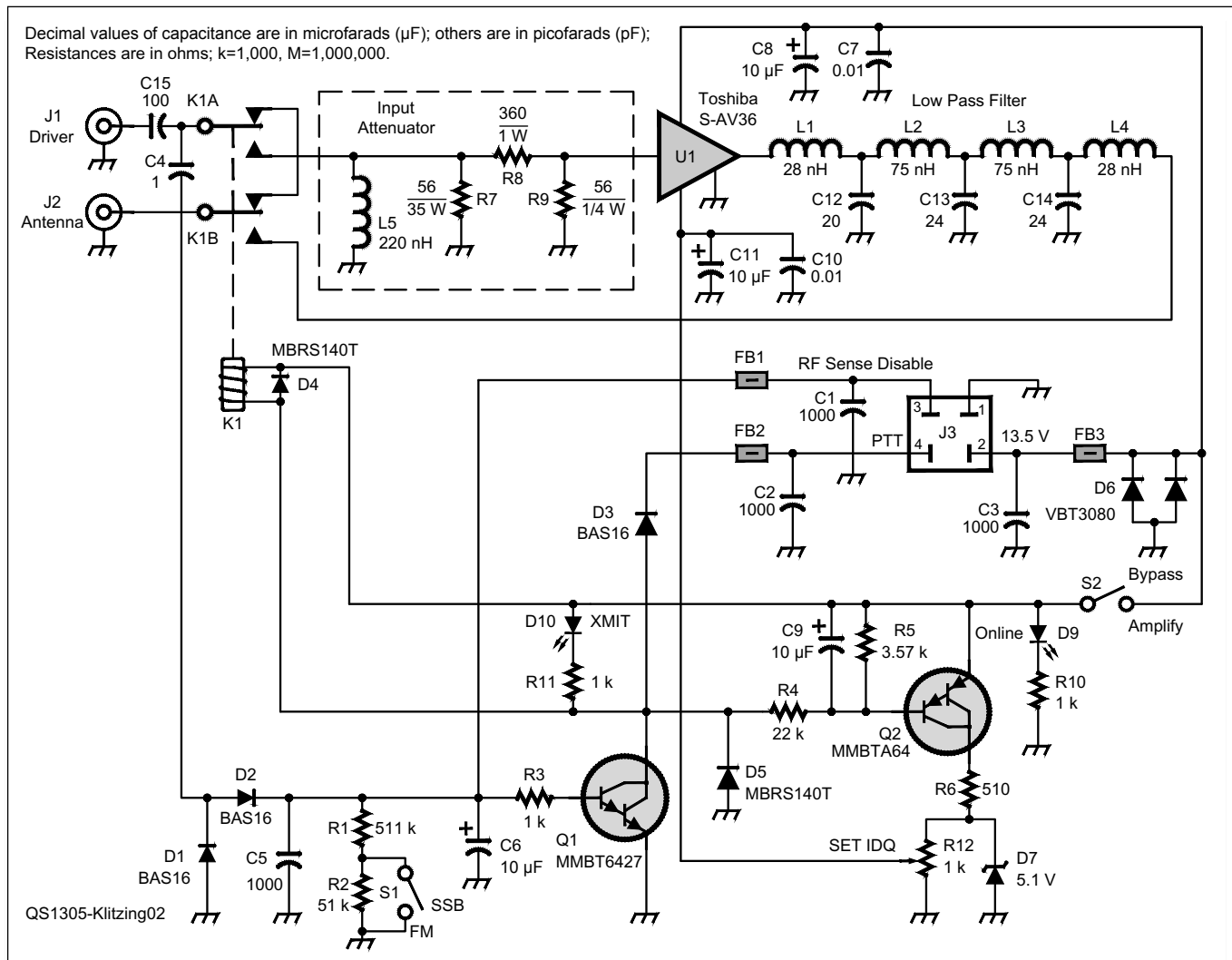

Figure 2 — Schematic diagram and parts list for the amplifier. For parts supplied by Mouser, you can order all of these by ordering the project list from their website, or order individual parts if your prefer. www.mouser.com/tools/projectcartsharing.aspx. The access ID code for the project is **c3ad150d1a**. RFPARTS (www.rfparts.com) is the supplier for the Toshiba module and coax connectors. Heat Sink USA parts are available at www.heatsinkusa.com. Artwork for the PC board is provided on the QST in Depth web page, along with fabrication drawings for sheet metal parts. For those not wishing to make their own board, commercially made boards are available from www.w6pql.com.

- | | | |
|---|--|---|
| <p>C1, C2, C3 — 1000 pF ceramic capacitor (Mouser S102K29Y5PN6TJ5R).</p> <p>C4 — 1 pF SMT capacitor (Mouser 12061A1R0CAT2A).</p> <p>C5 — 1000 pF 1206 (SMT) capacitor (Mouser 12065C102KAT2A).</p> <p>C6, C8, C9, C11 — 10 μF 1206 (SMT) ceramic capacitor (Mouser 581-TAJA106M016R).</p> <p>C7, C10 — 0.01 μF 1206 (SMT) capacitor (Mouser VJ1206Y103KXXCW1BC).</p> <p>C12 — 20 pF metal mica capacitor (Mouser MIN02-20J-F).</p> <p>C13, C14 — 24 pF metal mica capacitor (Mouser MIN02-24J-F).</p> <p>C15 — 100 pF metal mica capacitor (Mouser MIN02-100J-F).</p> <p>D1, D2, D3 — SMT switching diode (Mouser 512-BAS16).</p> <p>D4, D5 — 1 A surface mount diode (Mouser MBRS140TRPBF).</p> <p>D6 — SMT dual diode, 30 A (Mouser VBT3080S-E3/8W).</p> <p>D7 — 5.1 V SMT Zener diode (Mouser MMBZ5231B-V-GS08).</p> <p>D9 — 5 mm green LED (Mouser 941-C503BGCNCYC0791).</p> <p>D10 — 5 mm red LED (Mouser 941-C566CRFSC70W0BB2).</p> <p>F1 — 20 A fuse to fit the fuse holder in the power cable called out below.</p> | <p>FB1, FB2 — Small ferrite bead (Mouser 623-2643000701).</p> <p>FB3 — Large ferrite bead (Mouser 623-2643000801).</p> <p>J1, J2 — Panel mount SO-239 coax socket.</p> <p>J3 — Power connector, 4 Pin cable mount (Mouser 38331-8004).</p> <p>K1 (RL1) — Omron DPDT relay (Mouser G2RL-2-DC12).</p> <p>L1, L4 — Inductor, 28 nH. 4 turns #18 AWG, 4 mm inside diameter, 8 mm long.</p> <p>L2, L3 — Inductor, 75 nH. 7 turns #18 AWG, 4 mm inside diameter, 10 mm long.</p> <p>L5 — Inductor, 220 nH. (Mouser 70-IMC10008ERR22J).</p> <p>Q1 — NPN Darlington transistor (SMT) (Mouser MMBT6427).</p> <p>Q2 — PNP Darlington transistor (SMT) (Mouser MMBTA64).</p> <p>R1 — 511 kΩ 1206 (SMT) resistor (Mouser CR1206-FX-5118ELF).</p> <p>R2 — 51 kΩ SMT resistor (Mouser CR1206-FX-5102ELF).</p> <p>R3 — 1 kΩ 1206 SMT resistor (Mouser CR1206-FX-1001ELF).</p> <p>R4 — 22 kΩ SMT resistor (Mouser CR1206-FX-2202ELF).</p> <p>R5 — 3.57 kΩ SMT resistor (Mouser CR1206-FX-3571ELF).</p> | <p>R6 — 510 Ω SMT resistor (Mouser CR1206-FX-5100ELF).</p> <p>R7 — 56 Ω, 35 W SMT resistor (Mouser PWR263S3556R0F)*.</p> <p>R8 — 360 Ω, 1 W SMT resistor (Mouser RK73B3ATTE361J)*.</p> <p>R9 — 56 Ω, 1/4 W SMT resistor (Mouser CR1206-FX-56R0ELF)*.</p> <p>R10, R11 — 1 kΩ, 1/4 W metal film resistor (Mouser 660-1/4DCT52R1001F).</p> <p>R12 (VR1) — 1 kΩ potentiometer (Mouser TC33X-2-102E).</p> <p>S1, S2 — SPST miniature toggle switch (Mouser A101SYZQ04).</p> <p>U1 — Toshiba S-AV36 amplifier module (RF Parts)</p> <p>Heat sink extrusion 5.375 x 8 x 1.376 inches (Heat Sink USA A009).</p> <p>Heat sink extrusion 5.375 x 8 x 1.375 inches (Heat Sink USA A008).</p> <p>In-line fuse holder (Mouser 441-R-332B-GR).</p> <p>RG-316 50 Ω Teflon coax to go from J1 and J2 to K1.</p> |
|---|--|---|

*These parts provide the input attenuation required for a 10 W input. For other levels of driving power, see Table 2.

very little adjustment is necessary.

- Using heat sink compound, mount the Toshiba module with #6-32 machine screws. Note that the mounting bar of the module is slightly concave; this is not a defect, the man-

ufacturer makes them this way, as do other module makers. Do not attempt to sand this footing flat or otherwise fill with any material except for heat sink compound. There is still plenty of contact area for heat transfer. I'm

just guessing, but I believe the manufacturer makes the footing this way for strain relief in order to protect the mechanical bonds inside. Solder the module wires to the appropriate traces on the PC board (cut off the excess wire length if necessary, see Figure 3).

- Mount the connectors, switches and LEDs, and complete the chassis wiring (see Figure 4). The LEDs have their 1 kΩ resistors soldered directly to their leads, with the wire connected to the other side of the resistor; heat shrink is used to cover the resistor and connections. Use solder lugs under the mounting screws for the connectors on the rear panel; these are for connecting coax shields, dc chassis ground, and bypass capacitors as shown in Figure 5.

- Make the power cord from #14 AWG wire. Make certain to use an in-line fuse on the positive lead, and fuse it for no more than 20 A. If you will be hard keying your amplifier from your radio, jumper Pin 3 of the connector to ground, and carry Pin 4 back to your keying connection from the radio. The radio's PTT relay contacts or other switching must be capable of sinking 12 V at 50 mA to ground.

Testing the Amplifier

Once everything is wired and in place, you can test the amplifier using the following procedure:

- Connect the output to a suitable wattmeter and dummy load, and the input to your driving radio.
- Connect the power cord to a power supply

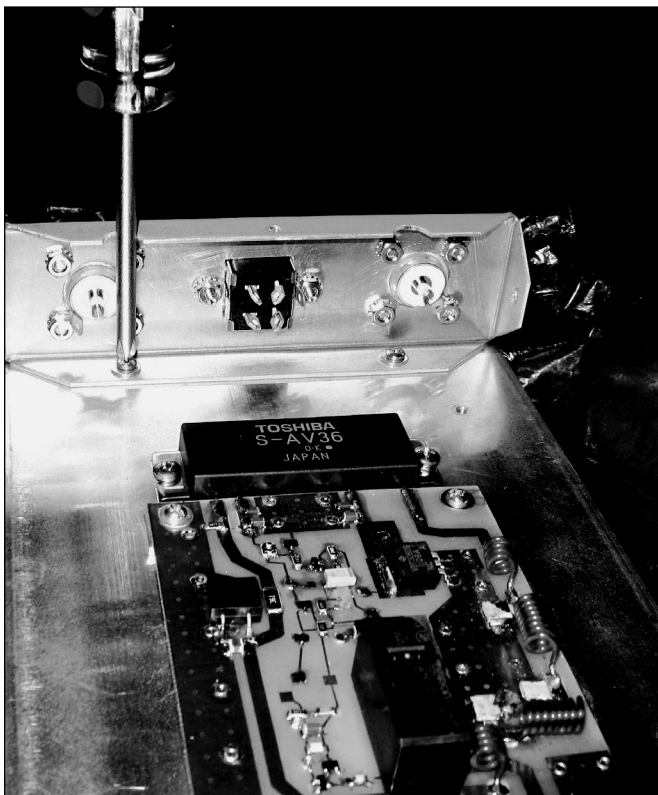

Figure 3 — The rear panel is attached using #6-32 machine screws. The module connections are soldered to the PC board as shown.

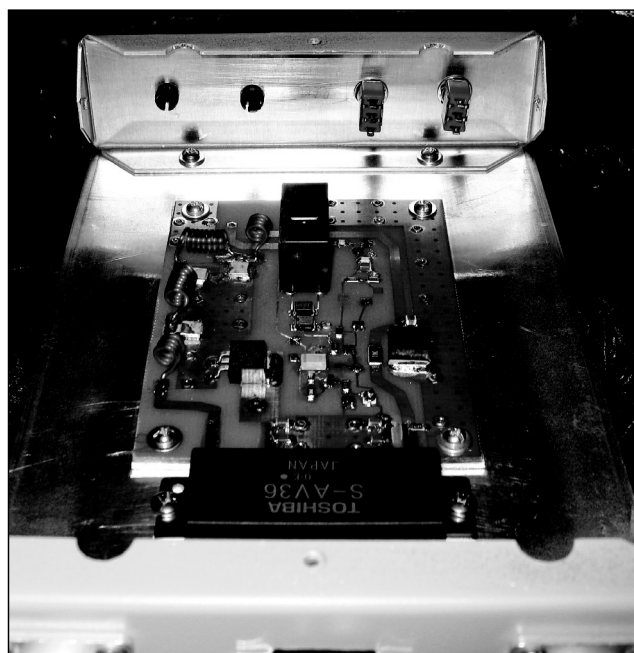

Figure 4 — View of the inside of the front panel before wiring.

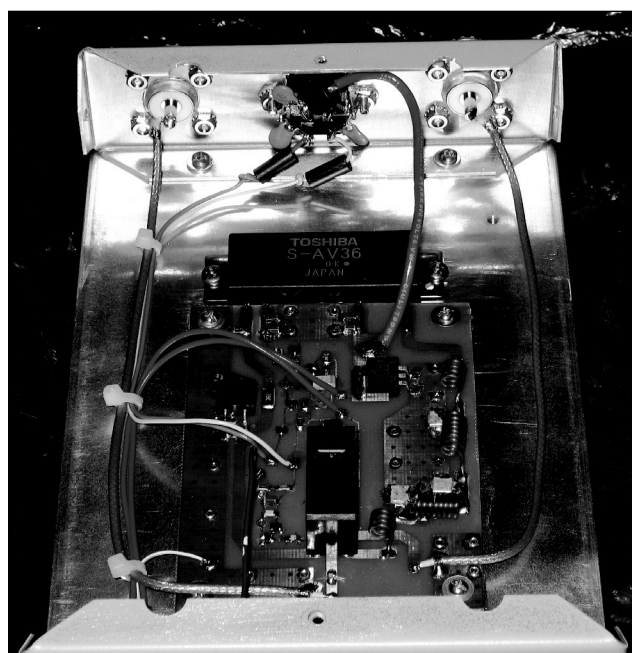

Figure 5 — Details of the rear panel wiring.

A Quest for a More Linear Amplifier

Your editor, in common with many casual VHF operators, uses a transverter with a power output of 10 W. In my case it is an Elecraft K3 HF and 6 meter transceiver with an internal 2 meter transverter. This unit has a very low noise receiver with the result that I can hear many more 2 meter stations than can hear me.

In an effort to put my station on an equal footing with stations with the frequently encountered 100 W multimode radios, I wanted to find an amplifier that could be added to my station to make up the difference. I tested a number of “brick” amplifiers in the hopes of finding one that would provide the needed power with appropriate intermod products for use on SSB.^{1,2} While the tested units delivered the desired power, and indicated that they were suitable for SSB, the intermod levels were high enough that I thought they would cause trouble for other stations during contests. These amplifiers work fine on FM, their primary use

design goal, as well as on CW. It is only using them in SSB operation that generates the spurious signals due to the multiple simultaneous frequency components.

There was an alternative, a much higher priced, higher powered, amplifier (now discontinued) that showed HF type

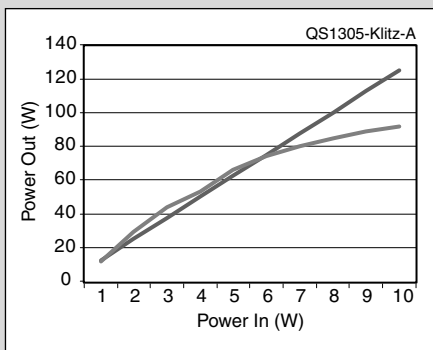

Figure A — Power output versus input, as measured in the ARRL Lab. A straight line (red) is shown for comparison.

capable of delivering 13.5 V at up to 15 A.

Place the AMPLIFY/BYPASS switch in BYPASS mode. Transmit, and verify that bypass mode works (most of the driver’s power should pass through the amplifier to the load). The bypass mode insertion loss is only about 0.1 dB.

Turn off the driving radio and put the amplifier in AMPLIFY mode. The READY LED should illuminate. Jumper PTT to ground, and the XMIT LED should also illuminate. Adjust the IDQ trimmer (VR1) for 8 A. Place the amplifier back in BYPASS mode and remove the PTT jumper.

Turn the radio back on, place the amplifier in AMPLIFY mode, and transmit. Performance should be similar to the data shown in Table 1.

I experimented some with various IDQ settings, and concluded that Toshiba must have designed the module to operate close to Class A. Setting IDQ too low tended to intro-

duce lower overall gain and crossover distortion in SSB, while setting it too high resulted in higher gain and saturated output power. At 10 A IDQ, for example, the amplifier could be driven to over 100 W output with about half the drive required at 8 A IDQ. This current drawn at this level is close to the manufacturer’s absolute maximum ratings for the device, and really doesn’t make any difference on the air, so I resisted the temptation to leave it that way. For all mode versatility, leaving IDQ set at 8 A is best.

One last note. At a drive level of 10 W, I noticed R7 (the 35 W attenuator input resistor) ran hot. This was due to the inadequate heat transfer of the PC board I made for the original prototype, which has just a few rivets where there should have been multiple plated through holes surrounding this part. My solution was to use a piece of 0.040 inch copper strip soldered to the ground tab of the resistor. I used this to transfer the heat to the heat sink by fastening the other end to it with a #4

screw. Most of us making our own prototype boards at home don’t have the ability to make plated through holes the way the commercial board houses do, so if you make your own board for this project, you’ll probably need to implement a similar solution.

ARRL member and Advanced class licensee James Klitzing, W6PQL, was first licensed in 1964 as WB6MYC. He has been a precision measurement specialist for the US Air Force and Hewlett-Packard Company. He retired in 2006 as an engineering manager for Agilent Technologies after 34 years with HP/Agilent. Jim has always enjoyed building his own equipment and is active on HF through 3456 MHz.

You can reach him at 38105 Paseo Padre Ct, Fremont, CA 94536, or at jim@w6pql.com. Jim’s website, www.w6pql.com, has all current updates to this and many other projects.

For updates to this article, see the QST Feedback page at www.arrl.org/feedback.

Table A
Intermodulation Response as a Function of PEP Output

Power Output	Intermodulation Products (dBc)			
PEP (W)	3rd	5th	7th	9th
55	-27	-44	-46	-56
75	-24	-42	-49	-53
100	-19	-28	-36	-47

IMD was indeed possible on VHF.³ There was also the very nice 2 meter kilowatt amplifier described by Jim Klitzing in a recent *QST* article.⁴ That inspired me to commission Jim to put his talents to work designing a lower powered amplifier that would meet my operational objectives, be easy to build and relatively inexpensive.

Jim has met my objectives in this very nice package. The IMD output, as measured in the ARRL Lab were as shown in Table A, and a plot of the input versus output power in Figure A. Note that it closely follows the straight line until 7.5 to 80 W, at which point the compression is evident.

¹J. Hallas, W1ZR, “Product Review — A Pair of Mirage 2 Meter Amplifiers” *QST*, Aug 2010, p 52.

²J. Hallas, W1ZR, “Product Review — TE Systems 1410G 2 Meter Linear Amplifier,” *QST*, Jan 2012, p 54.

³J. Hallas, W1ZR, “Product Review — Tokyo Hy-Power Labs HL 350V DX 2 Meter Linear Amplifier,” *QST*, Mar 2012 p 48.

⁴J. Klitzing, W6PQL, “Solid State 1 kW Linear Amplifier for 2 Meters,” *QST*, Oct 2012, p 32.