

Antenna Fundamentals

Antennas belong to a class of devices called *transducers*. This term is derived from two Latin words, meaning literally “to lead across” or “to transfer.” Thus, a transducer is a device that transfers, or converts, energy from one form to another. The purpose of an antenna is to convert radio-frequency electric current to *electromagnetic waves*, which are then *radiated* into space. [For more details on the properties of electromagnetic waves themselves, see Chapter 23, Radio Wave Propagation.]

We cannot directly see or hear, taste or touch electromagnetic waves, so it’s not surprising that the process by which they are launched into space from our antennas can be a little mystifying, especially to a newcomer. In everyday life we come across many types of transducers, although we don’t always recognize them as such. A comparison with a type of transducer that you can actually see and touch may be useful. You are no doubt familiar with a *loudspeaker*. It converts audio-frequency electric current from the output of your radio or stereo into acoustic pressure waves, also known as *sound waves*. The sound waves are propagated through the air to your ears, where they are converted into what you perceive as sound.

We normally think of a loudspeaker as something that converts electrical energy into sound energy, but we could just as well turn things around and apply sound energy to

a loudspeaker, which will then convert it into electrical energy. When used in this manner, the loudspeaker has become a microphone. The loudspeaker/microphone thus exhibits the principle of *reciprocity*, derived from the Latin word meaning to move back and forth.

Now, let’s look more closely at that special transducer we call an *antenna*. When fed by a transmitter with RF current (usually through a transmission line), the antenna launches electromagnetic waves, which are propagated through space. This is similar to the way sound waves are propagated through the air by a loudspeaker. In the next town, or perhaps on a distant continent, a similar transducer (that is, a receiving antenna) intercepts some of these electromagnetic waves and converts them into electrical current for a receiver to amplify and detect.

In the same fashion that a loudspeaker can act as a microphone, a radio antenna also follows the principle of reciprocity. In other words, an antenna can transmit as well as receive signals. However, unlike the loudspeaker, an antenna does not require a *medium*, such as air, through which it radiates electromagnetic waves. Electromagnetic waves can be propagated through air, the vacuum of outer space or the near vacuum of the upper ionosphere. This is the miracle of radio—electromagnetic waves can propagate without a physical medium.

Essential Characteristics of Antennas

What other things make an antenna different from an ordinary electronic circuit? In ordinary circuits, the dimensions of coils, capacitors and connections usually are small compared with the wavelength of the frequency in use. Here, we define wavelength as the distance in free space traveled during one complete cycle of a wave. The

velocity of a wave in free space is the speed of light, and the wavelength is thus:

$$\lambda_{\text{meters}} = \frac{299.7925 \times 10^6 \text{ meters/sec}}{f \text{ hertz}} = \frac{299.7925}{f \text{ MHz}} \quad (\text{Eq 1})$$

where λ_{meters} , the Greek letter lambda, is the free-space wavelength in meters.

Expressed in feet, Eq 1 becomes:

$$\lambda_{\text{feet}} = \frac{983.5712}{f \text{ MHz}} \approx \frac{983.6}{f \text{ MHz}} \quad (\text{Eq 2})$$

When circuit dimensions are small compared to λ , most of the electromagnetic energy is confined to the circuit itself, and is used up either performing useful work or is converted into heat. However, when the dimensions of wiring or components become significant compared with the wavelength, some of the energy escapes by radiation in the form of electromagnetic waves.

Antennas come in an enormous, even bewildering, assortment of shapes and sizes. This chapter on fundamentals will deal with the theory of simple forms of antennas, usually in *free space*, away from the influence of ground. Subsequent chapters will concentrate on more exotic or specialized antenna types. Chapter 3 deals with the complicated subject of the effect of ground, including the effect of uneven local terrain. Ground has a profound influence on how an antenna performs in the real world.

No matter what form an antenna takes, simple or complex, its electrical performance can be characterized according to the following important properties:

1. Feed-point Impedance
2. Directivity, Gain and Efficiency
3. Polarization

FEED-POINT IMPEDANCE

The first major characteristic defining an antenna is its *feed-point impedance*. Since we amateurs are free to choose our operating frequencies within assigned bands, we need to consider how the feed-point impedance of a particular antenna varies with frequency, within a particular band, or even in several different bands if we intend to use one antenna on multiple bands.

There are two forms of impedance associated with any antenna: *self impedance* and *mutual impedance*. As you might expect, self impedance is what you measure at the feed-point terminals of an antenna located completely away from the influence of any other conductors.

Mutual, or coupled, impedance is due to the parasitic effect of nearby conductors; that is, conductors located within the antenna's reactive near field. (The subject of fields around an antenna will be discussed in detail later.) This includes the effect of ground, which is a lossy conductor, but a conductor nonetheless. Mutual impedance is defined using Ohm's Law, just like self impedance. However, mutual impedance is the ratio of voltage in one conductor, divided by the current in another (coupled) conductor. Mutually coupled conductors can distort the pattern of a highly directive antenna, as well as change the impedance seen at the feed point.

In this chapter on fundamentals, we won't directly deal with mutual impedance, considering it as a side effect of nearby conductors. Instead, here we'll concentrate on simple antennas in free space, away from ground and any other conductors. Mutual impedance will be considered in detail in Chapter 11, HF Yagi Arrays, where it is essential for proper operation of these beam antennas.

Self Impedance

The current that flows into an antenna's feed point must be supplied at a finite voltage. The self impedance of the antenna is simply equal to the voltage applied to its feed point divided by the current flowing into the feed point. Where the current and voltage are exactly in phase, the impedance is purely resistive, with zero reactive component. For this case the antenna is termed *resonant*. (Amateurs often use the term "resonant" rather loosely, usually meaning "nearly resonant" or "close-to resonant.")

Please recognize that an antenna *need not be resonant* in order to be an effective radiator. There is in fact nothing magic about having a resonant antenna, provided of course that you can devise some efficient means to feed the antenna. Many amateurs use non-resonant (even random-length) antennas fed with open-wire transmission lines and antenna tuners. They radiate signals just as well as those using coaxial cable and resonant antennas, and as a bonus they usually can use these antenna systems on multiple frequency bands. It is important to consider an antenna and its feed line as a *system*, in which all losses should be kept to a minimum. See Chapter 24, Transmission Lines, for details on transmission-line loss as a function of impedance mismatch.

Except at the one frequency where it is truly resonant, the current in an antenna is at a different phase compared to the applied voltage. In other words, the antenna exhibits a feed-point *impedance*, not just a pure resistance. The feed-point impedance is composed of either capacitive or inductive reactance in series with a resistance.

Radiation Resistance

The power supplied to an antenna is dissipated in two ways: radiation of electromagnetic waves, and heat losses in the wire and nearby dielectrics. The radiated power is what we want, the useful part, but it represents a form of "loss" just as much as the power used in heating the wire or nearby dielectrics is a loss. In either case, the dissipated power is equal to I^2R . In the case of heat losses, R is a real resistance. In the case of radiation, however, R is a "virtual" resistance, which, if replaced with an actual resistor of the same value, would dissipate the power actually radiated from the antenna. This resistance is called the *radiation resistance*. The total power in the antenna is therefore equal to $I^2(R_0+R)$, where R_0 is the radiation resistance and R represents the total of all the loss resistances.

In ordinary antennas operated at amateur frequencies, the power lost as heat in the conductor does not exceed a few percent of the total power supplied to the antenna. Expressed in decibels, the loss is less than 0.1 dB. The RF loss resistance of copper wire even as small as #14 is very low compared with the radiation resistance of an antenna that is reasonably clear of surrounding objects and is not too close to the ground. You can therefore assume that the ohmic loss in a reasonably well-located antenna is negligible, and that the total resistance shown by the antenna (the feed-point resistance) is radiation resistance. As a radiator of electromagnetic waves, such an antenna is a highly efficient device.

Impedance of a Center-Fed Dipole

A fundamental type of antenna is the *center-fed half-wave dipole*. Historically, the $\lambda/2$ dipole has been the most popular antenna used by amateurs worldwide, largely because it is very simple to construct and because it is an effective performer. It is also a basic building block for many other antenna systems, including beam antennas, such as Yagis.

A center-fed half-wave *dipole* consists of a straight wire, one-half wavelength long as defined in Eq 1, and fed in the center. The term “dipole” derives from Greek words meaning “two poles.” See Fig 1. A $\lambda/2$ -long dipole is just one form a dipole can take. Actually, a center-fed dipole can be any length electrically, as long as it is configured in a symmetrical fashion with two equal-length legs. There are also versions of dipoles that are not fed in the center. These are called *off-center-fed dipoles*, sometimes abbreviated as “OCF dipoles.”

In free space—with the antenna remote from everything else—the theoretical impedance of a physically half-wave long antenna made of an infinitely thin conductor is $73 + j 42.5 \Omega$. This antenna exhibits both resistance and reactance. The positive sign in the $+ j 42.5\text{-}\Omega$ reactive term indicates that the antenna exhibits an inductive reactance at its feed point. The antenna is slightly long electrically, compared to the length necessary for exact

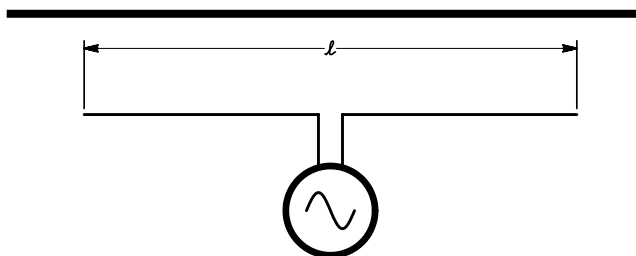

Fig 1—The center-fed dipole antenna. It is assumed that the source of power is directly at the antenna feed point, with no intervening transmission line. Most commonly in amateur applications, the overall length of the dipole is $\lambda/2$, but the antenna can in actuality be any length.

resonance, where the reactance is zero.

The feed-point impedance of any antenna is affected by the wavelength-to-diameter ratio (λ/dia) of the conductors used. Theoreticians like to specify an “infinitely thin” antenna because it is easier to handle mathematically.

What happens if we keep the physical length of an antenna constant, but change the thickness of the wire used in its construction? Further, what happens if we vary the frequency from well below to well above the half-wave resonance and measure the feed-point impedance? **Fig 2** graphs the impedance of a 100-foot long, center-fed dipole in free space, made with extremely thin wire—in this case, wire that is only 0.001 inches in diameter. There is nothing particularly significant about the choice here of 100 feet. This is simply a numerical example.

We could never actually build such a thin antenna (and neither could we install it in free space), but we can model how this antenna works using a very powerful piece of computer software called *NEC-4.1*. See Chapter 4, Antenna Modeling and System Planning, for details on antenna modeling.

The frequency applied to the antenna in Fig 2 is varied from 1 to 30 MHz. The x-axis has a logarithmic scale because of the wide range of feed-point resistance seen over the frequency range. The y-axis has a linear scale representing the reactive portion of the impedance. Inductive reactance is positive and capacitive reactance is negative on the y-axis. The bold figures centered on the spiraling line show the frequency in MHz.

At 1 MHz, the antenna is very short electrically, with a resistive component of about 2Ω and a series capaci-

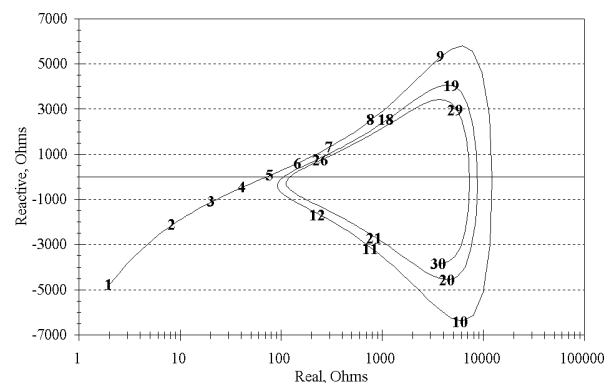

Fig 2—Feed-point impedance versus frequency for a theoretical 100-foot long dipole in free space, fed in the center and made of extremely thin 0.001-inch diameter wire. The y-axis is calibrated in positive (inductive) series reactance up from the zero line, and negative (capacitive) series reactance in the downward direction. The range of reactance goes from -6500Ω to $+6000 \Omega$. Note that the x-axis is logarithmic because of the wide range of the real, resistive component of the feed-point impedance, from roughly 2Ω to $10,000 \Omega$. The numbers placed along the curve show the frequency in MHz.

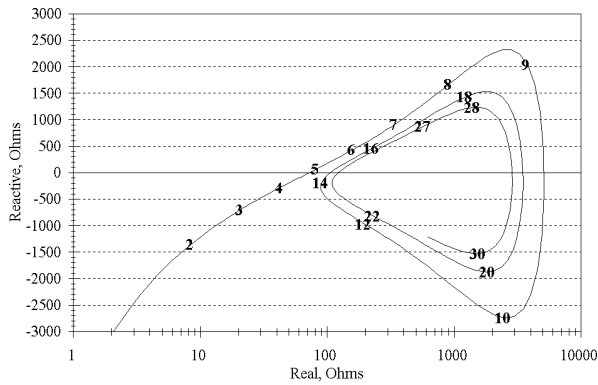

Fig 3—Feed-point impedance versus frequency for a theoretical 100-foot long dipole in free space, fed in the center and made of thin 0.1-inch (#10) diameter wire. Note that the range of change in reactance is less than that shown in Fig 2, ranging from -2700Ω to $+2300 \Omega$. At about $5,000 \Omega$, the maximum resistance is also less than that in Fig 2 for the thinner wire, where it is about $10,000 \Omega$.

tive reactance about -5000Ω . Close to 5 MHz, the line crosses the zero-reactance line, meaning that the antenna goes through half-wave resonance there. Between 9 and 10 MHz the antenna exhibits a peak inductive reactance of about 6000Ω . It goes through full-wave resonance (again crossing the zero-reactance line) between 9.5 and 9.6 MHz. At about 10 MHz, the reactance peaks at about -6500Ω . Around 14 MHz, the line again crosses the zero-reactance line, meaning that the antenna has now gone through $3/2$ -wave resonance.

Between 19 and 20 MHz, the antenna goes through $4/2$ -wave resonance, which is twice the full-wave resonance or four times the half-wave frequency. If you allow your mind's eye to trace out the curve for frequencies beyond 30 MHz, it eventually spirals down to a resistive component somewhere between 200 and 3000Ω . Thus, we have another way of looking at an antenna—as a sort of *transformer*, one that transforms the free-space impedance into the impedance seen at its feed point.

Now look at Fig 3, which shows the same kind of spiral curve, but for a thicker-diameter wire, one that is 0.1 inches in diameter. This diameter is close to #10 wire, a practical size we might actually use to build a real dipole. Note that the y-axis scale in Fig 3 is different from that in Fig 2. The range is from $\pm 3000 \Omega$ in Fig 3, while it was $\pm 7000 \Omega$ in Fig 2. The reactance for the thicker antenna ranges from $+2300$ to -2700Ω over the whole frequency range from 1 to 30 MHz. Compare this with the range of $+5800$ to -6400Ω for the very thin wire in Fig 2.

Fig 4 shows the impedance for a 100-foot long dipole using really thick, 1.0-inch diameter wire. The reactance varies from $+1000$ to -1500Ω , indicating once again that a larger diameter antenna exhibits less of an excursion in the reactive component with frequency. Note that at the

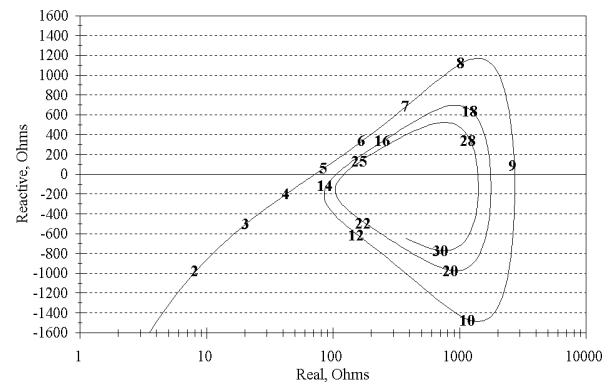

Fig 4—Feed-point impedance versus frequency for a theoretical 100-foot long dipole in free space, fed in the center and made of thick 1.0-inch diameter wire. Once again, the excursion in both reactance and resistance over the frequency range is less with this thick wire dipole than with thinner ones.

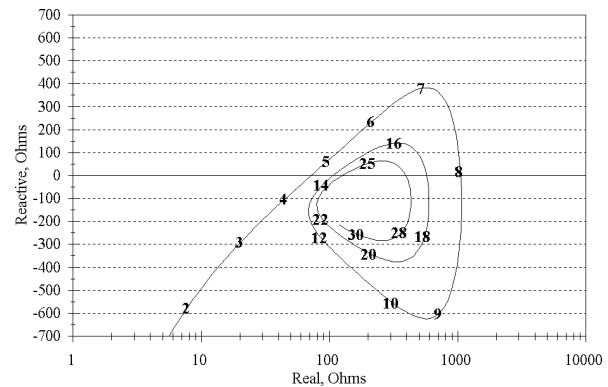

Fig 5—Feed-point impedance versus frequency for a theoretical 100-foot long dipole in free space, fed in the center and made of very thick 10.0-inch diameter wire. This ratio of length to diameter is about the same as a typical rod type of dipole element commonly used at 432 MHz. The maximum resistance is now about $1,000 \Omega$ and the peak reactance range is from about -625Ω to $+380 \Omega$. This performance is also found in “cage” dipoles, where a number of paralleled wires are used to simulate a fat conductor.

half-wave resonance just below 5 MHz, the resistive component of the impedance is still about 70Ω , just about what it is for a much thinner antenna. Unlike the reactance, the half-wave radiation resistance of an antenna doesn't radically change with wire diameter, although the maximum level of resistance at full-wave resonance is lower for thicker antennas.

Fig 5 shows the results for a very thick, 10-inch diameter wire. Here, the excursion in the reactive component is even less: about $+400$ to -600Ω . Note that the full-wave resonant frequency is about 8 MHz for this

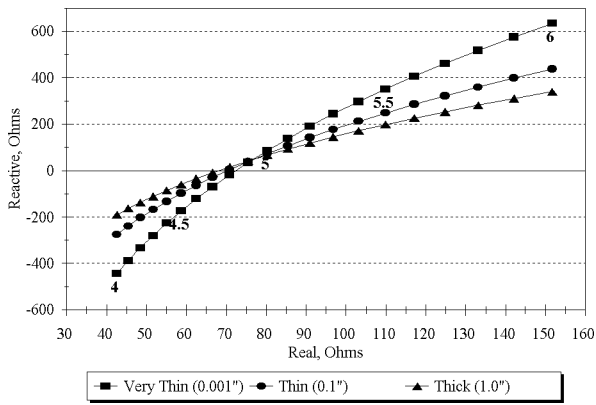

Fig 6—Expansion of frequency range around half-wave resonant point of three center-fed dipoles of three different thicknesses. The frequency is shown along the curves in MHz. The slope of change in series reactance versus series resistance is steeper for the thinner antennas than for the thick 1.0-inch antenna, indicating that the Q of the thinner antennas is higher.

extremely thick antenna, while thinner antennas have full-wave resonances closer to 9 MHz. Note also that the full-wave resistance for this extremely thick antenna is only about 1,000 Ω , compared to the 10,000 Ω shown in Fig 2. All half-wave resonances shown in Figs 2 through 5 remain close to 5 MHz, regardless of the diameter of the antenna wire. Once again, the extremely thick, 10-inch diameter antenna has a resistive component at half-wave resonance close to 70 Ω . And once again, the change in reactance near this frequency is very much less for the extremely thick antenna than for thinner ones.

Now, we grant you that a 100-foot long antenna made with 10-inch diameter wire sounds a little odd! A length of 100 feet and a diameter of 10 inches represent a ratio of 120:1 in length to diameter. However, this is about the same length-to-diameter ratio as a 432-MHz half-wave dipole using 0.25-inch diameter elements, where the ratio is 109:1. In other words, the ratio of length-to-diameter for the 10-inch diameter, 100-foot long dipole is not that far removed from what might actually be used at UHF.

Another way of highlighting the changes in reactance and resistance is shown in Fig 6. This shows an expanded portion of the frequency range around the half-wave resonant frequency, from 4 to 6 MHz. In this region, the shape of each spiral curve is almost a straight line. The slope of the curve for the very thin antenna (0.001-inch diameter) is steeper than that for the thicker antennas (0.1 and 1.0-inch diameters). Fig 7 illustrates another way of looking at the impedance data above and below the half-wave resonance. This is for a 100-foot dipole made of #14 wire. Instead of showing the frequency for each impedance point, the wavelength is

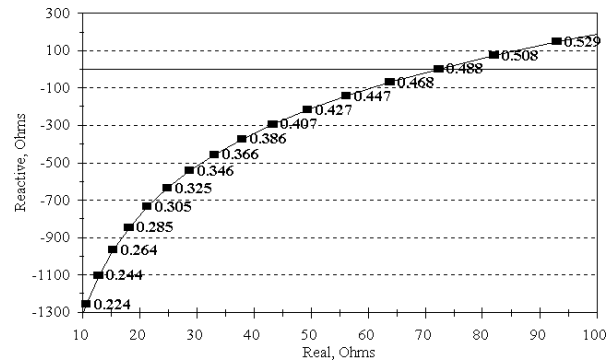

Fig 7—Another way of looking at the data for a 100-foot, center-fed dipole made of #14 wire in free space. The numbers along the curve represent the fractional wavelength, rather than frequency as shown in Fig 6. Note that this antenna goes through its half-wave resonance about 0.488 λ , rather than exactly at a half-wave physical length.

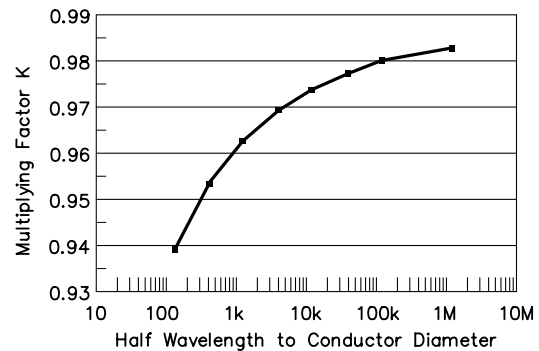

Fig 8—Effect of antenna diameter on length for half-wavelength resonance, shown as a multiplying factor, K, to be applied to the free-space, half-wavelength.

shown, making the graph more universal in application.

Just to show that there are lots of ways of looking at the same data, Fig 8 graphs the constant “K” used to multiply the free-space half-wavelength as a function of the ratio between the half-wavelength and the conductor diameter. The curve approaches the value of 1.00 for an infinitely thin conductor, in other words an infinitely large ratio of half-wavelength to diameter.

The behavior of antennas with different λ /diameter ratios corresponds to the behavior of ordinary series-resonant circuits having different values of Q. When the Q of a circuit is low, the reactance is small and changes rather slowly as the applied frequency is varied on either side of resonance. If the Q is high, the converse is true. The

response curve of the low-Q circuit is *broad*; that of the high-Q circuit *sharp*. So it is with antennas—the impedance of a thick antenna changes slowly over a comparatively wide band of frequencies, while a thin antenna has a faster change in impedance. Antenna Q is defined

$$Q = \frac{f_0 \Delta X}{2R_0 \Delta f} \quad (\text{Eq 3})$$

where f_0 is the center frequency, ΔX is the change in the reactance for a Δf change in frequency, and R_0 is the resistance at f_0 . For the “Very Thin,” 0.001-inch diameter dipole in Fig 2, a change of frequency from 5.0 to 5.5 MHz yields a reactance change from 86 to 351 Ω , with an R_0 of 95 Ω . The Q is thus 14.6. For the 1.0-inch-diameter “Thick” dipole in Fig 4, $\Delta X = 131 \Omega$ and R_0 is still 95 Ω , making $Q = 7.2$ for the thicker antenna, roughly half that of the thinner antenna.

Let’s recap. We have described an antenna first as a transducer, then as a sort of transformer to a range of free-space impedances. Now, we just compared the antenna to a series-tuned circuit. Near its half-wave resonant frequency, a center-fed $\lambda/2$ dipole exhibits much the same characteristics as a conventional series-resonant circuit. Exactly at resonance, the current at the input terminals is in phase with the applied voltage and the feed-point impedance is purely resistive. If the frequency is below resonance, the phase of the current leads the voltage; that is, the reactance of the antenna is capacitive. When the frequency is above resonance, the opposite occurs; the current lags the applied voltage and the antenna exhibits inductive reactance. Just like a conventional series-tuned circuit, the antenna’s reactance and resistance determines its Q.

ANTENNA DIRECTIVITY AND GAIN

The Isotropic Radiator

Before we can fully describe practical antennas, we must first introduce a completely theoretical antenna, the *isotropic radiator*. Envision, if you will, an infinitely small antenna, a point located in outer space, completely removed from anything else around it. Then consider an infinitely small transmitter feeding this infinitely small, point antenna. You now have an isotropic radiator.

The uniquely useful property of this theoretical *point-source* antenna is that it radiates equally well in all directions. That is to say, an isotropic antenna favors no direction at the expense of any other—in other words, it has absolutely no *directivity*. The isotropic radiator is useful as a *measuring stick* for comparison with actual antenna systems.

You will find later that real, practical antennas all exhibit some degree of directivity, which is the property of radiating more strongly in some directions than in others. The radiation from a practical antenna never has

the same intensity in all directions and may even have zero radiation in some directions. The fact that a practical antenna displays directivity (while an isotropic radiator does not) is not necessarily a bad thing. The directivity of a real antenna is often carefully tailored to emphasize radiation in particular directions. For example, a receiving antenna that favors certain directions can discriminate against interference or noise coming from other directions, thereby increasing the signal-to-noise ratio for desired signals coming from the favored direction.

Directivity and the Radiation Pattern— a Flashlight Analogy

The directivity of an antenna is directly related to the *pattern* of its radiated field intensity in free space. A graph showing the actual or relative field intensity at a fixed distance, as a function of the direction from the antenna system, is called a *radiation pattern*. Since we can’t actually see electromagnetic waves making up the radiation pattern of an antenna, we can consider an analogous situation.

Fig 9 represents a flashlight shining in a totally darkened room. To quantify what our eyes are seeing, we might use a sensitive light meter like those used by photographers, with a scale graduated in units from 0 to 10. We place the meter directly in front of the flashlight and adjust the distance so the meter reads 10, exactly full scale. We also carefully note the distance. Then, always keeping the meter the same distance from the flashlight and keeping it at the same height above the floor, we move the light meter around the flashlight, as indicated by the

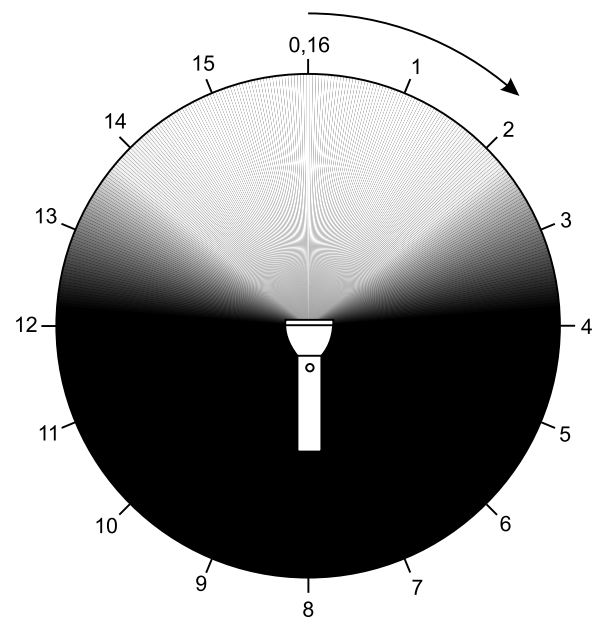

Fig 9—The beam from a flashlight illuminates a totally darkened area as shown here. Readings taken with a photographic light meter at the 16 points around the circle may be used to plot the radiation pattern of the flashlight.

arrow, and take light readings at a number of different positions.

After all the readings have been taken and recorded, we plot those values on a sheet of polar graph paper, like that shown in **Fig 10**. The values read on the meter are plotted at an angular position corresponding to that for which each meter reading was taken. Following this, we connect the plotted points with a smooth curve, also shown in Fig 10. When this is finished, we have completed a radiation pattern for the flashlight.

Antenna Pattern Measurements

Antenna radiation patterns can be constructed in a similar manner. Power is fed to the antenna under test, and a field-strength meter indicates the amount of signal. We might wish to rotate the antenna under test, rather than moving the measuring equipment to numerous positions about the antenna. Or we might make use of antenna reciprocity, since the pattern while receiving is the same as that while transmitting. A source antenna fed by a low-power transmitter illuminates the antenna under test, and the signal intercepted by the antenna under test is fed to a receiver and measuring equipment. Additional information on the mechanics of measuring antenna patterns is contained in Chapter 27, Antennas and Transmission-Line Measurements.

Some precautions must be taken to assure that the measurements are accurate and repeatable. In the case of the flashlight, let's assume that the separation between the light source and the light meter is 2 meters, about 6.5 feet. The wavelength of visible light is about one-half micron, where a micron is one-millionth of a meter.

For the flashlight, a separation of 2 meters between source and detector is $2.0 / (0.5 \times 10^{-6}) = 4$ million λ , a very large number of wavelengths. Measurements of practical HF or even VHF antennas are made at much closer distances, in terms of wavelength. For example, at 3.5 MHz a full wavelength is 85.7 meters, or 281.0 feet. To duplicate the flashlight-to-light-meter spacing in wavelengths at 3.5 MHz, we would have to place the field-strength measuring instrument almost on the surface of the Moon, about a quarter-million miles away!

The Fields Around an Antenna

Why should we be concerned with the separation between the source antenna and the field-strength meter, which has its own receiving antenna? One important reason is that if you place a receiving antenna very close to an antenna whose pattern you wish to measure, mutual coupling between the two antennas may actually alter the pattern you are trying to measure.

This sort of mutual coupling can occur in the region very close to the antenna under test. This region is called the *reactive near-field* region. The term "reactive" refers to the fact that the mutual impedance between the transmitting and receiving antennas can be either capacitive

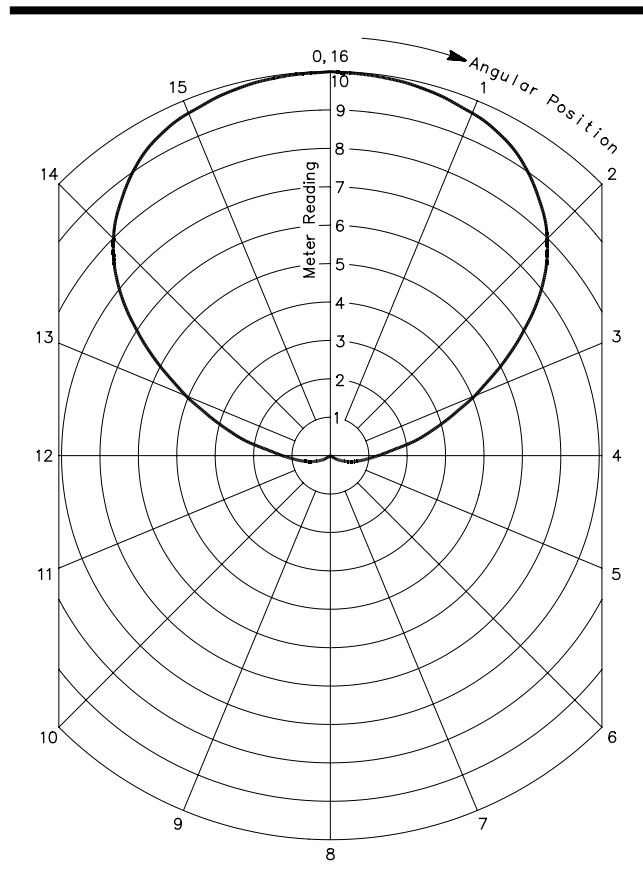

Fig 10—The radiation pattern of the flashlight in Fig 9. The measured values are plotted and connected with a smooth curve.

or inductive in nature. The reactive near field is sometimes called the "induction field," meaning that the magnetic field usually is predominant over the electric field in this region. The antenna acts as though it were a rather large, lumped-constant inductor or capacitor, storing energy in the reactive near field rather than propagating it into space.

For simple wire antennas, the reactive near field is considered to be within about a half wavelength from an antenna's radiating center. Later on, in the chapters dealing with Yagi and quad antennas, you will find that mutual coupling between elements can be put to good use to purposely shape the radiated pattern. For making pattern measurements, however, we do not want to be too close to the antenna being measured.

The strength of the reactive near field decreases in a complicated fashion as you increase the distance from the antenna. Beyond the reactive near field, the antenna's radiated field is divided into two other regions: the *radiating near field* and the *radiating far field*. Historically, the terms *Fresnel* and *Fraunhofer* fields have been used for the radiating near and far fields, but these terms have been largely supplanted by the more descriptive terminology used here. Even inside the reactive near-field

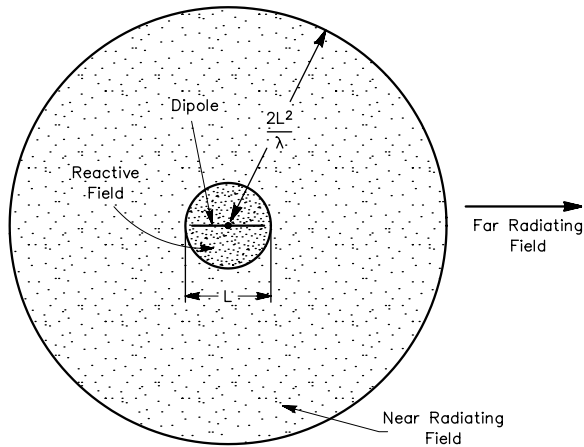

Fig 11—The fields around a radiating antenna. Very close to the antenna, the reactive field dominates. Within this area mutual impedances are observed between antenna and any other antennas used to measure response. Outside of the reactive field, the near radiating field dominates, up to a distance approximately equal to $2L^2/\lambda$, where L is the length of the largest dimension of the antenna. Beyond the near/far field boundary lies the far radiating field, where power density varies as the inverse square of radial distance.

region, both radiating and reactive fields coexist, although the reactive field predominates very close to the antenna.

Because the boundary between the fields is rather fuzzy, experts debate where one field begins and another leaves off, but the boundary between the radiating near and far fields is generally accepted as:

$$D \approx \frac{2L^2}{\lambda} \quad (\text{Eq 4})$$

where L is the largest dimension of the physical antenna, expressed in the same units of measurement as the wavelength λ . Remember, many specialized antennas do not follow the rule of thumb in Eq 4 exactly. **Fig 11** depicts the three fields in front of a simple wire antenna.

Throughout the rest of this book we will discuss mainly the radiating far-fields, those forming the traveling electromagnetic waves. Far-field radiation is distinguished by the fact that the intensity is inversely proportional to the distance, and that the electric and magnetic components, although perpendicular to each other in the wave front, are in time phase. The total energy is equally divided between the electric and magnetic fields. Beyond several wavelengths from the antenna, these are the only fields we need to consider. For accurate measurement of radiation patterns, we must place our measuring instrumentation at least several wavelengths away from the antenna under test.

Pattern Planes

Patterns obtained above represent the antenna radiation in just one plane. In the example of the flashlight, the plane of measurement was at one height above the floor. Actually, the pattern for any antenna is three dimensional, and therefore cannot be represented in a single-plane drawing. The *solid* radiation pattern of an antenna in free space would be found by measuring the field strength at every point on the surface of an imaginary sphere having the antenna at its center. The information so obtained would then be used to construct a solid figure, where the distance from a fixed point (representing the antenna) to the surface of the figure is proportional to the field strength from the antenna in any given direction. **Fig 12B** shows a three-dimensional wire-grid representation of the radiation pattern of a half-wave dipole.

For amateur work, *relative* values of field strength (rather than absolute) are quite adequate in pattern plotting. In other words, it is not necessary to know how many microvolts per meter a particular antenna will produce at a distance of 1 mile when excited with a specified power level. (This is the kind of specifications that AM broadcast stations must meet to certify their antenna systems to the FCC.)

For whatever data is collected (or calculated from theoretical equations), it is common to normalize the plotted values so the field strength in the direction of maximum radiation coincides with the outer edge of the chart. On a given system of polar coordinate scales, the *shape* of the pattern is not altered by proper normalization, only its size.

E and H-Plane Patterns

The solid 3-D pattern of an antenna in free space cannot adequately be shown with field-strength data on a flat sheet of paper. Cartographers making maps of a round Earth on flat pieces of paper face much the same kind of problem. As we discussed above, cross-sectional or plane diagrams are very useful for this purpose. Two such diagrams, one in the plane containing the straight wire of a dipole and one in the plane perpendicular to the wire, can convey a great deal of information. The pattern in the plane containing the axis of the antenna is called the *E-plane pattern*, and the one in the plane perpendicular to the axis is called the *H-plane pattern*. These designations are used because they represent the planes in which the electric (symbol E), and the magnetic (symbol H) lines of force lie, respectively.

The E lines represent the *polarization* of the antenna. Polarization will be covered in more detail later in this chapter. As an example, the electromagnetic field pictured in Fig 1 of Chapter 23, Radio Wave Propagation, is the field that would be radiated from a vertically polarized antenna; that is, an antenna in which the conductor is mounted perpendicular to the earth.

When a radiation pattern is shown for an antenna mounted over ground rather than in free space, we automatically gain two frames of reference—an *azimuth angle* and an *elevation angle*. The azimuth angle is usually ref-

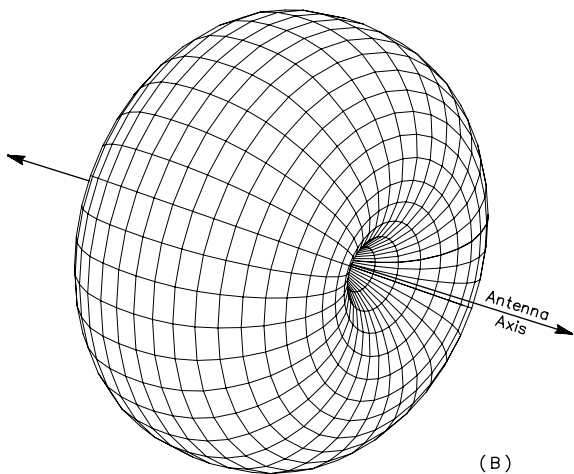
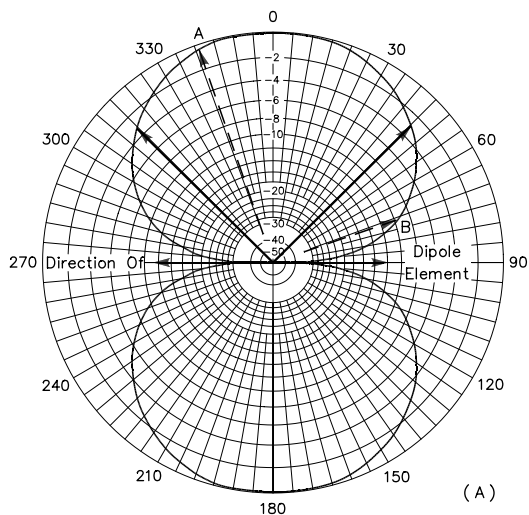

Fig 12—Directive diagram of a free-space dipole. At A, the pattern in the plane containing the wire axis. The length of each dashed-line arrow represents the relative field strength in that direction, referenced to the direction of maximum radiation, which is at right angles to the wire's axis. The arrows at approximately 45° and 315° are the half-power or -3 dB points. At B, a wire grid representation of the solid pattern for the same antenna. These same patterns apply to any center-fed dipole antenna less than a half wavelength long.

erenced to the maximum radiation lobe of the antenna, where the azimuth angle is defined at 0°, or it could be referenced to the Earth's True North direction for an antenna oriented in a particular compass direction. The E-plane pattern for an antenna over ground is now called the *azimuth pattern*.

The elevation angle is referenced to the horizon at the Earth's surface, where the elevation angle is 0°. Of course, the Earth is round but because its radius is so

Introduction to the Decibel

The power gain of an antenna system is usually expressed in *decibels*. The decibel is a practical unit for measuring power ratios because it is more closely related to the actual effect produced at a distant receiver than the power ratio itself. One decibel represents a just-detectable change in signal strength, regardless of the actual value of the signal voltage. A 20-decibel (20-dB) increase in signal, for example, represents 20 observable steps in increased signal. The power ratio (100 to 1) corresponding to 20 dB gives an entirely exaggerated idea of the improvement in communication to be expected. The number of decibels corresponding to any power ratio is equal to 10 times the common logarithm of the power ratio, or

$$\text{dB} = 10 \log_{10} \frac{P_1}{P_2}$$

If the voltage ratio is given, the number of decibels is equal to 20 times the common logarithm of the ratio. That is,

$$\text{dB} = 20 \log_{10} \frac{V_1}{V_2}$$

When a *voltage* ratio is used, both voltages must be measured across the same value of impedance. Unless this is done the decibel figure is meaningless, because it is fundamentally a measure of a *power* ratio.

The main reason a decibel is used is that successive power gains expressed in decibels may simply be added together. Thus a gain of 3 dB followed by a gain of 6 dB gives a total gain of 9 dB. In ordinary power ratios, the ratios must be multiplied together to find the total gain.

A *reduction* in power is handled simply by subtracting the requisite number of decibels. Thus, reducing the power to ½ is the same as *subtracting* 3 decibels. For example, a power gain of 4 in one part of a system and a reduction to ½ in another part gives a total power gain of $4 \times \frac{1}{2} = 2$. In decibels, this is $6 - 3 = 3$ dB. A power reduction or *loss* is simply indicated by including a negative sign in front of the appropriate number of decibels.

large, it can in this context be considered to be flat in the area directly under the antenna. An elevation angle of 90° is straight over the antenna, and a 180° elevation is toward the horizon directly behind the antenna.

Professional antenna engineers often describe an antenna's orientation with respect to the point directly overhead—using the *zenith angle*, rather than the elevation angle. The elevation angle is computed by subtracting the zenith angle from 90°.

Referenced to the horizon of the Earth, the H-plane pattern is now called the *elevation pattern*. Unlike the free-space H-plane pattern, the over-ground elevation pattern is drawn as a half-circle, representing only positive elevations above the Earth's surface. The ground reflects or blocks radiation at negative elevation angles, making below-surface radiation plots unnecessary.

After a little practice, and with the exercise of some imagination, the complete solid pattern can be visualized with fair accuracy from inspection of the two planar diagrams, provided of course that the solid pattern of the antenna is *smooth*, a condition that is true for simple antennas like $\lambda/2$ dipoles.

Plane diagrams are plotted on polar coordinate paper, as described earlier. The points on the pattern where the radiation is zero are called *nulls*. The curved section from one null to the next on the plane diagram, or the corresponding section on the solid pattern, is called a *lobe*. The strongest lobe is commonly called the *main lobe*. Fig 12A shows the E-plane pattern for a half-wave dipole. In Fig 12, the dipole is placed in free space. In addition to the labels showing the main lobe and nulls in the pattern, the so-called *half-power* points on the main lobe are shown. These are the points where the power is 3 dB down from the peak value in the main lobe.

Directivity and Gain

Let us now examine directivity more closely. As mentioned previously, all practical antennas, even the simplest types such as dipoles, exhibit directivity. Here's another picture that may help explain the concept of directivity. **Fig 13A** shows a balloon blown into its usual spherical shape. This represents a "reference" isotropic source. Squeezing the balloon in the middle in Fig 13B produces a dipole-like figure-8 pattern whose peak levels at top and bottom are larger than the reference sphere. Compare this with Fig 13C. Next, squeezing the bottom end of the balloon produces a pattern that gives even more "gain" compared to the reference.

Free-space directivity can be expressed quantitatively by comparing the three-dimensional pattern of the antenna under consideration with the perfectly spherical three-dimensional pattern of an isotropic antenna. The field strength (and thus power per unit area, or *power density*) is the same everywhere on the surface of an imaginary sphere having a radius of many wavelengths and having an isotropic antenna at its center. At the surface of the same imaginary sphere around an antenna radiating the same total power, the directive pattern results in greater power density at some points on this sphere and less at others. The ratio of the maximum power density to the average power density taken over the entire sphere (which is the same as from the isotropic antenna under the specified conditions) is the numerical measure of the directivity of the antenna. That is,

$$D = \frac{P}{P_{av}} \quad (\text{Eq 5})$$

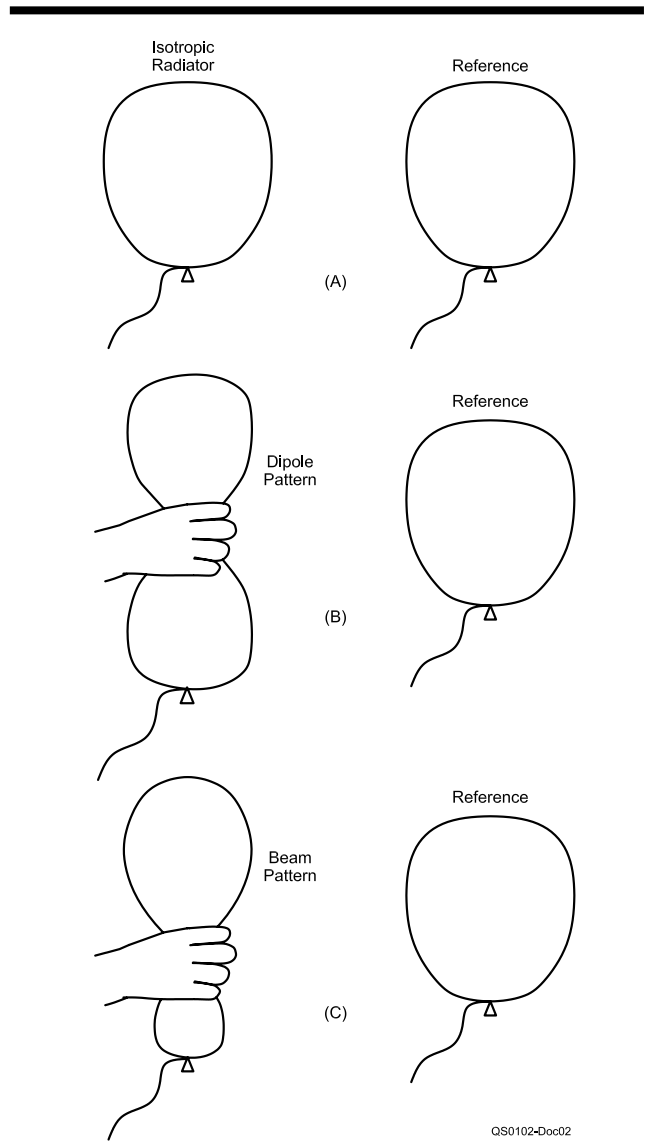

Fig 13—Demonstrating antenna pattern gain with balloons. Take a balloon, blow it up so that it is roughly circular in shape and then declare that this is a radiation pattern from an isotropic radiator. Next, blow up another balloon to the same size and shape and tell the audience that this will be the "reference" antenna (A). Then, squeeze the first balloon in the middle to form a sort of figure-8 shape and declare that this is a dipole and compare the maximum size to that of the reference "antenna" (B). The dipole can be seen to have some "gain" over the reference isotropic. Next, squeeze the end of the first balloon to come up with a sausage-like shape to demonstrate the sort of pattern a beam antenna creates (C).

where

D = directivity

P = power density at its maximum point on the surface of the sphere

P_{av} = average power density

The *gain* of an antenna is closely related to its direc-

tivity. Because directivity is based solely on the *shape* of the directive pattern, it does not take into account any power losses that may occur in an actual antenna system. To determine gain, these losses must be subtracted from the power supplied to the antenna. The loss is normally a constant percentage of the power input, so the antenna gain is

$$G = k \frac{P}{P_{av}} = kD \quad (\text{Eq 6})$$

where

- G = gain (expressed as a power ratio)
- D = directivity
- k = efficiency (power radiated divided by power input) of the antenna
- P and P_{av} are as above

For many of the antenna systems used by amateurs, the efficiency is quite high (the loss amounts to only a few percent of the total). In such cases the gain is essentially equal to the directivity. The more the directive diagram is compressed—or, in common terminology, the *sharper* the lobes—the greater the power gain of the antenna. This is a natural consequence of the fact that as power is taken away from a larger and larger portion of the sphere surrounding the radiator, it is added to the volume represented by the narrow lobes. Power is therefore concentrated in some directions, at the expense of others. In a general way, the smaller the volume of the solid radiation pattern, compared with the volume of a sphere having the same radius as the length of the largest lobe in the actual pattern, the greater the power gain.

As stated above, the gain of an antenna is related to its directivity, and directivity is related to the shape of the directive pattern. A commonly used index of directivity, and therefore the gain of an antenna, is a measure of the width of the major lobe (or lobes) of the plotted pattern. The width is expressed in degrees at the half-power or -3 dB points, and is often called the *beamwidth*.

This information provides only a general idea of relative gain, rather than an exact measure. This is because an absolute measure involves knowing the power density at every point on the surface of a sphere, while a single diagram shows the pattern shape in only one plane of that sphere. It is customary to examine at least the E-plane and the H-plane patterns before making any comparisons between antennas.

A simple approximation for gain over an isotropic radiator can be used, but only if the sidelobes in the antenna's pattern are small compared to the main lobe and if the resistive losses in the antenna are small. When the radiation pattern is complex, numerical integration is employed to give the actual gain.

$$G \approx \frac{41253}{H_{3dB} \times E_{3dB}} \quad (\text{Eq 7})$$

where H_{3dB} and E_{3dB} are the half-power points, in

degrees, for the H and E-plane patterns.

Radiation Patterns for Center-Fed Dipoles at Different Frequencies

Earlier, we saw how the feed-point impedance of a fixed-length center-fed dipole in free space varies as the frequency is changed. What happens to the radiation pattern of such an antenna as the frequency is changed?

In general, the greater the length of a center-fed antenna, in terms of wavelength, the larger the number of lobes into which the pattern splits. A feature of all such patterns is the fact that the main lobe—the one that gives the largest field strength at a given distance—always is the one that makes the smallest angle with the antenna wire. Furthermore, this angle becomes smaller as the length of the antenna is increased.

Let's examine how the free-space radiation pattern changes for a 100-foot long wire made of #14 wire as the frequency is varied. (Varying the frequency effectively changes the wavelength for a fixed-length wire.) **Fig 14** shows the E-plane pattern at the $\lambda/2$ resonant frequency of 4.8 MHz. This is a classical dipole pattern, with a gain in free space of 2.14 dBi referenced to an isotropic radiator.

Fig 15 shows the free-space E-plane pattern for the same antenna, but now at the full-wave ($2\lambda/2$) resonant frequency of 9.55 MHz. Note how the pattern has been pinched in at the top and bottom of the figure. In other words, the two main lobes have become sharper at this frequency, making the gain 3.73 dBi, higher than at the $\lambda/2$ frequency.

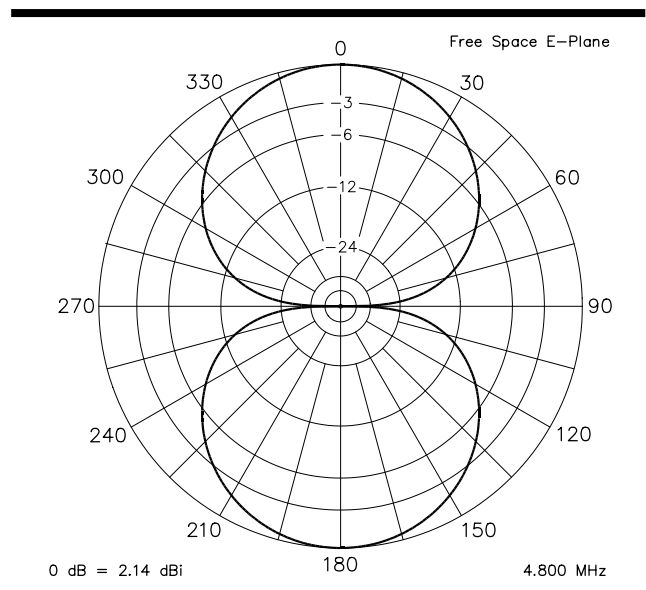

Fig 14—Free-space E-Plane radiation pattern for a 100-foot dipole at its half-wave resonant frequency of 4.80 MHz. This antenna has 2.14 dBi of gain. The dipole is located on the line from 90° to 270°.

Coordinate Scales for Radiation Patterns

A number of different systems of coordinate scales or *grids* are in use for plotting antenna patterns. Antenna patterns published for amateur audiences are sometimes placed on rectangular grids, but more often they are shown using polar coordinate systems. Polar coordinate systems may be divided generally into three classes: linear, logarithmic and modified logarithmic.

A very important point to remember is that the shape of a pattern (its general appearance) is highly dependent on the grid system used for the plotting. This is exemplified in **Fig A**, where the radiation pattern for a beam antenna is presented using three coordinate systems discussed in the paragraphs that follow.

Linear Coordinate Systems

The polar coordinate system for the flashlight radiation pattern, Fig 10, uses linear coordinates. The concentric circles are equally spaced, and are graduated from 0 to 10. Such a grid may be used to prepare a linear plot of the power contained in the signal. For ease of comparison, the equally spaced concentric circles have been replaced with appropriately placed circles representing the decibel response, referenced to 0 dB at the outer edge of the plot. In these plots the minor lobes are suppressed. Lobes with peaks more than 15 dB or so below the main lobe disappear completely because of their small size. This is a good way to show the pattern of an array having high directivity and small minor lobes.

Logarithmic Coordinate System

Another coordinate system used by antenna manufacturers is the logarithmic grid, where the concentric grid lines are spaced according to the logarithm of the voltage in the signal. If the logarithmically spaced concentric circles are replaced with appropriately placed circles representing the decibel response, the decibel circles are graduated linearly. In that sense, the logarithmic grid might be termed a linear-log grid, one having linear divisions calibrated in decibels.

This grid enhances the appearance of the minor lobes. If the intent is to show the radiation pattern of an array supposedly having an omnidirectional response, this grid enhances that appearance. An antenna having a difference of 8 or 10 dB in pattern response around the compass appears to be closer to omnidirectional on this grid than on any of the others. See Fig A-(B).

ARRL Log Coordinate System

The modified logarithmic grid used by the ARRL has a system of concentric grid lines spaced according to the logarithm of 0.89 times the value of the signal voltage. In this grid, minor lobes that are 30 and 40 dB down from the main lobe are distinguishable. Such lobes are of concern in VHF and UHF work. The spacing between plotted points at 0 dB and -3 dB is significantly greater than the spacing between -20 and -23 dB, which in turn is significantly greater than the spacing between -50 and -53 dB.

For example, the scale distance covered by 0 to -3 dB is about $1/10$ of the radius of the chart. The scale distance for the next 3-dB increment (to -6 dB) is slightly less, 89% of the first, to be exact. The scale distance for the next 3-dB increment (to -9 dB) is again 89% of the second. The scale is constructed so that the progression ends with -100 dB at chart center.

The periodicity of spacing thus corresponds generally to the relative significance of such changes in antenna performance. Antenna pattern plots in this publication are made on the modified-log grid similar to that shown in Fig A-(C).

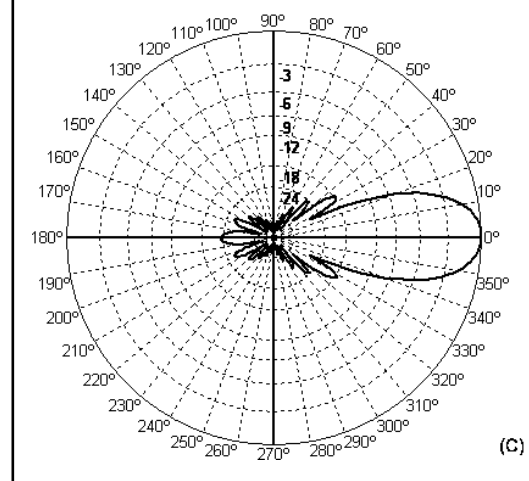
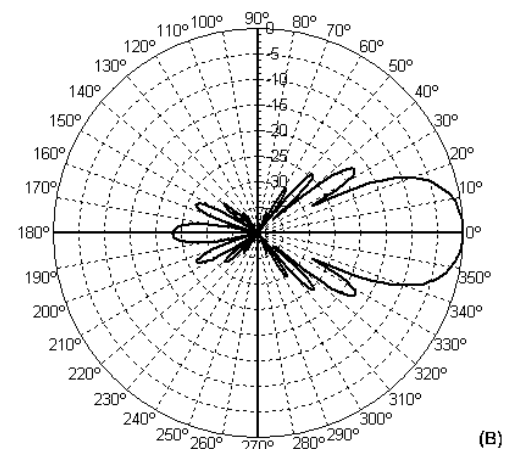
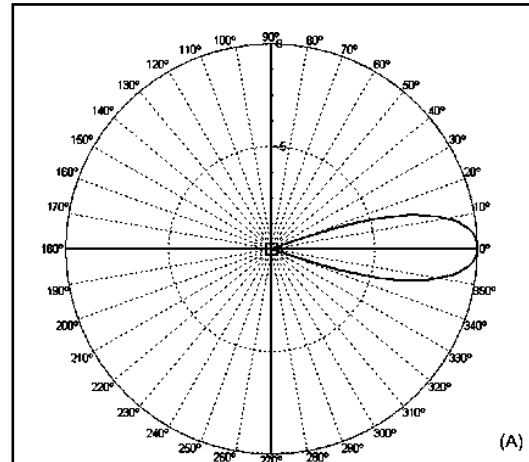

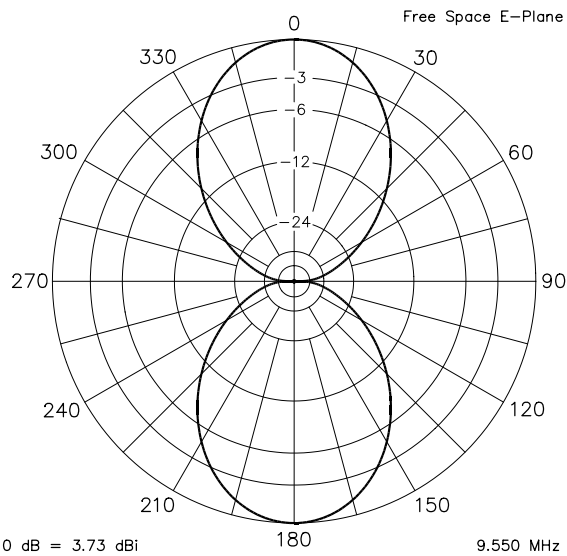

Fig 15—Free-space E-Plane radiation pattern for a 100-foot dipole at its full-wave resonant frequency of 9.55 MHz. The gain has increased to 3.73 dBi, because the main lobes have been focused and sharpened compared to Fig 13.

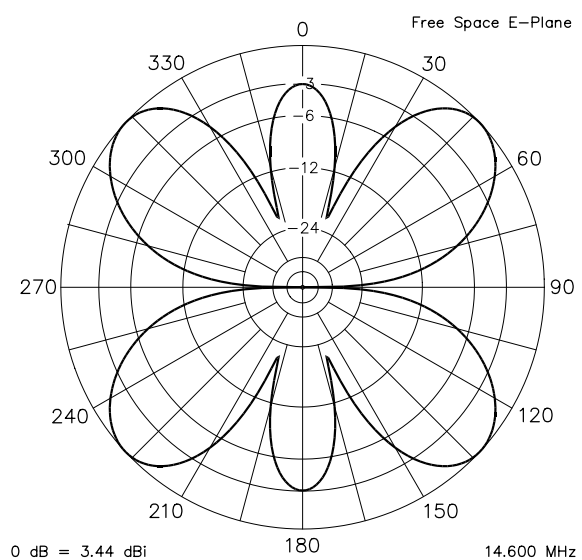

Fig 16—Free-space E-Plane radiation pattern for a 100-foot dipole at its $3/2\lambda$ resonant frequency of 14.60 MHz. The pattern has broken up into six lobes, and thus the peak gain has dropped to 3.44 dBi.

Fig 16 shows the pattern at the $3\lambda/2$ frequency of 14.6 MHz. More lobes have developed compared to Fig 14. This means that the power has split up into more lobes and consequently the gain decreases a small amount, down to 3.44 dBi. This is still higher than the dipole at its $\lambda/2$ frequency, but lower than at its full-wave frequency. **Fig 17** shows the E-plane response at 19.45 MHz, the $4\lambda/2$, or 2λ , resonant frequency. Now the pattern has reformed itself into only four lobes, and the gain has as a consequence risen to 3.96 dBi.

In **Fig 18** the response has become quite complex at the $5\lambda/2$ resonance point of 24.45 MHz, with ten lobes showing. Despite the presence all these lobes, the main lobes now show a gain of 4.78 dBi. Finally, **Fig 19** shows the pattern at the 3λ ($6\lambda/2$) resonance at 29.45 MHz. Despite the fact that there are fewer lobes taking up power

than at 24.45 MHz, the peak gain is slightly less at 29.45 MHz, at 4.70 dBi.

The pattern—and hence the gain—of a fixed-length antenna varies considerably as the frequency is changed. Of course, the pattern and gain change in the same fashion if the frequency is kept constant and the length of the wire is varied. In either case, the wavelength is changing. It is also evident that certain lengths reinforce the pattern to provide more peak gain. If an antenna is not rotated in azimuth when the frequency is changed, the peak gain may occur in a different direction than you might like. In other words, the main lobes change direction as the frequency is varied.

POLARIZATION

We've now examined the first two of the three major properties used to characterize antennas: the radiation pattern and the feed-point impedance. The third general property is *polarization*. An antenna's polarization is defined to be that of its electric field, in the direction where the field strength is maximum.

For example, if a $\lambda/2$ dipole is mounted horizontally over the Earth, the electric field is strongest perpendicular to its axis (that is, at right angle to the wire) and parallel to the earth. Thus, since the maximum electric field is horizontal, the polarization in this case is also considered to be *horizontal* with respect to the earth. If the dipole is mounted vertically, its polarization will be *vertical*. See **Fig 20**. Note that if an antenna is mounted in free space, there is no frame of reference and hence its

Fig A—Radiation pattern plots for a high-gain Yagi antenna on three different grid coordinate systems. At A, the pattern on a linear-power dB grid. Notice how details of sidelobe structure are lost with this grid. At B, the same pattern on a grid with constant 5 dB circles. The sidelobe level is exaggerated when this scale is employed. At C, the same pattern on the modified log grid used by ARRL. The side and rearward lobes are clearly visible on this grid. The concentric circles in all three grids are graduated in decibels referenced to 0 dB at the outer edge of the chart. The patterns look quite different, yet they all represent the same antenna response!

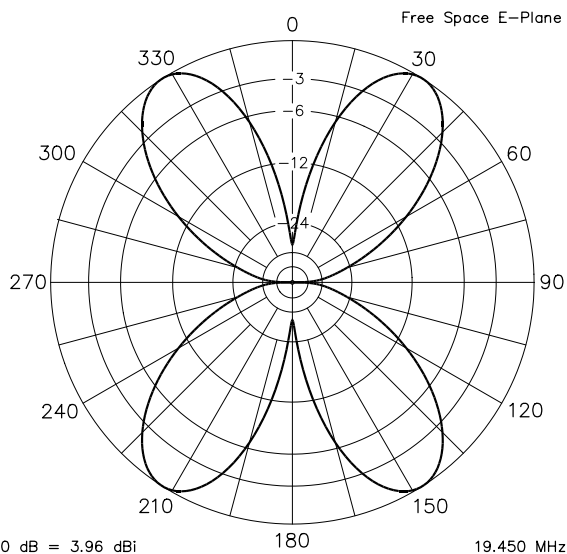

Fig 17—Free-space E-Plane radiation pattern for a 100-foot dipole at twice its full-wave resonant frequency of 19.45 MHz. The pattern has been refocused into four lobes, with a peak gain of 3.96 dBi.

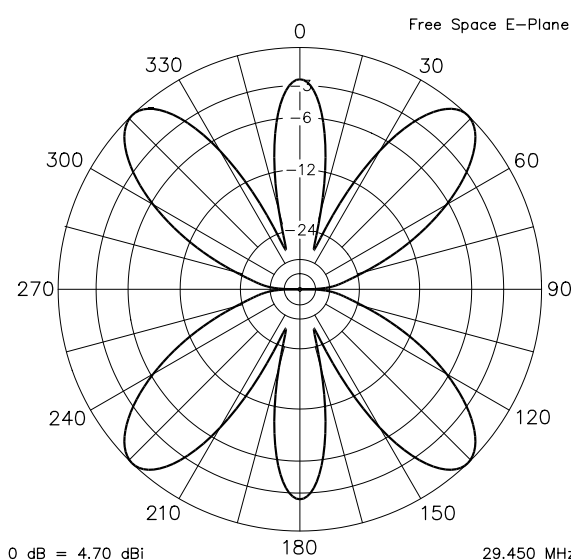

Fig 19—Free-space E-Plane radiation pattern for a 100-foot dipole at three times its full-wave resonant frequency of 29.45 MHz. The pattern has returned to six lobes, with a peak gain of 4.70 dBi.

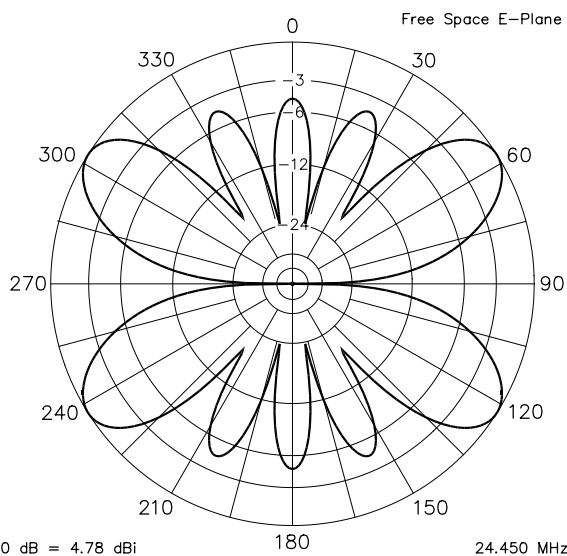

Fig 18—Free-space E-Plane radiation pattern for a 100-foot dipole at its $5/2\lambda$ resonant frequency of 24.45 MHz. The pattern has broken down into ten lobes, with a peak gain of 4.78 dBi.

polarization is indeterminate.

Antennas composed of a number of $\lambda/2$ elements arranged so that their axes lie in the same or parallel directions have the same polarization as that of any one of the elements. For example, a system composed of a group of horizontal dipoles is horizontally polarized. If both horizontal and vertical elements are used in the same plane and radiate in phase, however, the polarization is the

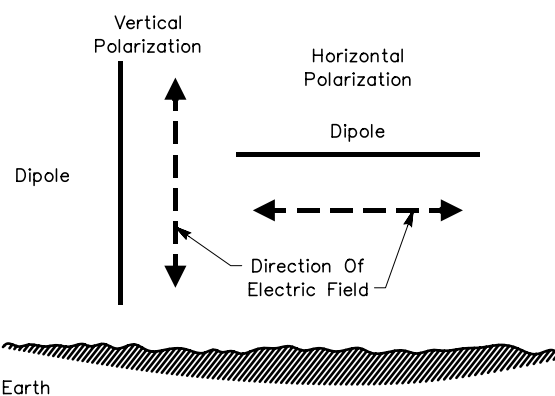

Fig 20—Vertical and horizontal polarization of a dipole above ground. The direction of polarization is the direction of the maximum electric field with respect to the earth.

resultant of the contributions made by each set of elements to the total electromagnetic field at a given point some distance from the antenna. In such a case the resultant polarization is still *linear*, but is tilted between horizontal and vertical.

In directions other than those where the radiation is maximum, the resultant wave even for a simple dipole is a combination of horizontally and vertically polarized components. The radiation off the ends of a horizontal dipole is actually vertically polarized, albeit at a greatly reduced amplitude compared to the broadside horizontally polarized radiation—the sense of polarization

changes with compass direction.

Thus it is often helpful to consider the radiation pattern from an antenna in terms of polar coordinates, rather than trying to think in purely linear horizontal or vertical coordinates. See **Fig 21**. The reference axis in a polar system is vertical to the earth under the antenna. The zenith

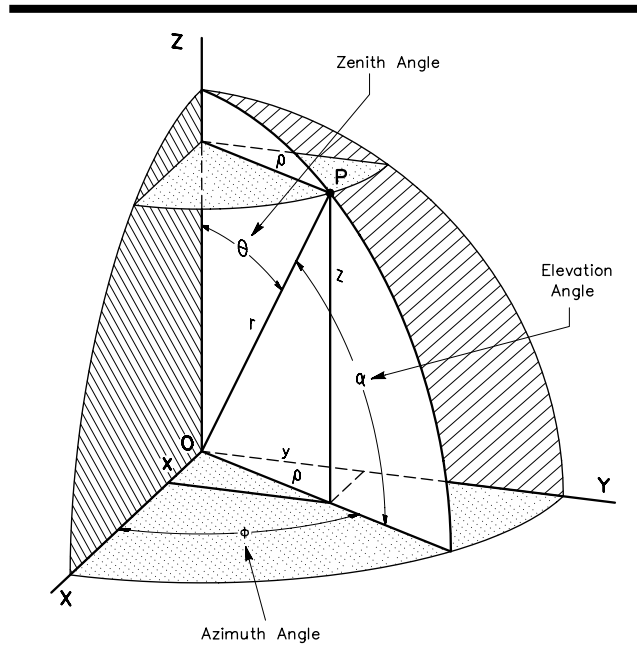

Fig 21—Diagram showing polar representation of a point P lying on an imaginary sphere surrounding a point-source antenna. The various angles associated with this coordinate system are shown referenced to the x, y and z-axes.

angle is usually referred to as θ (Greek letter theta), and the azimuth angle is referred to as ϕ (Greek letter phi). Instead of zenith angles, most amateurs are more familiar with *elevation angles*, where a zenith angle of 0° is the same as an elevation angle of 90° , straight overhead. Native *NEC* or *MININEC* computer programs use zenith angles rather than elevation angles, although most commercial versions automatically reduce these to elevation angles.

If vertical and horizontal elements in the same plane are fed out of phase (where the beginning of the RF period applied to the feed point of the vertical element is not in time phase with that applied to the horizontal), the resultant polarization is *elliptical*. Circular polarization is a special case of elliptical polarization. The wave front of a circularly polarized signal appears (in passing a fixed observer) to rotate every 90° between vertical and horizontal, making a complete 360° rotation once every period. Field intensities are *equal* at all instantaneous polarizations. Circular polarization is frequently used for space communications, and is discussed further in Chapter 19, *Antenna Systems for Space Communications*.

Sky-wave transmission usually changes the polarization of traveling waves. (This is discussed in Chapter 23, *Radio Wave Propagation*.) The polarization of receiving and transmitting antennas in the 3 to 30-MHz range, where almost all communication is by means of sky wave, need not be the same at both ends of a communication circuit (except for distances of a few miles). In this range the choice of polarization for the antenna is usually determined by factors such as the height of available antenna supports, polarization of man-made RF noise from nearby sources, probable energy losses in nearby objects, the likelihood of interfering with neighborhood broadcast or TV reception and general convenience.

Other Antenna Characteristics

Besides the three main characteristics of impedance, pattern (gain) and polarization, there are some other useful properties of antennas.

RECIPROcity IN RECEIVING AND TRANSMITTING

Many of the properties of a resonant antenna used for reception are the same as its properties in transmission. It has the same directive pattern in both cases, and delivers maximum signal to the receiver when the signal comes from a direction in which the antenna has its best response. The impedance of the antenna is the same, at the same point of measurement, in receiving as in transmitting.

In the receiving case, the antenna is the source of power delivered to the receiver, rather than the load for a source of power (as in transmitting). Maximum possible output from the receiving antenna is obtained when the

load to which the antenna is connected is the same as the impedance of the antenna. We say that the antenna is *matched* to its load.

The power gain in receiving is the same as the gain in transmitting, when certain conditions are met. One such condition is that both antennas (usually $\lambda/2$ -long antennas) must work into load impedances matched to their own impedances, so that maximum power is transferred in both cases. In addition, the comparison antenna should be oriented so it gives maximum response to the signal used in the test. That is, it should have the same polarization as the incoming signal and should be placed so its direction of maximum gain is toward the signal source.

In long-distance transmission and reception via the ionosphere, the relationship between receiving and transmitting, however, may not be exactly reciprocal. This is because the waves do not always follow exactly the same

paths at all times and so may show considerable variation in the time between alternations between transmitting and receiving. Also, when more than one ionospheric layer is involved in the wave travel (see Chapter 23, Radio Wave Propagation), it is sometimes possible for reception to be good in one direction and poor in the other, over the same path.

Wave polarization usually shifts in the ionosphere. The tendency is for the arriving wave to be elliptically polarized, regardless of the polarization of the transmitting antenna. Vertically polarized antennas can be expected to show no more difference between transmission and reception than horizontally polarized antennas. On the average, however, an antenna that transmits well in a certain direction also gives favorable reception from the same direction, despite ionospheric variations.

FREQUENCY SCALING

Any antenna design can be scaled in size for use on another frequency or on another amateur band. The dimensions of the antenna may be scaled with Eq 8 below.

$$D = \frac{f_1}{f_2} \times d \quad (\text{Eq 8})$$

where

D = scaled dimension

d = original design dimension

f₁ = original design frequency

f₂ = scaled frequency (frequency of intended operation)

From this equation, a published antenna design for, say, 14 MHz can be scaled in size and constructed for operation on 18 MHz, or any other desired band. Similarly, an antenna design could be developed experimentally at VHF or UHF and then scaled for operation in one of the HF bands. For example, from Eq 8, an element of 39.0 inches length at 144 MHz would be scaled to 14 MHz as follows: $D = 144/14 \times 39 = 401.1$ inches, or 33.43 feet.

To scale an antenna properly, *all* physical dimensions must be scaled, including element lengths, element spacings, boom diameters and element diameters. Lengths and spacings may be scaled in a straightforward manner as in the above example, but element diameters are often not as conveniently scaled. For example, assume a 14-MHz antenna is modeled at 144 MHz and perfected with ³/₈-inch cylindrical elements. For proper scaling to 14 MHz, the elements should be cylindrical, of $144/14 \times \frac{3}{8}$ or 3.86 inches diameter. From a realistic standpoint, a 4-inch diameter might be acceptable, but cylindrical elements of 4-inch diameter in lengths of 33 feet or so would be quite unwieldy (and quite expensive, not to mention heavy). Choosing another, more suitable diameter is the only practical answer.

Diameter Scaling

Simply changing the diameter of dipole type elements during the scaling process is not satisfactory without making a corresponding element-length correction. This is because changing the diameter results in a change in the λ/dia ratio from the original design, and this alters the corresponding resonant frequency of the element. The element length must be corrected to compensate for the effect of the different diameter actually used.

To be more precise, however, the purpose of diameter scaling is not to maintain the same resonant frequency for the element, but to maintain the same ratio of self-resistance to self-reactance at the operating frequency—that is, the Q of the scaled element should be the same as that of the original element. This is not always possible to achieve exactly for elements that use several telescoping sections of tubing.

Tapered Elements

Rotatable beam antennas are usually constructed with elements made of metal tubing. The general practice at HF is to taper the elements with lengths of telescoping tubing. The center section has a large diameter, but the ends are relatively small. This reduces not only the weight, but also the cost of materials for the elements. Tapering of HF Yagi elements is discussed in detail in Chapter 11, HF Yagi Arrays.

Length Correction for Tapered Elements

The effect of tapering an element is to alter its electrical length. That is to say, two elements of the same length, one cylindrical and one tapered but with the same average diameter as the cylindrical element, will not be resonant at the same frequency. The tapered element must be made longer than the cylindrical element for the same resonant frequency.

A procedure for calculating the length for tapered elements has been worked out by Dave Leeson, W6NL (ex-W6QHS), from work done by Schelkunoff at Bell Labs and is presented in Leeson's book, *Physical Design of Yagi Antennas*. In the software accompanying this book is a subroutine called EFFLEN.FOR. It is written in Fortran and is used in the *SCALE* program to compute the effective length of a tapered element. The algorithm uses the W6NL-Schelkunoff algorithm and is commented step-by-step to show what is happening. Calculations are made for only one half of an element, assuming the element is symmetrical about the point of boom attachment.

Also, read the documentation SCALE.PDF for the *SCALE* program, which will automatically do the complex mathematics to scale a Yagi design from one frequency to another, or from one taper schedule to another.

The Vertical Monopole

So far in this discussion on Antenna Fundamentals, we have been using the free-space, center-fed dipole as our main example. Another simple form of antenna derived from a dipole is called a *monopole*. The name suggests that this is one half of a dipole, and so it is. The monopole is always used in conjunction with a *ground plane*, which acts as a sort of electrical mirror. See **Fig 22**, where a $\lambda/2$ dipole and a $\lambda/4$ monopole are compared. The *image antenna* for the monopole is the dotted line beneath the ground plane. The image forms the missing second half of the antenna, transforming a monopole into the functional equivalent of a dipole. From this explanation you can see where the term *image plane* is sometimes used instead of ground plane.

Although we have been focusing throughout this chapter on antennas in free space, practical monopoles are usually mounted vertically with respect to the surface of the ground. As such, they are called *vertical monopoles*, or simply *verticals*. A practical vertical is supplied power by feeding the radiator against a ground system, usually made up of a series of paralleled wires radiating from and laid out in a circular pattern around the base of the antenna. These wires are termed *radials*.

The term *ground plane* is also used to describe a vertical antenna employing a $\lambda/4$ -long vertical radiator working against a *counterpoise* system, another name for the ground plane that supplies the missing half of the antenna. The counterpoise for a ground-plane antenna usually consists of four $\lambda/4$ -long radials elevated well above the earth. See **Fig 23**.

Chapter 3, *The Effects of Ground*, devotes much attention to the requirements for an efficient grounding system for vertical monopole antennas, and Chapter 6,

Low-Frequency Antennas, gives more information on ground-plane verticals.

Characteristics of a $\lambda/4$ Monopole

The free-space directional characteristics of a $\lambda/4$ monopole with its ground plane are very similar to that of a $\lambda/2$ antenna in free space. The gain for the $\lambda/4$ monopole is slightly less because the H-plane for the $\lambda/2$ antenna is compressed compared to the monopole. Like a $\lambda/2$ antenna, the $\lambda/4$ monopole has an *omnidirectional* radiation pattern in the plane perpendicular to the monopole.

The current in a $\lambda/4$ monopole varies practically sinusoidally (as is the case with a $\lambda/2$ wire), and is highest at the ground-plane connection. The RF voltage is highest at the open (top) end and minimum at the ground plane. The feed-point resistance close to $\lambda/4$ resonance of a vertical monopole over a perfect ground plane is one-half that for a $\lambda/2$ dipole at its $\lambda/2$ resonance. In this case, a “perfect ground plane” is an infinitely large, lossless conductor.

See **Fig 24**, which shows the feed-point impedance of a vertical antenna made of #14 wire, 50 feet long, located over perfect ground. This is over the whole HF range from 1 to 30 MHz. Again, there is nothing special about the choice of 50 feet for the length of the vertical radiator; it is simply a convenient length for evaluation. **Fig 25** shows an expanded portion of the frequency range above and below the $\lambda/4$ resonant point, but now calibrated in terms of wavelength. Note that this particular antenna goes through $\lambda/4$ resonance at a length of 0.244λ , not at exactly 0.25λ . The exact length for resonance varies with the diameter of the wire used, just as it does for the $\lambda/2$ dipole at its $\lambda/2$ resonance.

The word *height* is usually used for a vertical monopole antenna whose base is on or near the ground, and in this context, height has the same meaning as *length* when applied to $\lambda/2$ dipole antennas. Older texts often refer to heights in electrical degrees, referenced to a free-space wavelength of 360° , but here height is expressed in terms of the free-space wavelength. The range shown in **Fig 24** is from 0.132λ to 0.300λ , corresponding to a frequency range of 2.0 to 5.9 MHz.

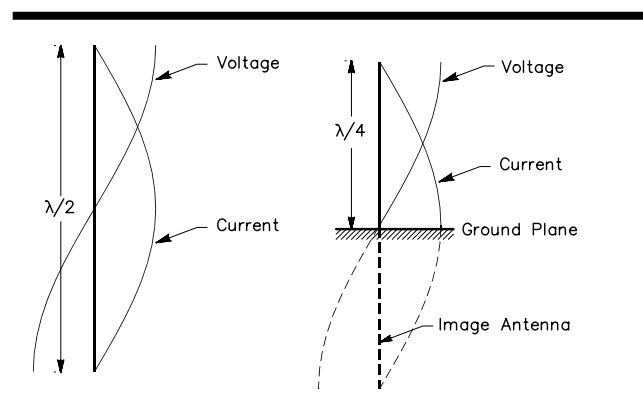

Fig 22—The $\lambda/2$ dipole antenna and its $\lambda/4$ ground-plane counterpart. The “missing” quarter wavelength is supplied as an image in “perfect” (that is, high-conductivity) ground.

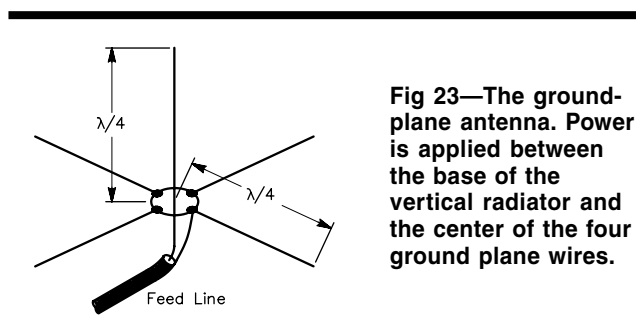

Fig 23—The ground-plane antenna. Power is applied between the base of the vertical radiator and the center of the four ground plane wires.

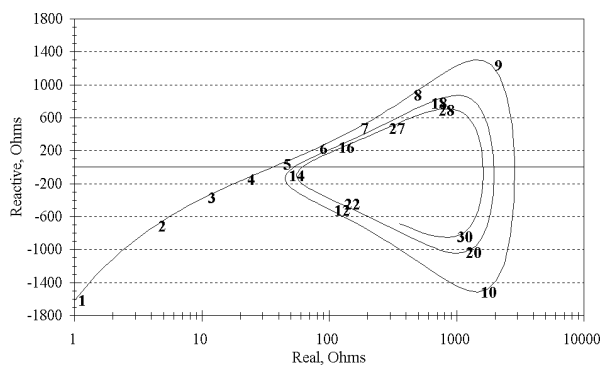

Fig 24—Feed-point impedance versus frequency for a theoretical 50-foot-high grounded vertical monopole made of #14 wire. The numbers along the curve show the frequency in MHz. This was computed using “perfect” ground. Real ground losses will add to the feed-point impedance shown in an actual antenna system.

The reactive portion of the feed-point impedance depends highly on the length/dia ratio of the conductor, as was discussed previously for a horizontal center-fed dipole. The impedance curve in Figs 24 and 25 is based on a #14 conductor having a length/dia ratio of about 800 to 1. As usual, thicker antennas can be expected to show less reactance at a given height, and thinner antennas will show more.

Efficiency of Vertical Monopoles

This topic of the efficiency of vertical monopole systems will be covered in detail in Chapter 3, The Effects of Ground, but it is worth noting at this point that the efficiency of a real vertical antenna over real earth often suffers dramatically compared with that of a $\lambda/2$ antenna. Without a fairly elaborate grounding system, the efficiency is not likely to exceed 50%, and it may be much less, particularly at monopole heights below $\lambda/4$.

BIBLIOGRAPHY

J. S. Belrose, “Short Antennas for Mobile Operation,” *QST*, Sep 1953.
 G. H. Brown, “The Phase and Magnitude of Earth Currents Near Radio Transmitting Antennas,” *Proc IRE*, Feb 1935.
 G. H. Brown, R. F. Lewis and J. Epstein, “Ground Systems as a Factor in Antenna Efficiency,” *Proc IRE*, Jun 1937, pp 753-787.
 G. H. Brown and O. M. Woodward, Jr., “Experimentally Determined Impedance Characteristics of Cylindrical Antennas,” *Proc IRE*, April 1945.
 A. Christman, “Elevated Vertical Antenna Systems,” *QST*, Aug 1988, pp 35-42.
 R. B. Dome, “Increased Radiating Efficiency for Short Antennas,” *QST*, Sep 1934, pp 9-12.

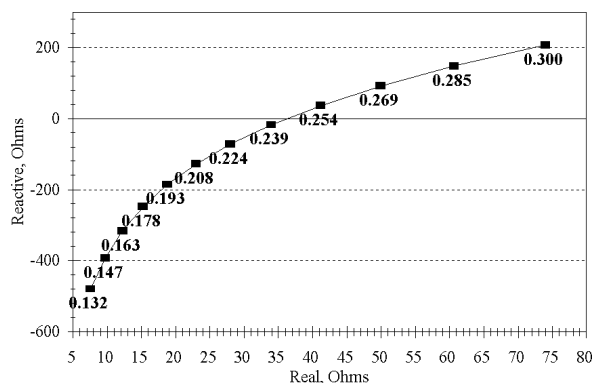

Fig 25—Feed-point impedance for the same antennas as in Fig 21, but calibrated in wavelength rather than frequency, over the range from 0.132 to 0.300 λ , above and below the quarter-wave resonance.

A. C. Doty, Jr., J. A. Frey and H. J. Mills, “Characteristics of the Counterpoise and Elevated Ground Screen,” Professional Program, Session 9, Southcon ‘83 (IEEE), Atlanta, GA, Jan 1983.
 A. C. Doty, Jr., J. A. Frey and H. J. Mills, “Efficient Ground Systems for Vertical Antennas,” *QST*, Feb 1983, pp 20-25.
 A. C. Doty, Jr., technical paper presentation, “Capacitive Bottom Loading and Other Aspects of Vertical Antennas,” Technical Symposium, Radio Club of America, New York City, Nov 20, 1987.
 A. C. Doty, Jr., J. A. Frey and H. J. Mills, “Vertical Antennas: New Design and Construction Data,” *The ARRL Antenna Compendium, Volume 2* (Newington: ARRL, 1989), pp 2-9.
 R. Fosberg, “Some Notes on Ground Systems for 160 Meters,” *QST*, Apr 1965, pp 65-67.
 G. Grammer, “More on the Directivity of Horizontal Antennas; Harmonic Operation—Effects of Tilting,” *QST*, Mar 1937, pp 38-40, 92, 94, 98.
 H. E. Green, “Design Data for Short and Medium Length Yagi-Uda Arrays,” *Trans IE Australia*, Vol EE-2, No. 1, Mar 1966.
 H. J. Mills, technical paper presentation, “Impedance Transformation Provided by Folded Monopole Antennas,” Technical Symposium, Radio Club of America, New York City, Nov 20, 1987.
 B. Myers, “The W2PV Four-Element Yagi,” *QST*, Oct 1986, pp 15-19.
 L. Richard, “Parallel Dipoles of 300-Ohm Ribbon,” *QST*, Mar 1957.
 J. H. Richmond, “Monopole Antenna on Circular Disc,” *IEEE Trans on Antennas and Propagation*, Vol. AP-32, No. 12, Dec 1984.
 W. Schulz, “Designing a Vertical Antenna,” *QST*, Sep 1978, pp 19- 21.

- J. Sevick, "The Ground-Image Vertical Antenna," *QST*, Jul 1971, pp 16-17, 22.
- J. Sevick, "The W2FMI 20-Meter Vertical Beam," *QST*, Jun 1972, pp 14-18.
- J. Sevick, "The W2FMI Ground-Mounted Short Vertical," *QST*, Mar 1973, pp. 13-18, 41.
- J. Sevick, "A High Performance 20-, 40- and 80-Meter Vertical System," *QST*, Dec 1973.
- J. Sevick, "Short Ground-Radial Systems for Short Verticals," *QST*, Apr 1978, pp 30-33.
- J. Sevick, *Transmission Line Transformers*, 3rd ed. (Tucker, GA: Noble Publishing, 1996).
- C. E. Smith and E. M. Johnson, "Performance of Short Antennas," *Proc IRE*, Oct 1947.
- J. Stanley, "Optimum Ground Systems for Vertical Antennas," *QST*, Dec 1976, pp 13-15.
- R. E. Stephens, "Admittance Matching the Ground-Plane Antenna to Coaxial Transmission Line," Technical Correspondence, *QST*, Apr 1973, pp 55-57.
- D. Sumner, "Cushcraft 32-19 'Boomer' and 324-QK Stacking Kit," Product Review, *QST*, Nov 1980, pp 48-49.
- W. van B. Roberts, "Input Impedance of a Folded Dipole," *RCA Review*, Jun 1947.
- E. M. Williams, "Radiating Characteristics of Short-Wave Loop Aerials," *Proc IRE*, Oct 1940.

TEXTBOOKS ON ANTENNAS

- C. A. Balanis, *Antenna Theory, Analysis and Design* (New York: Harper & Row, 1982).
- D. S. Bond, *Radio Direction Finders*, 1st ed. (New York: McGraw-Hill Book Co).
- W. N. Caron, *Antenna Impedance Matching* (Newington: ARRL, 1989).
- K. Davies, *Ionospheric Radio Propagation*—National Bureau of Standards Monograph 80 (Washington, DC: U.S. Government Printing Office, Apr 1, 1965).
- R. S. Elliott, *Antenna Theory and Design* (Englewood Cliffs, NJ: Prentice Hall, 1981).
- A. E. Harper, *Rhombic Antenna Design* (New York: D. Van Nostrand Co, Inc, 1941).
- K. Henney, *Principles of Radio* (New York: John Wiley and Sons, 1938), p 462.
- H. Jasik, *Antenna Engineering Handbook*, 1st ed. (New York: McGraw-Hill, 1961).
- W. C. Johnson, *Transmission Lines and Networks*, 1st ed. (New York: McGraw-Hill Book Co, 1950).
- R. C. Johnson and H. Jasik, *Antenna Engineering Handbook*, 2nd ed. (New York: McGraw-Hill, 1984).
- R. C. Johnson, *Antenna Engineering Handbook*, 3rd ed. (New York: McGraw-Hill, 1993).
- E. C. Jordan and K. G. Balmain, *Electromagnetic Waves and Radiating Systems*, 2nd ed. (Englewood Cliffs, NJ: Prentice-Hall, Inc, 1968).
- R. Keen, *Wireless Direction Finding*, 3rd ed. (London: Wireless World).
- R. W. P. King, *Theory of Linear Antennas* (Cambridge, MA: Harvard Univ. Press, 1956).
- R. W. P. King, H. R. Mimno and A. H. Wing, *Transmission Lines, Antennas and Waveguides* (New York: Dover Publications, Inc, 1965).
- King, Mack and Sandler, *Arrays of Cylindrical Dipoles* (London: Cambridge Univ Press, 1968).
- M. G. Knitter, Ed., *Loop Antennas—Design and Theory* (Cambridge, WI: National Radio Club, 1983).
- M. G. Knitter, Ed., *Beverage and Long Wire Antennas—Design and Theory* (Cambridge, WI: National Radio Club, 1983).
- J. D. Kraus, *Electromagnetics* (New York: McGraw-Hill Book Co).
- J. D. Kraus, *Antennas*, 2nd ed. (New York: McGraw-Hill Book Co, 1988).
- E. A. Laport, *Radio Antenna Engineering* (New York: McGraw-Hill Book Co, 1952).
- J. L. Lawson, *Yagi-Antenna Design*, 1st ed. (Newington: ARRL, 1986).
- P. H. Lee, *The Amateur Radio Vertical Antenna Handbook*, 2nd ed. (Port Washington, NY: Cowen Publishing Co., 1984).
- A. W. Lowe, *Reflector Antennas* (New York: IEEE Press, 1978).
- M. W. Maxwell, *Reflections—Transmission Lines and Antennas* (Newington: ARRL, 1990). Out of print.
- M. W. Maxwell, *Reflections II—Transmission Lines and Antennas* (Sacramento: Worldradio Books, 2001).
- G. M. Miller, *Modern Electronic Communication* (Englewood Cliffs, NJ: Prentice Hall, 1983).
- V. A. Mizek, *The Beverage Antenna Handbook* (Hudson, NH: V. A. Mizek, 1977).
- T. Moreno, *Microwave Transmission Design Data* (New York: McGraw-Hill, 1948).
- L. A. Moxon, *HF Antennas for All Locations* (Potters Bar, Herts: Radio Society of Great Britain, 1982), pp 109-111.
- Ramo and Whinnery, *Fields and Waves in Modern Radio* (New York: John Wiley & Sons).
- V. H. Rumsey, *Frequency Independent Antennas* (New York: Academic Press, 1966).
- P. N. Saveskie, *Radio Propagation Handbook* (Blue Ridge Summit, PA: Tab Books, Inc, 1980).
- S. A. Schelkunoff, *Advanced Antenna Theory* (New York: John Wiley & Sons, Inc, 1952).
- S. A. Schelkunoff and H. T. Friis, *Antennas Theory and Practice* (New York: John Wiley & Sons, Inc, 1952).
- J. Sevick, *Transmission Line Transformers* (Atlanta: Noble Publishing, 1996).
- H. H. Skilling, *Electric Transmission Lines* (New York: McGraw-Hill Book Co, Inc, 1951).
- M. Slurzburg and W. Osterheld, *Electrical Essentials of Radio* (New York: McGraw-Hill Book Co, Inc, 1944).
- G. Southworth, *Principles and Applications of Waveguide*

- Transmission* (New York: D. Van Nostrand Co, 1950).
- F. E. Terman, *Radio Engineers' Handbook*, 1st ed. (New York, London: McGraw-Hill Book Co, 1943).
- F. E. Terman, *Radio Engineering*, 3rd ed. (New York: McGraw-Hill, 1947).
- S. Uda and Y. Mushiake, *Yagi-Uda Antenna* (Sendai, Japan: Sasaki Publishing Co, 1954). [Published in English—Ed.]
- P. P. Viezbicke, "Yagi Antenna Design," NBS Technical Note 688 (U. S. Dept of Commerce/National Bureau of Standards, Boulder, CO), Dec 1976.
- G. B. Welch, *Wave Propagation and Antennas* (New York: D. Van Nostrand Co, 1958), pp 180-182.
- The GIANT Book of Amateur Radio Antennas* (Blue Ridge Summit, PA: Tab Books, 1979), pp 55-85.
- IEEE Standard Dictionary of Electrical and Electronics Terms*, 3rd ed. (New York: IEEE, 1984).
- Radio Broadcast Ground Systems*, available from Smith Electronics, Inc, 8200 Snowville Rd, Cleveland, OH 44141.
- Radio Communication Handbook*, 5th ed. (London: RSGB, 1976).
- Radio Direction Finding*, published by the Happy Flyer, 1811 Hillman Ave, Belmont, CA 94002