

Quad Arrays

Chapter 11, HF Yagi Arrays, discussed Yagi arrays as systems of approximately half-wave dipole elements that are coupled together mutually. You can also employ other kinds of elements using the same basic principles of analysis. For example, loops of various types may be combined into directive arrays. A popular type of parasitic array using loops is the *quad antenna*, in which loops having a perimeter of about one wavelength are used in much the same way as half-wave dipole elements in the Yagi antenna.

Clarence Moore, W9LZX, created the quad antenna in the early 1940s while he was at the Missionary Radio Station HCJB in Quito, Ecuador. He developed the quad to combat the effects of corona discharge at high altitudes. The problem at HCJB was that their large Yagi was literally destroying itself by melting its own element tips. This occurred due to the huge balls of corona it generated in the thin atmosphere of the high Andes mountains. Moore reasoned correctly that closed loop elements would generate less high voltage—and hence less corona—than would the high impedances at the ends of a half-wave dipole element.

Fig 1 shows the original version of the two-element quad, with a driven element and a parasitic reflector. The square loops may be mounted either with the corners lying on horizontal and vertical lines, as shown at the left, or with two sides horizontal and two vertical (right). The feed points shown for these two cases will result in horizontal polarization, which is commonly used.

Since its inception, there has been controversy whether the quad is a better performer than a Yagi. Chapter 11 showed that the three main electrical performance parameters of a Yagi are gain, response patterns (front-to-rear ratio, F/R) and drive impedance/SWR. Proper analysis of a quad also involves checking all these parameters across the entire frequency range over which you intend to use it. Both a quad and a Yagi are classified as “parasitic, end-fire arrays.” Modern antenna modeling by computer shows that monoband Yagis and quads with the same boom lengths and optimized for the same performance parameters have gains within about 1 dB of each other, with the quad slightly ahead of the Yagi.

Fig 2 plots the three parameters of gain, front-to-

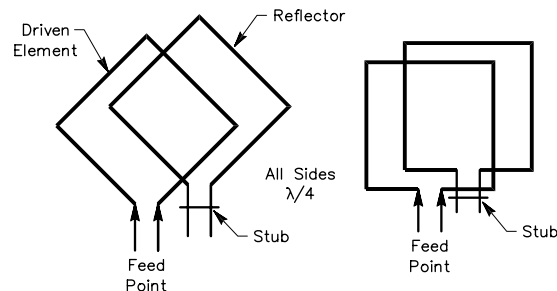

Fig 1—The basic two-element quad antenna, with driven-element loop and reflector loop. The driven loops are electrically one wavelength in circumference ($1/4$ wavelength on a side); the reflectors are slightly longer. Both configurations shown give horizontal polarization. For vertical polarization, the driven element should be fed at one of the side corners in the arrangement at the left, or at the center of a vertical side in the “square” quad at the right.

20-M Optimized Monoband Quad vs Yagi
3-Ele. Quad/4-Ele. Yagi, 26' Booms

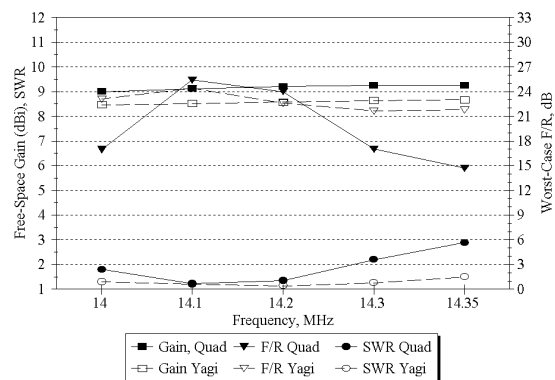

Fig 2—Comparison of gain, F/R and SWR over the 14.0 to 14.35-MHz range for an optimized three-element quad and an optimized three-element Yagi, both on 26-foot booms. The quad exhibits almost 0.5 dB more gain for the same boom length, but doesn’t have as good a rearward pattern over the whole frequency range compared to the Yagi. This is evidenced by the F/R curve. The quad’s SWR curve is also not quite as flat as the Yagi. The quad’s design emphasizes gain more than the other two parameters.

rear ratio (F/R) and SWR over the 14.0 to 14.35-MHz band for two representative antennas—a monoband three-element quad and a monoband four-element Yagi. Both of these have 26-foot booms and both are optimized for the best compromise of gain, F/R and SWR across the whole band.

While the quad in Fig 2 consistently exhibits about 0.5 dB more gain over the whole band, its F/R pattern toward the rear isn't quite as good as the Yagi's over that span of frequencies. This quad attains a maximum F/R of 25 dB at 14.1 MHz, but it falls to 17 dB at the bottom end of the band and 15 dB at the top. On the other hand, the Yagi's F/R stays consistently above 21 dB across the whole 20-meter band. The quad's SWR rises to just under 3:1 at the top end of the band, but stays below 2:1 from 14.0 to almost 14.3 MHz. The Yagi's SWR remains lower than 1.5:1 over the whole band.

The reason the Yagi in Fig 2 has more consistent responses for gain, F/R and SWR across the whole 20-meter band is that it has an additional parasitic element, giving two additional variables to play with—that is, the length of that additional element and the spacing of that element from the others on the boom.

Yagi advocates point out that it is easier to add extra elements to a Yagi, given the mechanical complexities of adding another element to a quad. Extra parasitic elements give a designer more flexibility to tailor all performance parameters over a wide frequency range. Quad designers have historically opted to optimize strictly for gain and, as stated before, they can achieve as much as 1 dB more gain than a Yagi with the same length boom. But in so doing, a quad designer typically has to settle for front-to-rear patterns that are peaked over more narrow frequency ranges. The 20-meter quad plots in Fig 2 actually represent an even-handed approach, where the gain is compromised slightly to obtain a more consistent pattern and SWR across the whole band.

Fig 3 plots gain, F/R and SWR for two 10-meter monoband designs: a five-element quad and a five-element Yagi, both placed on 26-foot booms. The quad now has the same degrees of freedom as the Yagi, and as a consequence the pattern and SWR are more consistent across the range from 28.0 to 28.8 MHz. The quad's F/R remains above about 18.5 dB from 28.0 to 28.8 MHz. Meanwhile, the Yagi maintains an F/R of greater than 22 dB over the same range, but has almost 0.8 dB less gain compared to the quad at the low end of the band, eventually catching up at the high end of the band. The SWR for the quad is just over 2:1 at the bottom of the band, but remains less than 2:1 up to 28.8 MHz. The SWR on the Yagi remains less than 1.6:1 over the whole band.

Fig 4 shows the performance parameters for two 15-meter monoband designs: a five-element quad and a five-element Yagi, both on 26-foot booms. The quad is still the leader in gain, but has a less optimal rearward pattern and a somewhat less flat SWR curve than the Yagi. One thing should be noted in Figs 2 through 4. The F/R pattern on the

10-M Optimized Monoband Quad vs Yagi
5-Ele. Quad/5-Ele. Yagi -- 26' Booms

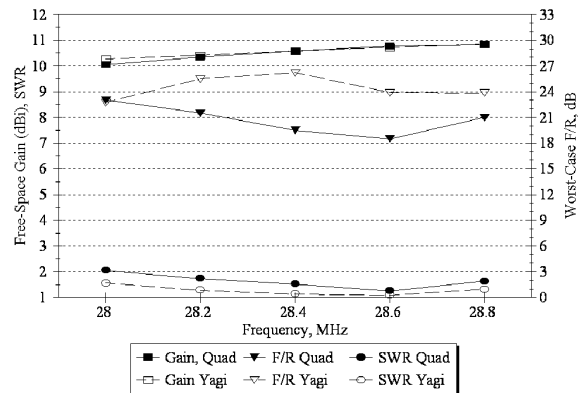

Fig 3—Comparison of gain, F/R and SWR over the 28.0 to 28.8-MHz range for an optimized five-element quad and an optimized five-element Yagi, both on 26-foot booms. The gain advantage of the quad is about 0.25 dB at the low end of the band. The F/R is more peaked in frequency for the quad, however, than the Yagi.

15-M Optimized Monoband Quad vs Yagi
5-Ele. Quad/5-Ele. Yagi, 26' Booms

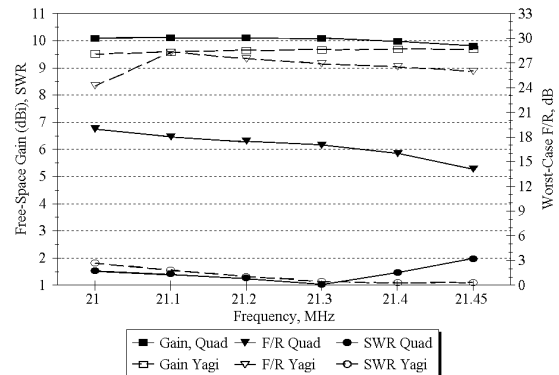

Fig 4—Comparison of gain, F/R and SWR over the 21.0 to 21.45-MHz range for an optimized 5-element quad and optimized 5-element Yagi, both on 26-foot booms. The quad enjoys a gain advantage of about 0.5 dB over most of the band. Its rearward pattern is not as good as the Yagi, which remains higher than 24 dB across the whole range, compared to the quad, which remains in the 16-dB average range.

Yagi is largely determined by the response at the 180° point, directly in back of the frontal lobe. This point is usually referred to when discussing the “front-to-back ratio.”

The quad on the other hand has what a sailor might term “quartering lobes” (referring to the direction back towards the “quarterdeck” at the stern of a sailing vessel) in the rearward pattern. These quartering lobes are often

15-Meter 5-Ele. Quad and 5-Ele. Yagi
21.2 MHz, 26-Foot Booms, Free Space

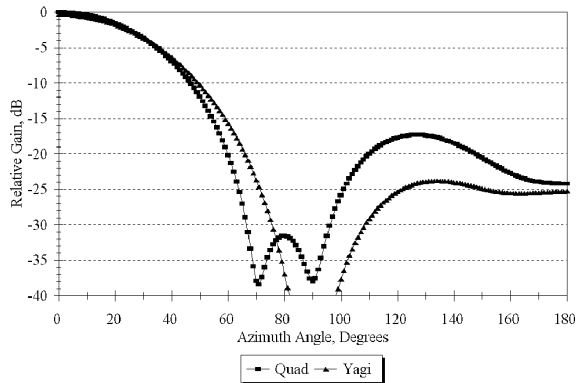

Fig 5—Comparing the pattern of the 15-meter quad and Yagi shown in Fig 4. The quad has a slightly narrower frontal beamwidth (it has 0.5 dB more gain than the Yagi), but has higher “rear quartering” sidelobes at about 125° (with a twin sidelobe, not shown, at 235°). These sidelobes limit the worst-case front-to-rear (F/R) to about 17 dB, while the F/B (at 180°, directly at the back of the quad) is more than 24 dB for each antenna.

worse than the response at 180°, directly in back of the main beam. **Fig 5** overlays the free-space E-Field responses of the 15-meter quad and Yagi together. At 21.2 MHz, the quad actually has a front-to-back ratio (F/B) of about 24 dB, excellent in anyone’s book. The Yagi at 180° has a F/B of about 25 dB, again excellent.

However, at an azimuth angle of about 125° (and at 235° azimuth on the other side of the main lobe) the quad’s “quartering lobe” is down only some 17 dB, setting the worst-case F/R at 17 dB also. As explained in Chapter 11, the reason F/R is more important than just the F/B is that on receive signals can come from any direction, not just from directly behind the main beam.

Table 1 lists the dimensions for the three computer-optimized monoband quads shown in Figs 2, 3 and 4.

Is a Quad Better at Low Heights than a Yagi?

Another belief held by some quads enthusiasts is that they need not be mounted very high off the ground to give excellent DX performance. Quads are somehow supposed to be greatly superior to a Yagi at the same height above ground. Unfortunately, this is mainly wishful thinking.

Fig 6 compares the same two 10-meter antennas as in Fig 3, but this time with each one mounted on a 50-foot tower over flat ground, rather than in theoretical free space. The quad does indeed have slightly more gain than a Yagi with the same boom length, as it has in free space. This is evidenced by the very slight compression of the quad’s main lobe, but is more obvious when you look at the third lobe, which peaks at about 53° elevation. In effect, the quad squeezes some energy out of its second

Table 1

Dimensions for Optimized Monoband Quads in Figs 2, 3 and 4, on 26-Foot Booms

	14.2 MHz	21.2 MHz	28.4 MHz
Reflector	73' 9"	49' 6"	37' 3"
R-DE Spacing	17' 8"	7'	6' 4"
Driven Element	71' 8"	47' 6"	35' 9"
DE-D1 Spacing	8' 3"	5'	5' 6"
Director 1	68' 7"	46' 8"	34' 8"
D1-D2 Spacing	—	6' 8"	6' 9"
Director 2	—	46' 10"	35' 2"
D2-D3 Spacing	—	7' 4"	7' 5"
Director 3	—	45' 8"	34' 2"
Feed method	Direct 50 Ω	Direct 50 Ω	Direct 50 Ω

10-Meter Optimized Quad and Yagi
28.4 MHz Gain, 50' Height

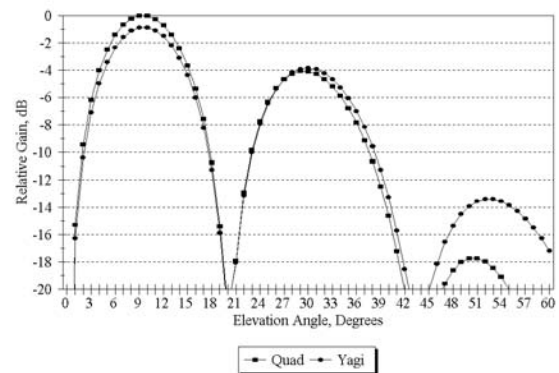

Fig 6—A comparison on 10 meters between an optimized five-element quad and an optimized five-element Yagi, both mounted 50 feet high over flat ground and both employing 26-foot booms. There is no appreciable difference in the peak elevation angle for either antenna. In other words, a quad does not have an appreciable elevation-angle advantage over a Yagi mounted at the same boom height. Note that the quad achieves its slightly higher gain by taking energy from higher-angle lobes and concentrating that energy in the main elevation lobe. This is a process that is similar to what happens with stacked Yagis.

and third lobes and adds that to the first lobe. However, the difference in gain compared to the Yagi is only 0.8 dB for this particular quad design at a 9° elevation angle. And while it’s true that every dB counts, you can also be certain that on the air you wouldn’t be able to tell the difference between the two antennas. After all, a 10- to 20-dB variation in the level of signals is pretty common because of fading at HF.

Multiband Quads

On the other hand, one of the valid reasons quads have remained popular over the years is that antenna homebrewers

can build multiband quads far more easily than they can construct multiband Yagis. In effect, all you have to do with a quad is add more wire to the existing support arms. It's not quite as simple as that, of course, but the idea of ready expandability for other bands is very appealing to experimenters.

Like the Yagi, the quad does suffer from interactions between wires of different frequencies, but the degree of interaction between bands is usually less for a quad. The higher-frequency bands are the ones that often suffer most from any interaction, for both Yagis and quads. For example, the 10- and 15-meter bands are usually the ones affected most by nearby 20-meter wires in a triband quad, while the 20-meter elements are not affected by the 10- or 15-meter elements.

Modern computer modeling software can help you counteract at least some of the interaction by allowing you to do virtual "retuning" of the quad on the computer screen — rather than clinging precariously to your tower fiddling with wires. However, the programs (such as *NEC-2* or *EZNEC*) that can model three-dimensional wire antennas such as quads typically run far more slowly than those designed for monoband Yagis (such as *YW* included with this book). This makes optimizing rather tedious, but you use the same considerations for tradeoffs between gain, pattern (F/R) and SWR over the operating bandwidth as you do with monoband Yagis.

CONSTRUCTING A QUAD

The parasitic element shown in Fig 1 is tuned in much the same way as the parasitic element in a Yagi antenna. That is, the parasitic loop is tuned to a lower frequency than the driven element when the parasitic is to act as a reflector, and to a higher frequency when it is to act as a director. Fig 1 shows the parasitic element with an adjustable tuning stub, a convenient method of tuning since the resonant frequency can be changed simply by changing the position of the shorting bar on the stub. In practice, it has been found that the length around the loop should be approximately 3.5% greater than the self-resonant length if the element is a reflector, and about 3.0% shorter than the self-resonant length if the parasitic element is a director. Approximate formulas for the loop lengths in feet are:

$$\text{Driven Element} = \frac{1008}{f_{\text{MHz}}}$$

$$\text{Reflector} = \frac{1045}{f_{\text{MHz}}}$$

$$\text{Director} = \frac{977}{f_{\text{MHz}}}$$

These are valid for quad antennas intended for operation below 30 MHz and using uninsulated #14 stranded copper wire. At VHF, where the ratio of loop circumference to conductor diameter is usually relatively small, the

circumference must be increased in comparison to the wavelength. For example, a one-wavelength loop constructed of 1/4-inch tubing for 144 MHz should have a circumference about 2% greater than in the above equation for the driven element.

Element spacings on the order of 0.14 to 0.2 free-space wavelengths are generally used. You would employ the smaller spacings for antennas with more than two elements, where the structural support for elements with larger spacings tends to become challenging. The feed-point impedances of antennas having element spacings on this order have been found to be in the 40- to 60-Ω range, so the driven element can be fed directly with coaxial cable with only a small mismatch.

For spacings on the order of 0.25 wavelength (physically feasible for two elements, or for several elements at 28 MHz) the impedance more closely approximates the impedance of a driven loop alone—that is, 80 to 100 Ω. The feed methods described in Chapter 26 can be used, just as in the case of the Yagi.

Making It Sturdy

The physical sturdiness of a quad is directly proportional to the quality of the material used and the care with which it is constructed. The size and type of wire selected for use with a quad antenna is important because it will determine the capability of the spreaders to withstand high winds and ice. One of the more common problems confronting the quad owner is that of broken wires. A solid conductor is more apt to break than stranded wire under constant flexing conditions. For this reason, stranded copper wire is recommended. For 14-, 21- or 28-MHz operation, #14 or #12 stranded wire is a good choice. Soldering of the stranded wire at points where flexing is likely to occur should be avoided.

You may connect the wires to the spreader arms in many ways. The simplest method is to drill holes through the fiberglass at the appropriate points on the arms and route the wires through the holes. Soldering a wire loop across the spreader, as shown later, is recommended. However, you should take care to prevent solder from flowing to the corner point where flexing could break it.

While a boom diameter of 2 inches is sufficient for smaller quads using two or even three elements for 14, 21 and 28 MHz, when the boom length reaches 20 feet or longer a 3-inch diameter boom is highly recommended. Wind creates two forces on the boom, vertical and horizontal. The vertical load on the boom can be reduced with a guy-wire truss cable. The horizontal forces on the boom are more difficult to relieve, so 3-inch diameter tubing is desirable.

Generally speaking, three grades of material can be used for quad spreaders. The least expensive material is bamboo. Bamboo, however, is also the weakest material normally used for quad construction. It has a short life, typically only three or four years, and will not withstand a harsh climate very well. Also, bamboo is heavy in con-

trast to fiberglass, which weighs only about a pound per 13-foot length. Fiberglass is the most popular type of spreader material, and will withstand normal winter climates. One step beyond the conventional fiberglass arm is the pole-vaulting arm. For quads designed to be used on 7 MHz, surplus “rejected” pole-vaulting poles are highly recommended. Their ability to withstand large amounts of bending is very desirable. The cost of these poles is high, and they are difficult to obtain. See Chapter 21 for dealers and manufacturers of spreaders.

Diamond or Square?

The question of how to orient the spreader arms has been raised many times over the years. Should you mount the loops in a diamond or a square configuration? Should one set of spreaders be horizontal to the earth as shown in Fig 1 (right), or should the wire itself be horizontal to the ground (spreaders mounted in the fashion of an X) as shown in Fig 1 (left)? From the electrical point of view, there is not enough difference in performance to worry about.

From the mechanical point of view there is no question which version is better. The diamond quad, with the

associated horizontal and vertical spreader arms, is capable of holding an ice load much better than a system where no vertical support exists to hold the wire loops upright. Put another way, the vertical poles of a diamond array, if sufficiently strong, will hold the rest of the system erect. When water droplets are accumulating and forming into ice, it is very reassuring to see water running down the wires to a corner and dripping off, rather than just sitting there on the wires and freezing. The wires of a loop (or several loops, in the case of a multiband antenna) help support the horizontal spreaders under a load of ice. A square quad will droop severely under heavy ice conditions because there is nothing to hold it up straight.

Of course, in climates where icing is not a problem, many amateurs point out that they like the aesthetics of the square configuration. There are thousands of square-configuration quads in temperate areas around the world.

Another consideration will enter into your choice of orientation for a quad. You must mount a diamond quad somewhat higher on the mast or tower than for an equivalent square array, just to keep the bottom spreader away from the tower guys when you rotate the antenna.

Two Multiband Quads

This section describes two multiband quad designs. The first is a large triband 20/15/10-meter quad built on a 26-foot boom made of 3-inch irrigation tubing. This antenna has three elements on 20 meters, four elements on 15 meters, and five elements on 10 meters. **Fig 7** shows a photograph of the five-element triband quad.

The second project is a compact two-element triband quad on an 8-foot boom that covers 20, 17, 15, 12 and 10 meters. We call this a “pentaband” quad since it covers five bands. This antenna uses five concentric wire loops mounted on each of the two sets of spreaders. Either antenna may be constructed in a diamond or square configuration.

While the same basic construction techniques are employed for both multiband quads, the scale of the larger triband antenna makes it a far more ambitious undertaking! The large quad requires a strong tower and a rugged rotator. It also requires a fair amount of real estate in order to raise the quad to the top of the tower without entangling trees or other antennas.

A FIVE-ELEMENT, 26-FOOT BOOM TRIBAND QUAD

Five sets of element spreaders are used to support the three elements used on 14 MHz, four elements on 21 MHz and five elements on 28-MHz. We chose to use four elements on 15 meters in this design (rather than the five we could have been employed on this length of boom) because

the difference in optimized performance wasn't great enough to warrant the extra complexity of using five elements. The dimensions are listed in **Table 2**, and are designed for center frequencies of 14.175, 21.2 and 28.4 MHz.

The spacing between elements has been chosen to provide good compromises in performance consistent with boom length and mechanical construction. You can see that the element spacings for 20 meters are quite different from those for the optimized monoband design. This is because the same set of spreaders is used for all

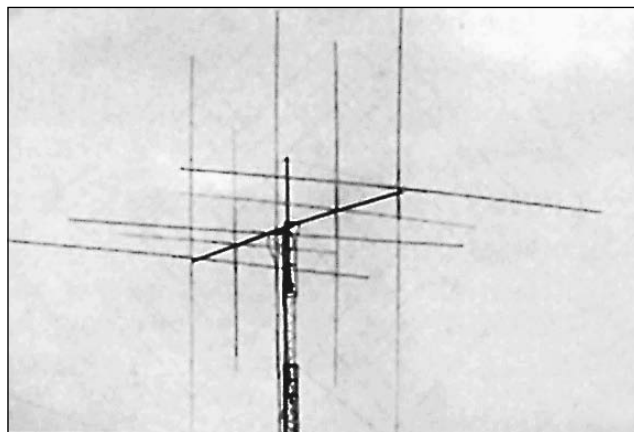

Fig 7—Photo of the three-band, five-element quad antenna.

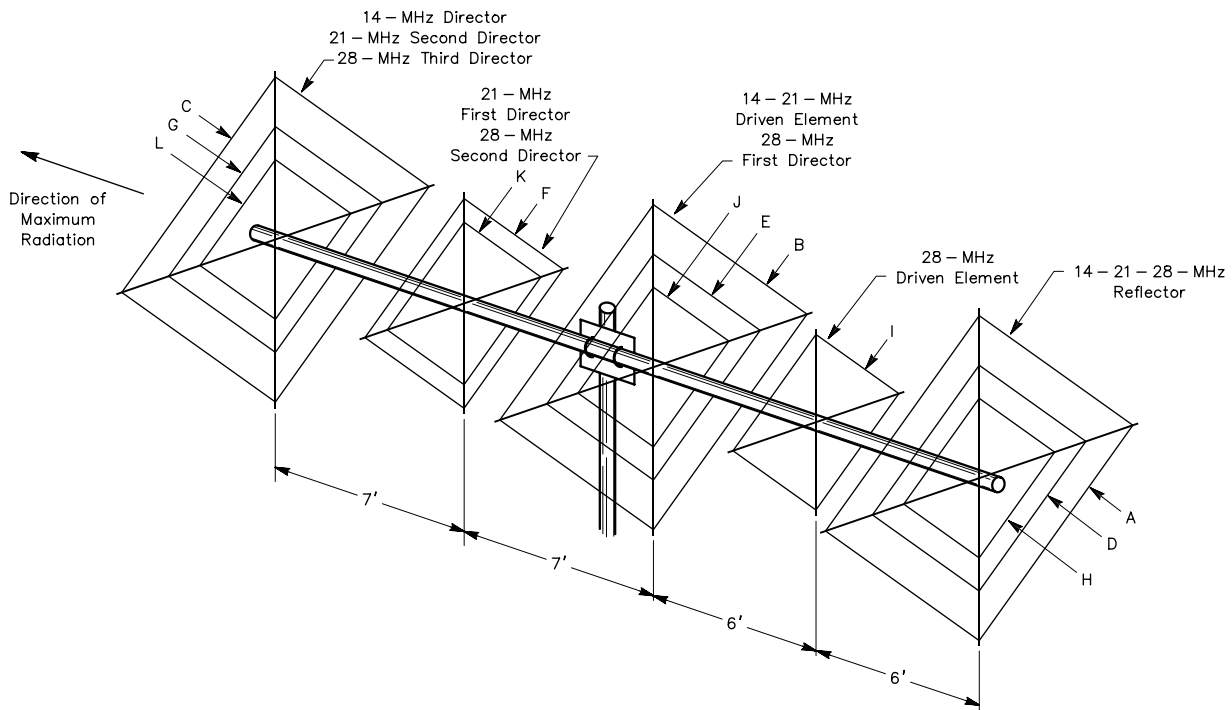

Fig 8—Layout for the three-band, five-element quad, not drawn to scale. See Table 2 for dimensions.

three bands on three out of the five elements, and the higher-frequency bands dictate the spacing because they are more critical.

Each of the parasitic loops is closed (ends soldered together) and requires no tuning. **Fig 8** shows the physical layout of the triband quad. **Fig 9** plots the computed free-space gain, front-to-rear ratio and SWR response across the 20-meter band. With only a few degrees of freedom in tuning and spacing of the three elements, it is impossible to spread the response out to cover the entire 20-meter band. The compromise design results in a rearward pattern that varies from a worst-case of just under 10 dB at the high end of the band, to a peak F/R of just

under 19 dB at 14.2 MHz, in the phone portion of the band. The F/R is about 11 dB at the low end of the band.

The SWR remains under 3:1 for the entire 20-meter band, rising to 2.8:1 at the high end. The feed system for this triband quad consists of three separate 50-Ω coax

**Table 2
Three-Band Five-Element Quad on 26-Foot Boom**

	14.15 MHz	21.2 MHz	28.4 MHz
Reflector	72' 6"	49' 4"	36' 8"
R-DE Spacing	12'	12'	6'
Driven Element	71'	47' 6"	35' 4"
DE-D1 Spacing	14'	7'	6'
Director 1	68' 6"	46' 8"	34' 8"
D1-D2 Spacing	—	14'	7'
Director 2	—	46' 5"	34' 8"
D2-D3 Spacing	—	—	7'
Director 3	—	—	34'
Feed method	Direct 50 Ω	Direct 50 Ω	Direct 50 Ω

**20-Meter Optimized Triband Quad
3-Ele. Quad, 26' Boom**

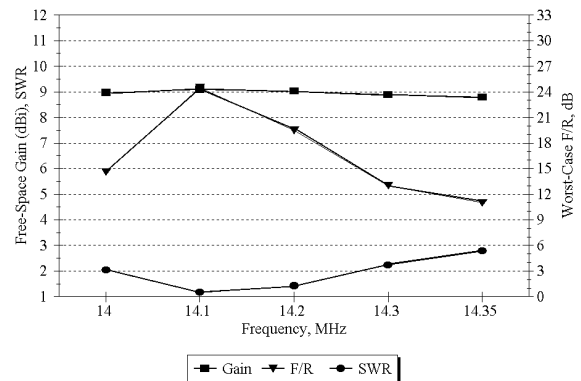

Fig 9—Computed performance of the triband, five-element quad over the 20-meter band. The direct 50-Ω feed system holds the SWR below 2.8: 1 across the whole band. This could be improved with a gamma-match system tuned to 14.1 MHz if the builder really desires a low SWR. The F/R peaks at 14.1 MHz and remains above 10 dB across the whole band.

lines, one per driven element, together with a relay switchbox mounted to the boom so that a single coax can be used back to the operating position. Each feed line uses a ferrite-bead balun to control common-mode currents and preserve the radiation pattern and each coax going to the switchbox is cut to be an electrical three-quarter wavelength on 15 meters. This presents a short at the unused driven elements since modeling indicated that the 15-meter band is adversely affected by the presence of the 20-meter driven element if it is left open-circuited. If you use RG-213 coax, the $3/4\lambda$ electrical length of each feed line is 23 feet long at 21.2 MHz. This is sufficient physical length to reach each driven element from the switchbox.

Fig 10 shows the free-space response for the 15-meter band. The rearward response is roughly 15 dB across the band. This is a result of the residual interaction between the 20-meter elements on 15 meters, and no further tuning could improve the F/R. Note how flat the SWR curve is. This SWR characteristic is what gives the quad the reputation of being “wideband.” A flat SWR curve, however, is not necessarily a good indicator of optimal performance for directional antennas like quads or Yagis, particularly multiband designs where compromises must be made by physical necessity.

Fig 11 shows the characteristics of the 10-meter portion of the two-element triband quad. The response favors the low-phone band, with the F/R falling to about 12 dB at the low end of the frequency range and rising to just about 23 dB at 28.4 MHz. The SWR curve is once again relatively flat across the major portion of the band up to 28.8 MHz.

Construction

The most obvious problem related to quad antennas is the ability to build a structurally sound system. If high

winds or heavy ice are a normal part of the environment, special precautions are necessary if the antenna is to survive a winter season. Another stumbling block for would-be quad builders is the installation of a three-dimensional system (assuming a Yagi has only two important dimensions) on top of a tower—especially if the tower needs guy wires for support. With proper planning, however, many of these obstacles can be overcome. For example, a tram system may be used.

Both multiband quad arrays use fiberglass spreaders (see Chapter 21 for suppliers). Bamboo is a suitable substitute (if economy is of great importance). However, the additional weight of the bamboo spreaders over fiberglass is an important consideration. A typical 12-foot bamboo pole weighs about 2 pounds; the fiberglass type weighs less than a pound. By multiplying the difference times 8 for a two-element array, times 12 for a three-element antenna, and so on, it quickly becomes apparent that fiberglass is worth the investment if weight is an important factor. Properly treated, bamboo has a useful life of three or four years, while fiberglass life is probably 10 times longer.

Spreader supports (sometimes called *spiders*) are available from many different manufacturers. If the builder is keeping the cost at a minimum, he should consider building his own. The expense is about half that of a commercially manufactured equivalent and, according to some authorities, the homemade arm supports described below are less likely to rotate on the boom as a result of wind pressure.

A 3-foot length of steel angle stock, 1 inch per side, is used to interconnect the pairs of spreader arms. The steel is drilled at the center to accept a muffler clamp of sufficient size to clamp the assembly to the boom. The fiberglass is clamped to the steel angle stock with auto-

15-Meter Optimized Triband Quad
4-Ele. Quad, 26' Boom

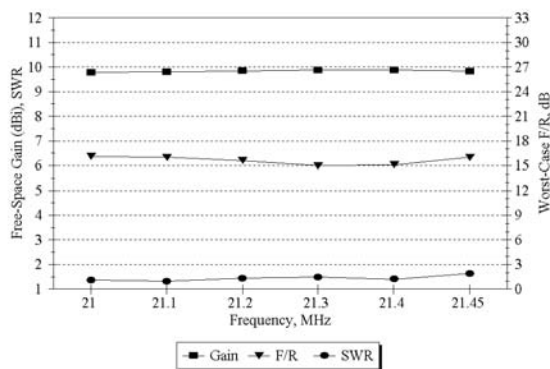

Fig 10—Computed performance of the triband, five-element quad over the 15-meter band. There is some degree of interaction with the 20-meter elements, limiting the worst-case F/R to about 15 dB. The gain and SWR curves are relatively flat across the band.

10-Meter Optimized Triband Quad
5-Ele. Quad, 26' Boom

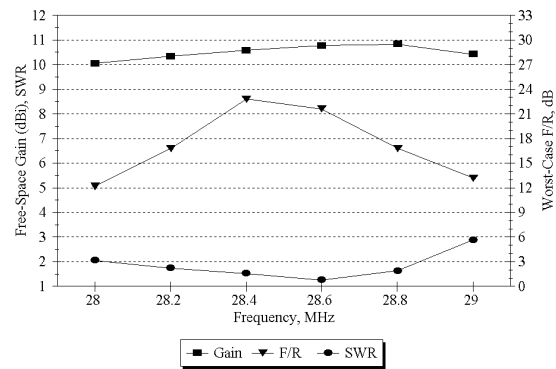

Fig 11—Computed performance of the triband, five-element quad over the 10-meter band. The F/R is higher than 12 dB across the band from 28.0 to 29.0 MHz, but the SWR rises at the top end of the band beyond 2:1. The free-space gain is higher than 10 dBi across the band.

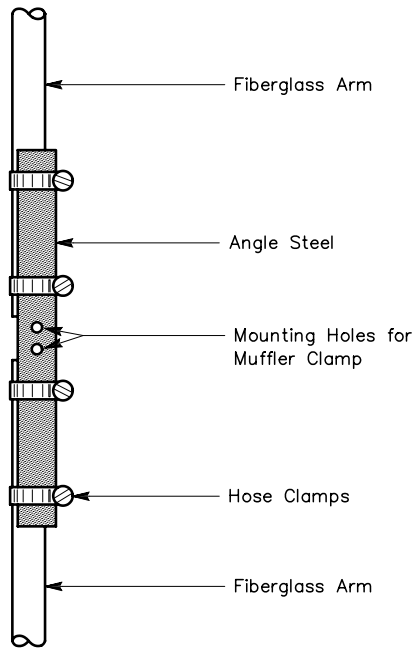

Fig 12—Details of one of two assemblies for a spreader frame. The two assemblies are joined back-to-back to form an X with a muffer clamp mounted at the position shown.

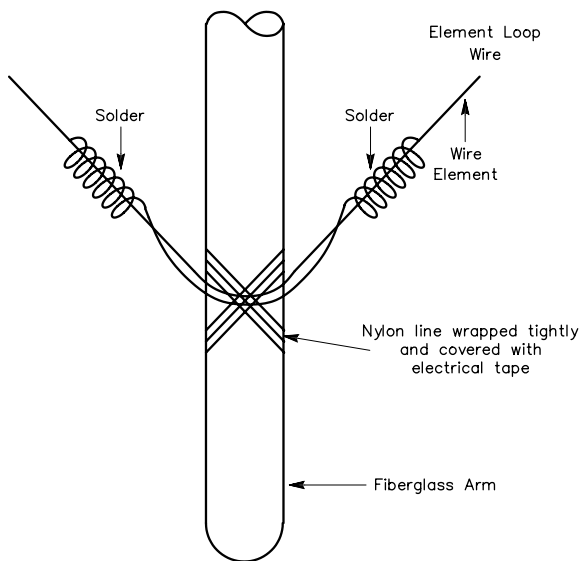

Fig 14—An alternative method of assembling the wire of a quad loop to the spreader arm.

motive hose clamps, two per pole. Each quad-loop spreader frame consists of two assemblies of the type shown in **Fig 12**.

Connecting the wires to the fiberglass can be done in a number of different ways. Holes can be drilled at the proper places on the spreader arms and the wires run through them. A separate wrap wire should be included

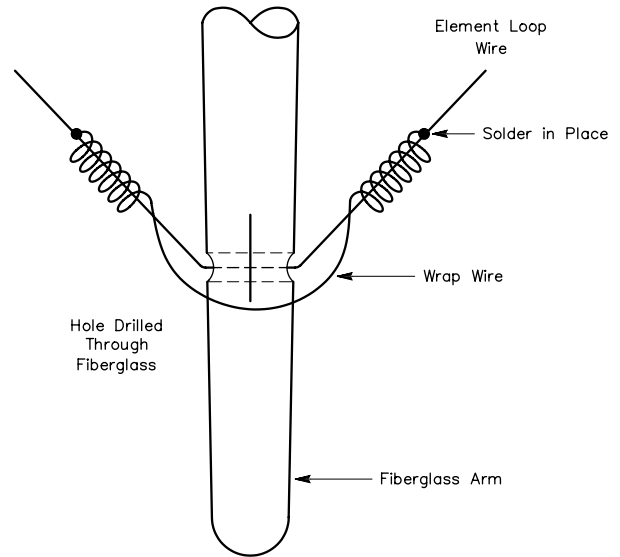

Fig 13—A method of assembling a corner of the wire loop of a quad element to the spreader arm.

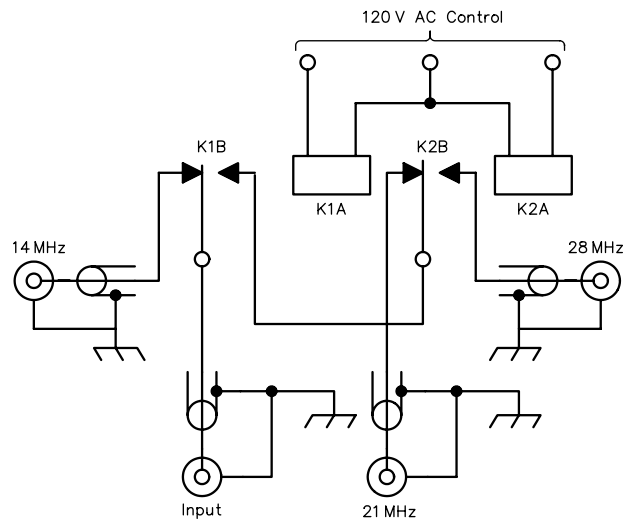

Fig 15—Suitable circuit for relay switching of bands for the three-band quad. A three-wire control cable is required. K1, K2—any type of relay suitable for RF switching, coaxial type not required (Potter and Brumfeld MR11A acceptable; although this type has double-pole contacts, mechanical arrangements of most single-pole relays make them unacceptable for switching of RF).

at the entry/exit point to prevent the loop from slipping. Details are presented in **Fig 13**. Some amateurs have experienced cracking of the fiberglass, which might be a result of drilling holes through the material. However, this seems to be the exception rather than the rule. The model described here has no holes in the spreader arms; the wires are attached to each arm with a few layers of

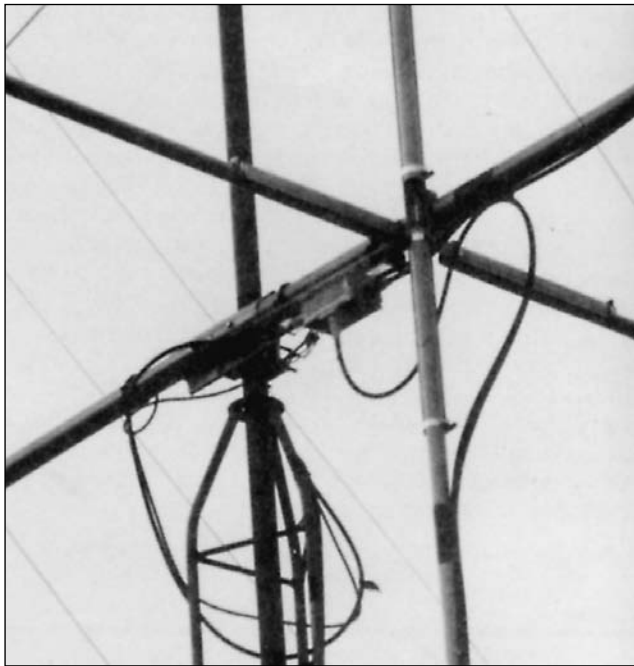

Fig 16—The relay box is mounted on the boom near the center. Each of the spreader-arm fiberglass poles is attached to steel angle stock with hose clamps.

plastic electrical tape and then wrapped approximately 20 times in a crisscross fashion with 1/8-inch diameter nylon string, followed by more electrical tape for UV protection, as shown in **Fig 14**.

The wire loops are left open at the bottom of each driven element where the feed-line coaxes are attached. All of the parasitic elements are continuous loops of wire; the solder joint is at the base of the diamond.

Although you could run three separate coax cables down to the shack, we suggest that you install a relay box at the center of the boom. A three-wire control system may be used to apply power to the proper relay for changing bands. The circuit diagram of a typical configuration is presented in **Fig 15** and its installation is shown in **Fig 16**.

Every effort must be placed upon proper construction if you want to have freedom from mechanical problems. Hardware must be secure or vibration created by the wind may cause separation of assemblies. Solder joints should be clamped in place to keep them from flexing, which might fracture a connection point.

A TWO-ELEMENT, 8-FOOT BOOM PENTABAND QUAD

This two-element pentaband (20/17/15/12/10-meter) quad uses the same construction techniques as its big brother above. Since only two elements are used, the boom can be less robust for this antenna, at 2 inches diameter rather than 3 inches. Those who like really rugged antennas can still use the 3-inch diameter boom, of course.

Table 3 lists the element dimensions for the pentaband quad. The following plots show the performance for each of the five bands covered. The feed system for the pentaband quad uses five, direct 50-Ω coaxes, one to each driven element. These five coaxes are cut to be $3/4\lambda$ electrically on 10 meters (17 feet, 2 inches for RG-213 at 28.4 MHz). In this design the 10-meter band is the one most affected by the presence of the other driven elements if they are left unshorted. The $3/4\lambda$ lines open-circuited at the switchbox are long enough physically to reach all elements from a centrally mounted switchbox. This length assumes that the switchbox open-circuits the unused coaxes. If the switchbox short-circuits unused coaxes (as several commercial switchboxes do), then use $1/2\lambda$ long lines to feed all five driven elements (11 feet,

20-Meters, Optimized Pentaband Quad
2-Ele. Quad, 8' Boom

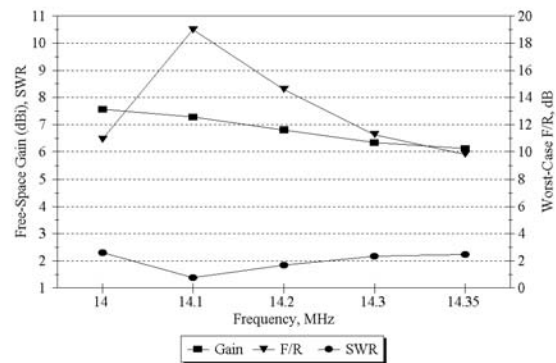

Fig 17—Computed performance of the pentaband two-element quad on 20 meters. With the simple direct-feed system, the SWR rises to about 2.3:1 at the low end of the band. A gamma match can bring the SWR down to 1:1 at 14.1 MHz, if desired.

Table 3
Five-Band Two-Element Quad on 8-Foot Boom

	14.2 MHz	18.1 MHz	21 MHz	24.9 MHz	28.4 MHz
Reflector	72' 4"	56' 4"	48' 6"	40' 11 1/4"	37' 5 1/2"
R-DE Spacing	8'	8'	8'	8'	8'
Driven Element	69' 10 1/2"	54' 10 1/2"	46' 7"	39' 10 1/2"	34' 6"

5 inches for RG-213 at 28.4 MHz).

The SWR curves do not necessarily go down to 1:1 because of this simple, direct feed system. If anyone is bothered by this, of course they can always implement individual matching systems, such as gamma matches. Most amateurs would agree that such a degree of complexity is not warranted. The worst-case SWR is less than 2.3:1 on each band, even with direct feed on 20 meters. With typical lengths of coaxial feed line from the shack to the switchbox at the antenna, say 100 feet of RG-213, the SWR at the transmitter would be less than 2.0:1 on all bands due to losses in the feed line.

Fig 17 shows the computed responses for the

pentaband quad over the 20-meter band. With only two degrees of freedom (spacing and element tuning) there is not much that can be done to spread the response out over the entire 20-meter band. Nonetheless, the performance over the band is still pretty reasonable for an antenna this small. The F/R pattern peaks at 19 dB at 14.1 MHz and falls to about 10 dB at either end of the band. The free-space gain varies from about 7.5 dBi to just above 6 dBi, comparable to a short-boom three-element Yagi. The SWR curve remains below 2.3:1 across the band. If you were to employ a gamma match tuned at 14.1 MHz, you could limit the peak SWR to less than 2.0:1, and this would still occur at 14.0 MHz.

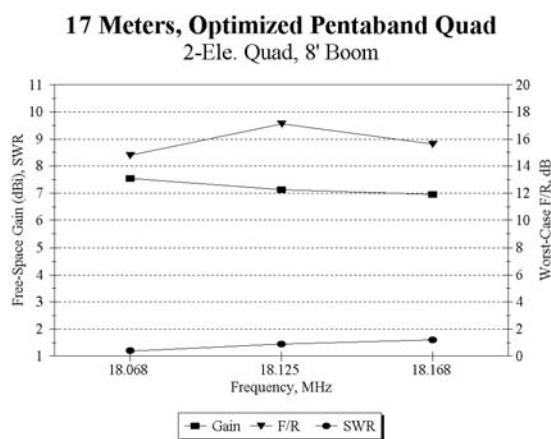

Fig 18—Computed performance of the pentaband two-element quad on 17 meters. There is some interaction with the other elements, but overall the performance is satisfactory on this band.

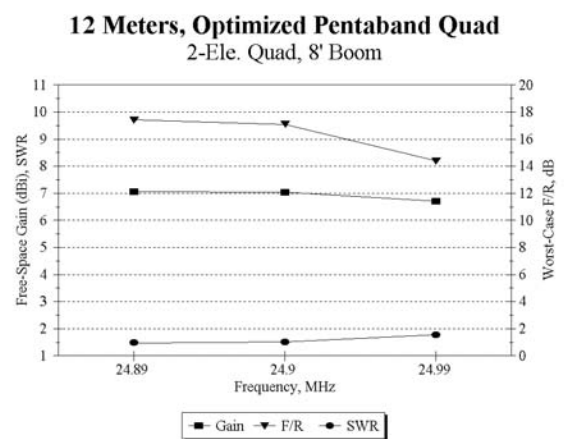

Fig 20—Computed performance of the pentaband two-element quad on 12 meters.

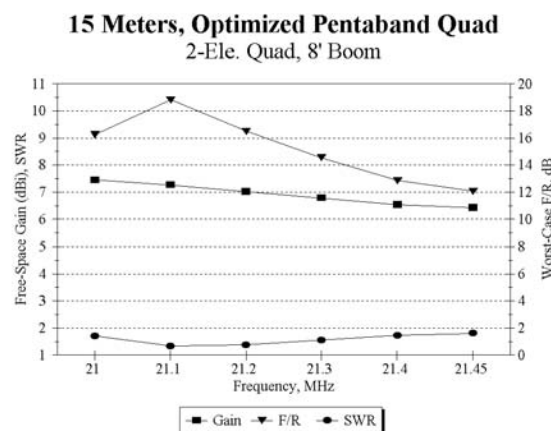

Fig 19—Computed performance of the pentaband two-element quad on 15 meters. The performance is acceptable across the whole band.

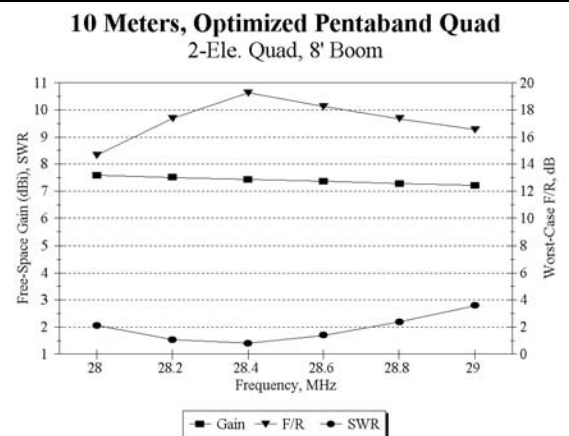

Fig 21—Computed performance of the pentaband two-element quad on 10 meters. The SWR curve is slightly above the target 2:1 at the low end of the band and rises to about 2.2:1 at 28.8 MHz. This unlikely to be a problem, even with rigs with automatic power-reduction due to SWR, since the SWR at the input of a typical coax feed line will be lower than that at the antenna due to losses in the line.

On 17 meters, **Fig 18** shows that the other elements are affecting 18 MHz, even with element-length optimization. Careful examination of the current induced on the other elements shows that the 20-meter driven element is interacting on 18 MHz, deteriorating the pattern and gain slightly. Even still, the performance on 17 meters is reasonable, especially for a five-band quad on an 8-foot boom.

On 15 meters, the interactions seems to have been contained, as **Fig 19** demonstrates. The F/R peaks at 21.1 MHz, at 19 dB and remains better than 12 dB past the top of the band. The SWR curve is low across the whole band.

On 12 meters, the interaction between bands is minor, leading to the good results shown in **Fig 20**. The SWR change across this band is quite flat, which isn't surprising given the narrow bandwidth of the 12-meter band.

On 10 meters, the interaction seems to have been tamed well by computer-tuning of the elements. The F/R remains higher than about 14 dB from 28 to 29 MHz. The SWR remains below 2.2:1 up to about 28.8 MHz, while the gain is relatively flat across the band at more than 7.2 dBi in free space. See **Fig 21**.

Overall, this pentaband quad is physically compact and yet it provides good performance across all five bands.

It is competitive with commercial Log Periodic Dipole Array (LPDA) designs and triband Yagi designs that employ longer booms.

BIBLIOGRAPHY

Source material and more extended discussions of the topics covered in this chapter can be found in the references given below and in the textbooks listed at the end of Chapter 2.

- P. S. Carter, C. W. Hansell and N. E. Lindenblad, "Development of Directive Transmitting Antennas by R.C.A. Communications," *Proc. IRE*, Oct 1931.
- C. Cleveland, "More'n One Way to Switch an Antenna," *Technical Correspondence, QST*, Nov 1986.
- D. Cutter, "Simple Switcher," *73*, May 1980.
- D. DeMaw, "A Remote Antenna Switcher for HF," *QST*, Jun 1986.
- M. G. Knitter, Ed., *Loop Antennas—Design and Theory* (Cambridge, WI: National Radio Club, 1983).
- H. Landskov, W7KAR, "Evolution of a Quad Array," *QST*, Mar 1977.
- J. Lindsay, "Quads and Yagis," *QST*, May 1968.
- F. E. Terman, *Radio Engineering*, 3rd ed. (New York: McGraw-Hill Book Co, 1947).
- E. M. Williams, "Radiating Characteristics of Short-Wave Loop Aerials," *Proc. IRE*, Oct 1940.

