

Portable Antennas

For many amateurs, the words *portable antennas* may conjure visions of antenna assemblies that can be broken down and carried in a backpack, suitcase, golf bag, or what-have-you, for transportation to some out-of-the-way place where they will be used. Or the vision could be of larger arrays that can be disassembled and moved by pickup truck to a Field Day site, and then erected quickly on temporary supports. Portable antennas come in a wide variety of sizes and shapes, and can be used on any amateur frequency.

Strictly speaking, the words “portable antenna” really means *transportable antenna*—one that is moved to some (usually temporary) operating position for use. As such, portable antennas are not placed into service when they are being transported. This puts them in a different class from mobile antennas, which are intended to be used while in motion. Of course this does not mean that mobile antennas cannot be used during portable operation. Rather, true portable antennas are designed to be packed up and moved, usually with quick reassembly being one of the design requisites. This chapter describes antennas that are designed for portability. However, many of these antennas can also be used in more permanent installations.

Any of several schemes can be employed to support an antenna during portable operation. For HF antennas made of wire, probably the most common support is a conveniently located tree at the operating site. Temporary, lightweight masts are also used. An aluminum extension ladder, properly guyed, can serve as a mast for Field Day operation. Such supports are discussed in Chapter 22, Antenna Supports.

A SIMPLE TWIN-LEAD ANTENNA FOR HF PORTABLE OPERATION

The typical portable HF antenna is a random-length wire flung over a tree and end-fed through an antenna tuner. Low-power antenna tuners can be made quite compact, but each additional piece of necessary equipment makes portable operation less attractive. The station can be simplified by using resonant impedance-matched antennas for the bands of interest. Perhaps the simplest antenna of this type is the half-wave dipole, center-fed with 50- or 75- Ω coax. Unfortunately, RG-58, RG-59 or RG-8 cable is quite heavy and bulky for backpacking, and the miniature cables such as RG-174 are too lossy.

A practical solution to the coax problem, developed by Jay Rusgrove, W1VD, and Jerry Hall, K1TD, is to use folded dipoles made from lightweight TV twin-lead. The characteristic impedance of this type of dipole is near 300 Ω , but this can easily be transformed to a 50- Ω impedance. The transformation is obtained by placing a lumped capacitive reactance at a strategic distance from the input end of the line. **Fig 1** illustrates the construction method and gives important dimensions for the twin-lead dipole.

A silver-mica capacitor is shown for the reactive element, but an open-end stub of twin-lead can serve as well, provided it is dressed at right angles to the transmission line for some distance. The stub method has the advantage of easy adjustment of the system resonant frequency.

The dimensions and capacitor values for twin-lead dipoles for the HF bands are given in **Table 1**. To pre-

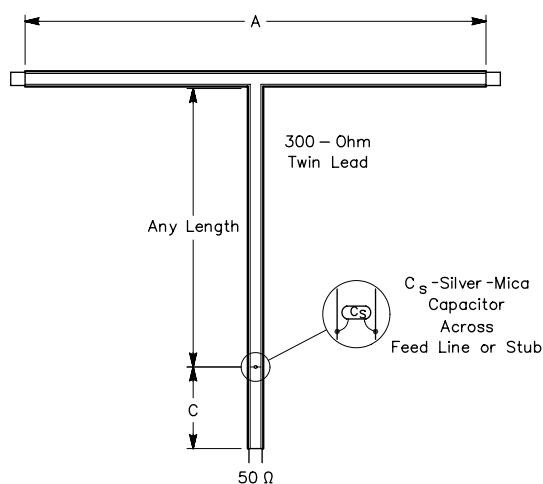

Fig 1—A twin-lead folded dipole makes an excellent portable antenna that is easily matched to 50- Ω equipment. See text and Table 1 for details.

serve the balance of the feeder, a 1:1 balun must be used at the end of the feed line. In most backpack QRP applications the balance is not critical, and the twin-lead can be connected directly to a coaxial output jack—one lead to the center contact, and one lead to the shell.

Because of the transmission-line effect of the shorted-radiator sections, a folded dipole exhibits a wider bandwidth than a single-conductor type. The antennas described here are not as broad as a standard folded dipole because the impedance-transformation mechanism is frequency selective. However, the bandwidth should be adequate. An antenna cut for 14.175 MHz, for example, will present an SWR of less than 2:1 over the entire 14-MHz band.

ZIP-CORD ANTENNAS

Zip cord is readily available at hardware and department stores, and it's not expensive. The nickname, *zip cord*, refers to that parallel-wire electrical cord with brown or white insulation used for lamps and many small appliances. The conductors are usually #18 stranded copper wire, although larger sizes may also be found. Zip cord is light in weight and easy to work with.

For these reasons, zip cord can be pressed into service as both the transmission line and the radiator section for an emergency dipole antenna system. This information by Jerry Hall, K1TD, appeared in *QST* for March 1979. The radiator section of a zip-cord antenna is obtained simply by “unzipping” or pulling the two conductors apart for the length needed to establish resonance for the operating frequency band. The initial dipole length can be determined from the equation $\ell = 468/f$, where ℓ is the length in feet and f is the frequency in MHz. (It would be necessary to unzip only half the length found

**Table 1
Twin-Lead Dipole Dimensions and Capacitor Values**

Frequency	Length A	Length C	C_s	Stub Length
3.75 MHz	124' 9½"	13' 0"	289 pF	37' 4"
7.15	65' 5½"	6' 10"	151 pF	19' 7"
10.125	46' 2½"	4' 10"	107 pF	13' 10"
14.175	33' 0"	3' 5½"	76 pF	9' 10½"
18.118	25' 10"	2' 8½"	60 pF	7' 9"
21.225	22' ½"	2' 3½"	51 pF	6' 7"
24.94	18' 9"	1' 11½"	43 pF	5' 7½"
28.5	16' 5"	1' 8½"	38 pF	4' 11"

from the formula, since each of the two wires becomes half of the dipole.) The insulation left on the wire will have some loading effect, so a bit of length trimming may be needed for exact resonance at the desired frequency.

For installation, you may want to use the electrician's knot shown in **Fig 2** at the dipole feed point. This is a balanced knot that will keep the transmission-line part of the system from unzipping itself under the tension of dipole suspension. This way, if zip cord of sufficient length for both the radiator and the feed line is obtained, a solder-free installation can be made right down to the input end of the line.

(Purists may argue that knots at the feed point will create an impedance mismatch or other complications, but as will become evident in the next section, this is not a major consideration.) Granny knots (or any other variety) can be used at the dipole ends with cotton cord to suspend the system. You end up with a lightweight, low-cost antenna system that can serve for portable or emergency use.

But just how efficient is a zip-cord antenna system? Since it is easy to locate the materials and simple to install, how about using such for a more permanent installation? Upon casual examination, zip cord looks about like 72- Ω balanced feed line. Does it work as well?

Zip Cord as a Transmission Line

To determine the electrical characteristics of zip cord as a radio-frequency transmission line, a 100-foot roll was subjected to tests in the ARRL laboratory with an RF impedance bridge. Zip cord is properly called *parallel power cord*. The variety tested was manufactured for GC Electronics, Rockford, IL, being 18-gauge, brown, plastic-insulated type SPT-1, GC cat. no. 14-118-2G42. Undoubtedly, minor variations in the electrical-characteristics will occur among similar cords from different manufacturers, but the results presented here are probably typical.

The characteristic impedance was determined to be 107 Ω at 10 MHz, dropping in value to 105 Ω at 15 MHz and to a slightly lower value at 29 MHz. The nominal

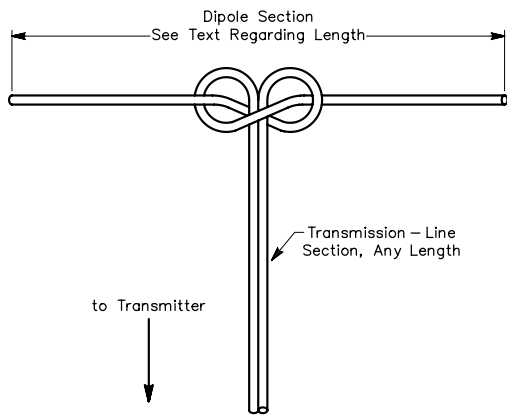

Fig 2—This electrician’s knot, often used inside lamp bases and appliances in lieu of a plastic grip, can also serve to prevent the transmission-line section of a zip-cord antenna from unzipping itself under the tension of dipole suspension. To tie the knot, first use the right-hand conductor to form a loop, passing the wire behind the unseparated zip cord and off to the left. Then pass the left-hand wire of the pair behind the wire extending off to the left, in front of the unseparated pair, and thread it through the loop already formed. Adjust the knot for symmetry while pulling on the two dipole wires.

value is 105 Ω at HF. The velocity factor of the line was determined to be 69.5%.

Who needs a 105-Ω line, especially to feed a dipole? A dipole in free space exhibits a feed-point resistance of 73 Ω, and at heights above ground of less than 1/4 wavelength the resistance can be even lower. An 80-meter dipole at 35 feet over average soil, for example, will exhibit a feed-point resistance of about 35 Ω. Thus, for a resonant antenna, the SWR in the zip-cord transmission line can be 105/35 or 3:1, and maybe even higher in some installations. Depending on the type of transmitter in use, the rig may not like working into the load presented by the zip-cord antenna system.

But the really bad news is still to come—line loss! **Fig 3** is a plot of line attenuation in decibels per hundred feet of line versus frequency. Chart values are based on the assumption that the line is perfectly matched (sees a 105-Ω load as its terminating impedance).

In a feed line, losses up to about 1 decibel or so can be tolerated, because at the receiver a 1-dB difference in signal strength is just barely detectable. But for losses above about 1 dB, beware. Remember that if the total losses are 3 dB, half of your power will be used just to heat the transmission line. Additional losses over those charted in Fig 3 will occur when standing waves are present. (See Chapter 24, Transmission Lines.) The trouble is, you can’t use a 50- or 75-Ω SWR instrument to measure the SWR in zip-cord line accurately.

Based on this information, we can see that a hun-

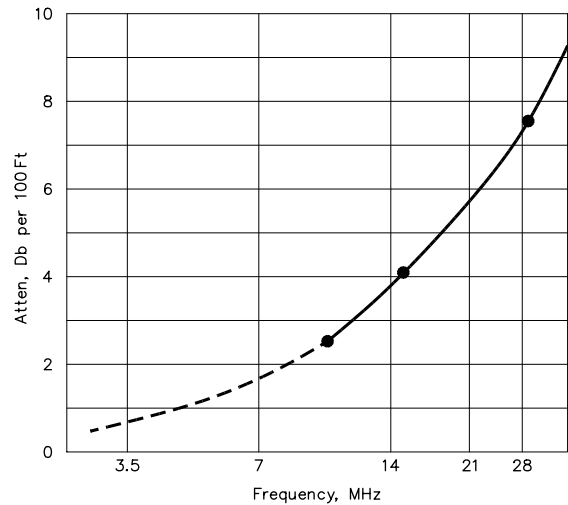

Fig 3—Attenuation of zip cord in decibels per hundred feet when used as a transmission line at radio frequencies. Measurements were made only at the three frequencies where plot points are shown, but the curve has been extrapolated to cover all high-frequency amateur bands.

dred feet or so of zip-cord transmission line on 80 meters might be acceptable, as might 50 feet on 40 meters. But for longer lengths and higher frequencies, the losses become appreciable.

Zip Cord Wire as the Radiator

For years, amateurs have been using ordinary copper house wire as the radiator section of an antenna, erecting it without bothering to strip the plastic insulation. Other than the loading effects of the insulation mentioned earlier, no noticeable change in performance has been noted with the insulation present. And the insulation does offer a measure of protection against the weather. These same statements can be applied to single conductors of zip cord.

The situation in a radiating wire covered with insulation is not quite the same as in two parallel conductors, where there may be a leaky dielectric path between the two conductors. In the parallel line, it is the current leakage that contributes to line losses. This leakage current is set up by the voltage potential that exists on the two adjacent wires. The current flowing through the insulation on a single radiating wire is quite small by comparison, and so as a radiator the efficiency is high.

In short, communications can certainly be established with a zip-cord antenna in a pinch on 160, 80, 40, 30 and perhaps 20 meters. For higher frequencies, especially with long line lengths for the feeder, the efficiency of the system is so low that its value becomes questionable.

A TREE-MOUNTED HF GROUND-PLANE ANTENNA

A tree-mounted, vertically polarized antenna may sound silly. But is it really? Perhaps engineering references do not recommend it, but such an antenna does not cost much, is inconspicuous, and it works. This idea was described by Chuck Hutchinson, K8CH, in *QST* for September 1984.

The antenna itself is simple, as shown in Fig 4. A piece of RG-58 cable runs to the feed point of the antenna, and is attached to a porcelain insulator. Two radial wires are soldered to the coax-line braid at this point. Another piece of wire forms the radiator. The top of the radiator section is suspended from a tree limb or other convenient support, and in turn supports the rest of the antenna.

The dimensions for the antenna are given in Fig 5. All three wires of the antenna are $\frac{1}{4}$ wavelength long. This generally limits the usefulness of the antenna for portable operation to 7 MHz and higher bands, as temporary supports higher than 35 or 40 feet are difficult to come by. Satisfactory operation might be had on 3.5 MHz with an inverted-L configuration of the radiator, if you can overcome the accompanying difficulty of erecting the antenna at the operating site.

The tree-mounted vertical idea can also be used for fixed station installations to make an invisible antenna.



Fig 4—The feed point of the tree-mounted ground-plane antenna. The opposite ends of the two radial wires may be connected to stakes or other convenient points.

Shallow trenches can be slit for burying the coax feeder and the radial wires. The radiator itself is difficult to see unless you are standing right next to the tree.

A PORTABLE DIPOLE FOR 80 TO 2 METERS

This dipole antenna, described by Robert Johns, W3JIP, in August 1998 *QST*, can be used for any band from 80 through 2 meters. One half of the dipole is an inductively loaded aluminum tube. Its length is adjustable from 4 to 11 feet, depending on how much room is available. The other half is flexible insulated wire that can be spooled out as necessary. The tube is supported by a flagpole bracket attached to a long carpenter's clamp. The clamp mounts the antenna to practically anything: a windowsill, railing, a chair or post. If there is no structure to mount the antenna (a parking lot or the beach), the clamp attaches to two light wooden legs to form a tripod, as shown in Fig 6.

The key to mounting flexibility is the large clamp. The key to electrical flexibility is a large adjustable coil that lets you resonate the tube on many bands. The coil is wound with #8 aluminum ground wire from RadioShack. The form is a four-inch (4 $\frac{1}{2}$ -inch OD) styrene drain coupling from the Home Depot or a large plumbing supply store. A movable tap adjusts the inductance to tune the upright tube to the desired band. The wire half of the antenna is always a bit less than $\lambda/4$ on each band. Hang it from any convenient support or drape it over bushes to keep it off the ground.

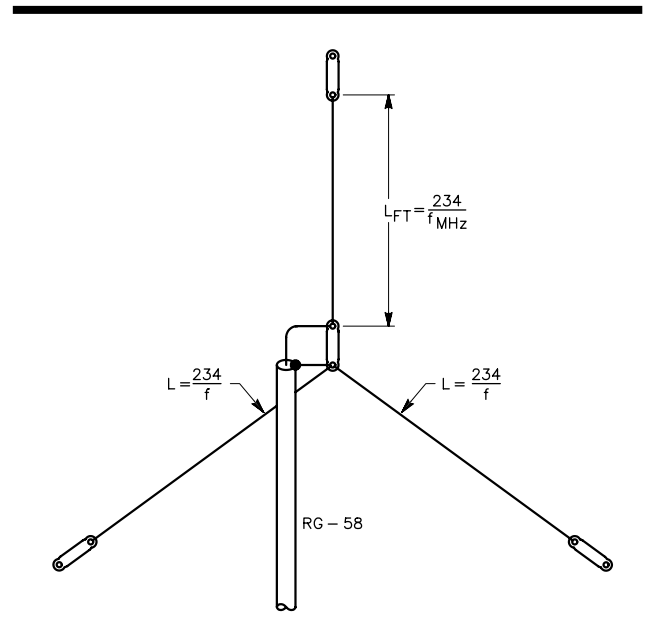

Fig 5—Dimensions and construction of the tree-mounted ground-plane antenna.



Fig 6—At top, the portable antenna in some of the many places it may be mounted around the house, porch and yard. At bottom, the simple ground-mounted legs that make a tripod.

Construction

The 18-inch carpenter's clamp (sometimes called a *bar clamp*, such as Jorgensen's No. 3718) and flagpole bracket that takes a $\frac{3}{4}$ -inch pole are common hardware items. Insulate the bracket from the clamp jaw with a $1\frac{1}{2}$ -inch length of 1-inch PVC pipe (see **Fig 7**). Hammer the PVC over the end clamp jaw to make it take the shape of the jaw. Secure the flagpole bracket to PVC with a large ground clamp (for $\frac{1}{2}$ or 1-inch conduit). The ground clamp includes $\frac{1}{4}$ -inch bolts; enlarge the flagpole bracket holes to accept them. Some flagpole brackets have an integral cleat; the author hammered the cleat ears flat on his.

Mount an SO-239 chassis connector on the flagpole bracket using RadioShack insulated standoffs (276-1381). The standoffs tightly press the center pin of the SO-239 against the bracket surface; no other connection is needed. Other mounting hardware may require a connection from the coax center conductor to the bracket. The spooled wire's inner end wraps around a standoff and connects to a ring terminal under a screw holding the SO-239 flange to the standoff.

The 1×2 -inch wooden legs for the tripod are each 30 inches long. Bolt them together at one end with a 1 or $1\frac{1}{4}$ -inch-long bolt. Countersink the bolt head and nut below the surface of the wood so they don't interfere with the clamp jaws.

Aluminum Element

You can make this element from three lengths of telescoping aluminum tubing ($\frac{3}{4}$, $\frac{5}{8}$ and $\frac{1}{2}$ inch, 0.058-inch walls). The author used tubing with thinner walls for less weight and easier handling. A 45-inch-long, $\frac{3}{4}$ -inch tube fits the flagpole bracket. He chose this length because it and the flagpole bracket make $\lambda/4$ on 6 meters. The two outer tubes are both $\frac{5}{8}$ inch, made by cutting a seven-foot aluminum clothesline pole in halves. They are

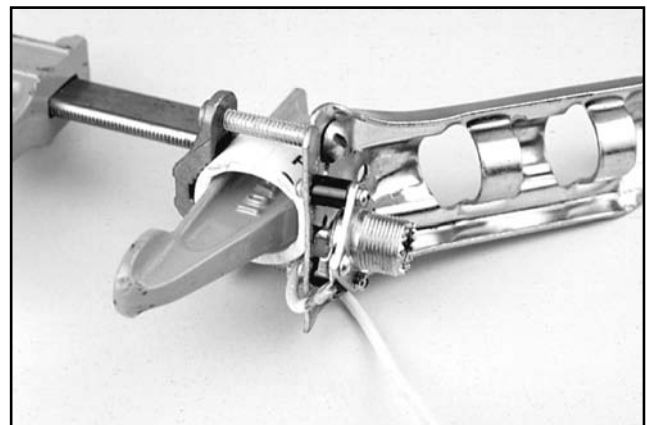

Fig 7—The flagpole bracket that supports the tubing elements is clamped to the long carpenter's clamp, but insulated from it by a small section of 1-inch PVC pipe. A coax connector is mounted to the bracket and the spool of wire is attached to the coax connector.

joined together with a copper coupling ($\frac{5}{8}$ -inch ID) for $\frac{1}{2}$ -inch copper pipe. The coupling is bolted to one of the $\frac{5}{8}$ -inch sections, and a slot is cut in the free half of the coupling. The remaining $\frac{5}{8}$ -inch tube is inserted there and secured with a hose clamp. See **Fig 8**.

One $\frac{5}{8}$ -inch tube slides into the $\frac{3}{4}$ -inch tube to provide a continuously variable element length from about 4 to $7\frac{1}{2}$ feet. This extends from $7\frac{1}{2}$ to 11 feet when the two $\frac{5}{8}$ -inch sections are joined together.

Loading Coil

The loading coil has 12 turns of bare aluminum wire spaced to fill the $3\frac{1}{2}$ -inch length of the drain coupling. Drill $\frac{9}{64}$ -inch holes at the ends of the coil form to accept the ends of the coil wire. (See **Fig 9**.) To wind the coil, feed four inches of wire through the form, make a sharp bend in the wire and start winding away from the nearby mounting hole. Wind 12 turns on the form, spacing them only approximately. Cut the wire for a 4-inch lead and feed it through the other hole in the form. Tighten the wire as best you can and bend it into another acute angle where it passes into the form. Space the turns about equally, but don't fuss with them. Final spacing will be set after the wire is tightened.

Tighten the coil wire by putting a screwdriver or a needle-nose pliers jaw under one turn, and pry the wire up and away from the surface of the coil form. While this can be done anywhere, it's best to put these kinks on the backside, away from the mounting shaft. Put kinks in every other turn, removing any slack from the coil and holding the turns in place. Should the coil ever loosen, simply retighten it with a screwdriver. If you prefer, glue the coil turns in place with epoxy or coil dope. Use a thin bead of glue that won't interfere with the clip that connects to the coil.

The coil form mounts on a nine-inch-long $\frac{3}{4}$ -inch PVC pipe. (See Fig 9 and **Fig 10**.) The inside diameter is slightly larger than the $\frac{3}{4}$ -inch aluminum, but slotting the PVC and tightening it with a hose clamp secures the tube. (Use a wide saw to cut these slots, not a hacksaw.) The coil form mounts to the PVC pipe with #6-32 $\times 1\frac{1}{2}$ -inch bolts. A five-inch long, $\frac{3}{4}$ -inch aluminum tube permanently attaches to one end of the coil assembly and slides into the

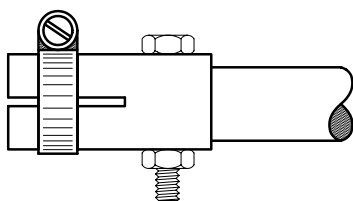

Fig 8—The joint between two sections of $\frac{5}{8}$ -inch tubing is made from a $\frac{1}{2}$ -inch copper pipe coupling, bolted to one section and hose clamped to the other.

flagpole bracket. One end of the coil wire connects to this short tube. Flatten the wire end by hammering it on something hard, then drill a $\frac{9}{64}$ -inch hole in the flattened end and attach it to the short tube with a #6-32 $\times 1$ -inch bolt. Tighten the bolt until the $\frac{1}{2}$ -inch tube starts to flatten. This will keep pressure on the aluminum-to-aluminum joint.

The aluminum element slides into the opposite end of the coil assembly. The hose clamp there can be tightened until the element just slides in snugly.

A 12-inch clip lead connects the aluminum element to the coil. Bolt the plain wire end to the $\frac{3}{4}$ -inch tube three inches from its end. Many alligator clips will fit in the space between the turns of the coil (about $\frac{3}{16}$ inch), but W3JIP preferred using a solid-copper clip (Mueller TC-1). Cut off most of the jaws, so that only the part close to the hinge grabs the coil. This shorter lever grips very tightly.

Wire and Spool

The lower half of the antenna is insulated wire that is about $\lambda/4$ on the band of operation. The wire is pulled from the spool, and the remaining wire forms an inductance that doesn't add much to the antenna length. The Home Depot sells #12 and #14 insulated stranded copper wire in 50 and 100-foot lengths, on plastic spools. (See **Fig 11**.) A $\frac{1}{2}$ -inch dowel fits into the spool to make a

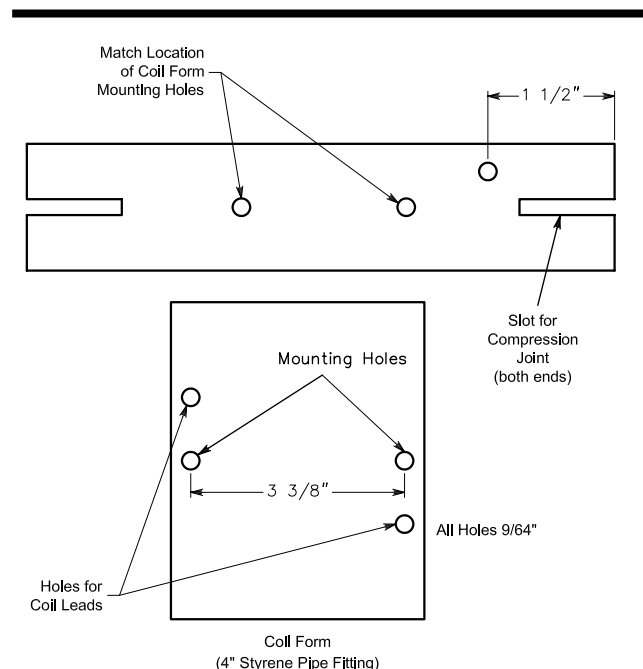

Fig 9—Holes to be drilled in the styrene coupling and the $\frac{3}{4}$ -inch PVC pipe. All holes are $\frac{9}{64}$ -inch diameter, to provide clearance for #6-32 bolts. The hole $1\frac{1}{2}$ inches from one end holds a bolt that serves as a stop, so that the antenna tube does not slide in too far. Space the holes for coil leads far enough from the mounting holes to clear the $\frac{3}{4}$ -inch pipe.

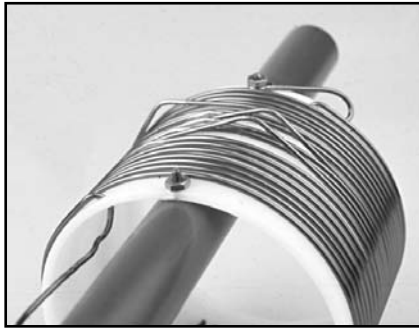
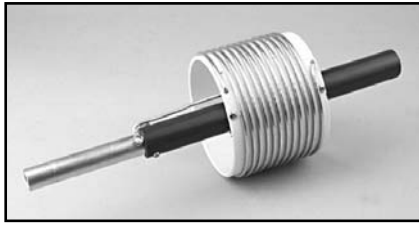

Fig 10—Top photo shows the loading coil for the 20, 30, and 40-meter band coverage. The short aluminum tube on the coil slides into the flagpole bracket, and the tubing element slides into the other end of the PVC pipe. The wire and clip connect the element to the coil. Bottom photo shows the coil for operating the antenna on 80 meters. This is placed in the flagpole bracket and the 40-meter aluminum coil plus the tubing element is inserted into it.

handle and spool axle. Bolts through the dowel on either side of the spool hold it in place. A crank handle is made by putting a one-inch-long bolt through the spool flange.

The author calibrates the wire on the spool with markers and electrical-tape flags. There's a mark (from a permanent marking pen) at each foot, a black flag every five feet and a length-marked colored flag every 10 feet. Simply mark the length for each band, if you like.

Make sure you prevent the wire from unspooling, especially when it's hanging from a window mounting. A heavy rubber band works, but it doesn't last long. A better solution is a loop of light bungee cord, preferably with a knot for grip. The bungee loop runs from the axle/handle around the spool making a half twist on the way, and then passes over the axle end on the other side of the spool. (See Fig 11.)

Operation

Table 2 lists element length, wire length and coil tap point for various bands. When the number of turns shown is zero, the coil is not needed. On all bands except 6 meters, you can simply bypass the coil with the clip lead—the extra length just lowers the frequency a bit. For 6 meters, the coil *must* be removed. The location of the unspooled wire greatly affects the settings, so these numbers are only starting points. The lengths in the table were taken with the wire one to three feet above ground, draped

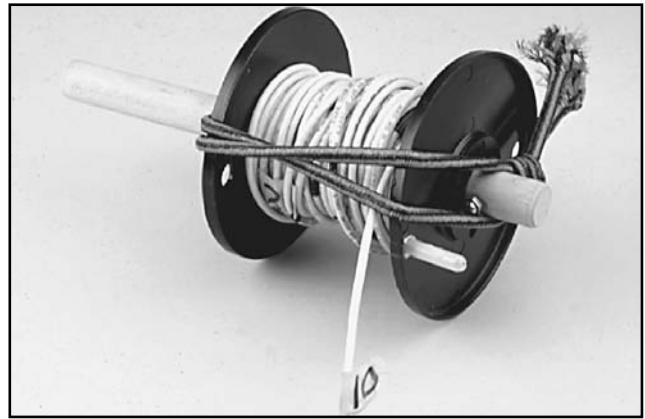

Fig 11—The wire spool has a wooden axle/handle and small handle for winding the wire. A bungee cord stretched over the spool and around the axle prevents the wire from unwinding.

Table 2

	<i>Tubing Length (feet)</i>	<i>Coil Turns</i>	<i>Wire Length (feet)</i>
6 meters	4	0	4
10 meters	7	0	8
	4	1.7	7
12 meters	8	0	8.3
	4	1.8	9
15 meters	10	0	10.3
	8	1.8	10
	4	3.5	10
17 meters	11	0	13
	8	2.2	13
	4	4.2	13
20 meters	11	1	16
	8	4	16
	4	6.2	16
30 meters	11	4	24
	8	7	24
	4	10.5	24
40 meters	11	9	32
	8	12	32

over and through bushes and flowerbeds. The antenna will still work if the wire is lying on the ground, but it will require less unspooled wire to resonate. A balun is not needed, and an SWR analyzer is very helpful while adjusting this antenna.

The SWR is less than 1.5:1 on all bands, and it's usually below 1.2:1. Occasionally, a band shows a higher SWR (still less than 2:1), but that can always be lowered by adjusting the length or location of the lower wire. Never set up the antenna where it could fall and injure someone, or where the unwary could get an RF burn by touching it.

The author's results with this antenna have been excellent, both from home and on vacation. If you haven't

yet operated from a seashore location, be prepared for a pleasant surprise! The good ground afforded by the salt water really makes a difference.

80 Meters

It's easy to add this lower frequency band. Fig 10 shows a 35 μ H coil for 80 meters. It's constructed and tightened just like the 40-meter coil, but has 20 turns of #12 magnet wire.

To operate on 75/80 meters, insert the new coil into the flagpole bracket and plug the 40-meter coil into it. Tune across the band with the movable tap on the 40-meter coil. This varies antenna resonance from below 3.5 to above 4.0 MHz, with the full 11 feet of tubing extended. If your version doesn't achieve this tuning range, adjust the spacing of the turns on the 80-meter coil.

The 80-meter coil has a five-inch length of $3/4$ -inch aluminum tube inserted into one end of the $1/2$ -inch PVC pipe that supports the coil form. One end of the coil is connected to this aluminum tube. The other end is secured under the bolt that holds the coil form to the PVC pipe. A second clip lead connects the base of the 40-meter coil to the outer end of the larger coil. The length of wire on the spool must also be increased to about 64 feet.

2 Meters

A $\lambda/2$ dipole for 2 meters can be made with about 15 inches of $1/2$ -inch aluminum tubing in the flagpole bracket, and 18 inches of wire. The tubing element is shorter than normal for 2 meters because the bracket is also part of the antenna. You can also shorten the 6-meter wire a bit and operate the 6-meter antenna as a $3\lambda/2$ on 2 meters, with a somewhat higher SWR.

Continuous Coverage

With easily changed element lengths and a continuously variable loading coil, you may operate the antenna on any frequency from 6.5 to 60 MHz, if coverage for other services is needed. With taps in the 80-meter coil at 8, 11 and 14 turns, the antenna will also tune from 4 to 7 MHz.

THE HF CABOVER ANTENNA

If you have ever had the pleasure of traveling across the country with an HF mobile in a camper, trailer or motor home you may want to duplicate this antenna for use when you park. This antenna was described in *The ARRL Antenna Compendium, Vol 5*, by Jim Ford, N6JF.

The author's camper has limited spots on which to mount an HF mobile antenna. The back ladder is a convenient place to mount a small mobile whip. However, the efficiency of typical mobile center-loaded antennas, depending on coil Q and other assumptions, is often less than 2% for 80 meters and 10% for 40 meters. (These numbers come from the excellent, easy-to-use *MOBILE* antenna design program by Leon Braskamp, AA6GL, which is on the CD-ROM bundled with this book.)

At some locations, N6JF used an 80-meter dipole, which was very efficient and worked great on all bands when fed with open-wire line and an antenna tuner. However, it took over 40 minutes to set up and about 20 minutes to tear down, working with a sling shot and many tree snags. This is too much time to make a schedule or for an early morning departure, although it's OK if you plan to stay for a while. Even more important, there were often too many trees or other barriers (perhaps some even social) to allow putting up the dipole at a campsite.

When this happened he was stuck with the mobile antenna with poor efficiency. There had to be a better antenna for camper operation. The author decided on a large vertical.

A telescoping aluminum extension pole used for roller painting would make a good bottom section for the loaded vertical. These are available at many local home supply centers. The author's was 1 inch in diameter and 6 feet long, telescoping to almost 12 feet. He disassembled both sections and cross-cut a 1-inch slot in the top of the bottom section with a hacksaw to allow compression clamping with a hose clamp. The tip of the top section was fitted with an aluminum plug that had a $3/8$ -24 hole tapped in it. This procedure was a simple machine-shop operation. The plug was pounded into the top section and is quite snug. He tapped some set screws through the pole into the plug, however, just to be sure. An insulated, lay-down marine antenna mount fit perfectly into the bottom of the aluminum base and was secured with a bolt that also served as the electrical connection from the capacitor matching box. See Fig 12 showing the aluminum base plate, the laydown mount and the antenna

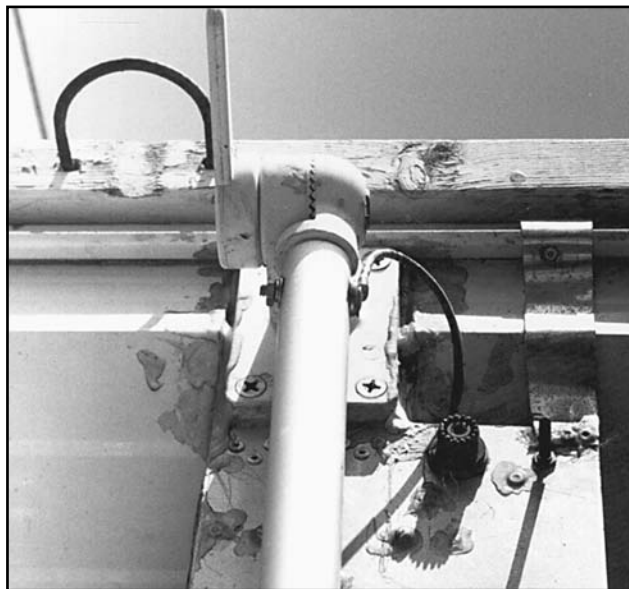

Fig 12—Photo of aluminum base plate, showing details of mounting to the camper. The four banana-plug jacks on the bottom are for extra radials, if desired.



Fig 13—Photo showing the back of the camper, with the antenna in the lowered position, parallel to the ladder. The “Outback” standby mobile antenna is shown clamped to the left side of the ladder.

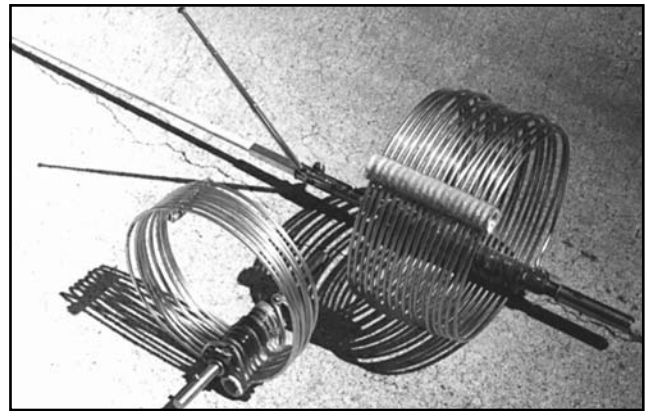

Fig 15—Close-up photo of 80 and 40-meter coils, with top section and telescoping whip antenna with swivel bracket for tuning the top section for the higher bands. Note quick-disconnect connectors at top and bottom of both coils. The top whip is a Fiberglass CB whip, used on 80 and 40 meters.

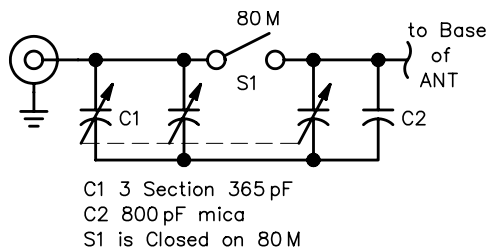

Fig 14—Schematic of tuning capacitor at base plate. C2 is an 800 pF transmitting mica capacitor. C1 is a three-section 365 pF broadcast tuning capacitor. S1 is closed for 80-meter operation.

mast itself lowered down the back of the camper. **Fig 13** shows the layout of the back of the camper, with the antenna on the right-hand side, laid down for travel.

The variable capacitor in the matching box is a surplus three-section 365-pF broadcast tuning capacitor. Two of three sections are connected in parallel and a switch parallels in the third section, along with an extra 800 pF mica capacitor for use on 80 meters. See the schematic in **Fig 14**.

The capacitor assembly was put in a custom-glued Plexiglas box to keep out the weather and mounted to a piece of plate aluminum, along with an SO-239 connector. The aluminum plate was riveted to the camper shell using a lot of aluminum rivets. Do not use steel. N6JF peeled back about a 4-inch wide section of the side of the camper for this direct aluminum-to-aluminum connection. People who are hesitant to modify their campers like this need to find an alternate low-resistance connection method. His camper was old enough not to be an issue.

For an extra low-resistance connection a 1½-inch aluminum strip was added from the top of the base plate to the camper, as shown in **Fig 12** near the 80-meter

switch. The tuning knob protrudes from the side of the Plexiglas box. The four bottom holes in the plate are for banana plugs to connect ground radials if extra efficiency is desired. However, the roof of a camper is one of the better places for a mobile antenna, so the author seldom hooks up the radials. When he does use them, the tuning changes only a little.

To keep losses down, N6JF used coils wound with aluminum clothes-line wire on old mobile coil center sections with quick disconnect fittings. See **Fig 15**, which shows both the 80 and 40 meter coils, together with the top portion of the antenna. An article by Robert Johns, W3JIP, in October 1992 *QST* described techniques for building your own loading coils. The coils ended with a little more inductance than calculated and the author had to remove some turns. Both coils are spaced at 4 turns per inch. The 8-inch long 80-meter coil has 18 turns. The 7-inch long 40-meter coil has 8 turns.

The matching network is actually an L-section step-up match, using the net inductive reactance of the antenna plus the center loading coil. The PVC coil construction technique was described in W3JIP’s *QST* article and a follow-up Technical Correspondence piece in October 1992 *QST*. Basically, it consists of drilling an accurate row of slightly undersized holes along a length of ½-inch PVC pipe and then carefully sawing down the center of the row of holes with a hack saw. Then, you trap the coil wires in the grooves between the two sawed halves and tie the two halves together with string. When you are satisfied that everything is proper, you then tighten the string and apply epoxy glue to make it strong and permanent.

One advantage of aluminum clothes line wire is that it is already coiled at the approximate diameter needed when you buy it and it is easy to position on the coil form.

The clothes line wire had a plastic coating, which wasn't removed except at the contact points. Once the epoxy dries, this method of construction does a good job of holding the finished coil together and it is lightweight.

The computed coil Q from the *MOBILE* antenna program is about 800 for the 80-meter coil and about 400 for the 40-meter coil. The author accidentally made the 40-meter coil 7 inches in diameter instead of a higher-Q 6 inch diameter. Even so, the whole antenna system with a 9-foot top section calculates as being 56% efficient on 80 meters and 85% for 40 meters.

The removable top section for 80 and 40 meters is a full-size fiberglass CB whip from RadioShack. The fiberglass whip has about a #16 hole in the center of it. Be sure to sand and paint the whip for protection against UV and to protect yourself against fiberglass spurs in the hands. N6JF tried a full-size stainless steel CB whip to get a slightly higher capacitance to ground because of larger conductor size but discovered it was far too heavy. That experience reinforced his decision that aluminum was a far more practical coil and base section material for this project.

Quick-disconnect connectors found years ago at a hamfest were used for both coil forms and for the top section. Bands higher than 40 meters don't need any loading coils and the antenna length can be telescoped to get a $\frac{1}{4}$ wavelength. Ten meters doesn't require any top section. Be sure to use some NOALOX or similar compound to prevent corrosion and poor connections at all aluminum joints. This is especially true for the telescoping sections and the aluminum rivets. The matching capacitor is in the circuit at all times but when the 80-meter switch is off you can set the capacitor at minimum (about 14 pF) and it is effectively out of the circuit, even at 10 meters. The author has not tried this antenna on power levels greater than about 100 W but the weakest link would probably be the matching capacitor. The voltage at the matching capacitor is low, so 200 W should be no problem.

You can achieve a 1:1 SWR match for 80 or 40 meters and a good SWR is obtained without retuning the base matching capacitor for approximately 100 kHz on 80 meters and most of 40 meters. The top section, however, does not have such low Q and needs to be tuned. The 2:1 SWR bandwidth on 80 meters is about 25 kHz and 150 kHz for 40 meters. Tuning is accomplished by using a telescoping FM portable radio antenna connected to the top-section whip with a stainless steel hose clamp. The maximum length of the telescoping section used was 29 inches, and it collapses down to 7 inches. A whip with an elbow was used to adjust the angle of the whip as well. A telescoping whip half the length would still be long enough for the full adjustment of both bands.

Adjustment of the top section is one of the penalties paid to achieve high efficiency for operation on 80 and 40 meters. Substituting an automatic antenna tuner would likely lose efficiency, particularly on 80 meters since the

base resistance calculates to about 10Ω . N6JF has not tried to make the antenna work on 160 meters. The SWR for the higher bands was good enough without any matching network.

As light as the antenna is, it still won't hold up in a moderate wind without some support guys. N6JF used $\frac{3}{4}$ -inch and $\frac{1}{2}$ -inch PVC support pipes in a telescoping arrangement for storage, but expanding to give an approximate 45° support at the top of the bottom section from both directions. One end of the telescoping section was connected to the camper roof with a hinge. The other end formed a snap-fit out of a PVC barrel that was cut lengthwise. See **Fig 16** and **Fig 17** for details. Even though it formed a good snap fit, N6JF didn't trust the joint for strong winds so he glued a piece of Velcro to the joint to close up the open end. Be careful, though, because Velcro deteriorates with exposure.

Another hose clamp near the top of the bottom section holds an $\frac{1}{8}$ -inch line taken up the ladder to pull up the antenna without the need of an assistant. The disadvantage is you have to climb the roof. Use a non-slip floor mat or something similar to spread the load on the roof and to avoid slipping. Once on the roof, however, the coil is at a height for easy adjustment when the telescoping section is in the down position.

An advantage of being able to assemble the whole antenna on the roof is that you don't need a lot of swing-up room and you can clear trees easily. You can put calibration marks on the upper aluminum section for resonant lengths on the higher bands but just raise the top section up all the way for 80 or 40 meters. Mark also the small

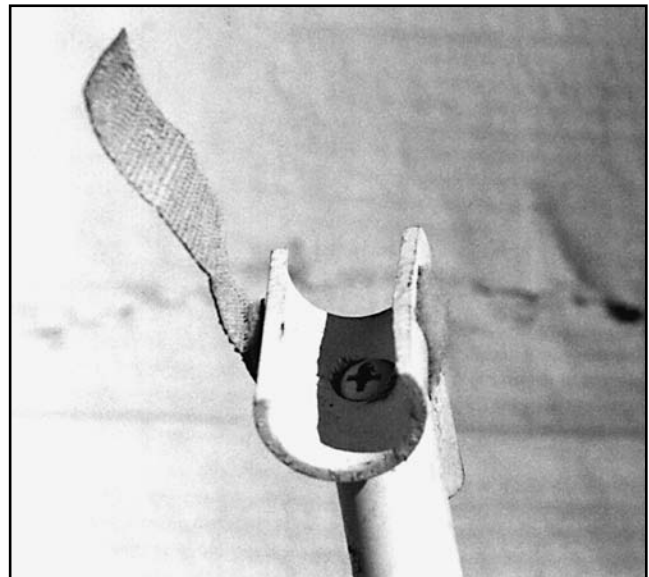

Fig 16—Close-up of one of the snap-on support brackets used to brace the antenna. Note the Velcro pieces used to ensure that the antenna doesn't pop out of the bracket in the wind.

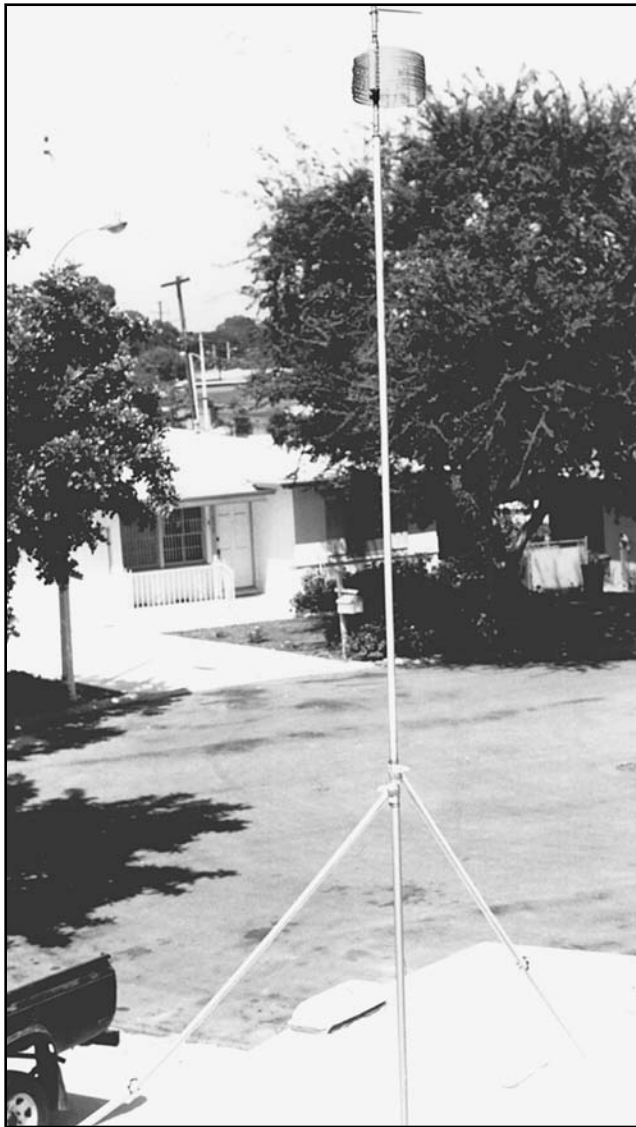

Fig 17—Photo showing the two support bracket poles bracing the bottom section of the antenna. The top tuning whip is evident above the homemade loading coil at the top of the bottom section.

coil tuning whip for 80 or 40 meters, although different locations may require slightly different settings due to detuning from nearby metal objects.

The overall length is about 21 feet. The top of the author's camper is about 10 feet high when on the truck, putting the tip at 31 feet. This antenna is definitely designed for use when you are parked at a fixed location. N6JF can put up this antenna in less than 5 minutes and can take it down in half the time. The success of this project has as much to do with knowing how and where you operate as it does paying attention to mechanical and electrical details. The antenna has been a good compromise between efficiency and convenience.

TWO PORTABLE 6-METER ANTENNAS

These antennas were described by Markus Hansen, VE7CA, in *The ARRL Antenna Compendium, Vol 5*. After years of HF operation, he became enthusiastic about VHF/UHF operation when he found a used Yaesu FT-726R VHF/UHF all-mode transceiver at a reasonable price.

But he became really enthused when he got on 6 meters and discovered the joys of driving to high mountain peaks to operate. Not only does an antenna have to be portable for this kind of operation, it must be easily assembled and disassembled, just in case you have to move quickly to a better location.

A Portable Two-Element Six-Meter Quad

VE7CA's primary objective was to construct a two-element quad using material found in any small town. It should not use a complicated matching network. The Gamma matches commonly used on quads do not hold up well when you are setting up and taking down these antennas in the field. The final design adjusted the distance between the driven and the reflector elements so that the intrinsic feed-point impedance was 50 Ω .

Fig 18 shows the dimensions for the boom and the boom-to-mast bracket. The boom is made from a 27 $\frac{1}{4}$ -inch length of 2 \times 2. (The actual dimension of 2 \times 2 is closer to 1 $\frac{3}{4}$ by 1 $\frac{3}{4}$ inches but it is commonly known in lumber yards as a 2 \times 2.) Use whatever material is available in your area, but lightweight wood is preferred, so clear cedar or pine is ideal. Drill the four $\frac{1}{2}$ -inch holes for the spreaders with a wood bit, two at each end, through one of the faces of the 2 \times 2 and the other through the other face. The boom-to-mast bracket is made from $\frac{1}{4}$ -inch fir plywood.

The spreaders are $\frac{1}{2}$ -inch dowel. The local lumberyard had a good supply of fir dowels but other species of wood are available. The exact material is not important. Maple is stronger but expensive. Fiberglass would be ideal but it is not always available locally. Cut two of the $\frac{1}{2}$ -inch dowels to a length of 83 $\frac{5}{8}$ inches for the driven element spreaders and two to 88 inches for the reflector spreaders. **Fig 19** shows one end of the boom with the two spreaders inserted. The mast was made from two six-foot lengths of 1 $\frac{3}{4}$ -inch fir dowel. Again, use whatever you may have available. Waterproof all wooden parts with at least two coats of exterior varnish.

While you are at the lumberyard or hardware store look for plastic pipe that fits over the end of the $\frac{1}{2}$ -inch spreaders. You will need a one-foot length, with some to spare. Cut it into seven equal lengths, approximately one inch long, and one to a length of 1 $\frac{1}{2}$ inches. Drill a $\frac{1}{16}$ -inch hole through the seven equal lengths $\frac{1}{4}$ inch from the ends, and two holes one above the other $\frac{1}{4}$ -inch apart on the 1 $\frac{1}{2}$ -inch sleeve. VE7CA used #14 hard-drawn stranded bare copper wire for the elements. Do not use insulated wire unless you are willing to experimentally

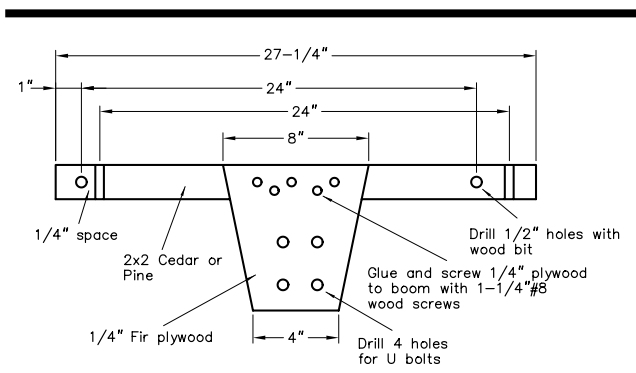

Fig 18—Dimensions for the boom-to-mast bracket for VE7CA's portable two-element 6-meter quad.

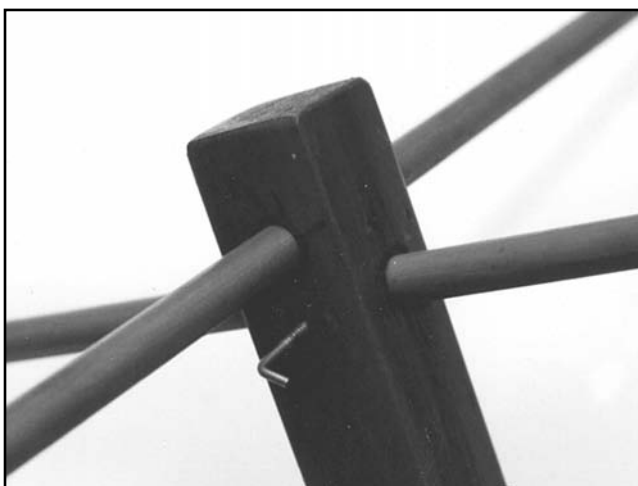

Fig 19—Photo of one end of the VE7CA quad with the two spreaders inserted.

determine the element lengths, since the insulation detunes each element slightly.

Cut the reflector element 251 inches long and slip one end of the wire through the holes you drilled in four of the plastic sleeves. Don't attempt to secure the wire to the plastic sleeves at this point. Cross the end of the reflector elements one inch from their respective ends and twist and solder together. The total circumference of the reflector element should be 249 inches when the ends are connected together.

Cut the driven element wire to 241 inches and slip three of the 1-inch sleeves onto the wire. Again, don't secure the wires to the sleeves yet. Then the ends are passed through the two holes in the 1½-inch pipe. Wrap the ends around the pipe and twist them back onto themselves to secure the wire. The coax feed line is attached directly to the two ends at this point. The circumference of the driven-element loop from the points where the coax is attached should be 236⁵/₈ inches. Solder the coax feed

line to the driven element and waterproof the coax with silicone seal. The author used RG-58, as it is lightweight. The length required for a portable installation is typically not very long, maybe 20 feet, so the loss in the small cable is not excessive. Near the feed point, coil the coax into six turns with an inside diameter of two inches. This is an effective method of choking any RF from flowing on the outside of the coax shield.

Begin assembling the quad by pushing the two reflector spreaders, without wires attached, through one end of the boom and the two shorter driven-element spreaders through the holes in the other end of the boom. Center the spreaders and mark the spreaders with a black felt-tip pen next to the boom. Now insert a 1½ #8 wood screw or a threaded L-hook into the boom so that it just touches one of the spreaders. Take the screw or L-hook out and file the end flat, then reinsert it so that it is just snug against the spreaders. The author only used two L-hooks for the two vertical spreaders; the horizontal spreaders are held in the proper position by the tension of the wire loops. If you use an L-hook, you can unscrew it with your hands—you won't have to worry about leaving the screwdriver at home.

You are now ready to assemble the wire loops. Take the reflector loop and place the four plastic caps over the ends of the reflector spreaders. Equalize the wire lengths between the spreader so that the loop is square. Now, secure the plastic sleeve pipes by tightly wrapping wire around the sleeve and the wire element and soldering the wire in place. See **Fig 20**, a photo showing one of the plastic sleeves slipped over one of the spreader ends, with the wire element through the hole and fastened in place. Follow the same procedure with the driven element.

Fig 21 shows the quad's boom, with the plywood boom-to-mast bracket fastened with wood screws and glue. Two U-bolts are used to attach to the mast. When the quad is raised, the shape of the loop is commonly known as a diamond configuration. The mast consists of two six-foot lengths of doweling joined together with a two-foot length of PVC plastic pipe, held together with wood screws.

Make a slot the width of a #8 wood screw about one inch deep from the top of the plastic PVC pipe and then put the top mast into the plastic pipe. Insert a one inch #8 wood screw into the bottom of the slot you cut into the top of the pipe and tighten only enough so that the top mast can be removed without unscrewing it. VE7CA drove a nail into the end of the lower mast and left it exposed an inch or more. This end is placed in the ground and the nail holds the pole in place. A strip of wood approximately 1 × 3 and long enough to cross over the roof rack of the family van is used to hold the center of the antenna mast to the roof rack of the van with small diameter rope. See **Fig 22** for a photo of the quad in action next to the family van.

To disassemble the quad, lay it on its side, slip the plastic sleeves off the ends of the spreaders and roll up

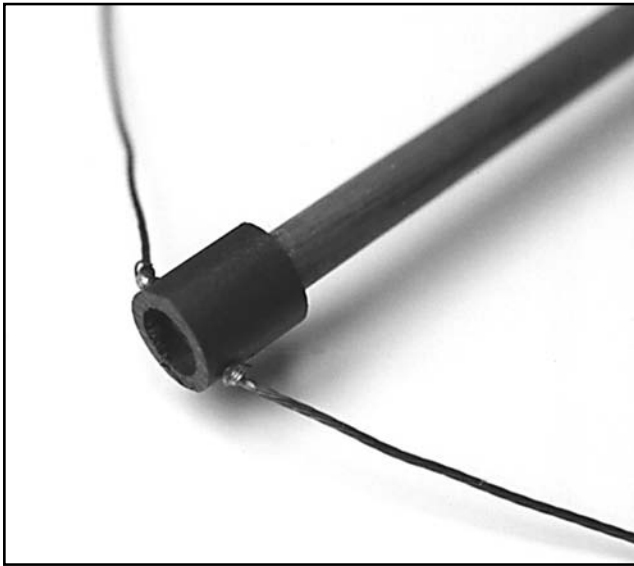

Fig 20—Photo showing one of the plastic sleeves slipped over end of a spreader to provide a mechanical mounting point and support for the wires.



Fig 21—Photo of the two-element quad's boom, with the plywood boom-to-mast bracket secured with wood screws and glue.

the wire loops. Loosen the L-hooks holding the vertical spreaders in place. Push the spreaders out of the boom, loosen the U-bolts and free the mast from the boom.

That is all there is to it. It takes about two minutes to put it up, or take it down. It is quite sturdy and has survived several high-wind storms.

A Three-Element Portable 6-Meter Yagi

The idea to build a Yagi antenna resulted when the author traded the family van for a compact car. He needed something that would fit into the trunk of the car. At close to 7-feet long, the quad spreaders were too long. Computer modeling showed that a three-element Yagi on a five-foot boom also could pick up about 1.5 dB gain over the short-boom two-element quad. A five-foot boom fits into the trunk or across the back seat of the car, but something had to be done about the nine-foot elements!

One day VE7CA noticed a box of portable-radio telescoping antenna elements at the radio parts store. They



Fig 22—Ready for action! VE7CA has set up his quad next to the family van.

were 54 inches long when fully extended. He next found a 60-inch length of aluminum tubing that fit over the end of the telescoping elements. There are many different sizes of telescoping antenna elements, with different diameters. This is where you will have to use your scrounging skills! **Fig 23** shows how the tubing is used as a center section to join two telescoping elements together. It also serves to extend the total length of each element, since two telescoping elements themselves are not long enough to resonate on six meters. See **Table 3** for dimensions and element spacings. Each center section is slotted at both ends with a hacksaw, and stainless-steel hose clamps are used to secure the telescoping elements.

Fig 24 shows the center sections of the three elements with their mounting brackets. A square boom was used to obtain a flat surface to work with. **Fig 25** shows how the reflector is attached to the end of the boom with two 1½-inch 10-32 bolts and wingnuts. **Fig 26A** provides the dimensions and details for the reflector and director element-to-boom brackets, which are formed from ¼-inch plate aluminum. The driven element is split in the center and is insulated from the boom. **Fig 26B** shows details for the driven-element bracket. **Fig 27** is a photo

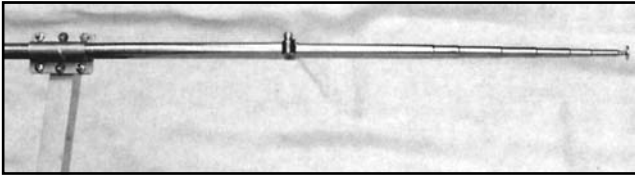

Fig 23—Photo showing a piece of aluminum tubing used as a center section to join the two telescoping tips together.

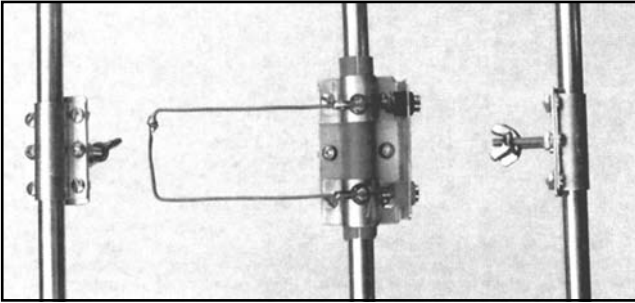

Fig 24—A view of the center sections of the three Yagi elements with their mounting brackets.

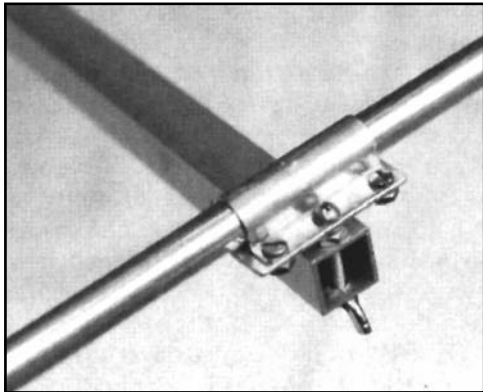

Fig 25—Photo detailing attachment of the reflector to the square-section boom, using two #10 bolts and wingnuts.

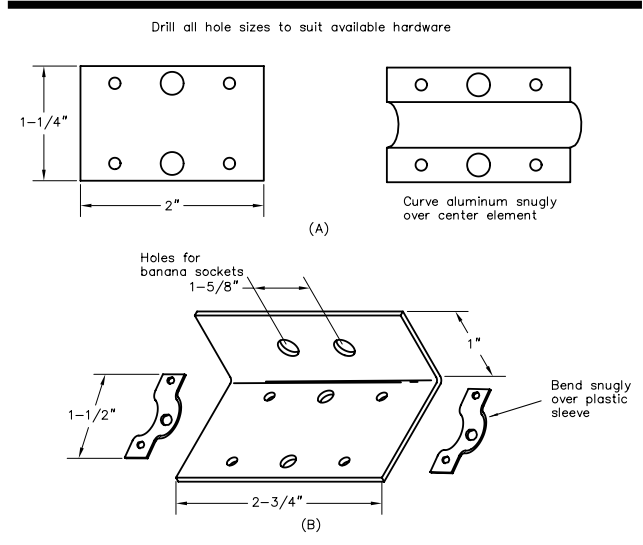

Fig 26—At A, details for the reflector and director element-to-boom brackets, made of $1/16$ -inch plate aluminum. At B, details for the driven-element bracket. These are screwed to the square boom.

of the driven element with the hairpin matching wire and the banana plugs used to connect the coax to the driven element. You could use a female PL-259 connector if you wish. VE7CA used #14 solid bare copper wire for the hairpin. It is very durable—even after being severely warped in the car trunk, it can be bent back into shape quickly and easily.

The boom is $3/4$ -inch square aluminum, 65 inches long. The material was found at a local hardware store. To detach the elements, just loosen the wing nuts and remove the elements from the boom. A similar method was used to attach the support mast to the boom.

As with the quad, a choke balun was used, consisting of a coil of 6 turns of coax with an inside diameter of 2 inches. To tune the hairpin match, assemble the Yagi on its mast and extend the elements. Spray switch contact solution on a cloth and wipe any dirt and grease from the elements. Push the elements together and apart a

Table 3
Three-Element Yagi, Element Lengths and Spacing Along the Boom, and Hairpin Dimensions

Element	Spacing Along Boom Section Ele. (inches)	Center Length (inches)	Telescoping (inches)	Total Length (inches)
Reflector	0	$22\frac{3}{4}$	$51\frac{1}{2}$	$125\frac{3}{4}$
Driven	28	$9\frac{3}{4}$ *	$48\frac{5}{8}$	$58\frac{3}{16}$
Director	$63\frac{3}{8}$	$14\frac{1}{2}$	$51\frac{1}{4}$	117
Hairpin	#14 wire	4 long	$1\frac{5}{8}$ spacing	

* Driven-element uses 2 sections insulated at center

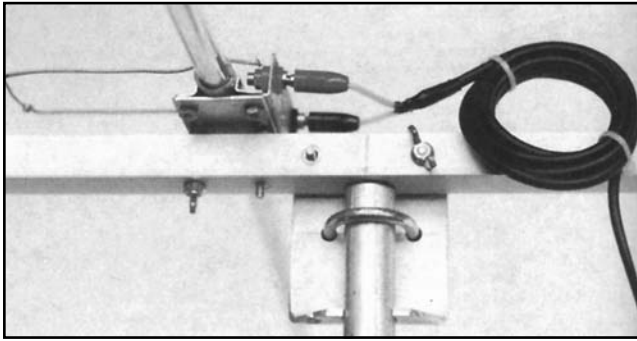

Fig 27—Photo of the driven element, complete with hairpin match and the banana plugs used to connect the coax cable to the driven element.

couple of times so that the contact solution cleans the elements thoroughly. Attach the antenna mast to your vehicle or use whatever method of support you intend to use in the field. Connect an SWR meter and a transmitter to the coax feeding the antenna. VE7CA used two alligator clips soldered together to slide along the two hairpin wires to find the position for the lowest SWR. The dimensions computed by computer were correct! The SWR was below 1.16:1 from 50.05 to 50.2 MHz.

You can take this antenna out of the trunk of the car and assemble it in less than two minutes. One caution: the telescoping elements when fully extended are quite fragile. VE7CA has not broken one as yet, but carrying a spare element just in case would be a good idea.

VE7CA 2-Element Portable HF Triband Yagis

These portable HF wire Yagis were described by Markus Hansen, VE7CA, in November 2001 *QST* and in *The ARRL Antenna Compendium, Vol 7*.

A 20/15/10-Meter Triband 2-Element Yagi

VE7CA wanted a simple 2-element wire Yagi for 20/15/10 meters that could be stored in the ski boot of his car. The basic concept comprises three individual dipole driven elements, one each for 20, 15 and for 10 meters tied to a common feed point, plus three separate reflector elements. The elements are strung between two 2.13-meter (7-foot) long, 2 × 2-inch wood spreaders, each just long enough to fit into the ski boot of his car.

By playing with the reflector-to-driven element spacing and the initial driven-element lengths, VE7CA was able to come up with a feed-point impedance on each band that allowed the use of a single setting for the shorting bar on a hairpin match. The result was a very acceptable match over the lower portions of each band. The layout of the 20/15/10-meter triband wire Yagi is shown in **Fig 28**, with the dimensions provided in **Table 4**.

The dimensions shown in Table 4 are what resulted after tuning for the lowest SWR in the middle of the lower portion of each band. VE7CA set his system up by hang-

ing one end of the antenna from a tree and sloped it downwards at 45°, tying the lower end to a peg in the ground. The height at the feed point was 30 feet.

The feed-point impedance of an antenna is affected by many environmental factors. The presence of a reflector relatively close to the driven element has a major effect, since the impedance at the driven element in a Yagi is affected by the tuning of the driven element itself, by the spacing and length of the reflector element and to a lesser extent the height of the antenna above ground and the character of the soil itself. The real challenge in a multiband Yagi with a single feed line is to obtain a low SWR on all the bands.

The hairpin match is one of the easiest matching systems to make. It is easy to adjust and since wire is the only ingredient, it can be coiled up with the rest of the antenna when the antenna is disassembled. The feed-point impedance of the Yagi with a reflector element spaced 0.1λ behind the driven element typically produces a resistance around 20 Ω . By shortening the driven element from its resonant length, capacitive reactance is added to the feed-point resistance. This can be cancelled by shunting the feed point with an inductor in the shape of a wire loop resembling a *hairpin*. This causes a step up of the 20- Ω feed-point resistance to 50 Ω .

Table 4
Dimensions for 20/15/10-Meter Tribander

Frequency MHz	Spacing DE to Refl cm (feet)	Driven Element Half Length cm (feet)	Reflector Length cm (feet)	Hairpin Length cm (inches)
14.1	213 (6.99)	488 (16.01)	1065 (34.94)	43 (14.9)
21.1	175 (5.74)	335 (10.99)	708 (23.23)	
28.25	125 (4.1)	254 (8.33)	531 (17.42)	

Spacing between hairpin wires is 10 cm (4 inches).

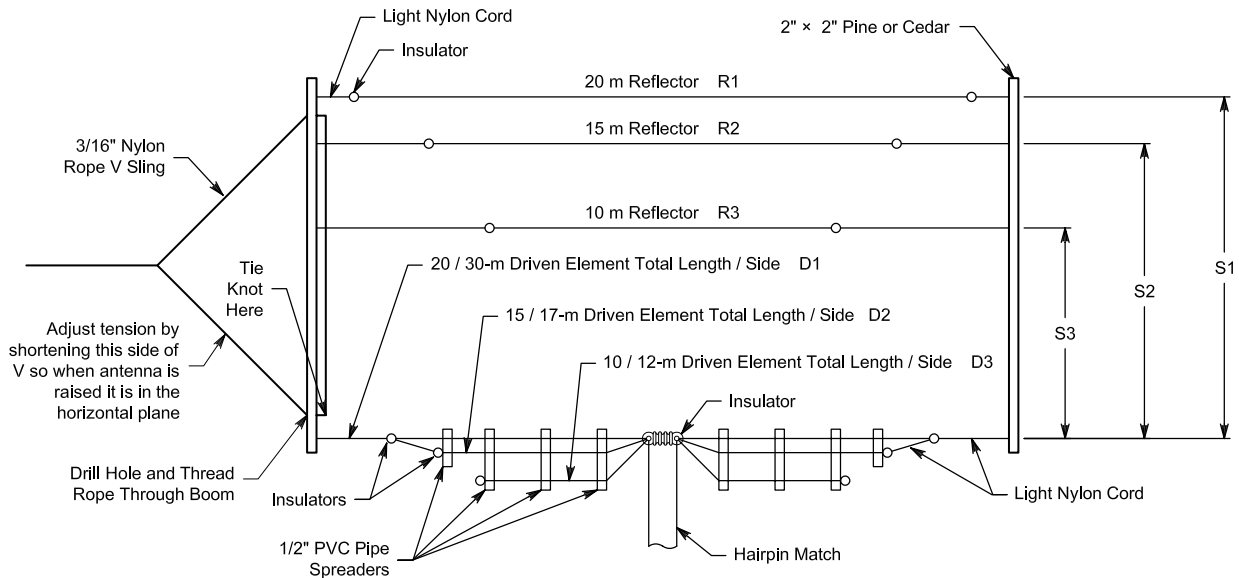

Fig 28—Dimensions for VE7CA's 2-element 20/15/10-meter triband Yagi.

The Balun

Fig 29 shows the hairpin match and the common-mode choke balun for the 10/15/20-meter triband wire Yagi. You should let the coax drop straight down from the center insulator and attach it to the center of the hairpin shorting bar. Continue by making a coil using the coax of 8 turns, with a diameter of about 4 inches. This balun will choke off RF flowing along the outside of the coax shield that would otherwise distort the radiation pattern of the antenna. The center of the shorting bar is at a neutral potential, so there is no harm in attaching the coax feed line at that point.

Flattop or Tilted?

If DX is your main interest, then you want to tilt the antenna towards the vertical to emphasize the lower elevation angles. Remember that the radiation pattern is quite dependent on ground conductivity and dielectric constant for a vertically polarized antenna. A location close to salt-water will yield the highest gain and the lowest radiation angle. With very poor soil in the near and far field, the peak radiation angle will be higher and the gain less.

VE7CA has had numerous opportunities to test this out while operating portable at his favorite location. Using two trees as supports he can pull the antenna to horizontal with the feed line about 7 meters above the ground. In this position, with 20 meters open to Europe, he found it difficult to work DX on CW with 3 W of output power. However, when he changed the slope of the antenna so that it is nearly vertical he not only heard more DX stations, but he found it relatively easy to work DX. The sloping antenna always performs much better for working DX than a low horizontal antenna.

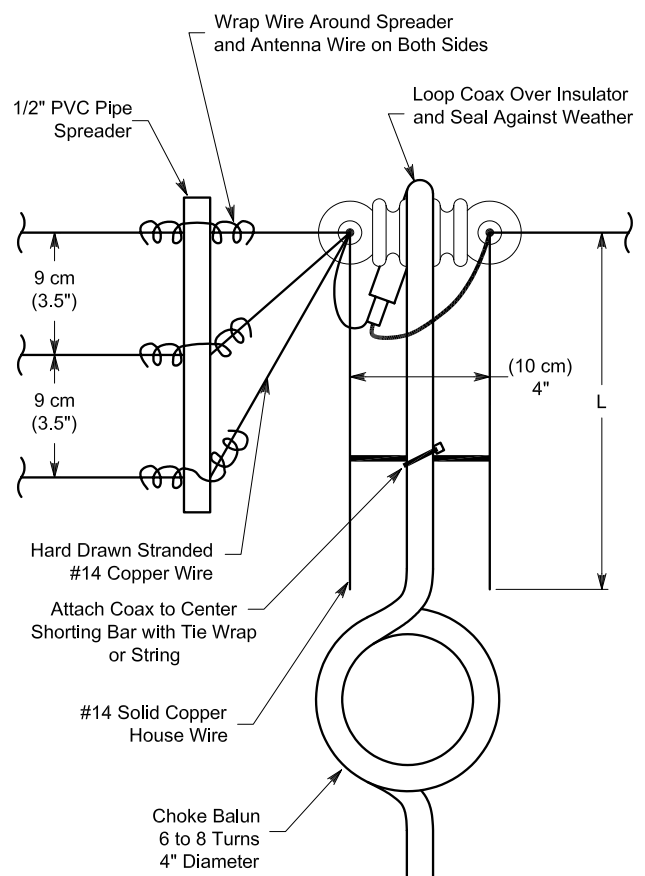

Fig 29—Details of feed point for 20/15/10-meter triband Yagi. The same mechanical support is provided for the balun and feed coax for the 30/17/12-meter tribander.

A 30/17/12-Meter Triband 2-Element Yagi

When the author attempted to add 17 and 12 meter elements to the existing 20/15/10-meter Yagi model he became exasperated. Adding two more driven elements and reflectors brings many more variables into the equation! It became clear that there was serious interaction between the elements. He could not obtain a workable feed-point impedance on all five bands that could be transformed to 50 Ω using a single hairpin match. There was also serious pattern distortion on 12 meters.

Even building a WARC-only triband Yagi for 30/17/12 meters turned out to be a real challenge. VE7CA had difficulty finding a combination that would allow him to use a single matching system to transform the feed-point impedance of the combined driven elements to 50 Ω . He couldn't create a 30/17/12 triband Yagi using the same design principles as his 20/15/10-meter version. The main problem occurred on 12 meters. Not only was the feed-point impedance unmanageable, but the radiation pattern had four lobes, not the single lobe you'd like from a Yagi.

He decided to try the *Modified Coaxial-Sleeve* method, more aptly termed by K9AY the *Coupled-Resonator (C-R)* in his article in *The ARRL Antenna Compendium, Vol 5*. The K9AY method uses a single driven element, with other elements placed in very close proximity (but not physically connected) to the driven element. By starting with the dimensions suggested by K9AY for a triband 30/17/12-meter dipole, VE7CA was able to develop a 2-element Yagi with acceptable feed-point impedances on all three bands using a single hairpin match. Notice that this WARC design uses a 2 \times 2-inch wooden boom length that is 230 cm (7.5 feet) long. Of course, the antenna can't fit into a typical ski boot anymore, so VE7CA had to put it on a roof rack for transportation.

The space between the tightly coupled driven elements is only 3.7 cm (1.5 inches), so you need to use more PVC pipe spreaders than in the 20/15/10 design to make sure the driven-element wires stay as close as possible to the desired spacing without physically touching each other. The driven elements lie in the horizontal plane

and the hairpin match and feed line hang down vertically from the center of the 30-meter driven element.

The spacing between the 30-meter driven elements and the other two conductors and the size of the wire all played a part in developing this antenna for a single feed line with the common hairpin match. Do not change the wire size from the recommended #14 for the driven elements unless you are willing to spend a considerable amount of time with a NEC-based modeling program retweaking the antenna. This is not the case with the 20/15/10 tri-band Yagi, where any convenient sized wire is acceptable.

Using #14 gauge wire allows all the Yagi antennas in this article to be used at the maximum power levels allowed in North America. The only limiting factor is the power handling capability of the feed line. However, even RG-58 should work for the relatively short length from the feed point down to ground level, where you can change to RG-8 or some other higher-power, lower-loss coaxial cable if you wish. **Fig 30** is a detailed drawing of the 30/17/12-meter driven element. The other dimensions for the 30/17/12-meter triband Yagi are shown in **Table 5**.

Assembly

When you are ready to assemble your wire Yagi, start by attaching the longest reflector element and the driven element assembly to the wood end booms. Do this with the wires and the booms on the ground. Next attach the V slings to both of the booms and with ropes attached to the V slings pull the array up off the ground between two supports (perhaps two trees). A height of 1.5 meters (5 feet) above the ground makes it easy to work on the antenna while you add the other reflector elements and adjust the V slings. Pull them tight so that the array is fairly flat. It won't stay horizontal, because the driven elements are heavier than a single reflector element. So you will need to support the 2 \times 2-inch spreaders so they are horizontal. Lean the booms on something at a convenient height, such as the rungs of two step ladders. Now add the two other reflector elements, but don't pull them as tight as the longest reflector. Next attach the feed line.

Table 5
Dimensions for 30/17/12-Meter Tribander

Frequency MHz	Spacing DE to Refl cm (feet)	Driven Element Length cm (feet)	Reflector Length cm (feet)	Hairpin Length cm (inches)
10.12	230 (7.5)	713 (23.4)	Half	1476 (48.4)
18.11	165 (5.4)	808 (26.5)		24.5 (9.5)
24.91	120 (3.9)	570 (18.7)		822 (27.0)
				606 (19.9)

Spacing between hairpin wires is 10 cm (4 inches). Note that dimensions for 17 and 12-meter driven elements are full lengths, since they are not broken with insulator in the middle, unlike all driven elements for 20/15/10-meter triband design in Table 4.

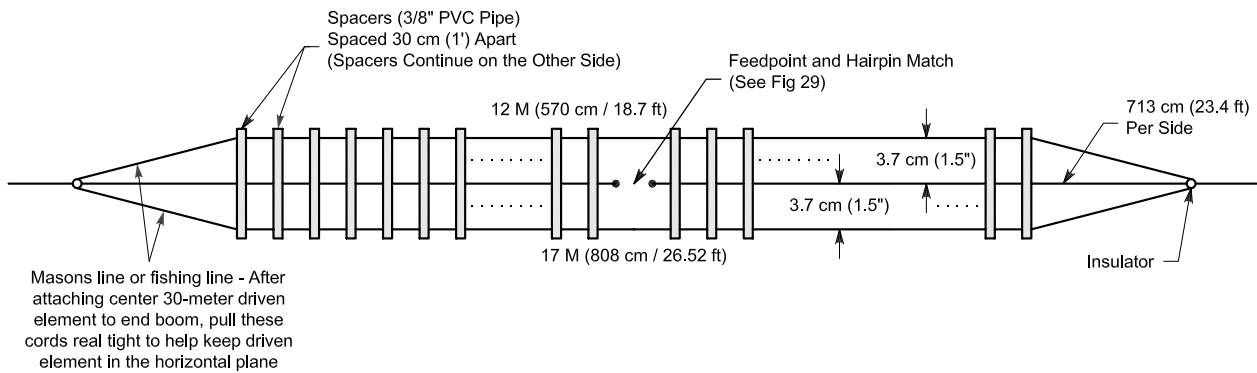

Fig 30—Layout of 30-meter driven element with coupled resonators for 17 and 12 meters.

V Slings

Since the author wanted to be able to raise the 30/17/12-meter triband antenna by himself, he again used only one rope on either end of the array. One end goes over a tree limb and the other end is tied to a stake in the ground or some other nearby support, perhaps a tree trunk. Using only one attachment rope on either end makes it very easy to change beam direction by walking the antenna around the antenna support tree or tower. To accomplish this he used two V slings, one on each end attached to the 2 × 2-inch spreaders.

The secret to keeping the antenna level in the horizontal plane is that the V slings are not equilateral in shape. The combined weight of driven elements, balun and feed line is heavier than the reflectors. If the length of the sides of the V are equal, the array will rotate downwards. The driven elements will end up facing the ground, with the reflectors facing up. Adjust the V slings so that the antenna will stay level in the horizontal plane by shortening the length of the side of the V attached to the driven elements. It is quite easy to adjust in the field, and once you have it adjusted it stays balanced.

Once you raise the antenna to its operating position and in the horizontal plane, you can change direction 180° by pulling on the feed line. As you pull, the whole array will slowly turn over. Stop it from turning by holding onto the feed line once the array has swung over to face the opposite direction.

SWR Adjustment

Since you may situate your antenna in an entirely different position than VE7CA did, you may need to fine tune your antenna. Begin with the dimensions in Table 5 as a starting point. Make a temporary shorting bar using two alligator clips joined by a piece of wire and attach them at the recommended position. Next raise the antenna to the desired final position. Using an antenna analyzer (or transmitter and SWR meter) plot the SWR over all three bands. Start with the lowest band, 30 meters and

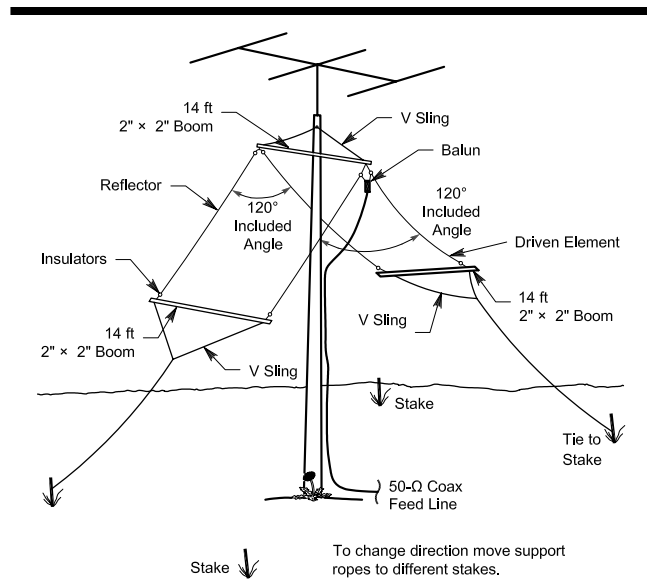

Fig 31—Layout for inverted-V 40-meter portable wire Yagi suspended from tower.

adjust the shorting bar up or down to find the lowest SWR point in the portion of the band you plan to operate in. (This procedure also works if you wish to adjust the 20/15/10-meter tribander. Start with the lowest frequency.)

You shouldn't have to move the shorting bar very far from the suggested length. Now that you have determined the right shorting-bar position, adjust the other two driven element lengths for the lowest SWR in the portion of those bands in which you plan to operate. You may have to compromise with the position of the shorting bar to find a satisfactory range where the SWR is acceptable on all three bands. After satisfying himself with the position of the shorting bar, VE7CA replaced the alligator clips simply by folding one side of the parallel hair-pin

wire lengths over to the other side and soldering it in the position where the alligator clips had been attached. The author does not recommend changing the reflector element lengths unless you are familiar with antenna modeling programs and are willing to model different spacing or element lengths.

40-Meter Wire Yagis

After his November 2001 *QST* article, VE7CA received several requests for a 40-meter wire Yagi. One ham mentioned that he wanted to be able to pull up a 40-meter Yagi between two towers and to be able to flip it over to change direction. Another wanted a 40-meter Yagi he could pull up on a single tower for the winter DX contests and then put it away during the summer. So VE7CA ran four different 40-meter scenarios in his computer models:

1. A horizontal 2-element wire Yagi at 65 feet.
2. A sloping 2-element wire Yagi, with one end at 65 feet and sloping downward 30° from vertical.
3. A sloping 2-element wire Yagi, with one end at 65 feet and sloping downward 65° from vertical.
4. An inverted-V 2-element wire Yagi with the apex at 65 feet and an included angle between the wires of 120°.

Fig 31 shows the layout for an inverted-V system and **Table 6** lists the element and hairpin lengths. Elevation patterns for the 40 meter antennas are compared in **Fig 32**, with a reference antenna of a single flattop dipole at 65 feet. As they say, a picture is worth a thousand words. If your interest is DX, it is very clear that horizontal and high is a very good rule of thumb for most antennas.

Yes, a 1/4 wave vertical over salt water or 120 1/4-wave radials over good ground will produce very low radiation angles, but such systems are not exactly portable and we don't all live near the ocean. Mind you, if you can manage to locate antenna Number 3 (the most vertically oriented wire Yagi) next to the ocean, you would be very happy.

The point here is that if you have two towers and you're not fortunate enough to be located on a saltwater marsh, you should pull the 40-meter array up as high and as horizontal as you can. If you have only one tower and don't need to change direction often, then try the inverted-V configuration. You can still change the direction by walking each end around the tower.

However, even the sloping 40-meter Yagi with one end at 65 feet up a tower (or tree) and the other end attached with a long rope as far as possible from the tower will still put out a very respectable signal. It is directional, and you can walk it around the tower to change direction or you can

Table 6
40-Meter Wire Yagi Configurations

Configuration	Driven Element cm (feet)	Reflector cm (feet)	Hairpin Length cm (feet)
1. Horizontal	1978 (64.90)	2098 (68.83)	Approx 50 cm
2. -30° Sloper	1978 (64.90)	2113 (69.32)	(22 inches)
3. -65° Sloper	1978 (64.90)	2101 (68.93)	
4. Inverted V	2040 (66.93)	2126 (69.75)	

Spacing between driven element and reflector is 427 cm (14 feet). Spacing between parallel hairpin wires is 10 cm (4 inches). The lengths shown above are the total wire length for each element.

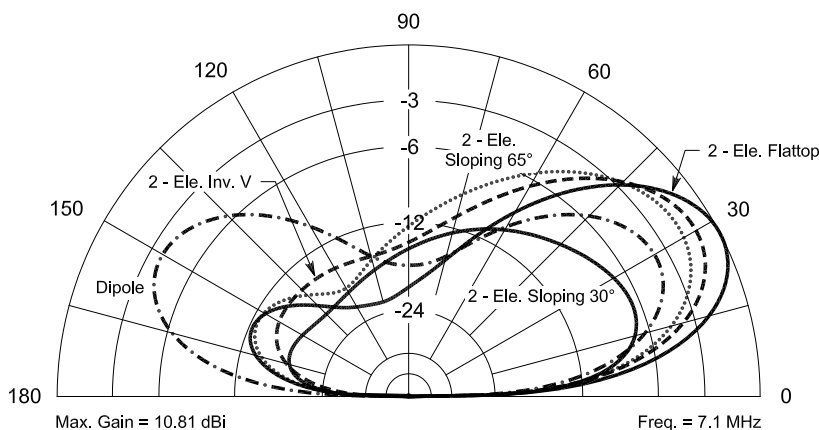

Fig 32—Comparisons of elevation patterns for five 40-meter antennas: a 2-element flattop Yagi at 65 feet; a 2-element inverted-V Yagi at 65 feet; a 2-element Yagi sloped 65° from the vertical plane; a 2-element Yagi sloped 30° from the vertical plane; and a horizontal dipole at 65 feet.



Fig 33 — VE7CA portable 2-element 20/15/10-meter wire Yagi installed at Plimoth Plantation in Plymouth, Massachusetts. (Photo courtesy K1HTN).

flip the antenna over and change direction 180° very quickly.

Summary

You don't need a 10-meter (60-foot) high tower, a commercial triband Yagi and a rotator to put out a good signal on the HF bands. Wire Yagis work very well and they can be inexpensive and easy-to-build, using components found at your local hardware store. **Fig 33** is a photograph of a successful portable installation in Massachusetts.

BIBLIOGRAPHY

Source material and more extended discussion of topics covered in this chapter can be found in the references given below.

G. Breed, K9AY, "The Coupled-Resonator Principle: A Flexible Method for Multiband Antennas," *The ARRL*

Antenna Compendium, Vol 5 (Newington: ARRL, 1996), p 109ff.

R. J. Decesari, "A Portable Quad for 2 Meters," *QST*, Oct 1980, and "Portable Quad for 2 Meters, Part 2," Technical Correspondence, *QST*, Jun 1981, p 39ff.

D. DeMaw, "A Traveling Ham's Trap Vertical," *QST*, Oct 1980, p 28ff.

J. Hall, "Zip-Cord Antennas—Do They Work?" *QST*, Mar 1979, p 31ff.

M. Hansen, "A Portable 2-Element Triband Yagi," *QST*, Nov 2001, p 35ff.

M. Hansen, "Some More VE7CA 2-Element Portable Yagis," *The ARRL Antenna Compendium, Vol7* (Newington: ARRL, 2002, p 183ff.

C. L. Hutchinson, "A Tree-Mounted 30-Meter Ground-Plane Antenna," *QST*, Sep 1974, p 16ff.

C. W. Schecter, "A Deluxe RV 5-Band Antenna," *QST*, Oct 1980, p 38.