

Coupling the Line to the Antenna

Chapter 25, *Coupling the Transmitter to the Line*, looked at system design from the point of view of the transmitter, examining what could be done to ensure that the transmitter works into $50\ \Omega$, its design load. In many systems it was desirable—or necessary—to place an antenna tuner between the transmitter and the transmission line going to the antenna. This is particularly true

for a single-wire antenna used on multiple amateur bands.

In this chapter, we will look at system design from the point of view of the transmission line. We will examine what should be done to ensure that the transmission line operates at best efficiency, once a particular antenna is chosen to do a particular job.

Choosing a Transmission Line

Until you get into the microwave region, where waveguides become practical, there are only two practical choices for transmission lines: coaxial cable (usually called *coax*) and parallel-conductor lines (often called *open-wire* lines).

The shielding of coaxial cable offers advantages in incidental radiation and routing flexibility. Coax can be tied or taped to the legs of a metal tower without problem, for example. Some varieties of coax can even be buried underground. Coaxial cable can perform acceptably even with significant SWR. (Refer to information in Chapter 24.) A 100-foot length of RG-8 coax has 1.1 dB matched-line loss at 30 MHz. If this line were used with a load of $250 + j0\ \Omega$ (an SWR of 5:1), the total line loss would be 2.2 dB. This represents about a half S unit on most receivers.

On the other hand, open-wire line has the advantage of both lower loss and lower cost compared to coax. 600- Ω open-wire line at 30 MHz has a matched loss of only 0.1 dB. If you use such open-wire line with the same 5:1 SWR, the total loss would be about 0.3 dB. In fact, even if the SWR rose to 20:1, the total loss would be less than 1 dB. Typical open-wire line sells for about $\frac{1}{3}$ the cost of good quality coax cable.

Open-wire line is enjoying a renaissance of sorts with

amateurs wishing to cover multiple HF bands with a single-wire antenna. This is particularly true since the bands at 30, 17 and 12 meters became available in the early 1980s. The 102-foot long *G5RV dipole*, fed with open-wire ladder line into an antenna tuner, has become popular as a simple all-band antenna. The simple 135-foot long flat-top dipole, fed with open-wire 450- Ω *window* ladder-line, is also very popular among all-band enthusiasts.

Despite their inherently low-loss characteristics, open-wire lines are not often employed above about 100 MHz. This is because the physical spacing between the two wires begins to become an appreciable fraction of a wavelength, leading to undesirable radiation by the line itself. Some form of coaxial cable is almost universally used in the VHF and UHF amateur bands.

So, apart from concerns about convenience and the matter of cost, how do you go about choosing a transmission line for a particular antenna? Let's start with some simple cases.

FEEDING A SINGLE-BAND ANTENNA

If the system is for a single frequency band, and if the impedance of the antenna doesn't vary too radically over the frequency band, then the choice of transmission line is easy. Most amateurs would opt for convenience—

they would use coaxial cable to feed the antenna, usually without an antenna tuner.

An example of such an installation is a half-wave 80-meter dipole fed with 50- Ω coax. The matched-line loss for 100 feet of 50- Ω RG-8 coax at 3.5 MHz is only 0.33 dB. At each end of the 80-meter band, this dipole will exhibit an SWR of about 6:1. The additional loss caused by this level of SWR at this frequency is less than 0.6 dB, for a total line loss of 0.9 dB. Since 1 dB represents an almost undetectable change in signal strength at the receiving end, it does not matter whether the line is flat or not for this 80-meter system.

This is true provided that the transmitter can operate properly into the load presented to it by the impedance at the input of the transmission line. An antenna tuner is sometimes used as a *line flattener* to ensure that the transmitter operates into its design load impedance. On the other amateur bands, where the percentage bandwidth is smaller than that on 75/80 meters, a simple dipole fed with coax will provide an acceptable SWR for most transmitters—without an antenna tuner.

If you want a better match at the antenna feed point of a single-band antenna to coax, you can provide some sort of matching network at the antenna. We'll look further into schemes for achieving matched antenna systems later in this chapter, when we'll examine single-band beta, gamma and omega matches.

FEEDING A MULTIBAND RESONANT ANTENNA

A *multiband resonant antenna* is one where special measures are used to make a single antenna act as though it were resonant on each of several amateur bands. Often, *trap* circuits are employed. (Information on traps is given in Chapter 7.) For example, a trap dipole is equivalent to a resonant $\lambda/2$ dipole on each of the bands for which it is designed.

Another common multiband resonant antenna is one where several dipoles cut for different frequencies are paralleled together at a common feed point and fed with a single coax cable. This arrangement acts as though it had an independent, resonant $\lambda/2$ dipole on each frequency band. (There is some interaction between the individual wires, which should be separated physically as far as practical to reduce mutual coupling.)

Another type of multiband resonant antenna is a *log-periodic dipole array* (LPDA), although this can hardly be called a simple amateur antenna. The log periodic features moderate gain and pattern, with a low SWR across a fairly wide band of frequencies. See Chapter 10 for more details.

Yet another popular multiband resonant antenna is the trapped *triband Yagi*, or a multiband interlaced quad. On the amateur HF bands, the triband Yagi is almost as popular as the simple $\lambda/2$ dipole. See Chapter 11 for more information on Yagis.

A multiband resonant antenna doesn't present much

of a design challenge—you simply feed it with coax that has characteristic impedance close to the antenna's feed-point impedance. Usually, 50- Ω cable, such as RG-8, is used.

FEEDING A MULTIBAND NON-RESONANT ANTENNA

Let's say that you wish to use a single antenna, such as a 100-foot long dipole, on multiple amateur bands. You know from Chapter 2 that since the physical length of the antenna is fixed, the feed-point impedance of the antenna will vary on each band. In other words, except by chance, the antenna will *not* be resonant—or even close to resonant—on multiple bands.

For multiband non-resonant antenna systems, the most appropriate transmission line is often an open-wire, parallel-conductor line, because of the inherently low matched-line loss characteristic of these types of lines. Such a system is called an *unmatched* system, because no attempt is made to match the impedance at the antenna's feed point to the Z_0 of the transmission line. Commercial 450- Ω window ladder line has become popular for this kind of application. It is almost as good as traditional homemade open-wire line for most amateur systems.

The transmission line will be mismatched most of the time, and on some frequencies it will be severely mismatched. Because of the mismatch, the SWR on the line will vary widely with frequency. As shown in Chapter 24, such a variation in load impedance has an impact on the loss suffered in the feed line. Let's look at the losses suffered in a typical multiband non-resonant system.

Table 1 summarizes the feed-point information over the HF amateur bands for a 100-foot long dipole, mounted as a flattop, 50 feet high over typical earth. In addition, Table 1 shows the total line loss and the SWR at the antenna feed point. As usual, there is nothing particularly significant about the choice of a 100-foot long antenna. Neither is there anything significant about a 100-foot long transmission line from that antenna to the operating position. Both are practical lengths that could very well be encountered in a real-world situation. At 1.8 MHz, the loss in the transmission line is large—8.9 dB. This is due to the fact that the SWR at the feed point is a very high 793:1, a direct result of the fact that the antenna is extremely short in terms of wavelength.

Table 2 summarizes the same information as in Table 1, but this time for a 66-foot long inverted-V dipole, whose apex is 50 feet over typical earth and whose included angle between its two legs is 120°. The situation at 1.83 MHz is even worse, as might be expected because this antenna is even shorter electrically than its 100-foot flat-top cousin. The line loss has risen to 15.1 dB!

Under such severe mismatches, another problem can arise. Transmission lines with solid dielectric have voltage and current limitations. At lower frequencies with electrically short antennas, this can be a more compelling limitation than the amount of power loss. The ability

Table 1**Impedance of Center-Fed 100' Flattop Dipole, 50' High Over Average Ground**

Frequency MHz	Antenna Feed-Point Impedance, Ω	Loss for 100' 450- Ω Line, dB	SWR
1.83	$4.5 - j 1673$	8.9	792.9
3.8	$39 - j 362$	0.5	18.3
7.1	$481 + j 964$	0.2	6.7
10.1	$2584 - j 3292$	0.6	16.8
14.1	$85 - j 123$	0.3	5.2
18.1	$2097 + j 1552$	0.4	8.1
21.1	$345 - j 1073$	0.6	10.1
24.9	$202 + j 367$	0.3	3.9
28.4	$2493 - j 1375$	0.6	8.1

Table 2**Impedance of Center-Fed 66' Inv-V Dipole, 50' Apex Over Average Ground**

Frequency MHz	Antenna Feed-Point Impedance, Ω	Loss for 100' 450- Ω Line, dB	SWR
1.83	$1.6 - j 2257$	15.1	1627.7
3.8	$10 - j 879$	3.9	195.7
7.1	$65 - j 41$	0.2	6.3
10.1	$22 + j 648$	1.9	68.3
14.1	$5287 - j 1310$	0.6	13.9
18.1	$198 - j 820$	0.6	10.8
21.1	$103 - j 181$	0.3	4.8
24.9	$269 + j 570$	0.3	4.9
28.4	$3089 + j 774$	0.6	8.1

of a line to handle RF power is inversely proportional to the SWR. For example, a line rated for 1.5 kW when matched, should be operated at only 150 W when the SWR is 10:1.

At the mismatch on 1.83 MHz illustrated for the 66-foot inverted-V dipole in Table 2, the line may well arc over or burn up due to the extremely high level of SWR (at 1627.7:1).

450- Ω window-type ladder line using two #16 conductors should be safe up to the 1500 W level for frequencies where the antenna is nearly a half-wavelength long. For the 100-foot dipole, this would be above 3.8 MHz, and for the 66-foot long dipole, this would be above 7 MHz. For the very short antennas illustrated above, however, even 450- Ω window line may not be able to take full amateur legal power.

Matched Lines

The rest of this chapter will deal with systems where the feed-point impedance of the antenna is manipulated to match the Z_0 of the transmission line feeding the system. Since operating a transmission line at a low SWR requires that the line be terminated in a load matching the line's characteristic impedance, the problem can be approached from two standpoints:

- (1) selecting a transmission line having a characteristic impedance that matches the antenna impedance at the point of connection, or
- (2) transforming the antenna resistance to a value that matches the Z_0 of the line selected.

The first approach is simple and direct, but its application is obviously limited—the antenna impedance and the line impedance are alike only in a few special cases. Commercial transmission lines come in a limited variety of characteristic impedances. Antenna feed-point impedances vary all over the place.

The second approach provides a good deal of freedom in that the antenna and line can be selected independently. The disadvantage of the second approach is that it is more complicated in terms of actually constructing the matching system at the antenna. Further, this approach sometimes calls for a tedious routine of measurement and adjustment before the desired match is achieved.

Operating Considerations

Most antenna systems show a marked change in impedance when the frequency is changed greatly. For this reason it is usually possible to match the line impedance only on one frequency. A matched antenna system is consequently a one-band affair, in most cases. It can, however, usually be operated over a fair frequency range within a given band.

The frequency range over which the SWR is low is determined by how rapidly the impedance changes as the frequency is changed. If the change in impedance is small for a given change in frequency, the SWR will be low over a fairly wide band of frequencies. However, if the impedance change is rapid (implying a sharply resonant or high-Q antenna), the SWR will also rise rapidly as the operating frequency is shifted away from antenna resonance, where the line is matched. See the discussion of Q in Chapter 2.

Antenna Resonance

In general, achieving a good match to a transmission line means that the antenna is resonant. (Some types of long-wire antennas, such as rhombics, are exceptions. Their input impedances are resistive over a wide band of frequencies, making such systems essentially non-resonant.)

The higher the Q of an antenna system, the more

essential it is that resonance be established before an attempt is made to match the line. This is particularly true of close-spaced parasitic arrays. With simple dipole antennas, the tuning is not so critical, and it is usually sufficient to cut the antenna to the length given by the appropriate equation. The frequency should be selected to be at the center of the range of frequencies (which may be the entire width of an amateur band) over which the antenna is to be used.

DIRECT MATCHING TO THE ANTENNA

Open-Wire Line

As discussed previously, the impedance at the center of a resonant $\lambda/2$ antenna at heights of the order of $\lambda/4$ and more is resistive and is in the neighborhood of 50 to 70 Ω . This is well matched by open-wire line with a characteristic impedance of 75 Ω . However, transmitting 75- Ω twin-lead is becoming increasingly difficult to find in the US, although it is apparently more commonly available in the UK.

A typical direct-matching system is shown in **Fig 1**. No precautions are necessary beyond keeping the line dressed away from the feed point symmetrically with respect to the antenna. This system is designed for single-band operation, although it can be operated at *odd* multiples of the fundamental. For example, an antenna that is resonant near the low-frequency end of the 7-MHz band will operate with a relatively low SWR across the 21-MHz band.

At the fundamental frequency, the SWR should not exceed about 2:1 within a frequency range $\pm 2\%$ from the frequency of exact resonance. Such a variation corresponds approximately to the entire width of the 7-MHz band, if the antenna is resonant at the center of the band. A wire antenna is assumed. Antennas having a greater ratio of diameter to length will have a lower change in SWR with frequency.

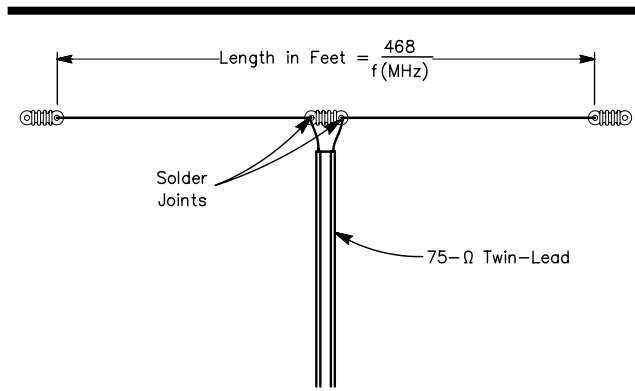

Fig 1—A $\lambda/2$ dipole fed directly with 75- Ω twin-lead, giving a close match between antenna and feed-line impedance. The leads in the “Y” from the end of the line to the ends of the center insulator should be as short as possible.

Coaxial Cable

Instead of using twin-lead as just described, the center of a $\lambda/2$ dipole may be fed through 75- Ω coaxial cable such as RG-11, as shown in **Fig 2**. Cable having a characteristic impedance of 50 Ω , such as RG-8, may also be used. RG-8 may actually be preferable, because at the heights many amateurs install their antennas, the feed-point impedance is closer to 50 Ω than it is to 75 Ω . The principle of operation is exactly the same as with twin-lead, and the same remarks about SWR apply. However, there is a considerable practical difference between the two types of line. With the parallel-conductor line the system is symmetrical, but with coaxial line it is inherently *unbalanced*.

Stated broadly, the unbalance with coaxial line is caused by the fact that the outside surface of the outer braid is not coupled to the antenna in the same way as the inner conductor and the inner surface of the outer braid. The overall result is that current will flow on the outside of the outer conductor in the simple arrangement shown in **Fig 2**. The unbalance is small if the line diameter is very small compared with the length of the antenna, a condition that is met fairly well at the lower amateur frequencies. It is not negligible in the VHF and UHF range, however, nor should it be ignored at 28 MHz. The system must be detuned for currents on the outside of the line. See the section on Baluns later in this chapter for more details about balanced loads used with unbalanced transmission lines.

MATCHING DEVICES AT THE ANTENNA

Quarter-Wave Transformers

The impedance-transforming properties of a $\lambda/4$ transmission line can be used to good advantage for matching the feed-point impedance of an antenna to the characteristic impedance of the line. As described in

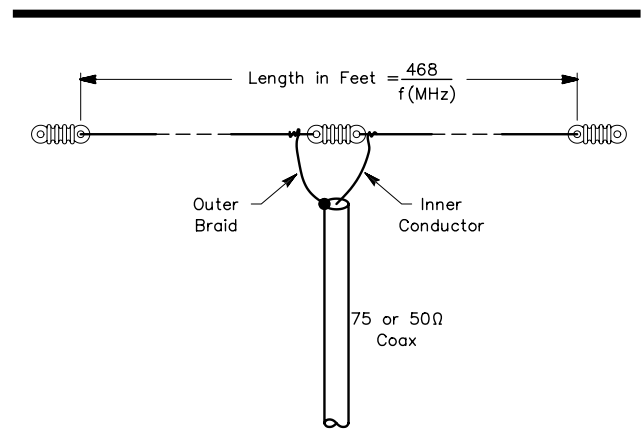

Fig 2—A $\lambda/2$ antenna fed with 75- Ω coaxial cable. The outside of the outer conductor of the line may be grounded for lightning protection.

Chapter 24, the input impedance of a $\lambda/4$ line terminated in a resistive impedance Z_R is

$$Z_i = \frac{Z_0^2}{Z_L} \quad (\text{Eq 1})$$

where

Z_i = the impedance at the input end of the line

Z_0 = the characteristic impedance of the line

Z_L = the impedance at the load end of the line

Rearranging this equation gives

$$Z_0 = \sqrt{Z_i Z_L} \quad (\text{Eq 2})$$

This means that any value of load impedance Z_L can be transformed into any desired value of impedance Z_i at the input terminals of a $\lambda/4$ line, provided the line can be constructed to have a characteristic impedance Z_0 equal to the square root of the product of the other two impedances. The factor that limits the range of impedances that can be matched by this method is the range of values for Z_0 that is physically realizable. The latter range is approximately 50 to 600 Ω . Practically any type of line can be used for the matching section, including both air-insulated and solid-dielectric lines.

The $\lambda/4$ transformer may be adjusted to resonance before being connected to the antenna by short-circuiting one end and coupling that end inductively to a dip meter. The length of the short-circuiting conductor lowers the frequency slightly, but this can be compensated for by adding half the length of the shorting bar to each conductor after resonating, measuring the shorting-bar length between the centers of the conductors.

Yagi Driven Elements

Another application for the $\lambda/4$ linear transformer is in matching the low antenna impedance encountered in close-spaced, monoband Yagi arrays to a 50- Ω transmission line. The impedances at the antenna feed point for typical Yagis range from about 8 to 30 Ω . Let's assume that the feed-point impedance is 25 Ω . A matching section having $Z_0 = \sqrt{50 \times 25} = 35.4 \Omega$ is needed. Since there is no commercially available cable with a Z_0 of 35.4 Ω , a pair of $\lambda/4$ -long 75- Ω RG-11 coax cables connected in parallel will have a net Z_0 of $75/2 = 37.5 \Omega$, close enough for practical purposes.

Series-Section Transformers

The *series-section transformer* has advantages over either stub tuning or the $\lambda/4$ transformer. Illustrated in **Fig 3**, the series-section transformer bears considerable resemblance to the $\lambda/4$ transformer. (Actually, the $\lambda/4$ transformer is a special case of the series-section transformer.) The important differences are (1) that the matching section need not be located exactly at the load, (2) the matching section may be less than a quarter wavelength long, and (3) there is great freedom in the choice

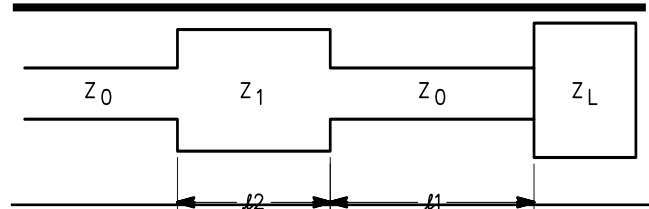

Fig 3—Series section transformer Z_1 for matching transmission-line Z_0 to load, Z_L .

of the characteristic impedance of the matching section.

In fact, the matching section can have *any* characteristic impedance that is not too close to that of the main line. Because of this freedom, it is almost always possible to find a length of commercially available line that will be suitable as a matching section. As an example, consider a 75- Ω line, a 300- Ω matching section, and a pure-resistance load. It can be shown that a series-section transformer of 300- Ω line may be used to match *any* resistance between 5 Ω and 1200 Ω to the main line.

Frank Regier, OD5CG, described series-section transformers in Jul 1978 *QST*. This information is based on that article. The design of a series-section transformer consists of determining the length l_2 of the series or matching section and the distance l_1 from the load to the point where the section should be inserted into the main line. Three quantities must be known. These are the characteristic impedances of the main line and of the matching section, both assumed purely resistive, and the complex-load impedance. Either of two design methods may be used. One is a graphic method using the Smith Chart, and the other is algebraic. You can take your choice. (Of course the algebraic method may be adapted to obtaining a computer solution.) The Smith Chart graphic method is described in Chapter 28.

Algebraic Design Method

The two lengths l_1 and l_2 are to be determined from the characteristic impedances of the main line and the matching section, Z_0 and Z_1 , respectively, and the load impedance $Z_L = R_L + j X_L$. The first step is to determine the normalized impedances.

$$n = \frac{Z_1}{Z_0} \quad (\text{Eq 3})$$

$$r = \frac{R_L}{Z_0} \quad (\text{Eq 4})$$

$$x = \frac{X_L}{Z_0} \quad (\text{Eq 5})$$

Next, l_2 and l_1 are determined from $l_2 = \arctan B$ where

$$B = \pm \frac{\sqrt{(r-1)^2 + x^2}}{r\left(n - \frac{1}{n}\right)^2 - (r-1)^2 - x^2} \quad (\text{Eq 6})$$

$\ell_1 = \arctan A$ where

$$A = \frac{\left(n - \frac{r}{n}\right)B + x}{r + xnB - 1} \quad (\text{Eq 7})$$

Lengths ℓ_2 and ℓ_1 as thus determined are electrical lengths in degrees (or radians). The electrical lengths in wavelengths are obtained by dividing by 360° (or by 2π radians). The physical lengths (main line or matching section, as the case may be), are then determined from multiplying by the free-space wavelength and by the velocity factor of the line.

The sign of B may be chosen either positive or negative, but the positive sign is preferred because it results in a shorter matching section. The sign of A may not be chosen but can turn out to be either positive or negative. If a negative sign occurs and a computer or electronic calculator is then used to determine ℓ_1 , a negative electrical length will result for ℓ_1 . If this happens, add 180° . The resultant electrical length will be correct both physically and mathematically.

In calculating B , if the quantity under the radical is negative, an imaginary value for B results. This would mean that Z_1 , the impedance of the matching section, is too close to Z_0 and should be changed.

Limits on the characteristic impedance of Z_1 may be calculated in terms of the SWR produced by the load on the main line without matching. For matching to occur, Z_1 should either be greater than $Z_0 \sqrt{\text{SWR}}$ or less than $Z_0 / \sqrt{\text{SWR}}$.

An Example

As an example, suppose we want to feed a 29-MHz ground-plane vertical antenna with RG-58 type foam-dielectric coax. We'll assume the antenna impedance to be 36Ω , pure resistance, and use a length of RG-59 foam-dielectric coax as the series section. See Fig 4.

Z_0 is 50Ω , Z_1 is 75Ω , and both cables have a velocity factor of 0.79. Because the load is a pure resistance we may determine the SWR to be $50/36 = 1.389$. From the above, Z_1 must have an impedance greater than $50 \sqrt{1.389} = 58.9 \Omega$. From the earlier equations, $n = 75/50 = 1.50$, $r = 36/50 = 0.720$, and $x = 0$.

Further, $B = 0.431$ (positive sign chosen), and $\ell_2 = 23.3^\circ$ or 0.065λ . The value of A is -1.570 . Calculating ℓ_1 yields -57.5° . Adding 180° to obtain a positive result gives $\ell_1 = 122.5^\circ$, or 0.340λ .

To find the physical lengths ℓ_1 and ℓ_2 we first find the free-space wavelength.

$$\lambda = \frac{984}{f(\text{MHz})} = 33.93 \text{ feet}$$

Multiply this value by 0.79 (the velocity factor for both types of line), and we obtain the electrical wavelength in coax as 26.81 feet. From this, $\ell_1 = 0.340 \times 26.81 = 9.12$ feet, and $\ell_2 = 0.065 \times 26.81 = 1.74$ feet.

This completes the calculations. Construction consists of cutting the main coax at a point 9.12 feet from the antenna and inserting a 1.74-foot length of the $75\text{-}\Omega$ cable.

The Quarter-Wave Transformer

The antenna in the preceding example could also have been matched by a $\lambda/4$ transformer at the load. Such a transformer would use a line with a characteristic impedance of 42.43Ω . It is interesting to see what happens in the design of a series-section transformer if this value is chosen as the characteristic impedance of the series section.

Following the same steps as before, we find $n = 0.849$, $r = 0.720$, and $x = 0$. From these values we find $B = 8$ and $\ell_2 = 90^\circ$. Further, $A = 0$ and $\ell_1 = 0^\circ$. These results represent a $\lambda/4$ section at the load, and indicate that, as stated earlier, the $\lambda/4$ transformer is indeed a special case of the series-section transformer.

Tapered Lines

A tapered line is a specially constructed transmission line in which the impedance changes gradually from one end of the line to the other. Such a line operates as a broadband impedance transformer. Because tapered lines are used almost exclusively for matching applications, they are discussed in this chapter rather than in Chapter 24.

The characteristic impedance of an open-wire line can be tapered by varying the spacing between the conductors, as shown in Fig 5. Coaxial lines can be tapered by varying the diameter of either the inner conductor or

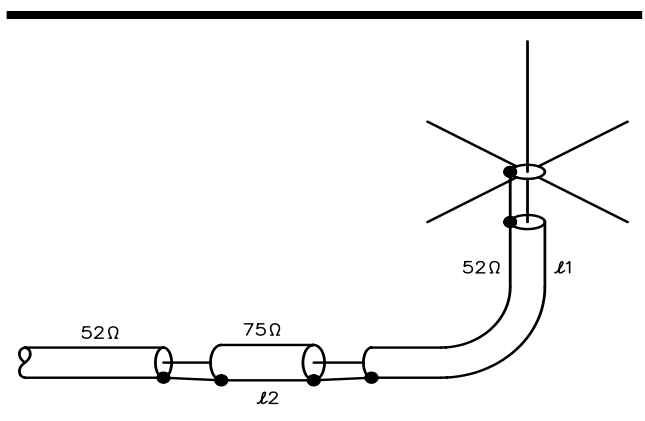

Fig 4—Example of series-section matching. A $36\text{-}\Omega$ antenna is matched to $50\text{-}\Omega$ coax by means of a length of $75\text{-}\Omega$ cable.

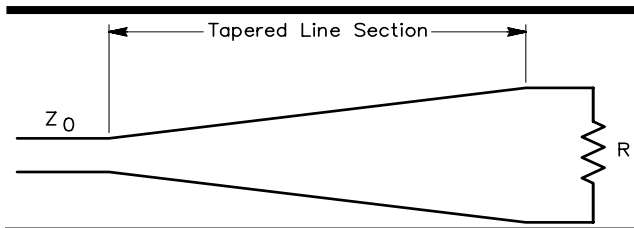

Fig 5—A tapered line provides a broadband frequency transformation if it is one wavelength long or more. From a practical construction standpoint, the taper may be linear.

the outer conductor, or both. The construction of coaxial tapered lines is beyond the means of most amateurs, but open-wire tapered lines can be made rather easily by using spacers of varied lengths. In theory, optimum broadband impedance transformation is obtained with lines having an exponential taper, but in practice, lines with a linear taper as shown in Fig 5 work very well.

A tapered line provides a match from high frequencies down to the frequency at which the line is approximately 1λ long. At lower frequencies, especially when the tapered line length is $\lambda/2$ or less, the line acts more as an impedance lump than a transformer. Tapered lines are most useful at VHF and UHF, because the length requirement becomes unwieldy at HF.

Air-insulated open-wire lines can be designed from the equation

$$S = \frac{d \times 10^{Z_0/276}}{2} \quad (\text{Eq 8})$$

where

- S = center-to-center spacing between conductors
- d = diameter of conductors (same units as S)
- Z_0 = characteristic impedance, Ω

For example, for a tapered line to match a 300- Ω source to an 800- Ω load, the spacing for the selected conductor diameter would be adjusted for a 300- Ω characteristic impedance at one end of the line, and for an 800- Ω characteristic impedance at the other end of the line. The disadvantage of using open-wire tapered lines is that characteristic impedances of 100 Ω and less are impractical.

Multiple Quarter-Wave Sections

An approach to the smooth-impedance transformation of the tapered line is provided by using two or more $\lambda/4$ transformer sections in series, as shown in Fig 6. Each section has a different characteristic impedance, selected to transform the impedance at its input to that at its output. Thus, the overall impedance transformation from source to load takes place as a series of gradual transformations. The frequency bandwidth with multiple sections is greater than for a single section. This technique is useful at the upper end of the HF range and at VHF

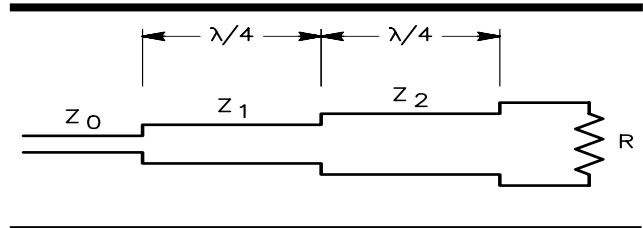

Fig 6—Multiple quarter-wave matching sections approximate the broadband matching transformation provided by a tapered line. Two sections are shown here, but more may be used. The more sections in the line, the broader is the matching bandwidth. Z_0 is the characteristic impedance of the main feed line, while Z_1 and Z_2 are the intermediate impedances of the matching sections. See text for design equations.

and UHF. Here, too, the total line length that is required may become unwieldy at the lower frequencies.

A multiple-section line may contain two or more $\lambda/4$ transformer sections; the more sections in the line, the broader is the matching bandwidth. Coaxial transmission lines may be used to make a multiple-section line, but standard coax lines are available in only a few characteristic impedances. Open-wire lines can be constructed rather easily for a specific impedance, designed from Eq 8 above.

The following equations may be used to calculate the intermediate characteristic impedances for a two-section line.

$$Z_1 = \sqrt[4]{RZ_0^3} \quad (\text{Eq 9})$$

$$Z_2 = \sqrt[3]{R^2 Z_1} \quad (\text{Eq 10})$$

where terms are as illustrated in Fig 6. For example, assume we wish to match a 75- Ω source (Z_0) to an 800- Ω load. From Eq 9, calculate Z_1 to be 135.5 Ω . Then from Eq 10, calculate Z_2 to be 442.7 Ω . As a matter of interest, for this example the virtual impedance at the junction of Z_1 and Z_2 is 244.9 Ω . (This is the same impedance that would be required for a single-section $\lambda/4$ matching section.)

Delta Matching

Among the properties of a coil and capacitor resonant circuit is that of transforming impedances. If a resistive impedance, Z_1 in Fig 7, is connected across the outer terminals AB of a resonant LC circuit, the impedance Z_2 as viewed looking into another pair of terminals such as BC will also be resistive, but will have a different value depending on the mutual coupling between the parts of the coil associated with each pair of terminals. Z_2 will be less than Z_1 in the circuit shown. Of course this relationship will be reversed if Z_1 is connected across terminals BC and Z_2 is viewed from terminals AB.

As stated in Chapter 2, a resonant antenna has prop-

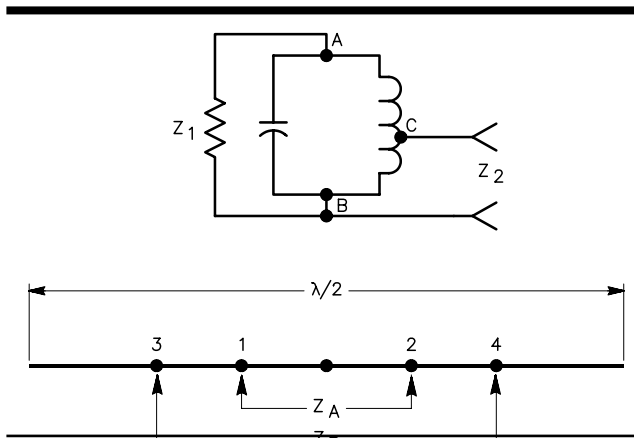

Fig 7—Impedance transformation with a resonant circuit, together with antenna analogy.

erties similar to those of a tuned circuit. The impedance presented between any two points symmetrically placed with respect to the center of a $\lambda/2$ antenna will depend on the distance between the points. The greater the separation, the higher the value of impedance, up to the limiting value that exists between the open ends of the antenna. This is also suggested in Fig 7, in the lower drawing. The impedance Z_A between terminals 1 and 2 is lower than the impedance Z_B between terminals 3 and 4. Both impedances, however, are purely resistive if the antenna is resonant.

This principle is used in the *delta matching system* shown in Fig 8. The center impedance of a $\lambda/2$ dipole is too low to be matched directly by any practical type of air-insulated parallel-conductor line. However, it is possible to find, between two points, a value of impedance that can be matched to such a line when a “fanned” section or delta is used to couple the line and antenna. The antenna length ℓ is that required for resonance. The ends of the delta or “Y” should be attached at points equidistant from the center of the antenna. When so connected, the terminating impedance for the line will be resistive. Obviously, this technique is useful only when the Z_0 of the chosen transmission line is higher than the feed-point impedance of the antenna.

Based on experimental data for the case of a typical $\lambda/2$ antenna coupled to a 600- Ω line, the total distance, A , between the ends of the delta should be 0.120λ for frequencies below 30 MHz, and 0.115λ for frequencies above 30 MHz. The length of the delta, distance B , should be 0.150λ . These values are based on a wavelength in air, and on the assumption that the center impedance of the antenna is approximately 70 Ω . The dimensions will require modifications if the actual impedance is very much different.

The delta match can be used for matching the driven element of a directive array to a transmission line, but if the impedance of the element is low—as is frequently

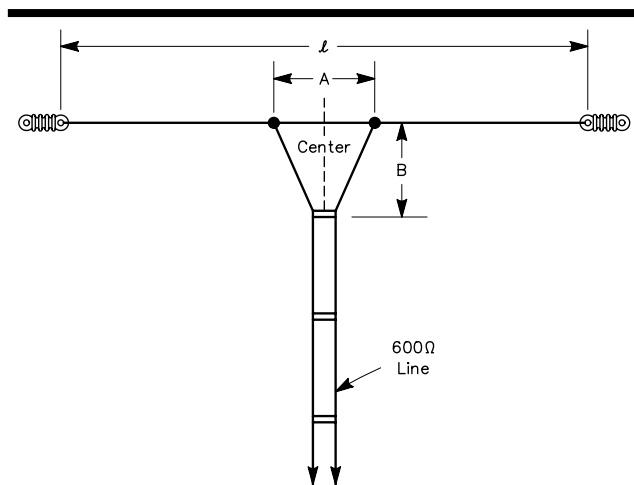

Fig 8—The delta matching system.

the case—the proper dimensions for A and B must be found by experimentation.

The delta match is somewhat awkward to adjust when the proper dimensions are unknown, because both the length and width of the delta must be varied. An additional disadvantage is that there is always some radiation from the delta. This is because the conductor spacing does not meet the requirement for negligible radiation: The spacing should be very small in comparison with the wavelength.

Folded Dipoles

Basic information on the folded dipole antenna appears in Chapter 6. The input impedance of a two-wire folded dipole is so close to 300 Ω that it can be fed directly with 300- Ω twin-lead or with open-wire line without any other matching arrangement, and the line will operate with a low SWR. The antenna itself can be built like an open-wire line; that is, the two conductors can be held apart by regular feeder spreaders. TV ladder line is quite suitable. It is also possible to use 300- Ω line for the antenna, in addition to using it for the transmission line.

Since the antenna section does not operate as a transmission line, but simply as two wires in parallel, the velocity factor of twin-lead can be ignored in computing the antenna length. The reactance of the folded-dipole antenna varies less rapidly with frequency changes away from resonance than a single-wire antenna. Therefore it is possible to operate over a wider range of frequencies, while maintaining a low SWR on the line, than with a simple dipole. This is partly explained by the fact that the two conductors in parallel form a single conductor of greater effective diameter.

A folded dipole will not accept power at twice the fundamental frequency. However, the current distribution is correct for harmonic operation on odd multiples of the

fundamental. Because the feed-point resistance is not greatly different for a $3\lambda/2$ antenna and one that is $\lambda/2$, a folded dipole can be operated on its third harmonic with a low SWR in a 300- Ω line. A 7-MHz folded dipole, consequently, can be used for the 21-MHz band as well.

The T and Gamma Matches

The T Match

The current flowing at the input terminals of the T match consists of the normal antenna current divided between the radiator and the T conductors in a way that depends on their relative diameters and the spacing between them, with a superimposed transmission-line current flowing in each half of the T and its associated section of the antenna. See Fig 9. Each such T conductor and the associated antenna conductor can be looked upon as a section of transmission line shorted at the end. Because it is shorter than $\lambda/4$ it has inductive reactance. As a consequence, if the antenna itself is exactly resonant at the operating frequency, the input impedance of the T will show inductive reactance as well as resistance. The reactance must be tuned out if a good match to the transmission line is to be obtained. This can be done either by shortening the antenna to obtain a value of capacitive reactance that will reflect through the matching system to cancel the inductive reactance at the input terminals, or by inserting a capacitance of the proper value in series at the input terminals as shown in Fig 10A.

Theoretical analyses have shown that the part of the impedance step-up arising from the spacing and ratio of conductor diameters is approximately the same as given for a folded dipole. The actual impedance ratio is, however, considerably modified by the length A of the matching section (Fig 9). The trends can be stated as follows:

- 1) The input impedance increases as the distance A is made larger, but not indefinitely. In general there is

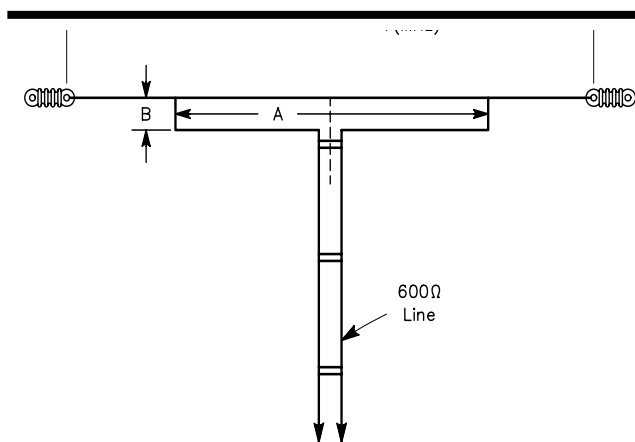

Fig 9—The T matching system, applied to a $\frac{1}{2}\lambda$ antenna and 600- Ω line.

a distance A that will give a maximum value of input impedance, after which further increase in A will cause the impedance to decrease.

- 2) The distance A at which the input impedance reaches a maximum is smaller as d_2/d_1 is made larger, and becomes smaller as the spacing between the conductors is increased.
- 3) The maximum impedance values occur in the region where A is 40% to 60% of the antenna length in the average case.
- 4) Higher values of input impedance can be realized when the antenna is shortened to cancel the inductive reactance of the matching section.

The T match has become popular for transforming the balanced feed-point impedance of a VHF or UHF Yagi up to 200 Ω . From that impedance a 4:1 balun is used to transform down to the unbalanced 50 Ω level for the coax cable feeding the Yagi. See the various K1FO Yagis in Chapter 18 and the section later in this chapter concerning baluns.

The Gamma Match

The gamma-match arrangement shown in Fig 10B is an unbalanced version of the T, suitable for use directly with coaxial lines. Except for the matching section being connected between the center and one side of the antenna, the remarks above about the behavior of the

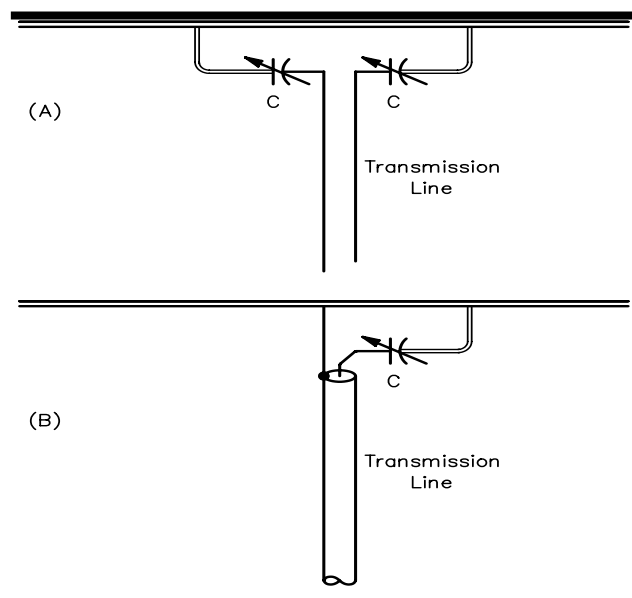

Fig 10—Series capacitors for tuning out residual reactance with the T and gamma matching systems. A maximum capacitance of 150 pF in each capacitor should provide sufficient adjustment range, in the average case, for 14-MHz operation. Proportionately smaller capacitance values can be used on higher frequency bands. Receiving-type plate spacing will be satisfactory for power levels up to a few hundred watts.

T apply equally well. The inherent reactance of the matching section can be canceled either by shortening the antenna appropriately or by using the resonant length and installing a capacitor C, as shown in Fig 10B.

For a number of years the gamma match has been widely used for matching coaxial cable to all-metal parasitic beams. Because it is well suited to *plumber's delight* construction, where all the metal parts are electrically and mechanically connected, it has become quite popular for amateur arrays.

Because of the many variable factors—driven-element length, gamma rod length, rod diameter, spacing between rod and driven element, and value of series capacitors—a number of combinations will provide the desired match. The task of finding a proper combination can be a tedious one, as the settings are interrelated. A few rules of thumb have evolved that provide a starting point for the various factors. For matching a multielement array made of aluminum tubing to 50-Ω line, the length of the rod should be 0.04 to 0.05 λ , its diameter $\frac{1}{3}$ to $\frac{1}{2}$ that of the driven element, and its spacing (center-to-center from the driven element), approximately 0.007 λ . The capacitance value should be approximately 7 pF per meter of wavelength. This translates to about 140 pF for 20-meter operation. The exact gamma dimensions and value for the capacitor will depend on the radiation resistance of the driven element, and whether or not it is resonant. These starting-point dimensions are for an array having a feed-point impedance of about 25 Ω , with the driven element shortened approximately 3% from resonance.

Calculating Gamma Dimensions

A starting point for the gamma dimensions and capacitance value may be determined by calculation. H. F. Tolles, W7ITB, has developed a method for determining a set of parameters that will be quite close to providing the desired impedance transformation. (See Bibliography at the end of this chapter.) The impedance of the antenna must be measured or computed for Tolles' procedure. If the antenna impedance is not accurately known, modeling calculations provide a very good starting point for initial settings of the gamma match.

The math involved in Tolles' procedure is tedious, especially if several iterations are needed to find a practical set of dimensions. The procedure has been adapted for computer calculations by R. A. Nelson, WBØIKN, who wrote his program in Applesoft BASIC (see Bibliography). A similar program for the IBM PC and compatible computers called *GAMMA* is included on the disk bundled with this book, in BASIC source code, with modifications suggested by Dave Leeson, W6NL. The program can be used for calculating a gamma match for a dipole (or driven element of an array) or for a vertical monopole, such as a shunt-fed tower.

As an example of computer calculations, assume a 14.3-MHz Yagi beam is to be matched to 50-Ω line. The

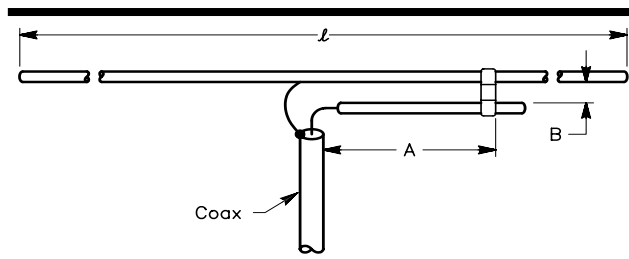

Fig 11—The gamma match, as used with tubing elements. The transmission line may be either 50-Ω or 75-Ω coax.

driven element is $1\frac{1}{2}$ inches in diameter, and the gamma rod is a length of $\frac{1}{2}$ -inch tubing, spaced 6 inches from the element (center to center). The driven element has been shortened by 3% from its resonant length. Assume the antenna has a radiation resistance of 25 Ω and a capacitive reactance component of 25 Ω (about the reactance that would result from the 3% shortening). The overall impedance of the driven element is therefore 25 $-j$ 25 Ω . At the program prompts, enter the choice for a dipole, the frequency, the feed-point resistance and reactance (don't forget the minus sign), the line characteristic impedance (50 Ω), and the element and rod diameters and center-to-center spacing. *GAMMA* computes that the gamma rod is 38.9 inches long and the gamma capacitor is 96.1 pF at 14.3 MHz.

As another example, say we wish to shunt feed a tower at 3.5 MHz with 50-Ω line. The driven element (tower) is 12 inches in diameter, and #12 wire (diameter = 0.0808 inch) with a spacing of 12 inches from the tower is to be used for the "gamma rod." The tower is 50 feet tall with a 5-foot mast and beam antenna at the top. The total height, 55 feet, is approximately 0.19 λ . We assume its electrical length is 0.2 λ or 72°. Modeling shows that the approximate base feed-point impedance is 20 $-j$ 100 Ω . *GAMMA* says that the gamma rod should be 57.1 feet long, with a gamma capacitor of 32.1 pF.

Immediately we see this set of gamma dimensions is impractical—the rod length is greater than the tower height. So we make another set of calculations, this time using a spacing of 18 inches between the rod and tower. The results this time are that the gamma rod is 49.3 feet long, with a capacitor of 43.8 pF. This gives us a practical set of starting dimensions for the shunt-feed arrangement.

Adjustment

After installation of the antenna, the proper constants for the T and gamma generally must be determined experimentally. The use of the variable series capacitors, as shown in Fig 10, is recommended for ease of adjustment. With a trial position of the tap or taps on the antenna, measure the SWR on the transmission line and adjust C (both capacitors simultaneously in the case of the

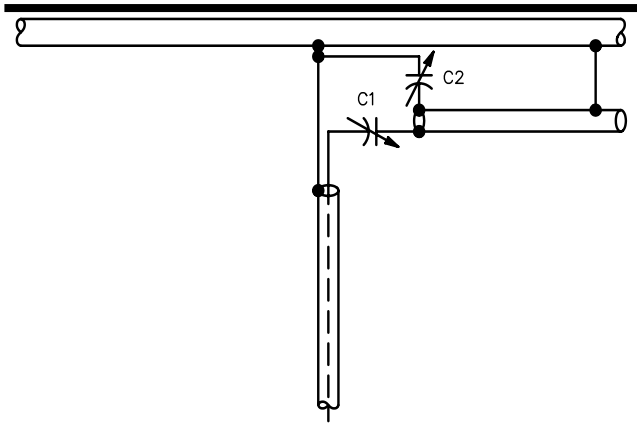

Fig 12—The omega match.

T) for minimum SWR. If it is not close to 1:1, try another tap position and repeat. It may be necessary to try another size of conductor for the matching section if satisfactory results cannot be brought about. Changing the spacing will show which direction to go in this respect.

The Omega Match

The omega match is a slightly modified form of the gamma match. In addition to the series capacitor, a shunt capacitor is used to aid in canceling a portion of the inductive reactance introduced by the gamma section. This is shown in Fig 12. C1 is the usual series capacitor. The addition of C2 makes it possible to use a shorter gamma rod, or makes it easier to obtain the desired match when the driven element is resonant. During adjustment, C2 will serve primarily to determine the resistive component of the load as seen by the coax line, and C1 serves to cancel any reactance.

The Hairpin and Beta Matches

The usual form of the *hairpin match* is shown in Fig 13. Basically, the hairpin is a form of an L-matching network. Because it is somewhat easier to adjust for the desired terminating impedance than the gamma match, it is preferred by many amateurs. Its disadvantages, compared with the gamma, are that it must be fed with a balanced line (a balun may be used with a coax feeder, as shown in Fig 13—see the section later in this chapter about baluns), and the driven element must be split at the center and insulated from the boom. This latter requirement complicates the mechanical mounting arrangement for the element, by ruling out *plumber's delight* construction.

As indicated in Fig 13, the center point of the hairpin is electrically neutral. As such, it may be grounded or connected to the remainder of the antenna structure. The hairpin itself is usually secured by attaching this neutral point to the boom of the antenna array. The Hy-Gain *beta match* is electrically identical to the hairpin match,

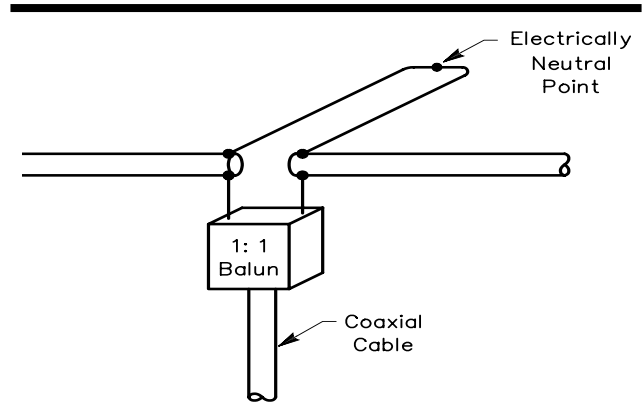

Fig 13—The hairpin match.

the difference being in the mechanical construction of the matching section. With the beta match, the conductors of the matching section straddle the Yagi's boom, one conductor being located on either side, and the electrically neutral point consists of a sliding or adjustable shorting clamp placed around the boom and the two matching-section conductors.

The capacitive portion of the L-network circuit is produced by slightly shortening the antenna driven element, shown in Fig 14A. For a given frequency the impedance of a shortened $\lambda/2$ element appears as the antenna resistance and a capacitance in series, as indicated schematically in Fig 14B. The inductive portion of the resonant circuit at C is a hairpin of heavy wire or small tubing that is connected across the driven-element center terminals. The diagram of C is redrawn in D to show the circuit in conventional L-network form. R_A , the radiation resistance, must be a smaller value than R_{IN} , the impedance of the feed line, usually 50 Ω .

If the approximate radiation resistance of the antenna system is known, Figs 15 and 16 may be used to gain an idea of the hairpin dimensions necessary for the desired match. The curves of Fig 15 were obtained from design equations for L-network matching. See Chapter 25, Coupling the Transmitter to the Line. Fig 15 is based on the equation, $X_p = j \tan \theta$, which gives the inductive reactance as normalized to the Z_0 of the hairpin, looking at it as a length of transmission line terminated in a short circuit. For example, if an antenna-system impedance of 20 Ω is to be matched to 50- Ω line, Fig 16 shows that the inductive reactance required for the hairpin is +41 Ω . If the hairpin is constructed of $1/4$ -inch tubing spaced $1\frac{1}{2}$ inches, its characteristic impedance is 300 Ω (from Chapter 24.) Normalizing the required 41- Ω reactance to this impedance, $41/300 = 0.137$.

By entering the graph of Fig 16 with this value, 0.137, on the scale at the bottom, you can see that the hairpin length should be 7.8 electrical degrees, or

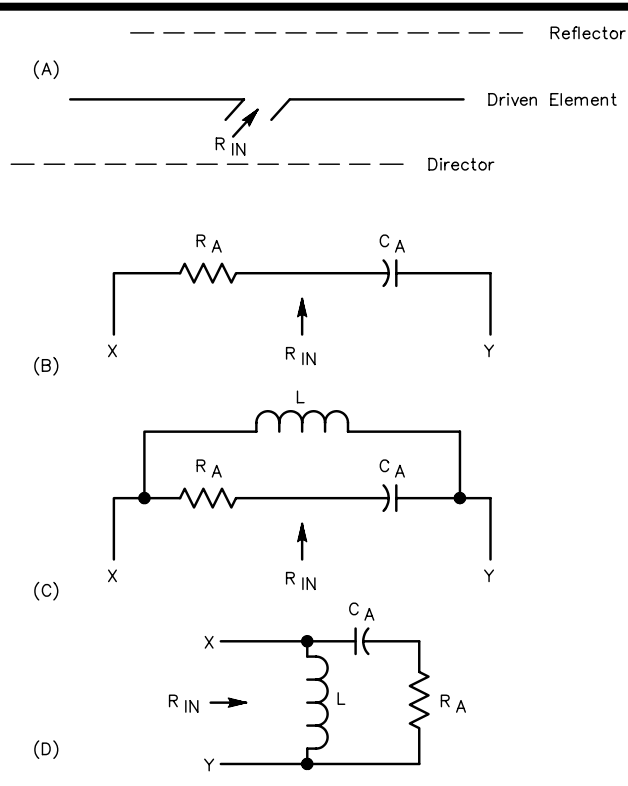

Fig 14—For the Yagi antenna shown at A, the driven element is shorter than its resonant length. The input impedance at resonance is represented at B. By adding an inductor, as shown at C, a low value of R_A is made to appear as a higher impedance at terminals XY. At D, the diagram of C is redrawn in the usual L-network configuration.

$7.8/360 \lambda$. For purposes of these calculations, taking a 97.5% velocity factor into account, the wavelength in inches is $11,508/f$ (MHz). If the antenna is to be used on 14 MHz, the required hairpin length is $7.8/360 \times 11,508/14.0 = 17.8$ inches. The length of the hairpin affects primarily the resistive component of the terminating impedance, as seen by the feed line. Greater resistances are obtained with longer hairpin sections—meaning a larger value of shunt inductor—and smaller resistances with shorter sections. Reactance at the feed-point terminals is tuned out by adjusting the length of the driven element, as necessary. If a fixed-length hairpin section is in use, a small range of adjustment may be made in the effective value of the inductance by spreading or squeezing together the conductors of the hairpin. Spreading the conductors apart will have the same effect as lengthening the hairpin, while placing them closer together will effectively shorten it.

Instead of using a hairpin of stiff wire or tubing, this same matching technique may be used with a lumped-constant inductor connected across the antenna terminals. Such a method of matching has been dubbed, tongue firmly in cheek, as the “helical hairpin.” The inductor, of course, must exhibit the same reactance at the operating

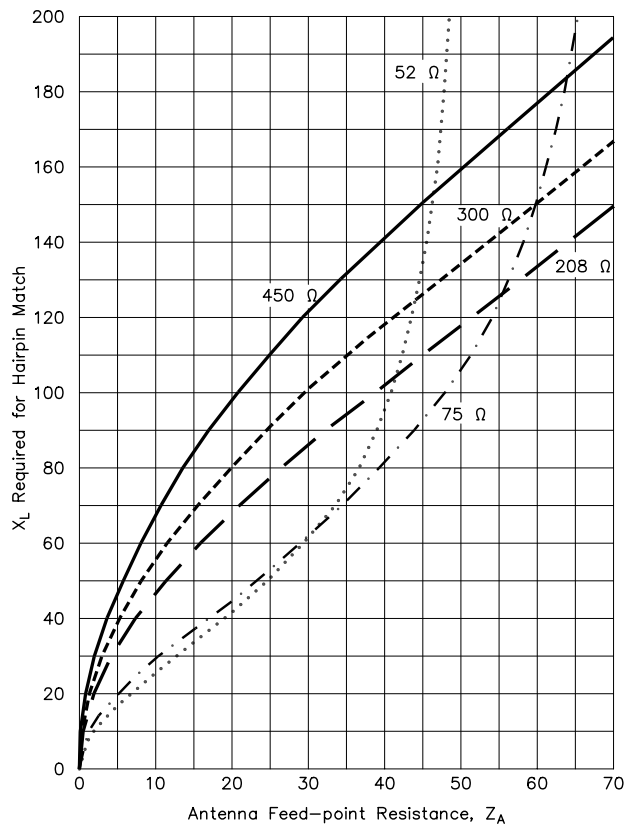

Fig 15—Reactance required for a hairpin to match various antenna resistances to common line or balun impedance.

frequency as the hairpin it replaces. A cursory examination with computer calculations indicates that a helical hairpin may offer a very slightly improved SWR bandwidth over a true hairpin.

Matching Stubs

As explained in Chapter 24, Transmission Lines, a mismatch-terminated transmission line less than $\lambda/4$ long has an input impedance that is both resistive and reactive. The equivalent circuit of the line input impedance at any one frequency can be formed either of resistance and reactance in series, or resistance and reactance in parallel. Depending on the line length, the series resistance component, R_S , can have any value between the terminating resistance Z_R (when the line has zero length) and Z_0^2/Z_R (when the line is exactly $\lambda/4$ long). The same thing is true of R_P , the parallel-resistance component.

R_S and R_P do not have the same values at the same line length, however, other than zero and $\lambda/4$. With either equivalent there is some line length that will give a value of R_S or R_P equal to the characteristic impedance of the line. However, there will be reactance along with the resistance. But if provision is made for canceling or tun-

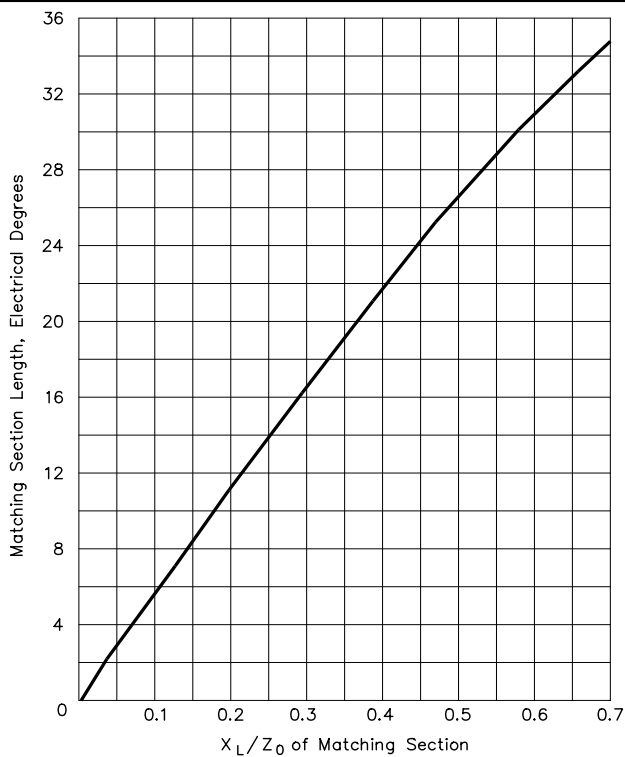

Fig 16—Inductive reactance (normalized to Z_0 of matching section), scale at bottom, versus required hairpin matching section length, scale at left. To determine the length in wavelengths divide the number of electrical degrees by 360. For open-wire line, a velocity factor of 97.5% should be taken into account when determining the electrical length.

ing out this reactive part of the input impedance, only the resistance will remain. Since this resistance is equal to the Z_0 of the transmission line, the section from the reactance-cancellation point back to the generator will be properly matched.

Tuning out the reactance in the equivalent series circuit requires that a reactance of the same value as X_S (but of opposite kind) be inserted in series with the line. Tuning out the reactance in the equivalent parallel circuit requires that a reactance of the same value as X_P (but of opposite kind) be connected across the line. In practice it is more convenient to use the parallel-equivalent circuit. The transmission line is simply connected to the load (which of course is usually a resonant antenna) and then a reactance of the proper value is connected across the line at the proper distance from the load. From this point back to the transmitter there are no standing waves on the line.

A convenient type of reactance to use is a section of transmission line less than $\lambda/4$ long, terminated with either an open circuit or a short circuit, depending on whether capacitive reactance or inductive reactance is called for. Reactances formed from sections of transmission line are called *matching stubs*, and are designated as

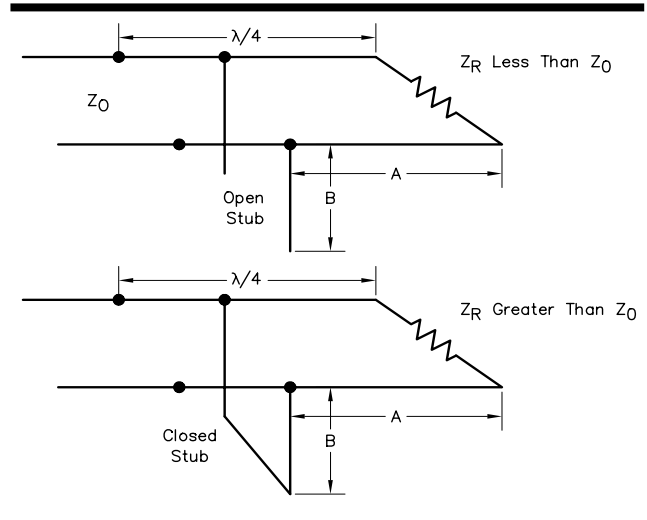

Fig 17—Use of open or closed stubs for canceling the parallel reactive component of input impedance.

open or *closed* depending on whether the free end is open or short circuited. The two types of matching stubs are shown in the sketches in **Fig 17**.

The distance from the load to the stub (dimension A in Fig 17) and the length of the stub, B, depend on the characteristic impedances of the line and stub and on the ratio of Z_R to Z_0 . Since the ratio of Z_R to Z_0 is also the standing-wave ratio in the absence of matching (and with a resonant antenna), the dimensions are a function of the SWR. If the line and stub have the same Z_0 , dimensions A and B are dependent on the SWR only. Consequently, if the SWR can be measured before the stub is installed, the stub can be properly located and its length determined even though the actual value of load impedance is not known.

Typical applications of matching stubs are shown in **Fig 18**, where open-wire line is being used. From inspection of these drawings it will be recognized that when an antenna is fed at a current loop, as in Fig 18A, Z_R is less than Z_0 (in the average case) and therefore an open stub is called for, installed within the first $\lambda/4$ of line measured from the antenna. Voltage feed, as at B, corresponds to Z_R greater than Z_0 and therefore requires a closed stub.

The Smith Chart may be used to determine the length of the stub and its distance from the load (see Chapter 28, Smith Chart Calculations) or the ARRL program *TLW* on the CD-ROM in the back of this book may be used. If the load is a pure resistance and the characteristic impedances of the line and stub are identical, the lengths may be determined by equations. For the closed stub when Z_R is greater than Z_0 , they are

$$A = \arctan \sqrt{\text{SWR}} \quad (\text{Eq 12})$$

$$B = \arctan \frac{\sqrt{\text{SWR}}}{\text{SWR} - 1} \quad (\text{Eq 13})$$

For the open stub when Z_R is less than Z_0

$$A = \arctan \frac{1}{\sqrt{\text{SWR}}} \quad (\text{Eq 14})$$

$$B = \arctan \frac{\text{SWR} - 1}{\sqrt{\text{SWR}}} \quad (\text{Eq 15})$$

In these equations the lengths A and B are the distance from the stub to the load and the length of the stub, respectively, as shown in Fig 18. These lengths are expressed in electrical degrees, equal to 360 times the lengths in wavelengths.

In using the above equations it must be remembered that the wavelength along the line is not the same as in free space. If an open-wire line is used the velocity factor of 0.975 will apply. When solid-dielectric line is used, the free-space wavelength as determined above must be multiplied by the appropriate velocity factor to obtain the actual lengths of A and B (see Chapter 24.)

Although the equations above do not apply when the characteristic impedances of the line and stub are not the same, this does not mean that the line cannot be matched under such conditions. The stub can have any desired characteristic impedance if its length is chosen so that it has

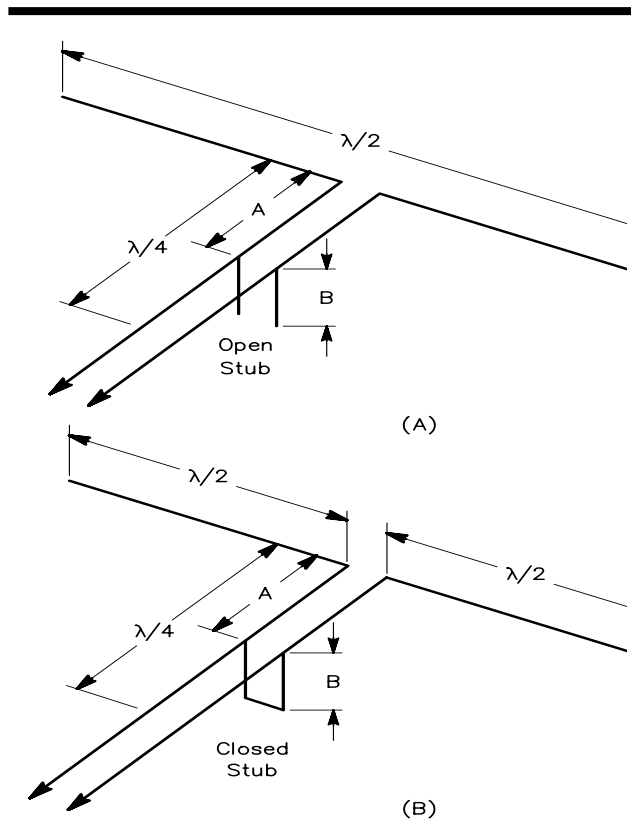

Fig 18—Application of matching stubs to common types of antennas.

the proper value of reactance. By using the Smith Chart, the correct lengths can be determined without difficulty for dissimilar types of line.

In using matching stubs it should be noted that the length and location of the stub should be based on the SWR at the load. If the line is long and has fairly high losses, measuring the SWR at the input end will not give the true value at the load. This point is discussed in Chapter 24 in the section on attenuation.

Reactive Loads

In this discussion of matching stubs it has been assumed that the load is a pure resistance. This is the most desirable condition, since the antenna that represents the load preferably should be tuned to resonance before any attempt is made to match the line. Nevertheless, matching stubs can be used even when the load is considerably reactive. A reactive load simply means that the loops and nodes of the standing waves of voltage and current along the line do not occur at integral multiples of $\lambda/4$ from the load. If the reactance at the load is known, the Smith Chart or TLW may be used to determine the correct dimensions for a stub match.

Stubs on Coaxial Lines

The principles outlined in the preceding section apply also to coaxial lines. The coaxial cases corresponding to the open-wire cases shown in Fig 18 are given in Fig 19. The equations given earlier may be used to determine dimensions A and B. In a practical installation the junction of the transmission line and stub would be a T connector.

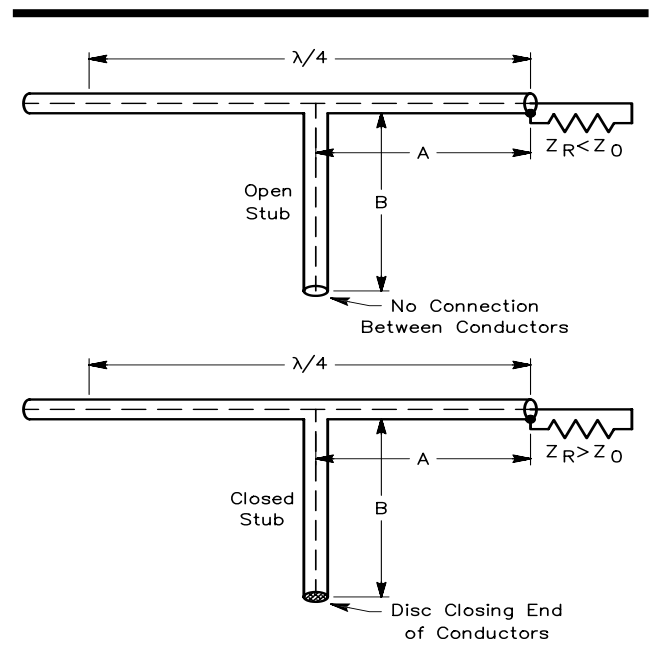

Fig 19—Open and closed stubs on coaxial lines.

A special case is the use of a coaxial matching stub, in which the stub is associated with the transmission line in such a way as to form a balun. This is described in detail later on in this chapter. The antenna is shortened to introduce just enough reactance at its feed point to permit the matching stub to be connected there, rather than at some other point along the transmission line as in the general cases discussed here. To use this method the antenna resistance must be lower than the Z_0 of the main transmission line, since the resistance is transformed to a higher value. In beam antennas such as Yagis, this will nearly always be the case.

Matching Sections

If the two antenna systems in Fig 18 are redrawn in somewhat different fashion, as shown in Fig 20, a system results that differs in no consequential way from the matching stubs described previously, but in which the stub formed by A and B together is called a *quarter-wave matching section*. The justification for this is that a $\lambda/4$ section of

line is similar to a resonant circuit, as described earlier in this chapter. It is therefore possible to use the $\lambda/4$ section to transform impedances by tapping at the appropriate point along the line.

Earlier equations give design data for matching sections, A being the distance from the antenna to the point at which the line is connected, and A + B being the total length of the matching section. The equations apply only in the case where the characteristic impedance of the matching section and transmission line are the same. Equations are available for the case where the matching section has a different Z_0 than the line, but are somewhat complicated. A graphic solution for different line impedances may be obtained with the Smith Chart (Chapter 28).

Adjustment

In the experimental adjustment of any type of matched line it is necessary to measure the SWR with fair accuracy in order to tell when the adjustments are being made in the proper direction. In the case of matching stubs, experience has shown that experimental adjustment is unnecessary, from a practical standpoint, if the SWR is first measured with the stub not connected to the transmission line, and the stub is then installed according to the design data.

Broadband Matching Transformers

Broadband transformers have been used widely because of their inherent bandwidth ratios (as high as 20,000:1) from a few tens of kilohertz to over a thousand megahertz. This is possible because of the transmission-line nature of the windings. The interwinding capacitance is a component of the characteristic impedance and therefore, unlike a conventional transformer, forms no resonances that seriously limit the bandwidth.

At low frequencies, where interwinding capacitances can be neglected, these transformers are similar in operation to a conventional transformer. The main difference (and a very important one from a power standpoint) is that the windings tend to cancel out the induced flux in the core. Thus, high permeability ferrite cores, which are not only highly nonlinear but also suffer serious damage even at flux levels as low as 200 to 500 gauss, can be used. This greatly extends the low frequency range of performance. Since higher permeability also permits fewer turns at the lower frequencies, HF performance is also improved since the upper cutoff is determined mainly from transmission line considerations. At the high frequency cutoff, the effect of the core is negligible.

Bifilar matching transformers lend themselves to unbalanced operation. That is, both input and output terminals can have a common ground connection. This eliminates the third magnetizing winding required in balanced to unbalanced (*voltage balun*) operation. By adding third and fourth windings, as well as by tapping windings at appropriate points, various combinations of broadband matching can be obtained. Fig 21 shows a 4:1 unbalanced

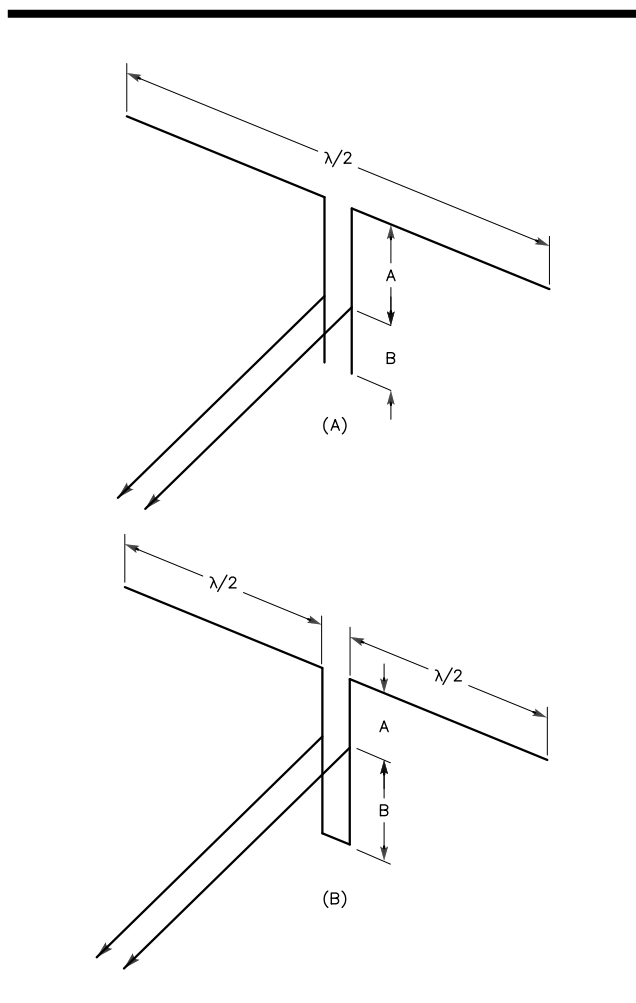

Fig 20—Application of matching sections to common antenna types.

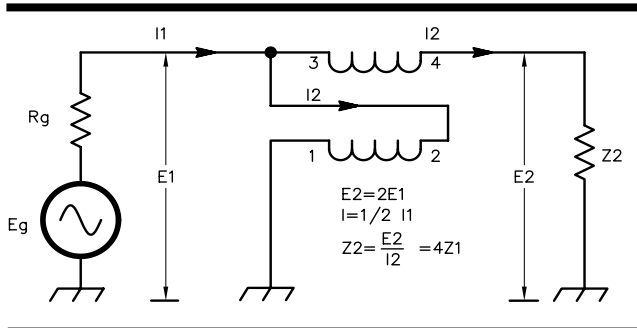

Fig 21—Broadband bifilar transformer with a 4:1 impedance ratio. The upper winding can be tapped at appropriate points to obtain other ratios such as 1.5:1, 2:1 and 3:1.

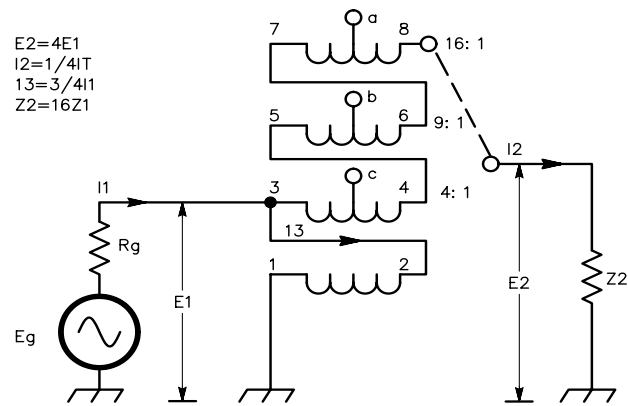

Fig 22—Four-winding, broadband, variable impedance transformer. Connections a, b and c can be placed at appropriate points to yield various ratios from 1.5:1 to 16:1.

to unbalanced configuration using #14 wire. It will easily handle 1000 W of power. By tapping at points $\frac{1}{4}$, $\frac{1}{2}$ and $\frac{3}{4}$ of the way along the top winding, ratios of approximately 1.5:1, 2:1 and 3:1 can also be obtained. One of the wires should be covered with vinyl electrical tape in order to prevent voltage breakdown between the windings. This is necessary when a step-up ratio is used at high power to match antennas with impedances greater than 50 Ω .

Fig 22 shows a transformer with four windings, permitting wide-band matching ratios as high as 16:1. **Fig 23** shows a four-winding transformer with taps at 4:1, 6:1, 9:1, and 16:1. In tracing the current flow in the windings when using the 16:1 tap, one sees that the top three windings carry the same current. The bottom winding, in order to maintain the proper potentials, sustains a current three times greater. The bottom current cancels out the core flux caused by the other three windings. If this transformer is used to match into low impedances, such as 3 to 4 Ω , the current in the bottom winding can be as

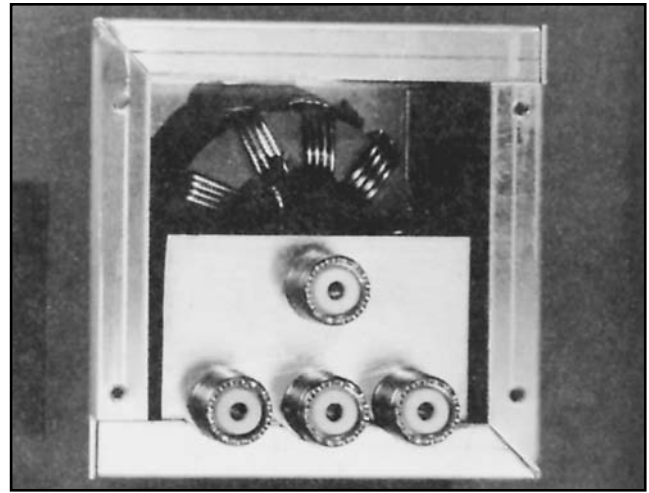

Fig 23—A 4-winding, wide-band transformer (with front cover removed) with connections made for matching ratios of 4:1, 6:1, 9:1 and 16:1. The 6:1 ratio is the top coaxial connector and, from left to right, 16:1, 9:1 and 4:1 are the others. There are 10 quadrifilar turns of #14 enameled wire on a Q1, 2.5-in. OD ferrite core.

high as 15 amperes. This value is based on the high side of the transformer being fed with 50- Ω cable handling a kilowatt of power. If one needs a 16:1 match like this at high power, then cascading two 4:1 transformers is recommended. In this case, the transformer at the lowest impedance side requires each winding to handle only 7.5 A. Thus, even #14 wire would suffice in this application.

The popular cores used in these applications are 2.5 inches OD ferrites of Q1 and Q2 material, and powdered-iron cores of 2 inches OD. The permeabilities of these cores, μ , are nominally 125, 40 and 10 respectively. Powdered-iron cores of permeabilities 8 and 25 are also available.

In all cases these cores can be made to operate over the 1.8 to 28-MHz bands with full power capability and very low loss. The main difference in their design is that lower permeability cores require more turns at the lower frequencies. For example, Q1 material requires 10 turns to cover the 1.8-MHz band. Q2 requires 12 turns, and powdered-iron ($\mu = 10$) requires 14 turns. Since the more common powdered iron core is generally smaller in diameter and requires more turns because of lower permeability, higher ratios are sometimes difficult to obtain because of physical limitations. When you are working with low impedance levels, unwanted parasitic inductances come into play, particularly on 14 MHz and above. In this case lead lengths should be kept to a minimum.

Common-Mode Transmission-Line Currents

In discussions so far about transmission-line operation, it was always assumed that the two conductors carry equal and opposite currents throughout their length. This is an ideal condition that may or may not be realized in practice. In the average case, the chances are rather good that the currents will not be balanced unless special precautions are taken. The degree of imbalance—and whether that imbalance is actually important—is what we will examine in the rest of this chapter, along with measures that can be taken to restore balance in the system.

There are two common conditions that will cause an imbalance of transmission-line currents. Both are related to the symmetry of the system. The first condition involves the lack of symmetry when an inherently *unbalanced* coaxial line feeds a *balanced* antenna (such as a dipole or a Yagi driven element) directly. The second condition involves asymmetrical routing of a transmission line near the antenna it is feeding.

UNBALANCED COAX FEEDING A BALANCED DIPOLE

Fig 24 shows a coaxial cable feeding a hypothetical balanced dipole fed in the center. The coax has been drawn highly enlarged to show all currents involved. In this drawing the feed line drops at right angles down from the feed point and the antenna is assumed to be perfectly symmetrical. Because of this symmetry, one side of the antenna induces current on the feed line that is completely cancelled by the current induced from the other side of the antenna.

Currents I_1 and I_2 from the transmitter flow on the inside of the coax. I_1 flows on the *outer surface* of the coax's inner conductor and I_2 flows on the *inner surface* of the shield. Skin effect keeps I_1 and I_2 inside the transmission line confined to where they are within the line. The field outside the coax is zero, since I_1 and I_2 have equal amplitudes but are 180° out of phase with respect to each other.

The currents flowing on the antenna itself are labeled I_1 and I_4 , and both flow in the same direction at any instant in time for a resonant half-wave dipole. On Arm 1 of the dipole, I_1 is shown going directly into the center conductor of the feed coax. However, the situation is different for the other side of this dipole. Once current I_2 reaches the end of the coax, it splits into two components. One is I_4 , going directly into Arm 2 of the dipole. The other is I_3 and this flows down the *outer surface* of the coax shield. Again, because of skin effect, I_3 is separate and distinct from the current I_2 on the inner surface. The antenna current in Arm 2 is thus equal to the difference between I_2 and I_3 .

The magnitude of I_3 is proportional to the relative impedances in each current path beyond the split. The feed-point impedance of the dipole by itself is somewhere

between 50 to 75 Ω , depending on the height above ground. The impedance seen looking into one half of the dipole is half, or 25 to 37.5 Ω . The impedance seen looking down the outside surface of the coax's outer shield to ground is called the *common-mode impedance*, and I_3 is aptly called the *common-mode current*. (The term common mode is more readily appreciated if parallel-conductor line is substituted for the coaxial cable used in this illustration. Current induced by radiation onto both conductors of a two-wire line is a common-mode current, since it flows in the *same direction* on both conductors, rather than in opposite directions as it does for transmission-line current. The outer braid for a coaxial cable shields the inner conductor from such an induced current, but the unwanted current on the outside braid is still called *common-mode current*.)

The common-mode impedance will vary with the length of the coaxial feed line, its diameter and the path length from the transmitter chassis to whatever is actually "RF ground." Note that the path from the transmitter chassis to ground may go through the station's grounding bus, the transmitter power cord, the house wiring and even the power-line service ground. In other words, the overall length of the coaxial outer surface and the other components making up ground can actually be quite a bit different from what you might expect by casual inspection.

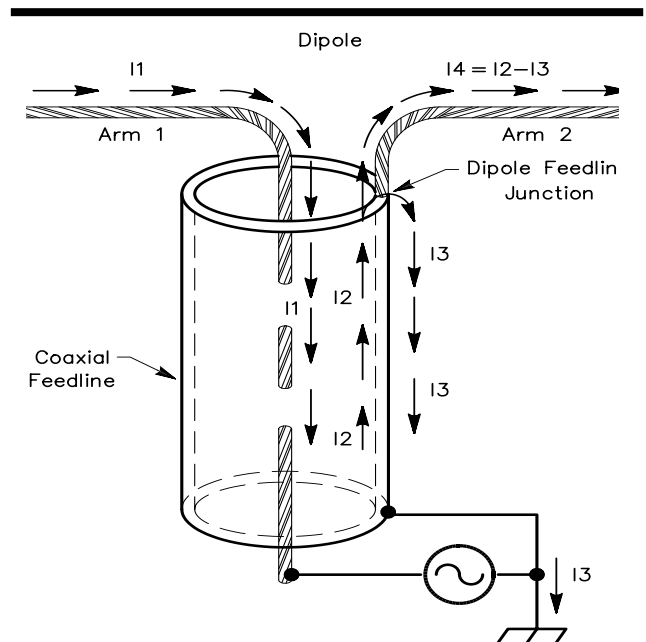

Fig 24—Drawing showing various current paths at feed point of a balanced dipole fed with unbalanced coaxial cable. The diameter of the coax is exaggerated to show currents clearly.

The worst-case common-mode impedance occurs when the overall effective path length to ground is a multiple of $\lambda/2$, making this path half-wave resonant. In effect, the line and ground-wire system acts like a sort of transmission line, transforming the short circuit to ground at its end to a low impedance at the dipole's feed point. This causes I3 to be a significant part of I2.

I3 not only causes an imbalance in the amount of current flowing in each arm of the otherwise symmetrical dipole, but it also radiates by itself. The radiation in Fig 24 due to I3 would be mainly vertically polarized, since the coax is drawn as being mainly vertical. However the polarization is a mixture of horizontal and vertical, depending on the orientation of the ground wiring from the transmitter chassis to the rest of the station's grounding system.

Pattern Distortion for a Simple Dipole with Symmetrical Coax Feed

Fig 25 compares the azimuthal radiation pattern for two $\lambda/2$ -long 14-MHz dipoles mounted horizontally $\lambda/2$ above average ground. Both patterns were computed for a 28° elevation angle, the peak response for a $\lambda/2$ -high dipole. The model for the first antenna, the reference dipole shown as a solid line, has no feed line associated with it—it is as though the transmitter were somehow remotely located right at the center of the dipole. This antenna displays a classical figure-8 pattern. Both side nulls dip symmetrically about 10 dB below the peak response, typical for a 20-meter dipole 33 feet above ground (or an 80-meter dipole placed 137 feet above ground).

The second dipole, shown as a dashed line, is modeled using a $\lambda/2$ -long coaxial feed line dropped vertically to the ground below the feed point. Now, the azimuthal response of the second dipole is no longer perfectly symmetrical. It is shifted to the left a few dB in the area of the side nulls and the peak response is down about 0.1 dB compared to the reference dipole. Many would argue that this sort of response isn't all that bad! However, do keep in mind that this is for a feed line placed in a symmetrical manner, at a right angle below the dipole. Asymmetry in dressing the coax feed line will result in more pattern distortion.

SWR Change with Common-Mode Current

If an SWR meter is placed at the bottom end of the coax feeding the second dipole, it would show an SWR of 1.38:1 for a 50- Ω coax such as RG-213, since the antenna's feed-point impedance is $69.20 + j 0.69 \Omega$. The SWR for the reference dipole would be 1.39:1, since its feed-point impedance is $69.47 - j 0.35 \Omega$. As could be expected, the common-mode impedance in parallel with the dipole's natural feed-point impedance has lowered the net impedance seen at the feed point, although the degree of impedance change is miniscule in this particular case with a symmetrical feed line dressed away from the antenna.

In theory at least, we have a situation where a change

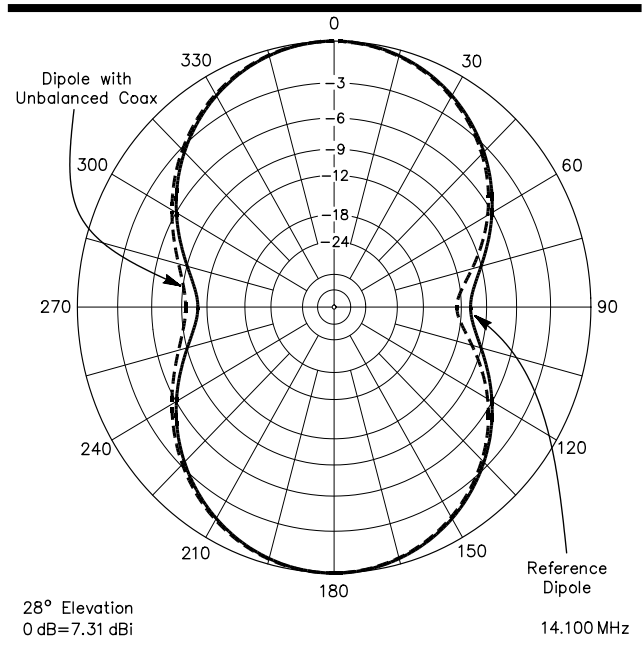

Fig 25—Comparison of azimuthal patterns of two $\lambda/2$ -long 14-MHz dipoles mounted $\lambda/2$ over average ground. The reference dipole without effect of feed-line distortion (modeled as though the transmitter were located right at the feed point) is the solid line. The dashed line shows the pattern for the dipole affected by common-mode current on its feed line due to the use of unbalanced coax to feed a balanced antenna. The feed line is dropped directly from the feed point to ground in a symmetrical configuration changes only a small amount compared to the reference antenna.

in the length of the unbalanced coaxial cable feeding a balanced dipole will cause the SWR on the line to change also. This is due to the changing common-mode impedance to ground at the feed point. The SWR may even change if the operator touches the SWR meter, since the path to RF ground is subtly altered when this happens. Even changing the length of an antenna to prune it for resonance may also yield unexpected, and confusing, results on the SWR meter because of the common-mode impedance.

When the overall effective length of the coaxial feed line to ground is not a multiple of a $\lambda/2$ resonant length but is an odd multiple of $\lambda/4$, the common-mode impedance transformed to the feed point is high in comparison to the dipole's natural feed-point impedance. This will cause I3 to be small in comparison to I2, meaning that radiation by I3 itself and the imbalance between I1 and I4 will be minimal. Modeling this case produces no difference in response between the dipole with unbalanced feed line and the reference dipole with no feed line. Thus, a multiple of a half-wave length for coax and ground wiring represents the *worst case* for this kind of imbalance.

ance, when the system is otherwise symmetrical.

If the coax in Fig 25 were replaced with balanced transmission line, the SWR would remain constant along the line, no matter what the length. (To put a fine point on it, the SWR would actually decrease slightly toward the transmitter end. This is because of line loss with SWR. However, the decrease would be slight, because the loss in open-wire balanced transmission line is small, even with relatively high SWR on the line. See Chapter 24 for a thorough discussion on additional line loss due to SWR.)

Size of Coax

At HF, the diameter of the coax feeding a $\lambda/2$ dipole is only a tiny fraction of the length of the dipole itself. In the case of Fig 25 above, the model of the coax used assumed an exaggerated 9-inch diameter, just to simulate a worst-case effect of coax spacing at HF.

However, on the higher UHF and microwave frequencies, the assumption that the coax spacing is not a significant portion of a wavelength is no longer true. The plane bisecting the feed point of the dipole in Fig 25 down through the space below the feed point and in-between the center conductor and shield of the coax is the “center” of the system. If the coax diameter is a significant percentage of the wavelength, the center is no longer symmetrical with reference to the dipole itself and significant imbalance will result. Measurements done at microwave frequencies showing extreme pattern distortion for balunless dipoles may well have suffered from this problem.

ASYMMETRICAL ROUTING OF THE FEED LINE FOR A DIPOLE

Fig 25 shows a symmetrically located coax feed line, one that drops vertically at a 90° angle directly below the feed point of the symmetrical dipole. What happens if the feed line is not dressed away from the antenna in a completely symmetrical fashion—that is, not at a right angle to the dipole?

Fig 26 illustrates a situation where the feed line goes to the transmitter and ground at a 45° angle from the dipole. Now, one side of the dipole can radiate more strongly onto the feed line than the other half can. Thus, the currents radiated onto the feed line from each half of the symmetrical dipole won't cancel each other. In other words, the antenna itself radiates a common-mode current onto the transmission line. This is a different form of common-mode current from what was discussed above in connection with an unbalanced coax feeding a balanced dipole, but it has similar effects.

Fig 27 shows the azimuthal response of a $0.71\text{-}\lambda$ -high reference dipole with no feed line (as though the transmitter were located right at the feed point) compared to a $0.71\text{-}\lambda$ -high dipole that uses a $1\text{-}\lambda$ -long coax feed line, slanted 45° from the feed point down to ground through the transmitter. The $0.71\text{-}\lambda$ height was used so that the slanted coax could be exactly 1λ long, directly grounded

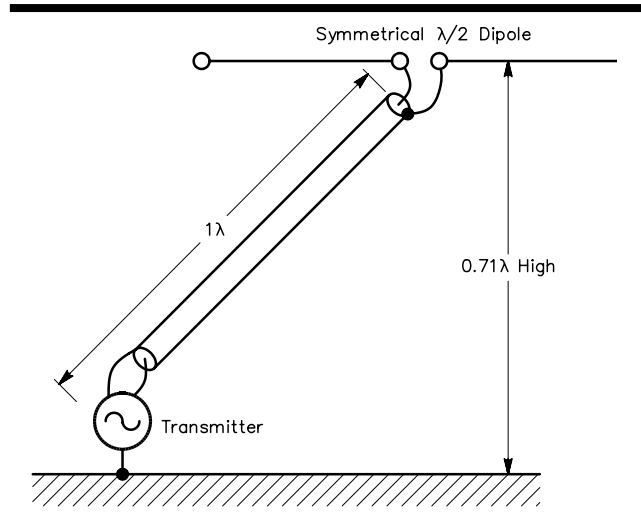

Fig 26—Drawing of $\lambda/2$ dipole, placed 0.71λ above average ground, with a $1\text{-}\lambda$ long coax feed line connected at far end to ground through a transmitter. Worst-case feed line radiation due to common-mode current induced on the outer shield braid occurs for lengths that are multiples of $\lambda/2$.

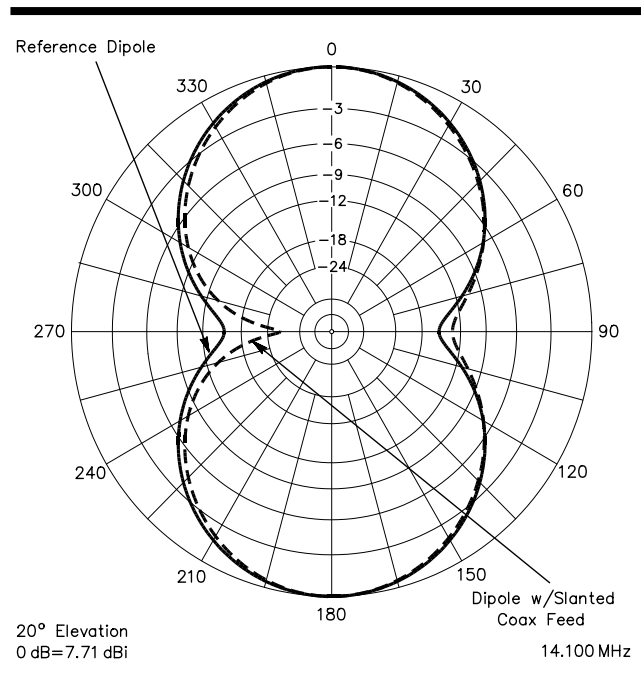

Fig 27—Azimuthal response for two dipoles placed as shown in Fig 26. The solid line represents a reference dipole with no feed line (modeled as though the transmitter were located directly at the feed point). The dashed line shows the response of the antenna with feed line slanted 45° down to ground. Current induced on the outer braid of the $1\text{-}\lambda$ -long coax by its asymmetry with respect to the antenna causes the pattern distortion. The feed-point impedance also changes, causing a different SWR from that for the unaffected reference dipole.

at its end through the transmitter and so that the low-elevation angle response could be emphasized to show pattern distortion. The feed line was made 1λ long in this case, because when the feed line length is only 0.5λ and is slanted 45° to ground, the height of the dipole is only 0.35λ . This low height masks changes in the nulls in the azimuthal response due to feed line common-mode currents. Worst-case pattern distortion occurs for lengths that are multiples of $\lambda/2$, as before.

The degree of pattern distortion is now slightly worse than that for the symmetrically placed coax, but once again, the overall effect is not really severe. Interestingly enough, the slanted-feed line dipole actually has about 0.2 dB more gain than the reference dipole. This is because the left-hand side null is deeper for the slanted-feed line antenna, adding power to the frontal lobes at 0° and 180° .

The feed-point impedance for this dipole with slanted feed line is $62.48 - j 1.28 \Omega$ for an SWR of 1.25:1, compared to the reference dipole's feed-point impedance of $72.00 + j 16.76 \Omega$ for an SWR of 1.59:1. Here, the reactive part of the net feed-point impedance is smaller than that for the reference dipole, indicating that detuning has occurred due to mutual coupling to its own feed line. This change of SWR is slightly larger than for the previous case and could be seen on a typical SWR meter.

You should recognize that common-mode current arising from radiation from a balanced antenna back onto its transmission line due to a lack of symmetry occurs for *both* coaxial or balanced transmission lines. For a coax, the inner surface of the shield and the inner conductor are shielded from such radiation by the outer braid. However, the outer surface of the braid carries common-mode current radiated from the antenna and then subsequently reradiated by the line. For a balanced line, common-mode current are induced onto both conductors of the balanced line, again resulting in reradiation from the balanced line.

If the *antenna or its environment* are not perfectly symmetrical in all respects, there will also be some degree of common-mode current generated on the transmission line, either coax or balanced. Perfect symmetry means that the ground would have to be perfectly flat everywhere under the antenna, and that the physical length of each leg of the antenna would have to be exactly the same. It also means that the height of the dipole must be exactly symmetrical all along its length, and it even means that nearby conductors, such as power lines, must be completely symmetrical with respect to the antenna.

In the real world, where the ground isn't always perfectly flat under the whole length of a dipole and where wire legs aren't cut with micrometer precision, a balanced line feeding a supposedly balanced antenna is no guarantee that common-mode transmission-line currents will not occur! However, dressing the feed line so that it is symmetrical to the antenna will lead to fewer problems in all cases.

COMMON-MODE EFFECTS WITH DIRECTIONAL ANTENNAS

For a simple dipole, many amateurs would look at Fig 25 or Fig 27 and say that the worst-case pattern asymmetry doesn't look very important, and they would be right. Any minor, unexpected change in SWR due to common-mode current would be shrugged off as inconsequential—if indeed it is even noticed. All around the world, there are many thousands of coax-fed dipoles in use, where no special effort has been made to smooth the transition from unbalanced coax to balanced dipole.

For antennas that are specifically designed to be highly directional, however, pattern deterioration resulting from common-mode currents is a very different matter. Much care is usually taken during design of a directional antenna like a Yagi or a quad to tune each element in the system for the best compromise between directional pattern, gain and SWR bandwidth. What happens if we feed such a carefully tailored antenna in a fashion that creates common-mode feed line currents?

Fig 28 compares the azimuthal response of two five-element 20-meter Yagis, each located horizontally $\lambda/2$ above average ground. The solid line represents the reference antenna, where it is assumed that the transmitter is located right at the balanced driven element's feed point without the need for an intervening feed line. The dashed line represents the second Yagi, which is modeled with a $\lambda/2$ -long unbalanced coaxial feed line going to ground directly under the balanced driven element's feed point.

Minor pattern skewing evident in the case of the dipole now becomes definite deterioration in the rearward pattern of the otherwise superb pattern of the reference Yagi. The side nulls deteriorate from more than 40 dB to about 25 dB. The rearward lobe at 180° goes from 26 dB to about 22 dB. In short, the pattern gets a bit ugly and the gain decreases as well.

Fig 29 shows a comparison at 0.71λ height between a reference Yagi with no feed line and a Yagi with a 1λ -long feed line slanted 45° to ground. Side nulls that were deep (at more than 30 dB down) for the reference Yagi have been reduced to less than 18 dB in the common-mode afflicted antenna. The rear lobe at 180° has deteriorated mildly, from 28 dB to about 26 dB. The forward gain of the antenna has fallen 0.4 dB from that of the reference antenna. As expected, the feed-point impedance also changes, from $22.3 - j 25.2 \Omega$ for the reference Yagi to $18.5 - j 29.8 \Omega$ for the antenna with the unbalanced feed. The SWR will also change with line length on the balanced Yagi fed with unbalanced line, just as it did for the simple dipole.

Clearly, the pattern of what is supposed to be a highly directional antenna can be seriously degraded by the presence of common-mode currents on the coax feed line. As in the case of the simple dipole, an odd multiple of $\lambda/2$ -long resonant feed line to ground represents the worst-case feed system, even when the feed line is dressed

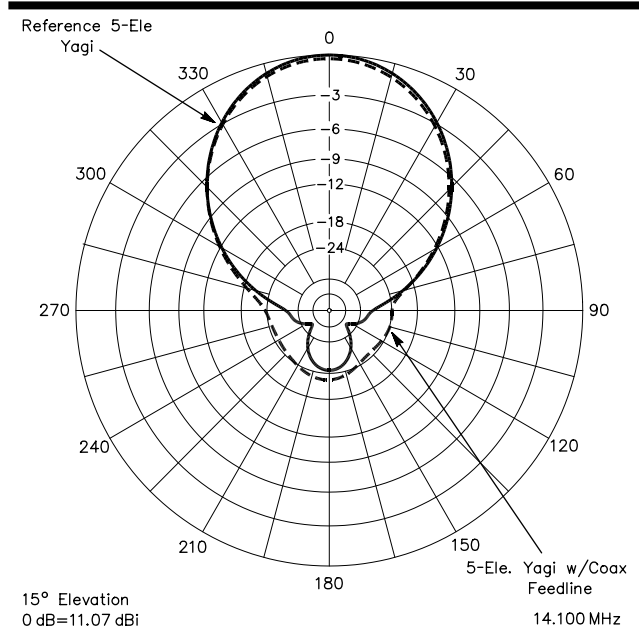

Fig 28—Azimuthal response for two five-element 20-meter Yagis placed $\lambda/2$ over average ground. The solid line represents an antenna fed with no feed line, as though the transmitter were located right at the feed point. The dashed line represents a dipole fed with a $\lambda/2$ length of unbalanced coax line directly going to ground (through a transmitter at ground level). The distortion in the rearward pattern is evident, and the Yagi loses a small amount of forward gain (0.3 dB) compared to the reference antenna. In this case, placing a common-mode choke of $+j 1000 \Omega$ at the feed point eliminated the pattern distortion.

symmetrically at right angles below the antenna. And as found with the dipole, the pattern deterioration becomes even worse if the feed line is dressed at a slant under the antenna to ground, although this sort of installation with a Yagi is not very common. For least interaction, the feed line still should be dressed so that it is symmetrical with respect to the antenna.

ELIMINATING COMMON-MODE CURRENTS—THE BALUN

In the preceding sections, the problems of directional pattern distortion and unpredictable SWR readings were traced to common-mode currents on transmission lines. Such common-mode currents arise from several types of asymmetry in the antenna-feed line system—either a mismatch between unbalanced feed line and a balanced antenna, or lack of symmetry in placement of the feed line. A device called a *balun* can be used to eliminate these common-mode currents.

The word *balun* is a contraction of the words *balanced* to *unbalanced*. Its primary function is to prevent common-mode currents, while making the transition from

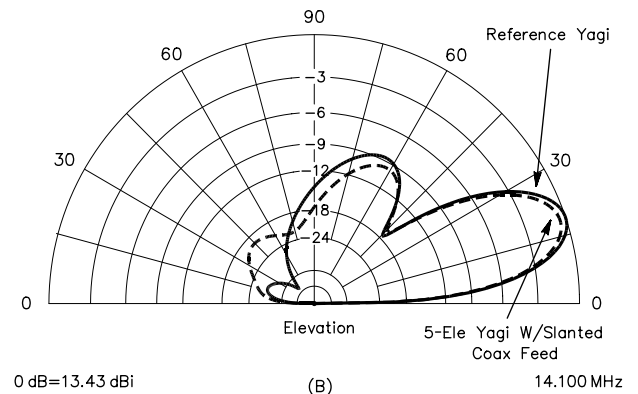
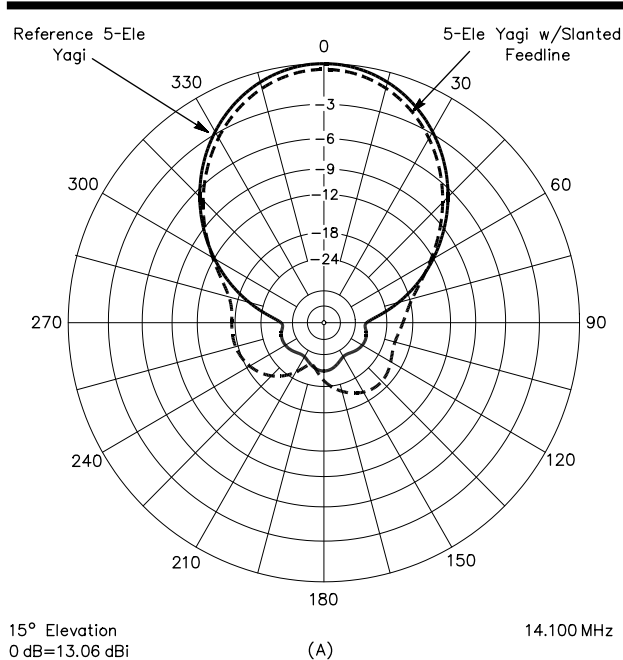

Fig 29— At A, azimuthal response for two five-element 20-meter Yagis placed 0.71λ over average ground. The solid line represents an antenna fed with no feed line. The dashed line represents a dipole fed with a $1-\lambda$ length of unbalanced coax line slanted at 45° to ground (through a transmitter at ground level). The distortion in the rearward pattern is even more evident than in Fig 28. This Yagi loses a bit more forward gain (0.4 dB) compared to the reference antenna. At B, elevation response comparison. The slant of the feed line causes more common-mode current due to asymmetry. In this case, placing a common-mode choke of $+j 1000 \Omega$ at the feed point was not sufficient to eliminate the pattern distortion substantially. Another choke was required $\lambda/4$ farther down the transmission line to eliminate common-mode currents of all varieties.

an unbalanced transmission line to a balanced load such as an antenna. Baluns come in a variety of forms, which we will explore in this section.

The Common-Mode Coax Choke Balun

In the computer models used to create Figs 25, 27 and 28, placing a *common-mode choke* whose reactance

is $+j 1000 \Omega$ at the antenna's feed point removed virtually all traces of the problem. This was always true for the simple case where the feed line was dressed symmetrically, directly down under the feed point. Certain slanted-feed line lengths required additional common-mode chokes, placed at $\lambda/4$ intervals down the transmission line from the feed point.

The simplest method to create a common-mode choke balun with coaxial cable is to wind up some of it into a coil at the feed point of the antenna. The normal transmission-line currents inside the coax are unaffected by the coiled configuration, but common-mode currents trying to flow on the outside of the coax braid are *choked off* by the reactance of the coil. This coax-coil choke could also be referred to as an "air-wound" choke, since no ferrite-core material is used to help boost the common-mode reactance at low frequencies.

A coax choke can be made like a flat coil—that is, like a coil of rope whose adjacent turns are carefully placed side-by-side to reduce inter-turn distributed capacity, rather than in a *scramble-wound* fashion. Sometimes a coil form made of PVC is used to keep things orderly. This type of choke shows a broad resonance due to its inductance and distributed capacity that can easily cover three amateur bands; for example, 14 to 30 MHz. **Fig 30** shows such a balun—a 6-turn coil of RG-213 wound into a 6½-inch OD coil, held together with black vinyl electrical tape. This construction technique is not effective with twin lead because of excessive coupling between adjacent turns.

Ed Gilbert, K2SQ (ex-WA2SRQ) measured a series of coaxial-coil baluns with a Hewlett-Packard 4193A vector-impedance meter. He constructed the coiled-coax baluns using either 4-inch plastic "sewer pipe" or 6-inch "schedule 40" PVC pipe for a coil form and close-wound the coax onto each form. He also "bunched up" the coax coil without using a coil form to see the effect on the parallel-resonant frequency formed by the coil inductance



Fig 30—An RF choke is formed by coiling the coax at the point of connection to the antenna. The inductance of the choke isolates the antenna from the remainder of the feed line. See text for details.

and coil capacitance between turns. Above the parallel-resonant frequency, the impedance becomes capacitive and the choking performance decreases with increasing frequency.

Table 3 lists K2SQ's results. He recommended 6 turns of RG-213 on a 4-inch form for 14 to 30 MHz operation, and 12 turns of RG-213 on a 4-inch form for 7 or 10 MHz operation. K2SQ's measurements suggest that better and more-predictable performance can be achieved with a single layer of coax used as a coil winding—rather than bunching the turns together, where you increase the interwinding capacitance.

Schematic Representation of a Choke Balun

The choke-type of balun is sometimes referred to as a *current balun* since it has the hybrid properties of a tightly coupled transmission-line transformer (with a 1:1 transformation ratio) and a coil. The transmission-line transformer forces the current at the output terminals to be equal, and the coil portion chokes off common-mode currents.

See **Fig 31** for a schematic representation of such a balun. This characterization is attributed to Frank Witt, AI1H. Z_W is the winding impedance that chokes off common-mode currents. The winding impedance is mainly inductive if a high-frequency ferrite core is involved, while it is mainly resistive if a low-frequency ferrite core is used. The *ideal transformer* in this characterization models what happens either inside a coax or for a pair of perfectly coupled parallel wires in a two-wire transmission line. Although Z_W is shown here as a single impedance, it could be split into two equal parts, with one placed on each side of the ideal transformer.

Note that you can compute the amount of power lost in a balun by transforming the polar representation (impedance magnitude and phase angle) shown in Table 3 to the equivalent parallel form (R_p resistance and X_p shunt reactance). The power lost in the balun is then the square of half the voltage across the load divided by the

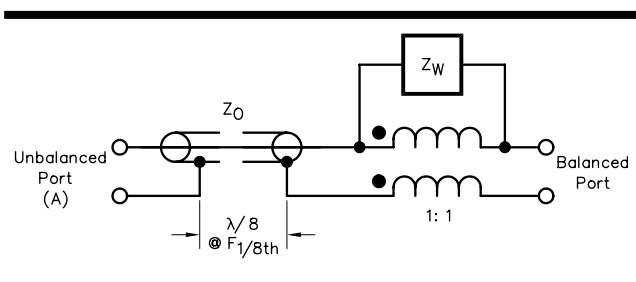

Fig 31—Choke balun model, also known as a 1:1 current balun. The transformer is an ideal transformer. Z_W is the common-mode winding impedance. Sources of loss are the resistive part of the winding impedance and loss in the transmission line. This model is by Frank Witt, AI1H.

Table 3

K2SQ (ex-WA2SRQ) Measurements on Coiled-Coax Baluns

Freq. MHz	6 T, 4.25" 1 Layer	12 T, 4.25" 1 Layer	4 T, 6.625" 1 Layer	8 T, 6.625" 1 Layer	8 T, 6.625" Bunched
	Z, Phase Ω/\circ	Z, Phase Ω/\circ	Z, Phase Ω/\circ	Z, Phase Ω/\circ	Z, Phase Ω/\circ
1	26/88.1	65/89.2	26/88.3	74/89.2	94/89.3
2	51/88.7	131/89.3	52/88.8	150/89.3	202/89.2
3	77/88.9	200/89.4	79/89.1	232/89.3	355/88.9
4	103/89.1	273/89.5	106/89.3	324/89.4	620/88.3
5	131/89.1	356/89.4	136/89.2	436/89.3	1300/86.2
6	160/89.3	451/89.5	167/89.3	576/89.1	8530/59.9
7	190/89.4	561/89.5	201/89.4	759/89.1	2120/-81.9
8	222/89.4	696/89.6	239/89.4	1033/88.8	1019/-85.7
9	258/89.4	869/89.5	283/89.4	1514/87.3	681/-86.5
10	298/89.3	1103/89.3	333/89.2	2300/83.1	518/-86.9
11	340/89.3	1440/89.1	393/89.2	4700/73.1	418/-87.1
12	390/89.3	1983/88.7	467/88.9	15840/-5.2	350/-87.2
13	447/89.2	3010/87.7	556/88.3	4470/-62.6	300/-86.9
14	514/89.3	5850/85.6	675/88.3	2830/-71.6	262/-86.9
15	594/88.9	42000/44.0	834/87.5	1910/-79.9	231/-87.0
16	694/88.8	7210/-81.5	1098/86.9	1375/-84.1	203/-87.2
17	830/88.1	3250/-82.0	1651/81.8	991/-82.4	180/-86.9
18	955/86.0	2720/-76.1	1796/70.3	986/-67.2	164/-84.9
19	1203/85.4	1860/-80.1	3260/44.6	742/-71.0	145/-85.1
20	1419/85.2	1738/-83.8	3710/59.0	1123/-67.7	138/-84.5
21	1955/85.7	1368/-87.2	12940/-31.3	859/-84.3	122/-86.1
22	3010/83.9	1133/-87.7	3620/-77.5	708/-86.1	107/-85.9
23	6380/76.8	955/-88.0	2050/-83.0	613/-86.9	94/-85.5
24	15980/-29.6	807/-86.3	1440/-84.6	535/-86.3	82/-85.0
25	5230/-56.7	754/-82.2	1099/-84.1	466/-84.1	70/-84.3
26	3210/-78.9	682/-86.4	967/-83.4	467/-81.6	60/-82.7
27	2000/-84.4	578/-87.3	809/-86.5	419/-85.5	49/-81.7
28	1426/-85.6	483/-86.5	685/-87.1	364/-86.2	38/-79.6
29	1074/-85.1	383/-84.1	590/-87.3	308/-85.6	28/-75.2
30	840/-83.2	287/-75.0	508/-87.0	244/-82.1	18/-66.3
31	661/-81.7	188/-52.3	442/-85.7	174/-69.9	9/-34.3
32	484/-78.2	258/20.4	385/-83.6	155/-18.0	11/37.2
33	335/-41.4	1162/-13.5	326/-78.2	569/-0.3	21/63.6
34	607/-32.2	839/-45.9	316/-63.4	716/-57.6	32/71.4
35	705/-58.2	564/-56.3	379/-69.5	513/-72.5	46/76.0

equivalent parallel resistance: $(E/2)^2/R_p$. For example, in Table 3 the balun made with 8 turns of RG-213 on a 6⁵/₈-inch diameter coil form at 14 MHz has an impedance of $262 \angle -86.9^\circ \Omega$. Converting polar to rectangular, this is $= 14.17 - j261.62 \Omega$ and converting series to parallel, we have $4844.8 \parallel -j262.38$. For an RF voltage of 273.9 V rms, the power lost in the balun is $(273.9/2)^2/(4844.8) = 3.9 \text{ W}$, while for a 50- Ω load the power is $273.9^2/50 = 1500 \text{ W}$. The amount of power lost in the balun is very small compared to the power delivered to the load.

Ferrite-Core Baluns

Ferrite-core baluns enlist magnetic materials to help provide a high common-mode impedance over the entire HF range. These baluns may be wound either with two conductors in bifilar fashion, or with a single coaxial

cable, onto rod or toroidal cores. A toroidal core is generally preferred because greater common-mode inductance can be achieved with fewer turns. See Fig 32. Like the coax balun in Fig 30, more inductance is needed for good low-frequency response, while fewer turns tends to aid high-frequency performance because less stray distributed capacity is present if the windings are spread out evenly around the circumference of the toroid.

All baluns used for high-power operation should be tested by checking for temperature rise before being put into full service. If the core overheats, especially at low frequencies, turns must be added or a larger or lower-loss core must be used. It also would be wise to investigate the cause of unusually high common-mode currents. Type 72, 73 or 77 ferrite will give the greatest impedance over the HF range. Type 43 ferrite has lower loss, but

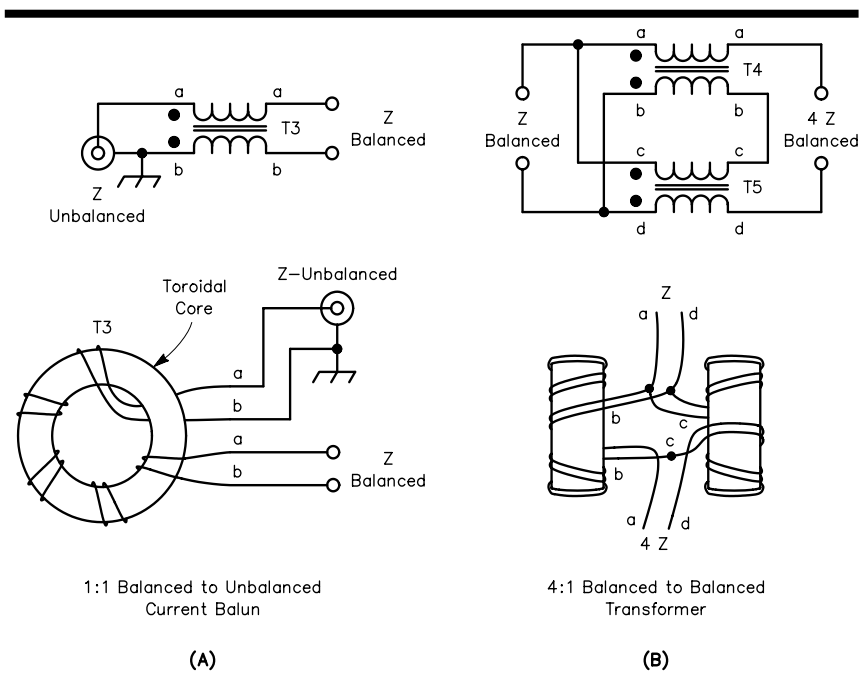

Fig 32—Ferrite-core baluns. Each uses transmission line techniques to achieve wide frequency coverage. The transmission line can consist of coaxial cable or tightly coupled (side-by-side) bifilar enameled wires. Typically, twelve turns of #10 wires wound on 2.4-inch toroidal cores with $\mu = 850$ will cover the whole range from 1.8 to 30 MHz. The 4:1 current balun at the right is wound on two cores, which are physically separated from each other.

somewhat less permeability. Core saturation is not a problem with these ferrites at HF; they will overheat because of losses at flux levels well below saturation.

Twelve turns of #10 wire on a 2.0 or 2.5-inch OD toroidal core with $\mu = 850$, such as an 2.4-inch OD Type 43 core, Amidon FT240-43, are typical values for 1:1 baluns that can cover the full HF range. **Table 4** lists the measured impedance over the MF-HF range for a balun made with #14 wires and #61 core material. This balun was a prototype for the High-Power ARRL Antenna Tuner described in Chapter 25. The final design used #10 wires, which had the same effectiveness in choking off common-mode currents but which could dissipate power better.

The W2DU Balun

Another type of choke balun that is very effective was originated by M. Walter Maxwell, W2DU. See **Fig 33**. A number of small ferrite cores may be placed directly over the coax where it is connected to the antenna. The bead balun shown in Fig 32 consists of 50 Amidon no. FB-73-2401 ferrite beads slipped over a 1-foot length of RG-58A coax, which basically serves as a “single-turn” inductor. The beads fit nicely over the insulating jacket of the coax and occupy a total length of 9½ inches.

Type 73 material is recommended for 1.8 to 30 MHz use, but type 77 material may be substituted; use type 43 material for 30 to 250 MHz. The cores present a high impedance to any RF current that would otherwise flow on the outside of the shield. The total impedance is in approximate proportion to the stacked length of the cores. Like the ferrite-core baluns described above, the impedance stays fairly constant over a wide range of frequen-

Table 4
Measurements on Ferrite Toroidal-Core 1:1 Current Balun

Frequency, MHz	Impedance, Ω
1.8	340
3.5	690
7.1	1860
14.3	7300
21.4	1820
29.7	470

12 bifilar turns #14 on FT240-61 core.

cies. Again, 70-series ferrites are a good choice for the HF range, with type 43 being useful if heating due to large common-mode currents is a problem. Type 43 or 61 is the best choice for the VHF range. Cores of various materials can be used in combination, permitting construction of baluns effective over a very wide frequency range, such as from 2 to 250 MHz.

Twelve Amidon FB-77-1024 or equivalent beads will come close to doing the same job using RG-8 or RG-213 coax. **Fig 34** shows a bead balun built by N6BV. This design uses a foot of RG-213, with a series of seven large ferrite beads strung together end-to-end over the coax’s outside vinyl jacket. The assembly in Fig 34 is shown without the vinyl electrical tape that will eventually be wound over the ferrite beads to secure and weather-proof them.

Table 5 shows impedance measurements made on the two homemade baluns shown in Figs 30 and 34, using an Autek RF-1 with alligator clips on short leads.

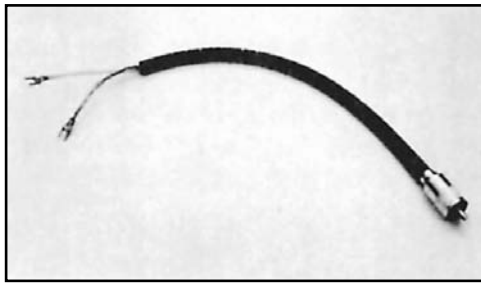

Fig 33—A W2DU bead balun consisting of 50 Amidon no. FB-73-2401 ferrite beads over a length of RG-58A coax. See text for details.



Fig 34—Choke balun made by N6BV, consisting of seven large ferrite beads strung over the jacket of a piece of RG-213 coax. This photo was taken before a layer of black electrical tape was wound over the beads to secure and waterproof the assembly on the cable.

An adequate balun shows a choking impedance greater than about ten times the characteristic impedance of the coax, or about 500 Ω for 50- Ω coax.

In his book *Reflections* W2DU listed the results of measurements he made on 50 small-diameter #73 ferrite beads (each 0.197-inch ID and 0.190 inches long) slipped over Teflon-dielectric RG-313, similar to the balun shown in Fig 33. Over the HF range from 2 to 30 MHz the impedance remained higher than 750 Ω . For VHF use, W2DU placed 25 #73 ferrite beads over a piece of RG-313 and measured a common-mode shield impedance of 500 Ω from 20 to 200 MHz.

You should be aware that the heat-dissipating capability of small-diameter ferrite beads can be exceeded where there is a serious imbalance that results in large common-mode currents. Beads nearest the feed point can become very warm and can even shatter under extreme conditions of imbalance. Be careful not to skimp on using sufficient beads to choke off common-mode currents in the first place.

Detuning Sleeves

**Table 5
N6BV Measurements on Coiled-Coax and Bead Baluns**

Frequency, MHz	Coil Balun Impedance, Ω	Bead Balun Impedance, Ω
3.5	432	2090
7.1	471	1010
14.3	> 2000	729
21.4	738	724
28.3	370	527

Coil balun is 6 turns RG-213, 6 $\frac{1}{2}$ -inch OD (see Fig 30). Bead Balun consists of 7 Chomerics CHO-SORB 9754 beads over RG-213 (see Fig 34).

The simple coax-coil balun covers the upper three HF bands reasonably well, while the bead balun covers the HF bands from 3.5 to 30 MHz even better.

The detuning sleeve shown in **Fig 35B** is essentially an air-insulated $\lambda/4$ line, but of the coaxial type, with the sleeve constituting the outer conductor and the outside of the coax line being the inner conductor. Because the impedance at the open end is very high, the unbalanced voltage on the coax line cannot cause much current to flow on the outside of the sleeve. Thus the sleeve acts just like a choke coil to isolate the remainder of the line from the antenna. (The same viewpoint can be used in explaining the action of the $\lambda/4$ arrangement shown at Fig 35A, but is less easy to understand in the case of baluns less than $\lambda/4$ long.)

A sleeve of this type may be resonated by cutting a small longitudinal slot near the bottom, just large enough to take a single-turn loop which is, in turn, link-coupled to a dip meter. If the sleeve is a little long to start with, a bit at a time can be cut off the top until the stub is resonant.

The diameter of the coaxial detuning sleeve in Fig 35B should be fairly large compared with the diameter of the cable it surrounds. A diameter of two inches or so is satisfactory with half-inch cable. The sleeve should be symmetrically placed with respect to the center of the antenna so that it will be equally coupled to both sides. Otherwise a current will be induced from the antenna to the outside of the sleeve. This is particularly important at VHF and UHF.

In both the balancing methods shown in Fig 35 the $\lambda/4$ section should be cut to be resonant at exactly the same frequency as the antenna itself. These sections tend to have a beneficial effect on the impedance-frequency characteristic of the system, because their reactance varies in the opposite direction to that of the antenna. For instance, if the operating frequency is slightly below resonance the antenna has capacitive reactance, but the shorted $\lambda/4$ sections or stubs have inductive reactance. Thus the reactances tend to cancel, which prevents the impedance from changing rapidly and helps maintain a low SWR on

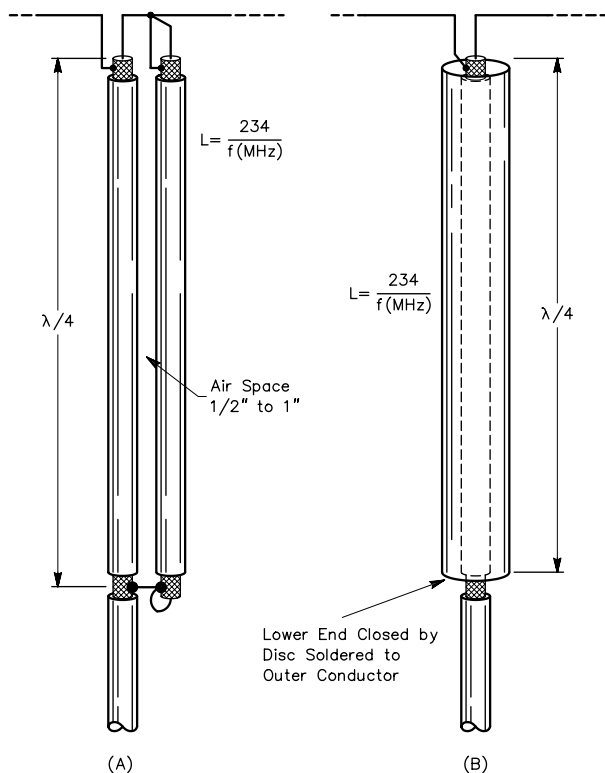

Fig 35—Fixed-balun methods for balancing the termination when a coaxial cable is connected to a balanced antenna. These baluns work at a single frequency. The balun at B is known as a “sleeve balun” and is often found at VHF.

the line over a band of frequencies.

Combined Balun and Matching Stub

In certain antenna systems the balun length can be considerably shorter than $\lambda/4$; the balun is, in fact, used as part of the matching system. This requires that the radiation resistance be fairly low as compared with the line Z_0 so that a match can be brought about by first shortening the antenna to make it have a capacitive reactance, and then using a shunt inductor across the antenna terminals to resonate the antenna and simultaneously raise the impedance to a value equal to the line Z_0 . This is the same principle used for hairpin matches. The balun is then made the proper length to exhibit the desired value of inductive reactance.

The basic matching method is shown in **Fig 36A**, and the balun adaptation to coaxial feed is shown in **Fig 36B**. The matching stub in **Fig 36B** is a parallel-line section, one conductor of which is the outside of the coax between point X and the antenna; the other stub conductor is an equal length of wire. (A piece of coax may be used instead, as in the balun in **Fig 35A**.) The spacing between

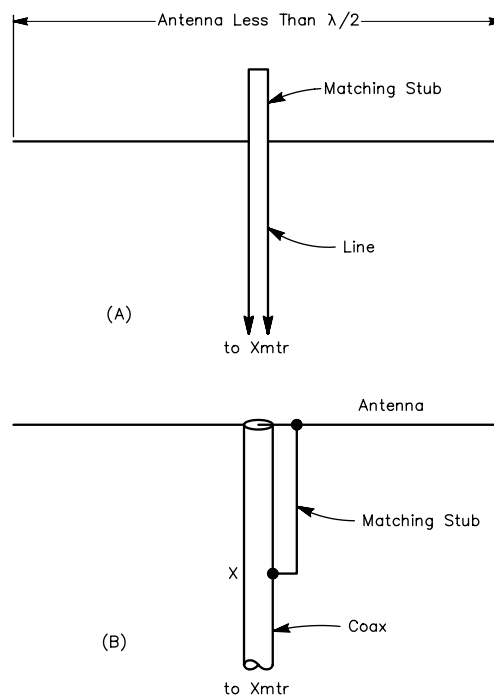

Fig 36—Combined matching stub and balun. The basic arrangement is shown at A. At B, the balun arrangement is achieved by using a section of the outside of the coax feed line as one conductor of a matching stub.

the stub conductors can be 2 to 3 inches. The stub of **Fig 36** is ordinarily much shorter than $\lambda/4$, and the impedance match can be adjusted by altering the stub length along with the antenna length. With simple coax feed, even with a $\lambda/4$ balun as in **Fig 35**, the match depends entirely on the actual antenna impedance and the Z_0 of the cable; no adjustment is possible.

Adjustment

When a $\lambda/4$ balun is used it is advisable to resonate it before connecting the antenna. This can be done without much difficulty if a dip meter or impedance analyzer is available. In the system shown in **Fig 35A**, the section formed by the two parallel pieces of line should first be made slightly longer than the length given by the equation. The shorting connection at the bottom may be installed permanently. With the dip meter coupled to the shorted end, check the frequency and cut off small lengths of the shield braid (cutting both lines equally) at the open ends until the stub is resonant at the desired frequency. In each case leave just enough inner conductor remaining to make a short connection to the antenna. After resonance has been established, solder the inner and outer conductors of the second piece of coax together and complete the

connections indicated in Fig 35A.

Another method is to first adjust the antenna length to the desired frequency, with the line and stub disconnected, then connect the balun and recheck the frequency. Its length may then be adjusted so that the overall system is again resonant at the desired frequency.

Construction

In constructing a balun of the type shown in Fig 35A, the additional conductor and the line should be maintained parallel by suitable spacers. It is convenient to use a piece of coax for the second conductor; the inner conductor can simply be soldered to the outer conductor at both ends since it does not enter into the operation of the device. The two cables should be separated sufficiently so that the vinyl covering represents only a small proportion of the dielectric between them. Since the principal dielectric is air, the length of the $\lambda/4$ section is based on a velocity factor of 0.95, approximately.

Impedance Step-Up/Step-Down Balun

A coax-line balun may also be constructed to give an impedance step-up ratio of 4:1. This form of balun is shown in Fig 37. If 75- Ω line is used, as indicated, the balun will provide a match for a 300- Ω terminating impedance. If 50- Ω line is used, the balun will provide a match for a 200- Ω terminating impedance. The U-shaped section of line must be an electrical length of $\lambda/2$ long, taking the velocity factor of the line into account. In most installations using this type of balun, it is customary to roll up the length of line represented by the U-shaped section into a coil of several inches in diameter. The coil turns may be bound together with electrical tape.

Because of the bulk and weight of the balun, this type is seldom used with wire-line antennas suspended by insulators at the antenna ends. More commonly it is used with multielement Yagi antennas, where its weight may be supported by the boom of the antenna system. See the K1FO designs in Chapter 18, VHF and UHF Antennas, where 200- Ω T-matches are used with such a balun.

Voltage Baluns

The voltage baluns shown in Fig 38A and Fig 38B, cause equal and opposite voltages to appear at the two output terminals, relative to the voltage at the cold side of the input. If the two antenna halves are perfectly balanced with respect to ground, the currents flowing from the output terminals will be equal and opposite and no common-mode current will flow on the line. This means that, if the line is coaxial, there will be no current flowing on the outside of the shield; if the line is balanced, the currents in the two conductors will be equal and opposite. These are the conditions for a nonradiating line.

Under this condition, the 1:1 voltage balun of Fig 38A performs exactly the same function as the cur-

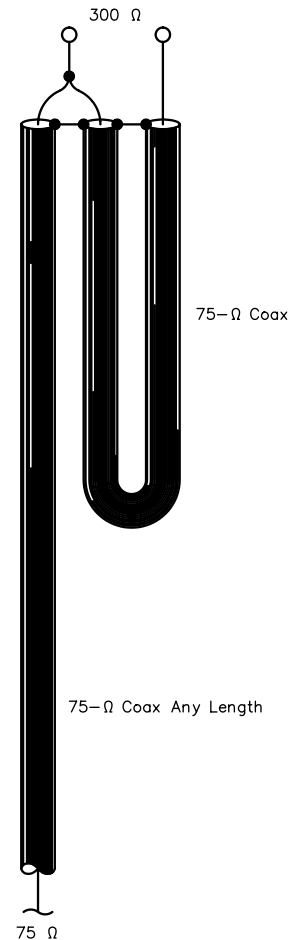

Fig 37—A balun that provides an impedance step-up ratio of 4:1. The electrical length of the U-shaped section of line is $\lambda/2$.

rent balun of Fig 34A, as there is no current in winding b. If the antenna isn't perfectly symmetrical, however, unequal currents will appear at the balun output, causing antenna current to flow on the line, an undesirable condition. Another potential shortcoming of the 1:1 voltage balun is that winding b appears across the line. If this winding has insufficient impedance (a common problem, particularly near the lower frequency end of its range), the system SWR will be degraded.

The 1:1 common-mode choke balun in Fig 33 or 34 is recommended for use at the junction of the antenna and feed line. However, voltage baluns still are commonly used in this application and may serve a useful function if the user is aware of their shortcomings.

ONE FINAL WORD

This is a good point to debunk a persistent myth among amateurs that a mismatched transmission line somehow radiates. This is absolutely not true! The loss

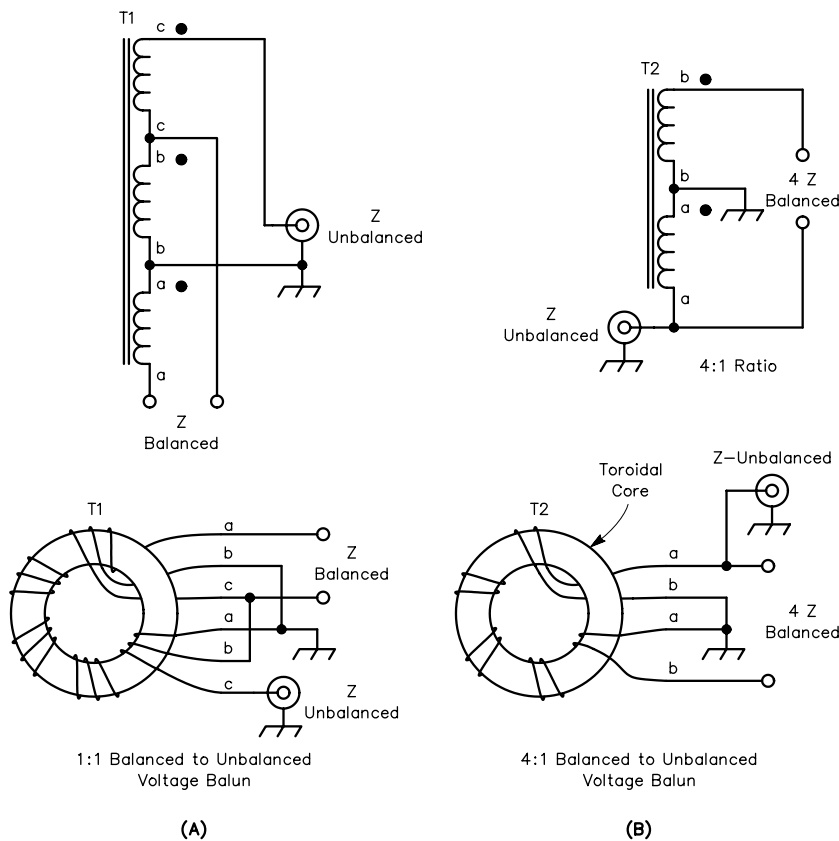

Fig 38—Voltage-type baluns. These have largely been supplanted by the current (choke) type of balun.

by radiation from a properly balanced line—whether coax or open-wire line—is miniscule. Whenever a line radiates it is because of an unbalanced condition somewhere in the system (on the antenna or its environment or on the line itself) or because of common-mode currents radiated by the antenna back onto the line because of asymmetry in the system. The SWR on the line has nothing to do with unwanted radiation from a transmission line.

BIBLIOGRAPHY

Source material and more extended discussions of topics covered in this chapter can be found in the references given below and in the textbooks listed at the end of Chapter 2, Antenna Fundamentals.

- B. A. Eggers, "An Analysis of the Balun," *QST*, Apr 1980, pp 19-21.
- D. Geiser, "Resistive Impedance Matching with Quarter-Wave Lines," *QST*, Feb 1963, pp 63-67.
- J. D. Gooch, O. E. Gardner, and G. L. Roberts, "The Hairpin Match," *QST*, Apr 1962, pp 11-14, 146, 156.
- G. Grammer, "Simplified Design of Impedance-Matching Networks," in three parts, *QST*, Mar, Apr and May 1957.
- D. J. Healey, "An Examination of the Gamma Match," *QST*, Apr 1969, pp 11-15, 57.
- J. D. Kraus and S. S. Sturgeon, "The T-Matched Antenna," *QST*, Sep 1940, pp 24-25.
- R. W. Lewallen, "Baluns: What They Do and How They Do It," *The ARRL Antenna Compendium, Vol 1* (Newington: ARRL, 1985), pp 157-164.
- M. W. Maxwell, "Some Aspects of the Balun Problem," Mar 1983, *QST*, pp 38-40.
- M. W. Maxwell, *Reflections, Transmission Lines and Antennas* (Newington: ARRL, 1990).
- R. A. Nelson, "Basic Gamma Matching," *Ham Radio*, Jan 1985, pp 29-31, 33.
- F. A. Regier, "Series-Section Transmission-Line Impedance Matching," *QST*, Jul 1978, pp 14-16.
- J. Sevick, "Simple Broadband Matching Networks," *QST*, Jan 1976, pp 20-23.
- R. E. Stephens, "Admittance Matching the Ground-Plane Antenna to Coaxial Transmission Line," Technical Correspondence, *QST*, Apr 1973, pp 55-57.
- H. F. Tolles, "How to Design Gamma-Matching Networks," *Ham Radio*, May 1973, pp 46-55.
- F. Witt, "Baluns in the Real (and Complex) World," *The ARRL Antenna Compendium, Vol 5* (Newington: ARRL, 1997), pp 171-181.