



QEX

INCLUDING:
COMMUNICATIONS
QUARTERLY

Forum for Communications Experimenters

January/February 2004
Issue No. 222

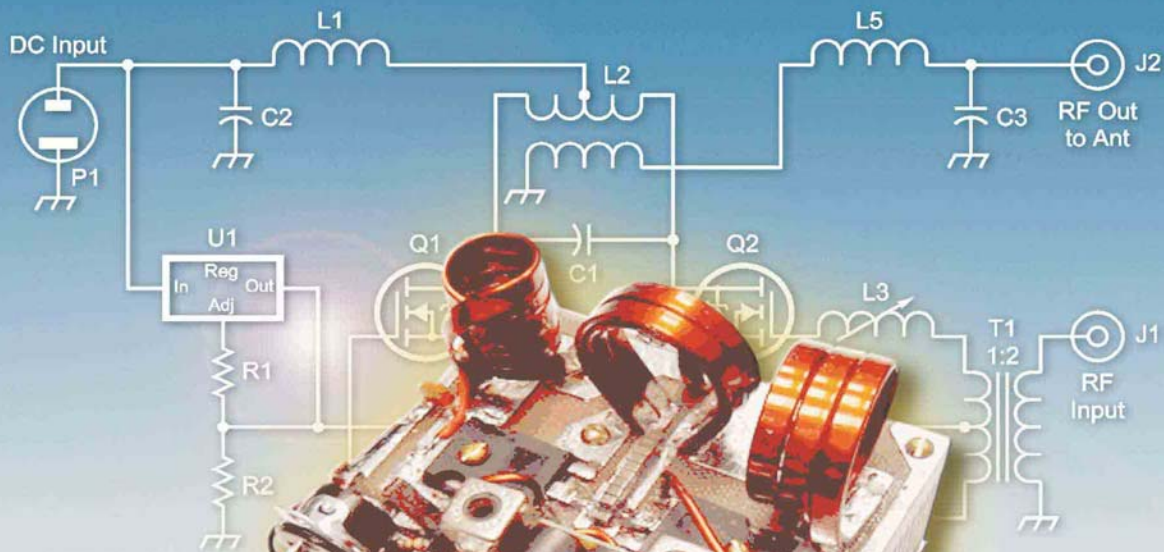

From Caltech — **Taniguchi's** efficient, inexpensive
40-meter PA for CW

ARRL The national association for
AMATEUR RADIO

225 Main Street
Newington, CT USA 06111-1494

The ARRL Antenna Classics series!

NEW!

Build portable, mobile and fixed antenna designs

ARRL's VHF/UHF Antenna Classics

Ground planes, J-poles, mobile antennas, Yagis and more. Build a better antenna for your hand-held radio. Construct a 2-meter Yagi that will rival similar commercial antennas. Build a dual-band vertical for 146 and 445-MHz. The results will be rewarding! Includes projects gathered from the 1980 to 2003 issues of QST.

ARRL Order No. 9078—\$14.95 plus shipping*

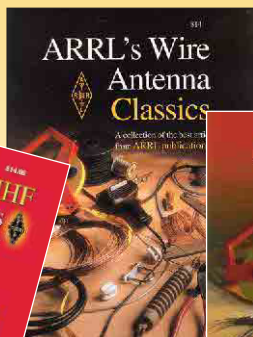
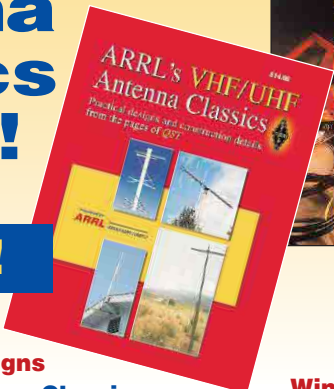

ARRL's Wire Antenna Classics and More Wire Antenna Classics

So many wire antenna designs have proven to be first class performers! Here's an entire book devoted to wire antennas, from the simple to the complex. Includes articles on dipoles, loops, rhombics, wire beams and receive antennas—and some time-proven classics! An ideal book for Field Day planners or the next wire antenna project at your home station.

Volume 1. ARRL Order No. 7075

—\$14 plus shipping*

Volume 2. ARRL Order No. 7709

—\$14 plus shipping*

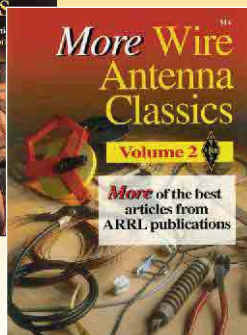

Winning Performance!

Vertical Antenna Classics

Vertical antennas are everywhere — on cell phones, broadcast towers and portable radios. You'll also see them on the roofs, towers and vehicles from Altoona to Australia. And for good reason! Here are some top-notch performers from ARRL publications, brought together in one book. Vertical antenna theory and modeling, VHF and UHF, HF, directional arrays, radials and ground systems, and more.

ARRL Order No. 5218—\$12 plus shipping*

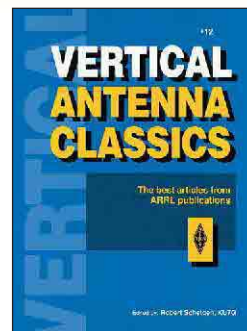

ARRL Antenna Compendiums



More antennas — ideas and practical projects

ARRL's Yagi Antenna Classics

Yagis, Quads, Loops, and other Beam Antennas
A wealth of ideas from some of the leaders in antenna design and experimentation of the last 70 years. Covers monobanders; multibanders; HF, VHF and UHF beams from 80 meters to 2304 MHz; computer modeling; towers, masts and guys. Some of the very best articles from QST, QEX, NCJ and other ARRL publications.

ARRL Order No. 8187—\$17.95 plus shipping*

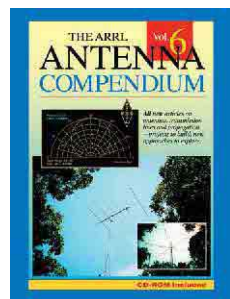
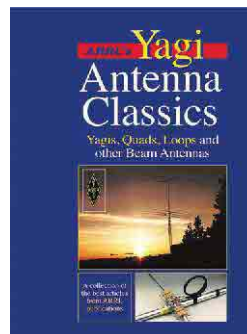

Volume 6

All new articles covering low-band antennas and operating, 10-meter designs, multiband antennas, propagation and terrain assessment. CD-ROM included with propagation prediction software!

#7431 \$22.95*—Includes software

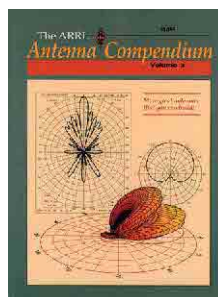

Volume 3

Quench your thirst for new antenna designs, from Allen's Log Periodic Loop Array to Zavrel's Triband Triangle. Discover a 12-meter quad, a discone, modeling with MININEC and VHF/UHF ray tracing.

#4017 \$14*

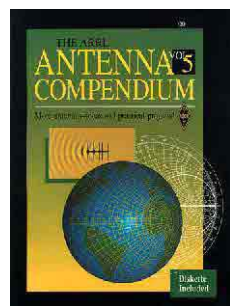

Volume 5

Enjoy excellent coverage of baluns, an HF beam from PVC, low-band Yagis, quads and verticals, curtain arrays, and more!

#5625 \$20*—Includes software

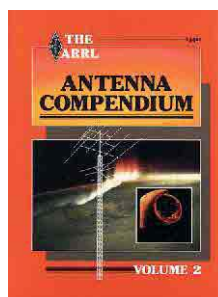

Volume 2

Covers a wide range of antenna types and related topics, including innovative verticals, an attic tri-bander, antenna modeling and propagation.

#2545 \$14*

Volume 4 is out-of-print

Volume 1

The premiere volume includes articles on a multiband portable, quads and loops, baluns, the Smith Chart, and more.

#0194 \$10*

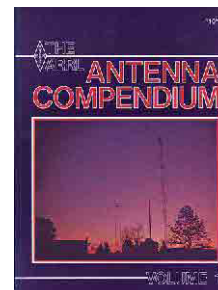

*Shipping: US orders add \$5 for one item, plus \$1 for each additional item (\$10 max.). International orders add \$2.00 to US rate (\$12.00 max.). US orders shipped via UPS.

Sales Tax is required for shipments to CT, VA, CA and Canada.

ARRL The national association for **AMATEUR RADIO**

225 Main Street, Newington, CT 06111-1494 tel: 860-594-0355 fax: 860-594-0303

In the US call our toll-free number **1-888-277-5289** 8 AM-8 PM Eastern time Mon.-Fri. www.arrl.org/shop



INCLUDING: COMMUNICATIONS QUARTERLY

QEX (ISSN: 0886-8093) is published bimonthly in January, March, May, July, September, and November by the American Radio Relay League, 225 Main Street, Newington CT 06111-1494. Periodicals postage paid at Hartford, CT and at additional mailing offices.

POSTMASTER: Send address changes to: *QEX*, 225 Main St, Newington, CT 06111-1494 Issue No 222

Mark J. Wilson, K1RO
Publisher

Doug Smith, KF6DX
Editor

Robert Schetgen, KU7G
Managing Editor

Lori Weinberg, KB1EIB
Assistant Editor

Zack Lau, W1VT
Ray Mack, WD5IFS
Contributing Editors

Production Department

Steve Ford, WB8IMY
Publications Manager

Michelle Bloom, WB1ENT
Production Supervisor

Sue Fagan
Graphic Design Supervisor

Mike Daniels
Technical Illustrator

Joe Shea
Production Assistant

Advertising Information Contact:

Joe Bottiglieri, AA1GW, *Account Manager*
860-594-0329 direct
860-594-0200 ARRL
860-594-4285 fax

Circulation Department

Kathy Capodicasa, *Circulation Manager*
Cathy Stepina, *QEX Circulation*

Offices

225 Main St, Newington, CT 06111-1494 USA
Telephone: 860-594-0200
Telex: 650215-5052 MCI
Fax: 860-594-0259 (24 hour direct line)
e-mail: qex@arrl.org

Subscription rate for 6 issues:

In the US: ARRL Member \$24,
nonmember \$36;

US by First Class Mail:
ARRL member \$37, nonmember \$49;

Elsewhere by Surface Mail (4-8 week delivery):
ARRL member \$31, nonmember \$43;

Canada by Airmail: ARRL member \$40,
nonmember \$52;

Elsewhere by Airmail: ARRL member \$59,
nonmember \$71.

Members are asked to include their membership control number or a label from their *QST* when applying.

In order to ensure prompt delivery, we ask that you periodically check the address information on your mailing label. If you find any inaccuracies, please contact the Circulation Department immediately. Thank you for your assistance.

Copyright ©2003 by the American Radio Relay League Inc. For permission to quote or reprint material from *QEX* or any ARRL publication, send a written request including the issue date (or book title), article, page numbers and a description of where you intend to use the reprinted material. Send the request to the office of the Publications Manager (permission@arrl.org)

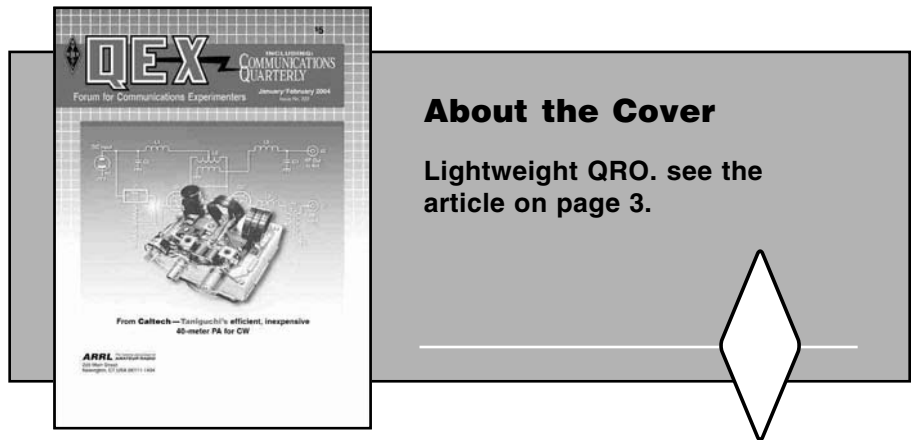

Features

- 3 A 200 W Power Amplifier**
By Takahiro Taniguchi; Kent Potter, KC6OKH; and Dave Rutledge, KN6EK
- 7 A Cascade Regenerative Receiver**
By Bill Young, WD5HOH
- 12 Twin-C Antennas**
By Brian Cake, KF2YN
- 20 Linrad with High-Performance Hardware**
By Leif Åsbrink, SM5BSZ
- 32 Getting the Most from Half-Wave Sloper Arrays**
By Rudy Severns, N6LF
- 42 The Primary Source of Automotive RFI: Ignition Noise**
By Stu Downs, WY6EE
- 47 Accurate Measurement of Small Inductances**
By Dave Lyndon, AK4AA
- 51 A Simple RF Power Calibrator**
By Bob Kopski, K3NHI

Columns

- 46 New Book**
- 55 RF** *By Zack Lau, W1VT*
- 59 Tech Notes**
- 61 Letters to the Editor**
- 62 Next issue in QEX**

Jan/Feb 2004 QEX Advertising Index

American Radio Relay League: Cov II, 62, Cov III, Cov IV	National RF: 64
Atomic Time, Inc.: 63	Nemal Electronics International, Inc.: 93
Buylegacy.com: 58	Noble Publishing Corp: 64
Down East Microwave Inc.: 63	Teri Software: 58
FlexRadio Systems: 63	Tucson Amateur Packet Radio Corp: 11
Roy Lewallen, W7EL: 64	Watts Unlimited: 64

THE AMERICAN RADIO RELAY LEAGUE



The American Radio Relay League, Inc. is a noncommercial association of radio amateurs, organized for the promotion of interests in Amateur Radio communication and experimentation, for the establishment of networks to provide communications in the event of disasters or other emergencies, for the advancement of radio art and of the public welfare, for the representation of the radio amateur in legislative matters, and for the maintenance of fraternalism and a high standard of conduct.

ARRL is an incorporated association without capital stock chartered under the laws of the state of Connecticut, and is an exempt organization under Section 501(c)(3) of the Internal Revenue Code of 1986. Its affairs are governed by a Board of Directors, whose voting members are elected every two years by the general membership. The officers are elected or appointed by the Directors. The League is noncommercial, and no one who could gain financially from the shaping of its affairs is eligible for membership on its Board.

"Of, by, and for the radio amateur," ARRL numbers within its ranks the vast majority of active amateurs in the nation and has a proud history of achievement as the standard-bearer in amateur affairs.

A bona fide interest in Amateur Radio is the only essential qualification of membership; an Amateur Radio license is not a prerequisite, although full voting membership is granted only to licensed amateurs in the US.

Membership inquiries and general correspondence should be addressed to the administrative headquarters at 225 Main Street, Newington, CT 06111 USA.

Telephone: 860-594-0200
Telex: 650215-5052 MCI
MCIMAIL (electronic mail system) ID: 215-5052
FAX: 860-594-0259 (24-hour direct line)

Officers

President: JIM D. HAYNIE, W5JBP
3226 Newcastle Dr, Dallas, TX 75220-1640
Executive Vice President: DAVID SUMNER, K1ZZ

The purpose of QEX is to:

- 1) provide a medium for the exchange of ideas and information among Amateur Radio experimenters,
- 2) document advanced technical work in the Amateur Radio field, and
- 3) support efforts to advance the state of the Amateur Radio art.

All correspondence concerning QEX should be addressed to the American Radio Relay League, 225 Main Street, Newington, CT 06111 USA. Envelopes containing manuscripts and letters for publication in QEX should be marked Editor, QEX.

Both theoretical and practical technical articles are welcomed. Manuscripts should be submitted on IBM or Mac format 3.5-inch diskette in word-processor format, if possible. We can redraw any figures as long as their content is clear. Photos should be glossy, color or black-and-white prints of at least the size they are to appear in QEX. Further information for authors can be found on the Web at www.arrl.org/qex/ or by e-mail to qex@arrl.org.

Any opinions expressed in QEX are those of the authors, not necessarily those of the Editor or the League. While we strive to ensure all material is technically correct, authors are expected to defend their own assertions. Products mentioned are included for your information only; no endorsement is implied. Readers are cautioned to verify the availability of products before sending money to vendors.

Empirical Outlook

A Full Understanding

A former mentor of mine felt that the best education was obtained when a student had reached the fullest possible understanding of a subject. He insisted, in several books and lectures, that full understanding somehow required approaching the limit of the total of human knowledge on the subject. Naturally, that is a difficult journey.

We recognize, as one letter writer has pointed out in this issue, that beginners cannot necessarily grasp everything at one go. Folks have to be able to learn in steps; but those steps must contain all the information necessary to impart full understanding, and they must not exclude critical knowledge that would be useful later.

Still, it seems to us that much of what we read in the literature lacks all the information necessary for full understanding. For example, descriptions of why antennas radiate do not include explanations of all the underlying mechanisms. Additionally, explanations of current flow in wires do not usually include full descriptions of why wires exhibit resistance, why conduction electrons are mobile and so forth.

We acknowledge that it is difficult. Complete explanations are not always simple and simple explanations not always complete. In addition, a very wide variety of ages and education levels exist out there in the communications field. In other words, one size may not fit all. In turn, that means that not every article will be interesting to every reader; but we do try to provide something for all readers.

As we begin our sixth calendar year in this format, we wish to rededicate ourselves to broadening our scope, our purpose and our readership. We count on you to fill our pages and sustain us. Remember: Without you, QEX would not be here.

Now what else can we do to improve? What else is it you want to read? Our doors are always open at qex@arrl.org. If you haven't already done so, check out our Web page at www.arrl.org/qex. We are not par-

ticularly starving for articles, but we do want to maximize the quality of our content.

Antenna articles are perennially popular. Any article that describes something useful that can be simply built is also popular. Additionally, we continue to seek state-of-the-art project descriptions. Finally, in keeping with the above, any article that explains something in a new and better way is welcome. Keep those projects going!

In This Issue

Dave Rutledge, KN6EK; Kent Potter, KC6OKH; and Takahiro Taniguchi from Caltech in beautiful Pasadena, California, bring us a modern 200-W PA design. Bill Young, WD5HOH, returns with a cascade regenerative receiver design. Although some consider "regens" to be old technology, enthusiasts continue to improve the breed.

Brian Cake, KF2YN, takes us into an adventure in "Twin Cs." It's not a trip to the toy store, but Part 1 of a description of some seemingly original antenna designs. Check it out.

Leif Åsbrink, SM5BSZ, presents a fifth article of his continuing series for *Linrad*: the software radio system for *Linux*. He has a few things to say about receiver measurements, too. So does Klaus Eichel, DL6SES/KF200. Former QEX Editor, Rudy Severns, N6LF, brings us a piece on getting the most from half-wave slopers. Slopers may be amongst the most misunderstood of all antennas; Rudy sets the record straight.

Stu Downs, WY6EE, explains the secondary side of modern automotive ignition systems and the primary causes of automotive RFI. Dave Lyndon, AK4AA, shows how to make accurate measurements of small inductances. Bob Kopski, K3NHI, contributes a simple RF calibrator to go with his Advanced VHF Wattmeter originally presented in May/June 2002. In RF, Contributing Editor Zack Lau, W1VT, writes about power dissipation in baluns—*Happy New Year! de Doug Smith, KF6DX; kf6dx@arrl.org* □□

A 200 W Power Amplifier

This efficient, inexpensive Class E/F amplifier for 40-meter CW operation needs only a 12 V supply.

By Takahiro Taniguchi; Kent Potter, KC6OKH; and Dave Rutledge, KN6EK

In recent years, a series of inexpensive, highly efficient 30 and 40 meter power amplifiers for CW operation have been developed at Caltech. They include 300 and 500 W, 40-meter Class-E amplifiers¹, a 200-W, 30-meter Class-E amplifier,² and a 1.1-kW, 40-meter Class-E/F amplifier.³ These amplifiers require 100-V keyed power supplies that are much more complicated, costly and heavy than the amplifiers themselves. In other work, Todd Roberts and Frederick Raab reported a 700 W

¹Notes appear on page 6.

California Institute of Technology
Department of Electrical Engineering
California Institute of Technology
Pasadena, CA 91125-9300
rutledge@caltech.edu

Class-E amplifier for the 160-meter band that also needs a 100 V power supply.⁵ These high-efficiency amplifiers would be much more practical for amateur use if they used readily available 12 V power supplies. Here we describe such a 40-meter Class-E/F amplifier. It has an output of 200 W and a drain efficiency of 83%. It uses a pair of International Rectifier IRFP044N power MOSFETs that cost \$3 each. These transistors have a maximum drain voltage of 55 V and a maximum RMS drain current of 53 A. The amplifier is quite compact, measuring only 3×3×4 inches.

The Class-E/F Amplifier

The Class E/F amplifier is a new class of switching amplifiers that was developed by Scott Kee at Caltech (see Note 3). It combines the zero-voltage

switching that makes the Class-E amplifier so efficient, together with the harmonic terminations that are used in Class inverse-F amplifiers to reduce the peak voltage and current. In a switching amplifier, the transistors are operated in a high-resistance state (off) for part of the cycle and in a low-resistance state (on), for the rest of the cycle. Both of these states have low loss. The loss is low when the transistor is off because the resistive current is only a small leakage current. The loss is larger, but still low, when the transistor is on, because the on resistance can be quite small and this limits the voltage. For example, the IRFP044N that we use has an on-resistance of only 20 mΩ. However, the transitions between the on and off states can still be a major source of loss. This is particularly true for

transition from off to on, when the charge associated with the drain capacitance of the transistor discharges through the channel. However, there is a solution to this problem. The load network can be designed to produce a ringing drain voltage that is zero at the time of turn-on, eliminating the capacitive-discharge loss. This is the approach used in Class-E amplifiers, which can achieve efficiencies as high as 90%. Nathan Sokal, WA1HQC, has recently written an excellent guide to the Class-E amplifier with a good list of references.⁶ While the efficiency of the Class-E amplifier is excellent, there are disadvantages that have limited its use. The peak voltage and peak current are relatively high, and this limits the output power that can be achieved. In the Class-E/F amplifier, the higher harmonics are terminated with alternating short circuits and open circuits to reduce the peak voltage and current, while still maintaining zero-voltage switching. This alternating pattern is the same one that is used in Class inverse-F amplifiers. For a detailed discussion, see Note 7.

Fig 1 shows a simple circuit for a Class E/F amplifier. There are two transistors that are represented as switches in parallel with a drain capacitance. The switches operate out of phase with each other at the RF frequency with a 50% duty cycle. This phasing between the switches presents a high impedance to the even harmonics. There is a parallel-resonant load circuit, which effectively includes the two drain capacitances in

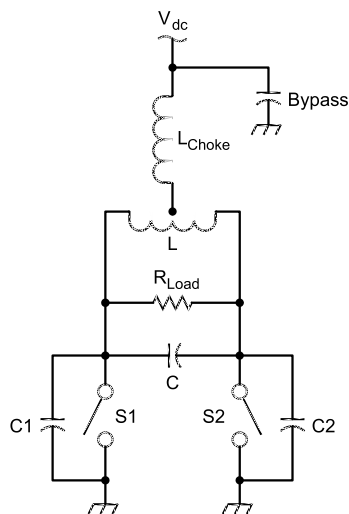

Fig 1—A simplified Class-E/F amplifier circuit. The bias connection is shown as a center tap on the inductor. The symmetry of the connection reduces the RF coupling to the bias circuit.

series with each other. The amplifier is operated somewhat below the resonant frequency, to give an inductive reactive component, which is necessary for zero-voltage switching. At the higher harmonics, the impedance of the tank circuit is low. This means that the circuit presents near short circuits for odd harmonics and near open

circuits for even harmonics.

Fig 2 shows the voltage and current plots for a Class E/F amplifier, normalized to the average value. The voltage is a half sine wave, while the current is a distorted square wave. The shape of the current plot depends on the transistor capacitance, and it is discussed in Note 7. In a transistor with

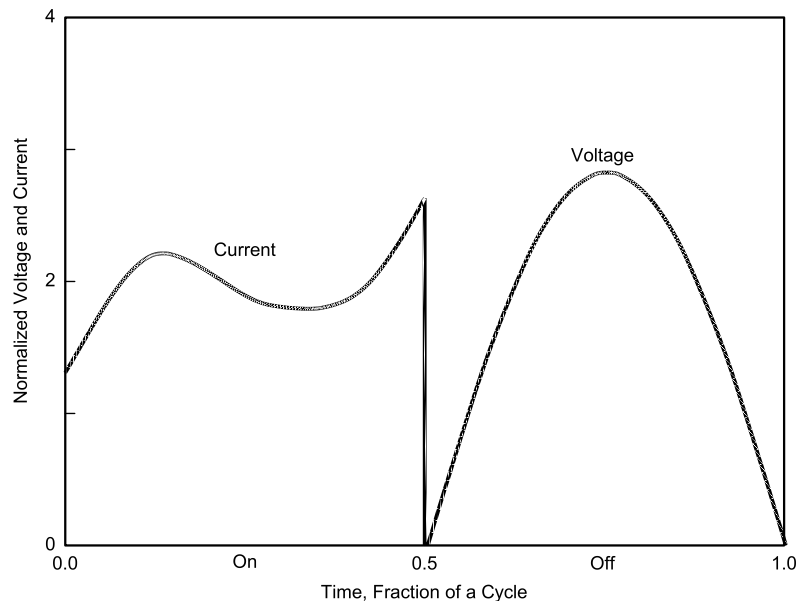

Fig 2—Drain voltage and current for a Class E/F amplifier versus time, normalized to the average value.

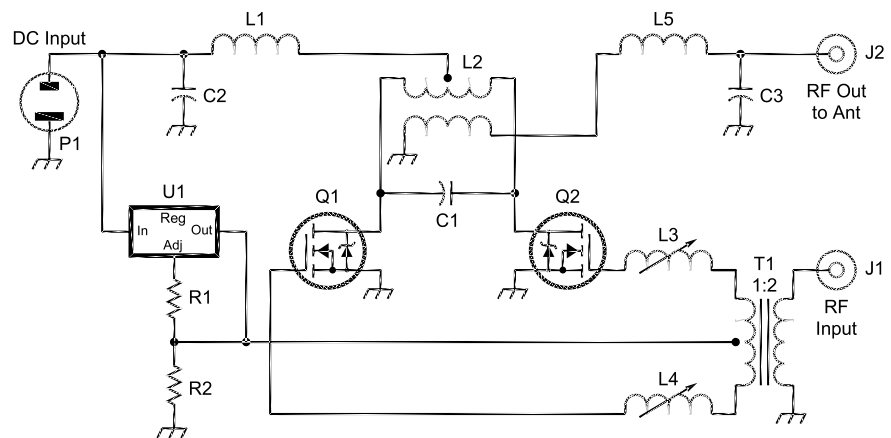

Fig 3—Circuit diagram and parts list for the 200-W, 12-V amplifier.

C1—1900 pF (19x100 pF ATC 700B)

C2—20 nF

C3—2.1 nF (7x300 pF, ATC 200B).

J1—BNC connector.

J2—UHF SO-239 connector.

L1—150 nH, 5 turns on a 1/2 inch form.

L2—216 nH, 3 turns on a 1 inch form.

L3, L4—0.15 nH TOKO variable inductor.

P1—Cinch-Jones P302AB dc supply connector.

Q1, Q2—IRFP044N from International Rectifier.

T1—Two turns on RF400-0 core from Communications Concepts.

T2 1:1.

U1—LM317L 3-terminal adjustable regulator.

R1—680 Ω.

R2—1.2 kΩ.

zero switch capacitance, the current would be a square wave, as in an ideal Class inverse-F amplifier.

The Caltech Power Amplifier

Fig 3 is the schematic for our amplifier. Components are added for converting differential voltages to single-ended voltages, for matching the input and output, and for providing a gate bias voltage. At the input, T1 reduces the 50-Ω impedance of the drive circuit to match the resistance of the gates. L3 and L4 are adjustable inductors for tuning out the gate capacitance. U1 is a regulator that sets the gate bias at 3.5 V. At the output, C3 and L5 transform the 50-Ω antenna impedance to about 2 Ω. The magnetizing inductance for output transformer L2 acts as the load tank inductance. C1 consists of 19 100-pF 700B capacitors from American Technical Ceramics. We used many capacitors in parallel to reduce the series resistance. When we used fewer capacitors, the solder melted. Even so, the C1 capacitors are the hottest components in the amplifier. The peak current in each capacitor is almost 1 A. With a thermal camera, we found temperatures for these capacitors of up to 95°C with a 50%-duty-cycle, 200-W peak output. In comparison, the maximum temperature of the transistors was only 50°C.

The completed 200-W amplifier is shown in Fig 4. All the components are mounted on a 69×83×37-mm heat sink with a 12-V, 0.26-A fan attached below. A series resistor drops the supply voltage for the fan to 7 V to reduce the acoustical noise. T2 is a 1:1 transformer with the secondary wound outside the primary. Each turn consists of two pieces of 3/16-inch copper tape laid side by side. The inside dimensions are 1.2 inches high by 0.9 inches wide. To electrically isolate the transistors from the heat sink, we use thermal pads manufactured by Berquist (Sil-Pad 600).

Performance

Fig 5 shows the output power, amplifier dissipation and drain efficiency versus input power at a supply voltage of 12.8 V. We recommend a drive power between 5 and 10 W to minimize dissipation. The input SWR is typically 1.6:1 for 5-W input, and 2:1 at 10 W. Fig 6 shows the relationship between output power, input power and supply voltage. Notice that in Figs 5 and 6, the output power varies nearly linearly with input power at low drive levels. This means that the amplifier can be used for CW operation without a special keyed power

supply to shape the pulses (see Notes 1-4). Fig 7 shows a spectrum analyzer plot of the amplifier output. The only spurious component that can be seen is the third harmonic at 60 dB below the carrier. The harmonic suppression is excellent, easily satisfying the FCC

requirement that spurious harmonic components be at least 40 dB below the carrier. No external filter would be needed.

On the Air

The setup we use for operating with

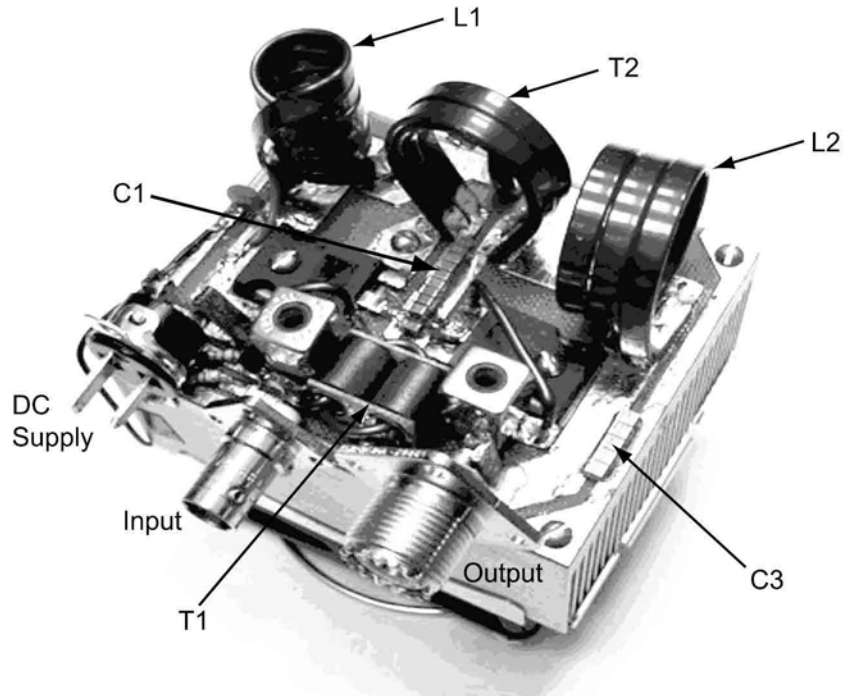

Fig 4—Photograph of the completed amplifier with its cover removed.

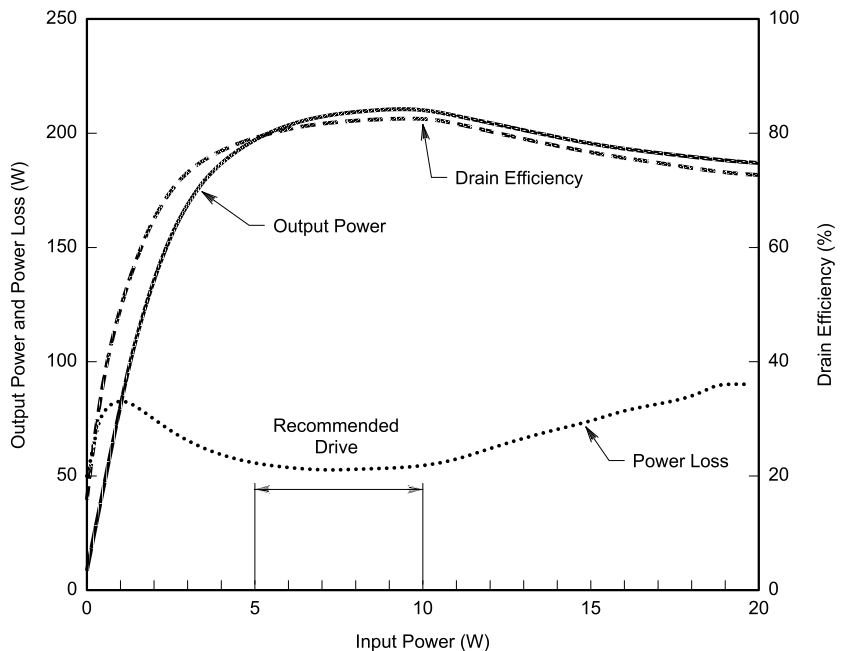

Fig 5—Output power, amplifier dissipation and drain efficiency as a function of drive power for a supply voltage of 12.8 V. The maximum efficiency is 83%.

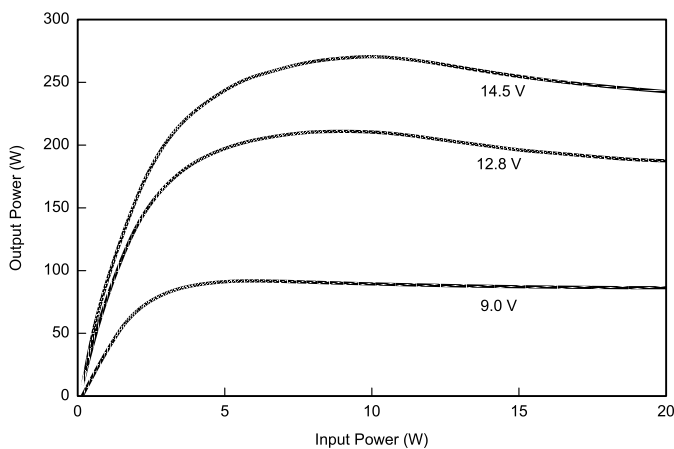

Fig 6—Output power for different supply voltages. The output power reaches 200 W for a 12.8-V supply.

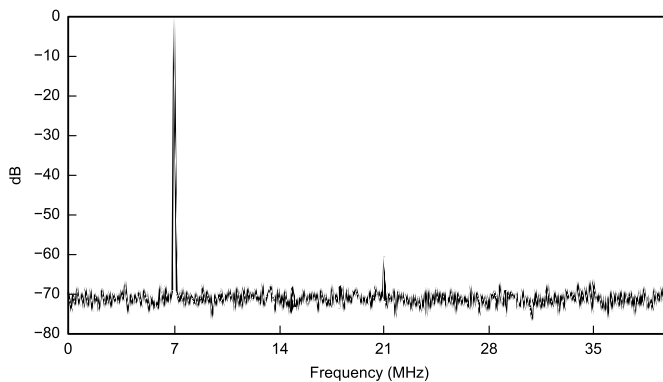

Fig 7—Power spectrum of the amplifier at 200-W output. The only visible harmonic is the third, 60 dB below the carrier.

the amplifier is shown in Fig 8. For the power supply, we use a Yuasa 12-V, 24-A-hr lead-acid battery. When the station is not being used, the battery is charged with a 2-A battery-charger kit from A&A Engineering (www.a-a-engineering.com). We drive the amplifier with a NorCal40A transceiver from Wilderness Radio. It has been modified to increase its output from the normal value of 2 W to 6 W (see Note 1). We did not have a transmit-receive switch, but simply received backwards through the amplifier. This gave a loss in reception of 22 dB. This loss is not a serious problem, because the NorCal 40A is a very sensitive radio with an MDS of about -140 dBm. However, a possible future improvement would be to incorporate a T/R switch onto the circuit board to reduce this loss.

Acknowledgements

This work was done as a Master's degree project by Takahiro Taniguchi at Caltech. He is currently with the Signals Service in the Japanese Ground Self-Defense Force. The authors would like to thank the Jet Propulsion Laboratory and the Japan Defense Agency for their support. Thanks also to Scott Kee and Lawrence Cheung for their advice and assistance.

Notes

¹E. Lau, KE6VWU; K. Chiu, KF6GHS; J. Qin, KF6GHY; J. Davis, K. Potter, KC6OKH and D. Rutledge, KN6EK, "High-Efficiency, Class-E Power Amplifiers," *QST*, Part 1, May, 1997, pp 39-42; Part 2,

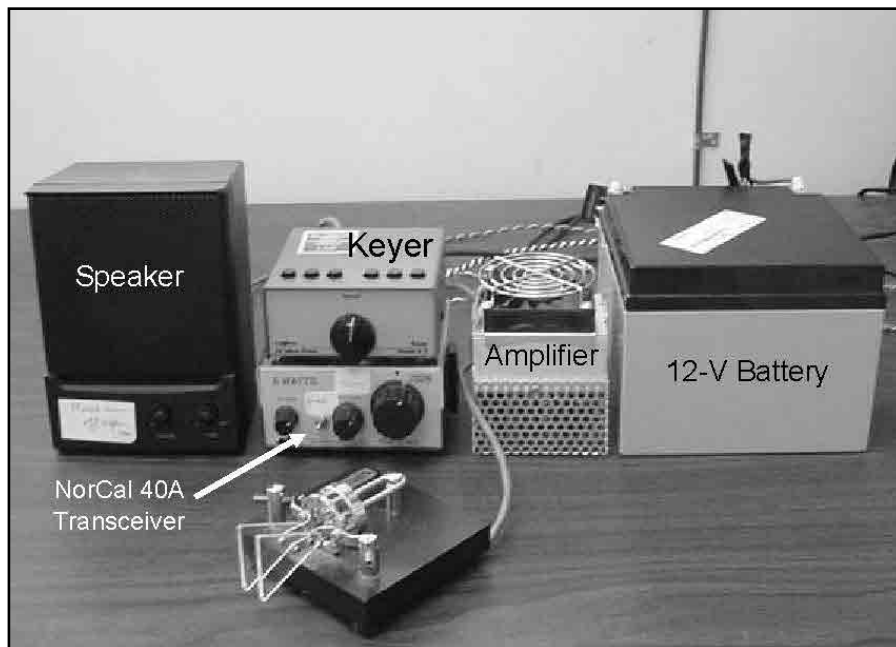

Fig 8—A complete operating station with the 12-V, 200-W Class E/F amplifier. This photograph shows the fan and the amplifier with the mesh cover in place.

June, 1997, pp 39-42.
²T. Stepanians, KF6NNZ, and David B. Rutledge, KN6EK, "10-MHz Class-E Power Amplifiers," *Communications Quarterly*, Winter 1999, pp 31-38.
³S. Kee, I. Aoki and D. Rutledge, KN6EK, "7-MHz, 1.1-kW Demonstration of the New E/F2, odd Switching Amplifier Class," *International Microwave Symposium Digest*, Phoenix, May 2001, pp 1505-8.
⁴J. Buckwalter, KF6SWC; J. Davis, KF6EDB; D. Maric, K. Potter, KC6OKH and D. Rutledge, KN6EK, "A Keyed Power

Supply for Class-E Amplifiers," *QEX*, Jan/Feb 2001, pp 21-28.
⁵T. Roberts, WD4NGG, and F. Raab, W1FR, "Class-E Power Amplifier and Digital Driver for 160 Meters," *Communications Quarterly*, Fall 1998, pp 9-19.
⁶N. Sokal, WA1HQC, "Class-E RF Power Amplifiers," *QEX*, Jan/Feb 2001, pp 9-20.
⁷S. Kee, A. Hajimiri, and D. Rutledge, KN6EK, "The Class E/F Family of ZVS Switching Amplifiers," *IEEE Transactions on Microwave Theory and Techniques*, *MTT-51*, May 2003. □□

A Cascade Regenerative Receiver

*Extreme selectivity—here's a receiver
with two regenerative stages.*

By Bill Young, WD5HOH

A reference to a cascade regenerative receiver can be found on page 78, Fig 47 of *Vacuum Tubes in Wireless Communication* originally published in 1918.¹ The tickler coils in the 1918 circuit are located at or near circuit ground as they are in my cascade regenerative receiver and in the regenerative superheterodyne receiver recently published in *QEX*.² I used two circuits that I have used in other receivers that seemed amenable to being connected in cascade. I wanted to try a receiver design that offered the gain and selectivity of a regenerative receiver incorporating two tuned circuits without any of the complications associated with heterodyning. This cascade regenerative receiver tunes from just above 3 MHz to just above 5 MHz. The selectivity, in my opinion, justifies the effort expended to build and operate the extra regenerative stage. One must learn to turn one knob only about half as far as usual and then turn the second knob about the same distance to avoid tuning past stations. In retrospect, I would say that anyone building a cascade regenerative receiver should buy the best vernier drives available.

I'm sure some readers will wonder why I have written an article about a regenerative receiver in 2003 when

other experimenters are working on software defined receivers and other advanced concepts. Interest in regenerative receivers hasn't gone away. Every now and then, one appears in print. I have written this article because other experimenters might like to build this or a similar circuit

Nothing in a regenerative receiver should move with respect to anything else except variable capacitor rotors, potentiometer wipers and switch contacts. Even those items can cause problems. Conducting paths should not move or vibrate. Everything must be tied down. Components that exhibit any tendency to move when held by their leads alone should be held down with hot glue. The largest possible wire gage should be used. Use lacing cord liberally. Where two or more wires run together for any distance (assuming it's electrically permissible for them to do so) they should be tied together. It need not be pretty; but it cannot move. I have made this receiver as mechanically and electrically stable as I could, and since it's primarily used to tune AM signals with the RF amplifiers at high gain but not oscillating, it's very stable and free of microphonics.

There is a common-source, untuned RF stage between the antenna and the first regenerative RF stage. This serves—as similar stages have for over 80 years—to isolate the regenerative circuits from the antenna, and it presents high impedance to the electrically short wire antenna. The high impedance that the antenna sees

makes receiver performance somewhat independent of antenna length. The “gimmick” coupling capacitor allows surprisingly high signal strength on strong signals and, so far, has eliminated any interference from nearby strong stations.

There are two regenerative RF amplifier stages ahead of the bridge detector. Coupling between the first and second stages and the second and third stages is accomplished by 1.8 pF to 10 pF trimmer capacitors. These coupling capacitors should be adjusted for the best possible regeneration control for both stages.

The first regenerative stage design was worked out experimentally with a breadboard circuit. The 560 Ω drain load was determined by temporarily installing a resistance decade box as a drain load and varying the drain load resistance until regeneration occurred.

Each of the two JFET regenerative stages has a tickler winding in series with the drain load at the bottom or “cold” end of the drain load. This circuit was worked out experimentally with “breadboard” receivers, and it results in better, more positive control of regeneration in my opinion. The apparent reason for this is that changing the regeneration controls in this circuit does not change the drain load impedance very much. My article “A Mathematical Model for Regenerative RF Amplifiers,”³ is a brief discussion of the relationship between regeneration control and drain load impedance.

¹Notes appear on page 11.

Also, each tickler winding is positioned directly over the tuned circuit winding. This configuration results in better control of regeneration, but I don't really know why. I've tried the conventional configuration with the tickler winding separated from the tuned circuit winding by a small gap, but regeneration control was rough and erratic that way. I suspect that this behavior is unique to this circuit. Other experimenters apparently get better results with a separated tickler winding and their "leak" detector circuits, but this circuit works best

with the tickler winding over the center of the tuned winding. Furthermore, the ratio of tickler turns to tuned-winding turns was determined by trial and error in earlier breadboard circuits, but once determined, seems to remain about the same over a frequency range from below 2 MHz to above 5 MHz, as long as the regeneration control resistances remain about the same.

Each 140 pF tuning capacitor is mounted to the aluminum chassis by its rear mounting lug alone. This makes tuning a little smoother by allowing

some motion of the capacitor. The first regenerative stage (second stage) has a "floating rotor" FINE tuning capacitor which consists of a moving aluminum plate or rotor held by a nylon screw and turned by a small vernier drive (see Fig 1). The rotor swings in and out of the space between a grounded plate screwed to the chassis and an insulated plate held at a fixed distance from the grounded plate by nylon screws and spacers. The rotor or moving plate is shaped to have a greater perimeter with less area. The capacitance of the floating rotor capacitor appears to depend more on the "fringe effect" at the edges of the plates and less on the area of the plates. This concept has come from experience with an earlier receiver that incorporated an earlier version of the floating rotor capacitor (see Note 2). The observed change in capacitance is much less than can be accounted for by applying the usual expression for the capacitance of parallel plates with air dielectric. Further experimentation is called for, but the floating rotor capacitor as it exists is very useful when connected in parallel with the tuning

The floating rotor rotates in and out between the fixed metal plates without touching either of them. Capacitance is maximum when the rotor is fully between the fixed plates and minimum when it is as far out as it will go.

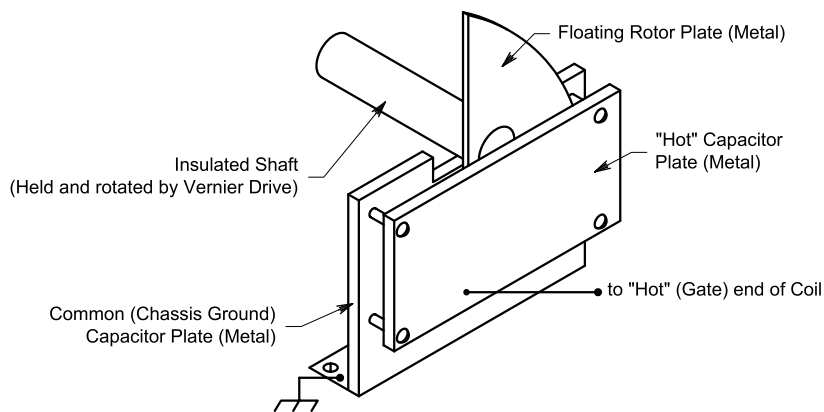

Fig 1—The floating-rotor capacitor.

Tuning and Transformer Resonance

I suspect that self-resonance of a bifilar coupling transformer driving a diode bridge detector results in increased "smoothness" of regeneration control in receivers of this type.

A 90-turn bifilar transformer similar but not identical to T3 exhibited a "dip" or resonance very near 17 MHz. This dip was present with power on and with power off. Regeneration control was smoother near 17 MHz than anywhere else within its tuning range, although the 19-meter band above 15 MHz was almost as good. The 22 meter band just below 14 MHz was noticeably worse, as was the 13 meter band just below 22 MHz. This result, if it's correct seems to agree with the information published in my earlier QEX article (see Note 3). Self-resonance would result in increased impedance and improved control. I further suspect that if self-resonance was occurring in the receiver referred to above (not the present cascade regenerative receiver), the only reason the stage wasn't oscillating uncontrollably was the diode-bridge load on the secondary of the bifilar transformer.

The most obvious application of the self-resonant bifilar transformer is in a regenerative intermediate amplifier stage as part of a superheterodyne receiver. The gate tuned circuit and the bifilar transformer could be made resonant at a chosen frequency and left there. Designing such a receiver may not be straightforward, though. Arranging for optimum coupling between a doubly or triply balance mixer and the regenerative IF stage will require some thought.

It may be possible to establish self-resonance of the bifilar transformer at the upper end of the tuning range of a regenerative receiver and switch small, fixed capacitors across the primary of the bifilar transformer to extend resonance across the rest of the tuning range. I'm sure, however, that there's a limit to how far the Q of the bifilar transformer can be increased without loss of regeneration control.

Fig 2—A schematic of the Cascade Regenerative Receiver. The Very Fine regeneration controls were added after the photo in Fig 3 was taken. The MPS2222A stage is an audio preamplifier circuit from the 1992 ARRL Handbook. Unless otherwise specified, use 1/4 W, 5%-tolerance carbon composition or film resistors. You can contact Mouser at 958 N Main St, Mansfield, TX 76063; tel 817-483-4422; fax 817-483-0931; e-mail sales@mouser.com; Web www.mouser.com.

- B1—Rayovac NM1604, 150 mAh 8.4 V (for 9 V applications, rechargeable).
- C1—"Gimmick" capacitor, 4 turns of insulated solid hook-up wire.
- C2, C5—1.8-10 pF ceramic trimmer capacitor (Mouser 242-1810).
- C3—140 pF variable capacitor.
- C4—Floating-rotor capacitor, see text and Fig 1.
- C5—1 μ F 25 V, low leakage capacitor.
- FB—Fair-Rite EMI shield bead (Mouser 623-2643000101).
- S1—SPST ganged with the fine regeneration pot in the third stage.
- T1—Transformer 22 t primary 3/4 inch long on a 7/8 inch PEX form, with a 4 t secondary wound over the primary's cold end. The lead to the potentiometers is RG-174 coax. Shield the transformer by covering it with a small metal food can, such as that for Mandarin oranges.
- T2—Transformer 22 t primary 3/4 inch long on a 7/8 inch PEX form, with a 4 t secondary wound over the primary's cold end. The lead to the potentiometers is a twisted pair. Shield the transformer by covering it with a small metal food can, such as that for Mandarin oranges.
- T3—Bifilar transformer, 90 t 24 AWG enameled wire twisted, and then wound over two inches on a 3/8 inch diameter PEX form. T3 is mounted inside the aluminum chassis box.

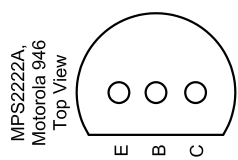
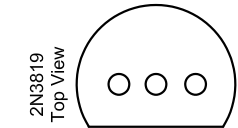
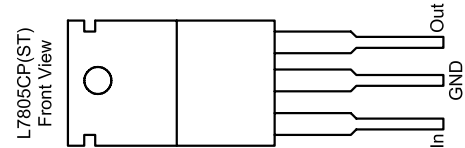
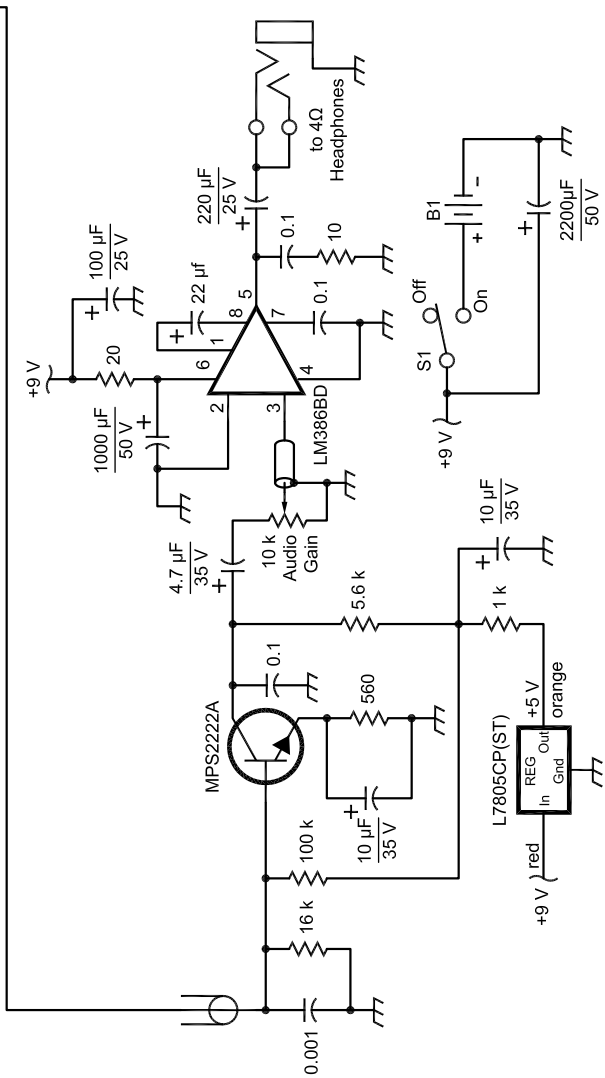
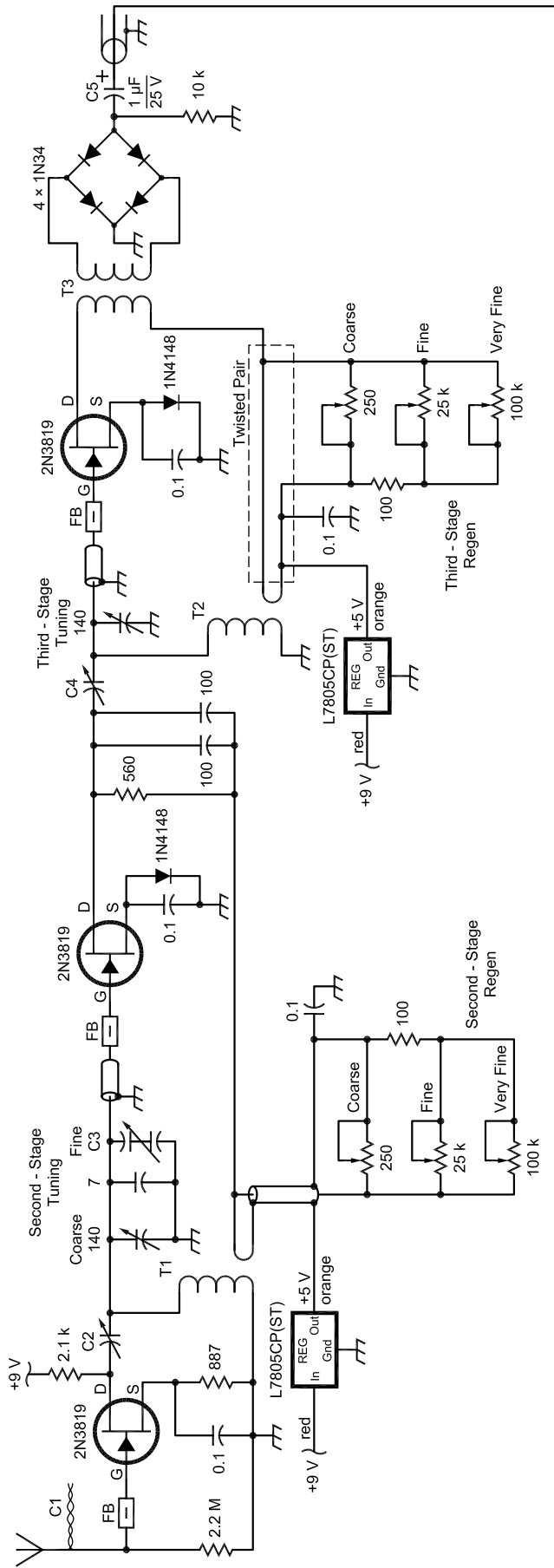

Except as indicated, decimal values of capacitance are in microfarads (μF); others are in picofarads (pF); resistances are in ohms; k = 1,000, M = 1,000,000.

capacitor of a regenerative stage. It enables very accurate tuning of AM signals. This accurate tuning when used together with precise control of regeneration made possible by the combination of COARSE, FINE and VERY FINE regeneration control potentiometers results in improved sensitivity and selectivity. An increment of one small division of the FINE tuning control can result in a noticeable change in signal level, so the FINE tuning control does serve a useful purpose.

Some builders of regenerative receivers advocate a single-point ground. The circuit board for this receiver has a buss wire "fence" around the edge of the board. The "fence" does not form a closed loop. All ground connections are made to this wire which is then connected to a single ground lug held to the aluminum chassis by a machine screw and nut. There are several other connections at some distance from the board made in the same way with a lug and a machine screw. The receiver performs well, so I assume the grounding scheme is adequate.

I have attempted to evaluate potential RF coil form materials by placing them, one at a time, in the field of an RF coil connected to an oscillating RF regenerative amplifier stage. I set the tuning for an audible beat note and then placed a small sample of the material in the field of the coil. I have tried cardboard, glass, wood, PVC, acrylic, PEX (cross-linked polyethylene), the much recommended black-plastic film container and a plastic "pill bottle." Each of these changed the frequency of oscillation substantially, some more than others. Each was suspended in the field of the coil at the end of a length of waxed nylon lacing cord. The length of lacing cord was shown to affect the frequency very little by itself. I decided by a process of repeated comparison that the PEX would be the material of choice. It doesn't crack as easily as acrylic, and it's easier to cut and drill. The two coils are mounted above the chassis deck on square pieces of Vector board, and each coil is enclosed in a cylindrical metal shield can (formerly filled with Mandarin orange slices).

I have been reminded recently that conventional regenerative detectors tend to exhibit capture effect, where a strong signal close in frequency to a weak signal takes over the receiver from the weak signal. That does not appear to happen with this circuit. Strong signals are audible "behind" or "under" weak signals, but there is no capture.

Each of the regenerative RF stages incorporates a silicon 1N4148 diode in

the source circuit of the 2N3819 JFET. This idea was suggested in an unpublished private correspondence with Charles Kitchen, N1TEV. It is something he said he had thought of but not tried. I tried it and have been much impressed with the performance it contributes. It makes the receiver much more capable of tuning AM signals below oscillation and somewhat less capable of tuning CW signals above oscillation. This trade off is fine with me. I have been trying to do this for years with partial success. The diode seems to delay the onset of oscillation allowing higher gain below oscillation.

The cascade regenerative receiver was originally constructed as a single board receiver. All of the transistors, diodes and the integrated circuits were mounted on a single perforated board. The board is mounted about an inch below the underside of the chassis deck on six nylon standoff insulators. I have now added a single MPS2222A junction-transistor audio preamplifier taken from page 28-5 of the *1992 ARRL Handbook* and mounted on a small board adjacent to the main board. I removed the transformer-coupled 2N3819 audio amplifier circuit originally placed between the bridge detector and the LM386 because it contributed too little gain and caused an annoying audible "quench" frequency. The MPS2222A stage works well, and I'm confident that the receiver can be built as a single-board receiver. There's plenty of room on the main board for the MPS2222A stage.

The LM386 final audio stage is conventional except possibly for the 2200 μF capacitor across the 9 V dc supply, which is necessary to prevent

"motorboating" or instability.

The cascade regenerative receiver can be operated as follows: Start by setting both main tuning capacitors to about 80 on their logging scales. With FINE and VERY FINE regeneration controls fully clockwise adjust the COARSE control so that the stage is just oscillating. Do this at reduced audio gain. Then turn the FINE control counter-clockwise so that oscillation just stops and then go back clockwise with the FINE control until the stage is just oscillating. Now, turn the VERY FINE control counter-clockwise until the stage stops oscillating, and use the VERY FINE control to adjust stage gain just short of oscillation. Turn the AUDIO GAIN pot clockwise to increase audio gain. This procedure can be followed with each of the two regenerative RF stages. Some careful tuning will help as these adjustments are made. It may be necessary to repeat some of the adjustments until the receiver has stabilized after several minutes, but it will stabilize and can be maintained at high gain for extended listening.

Now, turn each of the two main tuning knobs to discover which one causes oscillation to stop when tuned in the direction you want to tune. Oscillation can then be started again by turning the other main tuning knob in the same direction. Proceed to tune incrementally this way (turning one main tuning knob, then, the other) until an interesting signal is heard.

When you have acquired a signal adjust the FINE regeneration controls appropriately depending on what you're trying to receive (AM, CW, RTTY and so on). For AM signals, back



Fig 3—Front view of receiver.

off the FINE controls until you have a clear AM signal, and then advance each VERY FINE control in turn for maximum signal level. Work with the two FINE regeneration controls and the VERY FINE tuning control to tune exactly to the center of an AM signal at maximum gain. Increasing the VERY FINE regeneration controls beyond a certain point results in distortion and the onset of "fringe howl." It's easy with this selective receiver to tune past a signal without hearing it.

If you have reached the conclusion that this receiver is laborious to tune, you're right. It is. Now you know one reason why the superhet came to be dominant. If you need to switch quickly and repeatedly between several air-to-ground frequencies, you really can't do it with a receiver like this. That's one of the things a crystal controlled superhet could do well.

On the other hand it's fun to tune in a weak signal, peak both RF stages to that signal and then pull it up out of the "mud" using the two VERY FINE regeneration controls without either stage going into oscillation. A disadvantage of this receiver is the presence of the "skirts" of powerful shortwave broadcast signals tens of kilohertz

away from their carrier frequency. However, most of the weaker signals will increase in signal strength as they are tuned in and as the regeneration is increased enough to overcome this interference. At my location, this has been a problem only around 5 MHz.

There are a couple of things about the performance of this receiver that are puzzling:

1. Even if both regenerative stages are oscillating and are not tuned to the same frequency there is no audible heterodyne.
2. There is some interaction between the two regenerative RF stages at high gain even though their coils are shielded and they are both voltage regulated.

This receiver was powered at first by disposable 9 V alkaline batteries, but I am now using a Rayovac NM 1604 NiMH rechargeable battery with good results. This battery powers this receiver for about three hours between charges. The internal impedance is low enough for good performance until the battery voltage drops off the "plateau" and needs recharging. The transition from plateau to a weak battery is abrupt. It suddenly becomes necessary to increase regeneration to maintain

gain, but gain decays faster than regeneration is increased. At this point switch the receiver off, and recharge the battery.

You will probably notice that the ON/OFF switch is built into one of the FINE regeneration controls rather than the audio gain potentiometer as is usual. This choice is a result of parts availability only. If you can find a 10 kΩ pot with a switch, use it.

Bill is retired following a 36-year career as a project engineer and manager with NASA in the biomedical-hardware area. He was first licensed as KN5DNM in about 1953 and has been WD5HOH (General class) since about 1980. He holds a BSEE from the University of Texas (1961) and an MS in environmental management from the University of Houston (1981) at Clear Lake.

Notes

- ¹E. Bucher, *Vacuum Tubes in Wireless Communication*, (New York: Wireless Press, 1918).
- ²B. Young, WD5HOH, "A Homebrew Regenerative Superheterodyne Receiver," *QEX*, May/June 2002, pp 26-35.
- ³W. Young, WD5HOH, "A Mathematical Model for Regenerative RF Amplifiers," *Jul/Aug 2001*, pp 53-54. □□

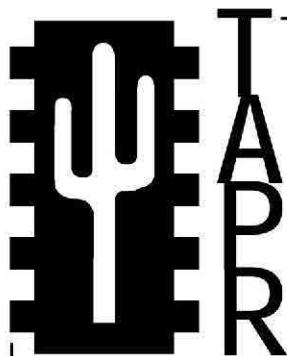

Join the effort in developing Spread Spectrum Communications for the amateur radio service. Join TAPR and become part of the largest packet radio group in the world. TAPR is a non-profit amateur radio organization that develops new communications technology, provides useful/affordable kits, and promotes the advancement of the amateur art through publications, meetings, and standards. Membership includes a subscription to the *TAPR Packet Status Register* quarterly newsletter, which provides up-to-date news and user/technical information. Annual membership \$20 worldwide.

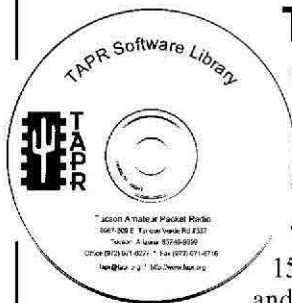

TAPR CD-ROM

Over 600 Megs of Data in ISO 9660 format. TAPR Software Library: 40 megs of software on BBSs, Satellites, Switches, TNCs, Terminals, TCP/IP, and more!

150Megs of APRS Software and Maps. RealAudio Files.

Quicktime Movies. Mail Archives from TAPR's SIGs, and much, much more!

Wireless Digital Communications: Design and Theory

Finally a book covering a broad spectrum of wireless digital subjects in one place, written by Tom McDermott, N5EG. Topics include: DSP-based modem filters, forward-error-correcting codes, carrier transmission types, data codes, data slicers, clock recovery, matched filters, carrier recovery, propagation channel models, and much more! Includes a disk!

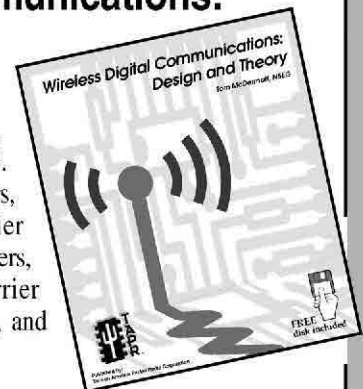

Tucson Amateur Packet Radio

8987-309 E Tanque Verde Rd #337 • Tucson, Arizona • 85749-9399

Office: (972) 671-8277 • Fax (972) 671-8716 • Internet: tapr@tapr.org www.tapr.org

Non-Profit Research and Development Corporation

Twin-C Antennas

A simple antenna that uses coupled bent dipoles provides some surprising benefits.

By Brian Cake, KF2YN

In my eyes, there are two basic antenna structures that are remarkable: the half-wave dipole and the long Yagi antenna. The half-wave dipole is simplicity personified: almost one-dimensional, slim, with wide bandwidth and it forms the basic building block for umpteen varieties of more complex antennas.

The long Yagi antenna is close to one-dimensional and it is also beautifully simple—if you don't need to design one! The problem with both the half-wave dipole and the long Yagi is that *they are way too long*. For some years now I have been intrigued by the problems associated with improving

short antennas; and, in particular, getting high gain from a short-boom Yagi-like antenna. It seemed to me that I ought to be able to squeeze more gain out of a given boom length by moving from what is virtually a two-dimensional structure to a three-dimensional structure. Stacking is the traditional method of doing this, but it involves mechanically assembling two or more Yagis and feeding power to each of them. Besides, there was no challenge here: It had all been done before. I went looking for a new way to achieve the same result. The search led to both reduced boom-length beams and to a new physically small dipole element with very interesting properties. The following article is the first of two parts that will present some results of my study. I hope you will find at least something of inter-

est. I must cover quite a bit of ground here, so the depth of coverage of individual antennas may not be ideal; I hope that the principles will be clear.

Unless otherwise stated, the data I provide are derived from computer simulation using *EZNEC pro 3.0* as the modeling program.¹ Don't worry. I have built and range-tested a large number of antennas based on this simulation software, and the accuracy of the simulations is incredibly good.

Short Dipole Problems

When the length of a dipole is reduced, some well-known problems arise:

- The feed-point impedance drops dramatically, even if end loading is used. Some form of matching

¹Notes appear on page 18.

248 Barrataria Dr
St Augustine, FL 32080
bcake@bellsouth.net

circuit is necessary in order to allow the antenna to be driven by a transmitter and feeder system that is designed to drive 50 ohms.

- The self-resonant feature is lost, and the antenna must be brought to resonance somehow. This normally involves the use of inductors, with their associated losses.
- The bandwidth is reduced.
- To radiate the same power from a short antenna, the antenna currents and voltages increase dramatically as the length is reduced.

In the following, I'll describe new methods of reducing the length of a dipole, while avoiding or minimizing some of the above effects.² The resulting basic antenna element has a square perimeter with side lengths of around $\lambda/6$, or about one-third the length of a half-wave dipole. It is self-resonant, with a feed point resistance at resonance of 50 Ω . The feed-point resistance may be changed over a greater than 2:1 range by changing the aspect ratio of the element while still maintaining self-resonance. The efficiency is virtually 100% when copper or aluminum elements of sensible diameter are used. The SWR bandwidth is about 3.5% of the center frequency, as compared to about 10% for a full size dipole. Elements may be connected in parallel to provide multiband coverage without band switching. Ground-plane antennas using the element reduce the size still further. The element may be used in directional antennas. In one particular case that will be described in the

second part, it can provide high directivity (high gain) on two harmonically related frequencies, such as 2 m and 70 cm, while providing an excellent, broadband match to a single feeder on both bands. For these Yagi-like antennas, the gain of the antenna on the higher of the two bands is substantially greater, for a given boom length, than that of a high performance conventional Yagi.

I have called the basic element the "Twin C" simply because its outline resembles two stylized "C" shapes back-to-back. A more appropriate name might be "open folded dipole," as we shall see, but this is already in use for a special version of a folded dipole.³ I use the name "Box Kite" to describe the dual-band Yagi that uses a version of the basic element. (The structure reminds me of happy days

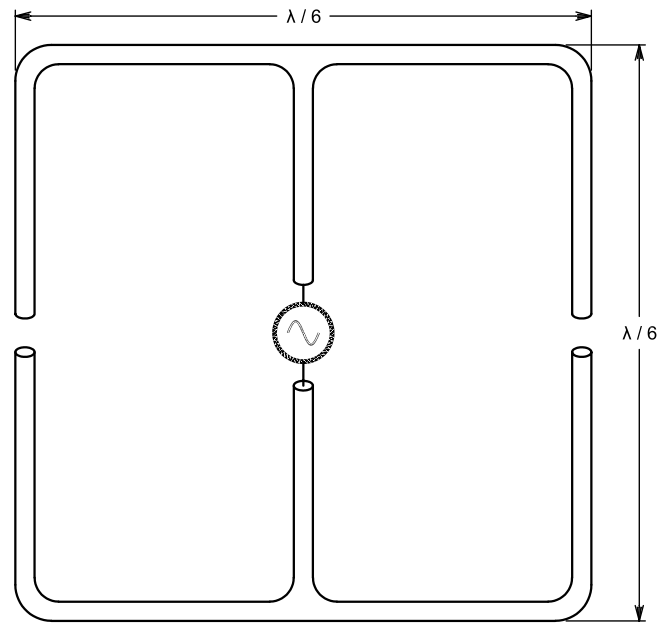

Fig 2—A wide bandwidth bent half-wave dipole.

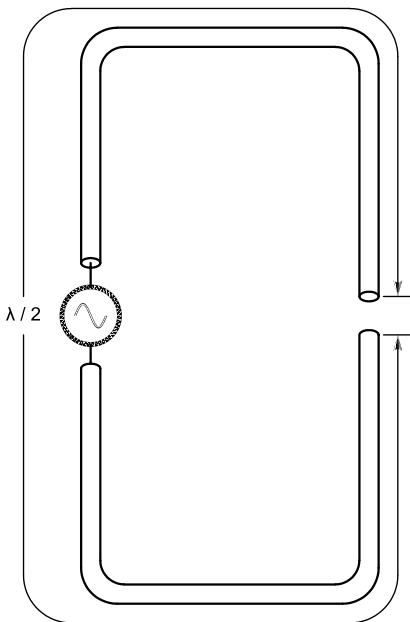

Fig 1—A bent half-wave dipole.

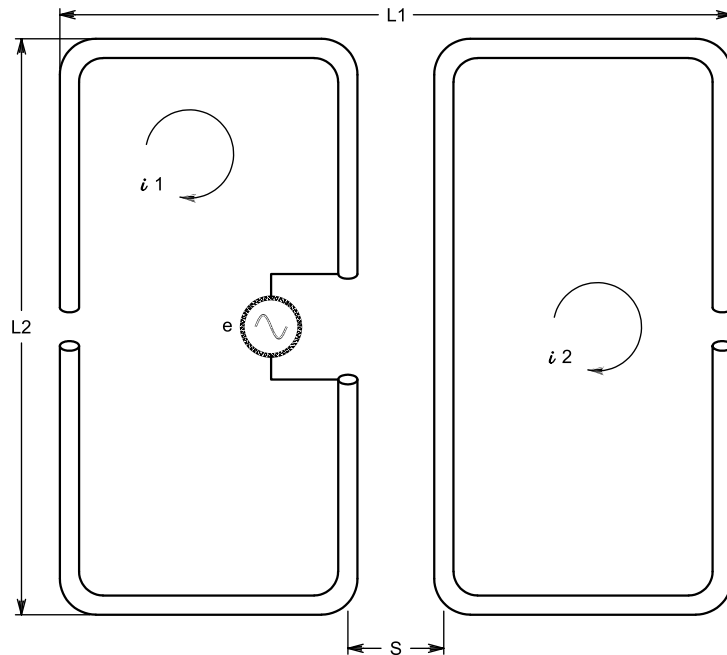

Fig 3—A Twin C dipole.

flying kites an awfully long time ago, with the structure of the antenna resembling in some way the support rods for box-kite fabric!

Twin-C Theory

The evolution of the Twin C antenna from a full size half-wave dipole is illustrated in Figs 1 through 3. A half-wave dipole is slightly shorter than $\lambda/2$ and has a feed-point resistance of around 73Ω at resonance, with a 2:1 SWR bandwidth of about 10% of the resonant frequency for common length-to-diameter ratios. First, we take the $\lambda/2$ dipole and bend it as shown in Fig 1, so that the side length of the resulting antenna is about $\lambda/6$ and the width about $\lambda/12$, and there is a small gap between the open ends. As may be expected, the resonant frequency is shifted somewhat by the reshaping; but by adjusting the lengths of the open ends, the antenna will again resonate at the original frequency. Since the effective length of the antenna is reduced, the feed-point resistance is reduced, for the dimensions shown, to around 13Ω , and the SWR bandwidth is reduced to about 2.5% of the resonant frequency, or one-quarter of the bandwidth of a full size half-wave dipole. The SWR bandwidth can be improved somewhat by arranging the antenna element as shown in Fig 2, where a second pair of "wings" is connected to the center section. This does not significantly change the feed-point resistance, but the SWR bandwidth is raised to about 3.5% of the resonant frequency or one-third that of a dipole.

The Twin C antenna is similar in shape to Fig 2, but consists of two identical subelements bent into back-to-back "C" shapes, with a close parallel section, as shown in Fig 3. The center of one of the subelements, or halves, is driven by the source, preferably via a 1:1 balun, because the antenna is balanced. The total length of wire in each half is close to $\lambda/2$ at the operating frequency, and the dimensions L1 and L2 in Fig 3 are approximately $\lambda/6$. The spacing, S, between the par-

allel sections should be less than about $\lambda/20$. The close parallel sections magnetically couple the driven and undriven halves, so currents flow in both halves. The magnitude and phase of these two currents is determined by the coupling between the two halves and by the operating frequency.

The lumped equivalent circuit is shown in Fig 4. This shows two identical halves coupled by mutual inductance. With the dimensions shown, in coupled tuned circuit parlance, the two halves are overcoupled. The resistances, R, represent the radiation and loss resistances of the two halves. An analysis of Fig 4 shows that, as is usual with overcoupled tuned circuits, there are two resonant frequencies: one below and one above the natural resonant frequency of each half. We'll call these two frequencies F1 and F2, respectively.

At F1, i_1 and i_2 are approximately equal in amplitude and are in antiphase, so they flow in the same direction through the close parallel sections. At F2, the currents are in phase and flow in opposite directions through the close parallel sections. The operating frequency is F1. It can be shown that the effect of the two almost identical currents flowing in the same direction in the two halves increases the feed impedance by a factor of four. Also, the radiation pattern is virtually identical to that of a single wire of the same length, occupying the mean position of the two wires. This is similar to the manner in which the feed-point resis-

tance of a conventional folded dipole is increased. Thus, although the radiation resistance of an element as shown in Fig 2 is approximately 13Ω , the feed-point resistance for the Twin C antenna is four times this, or close to 50Ω , at F1. At F2, the currents flowing in opposite directions in the two halves cause a reduction in the feed-point resistance. This is a problem only if elements are connected in parallel in order to provide multiband operation, as we shall see later.

The 2:1 SWR bandwidth for the Twin C described above is similar to that of the element shown in Fig.2. That is, approximately 3.4% for normal conductor diameter-to-wavelength ratios, as compared to about 10% for a conventional half-wave dipole. It is important that the amplitudes of the currents in the two halves are approximately half those needed to radiate the same power in a single wire. Because of this, the power loss caused by any resistive loss in a Twin C is smaller by a factor of two than that for a conventional single-wire dipole. This means that inductive loading of somewhat shorter subelements is possible without seriously degrading the efficiency.

Reverse Twin Cs and Double Dipoles

It is well-known that a pair of tuned circuits can be coupled in many different ways, the above being just one example. A pair of Twin C halves may be capacitively coupled by simply re-

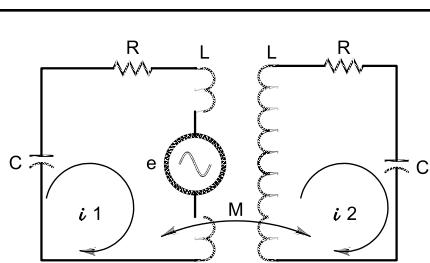

Fig 4—A lumped-element equivalent circuit of the Twin C dipole.

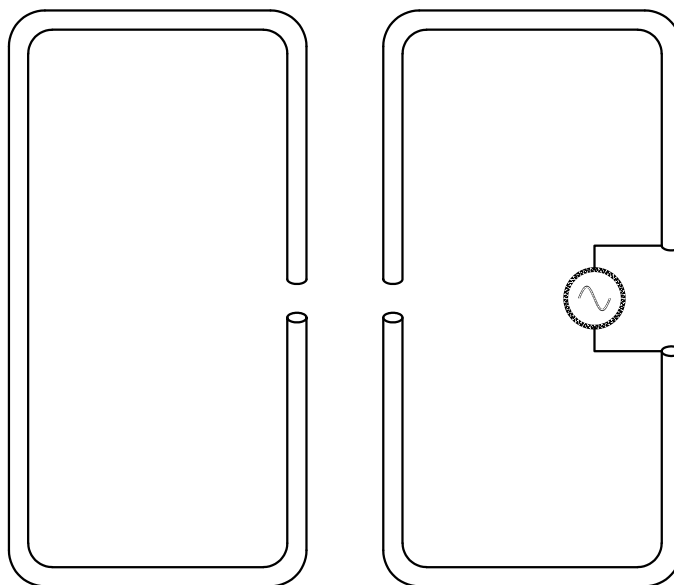

Fig 5—A reverse Twin C dipole.

versing each half so that the Cs are “front-to-front” as illustrated in Fig 5. Now the coupling is predominantly capacitive because the high impedance ends of each half are close to each other, and the low impedance sections are well separated. It can be shown from coupled-circuit theory that, with two identical tuned circuits capacitively coupled, there are again two resonances: one above and one below the natural resonant frequency of each half. Yet now the currents in the center of each C are in the same direction and equal in magnitude at the upper of the two resonant frequencies, as opposed to the lower frequency for the Twin C. The feed point resistance is multiplied just as before. The Reverse Twin C, as I call it, has the disadvantage that it does not behave as a simple vertical dipole when vertically mounted because the high current sections are well separated, and there is considerable directionality in the H-plane pattern. However, for some applications this might be useful.

Short dipoles that use inductive loading at their centers to bring them to resonance can also be coupled capacitively, simply by mounting two such dipoles very close together, as shown in Fig 6. I call this arrangement a Double Dipole. Feed-point resistance multiplication occurs just as for the Twin Cs, and power loss in the loading inductors is reduced because of reduced current. The pairs of dipoles can be paralleled with pairs for other bands, provided that capacitive coupling between pairs for different bands is not too high. It is very important that the mutual inductance between the two loading coils should be small, otherwise inductive and capacitive coupling fight each other and full impedance multiplication will not be possible.

The Double Dipole antenna is not as rosy as it may seem, however. The operating frequency is $F2$, which is higher than the self-resonant frequency of the two dipoles. This means that the loading inductance, and therefore its loss resistance, is larger than for a single dipole, so the gain in efficiency is not as high as we might first expect.

As an example, let's consider a Double Dipole for the 15-m band: two 10' long 1" diameter dipoles, each center loaded with 5- μ H inductors ($Q \approx 100$) mounted in free space with a spacing of 10" between them. This gives an efficiency of about 75%, a minimum SWR of 1:1 and a 2:1 SWR bandwidth of 500 kHz. No matching circuit is necessary when fed with 50 Ω cable: The feed point needs only a good 1:1 balun, the simplest of these being a few turns

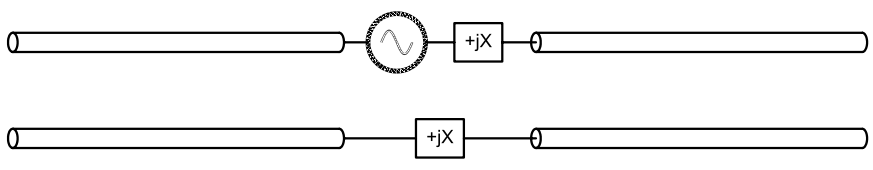

Fig 6—A “Double Dipole.”

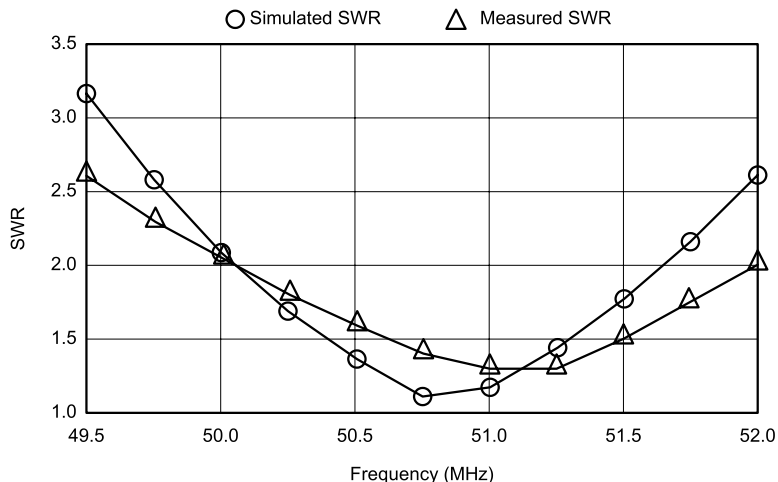
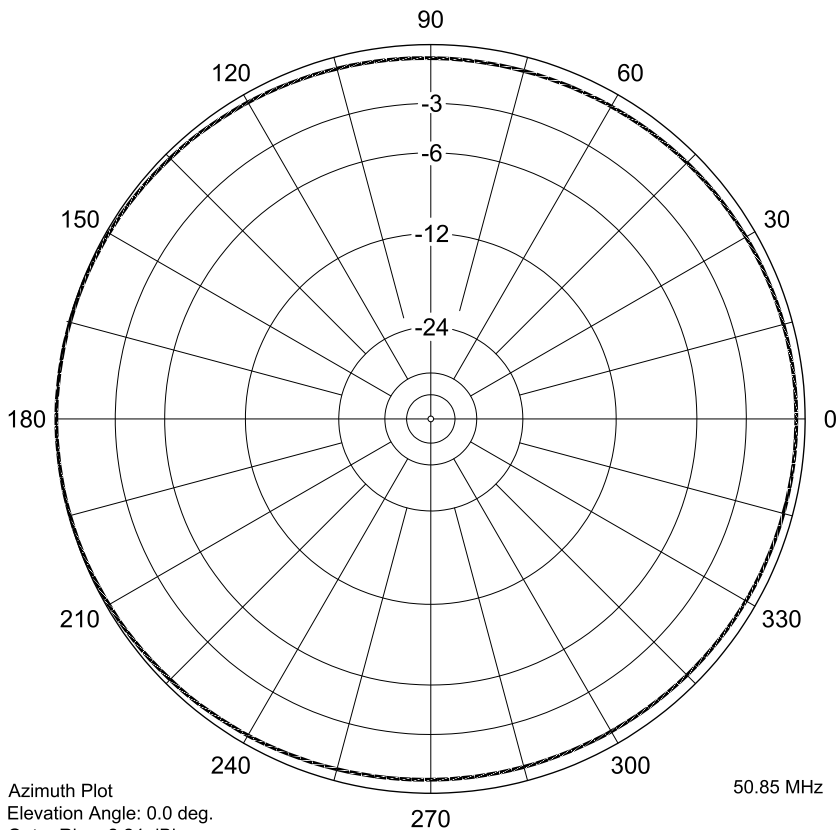

Fig 7—Simulated and measured SWR curves for a prototype 6 m Twin C.



Azimuth Plot
 Elevation Angle: 0.0 deg.
 Outer Ring: 2.24 dBi
 Slice Max Gain: 2.24 @ Az Angle = 180.0 deg.
 Front / Back: 0.4 dB
 Beamwidth: ?
 Sidelobe Gain: 1.84 dBi @ Az Angle = 0.0 deg.
 Front / Sidelobe: 0.4 dB

Fig 8—A predicted H-plane pattern for the vertical Twin C prototype.

of the feed cable around a suitable ferrite toroid. The single-dipole equivalent with the same length and diameter uses a 4- μ H inductor with a Q of 100; it has a feed-point resistance of 15 Ω , an SWR bandwidth in a 15- Ω system of 350 kHz, and an efficiency of 66%. Any loss in the matching circuit will of course further reduce efficiency. Ground-plane versions of these antennas are of course practical, although efficiencies are likely to be lower.

Practical Twin Cs

As an example of Twin C antenna design, let's use the prototype that I built for 6 m. In Fig 3, $L1$ is 36 inches, $L2$ is 40 inches and S is 2 inches. The antenna was fabricated from 1/2-inch copper pipe and fed via a current balun consisting of a few toroids slid over the feed cable. The closely coupled parallel sections were secured to opposite sides of a plastic construction level. The SWR plots from both computer model and measurements of a prototype (mounted about 25 feet above ground on my deck) agree reasonably closely: The simulated and measured results are shown in Fig 7. Notice that I have found on several occasions that the presence of wood in the near field area of VHF or UHF antennas affects the SWR somewhat. The simulation results assume a free-space environment. The measured 2:1 SWR bandwidth is about 2 MHz, or about 4% of the center frequency. A full-size half-wave dipole for 6 m is almost 10 feet long, whereas the Twin C equivalent is around 3 feet on a side. There is a difference in directivity, or gain. A full-size dipole has a directivity of 2.14 dBi, whereas the Twin C in theory behaves as a short Hertzian dipole with a directivity of about 1.8 dBi.

However, when used as a vertical, the pattern is not perfectly omnidirectional because of the currents flowing in the outer vertical wires. The simulated H-plane pattern for the vertical prototype Twin C is shown in Fig 8.

More than two identical subelements may be coupled together in similar manner to the Twin C. With three subelements, the feed impedance is increased by roughly three squared, or nine times, and so forth.

The Twin C shown in Fig 3 has both subelements in the same plane. In fact, one of the halves may be rotated around the vertical axis of the antenna with little effect on performance, except for a slight reduction in SWR bandwidth and center frequency, until the angle between the halves is roughly 30°. For angles less than 30°, the capacitive coupling between the halves increases and the feed point resistance drops rapidly.

The Twin C SWR is very tolerant of changes in the dimensions $L1$ and $L2$. Fig 9 shows how the SWR for the 50-MHz prototype varies with dimensions in a 50 Ω system. As the length $L2$ increases ($L1$ must be decreased to maintain resonance), so does the feed-point resistance, and vice versa. However, changing the spacing between the two halves changes the coupling coefficient, and thus changes the resonant frequency. Shifts in resonant frequency of a few percent can be achieved simply by changing S , but this does of course mean that construction should be such that S is well defined in order to ensure frequency stability. In the prototype 6-m antenna, a change in spacing of 1 inch, from $S = 2''$ to $S = 3''$, shifted the resonant frequency by 700 kHz, and changed the resonant SWR from 1.14 to 1.2. A change in S of 4 inches, from $S = 2''$ to $S = 6''$, shifted the resonant frequency by 1.8 MHz, and changed the resonant SWR from 1.14 to 1.32. From a practical standpoint, frequency adjustment could be provided either by physically moving the two halves closer together; or, perhaps simpler, by providing a small loop, in one or both of the parallel sections, that can be adjusted to change the coupling coefficient.

Dimensions for Twin C dipoles for the 20-, 15- and 10-m bands are shown in Table 1. These are for Twin Cs mounted vertically, as in Fig 3, so that the center of the antenna is located 8 feet above ground with average conductivity. The antennas are made of

0.0625" copper wire, but this dimension is not at all critical. In all cases, the gap in the ends of the Cs is 4", and the dimensions referred to are those shown in Fig 3.

Notice that these dimensions are considerably shorter and "fatter" than those for the Twin C in free space, simply because the presence of the ground increases the feed-point resistance. The dimension $L2$ is reduced in each case to bring the feed-point resistance back to 50 Ω , and $L1$ is increased to maintain resonance at the design center frequency. These dimensions should be treated as good starting points: Be prepared to trim the dimensions to accommodate your local conditions.

Basic Twin C dipoles can also be connected in parallel, just as full size dipoles, to provide multiband operation. One might ask whether a folded-up folded dipole could be used. The well-known problem with folded dipoles is that the feed-point impedance drops to a very low level at the second harmonic. This has to do with the behavior of the short-circuited transmission line that is inherent in the structure. This effect means that folded *folded* dipoles (intentional double adjective) cannot be connected in parallel and operated at a frequency that is near their second harmonic of the dipole cut for the lowest frequency. For example, operation on 20 m and 10 m is not possible: The low impedance of the 20-m dipole on 10 m effectively shorts out the 10-m dipole. This is not the case with parallel-connected Twin C dipoles. There is a frequency for each dipole at which the feed

Table 1—Dimensions for Vertical Twin-C Antennas

Band	$L1$	$L2$	S	SWR Bandwidth
20 m	212"	96"	6"	400 kHz
15 m	126"	76"	6"	550 kHz
10 m	82"	64"	6"	800 kHz

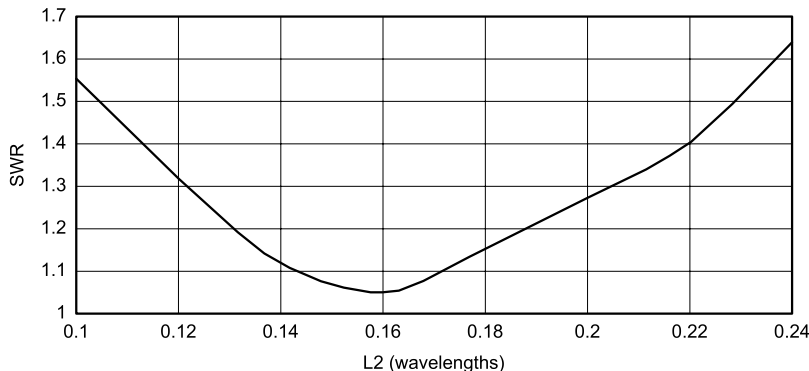

Fig 9—SWR plot for the prototype 6 m Twin C as a function of dimension $L2$ (see Fig 4).

point impedance is very low; but this can be shifted up or down simply by changing the coupling coefficient between the two halves, as noted above. As with parallel full-size dipoles, there is interaction between the individual elements, and generally the SWR bandwidth is reduced significantly on the higher frequency bands. For a three-band (10-, 15- and 20-m) Twin C antenna, mounted with the center 8 feet above ground with average conductivity, the modeled 2:1 SWR bandwidths are >400 kHz on 20 m, 250 kHz on 15 m and 300 kHz on 10 m. This antenna has maximum dimensions of 14 feet wide by 9 feet high. The Twin Cs are spaced apart eight inches, giving a total antenna thickness of 16 inches. They can, of course, be spaced by more than this if you have the room, or they can be interleaved radially, like a paddle wheel.

The outer wings of the Twin C do not have to conform to the shape shown in Fig 3. They may be “dressed out” from the close parallel sections in quite a number of ways, as long as the capacitive coupling between the halves is kept reasonably low. Capacitive coupling can significantly change the total coupling between the two halves.

Before moving on to beams using Twin C elements, let’s look briefly at some Twin C ground planes. A design for 2 m is shown in Fig 10. This antenna has a height of a fraction under 9 inches, and a width of 10 inches. It is essentially omnidirectional, and has an SWR of less than 2:1 from 141-148 MHz. Its 1.5:1 SWR bandwidth is 4 MHz.

I mentioned the use of more than two Cs earlier on. As an example, Fig 11 shows a double Twin C ground plane for 2 m, that uses four subelements. The antenna is 3.5 inches tall and has a diameter of 26 inches. SWR bandwidth is 4 MHz. For 1/8” elements of aluminum or copper, the efficiency is well over 90%. A three subelement version of this for 10 meters is 22 inches tall with a diameter of about 7 feet. This antenna has bent outer wings, and is shown in Fig 12. SWR bandwidth is 800 kHz when using 1/2” elements and 700 kHz when using 1/16” elements. For the Twin C ground planes, it is important that the total ground current is the sum of the currents in the individual subelements, so the ground plane must be made of low-resistance conductors or efficiency will suffer.

Twin C Beams

So much for the basic Twin C dipole—for the moment. We will revisit the basic element and look at its behavior on the third harmonic later. The Twin C dipole may be used as a short

driven element in a Yagi-like antenna. Initially one might think that only one subelement is necessary for the parasitic elements. However, the use of a full Twin C element substantially improves the SWR and gain bandwidths. Fig 13 shows a three-element beam for 6 m; Fig 14 shows the pattern at 50.2 MHz, and Fig 15 shows the SWR plot, both the latter being derived from computer

simulation in free space. The elements are constructed from 1/2” aluminum, and the pattern shown incorporates the conductor loss resistance. For a full-size three-element beam (in this example based on the NBS dimensions), the gain is 9.5 dBi. It can be seen from Fig 14 that the gain for the Twin C is 8.1 dBi, a perfectly tolerable reduction from full size given the significant reduction in

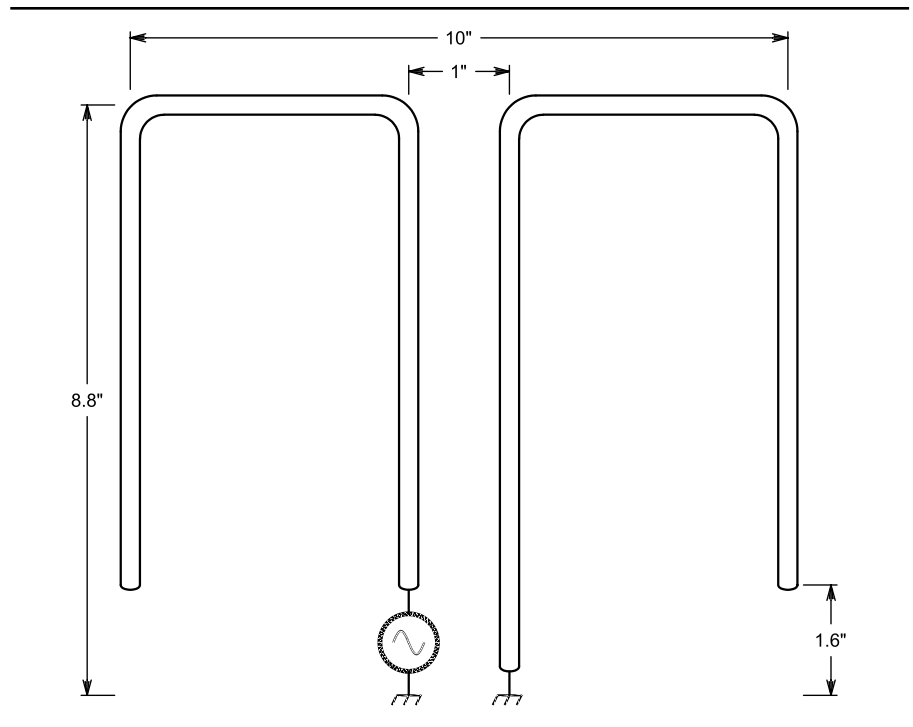

Fig 10—Twin C ground plane for 2 m. Element diameter is 1/8”.

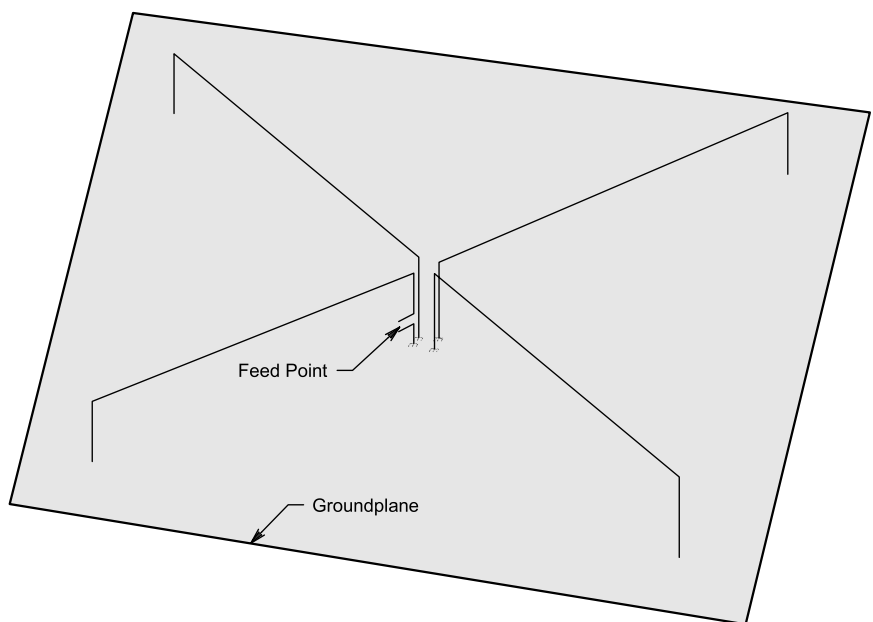

Fig 11—Double Twin C for 2 m.

size. Gain bandwidth (to 1dB down) and SWR bandwidth are 2.8 MHz and 1.2 MHz respectively, compared to 1.5 MHz and 700 kHz for the full-sized beam.

This particular implementation of the Twin C beam is with all elements coplanar. This means that for a horizontally polarized beam, the vertical dimension is just the thickness of the elements. This arrangement gives greater gain than if the orientation of each element is vertical, because of the directivity of the basic element as described earlier. It is also easier to construct, but be warned that you must make sure that the spacing between the close parallel sections of the subelements is well defined, and can't blow around in the breeze! As mentioned earlier with respect to the Twin C dipole, the beam can be tuned by adjusting the spacing of the subelements. The 6-m, three-element Twin C beam is 55" wide by 95" long; whereas the full size beam is 115" wide by 95" long, so the "wingspan" of the Twin C beam is less than half that of the full size beam and is comparable with that of a quad antenna. This reduction in the maximum dimension of course applies to Twin C beams designed for any band. A 10-m version of the three-element Twin C has dimensions of about 15' long by about 8' wide. The 2:1 SWR bandwidth is about 600 kHz, and the gain bandwidth (to the -1dB points) is 1.5 MHz.

A Twin C beam has a constructional bonus, in that the element diameter can be smaller than that of a full-size beam because the bent-back element ends can be supported on insulators mounted on the boom. This means that the element diameter needs to be sufficient to support just one quarter of the span of a full size element, rather than half the span. I rather suspect this might be important in beams for the lower HF

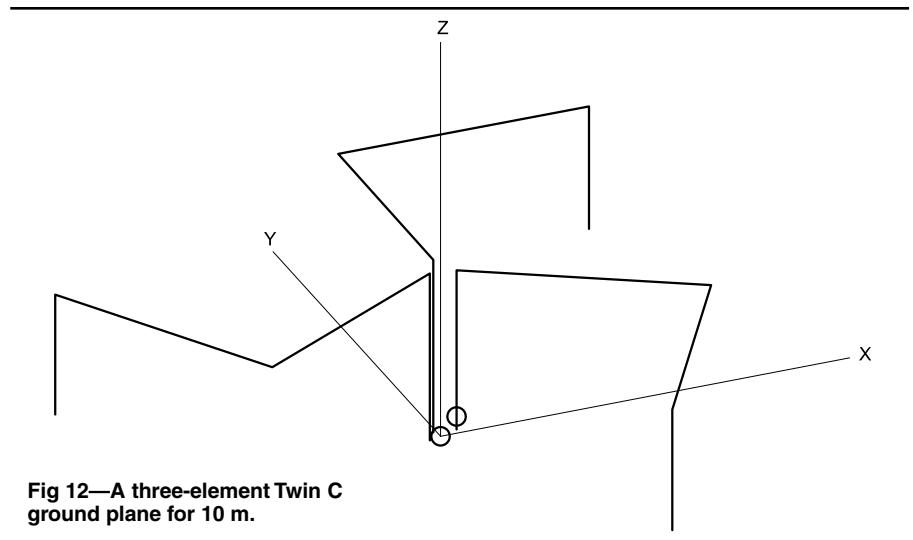

Fig 12—A three-element Twin C ground plane for 10 m.

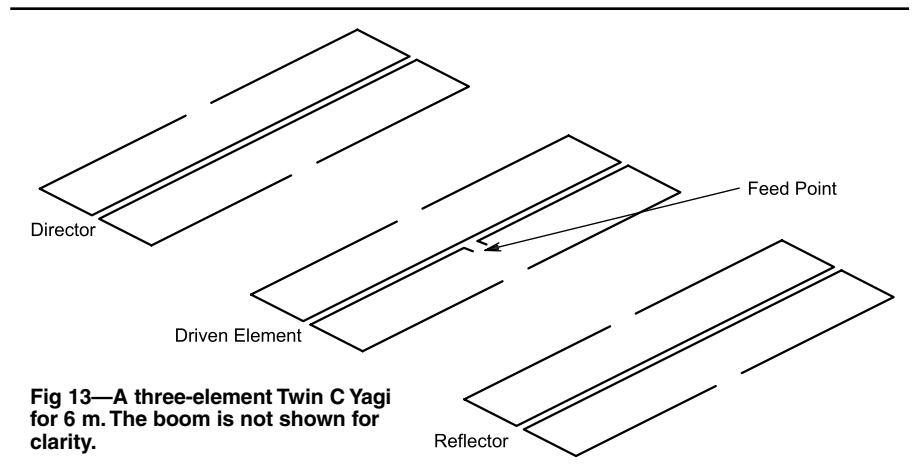

Fig 13—A three-element Twin C Yagi for 6 m. The boom is not shown for clarity.

bands. In my next article we will further explore beams made from Twin C elements: Box Kites.

Notes

¹EZNEC pro 3.0 is available from Roy

Lewallen, W7EL, at www.eznec.com.

²The new methods described are patent pending.

³R. Johnson, *Antenna Engineering Handbook*, third edition, (New York: McGraw-Hill, 1987).

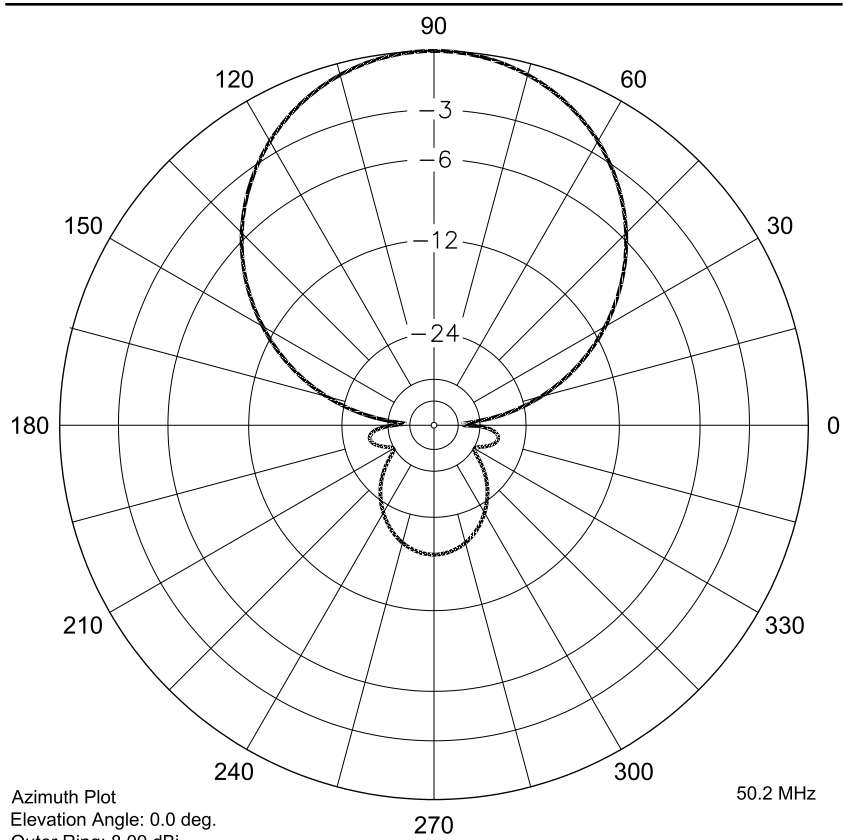

Azimuth Plot
 Elevation Angle: 0.0 deg.
 Outer Ring: 8.09 dBi

Slice Max Gain: 8.09 @ Az Angle = 90.0 deg.
 Front / Back: 18.23 dB
 Beamwidth: 68.4 deg., -3 dBi @ 55.8, 124.2 deg.
 Sidelobe Gain: -10.14 dBi @ Az Angle = 270.0 deg.
 Front / Sidelobe: 18.23 dB

Fig 14—E-plane pattern for 3 element Twin C 6 m Yagi.

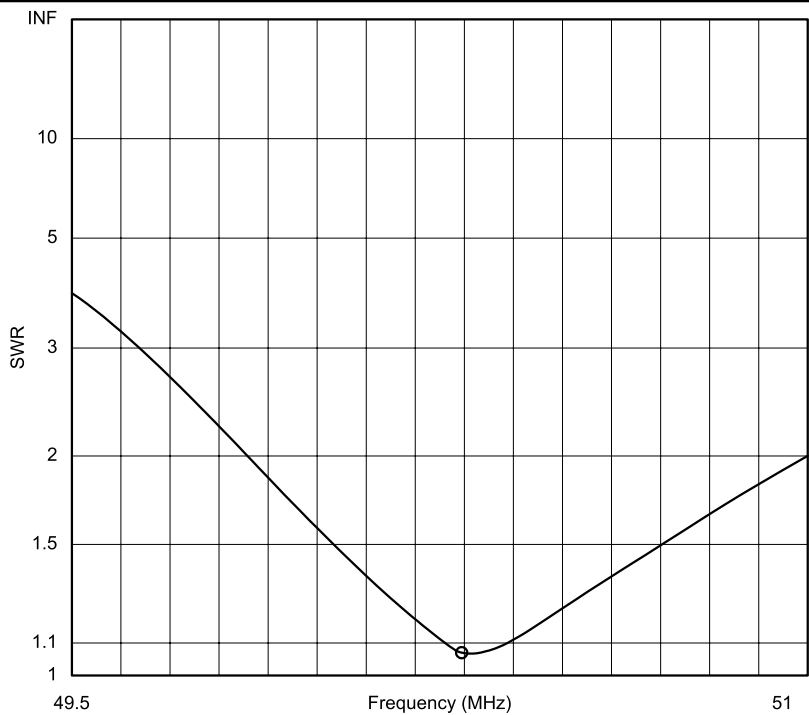

Freq 50.3 MHz Source # 1
 SWR 1.055 Z0 50 ohms
 Z 47.56 + j 0.9487 ohms
 Refl Coeff 0.02686 at 158.22 deg.

Fig 15—SWR plot for three-element Twin C 6 m Yagi.

□ □

Linrad *with* *High-Performance Hardware*

Together with the WSE RX converters, Linrad is a software-defined receiver that should exceed any other receiver in dynamic-range performance.

By Leif Åsbrink, SM5BSZ

Linrad has evolved from earlier systems that I have worked with since about 10 years. My main interest in Amateur Radio has always been the technology for weak-signal communication. In 1993 I erected a cross-Yagi array, 4×14 elements and started working EME on 144 MHz. Being able to eliminate Faraday rotation turned out to be very efficient but not so easy on extremely weak signals. I needed a computer to assist.

The first version of what is now *Linrad* was implemented on a TMS320C25 system. This system could display a 3 kHz wide window on an oscilloscope as the summed power spectrum from both the polarizations. With an averaging time of a few seconds and about 10 Hz resolution, signals could be seen before they were

possible to copy. In the 1995 ARRL EME contest, the TMS320 system was capable of locking to a signal, filtering it through 17-Hz band-pass filters and combining the two signals from the two orthogonal antennas automatically to produce the optimum fit to the polarization of the incoming wave. The signal produced by a receiver automatically keeping the filter centered and the polarization aligned was then sent to my headphones. I scored number two, after W5UN, in the single-operator class that year and was very happy with this system even though it was completely inflexible, with all code in an EPROM that had to be produced on another system. With a 12-bit A/D converter, this system had a poor dynamic range, so it was completely saturated when a local station entered the pass-band. Having to keep SM5FRH, SM5DCX and a few others outside a “3-kHz window” most of the time was of course a limitation for this system, but not a serious one.

In 1997, I started to move the algorithms into the PC and had a working system in 2×20 kHz bandwidth about one year later. This system was under MSDOS and the increased bandwidth made operation much more exciting. The SoundBlaster 16-bit A/D converters allowed a much better dynamic range; this system was only saturated for about one hour at moonset when SM5DCX had his main lobe straight into my back lobe. (My antenna was an extreme “maximum-gain design” with a large back lobe.)

Having software running in a real computer, with all the flexibility coming along with that, made it possible to analyze the EME signals better. As it turned out, “144-MHz EME signals” are only about 0.25 Hz widened by multi-path propagation, so introducing coherent processing was an obvious thing to do. By the time I found that coherent averaging is possible and started to include routines for that, I found that I had to restart the entire project because the code was

Jaders Prastgard 3265
63505 Eskilstuna, Sweden
leif.asbrink@mbox300.swipnet.se

becoming too messy and my home-made drive routines were becoming obsolete. This was in 2001, when I made a new start under *Linux*. This time I had a much better idea about what I wanted the program to do. First of all, I wanted flexibility and hardware independence. By now, autumn 2003, *Linrad* contains everything that was ever included in the older systems but not much more. Many more things are planned for the future, but at present my focus is on high-performance hardware to use with *Linrad*. In recent years, EME activity has spread out over a much wider frequency range—20 kHz is no longer enough. Terrestrial communication also calls for more bandwidth. More bandwidth calls for more dynamic range. It is not possible to keep strong local stations outside the passband, so the D/A converter must have the dynamic range required to handle very strong signals. This article focuses on the system I am currently putting together for 144 MHz EME. *Linrad* and the hardware is in no way limited to this usage, it just happens to be at the focus of my own personal interest and technically it is a very demanding mode of operation.

The WSE Converters

To go from 144 MHz or other amateur bands to a digital data stream, I am using several cascaded converters. This may seem very complicated, but in a way it is not. A complicated problem is split into several less complicated problems. Each converter is doing just one simple task. It is well matched to 50 Ω at both input and output. Each unit can be evaluated separately, and it is not difficult to find out what the limiting factors are.

The WSE RX converters are designed for low noise and low gain. They are open designs, described in detail at www.antennspecialisten.se/~sm5bsz/linuxdsp/optrx.htm. The entire system is kind of a brute-force solution to the problem of receiver dynamic-range limitations. Each converter uses about 18 W, mainly for the class-A buffer amplifiers, so the boxes must be rather big to provide a low temperature without forced air cooling. The design uses through-hole-mounted components only and is experimenter-friendly. Assembled and tested units are available from www.antennspecialisten.se.

For 144 MHz, the four converters listed in Table 1 are used after one another. The system does not have any VFO, only low noise crystal oscillators, so dynamic range is not limited by reciprocal mixing. Each converter has two

channels with a common local oscillator. Each channel has an RF input amplifier, an RF filter, a mixer and an IF output amplifier. The amplifiers have low gain, typically 8 to 10 dB, and they use noiseless feedback. In order to get some isolation, an attenuator follows each amplifier. Noiseless feedback transfers the output load impedance of an amplifier to the input. With 3 or 4 dB in each attenuator and 1 or 2 dB attenuation in the filter, there is enough gain to overcome the conversion loss of the mixer and provide between 0 and 4 dB gain, different for different units. There will also be at least one RXHF unit built in a similar fashion to convert from the HF bands to 70 MHz. The RXHFA will probably work for 1.8, 3.5, 7, 10 and 14 MHz. At present, the RX144 unit is in a late prototype stage, while RX70, RX10700 and RX2500 are available.

The WSE receive system is about 20 dB better than a conventional transceiver. This is a bigger difference than one can really use on the air, because the lack of spectral purity of the interfering station(s) will be the limiting factor. It will be possible to produce a transmitter the same way and get a similar transmit performance. There are several other ways to make an ultra pure transmitter, at least in CW mode. *Linrad* with the WSE converters is an excellent spectrum analyzer to use when building high-performance transmitters or when modifying standard transceivers for better transmit performance.

It should be obvious that far simpler solutions than the WSE RX converters will be adequate at most locations. I have made the WSE products for my own use. I will make a limited number of units available, and if demand is sufficient, there will be a continued supply from Antennspecialisten. Software-defined radios have different characteristics than conventional receivers. There will probably be SDRs available with seemingly good performance data that do not perform well when compared

to a “good old analog” radio. The reason would not be the digital technology as such; the way dynamic range is specified may be misleading. IP3 is one of the commonly used figures of merit for receivers and it is discussed in some detail below. An analog radio will typically work fine with instantaneous voltages up to about 20 dB below IP3 while a digital one may become overloaded 40 dB below IP3 or wherever the A/D converter saturates. Together with the WSE RX converters, *Linrad* is a software-defined receiver that should outperform any other receiver when it comes to dynamic range. There is no limitation in the digital technology as such. Problems may arise when an A/D converter is fed with a large bandwidth because the instantaneous voltage caused by the summed amplitude of many signals may occasionally exceed the A/D converter range, and the conventional way of measuring receiver dynamic range might not show the limitations.

The A/D and D/A converters

The output from the RX2500 is four audio signals with a bandwidth of nearly 48 kHz each. To sample them, an A/D-converter with four channels and 96 kHz sampling speed is required. The second article of this series¹ gives some information about the RX2500 unit and the modified Delta44 sound card that I use to sample the four audio channels.

Better sound cards are available now, and replacing the Delta44 would improve the performance of the entire system. Someday, I hope someone else will determine what cards are best. Once the proper drive routines are installed, *Linrad* should work automatically.

The Delta44 uses the same speed for input and output. There is no reason at all to produce the output at a sampling rate of 96 kHz. *Linrad* is not written for that and the current code would be extremely inefficient. I

¹Notes appear on page 31.

Table 1

With these four converters and a Delta44 sound-card, a 90 kHz wide passband at 144 MHz is converted to a digital data stream inside *Linrad*. The center frequency can be selected anywhere between 143.975 MHz and 145.975 MHz in steps of 25 kHz.

Name	Input (MHz)	Output (MHz)	Crystals	Crystal Separation (kHz)
RX144	144	70	4	500
RX70	70	10.7	5	100
RX10700	10.7	2.5	4	25
RX2500	2.5 baseband		1	—

use a standard audio card for the output at a sampling speed of 5 kHz for CW modes and 8 kHz for SSB. Internally in *Linrad*, the sampling rate at the output of the final filter is not higher than required for the bandwidth, an EME signal that has passed a 20 Hz filter is typically sampled at 46.875 Hz (96 kHz divided by 2048). In the final processing step, the signal is resampled by a fractional number to fit the output speed of the D/A converter. The signal is also frequency shifted by the BFO setting.

The output is kept synchronized with the input by gradually changing the fractional resampling rate. Since separate crystal oscillators generate the input and output sampling rates, the resampling rate will change with time. The total amount of sampled data points waiting in the various processing stages should correspond to a constant time. By monitoring the total processing delay it is possible to detect the need for a resampling rate change.

Linrad Setup: FFT Versions, Sizes and Windows

Assuming a cross-Yagi array and preamplifiers with adequate gain connected to the RX144, a system optimized for 144 MHz EME will need a waterfall bin bandwidth somewhere between 1 and 10 Hz. A good noise

blanker is essential in most locations so the second FFT must be enabled. Running two channels at a processing bandwidth of 96 kHz requires a Pentium III or better, so version 5 should be selected for the first FFT. This is the fastest floating-point implementation, which uses the SIMD instructions (single instruction multiple data) to compute the transforms of both channels simultaneously.

The processing delay through *Linrad* is long, up to 10 seconds, for optimum readability of weak EME signals. This has nothing to do with processor speed, it is a consequence of the character of the EME path and the optimum parameters for the AFC. This means that there is no reason to select a small size for the first FFT to minimize processing delay. Adding 0.2 seconds by making the first FFT band-

Table 2

A 144 MHz preamplifier will lower the system noise figure. Assuming a noise figure of 0.2 dB for the preamplifier and 11 dB at the RX144 input, total system noise figure and dynamic range depend on the preamplifier gain as given by this table. The antenna temperature, Tsky is assumed to be 200 K and S/N loss is relative to an ideal (noise-free) receiver.

Gain (dB)	NF (dB)	Temp (K)	S/N Loss (dB)	Dynamic-Range Loss (dB)
0	11.0	3561	12.51	0
3	8.36	1898	9.77	0.26
6	5.97	1057	7.22	0.71
9	3.99	637	5.03	1.52
12	2.50	426	3.28	2.77
15	1.50	320	2.04	4.53
18	0.90	267	1.25	6.74
21	0.57	241	0.80	9.29
24	0.39	227	0.55	12.04
27	0.29	220	0.41	14.90
30	0.25	217	0.36	17.85
33	0.22	215	0.31	20.80

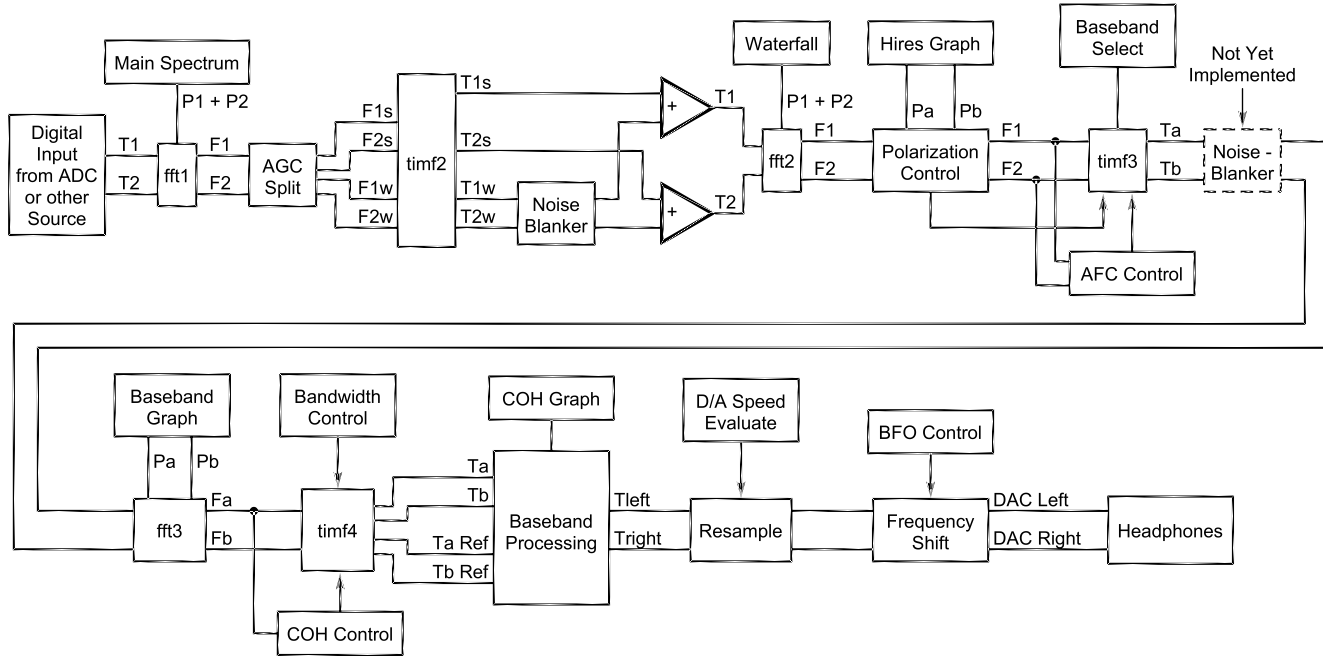

Fig 1—The block diagram of *Linrad* with two receive channels and the second FFT. T1 and T2 are signals in the time domain from two antennas 1 and 2. F1 and F2 are the corresponding signals in the frequency domain. Ta and Tb are linear combinations of T1 and T2 that make the desired signal zero in Tb and consequently maximizes the desired signal in Ta. Ta-ref is a time function constructed from a much narrower bandwidth than Ta. For Morse coded signals, it will be the CW carrier that is useful for coherent processing.

width 10 Hz is no significant disadvantage. Keeping a modest ratio between the sizes of the second and the first FFT makes it easier to ensure that very strong signals will not saturate the second FFT even if they are stable enough to put nearly all their energy in one single frequency bin.

Typical parameters would be a first FFT bandwidth of 30 Hz and second FFT bandwidth eight times narrower. The parameter is in powers of two, so it should be three that is 2^3 . With large transforms, a window of \sin^2 is sufficient for the first FFT and for the second FFT the sine function itself ($N = 1$) is perfectly adequate. With *Linrad-01.01* and later, these parameters will give the size 8192 for the first FFT and 65536 for the second with bandwidths of 23 and 2 Hz, respectively. The transform sizes come in powers of two, so you never get exactly what you ask for. The resampling spurs surrounding a very strong signal disappear into the noise about 2 kHz away from and 145 dB/Hz below a near saturating carrier with these parameters. By setting the first FFT window to \sin^4 , it is possible to eliminate these spurs completely. They then disappear into the phase noise of the 2.5 MHz test oscillator 140 dB/Hz below the carrier at a frequency separation of 200 Hz. That would be a waste of CPU power because no interference source could be expected to have a spectral purity anywhere near -145 dB/Hz as close as 2 kHz.

Linrad Setup: FFT Signal Levels

First of all, the gain of the analog hardware should be set for the desired compromise between dynamic range and system noise figure. With the WSE converters, "setting the gain" is simply setting the gain of the 144 MHz preamplifier. With a system noise figure of 11 dB at the RX144 input and with a preamplifier noise figure of 0.2 dB, the in-band dynamic-range loss, system noise figure and preamplifier gain relate as illustrated in Table 2 for an antenna temperature of 200 K.

Table 2 shows the usual thing. One wants the preamplifier to lift the noise floor by something between 10 and 20 dB for a compromise between dynamic-range loss and noise figure. Dynamic-range loss is the amount by which the noise floor is lifted when the preamplifier is connected. The WSE converters, using only crystal oscillators, are not much affected by reciprocal mixing, so the dynamic range is the distance from the noise floor to a fixed power level where something becomes nonlinear.

As can be seen from Table 2, really low noise figures require high gain

and will degrade the dynamic range by nearly 20 dB. In cases where dynamic range is the limitation, a preamplifier gain of 12 dB only will provide a noise figure of 2.5 dB, which will degrade an EME signal by 3.3 dB for an antenna pointing towards cold sky. For terrestrial modes, an antenna temperature of 1000 K is often assumed, in such cases even less gain could be considered.

The block diagram of *Linrad* is reproduced here as Fig 1. The major processing blocks are *fft1*, *timf2* and *fft2*. These blocks compute forward, reverse and again forward FFTs at the full sampling rate. The design of a digital receiver is no different from the design of an analog radio. Each processing block has a saturation level and a noise floor. In the digital world one can make the dynamic range extremely large by use of many bits for each data point, but that has a penalty in CPU load. The 16-bit multimedia instructions run three times faster than floating point and therefore 16 bit data is used for *timf2* and *fft2*. This leads to several complications, but computers were not fast enough when I wrote the code. There are several compromises in the *Linrad* architecture that may be removed in the future when CPU speed is no longer a limitation. The 16-bit processing blocks do give a small contribution to the system noise floor and they may limit the performance of the smart noise blanker. Going from 16 to 32 bit data words could improve dynamic range by a few tenths of a decibel, but spare CPU capacity may be used for many interesting things, so I have no plans for a change in the near future.

Fft1 must use 32-bit data to handle the full dynamic range. The output of *fft1* is split into two blocks and an AGC makes sure no signal is strong enough to saturate when converted to 16 bits. The maximum level of the output from the AGC depends on several factors. The attenuation to use at frequencies where strong signals are present is calculated from power spectra. Three different power spectra are used for this purpose: A fast and a slow *fft1* spectrum and a *fft2* spectrum. The fast *fft1* spectrum is intended to prevent overflows when a very strong signal starts suddenly. The averaged spectra are needed to find weaker signals that may be strong enough to degrade the noise blanker but do not have S/N enough to be found in a single *fft1* power spectrum. A relatively strong signal may be hidden in the pulse noise that the blanker will remove and reasonably good statistics are required to find it. The *fft2* spectrum does not

have this problem, but there are some stability problems in using it because of the way *Linrad* is designed. The interference that will not be removed from a frequency on which there has been a strong signal can be interpreted as a strong signal if the blanker controls are used carelessly. For details about this phenomenon, look at antennspecialisten.se/~sm5bsz/linuxdsp/blanker/leonids.htm. When the *fft1* bandwidth is as narrow as 23 Hz, it is a good idea to use unaveraged power spectra for the fast *fft1* spectrum. Use the little box in the lower right corner of the main spectrum to set the number of spectra for the first average. Set it to one, the default value is five. Using unaveraged power spectra will cost some CPU time. It is necessary to do the averaging in two steps when the *fft1* bandwidth is very large, but with the parameters given here the increased CPU load should not be a problem. Since the transform size is eight times bigger for *fft2* than for *fft1*, strong signals that occupy one bin in *fft1* only must be limited to eight times less power than the saturation limit. In the worst case, when all the energy comes in a single frequency bin in *fft2* too, the energy is collected over an eight-times longer period.

Exactly as for analog processing blocks, it is essential that the noise floor is placed correctly for the digital processing blocks. 16 bits is marginal for the dynamic range needed. The WSE converters add 0.5 to 1 dB, each, to the system noise floor. *Timf2* and *fft2* add a few tenths of a dB each, as will be discussed below. The weakest link in the signal processing chain is the Delta 4 A/D converter. Despite the modification that lowers the noise floor by typically 3 dB, the Delta 44 produces about 40% of the system noise floor at the RX144 input. The system noise figure of 11 dB at the RX144 input is due to the summed effect of all the noise sources. The noise figure of the RX144 itself is about 6 dB.

When you start *Linrad* for the very first time, you are prompted to setup routines. Select the appropriate parameters for your sound card and enter a receive mode. You are again prompted for parameters, select the default ones or something else that seems appropriate. After the last parameter screen you get to the normal processing routine. Press "A" to make *Linrad* show amplitude information. The lower left corner of the screen will look like Fig 2. None of the values should become zero under normal operation. The numbers hold the minimum value and they may become zero

due to the transient that may occur in case the A/D converter is stopped and restarted. They may also become zero at extreme events like changing the local oscillator frequencies while a very strong signal is present. Clear the minimum value by pressing “Z.” If any of the numbers tends to become zero often, some signal level is too high.

These parameters are digital volume controls:

“First FFT amplitude” is `fft1` input.

“First backward FFT *att. N*” is `timf2` output.

“Second forward FFT *att. N*” is `fft2` output.

These volume controls affect the signal levels inside the major processing blocks. The 16-bit processing blocks `timf2` and `fft2` are the critical ones. The volume controls should be set for the `timf2` and `fft2` noise contributions to become negligible. The dominating contribution for `timf2` is the rounding error in going from floating point to integers, about 0.3 bits RMS. Since the rounding errors at the `timf2` input are made in the frequency domain, lowering the input volume control for the quantization noise to grow to a substantial fraction of the noise floor does not lead to a S/N decrease. It works the other way around. The signal becomes enhanced! Not very surprising at second thought because when all the frequency bins containing only noise have amplitudes below one bit, the noise disappears completely. The signal will not disappear if its amplitude is above one bit. This is an artifact. When back transformed, such a signal is distorted and completely useless if it is near the noise floor. To really verify the S/N loss caused by rounding errors, the signal must be well below the noise in a single bin. By setting the first FFT bandwidth to 800 Hz and using a signal that lifts the main spectrum by

less than 1 dB, one can find the expected behavior when analyzing S/N in the baseband with a narrow filter. The noise level at the `timf2` input is the “Floor” value. See Fig 2. The “First FFT amplitude” should be set for this value to be about 1.5, 14 dB above the quantization noise, when nothing is connected to the RX144 input. For a system noise figure of 0.4 dB, using the assumptions of Table 2, the “Floor” value will grow to about 5.7 when the preamplifiers are connected.

In `timf2`, the reverse FFT in 8192 points, the signal would grow by up to 8192 times or 13 bits if no right shifts were used in the butterfly loops of the reverse FFT routine. A number of the butterfly loops use a right shift to prevent the signal from growing and these right shifts introduce errors, another form of quantization noise. It is important not to set the number of butterfly loops with a right shift larger than necessary to avoid this noise but on the other hand it is important to have as many right shifts as possible to allow large interference pulses in the `timf2` output. A continuous carrier, a single large frequency bin, will not cause saturation in a reverse transform. Its large amplitude will not grow, it just spreads out over the entire time spanned by the backward transform. Pulses behave differently. A noise pulse in the frequency domain is spread out over all frequency bins. The back transformation will collect all the energy into a single point in time, causing very large amplitude and possibly an overflow since only 16 bits are used.

Table 3 shows the effect of different values of “First backward FFT *att. N*” with the other parameters as described above. The table shows signal and noise levels when a weak signal is injected into one of the RX144 inputs. Rounding errors cause a small loss of signal and an increased noise floor. The signal level is equal to the

noise level in 4 kHz bandwidth, but the levels are measured in 1 Hz bandwidth to provide the 0.1 dB accuracy of the table while the noise is measured in a bandwidth of 1 kHz. The test signal is 22 dB above the noise in the bin bandwidth of the first fft. A strong signal will be less attenuated, but a really weak signal will not be more attenuated. The right shifts are placed as late as possible among the fft butterfly loops and the test signal is already below the noise floor when it becomes attenuated as shown in the table. An inspection of Table 3 indicates that the correct value for “First backward FFT *att. N*” is five. The associated loss of noise figure at the RX144 input is about 0.2 dB.

The 1-dB compression point of the RX144 is about +15 dBm. Pulses that have a peak power of +15 dBm after passing a filter with a bandwidth of 2 MHz reach the input of the RX2500 with a peak power of +3 dBm. The reduced power level is not due to amplitude clipping; it is because of the reduced bandwidth. The output bandwidth of the RX10700 is about 0.5 MHz, so the pulses are stretched by a factor of four with four times less power in each pulse causing a peak power reduction of 16 times (12 dB). The pulses that nearly saturate the RX144 input do not saturate the Delta 44 A/D converter although the margin is only 2 dB. Very large pulses do saturate `timf2` to an extent that is determined by the “First backward FFT *att. N*” parameter. Table 3 shows the maximum pulse level at the RX144 input that will not saturate `timf2` for different values of the parameter. The data is from measurements with a preamplifier having a bandwidth of 2 MHz.

The last entry of Table 3 is the level in dBm at the RX144 input that will cause saturation at the output of the first reverse transform when a signal

Amplitude margins (dB)			
fft1	St	24.29	37.32
fft1	Wk	26.36	41.98
timf2	St	32.78	50.31
timf2	Wk	30.94	6.84
	fft2	3.64	17.33
A/D	0.96	1.04	29.31 30.00
	66.1%	0.0009	Floor 49.20

Fig 2—The lower left corner of the Linrad screen when “A” has been pressed. A strong carrier, 3 dB from A/D saturation is fed into channel 1 of the RX144, while -16 dBm interference pulses with a repetition frequency of 100 Hz are fed into channel 2 (see text).

Table 3

The number of butterfly loops with a right shift affects S/N and the saturation level of `timf2`. The gain levels of earlier stages affect this table, which is for an `fft1` size of 8192 with a \sin^2 window and with “First FFT amplitude” 1100 to place the noise floor at 1.5 bits RMS with dummy loads at the RX144 input.

<i>Att. N</i>	Signal (dB)	Noise (dB/1 kHz)	Max Pulse (dBm)	Max Abrupt (dBm)
2	24.7	18.4	-28	-54
3	24.7	18.4	-22	-48
4	24.7	18.4	-16	-42
5	24.6	18.5	-10	-36
6	24.4	19.0	-4	-30
7	23.8	21.0	+2	-24
8	23.1	25.5	+8	-18

is switched on or off abruptly within the visible passband. An abrupt switching will cause a keying click that spreads its energy over the entire passband. The mechanism is the same as for the interference pulses. This maximum abrupt signal level becomes smaller if the operator selects to use averaged spectra to locate very strong signals. It is not really a big problem because the interference spike created will happen only once for each transmission period. The strong signal must be absent for a few seconds for the gain to go back to normal at the frequency in question.

The strongest interference pulses that will be correctly treated by the smart blanker is -10 dBm. Pulses above this level will be removed by the dumb blanker.

The quantization noise gives rise to spurs, but these spurs are harmless because they disappear when the preamplifier is added, a phenomenon usually referred to as dithering. The amplitudes of the quantization noise spurs are generally independent of the signal level. When a single weak signal is fed into the RX144 input with the above parameters, and only two or three frequency bins are routed to "fft1 St", the group of strong signals, the output, "timf2 St", will be zero most of the time with occasional occurrences of one bit in either direction. This is, of course, no good representation of a sine wave, the signal is surrounded by strong spurs. When preamplifier noise and/or other signals are added, statistics will take care of these spurs.

With the parameters described above, my 600 MHz Pentium III uses 66% of the time available to *Linrad* for computing while spending 34% in the idle loop as can be seen in Fig 2. The idle loop goes to sleep regularly so the *Linux* kernel or other programs may be active in parallel. One cannot be sure all the 34% would be available to *Linrad* if the sleep statement were replaced by useful processing. It may depend on *Linux* activities that I do not know anything about.

The second number on the last line of Fig 2 is 0.0009. This is the longest time in seconds encountered for the idle loop. If the kernel makes lengthy activities due to some other program this number will grow if it happens while *Linrad* is in the idle loop. This number is an indicator for *Linux* doing other tasks than *Linrad's* signal processing. It will grow while data is saved to disk for example.

The value 49.2 for "Floor" in Fig 2 is the flat noise floor of the pulse train in channel 2. It is about 30 dB above the level of 1.5 with nothing connected

to the RX144 inputs. At a repetition frequency of 100 Hz, pulse noise up to 36 dB above the RX144 noise floor will be properly treated by the smart blanker, which means that pulse noise up to about 20 dB above the preamplifier noise floor will be properly handled. This may seem inadequate, but a comparison with the peak power S-meter readings of a conventional radio is irrelevant. For real power-line interference, typically a few thousand pulses per second, the smart blanker will completely eliminate pulses that lift the noise floor by more than 30 dB above the preamplifier noise floor.

The timf2 margins reflect the "First backward FFT att. N" setting. Pulses about 30 dB from saturating the A/D converter leave a margin of about 7 dB until saturation occurs in timf2 Wk. It is ok for timf2 Wk to saturate occasionally, but nothing else should saturate. If fft1 or fft2 saturate, strong spurious signals would be generated.

The "Second forward FFT att. N" parameter is set to 9 for the result shown in Fig 2. This parameter adjusts the gain of fft2 by selecting how many of the butterfly loops should have a right shift. If this parameter is set too high, quantization noise will add to the noise floor as one can see in Table 4. "Sellim maxlevel," the parameter that controls the maximum permitted amplitude in a single fft1 frequency bin must be set to 4000 or less in order to avoid fft2 saturation for a strong and very stable carrier. Such signals are unlikely in real usage, and if you note fft2 is never near saturation you may make this parameter bigger, which will make the waterfall diagram give a better representation of strong signals.

Summing up, for the WSE RX converters, the following FFT parameters should be close to optimum for 144 MHz EME:

- First FFT bandwidth (Hz) = 30.

Table 4

The number of right shifted butterfly loops in fft2 affects the noise floor. Parameters are as in Table 3 with "First FFT att. N" = 5.

Att. N	Signal	Noise
6	35.8	-12.4
7	35.8	-12.4
8	35.8	-12.4
9	35.8	-12.4
10	35.8	-12.2
11	35.8	-11.6
12	35.8	-9.9
13	35.8	-6.0
14	35.7	-0.9

- First FFT window (power of sin) = 2.
- First forward FFT version = 5.
- First FFT storage time (s) = 4.
- First FFT amplitude = 1100.
- Enable second FFT = 1.
- First backward FFT version = 1.
- Sellim maxlevel = 4000.
- First backward FFT att. N = 5.
- Second FFT bandwidth factor in powers of 2 = 3.
- Second FFT window (power of sin) = 1.
- Second forward FFT version = 2.
- Second forward FFT att. N = 9.
- Second FFT storage time (s) = 20.

Linrad Setup: AFC, Spurs and Baseband

When AFC is enabled, the user must supply parameters that determine how much memory will be allocated. One of these parameters is "Second FFT storage time (s)," for which 20 seconds is a reasonable value. EME signals on 144 MHz are fairly stable, the default values "AFC lock range Hz" = 150 and "AFC max drift Hz/minute" = 100 should be perfectly adequate. Do not enable Morse decoding, those routines are experimental and will not be useful in the near future.

The spur-removal algorithm uses the same spectra as those used by the AFC. The AFC needs high resolution for optimum sensitivity and that is the reason the fft2 bandwidth is set to 2 Hz with the parameters suggested above. The spur removal works like a PLL that sets up a sine wave with the correct amplitude and phase to match the amplitude and phase found in the fft2 transforms over some time selected by the user. The minimum number of transforms is three, the spur-cancellation PLL will fail if the bandwidth of a spur is above 0.2 Hz or so with the above parameters. The spur-removal routine can lock to a peak in the fft 2 spectrum and remove it only if it is coherent from transform to transform. This means that only spurs that are narrow with respect to a 2 Hz bandwidth will be removed. Set "Max no of spurs to cancel" to 100 and make "Spur time constant (0.1sek)" equal to 1.

The maximum bandwidth one would ever want when listening to an EME signal is 2 kHz, which means that the baseband sampling speed should be set to at least 4 kHz. The baseband is filtered out from the fft2 spectra and the total spectrum width must be about 4 kHz for a flat region of 2 kHz. The baseband sampling speed must be a power of two smaller than the input sampling speed so the desired value for "First mixer bandwidth reduction in powers of 2" is four, which leads to a baseband sampling

speed of 6857 Hz and a maximum bandwidth of 3.0 kHz. On my 600 MHz Pentium III, the largest baseband transform, `fft3`, that can be used is 16384 at this relatively high baseband sampling speed. That means that the largest usable baseband filter spans 2.4 seconds so the narrowest carrier filter that can be used for coherent CW will be about 0.5 Hz. This is perfectly adequate for EME but for low bands one may select a much lower baseband sampling rate for coherent CW at very slow speeds.

The "First mixer no. of channels" must be set to one. Some day, when the Morse decoding routines are in place, it will be possible to have the CW transmissions of several stations decoded simultaneously on the screen. The idea is to be able to see what other stations do while operating. This should be very useful in contests for example. The "Baseband storage time (s)" is mainly for Morse decoding. Set it to 20 seconds to not waste memory. When you select 3 kHz bandwidth, the baseband storage will then need 13 MB, but for CW reception with a bandwidth of 20 Hz the memory needed will be 200 kB only. The baseband power spectrum can then be averaged over 20 seconds maximum but that is sufficient for EME CW.

The "Output delay margin (0.1sek)" parameter adds an extra delay between input and output to allow for the computing delay. On my computer, three is enough here. When this parameter is set too low, there will be gaps in the output signal occasionally when the computed data is not available in time for the output. Press "T" on the main screen to see the timing information. The line "D/A" shows the current value and the minimum value encountered. If the minimum becomes zero, the delay margin is set too small or the computer is doing other tasks that slow down processing temporarily. There is no reason to set "Output sampling speed (Hz)" above 6000. High speeds here cost a lot of CPU time because I have not optimized the code for that. The baseband data is present at a sampling rate corresponding to the bandwidth of the baseband filter. For a 20-Hz baseband filter bandwidth, the baseband sampling rate for `timf4`, is only 47 Hz. To convert this to the desired output frequency, Lagrange's interpolation formula is used to interpolate each output point from four baseband data points, a third-order polynomial fit. The reason is that the output may be on a different sound card with a noninteger ratio between input and output sampling speeds. The proce-

cedure is efficient to convert between similar sampling speeds that are related by fractional numbers when the signal is not over-sampled. Four terms are then needed to avoid introducing distortion. When the output sampling speed is set to 96 kHz, this procedure becomes ridiculously inefficient. I see no reason to provide a routine for converting a narrowbandwidth signal to a high sampling rate.

The output mode is a number that characterizes the baseband processing. This number changes when you click on the different boxes in the baseband graph. The current value is shown in the lower right corner of the baseband graph. Set "Default output mode" to the number you want as the default mode. The last parameter "Audio expander exponent" is the exponent by which the amplitude is expanded when the operator clicks the "Exp" box. Expanding the audio volume may be helpful when a very narrow bandwidth is selected. The ears have a logarithmic response for amplitudes. When a matched filter that will only let through the signal and the principal sidebands is used, the ears will have to rely on amplitude information only because the human hearing system does not have the selectivity to distinguish different frequencies within a 15 or 20 Hz wide passband. It then helps to expand the dynamic range of the audio signal. The default value is three.

Summing up, the optimum AFC, spur and baseband parameters for 144 MHz EME should be something like this:

- Enable AFC/SPUR/DECODE = 1.
- AFC lock range Hz = 150.
- AFC max drift Hz/minute = 100.
- Enable Morse decoding = 0.
- Max no of spurs to cancel = 100.
- Spur time constant (0.1sek) = 1.
- First mixer bandwidth reduction in powers of 2 = 4.
- First mixer no of channels = 1.
- Output delay margin (0.1sek) = 3.
- Output sampling speed (Hz) = 6000.
- Default output mode = 1.
- Audio expander exponent = 3.

Receiving a Weak EME CW Signal

With the parameters listed above, the waterfall graph is very sensitive. The FFT size is 65536, but the screen is only 1024 points on my computer. Consequently each pixel on the screen represents 64 frequency bins of the `fft2` spectra.

Rather than showing the average power over 64 frequency bins, which would produce the same result as an average over 64 transforms of size

1024, each pixel on the screen shows the strongest frequency bin out of the 64 behind each pixel. This becomes particularly favorable when the `fft2` spectra are averaged before the strongest frequency bin is picked.

Setting "Waterfall avg" to six will give a new line on the waterfall every three seconds with a sensitivity that will allow the operator to see all signals present on a 90 kHz segment of the 144 MHz band well below what will be possible to copy. A one-minute transmission is well visible if the S/N ratio is -6 dB in 20 Hz bandwidth. To copy Morse code, one needs something like 14 dB more. Taking the effects of fading into account, copying is done during a few signal peaks when a few letters are above the threshold and while the average signal is at S/N close to zero. When the waterfall graph is expanded to show 1/64 of the spectrum only, the sensitivity is about 3 dB better. Picking the best peak rather than computing the average is an advantage of about 6 dB with the above parameters.

The waterfall graph of *Linrad* shows the total power spectrum summed over both polarizations when a crossed-Yagi array is used. Compared to a perfectly aligned antenna, this means a loss of 3 dB in detection sensitivity. It is not a simple sum of two power spectra because that would lead to an even greater loss in case the polarization is not aligned to one or the other antenna. For each frequency bin, the power of each channel is averaged separately and the complex correlation between the two amplitudes is also averaged. A signal that is present in both channels simultaneously will produce a non-zero average correlation, which is taken into account when computing the energy content of a frequency bin. This is necessary to have a good sensitivity for signals that have a polarization that puts about 50% of the power in each channel.

With the parameters listed above, the minimum processing delay is four seconds when the AFC delay is set to zero. For extremely weak signals delays up to about 10 seconds may be useful. The operation does not differ from the operation described earlier.³ When the mouse is clicked on a signal, the two channels are analyzed and the polarization is extracted. Depending on the operator's preferences, the two channels can be combined to two new orthogonal polarizations, one has all the signal energy or they can be both routed to stereo headphones.

The EME window, Fig 3, uses the polarization of the received signal to calculate the optimal transmit polarization. This way the adverse effects

of Faraday rotation can be eliminated both for receive and transmit. The EME window shows the moon position for this location and for a DX location. A call sign, or fragments thereof, can be entered in the largest box. Fragments must be separated by question marks or stars to indicate one or many unknown characters. Typing in V?2F* will hit VK2FLR as the only answer. VK2* will suggest three call signs while *2FL* will suggest JO2FLD besides VK2FLR and V*LR will suggest VE6LR and VK2FLR. The EME database files dir.skd, eme.dta and allcalls.dta can all be downloaded from the Internet. The EME installation procedure will search them all and collect inconsistencies in a file, while creating a text file containing call signs and locations only. The text file can be loaded automatically when *Linrad* is started.

The Future

In my experience, more bandwidth is more important than anything else. An analog noise-blanker that operates at a bandwidth of 5 MHz is capable of removing very strong static rain noise. S9 noise that sounds exactly like normal white noise can be completely removed. I think the *Linrad* blanker will do it at much lower bandwidth than 5 MHz but 90 kHz is most probably not enough. I have not had any opportunity to make a test, I am still without an antenna since a big storm two years ago.

In the future, when the "standard PC" has a lot of unused CPU power when processing a 0.5-MHz bandwidth, one can make significant improvements to *Linrad*. An improved process could look like this:

1. Forward fft from raw data

2. Back transform for weak signals only
3. Smart blanker subtracts pulses from raw data and remembers what was subtracted
4. New forward fft from improved raw data
5. Strong signals of known types are analyzed. It is possible to model the nonlinearities of, for example, an SSB transmitter and calculate the signal components over the entire spectrum. Known signals are subtracted from the improved raw data to produce new raw data with much lower signal and interference levels. What is subtracted is remembered for further use.
6. New forward fft from better improved raw data
7. Back transform for weak signals only
8. Add the pulses that were subtracted in step 3 and run the smart blanker again. This time the pulse shapes will be very accurate. They are removed from the original raw data.
9. Refine the strong signals and remove them.

The basic idea is to split the total

input signal into a few groups of accurately known signals for which *Linrad* can calculate the true waveform based on knowledge of the signal source. The operator can select one of these signals or use a receiver that operates on whatever remains when the strong signals are subtracted.

For the HF bands, a very large bandwidth is probably not so useful. A large number of channels on the other hand would be extremely useful, since *Linrad* could then form an adaptive antenna that optimizes the pattern for optimum S/N for each interference source. In that way it will be possible to overcome very large interference levels from all the modern electronics and so on. With many channels, it will be sufficient with a mediocre dynamic range for each channel so simple systems sampling directly from the antennas would be adequate. We just have to wait for the hardware cost to become low enough.

Comparing the WSE Converters to Conventional Receivers

Blocking Dynamic Range

Blocking dynamic range, BDR is

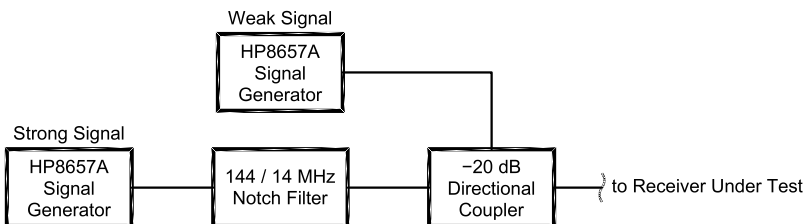

Fig 4—The strong signal passes a notch filter that removes the phase noise from the HP 8657 at a fixed frequency. A weak signal at the notch frequency is injected through a directional coupler towards the receiver under test while the strong signal is picked up by the directional coupler to allow a precise determination of the level entering the test object.

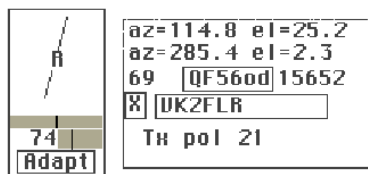

Fig 3—The polarization graph, left and the EME graph right. At this moment, the signal from VK2FLR was received in a nearly vertical polarization. The optimum transmit polarization is 21°. When using H for transmit, the loss due to misalignment is 0.6 dB, but when using V for transmit, the loss is 9 dB. Knowing what to choose improves the QSO chance by a factor of two in this case. The direction to VK2FLR is 69° and the distance is 15,652 km. Direction and distance are intended for terrestrial work. It is possible to enter a locator in the locator field.

Table 5

Blocking and BDR for WSE RX144 system and for a IC-706MKIIG on 144 MHz. N indicates abrupt increase of noise floor due to op-amp saturation in RX2500. The preamplifier is off for the IC-706.

Frequency (kHz)	WSE+Linrad Level for		IC-706 144 MHz Level for	
	3 dB S/N loss	1 dB sat	3 dB S/N loss	1 dB sat
offset				
5	145	A/D sat	102	119
10	145	A/D sat	107	133
20	150	151N	116	139
30	162	163N	120	142
40	164	165N	123	145
50	166	168N	125	146
100	167	172	131	146
250	171	173	133	146

defined in words as: "The ratio (difference in dB) between the weakest on-channel signal a receiver can hear and the strongest off-channel signal a receiver can tolerate without degradation of the received signal." Notice that this is quite different from BDR as measured by ARRL Lab. They measure the level at which blocking occurs.

To measure the dynamic range properly, one needs a strong signal of extreme purity and a weak signal that is not critical. To demonstrate the performance of the WSE converters used together with a modified Delta 44 sound card, I have made the BDR measurements shown in Tables 5 and 6. The measurements were made with the setup shown in Fig 4. Table 5 shows a comparison of the RX144 in a late prototype stage together with production units of the RX70, RX10700 and RX2500.

The RXHFA converter was in a very early prototype stage when this was written. The system noise figure of the entire 14 MHz receiver with the RXHFA prototype operated together with the RX70, RX10700, RX2500 units and a Delta44 in minimum gain mode is 17 dB. A comparison between Tables 5 and 6 shows that the local oscillator of the RXHFA prototype needs some further improvements. This oscillator must operate at several well-separated frequencies to cover amateur bands from 1.8 to 14 MHz, the LO buffer amplifier is the dominating noise source.

The weak signal was set to a level

of about 10 dB above the noise floor and the level at which the strong signal degrades S/N by 3 dB was located at several frequencies. The AGC of the transceivers was not switched off, AGC makes no difference because both signal and noise were monitored with *Linrad* running as an audio spectrum analyzer. Table 6 shows that the Japanese transceivers are limited by reciprocal mixing and that *Linrad* and the WSE converters can tolerate about 20 dB higher interference levels. The RXHFA unit may need an attenuator to shift the A/D saturation level upwards in case peak powers above -12 dBm are encountered within the 90 kHz passband. The FT-1000D can receive such signals without an attenuator, but S/N would be degraded seriously by reciprocal mixing so the RXHFA unit will perform better even with an attenuator in front of it. Note that the IC-706 is better than the FT-1000D in case the interference is within ± 25 kHz because the LO phase noise is lower.

In the BDR test, I have chosen to measure the level at which S/N is degraded by 3 dB. There is a good reason for selecting this rather than the 1-dB degradation point, which would be more conventional. The time for the measurement increases drastically, or the accuracy is degraded, if one looks for the point of 1-dB degradation. Noise adds by power, converted to a decibel scale it looks like Table 7.

If one wants to determine the level of the added noise within ± 1 dB, one

must measure a 3 dB change within ± 0.5 dB, but one would need to measure a 1 dB change within ± 0.2 dB, something that would require a 6.25 times longer integration time when measuring the noise floor.

For use on crowded HF bands, it might be useful to measure the level of the strong signal required for say 15 and 30 dB S/N degradation. In some receivers, the 1 dB and the 30 dB degradation points are very close, maybe 1 dB apart, while in others they may be separated by up to 35 dB. A saturated A/D converter as well as several other saturation processes cause a highly nonlinear interference growth while reciprocal mixing has a nicely linear behavior. A good operator will know how to insert an attenuator between the antenna and the receiver—or to use the built-in attenuator properly. The attenuator insertion could be automated as suggested by Ulrich Rohde.⁴ Personally, I prefer to take such decisions myself depending on the circumstances, but adding a circuit like Ulrich's (in his figure 43) to the WSE converters would be trivial.

The dynamic-range data of Table 6 can be converted from dBHz to dB in 500 Hz bandwidth by subtracting 27 dB. At 20-kHz frequency separation, the result is 100 dB for the IC-706 while it is 97 dB for the FT-1000D. These values represent the true dynamic range in a weak signal usage of the receivers. This is the natural concept to me with a bias from the

Table 6

Blocking and BDR for a WSE RXHFA prototype system, an IC-706MKIIG and a FT-1000D on 14 MHz. G+ indicates that the gain increases rather than decreases when the interference is added. N indicates abrupt increase of noise floor due to op-amp saturation in RX2500. The preamplifier is off for IC-706 and the Front End switch is in position IP0 for the FT-1000D. For FT-1000D blocking is measured indirectly through the cross-modulation from an AM modulated carrier

Freq offset (kHz)	WSE+Linrad Level for		IC-706 14 MHz Level for		FT-1000 14 MHz Level for	
	3 dB S/N loss (dBHz)	1 dB sat (dBHz)	3 dB S/N loss (dBHz)	1 dB sat (dBHz)	3 dB S/N loss (dBHz)	1 dB sat (dBHz)
5	145	A/D sat	114	122	113	149
10	146	A/D sat	122	129	116	156
20	145	A/D sat	127	143	124	163
30	145	A/D sat	131	149	129	165
40	153	163N	134	149	132	166
50	156	165N	135	150	135	166
100	156	170	140	G+	144	168
250	164	171	148	G+	155	169
500	171	172	149	G+	155	170

Table 7

Adding a second noise source increases the noise level like this. If both noise levels are equal the sum is 3 dB above a single signal and the sensitivity is 0.5 dB for 1 dB change of the added signal. If the added noise is 6 dB below the original noise, the sum is 1 dB above the original noise but the sensitivity is only 0.2 dB for 1 dB change of the added signal.

Added Signal Relative to First Signal (dB)	Signal Level Change (dB)
-7	0.79
-6	0.97
-5	1.19
-4	1.46
-3	1.76
-2	2.12
-1	2.54
0	3.01
1	3.54

144 MHz weak-signal community. HF operators may find the distance from the noise floor up to blocking more relevant. Then the ARRL lab procedure might be more relevant. The two methods give numbers that differ by 60 dB! Knowing what the numbers really mean is essential when deciding which radio to buy.

Third-Order Intermodulation

Third order intermodulation, IM3, is typically the phenomenon that limits the dynamic-range performance of a receiver when BDR is not the limiting factor. IM3 can be described as frequency mixing due to the nonlinearity of amplifier, mixer or other stages that arises when the signal levels are very high. When two signals f_1 and f_2 enter a receiver, IM3 is produced at frequencies that can be described as the difference between one signal and the overtone of the other signal, $2f_1-f_2$ for example. In this case, the IM3 level is proportional the f_2 and to the square of the f_1 signal levels. In a two-tone test with equal amplitudes for f_1 and f_2 , the IM3 level is proportional to the common signal level to the power of three. This is the third-order law saying that for a 1 dB increase of the signal levels the IM3 levels will increase by 3 dB. The third-order law is the basis for this definition: *The third order intercept point (IP3) is the point at which the extrapolated third-order intermodulation level (IM3) is equal to the signal levels in the output of a two-tone test when the extrapolation is made from a point at which and below the third-order intermodulation follows the third-order law.*

There are different procedures suggested for the measurement of IP3. How to make the measurement on a mixer or preamplifier is uncontroversial, but how to handle a "black box" with an antenna input and a loudspeaker output is less clear. Some receivers have an AGC that cannot be switched off, and there may be other complications. Procedures to measure IP3 may give a result that is inconsistent with procedures that measure two-tone, third-order intermodulation dynamic range, IM3DR, despite the

fact that these two measurements should have an exact relation. They are coupled through bandwidth and noise figure by the third-order law in the relation $IP3 = 1.5 \times IM3DR + NOISE FLOOR$. A receiver that does not follow the third-order law^{5, 6, 7, 8, 9} cannot be characterized by an IP3 number. The references show a discrepancy of more than 10 dB in the IP3 relation and indicate design inadequacies or measurement errors. I have tried to reproduce the peculiar response reported in Note 5, but found nothing but normal third-order behavior. The TS-450S I looked at had a much later serial number than the one tested in the ARRL Lab and some design inadequacy may have been corrected by the maker in later production units.

There is a simple way to measure third-order intermodulation that will give accurate results regardless of the receiver architecture. It works equally well with AGC on or off and it is very easy to perform. Just combine two equally strong signals and a third, weak one. The IM3 product and the weak signal are placed something like 10 to 100 Hz apart and a spectrum analyzer (*Linrad* for example) is connected to the loudspeaker output. The weak signal is set to give the same amplitude as the IM3 product on the screen. This measurement is fast, easy, reproducible and accurate. The true power levels of the strong signals and of the weak signal that gives an equally strong signal as the IM3 product are measured directly. AGC or AF saturation does not matter. The point of equal amplitudes is independent of the nonlinearities in the stages following the filters that exclude the strong signals. At large frequency separations, a notch filter is useful, just replace the strong signal in Fig 4 by a pair of strong signals that have a frequency relationship that places a third-order intermodulation product at the frequency of the notch. Notice that the quartz crystals in the notch filter produce IM3 at close frequency separations and that a second measurement with an attenuator at the receiver input will show if this is a limitation of the measurement. For

measurements at close frequency separations, where a notch filter is useless, the third generator and the audio spectrum analyzer are essential. This is so because the noise and spurs in the two strong signals as well as in the local oscillator of the test object easily lead to incorrect measurements at low IM3 levels.

Real receivers may have peculiarities that make them deviate from the third-order law that is accurately valid for a simple chain of amplifiers and mixers. The reason may be nonlinearities in circuits that are not in the signal path. The noise blanker may have AGC controlled amplifiers that produce modest levels of intermodulation more or less independently of the input signal level. At low signal levels where the intermodulation produced in the signal path is very low, inadequate screening or buffering may allow IM3 from such side paths to interfere with the desired signal. Look at antennspecialisten.se/~sm5bsz/dynrange/intermod.htm for a discussion of IM3 measurements, theory, spectra and time-domain waveforms. The site also contains details of the measurements behind the IP3 values presented in Table 8.

For both FT-1000 and IC-706MKIIG, IP3 and IM3DR are degraded by a very small amount if the frequency separation is reduced to 20 kHz from 100 kHz. For the RXHFA unit it is quite different. The bit errors in the A/D conversion process give rise to IM3 that is varying in a seemingly random fashion with the level of the two test tones. The IM3 from the A/D conversion process is at about -140 dBm, below MDS in 500 Hz bandwidth, but it is there. This kind of intermodulation disappears completely if other signals are present in the pass-band as will practically always be the case in the real usage of a receiver. Fig 5 shows the IM3 response of the RXHFA unit for two signals within the A/D converter passband.

As can be seen from Fig 5, the close range IM3 is at the 500 Hz MDS level for a two-tone input of -29 dBm, which means that IM3DR is 101 dB. The A/D converter in the Delta 44 saturates when the levels in the two-tone test are

Table 8

Two-tone third-order intermodulation data at 14 MHz and 100-kHz frequency separation.

Receiver Type	IP3 absolute (dBm)	NF (dB)	IP3 to noise floor (dBHz)	MDS at 500 Hz bw (dBm)	IM3DR in 500 Hz bw (dB)
RXHFA	25	17	182	-130	103
FT-1000	22	21	175	-126	99
IC-706MKIIG	-4	12	156	-135	86

set to about -18 dBm. The digital output is limited by the number of bits and can simply not represent an analog signal outside the digital range. In the range -30 to -18 dBm, the RXHFA/Linrad system follows the third-order law, but it is not fair to characterize the system with the IP3 of +20 dBm one can get from an extrapolation. The RXHFA/Linrad system will behave as if it had an IP3 in the order of -8 dBm for multiple input signals that reach a peak power above -18 dBm within the 95 kHz bandwidth seen by the A/D converter. Looking only at the intermodulation, one would conclude that the FT-1000 would be much better in such cases, but the FT-1000 front end will see much higher peak powers because it must handle much more bandwidth. More importantly, the FT-1000 will be limited by reciprocal mixing, the noise floor is degraded by 3 dB at an average signal level of about -30 dBm already. Knowing this fundamental difference between analog and digital receivers is very important. If the bandwidth seen by the A/D converter is even wider or if the dynamic range is lower, IP3 values may still be impressive, but the real intermodulation resistance may be poor compared to "good old analog receivers" with similar IP3 and IM3DR numbers.

The intermodulation characteristics of the WSE converter chain are the same for all frequency bands. The RX144 and the RXHFA units have the same IM3DR. The RX144 is definitely intended to be used with amplifiers in front of it and it will have a noise figure of about 11 dB, which means that IP3 will be about +19 dBm. I have not yet decided whether it is a good idea to incorporate an RF amplifier in the RXHFA to shift the levels downwards. The data given above is without any RF amplifier in the RXHFA prototype and it is compared to the FT-1000D and the IC-706MKIIG with the RF amplifier disabled.

How Much Dynamic Range do We Need?

On the HF bands, the answer is 100 dB for BDR in 3 kHz bandwidth according to Chadwick.¹⁰ This is equivalent to 135 dBHz, which is met easily by the WSE converter chain at all frequency separations, but which is also met by IC-706MKIIG and FT-1000D at frequency separations above 50 kHz. As I read the referent of Note 10, this is good enough on the HF bands. On 7 MHz one may need an IP3 of +36 dBm at a noise figure of 33 dB, which is just about what the FT-1000D can perform with 12 dB attenuation, but which is met with some

margin by the RXHFA unit when a 15 dB attenuator is added. At other times, a noise figure of 22 dB is needed. The operator must be able to move the dynamic range levels up and down with an attenuator, but with that con-

straint, modern receivers are good enough for the HF bands.

On 144 MHz, my favorite band, it is quite different. Fellow amateurs typically cause the most difficult problems. A 2 m station may put 100 W

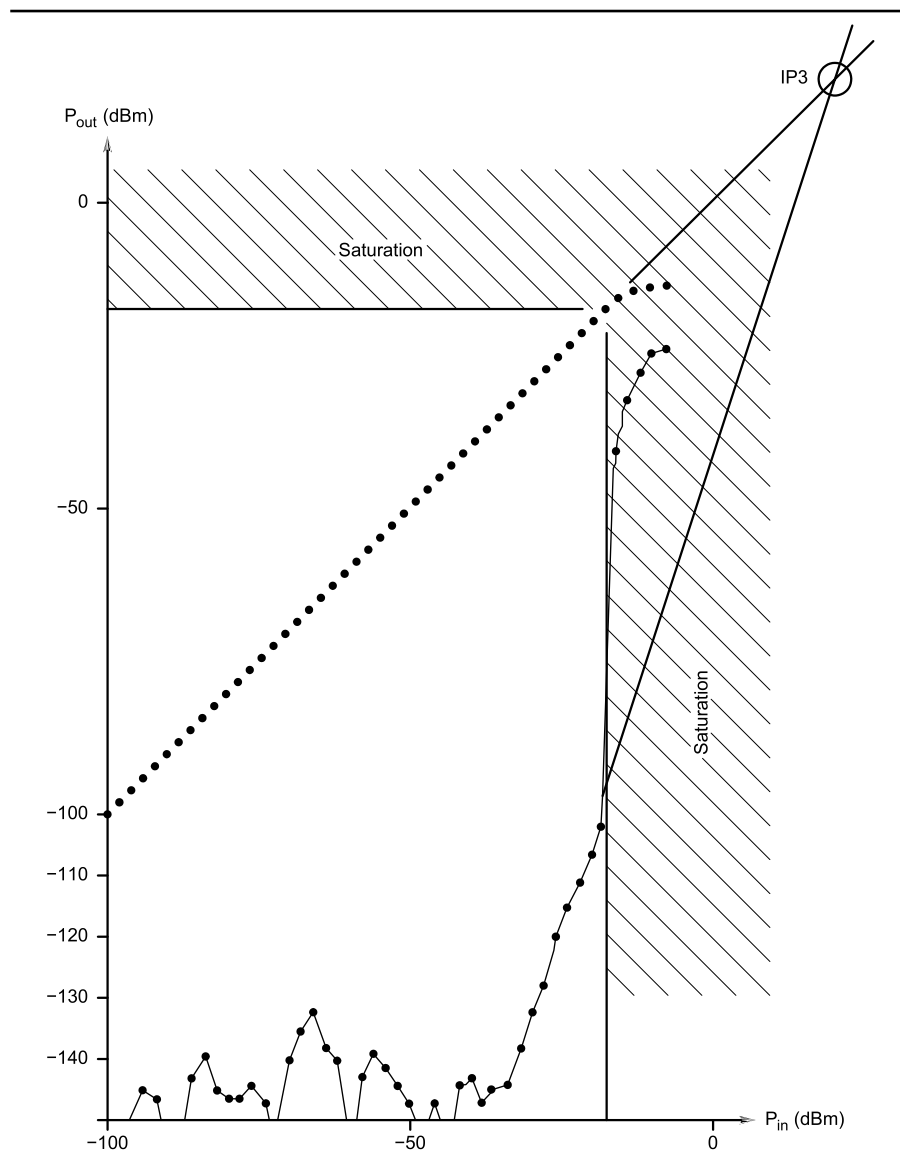

Fig 5—IM3 response for the RXHFA unit in a two-tone test. Notice that the IM3 below -35 dBm is real but that it disappears due to dithering if noise or another signal is added.

Table 9

Received power levels with antennas pointing into each other on 144 MHz, at two different distances assuming free space propagation.

Distance (km)	Tx ERP (kW)	Rx Power	
		Ant = 13 dBd (dBm)	Ant = 18 dBd (dBm)
1	3	+2.4	+7.4
1	100	+17.4	+22.4
10	3	-17.6	-12.6
10	100	-2.6	+2.4

into a 13 dBd antenna to produce an effective radiated power of 3 kW. Much higher ERPs are not uncommon, 1 kW into four modest Yagis will easily give an ERP of 100 kW. Add to these high power levels the much greater receiver sensitivities, and the directional gain at the receiver side and you will find received powers at some different distances as illustrated in Table 9.

Contrary to the HF bands, interference on 144 MHz is likely to be caused by one or very few signals. The reason is the high directivity of the antennas. Having one of the local high power stations pointing his antenna into my direction while I point my antenna in his direction is not likely to happen simultaneously for many local high power stations. This means that BDR is generally more important than IM3DR on 144 MHz. RX144 provides 145 dBHz for close spaced signals and with a noise floor of -174 dBm/Hz it means that the maximum permitted signal level is -29 dBm. Table 9 indicates the need for much higher levels. On 144 MHz, we often run into mutual interference because of inadequate dynamic range. At frequency separations above 50 kHz, the RX144 provides 166 dBHz so the maximum permitted signal level is -8 dBm. Table 9 indicates that much more could be useful sometimes, and -8 dBm does not allow unperturbed reception, it is the level where S/N is degraded by 3 dB. Here the influence of dynamic range loss and noise figure due to the preamplifier as illustrated by Table 2 is neglected, but these effects work in opposite direction and cancel if both are made about 3 dB.

Conventional transceivers often produce strong noise sidebands. I have measured several transceivers using RX144 and *Linrad* as a spectrum analyzer. The data is available at antennspecialisten.se/~sm5bsz/dynrange/gavelstad/gav.htm. The noise floor is typically at -110 to -120 dBc/Hz at a frequency separation of 20 kHz and -125 dBc/Hz at 50 kHz. To me the WSE converters and *Linrad* is not only a radio receiver, the system is also an instrument for finding cures to the problems caused by design inadequacies in commercial transceivers. A good LO, such as the one in TM255E is at -137 dBc/Hz at 20 kHz, something that is proven by the excellent BDR value, but the transmitter noise is at -122 dBc/Hz because other noise sources than the LO dominate the transmitted signal. The dynamic range needed to make the WSE converters useful as laboratory instruments is 10 dB better than the best transmitters one would want

to investigate. At today's state of the art, the performance is just about good enough in the close range, but as soon as the interference is outside the frequency range routed to the A/D converter the performance is adequate with a good margin.

Notice that noise levels I present are always RMS values. They truly reflect the power ratio between the noise power in a defined bandwidth and the power of a carrier. It is a bad habit among engineers to interpret as dBc/Hz decibel numbers that come from the display of a spectrum analyzer that averages the output from a logarithmic detector. Such decibel values are about 6 dB lower than the true dBc/Hz values in which the ARRL Lab composite noise test is defined.¹¹

When *Linrad* and the WSE converters are used to measure sideband noise, the numbers obtained are about 6 dB worse than those published in *QST* because *Linrad* computes the true RMS power levels. The -145 dBc/Hz noise floor within the frequency range seen by the A/D converter therefore corresponds to -151 dB in the ARRL Lab scale.

Conclusions

It is demonstrated above that the WSE converters and *Linrad* give a third-order dynamic range that is comparable to good analog receivers while the BDR is much better. The data is based on measurements on prototypes, but the final outcome will not be very different.

Linrad is not designed for the WSE converters, it is intended to be used in the future with very much simpler digital hardware that makes the A/D conversion at VHF frequencies and samples the antenna signal directly. I have designed the WSE converters because it was reasonably simple with the tools at my disposal, and I did not want to wait for someone else to produce the digital hardware and drive routines for *Linux*. Another reason is that I believed it was a way to get a performance that is somewhat better than I can expect to ever get from a digital system. The WSE converters will be the radio I use in the future, but they will also constitute the tools needed to verify the operation of the digital hardware when it becomes available. The digital revolution will continue. As amateurs, we face a new and exciting situation in which we can take a leading role in the development of new technologies. By feeding more bandwidth from more antennas into a computer it will be possible to remove interference to an extent we

would not even dream of today. Imagine 16 ferrite rods that are placed around your location sending digital data to your computer, each one with a battery, a small digital processing block and a microwave link. The battery could be powered by solar cells. The computer can form an adaptive antenna with 12 dB gain for each interference source, then subtract the interference with a very high accuracy, if the interference has any characteristics that the computer can be programmed to identify. Finally, the adaptive lobe can be pointed towards the desired signal, which will become readable even if it is deep below the interference level in a single antenna. Personally, I think the strategies to identify and remove interference form the most exciting field for amateur development in the future. As amateurs, we might want to push the limits in a difficult interference situation on a particular frequency band while a professional would use another frequency or even another technology to avoid the problem. *Linrad* is an early attempt to get into this new field of qualified signal processing, it is *not* just a DSP package for EME enthusiasts.

Notes

- ¹L. Åsbrink, SM5BSZ, "Linrad: New Possibilities for the Communications Experimenter, Part 2," *QEX*, Jan/Feb 2003, p 41-48.
- ²L. Åsbrink, SM5BSZ, "Linrad: New Possibilities for the Communications Experimenter, Part 3," *QEX*, May/June 2003, p 36-43, Fig 1.
- ³L. Åsbrink, SM5BSZ, "Linrad: New Possibilities for the Communications Experimenter, Part 4," *QEX*, Jul/Aug 2003, pp 29-37.
- ⁴U. Rohde, KA2WEU, "Theory of Intermodulation and Reciprocal Mixing: Practice, Definitions and Measurements in Devices and Systems Part 2," *QEX*, Jan/Feb 2003, pp 21-31.
- ⁵J. Healy, NJ2L, "Product Review: Kenwood TS-450S and TS-690S Transceivers," *QST*, Apr 1992, pp 67-69.
- ⁶P. Danzer, N11I, "Product Review: Ten-Tec Pegasus HF Transceiver," *QST*, Feb 2000, pp 63-67.
- ⁷M. Wilson, K1RO, "Product Review: Watkins-Johnson HF-1000 General-Coverage Receiver," *QST*, Dec 1994, pp 76-79.
- ⁸R. Lindquist, N1RL, "Product Review: SGC SG-2020 Transceiver," *QST*, Oct 1998, pp 71-74.
- ⁹Rick Lindquist, Product Review: Yaesu MARK-V FT-1000MP HF Transceiver, *QST* Nov. 2000, p 64 - 69.
- ¹⁰P. Chadwick, G3RZP, "HF Receiver Dynamic Range: How Much Do We Need?" *QEX*, May/June 2002, pp 36-41.
- ¹¹M. Gruber, WA1SVF, "Improved Transmitted Composite-Noise Data Presentation," *QST*, Feb 1995, p 62. □□

Getting the Most from Half-Wave Sloper Arrays

So you want to put up a really big 160-meter directional array? Here are some tips.

By Rudy Severns, N6LF

For those who have a single tall support, $\lambda/4$ or higher, the half-wave sloper family of antennas described by K1WA,¹ K8UR,² K3LR^{3,4} and others can be a relatively simple way to make an antenna with modest gain, good F/B and an electrically steerable pattern on 80 or 160 meters. Previous articles have provided much information on this family of antennas. But having just come through a cycle of building several variations, I found that a lot more needed to be said. Fig 1A shows two different half-wave sloper array element shapes that I will refer to as the “K1WA” and the “K8UR,” with the understanding that many other arrays use these shapes. Fig 1B shows some other possible element shapes.

This article presents a 160-meter variation of this family of antennas and, more importantly, a discussion of the details of how to get such a beast working really well. You could simply put up four pre-cut dipoles, with $3/8\lambda$ phasing lines à la K1WA and the array will work with reasonable F/B. However, with extensive modeling I discovered that fanatical attention to detail and tuning and adding a first-class ground system will greatly enhance performance.

In the summer of 2000, I put up a pair of 150-foot wooden poles placed

east-west along a ridge. I called George, W2VJN, who had been using half-wave slopers for years and asked for his advice. That began a long series of conversations and experiments. George supplied many key insights while I was doing field testing and modeling work. I very quickly learned how difficult it is to actually obtain the performance predicted from modeling in a real 160-meter antenna. The configuration reported here is a bit different from earlier versions but is simpler to build and, more importantly, easier to get up and running at full performance.

Initial Experiments

You can use several slopers spaced uniformly around the support to produce a steerable pattern. These can be simple $\lambda/2$ slopers (K1WA) or diamond-shaped (K8UR), with the lower ends brought back to the base of the support. The slopers may be driven as a phased array (K8UR) or as a parasitic array (K1WA and K3LR). It is very common to drive and/or load the center of each element.

There is another possibility, however. You can voltage feed at the lower ends of the elements. This approach, while certainly known, has not gotten much press. It has some advantages when K8UR-shaped elements are used.

My experiments began with a 2-element version of the K3LR antenna, where the length of the feed line from the center of an element to a switch box is adjusted to tune one element as a reflector while the other element is open-

circuited at the switch box. This allowed me to switch the direction of the main lobe from east to west with a SPDT relay, selecting one or the other feed line. I quickly discovered how much the

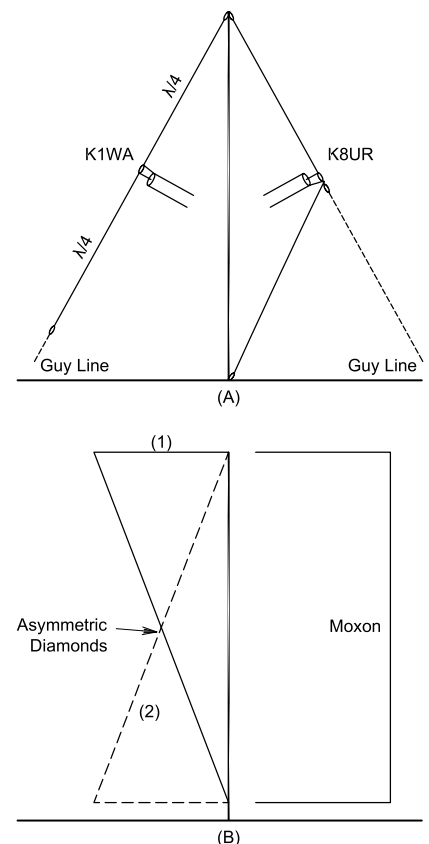

Fig 1—Half-wave sloper array element shapes.

¹Notes to appear on page 41.

PO Box 589
Cottage Grove, OR 97424
rudy@ordata.com

shape of the actual array differs from the nice straight-line wires we use in modeling.

First, there is the sag in the 130-foot wire spans on each side of the feed point where the guy lines used to spread the array are attached (see Fig 1A). I found I had to move the guy-line anchor point much farther away from the support to get enough tension to control sag. This was made worse by the weight of the roughly 114 feet of RG-8X feed line going back to the support.

Testing showed that the F/B was not very high—a few decibels at most—and the feed-point impedances were substantially different from predicted, making for a poor match. Further checking with a clip-on RF ammeter showed lots of current on the feed lines.

I then modeled the antenna with the actual sags in the elements and feed line I use Nittany Scientific's *GNEC*, which implements the *NEC-4* catenary wire (CW) and insulating sheath (IS) cards. Guess what? Lots of RF on the feed lines, lousy F/B and mediocre gain were indicated. I put common-mode chokes baluns at the feed points (more weight, more sag, more loss) and that helped, but only a bit. The extra weight also increased the tension in the wire and guy line to the point where wire stretch and subsequent detuning became a problem.

I also found that if I wanted to actually tune the elements so that they behaved as a parasitic array, I had to make measurements at ground level—at the end of about 200 feet of coax. I had to calibrate the coax and then transform the measurements by the transmission-line equation to get the actual feed-point impedance.

Then I had to lower the array and trim each end of the elements. This was doable but what a pain! It was clear from the modeling and measurements that the actual shape of the elements and whether or not insulated wire was used had a significant effect on the behavior of the array.

I groused about all this to George as we drove up to the Northwest DX convention last June (2001) and he said "Why not use voltage feed instead?" The light went on. I wanted a parasitic array in the K8UR configuration, but voltage-fed at the bottom of the driven element. The other elements would be open, acting as reflectors. This would have some advantages:

1. All the coax, baluns, relay boxes, etc, hanging up in the air are eliminated. That removes a lot of stress on the array and lowers the expense and the loss in the cable, even on 160 meters. The extent of cable loss was

- pointed out in the K3LR articles.
2. There is no longer any need for the elements to assume a symmetrical shape (equal lengths at top and bottom) to minimize coupling to the feed line hanging from the center point. They can have considerable deviation from symmetry, as shown in Fig 1B.
3. All the measurements, pruning, tuning and switching can be done at the base of the support, right at ground level. Very convenient!
4. With much less weight and wind-age the array is less susceptible to damage. This is particularly important if you live in an area where icing is a problem.
5. The loading on the support is much less. Not a big deal with a guyed tower, but important when using a tall wooden pole or other light support.

Of course, there are some disadvantages too:

1. The switching relay(s) must now be capable of handling high voltage (>5 kV), mandating vacuum relay(s).
2. A tuning unit is required at the base of the antenna.

The Array At N6LF

Fig 2 shows a side view of the array presently installed at N6LF. This has performed very well this winter (2001-2002). Note that the shape of the individual elements is not symmetrical—the triangle apex is well above the midpoint. In my installation I have an

other 150-foot pole 300-feet east and an anchor point at 100 feet in a tree 400 feet west of the main support. These allowed me to raise the apex (corner) of the element farther above ground, reducing ground losses somewhat.

The elevation pattern for this array is shown in Fig 3 at several points across the band. I maximized gain at 1.830 MHz, where the F/B is about 7 dB. Below that both the gain and F/B drop off but the gain is still quite useable. As you go up the band the gain falls slowly but the F/B improves. At 1.890 MHz the low-angle F/B is very good (about 24 decibel) but if you look at the full rear quadrant the F/R is only 12 dB, pretty much in line with the expectations from free-space modeling.

Because I almost always use a Beverage antenna for receiving I elected to go for maximum gain at 1.830 MHz. You could just as well go for high F/B and sacrifice a half dB or so of gain. I adjusted the tuner for minimum SWR at 1.830 MHz. This gave an SWR of 1.1:1 at 1.800 MHz and 2:1 at 1.970 MHz. It would have been quite possible to adjust for an SWR < 2:1 over the whole band but the gain starts dropping off above 1.900 MHz.

This antenna has been up since August 2001 and was used in the ARRL, Stew Perry and CQ CW 160-meter contests. It has performed very well indeed, despite the truly terrible conditions on 160 meters at this part of the sunspot cycle and due to my less-than-ideal location. During the

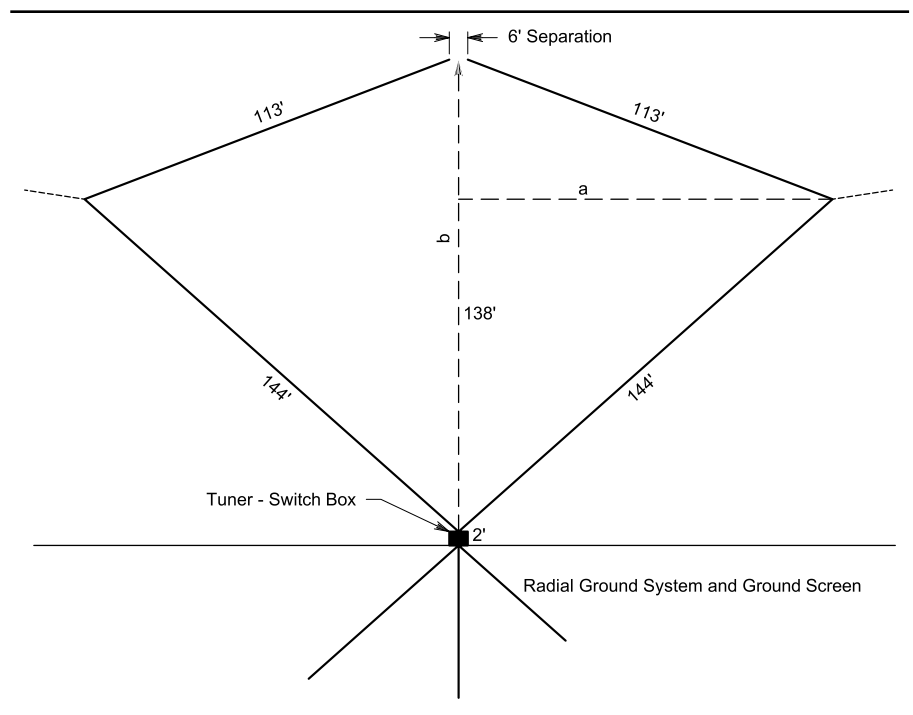

Fig 2—Present array at N6LF.

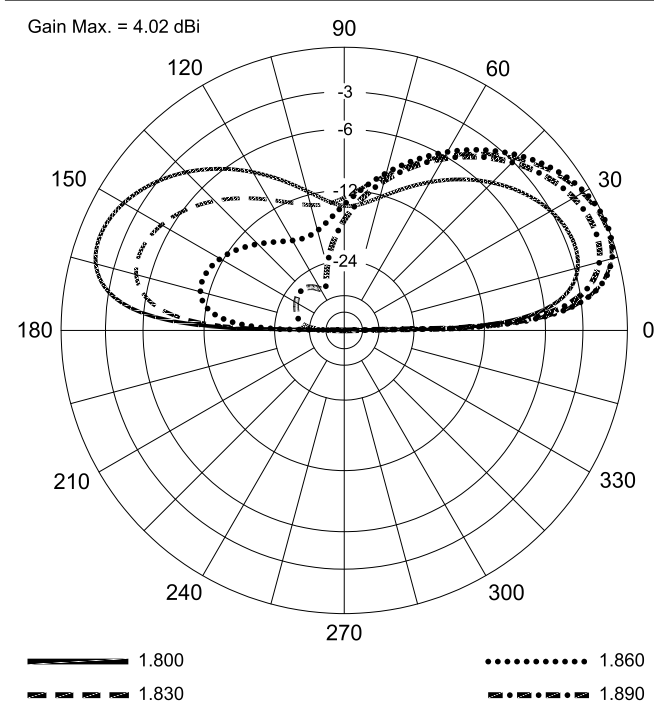

Fig 3—Elevation radiation patterns at 1.800, 1.830, 1.860 and 1.890 MHz for the N6LF two-element array.

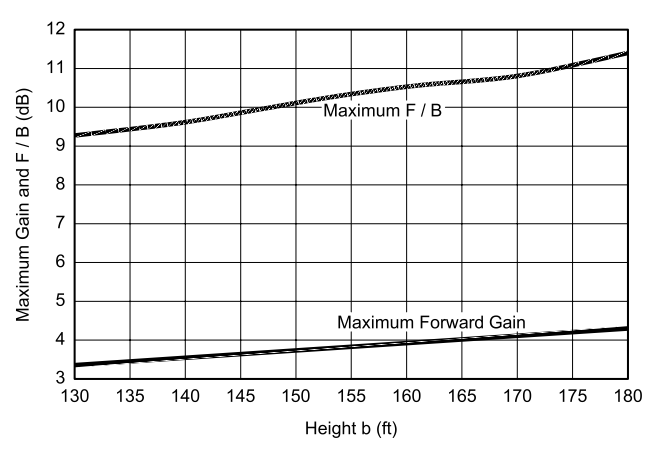

Fig 4—Typical maximum free-space gain and F/B for two-element diamond-shaped array.

ARRL 160-meter contest George was operating on the east coast from W3BGN's shack and he compared signals from the west-coast stations.

Of course, K6SE (who was using a balloon vertical over the Salton Sea salt flats) beat us all hands down. Compared to the other big stations, however, my signal was right in there, so the antenna is clearly starting to work well. And there is even more I can do to improve it. The following details how I achieved my level of performance and what could be done to improve it.

Comparison To Other Antennas

Even with the best design and construction, this antenna will not beat out an equally well-designed and installed four square. It will also be outperformed by the Spitfire antennas⁷ that are similar to this antenna. The Spitfire uses the supporting tower as the driven element and the parasitic elements as reflectors and directors to form a 3-element, rather than a 2-element, vertical Yagi with a steerable pattern. However, when done well, the full-wave sloper family of antennas is not hopelessly outclassed—and they are far easier and less expensive to build compared to a four-square system if a suitable support is already in place.

In all of the modeling to follow, ground is assumed to have $\sigma = 0.005$ S/m (conductivity) and $\epsilon = 13$

(relative dielectric constant). For the radiation patterns, the main axis of the array is in the (y, -y) direction (90° to 270°).

Element Length

In most two-element Yagi designs the length of the driven element is adjusted so that the feed-point impedance is resistive. The parasitic element length is adjusted to perform either as a director or a reflector. In low-frequency arrays, the size is usually much too large to allow the array to be physically rotated, and the driven and parasitic elements must be interchanged to switch the pattern. This can be accomplished in several ways. The most common is to add or subtract some length or loading and then interchange the element you wish to feed as the driven element.

There is another possibility that has not received much attention. If you take two equal-length parallel conductors, spaced on the order of 0.1 to 0.3 λ , one of which is driven and the other parasitic and do some free-space modeling, you will find that as you increase the length of the elements (keeping both the same length) that the parasitic element will first act as a director and then as a reflector as *both* are made longer. The advantage of this is that both elements are identical and there is no change in length or loading when you change direction. You simply change which element is driven.

This is particularly helpful when multiple elements are used and only one is driven at a time. For an end-fed element this makes it very easy to change directions. You simply use a system of relays to select which element is to be driven, leaving the other element open to act a reflector. A single tuning network at the base of the antenna is required, and it sees an impedance that does not change as the pattern direction is changed.

Of course the driven element in this case will not be resonant and will exhibit some reactance. With a simple parallel L-C tuner at the base, that is not a problem. Typically, the reactance will be equivalent to 5 to 10 pF, which can easily be accommodated by adjusting the tuning capacitor in the tuner.

Modeling two elements in free space gives a general idea of how this works for K8UR-shaped elements. The gain and F/B will depend on the overall height of the diamond (dimension "b" in Fig 2) and the width (dimension "a" in Fig 2). Fig 4 graphs typical free-space gain and F/B for elements varying in height from 130 to 180 feet at 1.830 MHz, using #12 bare copper wire. Notice these are the maximum values found by fixing the height and adjusting the width in the model.

As in any Yagi, maximum gain and maximum F/B do not occur for the same dimensions. In general, at the maximum F/B point the gain will be down by about 0.5 dB. There are no surprises here—the taller the array, the more gain and F/B you can obtain. However, even at $\lambda/4$ (≈ 130 feet), there is usable gain and F/B, even though this is half the length ($\lambda/2$) of normal Yagi elements.

Notice also from Fig 2 that I set the separation distance between the top ends at 6 feet. This is not a magic number, but the distance between the ends

of the elements does affect the behavior. Spacings of order of 1 to 3 feet each side away from the support structure seem to work fine, although others should work also. Chose a spacing during the design phase and be careful to stick with it when erecting the array.

Element Shape

Besides the obvious mechanical difference between the K1WA and K8UR elements, there are important radiation-pattern differences too. If you start with a single half-wave sloper, with the top at 150 feet, the radiation pattern in Fig 5 will have a combination of vertical and horizontal radiation. That's no real surprise, since you have a slanting dipole.

When you combine this into a two-element array, however, some funny things start to happen, as shown in Fig 6A for in-phase and Fig 6B for 180° out-of-phase excitation. The pattern doesn't look anything like the broadside-endfire you expect in a 2-element vertical array. The problem is that the vertical and horizontal fields add up differently and the array does not behave quite as you might expect. While 160-meter operators generally favor vertical polarization for transmitting, for receiving the combination of vertical and horizontal polarizations may help. I hasten to say that this is speculation on my part.

For a four-element half-wave sloper array, where three of the elements are reflectors, the radiation pattern is shown in Fig 7. The total pattern is quite reasonable but is made up of vertical and horizontal components

that individually have very different patterns. Again, it is not clear if there are any advantages or disadvantages to this mixed polarization.

The K8UR-element shape has a very different pattern. Fig 8 shows the

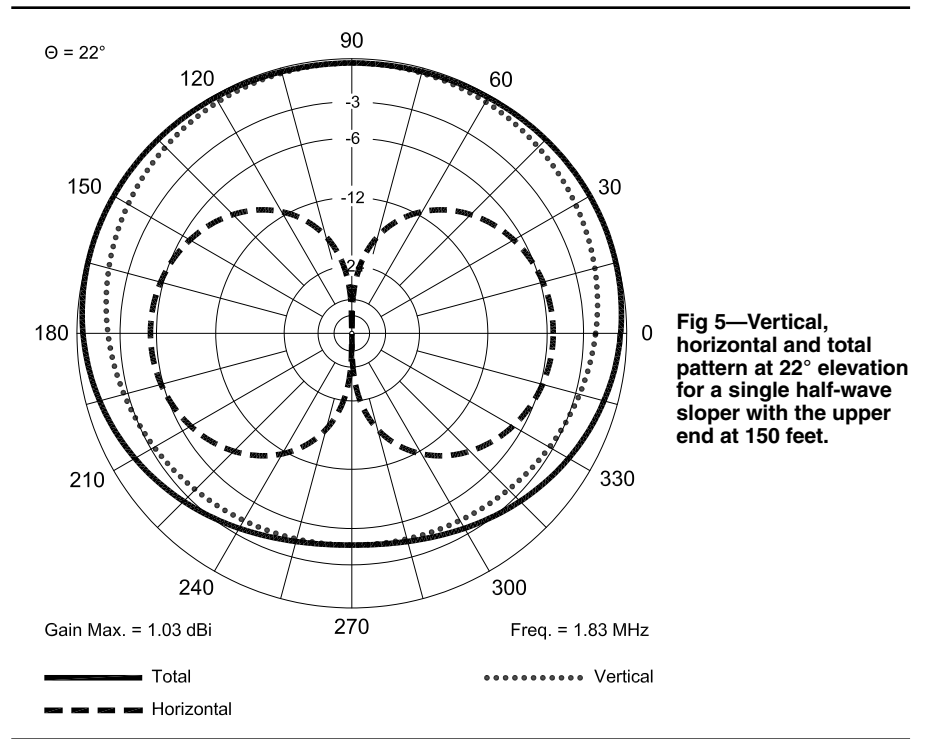

Fig 5—Vertical, horizontal and total pattern at 22° elevation for a single half-wave sloper with the upper end at 150 feet.

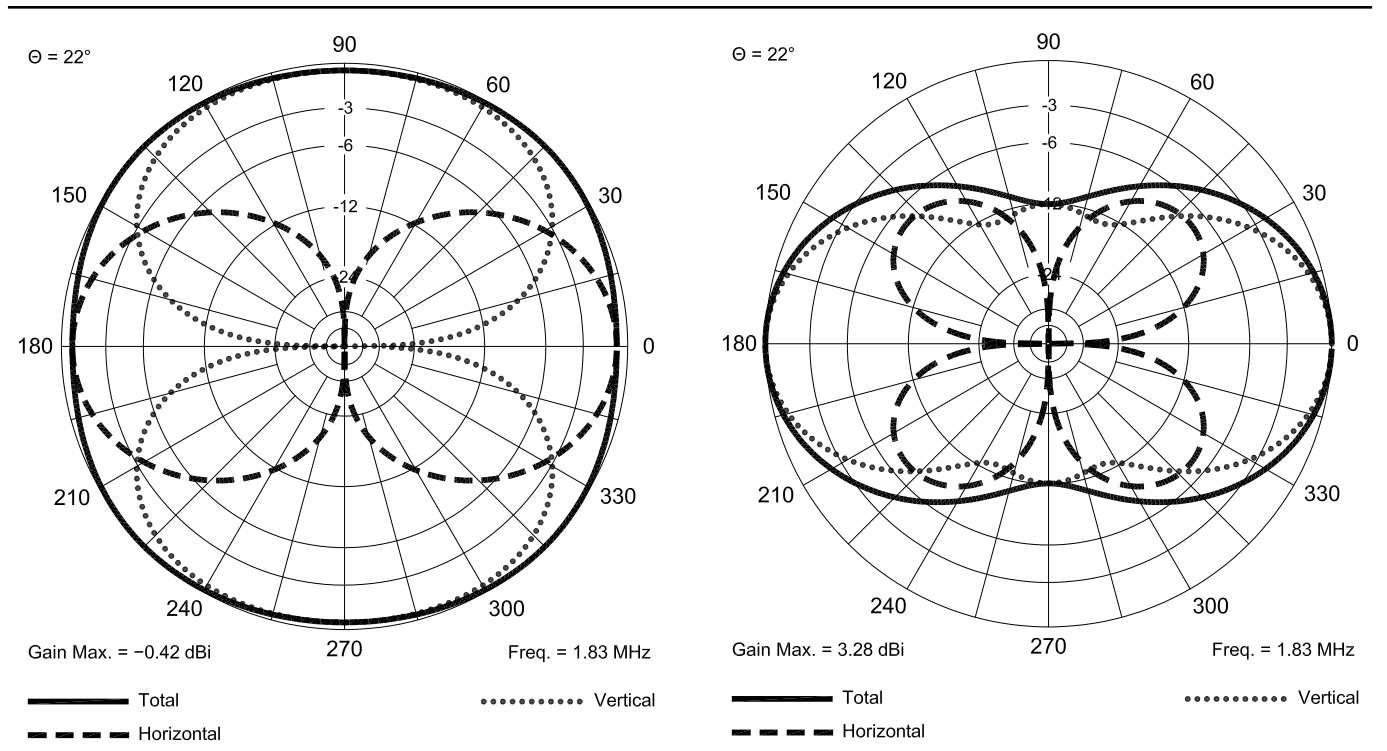

Fig 6—Vertical, horizontal and total pattern at 22° elevation for two half-wave slopers. At A, driven in-phase and at B, 180° out of phase, with the upper ends at 150 feet.

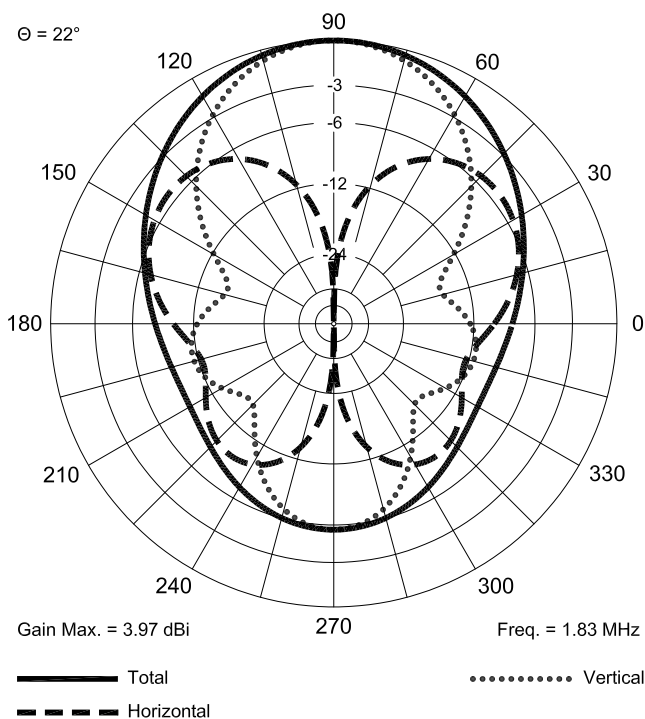

Fig 7—Vertical, horizontal and total pattern at 22° elevation for a four-element K1WA array, one driven element and three reflectors.

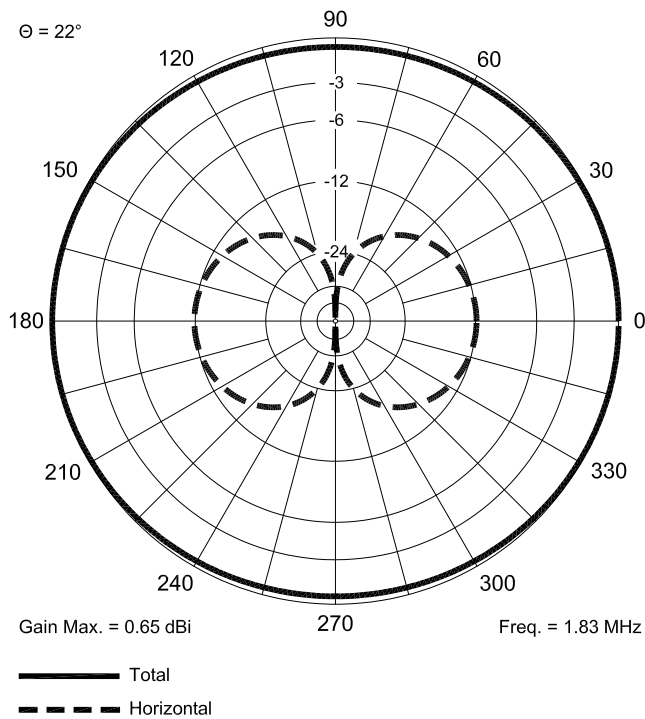

Fig 8—Vertical, horizontal and total pattern at 22° for a single K8UR-shaped element.

patterns for a single K8UR element. The horizontal component is much lower, -12 dB or more, and contributes little to the total pattern. This is one of the reasons that this shape is usually preferred if you are building a vertically polarized array.

In the K1WA and K8UR antenna models, I fed the elements at the center and I made every effort to keep things symmetrical to minimize coupling to the feed line. However, when fed from the end there is no necessity to make the element shape symmetrical. Fig 1B shows two asymmetric shapes (1 and 2). The advantage of shape 2 is that the anchor point for the guy line is much closer to the support. The overall space required for the antenna is greatly reduced. The downside of shape 2 is that it places a high E-field close to ground for a considerable distance. This increases ground losses if an extensive ground system is not used under the antenna.

Lifting the apex up, as shown in shape 1, reduces the ground loss significantly but requires a high anchor point for the guy lines. In the installation at N6LF these two points were available and the initial design did not use an extensive ground system. Later I realized just how much could be gained by adding a ground system. With a good ground system the additional loss due to shape 2 can be almost eliminated and the guy-line

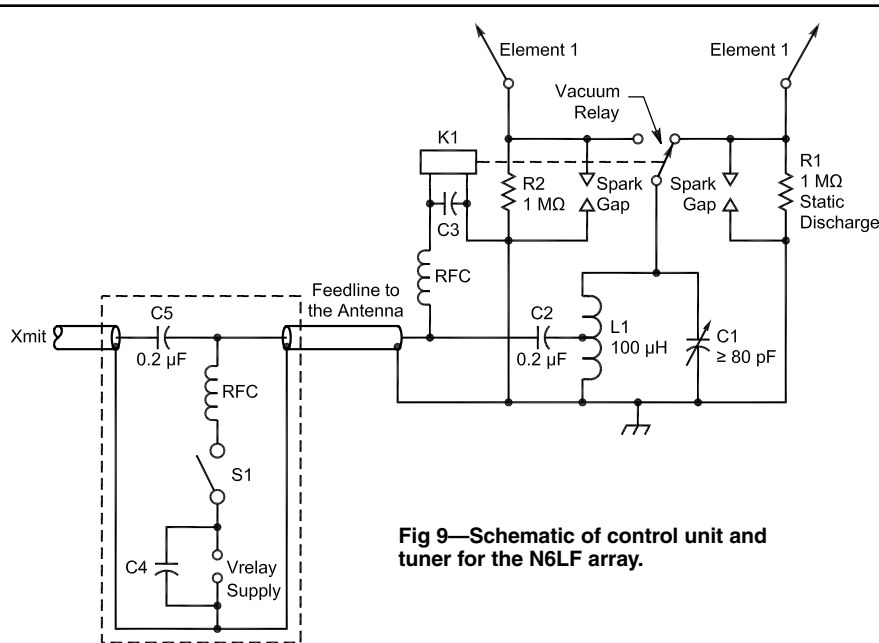

Fig 9—Schematic of control unit and tuner for the N6LF array.

anchor points moved in much closer to the main support.

If two high supports are available, then you can use the Moxon rectangle (shape 3 in Fig 1B). This yields somewhat better gain and F/B but does require two supports.

Tuner Design

Fig 9 is a schematic of the tuner.

The heart of the tuner is a simple parallel-resonant L-C circuit, with a tap on the inductor for matching to the feed line. *GNEC* predicted a feed-point impedance of $5318 - j 1776 \Omega$ and the actual array impedance was within 5% of this. Notice that this is the series-equivalent impedance shown in the sidebar, "Design of the Tuner".

To design the matching network,

the series-equivalent is transformed to the parallel-equivalent circuit. The parallel equivalent impedance is about 6 k Ω in parallel with 5 pF. The next step is to choose a loaded Q. Typically this would be in the range of 5 to 10, so I chose Q = 5 to minimize the size of the tuning capacitor (C1), which must be rated for > 5 kV peak at 1.5 kW operation. A lower loaded Q also reduces the circulating current and increases the match bandwidth somewhat.

The downside of a low loaded Q is that the inductor is larger, as are its losses. However, as shown in the sidebar, for unloaded coil Q > 200 the loss is less than 0.1 dB. The coil I used was 6 inches in diameter by 5 inches long, with 29 turns of #12 wire. It had a measured unloaded Q higher than 400 on an HP 4342A Q-meter. The coil loss is thus quite small.

I use 7/8-inch CATV cable for the long runs to the shack. To match the 75- Ω feed line, the tap was 4.5 turns from the bottom of the coil. George reminded me that this would be a good place to use a shielded loop made of coax with a series-tuning capacitor. This would give better harmonic suppression and provide dc decoupling and some improvement in lightning protection. It also would provide more isolation from BC station pickup, which can be a real problem in an antenna this large. In my case I went with the simpler direct tap and it has worked well but when I improve (translation: rebuild because I can't stop fooling with it) the antenna next summer I will probably incorporate a shielded coupling loop.

C₁ is a vacuum variable, but it could just as well be an air variable with widely spaced plates. The capacitance required is only of the order of 80 pF and not all of that needs to be variable. You could for example use a fixed 50-pF capacitor in parallel with a 30-pF air variable, which would be relatively small physically. Keep in mind that these network values are for a particular design. Other designs may have somewhat different impedances and the component values must be selected accordingly.

Relay K1 switches between the east and west elements in the array to switch the pattern. I used a surplus RB1H Jennings SPDT vacuum relay rated for 12 kV. The relay coil called for 26.5 V but I found that it would start to pull in at 16 V and worked just fine with 20 V or more to activate it. For the dc power source I used a wall transformer power supply rated for 18 V, but which actually puts out 22 V. The relay is activated through the feed

line using dc-blocking capacitors (C2 and C5) and RF chokes. The control unit is located in the shack and I simply flip switch S1 to change directions.

If you want to use three or four elements, then more relays will be needed. Fig 10 shows an arrangement of two relays for three elements. It is possible to use ac combined with dc and some diodes to control as many as three relays from the shack through the coax, as is done in the Ameritron RCS-4 remote coaxial switches. Of course, a separate control cable can be used also. In my case the distance from the shack to the array is > 700 feet, so I opted for feed-line control.

Capacitors C2 and C5 are for dc blocking. They must carry the full RF current, about 5.5 A at 1.5 kW when the load is matched to 50 Ω . I chose to use multiple NPO disk ceramic capacitors in parallel because they were readily available and inexpensive. NPO capacitors are larger for a given capacitance than other ceramic capacitors, but they have lower losses. You may be tempted to use 0.1 μ F capacitors instead of a number of 0.01 or 0.02 μ F capacitors in parallel, but be careful. The self-resonant frequencies for the larger disk ceramics can approach 1 MHz and you don't want the capacitor to be operated at or above its self-resonant frequency. In addition, a number of smaller capacitors in parallel will have much more surface area and cool much better, enhancing the current-carrying capability, which is primarily limited by temperature rise. Arrange the parallel capacitors with space between them so each one can cool itself.

There are a few other parts in the box that deserve some attention. The 1-M Ω resistors connected from the end of each element to ground are there for static discharge. The long wires in the array can develop high static potentials under some conditions. That potential on the free-floating reflector element can cause the relay to arc when transmitting. I happened to have on hand a bunch of 2-W, 100-k Ω car-

bon-composition resistors, so I simply built up R1 and R2 using 10 of these in series.

The 20-W overall power rating was not really necessary, but using several resistors in series increased the voltage rating. Thus I did not have to worry about arcing the resistors while transmitting, when there is a high potential at the ends of both the driven and parasitic elements. The loss introduced by these resistors is small. I also placed a spark-gap to ground across the drain resistors for lightning protection. A lightning strike anywhere within a quarter mile of this large antenna will induce very high voltages and full-up lightning protection is absolutely necessary.

The layout of the tuner is shown in Fig 11. I chose a plastic container for the enclosure because they are readily available in a wide variety of sizes and are economical. The use of a plastic enclosure also keeps the coil's unloaded Q high by keeping conducting surfaces away from it. A large metal box would also work and might have some advantages. One disadvantage of the plastic box is that ultraviolet from the sun will degrade it. In Oregon that is not a big problem but I do keep it covered with a shade cloth.

For ground within the box I used a 2-inch copper strap, which is brought out the bottom of the box to real ground. It is very important to have a good RF and lightning ground at this point. I use a 24-inch diameter by 8-foot culvert pipe surrounding the base of the support pole acting as a socket so that the pole can be removed with a crane for repair and alterations. This provides an excellent ground. If

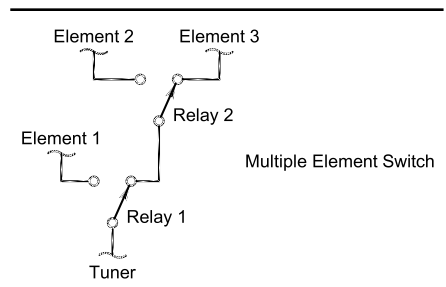

Fig 10—Relay connections for a three-element array.



Fig 11—Photograph of the tuner.

you use a tower, there should be a series of ground rods at the base for lightning grounding in any case and these can be used as a starting point for your RF ground system.

Tuning and Adjustment

One of the advantages of parasitic arrays is that the phasing of the element currents is automatically taken care of by tuning the element lengths properly. You can thus avoid the multiple matching networks and feed lines used in a phased array, where every element current and amplitude must be adjusted.

Unfortunately, the tuning in a parasitic array is strongly effected by the size and shape of the elements, which vary with tension and wire size. Sometimes I wonder whether the phase of the moon manages to get into the act!

When you use insulated wire for the elements, the insulation material itself has a considerable effect. For a typical 20-meter array made with aluminum tubing, dimensions derived from modeling are usually very close and any adjustments needed are merely for matching. For a large 160-meter wire array with an arbitrary element shape that is not the case. The elements *must* be carefully tuned in the field for full performance.

What I elected to do was to design the array in *GNEC* with the element shapes as close to reality as possible, including insulation, sag, etc. When I optimized the array, I modeled one element alone and determined its self-resonant frequency. In the field I then erected one element at a time and adjusted it to be resonant at the same frequency as the model. I used solid #12 THHN insulated wire because it was much more economical than bare #12 (for some strange reason) and available in 2500-foot reels at a retail outlet near me.

Besides cost, I prefer to avoid the surface oxidation normal in bare wire. As I showed in my *QEX* article,⁵ insulation in reasonable condition introduces very little loss, while an oxidized surface introduces significant loss, at least in low-impedance arrays. However, the insulation significantly changes the resonant frequency of an element and it increases the weight, requiring more tension to maintain the shape.

For the first pass I erected an element with the shape shown in Fig 2. The upper dimension for this first try was 113 feet and the lower section 153 feet. With bare wire, the resonant frequency was 1.838 MHz and with insulated wire the resonant frequency dropped to 1.789 MHz. That's a shift

of almost 3%—no big deal in a dipole but bad news for a Yagi element. I experimented with other wires and insulations that had even larger frequency shifts.

So I went back to *GNEC* and modeled the resonant frequency with bare wire and with two different types of insulation. The insulation on THHN wire is listed as having a dielectric constant in the range of 3 to 4, so I used a value of 4. Back in the field I erected elements using bare wire and the two different insulations. The correlation between the *GNEC* insulating sheath (IS card) calculation and the actual measurements in the field was very good. It was better than 0.1%, so long as I kept sufficient tension on the element. I did repeated measurements as a check.

For tensioning I used a filled 2.5-gallon water jug, approximately 25 lbs, on the halyard for hoisting the upper end of the element. Higher tension had very little effect on element resonant frequency. However, reducing the tension below about 15 lbs allowed the sag to visibly increase and the resonant frequency dropped by nearly 60 kHz. These two effects combined were more than sufficient to seriously mistune the element.

By trimming the length of the lower section to resonate the individual elements (one at a time, with the other element not present) and maintaining a constant tension, I was able to get the array to work very well. Testing of F/B in the ARRL, Stew Perry and CQ 160-meter contests when numerous stations were available showed that the antenna had a F/B of 8 to 10 dB. This was just about where it should have been and the performance was all I could ask for.

One problem I encountered was how to measure the resonant frequency of an end-fed element. For a single element, the feed-point impedance is approximately 6 k Ω at resonance. This is out of the range of most amateur impedance bridges. You could use a more professional bridge, such as a General Radio 916 or 1606A, but again the impedance is outside of the normal range and some range-extending tricks have to be used.

I tried using a dip meter, with very poor results. The frequency calibration is very poor in most dip meters and there is considerable frequency pulling at resonance. Even using a frequency counter to track the dip meter was not totally satisfactory because of the effect of the meter itself and the fact that hand capacitance altered the resonant frequency. The resonant frequency of the elements is very sensitive to small

amounts (a few pF) of capacitive loading at the ends—right where you are trying to make the measurement.

Another problem with the dip meter and with other ham test gear can come from broadcast-band (BC) signals. In my case there is a 1-kW BC station a few miles away. At the station frequency I get induced voltages of a volt or more at the open end of an element under test, and almost 100 mV on the transmission line back in the shack. I used an MFJ-249 SWR analyzer and the AEA complex-impedance analyzer to check the match at the tap point. Both instruments go bonkers in the presence of a large BC signal.

I could make the measurement with these instruments if I placed a BC high-pass filter between the instrument and the tap, but that doesn't help with the resonant frequency measurement. I found the use of a Bird directional wattmeter to be more satisfactory for SWR adjustment and used a Boonton 250A RX meter for the resonance check. It may be possible to adapt a noise bridge with a tuned detector to make direct measurements on the antenna but I did not try that.

Indeed, I am very fortunate to have my old Boonton 250A RX meter. This is a vacuum-tube instrument that seems to shrug off the BC signal. The RX meter measures parallel impedance up to 100 k Ω and proved ideal for these measurements. I picked up mine for \$35 at a corporate surplus sale many years ago and recently bought another for \$46 on eBay. For low-band antenna enthusiasts this is a very nice instrument to have. Keep an eye out at flea markets and on eBay.

The frequency calibration is not adequate in the 250A but I fixed that with an inexpensive external frequency counter to monitor the internal generator frequency. I also calibrated the RX meter using 1% film resistors to further improve the accuracy. These are inexpensive and readily available.

There are other impedance-measuring instruments on the used market that appear regularly on eBay and at flea markets. A more modern instrument that is fairly common is the HP 4815A vector impedance meter. These also go up to 100 k Ω but suffer from much greater sensitivity to BC interference than the Boonton 250A. While the HP 4815A is relatively inexpensive on the used market, you have to be very careful to get one with a functioning probe. The probes are easily damaged and prohibitively expensive to have repaired.

In making the actual measurements, I was very careful to keep the layout as

close as possible to the final one. I positioned the Boonton 250A in the same location the tuning unit would occupy. I then brought a 2-inch ground strap up to the same point it would be in the tuner and connected the strap to the "low" terminal of the 250A. I brought the end of the element down to where the tuner would be with a 12-inch pig-

tail from the insulator at the lower end of the element.

I zeroed the meter and then connected the pigtail to the "high" terminal of the 250A. Yes, all of this fussing around is necessary to get accurate measurements! An important check is to see if placing your hands on the test gear has any effect on the readings.

There should be none. If there is, then you have to work on your layout, most likely the grounding. You should also try to keep away from the bottom of the element. Holding a hand near the element will shift the resonant frequency.

In the end the array has worked very well, but at the low end of the band the F/B appears to be higher than

Design of the Tuner

The tuner is a simple parallel-tuned L-C network, with a tap on the inductor to match to the feed line, as shown in Fig 6 in the main article. The task at hand is to determine the values for L1 and C1.

An equivalent circuit for the tuner and the antenna is given in Fig A1A. The antenna is represented by R_a and X_a in series and the tuner by the parallel combination of L1, C1 and R1, where R1 represents the loss in the L-C network, almost entirely due to the finite unloaded Q of L1.

The values for R_a and X_a are determined using modeling and confirmed by measurements on the completed array:

$$R_a = 5318 \Omega \text{ and } X_a = -1776 \Omega \text{ (capacitive reactance)}$$

The next step is to convert the series-equivalent circuit for the antenna to a parallel equivalent, as shown in Figure A1B using the following expressions:

$$Q_a = \frac{|X_a|}{R_a} = \frac{1776}{5318} = 0.334$$

$$Q_a^2 = 0.334^2 = 0.112$$

Parallel equivalents of R_a and X_a are:

$$R_p = R_a \times [1 + Q_a^2] = 5318 \times [1 + 0.112] = 5914 \Omega$$

$$X_p = X_a \times \left[\frac{1}{1 + \frac{1}{Q_a^2}} \right] = -1776 \times \left[\frac{1}{1 + 0.112} \right] = -1763 \Omega$$

X_p is the impedance at 1.830 MHz for a shunt capacitance of 4.9 pF.

Selection of L1 and C1

The next step is to choose a loaded Q_L for the tuned circuit when the antenna is connected. A Q_L in the range of 2 to 10 would be typical. Smaller Q_L means a smaller capacitor and a larger inductor, along with somewhat wider matching bandwidth. The problem is that a larger inductor will have greater loss. I chose $Q_L = 5$, which works out very well, with minimal coil loss. For:

$$Q_L = 5$$

$$X_L = 2\pi f L_1$$

$$Q_L = \frac{R_p}{X_L} \text{ meaning } L_1 = \frac{R_p}{2\pi f Q_L} = \frac{5914}{2 \times 3.14 \times 1.83 \times 5} = 103 \mu\text{H}$$

$$C_0 = \frac{1}{4\pi^2 f^2 L_1} = \frac{1}{4 \times 3.14^2 \times 1.83^2 \times 103 \times 10^{-6}} = 73.4 \text{ pF}$$

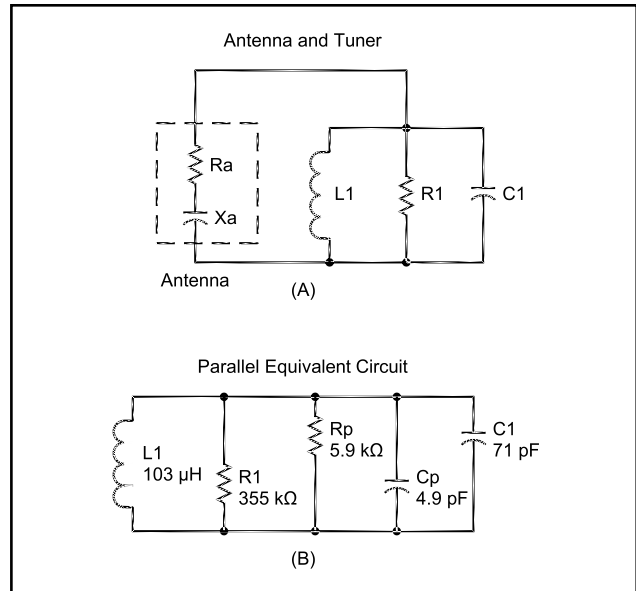

Fig A1—Equivalent circuits for the antenna and tuner.

C_0 is the capacitance needed to resonate at 1.830 MHz with L_1 .

$$C_1 = C_0 - C_p = 73.4 - 4.9 = 68.5 \text{ pF}$$

Loss Due to L1

R1 represents the loss in L1 and depends on the unloaded Q_1 of L1:

$$Q_1 = \frac{R_1}{X_L} \text{ which means that } R_1 = X_L Q_1$$

$$X_L = \frac{R_p}{Q_L} = \frac{5914}{5} = 1183 \Omega$$

$$\text{For } Q_1 = 300$$

$$R_1 = 1183 \times 300 = 355 \text{ k}\Omega$$

$$\text{Loss Ratio} = \frac{R_p}{R_1} = \frac{5914}{355000} = 0.0167$$

$$\text{Loss Ratio} = 10 \times \log(0.0167) = -0.07 \text{ dB}$$

This is pretty small, and you can ignore the coil loss as long as $Q_1 > 200$. Coil Q_s of 400 or more are not very difficult to obtain with a little care in construction.

predicted. I suspect that the final array is tuned a bit low in frequency due to stray capacitance loading at the bottom of the array, probably caused by the tuner and the final layout. Of course in an 80-meter array this effect could be exploited by switching in a small amount of capacitance to shift down from 3.790 to 3.510 MHz.

Ground System

One of the underlying assumptions for this family of antennas has been that since they use full-size half-wave dipoles, fed at the center, no ground system is required. It is true that the antennas will work reasonably well without the extensive ground system typical of a $\lambda/4$ vertical. However, the lower ends of the elements have a very high potential to ground. Using *GNEC* to plot the near-field electric (E) and magnetic (H) field intensities shows that the E field intensities are >800 V/m for 1.5 kW at ground level beneath the ends of the elements. This translates into high ground losses in the near field.

The K3LR articles mention the use of four elevated radials to improve performance somewhat, but that is about all that has been said on the subject. I began by modeling the fields under the array to get a feeling for ground losses and then modeled the array with 60 buried radials of progressively longer length out to 0.3λ . The result was a steady increase in peak gain due to lower ground loss. The gain increase amounted to 0.6 to 1.5 dB, depending to some extent on the modeling approach. Even at the low end of this range, this is a very worthwhile improvement.

In the present N6LF array there is a ground screen made from 2-inch mesh chicken wire with a radius of 50 feet. From there, I go out another 150 feet with #12 insulated radials lying on the surface of the ground. Because I use only two elements at present, the field intensities are not uniform in all directions around the array, being higher under the elements and lower off to the sides. I therefore have placed more copper and ground screen in the high-field regions. With three or four elements the field intensities are much more uniform as you go around the array and standard symmetrical radial systems would be more appropriate. The ground system is not yet complete but already it appears to make a difference. Certainly the modeling says it should.

Wire Issues

Conductor loss, using #12 solid copper wire, is about 0.5 dB, which is reasonable but it could be reduced. Using

a larger-diameter copper wire would help but also increases the weight of the element. Aluminum wire, although it has a lower conductivity than copper, can provide less resistance for the same weight. For example, a #7 aluminum wire will weigh about the same as a #12 copper wire, but will have a loss about 40% lower (taking into account skin effect, where resistance varies with the square root of conductivity). Of course, it will have more windage and the loss improvement is only a fraction of a decibel, so going to large aluminum wire may be a bit too picky.

Whether you decide to use copper or aluminum wire, stretching of the wire is a concern because it detunes the array. I tried a simple experiment: I took a 100-foot piece of copper wire, anchored one end and yanked really hard on the other end. It stretched a bit, about 6 inches ($\approx 1/2\%$). Conventional wisdom says that stretching the wire this way will increase its resistance by work-hardening the copper and also by reducing the diameter. I measured the wire resistance very carefully before and after stretching, using a Kelvin bridge good to a fraction of a milliohm. The dc resistance increase was right in line with the increase in length, $\approx 1/2\%$.

Work hardening and diameter reduction effects were too small to detect. For this reason I pre-stretched my elements and then trimmed them to length because it was more important to have the element correctly tuned than worry about a very small loss effect. This winter I had a lot of strong winds push the array around but no icing, which is very rare in any case. So far the pre-stretched elements have been stable. If you live in an area where icing is a problem, then you probably need to use either Copperweld or Alumoweld wire, both of which are much stronger but real pains to work with.

Another problem that caught me by surprise was the simple act of accurately measuring the length of a long piece of wire. I began by pulling the wire off the reel simultaneously with a long tape measure, both held in my hand. Every time I tried it I got a different final length—by a foot or more. The problem is that the wire slips with reference to the tape. So next I tried anchoring the end of the tape and stretching it out on the ground beforehand and then pulling the wire out and tensioning both the wire and the tape.

This was much more accurate and repeatable, but it also was a lot of trouble and requires a clear space of nearly 300 feet. George showed me his solution: a wire-length meter⁶ like you see in hardware stores. It measures

wire length to an inch in 300 feet without having to go out in the cold and wet. (It has been known to rain occasionally in Oregon.) It does the job quickly and easily and I was particularly glad I bought my own when I started to cut the numerous radials for the ground system. You have to build a simple 2x4 frame to hold the meter and a reel of wire but that's not difficult. If you want to do it right you can also buy an adjustable reel for the wire you cut off. That makes handling the long lengths much easier, especially when cutting numerous long radials.

Safety Issue

While end feeding the elements has many advantages, it presents a safety hazard because the fed ends are so close to ground level, where someone might be able to touch them. The voltages on the lower ends of the wires are very high while transmitting at high power. Some form of guard fence or safety screen is advisable if there is any likelihood of people or animals coming in contact with the wires.

Modeling Comments

Throughout this discussion I have emphasized the need for careful modeling. In my case I have no tower in the middle of things but most installations are likely to have one with HF Yagis attached. I began modeling a tower by obtaining an antenna file from Al Christman, K3LC (ex-KB8I), for a Rohn 55 tower, which models essentially every strut in the tower. The normal thing to do is to calculate the self-resonant frequency of the tower and then model it using a single wire with a diameter that results in the same resonant frequency. You can then use the simpler model in the overall antenna model. I found that I could find such an equivalent wire but the variation in feed-point impedance around resonance was not the same as for the tower. I got a better match in impedance characteristics by adjusting both the diameter *and* the height.

Using this equivalent model I then modeled George's antenna system. I found that his tower did not interact very much with his array. However, that represents a sample of one. It is perfectly possible that another tower, with a different collection of HF Yagis on it, might interact strongly and greatly modify the behavior. This has to be dealt with on a case-by-case basis for each installation.

The W2VJN Antenna

W2VJN has built a number of K1WA arrays over the years. When George was living in New Jersey, he

had used a K1WA configuration on 80 meters with very good results. He began with a one-element sloper, then added another element and finally went to four elements. After moving out to the wilderness in Oregon he erected a 150-foot Rohn 55 tower with an array of HF Yagis on it. About 2½ years ago he put two elements on 160 meters and then a year later added two more elements. The array drives one element at a time, with the remaining three acting as reflectors.

The original K1WA array used $\lambda/2$ elements, with the length of the coax cable going to the switch box tuned to make the element a reflector when not driven. The result is that the match at the drive element is not all that good for a 50- Ω line—SWR is typically on the order of 1.8:1 or so. George has a variation that improves the match. The elements are cut for 1.850 MHz (by calculation, $L=492/f_{\text{MHz}}$). With three elements open and acting as reflectors, the apparent resonant frequency measured at the switch box is 1.770 MHz. This means that at 1.830 MHz there is an inductive reactance at the feed point in the switch box. This is tuned out with a 1200 pF capacitor, resulting in a much better match, close to 1:1 at 1.830 MHz.

George's array can be switched in four different directions and he uses it for receiving as well as transmitting. He has found that selecting the right direction can make a considerable difference in some cases. He has found his antenna to be very effective on receive despite (or perhaps because of) the mix of vertical and horizontal polarization.

Future Improvements at N6LF

While the present array works very well, there is more that I can do. One idea is to add directors. At N6LF I have three tall poles in a row that would allow me to hang director elements for increased gain. I have already done this accidentally. After finishing with the 160-meter array I put up an 80-meter dipole on the east side of the 160-meter array, suspended between the poles that support the 160-meter array, as shown in Fig 12.

I checked to see if the 80-meter dipole had any effect on the 160-meter array by modeling the combination. It certainly did have an effect! With the 80-meter feed line grounded, the 80-meter dipole acted like a reflector and killed my gain to the east. Adding a coax common-mode choke balun turned the dipole into a director and this increased the gain to the east. The dipole is not a very reliable director, however, because as the wind blew it

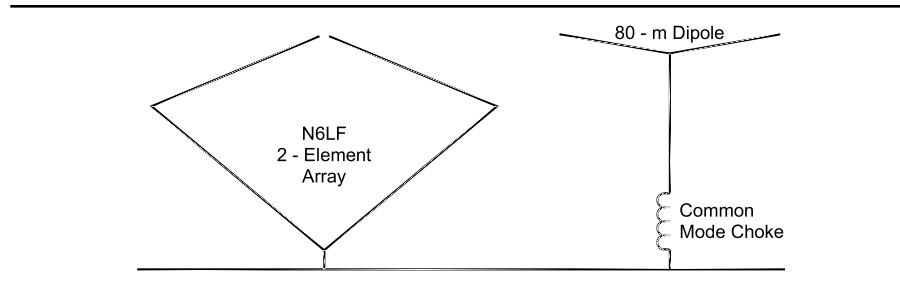

Fig 12—Combination of the N6LF array and an 80-meter dipole for modeling.

moved up and down, changing its characteristics. One minute it might be a director but a reflector at another. For now I drop the 80-meter dipole for contests or if I think there is the possibility of an opening to Europe. Next summer I plan to make other arrangements for the 80-meter antenna so that it does not interact with the 160-meter array.

And of course a three-element Yagi would have more gain and better F/B than a two-element Yagi. Next summer I will expand the array to three elements. I had originally planned to suspend the directors between the other available poles but after looking at the Spitfire antenna⁷ I changed my mind. Since I already have an extensive ground system in place, it makes more sense for me to simply hoist a wire up along the supporting pole and use it as a driven element, and then use the other two elements as director/reflectors. I could even suspend a second director between the supports and go to a four-element (or even five-element) Yagi on 160-meters. Of course, the beamwidth will narrow and I would have to go to at least four-direction switching for the pattern to have reasonable coverage.

Although I use only two elements that allow me to switch the pattern from east to west, the present array has been very useful. Going to three elements (one driven and two reflectors) would be worthwhile. The gain is changed very little by having two reflectors but there is some improvement in F/B. The real improvement would be the ability to slew the pattern in three different directions rather than two. It is possible to have two driven elements and have one as a reflector. This in combination with one driven and two reflectors would give six headings for the pattern. I am not convinced that this would be worth the trouble, however.

Acknowledgements

Much of the progress I made in this project was the result of endless discussions with George Cutsogeorge,

W2VJN. He was a tremendous help. I would also like to thank Dean Straw, N6BV, for putting me onto the antenna file for the Rohn tower and to Al Christman, K3LC, for sending it to me. This was very helpful in evaluating the effect of the tower on George's array and sloper arrays in general.

I have referenced only a few of the multitude of articles on sloper antennas. George told me to go to Google.com and enter "sloper arrays". I got over 500 references, about two thirds of which were for sloper antennas! No doubt everything said here has already been said many times but perhaps this forum will reach a wider audience.

John Devoldere's *Low-Band DXing*⁸ is another great reference source. At the last moment in preparing this article John, EI7BA, made me aware of a particularly good article by Tony Preedy, G3LNP.⁹ It deals with bent verticals less than $\lambda/2$ wavelength long and arrays made from them, which are very much like the arrays in this article. This is also a "must read" article.

References

- ¹D. Pietraszewski, K1WA, *The ARRL Antenna Book*, 16th Ed. (Newington: ARRL, 1988), pp 4-12 to 4-14.
- ²D. C. Mitchell, K8UR, "The K8UR Low-Band Vertical Array," *CQ Magazine*, Dec 1989, pp 42-45.
- ³Christman, Duffy and Breakall, "The 160-Meter Sloper System at K3LR," *QST*, Dec 1994, pp 36-38.
- ⁴Christman, Duffy and Breakall, "The 160-Meter Sloper System at K3LR," *The ARRL Antenna Compendium, Vol 4*, (Newington: ARRL, 1995), pp 9-17.
- ⁵R. Severns, N6LF, "Conductors for HF Antennas," *QEX*, Nov/Dec 2000, pp 20-29.
- ⁶HYKON model 1410 wire-length meter, HYKON Manufacturing; 1-800-458-1480; www.hykon.com.
- ⁷Kaufmann, W1FV, and Hopengarten, K1VR, "The FVR Spitfire Array," Dayton Hamfest presentation, 1998. Copies of this can be found on the Yankee Clipper Contest Club Web site; www.4CCC.org/Articles/Spitfire/spitfire.html.
- ⁸J. Devoldere, *Low-Band DXing*, 3rd Ed. (Newington, ARRL: 1999).
- ⁹T. Preedy, G3LNP, "Single Support Directional Wires," *RADCOM*, Aug and Sep 1997. □□

The Primary Source of Automotive RFI: Ignition Noise

*To free your mobile station from annoying interference,
you need to know about the noise source.*

By Stu Downs, WY6EE

It has been a couple of years since I wrote an article for *QEX* on automotive RFI elimination (Jan/Feb 2000). That article showed how to eliminate RFI in a 1995 Toyota 4Runner. There have been many responses from hams all over the country concerning that article. Many have shared interesting stories on their particular automotive RFI problems.

It has been my experience however, that automotive RFI is still driving hams crazy. Indeed, solving automotive RFI problems has been elusive for the average ham. Therefore, I shall attempt to explain in greater detail what the source of automotive RFI is.

Part of solving a problem is learning to understand it.

First, I would be remiss unless I told you a true story about a couple of great men—adventurers—not altogether different from you, dedicated to being “out there,” breaking the mold, not following the herd or doing what everyone else does. I would not be surprised if these two men became radio amateurs—if they had been born in the 20th century! Amateur Radio is still the greatest of services.

About 150 years ago, there was an Englishman named Michael Faraday. He was not educated in the classical sense, yet he was very bright. He knew how electricity and magnetism worked. He was a master experimenter. He completed many experiments and could explain how the electricity and magnetism relation-

ship worked. Later in his life, he made the acquaintance of a man 40 years his younger named James Clerk Maxwell—a Scot. Now James Maxwell was also brilliant, but in a different way. He was a mathematical prodigy. The older man took a liking to the young man and exchanged with him everything he knew with respect to electricity and magnetism. This union and mutual respect turned out to be one of the greatest serendipitous relationships in all of history, for they were both to change the course of scientific history. What did they do? Maxwell formulated the results of one of Faraday’s experiments—Faraday’s law of induction—and put it with other formulas including his own. This set of four equations described completely how electricity and magnetism works!

Consider this interesting side note:

11581 Aspendell Dr
San Diego, CA 92131
stuardowns@earthlink.net

At University of California San Diego, it takes longer to become an experimental physicist than a theoretical physicist. Don't underestimate the importance of experiments and practicality! One question has come up many times since my first article was written: "How can one of the newer automotive ignition systems be modified to minimize RFI? I've grounded everything and I still get noise." I sold my 1995 Toyota 4Runner (my original article was based on that truck) and purchased a 2002 Toyota 4Runner (I like Toyotas). I am going to show you what I found on this new vehicle. Most other vehicles are very similar to this one.

Spectrum Analyzer Baseline Measurements

I connected my Toyota's ham stick antenna (17-meter band) to a spectrum analyzer. I then made ambient signal and noise measurement with the engine off, to get an ambient baseline—see Fig 1. Around 18 MHz or so, the ham stick's signal strength was about -56 dBm. This is the signal my ICOM 706 transceiver sees at its RF input.

Next, I made a measurement with the engine on (see Fig 2). I increased the persistence on the spectrum analyzer to capture the ignition noise. Ignition noise on the spectrum analyzer appears as broadband impulse spikes. I have drawn an envelope around the peak impulse ignition noise so that it can easily be seen and compared to Fig 1. Observe that the ignition noise is around -54 dBm and it is broadband! The ignition noise in this vehicle is greater than the received ambient RF signal, with the engine off, by about 2 dB (almost two times greater). This means that my automobile is creating interfering signals (electromagnetic interference) that are seen at the input to my radio! It would be ideal to reduce the ignition noise to a very low level. In relative terms compared to the spectrum analyzer noise floor, a 40-dB reduction in ignition noise would be very nice. That way I would have a very good signal-to-RFI noise ratio. In fact I would like to propose such a new ratio: *Signal/Automotive RFI Noise Ratio*. Why not rate automobiles this way?

No amount of grounding the hood to the frame and so forth will get rid of this type of noise. This noise is caused by a radiating electromagnetic field. Electromagnetic field lines will couple out the bottom of your engine, through the seams in your hood and couple directly into your antenna. Your antenna and radio are doing what they're supposed to do: receiving! The

car system is the culprit here; your antenna and radio are the victims!

The primary source of RFI noise from my vehicle is its ignition system. The 2002 Toyota V6 engine has three ignition-coil assemblies mounted on top of one of the valve covers. Each coil assembly drives a spark plug directly beneath it and another spark plug on

the other side of the engine, through an ignition cable. Each pair of spark plugs are connected in series through one ignition coil. The series path is from one side of the coil secondary through a spark plug, through the engine block ground, back up through the other spark plug, back to the other side of the coil.

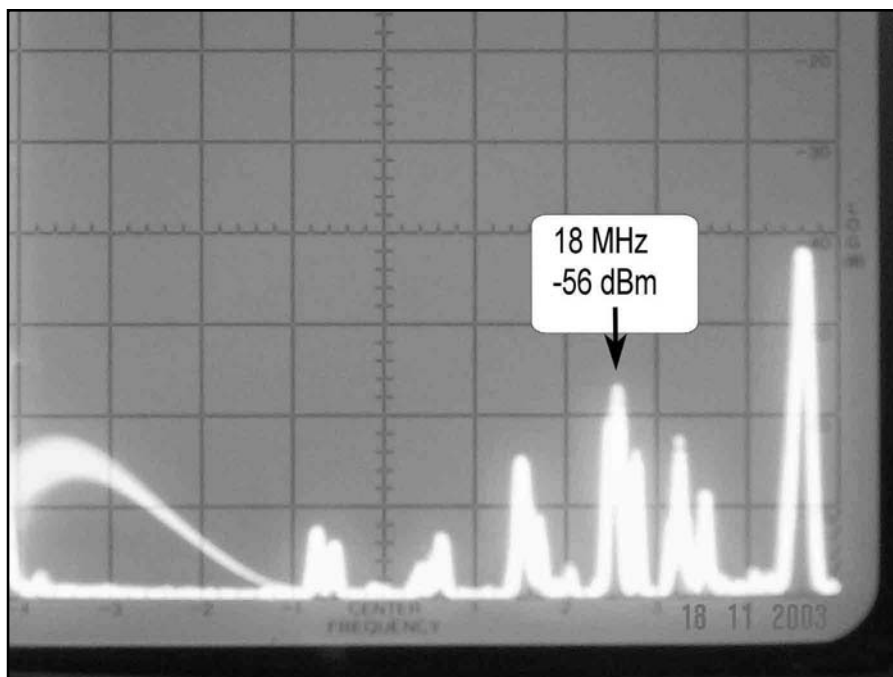

Fig 1—Noise received with engine off through a 17-meter Ham Stick. Vertical scale: 10 dBm per division; reference 0 dB; horizontal scale: 2 MHz per division.

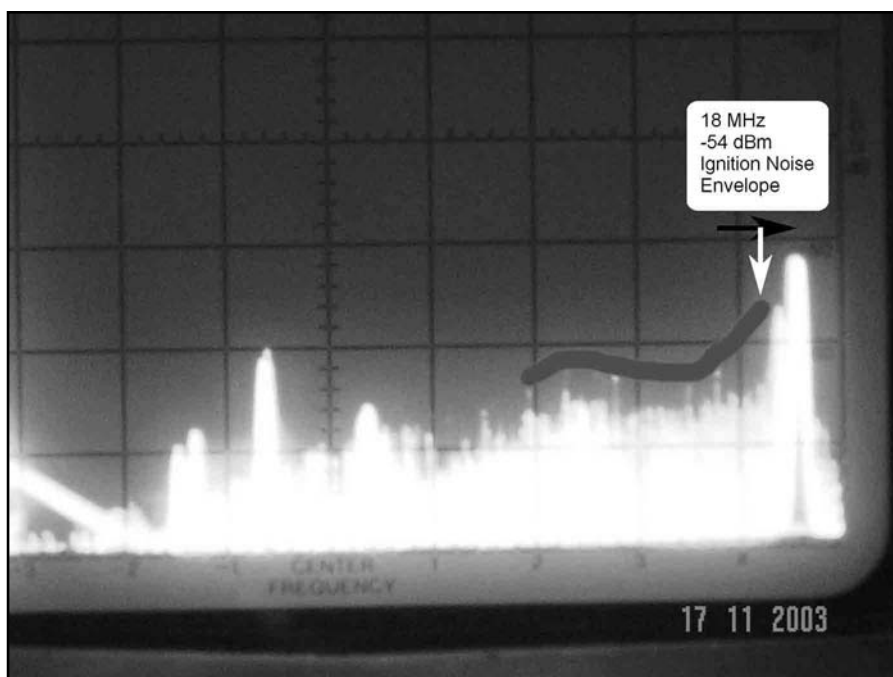

Fig 2—Noise profile with engine on through a 17-meter Ham Stick. Vertical scale: 10 dBm per division; reference 0 dB; horizontal scale: 2 MHz per division.

There are about 5-6 inches of spark plug ignition wire encased in rubber protruding from the bottom of the ignition-coil-head assembly to the spark plug beneath it (see Fig 3). Notice the coil at the head of the assembly, with the spark plug end to the right. The other end of the coil, facing away, has a connector for an ignition cable. The connector facing you is the primary side of the coil transformer.

The unseen connector end of the coil assembly connects to the other spark plug through an ignition wire (see Figs 4 and 5). The ignition coil secondary fires both spark plugs at the same time; one cylinder being in an exhaust cycle, the other in a compression cycle.

To understand the source of the automotive RFI ignition noise, consider Fig 6, a simple lumped-element schematic which depicts one third of the secondary side of a modern automotive ignition system (six cylinders), the same kind as in the 2002 Toyota 4Runner. The ignition coil acts as a step-up transformer, transforming a low-voltage synchronous pulse drive signal into secondary high voltage. The secondary is series connected to two spark plugs through a single ignition cable and the vehicle's chassis ground. Believe it or not, this is a big improvement over previous ignition systems, as it produces proportionally less radiated RFI. Ignition cable lengths are shorter and there is a smaller ignition-loop area. Even though this is an improvement, it's still not optimal.

An Idealized Spark Plug Voltage Waveform

An idealized ignition voltage waveform appearing across the spark plug terminals is depicted in Fig 7. This waveform yields insight into spark plug and ignition-system performance. The ignition coil at the proper time generates a high voltage across both spark-plug terminals. This creates a very high electric field between the two spark-plug terminals, forcing electrons to jump the gap and form an arc. Once the arc is formed, the voltage across the terminals drops to a sustaining level. The fuel-air mixture is ionized during this time and current flow occurs between the two spark-plug terminals. The voltage across the arc during current flow is on the order of 1 to 2 kV. The arc voltage is a function of fuel mixture and cylinder pressure. That voltage drop does vary. Glenn Borland claims he can hear the difference in the RFI electric field magnitude (a change in the ignition systems RFI noise) as a function of cylinder head pressure, since the arc voltage changes by hundreds of volts

with the particular fuel air mixture.

Ignition Antennas

There are two antenna mechanisms at work here that radiate RFI ignition noise:

1. An ignition cable that looks like an

electrically short antenna working against its counterpoise, the engine block ground.

2. An electrically short low-current loop antenna.

Both antennas are capable of radiating electromagnetic RFI ignition

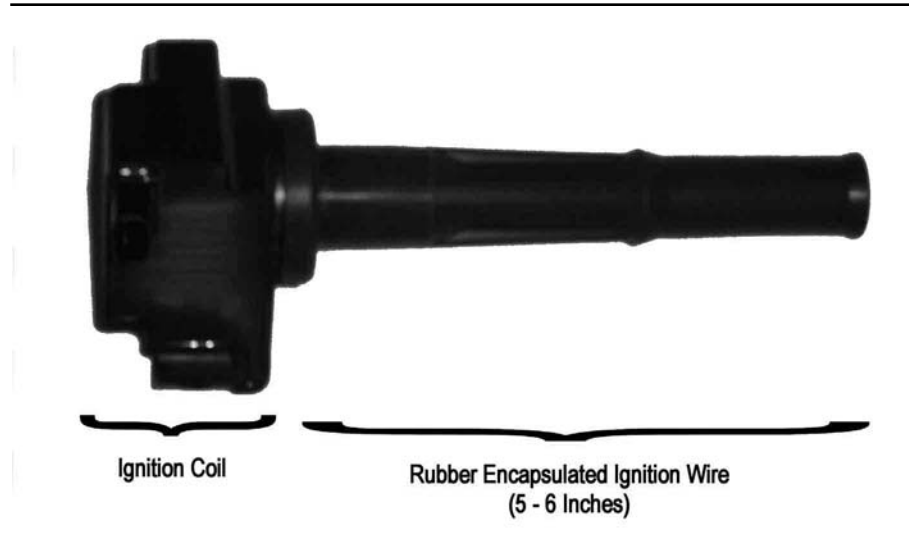

Fig 3—An ignition-coil assembly.



Fig 4—One end of an ignition cable.

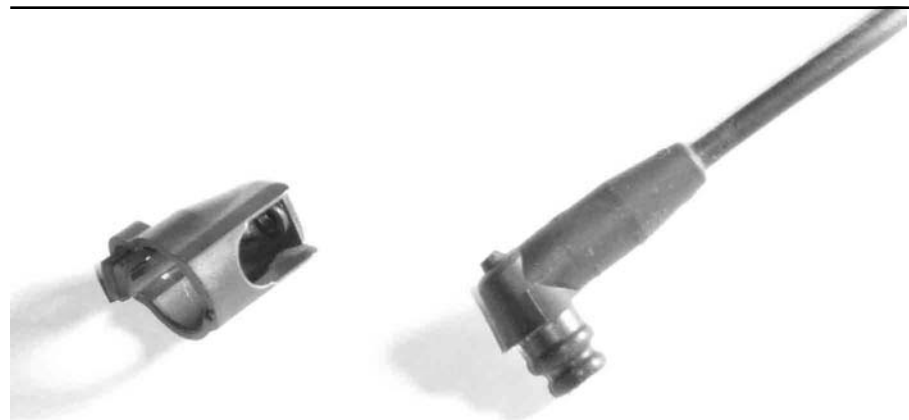
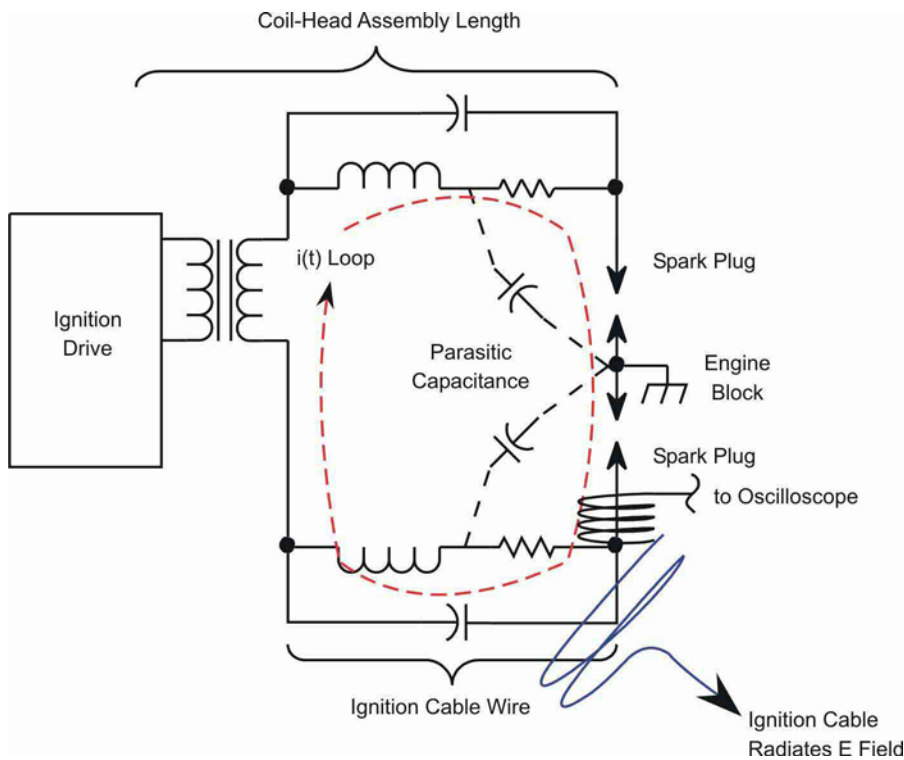

Fig 5—The other end of the ignition cable.



$\Phi_B(t) = \int B(t) \cdot da$
 $\oint E \cdot dl = -\frac{d\Phi_B}{dt}$
 Faraday's Loop Law
 Produces Magnetic Field

$V(t) \oint E \cdot dl$
 Cable Length
 Produces E Field

Fig 6—A schematic of a simple automotive ignition circuit. The measured component values are in Table 1.

noise. One is an E field, the other a magnetic field. Of course, once the electromagnetic field is launched, they both create electromagnetic waves by inducing a magnetic field from an E field and vice versa. The question is: Which one dominates, and what can be done to keep it from radiating RFI?

The Ignition Loop Antenna (Magnetic Field)

The coil, ignition cable, spark plugs and engine block form a conductive loop. This loop begins at the coil with its co-located spark plug, passes through the engine block to the other spark plug, and returns through a length of ignition cable to the other side of the coil. The length of this loop commonly approaches fractions of a quarter wavelength circumference (2-30 MHz). One could say that it has the appearance of an electrically short loop antenna. Newer automobiles have less loop circumference length and therefore less loop area. The equation for magnetic field flux $\Phi(t)$ is indicated in Fig 6. Once this magnetic field is launched, it produces an $E(t)$ field as predicted by Faraday's law. That's right: Magnetic field flux through a loop area creates an E field around that same loop—it's called curl. The magnitude of this field depends upon loop area, loop Q and current. To minimize the magnetic field, reduce the loop area or the current.

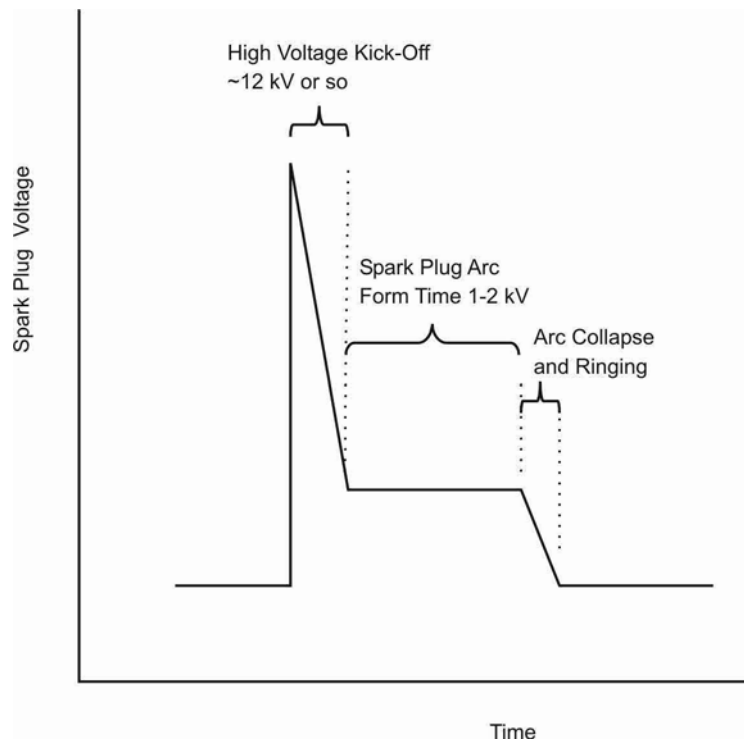

Fig 7—An idealized spark voltage waveform.

The Ignition Cable Antenna (E Field)

The long ignition wire cable from the coil to the far-end spark plug forms

an electrically short antenna. It looks like a low-Q (broadband) capacitive antenna. Parasitic capacitance also couples from this length to the engine

block. During spark formation and cessation, the end of the cable rings (a high-voltage exponentially decreasing damped sinusoid). The voltage ringing along that length of wire produces an E field and it radiates. The E field flux lines couple between the cable antenna and its counterpoise, the engine block. The ringing voltage, which eventually dampens out, can be on the order of a couple of thousand of volts or so.

Fig 8 shows an oscilloscope waveform of the voltage at one end of the spark-plug cable. Don't assume that this is the frequency of your interference, since the scope-probe inductance and capacitance and the pick-up loop circuit contain parasitic elements, which have everything to do with the frequency depicted here. A better measurement would require a current loop. This just illustrates that there is high-voltage exponentially damped sinusoid that varies with frequency on the ignition cable. This radiates an E field, and it is the biggest source of ignition noise! Why? Because electrons are being accelerated by a time-varying signal.

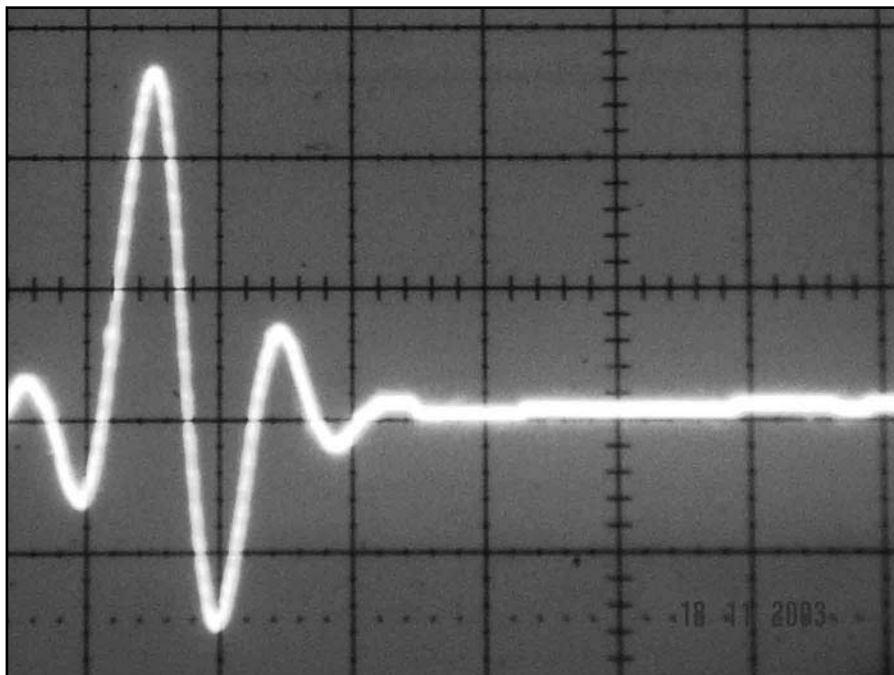

Fig 8—A capacitively coupled spark plug cable waveform. Time Base: 1 cm = 0.1 μ s; frequency ~28 MHz.

Summary

Automotive manufacturers will continue to use ignition cable inductance and resistance together with resistive spark plugs to decrease the magnitude of loop current flow, which has the effect of reducing RFI. They have also minimized ignition-cable loop area. They do this by running ignition cable wires next to the engine block, in addition to reducing the loop-area circumference. This primarily reduces the effect of the loop antenna.

It also helps some with the cable length antenna since ignition wire cable length is shortened. I have noticed considerably less RFI in my 2002 Toyota than the 1995 vehicle.

The greatest producer of automotive RFI is still the E field generated by, during and after spark formation. This voltage rings along a broadband electrically short low-Q capacitively-looking ignition-cable antenna, transmitting all kinds of RFI. Manufacturers need to either shield the entire ig-

nitiation system to get rid of it, or do something altogether different. The high voltage system invented in the early 20th century to ignite fuel mixtures should become obsolete someday as more and more radios, computers and such become integrated into automobiles. Hey how about this idea—an RF arc controlled at a certain frequency. How about it automotive manufacturers? Until that time most hams will just have to put up with the noise. □□

New Book

NEWNES GUIDE TO RADIO AND COMMUNICATIONS TECHNOLOGY

By Ian Poole

Elsevier Limited, Oxford, 2003; ISBN 0 7506 56123; \$25, paperback, 320 pages

In this brand new volume, Ian Poole begins with a fine introduction to radio, suitable for almost all readers. He explains about the history and development of the art from the work of Gilbert, Faraday and onward. He correctly attributes Maxwell with the prediction of radio waves that travel at the speed of light and the first proven radio transmission to Hertz. He puts Marconi's role in its proper

perspective—as a developer.

Marconi's alleged transatlantic reception of three dits—the letter S—late in 1901 is not questioned. It seems to me that any scientifically minded individual should question it. First, there is no tangible proof of the event. Second, if a long string of dits were sent and Marconi received only three, the information sent was not correctly received and it would have been quite limited information at that. Third, propagation on the frequencies supposedly used is very unlikely to have existed at the power levels employed. Edouard Branly, who invented the coherer used in the experiment to detect the signals, is not mentioned. Finally, also unmentioned are Lord Kelvin, Lord Rayleigh, Einstein, Hall, Schockley, Bardeen or Brattain, among others along the timeline of developmental events throughout the years.

Despite those omissions, the book is an excellent way for neophytes to step into radio and learn something about it. It begins with the basics and gradually brings in more advanced concepts. Propagation modes, modulation—including spread spectrum, antenna systems and the basis of superheterodyne receivers are all covered in quite some detail, along with circuit specifics. Transmitters are also covered, with analysis of standard FM, SSB and AM methods. No DSP-centric information is included.

The remainder of the book discusses broadcasting—including digital audio broadcasting, cellular, satellite and short-range wireless communications. It is an interesting read, even for the advanced engineer. I recommend it as an addition to your technical library—Doug Smith, KF6DX, QEX Editor □□

Accurate Measurement of Small Inductances

*Build a homebrew test oscillator for measuring inductance.
Calculate L from the fixture's operating frequency.*

By Dave Lyndon, AK4AA

When I embarked on a major project to build an amateur-band receiver, a number of interesting and a few difficult problems arose. Almost all of those issues could be addressed *a priori* because of the richness of the literature, but there was a notable exception. I lacked access to laboratory-standard test equipment—which is the case with most hams I expect. How does one measure small inductances with a precision of at least two, and possibly three, significant digits?

A search of the literature produced scanty results. One interesting circuit was described in *The 2001 ARRL*

Handbook on p 26.22. I built a replica, and duplicated the results. Measurements with accuracy of $\pm 10\%$ can be made with that clever device from about 3 to 3000 μH , and that is good enough for many ham applications. A more accurate and direct reading device was described by Robert Vreeland, W6YBT, in *QEX* (May 1989); but an expensive Fluke DMM is required. Evidently, accuracy in the 3-5% range can be expected with W6YBT's elegant method. Nonetheless, 1% accuracy and measurement of smaller inductors (down to about 0.5 μH) was the goal, even if elusive.

I attempted numerous approaches, including various unsatisfactory bridges and the old standby grid-dipper method. By forming a parallel resonant circuit with a known-value capacitor and finding the resonant fre-

quency with a grid-dip meter, the value of the inductor can be estimated. At best, this yields $\pm 10\%$ accuracy. A serious shortcoming of this method is that coupling to toroidal inductors is nearly impossible since the magnetic field is concentrated in the core. (Did I miss something? Has someone found a way to do this without influencing the unknown tuned circuit's resonant frequency?) Finally, a simple solution occurred to me: the converse of the grid-dipper method. If we put the unknown inductor in parallel with a known capacitance in an oscillator and measure the frequency of oscillation with a counter or accurately calibrated receiver, we can calculate the inductance from the known tuned circuit capacitance and oscillator frequency. This method works very well, and I am convinced that it yields measure-

85 Woody Farm Rd
Hot Springs, NC 28743
dlyndon@direcpc.com

ments of very good accuracy using equipment and common parts available to the average ham.

A simple—and admittedly ugly—breadboard was built on a small scrap of PC board. Fig 1 shows the circuit diagram, and Figs 2 and 3 are photographs of the breadboard and some of the inductors used to test it.

The circuit is a Colpitts oscillator followed by an isolating source follower. The junction FETs are MPF-102s, and all frequency-influencing capacitors are zero temperature coefficient (NPO) ceramics. Metal-film resistors are used for their stable RF characteristics, but exact values are not critical, so $\pm 5\%$ resistors will do nicely. Megohm resistors with one end soldered to the PC board are used as standoff insulators where needed. A 9-V battery provides power. Small alligator clips are soldered directly to the board for connection to the unknown inductor and for connection to the frequency counter or receiver. Half-inch square pads were etched into the copper with a small drill for the ungrounded alligator clip connections. Among other considerations, pay careful attention to minimizing series inductance in the tuned-circuit path. The small clips appear to be suitable for the

inductance range of interest.

The circuit in Fig 1 is satisfactory over the range of $0.5 \mu\text{H}$ or less to over 1 mH. The oscillator operates reliably over the range from a few hundred kilohertz to over 25 MHz. The signal level does fall off at the high-frequency (low-inductance) end, but there is sufficient output to drive a counter or to be heard in a receiver. Some unknown toroidal inductors from the junk box were re-

luctant to support oscillation—possibly because of low Q, but well-characterized ferrite and iron-core toroids worked in the circuit, along with a variety of other types as shown in Fig 2. Fig 3 is a close-up view of the breadboard—not pretty but competent.

I intended the circuit for direct connection to a frequency counter, but very loose coupling to a general-coverage receiver can be used if a counter

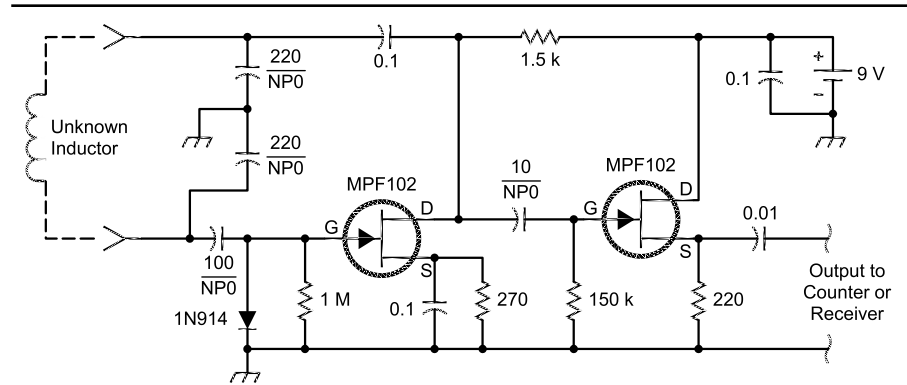

Except as indicated, decimal values of capacitance are in microfarads (μF); others are in picofarads (pF); resistances are in ohms; k = 1,000, M = 1,000,000.

Fig 1—L-meter schematic diagram. Resistors are $\pm 5\%$ metal film; 5% NPO capacitors are used in frequency determining locations.

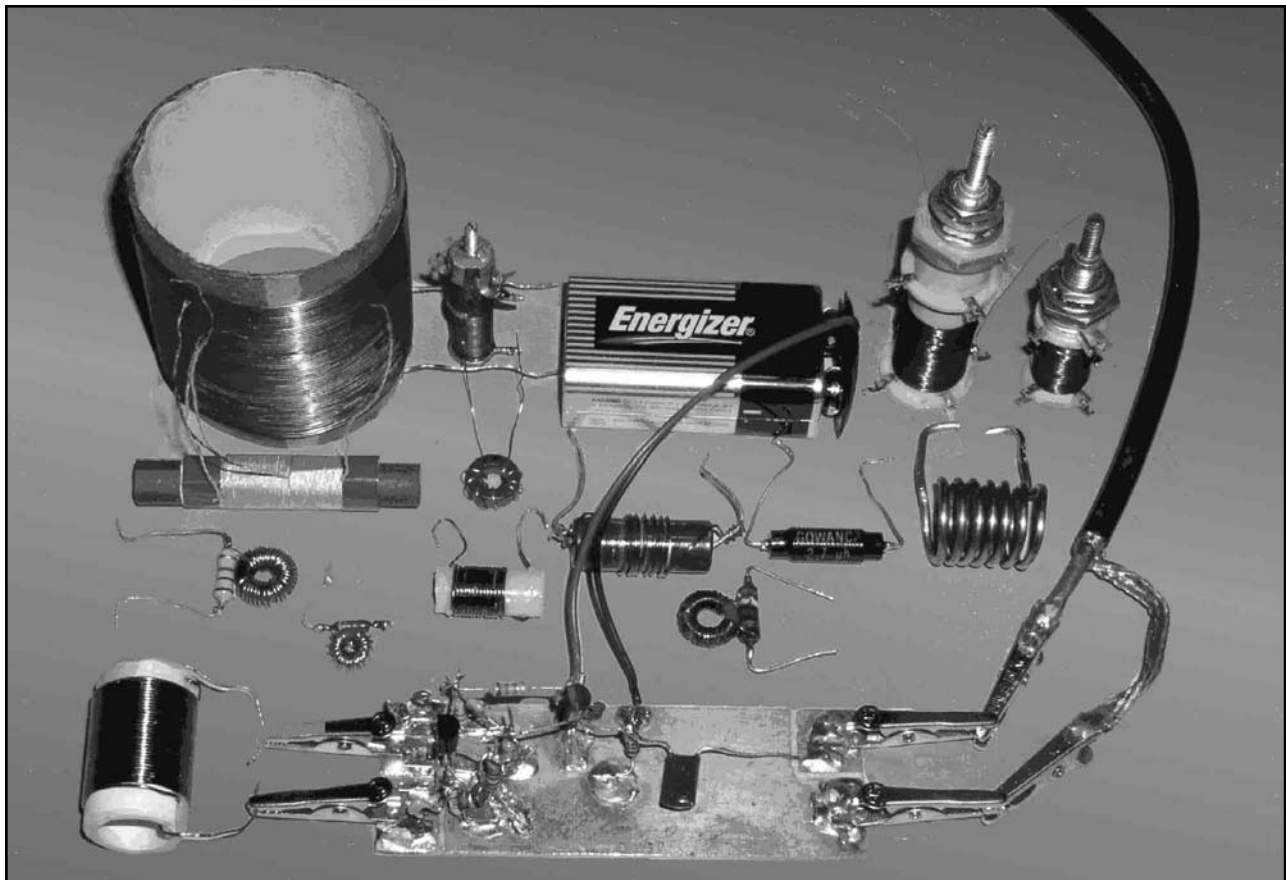

Fig 2—The “ugly” breadboard and typical inductors. The unknown inductor is connected to the alligator clips on the left. The counter or receiver is connected to the clips on the right via a shielded cable.

is not available. Disconnect the receiver from its antenna to minimize reception of interfering signals, then connect the output to the receiver through coaxial cable and a gimmick coupling capacitor consisting of a few twisted turns of insulated hookup wire. A receiver with digital frequency display is as good as a counter in this application. Keep in mind that the displayed frequency in some receivers may be offset from the receiver's oscillators, and you must zero-beat them with the test oscillator signal. You must make this correction if so. Receivers with analog dials will need

calibration accuracy of four significant figures to achieve the desired measurement accuracy. (Many analog receivers meet that requirement.) It is possible, of course, to detect harmonics of the oscillator frequency, so a rough idea of the unknown inductance will put you near the right frequency. To distinguish the fundamental from its harmonics, the lowest (and strongest) frequency you can detect is most likely the fundamental, and you should detect its harmonics only at exact multiples of the fundamental frequency.

To obtain the desired accuracy, it is

necessary to determine the actual value of the capacitance across which you will connect the unknown inductor. In the circuit shown, that value should be on the order of 110 pF. Here's how to determine the actual value of the input capacitance including all stray reactances. You will need a test inductor, preferably about 10 μ H. The exact value is unimportant because it will cancel out in the following calculations. You will also need a calibration capacitor of known value in the range of 100-150 pF. You can probably trust a 1% NPO capacitor; but since many inexpensive digital multimeters claim to

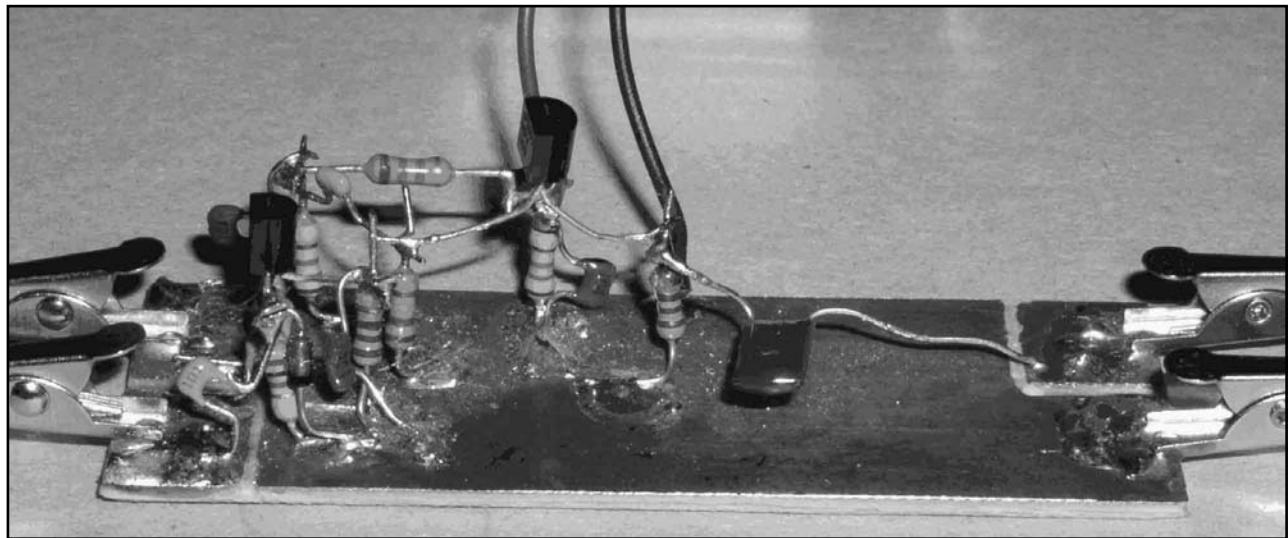

Fig 3—A close-up view of the “ugly” breadboard. The PC board’s copper foil is circuit ground. Megohm resistors with one lead soldered to the foil serve as standoff insulators. The ungrounded alligator clips are soldered to hand-etched pads. Component leads in the oscillator circuit are kept as short as possible.

Table 1—Measurement Data

The measurements and calculations validate the use of a common K factor in the range of 0.5 to 50 μ H. The dK and $dK\%$ columns represent deviation from the average value of K . The values for the larger inductors at the bottom of the table were computed using their independent K factors.

f_1 (MHz)	f_2 (MHz)	R	C_k (pF)	C_i (pF)	K (μ H/MHz ²)	dK	$dK\%$	L (μ H)
23.03	16.83	0.5340	100	114.6	221.0	1.87	0.84	0.420
21.63	15.81	0.5343	100	114.7	220.8	2.05	0.92	0.476
16.35	11.93	0.5324	100	113.9	222.5	0.41	0.18	0.834
15.34	11.18	0.5312	100	113.3	223.6	-0.70	-0.32	0.947
8.999	6.556	0.5307	100	113.1	224.0	-1.08	-0.49	2.75
4.565	3.325	0.5305	100	113.0	224.2	-1.29	-0.58	10.7
4.508	3.285	0.5310	100	113.2	223.7	-0.85	-0.38	11.0
3.443	2.506	0.5298	100	112.7	224.8	-1.96	-0.88	18.8
3.057	2.227	0.5307	100	113.1	224.0	-1.12	-0.50	23.8
2.293	1.674	0.5330	100	114.1	222.0	0.91	0.41	42.4
2.009	1.468	0.5339	100	114.6	221.1	1.77	0.79	55.2
AVERAGE		0.5320		113.7	222.9			
1.482	1.089	0.5400	100	117.4	215.8			98.3
0.8185	0.6054	0.5471	100	120.8	209.7			313
0.5035	0.373	0.5488	100	121.6	208.3			821

measure capacitance to 1% accuracy, make a measurement if you can to be sure. Better still, if you have a number of like 1% candidates of the same indicated value, select the one nearest the average measured value; then the accuracy of the multimeter doesn't matter. Statistically, the capacitor nearest the average value will probably be closest to the indicated value even if the DMM is off a bit or two.

Insert the test inductor in the alligator clips and measure the oscillator frequency with a counter or receiver. Then put the known calibration capacitor in parallel with the inductor. This can be done by inserting it in the clips along with the inductor, but it is better to tack-solder it directly on the board temporarily. Then measure the new, lower frequency. Since the frequency of a tuned circuit is inversely proportional to the square root of the capacitance, we can calculate the input capacitance as shown in Eqs 1 and 2:

$$\frac{C_i}{C_i + C_k} \frac{F_2^2}{F_1^2} R \quad (\text{Eq 1})$$

Where C_i = unknown input capacitance of the oscillator.

C_k = known capacitance

F_1 = frequency with C_i only

F_2 = frequency with C_k added to C_i

R = the ratio of the frequencies squared

From the ratio R , and the value of the known capacitor, we compute in Eq 2 the input capacitance:

$$C_i = \frac{C_k R}{1 - R} \quad (\text{Eq 2})$$

Now, with a known C_i we can compute the value of an unknown parallel inductance from Eq 3, the resonance formula:

$$L = \frac{1}{(2\pi f)^2 C_i} \quad (\text{Eq 3})$$

where f is the measured oscillator frequency and L the unknown inductance.

To simplify future calculations, we can establish a constant calibration factor for the device to compute L more directly:

$$L = \frac{K}{f^2} \quad (\text{Eq 4})$$

where

$$K = \frac{1}{(2\pi)^2 C_i} \quad (\text{Eq 5})$$

The dimension of K in Eq 5 can be adjusted to yield inductance in microhenries from frequency in megahertz.

Here's an example based on my breadboard. I used an inductor estimated to be about 10 μH from previous measurement attempts and a selected 100-pF calibration capacitor. As noted above, the actual value of the calibration inductor is unimportant because it cancels out in the calculations. The frequency of oscillation with the inductor only was 4.565 MHz. When the 100-pF capacitor was added in parallel, the measured frequency was 3.325 MHz. R , the ratio of the frequencies squared, was computed as 0.5305 according to Eq 1. Then using $R = 0.5305$ and $C_k = 100$ pF, the input capacitance was computed according to Eq 2 and found to be 113.0 pF. The calibration factor, K , was then computed according to Eq 5 and is 224.2. This gives Eq 6 for this specific device:

$$L = \frac{224.2}{f^2} \quad (\text{Eq 6})$$

where L is in microhenries and f is in megahertz.

Using the same inductor to demonstrate the measurement process, we see from above that the measured frequency with the inductor alone was 4.565 MHz. From Eq 6, we compute L as 10.76 μH , and we round it to 10.8 μH . Don't trust that fourth digit since the calibration capacitor's value is known to only three significant digits. Notice, however, that by using four digits in all calculations, we minimize cumulative rounding errors in the third digit of the result.

To provide confidence in the calibration method, C_i was measured using various inductors over the range of 0.5 to 50 μH —two orders of magnitude. It does vary slightly due to differences in stray capacitance in the inductors, in this case between a computed minimum of 112.7 pF and maximum of 114.7 pF. That's about 1.5% difference. The average value of measured C_i over this range was 113.7 pF, and the average value of K was 222.9 $\mu\text{H}/\text{MHz}^2$. The measurement data and computations are shown in Table 1. All of the measured K s up to

50 μH fall within 1% of the average value. So, we can use the average K of 222.9 in this range, retain some confidence in that illusive third digit of precision and swear to the second digit under oath.

Apparently, the device provides repeatable measurement accuracy approaching $\pm 1\%$ in the range of 0.5 μH to 50 μH using the common K factor. If inductors above this range are measured, the accuracy declines, but the common K factor is still useful up to 1000 μH or so, if high accuracy is not required. The difficulty in measuring inductance of larger inductors is caused by their significant interwinding capacitance. If accurate measurement of a given inductor is required, a unique K value can be determined for that inductor, thus treating its self-capacitance as a contributor to the input capacitance, C_i . Three examples of this are shown at the bottom of Table 1, and it is obvious that their contribution to input capacitance is significant. In fact, a good estimate of the self-capacitance of such an inductor is the difference between its uniquely computed C_i and the average value of C_i obtained with the smaller inductors that have little self capacitance. For example, the second listed of the three larger inductors in Table 1 shows a C_i of 121 pF compared to an average of 114 pF for the smaller inductance group, indicating that this inductor has about 7 pF of self-capacitance. [Remember that the 7 pF travels with the inductor to its application circuit. Therefore, it is probably more useful to measure its inductance the first way, without consideration of the self-capacitance.—*Ed.*]

The circuit could be optimized for these larger inductors since it is simple enough to construct large, intermediate, and small inductor versions. Some day I'll build three "pretty" versions with optimized configurations for each inductance range. Taken to the extreme, an automated device with direct reading digital display could be constructed. Below 0.5 μH , the error may increase due to series inductance but the device is still useful. That is another problem for another day.

Now, I will endeavor to finish the project that led to this diversion. In the meantime, please let me know your results if you experiment further with this method. □□

A Simple RF Power Calibrator

This compact, self-contained, accurate RF power calibrator is easy to build and fills a long-standing Amateur Radio experimenter need.

By Bob Kopski, K3NHI

In recent years, both *QST* and *QEX* have featured several homebrew RF measurement instruments. These included two RF power meters^{1, 2} and a spectrum analyzer.³ Additionally, some enthusiasts are fortunate enough to have commercial instruments available for home use. All of these RF instruments share one common need—calibration.

RF calibration often becomes a “sticking point” for the hobbyist because this normally requires another piece of commercial gear—one that’s not always readily available. Not anymore! Here is an easily built, low-cost

¹Notes appear on page 54.

battery-operated RF calibration source that is accurate and readily meets the needs above.

The calibrator presented here is based on a standard CMOS clock oscillator. These are low in cost, easy to use and available in a wide range of crystal-controlled frequencies from many mail-order houses. This design uses one for 10 MHz (see Figs 1 and 2).

Because it is CMOS based, the output square wave is a near full-supply voltage swing into a light load: from ground to near the supply voltage of 5 V, nominal. (A TTL output clock with a less-defined swing will *not* work properly in this design.)

If a regulated voltage is supplied to the CMOS oscillator and the load is fixed, the known output signal swing remains stable and has a predictable power level associated with

it. This signal—a square wave shape notwithstanding—is the basis of this calibrator. Incidental to this is the fact that the frequency is also a known stable value; this is of some additional utility as will be seen later.

Design and Operation

Because the clock waveform is square-shaped and swings from ground upward, it has an easily measured average dc value: $\frac{1}{2} V_{\text{pk-pk}}$. This nifty detail and some arithmetic make it easy to produce an accurate calibration source. However, the nominal 5 V_{pk-pk} clock output is much too large for our purposes, so it is divided down to a smaller value. As seen in the schematic, the clock output is routed through R1 and R2 to a nominal 20 dB attenuator (pad) consisting of R4, R5 and R6 and then to the output.

The calibrator output impedance is very close to 50 Ω .

A test point located at the R2 / pad-interface allows easy measurement and adjustment of the average dc value. The low-pass components, R3 and C3, remove any concerns about the square wave affecting the reading. The voltage at this point is high enough to permit a quality measurement, but it is still too high for our end use. Thus, the pad further attenuates the signal with known accuracy and provides a good output match as well.

Adjustable resistor R2 trims the test-point signal level to a specific 158 mV dc value as measured with a standard DVM. This represents a peak-to-peak square wave of 316 mV at the pad input and 31.6 mV_{pk-pk} on a 50 Ω load following the 20 dB pad. I selected 31.6 mV_{pk-pk} as a "good" calibration level for my (QEX) power meter design and for the similar QST version too. (They have the same RF sections.) However, it's also perfectly good for other RF instruments. Here's the "how" and "why."

Both the QST and QEX instruments are based on the Analog Devices AD8307 500 MHz logarithmic amplifier IC. This device is itself *not* directly a power measuring device. Sophisticated power meters employ heat-measuring techniques to determine the applied power level. The 8307 simply provides a log-voltage output representative of the applied input voltage. These two power meters use this characteristic, apply it to an assumed sinusoidal RF voltage on a 50 Ω input impedance, and then represent that signal as a power reading. While the meters do an excel-

lent job at this, the operative word here is "sinusoidal."

Should an applied waveform not be sinusoidal, such as with a harmonic-rich signal, the displayed power will be in error. (This would not be so with heat-measuring power meters.) While working with my QEX meter, I stumbled upon the apparent fact that applied square waves having a peak-to-peak value of one-half of a sinusoid peak-to-peak waveform results in the same power reading as the latter.

Being unsure if this was a quirk or (hopefully) an operational behavior based on solid rationale, I inquired of Analog Devices Applications Engineering. I got the happy response that this behavior is solidly based on the design behavior of the AD8307. It all has to do with the way the chip measures voltage and on the crest factor of the applied waveform. In fact, AD referred me to their data sheet on a similar product, the AD640, which describes this same operational behavior in greater detail.

This is a serendipitous discovery, because it makes accurate calibration of the 8307-based power meter very easy to do. One needs only an easy-to-measure square wave and to apply the waveform relationship above. Thus, the 31.6 mV_{pk-pk} square-wave output of this calibrator has a 63.2 mV peak-to-peak sine equivalent, or $63 / 2.83 = 22.3$ mV_{RMS}, as far as the AD8307 is concerned.

The power in 50 Ω associated with the 22.3 mV_{RMS} is $(V_{RMS} \times V_{RMS} / R = 0.00995$ W, or essentially 10 mW. In dBm (which the meter displays), this is $10 \log(0.01)$ or -20 dBm. The QST /

QEX power meters can be calibrated simply by connecting this source and adjusting them to read -20 ". What if you have a power meter based on thermal measurements, which most lab instruments are?

It turns out this calibrator is just as useful, but the numbers are different. The ac RMS value ("heat value") of the 31.6 mV square wave is simply $31.6/2 = 15.8$ mV. The power on 50 Ω is $(15.8 \text{ mV} \times 15.8 \text{ mV}) / 50 = 4.992$ mW. This is -23 dBm. Thus, one could connect this calibrator to any standard lab power meter sensor and look for -23 dBm" as the proper instrument response, but there is more.

Like power meters, spectrum analyzers (SA) need a known power level reference to be most useful. Because SAs display the harmonic makeup of an applied non-sinusoid, the waveform from this calibrator produces a crisp comb display. Thus, the simple square wave is represented by its frequency component makeup, and being a symmetrical waveform only odd-order harmonics should be present. Fig 3 shows what the spectral lines of this calibrator look like up to 100 MHz.

Clearly, the dominant lines begin at 10 MHz—the fundamental frequency—and then appear in diminishing amplitude at every odd harmonic: 30, 50, 70 and 90 MHz. Smaller lines appear at the even frequencies

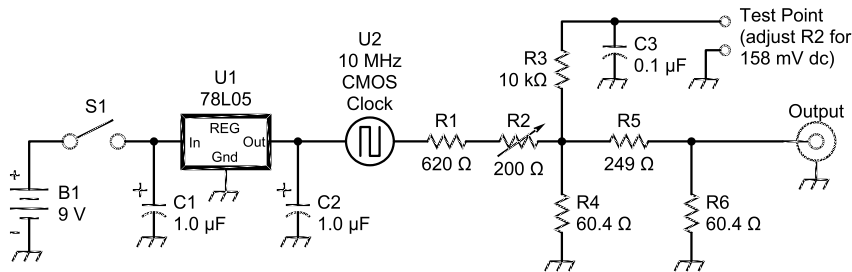

Fig 1—Schematic of the RF power calibrator. Unless otherwise specified, use $1/4$ W, 5%-tolerance carbon composition or film resistors.

C1, C2—1.0 μ F, 35 V tantalum

C3—0.1 μ F, ceramic

R1—620 Ω

R2—200 Ω trim pot, Digi Key EVM-36GA00B22 or equivalent

R3—10 k Ω

R4, R6—60.4 Ω , $1/4$ W, $\pm 1\%$ film

R5—249 Ω , $1/4$ W, $\pm 1\%$ film

U1—5 V regulator, LM78L05

U2—Oscillator, 10 MHz, CTX 045, Digi Key CTX114-ND or equivalent.

Battery, 9 V, alkaline

Battery snap-on connector, Mouser 12BC016 or equivalent

Housing, LMB, Mouser 537-M00-P or as desired.

$1/4$ -inch threaded standoffs, Mouser 534-8712 or equivalent

DPDT slide switch, Mouser 629-GF-1126-1110 or equivalent

Output connector as desired

Assorted screws, solder, tie wrap, pc board, assorted hardware, etc

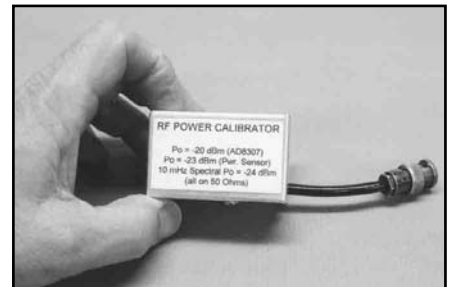

(A)



(B)

Fig 2—Compact, self-contained, accurate RF power calibrator is easy to build and fills a long-standing Amateur Radio experimenter need.

(20 MHz, 40 MHz, etc) because the waveform is not perfectly symmetrical in every respect. However, the power associated with the “evens” is clearly well below that of the “odds,” and the first (or fundamental) power is the “heaviest hitter” of all—just as it should be. Just how much power should this spectral line represent?

The sine peak-to-peak equivalent voltage associated with a given harmonic in an ideal square wave is given by:

$$V_{pk-pk} = \frac{4 \times V_{pk-pk}}{n \times \pi} \quad (\text{Eq 1})$$

where

n = the harmonic of interest

Since the 10-MHz fundamental is the “first harmonic,” its peak-to-peak sine equivalent voltage is $(4 \times 31.6) / 3.1416 = 40.2$ mV. Therefore, the RMS sine-equivalent voltage is $40.2 / 2.83 = 14.2$ mV_{RMS}. The power in 50 Ω associated with this voltage is $(14.2 \text{ mV} \times 14.2 \text{ mV}) / 50 = 4.03 \mu\text{W}$ or -24 dBm. This known value can be used to set up the scale of any spectrum analyzer, that is, to establish a “reference level” with which to compare other spectral lines on a display.

As an example, consider the line at 50 MHz in the Fig 3. What is the power associated with this harmonic? Using the same simple math, but with $n = 5$ (the fifth harmonic), we get $(4 \times 31.6) / (5 \times 3.1416) = 8.04$ mV_{pk-pk} sine equivalent. The RMS sine equivalent is 2.84 mV_{RMS}, and the associated power in 50 Ω is $0.162 \mu\text{W}$ or -37.9 dBm. The spectrum analyzer is actually displaying just about -38.1 dBm—not shabby! (I read this more accurately by expanding the vertical scale of the SA to 5 dB / div.)

As a “final test” I also looked at the ninth harmonic (90 MHz) and found it to be -45 dBm on the SA display. The calculated value is -43 dBm. I believe the discrepancy at this high harmonic value is largely due to imperfection in the waveform. Basically, the waveform rise and fall times are just not fast enough to accurately contain and represent such a high harmonic frequency, I feel. Nevertheless, even this incidental performance is quite good.

Speaking of incidental performance, that previously mentioned utility of the clock being 10 MHz allows the specific harmonics discussed above. Thus, the 10 MHz is a very convenient frequency with which to place markers and/or check-out the sweep linearity of a homebrew (or any other) SA, at least up through some reasonable frequency span.

As an aside, the homebrew spectrum

analyzer pictured is my rendering of the QST SA. It is a “stretched” version of this popular published design and tunes to a bit over 100 MHz. I also added more panel features than the original. While fully useful as is, it is still an evolving work in progress—an ongoing fun project in its own right.

Here are three design and operational notes of interest for the calibrator. First, be sure to have a 50 Ω termination on the calibrator output when adjusting R2 for the specified 158 mV DVM reading as above. This is to correctly represent how the calibrator will be used since RF instruments normally have a 50 Ω input impedance. In fact, you can trim R2 for the 158 mV dc test-point value while the calibrator is connected to such an instrument.

Second, what happens if the CMOS clock does not have a symmetrical output waveform? Based on 11 oscillators I’ve looked at, this is very unlikely. In any case, I’ve experimentally determined that asymmetry by as much as 5% only results in about a 0.5 dB error. Not to worry!

Finally, even though the output signal does have an average dc component, all RF instruments of which I’m aware have either ac-coupled inputs or inputs that are not affected by this low-level dc component—this for those who caught this subtlety!

Assembly Notes

There is not much that is assem-

bly-critical in this calibrator. As the photos show, mine is “ugly constructed.” You can download a diagram of how I placed the components from ARRLWeb.⁴ Follow this approach or another as you wish. In any case, I recommend staying with the basic pc-board “ground plane” idea as shown. This helps assure proper operation of the resistive divider and pad and maintains a quality waveform shape at the output. (Point to point wiring on perforated board would likely degrade these performance aspects.)

The pc board can be copper coated on either one or both sides. Whatever your choice, be sure to countersink away copper clearance for leads that go through the board—on both sides! I chose to drill #60 holes for the components with through-leads and then clear the unwanted copper with a finger-twisted $3/32$ -inch drill bit. Of course, any leads that get soldered to the ground plane are not countersunk. These include two pins on the clock oscillator as shown in Fig 4. Be sure to correctly orient U1 and the clock—these details are also visible in the Figs 4, 5 and 6.

My power switch—a DPDT slide switch used as a SPST—was easy to mount by simply bending the solder lugs inward along each of the two rows until they were about $1/16$ -inch apart, near the middle line. Just solder the six lugs to the copper lands as shown. Make sure the very edge of the pc-

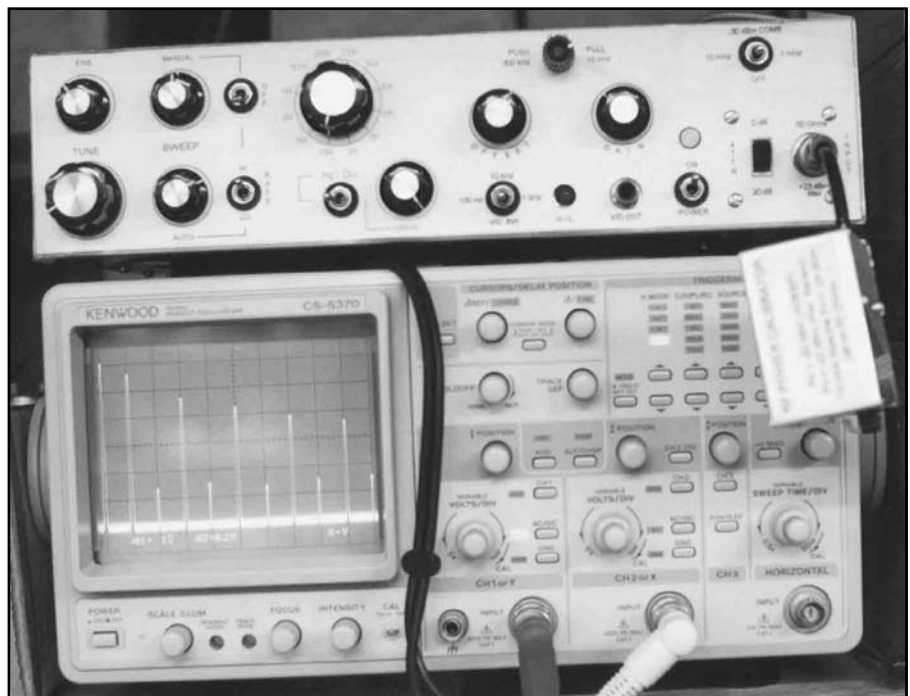

Fig 3—Spectrum-analyzer display of calibrator output. Grid spacing is 10 dB/div vertical, 10 MHz/div horizontal. Tall line at 10 MHz is -24 dBm reference. Note dominance of odd harmonics.

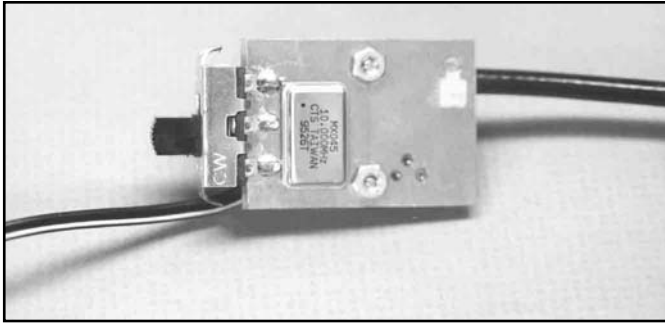

Fig 4—Backside of pc-board chassis. Notice countersunk copper clearance cuts around trimmer pot leads. The switch mounting lugs have been bent back a bit to fit the box.

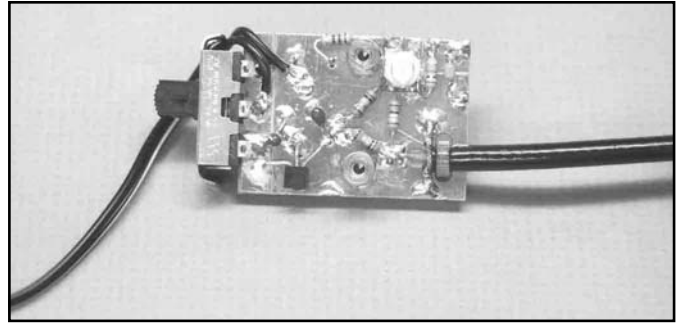

Fig 5—Component-side wiring uses “ugly construction” approach—very easy and effective for assemblies like this. Notice the output cable braid dressed and soldered to the chassis board.

board copper is chamfered back a bit, to not short the switch lugs at the switch body.

The metal enclosure shown (see Fig 6) is a convenience and not a requirement—any containment method is okay. I actually used an “open board” version of the calibrator (with an external power supply via clip leads) for two years before making the much more convenient version shown here. The BNC “pigtail” output has proven convenient for all the applications I have, but a housing-mounted connector would also work just fine.

I used two #4-40 threaded stand-offs to mount the board assembly to the housing. The 9 V battery is wrapped with a single layer of 1/8-inch-thick plastic foam and wedges nicely between the oscillator side of the board assembly and the opposite side of the box. Just make sure the housing cover screws are not long enough to “squeeze” the battery!

Summary

This easily built RF calibrator is useful with a broad range of homebrew and commercial RF instruments. Its accuracy is very good and largely dependent on the DVM used to set it up in the first place—not a very challenging task these days. As an estimate, you should expect accurate power-level representation within about 1/2 dB when applied as described herein. Just remember the calibration values obtained are -20, -23, or -24 dBm depending on the instrument under calibration. In effect, that “sticking point” mentioned in the beginning of this article has just become “well greased”! Enjoy!

Acknowledgement

My gratitude goes out to friend John Hickey, K3HZA, for evaluating the calibrator pictured herein. John

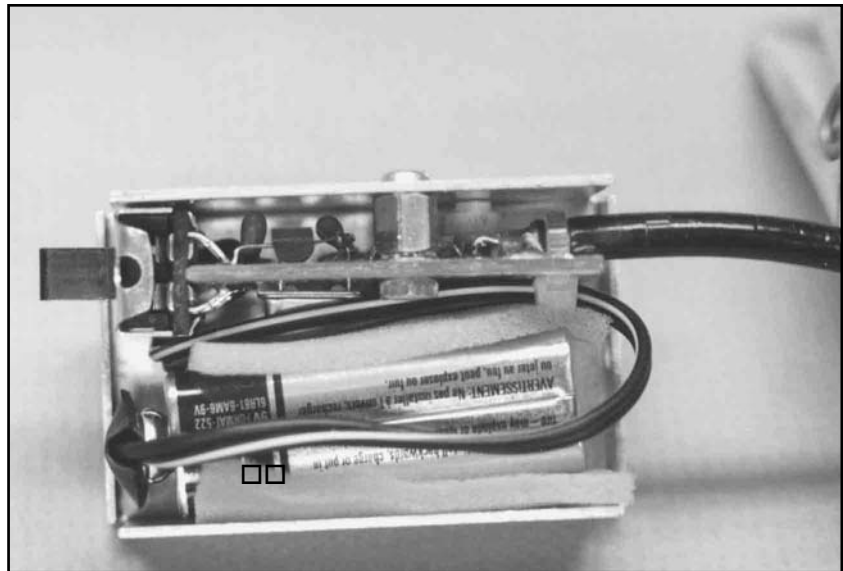

Fig 6—Inside the LMB enclosure. Shielding is not needed; the box is for compact convenience. Notice the DPDT slide-switch attachment to the pc board.

measured the performance using calibration-certified professional laboratory quality power meters and a spectrum analyzer. Two power meters read -23.3 and -23.4 dBm. The spectrum analyzer yielded -24.2 dBm.

Notes

- ¹ W. Hayward, W7ZOI, and R. Larkin, W7PUA, “Simple RF Power Measurement,” *QST*, June 2001, pp 38-43.
- ² R. Kopski, K3NHI, “An Advanced VHF Wattmeter,” *QEX*, May/June 2002, pp 3-8; and “A Simple Enhancement for the Advanced VHF Wattmeter,” *QEX*, Sep/Oct 2003, pp 50-52.
- ³ W. Hayward, W7ZOI, and T. White, K7TAU, “A Spectrum Analyzer for the Radio Amateur,” *QST*, Aug 1998, pp 35-43.
- ⁴ You can download this package from the ARRLWeb www.arrl.org/qexfiles/. Look for 0311KOPSKI.ZIP.

Bob is a recently retired Senior Design Engineer from a major defense

contractor. He holds BSEE and BSEP degrees from Lehigh University.

As a life-long electronics, ham and aeromodeling hobbyist, he routinely combines all three pursuits for the fun of it. His Technician ticket dates to about 1959 when he wanted to homebrew 6-meter radio-control equipment for RC models. He still routinely flies on 6 meters and has also operated fixed and mobile there. His broad-based aeromodeling interest dates to the early 1950s, but he has specialized in electric powered RC models for over 25 years. A Contributing Editor to *Model Aviation* magazine for over 20 years, he has a regular monthly column devoted to the electric flying specialty. Additionally, he has published many construction articles covering both model-aircraft design and aeromodeling related electronics. He enjoys it all! □□

RF

By Zack Lau, W1VT

WHY DO BALUNS BURN UP?

A common complaint about baluns is their lack of power handling capability. Hams want a broadband 3 to 30 MHz balun they can use with an antenna tuner—to load up any balanced antenna on any HF band. A balun is used to connect a balanced antenna, such as a center fed dipole, to an unbalanced coaxial feedline and tuner. It is not unusual for high-power baluns to exhibit overheating and even failure when operated at the 100 W level. I'll explain why this happens and suggest ways to prevent the destruction of radio equipment.

What is balance?

The first step to understanding baluns is to learn what is meant by "balanced." Transmission lines do not radiate in the far field if you can arrange the fields on the conductors to cancel each other. With open wire or twin lead, this is accomplished by placing currents of equal magnitude but opposite phase on the two conductors. If the magnitudes are different, complete cancellation will not occur and the line will radiate.

This also occurs with coax—if the current on the inside of the shield is

¹Notes appear on page 58.

equal to the current on the center conductor, the fields cancel. However, due to the skin effect, the inside of the shield and the outside of the shield are two separate conductors. No big surprise, the shield is just doing its job. What about a current on the outside of the shield? There is no current to cancel it, so it radiates, just like an antenna element.^{1, 2} This is why a balun is required: When open wire is connected to coax, something is needed to keep current from flowing on the outside of the shield, while maintaining equal and opposite currents on the open wire transmission line. A failure to keep current off the shield or unbalanced currents will result in unwanted transmission-line radiation.

Unbalanced currents can easily occur if the antenna is not balanced, for example if one side of a dipole is significantly longer than the other side. Nearby objects, such as other antennas or metal masts can also unbalance the currents. Unlike coax, open wire is sensitive to nearby metal objects and must be spaced away from conductors. Coax can actually be wound around metal objects with little detrimental effect—unless the winding is so tight that mechanical damage results. Coax manufacturers typically specify a minimum turn radius—for Times Microwave LMR-400 the radius is 1 inch, while 3 inches is specified for Belden 9913F7.

Now, we can see the effect of not

using a balun. Fig 1 shows a balanced antenna: a center fed dipole. Fig 2 shows how the balance is upset by feeding the dipole directly with coax. The shield of the coax unbalances the antenna, as it is connected to only one side of the dipole. Not surprisingly, the outside of the shield now forms part of the antenna. The center conductor of the coax does not balance the shield because it is hidden by the shield of the coax. Fig 3 shows how balance is maintained with a twin-lead feeder—each side of the feeder connects to one half of the dipole. Notice how symmetry is maintained. Fig 4 shows how a balun is suppose to work—the balun stops the shield current, ideally looking like an open circuit, so that symmetry is maintained.

A balun allows the connection between a two-conductor system and a three-conductor system with minimal unwanted current flow. A coaxial cable is actually a three-conductor system: center conductor, outside of the shield and the inside of the shield. Because the skin effect only allows current to flow on the surface of a highly conductive material, current can flow from the inside of the shield to the outside of the shield only at breaks in the cable. The shield forms two distinct conductive paths for RF. For direct current or very low frequency ac, the shield forms a single conductor. This difference is essential for understanding the purpose of a balun.

To simplify analysis of balun power loss, I separate the total current into common-mode and differential-mode currents. The differential-mode current is the desired current flowing through the balun; ideally, it flows with little or no loss. The common-mode current is the undesired shield current. The common-mode loss is complicated. One might assume that greater current produces more loss. This isn't always true. If the common-mode impedance is very low, much current can flow with little loss. The impedance could also be highly reactive—highly reactive impedances often do not dissipate much power. However, high current flow indicates poor balun performance, even if the balun does not burn up. The balun is not accomplishing its intended function. This is analogous to a dam that did not break, but only diverted a fraction of the water, allowing a city to be devastated by a flash flood.

The theory behind using baluns is quite sound—up to a point. The balun provides sufficiently high impedance to shield currents. The difficulty is finding a real balun that will choke the shield current to zero. Practical baluns typically don't have enough impedance to reduce the feedline current to negligible levels under all conditions. This is just like building a dam high enough to stop all floods. What typically works each year often is inadequate over many years. For example, a gauge that never measured over 2600 cubic feet/s over 20 years recorded 31,200 cubic feet/s in a flash flood.³ I'll present a model of a typical situation that can destroy baluns and present computer results to quantify the situation.

Types of Baluns

There are several different methods of implementing a balun. The simplest is just a coil of coax, formed into a parallel resonant tuned circuit. The outside of the coax shield forms an inductor, which resonates with the stray capacitance to form a tuned circuit. It works great on a single band, and may offer multiband performance in non-critical applications, such as trapped Yagi antennas. Adding a ferrite or iron powder core can increase the balun bandwidth. This generally results in a lower Q balun—the performance isn't as optimized for a single band, but "acceptable" performance over a wider bandwidth is obtained. Power is a function of the core size; a bigger core handles more power. However, a larger core requires longer wires, which generally reduces bandwidth. A higher permeability core requires less wire, but increasing permeability generally results in greater

core losses, resulting in a balun that can't handle as much power. Such a balun is usually less effective in blocking shield currents than one with a more optimized ferrite material. Effective baluns can also use the impedance transformation obtained with $\lambda/4$ transmission lines, transforming a low-impedance ground connection to a high-impedance open circuit. This technique is more common at VHF, where the dimensions become more practical.

A Balun in Distress

Fig 5 shows an 80 meter dipole fed with 70 feet of coax. The goal is to operate this antenna on 20 meters as a DX antenna. Working distant stations is much easier on 20 meters than 80 meters, even if a compromise antenna is used. A balun is placed between the antenna feedpoint and the 70-foot coax cable. The transmitter end of the coax cable is grounded. The shield is modeled as a bare 0.405-inch-diameter wire. The challenge for the balun is to provide excellent choking action, so the feedline does not act like an antenna. A 1λ vertical antenna is too high to be an effective low angle radiator; it will have undesirable high angle lobes. The task is not easy. A center fed 2λ dipole has a relatively high feedpoint impedance. Conversely, a grounded 1λ vertical presents a low impedance at the balun. The balun will need to present very high impedance to make the coaxial shield path unattractive compared to the center fed 2λ dipole.

This situation is easily modeled with Roy LeWallen's *EZNEC* and a *NEC-4* computing engine, with some small simplifications. Instead of modeling the coaxial shield at the feedpoint, I offset it by one foot. This allowed me to center feed the dipole. It is also possible to offset the feed point and put the shield at the center. The program does not want to see wire junctions and sources at the same point. I also modeled the shield as a bare 0.405-inch wire, ignoring the insulation. In practice, the insulation will slightly lower the velocity factor, making the wire appear electrically longer than its physical length. The results are shown in Table 1. Thanks to Steve, WF3T, for publishing measured balun data on the Web.⁴

The only practical balun that worked well was a 12-turn coaxial choke design. Other air-wound choke designs were ineffective at choking off the shield current. The W2DU bead balun showed significant loss—its impedance was not high enough to be effective. Walt slipped 50 type 73 ferrite beads over Teflon coax to make a

simple balun.⁵ Parallel-resonant baluns of different impedances were also modeled. At parallel resonance, the impedance is not only maximized, but it becomes purely resistive. The resistance had to be quite high for the

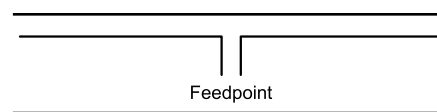

Fig 1—A balanced dipole.

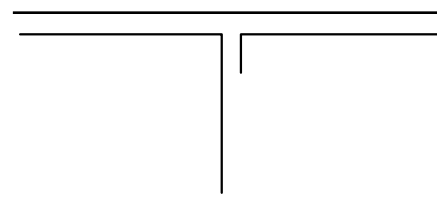

Fig 2—Coax shield unbalanced dipole.

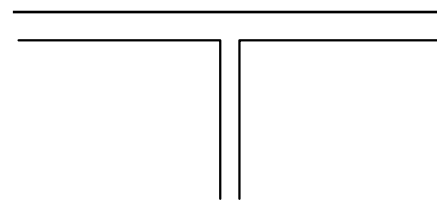

Fig 3—Balanced line keeps the antenna system balanced.

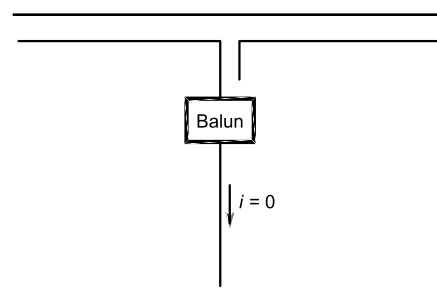

Fig 4—Balun stops the shield current.

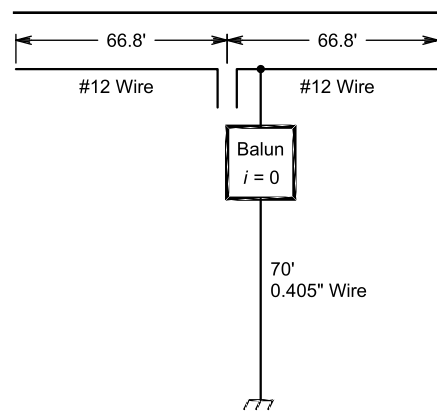

Fig 5—Model of the dual band 80/20M dipole.

balun to become effective—even a 2000 Ω resistance showed significant loss.

Is the 12-turn coaxial balun really a useful solution for the all-band center fed dipole? Not really; it only works well on a single band. The proper way to see this is to keep our reference—the 80 meter antenna operated on 20 meters, with choking impedances measured for other bands. Thus, we plug in the impedances for 40 and 10 meters, and see if the balun provides adequate performance. It is clear from Table 1 that it does not. While the balun loss is low, the current is excessive.

Why not evaluate balun performance by looking at the performance of the balun on all the different bands, and choosing the best one? The difficulty is the number of variables. Not only does the antenna feedpoint impedance change, but the effect of the feedline changes with frequency. As more variables are introduced, it becomes more difficult to figure out what is really happening. This can result in erroneous conclusions. By changing only one variable at a time, the effect of changes is much easier to track.

However, once you have a good understanding of the situation it may be practical to design more sophisticated

antennas that use elements that complement each other's strengths and weaknesses.

Dual band antennas are relatively easy to design once you understand the theory. Adding extra bands adds complexity, possibly making good solutions impossible to find.

The 80/20 meter dipole shown in Fig 5 is an example. It works well on both 80 and 20 meters. It doesn't need a balun on 80 meters—the grounded $\lambda/4$ shield presents a high impedance on 80 meters, so the current is small even without a balun. Table 2 shows the effect of using different baluns—the shield current is low in all cases. Unfortunately, it is generally not possible to use a $\lambda/4$ shield on all bands of an all-band HF antenna. The feedline length is usually fixed.

One solution may be to use the balun losses to our advantage. High loss is easily measured as a temperature rise. If we install a remote thermometer at the balun, we can easily detect high balun loss, just by measuring the absolute temperature. We know the balun is in trouble if a certain threshold is exceeded. This is like measuring the amount of oil burned by an engine that burns a lot of oil. When a certain quantity of oil has

burned, we know it is time for an oil change. This is even simpler than using an odometer reading or a clock—no knowledge of past history is required. Just like too little oil in a car can cause damage, it is a specific temperature that can damage a balun, not the temperature rise.

Table 1 also shows the effect of purely resistive baluns—a rather high resistance is required to make the shield current negligible. Purely resistive baluns are quite common. To obtain maximum bandwidth, a balun is typically operated above and below its parallel-resonant frequency. Thus, at midband, the balun is at its parallel-resonant frequency. The balun presents purely resistive impedance at this frequency. At low frequencies, the balun is inductive. At high frequencies, the balun becomes capacitive. The sign of the reactance is quite important when you cascade different baluns to improve multiband performance. The reactances can cancel, so you will not get the performance enhancement one might expect from adding additional baluns.

The poor multiband performance of an air-wound coaxial choke balun does not apply to antennas with a resistive 50 Ω feedpoint impedance, such as a well designed multiband Yagi. Consider the requirements of an RF choke used to supply phantom power to a tower mounted relay. A highly reactive impedance of just 200 Ω is often entirely adequate, while a 200 Ω resistance would soak up 20% of the power. Thus, while a choke may have much less impedance at frequencies away from resonance, it is often adequate if the feed point is well behaved. In contrast, the 80-meter dipole presents a feed-point impedance of $2834 + j1214 \Omega$ on 20 meters. The vertical feedline is a much better load than the dipole wires—no wonder it wants to radiate. Similarly, the W2DU balun is an excellent design when properly used.

Table 1
A Difficult Situation for a Balun

A high-impedance antenna and a low-impedance path to ground via the coax shield. The applied power is 1-kW at 14.0 MHz.

Balun	Shield Current		Balun Loss	
	(A)	(W)	(dB)	
1000 Ω	0.5	253	1.3	
2000 Ω	0.3	211	1.0	
4000 Ω	0.2	144	0.7	
10000 Ω	0.08	72	0.3	
20000 Ω	0.04	39	0.2	
W2DU bead balun				
1300 -j400	0.44	258	1.3	
6t RG-213				
4-1/4" dia	0.74	3	0.01	
6 + j514				
12t RG-213				
4-1/4" dia	0.14	9	0.04	
449 + j5833				
12t RG-213				
@7.00MHz				
5 + j561	0.72	2.6	0.01	
12t RG-213				
@28.00MHz	1.34	54	0.2	
30 -j482				

Table 2

The balun makes little difference with this 80M antenna. The applied power is 1kW at 3.5 MHz.

Balun (Ω)	Shield Current (A)	Balun Loss (W)	Balun Loss (dB)
50	0.02	0.022	0.0
200	0.020	0.08	0.0
2 k	0.015	0.45	0.002
5 + j561	0.022	0.0024	0.0
30 -j482	0.021	0.013	0.0
No balun	0.021	0.000	0.0

Ferrite Power Handling Capability

Thanks to the work by Jerry Sevick, there are extremely efficient balun designs using ferrite cores—there are designs that are 99.5% efficient. Thus, a 1 kW balun may lose only 5 W under the intended design conditions. Many amateurs think that any 1-kW balun ought to be suitable for 100 W under any conditions. Some actual calculations can indicate the fallacy of this thinking.

The high efficiency is obtained by carefully designing the windings to specific impedances. A high efficiency 4:1 balun will typically work well from 12.5 to 50 Ω or 50 to 200 Ω, but not both. Changing the impedances will degrade the efficiency and increase the losses, reducing the power handling of the balun. Suppose the loss is degraded to 1 dB—20.6% of the applied power is lost as heat. If 100 W is applied, 20.6 W is lost as heat. This is considerably more than what 99.5% efficient 1-kW balun loses in normal operation. It would be more reasonable to rate with the balun with 1 dB of loss at 24 W.

Conjugate matching theory could be used to roughly estimate the maximum loss of the balun—half the loss is in the balun and the other half is lost in the rest of the circuit. This would set the worst case loss at 3 dB. Thus, the efficient 1-kW balun may have a rating of just 10 W. This is *not* the absolute worst case—which occurs when the balun has to absorb all of the power. However, it may be reasonable to assume that some sort of antenna system will be provided to absorb half the power—that the user will not try to force feed a balun with no antenna attached.

The difference between best- and worst-case losses becomes less pronounced as the quality gets worse. Fortunately, elaborate measurements are not required to characterize the power handling capability of baluns for worst-case losses. We already know

the worst-case loss—we just need to calculate the power level that corresponds to that amount of loss. This is a simple equation based on power, surface area and temperature rise.⁶

$$\Delta F \left(\frac{P_{dis}}{= A} \right)^{0.833} = \quad (\text{Eq 2})$$

where

ΔT = Temperature rise (°C)

P_{dis} = Power dissipation in milliwatts

A = Surface area in cm²

The calculated power ratings are surprisingly low—about 4 W continuous duty for a big 2-inch toroid, allowing for 25°C of temperature rise. The problem is the difficulty of removing heat from the core. The thermal conductivity of cores is low compared to solid metal, such as copper windings. Since the heat is generated throughout the core, and not just at the surface, it can take a long time for the heat to be dissipated. Ceramics with good thermal conductivity are extremely rare; highly toxic Beryllium oxide is one of the few examples. At lower frequencies, it may be possible to shift the loss to the copper windings, to ease the extraction of heat. Generally, this is not practical with broadband RF circuits, where core losses are dominant. Air-core techniques eliminate the core-loss problem, at the expense of size and bandwidth.

Conclusion

Present day balun technology does not meet the expectations of most hams. A broadband 3 to 30 MHz 1-kW balun cannot be used without consideration for the stresses it must endure, even if the transmit power is just 100 W. Another decade of power reduction—to just 10 W, is necessary for a 1-kW balun to survive any likely operating condition. High balun stress is likely to

occur when high antenna feed point impedance is combined with a coaxial shield that presents low impedance at the balun. The difficulty of removing heat from ferrite materials adds to the problem. Air-core baluns can handle the power, but multiband balun performance leaves a lot to be desired. Practical solutions are to monitor the temperature of the balun for improper performance, and to only use baluns in properly designed applications. Ferrite-core baluns should not be used haphazardly at high power levels.

Notes

¹J. Taylor, W2OZH, has designed a dipole that uses the shield as half of the antenna. "A Resonant Feed-Line Dipole," *The ARRL Handbook for Radio Communications*, 2003, p 20.17; *QST*, Aug 1991, pp 24-27.

²Z. Lau, "Making Off-Center Fed Dipoles Work," *RF, QEX*, Mar 2001, pp 55-56.

³sd.water.usgs.gov/projects/1972flood/photos.html

⁴www.k1ttt.net/technote/airbalun.html

⁵W. Maxwell, W2DU, "Some Aspects of the Balun Problem," *QST*, Mar 1983, pp 38-40.

⁶Z. Lau, W1VT, "Calculating the Power Limit of Circuits with Toroids," *RF, QEX*, Mar 1995, pp 24-30. □□

A picture is worth a thousand words...

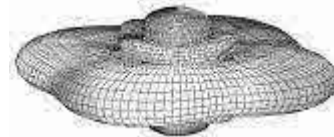

With the all-new

ANTENNA MODEL™

wire antenna analysis program for Windows you get true 3D far field patterns that are far more informative than conventional 2D patterns or wire-frame pseudo-3D patterns.

Describe the antenna to the program in an easy-to-use spreadsheet-style format, and then with one mouse-click the program shows you the antenna pattern, front/back ratio, front/rear ratio, input impedance, efficiency, SWR, and more.

An optional **Symbols** window with formula evaluation capability can do your computations for you. A **Match Wizard** designs Gamma, T, or Hairpin matches for Yagi antennas. A **Clamp Wizard** calculates the equivalent diameter of Yagi element clamps. A **Yagi Optimizer** finds Yagi dimensions that satisfy performance objectives you specify. Major antenna properties can be graphed as a function of frequency.

There is **no built-in segment limit**. Your models can be as large and complicated as your system permits.

ANTENNA MODEL is only \$85US. This includes a Web site download **and** a permanent backup copy on CD-ROM. Visit our Web site for more information about **ANTENNA MODEL**.

Teri Software
P.O. Box 277
Lincoln, TX 78948

www.antennamodel.com

e-mail sales@antennamodel.com
phone 979-542-7952

HP® GPS RECEIVER DISCIPLINE CLOCK

Limited Supply!

As seen in
QEX

Nov/Dec 2002

- Disseminating precise time and frequency (time acc. <1 mS)
- NIST traceable frequency reference, 10 MHz • Manual and *StatSAT* Software included
- 48V dc/600 mA power supply and GPS antenna available
- One-time closeout inventory from major telecom company, limited stock



\$249
(Org. list \$4,800)

Model: Z3801A®

(Refurbished—90 day warranty).



www.buylegacy.com info@buylegacy.com
760-891-0810 • 800-276-1010 • Fax 760-891-0815

HP® and Z3801A® are registered trademarks of Hewlett Packard.



Tech Notes

Avoiding Pitfalls During Measurements of High-Performance HF Receivers

by Klaus H. Eichel, DL6SES, KF200

The verification of high-performance HF receivers with respect to IP3 measurements is prone to errors that can easily be avoided by some simple precautions. High-performance is considered to be an input IP3 (third-order intercept point) of +30 dBm or more.

The test setup must deliver a two-tone signal (2×0 dBm), with IMD products at least 100 dB down, to a 50- Ω load with a SWR up to 2:1. The reason for this is that most receivers have some form of preselection that is responsible for a mediocre input SWR.

In the past, publications have emphasized the necessity of very high isolation in the combiner of the two signal-sources. Figures of up to 60 dB were given to avoid the creation of intermodulation products in the signal sources. Yet the isolation of an ideal coupler is only infinite with a load SWR of 1:1. The isolation (ideally) is only $6 + RL$ dB, where RL is the return loss of the load. Therefore, a standard coupler yields only about 16 dB of isolation for loads of 10 dB return loss (SWR about 2:1).

Step # 1 in test-setup verification is to measure the intermodulation products at the output port of the coupler. The test should be made with 50- and 25- Ω loads. Of course, a high-performance spectrum analyzer is needed for this task.

I use a spectrum analyzer, input attenuator set at 50 dB, with bandwidth set to 10 Hz. With the video filter set to 3 Hz, the instrument's noise floor is -100 dBm with an input IP3 of 62 dBm. With this setting (signals are 7.02 and 7.06 MHz), the IMD products are well below -106 dBm, even with another 50- Ω termination connected in parallel to the analyzer-input. (Note: A -106 dBm signal shows up approximately 0.1 dB over the -100-dBm noise floor of the analyzer.) The analyzer was set to 7.14 MHz; span, 50 Hz; RBW, 10 Hz. After this check, you can be sure that your source has IMD3 products more than 100 dB down—or its IP3 is above +50 dBm.

If the setup does not meet this requirement because of IMD products created in the output stages of the signal generators, we must modify our hardware. The solution is to use lin-

ear power amplifiers after each signal generator that can deliver power levels from one to several watts. These amplifiers are driven to an output level at least 10 dB below their 1-dB-compression levels. The reason for this is that a class-A final stage of such an instrumentation amplifier is much more linear and insensitive to backward IMD if its output power is kept well below saturation. Because the amplifiers can then deliver about +20 dBm (or even +30 dBm in the case of 10 W-models), we can introduce up to 16 dB of attenuation between the amplifier outputs and the combiner to get both signals down to 0 dBm each at the combiner output.

If the receiver under test exhibits again an SWR of 2:1 at the antenna input, which is equivalent to 10 dB return loss, the isolation between the amplifiers is now $6 + 10 + 16 + 16 = 48$ dB in the case of 1 W models driven to about +20 dBm each. This should be normally sufficient to achieve an IMD ratio of more than 100 dB.

A word of caution regarding harmonic distortion of the test signals. Signal-generators typically offer harmonics some 30 to 40 dB down. In the case of amplifiers under-driven by 10 dB or so, this value will not be degraded significantly. However, as the IMD products are created as $(2f_1 - f_2)$ or $(2f_2 - f_1)$, it is clear that the second harmonic plays a significant role. As modern receivers have sub-octave filters in the input circuit, the harmonics of the signal generators are sufficiently attenuated before reaching the first mixer. However, in the case of a receiver with a wide-open front end, that is, with only a 32-MHz low-pass filter preceding the first mixer, the second harmonic of the test signals should be down at least 80 dB. In this case, additional harmonic filters at each amplifier output are necessary.

Amplifier backward isolation (S12) is not really an issue. If the amplifiers have a gain of 20 dB or more (needed to amplify 0 dBm to about +20 dBm), the backward isolation or S12 is surely more than their gain to be stable. The isolation of the signal generators is at least 50-60 dB above the isolation between the amplifier outputs.

Last item: Is there a way to check a test setup without a high-performance spectrum analyzer? For larger separations of the test tones: yes, with a selective filter or a diplexer that attenuates both test signals and passes only the IMD products. Then a lower-performance analyzer or test receiver can be used, but when it comes to a separation of 20 kHz or even less, only a crystal filter can do that job. *Caution:*

Crystal filters are nonlinear too. They also have third-order intercept points, which are typically in the +45-55 dBm range; whereas the setup should have +50 dBm minimum at two tones of 0 dBm output each. So only very good and expensive filters could help.

The receiver under test is connected to the combiner output through a step attenuator. This must be a very good one, with clean, solid contacts, so that it does not create IMD at these fairly high levels—remember the rusty-bolt effect?

Key question: At what level should the measurements be done? Purists prefer a level at which the receiver-created IMD products are equal to the noise-level of the receiver. To measure this, simply connect a true-RMS voltmeter to the audio output of the receiver and increase the level of the two-tone signal until you see an increase of the output by 3 dB. The receiver, of course, must be tuned to a frequency where the IMD products are present, but this method most likely will create a measurement error.

Has the AGC been disabled? How about reciprocal mixing, or phase-noise of the signal-generators? The increase of the background noise for whatever reason should be considered because you may be setting the test signal level so that the IMD products are equal to an artificially elevated noise background.

By detuning the receiver ± 3 kHz, it must be verified that the output increases by 3 dB above the now increased noise-level which must be measured also.

Example:

Receiver: ICOM IC-765 (modified)
Mode: LSB, Bandwidth approximately 2.4 kHz (34 dB above 1 Hz)
Frequencies: 7.02 and 7.06 MHz
IMD products at 6.96 / 7.14 MHz
AF-noise-level set to -20 dBV (RMS-voltmeter URE)
Output with IMD: -13.5 dBV, background noise: -16.5 dBV.
MDS: -124 dBm measured, because of reciprocal mixing, now MDS': -120.5 dBm
IMD products also -120.5 dBm with an input of 2×-21 dBm \Rightarrow IMD = -99.5 dBc.

The input IP3 therefore is $P_{in} + 1/2 (P_{in} - MDS') = (-21 + 1/2 \times 99.5)$ dBm = +28.75 dBm. Clearly, the IMD ratio in this case is about 100 dB, which asks for the above-mentioned clean two-tone source.

A more realistic reference level is about 1 μ V, which is the typical noise received on a medium-sized antenna

on 7 MHz in Europe. For ease of measurement, I used -97 dBm, a level indicated with S2 on the meter (when AGC was enabled!).

For this, both signals were at -13 dBm, and the resulting IP3 therefore is +29 dBm = (-13 + 1/2 (-13 -97)) dBm. This is close enough to the value calculated above with the IMD products at -120.5 dBm.

In the above example with the quite good but not outstanding receiver, the method of IMD measurement down to the MDS requires a dynamic range of about 100 dB. With a really good receiver, even more than 100 dB is necessary: More than 100 dB in a 2.4 kHz bandwidth for the local oscillator and both signal sources together at an offset of 20 to 50 or more kHz. Most receivers and signal-generators don't offer that performance and that is the reason for using higher reference levels.

To Illustrate the Effect of Reciprocal Mixing, the IC-765 was Tested at 10.0 MHz

Table 1 lists the RF level needed to increase the background noise by 3 dB as a function of the offset (SSB, 2.4 kHz). The signal source was a low-noise OXCO.

Table 1

RF Needed to Increase the Background Noise by 3 dB as a Function of the Offset (SSB, 2.4 kHz)

P_{in} (dBm)	Offset (kHz)	dBc/Hz
-35	10	-123
-30	20	-128
-20	50	-138
-13	100	-145
-8	200	-150
-5	500	-153

Not accounting for the reciprocal mixing from LO phase noise or the phase noise of the signal sources can give serious errors when making IMD measurements down to the receiver noise-floor. The result often is a reduced IP3 value.

Any modern receiver without a preamplifier or other nonlinear elements in the front end except the mixer usually behaves strictly according to theory. It has a constant IP3 independent of the reference level as long as the IMD ratio is *not* worse than 50-60 dB.

Another example is the Rohde & Schwarz transceiver XK2100L, which offers a remarkable IP3 of about

+40 dBm. At 2x0 dBm, the IMD products were down by 81 dB and the IP3 = +40.5 dBm; at 2x-10 dBm, the IMD was at -100 dB for an IP3 = +40 dBm.

An IMD-measurement down to the MDS (about -125 dBm) would drive the test set to its limits with respect to the phase-noise performance of the signal generator generating the nearest signal, at only 60 kHz offset. The required phase noise then is less than -154 dBc/Hz at 60 kHz (110 dB dynamic range, 34 dB for 2.4 kHz over 1 Hz, 10 dB spare for contribution of less than 0.5 dB).

To Summarize the Precautions

- Check your two-tone source for an IMD-ratio well above 100 dB, also check for the desired output level (2x0 or -10 dBm) with a return loss of 10 dB at the load.
- Verify the effects of reciprocal mixing, other spurs and so forth to assure that the correct value of the IMD products is measured.
- Check for symmetry of the IMD products; if they are very asymmetrical, there are at least two sources of IMD.
- Verify that the IP3 stays approximately constant for at least 10 dB of input-level range. □□

ARRL 2003 Technical Awards Call for Nominations

ARRL members are encouraged to send nominations to ARRL Headquarters. Please include basic contact information for both you and the nominee. Submit support information along with a nomination letter, including endorsements of ARRL affiliated clubs and League officials. Nominations should thoroughly document the nominee's record of technical service and accomplishments. The nomination form for these awards can be found at www.arrl.org/ead/award/application.html.

ARRL Technical Service Award is to be given annually to the licensed radio amateur whose service to the amateur community and/or society at large is of the most exemplary nature within the framework of Amateur Radio technical activities. These include, but are not limited to:

- Leadership or participation in technically oriented organizational affairs at the local or national level.
- Service as an official ARRL technical volunteer.
- Service as a technical advisor to clubs sponsoring classes to obtain or upgrade amateur licenses.

The Technical Service Award winner will receive an engraved plaque. In addition, the winner may request ARRL publications of a value up to \$100.

ARRL Technical Innovation Award is granted annually to the licensed radio amateur whose accomplishments and contributions are of the most exemplary nature within the framework of technical research, development and application of new ideas and future systems. These include, but are not limited to:

- Development of higher-speed modems and improved protocols.
- Promotion of personal computers in Amateur Radio applications.
- Activities to increase efficient use of the amateur spectrum.
- Digital voice experimentation.

The Technical Innovation Award winner will receive a cash award of \$500 and an engraved plaque.

ARRL Microwave Development Award is given each year to the amateur (individual or group) who conducts research and application of new and refined uses and activity in the amateur microwave bands. This includes adaptation of new modes both in terrestrial formats and satellite techniques.

The Microwave Development Award winner will receive an engraved plaque. In addition, the winner may request ARRL publications of a value up to \$100.

Nominate Now!

Send nominations to: ARRL Technical Awards, 225 Main St, Newington, CT 06111. Nominations must be received at Headquarters by March 31, 2004. Send any questions to Headquarters or e-mail jwolgang@arrl.org.

Letters to the Editor

RF (Nov/Dec 2003)

Dear Zack and Doug,

On p 54, in the right-hand column, top paragraph: "For instance, flipping over your Yagi will also invert the phase." You can flip Mr Yagi over if you want, but it will not affect phase. The sentence should be, "For instance, flipping over *one of the* Yagis will also invert the phase."

Something is amiss with the endnotes starting with number 8. In the body of the text on p 55, the right-hand column, at the end of paragraph two: "Avery Fine, KA3NTX, published a design with a 1.7:1 SWR, not having enough time to devise a better network." End note 8 is G. Fletcher, VK2U, "Effects of Boom and Element Diameters on Yagi Element Lengths at 144, 432 and 1296 MHz," Jan 2000 *QEX*, p 16. In the body of the text, this endnote is referenced as number 9.—*Larry Joy, WN8P, 2116 E Mohawk Dr, Olathe, KS 66062-2432, ARRL LM; lawrence_joy@yahoo.com*

Hi Larry and Doug,

The original text about Avery Fine's Yagi was: "...not having enough time to devise a better network."

Yes, there does appear to be a problem with the endnotes—the text numbers got incremented by one at note 6/7, so they don't correspond correctly. G. Fletcher's call of, VK2KU appears correctly in the article. I did make a error about phrasing the topic of phasing.

Bob, KU7G, and I suspected there might be some problems—my wife's big birthday bash occurred during the same week I normally review the final page layout, so I was not around to check this article for any errors that may have occurred.—73, *Zack Lau, W1VT; w1vt@arrl.org*

The EMI Finder (Nov/Dec 2003)

Hi Doug:

I am surprised that no effort was made to allow for such a useful project to be built by others with minimal effort. This receiver would be great for many, many hams who have noise trouble, but with no support from ARRL or the author so others can share in the technology—why publish such an article? Is there any way to make PC boards and parts available?—73, *Tim Duffy, K3LR, 44 Elliot Rd, West Middlesex, PA 16159; k3lr@arrl.net*

Hi Tim,

Thanks for your note. Your question about availability of PC boards or a kit is a common one here at *QEX*. I guess the answer is that we publish the article to get folks thinking about the possibilities and leave the actual construction of such things to experimenters.

That is not to state that assistance is unavailable. Have you contacted the author? We would be surprised were he not interested in helping you. Let us know.—73, *Doug Smith, KF6DX, QEX Editor; kf6dx@arrl.org*

Doug,

On page 50, in the left-hand column, under "Receiver Circuit Description," the second sentence is "Refer to the schematic diagram in Fig 8." It should be Fig 4. On page 51, in the left-hand column, third paragraph, first sentence, "...and is adjusted by the operator with a knob (see Fig 4)." This should be Fig 5.

On page 51, in the left-hand column, third paragraph, next to last sentence, "The 3-V output of the battery is regulated down to 2.2 V by the Linear Technology LT174 low-dropout regulator." The schematic shows the regulator as an LT1761.

A comment about class letters in reference designators: IEEE Std 315, section 22.2.4, specific versus general, says, "The letters A and U (for assembly) shall not be used if more specific class letters are listed in paragraph 22.4 for a particular item." Section 22.4 lists the class letters VR, which means voltage regulator; FL for filter; Z for general network (where specific class letters do not fit, and a number of other items); AR for amplifier; Y for crystal; HT for electrical headset, BT for battery or battery cell; E for antenna (and a lot of other things).

Therefore: U1 should be FL1; U2 should be Z1; U3 should be Y1; U7 should be VR1; S1 would be U2S1 with the Audio Volume pot being U2R1. The battery would be BT1 with the battery holder (socket?) being XBT1 (on PL only). The antenna would be E1, and the headphones would be HT1.—*Larry Joy, WN8P, ARRL LM*

D-STAR, Part 3: Implementation

On page 46, in the left-hand column, under "Power to the People!", in the third paragraph, "Tom McDermott, N5EG..." Endnote 1 has Tom McCermott. On page 46, in the left-hand column, the last sentence, "Perhaps some enterprising ham can discover the way to make just as dramatic improvement in radio." It seems to me there is an "an" missing between "dra-

matic" and "improvement."—*Regards, Larry Joy, WN8P, ARRL LM*

Energy Conversion in Capacitors (Jul/Aug 2003)

Mr. Smith:

I've been following with interest the controversy that followed the publication of your article, "Energy Conversion in Capacitors" in the Jul/Aug 2003 issue of *QEX*. In that article, you found that when a charged capacitor is connected in parallel with an identical charged capacitor, half of the system's initial energy is transformed into forms of energy other than that of the electric field. The storage of energy in capacitors is discussed by Wolfgang K. H. Panofsky and Melba Phillips in their book *Classical Electricity and Magnetism* (Reading, Massachusetts: Addison-Wesley, 1962) on pages 100 and 101.

Notice that the temperature dependence of the dielectric constant of the capacitor's dielectric is never mentioned in discussions of the energy of a charged capacitor. According to Panofsky, transfers of charge to or from capacitors are tacitly assumed to occur at constant temperature. However, the energy in a capacitor is defined only as the maximum work—not work plus heat, radiation, or other forms of energy—that can be extracted from the capacitor at constant temperature. In thermodynamics, this measure of energy is called the "Helmholtz free energy" or just the "free energy." Because this measure of energy includes only mechanical or field energy—not heat or radiation—then, if any of a capacitor's electric field energy is transformed into heat during discharge, the heat energy won't appear in calculations of the capacitor's energy. This omission causes the discrepancies that you noted in the amounts of energy in the two capacitors before and after discharge.

Similar discrepancies also arise in mechanics. For example, when two objects collide inelastically, some of the mechanical energy is converted into heat or other forms of energy. But because mechanics uses free energy as its measure of energy, the heat and other forms of energy that are produced in the collision aren't included in the calculation of the system's energy.

Thus, in this case too, energy seems to mysteriously vanish from the system.

The confusion in both cases would be resolved if thermodynamics were applied to analyses of systems; but undergraduates have enough trouble learning the basics of physics without complicating their studies by requiring them to constantly consider thermodynamics as well.—73, *Chris Kirk,*

NV1E, 40 Westwood Rd, Shrewsbury, MA 01545-1830; Cwkmal@aol.com

Dear Chris Kirk,

Thank you for your observations. In the case cited, you are right that some energy goes to heat in the dielectric material of each capacitor. Further, you correctly point out that a full understanding of a seemingly simple problem involves learning advanced concepts that normally would stymie those who are just getting started.

As you may see from the Sep/Oct and Nov/Dec letters columns, readers have astutely explained the transient and steady states in quite some detail. Dick Feynman, one of my idols, insisted that such full understanding not be omitted at any level of higher education. Another area in which that happens is in explaining why and how antennas radiate. We are working with authors to bring ungarbled words to QEX—and perhaps the *Handbook*—on that.—73, Doug, KF6DX

Hi Doug,

I'm confused. Why then, doesn't a tuned circuit lose at least 50% of the stored energy every time it charges and discharges the capacitor?

For example, charge the capacitor C1 of Fig 1 just as before, but replace C2 with a high Q inductor. Close the

switch and the circuit will ring at the resonant frequency, charging and discharging C1. Circuit theory and observation tells us that energy lost per cycle is the reciprocal of the circuit Q. Q values of 100+ are easily achievable. So with a Q of 100, only 1% of the energy is lost per cycle. And the resonant circuit charges C1 to the full voltage, not just V/2. Your analysis implies that charging a capacitor from zero potential can only be at most 50% efficient.—73, Ed Milcarsky, KG4ARN, 6017 Park Ridge Dr, Pt Orange, FL 32127-7593; kg4arn@bellsouth.net

Hi Ed,

I think, in a resonant circuit, as the capacitor first reaches its intended voltage (V/2), half the energy is in the capacitor and half in the inductor. In the Nov/Dec 2003 issue, Mr. Bruene, W5OLY, has explained how to sidestep that situation for charging a capacitor to V. Other references to efficient techniques were given in the Sep/Oct 2003 issue's letters column. I hope that makes clear what really happens. Let me know if it does not.—73, Doug, KF6DX

Dear Doug,

Thanks for running my letter. The only error I noticed was in Eq 2.

$$0 \frac{V}{2} - \frac{V}{2} \cos \theta = \text{when } \theta = 0 \quad (\text{Eq 2})$$

The preceding sentence says what I intended it to be. In retrospect, it would have been clearer if I had written it:

$$0 \bullet V_{C1} \frac{V}{2} - \frac{V}{2} \cos \theta = \text{when } \theta = 0 \quad (\text{Eq 2A})$$

For consistency, Eq 1 could be changed to:

$$V_{C2} V \frac{V}{2} + \frac{V}{2} \cos \theta = \text{when } \theta = 0 \quad (\text{Eq 1})$$

I think that a serious reader could figure all that out for himself.—Warren Bruene, W5OLY, 7805 Chattington Dr, Dallas, TX 75248 □□

Next Issue in QEX/Communications Quarterly

In the Mar/Apr 2004 QEX, Al Buxton, W8NX, discusses "The Dominant-Element Principle of Loaded Dipoles." His analysis and theories may intrigue you antenna designers. You can test them for yourselves with computer simulations. □□



ARRL
225 Main Street
Newington, CT 06111-1494 USA

For one year (6 bi-monthly issues) of QEX:

In the US

- ARRL Member \$24.00
- Non-Member \$36.00

In the US by First Class mail

- ARRL Member \$37.00
- Non-Member \$49.00

Elsewhere by Surface Mail
(4-8 week delivery)

- ARRL Member \$31.00
- Non-Member \$43.00

Canada by Airmail

- ARRL Member \$40.00
- Non-Member \$52.00

Elsewhere by Airmail

- ARRL Member \$59.00
- Non-Member \$71.00

Remittance must be in US funds and checks must be drawn on a bank in the US.
Prices subject to change without notice.

QEX Subscription Order Card

QEX, the Forum for Communications Experimenters is available at the rates shown at left. Maximum term is 6 issues, and because of the uncertainty of postal rates, prices are subject to change without notice.

Subscribe toll-free with your credit card **1-888-277-5289**

- Renewal New Subscription

Name _____ Call _____

Address _____

City _____ State or Province _____ Postal Code _____

- Payment Enclosed to ARRL

Charge:



Account # _____ Good thru _____

Signature _____ Date _____

06/01

Down East Microwave Inc.

We are your #1 source for 50 MHz to 10 GHz components, kits and assemblies for all your amateur radio and satellite projects.

Transverters & down converters, linear power amplifiers, low noise preamps, loop yagi and other antennas, power dividers, coaxial components, hybrid power modules, relays, GaAsFET, PHEMT's & FET's, MMIC's, mixers, chip components, and other hard to find items for small signal and low noise applications.

We can interface our transverters with most radios.

Please call, write or see our web site

www.downeastmicrowave.com

for our catalog, detailed product descriptions and interfacing details.

Down East Microwave Inc.
954 Rt. 519
Frenchtown, NJ 08825 USA
Tel. (908) 996-3584
Fax. (908) 996-3702

ATOMIC TIME

1010 Jorie Blvd. #332
Oak Brook, IL 60523
1-800-985-8463
www.atomictime.com



WVA-104HA-1AV

Office School Clock #1
WT-3121A \$39.95
This wall clock is great for an office, school, or home. It has a professional look, along with professional reliability. Features a manual set option, daylight saving time disable option, and a safe plastic lens and case.

Casio Analog/Digital Sport
< WVA-104HA-1AV \$64.95
Casio's Analog-Digital shows you not only the time, but the date, day, and other important information. Also features stopwatch, backlight, alarm, and world time. 50m water resistant.



WT-3131A



016/7067.00

Arcron Atomic Watch
<56G24-4 \$249.99
This elegant watch features a shock-resistant titanium case with hardened mineral lens. Silver dial with arabic numerals, and high quality replaceable leather band. Watch can change to any world time zone. Case diameter 40mm. Made in Germany.

1-800-985-8463
www.atomictime.com



WS-8007U-C

LaCrosse Digital Wall Clock \$34.95
This digital wall / desk clock comes with a beautiful cherry wood frame. It shows time, date, day of week, temperature and moon phase. 12/24 format.

Tell time by the U.S. Atomic Clock - The official U.S. time that governs ship movements, radio stations, space flights, and war-planes. With small radio receivers hidden inside our timepieces, they automatically synchronize to the U.S. Atomic Clock (which measures each second of time as 9,192,631,770 vibrations of a cesium 133 atom in a vacuum) and give time which is accurate to approx. 1 second every million years. Our timepieces even account automatically for daylight saving time, leap years, and leap seconds. \$7.95 Shipping & Handling via UPS. (Rush available at additional cost) Call M-F 9-5 CST for our free catalog.

We Design And Manufacture To Meet Your Requirements

*Prototype or Production Quantities

800-522-2253

This Number May Not Save Your Life...

But it could make it a lot easier! Especially when it comes to ordering non-standard connectors.

RF/MICROWAVE CONNECTORS, CABLES AND ASSEMBLIES

- Specials our specialty. Virtually any SMA, N, TNC, HN, LC, RP, BNC, SMB, or SMC delivered in 2-4 weeks.
- Cross reference library to all major manufacturers.
- Experts in supplying "hard to get" RF connectors.
- Our adapters can satisfy virtually any combination of requirements between series.
- Extensive inventory of passive RF/Microwave components including attenuators, terminations and dividers.
- No minimum order.

NEMAL

Cable & Connectors for the Electronics Industry

NEMAL ELECTRONICS INTERNATIONAL, INC.
12240 N.E. 14TH AVENUE
NORTH MIAMI, FL 33161
TEL: 305-899-0900 • FAX: 305-895-8178
E-MAIL: INFO@NEMAL.COM
BRASIL: (011) 5535-2368

URL: WWW.NEMAL.COM

Software Defined Radio Transceiver The FlexRadio SDR-1000

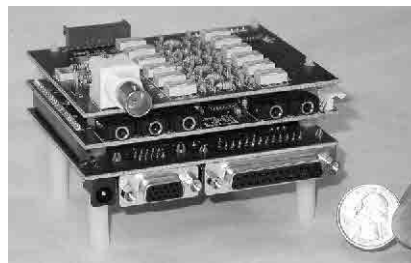

- DC-65MHz
- Multimode RX/TX
- 2W PEP TX
- PC DSP Based
- Open Source
- Assembled/Tested
- Intro Price \$499

AC50G's *QEX* article series, "A Software Defined Radio for the Masses" – describing the development of the SDR-1000 – received the ARRL's 2002 Doug DeMaw, W1FB, Technical Excellence Award.

Now you can participate in the future of Amateur Radio today. If you enjoy experimentation, you will love the SDR-1000. It's the radio that can be whatever you want it to be! It connects to the PC sound card so that all modulation, demodulation, and the user interface are defined in software under open source, GPL license. Support is available under Windows and Linux/GNURadio. Purchase the assembled three-board set and add your own PA and enclosure. A high quality sound card and >600MHz PC are required. The SDR-1000 has been chosen as the platform for future Amateur Radio high speed multimedia development by the ARRL Technology Task Force HSMM Working Group.

To order your own SDR-1000 visit
www.Flex-Radio.com
or contact
sales@Flex-Radio.com

FlexRadio Systems
Software Defined Radios



Innovative Resources for RF, Microwave and Wireless Engineering

Just Published!

The Radioman's Manual of RF Devices

by Harold Kinley

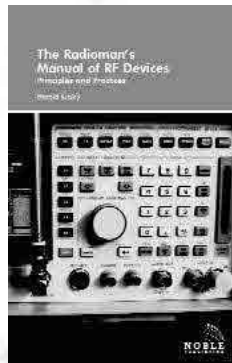

This book deals with the RF aspects of radio communication. Whether you're involved in land mobile radio, ham radio, marine radio or aviation radio--this book has something for you! How high is the voltage on the transmission line with a given load VSWR? Where is the highest voltage point located on the line? What are duplexers and how are they tuned and tested? These are just a few of the questions that are not only answered but fully explained in this manual.

See www.noblepub.com for details and a complete list of titles.

NP-64 \$94

Related Software from Noble Publishing:

<p>winSMITH 2.0 Software An electronic version of the Smith Chart One 3.5" disk plus 24-page manual (for Windows PC)</p> <p>NP-5\$79</p>	<p>winLINE Software Computes the impedance and other parameters for a wide range of transmission line geometries Two 3.5" disks plus 54-page manual (for Windows PC)</p> <p>NP-11\$99</p>
---	--



Noble Publishing Corporation
630 Pinnacle Court
Norcross, GA 30071 USA

CALL 770-449-6774
FAX 770-448-2839
E-MAIL orders@noblepub.com

New titles are being added continuously! Visit www.noblepub.com.

ARE YOU BUILDING A HIGH POWER AMPLIFIER? DO YOU WANT TO TAKE A LIGHT-WEIGHT ON A TRIP? You must check out the PS-2500A High Voltage Power Supply

- 240VAC IN/2.5KVDC @ 1.1A OUT
- WEIGHT: 10 LBS
- Size: 11 3/4 X 5 5/8 X 5 INCHES
- RF "QUIET"
- FOR BUILT-IN OR OUTBOARD USE
- NEW CONSTRUCTION OR RETROFIT
- TWO MAY BE CONNECTED IN OUTPUT SERIES AND PARALLEL FOR HIGHER V AND I



\$585 KIT/\$698 BUILT AND TESTED (POSTPAID IN CNTL US)
FOR FULL SPECS AND EASY ONLINE ORDERING, VISIT
WWW.WATTSUNLIMITED.COM

NATIONAL RF, INC.



VECTOR-FINDER
Handheld VHF direction finder. Uses any FM xcvr. Audible & LED display.
VF-142Q, 130-300 MHz \$239.95
VF-142QM, 130-500 MHz \$289.95

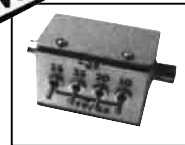

ATTENUATOR
Switchable, T-Pad Attenuator, 100 dB max - 10 dB min BNC connectors
AT-100, \$89.95

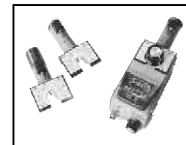

DIP METER
Find the resonant frequency of tuned circuits or resonant networks--ie antennas.
NRM-2, with 1 coil set, \$219.95
NRM-2D, with 3 coil sets (1.5-40 MHz), and Pelican case, \$299.95
Additional coils (ranges between 400 kHz and 70 MHz avail.), \$39.95 each



DIAL SCALES
The perfect finishing touch for your homebrew projects. 1/4-inch shaft couplings.
NPD-1, 3 3/4 x 2 1/4 inches 7:1 drive, \$34.95
NPD-2, 5 1/8 x 3 3/8 inches 8:1 drive, \$44.95
NPD-3, 5 1/8 x 3 3/8 inches 6:1 drive, \$49.95

S/H Extra, CA add tax

NATIONAL RF, INC
7969 ENGINEER ROAD, #102
SAN DIEGO, CA 92111

858.565.1319 FAX 858.571.5909
www.NationalRF.com

EZNEC 3.0

All New Windows Antenna Software by W7EL

EZNEC 3.0 is an all-new antenna analysis program for Windows 95/98/NT/2000. It incorporates all the features that have made **EZNEC** the standard program for antenna modeling, plus the power and convenience of a full Windows interface.

EZNEC 3.0 can analyze most types of antennas in a realistic operating environment. You describe the antenna to the program, and with the click of the mouse, **EZNEC 3.0** shows you the antenna pattern, front/back ratio, input impedance, SWR, and much more. Use **EZNEC 3.0** to analyze antenna interactions as well as any changes you want to try. **EZNEC 3.0** also includes near field analysis for FCC RF exposure analysis.

See for yourself

The **EZNEC 3.0 demo** is the complete program, with on-line manual and all features, just limited in antenna complexity. It's free, and there's no time limit. Download it from the web site below.

Prices - Web site download only: \$89. CD-ROM \$99 (+ \$3 outside U.S./Canada). VISA, MasterCard, and American Express accepted.

Roy Lewallen, W7EL Phone: 503-646-2885
P.O. Box 6658 fax: 503-671-9046
Beaverton, OR 97007 e-mail w7el@eznec.com

<http://eznec.com>



RSGB

Imported by ARRL—

PRODUCTS

from the Radio Society of Great Britain



Radio Communication Handbook

One of the most comprehensive guides to the theory and practice of Amateur Radio communication. Find the latest technical innovations and techniques, from LF (including a new chapter for LowFERS!) to the GHz bands. For professionals and students alike. 820 pages.

ARRL Order No. 5234—\$53

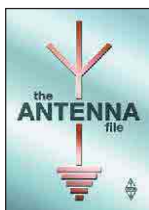

The Antenna File

The best work from the last ten years of RSGB's *RadCom* magazine. 50 HF antennas, 14 VHF/UHF/SHF, 3 on receiving, 6 articles on masts and supports, 9 on tuning and measuring, 4 on antenna construction, 5 on design and theory. Beams, wire antennas, verticals, loops, mobile whips and more. 288 pages.

ARRL Order No. 8558—\$34.95

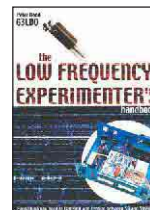

The Low Frequency Experimenter's Handbook

Invaluable reference and techniques for transmitting and receiving between 50 and 500 kHz. 112 pages.

ARRL Order No. RLFS—\$32

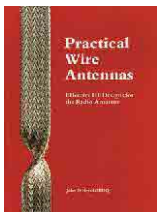

Practical Wire Antennas

The practical aspects of HF wire antennas: how the various types work, and how to buy or build one that's right for you. Marconis, Windoms, loops, dipoles and even underground antennas! The final chapter covers matching systems. 100 pages.

Order No. R878—\$17

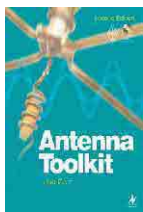

Antenna Toolkit 2

The complete solution for understanding and designing antennas. Book includes a powerful suite of antenna design software (CD-ROM requires Windows). Select antenna type and frequency for quick calculations. 256 pages.

ARRL Order No. 8547—\$43.95

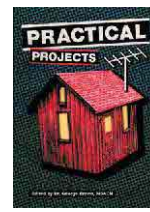

Practical Projects

Packed with 50 simple "weekend projects." A wide variety of radio and electronic ideas are covered, including an 80-m transceiver, antennas, ATUs and simple keyers.

ARRL Order No. 8971—\$24.95

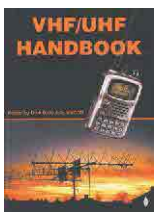

VHF/UHF Handbook

The theory and practice of VHF/UHF operating and transmission lines. Background on antennas, EMC, propagation, receivers and transmitters, and construction details for many projects. Plus, specialized modes such as data and TV. 317 pages.

ARRL Order No. 6559—\$35



HF Antennas for All Locations

Design and construction details for hundreds of antennas, including some unusual designs. Don't let a lack of real estate keep you off the air! 322 pages.

ARRL Order No. 4300—\$34.95

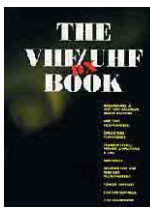

The VHF/UHF DX Book

Assemble a VHF/UHF station, and learn about VHF/UHF propagation, operating techniques, transmitters, power amplifiers and EMC. Includes designs for VHF and UHF transverters, power supplies, test equipment and much more. 448 pages.

Order No. 5668—\$35

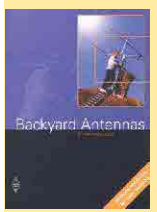

Backyard Antennas

With a variety of simple techniques, you can build high performance antennas. Create compact multi-band antennas, end-fed and center-fed antennas, rotary beams, loops, tuning units, VHF/UHF antennas, and more! 208 pages.

ARRL Order No. RBYA—\$32

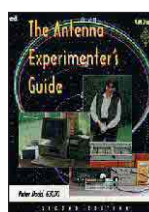

The Antenna Experimenter's Guide

Build and use simple RF equipment to measure antenna impedance, resonance and performance. General antenna construction methods, how to test theories, and using a computer to model antennas. 158 pages.

ARRL Order No. 6087—\$30

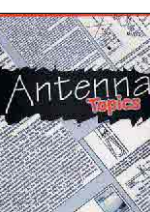

Antenna Topics

A goldmine of information and ideas! This book follows the writings of Pat Hawker, G3VA and his "Technical Topics" column, published in *Radcom*. Forty years of antenna design.

ARRL Order No. 8963—\$34.95

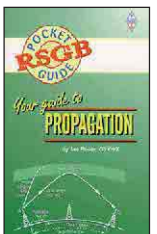

Your Guide to Propagation

This handy, easy-to-read guide takes the mystery out of radio wave propagation. It will benefit anyone who wants to understand how to get better results from their station.

ARRL Order No. 7296—\$17

Guide to EMC #7350 \$34

IOTA Directory—11th Edition #8745 \$16

NEW! Microwave Projects #9022 \$26

NEW! QRP Basics #9031 \$26

Radio & Electronics Cookbook #RREC \$28

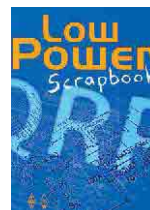

Low Power Scrapbook

Build it yourself! Low power transmitters, simple receivers, accessories, circuit and construction hints and antennas. Projects from the G-QRP Club's magazine *Sprat*. 320 pages.

ARRL Order No. LPSB—\$19.95

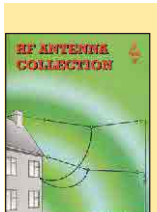

HF Antenna Collection

Articles from RSGB's *RadCom* magazine. Single- and multi-element horizontal and vertical antennas, very small transmitting and receiving antennas, feeders, tuners and more. 240 pages.

ARRL Order No. 3770—\$34.95

NEW! RSGB Prefix Guide—6th Edition #9046 \$16

Technical Compendium #RTCP \$30

Technical Topics Scrapbook

1985-1989 edition #RT85 \$18

1990-1994 edition #7423 \$25

1995-1999 edition #RT95 \$25

Order Toll-Free
1-888-277-5289
www.arrrl.org/shop

Shipping: US orders add \$5 for one item, plus \$1 for each additional item (\$10 max.). International orders add \$2.00 to US rate (\$12.00 max.). US orders shipped via UPS

"I can build it."

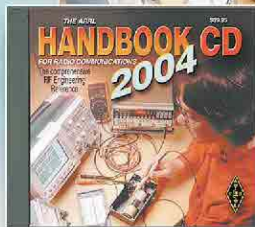
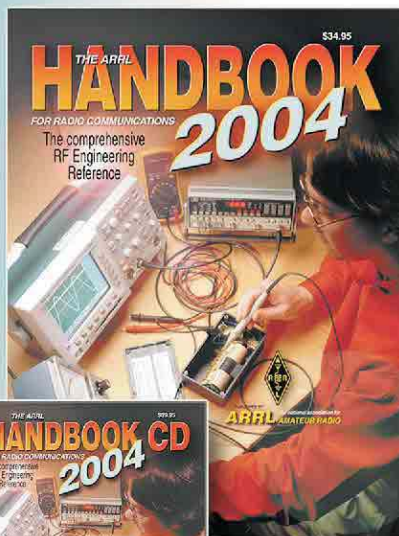

**Some supplementary software utilities included—for Windows and DOS only.

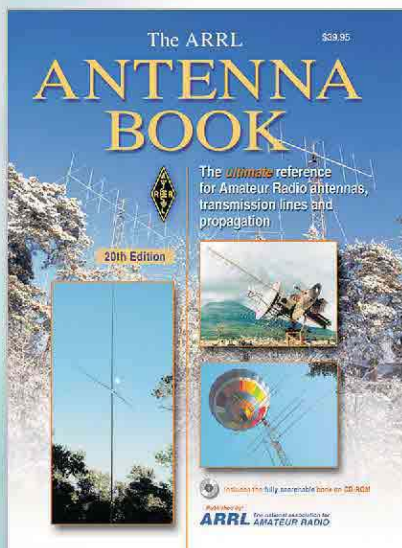

New Eighty-First Edition
The ARRL Handbook for Radio Communications—2004
The Standard in applied electronics and communications! Filled with projects, antennas, and indispensable references. Always revised. Now including a commercial-quality, high-voltage power (plate) supply, and a revised version of a high-performance, easy-to-build passive CW filter.

Softcover
 ARRL Order No. 1964 **\$34.95***
Hardcover
 ARRL Order No. 1972 **\$49.95***

The ARRL Handbook CD for Radio Communications
 Version 8.0—for Windows and Macintosh**
 View, Search and Print from the entire 2004 edition book!

CD-ROM
 ARRL Order No. 1980 **\$39.95***

New Twentieth Edition
 Hams rely on **The ARRL Antenna Book** for current antenna theory and a wealth of practical, how-to construction projects. Extensively revised, and featuring antenna designs enhanced by the latest advances in computer modeling. **Includes the fully-searchable book on CD-ROM** and additional software utilities.

Book with CD-ROM
 ARRL Order No. 9043 **\$39.95***

Try these other ARRL Publications

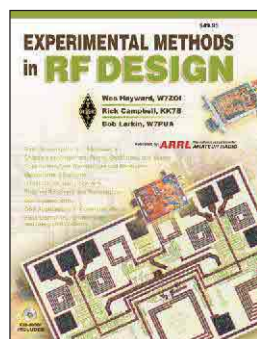

Experimental Methods in RF Design
 ARRL Order No. 8799 **\$49.95***

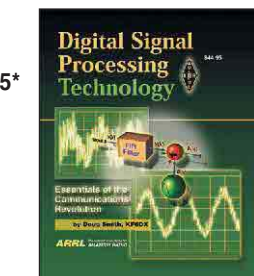
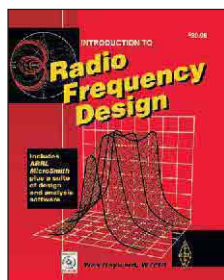

Digital Signal Processing Technology—Essentials of the Communications Revolution
 ARRL Order No. 8195 **\$44.95***

Introduction to Radio Frequency Design includes software.
 ARRL Order No. 4920 **\$39.95***

*Shipping: in the US, add the following amounts to your order (UPS). An additional \$2.00 will be added to the US rate for shipment outside the US (surface). Air delivery and other shipping services are available.

Amount of Order	Add
\$30.01 to \$40.00	\$7.00
\$40.01 to \$50.00	\$8.00
\$50.01 to \$75.00	\$9.00
Over \$75.00	\$10.00
CD-ROM only	\$5.00

Sales tax is required for orders shipped to CA, CT, VA, and Canada. Prices subject to change without notice.



ARRL The national association for **AMATEUR RADIO** 225 Main Street, Newington, CT 06111-1494 tel: 860-594-0355 fax: 860-594-0303

In the US call our toll-free number **1-888-277-5289** 8 AM-8 PM Eastern time Mon.-Fri.

www.arrl.org/shop