

QOQ

APRIL, 1950

IN THIS ISSUE

- A Midget Station for the Traffic Man
- Engineering Your Rotary Beam Antenna
- Compact 10-Meter Mobile Phone Rig
- A Beginner's 160-Meter Transmitter

35 Cents

The Radio Amateurs' Journal



for the HAM, TECHNICIAN, NOVICE and SWL

no other set gives you so much

HAM PERFORMANCE

so economically as the new... **SX-71**

\$179⁵⁰



Check These Features Before You Buy!

DOUBLE CONVERSION — images practically eliminated. First i-f 2075 kc.

SELECTIVITY — plenty of it. 11 tuned circuits, one r-f, two conversion, and 3 i-f stages. 2½ kc "nose" selectivity.

BUILT-IN NBFM — controllable from front panel. Increasingly important as more hams switch to NBFM to avoid TVI and BCI. Sensitivity approximately 1 microvolt at 28 Mc for 500 milliwatts output.

AVC — essentially flat—far surpassing comparable sets now on the market.

TEMPERATURE COMPENSATION — it's good! Ceramic coil forms—wound in Hallicrafters own coil plant. Special band switch insulation, special trimmers.

SIGNAL TO NOISE RATIO — Amazingly high, almost twice as good as the SX-28.

TUNING — Calibrated Bandsread—Parallel drive dial pointers. Logging scales on both dials.

OTHER FEATURES — 11 tubes plus Regulator and Rectifier. Range 538 kc to 35 Mc and 46-56 Mc. Crystal filter. "S" meter.

See it at your Parts Distributor
or write direct to us for a spec sheet

hallicrafters
"The Radio Man's Radio"

4401 W. FIFTH AVE., CHICAGO 24, ILL.



SUPERIOR SHIELDING

here... and elsewhere
MARKS G.E.'s GREAT GL-813



GL-813 BEAM POWER TETRODE

Filament voltage	10 v
current	5 amp
Max plate voltage	2,500 v
current	225 ma
Frequency at max ratings	30 mc

TAKE care, when you install a GL-813 as replacement for another-make tube of the same type—*neutralizing no longer may be needed!* In which case, to simplify your circuit becomes a “must”, and a welcome one.

A prime example of the tube's superior shielding, is the large ground-plane barrier. By adding to a GL-813 the customary short external base shield, you have as fine all-around protection from feedback as may be obtained. Consequently, the need to neutralize disappears in most cases.

And what a miser for drive this high-gain G-E tube is! Using only .35 w of driving power, a pair of GL-813's in Class AB₂ modulator service will deliver 650 w of audio.

Quality where quality counts, has been the creed in every detail of the tube's design, at every stage of its manufacture and testing. See the GL-813 at your nearby General Electric tube distributor! Study its many features that are *better . . . giving you better performance* in all the ham applications which the GL-813's famed versatility makes possible! *Electronics Department, General Electric Co., Schenectady 5, N. Y.*

Series 8 in a listing, by areas, of tube distributors who can supply you with Ham News, G.E.'s bi-monthly magazine:

Abilene, Tex.: R. and R. Electronics Co.
 Albuquerque, N. M.: Electric Supply Co.
 Amarillo, Tex.: R. and R. Electronics Co.
 Austin, Tex.: Hargis Co.
 Billings, Mont.: General Electric Supply Corp.
 Boise, Idaho: Craddochs Radio Supply; General Electric Supply Corp.
 Brownwood, Tex.: Central Supply Co.
 Butte, Mont.: General Electric Supply Corp.
 Corpus Christi, Tex.: Wicks DeVilbiss Co.
 Dallas, Tex.: Crabtree Wholesale Radio Co.; General Electric Supply Corp.
 El Paso, Tex.: Mr. C. C. McNichol; Reeves-Radio Supply; Triangle Electric Supply Co.
 Fargo, N. D.: Dakota Electric Supply.
 Fort Worth, Tex.: Fort Worth Radio Supply Co.; Scooter's Radio Supply.
 Houston, Tex.: General Electric Supply Corp.; Hall, Inc.; Lenert Co.
 Lubbock, Tex.: R. and R. Parts and Supply Co., Inc.
 McAlester, Okla.: Southeast Oklahoma Radio Supply.
 Oklahoma City, Okla.: Radio Supply Co., Inc.; Wolfe Distributors.
 Omaha, Neb.: General Electric Supply Corp.; Omaha Appliance Co.; Radio Equipment Co.
 Phoenix, Ariz.: Radio Specialties and Appliance Corp.
 Salt Lake City, Utah: General Electric Supply Corp.; O'Laughlin's Radio Supply Co.; Radio Supply Co.; S. R. Ross, Inc.
 San Antonio, Tex.: Modern Radio Supply, Inc.; W5HJY Radio Supply.
 Topeka, Kan.: Acme Radio Supply.
 Tucson, Ariz.: Elliott Electronics.
 Tulsa, Okla.: Radio, Inc.; S. and S. Radio Supply.
 Tyler, Tex.: Lavender Radio Supply Co., Inc.
 Waco, Tex.: Hargis Co.
 Wichita, Kan.: Interstate Distributors, Inc.

(List as of Dec. 27, 1949)

ELECTRONIC TUBES OF ALL TYPES FOR THE RADIO AMATEUR

GENERAL ELECTRIC

180-JA2

When writing to our advertisers say you saw it in CQ

Superior Performance! ASK ANY USER

Landslide of orders on first announcement of NEW BUD PRODUCTS is proof of superior performance. Here is another chance to check your needs!

BUD MINIBOXES

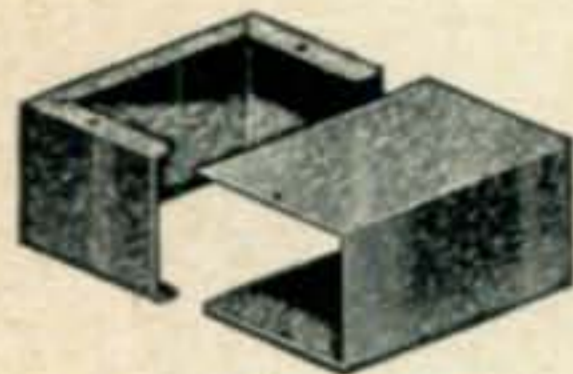

There are thousands of uses in the fields of radio and electronics for these new boxes. They are made from heavy gauge aluminum. The design of the box permits installation of more components than would be possible in the conventionally designed box of the same size. It is of two piece construction,

each half forming three sides. The flange type construction assures adequate shielding. Available in etched aluminum finish and gray hammerloid finish.

Catalog Numbers		Length	Width	Height	Dealer Cost
Gray	Etched				
CU-2100	CU-3000	2 3/4"	2 1/2"	1 5/8"	\$.50
CU-2101	CU-3001	3 1/4"	2 1/2"	1 5/8"	.50
CU-2102	CU-3002	4"	2 1/2"	1 5/8"	.50
CU-2103	CU-3003	4"	2 1/4"	2 1/4"	.70
CU-2104	CU-3004	5"	2 1/4"	2 1/4"	.72
CU-2105	CU-3005	5"	4"	3"	.72
CU-2106	CU-3006	5 1/4"	3"	2 1/8"	.72
CU-2107	CU-3007	6"	5"	4"	.81
CU-2108	CU-3008	7"	5"	3"	1.05
CU-2109	CU-3009	8"	6"	3 1/2"	1.68
CU-2110	CU-3010	10"	6"	3 1/2"	1.80
CU-2111	CU-3011	12"	7"	4"	2.34
CU-2112	CU-3012	17"	5"	4"	2.76

Prices 10% higher west of the Mississippi River



NEW SHIELDED COIL LINKS

These links are made to fit RLS, VLS, and MLS series of coils. This link will prevent capacity coupling between the tank coil and the link and would reduce TVI by greatly attenuating harmonics. The links can be used on co-ax or balanced lines.

Catalog Number	Description	Dealer Costs
AM-1300	Used with RLS coils (150 W)	\$1.53
AM-1301	Used with VLS coils (500 W)	1.89
AM-1302	Used with MLS coils (Kilowatt)	2.25



NEW ADD-A-LINK

When the circuit that you are using requires a different number of turns on the coil link than is furnished with the standard coil, the links listed below can be used to replace the standard link.

Catalog Number	Used With	Number of Turns	Dealer Cost
AM-1303	RLS	3 1/2	\$.52
AM-1304	RLS	4 1/2	.54
AM-1305	RLS	5 1/2	.63
AM-1307	VLS	3 1/2	.52
AM-1308	VLS	4 1/2	.54
AM-1309	VLS	5 1/2	.63
AM-1310	VLS	6 1/2	.72
AM-1311	MLS	3 1/2	.81
AM-1312	MLS	4 1/2	.96
AM-1313	MLS	5 1/2	1.05
AM-1314	MLS	6 1/2	1.14

BUD ALUMINUM CHASSIS



The construction and design of these chassis is exactly the same as our steel chassis. The aluminum chassis are welded on government approved spot welders that are the same as used in the welding of aluminum airplane parts. The gauges in the table below are aluminum gauges. As a result you can depend on BUD Aluminum Chassis to do a perfect job. Etched aluminum finish. NEW ADDITIONS TO THIS LINE ARE MARKED WITH AN ASTERISK.

Catalog Number	Depth	Width	Height	Gauge	Dealer Cost	Catalog Number	Depth	Width	Height	Gauge	Dealer Cost
*AC-430	4"	6"	3"	18	\$.78	AC-424	8"	12"	3"	16	\$1.38
*AC-431	4"	6"	2"	18	.78	AC-425	8"	17"	2"	16	1.52
*AC-432	4"	17"	3"	16	1.43	AC-412	8"	17"	3"	16	1.77
AC-402	5"	7"	2"	18	.69	AC-413	10"	12"	3"	16	1.44
*AC-429	5"	7"	3"	18	.81	AC-414	10"	14"	3"	16	1.92
AC-403	5"	9 1/2"	2"	18	.81	AC-415	10"	17"	2"	16	1.80
AC-421	5"	9 1/2"	3"	18	.89	AC-416	10"	17"	3"	16	2.04
AC-404	5"	10"	3"	18	.99	AC-426	11"	17"	2"	14	1.89
AC-422	5"	13"	3"	18	.98	AC-417	11"	17"	3"	14	2.40
*AC-433	6"	17"	3"	16	1.44	AC-418	12"	17"	3"	14	2.52
AC-405	7"	7"	2"	18	.81	AC-419	13"	17"	2"	14	2.25
AC-406	7"	9"	2"	18	.90	AC-420	13"	17"	3"	14	2.67
AC-407	7"	11"	2"	18	.96	AC-427	10"	17"	4"	14	2.36
AC-408	7"	12"	3"	18	1.14	AC-428	13"	17"	4"	14	3.05
AC-409	7"	13"	2"	18	1.02						
AC-411	7"	15"	3"	16	1.68						
AC-423	7"	17"	2"	16	1.43						

Prices 10% higher west of the Mississippi River



THESE ARE SOME OF THE 1274 ITEMS AVAILABLE FROM BUD RADIO, INC.

BUD RADIO, INC.



2120 E. 55th ST. • CLEVELAND 3, OHIO

When writing to our advertisers say you saw it in CQ

CQ

The Radio Amateurs' Journal

Published monthly at 10 McGovern Ave., Lancaster, Pa., by RADIO MAGAZINES, INC., Executive and Editorial offices at 342 Madison Ave., New York 17, N. Y. Telephone MUrray Hill 2-1346. Entered as Second Class Matter February 1, 1950 at the Post Office, Lancaster, Pa., under the Act of March 3, 1879.

Vol. 6

April, 1950

No. 4

EDITORIAL STAFF

EDITOR

ALBERT E. HAYES, JR., W2BYF

ASSOCIATE EDITORS

HERBERT BECKER, W6QD, DX Editor
LOUISA B. SANDO, W7OOH, YL Editor
E. M. BROWN, W2PAU, VHF-UHF Editor
RALPH ANDERSON, W3NL, Mobile Editor

CONTRIBUTING EDITORS

JACK E. WILLSON, W2AQX
ROBERT C. CHEEK, W3LOE
FRANK C. JONES, W6AJF
R. LEIGH NORTON, W6CEM

SCIENTIFIC OBSERVATIONS

O. P. FERRELL* Project Supervisor

EDITORIAL PRODUCTION MANAGER

LUCI TURNER

TECHNICAL DRAFTSMAN

FRANK Y. HAYAMI, W2TNE

BUSINESS STAFF

D. S. POTTS, President & Publisher
H. A. SCHOBBER, Vice President
S. L. CAHN, General Manager
H. N. REIZES, Advertising Manager
D. SALTMAN, Production Manager
E. E. NEWMAN, W2RPZ, Circulation Mgr.
HAROLD WEISNER, Asst. Circ. Mgr.

*Radio Amateur Scientific Observations—212 S. Broad St., Philadelphia 7, Pa.

Branch Office: Los Angeles—J. C. Galloway, 816 W. 5th St., Los Angeles 17, Calif. MUtual 8335. Midwest Representative—S. R. Cowan, 342 Madison Ave., New York 17, N. Y., MU. 7-6375.

Subscription Rates: in U.S.A., U.S. Possessions, Canada and Pan American Union—1 year \$3.00, 2 years \$5.00. Elsewhere \$4.00 per year. Single copies 35 cents. (Title Reg. U. S. Pat. Off.) Printed in U.S.A. Copyright 1950 by Radio Magazines, Inc.

Foreign Subscription Representatives: Radio Society of Great Britain, New Ruskin House, Little Russel St., London, WC 1, England. Technical Book & Magazine Co., 297 Swanston St., Melbourne C1, Victoria, Australia.

In This Issue

OUR COVER—The new 807W sits for its first formal portrait, behaving itself nicely. Although this bottle won't be ready for general distribution until late summer or early fall, we present a preview of it on page 26.

Scratchi	4
Letters	6
Zero Bias (<i>Editorial</i>)	9
Building a Rotary Beam <i>William I. Orr, W6SAI</i>	11
The Traffic Midget <i>William E. Johnson, W8VOK</i>	15
The Ham and Public Relations <i>Michiana Amateur Radio Club</i>	17
Economical 10-Meter Mobile Transmitter <i>Wayne W. Cooper, W8EWC</i>	18
Beginner's 160-Meter Transmitter <i>Clinton Clark, W1KLS</i>	20
A Senior-Grade 807 Transmitter <i>Edwin W. Hill, W4PQA</i>	22
The 6-Meter Observing Project	25
Stabilized Low-Power Tetrode <i>Albert E. Hayes, Jr., W2BYF</i>	26
New Products	27
Extending the Range of the Grid-Dipper <i>Wilfred M. Scherer, W2AEF</i>	28
Postscripts	29
Don't Tell My Wife <i>William A. Wildenhein, W8YFB</i>	30
The M.A.R.S. Page	31
V.H.F.—U.H.F.	32
DX and Overseas News	34
WAZ Honor Roll	35
The Monitoring Post	36
Inside the Shack & Workshop	38
The YL's Frequency	40
Advertising Index	71

Designed for



Application

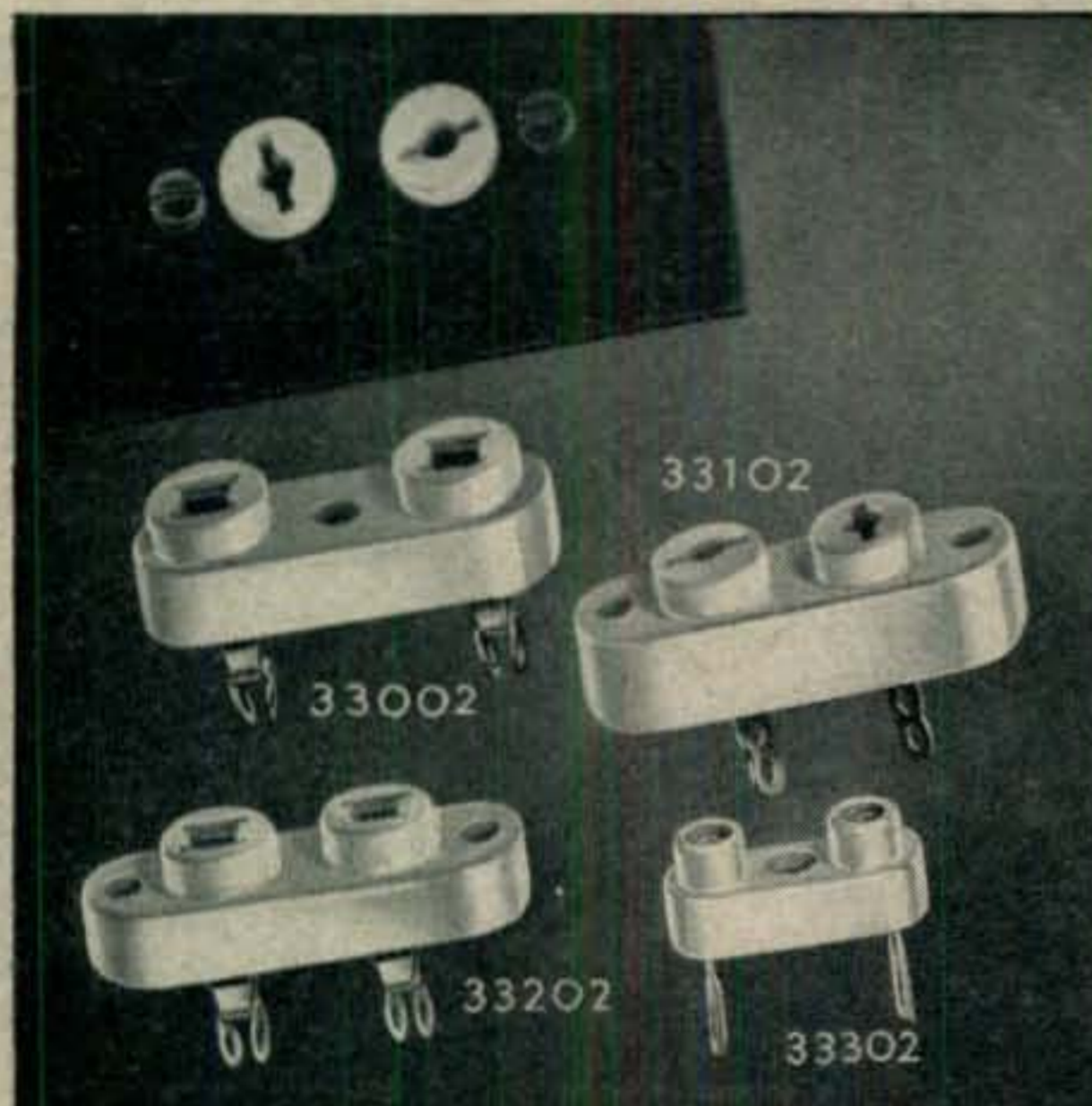

**Crystal Holder Sockets
33002, 33102, and 33202
Plus new 33302 for CR7**

In addition to the original 33002, 33102 and 33202 exclusive Millen "Designed for Application" steatite crystal holder sockets, there is now also available the new 33302 for the new CR7 holder. Essential data:

Type	Pin. Dia.	Pin Spacing
33002.....	.125	.750
33102.....	.095	.500
33202.....	.125	.500
33302.....	.050	.500

**JAMES MILLEN
MFG. CO., INC.**

MAIN OFFICE AND FACTORY
MALDEN
MASSACHUSETTS



Feenix, Ariz.

Deer Hon. Ed:

I am knowing that you are well-known authority on emergency communications and net operation on see-w so Scratchi are post-hasting to tell you about most bemusing experience which are occurring to him recently.

The past few weeks there is much to do about all the local hams not being ready if some emergency is happening, like having big flood here on desert, or having all power fail because Boulder Dam is springing leak, or some such thing. This is striking home and hurting Scratchi's civic pride, so I decided to join bunch of fellows forming emergency club.

For first cupple of weeks we are meeting practically every other night, talking over plans for emergency operation, deciding on what frequencies to use, and even having hams from other states come over to give us lowdown on best ways to do things. Finally we reach the point where we decide to operate on eighty meter see-w and get into regular net operation.

Unfortunately my rig just happen not to be working on acct. having bad case of toobs with holes in plates, so Scratchi are unable to participate in first drill. Howsomever I are listening on the band when net control comes on and asks members to report in. One fellow are swinging VFO down on net control frequency and calling in reel snappy like, but no one else is coming on. Net control again coming on and asking where everyone are, but still no one on the air.

This are going on for a little while, and still nobody even calling in. In fact, it is so quiet on the net frequency that I are heering some VK calling CQ DX. Just then telephone is ringing and it turns out to be net control, asking me why I'm not on the air. I tell him my rig not working, but I are there in spirit because I am monitoring the frequency. Net control ask me to please tune over the band to see what happening.

Gracious to goodness saki, when tuning receiver, are finding almost everybody are on for drill. Only, getting this Hon. Ed., they are all over the band. Stations are spread out twenty kilocycles on either side of net frequency. I quick-like get net control on landline and tell him this, so he comes on air and tells everybody to QNZ to his frequency. This is causing mad noises on band as signals are shifting around, but when it are all over, signals are still not even close to net frequency.

Net control is now being able to hear other stations, on acct. he know that they not exactly on net frequency, but I can see by his nervous fist that he are mad about something.

We are having meeting of emergency club next night, and net control are reely mad. He saying that any bunch of hams that can't even get their frequency within twenty kilocycles of the right frequency not even deserving to own VFO, and

(Continued on page 72)

"Thanks for the dope on the new Sylvania 807W"

—says Joe Furrier, W1PZ



Mr. Furrier is another radio amateur who likes the convenience of dropping in at his local Sylvania distributor for friendly advice . . . as well as for those top quality Sylvania transmitting tubes.

The Sylvania line now consists of 28 different types of transmitting tubes . . . especially engineered for amateur and small commercial stations. Soon to augment this outstanding line is the new ruggedized Type 807W, a smaller, vibration and shock-tested version of one of the most popular ham tubes.

All Sylvania transmitting tubes are listed, rated, and fully described in a new transmitting tube catalog, now awaiting you at your nearest Sylvania distributor (one of 340 throughout the country).

Call or write your Sylvania distributor for free copy now, or mail the coupon *today!*

Mail this
coupon for your
free Sylvania Trans-
mitting Tube Catalog
today!



Sylvania Electric Products Inc.
Advertising Dept. L-2704
Emporium, Pa.

Please send me your new free Trans-
mitting Tube Catalog, and list of Sylvania
distributors.

Name _____

Address _____

City _____ Zone _____

State _____

SYLVANIA ELECTRIC

RADIO TUBES; CATHODE RAY TUBES; ELECTRONIC DEVICES; FLUORESCENT LAMPS, FIXTURES, WIRING DEVICES, SIGN TUBING; LIGHT BULBS; PHOTOLAMPS

Only

SPRAGUE

Makes

HYPASS[®] CAPACITORS

for TVI



This exclusive Sprague capacitor design is curing TVI problems all over the country. Unlike ordinary capacitors, it is an effective v-h-f filter and bypass unit... ideal for eliminating harmonics in transmitter circuits and for filtering interference on a-c mains and on control circuits. Developed in cooperation with ARRL HQ. See QST for Feb. and Oct. 1949 and CQ for Sept. 1949 for details on how these capacitors solve tough amateur TV interference problems.

Write for bulletin 432 or see your Sprague jobber today.

Catalog Number	Mfd.	Working Voltage	Size Diam. - Length	List Price
48P9*†	.1	250 a-c	11/16 x 1 13/16	\$2.60
46P8	.005	600 d-c	1/4 x 1 5/8	2.15
47P6	.01	600 d-c	7/16 x 1 1/4	2.35
47P12†	.005	1000 d-c	7/16 x 1 1/4	2.40
47P13†	.01	1000 d-c	7/16 x 1 1/2	2.60
47P14†	.005	2500 d-c	1 x 1 9/16	2.90
47P15†	.01	2500 d-c	1 x 1 9/16	3.10
47P16†	.002	5000 d-c	1 x 1 9/16	3.20

*Recommended for power lines, filaments, and control circuits up to 20 amps line current. Often more effective than a choke-capacitor filter. Has female screw terminals.

†Circulating current to ground at 14 and 28 mc should not exceed 2 amps for 47P15 and 47P16, 3 amps for 47P13 and 47P14, 4 amps for 47P12.

SPRAGUE PRODUCTS COMPANY

85 Marshall Street

NORTH ADAMS

MASSACHUSETTS

★ ★ Letters ★ ★

More on BC-610 TVI

614 Woodland Ave., Avon-by-the Sea, N. J.

Editor, CQ:

Read a letter in your correspondence column from W9IHM begging for assistance and relief of TVI on the BC-610. This transmitter is the worst harmonic generator in existence. Even on 3.5 mc the harmonics wipe out every TV channel. I have licked the TVI problem on the BC-610 and will forward the dope to anyone who will write to me and enclose a self-addressed stamped envelope.

Karl A. Woehrer, W2CTI

2625 Adams Ave., Baton Rouge, La.

Editor, CQ:

In answer to the letter in your January issue relative to curing TVI in a BC-610—Mr. Guetter should contact W5DHE here for his sure-fire cure. Since he started working a 3 to 11 P.M. shift at a local industrial plant he hasn't received a single complaint from local TV fans.

Everett E. Magee

Amateur Radioteletype

38-06 Sixty-first St., Woodside, N. Y.

Editor, CQ:

It will be a long time before you can smooth my ruffled pride! We got a big kick out of CQ's reporting of the election return and Turkey Run doings, but where did you get that information about the Bell System teletype between W2TYU and WNYC?

We used W2PCD's printer equipment on the WNYC-W2NJK-W2QGH circuit and two of mine on the W2TYU-WNYC link, with yours truly pounding the keyboard in Studio "A", under the eye of two WNBT television cameras. Altogether there were five complete amateur teletype systems at work.

The fact of the matter is that the wire services furnished only one message that was used during the entire evening. The hams upstate should be proud to know that their stuff came through so promptly that the four wire-service printers alongside our two merely supplied the wastebasket, as their material had been posted on the bulletin board by us about an hour earlier. Forget those Bell System teletypes, they did not exist!

John E. Williams, W2BFD

Help Wanted

104 Herman St., Buffalo 12, N. Y.

Editor, CQ:

I would appreciate hearing from any of CQ's readers who might be able to supply me with information on the use of the old RCA IP501A receiver with its low-frequency loading coil. The receiver works fine on the higher ranges, but I can't get a squeak out of it when I connect the loading unit.

R. G. Summers

Docket 9295

WATERTOWN, NEW YORK

EDITOR, CQ:

THIS IS TO CALL YOUR ATTENTION TO A GLARING ERROR OF OMISSION IN PROPOSED RULE 12 SECTION 12.0 BASIS AND PURPOSE SUB SECTION QUOTE (F) PROVISION OF GENEROUS SEGMENTS OF THE COMMUNICATION SPECTRUM TO A SERVICE WHICH MAY GRACEFULLY VACATE IMMEDIATELY UPON DEMAND IN CASES OF INTERNATIONAL EMERGENCY UNQUOTE. WE MUST ADMIT THIS OR ELSE DENY THE LAST TWO WORLD WARS AND THE PRESENT ATLANTIC PACT.

GEORGE BONADIO, W2WLR

When writing to our advertisers say you saw it in CQ

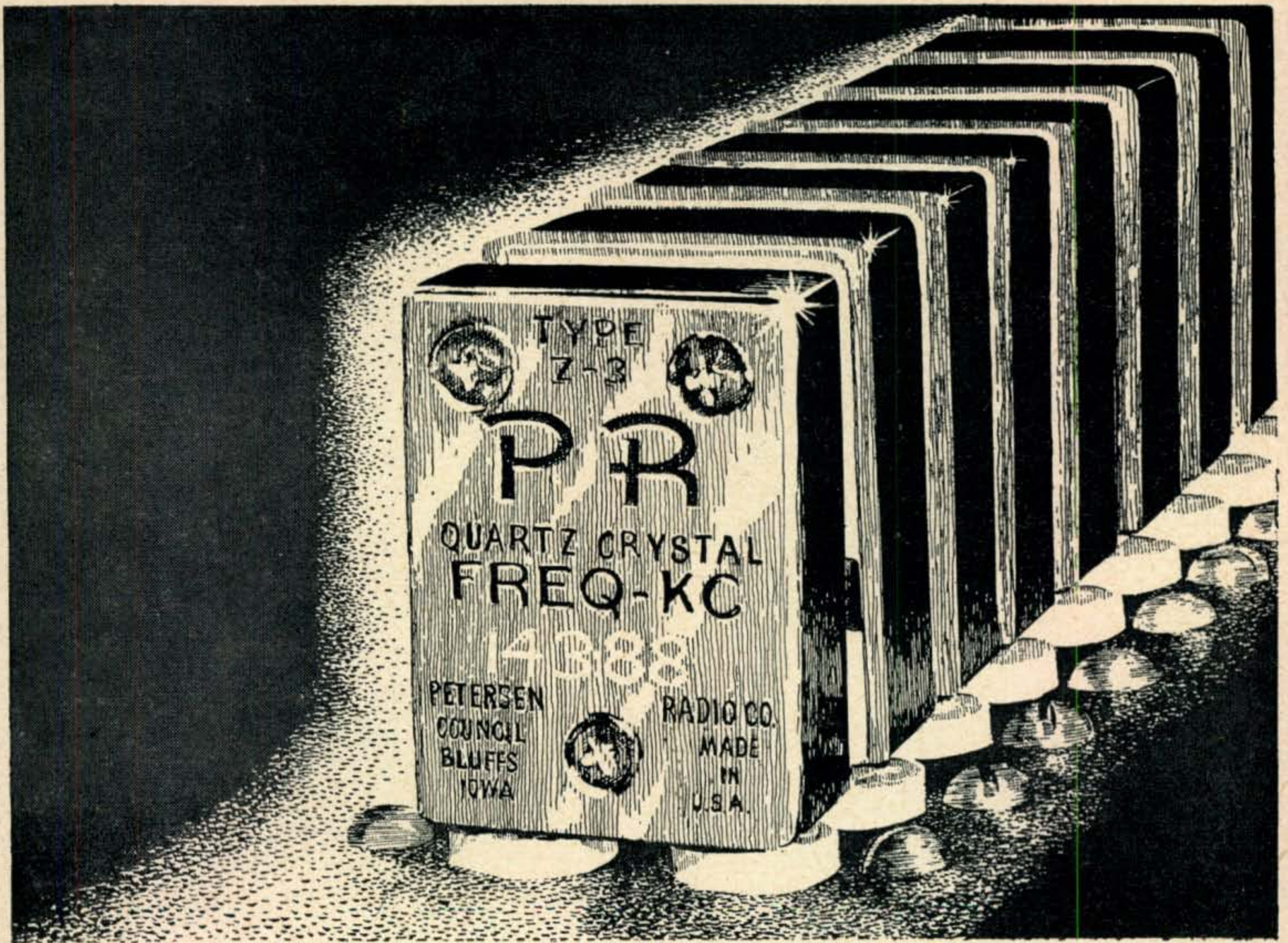

LESS PANEL SPACE WITH ... PR's

If you are one of those (and who isn't) that like to move around the band... stick a whole handful of PRs in your rig. They're small... occupy 25 per cent less panel space than ordinary crystals. You can put a dozen PRs in amazing little space. That's why more and more hams the world around are saying: "I'm crystal controlled but NOT rock bound!"

• 20 METERS, Type Z-3, \$3.75 • 40, 80 & 160 METERS, Type Z-2, \$2.75

PR

Crystals



Since 1934

USE **PR** AND KNOW WHERE YOU ARE

PETERSEN RADIO COMPANY, INC.
2800 W. BROADWAY • COUNCIL BLUFFS, IOWA

When writing to our advertisers say you saw it in CQ

Follow the Leaders to

Eimac
TUBES
The Power for R-F

ABRACADABRA



No, we don't pull them out of a hat. Nor is there any magic about the Eimac 4-125A tetrode. To make one you need only the tried and proven Eimac design, first-rate materials, painstaking workmanship, plenty of know-how, and Eimac processing.

But some of the tricks you can do with this versatile tube may seem like magic if you haven't yet had the experience of putting one through its paces. From audio frequencies to UHF, the Eimac 4-125A offers real advantages over old-fashioned tubes.

Your dealer will be glad to show you this tube that has revolutionized transmitter design. After you cradle one of these beauties in your hand, you'll find it hard to leave without taking it along. If you like to look twice before you leap, write the Eimac Field Engineering Department for free complete characteristics and operational data on the 4-125A.

GENERAL CHARACTERISTICS

ELECTRICAL

Filament: Thoriated tungsten	
Voltage - - - - -	5.0 volts
Current - - - - -	6.5 amperes
Grid-Screen Amplification Factor (Average) - - - - -	6.2
Direct Interelectrode Capacitances (Average)	
Grid-Plate (without shielding, base grounded)	0.05 μ fd.
Input - - - - -	10.8 μ fd.
Output - - - - -	3.1 μ fd.
Transconductance ($i_b = 50$ ma., $E_b = 2500$ v., $E_{c2} = 400$ v.) - - - - -	2450 μ mhos

RADIO FREQUENCY POWER

AMPLIFIER AND OSCILLATOR
Class-C Telegraphy or FM Telephony
(Key-down conditions 1 tube)

MAXIMUM RATINGS

D-C Plate Voltage -	3000 Max. Volts
D-C Screen Voltage -	400 Max. Volts
D-C Grid Voltage -	-500 Max. Volts
D-C Plate Current -	225 Max. Ma.
Plate Dissipation -	125 Max. Watts
Screen Dissipation -	20 Max. Watts
Grid Dissipation -	5 Max. Watts

248

E I T E L - M c C U L L O U G H , I N C .
S a n B r u n o , C a l i f o r n i a

Export Agents: Frazar & Hansen, 301 Clay Street, San Francisco, California

When writing to our advertisers say you saw it in CQ

ZERO BIAS

E D I T O R I A L

Contributing Editor Bob Cheek, W3LOE, recipient of Eta Kappa Nu's award as "Outstanding Young Electrical Engineer of the Year," delivered a talk entitled "Amateur Radio—A Public Service" on the occasion of his acceptance of the award at the Henry Hudson Hotel, in New York City, on January 30th. We consider it a masterful expression of the aims and purposes of amateur radio, phrased in a manner suited to the non-amateur audience at the presentation banquet. We take pleasure in printing it here in the hope that amateur organizations throughout this country will take advantage of its excellent phraseology to further public relations. As an expression of a prominent engineer's feeling toward his hobby, and as a statement by a CQ staff member of CQ's position, we commend it to your attention.—A.E.H.

This is a welcome opportunity for me to "lobby for my hobby," as they used to say on that radio program. It was through amateur radio that I first became interested in electrical engineering, and it was the experience I gained as an amateur operator that made it possible for me to work as a commercial operator at sea and at broadcast stations to finance my education.

Many people picture radio amateurs as a bunch of youngsters who tinker around endlessly with home-made transmitting and receiving equipment, chattering continually at each other about practically nothing at all and generally using valuable space in the short-wave spectrum for no apparently useful purpose.

However, the members of the amateur radio fraternity are not all youngsters by any means, as is evidenced by the fact that the average age of the approximately 80,000 amateurs in this country is 35 years. Furthermore, since radio stations of all kinds are licensed by the Federal Communications Commission only "in the public interest, convenience and necessity," these radio amateurs must serve at least a few useful purposes in our scheme of things.

These useful purposes have nowhere been better summarized than by the F.C.C. itself in the preamble to its recently proposed revision of the amateur regulations. I quote directly from these regulations:

"Basis and Purpose.—These rules and regulations are designed to provide an Amateur Radio Service having a fundamental purpose as expressed by the following principles:

"(a) Recognition and enhancement of the value of the amateur service to the public as a voluntary non-commercial communication service, particularly with respect to providing emergency communications.

"(b) Continuation and extension of the amateur's proven ability to contribute to the advancement of the radio art.

"(c) Encouragement and improvement of the amateur radio service through rules which provide for advancing skills in both the communication and technical phases of the art.

"(d) Expansion of the existing reservoir within the amateur radio service of trained operators, technicians, and electronics experts.

"(e) Continuation and extension of the amateur's unique ability to enhance international good will."

Most of you who have attended national or regional fairs or expositions will recall having seen booths where amateur radio stations were set up, with placards about, inviting you to send radiograms free to the folks back home. But these are the exceptional examples of the activity of an important group of amateurs whose major satisfaction in their hobby is that of providing, day in and day out, an entirely voluntary and self-financed communications service to the public. This is a highly organized group, as evidenced by the fact that they have established fourteen permanent east-west and north-south trunk lines with stations at key points along these routes from one end of the country to the other, a few extending even into Japan, Germany, Alaska, and other U.S. possessions and occupied territories. These stations in turn operate with numerous sectional and local networks to provide speedy and efficient handling and delivery of message traffic. They have route managers, section communications managers, and net control stations, whose authority in matters within their defined jurisdiction is undisputed.

Do not assume that the messages handled by these amateurs are all of a personal and relatively unimportant nature. They can handle any type of message, regardless of its importance or its commercial implications provided only that they receive no pecuniary reward for their efforts—and none of them expects or would accept any reward other than the sheer satisfaction that he gets out of being part of a smoothly functioning and efficient operating team.

Closely allied with the day-by-day message handlers is another group within the amateur service, a group which is equally highly organized. This is the Amateur Emergency Corps. Regardless of what section of the country that any of you in the audience tonight may be from, there is a group of public-spirited amateurs in your vicinity who have pledged themselves to maintain radio equipment that will be usable in case of emergencies or disasters which interrupt normal communications and regular sources of power. These same operators, along with others who have volunteered to provide supplementary service in case of emergency, have worked out in conjunction with your local relief organizations, such as the Red Cross, with the utilities, and with the state, municipal, and military authorities, a thorough and detailed program for the provision of communications service at times of local disaster. This program is tested and revised

as necessary by periodic simulated emergency drills. These groups are organized and headed up in each community by an emergency coordinator, who reports to a section emergency coordinator, of whom there are 72 in the U.S.A. and Canada, all serving voluntarily and without remuneration. These, in turn, report to a national emergency coordinator whose full-time job is the administering of this service and whose salary is paid by an amateur organization.

The records of the disasters, big and small, that have struck within our country since amateur radio came into existence are replete with accounts of the unselfish service and in some cases of the actual heroism of individual amateurs, as well as of these organized emergency groups. To mention only a few of the most recent cases of service in major emergencies, I might cite the Texas-Oklahoma tornadoes and the Texas City explosions, which occurred almost simultaneously in the Spring of 1947. In the latter case, amateur portable and mobile communications equipment had been moved into Texas City from nearby Houston and was operating within three hours after the initial series of blasts. Several of these groups remained in Texas City continuously thereafter, disregarding all warnings to evacuate, and handled hundreds of messages for the Red Cross, police, and others. All were badly shaken up in the subsequent explosions, and the members of one group which was operating within 100 feet of a ship that exploded received more serious injuries, although all fortunately survived.

There is not time to go into the extensive story of the service rendered by amateurs during and immediately subsequent to the destructive Florida-Gulf Coast Hurricane of 1947. However, it is significant to note that the Florida Legislature, in recognition of the efforts of the state's amateur operators in this and many other such emergencies, recently passed a bill which provides all Florida amateurs with automobile license plates bearing their amateur call letters instead of the usual numbers.

The F.C.C. has mentioned the ability of radio amateurs to contribute to the technical advancement of the art. It is a well-known fact, of course, that the utility of the wavelengths below 200 meters, to which they were relegated after the First World War, was first demonstrated by the amateurs. Less well known is the fact that the crystal filter, universally used in all military and commercial communications receivers today, was developed by an amateur in an amateur laboratory, and that the Class B modulator, used in nearly all high-powered broadcast transmitters, was adopted and developed by amateurs long before it was used commercially.

In view of the state of complexity to which the radio art has now progressed, however, one may well wonder how lone experimenters, working on limited time in their own homes and within the limits of their personal financial resources, can possibly contribute anything further to the technical advancement of radio. But do not discount the amateurs too quickly. Consider the fact that there are more amateur radio stations in this country than all other types of stations combined, and more amateur operators than all grades of commercial operators combined. Consider, too, the fact that these amateurs are dispersed throughout every part of the country. The Government, recently becoming vitally interested in correlating and confirming the theories of sporadic propagation effects at the very high frequencies, found itself in need of an army

of trained observers, in numbers that even it could not provide, to monitor the very-high-frequency spectrum regularly and to submit regular and systematic reports on all unusual propagation effects. All that was required for the amateurs to fill this need was an appeal in the Radio Amateur's Journal, stating the problem and telling where to write for reporting forms. Even as I speak to you at this moment, there are hundreds of amateurs transmitting on these very high frequencies, and other hundreds listening; and anything unusual that is occurring, especially any unusually long-distance reception, is being duly noted in systematic form. These reports will be sent to a central point, which will analyze and correlate the observations and transmit them to government laboratories.

It is expected that these observations will contribute materially to our general knowledge of very high frequency propagation and the weather conditions that influence it, with direct effects upon developments in the fields of dynamic meteorology, rocket aeronautics, and others. And to get a little closer to our own particular interests, who can deny that the work of these self-financed and unselfish workers will play a part in accelerating the lifting of the present "freeze" on television allocations, which originally came about because of unexpected propagation effects in the very-high-frequency television bands, and which has remained in effect for so long pending studies of these phenomena.

Our government, especially the Army and the Navy, recognizes the value of the amateurs as a reservoir of trained operators and technicians, able to step in at a moment's notice to serve their country in these capacities at times of national emergency. It has been estimated that 25,000 licensed amateurs served in the armed forces during World War II, most of them in the Signal Corps, as operators, instructors, and radar and communications technicians. Other thousands served as civilians in the War Emergency Radio Service, which was organized by the Office of Civilian Defense.

Today thousands of amateurs are enrolled in the Military Amateur Radio Service and in Naval Reserve Communication Networks and participate in regular drills on military frequencies, keeping themselves up to date and in practice on the latest operating and message handling procedures used by the Armed Forces.

The F.C.C. has mentioned the unique part that amateurs can play in the promotion of international good will. It is apparently surprising to some people to learn that for radio amateurs there is no "iron curtain" in eastern Europe. The government of the U.S.S.R., you may be sure, also recognizes the military value of a large and active amateur radio service. Dozens of conversations take place every day between U.S. amateurs and their counterparts in every part of the U.S.S.R., from White Russia to Far Eastern Siberia. In most of the conversations language is to some extent a barrier, but all the Russian operators seem to know enough stock English phrases to pass along routine remarks about signal strengths and equipment details. With the few who do speak English well, many of us have had some enjoyable conversations. One of these is a radio engineer of about my age in Leningrad who calls himself Bob, although his name is actually Boris. He is married and has two young sons. He is a receiver designer at a radio factory there. Since receiver design is a particular interest of my own, and since we have some other

(Continued on page 69)

Building a Wide-Spaced Twenty-Meter Rotary Beam

WILLIAM I. ORR, W6SAI*

When Bill Orr built his new beam he really engineered it from the ground up! Here, in part one of a two-part presentation, are general considerations for all beam builders. Next month Bill will give us the specific electrical design he found best, and plenty of dope on adjusting his (or any other) rotary beam.

A YEAR OR SO AGO W6SAI put up a 3-element wide-spaced 14-mc beam antenna. This beam did yeoman service for about sixteen months—and then came the day when a move in QTH for SAI and family loomed upon the horizon. A few days after a “For Sale” sign was placed in front of the house it became apparent that only another ham would buy a house that had a 3-element wide-spaced rotary sitting atop its ridge-pole. Since the supply of hams who were in the market for a house seemed to be at a seasonal low, it was decided to take the beam down.

Alas, this was easier said than done. The first thing I discovered upon climbing the 4×4 mast was that all of the stove bolts holding the beam to the supporting framework were immovable, and the nuts were firmly welded to the bolt threads by a thick coat of rust. The few bolts that had a minimum of rust upon them had stripped heads, out of which a screwdriver would slither at the slightest application of pressure. I realized that getting the beam down would be a major project compared to the problem of getting it up in the air!

The job was finally tackled with a hacksaw and a cold chisel. After a great deal of vein-bursting effort, the beam was dismantled and an oath was taken that the *next* beam built at the new QTH would be designed not only to go *up*, but to come *down*!

This paper describes the design and construction of a specific 14-mc beam antenna. I don't expect that the reader will make a Chinese copy of it, but the basic ideas of construction and tuning are applicable to any beam—be it a 14-mc one, or a 28- or 50-mc array. The problem of finding the proper materials for the construction is daily becoming greater, as the surplus stocks of tubing and aluminium sheet are dwindling. However, these ideas are presented as a general guide, not as a static blueprint to be rigidly followed, and they can be modified to suit your pocketbook or the contents of your local salvage yard!

A rotary beam antenna is mechanically composed of four separate, basic parts. They are: 1) thrust bearing and support; 2) rotating mechanism; 3) beam mounting assembly, and 4) antenna.

Beware! Do not let any one of these parts do the work of the others, or you will find yourself

* 555 Crestline Drive, Los Angeles 49, Calif.

trapped in a mechanical snare that will be your downfall. See what happened to SAI later in the story when he violated this basic rule!

Thrust Bearing and Support

The thrust bearing should consist of a low-friction bearing designed to take the weight of the beam off the rotating mechanism. The support bearings will take no vertical thrust, but will prevent side play of the beam. A typical example of this arrangement is shown in *Fig. 1*. It is extremely important that the thrust bearing not be a part of the rotating mechanism! Several years ago I built a beam and supported and rotated it with a “prop pitch” motor (violating the cardinal rule mentioned above). The rotation pipe was bolted to the prop pitch motor gear, and the motor sat atop a short lattice tower. One fine day it became necessary to replace the motor brushes. In order to get at the brushes, the rain shield of the motor had to be removed and the electric motor removed from the gear chamber. To do this, the beam had to be taken down completely to allow

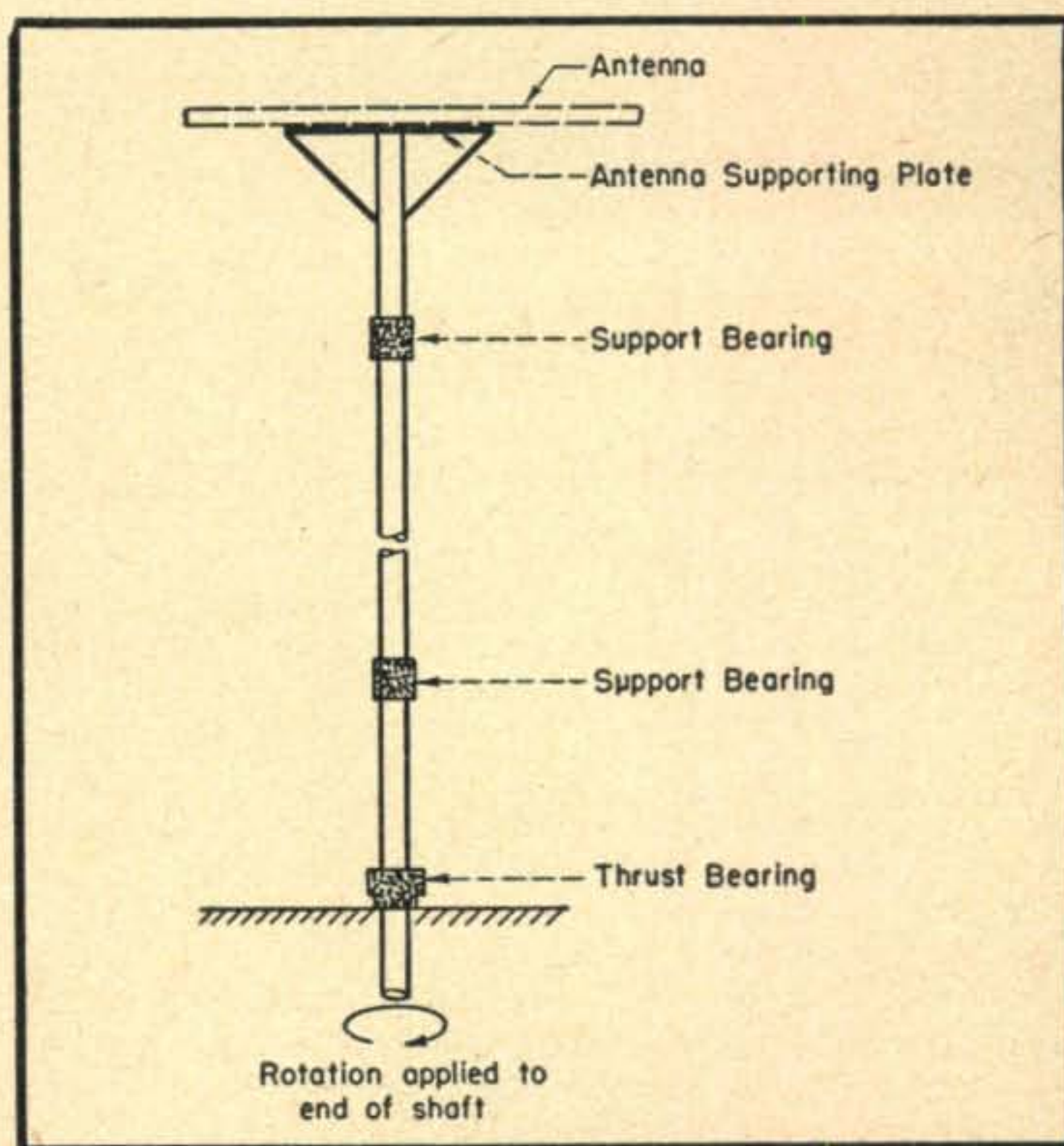

Fig. 1. The antenna supporting structure should have both support bearings and thrust bearings. Don't try to make one bearing take both roles!

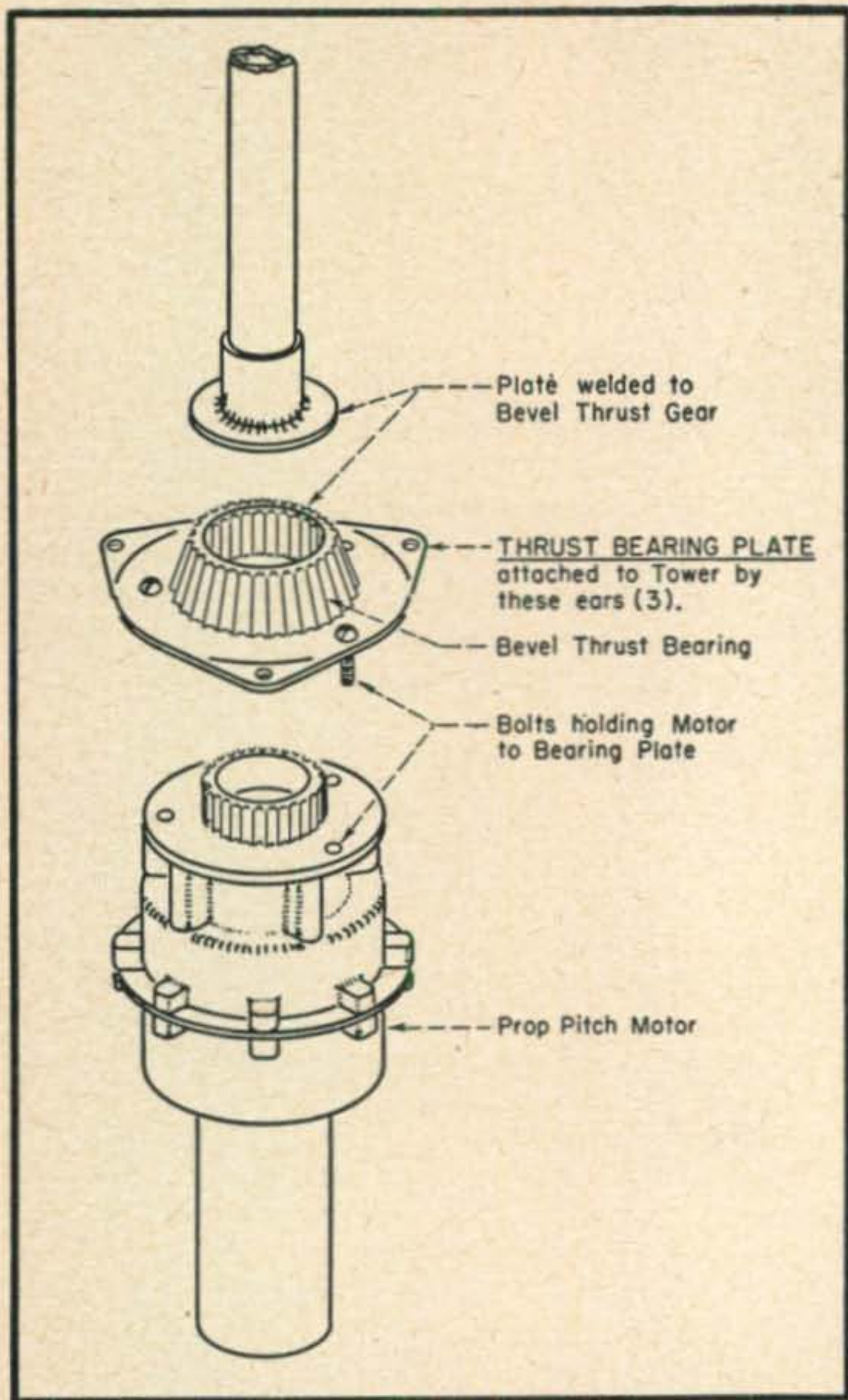

Fig. 2. The familiar "prop pitch" motor provides an excellent thrust bearing as well as a good source of torque. See text for details.

the supporting pipe to be raised a few feet in order to free the motor! The simple task of replacing the motor brushes demanded the complete dismemberment of the beam and took a whole weekend. Therefore, never support the weight of the beam directly on the rotating mechanism. It is too difficult to remove the rotator for service and repair.

Fortunately, the popular prop pitch motor, if mounted properly, will supply its own thrust bearing. The bevel ring gear on the top of the motor is seated on a thrust bearing that transmits all vertical thrust to the motor mounting plate. In fact, if the three flat-headed screws holding the prop pitch motor to its mounting plate are removed, the plate may be attached permanently to the tower as a thrust bearing. The bevel gear and supporting pipe will now drop directly into the thrust bearing of the plate, and the motor may be raised into position beneath the plate and held in place by the flat head screws, plus several $\frac{1}{4}$ -28 machine bolts. If it is desired to remove the motor, it may easily be done by removing these bolts and screws and allowing the motor to drop a few inches to disengage the spline drive. The mounting plate and ring gear remain permanently attached to the tower (Fig. 2).

The supporting pipe should not be less than $1\frac{1}{4}$ " outside diameter and not be over ten feet long, or a bad axial twist in the pipe will develop when the beam is rotated. The pipe must have at least one intermediate support bearing to prevent bowing of the pipe under heavy wind loads on the beam. (Figure 1). The supporting pipe may be fastened to the bevel ring gear by means of a simple coupling (Fig. 3). The supporting pipe may be screwed into the coupling and then pinned by a $\frac{1}{4}$ -28 bolt as shown. To remove the pipe, merely take out the retaining bolt and unscrew the pipe.

The intermediate support bearing may consist of a loose-fit sleeve attached to the mast. It should be adjustable in a horizontal plane to compensate for variations in the mount. A suggested bearing is shown in Fig. 4. The four turnbuckles may be adjusted to provide an even tension on the rotating pipe. They should be tightened and safety-wired to prevent them from working loose.

The bearing at the top of the tower may consist simply of a plate cut to fit the tower with a hole drilled in the center of it to pass the rotating pipe. The plate should be at least $\frac{1}{4}$ " thick to prevent cutting of the pipe. This plate may be made of wood instead of metal if desired. No elaborate bearing is needed at this point.

Rotating Mechanism

If you will get out your copy of August, 1949 CQ, and turn to page 20, you will find that W6MUO, Dick Saunders, has all the answers regarding an excellent rotating system. When I first installed my prop-pitch motor I soon noticed an S9 power noise in my receiver that would come on the air shortly after I had fired up the rig and turned the beam "the long way," preparatory to the pre-breakfast band combing. The noise would completely blank out 14 mc, leaving me nothing to do except read the funnies and do the daily crossword puzzle in the paper. One day I noticed that the noise would not come on until I *turned* my antenna. If I went on the air without rotating my beam, all was quiet and serene! But as soon as I turned on the rotating device, the noise would shortly appear in all its pristine glory. Well, I soon found out that my nextdoor neighbor liked to sleep later than 5 a.m. and was getting very

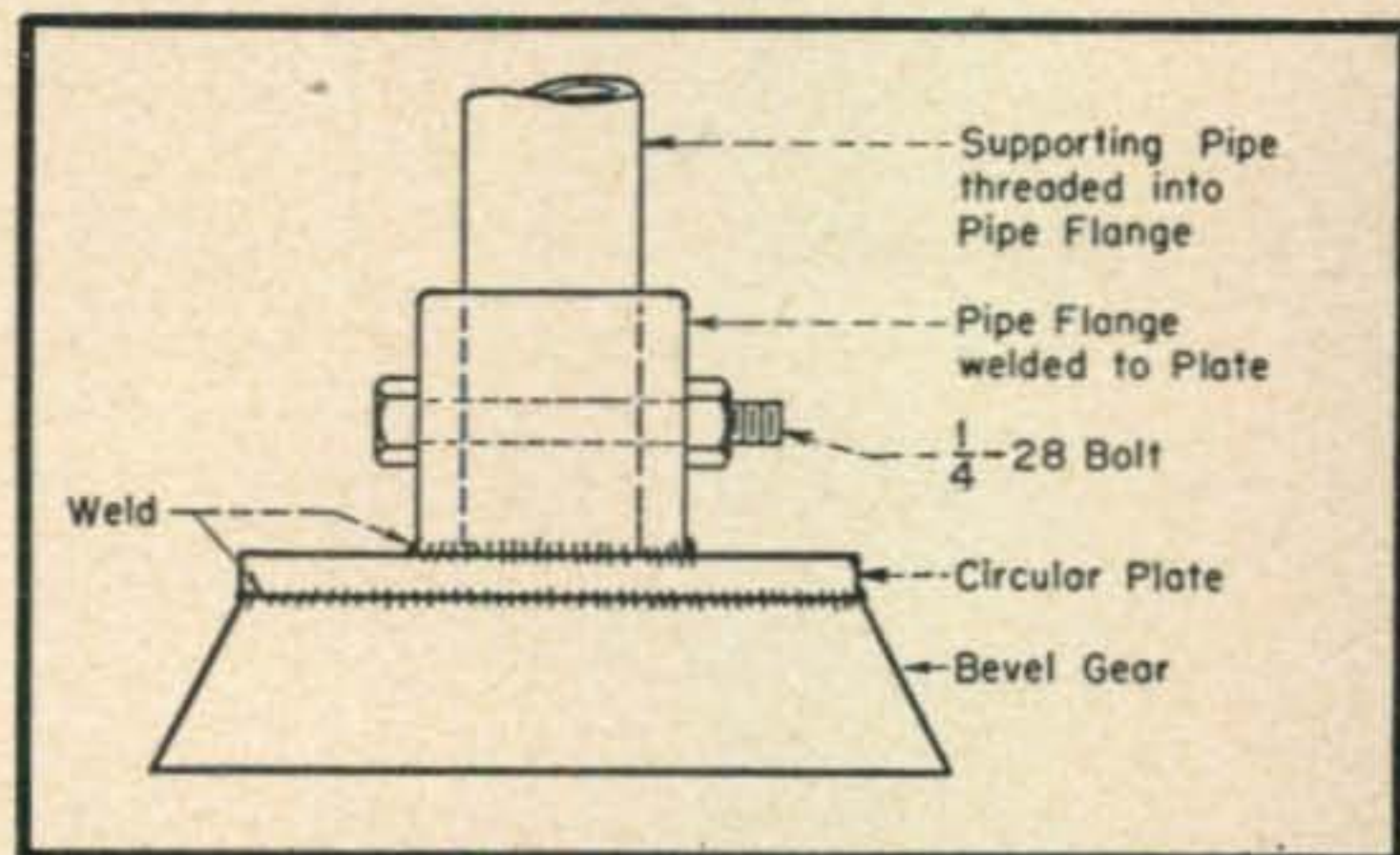

Fig. 3. The antenna-supporting pipe should be both welded and pinned to the bevel gear when the prop pitch motor is used.

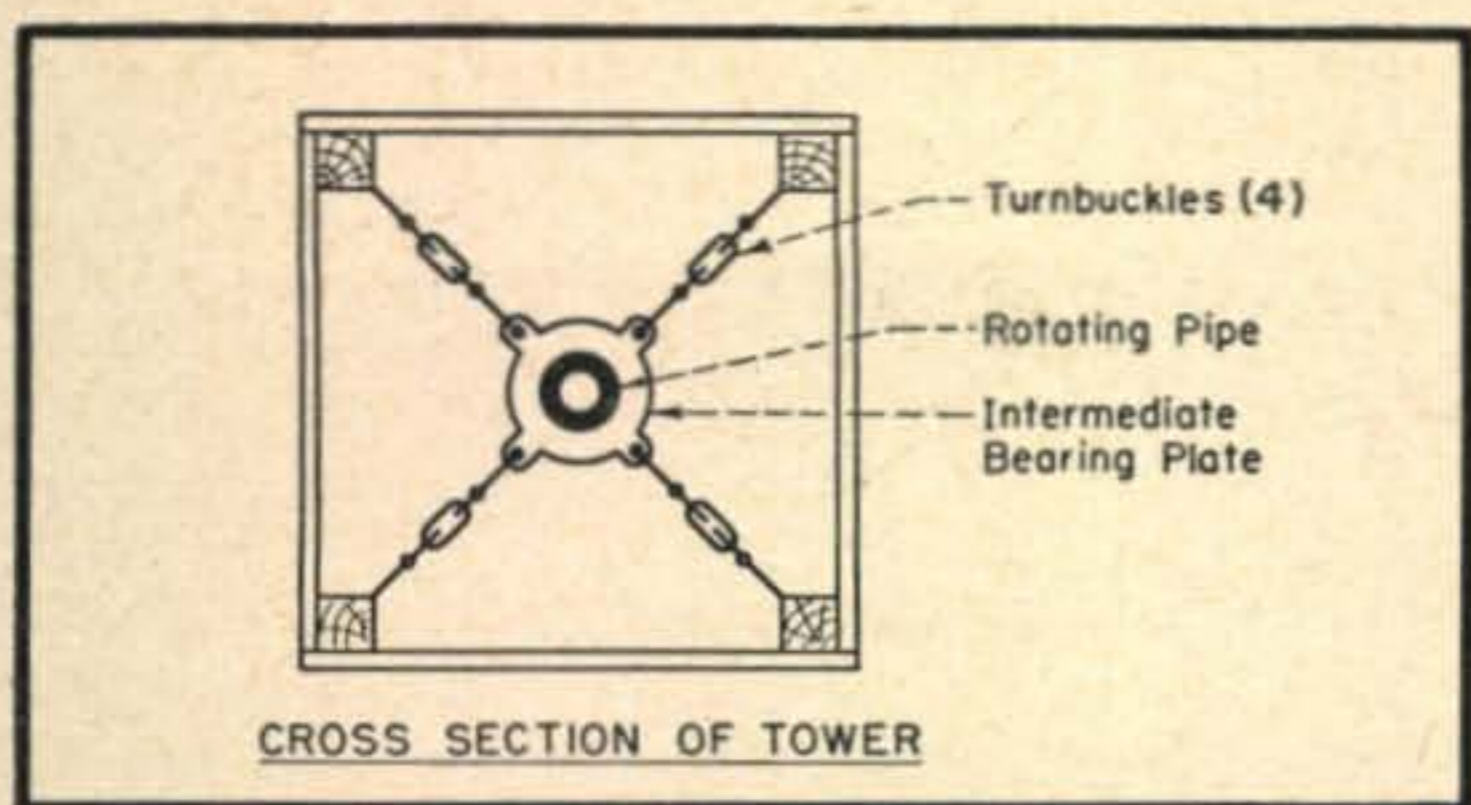

Fig. 4. Here is a suggested structure for the intermediate support bearing. The turnbuckles permit the rotating pipe to be centered in the tower.

touchy at being aroused each morning by the screeching whine of the prop-pitch motor as I aimed my beam "down the slot" at 225° west. This joker, upon being awakened, would stride into his bathroom, plug in his electric razor, take an aspirin and go back to bed, leaving the razor running until 8 a.m. or so!

Being naturally a bright lad, I soon got the idea and re-worked the motor à la W6MUO, and now all is well. I might suggest, however, that if you are planning an array of any size that you make a slight modification in Mr. Saunders design, to wit:

Dick chucks the bell gear (M) in a lathe and cuts the internal gear off just *inside* the ring of holes encircling the gear. I suggest that you cut the teeth off just *outside* these holes, say $\frac{1}{4}$ " away, thus leaving the ring of holes on the center section of the bell gear (Fig. 5). Now, if the bell gear is dropped over the differential gear, it will be seen that the three large $\frac{7}{8}$ " holes in the differential gear fall in axial alignment with the holes drilled in the bell gear. Three special off-center pins can be turned easily in a lathe that will engage the three holes in the bell gear with those in the differential gear (Fig. 6). The three pins may be fastened to the differential gear by means of $\frac{1}{4}$ "-28 bolts tapped through the side wall of the gear frame. The bell gear will now drop over these off-center pins and provide a very strong power transfer. The danger of using common bolts at this point is that there is a tendency for the bolts to work loose in the soft aluminum of the differential gear. These special pins solve this problem very nicely. Since you need a lathe to cut the bell gear, anyway, you might as well turn out the pins and do the job up brown. Right?

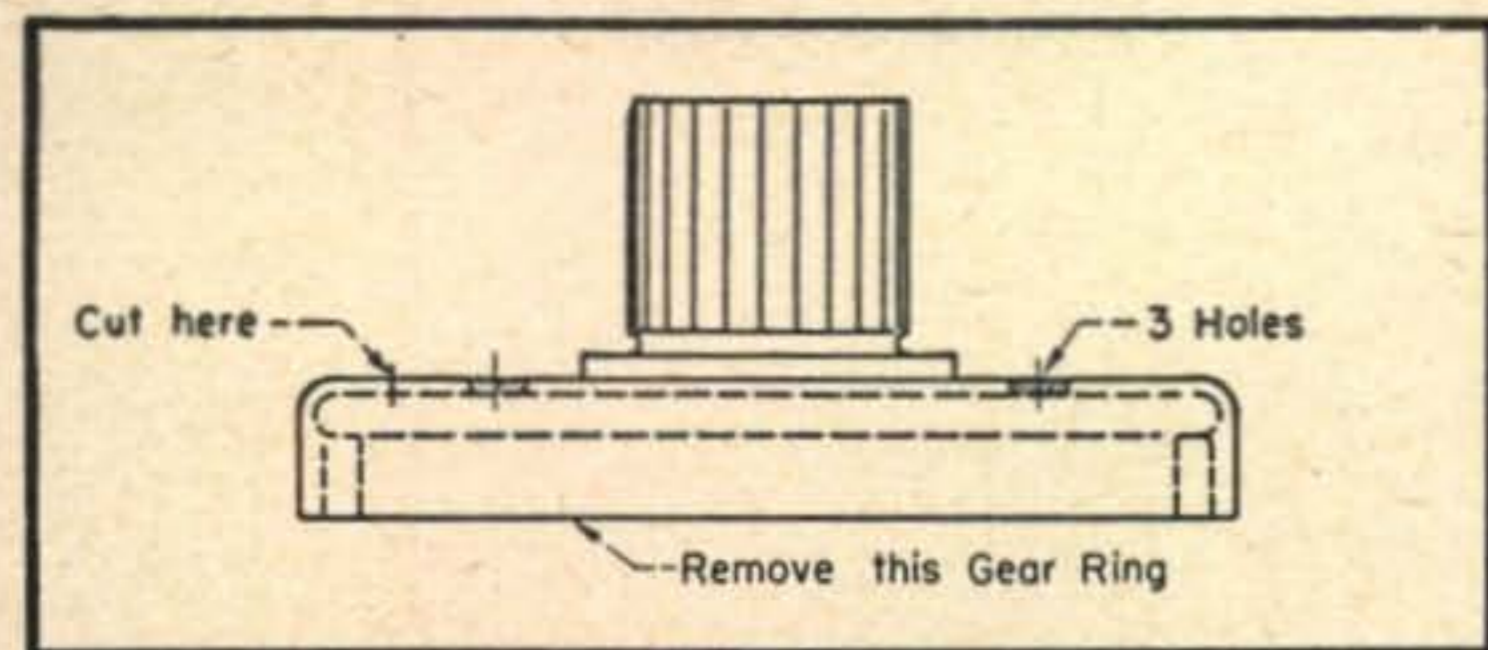

Fig. 5. The modification of the bell gear in the prop pitch motor.

Beam Mounting Assembly

The beam mounting assembly should provide a rigid junction between the beam and the rotating pipe. It should also provide a means of raising and lowering the beam. A practical system is shown in Fig. 7 and the photo. A sheet of cold-rolled-steel 10" x 15" (A) is butt-welded to the rotation pipe (C). Four short pieces of angle iron (B) are welded as braces from the pipe to the corners of the steel plate. Be sure the plate is truly horizontal with respect to the vertical pipe; this determines the plane of the antenna. Any deviation of the plate from the horizontal will tilt the beam from the proper horizontal plane. Two pieces of 2" x 2" dural angle stock 26" long (D)

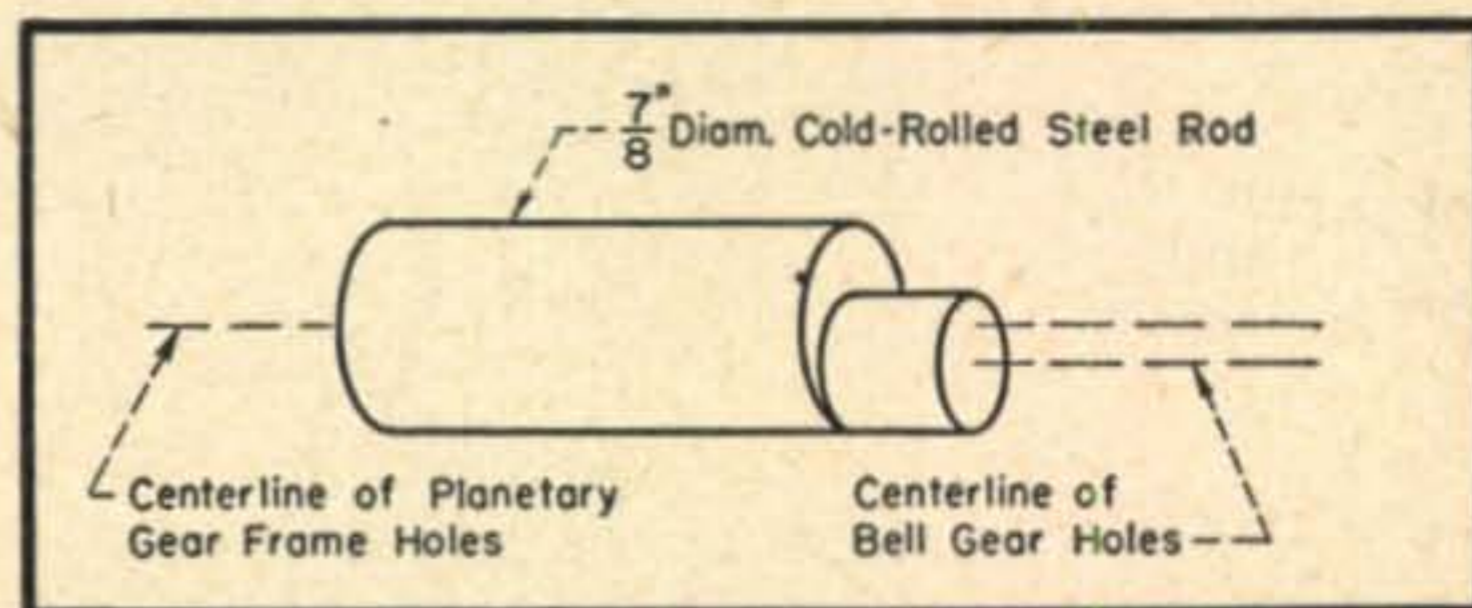

Fig. 6. Off-center pins are needed for the bell gear, as explained in the text.

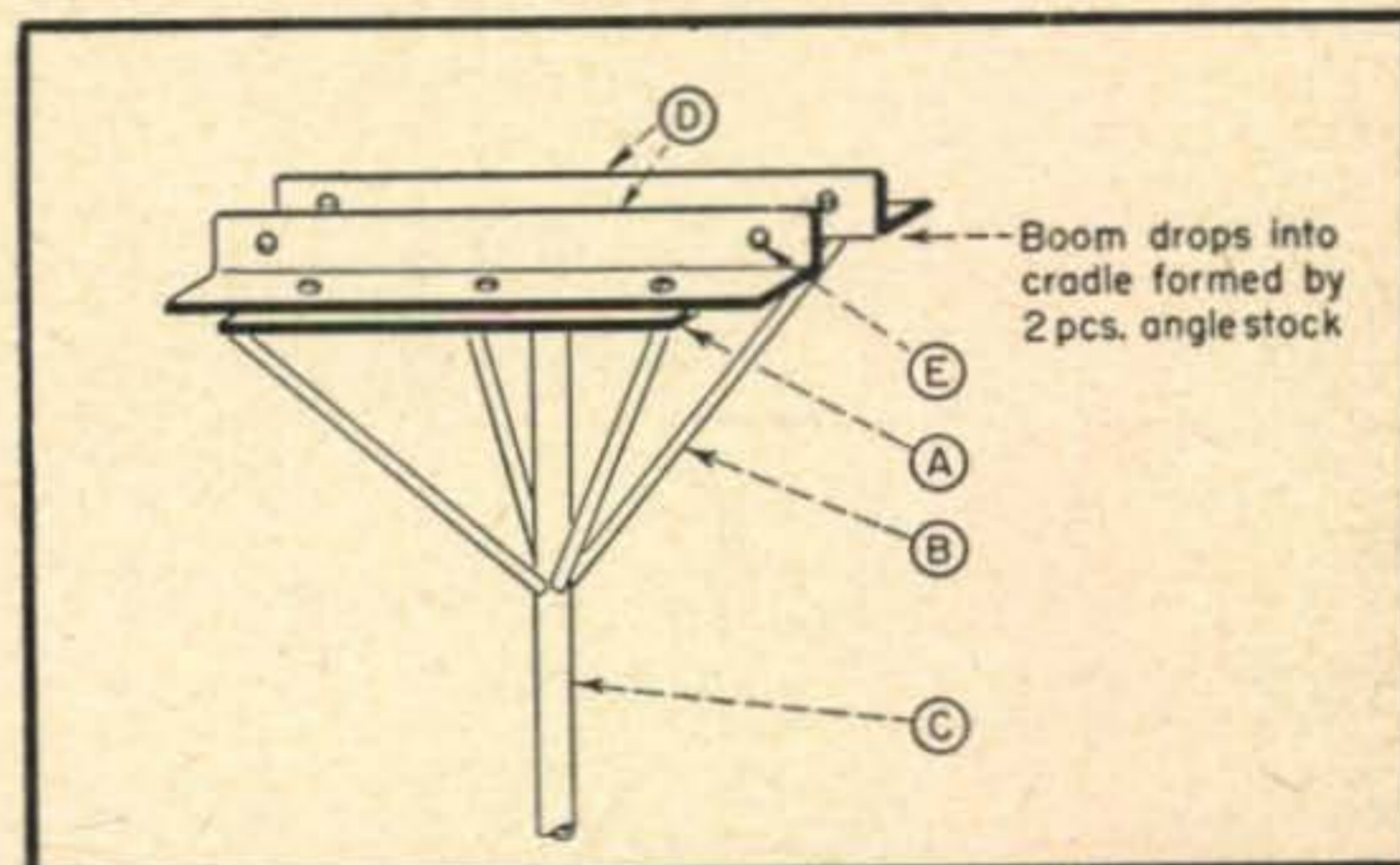
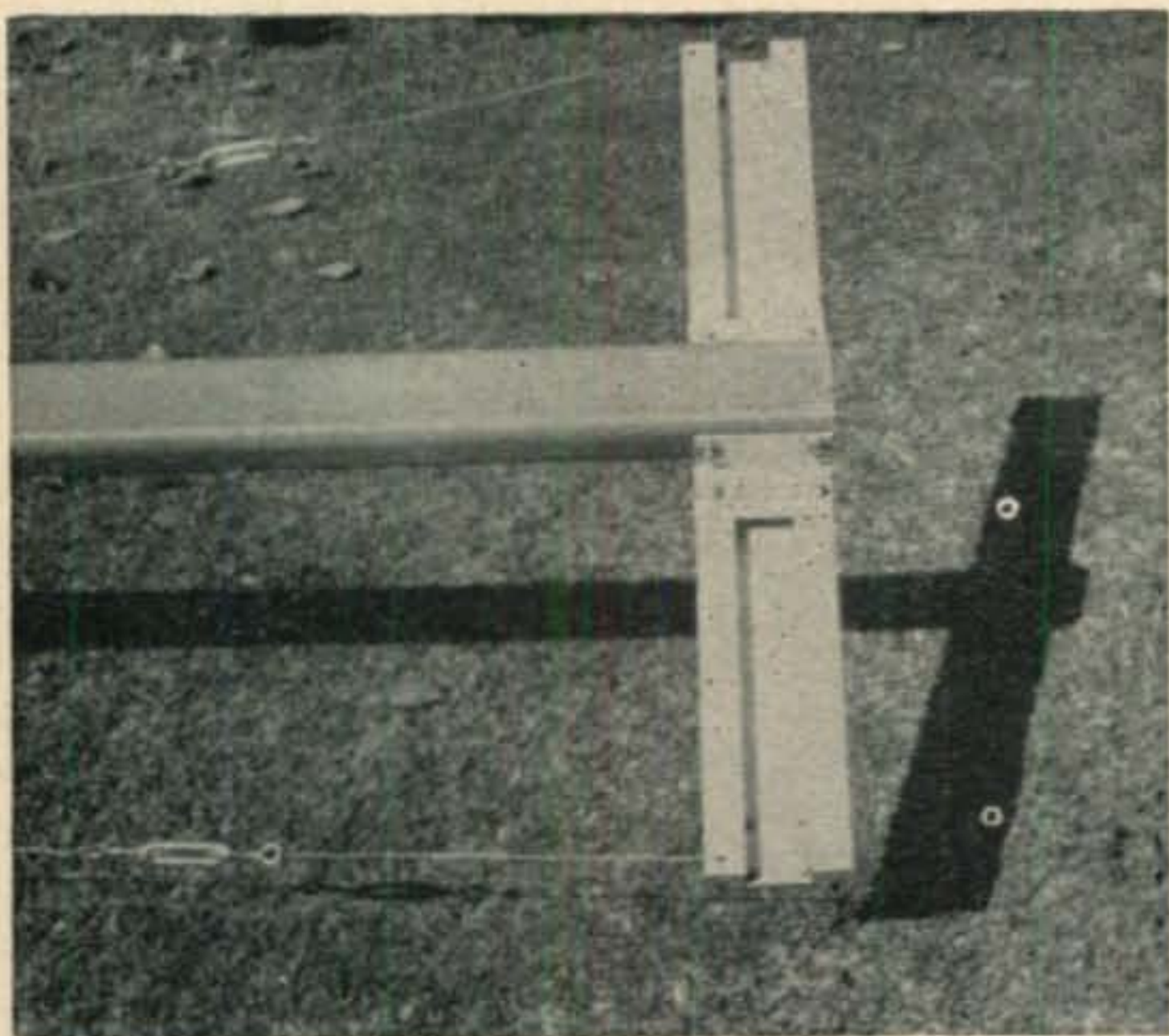

Fig. 7. The beam mounting assembly sits atop the rotating pipe. A little careful work here makes the beam much easier to put up or take down.

are bolted to the steel plate. The separation between these pieces should be just enough so that the supporting boom of the antenna can drop easily in between them. This will form a cradle support for the antenna. The two angle pieces are now drilled through at their respective ends with a $\frac{1}{4}$ " hole (E). These holes should line up so a $\frac{1}{4}$ "-28 bolt may pass through them. The boom should now be placed in position in the cradle and drilled to match the holes in the angle stock. When the two bolts are in place, a rigid union is provided. If it is desired to lower the beam, one bolt may be removed and the beam tilted downwards, using the other bolt as a hinge. When the beam is securely roped, the second bolt may be removed, and "down she comes!"

The Antenna Framework

The beam described here is the offspring of four previous models, all basically alike, but differing in many small details. The object of the



One of the reflector (or director) supporting sections, showing the fastening of the umbrella guys.

evolution was to develop a structure that would be light and easy to handle (30 pounds), but at the same time be rugged enough to stand severe winds and inclement weather.

The boom consists of two twelve foot lengths of square dural tubing, approximately 2" x 4" on

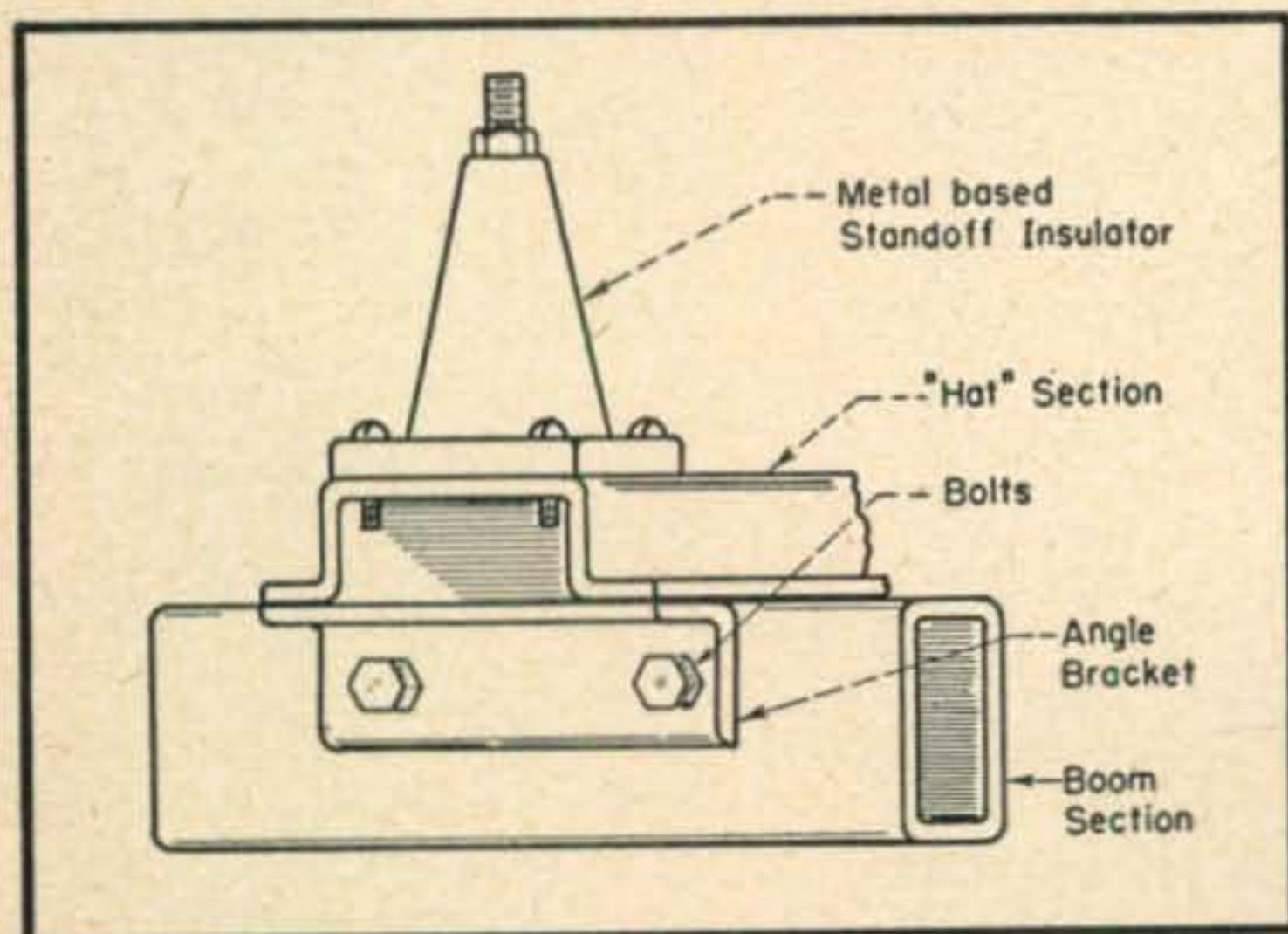

Fig. 8. The element mounting assembly. It is a good idea to use really long screws atop the standoff insulator.

sides, with a wall thickness of .125". A telescoping piece of tubing was found (after a long hunt), and this is inserted at the center of the two pieces, which are then bolted together to form a rigid, twenty-four foot boom. A short section of 1/2" water pipe is flanged to the boom at the center and is used as a support for two top umbrella guys. Each section of the guy is electrically broken by strain insulators, and contains a turnbuckle to be used in levelling the boom. The photo illustrates the beam mounting plate attached to the boom, the top guys, and supporting pipe. The driven-element support may also be seen. It consists of a five-foot piece of "hat section" dural, onto which are bolted four metal-based standoff insulators. Fig. 8 illustrates this support in section. The hat section is tapped for the four 10-32 screws that hold the insulators. It, in turn, is held to the boom by two short pieces of 2" x 2" dural

angle stock, as shown. The reflector and director "hats" have holes drilled at their extremities to receive the umbrella guys. The whole assembly is held to the boom by two long 1/4"-28 bolts that pass through both brackets and the boom. To remove an element, merely remove these two bolts and open the two turnbuckles, and the element comes clear.

In this way, the beam may be tilted and the reflector and director easily removed. However, the complete beam is so light that it is as easy to lower the whole beam as it is to remove an element!

The Elements

Each element is composed of three 14' telescoping pieces of dural tubing. The center piece is 1 1/8" diameter, with a .050" wall, and the two tip pieces are 1 1/2" diameter with a .050" or .032" wall. Either 24ST or 52ST may be used. The center section is slotted at each end for a foot or so, and an aircraft cable clamp is slid over the tubing and tightened after all adjustments are completed.

During the past year or so I have helped to take down my share of beam antennas, and I have noticed that invariably there is bad corrosion at the joints of the dural tubes. On one fellow's beam this corrosion was so bad that it was impossible to

(Continued on page 63)

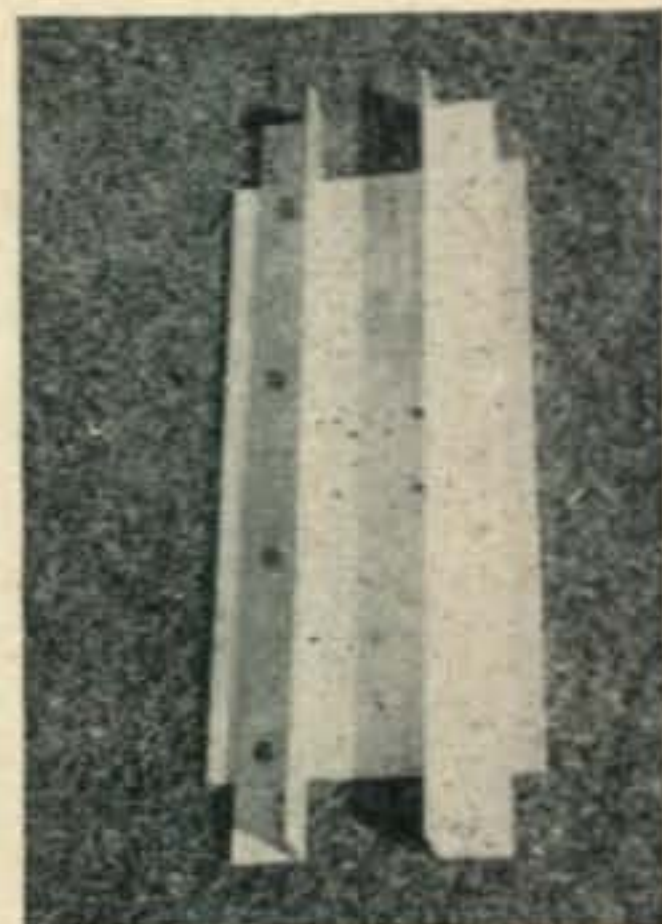

The beam mounting plate.



The beam mounting plate attached to the boom, illustrating the top guys and the method of mounting the support for the driven element.

The Traffic Midget

WILLIAM E. JOHNSON, W8VOK*



Here's a complete 80-meter c.w. station in a single box not much bigger than a shoe box. If you have space problems, or if you want to give that DX rock-crusher a rest, this is your dish.

THIS ARTICLE DESCRIBES A LOW POWER TRANSMITTER and a six tube receiver, assembled as a complete package.

The need for a station of this type is well appreciated by the apartment dweller whose space is at a premium. This station is also valuable for portable operation.

When attempting to design a station in the limited space available, several factors must be considered. The power input of the final amplifier cannot be too great, as the power supply would require too much space. As low power is to be used, it is necessary to use a variable frequency oscillator. The circuit decided upon utilizes a power input of 25 watts to the final amplifier.

The transmitter and receiver are designed to work in the 80-meter band, although plug-in coils are utilized and the station could be operated on 160 or 40 meters with slight changes in the tuned circuits.

The transmitter employs only two tubes. A 6F6 in an electron-coupled oscillator whose grid is tuned to the 160 meter band and whose plate

is fixed-tuned to the center of the 80-meter c.w. band. The plate circuit of the oscillator, having been adjusted once, requires no further attention over the entire band. The final amplifier uses a 6L6 in an inverted cathode circuit, which requires no neutralization and is foolproof. Anyone who has spent hours attempting to get a 6L6 to operate as a power amplifier in a conventional circuit without going into self oscillation will appreciate this application of the 6L6.

The receiver uses a 6K8 first detector and oscillator, 6SG7 first and second intermediate frequency amplifiers, a 6SQ7 second detector and first audio amplifier, a 6C4 beat frequency oscillator, and a 6F6 audio output feeding a 5-inch speaker.

Receiver Details

The receiver is a conventional superheterodyne, as shown by the wiring diagram. It utilizes an i.f. frequency of 2.8 megacycles. It is realized that by using a high i.f. frequency the selectivity is not as good as that obtained with one of lower frequency, but the choice was made to eliminate images within the ham band, as no radio fre-

* 18839 Schoenherr Rd., Detroit 5, Mich.

The circuit diagram of the transmitter.

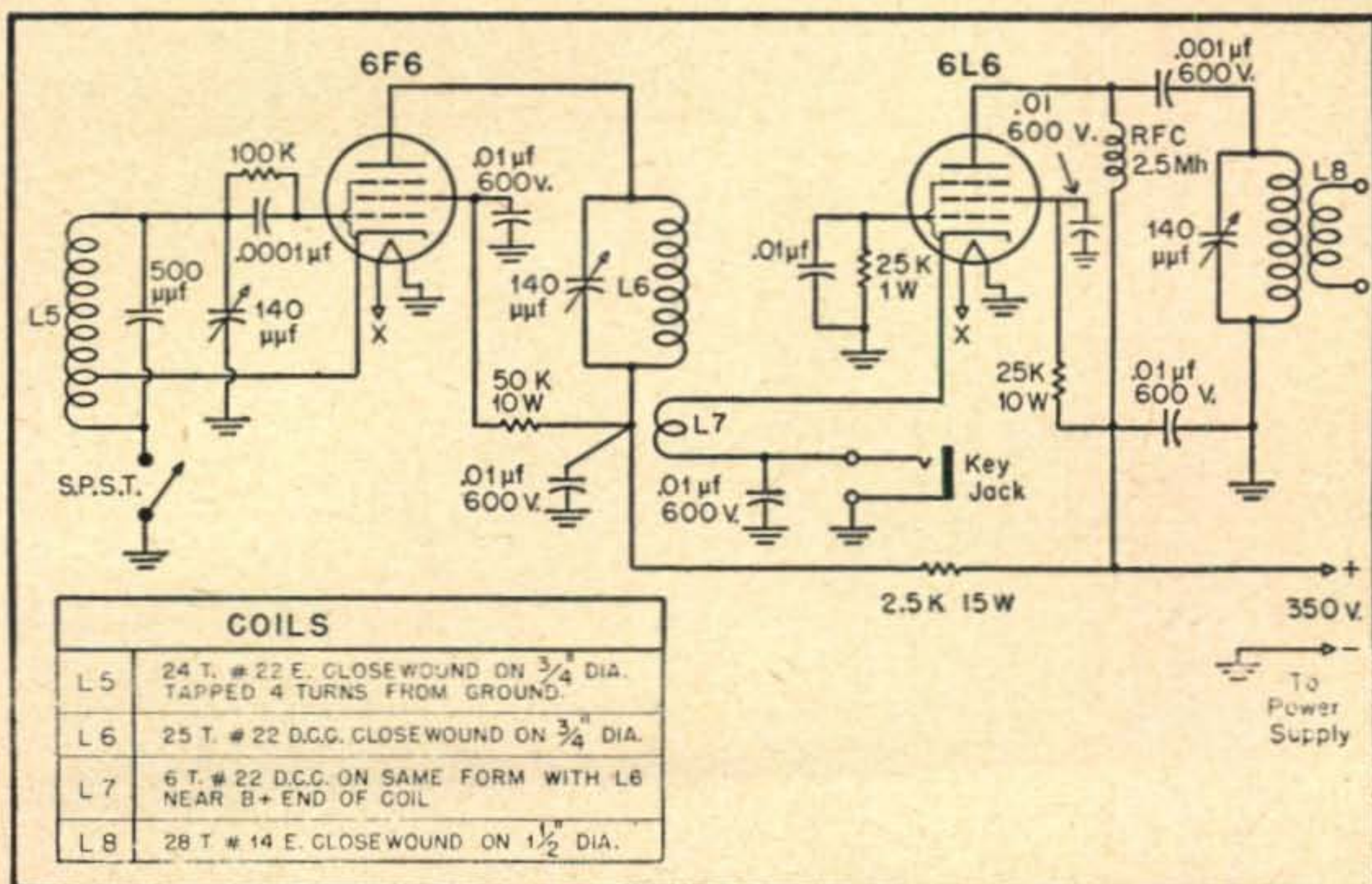

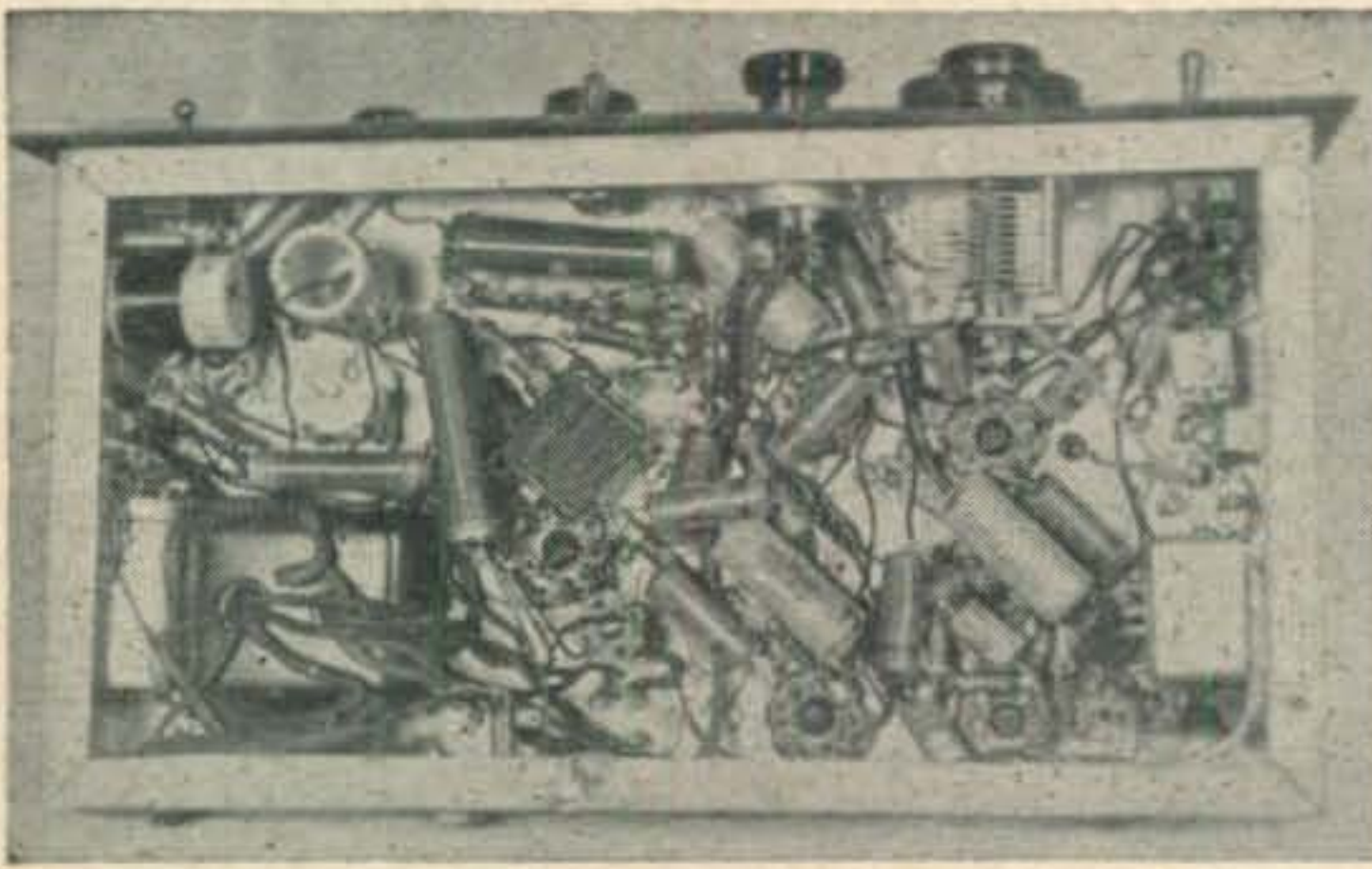

There are a lot of parts below the chassis, but a close look should convince you that everything is readily accessible.

quency amplifier is employed. The entire 80-meter band is spread out over 58 of the 100 divisions of the dial. This calibrated dial controls the high frequency oscillator, while the mixer is tuned by the control directly under the calibrated oscillator dial. The mixer condenser has to be peaked about every 50 kilocycles for optimum results. The i.f. transformers were obtained as surplus from the 6-9 mc aircraft receiver series. These transformers were available in the local surplus center here at reasonable cost. There was one important change made in the i.f. transformer coupling into the 6SQ7 second detector. The surplus transformer was originally designed to operate into a triode detector, and, as the 6SQ7 is used as a diode detector, a change had to be made in the last i.f. transformer.

Figure 1 shows the original hookup of the

transformer to be altered. The trimmer condenser is grounded to one of the four supporting uprights of the transformer. This ground connection is satisfactory when a triode second detector is employed. But in our case a diode was desired, so this upright had to be removed and a wire soldered to the rotor of the trimmer and then connected to the bottom end of the i.f. secondary coil, as shown in Fig. 1.

The control to the left of the mixer condenser is the volume control, and the switch to the right of the mixer control is the b.f.o. switch. The omission of an automatic volume control was intentional, as the receiver was designed for c.w. use only.

The transmitter utilizes a 6F6 as an electron-
(Continued on page 61)

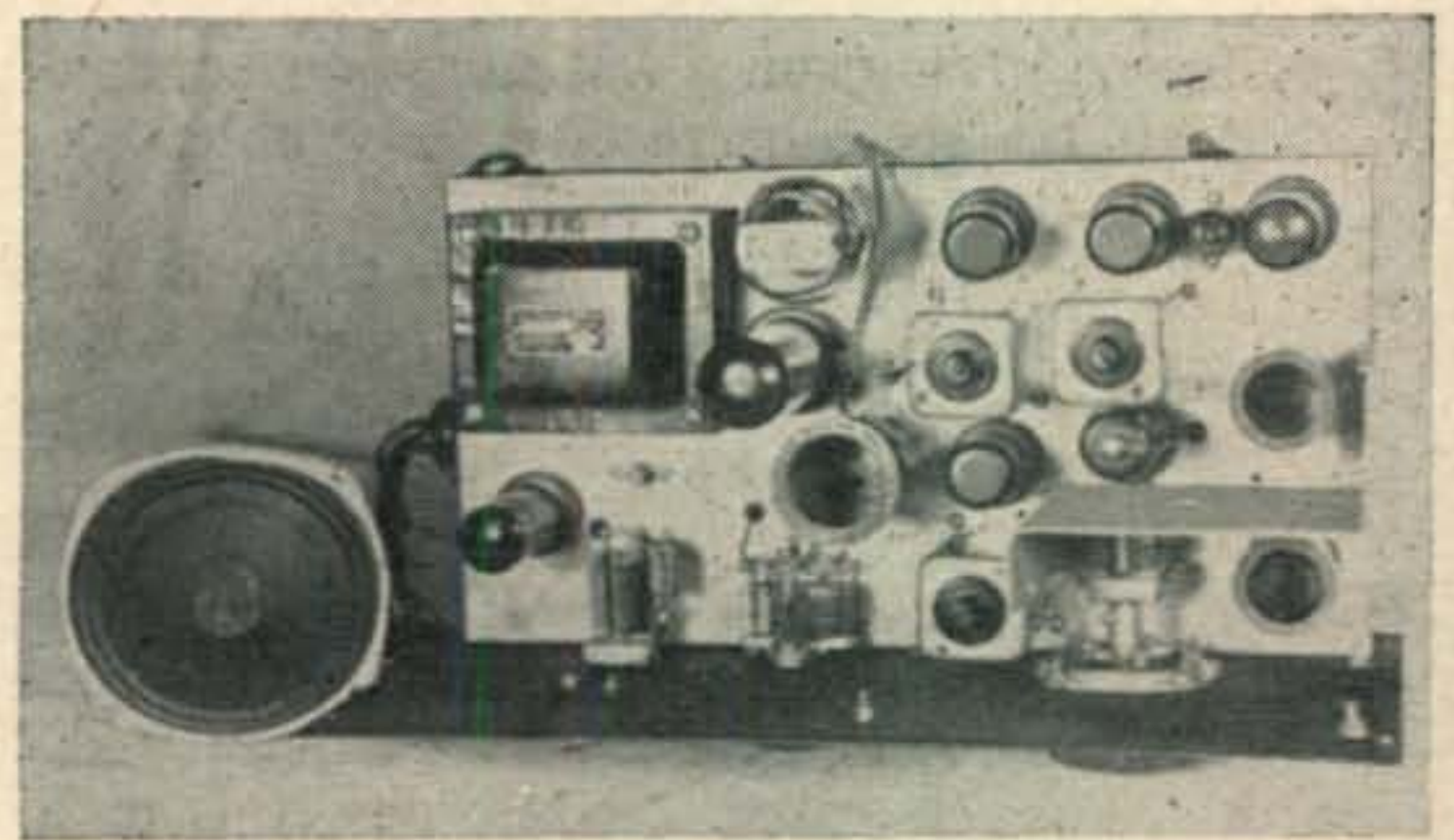

Looking down at the "business" from the top, the receiver occupies most of the right half of the chassis, while the transmitter and the power supply share the left side.

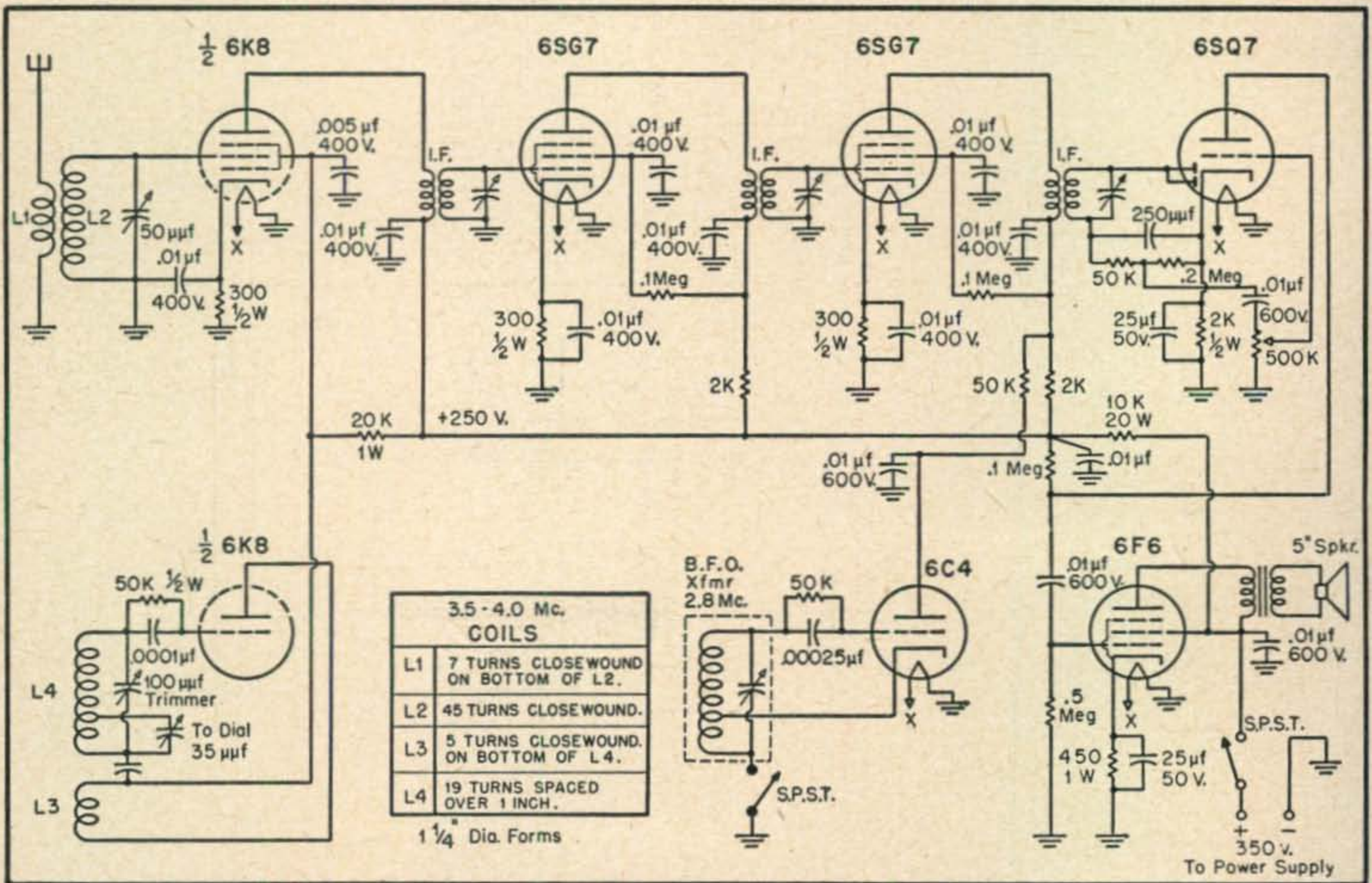

Receiver circuit. See text for I.f. transformer details.

The Ham and Public Relations

THE MICHIANA AMATEUR RADIO CLUB, INC.*

IN HARMONY WITH PRESENT PLANS of the Armed Services and various civic minded groups, the Michiana Amateur Radio Club, Inc. of South Bend, Indiana, has undertaken a public relations program which has as its prime purpose the perpetuation and encouragement of amateur radio. It is striving to accomplish this purpose by presenting an informative and entertaining program to the various civic and service organizations in the Michiana area. This area includes South Bend and surrounding towns, which are all within fringe area TV range of Chicago. Already results have been realized which are tending to create better understanding between the ham fraternity and TV viewers, to interest potential hobbyists in amateur radio, and to attract the attention of the community at large as to how the amateurs actually serve the public. Since the results of the Club's public relations venture have been so gratifying, it is believed that others around the country would appreciate knowing the means by which these results are being realized.

The programs are performed by seven licensed club members comprising the Public Relations Committee. The program is generally divided into three parts: first, a thirty-minute talk by the narrator on the history of ham radio and how it serves the public; secondly, an explanation of a silent display which consists of various pieces of ham-built equipment and two portable bulletin boards upon which are affixed various items of documentary evidence of ham radio; and thirdly, an actual demonstration of ham radio at work. The third item is the most dramatic part of the program and serves to drive home the preceding informative bits. It is executed by two mobile units and a portable station placed on a table near the front of the meeting room. One member operates the receiver and the other the transmitter. All operations are confined to the ten meter phone band. As an aid in snappy operating, all

* South Bend, Indiana



The Publicity Committee and the portable display. Illustrated are (l. to r.) Vice-President W9MYE, Secretary W9PDF, Narrator W9PDS, President W9WRH, Treasurer W9BYY, and W9MYI.

stations are on a single frequency.

Since the above general description would be of little assistance to one interested in duplicating this program, a brief outline will be made of each of the three program parts.

The first phase contains the entire message to be conveyed, and the two following phases provide both proof of statements and entertainment for the assembly. It is pointed out that the first two-way transatlantic communication was carried on by amateurs and that much of the early development in radio was due to the efforts of hams. A definition of the amateur radio operator is given, taking special care in pointing out that usually the amateur is so called because he is a hobbyist taking part without pay, and that he is not a novice as the name might imply to the layman. Anecdotes are given telling how hams have helped in time of emergency and how the armed services have genuinely appreciated what amateur radio meant to our war and defense efforts. Mention is made of how hams are born through examination and licensing by the FCC and of the various local, national, and international organizations of hams. Other items are presented, but these listed will certainly give the reader an idea of how the public service angle is emphasized and the hobby aspect brought in as a possible second in importance. The first phase is completed with a discussion of causes and remedies for BCI and TVI. A general discussion terminated with a few specific examples of cases have proven very enlightening to those addressed. In every case all misapprehension concerning the ham and TVI has been cleared up in the mind of the set owner addressed. Servicemen, too, who have heard the discussion report success in dealing with cases of TVI due to the ham through their mutual understanding of the problem and the application of the proper filters.

(Continued on page 62)



W9ZIB points out his mobile equipment used for the demonstration to W9MYI, a mobile fan himself.

An Economical 10-Meter Mobile Phone Transmitter

WAYNE W. COOPER, W8EWC*

If you're looking for something both compact and economical to install in the family chariot for the pleasant days ahead, here's a little rig which will fill the bill.

THIS TRANSMITTER was designed to give the maximum power output and efficiency in a minimum of space and weight, making it an ideal transmitter for portable/mobile operation.

The transmitter is designed for complete push-to-talk operation. The plate and filament supply, the microphone, and starting contactor come on when the push-to-talk switch is depressed. This makes for economy in operation since there is no standby power consumption. To meet this requirement, "quick heating" filament-type tubes are used. The complement includes a 2E24 final amplifier, 2E30 Tri-tet oscillator-doubler, and push-pull 2E30s in Class AB as modulators.

The Tri-tet type oscillator-doubler is used with a 14.5 mc crystal, and the output is tuned to 29 mc. The usual circuit had to be modified to use direct heating filament-type tubes. A dual-wound 1- μ hy inductance, L_1 , is used in the filament leads to replace the normal cathode coil, and the 29-mc output transformer, L_2 - L_3 , is slug-tuned.

No extra capacity is used across this circuit as it is considered that the sum of the output capacity of the 2E30 and the input capacity of the

* 311 Shawnee Path, Akron 5, Ohio

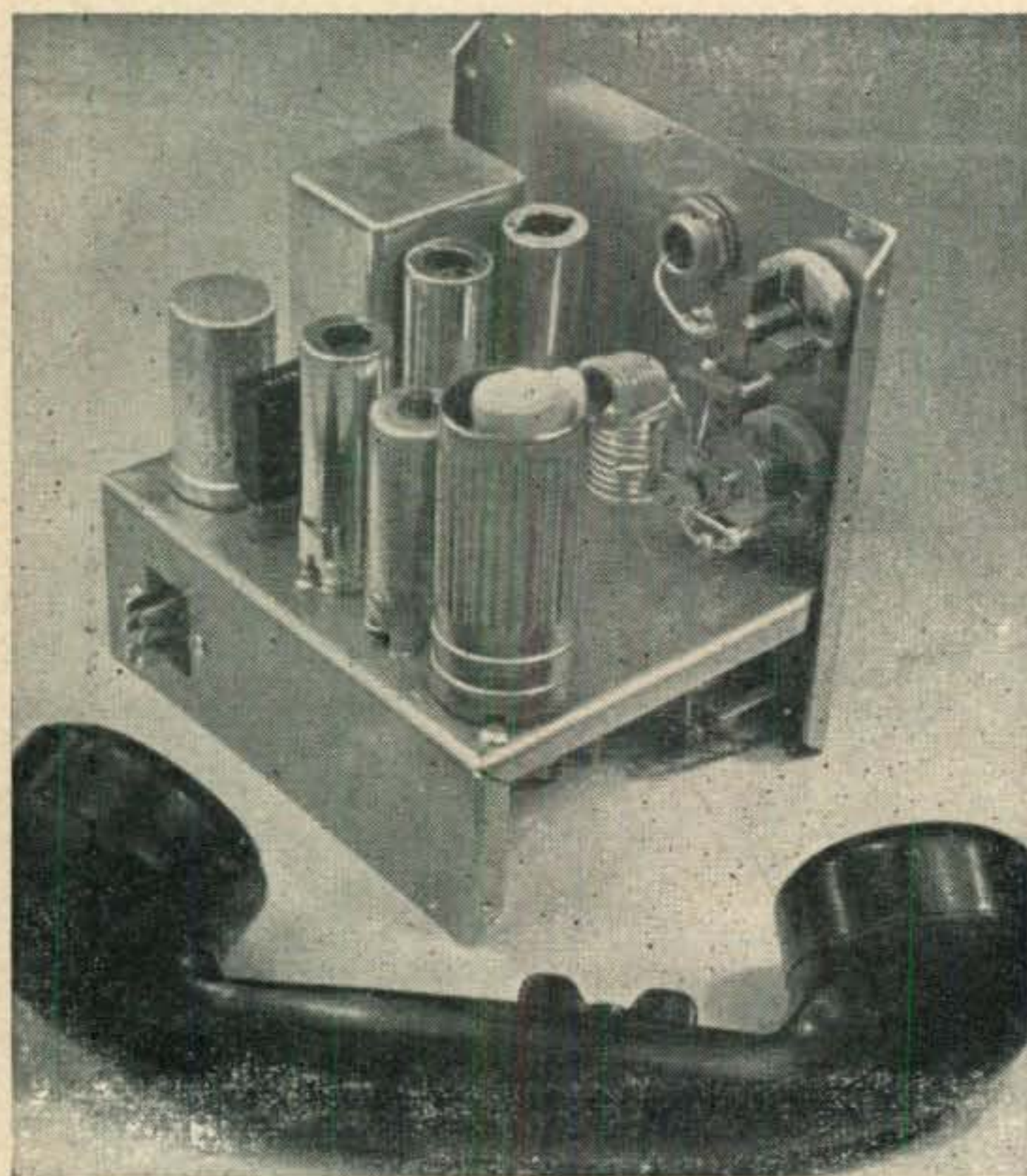

A pretty good idea of the size of the transmitter can be had from this view. The layout of the output circuit is apparent.

2E24 is adequate for 29-mc band doubler operation. The final amplifier is connected through a parasitic suppressor consisting of a 100-ohm non-inductive resistor.

The output tank circuit is conventional, and the final amplifier tube is connected through a small parasitic choke directly at the plate cap. The tank coil is air-wound and supported by the terminals of the tank condenser. The r.f. bypass condenser is made as large as possible, not only to reduce the r.f. impedance to ground, but also to reduce the audio frequency response above 2500 cycles. The antenna is tapped directly on the tank coil through a variable coupling capacitor to a low impedance transmission line or antenna. The tank coil is wound with enough inductance so that a minimum of external capacity is required. This keeps the losses low.

The Modulator

The two type 2E30 tubes in the modulator are operated in Class AB. A small 22½-volt hearing aid battery is used to supply most of the bias. This bias source will last the shelf life of the battery as no current is being drawn. The modulator tubes are driven directly by a single-button carbon microphone. A Signal Corps type TS-13 handset is used in this installation. With 6 volts on the microphone the current is around 50 ma. This is slightly low, but the additional complication of adding a microphone battery is avoided. The voltage drive is adequate for 100% modulation using a normal speaking voice.

The front panel layout has been kept simple and uncluttered with knobs and dials. This is desirable, because it discourages unauthorized tampering with the controls. Besides the tuning and loading controls, which are screw driver adjustments, there are four jacks; microphone, oscillator, plate, amplifier grid, and final/modulator plate current.

All the metal work is of 1/16" soft aluminum. The chassis is bent L-shaped, 5" x 6" x 2½", and attached to a 6" x 6" front panel. The general layout of parts can be seen from the accompanying photograph which can be used as a guide. Top, bottom, back and side panels are bent up using the same material and type of construction. One-quarter inch 4-40 screws are used to hold the shielded box together, and the panels are tapped to receive them.

The oscillator filament coil, L_1 , is dual wound on a mandrel, which is then removed and the coil heavily doped with DuPont cement. It is rigidly supported by its leads on a small terminal strip.

The oscillator-to-final coupling transformer, as specified in the parts list, is a special commercial item and may not be easily obtained. A coil of approximately 15 turns, #18 enameled wire, wound on a National XR-50 slug-tuned form and mounted under the chassis in the same relative position may be substituted. It should be connected in place of L_2 , and R_3 should be connected to the junction of C_7 and R_4 . L_3 is eliminated, and C_6 is removed.

Another special item is the combination microphone and modulation transformer. The transformer listed can be obtained as a spare part item from some dealers in surplus equipment. Standard separate midget transformers of the same characteristics can be substituted. They can be mounted so that no increase in chassis sizes is required.

All bypass condensers are mounted directly at the point they are to bypass to ground. This reduces stray coupling that would result if condensers were mounted on a terminal board and leads brought to them. It will be appreciated that if, for instance, the bypass condenser to a coil is connected to it by a few inches of wire, this wire will be part of, and add to, the inductance of the coil. At high frequencies—a few inches of hook-up wire will often have almost as much inductance as the coil itself.

The six-connector male Jones socket on the back of the chassis is for the power leads to the power supply and the control circuit. The power requirements are 300 volts d.c. at 200 ma and 6.3 v. d.c. If it is desirable to use a.c. on the filaments in some installations, separate connec-

tions may be brought out for a microphone battery. In addition, the bias battery will have to be returned to ground instead of to the negative side of the filament.

To place in operation, the oscillator-doubler is tuned up in the conventional manner, i.e. the filament condenser is tuned from the minimum capacity side for maximum stable output. The doubler transformer is adjusted for maximum final grid current. An open plug should be inserted in the final/modulator plate current jack so that no current will be drawn by these tubes while these adjustments are being made. In addition, for the initial tune-up, the modulator tubes should be removed so that the current drawn by the final can be checked separately. If a modulation transformer other than the one specified is used, it might be advisable to connect the jack so that only the final amplifier current is read. After the final amplifier is tuned up, the modulator tubes can be reinserted and the modulation checked by an oscilloscope or other means under normal operating conditions.

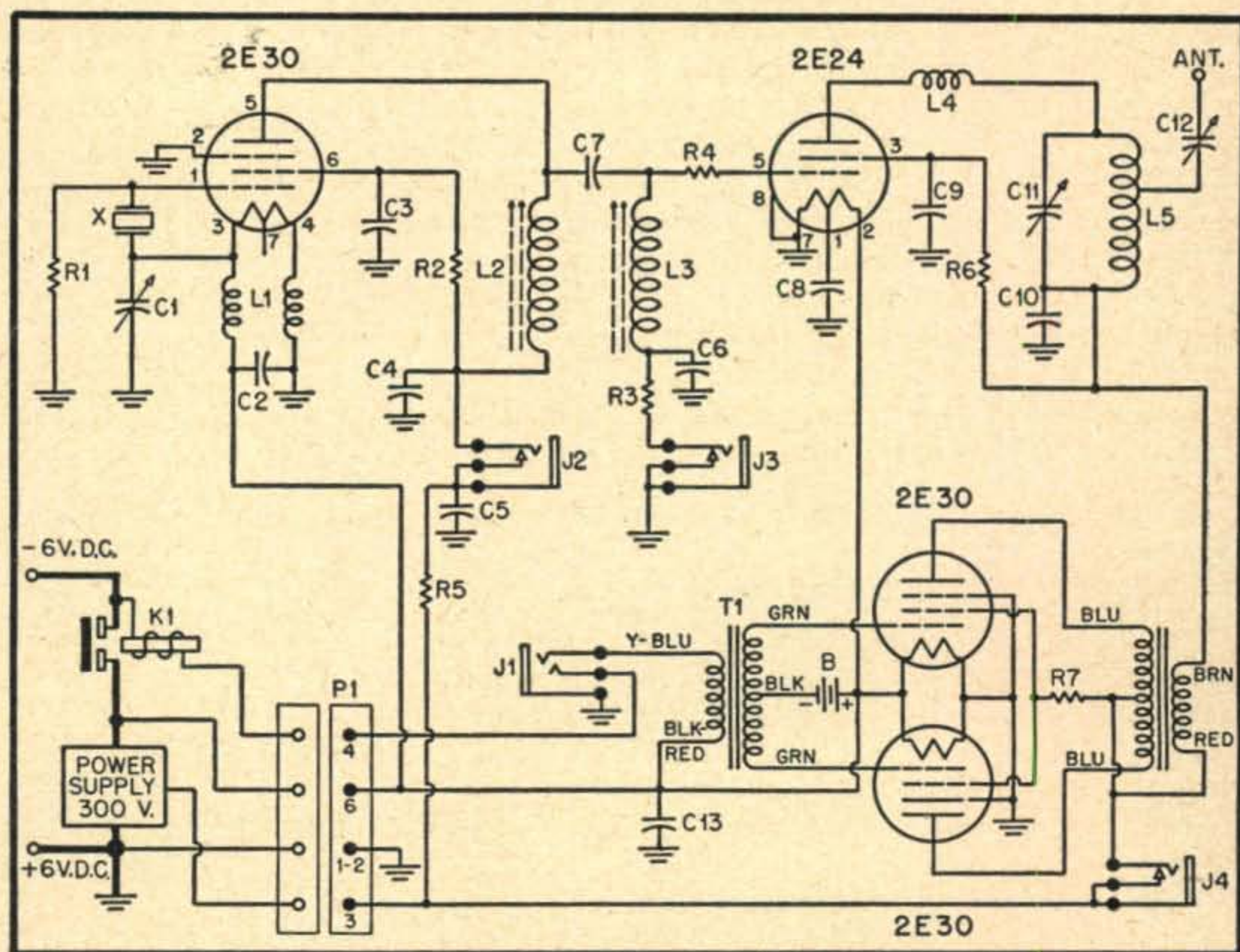

- C1—100 μf , variable midget.
 C2, C3, C4, C6, C8, C9—.001 μf , 500 v. molded mica.
 C5—10 μf 400 v. electrolytic, part of C13, Sprague 7476442-2.
 C7—50 μf , 500 v. molded mica.
 C10—.01 μf 500 v. molded mica.
 C11, C12—50 μf , variable midget, APC-50.
 C13—20-20 μf , 50 v. electrolytic, part of C5.
 J1—Two-circuit microphone jack.
 J2, J3, J4—Closed-circuit jack, insulated.
 K1—Single-circuit 25A contacts, 6 v. coil contactor.
 L1—11 turns $\frac{3}{4}$ " dia. #20 enameled wire, see text.
 L2, L3—GE Type 7479124-1 transformer with padders removed.

- L4—7 $\frac{1}{2}$ turns $\frac{1}{2}$ " dia. #20 cambric covered.
 L5—10 turns $\frac{3}{4}$ " dia. #14 tinned wire, tapped 4 turns down.
 P1—6-contact Jones male connector.
 R1, R3—100K $\frac{1}{2}$ w.
 R2—10K 1 w.
 R4—100 ohms, $\frac{1}{2}$ w. carbon.
 R5—1K 2 w.
 R6—4.3K 2 w.
 R7—5.6K 1 w.
 T1—single-button carbon microphone to push-pull grids.
 T2—Class B modulator output, part of T1, GE Type T477744-1.
 X—20-meter crystal.
 B—Hearing aid battery, 22 $\frac{1}{2}$ V-2 $\frac{1}{2}$ " x 1 $\frac{1}{4}$ " x $\frac{7}{8}$ "

A Beginner's Transmitter for the 160-Meter Band

CLINTON CLARK, W1KLS*

The fact that most of the commercially-built ham rigs don't go below 3.5 mc is no reason for not using 160 a lot more than we're using it now. Clint Clark shows how he did it without straining the budget.

THE REOPENING OF THE 160-METER BAND for all amateurs presents some opportunities for the beginner and the old-timer as well. It may well be the first phone band for the beginner, since a very simple, low-powered outfit is perfectly feasible. The need for frequency multiplication that is the necessary evil for ten, six, and two meters is eliminated on this band because only a relatively simple oscillator-amplifier is necessary. Practically all of the bugs that beset the operator who chooses the v.h.f. (144 mc and higher) for his field of operation are by-passed on this low frequency. For the old-timer who is already established on the other low-frequency bands, this may well be the means of renewing old acquaintances and forming new ones of a local nature. (The author recalls the old days of self-excited oscillators on five meters and making friends with the local boys—fellows that we didn't even know existed until we met them on the air.) A compact, low-powered rig will work locals fb and also has the advantage of holding down QRM and giving the other fellow a break. TVI problems are either not met with or easily eliminated on this band. As for dx, why bother with dx when real dx is so easily obtainable on other bands?

With the preceding ideas in mind, the author dug into the junkbox, and the outfit presented herewith is the result. With the exception of the new chassis, practically all of the other components should be items that would be found in the average junkbox. The power supply that will be required may be a pretty modest affair, such as

* 22 Webster Street, Middleboro, Mass.

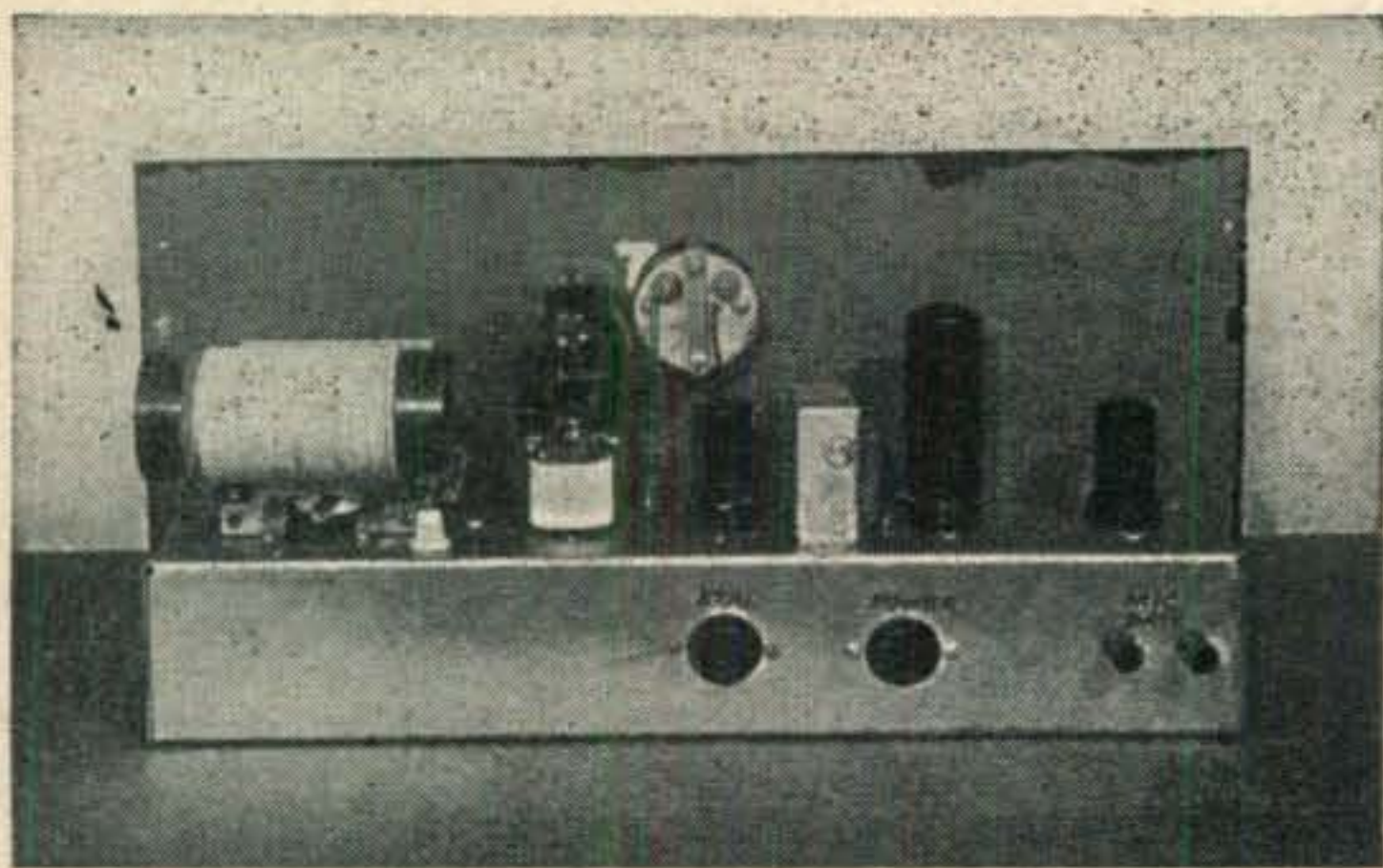

The rear view of the transmitter, illustrating, (l. to r.) final tank assembly, the 6L6GX amplifier, oscillator stage, modulation choke, modulator, and the speech amplifier tube. Compactness is the keynote.

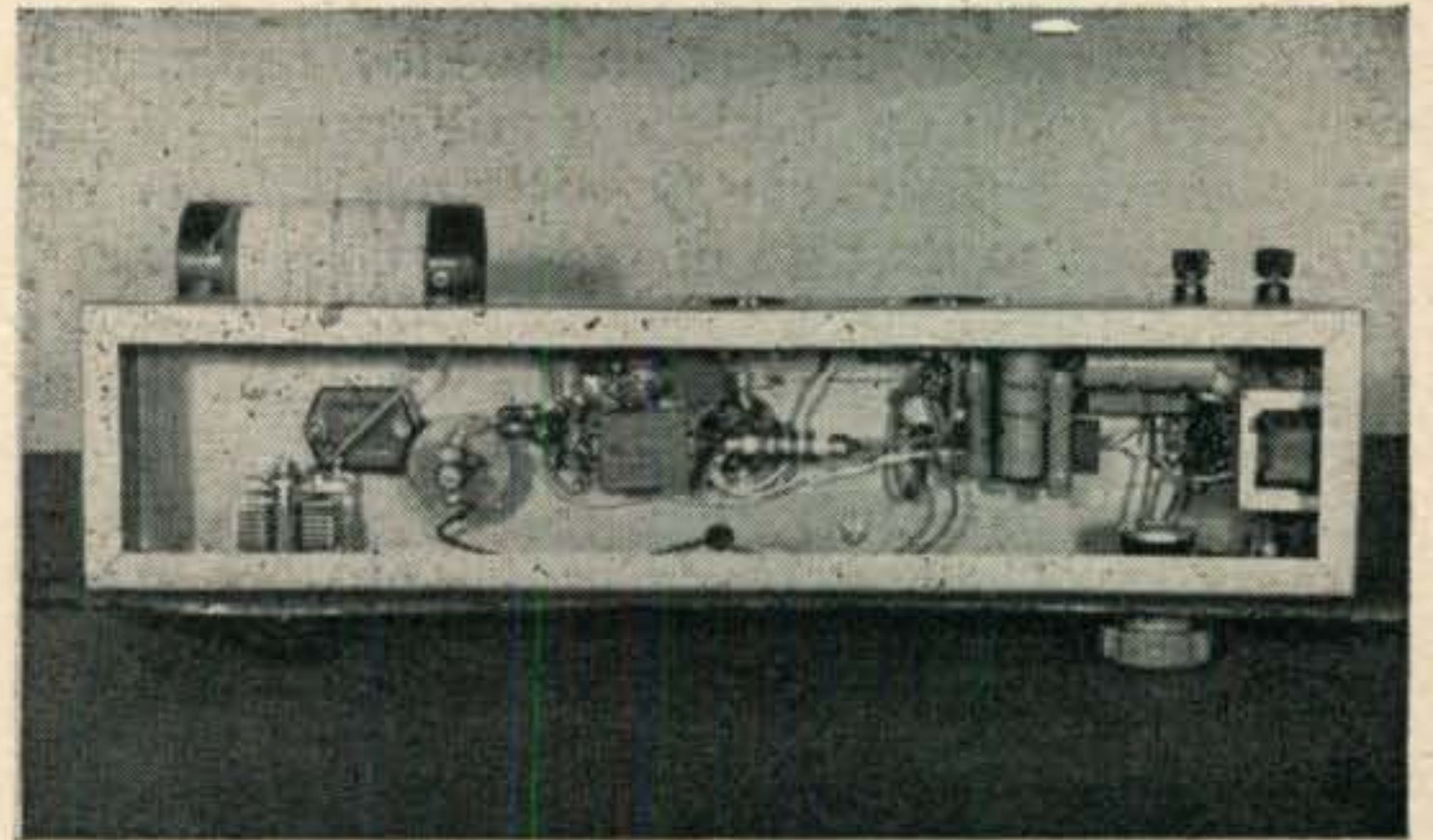

The elongated chassis is admirably suited for short leads and adequate spacing between r.f. and low-level audio components. Wiring is no problem.

one built up from the parts of a broadcast receiver of the heavy duty type. A supply furnishing between 300 and 400 volts at about 150 milliamperes is a common one and would be suitable to power this rig. All in all, the whole outfit can be a very economical layout and, for the investment involved, should provide many pleasant hours of local rag-chewing.

The Circuit

The r.f. portion of the transmitter will be recognized as a 6C5 Pierce oscillator and a 6L6G or 6L6GX as an amplifier. This combination is a time-tried lineup and is practically bugfree. The oscillator will work well on all crystals that are the type designed to give output on the fundamental. Since this stage requires no tuned circuits, simplicity of operation is easily attained. The final amplifier has a built-in pi network for tuning the final and coupling to almost any length of wire. No neutralization is required, since the grid circuit is untuned and is loaded by the oscillator. For local work the antenna problem can be boiled down to the use of almost any skywire that is up at present or by running a random piece of wire to a handy tree. This will be a relief to the ham who has an aversion to coping with the antenna problems of some of the higher frequency bands.

The audio section of the transmitter is really pretty elementary, consisting of single stage of speech (sufficient, when using a single button carbon mike) into a 6L6 employed as a Heising modulator. This type of modulation has the high voltage feed to the final pass through a filter which performs the dual purpose of acting as a plate load for the 6L6 modulator and also keeping

audio voltage out of the power supply. Audio frequency is thus imposed on the r.f. carrier and intelligence is transmitted. More than ample power is obtained, and the gain control can usually be run at a pretty low setting for ample pickup for a T-17B mike when talking close. Using a telephone-type mike, the gain may be advanced and the microphone set on the operating table for convenience.

Referring to the circuit diagram, it will be observed that an intermediate value of B voltage is needed for supplying the oscillator plate, as well as the speech tube. This is obtained from the bleeder on the power supply and is adjusted for correct value under load. The standby switch is incorporated in the power supply proper, and not on the transmitter; it is a fairly well insulated s.p.s.t. toggle and is placed in the center-tap of the power transformer. This method may be varied to the individual and his particular setup of power supply arrangement.

Construction

As will be observed from the photos, the entire rig is assembled on a chassis base of the dimensions 17" wide 4" deep, and 3" high. This is a standard item (Bud Radio No. CB-1066) and is the same type that is used for a popular all-band exciter unit. The "linear" arrangement makes for short leads and placement of parts in close proximity to each other. Looking at the rear view of the assembly, the tube lineup, starting at the right, is 6C5 speech, 6L6 modulator, 6C5 xtal oscillator, and 6L6GX final amplifier. The modulation choke is mounted between the 6L6 modulator and the oscillator. The final amplifier coil and condenser are at the extreme left of the chassis. The coil form is 2" diameter and 4½" long, which allows ample room for the winding, which consists of approximately 75 turns of No. 22 or 20 DCC. This wire happened to be available, but if enameled, or DSC, is on hand this could be used just as well.



If your operating position is so located that it must be of pleasant appearance, this little transmitter will fill the bill without damaging the bank account.

With the tuning condenser that we used for C₁, this coil resonated at about half capacity.

Since the photos show the parts layout pretty clearly, explicit directions for placement and mounting of the various components will not be given. As much as possible, it is advisable to make the wiring point-to-point, and the smaller items, resistors and capacitors, may be wired in direct with their pigtails. The panel is made from masonite and the cabinet fabricated from some selected boxboards. Decoration in the form of the light colored strip across the top and down at the right was done with aluminum paint, it being accurately aligned with masking tape. The battery which furnishes current for the microphone may be a couple of flashlight batteries in series, or a 4½-volt C battery makes a good compact source.

When wiring is completed and checked thoroughly for accuracy, the little rig may be fired up. Insert tubes into their proper sockets and the crystal into its socket on the chassis backdrop. Proper connections to the power supply should be

made and the microphone battery connected to the binding posts provided. The author brought his power connections into the chassis via a homemade cable and an old tube base which plugs into the socket on the chassis backdrop. Not indicated on the circuit diagram is the fact that the microphone connection is made by means of a phone plug which is inserted into a single-circuit jack on the front panel. Use of a single-circuit jack means that every time the station is shut down, the mike plug

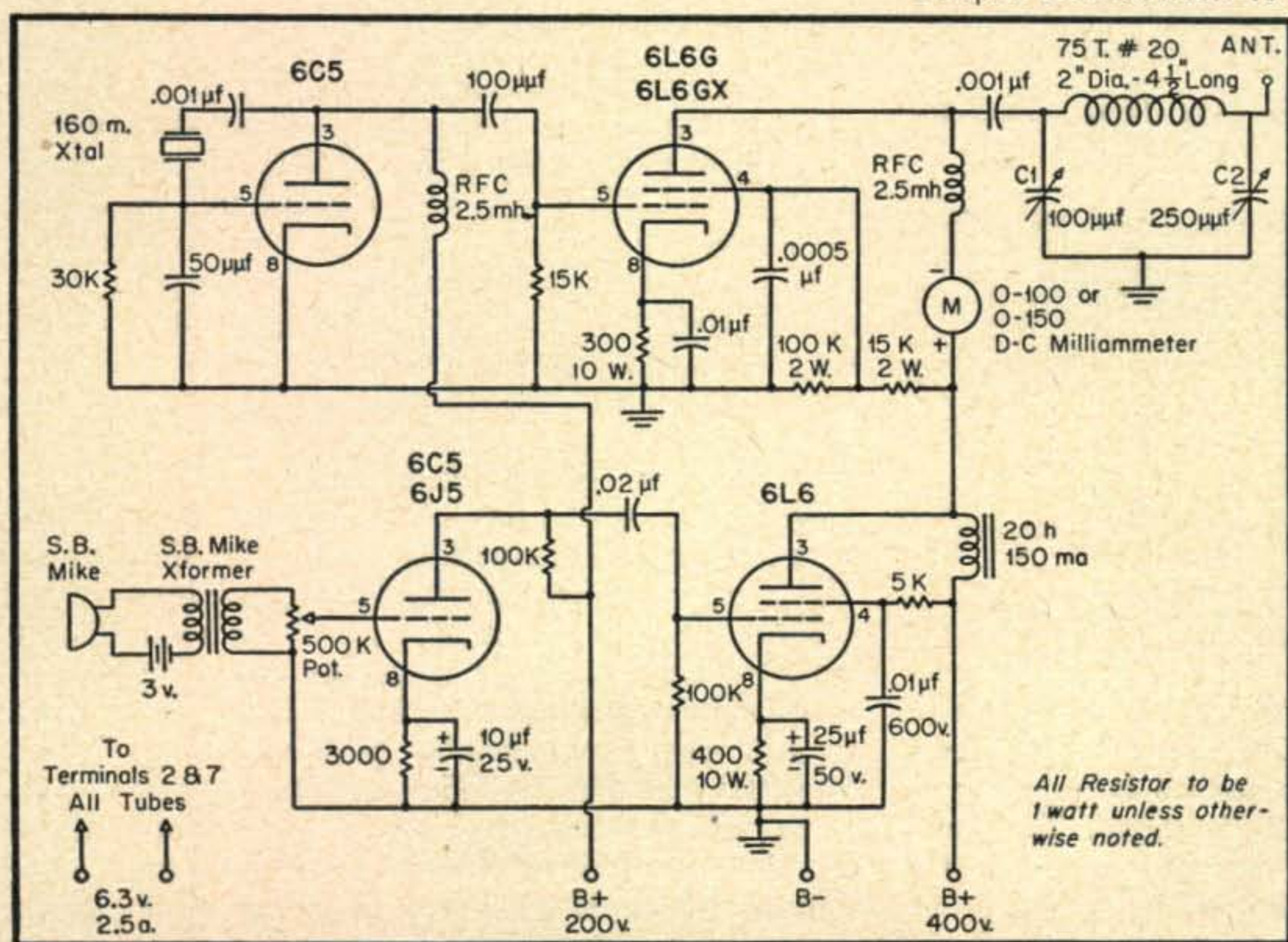

(Con't. on page 60)

A Senior-Grade 807 Transmitter

EDWIN W. HILL, W4PQA*

A compact 40- to 60-watt bandswitching ham rig featuring stability, versatility, and excellent signal quality.

AMONG AMATEURS, THE 807 is probably the most universally used transmitting tube type in the world. If properly handled, it is capable of giving almost unmatched performance from the standpoint of economy, reliability, and circuit simplicity. Unfortunately, the 807 has gained somewhat of a reputation of being only a beginner's tube, and just because it has become so popular with the newcomer, who more often than not uses it in a way that unavoidably leads to trouble, it has been condemned more than once as being tricky and hard to handle. That this is a fallacy is demonstrated by this transmitter which uses 807s in *two* cascade amplifier stages and yet is completely free from the parasitic oscillations and instability so commonly associated with beam tetrode circuits. It is, in fact, the sweetest operating rig that it has been the author's experience to construct.

Modern design trends are incorporated in this transmitter. Bandswitching is used throughout, and it is well shielded as a help against TVI. Once the last adjustments have been made and the sides of the cabinet fastened in place, all operations are controlled from the front panel, and there is no possibility of accidental electrical shock. Four ham bands, from 3.5 to 21 mc, are available at the flick of a switch, and output on all bands is possible with just one crystal. If desired, output on the 21-mc band may be dispensed with in favor of operation in the 28-mc band. Between these limits the output is good and operation efficient. Although the rig contains

* Chief Engineer, WDHL, Box 1191, Bradenton, Fla.

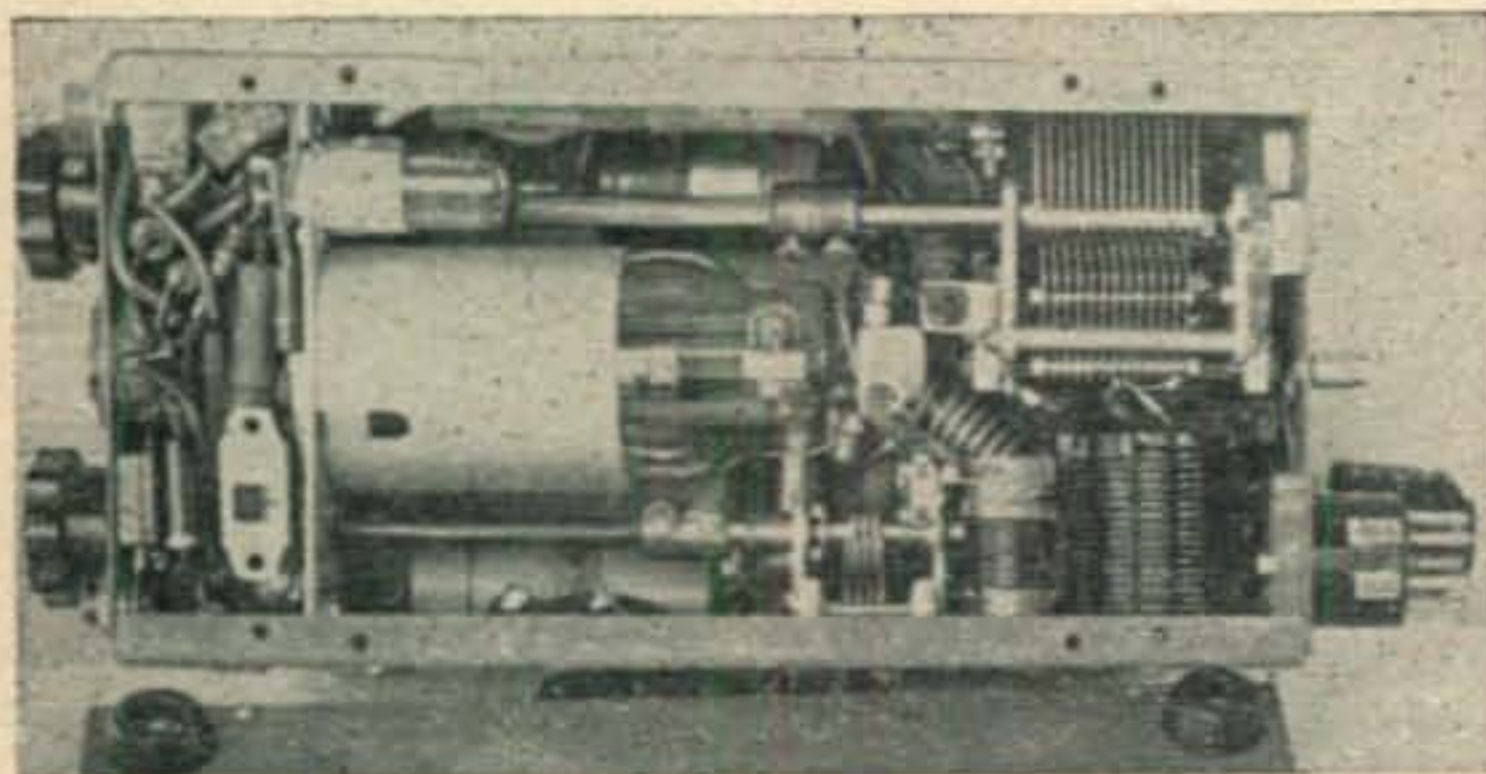

The bottom view with the bottom plate removed. The intermediate 807 and the 6C4 oscillator are shown mounted on a baffle plate. The method of mounting of the tuning condensers and coils is shown. The small binding post at the rear of the transmitter is for grounding purposes.

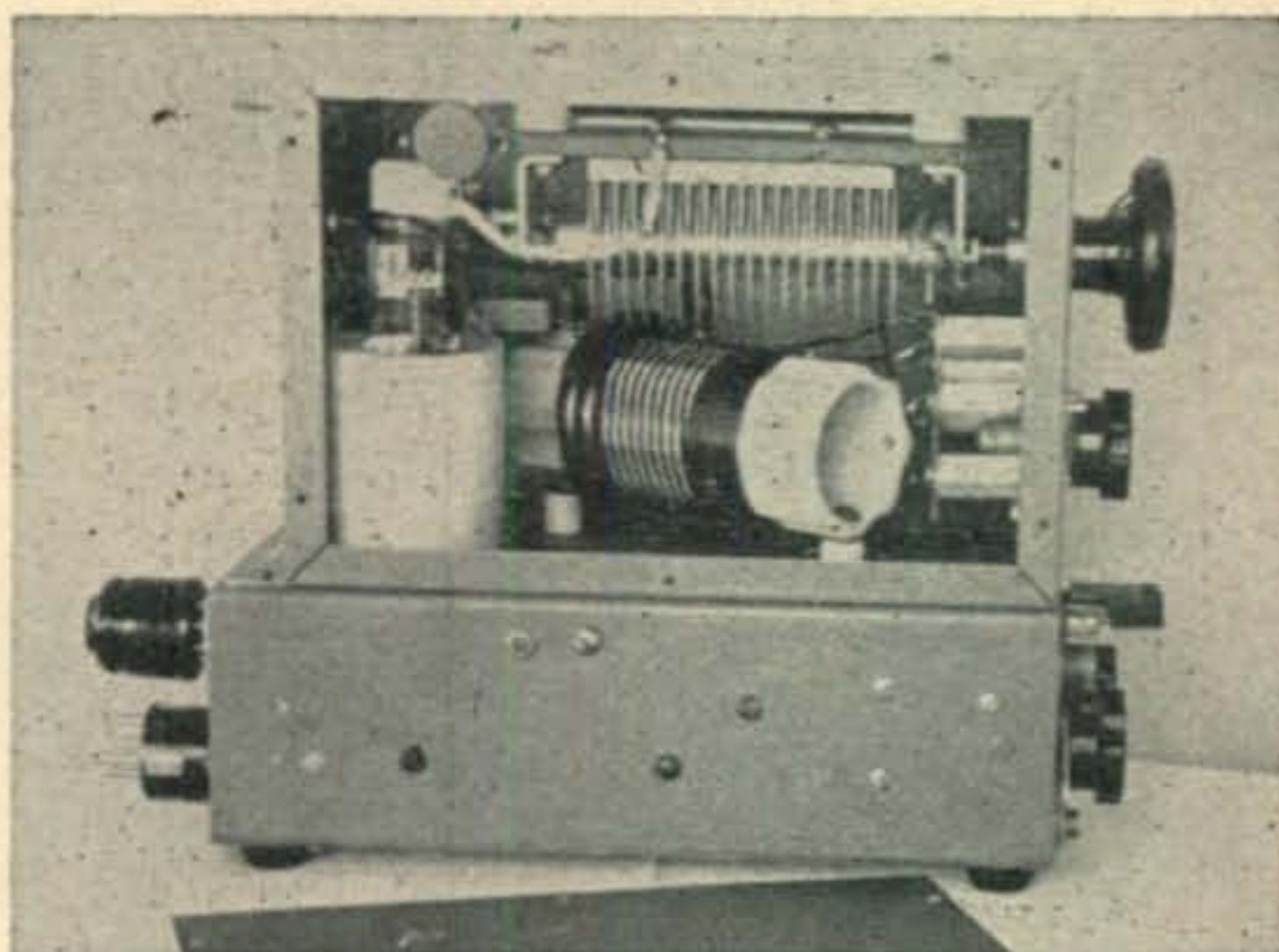

Looking at the right side of the rig with the cover plate off. The final amplifier plate circuit components and the band-switching details are clearly shown.

several circuit features that are quite novel, construction is neither complicated nor particularly difficult, and any ham who has had the experience of putting together his first transmitter or two should be able to duplicate it without trouble. The essential thing is to treat the little 807s, construction-wise with the same respect and careful attention to sound practice that is given to their higher-powered counterparts.

Shielding Considerations

The first consideration is shielding, and lack of attention to this is the source of all subsequent difficulties with many 807 rigs. Tube manuals tell us that the 807 must be "adequately" shielded. This means just what it says, and merely putting a half-shield on the tube and a baffle plate here and there is not adequate shielding in any sense of the term. The power sensitivity of the 807 is tremendous, and the input circuits must be entirely isolated from the output circuits. The only way this can be done is by very tight shielding. Like it or not, the day of the "open" ham transmitter is over, particularly with the number of TV viewers increasing by leaps and bounds.

Very efficient shielding, as well as mechanically rugged and physically attractive construction, is secured in this transmitter by mounting a standard 5" x 9" x 6" steel utility cabinet on top of a 5" x 10" x 3" chassis. The top compartment contains only the output plate circuit components of the final amplifier. These are the final tank condenser, which is insulated from the cabinet; the

tapped final plate coil; the bandswitch; and the r.f. plate choke and bypass condenser. The upper portion of the final 807 extends into this compartment, but a hole is drilled in both cabinet and chassis and the socket for the 807 is sunk-mounted so that the lower (input) part of the tube is in the lower compartment. In this way, the shielding between output and input circuits is complete. A half-shield is also put around the tube in accordance with standard practice. The result is a final amplifier which is absolutely stable and shows no sign of self-oscillation, with or without excitation.

The lower compartment, or chassis, holds the 807 intermediate amplifier and the crystal oscillator. In this case, a shielding plate is used to mount the 807 in a horizontal position, and this plate, combined with the bottom plate of the chassis, forms another effective shielding arrangement. This 807 is just as stable as the final amplifier and cannot be made to oscillate under any conditions.

The Circuit

Now for the circuit details. Reading the circuit diagram from left to right, we come first to the crystal oscillator. This is a triode oscillator of the "hot cathode" Pierce type and uses a 6C4, which is mounted horizontally alongside the 807. This oscillator works well, with low crystal current, and is easy to get going. It has the advantage over other Pierce Circuits that one side of the crystal may be grounded. The only critical component is the mica feedback condenser between grid and cathode. The tube will not oscillate without this condenser, and in this particular layout the

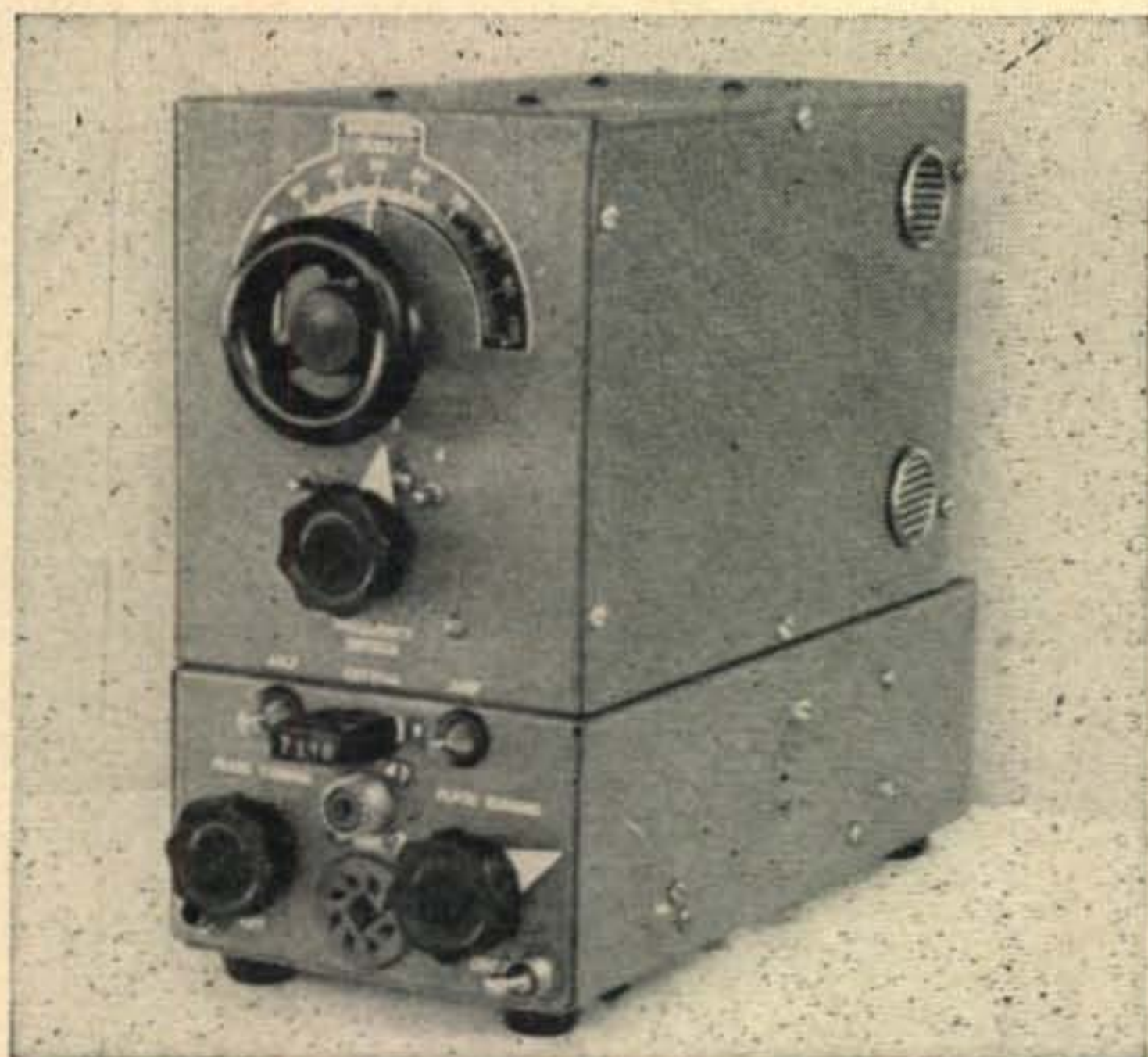

This shows all the operating controls. The handwheel is the final tank tuning condenser. Immediately below this is the band switch for the final amplifier. The crystal plugs in between the two pilot light plate-current indicators. The coax fitting for VFO input is just below the crystal, and the meter socket is below the VFO input. The two pointer-knobs tune the two intermediate amplifier tank circuits.



A view of the transmitter with its attendant accessories.

optimum value was found to be 68 μf . The oscillator keys well, but it might be well to experiment with this condenser for best results. The author does not like oscillator keying; however, either oscillator or amplifier keying is optional in this rig and may be selected by means of the slide switch mounted on the bottom plate. The plate potential on the 6C4 is about 115 volts under operating conditions. A regulated voltage is used, but this refinement is not absolutely necessary. A s.p.s.t. toggle switch, which is the one in the lower right corner of the front of the transmitter, turns the oscillator off for listening on your own frequency or when VFO input is used. Crystals are plugged in on the front panel so that frequency changing is a handy process.

The output of the crystal oscillator is taken from the cathode and fed to the first 807 through a 56- μf . mica coupling condenser. There is sufficient r.f. to drive the 807 to good output. If a VFO is used, it is fed to the grid of this 807 by means of the front panel coax fitting. When VFO operation is desired, the crystal oscillator is generally switched off, although it is possible to use both simultaneously—which might be useful, say, for frequency marker purposes or for setting the VFO to a desired crystal frequency.

The first 807 can be worked as a straight amplifier or as a frequency multiplier. Cathode bias is used for protective purposes, and it is possible to remove all excitation to this transmitter with no damage to any of the tubes. The output circuit of this stage is interesting in that a novel system of bandswitching is used.

A Novel Band-Switching System

Briefly, the idea is to use two tuned plate tanks in series. The tuning condenser for each tank is made large enough to cover two adjacent bands. One of the outer plates of the condenser rotor is bent inward slightly at the corner so that at full or minimum capacity the condenser will short. In this way, it is possible to use one of the tanks at a time or both together. This arrangement works very well. The larger tank circuit covers the 3.5- and 7-mc bands, as well as all of the spectrum in between, and the smaller tank circuit tunes the 14- and 21-mc bands. Generally, only one of the tanks is used at a time. However, it will be found

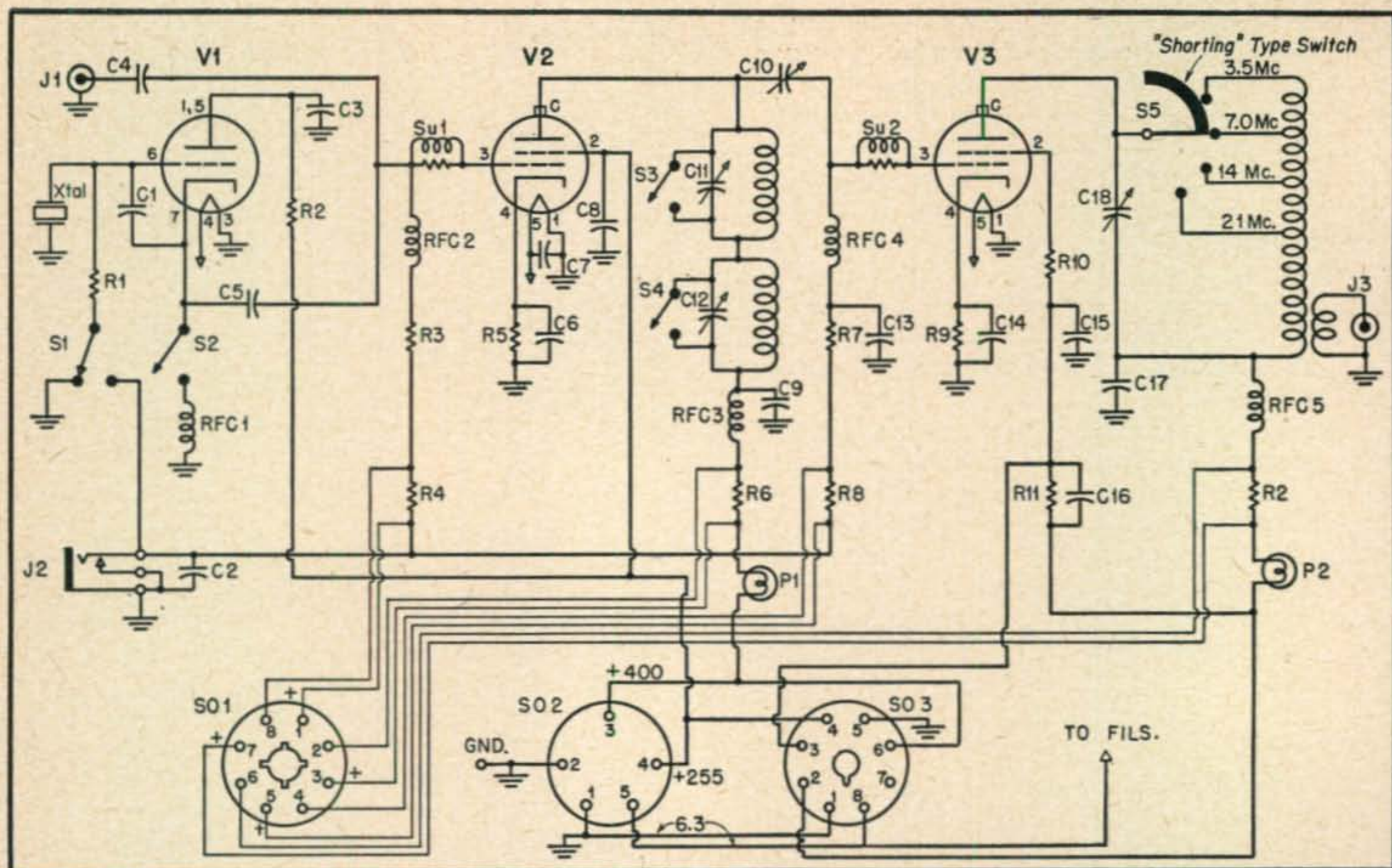

- C1—68 μf , silver mica (see text)
 C2, C4, C6, C7, C8—.01 μf , mica
 C3—.01 μf , 400 v., paper or mica
 C5—56 μf , silver mica
 C9—.01 μf , 1200 v., mica
 C10—3/30 μf , mica trimmer, isolantite insulation
 C11—50 μf , midget variable (mounted on lucite block for insulation from chassis)
 C12—300 μf , receiving type variable (National STH300, mounted on a lucite block and ceramic "buttons" for insulation from chassis)
 C13—.001 μf , mica
 C14—.01 μf , mica, and 1. μf , 600 v., paper, in parallel
 C15—.005 μf , mica, 1200 v. rating
 C16—.5 μf , 600 v., paper
 C17—.01 μf , mica, 1200 v. rating
 C18—150 μf , variable spaced for 1500 v. (mounted on ceramic "buttons" for insulation from chassis)
 R1—51K ohms, 1 w., carbon
 R2, R3—22K ohms, 1 w., carbon
 R4, R8—220 ohms, 1 w., carbon
 R5—500 ohms, 10 w., wirewound

- R6, R12—56 ohms, 1 w., carbon
 R7—6800 ohms, 5 w., wirewound
 R9—250 ohms, 10 w., wirewound
 R10—68 ohms, 1 w., carbon
 R11—50K ohms, 20 w., wirewound
 J1—VFO input, coax fitting
 J2—keying jack, closed circuit tube. (See text for changing from blocked-grid keying to cathode keying.)
 J3—r.f. output, coax fitting
 P1 and P2—"brown bead" pilot bulb pressed into rubber grommet and mounted on front panel.
 RFC1, 2, 4—2.5 mh
 RFC3, 5—1.0 mh
 S1—s.p.d.t. slide switch for optional osc. or amp. keying (see text)
 S2—s.p.s.t. toggle switch (see text)
 S3, S4—"Gimmick" switches on tuning condensers made by bending one outer rotor plate (see text)
 S5—final amplifier bandswitch, heavy duty shorting type. Ceramic insulation.
 So1—meter switching socket with 3 additional locating grooves filed in it (see text)
 So2—5-prong male socket for power supply cable (made from 5-prong tube base)
 So3—octal power switching socket (see text)
 Su1, Su2—Ohmite P-300 parasitic suppressors
 V1—6C4 crystal oscillator
 V2—807 intermediate amplifier, frequency multiplier
 V3—807 final amplifier, frequency multiplier
 XTAL

that if the final 807 is being used as a doubler, its output may be increased appreciably by tuning one of these tanks to the doubled frequency while leaving the other tuned to the original frequency. For shortest leads, the high frequency tank is connected to the plate of the 807, and the low frequency tank is connected to the "cold" end of the high frequency tank. The screen voltage for this stage is 255 volts, which is a regulated voltage. Ohmite P300 parasitic suppressors are used in the grid circuits of both 807s to prevent any possibility of v.h.f. oscillations. No trouble of
 (Continued on page 47)

Bring all grounds for the crystal oscillator and first 807 stage to a common point, preferably the cathode of the 807.

Bring all grounds for the final amplifier to a common point at the cathode of the final 807.

The 6-meter Observing Project

O. P. FERRELL, Project Supervisor
EVELYN UHL, Tabulator

MARY T. BERGEN, Administrative Aide
ANN NEWBURY, Tabulator

(This work is supported in part by the non-profit cost-reimbursement Contract No. AF19(122)-72 and modifications with the U. S. Air Force, through the sponsorship of the Geophysical Research Directorate, Air Materiel Command.) The work of this project is conducted at the following address. Therefore, all mail should be addressed to RASO, c/o Radio Magazines, Inc., 121 S. Broad St., Philadelphia, Pa.

Status of the 6-meter Project

Total Number of Work Group Members:

North America—356
Oceania — 1
South America— 12
Africa — 2

Total Number of Screened Observations—7980
(1/10/48-5/31/49)

Number of Reports Received (to date)—1570

Observers Inactivated (1/20/50—2/20/50)—1

New Observers: W2CXE, W4LRR, W6FYM,
W6ZVD, W8MVG, W9FJI,
WØIWE, HK1HQ, ZS1DM,
ZS1P, Burr, Pickering, Sender,
Stanley

Raso Newsletter

In answer to many inquiries, the RASO monthly Newsletter is only distributed to cooperating ob-

servers of the 6-meter Project because of the limited number that are reproduced, and it is impossible to fill requests for copies from those outside the Project. A few special exceptions have been made, but these are being held to a very low number.

The RASO monthly Newsletter is reproduced on light-weight paper and dispatched via air mail to all cooperating observers outside the North American Continent. The Newsletter generally consists of six pages and includes a résumé of the 6-meter DX heard or worked during the preceding month. Recent Newsletters have also described numerous systems for automatically sweeping the 6-meter band. A portion of the recent Newsletter was also devoted to the "RASO Propagation Note Book" which described the phenomena of *back-scatter* and its use in predicting 6-meter F-2 layer openings.

WWV on 50-mc?

It has been suggested by several RASO observers that steps be instituted to request the CRPL, National Bureau of Standards, Washington, D. C., to delete their present 35-mc WWV service and substitute a similar service on 50-mc. It was pointed out that there are apparently very few users of the 35-mc service and that the institution of a 50-mc service would not only be beneficial to the amateurs, but also to the commercial services utilizing the band 42-50 mc.

The present radio carrier frequencies allocated by the International Telecommunication Conference at Atlantic City in 1947 for the broadcast of standard radio frequencies do not include an assignment at 50-mc. Channels at 2.5, 5, 10, 15, 20 and 25 mc are 10 kilocycles in width and are assigned on a full-time cleared-channel basis. It is, therefore, necessary to report that unless the amateurs themselves are willing to allocate temporarily the lower 5 kilocycles on their 6-meter band, no action can be taken on this proposal.

One of the principal reasons for requesting the 50-mc service is to provide a 24-hour beacon. As RASO observers are already aware, there are or have been within the past several months three amateurs independently operating 6-meter beacon transmitters. It is felt by many of the observers west of the Mississippi River and in South America that the 50-mc WWV service would make an excellent beacon to warn them of possible band openings.

SWLs Attention!

Do not forget the important part that the SWLs are playing in the RASO program. It is not necessary to be a licensed amateur to take part in this vitally-important program. If you have receiving equipment operative on the 6-meter band, drop us a note at RASO headquarters and learn how you can be of help. The mysteries of 6-meter propagation are many, and the help of every available receiver is needed.

SPECIAL NOTICE

50- and 144-mc Operators

A unique situation wherein amateur radio may play an important part is likely to develop in certain portions of Colorado, Nebraska, Kansas, Oklahoma, and Texas. We are interested particularly in obtaining the names of amateurs who have operated either 2 or 6 meters and who are located in fairly open and fairly quiet radio receiving locations. If you are in one of the areas mentioned below and would like to participate in an unusual radio experiment, please send a postcard to the RASO Office. A questionnaire will then be sent to you giving you further information on the requirements.

Operators are desired from the following areas:

Colorado—within the following counties; Logan, Sedgwick, Phillips, Yuma, Kit Carson, Cheyenne, Kiowa, Bent, Prowers, Baca.

Kansas—West of the line formed by these counties; Washington, Clay, Dickinson, Marion, Butler, Crowley.

Nebraska—West of the line formed by these counties; Jefferson, Fillmore, Hamilton, Merrick, Nance, Greeley, Garfield, Rock, Brown, Cherry.

Oklahoma—West of the line formed by these counties; Kay, Noble, Logan, Canadian, Caddo, Kiowa, Jackson.

Texas—North or West of the line formed by these counties; Handeman, Cottle, Motley, Floyd, Hale, Lamb, Bailey.

Stabilized Low-Power Tetrode To Be Available for Use in Ham Rigs

ALBERT E. HAYES, JR., W2BYF*

At last a stabilized tetrode you can plug into your 807 socket and forget. Sylvania's announcement of the 807W looks like the answer to the prayers of a large segment of the amateur body. This super-807 will be generally available for ham use in late summer or early fall.

THE 807 HAS PROVED TO BE the most misunderstood tube in the manual. There are probably more 807s in amateur transmitters today than all other tube types combined, and yet, if you ask the average ham what he thinks of the bottle, you're almost sure to hear a report of nearly-untamable parasitics, tendency for self-oscillation at or near the operating frequency, and inexplicable tendencies toward TVI production. And yet the gang loves the old 807 because it is indeed in a class by itself when you figure out what it can do.

Most of the shortcomings of the conventional 807 can be traced, in large measure, to the length of the screen lead from the screen itself to the socket connection—this due to "tradition" as much as anything else. When the 807 was introduced in the mid-30s, virtually all standard tubes were built along the same lines, with a "press" in the mount and a long meandering lead from each element to its base connection. The short mount, with the button base and its attendant short leads, as later exemplified by the 813 and the 2E26, to name two, was not in general use when the designers worked up the 807. It was a good tube for its day, and it filled a definite need in both amateur and commercial gear. If it was kept reasonably well loaded, if its shielding was "adequate," it behaved pretty well.

With the postwar advent of TVI as an important factor in the design of amateur gear, the attainment of nearly absolute stability, loaded or unloaded, became important, and those of us who examined the 807 with a critical eye realized that something better was sorely needed by the industry. "If only the screen lead were an inch or so shorter" was the cry. Some 807s marketed under the Westinghouse label, bearing the brand "made in Canada," showed up on the postwar surplus market, and these tubes were found to be a *little*, ever so slightly, easier to

* Editor, CQ

handle than the conventional tubes turned out by RCA, GE, Sylvania, et al. In looking for the cause of this difference, it was determined that the "Canadian 807s" had a screen lead which was about one-eighth of an inch shorter than that of the more usual tube. Just this slight difference in length, together with its decrease in inductance at high frequencies, was enough to make a noticeable difference. How we longed for a really "short" 807, built perhaps along the lines of the 813 or the 2E26!

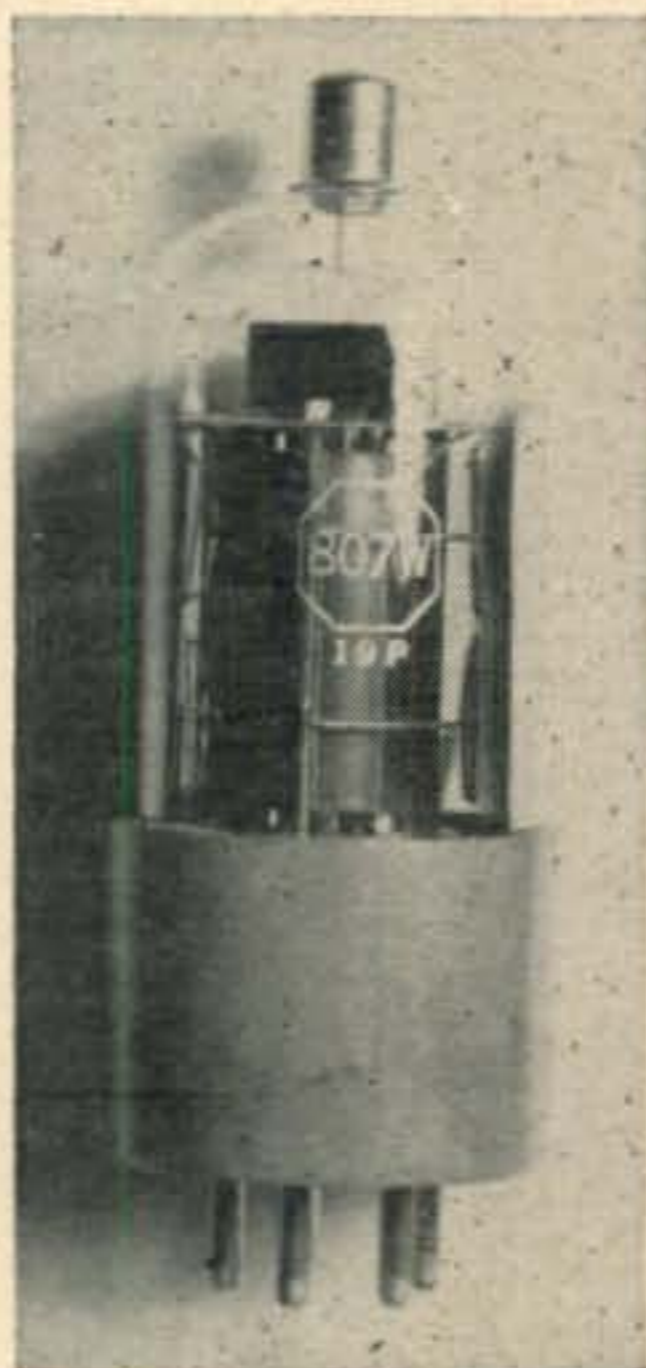

The Sylvania 807W

Now Sylvania has come along with a new bottle, the 807W, which seems to be the answer to the prayers of the ham who has sweated with parasitic suppressors, damping resistors, and traps to kill the instability in his 50-watt. The accompanying illustrations will give the reader an idea of the size of the tube compared with the 807. The ratings, as far as operating voltages and currents are concerned, are identical to those of the 807. The big difference, as far as we're concerned, is the shortness of the leads to the cathode, screen, and control grid.

Performance-wise, the 807W has proved to be far easier to stabilize than the 807. We took a little 75-watt rig we happened to have around the place for a standby job (an Eldico TR-75), and removed the parasitic-suppression chokes in the grid and plate leads of the 807 stage. Wow! We had troubles, okay. Not only did we get the v.h.f. parasitic we expected, but the tube also "took off" at the operating frequency. Here was a good example of an unruly 807 stage.

We then plugged our 807W into the 807 socket, gave it a few seconds to come up to temperature, and pressed the key. Believe it or not, that 807W was stone cold! Absolutely stable, with any variations of tuning elements in the grid or plate circuits having no effect whatever on the stability of the tube. You can see why we fell in love with Sylvania's new baby.

General Performance

Forgetting, for a moment, the excellent shielding and stability of the 807W, we then investigated its performance in comparison with the 807. As far as we can tell, the two tubes are twins on all bands up to 14.4 mc. On the 28-mc band the 807W seems to require a little less grid drive to attain normal output than did the 807. This will be a boon to the mobile gang who want to operate 28 mc with two stages, starting from a 7-mc crystal. We haven't had a chance to check it on six, but it's likely that it will be even better there.

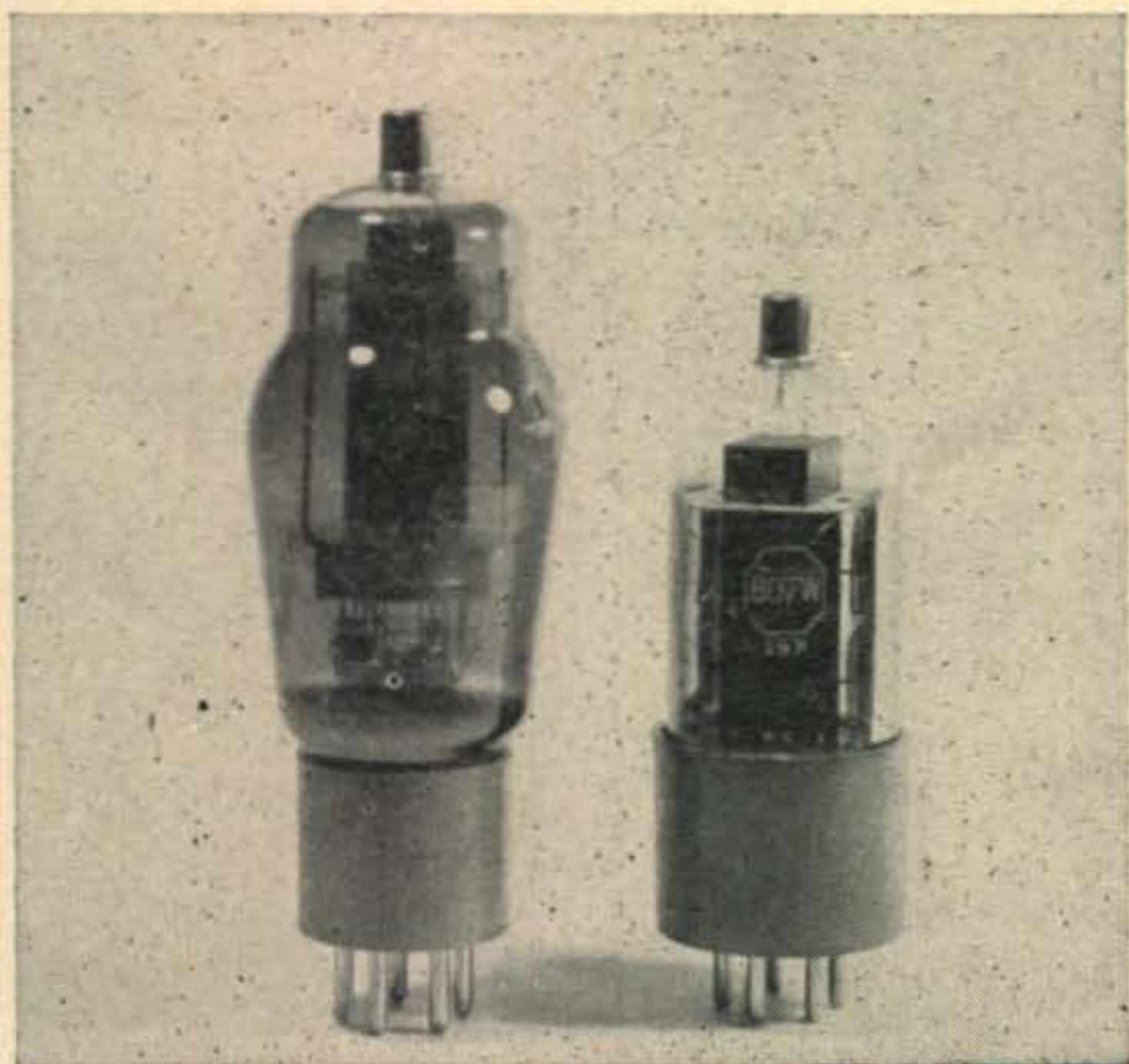

The comparative sizes of the 807W and the 807 can be seen in this illustration. The shorter leads between the elements themselves and the socket pins are the major reason for its improved characteristics.

How does it stand up? We've been using our 807W for two weeks now, at 750 volts and 100 ma, and it hasn't given us a bit of trouble, in spite of the fact that we've let it get pretty far off resonance many times while tuning up on new frequencies. Yes, we think the 807W is definitely the tube of the future in low-powered ham gear.



Just plug the 807W into the old rig. The socket connections are exactly the same as the good old 807.

NEW PRODUCTS

Jim Millen, W1HRX, announces the availability of a new series of three low-frequency coils for the Millen Grid Dip Meters. The three coils cover the range from 325 to 2000 kc, and bear the designations 46702 (925-2000 kc), 46703

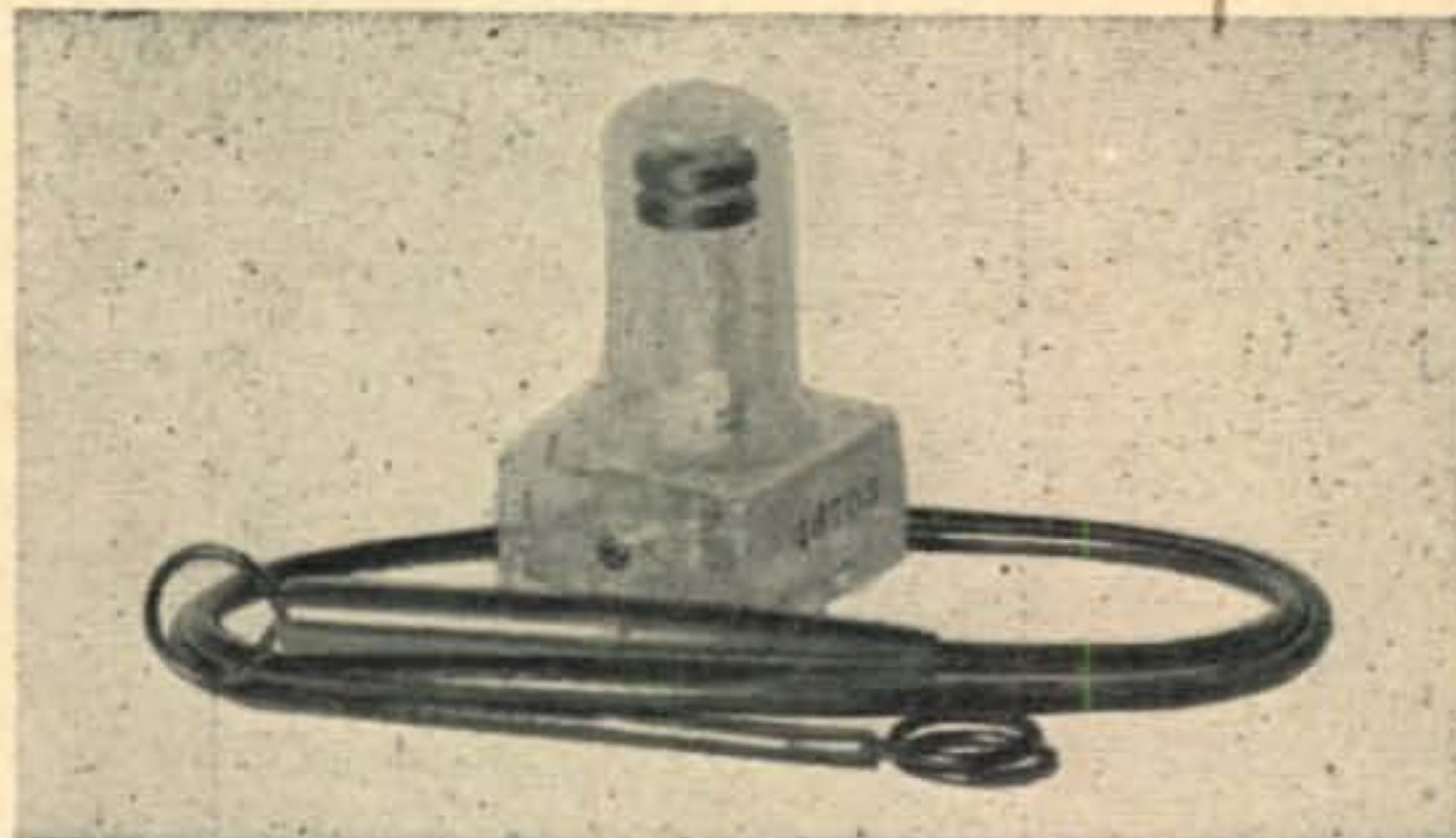

(500-1050 kc), and 46704 (325-600 kc). He has also come up with a probe for coupling the dip meter coil to a circuit when clearances won't permit more orthodox coupling. The 46703 coil and the probe are illustrated in the accompanying photograph. Write to James Millen Mfg. Co., Malden, Mass., for complete information.

Meters Built to "Take it"

The Marion Electrical Instrument Co., of Manchester, N. H., announces a new family of panel instruments—the "ruggedized" line. This development, sponsored by the Signal Corps Labs, has been in progress for some 2½ years and has resulted in panel meters of extraordinary performance capability. These new units should find wide use in ham mobile gear where conventional instruments frequently get beaten to death.



Detailed information about these new meters may be obtained by writing directly to the manufacturer.

New Mobile Antenna

Master Mobile Mounts, Los Angeles, announces the addition of a new all-band mobile antenna to their already extensive line. The new unit, the M-75, is a specially-designed center-loaded job, with plug-in loading coils available for use on all bands from 3.5 to 30 mc. As originally supplied, the M-75 is tuned for operation on about 3600 kc—sounds like they have some mobile c.w. men working for them. Drop MMM a line if you'd like further dope.



Extending the Range of the Grid-Dipper

WILFRED M. SCHERER, W2AEF*

The Grid-Dipper is a mighty handy device for low-frequency uses such as BC receiver servicing, i.f. work on your communications receiver, and 160-meter transmitter tank circuits. If you've built one that works on the higher frequencies, here's how to extend its range down to 650 kc.

IT HAS OFTEN BEEN NECESSARY to employ a grid-dipper on frequencies below the 2-mc limit of the original instrument described by the author in *CQ*.¹ Inquiries regarding lower frequency operation have also been received from many readers.

Operation below 2 mc does not simply mean the employment of a larger inductor. The *L/C* circuit easily can be made to resonate, but the tube will not oscillate. This is due to insufficient feedback at the low frequencies through the relatively small capacitive coupling afforded by the 100- $\mu\mu\text{f}$ split-stator variable capacitor.

Oscillation may be realized by shunting higher fixed capacitance across each section of the variable capacitor, but this will radically reduce the range or tuning ratio with any one inductor.

Ample feedback may be had by employing inductive coupling between grid and plate. This may be accomplished simply by center-tapping the inductor and then grounding this point. Instead of having a capacitive feedback type split-Colpitts oscillator, we will now have an inductive feedback circuit, which, in effect, is the familiar Hartley oscillator. A disadvantage, though, is one of inconvenience, as a third terminal must be provided for the grounded center-tap.

* 100 E. Palisade Ave., Englewood, N. J.

¹ "The Improved Dipper," Scherer, *CQ*, February 1949.

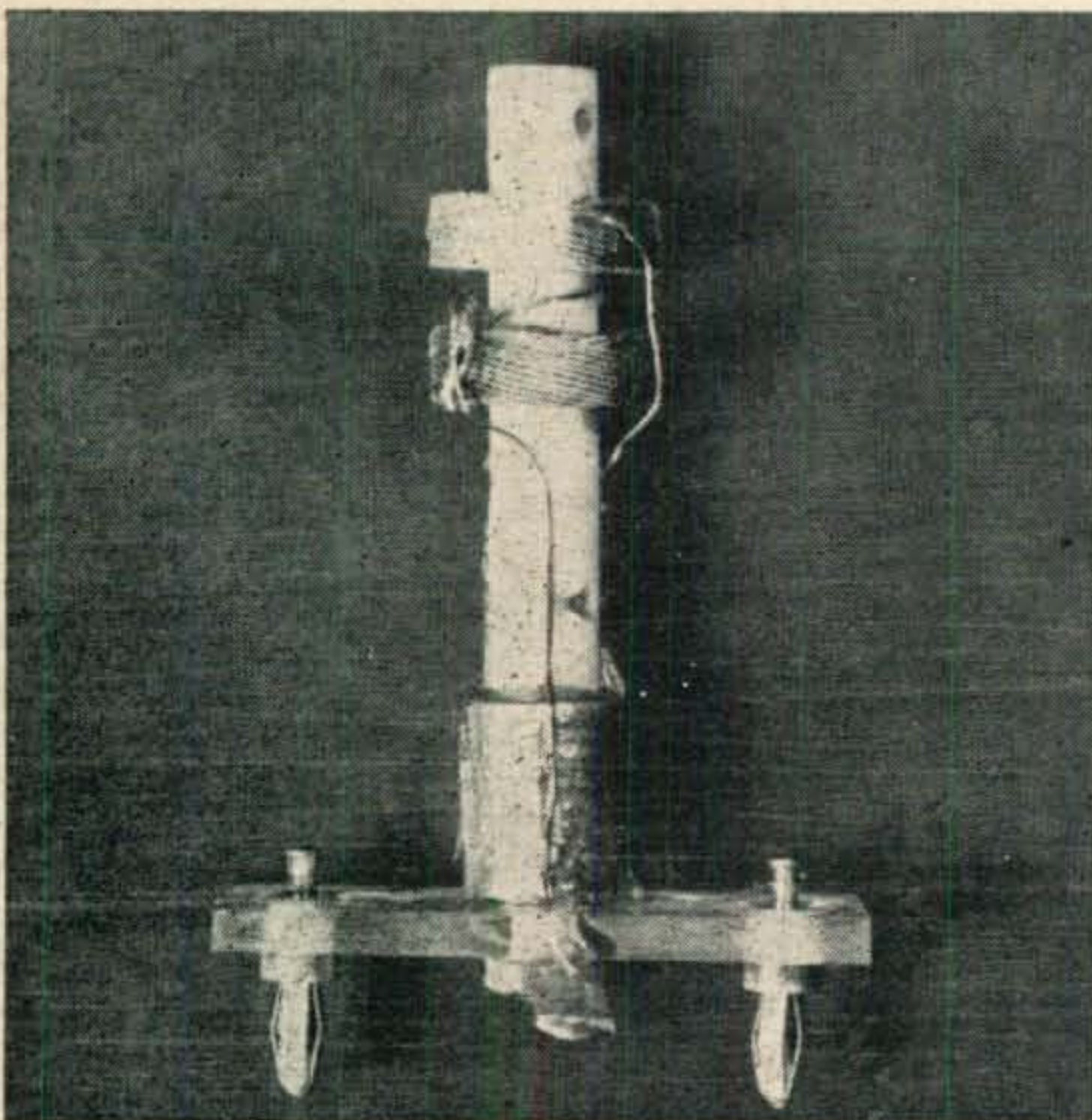

Inductors may be easily made from commercially manufactured pie-wound 1-mh and 2.5-mh r.f. chokes of the standoff type. These are nicely adaptable since they may be conveniently mounted on the plug-in coil strip.

All pies, except the two at the far end, should be removed. When removing the unwanted pie sections, be certain not to break the leads from the remaining ones. A two- or three-inch length of small size wire should be soldered to the wire

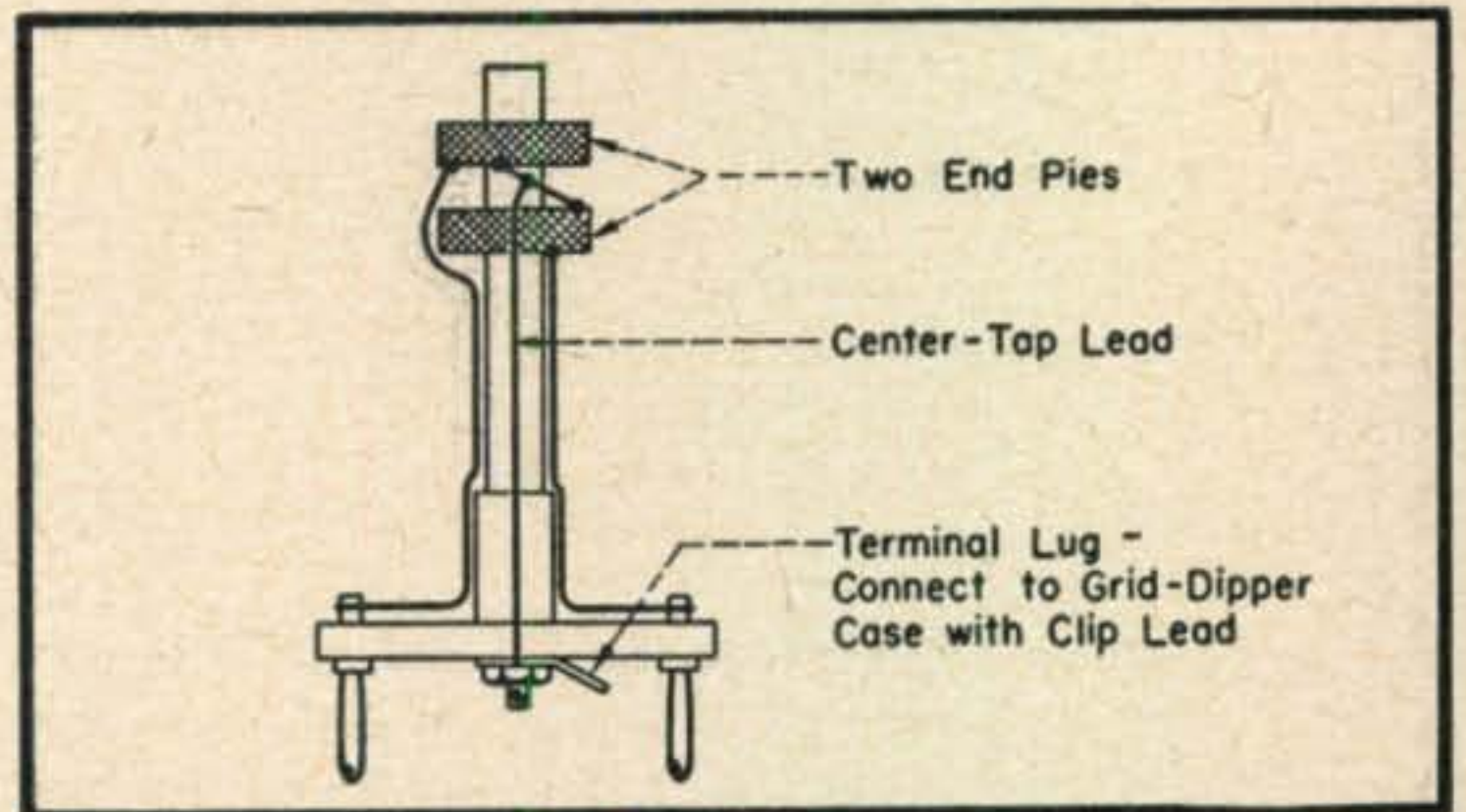

Fig. 1. The construction of the low-frequency coils. For the 650-1350 kc range use a Millen 34102 r.f. choke with the two bottom pies removed. For 950-1950 kc, use a Millen 34107 r.f. choke, remove the bottom pie section, and remove 20 turns from each of the remaining sections.

connecting the two remaining sections together. Longer leads will have to be soldered also to each of the outside connections for each pie.

The choke should be mounted as shown in *Fig. 1*. The center-tap should be connected to a terminal lug, which is held in place by the mounting screw. The connecting leads from the windings may be secured to the form with Duco cement to prevent their accidentally breaking off.

A short length of flexible wire should then be connected to the case of the grid-dipper with one of the screws holding the polystyrene end-piece. Be sure the paint has been removed from under the screw to permit a good contact between the case and the wire. The free end of the flexible wire should be connected to a clip, which may be clasped to the center-tap lug on the inductor in order to ground this point. Data is given in *Fig. 1* for the two frequency ranges down to 650 kcs. For still lower frequencies, the same principles should be followed, using choices of proportionately higher inductance.

Calibration may be made, as described in the original article, using a receiver covering the desired range. A calibration chart should be plotted according to the settings indicated on the 0-10 linear scale of the grid-dipper.

The pie-wound type of inductors require quite close coupling to the circuit under test, as compared to the flat single layer type of inductor. The latter type, for use at low frequencies, would have to be physically large and rather cumbersome. This is one of the reasons why the former is used. It is therefore necessary to couple closely during measurements when using the inductors described herein.

When the Q of the circuit under test is low, the dip on the meter will not be very pronounced; in fact, it may be difficult to locate. In this case, set the grid-dipper at an arbitrary frequency (or at the desired resonant frequency) and tune the test circuit itself until a dip is observed. Under low- Q conditions the dip will be rather broad. Several arbitrary settings of the instrument may have to be used before the resonant dip is located.

Probably the majority of situations involving low frequency readings will not readily permit close coupling due to physical conditions. When this is encountered, it is recommended that a low-impedance link be employed between the grid-dipper inductor and the inductive component of the unknown circuit. This was shown in an earlier article,² and is again indicated in Fig. 2. This type of coupling, of course, may be used on the higher frequency ranges also, and is of special aid when working within the small confines of TV receivers, etc.

² "Applications of the Grid Dip Oscillator," Scherer, CQ, January 1949.

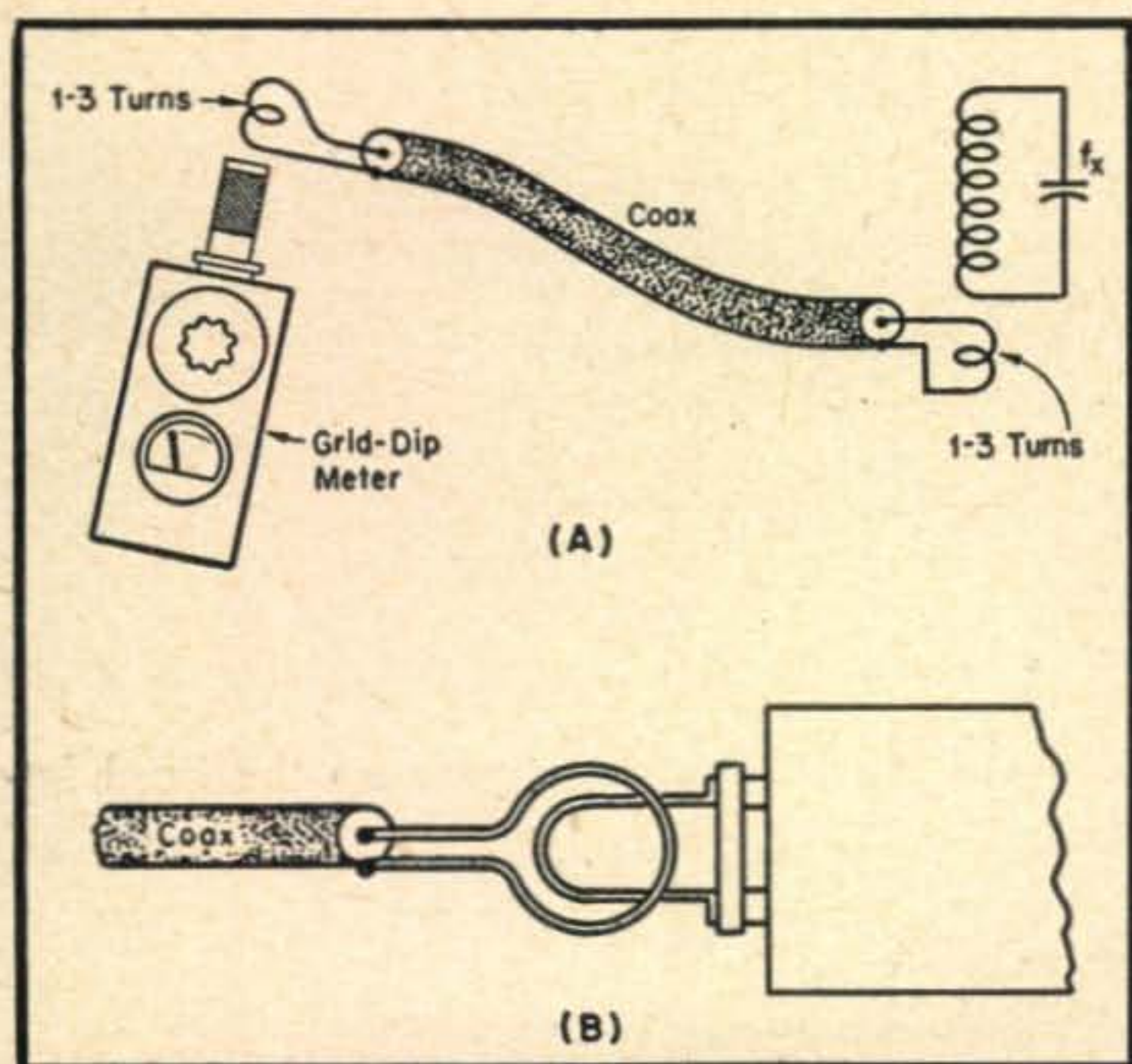

Fig. 2. Using link-coupling with the Grid-Dipper to reach out-of-the-way circuits. (A) Normal link coupling, and (B) method of coupling the one-turn loop to the high-frequency hairpin inductor.

Postscripts

Bremerton Hamfest

The Amateur Radio Association of Bremerton, Inc., will hold its annual hamfest on April 15th at the Elks Club, 5th and Pacific Streets, Bremerton, Wash. The program includes refreshments, entertainment, prizes, and a fried chicken dinner. Tickets are \$3.50, and may be obtained by writing to R. V. Mallette, W7MIK, 1245 8th Street, Bremerton, Washington.

Modernistic C.W. Technique

Listen to the chatter,

Clatter, splatter, of the bug!
How it gratifies the ego

Of the man who makes it chug.
Hear him clatter, splatter, ring,

With a synchopated swing . . .
Listen to his fist cut a rug.

This one-dah space for letters

And that two-dah one for words
Is good enough for those poor

Unimaginative birds.
Messrs. Wheatstone, Morse, et cetera

Can go and fly a kite—

This guy's poetic license

Tells him how to space them right.

Hear the tintinabulation

As he doodles on his way,
With a calculated rythm

And a subtle swing-and-sway
With a spacing that is different

And a timing that is gay;

Yes, sir—too bad that none but he

Knows what he has to say . . .

Steve, W2ZDE

Book Review

It isn't often that a non-radio publisher comes up with a book that we truly feel has a place in most ham shacks, but the dictionary people have done it this time. *Webster's Geographical Dictionary*, which has entries for more than 40,000 geographical names, and which includes 177 maps of localities of special interest, should be on every DXman's operating table. With this tome on hand (it has 1,352 pages), you'll find that you have a lot more to talk about when you raise a guy who says he lives 22 miles south of K2 (yep), or that he is on Kangaroo Island. Many local names which your DX contact may throw at you don't appear on any of the countries-lists, and this valuable book is what you need to translate his QTH into something someone else has heard of. *Webster's Geographical Dictionary* is published by G. & C. Merriam Co., Springfield 2, Mass., and you should be able to pick it up at any good book store.—A. E. H.

Don't Tell My Wife

WILLIAM A. WILDENHEIN, W8YFB*

IT WAS JUST ABOUT THREE MONTHS AGO that the Doc told me, "From all indications, I would say you were the victim of a persecution complex." That sounded to me like one of those neurotic class B movies. He asked me to tell him what had happened in the past few years, and I did.

After my Army discharge in early '46, I turned full attention to getting some r.f. into an antenna here. The various mail order companies didn't have too much in the line of hamgear, but a new word had entered the selling vocabulary since I had swapped my soldering iron for a Springfield. Surplus! Everybody seemed to be loaded with the stuff, and some of the prices didn't look bad. Fact is, after they found out a command set wouldn't bring thirty bucks, things started to plummet down into my class. Meanwhile, I hooked up with a local BC outfit and found plenty of time to read all the magazines while on the job. After a while it began to take on the aspect of a game. One month Schmoes' Surplus would advertise 211s for 38¢ and, instead of dashing up with my buck, I'd play foxy and wait. Sure enough! Pretty soon an ad would advertise them for 28¢. Being single and well paid, I soon found myself among the ranks of the surplus speculators. Even then, the symptoms were beginning to be apparent to everyone I was in contact with. Like the day the Ladies' Aid met at our place. I got home to find the new *CQ* and immediately turned to the last page, to read from there forward. Which, incidentally, is the unmistakable stamp of the surplus hound. As I headed for the closet to get my coat I overheard one of the ladies remark, "Rather queer of your son to read his magazine backwards." I would

* 219 Foster Ave., Elyria, Ohio.

AROUND CHRISTMAS I SUDDENLY
BECAME A GENEROUS NITWIT



have stopped to return a caustic reply except for the fact that I had just seen an ad by a Cleveland concern offering a fourteen-tube radar set for only \$9.95—limited quantities! So, as the Post Office motto says, "Neither rain nor snow nor fire nor pestilence shall stay these swift couriers in their way" . . . to Surplus Salvage Sales and Service, Inc.

But the stuff grows on you. It possesses you, body and soul. My original plans called for a 75-watt all-band fone-c.w. rig. That was until I saw an ad for a 3600 v.c.t. 350-mil transformer for ten pieces of Federal Lettuce. Things were going smoothly then until 304TLs went down to 59¢ apiece. Then it was separate rigs for each band. Oh, well, you know how it is. Every day at work I poured my heart into the job of designing new gear around the newest surplus releases until the Sunday I was called for a church remote. Not a bad deal, but it was a four-mike setup, and you had to follow the preacher around closely with the faders. All went well until I recalled a deal featuring a bunch of 1200 volt 750-mil transformers and immediately went into a trance over those wonderful items. A kw swam through my mind until I became aware of a notable lack of signal in the cans. I always maintained afterward that the preacher had somehow been spirited into the pulpit, because I never saw him cross over. Anyway, I only missed a few sentences before I ran up the gain on the pulpit mike.

The manager was, of course, properly indignant. I thought he was a bit too indignant. After all, when the filament bypass on the AM final blew, I happened to be tearing up a 375 tuning unit and had installed one of those condensers gratis.

But those troubles weren't too bad. What really got me was the local radio gang. Most of 'em are married, and you know how that goes. The OM comes home to his latest magazine and lapses into a rosy reverie in which he sees his shack resplendently adorned with ordered rows of 24Gs, 211s, BC-645s, and other juicy items "all for \$3.95."

"Did you remember to pick up the head lettuce?"

"Ummmm—6C4s, 14¢. 1625s, 18¢."

"I said, DID YOU PICK UP THE HEAD LETTUCE?!"

"What was that, dear?"

"Never mind, I'll open a can of peas. By the way, your cousin is in the hospital."

"HMM . . . let's see. APS 13—\$7.95 with tubes. Oh, that's nice, dear."

(Continued on page 57)



The M. A. R. S. Page



THE FIRST ARMED FORCES DAY will be observed May 20, 1950. The old individual service days (Army Day, Navy Day, and Air Force Day) are to be no more. In their stead the Department of Defense is putting on one super-duper unification show which combines the best of all that was good in each Service Day.

The MARS (representing the Army and the Air Force) and the Navy have cooked up a double-header attraction for radio amateurs—a receiving competition and a QSO-message relay contest.

The receiving competition will consist of transmission from Washington, D. C., and San Francisco, California, of a special greeting from the Secretary of Defense, the Honorable Louis A. Johnson, to all amateurs. Each listener who can copy the transmission (to be sent at 25 w.p.m.) and who sends the perfect copy to ARMED FORCES DAY CONTEST, Rm 5B519, The Pentagon, Washington, D. C., will receive a special Certificate of Merit.

The QSO and message relay contest will have for its main purpose the demonstration on a national scale of the effectiveness of point-to-point or person-to-person communication by amateur radio as a back-up for normal communications systems.

Short-haul circuits will be stressed in the contest. The contest is open to any radio amateur licensed by the FCC or by the Armed Forces of the United States. Single and multi-operator stations will be considered separately in scoring the contest. All amateur bands, either phone or c.w., can be used.

Contest log forms or further information concerning the May 20 contest, including times (your local area), etc., may be obtained by writing: Armed Forces Day Contest, Room 5B519, The Pentagon, Washington, D. C.

Emergency Activity

Friday the 13th was a memorable day for inhabitants of the Owensboro, Ky., and the Calhoun, Ky., areas in January. The Ohio and the Green Rivers had been rampaging for days, and everyone knew it was just a matter of time until some of the

flood waters would spill over and inundate the countryside.

MARS members and other amateurs in the area were busy getting ready for the call to emergency duty. Second Army Headquarters Station, A3USA, located at Ft. George G. Meade, Md., and Fifth Army Headquarters Station, A9USA, located at Chicago, Ill., were monitoring 6997.5 kc and 4025 kc for indication of trouble in the Ohio River Valley.

Dave Tooley, W4LUB, emergency coordinator for the Owensboro area, received a request for assistance in the Green River area near Calhoun, Ky., on Friday evening, Jan. 13. The Red Cross reported a lot of administrative traffic and no circuits with which to move them.

John R. Somerville, Jr., A4PDW/W4PDW, 1st Lt. in the Kentucky National Guard, was on the scene for MARS. Here's PDW's story in his own words.

"Saturday morning (Jan. 14), W4JXB, W4NIX/A4NIX and W4OYI/A4OYI went to Calhoun, Ky., with portable radio equipment. They took with them two battery powered TCS-12 transmitter-receiver units running about 25 watts, which were furnished by the local Naval Reserve, and some SCE-536 handie-talkies, furnished by the National Guard. Upon arrival in Calhoun, they set up a station operating as W4JXB/4 in the McLean County Court house. Communications were established with K4NRR, operated by W4PFQ, at the Naval Reserve Armory in Owensboro. The handie-talkies were on 3885 kc, so that was the frequency used for all transmissions.

"Saturday afternoon W4LTQ and W4NZO went to Calhoun to assist there; W4LUB relieved W4PFQ at K4NRR, and I went to K4NRR to help.

"Much trouble was experienced trying to operate on 3885 kc due to the poor selectivity of receivers in use at K4NRR and interference from other amateur stations. Weather reports, river stages, Navy, Coast Guard, and Red Cross traffic made up the Saturday load.

"Early Sunday (Jan. 15) W4NIX/A4NIX and
(Continued on page 60)

ARMED FORCES DAY RECEIVING COMPETITION 20 MAY 1950

TIME

NSS Wash- ington	0200 GCT (2100 EST)	122.4390, 9425,
	0400 GCT (2300 EST)	12630, 17000 kc
NPG San Francisco	0400 GCT (2300 PST)	115.4390, 9255,
	(2000 PST)	12540 kc
WAR Wash- ington	0200 GCT (2100 EST)	3497.5, 6997.5,
	0400 GCT (2300 EST)	14405, 20994, 27994 kc

ARMED FORCES DAY QSO PARTY MAY 20, 1950

TIME	START	END
PST	0900	2100
MST	1000	2200
CST	1100	2300
EST	1200	2400
GCT	1700	0500 (May 21)



Major General S. B. Akin, Chief Signal Officer, U.S. Army, is a frequent visitor at MARS headquarters station K4USA WAR.

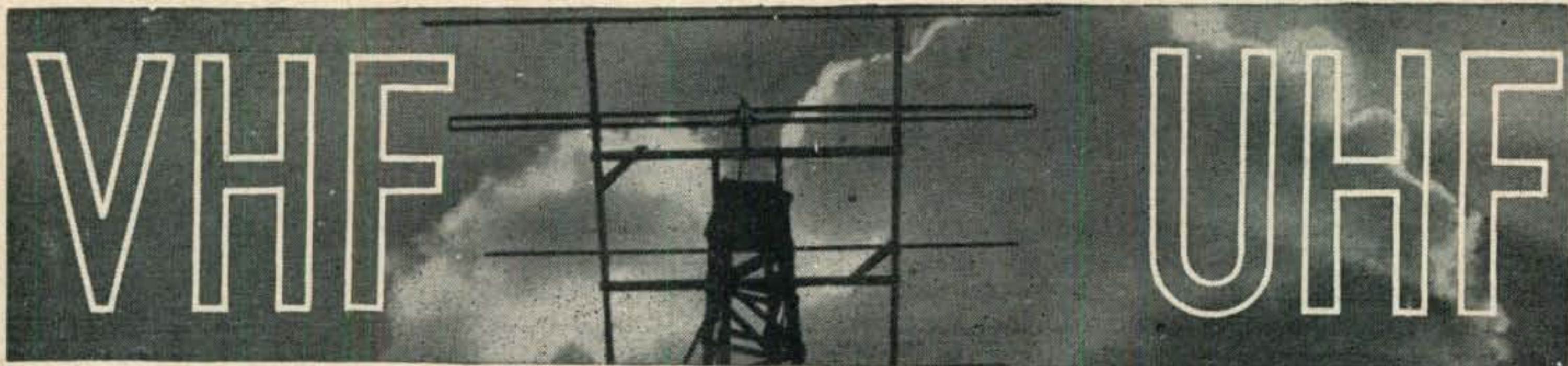

Conducted by E. M. BROWN, W2PAU*

BY THE TIME this column appears in print, balmy spring weather will be prevailing over most of the country. But winter still has us in its cold grip at this date, and much of the news which we have been hearing consists of "weather" items—ice storms and high winds playing havoc with elaborate antenna arrays, poor propagation conditions on two meters, the start of the spring aurora season on six meters, etc.

Few reports of outstanding accomplishments on the v.h.f. bands have been received during the past month. Some of the gang are off the air rebuilding their rigs for the coming DX season. Higher power, fancier antennas, low-noise re-

* Send all contributions to W2PAU, 88 Emerald Avenue, Westmont, N. J.

Ionosphere Storm Produces DX

As predicted well in advance by the "Warning Service" of the Central Radio Propagation Laboratory, a severe ionosphere storm began around noon EST on February 20th. The aurora borealis accompanying this storm scattered 6-meter radio signals between the hours of 1700–1745 and 1900–2130 EST. As a sample of the coverage, the last minute report from VE3DDT indicates that the following were heard: W1MEP, W1FTX, W9NJT, W1MPO, W1HDQ, W1PWW, W2PAU, W1KTF, W8NBM and W9ZHL.

This storm apparently did not produce a long path north-south opening. However, a second ionospheric disturbance began suddenly during the early morning hours of February 23rd. Aurora was observed that evening between the hours of 1800 and 2230 EST. W4LVA, Arlington, Va., worked W1AEP and W1MPO. W8CMS heard VE3AET, W1LLL, W9HGE, W9ZHL and W9VZP. WØTKX worked W9VZP and WØCJS. W1MPO heard W1RO, W1FX, VE3ANY and W2MEU. VE3DDT heard W8CMS, W1LLL, W1MPO, W1AEP and W9ZHL.

Possibly because of the suddenness and severity of this last storm, the 6-meter band opened on paths into South America the morning of February 24th. Pickering, an SWL in the RASO Group, heard LU1BV and LU9EV between 1007 and 1010 EST. Pickering also heard HC2OT work WØIPI, WØOLY and WØJOL from 1012 until 1032 EST. W8CMS worked both of the reported LUs and heard LU8AQ. Further details on these openings have already appeared in the RASO Newsletter.

ceivers—yes, we can expect a greater exploitation of our v.h.f. and u.h.f. bands during the coming season than we have ever experienced before. In addition to the changes that have been made to improve the coverage of their stations, many of the gang have decided that something must be done to solve the TVI problem and have waded into this situation with a vengeance.

On the other side of the Atlantic, conditions have been better. On December 11, at 1935 GMT, G5QA, at Exeter, heard a weak signal which he identified as OH2OK, of Helsinki, Finland. G5QA wrote to OH2OK and received confirmation that he was on the air at the time reception was reported. We have also received a report from W8LYS, who schedules OH2OK on ten meters, stating that Otto's signals have also been received by ON4CC (1,000 miles) and CN8BK (2,000 miles). The G5QA hop is about 1,250 miles. There is no explanation offered for these instances of extreme two-meter DX. G2XC, editor of the v.h.f. column of Short Wave Magazine, is carefully exploring the possibilities of sporadic-E ionization, atmospheric refraction, or "double-hop" reflections, and he concludes that none of the generally-accepted theories of propagation will supply a satisfactory explanation of this situation. In addition to these reports of extreme DX, a two-way QSO between G2BMZ and PAØEO on January 1 comes close to equalling, if not exceeding, the "G DX" record of 380 miles, held by G5BY and PAØZQ. Permission has been granted to the British v.h.f. operators to increase power from the former ceiling of 25 watts to 150 watts, so we may well expect to hear reports of improved performance from the stations utilizing the new power facilities.

Emergency Operations on Two Meters

During the severe ice storm which struck the area around Memphis on January 4th, several towns were cut off from power and telephone service. W4HIIK, of Collierville, Tennessee, was prepared. Equipped with a 522 transmitter, a 300-watt gasoline-powered generator, and a simple dipole antenna which was jury-rigged in place of the 16-element beam which was wrecked by the ice, consistent contact was maintained with W4DI in Memphis until telephone service was restored. Traffic from the local power company, railroad, and the general public was handled efficiently.

This episode serves to demonstrate the value of our v.h.f. bands, especially two meters, for emergency communications service. The use of v.h.f. equipment for mobile work has been widely accepted by the commercial and government services, but, in general, it appears that the hams have not been exploiting these channels to their fullest extent for emergency operations. Amateurs operating on the v.h.f. bands know that reliable communications can be maintained between stations over distances up to about 25 or 30 miles with low-powered rigs and simple antennas on each end of the link. QRM is seldom a problem. Man-made and natural noise are lower on the higher fre-

quencies. The chances of a band-opening permitting high-powered DX stations to horn in on the operations of the low-powered emergency stations (which they cannot hear) are nil.

This is a plea for greater exploitation of the v.h.f. bands by the many active emergency organizations, all over the country. W4HHK has shown how reliably the two-meter band served in the Memphis emergency. Why not face the fact that the propagation characteristics of the v.h.f. bands are better suited for emergency operations than the congested low-frequency assignments, and include one of these bands (probably the two meter band) in your planning?

More on Helix Antennas

A recent note in this column to the effect that a few enterprising hams have been experimenting with helical antennas apparently provoked considerable interest. W3ARL, of Bristol Pa., has received several inquiries concerning his results with the helix. His results have been good enough to stimulate several of the two-meter hams within his working radius to cooperate in his experiments to the extent of erecting full-scale helixes. Among those expressing intentions of installing cork-screw antennas are W3NXT, W2VX, and W2BV.

An article in a widely-read periodical on the subject of helical arrays bolstered their hopes quite considerably by listing the tremendous gains which might be expected from relatively simple combinations of helix antennas. The gain figures were attractive—in fact, too attractive! We wrote to the editor of the publication, asking for further details. It seems that we were not the only ones who wrote. The correct gain figures will appear in a subsequent issue! Guess we'll have to go back to the figures listed in *CQ* for April 1949. W8RNC and W8VRQ claim a gain of about 12 db for a helix a little over ten feet long, two feet in diameter, with a large ground-plane reflector. This is quite a healthy gain for such a simple configuration, and it may well be that the use of circular polarization will be one answer to the problem of deep fading in multi-path transmission.

Amateur Television

There have always been hams who are not content to confine their operations to simple code or voice transmissions. In their search for new fields to conquer, they have explored the by-ways of single-side-band transmitters, teletype and now they are turning their attention to television!

In the New York area Ray Clurman, W2LNP, has been demonstrating what may well become an acceptable system of ham TV. His objective has been to simplify and cheapen the system to the point where it can be utilized by the majority of the hams—not only the rich ones. In order to eliminate the complex and tricky synchronizing-signal generator, Ray "borrows" his synch signals from a TV receiver which is tuned to one of the local TV broadcast stations—any one will do. His blanking signals are derived from the receiver in like fashion. The kinescope tube of the receiver provides a bright raster with no picture information on it, synchronized with the "borrowed" synch pulses. The flying spot of light which forms this raster may be passed through a photographic transparency to a photo-cell or it may be projected optically onto the subject being scanned, and thence reflected onto the photo-cell. The amplified output of the photo-cell—the "video" signal—is mixed with the combined synch and blanking signals in a simple one-tube mixer circuit, and the result is a composite video signal which is standard in all respects. It will actuate the sweep and picture circuits of any conventional TV receiver.

The 420-mc band is the lowest frequency on which hams are permitted to use picture modulation. It is thus necessary to use a simple converter (shades of the F.C.C. hearings!) to adapt the normal TV receiver to this service. To avoid the complexity of a special sound-channel receiver, Ray proposes to modulate the 420 mc picture carrier with a 4.5 mc f.m. sub-carrier, which will ride right through on the nor-

mal sound-channel circuits of the standard receiver.

By using a receiver which is switchable from the broadcast channels to the u.h.f. converter, and with appropriate video and sweep-switching circuits it is possible to use a single receiver for both transmission and reception and reduce the investment required. On the other hand, by using surplus cathode-ray tubes, photocells, and only the bare minimum of receiver circuits, one can, starting from scratch create a workable ham TV station for less than 100 bucks. At this time, there are only a few operators around New York working with W2LNP in his experiments, but the interest expressed at his demonstrations is high. Some of the well-informed hams in that area predict that we may see an upsurge in amateur TV operations in the near future.

VHF DX, as per Schedule

W4HHK, of Collierville, near Memphis, Tennessee, is one of the outstanding v.h.f. operators of the South. His best consistent DX contacts are W5JTI (191 miles) and W5NYH (137 miles). They work almost daily, on phone, and have yet to miss a try. Those guys get to griping because they can only work a couple of hundred miles on two meters, day in, day out! Paul can't explain the reason why they are getting such outstanding results; he blames it on the "magic of the magnolia blossoms"—or perhaps the prevailing high humidity which rolls up the valley from the Gulf of Mexico. His location is quite favorable (375' elevation), but the path to the other stations is not line-of-sight. W4HHK's equipment has a lot to do with his success. His receiver uses a 6AK5-6J6 cascode pre-amp into an IFS which feeds an NC183. A pair of 4-65s put out a big signal with 300 watts input, and the 16-element horizontally-polarized beam 66 feet above the ground helps some, too! Paul emphasizes the importance of keeping faithful and accurate schedules to demonstrate what can be done over a difficult path. Knowing exactly where and when to listen for the other guy is half the battle. Looking for new fields to conquer, W4HHK is planning an elaborate set-up for 220 and 420 mc.

Speaking of schedules, W3OWW, of Stewartstown, Pa., sent us the dope on his regular rag-chews with W3AIR, of Glenmont, Md. Geary, W3OWW, uses a souped-up 522 receiver, a 522 transmitter with about 30 watts input and a six-element beam which was once flip-flop but has been stuck in the horizontal position for the past few months. This equipment accounted for 13 states in 6 call areas, plus VE3 during the past DX season. The 70-mile hop to W3AIR is over very rugged terrain, and the boys are proud of their accomplishment in maintaining consistent contacts. W3AIR uses several receivers, but the current one seems to be a 6AK5-6J4 cascode pre-amp into a BC639, with an HRO available for selectivity when needed. An eight-element beam is used for two meters, horizontally polarized. Frank is also all set for 220 and

(Continued on page 52)

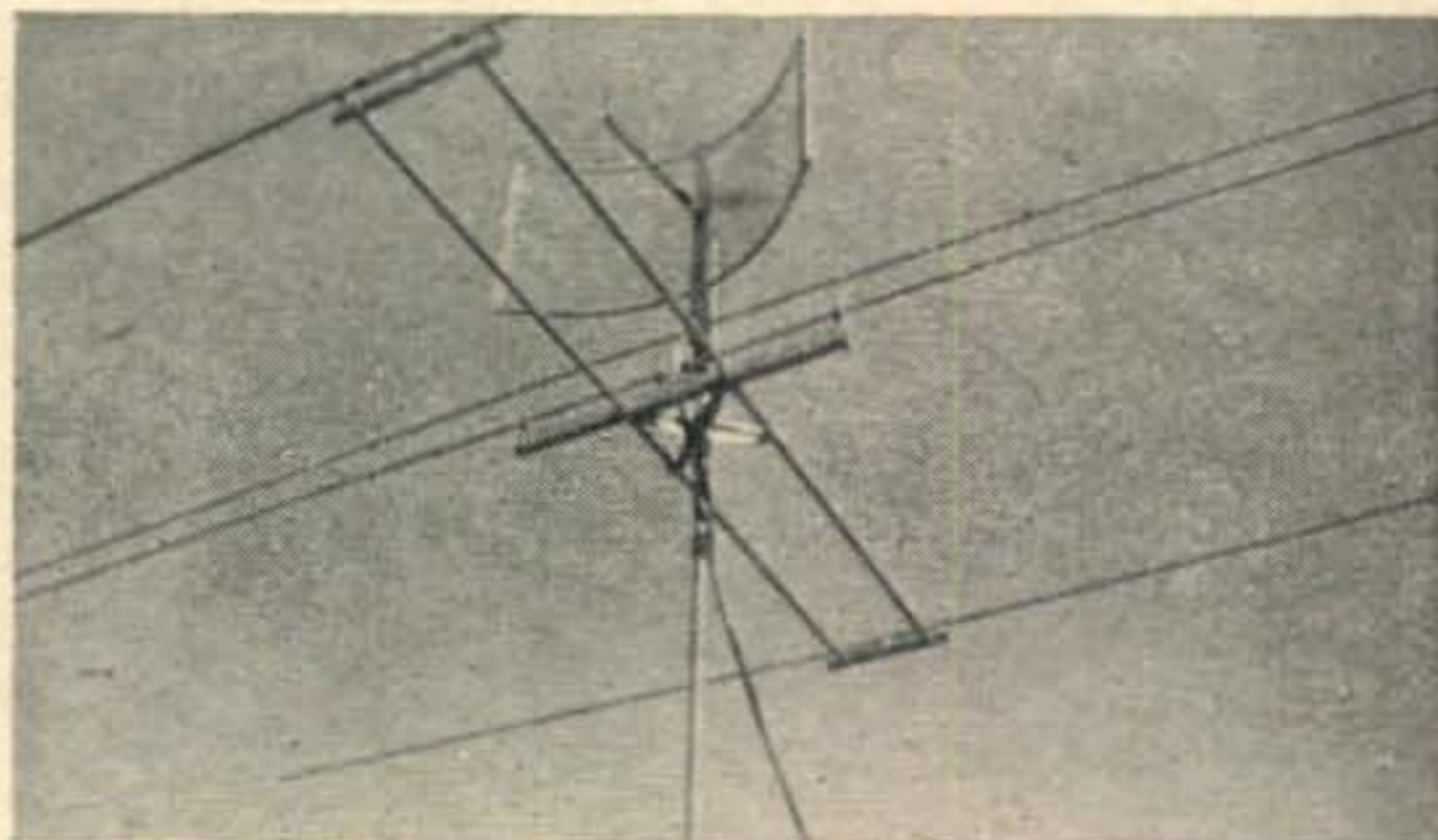

The 420-megacycle parabolic array of W7QLZ mounted above the ten meter beam. This combination replaces the system which was shown in February *CQ*. The old array was severely damaged by a wind storm.



Conducted by HERB BECKER, W6QD*

OUR SINCERE CONGRATULATIONS to the following six DXmen in achieving WAZ

185	VK6SA	S. C. Austin	40-103
186	G3ATU	Stanley A. Herbert	40-183
187	ZC1CL	Daniel E. C. Lockyer	40-138
188	W4AIT	Homer Apple	40-213
189	W6ID	Vaughn I. Parry	40-138
190	KH6QH	B. J. Hastin	40-177

It is good to see such a variation of talent as is listed above. Certainly no one section has a corner on WAZ in this issue. Naturally, anyone who achieves WAZ hardly needs an introduction to the DX gang, as you just can't get this award by staying off the air. Keep it up fellows.

Honor Roll

Last month, again, the Honor Roll was set up in type too large to accommodate those who were listed before we changed printers. We're sorry about this, but I believe you will notice that from

* Send all contributions to Herb Becker, 1406 South Grand Ave., Los Angeles 15, Calif.

WAZ HONOR ROLL

To enter the Honor Roll, fill out one of the Zone and Country List forms which we will supply on request. Please send a stamped, self-addressed envelope.

The Honor Roll contains totals of postwar contacts only, that is, contacts made since November 15, 1945.

It is not necessary to submit combinations until you are eligible for a WAZ certificate. To be awarded a WAZ certificate, send confirmations for the 40 zones, as well as a list of them, direct to the DX editor. If a Country List has not been previously submitted, then one must accompany the WAZ certificate application. For these lists, please use one of our standard Zone and Country List forms, and it will then become our permanent record.

The Honor Roll is in two divisions: the c.w. phone section, which gives the current total of zones and countries any station has worked while using c.w. or phone, or both; the other section contains a list of "ready" stations. All contacts claimed in this section must be on a "phone-to-phone" basis.

All-time WAZ certificates will be issued upon presentation of proper confirmation. The Certificate will be similar to the postwar certificate, although no listings of all-time WAZ certificate holders is anticipated at this time.

here on out there will be a much better press job on the magazine. While mentioning the Honor Roll, I would like to say that any of you fellows who have sent in your list of zones and countries, and your totals were too low to get on the page, please don't give up. We want you to keep plugging, and when your totals look high enough to make the page, send us the additions, and if you have previously sent us a master list, we will add your additions to the list and place you in the Honor Roll.

Every now and then, someone wants to know if all the fellows in the Honor Roll, listed at 40 Zones, have submitted confirmations. The answer is, "Yes!" Occasionally, we will get a Zone list which shows 40 Zones worked, but unless we have all 40 confirmations along with this list, it will show up in the Honor Roll as 39 Zones.

More on Galapagos

In the March column, we told about the Guayaquil Radio Club planning an expedition to the Galapagos during the latter part of March. According to HC2JR, here's the way it stacks up at this time. John has obtained the cooperation of the Minister of Defense, who is giving them passes to travel on units of the Ecuadorian Navy. They are going to operate two transmitters on phone—one on 10 and the other on 20. They also hope to get in a little 20 meter c.w. work. Unless plans change, they will leave Guayaquil on April 3, and they expect to be on the air in Galapagos on April 7. . . . frequency will be around 28,450 and 14,150. There is an outside chance that the expedition might divide into two groups, in which case one group might get on the air a little earlier, probably the latter part of March. The April 7th date is certain, however—this is, unless something goes haywire with the Navy schedule. The call they will use is HC8GRC.

W5LFM is located in Japan, and his call is now JA2FM. He will be operating on 10, 20, and 40 c.w. . . . Another new one over there is JA2VC on 10 phone—he is ex-KH6VC.

GM3CSM is still looking for Zone 23, and judging from the other DX Ian has been working, I am sure he will knock off one of those boys when they start popping through. At the moment, his antenna setup is not too hot, as he is using a 67' inverted "L" for 20, 40, and 80. On 10 he has a 3-element rotary, but he is waiting for a prop pitch motor before he raises the antenna to a respectable height. Ian is building a new broad-band band-switching transmitter for all bands and expects to have them going one of these days.

VE4RO thinks working DX on phone is a
(Continued on page 66)

The Monitoring Post

gleaned by THE BRASSPOUNDER*

ANSWERING A CALL from the "Flying Enterprise," a trading ship sailing east for Norfolk, Va., whose master was asking for QSO with any ham phone station, WØWEH learned there was no doctor on board and a six-year-old child was seriously ill; symptoms were given to WEH, who phoned his local hospital in Minneapolis and contacted Dr. Cherry Cedarleaf; the latter diagnosed the ailment and, after determining that a supply of drugs was on board, prescribed doses of sulfa and penicillin with lots of fluids and rest; an hour later WEH called the "Flying Enterprise" to learn that the child was feeling much better, and the following day's sked brought word that the ham radio QSO had probably saved another life; the child's father, on board with his family coming to this country, took about five minutes thanking WEH—in German; neither Dr. Cedarleaf nor WEH could understand the language, but WEH's father was on hand and listened and then translated the speech of thankfulness. . . . W6PH and W9NN recently chatted and, comparing notes, found it was 25 years to the month since their last QSO; they've made a sked for the same month in 1974, 25 years hence. . . . W2BSC claims he still likes the sound of the rotary spark gap that he used back in 1920 when a 1-kw rig burned the air.

Settling down in Salem, Conn., after 32 years in the U. S. Navy, though his ham days go back 40 years, WILF was on the air in 1910 with a 1-kw spark rig and in 1912 became 9LF in Chicago; in 1919 1QH was issued to him and later 1CJA and 1HBS, operating when he could spare the time from the Submarine Service. . . . W9YWQ, University of Chicago, has in its staff of active operators W9SYP, W1MWK, W9UUM, W8BDQ, W9DMN, and W9ESN as the radio club prexy; the station is set up on the football field where 150 watts goes either to a 600-foot or a 275-foot antenna, this location having no TV receivers nearby. . . . W1BVB says that since he's back on the air (1948), he has QSO'd 62 hams who are in the theatre business, of which 29 work as he does—motion picture projectionist; he started in that game in 1912, working after school, when his salary was ten bucks a week; W1WI is one of the 29, and in the same projection booth with WI is W1KKJ, whose yl is W1MDV; W6WYC is special effects cameraman for M-G-M studios in Hollywood. . . . BVB started in 1919 with a 1-kw spark rig with the call 1BVB, but since has had 1AAP for several years—the '48 call issued was his original BVB, and he says that's going to stay with him till his final QSO. . . . W1AQE hit the jackpot recently when he heard ZL stations on 80 for the first time and worked three of them within an hour.

There has been questionable comment on an item in this column in the January issue regarding the ability of W7RT to copy 40 wpm longhand, or,

* Send all contributions to "The Brasspounder," c/o CQ Magazine, 342 Madison Ave., New York 17, N. Y.

as was mentioned, hand-written copy; at the moment of this writing a certificate issued on Oct. 2, 1948, is on hand, having been sent by W7RT, which states: ". . . code transmission was set down correctly at 40 wpm . . . in competition with 25 participants . . . this transmission was copied in longhand" and is attested to by W6DDE, W6CMN, and W6KEI as witnesses—RT is looking for some competition in this style of copying and says with a little practice he can probably reach the 45 wpm mark in sustained copying, dotting the "i"s and crossing the "t"s so that anybody can read his writing. . . . W2PRE was heard on 80 coaching W2YIR in physics and W2ZDE with his thermodynamics just before the last exam period—let's hope PRE gave the boys the right answers.

W9VZM claims that southern Illinois comes alive on 40 and 80 after 2300 CST, when the TV stations shut down for the night. . . . W7FS/MM, having become well known because of his QSOs around the world, has settled down to plain W7FS with a 1-kw rig on 20 and 40, going after DX in a big way. . . . The Atlantic Radio Club's bulletin is a newsy sheet, but refrains from mentioning call letters, referring to the boys by name, but few of us know the members except by call. . . . W6HSB and W6HTS, Mr. & Mrs., are newcomers in ham radio and are the parents of W6GDO, who completes the all-ham family heard on 10 phone. . . . K4WAR, station of the Southeastern Signal School, operates separate transmitters on 160, 80, 40, 20, 10, 6, and 2 meters with separate and diverse styles of antennae. . . . More than a half dozen traffic nets include K4WAR, and last year's hurricane that swept the South proved the efficiency of WAR's emergency work; among the dozen or so hams stationed at Camp Gordon belonging to the radio club there are W8EEC and W4PZS, who do their share of operating traffic nets and rag-chewing. . . . W7IGM is back on the air after an illness and pushes through to the East Coast consistently on 10 phone; his xyl is W7JWC, who operates her own rig and is giving the om some competition. . . . Several of the Seattle, Wash., boys shipped a load of radio gear to New Caledonia, including a 500-watt Millen final, which means that soon the FK8 stations will produce better signals; there are seven FK8s now, with FK8AA coming through best at about 0230 EST on 7 mc.

The patience of W4PL was pushed to extremes recently while he was in the hospital. It seems a high old time was had by attendants trying to get PL to swallow that part of a stomach pump that should be swallowed, though he had not the least idea why he should need the contraption. He patiently cooperated for a solid two hours, without any appreciable success, when a nurse burst into the room looking for the attendants who should have been working with the pump on a Mr. Anderson in Room 717—not Mr. White (W4PL) in Room 702; the latter was happy to see the attendants and their torture gear moving out of Room

(Continued on page 65)

BOB HENRY, WØARA, OFFERS YOU:



LOW PRICES: I guarantee to sell to you as cheap or cheaper than you can buy anywhere.

COMPLETE STOCKS: Collins, Hallicrafters, National, Hammarlund, RME, Millen, Harvey-Wells, Meissner,

Gonset, Meck, Johnson, RCA, all other amateur receivers, transmitters, beams, TV, AM-FM, high fidelity amplifiers and speakers, test equipment, tubes, parts, etc. I can supply nearly any equipment shown in any catalog or advertisement and at lowest prices.

BEST TRADE-IN ALLOWANCE: Customers in all parts of the USA trade with me because I allow so much. Other jobbers say I allow too much. Tell me what you have to trade and what you want. I also buy equipment.

TIME PAYMENTS: You can order anything on terms. I finance the terms myself to save you time and bother. Customers everywhere in the USA find my terms best. Write for details.

QUICK DELIVERY: Mail, phone, or wire your order. It will be shipped promptly. I can be reached nearly 24 hours a day, 7 days a week.

TEN-DAY TRIAL: Try any receiver ten days—if you return it your only cost is shipping charges.

PERSONAL ATTENTION: The Butler store is run by Bob Henry, WØARA, and the Los Angeles store by Ted Henry, W6UOU. We make the deals ourselves. We finance the time payments ourselves. That way we have the lowest overhead and can do more for you. That's why YOU AND I CAN DO BUSINESS. Write, phone, or visit either store.

73,

Butler, 3, Missouri

HENRY RADIO STORES

11240 Olympic Blvd.
LOS ANGELES 25
CALIF.

“WORLD'S LARGEST DISTRIBUTORS OF SHORT WAVE RECEIVERS”

When writing to our advertisers say you saw it in CQ

Frequency-Halving your VFO for 160 Operation

You fellows who would like to use your v.f.o. equipment on 160 meters may be interested in this frequency-halving circuit. Take your lowest-power buffer stage that follows the v.f.o. and change it over to a mixer. Working on the same principle as your receiver, set up another local oscillator whose beat frequency with the v.f.o. is in the 160 meter band.

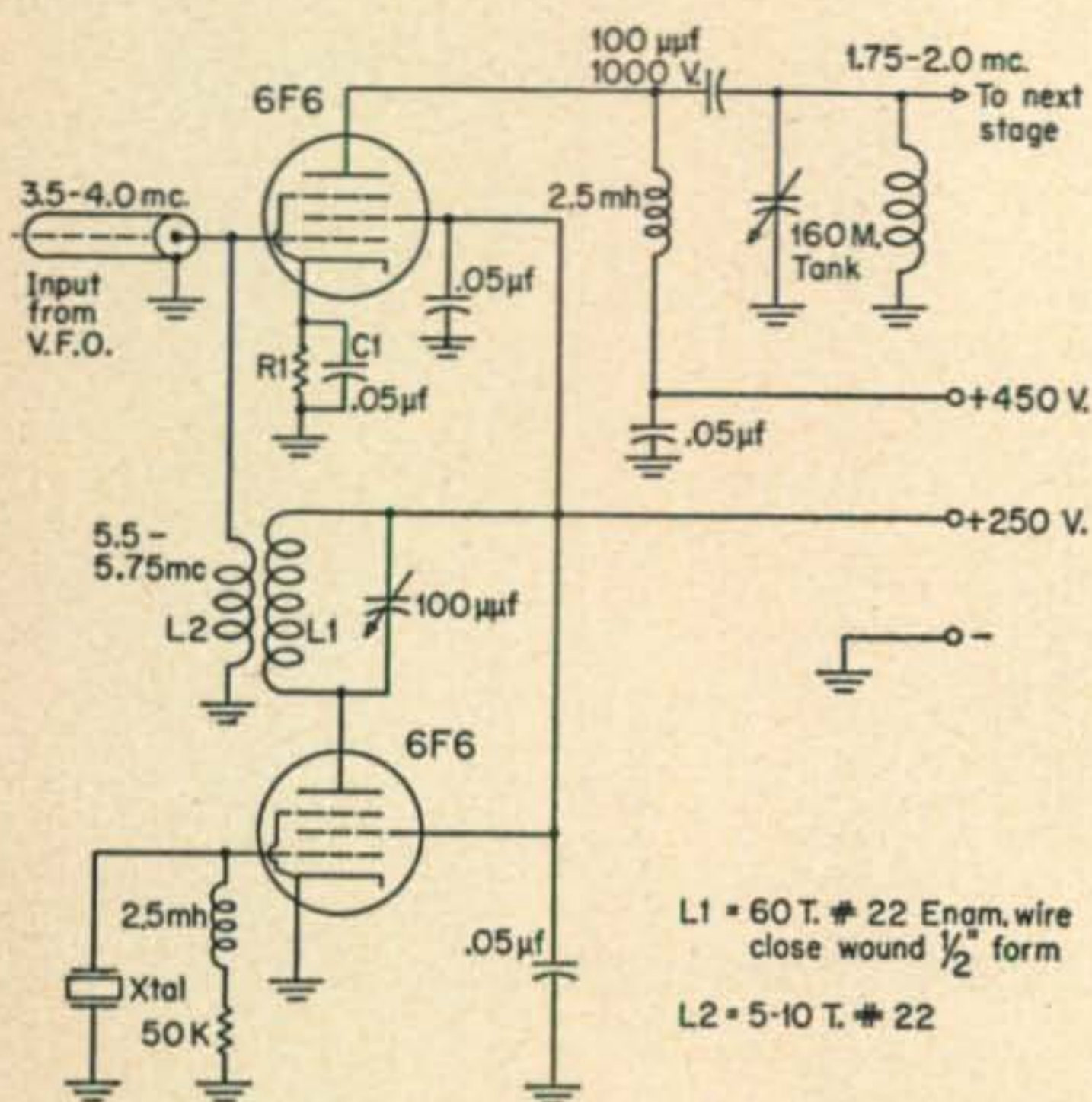

The circuit shown uses a 6F6 or comparable power pentode. The extra oscillator is crystal-controlled in the frequency range 5.50 to 5.75 mc. Beating the v.f.o. output against this oscillator results in a signal sufficiently strong to drive an 807 as a buffer or final amplifier. It is particularly necessary to make sure that the output of the crystal oscillator and the v.f.o. are approximately equal. This may be checked by reading the voltage drop across the mixer cathode resistor without applying screen or plate voltage to this tube. Pull out the crystal oscillator tube, fire up the v.f.o. and check the voltage drop. Then shut off the v.f.o., reinsert the oscillator tube and measure the voltage again. The output of the crystal stage is controlled by varying the plate tuning condenser.

As in all "conversion exciters," this unit should be thoroughly shielded to prevent the generation of spurious responses near the operating frequency.

Crystals in this range are readily available in the surplus markets.

Phillip Jones, WØLVH

Substitute for the ARC-5 Plug

I have noticed that around Los Angeles it is pretty difficult to locate surplus plugs for the ARC-5. However, the PL-153 plugs are quite common, and, with a slight modification, they may be used.

Take a PL-153 plug and draw a line through the center of pins 1 and 7, and then through pins 3 and 11. At the intersection of these two lines drill a #33 hole. This plug will now fit on the ARC-5 modulator and control box in place of rare ARC-9585 plugs. Every function will be available except the #1 channel selector. This makes it suitable for use on all models except the T-23, which must be on the #1 channel. It is necessary to paint an aligning mark on the plug and receptacle, as there is no longer a self-indexing feature in the pin arrangement, although possibly by plugging the number one socket with a length of wooden match it can be restored.

John B. Riley

Half Voltage from a Bridge Rectifier

This circuit is an improvement (for some fellows) over the "Low Voltage Tap" idea in CQ, October, 1949, page 30. Most textbooks usually include the "half-voltage tap" circuit of a bridge rectifier with the center tapped transformer, but I have never seen one that drops the output voltage to one-half. Such a circuit is shown in the schematic. It essentially consists of a full-wave center tapped rectifier in one switch position of S₁ and a bridge circuit in the other position.

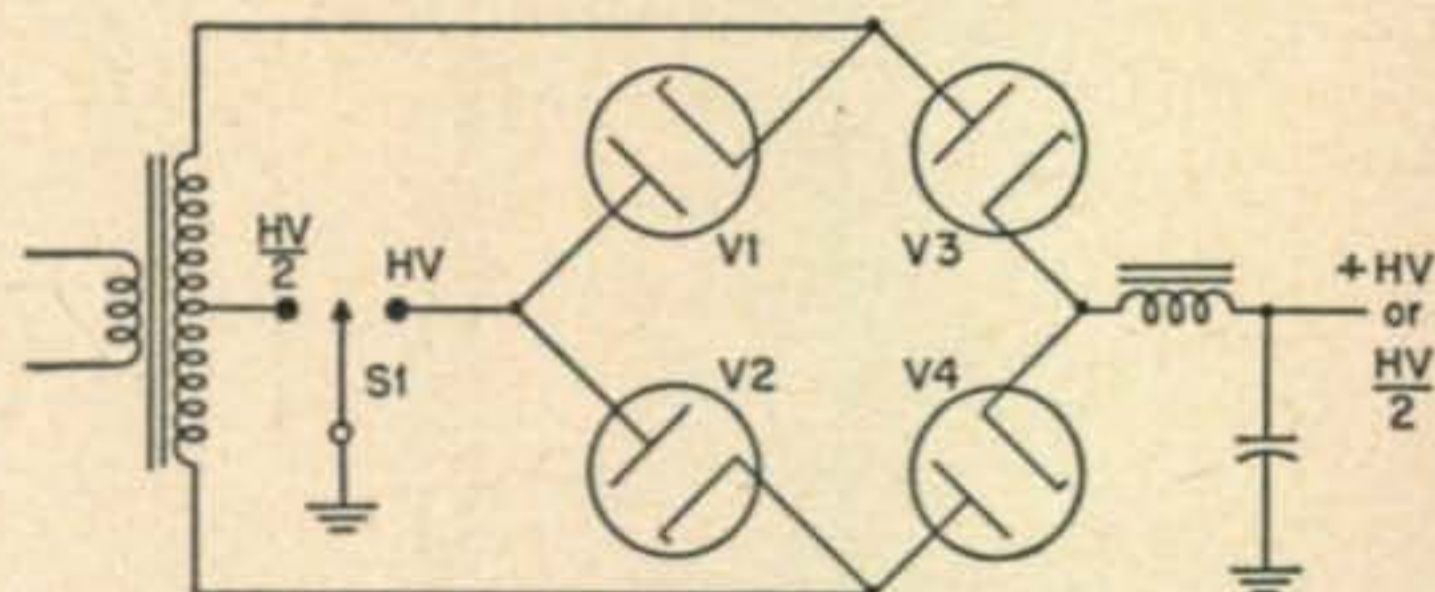

The switch S₁ should be well insulated since the voltage between the fixed contacts can be rather high.

The circuit is very handy for preliminary tuning of high power final because reducing the plate voltage will reduce the power input to one-fourth. The only precaution is to observe that S₁ is not a shorting-type switch. It can be seen from the circuit that if the plates of V₁ and V₂ are connected to the center tap of the transformer, each half of it will suffer a short circuit, through the tubes, on alternate cycles.

Georger J. Uminski, W9STN



SEND TODAY FOR YOUR BIG FREE 16 PAGE BARGAIN BULLETIN

CRAMMED FULL OF SURPLUS BUYS
TAKE ADVANTAGE OF THESE AMAZING LOW PRICES

FREE KNIFE

WITH THE PURCHASE OF \$3 OR MORE

Mottled grey Pyremite handle, 2 blades; 1 clip, 1 pen, both full mirror fin. Length closed 3"



FOR FM, TELEVISION AND ROTARY BEAM

Vertical Antenna MAST KITS

Fully ADJUSTABLE

5 to 35 Feet

Easy to Set-up

Complete with Guys, Hdw.

Doublet Antenna Kit

\$19.95

used with the famous Hallcrafters BC-610, consisting of 7 steel-alloy mast sections in a handy canvas bag. Each section is 5'6" long, 1 1/2" OD with the last 6" rolled to a smaller OD to telescope into the end of the preceding section. No taper. Assemble into mast up to 35' high or shorter by any multiple of 5'. Finished in weatherproof olive drab.

BRAND NEW

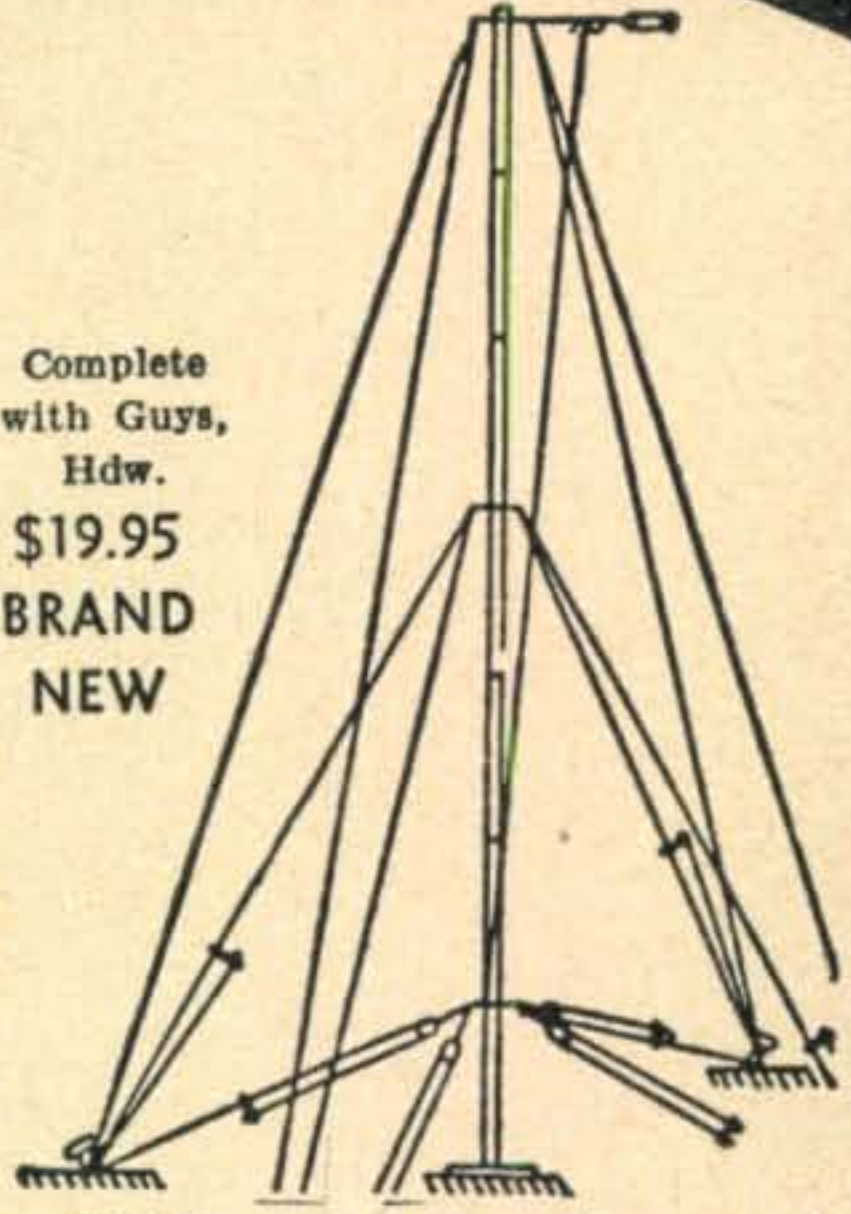

FOR your BEAM!

Ideal for erection of FM and Television Beams! Drop your coaxial cable right through the center! Brand new, export packed. **NEW! RUGGEDLY BUILT**

- Cable—6-wire No. 16, glass insul. shielded, plastic covered, for beam control. 12c per ft.- 100 ft. **\$10.00**
- Wire, shielded No. 20 stranded 100 ft. for **\$1.50**
- Twin Lead 300 ohm Amphenol ...per C **\$1.95**
- Twin Lead 75-ohm Amphenol per hund. **\$6.95**
- Toggle Switch, center off, -S.P.D.T.—4 for ... **\$1.00**
- Toggle Switch SPST & spring return—4 for .. **.75**
- Toggle Switch heavy duty 12 amp. 125V ea. .. **.49**
- CO-AX Amphenol—Beaded No. 72-20 per ft. .. **.04**
- 4-SPEED MOTOR—1/20th H.P. 115V 60-cycle AC motor with integral gear box having three 1/4" drive shafts turning simultaneously at the following speeds: 4000 RPM Grinders, Buffers. Slow Speed tools, 25 & 5 RPM

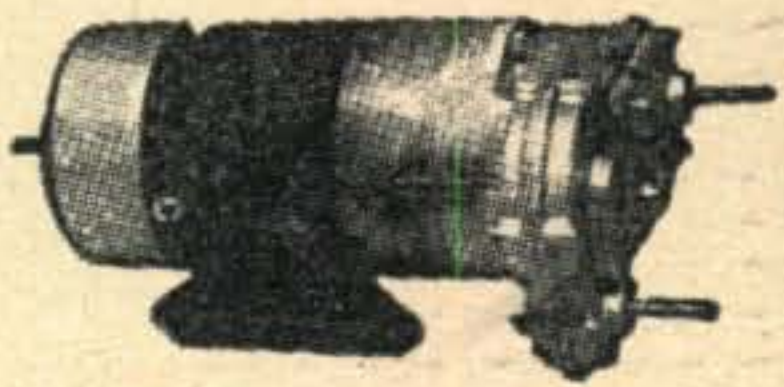

SENT POSTPAID **\$7.95**

A 1000 USES AROUND THE WORKSHOP



INTERVALOMETER

(Contains relays, switches pilot lights resistors knobs, etc.) Price... Good used \$2.25

R-5/ARN-7 COMPASS RECEIVER in excellent condition. SPECIAL! **\$19.95**

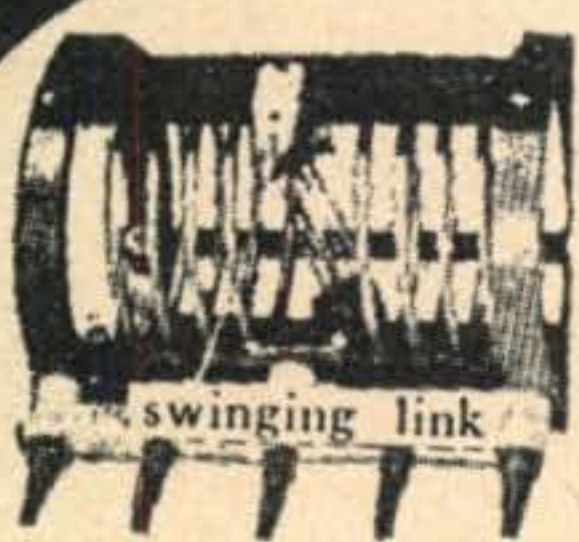

NEW B & W 500-Watt center tapped ceramic bars, banana plugs. 7 types:

3.5 — 4.5	8.0 — 11.0
4.5 — 5.7	11.0 — 14.0
5.7 — 8.0	14.0 — 18.0

Specify frequency range coil desired.

BARGAIN—EITHER TYPE \$1.50

- ANTENNA WIRE—250 ft. 10 gauge 7 strands No. 18 Phosphor Bronze **\$1.95**
- ANTENNA WIRE—1000 ft. No. 14 solid Copper-weld **\$6.96**
- 2200 ft. coils **\$12.95**
- CO-AX RG34—71 OHM Xmitting-New 50 foot coils—Bargain **\$1.95**

HRU-24-28 Volt at 70 Amps. DC Power Supply Gasoline Engine Generator with Electric Starter. A thousand Uses. This is in Excellent Condition **\$69.95**

EIMAC 304TL 79¢ EA.
BRAND NEW 4 for \$3.00

RECEIVER

Complete with 2 tubes and sensitive relay to control external circuits from received signals. The receiver to control models, open doors from a distance, etc. Used \$1.95



ALL USES

BC-733 D Localizer Receiver Used \$4.95
CATHODE RAY TUBE BUYS! Brand New Original Carton
5GP1. 3FP7. 3DP1. 3HP7. 5FP7. 5CP1 5BP1. **\$1.50**
Famous Makes • Boxed Special Each



"ROE" 100 FT STEEL TAPE \$4.95

DOW TRADING CO. 70 W. UNION ST., PASADENA, CALIF
THE HOME OF SURPLUS BARGAINS PHONES PASADENA SY 3-8281—LA RY 1-7944

When writing to our advertisers say you saw it in CQ



Conducted by LOUISA B. SANDO, W7OOH*

WHEN WE became W7OOH deep in Oak Creek Canyon, we felt *we* were really isolated—but we wonder just what it would be like to be in a spot 60 miles north of the Arctic Circle? That is where Jeanne Collins, KL7RN, and her OM, KL7IS, have their antenna farm, and they surely have ample uncluttered space for it. When we asked Jeanne what life was like up in KL7-land, her reply was so interesting we want to share it with you.

Wrote Jeanne: "Your letter was received about two *mails* ago. Then followed a siege of bad weather making it impossible to get an Alaskan picture that looked like Alaska without being too Alaskan and obscured by blowing snow. April is really the earliest month that pictures can be taken. The sun is still far in the southern latitudes even then, but at least we see it. We rarely take black and white pictures any more. Alaska is magnificent, and only color does her justice. An artist would be booted to the limit should he use without restraint the colors of this land in summer. In winter, blues are all that's necessary. Hang a harvest moon over a Vermont winter landscape and you can almost grasp one of our more beautiful scenes. We don't see the moon in summer, maybe that's why we love it in the dark months.

"We are located at a Civil Aeronautics Ad-
* Associate Editor, CQ. Send contributions to L. B. Sando, Verde Valley School, Sedona, Arizona.



KL7RN models her new sun-suit

ministration Airways Communication Station. The building is a converted trading post. Quite modern even to running water—if we keep the pipes thawed. We are 4 miles from Shungnak Village and 7 miles from Kobuk Village, on the banks of the Kobuk River. Just the OM, KL7IS, and I are here. In all, five white adults (school teachers at Shungnak Village) and two white children inhabit the area. Total population hits 120 in a 100-mile radius. We have plenty of room for an antenna farm!

"We generate our own power with a gasoline generator—my one source of local QRN. With a Vee beam running right over the generator building toward Stateside, I get plenty of the QRM on 10 meters. Usually receive on a 2-element wide-spaced beam to escape most of the racket. Both beams are made of #10 copper wire, the 2-element sporting a wooden frame which has disintegrated only once in our winter gales.

"At present I'm using 60 watts on 10, but W7GNJ (Bea's W7HHH, husband) is building me a 300-watt rig. Also we use the 60 watts on 20, 40 and 80 c.w., but at the moment waiting for nicer weather to extend the antenna farm. The OM is building a small 10-meter rig for the airplane, so someday we can see what altitude will do for signals. Also have a couple of 30-watt 40 and 80 portables for summer and emergency use.

"We both like c.w. and that was, of course, the easiest part of our ham exams since we had to qualify at 30 wpm sending and receiving for CAA. We both hope to get Class A if we can get to Kotzebue for the exams. We'll have to take turns flying down since we can't both leave the station at once. We have our own plane—use it constantly in summer when 24 hours of daylight make flying possible around the clock. Winter trips are less frequent due to short daylight hours and extreme cold. I don't fly as much as the OM. In winter he has to help me so much with pre-heating the engine et al that I think it unfair to run off and leave him behind. I used to be the farthest north based woman pilot in Alaska. Itinerants have come through though, and I don't know if I still hold the record. Shungnak, incidentally, is 60 miles north of the Arctic Circle, geographically 66°50' N lat., 157°05' W long.

"The Kobuk is navigable from the coast to 60

(Continued on page 56)

HARVEY presents the ELDICO Line

TVI Book Now Off Press

Get your free copy of "TVI Can Be Cured". Just drop us a postcard with your call, name and address and we'll shoot it right to you.

Eldico Transmitter Filters



Dual low-pass, 40 Mc cut-off, over 75 db harmonic attenuation. 52-72 ohm input and output. At other impedances use antenna tuning network. Good for 1 KW input, negligible fundamental attenuation. No effect on antenna performance.

Model TVT-62, \$7.99 kit, \$10.99 wired & tested.

Eldico Receiver Filters

Hi-pass, 40 Mc cut-off, no attenuation to sigs above 40 Mc. Efficient on any manufactured set. Will not affect picture, quality or strength. Available for coaxial or twinex.



TVR 300 for Twinex—TVR 62 for Coax
Either model \$1.98 in kit form
\$3.98 wired & tested

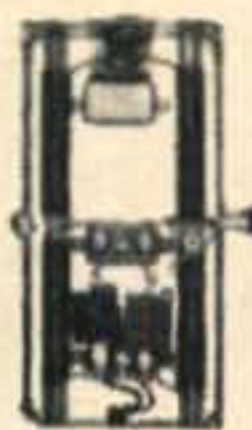

Brute Force Line Filter

Similar to one on Page 508 ARRL Handbook. Will handle 1 KW. Completely filtered and shielded. \$5.98 in kit form, \$8.98 wired & tested.

Copper Mesh Shielding

Heavy Duty, tightly wound, expensive but it really does the job right, the only screening we've found that will. 36" wide, minimum order 6 sq. ft. Per sq. ft. . \$85, plus \$5.50 per order packing.

GDA GRID DIP KIT



The most valuable piece of test equipment in the ham shack is the Grid Dipper. Build one with this kit and save countless hours in building, improving and de-bugging your rig. The GDA Kit builds an exact duplicate of the "Grid Dipper" and includes everything from the special handy case permitting one-hand operation down to a complete application and instruction book. With tube and internal power supply, range 3 Mc to 250 Mc in 6 steps, size 5 1/2" x 2 3/8" x 3". Complete Kit\$21.50

All prices Net, F.O.B., N.Y.C. Include ample postage with your remittance, any excess will be refunded. Prices subject to change without notice.

HARMONIC CHASER



A modified absorption-type wavemeter designed to eliminate swamping by the fundamental when the unit is tuned to

the harmonic. An extremely useful instrument for identifying and recording the strength of your harmonics falling into all 13 TV channels. Can be used with most volt-ohmmeters or with 500 microamp meter listed below.

TVH, complete kit, with instructions\$4.98
TVH, wired and tested..... 9.98
TVH 500 microamp meter in matching case 6.50

HIGH VOLTAGE POWER SUPPLY KITS

All standard brand, new components, power supplies designed to take it. Conservative as the big commercial jobs, you can safely count on trouble-free performance from the day you solder the last connection. Each supply comes complete (less chassis and rectifier tubes) with plate transformer, separate filament transformer (for HV1500-866A fil. trans. —other models supplied with 872 fil. trans.), control switch, pilot light assembly, smoothing chokes — two matched huskies—two oil-filled condensers, bleeder, rectifier sockets and safety plate caps, Jones strip for chassis connections, and heavy-duty a.c. line cord. Voltages available are:

Kit No.	Output	Price	Transformer only
HV-1500	1500 v. 350 ma.	\$29.50	\$19.50
HV-2000	2000 v. 500 ma.	69.50	39.50
HV-2000SP	2000 v. 700 ma.	89.95	49.95
HV-2500	2500 v. 500 ma.	99.95	69.95

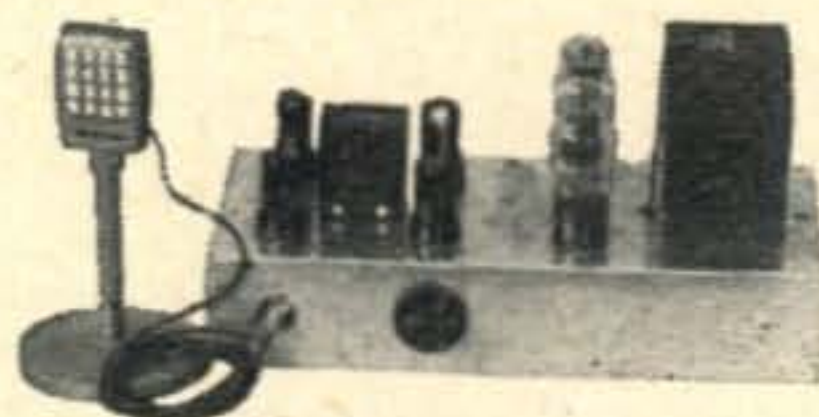

MD-40 LOW POWER MODULATOR

40 watts of audio, the MD-40 is a kit of the same superior parts that go into its bigger counterpart, the MD-100. In place of the 807's, two 6L6s are used. 200 ma. additional power available in MD-40-P. Complete, including the same standard communications Electro-Voice 915 high-level crystal microphone, only \$29.95

MD-40-P with built-in power supply \$39.95
Shpg. Wts. MD-40—15 Lbs. MD-40-P—30 Lbs.

Telephone: **3** LUXemburg 2-1500

HARVEY
RADIO COMPANY INC.

103 West 43rd St., New York 18, N. Y.



TR-1 TRANSMITTER KIT

A conservative 300-Watt phone and c.w. rig 6V6-6V6-6L6-813, Class B 811 modulators. All bands, 80, 40, 20, 15, 11, and 10. Exciter broad band, single control PA tuning. Three power supplies delivering 1500 v.d.c. at 350 ma, 500 v.d.c. at 200 ma, and bias supply. Punched aluminum chassis, tubes, transformers, capacitors, resistors, antenna changeover relay, meter, wire, hardware and coils included, but final tank coil for one band only. Electro-Voice 915 high level crystal microphone part of the package. Plug in the crystal and line cord and you're on the air. Shpg. Wt. 180 Lbs.....Only \$179.50



TR-75 TRANSMITTER KIT

Loafing along at 75 watts this is the c.w. man's buy of the year. Simple enough

for the beginner to assemble. Punched chassis. Uses the time proven 6L6 oscillator-807 amplifier combination. Pi-network output. Husky power supply delivers 600 volts to the 807. Complete...including a punched chassis and a smartly shielded cabinet to minimize television interference. Unbelievably low priced at\$34.95

Shpg. Wt. 80 Lbs.

NEW TR-75-TV KIT. Same as TR-75 above, but TVI proofed on all bands. Has built-in TVT-62 filter, also brute force line filter with specially devised RF bypassing of osc. and 807 stage. Has new 3" square meter. Plate transformer and all a.c. lines electrostatically shielded. Shpg. Wt. 90 lbs. Complete kit.....Only \$49.95

MD-100 MEDIUM POWER MODULATOR

100 watts of audio ending in two 807's. Includes E-V 915 mike. Shpg. Wt. 35 lbs. Kit form\$44.95
Speech clipper, if you want it, \$14.70 extra.

ELECTRONIC BUG

Similar to one described in Jan. 50, QST. Automatic dots and dashes, individual control of speed ratio and spacing. Permits you to set your own swing or characteristic of sending. Has built-in Johnson automatic key. Shp. Wt. 6 lbs. Kit form.....\$21.95

Completely wired and tested.....\$27.95

See our January ad for complete information on Eldico Transmitters, Power Supply, Modulators, etc.

When writing to our advertisers say you saw it in CQ

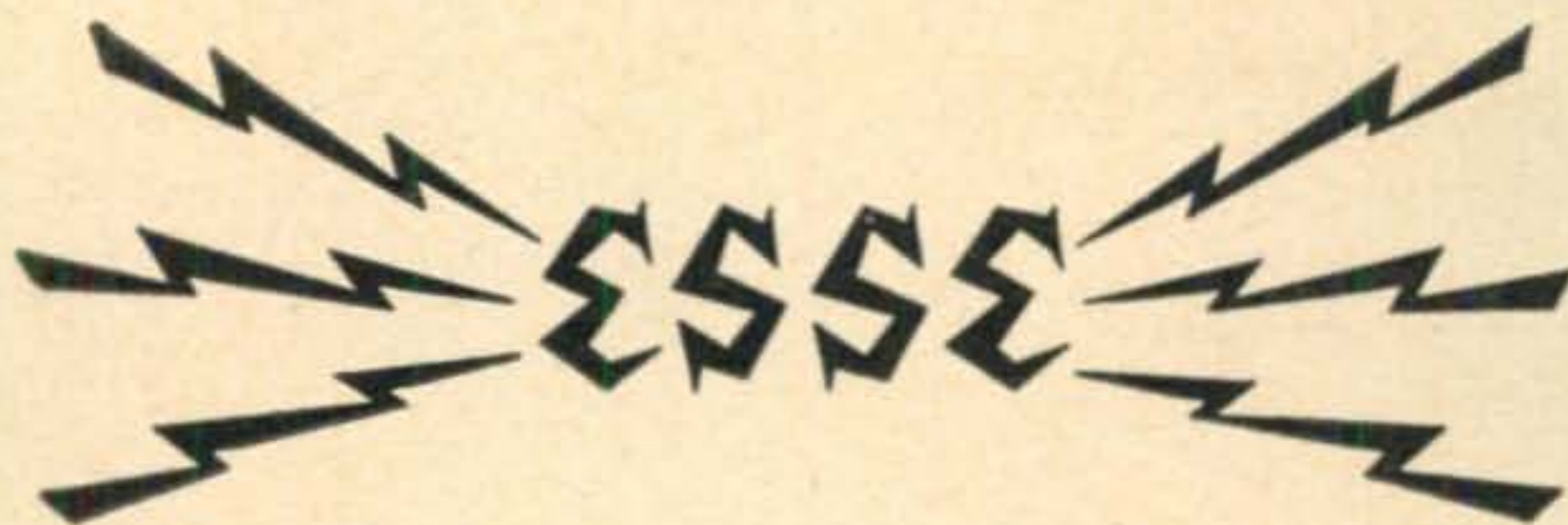

1 1/2" DIAMETER FIXED SHAFT CARBON CONTROLS

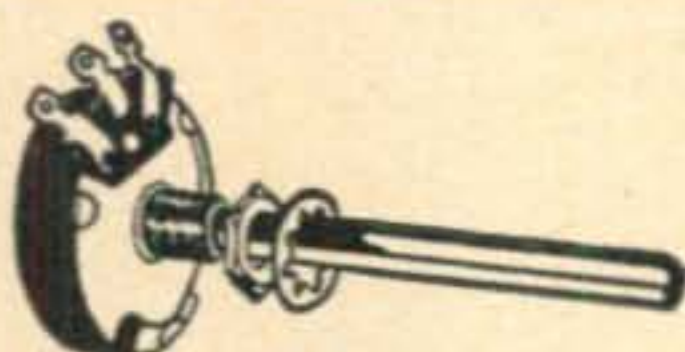

To be used as volume or tone control in audio circuits. All controls listed below are 1 1/2" carbon controls in a range of various resistances to satisfactorily cover the field. (Shaft description—a fixed channel or slotted shaft is provided, measuring 3" from lock-ring.) Accessories include one hexnut, one lockwasher and one shim with each control. An external adjustable resistor is furnished with each control marked *.

Catalog No.	Ohms Resistance	Price
201*	7500	35c
202*	15M	35c
203*	25M	35c
204	50M	35c
205*	50M	35c
206	250M	35c
207*	20M	35c
208*	75M	35c
209	75M	35c
210	200M	35c

1 1/2" DIA. FIXED SHAFT WIRE-WOUND CONTROLS

To be used as bias controls and voltage dividers in bridge circuits and test instruments. Rugged resistance strip and contactor assemblies are completely enclosed in a dust-proof case. Each will carry 4 watts of power. Each furnished with a fixed channel type shaft, measuring 3" from lock-ring. Accessories include one hexnut, one lockwasher and one shim furnished with each control. An external variable resistor is furnished where required. All controls with "ohms resistance" 2000 or more have adjustable bias feature providing 500 ohms in 100 ohm steps in all values over 1000 ohms.

Catalog No.	Ohms Resistance	Price
211	3000	50c
212	7500	50c
213	10000	50c

1 1/2" DIA. FIXED SHAFT CARBON CONTROLS

Catalog No.	Ohms Resistance	Price
214	150M	35c
215	3 Meg	35c
216	250M	50c
217	Slotted	50c
	1 Meg	
	Slotted	50c

DUAL CONTROLS



(Cat. No. 224 Illustrated)

Catalog No.	Ohms Resistance		Type Element		Price
	Front	Rear	Front	Rear	
218	3800	3800	Carbon	W-Wound	70c
219	25700	10000	W-Wound	W-Wound	70c
220	645	10M	W-Wound	W-Wound	70c
221	7500	10M	W-Wound	W-Wound	70c
222	10M	100M	W-Wound	W-Wound	70c
223	75M	32M	Carbon	Carbon	70c
224	50M	1M	Carbon	Carbon	70c
225	150M	250M	Carbon	Carbon	70c
		tapped			
		160M	Carbon	Carbon	70c

1 1/2" DIA. FIXED SHAFT CONTROLS

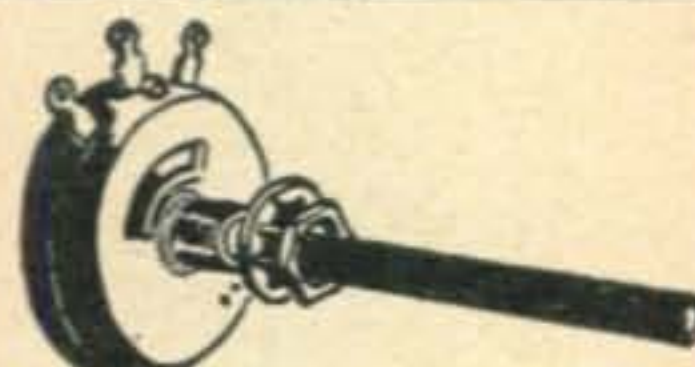

(Cat. No. 238 Illustrated)

Shaft is permanently attached. Accessories include hexnut and lockwasher.

Catalog No.	Ohms Resistance	Type Element	Price
226	4500	Wire-wound	50c
227	2900	Wire-wound	50c
228	60	Wire-wound	50c
229	13M	Wire-wound	50c
230	50M	Carbon	50c
231	125M	Carbon	50c
232	1500	Carbon	50c
233	450	Wire-wound strip	20c
234	6M	Wire-wound strip	20c
235	32M	Carbon	50c
236	350M	Carbon	50c
237	100M	Carbon	50c
238	1500	Wire-wound	50c
239	10M	Carbon	50c
240	1 Meg.	Carbon	50c

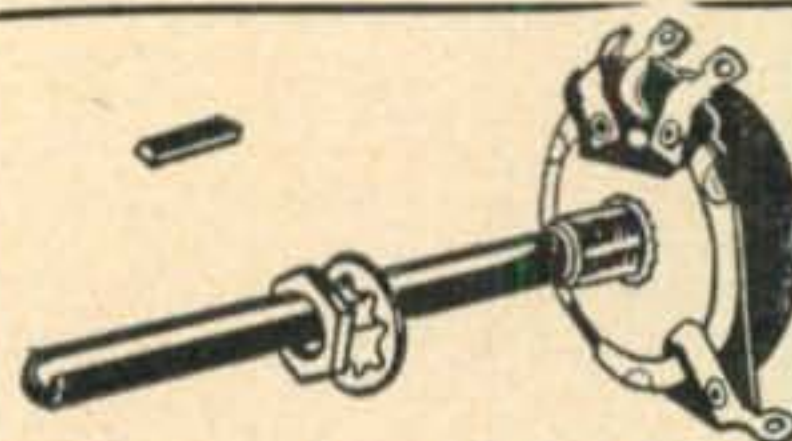

1 1/2" DIAMETER FIXED SHAFT SINGLE & DOUBLE TAPPED CONTROLS

Application—for volume control with tone compensation in audio circuits. These are 1 1/2" carbon controls made in a wide range of resistances, single and double tapped as indicated. An accurately finished shaft is permanently attached, measuring 3" from lock-ring. Accessories include one hexnut, one lockwasher and one shim furnished with each control.

SINGLE TAPPED

Catalog No.	Overall resistance	Tap resistance	Price
241	60M	4M	50c
242	250M	110M	50c
243	350M	20M	50c
244	350M	70M	50c
245	500M	100M	50c
246	1 Meg.	200M	50c
247	1 Meg.	500M	50c
248	1 Meg.	30M	50c
249	2 Meg.	15M	50c
250	2 Meg.	400M	50c
251	3 Meg.	900M	50c
252	60M	12M	50c
253	2 Meg.	250M	50c
254	2 Meg.	900M	50c
255	250M	50M	50c

DOUBLE TAPPED

Catalog No.	Overall resistance	Tap 1 resistance	Tap 2 resistance	Price
256	2.25 Meg.	250M	500M	50c
257	44M	7M	14M	50c

IMPORTANT

Because of the amount of work and expense involved in handling mail order sales, Esse cannot, any longer, accept orders for less than \$5.00. No COD orders accepted. All orders from within the United States will be shipped by us, shipping charges collect, so don't include, with your payment, any money for shipping. If you are not entirely satisfied with any merchandise purchased within these pages, Esse will cheerfully refund.

ESSE RADIO CO., 40 W. SOUTH ST., INDIANAPOLIS, INDIANA

When writing to our advertisers say you saw it in CQ

AUCTION SALE!

THE TIME: Saturday, April 8, 1950, starting at 10 AM 'til everything is sold if it takes until midnight.

WHERE: Esse Radio Company, 42 West South Street, Indianapolis, Indiana.

Esse Radio Company will sell, at public auction, new and used surplus and currently manufactured radio electronic gear at your prices. This is a gigantic undertaking. Thousands and thousands of dollars worth of merchandise will be sold. We invite you to come to this sale and promise it will be of tremendous interest.

Marlin P. Maddux, well-known auctioneer, will be in charge of this sale. Terms of the sale are cash. Come early to register. We are going to sell some or all of every item in our store during this sale. We especially want other dealers, who are interested in buying quantity, to attend this sale as well as individuals buying for their own use.

Although this sale, to be held April 8, 1950 will perhaps be the largest auction sale that Esse will hold, Esse will continue to have auction sales the 2nd Saturday of each month; so, if you can't come to our first sale, attend others.

Consign your surplus gear to Esse Radio Company for this sale. Esse will sell your equipment for a 15% commission. If you have anything that is connected with radio such as transmitters, receivers, tubes, test equipment, power supplies, condensers, speakers, amplifiers, modulators, dynamotors, etc., regardless of make, send it, or them, to Esse, transportation charges prepaid, and Esse will sell your merchandise for you on this sale. Your equipment should bring highest prices. Individuals, factories, radio clubs, other dealers, just anybody, send your equipment in to Esse for this tremendous sale. You will be placing your gear in the hands of experts for this sale but with the understanding that the consignment of material is final and without recourse as to the prices that it will bring. Everything sold on the sale goes to the highest bidder regardless of what the bid amounts to; however, we believe that the return that you receive for your gear will be fair. Help make this sale a bigger success. Send in your gear and what-not to Esse (all transportation charges must be prepaid). Within five days after the sale, Esse will send you a check for whatever your gear brings, except for a 15% commission that Esse will charge you for handling. Act today! You must hurry to get your equipment to Esse in time for the sale (you don't need to correspond or contact Esse. Just send the gear in). If you cannot get your equipment to Esse for this first sale, send it in anyway for the auction sale May 13, 1950. Remember, Esse will hold an auction sale the 2nd Saturday in every month and will accept consignment of merchandise for any sale.

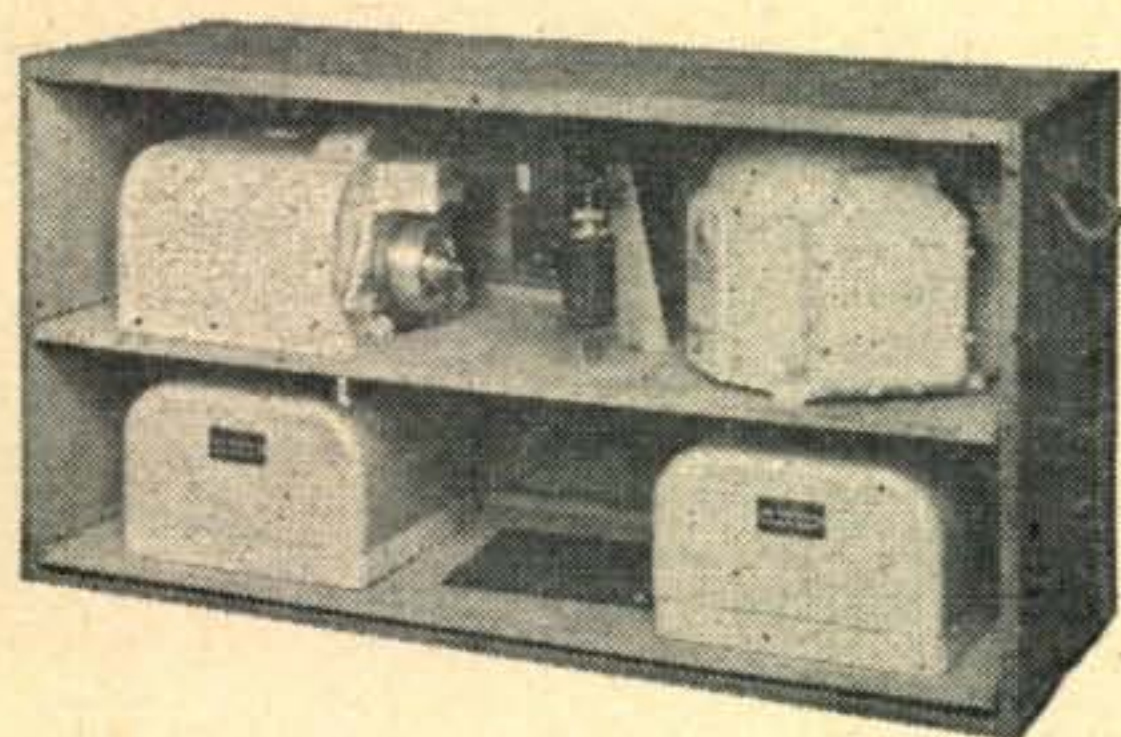

C-1 AUTO PILOT ASSEMBLY made by NORDEN

Stabilized bombing approach equipment type M-7. All the following units come housed in a steel case, size 36" long x 17" high x 12" deep. Weighs approximately 160 lbs. net.

Made by Norden. Consists of three C-1 Servo units, one C-1 Gyro and one Directional panel with dash-pot action. All contained in a metal box with carrying straps. Brand new. **\$24.50**

MULTI-SECTION ROTARY SWITCHES

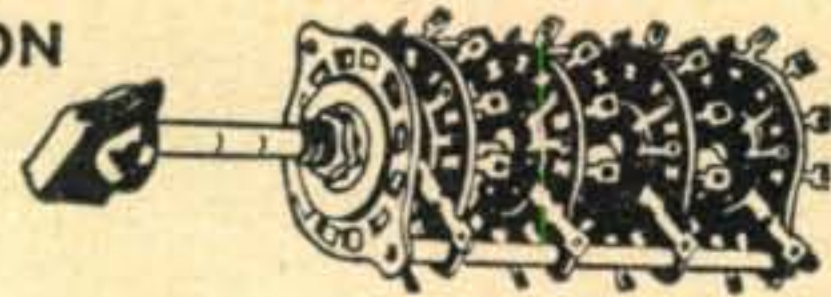

Ideally suited for test equipment, meter switching, and low current switching in industrial applications, including machine tool equipment. Also miscellaneous electronic devices, such as medical equipment, navigation instruments, and radar. All contacting members are silver-plated, except rotar contact slugs which are solid silver. This insures low contact resistance. These are long-life switches. An adjustable stop feature permits selection of desired number of positions for extremely flexible use. The insulation used in all sections is high-grade phenolic resin. All switches supplied with 3/8" dia., 3/8" long brass bushing and 2" long shaft, grooved for easy cutting at popular lengths. All switches have 1/2" spacing between sections. If closer spacing is required between sections, the switch can be disassembled and spacers cut to proper length. Each switch has a knob, nut, and lockwasher.

Catalog No.	No. of circuits per-section or gang	Total No. of circuits per switch	No. of Positions	No. of sections or gangs per switch	Price
269*	4	8	2 to 2	2	50c
270*	1	3	2 to 6	3	50c
271*	2	6	2 to 5	3	60c

* These switches are provided with an "off" position which is in addition to the "number of positions"—as listed.

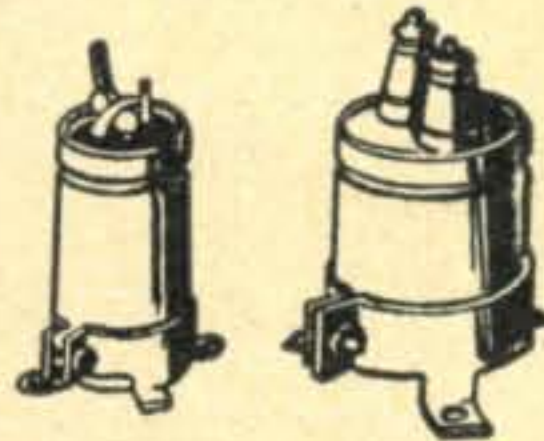

TRANSMITTING CAPACITORS

Application—For filter and bypass circuits in power amplifiers, television and transmitting equipment where compact round can units are desired.

Description—Oil-impregnated oil capacitors furnished in round containers for up-right or inverted mounting. All units internally insulated from case.

Terminals—The 1 3/8" dia. units have 2 solder lug terminals with ample insulation for the voltage ratings involved. The 2" dia. units have special stand-off insulated terminals.

Mounting—Supplied with bracket type mounting for inverted or upright mounting.

Catalog No.	Cap. Mfd.	Working Volts DC	Size, Dia. x Hgt.	Price
272	20	600	1 3/8 x 3 3/8	1.25
273	1.0	1000	1 3/8 x 2 5/8	1.25
274	2.0	1000	1 3/8 x 4 1/8	1.25
275	.5	1500	1 3/8 x 3 1/8	1.25
276	1.0	2000	2 x 3 1/4	1.25

CRYSTALS IN HOLDERS THAT FIT STANDARD —SONG SOCKETS

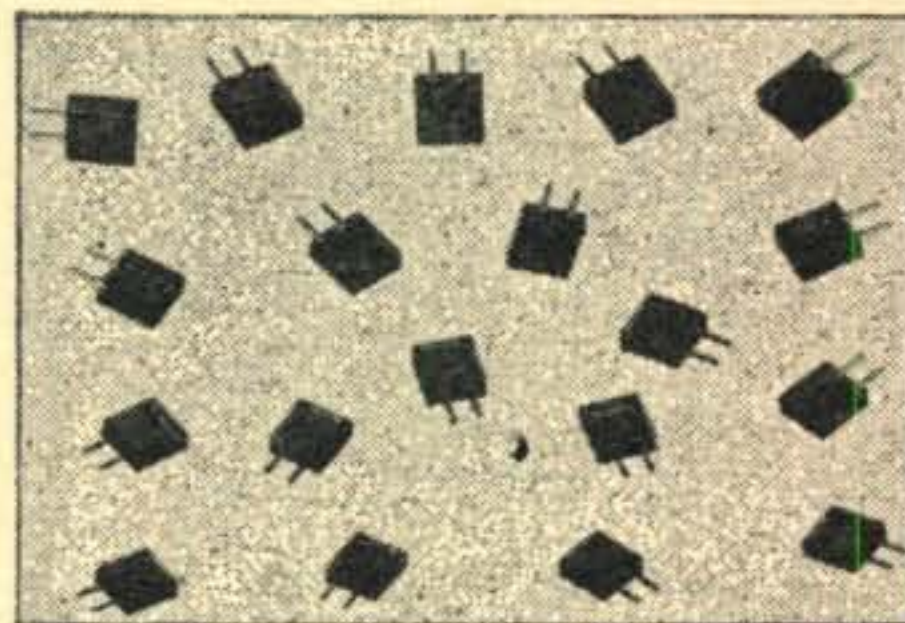

8547			7670
8541	8367	8130	7660
8520	8362	7990	7340
8488	8361	7970	7320
8486	8360	7950	7300
8480	8357	7710	7290
8477	8352	7700	7280
8476	8351	7690	7270
8452	8250	7680	7260
8451			

Price **\$1.00** each
Or Six (choice) for **5.00**

ESSE RADIO CO., 40 W. SOUTH ST., INDIANAPOLIS, INDIANA

When writing to our advertisers say you saw it in CQ

Important notice to every serviceman, amateur, radio-man, radio factory or anyone using condensers.

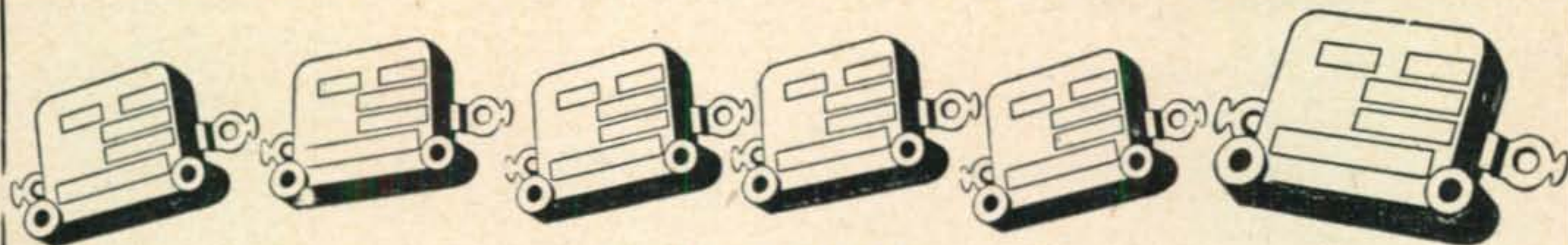

CONDENSERS

Listed below are several types of standard, silver and transmitting types of mica condensers which are of tremendous value. Many of you have been using and paying higher prices for paper condensers for uses in circuits where the mica type condensers would be better suited and, in all probability, could be purchased at a more reasonable price. In fact, in any circuit using a paper condenser, a mica condenser can be substituted

with better results. You will note very few Army electronic circuits were manufactured using paper type condensers. In nearly all cases, mica or bathtub type condensers were used. The prices listed below are only possible because the condensers listed are surplus. Their standard retail value elsewhere would probably be several times the prices asked herein by ESSE.

MICA CONDENSERS

.05	mfd.	1500 V. DC	40c	.001	mfd.	500 V. DC ± 10%	20c
.001	mfd.	400 V. DC	10c	.0015	mfd.	500 V. DC ± 10%	20c
.02	mfd.	600 V. DC	20c	.003	mfd.	500 V. DC ± 10%	20c
.25	mfd.	250 V. DC	30c	.004	mfd.	500 V. DC ± 10%	20c
.075	mfd.	1500 V. DC	40c	.007	mfd.	500 V. DC ± 10%	20c
390	mmfd.	600 V. DC 2%	20c	.008	mfd.	500 V. DC ± 10%	20c
150	mmfd.	2500 V. DC	30c	.0008	mfd.	500 V. DC ± 2%	20c
56	mmfd.	400 V. DC	10c	.0005	mfd.	500 V. DC ± 2%	20c
.00001	mfd.	500 V. DC ± 20%	10c	.0008	mfd.	500 V. DC ± 2%	20c
.007	mfd.	500 V. DC ± 20%	20c	.001	mfd.	500 V. DC ± 2%	20c
.000005	mfd.	500 V. DC ± 10%	10c	.0015	mfd.	500 V. DC ± 2%	20c
.00001	mfd.	500 V. DC ± 10%	10c	.002	mfd.	500 V. DC ± 2%	30c
.00004	mfd.	500 V. DC ± 10%	10c	.0025	mfd.	500 V. DC ± 2%	30c
.000015	mfd.	500 V. DC ± 10%	10c	.003	mfd.	500 V. DC ± 2%	30c
.00015	mfd.	500 V. DC ± 10%	10c	.004	mfd.	500 V. DC ± 2%	30c
.00025	mfd.	500 V. DC ± 10%	10c	.008	mfd.	500 V. DC ± 2%	30c
.0003	mfd.	500 V. DC ± 10%	10c	.0001	mfd.	600 V. DC ± 20%	20c
.0004	mfd.	500 V. DC ± 10%	10c	.001	mfd.	600 V. DC ± 20%	20c
.0005	mfd.	500 V. DC ± 10%	10c	.002	mfd.	600 V. DC ± 20%	20c
.0008	mfd.	500 V. DC ± 10%	10c	.01	mfd.	600 V. DC ± 20%	20c
				.02	mfd.	600 V. DC ± 20%	20c

BATHTUB ELECTROLYTIC CONDENSERS

8 mfd. 500 V. DC 30c

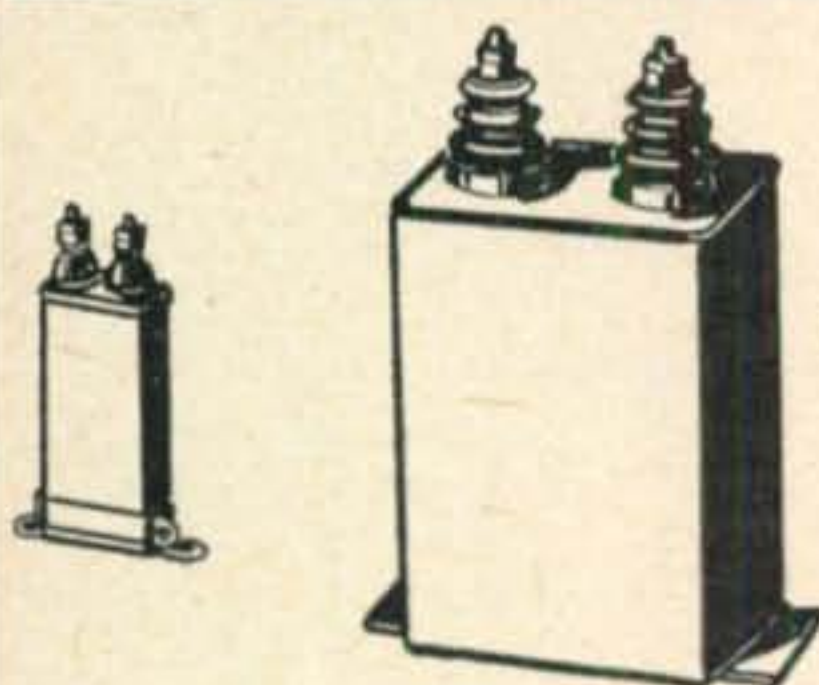

TRANSMITTING
CAPACITORS

Application—For radio, television, transmitting and all circuits requiring high voltage capacitors.

Description—Compact rectangular oil-filled capacitor of sturdy construction.

Terminals—Suitable stand-off insulated terminals at one end to safely cover maximum voltage rating of each unit.

Mounting—Base dimensions less than 3½ x 5⅞, by rectangular clamp providing either upright or inverted position. Base size of 3½ x 5⅞ and above, by permanent flanges at the unit base.

These prices are but a fraction of regular net prices on comparable quality transmitting capacitors that you can buy elsewhere; and remember, we fully guarantee anything sold within these pages to satisfy or we will cheerfully refund your money.

Catalog No.	Cap. Mfd.	Working Volts DC	Size, W x L x H	Price
277	1	600	1 x 1¾ x 2⅞	1.50
278	6	600	1 3/16 x 2½ x 4⅞	3.00
279	1	1000	1 x 3¾ x 2⅞	1.75
280	6	1000	1¼ x 3¾ x 4⅞	3.50
281	1	1500	1 x 1¾ x 4¼	2.00
282	2	1500	1 3/16 x 2½ x 4⅞	3.00
283	6	1500	1¾ x 3¾ x 4⅞	3.50
284	1	2500	1¾ x 3¾ x 3¼	3.00
285	2	2500	1¼ x 3¾ x 4¾	4.00
286	.25	3000	1 3/16 x 2½ x 3⅞	3.00
287	1	3000	1¾ x 3¾ x 4⅞	4.00
288	1	4000	2¼ x 3¼ x 4¾	8.00
289	1	5000	5⅞ x 3½ x 5⅞	9.00
290	2	5000	5⅞ x 3½ x 9	10.00
291	.5	6000	4⅞ x 5⅞ x 3½	12.00
292	1	6000	4 9/16 x 3⅞ x 8	15.00

IMPORTANT

Because of the amount of work and expense involved in handling mail order sales, Esse cannot, any longer, accept orders for less than \$5.00. No COD orders accepted. All us, shipping charges collect, so don't include, with your payment, any money for shipping.

If you are not entirely satisfied with any merchandise purchased within these pages, Esse will cheerfully refund.

ESSE RADIO CO., 40 W. SOUTH ST., INDIANAPOLIS, INDIANA

When writing to our advertisers say you saw it in CQ

CAPACITOR SELECTOR

To be used in determining correct capacity to use in making replacements of defective motor starting capacitors which have lost their identity. Here's a very very fine item that hundreds of you readers of "CQ" magazine have uses for.



Catalog No.	Description	Price
293	For checking capacity ranges from 26 to 161 mfd., 110 to 125 V. DC	\$5.00

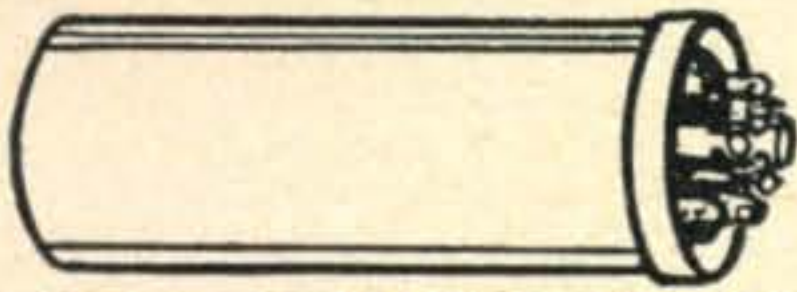

AC MOTOR STARTING CAPACITORS

Application: For any intermittent duty in starting AC capacitor motors in any application where round type cases are required.

Dry electrolytic non-polarized type capacitors housed in round cases. Rated at a minimum capacity value with a plus tolerance of 20%. Furnished in aluminum case with external insulating sleeve.

Terminals: Two solder lug terminals at one end.

Catalog No.	Mfd.	Volts AC	Size Dia. Length	Price
294	26	110	1 3/8 x 2 3/4	40c
295	32	110	1 3/8 x 2 3/4	40c

AC MOTOR STARTING CAPACITORS

Application: For replacement of rectangular cased type motor starting capacitors.
Terminals: Equipped with two capacitor terminals and two dummy terminals. The L and unmarked terminal are the capacitors while T and TL are dummies for convenience in wiring.

Description: Dry electrolytic intermittent duty AC capacitors

housed in rectangular cases and provided with terminal arrangement.

Catalog No.	Mfd.	Volts AC	Size Width, Length, Height	Price
296	86	110	1 1/4 x 4 1/2 x 4 1/2	80c
297	108	110	1 1/4 x 4 1/2 x 4 1/2	80c
298	124	110	1 1/4 x 4 1/2 x 4 1/2	80c
299	161	110	1 1/2 x 4 1/4 x 4 1/4	80c
300	32	220	1 1/4 x 4 1/2 x 4 1/2	1.50

AUTOMOTIVE NOISE SUPPRESSOR CAPACITORS

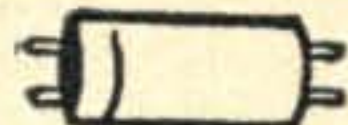

To be used for suppressing radio interference emanating from autogenerators, oil gauges, ammeters, and other automotive, aircraft, or marine equipment.

Description: Wax impregnated cartridge, hermetically sealed, provides low impedance, and is ideal for extreme climatic conditions. Rated capacity mfd. .5, working Volts DC 100, Size 1" dia., 1 5/8" long.

Catalog No. 301 Price 60c

CARDBOARD TUBULAR DRY ELECTROLYTIC CAPACITORS

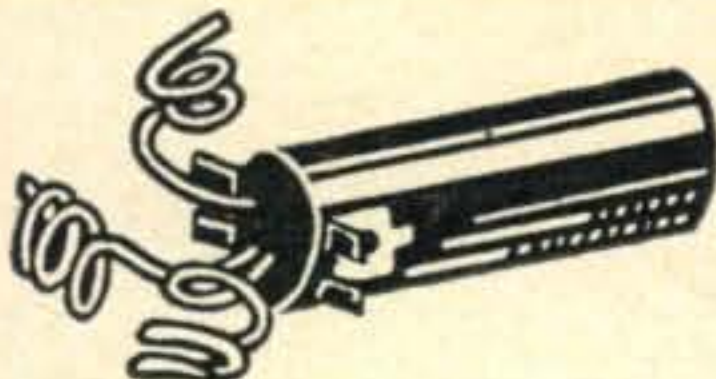

Application: Low-cost filter and bypass units for above or below chassis mounting.

Description: Dual unit in cardboard tube with extra inner seal and ample wax seal at ends.

Terminals: This capacitor supplied with flexible covered leads out one end.

Mounting: This capacitor supplied with an adjustable horizontal mounting strap and has special feet for vertical mounting in addition to the strap.
Rated capacity mfd 16-16 at 450 V. DC, Size 1 1/4" dia. x 3 7/8" length.

Catalog No. 302 Price 75c

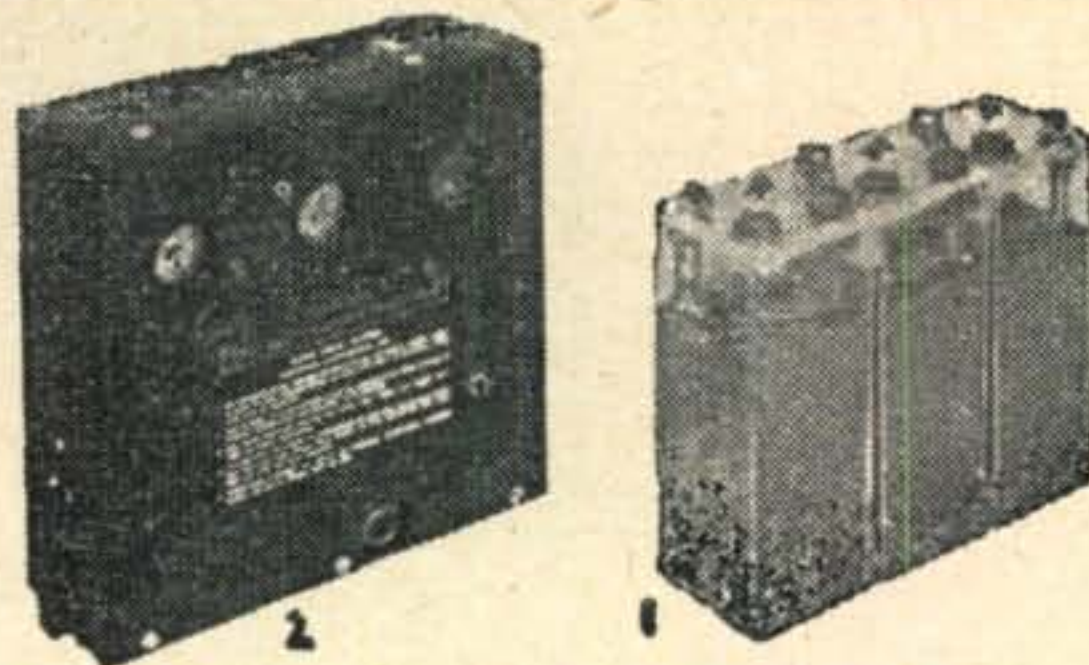

WILLARD BATTERIES

6 V. (New) (Dry-charged)	\$3.00
6 V. (In metal carrying case) (Add electrolyte specific gravity 1.265) (Drugstore)	\$4.00 ea.
BB-54-A 2 V. Willard Plastic Storage Battery. Shipped dry-charged	\$2.85

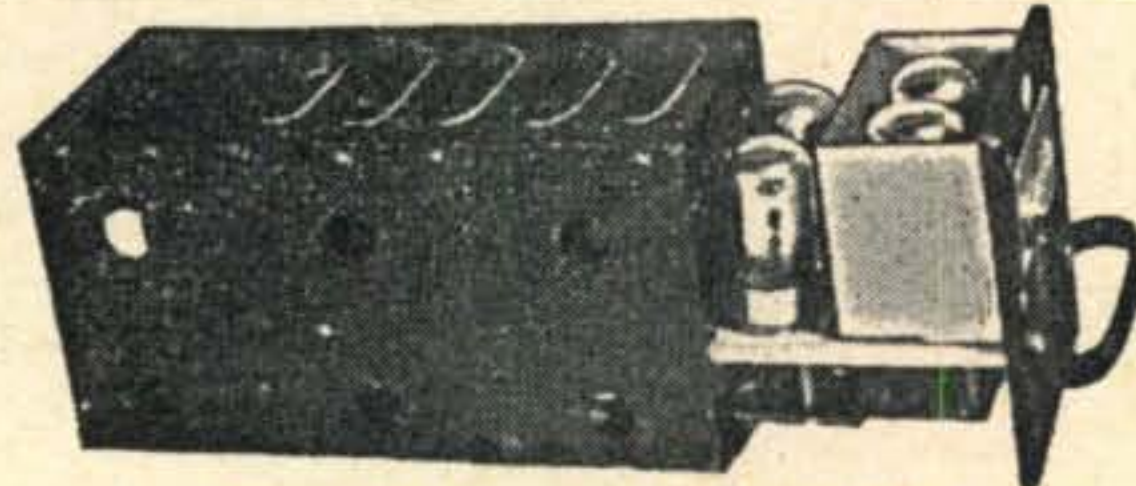

TURBO AMPLIFIER

Used for parts—shipped complete without tubes:
Price 40c ea.

T-39/APQ-9 RADAR TRANSMITTER

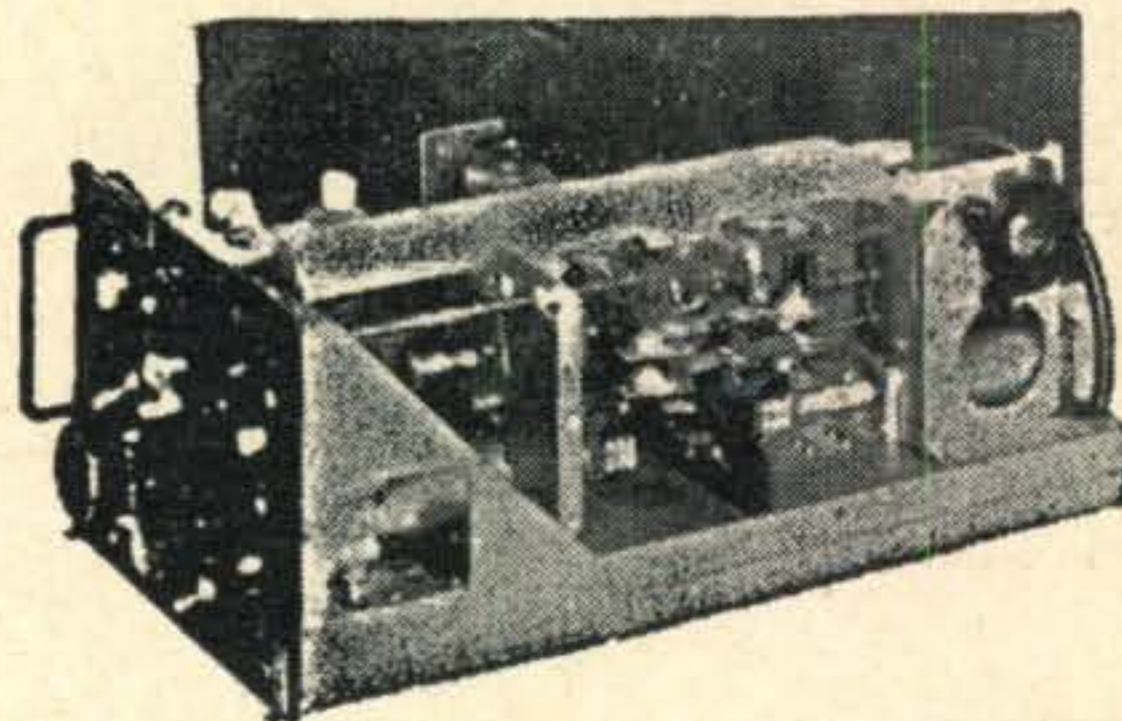

Contains many excellent parts for the VHF experimenter such as a cavity oscillator using 2-RCA 8012 tubes rated at full output to 500 Mc. Tubes are forced air cooled by 24 V. DC motor, which is easily converted for 110 V. AC operation. Other valuable parts such as a pair of 807's, 2-6AC7, 1-931 and 1-6AG7 tubes; ceramic switch, potentiometers gears, revolution-counter, etc.
Complete details for the conversion of this unit for operation in the 420-mc band will be supplied with each unit we sell. Our price for this radar transmitter . . . \$11.95

C-1 GYRO



E2L3
Part of the C-1 Auto Pilot which is sold separate and may be used to conduct many interesting and amusing experiments. Operates from 24 V. DC or may be operated for short periods on 110 V. AC Gyro will run for approx. 15 minutes after actuating. Size—approx. 8" x 8 1/2" x 8 1/2"
\$3.25 ea.

ESSE RADIO CO., 40 W. SOUTH ST., INDIANAPOLIS, INDIANA

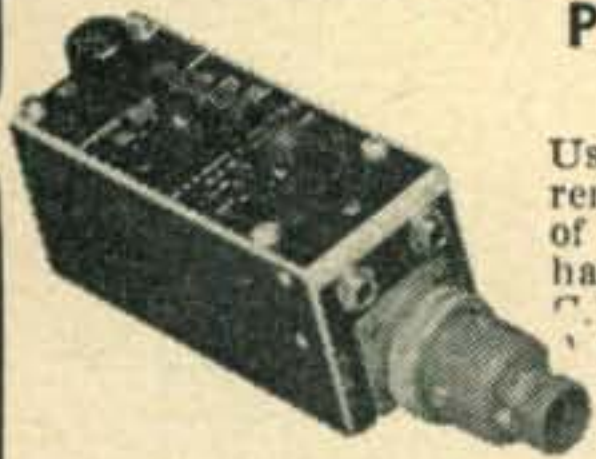

PILOTS CONTROL BOX TYPE-23254

Used with CRV-46151 Receiver for remote control of volume, selection of any one of six frequency bands, has off/on switch or selection of C.W. and M.C.W. and M.V.C. or V.C. Black crackle finish. Size 2" x 2 1/2" x 5" high. Brand New. **75c**

RECEIVER TUNING HEAD CRV-23253



Used with CRV-46151 Receiver for vernier tuning. Has beveled dial with hairline cursor. Bands are 200-560, 560-1600, 1600-4450, 4450-9050 Kcs. Each band spread over about 280 degrees of dial edge. Has provision for flexible tuning shaft or can be adapted for direct drive on any tuning shaft. Black crackle finish. Size 5" x 3" x 2" overall. Brand New **\$1.50**



SPERRY A-5 AUTO PILOT AMPLIFIER RACK

Contains 115 V. AC voltmeter and 350-450 cycle Frequency meter. A total of 4 amplifier chassis complete with following tubes included in rack: 2—1631's, 6—1632's, 3—1633's, 3—1934's and 2—1644 tubes. Numerous transformers, resistors and condensers make this

unit invaluable for parts. Weight 38 lbs. Size 12" L x 14" W 10 1/4" H. Price **\$3.75**

T-17 MICRO- PHONE

Brand New. **\$2.25**
Used **1.50**

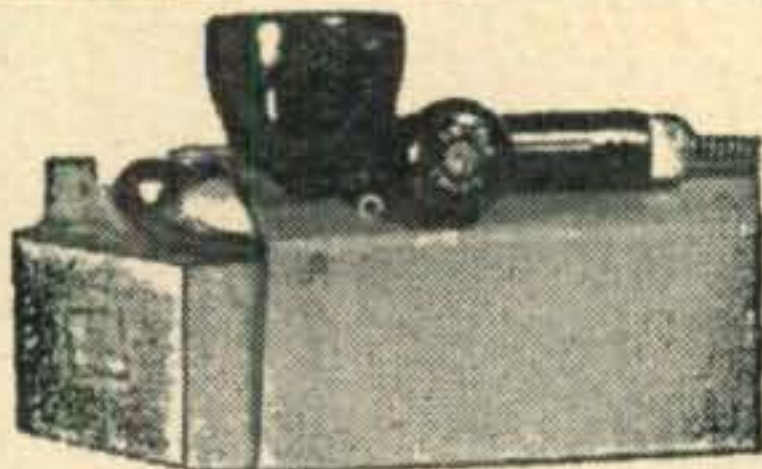

DYNAMOTOR PE101C

Size about 4" dia. x 14" long. Shipping weight approx. 15 lbs. Made to order for BC-645A 420 Mc. Citizens Band transmitter-receiver. Input 13 or 26 V. DC; output 400 and 800 V. DC and 9 V. AC. Brand new in original sealed cartons **\$1.95**

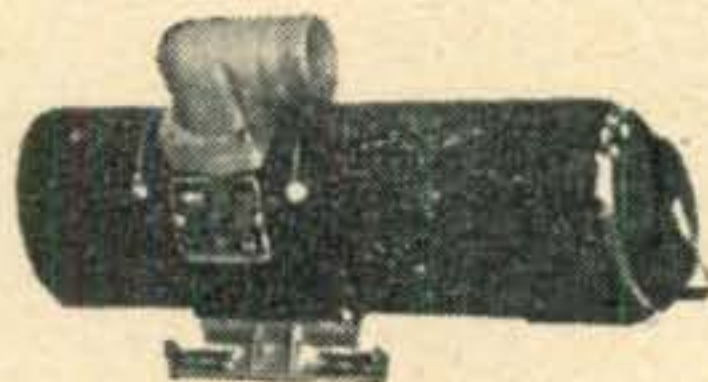

BL-SELENIUM RECTI- FIER TYPE 23751

A must for the radio man for the much needed 110 V. DC source. 110-120 V. AC input, 110-135 V. DC output at 75 amp. Connect in parallel for higher current requirements. Size 3 1/8 x 2 5/8 x 1 3/4 inches. PRICE—New **\$1.25**

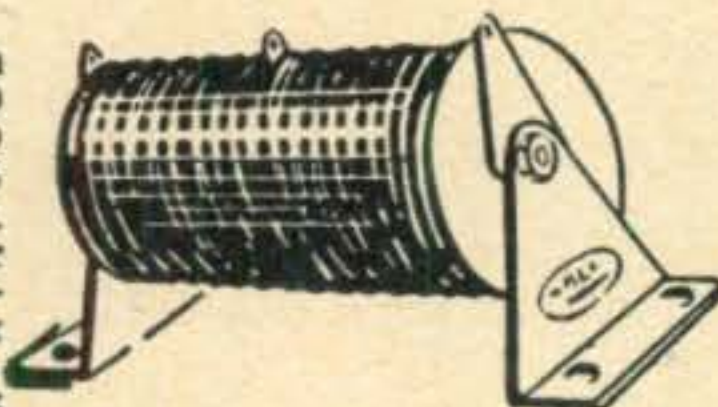

IMPORTANT

Because of the amount of work and expense involved in handling mail order sales, Esse cannot, any longer, accept orders for less than \$5.00. No COD orders accepted. All orders from within the United States will be shipped by us, shipping charges collect, so don't include, with your payment, any money for shipping. If you are not entirely satisfied with any merchandise purchased within these pages, Esse will cheerfully refund.

AUCTION SALE!

THE TIME: Saturday, April 8, 1950, starting at 10 AM 'til everything is sold if it takes until midnight.

WHERE: Esse Radio Company, 42 West South Street, Indianapolis, Indiana.

Esse Radio Company will sell, at public auction, new and used surplus and currently manufactured radio electronic gear at your prices. This is a gigantic undertaking. Thousands and thousands of dollars worth of merchandise will be sold. We invite you to come to this sale and promise it will be of tremendous interest.

Marlin P. Maddux, well-known auctioneer, will be in charge of this sale. Terms of the sale are cash. Come early to register. We are going to sell some or all of every item in our store during this sale. We especially want other dealers, who are interested in buying quantity, to attend this sale as well as individuals buying for their own use.

Although this sale, to be held April 8, 1950 will perhaps be the largest auction sale that Esse will hold, Esse will continue to have auction sales the 2nd Saturday of each month; so, if you can't come to our first sale, attend others.

Consign your surplus gear to Esse Radio Company for this sale. Esse will sell your equipment for a 15% commission. If you have anything that is connected with radio such as transmitters, receivers, tubes, test equipment, power supplies, condensers, speakers, amplifiers, modulators, dynamotors, etc., regardless of make, send it, or them, to Esse, transportation charges prepaid, and Esse will sell your merchandise for you on this sale. Your equipment should bring highest prices. Individuals, factories, radio clubs, other dealers, just anybody, send your equipment in to Esse for this tremendous sale. You will be placing your gear in the hands of experts for this sale but with the understanding that the consignment of material is final and without recourse as to the prices that it will bring. Everything sold on the sale goes to the highest bidder regardless of what the bid amounts to; however, we believe that the return that you receive for your gear will be fair. Help make this sale a bigger success. Send in your gear and what-not to Esse (all transportation charges must be prepaid). Within five days after the sale, Esse will send you a check for whatever your gear brings, except for a 15% commission that Esse will charge you for handling. Act today! You must hurry to get your equipment to Esse in time for the sale (you don't need to correspond or contact Esse. Just send the gear in). If you cannot get your equipment to Esse for this first sale, send it in anyway for the auction sale May 13, 1950. Remember, Esse will hold an auction sale the 2nd Saturday in every month and will accept consignment of merchandise for any sale.

BUDGIT ELECTRIC CHAIN OPERATED HOIST

10 ft. 1/4 hp., 110 V. 60 cycle AC single phase motor. Capacity of hoist 500 lbs. These hoists were sold as used by W.A.A.; however, we cannot tell them from new as appearance is new and they are packed in original shipping boxes. We are using these hoists in our warehouse and have lifted loads of over 1200 lbs. without difficulty. Here is a time and back saver for any business.

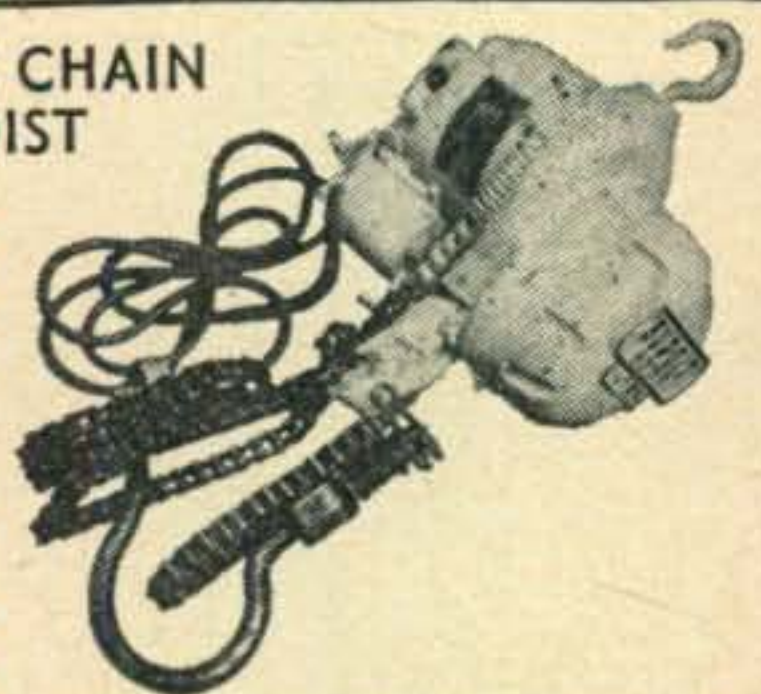

Brand new. Our Price **\$85.00** ea.
E3G2 QUICKSET VISE 3" jaws. Opens to 3" with adjustable clamp for fastening mounting.
New. **\$3.00**

ESSE RADIO CO., 40 W. SOUTH ST., INDIANAPOLIS, INDIANA

When writing to our advertisers say you saw it in CQ

SENIOR-GRADE RIG

(from page 24)

this kind was encountered, so either the suppressors are working, or there are no v.h.f. parasitics in the first place. There is no parasitic-suppressing resistor in the screen circuit of this stage, although one is used in the screen of the final stage.

The output from this 807 drives the final 807 through a 3/30 μf . mica trimmer. The amount of coupling need not be very great. In fact, the trimmer runs quite open. The capacity should be set at the value that gives rated grid current in the final 807 at full load. There is plenty of reserve driving power, as it is possible to increase the grid current beyond 15 ma by increasing the coupling capacity. Care should be taken not to overdrive the 807, as this will cause reduced output.

The Final Amplifier

The final amplifier stage uses the tapped-coil, shorted-turn method of bandswitching. The band-switch is a heavy duty affair obtained on surplus. Any similar switch could be used, the chief consideration being that the contacts be heavy, the insulation ceramic, and operation positive. The plate tank coil is wound on a ceramic former.

The pitch of the turns varies, being coarse, or double-spaced, at the "cold" end and fine, or single-spaced, at the "hot" end. This makes it easier to tap the coil. All coil data is given in the coil table and should work out to be satisfactory with a minimum of the usual cut-and-try. The plate tank condenser has a capacity of 150 μf , and practically all of it is used on 3.5 mc. The final tank circuit is designed to have a Q of 12, which means about 2 μf per meter. Thus, on 40 meters the condenser operates at about half-scale, on 20 meters at quarter-scale, and on 15 meters at slightly less than this. Many 807 rigs do not have enough tank Q , particularly at the lower frequencies, and it is not uncommon to have the point of maximum r.f. output quite far from the point of minimum plate current dip. In this transmitter, both occur at the same condenser setting. The r.f. output is link-coupled to a coax fitting at the rear of the unit. Insulation in the link is made extra heavy to avoid any danger of short-circuiting the plate voltage to the antenna circuits with the danger to life that this might entail. Also in the interest of safety, the final tuning condenser is connected to its dial by means of a flexible insulated coupling. The twin-post connection at the back of the transmitter is a spare for possible use with a folded dipole.

Screen voltage for the final 807 is obtained

SENSATIONAL *Savings* on NEW ELDICO KITS

made possible by "Surprise" Trade-In Allowances on your Used Equipment

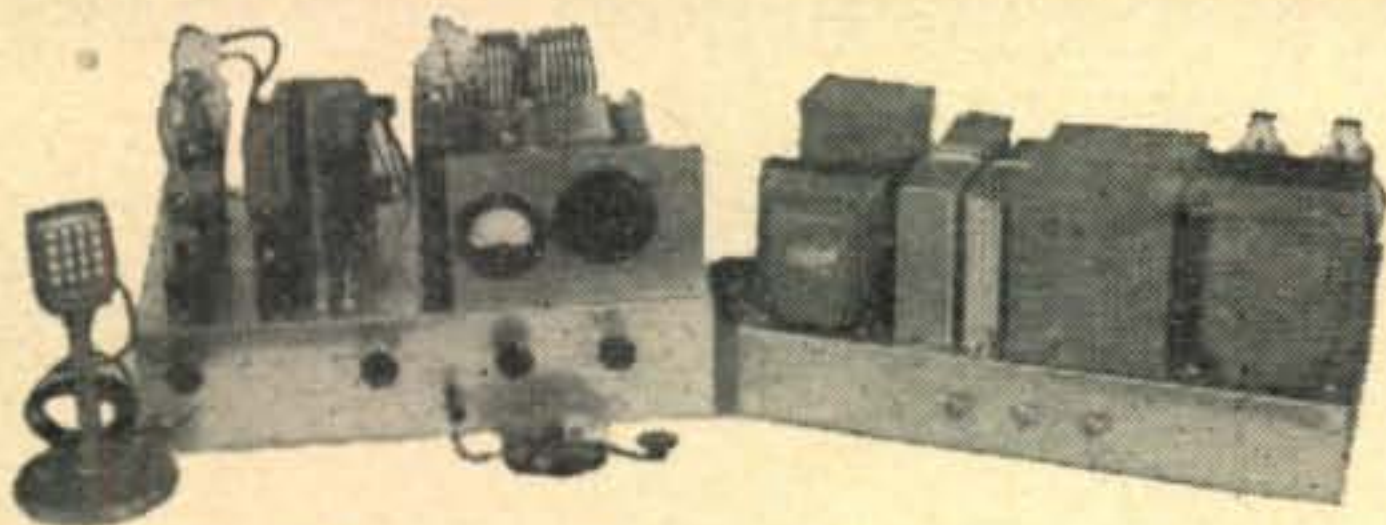

TR-1 300 watts Input Transmitter Kit

Phone & CW. 813 final. PP Class B 811 modulators. Complete with meter, antenna relay, microphone, tubes and final coil for one band.....ONLY **\$179.50**

MD-40 Low Power Modulator Kit	\$29.95
MD-100 Medium Power Modulator Kit	\$44.95
HV-1500 Hi Voltage Power Supply Kit	\$29.50
GDA Grid Dip Oscillator Kit	\$21.50

Walter Ashe
RADIO CO.
1125 PINE ST. • ST. LOUIS 1, MO.

TR-75

75 watt Input Transmitter Kit

For the CW man. 6L6 osc, 807 Final, Pi-network Ant. Tuner. Complete; nothing else to buy. Ideal for beginner or just the thing for the OT's standby rig.

ONLY **\$34.95**



TVI Filters

Receiver Hi Band Pass Filter Kit Model TVR-62 coax or TVR-300 twinexea. (wired and tested)....\$3.98	Transmitter Low Band Pass Filter Kit Model TVD-62
Line Filter Kit Model TVL \$5.98 (wired and tested)....\$8.98	TVL-62 (wired and tested)\$10.99

Trade used (factory-built) Test or Communication equipment now for the Eldico Kit of your choice. Wire, write or phone today!

All prices F. O. B. St. Louis Mo. Phone CHestnut 1125
Convenient Terms On Your New Equipment Purchases.

FREE! New Booklet, "TVI Can Be Cured." Send for your copy today.

When writing to our advertisers say you saw it in CQ

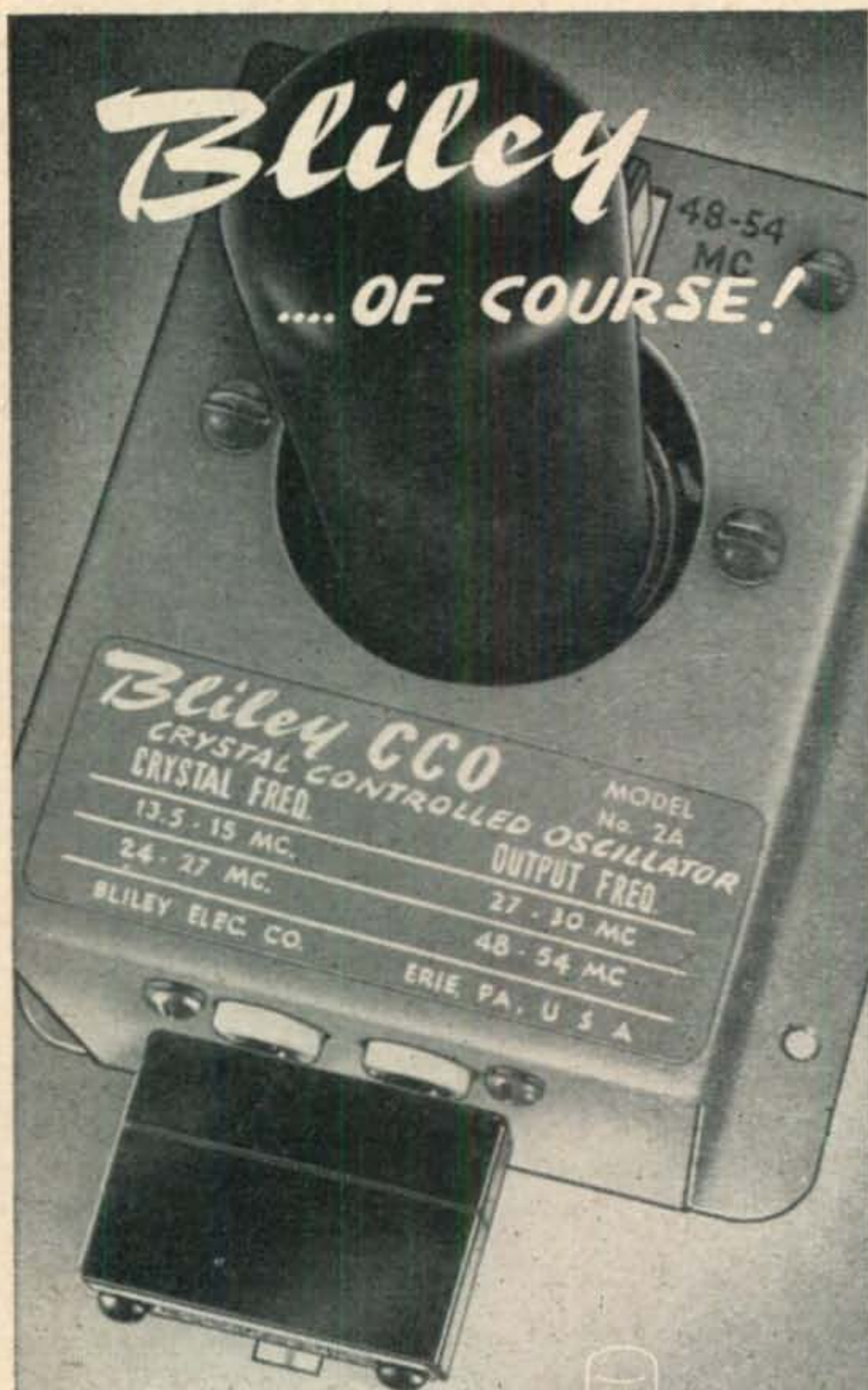

TEAMWORK!

High output at less cost with the Bliley CCO-2A Oscillator. Ample drive for VHF medium power tubes. Designed especially for use with Bliley types AX2 and AX3 crystal units on the 2, 6, 10 and 11 meter ham bands.

CCO - 2A Oscillator	\$9.95
AX2 Crystal	\$3.95
AX3 Crystal	\$3.95

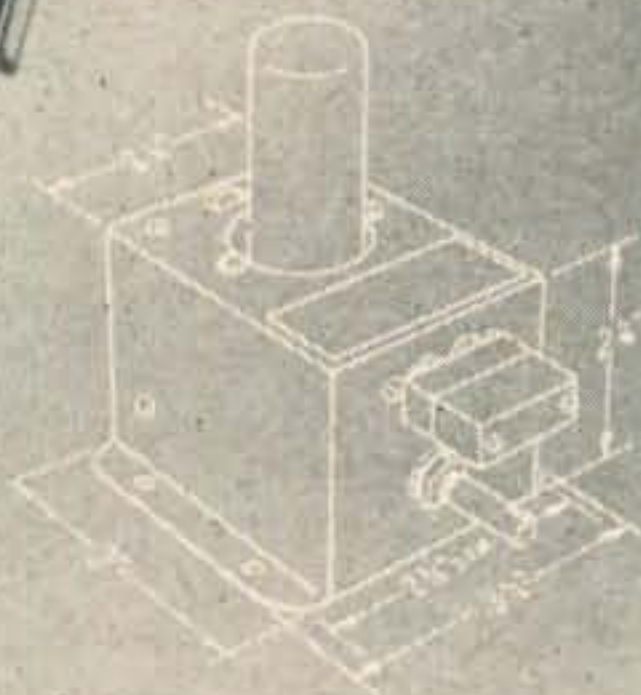

EXPERIENCED AMATEURS know they can rely upon Bliley craftsmanship for superior crystal performance on all ham bands! When you need precision, accuracy, and dependability ... IT'S BLILEY ... OF COURSE!

Bliley

CRYSTALS

BLILEY ELECTRIC COMPANY
UNION STATION BUILDING
ERIE, PA.

through a 50,000-ohm resistor from the plate supply. This is done, in preference to a fixed source of screen voltage, so that the stage may be modulated. This dropping resistor is shunted by a .5- μ f condenser to provide the necessary audio path to the screen. The large 1- μ f paper condenser across the cathode resistor is also necessary when phone is used.

An interesting feature of the final amplifier circuit is the voltage-switching plug arrangement which enables the stage to be operated in any one of several ways. First, when using c.w. with a common power supply for the whole rig, an octal plug with pins 2 and 6 jumpered is plugged into the socket. For phone the leads from the modulation transformer secondary plug into pins 2 and 6. Or, if it is desired to use the maximum voltage on the final from a separate power supply, this may be plugged into pins 2 and 5. This socket also provides a means of power takeoff for an auxiliary unit, such as a VFO, and it can be used as a handy point to measure all of the operating voltages of the rig.

Another novel feature is the meter plug switching scheme. The various circuits of the transmitter are metered by inserting a milliammeter across low-ohmage resistors which are in series with these circuits. However, instead of using a switch or jacks, the four metered circuits are brought to the pins of a bakelite octal socket, which is mounted on the front panel of the transmitter. Three additional locating grooves are filed in the socket with a small round file, so that an octal plug can be inserted in the socket in four different positions. Pins 1 and 8 of the plug are connected to the terminals of an external milliammeter. To read the various currents, it is only necessary to rotate the plug to the desired position. This method of meter switching is absolutely safe since there are no exposed live circuit elements, and it enables a single meter to serve for many different pieces of apparatus, provided the same system is used on all of them.

In addition to metering, brown bead pilot bulbs are inserted in series with the plate leads to the 807s. These provide a handy tuning indication, and they also act as fuses to protect against short circuit. The bulbs are replaceable from the front of the transmitter, enough slack being left in the wires which are soldered to them so that the bulbs can be pulled out of their rubber grommet holders entirely.

Although the bottom portion of the transmitter may appear somewhat crowded in the photograph, such is not actually the case. All of the various components fit into their places quite easily. The job is made simpler if as much of the wiring is done in sub-assembly style as possible. The male voltage input plug at the rear of the transmitter is made from an old five-prong tube base.

The transmitter requires 6.3 v. at 1.95 A. for heater power, 250 v. d.c. at less than 20 ma for the oscillator and screen, and 400 volts at 30 to 40 ma for the first 807. The final plate current depends upon the amount of loading and runs to a maximum of 100 ma. 600 volts may be used on

When writing to our advertisers say you saw it in CQ

SEE LEO FIRST . . . for **National** RECEIVERS

"Deal with the World's Most Personalized Radio Supply House"

I'LL STAND ON MY HEAD TO GIVE YOU FELLOWS A BETTER DEAL
I FINANCE MY OWN PAPER — MAKING IT EASIER AND CHEAPER
FOR YOU TO BUY FROM ME — LIBERAL TRADE-IN ALLOWANCE ON
YOUR PRESENT EQUIPMENT. LET'S GET ACQUAINTED!

W0GFQ
LEO J. MEYERSON

NATIONAL HRO-50 RECEIVER

Packed with important new features! Built-in power supply on separate chassis. Front panel oscillator compensation control. Illuminated, direct reading, linear scale with only range in use in view, has 20 to 1 precision gear drive. Provisions for NBFM adapter. Push-pull audio output. Speaker matching transformer built into receiver with 8 and 500/600 ohm output terminals.

\$335⁰⁰ (Less Speaker)

HRO-50 TS, 10" PM Speaker in matching cabinet \$14.00



Low Down Payments



THE WORLD'S LARGEST DISTRIBUTORS OF AMATEUR RADIO TRANSMITTING EQUIPMENT

NATIONAL'S NC-57 and SELECT-O-JECT

A sensitive, first-rate bandswitching receiver in the lower price bracket, complete with speaker and power supply in one cabinet. A superb receiver for the beginner. With the addition of a National Select-O-Ject, the NC-57 offers selectivity seldom achieved by receivers priced as high as \$300! The Select-O-Ject can be connected to the NC-57 or any receiver capable of supplying 6.3 v. at 0.6 amp. and 200-250 v. at 4 ma.

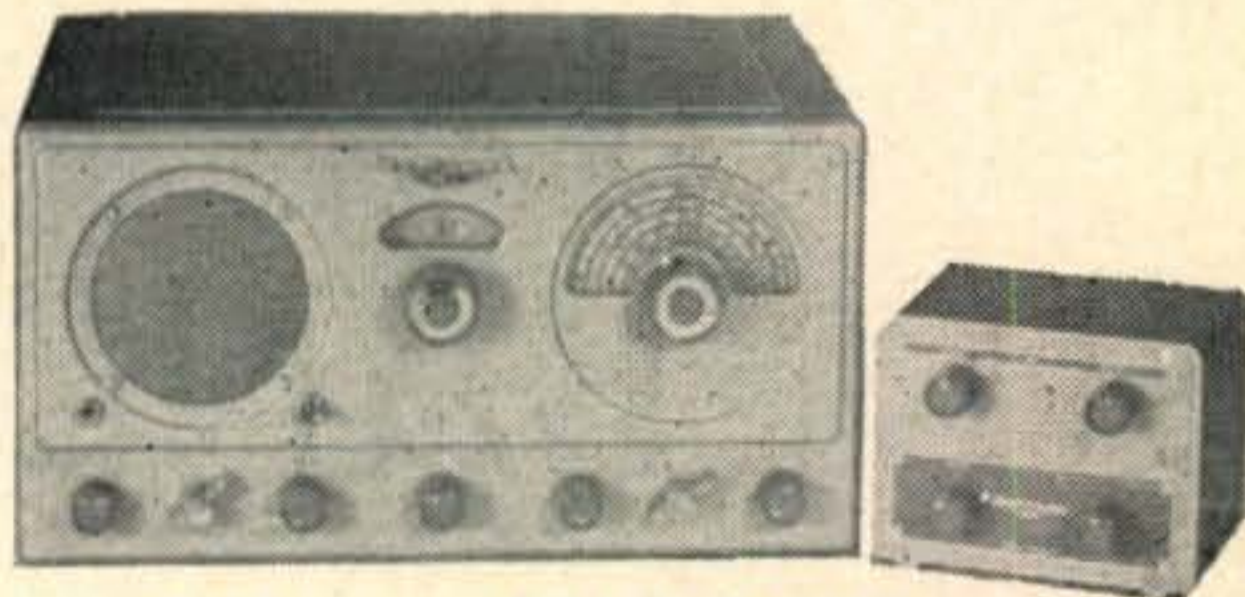

NC-183 Receiver (with matching speaker) . . \$282.00

NC-173 Receiver (with matching speaker) . . \$199.50

Low Down Payments

NC-57

\$89⁵⁰

SELECT-O-JECT

\$24⁹⁵



FREE

Deal with the "World's Most Personalized Radio Supply House". Send for your new complete WRL Catalog containing everything new in radio.

GIANT RADIO REFERENCE MAP



Just right for your control room wall. Approximately 28" x 42". Contains time zones, amateur zones, leading shortwave stations, monitoring stations. **25c**

WRITE—WIRE

PHONE 7795

World Radio
LABORATORIES INCORPORATED
COUNCIL BLUFFS, IOWA

WORLD RADIO LABORATORIES
744 West Broadway
Council Bluffs, Iowa

Please send me:

- Radio Map
- New Catalog

- NC-57 Info
- NC-183 Info
- NC-173 Info
- Select-O-JECT INFO
- HRO-50 INFO

Name

Address

City..... State.....

When writing to our advertisers say you saw it in CQ



**JOHN
ERHART,
W2TGO
used
HK257-B's**

in making
first 2-way
trans-Atlantic
single
sideband
contact

**HK257-B
beam
pentode**

JAN 4E27

A natural for

SINGLE SIDEBAND

Amplifiers!

Two Tubes in Push-Pull, Class B. RF Service

Plate volts.....	2000
Screen grid volts.....	750
Control grid bias.....	-160 (Note 1.)
Suppressor grid bias.....	0
RF grid voltage swing.....	320
Zero signal plate current.....	35 ma. per tube, 70 ma. 2 tubes
Maximum signal plate current....	200 ma. per tube, 400 ma. 2 tubes

Note 1. Adjust control grid bias until each tube draws 35 ma. static plate current.

Note 2. Plate load impedance must be adjusted for peak output conditions without introducing distortion.

HEINTZ and KAUFMAN DIVISION



THE ROBERT DOLLAR CO.
REDWOOD CITY, CALIF.

Export: The M. SIMONS & SON Co., Inc. • 25 Warren St. • NYC
Cable: Simonrice

Note new factory address

When writing to our advertisers say you saw it in CQ

the final for phone and up to 750 v. for c.w. provided the screen-dropping resistor is increased to 85,000 ohms.

Blocked-grid keying is used in this unit because it is keyed in conjunction with an auxiliary vacuum tube keyer. However, if cathode keying is preferred, it is necessary only to ground the grid return circuits and to bring the cathodes to the present keying network.

A finished touch is added by labelling the controls with "Tekni-Cals." The labels are made permanent by painting over them with colorless fingernail lacquer after they are thoroughly dry. This "soaks" the label right into the wrinkle finish, and it becomes as permanent as the paint itself.

The effort spent in constructing this rig has been very worthwhile. The stability is such that with full plate voltage applied and excitation removed, any or all of the tuning dials may be varied over any portion of the tuning range without the slightest flicker in plate current. About one half of the reports have been that desirable "599X" and many favorable comments have been received on the quality of the signals while working other stations—these bouquets being tossed without even a hint of a request for them.

Dollars for Watts

W7ESJ **PORTLAND**
ORE.
THAT BUM!
WHO DRAWS
THESE BETWEEN QSOs.



Are you an NSB?

(see page 53)

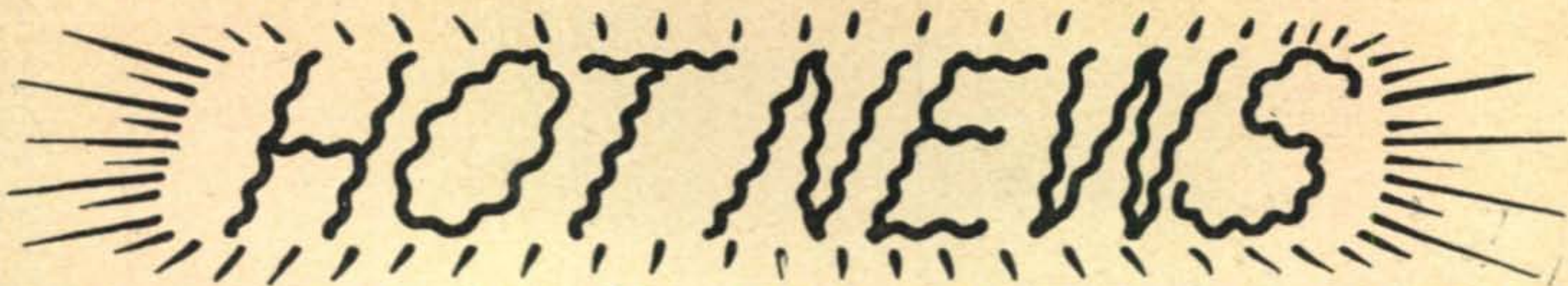

FROM THE HAM KIT HEADQUARTERS ELDICO ADDS 2 NEW KITS

TO THEIR FAST GROWING SENSATIONAL LINE OF HAM KITS

No. 1 - TR-75-TV A 75 WATT TVI'ed RIG



TR-75TV Basically this is the same top-value kit as the sturdy dependable TR-75. To it has been added all of Eldico's working tools to eliminate television interference. In addition to all of the components, the TR-75TV includes integral low-pass filters, pi-network output tuner for additional harmonic attenuation; fully shielded 807 grid circuit; 3" square meter fully shielded cabinet \$49.95 complete.

THE STANDARD TR-75 TVI components\$34.95

No. 2 - EE-1 A REALLY FINE ELECTRONIC BUG

Now Eldico electronic bugs! Eldico introduces an electronic bug incorporating every improvement known to the art. Proven designs . . . worked over by Eldico engineers . . . analyzed in the light of QST's January 1950 article "Debugging the Electronic Bug?" Eldico offers two basic models, one with a built-in monitor. Each key comes complete with all components, including a deluxe key assembly and a modern housing for the entire unit. Among the electrical features are self-completing dashes that automatically insure perfectly formed dashes; separate controls for speed and weight of characters; oversize components rated for heavy-duty continuous service.

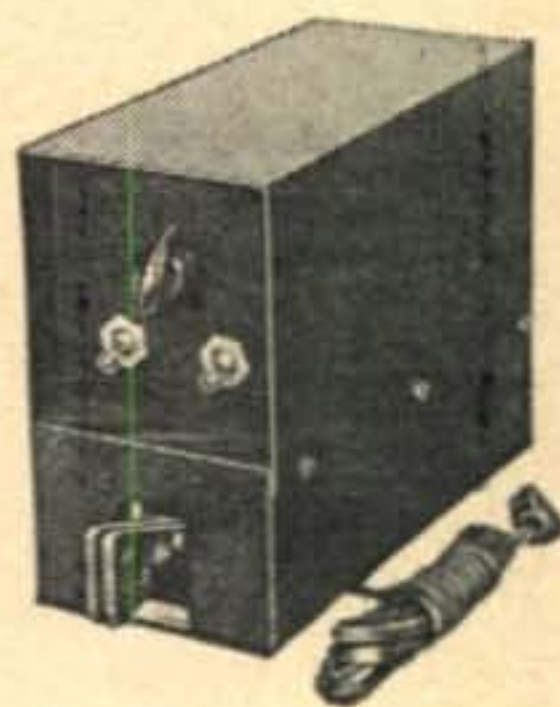

EE1 Electronic Bug in kit form \$21.95
EE2 Electronic Bug Kit including integral monitor \$29.95
EE3 Model EE1 completely assembled and tested \$27.95
EE4 Model EE2 completely assembled and tested \$39.95

The complete Eldico line of TVI FILTERS, TRANSMITTERS, and POWER SUPPLIES is available from top National Distributors throughout the United States. If your Distributor cannot supply you with Eldico kits write Eldico directly. WRITE NOW FOR YOUR FREE TVI BOOK. "TVI CAN BE CURED."

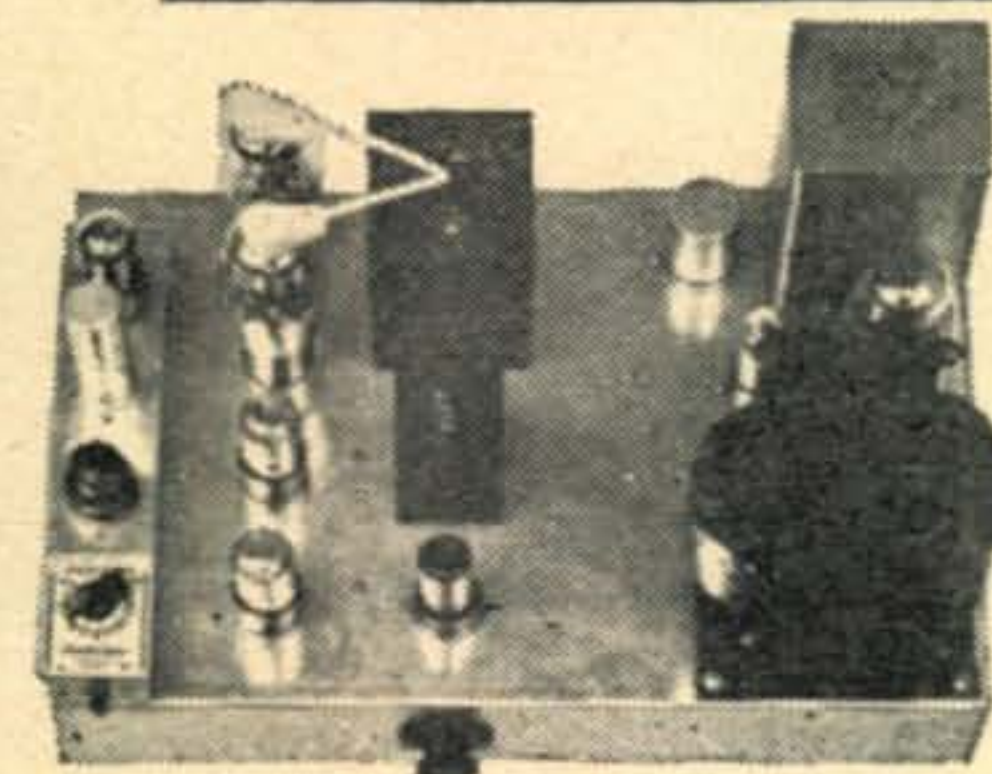

ELDICO MODULATOR KIT 100 WATTS 40 WATTS

Eldico makes two Modulators for the Ham, in Kit form, the MD-100 and the MD-40 (which also comes with a power supply MD-40P.) In keeping with the fine high quality design of all Eldico Kits

these Modulators come complete ready to assemble and put to work. Both units are designed to accommodate the Electro-Voice Speech Clipper and come complete with the Electro-Voice 915 high level crystal Mike.
MD-100..... complete kit\$44.95
MD-40 complete kit 29.95
MD-40P..... complete kit with Power Sup., 39.95
SPEECH CLIPPER 14.70



ELDICO GRID DIP OSCILLATOR

The "Grid-Dipper" is a really hot test unit in the shack. Save countless hours of building time, know your circuits are right. Complete with all parts and internal power supply. Range 3MC to 250MC covered in 6 steps. 5 1/2 x 2 3/8 x 3" \$21.50
Modification Kit including Instruction to convert to regeneration type \$3.00
NOTE All Prices F.O.B. N.Y.C. and are subject to change without notice.

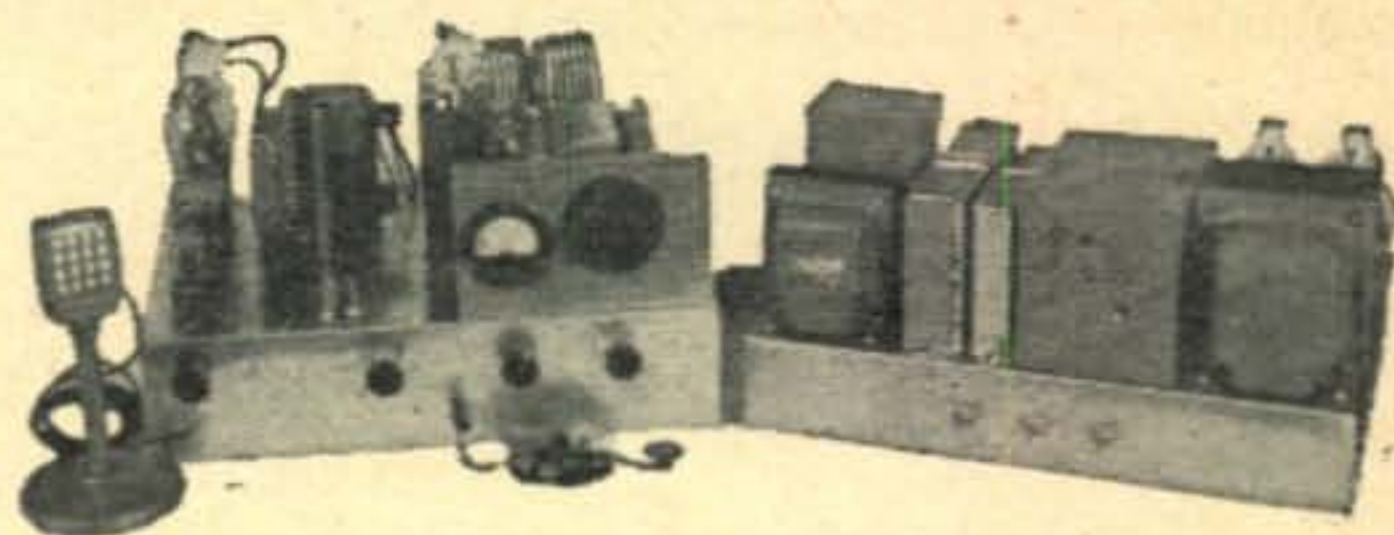

TR-1 TRANSMITTER KIT

A conservative 300-Watt phone and c.w. rig 6V6-6V6-6L6-813, Class B 811 modulators. All bands, 80, 40, 20, 15, 11, and 10. Exciter broad band, single control PA tuning. Three power supplies delivering 1500 v.d.c. at 350 ma. 500 v.d.c. at 200 ma, and bias supply. Aluminum chassis, tubes, transformers, capacitors, resistors, antenna changeover relay, meter, wire, hardware and coils included. Electro-Voice 915 high level crystal microphone part of the package. Plug in the crystal and line cord and you're on the air. Only \$179.50 cash or \$89.50 down payment plus six monthly payments of \$15.75.

FREE TVI BOOK - WRITE DEPART. CQ

W2UOL's ELDICO of N.Y.
I N C O R P O R A T E D
44-31 DOUGLSTON PARKWAY
DOUGLSTON, L. I., NEW YORK

When writing to our advertisers say you saw it in CQ

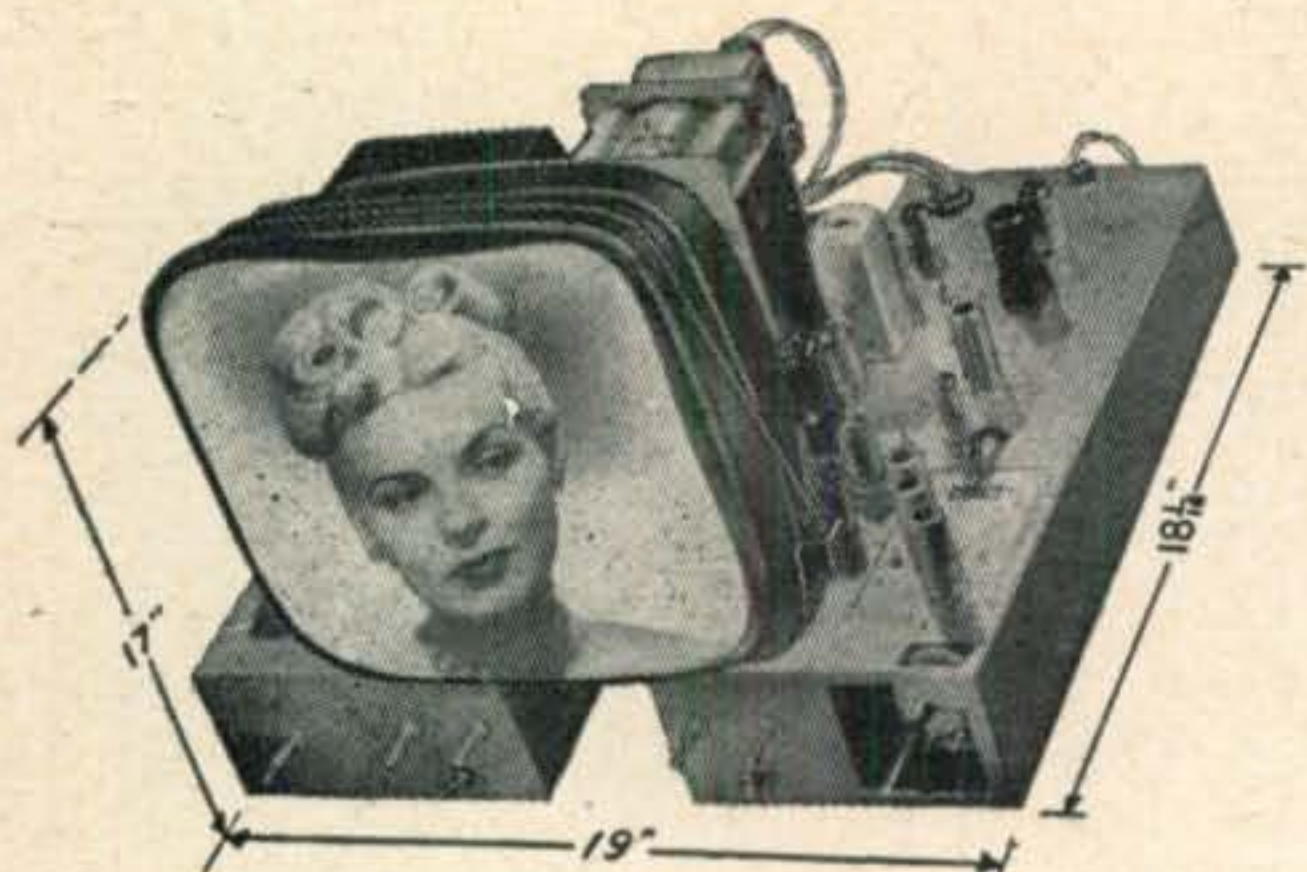

ALL-NEW, HIGH-GAIN

NATIONAL
TELEVISION
Chassis

**DESIGNED FOR THE NEW
 16" RECTANGULAR PICTURE TUBE**

This great new National Television Chassis features the new 16" rectangular "black face" picture tube — no lost corners or corner distortion! Has a highly sensitive new turret tuner and 4 stages of I.F. for extra gain, as well as a full 4 mc. video bandwidth for magnificent picture fidelity. Requires no more cabinet space than conventional 12" chassis! Unique 3-unit "building-block" design makes it the ideal choice for every custom installation.

\$189.95

(less picture tube)



Sixth Annual Old Timers' Night

The Delaware Valley Radio Association, of Trenton, N. J., will sponsor its 6th annual Old Timers' Night and banquet on Saturday evening, April 15th, 1950, in the Terrace Room of the Hotel Stacy-Trent, in downtown Trenton.

Guest speakers will include OTs in the wireless game and men who have been prominent in all branches of radio for many years.

Reservations must be made by April 8th. A letter to Ed Raser, W2ZI, General Chairman, 315 Beechwood Ave., Trenton, N. J., accompanied with \$5.00 for each reservation, will fix you up. Late comers who purchase tickets at the door will be taxed \$6.00. As in the past, the party will be stag.

V.H.F.—U.H.F.

(from page 33)

420 mc, using crystal-controlled 6J6 final amplifiers for both bands. Contacts on the u.h.f. bands have been strictly local to date.

W2UTH, who is, by the way, president of the Rochester, N. Y., V.H.F. Group, maintains a weekly schedule with VE3ANT, and to date has had 100% success. The 95-mile path from Rochester to Northmount, Ont. is not an easy one to span on the v.h.f. bands. Horizontal polarization is now used exclusively in the Rochester and Ithica areas. The line of demarcation between horizontal and vertical seems to be creeping east!

W3PR, near Harrisburg, Pa., and Ye Ed have proved the importance of maintaining schedules. Hooked up for the first time by means of a land-line call, we established contact on 144 mc on the very first try! Since then 100% results have been obtained on five consecutive tries, every Tuesday at 2230 EST. W3PR uses a 522 with 10 watts input, and a 16-element horizontal beam. We hope to get Jim set up for vertical polarization also, as this path would be a good proving ground—100 miles over rugged terrain.

Schedules are a "Must" on 420

The operators who are trying to break the ice on the 420 mc band are strong in their insistence that pre-arranged schedules must be set up to demonstrate the capabilities of this band. As we have pointed out before, the antennas for this band must have high gain if good results are to be expected. Such gain is easiest obtained by designing the array for high directivity in both the vertical and horizontal planes. With activity as low as it is now in most sections, and with signals as weak as they often will be in the experimental phases of u.h.f. operations, one must have a good idea of when and where to listen for a signal, or many hours may be wasted to no avail. The problems of antenna directivity will probably bring about many changes in our regular operating techniques as the 420 mc band becomes more occupied.

So, fellows, that's how it's done. Try setting up a few schedules to check the capabilities of your equipment. Pick a partner who can be depended upon to stick to the schedule, located far enough away so that you are both convinced that consistent contact cannot be maintained. Under these conditions even minor improvements in the equipment will show up. Then go ahead and work him consistently . . . on schedule.

F.M. vs. A.M.

Interest in f.m. transmission and reception has apparently revived, according to comments received from several sources lately. W1EYM and W1JKC are run-

When writing to our advertisers say you saw it in CQ

Are you an NSB?

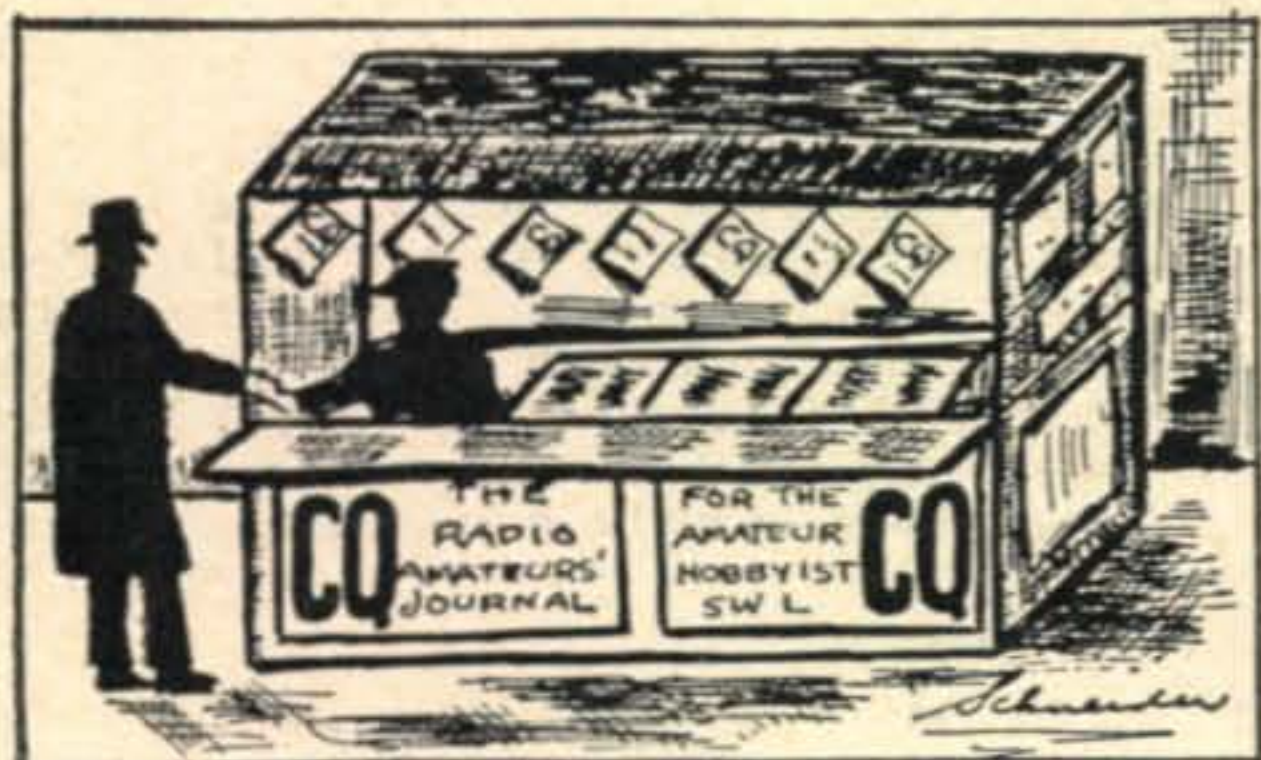

If you are . . .
 save money and
SUBSCRIBE NOW

CQ gives you first-hand knowledge of the most fascinating hobby in the world—Amateur Radio.

Be sure of getting all the latest innovations which have been proven successful by your fellow-hams by having CQ delivered right to your door—at a cost of less than 6c per week.

Grab a pencil—pen—or anything that's handy—and fill in the form below—Before you know it you'll graduate from the NSBs (News Stand Buyers) right into the C-CQ-R class (Contented CQ Reader).

One Year . . . \$3.00 Two Years . . . \$5.00
 in U.S., U.S. Possessions, Canada and countries in the Pan American union. All others \$4.00 per year.



NSB

CQ-RADIO MAGAZINES, INC.
342 MADISON AVE., NEW YORK 17, N. Y.

Enclosed find \$ for a year subscription
 to be sent to: New Renewal

Name Call

Address

City Zone State

ning tests on very-narrow-band f.m. They are using Q-5er techniques to cut the receiver band-width down to a few kc and are using all the usual tricks to improve articulation. Preliminary tests show results at least favorably comparable to a.m. for weak-signal reception.

W2VEN feels that the average ham receiving system falls far short of what v.h.f. mobile-service f.m. receivers will do. He points out that the degree of quieting of a typical commercial f.m. receiver with input signals less than a microvolt is greater than the average a.m. ham receiver will provide. We don't agree entirely with the figures which W2VEN quotes for the ham receivers—our tests have shown that the v.h.f. receivers have to be pretty darned good before the hams are satisfied with them—but maybe he does have a few strong points in his case for f.m. The lack of modulator power requirements in the transmitter is a pretty good selling point.

W9ECH, W9GCZ, and W9EKK are experimenting with a spot-frequency medium-wide-band f.m. system. Their results have been very encouraging. They are at present using receiver band-widths slightly greater than 100 kc, and the transmitter swing is held between 50 and 100 kc. They also employ the usual pre-emphasis techniques to gain the full benefit of the system. Look for these boys on 147.6 mc. They are using crystal-controlled transmitters and receivers.

Several of the boys are already using f.m., either consistently or on occasions, from their fixed stations. W2FTX of Millville, N. J. (144.1 mc, 500 watts) is all set with a surplus f.m. police rig, transmitter and receiver. Using swings in the order of ten kc, Russ is able to do fairly well even with the fellows using normal a.m. receivers. W2DFV, W2TM, W3FGN, and several others are ready with f.m. transmitters but the limited number of good f.m. receivers now in use has effectively discouraged extensive operations.

We would strongly suggest that those interested in f.m. on our v.h.f. bands get together and agree on reasonable standards for their system. There are many considerations, all important, which should affect the choice of standards. There are several n.f.m. adapters on the market for the low-frequency communications

receivers so often used for i.f. strips. The system should be adaptable to these sets. There are several surplus police-band f.m. sets available now, and it would be nice if the system could be adapted to these rigs. May the best system win!

Is f.m. going to be worthwhile? Required reading on this subject would be "A.M. and Narrow-Band F.M. in U.H.F. Communications" by E. Toth, in *Electronics* for February and March, 1950. This author makes a pretty good case for a.m. but he has been confined to some circumstances which do not necessarily apply to ham communications—receiver instability, for example. This is a classic example of a situation where there would be no argument unless there was a lot to be said on both sides. To those who would say that the mobile services chose f.m., one might point out that most of the armed-services and airline equipment designed for weak-signal work is still a.m. And so on, far into the night! Ye Ed would very much like to use f.m. efficiently. It would cut out at least 75% of our TVI—that due to audio blanketing.

Six Meter Activity

Things have been pretty quiet on six meters during the past couple of months; only a few scattered reports have been received. For the first week of January, no DX was reported except a very brief sporadic-E opening on the 4th, during which W5FSC, W7QLZ, W4CPZ and several W6s were active. On the 8th, HC2OT broke through and worked W5ONS with strong signals both ways. Apparently most of the rest of the gang were not at their listening posts at this time (1015 EST).

Our South American friends had things a little better, with band openings on January 14, 21, 26, and 29. KH6P heard ZL3LE on the 23rd for a very short period.

The North American gang took advantage of a slight aurora opening on January 24th, with VE3AET, W1PWW, W1EIO, VE3ANY, VE3DDT, and W9VPZ reporting aurora contacts.

Watching the 27-day cycle, the gang was ready for

BUILD IT YOURSELF IN A FEW EVENINGS!

TRANSMITTER TRIUMPH!

the JOHNSON VIKING I

Available in Complete Kit Form Only

Here it is! Commercial transmitter efficiency and appearance at kit prices!

Novice or oldtimer alike can assemble and get brilliant performance from the VIKING I. Everything is done for you . . . a wiring harness containing all AC and DC leads is furnished, eliminating assembly errors . . . chassis is drilled and punched. All bands, 160, 80, 40, 20, 15, 10 - 11.

All parts are furnished except tubes, mike, crystals and key. Tubes required—RF tubes: 6AU6, 6AQ5, 4D32-AF tubes: 6AU6, 6AU6, PP807S.

Write for your illustrated catalog today! **\$20950**
Amateur Net Price

E. F. JOHNSON CO.

WASECA, MINN



Check These Features

- Output—100 watts, with AM phone on all bands, 115 watts cw.
- Pi-section output stage—for operating ease—efficiency.
- Most any antenna can be used without external couplers.
- Advanced Design—there are no plug-in coils. It's entirely band switching, from front panel.
- Final Tank Circuit—has variable inductor with variable pitch for high Q throughout range. Additional inductance switched in for 160 meter band.
- Select any one of ten crystals from front panel.
- 807 modulators, frequency response limited from 300 to 3,000 cycles.
- Switch provides meter in all important circuits.
- Unique crystal oscillator.

another round of ionosphere activity on Feb. 20, when a strong aurora disturbance produced visible Northern Lights as far south as Philadelphia. W2MEU, W1PWW, W1EIO, VE3ANY, VE3DDT, and W9VPZ others were breaking through at our QTH at southern New Jersey, all signals being severely affected by the aurora roar. VE3ANY reported hearing plenty of activity from W1, W2, W3, W8, W9, and W0. Although the band was thoroughly searched on the following morning for signs of an F-2 opening we have not yet heard any reports that indicate that an opening occurred.

The early hour of the aurora opening found many of the city dwellers off six meters due to TVI. The problem of 50 mc TV interference is a tough one, as many TV sets which are apparently immune from overload effects on the other ham bands will go into a complete dither when a strong 50 mc signal is pumped into the antenna circuit. Of course, traps help, but it is often a problem to get to the offending set to install a trap or filter. We'd like to hear from some of the gang who have successfully met this problem.

420 Megacycle Notes

K2AH tells us to pass the word around that the gang around Northern New Jersey are looking to the south on Friday evenings between the hours of 8 and 9 p.m., EST. Among those active in the N.N.J. section are W2AOD, W2BQK, W2BLF and W2N1J. The first inter-city QSO on 420 is certain to give the band a big shot in the arm, so let's hope that the Philadelphia area boys will do their best to break through to the fellows about 80 miles to the north.

We have received a long epistle from W7QLZ describing his latest efforts on 420. Space does not permit a full discussion of Clyde's experiments, so we'll postpone it until next month when perhaps we can better do it justice!

Until next month, 73, and to those of you who have asked whether I can't get on ten or eleven meters to talk to you in person, be patient. The final amplifier for the l.f. rig should be finished any day now! . . . Brownie, W2PAU

N O W A TELEVISION TOWER YOU CAN AFFORD TO BUY!

All steel, welded construction, made of 1/2" Thinwall conduit, 1/4" Rod Braces, and 1" Steel Bands. Made in 10 Ft. triangular shaped sections, tapered, 18" at base to 3 1/2" at top. Hinged mounting plates and 2" mounting hole for Mast, with Guy Rings. 30 Foot Tower is self supporting when mounted on ground. Weight: 75 lbs. Towers dipped in aluminum paint for weather-proof protection and long life. Price: 30 FOOT TOWER, delivered anywhere in U.S.A. \$38.40
ADDITIONAL 10 Ft. SECTIONS—delivered . . . \$11.70 Ea.
GUY WIRE: 3/32" 7 x 7 Strand Aircraft Type, only .02c per Ft. WIRE CABLE CLAMPS: 10c Ea. TURNBUCKLES: 5 1/2" @ .25c Ea.; 9 1/2" @ .70c Ea.

NEW LOW PRICES: TRANSMITTERS & RECEIVERS

BC-453 RECEIVER—190-550 KC.	USED: \$11.95	NEW:
BC-455 RECEIVER—6-9.1 MC.	6.95	
BC-454 RECEIVER—3-6 MC.	4.95	
TRANSFORMER f/Comm. Rec. See CH-109 to right . .	\$3.50	
	USED:	NEW:
BC-696 TRANSMITTER—3-4 MC.	\$12.95	
BC-459 TRANSMITTER—7-9 MC.	9.95	
BC-457 TRANSMITTER—4-5.3 MC.	5.95	
BC-458 TRANSMITTER—5.3-7 MC.	5.95	
BC-456 TRANSMITTER MODULATOR	1.95	\$2.95
TRANSFORMER f/Comm. Trans. See CH-108 to right . .	7.75	
CHOKE—13 Hy. 250 MA. No. CH-121	4.95	

SELSYN TRANSMITTER & INDICATOR SYSTEM

Ideal for antenna direction indicator to remote position. Complete with Autosyn Trans., 3" I-81 Indicator, Transformer, and instructions \$6.75
Autosyn Trans. only: \$2.95 Plug f/I-81: \$1.00

BC-645-A Transceiver—

ALSO 110 VOLT TRANSFORMER AND CHOKE
15 Tube Transceiver, ideal for conversion to 400 MC. Frequency coverage 435 to 500 MC. With conversion instruction - Price: New and Boxed \$14.95
TRANSFORMER for BC-645-A — 110 Volt 60 cycle input, output 400 Volt 150 MA. after filter. 12, 9, and 6 V. AC. 4 amps and 5 V. 3 amps. No. CH-645 \$2.95
CHOKE—15 Hy. 150 MA. Order No. CH-646 \$2.95
PE-101 DYNAMOTOR—13/26 V. input \$2.95

BC-223 Transmitter

30 Watt Transmitter with crystal or MO control on four pre-selected channels, 2000 to 5250 KC., by use of three plug-in coils. Five Tubes: two 801 & three 4G. With TU-17 Tuning Unit 2000 to 3000 KC. and Cable, less mtg.
Prices NEW: \$24.95—USED: \$19.95
TUNING UNITS: TU-18 3 to 4.5 MC. TU-25 4.5 to 5.2 MC. Price - Either NEW: \$3.50—USED: \$2.50
PE-125 VIBRATOR POWER SUPPLY f/BC-223 Transmitter 12/24 Volt input; output 500 V. 150 MA. NEW: \$9.95
CABLE only—Transmitter to Power Supply \$1.75

GENERATOR — 12 VOLT 100 AMP.

Mfg. by Emers 340-0 RIM with 5/8" x 3/4" shaft and 4 mtg. holes on each end for right or left. Motor size: 7 3/8" x 4 3/8". Price \$12.95

New Transformers and Chokes:

CHOKES (Cased)	
TRANSFORMERS (Cased)—115 V.A.C. 60 CYCLE INPUT:	
OUTPUT: 750-0-750 V.A.C. 600 V.D.C. after choke input filter at 250 MA. Includes 6.3 V.A.C. winding at 5 amps and 5.0 V.A.C. winding at 4 amps. CH-106	\$8.75
OUTPUT: 600-0-600 V.A.C. at 250 MA. 12 V.A.C. at 3 amps; 12 V.A.C. at 3 amps; and 5 V.A.C. at 3 amps. Designed for Army Surplus transmitters. CH-108	\$7.75
OUTPUT: 250-0-250 V.A.C. at 60 MA. 24 V.A.C. at 6 amps; 6.3 V.A.C. at 6 amps. Designed for Army surplus Receivers. CH-109	\$3.50
TRANSFORMERS — 110 VOLT 60 CYCLE PRIMARIES:	
Sec. 12 V. 1 amp.	\$1.50
Sec. 24 V. 1 amp.	1.95
Sec. 14-14 or 28 Volt—7 1/2 or 15 amp.	4.95
Sec. 24 V. 5 amp.	\$1.50
Sec. 36 VAC 2.5 amp.	2.95
CH-115—8 Henries at 500 MA. filter choke, 5,000 volts insulation	\$10.95
CH-116—5-20 Henries at 500 MA. swinging choke, 5,000 volts insulation	\$10.95
CH-117—8 Henries at 700 MA. filter choke, 7,500 volts insulation	\$16.50
CH-118—5-20 Henries at 700 MA. swinging choke, 7,500 volts insulation	\$16.50
CH-121—13 Henries at 250 MA. filter choke, 1,500 volts insulation	\$4.95
CH-412—4-12 Henries 81 ohm. Gov't conservative test voltage 2500 V. 300 MA.	\$4.95

Whip Antenna Equipment Mast Bases—Insulated:

MP-132—1" heavy coil spring, 2" insulator. Overall length: 11 1/2". Weight 2 3/4 lbs. Price	\$3.95
MP-22—Spring action direction of bracket. 4" x 6" mounting. Price	\$2.95
MAST SECTIONS FOR ABOVE BASES:	
Tubular steel, copper coated, painted, 3 foot sections, screw-in type. MS-53 can be used to make any length, with MS-52-51-50-49 for taper. Price per section	
CANVAS BAG EG-56 for carrying above 5 mast sections 50c Ea	

DYNAMOTORS:

INPUT:	OUTPUT:	STOCK NO.:	PRICE:
12 V. DC.	680 V. 210 MA.	DM-680	\$7.95
@ 6 V. DC.	300 V. 150 MA.		
9 V. DC.	450 V. 60 MA.	DM-9450	3.95
@ 6 V. DC.	275 V. 50 MA.	w/Blower	
12/24 V. DC.	440 V. 200 MA. &		
	220 V. 100 MA.	D-104	9.95
18 V. DC.	450 V. 60 MA.	DM-175	2.95
12 V. DC.	600 V. 300 MA.	BD-86	7.95
PERMANENT MAGNET FIELD DYNAMOTORS:			
12/24 V. DC.	275 V. 110 MA.	USA/0516	3.95
12/24 V. DC.	500 V. 50 MA.	USA/0515	2.95
PM FIELD DYNAMOTOR POWER SUPPLY—Completely filtered. Has two PM Dynamotors as listed directly above.			
WRITE FOR QUOTATION ON OTHER DYNAMOTOR & INVERTER NEEDS!			

BLOWER BARGAINS:

110 VOLT 60 CYCLE BLOWER—4" intake, 2" outlet. Approx 100 Cu. Ft. Dis. Motor size: 3" x 3". 1750 RPM. Quiet running. Prices: NEW \$6.95 Motor only: \$3.95
24 VOLT DC OR 36 VOLT AC BLOWER—6" intake, 3" outlet. Approx. 200 Cu Ft. Dis. Also has adapter for Dual outlet. Unused. Price—only
\$5.95
FL-8A FILTER—1020 CPS
\$1.95
SELSYNS #V C-78248 110 V. 60 cycle & Instruct. pr.
\$5.95
CABLE f/BC-375 w/PL-59. 61 or 64 ea. end.
Each \$1.75
CABLE CD-280—one #6 wire, shielded RC 15 Ft.
\$1.00
BC-709 AMPLIFIER—with Tube, less battery
\$3.95

Address Dept. CQ • Minimum Order \$2.00 • Prices F.O.B. Lima • 25% Deposit On C.O.D. Orders

FAIR RADIO SALES • • • 132 SOUTH MAIN ST. LIMA, OHIO

When writing to our advertisers say you saw it in CQ

outstanding radio texts



ANTENNA MANUAL

The only practical, comprehensive book on antennas. 300 pages of down-to-earth help on antenna, feed line, radiation and propagation for all frequencies up to 1000 Mc. including FM and TV. Plain language; no need to brush up on math. A necessity for everyone interested in transmission or reception.

\$3.50

AT YOUR DEALER — On mail orders from us, \$3.60 postpaid. Add tax in California. Foreign orders, \$3.75 postpaid.



"RADIO-TELEVISION Questions and Answers"

A separate book for each element of the study-guide questions pertaining to the various classes of commercial U.S.A. radio operator licenses. You need buy only those elements required for the license you want.

NOW READY!

Element 2: Basic Theory and Practice
Element 3: Radiotelephony
Element 4: Advanced Radiotelephony

85¢

EACH AT YOUR DEALER — On mail orders from us, \$1 postpaid for one, or 90¢ each for two or more.



SURPLUS RADIO CONVERSION MANUAL IN TWO VOLUMES

This set of reference data has become standard for the most commonly used items of surplus electronic equipment. All conversions have been proven by testing on several units; each yields a useful item of equipment. For list of items covered see ad in July 1949 issue of CQ or write us.

\$2.50

FOR EITHER VOLUME AT YOUR DEALER — On mail orders from us, \$2.60 postpaid. Add sales tax in California.



RADIO AMATEUR NEWCOMER

Ideal for those just getting started (or interested) in radio. You need no other book to get your license and get on the air. How-to-build simple equipment for a complete station; operating instructions; simple theory; study questions needed to pass license exams; U.S.A. Amateur radio regulations. WRITTEN BY THE EDITORS OF "RADIO HANDBOOK."

\$1.00

AT YOUR DEALER — On mail orders from us, \$1.10 postpaid. Add sales tax in California.



WORLD'S RADIO TUBES (Radio Tube Vade Mecum)

The only book of its kind in the world. 18 languages with more than 15,000 tubes listed. The most complete set of tube data in existence. Many carefully prepared charts. Tube characteristic data of U.S., British, French, Czech, German, Swiss, Australian, Italian, Russian, Japanese, Scandinavian and all other available types . . . all in one book!

\$3.00

AT YOUR DEALER — On mail orders from us, \$3.20 postpaid. Add tax in Cal. Foreign, \$3.35

Editors and Engineers

1313 KENWOOD ROAD, SANTA BARBARA, CALIFORNIA

Are you an NSB?

(See page 53)

THE YL'S FREQUENCY

(from page 40)

miles east of us, a distance of 300 miles on the surface. It is the farthest north river on the west of Alaska on which large river boats ply. Our supplies come in once a year by boat and plane in July and August. Our cellar and pantry look like a country store for two. Our own plane comes in handy in those horrible years when I forget some staple item. One year it was baking powder. We have yet to run out of food, although we have gotten low enough to be very bored with the fare. Our meat is entirely reindeer with the exception of a few cuts of lamb, beef, et al, which we ship in in the fall. Good reindeer is much like beef, and we think better. Some of our ham contacts around Christmas think us a bit brutal though!

"All this may sound a bit back-woodish. It's the first year that's the hard part. After that one doesn't expect the impossible, and many appurtenances of civilization leave us cold. Before we knew Shungnak we said we'd come for one year; figured the isolation would be terrific. That first year was a bit difficult and I reluctantly bowed to another year's service, if we had leave Stateside first—our first leave in three years or so. Since then we've not thought of being lonely or isolated. Radio fills the need for daily gossip as it were, and we've finally been 'accepted' by the Eskimos, and our CAA work and maintenance keep us hopping. A few trips into the surrounding hinterland and we feel this end well populated. We've learned to be more self-sufficient and rely less (or not at all, really) on a social whirl to keep us happy. Our families in Oklahoma disowned us once, but since Dick's mother visited us last year they've begun to speak again. We're definitely black sheep, though!

"We have a great number of visitors due to 'interesting' geological formations and a convenient air field. Naturally, the bulk of them are male. Strangely enough, I get almost frantic at times for a chat with another white woman. In the years I've been here, seven white women have dropped in from the wide blue yonder. Little wonder YL contacts on the air mean so much? Last winter I kept almost daily skeds with Jean, W6PVV, at San Bruno. So between the girls and the magazines, I know how out of style my wardrobe is—hi!

"Sculpturing was my hobby, and education for that matter, until ham radio wandered in under pressure of winter isolation. Now I've little time to work at it. Radio does mean a lot to us. Just wish I could devote more time to it, but after all we do have a few CAA duties to perform each day."

In a later letter Jeanne added: "Just finished a new Vee beam, terminating pole 65 feet high, field ends 45 to 50, three field poles, one set for Stateside, the other for DX (we hope): all 16 wavelengths long. With the transmitter W7HHH's OM built on this end, maybe we'll get out!"

By the way, if you're thinking it might be rather cold at KL7RN's QTH, let me add a comment Jeanne made one day to W7HHH: "It wasn't so cold the other day," said Jeanne, "only 47 below zero." (!)

When writing to our advertisers say you saw it in CQ

OZ7YL

We seem to have been neglecting the DX YLs recently. Not that it's intentional, but there just never is space enough for all we'd like to publish. But, as a start toward remedying the situation, here is news of the first YL to be licensed in OZ-land. Dot Valbjørn is her name, and it all began back in 1925 when her brother, OZ7DV, was bitten by the shortwave bacillus. Dot became second operator of the station, and when OZ7DV became a soldier he presented his transmitter to Dot. She took her exam immediately and from that moment Dot's greatest interest was in the short waves, with all of Europe worked on 80, 40, and 20 meter c.w. (OZ7YL is an eager c.w. enthusiast.)

After April 9, 1940, all Danish hams had to turn their transmitters over to the police, and some years later OZ7YL's rig, together with all the equipment of all the amateurs from Odense, were destroyed by the RAF when it made an attack on the Gestapo headquarters in Odense. But after the war with a new QRP transmitter running 10 watts, OZ7YL has been working on 40 and 20 meters again.

Dot is another who enjoys a "busman's holiday," for she works as a telegraph assistant, where, as it were, she also daily works all the world.

Glad Tidings and Sad

Grievous news from San Diego. Early in January a son was born to Eleanor, W6AAW, but two days later he passed away. We're happy to report that Eleanor is doing nicely, though, and is at home with her OM and her two older jr. ops.

Many of you have heard about it over the air, and if not you no doubt noticed the change at the beginning of this column. Gosh, how does one announce it? Well, anyway, since January 28th yours truly has been answering to the name of Mrs. Sando. Since we love the West so much, what could be better than to wed one of her native sons and stay here permanently! Joe isn't a ham, but he takes to the mike with such ease that we doubt if it will be long before he goes after a call of his own—but in any case, he'll certainly feel at home around the shack.

Everything seems to happen down San Diego way! On the 3rd of February Jean, W6ZYD, was rushed to the hospital for an emergency operation for strangulated hernia. She came through the operation in fine shape and is now home recuperating—a good chance to work that rig, Jean!

DON'T TELL MY WIFE!

(from page 30)

"Ken Smalley! You never heard what I said! And after your cousin gives you twenty dollars for your birthday you spend it on that—that JUNK! You know Dicky needs new overshoes!"

"But honey, if I just get this transformer and a couple of these tubes—"

"Last week all you needed for your 300-watt rig was a condenser."

"But—Oh well, I'll get the head lettuce. Forgot

Outstanding **POWER CONVERSION UNITS**

for any Voltage and Amperage Rating

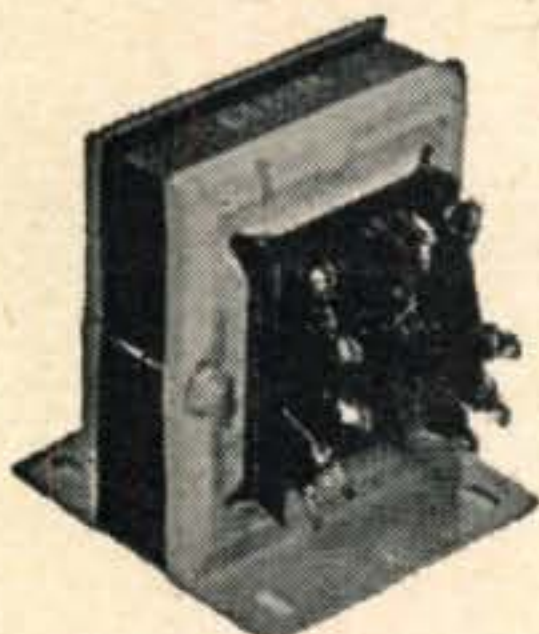

THERMADOR TRANSFORMER

R.P.S. Power Conversion Units specially designed to convert any d-c Receiver, Transmitter, etc., into a-c use. No rewiring necessary; simple, easy, quick installation. No Tubes! Instant Warm-up! Cool Operation! No Maintenance! Low Cost!

Installation Diagram with each unit. When ordering—be sure the input rating of your dynamotor does not exceed the d-c output rating of the rectifier. For

example, 12 V. 2 amp. dynamotors require Rectifier No. S-295A and Transformer RPS-8883.

Weights listed—contact freight agent for cheapest means of shipment and include charge with remittance.

All prices are F.O.B. Los Angeles (California purchasers add 3% sales tax). Include 25% with orders—balance on delivery. Foreign orders cash. Address correspondence Dept. C7.



VICKERS SELENIUM RECTIFIER

ALL NEW—FULL WAVE VICKERS SELENIUM RECTIFIERS

Code No. Rectifier	d-c Output Volts	Amps.	Ship. Wt. Lbs.	Amateurs Net Pr.
S-295A	14	2	1.25	\$ 6.95
S-458A	14	4.5	1.75	7.25
S-167A	14	10	3.75	10.95
S-292A	14	40	12	29.95
S-296A	28	1.8	1.25	5.75
S-344A	28	5	5.75	11.50
S-172A	28	10	6	16.50
S-291A	28	20	12	29.95
S-297A	28	40	23	52.25

ALL NEW—THERMADOR TRANSFORMERS 50/60 Cyc—117 Volt Primary Rating (For Taps, see Note A)

Code No. Transformer	Secondary Volts	Amps.	Ship. Wt. Lbs.	Amateurs Net Pr.
RPS-8883	18	3	3.5	\$ 3.75
RPS-8884	18	5.2	5.5	4.25
RPS-8885	18	12	12	6.15
RPS-8886	18	46	35	19.65
RPS-8888	36	2	5	4.15
RPS-8889	36	6	12	6.75
RPS-8892	36	12	25	11.65
RPS-8890	36	23	32	19.25
RPS-8891	36	46	78	51.25

NOTE A: All transformers have 3 extra taps—for example: 20, 19, 18, 17 volts and 38, 37, 36, 35 volts.

Distributed Nationally by

RADIO PRODUCTS SALES, INC.

1501 SOUTH HILL STREET • LOS ANGELES 15, CALIFORNIA • PHONE PROSPECT 7471



When writing to our advertisers say you saw it in CQ

ATTENTION MOBILE HAMS

COMPLETE MOBILE PACKAGE—NOTHING ELSE TO BUY. OUTSTANDING MOBILE SIGNALS USE MOTOROLA EQUIPMENT — BACKED BY YEARS OF COMMUNICATION EQUIPMENT EXPERIENCE—WORLD'S LARGEST PRODUCER OF 2-WAY MOBILE EQUIPMENT.

A mobile transmitter with a double feature FM or AM at flip of the switch, the MOTOROLA FMT-30-DMS 27-30 MC. **\$130.00**

P-7253 spring base rear—mount antenna **\$22.50**

MOTOROLA P-69-13-ARS receiver with special noise

limiter for use with any converter having 1500-3000 KC. . . . **\$60.00**

3-30 famous Gon-set converter complete to connect to the P-69-13-ARS receiver **\$39.95**

P-327-E Fire wall loud speaker **\$5.00**

The above comes complete with all necessary accessories and mounting hardware. Order direct or through the Motorola National Service Organization member in your area.

For further information write to:

MOTOROLA INC.

Amateur Sales Dept. CQ-APRIL
1327 W. Washington Blvd., Chicago 7, Ill.
Attention: Harry Harrison W9LLX
Telephone—Taylor 9-2200 Ext. 161

**JOBS
in
TELEVISION**

TELEVISION TECHNICIANS
NEEDED AT ONCE
QUALIFIED MEN ONLY • GOOD PAY
STEADY WORK • GOOD FUTURE

**AMERICAN
RADIO INSTITUTE**
CAN TRAIN YOU FOR THIS JOB

New York
2010 B'way (68th St.)
Buffalo, N. Y.
640 Main St.

Syracuse, N. Y.
131 Shonnard St.
Mount Vernon, N. Y.
174 Gramatan Ave.

FREE EMPLOYMENT SERVICE
GI APPROVED

it on the way home from work, you know."

"I know."

And so I found a rather desparate Ken Smalley at my shack door. He had a head of lettuce and a very furtive look. Almost malicious.

"Can't stay a minute, Bill. Here's nine fifty. Nine for one of those transformers you got last week and fifty for postage. OK?"

"Yeah. Grab the one you want."

"No, you have to bring it."

"What??! I gotta deliver it yet?"

"Well, Ellen better not find out. I got it all figured out."

He outlined a plot and I was a bit hesitant to go along with him, but felt sorry for him. So later that evening I dropped over to his place.

"Hi, Ellen!"

"Hi, Bill! W8 Young Foolish Bachelor to see you, Ken."

Ken came in from the kitchen.

"What's up?"

"Gotta have some tubes. Built a rig and figured I had 'em on hand. The rig's all done and I can't try it out."

"Well, we'll see. Wanta swap?"

"Suits me."

"You mean there's something you DON'T have??" (Ellen knows me too.)

We headed upstairs to his shack. He really had the tubes. A motley assortment of 112As, O1As, a burnt out 211E, and worst of all, an old Kellogg tube.

"For once I'm glad Ellen didn't take up ham radio."

"Think she fell?"

"Fell? We should be in Hollywood!"

So on the way out I made sure the family saw me walking off with an armload of tubes. I kind of got worried when Marilyn bounced over to grab the old Kellogg bottle and said, "What's this funny tube, Bill?"

Ellen called "Don't, honey! You might make Bill drop his tubes."

I explained to Marilyn that it was a special VHF tube. With that I left, to return later with Ken's transformer.

Naturally the word got around to the gang pretty fast. So when one of the guys got a couple bucks winnings from the factory check pool or made a fast fin repairing a radio, I would soon hear about it. Of course, the schemes grew more and more devious. Around Christmas I suddenly became a generous nitwit bringing "presents" of tubes and such small gear to the "henpecked" brethren. It wasn't long before I knew precisely which nights each wife attended what club meeting.

I didn't worry too much about taking bread out of anybody's mouth. The guys never averaged over maybe a buck or so a week. Once in a while there would be a flurry or two of good buys and they'd spring pretty handsomely, but it wasn't too much in the long run.

But it sure was a mess of monkey business. I was spending all my time, it seemed, on secret

When writing to our advertisers say you saw it in CQ

rendezvous, returning the "Swap Props" to the rightful owners, running up to the postoffice or checkreading six or seven different magazines to locate a desired article. But I always felt a little worried about the women. Funny, they had a loosely organized Radio Widows' Club, and I always was sure they'd compare notes and add two and two and find out it was four. But I guess they weren't interested in anything but who won at Bingo or who divorced what jerk.

Freddie Emerick, the local wholesaler, didn't help either. Every time the gang met at his place he would inquire, "What's it worth to you bums for me not to tell your wives?" Naturally we threatened him with everything from the dread Wouff-Hong to total dismemberment. He never did talk, though, but it did give the gang a lot of uneasy moments.

So that brings me up to date. I still haven't got the big rig done. Maybe someday I will—if I load my gear into the next V2 rocket for the moon and sit up there in solitude and tinker.

The Doc cleared his throat, grunted, and scratched his chin meditatively.

"So all this double dealing and trouble comes—for what? So a fellow can talk to the guy on the next block?" Properly indignant at this display of ignorance, I launched myself into a lecture on ham radio and backed up my claims by pointing out the latest DX column in a magazine I had in my pocket. After I had unwound and paused for breath, the Doc agreed that maybe an ordinary person COULD build a rig capable of working

the world. "But," he added, "I'm going to have to ask you to forget your tubes and wires for a while. I'm going to prescribe a little rest. After that you can return to your short wave. But remember! IT'S ONLY A HOBBY!!"

I had visions of straight jackets and padded cells, but found out that such wasn't the case. The place was a renovated mansion and rather pleasant—after the initial urges to tear up the a.c.-d.c. set in my room and stick it on 40 c.w. There was one really gone guy there, though. Used to bump into him every once in a while.

Seems he had me pegged right as a radio nut. He always blamed me for putting him in there. Said I "irradiated" him. I also ran into one ham there, but the nurse always kept us apart. Seems he had 75 watts and a dipole and lived a couple doors down from another local. The nurse said he, too, had a persecution complex. Worst stages.

But finally the house Doc came to me one day and said I was all fixed up and could return home. I grabbed my belongings, whistled one last wolf call at the nurse and headed for the door.

As I passed the receiving section I noticed my old Doc. Fact is, he reached out and grabbed me as I went by. Pulling me into a corner he glanced furtively about. He had a kind of wild, staring look. He said, "Hey, Boy! Remember that little talk we had? Well, I'm now-heh-heh-W8AACS! Only I got in when the good surplus was gone. For cripes sake, get me a couple of those surplus kw plate transformers before they're all gone! AND DON'T TELL MY WIFE!!"

BC 733D LOCALIZER RECEIVER:

Companion to Glide Path Receiver. Has a hot AVC system complete with crystals and tubes. Contains 10 tubes consisting of 3-717A, 2-12SG7, 2-125R7, 1-125Q7, 1-12A6 **\$4.95**

APQ-5 POWER SUPPLY: Electronically controlled power. Embraces 2-5U4G, 4-6Y6, 2-VR150, 1-6S17, 1-6X5. Operates from 115 V. 400 cycle. Replacing xformer with 60 cycle. Makes ideal lab or test supply. Excellent cond. Ea **\$4.95**

APN-1 ALTIMETER TRANSCEIVER

Operates approx. 420 MC. FM designed to give accurate height above ground. Unit can be revamped for the 420 mcs. ham or foundation for citizens' band. Contains 2-955, 2-9001, 5-12SH7, 2-12SJ7. A dynamic vibrating capacitance for producing FM signal. (Makes excellent unit for FM or TV sweep generators.) Many other useful parts. Excellent cond. With plugs **\$4.95**

APN-1 DIAGRAM **\$1.00**

HIGH VOLTAGE SUPPLY EQUIPMENT

3200 V. 400 ma. xformers Pair: **\$15.00**
 Filament xformer 2.5 V. 10 amp. Ea.: **4.00**
 866-A Tubes Pair: **2.18**
 2 mfd. 4000 V. Cond. 3 for: **7.50**

NOTE: PRICE FOR COMPLETE ABOVE KIT WITH SOCKETS, CHASSIS & BLEEDER **29.50**

RGSU COAX CABLE: 52 ohm imp. Not dried out. 5¢ per ft. **\$4.75** per 100 ft.

ANTENNA SECTIONS MS: Screw-in type. 3 ft. sections. ANY section for only **35¢**

ALL 7 sections (21') **\$2.25**

CONICAL TV ANTENNA: New **\$5.95**

BC 375 TRANSMITTER: 150W. Phone or CW 2-211 tubes in final. Complete with all tubes but less tuning unit **\$10.95**

274N ANT. RELAY BOX: Contains R. F. meter plus 50 mfd. 11. V. vacuum cond. and relay. New in carton **\$2.25**

BC 906 FREQUENCY METER: Powered by 1.5 and 45V. batt. Uses 1S₅ tube. Has a 500 microamp meter on front. Freq. range 17-23.5 mcs. Needs no conversion for use as a grid dip meter. Excel. cond. **\$12.95**



VARIABLE CONDENSER: 7 gang vernier drive as used in BC223 Transmitter. Made by Cardwell. New **\$2.50**

R.F. CHOKE: 25 Mh. 100 ma **15¢**

ARC-5 TRANSMITTERS: Complete! Excel. cond.!

3-4 mcs. **\$9.95**

2.1-3 mcs. **12.95**

4-5.3 mcs. **3.50**

5.3-7 mcs. **3.50**

7-9 mcs. **9.95**

COMPASS RECEIVER: MN'6 3

bands: 200-400 kes; 550-1200 kes; 2.9-6 mcs. 12 tubes, 2 RF stages, 1 loop stage. Great high gain receiver for hams & marine. Excel. cond. **\$19.95**

BC433 RECEIVER: Covers from 200 to 1750 kes. Makes a fine hi-fidelity B.C. Receiver 2 RF stages. Designed for A D F. Excel. cond. **\$12.95**

CONTROL BOX **2.95**

ARCS RECEIVER: 3-6 mcs. **\$3.95**

190-550 kes. **9.95**

SPECIAL! 450TL TUBES: New. Per pr. **\$37.50**

Each 450 TL Tube **19.95**

250 TL TUBES: Per pr. **\$32.00**

Each 250 TL Tube **16.50**

NOTE: For more hot buys on tubes see our ad P. 56 March/50 CQ.

METERS! HOT BUYS! METERS!

2" G. E. or Westinghouse Rd. **2" Weston Rd.**

0-1 ma. DC with 3 scales: **0-25 ma. DC . . . \$2.79**

0-140 ma. DC, 0-140 VDC: **0-1.5 amp RF . . . 3.49**

0-500 ma. DC w/ 3 shunts **\$4.50** **0-2 amp RF . . . 2.99**

0-1 amp R.F. **\$3.49** **20-0-20 amp DC. 1.75**

2" Hickok Rd. **2" Westinghouse Rd.**

0-1 ma. with 0-10 scale **\$3.29** **0-9 amp RF . . . \$2.50**

3" Westinghouse Rd. **2" Simpson Rd.**

0-15 ma. DC movement with 0-300 scale **\$3.49** **0-3 VDC \$2.50**

3" De Jur Sq. **0-800 ma. DC . . \$3.49**

25% deposit with order. F.O.B. Los Angeles

COLUMBIA ELECTRONICS SALES Dept. LS 522 S. San Pedro St. Los Angeles 13, California

FREE PARKING! Pay us a call. Let's GET TOGETHER IN PERSON!

When writing to our advertisers say you saw it in CQ

PREMAX

Ready for Your 6, 10 and 11 Meters

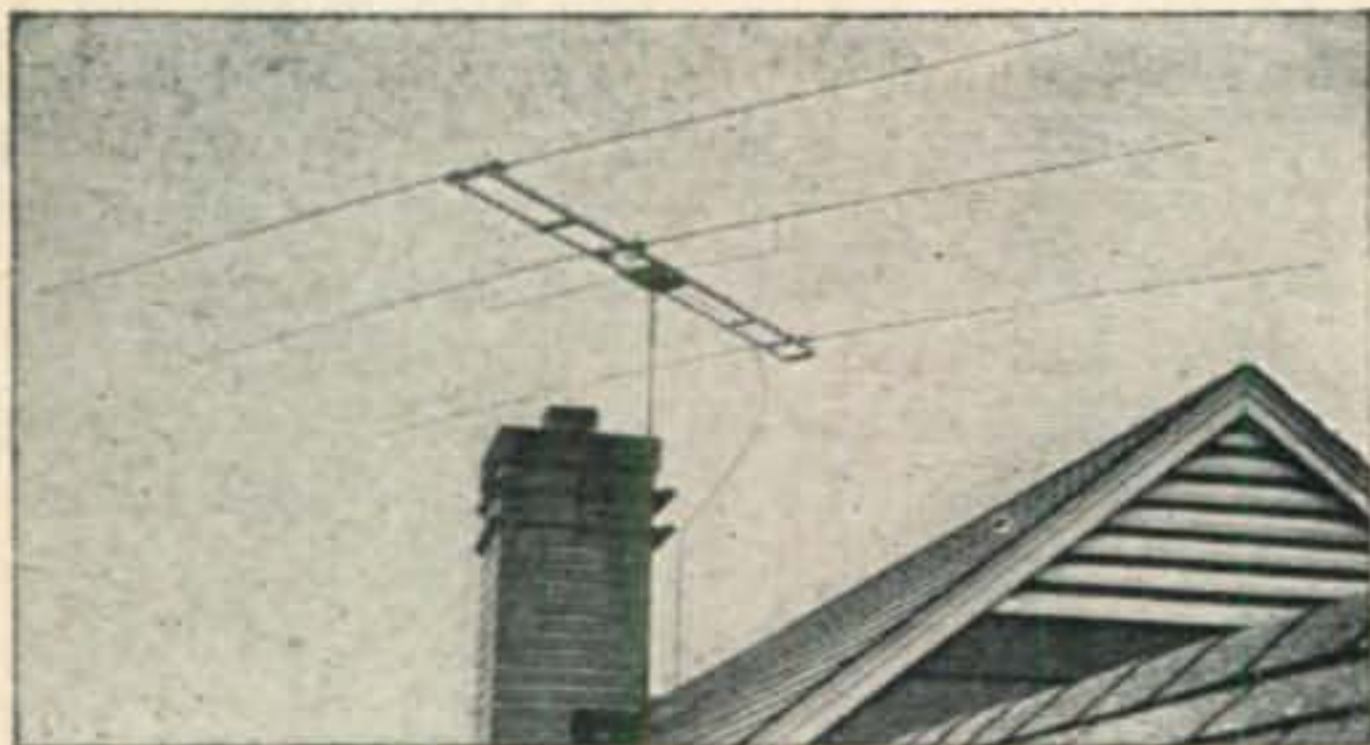

Rotary Beam Kit

High-gain, directive! Seamless duraluminum elements, readily adjustable in length for optimum efficiency. Aluminum frame, sturdy yet light weight. One man can easily assemble and erect. Packed complete with insulators, frame, three pairs elements and hardware including T-match accessories and diagram.

Send
for
Bulletin

PREMAX PRODUCTS
DIVISION CHISHOLM-RYDER CO., INC.

5007 Highland Ave., Niagara Falls, N. Y.

SPECIAL PURCHASE

SAVE 28%

BUD

VFO-21

Reg. \$52.50

NOW ONLY

\$37.49

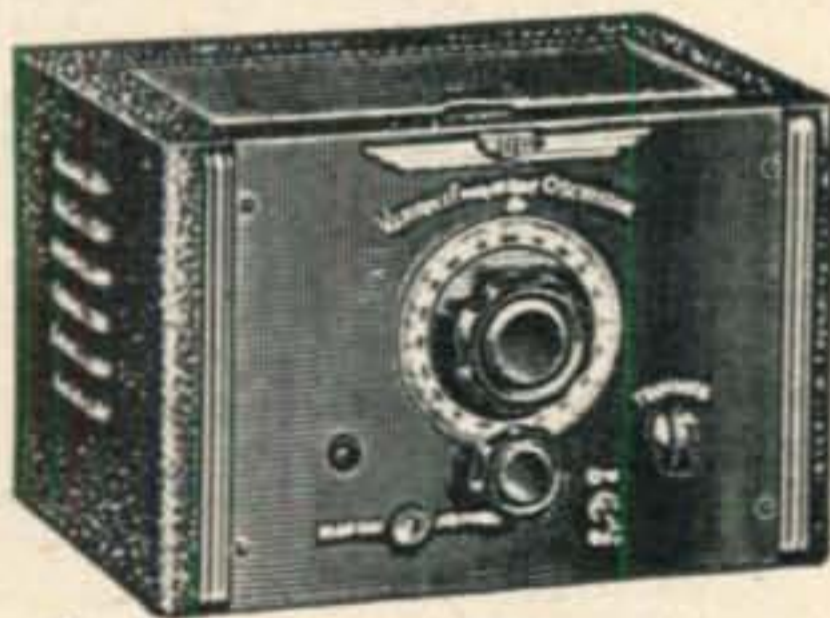

We have purchased the entire manufacturers stock of this high quality Variable Frequency Oscillator and are, therefore, able to sell it at this amazing new low price.

THIS UNIT IS IN ITSELF A CW TRANSMITTER.

Stability is comparable to Crystal. Plug in coils for highest efficiency. Has VFO operation and provision for switching to Crystal operation. Has more than enough output to drive low or medium power beam tubes. Comes with 40 meter coils. Coils for other bands available extra.

SEND IN YOUR ORDER WHILE THEY LAST.

Write to Radio & Electronic Parts Corp. when you need radio or electronic parts. We are authorized distributor for all major nationally advertised products.

RADIO & ELECTRONIC PARTS CORP.

3235 Prospect Ave. Dept. A. Cleveland 15, Ohio

M.A.R.S.

(from page 31)

I went to Calhoun and put into operation at TCS-12. In view of the previous day's experience, it was decided to put our portable equipment on 4085 kc (MARS frequency) and operate under the call A4NIX. This plan proved very successful. Owensboro stations who monitored our frequency included W4JXB, W4LTQ, W4LUB and W4PFQ. Both voice and c.w. were used to transmit Red Cross, flood victim, weather report, and Coast Guard traffic.

"While the emergency did not ever become very serious, the hams in this vicinity got some excellent practice under emergency conditions."

Future MARS emergency planning is being based on the lessons learned and reported by A4PDW in this operation. Some of these lessons are:

1. MARS frequencies provide clear channels which are invaluable for operating low-power portable equipment during emergencies.

2. Every ham should attain and maintain a code proficiency sufficient to handle traffic on c.w. when voice circuits fail.

BEGINNER'S TRANSMITTER

(from page 21)

should be removed from its jack so as to open the battery circuit and thus conserve battery life.

The filaments of all tubes should be lighted for a minute or so before applying plate voltage to allow for any small change of frequency due to tube heating. Now throw the plate switch and observe the plate milliammeter reading. Unless the final is already resonated, which is unlikely, the plate current will be rather high, so do not leave the voltage on until the output pi network is tuned for minimum current. This tuning procedure is as follows:

Tune-up and Operation

Antenna disconnected; set the variable condenser, which is mounted above the chassis (C_2), to about $\frac{3}{4}$ mesh; now apply plate voltage and tune C_1 to resonance immediately. This will be indicated by a pronounced dip in plate current, as indicated on M . Now attach the antenna and retune C_1 for the dip again; if the dip is too high, or if the setting of C_1 is very much different from the original setting, retune C_2 to an increase in capacitance and then retune C_1 for dip. Now, if the dip is too low (not enough loading), the capacitance of C_2 should be reduced a bit. Generally speaking, the idea is to keep the circuit in resonance, or as near to it as possible with C_1 , and tune C_2 for loading, realizing that the tuning of one has an effect on the other. You should be able to find a point on the setting of C_2 where, when the antenna is disconnected, C_1 will have to be readjusted very slightly for point of maximum dip. A Xmas tree bulb in series with antenna lead may help on this tuning procedure for an indica-

tion of antenna current. This whole tuning procedure reads and sounds a lot more complicated than it actually is, and the system works easy and well.

This little phone rig should provide an interesting construction project for the beginner, as well as many satisfying hours of QSO with the local boys. The old-timer who has a transmitter or two on the air already will find it a handy accessory outfit for the 160 meter band, eliminating the need for revamping the final of an existing rig. At the present writing the condition of the band is such that the output of this rig (between 15-25 watts) will be plenty for around-town operation, either daytime or after dark. The writer sincerely hopes that there can be coöperation on this band to the extent that the fellows with the half-gallon rigs will ease off a little on this limited frequency spectrum and let the little fellow have a chance.

THE TRAFFIC MIDGET

(from page 16)

coupled oscillator with a high C to L ratio in the grid circuit. When the transmitter is being used, the oscillator runs continuously, and the final amplifier is keyed. The switch at the extreme left controls the plate voltage to the oscillator. It may be turned off if receiving near the transmit-

ting frequency. The dial with the lock controls the oscillator frequency. The range of the oscillator covers the entire c.w. band with the exception of the last 50 kc on the low end of the band. This precaution was taken to prevent the transmitter from being tuned outside the band.

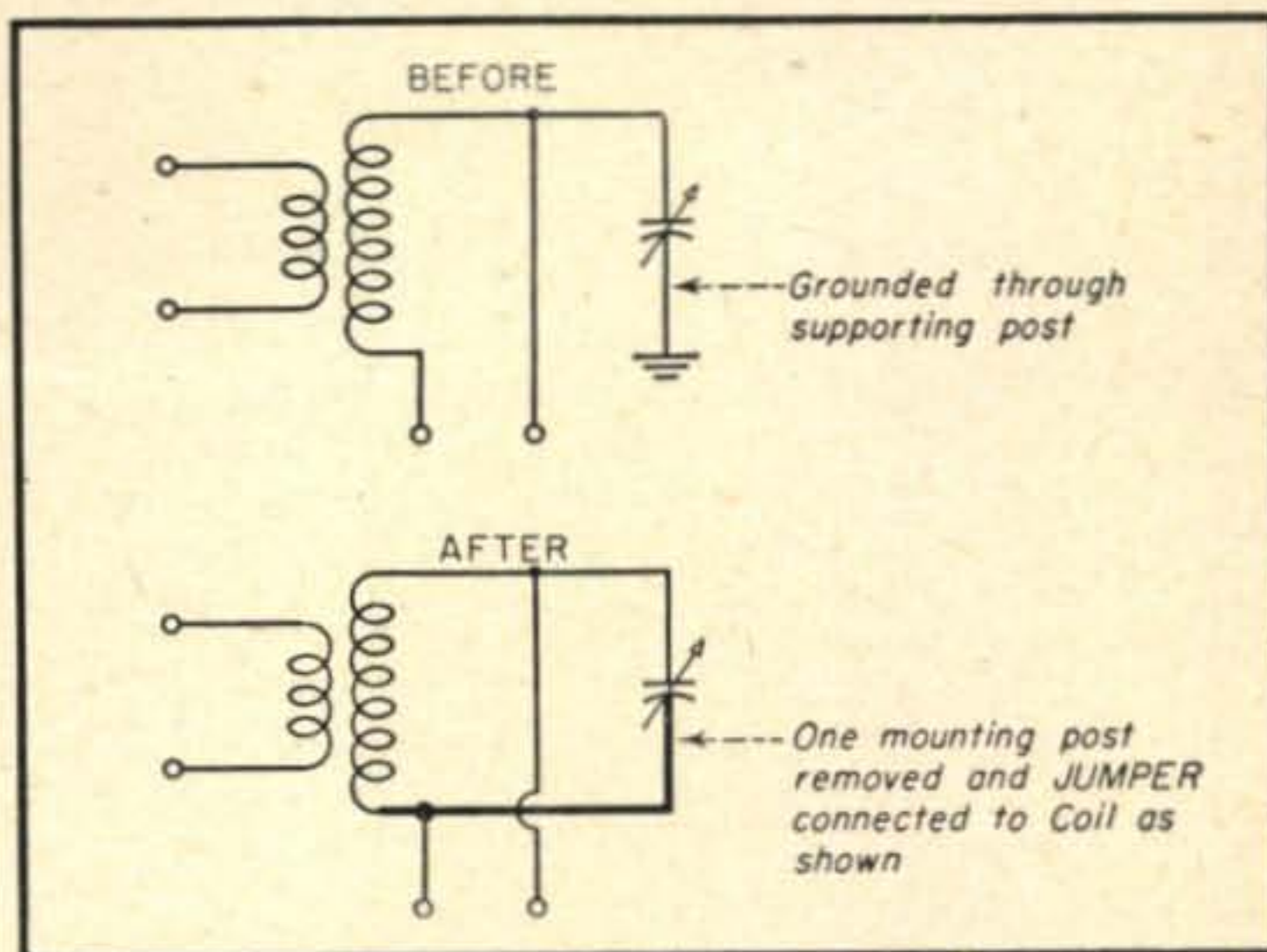

Fig. 1, illustrating the rebuilding of the last i.f. transformer as described in the text.

After the initial warmup period the oscillator has negligible drift.

The transformer used has a plate current rating of 120 ma. This necessitates that the power supply be switched from the receiver to

KEEP CQ at your fingertips

with a CQ Binder... ONLY \$200*

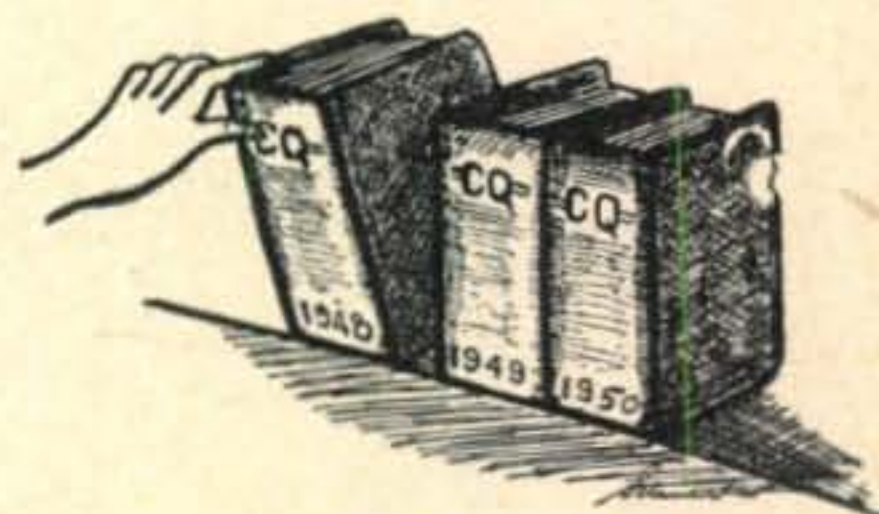

CONSIDER the

APPEARANCE . . . Your shack, den . . . or wherever you set up your "rig" can be kept in shipshape when all your copies of CQ are in one safe place. The deep, red shade will blend perfectly with any color scheme . . . and, in addition, the backbone will be gold stamped with CQ and any year you desire.

CONVENIENCE . . . In a few seconds you can locate any article you want . . . no more fumbling around for last month's issue . . . just reach for your Binder . . . turn to the index . . . and presto, there it is

WORKMANSHIP . . . Dupont Fabricord . . . stainproof and washable . . . Center channel to keep magazines securely in position.

Let your wife, sweetheart, or a friend, see this ad. . . . Tell them that a CQ Binder would make the perfect gift for the "Ham of their life" . . . for a birthday, anniversary . . . or any other "special" day . . . or you can always buy one for yourself.

*(Foreign Orders add 25¢ per binder)

CQ—Radio Magazines, Inc.
342 Madison Ave., New York 17, N. Y.

Enclosed find \$..... for Binders

Name Call

Address

City Zone State

Year wanted 1946 1947 1948 1949 1950. Stamping: CQ Plain



ADVANCE RELAYS

designed for
your application

Soundly engineered and built to famous standards of performance—you can install these outstanding relays in your rig with complete confidence.

ADVANCE offers a complete line of Time Delay, Overload, Antenna and Keying Relays with wide variations of types for special applications. Your inquiry will receive prompt and courteous attention.

Illustrated are
Coaxial & 300
ohm line relays



ADVANCE ELECTRIC & RELAY CO.

2435 NORTH NAOMI STREET • BURBANK, CALIFORNIA

Ready NOW ULTRASONIC FUNDAMENTALS

By S. YOUNG WHITE

The rapid increase in the use of ultrasonics during the last few years makes it natural that the well-informed sound engineer should want to learn something of the applications and potentialities of this amazing new field. But interest in ultrasonics is not confined to the sound engineer—it is of still greater importance to the industrial engineer for he is the one who will visualize its uses in his own processes.

Elementary in character, **ULTRASONIC FUNDAMENTALS** was written originally as a series of magazine articles just for the purpose of acquainting the novice in this field with the enormous possibilities of a new tool for industry. It serves the double purpose of introducing ultrasonics to both sound and industrial engineers. The list of chapter headings will indicate how it can help you.

CHAPTER HEADLINES

Too Much Audio. Opportunities in Ultrasonics. Elements of Ultrasonics. Experimental Ultrasonics. Coupling Ultrasonic Energy to a Load. Ultrasonics in Liquids. Ultrasonics in Solids. Testing by Ultrasonics. High-Power Ultrasonics. Notes on Using High-Power Ultrasonics. Applications of Ultrasonics to Biology. Economics of Industrial Ultrasonics.

The applications of ultrasonics have already extended to many industries, and as its possibilities are explored they will increase a hundredfold. To keep abreast of its growth, engineers in all fields must know what they may expect from ultrasonics, how it is used, how the energy is generated, and the techniques of applying ultrasonic treatment to many processes.

ULTRASONIC FUNDAMENTALS is not a big book—it does not cover the entire field of ultrasonics with hundreds of pages of dull reading. But in the three hours it will take you to read it, you will get a down-to-earth glimpse into the far-reaching possibilities of a new art.

ULTRASONIC FUNDAMENTALS

By S. YOUNG WHITE

36 pages, 40 ill., 8½ x 11, paper cover
\$1.75

Book Division, Dept. C
RADIO MAGAZINES, INC.

342 Madison Avenue

New York 17, N. Y.

the transmitter, so as not to overload the transformer. This is accomplished by means of the switch at the left of the volume control. Directly above this switch is the tank condenser of the power amplifier. The keying jack is mounted

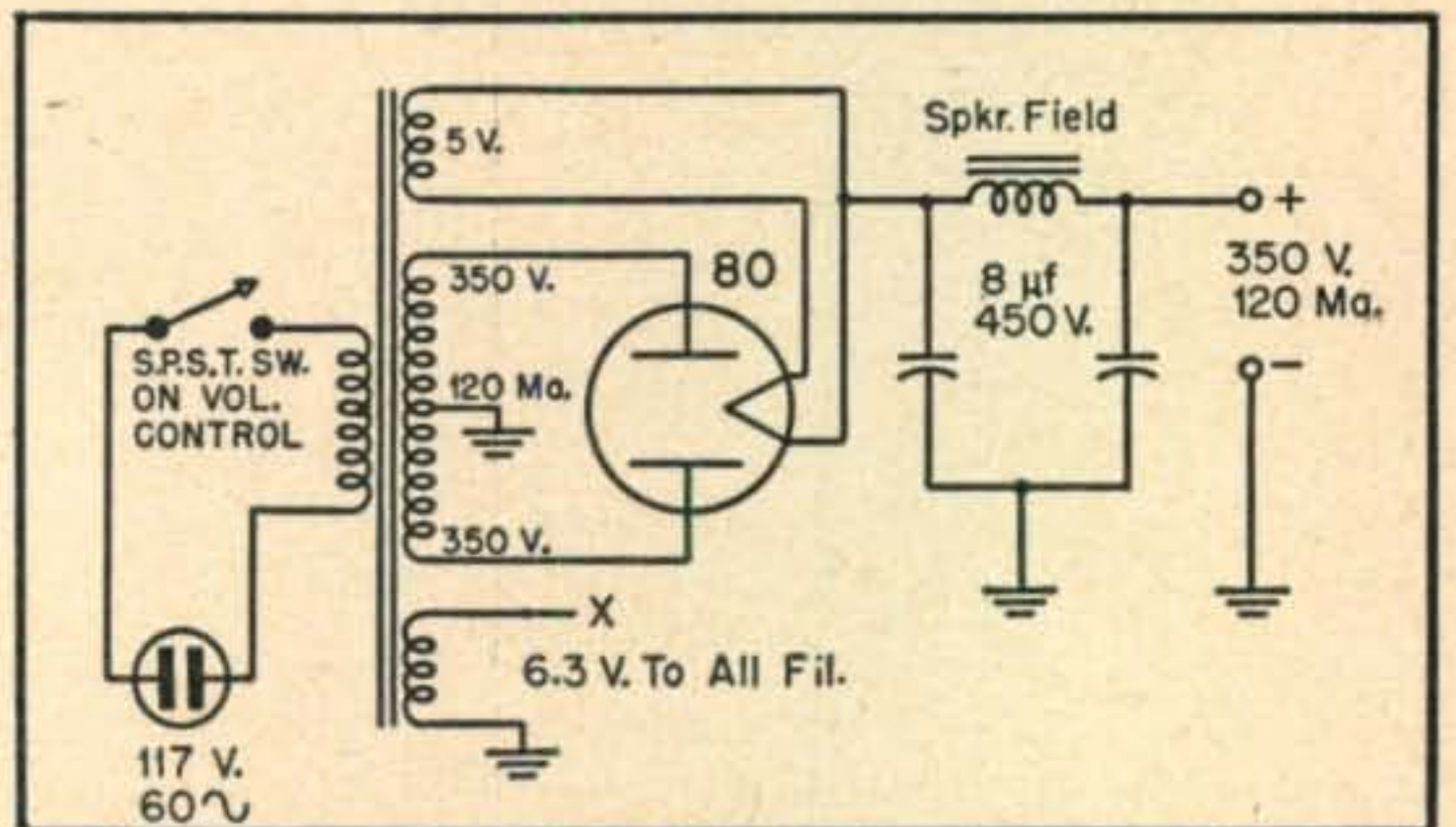

There is practically nothing to the power supply.

on the rear of the chassis. No difficulty should be encountered in getting the transmitter to operate if the coils are wound as directed.

Operation

The operation of the station is straightforward. The control circuits are wired so as to be able to turn the VFO on simultaneously with the receiver for purposes of zero beating the frequency of stations to be called. When the power amplifier is to be keyed, the second switch from the left is thrown, which disconnects the plate voltage from the receiver and leaves the transformer plate supply capacity available for the transmitter.

The range of the station is mostly a function of the antenna. When it is used in conjunction with a half wave antenna a range of 500 miles is not too much to expect, for with the VFO a clear channel can always be found.

PUBLIC RELATIONS

(from page 17)

The second phase is best described by making reference to *Fig. 1*. Here we have an illustration of the two portable bulletin boards and some of the material thereon. Space on the right hand board is occupied by the covers of several of the principal radio publications and are described as a means of keeping the ham abreast of the latest electronic developments. At the extreme left, a number of ham certificates are posted, including an enlarged replica of a ham license. Centrally displayed on the board are maps of the U. S. and the world with QSL cards fastened near the areas which they represent. We are favored with a member who has collected cards from many remote spots and by carefully selecting the most exotic of these cards great interest is created in the card display.

The third phase of the program is the practical demonstration. The use of "CQ" is demon-

When writing to our advertisers say you saw it in CQ

strated and explained, then an emergency situation is simulated and an emergency net of mobile units is formed. In accordance with prearranged plans, the mobile units deploy around the area, giving reports as they go. One trick used very successfully involves stationing a mobile unit at the residence of the president of the club before whom the program is being given. While the president and members are listening to the speaker in the meeting room, the president's wife is put on the air via the mobile mike. (Don't forget the FCC requires that a licensed operator control the transmitter.) There is always much surprise and laughter and a perfect program climax is effected. To guard against mike fright, an outline is prepared, and the wife uses this for guidance.

The seven members of the public relations committee operate with two members alternating as narrators, one describing the bulletin boards, two operating the meeting room portable station, and two operating the mobile units.

BUILDING A BEAM

(from page 14)

pull the tubing apart. Here's the solution for that:

The next time you go to an aircraft surplus store, pick up a few large aircraft soldering lugs that are capped with a red plastic cover. Under this cover is a gob of anti-oxidizing compound that you can smear over the ends of the outside sections of tubing. When this tubing is inserted in the center section, this compound will form an air-tight joint between the tubes and absolutely prevent any corrosive action at the joint. Wonderful stuff!

After the element is assembled, it should be sanded and then given a coat of aluminum paint. That will keep it in good shape for several years.

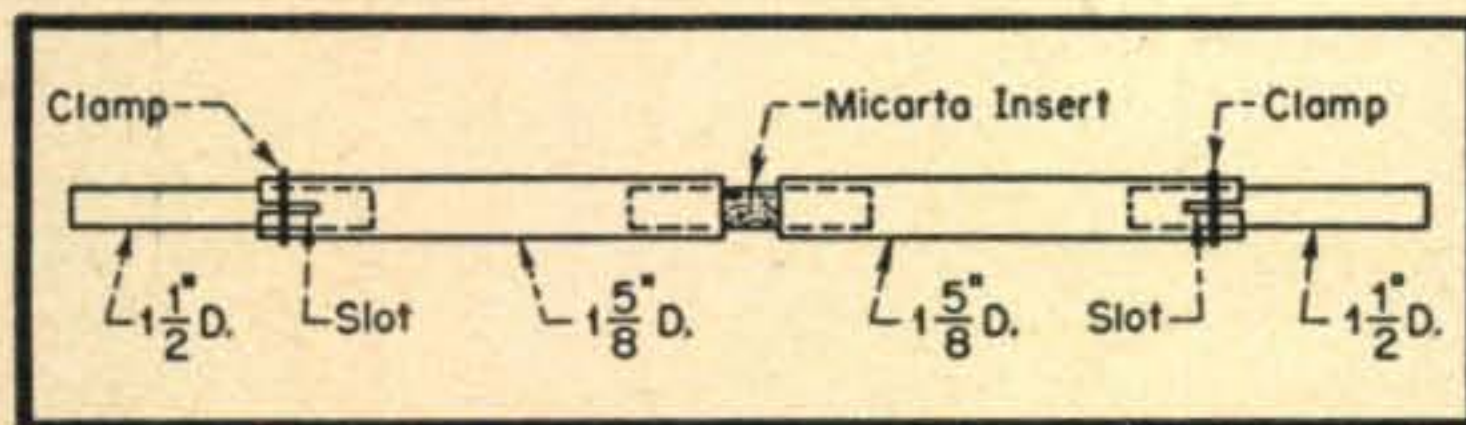
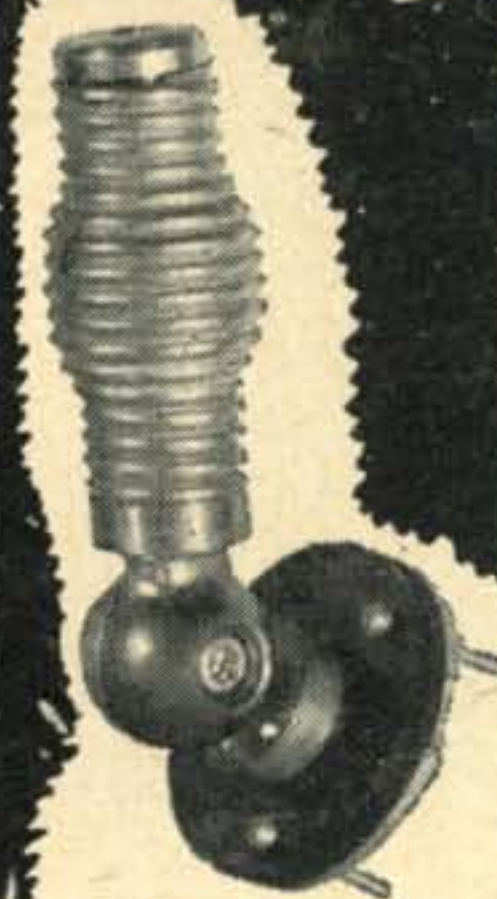

Fig. 9. The assembly of the driven element when a split element is used. Micarta or dried oak will provide good insulation while still making for mechanical rigidity.

If a balanced feed system is used, the driven element should be split at the center and each half mounted on two insulators. The "hat section" should be made five feet long to take the extra torque. To eliminate the twist thrown on the insulators by the uneven load distribution, a piece of insulating material such as dry oak or micarta should be turned down to present a tight fit to the tubing and pressed into the center ends of the element (Fig. 9). This will make the split element

MOBILE RIG?

ANTENNAS Master Mobile MOUNTS



BODY MOUNT
MOD 132
\$7.95
NET



BUMPER MOUNT
Mod. 140
\$5.95
NET

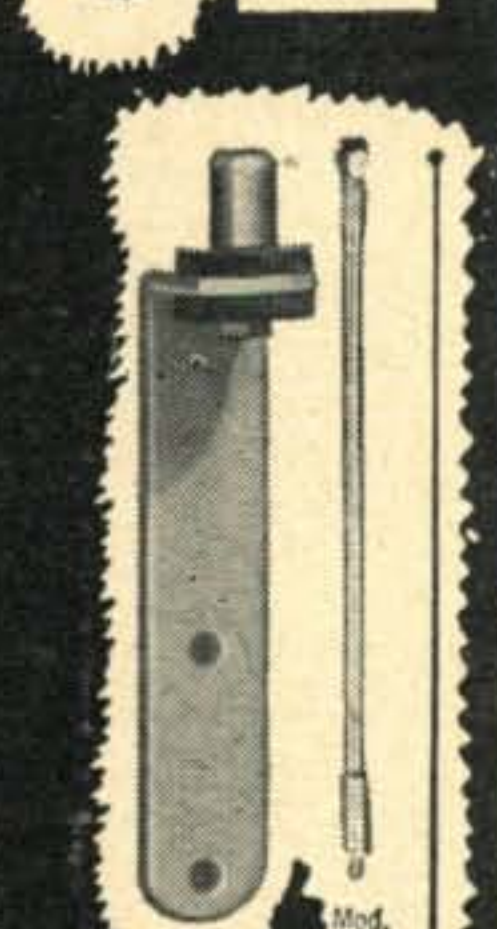

BUMPER MOUNT
Mod. 142
\$2.95
NET

MASTER MOUNTS

- Hefty shock absorbing springs. Two types, straight and double tapered. Body Mounts fit any body contour. Bumper Mounts clamp to bumper in few seconds. Cad plated. Heavy bakelite or micarta insulation.

- **Model 132—Body Mount.** Shipping weight 3½ lbs.

Net price **\$7.95**

- **Model 140 — Bumper Mount.** Shipping weight 3½ lbs Net Price **\$5.95**

- **Model 142 — Bumper Mount.** Less spring insulated for direct mounting for Series 100 antenna. Shipping weight 2 lbs.

Net Price **\$2.95**

MASTER WHIP ANTENNAS

- One piece stainless steel designed and tapered to prevent excessive swinging.

- **Series 100** in stainless steel with 3/8" stud fitting. Screws directly into mount. Available in 72", 78", 86", 90" and 96" length. Postage rate 10 lbs. min.

Net Price **\$4.77**

- **Series 106** in stainless steel — same as series 100. Has plain end. Fits **Model 92** extension.—Available in 72", 78", 86", 90" and 96" length. Postage rate 10 lbs. min.

Net Price **\$4.11**

MASTER EXTENSION

- **Model 92.** Chrome plated. Provides for additional 18" adjustment for Series 106 Antenna.—Shipping weight 14 ounces.

Net Price **\$2.95**

MASTER ALL BAND ANTENNA

CENTER-LOADED—20-40 OR 75 METERS

- Antennas come with one coil—20, 40 or 75 meters.
 - Change coils to any band 80 through 20.
 - **10 meter operation**—short out coil in use.
 - Fits any Master Mount or 3/8 SAE thrd.
 - Chrome-plated.
 - Length: 8' 10" overall. Wt.: 28 oz. Shpg. wt. 3 lbs.
- Antenna (Specify coil desired). Net . . . \$7.95**
Extra coils, 20, 40 or 75 M. Each . . . \$2.95

Master products guaranteed for one year against defective materials or workmanship.

ALL BAND ANT. does not incl. mount

REP. and DEALER INQUIRIES INVITED

Order from your dealer or write:

MASTER MOBILE MOUNTS, INC.
5200 Wilshire Blvd., Los Angeles 36, Calif.

Gen. Sales Agent: Harry Appleton Co.
311 W. Pico Blvd., Los Angeles 15, Calif.

When writing to our advertisers say you saw it in CQ

ATTENTION HAMS!

THE BUY OF A LIFETIME!

MODEL 240



This beautiful transmitter originally sold for \$98. Buy it direct from our factory for only \$69.95, complete with instructions for TVI reduction. Even if you already have a transmitter of your own, this rig makes an excellent standby. You can't afford to miss this opportunity.

The 240 is a complete 40 watt Phone-CW rig, working all bands from 160 to 10 meters; complete with (8 x 14 x 8) cabinet, self contained power supply, meter, tubes, crystal and coils for 40 meters. Tube line-up: 6V6 osc., 807 final, 6SJ7 mike amp., 6N7 phase inverter, 2 6L6s mod., 5U4G rect.—weight 30 lbs.—90 day guarantee. PRICE **\$69.95** \$20 deposit with order—the balance C.O.D. Coils for 80, 20 and 10 meters \$2.42 per set. Coils for 160 meters \$3.00.

LETLINE RADIO MFG. CO.

62 Berkley St. Valley Stream, N. Y.
PHONE: Valley Stream 5-9387



RADIO AMATEUR CALL BOOK

Contains a complete and up to date list of all licensed radio amateurs throughout the world. Also each issue lists radio amateur prefixes, Great Circle Maps, Great Circle Bearing Tables, Prefix Map of the World, Distance Table and other valuable information.

Published quarterly, Spring, Summer, Fall and Winter. Single copies in the U. S. and Possessions \$2.00. Elsewhere \$2.25. Annual subscription, U. S. and Possessions \$6.50. Elsewhere \$7.50.

ORDER YOUR COPY TODAY
RADIO AMATEUR CALL BOOK, Inc.
612 SOUTH DEARBORN STREET
CHICAGO 5, ILLINOIS, U.S.A.

a mechanical unity and take most of the twist off of the insulators.

The beam should now be completely assembled and placed atop a box or sawhorse and balanced at its physical center. The guy turnbuckles should be adjusted to level the beam, and then they *must* be safety wired into place.

Last Minute Notes

1. Use plated hardware! DON'T use stove bolts or any bolts that lack an oxide-proof coating. Brother, if you do, don't call on me to help you take your beam down!

2. If possible, use hexagonal-headed bolts and elastic stop-nuts. Standard A-N bolts (and others, no doubt have matched heads and stop-nuts so that a single sized wrench may be used on each end. It is much easier to manipulate two end wrenches atop a tower than to use a wrench and a screw driver. Also, you will not slash yourself if the wrench slips. I recommend $\frac{1}{4}$ -28 A-N bolts be made standard and used throughout the beam and tower. It is a great help when all nuts and bolts are of the same thread and diameter.

3. I have attached my elements to the stand-off insulators by means of aluminum aircraft hose clamps. This is turning out to be the weak point of the beam. These clamps are fairly brittle, and already one of them has snapped in a heavy wind. The next project is to remove all these clamps and put super-long bolts in the top of the stand-offs, the bolts being long enough to go through the $1\frac{5}{8}$ " element. A stop-nut on the top of the bolt will hold the element securely in place. However, the XYL says if the beam comes down *once more*, it will stay down! So. . . .

Getting the beam UP

Well, here we are, in the back yard all set to have an antenna party. It would be folly to give an explicit pattern to follow—such hazards as clothes lines, power poles, poison ivy, and TV antennas tend to "louse up" the ideal procedure. If you are lucky and have a reasonable amount of room, here is an easy way to get the beam atop the tower: Briefly, the beam is pulled up the tower by a block and tackle arrangement. If round strain insulators are used on the guy wires, the beam may be slid right up the guys. The tackle is tied about the center of the boom, and a second rope is tied to the "top" of the boom. One ham at the base of the tower heaves on the tackle, and a second atop the tower pulls on the guide rope to keep the beam in a vertical position. As soon as the top of the boom is at the cradle, it may be inserted into it, and the cradle will act as a guide. If the tackle has been tied low enough on the boom, it is possible to hoist the beam from the ground right up to correct position so that the man on the top of the tower can drop the first retaining bolt in place. Two men are all that are needed—personally, I like to be the one on the ground.

(To be concluded)

When writing to our advertisers say you saw it in CQ

THE MONITORING POST

(from page 36)

702. W4PL is expected to be heard soon again pushing traffic through to all sorts of places as heretofore. . . . W1SAJ, Marg, is the xyl of WIQVC, formerly a W9, who keeps after SAJ to spend her time on c.w. until she can at least copy 50 wpm. . . . VE2AAU stepped out recently with a 6-watt n.b.f.m. rig to QSO W5PNB on ten while using an indoor antenna; his other accomplishments are 47 states and seven VE districts, Europeans and Cubans on 40 with a 140-watt rig.

W4PGB is anxious to get a net started with Morse ops, he being one himself, and asks that all Morse men hearing him give him a call so things can get started. . . . In its second year the Nor-town ARC lists more than 100 active members. . . . Dick Roberts, an avid SWL since 1928, whose cards can be found in shacks all over the world, can now be heard on 40 with the call VE3AHA—he's known as "Capt. Morgan." . . . VE3RU has passed the 200 mark in QSOs with VE5DC—looks as though Ethel can be depended upon as a good sked station. . . . Over 100 countries worked using FM on ten is the score for VE3BQP. . . . W5MAV is on the air again at a new QTH. . . . W5MRS, W5NC, and W5PIN can be heard the same as ever batting it back and forth. . . . W5MUZ. Club held elections recently with W5MRS coming out as Prexy. . . . W5MRS (Pappy), W5MRT (Yankee), and W5MRU (Cotton) are dad and two sons, respectively, all being Morse ops for the Mo. Pac. RR.

W0WY, brother of W0FCC, became a member of the Minneapolis RC recently. . . . Congrats to W0QIN, daddy of a jr. op. . . . YV5OA visited the Milwaukee RAC recently to meet some of the boys he's QSOd so often. . . . W2TXB has added PJ, VU, UL, HZ, and VS to his list of countries worked making the total 196, and W2PZM added YO, CR, HL, and others for his total of 109 worked. . . . A 10-page bulletin is turned out by the Rochester (N.Y.) ARA, just full of news—called The RARA Rag.

W1QLL read about a little fellow who liked receiving post cards from far-off places while hospitalized with leukemia at Children's Hospital, Milwaukee, Wis., and started things going by requesting the gang to send cards to make this boy happy. More than 6,000 QSL cards from hams, and others, including a few collections, one such from a person in Rhode Island, numbering 1,700 pictures dating back to Theodore Roosevelt's big game hunting days has to date brought the total to more than 17,000 cards received by Armand Schultz, 2101a W. Lloyd St., Milwaukee. Then the Milwaukee ARC voted the 9-year-old an associate member; a certificate of membership presented to him recently by Veepee W9ONY is proudly displayed by Armand; Armand's parents request their thanks be extended in ham publications; a QSO was arranged between W9ONY and W1QLL when Armand talked with the latter at length—a receiver has been installed at the boy's bedside, and he spends a great deal of time listening to phone QSOs—it is not known whether Armand will survive his illness, and he has been gradually weakening since last August, so let's get some traffic going addressed to him.

BARGAINS

WHILE THEY LAST!

We are disposing of our overstock on certain variable transmitting condensers. These are all standard condensers made by well-known manufacturers. THEY ARE NOT WAR SURPLUS. All are brand-new merchandise.

WE BOUGHT TOO HEAVILY

We must reduce our stock!

Cat. No.	Cap. per sec. in Mmfd		Air Gap	Price
	MAX.	MIN.		
Single Section				
CO-101	50	4	.051"	\$1.36
CO-102	100	7	.051"	1.48
CO-103	145	9	.051"	1.63
CO-104	250	12	.051"	2.09
CO-105	340	15	.051"	2.34
CO-106	25	4	.078"	1.32
CO-107	35	4	.078"	.92
CO-108	55	8	.078"	1.35
CO-109	80	7	.078"	1.06
CO-110	150	11	.078"	2.12
CO-111	20	5	.144"	1.52
CO-112	40	7	.144"	1.06
CO-113	55	10	.144"	1.68
CO-114	105	15	.144"	2.42
CO-115	18	6	.175"	1.55
CO-116	40	11	.175"	1.87
CO-117	55	13	.175"	2.30
CO-118	85	16	.175"	1.78
CO-119	100	18	.175"	2.68
CO-126	40	7	.100"	2.43
CO-127	340	27	.100"	3.89
CO-128	100	28	.300"	5.98
Dual Condensers				
CO-120	200	10	.051"	2.99
CO-121	250	12	.051"	3.59
CO-122	35	4	.070"	1.94
CO-123	25	4	.078"	2.25
CO-124	20	5	.144"	2.64
CO-125	18	6	.175"	2.74
CO-129	100	10	.070"	3.53
CO-130	250	15	.070"	4.86
CO-131	35	12	.200"	7.99
CO-132	50	13	.200"	8.69

ORDER TODAY—Get these bargains

Add 12¢ each for Parcel Post and handling.
In Ohio add 3% sales tax.

RADIO & ELECTRONICS PARTS CORP.

3235 Prospect Ave., Dept. A, Cleveland, Ohio

SAVE UP TO 95% ON SURPLUS RADIO AND ELECTRONICS

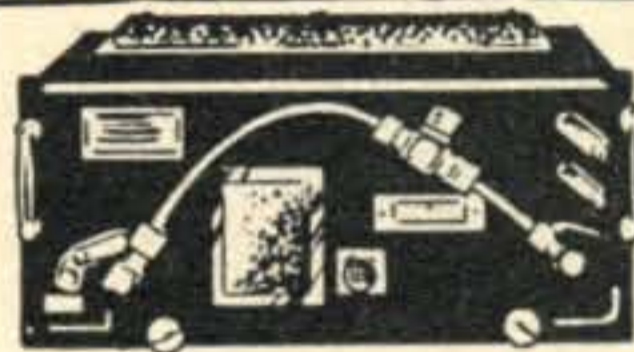

BRAND NEW APS-13 WARNING RADAR
17 Tubes as follows: 9-6AB5, 5-6J6, 2-2D21, and VR-105. 410 to 420 Mc. and 30 Mc. IF. Good deal for conversion and Citizen Band or for Radar Detection on boats. With Instruction Book. Originally over \$100.00 **\$16.95**

COMMAND XMITTERS
BC-459, 7-9.7 MC
Excell. Cond. . . . \$8.95
T-22 ARC-5.7-9.1.
New 12.75
3-4 MC. Used 12.50
5.3-7 MC. Used 3.95
T-21 ARC-5.5.3-7.
New 5.95
4-5.3 MC. Used 3.49
T-20 ARC-5. New . . . 6.95
2.1-3 MC. Like new. 9.95
COMMAND RCVR—TESTED
190-550 KC Used. . . \$9.95
3-6 MC Used 4.95
3-6 MC New 6.50
6-9.1 MC Used. . . . 7.95
1.5-3 Meg. Used. Ex-
cellent 14.95
ARR-2. Used. 9.95

ARC-5 VHF SET
MD-7 MODULATOR: Contains all necessary circuits, and components for plate mod of T-23 Xmitter, w/dyn. which supplies plate and screen voltages for mod. Used. **\$8.95**
T-23 XMITTER: MCW and phone on 4 channels, 100-156 MC, automatic turret-tuning, tank circuits remote controlled. 4-tubes—2—1625, 2—832A. Originally \$50.00. **\$14.95**

IMPORTANT: NO ORDER LESS THAN \$5.00. Send 30% deposit. Don't send shipping cost which will be COD at no extra charge. Shipment sent via railway express unless otherwise specified. Merchandise subject prior sale. Prices subject to change.

V & H RADIO & ELECTRONICS SUPPLY
Dept. C-14, 2033-37 W. Venice Blvd.
Los Angeles 6, California

When writing to our advertisers say you saw it in CQ

HOW TO LEARN CODE FASTEST

GET YOUR FCC LICENSE SOONER

NEW DUPLEX PRACTICODE Code Practice Sets generate high volume and "easy-to-copy" tone comparable to "pure d.c. note". Contain high efficiency 4-inch PM Speaker driven by two vacuum tubes! Work 6 months on only one 1½-volt cell—No parts to



(left): Hammertone factory guarantee.

Complete with professional key and cell—Nothing else to buy! Absolutely no RI or TVI. External terminals included: 6 sets may operate on one line. Finest quality components throughout. Model "A" (right): Wood Cabinet, red, green, yellow or blue pastels, 3½" x 5 x 10½". Model "B" Complete grey metal cabinet, 3 x 6 x 6". One-year

Complete Build-It kits available for as low as \$5.95 each. Send M.O. or Check, we ship postpaid. Write for Catalog Q. DEALERS WRITE.

MARTIN MFG. CO., Dept. CQ, 194 Gelston Ave., Bklyn 9, N. Y.

EASY TO LEARN CODE

It is easy and pleasant to learn or increase speed the modern way—with an **Instructograph Code Teacher**. Excellent for the beginner or advanced student. A quick, practical and dependable method. Available tapes from beginner's alphabet to typical messages on all subjects. Speed range 5 to 40 WPM. Always ready, no QRM, beats having someone send to you.



ENDORSED BY THOUSANDS!

The **Instructograph Code Teacher** literally takes the place of an operator-instructor and enables anyone to learn and master code without further assistance. Thousands of successful operators have "acquired the code" with the **Instructograph System**. Write today for full particulars and convenient rental plans.

INSTRUCTOGRAPH COMPANY

Dept. C, 4701 SHERIDAN ROAD, CHICAGO 40, ILL

AMAZING NEW VIBROPLEX

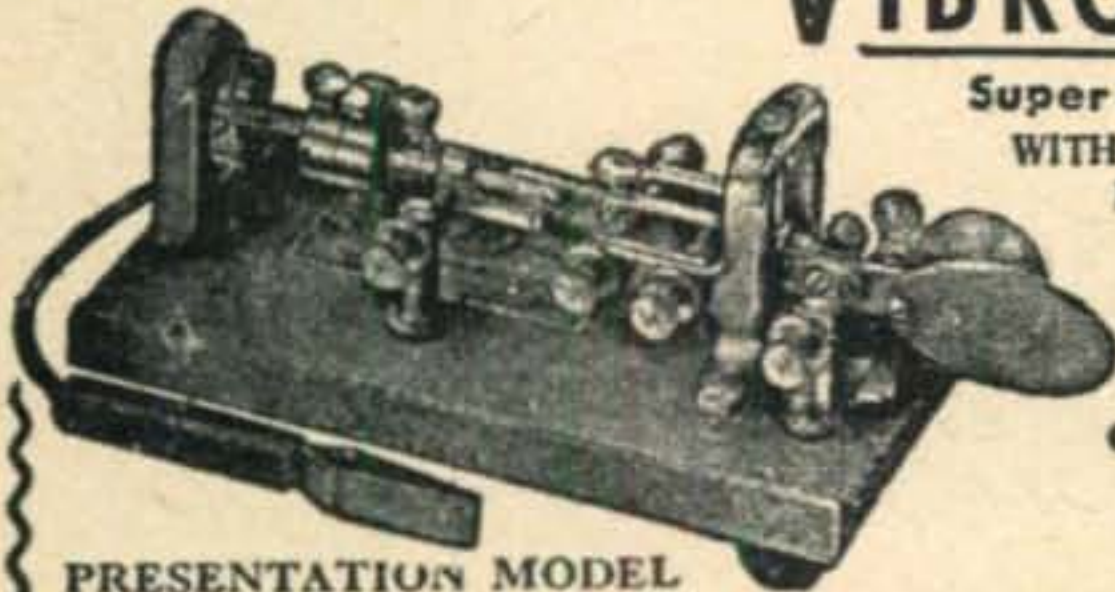

Super DeLuxe
WITH ADJUSTABLE
MAIN SPRING
AND OTHER
GREAT
FEATURES
24-K
GOLD-PLATED
BASE TOP

\$27.50

PRESENTATION MODEL

Vibroplex presents the first really speed control key. An adjustable main spring permits operator to send slower or faster as desired. No more muddy signals . . . no sacrifice of signal quality. Suits any hand or any style of sending. Free of arm tension. Sends easily as pressing a button. Praised by operators and beginners alike. Try this new Vibroplex key! You'll be delighted. Other new popular Vibroplex keys from \$9.95 up. At your dealer or

THE VIBROPLEX CO., INC. 833 Broadway, N. Y. 3, N. Y.

HQ FOR ALL H.F. MICROWAVE PARTS

WE OWN WHAT WE SELL AT SURPLUS PRICES

SA, SC, SD, SE, SF, SG, SL, SN, SO1, SO3, SO8, SO9, SO13, SQ, SU, TAJ, TBK, TBL, TBM, AP5, APR, APS2, APS3, APS4, APS6, APS10, APS15, ABA, QBF, QBG, QCC, WEA, RAK, CPN3, CPN6, DAB, RC145, RC148.

Write Us Your Needs and Let Us Quote
AVAILABLE IN STOCK ARC/5 EQUIPMENT
COMMUNICATIONS EQUIPMENT CO.
131 Liberty St., Dept. Q4 New York 7, N. Y.

DX & OVERSEAS

(from page 34)

pushover compared to working it on c.w., at least, that's the way it is for the VEs. George's latest on phone are ZS8A, AR8AB, VR3A, and CR5UP. . . . It is good to see VE1PQ bring his countries up to date . . . they now total 123. . . . The same goes for VE3ACS. Some of his newest and best are PJ5RE, MD7DC, SP5AC, SVØWH, and XZ2FK.

W9NZZ has been having fun lately working such stuff as ZS9D, HR2RF, EA6AF, SP5ZPZ, and let's not overlook CT2AB. . . . W4BYF is receiving a copy of PJ5TR's log each week for QSLing purposes.

LU8BF, the DX editor of Radio Onda, tells me that PZ1A uses an 815 in his final, and he, 8BF, worked EL5B while LU3BY was operating. He says he is in Africa hunting lions. LU8BF worked CR5UP, who passed word along that he was returning to Portugal; however, CR5NF will be on the air in Portuguese Guinea. Radio Onda is awarding a DX certificate to anyone who has worked 50 different countries and has had them confirmed. All that is necessary to achieve this certification is to send a list showing the stations worked, the country, time, band, and phone or c.w. This list must be confirmed by your local radio club or any group of amateurs who will vouch for the authenticity of the list of DX worked. *Do not send QSL cards.* Send only the list of countries.

LU8BF says that LU2ZA is operated by LU4HU, and QSLs for LU2ZA may be sent to the QTH of LU4HU.

W9WCE relates that he was about ready to slip off the page in the Honor Roll, so he got to work and fired up the rig—resulting in knocking off two or three more countries. Joe has been laying it on heavy on 10 phone lately, working CR7IL, GC2FZC, MI3SC, ZC6UNJ, DU1VVS, EA2CA, and FF8AH.

W2HMJ is grieving because he has to leave top spot in the 37 Zone column, all because he worked XZ2FK for his 38th Zone. . . . W4AZK has added a few such as UAØAA, UN1AB, VS6JH, ZS9D, and EA6AF. . . . W3DKT, I see, has some nice new ones in FN8AD, ZS7C, ZS9D, and FY8AA.

W6TT adds a few on phone—ZS7C, CR5UP, and YK1AC. A few others he has worked on c.w. are FY8AA, VP8AO, and FB8AX. . . . W1MCW has salted away another one in YK1AC. Yep, this was on 10 phone. . . . Another one concentrating on 10 phone is W2ZVS. He also worked YK1AC, KR6AS, VU2GB, KJ6AF, KX6BA, KM6AO, and CT2AE. Lots of good Pacific stuff on 10.

ZL1HY started out the new year with a couple of new countries—FY8AA, and ZS7C. . . .

VK2ACX took time out to bring his list of countries up to date, and barring any accidents, his total should be around 200. Art's list is pretty long, but the last few are ZS3B, ZS9D, HR2RF, and FQ8HC.

1950 has done alright for W2WZ, as his log shows the addition of FQ8HC, ZS9D, and EA9BB. . . . Even the W9s are working DX!! W9FKC had the velvet touch when he hooked SP5AC, FN8AD, ZS9D (Gee, everyone is working him!), and last, but by no means least, AC4RF. . . . Another W9 heard from—this one is W9HP who does his work

When writing to our advertisers say you saw it in CQ

on phone. Frank's last ones include VS7GR, KS4AN, VQ2HC, and GD3UB.

While we are in the 9th district, we might as well pass along an idea coming out of W9DKV. Pat says he has quite a number of fairly recent Call Books, and he knows there must be foreign hams somewhere who could use these books. He wants to know if there is some place in the country that is used as a headquarters for mailing out Call Books to the boys overseas who can use them. I agree with Pat that if there was some central spot, there surely would be thousands of Call Books from the Ws that could get in the hands of the boys overseas who could not normally afford them. If you have any ideas, you might pass them along to W9DKV.

HL1AL passes along a list of the licensed amateurs in Korea at the present time: HL1AF, AL, BJ, BQ, BM, CQ, and US. Incidentally, HL1US is the newly licensed station of the American Amateur Radio Club of Korea and should be on the air by the time you read this. They will be using a TBS-50 and will operate on 10 phone, as well as 20 and 40 c.w. A great deal of the operating will be done by W3PKU and W4MNW. Any of you fellows who have not received QSL cards from HL1 stations which were formerly operated by personnel of the Military Government, and which are now non-existent, can probably secure information on their new QTH by getting in touch with Captain R. U. Mauby, HL1BJ.

Some of you would possibly like to know the new address of the headquarters offices of the South African Radio League. It is P. O. Box 3911, Capetown, South Africa. Do not confuse this with the QSL Bureau, as that address remains unchanged. We may as well repeat it, so here it is: QSL Bureau, P. O. Box 3037, Capetown, South Africa.

W3FYS suggests having a silent day once a week for each W call area. He says in this way, with the W6s off, they would stand a better chance of getting through to the Asians as well as the Pacific. He says the same thing would be true for the W6s to get through to Europe and North Africa when the East Coasters are off the air. Who wants to start it??? If a deal like this went through, I can almost hear some W6, shall we say "unknowingly," turning on his receiver on the W6 silent day, and hearing none of the QRM piling up, proceeds to work everything in sight with little or no competition. From then on, it would be every man for himself again. I don't imagine this could happen on the East Coast, because everyone there is so cooperative!

By the way, while we are still talking about W3FYS, he said he learned something the other day when he sent in his cards for BERTA. He discovered that somewhere in the past the rules had been changed, and their requirements for BERTA now cover almost half the country list.

Every now and then someone lets up a yowl about PXs not sending cards. Now, it looks as though PX1A (at least one of them) has whipped up a card and is sending them, because a couple of the fellows (W1BIH and W3CBT) have sent us cards from PX1A which were mailed from his present QTH in Mexico. I think XE1AC mentioned sometime ago that you might try getting in touch with PX1A via Box 273, Chihuahua, Mexico. On his card is this line, "I am the sole Ham in Andorra. Other PXs you may hear are pirates." The card is signed "Rick."

ZL2GX is still ticking them off. Here are a few of them: AC4NC, FY8AA, FF3CN, FQ8HC,

When writing to our advertisers say you saw it in CQ

SAM'S SURPLUS SELLS FOR LESS!

RECEIVER & XMITTER
NEW BC-454 (3-6 mc) Rcvr. & choice of either a 274N or ARC-5. 4-5-3 mc or 5.3-7 mc Xmtr. (slightly used) with Schematic.
RCVR. & CHOICE of EITHER **\$8.95**
ALL 3 **\$11.95**

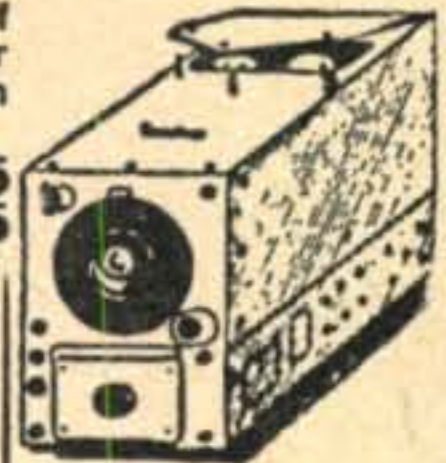

RL-42 ANTENNA REELS. Rotator.
New. **\$2.95**
ARC-5 MOD. PP 1625. Used **9.95**
TU 5-26 **2.49**
COAX RG8Q. 100 ft. **4.95**
APS-13. New **16.95**

COMMAND RECEIVERS (274N)
Complete with tubes **USED NEW**
BC-453: 190-550 kc. **\$9.95 \$12.95**
BC-454: 3-6 mc. **3.95 5.95**
BC-455: 6-9 mc. **5.95 8.95**

COMMAND XMITTERS (274N & ARC-5)
Complete with tubes & xtals **USED NEW**
BC-457 or ARC-5: 4-5.3 mc. **\$3.95 \$ 5.95**
BC-458 or ARC-5: 5.3-7 mc. **3.95 5.95**
BC-459: 7-9.1 mc. **14.95**
BC-456: Mod. with tubes **1.95**
ARC-5: 7-9.1 mc. **6.95 9.95**
BC-375: **11.95**
BC-375: Mod. Trans. **1.49**
BC-191 (Excell. Cond.) **17.95**

MAGNESYN XMITTER and INDICATOR



For Ham. TV or Comml.
110 V 60 cy. oper. Complete
kit, instructions **\$4.95**

FL-8 Filter. .. **\$1.79**

MOBILE DYNAMOTOR
DYN.—9 VDC input;
output 450 V 60 MA. 6
VDC input; output 275
V 50 MA **\$3.95**
Single throw double pole,
6 V or 12 V.
Leach **69c**

PROP PITCH MOTORS
New. Original case. Ship-
ping wt. 55 lbs. **\$13.95**
With transformer 5. 24
& 30 V @
15 amps **\$17.95**
Transformer alone **\$4.95**
Extra Motor ... **\$3.95**

EE-8 Field Phones. Used.
Excell. cond. .. **\$6.95**

RAX RECEIVERS

8 tubes, 1 antenna and 2 R.F. sections. Frequency range
of RCVR. No. 1: 200-1500 kcs; RCVR. No. 2: 1500-
9000 kcs; RCVR. No. 3: 7000-27000 kcs. Used, good
cond. electrically perfect **EACH \$15.95**

ESEGE SALES COMPANY LTD.

Distributors Electronic Parts
1306 Bond Street at Pico Los Angeles 15, Cal.
Terms: Cash With Order — Prices Subject to Change

THE NEW AMATEUR 144 MC THROUGH LINE FRONT END

2 stage RF amp.—mixer-oscillator—the hottest and most stable front end MODEL 1 (140-160 MC); MODEL 2 (80-120 MC).

These tuners have high gain, high image rejection, low noise factor. Can be used as converter or fed directly into IF amp.

10.7 MC IF amp.—80db gain—for FM or AM.

Special purpose receivers using trough line front ends, either tunable or fixed freq. crystal controlled up to 500 MC.

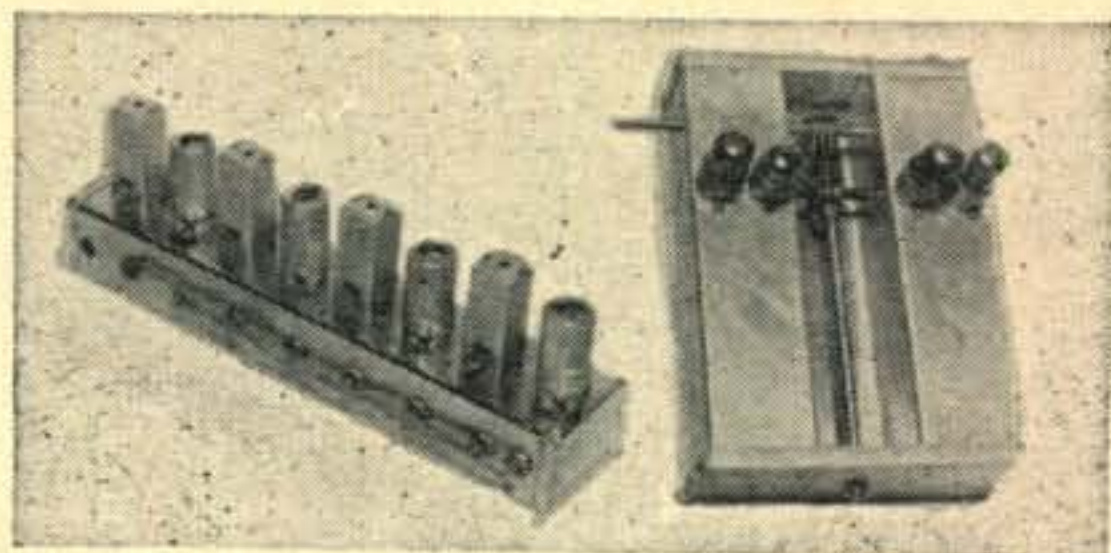

IF Amplifier **\$50.00**

Tuner **\$18.95**

WARDELL SMITH, W2BRQ

Manufacturing Communications Engineer

65 Glenwood Rd.

Upper Montclair, N. J.

SPECIAL BUTTERFLY TUNERS
70 - 300 Mc
\$1.50
Atronic Corp.
Dept. C-4
1253 Loyola Ave.,
Chicago 26, Ill.

10 METER BEAM ANTENNA
\$15.95
3 ELEMENTS
SPECIAL

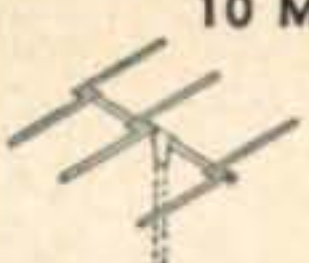

Volt-Ohm-Milliameter 0-1 MA. 4"
Fan Type. Diagram Incl. Makes 1000
ohm per volt unit. Meter Only \$2.95
METERS—3" PANEL TYPE
0-10MA..\$2.00 0-1MA..\$2.50

National
radio and television products distributed by
RADELCO, INC.
246 W. First St., Mt. Vernon, N. Y. MO Ver 8-6173

10 METER CONVERTER BUY
RF24 3 tube 20-30mc broad band high gain converter requiring 6.3v @ 1.2 amps plus 250vdc @ 25ma for operation. No modifications necessary when connected up to your present receiver; output frequency 5mc, slug tuned. These units, although used, have each been checked for performance and are guaranteed; furnished with 3 spare tubes and coaxial connector type 831R. Measures only 5" x 7" x 10". Shipped postpaid to any place in the United States for \$16.00. Order yours today.
Overbrook Company, Overbrook 81, Mass.

RADIO
OPERATING TYPING • SERVICING VIBROPLEX • CODE
FM • TELEVISION
APPROVED FOR VETERANS
Send for Catalog T.C.

YMCA

TRADE & TECH. SCHOOL 229 W. 66 St., N. Y. 23
ENdIcort 2-8117

8 WIRE CONTROL CABLE
Two No. 16, Six No. 20 tinned, stranded, copper, rubber insulated, coded leads. Waterproof rubber jacket. Woven copper armor shield overall. Wt. 16 lbs./100 ft. Lengths to 400 ft. **LOW PRICE**
FOB warehouse. Min. order 100 ft. **5c ft.**
Add 25c charge on P. P. shipments.
Trans-World Radio-Television Corp.
6639 S. Aberdeen St. Chicago 21, Ill.
Phone: AUstin 7-4538

Cancer's danger signals

1. Any sore that does not heal
2. A lump or thickening in the breast or elsewhere
3. Unusual bleeding or discharge
4. Any change in a wart or mole
5. Persistent indigestion or difficulty in swallowing
6. Persistent hoarseness or cough
7. Any change in normal bowel habits

Can be your safety signals

Cancer is curable if discovered early and treated properly
AMERICAN CANCER SOCIETY, INC.

When writing to our advertisers say you saw it in CQ

F9JD (on Corsica), CR4SS, and ZS9D. . . . Oh, yes, W3EVW also received a card from PX1A. Roger hooked VQ3KIF on phone, and while on c.w., he worked ZD2FAR, ZD2TBS, and VQ3BNU. . . . G2BVN, who works phone, has a few god ones in VP3LF, PZ1QM, MD2MD, and YK1AC.

If there are any DXmen in North and South Dakota who would like to make VQ2GW happy, you can do it simply by working him. He needs these two States for WAS.

KL7PJ took a little vacation and headed for W2 where he met W2ALO and the No. 1 WAZman, W2BXA. Chuck said he was glad to get back in Anchorage, however, even if it was cold. KL7GG has now worked 39 Zones and is gunning for Zone 23. Frank runs a kw, and uses a 4-element beam on a 50' steel tower.

While still up Alaska way, I might as well tell you that KL7UM has hooked his last zone, this being OA5A. He still needs a few cards, but it looks as though Bran is getting pretty close. . . . For those who have been on the air for years and years, you may remember him in 1921 when he had the call 7UM and was running an old spark outfit. After a layoff, he got back on the air in 1930, and he had the calls W7QI and then K7QI. After the war, he applied for KL7UM, and that is what he is now using. Whenever someone mentions "the old spark days," it sort of strikes a soft spot in my heart. But, on the other hand, maybe it shouldn't even be mentioned, because it kind of dates a guy!

In a letter to W6TT, VR5PL relates that VR5IP is married and is now in VR2. The only other ham on Tonga is VR5GA, and at present, he seems to be operating phone on 14,380. VR5PL has only two crystals and operates 14,092 on c.w. and 14,120 on phone. Noel says that VR5GA is an electrical engineer and is installing power on Tonga. At this time, they have restricted hours for using the power lines, but they expect to be able to use them 24 hours a day by next July.

I1IR tells us that he has heard from M1B, who says he is the only genuine station in M1. If you hear other M1s, they are pirates somewhere else in Europe. He is also quite sure that his own call is being pirated somewhat, and, naturally he could not be expected to QSL these contacts. I1IR has also received a very nice letter from the Government of Monaco, which said that the new CZ2AC is unknown there. Gee! People sure like to kick this call around . . . don't they? Who's next?

According to W3JTC, FW5AA is on Corsica. Of course, you have heard that FW5 is the new prefix for the island. Larry also says that FW8AA will be on shortly from Wallis Island, which is in or near the Tonga and Friendly group.

While on the subject of new French prefixes, there might be one or two of you who are wondering about FM7WE. He is none other than F9QU/FM8. In the February issue, something was said about CR5UP leaving Sao Thomas Island to become CT1BW. Don't blame W4LZM for this, because CR5UP apparently changed his mind on his date of departure, as, at this writing, he is still there.

VE1EA is still DXing on 160, his latest being G2PL, GD3UB, G8NF, G6BQ, and G3PU. . . . It is old stuff by now, but a few of you possibly might not know that 3V8AB is ex-FT4AB. Sounds more like a new type of receiving tube to me. . . . KH6PY is keeping his fingers crossed and hoping

that when he worked AC4RF, he was in Zone 23. Jack finds that taking care of his new 5th Harmonic somewhat curtails his DX operating. . . . By the way, XZ2EM is now off the air and probably headed for England.

Some of the fellows have written in during the past few months wondering if it wouldn't be a good idea for the boys to add the Zone number when they have their QSL cards printed. It might not be a bad idea, and it certainly won't take up very much room. . . . Why not give it a thought the next time you have some cards printed?

A few of the good ones that have been on lately are CR5AM in Portuguese Guinea 14,115, FB8AX in Antarctica at approximately 140° E and 67° S. Then, the other day, W6EBG worked VQ9ON, who is supposed to be on Seychelles. . . . Some of the boys are still having a good time working CR1ØAA. He is sometimes found around 14,070. . . . While we are talking about working stuff—some of the boys wonder what goes with TZ1J. Consensus of opinion around here seems to indicate he is one of the lads on a boat somewhere.

Lacking any suitable material for the usual soap-box oratory, I'll just wind this thing up and see you at the next session. 73.

QTHs

CR5AM	Armando Mariano, P. O. Box 206, Portuguese Guinea
EP1AC	Box 108, Abadan, Iran
FM7WE	Box 281, Fort-de-France, Mar- tinique, French West Indies
HL1s	APO 404, c/o P.M. San Francisco, California
VP7NN	QSL to home QTH which is W2ZK
ZD1KO	Sierra Leone Signal Squadron, Freetown, Sierra Leone, West Africa

ZERO BIAS

(from page 10)

things in common, we have enjoyed some pleasant contacts discussing both technical and personal matters. However, the Russian amateurs are apparently under strict orders to confine their remarks to these two subjects, because they simply ignore any questions or remarks that fall in any other category.

Amateurs of other foreign countries, however, are free to discuss with us almost any subject that happens to strike their fancy, from the Laps and their reindeer in Finland to the way the zebras destroy the crops in Southwest Africa, to mention two examples.

Surely you will agree that these casual conversations between the amateurs of this country and those of others, all with one burning mutual interest that bridges thousands of miles of ocean and hurdles all political barriers, must inevitably lead each to a better understanding and appreciation of the other's way of life. This is the contribution of amateur radio to international good will.

I hope that in this very brief review of the public service aspects of amateur radio I have not given the impression that amateurs do any of

(QSY to page 72)

When writing to our advertisers say you saw it in CQ

A **SPEED**

FOR
Only \$8¹⁰

(Amateur Net)

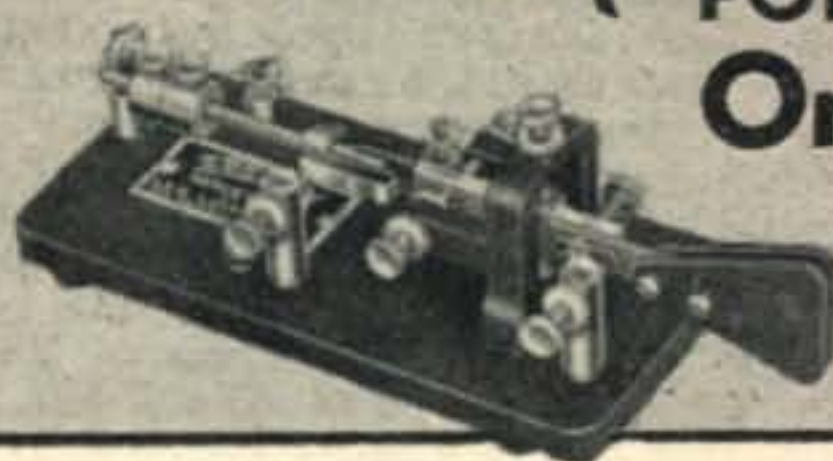

Here's a high speed semi-automatic key any amateur will be proud to own! It's a joy to use — a real precision instrument that encourages faster, better cw.

● HAS SMOOTH, SNAPPY ACTION

Main spring and U-spring of the model 114-515 are made of carefully tempered clock spring for smooth, snappy action. Adjustable weight. There are two adjustable black fibre paddles and two sets of 1/8" coil silver contacts. Lock nuts are provided for every adjustment.

● HAS ALL ADJUSTMENTS

Steel base is finished in attractive baked black wrinkle enamel. Base is 6-1/4" x 3" x 3/8" with four rubber feet to prevent slipping or tilting. Connector strips are heavy brass.

This amateur model 114-515 represents a truly outstanding value—in quality, performance, price!

Amateur Model 114-515

Only \$8¹⁰ (Amateur Net)



E. F. JOHNSON CO.
WASECA, MINNESOTA

SCOOP!!

BRAND NEW!

FL-8 FILTER
AND
"FILTER FACTS"
BOOKLET

BOTH FOR

98^c

This great value made possible by a special purchase. An unheard-of price on the highly useful and effective FL-8 filter . . . brand new! And a big "plus" . . . "FL-8 FILTER FACTS", our exclusive booklet by Bane WGB. Another O & R, "can't miss" value! Get yours at once!

TROUBLED WITH BCI

Put a stop to it with NFM or NPM. O & R offers a complete, easy-to-assemble kit that anyone can get perking in short order. Comes to you with punched aluminum chassis, tubes, all parts. Instructions are complete and leave no guess-work. Priced cheaper than you can buy the parts alone . . . far less than a factory assembled unit. These jobs are on the air, they're practical, they really perform! Your choice of frequency or phase modulation.



NFM-3C complete kit only \$8.75
NPM-3C complete kit only \$8.75

PHONE PATCH!

O & R presents their new, #6008 phone patch. The ideal unit for coupling transmitter and receiver to your phone line. Will work into hi-impedance xtal mike transmitter input without need for additional matching transformer. Receiver input portion has two taps to insure proper line level from receivers with either hi or lo impedance audio outputs. Really a sweet performing job. Complete, ready to patch into phone line.

Only \$3.95 ea.

4 HOUR MAIL-ORDER SERVICE. WE SHIP ANYWHERE
20% Deposit must accompany all orders. balance C.O.D.

OFFENBACH & REIMUS CO.

372 Ellis St., San Francisco, Calif. Phone ORday 3-8551

Classified Ads

Advertising in this section must pertain to amateur radio activities. Rates: 25c per word per insertion for commercial advertisements. 5c per word for non-commercial advertisements by bona fide amateurs. Remittance in full must accompany copy. Phone orders not accepted. No agency or term or cash discounts allowed. No display or special typographical ad setups allowed. "CQ" does not guarantee any product or service advertised in the Classified Section. Closing date for ads is the 25th of the 2nd month preceding publication date.

GREAT LAKES DIVISION A.R.R.L. CONVENTION. Hotel Statler, Detroit, May 27-28-29. Registration and banquet \$7.50. Mammoth Swap 'n' Shop session! Prizes! Prize-1 Write Box 903, Detroit 31, Michigan, for tickets or buy through local club or dealer.

VHF 152-A factory reconditioned \$50.00. WØPLJ Jackson, Mo.

QSLs? SWLs? "America's Finest!" Samples 3¢. Sackers, W8DED, Holland, Michigan.

FOR SALE: BC348 converted to AC in excellent condition \$60.00; SCR522 like new \$25.00; 9 amp 230 volt variac, can be used on 115, best offer; several 872A's, good as new. \$1.25 each. Address Box 261, Manderville, La.

SELL: T-23/ARC-5 100-156 mc. original carton with tubes, less crystals, \$15.00. MD-7/ARC-5, original carton, \$10.00. W2GVF, 82 B'way, Bayonne, N. J.

BARGAINS—NEW AND USED TRANSMITTERS—RECEIVERS—PARTS: Globe King \$299.00; HT-9 \$275.00; Supreme AF100 \$299.00; Sonar SRT-75 \$149.00; new 150 watt phone \$199.00; 60 watt phone \$99.00; Globe Trotter \$57.50; HT-17 \$29.50; New Meissner signal calibrators \$29.95; MB611 \$29.50; NC240D \$165.00; HRO complete \$129.00. SX43, NC173, HQ129X \$139.00; RME45, SX25 \$99.00; S38 \$29.95; S41 \$22.50; latest signal shifter \$59.50; DB22A \$49.00; BC610's and many others. Large stock, trade-ins. Free trial. Terms financed by Leo, WØGFQ. Write for catalog and best deal to World Radio Labs., Council Bluffs, Iowa.

10-METER 3-ELEMENT BEAMS—\$19.50. Send card for free information, Riverside Tool Co., Box 87, Riverside, Illinois.

AMATEUR RADIO LICENSES. Complete theory preparation for passing amateur radio examinations. Home study and resident courses. American Radio Institute, 101 West 63rd Street, New York City.

HOTTEST SURPLUS LIST in the country. Electronics-hydraulics-aircraft gadgets. Dick Rose, Everett, Wash.

QSLs, SWLs. Made the way you want them. Samples? W9BHV QSL Factory, 857 Burlington, Frankfort, Ind.

WANTED: AN/ART-13, BC-348, RTA-1B, AN/APN-9, R5A/ARN-7, AN/ARC-1, AN/ARC-3, BC-788-C, 1-152, MN-26, test sets with TS- or 1- prefix, dynamotors, control boxes, transmitters, receivers, power supplies, etc. State quantity, condition and best price first letter. HLM Electronics, Box 195, New Haven, Conn.

QSLs! G. L. Taylor, Sumrall, Mississippi.

QSLs. HIGH QUALITY, fair prices, samples? W7GPP, 1380 F. The Dalles, Oregon.

COLORTONE QSL's! top quality! Samples? Mobile QSL's? Colortone Press, Tupelo, Miss.

BC348 unconverted \$50.00—AC converted \$50.00; BC224 unconverted \$35.00; SCR 522 and dynamotor \$20.00; Weston Radio test set 156-A new and complete with tube tester, set analyzer, volt ohmmeter and instructions, A. L. McMullen, W5PHO, 520 Center St., Alva, Oklahoma.

BC-614-E, JB-70A, BC-610 (built from original surplus parts) best offer over \$250.00. Must inspect before offer. W9QGH.

NC240-D receiver for sale, used very limitedly. Any reasonable offer accepted. Louis Gruenberg, 90 Goffle Hill Road, Haworth, New Jersey.

SELL OR TRADE: Brush VP-5 vibration pickup excellent condition, Dapre B flat wood clarinet no cracks needs pad job but otherwise excellent condition. Want good 5-amp variac and a deal for Millen grid dip meter or Jackson 650-A condenser analyzer or other ham equipment. F. C. Breeden, W2SIJ, 61-17 224th St., Bayside, N. Y.

Sonar NBFM NE-10 unit \$15.00. Telvar T-60-2 transmitter with tubes and coils for ten meters, \$105.00. Four oil filled condensers 12 mfd. 2000 vdc \$5.50. Four for \$21.00. W2ODH, Garfield, N. J.

Large lot ham equipment and miscellaneous parts reasonably priced. Send for list. WØSGG, 535 East Platte Ave., Colorado Springs, Colo.

GOING TO TRY for your Amateur Radio Operator's License? Check yourself with a written test similar to those used by the F.C.C. Complete coverage, multiple-choice questions with answer key. Class B & C test \$1.75. Class A test \$2.00. Amateur Radio Supply, 1013 Seventh Ave., Worthington, Minnesota.

10 AND 20 METER BEAMS \$19.25, up. Aluminum tubing etc. Willard Radcliff, Fostoria, Ohio.

BARGAINS: New and reconditioned Collins, National, Hallicrafters, Hammerlund, RME, Millen, Meissner, Gonset, etc. Reconditioned S38 \$29.00, S53 \$49.00, S40A \$59.00, SX42 \$179.00, NC57 \$59.00, NC173 \$139.00, HQ129X \$129.00, RME84, RME45, DB22A, HF-10-20, VHF152A, SX43, NC240D, NC183, HRO7, Collins 75A, Collins 32V, BC610, Meissner bandswitching VFO complete, \$49.00. Shipped on trial. Terms. List free. Henry Radio, Butler, Mo.

2 HANDY-TALKIES, Sperti, used, good condition, \$22.00 each. APR 4 receiver less tuners, \$100.00 prepaid. W8KKE J. Rapien, 59-07 East Woodmont Ave., Cincinnati 13, Ohio.

SELL: Motorola 10-meter mobile transmitter, 3-30 mc Gonset 4D32 tube, etc. Send for list. E. L. Felder, Tyler-town, Miss.

PLATE TRANSFORMERS 3600-3000-2500 at 375 ma \$39.95, 2500-2000-1500 at 550 ma \$39.95, 2100-1800-1500 at 350 ma \$21.95. All each side CT, Primary 110-220 volts fully cased, hermetically sealed, not surplus. Frampton Transformer, Box 109, Blackwell, Okla.

SELL: 3 element 20-meter rotary beam and six foot tower with built in prop-pitch motor, selsyns, four slip rings and change over relay for proposed 15-meter beam control box. Don McNamara, 829 North 12th St., Milwaukee, Wis.

NEED CASH—MUST SELL. Beautifully constructed Eldico 1500 volt supply for cost of kit plus tubes etc. \$35.00. Also BC-348R, converted to 110, S-Meter, noise limiter and speaker \$75.00. Both guaranteed. Don McNamara, 829 North 12th St., Milwaukee, Wis.

CALIBRATION-REPAIR SERVICE: Instruments, test equipment. Audio oscillators calibrated. Precision standards employed. Breon Laboratories, quartz crystal manufacturers, Williamsport, Penna.

WANTED: Code practise machines, and tapes—new, used. Arthur Blau, 625 W. 164th St., New York 32, N. Y.

FOR SALE: SX43 and Jensen B151 base reflex with 12" speaker, nearly new, \$145.00 complete. John Anderson WØKVP/6, 649 S. Santa Fe, Compton, Calif.

FOR SALE—BC-610-E, 80 thru 10, excellent condition. Write WØHRQ, Box 1314, Chadron, Nebr.

LM 13 frequency meter, new, with power supply and cal. bk. \$80.00. W6VWA, 10306 Otis St., So. Gate, Calif. LO 65045.

SELL AT BARGAIN. Want to hear elusive DX? HRO-W plus DB-22A Gonset Clipper power supply and speaker completely lined on the nose \$150.00 shipped prepaid in USA. This line-up heard and worked 175 countries with apartment dipole. Write, wire, phone RE 9-4253 R. O. Strook, W2YW, 84-49 168th St., Jamaica 3, New York.

FOR SALE: Used, unconverted ART/13, \$100. Prefer to sell but will consider trade. W7JFR.

QSLs OF DISTINCTION! Three colors and up. Samples? Uncle Fred, Box 86 Lynn, Penna.

"New 2 1/2" Weston 1.2 ma movement meter with linear scale marked 0-100, suitable for use as field strength indicators, tuning meters, multimeters, etc. Only \$3.00 postpaid. Overbrook Company, Overbrook 81, Mass.

QSL's—Still at our low prices. VYS Print, 1704 Hale Ave., Ft Wayne, Indiana.

CLUB SECRETARIES AND OFFICERS: WRITE TODAY to the Club Secretary, c/o Radio Magazines, Inc., 342 Madison Ave., New York 17, New York, for free information and offers to benefit your organization.

ATTRACTIVE BUY—COMPLETE STATION: Includes Super Pro with power supply and speaker, 125 kc to 30 mc. NE10 and ten crystals. Fully shielded; metered rack and panel 220 watt input transmitter, 6L6/807 pp24G's. Covers all bands; supplied with ten meter coils. Relay, shure 707A mike, key. All set to go! Also two meter modulated oscillator transmitter-receiver, 274N V.F.O. new, not converted, plus parts for power supply. Best offer! W2QNW, Herbert Spingeld, 35-50 78th Street, Jackson Heights, N. Y. Butterfield 8-7384.

CQ Ad Index

Advance Electric & Relay Co.	62
American Radio Institute	58
Ashe, Walter Radio Co.	47
Atronic Corp.	68
Bliley Electric Co.	48
Bud Radio, Inc.	2
Columbia Electronic Sales	59
Communications Equipment Co.	66
Dow Radio, Inc.	39
Editors & Engineers, Ltd.	56
Eitel-McCullough, Inc.	8
Eldico of N. Y., Inc.	51
Electronicraft, Inc.	71
Esege Sales Co., Ltd.	67
Esse Radio Company	42, 43, 44, 45, 46
Fair Radio Sales	55
General Electric Co. (Tube Div.)	1
Hallicrafters Company	Cover 2
Harvey Radio Company, Inc.	41
Heintz & Kaufman	50
Henry Radio Stores	37
Instructograph Company	66
Johnson, E. F. Co.	54, 69
Lettine Radio Mfg. Co.	64
Martin Manufacturing Co.	66
Master Mobile Mounts, Inc.	63
Millen, James Mfg. Co., Inc.	4
Motorola, Inc.	58
National Company, Inc.	52, 72, Cover 3
Offenbach & Reimus Co.	69
Overbrook Company, The	68
Petersen Radio Company, Inc.	7
Pioneer Broach Company	72
Premax Products	60
Radelco, Inc.	68
Radio Amateur Call Book	64
Radio Corp. of America	Cover 4
Radio & Electronic Parts Corp.	60, 65
Radio Products Sales, Inc.	57
Smith, Wardell	67
Sprague Products Company	6
Sylvania Electric Products, Inc.	5
Trans-World Radio-Television Corp.	68
V & H Radio Supply Co.	65
Vibroplex Co., Inc.	66
World Radio Laboratories, Inc.	49
YMCA	68

New HAM-R-PRESS

TRADE MARK

by PIONEER

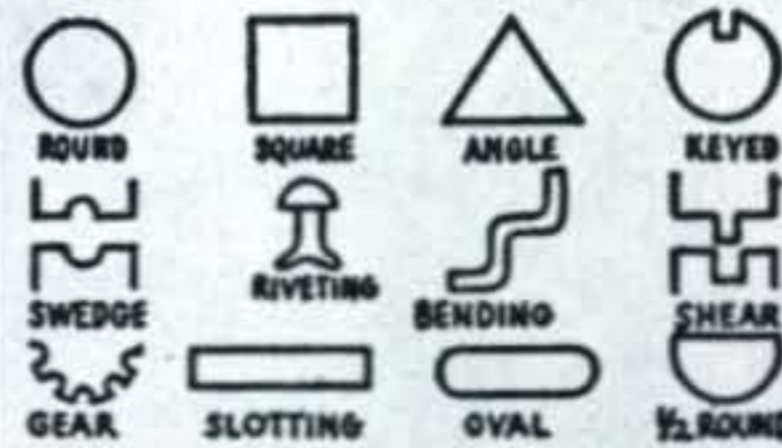

HAMMER BLOW POWER

MODEL H75
7 1/2" THROAT

\$16.95 NET

PUNCH AND DIE EXTRA

PAT. PENDING

Now chassis punching in almost every size and shape may be done in your own workshop with the unique **NEW PIONEER BROACH "HAM-R-PRESS"**. Punch mounting hole for ANY electronic part. Easily. No drilling. . . Slip punch on ram. Insert die in work table. Lower ram to chassis and strike top of ram with hammer. Hole complete. . . Some of its features: Simple operation—Precision alignment—Deep throat—**LOW COST. No Starting Hole Needed.**

H50—5" Throat \$ 9.95 H120—12" Throat \$24.95
H75—7 1/2" Throat 16.95 H240—24" Throat 39.95

ROUNDS	Punches	Dies
1/8, 1/4, 3/8, 1/2	\$.80	\$.65
5/8, 11/16, 3/4, 7/8, 1, 1 1/16	1.20	.80
1 1/8, 1 5/32, 1 11/64, 1 3/16, 1 1/4	1.20	.80
SQUARES —5/8, 11/16	1.25	1.00
3/4, 7/8	1.50	1.25
KEYED —1 11/64	1.40	1.20
RIVETING SET —Requires Adaptor HAD-5 ..		1.50
SHEARING SET —(1" length of cut)		3.75
CABLE SWAGER SET		2.75
DIE RAISER —3" high		3.95
HAD-5 ADAPTOR —For 1/2" and under dies ..		1.00

PIONEER CHASSIS PUNCHES
CUT ROUND-SQUARE-KEYED HOLES

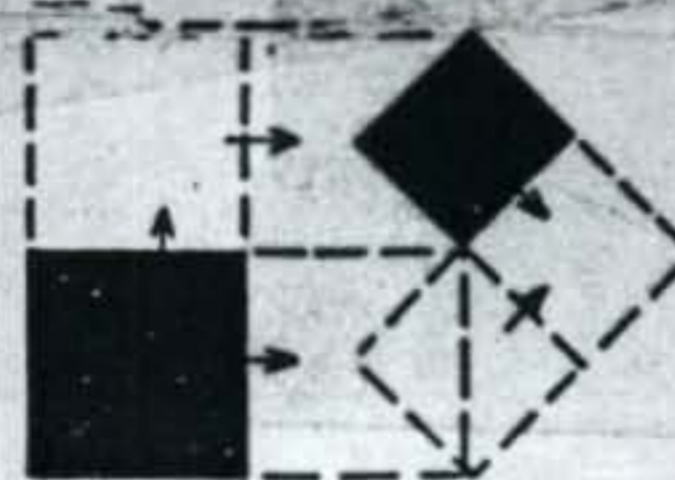

Type C5
Square
Punch
(Right)



CUTS ANY SIZE HOLE LARGER.
SQUARES: 5/8—\$2.95, 11/16—\$3.25, 3/4—\$3.50, 7/8—\$3.95
ROUNDS: 1/2 to 7/8—\$1.95, 1—\$2.15, 1 1/16 to 1 1/4—\$2.30. **KEYED:** 1 11/64—\$3.50. For mounting IF's, Terminal Strips, Sockets, Plugs, Meters, Controls, Xfmers, Switches, Panel Lites, Etc. . . **SIMPLE HAND WRENCH SCREW ACTION. . . CUTS CLEAN.**

Available with Descriptive Literature
"AT YOUR FAVORITE DISTRIBUTOR"

PIONEER BROACH COMPANY

LOS ANGELES 15, CALIF.



GOLD PLATED XTALS!
Western Elec. 1/2" Pin-Spaced
2 For \$1.00 Postpaid
Anywhere in U.S.A.
All fundamental freqs. in Kilocycles

5910	6670	7390
6350	6940	7480
6370	6690	7580
6470	7270	9720
6510	7350	Guaran-
6610	7380	teed

Electronicraft, Inc.
5 Waverly Place Tuckahoe 7, N. Y.

NATIONAL

- Proven
- Dependable
- Quality

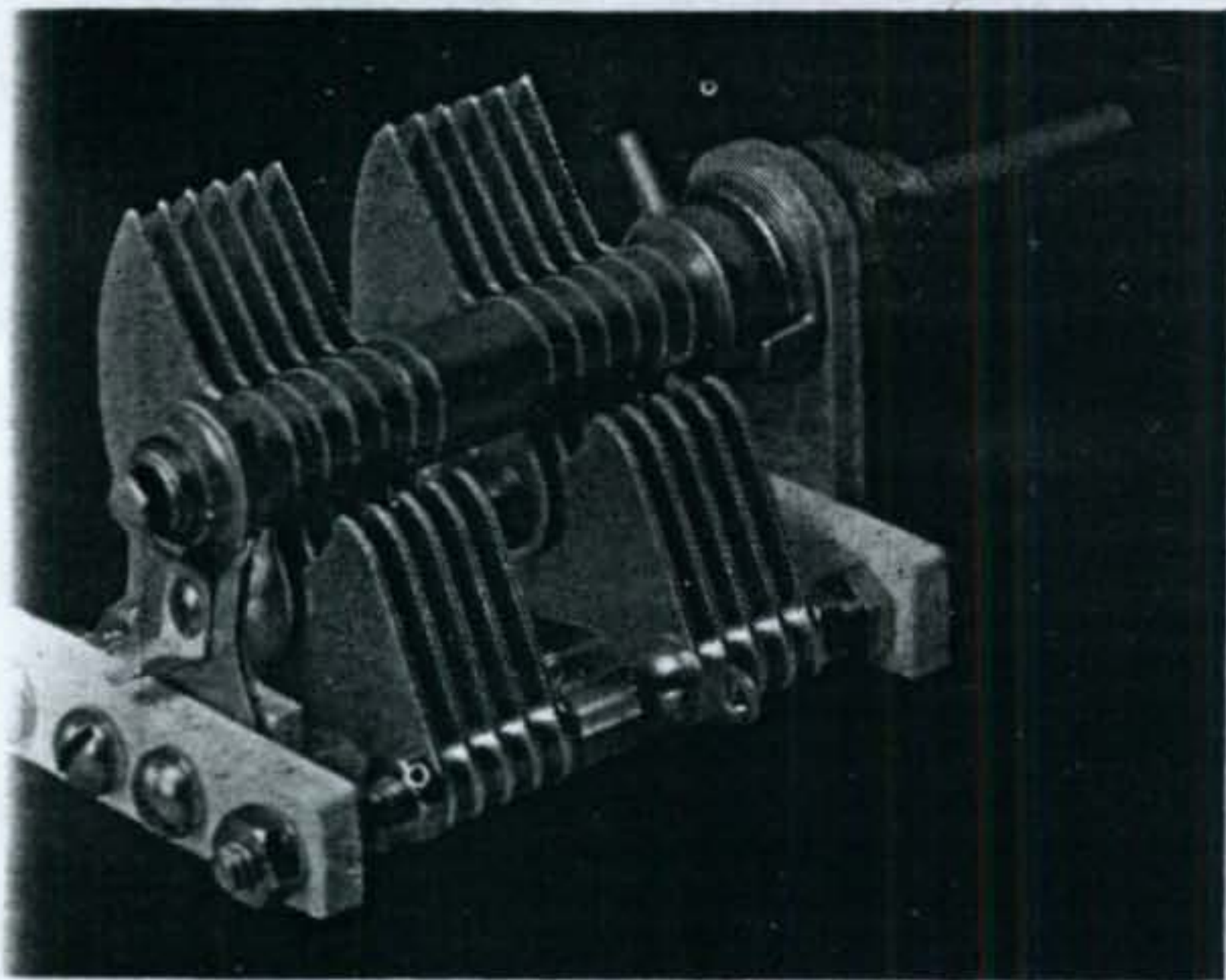

RECEIVING TYPE CONDENSERS

National's famous receiving-type condensers are available with either straight-line wave-length plate shape or straight-line capacity plate shape. Special features can be supplied in quantity, such as serrated rotor plates, staked rotor and stator plates, shaft extensions for ganging and special capacities as high as 335 mmf. for single-section and 100 mmf. per section for dual condensers. Commercial inquiries invited.

National



NATIONAL COMPANY, Inc.
MALDEN, MASSACHUSETTS

these things because they feel it is their duty to do so in order to justify their existence. Those who handle messages in the traffic nets do so simply because they derive so much pleasure from the fast, snappy operating used in them, and because they enjoy being part of these efficient organizations. The men who have served in emergencies are sufficiently rewarded by the satisfaction anyone would derive from having done a difficult job well under the most trying circumstances. The ones who serve as propagation observers on the very high frequencies are just as interested in knowing the answers to some of the mysteries of unpredictable propagation effects as the government laboratories that are investigating them. Those who participate in the military and naval reserve amateur systems are secure in the knowledge that they are prepared to step into the armed services with advanced ratings when another national emergency arises.

It's things like this, you see, that to me, and to 100,000 other amateur operators throughout the world, make amateur radio the most interesting, the most exciting, and the most satisfying of all conceivable hobbies.

SCRATCHI

(from page 4)

that he has already bought some crystals, all on same frequency. With that he are passing out the crystals—after relieving each one of us of two bux—and closing the meeting.

Next drill night Scratchi are getting his transmitter all fixed up and ready to go. Not using crystal, on acct. having strictly VFO rig, but then I am not worrying about being able to get my rig on the right frequency. After all, Scratchi are expert on frequency control and measurement.

I carefully put VFO on exact frequency, wait my turn, then call in. Net control are not acknowledging, but this not worrying me just then. Later on, when other fellows sending practise messages, one follow asking how some Scratchi not on. I smile, throw on the rig, and send cupple of quick dits and dahs to show I'm there. How come now? —net control come back to other fellow and say maybe my rig not yet working.

Scratchi now getting kinda worried. I listen on receiver, turn on VFO, and sure enough, my signal are there like million bux. Then I reduce receiver gain, turn on main signal, and are still hearing myself, except signal not very loud. A little tuning with receiver shows my main signal is a cupple hundred kilocycles higher. Next ten minutes are futilely spent trying to change frequency of main signal, but whatever I do, it are stubbornly staying at same spot. I turn the VFO off. Hokendoki!! main signal are still on. I take out driving stage—main signal still on same frequency.

As last resort pull final stage out of rack and put it on the floor, connect the high voltage to it, and Hon. Ed., you wouldn't believing it, but it are still oscillating and still on same frequency. Upshoot of it all are that the final are self oscillating on one frequency whenever high voltage applied.

Hon. Ed., you having any information on how to make pads for diathermy machine? I thinking of using my final for same, to ease my aching back.

Yours respectfully,
Hashafisti Scratchi

CQ

WEIGH THE DIFFERENCE

The National NC-173 communication receiver weighs 46 pounds. This adds up to good solid construction using the finest quality components to assure you years of satisfaction and service.

Covers 540 kcs. to 31 mcs.
plus 48 to 56 mcs.
for amateur 6-meter band with
average sensitivity of
3 microvolts. Separate

bandsread dial calibrated for 80,40,20,15,10

and 6 meter bands. New double-diode noise limiter with variable threshold effective on both phone and CW. Separate AVC useable on phone and CW. New wide-range, 6-position crystal filter, S-meter, antenna trimmer for maximum performance

with any antenna, phono input. Provision for addition of NFM adaptor and new National Select-O-Ject 1-6SG7 tuned R.F.; 1-6SA7 1st det.; 1-6J5 osc.; 2-6SG7 I.F.; 1-6H6 2nd det. — AVC; 1-6AC7, AVC; 1-6SJ7 BFO; 1-6H6 noise limiter; 1-6SJ7 audio; 1-6V6 output; 1-VR 150 volt reg.; 5Y3GT/G rect.



\$189.50 net* (less speaker)

*Slightly higher west of the Rockies

Up to 3000 Mc!



THE FOUNTAINHEAD OF MODERN TUBE DEVELOPMENT IS RCA

The RCA-5675

... a new "Pencil Triode" for UHF applications

ANOTHER "RCA FIRST" in advanced tube design . . . the RCA-5675 "Pencil Type" triode for UHF applications is typical of RCA engineering leadership in developing new and better tubes for communications and industry.

The RCA-5675 is a medium-mu triode employing a double-ended coaxial-electrode structure. As a local oscillator with a plate potential of 120 volts, it is capable of a power output of 475 milliwatts at 1700 Mc., and about 50 milliwatts at 3000 Mc. The tube is less than 2 $\frac{3}{8}$ " long . . . and has a heater that requires only 0.135 ampere at 6.3 volts.

The "pencil-type" construction of the RCA-5675 provides low lead inductance and low interelectrode capacitances. Because of these features the tube can

be used at medium frequencies with circuits of the line type and lumped-circuit type. It is especially designed for utilizing coaxial-cylinder circuits at the higher frequencies. The 5675 employs a coaxial electrode structure in which the plate cylinder and cathode cylinder extend outward from the grid flange. The latter is particularly effective in isolating the plate from the cathode in grounded-grid amplifier circuits.

In the future, as in the past, the resources of RCA—its manufacturing experience and skill—are dedicated to the development and production of progressively better electron tubes—of which the 5675 "Pencil Triode" is a recent example.

Watch for the new HAM TIPS



RADIO CORPORATION of AMERICA
ELECTRON TUBES

HARRISON, N. J.