

**DECEMBER
1951**

Q



The Radio Amateurs' Journal

35¢

the HAM lanes are HUMMING with...

hallicrafters



S-76



Everyone who qualifies WINS!

Remember, everyone who completes the course wins! The *first ten* Novices who complete the following will receive, absolutely FREE, a Hallicrafters S-76 Receiver. All of the other Novices who complete will receive \$25 in cash, each.

1 HALLICRAFTERS Merit Awards will be given to every Novice who, during the period beginning 12:01 A. M., September 8, 1951, and ending 12:00 P. M. September 7, 1952, (local time) works all states and has obtained by September 7, 1952, a General or Conditional Class Amateur License. Both Novice-Class and "regular" QSOs can be used to make up the total of 48 contacts.

2 Rules governing contacts and verifications thereof are the same as for ARRL W.A.S. Certificates (see page 6, "Operating an Amateur Station"). Your package of verifications must be postmarked not later than October 7, 1952.

Thanks to all of you who have already dropped us a line that you are "working all states" for the 1951-1952 Merit Awards. We would like to know the names of everyone who is competing —so we can publish later a list of calls, names and addresses of those in the running. This list will help you in your contacts.

So please mail in postcard, or the coupon below:

hallicrafters
"The Radio Man's Radio"

WORLD'S LEADING MANUFACTURERS OF PRECISION
RADIO & TELEVISION • CHICAGO 24, ILLINOIS

Bill Halligan, Jr. WN90EP
The HALLICRAFTERS Company, Chicago 24, Ill.

Dear Bill: I've started working on my ARRL W.A.S. Certificate. Have contacted _____ states so far.

MY CALL _____ DATE OF LICENSE _____

NAME _____

STREET _____

CITY _____ ZONE _____ STATE _____

C Q

NOW, for civil defense on 2 and 6 meters . . .

CASCADE

— with one tube,
bargain-priced!

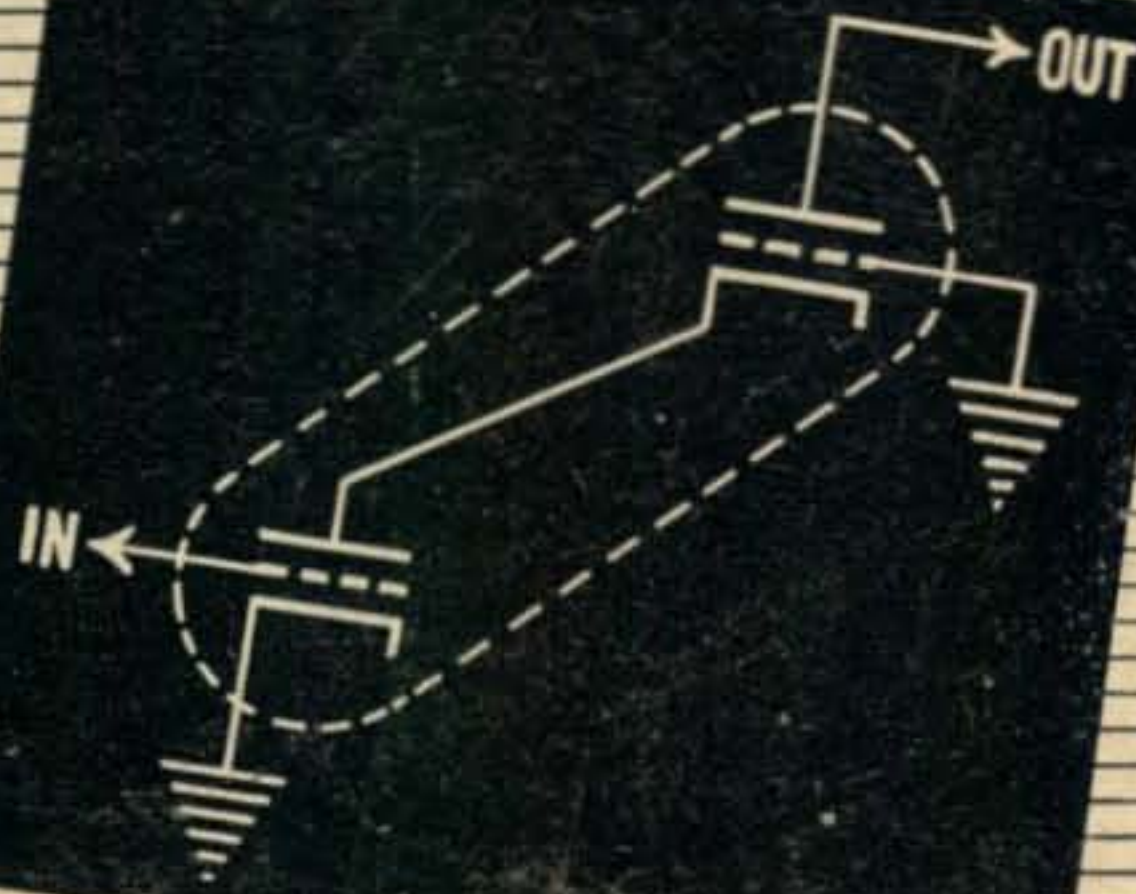

6BK7 HIGH-GM TWIN TRIODE

Typical operating conditions, each section



Plate supply voltage	150 v
Cathode bias resistor	56 ohms
Amplification factor	40
Plate resistance	4,700 ohms
Transconductance	8,500 micromhos
Plate current	18 ma
Noise factor, as a cascode amplifier at 216 mc	7 db

A **LOW-NOISE FRONT END** means clearer signal reception in emergencies—fewer delays from asking the other fellow to repeat, less misunderstanding. Leads between tubes in cascode circuits *were* noise-breeders. Now this problem disappears, for one twin triode does the job and does it well—G. E.'s new 6BK7.

SPECIALLY DESIGNED FOR CASCADE! You can apply the 6BK7 with assurance that this well-shielded tube will perform 100-percent. *Precision-built in quantities, so low-priced!* Right now the 6BK7 is serving as a tuner tube in modern TV sets. Production is high and costs are pro-rated over many thousand tubes to achieve real economy for you, the buyer.

GET THE BARGAIN PRICE of the new 6BK7 at your nearby G-E tube distributor, to learn how much you'll save by "going cascode" with one tube, developed especially for that field. Less front-end tube circuitry—improved reception—you can chalk these up as additional gains! *Electronics Division, General Electric Company, Schenectady 5, New York.*

JUST WHAT IS NOISE?

This question was answered for you in Sept.-Oct. Ham News. If you didn't obtain a copy, ask your G-E tube distributor for one, or write Lighthouse Larry at the G-E address given at left. Under "Receiver Noise Figures" you'll find clear, simple explanations of what causes noise, what are meant by the terms "noise figure" and "signal-to-noise ratio", etc. Here's a basic discussion of the whole noise problem that will improve your circuit designing. Read Ham News to *stay posted!*

ELECTRONIC TUBES OF ALL TYPES FOR THE RADIO AMATEUR

GENERAL



ELECTRIC

184-KA11



EVERY DAY
can be
Christmas
IF YOU USE
Bud Products

Be your own Santa Claus — treat yourself to the best! With Bud Products you can assure yourself of 366 days of finer results and extra pleasure next year. For over 23 years Bud has made the most outstanding line of Electronic Components and Sheet Metal Products. Today it is the most complete line in the field.

Illustrated below are two of the many Bud Products that will give you "top-flight" performance. See them at your Bud distributor.

**BUD—75 WATT COIL
with Polystyrene Base**

Polystyrene has proven superior to porcelain for many reasons, including far greater resistance to breaking or cracking—the Q of the coil is exceptionally high due to the low power factor—pins are molded in place and always remain perfectly aligned—sharp corners are eliminated. Coils are furnished with fixed or adjustable center links or fixed or adjustable end links. They can be used on bands from 6 meter to 160 meter or in circuits using Pentode tubes.

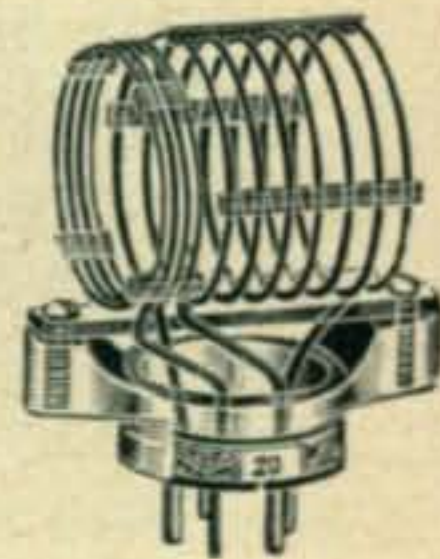

BUD "CE" MIDGET CONDENSERS

Designed to meet the most rigid requirements in design of efficient ultra-high frequency electronic devices and precision laboratory equipment. Brass rotor and stator plate stacks are assembled into permanent units by means of electro-soldering, which assures long life and accurate plate spacing. Sleeve and ball bearings assure smooth rotation. Fully insulated. Available in single or dual section in 25 sizes and capacities.

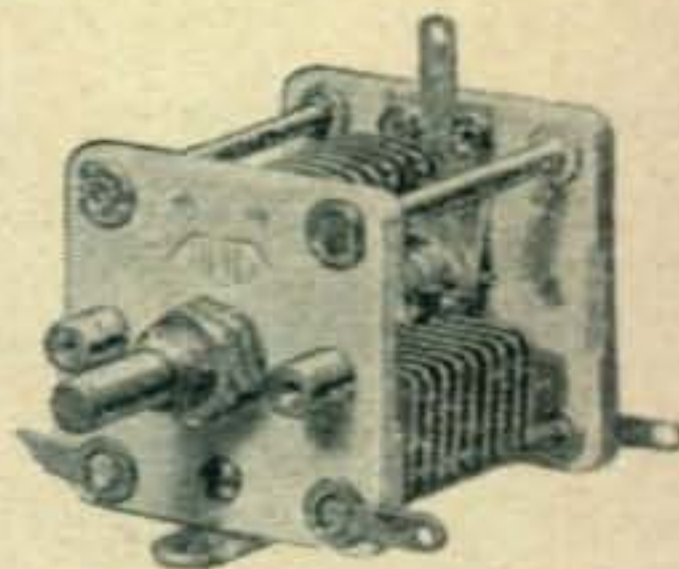

See the Complete Bud Line at Your Local Distributors.



BUD RADIO, Inc.

2120 East 55th Street



Cleveland 3, Ohio



EDITORIAL STAFF

MANAGING EDITOR
OLIVER P. FERRELL

TECHNICAL EDITOR
E. M. BROWN, W2PAU

DEPARTMENT EDITORS

Ralph Anderson, W3NL	Mobile
Herbert Becker, W6QD	DX
Wayne Green, W2NSD	Teletype
George Jacobs, W2PAJ	Propagation
V. E. McNatt, W9NFK	VHF-UHF
Louisa B. Sando, W5RZJ	YL

CONTRIBUTING EDITORS

G. F. MONTGOMERY, W3FQB
FRANK C. JONES, W6AJF
R. LEIGH NORTON, W6CEM

ILLUSTRATORS

Thomas Smith, W2MCJ
Don Hollister, W2WZF

BUSINESS STAFF

S. R. COWAN,	Publisher
S. L. CAHN,	Adv. Director
H. N. REIZES,	Adv. Mgr.
D. SALTMAN,	Prod. Mgr.
W. SCHNEIDER,	Edit. Prod.
H. WEISNER,	Circ. Mgr.

Branch Offices: Ted E. Schell, 112 West 14th Street, Los Angeles 15, Calif. H. Metzger, 230 S. Wells St., Chicago, Ill., WEbster 9-2666.

Foreign Subscription Representatives: Radio Society of Great Britain, New Uskin House, Little Russel St., London, W.C. 1, England. Technical Book & Magazine Co., 297 Swanston St., Melbourne Cl, Victoria, Australia.

OUR COVER

Major General Raymond C. Maude and Brigadier General Ivan L. Farman, Director, and Deputy Director of USAF Communications respectively, take a special interest in the MARS teletype operation.

Air Force MARS teletype circuits have been put in operation on 7635 kcs. Daily schedules are held between AIR/K4AF at the Pentagon, AF2AIR/K2AIR Mitchel Air Force Base, New York, and AF8AIR/K8AIR Wright-Patterson Air Force Base, Dayton, Ohio at 1000 to 1100 hours and 1600 to 1700 hours EST.

In addition to the above K4AF/AIR has operated AFSK teletype on 2 meters and is contemplating operating FSK on 6 meters.

Scratchi	4
The Private Life of CQ	6
Letters	8
Zero Bias	11
Six — The Easy Way <i>James M. Price, W5FXN</i>	13
The "Minipak" <i>Ron Pickett</i>	17
Radio Teletype <i>Wayne Green, W2NSD</i>	20
The 28-28 <i>J. Roy Smith, W6WYA</i>	23
The "Matchmaker" <i>William I. Orr, W6SAI</i>	27
V.H.F. — U.H.F.	32
Ionospheric Propagation Conditions	37
The Skywire and the Law <i>Maurice J. Hindin, W6EUV</i>	40
Page From A Designer's Notebook <i>John L. Reinartz, K6BJ</i>	43
The YL's Frequency	44
DX & Overseas News	46
Honor Roll	48
Mobile Corner	49
New FCC Proposals	52
Classified Ads	68
Annual Index to CQ, 1951	70
Advertising Index	72

CQ—(Title Reg. U. S. Pat. Office)—is published monthly by Cowan Publishing Corp. Executive and Editorial offices at 67 West 44th Street, New York 18, N. Y. Phone MUrray Hill 7-2080. Reentered as Second Class Matter February 6, 1951 at the Post Office, New York, N. Y. under the Act of Mar. 3, 1879. Subscription Rates: in U. S. A. & Possessions, Canada & Pan American Union—1 year \$3.00; 2 years \$5.00. Elsewhere \$4.00 per year. Single copies 35 cents. Printed in U. S. A. Entire contents copyright 1951 by Cowan Publishing Corp.



Designed for



Application



**The No. 90651
GRID DIP METER**

The No. 90651 MILLEN GRID DIP METER is compact and completely self contained. The AC power supply is of the "transformer" type. The drum dial has seven calibrated uniform length scales from 1.5 MC to 300 MC plus an arbitrary scale for use with the 4 additional inductors available to extend the range to 220 kc. Internal terminal strip permits battery operation for antenna measurement.

**JAMES MILLEN
MFG. CO., INC.**

MAIN OFFICE AND FACTORY
**MALDEN
MASSACHUSETTS**



Feenix, Ari

Deer Hon. Ed:

Scratchi are rescently having privilege of being law-abiding citizen for period of cupple hour but are having to give it up, not only on acc of my repatashon, but because it are too tough on me. Normally I are just like most people. If running threw red light and nobuddy from stron arm of law are looking, I not advertising in paper next day about it. If I trading cupple of old tool to some amchoor friend of mine, and he not bothering to see if filiment still continuous, I not lending him ohmmeter to finding out. Not that I saying, Hon. Ed., that honesty doesn't pay, because where would smart gentlefellow like George Washington have be if he not telling how he chop chop at cherry tree. No, Scratchi meening that the stuff not for me—after all, I don't want to be president.

How I ever getting talked into idear of being honest, uprite citizen I never knowing. Howsoever, Brother Itchi and gal-friend Lil Watanabe are deciding that I should be making really grand revolutions for the New Year, so they thinking and thinking, and finally coming to konklusio that most stewpendus thing I can doing is turning over new leaf. Next they making list of all things I shouldn't be doing, like: 1) never use wrong call when on the air (HA HA, they not knowin I not have any legal call); 2) stop printing QSL cards from reel DX countries; 3) stop using short around electric light meter; 4) redoocin power down to only three or four kilowhats, a bunch of more horribul idears.

At this juncture I reelizing that I better do something fast, so I telling them not to bother with list of things like that, and I will be good without any list to telling me where to go and when to stop. I telling them I be reel grand citizen..... starting after the first of the year. Lil and Itchi are agreeing, only saying that should be starting now to get into practise, and if I do starting now, they making up another list. Whoop what a mess! If I not doing this, Lil says I gotta go to work more dates, and Itchi says I gotta go to work at the ranch. So, I deciding to try it, on thee having nothing to lose.

I go into radio shack, start to go on the air
(Continued on page 6)



MERRY CHRISTMAS

B I L L P E T E R S E N , W O J R Y



PETERSEN RADIO COMPANY, Inc.

2800 WEST BROADWAY, COUNCIL BLUFFS, IOWA

Specify

AMPHENOL

for
Quality
in...

- ★ Low Loss RF Cables
- ★ Remote Control Cables
- ★ Antennas
- ★ Twin Lead Transmission Lines
- ★ AN Connectors
- ★ Submersion—Proof Connectors
- ★ Heavy Duty Power Plugs
- ★ Audio Connectors
- ★ 100 Contact Connectors
- ★ Quick Disconnect Connectors
- ★ Cable Connectors
- ★ Power Plugs
- ★ Rack & Panel Connectors
- ★ Miniature Connectors
- ★ Sealed Relay Plugs
- ★ RF Connectors
- ★ Heavy Duty Radio Connectors

AMPHENOL

AMERICAN PHENOLIC CORPORATION
1830 South 54th Avenue, Chicago 50, Ill.

- Send me the 48 page general CATALOG No. 74.
- Add my name to your mailing list for monthly information on currently new products and technical data . . . AMPHENOL ENGINEERING NEWS.

NAME _____

FIRM NAME _____

ADDRESS _____

CITY _____ STATE _____

the

O.P.FEI

Private Life

of **CQ**



The Radio Teletype Department

We were quite surprised at the enthusiasm the gang has whooped up over amateur radio teletype operation. To all means and purposes there are no more fellows actively engaged in teletype than there are working on single sideband. Thus, it was with little misgivings that we decided to start a bi-monthly department devoted entirely to this phase.

Handling this department will be Wayne Green, W2NSD/8, from Cleveland, Ohio. Wayne has been actively interested in teletype operation and has been publishing and distributing a monthly mimeographed newsletter. After seeing several issues it became immediately obvious that the time was ripe for CQ to seriously consider adding this new department.

Frankly, you really ought to take a crack at it or at least visit one of the fellows set up for teletype operation. It's really fascinating.

Cover Photographs

Just in case you missed the last item in the November copy of *the Private Life of CQ*, we have a standing offer of at least \$25.00 for cover photographs. We are particularly interested in "eye-catching" photos with a human as well as ham appeal. In submitting entries, or suggestions, be sure to send along a snapshot of how the final photo would appear if used on the cover. If we accept the idea, we will probably authorize a professional photographer to take the cover shot.

By the way, we also invite your comments on whether or not CQ is available from your local newsstand. If not, drop us a line and we'll be glad to remedy that situation pronto—if you want to remain a newsstand buyer.

Tsk-Tsk!

Sometimes you just can't win. After rushing the W3HH articles on "Performance of the Terminated Folded Dipole" into print we suddenly noted the footnote reference 1 had been mysteriously deleted. Apparently there is no one in particular that we can blame. Our sincere apologies to the author for neglecting to use his original reference to his article on the dipole in the June, 1949 issue of QST.

Calling Mr. Jay C. Alpern

This is to let you know that we still have a one year subscription of CQ outstanding in your name. Please let us know of your whereabouts if you read this—and anyone knowing this fellow's latest address please advise our Circulation Manager.

HARVEY says Merry Christmas

...and for that really "special" gift HARVEY recommends one of these NEW



VOLT-OHMYSTS

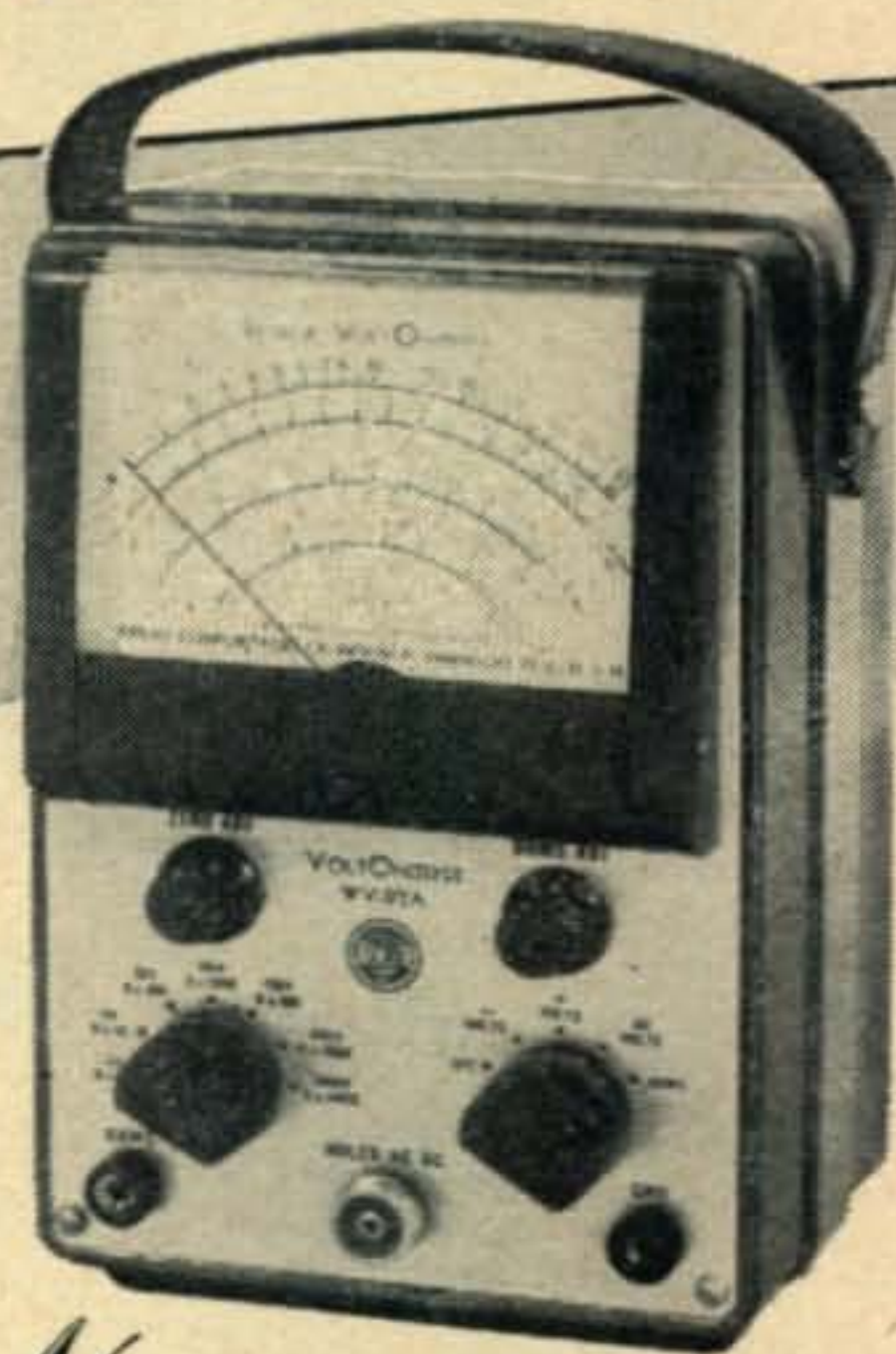

New WV-77A JUNIOR

An all-electronic ac-operated vacuum-tube volt-ohmmeter by RCA

Using the famous Volt-Ohmyst electronic bridge circuit, 200-microampere meter movement, and carbon-film multiplier resistors, the WV-77A incorporates features you would expect to find only in more expensive instruments. Sturdily built and calibrated against laboratory standards.

As a DC VOLTMETER

It measures dc from 0.05 volt to 1200 volts in five ranges. Uses 1-megohm resistor in isolating probe; probe has less than 2-uuf input capacitance. Has 11-megohm input; useful for measuring high-resistance circuits such as oscillator, discriminator, and avc.

As an AC Voltmeter

It measures ac from 0.1 volt to 1200 volts rms in five ranges. Uses high-impedance diode tube as signal rectifier. Frequency range is more than adequate for measurement of power line, audio, and ultrasonic frequencies.

As a wide-range Ohmmeter

The WV-77A measures resistance from 0.2 ohm to 1 billion ohms in five ranges. Required only 1.5-volt battery as burn-out protection in measuring such low-power elements as battery-type tube filaments.

The all-new RCA WV-77A Volt-Ohmyst comes completely equipped with probes and cables as illustrated.

LOW PRICED at Only **\$4750**

New WV-97A SENIOR

Reads Peak-to-Peak Voltages Directly!

The WV-97A has a range of usefulness extending beyond that of any other instrument in the field. Its quality, dependability, and accuracy make it a true laboratory instrument; it is exactly what is needed for television in the design laboratory, factory, and service shop.

TEN WAYS BETTER!

1. Directly measures complex waves from 0.2 volt to 2000 volts, peak-to-peak.
2. Has an over-all accuracy for dc measurements of $\pm 3\%$ of full scale.
3. Measures DC voltages from 0.02 volt to 1500 volts.
4. Measures rms values of sine-wave voltages from 0.1 volt to 1500 volts.
5. Has 7 non-skip ranges for both resistance and voltage.
6. All full-scale voltage points increase in a uniform "3-to-1" ratio.
7. Frequency response flat from 30 cps to approximately 3Mc.
8. Negative-feedback circuit provides better over-all stability.
9. Fully enclosed metal case shields sensitive electronic-bridge from rf fields.
10. More convenient to use because of smaller size and new slip-on probes.

Complete with direct probe and cable, dc probe, ohms lead, ground lead, and slip-on alligator clip.only

\$6750

Telephone **hrc** Luxembourg 2-1500

HARVEY
RADIO COMPANY, INC.

103 West 43rd St., New York 18, N. Y.

VISIT HARVEY'S AUDIO-TORIUM — Come in and visit our new Sound Department... all these items and many more on working display at all times.

NOTE: In view of the rapidly changing price situation in both complete units and components we wish to emphasize that all prices are subject to change without notice, and are Net, F.O.B., N.Y.C.



TYPE
BH6A
RANGE:
1.4 - 75.0 mc

Supplied per Mil type CR-18; CR-19; CR-23; CR-27; CR-28; CR-32; CR-33; CR-35; CR-36 when specified.

It's

Knowledge

A finished crystal unit, by Bliley, typifies the accumulated know-how of 21 years experience. This includes craftsmanship and engineering, methods and techniques, production and quality.

Such **knowledge** is gained only from actual experience. It's basic with Bliley, and, your assurance of complete satisfaction.



TYPE AR23W: RANGE:
0.080 - 0.19999 mc Supplied per Mil type CR-15; CR-16; CR-29; CR-30 when specified.



TYPE MC9: RANGE: 1.0-10.0 mc
Supplied per Mil type CR-5; CR-6; CR-8; CR-10 when specified.



TYPE SR5A
RANGE: 2.0-15.0 mc
Supplied per Mil type CR-1A when specified.



TYPE TCO-1 Temp-
erature Control
Oven.

Bliley
CRYSTALS

**BLILEY ELECTRIC COMPANY
UNION STATION BUILDING
ERIE, PENNSYLVANIA**

★ ★ *Letters* ★ ★

An Old Timer Says Why Not Tune

1205 N. Lafayette Blvd.
South Bend, Ind.

Editor, CQ:

I have been in Ham Radio since 1924 with the call letters W9AMI. During all these years I have seen many changes take place, but there is one thing that I have noticed that seems to have changed Ham Radio and that is spot frequency operation. Now I know it has its value when one is bothered with QRM, but in the good old days back in 1924 when I was on 80, as I am now, one could call CQ and get an answer from any place in the band and sometimes even phone hams would answer a c.w. CQ. The way it is now when you call and if no one is listening on your frequency you get no answer and sometimes wonder if you are getting out. Also your number of contacts are few and you know only those who are on your frequency or very close to it.

It seems to me all Hams who listen for a CQ or send one out would have more contacts if they would tune over the band they are operating on. In this manner we would be better acquainted with the band we are operating on and the amateur operator we would contact.

73,
Francis J. Bock, W9AMI

New Amateur Antenna Design Wanted

262 La Casa Ave
San Mateo, Calif

Editor, CQ:

I have come to the conclusion that the most sadly neglected and perhaps the most important phase of our art of amateur radio is "antennas".

Tubes, circuits, design have leaped ahead, and yet the simplest portion of our field is not much further advanced than it was twenty years ago—the antenna.

Listening over the air and comparing notes it would appear that quite a few of the thinking fellows have made many improvements over known antennas. Look what a furor the cubicle quad caused, yet it was still no more than the old time loop antenna.

My thought is this, is the time not ripe that "CQ" should get behind a contest to inspire NEW design in the amateur radio man's antenna? To further clarify, it is almost a certainty that some really new ideas will come forth from the effort, and perhaps the final results will show where a combination of these (we hope) ideas may be combined into one really new and efficient antenna.

There can really be more to this effort than just for the transmitting amateur, no doubt our Government could benefit as well.

73,
Amos Kanaga, W6BAA

Error Crept In

Albuquerque, New Mexico

Editor, CQ:

Regarding your October CQ. Very much interested in a statement under "Radio Control of Your Garage" (Continued on page 65)

LEO I. MEYERSON
WØGFO



JUST OFF THE PRESS WRL 1952 CATALOG



IT'S NEW! IT'S FREE!

Send For Your Copy

**LIBERAL TRADE-INS
LOW DOWN PAYMENTS
Personalized Service**

CU ON 10-20 & 75 METERS

**GOOD NEWS
for the NOVICE**



NEW NOVICE CW 7 KIT \$19.95

Here is a complete novice 80 meter AC-DC 7 watt transmitting kit — complete with tubes, power supply, tuning indicator, antenna, pi-network, key and crystal. Nothing left to buy — simply wire (complete instructions included) plug into AC socket and go on the air. Will operate on either 110 volts AC or DC.

**GUARANTEED CRYSTALS
IN HOLDERS Type FT-243**

160 METER \$1.50 ea.

1.8 to 1.825 1.875 to 1.9

1.9 to 1.925 1.925 to 2.0

80-40 METER \$1.25 ea.

3.5 to 4.0 7.0 to 7.4

Please state frequency. We will come as close as possible. No refunds or exchanges, please.

NEW LOG BOOK

For mobile or fixed station. Spiral binding — turns up — lies flat. Full column log listing all FCC required info. Log will accommodate 1,525 stations. Front and back covers show "Q" signals, phonetic alphabet, and amateur international prefixes. **25¢**



RADIO REFERENCE MAP



25¢

**HANDY
WALL
SIZE**

LEO GIVES BEST DEAL ON . . .

National RECEIVERS

ON HAND FOR IMMEDIATE DELIVERY!

HRO-50-1 RECEIVER

Additional I.F. Stage and 12 permeability tuned I.F. circuits result in the ultimate in selectivity!

Built-in power supply on separate chassis. Front panel oscillator compensation control. 20 to 1 precision gear drive. Provisions for NBFM adapter. Push-pull audio output. Speaker matching transformer built into receiver with 8 and 500/600 ohm output terminals.



\$383.50

(less speaker)

LOW DOWN PAYMENT

10" PM Speaker
matching cabinet

\$16.00

NC-183 RECEIVER

Sixteen tubes (including rectifier and voltage regulator) are employed in a modern high-gain super-heterodyne circuit. HF oscillator temperature-compensated on all bands; phonograph pick-up jack; accessory connector socket; illuminated signal strength meter with adjustable sensitivity; self-contained output transformer with 500 ohm and 8 ohm terminals; operates from 115 or 230 volts 50/60 cycles or, in emergency, from batteries or vibrator power supply; narrow band FM adaptor available. Frequency coverage: 540kc. to 31mc. and 48 to 56 mc.



\$279.00

(less speaker)

LOW DOWN PAYMENT

10" PM Speaker
matching cabinet

\$16.00

NATIONAL RECEIVERS

NC-125	\$149.50	Matching Speaker	\$11.00
SELECT-O-JET (#2 or #3)			\$28.75
SW-54			\$49.95

Write for detailed XMTR specification sheets.

WRITE - WIRE

PHONE 7795

**World
LABORATORIES
COUNCIL BLUFFS.**



**Radio
INCORPORATED
IOWA**

World Radio Laboratories, Inc.
744 West Broadway
Council Bluffs, Iowa

Please send me:

- New Log Book
- New Catalog
- Radio Map

- SW-54 Info C-12
- Select-O-Jet Info
- HRO-50-1 Info
- CW 7 Kit Info
- NC-183 Info
- NC-125 Info
- Used Equipment List

Name _____

Address _____

City _____ State _____

START RIGHT...



Whether you're going higher power, de-bugging TVI, or building your first rig . . . start right - with Eimac tetrodes. Low driving power, compatibility to modern circuit techniques, and long life will work to your advantage.

A wide selection of input powers is available from the four tube types specially suited to amateur transmitters:

Type	Plate Dissipation (Watts)	Typical Power		
		class C CW (Watts input)	class C Plate Mod. (Watts input)	class B Mod. (Watts output)
4-65A	65	345	270	270
4-125A	125	500	380	350
4-250A	250	1000*	675	1040
4-400A	400	1000*	825	1650

* Max. input in excess of 1 kw. Capable of conservative 1 kw. operation.

Write today for free complete data on these and other Eimac tubes. Also, remember Eimac offers a personalized engineering service to help amateurs get the most out of Eimac tubes.

Eimac
TUBES

EITEL-McCULLOUGH, INC.
San Bruno, California

Export Agents: Frazar & Hansen, 301 Clay St., San Francisco, California

ZERO BIAS

E D I T O R I A L

To all our readers
Merry Christmas
and
Happy New Year
from the staff

TO TALK ABOUT ANY particular bygone year as being one of outstanding importance in our hobby is to trifle with history, for amateur radio is almost too new as an art to permit an accurate, impartial appraisal of its past heritage. To predict what lies ahead in 1952, is fraught with even greater uncertainty—for just as 1952 portends momentous world events, so could it be the year of decision for amateur radio.

You may well ask why should 1952 be any different than previous years. We say there is no single contributing factor . . . but those of us who live very close to our hobby are able to discern a very definite building-up of events that *will be* of great importance. Let's look at some of them.

Television interference—despite efforts to overcome it, has seriously depleted the ranks of active radio amateurs. Initial enthusiasm for TV was so tremendous that it was often easier for the ham to go off the air and join the ranks of television fans, rather than try to overcome his difficulties. Now the novelty of TV is wearing off and the urge to get back on the air is increasing.

Add to this normal rekindling of interest, the accumulative effect of all our knowledge about TVI which has made it possible to overcome interference conditions that were considered "impossible" only a few years ago. As a result many more amateurs are going through the stage of cleaning up their stations. Then there are four extremely important developments in the television

field itself. These developments are the steps to the threshold which, once passed, will see the end of TVI as a major problem.

Television stations are increasing their power, giving them greater single strength coverage throughout their service area; and while it is true this increase in power merely extends their fringe area, it is equally true that the greatest concentration of population (and amateurs) lies close to the big cities. It is anticipated that the FCC freeze against new television station operation will soon be lifted. This means that many communities, now only in the fringe area for television, will have their own stations with high intensity local signals. Then too, there is the certainty that UHF television is really coming. With UHF channels far removed from amateur harmonics, there will be considerably less likelihood of interference. Finally, in the fierce competitive battle for consumer dollars, television set manufacturers have been forced to reverse the trend towards the degraded design of television receivers and are now embarking on programs of sound engineering principles, utilizing new and better techniques.

There are other heartening signs on the horizon. Sufficient time has passed to evaluate the effect of the new novice and technician licenses. It is good! There are already thousands of novices on the air and a large number of technicians have been licensed. The novice, in most cases, is a youngster bringing into the hobby a surge of new blood. There is a greater demand for the services of amateurs in Civil Defense, the Armed Forces, and industry. His value to the community and country is higher than perhaps any time in the past, except the terrible months following our entry into World War II.

As electronics continues to play an increasingly important part in our nation's economy, there will be more and more people active in the industry and some one of its many phases. It is up to we amateurs to make certain that our ranks increase at the same rate—or faster—as the industry itself expands. The tools are available in the new FCC licenses! Our most serious technical problems are rapidly being overcome. Enthusiasm, lying dormant in many amateurs is being awakened! Yes, if amateur radio keeps apace of the growth of the electronics field, 1952 may indeed go down in the yet to be written history, as *the* year of decision.

—O.P.F.

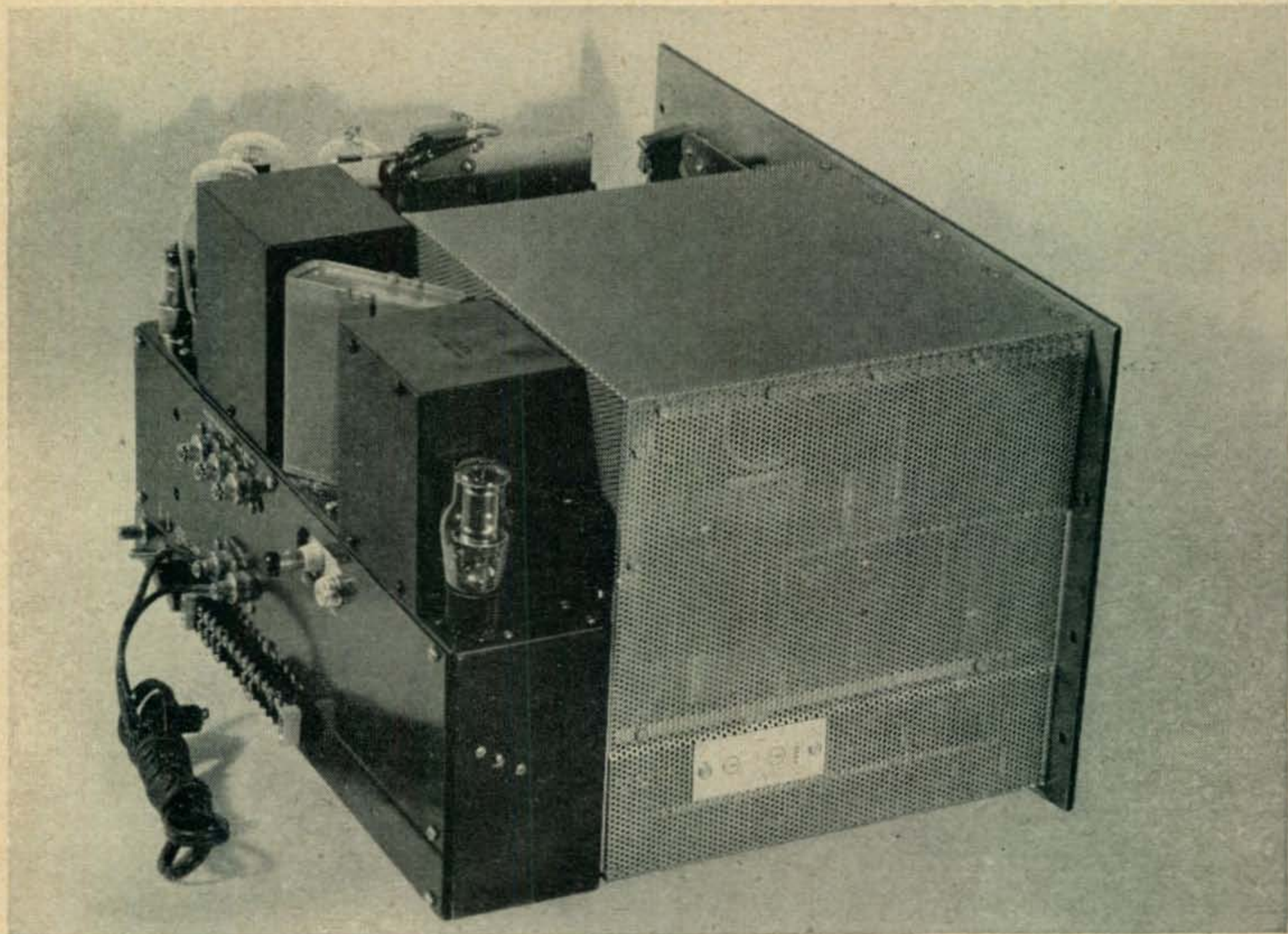

ROAD BLOCKS AGAINST TVI

This view of the Collins 32V-3 chassis will give you an idea of the shielding and filtering which have been added to reduce the possibility of television interference on all amateur bands.

The entire r-f section has been completely enclosed in an outer shield of perforated metal which permits adequate ventilation while blocking radiation of troublesome harmonics. This is in addition to the r-f shielding used in the 32V-2.

Low pass filters in the following outgoing leads are visible at the back of the chassis: both sides of the a-c power line and (above) the antenna relay line and both sides of the receiver disabling circuit. Additional low pass filters, not visible, are installed at the microphone connector and the key circuit, and one in each lead to each of the two meters.

See the September issue of this publication for a description of cabinet construction.

FOR THE BEST IN AMATEUR EQUIPMENT, IT'S . . .



COLLINS RADIO COMPANY, Cedar Rapids, Iowa

11 W. 42nd St., NEW YORK 18

1937 Irving Blvd., DALLAS 2

2700 W. Olive Ave., BURBANK

Six—The Easy Way

JAMES M. PRICE, W5FXN*

At the risk (?) of being called a rabid 50 mc man, we present our first transmitter designed solely for six meter operation. Naturally, with only modifications in LC circuitry this transmitter could be used on 10-11 meters. However, its primary purpose is really to show how quick one can set up for 50 mc operation with a fair amount of power—Editor.

THE WAY I FIGURE IT—this VHF game is strictly like standing around a dice table. You almost never shoot a natural on your first throw, but you can set a point and go after it—either the hard way or—the easy way. Frankly, I have been trying the hard way too long. It is not easy to find that 18th harmonic and those tetrodes that require extra neutralizing often have a habit of putting out signals in the derndest places. After two years of trying to work through weak 50 mc openings with anywhere from 10 to 85% modulation, I'll have to agree with the boys that have told me that you will need 200% modulation—or its equivalent.

Ever since Wilmer, W5VV, looked down his nose at my brand new DXCC and calmly informed me that my cherished QSO with ZD8B constituted only a minor thrill to that experienced in just one double-hop opening on six meters, I have been trying to find the easy way of producing a respectable amount of power on that band. Working towards that end, I set up the following "house rules": (1) Plenty of modulation, or something that sounded like plenty. (2) Provisions for c.w. or preferably m.c.w. (3) Provisions for working QRP without lots of unnecessary switching. (4) Simplicity in design, construction, and operation. (5) Compactness and space saving. (6) Money!

The Design

The r-f lineup was tackled first and I doubt that any Scotchman could have pared more parts from any rig quicker than I did. The natural choice for an exciter stage was a 5763 tube operating with a 25-mc third overtone crystal. The 5763 tube is designed for service up to 175 mc at full ratings. The 25-mc crystal does cost more than the FT-243 units that are available on the surplus market. However, the 25-mc rocks do not require special circuits, or a scad of multiplier stages, and besides you have a standard manufacturers guarantee of performance.

*804 Bouldin Ave., Austin, Texas

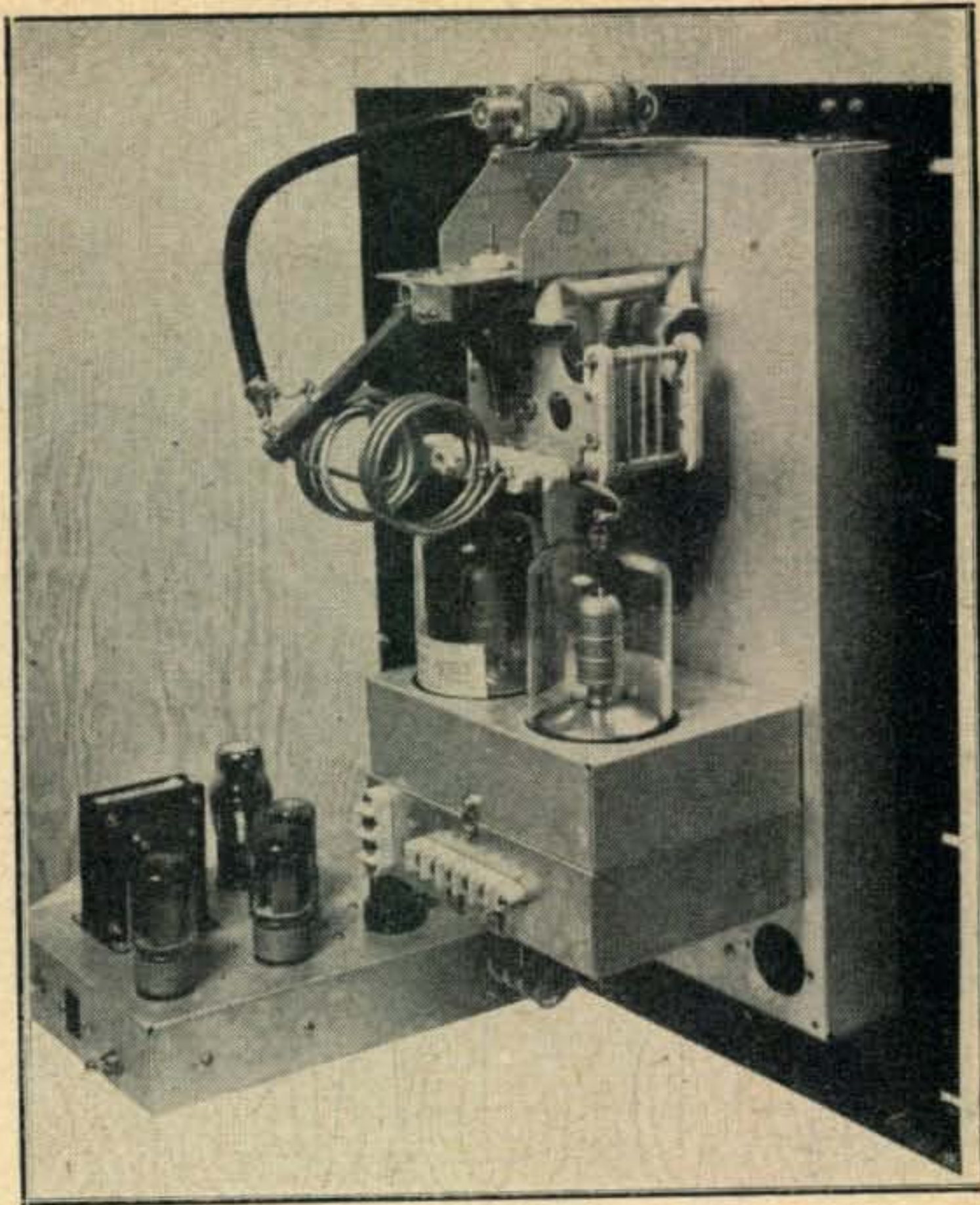

The resulting oscillator circuit, shown in *Fig. 1*, is recommended by most crystal manufacturers for use with harmonic type crystals. The crystal oscillates at 25 mc and doubling to 50 mc is accomplished in the plate circuit. Part values in the exciter stage are those generally available and can be varied considerably without encountering difficulties. Coupling to the final is accomplished with the aid of a short section of 150-ohm Twin Lead. In order to eliminate parasitics, I kept all leads as short as possible, and went overboard in shielding.

With 10-grid mils of drive available, the problem of tubes for the final amplifier raised its head. Fortunately tubes are available that require much less than this drive. Types 8001, 4E27A, and HK257B have all been used in this rig with no adjustments necessary, other than resonating the grid and plate tank. The final amplifier section is conventional, except for the bypassing of both base pins for both suppressor and screen grid. Midget disc ceramic capacitors are used for all bypassing except in the screen and plate circuits. Since all the indicated ceramic discs are .002 μ f, a standard package of 10 units will do the job very nicely. No protective bias is required, as the modulator places 75 volts of negative voltage on the screen when no modulation is present. If you plan to use voltages above 2500 on the plates, it is desirable to use a VR105 or VR150 in place of a VR75. It is unlikely that leakage current (idling current) would be high enough to warrant such action, unless excessive driving and excessive plate voltage were present.

No special precautions, other than adequate shielding, were taken on behalf of several hundred TV set owners. No TVI reports have been re-

Fig. 1. Circuit schematic of the complete six-meter transmitter.

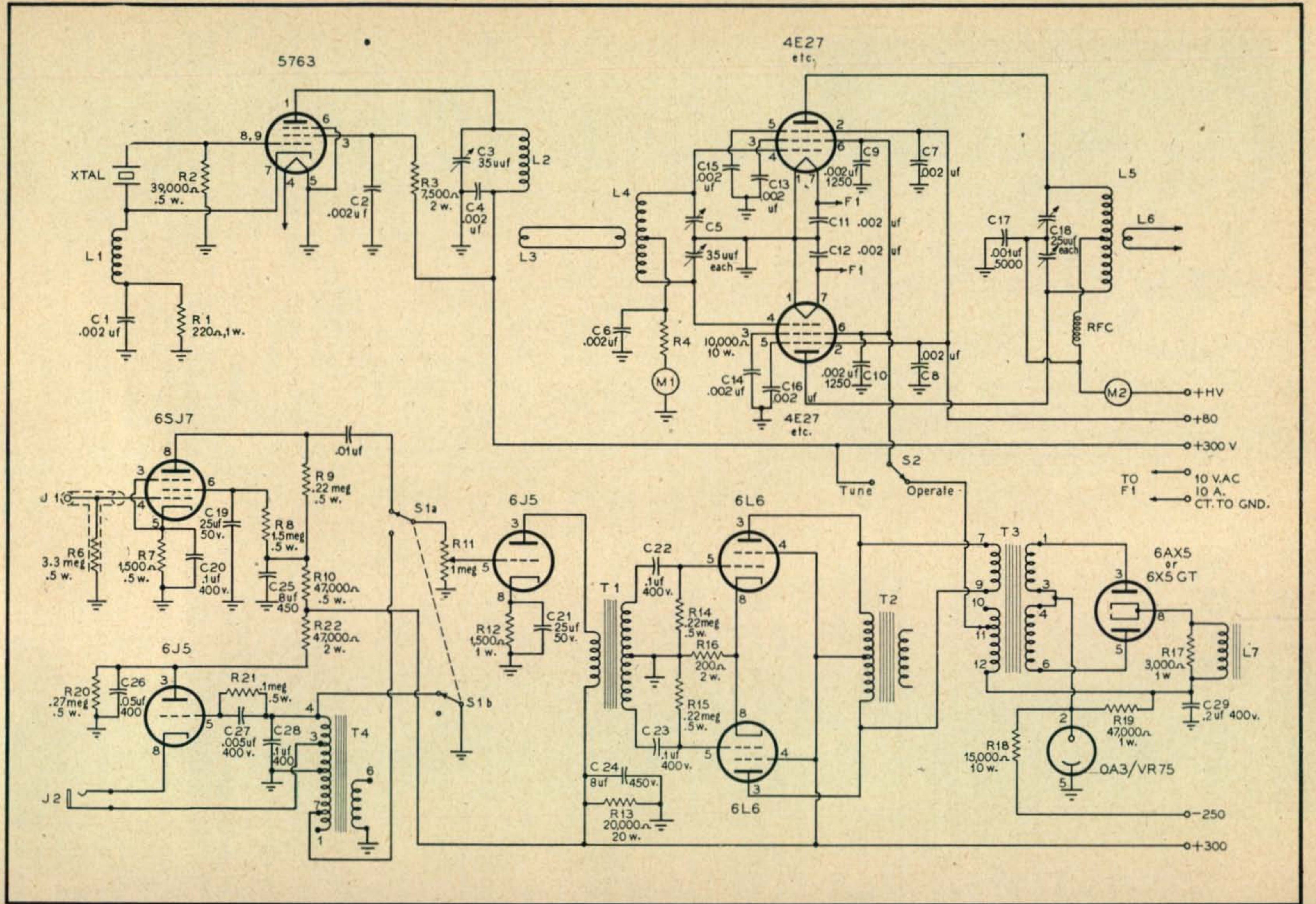

- | | | | |
|--|--|---|---|
| C1, C2, C4, C6, C7, C8, C11, C12, C15, C16—.002 midget disc ceramics | C27—.005 μ f, 400 v paper | RFC—36 T #24 A.W.G. on 1/4" form, or Z-50 choke | BO456A) has no tap 7. |
| C3—35 μ f, midget variable, air padder type | C29—.2 μ f, 400 v paper | J1—Amphenol shorting microphone jack | M1—0-25 d.c. ma |
| C5—35 μ f per section, midget variable | R1—220 ohms, 1 w | J2—Open circuit phone jack | M2—0-500 d.c. ma |
| C9, C10, C13, C14—.002 μ f, 1250 v (working) mica | R2—39,000 ohms, 1/2 w | T1—Single plate to p.p. grids, interstate transformer, 3:1 ratio | S1—DPDT rotary, phenolic or ceramic |
| C17—.001 μ f, 5000 working v, transmitting type, mica | R3—7,500 ohms, 2 w | T2—Merit A-2935 or similar (secondary not used) | S2—S P D T toggle switch |
| C18—25 μ f per section butterfly, B & W JCX25E | R4—10,000 ohms, 10 w | T3—Merit A-3104 modulation transformer, 15 w | L1—9 T #14 close wound, 1/2" diam. |
| C19, C21—25 μ f, 50 v electrolytic | R6—3.3 meg., 1/2 w | T4—Tone oscillator transformer, Type ES691026 or 6307. (See text). If 6307 used it will be necessary to use tap 1 or tap 6 as this unit {from | L2—9 T #14, space wound one turn, 1/2" diam. |
| C20, C22, C23, C28—.1 μ f, 400 v paper | R7—1,500 ohms, 1/2 w | | L3—2 T #22 plastic insulated hookup wire, wound over cold end of L2 |
| C24, C25—8 μ f, 450 v electrolytic | R8—1.5 meg., 1/2 w | | L4—National AR16-5C coil |
| C26—.05 μ f, 400 v paper | R9, R14, R15—.22 meg., 1/2 w | | L5—Millen 41005 or any 50 mc 500 w center tapped coil |
| | R10—47,000 ohms, 1/2 w | | L6—1 1/2 T #10 wound to same diameter as L5. |
| | R11—1 meg. volume control | | |
| | R12—1,500 ohms, 1 w | | |
| | R13—20,000 ohms, 20 w | | |
| | R16—200 ohms, 2 w | | |
| | R17—3,000 ohms, 1 w | | |
| | R18—15,000 ohms, 10 w | | |
| | R19—47,000 ohms, 1 w | | |
| | R20—.27 meg., 1/2 w | | |
| | R21—.1 meg., 1/2 w | | |
| | R22—47,000 ohms, 2 w | | |
| | Xtal—25 mc, third overtone, Bliley AX3 | | |

ceived during 60 days of operation, although Channel 2 is 140 miles away and Channels 4 and 5 are 75 miles away.

With the r-f circuit completed I ran head on into modulator headaches. After searching through dozens of texts, piles of magazines, and 15 years of accumulated notes, I decided to take a shot at George Lippert's, W8YHR, much publicized system of "constant modulation." This system has the advantage of offering high level modulation of the r-f carrier, regardless of audio level. The main difference, as compared with the conventional systems, is that the amount of carrier you produce depends upon the "weight" of audio. While this business of having your carrier swing up and down with modulation might be a handicap on the lower frequency bands, it is quite the reverse on the v.h.f. Constant modulation, due to the fact that

both carrier and modulation go from almost zero to peak power instantaneously, seems to punch through, when other types of modulation fail to produce anything in the form of a readable statement. One can get awfully tired of the conversations which go, "Sorry, OM, I can hear your carrier but cannot read your modulation."

One other decided advantage in this system is that since the modulation "turns" the carrier off and on, both carrier and modulation may be keyed with an audio note to provide m.c.w. without switching! In addition, using constant modulation permits using components at their c-w rating. This saved enough dough on the final tank condenser alone to pay for several of those brown 807s.

The speech amplifier is conventional and is identical to that found in almost any handbook. The audio oscillator for i-c-w work, was borrowed

◆

Looking under the high powered 50 mc constant-modulation transmitter. The modulator chassis is on the left. The grid coil of the 4E27s in push-pull is visible inside the chassis box on the right.

◆

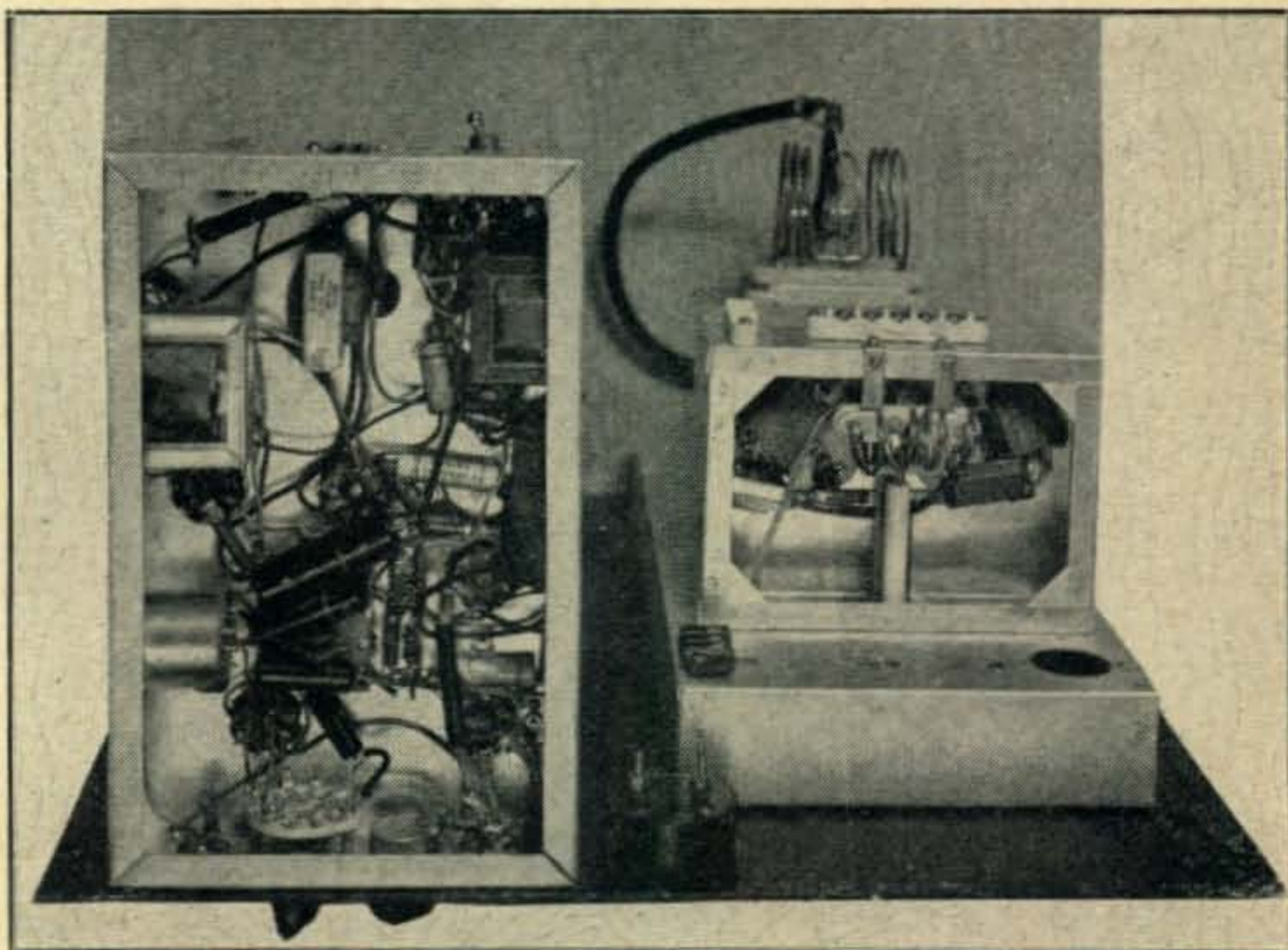

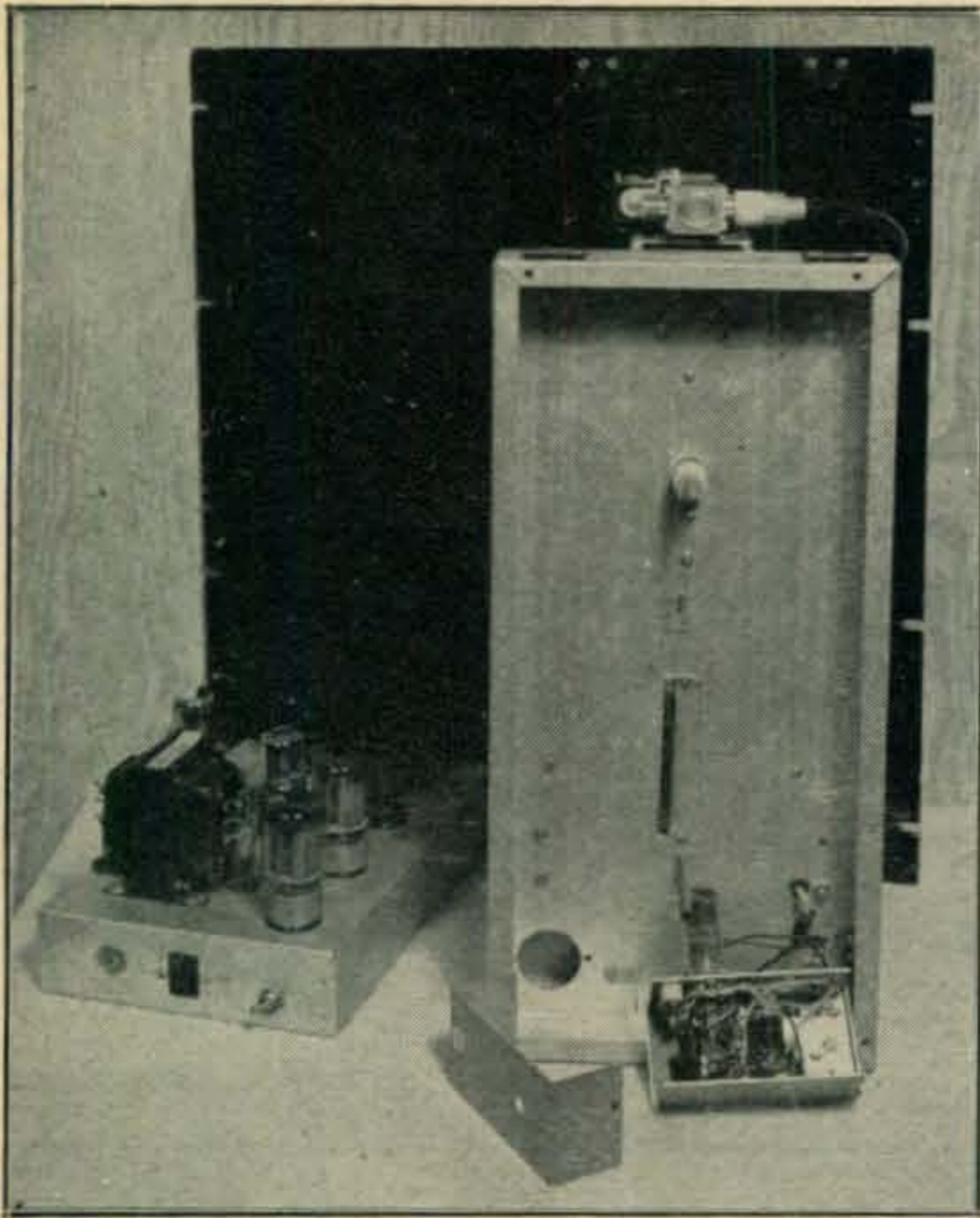

Underneath the final amplifier chassis is the small aluminum box containing the 25 mc crystal oscillator.

from Cecil Nelin's "Omnibox," as described in *CQ* for March 1950. The transformer, *T4* was obtained from a BC-456 modulator unit. Frankly, this is the only use we have ever been able to find for this particular transformer. With the components shown, a note of roughly 1000 cycles is obtained. Changing the capacity between tap 4 of the transformer and ground will change the audio frequency. In the photographs, you may note that Type 5881 tubes are shown rather than the 6L6s as specified in the circuit schematic. These tubes are identical except that they will take quite a bit of rougher handling than the common 6L6.

With this particular final amplifier I found it unnecessary to tune out any plate/filament capacity, nor did I find any tendency towards oscillation due to long screen grid leads. The transmitter modulates nicely with 5 or 6 ma of grid current. The usual precautions were of course taken concerning r-f feedback. A tune/operate switch (*S2*) is provided because it is almost impossible to resonate the final amplifier without some means of obtaining "normal" conditions. Acceptable results may also be obtained by closing the key and tuning while modulating with 1000 cycle tone. Needless to say, too much voltage on the screen grids during the tuning process will result in your having to scare up some new bottles.

Construction

The final amplifier was designed to mount vertically in order that a similar unit, for the 2-meter band could be placed beside it on a standard rack panel. The vertical chassis is a standard

17" x 8" x 2" unit fastened to the panel with two hinges. This permits access to the crystal oscillator/doubler. The final grid assembly and final tube sockets are mounted on 7" x 5" x 2" chassis bolted at right angles to the vertical chassis. An identical chassis is mounted on top of the horizontal unit in order to provide the shielding required by the 4E27s. Two and one-half inch diameter holes are just right with the glass envelopes of the 4E27 tubes. The top of the uppermost chassis should be in the same plane as the bottom of the skirt (internal shield) of the final tubes. Small pieces of phosphorus bronze are used to insure a good ground to the metal of the 4E27s. These are grounded to the chassis by the screws mounting the sockets.

In order to conserve space, and to insure adequate shielding, the oscillator was mounted in a small aluminum box inside the vertical chassis. Similar units are available from the Bud Radio Co., L. M. Bender Co., etc. All oscillator components were mounted directly to the tube socket terminals wherever possible, in order to eliminate bug chasing.

Tuning

The tuning procedure is no different than that used with any other type of transmitter. On the initial tune-up it may be necessary to place the grid meter in the oscillator plate circuit supply in order to insure a maximum output from that stage. After resonating the exciter, and the final grid circuits, place switch *S2* in the tune position and follow standard procedures. On putting the rig on the air for your first QSO you will probably have some difficulty in getting acclimated to the plate meter. It will drop to 40 or 50 ma when you pause in your speech. Incidentally, do not load the final to more than 360 ma as the plates will get white hot. Do not be alarmed when your grid drive kicks up a mil or so as you modulate. Feeding the final screen from tap 10 on the modulator transformer, *T3* will give somewhat more modulation, with a slight amount of distortion.

Operation

If ability to get through when the six meter band is very poor can be accepted as any indication, this transmitter certainly does the job. With so many variables and different band conditions ruling out comparisons with local stations, it is heartening to receive reports of—"the most consistent W5 during the entire opening." Phone CQs have often brought back replies that were barely readable on c.w. A call by W1DEI after a CQ on a dead band proved almost as exciting as being answered by VP7NQ, under the same band conditions.

None of the circuits are original with W5FXN, the credit for their efficiency certainly goes to their originators. This transmitter further proves that through the proper selection from the many excellent circuits available to the average amateur, even a newcomer to the VHF game can make six—the easy way.



The "Minipak" using three miniature tubes can be constructed on a chassis only slightly larger than the base of the transformer itself.

The "MINIPAK"

RON PICKETT*

If you have a piece of equipment subject to critical voltage fluctuations this regulated supply is the answer to your problems. It will give a much better controlled output than any of the usual VR tube systems, and best of all its output is completely adjustable. —Editor

THE ONE GADGET in this writer's shop that has proved most useful in circuitry experiments is the slightly less than glamorous, regulated power supply. True, each piece of home constructed gear usually ends up with the power supply problem solved by in-building or robbing from another piece of equipment, but during the early stages of a new project, a small, complete, and well filtered power source has proven to be invaluable.

One of the characteristics of regulated supplies which occupies a prominent place in the specifications for commercially built units is output impedance, or perhaps more accurately stated, effective output resistance. By definition, this characteristic is nothing more than another name for an old friend called "regulation". This has often required us to use such space and money wasters as swinging chokes, choke input filters, and noisy mercury-vapor rectifier tubes. Not that these devices are all bad, but if their use is unnecessary, a lot of space in a portable rig might be saved.

Let's examine this term 'output impedance'. Mathematically, it can be expressed as $Z_o = \Delta E / \Delta I$. This means simply that if we apply a load of, say, 100 milliamperes to a power supply and find that the output voltage drops from 350 without the load to 250 with it, the output impedance of the power supply is $100/.1$ or 1000 ohms. If a high gain speech amplifier were supplied from such a source, it is apparent that a good deal of additional filtering would be necessary to reduce the possibility of interstage coupling across this high resistance, which, of course, appears to be in series with the power supply and is common to all amplifier stages. Hence, a low output impedance is a desirable feature. The question then arises—how can this be achieved? For many years, most hams have been simply adding more filter. A two section filter produces better regulation (lower output impedance) than a single section. A swinging input choke or larger filter capacitors have much the same effect. But chokes and capacitors are expensive and take a lot of room, so let's see if we can find a better way.

*Ex-KH6AAD/6, Turf Club, Casa 6, Km. 16, Carretera Toluca, Mexico 10, D. F., Mexico

If by some means, preferably electronic, we could compensate for changes in output load current by corresponding changes in voltage, the output impedance could be made zero ohms, or for that matter, possibly negative; that is, the output voltage made to increase with an increase in load current.

This problem seems to be not too difficult. There are at least three fairly well known methods, each of which has its own particular advantages and shortcomings.

One way is to insert a variable resistance in series with the output leads, decreasing the resistance as the load current increases. It is thus possible to maintain a constant current through the load. If the load is also a resistance, the voltage applied to it will remain constant. A good example of this type of regulator is known as a ballast tube. Appropriately enough, this type is called a "current regulator".

Another method is to place a similar variable resistance in parallel with the load on the power supply. In this case, the resistance is decreased as the voltage across it increases, so that a constant voltage is maintained between its terminals. The load current from the supply remains essentially constant, since that part not used in the working load is "soaked up" in the variable resistor. This type, also appropriately, is called a voltage regulator, and is commonly seen in a glass envelope marked VR-75 or VR-150.

A third method, perhaps not so common, but none-the-less useful in many applications is the capacitance multiplier; in which an amplifier tube is used to greatly increase the effective capacitance of a filter.

To return to the current regulator solution of this problem, let's see if we can make an automatic variable resistance which will do an effective job. Vacuum tubes are known to have the property of a variable resistance (called plate resistance), which is controlled by the voltage applied between the grid and cathode, and which appears between the plate and cathode. If the grid to cathode voltage has a high negative value, no current will flow between cathode and plate, and the tube is said to be "cut-off". In other words, the plate

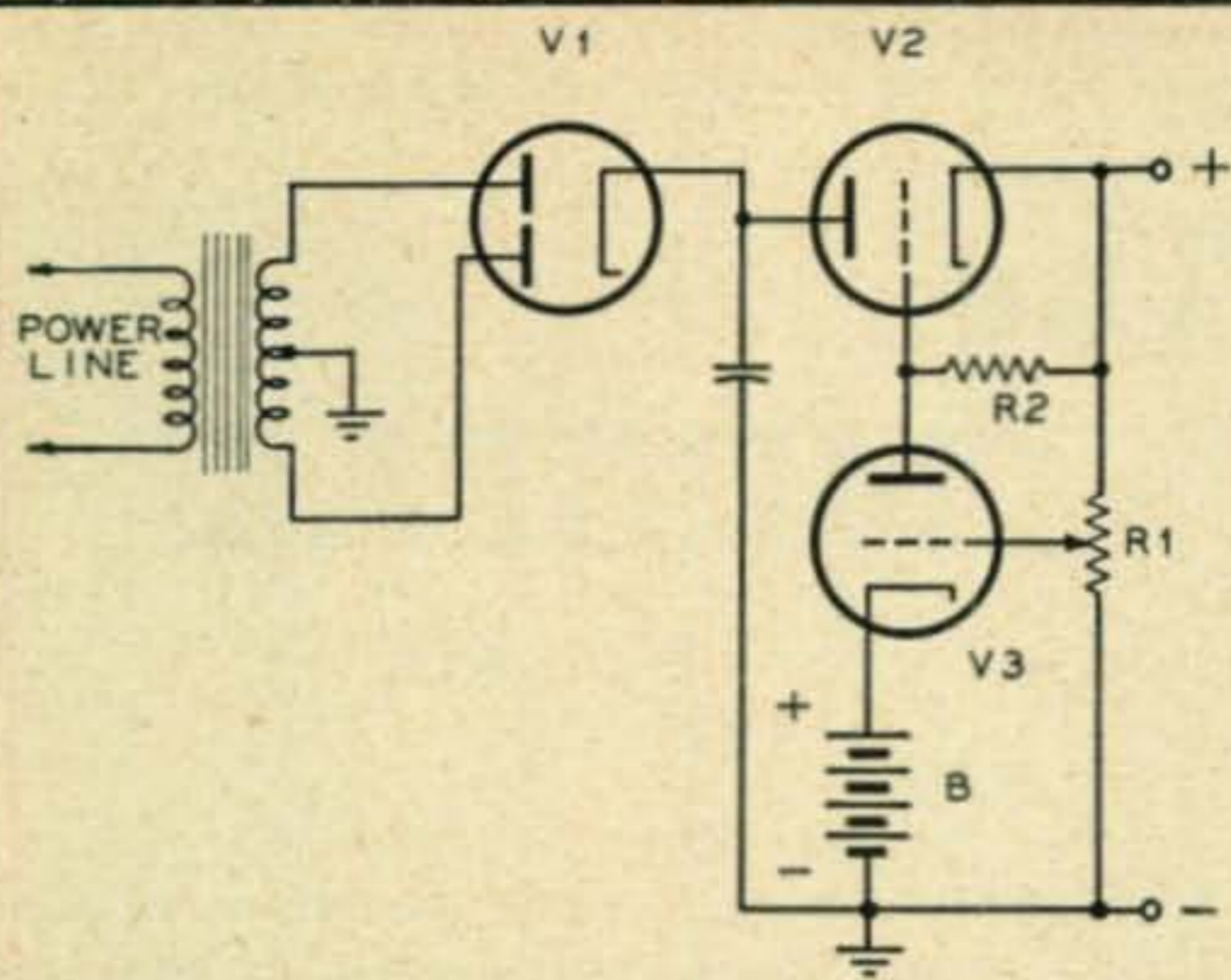

Fig. 1. Basic current regulator circuit schematic.

(to cathode) resistance is extremely high, approaching infinity in some cases. On the other hand, if the grid to cathode voltage is near zero, or positive, very high current will flow between cathode and plate, decreasing the plate resistance to a low figure.

It would appear that we can insert a vacuum tube in series with the power supply output leads, and by appropriately controlling its grid voltage, cause the plate resistance to change in the manner desired. A circuit for accomplishing this is shown in Fig. 1. Here $V2$, which might be a triode connected 6V6GT is the variable series resistor, while $V3$ is simply a d. c. amplifier between the output voltage sampling potentiometer $R1$ and the grid of $V2$. $V3$ can be a triode or a pentode, but as will be seen later, a high gain amplifier is usually desirable. Battery B is used to provide a bias voltage for amplifier $V3$, and $R2$ is the plate load resistor for $V3$, serving at the same time as the grid coupling resistance for $V2$.

Suppose the arm of potentiometer $R1$ is moved to the negative, or grounded end. In this position none of the output voltage, but all of the bias battery voltage is applied to the grid of $V3$. If the battery has enough voltage to cut off the plate current of $V3$, no voltage drop will appear across $R2$, and for practical purposes, we can say that the grid of $V2$ is tied directly to its cathode. Hence, the plate resistance of $V2$ is at its lowest and the output voltage is at its highest. Now as the arm of $R1$ is moved toward the positive end, some of the positive output voltage will cancel some of the negative bias battery voltage, so that $V3$ begins to draw plate current. Then a voltage appears across $R2$, which provides a biasing voltage for $V2$, since its grid is then more negative (less positive) than the cathode. Under these conditions the plate resistance of $V2$ is increased, and the output voltage is thereby decreased.

All well and good, except that with ordinary triodes at $V3$, the regulation is still not perfect—that is, the output impedance is not zero, and in addition, this circuit requires a battery which could get to be a nuisance.

To improve the regulation, we can either add more stages of amplification, or provide more gain in the one stage we have. The latter sounds easiest, although both methods are in use commercially. To provide more gain in one stage, we can either

use a very high μ triode or a pentode, and again both methods are in commercial use.

The battery problem can be overcome by using a part of the output voltage, since what we need is a voltage which is positive with respect to ground, and that is how we have arranged the output connections. To simply use a bleeder tap for this voltage is not satisfactory because the voltage at the tap is going to vary exactly in proportion to the total output voltage, and the bias voltage on $V3$ must be constant. So let's put in one of the devices mentioned earlier—one of the VR tubes, or even a neon lamp. If we use a neon lamp, however, it must not have a resistor in its base as many of them do, since the voltage across the external terminals will then not be constant, but will be a function of that resistance. We must have access to both terminals of the lamp itself. Neon lamps such as the NE-2, NE-16 and NE-48 are suitable. Sometimes the total current flowing through the VR tube is supplied by the cathode current of the amplifier, but if the amplifier is to approach cut-off, it is necessary to supply some of the VR tube current from a separate source to keep it ionized.

This brings us to the final circuit dimensions for the Minipak, Fig. 2. As before, $V2$ is the series tube, and since compactness is desirable, we used a miniature 6AQ5 which is equivalent to the 6V6GT. $V3$ is the pentode amplifier, and a 6BH6 is ideal here because of its low heater power requirements. $V4$ is the reference bias neon lamp, the NE-2 being both cheap and compact, is called for here. $R1$ sets the output voltage, but its range is limited by $R4$ and $R5$ so that we will not be tempted to try to get output voltages which are not well regulated.

$R7$ and $R8$ provide a voltage divider for the screen grid of $V3$, and at the same time samples the input voltage applied to $V2$, causing the $V3$ plate current and $V2$ bias voltage to vary in much the same manner as the control grid voltage applied to $V3$. This effectively provides additional gain in the d. c. amplifier. The screen voltage

The "Minipak" is wired for test bench experimental purposes. The output of the power supply appears along a terminal strip.

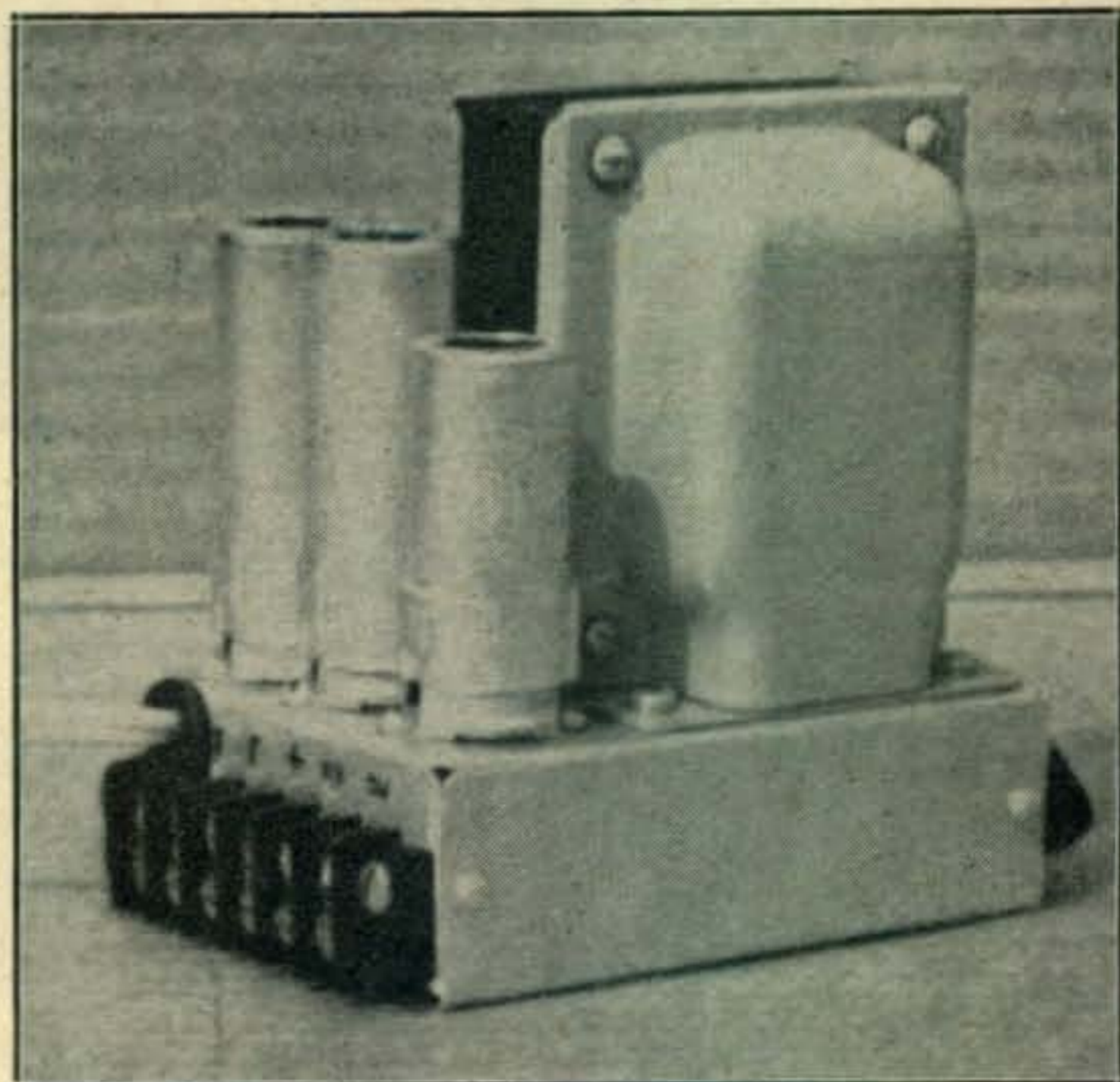

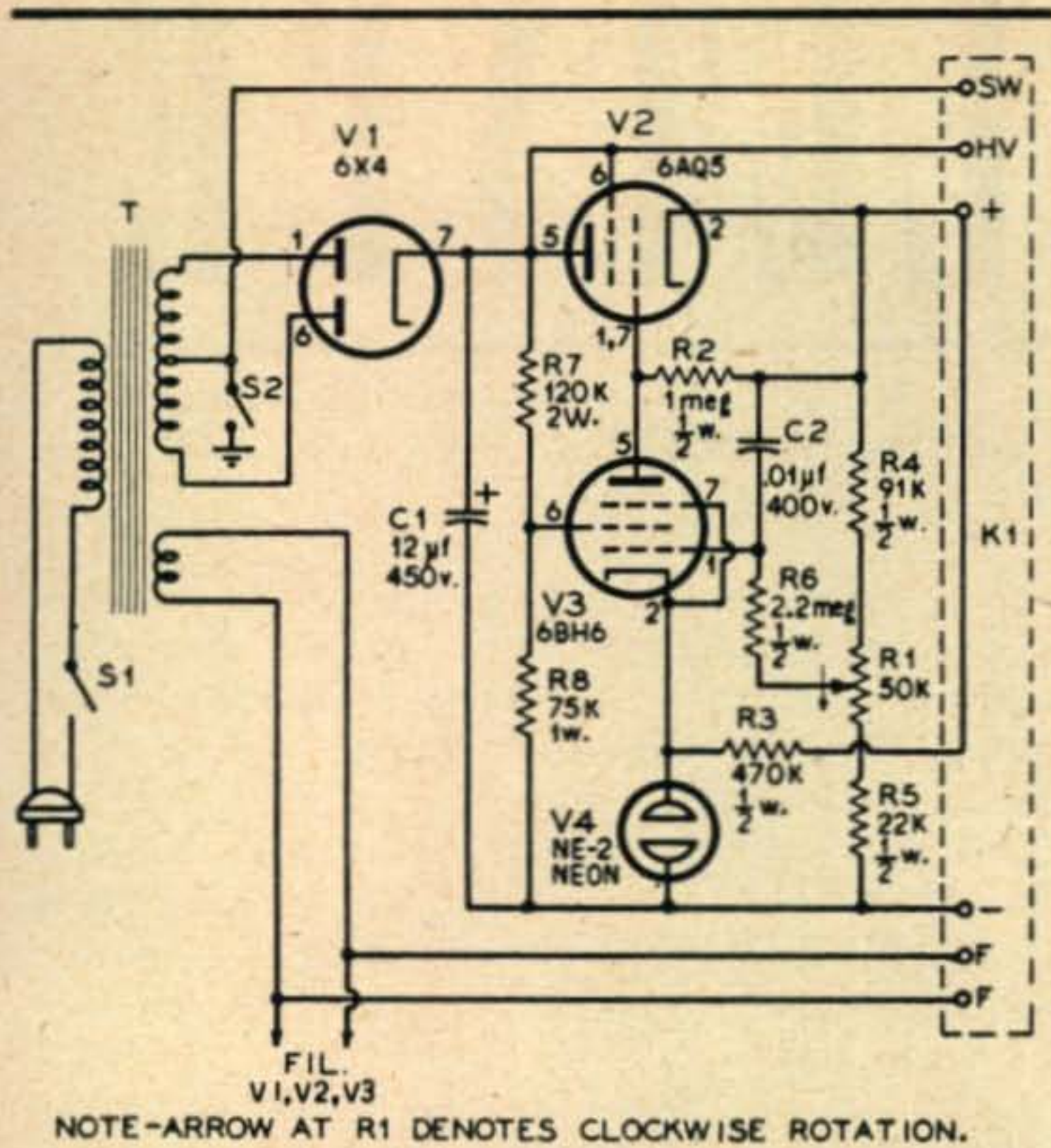

Fig. 2. Circuit schematic of the "Minipak" regulated voltage power supply.

- | | |
|---|---|
| C1—12 μ f, 450 v electrolytic, Cornell-Dubilier BR-1245 | R6—2.2 Meg., 1/2 w Ohmite |
| C2—.01 μ f, 400 v paper, Cornell - Dubilier GT451 | R7—120,000 ohms, 2 w Ohmite |
| K1—6 Terminal Barrier Strip, Howard B. Jones 6-140 | R8—75,000 ohms, 1 w Ohmite |
| R1—50,000 ohm Pot. linear taper Ohmite CU5031 | S1—s.p.s.t. bat handled toggle switch, Bud SW-1115 (Filament) |
| R2—1.0 Meg., 1/2 w Ohmite | S2—s.p.s.t. bat handled toggle switch, Bud SW-1115 (Plate) |
| R3—470,000 ohms, 1/2 w Ohmite | T—300-0-300 v, 40 ma: 6.3 v, 3 a, midget power transformer |
| R4—91,000 ohms, 1/2 w Ohmite | V1—6X4 |
| R5—22,000 ohms, 1/2 w Ohmite | V2—6AQ5 |
| | V3—6BH6 |
| | V4—NE-2 Neon Lamp |

applied to $V3$ is rather critical, and can readily cause the output impedance of the power supply to become negative if the screen voltage is made too high.

$R6$ and $C2$ are used to couple the ripple voltage which might be present on the positive output lead, into $V3$ in the correct phase to cause cancellation of the ripple, and thus greatly to improve the filtering action provided by $V2$.

Further modifications might have been made, but they were found to be unnecessary. With the components as specified for Fig. 2, the performance of the Minipak is all that can be desired. The curves in Fig. 3 show the output voltage variations at various settings for $R1$ and with various load currents. It should be noted that at the higher output voltages, the regulation is not effective over as wide a range of output current as at lower voltages. This is due to the minimum resistance obtain-

able in $V2$ being something more than zero. This effect could be compensated by using two or more tubes in parallel at $V2$, but then the transformer could be of larger capacity, and we would find ourselves designing a larger power supply.

The line forms on the right for the purists to inveigh this design. They will point out that a 6AQ5 is rated at only 90 volts between heater and cathode, and of course grounding one side of the filament line will put the full output voltage between heater and cathode of the 6AQ5. Nevertheless, two of these Minipaks have been in service more than a year with their original tubes—35 cent ones at that.

Another point our more conservative brothers will pick up is the advisability of loading the Minipak beyond the 40 milliamper rating of the transformer. The answer to this is one of degree and depends on the transformer. If a 60 or 70 milliamper load causes excessive heating of the transformer or the 6AQ5, then one should either reduce the load or allow cooling periods between load periods.

Construction of the Minipak is straightforward and uncomplicated. Since the chassis dimensions and layout will depend on the parts available for use, no constructional information is given here. As shown in the photographs, however, the entire assembly can be made only slightly larger than the transformer itself.

Testing the Minipak is quite simple. A voltmeter and a few ten watt resistors ranging from about 1500 to 10,000 ohms are all that is required. Curves similar to those of Fig. 3 can be plotted by applying various loads and noting the change in output voltage. The current in the load resistor is, of course, $I = E/R$. If the regulation is too far negative, indicated by a rise of several volts when the load is applied, reduce the value of $R8$. At the lower voltages some negative regulation is desirable to keep the curves more flat at the extremes of voltage and current range.

The ripple content can best be measured with a calibrated oscillograph. However, a rough check

(Continued on page 66)

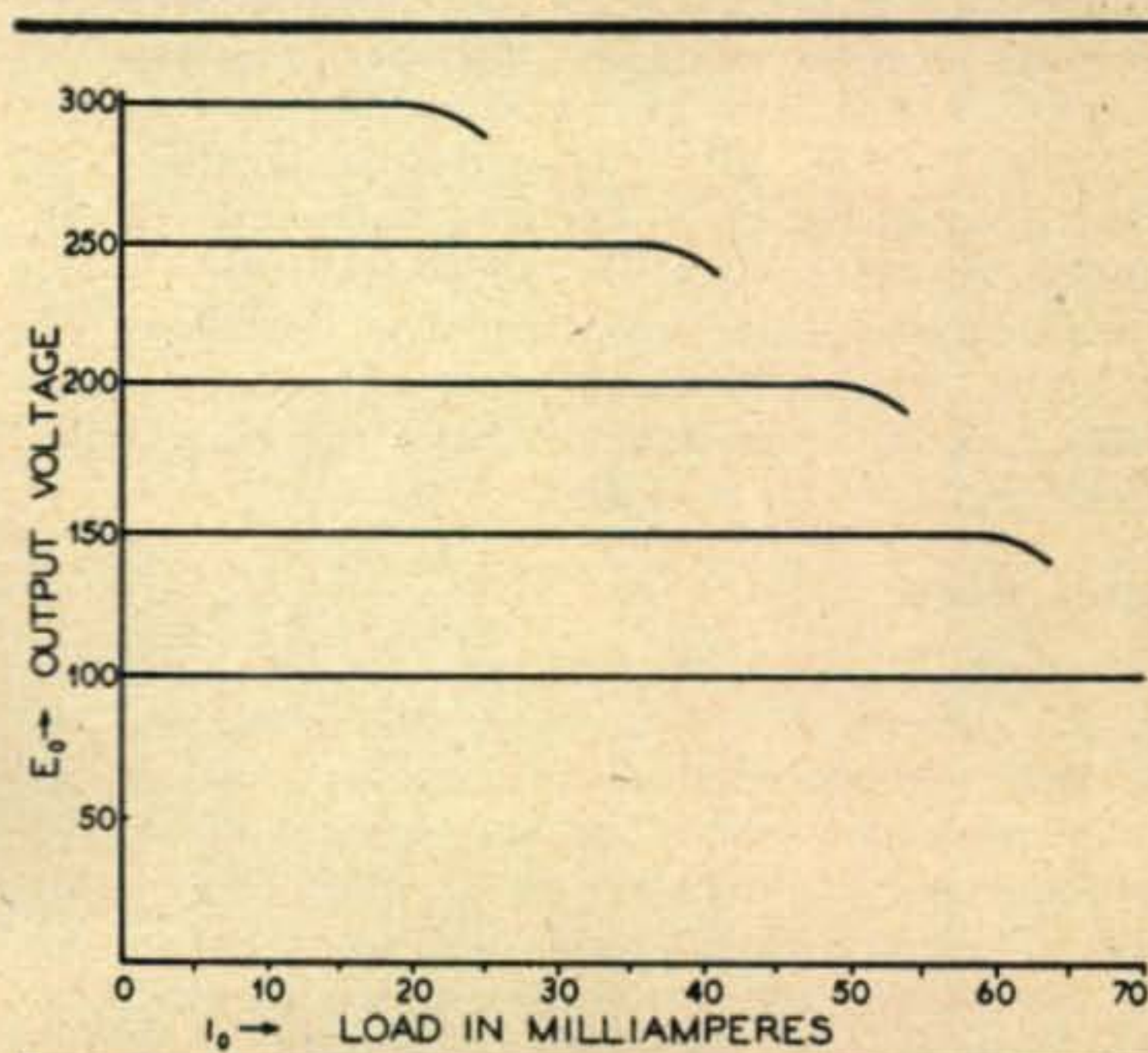

Fig. 3. Voltage output regulation curve under various conditions of load.

Radio TELETYPE

Conducted by WAYNE GREEN, W2NSD*

YES, TELETYPE, AMATEUR RADIO TELETYPE, is with us and is enjoying ever-increasing popularity. This is one of the newest facets of our diversified hobby and, apparently, one of the fastest growing.

During the last four years, amateur teletype was conceived, born and, in spite of formidable difficulties, developed into a healthy division of amateur endeavor. To get some idea of the difficulties that faced the pioneers, just put yourself in their shoes for a moment. Where can you get a teletype machine? How does one work? What kind of equipment is necessary to adapt it to radio? Can these signals be sent on the ham bands? Where can diagrams of the necessary equipment be obtained? Even if you get it working, who can you talk to? Now, how many of these questions can you answer? So far, little pertinent information has appeared in amateur publications to help you.

Under these circumstances it is strange that teletype managed to start at all. Fortunately there were a few men that knew some of the answers and had the interest to find out the rest of them. These few got together, ran tests, experimented, interested friends, and slowly built up the interest that we see at present in the country. The most outstanding of these was John Williams, W2BFD, who developed many of the circuits and standards now in universal use.

There are at present over four hundred teletype machines in the hands of amateurs and experimenters. About half of these are actually being operated on the air, while the remainder are either completing the associated equipment or, if unlicensed, waiting for the necessary ham ticket. These machines are not expensive. Amateurs of all types, from millionaires to schoolboys, own them. Like all other ham activities there are only a few engineers to be found.

Bands Used

Most of the active stations are (for the present) on two meters. The frequency, 147.96 mc, is the standard teletype channel throughout the country. Many two-meter operators have frequently heard the teletype "Jingle Bells" on the high end of the band. They are particularly difficult to avoid on the east coast where stations from Virginia to New York run up to 800 watts nightly.¹

Since many of the teletype gang have the best of two-meter equipment, it is natural that there would be frequent DX contacts. W3PYW (Silver Spring) reports "fair-to-middling" signals from W8WJC (280 miles) on a series of tests. W3PKF copies W2JAV (145 miles) consistently. W2QGH and W2AUS (Larchmont, N.Y.) have both worked W4JCV (240 miles) using low power. W2PAU worked W1WB recently (300 miles)—and so it goes.

Eleven meters achieved some small degree of popularity in the dim dark past when it was usable. Since its demise for DX, it is occasionally used for short distance work. During its heyday the band supported considerable DX work and consistent cross country QSO's. W2QGH worked Japan and several west coast stations. W6ITH worked Japan, Hawaii, and stations from Iowa to New York.

Operation on the lower frequencies has been mostly experimental in nature. W6NRM, W6DOU, W6ITH, WØBP, W7LUK, W2AUS, W2NSD, W3ODF, and others have run many tests to determine the most effective types of keying to use, and the distances that might be covered.

The F.C.C. is expected to permit teletype operation on the high end of forty meters in the near future. When this permission comes through it is expected that almost every teletype station in the country will have some sort of equipment set up to operate on this band.

Types of Keying

At present there are three different methods of sending teletype signals by radio. They are: (1) frequency shift keying (FSK); (2) make-break keying (MBK); (3) audio frequency shift keying (AFSK). AFSK is sometimes called "subcarrier frequency shift keying" or "tone shift keying". In F.C.C. parlance, FSK is type F1 emission, MBK type A1 emission, and AFSK is type F2 emission.

Frequency shift keying is obtained by sending an uninterrupted c.w. signal and then making it shift frequency by 850 cycles when the transmitter is keyed, rather than having the transmitter go "on" and "off" as in normal c.w. operation. This shift in frequency is easily accomplished by any of the standard methods for FM modulation. The major difficulty with FSK is in reducing receiver and transmitter drift to suitable limits. FSK is

*Send all contributions to Wayne Green, c/o WXEL, Cleveland, Ohio

¹"CQ," September, 1951, p. 32.

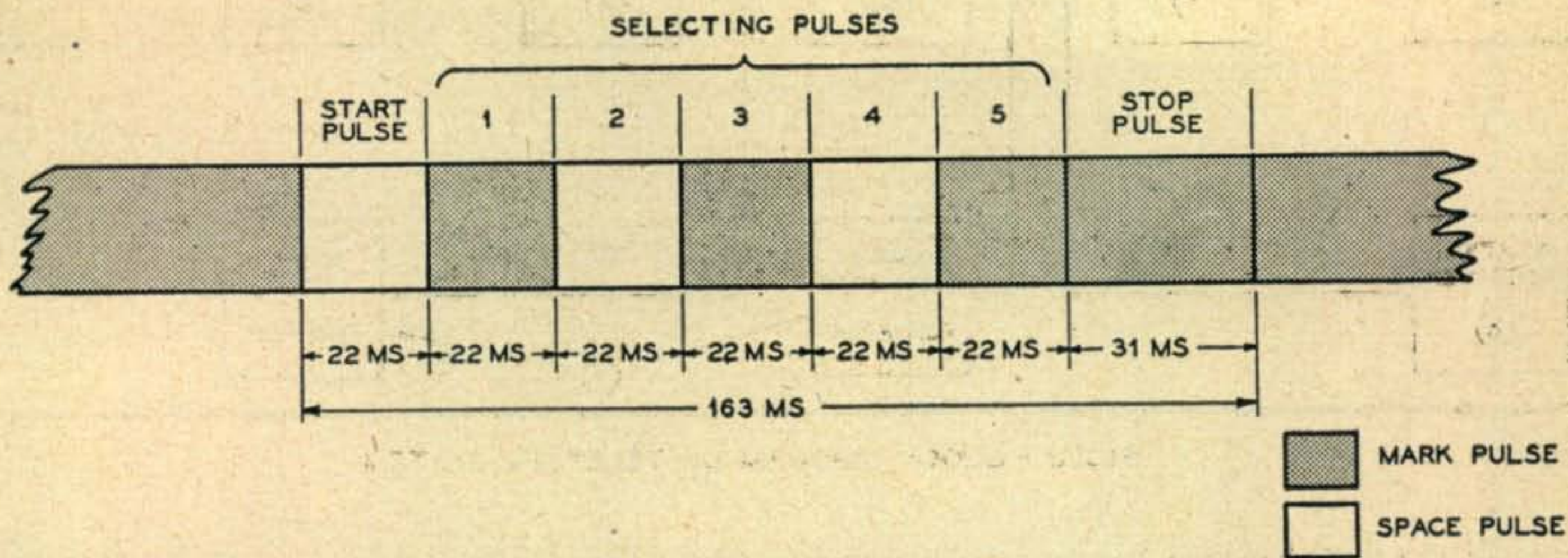

FIG. 1. - TELETYPE CODE FOR LETTER "Y"

permitted at present on eleven meters, the high end of ten meters, and from there on down. The expected teletype authorization from the F.C.C. will be for FSK in the 7250-7300 kc part of the forty meter band.

Make-break keying, like c.w. consists of keying the transmitter "on" and "off". The difference being that the transmitted code is the teletype code rather than the Morse code. This system is permitted on any amateur band. In all of the tests of this type of keying it has been found to be far inferior to FSK. Fading, static, or interference from other stations caused serious loss of intelligence in the received signals. The entire Pacific Division of the United Press has replaced their c.w. circuits with FSK radio teletype. They now get 100% 24 hour-a-day results on circuits that before could not carry 5 w.p.m. Morse.

The third, and at present most used system, is audio frequency shift keying. AFSK is one of the easiest systems to use since it requires only fair stability of the transmitter and receiver. Part of the standard teletype equipment is an audio oscillator that is shifted in frequency by the teletype keying. This oscillator can easily be fed not only to the printer circuits, but to the transmitter modulator (Fig. 2). Thus we have the transmitted carrier modulated by a varying audio tone. All of the two meter teletype stations use this type of keying.

The Teletype Code

Teletype uses what is called a "seven unit" code. Each letter or character that is sent is changed into a code consisting of seven parts. In c.w. we use the "on" pulses to carry information. In teletype both the "on" pulses and the "off" pulses are used to carry information. These "on" pulses are called "mark" and the "off" are called "space".

In Figure 1 is a representation of the seven unit code. The first unit is the "start" pulse, which is always a spacing pulse. Following that are five

more pulses of mark or space which cause the teletype printer to select a letter or character. The choice of mark or space for five units gives us 25 possible combinations. This is 32 possibilities. There are 32 keys on the teletype keyboard, each key selecting one of these 32 possible groups of mark and space pulses. After these five selecting pulses comes the stop pulse. This seventh pulse is always a marking pulse. This pulse indicates the end of a character and is used to actuate a magnet in the printer which causes the printing of the letter selected by the previous five pulses.

In Figure 1, the shaded parts of the signal indicates a marking condition, the unshaded indicates a spacing condition. Thus you can see that there is no pause between the marking and spacing pulses. There is no other condition except mark or space. There is no "off" and no "on", only mark and space. The start pulse and the five selecting pulses are 22 milliseconds long. The stop pulse is 31 milliseconds long. Thus the length of the entire character is 163 milliseconds. This means that we can send a maximum of 368 characters per minute, which is about 65 words per minute. The letter "Y" used in the illustration has the code 1-3-5, i.e., mark pulses are sent for the first, third, and fifth selecting pulses while spacing pulses are sent for the second and fourth selecting pulses. The letter "R" is the reverse with marking pulses #2 and #4, and so on for the other letters and characters.

The 32 keys on the keyboard consist of the 26

Continuing our expanding coverage of the many new facets of the hobby, CQ introduces a new bi-monthly department. Interest in radio teletype work is increasing daily with the Armed Services through the MARS urging amateur participation. If you are experimentally minded there is little doubt that this will catch your eye. Don't say we didn't tell you. —Editor

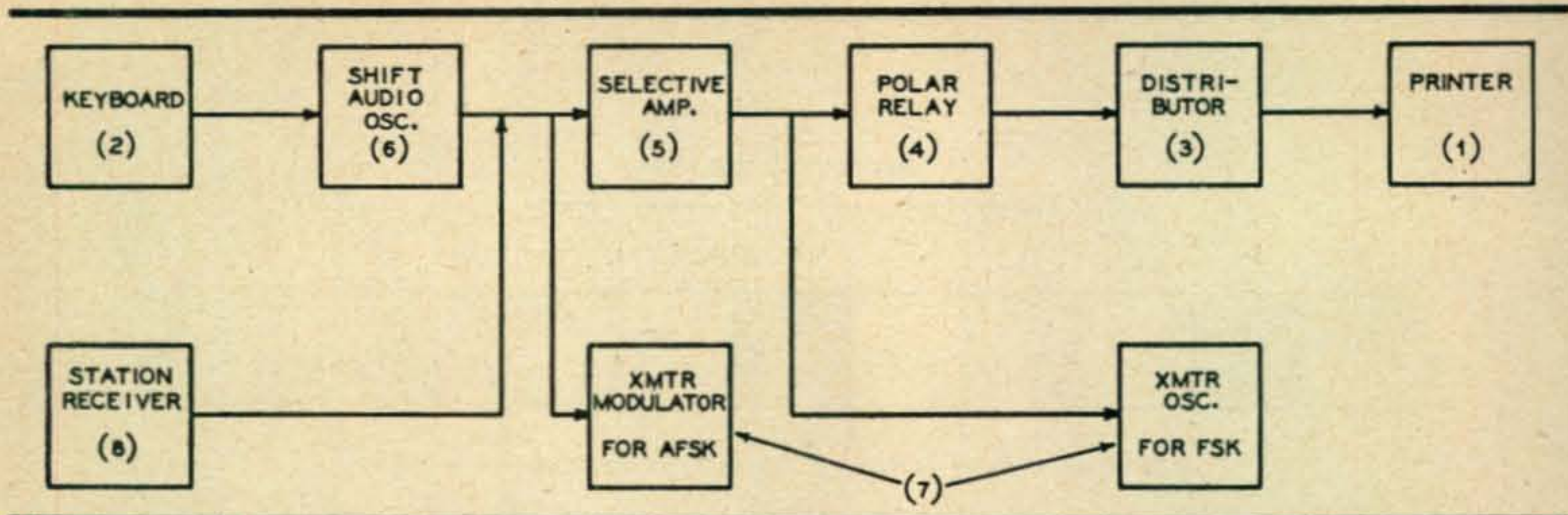

FIG. 2 - BLOCK DIAGRAM OF TELETYPE SYSTEM

letters of the alphabet, one key for space, one for line feed, one for carriage return, one for the bell, one for upper case, and one to bring the carriage back to lower case. Since all letters are capital the upper case has only numbers, symbols, and punctuation.

When FSK is used the space signal is usually the higher frequency, while the mark signal is 850 cycles lower than the mark. In AFSK the standards, both amateur and commercial, are for the space signal to be 2975 cycles and the mark signal to be 2125 cycles. Thus again there is a 850 cycle difference.

Parts Necessary for Radio Teletype

- 1) Teletype printer
- 2) Teletype keyboard
- 3) Receiving distributor
- 4) Polar relay
- 5) Selective audio amplifier
- 6) Frequency shift audio oscillator
- 7) Radio transmitter
- 8) Radio receiver

Items 1, 2, 3, and 4 are part of the teletype machine. They are listed individually because they perform separate functions. Items 5 and 6 are normally constructed by the amateur,² although they can be purchased completely constructed.³ Items 7 and 8 should be on hand.

The teletype machine is, of course, the most difficult part of the apparatus to obtain. If you, like most of the rest of us, don't have one in the cellar, there are several courses of action that might end up in your owning one. You can visit the local junk yards until you spot where they have been junked and, professing little interest in them, probably haggle one for a little over the scrap metal price. You can advertise for one. You can write W2BFD or W6LS and see if they can help you. They probably can. The cost should be in the neighborhood of \$55 for the machine, complete with polar relay and table.

The construction of items 5 and 6 has been greatly simplified by the recent work of W2BFD. John has worked out a circuit that makes feasible

² Costs about \$40 to \$50.

³ Costs about \$150.

every possible type of operation of the teletype now considered desirable. The diagram of this circuit, complete with full scale drilling template and full instructions for building and adjusting the teletype "panel", are available at cost from John. This circuit has full automatic start and stop for operation of the equipment when the operator is not present. In this way a message can be left for you whether or not you were present at the time it was sent. When you return there is the message, waiting for you. This panel is designed to mount (on a standard 19 inch rack panel) under the teletype table that comes with the Model 12 teletype machine.

The automatic start system is normally operated when the operator is not present by a small clock (built into the panel) which turns on the receiver and the panel. The receiver is fixed tuned to the teletype channel. Most stations set their clocks to operate every hour on the hour. If, after one minute, no standard starting signal has been received, the one minute timing circuit turns the receiver and panel off again. The standard starting signal for unattended printers is one full minute of marking signal (2125 cycles). When this signal is received it operates a relay on the panel which turns on the teletype printer and then waits for the message to follow. The machine will then sit there and copy the messages as they come in until the standard stop signal is received, or until there has been no received signals for a one minute period. This is in case the received signal is interrupted for any reason. If this happens, the one minute timing circuit shuts down the whole works until the clock turns the equipment back on for the next "listen" period. The standard "stop" circuit operates when two seconds of space signal are received. This turns the printer off, but allows the receiver to "listen" for one minute before turning off. As long as "marking" signals are coming into the receiver the panel will not turn off.

When the operator is present he generally leaves the panel and receiver turned on. In this condition it takes but two seconds of "marking" signal to start the printer. Thus when two stations are in QSO,

(Continued on page 66)

The 28-28

J. ROY SMITH, W6WYA*

The transmitter is shown in comparison with the lady photographer's hand. The modulation transformer is alongside the two 6AQ5 modulator tubes. The pi coupler capacitor C10 is in the center with the r-f driver at the extreme right.

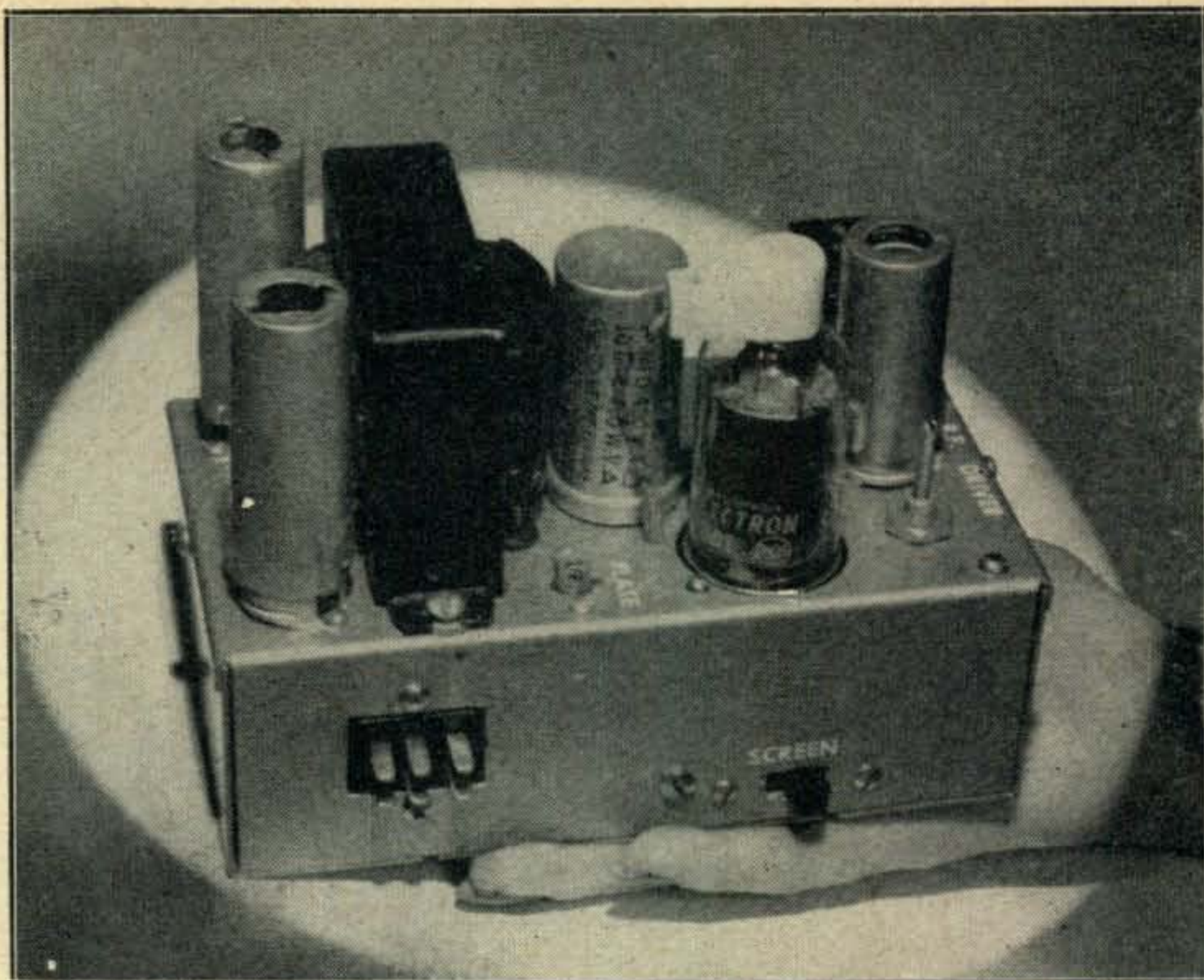

Mobile transmitters should not only be known for their efficiency, but for their flexibility as well. The design of this little, yet potent, 28 watts on 28 megacycles lends itself for use in home station, emergency, mobile, or field day. It has been a long time since we saw four tubes used to such advantage. —Editor

HAVE YOU BEEN LOOKING for a mobile transmitter that is small, compact, and draws but a minimum of precious plate and battery current? Well, OM, here you are! This rig, complete with tubes, transformers, and send-receive relay, weighs 3½ pounds . . . avoirdupois! Measuring 3½" x 6¼" x 4½", it is small enough to be placed in a Studebaker glove compartment or beneath the dash of a Nash ('50, that is).

The 28-28 uses 3 miniature tubes plus a miniature beam pentode in a simple, yet quite complete circuit. It may be loaded up to 28 watts input to the final stage and still have full high level plate modulation. The r-f driver stage is crystal controlled and there is no doubling in the class C modulated stage. The transmitter operates on a.c. or d.c. which enables it to be moved about and used in any amateur service, be it home station, portable, emergency rig, field-day operations, or as a mobile unit in any vehicle.

The power requirements are 6 volts at 2.15 amperes a.c. or d.c., and any plate voltage of 300 volts to 500 volts.

Design Considerations

Indirectly heated cathode tubes are used because they (1) are inexpensive, (2) operate equally well on a.c. or d.c., and (3) permit instantaneous break-in operation. The so-called instant-heating filament tubes do take appreciable warm-up time (sufficient to miss the first 3 letters of a call), are compara-

tively expensive and would complicate a.c. operation. During an average QSO, the filament power used is about the same for both types of tubes. When one has a PE-103 generator for use in a mobile installation it is certainly desirable that the transmitter use the rated generated power. This design fulfills this requirement. Standard components are specified, although parts were chosen with low cost in mind. Components are mounted on the tube sockets and all leads are kept at a minimum length. Such short leads eliminate the usual "bugs" that show up in most home-constructed gear. All parts not absolutely necessary are omitted to reduce the total number of components. Each part serves a real purpose.

All tuning adjustments are made with a screw driver to slotted coil slugs and condenser shafts to prevent accidental detuning.

The r-f driver circuit uses a 6J6 in a frequency quadrupling circuit starting with a 7 mc crystal. The problem of finding a circuit for r-f doubling and driving the final is an old one. The usual practice is to have a string of pentode doublers that take a lot of valuable plate current and space. Some rigs use a standard tri-tet oscillator to arrive at 14 mc, letting the final stage act as a frequency doubler. The obvious disadvantage of this method is that a doubling final operates at less efficiency, hence a lower power output, and puts an occasional 14 mc signal on the air. Until VP3TR (W6SMU) made known his wonderful single-tube driver circuit¹ the problem of cheap r-f drive was largely an expensive compromise.

It will be noted in *Fig. 1* that the first half of the 6J6 is basically a modified Pierce oscillator² using

¹"Miniature 10-Meter Exciter", Theodore W. Rust, VP3TR (W6SMU), Hints and Kinks, *QST*, October, 1949, p. 57

²ARRL Handbook, Vol. 27, 1950, pp 147-148

*2052 Venice St., San Diego 7, Calif.

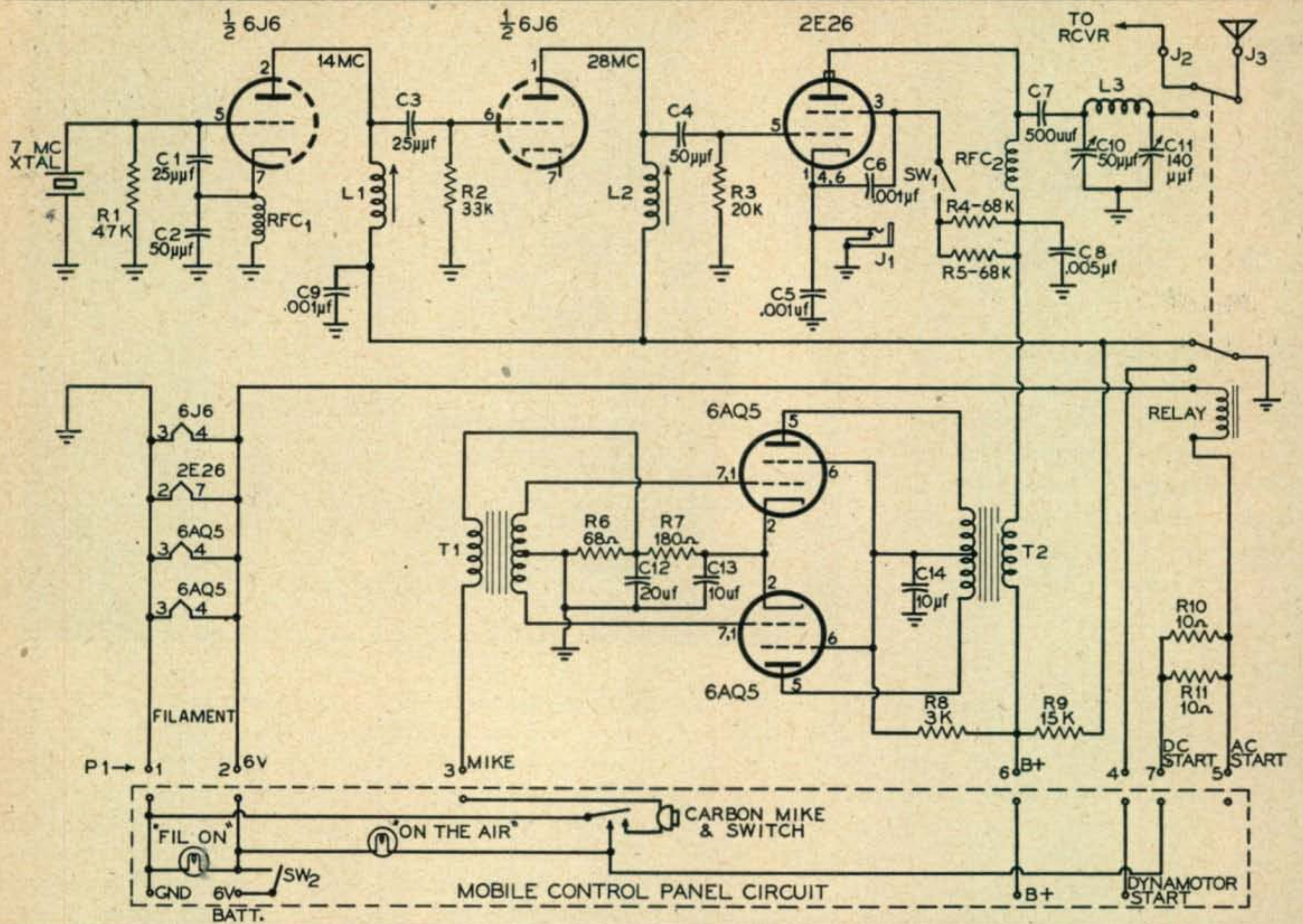

Fig. 1. Wiring schematic of the 28 watt 10 meter transmitter.

R1—47,000 ohms, $\frac{1}{2}$ w
 R2—33,000 ohms, $\frac{1}{2}$ w
 R3—20,000 ohms, $\frac{1}{2}$ w
 R4, R5—68,000 ohms, 1 w
 R6—68 ohms, 1 w
 R7—180 ohms, 1 w
 R8—3,000 ohms, 20 w
 R9—15,000 ohms, 10 w
 R10, R11—10 ohms, 1 w
 C1, C3—25 $\mu\mu\text{f}$ ceramic
 C2, C4—50 $\mu\mu\text{f}$ ceramic
 C5, C6, C9—.001 μf Discap
 C7—500 $\mu\mu\text{f}$ mica

C8—.005 μf Discap
 C10—50 $\mu\mu\text{f}$ variable APC
 C11—140 $\mu\mu\text{f}$ variable APC
 C12—20 μf , 25 v electrolytic
 C13—10 μf , 25 v electrolytic
 C14—10 μf , 450 v electrolytic
 J1—Closed circuit jack
 J2—"Rcvr" phono jack
 J3—"Ant" Motorola type jack

Relay—6.3 v a.c. dpdt (Advance KI504)
 T1—Mike transformer 1:84 turns ratio (Peerless K-007X)
 T2—Modulation transformer, 10,000 ohms to 8,000 ohms (Peerless M-013X)
 RFC1—3.5 mh
 RFC2—2-28 ohmite choke
 L1—28 T #20 enam., (National XR-50 coil form)

L2—13 T #14 enam., (National XR-50 coil form)
 L3—8 T #18 1" long $\frac{3}{4}$ " (B&W #3010)
 SW1—s. p. s. t. slide switch
 SW2—s. p. s. t. toggle switch
 Chassis—2 $\frac{1}{8}$ x3 $\frac{1}{2}$ x6 $\frac{1}{2}$ inches #LMB-138 (L. M. Bender Co., Los Angeles)

the capacitance feedback divider C_1 and C_2 . The r-f choke in the cathode circuit is conventional except that it should represent a capacitive reactance at 7 mc. The distributed capacitance within the choke itself is not detrimental as it actually adds to the capacitance of C_2 . As far as the oscillating part (grid and cathode) of the first half of the 6J6 is concerned, the first plate (pin 2) could be by-passed to ground (at zero voltage at the xtal frequency). However, the presence of a resonant circuit in this plate, tuned to the second harmonic (14 mc), enables sufficient second harmonic voltage to be developed to drive the grid of the second half of the 6J6. As VP3TR pointed out, it is essential that the dielectric portions of the circuit (tube socket, coil forms, etc.) be made of low loss Ceramic or mica-filled bakelite.

One may wonder why no resonating capacitors are shown across the variable inductors. The interelectrode capacitance of the tube, plus the wiring and stray capacitance in the circuit, all add to bring the slug-tuned coils to resonance. This gives a relatively high L/C ratio. Using the coil forms, turns, and wire size recommended, the measured Q was 110. With the 150 volts plate voltage and 14 ma plate current, this r-f driver provides more than adequate grid drive to the 2E26 operating class C at maximum power.

Class C Modulated Stage

The 2E26 class C stage has a metering jack in the cathode circuit. This is a shorting jack so the meter may be removed after tune-up. The same jack is used for indicating either the 2E26 grid

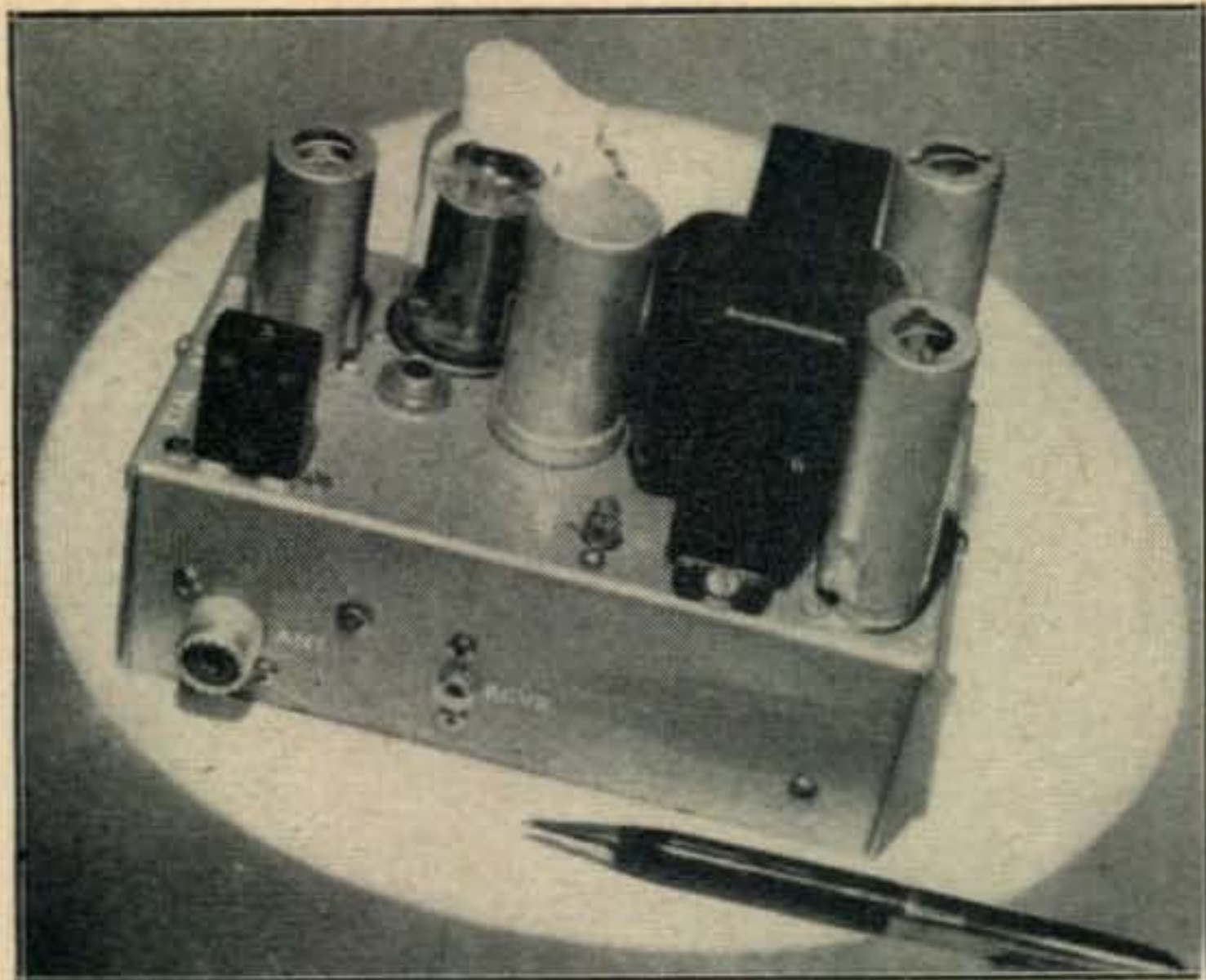

This view shows the metering jack next to the 2E26 and next to the 6J6 r-f driver. The antenna coupling adjusting capacitor C11 is in the center near the modulation transformer.

current or the total cathode current (plate, screen grid and grid currents all added together). When switch *SW1* is opened, the d.c. screen voltage is removed and the plate current is cut off. This leaves the meter reading only the grid current. Closing the switch restores the screen voltage and permits plate current to flow. Since the meter is needed only during tune-up operations, it is unnecessary to permanently install a meter. The average volt-ohm-mil-ammeter does the job in fine style.

Another important feature is the use of an inductive r-f plate choke, *RFC 2*. The recommended choke (Ohmite Z-28) is self resonant at about 50 mc. As used in this circuit, the choke still looks like a very high reactance. The stray circuit capacitance across the choke lowers its resonance frequency, but does not bring it below 30 mc.³

This transmitter was designed to be removed from the car for use as a home station or for portable operation in field day activities. This prerequisite necessitated a coupling system that would match any antenna, large or small, whether it would be simply a wire thrown over a tree or an elaborate multi-element beam. Our old friend, the *pi coupler*, does this job and does it well. The *pi coupler*, which is actually the tank circuit shown in *Fig. 1*, will match any antenna within the impedance range of 50 to 1000 ohms. Believe it or not, the regular receiving antenna that comes with the automobile BC set works quite well with this little transmitter, although the transmission line to such an antenna may require some adjustment in length to reduce loading the class C stage. For

³It might be well to mention that the standard 4-pi 2.5 millihenry r-f choke is self resonant at about 2.6 mc, and goes in and out of resonance several times between 2.6 mc and 30 mc. At several spots in this frequency range, the choke looks like a capacitive low impedance circuit. At some frequencies it is simply a capacitor that passes direct-current. An excellent discussion on r-f chokes and instructions for making good ones has been published in "Technical Tidbits", GE Ham News, Vol. 4, No. 1, pp 5-6, January - February, 1949.

demonstrations at ham clubs this writer has satisfactorily used a cheap 4-foot automobile receiving antenna and its 3-foot transmission line with results comparable to a quarter wave resonant whip antenna.

Admittedly, a quarter wave whip is the best mobile antenna if it is placed high on the car, or as far away from the car body as the bumper will permit. The accepted input impedance to this antenna is about 36 ohms. This is somewhat low for a *pi*-coupler to match. A much better match is obtained if the impedance at the transmitter end of the transmission line is raised to more than 72 ohms. A quarter-wave transmission line transformer will bring the impedance from 36 ohms up to 72 ohms. A 50 ohm coaxial cable will do the job if made from a quarter wave length of RG-8/U or RG-8/U.⁴ One end of this quarter wave matching section is connected to the antenna as shown in *Fig. 2*, while the other end is spliced to a 72 ohm coax line of any length.

As for coupling to a single wire antenna, such as a wire tossed over a tree, you simply ground the rig to the best available ground and connect the antenna wire to the antenna jack.

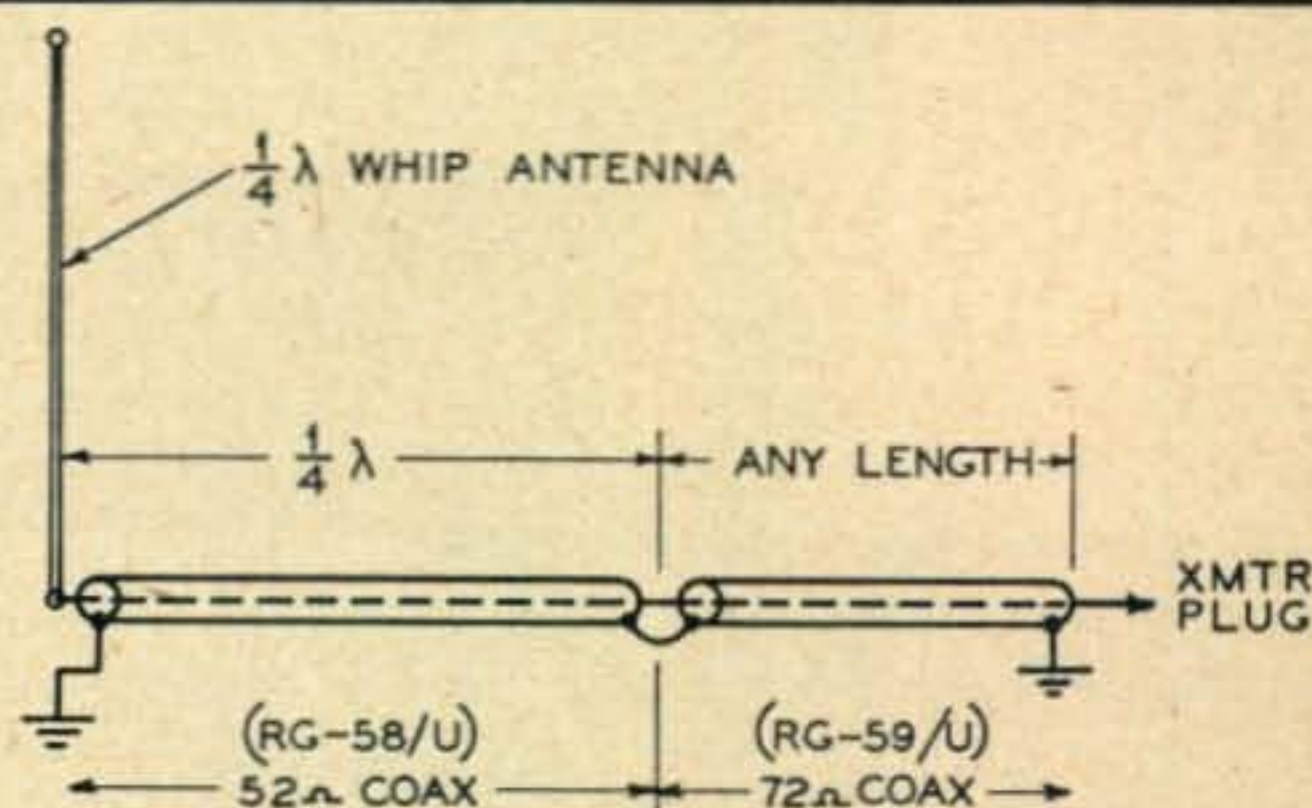

Fig. 2. Quarter wave matching section as used to match a resonant whip to 72-ohm line. The car body is used as ground.

In some installations, in order to reduce loading to a safe level, it may be necessary to add more capacitance to the output capacitor *C11*. This may be accomplished by adding a 100 $\mu\text{mf.}$ or 150 $\mu\text{mf.}$ fixed mica or ceramic condenser across *C11*.

The *pi*-coupler is one of the simplest devices to help in the reduction of TVI. This writer has found that if the antenna loading is not excessive (that the loading is low enough so that adjusting *C10* causes a definite dip in the plate current) there is only mild TVI noticeable only on Channel 2 of a television receiver of good engineering design. Reduction of antenna loading is, in effect,

⁴The electrical quarter wave length of a line is equal to a quarter wave length in space times the velocity factor of the line being used. The velocity factor of the common coaxial lines is 0.66.

$$\frac{1}{4} \lambda = \frac{246}{f_{\text{mc}}} \times 0.66 \text{ feet}$$

$$\text{For 29 mc: } \frac{1}{4} \lambda = \frac{246}{29} \times 0.66 = 5.6 \text{ ft. (67 inches)}$$

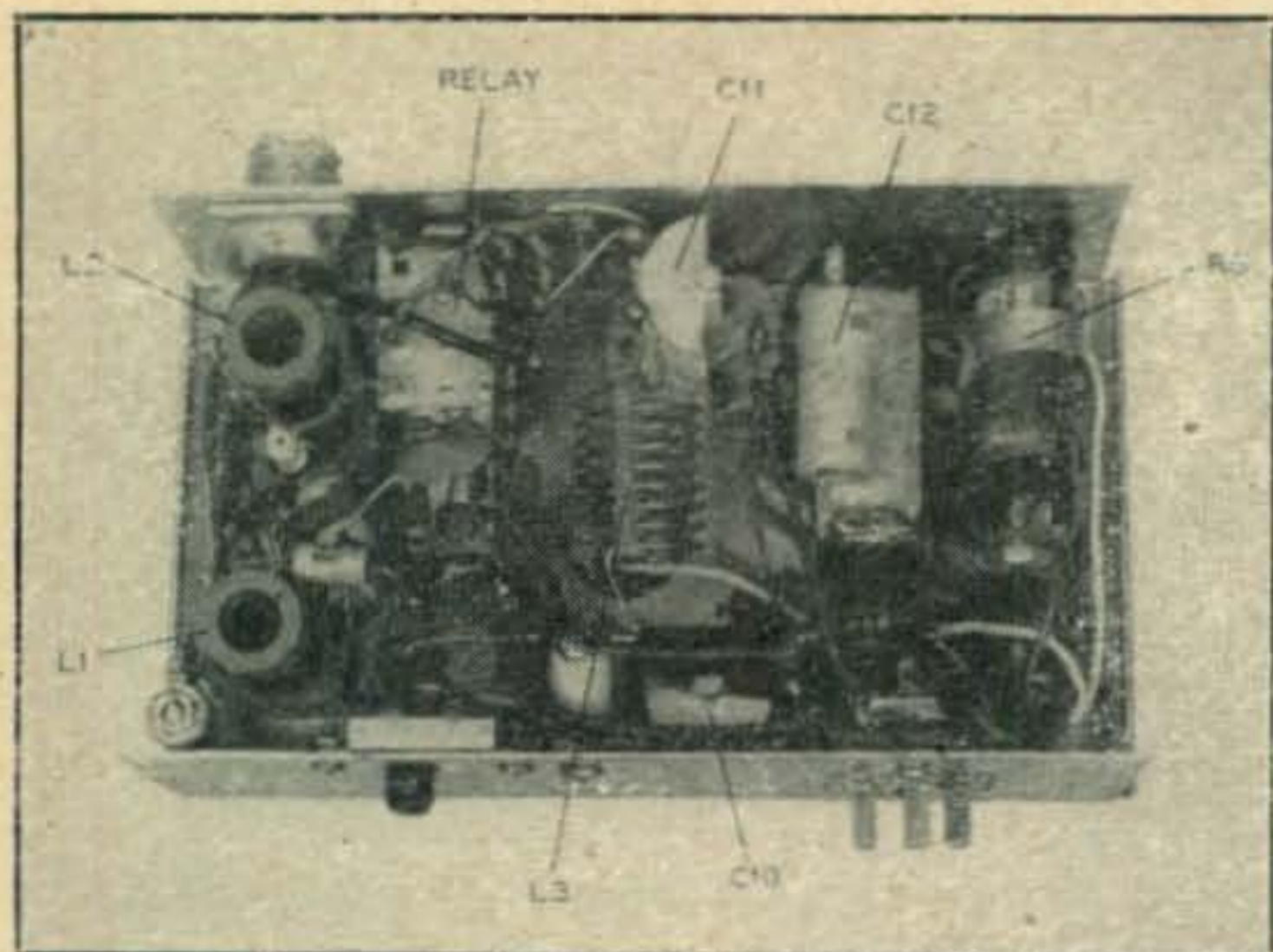

Under chassis view of the 28-28 showing the location of the important components

the increasing of loaded Q of the pi-section tank circuit. Such a tank circuit is actually a low pass filter with resonance at the fundamental frequency.

Balanced Antenna Connections

The output connections of the transmitter are unbalanced. A rotary beam which uses a coax line or unbalanced line may be connected directly to the rig. However, if the antenna feed line is a balanced line such as a 300 ohm line, one might use a resonant tuner as shown in Fig. 3-a. This method feeds the transmitter's output through a 72 ohm coax, of no critical length, connected to a link of few turns which is coupled to a balanced circuit, tuned to the operating frequency. The balanced line to the antenna is tapped a turn or a fraction of a turn each side of the center of the coil. By keeping the coil connections as close to center of the coil as possible, much of the resonant circuit's Q is retained which considerably attenuates harmonics that cause TVI.

Another method makes use of a transmission line coupler known as a "balun". A balun for use with a 300 ohm balanced line consists of a half wave length of 72 ohm coax line such as RG-59/U. This length must be an electrical half wave length. Choosing 29.0 mc as an average design frequency the determination of this length is as follows:

$$1/2 \lambda = 2 \times \frac{246}{f_{mc}} \times V.F. = 2 \times \frac{246}{29 mc} \times 0.66 = 11.2 \text{ feet}$$

The length of the 72 ohm coax used to make this balun is 11 feet 2½ inches as shown in Fig. 3-b. It is recommended that the ½ wave length line be strung out, doubled like a trombone, instead of being coiled up. It will be observed that this balun will work nicely over a wide band of frequencies which means that its length is not overly critical.

The Audio Circuit

The need for conserving precious plate current was quite important in arriving at the final audio design. Tube handbooks rate the class AB1 output of push-pull 6V6's and 6AQ5's at 10 watts with reasonable distortion. However, it was found that these tubes will produce sufficient peak power of a

complex speech wave to fully modulate a class C stage operating at 28 watts plate input. The plate voltage is increased a little above 250 volts and the grids are driven slightly harder. The real secret of this circuit is the microphone transformer. The usual microphone transformer just doesn't drive the grids hard enough to develop adequate speech power. A commercial transformer T1 with a turns ratio of 1:84 was found to be just the ticket. When using a good carbon mike, this transformer actually feeds the grids more voltage than needed. No additional speech amplification is necessary. On peaks, the drawing of grid current causes the voltage to drop to some value just at the point of grid current flow. Hence the circuit is an effective modulation limiter preventing over-modulation while, at the same time, keeping the modulation at a higher average level.

Another beautiful feature of this transformer is that it is an effective band pass filter. The secondary winding is in parallel resonance at 1400 cps, which is the mid-band frequency of the audio necessary for effective transmission of speech. This "communication quality" filter effect is true only

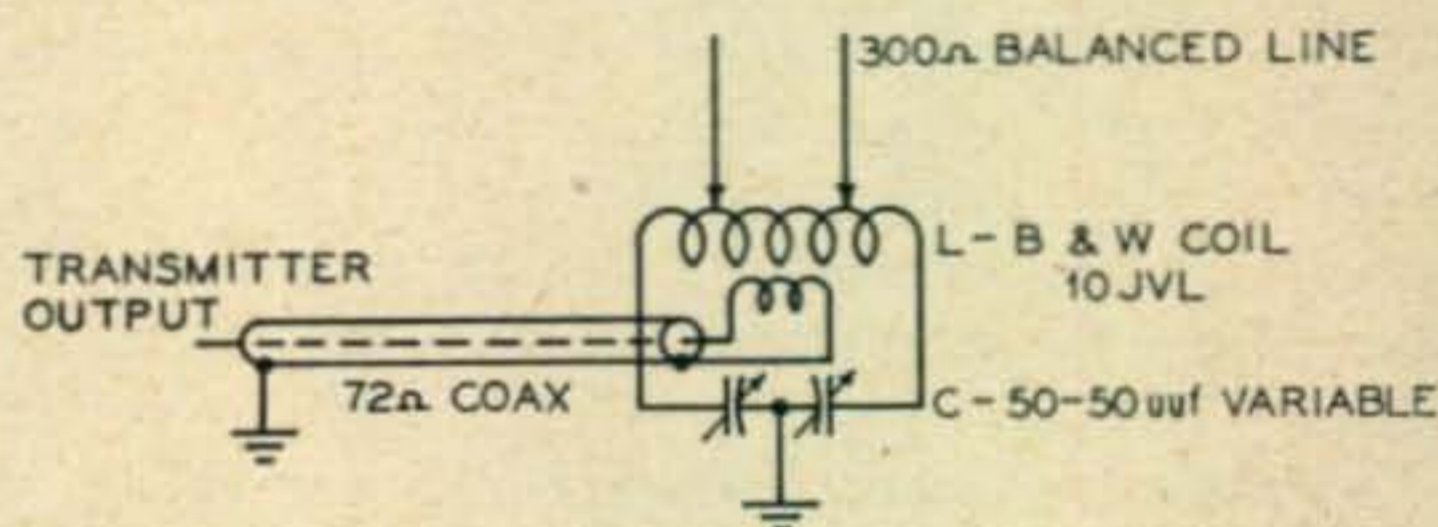

FIGURE 3a. BALANCED RESONANT TUNER

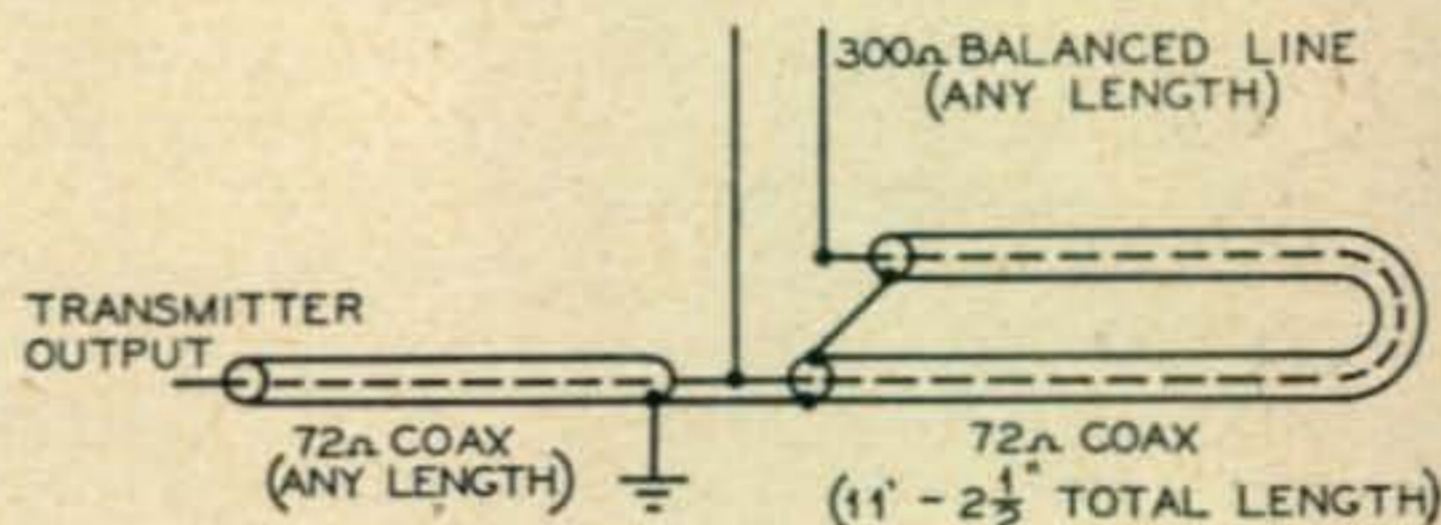

FIGURE 3b. THE BALUN

Fig. 2. At some locations the antenna may have a balanced line. In such an instance one of these line balancing devices should be employed.

if the secondary is not loaded with a resistor. With the carbon mike connected, the transformer was found to be down approximately 6 db at 350 cps and 4000 cps. With the aid of C8 across the output winding of the modulation transformer, the overall response of the modulator is within the range of 350 cps to 3500 cps. All of this means that no precious power is wasted on audio frequencies not needed in "getting through" and the spectrum is not cluttered up with excessive side bands.

(Continued on page 62)

The "Matchmaker"

WILLIAM I. ORR, W6SAI*

This gadget was the winner of the 7th prize in the CQ "Home Brew" Contest. We think it is quite interesting and has great possibilities in helping to determine the radiation resistance of parasitic arrays. —Editor

DURING THE ADJUSTMENT and tuning of the author's beam antenna¹ several attempts were made to measure the radiation resistance of the driven element. This was finally accomplished, after a fashion, by feeding the center of the dipole with various different feedlines of known impedances and comparing the S.W.R. produced on these lines when terminated by the driven element. This was an involved and complicated procedure necessitating our scrambling up and down the forty-five foot tower innumerable times. At long last, a value of radiation resistance was obtained that was purely an interpolation of many S.W.R. measurements. The accuracy of this value depended upon too many variables to satisfy the grandstand quarterbacks coaching the operations, but at the same time, no one professed a burning desire to repeat the series of tower climbs! As a result of this, an investigation was started to develop a simple device capable of accurately measuring the radiation resistance of a beam antenna. The *Matchmaker* is the resulting instrument.

Radiation Resistance — Why Worry About It?

The radiation resistance of any antenna is defined as that value of resistance which, when substituted at a current loop in the antenna system for the antenna, would dissipate the same amount of energy as the antenna radiates into space.

¹The Electrical Design of the 20 Meter Wide Spaced Rotary, April/May "CQ", 1950

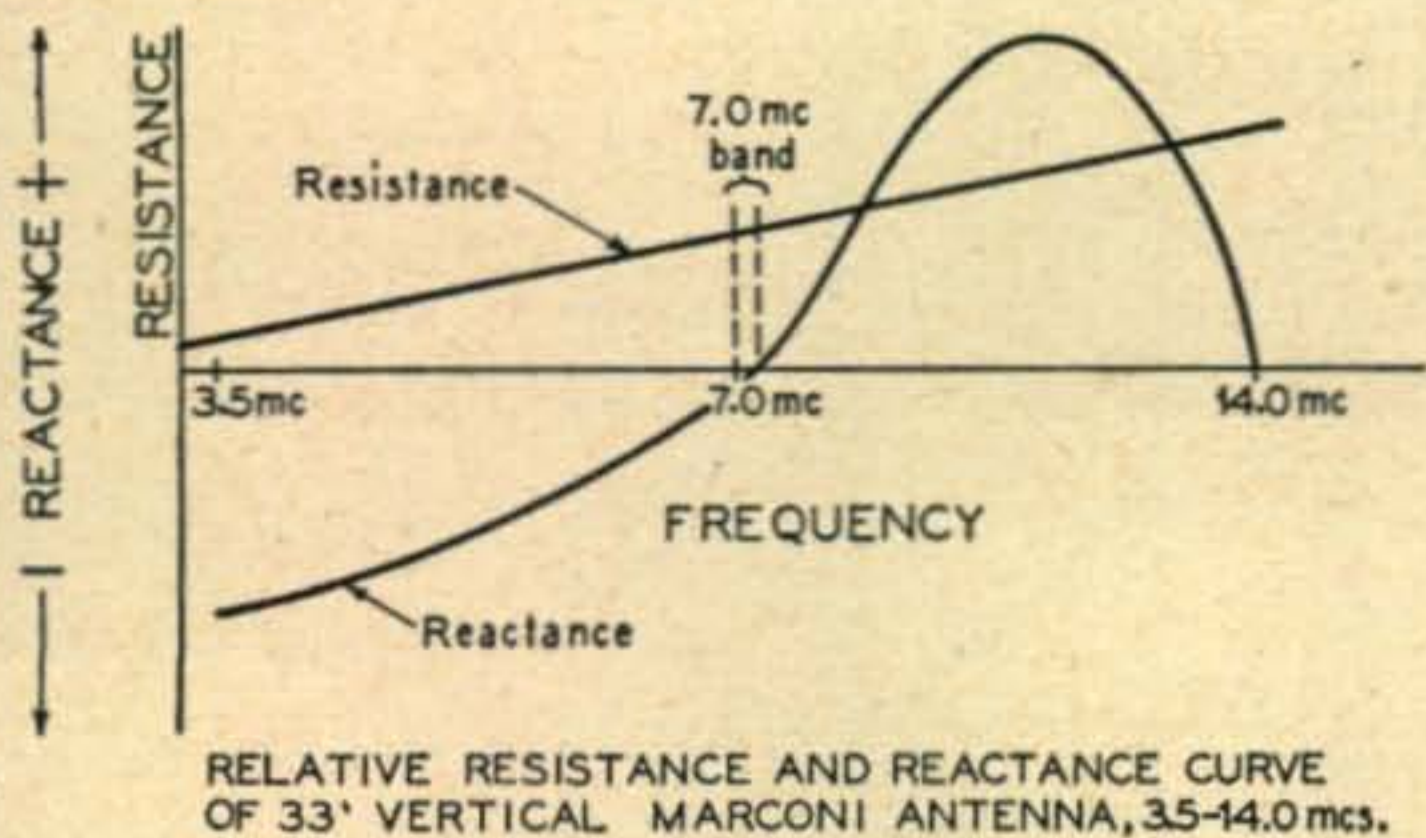
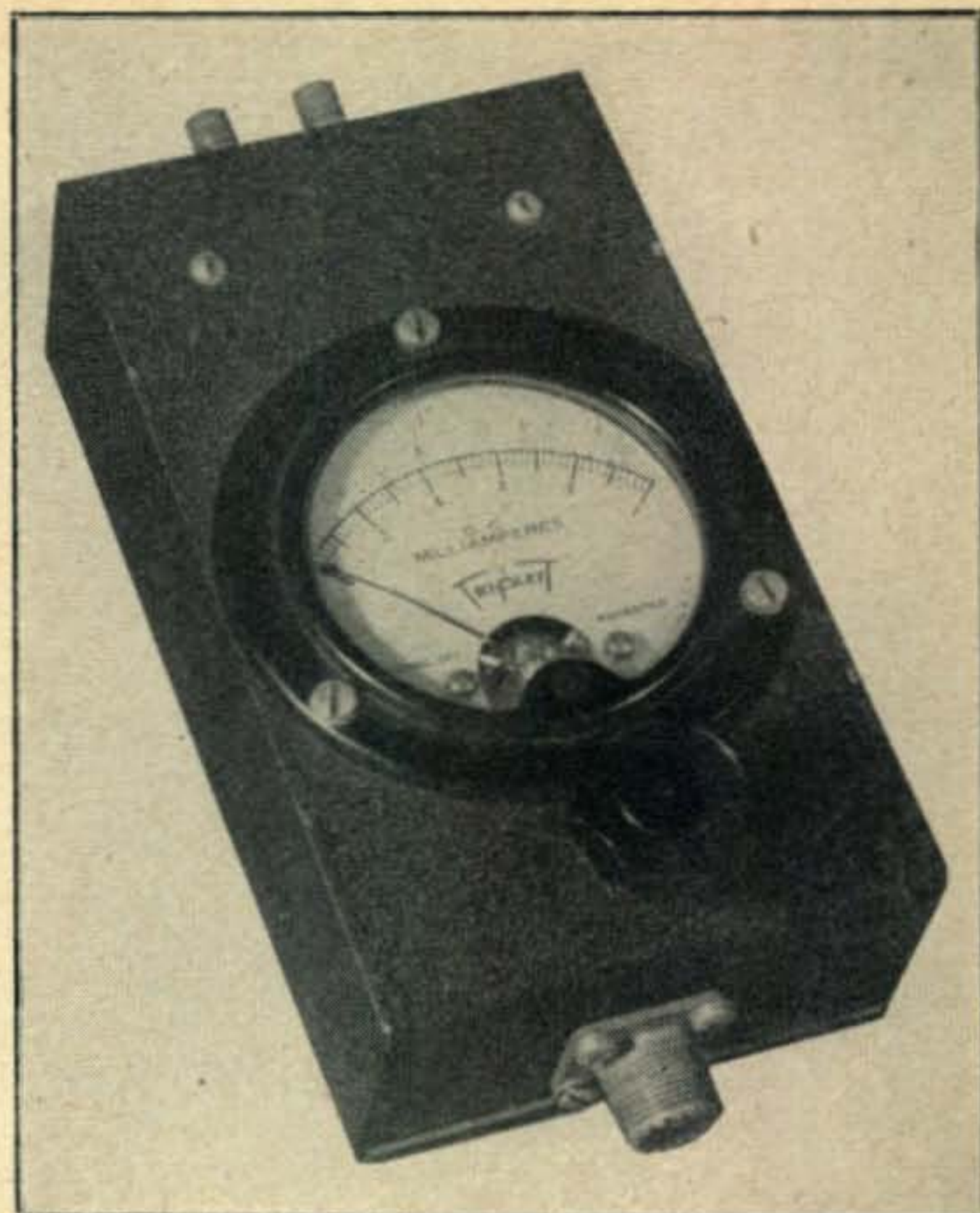

Fig. 1. Typical plot covering the three principal amateur bands.



The value of radiation resistance varies from one antenna to another, and reaches a rather small value in multi-element parasitic arrays. If the radiation resistance approaches the d.c. resistance value of the antenna the efficiency of the antenna drops sharply.

In order to efficiently transfer the power from the feedline to the antenna, the feedline must terminate in an impedance of such value and phase to produce a low S.W.R. on the line. As the S.W.R. increases, line losses rise and the resulting mismatch plays havoc with the proper operation of the antenna, contrary optimistic reports notwithstanding.

For these reasons it is necessary to determine the radiation resistance of any antenna to set the feedline parameters for best performance. The *Matchmaker* makes it possible to measure the radiation resistance of an antenna directly and with a minimum of fuss and bother.

What Is An Antenna Made Of?

Not "sugar and spice and everything nice" but merely of various ohmic values of r (resistance) and x (reactance). Let us take, for example, a 7 mc antenna consisting of a vertical wire about 33' long, suspended over a perfect ground. Let us take a r.f. impedance bridge and make a series of measurements between the base of this wire and ground at various frequencies in the range of 3.5 mc to 14 mc. At any one given frequency in this range the antenna will present a certain amount of r , and a certain negative or positive amount of x . If we plot a curve of the measure-

*555 Crestline Drive, Los Angeles 49, Calif.

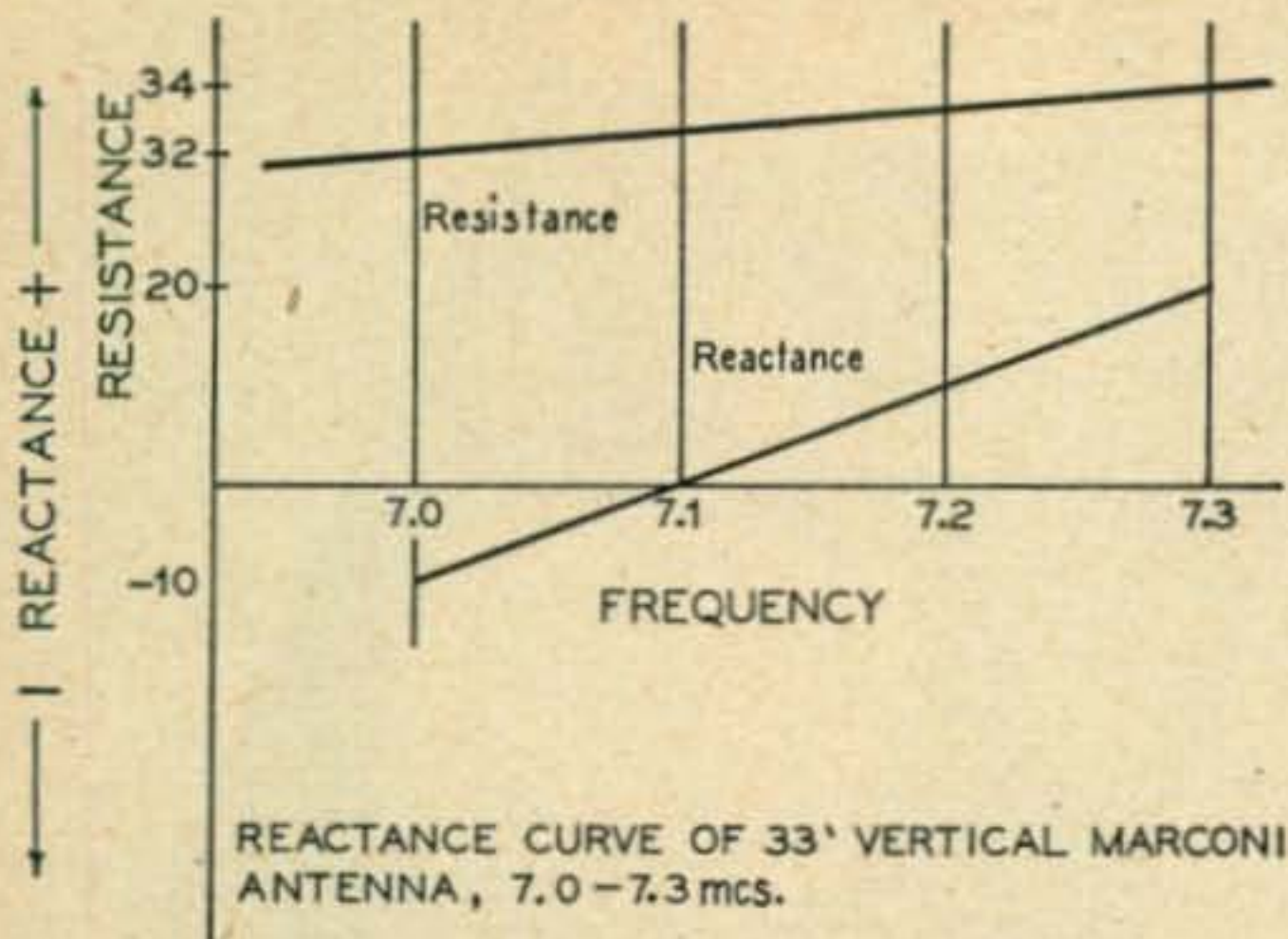

Fig. 2. Determining the radiation resistance at antenna resonance.

ments made with the bridge we would obtain something similar to Fig. 1. We can observe from this curve that r starts from a low value of 10 ohms at 3.5 mc, goes up to 34 ohms at 7 mc, and up to a maximum value of perhaps 2,500 ohms at 14 mc. The reactance curve, x , is negative (capacitive) by at least several thousand ohms at 3.5 mc, measures approximately zero ohms at 7 mc, and plus several thousand ohms (inductive) at 10 mc. It is back to about zero ohms again at 14 mc. This antenna will work at any frequency within this range, but in order to make it accept power in an efficient manner we must cancel out the reactive component appearing at the base, and in some way match the radiation resistance r to the feedline impedance. At the frequency we are interested (7 mc) the antenna is approximately $\frac{1}{4}$ wavelength long and the reactive term is very small. Let us apply a magnifying glass to that portion of the graph around the 7 mc point and examine it more closely as shown in Fig. 2. We see now that r varies from 32 to 34 ohms and x varies from -10 to +20 ohms, and at 7.1 mc the x term is equal to zero. At this frequency the antenna is resonant and has a radiation resistance of 33 ohms.

Figure 2 can be redrawn giving an absolute value to the x term and graphing the value $r+j(x)$, as in Fig. 3. Again it may be seen that the antenna is resonant at 7.1 mc and has a radiation resistance of 33 ohms with zero reactance. At either side of this frequency the reactive term starts to grow and it increases much faster than the radiation resistance. Actually the matching problem becomes simple since we have found the resonant frequency of the antenna and know the radiation resistance at this frequency. The factor of increasing antenna reactance at frequencies removed from resonance is a function of the Q of the system and may be treated by various broadbanding methods. The *Matchmaker* is designed to enable anyone to find the basic curve of Fig. 3, giving the relative amplitude of $r+j(x)$ and the actual value of radiation resistance at resonance.

The Matchmaker

The *Matchmaker* is a r.f. ohmmeter designed to

measure the radiation resistance of either a balanced or unbalanced radiator. It operates on the same basic principle as a low range shunt reading d.c. ohmmeter. The voltage drop across a known resistance is measured for an initial zero setting and then measured again with the radiation resistance of the antenna applied in parallel with the meter. The basic circuit for a d.c. ohmmeter is shown in Fig. 4a. The meter M reads the voltage across points x and y . With no external resistance, $R1$ is set so that M reads full scale. As various resistances are applied across x and y the voltage across the meter varies in direct proportion to the resistance. The operation of this ohmmeter depends upon the poor regulation of voltage across x and y caused by the series resistor $R1$. In Fig. 4b the battery has been replaced by a r.f. generator G . A r.f. voltmeter is used for M and $R1$ is now a non-inductive resistor. Basically, the operation is the same as the d.c. ohmmeter, although a source of r.f. energy is used, and measurements may be made of antennas which possess that ethereal substance—radiation resistance. If the source G is far removed from M , x and y as in Fig. 4c a standing wave will appear along the distance D and the voltage at x and y will vary both with the frequency of G and the distance D . This effect may be substantially eliminated by making D in the form of a coaxial line and causing the combined impedance of $R1$ and M to match the surge impedance of the coaxial line (Fig. 4d). In our case $R1$ is used as the terminating resistance for the coaxial line. The take-off point for the ohmmeter circuit is located near the low potential end of $R1$ to minimize the changes in S.W.R. on the line when different values of resistance are placed across x and y . $R2$ is used as the series dropping resistor. This is the basic circuit of the *Matchmaker*. The actual circuit, complete with necessary r.f. filters for the meter and a zero set potentiometer, is shown in Fig. 5. The r.f. voltmeter consists of crystal X , meter M and load resistors $R4$ and $R5$. A suitable source of r.f. energy is fed to the *Matchmaker* through a 52 ohm coaxial line and into socket S . The antenna under measure-

Fig. 3. Obtaining the absolute values.

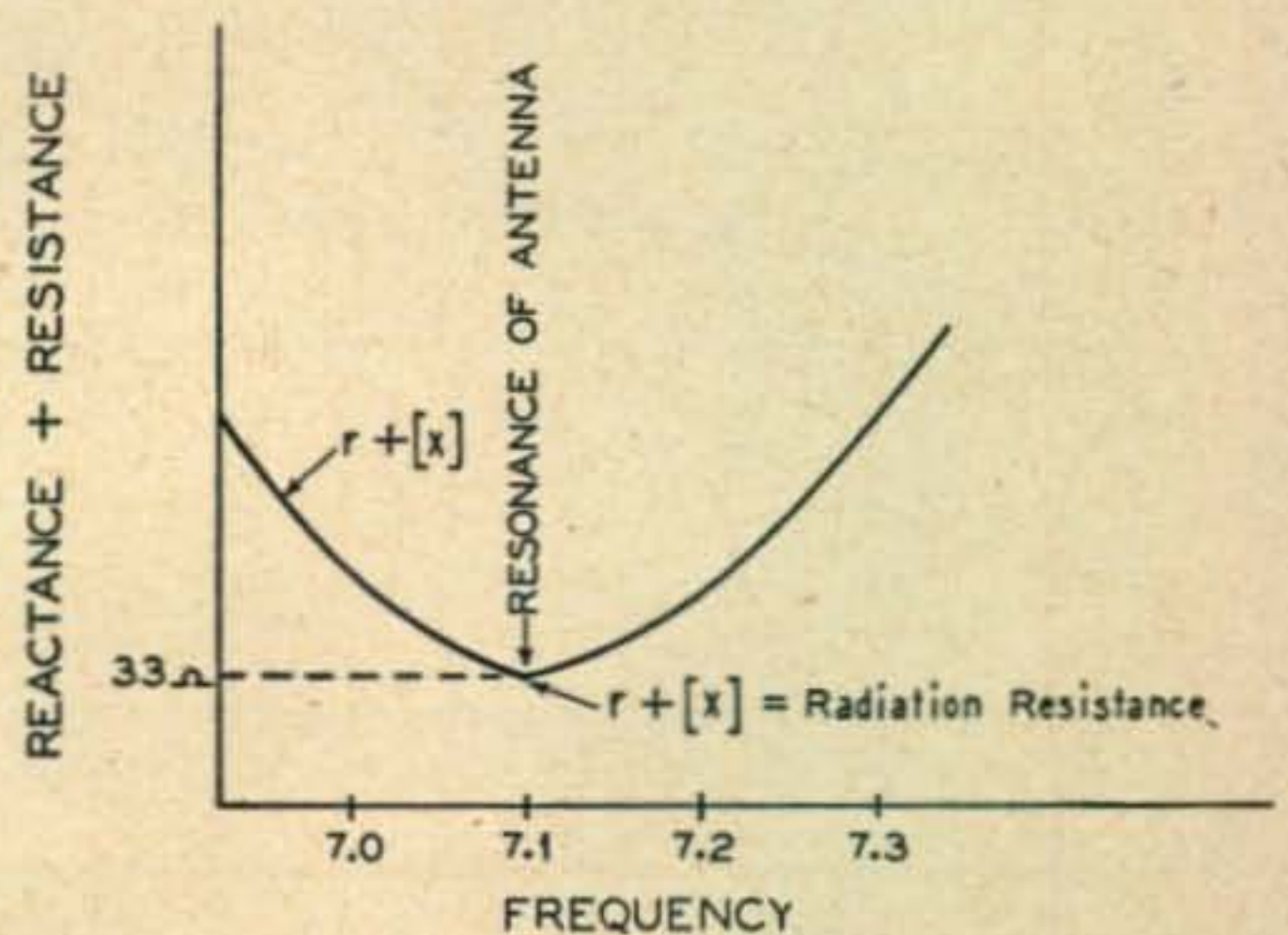

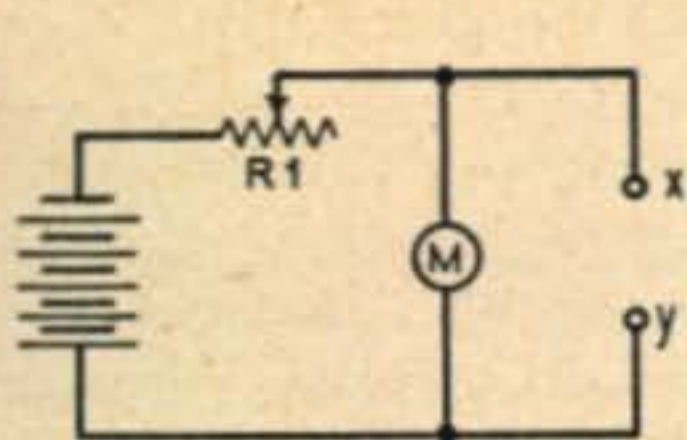

FIG. 4a

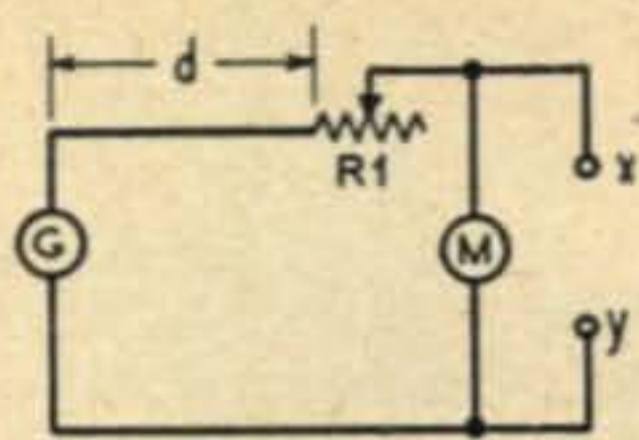

FIG. 4c

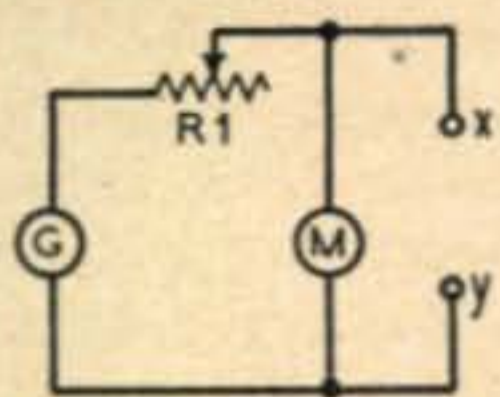

FIG. 4b

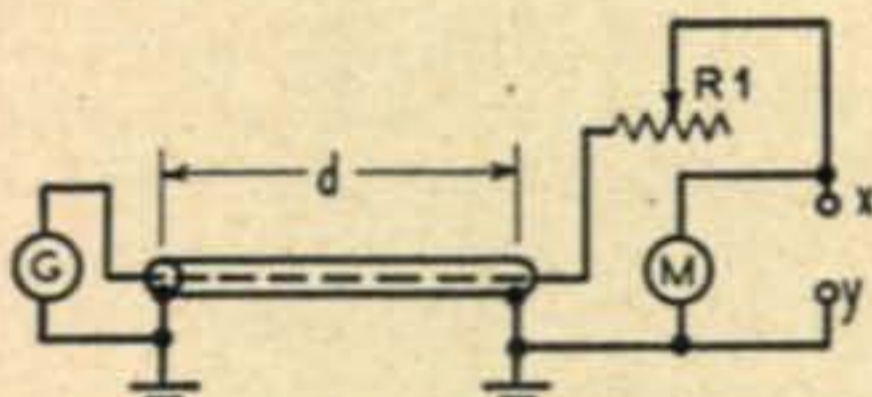

FIG. 4d

Fig. 4. Deriving the circuit for the r-f ohmmeter.

ment is connected to terminal B. The *Matchmaker* is designed to permit any low powered exciter that will deliver seven watts or so at the measuring frequency to be used as the r.f. generator.

Construction

The *Matchmaker* is housed in a small steel or dural box measuring $3\frac{1}{2}'' \times 6''$. The meter is mounted slightly below center on the face of the box, with the potentiometer (R5) centered directly below it. The coaxial socket is mounted at one end of the box and terminal B is mounted on the opposite end. A short length of RG-59/U coaxial line runs from socket S to a terminal strip that supports one end of R1. The crystal is mounted close to terminal B and is bypassed to the metal box by C2 using the shortest possible leads. The ground terminal of strip B is grounded inside the box with a short jumper, and is also grounded on the outside of the box by a short, wide piece of copper strap.

As with other r.f. indicating devices, the resistors should be non-inductive. Unfortunately, non-inductive resistors are a little rich for the blood, financially speaking. Composition resistors, costing under twenty cents apiece, may be used if a little discretion is employed. If you feel financially "loaded", by all means employ real non-inductive resistors. The effect of composition resistors upon calibration is to shift the whole calibration curve to the left, as shown in Fig. 6. It is suggested that the *Matchmaker* be calibrated at the frequency of intended usage, thus minimizing the resistor inductance error for that particular frequency. It will be noted, the error introduced by composition resistors shows up greatest at low values of load impedance. To date, no check of the *Matchmaker* has been made higher than 29.7 mc.

Calibration

It is necessary to calibrate the *Matchmaker* with a set of load resistors of known values. The

closer the actual known ohmic value of each resistor the closer the calibration of the *Matchmaker*. If the *Matchmaker* is calibrated at 28 mc or below ordinary composition resistors will suffice. Five percent tolerance resistors may be used.

A low power exciter should be used for the calibration of the *Matchmaker*. Variable coupling between the exciter and the *Matchmaker* is mandatory, as it is very easy to overload the circuit. Care should be taken to prevent an overload as it will heat the resistors and may cause them to shift in value. Initially, a small amount of r.f. should be fed to the *Matchmaker* through a coaxial line. The VFO coupling and R4 are adjusted until a full scale deflection is obtained on the meter. This is the zero point, and all calibration is based upon this reading. Various calibrating resistors are now placed across the terminals of the *Matchmaker* and the resulting readings recorded as in Table I. Recheck the full scale "open" reading before each measurement, as it is very important to "start from the same place" for each calibration reading. If the terminals are shorted with a piece of copper wire the meter should fall to within one or two divisions of a zero reading depending upon the inherent inductance of the instrument. A graph is now drawn from the calibrated points (similar to Fig. 6) and a small copy of it attached to the case of the Micromatch, or a special scale may be drawn up for the meter face.

Looking under the chassis to see the location of the more important components.

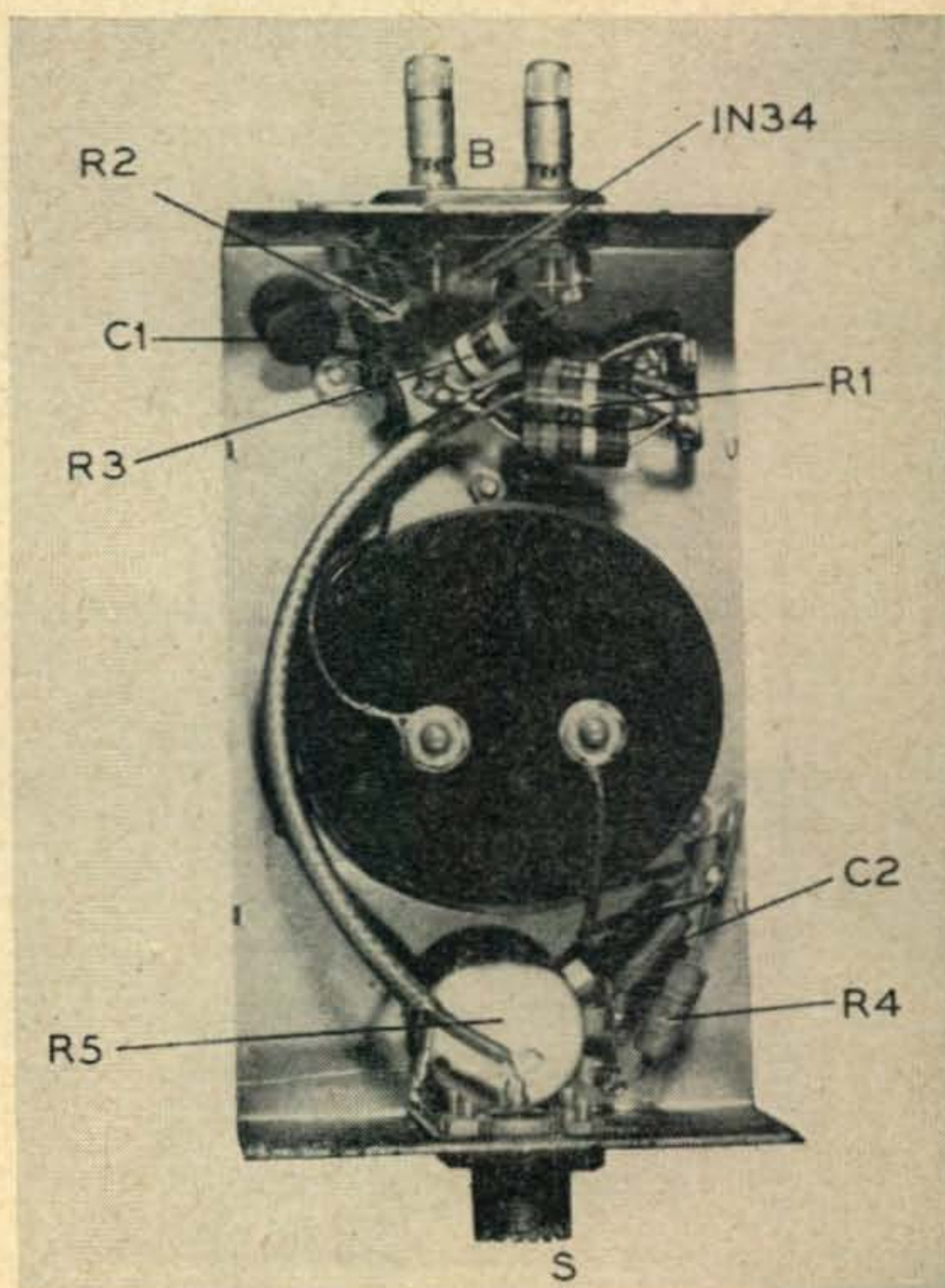

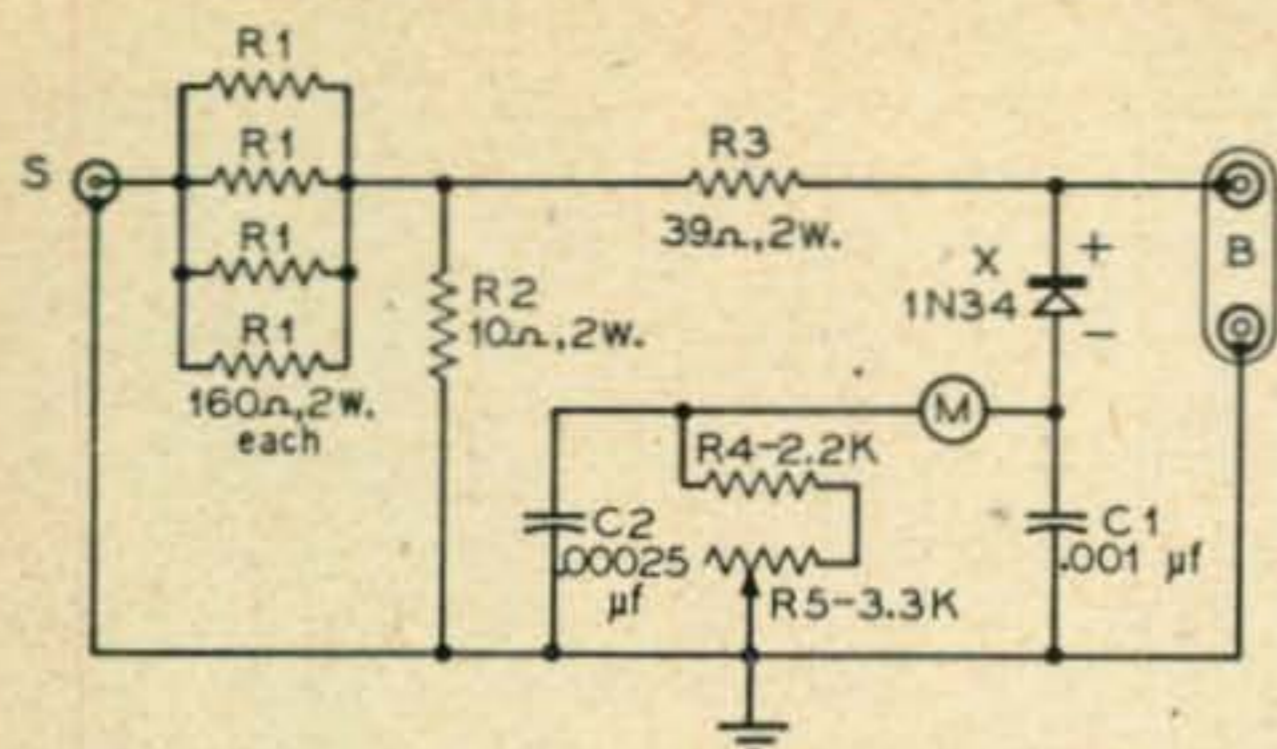

Fig. 5. Schematic of the "Matchmaker." This unit operates on the same basic principle as a low range shunt reading d.c. ohmmeter. The following values of 1 watt composition resistors are necessary for calibration: 5.6, 12, 22, 33, 55, 68, 82, 100, 220 and 350.

Use of the Matchmaker

Since it is necessary to be able to control the amount of r.f. input to the *Matchmaker* it is convenient to couple it, as in Fig. 7, to the exciter through an auxiliary tank circuit. Excitation may be varied by the tap on the coil and the setting of the tuning condenser. If the exciter has some other means of controlling the output, this tank circuit is not necessary. In either case, the outer shield of the coaxial line should be grounded to the exciter. The length of the line is immaterial—make it long enough to reach from the exciter to your beam! The *Matchmaker* is then placed near the beam and set for a full scale reading with terminals *B open*. The two halves of the driven element are connected to the measuring terminals by *short* pieces of wire and a reading is taken. If the beam construction is such that the dipole is grounded to the supporting arms, it must be temporarily insulated while the measurements are being made. Measurements should be made at several points in the band and at both ends of the band. Extreme care must be exercised to maintain a constant output from the v.f.o. Thus operating the *Matchmaker* is a two man proposition. One man at the transmitter shifting the frequency and the second man at the beam noting the

readings and checking the v.f.o. output. A typical graph of readings is shown for the author's three element 14 mc beam in Fig. 8.

At a frequency of 14,050 kc the beam dipole is resonant and has a radiation resistance of 20 ohms. The reactance is zero, and becomes negative at a lower frequency and positive at a higher frequency. The *true* reading of radiation resistance occurs at the frequency of resonance. It is this value of resistance to which we must match our feed system. Since the feedline can only have a unity S.W.R. when it matches a purely resistive load, it follows that the driven element of the beam should be resonant at some desirable "matching frequency", and all components of the antenna system chosen to electrically meet at this frequency. Matching transformers should be resonated at this frequency and the electrical resonance of the whole antenna system should fall at this frequency. The radiation resistance is determined for this frequency and then all else falls into place—just like the pieces of a jig-saw puzzle.

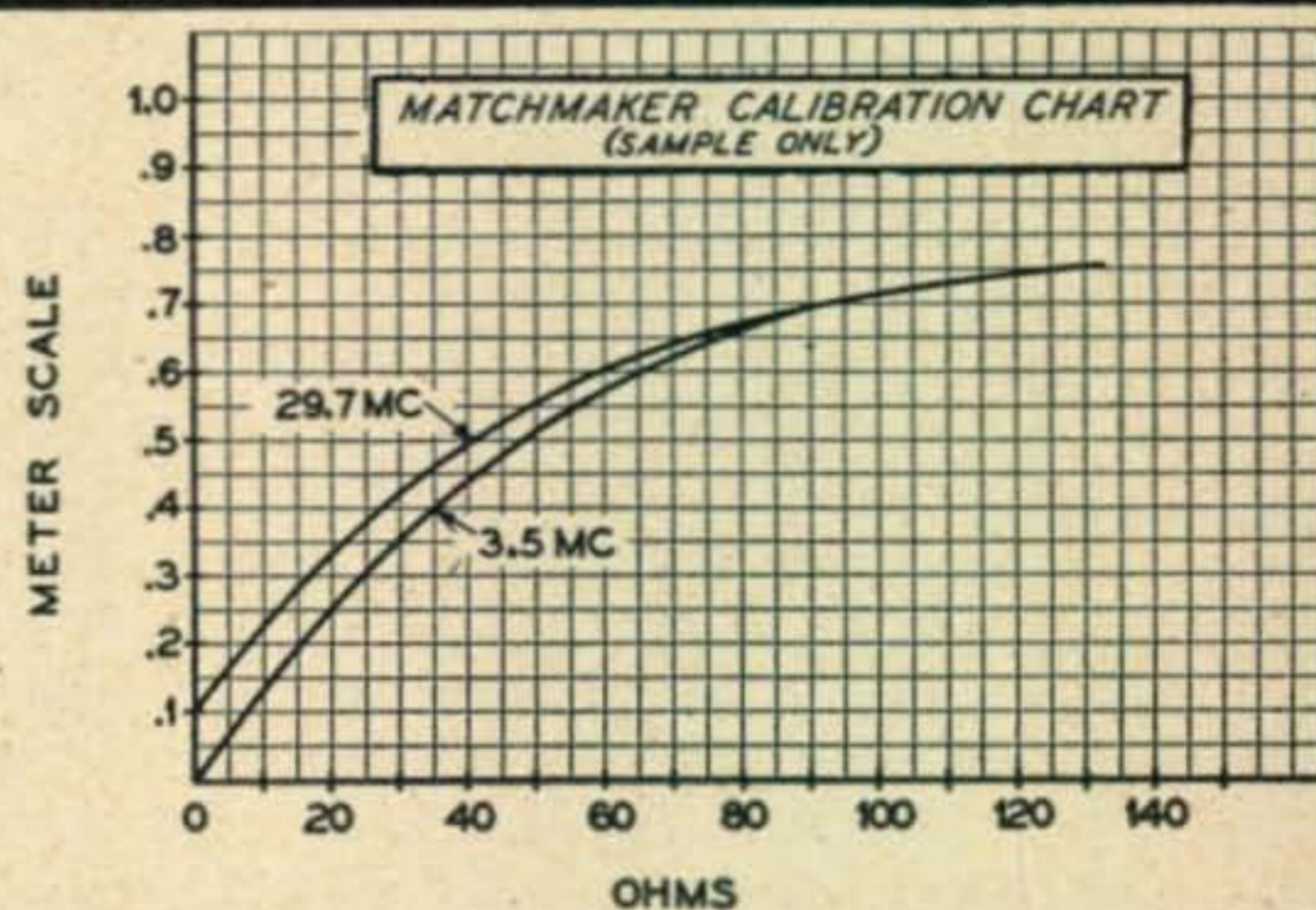

Fig. 6. Typical calibration chart also showing the shift in calibration due to the use of inductive resistors. If expensive non-inductive resistors are employed this shift will disappear.

TABLE I

Sample Calibration Chart

Standard Resistor	Meter Reading
0	0
5.6	.10
12.0	.21
22.0	.32
33.0	.42
68.0	.62
82.0	.67
100.0	.73
350.0	.91

Matching the Feedline

Knowing the radiation resistance of the beam antenna is a great comfort. We can now start thinking about "Q" sections in a greatly relaxed frame of mind. We know all the important variable factors needed to determine a suitable matching device.

For example: We want to feed our beam with a 300 ohm ribbon. We have a radiation resistance of 20 ohms. What do we use for a matching transformer? Dusting off the old ratio equation we can set our problem up: 300 is to x as x is to 20, where the term x is the impedance of the quarter wave transformer. Solving, we find x is equal to about 77 ohms. How nice! A piece of 75 ohm line will work just fine. The S.W.R. will be 77/75 or 1.03:1 at the frequency of resonance. Should we use a twin RG-8/U feed line of 104 ohms we would find: 104/ x as x /20, and x is approximately 46 ohms. Two parallel pieces of

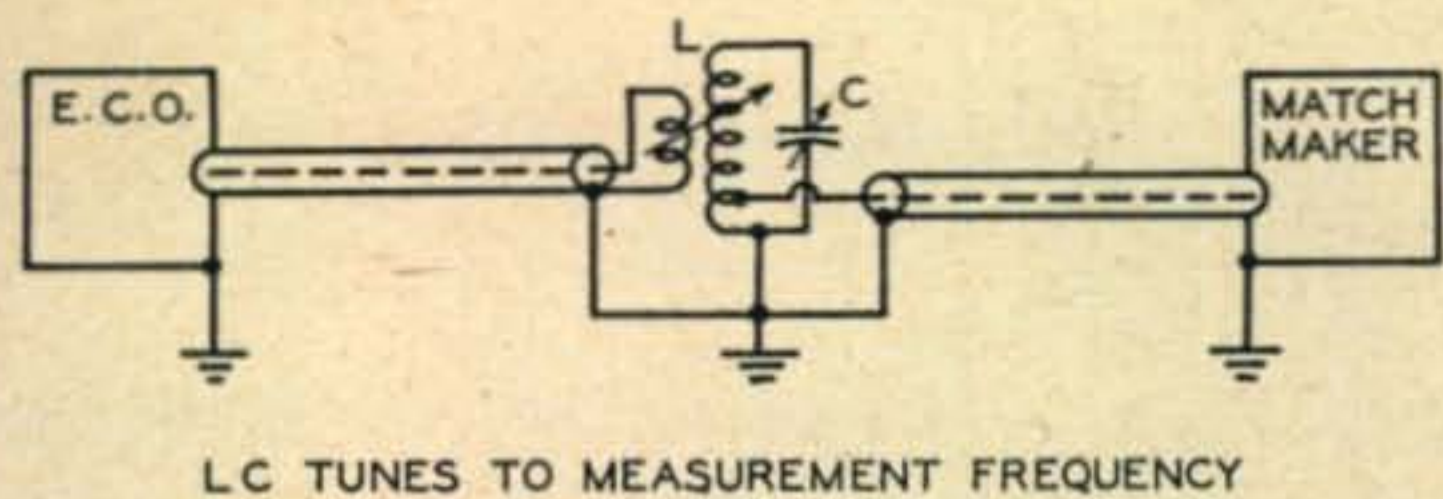

Fig. 7. A method of coupling permitting control of the r-f input.

72 ohm line for the matching stub will work in this case. The impedance of two parallel pieces of "72 ohm" line is in the vicinity of 35-45 ohms. (All 72 ohm line is not 72 ohms!!) In all cases, the S.W.R. derived by formula is the *best* possible value. You can't beat this, and if you are working the system at a frequency removed from resonance the S.W.R. will be greater—by an amount depending upon the Q of the overall system.

Other Uses of the Matchmaker

The *Matchmaker* is very useful in determining the radiation resistance of a cage radiator used in multi-element beams. It will give you the transformation ratio in a minute. Once you find the radiation resistance of your beam, you may determine by Ohm's law and a r.f. ammeter the amount of power actually reaching your beam—try it, you may be surprised at what you find!

Appendix

Some of the information and curves obtained in the design and calibration of the *Matchmaker* may prove of interest to the reader. *Figure 9* shows curves run by the *Matchmaker* at 3,500 kc. *Curve 1*

Fig. 8. Your final graph should look something like this. The radiation resistance is the value at the lowest meter reading.

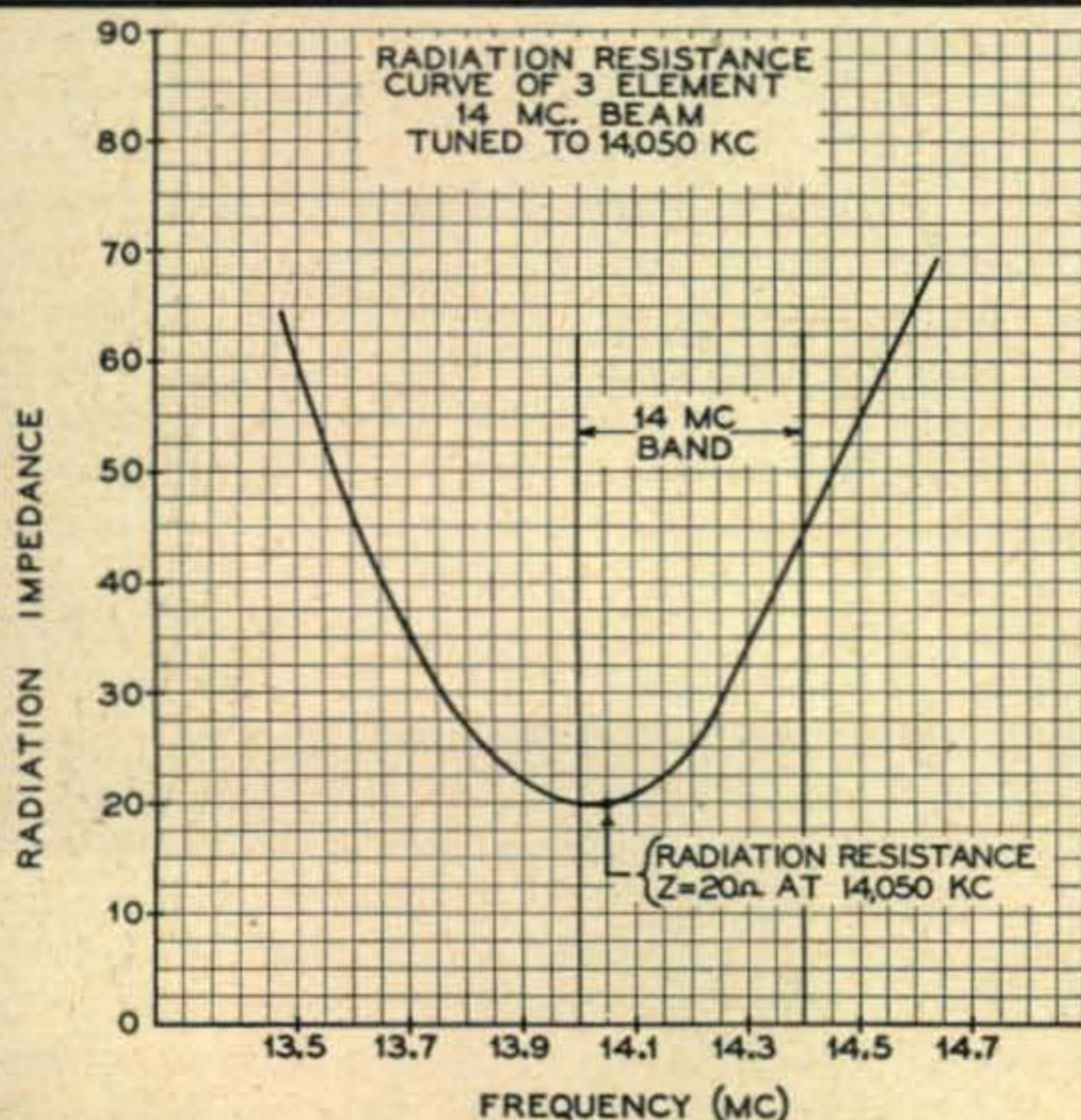

is a plot of meter readings for various values of load resistances from 0 to 100 ohms. This is the type curve used for calibration of the *Matchmaker*. *Curve 2* is a plot of meter readings for various values of negative reactance from 9 to 45 ohms. It is apparent from these two curves that equal amounts of resistance and reactance will not result in the same meter reading. Thus a reactance of 23 ohms will produce a reading of 33 ohms on the resistor calibrated scale. A complex reactance of $33-j23$ (33 ohms and $.002 \mu\mu\text{f}$ in series) will produce point *A* which falls between the two curves. It is evident that the calibrated scale is only true for non-reactive loads, and the apparent "error" grows with smaller values of reactive load (large values of capacity). This, however, is no detriment to the *Matchmaker* as we seek the *correct* value of radiation resistance at antenna resonance, or the point of no antenna reactance.

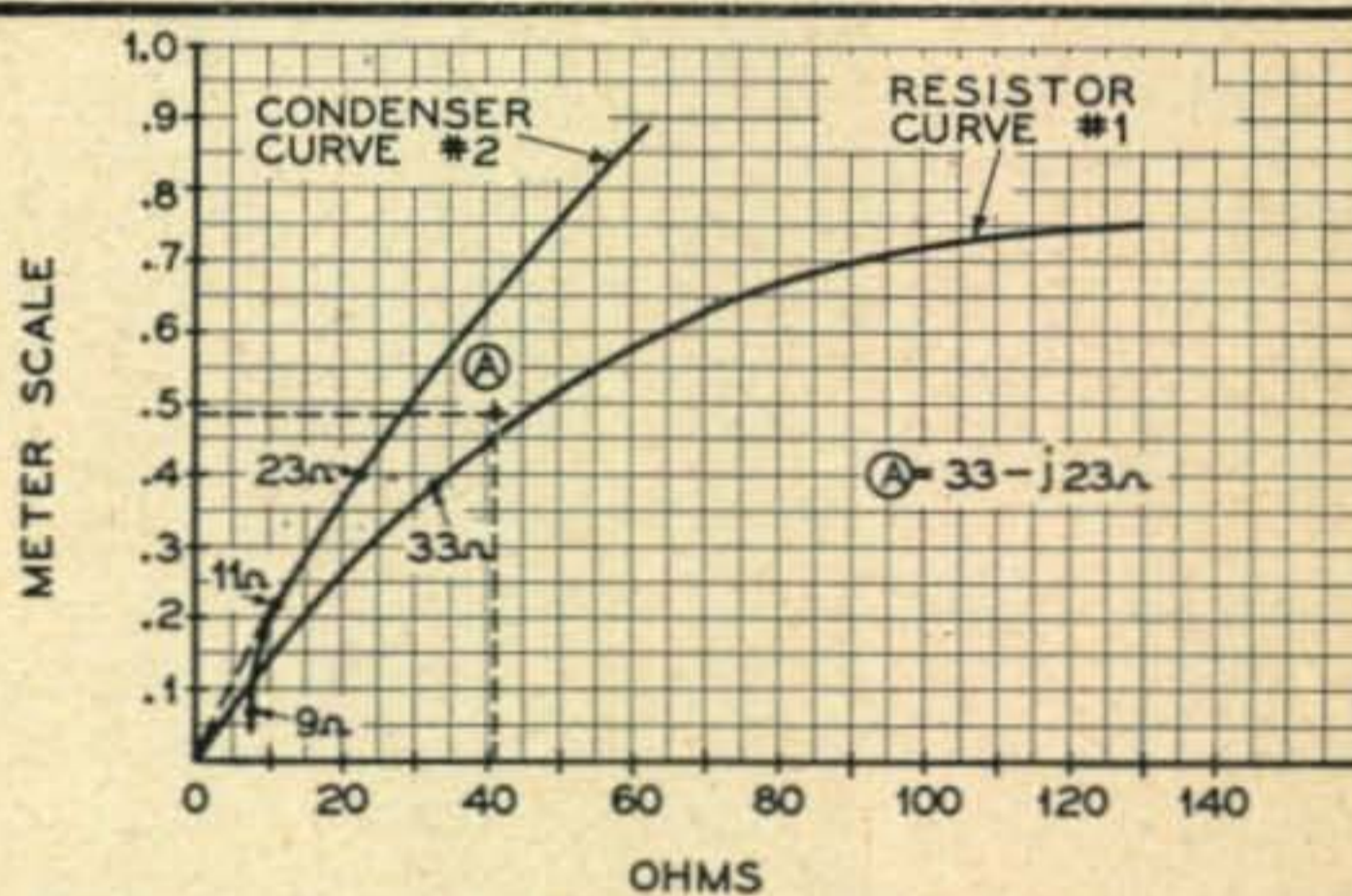

Fig. 9. The "Matchmaker" will not read correctly when the load is largely reactive. The magnitude of some tests taken at 3.5 mc are shown above.

This is the point of minimum reading on the meter. Readings taken off-resonance on the system merely indicate the presence of reactance, they do not indicate the amplitude.

The reactive variance in the *Matchmaker* is due to the design. A simplified schematic is shown in *Fig. 10*. The voltmeter, calibrated by resistive loads, reads the voltage drop across a test condenser X_c , which is in series with R across the supply e . The current i , is the same in both R and X_c since they are in series. The voltage eR across the resistance is in phase with the current and is equal to iR . The voltage eC (read by the meter) across the reactance X_c lags the current by 90° and is equal to iX_c . The applied voltage is the vector sum of iR and iX_c and is the hypotenuse of a right triangle having the two above-mentioned voltages as the sides. If we let X_c be equal in value to R it is apparent that the voltmeter reading will be 0.707 of the applied voltage e . If X_c is removed and a resistor equal in value to R is substituted for X_c , the meter will then read 0.5 of the applied voltage e . The first reading is a point on *curve 1* in *Fig. 9*.

(Continued on page 58)

the

VHF

news

Conducted by
W. E. McNATT, W9NFK*

HELLO! Nice to have you in our new quarters! We are very glad to be here to continue the many, many friendships made during the five years we published "The VHF News." To the gang who came with me from "The VHF News": thanks, again, for your past support, and I hope it will continue.

Now for the reports. Thanks to Brownie, W2PAU, for debunking the "prejudiced reporter" idea in the last issue of "CQ". "Most columnists will gladly print any news that is sent in," wrote Brownie, and I most certainly agree with him. The job is to get the news in!

October Openings

The October 2 Aurora opening brought out quite a bunch of fellows, but not too many reports. On the previous night, a general tropospheric opening occurred in the middle west and brought the Kentucky - Indiana - Ohio - Illinois gang together. W4JDN was putting a terrific signal in from Erlanger, Ky., and W8LPD, Cincinnati, Ohio, was nearly as good. W9s JGA, NW, HKQ, EQC, DRN, NFK and others made the most of one of the best openings of the year. On the same night, the Texas gang worked into Georgia, Missouri, Arkansas and Illinois. WØIHD reports that the Texans began to come through on the night of October 1, but not well enough to work. But, next night, Charles got his 15th state when he worked W5MWW, New Boston. W5QNL was heard. On October 1, WØIHD reports, signals from Ohio and Kentucky were like locals, and northern Illinois and Indiana stations were quite good. Heard but not worked: W8SDJ, W4JDN, W9EWO, W9NSF, W9EGH, to mention a few. W9BPV was heard working the Michigan and Pennsylvania stations.

W5AJG observed the arrival of extended range conditions in late September and early October. "Conditions really opened up for around 400 miles or so," says Leroy. "The night of October 3, from 10 p.m. until around midnight, the Atlanta, Ga., boys came through. I worked W4LRR at 11:39 p.m. with very fine, S8 signals." Leroy now has 9 states, 3 call areas for the DX Scoreboard, which we plan to resume in the near future.

*Send all contributions to W. E. McNatt, W9NFK, 2433 Elder Lane, Franklin Park, Ill.

The Republic of Texas Report

John Naff, Port Neches, Texas, was for many, many months a SWL reporter to "The VHF News". It certainly is a pleasure, now, to announce that he holds WN5TFW! He was all ready to go on 2, the day the ticket came, and worked a number of the boys in the Sabine - Houston area. FB, John, but don't forget that c.w.!

W5SFW, Amarillo, Texas, is active on 6 meters with 100 watts to an 829B and a 3-element beam. However, he plans to be on 2 in '52. Active 2-meter stations in the Amarillo area are W5s MJD, RRA, CYX, BGT, IEA, BFA, PZX, LJG and, soon, MYH. Six-meter stations are: W5s MJD, WX, SFW, BFA, and HVP. Thanks, Phil.

W5SVB is the new call of George Saylor, ex-W3FZQ, now located in Houston, according to W5FEK. Waldo's comments on Gulf-area activity generally reflect the situation reported from many areas throughout the country: "This summer has been very poor!" A bright spot in southern activity has been W5JBW, Maplewood, La., who is heard almost nightly in the Houston area since he put up the 24-element beam, according to W5FEK. To the southwest, W5IVU, Edna, Texas, is quite active and has been worked almost nightly since putting up W2PAU's version of the twin-5 seventy-five feet in the air. W5ONS, Victoria, is active but seems to have transmission-line trouble.

The terrific heat and humidity in the Houston area have discouraged construction on new gear, according to W5FEK. Bud, W5FSC, is still a-building his 4-125 rig. W5TAF has a p.p. 4-65A final nearly ready. W5FEK fears his 829B final will fall apart if he doesn't attend to it, soon. A new, crystal-controlled Wallman Cascode converter, using a 6BQ7, is also planned. The local gang is interested in the 5763 tube and are after W2PAU for some "inside dope". Maybe Brownie will pass it along to the rest of the gang via these pages.

Most of the time, we think of the v.h.f gang as amateurs, only, and seldom have a chance to know what their jobs are. W5FEK presents an interesting roundup of the vocations of the Gulf area gang: W5FSC builds geophysical equipment for an oil company. W5s ONS and IVU are radio servicemen as is W5ON, 79 years old, believed to be the oldest active 2-meter ham in the country and

certainly one of the oldest active hams! W5QIO is an electrician for the Beaumont refinery of an oil company. W5MKP, a graduate electrical engineer, is an accountant. W5AXY, Austin, owns a machine shop. W5IRP, Bob Kurth, is a senior medical student at Baylor U. W5BDI is a counter salesman for one of the Houston jobbers. W5DSB, Beaumont, is an accountant. W5QME, also of Beaumont, is proprietor of his welding shop. W5AQS, Palmer, is a farmer. W5FBT, Baytown, is an engineer at KTRH.

On October 6, W9NFK enjoyed the hospitality of W5FSC and Mrs. Beck, who kindly arranged a small hamfest with W5s FEK, IRP, ON, and TAF. The gang really enjoyed an evening of ragchewing in person, and working W5s JBW, TVU and TAF. Mrs. Beck presented a very tasty snack table to the gang at about midnight. The "yak" session continued until, to my great surprise, nearly 3 a.m.! Then, with W5IRP as "pilot", we dashed over to W5FEK's place for a very quick tour, and then to the hotel. Thanks, fellows! W5ON, "Pop" is a very vigorous gentleman whose appearance and enthusiasm belies his very creditable number of years. He sparkplugs the local emergency net, which meets weekly, and—believe you me—you are to show up, or *else!* Hi!

My stay in Texas lasted 10 days, but the available spare time for visiting was limited heavily by business requirements. Accordingly, my next opportunity for a visit did not occur until my return home, which was routed through Dallas and Fort Worth so that I could spend a few hours with relatives in "Cowtown". Late on Friday night, October 12, a telephone call to W5CVW brought Bill to pick me up for a visit to his home. He lives only about 2 miles north of the home of my Aunt and Uncle. Bill's new 60 ft. tower is beautiful, and required a lot of hard work to erect.

A phone call to Leroy, W5AJG, next day, resulted in the news that Mr. May was all tied up on a TV-cast of the Oklahoma - Texas football game. But, we had a very pleasant telephone QSO with Leroy while, apparently, the "boss" was wondering why the sideband traps of the TV rig were not being tuned up!

And, so to home in 3 hours and 5 minutes, flat, on a DC-6, non-stop. Helen, the kids and I went out for supper, that night. Enough, now, of the travelogue!" (It was enjoyable, however, hi!)

Midwest Activity

WNØEEU, Sioux City, Ia., is trying to stir up some activity on 2 in the northwest corner of Iowa. According to WØIHD, he will be operating mobile with a TBS transmitter and a Gon-Set - meter converter during his travels throughout six or seven states of his territory. WØYRX is still trying to get his 6J6 pre-amp to work on two, and he is trying to figure out a way to get his antenna up higher and rotate it faster than the present TV rotator will permit. WØIHD further reports that WØKYF still faithfully calls the 2-meter net together on Tuesday nights at 7:30



Hottest two-meter man ever photographed. W5CVW digging post holes for his 60 ft. tower at 125° F.

p.m. Bill is also busy with a 2-meter converter that he is building for his cousin, Dave, in Texas. Incidentally, only one failure of Bill's roll-call for the net occurred a few weeks back. Investigation revealed that one side of his 300-ohm line had been *cut* by the carpenters who had re-roofed his house!

Charles, WØIHD, offers his plea—as so many of us do—for more activity. Conditions have been excellent many, many times in the St. Louis area, but the stations just haven't been on! Familiar plea, isn't it?

WØBNQ, E. F. Henning, Lees Summit, Mo., says he is still not in a position to do anything seriously with v.h.f., in spite of his interest, because he doesn't wish to take undue advantage of his landlord. He is successfully active on 80, 40 and 20 in spite of the fact that the proprietors now have a TV receiver! "Lucky!" says Errett, who was W5BMI when I worked him, years ago, as W6FEW. (Incidentally, "EF", WØCMV is in town and Opal will tell us *more* about *those* schedules. Hi!)

Around Chicago

Ken Caldwell, W9NW, the "*Dean of the Two-Meter Band*" in the Chicago, Illinois, area continues to prove his right to the title by being more consistently active than any other operator in the area, to our best knowledge. On September 30, Ken worked W9BTI, Wauwatosa, (Milwaukee) Wisc., and, later, W9JBF, Wausau, who hooked Ken up with WØOAC, White Beak Lake, Minn., giving Ken another state. On the night of October 1, Ken was lined up by W9s HKQ and SUV

as well as W8LPØ for a contact with W4JDN, Erlanger, Ky. So far, this year, Ken gained 3 new states for a total of 10, which he thought he'd never get. Since October 2, Ken heard W9s FAN and LJV; worked W9HDB, KJU, VNW, CX, BPV, IPO and WN9OKF. On the morning of October 7, the Sunday a.m. roundtable included W9s RTY, UMD, CT, IWE, KDX, JGA and NW. The Sunday morning roundtables are a revival of W9NW's suggestion of 2 years ago, namely that the gang get on the air on Sunday morning at about 10:00 a.m. This word has been passed around, and it's hoped that quite a gang will show up for Christmas Sunday, December 23.

W9s UMD, PEN, KJU, CT, DRN, JGA, MOJ, IPO, NFK, FI, KCW, WOK and others besides "The Dean" (W9NW) keep Chicago represented on 2. W9EQC, W9CEW, W9HQZ, W9BBU, W9IMQ, W9GDM, W9NZ, W9OS also maintain activity in the outlying towns. W9s HKQ, De Motte, Ind., W9HDB, Valparaiso, W9EGH, Goshen, and W9DHJ, Crown Point, are heard most often.

The "Party Line" Net gang, on 147.5 FM, fixed-tuned transmit-receive, goes on and on. Originally conceived by W9LLX and W9NFK as a local "yak" net, the circuit has progressively and successfully attained the status of both a "party-line" net as well as an emergency, civil defense net. Many stations are regularly active, regardless of seasons. W9s FME, EKK, IGH, UDD and WJU are all active in Indiana and enjoy frequent

It sure was worth all the trouble - 60 ft. of beautiful steel tower at W5CVW. The 144 mc array will be 73 ft. high at the top.

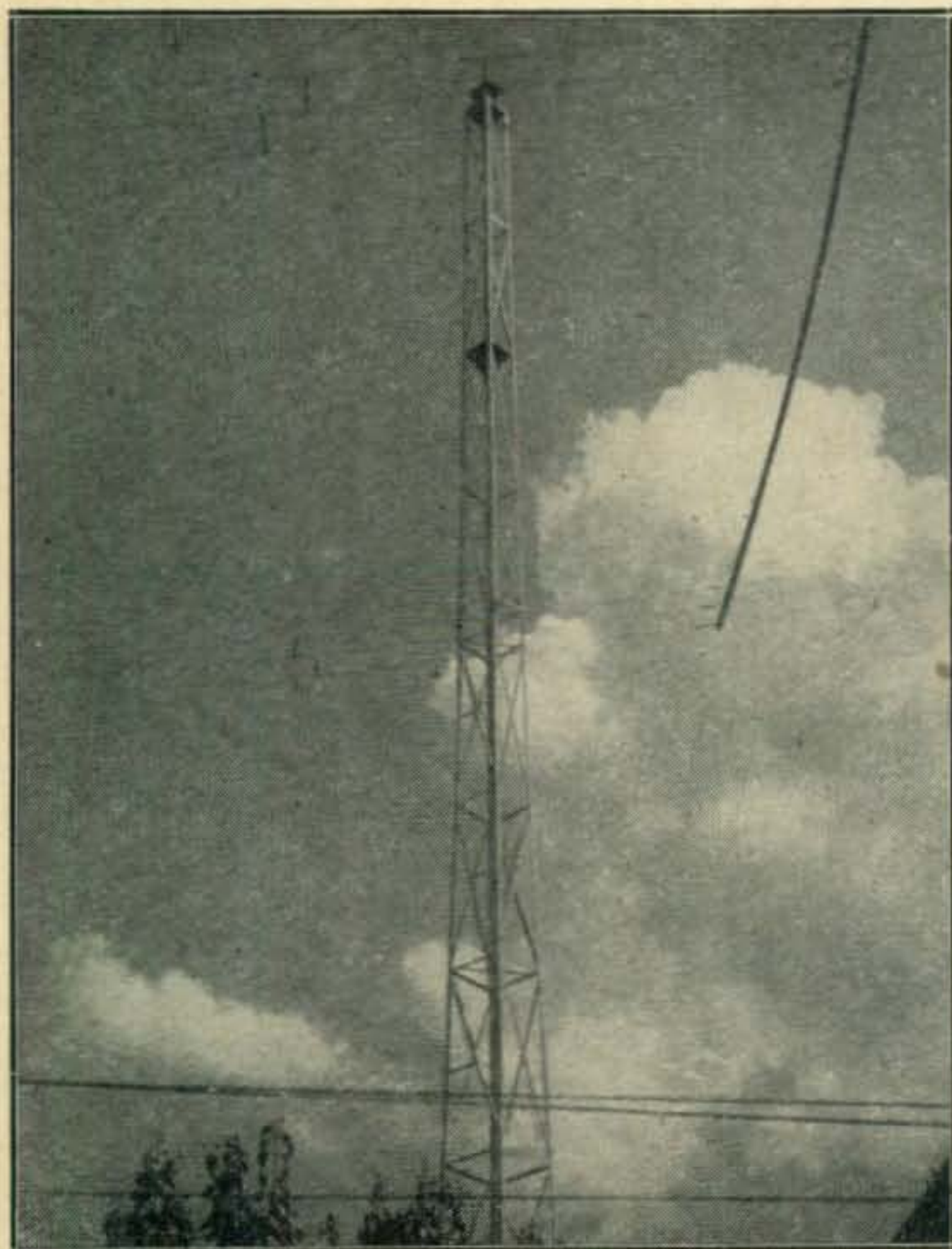

QSOs with the Illinois gang, consisting of W9s ZNX, EQC, LLX, ZOX, MDO, CPF, CYT, MOE, CEW, QM, LLZ, HPJ, IPO, CG, KJQ, WMR, OBH, ZVV, ZYF, ESG, LSY, KLB, HH, KCW, EH, UDT, QIO, NFK and others. Some stations are equipped not only for home station operation and mobile contacts, but also for "Handie Talkie" unit and airborne-mobile operation!

The Chicago-area Two-Meter activity contest continues under the inspiration and guidance of Walt, W9CT. His project is named, appropriately "STAPERMO" Contest, or "Stations Per Month". As of mid-September, scores were: W9JGA - 39, W9NW - 38; W9CT - 37; W9KCW - 22, W9PEN - 16; W9HAA - 4; W9KJU - 25. "This," says Walt, "is the first month of this year in which Ken did not make first place!" Understandable, we say, in view of Ken getting a car, taking a vacation, having power-supply troubles and doing a lot of visiting! In other words, Ken really loafed, but yet came in 2nd for the month!

Alice Bourke, W9DXX, has been plagued with a "devil" insofar as 2-meters has been concerned for the past several months. First, it was antennas; then, it was the rig; then it was antennas; then it was both the rig *and* the antennas! Finally things were straightened out, and Alice came back to 2. In the meantime, she became interested in the "FM Party Line Net", on 147.5 mc, and it is hoped that she will be on, soon. Ed Webb, W9IPO, and son, Ladd, assisted by "Bob", trekked to Alice's Homewood home in early October and installed the vertical groundplane antenna on top of a high power pole, amidst flying wrenches and dropping tools. (Ask "Bob"!) The equipment will be installed, later.

W9ALU, Metamora, likes W2PAU's "Twice Five". But, according to "Hod", power competition in the Peoria area must be coped with. W9L runs 200 watts; W9BPV, Armington, runs 100 to 200 watts; W9MAL runs about 100 watts and W9EHX runs 200 plus! All stations have their antennas up at least 60 feet, Hod observes. W9ALU's power is 50 watts; W9CAW, "Gus", is a private in the army, now located at Fort Leonard Wood, Mo. He sure does miss the two-meter gang; he doesn't even have a receiver with which to listen to the band. Keep us posted, Gus. W9ZHL, Terre Haute, Ind., enjoyed the Indiana - Illinois - Ohio - Kentucky - Missouri - Pennsylvania opening in early October, but couldn't hear the W5s.

W2PAU says that a new crop of novice operators is doing its share of keeping local activity going in the Collingswood, N.J., area. Conditions during late September and early October weren't exceptionally good, although 300-mile contacts up and down the coast were good on October 14, 15, 16. W2YXE, Troy, N. Y., is maintaining schedule with Brownie. The 200-mile QSOs usually start off c.w. but phone is good, most of the time. Some tests on polarization will be made; Brownie, please don't start "it" all over, again, hi! W2PAU promises to keep eastern news flowing to these columns.

Thanks! Hope some of the gang in other parts of the country will do the same.

Two-Meter Beacons?

W8WRN, Columbus, O., hopes to operate a beacon transmitter on two meters next year, probably on 146 mc. Ken's idea is that such stations would be invaluable for propagation-minded v.h.f. men who could know where to look for signals for observation purposes, especially when 6 meters might be open. Ken has experienced difficulty in getting northern six-meter stations to check 2-meters for E_s skip when 6 was open, but reports that the gang down south is very cooperative. What about 2-meter beacons?

Ken, like many other 2-meter men, bewails the absence of openings in the midwestern states this year, although Kansas, Missouri, Iowa and Wisconsin have been heard from. Local activity has been low, but W8BAX and W8WAB are heard from; W8WRN gets on when the XYL or the job permits. W8AMR, Troy, is on, nearly every night. The Dayton and Toledo groups seem to be quite active. The Columbus gang seems to have given up on the club-sponsored 144 mc mobile emergency gear; cost is too high for *good* gear, they say! In fact, says W8WRN, civil defense efforts were practically nil in late September. The psychology of this civil defense matter is odd. So many people feel that "it can't happen here", yet most of them would cringe at the idea of driving 10 miles without *spare tire!*

Miscellany

Al Burson, W8WXV/Army, Ft. Monmouth, N.J., and W9NJB have K2USA on 2-meters. Al built a crystal-controlled Wallman Cascode. Chuck, W9NJB, built the antenna, a 90° corner reflector with 2 half-waves in phase, driven. Both fellows got an 829B final going and have worked out quite well: 9 states, VE1QY! The main problem with the station is in keeping the antenna in the air, 100 feet high!

W8UZ, Columbus, O., is in need of a copy of "The VHF News", May, 1950. Can you help him? *We're out.*

W8YEG, Coschocton, O., caught W2NLY and W2PAU on the September 25 Aurora opening. The east-coast boys, according to Wig, were coming in about 20 to 30 degrees *west* of North while W9BBU and W9GSY were received with the beam about 20° *east* of North! Very interesting. W8YEG is still gunning for New York and the New England states.

W6MHF is still on the trail of the weak DX signals heard on July 15. He is convinced that they were from the eastern states, and that he was not "noise happy." Dave feels that the propagation path may have involved a couple of E_s hops plus some ionospheric assistance. Quite possible. As time goes on, I feel that similar conditions probably prevailed on past DX contacts. W6MHF is quite anxious to establish contact via the mails with any eastern or midwestern v.h.f. ham who is sincerely interested in serious propagation tests. Pointed up,

here, is the usefulness of beacon stations if they can be set up on a reliable basis.

W5CA, Dave Middleton, reports that the v.h.f. meeting held at Austin, Texas, was a bang-up success. The communique from W1HDQ, W2PAU and W9NFK were well received. A lot of laughs were had when v.h.f. men won prizes suitable for l.f., and l.f. operators won v.h.f. gear! Just like the c.w. man winning a mike!

The Balloon Went Up!

It was working when it went up, says W5CA. No authenticated reports have been received, so far. It was released at 7:35 p.m., MST, August 11, with all gear working. The keying was c.w., not m.c.w. as announced. We'll probably hear more about this, later.

Canadian Capers

Iris Weir, VE3DER (XYL, VE3AIB) reports from Ontario that over 100 Canadian and U.S. v.h.f. operators assembled at Riverside Lodge Tavern, Oakville, Ont., on September 7, for the fourth meeting of Southern Ontario VHFers under the able leadership of the Oshawa Club. Chairman VE3AZV opened the meeting with general business, and it was decided that the Buffalo, N. Y., gang will hold the next "do" on January 19, 1952. Tom Stewart, W2TBD, will sparkplug the affair. VE3AZV then introduced Ed Tilton, W1HDQ, who proceeded with a question-and-answer session, followed by an interesting talk on the advantage of sharp-selectivity v.h.f. receivers.

Following W1HDQ's talk, prizes were awarded. VE3AXX and DAT won circle cutters donated by VE3AZV. VE3AET and VE3DGZ won subscription certificates to "The VHF News", donated by W9NFK.

Attendance was very good. A surprising number of Ws were present: 12 W2s from the Rochester and Buffalo areas; W3QKI and WBM, who came up from Erie, Penna., with W8DUL, Ypsilanti, Mich., and — of course — W1HRQ, plus 84 VE3s, four of which were XYLs: VE3DMN, VE3DER and XYLs of VE3BOW and AXT.

On Sunday, VE3ANY arranged a tour of shacks for W1HDQ which covered 14 stations and 83 miles! With two stations yet to visit, the gang stopped off at the AIB-DER homestead for a buffet supper. It served as a good ragchew session for the group of 10 or so present. The visits wound up at VE3DAN for a 420 mc QSO with W2ORI.

On September 11, the first meeting of the season was held on Six Meters by the *TASMEN* (Toronto Amateur Six Meter Emergency Net). VE3BOW has kindly put up a trophy for the coming sweepstakes contest, which is the equivalent of the VE3BQN trophy for two meters. The VE3BOW trophy is for six meters, only.

Two new 2-meter stations are reported heard by VE3BOW; VE3BIQ, Waterloo, Ontario, and VE3EI, Forest, near Lake Huron. EI has a 16-element beam 75 feet high. Thanks to VE3AVE, also of Forest, who passed the information to BOW.

Early scores for the Sweepstakes contest indi-

cate that VE3ANY had 4 sections on 2 and about 40 contacts. Although AIB had high score for 2-meters, alone. VE3DER commends DIR for a total of 77, in all. VE3AIB won the 2-meter trophy and VE3ANY copped the 6-meter trophy. ANY hooked WIHDQ on Aurora, thus getting the winning multiplier!

VE5JK, Regina, Sask., had a run of tough luck which hospitalized his XYL for two months, but she's pulling through! Jack—getting to ham radio—says that 420 is one of the best bands to develop since it has wonderful possibilities. He proposes that the gang voluntarily divide the band as follows: 420-432 mc, modulated oscillators and miscellaneous experimenters; 432-444, crystal-controlled (tripling from 144-148 mc) for the "band pioneers" of v.h.f.; 444-450 mc, amateur TV and radioteletype plus other experimental. This strikes me as a very logical proposition. Your comments will be appreciated very much.

W2QED, Seabrook, N.J., is a very active 420 mc operator. During September, he worked W3DOG, Laurel, Del., for state No. 7 on 420! W2QED's log for September on 420 is impressive: 52 contacts, of which 10 were oneway, representing 12 different stations in 3 call-areas: WIHDQ, W1PBB, W2TP, W2TM, W2PWP, W3BSV, W3OWW, W3AIR, W3RE, W3OFK, W3NAG, W3DOG, in Connecticut, New Jersey, Maryland, Pennsylvania, District of Columbia and Delaware! Congratulations, Ken! We'd like to have more 420 Mc. Information from every single operator on the band, including W9s ZHB and MBI as well as WØHAQ. Those fellows are working out well, too. But, the states are just a little bit farther apart in the midwest, hi! Note to W9s ZHB—MBI: all right, I'll come out one of these days, as promised!

Letters!

So many of you fine fellows sent in such nice letters regarding the closing of "The VHF News" that it will take Helen and I some time to answer them all. But, let me say, here, that *not one* single gripe or complaint was received. Some very wonderful expressions came from little notes, only a sentence or two in length, as well as from letters of five and six pages in length. Some of you even offered to organize financial backing for continuance of "The VHF News" by means of dances, equipment auctions, "beating advertisers over the head" or by individual, private subsidies from financially independent hams. But, the day of closure was bound to come, for reasons stated in my letter to the "News" gang. It was an especial amount of satisfaction to us that every last one of your letters approved our arrangements with CQ. Now that we are well under way in new pages, I hope that all of my old friends and you, my new friends, will continue the support given so loyally in the past. My purpose is to report v.h.f. activity, period. But, this can be done by no man *singly*—he must have the help of the man who is active. *That's you!*

Significance of VHF

Unfortunately, in spite of many years of public notice via the pages of several leading amateur radio journals, the average low-frequency radio amateur is *still* not cognizant of the proven usefulness of the 50 mc, 144 mc, 230 mc and 420 mc bands. Perhaps even some of us v.h.f. men are not completely awake in this respect, either. There is neither time nor space available, now, for a detailed presentation of the situation. Yet, think of these generally-known, apparent facts: the Loran and Shoran systems sharing 160 meters; the requirement by the Armed Services of the portion of the 80-meter and 75 meter phone band this summer; the military and civil defense strategic requirements for close control of 40, 20 and—to some extent—10 meters. Civil defense planning by some municipalities for extended usage of 50 mc, 144 mc, and 230 mc. The literal "screaming" for more channels in the 152-164 mc band by cabs, 'phone companies, and dozens of other commercial interests. This applies also to the 25-50 mc commercial allocations. These, alone, imply the pressure against amateur radio interests on 6 and 2. But, even now, the commercial occupancy of the 450 mc band is growing by leaps and bounds. In Chicago, taxicab service has been in operation on the 450 mc band for some months; the Detroit area will see it, soon; the same for New York. Commercial communications employ 450 mc circuits for repeater, or relay service in many types of business. Long ago, telephone interests completely surveyed the city of New York for mobile telephone service on the commercial 450 mc band!

In the face of these facts, and many others for which we haven't space, where does any amateur radio man, low-frequency or v.h.f., have a point of question as to the *usefulness* of the v.h.f. bands?

These frequencies, even if occupied by amateurs with the simplest of crystal-controlled transmitters, superhet receivers and simple antennas, can provide short-haul communications from 10 to 50 miles that are completely free from QRM, unless crystals of the same frequency are chosen. The backyard QSOs on 10, 20 and 75, with *500 watts to a kilowatt* and the attendant QRM and noise, could be such a pleasure on v.h.f.! Witness: the many low-frequency operators now on v.h.f. But, the problem remains: to convince more low-frequency operators that communications can be had without being an electronics genius! The "genius" angle is another line of *propaganda* being put out by some of the mentally-laggard low-frequency men. They plead "plaintively", that "this v.h.f. gear is just too critical of adjustment!" Yet, in commercial v.h.f. work there are maintenance men who wouldn't even make good l.f. hams, who are maintaining 150 mc systems, daily!

How can we overcome *mental* lethargy, or the "good old horse and buggy days" attitude?

73, Gang.

—Bill McNatt, W9NFK

Ionospheric Propagation Conditions

GEORGE JACOBS, W2PAJ*

December 22 is the day that the winter solstice occurs. It is the day that the sun reaches its most southern point in its travels from northern to southern skies, also at this time the sun is at its nearest distance to the earth. This astronomical phenomena has its associated affects on radio propagation.

It is known that shortwave radio depends upon the ionosphere as its medium of propagation. The ionosphere is created by the ultraviolet radiation of the sun. The more ultraviolet radiation received, the more highly ionized is the ionosphere, and the higher are the frequencies that can be used for a particular radio circuit. When the sun is nearer to the earth, intense ultraviolet radiation sweeps across the ionosphere. This accounts for the seasonally higher daytime frequencies usable in the Northern Hemisphere during the winter months, with the peak reached at approximately the time of the winter solstice. However, with the sun so far in the southern skies during this period, the hours of darkness in the Northern Hemisphere are considerably increased. This increase in the hours of darkness permits extensive night deionization of the layers of the ionosphere and considerable lowering of the MUF. For this reason nighttime MUF's are at their yearly low during December.

These characteristics can best be understood by referring to *Fig. 1*, a comparison between December and June (when the sun is highest in the northern skies), MUF's for an East Coast to Central Europe transmission path. It can be seen that the December day frequencies are considerably higher, but for a shorter period of time than in June, and the night frequencies are considerably lower.

The forecast for December then is for DX possibilities on all bands from 10 meters to 160. The predicted smoothed monthly sunspot number for December is 60.

3620 Bedford Ave., Brooklyn 10, N. Y.

Last Minute Ionospheric Storm Predictions

During December, at the time of writing and based upon the 27 day recurrence cycle, moderate to severe radio disturbances are most likely to occur during 1-4, 7-12, and 28-31. Other disturbed periods may occur December 15-17 and 22-24. A period of better than normal radio conditions is expected December 18-21.

General Propagation Conditions for December, 1951

The following is a brief description of expected propagation conditions for Amateur circuits from the United States to the five major areas of the world for December, 1951. For times of band openings for any particular circuit refer to the Propagation tables.

EUROPE:

The daytime maximum usable frequencies on paths from the Eastern and Central areas of the United States to Europe should peak during days of normal ionospheric behavior, to almost 30 mc.

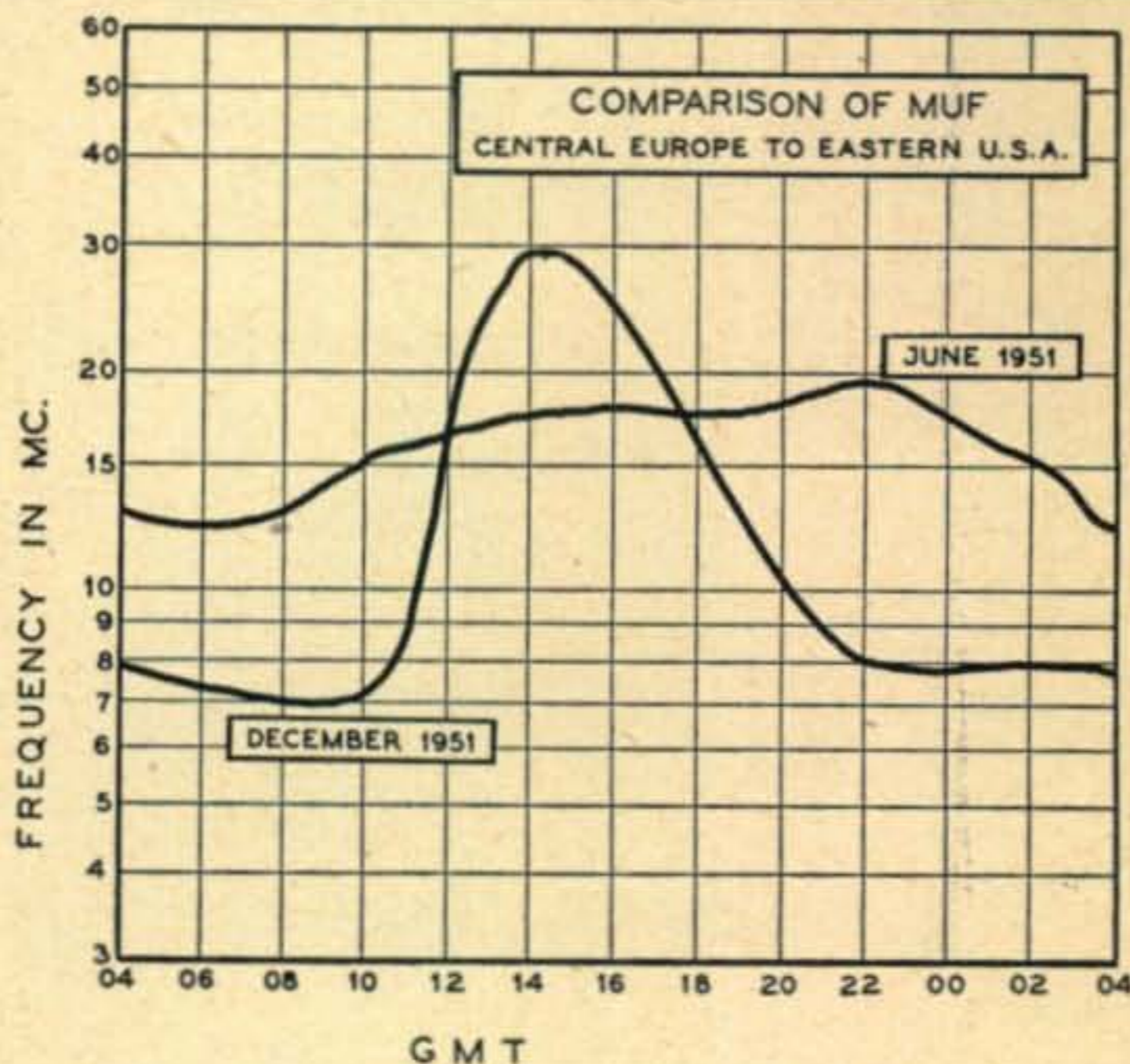

Fig. 1. MUF characteristics at the winter and summer solstice.

DX conditions are expected to be fair to good on 10 meters for these transmission paths. From the Pacific Coast to Europe, conditions on 10 meters are expected to be poor with few openings. This is due to the long distances involved and the increased absorption and depressed MUF's resulting from auroral zone penetration.

Plenty of DX activity is expected on 20 meters. This band will go out about an hour earlier than it did in November. However, good DX conditions are expected from most areas of the USA to most areas of Europe. Conditions favor the East and Central areas of the USA on these transmission paths.

(Continued on page 60)

DECEMBER 1951

EAST COAST TO: (Centered on Washington, D. C.)	10 Meters	20 Meters	40 Meters	80 Meters
	A L L T I M E S I N G M T			
Scandinavia	1330-1530 (1)	1130-1400 (3) 1400-1730 (2-3) 1730-1830 (3)	2000-2100 (1-2)	2200-1000 (2-3)
Great Britain & Western Europe	1430-1630 (3)	1130-1400 (3) 1400-1900 (2) 1900-2130 (3-4)	2200-0930 (3-4)	2200-1000 (3-4)
Balkans	1300-1530 (2-3)	1130-1600 (2) 1600-1800 (3-4)	2200-0500 (3) 0500-1100 (2)	2200-1100 (2-3)
Central Europe	1300-1600 (3)	1130-1330 (3) 1330-1700 (2) 1700-1900 (3-4)	2200-0500 (3) 0500-0900 (2)	2300-0800 (3)
Southern Europe & North Africa	1300-1800 (3-4)	1100-1300 (3-4) 1300-1800 (2-3) 1800-2100 (3-4)	2200-0400 (3-4) 0400-1000 (3)	2200-1000 (3)
Near East	1300-1500 (2-3)	1100-1530 (1-2) 1530-1800 (3)	2200-0600 (2-3)	2200-0700 (2)
South Africa	1200-2000 (3-4)	1100-1800 (0-1) 1800-2300 (2)	0000-0300 (0-1)	Nil
South America, East Coast	1200-1500 (3) 1500-1700 (2) 1700-2100 (3-4)	1030-1300 (2-3) 1300-2000 (1) 2000-0000 (4) 0500-0700 (2)	2300-0900 (3-4)	2300-0800 (2-3)
Hawaii	1800-2230 (4-5)	1530-1900 (2-3) 1900-2230 (1) 2230-0230 (4)	0330-1430 (4)	0400-1430 (3-4)
Oceania	2100-2300 (2)	1230-1500 (2-3) 1500-2200 (1) 2200-0200 (2)	0700-0900 (0-1) 0900-1230 (1-2)	Nil
Guam	2130-2300 (2-3)	1930-2200 (3) 2200-2300 (2-3) 2300-0130 (3)	0800-1300 (2)	0800-1300 (0-1)
Japan	Nil	1130-1300 (0-1) 2030-0100 (2)	0800-1200 (2)	0800-1200 (0-1)
India	Nil	1300-1500 (1) 2300-0300 (1)	1100-1300 (0-1) 2300-0200 (0-1)	Nil
CENTRAL USA TO: (Centered on St. Louis, Mo.)	10 Meters	20 Meters	40 Meters	80 Meters
Great Britain & West Europe	1500-1730 (2-3)	1130-1500 (3) 1500-1900 (2) 1900-2130 (3)	2300-0400 (3) 0400-0830 (1) 0830-1000 (2-3)	2300-1000 (3)
Central Europe	1500-1630 (2-3)	1300-1900 (2-3)	2200-0400 (3) 0400-0830 (1) 0900-1000 (3)	2200-1000 (3)
Southern Europe & North Africa	1430-1730 (3-4)	1130-1400 (3-4) 1400-1900 (2-3) 1900-2200 (4)	2300-0900 (4)	2300-0900 (4)
South Africa	1300-1600 (2) 1600-2030 (3-4)	1130-1900 (0-1) 1900-2300 (3)	0200-0400 (1-2)	Nil
South America, East Coast	1200-2130 (4)	1030-1430 (3) 1430-2100 (1-2) 2100-0100 (4) 0500-0700 (2)	2300-0900 (4)	2300-0800 (3-4)

DECEMBER 1951

CENTRAL USA TO: (Centered on St. Louis, Mo.)	10 Meters	20 Meters	40 Meters	80 Meters
	A L L T I M E S I N G M T			
Hawaii	1830-2300 (4-5)	1600-1930 (3) 1930-2130 (2) 2130-0230 (4)	0400-1500 (4)	0400-1500 (3-4)
Oceania	2230-0000 (3)	1430-1800 (2-3) 1800-2300 (1-2) 2300-0300 (3)	0800-1400 (2)	0800-1400 (0-1)
Japan	Nil	1300-1400 (1) 2100-2200 (3) 2200-2330 (1-2) 2330-0130 (3)	0800-1300 (2)	0800-1300 (1-2)
India	Nil	1300-1500 (1) 2300-0300 (1)	1100-1400 (0-1) 2300-0200 (0-1)	Nil

WEST COAST TO: (Centered on Sacramento, Calif.)	10 Meters	20 Meters	40 Meters	80 Meters
Europe	1530-1630 (0-1)	1500-1800 (2)	2200-0900 (2)	2200-0900 (1-2)
South America, East Coast	1530-0000 (3-4)	1300-1400 (2) 1400-2300 (1-2) 2300-0230 (3) 0800-1000 (1-2)	0400-1000 (3)	0400-1000 (2)
Oceania	2100-0200 (3-4)	1500-1800 (3) 1800-0300 (1-2) 0300-0500 (3)	0700-1400 (2-3)	0700-1400 (0-1)
Japan	2200-0100 (3)	2030-0000 (2) 0000-0400 (3-4)	0800-1600 (3-4)	0900-1500 (2)
Philippines & East Indies	2100-0100 (2-3)	2100-2300 (1-2) 2300-0200 (0-1) 0200-0400 (2-3)	1000-1400 (2)	1000-1400 (0-1)
Alaska	2100-2330 (3)	1900-2100 (4) 2100-0000 (3) 0000-0300 (4)	0300-1600 (4)	0300-1600 (3-4)
Marshall Islands	1930-0130 (4)	1800-2000 (3) 2000-0200 (2) 0200-0430 (3-4)	0700-1500 (3-4)	0800-1400 (1-2)
India	Nil	0130-0300 (1-2)	1300-1500 (1-2)	Nil
South Africa	1700-2300 (3)	1300-1600 (2-3) 1600-2200 (1-2) 2200-0230 (2-3)	0400-1200 (1)	Nil
Marianas	2030-0100 (4)	1930-2200 (3) 2200-0200 (2) 0200-0430 (3-4)	0800-1700 (3-4)	0800-1700 (1-2)
Guam	2030-0030 (4)	1930-2100 (3-4) 2100-0200 (2) 0200-0430 (3)	0800-1600 (3)	0800-1500 (1)

All basic propagation information used for determining the Prediction Charts has been obtained from the National Bureau of Standards. Series D-85, publication entitled, "Basic Radio Propagation Conditions for December, 1951".

All predictions are based on an effective radiated CW power of 150 watts.

Symbols for Expected Percentage of Days Of Month Path Open

(0) None (1) 10% (2) 25% (3) 50% (4) 70% (5) 85% or more.

The Skywire and the Law

MAURICE J. HINDIN, W6EUV*

Recent developments clearly indicate that the number of supposed violations of zoning ordinances is on the increase. Many of these have no basis in fact, but are often cast in such a light as to discourage any protest from the involved amateur. In order to keep the amateur fully informed of what he can do, CQ has commissioned a well known amateur, and lawyer, to write at length concerning this subject. W6EUV is an oldtimer and has been admitted to practice before the U.S. Supreme Court, the F.C.C. and the Courts of the State of California. His article is a "must read."—Editor.

NOT ONLY HAS THE POPULARITY of television increased the amateur's technical problems, but it has increased the frequency of legal attack on amateurs as well.irate neighbors whose propensity to blame the amateur for all of their television woes have, in many instances, found new expression of their anger through the so-called local zoning and building codes' restrictions.

The purpose of this article is to primarily point out some matters for consideration, which an amateur confronted with a zoning problem should be prepared to meet. It is written to serve in the legal field where the popular books on "what to do until the doctor gets there" propose to do in the field of first-aid. Basically speaking, there is still no substitute for adequate legal representation before local Zoning Boards and Commissions. However, in some instances it is impractical for the amateur to secure competent legal advice. It is in these presentations that this article may serve as a series of guideposts.

Of all amateur equipment, the outdoor antenna is the most prolific source of zoning and safety difficulties for amateurs. This article will confine itself to a discussion of the chief objections raised in Zoning Board cases and will make suggestions as to how the amateur may best meet these ob-

*10471 Le Conte Ave., Los Angeles 24, Calif.

jections, if they are raised in his particular case.

It should be pointed out that almost every city and incorporated community has general zoning laws or regulations, as well as, building and safety rules and regulations. These local zoning ordinances vary greatly from community to community. The first item of preparation should be to secure a copy of the local zoning regulations and local building and safety regulations. These regulations can usually be secured at a nominal cost from the City Clerk, or from the offices of the local Zoning Board or City Engineer.

You cannot prepare to defend yourself unless you know what the ordinance says and exactly how you are charged with the violation. Next do not underestimate the potency of that local zoning board. Although the proceedings are generally informal, the action of the amateur before the board will, to a large extent, determine the ultimate outcome of the case. The care with which the amateur prepares his case will probably determine the outcome.

After the amateur has studied the zoning ordinance he is charged with violating and has determined how he is supposed to be violating it, he should then prepare his case. The following is intended as a check list, a suggestion table and a handy table of citations to assist the amateur. Under each of the main charges is set forth the facts and legal precedents. They are not all-inclusive, but should help channel the hams' thoughts along proper legal lines.

Principle Zoning Objections

The objections most frequently raised against radio antennas are as follows:

- (1) The proposed antenna is not a usual accessory or appurtenance to a home in a residential zone.
- (2) The proposed antenna is injurious to the public health or safety of the area.
- (3) The proposed antenna violates the restrictions on the height of buildings.
- (4) The proposed antenna is unsightly and does violence to the area's aesthetic qualities.

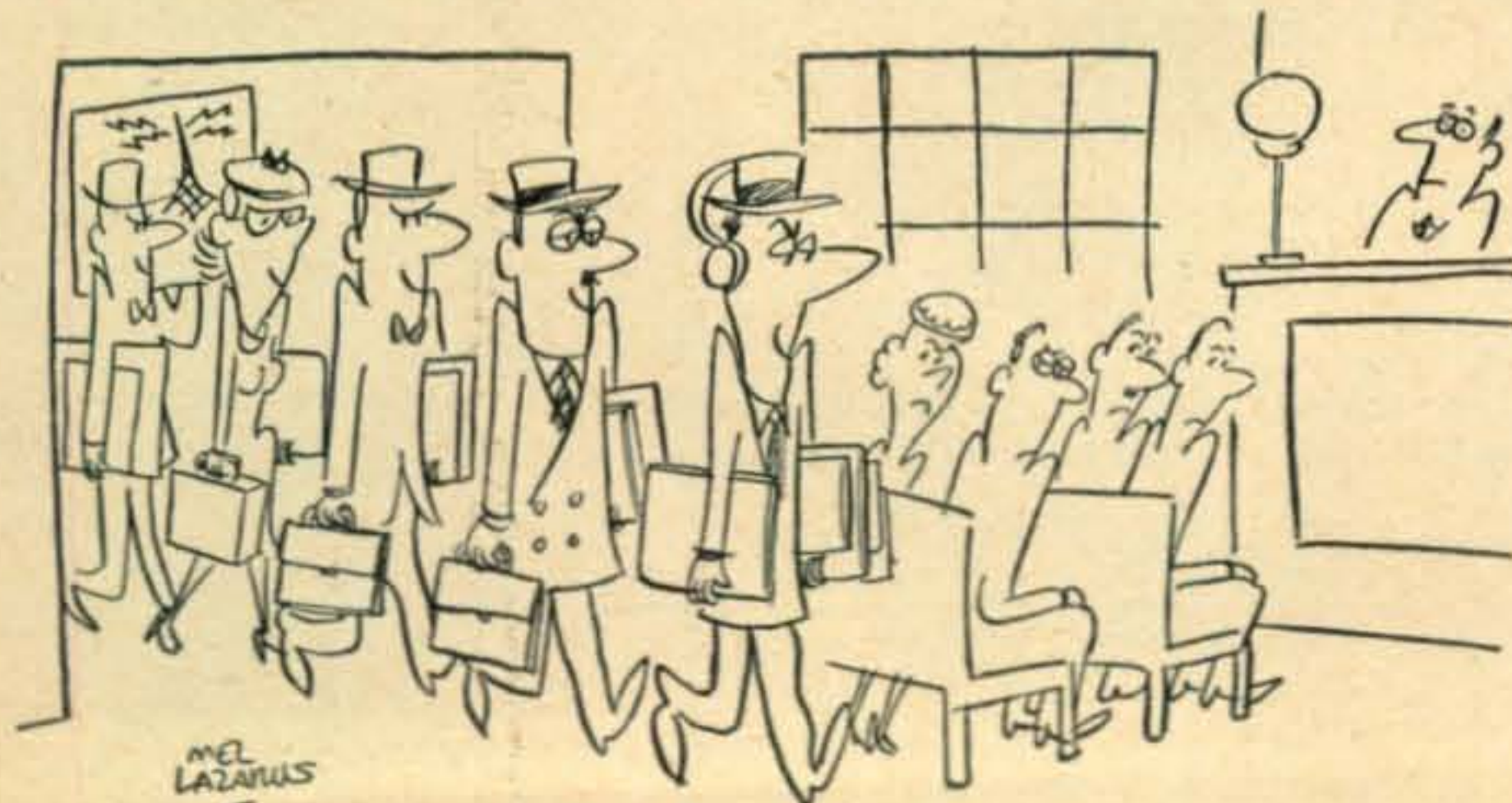

♦
". . . too much emphasis cannot be placed on the necessity and desirability of presenting a well-prepared case at all stages."
♦

(5) The proposed antenna will cause electrical disturbances, or increase radio or television interference.

(6) The presence of the proposed antenna would depreciate real estate values.

If these arguments are raised, the immediate problem is what to do about it. Some suggestions follow:

I. The Proposed Antenna is not a Usual Accessory or Appurtenance to a Home.

A. How to Refute This Contention.

The amateur should be prepared to present evidence to show: (1) That there are some 90,000 amateurs in the United States licensed to operate amateur stations and all of them use an antenna of one form or another; (2) The majority of these amateurs use outside antennas; (3) That being non-commercial in nature, the activity of amateur radio is conducted almost entirely from the home; (4) Antennas of the proposed type have already been erected and are in operation in the same community. (In this connection, it is useful to have a list of the names, addresses and call letters of other amateurs in the vicinity who have, or use antennas similar to the proposed antenna. Photographs of the other installations are helpful.) (5) Evidence as to the number and location of other types of antennas, such as television antennas, in the neighborhood is useful. This is particularly true, if the objection is entered as to the unsightliness of the proposed antenna. In one instance where this argument was raised it was effectively demonstrated that almost every home in the vicinity of the involved amateur had a television antenna of varying heights, aspect and dimension. The degree of difference between the appearance of a multitude of television antennas and the proposed amateur's antenna instantly became apparent to the advantage of the amateur's position.

B. Legal Citations and Precedents to Refute This Contention

(1) The Supreme Court of the State of Minnesota in the case of *Village of St. Louis Park vs. Casey*,¹ which upheld the right of the amateur to maintain a beam antenna, held that such an antenna was an accessory use of residential property.

(2) The same conclusion was reached in another case by Pennsylvania in the case of: *In re Appeal of Lord*.² In the Lord case, the contention was made by the amateur's opposition that the proposed antenna was not an accessory use of residential property within the meaning of the local ordinance. The court held it was a proper and usual residential use. The same ruling was made by the Supreme Court of New Jersey in the case of *Wright v. Vogt*³ in May of 1951.

(3) Likewise, it has been held that a pole used alone and which does not invade easements of

light and air is not a building within the meaning of an ordinance using the term "building of any character".⁴

II. The Proposed Antenna is Injurious to the Public Health or Safety of the Area

A. How This Contention can be Refuted:

(1) The amateur should be prepared to offer evidence that the proposed antenna is well designed from an engineering safety point of view. It is desirable to support this evidence with a qualified structural engineer. You should show that the antenna is designed to withstand the normal wind velocities present in the area and could also withstand the maximum wind velocity recorded for that area. Good structural design would require that a sufficient margin of safety be maintained; (2) Evidence should be offered that in the event of a structural failure, the antenna would fall wholly on the premises of the amateur and not fall at a place likely to result in injury or damage to property; (3) It may be desirable for the amateur to show the Board that he carries adequate public liability insurance to guard against unforeseen damage.

B. Legal Precedent to Refute the Arguments.

The courts have held that a radio antenna is not as a matter of law or fact, injurious to the public health or safety.⁵



"... the proposed antenna is unsightly and does violence to the area's aesthetic qualities."

III. The Proposed Antenna Violates Restrictions on Height of Buildings

A. How This Contention can be Refuted:

(1) If the proposed antenna is affixed to the top or side of a building, a more serious problem is presented than if the antenna is placed on a pole

¹ 218 Minnesota, 394; 16 N.W. (2) 459;

² Supreme Court of Pennsylvania, Western District, filed July 27, 1951, 368 Pa. 121.

³ Wright v. Vogt, 7NJ1, 80A.2d, 108, April, 1951.

⁴ Fidelity Trust Co. vs. Charles, 83 P. L. J., 591.

See also: Cases collected in 49 A. L. R., 1364.

⁵ Village of St. Louis Park vs. Casey, 218 Minnesota, 394; 16 N.W. (2), 459; 155 A.L.R. 1128.

removed from the building. The exact height of the top of the building itself should be ascertained and evidence offered to the Board. (2) The overall height of other antennas in the neighborhood should be ascertained, since a forceful argument can be made if the overall height from the ground of other antennas in the neighborhood equals, or exceeds the height of the proposed antenna; for example a 12-foot antenna on top of a two-story building having a roof-height of 40 feet off the ground would be the equivalent of a 25-foot antenna affixed on the top of a single story dwelling whose roof had a height of only 27 feet.

(3) The contour of the land, especially in hilly areas, might be used to bolster the argument in favor of the proposed antenna. A survey of the area would show the mean, or average elevation of the land. The average elevation could be argued to be the point from which the antenna heights should be measured. If this argument were sustained, an amateur living in a low part of the community might enjoy the privilege of a little higher antenna, than one living on the top of the adjoining hill, the mean elevation working to the advantage of the antenna at the lower location.



"... the proposed antenna will increase television interference."

B. Legal Precedent to Refute the Arguments.

There are several legal precedents supporting the amateur's position. In every case where it is contended that the antenna violates the height restrictions on buildings, a legal question is presented as to whether or not the antenna is "a building" within the meaning of the ordinance involved. As has been pointed out above, a pole used alone was held not to be a "building" in the case of *Fidelity Trust Co. vs. Charles*.⁶

In the case of *Hamilton vs. McKinley Fire Co.*, 61 *Montgomery L. Rep.*, 150, the Court, citing Webster's International Dictionary, indicated that flagpoles, electric poles, clothes poles and similar appurtenances to a home would not be construed as a "building" within the meaning of zoning restrictions.

Contrary legal authority however, is available.

The court, while upholding the right of an amateur to maintain his antenna: for other reasons, in the case of *Village of St. Louis Park vs. Casey*¹ held that an antenna pole was a "structure" within the meaning of the ordinance being considered.

The entire validity of ordinances relating to the height of buildings or appurtenances may be questioned, unless the height limitations bear a reasonable relationship to public health, safety or general welfare.⁷

IV. The Proposed Antenna is Unsightly and Does Violence to the Area's Aesthetic Qualities

A. How this Contention can be Refuted:

(1) The matter of appearances and aesthetic matters are difficult to establish factually. A beautiful antenna to an amateur may be an unsightly mess of wires to an irate neighbor. To protect the record, however, in most cases it is desirable for the amateur to have several witnesses available to testify that in their opinion the proposed antenna is not unsightly or objectionable from an aesthetic point of view. (2) Evidence of similar antennas in the vicinity, as well as evidence of widespread use of television antennas in the community, weaken the arguments based on the question of beauty of the proposed antenna. (3) Evidence tending to establish the trimness, and streamlined appearance of the antenna and surrounding buildings also tend to refute this argument.

The amateur should not go into a zoning hearing without being prepared to offer rebutting evidence, if there is any indication this argument will be used against him.

B. Legal Precedent to Refute This Argument.

There are a number of legal precedents supporting the proposition that matters of beauty and aesthetic considerations are not sufficient to warrant restrictive ordinances based on such considerations alone.⁸

V. The Proposed Antenna Will Cause Electrical Disturbances or Increase Radio or Television Interference

A. How this Contention can be Refuted:

(1) If this contention is made, it will be well if the amateur is prepared to present evidence to technically show that the proposed antenna will not increase the incidence of electrical disturbances, or increase interference to radio or television sets.

(2) Evidence showing the characteristics of radiation from the proposed antenna is useful. (3) If

(Continued on page 54)

⁶ 83 P. L. J. 591.

⁷ *Federal Electric Co. vs. Zoning Board*, 398 Ill. 142; 75 N.E. (2) 359.

Brookdale Homes, Inc. vs. Johnson, 123 N.J.L., 602; 10 Atl. (2), 477.

Clinton vs. Ross, 226 N.C., 682; 40 S.E. (2), 593

Hart vs. Tenack Township, 135 N.J.L. 174; 50 Atl. (2), 856.

White's Appeal, 287 Pennsylvania, 259; 134 Atl. 409

⁸ *Passaic vs. Patterson Bill Posting Co.*, 72 N.J.L. 285; 62 Atl., 267

Barney and Casey vs. Town of Milton, 324 Mass. 4; 87 N.E. (2) 9

Wolverine Sign Works vs. Bloomfield, 279 Mich., 205; 271 N.W., 823.

PAGE FROM A DESIGNER'S NOTEBOOK

From JOHN L. REINARTZ, K6BJ
Eitel-McCullough, Inc., San Bruno, Calif.

Screen and Grid Modulation

BECAUSE OF THE POPULARITY of simple methods of modulation, especially in mobile applications where power consumption may present a problem, the applicability of a combination of controlled carrier, screen and grid modulation to tetrodes was investigated. The results are gratifying; 100% modulation with negligible distortion being possible with the circuit arrangement shown in the accompanying schematics.

Adjustment is simple. The variable resistor in the cathode of the 6L6 is adjusted so that the screen voltage of the tetrode is at the normal class C typical operating voltage.¹ During modulation this voltage will rise to about 120% of the normal class C typical operating voltage, thus giving rise to controlled carrier conditions. The only other adjustment for 100% modulation is to reduce the grid drive to approximately 60% of the normal grid current requirement.

Some screen voltage reduction may be necessary in order that it may swing from nearly zero to twice the indicated d.c. voltage during modulation, along the linear portion of the screen voltage characteristic curve.

In order that the screen voltage may swing down toward zero during modulation, it is necessary that the grid voltage also swing downward

¹Revised circuit from "Modulate A KW," Kline, Radio & Television News, Sept. 1950, page 38.

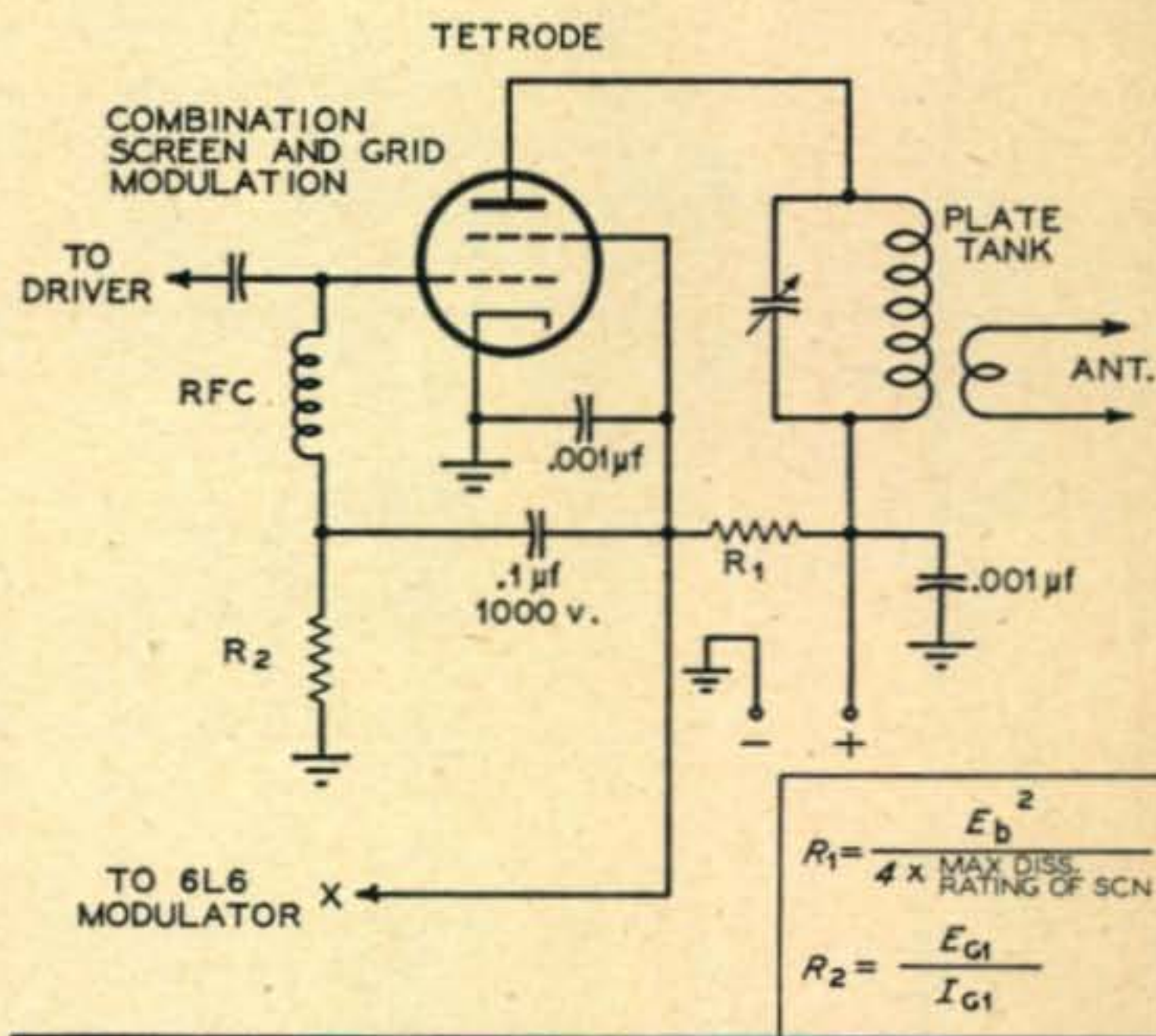

at the same instant. The 0.1 µf capacitor connected between the screen and grid as shown in the diagram accomplishes this, and the result is practically distortionless 100% modulation.

Plate voltage values up to the maximum class C telegraphy conditions allowable, for the tetrode in question, may be used. Loading is not critical and should be adjusted so that without modulation applied, the plate dissipation rating is not exceeded.

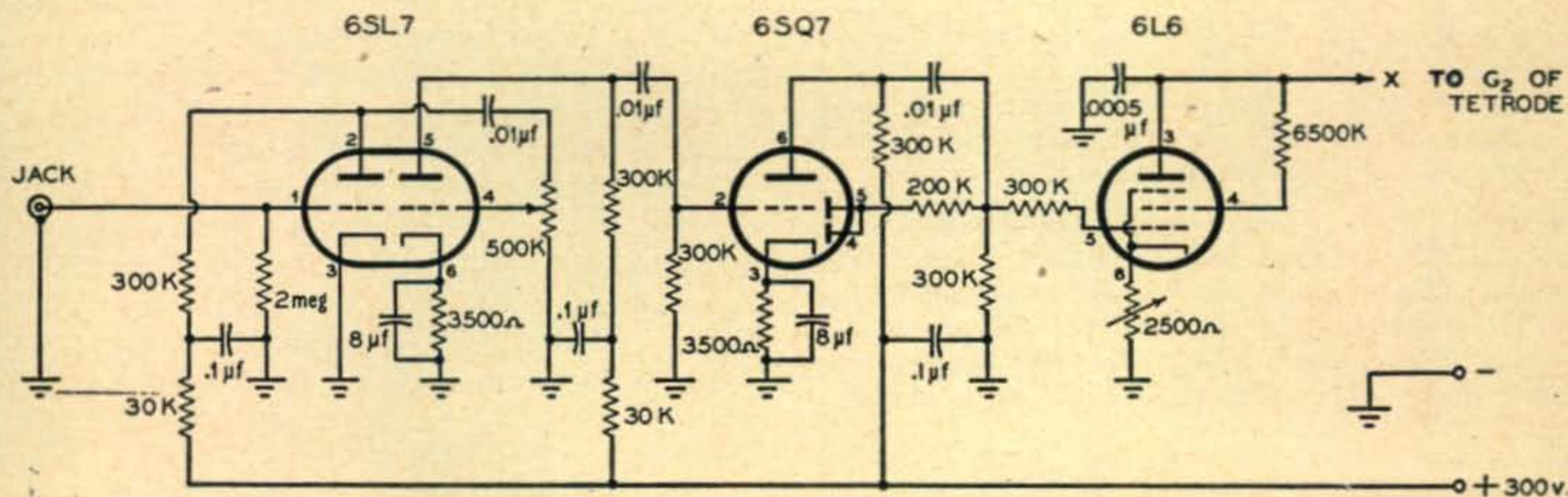

SPEECH AMPLIFIER AND 6L6 MODULATOR
TO MODULATE SCREEN OF TETRODES

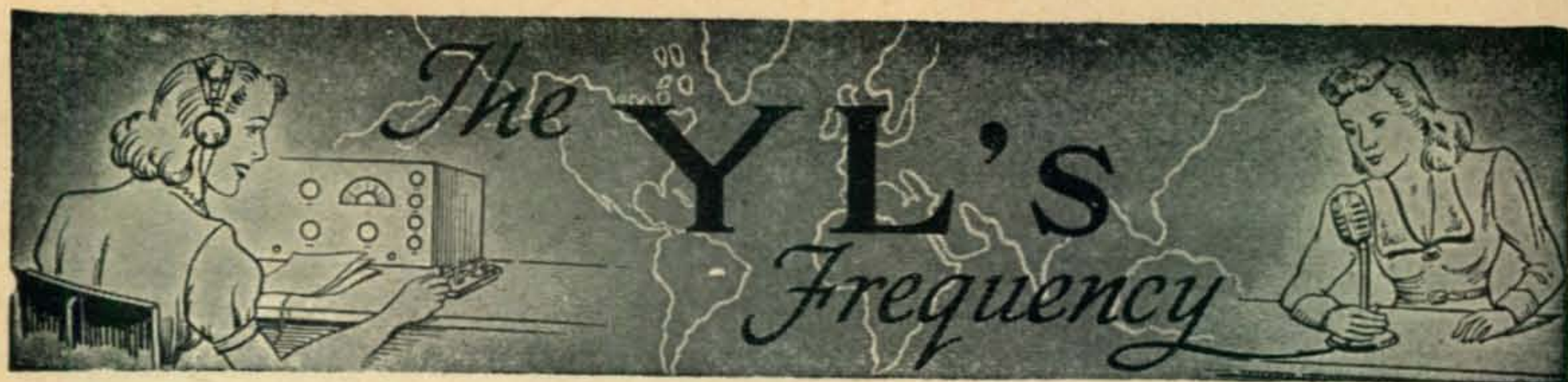

Conducted by LOUISA B. SANDO, W5RZJ*

HIGHLIGHT FOR DECEMBER will be the annual YLRL contest—the 12th Anniversary Party. So while your OMs are recuperating from the Sweepstakes just completed, let them take care of junior and serve *you* coffee at the rig while you run up a score. Here's the dope:

DATES: Phone—December 1-2
CW—December 8-9

HOURS: Dec. 1 & 8	Dec. 3 & 10
Begin	End
EST 7:00 p.m.	EST 3:01 a.m.
CST 6:00 p.m.	CST 2:01 a.m.
MST 5:00 p.m.	MST 1:01 a.m.
PST 4:00 p.m.	PST 12:01 a.m.

FREQUENCIES: All bands.

ELIGIBILITY: Only YLRL members eligible to compete for awards.

EXCHANGE: RS report (phone) or RST report (CW) and name of state, U. S. possession (KL7, KH6, etc.), VE district, or country.

OPERATING: Call "CQ YLRL." Skeds and cross-band operation permitted. CW stations work only CW stations, and phone stations work only phone stations.

SCORING: (1) 10 points for each YLRL member station worked, multiplied by the number of different states (Md. & D.C. count as one state), U. S. possessions, VE districts and countries (except W and VE). Each station, state, possession, etc., will count once only, regardless of the frequency band. (2) 1 point for each non-member YL station worked during the contest period—these points to be added to total after multiplying. Report and state must be exchanged on these contacts also, but these states, etc., will not count as multipliers.

AWARDS: Highest phone score—Cup donated by W1MCW, now held by W3UUG. Highest CW score—Cup donated by W4HWR, now held by W1FTJ. These cups are awarded on a yearly basis. A member winning the same cup three times gains permanent possession. 2nd and 3rd place awards for both phone and CW donated by W3CDQ. A certificate for high score in each U. S. district and country.

Logs must be postmarked not later than Dec. 16, 1951, and mailed to YLRL Vice President Kay Barclay, W3LSX, 202 Columbia Rd., N. W., Washington 9, D. C.

YLRL Nets

While we're on the subject of YLRL, here is the latest on the nets. Don't forget, all YLs are welcome, whether or not members of YLRL.

<u>Band</u>	<u>Day</u>	<u>Time</u>	<u>Freq. (kc)</u>	<u>NCS</u>
75 phone	Mon.	8 p.m. PST	3900	W7FJB
80 c.w.	Wed.	9 p.m. EST	3610	W9JTX
40 c.w.	Tues.	10 p.m. EST	7105	W3CDQ
40 c.w.	Fri.	9 p.m. PST	7040	W7NOB
20 phone	Thurs.	2 p.m. EST	14240	W9GME & W6FEA

W7NOB is calling her net the "YL Tortoise Speed Net." CW will be at 15 wpm or slower for anyone who desires to join. W7NOB also will listen on Wednesdays at 2 p.m. PST on 7040 kc for any who prefer a daytime net.

Conventions

As well as its glory of fall colors, New England has been breaking out with conventions. On Sept. 16th the Vermont State Convention was held at Brattleboro and brought together W1MVX, Ruth Estey; 1SAJ, Marguerite Bourell; 1OAK, Ann Chandler; 1FTJ, Dot Evans, and W2BNC, Helen Law. There were some WN YLs, too, but with no special YL meeting it was hard to find them. W1SAJ is the XYL of Harold Bourell, FCC man at Boston. She took her Class A exam at the convention, passed, and had her first sked on 75 the following night with 1FTJ. Although she was unable to attend, W1PIG, Edith, sent an apron for the girls to see that had been given her by another XYL's 12-year old daughter. It has a key applied on one side and a mike on the other together with names and calls in code. A cute idea for those who are deft with a needle.

October 6th brought a bigger group of YLs together at the New Hampshire State Convention in Manchester—W1FTJ, Dot Evans; MDV, Louise Bruya; MUW, Norma Moskey; MWI, Eleanor Blake; OAK, Ann Chandler; QJX, Charlotte Spaulding; QJY, Olga Apostolos; RYJ, Esther Routheir; SAJ, Marguerite Bourell, SVN, Millie Doremus; TRE, Barbara; W2BTB, Jeanne Walker, and CM2AC, Lily Pividal. A YLRL meeting was held in the afternoon, with SVN and TRE signing up as new members.

*Address all correspondence to 959C-24th St., Los Alamos, New Mexico.

◆

Most of the YLs attending the 14th New Hampshire Hamfest and ARRL Convention at Manchester on October 6th. L. to r., back row: WIRYJ, CM2AC, WIMUW and SVN. Front row: WIFTJ, TRE, MWI, OAK, QJY, QJX and SAJ.

◆



Club Activities

A total of 16 licensed YLs attended the YL Club of Los Angeles September meeting, opening one of the season. Visitors included W6MFP, a newly arrived transfer from Peekskill, N. Y. Also WN6MWU, Mary (XYL of 6IOK), and 6YXI, Neva, who both came up from San Diego "just for the ride that day"! Local members included W6JMC, JMS, GAI, KER, AVF, CEE, WSV, EHA, NZP, YZU, UHA, NLM, and VE5QL.

W6AVF, Mary, is to be club trustee for the club call, W6MWO, in memory of Helen Cook.

The club is sponsoring an activity contest for members, lasting from Sept. through May, and points will be awarded for such activities as attendance at meetings and bringing back old members to QSOs and special club work. (An idea for some other clubs.)

W6WSV reports the biggest project on the fire for the club is a toy and clothing drive among members for the children of the Yokosuka, Japan, orphanage. 6UHA, who handles much of the GI traffic from JA2MB at the Marine Barracks, found out about the orphanage from the ops at JA2MB. They are taking it upon themselves to make Christmas a little merrier for the 40 orphans who are reportedly clean but ragged. Ages range from 18 months to 15 years so the girls will have a wide size and age range to accommodate.

A Novice Discovers Ham Radio

From Peg Ferber, WN3RXV, comes this enthusiastic report, and a query.

"My OM (now W3RXV) and I took the Novice exam on July 2nd in New York City," writes Peg. "We know we are the first married couple to pass the Novice test in the State of New York. Here's the question: Are we the first married couple in the U.S. to pass the Novice exam together? [Any other bidders?]

"This Novice class is the best thing that could

have happened in ham radio. I know I'd have a terrible time, in fact, I'd have lost interest in ham radio if I'd had to *start* at 13 wpm. Now I can send and receive at 13 to 15 wpm and don't mind it—but only because I've had the actual experience of working other hams.

"Through being a Novice my life has been changed almost completely. I've made *many* new friends and my leisure time is devoted to something entirely different. Each day I marvel over the thrill and excitement of working other hams, and making their acquaintance. We've been invited to so many hams' homes that I can't get over the hospitality and friendliness they show. And it is not just put on; they really mean it.

"Can you understand why I had to write and say I'm so very glad I'm a ham?"

Ham Wedding

In the August issues of *CQ* and *Harmonics* you no doubt read of and saw the photo of the wedding of W6JMS, Lucille, and W6DJU, Jim, held at the San Fernando Valley Radio Club meeting in May. But these told only half the story. As was reported, W6ABM was the Minister, W6CSS served as best man and his XYL was matron of honor. In addition, the wedding march was played by W6HVC, the OM of Betty, W6KOY, who made the wedding cake. The club room was decorated with lovely flowers furnished by W6HK, W6LYG and W6WPF. A wire recording of the ceremony was made by W6HOV and W6VFG, while W6APQ was the photographer. Truly an all-ham affair!

Of course it was ham radio that started the romance in the first place. W6DJU helped Lucille with code and theory until she was able to pass her Class B exam a year ago last August. Now she's passed the A exam and will be active on 75 and 20.

(Continued on page 63)

DX

AND OVERSEAS NEWS

Conducted by HERB BECKER, W6QD*

CONGRATULATIONS TO THE following on achieving WAZ.

269	DLIAU	Helmut Hoschke	40 - 168
270	ZS6A	W. H. Browning	40 - 155
271	WØFFV	John H. McMahon	40 - 158
272	VK2PV	J. P. Vester	40 - 140

As you probably have noticed, "Perry" Ferrell is our new Editor. We are lucky to have Perry, as he has been mixed up in this magazine business for quite some time. With Perry's energy, knowledge, and meticulous managing, I am sure he will make a good skipper. In fact, I am very glad to see him at the wheel.

Now that the 1951 World Wide DX Contest is history, please make every effort to get your logs in as soon as possible. Don't send them to me, but send them all to "CQ, 67 West 44th Street, New York 18, New York." Again this year, I would like to emphasize that no matter how small your score might be, we would like to have you submit your log. This will help for possible credit claimed by others, as well as simplify and verify our checking. Just because your total score will not be a 1st, 2nd, or 3rd place winner doesn't mean that you shouldn't send it in. Hundreds of DX men just can't spend the amount of time on the air to rack up a large score, and yet proportionately they get just as much fun out of it.

I know there are some who feel because they have small scores, it is of no consequence when

A post convention scene. From left to right, W7HXG, Lee; W7AMX, Art; W7HIA, Herb; W7RT, Johnny and ZK2AA, Bill.



sent in. Either that, or they are disgusted or ashamed of their showing. I don't think anyone should really feel that way about it. It is impossible for DX men to accomplish the same results year after year. Just because some guy won a contest four or five years ago, or maybe ten or fifteen years ago, but today he can't do it—is no reason to renege on the log.

The personal life of the average DX man contains many cycles (no pun intended). One of the cycles that takes a guy off the air, or at least reduces his DXing, is women. Just plain women. This is especially true with the younger ones. Then sometimes you get stuck plenty—I mean married—and you are off the air again for a while. Other cycles naturally include such things as sickness, business, and what the heck, you know the stuff as well as I do.

Thus endeth another soap-box cycle of OM Becker. But, don't forget to send in your logs.

Tuning the Band

That is a lousy caption, but let's see what we can dig up anyway. W4LVV says a lot of the Gang have worked UAØKFD, but no card. He wants to know if anyone has received his card yet. The answer is "yes", but things nowadays are pretty tough in that direction—the curtain, you know. Chuck has other problems too. What to do about QSL's from ZD2RGY, VP8AI, KC6WA, and ZP8BL.

W8BHW climbs up a few with LB8CH, FB8ZZ, FR7ZA, 3A2AD, and EAØAB W3BES just doesn't miss—FD8AA and FB8BB. . . . WØDU has a few real late ones in PX1AR, LB8CH, and ZD2DCP. Late, that is, at the time of this writing. . . . W1ONV submits a phony to end all phonies: KI8UOM. He is supposedly located on Pupule, Kau Kau. (Time out while I think up one too). By the way, many of you probably will remember W1ONV when I tell you that he is Art Bates, ex-W9FO of the Call-Book fame and in the 20's, 8RY.

WØTFW says there has been some mistake as to the town in which VP3YG is located. It is Georgetown, British Guiana, and not Charlestown. . . . W7HXG picks up some good ones in VK9BI,

*Send all contributions to Herb Becker, 1406 South Grand Ave., Los Angeles 15, Calif.

VK9XK, and VP5BF. . . . W4RBQ's latest are PX1AR and EAØAC. . . .

After WØTKX finished filling out one of the country list forms, he said he felt as though he had just engraved the Lord's Prayer on the head of a pin. . . . W2BJ is wondering if the guy signing CR8EA might be a W2 over there? . . . W9ESQ finds 40 pretty good between 6:00 PM and 10:00 PM. He is about right with stuff like HA4SA, VP8AP, VQ3KIF, FP8PM, OZ5PA, FG7XA, plus a flock of others.

I1KN hasn't been spending very much time on the air lately. In fact, so little that he sent his letter to San Francisco. Eventually I got it, however, and he moans about not having too much of a chance to compete with QRO stations and fancy beams. Well, that guy has been on the air for a long time, and I guess we can't expect him to keep the pace up forever. . . . I1ER added a new zone in KG6GU. A new phone country for Mario is CE7ZN.

ZL2GX has been a busy man since moving into his new QTH. In addition to the alleged important things the XYL had lined up for him to do, he had a few of his own particular chores to take care of, such as going over his complete QSL's and log sheets. This paid off, as he located EL8A, which he worked three years ago, and hadn't reported. Jock has a couple of new ones too, frinstance FR7ZA and ZD2DCP. . . . G6QX has knocked off some good ones lately, including PK4DA, 8W4AF Yemen, VU7FK, and VP8AO—all of these on 7 mc. Then on 14 mc he hooked FI8RO for a new zone. This fellow is OK, and the R.E.F. is the place to send your cards. . . . VE2BV has lapped up a few of the better quality stations—MP4BBD, KB6AT, VS7NG, VT1AF, VK9XK, and 3A2AD. He also worked a station signing AC3BA on which we have absolutely no dope . . . the only ones we know anything good about are AC3PT, and AC3SQ.

W5KUJ picked up four on 20—FB8BB, FY7YC, EAØAB, and FB8ZZ. . . . A few of the newer ones for CE3DZ are FR8IO, VK9XK, OY3IGO, I1AHR/M1, FG7XA, and AC3AA. Whozis? Where did he come from? . . . The late ones for CE3AG are FB8BB and FI8RO. . . . W6AM, who just never quits, yelled loud enough into his mike to raise HA5BD. Then on c.w. it was FB8BB. . . . G6ZO pulled out all of the stops and in came FB8BB and 8W4AF. . . . DL7AA worked FR8IO, FB8BB, ZS7C, FB8ZZ, FD8AA, and PK5AA. These were all done in September.

Some time ago I received a letter from pre-War J2NG, Harry Yoneda. He is over in this country on the U.S. Government-Sponsored "Exchange Persons Program." Harry is spending a year at Ohio State University, and studying radio engineering. He is very thankful, and says he owes this trip to USA. If any of you pre-War fellows want to contact him, that is where you will find him.

XE1AC latched on to FI8RO on c.w. . . .

KZ5PC is pretty well anchored on 75 phone, and



has worked a whole flock of W's. Jerry says that probably a lot of the 75 meter Gang would like to know that he intends to remain on 75 phone, so there is a chance to work a KZ5. . . . Due to W6WO's night trick at KFAC—a local BC station—he doesn't get a crack at a lot of the stuff that other people do. Len has done alright though, with 39 and 152. . . . W8NBK grabbed off FD8AA for what looks like number 231.

Here is something you stamp collectors, or as LeKashman would say, philatelists, should be interested in. There is a Hospital Stamp Club at a Vets Hospital who is looking for people with foreign correspondence, and who are willing to send them some stamps. Any of you fellows having foreign stamps which you can't use, how about sending them to a worthy spot by addressing them to the: U.S. Vets Hospital, c/o Stephen J. Molnare, Castle Point, New York. . . . We regret to report W6SAI received a wire from W3BXE, telling of the death of FP8BX.

W2WZ seems to work his new stuff in pairs. This time it is EAØAD and FB8BB. Al says the 20 meter band has been painfully bad. . . . W2EMW seems to have been TVI'd off the air during most of 1951. Better get things fixed, Bob, and hitch her up again. . . . We hear that ZM6AK leaves British Samoa around October 22nd. He is headed for ZL and this will leave ZM6 inactive. . . . W2GVZ hooked KM6AX, 14030, and this was apparently his first New Jersey QSO. . . . W1MIJ received word that ZB1CH has left for an undisclosed QTH and will be on with a new call. . . . W8SYC, has picked up a couple of new ones also, in FB8BB and YI3BES. . . . Speaking of FB8BB, he has really been knocking them off

(Continued on page 54)

W. A. Z. HONOR ROLL

CW & PHONE		CW & PHONE		CW & PHONE		CW & PHONE		CW & PHONE		CW & PHONE	
WAZ		W6WB	196	G3TK	157	W2AGO	191	VE2BV	159	W1NLM	130
W1FH	244	G2FSR	196	W6BUY	157	W1AWX	191	W8EYE	158	W4IYT	127
W6VFR	241	W5GEL	196	W6QD	157	OK1VW	190	W2UEI	156	W1RAN	122
W3BES	241	VK4HR	196	ZS6FN	157	W2BJ	190	W3FYS	156	W5NTT	107
W6ENV	238	W6UCX	195	W7BE	156	W9FKC	189	LU7CD	155	W8JM	102
W0YXO	237	W5KC	195	KH6LG	156	KP4KD	189	W3LVJ	151	PHONE ONLY	
W6ADP	236	G6QB	195	W6BAX	155	W3JKO	186	W5MET	150	39 Zones	
W6GRL	234	OK1FF	194	VK5KO	155	W0EYR	186	G6QX	148	XE1AC	207
W6MEK	234	W6GAL	193	ZS6A	155	W7PGS	185	W8ZMC	142	VQ4ERR	203
G6Z0	234	W6RLN	193	G3AAM	154	W8RDZ	184	W0AZT	143	W6DI	192
W2BXA	233	W0SQ0	192	G2IO	154	W9TQL	184	ZL3AB	143	W6VFR	175
W3GHD	232	G3DO	192	W6ATO	154	4X4RE	184	W0RBA	140	PK4DA	175
W6SN	232	VK2NS	191	W6KEV	153	W3DRD	183	W9FKH	135	G8IG	169
W8NBK	231	I1KN	191	OK1RW	153	W4INL	183	VE3ACS	134	W7HTB	161
W3EVW	230	W6RW	190	W6NTR	153	VE3AAZ	182	TF3SF	134	W8HUD	160
W6AM	230	W6SRU	190	G3YF	152	W1DQH	181	MP4BAD	133	F9BO	150
G6RH	229	W6EPZ	190	KP6AA	152	W2CNT	181	W6ETJ	132	VE7ZM	145
W8JIN	229	CE3DZ	190	W6RLQ	152	W2RDK	180	W4FPK	131	DL1FK	125
W6EBG	227	VK3JE	189	VK2QL	151	VE3IJ	180	W2PQJ	130	38 Zones	
W6SYG	227	ON4JW	189	W6LEE	150	VO6EP	179	W4LQN	130	W2BXA	192
W6PFD	226	W6EHV	189	W6FHE	150	W9HUZ	178	W3ZN	129	W9RBI	191
W8BHW	226	W0NTA	188	W6EYR	150	W4RBQ	178	W9MZP	126	W6KQY	161
W3KT	225	W7OY	187	W6LER	150	W8CVU	172	FESAB	126	W4CYU	160
W3JTC	224	W8SDR	186	OK1CX	147	W4DKA	172	W9TB	122	W6AM	158
W2AGW	224	VK6RU	186	W6LS	147	W2RGV	171	GW4CX	120	ZL1HY	157
W8BRA	223	W6DFY	186	W7KWC	147	W9LM	170	EA1AB	119	W1HKK	153
W3LOE	222	W2CZO	185	KH6PY	147	W5FFW	170	W0FET	118	W9NDA	149
W6FSJ	222	W1AB	185	W7DXZ	146	W6CTL	169	KL7PJ	117	37 Zones	
W6AMA	222	W6BUD	185	W6AYZ	146	W1NMP	169	W6CAE	113	W1JCN	189
CE3AG	222	W6SA	184	VE6GD	146	W3JTK	169	W7EYS	107	W3BES	186
W6MVQ	221	KH6VP	184	W9NRB	145	OZ7EU	169	VK6DX	103	W8REU	176
W6MX	221	W3GAU	183	W6MUC	145	W4VE	169	W6FXL	92	W3LTU	169
VK3BZ	221	W2JVU	183	OK2SO	145	HC2OT	169	C1CH	84	VK3BZ	167
VE4RO	220	LA7Y	182	ON4TA	144	PY2AC	168	37 Zones		G3DO	164
W6ITA	219	W0ELA	182	G3BI	144	W2CYS	167	W1KfV	171	CE3AB	163
W6DZZ	219	W6LN	181	W7LYL	143	W4AZK	167	GM2UU	161	W9HB	161
W6TT	218	W6IFW	180	W3IXN	141	W8LEC	166	W2ZA	160	W7MBX	158
W0NUC	218	W6SR	180	I1XK	140	W9ABA	163	IS1AHK	160	W6WNH	157
G4CP	218	W6UHA	179	W6AOD	140	W4BRB	162	W2WC	158	W6PXH	153
W0PNQ	217	OE1CD	179	VK2PV	140	W8VLK	160	W3WU	157	W3GHD	152
W9DUY	217	PY1BG	179	W6ONZ	139	GM3CSM	159	W4IWO	149	W3JNN	150
LU6DJX	217	W9VND	178	W6ID	138	W4OM	158	F9AH	146	W8BF	146
G2PL	216	W7DL	177	ZC1CL	138	W0AIW	157	OZ7BG	144	W6TT	143
W6PQT	216	W0UOX	177	OK1WX	135	I1AY	157	W4ML	140	F8VC	124
W2PEO	215	VK6KW	177	G3AZ	133	VK4DO	156	W9WCE	140	W7MBW	107
W7AMX	215	W6UZX	177	W6TEU	133	W9YNB	155	OE1FF	136	C1CH	83
W3JNN	215	CX1FY	176	W6RDR	133	DL1FK	155	W2AYJ	133	36 Zones	
ZL2GX	215	W6IBD	176	W6AUT	133	W8WWU	155	W1APA	131	W1NWO	183
W3IYE	214	KH6CD	176	W6OBD	131	I1AIV	154	W7HKT	130	W1MCW	178
PY1DH	214	VK4EL	176	ZS2CR	131	ZS2AT	152	W4DIA	129	W1BEQ	164
ZS2X	214	PK4DA	175	W6IDZ	130	G3AKU	150	VE5JV	126	W4ESP	154
KH6BA	214	W6WKU	174	W6BIL	130	DL1AT	150	W9LNH	122	GM2UU	154
W6OEG	213	W6CIS	174	W7ASG	129	W6WO	150	VE1EA	116	W2DYR	140
W4AIT	213	W7FZA	174	W7GBW	127	W6LGD	149	G3BPP	112	W9BZB	139
KH6CT	213	W6PCS	174	G8IP	127	VE7VC	149	W6AX	110	W9HP	139
W6SAI	213	W6KUT	174	G5BJ	126	SM5WI	148	W0FWW	108	W8AUP	131
W6HX	212	W8HUD	174	VK6SA	126	W2GUR	146	OH3OE	108	W6PDB	130
VE7HC	212	W6TZD	173	PK6HA	124	W2MEL	145	W7PK	104	VE3BNQ	130
W6NNV	211	G5YV	172	G5VU	124	OK1AW	144	W8HSW	104	W4INL	129
VK2ACX	211	OK1LM	172	W6NRQ	123	W6KYV	143	W2BLS	99	W1FJN	128
KH6IJ	211	W6WWQ	172	W6MLY	123	VK4FJ	143	W6WWW	99	G6BW	127
W6BPD	210	W6SRF	171	ZL1GX	122	TF3EA	142	KL7KV	88	VE7HC	123
W6MJB	210	PY1AHL	171	VK5MF	121	V87NX	140	36 Zones		W0HX	120
W6PB	210	OK1HI	171	ZS2EC	116	W5FXN	140	W4HA	166	W8CYL	112
W6TS	210	VK2HZ	171	ZS6CT	113	W9NZZ	139	W2OST	163	W3DHM	96
W9VW	209	W6BAM	170	KG6AL	103	W6KYT	135	W5KUJ	158	W6SA	92
W0DU	209	W7ENW	170	W7KWA	98	VE7KC	133	W1BFT	156	F8DC	87
W2AQW	208	W6PZ	169	W6DUB	89	W7ETK	132	W0TKX	144	35 Zones	
W8HGW	208	W5AFX	169	W7IYA	59	W6TE	131	W3MZE	141	HC2JR	171
W9NDA	208	G2VD	169	39 Zones		W6WJX	131	I1IT	140	W4HA	159
ZL1HY	208	W6JZP	168	W2NSZ	225	W7BTH	131	W0CU	139	ZS6Q	156
W6GDJ	208	DL1AU	168	W3DPA	224	W5CPI	130	W9LI	131	W9RNX	149
W6SC	207	W6ANN	167	F8BS	219	W6NZ	129	OA4AK	128	W6PCK	148
VE7VM	206	VK3CN	167	W9ANT	218	W7HXG	129	VE1PQ	128	W3EVW	148
W4BPD	206	W6LDD	167	W9RBI	218	OE3CC	128	I1IZ	128	W9BVX	148
W6DLY	206	W6BVM	167	W1ENE	216	DL1DA	127	W3AYS	124	W2GHV	137
W6KRI	205	W6DUC	166	W1JYH	215	W6EYC	126	F8TM	124	W2RGV	136
DL1FF	205	KH6MI	166	XE1AC	215	W6MUF	125	W2BF	115	W6CHV	135
W6ZCY	204	W6CEM	166	W3EPV	214	VR5PL	124	4X4BX	112	W0PUE	135
W6DI	204	W6JK	165	W5ASG	214	KG6GD	121	W5CD	108	HC2OT	134
W6PKO	204	VE7GI	165	W2WZ	214	DL3DU	118	W2JA	102	W0EYR	131
VK2DI	204	W6LRU	165	W3OCU	210	W6NRZ	117	35 Zones		W0ANF	130
W6AVM	204	W6BZE	165	W1BIH	209	KL7UM	117	W1DEP	159	W0PRZ	124
W4CYU	203	W6PH	164	W2HHF	208	W6JWL	114	W5JUF	152	W9CKP	124
W7GUI	203	W6EAK	163	VE3QD	206	KL7GG	114	W4DHZ	132	G8QX	123
W6EFM	203	W6YZU	163	W5LVD	203	W6FBC	114	W9CKP	132	W8ZMC	122
W6VE	203	G5GK	163	W8SYC	202	W6VAT	110	W1MRP	130	W5LVV	108
ZL1BY	203	VE7VO	162	W9IU	201	DL3AB	107	ZL1QW	123	W4OM	106
W6RBQ	203	ZS6DW	162	W1GKK	201	W7GXA	105	OE5YL	122	W3PA	105
W6RM	202	I1IR	162	W8HFE	201	W6LEV	103	W6ZZ	121	PY2JU	103
W6OMC	202	W6NGA	162	W3DKT	201	W7LEE	91	35 Zones		34 Zones	
W6AOA	202	W6PDB	161	W2HZY	200	38 Zones		W9RQM	119	W5ASG	152
G8IG	201	W4CYY	161	W9LNM	200	W2HMJ	196	CO6AJ	119	W3KT	152
W9KOK	200	OK1SV	160	W4GG	197	W2PUD	181	W9DGA	115	W5JUF	137
VK5JS	200	VK3EK	160	W9MXX	197	CM2SW	174	W9FNR	114	I1AXD	130
PY1GJ	199	W6PUY	160	W1HX	195	W8KPL	173	W8AVB	113	YV5AB	129
W6TI	199	JA2KG	160	W2EMW	195	W8FJN	173	W0GBJ	113	LU8CW	129
DL7AA	199	W6MHB	160	F9BO	193	W2SHZ	169	W2HAZ	111	W2ZVS	128
W2IOP	197	W0FFV	158	W2CWE	192	W2GVZ	163	KZ5IP	108	W5KC	125
KH6QH	197	W6CYI	157	W3KDP	192	I1UV	160	KL7CZ	80	W4LZM	124
PY1AJ	196	W7BD	157	W1ZL	192	SM7MS	159	34 Zones		W6UZX	123
		W0OUH	157	W4LVV	192	ZL3CC	159	W8NSS	133		

MOBILE CORNER

Conducted by RALPH V. ANDERSON, W3NL*

AT THIS WRITING this year's Simulated Emergency Tests have just been completed. The mobile station has really come into its own for this type of operation, in fact practically all of the tests with which we are familiar were almost exclusively mobile. It is "music to the ears" to hear the snap and precision with which some of the nets conduct their business. On the other hand, some nets are slowed down because of operating difficulties. Surprising as it might seem, the greatest cause of holding up the net seems to be the few mobiles who have neglected to provide a means of stopping the oscillator instantly when the transmitter is switched off; this fellow has to wait until the dynamotor has "run down" before he can hear anything. He misses the first of the other fellow's transmission, has to call for a repeat which he misses for the same reason, etc. Another cause of confusion is operating procedure—such simple things as the call-up. Regulations require the use of the sequence: called station, the words "this is" or "from", then the calling station. Some fellows insist on doing it backwards to the confusion of the whole net. We don't wish to be accused of moralizing but one net we heard proceeded so smoothly about half the way through

the drill and then was thrown into utter confusion with resultant loss of time because of both the above reasons. Generally speaking, however, all mobile nets can operate very efficiently when it comes to handling simulated emergency traffic.

Grounded Cathode Oscillators for Quick Heaters

Quick-heating tubes such as the 2E30 are often not used in harmonic oscillators because the usual circuits require the cathode to be operated at an r.f. potential above ground. This requires chokes to be placed in the filament leads and in some cases, these must be resonant to certain frequencies. Fig. 1 illustrates a circuit in which the filament of the 2E30 may be operated at ground potential.

A small amount of r.f. exists at the junction of the plate tank and the r-f choke. C1 and C2 provide a feed back circuit, the amount of feed back being controlled by the ratio of these capacitors. This ratio, in turn, depends upon the harmonic of the crystal at which the plate tank is operated. C1 will be quite low, around 20 $\mu\mu\text{f}$ when doubling, and is increased for higher order harmonics, about 100 $\mu\mu\text{f}$ being used for the fourth harmonic. Increasing C1 will produce more drive but at the expense of crystal heating.

When setting up the circuit for the first time, C1 should be made variable and an .06 pilot lamp should be placed in series with the grid. Adjust-

*Send contributions to R. V. Anderson, 2509 32nd St., S. E., Washington 20, D. C.

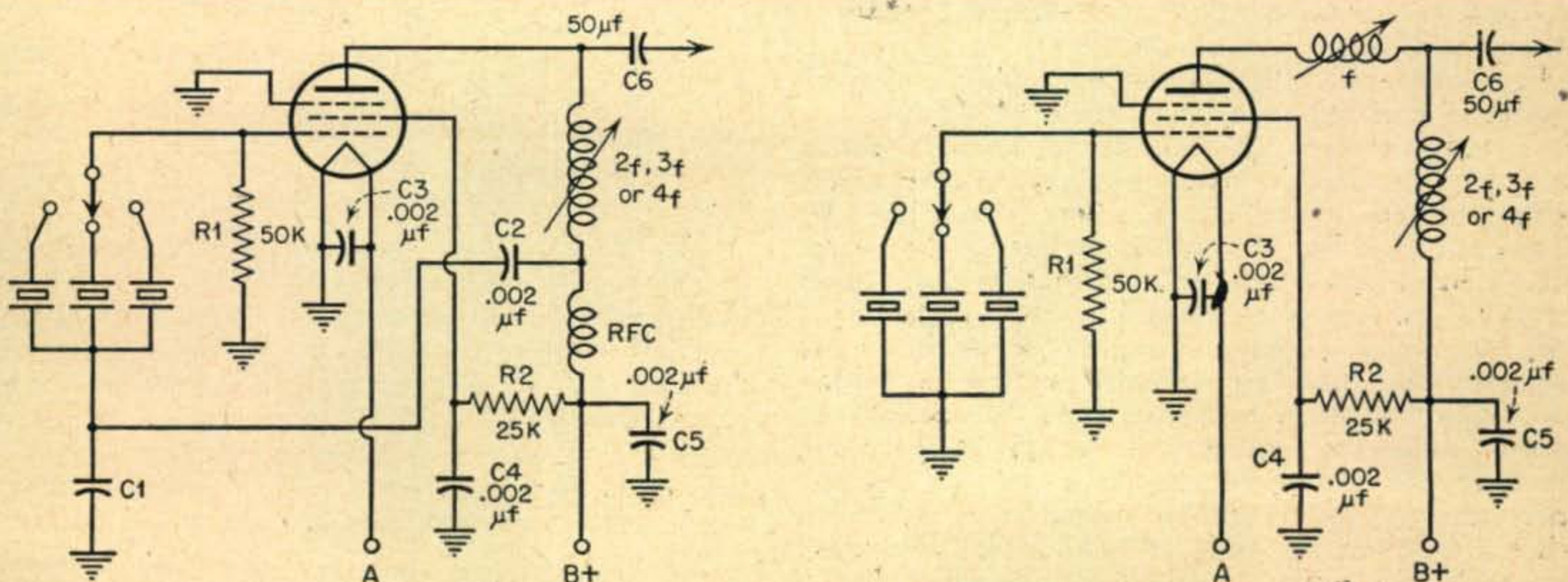

Fig. 1 (left). A method of operating quick-heating tubes with the filament at ground potential. For the value of C1 see text. Fig. 2 (right). A harmonic oscillator using tubes similar to the 2E30.

The Newcomer's Buyway

Advertising

Allied Catalog

In amateur radio, a new youngster is affectionately called a "Young Squirt." We'd like to say a few words to the Young Squirts, (and OM's), reading this. In ham radio there are all kinds of gadgets, accessories and essential parts to be bought. You'll acquire some of these items as soon as you start to build your equipment. Others you'll only "look at" for years. However — before you buy anything — think of Allied's complete, free catalog.



Here is the new, complete Buying Guide to *everything* in Amateur Radio. It's ALLIED's 212-page 1952 catalog—packed with full selections of quality receivers, transmitters and station gear of every description—everything you need to operate an efficient Ham station at lowest money-saving cost. Here, too, are the widest selections of parts, tubes, kits, tools, books and diagrams, ready for fast, dependable shipment from ALLIED's huge stocks.

You can count on ALLIED for expert service, the most generous time payment terms and down-to-earth practical help from our large staff of old-time Hams. Have the complete, dependable service enjoyed by thousands of Amateurs over the past 30 years. Send today for your FREE copy of the new ALLIED Catalog, finest Buying Guide in Amateur Radio. ALLIED RADIO CORP., 833 W. Jackson Blvd., Dept. 16-MM-1, Chicago 7.

"The Hercules"

In amateur radio, just like lots of other hobbies, there are all kinds of gadgets and accessories which one acquires in time as a matter of course. However, probably the first item a radio amateur requires after obtaining his basic receiver and transmitter, is a dependable microphone, so voice "contacts" can be made. Regardless of whether you are a new-comer or an old-timer in amateur radio, the new Controlled Reluctance mike, the "Hercules" (manufactured by Shure Brothers, Inc., 225 W. Huron St., Chicago, Ill.) warrants your consideration. It is a hand-held magnetic unit that provides clear reproduction, high speech intelligibility, high output and ruggedness at an amazingly low price. Being magnetic, this mike is practically immune to varying conditions of heat or humidity. The "Hercules" can be used indoors or outdoors, fits snugly in the hand, sits firmly on a desk or can be placed on a stand. There are two models with an output level of 52.5 db below 1 volt per microbar. Model 510C "Hercules" lists at \$15.00 while the Model 510S, which has a built-in switch, lists for only \$17.00. The "Hercules" has a die-cast case, with a Metallic Green finish. See the "Hercules" at your Distributor or write Shure Brothers for further details.

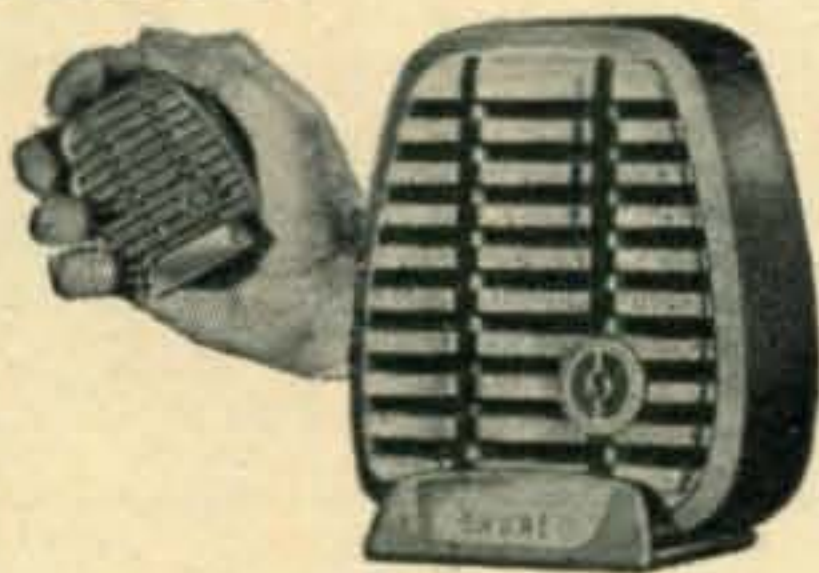

The Turner 20X



Nearly every Novice faces the problem of setting up his first rig with an eye toward equipment quality as well as economy. When you choose a Turner

20X Microphone, you make no compromise on either quality or economy—that's why the Turner 20X has enjoyed the popular approval of radio amateurs for many years. This light-weight, convenient, hand-held crystal microphone has the design, high output, dependability and unusually fine response to make it a natural for the ham.

The Model 20X (illustrated) lists at \$12.85, while the S20X, which has a built-in push-to-talk switch, lists at \$14.85. Both microphones have output level of 52 db below 1 volt/dyne/sq.cm, response of 60-7000 c.p.s., and die-cast metal case with rich bronze metalustre finish. For more information see your Distributor or write THE TURNER COMPANY, 929 17th Street, N.E., Cedar Rapids, Iowa.

The S-81 Receiver

Many amateurs and novice licensees will soon do their part in this National Emergency by participating in the various civil defense programs. An extremely important piece of gear is going to be a receiver capable of tuning in the police, fire, taxicab, railroad, and other industrial frequencies. The Hallicrafters Company of Chicago have announced a reliable low-cost receiver with this thought in mind. It is the S-81 "Civil Patrol."



The "Civil Patrol" covers the VHF band from 152 to 174 mc. A low-band version of the "Civil Patrol" is also available to cover the band from 30 to 50 mc—it is known as the S-82. Both receivers are newly designed FM chassis featuring low drift and a high signal-to-noise ratio. The receivers are so easy to operate that only a volume and tuning control are necessary. A single wire or twin antenna may be used. Headphone terminals are also provided.

The "Civil Patrol" uses six tubes and a Selenium rectifier. The speaker is built-in.

If you are going into Civilian Defense projects this Hallicrafters receiver will prove valuable as a liaison with your local authorities.

ment should be made to give the best balance between adequate drive to the following stage with the smallest amount of crystal current.

Figure 2 illustrates a circuit which is probably the simplest of all oscillators producing r.f. at harmonics of the crystal frequency. It has the disadvantage that it does not produce as much drive as the usual circuits, however, sufficient drive is available for some applications. It works excellently, for instance, in crystal controlled receiver applications in which case the "harmonic tank" can be tuned to frequencies several times the fundamental. For transmitter use, the drive falls off rapidly after the third harmonic.

The BC457A

W1ABZ sends us a couple of tricks the New England boys are using with the BC457A. Two of the original surplus 15 foot remote control cables are used, one in the normal fashion to set frequency. The other is used to turn the loading coil so the antenna system can be resonated for each change in frequency. A hole is drilled in the side of the case and the shaft soldered directly on the coil bushing. Frequency and output can thus be varied by remote control. The surplus BC450 A Radio Control Box can be used directly on the dash to make a FB job.

For spotting frequency, the B plus lead of the oscillator is brought up to a switch on the dash. A 7½" volt battery is employed to furnish plate voltage when the switch is closed. Sufficient output from the oscillator is realized to spot the frequency.

Police Authority

An incident reported from the mid-west serves as a reminder that all organized nets should take steps to see that the mobiles are supplied with some type of authorization by the local police authorities. In this case, the mobile operator was refused admission to an emergency area. He had a sign, made locally, which could be read a mile away, stating he was an emergency mobile unit but he didn't have local police authorization. In some cities, obtaining such permits are relatively easy, in others it's quite difficult. In any event it is a good practice to get all the preliminary work done in advance of any emergency.

Maritime Mobile Amateur Radio Club

Sec'y: W3OB. Fixed stations send your 30 MM QSL's to the secretary for the MM certificate. No return postage required; cards will be registered. Election of officers of the MM club is now underway.

Here is a story from Ady, W6YYT which will give an idea of how valuable ham radio is to a merchant vessel:

"On 9/13/51, when we were about 800 miles NE of Singapore, position 11.54 North, 111.40 East, the Skipper came to me in the afternoon and said that I had to get in touch with either Singapore or Manila right away as one of the crew was very sick and had a temperature of 103° and pulse of 102°. I suggested that we get on the ham rig and call Guam because I had been chewing the rag with them plenty every

day, that they had Doctors there and it would probably be better that way because he could describe the symptoms and answer any questions the Doctor had. We got on the ham rig and I called CQ Emergency Guam for medical aid. Then had previously been on the band all day for the past 4 or 5 days. Naturally the band seemed dead, no signals at all. But I called about five minutes and KH6ACQ/Mobile on Guam, Ken, came back to me. He was just a 6 or 7, but the noise level due to these darn fans we have on board is just about the same. I told Ken we wanted a Doctor but to try and get KG6AAC, Bill, who runs about 800 watts there, as he had a phone patch, and we could talk to the Doctor that way. Ken said he would drive to the Dispensary and get a Doctor so that we could talk to him, but in the meanwhile KG6AAV, which is sort of a club station there in Guam came back to me and said they were just across the street from the Dispensary and he would send out for a Doctor. Mac was at the mike. They got a Doctor over and Captain Coleman told him the symptoms and the Doctor prescribed the treatment and what tests to make. I recorded it and afterward played it back to the Skipper so that there would be no slip up.

"When we were thru, JA2KW, Bill at the mike called in and said he was standing by if we lost Guam we could get help up there in Japan. Then KR6FT, Okinawa, called in and said he was also standing by, if we needed help he could get it there in Okinawa. So, you see, we had half the Pacific standing by to help us. Anyway we made a sked with KG6AAV and Mac and the fellows stood by on an hourly schedule. Also KG6AAC called in and said he was standing by with a phone patch if KG6AAV faded out. They stood by there on Guam until 2 AM and we kept hourly skeds until the Skipper said the fever was coming down. At four-thirty ship's time the fever broke and the man is OK now. But you can see that ham radio sure helped. By the way, the Doctor on Guam, J. K. Hill, said that he would stand by that night, would not go out. So you can see how helpful they all were. The next morning I called KG6AAC, with whom I had a sked at 8 AM ship's time, and told him the man was out of danger and there was no necessity to stand-by any longer."

Odds and Ends

The FCC Regs for amateurs has been reprinted in a new form obtainable from the Government Printing Office for 10 cents. Ask for FCC publication, Part 12—Rules Governing Amateur Radio Service. . . . We'd like to hear from mobile clubs as to what is done to keep up interest. CD drills are likely to be the same old thing, drill after drill with consequent loss of interest. What do you use? Parades, demonstrations to civic organizations, etc.? . . . W1ABZ wants to know what the gang uses for increased receiver selectivity for 75 phone since the standard broadcast receiver seems to be lacking somewhat in this respect. . . . We'd like to see plans for "standard" Pack Sets that any of the clubs have made. . . . KT1OC (ex W71OC) reports

(Continued on page 65)

New FCC Proposals Regarding FSK and NBFM

On 1 November 1951 the Federal Communications Commission issued two new Dockets relative to the proposals made by the American Radio Relay League, the National Amateur Radio Council and private individuals concerning the use of FSK and NBFM in the amateur bands.

NBFM (Docket No. 10077)

The original petition filed by the ARRL requested amendment of Section 12.111 to permit the use of narrow-band frequency or phase modulation in all bands presently available for AM.

The FCC has proposed to authorize use of NBFM in the segments 3800 to 4000 kc, and 14200 to 14300 kc. The present authorization is for 3800 to 3850 kc, and 14200 to 14250 kc. The FCC does not feel that the use of NBFM in the 160 meter band is justified because of existing limitations concerning the operation of amateur stations and the priority of the Loran system in that band.

FSK or A-3 on 40 Meters (Docket No. 10073)

Two specific petitions have been filed with the FCC requesting amendment of Section 12.111 to permit additional types of emission on 40 meters.

The ARRL asks that the segment from 7250 to 7300 kc be open to permit frequency shift keying (Type F-1 emission). The NARC has requested that any 100 kc segment of the 40 meter band be open for radio-telephony.

The FCC feels that these two proposals regarding possible subdivision of the 40 meter band should be considered before a possible amendment is written. Accordingly, the FCC has supplied notice that they will consider all written statements or briefs relating to these two subjects if filed not later than 2 January 1952. An original and two copies of all statements, briefs or comments should be supplied.

The FCC visualizes that the following issues should be considered:

1. Which amateur frequency band or bands, in whole or in part, below 27 mc would be the most appropriate, in the light of technical and other considerations including those of the greatest public interest, convenience, and necessity, in which to permit the use of the amateur frequency band 7000-7300 kc, frequency-shift keying (Type F-1 emission) for amateur radio-teleprinter and other similar purposes?
2. Would normal amateur activity, as now being practised in the amateur frequency band 7000-7300 kc, be adversely affected if frequency-shift keying (Type-1 emission) were permitted to be used in that band, and, if so, to what extent?

3. If frequency-shift keying (Type F-1 emission) were to be authorized to be used in the amateur frequency band 7000-7300 kc, what portion of that band should be made available for that type of operation?
4. Would normal amateur activity, as now being practised in the amateur frequency band 7000-7300 kc, adversely affect the use of amplitude-modulated telephony (Type A-3 emission) were permitted to be used in that band, and, if so, to what extent?
5. If amplitude-modulated telephony (Type A-3 emission) and amplitude-modulated telephony the amateur frequency band 7000-7300 kc, what portion of that band should be made available for that type of operation?
6. Would simultaneous authorization for the use of frequency-shift keying (Type F-1 emission) were to be authorized to be used in any (Type A-3 emission) in the same segment or segments of the amateur frequency band 7000-7300 kc, be adversely affected if amplitude-modulated telephony were to be authorized to be used in that band, and, if so, to what extent?
7. In consideration of possible changes in the types of emission authorized to be used in the amateur frequency band 7000-7300 kc, should all or part of the operation using any of the authorized types of emission be limited to holders of at least Advanced Class licenses, or General and Conditional Class licenses?

◁ SPARE PARTS ▷

Few amateurs can equal Phil Rand, W1DBM, in the attention he has given to the subject of TVI. Recently W1DBM collected all of his various articles on TVI and reprinted them in a marvelous booklet. Copies are available to all "Hams" who request it on a postal card. The cards should contain the sender's name and address and should be mailed to Phil, c/o Remington Rand, Inc., Laboratory of Advanced Research, Wilson Ave., South Norwalk, Conn.

Sorry, fellas, but in order to squeeze as much feature material as possible into this issue we had to cut out both *Shack and Workshop* and the new *Novice Department*. *Shack and Workshop* will be back again in the January issue with at least two pages to make up for the omission. By the way, if you send in a contribution for *Shack and Workshop* be sure to specify whether we are to send you the \$2.50 cash, or credit you with a new or extended CQ subscription. This is very important for our records.

In next month's issue: "A Foolproof Novice Transmitter," "The Modified Single-Sider," "Get Your Circuits Untangled," and many more just as interesting.

Corrected FCC Proposals to replace page 52

New FCC Proposals Regarding FSK and NBFM

On 1 November 1951 the Federal Communications Commission issued two new Dockets relative to the proposals made by the American Radio Relay League, the National Amateur Radio Council and private individuals concerning the use of FSK and NBFM in the amateur bands.

NBFM (Docket No. 10077)

The original petition filed by the ARRL requested amendment of Section 12.111 to permit the use of narrow-band frequency or phase modulation in all bands presently available for AM.

The FCC has proposed to authorize use of NBFM in the segments 3800 to 4000 kc, and 14200 to 14300 kc. The present authorization is for 3800 to 3850 kc, and 14200 to 14250 kc. The FCC does not feel that the use of NBFM in the 160 meter band is justified because of existing limitations concerning the operation of amateur stations and the priority of the Loran system in that band.

FSK or A-3 on 40 Meters (Docket No. 10073)

Two specific petitions have been filed with the FCC requesting amendment of Section 12.111 to permit additional types of emission on 40 meters.

The ARRL asks that the segment from 7250 to 7300 kc be open to permit frequency shift keying (Type F-1 emission). The NARC has requested that any 100 kc segment of the 40 meter band be open for radio-telephony.

The FCC feels that these two proposals regarding possible subdivision of the 40 meter band should be considered carefully and that more diversified opinions are necessary before a possible amendment is written. Accordingly, the FCC has supplied notice that they will consider all written statements or briefs relating to these two subjects if filed not later than 2 January 1952. An original and two copies of all statements, briefs or comments should be supplied.

The FCC visualizes that the following issues should be considered:

1. Which amateur frequency band or bands, in whole or in part, below 27 mc would be the most appropriate, in the light of technical

and other considerations including those of the greatest public interest, convenience, and necessity, in which to permit the use of frequency-shift keying (Type F-1 emission) for amateur radio-teleprinter and other similar purposes?

2. Would normal amateur activity, as now being practised in the amateur frequency band 7000-7300 kc, be adversely affected if frequency-shift keying (Type F-1 emission) were permitted to be used in that band, and, if so, to what extent?
3. If frequency-shift keying (Type F-1 emission) were to be authorized to be used in the amateur frequency band 7000-7300 kc, what portion of that band should be made available for that type of operation?
4. Would normal amateur activity, as now being practised in the amateur frequency band 7000-7300 kc, be adversely affected if amplitude-modulated telephony (Type A-3 emission) were permitted to be used in that band, and, if so, to what extent?
5. If amplitude-modulated telephony (Type A-3 emission) were to be authorized to be used in the amateur frequency band 7000-7300 kc, what portion of that band should be made available for that type of operation?
6. Would simultaneous authorization for the use of frequency-shift keying (Type F-1 emission) and amplitude-modulated telephony (Type A-3 emission) in the same segment or segments of the amateur frequency band 7000-7300 kc, adversely affect the use of either, and, if so, to what extent?
7. In consideration of possible changes in the types of emission authorized to be used in the amateur frequency band 7000-7300 kc, should all or part of the operation using any of the authorized types of emission be limited to holders of at least Advanced Class licenses, or General and Conditional Class licenses?

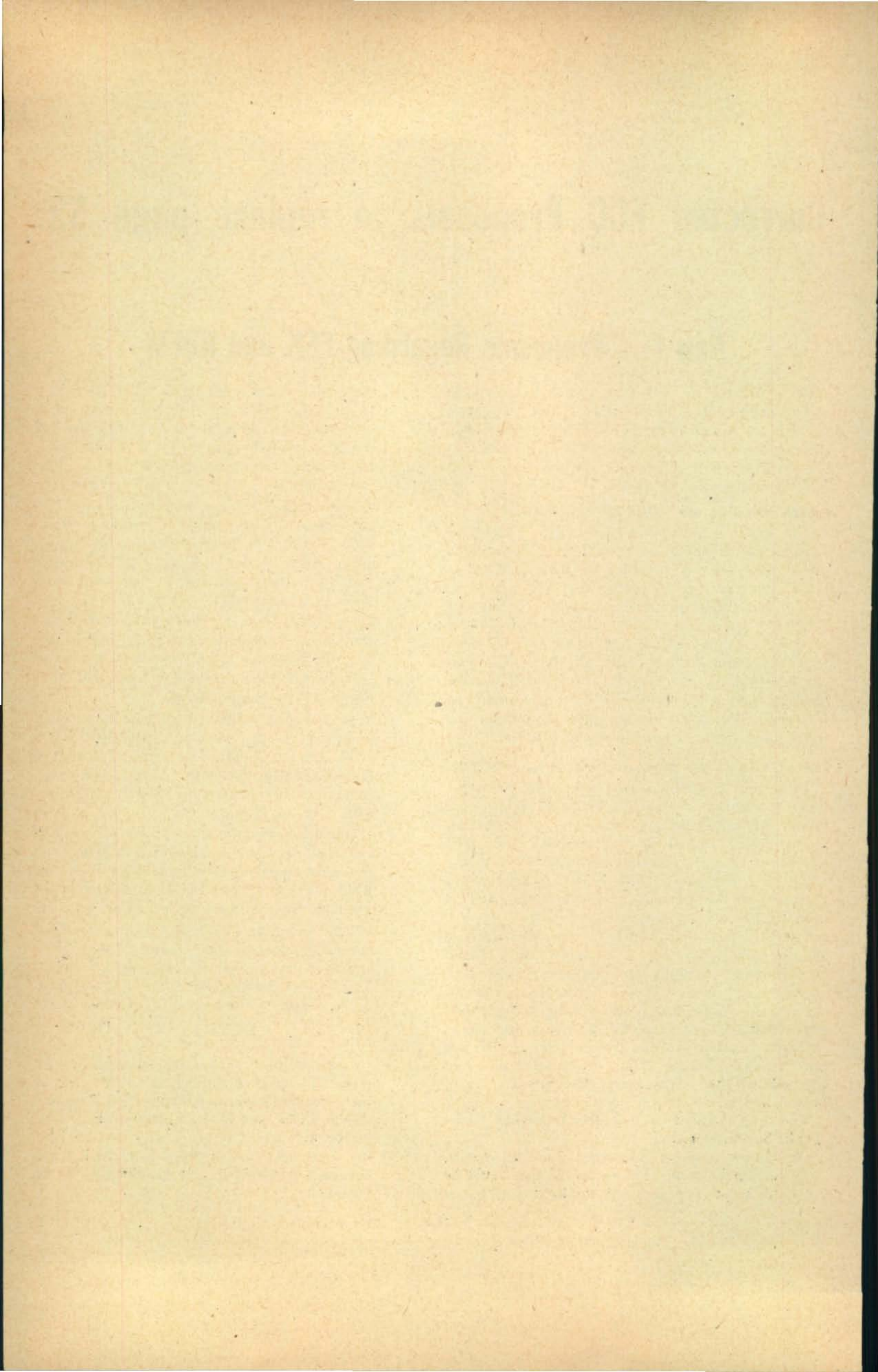

Special Purchase FM Radio Chassis

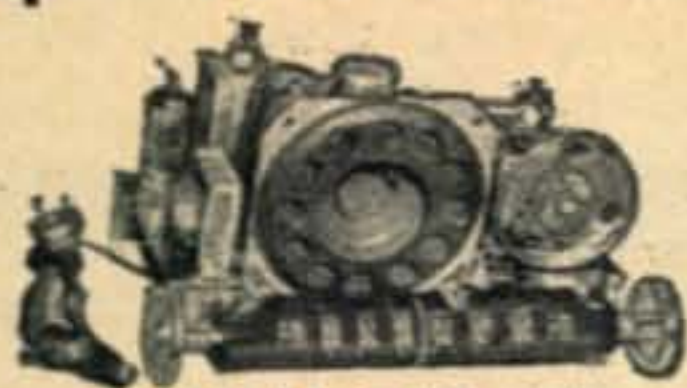

88-108 MC
Complete with 6 tubes. Built-in Antenna and Speaker. Product of Famous Radio & TV Manufacturer whose name we promised not to mention.

TUBE LINEUP
1-12BA7 1-12S8
2-12BA6 1-35W4
1-35B5

May also be used as an FM Tuner by picking signal off detector.

Regularly 29.95
Brand New

\$16.95

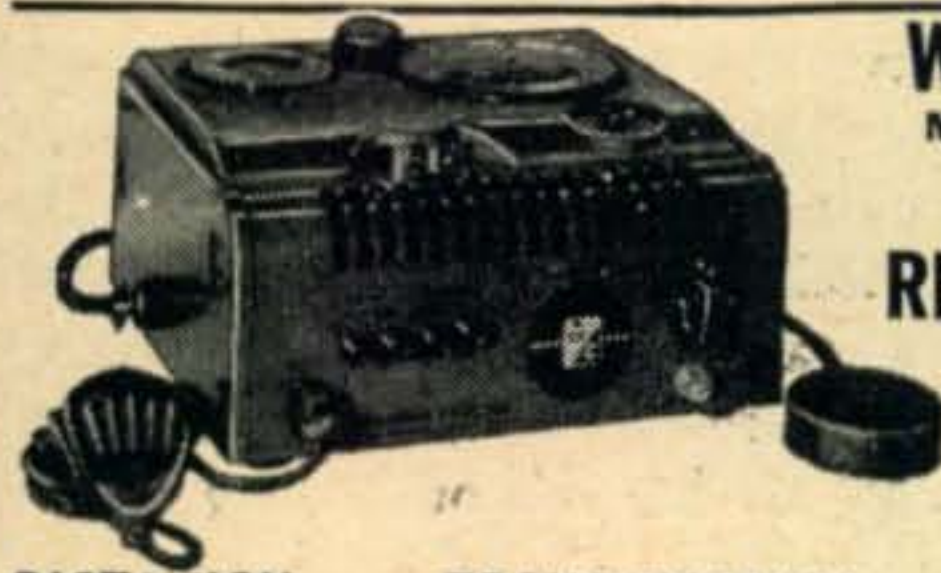

WEBSTER MODEL 18 WIRE RECORDER

BRAND NEW

DICTATION • TRANSCRIPTION • PLAYBACK
• Automatic stops—shut off machine at end of wire
• Pushbutton record-listen switch.
• Immediate playback thru 2 inch speaker
• Neon recording volume indicator
• Removable take-up drum
• Elapsed time indicator

Includes microphone with stand, 1/4 hour spool wire, plastic dust cover, and removable foot switch. Drastically reduced from Original Price of \$135.00 to an all time low of only

\$89.50

RECORDING WIRE

1 hour 1/2 hour 1/4 hour
\$3.50 \$2.10 \$1.40

NOTE: Do not send money for postage on above items, we ship best way—charges collect.

LOW FREQ. XTALS - FT
241A. For SSB, lattice filter, etc. 1/2" spc. 54th or 72nd harm. channels. Listed by fund. Fractions omitted.

SCR 522 XTALS		BC-610 XTALS	
1/8" PINS	1/2" SPC	2 banana plugs	3/4" SPC
372 404 435 506 400 462	5910	2030 2442	
374 405 436 507 440 463	6370	2045 2532	
375 406 437 508 441 464	6450	2105 2545	
377 407 438 509 442 466	6470	2125 2557	
379 408 481 511 444 468	6497	2145 3202	
380 409 483 512 446 469	6522	2155 3215	
381 411 484 514 447 470	6547	2220 3237	
383 412 485 515 448 472	6610	2258 3250	
384 413 487 516 450 474	7350	2280 3322	
385 414 488 518 451 475	7480	2282 3510	
386 415 490 519 452 476	7580	2290 3520	
387 416 491 520 455 477	7810	2360 3945	
388 418 492 522 457 479	7930	2390 3955	
390 419 493 525 459 480		2300 3550	
391 420 494 526 461		2305 3570	
392 422 495 530		2320 3580	
393 423 496 531	99c EA	2415 3995	
394 424 497 533	10 FOR	2435	
395 425 498 537	\$9.00		
396 426 503 538			
397 427 504			
398 429			
401 431 49c EA			
402 433 10 FOR			
403 434 \$4.50			

SPECIAL
200 KC XTALS
without holders
69c EACH
3 FOR \$2.00

HAM XTALS—FT 243 HOLDERS—1/2" pin spc.	
4190 6773 7840	1015 5825 6440 6740 7640
5030 6873 7873	1129 5840 6450 7340 7650
5485 6906 7906	2045 5850 6473 7440 7673
3040 6973 7940	3735 5873 6475 7473 7706
3073 7740 7973	5305 5875 6506 7506 7806
8106 7773 8273	5677 5906 6540 7540 8240
3125 7806 8306	5706 5940 6573 7573 8340
3140	5725 5973 6575 7606 8400
8173 49c EA	5740 6273 6600
8175 10 FOR	5750 6306 6606
8206 \$4.50	5760 6325 6625
	5773 6340 6640
	5800 6373 6673
	5806 6406 6706

Add 20c for each 10 xtals or less for postage and handling.

SUN RADIO
OF WASHINGTON, D. C.
938 F STREET, N. W. WASH. 4. D. C.

VARIABLE CONDENSERS

From SCR-522

2 GANG - 25
MMF
per section
\$1.29



3 GANG - 25
MMF
per section
\$1.59

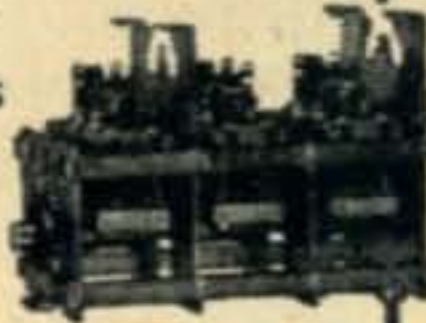

BRAND NEW with CONCENTRIC AIR TRIMMERS

BC-306A ANTENNA TUNING UNIT

Contains - antenna variometer heavy duty 3 pole 5 pos. ceramic switch, velvet vernier dial. Standoff insulators housed in heavy aluminum case only

\$2.95



REEL

RL-42B ANTENNA

24 V D C — can work on A C convert to antenna rotator. Only

\$3.95

BC-706D SWITCH BOX

Contains Micro Switch only

69c



CD-716 CORDS

with PL 55 Plug & JK 56 Jack

\$1.29



BC-221T FREQ. METERS

BRAND NEW

complete with XTAL—spare tubes, manual and calibration book with canvas carrying case

\$125.00

TERMS

All items F.O.B., Washington, D.C. All orders \$30.00 or less, cash with order. Above \$30.00, 25 per cent with order, balance C.O.D. Foreign orders cash with orders, plus exchange rate.

I-82A RADIO COMPASS INDICATOR



Compass indicator with built-in selsyn only

\$3.95

VARIABLE CONDENSER

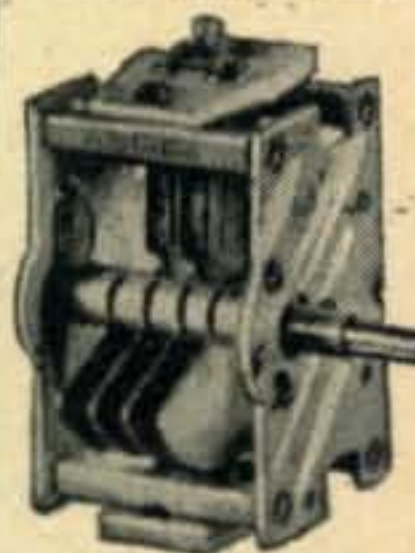

26 MMF—
.10 Spacing
only

99c

SINGLE EARPHONE TYPE AND H-I

Magnetic — no cord only **69c** ea. 2 for **\$1.25**

BC-347 INTERPHONE AMPLIFIER

less tube — contains one miniature carbon mike input trans and one interstage trans. only

\$2.95

DM-35 DYNAMOTOR

12V input—625V, .225A output with 6V input output is 300V at .150A

\$12.95



12-GP-7 CATHODE RAY TUBE

only **\$12.95**

CQ TO ALL HAMS DE W3PPQ

Handle here is "Pick" . . . call or write me for anything you need in ham gear or parts—Will be happy to expedite your order with best quality merchandise. 73's

SKYWIRE AND LAW

(from page 42)

the proposed antenna is a beam type, evidence showing the reduced radiation in directions other than where the beam is aimed is pertinent. (4) Evidence showing the precautions taken to prevent spurious radiation is also valuable in refuting this type of argument. Evidence of this type is by necessity, technical in nature. Since Zoning Boards normally do not have engineering personnel attached to them, it would be desirable to supplement evidence of this type with drawings, or other illustrations which would appear reasonable to a person with a non-technical background.

B. Legal Precedent to Refute This Argument.

There is considerable precedent to support the amateur position on this point. Ordinances setting up restrictions for the purpose of preventing or minimizing electrical disturbances, or for the purpose of preventing or reducing interference to radio or television reception are generally held invalid, because exclusive jurisdiction over all forms of radio communication are vested in the Federal Communications Commission⁹. In several cases local ordinances attempting to regulate or otherwise deal with the regulation of radio stations have been held valid by the courts.¹⁰

VI. The Presence of the Proposed Antenna Would Depreciate Real Estate Values

A. How This Contention can be Refuted:

(1) If this contention is raised, evidence as to the effect of the proposed antenna on real estate values should be presented. Local real estate brokers are usually competent to testify regarding the effect of the proposed antenna on real estate values. The amateur should be prepared to offer witnesses who will testify, that in their opinion, the proposed antenna will not depreciate the value of the property in the neighborhood. (2) Evidence of other similar antennas in the neighborhood is also useful in connection with refuting this argument. (3) Evidence that the proposed antenna will diminish radio or television interference in the immediate vicinity may also prove of value in connection with this point. The value of testimony as to real estate values will to a large extent depend upon the reputation and credibility of the witness. The amateur should attempt, if possible, to secure reputable real estate brokers, real estate appraisers, or other persons enjoying a good reputation in the community for this purpose.

⁹ Federal Radio Commission vs. Nelson Bros. Bond and Mortgage Co., 289 U.S., 266

Whitehurst vs. Grimes, 21 Fed. (2) 787

Tampa Times vs. Burnett, 45 Fed. Supp., 166

Dumont Laboratories vs. Carroll, 189 Fed. (2) 183

¹⁰ N.B.C. vs. Board of Public Utilities Commissioners, 25 Fed. Supp. 761

K.V.L., Inc. vs. Tax Commission, 12 Fed Supp., 497

See also: State and Municipal Regulations of Radio Communications (Government Printing Office 1929)

¹¹ White's Appeal, 287 Pennsylvania, 259; 138 Atl., 409
Women's Kansas City, et al vs. Kansas City, 58 Fed. (2), 393

B. Legal Precedent to Refute This Argument.

There is legal precedent which supports the proposition that even a proposed activity which, in fact, might depreciate the value of adjoining property is not sufficient reason alone, to uphold an otherwise unreasonable zoning restriction.¹¹

From the foregoing discussion, it may readily be seen that the matter of the presentation of the amateur's case before local Zoning Boards is of particular interest and concern to amateurs throughout the country. Each individual zoning case generally differs in some way from others, although most of the cases have one or more of the general problems which have been discussed in this article.

Too much emphasis cannot be placed on the necessity and desirability of presenting a well prepared case at all stages. Often valuable rights are lost, and the amateur's position jeopardized in subsequent court cases arising out of Zoning Board actions³, unless the record is carefully prepared and protected before the Zoning Board. It is also well to consider that it is much less costly, in terms of time and money, to win before a local Zoning Board, than to seek support of your position in the courts. If possible, the amateur should be represented by an attorney before the Zoning Board, since it is really a legal matter, rather than a technical radio matter. But the ham can do much to prepare his own case even if represented by counsel.

DX & OVERSEAS

(from page 47)

lately. This is fortunate for the Gang, as Madagascar has been a scarce article since the end of the War. W3DPA, in addition to FB8BB, nabbed 9S4AL, 14080.

Now I am going to swipe a little news from the various bulletins. From the "Northern California DX'er", W6OMC has been building a new room on his house, and 'tis said it will be for his new final. . . . W6TI had a letter from OX3SF, who stated that there was only one ship a year to his spot so everyone must be patient for QSL's. . . . 3A2AB is trying to get stationed in San Francisco as well as planning to go to Clipperton and Cocos. Ye Gods, another one! Let's hope he makes it.

(By the way, ENV and I saw W6GRL a week or so ago, who started out by saying he was getting too old for DX Contests. However, he hadn't quite finished putting the period on that sentence before he wondered where he could get another socket for a transmitting jug.)

A couple of months ago a West Gulf Division DX Club was formed, and W5KUC puts out their bulletins—and man, what bulletins! KUC cranks these out once or twice a week, and brother, that is a lot of work. I hope his pals in the South West appreciate it. We are also going to lift a few items which I feel will be of interest to the majority. VS9AC works 40 c.w. only. . . . Mail to VR6AB is being returned with a notation stat-

Ask any Old Timer about Lafayette

(Chances are we sold him the parts for his first rig over 30 years ago.) He'll tell you: "Lafayette is a good place to do business with."

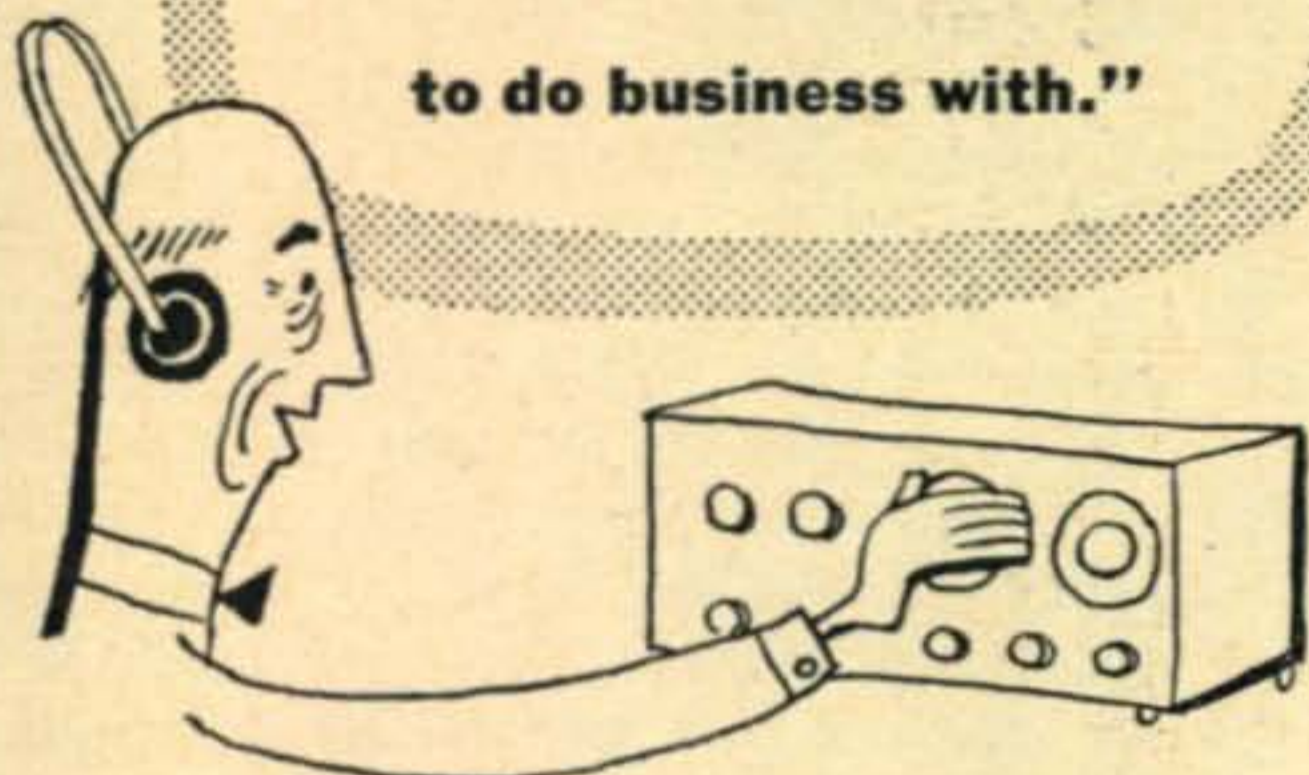

Getting more popular all the time:

JOHNSON VIKING 1 Transmitter Kit

Here is a rig that gives you that crisp clean CW note and the well-modulated phone signal of a commercial transmitter — at a price you can afford to pay. 115 watts CW, 100 watts AM phone output. Front panel band-switching; no plug-in coils. 10-position Xtal switch for rapid QSY. Provision for optional VFO input. All stages metered. 160, 80, 40, 20, 15 and 11-10 meter operation. Tubes to be used: 3-6AU6; 1-6AQ5; 2-807; 1-4D32 or 829B. This kit is complete in every detail, including wiring harness, drilled and punched chassis, panel and all parts.

Viking 1 Transmitter Kit (less tubes, crystals, mike and key). Shpg. wt.: 90 lbs. **\$209⁵⁰**



Give it for Xmas!

NATIONAL'S "Mighty Midget" SW54

The hottest little low-cost receiver on the market. (Makes a wonderful gift to get the new ham started). Covers from 540 kc. to 30 mc. with surprising sensitivity. For standard AM, foreign and domestic shortwave, police, ships, aircraft and amateur reception. Measures only 11" x 7" x 7". Complete with latest miniature tubes. Shpg. wt. 14 lbs.



\$49⁹⁵



JOHNSON VIKING VFO Kit

Ideal for use with the Viking 1. High stability, cleanest keying. Accurate frequency calibration (all bands). 5" calibrated dial with 6:1 reduction. Simple assembly; build it in an evening. (Tubes to be used: 1-6AU6, 1-OA2). Complete kit, less tubes: Shpg. wt.: 7 lbs. **\$42⁷⁵**

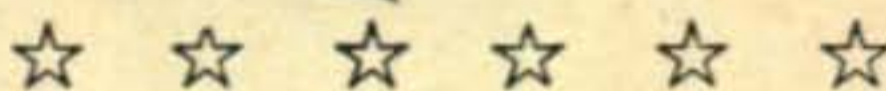

If you want more detailed info on items listed on this page, just write us.



Did you get the new 1952 Lafayette Catalog we sent you? If not, drop us a card today.

Radio Wire Television Inc.



NEW YORK 13, N. Y.
100 SIXTH AVENUE
REctor 2-8600

BOSTON 10, MASS.
110 FEDERAL STREET
HUBbard 2-7850

NEWARK 2, N. J.
24 CENTRAL AVENUE
MARket 2-1661

BRONX 58, N. Y.
542 E. FORDHAM RD.
FORDham 7-8813

ing he is no longer on the Island. . . . W5LVD wants to know if any one has received a card from FI8ZZ. . . . W5WI said nothing sensational was going on in Tulsa. (There used to be a lot of sensational stuff in Tulsa.)

W4CKB tells me that a few of the boys, including W4BRB, were discussing GD3UB not QSLing. Apparently letters and reply coupons were to no avail, and on this particular day while tuning over the band, CKB, of all things, heard GD3UB. After the preliminaries were over, GD3UB had this to say, "For six months I am going to be off work, and I will have nothing—absolutely nothing—to do, except to QSL. The XYL is going to help me, and I should be started on it as soon as I return from Paris later this month (October). I will answer all outstanding QSL's and every one should get one within a month."

W6MX wonders how many times the W5's in Los Angeles have to work FB8BB to make it official. Since the W5's are not in L. A., I can't answer that, and as far as the W6's are concerned in Los Angeles, maybe the grapes are getting a bit sour—eh, Walt.

It seems like years since we heard from GM2UU, but sooner or later they get around to kicking through with a little info. Doug brings his country list up to date, after about a two-year moratorium. Doug apparently found a new golf course, and he has been trying to reduce his handicap to the same number as his zone requirements. However, he seems to be having trouble with both. . . .

VK3BZ apparently has been dividing his efforts between phone and c.w. during the past year. However, Morrie thinks he is going to concentrate a bit more now on phone. . . . Some of you may not know it, but VK4HK is now G4HK. His old call will not be issued to any one else.

As you probably know, Tangier Zone has declared the prefix "EK" no longer legal, and has requested amateurs to apply for licenses and accept a new call using the prefix "CN2". Since it appears that the State Department has indicated the American amateurs are not subject to local administration, they are apparently not going to use this particular prefix. In accordance with the American Legation, they have discontinued using EK1, and have started using KT1 on an interim basis. There are several Hams there. For example, W7IOC is signing KT1OC. . . . A line from W5AD indicated he had worked KT1PU. How the situation will stand by the time you read this, your guess is as good as mine.

Well, apparently the Government of Macao is reissuing calls and CR9AG isn't any more, and yet he is. Confusing? Well, only slightly! It seems that the CR9AG who we used to know, John Alvares, is now CR9AH. The new CR9AG is ex-CR9AM, which in one way doesn't make sense, and yet, there it is. Now we have to get used to CR9AH. John tells me that CR9AF is still going strong and probably by the time you read this, the new CR9AG—that is Tiny Houghton—should be on 10 phone.

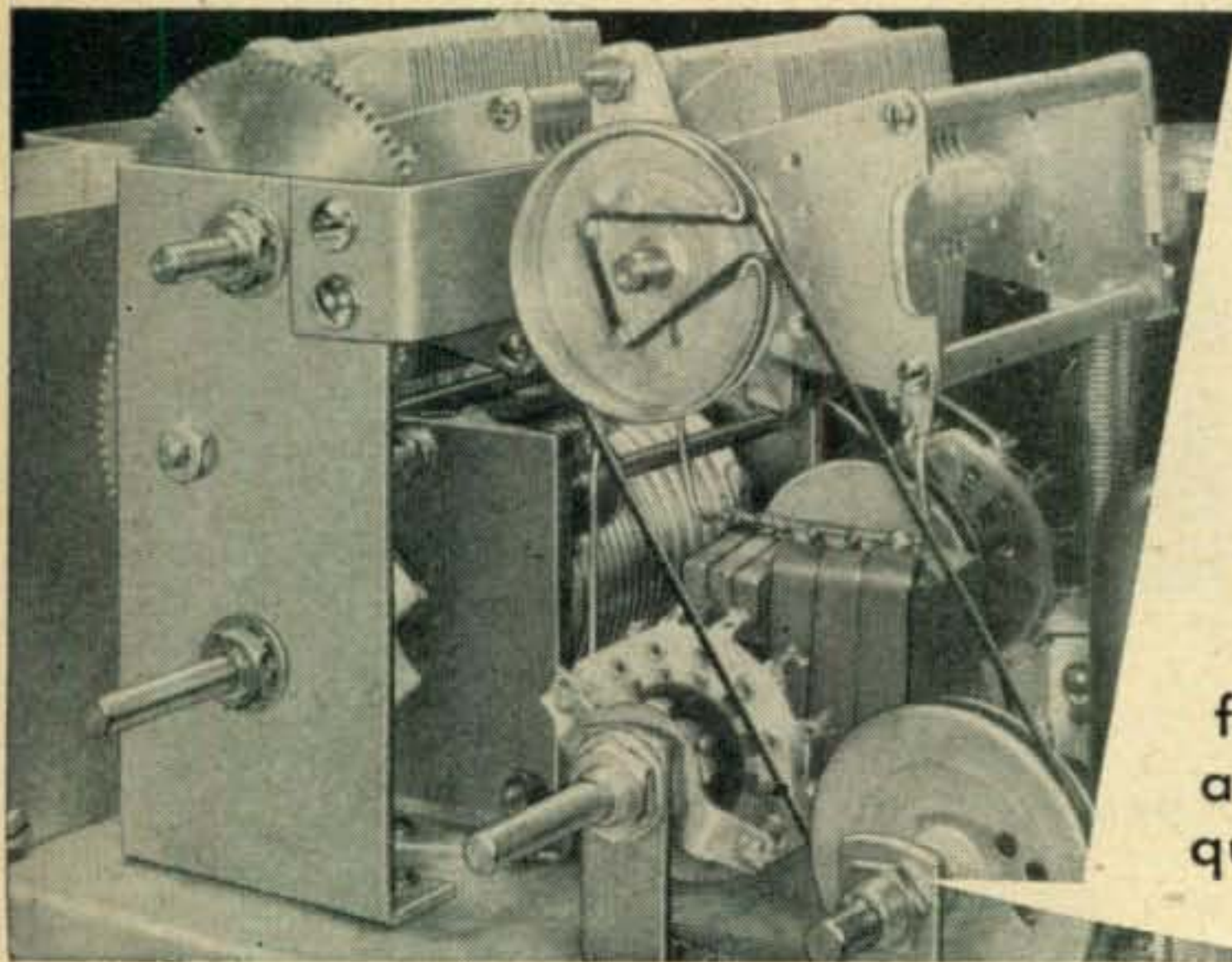

No Guesswork Here!

The key to smooth performance of the Viking 1, its continuous tuning pi-network final amplifier. Has nearly constant output throughout the range 1.8 to 30.0 mcs., perfect control of loading, freedom from parasitics.

Here's a kit with "commercial" performance, carefully designed, easy to assemble and built around JOHNSON quality components. Why settle for less?

FEATURES

Bandswitching, covers all amateur bands from 160 thru 10 meters. 4D32 final amplifier delivers 115 watts CW, 100 watts AM phone. Output of optional 829B amplifier is 100 watts CW, 85 watts phone. Modulators pp 807s. Input and power receptacles for JOHNSON VFO provided. Complete with 11-3/16" x 15" x 21" dark maroon desk cabinet but less tubes, crystals, mike and key,

Amateur Net (kit form) **\$209.50**

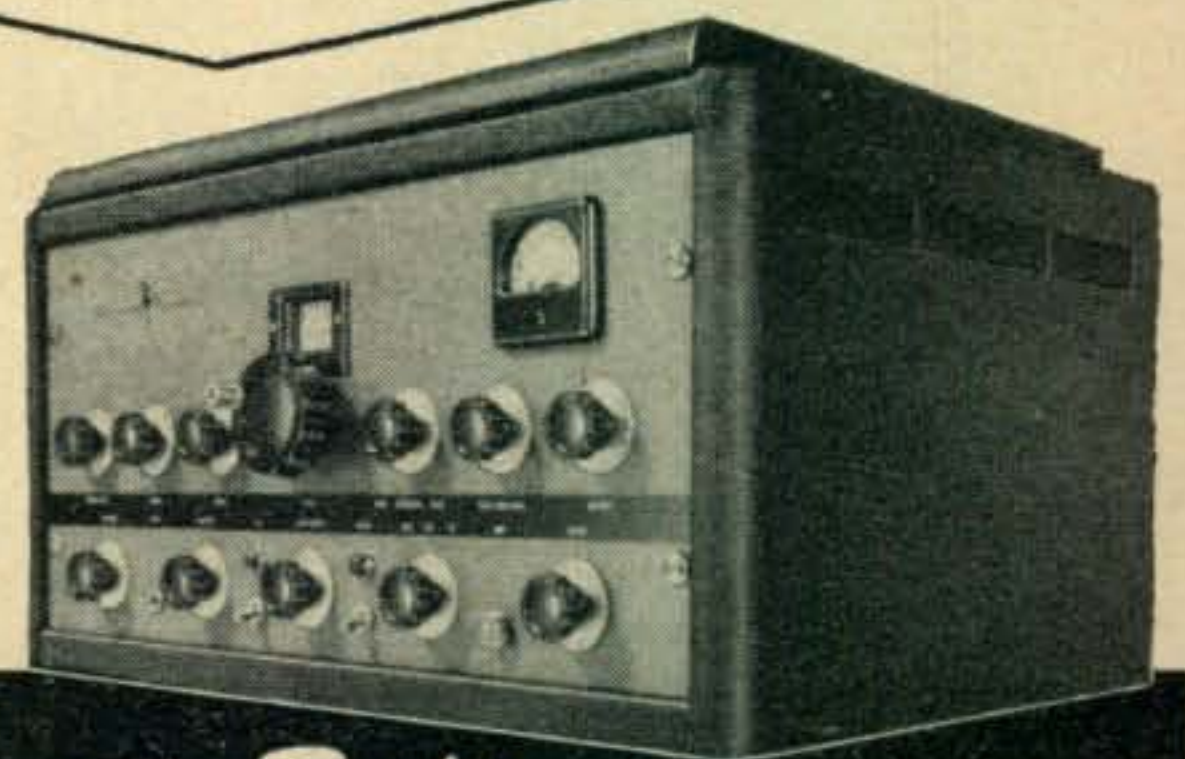

JOHNSON *a famous name in Radio*

E. F. JOHNSON CO., WASECA, MINNESOTA

ALLIED

YOUR COMPLETE SOURCE OF SUPPLY FOR ALL

Authorized



Distributor

RCA TEST EQUIPMENT

NEW RCA WV-77A JUNIOR VOLTOHMYST

Here it is—the new bigger value Junior VoltOhmyst! Includes all the fine features of the famous model it supersedes, plus (1) greater voltage range, (2) wider frequency response, (3) higher overall accuracy. Ideal for measurements in AVC, bias and other high-impedance circuits. With zero-center scale for FM discriminator alignment. Measures AC even in presence of DC. Easy-to-read completely shielded 4½" meter electronically protected against burnout. Uses electronic bridge circuit, 200 microampere meter movement and 1% carbon-film resistors. Ranges: DC and AC volts, 0-3-12-60-300-1200 (11 megs input impedance on DC, .2 meg and 75 mmf to 2.0 megs and 50 mmf on AC); resistance, 0-1000 megs in 5 ranges. Frequency response flat ± 1 db, 30 cps. to 3 mc (with WG-264 probe flat within ± 1 db, 50 kc to 250 mc). Supplied complete with tubes, battery, WG-218 AC probe and WG-217 DC probe, leads and instructions. Size: 8 x 5½ x 4½". For 105-125 volts, 50-60 cycles AC. Shpg. wt., 6 lbs.

84-087. RCA WV-77A Junior VoltOhmyst. Net. **\$4750**

WG-264 Demodulator Crystal Probe. Extends range of both Junior and Senior VoltOhmyst to 250 mc. Shpg. wt., 12 ozs. **\$775**

84-084. WF-264 Probe. Net.



WV-97A SENIOR VOLTOHMYST

The improved professional VTVM which reads peak-to-peak voltages of complex waves directly up to 2000 volts—even with DC present. Signal traces sync pulses and deflection voltages in TV sets. Wide response, 30 cps to 3 mc. Zero-center scale for FM discriminator alignment. Reads AC rms to 1500 volts; AC peak-to-peak, to 2000 volts with input impedance of .83 meg and 85 mmf to 1.5 megs and 85 mmf. Measures resistance 0.1 ohm to 1000 megs. Overall accuracy: on DC, ± 3%; AC, ± 5% (of full scale). Size, 7¼ x 5¼ x 3¼". With tubes, WG-218 direct AC probe, DC probe, and leads. For 105-125 volts, 50-60 cycle AC. Shpg. wt., 10 lbs.

84-075. WV-97A Senior VoltOhmyst. Net. **\$6750**



We can make quick shipment of all RCA test instruments, including the following well-known equipment:

- WO-56A 7" Oscilloscope
- WO-79B 3" Oscilloscope
- WO-57B 3" Oscilloscope
- 715-B 5" Lab Oscilloscope
- WV-84A DC Microammeter
- WR-39C TV Marker Generator
- WR-59B TV Sweep Generator



1952 ALLIED CATALOG

Refer to your 212-Page ALLIED Catalog for all of your electronic needs, including the world's largest stocks of station supplies. Save time, effort and money at dependable ALLIED RADIO. If you haven't a copy of our latest 1952 catalog, write for it today.

FREE

ALLIED RADIO

ALLIED RADIO CORP., DEPT. 16-M-1
833 W. Jackson Blvd., Chicago 7, Illinois

Send FREE 1952 ALLIED Catalog.

Ship the following:

WV-77A WV-97A

Enclosed \$ _____

Name _____

Address _____

City _____ Zone _____ State _____

ATTENTION MOBILE HAMS

COMPLETE MOBILE PACKAGE — NOTHING ELSE TO BUY. OUTSTANDING MOBILE SIGNALS USE MOTOROLA EQUIPMENT — BACKED BY YEARS OF COMMUNICATION EQUIPMENT EXPERIENCE—WORLD'S LARGEST PRODUCER OF 2-WAY MOBILE EQUIPMENT.

A mobile transmitter with a double feature FM or AM at flip of the switch, the MOTOROLA FMT-30-DMS 27-30 MC... **\$130.00**

P-7253 spring base rear-mount antenna. **\$24.75**

MOTOROLA P-69-13 or 18-ARS receiver with special noise limiter for use

with any converter having 1440-3000 KC. **\$60.00**
New Gon-set Tri-Band Spread Converter **\$47.60**

3-30 famous Gon-set converter complete to connect to the P-69-13 or 18-ARS receiver **\$44.75**

P-327-E Fire wall loud speaker **\$5.00**

The above comes complete with all necessary accessories and mounting hardware. Order direct or through the Motorola National Service Organization member in your area.

NOTE: This Receiver and Transmitter is equipment which has been returned from the field, modified and rebuilt for Amateur Service.

For further information write to:

MOTOROLA INC.

Amateur Sales Dept. CQ December
1327 W. Washington Blvd., Chicago 7, Ill.
Attention: Harry Harrison W9LLX
Telephone—Taylor 9-2200, Ext. 161

Back issues of CQ

Year	Issues
1945	July, August, September, November
1946	December
1947	February, May, June, September
1948	March, June, August, September, October, November, December
1949	June, August, October, December
1950	January, February, March, April, May, June, July, August, September, October, November, December
1951	January, February, March, April, May, June, July, August, September

Prices:

1945 to 1950 **50c each**

For 1951 **35c each**

CQ Magazine

67 West 44th St. New York 18, N. Y.

It might interest some of you (I should say all of you but it might go to his head) to know that Larry LeKashman, W2IOP, has pulled up stakes and will become, of all things, a W9. Ah, that's my boy . . . a W9. Larry will be working for a swell egg by the name of Al Kahn, W8DUS.

Well, that's the works for this month . . . and since here it is December here's hoping every one of you will have the Merriest of Christmas' and the Happiest of New Year's.

QTH COLUMN

- CR9AH John J. Alvares (ex-CR9AG), % Radio Vila Verde, Macao, Asia
- FQ8AE Georges Birepinte, Box 69, Fort Lamy, (Tchad), Fr. Equatorial Africa
- HA5BD Andy Sass, Budapest CSAP UI, Hungary
- KM6AX Navy 3080, % F.P.O., San Francisco, Calif.
- MP4KAG Antonio Mattos, Box 54, Kuwait, Persian Gulf
- 8W4AF Director of Harbourage, Post of Mocha, Yemen

MATCHMAKER

(from page 31)

In the *Matchmaker* this relationship is altered to a slight degree because of variances in e due to regulation of the source, and because of some inductance in the instrument. In the actual application of the *Matchmaker* these phenomena are of no importance and do not enter into the results when the proper resonance reading is taken.

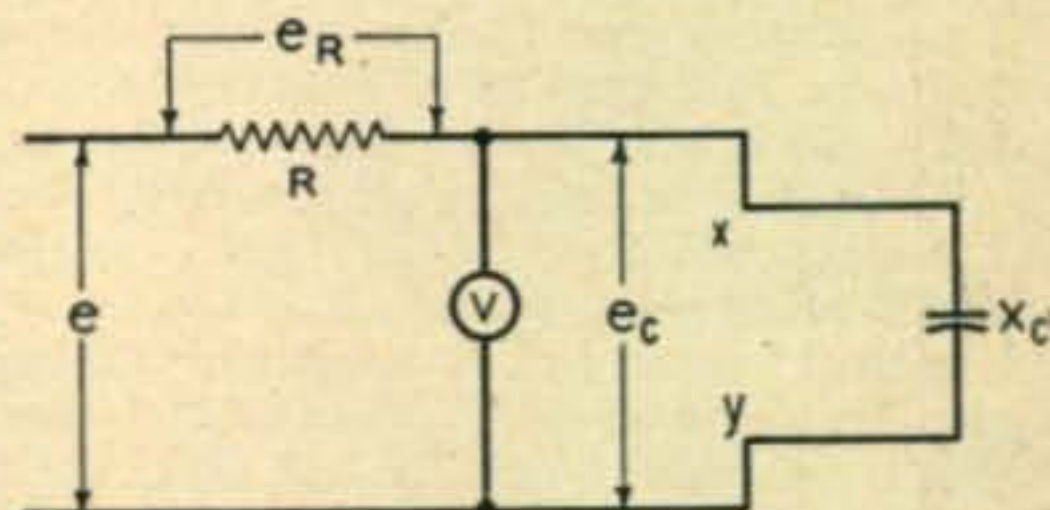

Fig. 10. The simplified "Matchmaker"

There is also a falling off in *curve 2* at low values of reactance caused by the inherent inductance of the *Matchmaker* cancelling a portion of the applied capacitive reactance. The result is to prevent a true "zero ohm" reading when the terminals are strapped together. However, a calibration curve run at 14 mc will hold over the 3.5 mc 14 mc range within a few percent. Composition resistors start to go "sour" around 14 mc and for 28 mc operation it is best to calibrate the unit directly at this frequency. If possible, use non-inductive resistors for best results. If care is taken during the assembly, composition resistors will perform well enough to obtain perfectly valid results at 28 mc.



TVI-Suppressed Johnson Viking

Here's America's biggest transmitter value! Harrison has it completely laboratory wired and tested, incorporating TVI-preventive measures. Conservatively rated at 100 watts Phone or 125 watts CW OUTPUT! Push-pull 807 modulators! Covers 160-80-40-20-15-11-10 meters - entirely band switching - oscillator keying for break-in CW - coaxial output - provision for VFO - xtal selector for 10 frequencies - all circuits metered. Everything self-contained in desk cabinet 11" x 15" x 21" wide. Supplied complete with tubes and instruction book - ready to operate.

Johnson Viking I
Wired, tested, complete! **Only \$308.50**
Standard Johnson Viking I Kit as supplied by the factory. Complete with instructions, less tubes. \$209.50

HARVEY-WELLS BANDMASTERS

For Portable - Mobile - Fixed Station
Here's America's most versatile xmtr! Ideal for old timer or novice operator. (Covers Novice Frequencies: 80 CW, 11 CW, and 2-Meter Phone) 40 to 50 watts to 807 final - Phone or CW - Completely bandswitching - just turn knob to work 80, 40, 20, 15, 11, 10, 6 or 2 meters. 100% break-in operation. All controls and xtal sockets located on front panel for quick QSY - provision for VFO input.

YOUR INVESTMENT PROTECTED!
All Bandmasters remain modern as unique factory plan permits addition of all newly developed features to older models.
BANDMASTER SENIOR - Carbon Microphone Input \$111.50
BANDMASTER DELUXE - With pre-amp for crystal mjk 137.50
APS-50 Power Supply for 110V AC Operation 39.50
DPS-50 Dynamotor Supply for 6V DC Operation 87.50

110V AC IN YOUR AUTOMOBILE!

Terado's new Senior Model Inverter delivers 45 watts of 110-volt, 60 cycle AC from any 6-volt DC source! Ideal for your car, cabin, boat, house trailer, etc. Use for operating phonographs, lamps, electric shavers, motors, fluorescent lights, etc., etc. Compact - only 2 1/2" x 2 1/2" x 4" long. Complete with cord and provision for plugging into cigarette lighter socket. Standard AC receptacle provided for output.
6V DC to 110V AC - 60 cycles
Model No. 6-1160 **\$10.95**

SONAR TWO-METER RECEIVER

Covers 143.8 to 148.2 Mc. 9 tubes. Over-all sensitivity better than .5 microvolt. Compact, universal-mounting cabinet. Designed for best reception. Use any external speaker. Model SR-9 **\$72.45**

SONAR 2-METER TRANSMITTER

Companion to the above. Rugged, power packed transmitter designed for better mobile operation. Complete with all plugs and connectors. **\$72.45**

2400-HOUR CLOCK

2400-hour time in every time-zone all over the world. Simply set hour hand and inner dial for your time-zone - read time in any zone easily, quickly, accurately. **only \$12.50**

NEW JOHNSON VIKING VFO
A companion unit for the Viking I Transmitter - can also be used with any similar transmitter. Features accurate frequency calibration on all bands, 10 through 160 meters - High Stability - Cleanest Keying - Assembly so simple that it can be built in one evening. Cabinet finished to match Viking I. Send orders now.
Wired, tested, with tubes **\$59.95**

NOVICE CLASS HAM-A-LOG
Our new Novice Class Ham-A-Log is now ready! Novice license aspirants and beginning amateurs will find it an invaluable aid. Send for your copy now! Club Secretaries and Boys' Group Radio Advisors - How Many Can You Use?
\$44.50
47.60
44.75
9.25
3.90

GONSET CONVERTERS
New! Two-Meter Converter - 144 to 148 MC
Tri-Band Converter for 75, 20, and 10 meters
6, 10-11, 20, or 75 meter converters. Your choice
Latest Model Gonset Noise Clipper
Universal Steering Post Mount for all Gonsets

A very Merry Christmas to you, O.M.!

... and here are some FB STOCKING STUFFERS that will make it even merrier!

Circle the items you want, and leave this page where St. Nick can find it. Or be your own Santa - Let me know what you want. We've got a big supply of most items here, ready for Christmas delivery. (But if you wait too long to order - Happy New Year!)

73, *Bil Harrison*
W2AVA

HARRISON
RADIO CORPORATION
225 GREENWICH STREET
(10 West Broadway, at Barclay St.)

EASY TO LEARN CODE

It is easy and pleasant to learn or increase speed the modern way—with an Instructograph Code Teacher. Excellent for the beginner or advanced student. A quick, practical and dependable method. Available tapes from beginner's alphabet to typical messages on all subjects. Speed range 5 to 40 WPM. Always ready, no QRM, beats having someone send to you.



ENDORSED BY THOUSANDS!

The Instructograph Code Teacher literally takes the place of an operator-instructor and enables anyone to learn and master code without further assistance. Thousands of successful operators have "acquired the code" with the Instructograph System. Write today for full particulars and convenient rental plans.

INSTRUCTOGRAPH COMPANY

Dept. C, 4701 SHERIDAN ROAD, CHICAGO 40, ILL.

**BECOME
A RADIO
AMATEUR**

Complete Home-Study
Course for Passing FCC

**AMATEUR
RADIO EXAMINATIONS**

• Low Cost • Personal Coaching •

Money Back Guarantee Write for Details

FEDERAL ELECTRONICS INSTITUTE
34 EAST PUTNAM AVE., (Dept. G)
GREENWICH, CONNECTICUT

WANTED

WE NEED YOUR
SURPLUS
ELECTRONIC EQUIPMENT

WE PAY TOP \$\$\$ FOR:

RADIO RECEIVERS TRANSMITTERS ARC-1 ARC-3 ART-13 CONTROL BOXES INDICATORS	AN CONNECTORS CLAMPS PLUGS CORDS RELAYS TELEPHONE MATERIALS WE BUY ANYTHING!
--	--

WRITE, WIRE TODAY!
TELL US WHAT YOU HAVE

TALLEN COMPANY, INC.
Dept. CQ,
159 CARLTON AVE. BROOKLYN 5, N. Y.

STERLING SILVER MICROPHONE

with your call letters engraved down the side. Illustrated actual size.

<input type="checkbox"/> Pin . . . \$3.50	<input type="checkbox"/> Earrings . \$5.50
<input type="checkbox"/> Tie Bar . 4.50	<input type="checkbox"/> Key Chain 4.50
<input type="checkbox"/> Cuff Links 7.50	<input type="checkbox"/> Charm . . 3.50

Prices include Federal Tax

Sterling Gold plated

Clip Ad and send with Check or Money
Order to: SEQUOIA CRAFT, BOX 582,
ROME, GEORGIA.

NAME _____ CALL LETTERS _____

ADDRESS _____

CITY _____ STATE _____

Check if Gift Box is desired.

PROPAGATION

(from page 37)

The longer hours of darkness in the Northern Hemisphere, also associated with a considerable decrease in ionospheric absorption, is expected to produce very good DX conditions on 40 and 80 meters. Strong signal levels should be noticed just before sundown local time, fading out on some nights a few hours after sundown and coming up strong again at sunup at the European control point which is at approximately 1000 GMT. When European signals are not heard on 40 meters be sure to check 80, as this indicates 80 meters is near the MUF, and signal levels should be strong.

Conditions on 160 meters during December are such that frequent openings should be possible from Europe to the East and Central sections of the USA. Time of band openings should be the same as openings for 80 meters, but will probably occur less frequently.

SOUTH AMERICA:

Very good daytime DX conditions are expected for 10 and 20 meters from all areas of the USA to all areas of Central and South America.

Good DX conditions are expected on the 40 and 80 meter bands during the all dark period which for these circuits is from just after sundown to just before sunup local time. Conditions on these two bands favor Latin American Countries North of the Equator. Conditions to countries South of the Equator will be poorer because of the higher noise levels and ionospheric absorption associated with the summer season now being enjoyed by our Southern compatriots. Fairly good 160 meter circuits should be possible to Central American countries during the dark hours.

These North-South circuits are little, if any, affected by ionospheric disturbances, so it is expected that these circuits will be very stable and reliable.

AFRICA:

Since African transmission paths generally clear the auroral zones by considerable distances, these circuits are usually stable even during ionospheric disturbances. Quite often it will be noted during a disturbance that European signals are not being heard, but the Africans are. One reason for this is that the ionospheric reflection points that control the circuit are in southern regions, characterized by a more dense ionosphere, which produces higher usable frequencies. Therefore, fairly good radio conditions exist for 10 meter DX possibilities from all sections of Africa to the USA. All ten meter openings will follow the short great circle path, and signals will arrive from an east-south-east direction. On many days when the ten meter band will be closed to Europe, the North and Central Africans will be heard quite well.

On 20 meters, conditions are expected to be good for North Africa, with these circuits more stable than European paths. The increase in distance on the Central and South African circuits, with its increased absorption will tend to decrease signal levels on these circuits. On some occasions the longer South African circuits may come around the "long" great circle route and be heard with the VKs and ZLs.

Forty and 80 meters should be good for North African paths during the all dark period, with conditions permitting, on propagationally quiet days, considerable 160 meter activity.

Forty and 80 meter transmission paths to Central and South Africa will become progressively poorer as the circuit becomes more southernly. This is the result of higher absorption and noise factors associated with these localities during December.

OCEANIA: (Australia & New Zealand)

It's summer time "down under," and associated with this winter-summer condition, are high day-time frequencies, fairly low night-time frequencies, and moderate absorption and noise factors at the Oceania end of the circuit. Conditions on ten meters are expected to be fair to the East and Central sections of the USA and good to the Pacific Coast section.

Twenty meters is expected to provide good strong signals on many days, with the usual openings just after sunrise and about sunset local time.

Fair conditions are expected on 40 meters, with some good openings on undisturbed days.

Not much 80 meter activity expected.

ASIA:

Propagation conditions on circuits to the Near East Asiatic countries are quite similar to European circuits. Signals will be weaker because of the longer distances of the paths, but band openings should be generally similar. Some 10, 20, 40 and 80 meter openings are expected.

From Japan to the USA Pacific Coast conditions are good for openings on all bands. Conditions are poorer to the Central and Eastern sections of the USA, with no 10 meter openings expected, and a decrease in 20 meter openings is also expected. The early morning 20 meter (about 7:00 AM local time), openings heard throughout the summer and early fall are not expected to come through in December.

Some 40 and 80 meter openings are expected to the Pacific Coast and to a lesser degree to the Central and Eastern sections of the USA.

Poor propagation conditions are expected to India and Central Asia. No 10 or 80 meter activity is expected, with some occasional openings possible on very quiet days on 20 and 40 meters. Openings will be characterized by weak signal levels and the usual auroral flutter.

Merry Christmas, Happy New Year and best wishes for lots of DX in 1952 from W2PAJ.

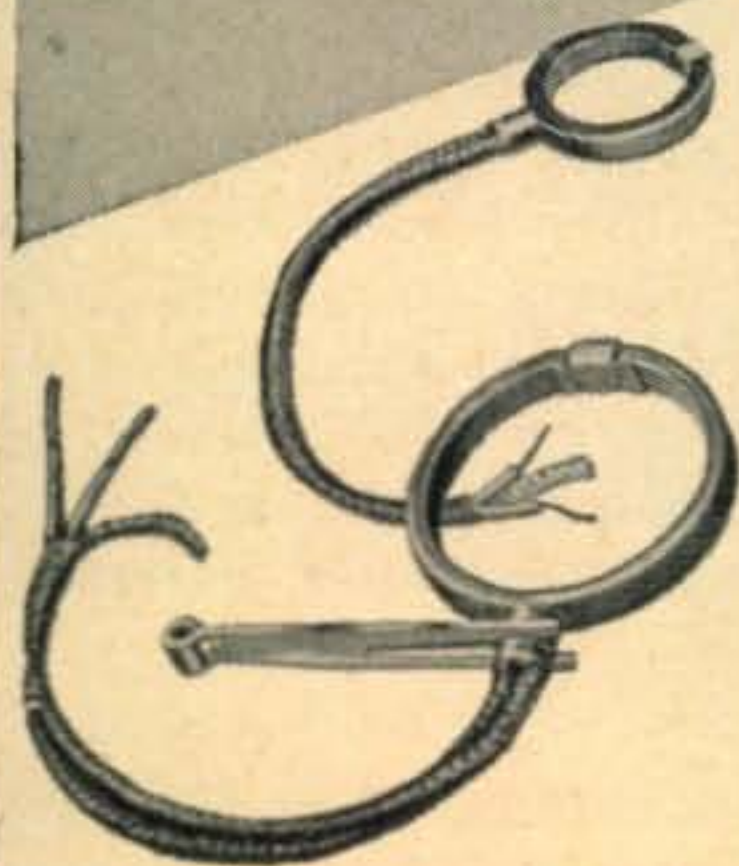
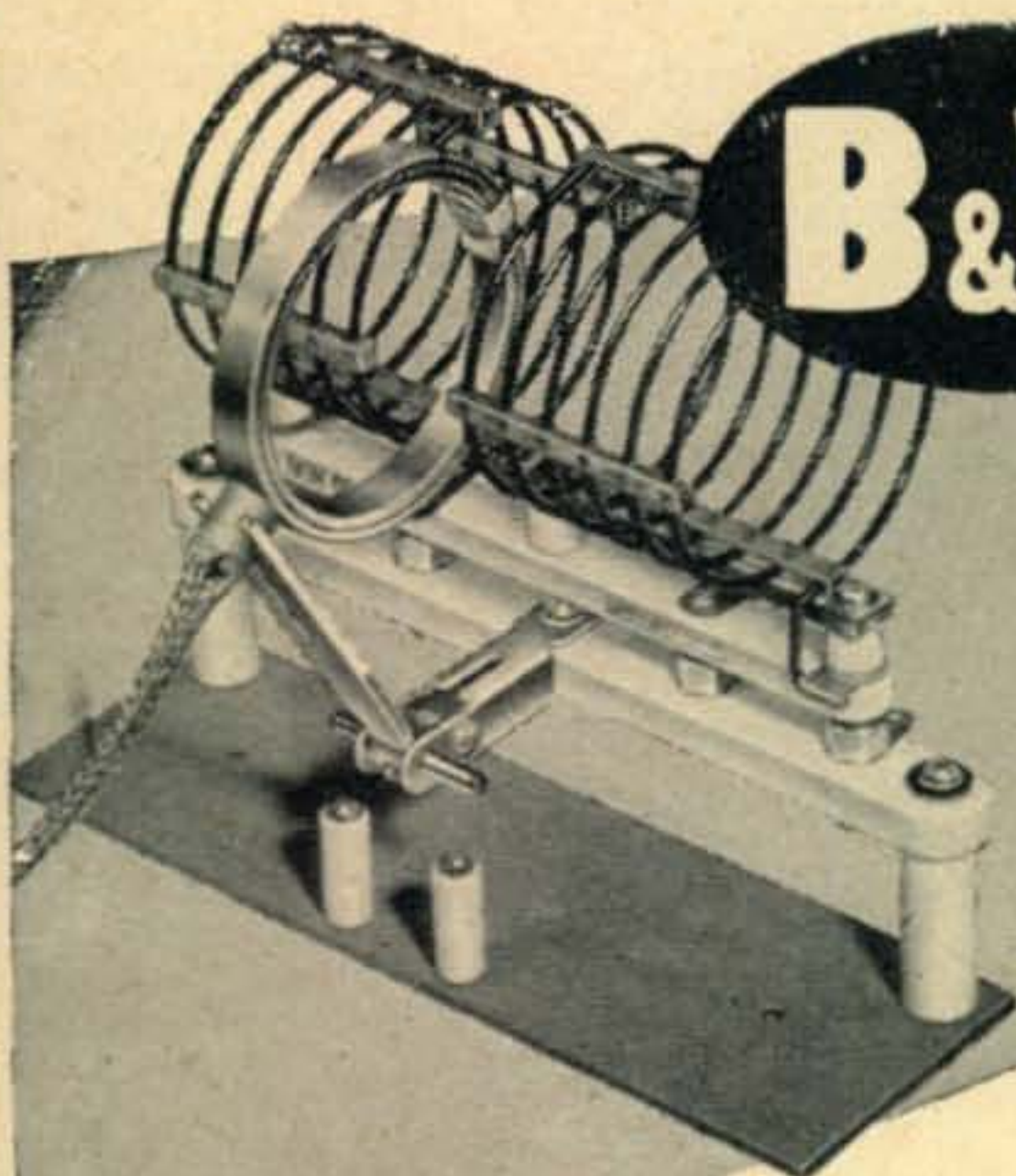

B&W FARADAY SHIELDED LINKS

... for reducing TV and BC interference

B&W Faraday Shielded Links are highly effective in reducing harmonic or spurious signal radiations, normally transferred by capacity coupling, and which are always present with an open wire link. They're easily adapted to all conventional link-coupled circuits and with external antenna units, or in conjunction with harmonic suppression filters of either the low-pass or band-pass type. Available for B & W Series HDVL, TVL, TVH, and BVL coils. Write for Bulletin 605.

BARKER & WILLIAMSON, INC.

237 FAIRFIELD AVE.

UPPER DARBY, PA.

The Largest Selling LIGHTNING ARRESTER At Any Price!

NO. AT102



APPROVED

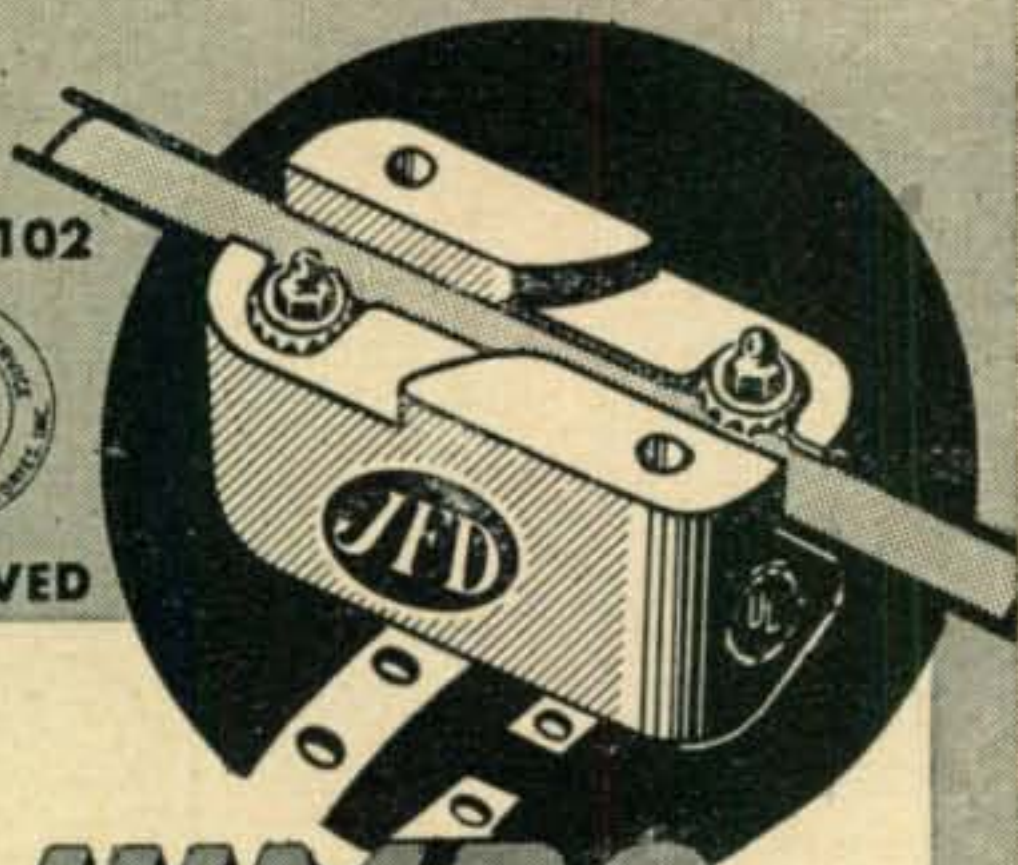

JUMBO

Protects Home and TV
Set Against Lightning
Hazards **\$2.25**
LIST

U.S. Patent No. D-4664

- Installs anywhere
- No wire stripping, cutting or splicing

(Complete with strap and ground wire.)

OVER 1,000,000 IN USE TODAY!

See Your Jobber or Write for
Form No. 84



JFD MANUFACTURING CO., Inc.
6157M 16th AVENUE, BROOKLYN 4, N. Y.
FIRST in Television Antennas and Accessories

SPECIAL

FILAMENT TRANS.

For 866's

2½V at 10 Amps.,
7KV Ins. 1.50

HALLICRAFTERS SX71-S76

Write for liberal trade-in offer.
Volt-Ohm-Milliammeter 0-1 Ma. 4"
Fan Type. Diagram Included. Makes
1000 ohm per volt unit.

Meter Only **\$2.95**

Resistor Kit For Above **\$2.45**

ATRONIC CORP., DEPT. C-12

1253 Loyola Ave., Chicago 26, Ill.

BC 348 REPLACEMENT PARTS

FOR MODELS C, E, H, K, L, M, P, R.

All front end coils, RF, Det. and Osc., 1st, 2nd, 3rd, 4th
I.F. Trans., C.W. Osc., and Xtal Filters, 4 Gang Condensers,
Engraved Front Panels, Complete Dial Assemblies, Etc.

Write for complete listing

ELECTRONICRAFT, INC.

27 MILBURN ST., BRONXVILLE 8, N. Y.

MOBILE MODULATION KITS

T-103 Mike to 6J5 grid.
T-102 6J5 to Modulators, PP 6V6 or PP 6L6.
T-104 Mod. Trans. PP 6V6 or PP 6L6 to 829, 832, or 2E26.
All components miniature, ruggedized, and hermetically sealed.
COMPLETE KIT & DIAGRAM..... **\$3.50**

MOBILES! CAPI CD MEN!

Sonar SR-9 Receiver: 2, 6, or 10 Meters..... **\$72.45**
Sonar MB26 Transmitter: 2 Meters..... **\$72.45**

WRITE FOR MORE INFO.

THE 28-28

(from page 26)

To eliminate the need for a mike battery in both a.c. and d.c. operation, the mike voltage is developed in the cathode bias divider *R6* and *7R*. *C12* provides adequate filtering of the mike voltage.

Of the several carbon microphones tried, the surplus *T-17b* and the Western Electric *F-1* were found to be the best in communication quality and level of developed audio voltage. Most of *T-17d* microphones tried were low in output. It is wise to protect a good mike by not using it on voltages greater than 4½ volts.

Control Circuits

The transmitter is controlled by the send-receive relay operated by the switch on the carbon mike. Notice that plate voltage to the driver is shorted out when the relay releases to the *receive* position. This is to permit quick "break-in" operation. *Pin 4* on power plug is grounded when the relay is in *send* position. This circuit will start a dynamotor supply such as the well known PE103, or it can be used to ground the center tap (B-) of a power transformer in an a.c. power supply for home use. The relay also switches the transmitting antenna from the transmitter to the receiver.

Filament voltage must be switched on from a control panel in mobile or battery operation.

Running the mike lead, control circuits and power through a single plug simplifies connections and makes removal of the rig from the car quick and easy. The indicator lamps on the suggested control panel are handy reminders of filaments being left "on", or that you are "on the air".

The relay is a standard 6.3 v 60 cycle relay but works quite well on about 3 volts d.c. In order to drop the d.c. voltage across the relay coil two 1-watt resistors *R10* and *R11* are wired in parallel and connected to plug *pin 7*, which in turn is grounded via the mike push-to-talk switch. The model photographed used only a 6-pin plug and does not illustrate this feature.

Tuning Procedure

Before starting the tune-up, check to make sure proper filament voltage has been applied, that plate voltage is available, and that a 7 mc crystal of the proper frequency is plugged in. Switch *S1* is opened to keep d.c. voltage from the screen of the final. A meter capable of reading 5 ma is plugged into the meter jack. Upon closing the relay the meter should indicate 2E26 grid current if coils *L1* and *L2* are near resonance. Should no current be observed, tune in the fundamental and harmonics on a receiver to be sure the circuit is oscillating. If a signal is observed, *L1* and *L2* are then adjusted for a maximum grid current between 3 ma and 4 ma.

The meter scale is changed to read a maximum of 100 ma. Switch *SW1* is closed to restore screen voltage to the final. Antenna coupling capac-

itor *C11* is set at full capacitance. When the relay is closed, the total cathode current is read by the meter. The pi-coupler (tank circuit) is resonated by varying *C10* with the meter indicating a dip. Loading is increased by opening *C11* slightly. Be sure to redip the plate current by varying *C10*. Continue adjusting *C11* and *C10* until the final is loaded as desired. Maximum loading will be at 70 ma cathode current.

A field strength meter located several feet from the radiating antenna also is useful in tuning the antenna coupling network. A field strength meter⁵ consisting of a current meter connected across an absorption wave meter through a germanium diode works best.

Conclusions

Several transmitters built like this one have been in use for several months with excellent results, including a good share of DX.

If good engineering construction is followed, the circuit will work in any reasonable mechanical arrangement.

This transmitter design can easily be modified for use on other bands. The r-f driver could be replaced by a single 6C4 Pierce oscillator for 75 meters. For 20 meter phone, only the first half of the 6J6 need be wired in, omitting the circuitry of the second half. The incorporation of an additional doubler would put the 2E26 on 6 meters. Also *C10* and *C11* would require greater capacitances, in proportion for the lower frequency bands. The tank coil *L3* would be the third and last modification for operation on other bands.

Experience has shown that the r-f driver produces sufficient drive throughout the band that its retuning is not necessary when changing frequency. It is desirable, however, to redip the final by adjusting *C10* when moving more than 200 kc.

⁵"Wave Meter/Field Strength Meter", Radio Handbook, Eleventh Edition, 1947, pp 423 - 424

YL'S FREQUENCY

(from page 45)

Tennessee YLs

A short time before W2ESO left the Editorship of CQ he told of the kick he got one evening when he worked his old friend W4AKJ in Tennessee only to find it was Frank's XYL at the key, she having just received her ticket. Jessie is on the air with her own call, too, W4BKI, running about 65 watts on 40 c.w. Her rig is made from a BC-375 tuning unit and employs a 6AG7 v.f.o. and an 807 amplifier. She shares an HRO-50 with her OM.

W4AKJ and BKI live on a 750-acre farm at Crockett Mills. "What with three jr. ops, ages 6, 4 and 2 (all girls), the housekeeping and all the jobs that go with life on a farm I don't have time for any other hobbies," says Jessie. "I had to learn the code and theory after the kids were asleep at night. Under this system it took a year

IMMEDIATE DELIVERY

on the new, improved
Collins 75A-2 Receiver

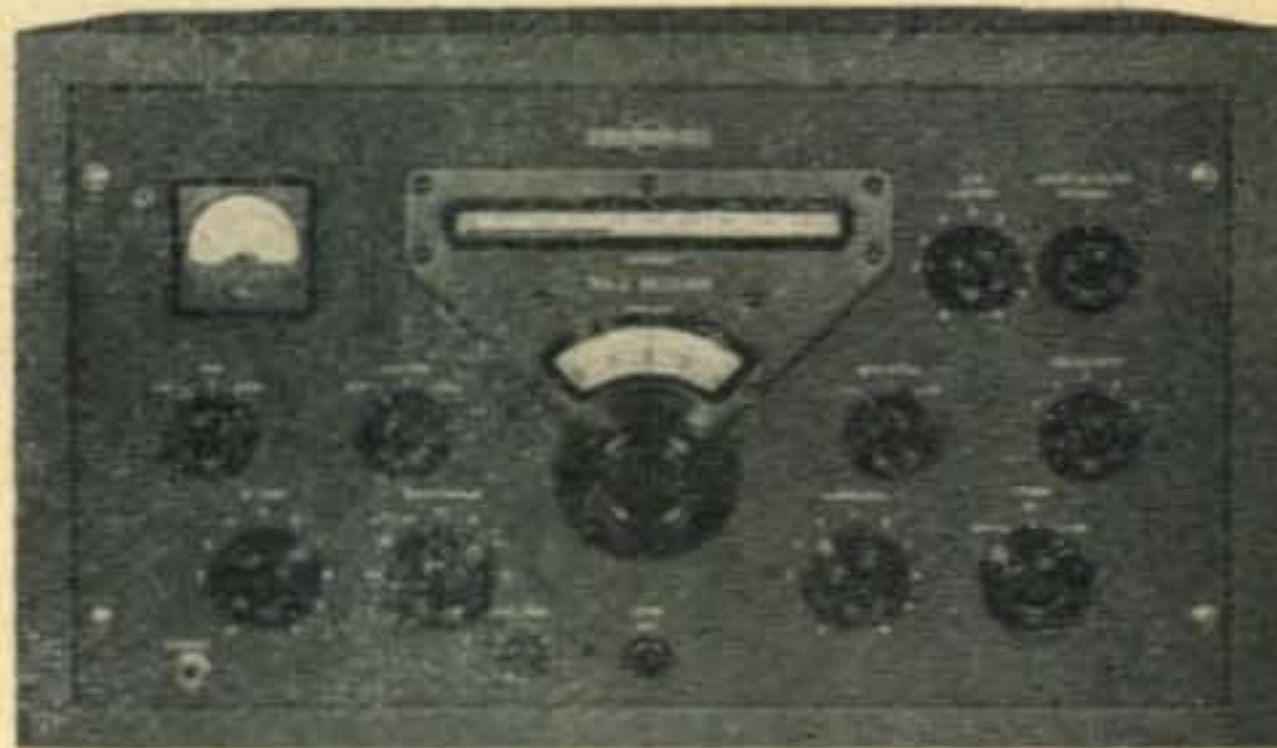

The Collins 75A-2 is the optimum receiver for radio amateur communication. Greatly improved over its predecessor this model has just the right amount of selectivity for either the 'phone man or c.w. operator. The stability is really solid and the c.w. noise limiter is a blessing during severe QRN. Of course the calibration beats anything in the amateur market today.

Phone, Wire, Write or Contact
Any Ham In Denver

RADIO PRODUCTS SALES CO.
1237 16th Street Denver 2, Colorado

Keep Your Shack Neat with a BOUND VOLUME

You'll appreciate the handy convenience of this compact volume of the 1951 issues of

CQ . . . handsomely
book-bound in tan
colored cloth . . .
distinctive gold foil
lettering embossed
in a black panel strip
. . . available NOW!

\$7.95

in U. S., Canada and
Pan-American
Union. Others,
\$1.00 more.

C Q M A G A Z I N E
67 West 44 Street New York 18, N. Y.

CQ

The Radio Amateurs' Journal

The Year Round Christmas Gift—

1. New and better issues filled with articles by world renown amateurs.
2. Complete coverage of the entire ham field through intensifying monthly departments:

DX and OVERSEAS NEWS

The VHF-UHF NEWS

The YL's FREQUENCY

The MOBILE CORNER

MONTHLY DX PREDICTIONS

The NOVICE SHACK

SHACK and WORKSHOP

THE FOREIGN SCENE

3. No other amateur magazine gives you material of interest to Hams, Novices, technicians, and engineers alike.

Within the past few months CQ has embarked on a specific improvement plan under the direction of a new and revised Editorial staff. The demand for CQ is increasing every month. Make sure you have your copy. (Place this advertisement where the XYL can take the hint and have her eliminate that last minute Christmas buying.)

Use the handy reply envelope



CQ Magazine

67 West 44th Street

New York 18, N. Y.

or two to get my license. I started learning the code to try to find out what Frank found so amusing in some of his contacts [How often that curiosity has gotten XYLs into hamming!] I continued studying partly to please him, but now that I'm on the air I enjoy it more than I ever thought I would." [P.S. Jessie became a Hamlet when she married W4AKJ—now he's made her a Ham.]

With YLs rather scarce in Tennessee, Jessie passed on info on several, for benefit especially of those looking for YL contacts for WAS /YL.

One is WN4TIE, Margaret, 2977 No. Radford, Memphis, Tenn. Her OM is W4TIZ.

Another is W4HPO, of Jackson, Tenn. Her OM, W4HXC, Bob Gordon, is chief engineer of WTJS, and Inez is one of the operators (or engineers as they call them). They live in an apartment connected with the FM transmitter house at the base of a 550-foot tower. They are on 20 and 75 phone with something like a kw. Inez has been a ham since she was about 15 years old.

Last but not least is a cousin of BKI-AKJ—Wille Kate Dean, WN4TGU, also of Crockett Mills, a 13-year old ninth grader. WN4TGU is using a 12A6-1625 rig on the 3.7 mc Novice band with about 35 watts input. She has two xtals—3710 and 3737 kc—and like most Novices are doing, she is trying to work all States. She built most of the rig herself with W4AKJ's guidance. Her receiver is a BC-224-F.

See you next month. 33 - W5RZJ.

MOBILE CORNER

(from page 51)

KT1BB is operating mobile in the Tangier Zone. He expects several more to be on shortly, on 20 and 75. Keep a look-out for them when the band is open. Cards for KT1's can be sent to the American Legation. . . . There are a number of MARS mobile nets operating. . . . Can anyone tell us how to get efficient vertical polarization on 75 at a fixed station without a high mast or an "umbrella"? . . . KP4JG is using a home-brew Auto-Call requiring three pulses for operation. It's on 29.1 pending completion of tests. . . . Don't forget to write in some news for the column.

LETTERS

(from page 8)

Door," on page 56, ". . . and the six volt lead tied to the amateur . . ."

I thought the trend was to keep the amateurs away from power supplies!

E. H. Morterud, W5FPB

Shame on our proofreader! The correct operation is of course to tie the six volt lead to the ammeter. Shucks, we only wanted to make sure that the amateur knew whether or not it was working. Ed.

One Call for All

FROM ALL AT HUDSON

*Season's
Greetings*

and Best Wishes for
A HAPPY NEW YEAR

UPTOWN: 48 West 48th St., New York 19, N. Y.

DOWNTOWN: 212 Fulton St., New York 7, N. Y.

HUDSON
RADIO & TELEVISION CORP.

Formerly Newark Electric Co., Inc. of New York

THE "MINIPAK"

(from page 19)

of the ripple voltage can be made by coupling the output of the Minipak through a suitable capacitor to the high impedance input of a phonograph amplifier. The hum level should not increase appreciably when the Minipak is turned on. It will be noted, however, that the hum increases abruptly whenever the Minipak is loaded beyond its regulating ability.

So there you are. Very little conventional filtering, but with only two extra tubes and a few resistors, a power supply capable of performance superior to batteries, and closely approaching the most expensive laboratory supplies.

RADIO-TELETYPE

(from page 22)

each turns on and off the other stations' printer, taking two seconds for each operation.

This automatic feature of teletype is one of the greatest assets for many of the gang since they are able to watch TV, build equipment, or anything else they want to, while they are receiving their messages. At their convenience they can turn on the other fellows' printer, type to him, and go back to what they were doing. Others like to watch every word as it is printed.

How It Works

When a key is pressed down on the keyboard it mechanically actuates a lever, coded for that particular key, which in turn sets up the five levers on the transmitting distributor. Thus if we press "Y", whose code is 1-3-5, we find the levers 1-3-5 on the transmitting distributor are in the "mark" position. The action of the key then is to translate the letter into the teletype code. The action of the transmitting distributor is to put this code in time sequential order and add the "start" and "stop" pulses. The transmitter distributor is an integral part of the keyboard and is not indicated separately in *Figure 2*.

The signal from the transmitter distributor may then be sent through any type of system you desire. In amateur use we normally change it to mark and space tones and handle it that way. Before we can use the signal to operate the printer it must be changed back into pulsating d.c. This is the function of the selective amplifier and polar relay. This signal is then fed into the receiving distributor which takes the seven incoming pulses and distributes them to the proper magnets on the printer. The five selector magnets mechanically select, by means of levers, the correct letter to be printed. The last pulse, the stop pulse, operates a sixth magnet which causes the letter to be printed and clears the magnets for the next letter.

The action of the intermediate stages, the selective amplifier, etc., will be discussed in the future.

KEEP CQ at your finger tips with a CQ Binder . . . ONLY \$2⁵⁰*

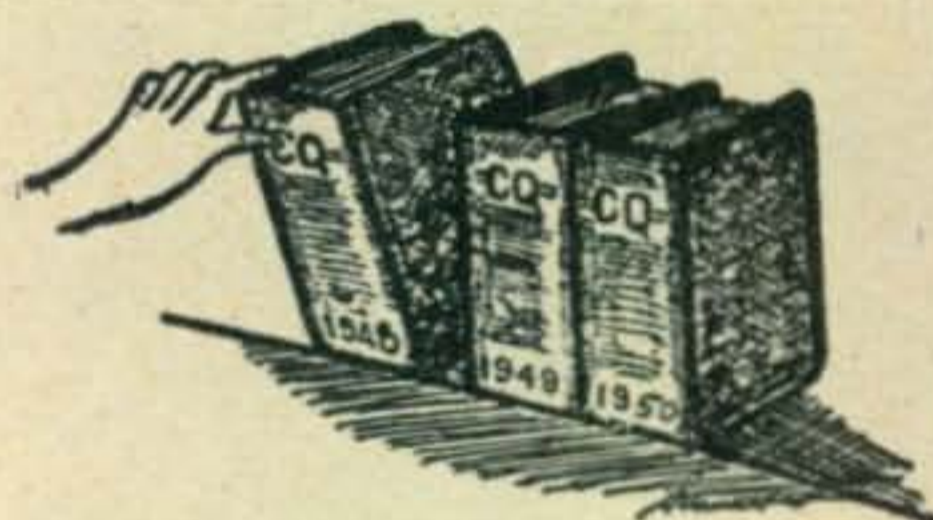

CONSIDER the

APPEARANCE . . . Your shack, den . . . or wherever you set up your rig can be kept in shipshape when all your copies of CQ are in one safe place. The deep, red shade will blend perfectly with any color scheme . . . and, in addition, the backbone will be gold stamped with CQ and any year you desire.

CONVENIENCE . . . In a few seconds you can locate any article you want . . . no more fumbling around for last month's issue . . . just reach for your Binder . . . turn to the index . . . and presto, there it is.

WORKMANSHIP . . . Dupont Fabricord . . . stainproof and washable . . . Center channel to keep magazines securely in position.

Let your wife, sweetheart, or a friend, see this ad . . . Tell them that a CQ Binder would make the perfect gift for the "Ham of their life" . . . for a birthday, anniversary . . . or any other "special" day . . . or you can always buy one for yourself.

*(Foreign Orders add 25c per binder)

CQ Magazine

67 West 44th St., New York 18, N. Y.

ENCLOSED FIND \$..... FOR BINDERS

NAME CALL

ADDRESS

CITY ZONE STATE.....

Year wanted 1947 1948 1949 1950 1951. Stamping: CQ Plain

Considerable data has been published on this phase in the past.⁴

That briefly (?) covers most of the fundamentals of teletype operation. Little has been said about the fun to be had with this system of radio operation, about the excitement of having messages waiting for you when you return home, about the pleasure of being able to express yourself with imagination. On phone or c.w. there is no great attention paid to the way you phrase things, but on teletype there is a lasting record of your every word.

The major item of interest to the teletype gang at present is the proposed opening of part of 40 meters. Almost to a man they are getting equipment ready for this band. Letters from W1OSX, W2PAT, W2PXR, W2BFD, W3POW, W3QPD, W5DNS, W5IJC, W5LCU, W6ITH, W6NWM, W6MRM, W6STA, W6ZQY, W7FOS, W7VS, and W9DDG indicate that they are all set for the 40 meter opening. Many more have written in to say that they expect to be ready before the authorization comes through. There should be quite a crowd there.

Diagrams of some of the frequency shift oscillators in commercial use, now being used as prototypes for amateur construction, are available from W2NSD.

If you have been doing any teletype work, how about dropping me a line. Any items of interest to the RTTY'ers will be printed. This column will be a bi-monthly feature of CQ, I hope you like it.

⁴"CQ," November, 1946.

SCRATCHI

(from page 4)

then realize are having crystal in rig which are especially ground to being one kilocycle outside the band. Are replacing same quickly, turning on filaments, and sound of blowers reminding me of my ten kilowatt final. I sadly coupling antenna into two kilowatt buffer and taking final out of action, and are about to put my foot on the key when are remembering my resonant filter in power supply. I really hate shorting it out of circuit, because it are tuned up to give Scratchi's signal most beautiful tone. Now I are all set to operate, legally, and Hon. Ed., my heart isn't in it. What would amchoors say if hearing Scratchi on air with legal signal?

At this point I are deciding to take ride in my car to clearing cobwebs from brain. Are getting in car when another idear striking. My muffler is also tuned up to sounding like P-47 jet coming out of crash dive. Should honest, upright, law-abiding Scratchi scaring people and horses with sooped-up muffler? In fact, no. I explaining this to Hon. Brother Itchi, and he giving me keys to his car.

Out on the highway, I beginning to feel better. Short while later I feeling so much better that I slowing down to speed limit and thinking that

Columbia
GEM OF THE SURPLUS

MAKE EXTRA XMAS MONEY!

"I never knew I could get so much money for my old radio gear—till I sold it to Columbia. You guys must really need it to pay such high prices."

J.M.C., Scranton, Penn.
Right you are, J.C.! We're hunting hi and lo for APR-4, ARC-3, APR-5, ARC-1, BC-348, T-47/ART-13, any and all types of ham or commercial gear. We guarantee to out-bid and out-pay any other outfit for used or new equipment. If you have any gear you wanna get rich on—
TELL IT — SELL IT — TO COLUMBIA!

ARC-5 OR 274-N TRANSMITTERS

2.1-3 mcs. Used	\$14.95
3-4 mcs. Used, excel. cond.	14.95
4-5.3 mcs. Used, good cond.	5.95
5.3-7 mcs.	5.50
7-9.1	12.50

ARC-5 OR 274-N RECEIVERS

.55-1.5 mcs. Brand new	\$49.50
1.5-3 mcs. Brand new	24.50
6-9.1 mcs. Brand new	11.95
28 V. RECEIVER DYNAMOTOR	\$.79
14 V. RECEIVER DYNAMOTOR	9.95
RACK FOR DUAL TRANSMITTER	2.95
TRIPLE RECEIVER RACK	3.95

PE-73 24 V. DYNAMOTOR: 1,000 V. @ 350 mills output. Exact replacement for 12 V. BD-77. See Sept/51 CQ P.27 for conversion dope. Fair cond. IT'S A GIFT FOR ONLY \$5.95

ALL ORDERS F.O.B. LOS ANGELES
25% deposit required. All items subject to prior sale
COLUMBIA ELECTRONICS SALES
Dept. LS—
522 S. SAN PEDRO ST., LOS ANGELES 13, CALIFORNIA

DID YOU GET IT? IF NOT...

SEND NOW FOR B-A's
136 BIG PAGE
FREE CATALOG



INCLUDING
21 PAGES OF
DOLLAR-SAVING
BARGAINS!



BURSTEIN-APPLEBEE CO.
1012-14 McGee St.
Kansas City 6, Mo.

FREE

Send your 1952 catalog to:

Name.....

Address.....

City..... State.....

BURSTEIN-APPLEBEE CO.

Classified Ads

Advertising in this section must pertain to amateur radio activities. Rates: 25c per word per insertion for commercial advertisements. 5c per word for non-commercial advertisements by bona fide amateurs. Remittance in full must accompany copy. Phone orders not accepted. No agency or term or cash discounts allowed. No display or special typographical ad setups allowed. "CQ" does not guarantee any product or service advertised in the Classified Section. Closing date for ads is the 25th of the 2nd month preceding publication date.

FOR SALE: BC344, AC model, good condition, \$25. SCR522 converted, plus AC power supply, \$30. SCR522 mobile with 12 v dynamotor plus cables and controls, \$20. F.O.B. Chas Rose, W8JUB, Belding, Mich.

WANTED: TS 117 and TS 125 frequency meters in new condition. Box 257, CQ Magazine, 67 West 44 Street, New York 18, N.Y.

FOR SALE: Harvey Wells TBS 50D xmitter, Gonset Tri-Band converter, Gonset noise clipper, dynamotor, Master Mobile antenna, complete package, \$175.00. W2ZRY, 141A 22nd Street, Brooklyn, N. Y.

FOR SALE: Hallicrafters SP-44, Panadapter, used very little, \$25.00 f. o. b., 215D Hancox Avenue, Nutley, N. J., Harold B. Lynn, W2DHE.

TRADE: \$130 Lord Elgin men's 14 kt gold wrist watch new for equivalent in transmitting gear mobile or fixed or measuring gear or what have you. A. W. Andersen, Box 644, Viboy, So. Dakota.

5 ELEMENT 2 meter beams, Riverside Tool Co., Box 87, Riverside, Ill.

HOTTEST SURPLUS LIST in the country. ELEC-RONICS-HYDRAULICS-AIRCRAFT GADGETS, Dick Rose, Everett, Washington.

REVOLUTIONARY copyrighted discovery! Learn Morse Code alphabet in 15 minutes with amazing new code teacher "Philkoda." 50c postpaid (group size \$5.00). Philip W. Miner, 7120 Lahser, Birmingham, Michigan.

TELETYPE: Need model 14 and 15 machine, parts or pieces. Am interested in any kind of teletype equipment. Have tech manuals on TG-7A. (Model 15) to trade for other manuals on teletype or electronics. All letters answered. Chas Patrick, W6OZE, 402 North Lucia, Redondo Beach, California.

SELL OR TRADE for good service test equipment, kilowatt final and power supply, P. P. 4-250A bandswitch turret grid, plug-in tank coils, ten through forty meters. Eimac vacuum variable tank with pair vacuum plate bypasses. Regulated and controlled bias supply with built-in filament supply. Heavy duty antenna coupler paralleled tuned coaxial connected through two shielded swinging links. Above equipment contains five meters TVI filters, Eldico, etc. mounted in Par-metal cabinet with dolly and hinged top. Power supply in matching cabinet. Amertran 6200 volt 700 mil transformer tandem Superior Powerstats 3.5 KVA. Double choke filter 872 rectifiers ample relay and safety control plus remote control four meters. Brand new Millen 2 inch rack mounted scope. Buyer gets plenty extra gear including filte.s, bypasses, relays cable, wire, hardware, rectifiers. Excellent construction, no junk. Will separate supply from final for sale. Parts cost \$1200 sell for \$400. George Bidwell, W9FIS, Abingdon, Illinois.

RADIO OFFICERS, \$600 monthly earnings, plus top union conditions. Men with 6 months American Merchant Marine radio operating experience since January 1935 can obtain special FCC license to sail immediately. Men with FCC radiotelegraph 2nd class license and 6 months sea time on Navy ships as radiomen can also qualify. Phone, wire, or write American Radio Ass'n CIO, 5 Beekman St., N. Y. C. Cortlandt 7-6397.

BARGAINS: Extra special! Motorola P-69-13 mobile receivers \$29.50; SCR-522 \$29.50; Globe King \$315.00; HT9 \$199.00; HRO7 \$199.00; Temco 75GA \$225.00; Collins 32MA \$99.50; Collins 75A1 \$295.00; HRO-5T \$175.00; Hallicrafters S-47 \$119.00; RME-45 \$99.00; Meissner EX Shifter; S-40A, \$69.50; VHF 152A \$69.00; HF-10-20 \$59.00; SX-24 \$69.00; Globe Trotter \$57.50; New Meissner signal calibrators \$24.95; MB611 \$29.00; 90800 exciter \$29.50; XE10 \$14.95; and many others. Large stock trade-ins: Free trial. Terms financed by Leo, W0GFQ. Write for catalog and best deal to World Radio Laboratories, Council Bluffs, Iowa.

MERRY XMAS and a Happy New Year from W0CVU, "Iowa's most truthful station". Using new Collins kilowatt KW-1 and 75-A2 receiver. 38 years on the air from one QTH.

TRANSMITTER CW 125 watts Stancor 202-A. New condition. Commercial appearance. Complete with tubes. Uses 35T in final. All bands. Worked WAC with rig \$75 f. o. b. Also class B modulator for sale. W7JXT, North 2504 Wall, Spokane, Wash.

TOP cash for APR-4 units and parts; Microwave test equipment, ARC-1, ARC-3, ART-13, etc.; TS-34 and other "TS-"; good quality laboratory equipment; manuals, tubes, meters and parts. Will also trade TV, SX-28, VTVM, astronomical telescope etc. Littell, Farhills Box 26, Dayton 9, Ohio.

DXers! "Ham's Interpreter"—ham words and phrases translated into 7 languages—\$1.00. For SWLs—"World Radio Handbook"—complete information on international stations—\$1.50. "How to Listen"—for SWL novices, 30c. World Radio Publications, 1000 Connecticut Avenue, Washington 6, D. C.

SELL: SF-1 radar complete, TCS equipment, 1B22, 1B23, 1B24, 2J22, 2K25/723/B, 723A/B, 724B, 725A, 715B, 715C, 3B24. T. Clark Howard, 46 Mt. Vernon, Boston 8, Mass. (W-1-AFN).

FOR SALE: WRL Globe Trotter xmitr, \$60.00; Gonset 3 to 30, \$22.50; TBS-50 W/6 and 110 volt power supply, \$92.50; BC-57 Recvr \$65.00. All in good operating condition. W5LKM, 1909 Estes St., Abilene, Texas.

SELLING OUT: BC610 factory modified for ten meters, \$550 complete with speech amplifier. SX28A \$125. National NC240D \$115. RME152A converter \$55. All immaculate and in perfect condition. Act fast! W2UKK, 2465 Knapp St., Brooklyn 35, N. Y.

FOR SALE: excellent condition, 32V-1 transmitter with D-104 mike and instruction book for \$275 cash. W2YUB, 259 West 21st Street, New York City.

SELL OR SWAP: NC100ASD with speaker, transmitting tubes, 11 meter crystals, plate supply transformers, etc. Want 420 mc. and/or 220 mc. receiver, subminiature tubes, hearing aid parts. Send for my list. Leonard D'Airo, 2143 61 Street, Brooklyn 4, N. Y.

QSLs? SWLs? Made-to-order cards! Samples 10c. Sackers, W8DED, Holland, Michigan.

WANTED: Bargains in transmitters, receivers, test equipment and miscellaneous gear. What have you? W5ZZ, 718 N. Broadway, Oklahoma City, Okla.

QSLs. Samples for stamp. Harrison, 8001 Piney Branch Road, Silver Spring, Md.

FOR SALE: Complete ham set-up, SX71 receiver, 50 watt 10 meter fone xmitr, 25 watt Hallicrafters c.w. transmitter, all like new. W6YHH, Phil Mooers, 1580 Bay Road, Palo Alto, Calif.

WANTED: BC-654, SCR-284, PE-103, PE-104, GN-45, ART-13, DY-12, BC-348, RA-34, BC-610, SCR-536, BC-611, BC-721, BC-221, radar test equipment. Arrow Appliance, 525 Union, Lynn, Mass.

WOULD LIKE TO TRADE lady's blue white diamond set, certified appraisal, \$550.00, for complete transmitter, 150 watt or higher, Globe King, Collins, Hallicrafters, Johnson or what have you. Above diamond set was left with me as security on a loan and is considered good value. John Brownston, 2533 42nd St., Sacramento, Calif.

BARGAINS: New and reconditioned Collins, National, Hallicrafters, Hammarlund, RME, Millen, Gonset, others. Reconditioned S38 \$29.00, S40A \$69.00, HT18 \$79.00, SX71 \$149.00, SX42 \$199.00, NC57 \$69.00, NC173 \$139.00, HRO7 \$189.00, NC183 \$199.00, HQ129X \$139.00, HF-10-20 \$49.00, VHE152A \$59.00, RME84 \$69.00, RME45 \$89.00, SX25, SP400X, HRO50T, Collins 75A1, others. Shipped on approval. Terms. List free. Henry Radio, Butler, Mo.

GOING TO TRY for an amateur radio operator's license? Check yourself with a complete coverage multiple-choice type test similar to those used by the F. C. C. Surecheck tests with answer key, Novice Class \$1.50, Conditional and General Class \$1.75; Advanced Class \$2.00. Order your time-tested surecheck test today. Amateur Radio Supply, 1013 Seventh Ave., Worthington, Minnesota.

HELP WANTED

Radio amateur for reconditioning and aligning receivers and general amateur equipment. Permanent position. Contact Leo, World Radio Lab, 744 W. Broadway, Council Bluffs, Iowa.

this law-abiding stuff may be hokay at that. In no time are arriving in town, parking the car, putting penny in parking meter, and going into Joe's Triple-Dip Hunky-Dory Ice Cream and Used Magazine Parlor. Are having big time with one of Joe's specials, a Gila Monster. This are concoction made with orange sherbert, lime juice, chocolate ice cream, pineapple chunks and toasted rattlesnake rattles poured over half a watermelon. It are so good I thinking of having another, when reelizing I be late for lunch if not hurrying home. I rush out to car, and I see that the meter is red. Whooie, Scratchi have overparked. I quickly look at car, and no parking ticket.

Now what wud a reel, uprite citizen do? Naturaly—he'd report himself. So, I drive down block to local jale, parking in front, and going inside. I striding up to desk, and telling man I are law-breaker, as have been overparking, and where do I pay the fine? He are staring at me with fishy eye and saying "Hand over the ticket, Mac". At first I not thinking he speaking to me, but not seeing Mac around, I telling him I not having any ticket, on acct. no poleece are catching me. At this he dropping lower jaw far enough for me to seeing cupple gold teeth, then he throwing his head back and laughing like fury. Well, Scratchi don't mind being given horsy laff from poleeceman, so I explaining hole thing to him.

He evidently reelize I trying to be good citizen, so after I finish, he explaining that if I haven't got a ticket for parking, I don't need to pay a fine. I retorting right back that this are funny way to run a poleece station, and I standing up on my constitushonal rights and I want to pay a fine. A nice bunch of law-enforcers we having, I telling him, that lye down on there job and won't letting honest citizen pat fine when are lawbreaker. What are country coming to when fokes like me can't paying legel fine? Oh, I reely giving it to him. I doing all right, too, until he picking up telephone and asking information for number of local bug-house. Scratchi may be law-abiding, but he not a collosus idiot, so I leaving him in middle of telephone call.

Feeling much insulted, I getting into car, and starting to drive off when noticing are having trouble seeing threw windshield. Sumthing red are in the way. Hokendoke!! Are getting out and seeing it are a poleece ticket. Please reporting to Traffic Court tomorrow at 10 ayem regarding violation of City Code 8927, Section 103, Article 4, which are long way of saying I parked in No Parking zone.

Of all the champeen dopes—what does that poleeceman mean putting ticket on Brother Itchi's car? Here I trying to pay legel fine and they sneaking up behind my convertible. At this point Scratchi giving up. It are too hard to be good citizen. Letting Itchi worry about the ticket, I got other worries. Let's see now, how much is bus fare to Mexico?

Respectively yours,
Hashafisti Scratchi

RADIO Surplus Buys

500 KC CRYSTALS

500 KC Crystals in FT 241-A holders with 1/2" pin spc.

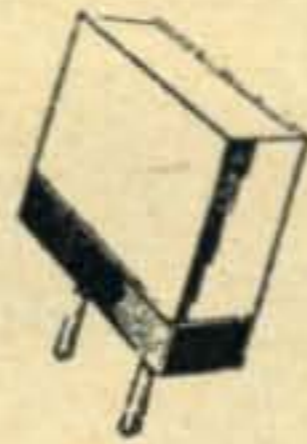

ONLY LIMITED
QUANTITY
AVAILABLE

\$1.95
each

TUNER FROM NAVY "BN" EQUIPMENT

Simply modified into 2-meter converter for car or communications receiver. Uses 1—6J6, 1—6SH7, 1—9006, 1—6J5 (Not Furnished).

Slug is tuned from 157 to 187 Megacycles. Includes schematic diagram for "BN" equipment.

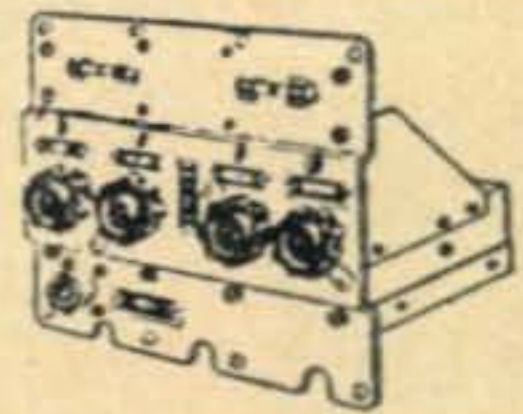

Now — A New LOW Price **\$4.95**

METERS, AIRCRAFT

1-Milliampere, zero center FB for field strength meters, grid dip or tuning meters.



Postpaid **\$1.95**

ALTIMETER, AIRCRAFT

U. S. Navy surplus aircraft altimeters, range 0-10,000 feet. Adjusts to sea level setting of terrain. Simple to install, requires no hook-up . . . for auto or aircraft.



BRAND NEW **\$7.95** each

Postpaid

SENSITIVE ALTIMETERS

Pioneer, Kollsman and Bendix Sensitive Altimeters. Range 0-35,000 feet, calibrated in 100's of feet. Barometric pressure setting adjustment. No hook up required . . . mounts easily in auto or aircraft.



Used, Good **\$12.95** each

Postpaid

BC - 605 INTERPHONE AMPLIFIER

Ideal for inter-com system in home; office to office, aircraft, boats, etc. Comes complete with tubes, case, and diagram. Easily converted. (See Page 140, April Issue RADIO & TELEVISION NEWS.)

BRAND NEW IN ORIGINAL CARTONS
Special Close-out Price,
each **\$3.95**



TYPE RL - 9

Interphone Amplifier

Easily converted to high fidelity phone amplifier or speech amp. Comes complete with tubes. Operates on 24 volt DC. Used, but in good condition. Less dynamotor.

A money-saving buy at, **\$2.95**
each



ALL EQUIPMENT F.O.B. PASADENA UNLESS OTHERWISE SPECIFIED. PLEASE ENCLOSE FULL AMOUNT WITH ORDER

C & H SALES CO.

BOX 356-DQ, East Pasadena Station, Pasadena 8, Calif.

8 WIRE CONTROL CABLE

Two No. 16, Six No. 20 tinned, stranded, copper, rubber insulated coded leads. Waterproof rubber jacket. Woven copper armor shield overall. Wt. 16 lbs./100 ft. Lengths to 400 ft. LOW PRICE FOB warehouse. Minimum order 100 ft. Shipment is made by Railway **5c ft.** Express—shipping charges collect.

TRANS-WORLD RADIO-TELEVISION CORP.
6639 S. ABERDEEN ST CHICAGO 21, ILL.
Phone: AUstin 7-4538

INDEX TO CQ

Issues of Vol. 7, Nos. 1 Through 12, for the year 1951

Antennas

Double Coax Matching Section (Montgomery)	Oct., 22
Go Fly a Kite (Conklin)	June, 26
High Efficiency Loading Coil (Brown)	Jan., 20
Impedance-Matcher, The (DeLong & Roberts)	May, 20
Lattice Boom for 14 MC Antennas -- (Orr & Abrahams)	April, 21
Matchmaker, The (W. Orr)	Dec., 27
One More Loading Coil (Kaiser)	Aug., 21
Performance of the Terminated Folded Dipole (Countryman)	Nov., 28
Power and Resistance of Light Bulbs (Nagle)	Jan., 30
Revamp Your Tower	Mar., 30
Streamlined Aircraft Antennas (Huber)	May, 30
Thoughts on Rotary Beam Construction -- (Bonner)	Aug., 11
Up and At 'Em (Weidenhammer)	Feb., 31
Water Tank Dummy Antennas (Hickin)	Apr., 24
40 and 80 Meter 8JK Beam, A (Cheek)	Mar., 16

DX

Care & Feeding of Contest Operators (Paddon)	Jan., 23
DX A La 3.5 MC (Sykes)	Feb., 20
Legitimate PX1A, A (Aleu & Flaque)	Nov., 29

Keying

More on W2ZDE's Keyer (Leibholz)	Mar., 53
New System for Perfect Keying (Leibholz)	Jan., 16
Simpler Corkey, A (Montgomery)	Mar., 24
Simplified Break-In System, A (Hairston)	July, 22

Miscellaneous

Amateur Publicity on the Faye Emerson Show (Kaufman)	June, 19
Amateur Communications & Civil Defense (Scherer)	Apr., 27
Calmly - And Peacefully!	May, 29
Contestmanship (Montgomery)	Aug., 18
How to Organize a Novice Club (Pedersen)	Aug., 14
MARS Open to Civilians	Jan., 19
Naval Reserve and the Ham (Hay)	Apr., 25
Nursery Juke-Box, The (Drenner)	July, 20
Portable Operating Table, A (Johnson)	June, 22
Power & Resistance Ratings of Incandescent Light Bulbs (Nagle)	Jan., 30
Radio as a Hobby in the Navy (Battey)	Nov., 27
Radio Control of your Garage Door (Helfrich)	Oct., 11
Rayo' to the Rescue (Purvis)	June, 24
Red Alert! (Drumm)	Apr., 18
Report on Hams & CD in NYC, A (Heuvelmans)	Sept., 29
Sail & Serve (Crane)	July, 13
Seedrick's Sendin' Station (Purvis)	Feb., 42
Taxes and the Ham (Gough)	Mar., 23

The Skywire and the Law (Hindin)	Dec., 40
Unfamiliar Proverbs (Mel)	Oct., 25
Zero Bandwidth (Nectar)	Apr., 28

Mobile and Portable

Another Standard of Comparison (Scherer)	Nov., 11
Auto Call, The (Anderson)	Feb., 33
CD 28 MC Walkie-Talkie, The (Rand)	Nov., 21
High Efficiency Loading Coil for Mobile Antennas (Brown)	Jan., 20
High-Power Mobile Supply (Kirby)	Sept., 27
Multi-Unit 2-Meter Mobile, A (Buckley)	May, 11
One More Loading Coil (Kaiser)	Aug., 21
Powerful Portable Pint (Lott)	Jan., 11
Shack in a Wallet	Apr., 30
Simpler "Auto Call", A (Anderson)	May, 17
28-28, The (Smith)	Dec., 23

Modulators and Modulation

Improved Clamp-Tube Modulation (Hickin)	July, 24
Screen and Grid Modulation (Reinartz)	Dec., 43

Power Supplies

High-Power Mobile Supply (Kirby)	Sept., 27
Minipak, The (Pickett)	Dec., 17

Propagation

Radio Wave Propagation (Part II) (Underhill)	Jan., 26
Radio Wave Propagation (Part III) (Underhill)	Feb., 17

Receiving

Another Standard of Comparison (Scherer)	Nov., 11
Miniaturized Q5er, The	Oct., 26
Modifications to the Collins 75A-1 Receiver -- (Orr)	Sept., 21
Tri-Band Crystal Converter, A (Montgomery)	June, 20

Shack and Workshop

Quieting A-C Relays Plug-in Miniductors Longer Bias Battery Life	Oct., 38
--	----------

Vernier Knob for Fine Tuning Neutralizing 813's Cure for Tunable Hum	Nov., 43
--	----------

Surplus Conversion

War Surplus for Civil Defense (Part I) (Rand) April, 11
 War Surplus for Civil Defense (Part II) (Rand) May, 23

Television Interference

Power Line Filters (Brauner)..... Aug., 22
 TVI-Proof 10-Meter Exciter, A (Clemens)... Feb., 13
 Versatile TVI-less 40 Watt Transmitter --
 (Fisher)..... Sept., 11

Test and Measuring Equipment

Matchmaker, The (Orr) Dec., 27
 Poor Ham's Grid Dipper, The (Johnson)..... Mar., 20
 RF Sniffer, The (Gottlieb)..... Mar., 33
 Heteronull, The (West)..... Feb., 24

Theory

Further Notes on Pi & L Networks (Pappenfus &
 Klippel) May, 50

Transmitting

Compact Half-Kilowatt, A (Part I) (Helfrich) June, 11
 Compact Half-Kilowatt, A (Part II) (Helfrich) July, 16
 Compact Milliwatt, The (Whitaker) Oct., 20
 Shack in a Wallet..... Apr., 30

Six - The Easy Way (Price) Dec., 13
 TVI-Proof 10-Meter Exciter (Clemens)..... Feb., 13
 Utility VFO, The (Pierce) Oct., 16
 Versatile TVI-less 40 Watt Transmitter, A --
 (Fisher) Sept., 11
 220 MC Transmitter, A (Heubner)..... June, 16
 28-28, The (Smith)..... Dec., 23
 80 Meter Novice Special, The (Reque)..... Mar., 11

VHF and UHF

Multi-Unit 2-Meter Mobile, A (Buckley)..... May, 11
 Six - The Easy Way (Price)..... Dec., 13
 For the Technician Licensee -- A 220 MC --
 Transmitter (Heubner) June, 16

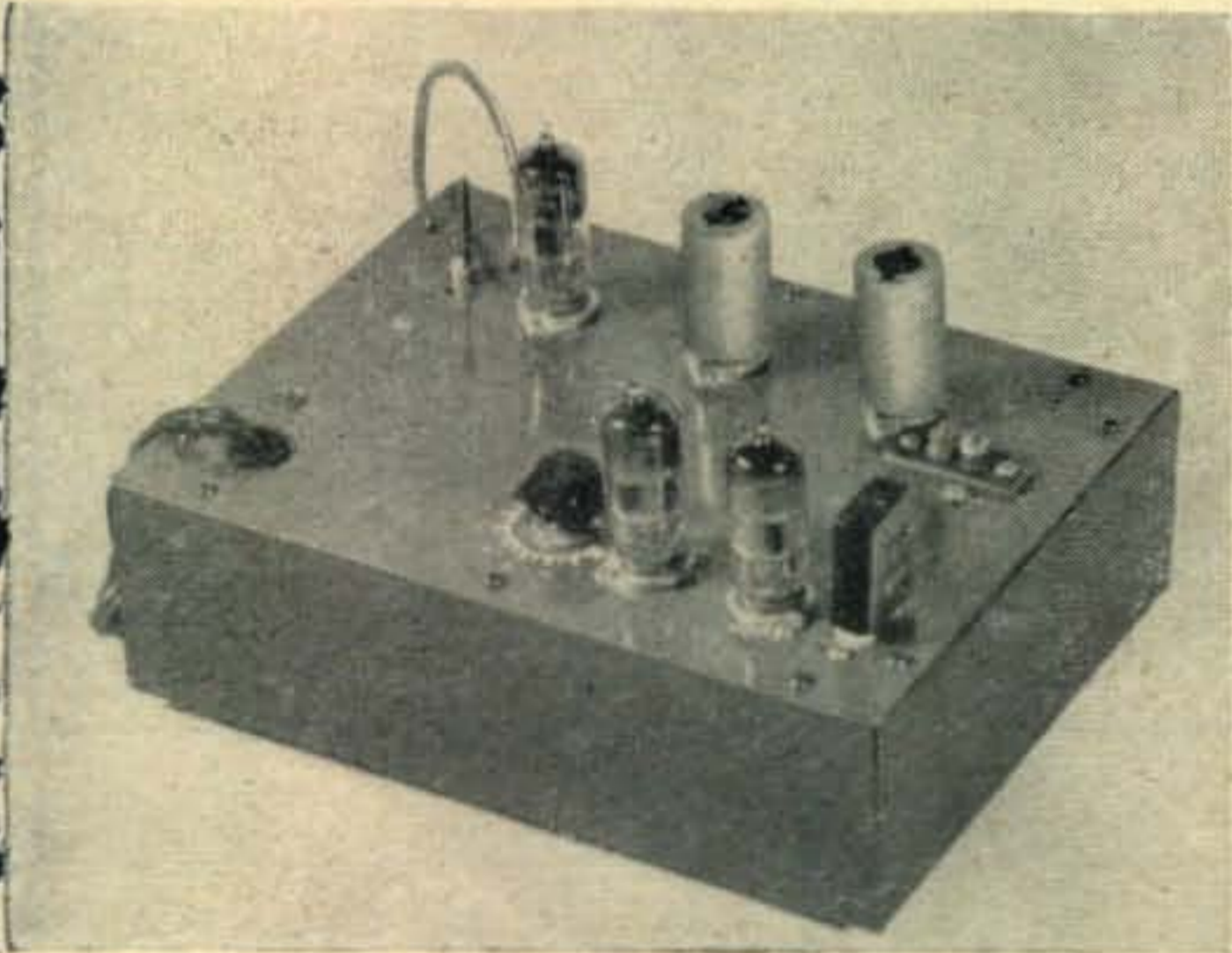

NEW! NEW!
RC-1-144A

**2 METER CRYSTAL CONVERTER
 FOR THE SERIOUS V.H.F. WORKER**

- Balanced Circuitry
- Push-Pull 6BQ7 Grounded Grid 1st R.F. Stage
- Cathode Coupled, Grounded Grid Push-Pull 6J6, 2nd R.F. Stage
- Push-Push 6J6 Mixer
- Built-in Isolated Power Supply
- Flat 4 mc. Band-Pass
- Conversion Frequency, 14-18 mc.
- Low Noise Figure. Approx. 8 db.

Complete with Tubes & Crystal

ONLY \$45.00 Net

NOTE: The new unit described in this 'ad' does not supersede our regular line of crystal converters pictured above. They are available for the 2, 6, 10-11, 15 and 20 meter bands.

ONLY \$21.50 net, less Tubes & Crystal. IMPORTANT: Do not buy any transmitter for H.F. or V.H.F., fixed or mobile, until you see what we have to offer.

Send for FREE Catalog.

SYLVAN ELECTRONIC LABORATORIES

• **BROADALBIN, NEW YORK**



NATIONAL

- **P**roven
- **D**ependable
- **Q**uality

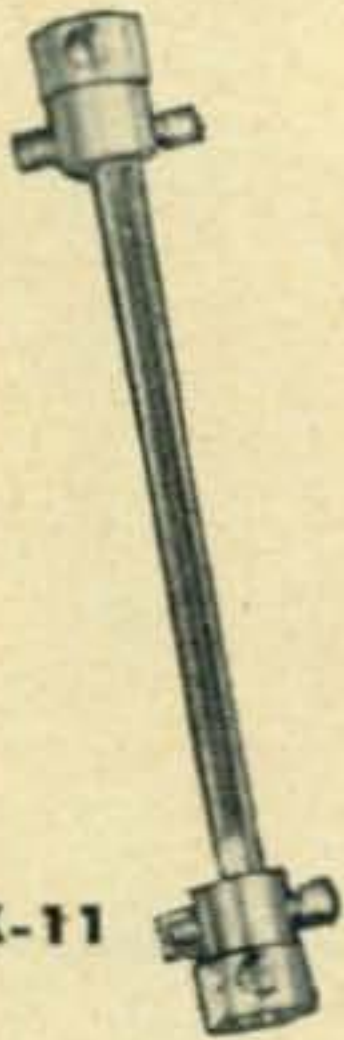

TX-11

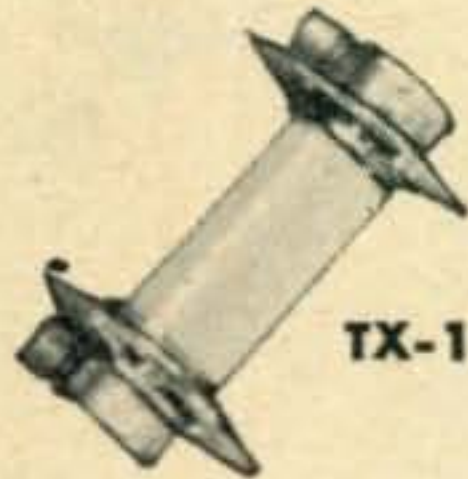

TX-1



TX-23



TX-10

VERSATILE SHAFT COUPLINGS

National makes a complete line of insulated and non-insulated, flexible and rigid shaft couplings designed for a wide variety of practical applications. They are free of backlash, mechanically strong and fit all popular shaft diameters. Write for drawings and specifications.

National



EST. 1914

NATIONAL COMPANY, Inc.
MALDEN, MASSACHUSETTS

CQ Ad Index

Allied Radio Corp.	50, 57
American Phenolic Corp.	6
Atronic Corp.	62
Barker & Williamson	61
Billey Electric Co.	8
Bud Radio, Inc.	2
Burstein-Applebee Co.	67
C & H Sales Co.	69
Collins Radio Company	12
Columbia Electronics Sales	67
Communications Equipment Co.	62
Eitel-McCullough, Inc.	10
Electronicraft, Inc.	62
Federal Electronics Institute	60
General Electric Co.	1
Hallicrafters Co.	50, Cover 2
Harrison Radio Corp.	59
Harvey Radio Co., Inc.	7
Hudson Radio & TV Corp.	65
Instructograph Co.	60
JFD Manufacturing Co., Inc.	62
Johnson, E. F. Co.	56
Millen, James Mfg. Co., Inc.	4
Motorola, Inc.	58
National Company, Inc.	72, Cover 3
Petersen Radio Company, Inc.	5
Radio Corp. of America (Tube Div.)	Cover 4
Radio Products Sales of Colorado	63
Radio Wire Television	55
Sequoia Craft	60
Shure Brothers, Inc.	50
Sun Radio of Washington, D.C.	53
Sylvan Electronic Labs	71
Tab	72
Tallen Company, Inc.	60
Trans-World Radio-TV Corp.	69
Turner Company, The	50
World Radio Laboratories, Inc.	9

WANTED IMMEDIATELY . . .
for CRITICAL DEFENSE NEEDS
TUBES - CRYSTALS - END EQUIPMENT

OAS/VR75	3C23	12SC7M	833A,884
OB3/VR90	3E29,829B	FG17,32,33	927, 1000T
OC3/VR105	4C35	100TH	1614, 2050
1N21,A,B	5C22	FG104,172	5725
1N23,A,B	5R4GY	250TH,TL	5727
1N25,26	6AC7M	304TH,TL	5749
Xtals: 100Kc,	6AG7M	368AS	5750
200Kc, 1000Kc	6B4G	450TH,TL	5751
2D21	6C21	KU627	5654, 5670
2K25, 723AB	6L6M	726C	5686
2J & 4J Magnet-	6SC7M	750T	5726
rons, Klystrons	7C7	807,810	5814
	7AG7	811,813	9001,2,3
All Army-Navy Gear: AN, ART, BC, I, PE, PU, RA, SCR, TG, TS. WAVE GUIDES: PL & UG CONNECTORS.			
TURN YOUR SURPLUS INTO SPOT CASH & SERVE YOUR COUNTRY'S NEEDS AS WELL.			
Send Lists & Prices—Immediate Reply! Dept. C.			

TAB 111 Liberty St., New York 6 N. Y.
That's A Buy Phone WOrth 2-7674

*great news
to hundreds who
want maximum
selectivity
at minimum cost!*

NC-125



*the only receiver
with the famed
select-o-ject
built in!*

NOW AVAILABLE
for immediate delivery!

Covers 550 kcs. — 36 mcs. in 4 bands. Voice, CW, NFM (with adapter). Edge-lighted, direct-reading scale. Amateur, police, foreign, ship frequencies clearly marked. National Select-O-Ject built-in (rejects any selected audio frequency 45 db — boosts 38 db). Three microvolt sensitivity (for 10 db signal/noise ratio on 10-meter band). S-meter. AVC, ANL, ant. trimmer. Variable CW pitch control. Separate R.F. and audio gain controls. Volt. reg., stabilized oscillator. Jack for phono or NFM Adapter. Audio essentially flat to 10,000 c.p.s.

Now at last, you can get immediate delivery on the receiver that gives you more selectivity per dollar — the *only* receiver with the famed Select-O-Ject circuit built in! And that's only one of the many fine features that make the NC-125 tops in receiver value!

National



EST. 1914

NATIONAL COMPANY, Inc.
MALDEN, MASSACHUSETTS

NC-125..... \$149⁵⁰*
NC-125TS (matching spkr.).... 11⁰⁰

*Slightly higher west of the Rockies.

Merry Christmas



**and good hunting in 1952
—from the Hams
of the RCA Tube Department**



RADIO CORPORATION of AMERICA

ELECTRON TUBES

HARRISON, N. J.

*Henry Radio Stores
Butler, Mo.*