

FEBRUARY
1952

CQ RADIO AMATEURS' JOURNAL

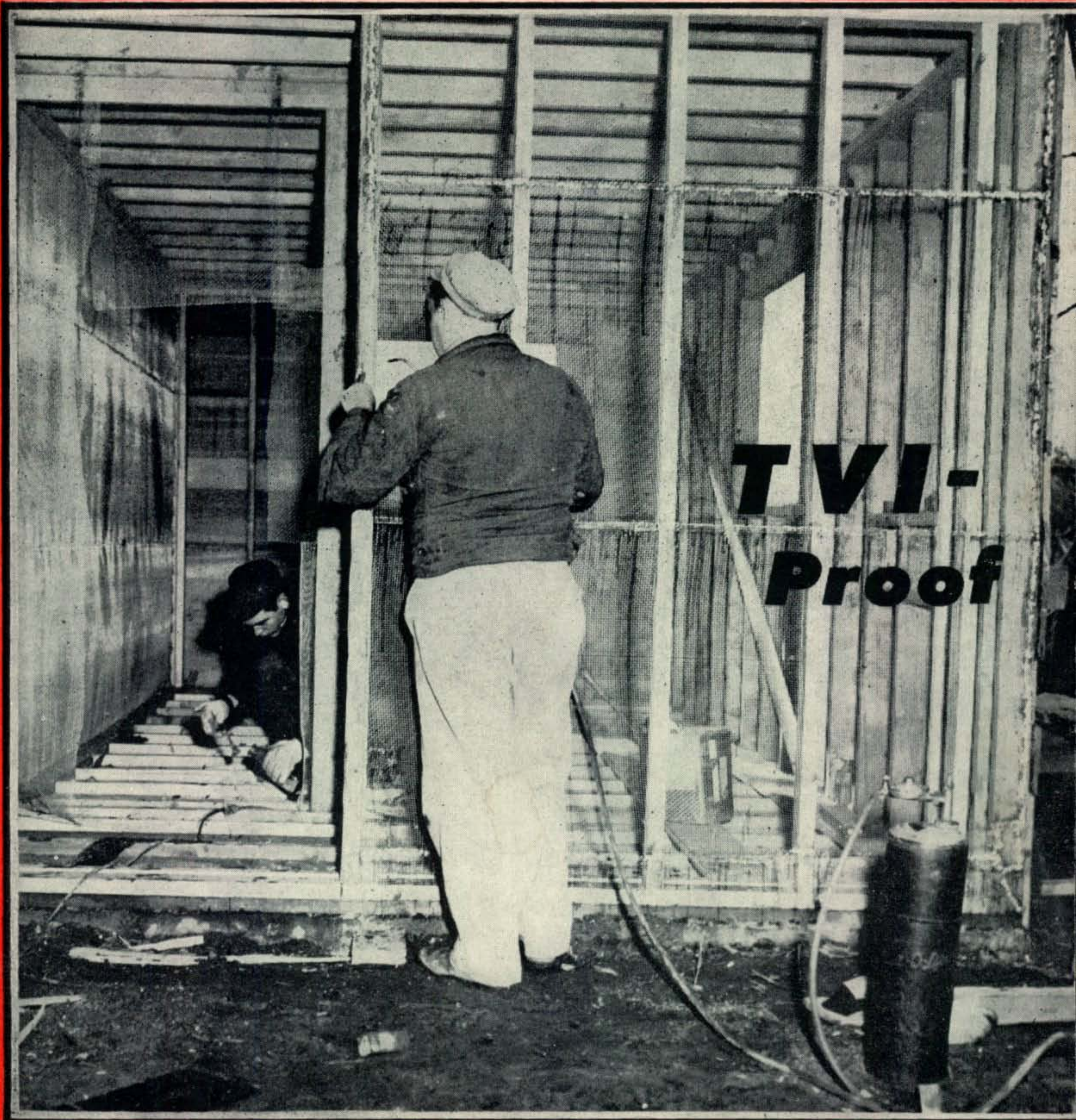

**TVI-
Proof**

Hallicrafters

new communications "TOOL" for industry!

the

littlefone®

2-WAY FM RADIO-TELEPHONE



HAND CARRY

HT-21 (25-50 Mc.)
HT-22 (150-174 Mc.)

- FULL TWO-WATT ANTENNA OUTPUT*
- Weighs only 14 pounds!
- Complete, self-contained 2-way radio-telephone station!
- Powered by Dry, or Wet Rechargeable Batteries (can be recharged from car battery or 117 Volts AC)
- Rugged, weatherproof
- 22 sub-miniature tubes!

*On 25-50 Mc. • One-Watt output on 150-174 Mc.

10 Lb. Lower powered Models also available.

CENTRAL STATION

HT-23 (25-50 Mc.) HT-24 (150-174 Mc.)

Same performance and specifications as the "Littlefone" Hand Carry.

- AC-operated Central Station
- Audio-amplifier, providing one watt of audio for loudspeaker
- Power consumption is 35 watts
- Plugs in any AC outlet (117 Volts)

Where one or more extra stationary receiving stations are desired, Hallicrafters economical S-81 receivers may be added.

A new Hallicrafters product—the "littlefone"—is now ready for thousands of important uses in hundreds of industries.

This light, rugged, dependable radio-phone will be offered through Hallicrafters distribution organization—by the men who know communications best.

USES OF "LITTLEFONE" CHALLENGE YOUR IMAGINATION!

There are literally thousands of industrial uses for the "littlefone" radio—anywhere where powerful, dependable, "on the move" contact is required.

AMONG THE MORE IMPORTANT PRESENT USES ARE:



- RAILROADING
- FREIGHT HANDLING
- WAREHOUSE OPERATIONS
- RANCHING & LARGE FARMS
- MINING (Above & Below Ground)
- PIPE LINE INSPECTION
- ROAD BUILDING
- SHIPPING (Dock Operations)
- CONSTRUCTION
- LUMBERING

Hallicrafters
"The Radio Man's Radio"

**BANTAMWEIGHT
WITH THE BIG PUNCH-
use it for your C.D. final!**



● **More-than-adequate input . . .** A single GL-2E26 will handle up to 27 w phone. Check this max against normal usage of 15 w (50 ma at 300 v) for local civil-defense work, and you find yourself with power to spare!

Compact, for compact transmitters! The smaller and lighter your rig the better, whether your purpose is C.D. work or merely to go modern in your home or portable equipment. Note how the GL-2E26 saves space! The tube's height, for example, is a good two inches less than an 807's.

V-h-f . . . up to 125 mc and 175 mc respectively, at max and reduced input! The GL-2E26 gives you band coverage on 2 . . . 6 . . . 10 meters, all popular in point-to-point or fixed-point-to-mobile C.D. service.

Economical! Price the GL-2E26, and you'll find it a real bargain.

Proved in service? Evidence of the tube's worth on the job is the fact that many commercial C.D. rigs use the GL-2E26. Your G-E tube distributor will be glad to tell you more. See him today! *Electronics Division, General Electric Company, Schenectady 5, New York.*

For design help toward a GL-2E26 emergency rig that's tested, practical, low in cost, see Jan.-Feb. Ham News—"A 6-meter C.D. Transmitter". Ask your distributor for your free copy!



**GL-2E26
V-h-f beam
power tube**

**G-E MILESTONE:
the screen-grid tube!**



Beam power design, typified by the modern, efficient GL-2E26, is a refinement of the screen-grid principle. This important advancement in electronics came from G-E research. In 1925 Dr. A. W. Hull of General Electric originated the screen-grid tube, and in 1927 G. E. made available to users the first screen-grid transmitting type, the 860 . . . More years of experience mean greater know-how in design and manufacture. That's why G.E.'s many electronic "firsts" stand for first quality in G-E tubes!

ELECTRONIC TUBES OF ALL TYPES FOR THE RADIO AMATEUR

GENERAL  ELECTRIC

166-1B1

the COIL that foils breakage

BUD 75 WATT COIL

with Polystyrene Plastic Base

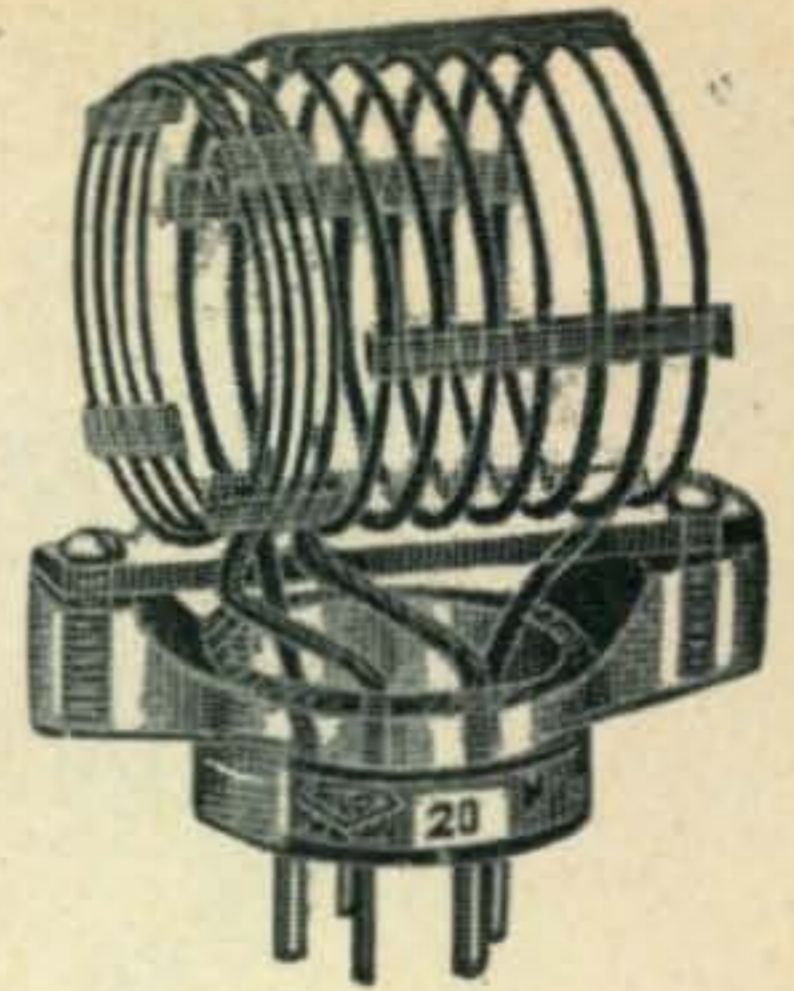

Now Bud gives you improved performance, better appearance and long lasting quality in these 75 watt coils with the new Polystyrene base. Polystyrene has proven superior to porcelain for many reasons, including

1. Far greater resistance to breaking or cracking.
2. The Q of the coil is exceptionally high due to the extremely low power factor.
3. Pins are moulded in place—always remain perfectly alligned.
4. Sharp corners eliminated—no danger of chipping.
5. Transparency adds to smooth modern appearance.

Bud 75 watt coils are furnished with fixed or adjustable center links and fixed or adjustable end links. They are air wound, mount into 5-prong tube sockets and can be used on bands from 6 meters to 160 meter. OEP and OCP Coils are designed for use in circuits using Pentode tubes with high output capacity such as 6L6, 807, etc.

Catalog No. Fixed End Link	Catalog No. Fixed Center Link	Catalog No. Adjustable Center Link	Catalog No. Adjustable End Link	Band	Capacity*	Dealer Cost
.....	OLS-160	160 Meter	100 MMFD	\$2.28
.....	OES-160	160 Meter	86 MMFD	2.28
OEL-80	OCL-80	OLS-80	OES-80	80 Meter	75 MMFD	1.95
OEL-40	OCL-40	OLS-40	OES-40	40 Meter	52 MMFD	1.92
OEL-20	OCL-20	OLS-20	OES-20	20 Meter	40 MMFD	1.83
OEL-15	OCL-15	OLS-15	OES-15	15 Meter	30 MMFD	1.80
OEL-10	OCL-10	OLS-10	OES-10	10 Meter	25 MMFD	1.74
OEL-6	OCL-6	6 Meter	17 MMFD	1.41
.....	OCP-10	OEP-10	10 Meter	45 MMFD	1.74
.....	OCP-20	OEP-20	20 Meter	50 MMFD	1.83

* Denotes tube plus circuit plus tank plus output coupling capacity required to resonate coil at low frequency end of band.



• SHIELDED • COIL LINKS

These links are made to fit RLS, VLS, and MLS series of coils. This link will prevent capacity coupling between the tank coil and the link and would reduce TVI by greatly attenuating harmonics. The links can be used on co-ax or balanced lines.

Catalog Number	DESCRIPTION	Dealer Costs
AM-1300	Used with RLS coils (150W)	\$1.92
AM-1301	Used with VLS coils (500W)	2.19
AM-1302	Used with MLS coils (Kilowatt)	2.61

Bud products include coils, condensers, R.F. chokes, sheet metal ware, etc. See the complete Bud line at your local distributors.



• ADD-A-LINKS

When the circuit that you are using requires a different number of turns on the coil link than is furnished with the standard coil, the links listed below can be used to replace the standard link.

Cat. No.	Used With	No. of Turns	Dealer Cost
AM-1303	RLS	3 1/2	\$.52
AM-1304	RLS	4 1/2	.54
AM-1305	RLS	5 1/2	.63
AM-1307	VLS	3 1/2	.52
AM-1308	VLS	4 1/2	.54
AM-1309	VLS	5 1/2	.63
AM-1310	VLS	6 1/2	.72
AM-1311	MLS	3 1/2	.81
AM-1312	MLS	4 1/2	.96
AM-1313	MLS	5 1/2	1.05
AM-1314	MLS	6 1/2	1.14



The Mark of
Perfection

BUD RADIO, Inc.

2120 EAST 55th STREET

CLEVELAND 3, OHIO



EDITORIAL STAFF

MANAGING EDITOR
OLIVER P. FERRELL
TECHNICAL EDITOR
E. M. BROWN, W2PAU

DEPARTMENT EDITORS

Ralph Anderson, W3NL	Mobile
Herb Brier, W9EGQ	Novice
Wayne Green, W2NSD	Teletype
George Jacobs, W2PAJ	Propagation
W. E. McNatt, W9NFK	VHF-UHF
Louisa B. Sando, W5RZJ	YL
R. C. Spenceley, KV4AA	DX

CONTRIBUTING EDITORS

Herb Becker,	W6QD
Frank C. Jones,	W6AJF
G. F. Montgomery,	W3FQB
William I. Orr,	W6SAI
W. M. Scherer,	W2AEF

ILLUSTRATOR

Thomas Smith, W2MCJ

BUSINESS STAFF

S. R. COWAN,	Publisher
S. L. CAHN,	Adv. Director
H. N. REIZES,	Adv. Mgr.
D. SALTMAN,	Prod. Mgr.
W. SCHNEIDER,	Edit. Prod.
H. WEISNER,	Circ. Mgr.

Branch Offices: Ted E. Schell, 112 West 9th Street, Los Angeles 15, Calif.
Foreign Subscription Representatives: Radio Society of Great Britain, New Ruskin House, Little Russel St., London, WC 1, England. Technical Book & Magazine Co., 297 Swanston St., Melbourne C1, Victoria, Australia.



OUR COVER

Is this the answer to curing TVI in fringe areas? W8DUS, Al Kahn, is going to build his shack inside a double walled screen room. In commercial practice a screen room is said to have an attenuation of the order of 90 db. The photograph shows workmen soldering the last section of the copper hardware cloth.

Broad Band	4
The Private Life of CQ	6
Scratchi	8
Guest Editorial	11
20-Meter Injun Chaser <i>Hartland B. Smith, W8VVD</i>	15
A Complete 144-Mc VFO with NBFM <i>David D. Bulkley, W2QUJ and Merritt Kirchhoff, W2FAR</i>	19
The Balun—Theory and Design <i>J. Roy Smith, W6WYA</i>	24
Radio Teletype	26
A Pair of Phased Ground Planes on 40 Meters <i>Richard J. Lawton, W6MVQ</i>	30
The YL's Frequency	33
The Worm Turns by Mrs. Ol' Joe	35
Novice Shack	36
Mobile Corner	38
DX & Overseas News	40
The VHF News	43
Ionospheric Propagation Conditions	47
Shack & Workshop	50
Latest Releases from the FCC	51
Radio's Master Reports	53
Quarter Century Wireless Association	54
An Opinion	56
Classified Ads	70, 71
Advertising Index	72

CQ—(Title Reg. U. S. Pat. Office)—is published monthly by Cowan Publishing Corp. Executive and Editorial offices at 67 West 44th Street, New York 18, N. Y. Phone MUrray Hill 7-2080. Reentered as Second Class Matter February 6, 1951 at the Post Office, New York, N. Y. under the Act of Mar. R, 1879. Subscription Rates: in U. S. A. & Possessions, Canada & Pan American Union—1 year \$3.00; 2 years \$5.00. Elsewhere \$4.00 per year. Single copies 35 cents. Printed in U. S. A. Entire contents copyright 1952 by Cowan Publishing Corp.

Designed for



Application

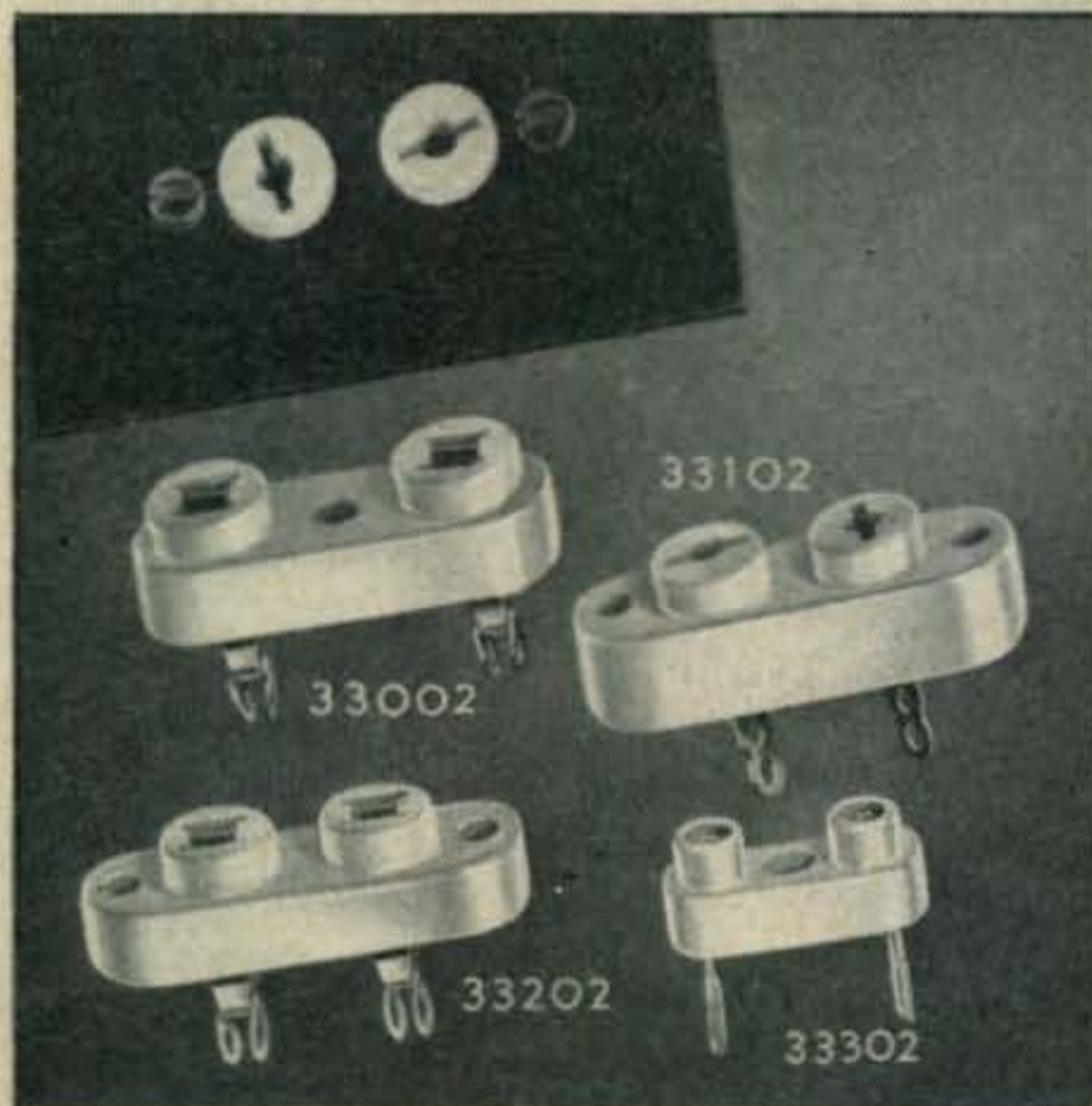

**Crystal Holder Sockets
33002, 33102, and 33202
Plus new 33302 for CR7**

In addition to the original 33002, 33102 and 33202 exclusive Millen "Designed for Application" steatite crystal holder sockets, there is now also available the new 33302 for the new CR7 holder. Essential data:

Type	Pin Dia.	Pin Spacing
33002.....	.125	.750
33102.....	.095	.500
33202.....	.125	.500
33302.....	.050	.500

**JAMES MILLEN
MFG. CO., INC.**

MAIN OFFICE AND FACTORY
MALDEN
MASSACHUSETTS



Broad Band . . .

Calling All Chess Players

San Jose, Calif.

Editor, CQ:

A recent check of the amateur bands has brought to light a conspicuous absence of chess players. The institution known as Radio Chess seems to have disappeared from the amateur segments of the spectrum. The cause of this disappointing situation is not known, but I for one would like to see a return of popularity of this most worthwhile expenditure of operating time. A possible means of uniting existing interested amateurs, and of stimulating further interest in Radio Chess, might be the formation of local affiliated on-the-air chess clubs. On-the-air meetings could be held at fixed intervals of say, once a week, and games between club members could be scheduled. Any further ideas or suggestions would be appreciated.

Sincerely yours,

Denis J. Kiely, W6ZDB

News On The Antennascope

Hartford, Conn.

Editor, CQ:

Having built an Antennascope but with one variation from your published model, I thought you might be interested in my idea. Since my Antennascope is built in a small aluminum chassis it leaves the back open, so, rather than calibrate the variable resistor in tens and hundreds of ohms, I leave it unmarked. Upon finding the null I disconnect the load and the source, turn over the instrument and with my ohmmeter merely measure the value of the variable resistor.

To some this may seem too complicated but, since this instrument is used infrequently, a little extra effort is compensated for by greater accuracy in the end result. The only precaution is to be careful not to connect the ohmmeter to any other parts of the scope lest one damage either the microammeter or the crystal.

Respectfully,

W. R. Marks, W1DEF

Encode Those Lengthy Titles

c/o Postmaster
Seattle, Wash

Editor, CQ:

On behalf of the operators of our two stations located here on Adak, KL7AKJ and KL7AIZ, and all stations located in the Pacific Area, we are appealing to those operators located at Fairs and Expositions throughout the United States to please use encoded ARRL messages whenever possible. The volume of such traffic seems to have increased tremendously during the last few months.

In addition, if some code could be assigned to the specific exposition, it would eliminate unnecessary and lengthy titles, e.g., "ALICE" could be a group standing for "THE INTERNATIONAL EXPOSITION OF ELECTRONICS ENGINEERS."

Any assistance will certainly be appreciated.

Sincerely yours,

B. M. Sexton, Secy.

Two Letter Novice Call

Manitou Beach, Mich.

Editor, CQ:

I cannot say positively but after looking through the last issue (Winter 1951) of Radio Amateur Call Book Magazine, I believe I am the only two letter Novice in the United States. Will someone correct me if I am wrong.

My main reason for writing is that many hams will not answer my calls or CQs because they figure I'm bootlegging. That is incorrect, I have my ticket here and have had it since October 3, 1951.

Sincerely yours,

Martin W. Tausend, WN8UJ

NOW AT HOME IN SPARE TIME!
Get the "BASICS" you've missed!



LEARN RADIO *plus* TELEVISION AND ELECTRONICS

**LEARN IT THOROUGHLY! FROM AMERICA'S
 MOST COMPLETE HOME TRAINING SCHOOL!**

**You Get All The Parts
 -Even Tubes-** for this modern
 Superheterodyne Receiver - and lots of
 other equipment. And you get to keep it!

Let **NATIONAL SCHOOLS**—the famous resident-training school founded in 1905—train you as you want to be trained. One of the largest schools of its kind, National is located in Los Angeles—center of Radio-Television world! You learn from lessons prepared by men who are successful Radio and Television technicians.



**ONLY NATIONAL SCHOOLS GIVES YOU THIS
 PROFESSIONAL MULTI-TESTER!**

You get this amazing new testing instrument—complete. It's specially factory-made and tested. Ready to use! Simple to operate. Accurate and dependable. And—it's light enough to carry around—so you can use it at home or on service calls.

**HERE ARE ONLY A FEW OF THE
 GOOD-PAYING JOBS YOU CAN CHOOSE!**

- Radio Station Engineer
- District Service Manager
- Aircraft Radio Inspector
- Own Your Own Repair Shop
- Inspector Technician
- Service Specialist
- Special Gov't Positions
- Sound Truck Operator

Attention! Men Going into the Service Soon!

This National Schools Home Training course prepares you for many important jobs in the Service. With this training you can get into *special* service classifications—with higher pay and grade—fast!

FREE SERVICE FOR GRADUATES!

National Schools uses its influence and prestige to help you find your place in the field of your choice. We help you start toward the good pay you've dreamed of. Don't put it off! Get the *professional training* you've always wanted! The training *you* should have. Mail the coupon for the facts—today.

NATIONAL SCHOOLS
 LOS ANGELES 37, CALIFORNIA • ESTABLISHED 1905
 In Canada: 193 E. Hastings St., Vancouver, B.C.



**BIG FREE
 BOOK TELLS YOU HOW**
 Page after page—in **COLOR**—tells you everything you want to know! Mail the coupon. Get yours—today!
PLUS A FREE SAMPLE LESSON!

You Train at Home—In Your Spare Time!

National Schools Shop-Method Home Training gives you basic and advanced instruction in *all* the phases of Radio-Television-Electronics.

You learn *fast* from hundreds of diagrams and pictures. All instructions are written by experienced technicians who work in Radio and TV every day. All instructions have been developed and tested in National Schools' own big labs and studios, which are equipped with the latest RCA equipment. No wonder this National Schools course is so up-to-date, practical, interesting... and so easy to learn! And no wonder it is held in such high regard by leaders of American industry! What's more—this National Schools Shop-Method Home Training is approved for eligible veterans.

**We Teach You How To Make Welcome
 Extra Money—While You Learn!**

Many National Schools students—men like you—make plenty of extra dollars in spare time! Fixing neighbors' radios and appliances—and other ways we teach you. You can earn while you learn! Let us tell you the whole story. Mail coupon today.

**LOOK! WE SEND YOU ALL
 THESE PARTS!**



With famous National Schools Shop-Method Home Training, you learn *by doing*—the easy, practical, interesting way. The way *you* want to learn. We send you many parts—all of modern professional quality. You do lots of practical experiments. You advance day by day, step by step. The free book tells you all about it. Answers all your questions. Use the coupon. And do it now—while you're thinking of it.

**Today's Shortage of Trained Technicians
 Creates Chance of a Lifetime For You!**

Think of it! With guided missiles, radar, and other electronic devices so important to defense! And with over 90,000,000 radios, over 12,000,000 TV sets. With more than 3100 radio stations... over 100 TV stations—and more building every day—*what* an opportunity for you! If you act quickly! Men are wanted in Radio-Television-Electronics—America's fastest-growing field—now! Good-paying jobs—the kind *you* should have—can be yours!

**Job Security! Big Money! For YOU!
 in Today's Expanding Industries!**

National Schools graduates—men just like you—are earning good money all over the country. Why not you? National Schools graduates have the personal satisfaction of being highly-skilled technicians. Men who *enjoy* their work—rather than having to drag along in just any old job. So can you! Mail coupon today—find out how easy it is.

**National Schools Has Trained 1000's of
 Successful Men! Why Not YOU?**

In almost every state—and many foreign countries—National Schools graduates are filling big jobs with national companies. Or running their own successful businesses. What are *YOU* waiting for? National Schools Shop-Method Home Training is *complete* training. So when you graduate you can take advantage of today's great opportunities in Radio-Television-Electronics—fast.

**DON'T PUT
 IT OFF!
 GET THE
 BIG SALARY
 YOU HAVE
 ALWAYS
 WANTED!**

MAIL THIS COUPON TODAY—WITHOUT FAIL!

NATIONAL SCHOOLS, Dept. TR-22
 4000 South Figueroa Street
 Los Angeles 37, California

Mail in envelope
 or paste on
 postal card

Mail me FREE the book mentioned in this ad. Also a free sample lesson. I understand no salesman will call on me and that there is no obligation.

NAME _____ AGE _____

ADDRESS _____

CITY _____ ZONE _____ STATE _____

Vets! Check here if released from service less than 4 years ago.

Specify

AMPHENOL

for
Quality
in...

- ★ Low Loss RF Cables
- ★ Remote Control Cables
- ★ Antennas
- ★ Twin Lead Transmission Lines
- ★ AN Connectors
- ★ Submersion—Proof Connectors
- ★ Heavy Duty Power Plugs
- ★ Audio Connectors
- ★ 100 Contact Connectors
- ★ Quick Disconnect Connectors
- ★ Cable Connectors
- ★ Power Plugs
- ★ Rack & Panel Connectors
- ★ Miniature Connectors
- ★ Sealed Relay Plugs
- ★ RF Connectors
- ★ Heavy Duty Radio Connectors

AMPHENOL

AMERICAN PHENOLIC CORPORATION
1830 South 54th Avenue, Chicago 50, Ill.

- Send me the 48 page general CATALOG No. 74.
- Add my name to your mailing list for monthly information on currently new products and technical data . . . AMPHENOL ENGINEERING NEWS.

NAME _____

FIRM NAME _____

ADDRESS _____

CITY _____ STATE _____



O.R.FEI

the Private Life of CQ

Is This CQ?

Undoubtedly, a few apropos words should be written about the "new look" for CQ. Actually there isn't much to tell although for quite some time a frequently discussed subject around the Editor's desk was the possibility of making a number of changes in the "page makeup." Those of you with a discerning eye may have noted that in the December and January issues a little experimenting took place in certain feature articles. At the same time an evaluation was made of a number of page styles in order to make each CQ more attractive.

Redesigning the cover was a natural step while we were working with the inside of the "book." With the rather unexpectedly large new interest in amateur radio, it was suddenly brought to our attention that the phrase "CQ" restricted our readership to those who know of this particular publication. Unlike our contemporaries in the other hobbies—motor boating, flying, model trains, etc.—the term "CQ" does not immediately convey, nor to the outsider is it particularly synonymous to "amateur radio." Thus, we are now placing greater emphasis on our second, or subtitle, "The Radio Amateurs' Journal."

We must beg your indulgence during our renovation period. Unlike a grocery store that can close down while remodeling, we must continue to put out an issue each month. As a result, the next few months will be a little hectic and, in some cases, it may seem as though we have a couple of short circuits. The end product is in sight—we think it will look swell—we hope you will think so too.

Calling Mr. Alpern

The note at the bottom of the December *Private Life* copy labelled "Calling Mr. Jay C. Alpern" was an experiment in more ways than one. Frankly, we were principally interested in whether or not anyone ever read this column. A welcomed surprise was a letter from Mr. Alpern explaining his mysterious absence. It was received by Circulation Manager Weisner only a few days after the December issue had been released.

Mr. Alpern's subscription has now been straightened out and now feeling the flush of success the Circulation Department is taking steps to run a complete listing of "nixies"—or names and calls of subscribers who have failed to supply us with a correct address. More on this in the March *Private Life*.

By the way, Mr. Alpern is now WN2EJC—congratulations!

**SOLID
AS A
ROCK**

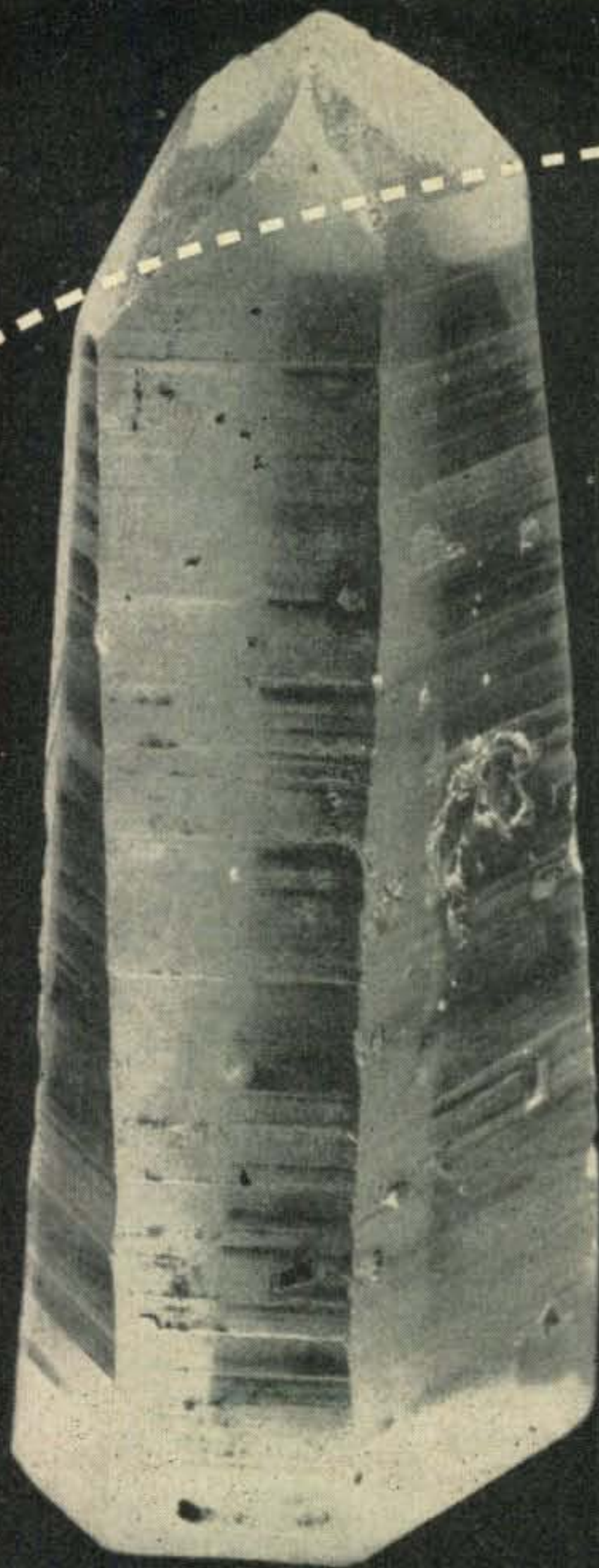

PRs STAY PUT! In aircraft, in the marine, in broadcast and point-to-point, in police and military installations . . . in fact, wherever frequencies **MUST** be in channel . . . you will find PRs on the job. PRs for commercial service are *precision made* . . . low drift cut for the utmost in stability . . . with temperature coefficient less than 2 cycles per megacycle per degree Centigrade . . . cali-

brated within .005 per cent of specified frequency . . . contamination and moisture-proof . . . weight less than $\frac{3}{8}$ ounce. Power output is exceptional, both for fundamental and harmonic oscillators. Since 1934 PR has become a standard of excellence for crystal controls . . . in all fields — commercial, amateur and industrial. It's no wonder that amateurs prefer PRs in their rigs at all frequencies.

PR

Crystals



USE **PR** AND **KNOW** WHERE YOU ARE

PETERSEN RADIO COMPANY, INC.
2800 W. BROADWAY • COUNCIL BLUFFS, IOWA



NOW!
Revised
Enlarged
Improved

6th
 EDITION

PRINCIPLES OF RADIO

By KEITH HENNEY, *W1QGU, K2BH*
 and GLEN A. RICHARDSON,
Iowa State College

**The bedrock of radio,
 clearly and simply explained.**

Proved valuable and dependable in 5 previous editions, here is a new, revised, enlarged 6th edition of one of the most popular radio books ever published. Easier to understand and *apply* than ever before, this material has been tested and improved by men of wide experience. The resulting book is completely up-to-the-minute... a standby in a growing field.

- Many chapters extensively revised; many new chapters; more than half of illustrations are new; all problems completely rewritten, many added
- No math required beyond high school algebra
- The operation of radio equipment is clearly explained in simple English
- Covers the ground thoroughly, from DC, AC and magnetic circuits through FM, radar and TV
- Major emphasis is on operation of basic radio circuits, with many step-by-step examples
- All experiments have been worked out in the lab
- Offers characteristic curves of typical tubes, design equations, completely worked-out problems, etc.

1952 655 pages \$5.50

Send coupon now for free 10-day examination

APPROVAL COUPON

**JOHN WILEY & SONS, INC., Dept. CQ-252
 440 Fourth Ave., New York 16, N. Y.**

On 10 days' approval, send Henney & Richardson's *Principles of Radio*. I will remit \$5.50 plus postage or return book postpaid. (Offer not valid outside U. S.)

Name

Address

City, Zone, State

SAVE POSTAGE — We pay postage if you enclose \$5.50. Money back on same return privilege.



Phoenix, Ariz.

Dear Hon. Ed:

Blew sky, warm winds, invigorating air, nice climate—Arizona in February are real 1/c month of the year. No, Hon. Ed., I am not on payroll of Chamber of Commerce, but I just telling you so you realizing that it are ideal month for holding hidden transmitter hunt, which are exactly what local ham club are doing last week. It sounding like real peachy idea at the time, but it are certainly ending in a horribul mess—but I better backing up, as I getting ahead of my story.

At Janyouary club meeting the new officers are deciding to get activities rolling so in spearit of grate enthusiasm they telling members that in February having hidden transmitter hunt. Cupple of local merchants are donating prizes for winners. First prize are complete 100 watt rig, and second prize are mobile receiver. Natchurally, with such stewpendus prizes all hams in area are interested, so we all putting receivers in our cars and making directional loop antennas. Hon. Brother Itchi are even getting excited about contest, so he joining up with yours truly Hashafisti, to making one team. Itchi are going to act as driver and me myself as radio operator.

The club officers are taking job of hiding the transmitter, and they telling everyone that it won't be easy to finding rig, and be sure and wearing your old clothes. This are making sum club members a little worried, but not Scratchi, as I knowing this country like the inside of the Handbook (especially the page with Ohm's Law on it).

The day of the contest the wether are reely beautiful, Itchi and I arrive at starting point on time, and find about 30 cars all lined up and ready to go. One of the officers are there to giving final instructions, and he telling us that the hidden xmitter may not be where we can get to it by car, so we may have to walk to where it is after getting close to it by car. With that he wishing us good luck and he walking away with smile on his face. We turn on receiver, and right on schedule we heering signal from hidden rig. Taking quick reeding, and telling Itchi to get going toward the south. Other cars evidently getting same idea, and first thing you knowing everybuddy rushing like madly toward south end of city. Itchi are knowing shortcut, so we leaving other cars and proceeding alone.

All this while I taking more reedings, and plotting them on map I have handy. Reedings all seem to checking out ok, except are making me plenty worried, on acct. it looks like xmitter are on top of local mountain (it's not reely a Western mountain, but it a big hill which peepel back East would call-

(Continued on page 64)

AVOID RESISTOR BREAKDOWNS



OHMITE LITTLE DEVIL RESISTORS



Provide EXTRA MARGIN of SAFETY

Where dependability is of the utmost importance, play safe with Ohmite Little Devil molded composition resistors. While they are tiny in size, these units have exceptional ruggedness, stability, and current-carrying capacity. Little Devils are completely sealed and insulated by molded plastic. Under continuous full load for 1000 hours, their resistance change is less than 5%.

Ohmite Little Devils are available in $\frac{1}{2}$, 1, and 2-watt sizes, in $\pm 5\%$ or $\pm 10\%$ tolerance. Standard RTMA values, 10 ohms to 22 megohms are furnished. In the 1-watt size, $\pm 10\%$ tolerance, values as low as 2.7 ohms are provided.

AVAILABLE ONLY FROM YOUR DISTRIBUTOR

OHMITE MANUFACTURING CO.

4830 Flournoy Street, Chicago 44, Illinois

- **RATED AT 70C**—Little Devils have a wide margin of safety—being rated at 70C instead of 40C.
- **WITHSTAND TEMPERATURE, HUMIDITY**—Meet all JAN-R-11 requirements, including salt water immersion and humidity tests.
- **RESISTANCE AND WATTAGE CLEARLY MARKED**—In addition to color coding, the resistance value and wattage are marked on every unit.
- **TEMPERED LEADS**—Tinned copper leads are differentially tempered to prevent sharp bends.

Be Right with **OHMITE** RHEOSTATS
RESISTORS
TAP SWITCHES

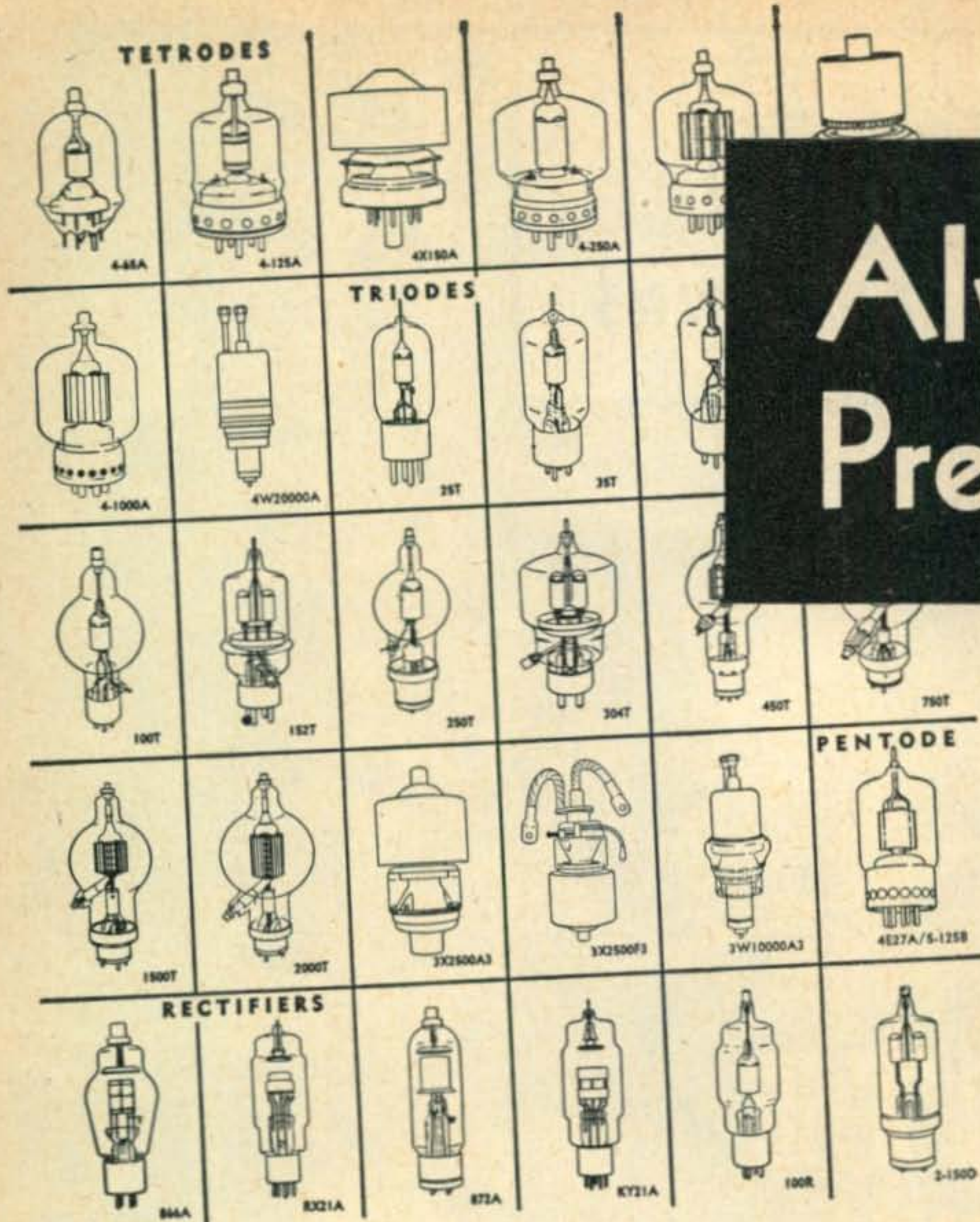

**Always
Preferred...**

For almost two decades Eimac transmitting tubes have been the undeniable choice of performance-conscious amateurs as well as of commercial electronic engineering groups. These two decades are important because during this time the electron art has undergone great changes and advancement. Throughout this period Eimac tubes have proved themselves — proved themselves not only under normal but also under adverse conditions where other tubes failed.

Eimac tubes are available for all amateur power categories. Invariably their use allows considerable economies in associated circuit and driver stages — this is especially true in the case of Eimac tetrodes.

Complete technical data, prices, and other valuable application information is available without cost or obligation. Write Amateur Service Department, Eimac, San Bruno, California.

JUST OFF THE PRESS. A handy book to have around the shack, "The Care and Feeding of Power Tetrodes", price 25 cents. It's all the name implies. Twenty-eight pages jam-packed with helpful information.

Eimac
TUBES

EITEL-McCULLOUGH, INC.
San Bruno, California

Export Agents: Frazar & Hansen, 301 Clay St., San Francisco, California

Guest Editorial

by GEORGE E. STERLING, Commissioner

Federal Communications Commission

We are proud and privileged to introduce our series of Guest Editorials with a few appropriate words by W3DF on a subject that needs positive analysis —Editor.

Operation — Good Will

Many years ago a decision was made that it was in the public interest for the regulatory agency established by the Congress to license amateur radio stations. Subsequently, rules and regulations were established governing the operation of stations in the amateur service. In these rules there are certain technical requirements that must be complied with by the licensee, likened to the rules prescribed by the Federal Communications Commission for other classes of radio stations licensed to operate in the public interest. The regulatory agency has reserved the right within the rules to restrict the operation of amateur stations by limiting their period of operation on frequencies which cause interference to broadcast reception to the public. While these restrictions were originally employed in cases of interference to aural broadcasting, they have in recent years been utilized in some cases of interference to the TV reception.

When interference results from the operation of an amateur station, experience has shown that where cooperation is entered into on the part of the complainant and the amateur, mutually beneficial results are generally obtained, making it unnecessary to invoke quiet hours or to take other action within the powers of the regulatory agency. In the case of TVI, many manufacturers have cooperated through their service organizations in ironing out difficulties, especially in cases where a high-pass filter is the solution to the problem. The amateurs of Dallas, Texas, deserve credit for the firm stand they took on this problem which led to cooperative efforts on the part of many manufacturers. On the other hand, circumstances have required the imposition of quiet hours and also voluntary reductions in power on the part of the amateur operator.

Unfortunately, there are a few licensed amateurs laboring under a misconception of their obligations as citizens, who feel that since they have a Federal license they can operate as they please without regard to their neighbors. Within this small group we find two classes of stations; one, those whose transmitters are in trouble to the extent that harmonics have not been attenuated, radio frequency feed-back into the power

lines has not been suppressed, keying impacts or over-modulation is permitted resulting in spurious radiations. The other class embraces those who may be operating within the requirements of the rules but who nevertheless use poor judgment in their manner and method of operation. This latter minority supposedly predicate their claim to operate as they please, without regard to general or blanket interference being experienced, either on the record the amateur fraternity has established in providing communications in emergencies or based on their own selfish interests without regard to the possibility of resolving such interference by mutual cooperation.

Obviously, the first group is not only jeopardizing their good standing in their community, but with the Commission as well. The second group, while complying with the technical requirements of the rules, by their arbitrary and uncooperative attitude, fail miserably when measured by the standard of what constitutes a good citizen in our modern society. Such individuals are unworthy of being identified as amateurs and they cannot meet the test of operation in the public interest.

It should be remembered that the Federal Communications Commission does not own that part of the public domain represented by the radio spectrum, it can only choose those who can operate therein. Radio frequencies are owned by the people, by one's neighbors as well as the amateur, and must be shared by more than fifty other services beside the amateurs. If there are abuses in the uses of the radio spectrum, the owners (the public) have recourse to their representatives in Congress and the regulatory agency established by the Congress, the Federal Communications Commission. The granting of an amateur license is not a permanent franchise to operate in the public domain and each authorization contains this language:

"This license shall not vest in the licensee any right to operate the station nor any right in the use of authorized frequencies beyond the term hereof, nor in any other manner than authorized herein."

Since the regulatory agency must determine, in granting the renewal of a license, that the criteria of public interest, convenience and necessity have been met, it may review the past performance of a licensee. This point is much too often overlooked by licensed amateurs.

Do men of good will in a neighborhood deliberately burn their leaves in the fall when they

are aware that their neighbor's wife has just hung out the family wash? Do men of good will, when picking up a neighbor early in the morning, honk their automobile horns incessantly and in wanton disregard for others who may be sleeping? Yes, unfortunately, we do find such individuals and because of the callous disregard of their fellowmen they become the misfits in their neighborhood of good will, and so in the amateur who operates his station in total disregard of his neighbors, knowing well that he is causing annoyance. An individual's standing as a good neighbor is measured by the manner in which he meets his day-by-day social obligations which include respect for the rights of those in the community in which he and his family have mutual ties.

But what about the complainant who insists that he is standing on his rights and refuses to cooperate in eliminating interference? In some such cases we find an individual who insists on what he considers his rights and refuses to attach a filter to his receiver, or even to permit a friendly "look-see" to determine where the fault lies. He, too, is the misfit in this neighborhood of good will and is no longer entitled to consideration by either the amateur or the Commission.

We also find on occasion those who prefer to resort to the Law of the Pecos and under cover of darkness cut down the amateur's antenna or in some way, by annoyance, take it out on the family of the amateur. Those who commit such acts are enemies of a good society and if identified should be dealt with according to the civil statutes of the municipality.

The solution of interference problems requires understanding, cooperation, tact, patience and perseverance on the part of all concerned. This pertains to the complainant, the amateur, the dealer, the receiver manufacturer, and the Commission's field representatives. The records of the Commission show a very large percentage of success when such a policy is pursued.

Recently there was a case where the complainant was willing to have the amateur modify his receiver so as to eliminate interference. The amateur insisted that the service on the receiver had to be performed in his shop and he would not enter the complainant's house, nor would the complainant deliver the receiver to the amateur. In this case the Federal Communications Commission's field representative stepped in and delivered the receiver to the amateur who fixed it; the set was returned to the owner; and everybody was happy with the final result. Obviously, the Federal Communications Commission has neither the funds nor the manpower to arbitrate these cases to such an extent throughout the Nation. Complaints of interference to reception cannot be settled amicably by dealing at arms' length but only by the closest of mutual cooperation of all concerned.

Unfortunately, there are cases where, even after full cooperation has been extended by all concerned and the amateur has exhausted every technical means of eliminating interference at his transmitter as well as at the receiver, interference still exists. These cases generally fall in the fringe areas of TV reception of where inside TV antennas are employed and the amateur is confronted with the desire to operate but knows that interference results. Such a case sometimes involves interference to the small AC-DC broadcast receiver lacking preselection or deficient shielding, or both. It is in these the amateur often bears the burden of what properly is the manufacturer's. However, the situation is not unlike that of the broadcast licensee who is required to take care of complaints of receiver owners in blanket areas where his transmitter is close to a residential area. In these cases it is up to the amateur to make his own judgment.

In trying to find an answer the amateur must ask himself the following questions: Can he afford to jeopardize his standing as a man of good will in his neighborhood? Will his operation fall within the broad concept of public interest, convenience and necessity, the touchstones the Congress of the land laid down by which the regulatory agency licensed his station? Is the operation of the station under such circumstances in the best interest of all the other thousands of licensed amateurs throughout the country? Despite his large investment in equipment, can he ignore the investment of his neighbors regardless of whether it be a de luxe combination or the smallest of AC-DC receivers? Is he giving the same weight to the consideration of a complaint of a humble person with a small receiver that he would give to Mr. I. M. Influence with his de luxe installation? Will the faint voice of a complainant increase to the cry of an aroused neighborhood?

As the amateur wrestles with the problem in trying to arrive at a proper judgment, he must consider the possibilities of operation without interference on other frequencies or bands or by some mode of operation within the broad provisions of the Amateur Rules. Having determined a course of action, he must be prepared to cope with the result.

By and large, throughout the years amateurs have made the right decisions. This is proven by the insignificant number of revocations of their licenses. It is also pointed up by the fact that no single resolution or bill has been introduced in the Congress in late years seeking to curb the operation of amateur stations.

Today with the growing number of television receivers and their particular susceptibility to interference, amateurs must fight the good fight and keep it clean if they are to continue to be found worthy of operation in the public interest and maintain their standing as men of good will in their neighborhoods.

PUSH-PULL

POWER

with REDUCED CAPACITANCES

250 mc. 85 watts output

300 mc. 70 watts output

450 mc. 32 watts output

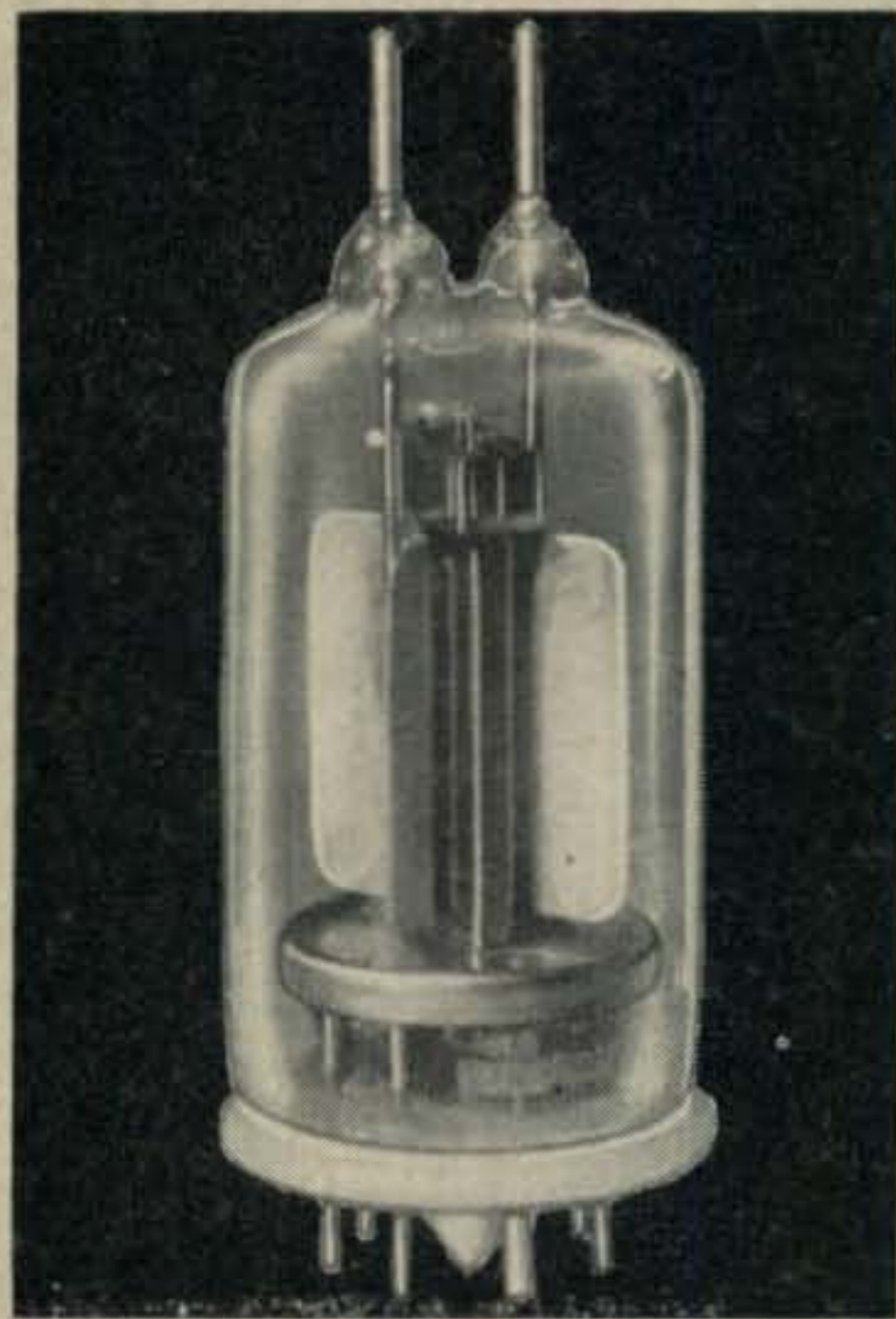

New! **AMPEREX** 5894 / AX-9903

UHF and VHF Twin Tetrode for W-I-D-E Band Operation
RF Amplifier, Modulator, Frequency Doubler, Tripler

5894 / AX-9903 CHARACTERISTICS

Filament Voltage

Series 12.6v.
Parallel 6.3v.

Filament Current

Series 0.9a.
Parallel 1.8a.

Maximum

d.c. Plate Voltage 600
d.c. Grid #2 Voltage 250
d.c. Grid #1 Voltage -175
Plate Dissipation (w.)..... 2 x 20
d.c. Plate Current (ma.).. 2 x 100

PER UNIT
Grid to Plate..... <0.08 mmfd.
Input 10.5 mmfd.
Output 3.2 mmfd.

MOUNTING POSITION: Base up or down. Horizontal with anode leads in horizontal plane.

Fits 829B Type Socket.

COMPARE CAPACITANCES of this tube with its nearest equivalent type.

PER UNIT
<0.12 mmfd.
14.5 mmfd.
7.0 mmfd.

● The AMPEREX 5894/AX-9903 is an improved version of the 829B. The design of this tube incorporates features which produce considerably smaller output capacitances and which, therefore, result in higher resonant frequencies (approximately 500mc. instead of 250mc.). In addition, because of the low inductances of the connections between the cathode and screen-grid, more stable operation of high frequencies is effected.

● A most desirable design characteristic, also, is the incorporation of internal neutralizing condensers which are connected directly to the control-grids, making impossible self-oscillation in a tuned-plate, tuned-grid transmitter.

● Of importance in this new design are such features as:

1. Direct and short connection between the pins and the anode, causing lower inductance and resistance.
2. No insulating parts (mica or ceramics) between anodes, causing losses at high frequencies.
3. "Screened" micas, thereby preventing possible losses due to contaminated mica.
4. Zirconium-coated moly anodes, giving a higher degree of vacuum than possible with nickel anodes and barium getters.

● For full data on the AMPEREX 5894/9903 AX- see your local radio distributor.

● IMMEDIATE DELIVERY Order from your local radio distributor.

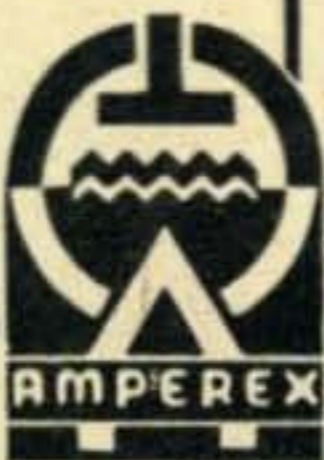

re-tube with **AMPEREX**

AMPEREX ELECTRONIC CORP.

25 WASHINGTON STREET, BROOKLYN 1, N. Y.

In Canada and Newfoundland: Rogers Majestic Limited
11-19 Brentcliffe Road, Leaside, Toronto, Ontario, Canada
Cable: AMPRONICS.

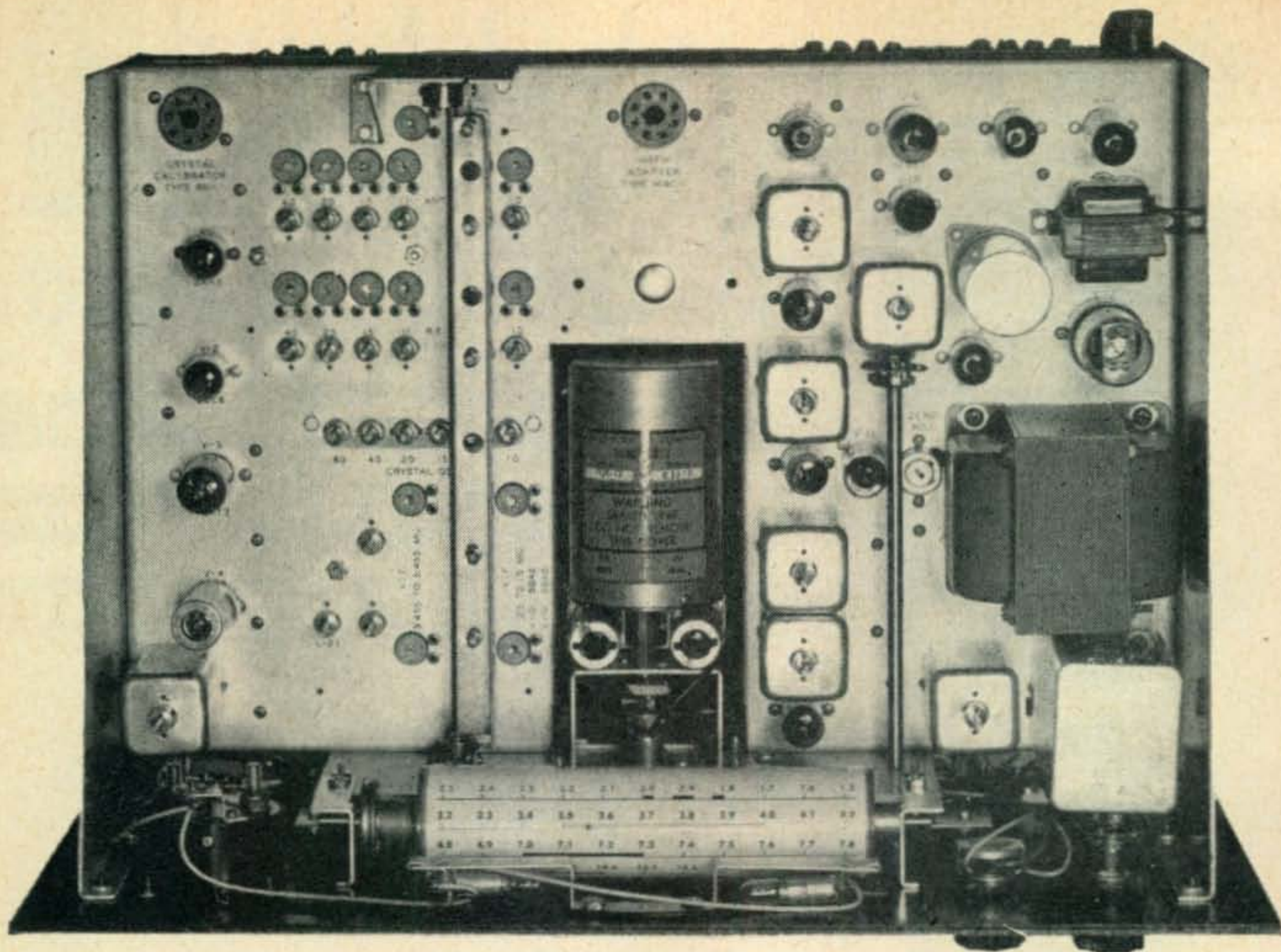

Characteristics of the 75A-2's VFO

The 70E-12 VFO, designed specially for the Collins 75A-2 amateur receiver, appears in the center of this topside chassis view. Engineered and constructed to have the precision of a fine watch, it must meet the following test specifications:

- Calibration — 750 cps
- Temperature 25° to 60°C — 500 cps
- + 10% line voltage — 100 cps
- Shock and vibration — 30 cps
- The average frequency stability is .05% and, under normal operating

conditions, a much higher order of stability is obtained. For example, after initial warm-up, units have held within .004% over a 24-hour period.

The hermetically sealed 70E-12 features a new two-tube circuit which has a triode-connected 6BA6 as isolation between the tuned circuit and the oscillator amplifier, another 6BA6.

This circuit assures improved stability, unaffected by variations in tubes. An OA2 voltage regulator is used in the 70E-12's plate supply.

A precision-ground leadscrew, mounted in two ball bearings, provides true linear tuning with a very high degree of accuracy.

FOR THE BEST IN AMATEUR RADIO, IT'S . . .

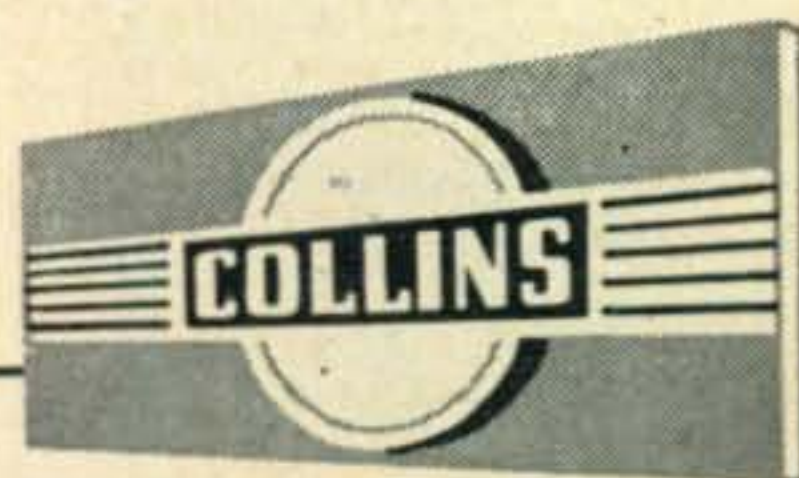

COLLINS RADIO COMPANY, Cedar Rapids, Iowa

11 W. 42nd St., NEW YORK 18

1937 Irving Blvd., DALLAS 2

2700 W. Olive Ave., BURBANK

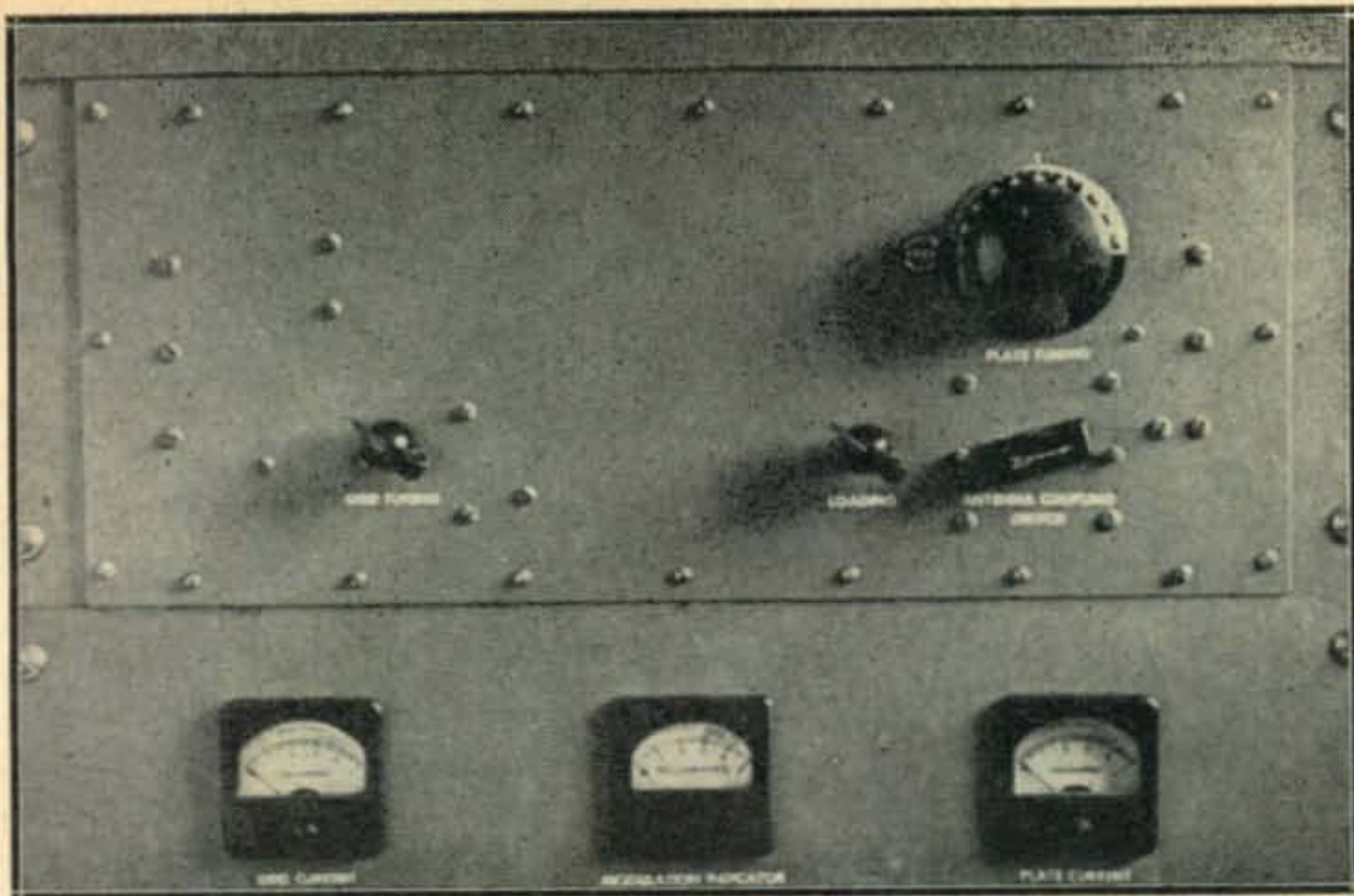

20-Meter Injun Chaser

HARTLAND B. SMITH, W8VVD*

Possibly we should have called this "A Case History and How I Cured TVI" but the author referred to those Tennessee Valley Indians so frequently that we decided to let his title go through. Obviously, one of the best ways to reduce TVI is to confine your operations to 20 meters, or above, and to make sure your final amplifier is really "clean." This article tells just how that very deed was accomplished with a medium power 813 running about 275 watts input — Editor.

If you happen to be one of those hams staying off the air because of harmonically caused TVI, you're in the position that I was a few months ago. After reading almost every available article on the subject, and after curing the TVI caused by my mobile rig and a couple of Command transmitters, I finally took that "big leap" and started tearing into my 250 watt ten-meter phone rig.

To my surprise, the de-lousing process wasn't nearly so difficult as I had anticipated. In fact, the job was accomplished so easily that I hope a description of what I did and how I did it may spur others to get back on the air with clear consciences.

Previous experience with TVI had led me to make the following conclusions:

1. Grid dippers, sensitive field strength meters, etc. are helpful, but by far the most important piece of equipment for use in curing TVI is a television receiver. You'll waste a lot of precious time that might otherwise be spent in hamming if you can't view the results of your harmonic reducing experiments on a set in your own home.

*467 Park Ave., Birmingham, Mich.

2. Adding a trap here, a little shielding there, and a grounded output link may reduce harmonic radiation to some extent, but the easiest, most sensible cure for TVI is the construction of a new final.

3. The lower the frequency of the fundamental, the easier it is to get rid of TVI harmonics.

With these views in mind, I felt that the best approach to my problem was to start from scratch and build a completely new final amplifier. My QTH doesn't provide room for an effective 75 meter antenna, and I'm not a 40 meter c.w. hound. Aside from the fact that 10 meters is going into a bad portion of the sunspot cycle, it also is difficult from the standpoint of TV receiver blanketing. Therefore, I decided to concentrate on 20 meters and to construct a simple, one band transmitter.

The old rig's final, modulator, and power supply were unshielded and were mounted in an open rack. Since there is little reason to shield a modulator and power supply as far as TVI is concerned, it was apparent that my new final would need to be in the only well shielded compartment. Looking about for an inexpensive metal case, I came across a TU-10B tuning unit from a surplus BC-375 transmitter.

The TU-10B seemed well suited to my needs so I removed all parts with the exception of the output switch, its associated coils and the vernier tuning mechanism. You will note that the rivets that hold the plate coil to its ceramic form pass through the form and permit arcs to develop between the plate coil and the tapped secondary, inside the ceramic form. Therefore, I sawed off

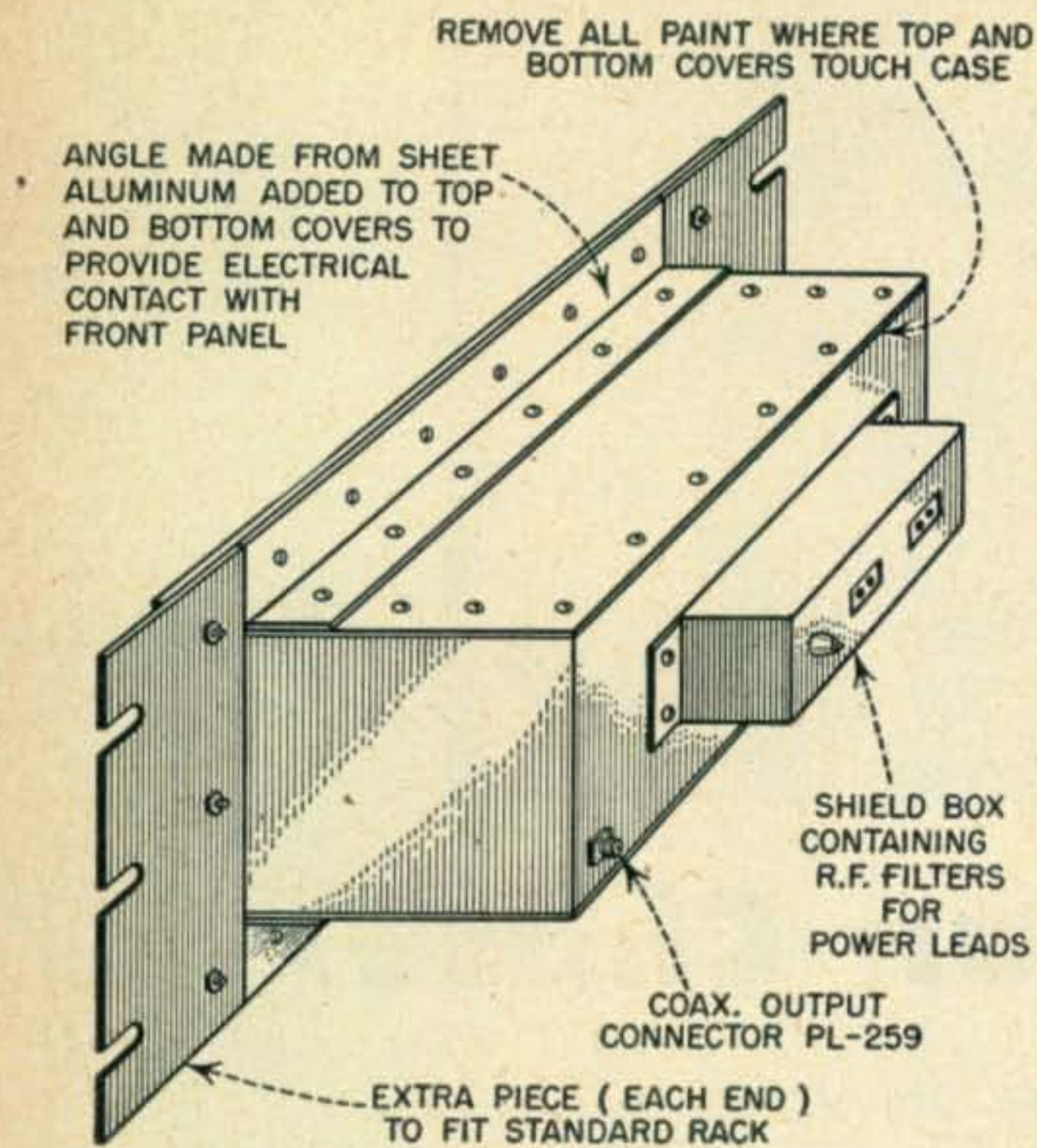

Fig. 1. Although the TU-10B is a good foundation for a shield around the final it will need the various finishing touches outlined above to be really effective in reducing harmonics.

a portion of the bakelite tubing on which the secondary is wound so that this coil could be moved forward just far enough to clear the "hot" rivets. At the same time one turn was removed from the plate coil.

Neither the top nor bottom cover plates of the TU-10B were originally fastened along the front panel. To provide for better contact shielding, strips of aluminum angle were added as shown in Fig. 1. Since the coverplates must also make a good electrical connection with the rest of the case, all points of contact were cleaned by applying paint remover and then scraping away the unwanted finish with a putty knife. Paint remover was also a help in loosening the many stubborn screws covered with green cement.

After all the unwanted and unnecessary parts had been removed from the case, the front panel was full of holes. This made a general facelifting almost mandatory. First, the old paint was removed from the panel. Then, holes larger than $\frac{1}{4}$ inch in diameter were covered from behind with small pieces of aluminum held to the panel by sheet metal screws. All holes were then filled with cold solder,¹ a puttylike material used for repairing auto bodies. When the cold solder hardened, the panel was filed and sanded smooth. As soon as the final had been wired and tested, I sprayed the panel with telephone gray lacquer, so that it would match the modulator and power supply from the old rig. For small jobs of this nature, an ordinary fly sprayer purchased at the five and ten does just as good work as one of the large electric paint sprayers.

¹Cold solder is listed in some mail order radio catalogs and is also sold by many auto parts dealers.

The TU-10B was too narrow to properly mount in a 19 inch relay rack. It was extended to the standard width by fastening $1\frac{3}{4}$ inch by $7\frac{5}{8}$ inch pieces of $\frac{1}{16}$ inch aluminum on either side of the panel.

813 Final Design

Beam tubes require little excitation and are thus well adapted to TVI reduction. I chose a single 813 not only for this reason, but also because 813's are still available on the surplus market at a fairly reasonable price.

The 813 was mounted horizontally, with its plate on edge. The compartment shield in the tuning unit was moved from its original position to a point where it offered maximum shielding of the input and output circuits. A piece of aluminum, bolted to the compartment shield, is bent at an angle and rubs against the metal base of the 813 to provide an electrical ground connection.

Both grid and plate circuits are tuned and have high C/L ratios for maximum harmonic discrimination. The vacuum condenser (C7) bypassing the 813 plate was removed from an antenna metering box designed for use with the SCR-274N Command transmitter series.

Since it is difficult to effectively filter r.f. from high current, low voltage leads, the 813 filament transformer was placed inside the case. Leads not carrying r.f. are enclosed in shield braid, while all r-f wiring is copper strip to obtain the lowest possible lead inductance.

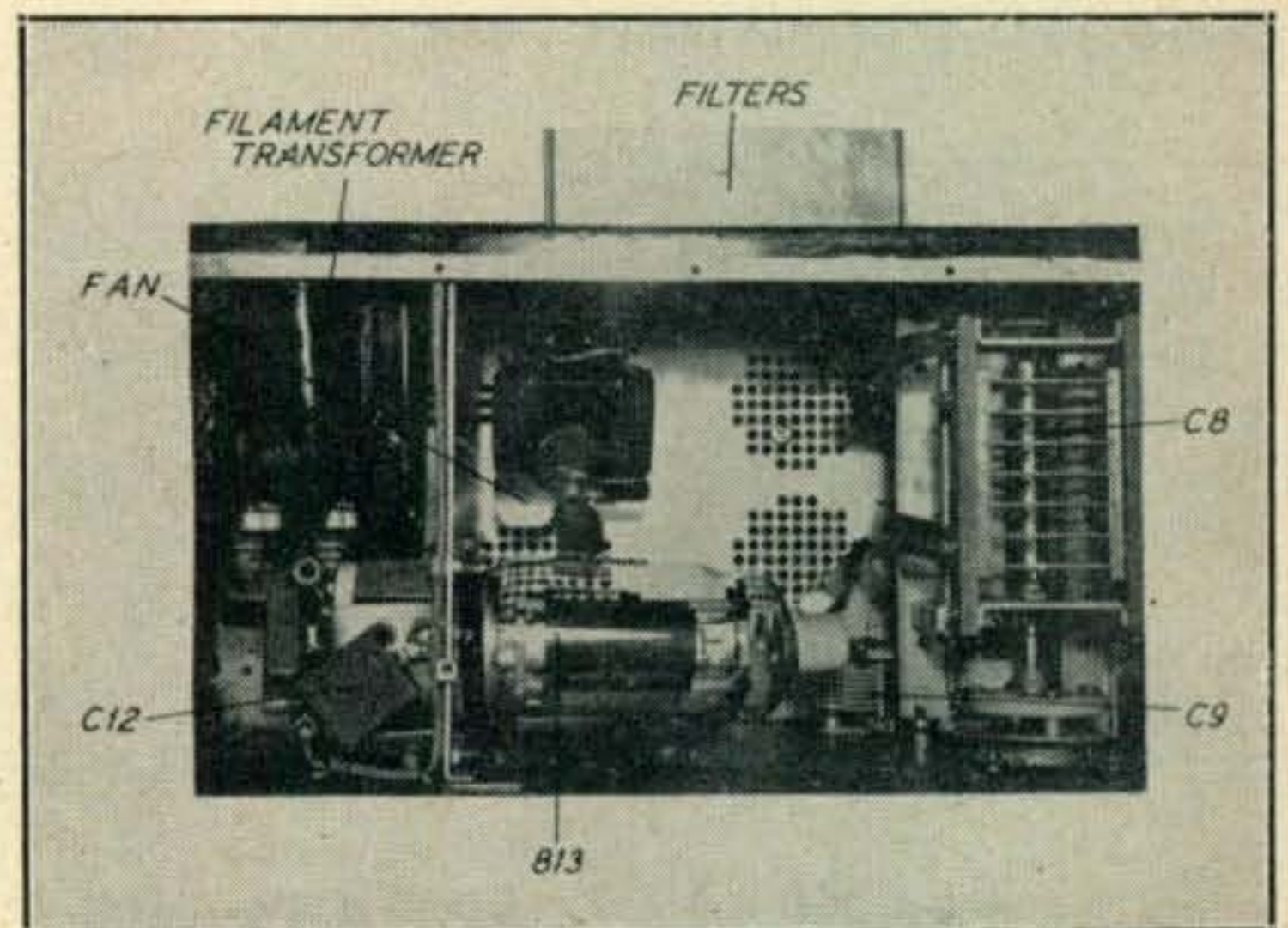

Inside view of final with top plate removed. Note how internal shield has been moved to the left. Low inductance copper strip leads can be seen running to 813 and plate tuning condenser.

In order to prevent significant harmonic radiation from wires entering the shielded case, all power leads to the final must have adequate r-f filtering. In the rig described, this filtering takes place in the shielded unit mounted on the back of the case. Current in each lead passes through an r-f choke and, except for the high voltage lead which employs micas, r-f bypassing is through disc-type ceramic condensers.

If a transmitter case is to perform an effective

job of harmonic reduction, large meter holes are out of the question. Some hams have gotten around this problem by mounting meters behind holes covered with copper screen, a method which is not only messy, but which also tends to make meter reading rather difficult. In this circuit both the grid and plate currents pass through harmonic filters at the rear of the case. Thus, metering of these currents can readily take place outside the r-f shield. In my transmitter, the final grid and plate meters are mounted on the front panel of the modulator chassis. Here they can be easily read and yet do not contribute to harmonic radiation.

Since an 813 with 250-300 watts input will give off plenty of heat, a small fan was mounted on the bottom cover plate at an angle that blows a constant stream of air toward the tube.

No parasitic suppressors were used and I had hoped that neutralization would be unnecessary. However, despite what would seem to be adequate shielding precautions, the 813 still needed a little taming. Since the rig in question is designed for one band, inductive neutralization was my choice. Adjustment of this system is simple. When the final is working into a resistive load, it is merely necessary to vary the position of the $L3$ grid link with respect to the grid coil ($L2$) until maximum power output is obtained at the exact center of the plate current dip. If it is impossible to realize this adjustment, reverse the connections to the grid link, since energy of the wrong polarity may be coming from the plate link ($L4$). These adjustments must be made with the high voltage supply on. BE CAREFUL! Once neutralized, the 813 is as calm as one could wish while the absence of parasitic suppressors makes the final very easy to drive.

Excitation for the 813 is obtained from a BC-459 Command transmitter doubling in its final. The BC-459 was easily de-TVI-ed by running screen wire around the inside of the cover and by filtering the power leads with r-f chokes and bypass condensers, just as in the 813 stage. The original r-f output connector on the BC-459 was changed to a female umbrella plug, the type used for phono input on most radios. RG-59/U coax runs from this connector on the exciter to a similar one on the final.

The output of the transmitter goes, via RG-8/U coax to a 52 ohm low-pass filter which, in turn,

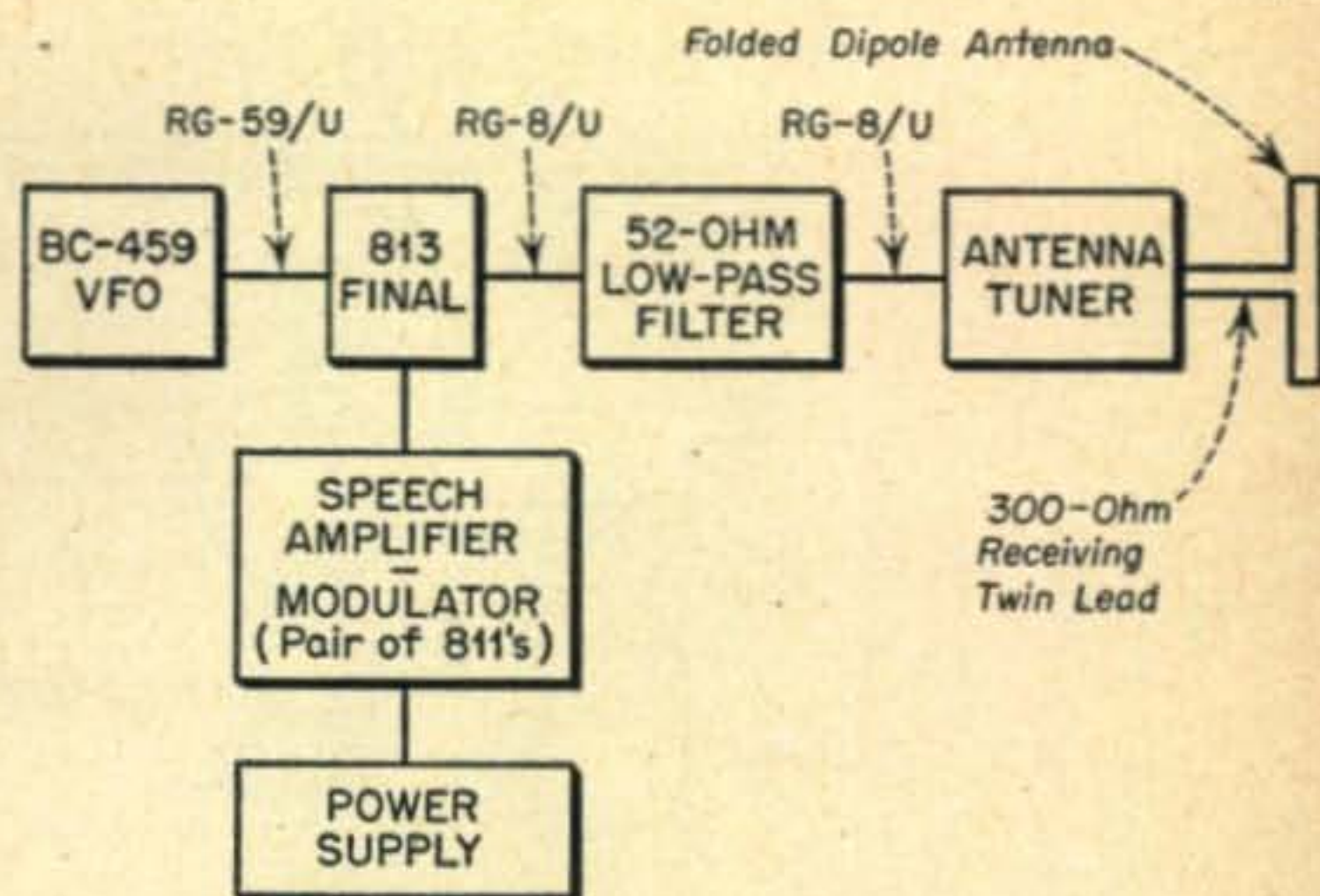

Block diagram of the transmitter.

is connected by coax to the link of an unshielded antenna tuner. The tuner feeds a folded dipole using 300 ohm receiving twin-lead. With this circuit, it is imperative that some form of indicator be used in order to properly tune the rig for maximum feeder current. A cheap way to accomplish this is to use two or three paralleled pilot bulbs in series with one side of the feedline.

Tuning Up

Despite the number of controls associated with the unit, tuning of the final is not difficult. First, the grid circuit is resonated and grid current adjusted to between 5 and 6 mils. Excitation and bias are purposely kept low in order to minimize the generation of harmonics. The plate current is then dipped by adjusting condenser C_8 . The output switch is put on position 5. C_9 should be advanced to a point where the plate current goes up appreciably. The feedline taps, the link on the tuner, and the condenser of the tuner should then all be adjusted for maximum feeder current. By this time, both C_8 and C_9 will probably need slight readjustment. If the desired plate current is not obtained, the tap switch may be changed to another position. Bear in mind that any change in the tap switch will require a change in the adjustment of C_9 .

From the standpoint of TVI reduction, the new final has proven highly satisfactory. The transmitting antenna is broadside to, and 30 feet from the TV antenna. With the transmitter amplitude modulated and running 275 watts input, absolutely no interference is visible on channel 7. Only faint interference, which can be completely removed by adjustment of the fine tuning, appears on channel 4. Channel 2 shows evidence of cross

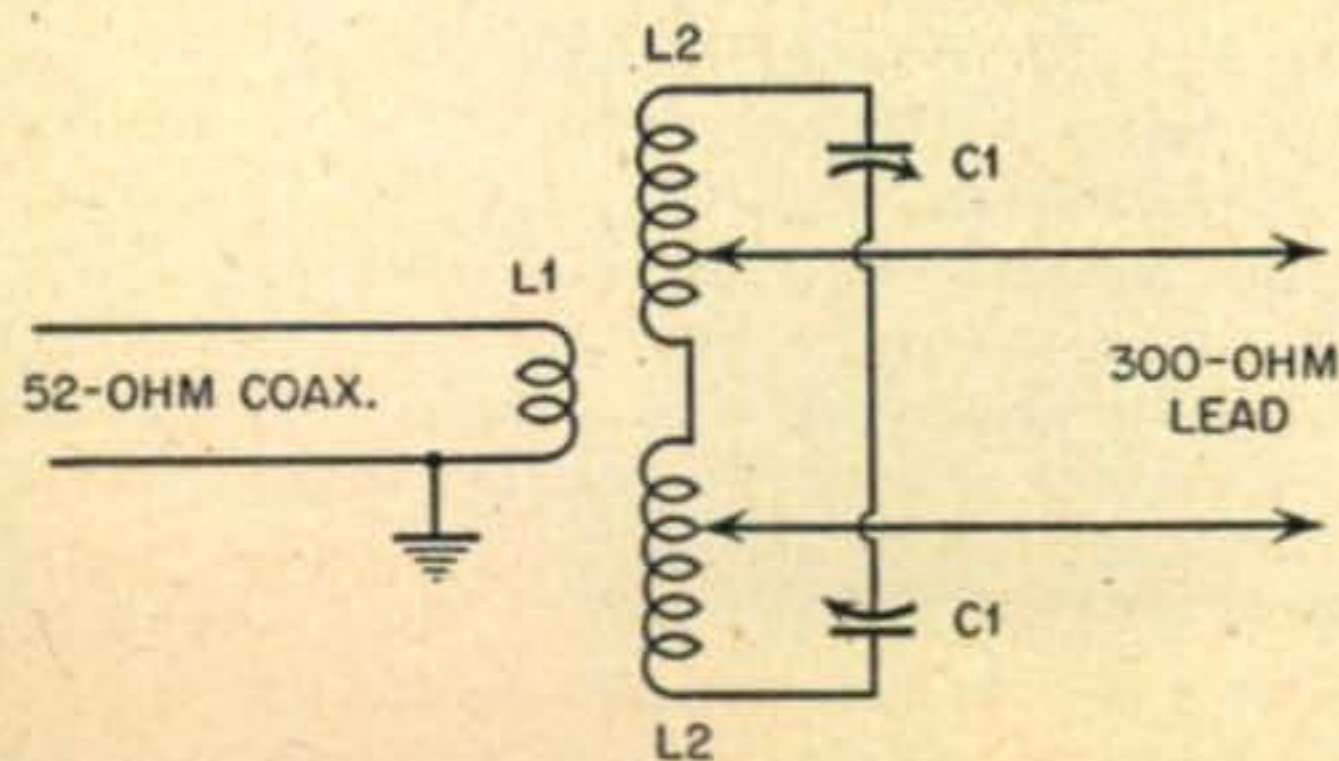

The antenna tuner used with the 20-meter transmitter.

- L1—4 T #12 1 1/2" diam. slight spacing between turns.
- L2—10 T #10 3 1/2" diam. (5 T each

- side of center).
- C1—50 $\mu\mu\text{f}$ per section dual transmitting variable.

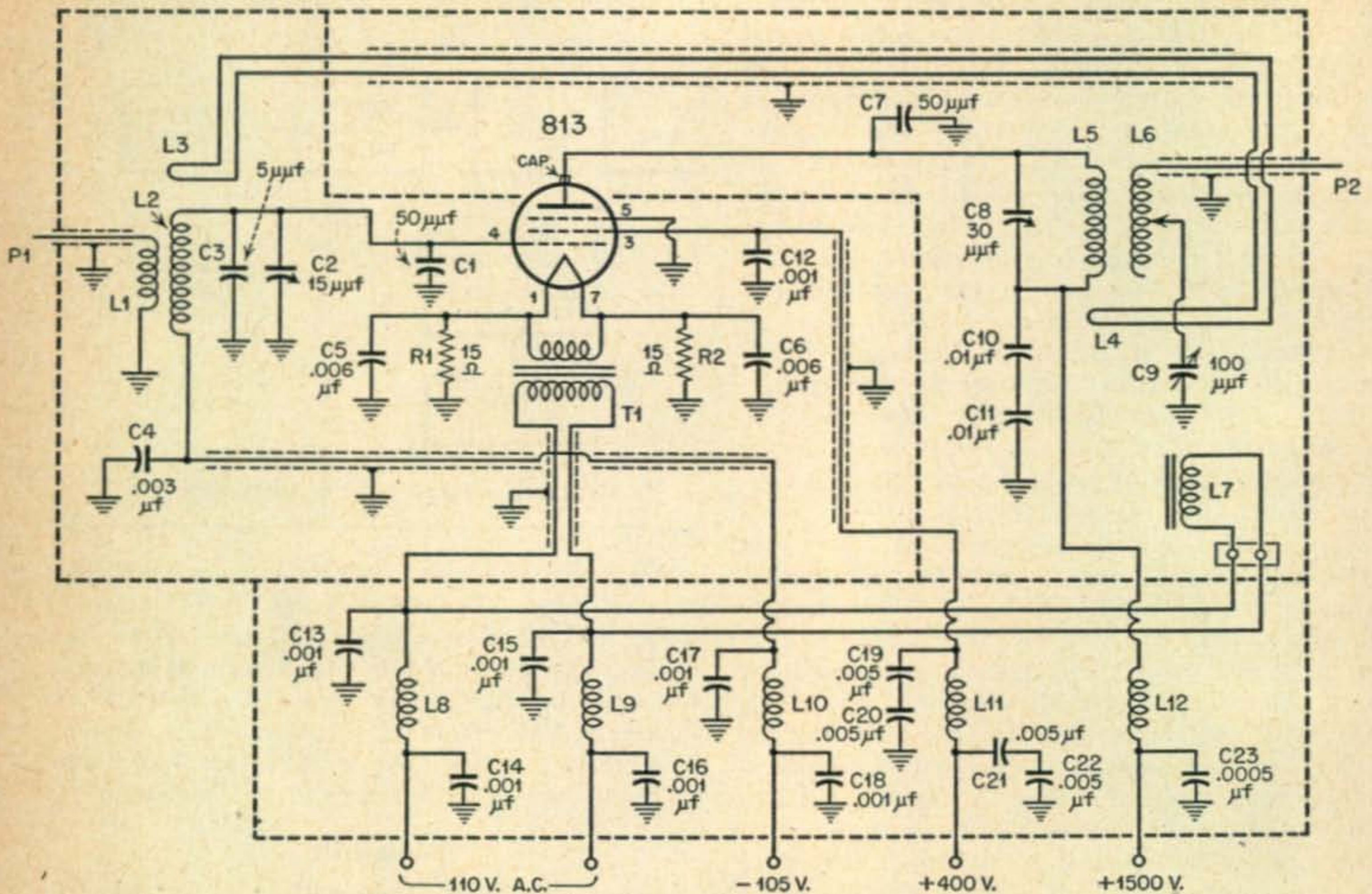

Schematic of the 20 meter final in the TU-10B cabinet.

C1—50 μmf 500 v mica
 C2—15 μmf , receiving type variable
 C3—5 μmf , ceramic 500 v. (not required if C2 is 20 μmf)
 C4—.003 μmf 300 v mica
 C5, C6—.006 μmf 2500 v mica
 C7—50 μmf 7500 v vacuum condenser
 C8—30 μmf transmitting variable
 C9—100 μmf receiver type variable (140 μmf would be more suitable)

C10, C11—.01 μmf 2500 v mica
 C12—.001 μmf 2500 v mica
 C13, C14, C15, C16, C17, C18—.001 μmf 500 v disc type ceramics
 C19, C20, C21, C22—.005 μmf 500 v disc type ceramics
 C23—.0005 μmf 5000 v mica
 L1—4 T #12 enam. closewound 1" inside diam.

L2—8 T #12 enam. closewound 1" inside diam.
 L3—1 T #20 hookup wire 1" inside diam. Spaced approximately $\frac{1}{2}$ " from grid coil. Exact position determined during process of neutralization.
 L4—1 T #20 hookup wire wound on plate coil form. Spaced $\frac{3}{4}$ " from cold end

of plate coil.
 L5, L6—See text.
 L7—Fan motor field coil.
 L8, L9, L10, L11, L12—2" of #22 enam. wire closewound on $\frac{3}{8}$ " lucite rod.
 R1, R2—15 ohms 5 w wirewound
 P1—RCA female umbrella phono plug.
 P2—PL-259 coax connector.
 T1—10 v 5 amp filament transformer.

hatching which is so slight that it becomes invisible at a distance of 6 feet from the 19 inch picture tube. Airline distance to the stations in question is of the order of 15 to 20 miles.

Every trace of interference disappears when the transmitter feeds an unshielded dummy, and no interference can be detected when a harmonic separator² is connected in series with the transmitting antenna feeder. These tests lead me to conclude that the slight, unobjectionable interference present on channel 2 is due either to receiver overload, or to rectification in a corroded metallic connection somewhere around the house.

The TV receiver I'm using has a front end that is poor with respect to interference rejection. Despite this fact, the only precaution I have taken

against receiver overload has been the insertion of a commercially built hi-pass filter at the receiver antenna input terminals. Without the hi-pass filter, channels 2 and 4 are almost obliterated and channel 7 is affected by tunable interference.

It is doubtful if any transmitter can ever lay claim to being TVI-proof under all circumstances. I do feel, though, that the spurious radiations from the rig described in this article are sufficiently low as to cause little or no harmonic interference to nearby receivers located within the primary service area of the stations being viewed. Thus, it is possible to get on the air without causing objectionable interference to your neighbors' sets. Put a new final in the old rig and you'll once more be able to operate day or night in spite of Howdy Doody, Uncle Miltie, et al.

²"Harmonic Separators", QST, December, 1950, p. 30

A Complete 144-Mc VFO

with NBFM

DAVID D. BULKLEY, W2QUJ* and MERRITT KIRCHHOFF, W2FAR**

This is a 144 mc transmitter designed for the serious VHF worker. Unlike many transmitters which seem to wander around half-starved for grid drive, this unit is built on commercial engineering standards. The over-all circuitry is clean and straightforward with no bad reports of TVI. A companion high power final amplifier and modulator is scheduled for an early issue —Editor.

VFO control on two meters is not yet essential to insure solid and efficient communication, but it is certainly a desirable addition to any 144-mc station. Although small in size (one standard 19-inch relay rack panel, seven inches high), this transmitter provides over 75 watts of NBFM output in the two meter amateur band. If AM plate modulation is desired in addition to NBFM, provisions are included wherein it is a simple matter

grid drive required by the AX-9903 is only five-tenths of one watt (0.5 watt) with only five milliamperes of grid current. The tube has internal neutralization which eliminates the necessity of external neutralization circuitry. Further, the output capacitance of the tube is approximately one-third that of the 829B. This low output capacitance permits operation at much higher frequencies with less likelihood of unstable operation. The AX-9903 is designed for operation at full ratings up to 150 megacycles and for operation up to 500 megacycles at reduced ratings. The tube fits the standard 829B socket and is approximately three-eighths of an inch taller than the 829B, but the manufacturer has recently announced that the tube will be reduced in size to a seated height of $3\frac{5}{8}$ inches.

Although the use of clipper filters in the speech portion of AM modulators has long been ac-

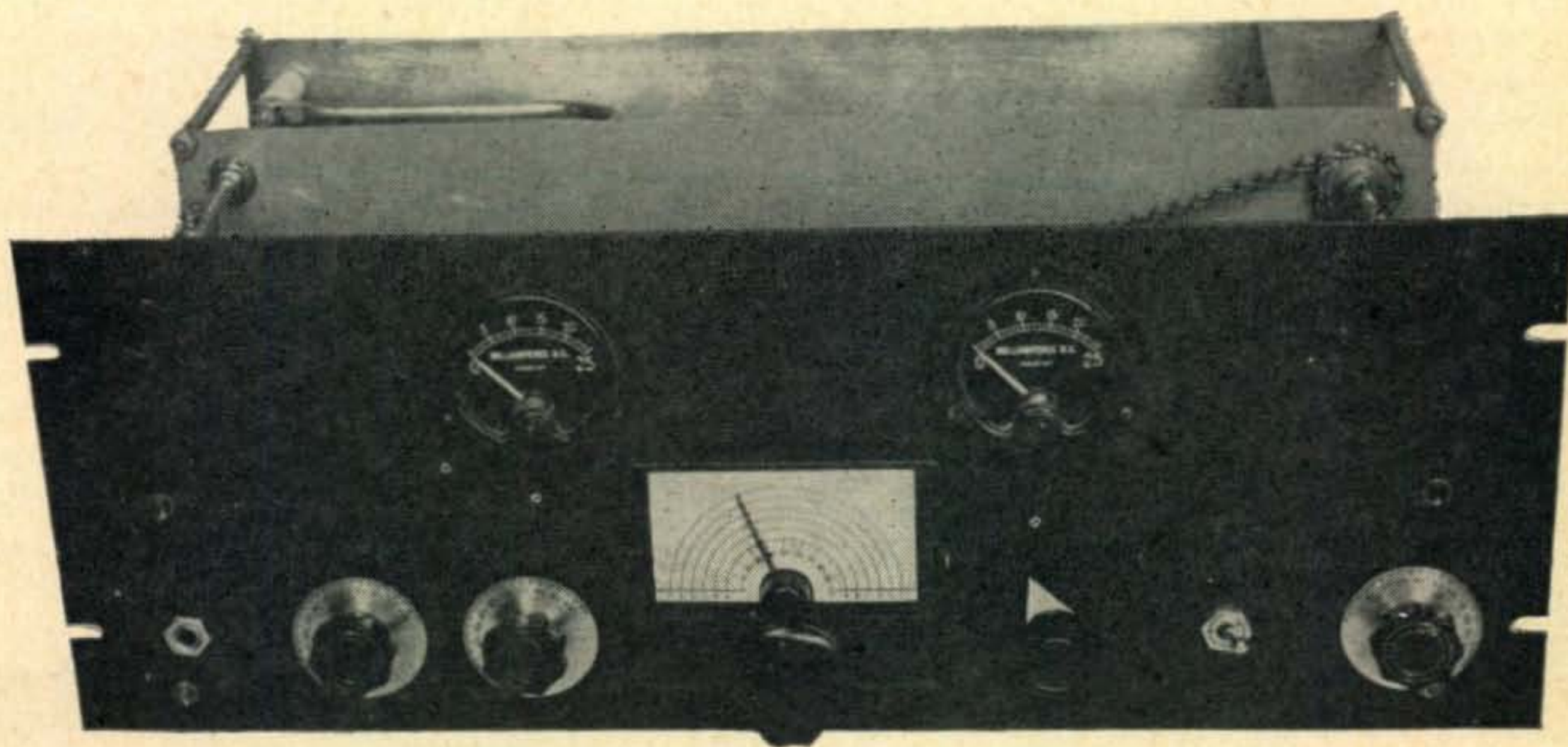

Fig. 1. Front view showing front panel layout. Although the left-hand meter has only a 25 milliampere scale, a 10X shunt is used providing 250 milliampere operation.

to attach an AM modulator to the unit. Approximately 55 watts of AM are required to 100 percent modulate the transmitter.

A single chassis contains all the stages needed in this transmitter with the exception of the power supply. An *Amperex* type AX-9903 twin-tetrode is used as a long lines final amplifier. Similar in operating characteristics to the familiar 829B, the AX-9903 embodies features which make it even more ideal for v.h.f. and u.h.f. applications. The

knowledge as a means of increasing modulation efficiency of speech signals, they have been overlooked for FM application. Using such a clipper-filter circuit in this transmitter provides adequate speech-frequency-limiting, yet when monitored on a standard AM receiver, it is difficult to identify that the signal is FM, except when tuned directly to the center of the carrier.

All frequency doubler stages, except the one preceding the final r-f amplifier, are slug-tuned and when set to the center of the 144-mc band provide broad-band output across the entire v.f.o. range. Tuning of the final frequency doubler V5

*1825-C Palmer Ave., Larchmont, N. Y.

**76 Myrtle Blvd., Larchmont, N. Y.

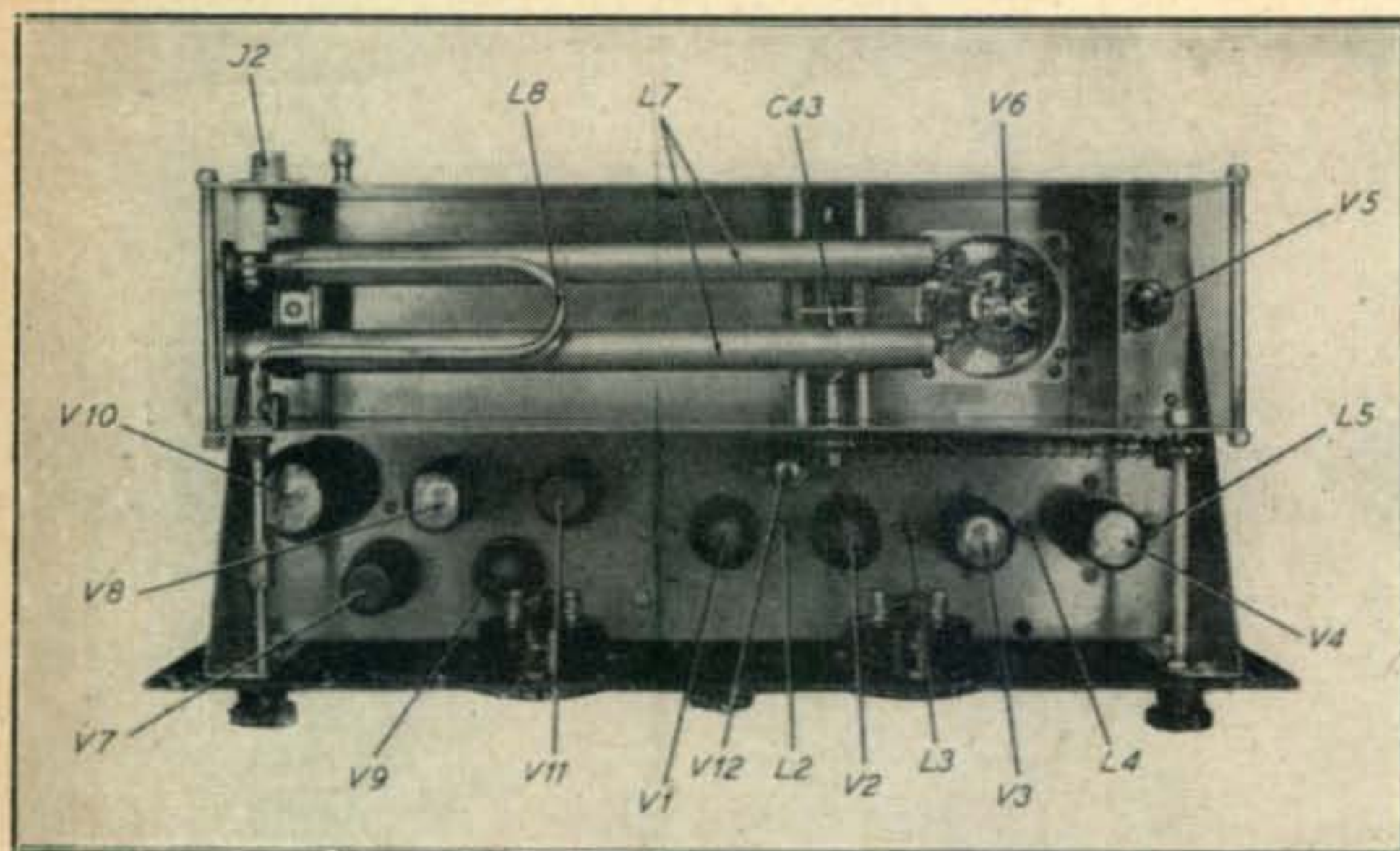

Fig. 2. Top view of chassis showing efficient use of space. Note the chain drive arrangement for tuning the final amplifier plate circuit and the antenna pickup coil arrangement.

is accomplished with a conventional coil-condenser combination. A potentiometer R11 in the grid circuit of the final frequency doubler permits flexible control of the r-f supplied to the grid of the final amplifier. The final doubler stage is capacity coupled to the grids of the AX-9903 amplifier as it was found that this provides considerably more stable operation than a coil-condenser circuit arrangement.

A clamper tube V11 is provided for the final r-f amplifier tube, V6, in lieu of fixed bias. Such addition assures safety of the amplifier should excitation fail, yet does away with the bother of bias supplies or batteries.

Design

Neat layout provides a balanced although not-quite-symmetrical front panel, Fig. 1. The under chassis, Fig. 3, is spread out to allow easy access to the various portions of the transmitter—a boon to assembly and servicing or modification.

Covering the tube line-up briefly, the r-f section of the transmitter consists of a 6AG7 Clapp oscillator, V1, with its grid circuit on 4.5 megacycles and its plate circuit doubling to 9 megacycles. Next, a 6AG7 doubler, V2, providing 18 megacycle output to a 6V6GT/G doubler, V3, with a 36 megacycle output. This 36 megacycle signal is fed to another 6V6GT/G, V4, doubling to 72 megacycles driving the final doubler, a 5763, V5, feeding a 144 megacycle signal to the final r-f amplifier, V6. The a-f portion of the transmitter consists of a 6SJ7, V7, microphone input stage which feeds a 6NS7, V8, and 6H6, V9, in the clipper-filter circuit already mentioned. The output from the clipper filter excites the 6SH7, V11, reactance tube FM modulator.

The front panel gives the appearance of commercial layout for it will be noted that every control is functionally placed. The knobs in the upper left and right-hand corners control the antenna coupling and final amplifier plate tuning respectively. The left-hand meter reads the r-f amplifier plate current while the right-hand meter reads grid current. The bottom of the front panel mounts the following controls, left-to-right: (1) micro-

phone input jack, J1; (2) audio gain/deviation control, R30; (3) NBFM clipper control R26; (to set the clipping level of the clipper-filter circuit); (4) the v.f.o. dial; (5) modulator cut-out switch, SW1A and B—this switch removes the plate and filament voltages from the a.f. and FM modulator portions of the transmitter in order that the transmitter can be AM modulated, as previously mentioned; (6) a heavy duty toggle switch, SW2, to remove the plate voltage from the final r-f amplifier during tuning-up operations to prevent damage to the final amplifier tube—SW2 should be in the "off" position when AM modulation is used; (7) the tuning control for the final double plate condenser, C44.

The rear edge of the chassis mounts the coaxial antenna output socket, J2, a heavy-duty potentiometer, R36, for adjustment of the screen voltage of the final amplifier (this feature is particularly useful to provide a flexible means of adjusting the drive to a succeeding r-f amplifier), and a 5-prong socket, SO-1, or power connector, to receive the power plug carrying the required voltages from the external power supply. The terminal for connection of an AM modulator is also mounted on the rear edge of the chassis. Although this connection is shown in the circuit diagram, it may be omitted if only NBFM operation is anticipated.

The entire transmitter is assembled on a 17x8x3 inch aluminum chassis. Figure 2 shows a top view of the complete transmitter with the a-f portion to the lower left of center and the r-f portion to the lower right of the center. The adjustment screws for the tuning slugs of the various frequency doublers may be seen between the doubler stages in the photograph. The final doubler, V5, is located in the compartment in the upper right-hand corner of the chassis while the final r-f amplifier with its long lines assembly occupies the remainder of the chassis. The various tubes and visible components are identified in the photograph.

The "Long Lines"

The photographs illustrate the ideal layout arrangement for the transmitter wherein a minimum of shielding is required for satisfactory operation.

The shielding around the final amplifier long lines, the final r-f amplifier tube and for the small compartment containing the final doubler stage may be made from sheet copper or aluminum; the former is better shielding material and is easier to work with, although the latter will be found easier to obtain and less expensive.

The long lines are easily constructed of two lengths of brass or copper tubing, each 12 inches long and $\frac{1}{2}$ to $\frac{5}{8}$ -inch in diameter. They are mounted at their left end (the end away from the final r-f amplifier tube) on an "L"-shaped bracket made of copper or aluminum. The bracket is $2\frac{3}{8}$ inches high and $2\frac{1}{4}$ inches wide with a large enough 'lip' at the bottom to secure it to two feed-through insulators which carry the high voltage to the final r-f amplifier. Two small copper inserts about $\frac{1}{16}$ -inch thick, filed to fit snugly into the end of each of the lines, permit mounting of the lines on the bracket. The inserts are soldered into the tubing to give them added strength. An 8-32 hole is drilled and tapped in each insert and the ends of the lines are then secured to the "L"-shaped bracket $1\frac{3}{4}$ inches apart, center-to-center and approximately $2\frac{1}{4}$ inches from the chassis.

The two lines are supported on the right end by means of two-inch ceramic standoff insulators $\frac{1}{2}$ -inch in diameter. An 8-32 hole is drilled through the underside of one wall in each line and secured to the threaded portion of the ceramic insulator with a short screw. This may easily be done by holding the head of the screw with the finger and turning the insulator body until the screw is tight. Copper braid is then soldered to the ends of the lines to provide leads to the plate connections of the final amplifier tube.

The shorting bar is made from strip copper approximately $\frac{1}{2}$ -inch wide and $4\frac{1}{2}$ inches long. This piece is bent into a "yoke" shape to fit over the two coaxial lines. A 6-32 hole is drilled in the center of the yoke and a flat strip of copper is placed on the underside of the coaxial lines with a hole drilled in its center to match that of the center of the yoke. The edges of the bottom strip may be bent up to form a channel to insure that it will be held at a right angle to the lines.

Antenna Coupling

The antenna link consists of a 12-inch piece of copper tubing, $\frac{1}{4}$ -inch in diameter. This tubing is bent into a "U" shape to fit neatly over the coaxial lines. One end should be flattened out and drilled to receive an 8-32 screw; the other end is inserted in a standard $\frac{1}{4}$ -inch shaft coupler. The flattened end of the link is mounted on the bolt of a ceramic standoff insulator mounted on the rear wall of the final r-f amplifier shield. This end of the antenna link feeds the antenna through a length of copper braid soldered to the coaxial socket. The other end of the link is grounded, as it should be, for it is inserted in the shaft-coupler which passes through the front wall of the final r-f amplifier shield via a panel bushing, thereby completing the circuit to ground.

In order to preclude the possibility of the "U"-shaped antenna link touching the coaxial lines and shorting the power supply, a small "L"-shaped bracket is mounted next to the shaft-coupler, previously mentioned. A set-screw somewhat longer than required, is used for one of the two or more shaft-coupler securing screws. The shaft-coupler is then adjusted on the shaft so that when tightened, and in place, the over-length screw will strike the small "L"-shaped bracket and prevent the shaft from turning too far and touching the lines. Further insurance against a short circuit of the lines might be to cement a small piece of polystyrene on the antenna link at the point where it might come in contact with the lines.

Final Tuning Control

In order that the plate condenser of the final r-f amplifier may be tuned without using costly right-angle drives, a sprocket and chain arrangement is employed. As may be seen in *Figures 1 and 2*, the shaft from the front panel goes through a standard panel-mounted bushing on the front panel. The shaft is terminated in a 12-tooth sprocket with flat-top teeth. By means of a length of ladder chain $\frac{1}{4}$ -inch wide, this sprocket transmits the movement of the tuning shaft to the condenser shaft through a second sprocket, identical in size. Approximately 13 inches of chain are used with the layout as

Fig. 3. Underneath the chassis. There are no cramped corners and the parts are located largely as convenience dictates, keeping in mind the necessity of separating the r-f input and output circuits to avoid feedback.

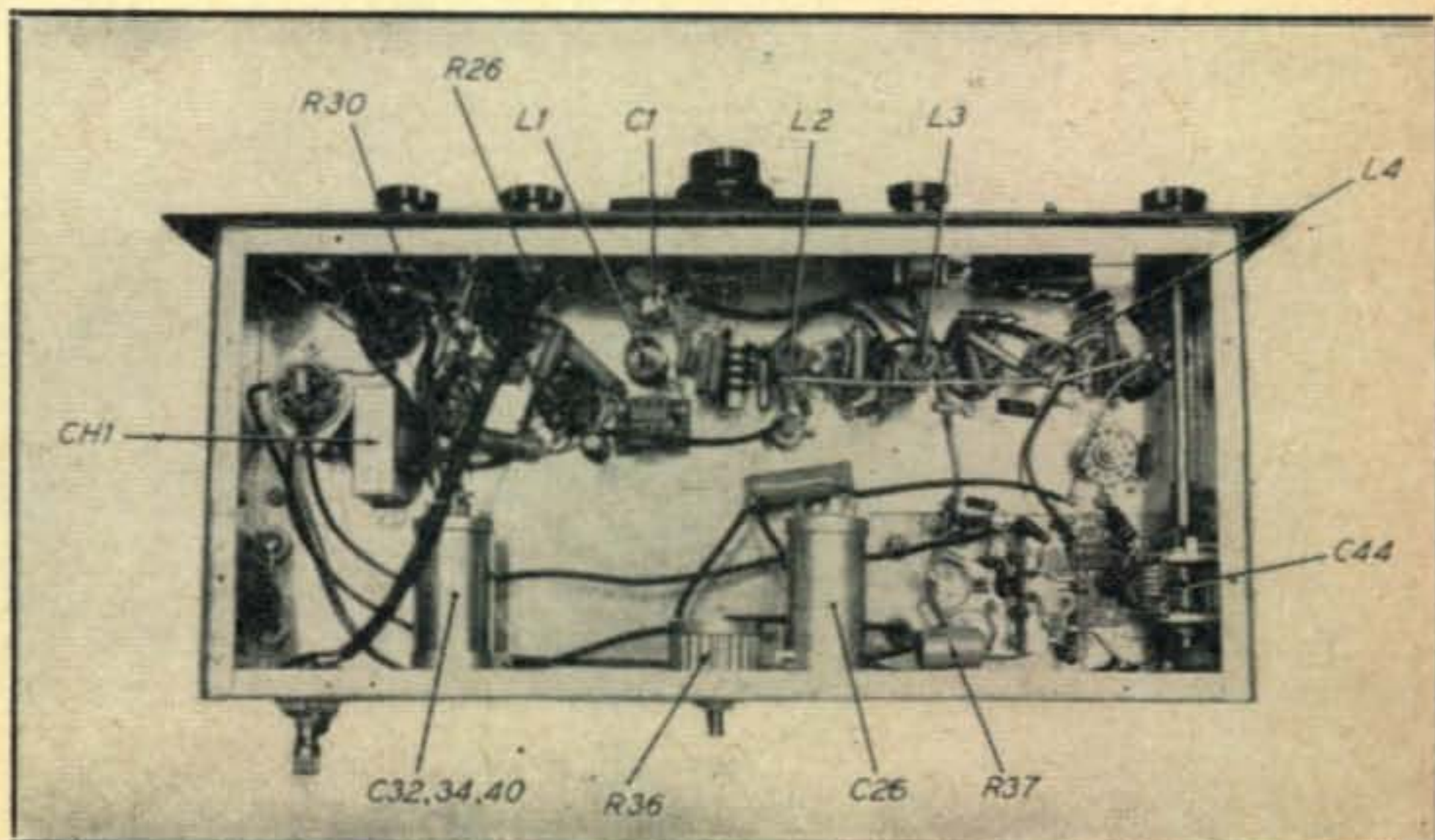

Circuit diagram for the VFO controlled 100 watt two meter transmitter.

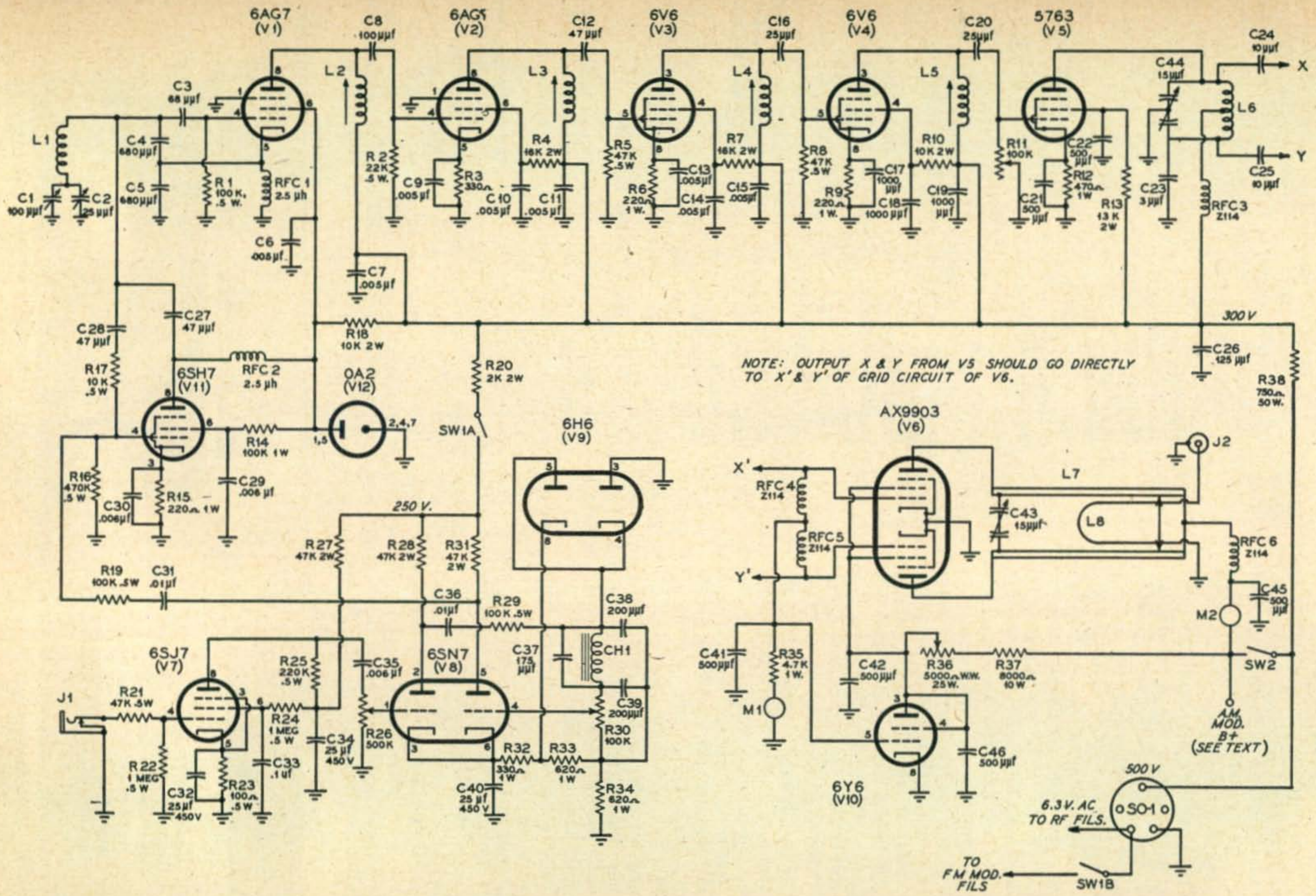

CQ

C1—100 μmf variable APC	C31, C36—.01 μf paper	R5, R8, R21—47,000 ohms, $\frac{1}{2}$ w	meter or rheostat, 25 w
C2—25 μmf variable	C32, C34, C40—25 μf 450 electrolytic (three in one can)	R11, R30—100,000 ohms potentiometer	R37—8,000 ohms, 10 w
C3—68 μmf silver mica	C33—.1 μf paper	R12—470 ohms, 1 w	R38—750 ohms, 50 w
C4, C5—680 μmf silver mica	C37—175 μmf mica	R13—13,000 ohms, 2 w	M1—Meter 25 ma
C6, C7, C9, C10, C11, C13, C14, C15—.005 μf , 600 v paper	C38, C39—200 μmf mica	R14—100,000 ohms, 1 w	M2—Meter 250 ma (25 ma meter with 250 ma shunt)
C8—100 μmf mica	C43—15 μmf variable split stator with all plates but one stator and one rotor removed	R16—470,000 ohms, $\frac{1}{2}$ w	SW1A, SW1B—Toggle DPST
C12, C27, C28—47 μmf mica	C44—15 μmf variable split stator	R17—10,000 ohms, $\frac{1}{2}$ w	SW2—Toggle switch, heavy duty
C16, C20—25 μmf mica		R20—2,000 ohms, 2 w	J1—Closed circuit jack
C17, C18, C19—1000 μmf mica, 600 v		R22, R24—1.0 meg., $\frac{1}{2}$ w	J2—Chassis mounting coaxial socket
C21, C22, C41, C42, C45, C46—500 μmf mica, 600 v	R1, R19, R29—100,000 ohms, $\frac{1}{2}$ w	R23—100 ohms, $\frac{1}{2}$ w	SO1—Socket 5 prong ceramic
C23—3 μmf mica	R2—22,000 ohms, $\frac{1}{2}$ w	R25—220,000 ohms, $\frac{1}{2}$ w	CHI—Choke 3.5 hy. (Stancor C1080)
C24, C25—10 μmf , mica 600 v	R3, R32—330 ohms, 1 w	R26—500,000 ohms, potentiometer	
C26—125 μmf 350 v electrolytic	R6, R9, R15—220 ohms, 1 w	R27, R28, R31—47,000 ohms, 2 w	
C29, C30, C35—.006 μf paper	R4, R7—16,000 ohms, 2 w	R33, R34—620 ohms, 1 w	RFC1, RFC2—2.5 mh r-f choke
	R10, R18—10,000 ohms, 2 w	R35—4,700 ohms, 1 w	RFC3, RFC4, RFC5, RFC6—Ohmite Z144 r-f choke
		R36—5,000 ohms wire-wound potentiometer	

shown in the photographs. The chain is loaded with a small medium-tension spring. This spring prevents backlash and permits extremely smooth tuning.

The sprockets, as well as the ladder chain, are standard items, readily available in any good hardware store, or they may be procured from the *Boston Gear Works*, 480 Canal St., New York, N.Y. If these parts are ordered by mail, a No. CB3-12 sprocket (retail cost: \$1.67) and No. 2 ladder (brass) chain (retail cost: 29¢ per foot) should be specified.

The construction of the oscillator and multiplier stages is straightforward and probably require no further comment. While it may appear that the number of multiplier stages is excessive and some space and components could be saved by tripling, the authors feel that this particular design is the easiest to get going. In addition, it provides plenty of drive in all stages and simplifies the v.f.o. operation.

Power supply requirements are easily met with one 500-volt d-c unit, delivering 400 milliamperes. Low voltages for the screens of the various tubes and plate voltages for the frequency doublers, etc., are obtained by means of dropping resistors as shown in the circuit diagram. Use of a good quality power transformer will ensure stable voltage output. The Clapp oscillator has added voltage stabilization with a gas-filled miniature regulator tube, *V13*. Of course, an amply large 6.3 volt a-c filament transformer (one delivering at least 6 amperes) must be provided.

Operation

After verifying that all circuits are wired properly, the power supply may be plugged into the socket on the rear of the transmitter chassis. *Before switching on the power supply, make certain that the switch, SW2, controlling the plate voltage to the final r-f amplifier is in the "off" position*

so that the tube will not be damaged while tuning the other stages of the transmitter. The switch, *SW1A and 1B*, controlling the FM modulator should also be in the "off" position during r-f tuning operations.

The v.f.o. should be roughly calibrated for dial readings between 4500 kilocycles and 4650 kilocycles as these frequencies will be at either end of the band when multiplied to the two-meter band. Of course, the v.f.o. should be very accurately calibrated if operation near the edges of the two meter band is anticipated. However, for preliminary tuning operations approximately tuning to 4550 kilocycles will be satisfactory.

All tuning adjustments should be done with a dummy antenna (a 75 watt light bulb connected to the r-f output); this is imperative when tuning the final r-f amplifier—the tube may be easily damaged if a dummy antenna is not used.

Since tuning-up operations of the r-f section of the transmitter are quite simple, all doublers ex-

(Continued on page 63)

COIL SPECIFICATIONS

- L1—35 T, $\frac{3}{4}$ " diam. #24 enam.
- L2—20 T, #28 enam. on National XR50 coil form
- L3—13 T, #28 enam. on National XR50 coil form
- L4—8 T, #24 enam. on National XR50 coil form
- L5—4 T, #18 enam. on National XR50 coil form
- L6—5 T, #12 enam. $\frac{1}{2}$ " diam. air wound 1" long, tapped at center
- L7, L8—Final r-f amplifier long lines and antenna link (see text)

Note: All coils closewound unless otherwise specified.

The Balun -

Theory and Design

J. ROY SMITH, W6WYA*

If you like your theory in short, mild doses—try this one. The author presents a very readable account of the "balun" with a discussion of its uses and applications in the ham field —Editor.

In the reduction of TVI, it has been found that the π coupler tank circuit and networks help to attenuate harmonics of the carrier frequency. The π coupler can be built for balanced output using twice the usual number of components which doubles the cost and complicates tuning adjustments. It is much cheaper, equally effective and easier to use the regular unbalanced π network and employ a device such as the "balun" to work into a balanced transmission line or antenna. The term "balun" is a contraction of the words *balanced* to *unbalanced* transformer.

Theory

Let us start our explanation of the "balun" with a typical problem. Referring to *Fig 1a*, we have a 300-ohm balanced¹ load (transmission line and antenna) which we want to connect to a generator (transmitter) whose internal impedance is 75 ohms (a π network so adjusted). Since we said the load was a balanced load we can connect the electrical midpoint or center tap to ground without disturbing the circuit as illustrated in *Fig. 1b*. Now there are two 150-ohm loads in series; one above ground and the other below ground. Stating it another way, each "hot" end of the load is of opposite polarity, or 180 degrees out of phase. Next, if we were to use some gadget to reverse the phase of one of the 150-ohm loads we could place them both in parallel. Everyone knows that two 150-ohm resistors in parallel equals 75 ohms. A 75-ohm load connected to a generator whose internal impedance is 75 ohms will result in a perfect match. This needed gadget is the balun. It consists of a half wave length section of coaxial transmission line—that's all.

In studying transmission lines as impedance matching devices there are two important and accepted facts²:

(1) The input impedance of a half-wave length (electrical length) section of good transmission line is equal to the terminal impedance.

(2) For such a half-wave section there is a 180 degree phase shift in the voltage and current without any change in magnitude. Simplifying, this means that if we place a 150-ohm load at one end of a half-wave section of line and "look in" at the other end we will see 150-ohms load but it will be shifted in phase 180 degrees or completely reversed in polarity. Impedance consists of resistance and reactance. Considering a half-wave section of good line we can measure the resistance between the conductors and find it greater than a megohm. To measure the reactance along the line we could apply a source of signal through a slotted line measuring device to one end of the line leaving the other end open and measure the standing waves. Since no current is flowing across the open end, the standing waves measured is also the measure of reactance. However, to illustrate

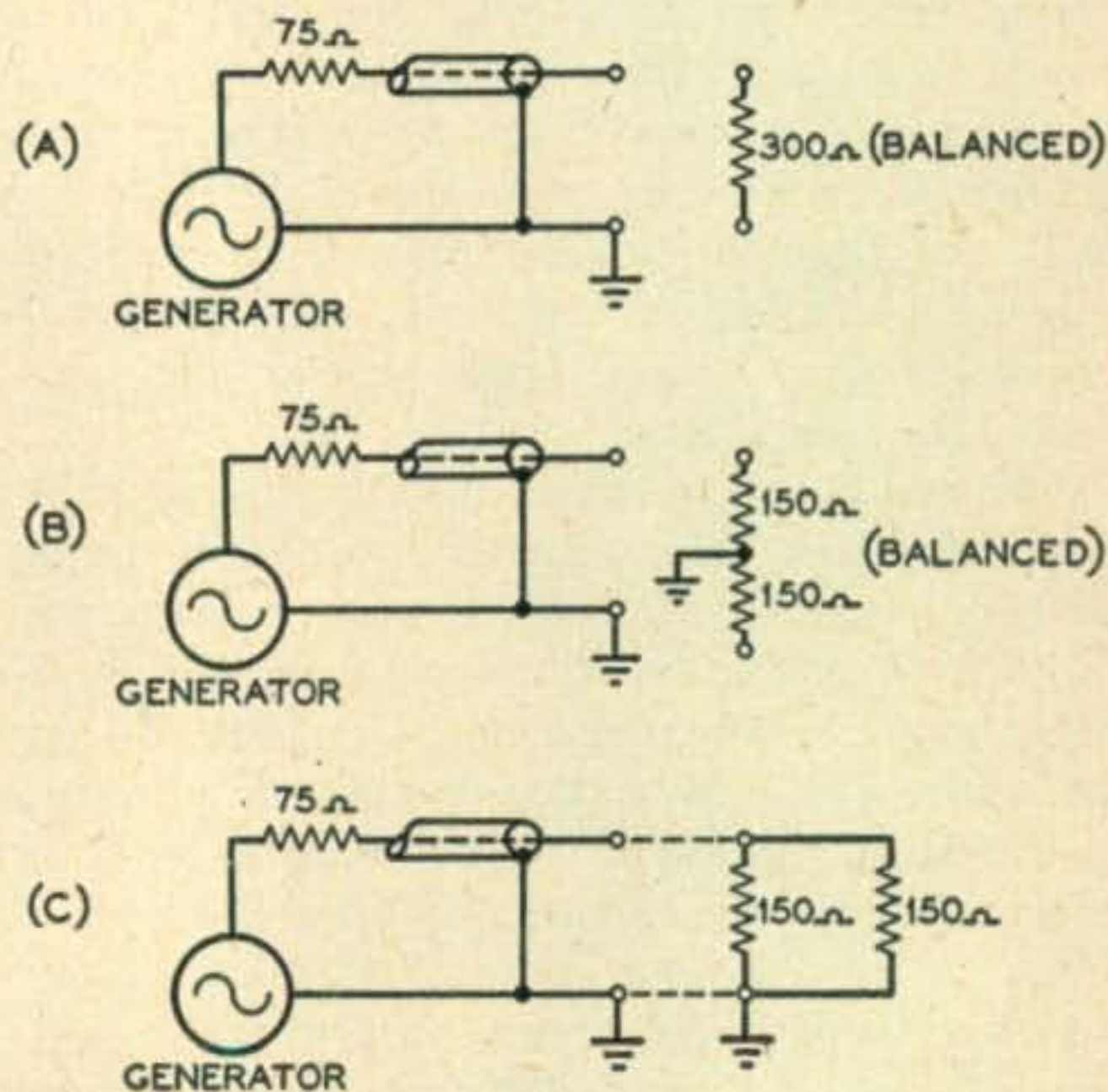

Fig. 1. The basic problem is how to connect a 300-ohm balanced line to a 75-ohm unbalanced line.

the change in polarity or phase of the reactance refer to the curve in *Fig. 2c*. If the high impedance of the open end is shunted with a 150-ohm resistor, the impedance along the line may be visualized by referring to the curve in *Fig. 2d*. Folding this half-wave section, doubling back in a "hair pin" fashion does not affect its phase reversing characteristics in any manner.

*2052 Venice St., San Diego, Calif.

¹ARRL, "Radio Amateur's Handbook", 28th Edition 1951, p. 56

²King, Mimno and Wing, "Transmission Lines, Antennas and Wave Guides", McGraw-Hill Book Co., 1945, p. 44

Going back to Fig. 1b apply this balun to one of the 150-ohm loads as shown in Fig. 3a. The balun reverses the phase of half of the load or 150 ohms and places it in parallel, in phase, with the other half of the load, resulting in an equivalent load of 75 ohms. Since the ends of the section's outer conductor are connected to ground points, they may also be connected together as presented in Fig. 3b.

It should be pointed out that the balun, while being a balanced to unbalanced transformer, is also an impedance transformer with a 4:1 ratio. It can be used at other impedances such as 200:50 ohms or 600:150 ohms. The balun is a linear device and may be used to transmit energy in either direction. It works equally well with the balanced terminals connected to a balanced transmitter output in order to couple to a lower impedance unbalanced antenna, such as a quarter wave vertical whip.

The balun is just as effective as a balancing device at the third and other odd harmonics. This accounts for the use of the balun that the television industry has made in matching TV receivers to some antennas.

Designing a Balun

In designing a balun the length of the coax must be the electrical half-wave length which is less than a half-wave length in free space. It is determined by:

$$\text{half-wave length} = \frac{492 \times V_f}{f} \text{ (in feet)}$$

where f = frequency in megacycles
 V_f = Velocity factor of the line used.

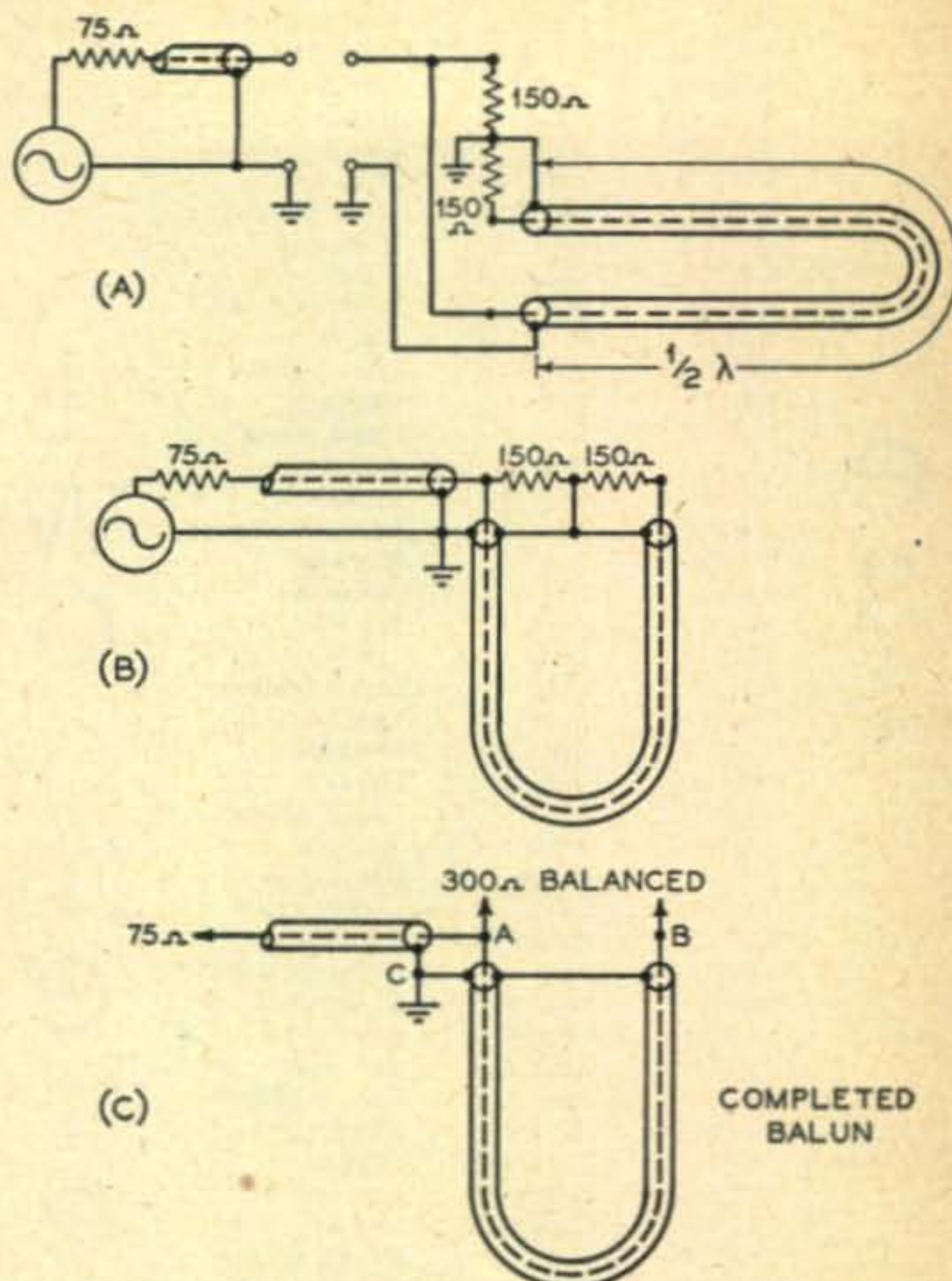

Fig. 3. Physical derivation of the "balun."

The velocity factor for various coaxial transmission lines are given in most handbooks³. Choosing 14.2 megacycles as an example, the length of RG 8/U cable is:

$$\frac{1}{2} \lambda = \frac{492 \times 0.66}{14.2} = 22.8 \text{ feet}$$

For 29.5 mc the length of coax is:

$$\frac{1}{2} \lambda = \frac{492 \times 0.66}{29.5} = 11 \text{ feet}$$

The half-wave length section of line is measured from connection A to connection B in Fig. 3c. The outer conductor should extend reasonably close to these connections A and B.

Any of the popular coaxial lines may be used in a balun for any 4:1 ratio of impedances. Since many hams work with 300-ohm balanced lines (fixing the input impedance to the balun at 75 ohms), RG 59/U cable is generally preferred for feeding the unbalanced connections. However, RG 59/U cable is not likely to handle more than 680 watts at 30 mc without overheating. The low impedance unbalanced terminals may be connected to any length of coaxial cable whose characteristic impedance (Z_0) is equal to or reasonably close to the desired value, or it may be connected directly to the transmitter. In like manner the balanced

³ARRL, "Radio Amateur's Handbook", 28th Edition, 1951, p. 319

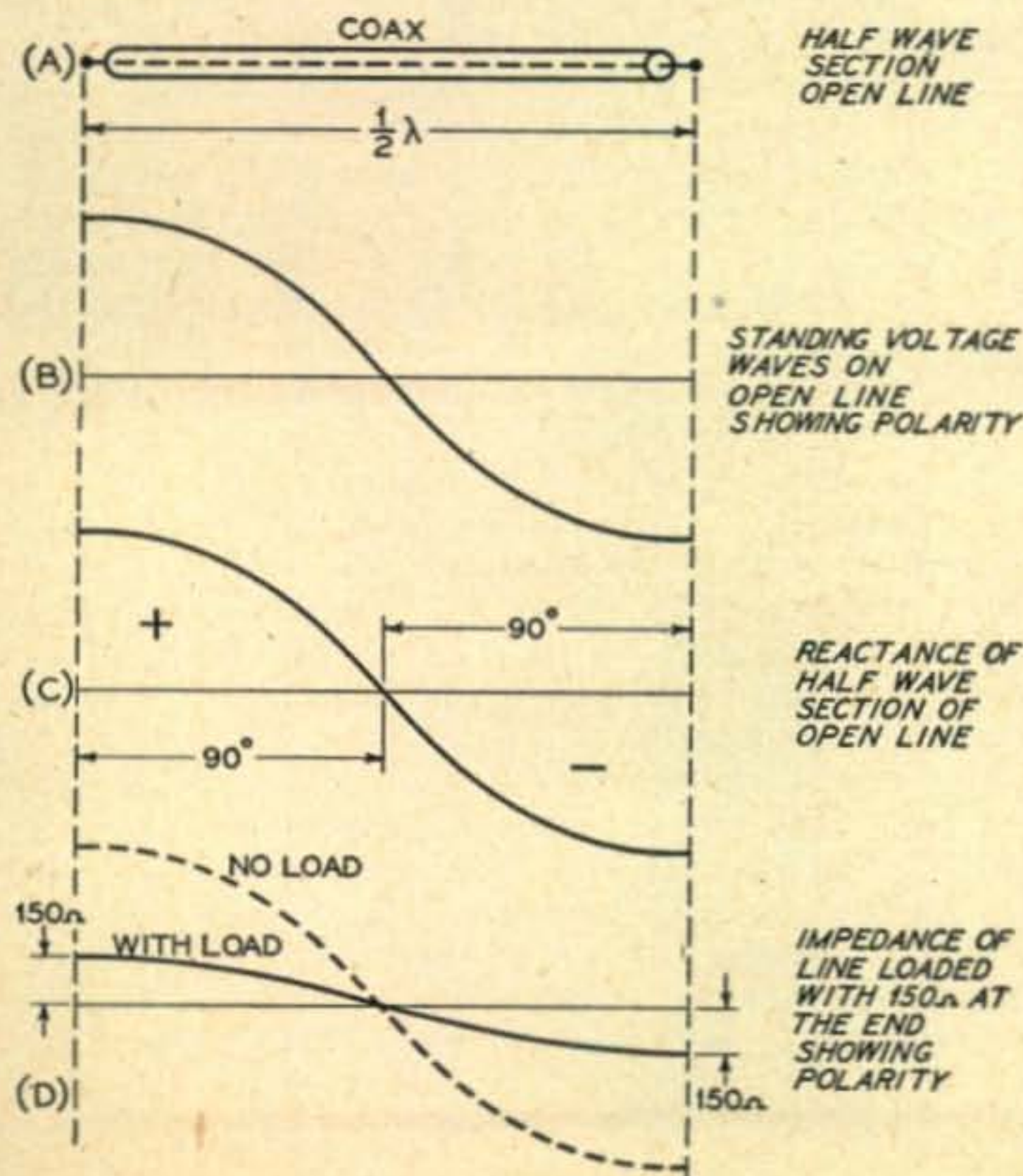

Fig. 2. Phase, voltage and reactance relationships along a half-wave coax line.

(Continued on page 68)

O u t W e s t

W6AEE	Merrill	Pasadena
W6BGN	Vince	San Pedro
W6BWQ	Bud	San Marino
W6CL	Bert	Los Angeles
W6CLW	Ed	Pasadena
W6CMQ	Ted	San Marino
W6DOU	Paul	Hayward
W6DQW	Bud	Los Angeles
W6DRL	Art	Pasadena
W6EAL	Hy	W. Los Angeles
W6EFE	Al	Wilmington
W6EKO	Leonard	Inglewood
W6EZF	Don	S. Pasadena
W6FGS	Virg	Alhambra
W6GFI	Roy	Los Angeles
W6GFY	Van	Burbank
W6GPF	Benny	Chula Vista
W6IAL	Frank	Van Nuys
W6IIV	George	Pasadena
W6IPM	Bill	Hermosa Beach
W6ITH	Reg	Moraga
W6JAU	Bob	Arcadia
W6KAT	Ford	San Marino
W6LIZ	Leon	Los Angeles
W6LS	Shep	Los Angeles
W6LSG	Larry	Los Angeles
W6NAT	Bill	Montebello
W6NRM	Bob	Oxnard
W6NSS	Al	Los Angeles
W6NWM	Johnny	Yucaipa
W6OCP	Ralph	Glendale
W6OPM	Cal	Los Angeles
W6OQB	Ralph	Arcadia
W6OZE	Pat	Redondo Beach
W6RL	Shorty	El Segundo
W6SCQ	Louie	San Gabriel
W6STA	Bill	Glendale
W6STN	Bob	Los Angeles
W6TAC	Ed	Los Angeles
W6TD	Jean	Covina
W6VEG	Larry	Los Angeles
W6VHR	George	Los Angeles
W6VKF	Jim	Sierra Madre
W6WKG	Bill	Los Angeles
W6WTS	Larry	Monterey Park
W6WTU	Hugh	Hawthorne
W6YMX	Bill	Reseda
W6ZEM	Syd	Pacoima
W6ZH	Herb	San Marino
W6ZQY	Jack	Santa Monica

t W O m e t e r s

Polemic No. 10073

The sudden appearance of the FCC's Docket 10073 in November brought amateur radio teletype to the awareness of most everyone. Many questions have been asked and my mail box runneth over. The following will, I hope, fill in some of the blanks for you.

There are at present over two hundred active TT stations in the country, most of which are operating in the two meter band using AFSK (type F2 emission). Teletype is not practical on the lower frequencies unless frequency shift keying (FSK or F1) can be used. Thus stranded on the high frequencies, teletype has pretty well been restricted to small

groups in the larger cities. When the low frequencies are opened to F1 these groups will be able to work each other and stations far from the well populated centers will be able to join the fun. Then, too, there are stations in other countries that are impatiently waiting for us to get on 20, 40, or 80 meters with teletype so they can work us. Letters have come in in the last few weeks from Alaska, New Zealand, Canal Zone, British Honduras, Israel, and Japan.

So far, over forty stations have written in saying that they are all set to go on forty meters whenever the starting whistle blows. Dozens more are busy incorporating frequency shift exciters in their low frequency rigs and will be ready for FSK soon.

Now, to allay any fears of the c.w. men that teletype might gobble up their frequencies, it should be made clear that teletype will probably never be used by more than a small minority of stations since teletype machines are difficult to procure. One other factor that will further preserve frequencies for c.w. use is that the teletype stations normally operate all on one frequency. All in all, then, interference from teletype stations should be negligible. At present all of our c.w. bands seem to have ample room for teletype with no detriment to the present activity.

RADIO

Without exception, all of the letters I have received have clearly stated that it would be in the best interest of all amateurs if FSK teletype were permitted on all amateur frequencies below 27 mc, thereby allowing the teletype stations to select frequencies that would cause the least amount of interference to other stations. This attitude was expressed to the FCC in a petition from Bob Weitbrecht, W6NRM, which was filed early last year.

The NARC, after examining the facts of teletype transmission, agreed with the Weitbrecht petition. In a brief, filed with the FCC, the NARC said, "Type F-1 emission is the most efficient means of code transmission generally available to amateurs. It should be permitted on any frequency now available for manual c.w. operation in order to provide the most satisfactory radio circuits throughout the nation for the maximum number of hours of the day, during varying propagation conditions.

"Opening entire bands of frequencies for F-1 emission will provide for minimum interference in the future from and to amateur radio-teletype communication, as the operator who uses F-1 emission will have the widest selection of operating frequency, and will be able to choose that portion of an amateur band where the least activity exists at any given time."

The ARRL apparently disagrees with this idea and feels that teletype should be permitted only in the top fifty kilocycles of the forty meter band. Unfortunately, the ARRL proposal for FSK from 7250-7300 kc, which looks innocent enough by itself, was introduced at a time when it would conflict with two other petitions before the FCC, the Weit-



← Model 12 Keyboard

brecht and the NARC petitions. The ARRL's attitude is that no one else should have entered a petition and that the blame for the confusion is on the shoulders of the enterers of the conflicting petitions, even though they may have been entered several months before the AARRL petition. Their indignation is difficult to justify in this case.

At the present writing the ARRL is reported attempting to have the FCC put off discussion of the matter for another six months. This could hold up the authorization for A-3 and F-1 on 40 meters for a year or more. Let us hope that this doesn't happen.

Noms Des Scripts

Since the first column appeared in the December CQ there has been a flood of mail and even some phone calls. The response is wonderful, thanks. The groundwork is well laid for a shortage of equipment. In Canada several fellows are trying to find printers, but seem to be having difficulty. If you know where there is any available teletype equipment in Canada or in the U.S., please let me know about it. Perhaps we can keep up with the rapidly expanding demand for printers.

Many of the fellows that have their equipment all set for forty meter operation have been sort of warming up by tuning in the Air Force MARS daily TT network (mentioned in January CQ). The front cover of the December CQ showed the headquarters station AIR/K4AF. Tune in and hear 'em, watch them print. Says Bob, W6NRM/9, "They sure do have a lot of fun playing with RTTY on that spot

Conducted by WAYNE GREEN, W2NSD

1379 East 15th St., Brooklyn 30, N. Y.

permission in Japan, but no luck yet. He would like to sked MARS stations on 15 meters, any takers? ZL1PL is looking for stations to run tests on 10 or 20 meters. KL7DR has just gotten quite a bit of TT gear from a fellow who has just returned to the States, maybe we will hear him on 40 too? W4FJ has 600 watts ready for 7 mc. Andy, W3NL (your Mobile Editor) is back on RTTY again with a five element beam to solidify him where he was weak before. W6CK has joined the Los Angeles gang. He has a model 14 printer and keyboard. W6QQM is another new addition to the southern California two-meter net. Walt sports a model 12.

One of the drawbacks of using old machines is in trying to replace any parts that break. Several of the gang have solved this problem by buying two machines and keeping one for spare parts. This, of course, does not represent a very economical method of handling the situation. Recently I have been buying any available collections of parts for the model 12 and they will be available at cost to any distressed parties.

Several of the gang have been experimenting with torroid coil filters and have been reporting them as being considerably better than the regular filters. Unfortunately these gems are about as rare as—(you finish the cliché). They are rare, anyway. There will be more information on the filter prob-

TELETYPE

(7635 kc). Some fellows are having frequency and/or shift troubles and it sure is fun to watch AIR tell 'em off about what's wrong with their signals. One fellow had hum on the mark tone and no hum on the space, so AIR told him. Another fellow (actually the usual trouble) was shifting about 600 cycles instead of the customary 850 cps, and AIR told him. Off frequency stations get rough treatment."

Bob goes on to say that he has put a reactance modulator on his receiver local oscillator, thereby making it possible to have a knob by the printer with which to make fine adjustments in the receiver tuning. He uses the same circuit used by the 709D-1 Collins frequency shift exciter. This circuit was printed in the Teletype Bulletin #2. A few copies of this bulletin are still left for those interested. Write me. This ultra-simple circuit is being used by most of the fellows for their frequency shift exciters.

W1HOD is looking for the west coast stations on 27 mc every day at noon, and all day Sundays. When the band is open to Mass. listen for him. W1JVE is looking slyly from behind a pair of 833's for 40 to be opened up for F-1. One of the west coast brethren, while visiting W3PYW in Washington recently, observed, "Looks like the west coast gang is missing out on half of the fun without that auto-start deal. This is my first chance to see them work. Really swell." (I wouldn't be without it). JA2DS (W7JCU in disguise) has been trying to get RTTY

lem in the April column when I get into the discussion of the panel. Data has been published in the Bulletin on the conversion of the BC-733D filters and on the W3ODF R-C filter networks.

FSK requires extreme accuracy of frequency and a standard might well be considered a necessity. W6NRM is using a simple one that works fine. It starts with a 100 kc crystal and has 10 kc, 2.5 kc, and 2 kc multivibrators. With this standard he is able to set his receiver for AIR on 7635 and be exactly in tune when the schedule starts some time later.

Tape Equipment

Teletype tape is thick, oiled paper, almost $\frac{3}{4}$ " wide. Holes are punched in the tape corresponding with the teletype code by either a tape perforator or a tape reperfator. The tape is then fed into a tape transmitter. This has five small pins with which to "feel" the holes punched in the tape. Whenever a hole is encountered by a pin it closes a contact, transmitting a mark signal. Thus the holes in the tape are translated into mark signals and the unpunched part of the tape into space signals.

Tape can be used in many ways to save time and effort. When sending a message it is handy to punch it first in tape. In this way you can check it for mistakes before sending it out. If for any reason the other station misses a letter or word

you can easily run the tape through again and repeat the message. Tape saves time by always sending at top speed. There is no way to put pauses on tape, therefore all it sends is the record of the keys pressed. This is sent at 65 words per minute even if the tape was punched at five words per minute.

Tape is also handy when something is to be repeated several times. CQ's, test transmissions, descriptions of equipment, etc., fall in this category. These tapes can be made endless by gluing the ends together. Endless tapes, though handy, are sometimes subject to overuse on the air. This tendency, fortunately, is not widespread.

The tape perforator, usually called the keyboard perforator, has its own keyboard and operates independently from the other teletype equipment. There are two important reasons for using this: a) you can punch a tape while the teletype is occupied with sending or receiving; b) it is quite inexpensive.

The reperforator has no keyboard of its own and punches tape from any incoming teletype signals. The teletype keyboard may thus be used to punch tape or tape may be punched of an incoming signal directly. With more intricate control circuits the printer may be made to print an incoming signal while the reperforator is punching tape from the teletype keyboard. Shall I repeat that?

Message handling is greatly simplified when you have a reperforator. The incoming message is put on tape as received and printed locally at the same time. The taped message is then run through the tape transmitter and a new tape is made from it. Any errors that were in the received tape can then be easily corrected in the making of the new tape. The message, now restored to its original shape, can be sent on to the next station. Most of the two meter teletype circuits have eliminated any need for corrections by having good signals available, however, there are a few stations that are heard about S-1 by those that can hear them at all. W2NSD is one of these.

To summarize: Tape equipment results in quite a saving in time and effort in the operation of an amateur teletype station. It is relatively inexpensive (with the exception of the reperforator) and should be considered as worth while.

Figure 1

At right is a complete diagram of the model 12 teletype machine, showing the units involved and their interconnection.

The printer section is mostly mechanical. Electrically it consists of six magnets and an electric motor. Five of the magnets select the letter to be printed (L1-L5), the print magnet (L6) causes the selected letter to be printed. Most model 12's use an A.C. motor as shown.

The keyboard consists (electrically) of another A.C. motor, the latch magnet (L7), and two distributors. The motor drives both the receiving distributor and the transmitting distributor.

The table acts primarily as an interconnection mechanism between the units of the teletype. There is a jack-base with ten contacts for the printer to plug into, and metal tracks so that the printer will easily slide into the jack-base. The keyboard has a sixteen contact jack-base and it, too, has metal tracks to sit on. A terminal strip (eleven terminals) is bolted to the table in place of the four terminal strip that normally comes with the table. An eleven wire cable connects this terminal strip to the "panel." There is a hole in the table near the terminal strip through which the cable can

be passed. The cable should be terminated in a standard Amphenol eleven prong socket. This socket then plugs onto the male plug which is mounted on the "panel." It is recommended that this standard be followed so that it will be possible to use any machine with any panel.

The "panel" is usually mounted under the table or in a relay rack nearby. This unit will be described in a later column. It contains the selective amplifier and associated control circuits.

The wiring diagram of the table is considerably confused by the addition of switch S1 and connector P1 to permit the use of a vacuum tube keyer. The keyer is not too necessary for two meter operation, but at lower frequencies it becomes very important. Without the keyer the contacts on the receiving distributor spark quite a bit and cause serious interference to reception of weak signals. The V.T. keyer is simple to build, so every table should have a provision for it to be plugged in. It is important that all wires going to S1 and P1 be shielded and the shields well grounded.

Under the table is a fuse box. This normally contains the fuses for the A.C. motors, two 2000 ohm resistors (not used), R1 the 250 ohm protecting resistor, and C9. The by-pass condensers C1-8 are either mounted under the table or under the printer. These are important to the operation of the selector magnets and should be left alone. They buffer the high voltage generated by the collapse of the field in the selector magnets when the current through them is cut off. S1, the switch that provides either local or vacuum tube keyer operation of the printer can be mounted to the left of the keyboard, just behind the push button (S2) which comes with the table. S3 also comes with the table and is found to the right of the keyboard.

In the interest of explaining the operation of the machine as a whole some of the pertinent connections between the panel and the table are indicated beside the terminal strip. The 110 volt D.C. source in the panel (small selenium rectifier) is connected with the positive to terminal 8 and negative to terminal 9 (ground). The D.C. goes through the 250 ohm protective resistor (in the fuse box under the table) and thence back to the panel to the arm of the polar relay. The resistor protects the selenium supply in case of a short. The polar relay effectively switches the B voltage to terminal 4 (on a spacing signal) or to terminal 3 (on a marking signal). Terminal 4 connects to contact 15 on the keyboard, while terminal 3 connects to contact 16 on the keyboard. Thus the B+ is switched to 15 on space and 16 on mark.

The distributors may be thought of as seven position rotary switches which are rotated by the motor. Referring to *Figure 1*, in December CQ we see that each letter starts with a spacing pulse. As long as a marking signal is being received the printer will sit quietly, but when a spacing pulse is received the polar relay switches B+ to contact 15. Current then flows through the normally closed contact on the receiving distributor (R.D.) to contact 11. This is connected to contact 10, so the current flows through the latch relay L7 to ground. L7 energizes, pulling back the latch which allows the R.D. to rotate one full turn. As the R.D. rotates, the normally closed contact is opened so that the latch relay is disconnected from the polar relay. This lets the latch fall back against the R.D. and stop it when it has completed one full turn.

(Continued on page 68)

PRINTER

Figure 1, Model 12 Teletype Machine

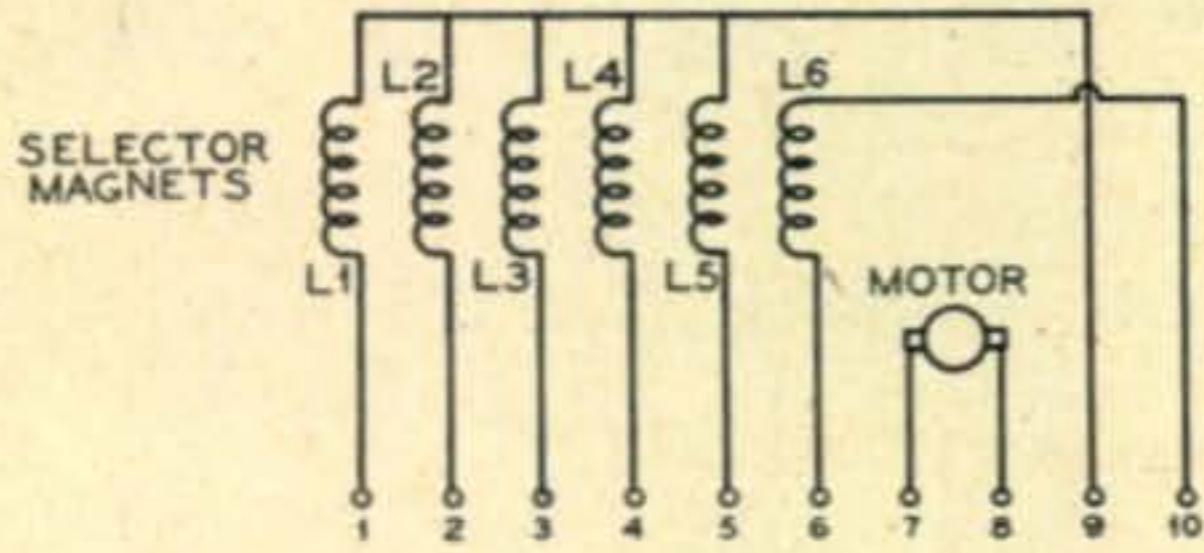

- L1-L5—Selector Magnets, 175 ohms each
- L6—Print Magnet, 300 ohms
- L7—Latch Magnet, 125 ohms
- C1-C6—1.0 μ f (Built in table)
- C7, C8—0.5 μ f (Built in table)
- C9—2.0 μ f (Under table)
- R1—250 ohm—50 watt (Under table)
- S1—8 pole 2 position rotary switch
- S2—Normally closed Push Button (Built in table)
- S3—DPDT Switch (Built in table)

Ground machine to good water pipe ground.
All wiring to S1 and to the vacuum tube keyer should be shielded and the shield well grounded.

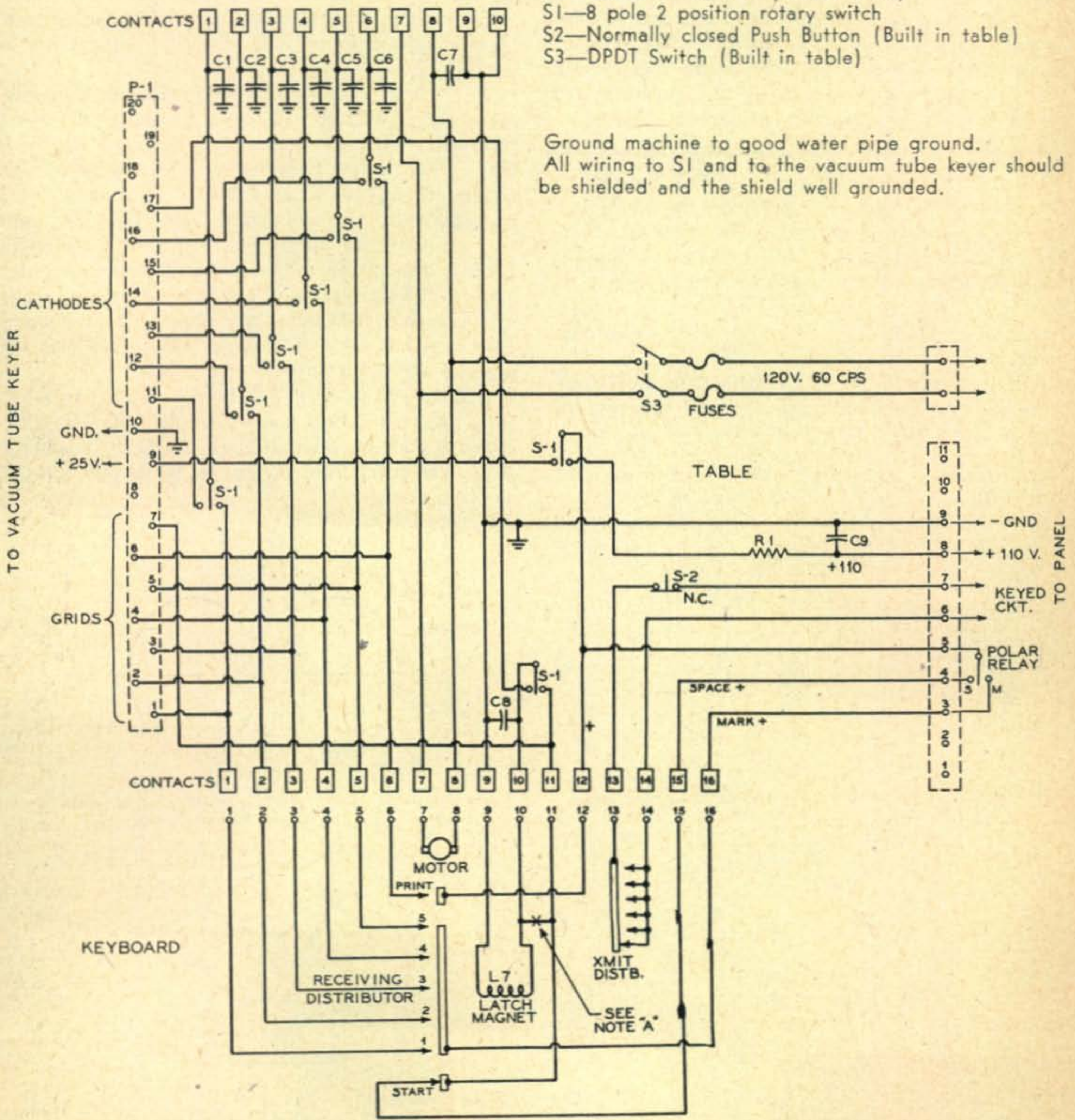

KEYBOARD

TO VACUUM TUBE KEYS

TO PANEL

TABLE

SPACE +
MARK +

XMIT DISTB.
SEE NOTE 'A'

L7 LATCH MAGNET

START

RECEIVING DISTRIBUTOR

MOTOR

PRINT

C8

S-1

S-2 N.C.

R1

C9 +110

+25V

GND.

S-1

S-1

S-1

S-1

S-1

S-1

S-1

S-1

S-1

S-1

S-1

S-1

S-1

S-1

S-1

S-1

S-1

S-1

S-1

S-1

S-1

S-1

S-1

S-1

S-1

S-1

S-1

A Pair of Phased Ground Planes on 40 Meters

RICHARD J. LAWTON, W6MVQ*

No doubt you could also call this "More Gain From Your 40 Meter Antenna System." Actually the stunt of feeding two or more vertical radiators in-phase is not new but is more or less standard procedure in low frequency broadcast channels. If you are interested in low angle DX coverage at 7 mc, you should investigate this idea —Editor.

Within the past year increased DX activity on 7 mc (and 3.5 mc) has started DX enthusiasts looking around for new and better antennas. Some have settled for folded dipoles, others have gone in for 8JK flat-top beams, long wires, and even rotaries. But by far the most interesting antenna from the simplicity standpoint has been the ground plane.

Now just what is so "hot" about a "quarter-wave vertical"? A few of the pre-war DX hunters will

*25528 Valley View Dr., Hayward, Calif.

claim that "a half-wave vertical is an antenna that radiates equally poor in all directions." So a quarter wave vertical with radials should be twice as poor. Sorry! I have found it is closer to being twice as good!

A certain commercial VHF antenna manufacturer claims 3.22 db gain for a ground plane over a half-wave vertical (coaxial antenna), which is better than twice the effective radiated power. Of course, this is at a very low vertical angle, but nevertheless it is a substantial gain. This low angle vertical directivity is the secret of the success of the 7-mc ground plane. Little power is lost at the high angles, and on receive, the static crashes and other QRN within 1500 miles are noticeably attenuated. This helps the signal-to-noise ratio when you are digging down for those weak ones.

A 7-mc ground plane has been in use at W6MVQ since December 1949 and the antenna has certainly given a good account of itself on DX. Incidentally, if anyone is thinking of putting up a 7-mc ground

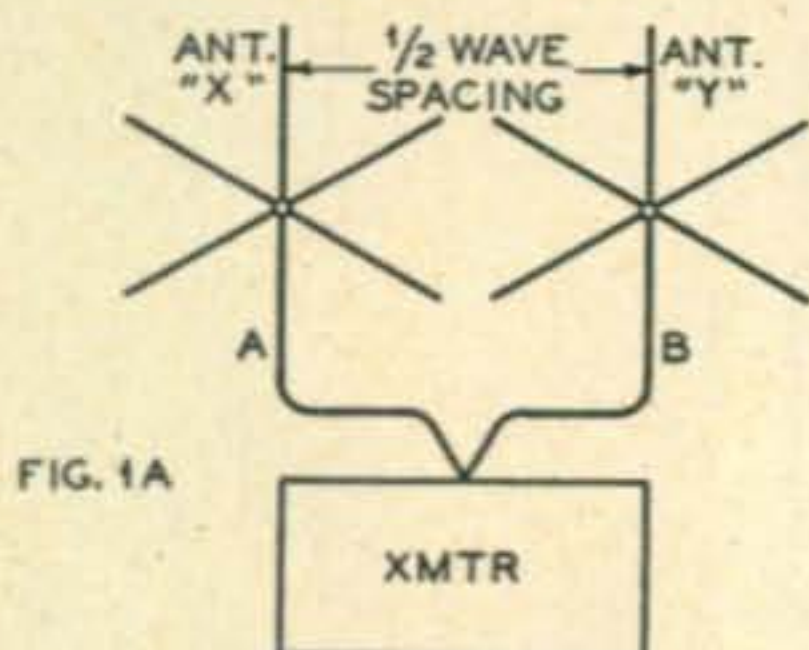
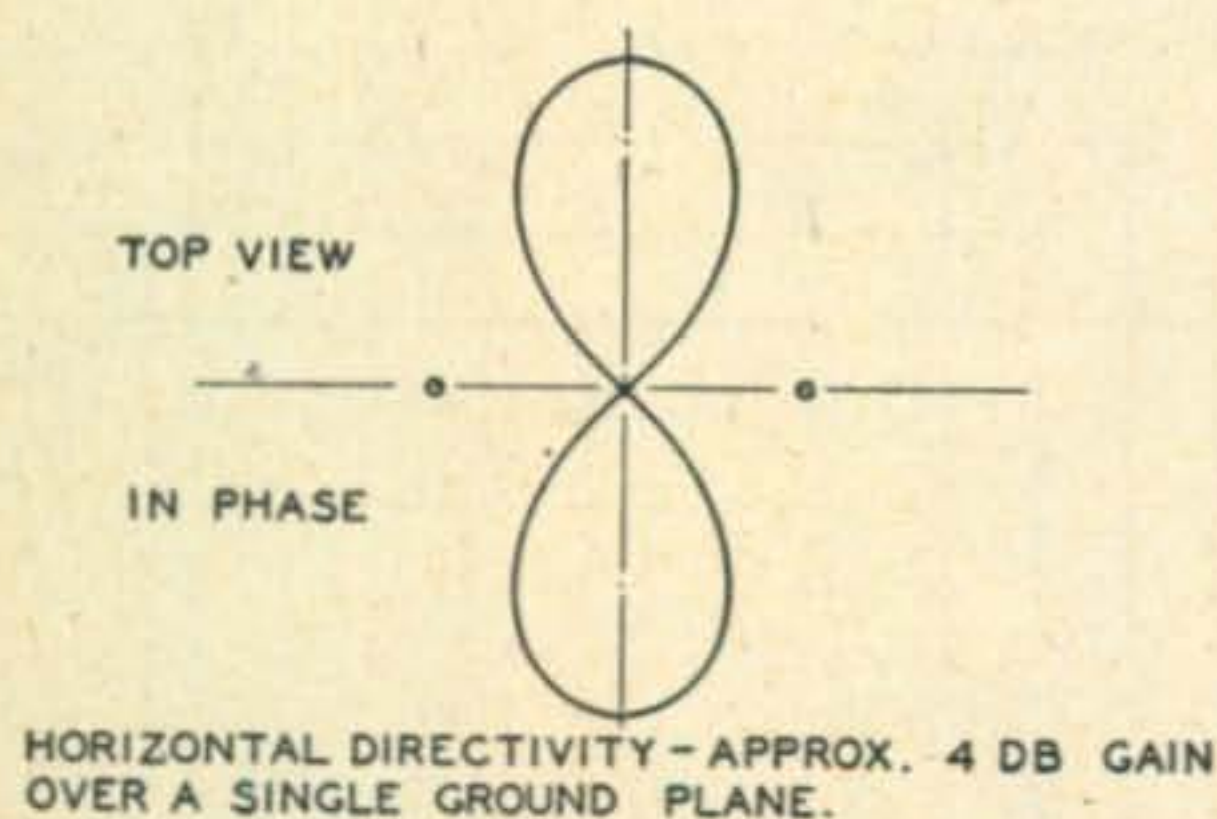

When feedline "A" is the same length as feedline "B", the currents arrive at the base of each antenna at the same time, giving the "in-phase" pattern shown above.

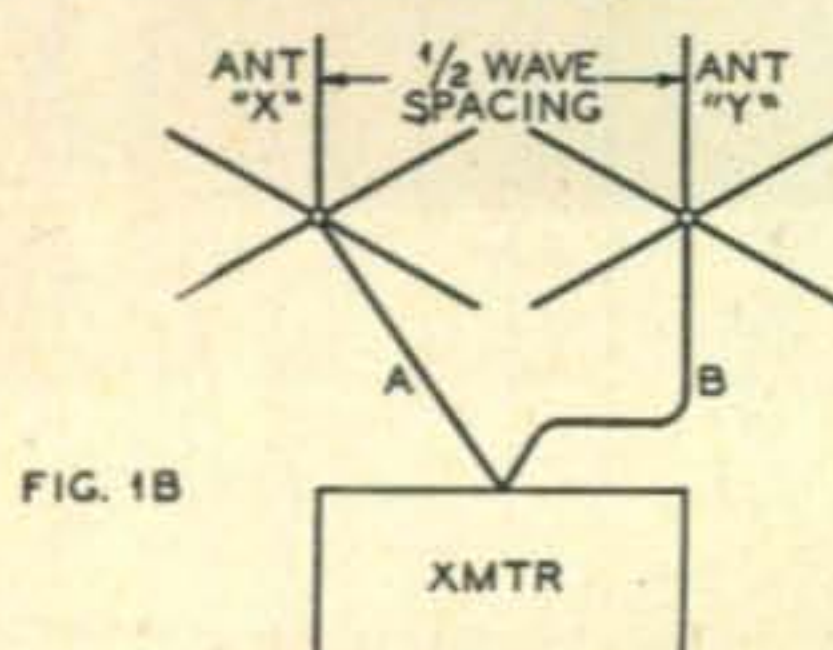
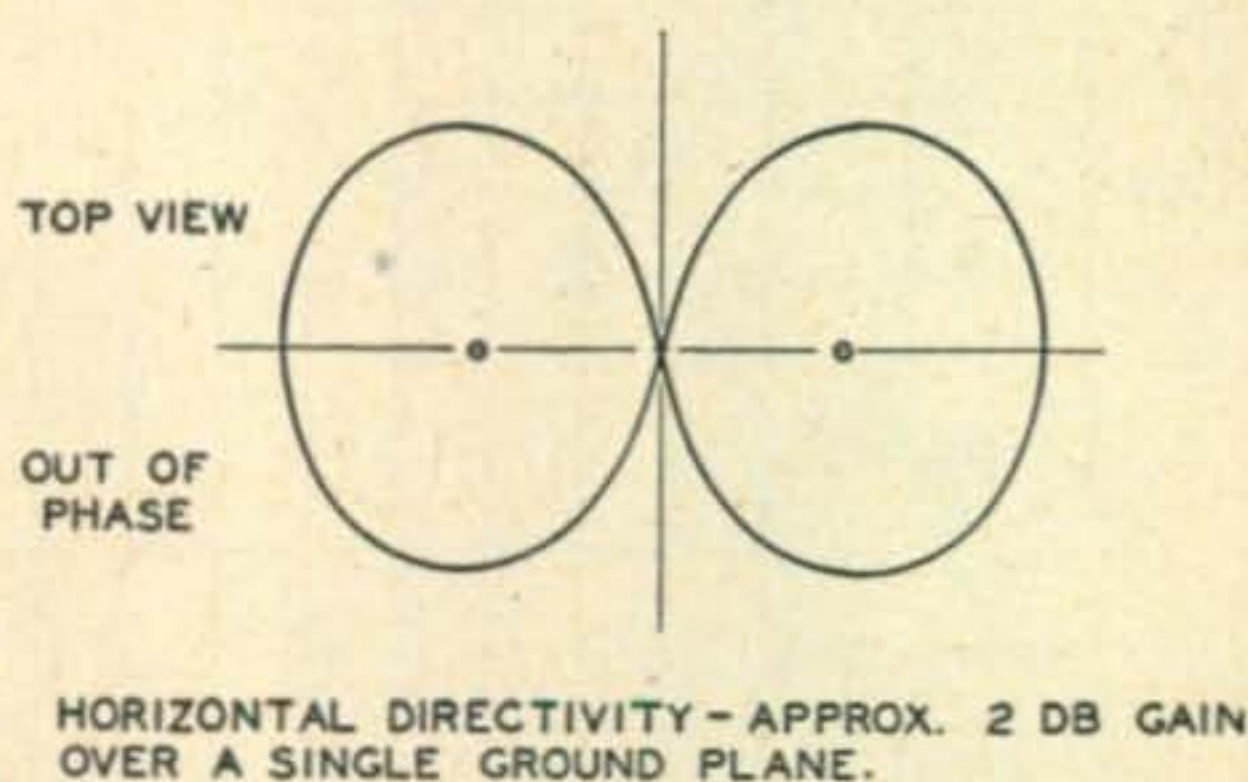

When feedline "A" is 1/2 wave length shorter than feedline "B", the current arrives at antenna "X" 1/2 wave sooner (180 degrees) than at antenna "Y", giving the out-of-phase (and fire) pattern shown above.

CQ

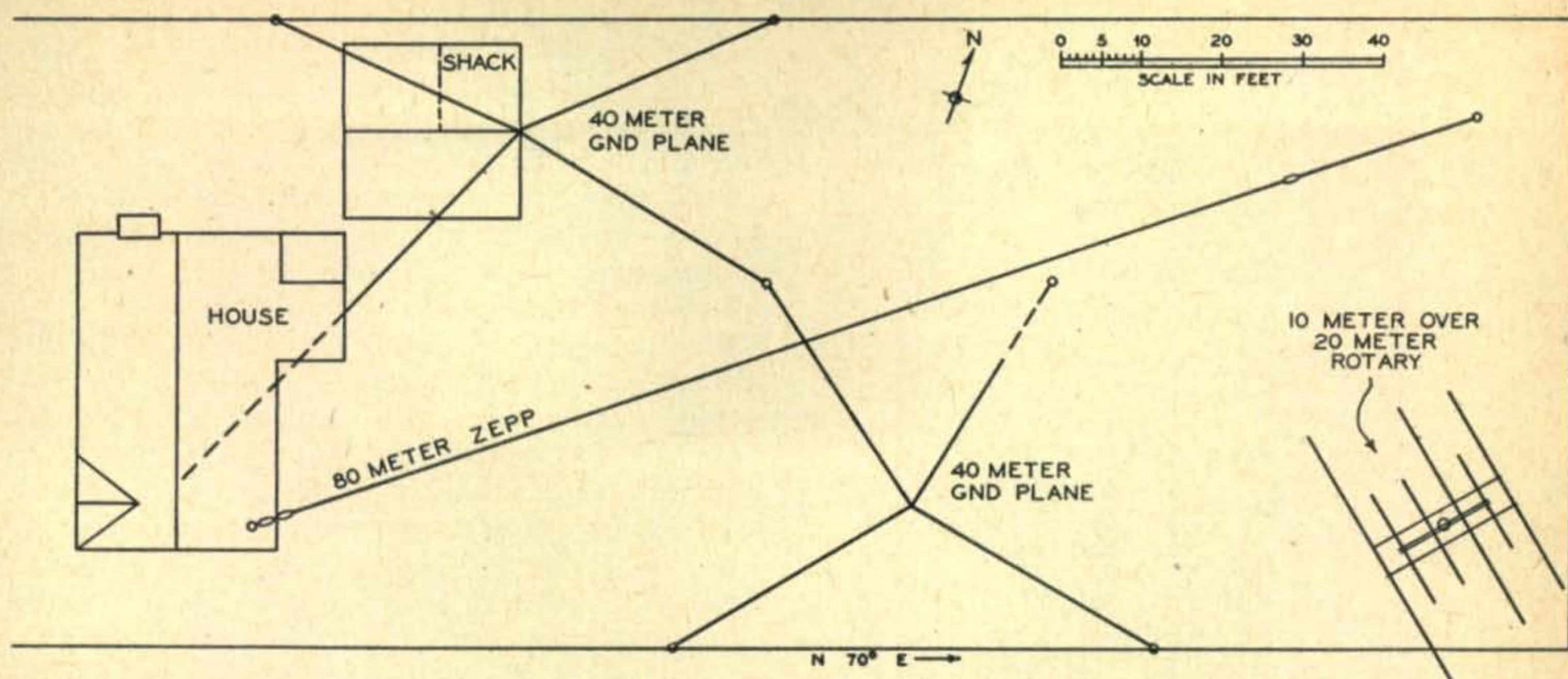

Fig. 2. A view of the W6MVQ antenna layout.

plane to work stations less than 1500 miles away—one word—don't. This is strictly a DX antenna and its low vertical angle will not give you a signal equal to a horizontal antenna at that short a distance.

Improving the Ground Plane Antenna

In October 1950 and between the week-ends of the VK/ZL Contest some thought was given toward improving the signal to VK/ZL land on 7 mc. The ground plane was good but could it be improved? The first thought was—how about adding a reflector behind the beast? Literature was consulted and it was found that the probable gain with reflector would be around 3.5 db (depending on the spacing) with a rather broad forward lobe. Bull sessions followed, and here an idea was born! It was suggested that if a quarter-wave whip was available for a reflector, why not use it as another ground plane and phase the two together? PHASED ground planes? Never heard of such a thing! How does one feed it? What spacing gives what kind of gain?

Terman's *Handbook* was consulted. In broadcast work two verticals are quite often used to obtain almost any desired field pattern by varying the spacing and phasing. With half-wave spacing, "in-phase" operation is supposed to give a bi-directional broadside pattern with approximately 4 db gain. Out-of-phase by 180 degrees at the same spacing should give a broader bi-directional pattern through the plane of the two verticals with approximately 2 db gain. Bringing both of the coax feeders into the shack and making their lengths equal, connecting them together at the antenna change-over relay would give the "in-phase" operation. By adding or subtracting a half-wave of coax to one of the feeders, the current would arrive at the base of one of the ground planes just 180 degrees later than the other, producing the "end fire" operation. Thus two different radiation patterns were obtainable by a simple control at the shack. (See Figure 1.)

An alternative idea was suggested by W6SAI. Use two ground planes in phase but with $\frac{5}{8}$ th

wave spacing, which would give 4.8 db broadside gain. For any other direction use just one ground plane as the gain in the out-of-phase position with that wide spacing would be very low. This

Fig. 3. The ground planes are easily constructed. The box at the base of the vertical radiator contains the resonating coil. The four radials are in a plane normal to the vertical element.

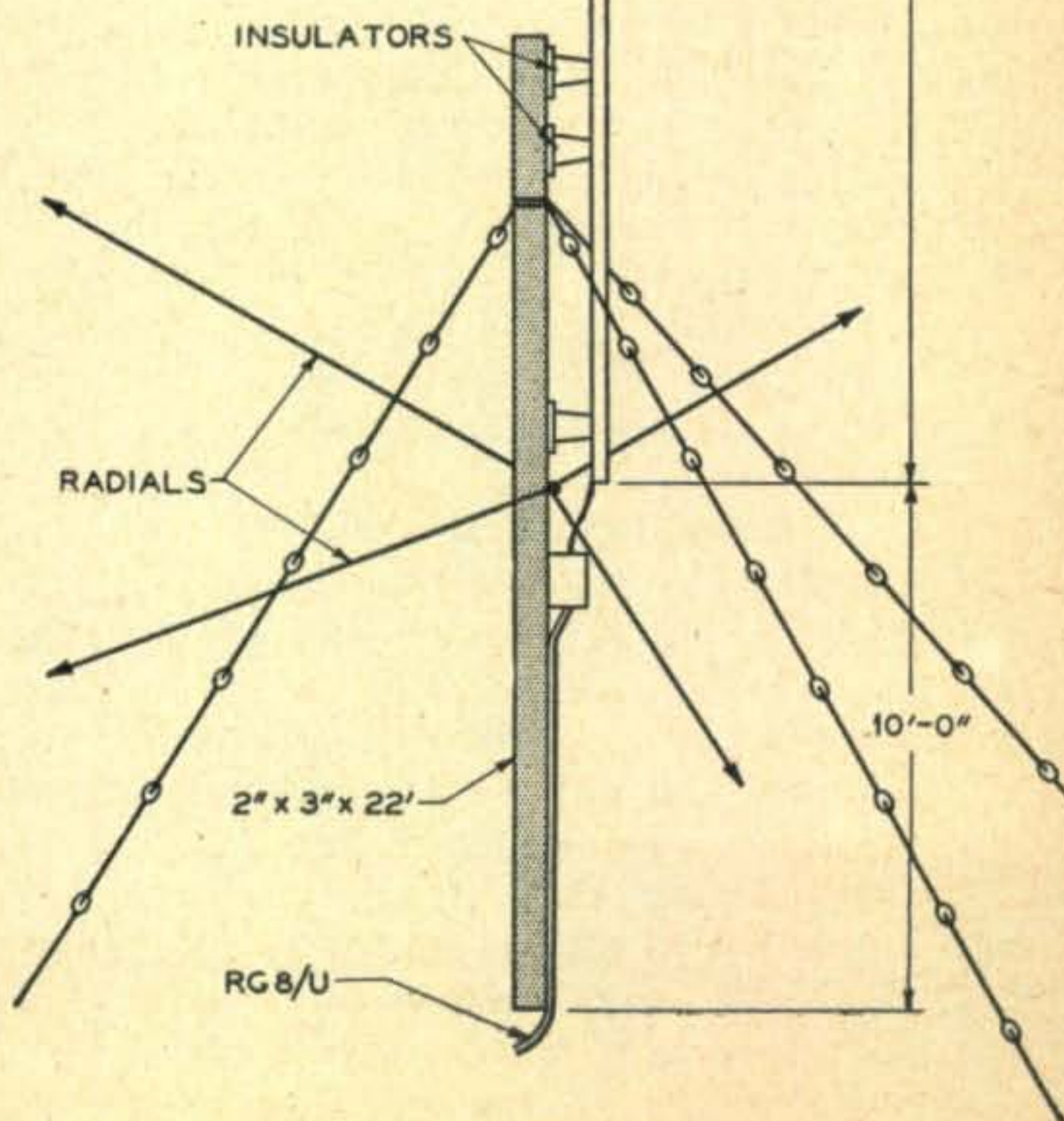

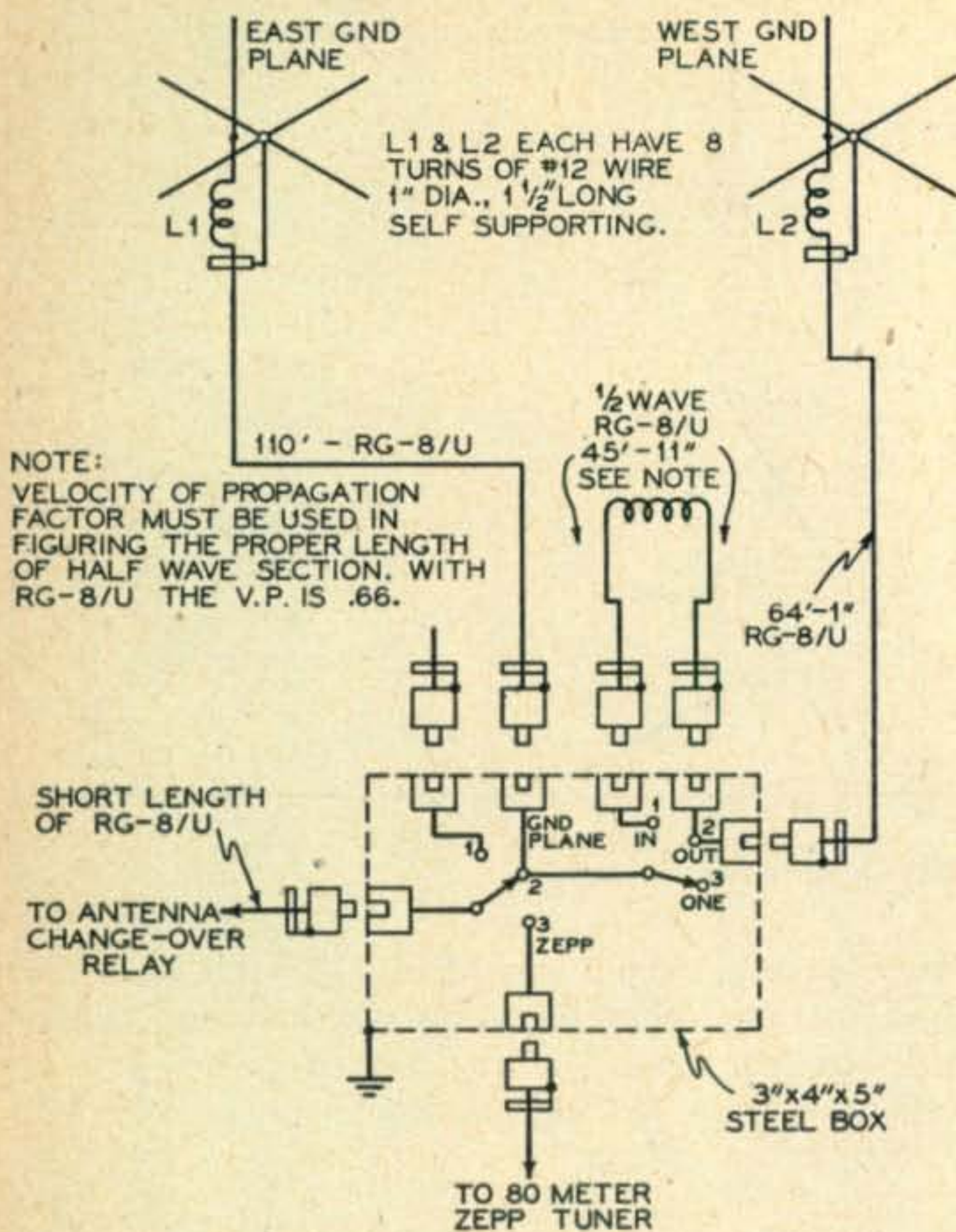

Fig. 4. Antenna switching arrangements at W6MVQ. The two ground planes and a Zepp are controlled from the same position. The east ground plane is always in the circuit when the left hand switch is in the #2 position. The right hand switch places the two ground planes in either an in or out of phase relationship.

sounded fine until it was discovered that $\frac{5}{8}$ th wave spacing was 85 feet, which is a sizable chunk of dirt to cover.

The next logical step was to make an accurately scaled plan view of the house and lot. It developed that using half-wave spacing (67 feet) and spreading the radials a little, they could be squeezed in and still be broadside to Europe. Each whip had to be mounted about 18 feet in from opposite sides of the lot. (See Figure 2.) Some consideration was given to using 3 radials on each ground plane, thus making the spacing angle 120 degrees instead of 90 degrees. However, it was felt that reducing the number of radials would reduce the effectiveness of the ground plane itself, allowing some of the r.f. field to "spill thru" the radials.

Construction Details

Three holes were dug for guy anchors at the new location of the existing ground plane. This ground plane is a 33-foot 6-inch whip mounted on a 22-foot 2" x 3" with 3 husky insulators. (See Figure 3.) The guy wires, which are broken up liberally with egg insulators, are fastened to the 2" x 3" support near the top and run 120 degrees apart to the anchors buried 15 feet away. The whip, by the way, is made of 6 sections of MS-53 surplus whip sections, plus 2 tapering sections MS-52 and MS-51, and topped off by a surplus aluminum whip about 8 feet long.

The four radials are made of #12 copper wire each $34\frac{1}{2}$ feet long. These radials are soldered together at the junction point and then their junction is mounted right on the supporting pole with a wood screw. The voltage at this point is practically zero so no particular precaution about insulation is necessary. Larger size wire for these radials is probably a good idea if it is available.

The new ground plane was made of an old Premax self-supporting whip 35 feet long. The two bottom sections were discarded and a surplus 16-foot whip was mounted on top. The length is also adjusted to 33 feet 6 inches. The base insulator used is an ordinary tapered pillar insulator 2 inches long that slips inside the bottom section. The pillar is bolted to a $\frac{1}{8}$ th inch piece of dural about 3 inches square which, in turn, is fastened down to a 1-foot piece of 4" x 6" wood with wood screws. This 4" x 6" is bolted to the peak of the eaves of the garage. Three guy wires fastened to the whip 10 feet above the bottom hold the whip in place. These guys are also liberally broken up with egg insulators.

The four radials are made of #9 galvanized bailing wire $34\frac{1}{2}$ feet long. Yes, that's right, bailing wire. If the galvanizing is good and the wire size fairly large, the losses should be negligible at 7 mc. By the way, zinc used for galvanizing has less resistance than brass. Bailing wire is available at most hardware stores and sells for around 14 cents a pound. These radials were also soldered together at their junction point and fastened to the 4" x 6" with a husky woodscrew. All the radials should be run fairly level and not necessarily with respect to sloping terrain.

Matching to 52 Ohm Coax

The radiation resistance of a 7 mc ground plane of this type will vary with location. Power wires, other antennas, house wiring and plumbing, as well as height above ground all have some effect, not to mention the length of the whip. (Radials were not found to be critical, although they should be made to appear inductive at the lowest frequency to be used, which means just make them longer than 34 feet.) The radiation resistance of each of these whips was around 20 ohms. Adjustment of loading could be accomplished by altering the length of the feed line or by just sticking a variable condenser in series with the swinging link to tune out the reactance. Others have secured a very good match by sloping the radials down 20 or 30 degrees. This sloping of the radials will raise the radiation resistance because if all the radials were sloped steeper and steeper until they were straight up and down the antenna would end up being a coaxial antenna with a radiation resistance of about 74 ohms. However, I personally feel that with an antenna so close to actual ground the sloping radials would tend to foul up the vertical radiation pattern.

At first getting a good match looked real easy. Just calculate some sort of "T" network or "L"

(Continued on page 60)

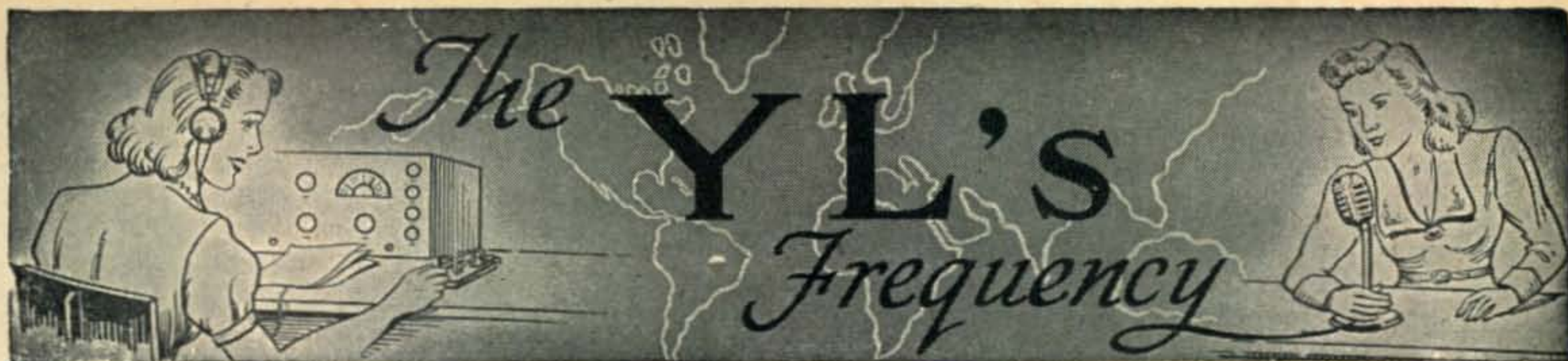

Conducted by LOUISA B. SANDO, W5RZJ*

Here it is again—the now annual YL/OM Contest. The dates are February 23-24. Previous years the OMs have complained that they couldn't find the YLs—so let's all get on and give them a chance. It is especially hard to locate the YLs on cw and it has been suggested that the YLs stick near the frequencies of the regular YL cw nets so the OMs might have better luck finding them. These net frequencies are 3610, 7040 and 7105 kc. Only a suggestion—you can operate any frequency you wish. The contest details:

HOURS: Feb. 23	Feb. 25
Begin	End
EST 6:00 p.m.	EST 3:01 a.m.
CST 5:00 p.m.	CST 2:01 a.m.
MST 4:00 p.m.	MST 1:01 a.m.
PST 3:00 p.m.	PST 12:01 a.m.

FREQUENCIES: All bands may be used.

ELIGIBILITY: OMs—any licensed OM is eligible to compete. YLs—only YLRL members are eligible to compete.

OPERATING: Phone—Call "CQ YL-OM Contest"
 CW—YLs call "CQ OM/YL."
 OMs call "CQ YL/OM."

Exchange QSO number and state, U.S. possession, VE district or country. Use phone, CW or both. Skeds, crossband and CW to phone permitted.

SCORING: 1 point for each station worked (YL to OM, or OM to YL only), multiplied by number of different states, U.S. possessions, VE districts or countries (except W/VE) worked. Any station, state, country, etc., will count once only regardless of frequency band or mode of operation.

AWARDS: Highest OM score—Gold loving cup donated by W8UDA, now held by WIBFT. Highest YL score—Silver loving cup donated by WIBFT, now held by W6YYM. The cups are awarded on a yearly basis, with a three-time winner obtaining permanent possession. Certificates to be awarded to 2nd and 3rd place winners.

Logs must be postmarked not later than March 2, 1952, and mailed to YLRL Vice President Kay Barclay, W3LSX, 2022 Columbia Rd., N.W., Washington 9, D.C.

Nets.

Several changes in the YLRL nets. Another 75 phone net has been started with W8ATB as NCS. W3UUG is taking over as NCS on the 20 phone net for W9GME. We'll list them all again to keep you up to date. Remember, all YLs are welcome.

Band	Freq. (kc)	Day	Time	NCS
75 phone	3900	Mon.	8:00 p.m. PST	W7HHH
75 phone	3900	Wed.	9:00 a.m. EST	W8ATB
80 CW	3610	Wed.	9:00 p.m. EST	W9JTX
40 CW	7105	Tues.	10:00 p.m. EST	W3CDQ
40 CW	7040	Fri.	9:00 p.m. PST	W7NOB
20 phone	14240	Thurs.	2:00 p.m. EST	W2UUG & W6FEA

W3LSX is trying to start a net on 10 phone. In the meantime, many of the YLs get on Tuesdays at the old net time, 1-3 p.m. EST.

A local 10-meter net is underway in the Chicago area. Tuesday evenings at 10 p.m. CST around 29 mc the gals have a quick roll call and spend a couple of hours ragchewing. W9GME reports the response has been FB with W9MYC, KXL, FZO, LOY and GME participating, with SVN to join soon. These YLs would like any others in the area to join in, and when the band is open for short skip any YL hearing the net is invited to break in.

The New Mexico YL MARS Net got under way October 23rd. It meets each Tuesday on 4025 kc at 1900 MST, with A5RTS, Cleta, as NCS. This is the first, and so far the only, state to have an established YL MARS net. To start with A5RTS, A5RFK and A5RMH were the only authorized YLs, but more are completing MARS applications. A5PTR, Min, of San Antonio has reported in, and several other Texas stations.

Clubs

Congratulations and greetings to the newly formed YL club of Long Island (N.Y.). Its officers are W2JZX, Vi Grossman, president; WN2KDP, Doty Gutman, vice president, and WN2KEB, Georgie Mezey, secretary-treasurer. Other members are W2UXM, Sally Lobenthal; W2SWU, Lillian Getman; W2TTI, Helen Heckendorn; WN2BXT, Marie Manthe; W2SPI, Dot Miller, WN2???, Ethel Witte (awaiting her call), and non-licensed Jean Merten, XYL of W2UOL; Winnie Breese, XYL of W2UXY, and Anne Hahan, XYL of W2IWE. The WNs, of whom WN2KAE and WN2KEB have tech licenses, are the result of the Nassau Radio Club code and theory school. The club has started a 2-meter net held every Monday and Thursday at 10:00 a.m. EST with W2JZX, WN2KDP, WN2KEB and W2SPI, with WN2BXT to join as soon as her OM puts the finishing touches on the 2-meter rig.

FB gals! Maybe this will be encouraging to the

*Address all correspondence to 959C-24th St., Los Alamos, New Mexico

Chicago YLs who plan to start a club the first of the year. Any others?

The YL Club of Los Angeles held its December meeting on Dec. 8th. Fifteen members attended, including two new hams, W6LBO and 6KYZ, Novices WN6CQV and her daughter, who is expecting her call shortly, and "old-timers" W6NZZ, GKJ, UHA, JMC, KER, JMS, NLM, AVF, CEE, MFP and WSV. (Keep these calls in mind; the club will soon announce an award for those who work 20 of the club members.)

W6WSV says the biggest event on the L.A. club schedule for December is a QSO with JA2MB on Christmas Eve at 4 p.m. from Beulah's, W6NLM. Club members will gather there and will talk to JA2MB at the orphanage in Yokosuka where he will have his rig set up. It will be about 9 a.m. Christmas Day there and the kids will just be seeing their gifts. Santa Claus will be a fat Marine sergeant drafted for the job—and who will be dropped from a helicopter! The sked is planned for 20 meters. A reporter from the *Los Angeles Times*—biggest daily in L.A.—will be on hand to get dope for a story and take pictures. More good publicity for ham radio! The YLs are very pleased over their efforts—they sent to the orphanage 76 individual Christmas presents and six big boxes of clothing!



To make you feel warmer (or colder?) while you shovel off February's snow, here is KH6TI, Dell Johnson, at Waikiki in Hawaii.

Last month we mentioned the XYL Club, Alpha Chapter, of Fort Wayne, Ind. Now we have some more details from Ruby Pembleton, resident agent: "The XYL Club, Alpha Chapter, was incorporated Dec. 11, 1946, in the State of Indiana and is filed and approved by the State of Indiana and the Federal Government as a non-profit organization. Its purpose is to further acquaintance of wives of members of the Fort Wayne Radio Club and other amateurs of the vicinity, and also the general study of radio. Of course, all wives of amateurs are known over the air as XYLs and it is not our intention to infringe upon the right of the individual to call herself an

XYL. It does place a limitation upon any group using the letters XYL as the name of a club. We are very proud of our club and wish to extend to any group of wives of amateurs the right to use the letters XYL, using the Greek alphabet to designate the various chapters. These chapters would be affiliated with the parent club in Fort Wayne and abide by the articles of incorporation."

Here and There

Here's a YL maritime mobile coming up for you. W6NZZ, Evelyn Scott, and her OM will soon be touring South America by plane and freighter. Evelyn says she has been invited by the ship's chief op, W7CZU, to operate maritime mobile on board, so if anyone is interested in a sked, listen for her call, W6NZZ, or W7CZU, on 28,500 or 28,600 kc during the month of March. The name of the ship is the *Santa Adela*, and its destination will be Santiago, Chile. Evelyn and her OM will return by way of Haiti and Havana, with about three months for the whole trip.

W9GME writes of three new YLs who have received their Novice licenses—WN9OTO, Honey, and WN9OTM, June, who are mother and daughter from Elgin, Ill., and WN9PEX, Roxanna, who's QTH is Goshen, Ind. They all are operating 80 c.w. in the Novice band and will be looking for other YLs. We all wish you good luck, and the Chicago area YLs especially invite you to join any of their activities which may interest you.

Speaking of Novices, remember the enthusiastic letter from Peg Ferber, WN3RXV, in December CQ? Peg is now happy to be operating as W3RXV.

Our condolences to YLRL President W9JTX, Louise Beringer, on the loss of her son. Born November 11th, he lived only a few days.

Many YLs are participating in emergency nets. Among them are W3QPQ, Jeanette Ebur, secretary, and W3NXU, Elizabeth Horner, corresponding secretary, of the Western Pennsylvania Emergency Network. There are over 100 members in the net and it covers not only Penna. but Ohio, West Va., New York, and they have contacts on other bands into other states if necessary. Operating on 29,425, they have roll call and drills each Wednesday and Saturday evening, with an average of thirty stations checking in each night. W3QPQ is NCS the second Wed. and W3NXU is NCS each fourth Wednesday of every month. During the heavy snow a year ago the net handled over 200 messages.

Just to keep herself busy W3QPQ also is secretary of one of the oldest radio clubs in the country, The Amateur Transmitters' Association of Western Penna.

YL of the Month

While most of us Stateside are shivering midst ice and snow and wintry blasts, let's take a fast trip to the Hawaiian Islands paradise and drop in on KH6TI, Dell Johnson. She's well-known to many of you for up until December, KH6TI had QSOed 2600 U.S. stations and 65 countries.

As with many a YL, or XYL, Dell's introduction to ham radio was all in innocence. When she went to Hawaii in the summer of '46 she had never seen a ham station. All the time she and her OM had gone together in the States Dell didn't even know that Johnny was W9HTW! Soon after they were married in the Islands the OM, now KH6DH, built a 20-meter rig—and Dell was introduced to ham radio. She says she was sold on it from the first, but never dreamed she'd have a call of her own.

(Continued on page 69)

The Worm Turns

by MRS. OL' JOE

I am—may the Lord have pity on us—an XYL. A few years ago, I was an OW. Me—fresh from college, weighing 126, 5 feet 3, blonde, and, according to the entire senior class of Plutonium Polytech, the girl “Most Likely To”—an OW.

I should have known better—mother warned me—but the moon, Joe and I were zero beat one night, and here I am—Mrs. Joe, the wife of an amateur radio enthusiast, and I use that phrase to keep from scorching the paper with something stronger.



It all started on our wedding day. Joe was thirty minutes late for the ceremony and let a few veiled hints fall that he was held up by traffic. I found out a couple months later, when the QSL arrived, that the traffic was between Joe and a couple of LU's on 6 meters.

Honeymoon? Yes. I don't know what time Joe got to bed the first night of our trip. I heard the next morning that “10 was open most of the night.” Joe had a mobile rig in the car. We started for Yellowstone and might have made it had there been no radio stores along the way. At Council Bluffs, Iowa, we shipped two suitcases back home by express to make room for a stack of ##@@!!! radio equipment. We got as far west as the Black Hills before our money ran out.

My father gave us a new home for a wedding present. It was supposed to have two bedrooms, but immediately upon our arrival, one room was made into what is known to the amateur fraternity as a “shack,” and I was informed that that room was “out of bounds.” Holes were bored through the walls for feeders and I heard plenty of beefing about the minute brainpower of anyone who would build a house on a lot too short to hold a long wire without bending the ends.

I have been married to Joe for three years and have learned a lot about ham radio. CW—to me, that means “Contest Widow.” There are many

weekends during contest season that the only way I know my loving spouse is at home is by the flickering of the lights, and frantic howls from the shack to “put in a new fuse—hurry. I think ten is opening up.”

During the contests, I can't use the toaster. Fuses, you know. Refrigerator must be turned off for the same reason. SS—“Silly Season.” I spent last Sweepstakes weekend with my mother—Joe never even missed me.

Don't get the idea that Joe pays no attention to me. One night last winter he took me out to dinner and a show. Of course, there was a two-reel feature showing amateur emergency operation in a flood area.

I have lived through three DX contests. DX must mean “Don't Xpect” to see me for two weekends. There are DX cards nailed to the wall. There are burned spots on the floor where Joe has shaken hot solder from his iron.

We drive a 1938 car. We would have had a new car last year, but the Collins 51J came out. Walking is healthy. My household money has gone for CODs—surplus gear. I have cancelled invitations by the dozen because Joe is NCS of the “Yippee Net.” (NCS—“Not Quite Sane.”) I haven't heard my favorite radio programs for three years because of assorted key clicks and BCI. I have to brave the irate stares of my neighbors. More BCI. I have spent many days

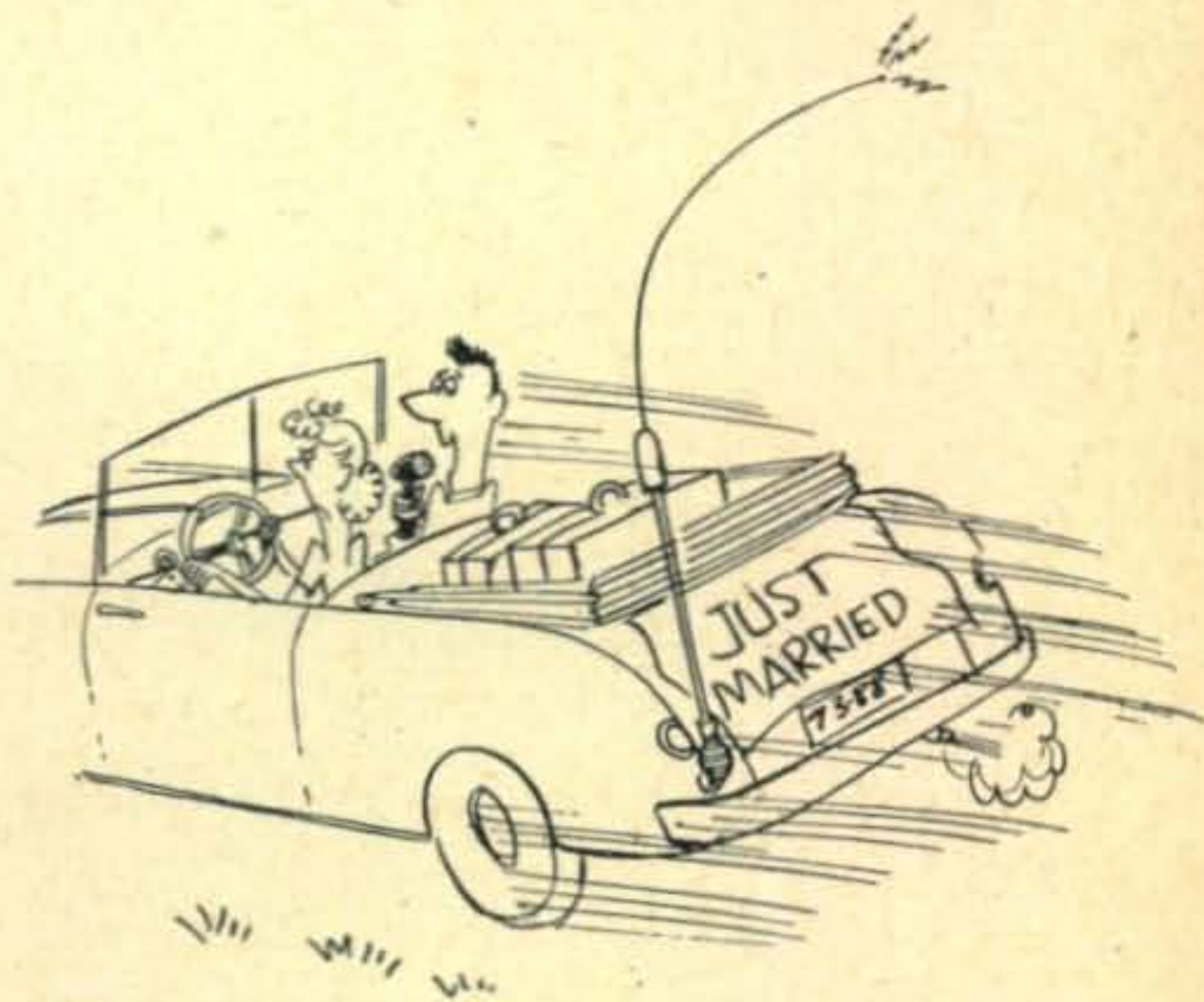

alone while Joe attended conventions, hamfests and other meetings. I've had many meals get cold while Joe pursued elusive DX.

BUT—it's a long worm that has no kinks. Joe doesn't know this yet, but a new day is here. Today I got my ticket. I sold my silver service to buy a rig, and those noises you're going to hear aren't going to be heterodynes but Joe screaming for his dinner.

NOVICE SHACK

Conducted by HERB BRIER, W9EGQ*

Regarding Your Transmitter

The simplest transmitter the Novice can use is diagrammed in Fig. 1. It is capable of about ten watts input at 250 volts on the plate and screen of the tube without danger to the crystal. By holding the screen voltage to 250 volts or less, up to 400 volts may be used on the plate, giving an input up to twenty watts, with some danger of fracturing the crystal.

This circuit requires detuning the plate-tank condenser to the low-capacity side of the point of maximum output to obtain satisfactory keying. The modified circuit, Fig. 1A, improves keying and makes tuning less critical. One tube transmitters are fairly satisfactory on the 3,700 kilocycle band; however satisfactory keying is difficult to obtain and output is quite low with them on the 27,000 kilocycle band. Although there are a number of one-tube circuits which will produce crystal-controlled output at 145 megacycles, it is hardly enough for them to be called transmitters.

For best results, it is more satisfactory to use the oscillator primarily to control frequency and depend

*385 Johnson St., Gary, Ind.

on amplifiers and frequency multipliers to raise the frequency and power to the desired level. For frequencies to thirty megacycles and powers to 75 watts, a two-stage circuit is used in most of the simpler home-built and commercial transmitters*. See Fig. 2 for the basic circuit.

Commercial versions include the *Millen 90800* (6L6-807), which sells for about \$65.00 with coils and crystals for the 3.7 and 27 megacycle Novice bands, and the *World Radio Laboratories (WRL) 6AG7-807* unit for about \$45.00. Both require a power supply delivering 400 to 750 volts at 200 milliamperes, and is capable of up to 75 watts input. Suitable power supplies can be built or purchased from \$30.00 up. A third transmitter using the same basic circuit is the *Eldico TR-75-TV*. It sells in kit form, complete with power supply, for about \$60.00. This unit has provisions for reducing TVI-producing spurious radiations.

More elaborate transmitters in the low-power range that are suitable for use in the Novice bands are also available. Among them are the various models of the *Harvey-Wells TBS-50* and the *Lysco 600*. The former features crystal controlled output on all amateur bands between 1.8 and 148 megacycles and ranges in price from about \$90.00 for the straight c.w. model to about \$140.00 for the "de luxe" phone/c.w. model. It requires a 400-500 volt, 200-275 ma power supply—depending on the model. The latter features optional crystal or variable-frequency control on all amateur bands to 30 megacycles, plus fairly adequate TVI filtering. It sells complete with built-in power supply and one crystal for about \$146.00. Both units feature "band-switching" (no plug-in coils) and are rated at 50 and 35 watts input respectively.

In addition to the above, there are a number of other transmitters using the basic two-stage circuit, plus a modulator, selling for \$80.00 to \$150.00, depending on how much auxiliary equipment is purchased. Others are not mentioned, because their rated power input exceeds the novice limit, they

* An interesting exception will be described on page 40, March, 1952.

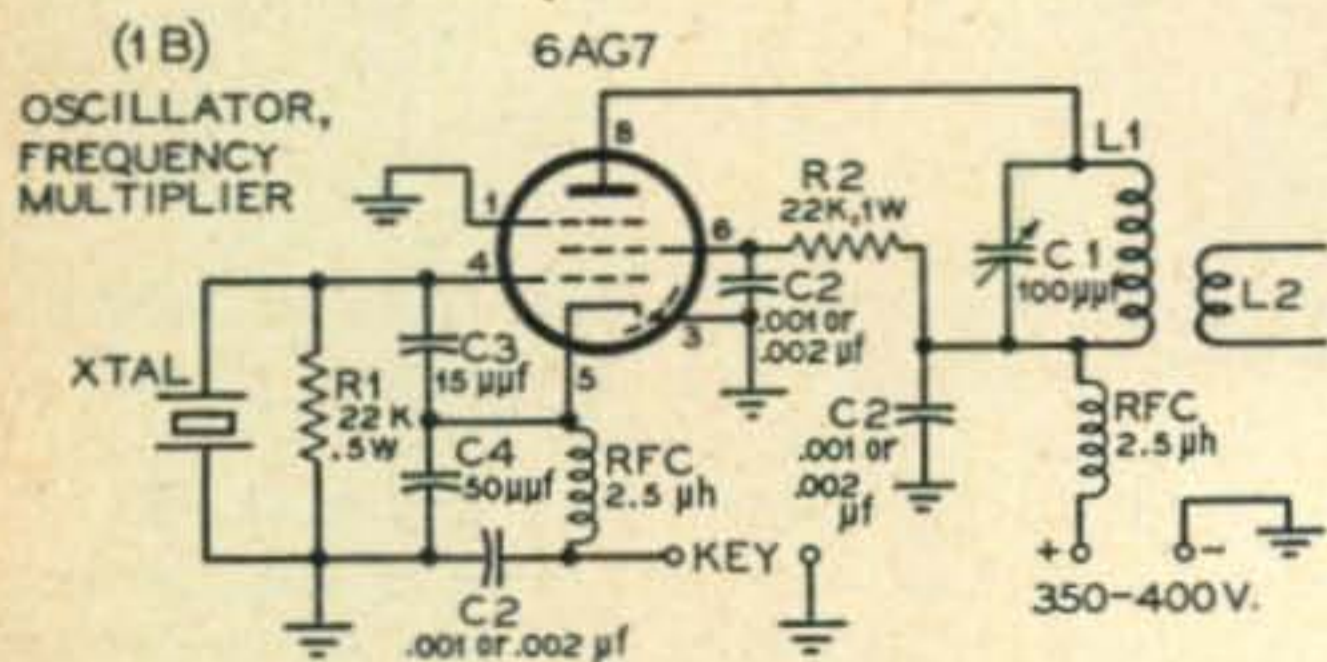
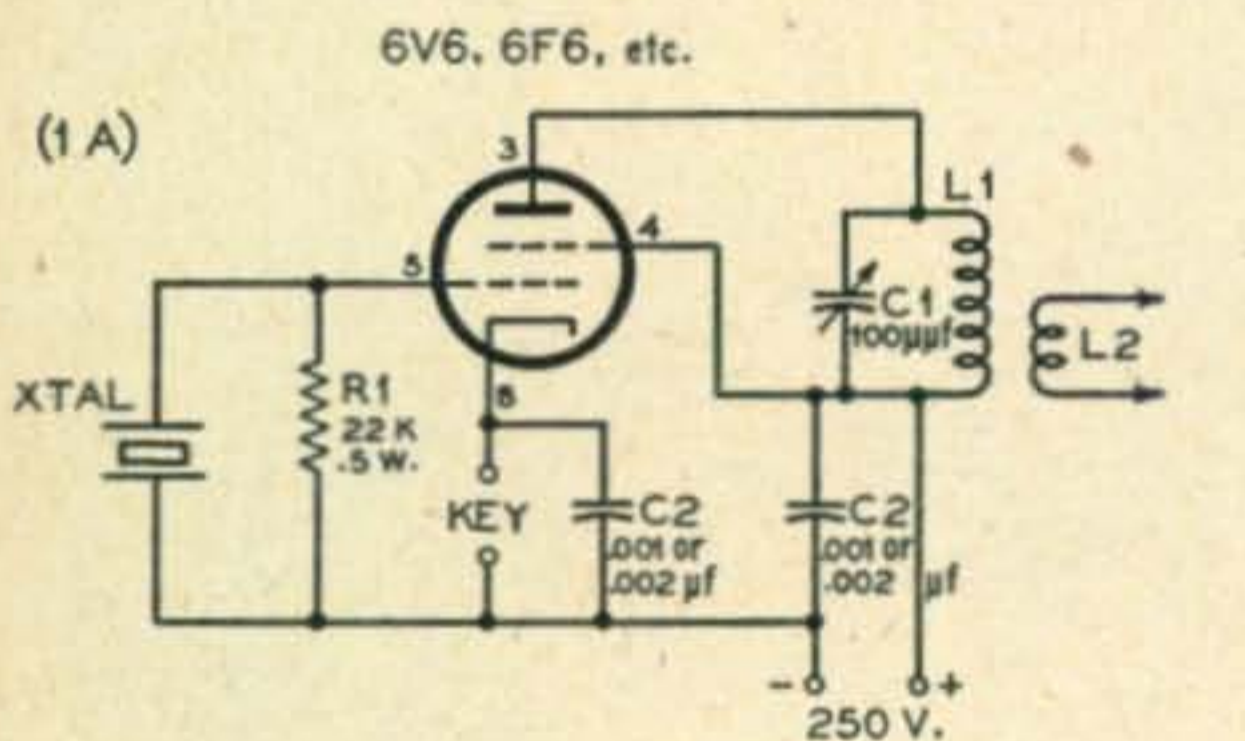

IN 1B, CRYSTALS OF HALF OR QUARTER THE DESIRED OUTPUT FREQUENCY WILL ALSO WORK, ALTHOUGH THE MORE THE CRYSTAL FREQUENCY IS MULTIPLIED, THE LOWER THE OUTPUT.

Fig. 1. Simple one-tube crystal oscillator circuits.

- | | |
|--|----------------------------------|
| C1—100 $\mu\mu\text{f}$ variable | R1—22,000 ohms, $\frac{1}{2}$ w |
| C2—.001 or .002 μf mica | R2—22,000 ohms, 1 w |
| C3—15 $\mu\mu\text{f}$ mica or ceramic | RFC—2.5 mh radio frequency choke |
| C4—50 $\mu\mu\text{f}$ mica or ceramic | XTAL—Crystal for desired freq. |

are not crystal-controlled, are designed primarily for mobile operation, or similar reasons. Also, the opening paragraphs pretty well cover the single-tube transmitters on the market. An interesting variation of them, however, is the *Hallicrafters TR-75*. It is essentially an S-38B receiver, with the 50L6 audio output tube doing double duty as the transmitter oscillator. The unit sells for about \$90.00.

Of the above transmitters, only the TBS-50 operates above 30 megacycles, and its output is very, very low at 145 megacycles. More efficient transmitters for two meters include the *Eldico* and *Sonar MB-29* 144-148 megacycle transmitters and the *Millen 90810* transmitter. The first two are 20-25 watt AM-modulated transmitters and sell, complete, except for power supply and microphone, for around \$75.00. Power supply requirements are approximately 300 volts at 200 milliamperes. The latter uses an 829B/3E29 in its output stage, is capable of 75 watts or more input and operates on the amateur 10-11, 6 and 2-meter bands. Complete with coils for 10-11 and 2-meters, it sells for about \$112.00. Tubes and crystals come to about \$30.00, and a power supply

I am a great believer in amateurs building their own equipment whenever possible. Besides the obvious value of the training it gives, one can put just the features he desires into the equipment he builds. Also, it reduces the cost of getting on the air. Another advantage today is that many advertised pieces of commercial gear are available only after a long delay—if at all. Having built a piece of equipment means that one knows it intimately; therefore, in the event of trouble, repairing it is usually a simple matter. Lastly, there is a real sense of achievement in operating a station that you built.

A great deal of space need not be devoted here to circuits and construction of home-built equipment, as the writers of how-to-build articles always explain why they chose the circuits and parts arrangements used. After reading a few such articles carefully, you can select the one that seems to meet your requirements the best. (See Bibliography.)

TVI

More important than the circuits used are the precautions taken by the author to minimize TVI.

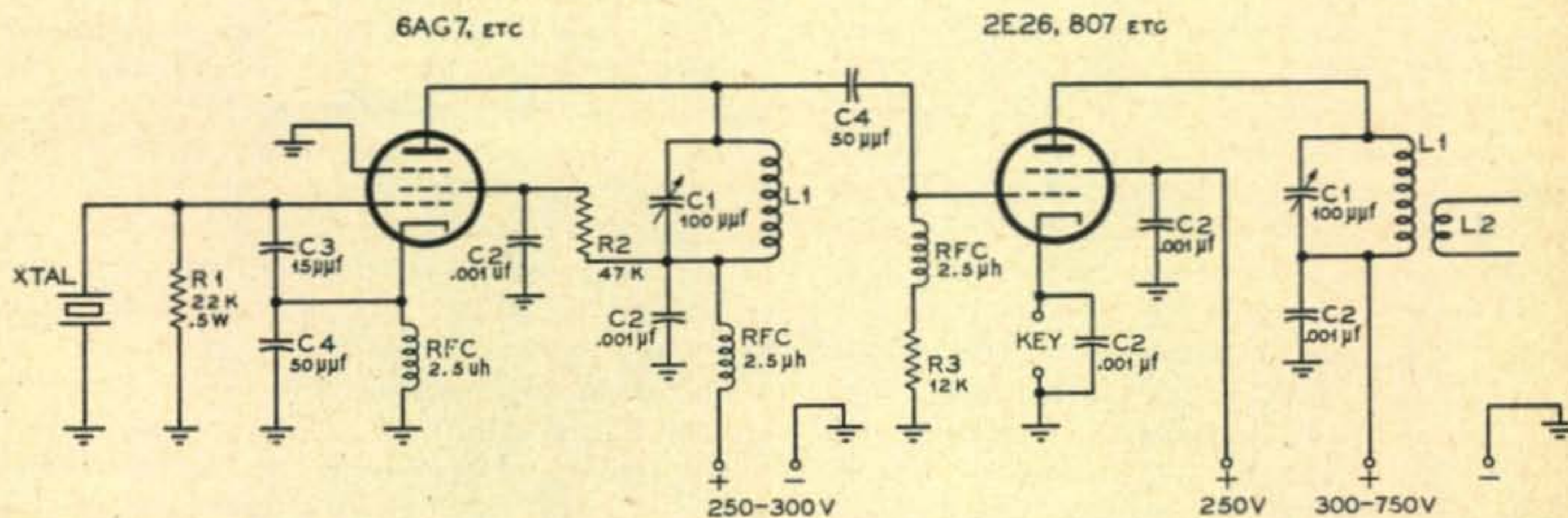

Fig. 2. One of several versions of the basic circuit used in many simple two-stage transmitters. (Only bare essentials shown.)

capable of furnishing 400 to 600 volts at 200 to 250 milliamperes is also required, plus a modulator for phone work.

War Surplus

"War-surplus" stocks are almost completely depleted of transmitting equipment useful to the Novice amateur. The few units that are available frequently cost more than it would to build or buy more-desirable new equipment. One exception is the BC-457 "Command" transmitter. At the time this is being written, it still advertised from between \$4.95 and \$15.00. If obtained for around \$10.00 or so, its oscillator may be rebuilt for crystal control, giving an economical 75-watts transmitter for 3,700-3,750 kilocycles.¹ Scanning the latest ads revealed nothing attractive (in price) for two meters. *CQ hamads*, though, still contain occasional offers of BC-522's at prices low enough to interest the prospective two-meter amateur. Incidentally, when purchasing such equipment, be sure to consider the cost of necessary accessory equipment in deciding whether its purchase will save money.

All hams who live in areas where television programs can be received soon realize that they have a TVI problem. Although much of it is caused by receiver deficiencies, a transmitter free of all spurious emissions is a tremendous help in solving the problem. Transmitters operating in the 27 to 30 megacycle region are the most-difficult to debug, but those operating on either 3.7 or 147 megacycles can also ruin television reception.

Low power is not sufficient to insure against TVI,

(Continued on page 65)

COIL SPECIFICATIONS

80 Meters

L1—30 T #18 enam. 1½" diam. closewound
L2—5 T #18 enam. ¼" below L1.

11 Meters

L1—5 T #18 enam. 1½" diam., 1" long.
L2—2 T #18 enam.

¹The Novice Conversion of a "Command" Transmitter, by R. M. Smith, W1FTX, and W. E. Bradley, W1FWH, page 22, QST, November, 1951



Conducted by RALPH V. ANDERSON, W3NL*

Radio Amateur Civil Emergency Service

As I am writing this FCC Docket No. 10102, concerning the RACES has just been released. While this is a tentative regulation and subject to various changes before final enactment, sufficient information is available to permit one to judge just how ham radio is to be integrated into the communication networks for civil defense.

Inasmuch as mobiles are one of the most important factors when considering civil defense communications it seems to us that the proposed RACES regulations are one of the most important FCC actions affecting mobile operation. RACES regulations are intended to be temporary in nature and may be terminated upon due notice at any time. Each amateur must recognize the temporary natures of RACES when applying.

The most important provision of the regulation, it seems to us, is that it is necessary for each amateur station to be additionally licensed, and before this license can be issued, the application must have been, in effect, approved by the local civil defense authorities. However, before such approval can be accepted by the FCC, a civil defense communications plan must have been filed with the commission or the plan must accompany the application.

Many of the mobile operators throughout the country are members of civil defense organizations which will have little if any difficulty in complying with the new regulations. Other mobile operators have no affiliation whatever with civil defense organizations and it will be up to these hams to get something going in their locality if they are to assist in civil defense communications.

Other provisions are covered in the proposed rules such as frequencies to be made available (previously published) and types of emissions permitted on those frequencies. RACES authorization is to run concurrently with the present amateur license, and generally speaking, station regulations parallel those now in existence for amateur service.

Having just received the proposed regulations it's a little too early to form any pros or cons relative to the various provisions but offhand it appears that it is a very workable, highly efficient

**Send contributions to R. V. Anderson, 2509 32nd St., S.E., Washington 20, D. C.*

plan. It does reflect that someone has placed a great deal of effort in trying to get a good set of regulations for RACES.

Bay Area Mobileers

Within the past year the San Francisco Bay Area has grown by leaps and bounds in mobile activity. Indication of this is the fact that there are now over 125 active mobiles on 75 whereas about a year or so ago there were only about 5. W6NTU has been responsible for a great deal of activity since he has been developing efficient methods of screen modulation. He has continued with his experiments and now has what he calls the Carter Mark 1-A modulation system. A great many of the fellows are using it and it's designed to get the most modulation with the minimum of effort and parts and with a respectable signal to listen to.

The main frequency is 3995 which has "degenerated" into a calling frequency because of the extreme activity. After initial contacts on 3995, mobiles "pair off" and go to other parts of the 75 meter band.

A Sunday morning "breakfast" every two weeks is one of the methods used to maintain activity. These are very well attended and give the gang a good chance to get together personally. Both 75 and 2 meters are used mobile traveling to and from the breakfast location.

We suggest that mobiles traveling through the Bay Area "sound off" on 3995 and meet the gang; you'll always find some one on the frequency.

Maritime Mobile Amateur Radio Club

Fixed stations: Send your 30 QSL's to W3OB for MM certificate. Cards and certificate will be returned registered mail. Send no stamps.

In spite of poor band conditions enough MM's are being worked that certificates can be issued. About 50 associate memberships have now been issued, with many going to foreign countries. Activity amongst the MM's is keeping up in fair fashion, enough so that an election was held resulting in W4RW as Commodore and W2PFL as Vice Commodore. Dues in the MM Club for active members was voted \$2.00 per year. Any MM's not a member contact W3OB.

Some of the gang have wondered where this column got the authority to state that a marine mo-

bile wasn't MM unless outside the 3 mile limit and other MM regulations. Since there have been a number of requests, here is a portion of an FCC letter, dated June 7, 1950 written to W5AXI in which certain questions were asked. The question is self-evident from the answer.

"1. An amateur station on board a ship is considered to be a mobile amateur station regardless of whether the ship is under way, anchored, or tied up to a dock. When within the United States, its territories or possessions, it should be identified in the manner outlined in Section 12.82 (b) of the rules for mobile amateur stations. On the high seas (i.e., beyond the 3-mile limit of the United States, its territories or possessions) the station should identify itself by using the indicator "MM" or the words "Maritime Mobile" as explained in Section 12.82 (e) (1) of the rules. These indicators should also be used when a foreign government has given its permission for the amateur station to be operated while the ship is in an area under its jurisdiction.

2. Whenever mobile operation is or is likely to be for a period in excess of 48 hours without return to the fixed transmitter location designated in the station license, the licensee shall give prior written notice to the Engineer in Charge of the radio inspection district in which such mobile operation is intended. When this mobile operation is within the United States, its territories or possessions, a notice must be submitted at least once each month giving the proposed itinerary as specifically as possible. If the proposed mobile operation is to be outside the United States, its territories or possessions, only one such notice is required during any continued absence. Upon return of the vessel to the United States, its territories or possessions, another notice and proposed itinerary should be submitted as soon as mail service becomes available.

3. Third party communications of a "strictly social nature" in which the amateur operators involved have no pecuniary interest and for which they receive no compensation may be transmitted between United States maritime mobile amateur stations and amateur stations in the United States, its territories or possessions.

4. In an emergency involving the loss of your ship's regular radio communication facilities, or where delay might endanger the safety of the ship, there is no objection to your handling ship's business via amateur radio provided there is no material compensation to the amateur radio operators involved either direct or indirect, paid or promised.

5. The Commission's rules do not prohibit the installation of amateur mobile equipment in a ship radio room provided that Section 12.94 of the amateur rules is strictly complied with in every case. Should there be any doubt about your particular amateur installation, it is suggested that you have it checked by both a Commission ship inspection engineer and a Coast Guard marine inspector. Applicable laws and regulations should of course be specifically referred to and complied with, in any event.

6. Full identification should be used at the beginning and the end of each transmission (complete "QSO") and at least once every ten minutes during every /single/ transmission of more than

ten minutes' duration. In the case of an exchange of several transmissions in sequence with each transmission less than three minutes' duration, the call signs of the communicating stations need be transmitted only once every ten minutes of operation as well as at the beginning and at the termination of the correspondence (complete "QSO"). The name of the vessel and its approximate geographical location shall be transmitted at the end of each transmission (complete "QSO") immediately prior to signing off.

7. Unless the vessel equipped with ship-to-ship phone is authorized by the Commission to use its ship phone station to communicate with amateur stations, the cross band operation to which you refer would be illegal. (See Sections 12.101 and 12.134 of the rules.)"

Odds and Ends

The 6BQ6, smaller than a 6V6 and with a plate cap on top is a tube that is finding great favor with the mobile boys. It is an excellent "all around" tube and can be used as a "low-power" 2E26.—An



"This is portable-mobile station W9HAM, portable-mob . . . er — fixed-portable station W9HAM. Aw, c'mon, fellers — send out a tow-truck, I'm stuck!"

open wound loading coil has greater gain than a coil wound on a poly form, not much, but every little bit helps. General consensus of opinion seems to be that a coil less than 2" in diameter and wire smaller than #14 produce poor loading coils for 75 meters.—One antenna manufacturer has indicated that an open wound coil with larger wire will be produced which will be interchangeable with the present loading-coil.—For minute antenna adjustments, put a small telescoping section on top.—Remember if your signal increases with modulation when using clamp-tube modulation, 'taint adjusted right.—A BC454 or 455 can be sharpened

(Continued on page 56)

DX



AND OVERSEAS NEWS

R. C. SPENCELEY, KV4AA*

Our sincere congratulations to the following station on achieving WAZ:

274 **W6BUO** Harold Humbrock 40-121

We also welcome the following on their first appearance on the Honor Roll:

WIHA 37-172

ZL3CP 34-113

A few Saturday p.m. ZS contacts, each messed up in varying degrees by one or more "TESTERS", brings forth the following effort from your narrator—

Joe Blotz, W8TEST, was feeling fine, he had just gotten outside of a hearty Saturday lunch and DX was on his mind. Casting a quick glance through the window to see if his skywire was still airborne, Joe threw in the switches. With key down, the 807 final, after a few preliminary blue flickers, settled down to business as indicated by a soft glow from the antenna series flashlight lamp . . . Are we now ready to go? Oh no! All this is just a starter at W8TEST, the next five minutes are consumed with critical adjustments of the plate tank condenser et al., until the overworked lamp shows maximum brilliance (mostly imaginary). This effort produced, possibly, two more r.f. mils in the Hertz but now Joe is all set. . . And what follows now, kiddies? you guessed it . . . our hero embarks on a long winded CQ DX—Well, Joey boy, you sure got a swell signal down here, it's really cookin' with gas. It is S8, pal, and it was S8 from the very first BLAH—but that CR6 that started to call me is now just a broken dream—I'd been

**Send all contributions to R. C. Spenceley, KV4AA, Box 403, St. Thomas, Virgin Islands.*

chasing him a week too, Joey. Well mebbe I'll get another one someday but your type outnumber the CR6s' so much that my chances look mighty dim. . . And you wanted DX, pal? Well along with that CR6, ZS8MK was a kc lower and ZD1SD two kc higher, both CQing. . . Be nice, Joey boy—let's live and let live. . .

In The Spotlight

VQ1RF.—Justifying our January comment the Zanzibar "safari" has come through in fine style. The first half of their stay seemed to be limited to A3, worrying the c.w. boys 'no end' but during the latter half, plenty of hours were put in on c.w. to the satisfaction of the dot and dash gang. Thanks are due to the West Gulf DX club and contributors who forwarded VQ1RF a 4D32 bottle, first cost \$22. air freight \$20.65!!!

4UAJ is a recent arrival on the scene giving his QTH as Jammu, Kashmir (see QTHs). He puts in a T9 chirpy signal here around 1100/1200 GMT on 14110. At present, no comment on his country status.

FL8BC has been active on 14078 and heard, mostly on week-ends, on 14078. (See QTHs.)

EA9DC, according to Batista, PY7WS, should put on an appearance in Rio de Oro about January 15th. After an indefinite stay there he will continue on to IFNI. When this is read we hope it will not be news!!!

KH6QY/KC6 is now active in Ponape, Caroline Islands, 14098 T9. John will be there a year. This one is East KC6 and counts separate from Palau, KC6WC, etc. (See QTHs.)

AP2K—rattles the headphones here from Quetta, Parkistan, Karl is VFO (14092 1130Z) and says, QSL via D.A.C. He is ex DL3ZV.

It Seems That

Twenty has been the best DX bet with CE3AG

IISM, Feruccio Crespi, Varese, Italy, is shown here with the XYL in relaxed but efficient operating position. IISM runs a cool kw on 14 and 28 phone. Modulation by 805s Class B. Receiver is SX-28. Sights are set on phone WAZ with a present total of 37-137. Two and four element beams are used.



going up to 224 with VQ1RF and 4W1AC . . . K2BU grabbed KW6AR, VP8AU and VQ2AB in the CQ contest while W6CYI nailed PX1AA in same. . . VP3VN made VK3FH and VK3YP happy. Still lots of VKs after you. Vasco!!! W5AVF reports that VP2MD made his debut on 005 0250z (see QTHs), he was LU7CDs No. 200. . . VP2KM showed on 100 1750z. . . VK5MY nicked 3A2AP 110 1630z. . . FN8AD is fighting hard for Zone 9, we have YV5AE on his trail 105 1100z. . . VK6RU says scratch ZC2AA NG. . . VK3CX hooked ZD2FFB. . . There's a new op at ZS2MI, Marion Is., watch 14300 A3 1900z Sundays, according to W1DR, he has world's lowest AUDIO!! Van will be there until April (see QTHs) . . . FL8BC popped up the other Sunday, 078, 1830z, worked a couple of Fs then signed, leaving W4TO, W4DOC, W2AGW, W2BJ, W5EGK and W2CTO dangling—AGW got him the following week though. . . KG4AF says VP2LE, A3 xtl 333/284, is the only active one in St. Lucia.

W5FXN grabbed VP8AP and EK1AR to make it 142. . . We heard VK3JJ QSOing FM7WF, nice going. . . ZL3CP made Honor Roll with SU1GB, ZK2AA, VK9GW and FI8YB, tough missing ZD7AD though. . . W6MX received a hand-made QSL from FB8BB and added MP4KAE and FD8AA. . . ZL2GX needs FF3CN and UI8KAA QSLs for phone WAZ. . . W8SYCs 4/125As pulled in VP8AP and FD8AB. . . W4KE comes through with an all band list which includes VQ4DO, FQ8AE, SP3PF, OQ5RA, HC2KB, VQ2AB, FD8AB, FF8AC, CR7AF and CR7CI on twenty!!!!—W9BAE reports VQ5AU will be operating ST2EB this month 7/14 m.c. . . W9NN snagged VQ2GW, KT1OC, CR7CD, LA5ZC and EK1AD with the 810s but says conditions were bad. . . W9ESQ lists ZL3HI, 1PM, 3JA, 3OA, VK9XK and VP8AI among contest QSOs.

FD8AA came through with a QSL to KV4AA, Togo stamps and all. . . WØTKX received a card from OY5EL and nabbed ZP4BB A3 0528Z and VQ1RF. . . We hear there is a new prefix on the way—its XX3—Hold your seats Gents, its only old CR9. . . CR9AG will be XX3BD and CR9AH will be XX3BC. . . HB9EU reports JY1AY, VFO chirpy, is a new one in Transjordan, (see QTHs) . . . MP4KAE and LZ1RF rang the bell at W6UQQ, W6CUQ and W6CYI. . . W6UQQ says VQ5AU may be found A3 156. . . VQ4KIF has been batting 'em out from Kenya but is back at VQ3KIF now. . . W6ATO snagged UH8KAA 097 1515z, chirpy. . . VE3CCK comes up with ZS8MK, 034 1820z, CR5AD, 064 2000z, VK9GW, 096 2045z and ZS3E, 047 2020z. . . W5NMA took over CR6AV, 360 2300z, ZP7AW, 300 0110z, and ZS3Z, 315 0030z, all A3. . . W5GEL hooked YI3BZL, 004 1410z T8 and FL8BC, 060 1555z. . . W2AGW received a QSL from 4W1AC (W2YEJ). . . VK3YP was FY7YBs first VK. . . PX1AA netted 380 c.w. QSOs and 200 A3 during his stay in Andorra. With help from VS6CG, KV4AA at long last nabbed XU6F, 050 1100z.

Eighty

Not too much DX going on here according to W4BRB but we overheard Gene getting an RST 559 from VP8AO xband, AO being on 7001. . . A YV BC station blankets 3500 to 3509 until 0330 down this way, but between 3510 and 3522 is nice and clear. KG4AF reports KG4AD active on 3501, this suits Burt on 14 mc as AD is only 200 ft. away. . . W2QHH grabbed CT2BO on 3502 this gives Howie No. 90 here. . . ZD4AB plans 3.5 operation and wants skeds. ZL2LB and ZL2GS hooked FA8RJ in CQ test. Watch for GD3FB, low end, 0200z.

One Sixty

During the Dec. 16th tests the following were heard in the Virgin Islands, 0500/0700z: GW3ZV, 1792 569, W2WWP 579, W3OKU 469, W1LYV 589, K2USA 579, W1BB 569, VE2AIE 569. . . QSOs were noted between K2USA/GW3ZV KV4AA/W1LYV. . . PY7WS tells us his license bans 160. . . During A QSO Oct. 28th 0600z W9CVQ and KV4AA were heard 549 by ZL1AH and ZL1BY. W2QHH advises 160 xtls have gone to VP5BF, VP1AA, TI2PZ, VP5FR and PJ5RE!!!!—Heard at G2PL Dec. 23rd were W1BB, W2EFN, W3FDY and W1LYV (QSO'd). VE1EA recently dropped in on W1BB—we can imagine the topic of conversation—hi! . . . See you during Feb. 3rd and 17th, tests on 1997 kc.

CONDITIONS

Everyone talks about conditions but nobody does anything about it—We now take time out to bring you our "Conditions" poll covering QSOs on all bands since WW2. Our tally is approximate! ! !:

Conditions stinko	968
Conditions bad	12,552
Conditions poor	8,309
Conditions fair	56
Conditions good	6
Conditions excellent	0

Discounting the 6 who voted "good". (There are screwballs in every walk of life), we gather that conditions have been rather bad which is probably pretty good!!!!

Here and There

ZL2GX is optimistic over ZC2 activity in the near future. . . PJ5FN has held in his hands the document legalizing ham radio in Dutch W.I. They should be legit by now. A PJ QSL Bureau will be announced. . . VQ2AB made a flying trip visiting VQ2GW and the gang. Buggy plans to catch up on QSLing during his boat voyage back to England in April. . . VQ3BNU leaves for G-land the end of February returning to VQ4 in Sept. . . CE3AG moves to a new house so will be off the air for awhile. We hope Luis has now fully recovered from his November illness. . . G5LI should be firmly settled in VE2 now. Let's hear from you George.

Anyone got a spare BUG for FF8AG??? . . .



(At left) No stranger to us on the air is Ivan Pastre, F3AT, FE8AB, now located at FF8AG, Bamako, French Sudan.

DL3DZ/P 14 mc is on a whaler bound Antarctica way. . . ZS8MK 038, has skedded G5RI for five years now without a miss. Doc says let him know via the Bureau or G5RI if any QSLs are missing. . . ZB1BS has been plagued with wrong QTH announcement. He QSO'd 440 Ws during Malta stay and QSLs 100%. If any are missing, advise him at the address in QTH list. . . OY5EL is horrified that his legitimacy is questioned. He ran 500w to a pair 813s, (see QTHs). . . In letter to W6MX, OY3IGO states OY2Z, OY2A, and OY3R are OK but exclusively 3.5 phone. From W8JIN we hear that SU1GO QSLs via a friend in England and requests all cards via RSGB only . . . W1GKK advises FP8BX, before his recent passing, made around 2000 QSOs but was unfortunately unable to make more than just a few NFM phone contacts with gear sent by GKK. If any 8BX QSLs missing advise W1GKK QSO details.

In a joint meeting of the Northern and Southern California DX clubs, January 19-20, Larry LeKashman was slated to be the featured speaker. W6SAI showed slides of the PX and 3A2 expeditions. Slides of the 238-country W6ENV "TVI proof" transmitter were seen. . . We know of an LU station that got a QSL from CR5UP (CT1BW), it seems he had an airline friend who visited CT1BW and grabbed it!!!! (see QTHs). . . W6NIG bets W6RRG's CQ phone test score is high for North America, Don piled up 70,064 points. W6AM ran up 58,000 this time. . . W6TI's letter from VS9GB asks the boys to be patient and he will QSL 100%. . . On FH8AB's frequency we have heard a station signing FG8 and then switching to FM7!!! Wish he would make up his mind. . . On a visit to the Virgin Islands, W2AOZ

(Continued on page 58)

Below we feature a "DX GRAB BAG" giving a resume of DX stations recently heard or worked from North America: Times are GMT . . . Frequencies 14 mc . . . :

<u>C W</u>				
		VP3VN	082	2200
		VP5BH	7060	0100
AP2K	095 1100	VP8AD	001	0030
AP4A	060 1345	VP8AO	001	0000
CR5AD	064 2000	VP8AS	035	0200
CR7AX	098 2030	VP8AT	002	0000
DU1AL	040 1415	VP8AU	007	0030
DU1DO	052 1340	VP9AR	095	1945
EA9AP	010 2200	VQ2AB	001	2030
EAØAC	020 1715	VQ2GW	013	2100
EK1AR	020 0000	VQ3BNU	034	1800
F8EX/AR	050 1500	VQ4HJP	035	1400
FB8BB	060 1545	VQ4KRL	022	1525
F9QV/FC	093 1515	VQ8AD	010	1525
FD8AA	070 2100	VQ8CB	018	1530
FD8AB	050 2330	VS6CG	050	1100
FF8AG	000 2000	VS7GV	065	1450
FK8AL	085 1200	VS7NG	066	1400
FL8BC	078 1730	VU2BB	068	1430
FM7WF	082 1950	VU2EJ	025	1510
FN8AD	105 1100	VU2NB	056	1300
FO8AC	155 1530	XU6F	050	1100
FQ8AG	006 2010	XZ2EM	030	1445
FQ8AK	075 2000	YI3BZL	075	1430
FY7YB	050 1900	ZB1AJX	070	1515
GC2FZ	084 1845	ZC4DT	056	1700
HS1SS	098 1100	ZD1BM	040	1315
HZ1FH	080 1400	ZD1SD	098	1800
IS1FIC	020 1345	ZD2JAB	047	2220
JA8AB	027 2330	ZD6DU	050	1900
KH6QY/		ZS1LN	015	1940
KS6	098 0600	ZS3E	047	2020
KM6AW/		ZS6WO	030	2050
KS6	070 0630	ZS8MK	034	1820
LU5ZB	015 0300	ZS9G	076	2120
MI3DD	087 2015	4UAJ	110	1130
MP4KAE	050 1500	4X4CL	100	1435
OA4AH	VFO 0030	4X4DE	028	1430
OX3BI	007 1730	4X4DF	050	1435
OX3UD	025 2200			
PJ5RE	060 0450			
PK4DA	095 1130			
PY3QX	040 2335	CR6AL	340	1930
ST2GL	020 2000	CR6AV	307	1900
SU1GO	040 1400	CR6BC	200	1620
SU1SP	060 1455	CT1SX	320	2110
SU1XZ	060 1445	EL9A	343	2200
SV1SP	060 1455	MP4KAD	153	1400
SVØWP	085 1445	PZ1WK	390	2300
TA3FAS	045 1335	VK1BS	175	1445
TF3AB	075 2235	VP8AP	105	0300
UA9AR	106 1520	XE3BR	320	1535
UA9KOG	070 1100	YI3BZL	175	1315
VK1WO	094 1315	YN4CB	180	2310
VK9GW	096 2045	YU1AD	198	1340
VK9XK	110 1100	ZP7AW	300	0510
VP2KM	065 1445	ZS2MI	305	1955
VP2MD	005 0250	ZS3Z	315	0030

PHONE

We wish to thank the fine West Gulf, Northern and Southern California DX Bulletins from which some calls and items were lifted.

the

VHF

news

Conducted by
W. E. McNATT, W9NFK*

SPRING approaches, rapidly, fellows! Is the winter v.h.f. project nearly completed? The new beam, converter or transmitter should be all checked out and in service by April. Then you'll be all set! Well, at least I've reminded you *and myself!* My, how time zips by!

Two-Meter Beacon Stations

If present expectations materialize, two or three beacons may be activated in the late spring. W8WRN, Columbus, Ohio, started the ball rolling in our December column. He's planning, tentatively, to use 146 mc. In southern California, W6NCP, "Beck", states that he's all for the idea and may activate a beacon, *horizontally polarized*, to the east. Directional beacons could also be set up in the eastern states, such as New York, New Jersey, Connecticut, etc., beamed to the midwestern area. In the midwest, however, it would seem logical that beacon stations use omnidirectional, horizontally-polarized radiators so as to favor all directions; or, some areas could "pair up" on a directional basis. In the midwestern area, there are several serious-minded v.h.f. operators capable of activating beacons in Indiana, Illinois and Wisconsin. The same is true of several stations in the southern States. Why not give the idea a thought and drop a line to me within a week or so? Are there any VEs or WIs interested?

"Smoke Signals"

"Ol' Smoke", W8EP, Terra Alta, West Virginia, writes that his last good opening occurred on October 25, '50, when 13 stations in Indiana, Michigan and Ohio were worked. "Now, the boys are just not on!" writes "Smoke," who has been calling and listening every day. Weekly schedules are maintained with W8TDJ, ground-wave.

W8EP's p.p. 826s are working nicely with 250 watts, and Smoke says the signal reports confirm it. A 220-mc converter is in the works, but sensitivity requires improvement. The 420-mc rig is operating but, says W8EP, "I have the State *all to myself on vhf-uhf!*"

Over in Ohio, Jerry, W8WJC, Everett, reports that on-the-air activity has been minimized because RTTY, transmitter construction for a local ham, and experimentation with 1215 and 2400 mc. gear.

"The uhf gear is activated for contests," says

Jerry, "and the 220 and 420 mc rigs are operative but activity is so low that it takes a *phone* call to get a contact! This kills my interest deader than a duck! Still hope that some technicians get on, locally, with stable gear!" So, if you're in the Cleveland/Everett area and are on 220 and higher, let W8WJC know about it; see what you can stir up. Margaret, W8BFQ (XYL-W8WJC) has been active on 2, but is not carrying schedules this winter. She hasn't had the usual DX, so far. Probably the result of inactivity rather than conditions.

Australia VHF - 6 Meters

Our DX Editor, Dick Spenceley, KV4AA, reports VK9XK has worked VK3UI, VK4BT and VK2WH for the first 6-meter QSOs between VK9 and these districts—Congratulations!

What Happened to the Six-Meter Gang?

This inquiry was originated by Phil Patterson, W5SFW. The answer is, from this point, that relatively little 6-meter activity has been *reported*. But, such activity that has been reported *has* appeared in the column. Accordingly, Phil's report is *very welcome*.

W5SFW reports hearing and working W6WSO, the only signal, on November 19 at 9:15 PM CST. On November 20, Phil's CQ was answered, he believes, by W8CMS, Claire, whose signal faded. On November 25 the band opened to southern California and W6QUK, KUH and TMI were heard between 7:20 and 8:00 p.m., CST. Later, Phil found that Bud, W5FSC, Houston, had heard him at 7:00 p.m. On the 26th, conditions were good to southern Texas, but W5FSC was the only station heard. W5MJD, Amarillo, QSY'd to 10 and got W5GYP, Edinburgh, on 6. He called W5GYP, but the band was folding. The opening lasted from 7:35 p.m. until 8:30 p.m., CST.

On December 2nd, 6 meters was wide open to the Pacific Coast. Between 7:25 and 8:30 p.m., CST, W5SFW worked W6WSQ, IF, TMI, EIB, IWS, ANN and W7HEA. Because of other commitments, W5SFW had to QRT at 8:30 with the band still open! During the opening, W6TMI, Orin, mentioned that TV channel 5 was being QRM'd which is evidence that the MUF was quite high for wintertime sporadic-E, says Phil, who adds, "Have worked a number of fellows on 10 that will be on 6, soon; they hope! These include VE5LZ, Yorkton, Sask., and KH6AHU, Honolulu. Next summer, sure? Activity is really low on

*Send all contributions to W. E. McNatt, W9NFK, 2433 Elder Lane, Franklin Park, Ill.

6. Have called, many times, when signals should have popped in! Wish somebody would get on, next summer, in North Dakota, Nebraska, eastern Kansas and Oklahoma! Also, in spite of the expeditions; last year (1951) to Nevada, that state is still needed, badly!" (Write to W9EET, Gordon Stars, 6426 Peoria St., Chicago, Ill., for a new-state schedule; Gordon operates portable on 6, during vacation. -VHF Ed.)

"Megacycle Acres"

The above, Sir, is the name of WØINI's QTH at Pleasant Hill, Mo. Harry is the only active v.h.f. operator at present, but is interested in contacts on 144 and 430 mc. "Can't seem to get the Kansas City boys fired up on 432 mc. WØMNQ did finally hear me, but later found out his receiver wasn't up to par! I'm all ready to go; just throw the switch!" says Harry. The rig is an APQ-66, 18 watts input, and an APS-13 receiver.

A good opening hasn't been caught on 144 mc for quite some time now, according to WØINI, who states, however, "Of course, the Kansas City stations come in, here."

Until last year, Harry's location was poor; he is now situated on the highest hill in town. The rig consists of an ARC-3 transmitter, a VHF-152A into an HRO-5AT1; the antenna consists of a 16-element array on the east side of a 50-foot steel tower.

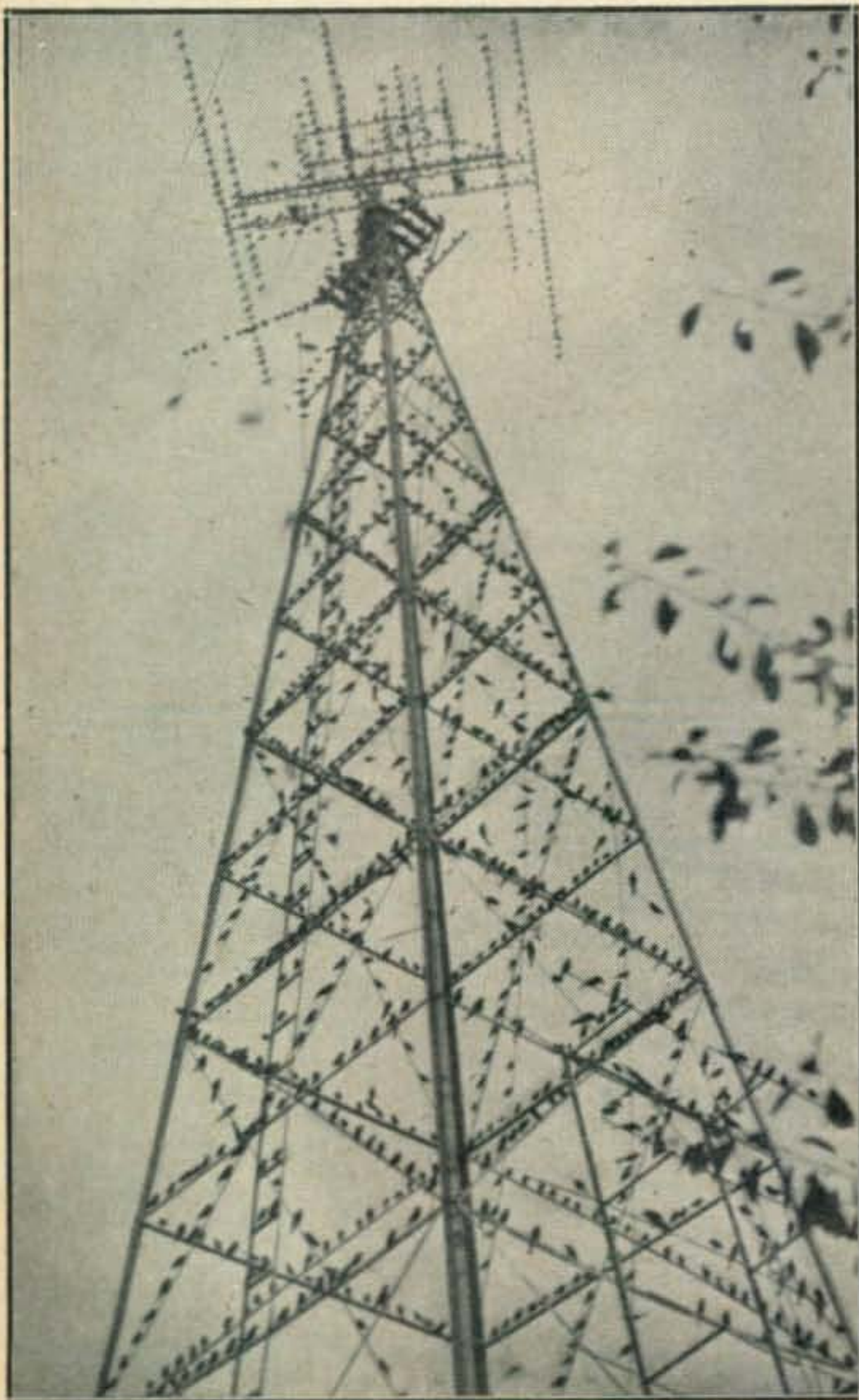

(Photo by Bernice May, W5JKM.)

After a 2-year wait, Harry recently got Nebraska for #48 state on Six!

Little Rock Hams Maintain VHF Activity

"Whit," W5HAA, is active on almost every night and listens in all directions because, he says, "This is necessary, since no other stations are known to be on (v.h.f.), except in Little Rock. It takes a minor opening to get out of the State!"

W5EMZ is involved, deeply, in building a receiver that will compare with WØBJL's converter; so far, many "bugs" have prevented this. But, W5EMZ is active, every night, regardless of conditions As for WØBJL, he is now established in Little Rock with the call W5TOE and should be very active by the time you read this W5VX is on, only occasionally, along with W5FAL and W5OCP. (Willie! Helen and I still intend to write you! Tell W5DVI to get off of the coil-and-condenser-bands and enjoy v.h.f.! —Ed.)

"Whit" hopes for more activity, and believes that better receivers—and a better understanding of them—will encourage more activity. Agreed, Whit!

Announcement! — Fanfare!!

"DB"—the lovely and popular XYL of W4HHK received her Novice Class License, WN4UDQ, in early December! Equally popular "Poppa" and v.h.f. DX-shooter, W4HHK, Paul, states that "DB," is active on 3745 kc and on 145.35 mc! Congratulations, "DB"; just stick to that *c.w.* and get the General Class license *before* you succumb to the 2-meter, 75-watt phone rig that Paul wants you to use because he won't be on, at nighttime, until April or May! How-some-ever, ef'n you do just get the chance to get on 2 on a "good" night, we'll surely be lookin' for ya! (This should reactivate W9WOK!) Paul, W4HHK, hopes to be active on Tuesday, Thursday and Friday nights, at this writing.

W5JTI, Tim, has little time for DX-ing but does get on, especially during week-ends, according to W4HHK who also reports that W5RCI, Marks, Miss., is active almost every night in spite of some TVI; he's in the fringe area of the Memphis TV station. Two-meter activity, in the opinion of W4HHK, will pick-up, slowly, in the Memphis area, aided by the Novice Class licensees. Paul reports that the Little Rock gang gets on, frequently. (See "Little Rock Hams Maintain VHF Activity", these pages. -Ed.)

W4HHK further reports that 420 mc activity is low, at present, "But, time permitting, we'll have something to report, later on." The 50.1 mc Raso Coop beacon has been inactivated since October 1, but at least one "ear" remains *activated* on the band! As a parting comment, Paul states that the W4HHK/WN4UDQ 5-over-5 Yagi array is rotatable, 80 ft. above ground, at one of the highest

Leroy May, W5AJG, says, "Did you ever have to argue with anyone that amateur radio was not for the birds? If so, that's bad! The above picture shows, definitely, that ham radio is for the birds, literally!"

spots in Collierville, Tenn. The 2-meter receiver is still good, p.p. 6J6 r.f., 6J6 push-push mixer, crystal-controlled, into an NC-183.

Baton Rouge Briefs

Thanks to W5MKP, we find that two-meter activity is steady and that the boys are improving gear. Since W5EVQ, Alexandria, improved his whole set-up, he puts a solid signal into W5MKP . . . W5GIX, by this time, should have his new antenna and higher power on . . . W5HEZ, 6-meter stalwart, is preparing for some 2-meter activity with completely separate gear so that he can stay active on 6 . . . Rad, W5MKP, keeps schedules nightly with W5QIO, Beaumont, Texas, W5HCM, New Orleans, and W5EVQ, Alexandria, La. As for the big opening, last October, Rad says he got home from a ham meeting just in time to hear W4LRR fade out while in QSO with W5AJG. However, on the second night, W5MKP worked W4KIP, Atlanta, for a total of 6 states, 3 call areas and 650 miles DX for the VHF Scoreboard.

In Oil City, W5ML complained in mid-winter, "Nothing going on on v.h.f. in northern Louisiana; they've all quit 144 since last summer, just like they quit 50 mc about 2 years ago!" Too bad, Art, but maybe they'll come back.

W5DXB, Vivian, is on 422 mc as is W5ML. The antennas are 16-element colinear arrays 45 feet high, fed with 300-ohm line. The transmitters are 2C39s in push-pull, modulated oscillator with about 60 watts input. W5DXB uses a 6J6-6J6 W1HDQ converter and W5ML has a converted BC645. Contacts have been maintained since last July with consistent S9 plus reports both ways over the 9-mile path. Both stations hear the Barksdale Field weather balloons for over an hour and a half after release, which is about 25 to 40 miles in slant range. But, as Art points out, they're high and in the clear; on the other hand, the power is very low. Both stations would be glad to line up schedules with more distant 420 mc stations.

W5ML's report to the *VHF-UHF DX Scoreboard* is: Six Meters, 44 states, 4 countries, 10 call areas, plus VE1 2, 3, 4, 5. Two Meters, 9 states, 3 call-areas and DX, 750 miles. Send in your score, too; we're resuming the 6 and 2 Meter Scoreboards.

VHF Topics In Texas

WN5TFW, John Naff, Port Neches, reports that a December 5th opening to the west brought contacts with W5JBW, ONS, TAF, HMM, FSC, FEK, PMM, AXY, WNs, 5TNJ and TQP. W5s IVU and NHB were heard but not worked at WN5TFW. W5ONS was still strong at 2300, when John had to QRT for work. Houston stations were calling W5QER(?) in New Orleans. W5JBW and EVO were filling their logs at a fast rate. Corpus Christi stations were heard well. The DX wasn't outstanding, but a lot of nice contacts were made which enlivened interest.

W5DSB is expected back on 2 . . . W5QIO is putting the new transmitter through its paces . . . W5STP certainly supports activity . . . W5AVW

rounds up the Gulf Coast Emergency Net regularly . . . Activity in Port Arthur and Orange has subsided . . . It's reported that *MARS* will activate a frequency near 2-meters so the WNs can operate on v.h.f. as well as on 3497.5 kc . . . W5JBW, Maplewood, La., has W5IYG on 2 and is trying to secure his interest . . . WN5TFW's beam is at last outside, in the air. John needs only to pass the c.w. test for General Class; he's already got the Technician rating. Keep plugging, OM!

Up in Dallas, W5AJG reports that general v.h.f. activity dropped off during the winter months, as it seems to do almost every where else, but that 6 meters was lively on December 2. During the afternoon, W6WSQ, TMI and EIB came through, and an attempt was made to repeat last summer's W5-W6 2-meter contact, but nothing was heard in either direction. Last November 20 and 21, W4LAW and FNR came through at about 7:30 p.m. CST.

Leroy has received a lot of encouragement from the 6-meter gang to resume the RASO coop beacon this coming summer. He wonders if you would send a postcard with your thoughts on the matter. As for reports of beacons or any v.h.f. activity, I'll be glad to report them, here. A great service such as the beacons must be encouraged and supported.

VK/ZL 144-MC Record

On December 15, 1951, there was a 144 mc QSO between VK2AH and ZL3AR at 0830 GMT. The QSO lasted 7 minutes and signals were between S6 and S8. On the same day the 50-mc band was wide open in VK3 with all districts coming through and the ZL stations coming through from about 5 p.m. till 8:30 p.m. VK3CP worked a half dozen ZLs. ZLIUZ said that VK3CP was his 28th VK, ZLIUZ also QSO'd VK9XX.

Two-meter activity at W5AJG involves contacts with the Texarkana stations, about 180 miles, and locals within a 30-mile radius. 420-mc activity is growing. W5TJE, Dallas, has worked W5AJG and, although they're the first on 3/4 meters in the Dallas area, they may be followed, soon, by several of the gang at *KRLD-TV* who are busy with building or converting. 420-mc gear at W5AJG consists of a converted ASB7 into an SX43 tuned to the FM band. The transmitter is an APT5, modulated oscillator. "I can see that crystal control is going to be a necessity on 420," says Leroy, "I can get another 522 and get started. The AX-9903 is still expensive for the amateur, and I'm still casting around for a less costly combination."

220-mc gear at W5AJG consists of a 522 with about 8 watts output. An 829B amplifier, if successful, will be superceded by p.p. 826's. 4-65A's are available, but the aim of the project is to determine what can be done with cheaper tubes so that more of the fellows might have a chance to get on. Leroy will report his progress.

In Fort Worth, W5CVW has revised his beam

plans and expects to be in business with a less wind-resistant beam than the originally planned 16-element array. W5DFU built and delivered, in person, a beautiful 4-over-4 stacked Yagi array. At W5DFU's QTH, an identical array has proven itself by withstanding a 70-mile per hour blow and a 2-inch ice-storm.

W5FEK, Waldo Townley, says that the Houston gang certainly enjoyed the 2-meter Gulf Coast opening on December 5th, the band being wide open from New Orleans, La., to Austin, Texas. It made little difference which way one's beam was pointed, according to Waldo, the signals just came through. The opening was considered as "rare" for the wintertime months in Texas. (Please refer to my January column. -VHF Ed.) Participating in the abnormal propagation session were W5FSC, PMM, LLT, QMY, NHB, HMN, FEK, WN-5TQP, TNJ in the Houston area; W5AXY, BDT and BWQ, Austin; W5IVU, Edna; W5ONS, Victoria; WN5TFW, Port Neches; W5EVQ, Alexandria, La.; W5JBW, Maplewood; W5QER, New Orleans; W5STP and QIO, Beaumont, Texas. W5MKP, as usual, when there's a slap-bang opening, was at the radio club meeting in Baton Rouge. He claims "it happens every time!"

W5TAF now has his 4-65As operating with about 300 watts input . . . PMM's 15 element beam is 50 feet in the air . . . W5AXY, Austin, and ONS, Victoria, now use 4-125As . . . Recent additions to the southern Texas gang are: W5GSL, GOZ, HMN; WN5, TQP, TNJ, TNK, TWS, TPP and W5TEQ . . . W5QMY is checking out a BC645A converted for 420 to be able to join W5s AYU, IRP and UW . . . 220-mc activity is supported by W5s AXY and BDT, Austin; W5UB, San Antonio, is expected on, soon.

Regarding normal 2-meter activity in the Houston area, W5IRP reactivated the 2-meter gear after Christmas. W5FSC, BDI, TAF, ON, FEK and EEX keep the band alive . . . W5FEKs' Christmas present was a nice Argus C3 camera, and Waldo says that you can expect to see some pictures with his reports, in the future . . . Two-meter contacts into Austin, Victoria and Edna were maintained throughout the midwinter months; also, W5JBW and QIO were heard almost nightly.

Steve, ex-HC2OT, was in Houston in late December; reports are that Cubas' climate disagreed with his operation.

W5FEK qualified for the "2-meter Century Club", if there is such a thing. Waldo has 100 confirmed and 38 unconfirmed (by QSL) contacts on 2. *(One of the unconfirmed contacts was with one of those examples of the human race who prides himself on the principle that he won't QSL "anybody!" W5FEK is not the only victim. I well recall the night that a new state was worked and this so-called ham glibly promised QSLs "for all, just as soon as my new cards come in!" That was over two years ago, and neither I, nor the rest of the gang who worked this character have had one written word. Pressure of personal and business affairs comprise an honest excuse for delay of*

QSLs; right now, I'm behind several months, myself, but the cards will be sent, per promise. As for these "characters"—if you do not intend to QSL, be man enough to say so, instead of promising! -VHF Ed.)

Canadian Capers

According to Iris Weir, VE3DER (XYL-VE3AIB) the Toronto gang is happy to work the new WN's who are becoming increasingly active in the Buffalo/Rochester area. Other new contacts are far and few between, says Iris. The usually reliable Ontario v.h.f. gang "seem to be busy on other projects, for we certainly don't hear much from them," reports VE3DER. Extended-range, tropospheric openings during 1951 were not equal to those experienced during 1950, in Iris' opinion. She states, "VE3AIB was unable to log a single new state, nor has anyone else in our VE3 area been able to do so, to my best knowledge."

VE3DAV and DAT, of the Blue Arc Amateur Radio Club, have had a lot of fun with their 6-meter walkie-talkie units. While travelling on a Toronto street car, they worked VE3AIB! The walkie-talkie rigs have really proven their usefulness in the simulated National Emergency Test.

VE3BOW has moved, finally, but only to temporary quarters. We expect to hear more from Norm as soon as he is settled. (Ed. Note: Sorry the Oakville "Do" date was published as January 19th instead of the 18th; hope it didn't inconvenience you too greatly.)

Around Chicago

Sympathies of the Chicago-area gang were extended to W9OS, Dr. Richard S. Rae, on December 10, 1951, when his wife, Dorothy Atchison Rae passed away most unexpectedly. Sons; Richard J., John and George carry on. On the same day, W9BYQ, Dr. E. L. Masterton, also passed away. An old-time amateur, "Doc" had also been very active in CAP work.

Activity has been improving steadily. During the first nine days of December, more stations were worked at W9NW than in the entire month in 1950. Contacts were made with W9EGH, Goshen, Indiana; W9DHJ, Crown Point; W9HDB, Valparaiso, W9DLI, Hobart; W9LJV, Waukesha, Wisconsin; W9TQ and BTI, Milwaukee; and W9FAN, Sheboygan as well as 18 or 20 "locals," according to W9NW.

W9NW scored Contact #5000 on two meters on December 9, 1951, when he worked WN9PUW! Bob wonders what his prize is! Ken says it'll be the drip pan for the old grid leak, if he can find it.

W9DHJ and DLI alternate between 80 and 2. DLI expects to be more active now that the home repairs are done . . . EGH still looks to Chicago for contacts, finds few. Put your beams on Goshen, fellows . . . JGA and CX like their new crystal converters very much; good stability . . . VNW will be on 2 all winter; keep him company . . . TQ, on vacation, enjoyed night-time QSOs for a change.

(Continued on page 56)

Ionospheric Propagation Conditions

GEORGE JACOBS, W2PAJ*

During February the sun continues its travels towards northern skies, and as it does so, its distance from the earth is also increasing. These astronomical phenomena have their associated effects on radio propagation. As the distance between the sun and the earth increases, the intensity of the ultra-violet radiations received by the ionosphere from the sun decreases. This results in lower peak daytime maximum usable frequencies than during the winter months. As the sun travels into more northern regions, the hours of daylight in the Northern Hemisphere increases. This means that the ionosphere will receive ultra-violet radiations for a greater period of time and results in daytime high frequencies (twenty meters) being useful for a longer period of time.

The forecast for February is for DX possibilities on all bands, but becoming poorer on ten, improving on twenty, and generally about the same on forty and eighty as during the winter months. The predicted smoothed monthly sunspot number for February is 54.

I would like to thank the many persons throughout the world who have sent CQ their observations of propagation conditions during the CQ-DX contest. It is most gratifying to know that the prediction tables and suggested work plan worked out so well. With very few exceptions, all the reports analyzed show agreement within a half hour, to predicted conditions. The c.w. period, November 3-5, was forecast as a disturbed period, the 3rd was observed to be slightly disturbed and the 4th severely disturbed. Conditions for the phone period, October 27-29, were forecast as falling between two disturbed periods, with a disturbance expected October 29. The disturbance actually started a few hours earlier when on October 28th at about 1600 GMT it was observed that most east-west circuits went out.

Your observations and comments on these monthly forecasts are sincerely requested. It is actual report analyses that makes it possible to check and increase the accuracy of propagation forecasts.

*3620 Bedford Ave., Brooklyn 10, N. Y.

Last Minute Ionospheric Storm Predictions

Below normal radio conditions are expected February 1-6, 20, 22-24 and 27-29. February 9-12 is expected to be very erratic. Ionospheric disturbances effect, to a far greater extent, transmission paths through or near the auroral zones, and they have little or no effect on other transmission paths.

General Propagation Conditions for February, 1952

The following is a brief description of expected propagation conditions for amateur circuits from the United States to the five major areas of the world for February, 1952. For times of band openings for any particular circuit refer to the *Propagation Tables*.

EUROPE

Daytime maximum usable frequencies on these paths are on the decrease. On ten meters some openings to Europe are expected from the East and Central sections of the USA to Europe. On many openings the Southern European stations will be heard very well, while no Northern or Central European stations are audible. For the most part, this will be the last month until next October that these circuits will open with any regularity on ten meters.

Conditions to Europe on twenty meters are improving. With increased hours of daylight, the band is expected to stay open until about 2300 GMT, with circuits possible to all areas of the USA.

Both 40 and 80 should hold up fairly well on an all dark path. Strong signal levels should be noticed just before sundown local time. When European signals are not heard on 40 meters be sure to check 80, as many times the MUF will drop below 7 mc but still be above 4 mc.

SOUTH AMERICA

These North-South transmission paths are usually very stable circuits. This is so because the circuit control points are located in southern regions where radiation from the sun is relatively intense. This radiation creates a rather stable ionosphere, which in turn produces good solid radio circuits.

Good daytime DX conditions are expected for 10 and 20 meters from all areas of the USA to all areas of Central and South America.

Good conditions are also forecast for night circuits on 40 and 80 meters, especially to countries north of the equator. These bands are most useful for these circuits just after sundown to just before sunrise local time.

AFRICA

These circuits clear the auroral absorption zones by considerable distances, and have control points that also are located in southern regions. It is expected that ten meters will open more frequently to Africa than to Europe, and many times the Africans will be coming through when the Europeans will not be heard.

(Continued on page 61)

FEBRUARY 1952

EAST COAST TO: (Centered on Washington, D. C.)	10 Meters	20 Meters	40 Meters	80 Meters
ALL TIMES IN GMT				
Scandinavia	1500-1700 (0-1)	1130-1300 (2) 1300-1800 (1) 1800-2000 (2-3)	2200-2330 (3) 2330-0800 (1)	2230-0600 (2)
Great Britain & Western Europe	1500-1700 (1-2)	1130-1430 (3-4) 1430-1900 (2-3) 1900-2130 (3-4)	2200-0600 (4) 0600-0800 (1-2)	2230-0600 (3)
Balkans	1300-1700 (2)	1100-1300 (3) 1300-1730 (1-2) 1730-2200 (3)	2200-0400 (3-4) 0400-0700 (1-2)	2230-0600 (2-3)
Southern Europe & North Africa	1430-1830 (3)	1100-1300 (3-4) 1300-1930 (-2-3) 1930-2300 (4)	2230-0400 (4) 0400-0730 (2-3)	2330-0700 (3)
South Africa	1430-1830 (3)	1100-1900 (1-2) 1900-2300 (3)	2300-0300 (2)	2330-0300 (0-1)
Near East	1400-1700 (2-3)	1130-1800 (1-2) 1800-2000 (3-4)	0000-0430 (2-3)	0030-0400 (1-2)
Central America & South America, Northern Section	1400-1700 (2-3) 1700-2300 (4-5)	1100-1500 (4-5) 1500-2100 (3-4) 2100-0100 (4-5) 0600-0730 (2-3)	0000-1030 (4-5)	0030-1030 (4)
South America	1230-2230 (3-4)	1100-1300 (3) 1300-2200 (1-2) 2200-0200 (4) 0600-0830 (2)	2330-1000 (3-4)	0000-0930 (2-3)
Hawaii	1800-2300 (3-4)	1400-1700 (2-3) 1700-0000 (1-2) 0000-0400 (4)	0400-1300 (3-4)	0430-1200 (3)
Oceania	2200-0000 (0-1)	1130-1300 (2-3) 1300-0000 (1-2) 0000-0300 (2)	0800-1300 (2-3)	0830-1230 (1)
Japan	Nil	2030-0000 (1-2) 0000-0200 (2-3)	0900-1130 (1-2)	0930-1100 (1)
India	Nil	1200-1500 (0-1) 1500-1600 (1-2)	2330-0130 (1) 0930-1030 (0-1)	Nil
Philippine Islands & East Indies	Nil	2130-0200 (0-1)	1000-1130 (1)	Nil
West Coast USA	1900-2200 (1)	1500-2000 (2-3) 2000-0130 (4-5)	0130-0600 (4-5) 0600-1200 (1-2) 1200-1400 (2)	0130-1230 (4)
CENTRAL USA TO: (Centered on St. Louis, Mo.)	10 Meters	20 Meters	40 Meters	80 Meters
ALL TIMES IN GMT				
Great Britain & Western Europe	1600-1700 (1-2)	1230-1500 (3) 1500-2000 (2) 2000-2100 (3)	2300-0100 (3) 0700-0800 (1)	2330-0730 (2-3)
Central Europe	1530-1800 (1-2)	1300-1430 (3) 1430-1800 (2) 1800-2000 (3)	2300-0100 (3) 0630-0730 (1)	2330-0700 (2)
Central America & Northern So. Amer.	1600-0000 (3-4)	1300-1630 (4-5) 1630-2300 (3-4) 2300-0300 (4-5) 0700-1030 (2)	0000-1400 (4-5)	0030-1330 (4)

FEBRUARY 1952

CENTRAL USA TO: (Centered on St. Louis, Mo.)	10 Meters	20 Meters	40 Meters	80 Meters
	ALL TIMES IN GMT			
South America	1400-0100 (4)	1100-1400 (3-4) 1400-2200 (2) 2200-0230 (4) 0600-0830 (2-3)	0100-1100 (3-4)	0130-1030 (3)
Hawaii	1800-2300 (3)	1430-0200 (2) 0200-0400 (4-5)	0400-1230 (4-5)	0430-1200 (4)
Oceania	2300-0100 (2)	1400-1800 (2) 1800-0200 (0-1) 0200-0400 (2-3)	0900-1230 (1-2)	0900-1230 (0-1)
Japan	2300-0000 (1)	2030-2130 (1-2) 2130-0130 (0-1) 0130-0300 (2-3)	0900-1230 (2-3)	0930-1200 (1-2)
Southern Europe & North Africa	1500-1900 (3)	1130-1400 (3) 1400-1900 (2-3) 1900-2230 (3)	2300-0800 (3)	2330-0730 (2-3)
South Africa	1500-1900 (3)	1130-2000 (1-2) 2000-0000 (3)	0100-0300 (2)	0100-0300 (0-1)
Philippine Islands & East Indies	Nil	2100-0100 (0-1) 0100-0230 (2)	1000-1230 (1-2)	Nil
India	Nil	1400-1500 (1) 1500-2100 (2)	0000-0130 (1) 1200-1300 (1)	Nil
WEST COAST TO: (Centered on Sacramento, Calif.)	10 Meters	20 Meters	40 Meters	80 Meters
	ALL TIMES IN GMT			
Europe	Nil	1500-1730 (1) 1730-2000 (2-3)	0200-0500 (1-2)	0230-0430 (1)
South Africa	1700-2300 (2-3)	1300-1900 (0-1) 1900-0200 (1-2) 0200-0400 (3)	0200-0400 (1-2)	0230-0330 (0-1)
South America	1600-0030 (3-4)	1300-1600 (3-4) 1600-2300 (2-3) 2300-0400 (4-5) 0800-1030 (2)	0230-1100 (3-4)	0300-1000 (2-3)
Hawaii	2000-0100 (2-3)	1730-0000 (3) 0000-0330 (5)	0300-1530 (5)	0330-1430 (5)
Oceania	2000-0300 (3)	1600-1830 (2-3) 1830-0500 (2)	0800-1600 (2-3)	0830-1500 (1-2)
Japan	2200-0200 (1-2)	2030-0200 (1-2) 0200-0600 (3)	0730-1600 (2-3)	0800-1530 (2)
Philippine & East Indies	2300-0200 (3)	1830-2100 (3) 2100-0300 (1-2) 0300-0600 (2-3)	1100-1300 (2)	1130-1300 (0-1)
Guam	2100-0200 (3-4)	1930-2100 (3) 2100-0330 (1-2) 0330-0530 (3)	1000-1500 (3)	1030-1430 (2)
Alaska	2100-0100 (2-3)	1730-0200 (2-3) 0200-0500 (3-4)	0500-1500 (4)	0530-1430 (3)
Marshall Islands	2000-0200 (3-4)	1900-0300 (2) 0300-0500 (2-3)	0700-1500 (3)	0730-1430 (1-2)

Symbols for Expected Percentage of Days of Month Path Open:

(0) None (1) 10% (2) 25% (3) 50% (4) 70% (5) 85% or more.

Souping Up the T-17

The T-17 microphone is used in the majority of amateur mobile phone stations and also appears in many fixed stations. Its availability, low cost, and convenience of operation have given it wide acceptance; but it still has one serious drawback—the quality is far from pleasing. Many amateurs have tried to overcome this fault by wedging the T-17 to an F-1 button, but the comparatively large size of the F-1 button makes this an unsightly combination in the average conversion.

It is possible to combine the F-1 button and the T-17 case in a neat and attractive manner and at very low cost. The only additional material required is an empty half-pound Calumet baking powder can and a small amount of battleship gray airplane dope. Tools needed are a pipe reamer, a

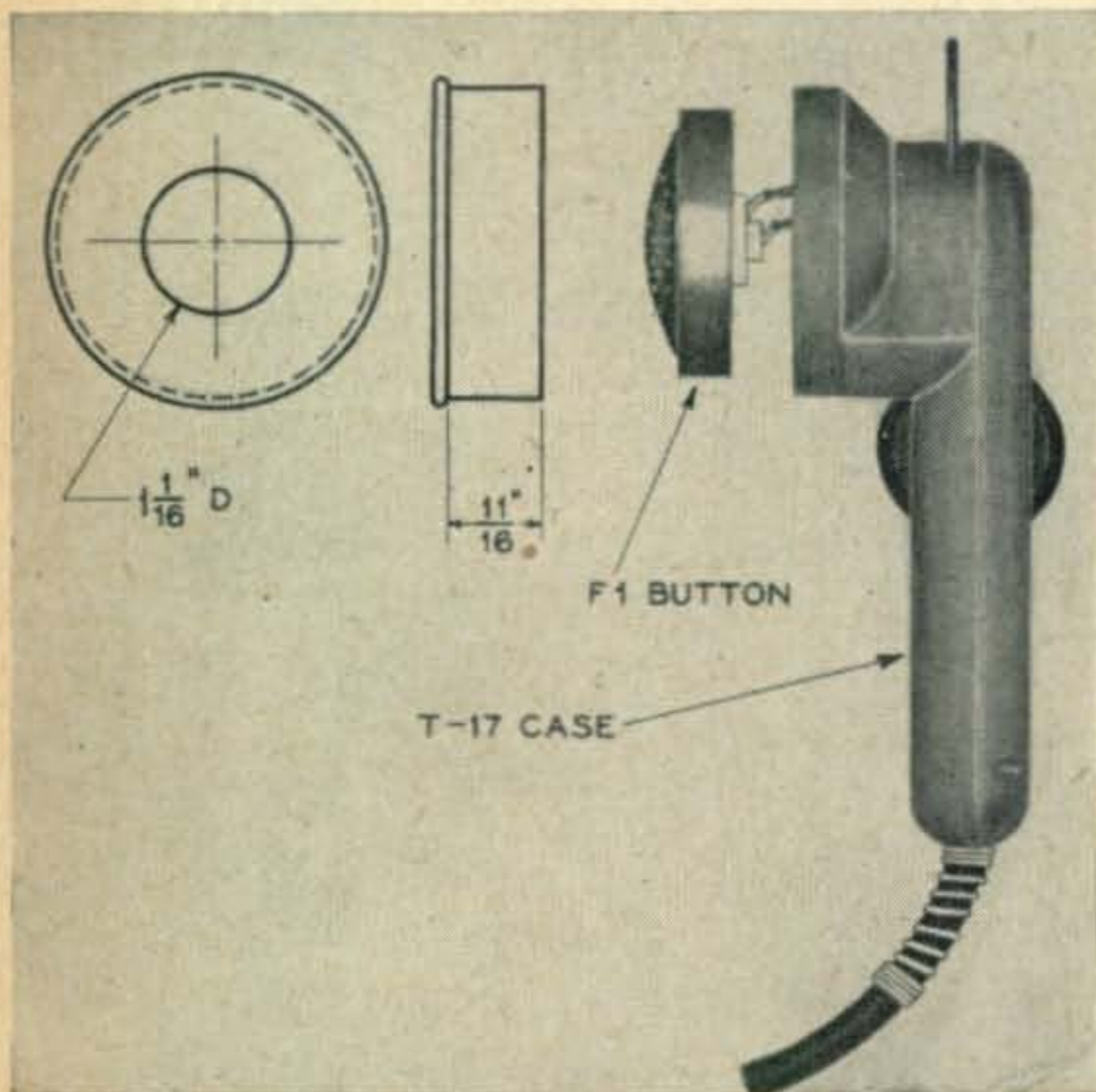

hacksaw, and a small paint brush. Ream a $1\frac{1}{4}$ " hole in the center of the bottom of the can, then cut the can off at $22/32$ " above the rolled lip at the bottom. Remove the original microphone button and solder in the F-1; then slide the can over the microphone case. You will find it to be a snug press fit. It will be noted that the Calumet can will exactly fit over the plastic handle model of T-17 but is a trifle large for the metallic; a layer of plastic tape over the microphone will facilitate a snug fit. Two coats of airplane dope over the entire microphone will result in a professional-looking job that will grace any ham shack.

Carl C. Drumeller, W5EHC/AF5EHC

Push Button VFO Setting

When you find it necessary to zero-beat your VFO with an incoming signal it is desirable to apply power to only the oscillator, leaving the buffer and multiplier stages idle. The ordinarily complicated circuit can be made very simple by using a push button on your receiver to supply oscillator plate voltage from the receiver itself. If you use the Clapp circuit the voltage need only be of the order of 20 to 30 volts.

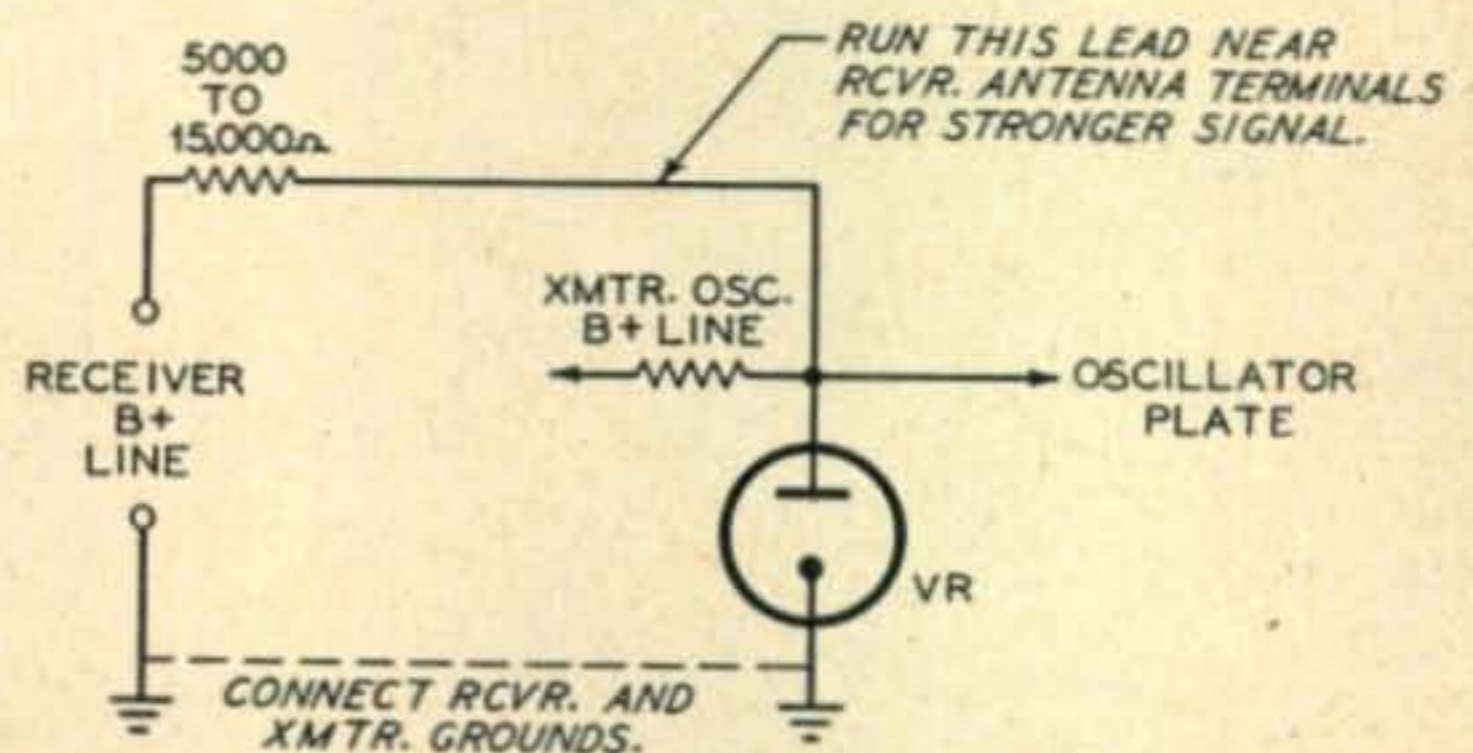

The main advantage of the push button over a toggle switch is that you are less likely to forget it—especially in a crowded band during a contest.

The signal from the average VFO should be about S6 or 7 in the receiver. If you need a stronger signal run the plate voltage lead near the antenna terminals. By the way, this assumes that your receiver has a good power supply and your oscillator in the receiver is stabilized—otherwise you would end up chasing yourself around the band.

Harald Bernhardt, OE-341
ex-LY1HB, RY1HB, OE7CA

A Simple RF Meter

A simple RF meter that will read relative values can be made from an old O-1 to O-5 ma meter, a IN34 crystal and a B&W 3016 coil. The full scale reading can be increased or reduced by either varying the spreading or increasing the turns of the inner coil, which should be covered with cambric

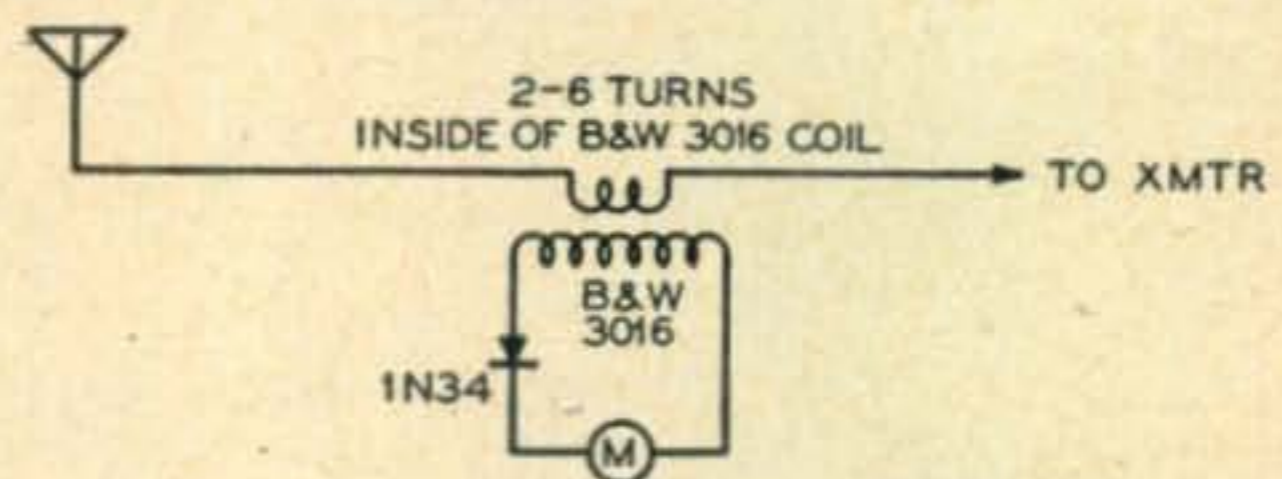

tubing. It may be necessary to reverse the polarity of the IN34 to obtain proper deflection of the meter needle. It is not suggested for use at the higher frequencies where the inner coil might change the antenna impedance.

Robert C. Green, W3RZD

Latest Releases From The FCC

The "RACES" (Docket 10102)

It is impossible to completely reprint all of this 17 page proposal. Some of the major points, however, are mentioned below. In general, it is a vast improvement over the World War II WERS. Careful study shows that the Government, in the proposal, evidences considerable trust in the amateur ranks. Although this is a proposal and briefs may be filed by any amateur commenting on the structure, etc. on or before 15 February 1952, there appears little left for the singular amateur to do. However, see that your CD coordinator is fully informed regarding this proposal and that he understands its policies and operation —Editor.

Proposed Regulations

The Commission, on January 17, 1951, issued a public notice to the effect that certain regularly allocated amateur frequency bands, named in the notice were to remain available for use by amateurs to provide for their participation in a civil defense radio-communications service, in the event normal amateur operation should be discontinued because of intensification of the national emergency. Prior to release of this public notice, it was agreed that to call upon the resources in radio equipment and trained operators which now comprise the Amateur Radio Service would undoubtedly yield a large nucleus of man-power and equipment which could prove invaluable in an emergency.

The new rules proposed provide for a new temporary amateur radio service designed to afford radio communication for civil defense purposes. These rules contemplate that persons now holding amateur radio licenses shall apply for an additional authorization to operate in the new service in order to participate in civil defense communications activities. Authorizations for individual amateur stations to operate in the Radio Amateur Civil Emergency Service will be granted upon the express understanding that such grant is subject to change or cancellation at any time without hearing if, in the discretion of the Commission, such action is deemed necessary for the national defense and security, and with the further understanding that the Commission, when normal conditions are restored, may terminate the Radio Amateur Civil Emergency Service by appropriate order giving 30 days' notice, or less, and thus invalidate outstanding authorizations to operate in this service prior to their normal expiration dates. Thus, the new service is intended to provide a temporary phase of amateur operation for Civil Defense communications purposes.

Station Authorization and Participation

An authorization to operate a station in the Radio Amateur Civil Emergency Service will be issued only to a person who holds an amateur radio operator license, other than Technician or Novice Class, and an appropriate amateur radio station license. Each application for a station authorization shall be submitted on FCC Form 480, which shall be signed under oath or affirmation by the applicant and countersigned by the appropriate civil defense radio officer.

The applicant must satisfy all requirements (both local and federal) for participation in the civil defense organization and must actually be enrolled as a member of the local organization which serves the area where the station will operate. In addition, the amateur station licensed in the name of the applicant has to be approved for and, when authorized by the Commission, will actually constitute a unit of a civil defense communications network in accordance with an approved civil defense communications plan.

Technical Requirements

The following tabulation indicates the frequency bands which are available for use by stations in the Radio Amateur Civil Emergency Service and may continue to be used by such stations after any suspension of normal amateur activity because of war or other national emergency.

Supervised Stations	
Frequency Band	Authorized Emission
1800-1825 kc	A1, A3
1875-1900 kc	A1, A3
1900-1925 kc	A1, A3
1975-2000 kc	A1, A3
3500-3510 kc	A1, F1
3990-4000 kc	A1, F1, A3, A4
For Use By All Authorized Stations:	
Frequency Band	Authorized Emission
28.55-28.75 mc	A1, A3, A4, F3
29.45-29.65 mc	A1, F1, A3, A4, F3
50.35-50.75 mc	A1, A2, A3, A4, F3
53.35-53.75 mc	A1, F1, A2, F2, A3, A4, F3
145.17-145.71 mc	A1, F1, A2, F2, A3, A4, F3
146.79-147.33 mc	A1, F1, A2, F2, A3, A4, F3
220-225 mc	A1, F1, A2, F2, A3, A4, F3

The selection and use of specific frequencies within the authorized frequency bands by stations in the Radio Amateur Civil Emergency Service shall be in accordance with a coordinated local area and adjacent area civil defense communications plan and applicable rules of this part.

"Grandpappy Clause" (Docket No. 10098)

On 27 December 1951 the Commission amended Part 12, "Rules Governing Amateur Radio Service" to provide that the Amateur Extra Class of license may be issued to any person who qualifies for or currently holds a valid amateur operator license of the General or Advanced Class and who can show that he held a valid amateur operator or station license issued by any agency of the United States Government during or before April, 1917.

Comments on this amendment had been filed by some thirty amateurs. For the most part, these comments were unanimously agreeable to and in favor of adoption of the proposed amendments, except that a few persons expressed some disagreement with the amendments proposed on the grounds that the Extra Class of license is intended to provide an incentive to all amateurs to become highly proficient in all phases of the radio art and that no means is provided by the proposed amendments to test that proficiency or to distinguish between the pioneer amateurs who have demonstrated a high degree of ability in the fields of amateur radio technique and those who let radio technique overtake and pass them.

The weight of comment was to the effect that any person who held an amateur license prior to April, 1917, and is still an amateur or has come back to amateur radio after a lapse of time may be recognized as a pioneer in the field of radio and in line with the practice or recognition of prior service in the issuance of such documents as registration certificate of Professional Engineers; may be issued an Amateur Extra Class Operator License.

FCC Reduces Their Work Load

In order to reduce the number of "paper" operations the FCC in early January made two amendments to the amateur rules and regulations. One of these exempted holders of Conditional Class Licenses from reporting for re-examination if they moved to within 125 miles of their old QTH. This is also in effect should the FCC establish an examination point within this radius.

The FCC has also eliminated the necessity of filing a special application for temporary portable operation when it will exceed a period of more than four months. This is made in order to simplify the portable operating procedures for the fellows in schools and in the Armed Services.

The waiver for "proof of operation" has again been placed into effect for those amateurs on active duty in the armed forces. This is applicable for all licenses which expire during the period 1 January 1951 to 31 December 1952.

The Newcomer's Buyway

Advertising

"The Hercules"

In amateur radio, just like lots of other hobbies, there are all kinds of gadgets and accessories which one acquires in time as a matter of course. However, probably the first item a radio amateur requires, after obtaining his basic receiver and transmitter, is a dependable microphone, so voice "contacts" can be made. Regardless of whether you are a new-comer or an old-timer in amateur radio, the new Controlled Reluctance mike, the "Hercules" (manufactured by Shure Brothers, Inc., 225 W. Huron St., Chicago, Ill.) warrants your consideration. It is a hand-held magnetic unit that provides clear reproduction, high speech intelligibility, high output and ruggedness at an amazingly low price. Being magnetic, this mike is practically immune to varying conditions of heat or humidity. The "Hercules" can be used indoors or outdoors, fits snugly in the hand, sits firmly on a desk or can be placed on a stand. There are two models with an output level of 52.5 db below 1 volt per microbar. Model 510C "Hercules" lists at \$15.00 while the Model 510S, which has a built-in switch, lists for only \$17.00. The "Hercules" has a die-cast case, with a Metallic Green finish. See the "Hercules" at your Distributor or write Shure Brothers for further details.

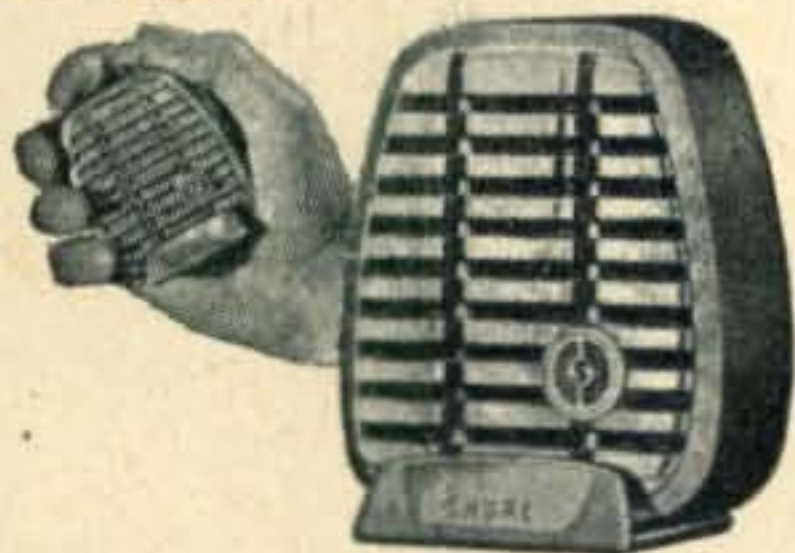

Allied Catalog

In amateur radio, a new youngster is affectionately called a "Young Squirt." We'd like to say a few words to the Young Squirts, (and OM's), reading this. In ham radio there are all kinds of gadgets, accessories and essential parts to be bought. You'll acquire some of these items as soon as you start to build your equipment. Others you'll only "look at" for years. However — before you buy anything — think of Allied's complete, free catalog.

Here is the new, complete Buying Guide to *everything* in Amateur Radio. It's ALLIED's 212-page 1952 catalog—packed with full selections of quality receivers, transmitters and station gear of every description—everything you need to operate an efficient Ham station at lowest money-saving cost. Here, too, are the widest selections of parts, tubes, kits, tools, books and diagrams, ready for fast, dependable shipment from ALLIED's huge stocks. You can count on ALLIED for expert service, the most generous time payment terms and down-to-earth practical help from our large staff of old-time Hams. Have the complete, dependable service enjoyed by thousands of Amateurs over the past 30 years. Send today for your FREE copy of the new ALLIED Catalog, finest Buying Guide in Amateur Radio. ALLIED RADIO CORP., 883 W. Jackson Blvd., Dept. 16-BB-2, Chicago 7.



"Littlefone"

The newest development from the Hallcrafters laboratories is called the "littlefone." It is a complete self-contained FM transceiver for two-way Communication.

Model HT-21 can be crystal controlled in the band from 25 to 50 mc. It has a full two-watt antenna output. Model HT-22 is designed for the 150-174 mc band. Both units weigh about 14 pounds and are easily hand carried. The batteries are either dry, or wet—the latter being rechargeable from a car battery or 117 volt power line and rectifier.



A "central station" is also available with the same performance and specifications as the "littlefones." It operates directly from the a.c. outlet and has its own antenna.

The possible uses of "littlefone" easily challenge your imagination. If your work calls for a rugged, dependable radio-telephone remember the Hallcrafters Co., Chicago 24, Ill.

The Turner 20X

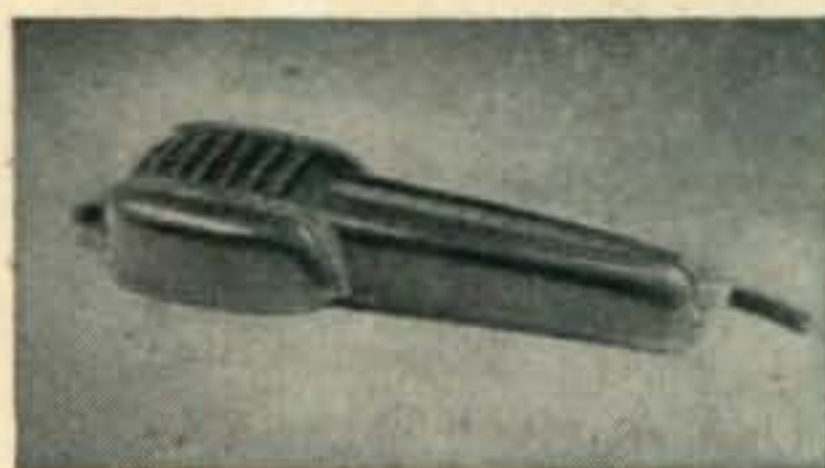

Nearly every Novice faces the problem of setting up his first rig with an eye toward equipment quality as well as economy. When you choose a Turner

20X Microphone, you make no compromise on either quality or economy—that's why the Turner 20X has enjoyed the popular approval of radio amateurs for many years. This light-weight, convenient, hand-held crystal microphone has the design, high output, dependability and unusually fine response to make it a natural for the ham.

The Model 20X (illustrated) lists at \$12.85, while the S20X, which has a built-in push-to-talk switch, lists at \$14.85. Both microphones have output level of 52 db below 1 volt/dyne/sq.cm, response of 60-7000 c.p.s., and die-cast metal case with rich bronze metalustre finish. For more information see your Distributor or write THE TURNER COMPANY, 929 17th Street, N.E., Cedar Rapids, Iowa.

"Private Tutor"

Amateur License Courses

The new Eldico "Private Tutor" Amateur Radio Course is a unique and tested method for learning theory and code for all classes of amateur radio licenses. Four courses will be available, leading to the Novice, Regular, Advanced and Extra Class license. Novice course is now available, other sections will be available shortly.



Profusely illustrated, the study sections of the course cover theory, rules and regulations, equipment operation, actual on-the-air techniques; included is step-by-step construction information which upon completion gives the builder practical operating transmitting equipment. By acquiring the material as suggested in the course, every item is useful. Both the code and study sections of each course provide individual instructions.

The code records are absolutely unique in the educational field. The Novice Code Course consists of five unbreakable long-playing 12" records, giving a total course of instructions equal to over 20 standard speed records. Code instructions are accompanied by the voice of the instructor. Code groups are gradually increased in speed. Communications-type sequences are interspersed, giving practical code experience. Actually, speed develops beyond the requirements of the FCC examinations. See it at your favorite distributor or write Eldico of N. Y., Douglaston, L. I.

Concord Catalog

You don't have to hunt far and wide or spend a lot of time to find the parts or equipment you want to build your first rig or improve the one you already have. With the big, new 1952 FREE Concord Catalog at your fingertips you can easily select exactly the right gear and get it quickly at the lowest price.

You'll find in it a complete selection of nationally-famous guaranteed receivers, xmitters, parts, tubes, kits, tools, books—in fact everything you need to get those QSO's.

These same vast stocks of parts and equipment ready for shipment assure you speedy delivery of that part you've been wanting. And the experienced hams at Concord's Ham Shack will know the answers when it comes to helping you set up your rig.

Send today for your FREE Catalog and Buying Guide No. 95. It's mighty handy to have around for quick and valuable reference. You'll soon discover why many thousands of the old-timers rely on Concord for all their ham needs. Write CONCORD RADIO CORP., Dept. CBA-52., 901 W. Jackson Blvd., Chicago 7, Ill.



To those of you who are ready to buy (or even to sell), these Reports will give you the latest price changes as well as the new and discontinued products. This monthly summary of the market is supplied by RADIO'S MASTER, The Industry's OFFICIAL Buying Guide, published by United Catalog Publishers, Inc., New York City. A complete description of each product is found in RADIO'S MASTER 16th Edition.

ANTENNAS & ACCESSORIES—TV, FM, AM

Master Mobile Mounts.—Introduced new series of 12 Junior Mounts.

BOOKS AND MANUALS

AKKL.—Increased prices on "The Radio Amateur's Handbook" to \$3.00.

Editors & Engineers, Ltd.—Withdrew "World's Radio Tubes", 8th Edition and advised 9th Edition to be published about February 1952.

Rider, John F.—Withdrew Catalogs "Oscillator At Work (No. 112) and "The Meter at Work (No. 116). Also introduced Rider's TEK-FILE, a new monthly data service at \$2.00 per pack.

MISCELLANEOUS RADIO, TV AND ELECTRONIC PARTS

Astron.—Introduced Type BT series of Electrolytic Motor Starting Capacitors; Type MX and Type ME series of Metallized Paper Capacitors and Type AQ series of Subminiature Paper Capacitors. Also added additional items consisting of Electrolytics and Capacitors.

Barker & Williamson, Inc.—Reduced price on Coaxial Connectors, CC50 to \$5.35 net and CC51 to \$6.45 net.

Cornell-Dubilier.—Added Communication Vibrator No. S-8050 at \$4.62 net.

Raytheon Mfg. Co.—Increased price of Rectifier Type RFR-1043-AR to \$150.00 User Price.

RECORDING EQUIPMENT, SPEAKERS, AMPLIFIERS, NEEDLES, TAPE, ETC.

Bogen, David Inc.—Added R 604, AM-FM Tuner at \$97.35 net. Also added Model HO 10, Power Amplifier at \$95.70 net, Model RXPX, Remote Controller and Preamplifier at \$54.45 net and EXT-20, 20 Ft. Extension Cable for RXPX at \$9.90 net.

Brush Development Co.—Added Model BA-206, Double Headphone at \$16.30 net; Model BA-207, Single Headphone at \$9.60 net and Model BA-208, Lorgnette Phone at \$13.77 net.

Electro-Voice, Inc.—Introduced Aristocrat 1, 2 and Royal 2, Two way Sound Systems; Models 108-111-114, Two way Speaker Component Package; Model X-825, Crossover Network; Model 8-HD Horn; Model 12BW, Low Freq. Drive; and Royal Speaker Enclosure.

Permoflux Corp.—Marketing 18 new items of Headsets, Earphones and Cushions.

Pickering & Co.—Withdrew No. 180L Loudspeaker.

TOOLS AND HARDWARE

Kester Solder Co.—Increased \$.02 per pound the price of their 1 pound, 5 pound and 20 pound spools of Acid-core, Plastic resin core and "Resin-Five" core of solder spools.

TUBES—RECEIVING, TELEVISION, SPECIAL PURPOSE, ETC.

G.E.—Added G7 series of Germanium products and G10 series of 1 Germanium Power Rectifier and 3 General Purpose rectifiers available in limited quantities within 2 months.

Sylvania.—Added Radio Receiving Tube 6BK7 at \$3.20 list; Special Purpose Tube 5932/6L6WGA at \$8.60 net; Transmitting Tube 5933/807W at \$12.85.

QCWA

December appears to have been the month for exceptional attendance records at the various Quarter Century Wireless Association meetings. In New York attendance hit a new record—130 guests. The guest of honor was George W. Bailey, President of the ARRL and Executive Secretary of the IRE, who was inducted as a member. The featured speakers were Philip S. Rand, W1DBM, who spoke on TVI elimination, and Robert W. Gunderson, W2JIO. The latter, who is totally blind, held the audience spellbound as he demonstrated test equipment of his own design and construction, which easily outperforms standard meters. Following his appeal for support of the Braille Technical Press, the gang spontaneously passed the hat and contributed a total of \$200, and also pledged about a dozen subscriptions in the names of various local clubs.

The present slate of officers was re-elected intact: John DiBlasi, W2FX, president; George Droste, W2IN, vice-president; David Talley, W2PF, treasurer; and Leon Hansen, W2FIT, secretary. Also, Frank Lester, W2AMJ, was elected as new director.

In Cleveland the gang attended the first annual banquet of their section of the QCWA. The main speaker was W8QV's spark set which spoke often and long in terms of ozone and burnt copper.



Philip S. Rand, W1DBM, delivering an interesting talk on TVI elimination.

At the New York dinner meeting of the QCWA on December 2, 1951, blind Bob Gunderson, W2JIO, demonstrated various test and measuring equipment with which he can perform all normal circuit investigations. George Droste, W2IN, left, looks on.



Bill Irwin, W8GW, took this photo of the gang attending the Cleveland, Ohio section of the QCWA. Front row from the left: W8DI, LY, AF, AWF, VK, VM, PM. Second row standing: W8BAH, ZHJ, exAON, GD, KC, BSS, RN, AZ, QV; Third row standing: W8EBJ, AOK, BF, COG, WV, NV, RYR, DBU, NCE, HXL and CKR.

HARVEY HAS THE GEAR YOU WANT!

FOR THE HAM WHO IS ALSO AN ENGINEER ACTIVE IN RESEARCH OR INDUSTRY HARVEY OFFERS THE

COSSOR

DOUBLE BEAM OSCILLOGRAPH



The most versatile laboratory instrument for quantitative measurements and waveform analyses in all electrical mechanical and marine engineering research and production. Sturdy construction. Simple to operate.

Model 1035, \$661.50

DOUBLE BEAM INDUSTRIAL OSCILLOGRAPH

Specifically designed for measurement of zero or very low frequencies and the photographic recording of transients requiring high photographic writing speed. Incorporates a 4" Diameter flat-screen tube.

Model 1049\$925.00

Accessories for above include:

Model 1428 CAMERA\$245.00

Model 1429 MOTOR DRIVE

for same\$182.50

Model 1430 PREAMPLIFIER\$390.50

Descriptive literature and specifications available on request.

HARVEY carries the complete line of

BEST THERMOCOUPLES

both Standard and ULTRA HIGH FREQUENCY types

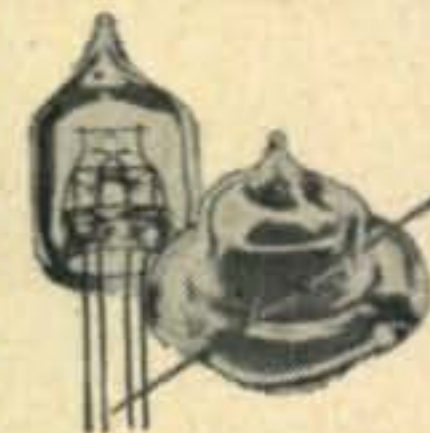

These units are electrically insulated from the heaters and tested to 100 volts D.C. Resistance tolerance are plus or minus 10%. Nominal output of 7 millivolts subject to sensitivity variation of plus or minus 12%. Current ratings can sustain 50% overload without damage.

tion of plus or minus 12%. Current ratings can sustain 50% overload without damage.

STANDARD TYPES

5 to 1000 MA.....Each \$ 7.50

1.25 MA\$36.00

2.5 MA\$29.00

ULTRA HIGH FREQUENCY TYPES

From 5 MA up.....Each \$12.00

Write for descriptive literature and specifications.

ELDICO TR-75-TV



TRANSMITTER KIT

This is an ideal unit for the novice. Very simple to assemble. New, revised circuit to

aid in the elimination of TVI. Uses 6L6 oscillator—807 amplifier combination PI-network output. Husky power supply delivers 600 volts to the 807. Complete... including a punched chassis and shielded cabinet. Unbelievably low priced at...

\$59.95

MD-40 modulator kit for above....\$34.95

MD-40P as above

but with power supply.....\$44.95

COLLINS 75A-2 RECEIVER



Double-conversion superhet with sensational stability, calibration accuracy and sensitivity... all the

good features of the 75A-1, plus many new ones. Price, complete with tubes \$420.; matching 10-inch speaker \$20.00.

Collins KW-1, 1kw. TRANSMITTER \$3,850.

New Collins 32V-3 TRANSMITTER \$ 775.

Place your order now for delivery.

IN STOCK FOR IMMEDIATE DELIVERY

MALLARD 10N, 20N and 75N

Mobile Converters\$39.95

MALLARD HI-Q 20 coil.....\$ 8.95

MALLARD HI-Q 75 coil.....\$ 7.95

SONAR SR-9 RECEIVER.....\$72.45

SONAR MB-26 TRANSMITTER.....\$72.45

A.C. POWER SUPPLY.....\$30.00

Make HARVEY your Headquarters

for CD Emergency and CAP

Communications Equipment, LF and VHF

... whatever your requirements may be

... from a 1½ volt cell to a 50,000 watt

gas engine driven generator. REMEMBER

...it will pay you well to ask HARVEY first.

IN STOCK...

THE COMPLETE LINE OF

TRIAD TRANSFORMER PRODUCTS

(Exclusive with HARVEY in the New York area)

Transformers for all applications — Military and Civilian — High Fidelity Audio Components, "Trijets" — Hermetically Sealed Midgets, Power Transformers, Replacements, Filters, Reactors, etc. ... for the laboratory, industrial, servicing, public address and radio amateur fields. Complete stocks of all components are on hand for immediate delivery.

The TRIAD "HS" series of transformers incorporates hum-bucking coils and nickel-alloy multiple shielding for minimum pickup. They are small in size, light in



weight, rigidly supported and hermetically sealed. Note actual appearance of the "HS"



case, on left, and the telescopic view on the right which illustrates the construction of this particular type.

Write for latest catalog.

SUPERIOR POWERSTATS

Smooth, efficient voltage control, 0-135 volts output from 115 volt AC line. Models also for 230 volt input. Write for free literature. Models for table and panel mounting.



Type 20, 3 amp.....\$12.50

116, 7.5 amps, table mtg..... 23.00

116U, 7.5 amps, panel mtg... 18.00

1126, 15 amps..... 46.00

1156, 45 amps.....118.00

Telephone **hrc** LUxemburg 2-1500

HARVEY

RADIO COMPANY, INC.

103 West 43rd St., New York 18, N. Y.

VISIT HARVEY'S AUDIOTORIUM — Come in and visit our new Sound Department... all these items and many more on working display at all times.

NOTE: In view of the rapidly changing price situation in both complete units and components we wish to emphasize that all prices are subject to change without notice, and are Net, F.O.B., N.Y.C.

An Opinion . . .

The FCC in Docket Number 10073 reports on two petitions for changes in the sub-divisions within the 40-meter amateur band. One of these proposals deals with frequency shift keying, the other with radio telephony.

While we do not wish to take sides with either of the two matters before the FCC, we believe that a third proposal, of even greater importance than the issues now under examination, should be considered as part of the Docket.

The Novice license is already proving its value by enabling thousands of new amateurs to speed up the process of acquiring their Class B License. The 80-meter Novice band is almost always crowded in large population centers. But, we believe now, as we did during the formulation of the Novice privileges, that it would be more practical to have the Novice band on 40 meters or to have an additional band of frequencies open for the Novice on 40.

One of the most important considerations behind our recommendations is that simple transmitting antennas are much more easily handled on 7 mc. In addition, propagation conditions are such that 40 meters during the daytime is vastly superior to 3.5 mc. Because ultimately, most Novices will be young men and women of high school age, the afternoon and early evening hours are important segments of their available operating time. Thus, a band of frequencies on 40 would make it easier for them to operate and encourage more operating.

A band of frequencies harmonically related to 20 meters would be desirable. Certainly the entrance of Novices in the middle of the 40-meter band would hardly be noticed in view of the sparse population in those regions, at the height of the most popular operating hours. —The Editor

TVI

W1DBM has just informed us that a 2nd Edition of his very popular book "Television Interference" will be available by the time this is in print. The new edition is greatly enlarged with six additional articles and a complete TVI cross index. This edition will only be available for 25c in coin (to cover postage and handling) from Remington-Rand, Inc., Attn: Miss Anne Smith, 315 Fourth Ave., New York 10, N. Y.

MOBILE CORNER

(from page 39)

a great deal by replacing one IF stage with a converter using an 85 kc IF. Replace one tube and one IF can and re-wire accordingly.—Don't forget to identify your station at least once each ten minutes. We know one ham that uses an "egg-timer" on the dash of his car to remind him when he's talked too long.—Is your main-power lead fused or protected with a circuit-breaker?—Many of the gang have the heavy power leads of the PE103 (which they aren't using anyway) stowed away in the trunk. When the old bus won't start because of

transmitting too long, these heavy leads are connected to the battery of an adjacent car to get a start.—Of the fellows who have tried resistor spark plugs, a few have reported inefficient engine performance. Remember that the engine must be properly adjusted for resistor plugs; you can't just "put 'em in" and expect perfect performance.—An Auto-Call has been installed in Dayton, Ohio. This makes 12 cities now equipped.—Remember that 29.640 (along with many others) is a national emergency and calling frequency. QSY when contact has been established.—We still hear an occasional "mobile 3" when outsiders come to Washington. Most of them are surprised when they learn that a call area number is not legal identification for mobile or portable use. —Send us some news, gang, we need it. —73, Andy.

VHF NEWS

(from page 46)

WN9OKF, OVL, PUW, PVK are on 2; PUO and OKR are expected. WN9QCG, Kenny (W9LLZ's), boy may be on 2, but is starting on 80 c.w.

W9RHL, Hobart, Ind., was the first DX from W9NW (then FFG) six years ago. Bob's been tied up, selling cars in the daytime and servicing TV in the evenings . . . Several stations are back on the band after an absence of from 2 months to 5 years: W9GBB, GPV, MMG, NZ, UDO, PK, QM and ZBH . . . W9EQC, Aurora, enjoyed a visit from W9TQ, LJV, IMQ and SWL "Yost" during TQ's vacation . . . W9CEW keeps Geneva on the 2-meter map . . . Somebody told us that ol' W9ODT, Lockport, had been heard on 2, but no other report on him has been received.

The 147.5 mc FM "Party Line Net" welcomed W9FQU, Park Ridge, and W9PXW, Ch.cago. W9DXX will be on as soon as the snow drifts melt down to mountain size!

Correction

Dunno how it happened, but the photo caption, page 46 of the January issue, stated, "The next 'do' will be in Oakville, Ontario . . ." It should have been "Buffalo, N. Y." Soddy, gentlemen!

Eastern and Western States Reports

We're not "isolationists," fellows—we want to report *everyone's* v.h.f. activity. How about some information from your area? Don't wait for something spectacular to happen before reporting; there'd be no "VHF News" if it depended upon the spectacular.

DX & OVERSEAS

(from page 42)

advised that W2BXA is moving to a new house. Steve made sure he stuck within the DXCC radius, of course!!!! W2AOZ's XYL kept tabs on him

Special Purchase FM Radio Chassis

88-108 MC

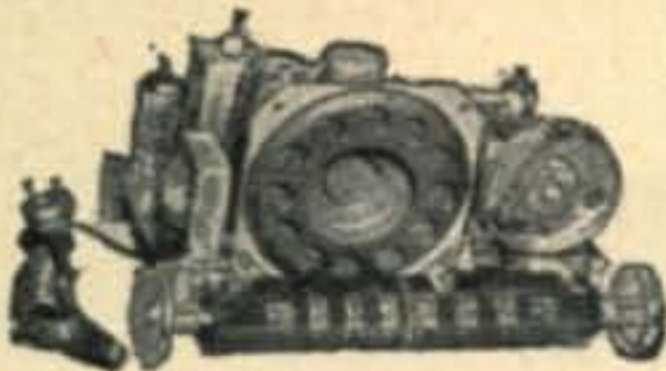

Complete with 6 tubes. Built-in Antenna and Speaker. Product of Famous Radio & TV Manufacturer whose name we promised not to mention.

TUBE LINEUP
1-12BA7 1-12S8
2-12BA6 1-35W4
1-35B5

Regularly 29.95

Brand New

May also be used as an FM Tuner by picking signal off detector.

\$16.95

SPECIAL PURCHASE! GENERAL INSTRUMENTS - 3 SPEED AUTOMATIC RECORD CHANGER

REGULARLY

\$34.95

BRAND

NEW

\$19.97



With flip-over dual cartridge. Plays 33 1/3-45 and 78 RPM records automatically.

NOTE: Do not send money for postage on above items, we ship best way—charges collect.

LOW FREQ. XTALS - FT	SCR 522 XTALS	BC-610 XTALS
241A. For SSB, lattice filter, etc. 1/2" spc. 54th or 72nd harm. channels. Listed by fund. Fractions omitted.	1/8" PINS 1/2" SPC	2 banana plugs 3/4" SPC
372 404 435 504 400 462	5910	2030 2442
374 405 436 506 440 463	6370	2045 2532
375 406 437 507 441 464	6450	2105 2545
377 407 438 508 442 466	6470	2125 2557
379 408 481 509 444 468	6497	2145 3202
380 409 483 511 446 470	6522	2155 3215
381 411 484 514 447 472	6547	2220 3237
383 412 485 515 448 474	6610	2258 3250
384 413 487 516 450 475	7350	2280 3322
385 414 488 518 451 476	7480	2282 3510
386 415 490 519 452 477	7580	2290 3520
387 416 491 520 457 479	7810	2360 3945
388 418 492 522 461 480	7930	2390 3955
390 419 493 525		2300 3550
391 420 494 526		2305 3570
392 422 495 530		2320 3580
393 423 496 531		2415 3995
394 424 497 533		2435
395 425 498 537		
396 426 503 538		
397 427		
398 429		
401 431 49c EA		
402 433 10 FOR		
403 434 \$4.50		
	99c EA 10 FOR \$9.00	
	\$1.29 EA	
	SPECIAL 200 KC XTALS without holders 69c EACH 3 FOR \$2.00	
		EACH \$1.29
HAM XTALS—FT 243 HOLDERS—1/2" pin spc.		
4190 6773 7840	1015 5840 6450	7440 7650
5030 6873 7873	1129 5850 6473	7473 7673
5485 6906 7906	2045 5873 6475	7506 7706
3040 6973 7940	3735 5875 6506	7540 7806
3073 7740 7973	5305 5906 6540	7573 8240
5106 7773 8273	5677 5940 6573	7606 8340
5125 7806 8306	5706 5973 6575	7640 8400
	5725 6273 6600	
	5740 6306 6606	
	5760 6325 6625	
	5773 6340 6640	
	5800 6373 6673	
	5806 6406 6706	
	5825 6440 6740	
		\$9.00
		10 FOR
		99c each

Add 20c for each 10 xtals or less for postage and handling.

SUN RADIO
OF WASHINGTON, D. C.
938 F STREET, N. W. WASH. 4, D. C.

VARIABLE CONDENSERS

From SCR-522

2 GANG - 25
MMF
per section
\$1.29



3 GANG - 25
MMF
per section
\$1.59

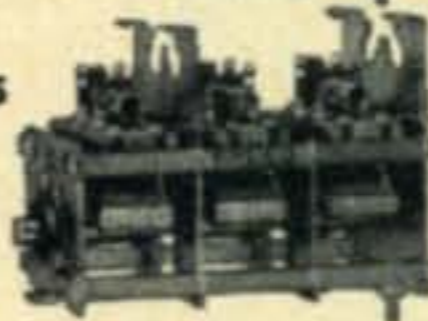

BRAND NEW with CONCENTRIC AIR TRIMMERS

BC-306A ANTENNA TUNING UNIT

Contains - antenna variometer heavy duty 3 pole 5 pos. ceramic switch, velvet vernier dial. Standoff insulators housed in heavy aluminum case only **\$1.95**



RL-42B ANTENNA REEL

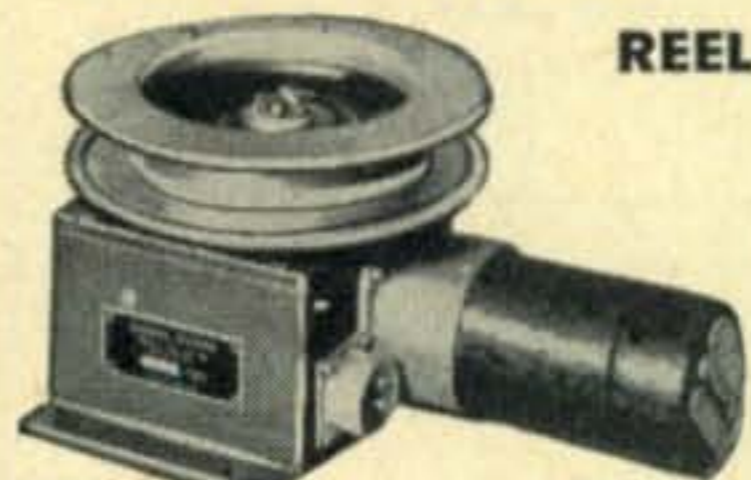

24 V D C — can work on A C convert to antenna rotator. Only **\$3.95**

BC-706D SWITCH BOX

Contains
Micro Switch
only



69c

CD-716 CORDS

with PL 55 Plug & 56 Jack **\$1.29**



BC-221T FREQ. METERS

BRAND NEW

complete with XTAL—spare tubes, manual and calibration book with canvas carrying case **\$125.00**

TERMS

All items F.O.B., Washington, D.C. All orders \$30.00 or less, cash with order. Above \$30.00, 2% per cent with order, balance C.O.D. Foreign orders cash with orders, plus exchange rate.

I-82A RADIO COMPASS INDICATOR



Compass indicator with built-in selsyn only

\$3.95

VARIABLE CONDENSER

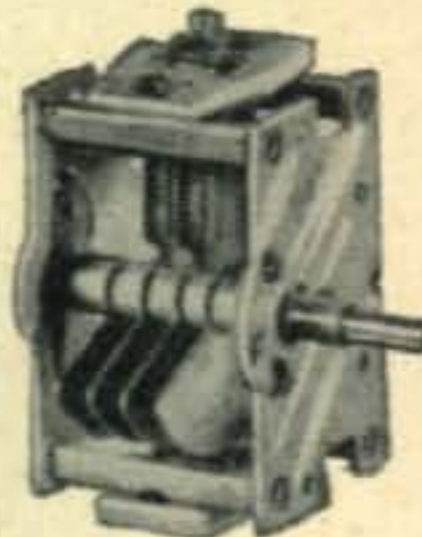

26 MMF—
.10 Spacing
only

99c

BC-347 INTERPHONE AMPLIFIER

less tube — contains one miniature carbon mike input trans and one interstage trans. only **\$2.95**

BC-603
FM RECEIVER
Only **\$19.95**

BC-604
FM TRANSMITTER
Only **\$19.95**

BC-684
FM TRANSMITTER
Only **\$19.95**

12-GP-7
CATHODE RAY TUBE
Only **\$12.95**

CQ TO ALL HAMS DE W3PPQ

Handle here is "Pick" . . . call or write me for anything you need in ham gear or parts—Will be happy to expedite your order with best quality merchandise. 73's

via W2LV/KV4AA sked. . . WØYXO wishes the gang to know that LZ1DX promised to send QSLs and logs to him but, so far, no dice. . . . Many hams have been asked to send gear, etc., to certain European countries. It is suggested they read Harold Stassen's letter, page 59, Nov. QST before so doing.

CQ

See you next month, gang, and let's have some contributions. 73's and see you in the contest—Dick.

Qth COLUMN

- AP2K Karl, DL3ZV, Quetta, Parkinstan. QSL via D.A.R.C.
- ex CR5UP Leonel Figueriredo Oias, RUA Braancamp, 10-4 DT Lisbon, Portugal.
- FD8AB Pierre Dubourdieu, P.O.Box 185, Lome, Togoland, F.W.A.
- FL8BC Gilbert Besset, c/o Station COTIER, Djibouti, Fr. Somaliland, Af.
- JYIAY c/o R.A.F. Station ARNMAN, Trans-jordan.
- KH6QY/KC6 John H. West, Mgr. Communications Station, Ponape, Caroline Is.
- OY5EL (OX5EL/OZ5EL) Eigil Larsen, Loran Station, Fredericksdahl, Greenland.
- VP2MD Cyril Volney, Montserrat, B.W.I.
- VP3VN Vasco, 146 Sixth St., Georgetown, British Guiana, S.A.
- VP7NW Bill Hergett 6540 DMT Sqdn PAFB, Coco, Fla.
- ZB1BS Bill Tennent, 55 Lancaster Road, Enfield, Mddx. England.
- ZS2MI J. L. Vander Westernhizen, 38 Paarl St., Vasco, Cape, Union of South Africa. (Marion Island)
- 4UAJ Radio Officer, Ted H. Gull, United Nations, Jammu, Kashmir.

EXPEDITION TO XE4

Manuel Angel Ortiz, XEISA, Arcos de Belem 13, Mexico 1, D.F., Mexico, QSL Manager for XE, informs us as follows: On or about the 21st of December a scientific expedition sponsored by the Institute of Science, Guadalajara, Jal. will leave from Manzanillo for the "Isles of Revillagigedo." This expedition will include one amateur radio station operating on all bands, phone and c.w., with an input of 150/200 watts to an 828. Crystal and e.c.o., along with a beam, will be used on 14 mc with folded dipoles on other bands. 50 mc will also be used and it is hoped many contacts will be made with v.h.f. men. The call letters XE4PK will be used — this is the first and only XE4 licensed by Mexico. The operator is Jose de Jesus Gomez, XEIFK. All QSLs should go to XEISA and bear the special serial number received from XE4PK at time of QSO. No SWL cards are desired unless accompanied by self addressed envelope and International Coupon. XE4PK will operate from Revillagigedo for 30 days.

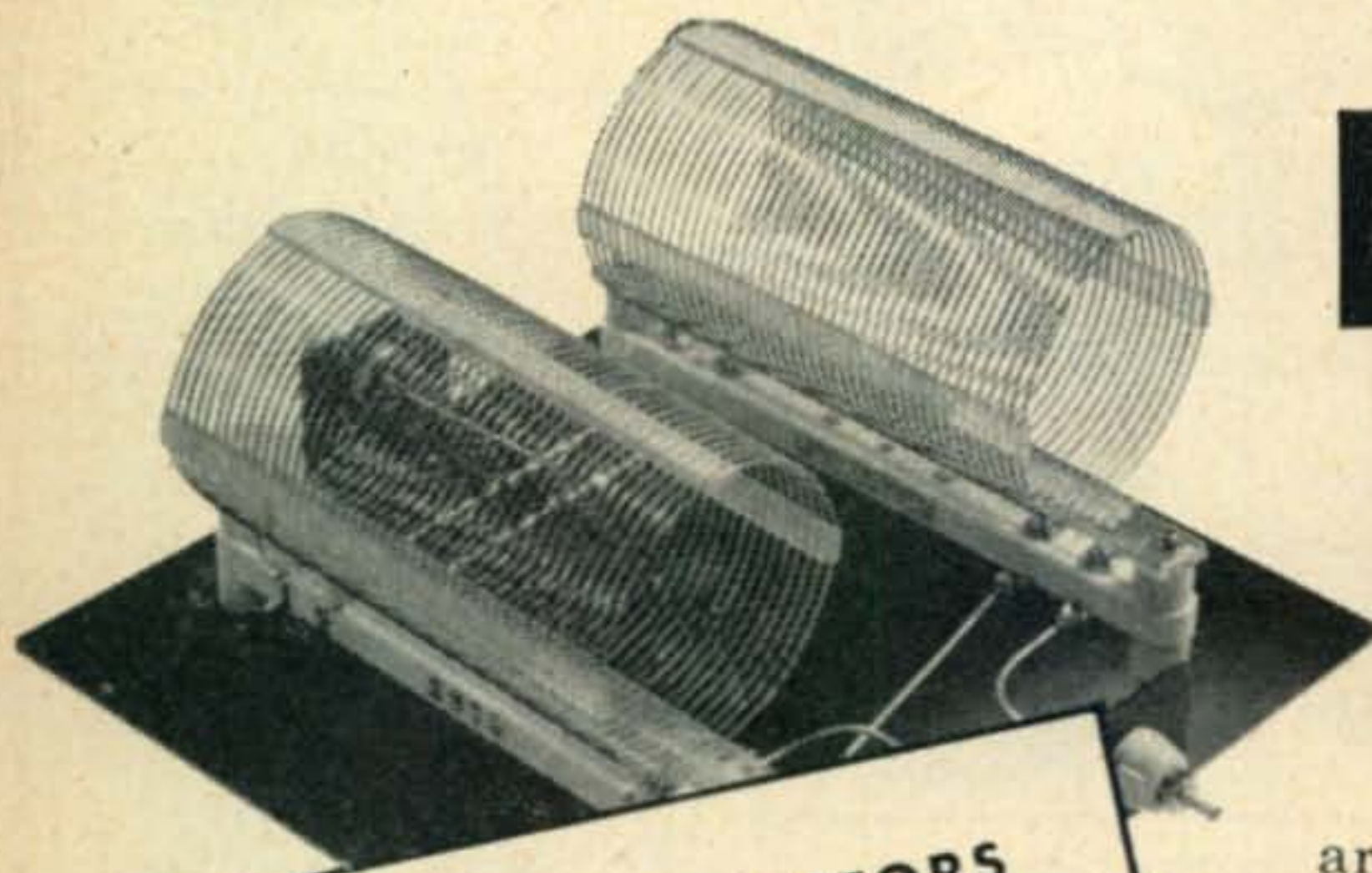

B & W BALUN INDUCTORS
Type 3975 Price: \$4.65 each coil

These sturdily-built air-wound coils can be connected to match 75 ohm unbalanced transmitter outputs to 75 and 300 ohm balanced antenna feed lines.

BALUN COILS!

These bifilar balun inductors are specially designed for use with Collins 32-V series and similar transmitters—see "The Impedance Matcher" as described in CQ Magazine for May 1951. Two coils mounted on an 8" square plate serve as a compact, highly efficient all-band (80-10 meters) unit for matching feed line systems to both transmitters and receivers. Full instructions included with each inductor.

B&W

BARKER & WILLIAMSON, Inc.

237 FAIRFIELD AVE., UPPER DARBY, PA.

We Have the Most Satisfied Customers

Ask the fellows who deal with me. They'll tell you that WRL will allow you more for your present equipment — that WRL's large volume of sales means faster turnover and greater savings. Our customers know that we finance our own paper, eliminating all red tape. WRL buys more equipment — WRL sells more equipment. We offer the most personalized service anywhere. Deal With One of the World's Largest Distributors of Amateur Radio Transmitting Equipment. Special Attention Given to Foreign Orders Through Our Special Export Department. CABLE ADDRESS WRL1.



Leo I. Meyerson, WØGFQ



FREE!
NEW
1952
WRL
CATALOG



NEW NOVICE CW 7 KIT \$19.95

Here is a complete novice 80 meter AC-DC 7 watt transmitting kit — complete with tubes, power supply, tuning indicator, antenna, pi-network, key and crystal. Nothing left to buy — simply wire (complete instructions included) plug into AC socket and go on the air. Will operate on either 110 volts AC or DC.

NEW LOG BOOK

For mobile or fixed station. Spiral binding — turns up — lies flat. Full column log listing all FCC required info. Log will accommodate 1,525 stations. Front and back covers show "Q" signals, phonetic alphabet, and amateur international prefixes. **25¢**



RADIO REFERENCE MAP



25¢
HANDY
WALL
SIZE

WRITE
WIRE

PHONE
7795

World Radio Laboratories
EVERYTHING IN RADIO
COUNCIL BLUFFS, IOWA

LEO GIVES BEST DEAL ON . . .

NATIONAL RECEIVERS

ON HAND FOR IMMEDIATE DELIVERY!

HRO-50-1 RECEIVER

Additional I.F. Stage and 12 permeability tuned I.F. circuits result in the ultimate in selectivity! Built-in power supply on separate chassis. Front panel oscillator compensation control. 20 to 1 precision gear drive. Provisions for NBFM adapter. Push-pull audio output. Speaker matching transformer built into receiver with 8 and 500/600 ohm output terminals.



\$383.50

(less speaker)
LOW DOWN PAYMENT

10" PM Speaker
matching cabinet

\$1600

NC-125 RECEIVER

Covers 560 kcs to 35 mc in 4 bands. Voice or CW. National Select-O-Jet built-in. Includes AVC, automatic noise limiter, antenna trimmer, variable CW pitch control, separate R. F. and audio gain controls, jack for phone or NFM-73B adapter, volt rg, stabilized oscillator.



\$149.50

(MATCHING SPEAKER) . . . \$11.00

LOW DOWN PAYMENT

NATIONAL RECEIVERS

SELECT-O-JET (#2 or #3)	\$ 28.75
NC-183 (WITH MATCHING SPEAKER)	\$295.00
SW-54	\$ 49.95

World Radio Laboratories, Inc.
744 West Broadway
Council Bluffs, Iowa

Please send me:

- New Log Book
- New Catalog
- Radio Map

- SW-54 Info C-2
- Select-O-Jet Info
- HRO-50-1 Info
- CW 7 Kit Info
- NC-183 Info
- NC-125 Info
- Used Equipment List

Name _____
Address _____
City _____ State _____

GROUND PLANES*(from page 32)*

THE NEW TR-1-144

TWO METER TRANSMITTER

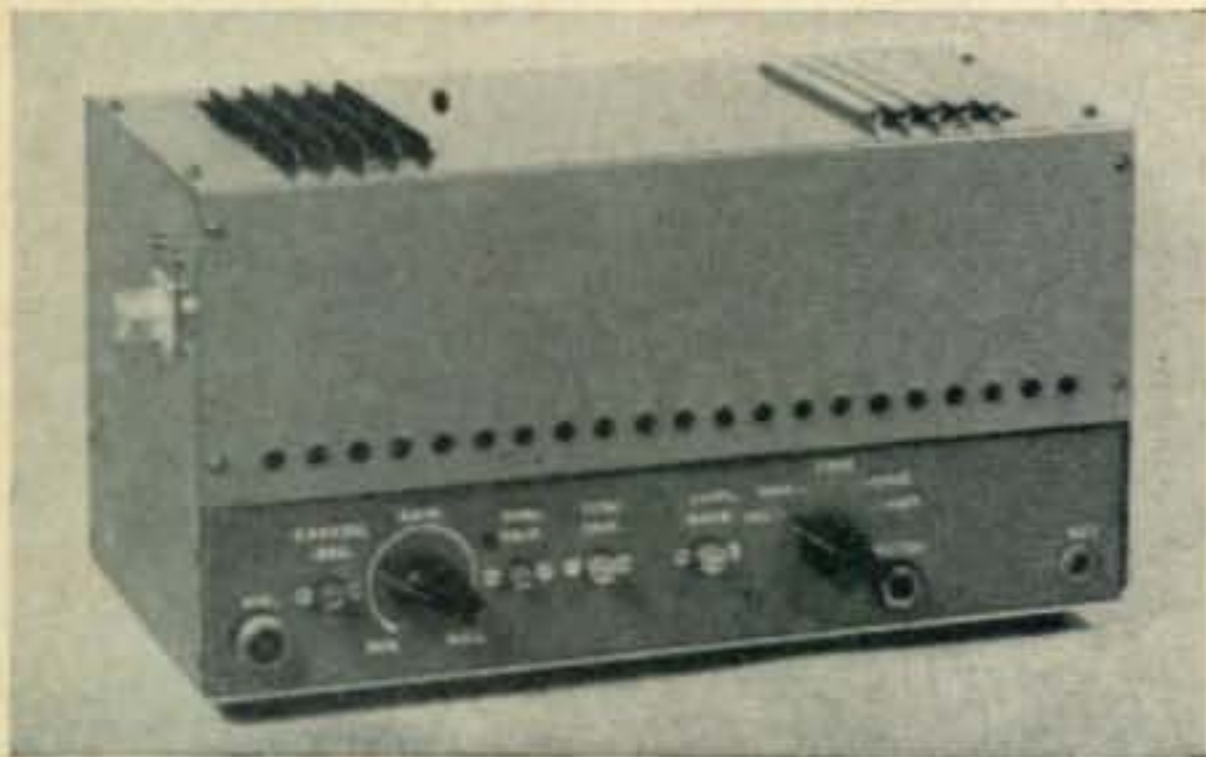

- Linear tank circuit.
- Up to 40 watts input.
- Built in Class "B" modulator.
- Two stages of speech amplification.
- 832A amplifier stage.
- Mobile model available.
- Your cost, complete, less tubes and crystal, only \$40.00.

SYLVAN ELECTRONIC LABS.
BROADALBIN, NEW YORK

Keep Your Shack Neat

with a

BOUND VOLUME

You'll appreciate the handy convenience of this compact volume of the 1951 issues of CQ . . . handsomely book-bound in tan colored cloth . . . distinctive gold foil lettering embossed in a black panel strip . . . available NOW!

\$7.95

in U. S., Canada and
Pan-American
Union. Others,
\$1.00 more.

CQ MAGAZINE
67 West 44 Street New York 18, N. Y.

network made up of fixed values, hang it at the base of each ground plane and that would be that. This was tried but it just didn't seem to work properly. It was found that the values in such networks are very critical and should be made variable to get the proper adjustment. Also, any network installed at the base of the antenna will alter its phase, so that whatever is done at one ground plane must be done at the other in order to hold our important phase relationship. "T" networks with two fixed inductances and a mica condenser were used for about six months, but left much to be desired.

Finally, a coax SWR indicator was built and the problem was tackled from the SWR angle. This SWR method proved to be the best approach. It was found that increasing the length of the whip by approximately 3 feet made the SWR at 7050 kc very close to 1:1. Another way to accomplish the same thing was to merely add a self-supporting air wound coil in series with the whip at the base and start clipping off turns until the best SWR was reached. The coil method is the one in use here at present. Naturally, whatever method is used on one ground plane should be used and copied very closely on the other.

Switching Arrangement

In devising the switching arrangement there are two methods that can be used. In the first, the out-of-phase operation is not used. The 2 db gain is hardly noticeable. All the coax shields are joined together at the metal switch box by using regular surplus coax plugs and receptacles. Just the inner conductors of the coax cables are switched. In the absence of out-of-phase operation the switch is simply a SPST. When closed, the inner conductors of each coax are joined together. Opening the switch disconnects one of the ground planes. See Figure 4. This switch, incidently, should be capable of carrying 2.5 amps for 1 kw input.

The second method, as shown in Fig. 4 uses both in and out-of-phase operation.

The Results

I could say that the first QSO with the phased ground planes was with AR8AB, but this would be a lie. Actually the first QSO was TF3MB and then the AR8! But really, it has been very interesting to notice the effect of switching from one ground plane to two in-phase when listening to Europeans, as well as noting their reports of my signal strength. Numerous reports of S9 have been received from England, with a drop of 1½ to 2 S-units when switching from in-phase to one only. (Switching to the out-of-phase position drops their reports 4 or 5 S-units.)

When used for receiving, the beam performs equally well. The gain is nothing colossal, but the QSB flutter characteristic of European signals

passing through the disturbing auroral zone is noticeably reduced. In other words, the signal may be slightly stronger but, more important, the signal doesn't fade down as far on the flutter, making it much easier to read. This may be due to the diversity effect of using two antennas.

The nulls to the sides are very sharp and very pronounced. Locals 20 miles away notice a drop of 3 S-units when switching from one ground plane to two in-phase. Certain stations drop completely out on two in-phase while on one they are 'S7.

The acid test for any antenna system is a DX contest because it tells you rather bluntly if you are getting out. This antenna system was completed before the 1951 ARRL DX Contest and, needless to say, the effort really paid off. Although conditions were pretty spotty, over 50 different countries were worked during the contest on 7 mc without necessarily concentrating on this band.

Now if I had three ground planes, I—nope—can't do it—got no more dirt.

PROPAGATION

(from page 47)

On twenty-meters good conditions are expected to North Africa, with circuits more stable than European circuits. The increase in distance on

circuits to Central and South Africa will introduce increased absorption and therefore decreased signal levels.

To North Africa, both 40 and 80 meters should be fairly good during the all-dark period. As the circuits become more southerly and increase in distance, conditions will become progressively poorer. This is due to the higher absorption and noise factors associated with these frequencies and circuits.

OCEANIA, (Australia and New Zealand)

Some ten meter openings should be possible to many areas of the United States, conditions favoring Pacific Coast QTHs. Openings to the East Coast will be very infrequent, if at all, and of a very erratic nature.

Conditions on twenty should improve from that observed during the winter months. Some good openings are expected just after sunrise local time, and again shortly after sunset.

Fair conditions are expected on 40 meters, with some good openings on quiet nights.

Not much 80 meter activity expected, but some possible.

ASIA

Propagation conditions to the Near East Asiatic Countries are quite similar to conditions to Europe. Signals can be expected to be weaker because of the increased absorption on these longer distance cir-

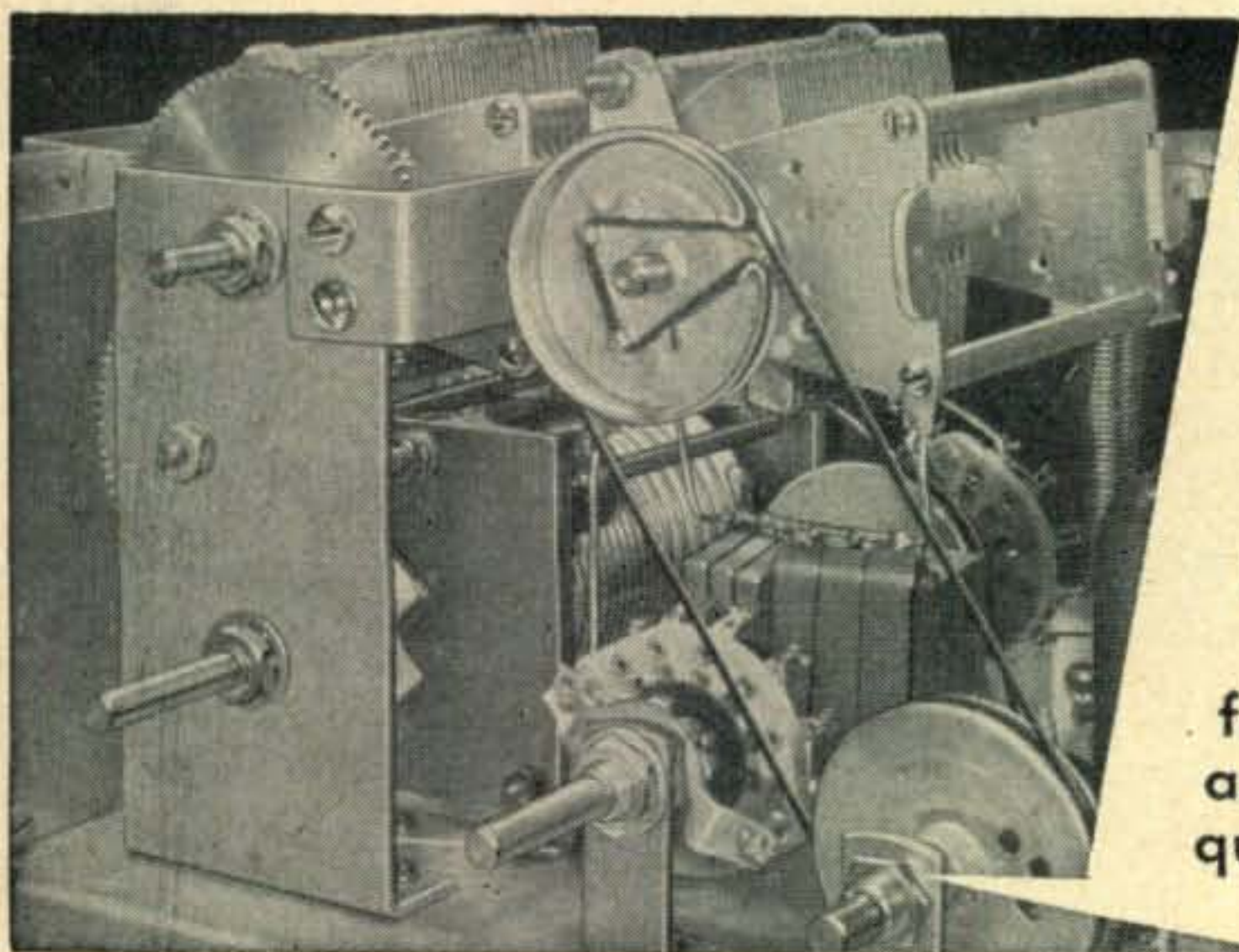

No Guesswork Here!

The key to smooth performance of the Viking 1, its continuous tuning pi-network final amplifier. Has nearly constant output throughout the range 1.8 to 30.0 mcs., perfect control of loading, freedom from parasitics.

Here's a kit with "commercial" performance, carefully designed, easy to assemble and built around JOHNSON quality components. Why settle for less?

FEATURES

Bandswitching, covers all amateur bands from 160 thru 10 meters. 4D32 final amplifier delivers 115 watts CW, 100 watts AM phone. Output of optional 829B amplifier is 100 watts CW, 85 watts phone. Modulators pp 807s. Input and power receptacles for JOHNSON VFO provided. Complete with 11-3/16" x 15" x 21" dark maroon desk cabinet but less tubes, crystals, mike and key,

Amateur Net (kit form) **\$209.50**

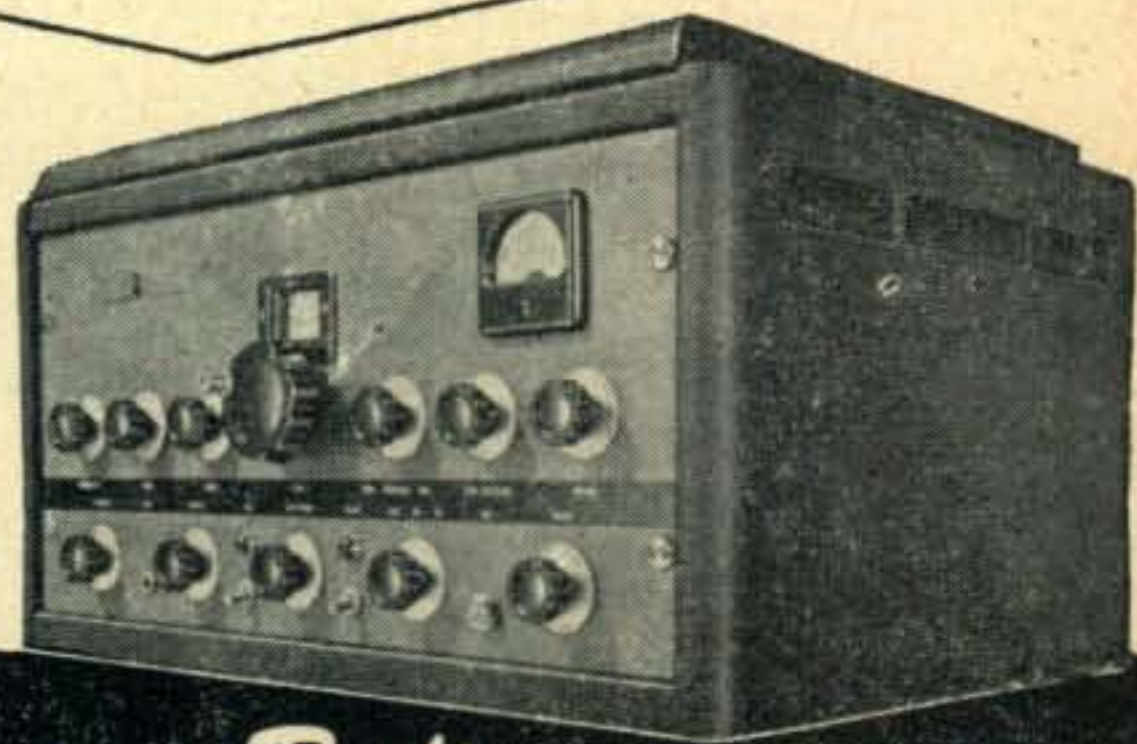

JOHNSON a famous name in Radio

E. F. JOHNSON CO., WASECA, MINNESOTA

★

★

Medal of Honor



Major General William F. Dean, of Berkeley, California—Medal of Honor. In the hard early days of the Korean War, when it was Red armor against American rifles, General Dean chose to fight in the most seriously threatened parts of the line with his men. At Taejon, just before his position was overrun, he was last seen hurling hand grenades defiantly at tanks.

General William Dean knew in his heart that it's every man's duty to defend America. You know it, too. The General's job was in Korea and he did it superbly well. Your defense job is here at home. And one of the best ways to do that job is to start right now buying your full share of United States Defense* Bonds. For remember, your Defense Bonds help keep America *strong*, just as soldiers like General Dean keep America safe. And only through America's strength can your nation . . . and your family . . . and you . . . have a life of security.

Defense is your job, too. For the sake of all our servicemen, for your own sake, help make this land so powerful that no American again may have to die in war. Buy United States Defense* Bonds now—for *peace!*

Remember when you're buying bonds for defense, you're also building personal cash savings. Remember, too, if you don't save *regularly*, you generally don't save at all. So sign up in

the Payroll Savings Plan where you work, or the Bond-A-Month Plan where you bank. For your country's security, and your own, buy United States Defense Bonds!

****U.S. Savings Bonds are Defense Bonds - Buy them regularly!***

The U. S. Government does not pay for this advertisement. It is donated by this publication in cooperation with the Advertising Council and the Magazine Publishers of America as a public service.



cuits. Band openings should be similar to European openings.

Best daytime circuits are expected on twenty meters, best nighttime circuits on forty meters. Some ten and eighty meter openings are also possible. These circuits favor East Coast QTHs and become poorer as the transmission paths extend further West.

From Japan to the USA Pacific Coast conditions are good for openings on all bands. These conditions become poorer as the circuits extend eastward. For East Coast locations, the best band for these paths should be 20 meters, with some activity possible on forty. No ten meter openings are expected.

Conditions are improving, but still poor, to India and Central Asia. No ten or eighty meter openings expected, but some daytime 20 meter openings possible on propagationally normal days. There is also the possibility of very infrequent 40 meter openings.

144-MC VFO

(from page 23)

cept the final doubler are slug-tuned, broad-band circuits. They need be set only once, to the center of the band (approximately 146 megacycles). A simple absorption type frequency meter, with vis-

ual r-f indicator, should be used to assure that the stage is tuned to the correct harmonic.

With the v.f.o. tuned to 4550 kilocycles, the plate section of the Clapp oscillator, *V1*, is tuned so it will double. With the pickup coil of the wavemeter held close to *L2*, the slug for this coil is adjusted until an r-f indication is seen on the wavemeter, showing that the stage is doubling to 9100 kilocycles. The next doubler stage, the 6AG7, *V2*, should be resonated in the same manner, but the wavemeter should be set at approximately 18200 kilocycles and held close to *L3*; then the slug of *L4* should be adjusted to tune the 6V6GT/G doubler, *V3*, to 36,400 kilocycles. The second 6V6GT/G doubler, *V4*, should be adjusted likewise, but to 72,800 kilocycles by adjusting the slug in *L5* with the wavemeter held close to the coil. The final doubler stage, the 5763, *V5*, is adjusted to tune to about 145,600 kilocycles by tuning *C44* while holding the wavemeter close to *I6*. Now this stage, *V5*, may be "peaked" for full output, by tuning *C44* for maximum current reading on *M-1*. Five milliamperes of grid current in the final amplifier are needed for full output. Should the grid current register more than this value on *M-1* when resonating the final doubler, the drive should be reduced by decreasing the "drive control," *R11*.

Before tuning the final r-f amplifier, *V6*, the shorting bar should be set at the left end of the long lines, and secured in place. Now *SW2* may be turned "on", applying plate voltage to the final

THE BUY OF '52
1 KW PLUS
PLATE TRANSFORMER
3100 VOLTS AC EACH SIDE OF CENTER TAP
WILL DELIVER

* **2600 VOLTS DC at 500 MA CCS OR 625 ICAS**

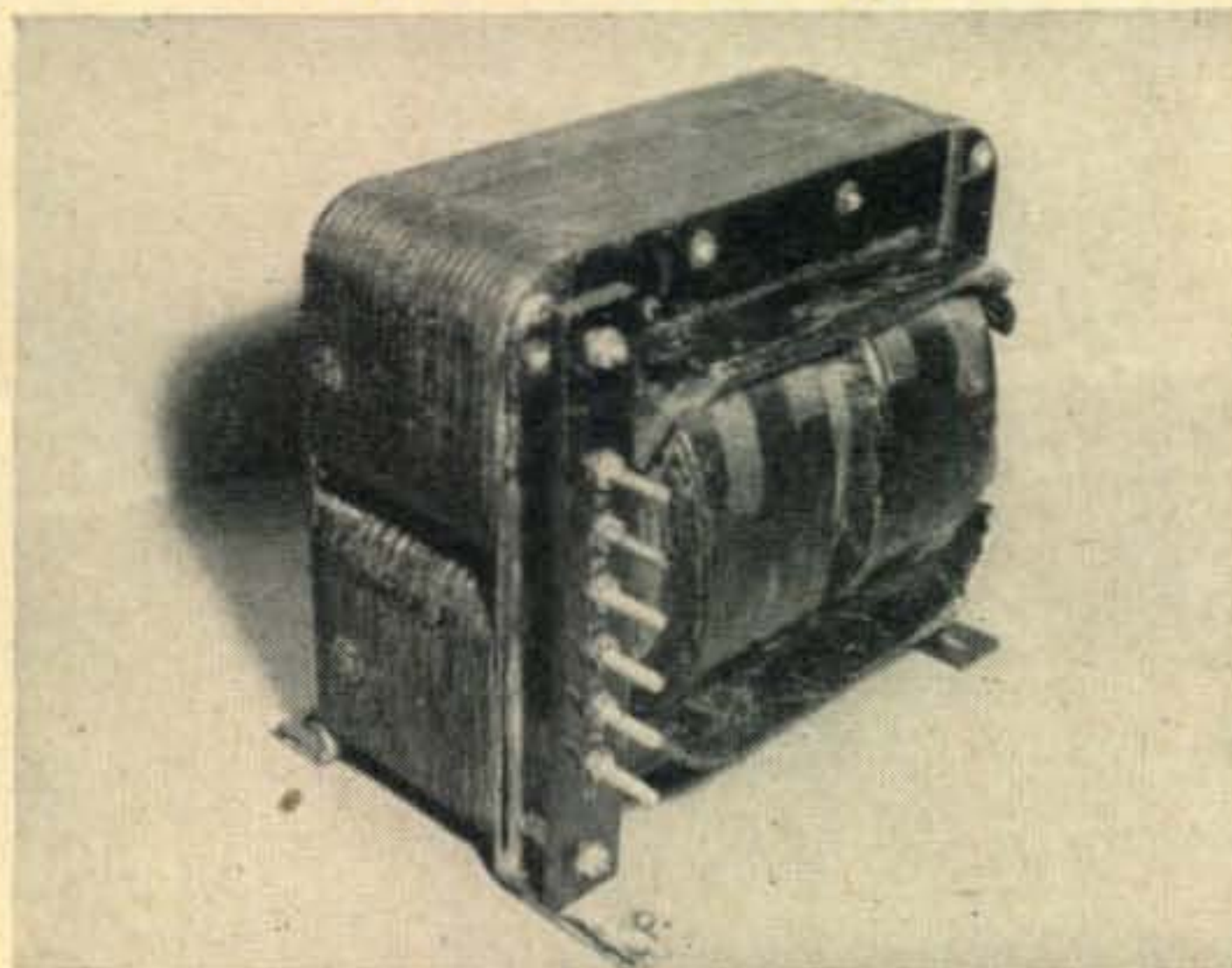

9"L x 8"H x 7 1/2"W — Wt. 50 lbs.

PRIMARY TAPPED

for 98, 104, 110, 116, 123 volts
60 cycle AC

115 volt line on taps
allows variation of DC output from

* **2400 to 3000 VOLTS**

*Choke Input Filter

SPECIAL AT

\$44.50

Express Only, FOB Chicago

EASTRONIC SALES CO.
1010 VERMONT N. W.

WASHINGTON 5, D. C.

r-f amplifier. The final amplifier is easily resonated by tuning *C43* for the familiar "dip" on the plate current milliammeter, *M-2*. Tuning operations should be done quickly to prevent damage to the final amplifier tube.

NBFM Settings

For proper adjustment of the deviation and clipping controls, an oscilloscope, a two-meter receiver, as well as an audio signal generator should be employed. Satisfactory "approximate" adjustment may be effected without these test instruments; both methods will be described briefly. If the aforementioned test equipment is available, the oscilloscope should be connected to the output of the receiver and a 3000 cycle audio tone applied to the grid of the input tube, *V7*, of the modulator. Then, while watching the oscilloscope pattern, with the transmitter emitting a signal, the FM deviation control, *R30*, should be adjusted until correct frequency swing results. Correct frequency "swing" occurs at approximately half scale on *R30*. The clipping control, *R26*, should then be adjusted so that the audio peaks of the 3000 cycle audio signal are just starting to level the signal off. This should occur with *R26* set at approximately 1/3 full scale. Speech should then be applied to the signal and the signal examined on the oscilloscope for correct clipping action. If test instruments are not available, the two controls may be adjusted to their approximate positions as noted above. They may be then "touched up" after requesting modulation re-

ports from stations on the air. It should be mentioned that too much deviation should not be employed lest trouble be experienced in receiving the signal on AM receivers due to the signal being too broad for the i-f bandpass; furthermore, interference to adjacent channels may result with the deviation control set too high.

The antenna pickup link, *L8*, may be attached to the proposed antenna and adjusted for optimum loading of the final r-f amplifier by regarding the final plate meter, *M2*. With an AX-9903 r-f amplifier tube and a plate voltage of 600 volts, the final plate current should not exceed 200 milliamperes or damage to the tube will result.

SCRATCHI

(from page 8)

ing mountain.) Itchi are reely making car move along, and he braking every law in the book except the one about stopping for school buses, and only reason he not braking that one is because it are Saturday and not being any school buses on the road.

Very shortly we getting to base of mountain, and I taking another reeding. Hokendokensake!! just like I figgering—rig are on top of mountain. When Itchi heering this he putting station wagon in low gear and we start up road which goes around mountain. When we getting on other side, Itchi suggesting we take another reeding, which I doing. Sacramento Boulevard!! Something are very pecooliar. Now we are receiving signal from side of mountain, nowhere

KEEP CQ at your finger tips with a CQ Binder . . . ONLY \$2.50*

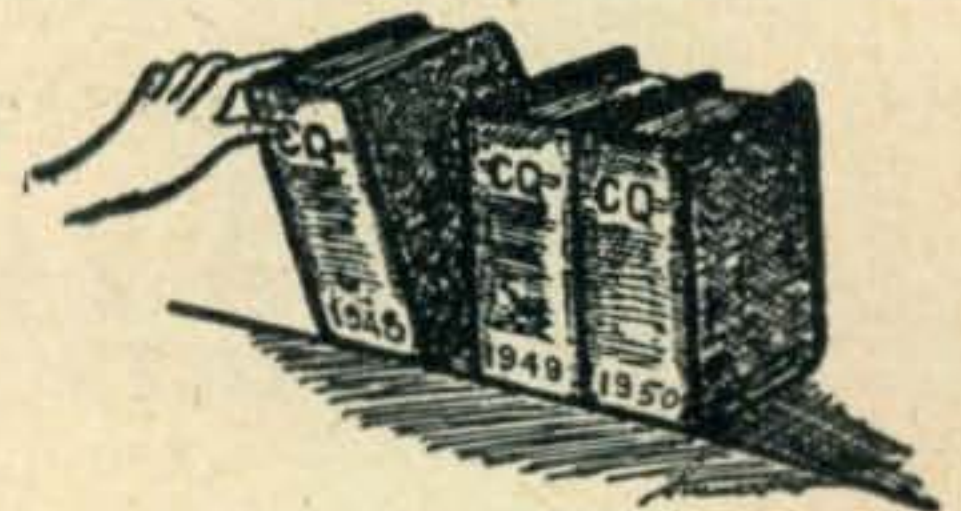

CONSIDER the

APPEARANCE . . . Your shack, den . . . or wherever you set up your rig can be kept in shipshape when all your copies of CQ are in one safe place. The deep, red shade will blend perfectly with any color scheme . . . and, in addition, the backbone will be gold stamped with CQ and any year you desire.

CONVENIENCE . . . In a few seconds you can locate any article you want . . . no more fumbling around for last month's issue . . . just reach for your Binder . . . turn to the index . . . and presto, there it is.

WORKMANSHIP . . . Dupont Fabricord . . . stainproof and washable . . . Center channel to keep magazines securely in position.

Let your wife, sweetheart, or a friend, see this ad . . . Tell them that a CQ Binder would make the perfect gift for the "Ham of their life" . . . for a birthday, anniversary . . . or any other "special" day . . . or you can always buy one for yourself.

*(Foreign Orders add 25c per binder)

CQ Magazine

67 West 44th St., New York 18, N. Y.

ENCLOSED FIND \$..... FOR..... BINDERS

NAME..... CALL.....

ADDRESS.....

CITY..... ZONE..... STATE.....

Year wanted 1948 1949 1950 1951 1952. Stamping: CQ Plain

CQ

near the top. We hesitating, then thinking maybe iron ore in mountain giving us trouble or something, so we going ahead. Later, near top, we again taking reeding, and this time signal seem to be coming from where we were down at base of mountain!!

Itchi and I getting out of car and looking around, and still wondering what to do when heering faint yelling. We look on top of mountain and see cupple guys waving at us. We driving up higher, and they come running down side of mountain toward us. Well, Hon. Ed., you could knocking me over with 160-meter vertical antenna if it isn't two of the club officers. They are coming to tell us we winning first prize, or at least that what Scratchi thinking. As you probably guessing, I are wrong.

Officers are quick jumping in car and telling us to take quick reeding and follow the transmitter. While we dashing down mountain they are telling us what happen. They deciding to put transmitter in reel hard spot to find, so rigging up xmitter on a mule. Having storage battery strapped on one side and xmitter on other side, and they walking up to top of mountain with mule. When getting there they stringing long-wire antenna from mule to nearby cactus, and everything going nicely till about ten minutes ago. Then the mule start getting restless, and in moving around the antenna wire are touching rear end of mule. There are slight arc as mule's tail gets singed, and much noise from mule as he taking off. Mule not doing any jumping, he just moving fast in a straight line, with club officers watching him. Every time mule slowed down the antenna would touch him on flank and he'd break into new burst of speed. This kept up as far as officers could see, with mule making beeline down side of mountain.

I taking more reedings on signal, which are now getting weak, and we taking off in pursoot of mule. He are sure going in straight line, but unfortunately not on any road. We zigging and zagging and trying to get close with car, but signal are getting weaker and weaker, and finally we not heering any signal at all. Last we know mule are hedding dew east, transmitter, power supply, antenna and all. We not knowing why signal are stopping, unless mule are going so fast he now in New Mexico.

Anyway, nobuddy has yet found hidden transmitter, Hon. E., so if you tuning across low end of eighty and heering a signal keyed with a series of vee's, you might checking in your front yard or nearby, on acct. if you find that mule and the transmitter, we have a nice 100 watt rig waiting for you as first prize. Oh, and by the way, the mule's name is Mabel.

Respestively yours,
Hashafisti Scratchi

NOVICE SHACK

(from page 37)

nor is buying a commercial transmitter. With few exceptions (you can almost count them on three fingers and have fingers to spare) all of them, including some "de-TVI'ed" models, may require additional shielding and filtering to insure that only the power generated on the design frequency is radiated.

Even if de-TVI'ing a transmitter were extremely difficult, it would still be necessary to do it if you expected to be on speaking terms with the viewers around you. Fortunately, it need not be too hard.

ATTENTION MOBILE HAMS

COMPLETE MOBILE PACKAGE — NOTHING ELSE TO BUY. OUTSTANDING MOBILE SIGNALS USE MOTOROLA EQUIPMENT—BACKED BY YEARS OF COMMUNICATION EQUIPMENT EXPERIENCE — WORLD'S LARGEST PRODUCER OF 2-WAY MOBILE EQUIPMENT.

A mobile transmitter with a double feature FM or AM at flip of the switch, the MOTOROLA FMT-30-DMS 27-30 MC. **\$130.00**

P-7253 spring base rear-mount antenna. **\$24.75**

MOTOROLA P-69-13 or 18-ARS receiver with special noise limiter for use

with any converter having 1440-3000 KC. **\$60.00**

New Gon-set Tri-Band Spread Converter. **\$47.60**

3-30 famous Gon-set converter complete to connect to the P-69-13 or 18-ARS receiver **\$44.75**

P-327-E Fire wall loud speaker **\$5.00**

The above comes complete with all necessary accessories and mounting hardware. Order direct or through the Motorola National Service Organization member in your area.

NOTE: This Receiver and Transmitter is equipment which has been returned from the field, modified and rebuilt for Amateur Service.

For further information write to:

MOTOROLA INC.

Amateur Sales Dept. CQ February
1327 W. Washington Blvd., Chicago 7, Ill.
Attention: Harry Harrison W9LLX
Telephone—TAYlor 9-2200, Ext. 161

Complete RIDER TV information in new form. Individual manufacturer's complete, factory authorized data, boxed separately. Indexed for easy filing, quick reference... faster, easier, more profitable servicing! Only \$2.00 at your jobber's.

RIDER JOHN F. RIDER Publisher, Inc.
480 Canal Street, New York 13, N. Y.

FREE!
Call
Letter
Decals



C'mon down to ARROW and pick up this handsome set of call-letter decals. For your car, your rack, etc.

These decals are free for the asking—nothing to buy, no strings. Just drop in to ARROW and shoot the breeze with "Herb" (W2PGP) Charrow. Give our new ham shack the once-over. You'll like it.

ARROW ELECTRONICS, INC.
 82 CORTLANDT ST., NEW YORK 7, N. Y., DIGBY 9-4714

WANTED

WE NEED YOUR SURPLUS ELECTRONIC EQUIPMENT

WE PAY TOP \$\$\$ FOR:

RADIO RECEIVERS
 TRANSMITTERS
 ARC-1
 ARC-3
 ART-13
 CONTROL BOXES
 INDICATORS

AN CONNECTORS
 CLAMPS
 PLUGS
 CORDS
 RELAYS
 TELEPHONE MATERIALS
 WE BUY ANYTHING!

WRITE, WIRE TODAY!
 TELL US WHAT YOU HAVE

TALLEN COMPANY, INC.

Dept. CQ.

159 CARLTON AVE. BROOKLYN 5, N. Y.

**REPAIR PARTS FOR RADIO RECEIVERS
 MODELS BC348-H K, L, R AND BC-224 F, K**

We can supply coils for all six bands for Ant., RF, Det., and Osc. Also all I.F. trans., C.W. Osc. and xtal filters, 4 gang condensers, engraved front panels, dial mechanisms, volume controls, etc.

Write for complete listing and circuit diagram.

ELECTRONICRAFT, INC.

27 Milburn St., Bronxville 8, New York

WE WANT . . .

Surplus Test Equipment, Transmitters, Receivers, Radar Equipment, Navigational Aids; Marine & Airborne Equipment. Be sure to name your price in full details. Write now to:

RADCOM ENGINEERING CO.

8 Livingston St., Newark 3, N. J.

CQ

In the past few years, CQ and other radio journals have published hundreds of articles on TVI prevention. "Phil" Rand, W1DBM, has written many of them, a number of which he has collected in an invaluable booklet, *Television Interference*. If you do not have a copy, you may obtain one by addressing a postal card to:

Mr. Philip S. Rand, W1DBM
 Remington-Rand, Inc.
 Laboratory for Advanced Research
 South Norwalk, Connecticut

and requesting it. You will be glad you did.

QRM

TVI is not the only kind of interference that Novices must contend with, as I can attest from personal observation, and this note from WN8HWL indicates: "Here I sit at my rig, thoroughly disgusted . . . Even if I were running the maximum legal power—75 watts—and I surely am not, I couldn't cut through the sidebands and splatterings from kilowatt alley! Give us a break, won't you? We have only fifty kilocycles in which to operate and usually only one crystal; so when our frequency is jammed for hours at a time, what can we do but wait? Wait for our tickets to expire while the Class-A fellows calmly shoot the breeze? Not me, and I am sure I speak for quite a few of us. I'm crying on your shoulder, because I know you can and will pass the word on to the band edgers."

Actually I doubt that "W" phone stations are causing Bob's anguish. The USA phone band is 3,800 to 4,000 kilocycles, a full fifty kilocycles from the Novice band. The Canadian phone band, however, starts at 3,725 kilocycles. Although it extends to 4,000 kilocycles, we may as well face it, if it is a choice of fighting US phone or Novice band interference, the Novice will lose almost every time. We can hope, however, that the VE phones who see this will operate above 3,750 kilocycles as much as possible.

Basically, the trouble is that there are not enough frequencies to go around; however, changing one's frequency a few kilocycles will often avoid an interfering station. At 3,700 kilocycles, most transmitters require no retuning for crystals within ten or fifteen kilocycles of each other. By preparing a chart of transmitter dial settings near each end and the middle of the band and arranging a number of crystals for easy changing, either with a multi-position double-pole switch or by mounting the crystal socket where it is easily accessible, rapid frequency shifting (QSY) becomes easy.

Equally as important as the ability to change one's transmitting frequency to avoid interference is high receiver selectivity. As mentioned last month, simple receivers lack selectivity more than any other feature. One of the more serious manifestations of this lack is that extremely strong signals overload or *block* the receiver and appear excessively broad. Receivers without an r-f amplifier ahead of the mixer stage are most susceptible to blocking, although more expensive ones, using sharp cut-off tubes in their input stages, may show a similar effect to a lesser extent.

Using the transmitting antenna for receiving aggravates receiver overloading, simply because it is such an efficient receiving antenna. A shorter one (less than thirty feet) usually helps when signals are loud. Also, try retarding the receiver "gain" or "sensitivity" control and advancing the "volume"

control. A wave trap, *Fig. 3*, in series with the receiver antenna lead will reduce the strength of local stations. It will reduce the strength of all signals near the frequency to which it is tuned; so a wave trap is only useful when the interfering local is operating in another section of the band.

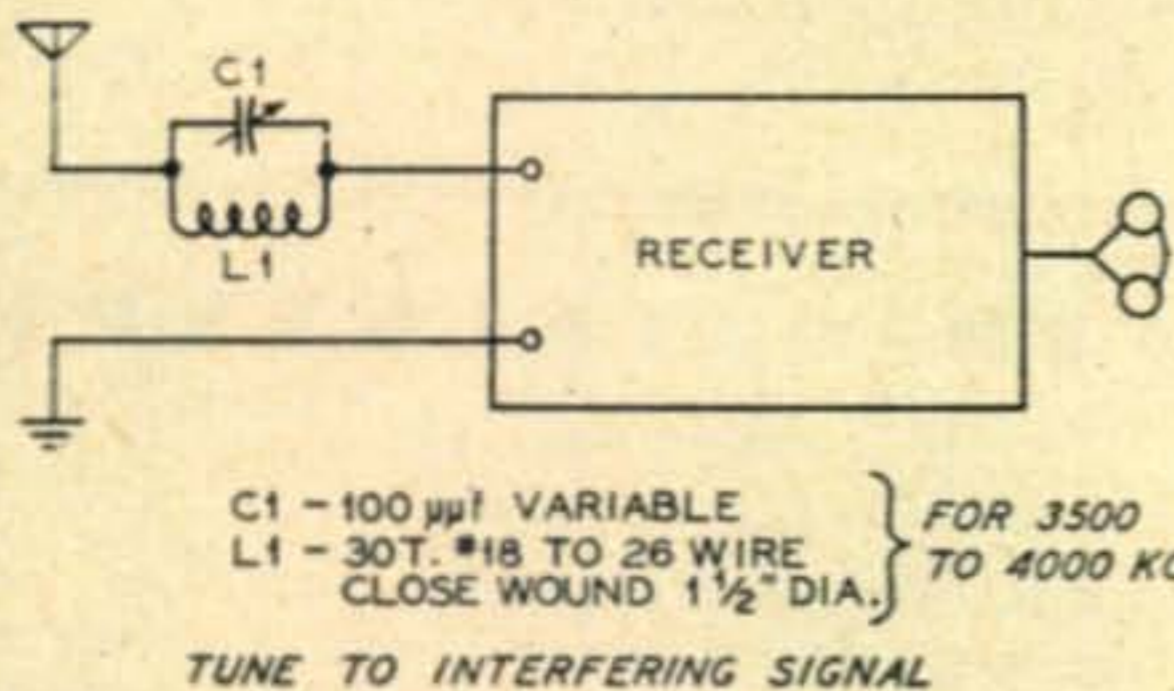

Fig. 3. Simple wave trap for decreasing strength of nearby interfering signals.

WN2IDK has as attractive a QSL card as I have seen in a long time. Marvin must really practice his code; he already has his receiving speed up to twenty words per minute! He operates on eighty-meter c.w. and two-meter phone and is a member of the Suffolk-Nassau two-meter emergency net. An up-and-coming ham, I would say. Incidentally, Marv is looking for a slogan to fit his call letters. Any suggestions?

Most of you undoubtedly know about the *Worked-All-States* contest for Novices being sponsored by the *Hallicrafters Company*. Full rules appear in their

advertisements, but briefly the first ten Novices to submit proof of WAS and have obtained a Conditional- or General-Class license will receive a *Hallicrafters S-76* receiver. All other Novices satisfying these requirements will each receive a \$25.00 cash prize. Contest closes September 7, 1952, and proof must be submitted to the *Hallicrafters Company* (not *The Novice Shack*), postmarked not later than October 7, 1952. How many states have you worked?

73, Herb, W9EGQ

BIBLIOGRAPHY

1. Robin W. Clark WØRVD, "Small Rig—Big Signal," CQ, p. 11, Jan. 1950
2. Edwin W. Hill, W4PQA, "Senior-Grade 807 Transmitter," CQ, p. 22, April 1950.
3. Howard J. Hanson, W7MRX, "The Secret Weapon," CQ, p. 26, July 1950. (25-watt transmitter and 80-40 meter receiver in one cabinet.)
4. Sterling Fisher, W2PEX, "Versatile TVI-less 40-watt Transmitter," CQ, p. 11, Sept. 1951. (Use crystal control.)
5. J. Roy Smith, W6WYA, "The 28-28," CQ, p. 23, Dec. 1951.
6. S. G. Reque, W2FZW, "The 80-Meter Novice Special," CQ, p. 11, March 1951.
7. Lawrence B. Peirce, W4KIX, "The Utility VFO," CQ, p. 16, Oct. 1951. (Use crystal, omitting VFO.)
8. Don H. Mix, W1TS, "Two-Stage Transmitter for the Beginner," QST, p. 14, April 1950.
9. Edward P. Tilton, W1HDQ, "A Two-Meter Station for the Novice," *The Transmitter R-F Section*, QST, p. 34, March 1950. Modulator, Power Supply, QST, p. 42, April 1950.
10. Donald H. Mix, W1TS, "A 75-Watt Transmitter for Three Bands," QST, p. 18, Oct. 1951.

CQ, the amateur's experimenter's, technician's publication. For beginner and old-timer!

Subscribe now and be sure of getting each issue chockful of intelligent, constructive articles edited for YOU. Subscribe now—Save \$1.20 per year.—You can't go wrong!

One Year \$3.00 Two Years \$5.00

in U.S., U.S. Possessions, Canada and countries in the Pan American union. All others \$4.00 per year.

CQ MAGAZINE

67 West 44th St., New York 18, N. Y.

Enclosed find \$ for a year subscription

to be sent to: New Renewal

Name Call

Address

City Zone State



The Largest Selling
LIGHTNING ARRESTER
At Any Price!

NO. AT102



APPROVED

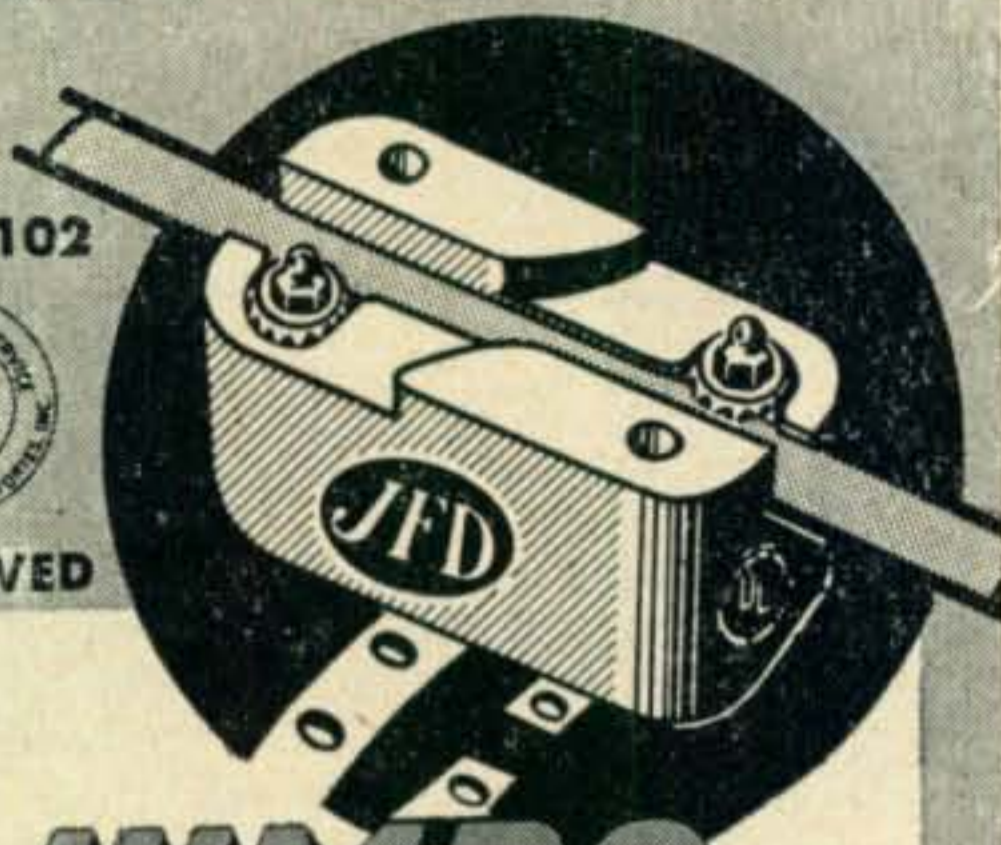

JUMBO

Protects Home and TV Set Against Lightning Hazards **\$2.25** LIST

U.S. Patent No. D-4664

- Installs anywhere
 - No wire stripping, cutting or splicing
- (Complete with strap and ground wire.)

OVER 1,000,000 IN USE TODAY!

See Your Jobber or Write for Form No. 84



JFD MANUFACTURING CO., Inc.
6157 B 16th AVENUE, BROOKLYN 4, N. Y.
FIRST in Television Antennas and Accessories

SPECIAL

FILAMENT TRANS.

6V at 3 Amps.,
\$1.45

HALLICRAFTERS SX71-S76

Write for liberal trade-in offer.
Volt-Ohm-Milliameter 0-1 Ma. 4"
Fan Type. Diagram Included. Makes
1000 ohm per volt unit.
Meter Only **\$2.95**
Resistor Kit for Above **\$2.45**
ATRONIC CORP., DEPT. C-14
1253 Loyola Ave., Chicago 26, Ill.

CRYSTAL UNITS

High quality Western Electric Type CR-1A/AR in holders with 1/2" prong spacing. Ideal for net frequency operation. Available in quantities:

5910-6350-6370-6470-6510 **\$1.25 each**
6610-6670-6690-6940-7270
7350-7380-7390-7480-7580-9720

All fundamental frequencies in kilocycles but make excellent multipliers at higher frequencies. The 9720 unit, for example, triples nicely to 29,160

ELECTRONICRAFT, INC.
27 Milburn St., Bronxville 8, New York

8 WIRE CONTROL CABLE

Two No. 16, Six No. 20 tinned, stranded, copper, rubber insulated coded leads. Waterproof rubber jacket. Woven copper armor shield overall. Wt. 16 lbs./100 ft. Lengths to 400 ft. **LOW PRICE FOB warehouse.** Minimum order 100 ft. Shipment is made by Railway Express—shipping charges collect. **5c ft.**

TRANS-WORLD RADIO-TELEVISION CORP.
6639 S. ABERDEEN ST. CHICAGO 21, ILL.
Phone: AUstin 7-4538

CQ

11. Donald H. Mix, W1TS, "The Novice One-Tuber," QST, p. 18, May 1951.
12. Richard M. Smith, W1FTX, "A Single-Control Low-Power Transmitter," QST, p. 11, Jan. 1951.

The above does not include all transmitters described in these magazines, but are representative, and it is suggested that the Novice read as many of them as possible, before deciding on which to build to obtain the "feel" of good design. Also consult **Radio and ARRL Handbooks.**

RADIO TELETYPE

(from page 28)

The R.D., during its rotation, connects contact 16 to the five selector magnets, one after the other. Any mark signal received during this period will switch B+ to contact 16, and energize whichever selector magnet happens to be connected at that instant. The selector magnets are trip affairs and require only a short pulse to trip them. Thus the letter "Y", which consists of mark signals on the first, third, and fifth pulse, will cause the first, third, and fifth selector magnets to trip, thereby moving levers 1, 3, and 5 into the mark position. These levers select the letter "Y", since they are notched like a key and the letter "Y" is the only letter that matches the notches of levers 1, 3, and 5 in the mark position and levers 2, and 4 in the space position.

When the R.D. rotates to the seventh position it connects contact 12 (which is always B+, no matter which way the polar relay is) to the print magnet L6. This magnet allows the motor in the printer to print the selected letter and to set up the selector magnets again ready for tripping on the next letter.

Shall I repeat that all again?

THE BALUN

(from page 25)

connections may be connected to any length of balanced transmission line or directly to an antenna whose input is balanced and reasonably close to the proper impedance. In many instances connecting the balun directly to the antenna enables one to use a single coaxial cable to feed an antenna, keeping standing waves from appearing in the outer conductor, and, in turn, aiding in the reduction of TVI.

It is suggested that the balun be strung out, doubled back upon itself as shown in the sketch and then have as few additional folds as possible. It is not recommended that it be coiled up to be placed in a small box.

Conclusions

In conclusion, the advantages of the balun are as follows:

- (1) It matches a balanced transmission system to an unbalanced one.
- (2) It is also a 4:1 impedance transforming device.
- (3) It works well over a wide band of frequencies.

(4) It can be used to aid in the reduction of TVI by coupling to balanced or unbalanced TVI reducing filters, by enabling the use of an unbalanced pi network or tank circuit with a balanced antenna system and by reducing unbalanced currents and standing waves on transmission lines.

(5) It is easily and cheaply built.

It does have two disadvantages, however:

(1) It is not a multiple band device for more than a single amateur band as it requires a separate design for each band.

(2) It gets to be quite long in dimensions for the low frequency bands such as 3.5 megacycles.

No attempt is made here to explain the "BA-ZOOKA", which is closely akin to the balun. The bazooka is considerably more difficult for most hams to construct.

YL'S FREQUENCY

(from page 34)

At that time they were living in Waikiki. Then they moved to the big island of Hawaii and lived at the Inter-Island telephone station on a ranch 5000 feet above sea level, 13 miles from the nearest town. Johnny did his best to get her to study for her ticket, but Dell insisted it was a "man's" hobby.

"Not too long after that," says Dell, "Johnny took me for a ride and to my surprise stopped at a home I had never seen and told me, 'come, I want you to meet someone.' Even though I was thinking what nerve he had and I would never do anything like that at home, I obeyed. A very attractive woman greeted us and invited us into her ham shack. It was Ella, KH6FD, known all over the world. She was wonderful and operated her rig for a couple of hours for us. When she told me she talked to Maine, my home QTH, I couldn't stand it any longer as I already was getting homesick."

Because of Ella, Dell started studying "so hard I dreamed code and theory." The RI was coming to Hilo the following month. Dell tried the exam, missed the code, but later took Class C and in another six months passed her Class B. She got her Class A two years ago.

Johnny built her a 50-watt rig and a cubical quad antenna, and KH6TI was on the air from Hawaii for ten months, then from the Island of Maui for a year, and for the last year and a half from Waikiki. She now has a 90-watt rig on all bands, phone and c.w., but is still using the quad.

"Ella was right about talking to Maine," says Dell. "I have had 186 contacts with W1BEU in Fairfield, Maine; 150 with W1DPX in Mystic, Conn., and 202 with W4NOV in Apex, N.C. So you see it isn't so far from Hawaii to the East Coast!"

"Anything can happen in ham radio and I love it," adds Dell. She has proof, too. Enclosed with her letter was a photograph of the most unusual QSL "card" she ever received—a turtle shell which was sent to her by KB6AR on Canton Island, and imprinted with their calls! It is 7 feet around and so big they hang it on the outside of the house.

With that Dell says "Aloha from Hawaii."

And we'll say "ge-wa-pa" from New Mexico—
33, W5RZJ.



FREE LICENSE FOR HAMS!

Absolutely! No strings attached! Every ham in the U.S. has a FREE LICENSE to write us immediately and tell us what new or used radio or electronics gear you want to sell. We pay sizzling high prices! Tell us what you have—TODAY—and see the color of our dough—FAST!

CONDENSER SPECIALS

.1 mfd. @ 400 VDC Ea. 10c or 10 for 69c
 16 mfd. @ 400 VDC, Paper electrolytic Ea. 30c, 5 for \$1.00
 .05 mfd. @ 5000 VDC, Paper Ea. 39c or 3 for \$1.00
 TRANSFORMER: 13 V @ 3 amp. \$1.89
 PE-103 DYNAMOTOR: With filter base and cords.
 6 or 12 V. input: 500 V. output. Excellent, like new
 condition. Limited quantity. ONLY \$24.95

ARC-5 OR 274-N TRANSMITTERS

2.1-3 mcs. Used \$14.95
 3-4 mcs. Used, excel. cond. 14.95
 4-5.3 mcs. Used, good cond. 6.95
 5.3-7 mcs. 5.50
 7-9.1 12.50

ARC-5 OR 274-N RECEIVERS

.55-1.5 mcs. Brand new \$49.50
 1.5-3 mcs. Brand new 24.50
 6-9.1 mcs. Brand new 11.95
 28 V. RECEIVER DYNAMOTOR 1.25
 14 V. RECEIVER DYNAMOTOR 9.95
 274-N DUAL TRANSMITTER RACK 2.95
 TRIPLE RECEIVER RACK, Good Cond. 5.00

ALL ORDERS F.O.B. LOS ANGELES
 25% deposit required. All items subject to prior sale

COLUMBIA ELECTRONICS SALES

Dept. LS—
 522 S. SAN PEDRO ST., LOS ANGELES 13, CALIFORNIA

DID YOU GET IT? IF NOT

SEND NOW FOR B-A's
 136 BIG PAGE
FREE CATALOG

INCLUDING
 21 PAGES OF
 DOLLAR-SAVING
 BARGAINS!

BA

BURSTEIN-APPLEBEE CO. 1012-14 McGEE ST. KANSAS CITY, MO.

FREE

Send your 1952 catalog to:

Name.....
 Address.....
 City..... State.....

BURSTEIN-APPLEBEE CO.

QSY?

The JOHNSON Viking VFO Kit is earning the respect and confidence of hams everywhere who appreciate its accurate calibration, unusual stability and high quality components.

JOHNSON Viking VFO Kit, complete, less tubes.

Amateur Net \$42.75



Features:

- Accurate frequency calibration on all bands—160 thru 10
- High stability—clean keying • 5-in. calibrated dial with 6:1 reduction • Air dielectric high & low frequency trimmers—ceramic insulation • Voltage regulated • Two separate rigid tank circuits minimize "shock" modulation • Output frequencies: 1.75—2.0 mcs., 7.0—7.425 mcs., 6.7—7.0 mcs.



E. F. JOHNSON CO.
WASECA, MINNESOTA

WANTED Engineers and Scientists

Unusual opportunities for outstanding and experienced men.

These top positions involve preliminary and production design in advanced military aircraft and special weapons, including guided missiles.

IMMEDIATE POSITIONS INCLUDE:

- Electronic project engineers
- Electronic instrumentation engineers
- Radar engineers
- Flight test engineers
- Stress engineers
- Aero- and thermodynamicists
- Servo-mechanists
- Power-plant installation designers
- Structural designers
- Electro-mechanical designers
- Electrical installation designers
- Weight-control engineers

Excellent location in Southern California. Generous allowance for travel expenses.

Write today for complete information on these essential, long-term positions. Please include resume of your experience & training. Address inquiry to Director of Engineering,

NORTHROP AIRCRAFT, Inc.

31 E. Broadway, Hawthorne
(Los Angeles County) Cal.



Classified Ads

Advertising in this section must pertain to amateur radio activities. Rates: 25c per word per insertion for commercial advertisements. 5c per word for non-commercial advertisements by bona fide amateurs. Remittance in full must accompany copy. Phone orders not accepted. No agency or term or cash discounts allowed. No display or special typographical ad setups allowed. "CQ" does not guarantee any product or service advertised in the Classified Section. Closing date for ads is the 25th of the 2nd month preceding publication date.

WANTED: RCA surplus modulation transformer—butterfly tank condenser. Sell BC-610 speech amplifier. E. L. Felder, W5FSS, Tylertown, Miss.

DXers! "Ham's Interpreter"—ham words and phrases translated into 7 languages—\$1.00. For SWL's—"World Radio Handbook"—complete information on international stations, \$1.50; "How to Listen"—for SWL novices, 30c. World Radio Publications, 1000 Connecticut Avenue, Washington 6, D.C.

WANTED—bargains in transmitters, receivers, test equipment and miscellaneous gear. What have you? W5ZZ, 718 N. Broadway, Oklahoma City, Oklahoma.

5 ELEMENT 2 meter beams. Riverside Tool Co., Box 87, Riverside, Ill.

HOTTEST surplus list in the country. Electronics—hydraulics—aircraft gadgets. Dick Rose, Everett, Wash.

REVOLUTIONARY copyrighted discovery! Learn Morse Code alphabet in 15 minutes with amazing new code teacher "PHILKODA". 50c postpaid (group size \$5.00). Philip W. Miner, 7120 Lahser, Birmingham, Michigan.

QSLs? SWLs? "Made-to-order cards!" Samples 20c. Sackers, W8DED, Holland, Michigan.

SELLING 51-J-1 COLLINS receiver in brand new condition. Will accept best offer over \$825.00. Write Joe Tabor, W8AES, 19215 Westphalia, Detroit 5, Michigan.

BARGAINS: Extra Special! Motorola P-69-13 mobile receivers \$29.50; Globe King \$315.00; HT9 \$199.00; HRO-50 \$299.00; Lysco 600 \$109.00; SP400X \$249.00; HRO7 \$199.00; Collins 75A1 \$295.00; HRO-5T \$175.00; Hallicrafters S-47 \$99.00; RME 2-11 \$99.50; RME-45 \$99.00; Meissner EX Shifter \$59.50; S-40A \$69.50; VHF 152A \$69.00; HF-10-20 \$59.00; SX-24 \$69.00; Globe Trotter \$79.50; Meissner signal calibrators \$24.95; MB611 mobile transmitter \$29.00; 90800 exciter \$29.50; XE10 \$14.95; and many others. Large stock trade-ins. Free trial. Terms financed by Leo, WØGFQ. Write for catalog and best deal, to World Radio Laboratories, Council Bluffs, Iowa.

WANTED: Collins 32V-1 or 32V-2 transmitter. Please state price and condition. W2VUN, 2110 Clinton Street, Buffalo 6, N. Y.

FOR SALE: National HFS \$100.00; McMurdo Silver frequency multiplier with 829B final \$25.00; Electro-Voice speech clipper \$12.00; Miller R-9er with 10 & 6 meter coils \$20.00; Bliley CCO unit \$7.50; Morrow converter for 75 and 10 meters \$35.00; National MB20 tuner \$5.00; Temco 75GA transmitter with 4-65A final \$225.00. T. Rutherford, 1723 Holly Avenue, San Bruno, Calif.

FOR SALE: Hammarlund HQ129X with speaker, excellent condition \$139.00. WNØFVG. Ernest Nettum, Kindred, North Dakota.

WANT: ART-13, SRC-284A, BC-654A, PE-103A, PE-104A, GN-45, BC-348, BC-342, BC-312, BC-221, RA-34, RA-20, RA-62. Test equipment. Radar, technical manuals. Cash or trade. Arrow Appliance, 525 Union, Lynn, Mass.

TOP cash for APR-4 units and parts; microwave test equipment, ARC-1, ARC-3, ART-13, etc.; TS-34 and other "TS-"; good quality laboratory equipment; manuals, tubes meters and parts. Will also trade TV, SX-28, VTVM, astronomical telescope, etc. Littell, Farhills Box 26, Dayton 9, Ohio.

SELL: Ferris 17B Microvolter signal generator 10kc-30MC \$345. RBB Navy receiver, 500 kc-4000 kc, two decibel meters, voltmeter, audio filter, 110 vac power supply, \$125. I-126 signal generator, 15-25 mc, 190-230 mc \$55. I-134A Dumont scope \$65. Tube tester \$20. TCS motor generator 115 vdc input \$35. Want: PE-104A, PE-103A, RA-34, RA-20, RA-62, ART-13, BC-348, BC-654A, BC-221. T. Clark Howard W-1HFN, 46 Mt. Vernon St., Boston 8, Mass.

FOR SALE: Master Mount antenna 20 and 75 loading coil. Dynamotor 12 v. input, 500 v. @ 300 ma. output. Tri-band Gonset converter and noise clipper. Lettine transmitter, 50 w. phone, CW, all bands, coils for 10, 20, 75, 160-807 final. 40 M. command transmitter. Hammarlund 4-11 modulator. Best offer takes any one or all. W6IQX, Randal Ochs, 1911 N. Ditman Ave., Los Angeles 32, Calif.

FOR SALE: Miscellaneous parts, transmitting and receiving tubes, high-voltage mica and variable condensers, 866A filament transformer, not junk. 3c stamp for list. W8HAW, 43450 Reservoir, Plymouth, Michigan.

GOING TO TRY for an amateur radio operator's license? Check yourself with a complete coverage multiple-choice type test similar to those used by the F.C.C. Surecheck tests with answer key, Novice Class \$1.50, Conditional and General Class \$1.75; Advanced Class \$2.00 Order your time-tested surecheck test today. Amateur Radio Supply, 1013 Seventh Ave., Worthington, Minnesota.

FOR SALE: 2, 6, 10 meter complete self contained transmitter phone and CW in A-1 condition 75 watts. Send for photo and complete description—\$150.00. Money back guarantee. W1CPI.

FOR SALE: Harvey-Wells TBS50C, also H. W. motor generator, all cables, control box, push to talk mike, a complete mobile set up. Price \$175.00. Money back guarantee. W1CPI.

BARGAINS: New and reconditioned Collins, National, Hallicrafters, Hammarlund, RME, Millen Gonset, others. Reconditioned S38 \$29.00, S40A \$69.00, SX43 \$119.00, SX71 \$149.00, SX42 \$199.00, SX62 \$199.00, NC57 \$69.00, NC173 \$139.00, NC183 \$199.00, HRO50T \$279.00, HRO50T1 \$339.00, HQ129X \$139.00, HF-10-20 \$49.00, VHF152A \$59.00, RME84 \$69.00, RME45, SX25, HRO7, SP400X, Collins 75A1, others. Shipped on approval. Terms. Lists free. Henry Radio, Butler, Mo.

WANTED: Tri-band converter, mobile transmitting equipment. State price, condition. Edgar Cole, W0CAM, 920 N. Cedar, Colorado Springs, Colo.

HELP WANTED

RADIO OFFICERS: \$7,200-\$10,000 annual earnings, top union conditions, 6 months radio operating experience U. S. Merchant ships on FCC license since Jan. 1935, can get emergency FCC license to sail at once. Also experienced USN Radiomen with 2nd class Radiotelegraph license plus 6 months sea Radio time. Phone, write, wire American Radio Association, CIO, 5 Beekman St., New York. CO 7-6397.

EASY TO LEARN CODE

It is easy and pleasant to learn or increase speed the modern way—with an Instructograph Code Teacher. Excellent for the beginner or advanced student. A quick, practical and dependable method. Available tapes from beginner's alphabet to typical messages on all subjects. Speed range 5 to 40 WPM. Always ready, no QRM, beats having someone send to you.

ENDORSED BY THOUSANDS!

The Instructograph Code Teacher literally takes the place of an operator-instructor and enables anyone to learn and master code without further assistance. Thousands of successful operators have "acquired the code" with the Instructograph System. Write today for full particulars and convenient rental plans.



INSTRUCTOGRAPH COMPANY

Dept. C, 4701 SHERIDAN ROAD, CHICAGO 40, ILL.

MOBILE MODULATION KITS

T-103 Mike to 6J5 grid.
T-102 6J5 to Modulators PP 6V6 or PP 6L6.
T-104 Mod. Trans. PP 6V6 or PP 6L6 to 829, 832, or 2E26. All components miniature, ruggedized, and hermetically sealed. COMPLETE KIT & DIAGRAM \$3.50

Send Check or M.O. Ship. Chgs. C.O.D.

COMMUNICATIONS EQUIPMENT CO.

131 Liberty St., Dept. Q2 New York 7, N. Y.

for the high-power man!

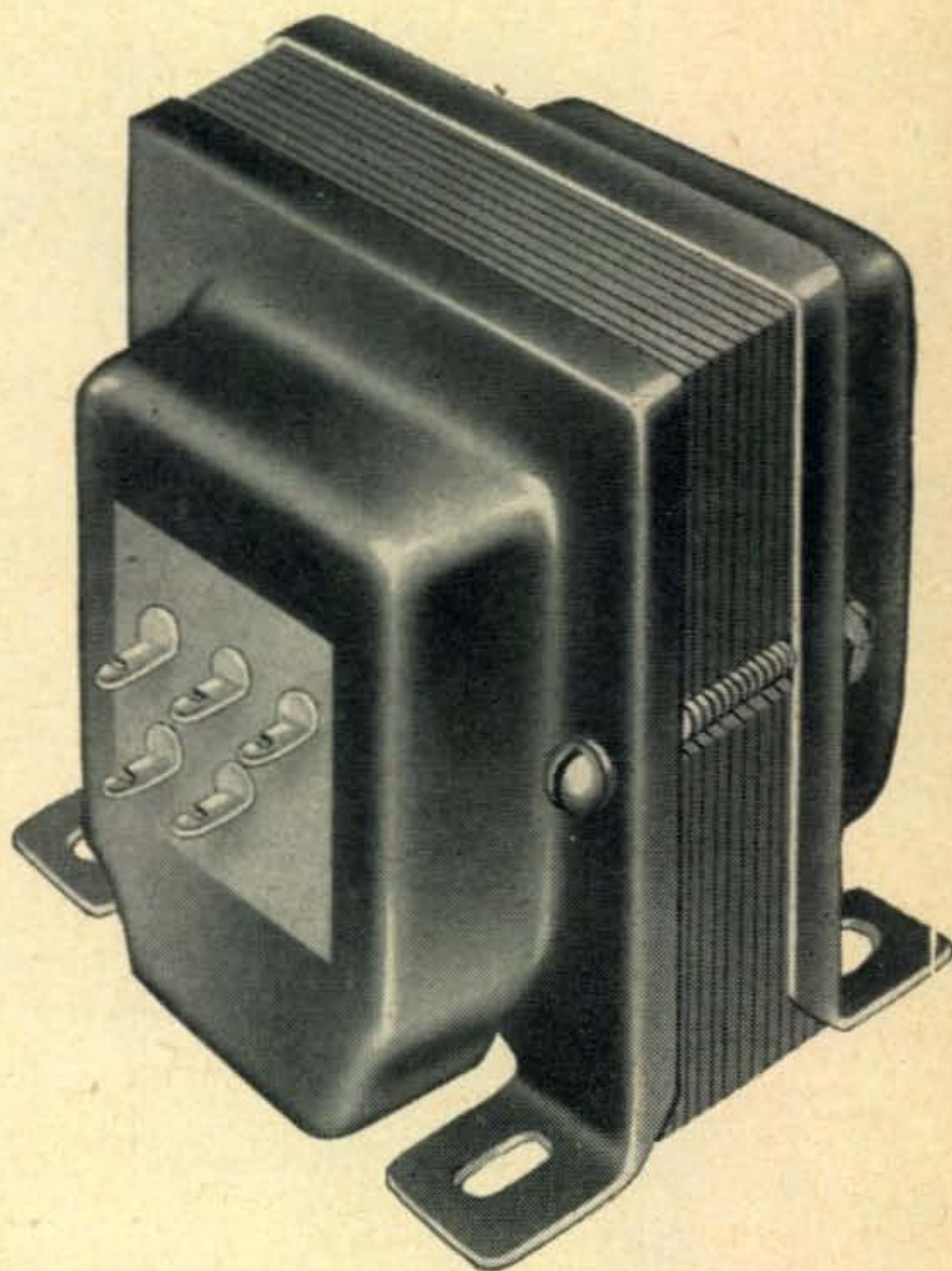

MERIT HIGHPOWER Filament Transformer P-2943

Designed for highpower use in both Amateur and industrial applications.

Specifications: Sec. Volts, 5—Sec. Amp., 30—Insulation Volts, 3000—Center tapped with primary taps for 110-115-120 volts, 60 cycles—Dimensions, 3 7/8 H. x 3-3/16 W. x 4 3/8 D.—DL Mounting... Will handle a pair of 250 TH's... 4-250 A's... 4-125 A's... 4-400 A's, etc.

Net Price — \$6.60

Merit Transformer Corporation
4427 North Clark Street
Chicago 40, Illinois



BURTON BROWNE ADVERTISING



NATIONAL

- **P**roven
- **D**ependable
- **Q**uality

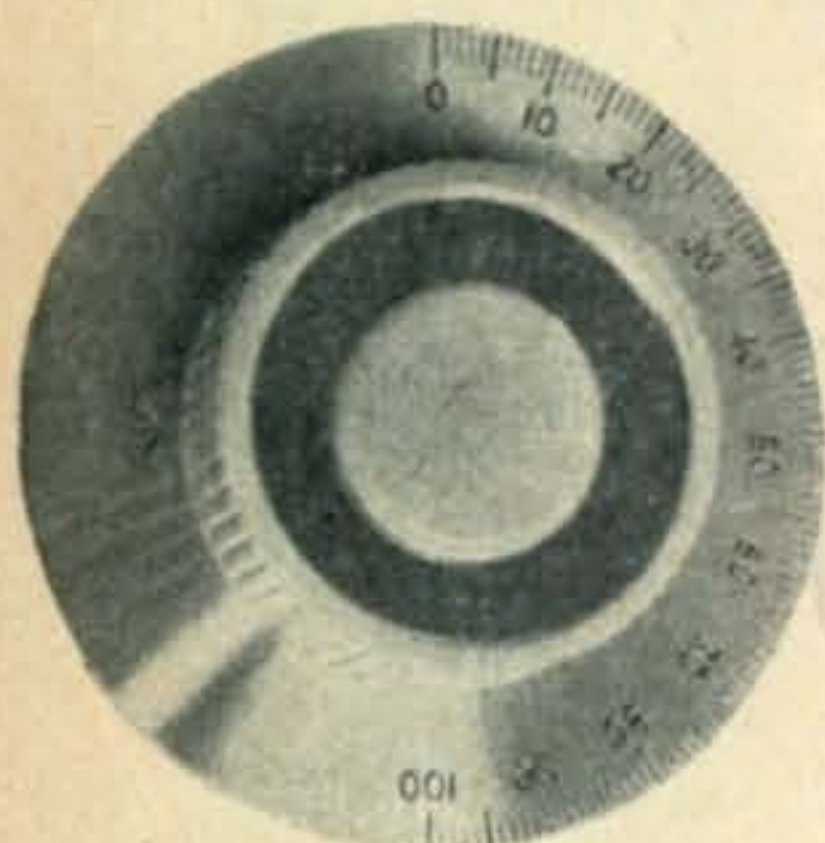

HRT-O DIAL



VD-16 KNOB

HRM KNOB



IFR (455kc)
IFS (1720kc)
I.F. TRANSFORMERS



NEW COMPONENTS

Pictured above are some of the new items we have added to our line of quality components. They have been especially designed to meet new and changing needs in electronics and, like all National components, are made better than industry standards. Write for drawings and specifications.

National



NATIONAL COMPANY, Inc.
MALDEN, MASSACHUSETTS

CQ Ad Index

Allied Radio Corp.	52
American Phenolic Corp.	6
Amperex Electronic Corp.	13
Arrow Electronics	66
Atronic Corp.	68
Barker & Williamson	58
Bud Radio, Inc.	2
Burstein-Applebee Co.	69
Collins Radio Company	14
Columbia Electronics Sales	69
Communications Equipment Co.	71
Concord Radio Corp.	53
Eastronic Sales Co.	63
Eitel-McCullough, Inc.	10
Eldico of N. Y., Inc.	53
Electronicraft, Inc.	66, 68
General Electric Company	1
Hallicrafters Company	52, Cover 2
Harvey Radio Company, Inc.	55
Instructograph Company	71
JFD Manufacturing Co.	68
Johnson, E. F. Co.	61, 70
Merit Transformer Corp.	71
Millen, James Mfg. Co., Inc.	4
Motorola, Inc.	65
National Company, Inc.	72, Cover 3
National Schools	5
Newcomer's Buyway	52, 53
Northrop Aircraft, Inc.	70
Ohmite Manufacturing Co.	9
Petersen Radio, Inc.	7
Radcom Engineering Co.	66
Radio Corp. of America	Cover 4
Rider, John F. Publisher, Inc.	65
Shure Brothers, Inc.	52
Sun Radio of Washington, D. C.	57
Sylvan Electronic Labs	60
Tab	72
Tallen Company, Inc.	66
Trans-World Radio-Tv Corp.	68
Turner Company	52
Wiley, John & Sons, Inc.	8
World Radio Laboratories, Inc.	59

WANTED IMMEDIATELY
for CRITICAL DEFENSE NEEDS
TUBES - CRYSTALS - END EQUIPMENT

OAS/VR75	3C23	12SC7M	833A,884
OB3/VR90	3E29,829B	FG17,32,33	927, 10007
OC3/VR105	4C35	100TH	1614, 2050
1N21,A,B	5C22	FG104,172	5725
1N23,A,B	5R4GY	250TH,TL	5727
1N25,26	6AC7M	304TH,TL	5749
Xtals: 100Kc,	6AG7M	368AS	5750
200Kc, 1000Kc	6B4G	450TH,TL	5751
2D21	6C21	KU627	5654, 5670
2K25, 723AB	6L6M	726C	5686
2J & 4J Magnet-	6SC7M	750T	5726
rons, Klystrons	7AG7	807,810	5814
		811,813	9001,2,3
All Army-Navy Gear: AN, ART, BC, I, PE, PU, RA, SCR			
TG, TS. WAVE GUIDES: PL & UG CONNECTORS.			
TURN YOUR SURPLUS INTO SPOT CASH & SERVE			
YOUR COUNTRY'S NEEDS AS WELL.			
Send Lists & Prices—Immediate Reply! Dept. C.			

"TAB" 111 Liberty St., New York 6 N. Y.
 That's A Buy: Phone WOrth 2-7674

*great news
to hundreds who
want maximum
selectivity
at minimum cost!*



NC-125

*the only receiver
with the famed
select-o-ject
built in!*

**NOW AVAILABLE FOR
IMMEDIATE DELIVERY**

Covers 550 kcs. — 36 mcs. in 4 bands. Voice, CW, NFM (with adapter). Edge-lighted, direct-reading scale. Amateur, police, foreign, ship frequencies clearly marked. National Select-O-Ject built-in (rejects any selected audio frequency 45 db — boosts 38 db). Three microvolt sensitivity (for 10 db signal/noise ratio on 10-meter band). S-meter. AVC, ANL, ant. trimmer. Variable CW pitch control. Separate R.F. and audio gain controls. Volt. reg., stabilized oscillator. Jack for phono or NFM Adapter. Audio essentially flat to 10,000 c.p.s.

Now at last, you can get immediate delivery on the receiver that gives you more selectivity per dollar — the *only* receiver with the famed Select-O-Ject circuit built in! And that's only one of the many fine features that make the NC-125 tops in receiver value!

National

©



EST.

1914

NATIONAL COMPANY, Inc.
MALDEN, MASSACHUSETTS

NC-125..... \$149⁵⁰*
NC-125TS (matching spkr.).... 11⁰⁰

*Slightly higher west of the Rockies.

Still unmatched
in its class...

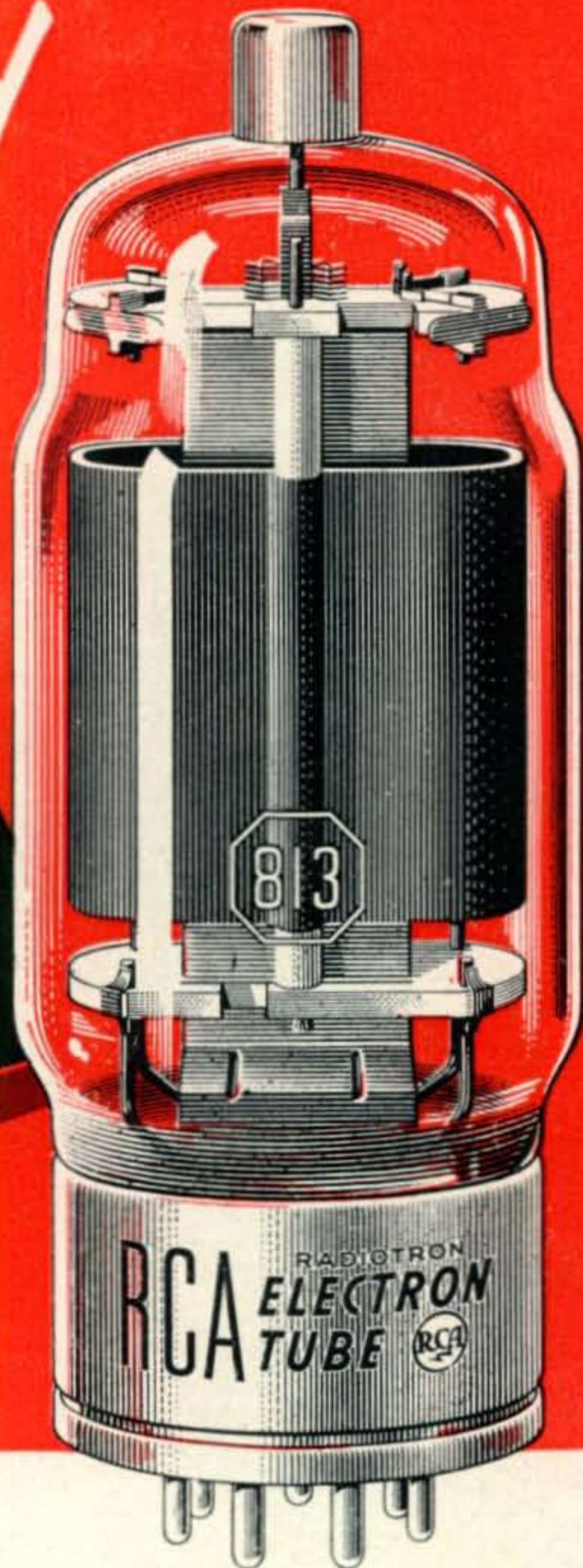
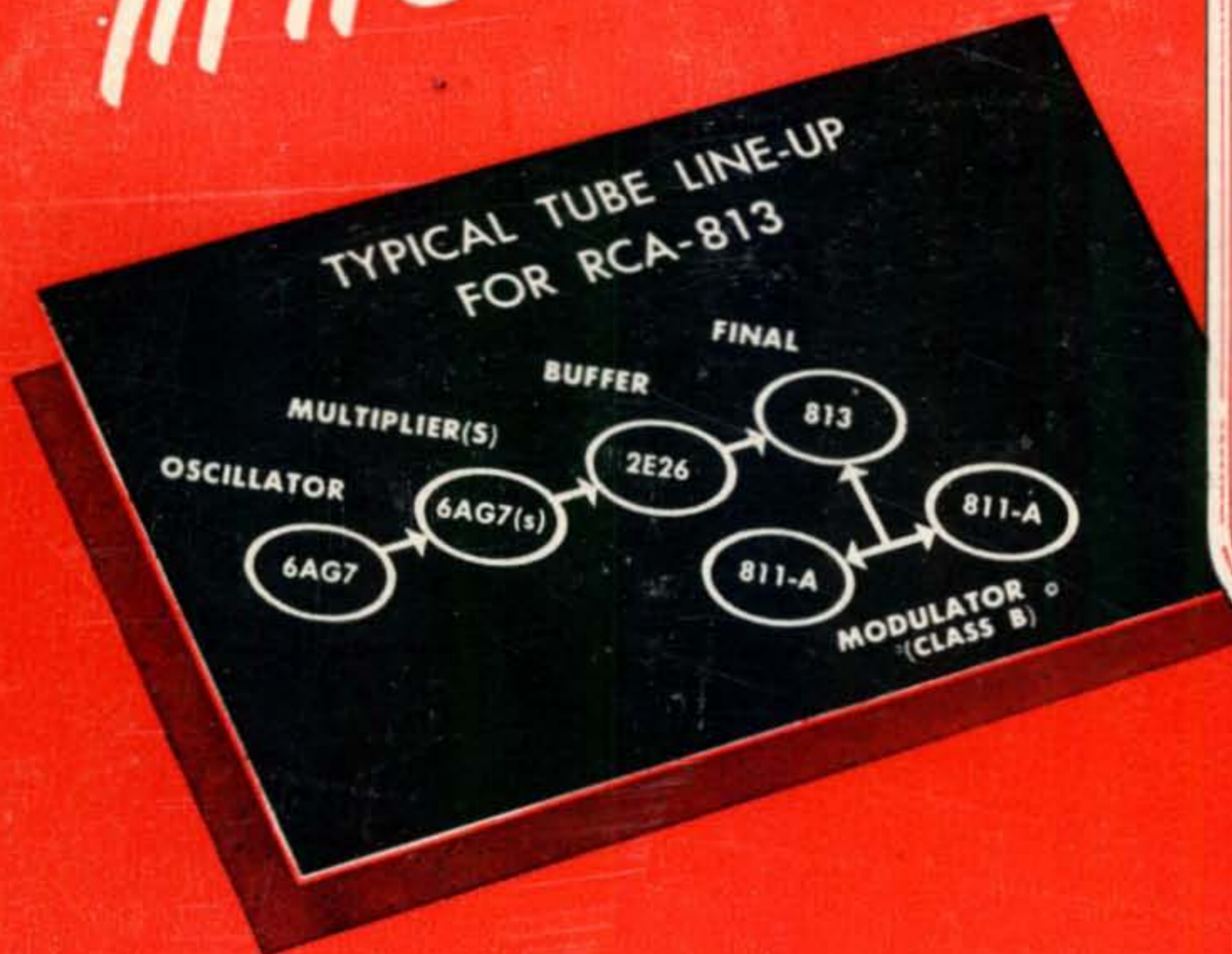

for price — power — performance

COMPARE an RCA-813 with any other tube in its class. Here's what you will find:

Economy—You get *more watts-per-dollar* input. You also save on the initial cost of the power supply because the 813 operates at relatively low plate voltage.

Power—A single RCA-813 easily takes an input of 500 watts on cw and 400 watts on phone. And, because it operates efficiently over a wide range of plate voltages, you can conveniently reduce power for local QSO's.

Performance—Because of its high power gain, the RCA-813 *beam power* tube can be driven to

full input at frequencies up to 30 Mc with a single RCA-2E26. High-level intermediate stages are not required . . . a big step toward the elimination of TVI!

In short, design that new, compact, efficient transmitter around a husky RCA-813 beam power tube.

Tubes for the Professional priced for the Amateur



The dependability of *commercially proved* RCA Tubes costs you no more. Buy genuine RCA Tubes and you buy the best. See your local *RCA Tube Distributor*.



RADIO CORPORATION of AMERICA
ELECTRON TUBES

HARRISON, N. J.