

CONGRATULATIONS...

TO

The World's Leading Novices

FROM

The World's Largest Maker of Ham Radio Equipment

hallicrafters

40 Contest Winners Share Hallicrafters 1951-1952 Merit Awards—Win Prizes

The following people were the first 40 to work all states and obtain a General or Conditional Class Amateur license during the Hallicrafters 1951-1952 Novice Class Radio Amateur Contest. Our heartiest congratulations!

Additional winners received after publication date will be notified by mail.

MERIT AWARD
hallicrafters
1951 • 1952
NOVICE CLASS
RADIO AMATEUR

WINNERS OF HALLICRAFTERS S-76 RECEIVERS

Chuck F. Riker, W5TPR
Levelland, Texas

Norma Jean Guile, W1UVM
Norwich, Connecticut

Ken Lamkin, W6NDP
Fresno, California

James R. Cromwell, W5TFD
Lacombe, Louisiana

William A. Brown, W4TED
Macon, Georgia

Philip E. Battey, W4TFX
Arlington, Virginia

Jack D. Reeder, WN6NGZ
Bakersfield, California

Ray Thacker, W5TFP
Ardmore, Oklahoma

Thomas J. Woodward, W8HEV
Detroit 6, Michigan

Fred G. Apple, Jr., WN5TIQ
N. Little Rock, Arkansas

WINNERS OF HALLICRAFTERS \$25 CASH MERIT AWARDS

William W. Varnedoe, Jr., W4TKL
Panama City, Florida
Ellis Rhea Hurd, Jr., WOFBT
Clayton 24, Missouri
Mason Friar, Jr., WN4TIU-W4TIU
Tarboro, North Carolina
Bucky Fountain, WN4TIV
Tarboro, North Carolina
Maureen Chambers, W6NTC
Los Angeles 45, California
Mrs. Margaret H. Pearre, W4TIE
Memphis 11, Tennessee

Marcus Barnes, W5TGV
San Angelo, Texas
Miss F. P. Hooper, W3SBE
Oreland, Pennsylvania
Miss Florence Gith ns. W3SR5
Rushland Pennsylvania
D. E. Morrison, W4TFB
Marietta, Georgia
Lowell S. Wildman, WN0FOG
Abilene, Kansas
Mel Whitaker W9OFR
New Lenox, Illinois

William Richard Powell, W8IJM
Charleston, West Virginia
George Landfield, W9PWV
Chicago, Illinois
Paul G. Cadwell, W5TPC
Tulsa, Oklahoma
Paul Klingemeier, W2FTY
Buffalo 23, New York
Gene Denison, W6NBP, EX-WN6NBP
Fresno 2, California
Charles E. Benjamin, W9QWW
Monroeville, Indiana
Harry Lowenstein, W2HWH
Maplewood, New Jersey
Robert Markel, W2IVS
New York 12, New York
Rev. C. L. Flickinger, WN0FTQ
Saronville, Nebraska

W. H. Bass, Jr., W4UWS
Falmouth, Virginia
Don Bybee, W6NAS
Fresno 2, California
Jerry Idelsohn, W8HJK
Detroit 21, Michigan
A. B. Smith, W7PRC
Maupin, Oregon
Clayton R. Brown, W3RZL
Philadelphia 31, Pa.
K. M. Frank, W6JYN
Emeryville 8, California
Mrs. J. S. Lawson, Jr., W9RGK
Urbana, Illinois
Wm. R. Taylor W2JMV
Buffalo, New York
Duane Farris, W0EHH
Des Moines, Iowa



Precise Selectivity—The S-76—Double conversion with 50 kc 2nd i-f. 4-in. "S" meter. 540-1580 kc, 1.72-32 mc in 4 bands. 1 r-f, 2 converters, 2 i-f stages. 5-position selectivity. Phono input jack, 3 watt output. 115 V. AC, 9 tubes, regulator, rectifier . . . **\$169.50**

hallicrafters

"The Radio Man's Radio"

THE HALLICRAFTERS CO.
Chicago 24, Illinois

Buy power output at 3 cents a watt . . .
FOR FOUR TUBE SERVICES!

B—MODULATOR

B—R-F LINEAR

C—CW

C—PHONE



**GL-811-A
 Power Triode**



GET substantial output at a bargain tube price . . . with G.E.'s economy GL-811-A! Then pile value on value by giving the triode a chance to prove its versatility!

Class B Modulator: a pair will put out 340 w of audio, enough for the average ham rig, and you can modulate a kilowatt final by installing four GL-811-A's in p-p parallel.

Class B R-f Linear: here one tube gives you a peak power output up to 200 w in single-sideband speech transmission. Sept.-Oct. Ham News described in detail an efficient SSB final using a single GL-811-A.

Class C Phone and CW: with 175 w and 260 w respectively the max input per tube, you can increase the power of your signal to a high level by using economy GL-811-A's.

Throughout, real tube efficiency! The GL-811-A is a high-perveance, low-drive triode, with superior design features such as (1) a radiating-fin plate structure that dissipates heat, (2) heavy internal leads with low r-f losses. Your G-E tube distributor will be glad to quote you the dollar-saving price. See him today! *Tube Department, General Electric Company, Schenectady 5, N. Y.*

**HAVE YOU NOMINATED YOUR
 CANDIDATE FOR THE
 1952 EDISON AWARD?**

● A month ago, this page announced the Edison Amateur Radio award for 1952, and told in detail how you can enter your candidate. Nov.-Dec. Ham News also will carry the facts. If your nominating letter hasn't been written and mailed, it would be well to get your candidate's name, address and call letters, and a description of his meritorious public service, on record with the Award Committee. Letters must be postmarked not later than December 31, 1952. Presentation of the Edison Award to the winner will be an important event, receiving national recognition.

ELECTRONIC TUBES OF ALL TYPES FOR THE RADIO AMATEUR

GENERAL  **ELECTRIC**

QUALITY

IS THE CHEAPEST THING YOU BUY!



There is a deep, understandable satisfaction in owning something truly fine. It can't be exactly measured in dollars or in words. Maybe it boils down to this: A good thing is worth a hundred times its price; a poor thing isn't worth having around. It's this way with Crystals. When you buy PRs you know you're getting many times your money's worth. You're buying the finest precision frequency control that modern science has made . . . you get (in super-abundance) the things you want most . . . dependability, accuracy, long life, freedom from drift, unfailing activity. Yes—you can be proud to own PRs . . . everybody is!

20 METERS, Type Z-3, \$3.75 • 40, 80 & 160 METERS, Type Z-2, \$2.75

PR Crystals

Since  1934

USE **PR** AND KNOW WHERE YOU ARE

PETERSEN RADIO COMPANY, INC.
2800 W. BROADWAY • COUNCIL BLUFFS, IOWA

EXPORT SALES ONLY: Royal National Company, Inc., 75 West Street, New York 6, N. Y., U. S. A.

CQ RADIO AMATEURS' JOURNAL

VOL. 8, NO. 11
NOVEMBER, 1952

EDITORIAL STAFF

MANAGING EDITOR
OLIVER P. FERRELL

TECHNICAL EDITOR
E. M. BROWN, W2PAU

DEPARTMENT EDITORS

Ralph Anderson, W3NL	Mobile
Herb Brier, W9EGQ	Novice
Wayne Green, W2NSD	Teletype
George Jacobs, W7PAJ	Propagation
W. E. McNatt, W5FEW	VHF-UHF
Louisa B. Sando, W5RZJ	YL
R. C. Spenceley, KV4AA	DX

CONTRIBUTING EDITORS

Herb Becker,	W6QD
Frank C. Jones,	W6AJF
G. F. Montgomery,	W3FQB
William I. Orr,	W6SAI
W. M. Scherer,	W2AEF

DRAFTSMAN

Thomas Smith, W2MCJ

BUSINESS STAFF

S. R. COWAN,	Publisher
S. L. CAHN,	Adv. Director
H. N. REIZES,	Adv. Mgr.
D. SALTMAN,	Prod. Mgr.
R. CAMPBELL,	Edit. Prod.
H. WEISNER,	Circ. Mgr.

Branch Offices: Ted E. Schell, 2700 West 3rd St., Los Angeles 5, Calif. Dunkirk 2-4889.

Foreign Subscription Representatives: Radio Society of Great Britain, New Ruskin House, Little Russel St., London, WC 1, England. Technical Book & Magazine Co., 297 Swanston St., Melbourne C1, Victoria, Australia.

CQ - (title Reg. U.S. Pat. Office) - is published monthly by Cowan Publishing Corp. Executive and Editorial offices, 67 West 44th Street, New York 36, N. Y. Phone MUrray Hill 7-2080. Reentered as Second Class Matter February 6, 1951 at the Post Office, New York, N. Y. under the Act of March 3, 1879. Subscription rates in U. S. A. and Possessions, Canada & Pan American Union, 1 year \$3.00, 2 years \$5.00. Elsewhere, \$4.00 per year. Single copies 35 cents. Printed in U. S. A. Entire contents copyright 1952 by Cowan Publishing Corp. CQ does not assume responsibility for unsolicited manuscripts.

FEATURE ARTICLES

For the Novice—

- Your Deluxe 30- or 50- Watter
Theodore G. Dell, KH6MS.....15
- A Two-Meter Converter—The Easy Way
E. Miles Brown, W2PAU.....20
- An All-Purpose Novice Power Supply
R. H. Mitchell, W6TZZB.....27
- How To Build an 80-Meter Midget Antenna
William I. Orr, W6SAI.....31
- “Just What I Needed—”
Harley E. Saltmarsh, W8CIB/2.....39
- Putting the 6146 on Two Meters
Robert V. Morris, WN2IHM.....43
- The Junk Box Jewel
C. W. Gwyn, W4QAG45

For the Technician—

- Come On-a My House on 220 Mc.
Frank Heubner, W2IQR.....34

Departments

- The Novice Shack.....49
- The YL's Frequency.....53
- DX and Overseas News.....55
- The VHF News.....58
- Ionospheric Propagation Conditions.....61

Miscellaneous

- Scratchi 4
- Broad Band 6
- Zero Bias13
- Book Reviews48
- Classified Ads94,95
- Advertising Index96

Designed for



Application

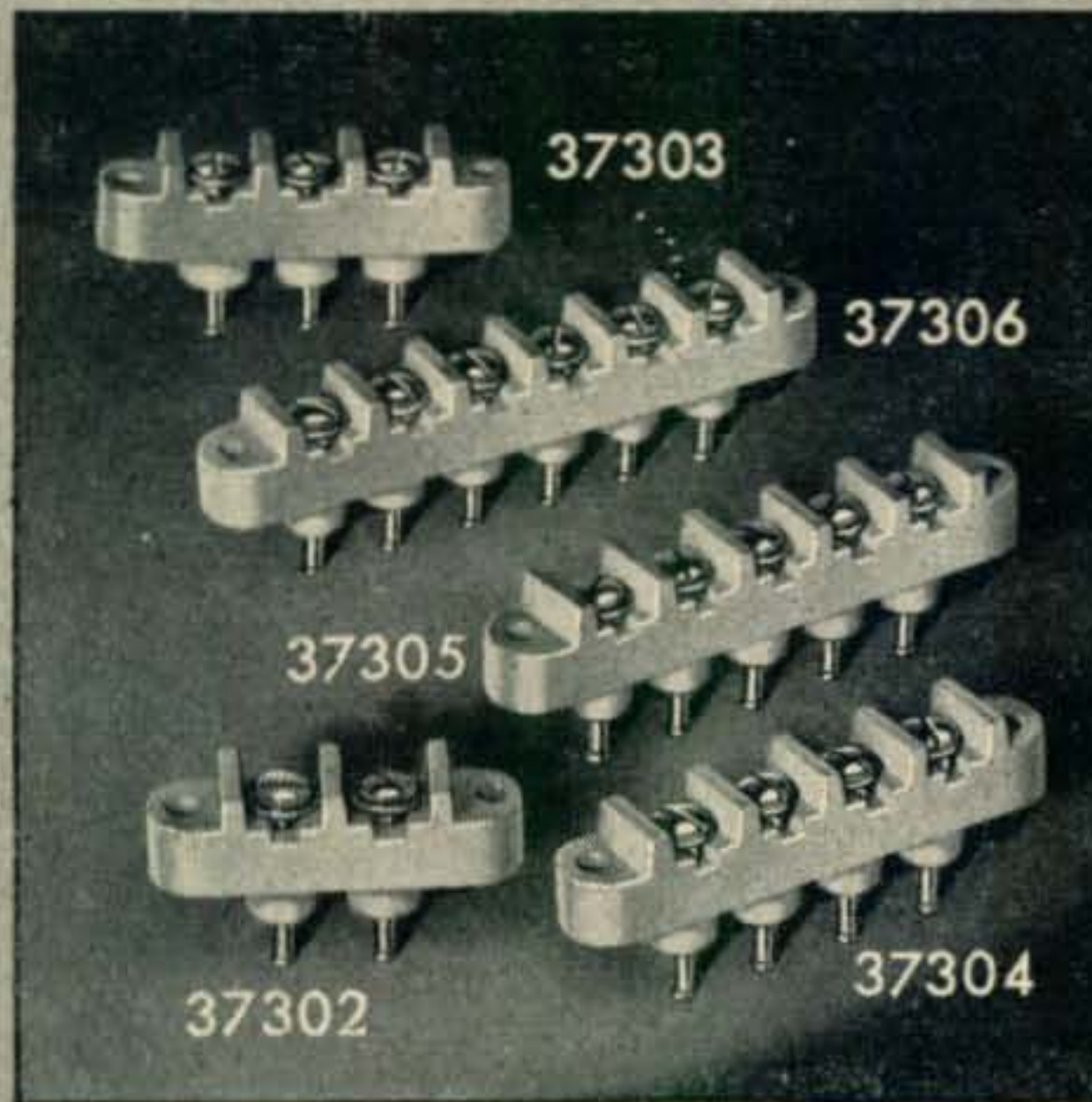

The No. 37300 Series Steatite Terminal Strips

Another exclusive Millen "Designed for Application" product is the series of steatite terminal strips. Terminal and lug are one piece. Lugs are Navy turret type and are free floating so as not to strain steatite during wide temperature variations. Easy to mount with series of round holes for integral chassis bushings. Ideal answer to the "tropicalization" prob'em.

**JAMES MILLEN
MFG. CO., INC.**

MAIN OFFICE AND FACTORY
MALDEN
MASSACHUSETTS



Feenix, Ariz.

Deer Hon. Ed:

Have you been reeding any of these scientific fick-shun stories resently? The kind where the ackshun are taking place somewhere out in free space between Wolf 359 and sum other star? Where the hero are wearing space soots equipped with anty-gravity belt, deionizing gun, paralyzing ray gun and concentrated food capsols? Have you noticed what kind of radio these space-happy characters are using? Boy oh boy, it is strictly from Jools Verne. From Scratchi these stories getting big horsy laff.

In one story the hero is exploring deepest space, and he are sum thousand years from home. That distance are sum stretch of mileage, on acct. it are the distance that lite and radio waves are travelling in 1000 years. (Gracious to goodness Hon. Ed., wouldn't that take the bux if he making a long-distance tellyfone call from there). In other words, if he turning on rig to talking back home, the signal are taking 1000 years to getting home, and answer are taking 1000 years to coming back. But our hero not knowing this, as he just flicking a switch in his rocket ship and calling in on the net, and acting like he on the tellyfone.

Are you thinking that sum geenyus in year 2750 are knowing how to speed up radio waves? Mabey so, but it far fetched to geenyus like me. Hackensake! —they even talking from rocket ship to rocket ship when going faster than lite waves. Mabey they firing the radio waves out with rocket guns.

And television!! There must not be a shortage of channel space on Mars or Mercury on acct. everyone has private channel. You can looking at picshures of rocket ships, and not even seeing any antennas, but these fokes from Mars are talking over television without even pointing an antenna where there talking. Honestly, if these authors not being more carefool of there facks, Scratchi will giving up reeding these stories.

No indeedy, giving me the technical magazines for facks every time. I are reeding one resently where fellows are showing how to calculate how much signal can getting at sum distant point on the earth, and he can doing it very eggsactly if knowing antenna height, transmitter power, signal path and how goods is receiver. Golly, Hon. Ed., if this are true, think what can doing in a few years. Can't you imagine what happening?

Ham in 1975 are coming home from work in helo-copter, grabbing quick bite to eat from capsol machine, floating into shack, turning off anty-gravity belt and settling down in front of rig. Deciding to talk to sum Australian hams, so he getting out propagation chart to see if band is open (not bothering to turn on receiver to find out). If band is open.

NOW AVAILABLE

ROTHMAN MODULATION

**BROADCAST QUALITY — NO OVER-MODULATION
HIGH EFFICIENCY — LESS EQUIPMENT**



MARMAX 50 WATT MOBILE TRANSMITTER

Model MT-52 Net **\$79.50**
With One Set of Plug-In Coils

- 50 Watt Peak Power.
- 400-600 V.D.C. @ 100-150 M.A. Input.
- Controlled Carrier.
- Low Battery Drain.
- All Band Operation 10 through 75 Meters.
- Extremely Compact.
- Dash Mounting.

The heart of the MARMAX MOBILE is the MARMAX MOBILE PLUG-IN MODULATOR MO-52. Also obtainable separately for your present Mobile Transmitter.

MARMAX MOBILE MODULATOR

Model MO-52

Net **\$12.50**

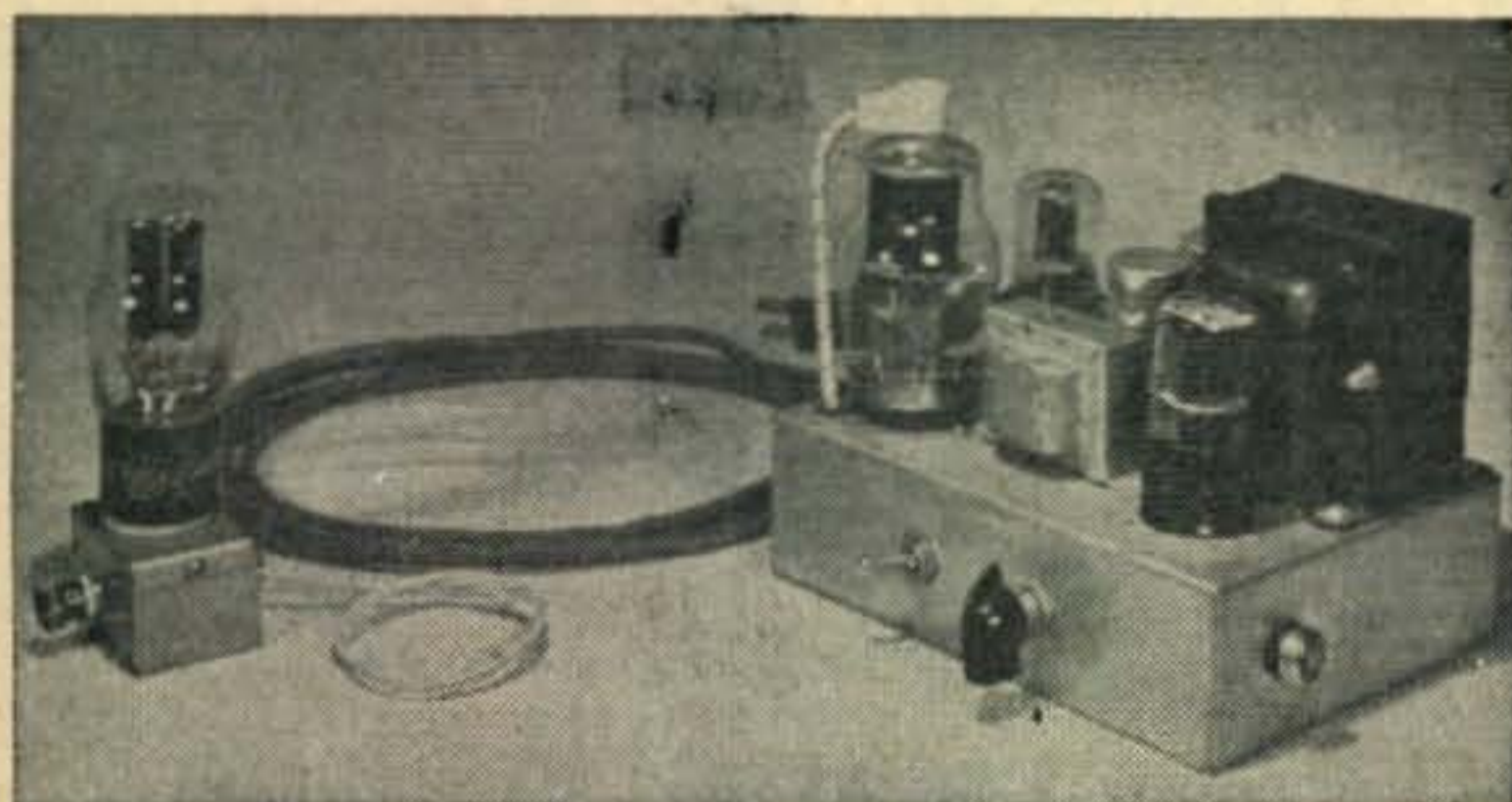

1 KW MARMAX MODULATOR

Model KW-52 Net **\$54.00**

High Fidelity Modulation for powers from 50 watts to 1 KW with built-in speech amplifier for high impedance microphones.

IMMEDIATELY AVAILABLE

If your favorite dealer cannot supply, write direct to factory.

All Units Complete With Tubes—Wired, Tested & Guaranteed

MARMAX ELECTRONICS

716 NEW YORK AVENUE

ALAMOGORDO, NEW MEXICO

B&W**MODEL 600**

Dip Meter



- ★ Frequency Range—1.75 to 260 MC. in 5 Bands
- ★ Adjustable Sensitivity Control
- ★ Wedge-shaped for Easy Access in Hard-to-get-at Places
- ★ Rust Proof Chassis, Sturdy Aluminum Case
- ★ Monitoring Jack and Diode Switch
- ★ Powered by 110 V. A.C. Line

PRICE

\$48⁰⁰
net

A HIGHLY USEFUL INSTRUMENT FOR THE

**Amateur • Engineer • Service Man
Laboratory Technician • Experimenter**

The New B & W Model 600 Dip Meter provides you with a convenient means of doing the job in a minimum of time with dependable accuracy.

It is an extremely sensitive and reliable piece of test equipment having innumerable uses in the Ham Shack, Service Shop, Electronic Laboratory, or Production Plant.

Armed with this versatile and indispensable instrument, you eliminate the guess-work during measurement of—tank circuit frequencies, antennas, feed line systems, parasitics, and other pertinent tuned circuit characteristics, with speed and accuracy.

The handy instruction manual furnished with each instrument covers full information on how to use the Model 600 as an Absorption Meter, Auxiliary Signal Generator, R. F. Signal Monitor, and several special applications as well. See it at all leading electronic parts distributors throughout the U. S. A. and Canada; or write for descriptive bulletin.

BARKER & WILLIAMSON, INC.

237 Fairfield Avenue • Upper Darby, Pa.

(from page 4)

he then looking up in big list to see what VK hams are on at that time of nite. Next he checking his transmitter power, gain of his antenna, and he giving this and other information to calculating machine he buying resently.

In cupple seconds machine are coming up with answer that he can working any VK what having receiver with one microvolt sensitivity or better. So, he again looking at VK list to see what hams have receiver that good, picking out cupple choice ones, putting them in log, and closing down for the evening. He didn't even get a filament warm and yet he worked two VK's!! He not even caring if have blown fuse, as he still getting out like furies!!

It not as bad as sounding, Hon. Ed. Just think, no drain on the power bill, no QRM on the band, two nice joocy contacts, and he still having time to jet out to the moon to see lunar movie with the XYL. (He wud have been working sum guy on Mars, or Jupiter, but he still having Novice license, and not allowed to working anybuddy off the earth).

The more I thinking about this, the more it are a collosus idea. We are finding out more and more about radio, us genyuses, and soon we not having to go on the air at all, as we knowing what will happen. Hey, if this are the case, are not much point in having any radio equipment, excepting for entertainment, so can heering radio cereal about Just Plain Oscar. My Sooper-Dooper communicashuns receiver, my five kilowhat transmitter, all will be obsolete.

Say, Hon. Ed., are you interested in big bargain? I are having slitley used receiver (Sooper-Dooper SD-2), nice five kilowhat transmitter, and assorted radio parts. Will trade all of it for downpayment on helicopter. What saying?

Respectively yours,
Hashafisti Scratchi

P.S. In case you deciding to take me up on this, can I keeping the stuff till after the next DX contest?

Broad Band . . .

Editor, CQ:

I am a reader of your magazine CQ and find it very interesting and enjoyable. I have been an Amateur for about 6 months, WH6ANQ Novice, and now wonder whether it was worth it to invest from \$100.00 to \$500.00 just for the period of one year as the Novice License is good only for one year. I now have about \$500.00 worth of radio equipment, including a National 183 Receiver, due to the distance from the Mainland one out here must have a good receiver.

I realize this one year rule was made in good faith, but there are always exceptions to every rule, and usually rules are made to change with conditions, some persons will not be able to put as much time in the study for the General License, or some people may become sick, or other Novice License holders will be tied up with their business or job, so at the end of the year they will have anywhere from \$100.00 to \$500.00 worth of radio equipment on their hands which is of no use to them, as you know radio equipment is very expensive now, also it takes about 3 months out here to get the equipment together and assembled, sometimes a person has to send all the way to Chicago for a piece of equipment and then has to wait sometimes as long as 3 months for the equipment, not so long ago I waited 5 months before I received a Signal Meter that I ordered, right now out here 90 ships are tied up on the West Coast on strike, and the strike has gone on now for

(Continued on page 8)

to the **E. E. or PHYSICS GRADUATE**

with experience in

RADAR OR ELECTRONICS

Hughes Research and Development Laboratories, one of the nation's large electronics organizations, is now creating a number of new openings in an important phase of its operation.

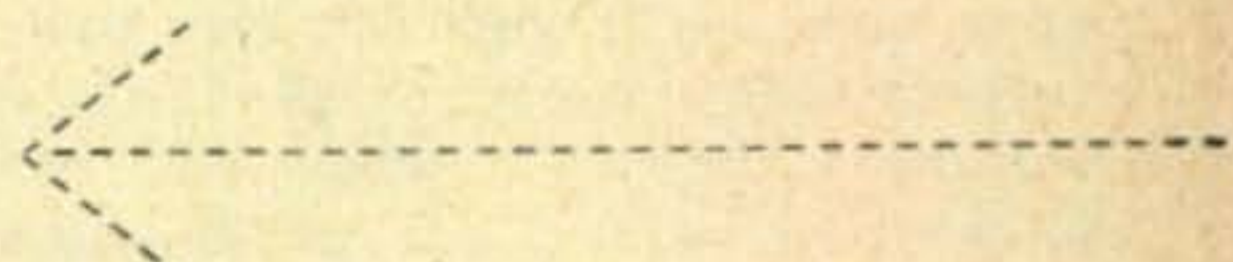

Here is what one of these positions offers you:

1. THE COMPANY

Hughes Research and Development Laboratories is located in Southern California. We are presently engaged in the development of advanced radar devices, electronic computers and guided missiles.

2. NEW OPENINGS

The positions are for men who will serve as technical advisors to the companies and government agencies purchasing Hughes equipment. Your specific job would be to help insure the successful operation of our equipment in the field.

3. THE TRAINING

Upon joining our organiza-

tion, you will work in our Laboratories for several months until you are thoroughly familiar with the equipment you will later help the Services to understand and properly employ.

4. WHERE YOU WORK

After your period of training (at full pay), you may (1) remain with the company Laboratories in Southern California in an instruction or administrative capacity, (2) become the Hughes representative at a company where our equipment is being installed, or (3) be the Hughes representative at a military base in this country—or

overseas (single men only). Compensation is made for traveling and for moving household effects, and married men keep their families with them at all times.

5. YOUR FUTURE

You will gain all-around experience that will increase your value to the company as it further expands in the field of electronics. The next few years are certain to see a large-scale commercial employment of electronic systems—and your training in the most advanced electronic techniques now will qualify you for even more important positions then.

HOW TO APPLY

If you are under thirty-five years of age, and if you have an E. E. or Physics degree, with some experience in radar or electronics,

write to:

HUGHES

RESEARCH AND DEVELOPMENT LABORATORIES

Engineering Personnel Department

CULVER CITY, LOS ANGELES COUNTY, CALIFORNIA

Assurance is required that relocation of the applicant will not cause disruption of an urgent military project.

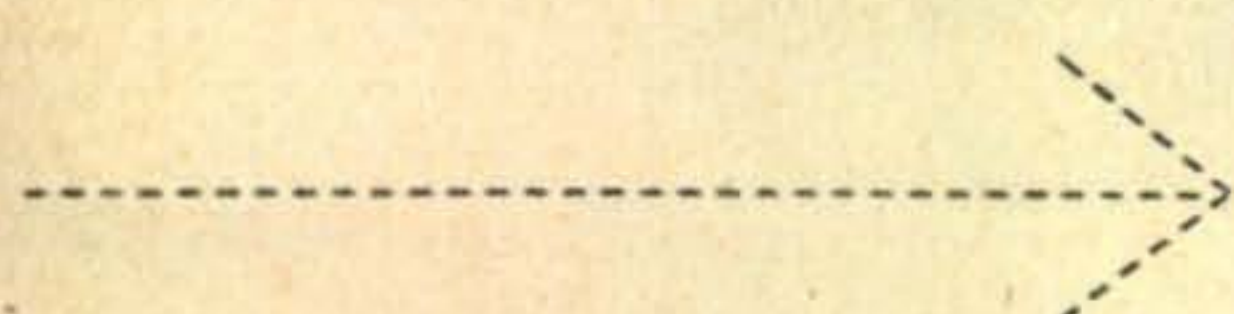

An open letter to all NOVICE LICENSEES

You are embarking on a hobby which we hope will give you full satisfaction for many years. Operating in the Novice Bands will be exciting and will give you all the more pleasure if you can get some real distance with a report of S9. The real thrill will come, however, when you get your General Ticket and can get on other frequencies which hitherto have been waiting for you just out of reach. At that time you want a transmitter which can go into immediate operation on any band; either phone or CW; and which you know will give you the satisfying experience of "getting out" To our way of thinking it makes sense to get that transmitter now because every ten dollar bill you waste on inadequate equipment can be put toward equipment which you can use for years. Such equipment is the Harvey-Wells Bandmaster which is being used by many top Hams throughout the country, and even around the world. It is manufactured by a firm experienced in making some of the best electronic equipment used by our armed services. It is not a Kit — it is fully assembled and tested at the factory — it is fully band-switching for all amateur frequencies — and it is priced right. Why not get in touch with your supply house now and see the Harvey-Wells Bandmaster? If there is none near you, we'll be happy to send you a descriptive folder. Just address Harvey-Wells Electronics, Inc., Southbridge, Massachusetts.

Richard A. Mahler, W1DQH
President



SENIOR
MODEL

\$111.50

DELUXE
MODEL

\$137.50

(From page 6)

about 3 months, and no material of any kind is reaching the Islands, lucky the Navy is bringing in food or else we would suffer, although we are now doing without some food items.

Suppose I as a Government worker stayed home from work for a long period of time due to sickness, would I lose my job, no, I would merely bring a slip from my doctor saying I was sick and still held my job, not so with the lowly holder of the Novice License, who can offer no excuse, but must dejectedly put his tail between his legs and crawl in a corner like a beaten wrestler or a pugilist, as I am still in favor of making the Novice License Renewable, just like any other Amateur License, due to the above conditions.

I don't think my voice alone would do any good, but I think that if your magazine published some articles on the subject it would bring out some of the other views of holders of Novice Licenses and other people who are interested in Radio, Short Wave Listeners, Experimenters, and Hobbyists who are thinking of trying to get the Novice License but do not want to invest in the money for equipment for one year, insomuch as during that year they may not get the higher class license and be stuck with a lot of useless radio equipment. I guess it is lucky they renew automobile licenses and drivers permits, otherwise we all would be walking, Ha, Ha, also, if doctors, drug stores, and nurses were refused licenses, even if they did a good job, we all would be sick. Well I hope you can see my point, hoping that members of your staff can do some good to relieve the above situation by making the Novice License renewable just like any other Amateur Radio License.

Adolph H. Bond, WH6ANQ

Honolulu, T.H.

This letter raises a very good point since obviously there are certain occasions where extenuating circumstances preclude the full use of a Novice license. However, the Novice must look upon his license as a stepping stone to obtaining a General class license. If the Novice license were renewable it would defeat its own purpose.—O. P. F.

What About a Little Help?

Editor, CQ:

I thought you would be interested in seeing a picture of 4X4AB who recently visited us in Milwaukee. In the photo he is shown with Doug Pavek, W9FDX who is Contest Chairman for the Milwaukee Radio Amateur Club.



Milwaukee Journal

W9FDX on the left with 4X4AB examining a QSL from a brother Ham.

It was a great pleasure to meet this swell fellow from Tel Aviv. I have learned from my conversations with him that his fellow amateurs are greatly interested in obtaining some of our war surplus Command sets which he says would be wonderful for conversion. They are also in

(Continued on page 10)

the COIL that foils breakage

BUD 75 WATT COIL

with Polystyrene Plastic Base

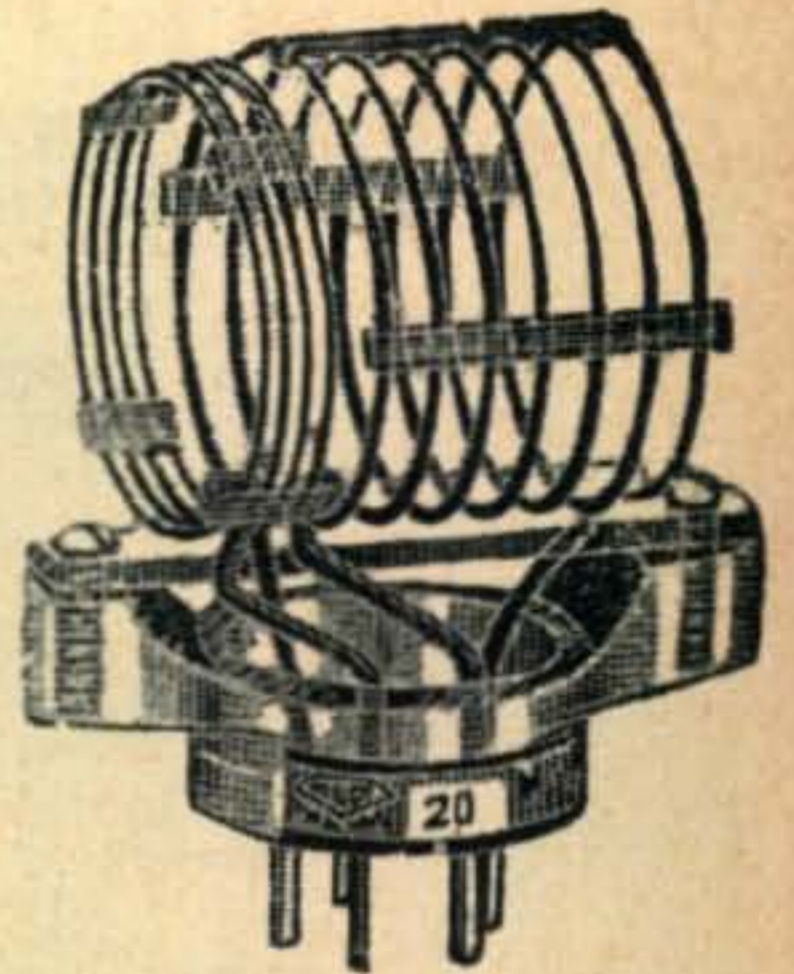

Now Bud gives you improved performance, better appearance and long lasting quality in these 75 watt coils with the new Polystyrene base. Polystyrene has proven superior to porcelain for many reasons, including

1. Far greater resistance to breaking or cracking.
2. The Q of the coil is exceptionally high due to the extremely low power factor.
3. Pins are moulded in place—always remain perfectly aligned.
4. Sharp corners eliminated—no danger of chipping.
5. Transparency adds to smooth modern appearance.

Bud 75 watt coils are furnished with fixed or adjustable center links and fixed or adjustable end links. They are air wound, mount into 5-prong tube sockets and can be used on bands from 6 meters to 160 meter. OEP and OCP Coils are designed for use in circuits using Pentode tubes with high output capacity such as 6L6, 807, etc.

Catalog No. Fixed End Link	Catalog No. Fixed Center Link	Catalog No. Adjustable Center Link	Catalog No. Adjustable End Link	Band	Capacity*	Amateur Net
.....	OLS-160	160 Meter	100 MMFD	\$2.28
.....	OES-160	160 Meter	86 MMFD	2.28
OEL-80	OCL-80	OLS-80	OES-80	80 Meter	75 MMFD	1.95
OEL-40	OCL-40	OLS-40	OES-40	40 Meter	52 MMFD	1.92
OEL-20	OCL-20	OLS-20	OES-20	20 Meter	40 MMFD	1.83
OEL-15	OCL-15	OLS-15	OES-15	15 Meter	30 MMFD	1.80
OEL-10	OCL-10	OLS-10	OES-10	10 Meter	25 MMFD	1.74
OEL-6	OCL-6	6 Meter	17 MMFD	1.41
.....	OCP-10	OEP-10	10 Meter	45 MMFD	1.74
.....	OCP-20	OEP-20	20 Meter	50 MMFD	1.83

* Denotes tube plus circuit plus tank plus output coupling capacity required to resonate coil at low frequency end of band.

• SHIELDED • COIL LINKS



These links are made to fit RLS, VLS, and MLS series of coils. This link will prevent capacity coupling between the tank coil and the link and would reduce TVI by greatly attenuating harmonics. The links can be used on co-ax or balanced lines.

Catalog Number	DESCRIPTION	Amateur Net
AM-1300	Used with RLS coils (150W)	\$1.92
AM-1301	Used with VLS coils (500W)	2.19
AM-1302	Used with MLS coils (Kilowatt)	2.61

Bud products include coils, condensers, R.F. chokes, sheet metal ware, etc. See the complete Bud line at your local distributors.

• ADD - A - LINKS



When the circuit that you are using requires a different number of turns on the coil link than is furnished with the standard coil, the links listed below can be used to replace the standard link.

Cat. No.	Used With	No. of Turns	Amateur Net
AM-1303	RLS	3 1/2	\$.52
AM-1304	RLS	4 1/2	.54
AM-1305	RLS	5 1/2	.63
AM-1307	VLS	3 1/2	.52
AM-1308	VLS	4 1/2	.54
AM-1309	VLS	5 1/2	.63
AM-1310	VLS	6 1/2	.72
AM-1311	MLS	3 1/2	.81
AM-1312	MLS	4 1/2	.96
AM-1313	MLS	5 1/2	1.05
AM-1314	MLS	6 1/2	1.14



The Mark of
Perfection

BUD RADIO, Inc.

2118 EAST 55th STREET

CLEVELAND 3, OHIO

TWIN-LEAD folded dipole



Buy the kit and assemble your own HAM ANTENNA

Tested — tried and proven components from which to build your HAM ANTENNA—complete with full instructions for assembly. Build for permanence and performance with quality components.

complete
kit . . .

2 lengths of #16 copper-clad steel conductor twin-lead—cut to band length.

1 75-foot length of standard 300 ohm twin-lead for lead-in.

1 high strength laminated "T" block.

Assembly and installation instructions.

Cut to 10, 20, 40 and 80 Meters

We all strive for the best in transmission and reception characteristics—now with the Amphenol Amateur Antenna Kit you are assured of the *BEST*. Designed by electronics engineers for the most efficient service.

amateur net as low as

\$535 for 10 meters

see your **AMPHENOL**
radio parts distributor

AMERICAN PHENOLIC CORPORATION

(From page 10)

great need of various types of radio parts and components. If anyone reading this would care to forward any extra parts and components they may have on hand, I will certainly see that they are shipped directly to our fellow amateurs in Israel.

Fred H. Zolin, W9ONY

Milwaukee, Wisc.

Sounds like a good idea. Fred's address is 2443 N. Cramer Street, Milwaukee 11, Wisc.—O.P.F.

"Little Country Mayor"

Editor, CQ:

Tell your readers that the next time they go mobile in Montana to look for this big sign.

Earl Mead, W7LCM

Huntley, Mont.



What! No more dog catchers certificates?—O.P.F.

Surplus Conversion Data

Editor, CQ:

I would like to see a good antenna article giving quite a bit of operational data and fact on designs for use with war surplus Command-type transmitters.

Many hams have used these transmitters, but it would do a lot of good to the other fellows if the hams who have had some success in getting out would send some of their secrets to CQ so that it could be passed along to the other hams in the form of a general consensus article.

F. J. Ryder, W2DQ

Sayville, L. I., N. Y.

There is undoubtedly considerable interest in war surplus gear. Although a lot of it has been taken off the local market, we do note that many hams have stored it away for possible future use.

The staff of CQ is presently giving some thought to the preparation of a "last gasp" war surplus conversion issue. We have received many, many good manuscripts on the surplus subject and if we can find sufficient interest in it, we will go about preparing such an issue for release in the early part of 1953.—O.P.F.

Comment on the "Modern" Exciter

Editor, CQ:

I would like to comment on the article in July's issue written by Don Wherry of W6EUM. I enjoyed the article very much as I have been looking for a satisfactory VFO and one that incorporates many such features as W6EUM's.

I have corresponded with W6EUM and he has been most gracious in replying to my letters and has been good enough to send more information plus photographs for accurate building of his rig. His cooperation has been most excellent—and I would say he has "bent over backwards" in his advice and help.

(Continued on page 76)

ENGINEERING PLUS CRAFTSMANSHIP SOLVED THIS UNUSUAL REQUIREMENT

THE PROBLEM:

The problem was to develop a crystal unit for AM broadcast (550-1600 kc) which would maintain frequency tolerance per FCC requirement (± 20 cycles) *without temperature control.*

THE SOLUTION:

When designing the crystal oscillator, the transmitter manufacturer gave primary consideration to voltage stability and low r.f. current. The resultant design provided an ideal environment for realization of the inherent stability of the crystal unit employed.

Bliley designed a plated crystal utilizing precision orientation to achieve the low drift characteristic needed. Contrary to ordinary practice in this frequency range, the crystal was soldered between rigid supports to prevent frequency deviation due to physical displacement. The assembly was then hermetically sealed in a dry nitrogen atmosphere to prevent contamination and minimize aging.

The resultant production units, type BH8, are calibrated at 30°C with maximum deviation not exceeding ± 10 cycles thru the temperature range from +10°C to +50°C.



TYPICAL STABILITY DATA

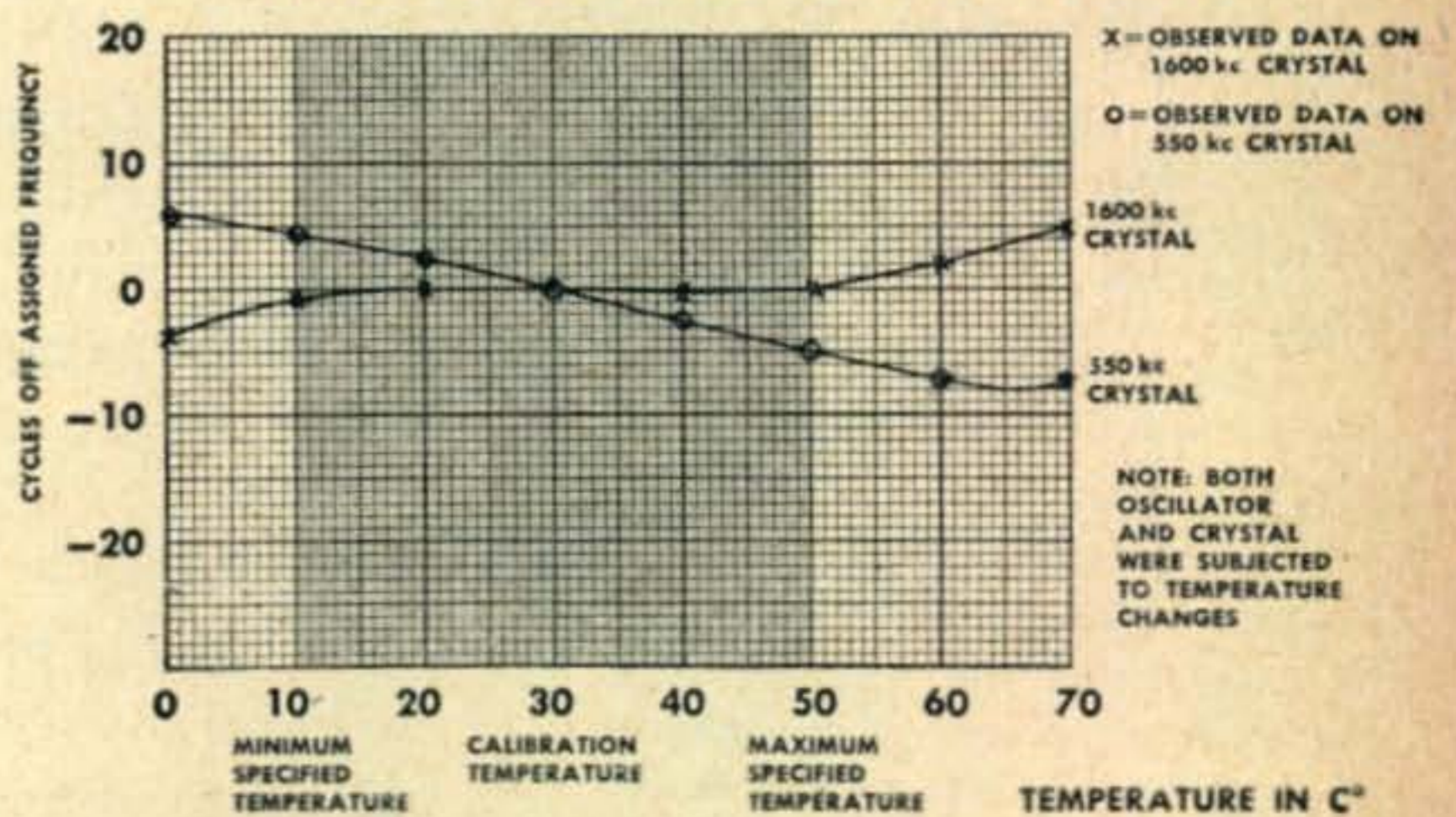

Bliley CRYSTALS

PLAN AHEAD

OSCILLATOR
(PRESENT
TRANSMITTER)

*
RESERVED

* FOR AN EIMAC
4-65A TETRODE



Typical Operation

Radio frequency power amplifier and oscillator Class-C telegraphy or FM telephony.

D-C Plate Voltage	-	2000 volts
D-C Screen Voltage	-	250 volts
D-C Grid Voltage	-	-80 volts
D-C Plate Current	-	150 ma.
Driving Power		
(approx.)	-	2.1 watts
Plate Power Input	-	300 watts
Plate Dissipation	-	65 watts
Plate Power Output	-	235 watts

Write our Amateurs' Service Bureau for further information. Also available at no cost is the handy 28 page booklet, "Care and Feeding of Power Tetrodes".

Hold a power amplifier in reserve, then you'll

be all set to go on the air with a wallop when those novice days are over. Your rig will be in style and the change over is easy, efficient and economical with an Eimac 4-65A radial-beam power tetrode. With only two watts needed to drive the 4-65A up to 345 watts input in Class-C telegraphy or FM fone, your present novice transmitter will do the job with power to spare. Circuit design is elementary, neutralization is unnecessary, in most cases, and TVI worry minimized with an Eimac 4-65A.

For mobile use this small, compact, rugged tetrode with a plate dissipation rating of 65 watts is a natural. Its instant heating filament eliminates battery drain during stand-by periods. And through application of filament and plate power simultaneously, no warm-up periods are required.

Eimac
TUBES

EITEL-McCULLOUGH, INC.

SAN BRUNO, CALIFORNIA

Export Agents: Frazar & Hansen, 301 Clay St., San Francisco, California

ZERO BIAS

E D I T O R I A L

The JTAC Ideal Approach to Allocation

In these days of proposals, counter-proposals, purposes and cross-purposes concerning the amateur bands, we are all quite prone to lose track of certain realities. To put it in one word, as far as frequency allocations are concerned, things are in a "mess." In practically every part of the radio frequency spectrum, broadcasting service vies with broadcasting service—not because of an overwhelming lack of frequency space but because too few thoughts have been given to reconciling government administration and a scientific approach to the allocation problem.

Since it was becoming more and more obvious that the government would be unable to properly analyze this monumental problem, industry, through the Joint Technical Advisory Committee, the Institute of Radio Engineers and the Radio-Television Manufacturers Association, spent four years working out a program of radio frequency conservation. The report of the JTAC has just been released in a book published by McGraw-Hill, under the title "Radio Spectrum Conservation."

Upon the receipt of this report we naturally turned our first attention to what they had to say about amateur radio. Their review was quite concise and appeared to be cognizant of the present situation of amateur radio as well as the future of this service. The report indicates that amateurs and the amateur bands present a very difficult allocation problem because the number of amateurs is steadily increasing while the amateur bands themselves have been reduced in size from time to time.

The JTAC proposes that the ideal allocation for amateur bands should include a number of frequency bands in harmonic relation. In addition, amateurs should be permitted to operate in the industrial, scientific and medical bands since this may help the development of techniques that will eventually overcome the interference problems resulting from these services.

JTAC Ideal Allocation for Amateur Service

3,500—3,750 kc. a reduction in the present 80-meter band with the top 250 kc. going to the mobile services. The portion from 3,622.5—3,627.5 would be shared with industrial, scientific and medical services.

7,000—7,500 kc. An increase in size in the present 40-meter band with industrial, scientific and medical sharing in the 10 kc. band between 7,245 and 7,255.

14,000—14,990 kc. A tremendous increase in the present 20-meter band with mobile services on the low edge and the upper edge of the band constituting the 15 mc. standard frequency guard channel. Shared with the industrial, scientific, and medical services between 14,490 and 14,510.

28,000—30,000 kc. The plan calls for the recovery of the top 300 kc. in the 10-meter band. Sharing with the industrial, scientific and medical services between 28,980 and 29,020.

43.47—43.53 mc. This band would be primarily identified with the industrial, scientific and medical services but would also be shared to the extent that amateur operation would be permitted.

50.0—54.0 mc. The present 6-meter band special services on the low side and a 46 mc.-wide mobile band on the high side.

720.0—770.0 mc. This band is apparently to replace the present 2-meter, 1 $\frac{1}{4}$ -meter and $\frac{3}{4}$ -meter amateur bands. It would be shared between 740 and 750 mc. with the industrial, scientific and medical services.

The plan also calls for amateur bands between 2,400—2,500, 4,800—5,000, 9,600—10,000, 19,200—20,000 and 28,800—40,000 mc.

The question of whether the JTAC's proposed allocations for the conservation of the radio spectrum will ever be accepted remains very doubtful. As the last paragraph in the report indicates, considerable resistance to any proposed program of dynamic conservation may be expected. While the proposals with regard to the amateur bands are rather astonishing and are certainly indicative of the excellent planning that entered into the preparation of this report, those proposals relating to the en masse shifting of TV stations etc. will be met by almost wholehearted resistance from the station operators as well as industry. However, such a report needs to be discussed and given consideration over a period of time. While there is little doubt of the value of the proposals, enactment is a totally different story. It is also worthy of consideration that many of the proposals influence not only amateurs in the United States but also those around the world which are subject to international treaty.

Late October Issue

To the many readers that did not bother to write—our sincere thanks. The lateness of the issue was purely and simply a matter beyond our control. Missing our editorial schedule made us miss our printing schedule, that threw the bindery off schedule and finally we were 8 days late. Boy, can these things mount up!!

This issue was one or two days late, but we should be completely back on our usual schedule by December.

o.p.f.

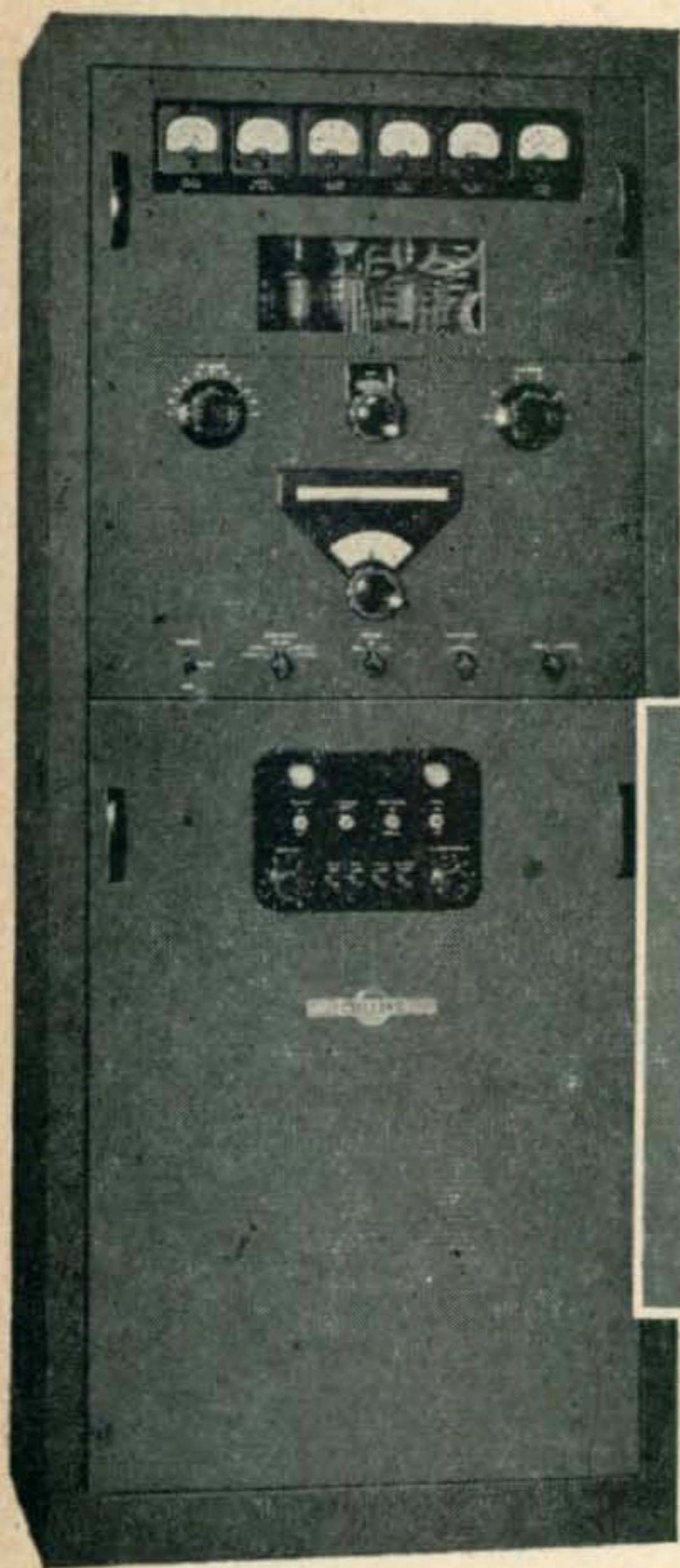

HITS A NEW LOW

with the Collins KW-1

THE KW-1 represents Collins' whole-hearted attempt to minimize higher order harmonics which tend to interfere with TV reception. All precautions possible were built into the transmitter by keeping the harmonic content of the various transmitter circuits at a low value, then filtering and shielding of all leads were added to minimize leakage of these harmonic voltages.

The exciter portion of the Collins KW-1 uses approximately twice the average number of tuned circuits used in ordinary transmitters, thus contributing to low harmonic output from the exciter with the added advantage of reduced subharmonic radiation from the antenna. In addition, another premium feature — a variable vacuum capacitor is used in the Class C amplifier with very short low inductance leads connecting from the plates of the

amplifier tubes to the variable capacitor — thus providing a low impedance path to ground for harmonic currents. A pi-L network — developed by Collins — provides increased harmonic attenuation without adding operating difficulties or additional controls.

- The r-f section is completely shielded with closely spaced screws to insure good bonding between the portions of the shield.
- All leads carrying power and control functions into the r-f unit are adequately filtered to minimize radiation of undesirable harmonic energy.
- A low pass filter at the output provides additional attenuation of harmonics, virtually eliminating the appearance of power at television frequencies at the antenna.

FOR THE BEST IN AMATEUR RADIO, IT'S . . .



COLLINS RADIO COMPANY, Cedar Rapids, Iowa

11 W. 42nd St., NEW YORK 36

1930 Hi-Line Drive, DALLAS 2

2700 W. Olive Ave., BURBANK

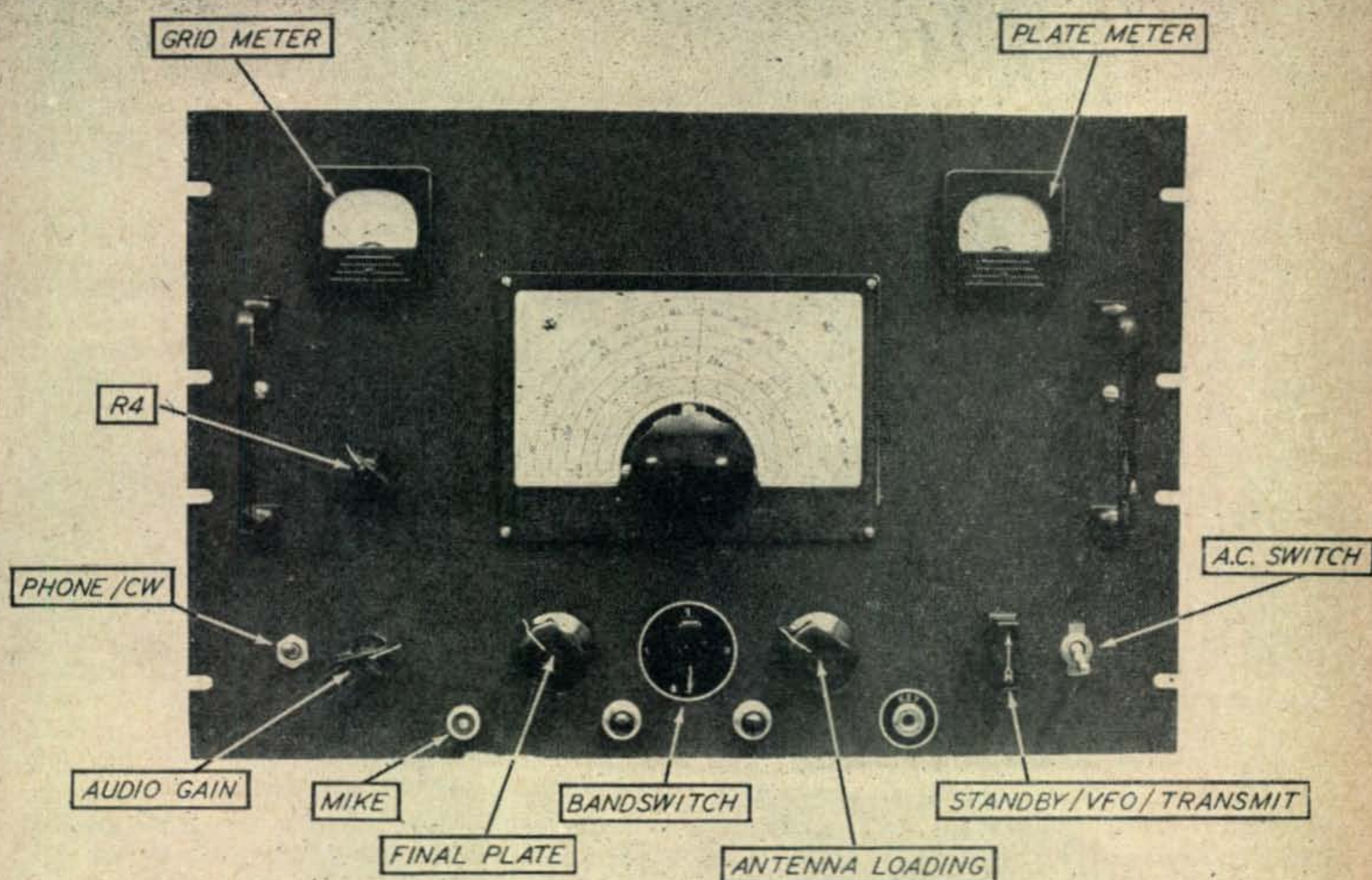

Your De luxe 30 - or 50-Watter

THEODORE G. DELL, KH6MS

Box 27, Makena Maui, Territory of Hawaii

This is a little self-contained phone or CW transmitter with a 2E26 (or 6146) final that we feel sure will appeal to the new ham and to the old-timer as well. To the new ham, it offers everything he could possibly ask for in the line of a transmitter. To the old-timer, it offers a compact all-band emergency or stand-by rig of great versatility.

Offhand, I would say the rig could be built out of new parts for around one hundred dollars, although the experimental rig cost me much more than that. But where on the market today can you

buy a thirty watter, so complete and versatile as this one for a hundred bucks? It seems to me it is still cheaper to build your own.

This entire transmitter grew around the pi network. I was quite impressed by the pi network used in the *Collins 32V-1* and from it I got the idea that I should like to make one, since, at that time no commercial networks were available. I could have made an exact copy of the *Collins*, but I didn't want that; I wanted something original. I checked all the handbooks and found only limited information about pi's, but with that to start, I began experiment-

ing and after many long weeks and many, many ruined *B&W Miniductors*, I finally found a pi, with the right L and C combination that would work very well from 80 to 10 meters. From there on I worked backwards to the oscillator, modulator and power supply.

Going a little unorthodox this time, we shall begin our technical description of this little rig backwards, beginning with the power supply and proceeding toward the r.f. section.

Description

The power supply is conventional, using combination filament and plate transformers. This may not be the best practice, but where space and weight is a factor, some exceptions may be tolerated. Both chokes were surplus and small in physical size, which was an advantage. However, standard open frame types will do just as well. The relay used was also a special, but any 117-volt a.c. operated d.p.d.t. relay will do. Some may not want to use a relay, in which case you may add one or two more ceramic sections to the *Transmit/Stand-by/v.f.o.* switch and parallel the contacts. Be sure to place this section of the switch at the end, so replacement, when it becomes necessary, can be accomplished without disturbing the other sections of the switch.

The modulator is also conventional with a few slight changes. The modulator is class AB1 and is capable of 20 watts. This is more than ample to modulate the 2E26 final amplifier to 100%. An r-f choke and capacitor on the input of the grid to the 6SJ7 was found advisable to eliminate any stray r.f. pickup by the crystal mike from reaching the grid of the tube and causing feedback. Because of the compactness of the transmitter with the r.f. and audio sections so close, it might be well not

to overlook this precaution. Originally the modulator was found to be somewhat on the deep bass side, so C2 was changed from .25 μ f. to a .1 μ f. and C5 from a .05 μ f. to a .004 μ f. The result was a very clean crisp speech. Also included with the modulator is a negative peak limiter, a very simple device and yet a very useful one which needs no adjustments. It may be eliminated, but the good it does more than outweighs its cost.

The r.f. section is the heart of this little transmitter, so great care and diligence should be exercised in its construction. Take a good look, and I mean, a good look, at the photo of the underside of the transmitter. Study and note the arrangements of parts, the switch, the placement of the coils, the shields between stages, and for best results, try to construct yours as near like this as possible.

Data on the coils is given in the *Coil Data Chart*. The coils to be hand wound, care should be taken to see that the coils are wound tightly and coated with several coats of coil dope. The other coils may be hand wound, but it is best to use the *B&W Miniductors*; they make a neater looking coil and when used as specified, no pruning will be necessary to line up the various stages. The selection of the Clapp oscillator circuit, makes it obvious that with that circuit, plus rigid mechanical construction, excellent frequency stability is almost assured. From a cold start to complete operating temperature, the frequency drift is not over 200 cycles, as noted on a BC-221 Frequency Meter.

Another outstanding characteristic of the Clapp circuit is its clean keying and here again, this little rig is no exception. The keying is clean and reports from all stations worked on CW report me as 9X.

Switch *SW-g* is a home-made special, made up out of a *Centralab #2546*, which contained five

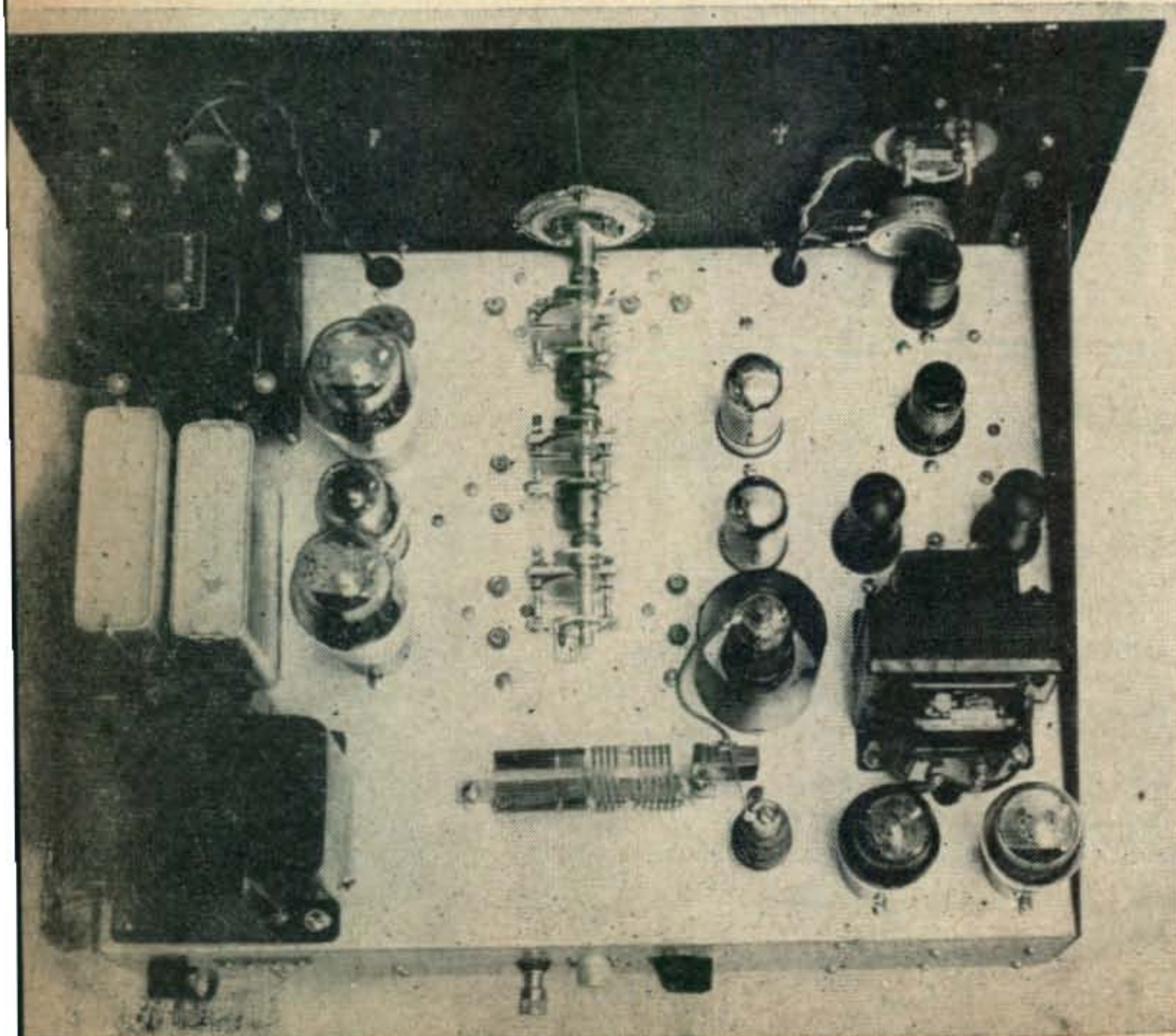

The top side view shows the clean appearance of the entire transmitter. The power supply is to the left, the r.f. section is in the center and the modulator is to the right. The controls on the rear skirt are fuse, a-c cord, external ground binding post, antenna terminal and co-ax antenna terminal and switch Sw1 for additional antenna loading.

The under chassis view again exemplifies the care taken in the wiring and construction. The preparation of the switch mechanism and the extension rods are explained in the text.

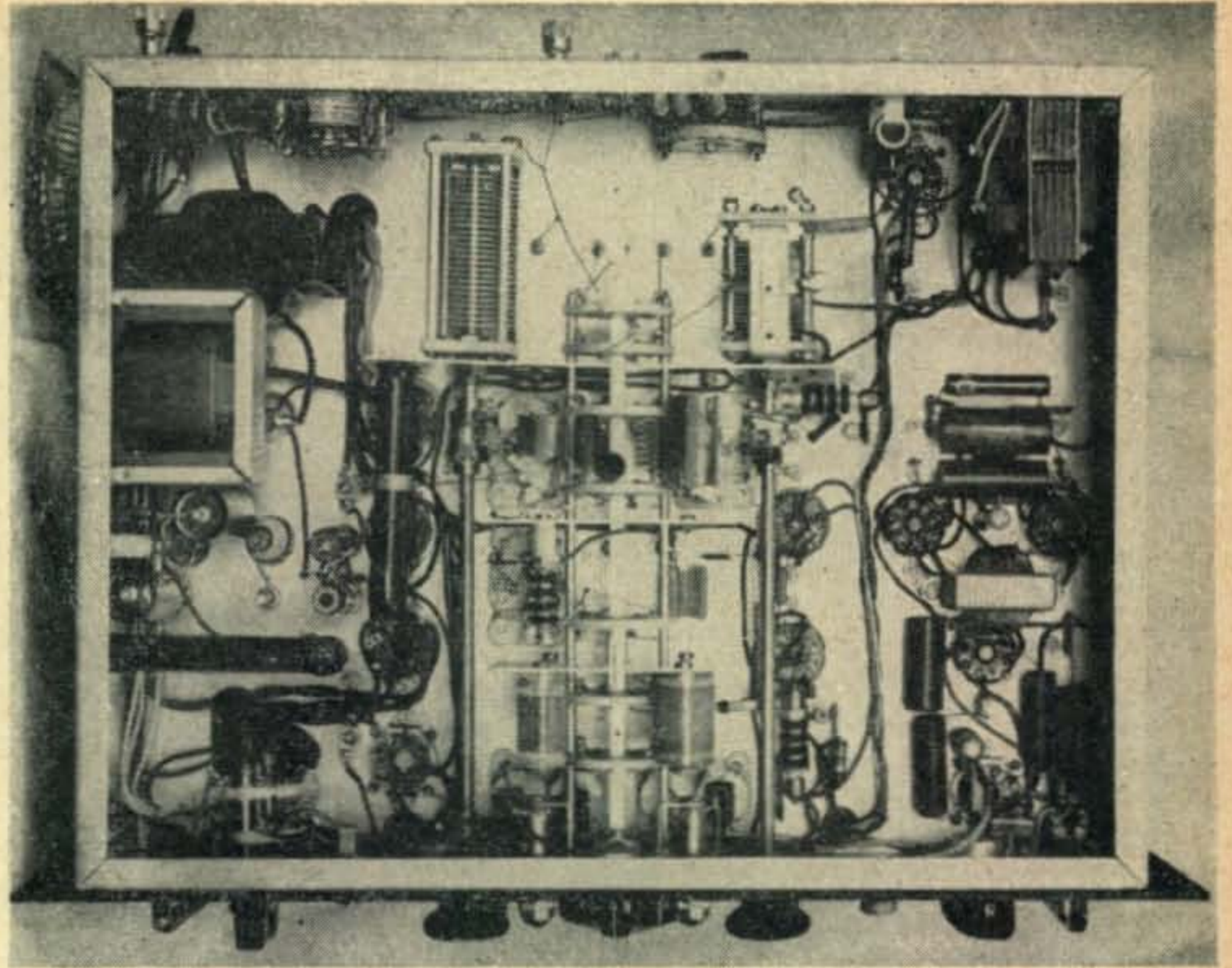

ceramic sections, one pole, two to four positions per pole per section, with 90° indexing. This switch was taken apart and reassembled so it would be 12" long and contain seven ceramic sections. To do this it was necessary to secure 12" tie rods and to couple an additional 7" flat shaft to the original one. To fit them together, bend a 1" x 5/8" piece of #18 or #20 gauge soft aluminum (I used the aluminum out of an aluminum base transcription disk) around the flat shaft to form a very snug

transcription disk. Two of the shields are cut 4" x 3 7/8" and one is cut 8" x 3 7/8" and all are drilled to allow the tie rods and shaft to pass through. Spade lugs are added to one side of each shield, making it possible to fasten the shields to the chassis and in so doing stabilize the entire switch assembly.*

The PI Network

Coil *L-10*, the pi network coil, is made up out of two *B&W Miniductors*, #3014 and #3015. First take #3014 which has 8 turns to the inch, unwind 1 turn so you will have a lead, then count in 6 1/2 turns, cut and unwind both ends 1/2 turn. Count five more turns and cut, unwind 1 turn for another lead. You will now have a 6 turn coil, a space, and a 4 turn coil. Next take #3015, which is 16 turns to the inch, unwind 1 turn, count in 7 1/2 turns, cut and unwind both ends of the cut 1/2 turn. Count 17 more turns, cut and unwind 1 turn. Now you will have another coil having 7 turns, a space, and 16 turns. The total number of turns in both coils is 33. Now take #3014 and #3015 and cement them together on a 1/8" x 1/4" x 4" strip of polystyrene. When dry, solder all leads of the different coils together, adding longer leads if necessary. You will now have a pi network coil. Looking at it from left to right, the six turn coil is for 10 meters, the 6 and 4 turn coil together are for 20 meters, the 6, 4 and 7 turns together are for 40 meters and the entire coil of 33 turns is for 80 meters. Take a good look at the photo of *L10* for further details if necessary.

Condensers *C5, 12, 17* are 25 μf each with extension rear shafts. The three condensers are ganged together, making for efficiency in tracking the stages of the r.f. section. Note that *SW1* switches in additional capacity, thus making it pos-

COIL DATA

- L1—95 turns of #30 en close wound on 1" diameter form
- L2—52 turns of #26 en close wound on 3/4" diameter form
- L3—24 turns of #22 en close wound on 3/4" diameter form
- L4—24 turns of #22 en close wound on 3/4" diameter form
- L5—13 turns of #20 en 3/4" diameter or B&W Miniductor #3011
- L6—48 turns of #24 en 3/4" diameter or B&W Miniductor #3012
- L7—19 turns of #24 en 3/4" diameter or B&W Miniductor #3012
- L8—13 turns of #20 en 3/4" diameter or B&W Miniductor #3011
- L9—7 turns of #20 en 3/4" diameter or B&W Miniductor #3006
- L10—(see text.) Made up of B&W Miniductors #3014 and #3015

fit. This sleeve is fitted over the two joining ends of the flat shafts, then made tight by applying a little pressure with either a pair of heavy pliers or a vise. The switch sections and the shields are then assembled on the switch in proper order and spacing to accommodate the coils.

The shields are also cut from an aluminum

* Since the construction of the switch, Centralab has been very kind in supplying me with 14" tie rods and 16" shafts. Any interested party may purchase same by writing Mr. G. M. Mills of Centralab.

R.F. Section	R. F. Section	Modulator Section	Power Supply Section
C1, C13, C21—50 $\mu\text{mf.}$ variable (screw-driver adjustment)	C29—200 $\mu\text{mf.}$ ceramic	C1—500 $\mu\text{mf.}$ ceramic	C1, C2—0.001 $\mu\text{f.}$ ceramic
C2, C3, C4, C18, C19, C20—75 $\mu\text{mf.}$ variable (screwdriver adjustment)	C30—400 $\mu\text{mf.}$ ceramic	C2, C3—0.1 $\mu\text{f.}$, 400v.	C3, C4—20 $\mu\text{f.}$, 450v. electrolytic
C5, C12, C17—25 $\mu\text{mf.}$ Bud MC-1852 variable with extension rear shaft. These are 33 $\mu\text{mf.}$ so all but four plates are removed, two stator and two rotor	C31—600 $\mu\text{mf.}$ ceramic	C4, C7—10 $\mu\text{f.}$, 450v. electrolytic	C5—4 $\mu\text{f.}$, 600v. oil. CD
C6, C14—100 $\mu\text{mf.}$ ceramic	C32—0.001 $\mu\text{f.}$ ceramic	C5—0.004 $\mu\text{f.}$ mica	C6—8 $\mu\text{f.}$, 600v. oil. CD
C7, C8—300 $\mu\text{mf.}$ ceramic, zero temp. coefficient	R1, R2—100,000 ohm, $\frac{1}{2}\text{w.}$	C6—25 $\mu\text{f.}$, 25v. electrolytic	R1—20,000 ohm 50w.
C9, C10, C11, C15, C16, C22, C24, C33—0.005 $\mu\text{f.}$ ceramic	R3—390 ohm, 1v.	C8—25 $\mu\text{f.}$, 50v. electrolytic	R2—30,000 ohm 50w.
C23—50 $\mu\text{mf.}$ ceramic	R4—20,000 ohm, 4w. wire wound pot.	R1—4.7 megohm, $\frac{1}{2}\text{w.}$	R3—3,000 ohm 20w.
C25—0.001 $\mu\text{f.}$ mica, 1200v.	R5—15,000 ohm, 1w.	R2—1,500 ohms, $\frac{1}{2}\text{w.}$	CH1—Stancor C1710, 7h. 150 ma.
C26—0.002 $\mu\text{f.}$ mica 1200v.	R6—100 ohm, $\frac{1}{2}\text{w.}$	R3—1.5 megohm, $\frac{1}{2}\text{w.}$	CH2—Stancor C1703, 7h. 150 ma. 4h. 250 ma.
C27—150/150 $\mu\text{mf.}$ variable, .03" spacing. Any make. Must be compact.	R7—25 ohm, $\frac{1}{2}\text{w.}$	R4—220,000 ohm, $\frac{1}{2}\text{w.}$	T1—Stancor P6014, 375-375v. @ 150 ma. 5v. @ 3a., 6.3v. @ 5a.
C28—300 $\mu\text{mf.}$ variable, National or Johnson. .03" spacing	R8—20,000 ohm, 25w.	R5—47,000 ohm, $\frac{1}{2}\text{w.}$	T2—Stancor P4010, 400-400v. @ 200 ma., 5v. @ 3a., 6.3v. @ 5a.
	RFC1, RFC2, RFC3—2.5 mh., 125 ma. r.f. choke	R6—1 megohm potentiometer	SW1—s.p.s.t. toggle
	RFC4—6 mh. 250 ma. (2 to 30 mc. RFC)	R7—1,500 ohm, 1w.	SW2—4 pole, 3 position ceramic, 2 poles per section, any make
	M1—0-15 ma. d.c. Triplett Model 327-T	R8—250 ohm, 10w.	RELAY—Advance #106AM a.c. relay, d.p.s.t.
	M2—0-100 ma. d.c. (or 0-200 ma. d.c.) Triplett Model 327-T	R9—2,000 ohm, 10w.	F—Fuse holder and 3 AG 3a. fuse
	SW1—Ceramic switch with one pole, five positions. Any make	RFC1—2.5 mh. 125 ma.	P1—Pilot light and assembly (green)
	SW-g—Centralab #2546 (see text)	T1—Stancor A4723, 3:1, single plate to PP grids	P2—Pilot light and assembly (red)
	CX—Female co-ax connector	T2—Stancor A3892, 25w. modulation transformer	V1, V2—5U4G
	V1, V2—7C5	T3—Stancor P4088, filament trans., 5v. @ 3a.	V3—VR150
	V3—2E26 or 6146	SW1—d.p.d.t. toggle switch	
	V4—6Y6	J1—Amphenol male chassis mike connector	
		V1—6SJ7	
		V3, V4—6V6 or 6L6	
		V2—6J5, V5—5Y3	

sible to load the transmitter into a wide range of antenna impedances.

Calibration

After construction has been completed, check all

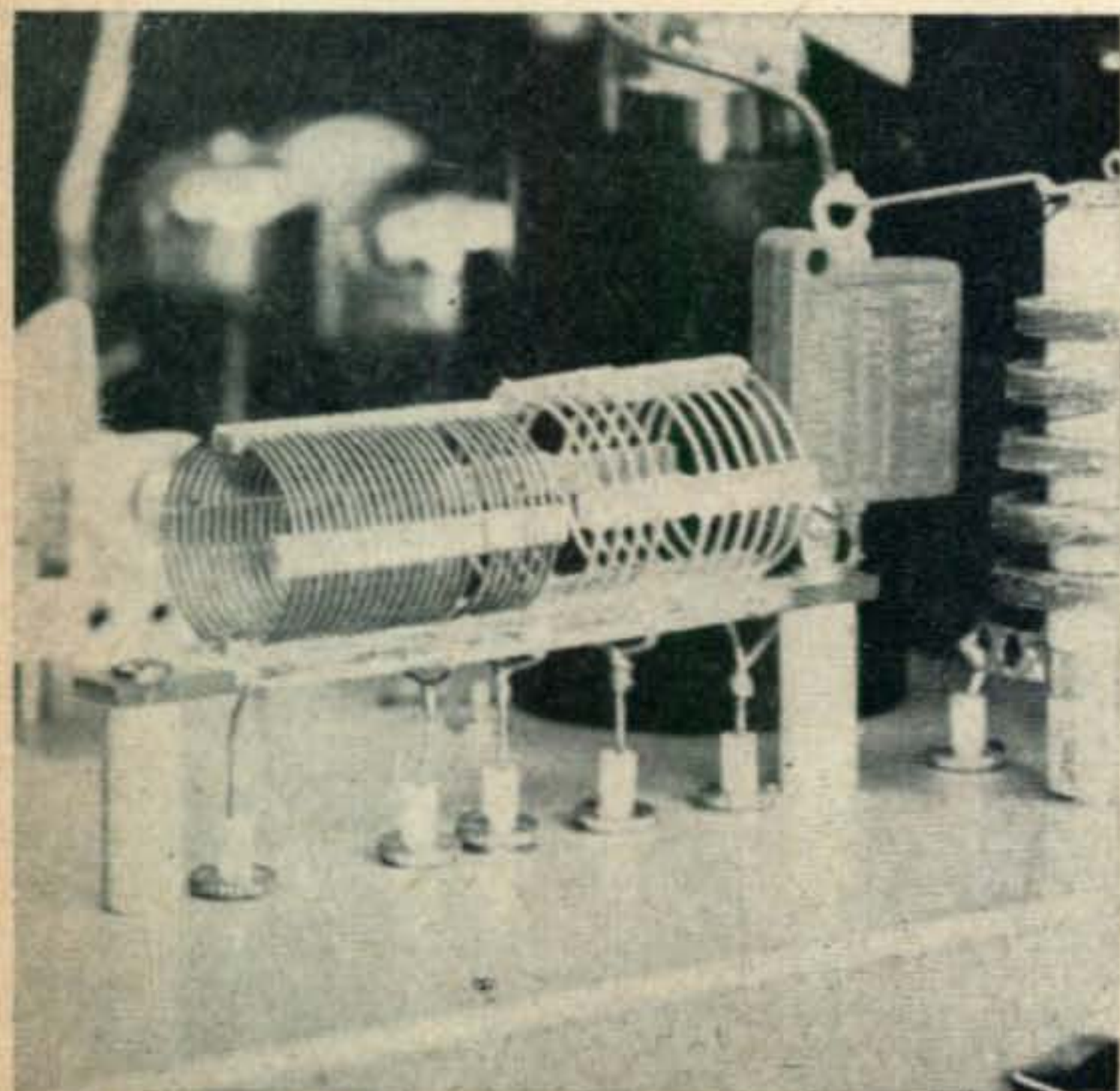

KH6MS built the transmitter around the pi-network. It is easily soldered together from two pieces of B&W Miniductors.

wiring for correctness. If all has been done correctly, plug in the tubes, the a-c plug and turn the a-c switch on. Have the *Transmit/Stand-by/v.f.o.* switch in the *Stand-by* position and the *Phone/CW* switch in the *CW* position. Allow thirty minutes for warm up before attempting to calibrate.

A good receiver, accurately calibrated, or a frequency meter is now necessary. The latter is preferred, however, a good receiver will do. Warm up the frequency meter and when both have reached operating temperature, begin to calibrate as follows:

Set the frequency standard at 4 mc. turn the band switch on the transmitter (*SW-g*) to band #4, then turn the *Transmit/Stand-by/v.f.o.* switch to *v.f.o.* Adjust C5, 12, 17 to minimum capacity, full open, then adjust with an insulated screwdriver, C1 till a beat note is heard at 4 mc. on the frequency meter. With 4 mc. appearing at minimum capacity, proceed to calibrate at 25 kc. intervals from 4 mc. down to 3.5 mc., which you will find occupies the entire dial, 100 divisions. Speaking of band spread, brother, that's it! When the calibration of the dial is complete, C18 should be adjusted for maximum grid drive as shown on the 0-15 ma. meter. A maximum of 12 mils can be had with R4 full out, but this of course is much too much

(Continued on page 89)

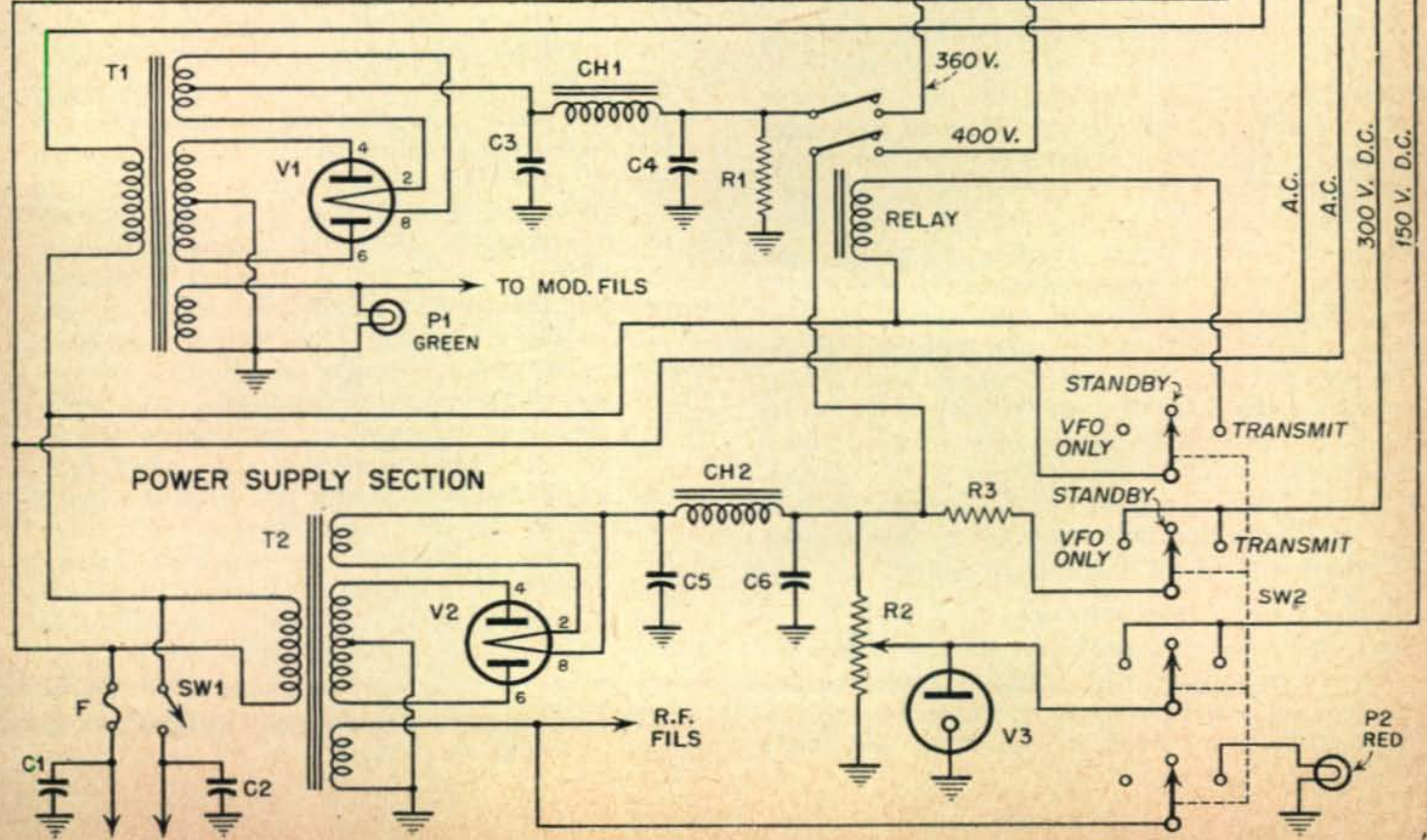
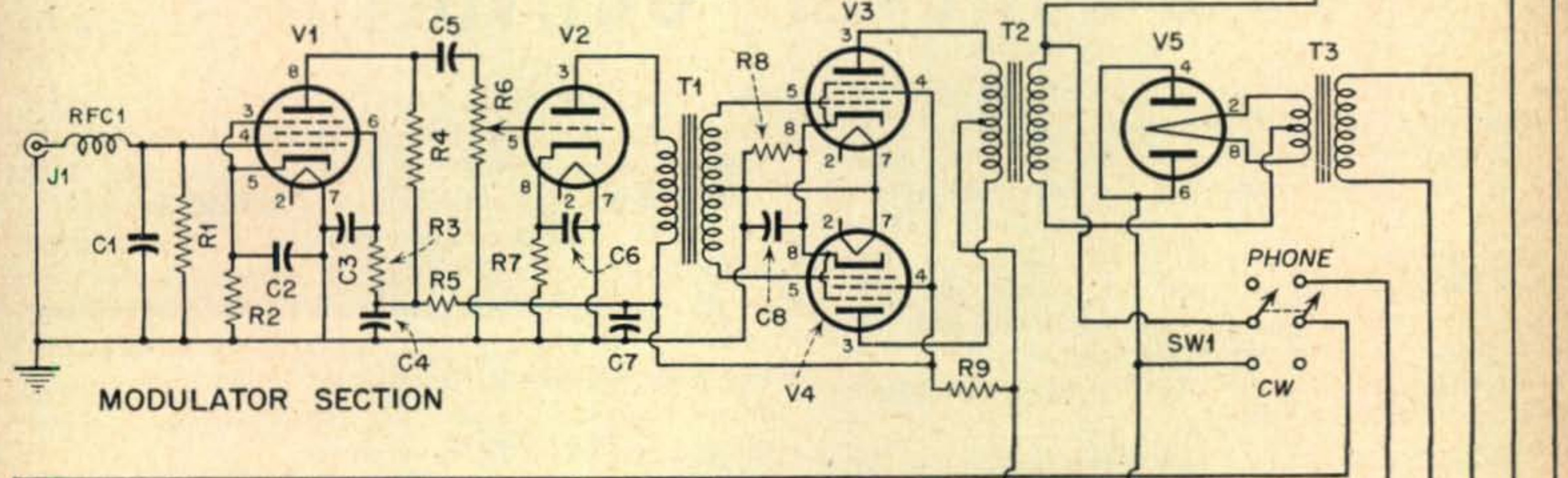
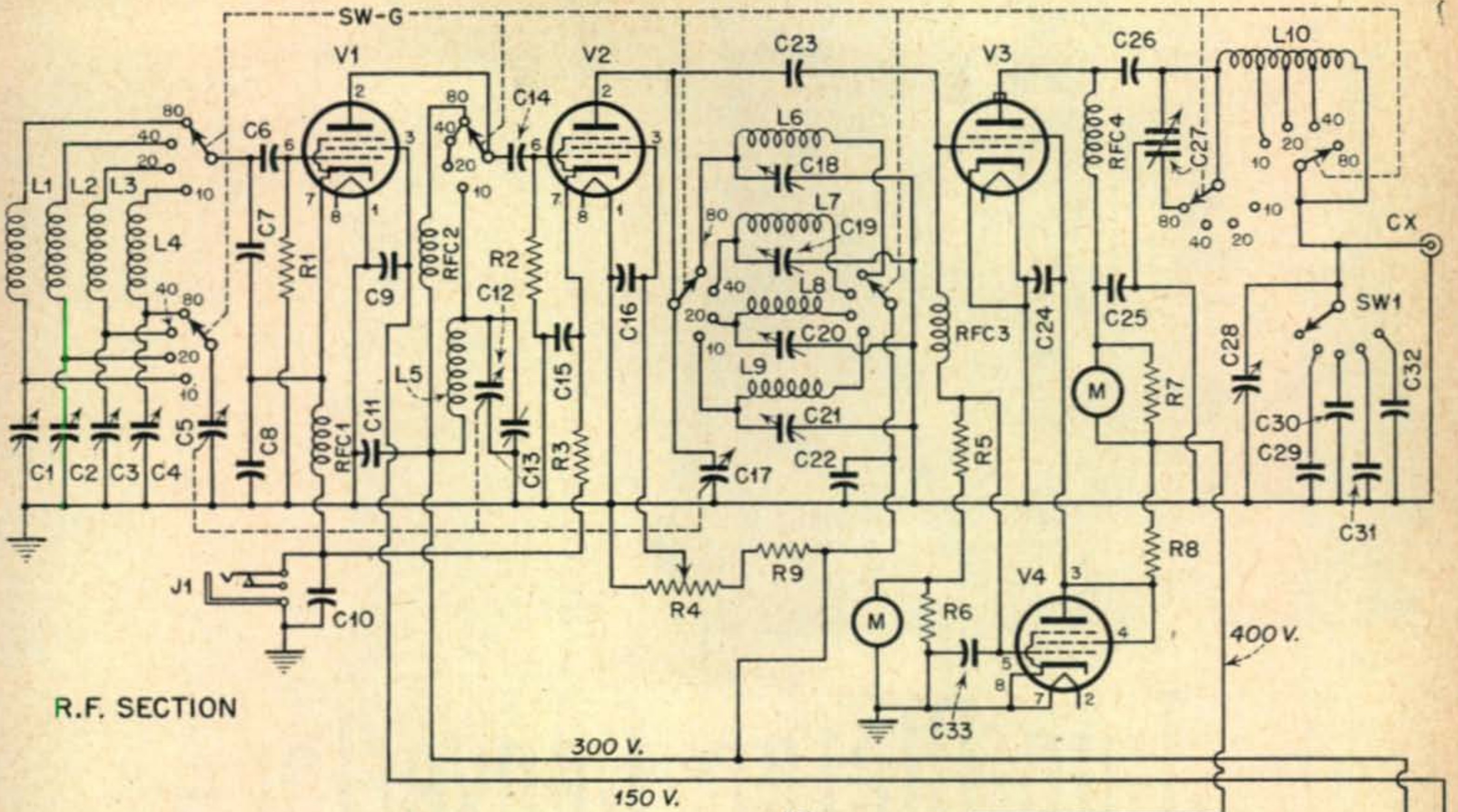

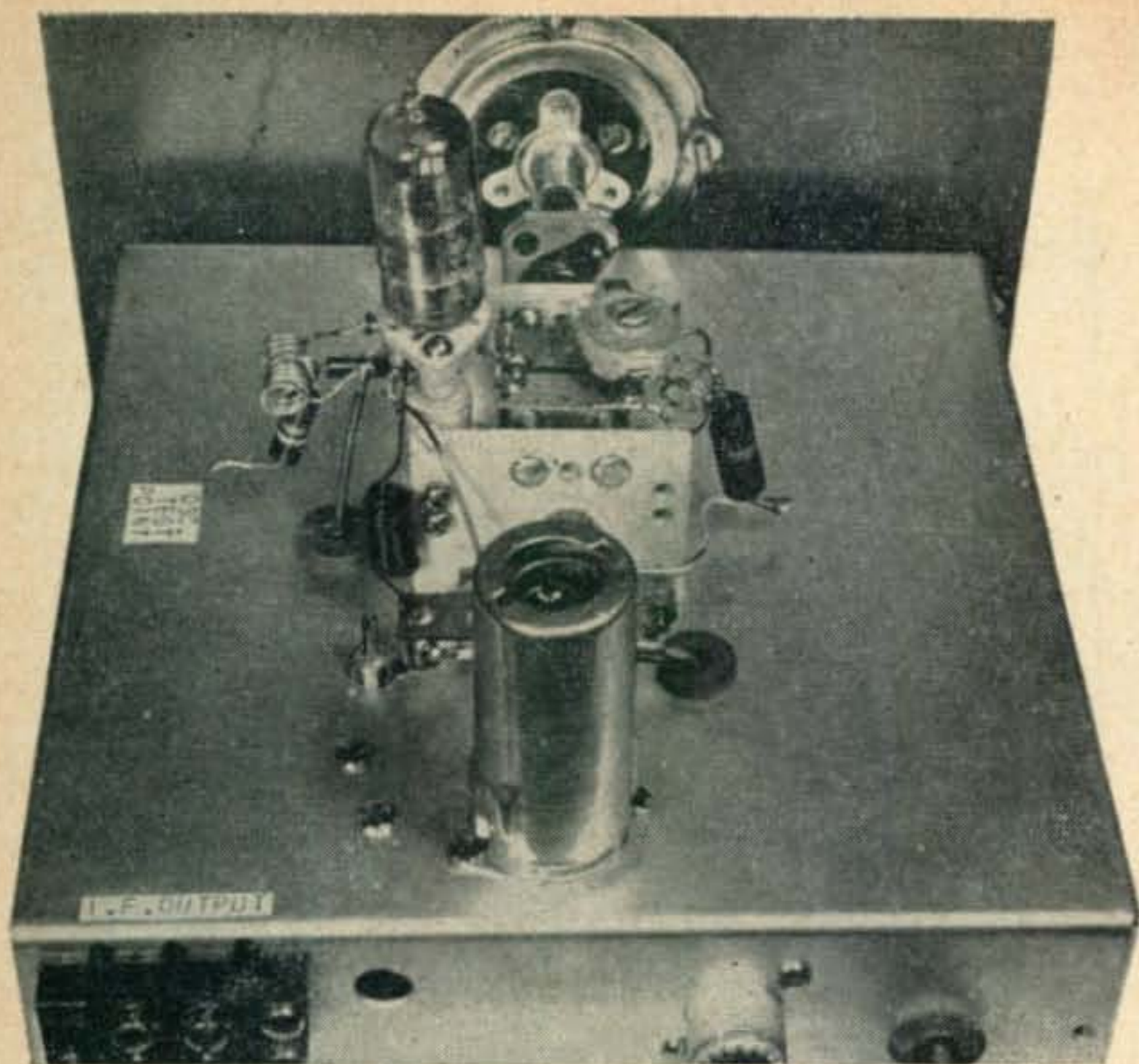

E. MILES BROWN, W2PAU

Technical Editor, CQ

A Two-Meter Converter—

"If you can't hear 'em you can't work 'em!" This oft-repeated adage applies even more emphatically on the two-meter band than on the lower frequencies, for at very high frequencies the reception of weak signals usually depends on the receiver's inherent noise level—not on the prevailing QRM or QRN! There has been a real need for a receiving system simple enough for the beginner to construct and cheap enough to appeal to the many hams who do not care to invest large amounts of cash in a two-meter set-up—this, we feel, is it.—Editor.

Here is the dope on a simple two-tube converter capable of performance in a class with the finest of the fancy low-noise designs. Its cost is reasonable—the bill for a complete set of brand new parts, including dial, cabinet and tubes (but less power supply) came to \$18.75 at current rates. The converter can be used in connection with any receiver capable of operation on a frequency of about 7 mc. This intermediate frequency was selected since most ham receivers tune the forty-meter band. If, however, some different intermediate frequency is desired, minor modifications will permit use of any frequency from 5 to 14 mc. The selectivity of the overall system will be determined by the characteristics of the "i-f" receiver—thus if the converter is used with a good-quality communications receiver all the desirable features of this receiver will be available for two-meter reception.

Performance

The performance of the converter leaves little to be desired. Sensitivity is surprisingly good. It compares favorably with converters using the popular 6J6 neutralized push-pull r-f amplifier and beats

out converters using 6AK5 pentode-connected r-f amplifiers hands down. Compared with our old faithful fixed-station receiver which uses 6J4 grounded-grid r-f amplification (at \$8.05 per 6J4!) the simple converter does measure a little inferior—1.5 db worse, to be exact! In short, it approaches sensitivity limits attainable when using the finest tubes on the Ham market. In our typical suburban location prevailing man-made and atmospheric noise levels on the two-meter band usually exceed the tube noise of the converter.

The converter's gain is high enough that its noise output overrides the tube noise of any normal i-f receiver, even of the simplest design. We could easily have built more gain into the converter by adding extra r-f amplification or by the addition of an i-f stage. But, contrary to popular opinion, high gain in the input stages of a v.h.f. receiver is not desirable. It is far from easy to provide sharp selectivity "up front." As a result, all signals present on the band are amplified more or less equally in the r-f section (though only one at a time may be coming through the selective i-f system). One exceptionally strong signal may overload the mixed or r-f amplifier and produce "cross-modulation" on weaker signals. By using only enough amplification to permit the weakest signals to override the inherent noise level in each stage of the receiver up to the point where real selectivity is obtainable, (i.e., the i-f system) the possibilities of overloading are minimized. In addition to reducing QRM from powerful local stations good "overload selectivity" characteristics make duplex operation easier. Using a 200-watt transmitter in the same room as the receiver has been much more

practicable with the new two-tube converter than with our ol' faithful multi-stage job.

The frequency stability which can be realized depends to a great extent on the care taken in the construction of the oscillator section of the converter. The potential stability of this design is at least as good as that of any other "tunable oscillator" type converter. Though not as good as a crystal controlled system in this respect, the simplicity gained through the use of a single-tube v.h.f. oscillator instead of a crystal oscillator and string of harmonic multipliers decided the issue in favor of the tunable job. Speaking from experience with many crystal-controlled units, yours truly feels safe in stating that they *all* have problems with images, stray oscillator harmonics and other types of spurious responses. With the tunable type of converter one need only worry about the "normal" type of image responses, located at twice the intermediate

usable sensitivity is determined almost entirely by the characteristics of the first tube. Much effort has gone into the design of special "low-noise" tubes. The best of the designs are prohibitively expensive or are still shrouded by military secrecy. But the need for better performance in television receivers has stimulated the development of several "economy" low-noise r-f tubes. The 6BQ7 is a good example of this class of tube.¹ It is especially designed to be used in the "driven-grounded-grid" or "cascode" amplifier described by Wallman.² The "cascode" is probably the best circuit arrangement developed to date from a noise standpoint. A tube designed for application in this circuit must have a reasonably high transconductance, low capacitances, and short leads. Internal shielding must be adequate to permit stable operation in a grounded-grid circuit—the 6BQ7 possesses these qualifications.

The EASY Way

frequency away from the desired response. And the tunable oscillator system allows one to use a wide-spread dial on the converter specifically calibrated over the two meter band. Thus it isn't necessary that the low-frequency receiver have good bandspread, or that it cover some special i-f band without range switching. Considering all these advantages of the tunable system, maybe the slight sacrifice in frequency stability is well worthwhile. It isn't so bad! The "engineering model" converter gives a good T9 beat note against a stable transmitter signal. After the first few minutes warm-up, it isn't necessary to touch up the tuning to hold a signal in tune, even using the sharpest non-crystal selectivity of our *Super Pro*. It's plenty good for CW work—if you can find any straight CW activity in your neck of the woods on two meters!

The image ratio of this converter is not too good. The front end includes only one selective circuit, which is hardly adequate to reject signals only 14 mc. off the desired frequency. If the oscillator is operated on the low side, the image frequency range includes several aircraft communications channels. If it is operated on the high side, fixed and mobile FM transmissions may be heard. We prefer the aircraft, as transmissions are less frequent and more scattered geographically! The signal-to-image ratio is in the order of 30 db, which is not sufficient to prevent strong image signals from being detected in the two-meter band but is enough to minimize the importance of random noises picked up via the image route. (Poor image rejection is a common failing in v.h.f. receivers—usually it isn't mentioned in the "specs"!)

The gain of this converter is flat within about 3 db over the whole two meter band.

Circuit Description

A v.h.f. receiver can be no better than its first r-f amplifier. In a normal two-meter receiver, the

However, the cascode circuit has several disadvantages. There are three critical tuned circuits involved in each cascode stage, though some designs neglect the importance of a good interstage tuned circuit. Neutralization of the first tube is required to obtain the full benefits of the design. In short, it is not easy to obtain ultimate performance from the circuit. It's a safe bet that a majority of the

- ¹ "Use of New Low-Noise Twin Triode in Television Tuners", Cohen "RCA Review", March, 1951.
- ² "A Low-Noise Amplifier", Wallman, Macnee and Gadsden, Proceedings of IRE, June, 1948.

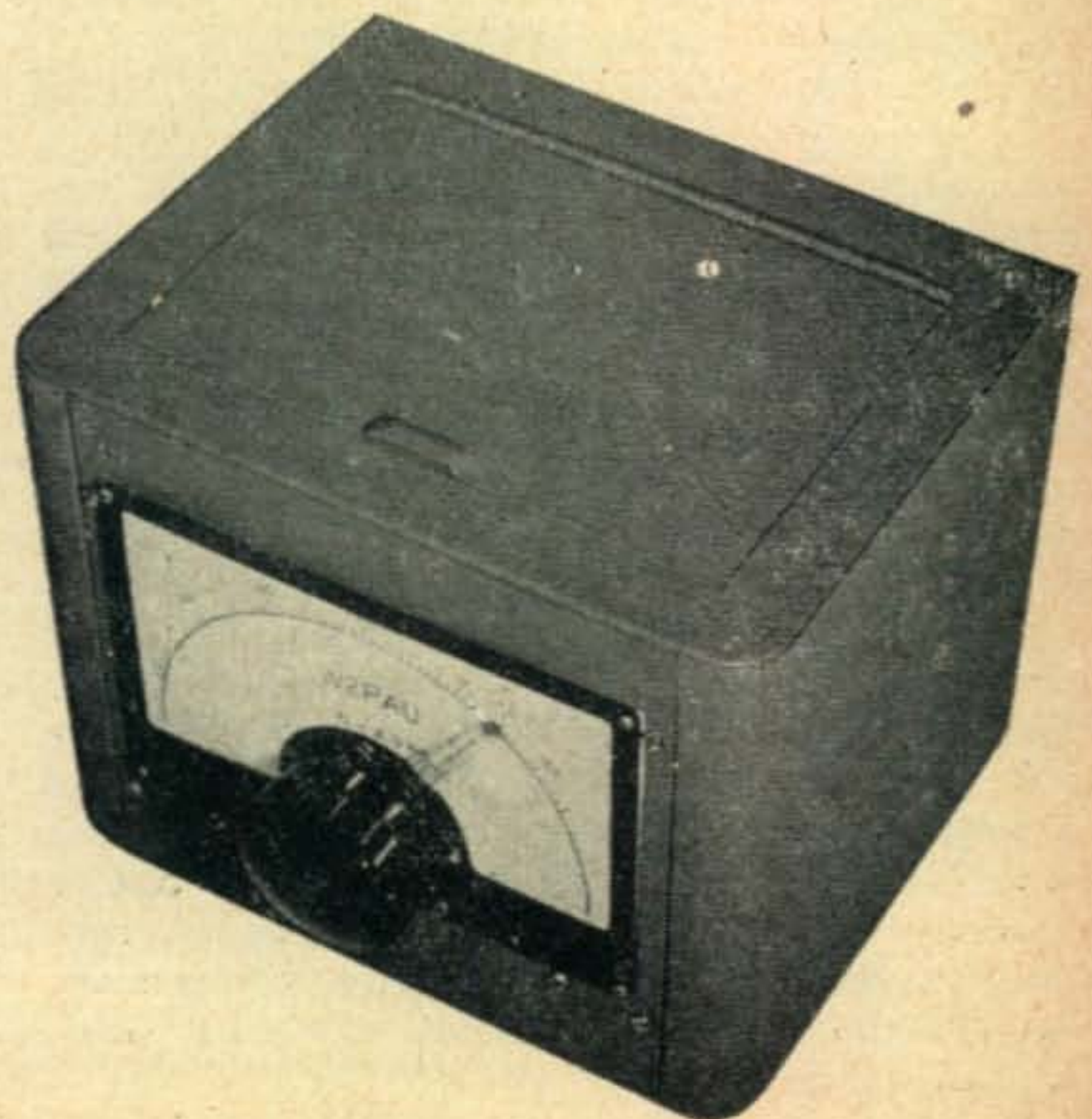

The converter when mounted in a small cabinet presents a commercial appearance. The band is spread over a good portion of the dial for maximum ease of re-set readability and accuracy.

COIL DATA

- L1—Oscillator Grid**—Self-supporting, airwound, 8 turns #18 AWG tinned copper on 1/4" O.D. mandrel, spaced to 1" overall length, center-tapped, both leads 1/2" long.
- L2—Oscillator Plate**—Self-supporting, airwound, 3 turns #12 AWG copper on 1/4" O.D. mandrel, spaced to approx. 3/4" length, center-tapped, leads less than 1/4" long.
- L3—R-F Input**—Self-supporting, air-wound, 4 1/4 turns #18 AWG tinned copper on 3/8" O.D. mandrel spaced to approximately 1/2" overall length, tapped 1 1/2 turns up from grounded end. Leads approx. 1/4" long.
- L4—R-F Plate**—Self-supporting, air-wound, 2 turns #18 AWG tinned copper on 1/4" mandrel, spaced to approx. 1/2" length. Leads very short—less than 1/4".
- L5—Mixer Plate**—Make from parts of RCA coil type 202L-1. This coil uses a 9/32" thin-walled bakelite coil tube, a chassis mounting clip powdered iron slug and a terminal collar. Remove all wire from original coil. Slip terminal collar to end away from mounting clip. Coat form with coil dope or Duco, then wind 30 turns of #30 AWG enameled copper wire, close-spaced as close as possible to the terminal collar. Use 2 of the terminals to anchor the coil leads.
- L6—Output link**—Wind approx. 10 turns of #30 enameled wire as close as possible to cold end of L-6. (This is the end nearest the mounting clip.) Twist L-6 leads together to hold coil in place and trim to reach terminal board as shown in illustrations.
- L7—Oscillator Filament Choke**—Self-supporting, air-wound, 20 turns of #20 AWG enameled copper close-spaced, leads approximately 1 1/2" long (trim to fit).

so-called cascode amplifiers currently in use in ham receivers are not capable of providing the excellent performance that might be achieved in an optimized set-up.

As a result, in our super-simple converter the first r-f stage uses only one half of a 6BQ7, connected as a simple grounded-grid triode amplifier. The tube is well suited to this application. It would provide the same excellent signal-to-noise ratio that the 6BQ7 gives in the cascode connection if it were not for the noise contribution of the second stage which explains why this converter is slightly noisier than an idealized unit. On the credit side of the ledger, the grounded-grid stage has only one critical tuned circuit (the cathode input coil is inherently broad-band), it does not require neutralization and it uses few expensive components. The plate circuit is tuned by a low cost mica "sandwich" capacitor.

The remaining 50% of the 6BQ7 offered good possibilities as a low-noise triode mixer. Tests showed that it did an excellent job as a frequency converter, and the very small deterioration of

overall noise performance due to the use of a mixer as the second stage proves this point. The mixer circuit uses grid-leak bias, as this system provides an easy method of checking the level of the oscillator injection signal. A tap point was provided on the mixer grid leak resistor for connection of a test meter during tune-up. The mixer i-f output coil is tuned by a molded powdered iron slug to the desired intermediate frequency. The possibility of v.h.f. parasitic oscillations is reduced by locating the i-f coil tuning capacitor directly at the tube socket terminals, thus minimizing the effective inductance in the mixer plate circuit. Use of a common r-f bypass capacitor for the mixer and r-f amplifier plate circuits introduces a certain amount of regeneration at the intermediate frequency, but if the capacitor is sufficiently large, no danger of i-f oscillation exists (and a saving of one resistor and one capacitor is realized). The i-f coil is link coupled to the converter output terminals.

The oscillator uses a 6J6 in the once-famous "T.N.T." (tuned-not-tuned) circuit. This arrangement was chosen for several good reasons. It uses a minimum number of critical components. The amount of self-excitation can be controlled by spreading turns of the oscillator grid coil with negligible effect on the frequency. The cathode and heater can be tied together and grounded, minimizing hum FM. The tuning capacitor is of the split-stator type and need not be insulated from ground since the rotor bearings do not carry r-f current. The very low plate-to-plate capacitance of the 6J6 (0.8 $\mu\text{mf.}$) minimizes frequency shift due to tube warm-up or tube change. The mixer injection signal is taken from the grid circuit of the oscillator since changes in loading on the grid tank will cause less frequency shift than changes on the tuned plate tank. A "gimmick" coupling capacitor made of a short length of insulated wire hooked over the mixer grid lead provides adequate coupling and permits easy adjustments of injection level.

The converter requires an external power supply, capable of supplying 6.3 volts (a.c. or d.c.) at 0.85 ampere for the heaters, plus well-filtered d.c. for the plates. Any voltage between 200 and 350 can be used without appreciable change in performance. Plate current runs about 20 milliamperes. If the ultimate in stability is desired, regulation of the supply voltages will help. But in practice, the stability of the converter with an unregulated power unit is acceptable. A small power supply such as the "Minipak"³ would be ideal if a regulated supply is required. It was deemed wise to make the power pack a separate unit to avoid unnecessary heating of the converter chassis and to reduce the effects of mechanical vibration and strong hum fields from the transformer.

No B+ switch is provided—it's better to leave the converter running continuously during an operating session.

Construction

The converter is housed in a standard 8x8x10 inch cabinet with a hinged top door. (Ours was

³ "The Minipak", Ron Pickett, CQ, Dec. 1951, p. 17.

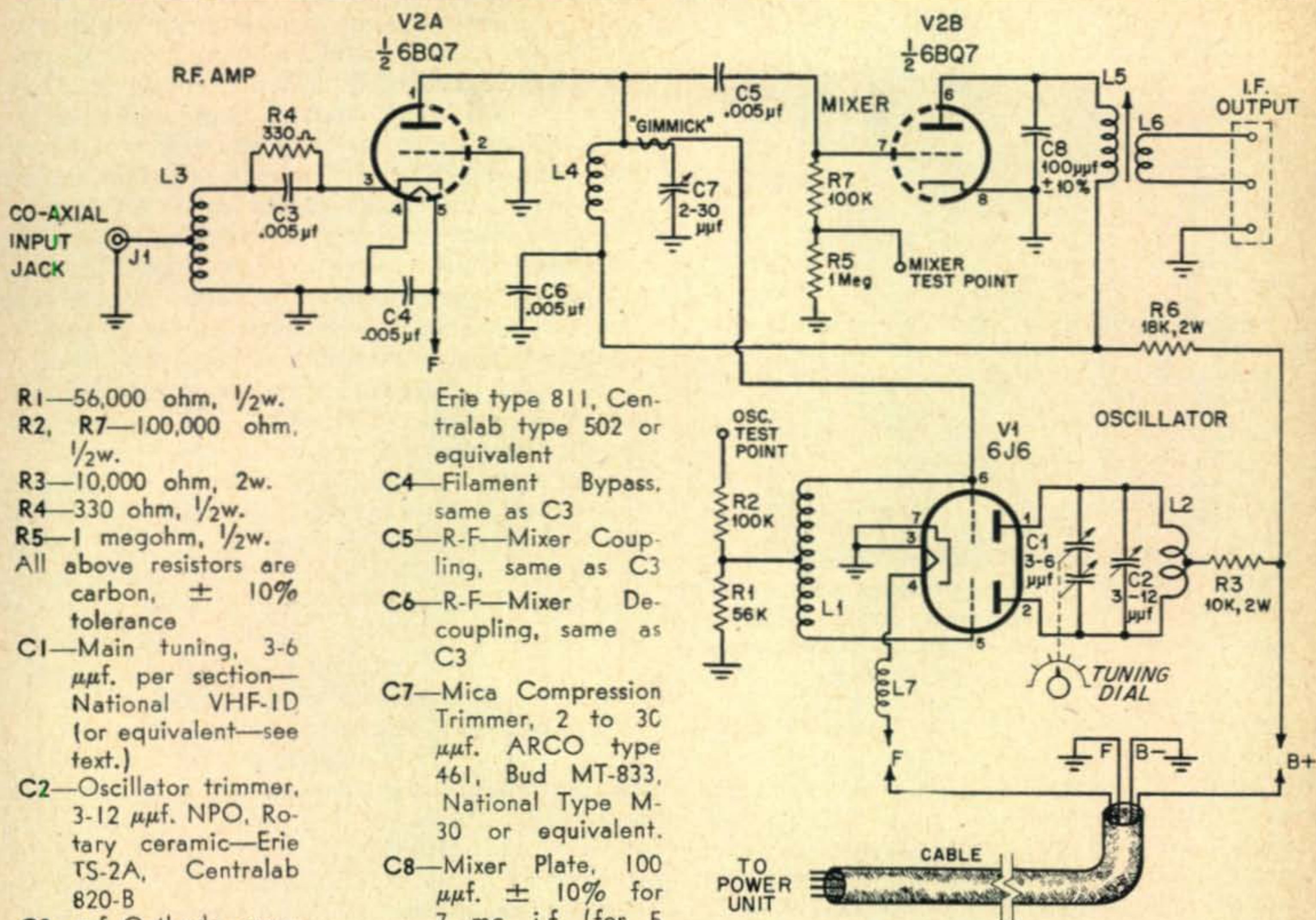

- R1—56,000 ohm, 1/2w.
- R2, R7—100,000 ohm, 1/2w.
- R3—10,000 ohm, 2w.
- R4—330 ohm, 1/2w.
- R5—1 megohm, 1/2w.
- All above resistors are carbon, ± 10% tolerance
- C1—Main tuning, 3-6 μmf. per section—National VHF-1D (or equivalent—see text.)
- C2—Oscillator trimmer, 3-12 μmf. NPO, Rotary ceramic—Erie TS-2A, Centralab 820-B
- C3—r-f Cathode coupling, 5,000 μmf. ± 100%—50%, Hi-K Ceramic disk type, 400 volt (min.), approx. 1/2" OD.

- Erie type 811, Centralab type 502 or equivalent
- C4—Filament Bypass, same as C3
- C5—R-F—Mixer Coupling, same as C3
- C6—R-F—Mixer Decoupling, same as C3
- C7—Mica Compression Trimmer, 2 to 30 μmf. ARCO type 461, Bud MT-833, National Type M-30 or equivalent.
- C8—Mixer Plate, 100 μmf. ± 10% for 7 mc. i-f (for 5 mc., use 200μmf. for 10 mc. use 56 μmf.) mica or high Q ceramic, 400 V d.c. (min.)

an ICA type #3925.) The chassis, 7x7x2 inches, was aluminum, but we regretted the choice of aluminum after all the corner spot welds broke out during the construction program! The chassis was bolted to the panel using long bolts and 1/2" spacers to allow room for the dial mechanism. The lack of the chassis rests on two rubber cushions cut from an art-gum eraser.

The photographs show the relative position of the parts. The oscillator was placed on top of the chassis and the amplifier-mixer unit on the bottom to avoid the possibility of stray oscillator voltages wandering around the input circuit and making the wrong tube the mixer! The co-axial input cable (more on this later), the output terminals, and the power cable are brought out through the rear lip of the chassis. A hole in the rear of the chassis permits access to the r-f trimmer capacitor, which is firmly bolted to the chassis.

Something should be said about the problems involved in substituting parts other than those specified in the parts list. Of course, it is standard practice among hams to make minor changes in construction and circuitry to suit the circumstances.⁴ Such tactics applied to v.h.f. circuits are, to say

the least, dangerous. If you've had plenty of experience in circuit layout and test methods, go ahead and the sky's the limit. But if not, I'd strongly recommend that you make every effort to procure the exact parts called for in the parts list. Sure, most of the parts are hard to get in these days of priorities and material shortages. But in several cases where we've accepted the salesman's cheerful "Just as good. . ." we've been rooked! The tuning capacitor and the dial are probably the hardest things to find good substitutes for. There are a few excellent v.h.f. tuning capacitors available in the stores, but there is also a lot of junk floating around. The tuner we have selected for this job has ball bearings fore and aft. The plates are all soldered to their moorings. The unit comes fitted with a flexible shaft coupling (this had been borrowed from the condenser shown in the photos necessitating a substitution). Best of all, brackets are provided to permit mounting the tube socket directly to the capacitor frame, resulting in a complete oscillator sub-assembly which can be mounted by its four studs on the chassis surface—neat and effective. Shop around a while before accepting a substitute on this item, but if you must, try to obtain a condenser with a velvet-smooth rotation, as even a little roughness or drag is bad. Get one that can be cut down easily to about 1 rotor and two stator plates per section.* Then arrange to

* This applies to small-sized single-spaced capacitors. Double-spaced units may require more plates, larger sizes may require fewer. A safe rule to follow is not to cut the available capacitor down until the receiver has been built and tested—then remove plates as required to produce the desired dial band spread.

⁴ "Stretching the Junk Box". Seymour, QST, April, 1952, p. 56.

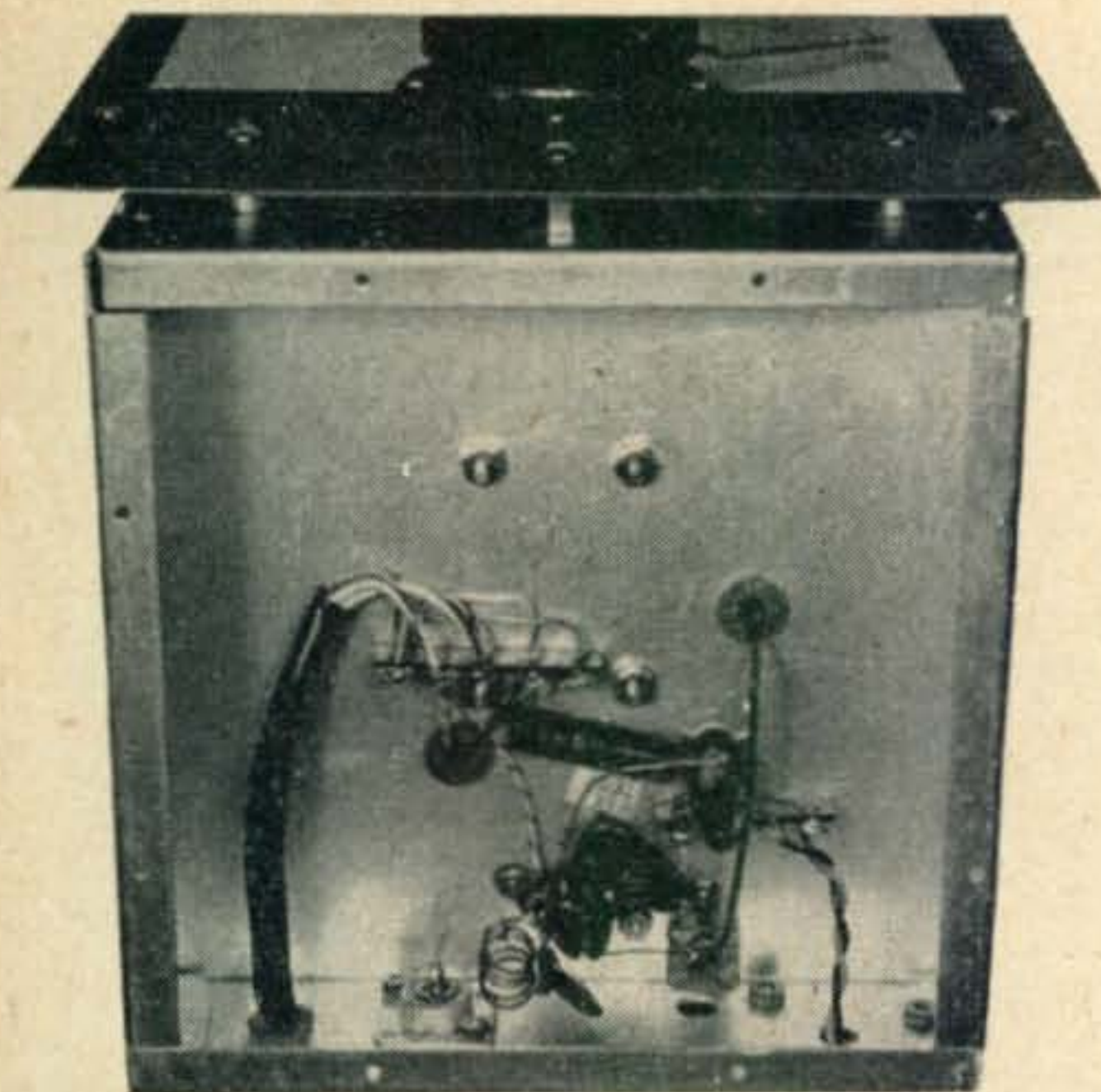

This under chassis photograph may be closely compared with the pictorial drawing on the opposite page. The slight changes are due to drafting modifications for the sake of clarity.

mount the 6J6 tube socket on a bracket in such a position that the leads to the stator terminals are only about $\frac{1}{4}$ " long. The tuning dial should likewise be a velvet-smooth drive, without backlash. A large knob is desirable. The torque required to rotate the dial should be small. High-drag units will cause minute distortions of the cabinet which will show up as tuning backlash. (We usually wind up by lapping our dials in with the aid of a high-speed electric drill on the knob shaft and some fine valve-grinding compound! It pays off.) An illuminated dial would be nice if you feel like spending the extra dough. The scale should be long enough to provide good readability and re-set accuracy.

The trimmer capacitors are likewise critical. The oscillator trimmer is a rotary ceramic unit, with a maximum capacitance of about $15 \mu\text{mf}$. It should be rated at zero temperature coefficient. A negative-coefficient capacitor may actually hurt stability. In an oscillator built like this one, the frequency might go either way with increasing temperature—one can't assume that it will drift lower. Even though you may have quite a collection of this

Mounting Components

SOCKETS:

- V1—Oscillator—National XOR-C-7 or equivalent.
- V2—R-F Mixer—Cinch 9-X-M with 9-S shield.
- J1—Co-axial input Jack—Amphenol 83-IR.

TUBES:

- 1—Type 6J6, 1—Type 6BQ7

CHASSIS—I.C.A. type 29005—7" x 7" x 2"

CABINET—I.C.A. type 3925 or equivalent, 8" x 8" 10"

DIAL—National type ACN

TERMINAL BOARDS—Output—Jones type 2-141 tie points—standard bakelite terminal strips—Allied Cat. #41-850 and 41-870.

DIAL SHAFT EXTENSION—1 piece bakelite or polystyrene rod, $\frac{1}{4}$ O.D. x 3" (approx.) long—cut to fit.

OSCILLATOR SOCKET SPACERS—2 spacers $\frac{3}{8}$ " long, $\frac{1}{4}$ " O.D., clearance for #4-40 machine screw. May be bakelite, ceramic or metal.

RUBBER GROMMETS—4 grommets, $\frac{3}{8}$ " chassis hole size—Allied Cat. #44-41 plus; assorted #4 screws, shakeproof lockwashers, nuts, shakeproof solder terminals; #8 screws, nuts and spacers for chassis mounting, etc.

sort of trimmer in your private stock it's best to play it safe and buy a nice new one from a reputable dealer. The other trimmer (mixer grid) is a mica sandwich unit. Stability is not too important here, but low minimum capacitance is. The adjusting screw should be long enough to permit the top plate to open far enough away from the bottom plate that the trimmer becomes virtually an air-dielectric condenser. Look closely to make sure that there are only two plates—one on each side. Also be sure that there are no silvered mica sheets in parallel with the trimmer. Mica sandwiches aren't all alike!

All of the r-f bypass and coupling condensers are shown as $5,000 \mu\text{mf}$. ($.005 \mu\text{f}$). This was done primarily to simplify the ordering (and they don't charge extra for more "C"). It is important that they be of the type specified—small disk ceramics. We've checked the effect of replacing each of these with more costly metal-cased low inductance capacitors (which get pretty expensive—some upward of \$1.00 apiece!) and have noted no improvements. We've tried three different manufacturer's ceramic disk units. No troubles were experienced.

We recommend use of co-axial connector for the antenna input. Even though the receiver will be used eventually with balanced line, it is far easier to arrange an effective termination for co-ax cable at the receiver chassis. One might as well build the receiver for co-ax input and then use a balun⁵ or elevator transformer⁶ mounted externally to adapt the receiver to 300-ohm or 450-ohm balanced lines if these are used. More than half of the two-meter receivers we've seen used co-ax input anyway, so it's wise to conform. The large-sized co-ax connector was used because it matches the rest of our equipment. Otherwise a smaller or cheaper co-ax fitting could have been used.

One last warning—accept *no* substitutes for the tube types specified. This doesn't mean that other types will not do as well, but we just haven't had time to investigate this problem completely to date.

Wiring

The photographs show the wiring quite clearly. The exact layout of the sockets and wiring aids should be planned after all parts are on hand so that the components can be "jig-saw puzzled" into place to produce the shortest possible lead lengths. A safe rule to follow is to cut the leads on *all* components to $\frac{1}{4}$ " length before laying out the wiring. Then make 'em fit! The grounds around the r-f mixer tube socket are made to soldering lugs under each of the socket mounting nuts. These lugs should be located as close to the body of the socket as possible, then bent around to make contact to the appropriate socket terminals directly. *Figure 2* shows the layout of the wiring around the 6BQ7 socket.

One of the terminals of the r-f trimmer is bolted flat against the chassis. It may be necessary to place a washer between the terminal and the chassis permit the trimmer to stand up straight. Be sure to ground the terminal which is connected to the

⁵ "The Balun—Theory and Design" by J. R. Smith, CQ, Feb. 1952, p. 24

⁶ RCA Stock #73578 or equivalent TV antenna balancing transformer

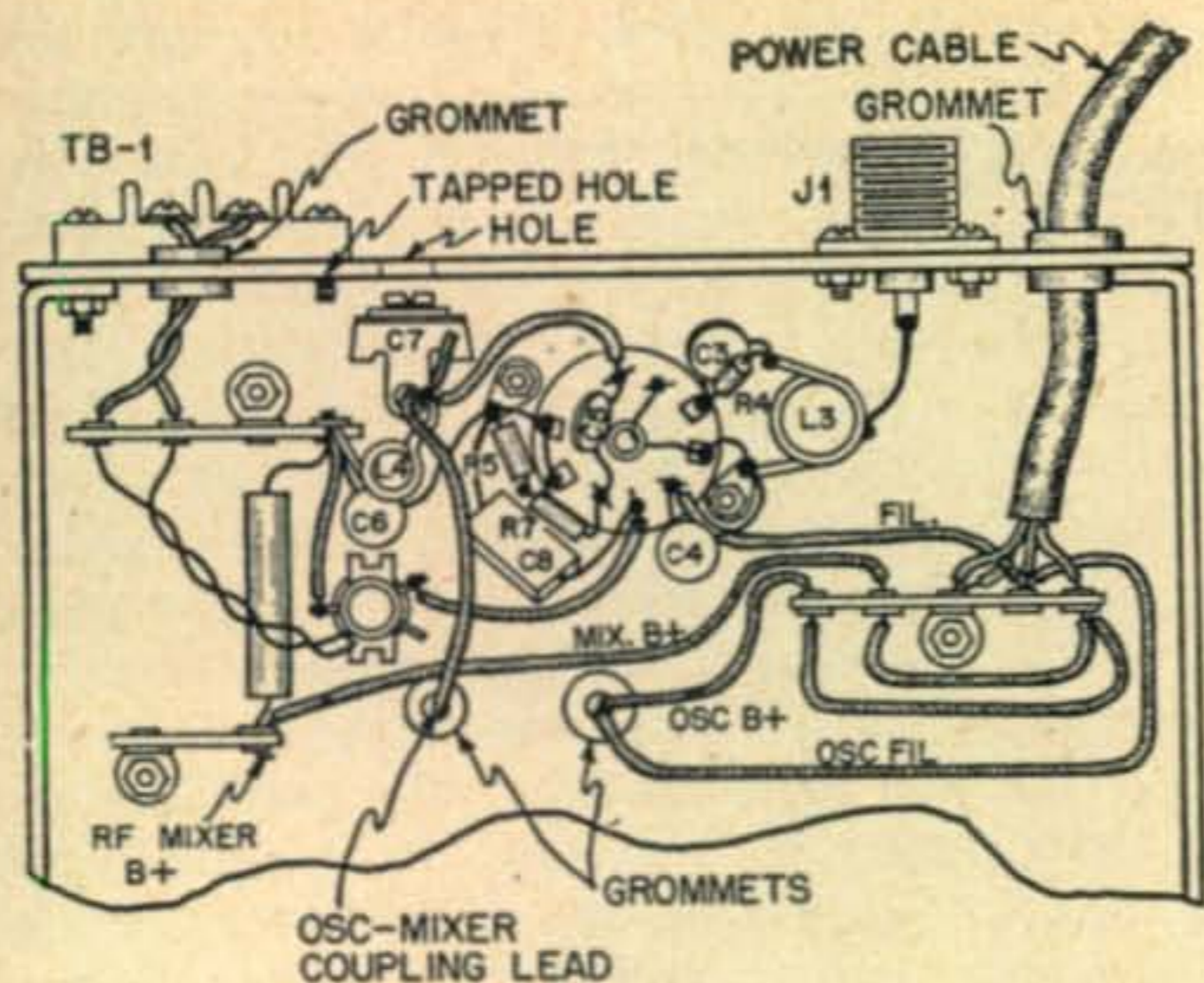

RF MIXER
(BOTTOM VIEW)

These pictorials should enable the novice to wire the two-meter converter with very little difficulty. The view on the left is the under chassis and the one on the right is the cluster of parts around the tuning coil and condenser. As in all VHF gear, short leads are quite important.

outside plate to avoid de-tuning effects when using a metal tuning tool.

The oscillator wiring layout is pretty obvious. The grid coil hangs directly on the terminals of the tube socket. The plate coil and the trimmer are mounted on the stator terminals of the tuning capacitor. Connections between the socket and the stator terminals were made with thin copper wire (about #20) which was kinked in such a way as to avoid the possibility of mechanical strains developing between the (thermally) hot tube terminals and the frequency-determining tuning unit. The relatively "limp" leads also tend to break up mechanical resonances and thus minimize microphonics. (But don't use braid!) The oscillator plate-voltage dropping resistor, R3 should also be supported by a "limp" lead. It gets hot and expands—don't let it push the coil around!

No shielded wire was used on the converter chassis. The leads from the i-f output link were twisted together to minimize stray signal pickup. The power supply cable was made of 4 lengths of stranded hook-up wire pulled into a piece of large-sized "spaghetti". (Four leads were used to permit carrying filament current to the converter via a path separate from the plate current path. Sometimes the small a-c voltage drop in a common lead can cause hum-modulation of the oscillator.) Rubber grommets were used to protect the wires which went through holes in the chassis.

The coupling lead between the oscillator and the mixer should be not over 5" long. It should be dressed away from all metal parts over its entire length. A large sized ($\frac{1}{4}$ " I.D.) rubber grommet was used to insulate this wire where it passed through the chassis. No other leads should be fed through this grommet.

Test and Operation

The converter should be connected to the communications receiver by means of a two-conductor

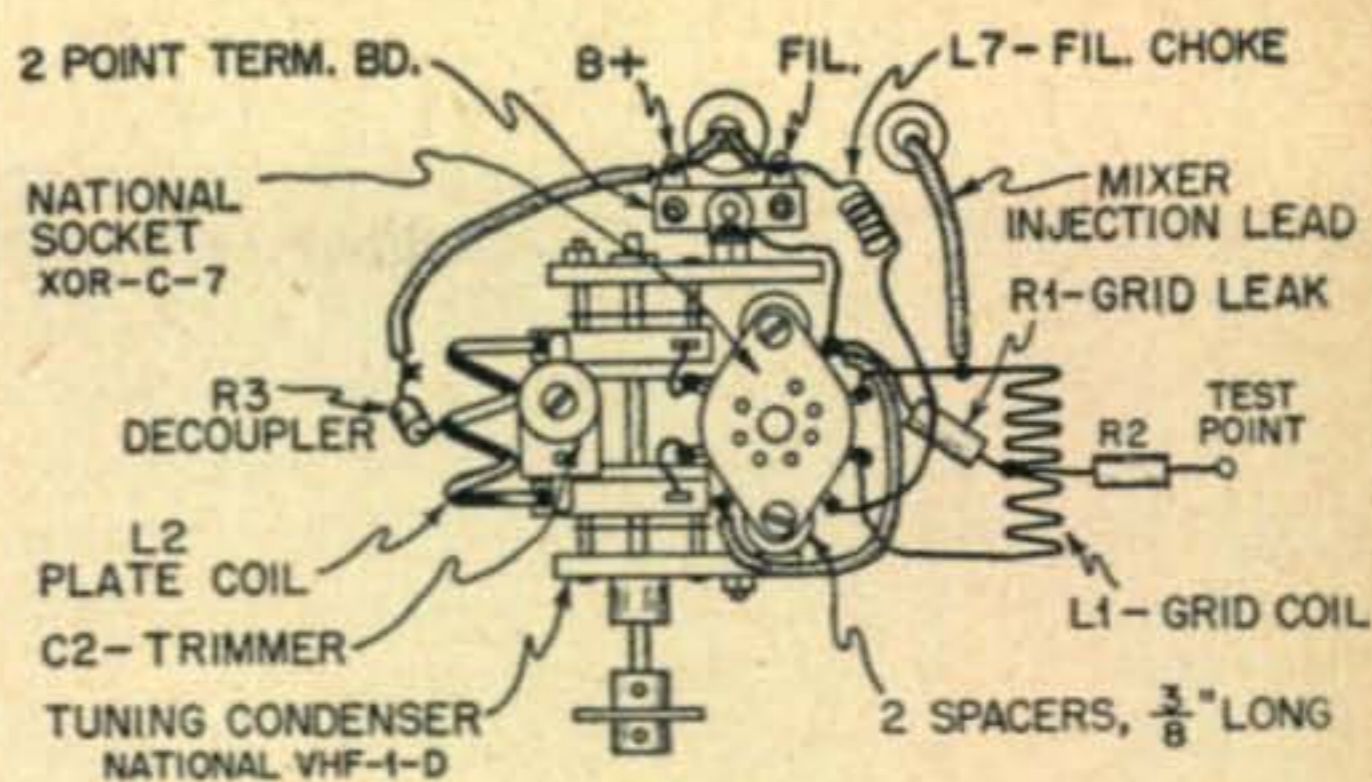

OSC. SUB-ASSEMBLY
(TOP VIEW)

shielded cable. A single co-ax cable can be used if one side of the receiver's input system is grounded. In this case, ground one side of the converter output link also. The cable should be as short as practical; lengths up to several feet probably wouldn't hurt too much. Connect the power cable to a suitable power supply. For a start don't bother with an antenna; just clip a wire onto the input jack.

Tuning up will be easier if you have a transmitter on the two-meter band. (If you don't, a grid dip meter will do, but it's less convenient and accurate.) Pull the converter oscillator tube out of its socket. Connect a test meter between the test point on the mixer grid leak and ground—ground is positive in this case. This meter can be either a vacuum-tube d-c voltmeter or a d-c microammeter. A 200 μ a. job will do fine but even a zero to one milliammeter may be used with some eye-strain! Turn on the filament and plate power supply. (Might take time out to check voltages at this point.) Now turn on that two-meter transmitter and lay the temporary converter antenna somewhere near the final amplifier or the antenna leads. (If a grid-dipper is used, tune it to 146 and couple the temporary antenna closely to the dipper coil.) It should be possible to tune the

Voltage Check List

1. Main plate supply—may be 200 to 350; 250v. nominal.
2. Voltage at center-tap of oscillator plate coil to ground—150v.
3. Voltage at plate of r-f amp. and mixer (measured from end of R6 to ground)—90 volts.
4. Voltage at cathode of r-f amplifier (Pin 3 of V2 to ground)—2.2 volts.
5. Filaments—pin 5 of V2 or pin 4 of V1 to ground— $6.3 \pm 10\%$ volts a-c or d-c
6. Oscillator test point to ground—minus 7 volts measured on a vacuum-tube d-c voltmeter, or 70 microamperes d-c to ground through a current indicating meter.
7. Mixer test point to ground—minus 2 volts d-c or 20 microamps measured as in (6).

r-f trimmer to produce a reading of grid current on the test meter. Tune the trimmer for maximum drive—just like a transmitter stage! This procedure checks the operation of the r-f amplifier (roughly) and insures tuning of the interstage coil to the two-meter band. We hope that it won't be necessary to spread or squeeze the turns on the r-f plate coil to obtain proper peaking, but it might! Once the trimmer is set it should be left alone until the final peaking operation. Turn off the test signal.

Next plug the oscillator tube back into its socket and watch the mixer grid current meter as the oscillator trimmer is slowly rotated. If oscillations exist there should be a fairly well-defined grid-current peak. Set the trimmer capacitor slightly off the setting that gave peak reading—drop the mixer current down to the point where only about 20 microamps (or 2 volts) of drive shows on the mixer. The oscillator should now be *somewhere* near the right operating frequency!

Next try to find some indication of output on the i-f receiver. Throw off the AVC and the BFO, run the a-f gain all the way up, and advance the r-f gain setting until some background noise is heard. Spin the i-f receiver tuning dial over the band around 7 mc. There should be a definite peak of the noise at one setting; if it's not at the desired frequency try tuning the i-f coil in the converter to move the noise peak to the proper spot. (If a grid dipper is available, it can be used to pre-tune the i-f coil to the desired intermediate frequency.)

The tuning dial of the converter oscillator should now be set at about $\frac{1}{2}$ scale and the oscillator trimmer should be rocked to produce the maximum amount of noise output from the i-f receiver. Don't make any very drastic changes in the trimmer setting—the oscillator should still be slightly off the setting that gave the peak mixer grid drive. If all went well, the converter should now be approximately lined up and ready for final peaking. This is about the time to start fishing for signals! Connect an antenna and tune the converter to see if

any stations can be heard. If you're not sure that there is any two-meter activity in your neighborhood, you'd be smart to call for help from some ham who can pump a signal into your antenna; don't forget to ask his frequency while you're at it. After you've located the two-meter signal you can start thinking about the dial coverage. If the test signal was on the low end of the band the oscillator trimmer should be set so that the main tuning capacitor is almost all "in," etc. After a little listening you'll be able to figure approximately what frequency range can be tuned. From this point on, it's easy.

Hook the test meter between the oscillator test point and ground. Set the tuning dial for the middle of the band. Squeeze or spread the turns of the oscillator grid coil to produce a reading of about 70 microamps (or 7 volts). Move the meter back to the mixer grid-leak test point and adjust the position of the coupling gimmick with respect to the r-f plate wiring to produce a meter reading of about 15 microamps (or 1.5 volts). This is not too critical, but the injection voltage should be at least 1.5 and not more than 5 volts. Then re-peak the r-f trimmer for maximum noise output. Be careful not to tune the trimmer to the image response—it is easy to cross over the oscillator frequency and hit the image peak by mistake. If there's any doubt that you're on the proper peak go back to the original test set-up and check mixer grid current due to your own transmitter. Check the peaking of the i-f output coil. And that's just about it.

Final Check

A few quick checks should indicate that things are in good order. When the power supply of the converter is turned *off* the noise output from the i-f receiver should drop from normal listening level to practically nothing. If it doesn't, check the tuning of the i-f coil carefully, and make certain that the interconnecting leads are not open or shorted. Your particular receiver may require a different

(Continued on page 93)

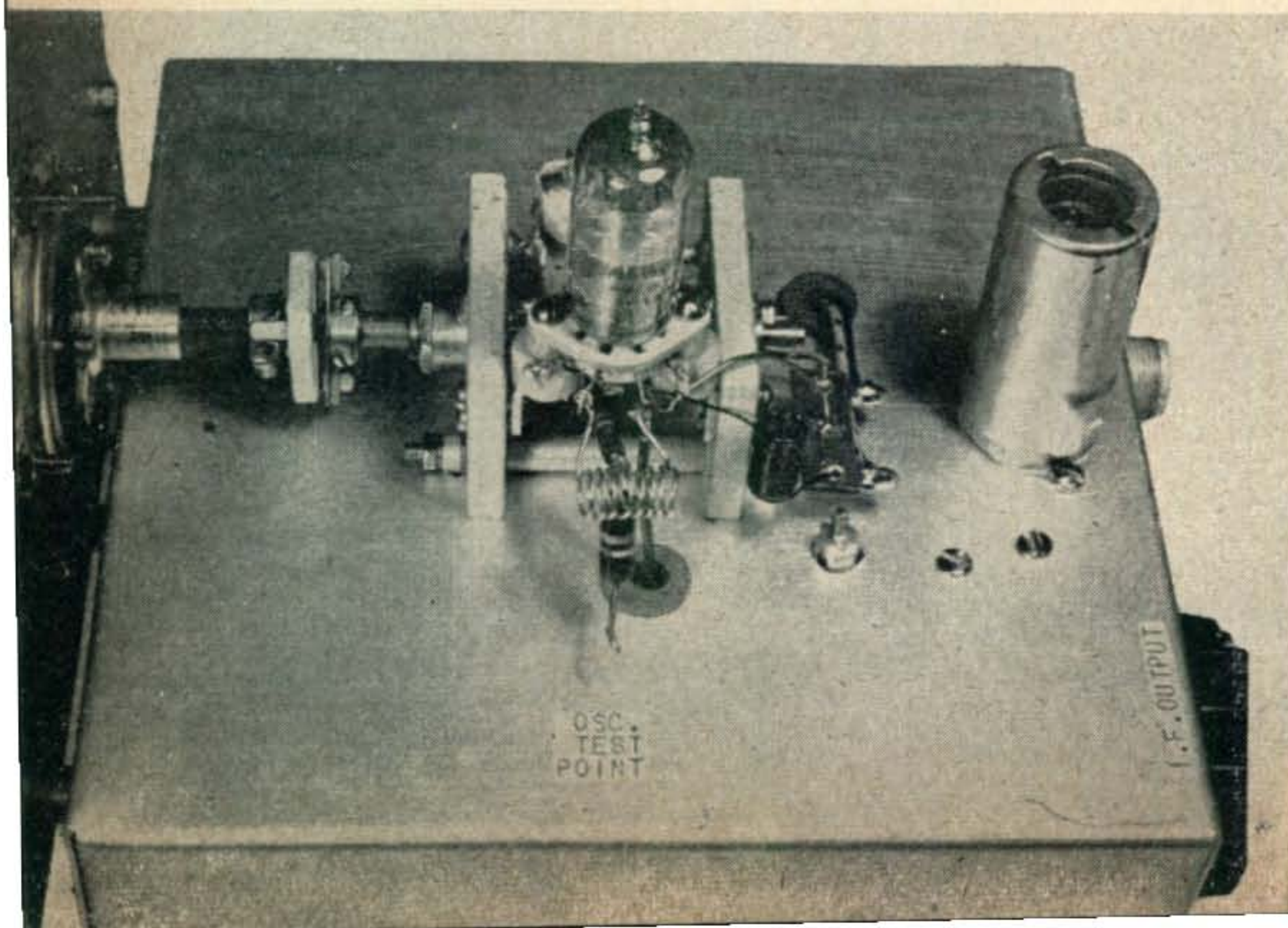

The side view of the converter shows the resistor network that forms the oscillator "test point." A reading taken here indicates whether the oscillator is producing the proper voltage for mixer injection.

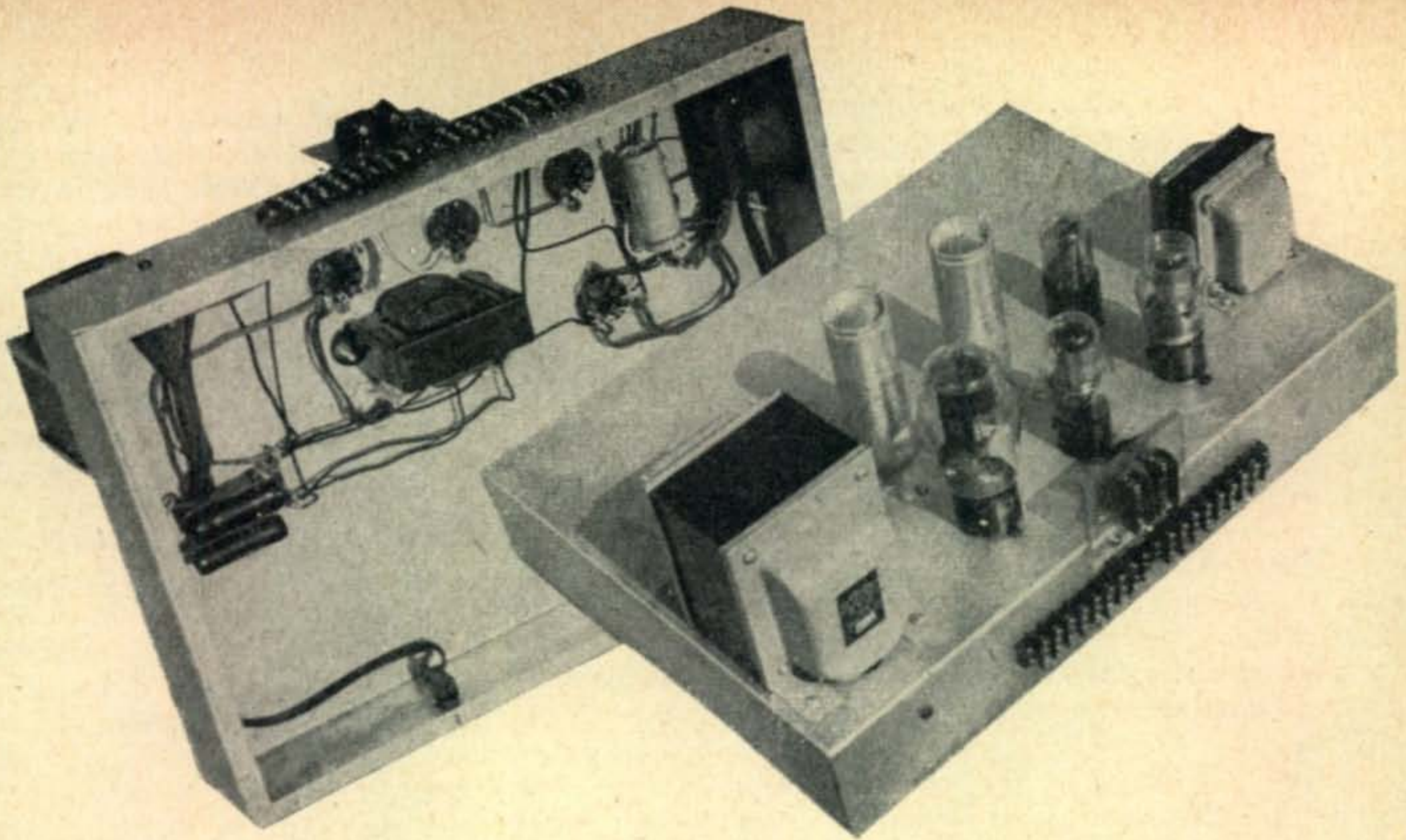

An All-Purpose Novice Power Supply

Major R. H. MITCHELL, W6TZB

Quarters AU, MCAS, El Toro, California

Every now and then, the staff reviews the current editorial situation to see if any significant trends have, or are, developing. Some months ago we observed that a number of good transmitter constructive manuscripts were arriving sans power supply. Obviously, the writers concluded that power supplies seldom vary and "stealing" someone else's supply was not a serious offense. To make a long story shorter, we commissioned W6TZB to build up a supply that would work within the Novice requirements. It is described below—think of it the next time you need 60 to 75 watts.—Editor.

The response to a recent article¹ by the writer was surprising in several distinctly different respects. Rather than requesting more information on the operation of the transmitter, most of the letters concerned themselves with the unspecified power supply.

Unfortunately, our power supply was not particularly suitable for reproduction. It contained a

¹ "The Old One-Two", R. H. Mitchell, CQ, March, 1952, page 38.

number of war surplus items that were no longer available. As a result, the writer started over from scratch and laid out a power supply that would be capable of handling the requirements for a Novice transmitter running close to 75 watts input.

Conceivably, any combination from 250 volts at 300 ma. to 1000 volts at 75 ma. should furnish 75 watts input to the final of a Novice rig. However, the cheapest power supply components are so-called "receiver replacement" line. This then dictates that the most economical 75-watt plate supply would furnish about 400 volts at 200 ma. The writer believes that these levels will meet the requirements of the majority of Novices running inputs close to the legal limit. If more voltage is required, methods for obtaining higher voltages are suggested at the conclusion of this article.

In addition to the final plate and screen voltages, any transmitter other than a single stage unit requires lower voltages and currents for the oscillator and possibly buffer-multiplier stages. Frequently,

well regulated low voltages are required. Low voltages may be obtained from the high voltage supply through dropping resistors or voltage dividers. However, we wanted to use all the output of the high voltage supply for the final amplifier. If huskier components are used to permit an increased current load for the low voltage stages, the cost of the power supply will then be increased by the amount of a separate power supply. The separate power supply is obviously more desirable from the standpoints of flexibility, voltage regulation, and circuit isolation.

Thus, our power supply requirements are crystallized. We need two supplies, one furnishing 400 volts at 200 ma. for the final amplifier, and one furnishing 200 to 250 volts at about 60 ma. for the oscillator-intermediate stages. The tested voltage-current output of the two supplies are shown in Table I and II.

The wiring schematic of the complete power supply unit is shown in Fig. 1. The upper circuit is that of the high voltage supply, the lower circuit is that of the low voltage supply. It will be noted that either power supply may be used independently, or that only one supply need be constructed, depending upon the individual builder's requirements. If a total of only 400 volts at a maximum of about 200 ma. is required, the high voltage supply will suffice. On the other hand, if a 15-20 watt power level is the goal, the low voltage supply will handle the job.

Theory

It is impossible to go into the complete theory

of operation of power supplies in this article. However, a brief amount of theory will be given to further the reader's understanding of the circuits used. Each power supply uses a full-wave rectifier circuit. Both V1 and V2 are full-wave rectifier tubes. Each is actually two tubes in one envelope, having two separate rectifier plates with a common filament (or cathode) circuit. The 6X5 V2, is a cathode type tube, having a cathode heated by the filament, but electrically separate therefrom. This separation of filament and cathode circuits permits using the 6.3 volt winding of T2 to supply filament voltage for the rectifier without having high voltage on the winding. Filament drain for the 6X5 is .5 amperes. The 6.3 volt winding of T2 is rated at 2.7 amperes, so 2.2 amperes are available across terminals 5 and 7 for filament power for other tubes. Unfortunately, this happy expedient is not possible with huskier rectifier tubes. These must be directly heated tubes, using the filament as the source of the high electron emission required in higher power rectifier circuits. Thus, V1, the 5U4G, requires a separate filament supply, because the full high voltage appears on this circuit, making it unsuitable as a source of filament power for the r.f. tubes in a transmitter.

The 400-volt supply uses a condenser-input filter, while the 230-volt supply uses a choke-input filter. These circuits, as their names imply, refer to the first filter component following the rectifier. Each has its advantages and disadvantages. The condenser-input filter gives more output voltage from a given transformer, while the choke-input filter has much better regulation and places less strain on the rectifier and transformer for a given current drain. The condenser-input filter also places higher peak voltages across the filter condensers, but has greater filtering action for a given amount of filter. Table II, the load voltage chart for the 230-volt supply, shows how much better the no-load to full-load regulation is than that of the 400-volt supply, shown in Table I. Should more output voltage be desired from the low-voltage supply, condenser-input may be used. This would require that an 8 μ f., 450-volt condenser be connected from

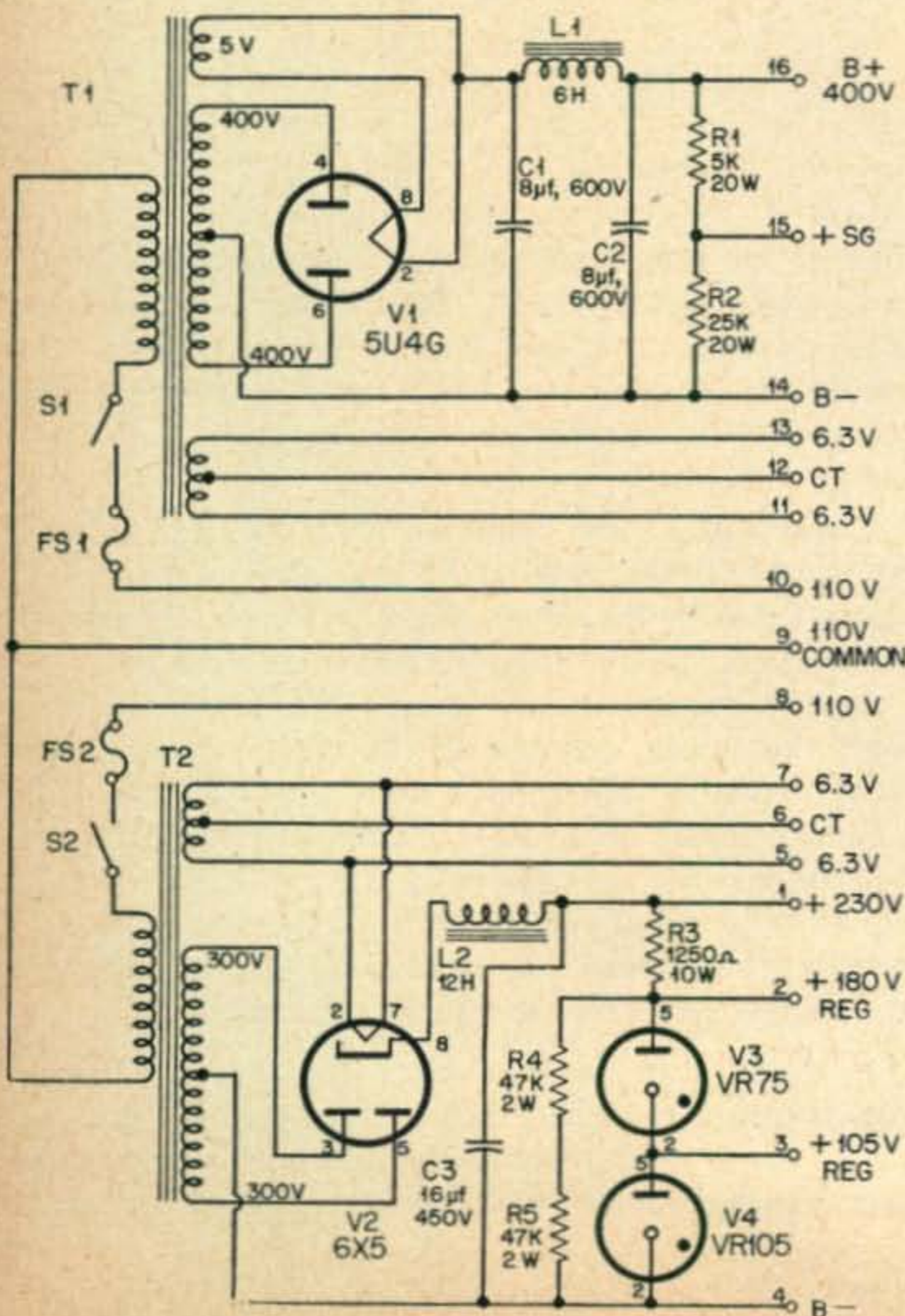

Fig. 1. Wiring schematic and parts list. Additional notes on the transformers and chokes are at the end of the text material.

- | | |
|---|---|
| R1—5000 ohms, 20w,
Mallory 1HJ | S1, S2—s.p.s.t. toggle,
ICA 1296 |
| R2—25,000 ohms, 20w,
Mallory 1HJ | T1—800v. c.t., 200 ma.,
6.3v. c.t., 6a., 5v.
6a. (Triad R21A) |
| R3—1250 ohms, 10w,
Sprague 10KT | T2—600v. c.t. 65 ma.,
6.3v. c.t. 2.7a. (Tri-
ad R5A) |
| R4, R5—47,000 ohms,
2w, IRC BW-2 | V1—5U4G |
| C1, C2—8 μ f., 600v,
Mallory HS-93 | V2—6X5 |
| C3—16 μ f., 450v,
Sprague UT-16 | V3—VR75 |
| L1—6h., 200 ma., Triad
C14X | V4—VR105 |
| L2—12h., 75 ma., Triad
C5X | Terminal blocks (2—
Cinch-Jones 8-140) |
| | Tube Sockets (4—Am-
phenol 77-MIP-8) |

the rectifier side of *L2* to the B-lead on the low voltage power supply. Output with the circuit connected in this manner varied from 325 volts with no-load across terminals 1 and 4, to 275 volts with a load of 70 ma. across these terminals. While the pros and cons of choke- and condenser-input filters could be argued through the pages of a large textbook, suffice it to say that, with the components shown, and with the rectifiers used, either system is satisfactory. Just choose the output voltage desired, then use the proper filter.

Resistors *R1* and *R2* in the high voltage supply comprise a combination "bleeder" and screen dropping resistor. The resistance total should be such that a drain of 5 to 15 per cent of maximum output current is drawn through the bleeder. These resistors total 30,000 ohms, which results in a current drain of approximately 17 ma. at the 520 volt no-load condition, dropping to about 13 ma. drain with 400 volts at 200 ma. output. This bleeder serves primarily to reduce voltage peaks with no-load, thereby lessening the probability of component breakdown. It also discharges the filter condensers when the power supply is shut off, thereby increasing the probable age of the amateur fraternity member. When the bleeder was disconnected from this supply, the no-load voltage soared to about 565. Since the peak a.c. component on the filter condensers always exceeds the d.c. value, the ratings of the 600-volt condensers used were closely approached or possibly exceeded.

Resistor *R1*, is the screen dropping resistor. Bleeder current and screen current flow through this resistor. Thus, both currents must be included in calculating the voltage drop. We needed 12 ma. for the screen supply. This, plus the 13 ma. bleeder current, gives a 25 ma. drain through *R1*. Since this is a 5000-ohm resistor, there is a drop of 125 volts across *R1*. Subtracting 125 from 400 shows that we have a 275-volt screen supply. Similar computations may be employed for other voltages and currents. It must always be remembered, however, that the total current drain across each resistor must be considered.

The voltage regulator circuit is comprised of *R3*, *V3*, and *V4*. Resistors *R4* and *R5* are not actually a part of this circuit, although they may appear to be. Together with *R3*, they form a high resistance bleeder to discharge filter condenser *C3*. These resistors were added to the supply after the photographs were taken. The action of this bleeder is not so rapid as that on the high voltage supply. If fast condenser discharge is desired, substitution of a single 25,000-ohm, 10-watt resistor for *R4* and *R5* is advisable. The value of resistor *R3* is determined by the formula:

$$R = \frac{1000 (E_s - E_r)}{I}$$

In this formula, *R* is the resistance of *R3* in ohms, *E_s* is the supply voltage appearing between terminals 1 and 4, *E_r* is the voltage total across *V3* and *V4*, and *I* is the maximum tube current in ma. Since

this supply gives 230 volts, desired voltage across *V3* and *V4* is 180, and the current drain can be calculated at a maximum of about 35 ma. for both regulated voltages, *R3* should have a value of 1400 ohms. In practice, either a 1250-ohm or a 1500-ohm resistor will be satisfactory.

Computation will reveal that *T1* and *L1* will be overloaded by about ten per cent if a screen current and bleeder current of 25 ma., plus a plate current of 200 ma. is drawn from the high voltage supply. To forestall any doubts as to the ability of these components to carry this overload, it must be pointed out that in amateur operation they are not going to be suffering under continuous conditions, and the overload will not be serious. This is not ultra-conservative design, but such design becomes ultra-expensive.

<u>VOLTAGE</u>	<u>CURRENT</u>
520	0 ma.
515	25 ma.
495	50 ma.
470	75 ma.
450	100 ma.
435	125 ma.
420	150 ma.
412	175 ma.
405	200 ma.
390	225 ma.
365	250 ma.

Table 1. Voltage regulation and output of the 400-volt supply with various degrees of loading.

The fusing and switching circuits are normal. The nonstandard fuse clips were employed because our local radio parts dealer had no manufactured clips. Either standard fuse clips or panel-type fuse holders will be satisfactory. The fuses are able to handle about twice the current normally drawn by their respective supplies. This is necessary to take care of keying surges and temporary overloads. The fuses will blow quickly enough to protect the components in the event of a serious overload. Switches are provided only in the primary circuit for each transformer. If a circuit is desired which will break the high voltage while leaving the filaments lighted, ceramic rotary switches can be placed in the B- leads.

Both B- leads were purposely left ungrounded for two reasons. First, in the event of a break in the B- lead between power supply and transmitter, it is much safer to have the B- ungrounded at the power supply. This could result in an unhealthy difference of potential between power supply chassis and transmitter chassis. Second, this permits keying or relay control in the negative lead.

No ground connections were made to the filament windings in order to increase the versatility of the power supply. Some transmitters have one side of the filaments grounded. With these, the filament winding center-taps will not be connected. Other transmitters have the ground connected to

the center-tap, in which case having one side of the filament winding grounded at the power supply would result in a shortened transformer.

Construction

The power supply unit was mounted on a 12x17x3 inch commercially prepared steel chassis. If an aluminum chassis is available, it will be well worth the few cents extra that it will cost. Cutting holes in metal is probably the toughest job which the home constructor will face, and an aluminum chassis makes that job a lot easier.

TERMINAL NO.	CURRENT	VOLTAGE
1	0 ma.	250
2	0	182
3	0	106
Total	0 ma.	
1	35 ma.	235
2	0	180
3	0	105
Total	35 ma.	
1	35 ma.	230
2	30	180
3	0	105
Total	65 ma.	
1	35 ma.	230
2	15	180
3	15	105
Total	65 ma.	

Table II. Voltage regulation of the 230-volt supply.

The chassis layout which was used is shown in Fig. 2. It must be emphasized that the hole placements shown apply only to the components used by the writer. Other components may have slightly different dimensions.

We have tried to hold tool requirements to a minimum. Thus, "upright mounting" transformers were chosen to avoid cutting large rectangular holes in the chassis. Unquestionably a faster job can be done if a large assortment of tools, particularly an electric drill or a drill press, are available. However, if care is taken with hand drills and tools, a nearly commercial appearing product is possible. As an example, quarter-inch holes can be reamed out to about a half-inch by the time honored expedient of putting a rattail file in a carpenter's brace, then rotating the brace in a counter-clockwise direction. While a reamer or an adjustable circle-cutter could have been employed to make the holes for tube sockets, condensers, and transformer leads, we used a $\frac{7}{8}$ -inch socket punch to make the holes for the transformer leads and condenser mountings, and a $1\frac{1}{8}$ inch punch to make the holes for the tube sockets. Actually, the tube sockets employed were determined by the size of the socket punch on hand.

There is one easy way (that few hams seem to think of) to get holes drilled in a chassis. Just

take the chassis to someone who has a drill press and a stock of drills and get them to do the job. At first glance, this might not seem practicable. However, drill presses are found in many garages, blacksmith shops, machine shops, and other businesses, as well as in home work shops. The writer has had chassis drilled by various firms for prices ranging from nothing to a dollar. Before taking a chassis to someone for drilling, all parts should be "spotted" on the chassis, and all hole locations and sizes should be marked carefully. Machinists seem to prefer that the mark be in the form of a small cross, with the arms of the cross parallel to the sides of the chassis.

Be careful in laying out the chassis and in drilling holes. Drilling holes in metal may seem to be difficult, but that doesn't compare with the difficulty which will be experienced in filling the same hole when it's in the wrong place.

After all of the holes have been drilled, components which go on top of the chassis and the chokes which go under the chassis should be mounted. Put the terminal blocks on the back of the chassis. Do not mount the switches at this time. Lock washers should be placed under each nut to preclude their working loose. The writer used several of the transformer mounting screws to secure bakelite lug type terminal strips which are used as wiring tie points.

Wiring

Cabled wiring was considered for this power supply, but we finally decided to use point-to-point wiring because of the relative simplicity of the latter system. For neatness with point-to-point wiring, all wires should be run parallel to the sides of the chassis, and bends in wires should be made at right angles. The wiring of the power supply proceeded along these lines, but we made some vibration tests and drop tests on the equipment, including one unscheduled drop of three feet during the photographing. These tests resulted in some displacement of the wiring, as is evident in the under-chassis photograph. The big drop also bent the top of one condenser slightly, but the unit worked as soon as it was plugged back into the 110-volt supply.

The type of wire to be used is a matter of personal preference. The writer prefers solid tinned pushback wire, size 18 or 20. Color coding may be used throughout for ease in trouble shooting. In any event, red wire should be used for all positive high voltage leads.

The high voltage supply is wired first. Run the two yellow leads of *T1* to pins 2 and 8 of the socket for *V1*. Next run the two red leads from *T1* to pins 4 and 6 of *V1*. The yellow wire on pin 8 may be soldered at this time, as may the red leads to pins 4 and 6. Connect the two green leads to *T1* to terminals 11 and 13 of the terminal block² on the

² Two eight connector terminal blocks were used. For convenience in identification these are numbered as one block, the numbers starting at the right of the chassis.

(Continued on page 80)

How to Build an 80-Meter Midget Antenna

WILLIAM I. ORR, W6SAI

Contributing Editor, CQ

We know of many Novice licensees who were chagrined to find that an 80-meter antenna when stretched out flat occupies quite a bit of space. Obviously, the answer for the fellow with the small backyard is to erect an antenna that goes straight up. This is often no solution either, so W6SAI has devised a "midget" to do the job.—Editor.

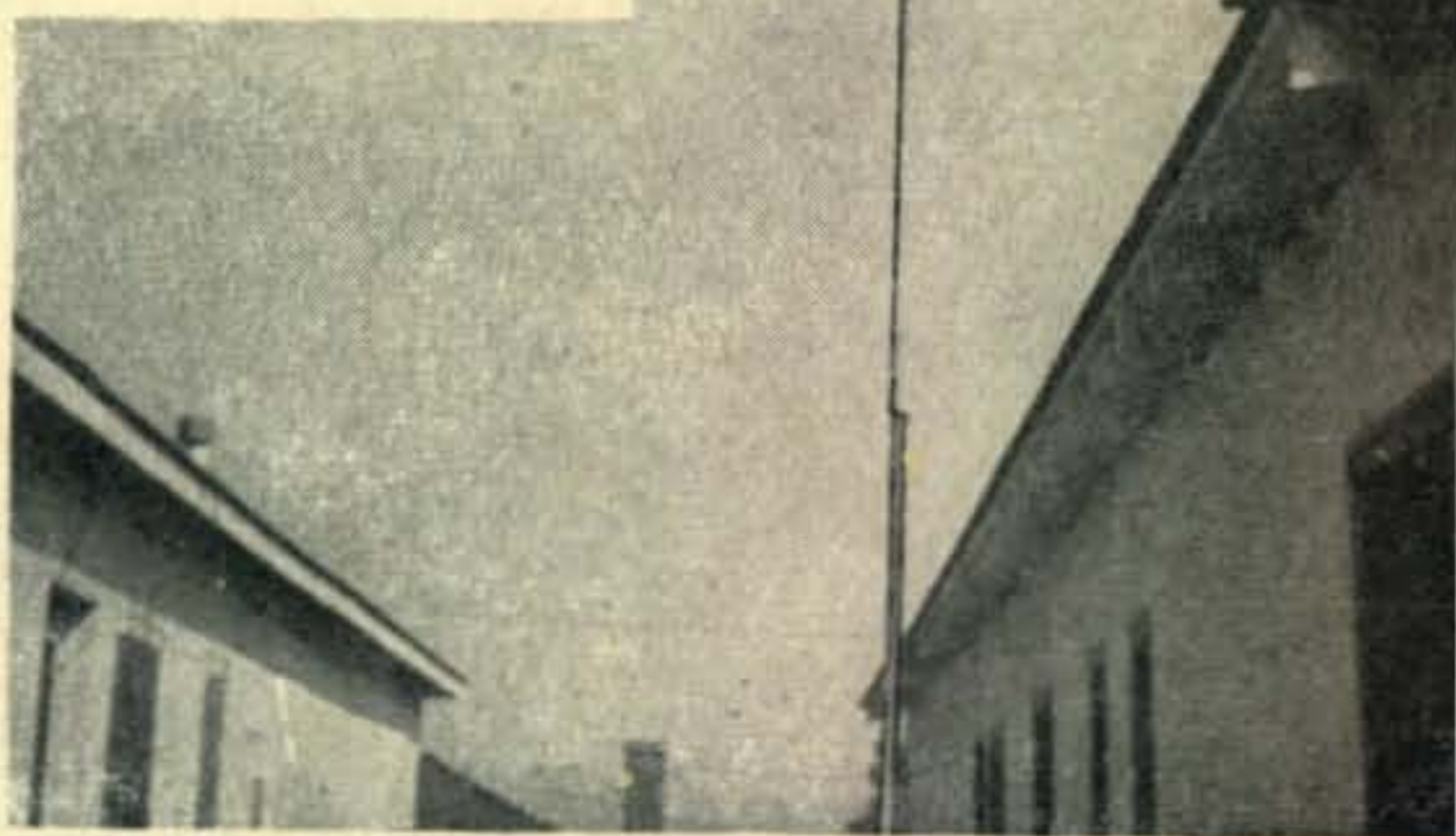

Now that the sunspot cycle is approaching a new eleven year low the trend of amateur operation is towards the use of the low frequency amateur bands. The 10-meter band, which held thousands of signals a few short years ago, will this winter be practically useless. Even 20-meters has become very spotty, and DX activity on this band is slowly dropping off. Imagine! One can even hear the QSL managers getting on the air nowadays!

To balance this slackening at high frequencies, activity on 40 and 80 meters is picking up. A lot of 14 and 28-mc followers have suddenly become aware that there are pleasant contacts and lots of DX on "eighty meters." The 7-mc antenna is not too much of a problem, but even a simple 80-meter dipole is often too huge for a city ham. The fellow usually ends up with a high-loss Marconi, and after pumping all his r-f energy into the neighbor's petunias, mutters, "Fooy with this band! Think I'll go back to ten and work some short skip stuff."

Fortunately there is a relatively simple solution. There is usually plenty of room straight UP. A quarter-wave whip antenna, however, is quite a thing for this band, becoming some sixty-odd feet long. One was erected at W6SAI, but died a quick death under the scowls of the neighbors. I sorrowfully took it down after a few contacts had given me

just a hint at how "hot" a vertical whip might be. (No guts!—Ed.)

After a few exploratory tries a simple and highly effective loaded whip only about twenty-four feet high was evolved. It is a big brother to the loaded whips that are employed for mobile operation. Such a whip, properly loaded and working against a good ground system, is a star performer in the eighty-meter band. This so-called midget ground plane has been in use at W6SAI and W6FHR for the past year or so and has proven very satisfactory in every respect. WAC has been made on 80-meter CW, and many European contacts have been made from the west coast. Contacts with Europe on 3.5-mc from W6-land certainly separate the men from the boys in regards to an efficient antenna system. This little whip will stand up to the best of 'em!

The Midget Ground Plane

The overall height of the whip is twenty-four feet. Four resonant radials are used as a ground system. These, as well as the whip, may be so loaded with inductances that they do not physically cover too much backyard area. The whip is composed of three parts: The lower part is eighteen feet of fairly heavy 24ST dural tubing. Two ten-foot pieces of telescoping tubing are used for this section. The base section is ten feet long and 1 5/8"

diameter; the telescoping piece is also ten feet long, and is $1\frac{1}{2}$ " diameter. Do not use tubing much smaller than this or it will tend to buckle when the antenna is raised. The two pieces of tubing are bolted together with 10-28 cadmium plated machine screws; the inner section of tubing being tapped to take the screws. The overlap should be a little over one foot.

The top section of the antenna consists of a five foot length of $\frac{3}{8}$ " diameter 24ST dural tubing. This section has very little wind loading, and almost any piece of tubing or rod will do. A flexible automobile whip will be excellent, if it is a one piece whip. A sectionalized whip will give noisy results on receiving after a short time, due to the wiper springs.

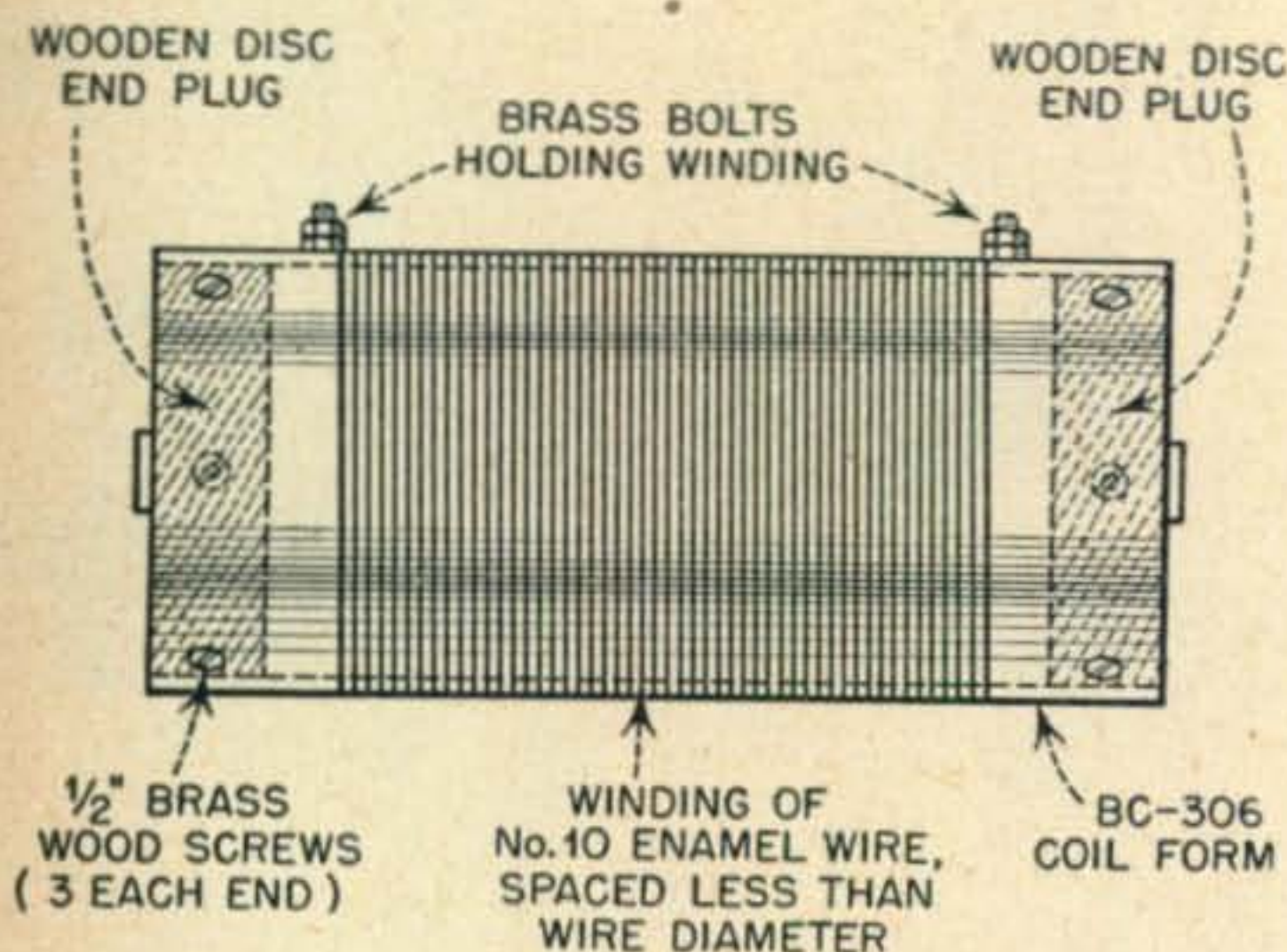

Fig. 1. The solution to the problem is to do just what the "mobiles" do. Build a center loaded vertical with dimensions that will improve the efficiency. The most important part of the antenna is the loading coil. While a war surplus coil form is specified, any form of the proper dimensions and strength could be used.

The heart of the antenna is the center loading coil. This coil—to keep the antenna efficiency high—must be made of heavy copper wire, wound on a large diameter, low-loss coil form. Upon looking through the radio catalogs you will certainly find a scarcity of "large diameter, low-loss coil forms." The surplus market is your only salvation. The *Antenna Loading Unit* (BC-306) for the defunct BC-191 liaison transmitter is still available for a few bucks on the surplus market, and is just the ticket. It was used to load a few hundred watts into a short wire over the range of 200-500 kc. If you purchase one, you will have a fine vernier dial, a ceramic bandchange switch, a nice black-crackle box full of holes AND a "large diameter, low-loss coil form." This form is made of very good material, and is exactly what we need.¹

All the hardware should be stripped from the metal cabinet and all the Litz wire from the coil. I momentarily toyed with the idea of leaving the little rotary inductance in the center of the coil

for tuning the whip from 3.5 mc. to 4.0-mc., but finally resisted temptation and junked the link. Now, here is what you do to this coil:

(1) Drill two holes at each end of the form (or you may use the old mounting holes) and insert brass 6-32 bolts in the holes. These bolts, when supplied with lockwashers, will serve as anchor points for the coil winding. The coil should now be space wound with #12 enamelled wire. The wire is spaced slightly less than its own diameter by concurrently winding the wire and a heavy string on the coil. After the wire is fastened securely to the brass bolts, the string may be unwound, leaving a perfectly spaced coil. Do not use any coil dope or shellac on the coil. The wire will stay in place just as it is. The coil consists of 64 turns and should occupy about $8\frac{1}{4}$ inches of the form.

(2) The next step is to borrow the use of a wood lathe and turn out two circular discs of wood that will make a close fit in each end of this coil. These plugs should be about 1" thick. They can be firmly held in place by $\frac{1}{2}$ " wood screws spaced circumferentially around the ends of the coil. The coil form should be drilled to pass the wood screws, and the screws should clear the winding on the coil by a reasonable amount. The completed coil will look like Fig. 1.

(3) Before the whole antenna is put together, the wooden plugs are center drilled to slide over and separate the two pieces of dural tubing used for the top and bottom sections of the antenna. Several holes are

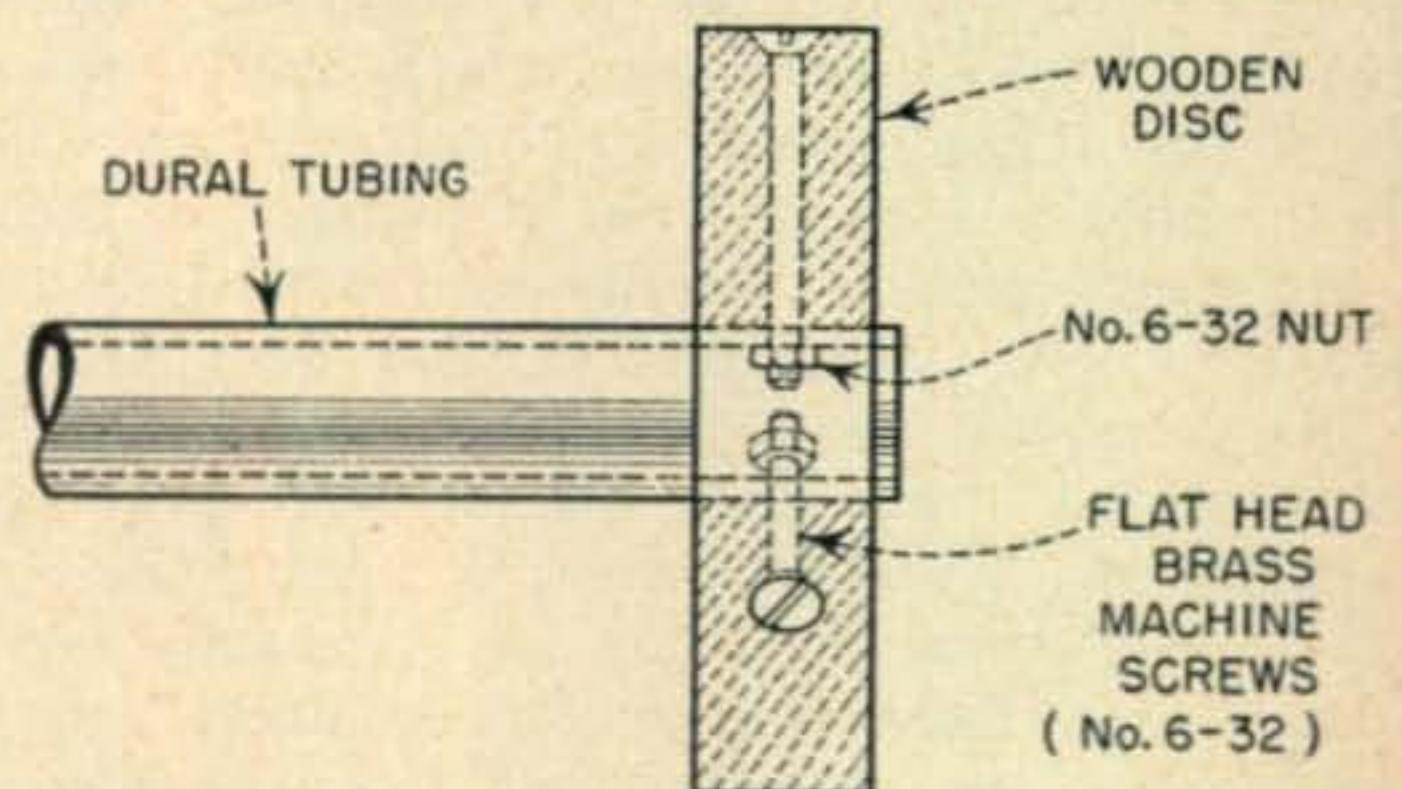

Fig. 2. The wood plugs at either end of the coil form are drilled out to permit attaching them to the dural tubing. The text surrounding this drawing gives additional details.

then drilled through the edge of the wooden discs into the tubing. Long, flat-head 6-32 brass machine screws may be run through the disc and tubing, and bolted inside the tubing to hold the two together (Fig. 2).

(4) The antenna may now be assembled into one piece by attaching the coil to the two wooden discs, using the flat-head woodscrews. The final step is to attach short jumpers from each end of the coil to the two antenna sections. The whip is now complete, and looks like Fig. 3.

¹ This coil form bears the Signal Corps part number 7462814. It is $9\frac{1}{4}$ inches long and $4\frac{1}{4}$ inches in diameter.

Construction of the Radials

At least three and preferably four radials should be used. They should be 66 feet long, and may be made of insulated wire, such as annunciator or bell wire. Their physical placement is not critical. They should radiate from the base of the whip in a generally horizontal plane and about 90 degrees apart. They may wrap around the house, run along fences, thru hedges, or otherwise disguise themselves. They may twist and turn with little effect upon the operation of the antenna; however, they should not run higher than the base of the whip, though they may run lower with no pronounced ill effect.

When the radials are in place, two of them should be connected together, and grid-dipped. The resonant frequency of the pair should fall within 100 kilocycles of your most-commonly-used operating frequency. If this is not the case, a small amount of wire should be added to or subtracted from the free end of the radials. After this is done, the remaining radials should be cut to the same length as the grid-dipped pair. This simple plan insures efficient operation of your ground system.

The voltage at the base of the whip is very low. A cheap and dirty mount is a ten-foot 4x4, one end sunk about a foot, or so, into the ground, the other end nailed to a roof stud. The vertical whip has two small holes drilled through the bottom tube, one about an inch up from the base and the other about two feet farther up. Two heavy nails are driven through these holes into the pole—attaching the whip directly to the wood without further insulation. Unless you expect high winds no guy wires are required.

Tuning the Whip

The whip should now be temporarily connected to the junction of the radials through a two-turn link. A grid dip meter is coupled to this coil and the resonant frequency of the antenna ascertained. If the antenna resonates too low, a few turns (one at a time) should be trimmed from the loading coil. However, the same effect can be accomplished by snipping off a few inches of the whip atop the loading coil. If, on the other hand, you find the resonant frequency of the antenna is too high, the easiest way to bring it to frequency is to add a small loading coil at the base of the whip to act as a trimming inductance. If this is needed, it should consist of nine or ten turns of #12 or #14 wire wound one inch in diameter and about 2 inches long. This will lower the resonant frequency some 400 kilocycles. It is much easier to add this small amount of loading at the base than lower the whip and fool around with the center loading coil. If a surplus coil can be obtained that has a roller contact, it will work as a cheap and dirty means of tuning the whip to any spot in the eighty-meter band. If the antenna resonates at too low a frequency, a few inches will have to be snipped off the whip atop the loading coil.

The radiation resistance of this antenna system

is in the order of 18 ohms. It will operate over a range of some 60 kilocycles (30 kilocycles plus or minus the resonant frequency) and exhibit very little reactance. One who does not make a fetish of antenna reactance can operate over a much wider range of frequency, provided his transmitter has means of tuning out the reflected reactance.

Feeding the Antenna

The best way to feed the midget ground plane is with a coaxial line, such as RG-8/U cable. Since the radiation resistance of the antenna is only about one-third the surge impedance of the RG-8/U cable, there will be a standing wave ratio on the line of 3:1 at the resonant frequency of the antenna. This v.s.w.r. will increase from the minimum value of 3:1 as the whip is operated at some frequency removed from the resonant frequency. If

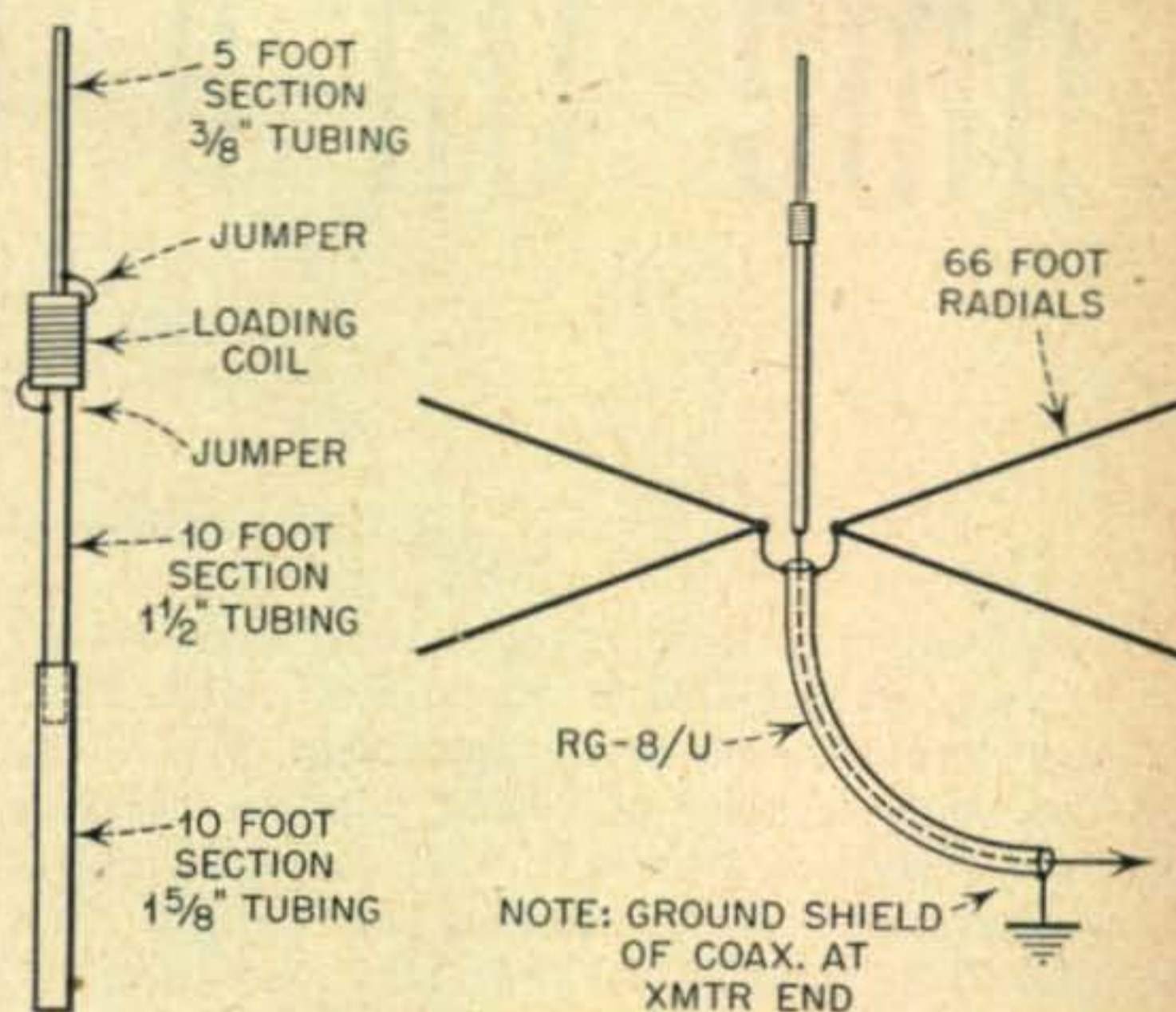

Fig. 3. The completed whip should look like the left hand drawing. Don't forget the connection jumpers between the loading coil terminals and the dural. The radial system is drawn at the right.

a 45-foot length of RG-8/U is used as a feedline, it will act as a quarter-wave matching transformer and the resulting load impedance presented to the transmitter and receiver will be of the order of 150 ohms, with a very low value of reactance. As the length of RG-8/U approaches 90 feet the load impedance at the transmitter drops down to about 18 ohms, since the coaxial line is now acting as a 1:1 transformer. In order to obtain low values of reactance at the transmitter, the coaxial feed line should be multiples of 45 feet. Deviations from these figures are perfectly permissible. For example, little difference will be noted with a coaxial feed line from 35 to 55 feet in length. Lengths in the order of 60 to 80 feet should be avoided, as they will present considerable reactance at the transmitter end of the line. Lengths of line below 30 feet may be used, but as the feed line gets shorter, the load impedance drops, and loading of the transmitter becomes difficult. The purist may insert a matching "L" network at the base of the whip to match the line in a more exact manner. Such a network is

(Continued on page 92)

One very good way to remain active in even the worst TVI area is to go to a higher frequency—say 220 mc.—and build a rig whose harmonics cannot fall within the TV channels. This was the Author's plan. With many new technician licensees getting warmed up the 1 $\frac{1}{4}$ -meter band is beginning to look very attractive.—Editor.

How about enjoying many pleasant hours rag chewing on this growing technician and ham band? In the greater New York Metropolitan Area a dozen stations are now active two or three times a week on 220 mc. This may not seem like many

Just a little conclusive proof that the rig is "TVI-free." Believe it or not, the glowing lamp on the open wire feed line is actually being ignited by the transmitter. The feedline is also gracefully (?) wrapped around the TV receiver.

Come On-a My House on

FRANK HUEBNER, W2IQR

10 Park Terrace East, New York 34, N. Y.

stations, but this is a friendly band and we are in no rush since QRM is no problem. Also, there are no interruptions from apartment 5B calling you on the telephone to report you are breaking up their television program. You can walk out of your apartment every morning an upright man, without that constant fear that Mrs. Goldberg will meet you at the main entrance with the usual bawling out, "You were interfering with my set all evening." The transmitter described here will again put you at ease with your neighbors while you enjoy yourself every evening. So, if you want to come on-a my house and on out to the rest of the gang here you'll have to do it on 220 mc.

There is nothing especially new in the design of this transmitter. All the circuits used here have been tried previously and found satisfactory. What might be considered new is their combination so as to produce a crystal controlled carrier on 220 mc. with only three tubes. The final amplifier tube is an 832 with 30 watts input giving a good 10 to 12 watts of carrier output in the 220-225-mc band. Special thought has been given to make certain no television interference is caused by this transmitter. Not only has it been totally shielded, but a special antenna coupler in a separate compartment has been provided to prevent any of the lower frequencies getting out on the antenna. You will note that all the tuning controls are located on the top of the chassis so that when the cover is put in place no harmonic leakage occurs. With front panel controls harmonic radiation frequently leaks through the holes for these controls. The front panel meter is shielded in the rear with a copper box to preclude

any r.f. exiting via this hole. The modulator which is included on the same chassis is push-pull throughout. Other modulators using less tubes and smaller ones were tried but these failed to give 100 per cent modulation. After all it's the modulation that your fellow hams hear and surely it should be good quality and enough of it. You will have some to spare with this rig.

The power supply is on a separate chassis. If you already have a supply which will furnish 325 volts at 250 milliamperes and 6.3 volts at 4 amperes you should use it. The power supply shown will furnish more than the above minimum requirements as it is also used to operate the 220-mc. receiver at this QTH.

The tube line up for the transformer is as follows: The first half of a 12AT7 is the crystal stage. This is a regenerative oscillator with its plate operating at 24.5 mc. The second half of this same 12AT7 operates as a frequency tripler bringing the frequency to 73.5 mc. The next 12AT7 is a push-pull tripler raising the frequency to 220.5 mc. This tube drives the final 832 amplifier.

Construction

Nothing about the construction, adjustment or operation of this transmitter should frighten any ham technician or Novice beginner. The transmitter is only three tubes and the modulator but three more. All the circuits are metered so one can isolate trouble quickly. Being crystal controlled takes the guess work out of wondering if you are within the band.

Looking at the front view photograph, the tube with the metal shield on it to the right of the



220 Mc.

crystal is the first modulator tube, a 12AT7. The shield was used to prevent any feed back trouble which usually starts in the first stage of a modulator. None has been experienced with this layout. Directly in back of this 12AT7 are the two 6V6 final modulator tubes. The modulation transformer on the right you can't miss. It is a wee bit big for this transmitter, being a 75 watt multi-match. It was not serving any useful purpose at the time this was built, so it has been put to work in this rig. Any good 20-watt modulation transformer with the proper impedances will do the job. Don't forget that an underrated or improperly designed transformer can cause a large amount of distortion in your output signal and on top of that cause you a serious loss of your audio power.

The bottom view shows both the meter and antenna coupler compartments which were made of thin copper flashing material. The paint has been removed from the bottom lip of the chassis so that a good electrical contact is made when the perforated metal sheeting is secured to it with self-threading screws and large washers. This bottom cover was not shown in the photographs but was made from a 6" x 14" piece of perforated metal sheeting with holes no larger than 1/16". Copper screening may also be used. As a matter of fact this is exactly what was used to completely line the top cover of the transmitter. The top cover you will notice has quite a few louvers and these are beautiful exits for TVI trouble so the inside copper screening is a must.

The 6-prong male power plug is just visible in the left upper corner of the bottom view. On the same end of the chassis but toward the front panel

is the microphone connector. The placing of miscellaneous condensers, resistors and the mike transformer is obvious. The crystal oscillator coil, *L1*, can be seen outside the right-hand corner of the meter compartment. To the rear of this coil is butterfly condenser, *C5*, with *L2* mounted over it. Just to the left of *C5* and connected to it is the 3-30 $\mu\mu\text{f.}$ trimmer, *C4*. In the upper right hand corner is the 832 socket. An RCA, UT-107 type socket is recommended at these frequencies as this socket has built-in r.f. by-pass condensers. Condensers *C9* and *C10* should each measure $2\frac{3}{4}$ " long including their wire lead lengths. They are connected between the grids of the 832 and the coil *L3*, which is soldered directly to the butterfly condenser *C8*. It seems that longer or shorter leads than those specified gave less grid drive to the 832. Try to keep the lead lengths to the plates and grids of the push-pull 12AT7 tripler short and equal.

Power Supply

The photograph of the power supply plus the wiring diagram should be about all that is required by the average ham to build a duplicate. The chassis size is 2"x7"x11". The two 5U4's are mounted in front of the power transformer while the two tall condensers, *C1* and *C2* mount in front of the choke *L1*. The 6-prong male plug, *M1*, shown on the end of the chassis is used for connection to the 220 mc. receiver. The transmitter may be operated without this receiver connection by short-circuiting terminals 3 and 4 and also terminals 2 and 5.

Twin-Lamp

In the foreground of the power supply photograph is shown the writer's version of a "twin-

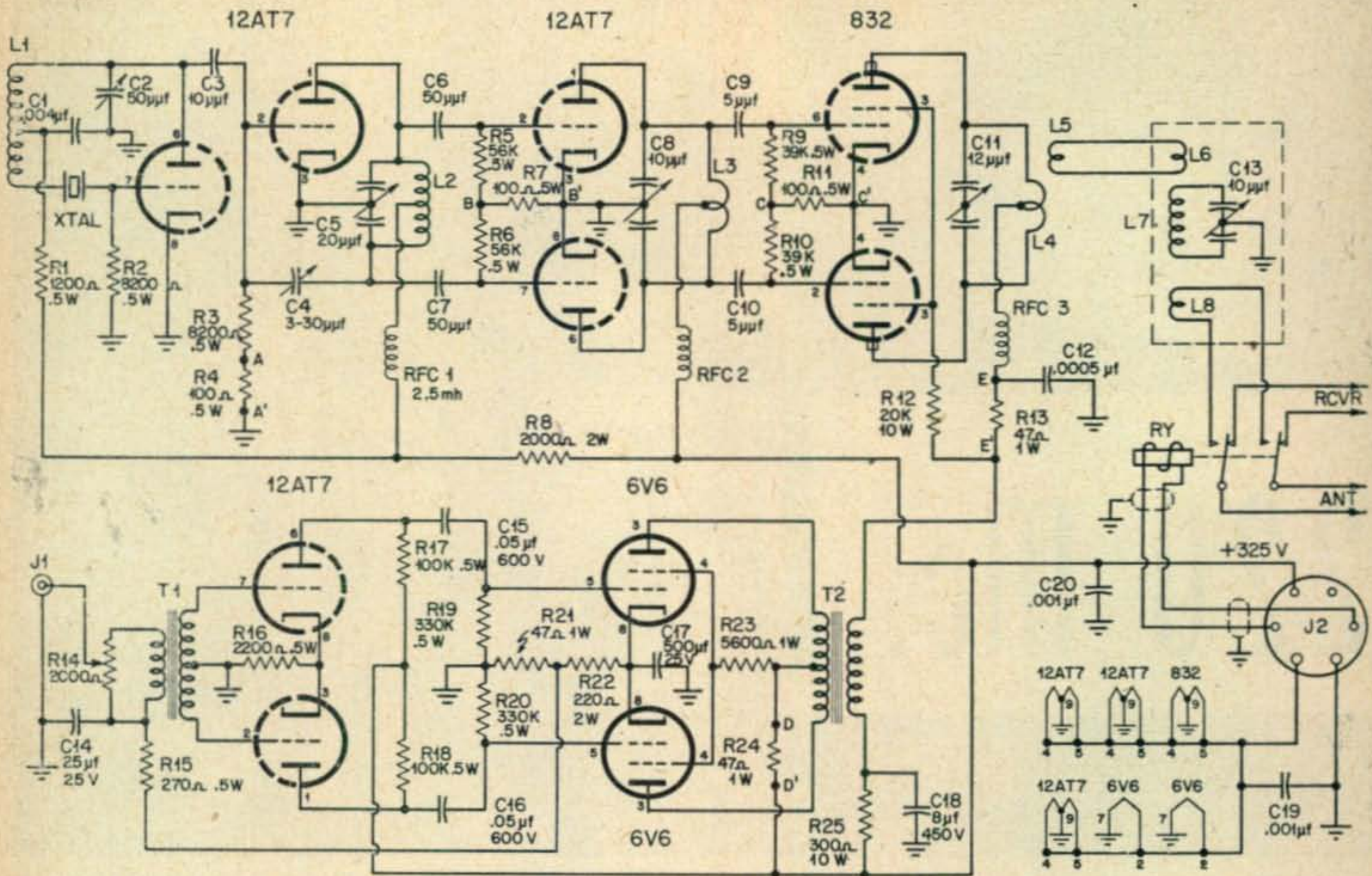

Wiring schematic of the transmitter minus power supply. The circuit starts off at 8 megacycles with the first 12AU7 tripling in both plates. The next tube is a push-pull tripler and the 832 works straight through on 220 mc.

- R1—1200 ohm 1/2w
- R2, R3—8200 ohm 1/2w
- R4, R7, R11—100 ohm 1/2w
- R5, R6—56000 ohm 1/2w
- R8—2000 ohm 2w
- R9, R10—39000 ohm 1/2w
- R12—20000 ohm 10w
- R13, R21, R24—47 ohm 1w
- R14—2000 ohm potentiometer
- R15—270 ohm 1/2w
- R16—2200 ohm 1/2w
- R17, R18—100,000 ohm 1/2w
- R19, R20—330,000 ohm 1/2w

- R22—220 ohm 2w
- R23—5600 ohm 1w
- R25—300 ohm 10w
- R26, R27—1400 ohm 1/2w
- RFC1—2 1/2 mh. choke
- RFC2, RFC3—20T 3/8" diam. #18 wire
- C1—.004 μmf. mica
- C2—50 μmf. variable, Hammarlund APC-50
- C3—10 μmf. ceramic, Erie Ceramicon, Style K, 500V
- C4—3-30 μmf. ceramic trimmer, National M30
- C5—20 μmf. butterfly variable, Hammarlund, 5 rotors, 5

- stators, BFC 38
- C6, C7—50 μmf. ceramic, Erie Ceramicon, Style K, 500v
- C8, C13—10 μmf. butterfly variable, Hammarlund, 3 rotors, 3 stators, BFC 25
- C9, C10—5 μmf. ceramic, Erie Ceramicon, Style K, 500v
- C11—12 μmf. per section split-stator variable, Comar 2 rotors, 2 stators, per section
- C12—.0005 μf. ceramic feed-thru, Centralab FT 500
- C14—25 μf. 25 volt electrolytic
- C15, C16—.05 μf. 600 volt paper
- C17—500 μf. 25 volt electrolytic
- C18—8 μf. 450 volt electrolytic
- C19, C20, C21—.001 μf. mica
- S1A&B—2 pole, 2 section, 6 position switch, non-shorting, Mallory 1321 L
- MA—2" diam. milliammeter, see text
- J1—Microphone con-

- necter, Amphenol male, 75-PCIM
- J2—6 prong male plug
- T1—Carbon mike to 2 grids transformer, Merit P-2918
- T2—Modulation transformer 20 watt, 8000 ohm center tapped to 3000 ohm, Thor-darson, T2IM61
- RY—d.p.d.t. 115 volt a.c. antenna relay, Advance Electric Type 1000
- XTAL—8155 to 8330 kc. Crystal
- See power supply for the following: →
- C1, C2—80 μf. 450 V. electrolytic
- R1—20,000 ohm 25w
- CH1—20 hy. 300 ma. 90 ohms, UTC—S33
- S1—s.p.s.t. toggle switch
- T1—Power transformer, 425-0-425 volts, 300 ma., 5 volt 6 amps., 6.3 volts 8 amps., Crest 6606
- J1—6 prong male plug (for receiver)
- J2—6 prong female plug on end of 3 foot cable

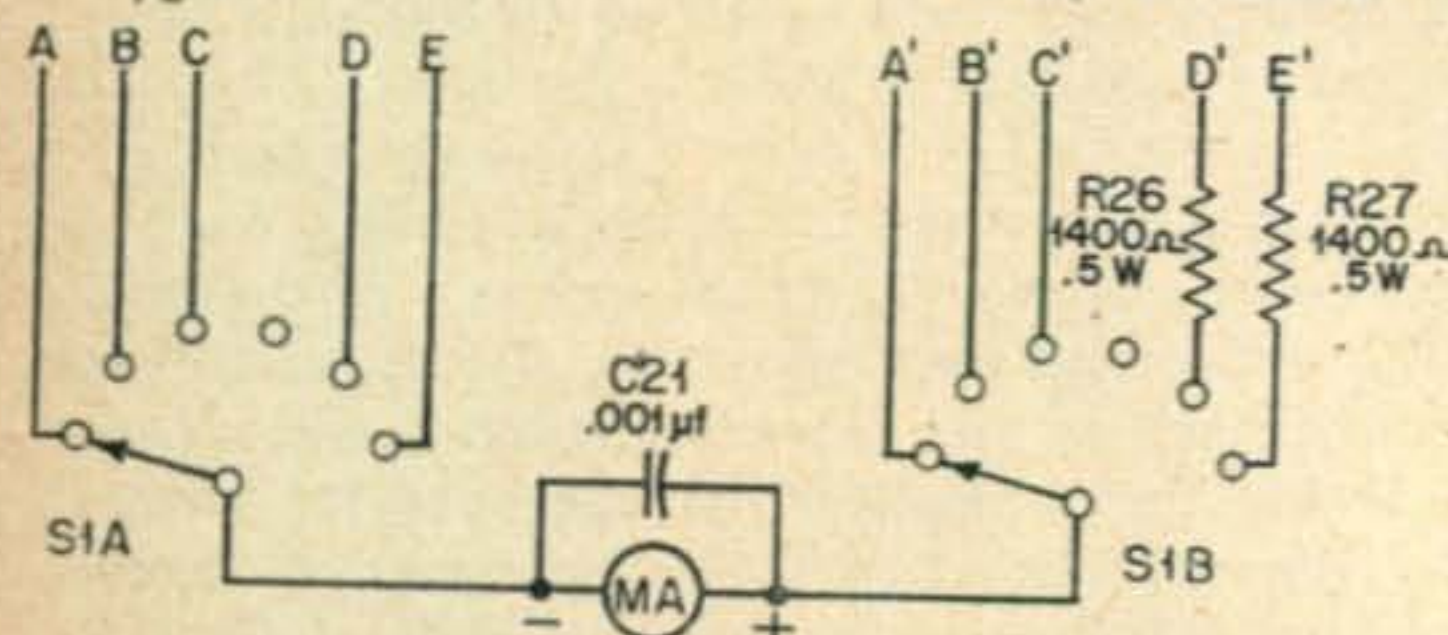

Meter switching has been used in this circuit. Position A-A' reads the second tripler grid current. B-B' reads push-pull tripler total plate current. C-C' reads cathode current on the 832 D-D' the modulator screens. E-E' reads 832 plate current.

on top of final coil *L4*. Reconnect the "B" supply to *R25* and tune final condenser, *C11*, for maximum brilliancy of the 10-watt lamp. To tune the antenna coupler proceed as follows: Connect the feed line from your antenna to the antenna relay. On the feed line connect the "twin-lamp" as previously described. Leave the 10-watt lamp coupled to *L4*. With the full "B" voltage (325) applied and the antenna relay closed, the 10-watt lamp should light when *C11* is tuned to resonance. Now tune the antenna coupler condenser *C13* to a point where the 10-watt lamp is at minimum and the "twin-lamp" is the brightest. Remove the 10-watt lamp and re-tune *C11* and *C13* slightly for maximum output as indicated by the "twin-lamp."

Condenser *C13* tunes quite sharp so tune slowly. Couple *L6* tightly into one end of *L7*. The antenna coil *L8* should be coupled to the other end of *L7* as loosely as possible and still transfer maximum power as indicated by the "twin-lamp." It is assumed you will remember all the above coils must be wound in the same direction if you expect any output.

Some hams might take exception to this step-by-step method of lining up the rig. Some prefer to turn on everything at one time with full voltage and quickly tune all the stages to resonance. Brother, they're your tubes; you do it the way you like best. The odds are, your final tube will have left this world before you get it on the air, on the frequency you want.

You will note that during the whole time the above adjustments were being made the three modulator tubes have been energized. If no smoke has appeared it's a good sign. Connect your carbon microphone to *J1* and adjust the modulation gain control to about three-quarters open. Turn the meter switch to *position 5* which is across *R24* where it will read the combined screen and plate currents of the two 6V6 tubes. With the transmitter energized, talking into the mike should make the meter reading fluctuate between 75 and 100 milliamperes. The "twin-lamp" should also change bril-

liancy with modulation. *Position 4* on the meter switch is not used, while *position 6* reads final plate current on 832. This will vary some with loading but will usually read between 80 and 100 milliamperes.

COIL WINDING DATA

- L1*—14T on 1/2" diam. coil form, #18 wire, tapped 5 1/2 T up from grid end, close spaced.
L2—6T 5/8" diam. #18 wire 7/8" long.
L3—1T 5/8" diam. #18 wire.
L4—1 1/2T 1/2" diam. #12 wire 3/8" long.
L5—1 1/2T 1/2" diam. #16 braid insulated wire.
L6—1 1/2T 3/8" diam. #16 braid insulated wire.
L7—4T 3/8" diam. #12 wire 3/4" long.
L8—2T 3/8" diam. #16 braid insulated wire.

Well, that's about all there is to it, fellows. There are a few little points which caused me some trouble that I might caution you about. Don't ground the center rotor of the final condenser *C11* as it causes TVI in channel 4 especially when not tuned exactly on frequency. Trimmer *C4* will cause oscillation on other than the crystal frequency if improperly adjusted. Start as previously suggested with two full turns open. With the meter in *position 2* you should read about 3 milliamperes. If you do, leave things alone; if not proceed as follows: Increase the capacity of *C4* by turning the trimmer tighter by 1/2 a turn. You will now have to retune *C5* for each readjustment of *C4*. This will increase the drive to 3 milliamperes. To determine if the transmitter is working properly listen on a 220-mc receiver with its antenna posts short-circuited. When the transmitter crystal is removed the output will drop and the carrier will shift to

(Continued on page 91)

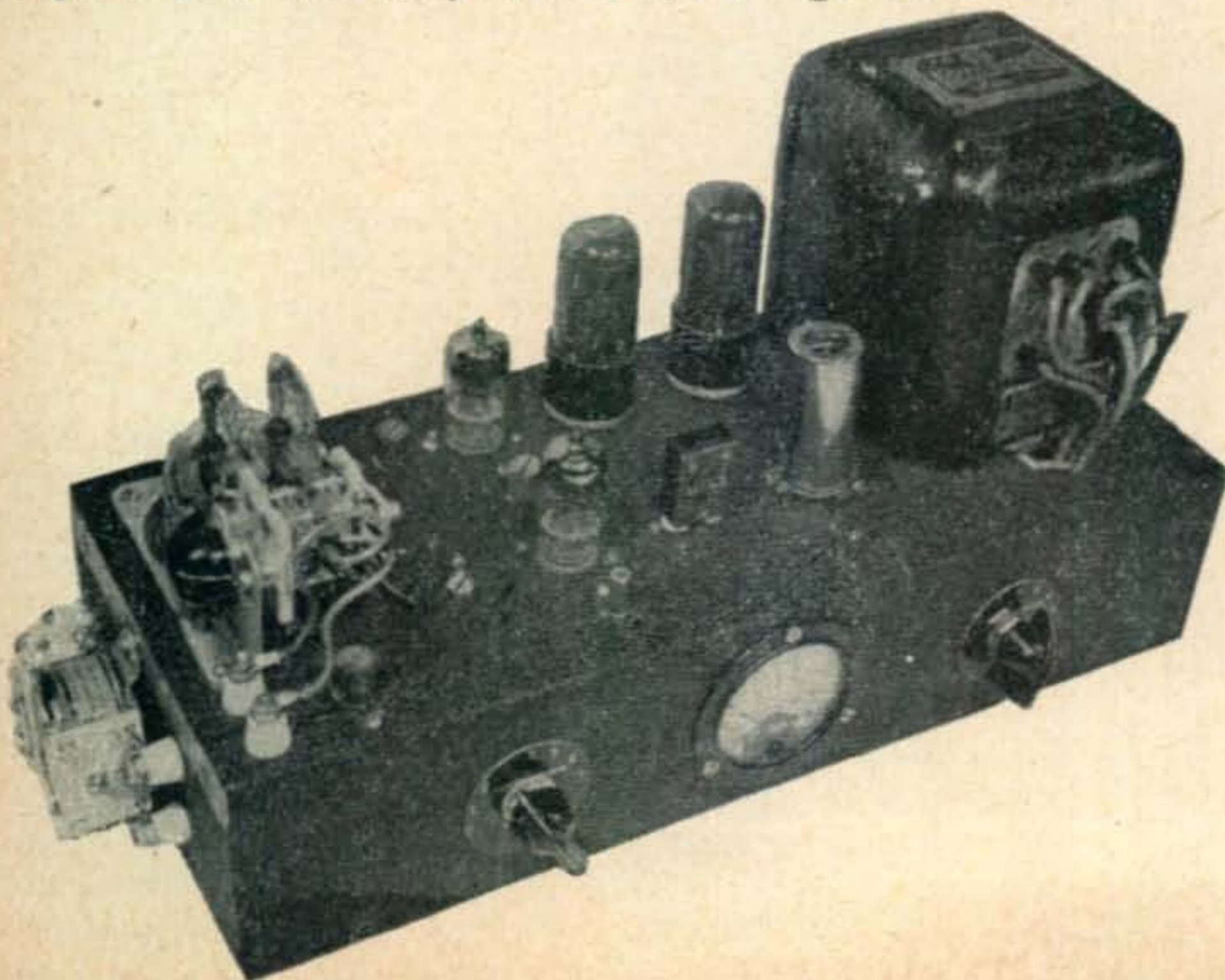

The tube at the right of the crystal is the modulator 12AU7. This tube is shielded to prevent audio feedback although none has ever been experienced. Behind this tube are the 6V6 modulators and to the left is the complete r.f. section.

"Just What I Needed —"

HARLEY E. SALTMARSH, W8CIB/2

775 Myrtle Avenue, Albany 3, N.Y.

One of the very first pieces of test equipment that should be constructed in the new Ham station is a frequency meter and monitor. This is just such a device. It is of excellent design and while we do not expect everyone to follow the mechanical layout, it may be reproduced as the builder wants and still retain its high degree of accuracy. When carefully calibrated this meter will more than fulfill the requirements of Part 12.135 (see "Novice Shack", page 52).—Editor.

Federal Communication Commission regulations require that all amateurs employ some frequency determining means independent of their transmitters to insure operation within the assigned amateur bands. The regulations also set forth minimum standards for the signals emitted by amateur transmitters. Satisfying both requirements necessitates an accurate frequency meter and monitor of some kind.

Some amateurs attempt to use their communications receiver. With low transmitter power and a better-than-average receiver, this can be fairly satisfactory. However, with high power (and with some receivers even at low power), it is often necessary to disconnect the receiving antenna, ground the antenna terminals, and detune the input circuit or remove the r-f amplifier tube to reduce receiver overloading. Only then is a true appraisal of the transmitted signal possible. Adding to the difficulties of using a receiver as a monitor, the frequency calibration of most of them is not sufficiently accurate for more than a rough frequency check.

Because of the stated difficulties, some amateurs depend almost entirely on the stations they work for information on the defects in their signals and off frequency operation. Supplementing their signal monitors (if any), many c-w operators use a simple audio oscillator as a keying monitor. The most popular type is powered by rectifying a small portion of the transmitter output. Such an r-f powered monitor will indicate a complete loss of transmitter output and will accurately follow the keying, but gives no indication of signal quality or frequency.

What almost everyone needs is a device that will act as a frequency meter, keying monitor, and quality monitor all at once. The simplest version of such a device is a shielded and calibrated, very low-power oscillator placed near the transmitter. By connecting a pair of phones in series with its plate supply lead, the oscillator becomes a simple receiver. It is tuned to zero beat with the transmitter and the frequency read directly on the dial. Then, detuning it 1,000 cycles or so produces a corresponding beat note in the phone, which may be used to monitor keying. Drift, clicks, chirps, and other defects are easy to detect. By tuning the oscillator to exact zero beat with the transmitter, audio quality of an AM phone signal may be roughly checked as well. This adjustment will also reveal frequency shift under modulation through the appearance of a beat note of varying frequency.

A Practical Circuit

Referring to Fig. 1, substituting a pair of phones for R9 would make the oscillator, consisting of V3 and associated components, just such a monitor. It

The frequency meter/monitor should be mounted in a rugged cabinet. It should also have a fine vernier dial on the order of this General Radio model, although any dial capable of being read down to a tenth of a dial division will generally suffice.



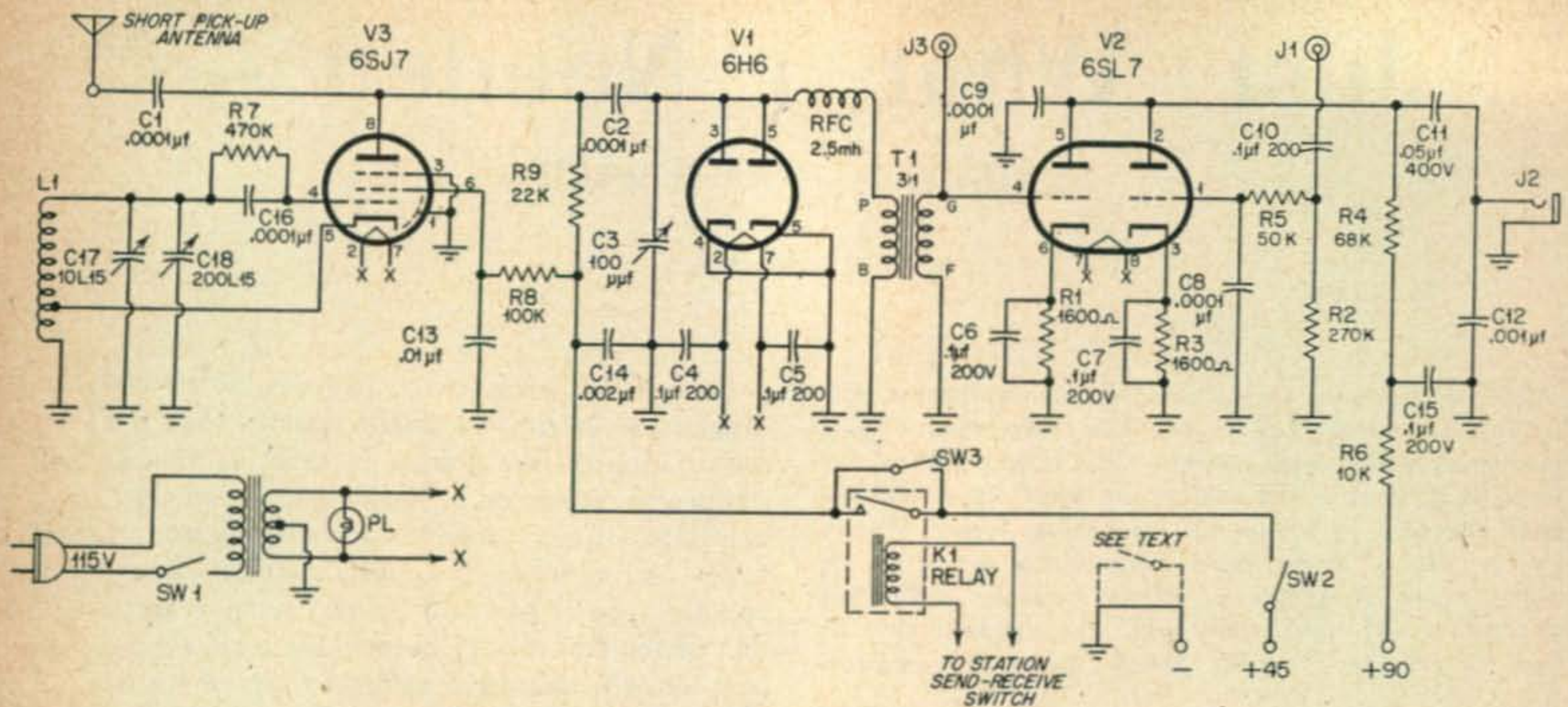

Fig. 1. Wiring schematic of the frequency meter/monitor.

C1, C2, C8, C9—0.0001
μf. mica
C3—100 μmf. variable
midget (APC type)
C4, C5, C6, C7, C10,
C15—.1 μf., 200v.
paper
C11—0.05 μf., 400v.
paper
C12—0.001 μf. mica
C13—0.01 μf. mica
C14—0.002 μf. mica

C16—0.0001 μf. silver
mica
C17—15 μmf. variable,
Johnson type L
(167 series)
#10L15 (see text)
C18—200 μmf. variable,
Johnson type L
(167 series)
#200L15
R1, R3—1600 ohm
R2—270,000 ohm
R4—68,000 ohm

R5—50,000 ohm
R6—10,000 ohm
R7—470,000 ohm
R8—100,000 ohm
R9—22,000 ohm
All above are 1/2w
resistors.
L1—21 turns #20, 1"
dia., 3" L., tapped
at fifth turn (part
of B&W #3015
Miniductor)
J1, J3—single contact,

screw on connec-
tors
J2—open circuit phone
jack
K1—s.p.s.t. relay, 115v.
a.c. coil
T1—3:1 audio trans-
former
SW1, SW2, SW3—s.p.
s.t. toggle
Batteries—45v. (Ever-
ready 482)
PL—6v. pilot bulb

would work exactly as outlined above, but would have a number of disadvantages. One is that the signal heard in the phones would probably be quite weak, because, for high stability, the monitor circuit must be designed primarily as an oscillator, rather than as a detector. Another is the necessity of switching the phones from monitor to receiver.

Building up the remainder of Fig. 1 eliminates these disadvantages and adds a number of operating conveniences. The heart of the instrument is naturally the ruggedly-constructed electron-coupled oscillator, whose fundamental frequency range is in the 3.5-mc band. Harmonics of this oscillator are used to cover the higher-frequency amateur bands.

Oscillator output combines with the signal intercepted by the pickup antenna and is fed to V1. There, the resultant is rectified and fed to T1 and one-half of V2, where it is audio amplified before reaching the phone jack, J2.

The control grid of the other half of V2 is driven from the phone jack of the station receiver through J1. As both 6SL7 plates are in parallel, signals from either source may be heard in the phones without switching. Jack, J3, permits other equipment, such as an r-f operated keying oscillator, to be heard through the phones, if desired.

Plate power for the monitor is furnished by ninety volts of B-batteries, and filament power is furnished by a small transformer. B-batteries are used, because they are one certain way to obtain pure direct

current. Their economy is good, as the low-current drain (less than three milliamperes) makes for long battery life. Also, a couple of sets of batteries may be purchased for the price of an equivalent, voltage-regulated, power supply.

Construction

It is doubtful that anyone will want to duplicate this instrument exactly; therefore reliance will be placed upon the photographs to tell most of the story. They will be supplemented with a few general remarks and suggestions for possible modifications.

The cabinet is made of 1/16-inch aluminum, and its dimensions are 10 x 7 x 8 inches. Both the panel and chassis plate are of 1/8-inch aluminum, and are 10 x 8 inches and 9 x 6-3/4 inches, respectively. Another piece of 1/16-inch aluminum is employed to hold the batteries to the cover of the cabinet.

Major components are bolted to the chassis. Small ones—fixed resistors, and fixed condensers, etc.—are supported on insulated tie points for rigidity and ease of servicing. The terminals we used are manufactured by The Cambridge Thermionic Corp. They are mounted in 1/4-inch holes and swedged in place with the aid of a tool obtained from the manufacturer. These terminals may be difficult to obtain in small quantities. In that event, it is suggested that conventional terminal strips be used.

Modifications

There are three modifications in the oscillator

section that might be desirable. Two of them affect the band-spread condenser, *C17*. Its small capacity, compared with the total in the circuit, results in a vast amount of bandspread. In fact, only about fifty kilocycles can be covered in the 3.5-mc band without resetting *C18*. This is convenient for covering a small segment of a band, say the 3.7 to 3.75-mc Novice band or the 14-mc phone band, which will be spread out over most of the *C17* dial.

A 75- μf . condenser at *C17* will permit covering the entire 3.5 to 4-mc band, with some overlap, at one sweep of the dial. A 25- μf . condenser will cover the 7 to 7.3-mc band. Of course, the capacity used in *C18* is decreased to compensate for additional capacity in *C17*.

The other possible change in *C17* is to substitute a condenser with front and rear bearings for the single-bearing type shown. This change will improve the mechanical stability of the oscillator. Similarly, substituting an equivalent coil, wound on a ceramic form, for the one shown at *L1* will improve thermal stability. Neither change will make a great deal of difference in over-all stability, but they are not hard to make and should be worth while from an operational viewpoint.

A 1N34 or equivalent germanium crystal may be substituted for the 6H6 at *V1*, with little difference in results, save for a reduction in the amount of heat generated within the cabinet.

Adding a switch in the B-negative lead of the batteries will permit cutting all battery drain when desired without shutting off the tube filaments.

Referring to the front panel, some constructors might not care to go to the expense of duplicating the *General Radio* dial on *C17*, or perhaps, they may prefer a dial suitable for direct frequency calibration. Fortunately, there are at least a half dozen dials available that may be used at this point, depending upon the whims of the constructor.

The panel lettering was accomplished in steps. First, the panel was anodized before painting. Then, the letters were cut through the crackle finish with a *Green Engraving Machine*. The anodized aluminum shows through as a sparkling white. Few amateurs have access to an engraving set; however, it is frequently possible in the larger cities to get such lettering done for a few cents a letter. You can also achieve professional-looking lettering by using any of the panel-marking decal sets offered by several manufacturers.

Calibration

As the fundamental frequency range of the monitor is in the 3.5-mc band, an accurately calibrated frequency meter, oscillator, or receiver tuning the same range offers the easiest method of calibrating the new monitor.

To use a frequency meter or calibrated oscillator for the purpose, do the following: set it to the lowest frequency that you want it to cover. Place its output lead close to the monitor antenna terminal; then set *C17* near maximum capacity, and plug a pair of phones into *J2*. Adjust *C18*, while listening to the phones, for zero beat between the monitor oscillator and the calibrating oscillator. Carefully lock *C18* at this setting.

After these preliminaries have been performed, calibrate the monitor by setting the frequency meter to 3500 kilocycles (assuming that the 3.5 to 4-mc band is to be calibrated), and adjust *C17* to exact zero beat with it. Note the dial reading and frequency on a chart. Next, set the frequency meter to a slightly higher frequency and repeat. Do this until you have covered the entire band. A permanent chart may then be made, or the frequencies may be transferred directly to the dial.

How far apart the calibrating points occur depends on the patience of the operator, the accuracy of the calibrating equipment, and how closely the

Top view of the frequency meter-monitor. *C17* is in the center of the panel. *C18* to the left and *C3* to the right. *V3*, the oscillator tube, is in the center of the chassis. To its right is *V1*, and behind it is *V2*. The three connectors behind *C18* are for the B batteries.

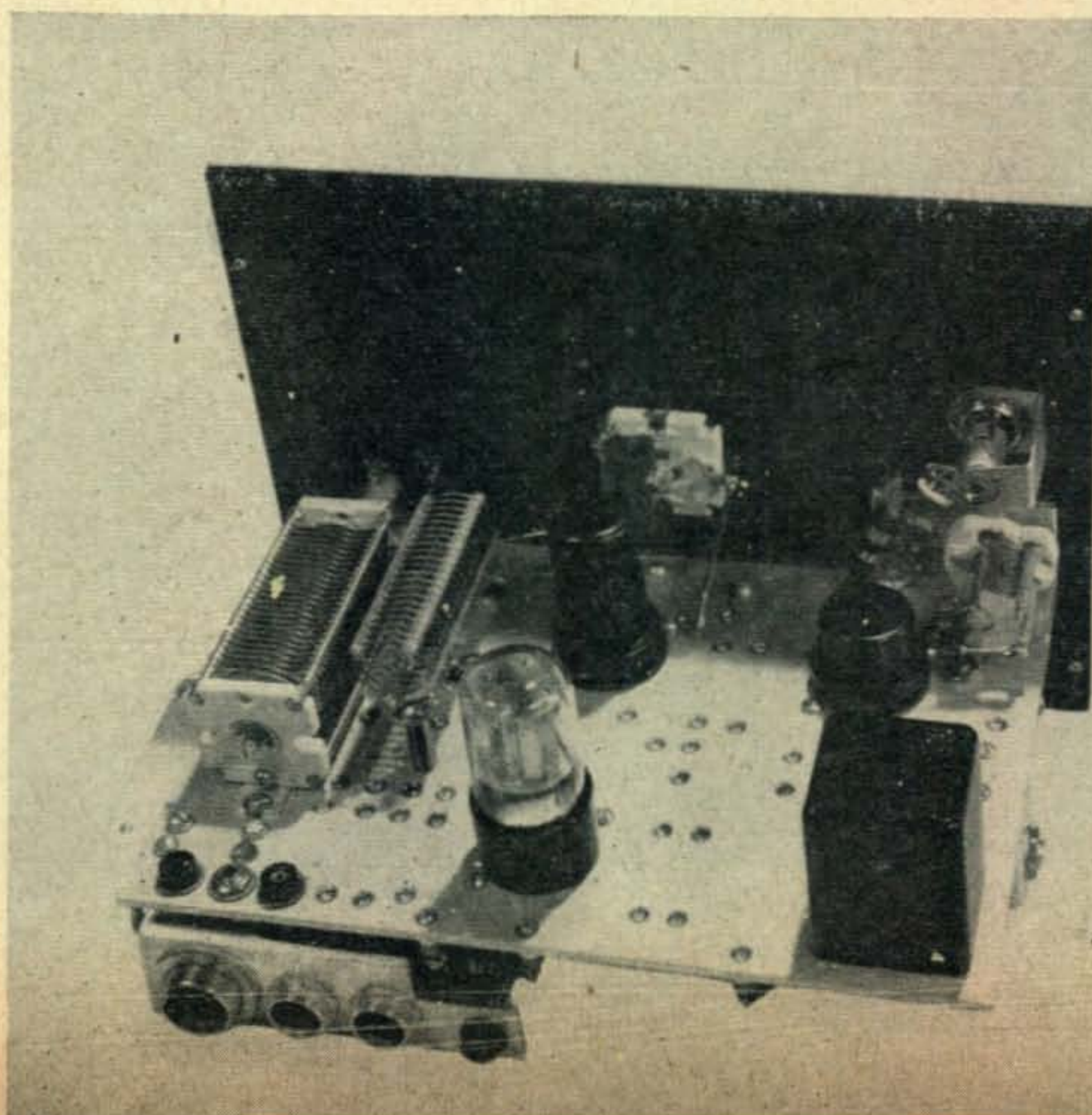

dial used on *C17* can be read. If possible, calibrate all points corresponding to the edge of an amateur band or sub-band; such as 3550 and 3575 kilocycles, whose fourth harmonics mark the edges of the 14-mc phone band; and 3650 kilocycles, whose second harmonic marks the high-frequency edge of the 7-mc band.

In using a calibrated receiver to calibrate the monitor, the process is approximately the same, except that the phones are transferred to the receiver for establishing zero beat. Be sure to set the receiver BFO to zero deviation, or the receiver calibration will be off.

A third method of calibration, usable when a "service" oscillator covering the broadcast band is available, is to zero beat this oscillator with various broadcast stations and use these harmonics to calibrate the monitor. The fifth harmonic of 700 kilocycles is 3500 kilocycles, and the fourth harmonic of 1000 kilocycles is 4000 kilocycles. The reader can work out dozens of other usable combinations. If the strength of the oscillator harmonic is too weak to be heard in the monitor directly, the harmonic may be tuned in first on the communications receiver, and there zero beat with the monitor.

Installation

To install the frequency meter-monitor in the station, place it at the operation position and run a patch cord between the receiver phone jack and *J1*. Turn on both receiver and monitor with *SW2* and *SW3* off, and plug the phones into *J2*. Tune in a signal on the receiver and adjust the receiver volume control for the desired signal level in the phones.

Next, place the monitor antenna near the receiving antenna lead-in. Turn on *SW2* and *SW3*, and tune *C17* until the monitor signal is heard in the receiver. Observe its strength. Now, shut off the

receiver and turn on the transmitter. Tune *C17* until the transmitter is heard. Observe its strength.

It will probably be necessary to juggle the length of the monitor antenna, its position relative to the transmitter and the receiver, and the setting of *C3* to balance the signal strength in the phones under the two conditions. Also, it may be necessary, when monitoring a multi-stage transmitter, to place the monitor antenna close to the transmitter antenna feed line to minimize pick up from the earlier stages.

Wiring the primary of the filament transformer to the receiver control circuit, and *Ry1* to the main send-receive switch will make the monitor's operation almost automatic. *SW3* will permit turning on the oscillator independent of the transmitter, in order to facilitate receiver frequency checking, and *SW2* will permit disabling it completely.

Using the monitor involves no special tricks. To check transmitter frequency, zero beat with *C17* and read frequency from the calibration curve. To measure the frequency of a received signal, zero beat it with the monitor signal in the receiver. To monitor phone transmissions, tune *C17* to exact zero beat with the carrier, as mentioned earlier. This adjustment will check both quality and carrier stability. Alternately, shut off *SW2*, thereby disabling *V3*, and use the remainder of the circuit as an untuned diode monitor.

Keying is monitored by detuning *C17* slightly to produce an audible beat note in the phones. Also, the output of an r-f powered audio oscillator may be plugged into *J3* after disabling *V3* with *SW2*.

Just how close to the edge of a band one can safely operate using a frequency meter-monitor of this type depends on many variables. Among them are quality of parts used, care exercised in construction and calibrating, and the accuracy with

(Continued on page 76)

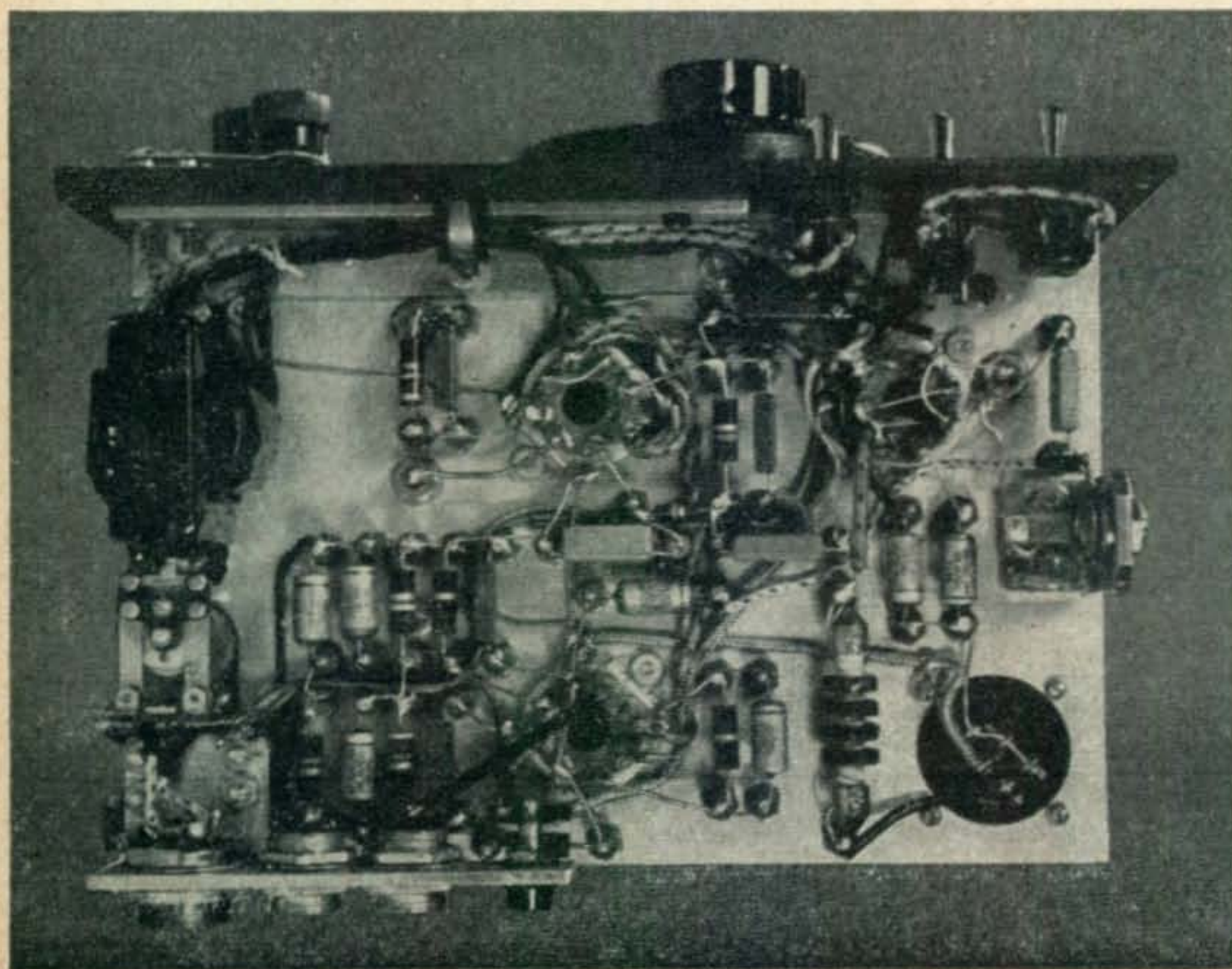

Bottom view. Note generous use of tie points. Connectors along lower left of picture are, reading from left to right, connector for relay winding, *J1*, and *J3*. The insulated phone tip jack at the right of the connector strip is for the pickup antenna. The jack at the center of the right side of the chassis is *J2*.

Putting the 6146 on Two Meters

ROBERT V. MORRIS, WN2IHM

230 Rose Street, Metuchen, N. J.

This transmitter is representative of a modern attempt to fire up on 144 mc. With the usual precautions in making short direct leads the Novice, or old-timer, should have no trouble airing a healthy sounding signal. One word of advice: provide plenty of ventilation for the 6146 final amplifier and do not place any pressure on the plate cap when the tube is hot.—Editor.

A number of months ago I decided to concentrate on designing a two-meter transmitter that would fit in nicely with my existing power supply (about 200 ma.) and modulator. Basically, it should be very simple and straightforward, using the latest tube types in the v.h.f. category. I wanted to use a starting crystal frequency around 8 mc. and multiply it 18 times in easy steps. The transmitter was for Novice operation, so the power input could not be more than 75 watts. I settled for something under this to be on the safe side.

Reviewing the currently available tubes showed that the final product could be constructed with far greater ease than I had anticipated. A dual triode tube (12AU7) would work as a crystal oscillator on an overtone mode from the 8-mc crystal¹ with the 24-mc output from the first triode section coupled to the second triode. This section

would then triple the frequency to about 72 mc. At this point a 5763 tube would be able to double the output of the 12AU7 stage into the two-meter band. The one watt from the doubler is more than sufficient to drive the 6146 final amplifier. Coupled to my 25-watt modulator, the 6146 would draw approximately 40 or 45 watts input—a nice respectable figure for a Novice phone transmitter. Also, if a smaller modulator was available it would be possible to directly substitute a 2E26 tube for the 6146 final amplifier. This would cut the power requirements about in half.

Construction

The assembling, wiring and chassis preparation need only take a few hours. The chassis itself is a Bud AC-405 aluminum with the dimensions of 7x7x2 inches. The panel was a piece of 1/16 inch thick 7x14 aluminum cut to make two equal 7x7 pieces. One piece is the front panel and the other is used as the bottom plate of the chassis. We also

1. As an overtone oscillator it will probably work on a very large percentage of 8-mc crystals. However, there may be one or two crystals that will refuse to oscillate. Obviously, if you are sure of the circuit wiring the best solution is to replace the crystal. The new one will probably start right off.—Tech. Ed.

The front view shows the clean simplicity of the transmitter. Only four tuning adjustments are necessary and three of them are mounted behind the panel. The tip jacks are for a 0-200 millimeter to measure the plate current.

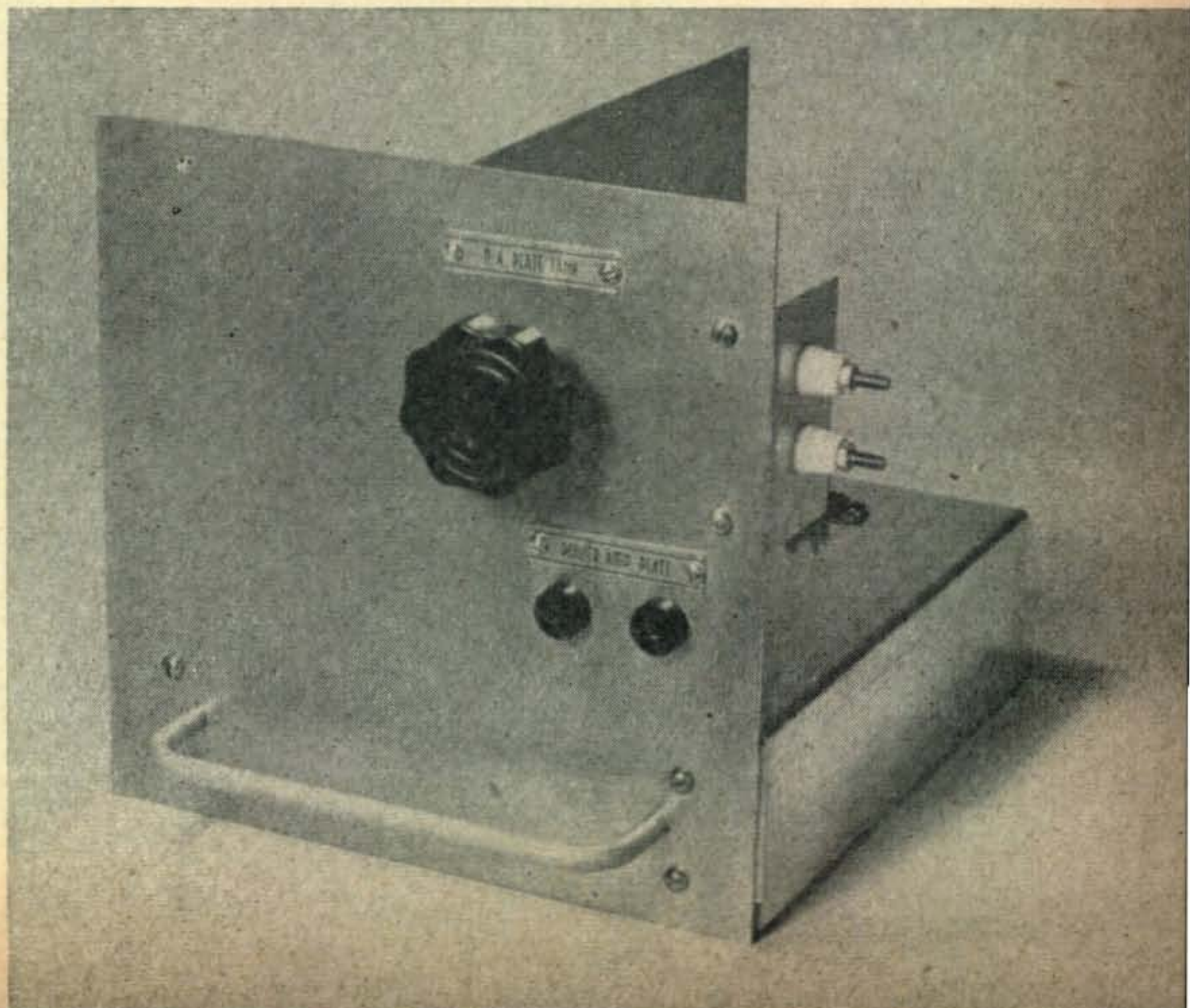

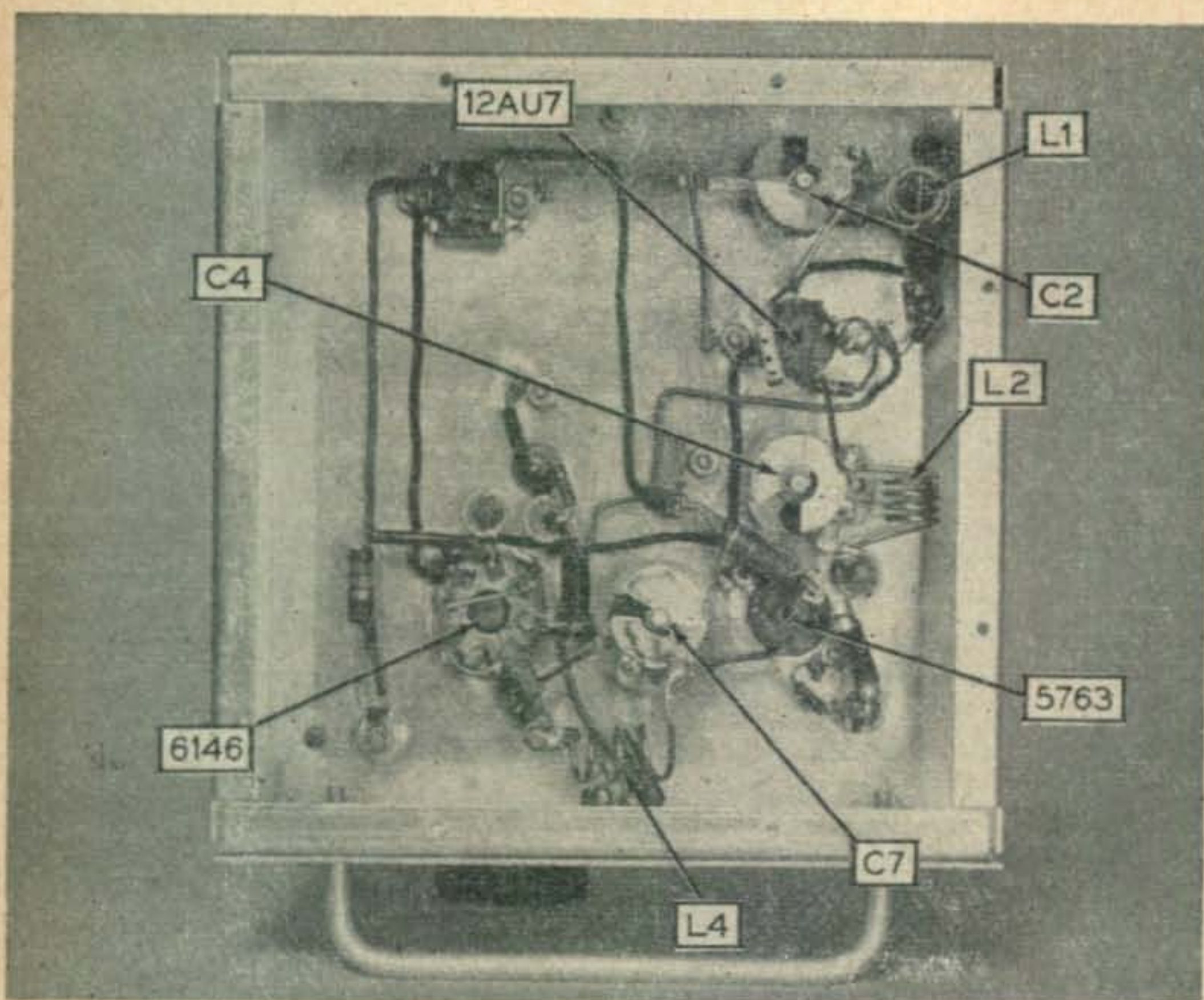

It probably doesn't seem possible to crank up on two-meters with so few parts. Any modulator having up to 25 watts output can be used with the 6146 power and a 2E26 final.

cut out a 4 3/4 x 7 inch piece which is mounted on spade lugs to become the shield between the driver and final output stages. Lastly, a small piece of aluminum that is about 2 x 2 should be bent to make the L-bracket that supports the antenna output terminals.

The actual location of tube sockets, etc. is not a critical item. The photographs show the positions of the major components quite clearly as very few parts are required in the construction of this transmitter. The tip jacks on the front panel are across the 100-ohm resistor R10. Variable condensers C2, C4 and C7 are all mounted to the top of the

chassis to insure short leads. The power cables go to a 4-prong Jones plug which could be easily replaced with a terminal strip if so desired.

Tuning Up

The first thing to look for after the wiring has been completed and thoroughly double checked is that the oscillator circuit is crystal controlled. The old stunt of pulling out the crystal is not a good check with this type of oscillator. A much better one is to apply about 150 volts to the first triode section of the 12AU7 tube. Connect a milliammeter

(Continued on page 88)

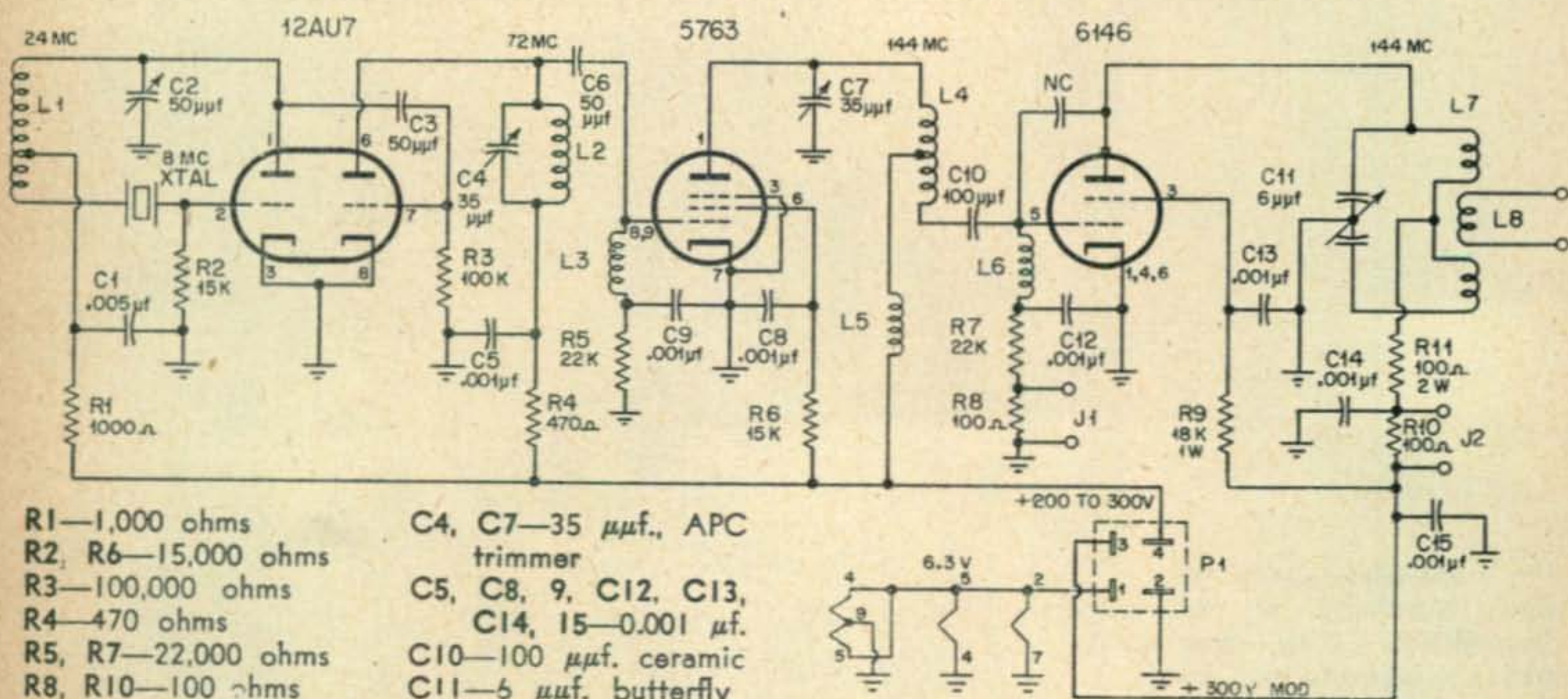

- R1—1,000 ohms
- R2, R6—15,000 ohms
- R3—100,000 ohms
- R4—470 ohms
- R5, R7—22,000 ohms
- R8, R10—100 ohms
- R9—18,000 ohms, 1w.
- C1—0.005 μ f.
- C2—50 μ f., APC trimmer
- C3, C6—50 μ f. ceramic

- C4, C7—35 μ f., APC trimmer
- C5, C8, 9, C12, C13, C14, 15—0.001 μ f.
- C10—100 μ f. ceramic
- C11—6 μ f. butterfly
- J1, J2—tip jacks
- P1—4 prong jones plug
- NC—see text
- Xtal—8 mc.
- Note: All resistor values are 1/2w. unless indicated

Wiring schematic and parts list of the 40 watt two-meter rig.

In an area not particularly bothered by TVI this mechanical design might be appropriate, but a complete shield would save a lot of future headaches. Actually, this construction was arranged so that the location of the parts could be spotted with ease.

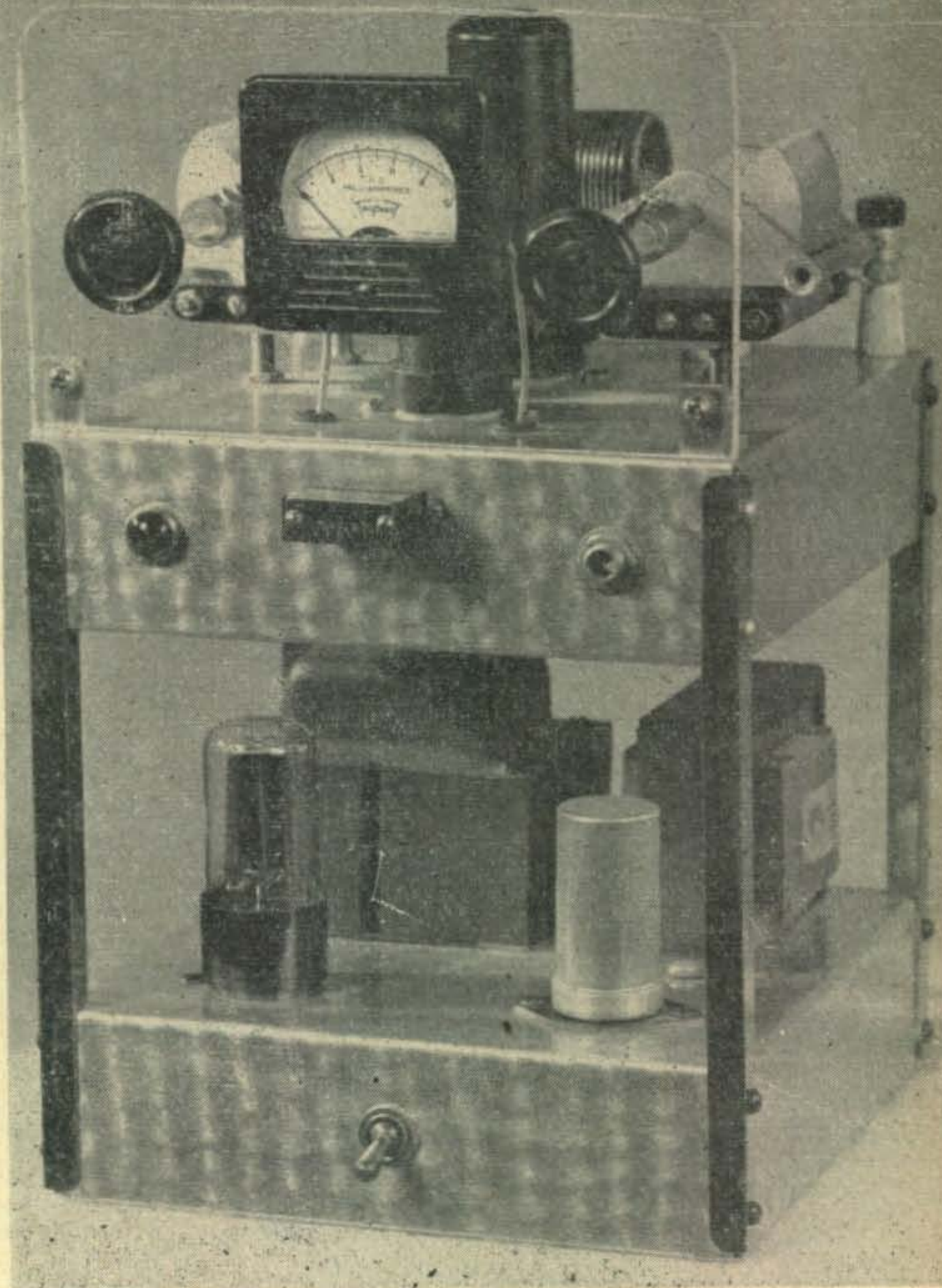

The Junk-Box Jewel

C. W. GWYN, W4QAG

c/o Radio Station WSNW, Seneca, S.C.

This is another of those familiar and overworked "junk-box" creations, but the results obtained from this excursion into the dusty box of discards were pleasing enough that we thought others, particularly the Novice licensee, would be interested.—Editor.

It all began one evening when we came across a pair of those gold plated variable condensers from the "Mae West" Transmitter of surplus fame. They looked too good not to be of some use and yet their capacity in relation to their physical size definitely limited their usefulness. At any rate they presented a challenge to our constructive ingenuity and armed with the pair, we began a perusal of back issues of *CQ* to see what would develop.

We ended up with a circuit that was of doubtful origin, being an accumulation of the better features of several low power transmitters and a few ideas of our own. With this circuit, a few more junk-box gleanings and an eye for a little different design, we proceeded to build the little transmitter we are about to describe.

It is inexpensive, yet attractive in appearance and though small in size and power, we were amazed with the results. No, we haven't worked ZS-Land with it yet, but we can sit down, even in the early evening when 40 is at its "QRM-est" and have a few nice contacts from all over the States and Canada even though we're rock bound. Reports

are generally always good, averaging 579X on both 40 and 80. Operation is anything but critical and we have successfully loaded everything for an antenna from a half a pound of bell wire strung out on the floor to the back-yard clothes-line. Not that we recommend such slipshod methods, but it does indicate that everything doesn't have to be measured and tuned to the Nth degree for the successful operation of a ham station.

The Design

There is no doubt but what a single tube transmitter is easier to construct and get on the air than an oscillator-amplifier type such as this, but the two stages have been simplified greatly, still retaining, however, the distinct advantage of a two stage rig. The chief advantage is that the emitted signal is more stable due to the fact that the oscillator is isolated from the antenna by the amplifier tube. Neither the output of the oscillator nor the input of the amplifier is tuned and this of course greatly simplifies construction.

The circuit is that of a Pierce oscillator using a 6C5 (see Fig. 1). Plate voltage to this tube is fed through a radio frequency choke (RFC1) and its output is fed to the grid of the amplifier by capacity coupling through C5. To eliminate the need of an external antenna coupler, the plate of the amplifier is also shunt fed, i.e., its plate voltage is fed through RFC2 and its output fed through capacitor C8 to the pi-type tuning system and thence to the antenna. Thus we have again eliminated a tuned circuit and made possible the use of almost any reasonable length of wire as a satisfactory antenna. The cathodes of both tubes are keyed simultaneously. The amplifier tube has

no protective bias but receives its operating bias through the grid leak resistor R4 while R2 provides the proper bias for the oscillator. R3 is a voltage dropping resistor to reduce the plate voltage on the 6C5. The value of this resistor is rather important since much greater voltage on the 6C5 plate will cause too much crystal current to flow, thus endangering the crystal.

Capacitor C7 is the screen by-pass for the 6L6. It is important that its leads be very short. It is suggested that either a ceramic disc or ceramic tubular capacitor be used to facilitate this arrangement. The most direct connection is to tie one of the C7 leads to pin 4 of the 6L6 and the other directly to pin 7 of the same tube. Pin 7 is then grounded to the nearest point on the chassis.

Both power supply and transmitter are mounted on 7 x 7 x 2 inch aluminum chassis on which we swirled a jeweler's design with a piece of wet Brillo (steel wool and soap) under the thumb. The transmitter is mounted over the power supply in rack fashion on four square corner posts. For these posts we used a discarded lingerie stand from a ladies' ready-to-wear store although aluminum angle would work as well and still be attractive(?). A piece of 1/4 inch lucite is used for the panel being supported by two small pieces of aluminum angle. Part placements shown in the illustrations result in short r.f. leads, compactness and easy wiring.

The 0-100 d.c. milliammeter is mounted just slightly above the center of the 4 x 7 inch panel. The tube sockets are mounted down the center of the chassis to the rear of the meter leaving room for the tank coil which is mounted horizontally across the rear center of the chassis.

Provision for changing coils is accomplished by

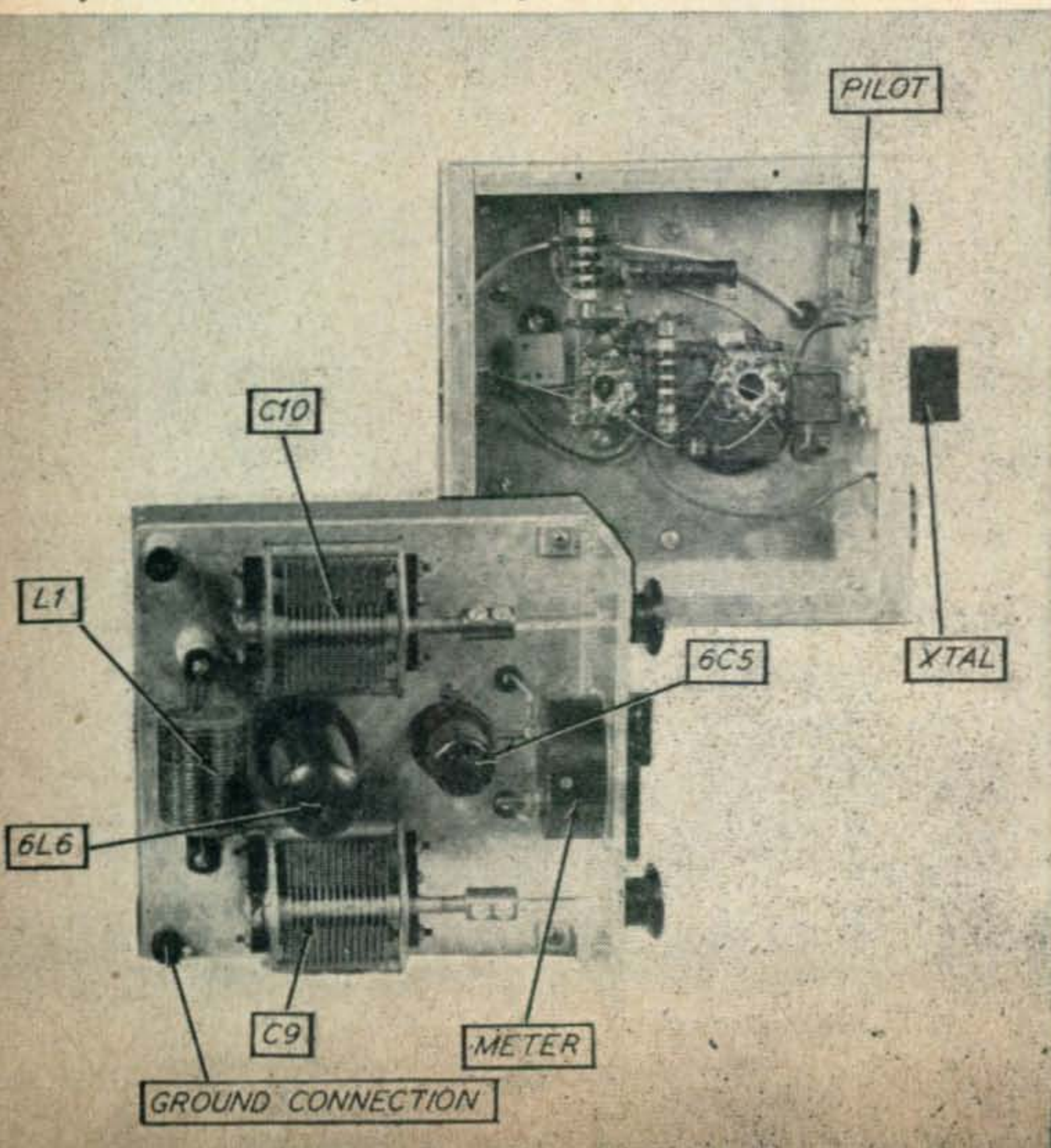

Top and bottom transmitter chassis views showing positions of some of the important components.

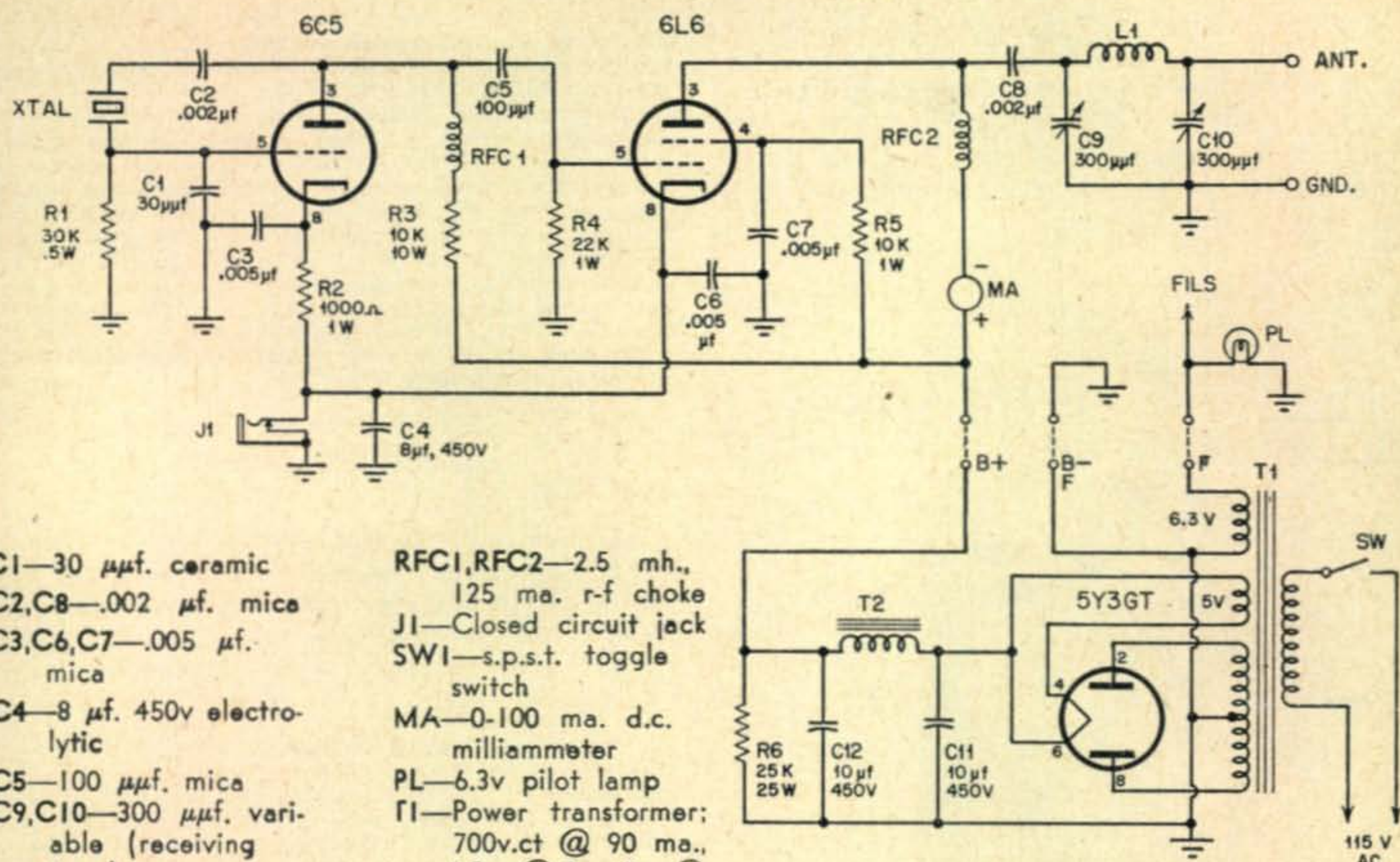

- C1—30 μf . ceramic
 C2,C8—.002 μf . mica
 C3,C6,C7—.005 μf . mica
 C4—8 μf . 450v electrolytic
 C5—100 μf . mica
 C9,C10—300 μf . variable (receiving type)
 C11-12—Dual 10 μf . 450v electrolytic
 R1—30,000 ohm, $\frac{1}{2}\text{w}$.
 R2—1,000 ohm, 1w.
 R3—10,000 ohm, 10w, wire wound
 R4—22,000 ohm, 1w.
 R5—10,000 ohm, 1w.
 R6—25,000 ohm, 25w, wire wound

- RFC1,RFC2—2.5 mh., 125 ma. r-f choke
 J1—Closed circuit jack
 SW1—s.p.s.t. toggle switch
 MA—0-100 ma. d.c. milliammeter
 PL—6.3v pilot lamp
 T1—Power transformer; 700v.ct @ 90 ma., 6.3v. @ 3a., 5v. @ 3a.
 L1—80 Meters—30 turns #20 enameled, close wound on $\frac{1}{2}$ inch form
 40 Meters—20 turns #20 enameled space $\frac{1}{2}$ inches on $\frac{1}{4}$ inch form.

Fig. 1. Wiring schematic and parts list.

using a pair of steatite pillars with banana jacks. These pillars are mounted, one to the rear of each tuning condenser. The coils are wound on bakelite forms $3\frac{1}{2}$ inches long by $1\frac{1}{4}$ inches in diameter. As shown in the photograph, we cut off the unused ends of the form leaving two tabs protruding through which were fastened two mounting lugs and banana plugs.

The tuning condensers are mounted on $\frac{3}{4}$ inch spacers on either side of the tube sockets. Shaft extensions were necessary and we used lucite rods for this purpose to carry out the panel scheme.

The ground connection is a binding post mounted on the left rear corner of the chassis and the antenna post is mounted on the opposite corner on a 1-inch steatite standoff insulator. A $\frac{3}{8}$ inch hole with a rubber grommet at the inside rear of the plate tuning condenser passes the r.f. lead (No. 18 solid wire) from the plate of the 6L6. Smaller grommet lined holes pass the meter leads at the front of the chassis. Power supply connections are at the rear, and on the front lip of the chassis are symmetrically mounted the pilot light, crystal socket and key jack in that order from left to right. Underchassis mounting and wiring is simplified through the use of terminal tie strips.

The power supply is conventional in every respect being a full wave rectifier with a condenser input

system. Parts placement on this unit is clearly shown in the photographs. The plate voltage is 375 volts with key-up and drops to 300 volts under load. Keying is clean and crisp in spite of this wide voltage swing and no chirp has ever been reported. An 8 μf . 450 volt electrolytic across the key terminals completely eliminated a slight key click which was experienced on first tests.

Tuning Up

Initial tests should be made with a dummy antenna (see Fig. 2). We used a 15 watt incandescent lamp. With crystal and coil for the desired band in place, turn on the power supply and after a 30 second warm-up and with both tuning con-

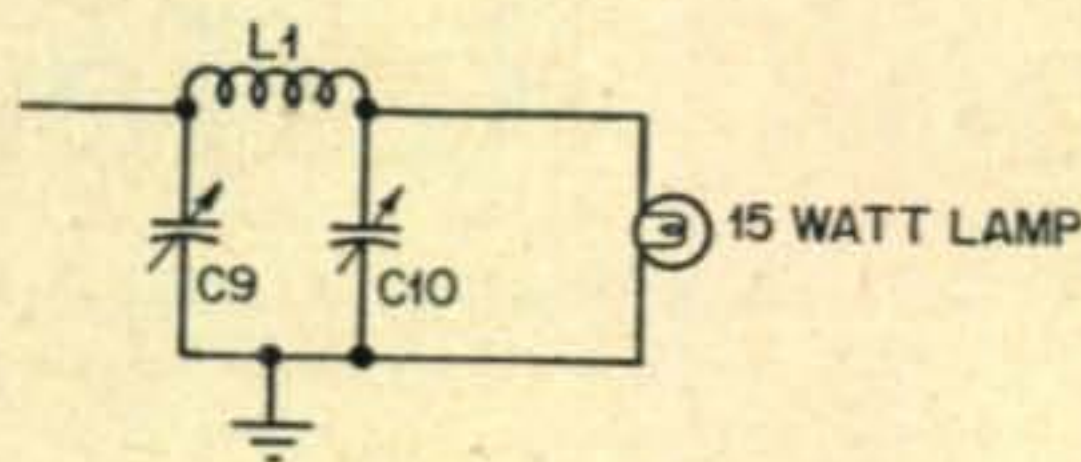
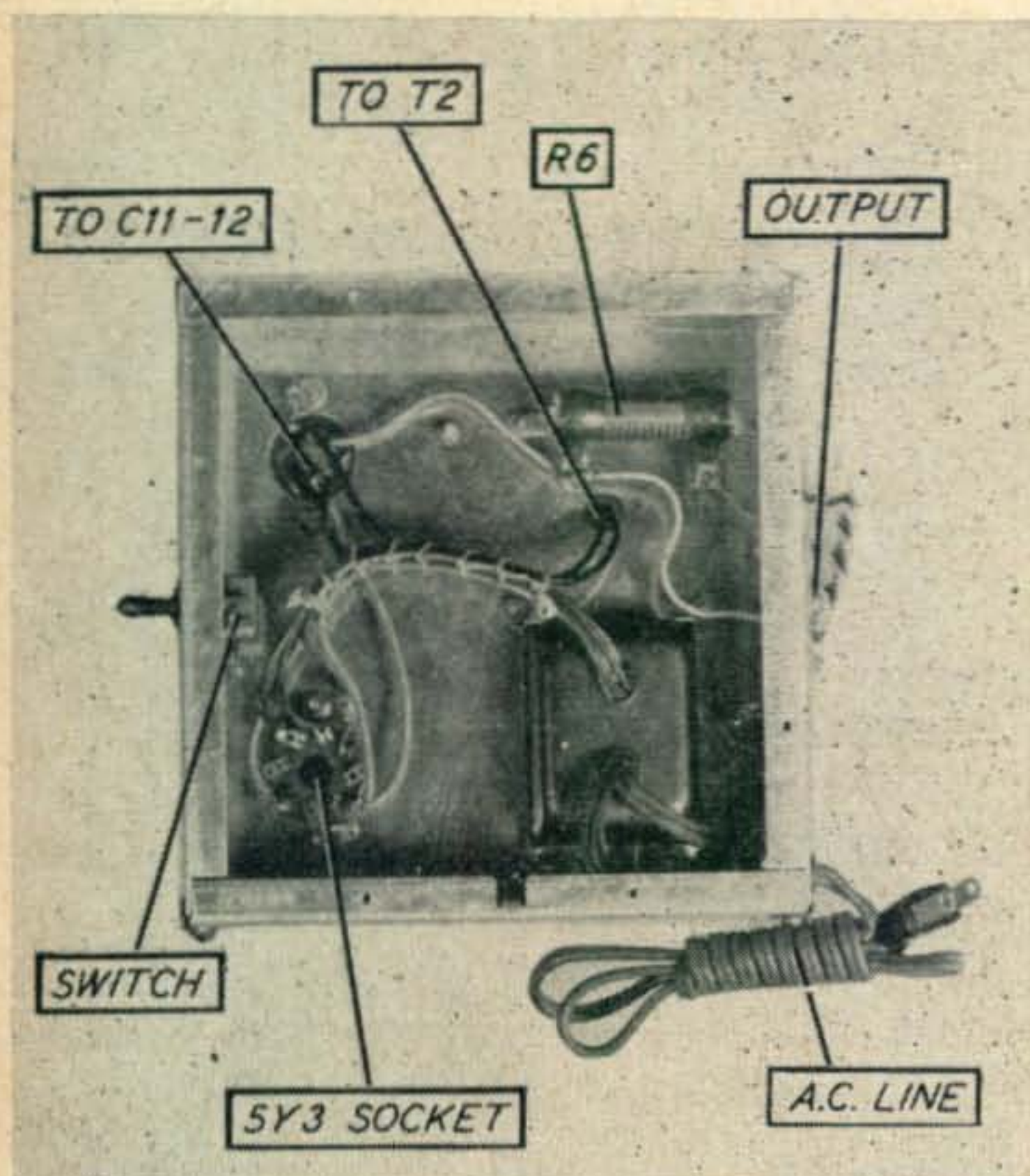

Fig. 2. Method of connecting the "dummy" load which consists of a 15-watt incandescent lamp bulb.

densers opened about half way, press the key. The meter should swing to almost full scale as off resonant operation will cause the 6L6 to draw about 100 ma. of current. Turning the plate tuning condenser through its range, the point of resonance will be found as noted by a sharp dip in plate current. The antenna tuning condenser is now adjusted for a rise in plate current to about 90 ma. The plate condenser is again tuned for the dip in current which will be less pronounced this time. The dummy antenna will light to full brilliance when properly tuned in this manner.

The signal should now be monitored by a receiver to make sure it is crisp and clean. A check with an absorption type wave meter to make sure the signal is within the band should also be made. If all is well, connect the antenna in place of the dummy, connect a good external ground and load up as before.



Looking under the bottom deck, or rectifier chassis.

You're on the air now, fellow friend of the ether, and when you get a 599X report from a thousand miles or so away, whether you're a Novice or an old-timer, that's a big thrill for 25 watts.

Book Reviews

UHF Practices and Principles by Allan Lytel, published by John F. Rider Publisher, Inc., 480 Canal Street, New York 13, N. Y. 390 pp. and 285 illustrations, 5 1/2 x 8 1/2. Price: \$6.60.

Somehow it just doesn't seem right to find a portion of the radio frequency spectrum available to radio amateurs wherein they are doing very little experimental operational work. While literally hundreds of different types of commercial activities take place daily on frequencies greater than 420 mc., the number of amateurs equipped to operate in this spectrum can almost be counted on the fingers of both hands. It is doubtful that the adventurous spirit behind amateur radio has been lost, but rather it is the sudden mushroom-like growth of the military and commercial services in the UHF spectrum that has left the amateur far behind. One cannot help but wonder if, in part, the reaction of the amateur is not due to the so-called "mysteries" of the UHF spectrum. If nothing else, this particular book, once read by the average amateur, will do much to dispel this notion and to replace it with a feeling of "let's get started."

This book is not designed to be a "how-to-build-it" text. It is rather a book designed for the student, tech-

nician or radio amateur who wants to understand and appreciate the differences between the UHF spectrum and the lower frequencies. The reader is taken through a very carefully guided tour of the various facets of UHF operation. These include propagation, receiving and transmitting antennas, wave guides, the new types of tuned circuits, oscillators and data on receivers, converters and transmitters. A careful reader cannot help but note that the author indicates that there is room for considerable developmental work, especially in the field of citizen radio. Many amateurs could do far worse than to spend a little experimenting on 420 mc. with an eye toward developing receivers and transmitters applicable to the 460 mc. citizen's band.

The book concludes with an extensive bibliography and numerous nomograms applicable to the UHF spectrum. o.p.f.

Television by F. Kerkhof and W. Werner, published by N. V. Philips, Gloeilampenfabrieken Eindhoven (Holland), distributed in the United States by Elsevier Press Incorporated, 402 Lovett Boulevard, Houston 6, Texas. 475 pp. 6 x 9" with 360 illustrations. Price: \$7.75.

Those of our readers working in the television field are undoubtedly aware of the crying need for a useful composite text on the physical and technical principles of television. This latest book in the "Philips' Technical Library" appears to more than sufficiently cover this important field. Because it was written by two experts who have been in television since the days of the whirling disc, it speaks with considerable authority on apparently all of the television systems employed in both Europe and the United States. Your reviewer cannot help but agree with the "Forward" by Geoffrey Parr wherein he states that, "Although radio engineering has an extensive bibliography and there are many text books on the subject, the same cannot be said for television . . . The student who enters television engineering without previous knowledge of radio communications cannot expect to find in one book all that he requires to become qualified in the subject, but he will have no difficulty in acquiring a sound knowledge of television practice if this book is rightly used in conjunction with basic radio text books."

To some readers the chapter sequence may seem a little odd, but after full consideration, the reader will concede that the sequence is a very realistic approach. Starting with the physical principles of electronic scanning, the authors investigate various pick-up and picture tubes, and then follow through with chapters devoted to the separation of the signal information, data on oscillators and saw-tooth generators, time-base generators, high voltage generators and then wide band r.f. and i.f. amplifiers. The last 100 pages of the book are devoted to antenna problem, picture synthesis and a short introduction to color television.

The appendix contains a number of useful tables and also a conversion from the rationalized system of units employed in the text.

All in all, to the budding television engineer this is a very worthwhile book. o.p.f.



NOVICE SHACK

A stylized illustration at the top of the page. On the left, the words "NOVICE SHACK" are written in large, outlined, sans-serif capital letters. To the right of the text is a simple line drawing of a small, two-story wooden shack with a gabled roof, a chimney, and several windows. Above the shack, a biplane is shown in flight, flying towards the right. The background consists of a few horizontal lines suggesting a sky or a horizon.

Conducted by HERB BRIER, W9EGQ

385 Johnson Street, Gary, Indiana

Most of the articles in this issue of *CQ* describe equipment of special interest to the new or prospective amateur. To supplement them, this *Novice Shack* will discuss briefly what amateur radio is and tell how to join its ranks.

Radio amateurs are people interested in radio purely as a hobby, who have government licenses to operate their own private radio stations and to communicate with each other. Special bands of radio frequencies are reserved by international agreement for their use.

In the United States, the Federal Communications Commission issues the necessary licenses without charge. They are issued in several grades, and children as young as seven and adults over eighty have qualified. The F.C.C. has even set up procedures; so that invalids and others who cannot travel to an examining point may take the examinations at home.

As stated, there are several grades of amateur licenses. I shall, however, limit this discussion to the Novice Class license, which is the simplest to obtain. The Novice license is good for one year and is nonrenewable. It authorizes the holder to operate a 75-watt (or less) transmitter in the three Novice bands, while obtaining the skill and knowledge to acquire a permanent amateur license. It might be well to state here that technically the operator license and the station license are separate licenses. However, a station license will be issued only to a licensed operator, is applied for on the same form, and both are issued as part of a single license card.

License Requirements

To qualify for a Novice license, you must be a United States citizen and have not held an amateur license previously. You must pass a written examination covering Novice regulation and elementary radio theory. In addition, you must demonstrate the ability to send and receive the International Morse Code at a speed of five words per minute.

The basic purpose of the written examination is to establish that you have sufficient knowledge to operate a radio station without causing unnecessary interference to other services. It is in the form of approximately twenty, multiple-choice questions. 74 is a passing grade.

Ability to use International Morse is required by international law. It is a basic part of all amateur licenses. The receiving code test consists of twenty-five, five-letter groups sent at a speed of five words

a minute. To pass, you must copy, without error, twenty-five consecutive letters. No numerals or punctuation are sent. To pass the sending test, you must be able to send simple text, which may contain numerals and simple punctuation, at the same speed.

If you live within 125 miles of one of the forty cities where the F.C.C. gives amateur examinations four or more times a year, and are physically able to do so, you must appear in person to take the examination. If you live more than 125 miles from the nearest such city or are unable to travel, you may take the examination by mail. The procedure is this:



A typical Novice station with Jack Howell, WN4VFX at the key. Jack is located in Mooreville, N.C. The transmitter runs about 40 watts to a 6L6. A long wire is used for an antenna while a Hallicrafters S-20R is the receiver. Jack has 26 states confirmed on the Novice bands.

Obtaining A License By Mail

Upon request, the Engineer in Charge of the nearest F.C.C. district office will send you an application blank, plus all material necessary for taking the examination, and full instructions on what to do. Read the instructions thoroughly.

A person who holds an amateur operator's license of any grade, except Novice or Technician Class,

and has held a commercial radiotelegraph license or has been employed in the services of the United States as a radiotelegraph operator within the past five years is authorized to administer the code test. Upon his certification that you have passed it, he or another person (who need not be licensed, but must be at least twenty-one years old) opens and hands you the sealed written examination. After you have answered the questions, he collects all papers and certifies that you accomplished the examination without help. Finally, the application and all papers are mailed to the Federal Communications Commission in the envelope provided for the purpose.

If you are taking the examination by mail because of inability to appear at an examination point, you will also have to enclose a doctor's certification of the fact with your application. In fact, some F.C.C. offices require such a certificate before they will mail the license material. Incidentally, those prevented from appearing at an examining point because of service in the United States Armed Forces may also take the examination by mail, even if within 125 miles of an examination point, by obtaining a certification of the facts from their Commanding Officer.

Whether taken in person or by mail, the scope of the examination and the privileges granted are exactly the same.

ALPHABET			
A	•—	N	—••
B	—•••	O	—•—•
C	—••—•	P	•—•—•
D	—•••	Q	—•—•—•
E	•	R	••—•
F	••—••	S	•••
G	—•—•	T	—
H	••••	U	••—
I	••	V	•••—
J	•—•—•	W	•—•—
K	—••—	X	—•••
L	••••	Y	—•—•—
M	—•—	Z	—•—••

NUMERALS			
1	•—•—•—•	6	—••••
2	••—•—•	7	—•—•••
3	•••—•—	8	—•—••••
4	••••—	9	—•—•—••
5	•••••	0	—•—•—•—

Privileges

A Novice license authorizes operation in all Novice bands. At present there are three of them, 3.7 to 3.75 mc., 26.96 to 27.23 mc., and 145 to 147 mc. International Morse code operation is permitted in the first two and either code or phone in the third.

The 3.7-mc. band is useful, day or night, for distances ranging up to several thousand miles, depending upon the time of the day and the time of the year. The 27-mc. band is much more erratic. When it is "open," daylight contacts over thousands of miles are easily possible. However, when it is "dead," ten to fifty miles is the usual range. Normal

range on 145 mc. is also limited, although, under unusual conditions, contacts over hundreds of miles are easily possible.

Which is the best Novice band depends on many things, of which personal preference is not the least. Many like 3.7 mc., because of its day and night reliability and the simplicity of the equipment required. Interference is bad on it, however, in the evening hours. The 27-mc. band is favored by those who like the thrill of occasional contacts with far-off places. The 145 mc. band is particularly interesting to those Novices who prefer to use radiophone instead of code. Because of its normally, rather-limited range, it is most used in urban parts of the country.

Code Versus Phone

To some, it might seem that radiophone would be more desirable than code operation. There are three reasons why this is not necessarily so. 1) Many amateurs equipped for both, prefer code operation. 2) Less elaborate equipment is required for equivalent results with a code transmitter than is required with a phone transmitter. 3) While only a code speed of five words per minute is required to obtain a Novice license, a speed of thirteen words a minute is required for a General Class license, which is the one most Novices strive to obtain before their Novice license expires. Thus, it behooves the Novice to get his code speed up as soon as possible. The easiest way to do so is by actual over-the-air contacts using the code.

Speaking of the General Class license, it (and the Conditional Class license, which is the same, except that it is obtained by mail) is the basic amateur license. It permits full code privileges on all amateur bands and full phone privileges on all but two phone sub-bands, which require a still higher grade of license to use. In addition to the thirteen word code speed requirement, a more comprehensive written examination is required to qualify for a General Class license.

The one remaining license is the Technician Class license. It is a full, renewable license granting all amateur privileges on all amateur bands above 225 mc. To qualify for it, you must pass the same written examination as for the General Class license, but the code requirements are the same as for a Novice Class license.

The "catch" in the Technician Class license for most Novices is that the operating privileges granted by it are in the very-high and ultra-high-frequency hands, where experimental and developmental work, rather than two-way contacts, are the major interests. It is, however, an ideal operator's license for those who like to work on new developments more than they like to operate. Another advantage is that it may be used as a stepping stone between the Novice and General Class licenses.

A Novice who is not quite sure of his ability to pass the code test for a General Class license can apply for both a Technician and a General Class license. If he passes the thirteen-word code test, he will receive a General Class license upon passing the written examination, but if he fails the code test, he will receive the Technician Class license by passing the written examination. He can later qualify for the General Class license merely by passing the code test. In fact, a prospective amateur can, if he desires, apply for all three classes of licenses. Should

he qualify for the General Class license, that is the only one he would be issued, because it covers all the privileges granted by the other two, plus many more. On the other hand, he would receive either or both the Novice or Technician Class license if he qualified for them.

The Scope of The Novice Examination

Following this section are the questions forming the F.C.C. suggested study guide for the Novice examination, with answers and a copy of the International Morse Code. The questions indicate the scope of the examination. If you can answer them and understand the answers, you will have no trouble with the examination, although the actual questions asked will be different.

With a little luck, you might be able to pass the examination merely by memorizing the questions and answers. If you are wise, however, you will use them to indicate what you should study to be sure that you have sufficient knowledge to pass.

One booklet you will find invaluable is *The License Manual*, published by the American Radio Relay League. It contains the complete F.C.C. rules and regulations governing amateur stations (eleven pages of fine print), the addresses of all F.C.C. examining points, and study guides for all classes of amateur operator licenses. The booklet costs fifty cents and may be obtained from many of the newsstands where *CQ* is sold or from any of the amateur supply houses that advertise in *CQ*.

Either *The Radio Amateur's Handbook*, \$3.00, or *The "Radio" Handbook*, \$6.00, also available through amateur supply houses, contain all the technical information to pass any amateur examination, plus much additional information. One or both should be on every amateur's bookshelf.

Very helpful, too, are the phonograph-record courses offered by several manufacturers. They teach both code and theory, and have been responsible for many amateurs obtaining their licenses. Many local amateur radio clubs and individual amateurs conduct classes to help prospective amateurs obtain their licenses. Often the big trouble is getting the right people together. And the *Novice Shack* can help here. See the *Correspondence Section* of this issue.

Although I include a copy of the code as part of this month's column, I strongly advise against learning the code visually. If at all possible, get someone to teach it to you by sound. A, for example is *didah*, and when you hear that sound, write down "A" and nothing else. Never write down the individual dots and dashes.

Study Guide For Novice Class License Examination

The following questions are based upon the F.C.C. study guide for the Novice Class license. The numbers preceding certain of the answers (Ex: #12.23 in question no. 1) is the number of the F.C.C. regulation covering that point.

1. What is the maximum input power permitted to the final stage of the transmitter in a station licensed to the holder of a Novice Class licensee or operated by such an operator?

#12.28: 75 watts.

2. What is the maximum penalty for a violation of the rules and regulations of the Federal Communications Commission?

Section 502 of the Communications Act of 1934: "Any person who willfully and knowingly violates any rule, regulation or restriction made or imposed by the Commission . . . shall be punished, upon conviction thereof by a fine of not more than \$500 for each and every day

during which such offense occurs."

3. On what frequency bands may the holder of a Novice Class License operate an amateur radio station?

#12.28: 3.7 to 3.75 mc., 26.96 to 27.23 mc., and 145 to 147 mc.

4. On what frequency bands may the holder of a Novice Class license operate an amateur radiotelephone station?

#12.28: 145 to 147 ma.



"Clif" WN5VOU, Comanche, in the center of Texas. The transmitter is a BC-457 converted to a crystal control. Five crystals for the 3.7-mc Novice band are available. The receiver is a converted war surplus BC-454.

5. What is the log of an amateur station, and what information is required to be entered therein? How long must it be preserved?

#12.136: A log is a record of the station's operation. It should contain the following:

(a) The date and time (beginning and end) of each communication.

(b) The signature of the licensed operator in control of the transmitter, and the names of any person who talks over an amateur radiotelephone transmitter.

(c) Call sign of the station called. (This entry need not be repeated for calls made to the same station during any sequence of communication, provided the time of signing off is given.)

(d) Power input.

(e) Frequency band used.

(f) Type of emission used.

(g) Location of the station (or the approximate geographical location of a mobile station) at the time of each transmission. When operating at other than a fixed location, the type and identity of the vehicle or other mobile unit in which the station is operated shall be shown.

(h) The message traffic handled. If record communications are handled in regular message form, a copy of each message sent and received shall be entered in the log or retained on file at the station for at least a year.

#12.137: The log shall be preserved for a period of at least one year following the last date of entry.

Data such as power, operator's signature, frequency, etc., need be entered only once until changed, if a statement to that effect is entered in the log.

6. What is the term of an amateur Novice Class license? Under what conditions may this license be renewed?

#12.29: One year. #12.27(b): It will not be renewed.

7. What are the rules and regulations regarding the transmission of improper language, false signals, or malicious interference?

#12.157, 12.158, 12.160: All are strictly forbidden.

8. What are the rules and regulations regarding purity and stability of emissions?

#12.133: "The frequency of the emitted carrier wave shall be as constant as the state of the art permits."

Spurious radiations from amateur transmitters operated on frequencies below 144 mc. shall be reduced in accordance with good engineering practice; so that they will not produce harmful interference to receivers of good engineering design which are tuned to channels outside of the frequency band of emission normally occupied by the type of emission being employed by the amateur station. When radiophone is used, a maximum of 100 per cent modulation is permitted, and means shall be employed to insure that the transmitter is not modulated in excess of its modulation capabilities for correct technical operation. Simultaneous amplitude and frequency modulation is forbidden.

9. What method of frequency control is required to be used in the transmitter of a station licensed to the holder of a Novice Class license?

#12.23: Crystal control.

10. What are the rules and regulations regarding the measurement of frequencies of the emissions of an amateur radio station?

#12.135: The licensee shall provide for measurement of his transmitter's emitted frequency and shall establish procedures for doing so regularly. Frequency measuring equipment shall be independent of that used to control the transmitter frequency. It shall be of sufficient accuracy to assure operation within the assigned amateur bands.

11. Who may be permitted to operate the transmitter of an amateur radio station licensed to the holder of a Novice Class license?

#12.28: Any licensed amateur, with the exception of the Technician Class.

12. Under what circumstances may an amateur station be used by a person who does not hold a valid license?

#12.28: The licensed operator in control of the transmitter may permit any person to talk over the microphone of an amateur radiotelephone station, as long as he maintains actual control, including turning the carrier on and off for each transmission and signing the station off at the conclusion of communication with each station.

13. What is the maximum permissible percentage of modulation of an amateur radiotelephone station?

#12.133: 100 per cent.

14. At what intervals must an amateur station be identified by the transmission of its call sign? May any transmission be made without identification of the station?

#12.28(a): "An operator of an amateur station shall transmit the call sign of the station called or being worked and the call sign assigned to the station he is operating at the beginning and end of each transmission and at least every ten minutes during every transmission of more than ten minutes duration. In the case of stations conducting an exchange of several transmissions in sequence, with each transmission less than three minutes' duration, the call signs of the communicating stations need be transmitted only once every ten minutes of operation, as well as at the beginning and at the termination of the correspondence."

15. Under what conditions is notice of portable or mobile operation required and to whom in each case?

#12.91(a): Whenever portable or mobile operation is, or is likely to be for a period in excess of forty-eight hours away from the fixed-station location, the licensee shall give prior written notice to the Engineer in Charge of radio inspection district where the operation is contemplated. Where portable operation is involved, such notice is required even if return trips are made to the fixed station during this overall period. Prior notification is not required for periods of mobile operation of less than forty-eight hours away from the fixed location.

16. What are the recognized abbreviations for: kilocycle, megacycle, Eastern Standard Time, Greenwich Mean Time, continuous wave, frequency modulation, amplitude modulation?

kilocycles: kc.

megacycles: mc.

Eastern Standard Time: EST

Greenwich Mean Time: GMT

continuous wave: c.w.

frequency modulation: f.m.

amplitude modulation: a.m.

17. What is the relationship between a fundamental frequency and its second harmonic, its third harmonic, etc?

A harmonic is always an integral multiple of a fundamental frequency; therefore, the second harmonic is twice the fundamental, the third harmonic is three times it, etc.

18. What is the relationship between a cycle, a kilocycle and a megacycle?

A kilocycle is 1,000 cycles, and a megacycle is 1,000,000 cycles.

19. What instrument is used to measure electrical potential? Electrical current? Electrical power? Electrical energy?

Electrical potential: voltmeter. Electrical current: ammeter, milliammeter, or microammeter. Electrical power: wattmeter. Electrical energy: watt-hour meter.

20. What is the purpose of a modulator? An amplifier? A rectifier? A filter?

A modulator varies the amplitude, frequency or phase of the emitted wave of a transmitter to transmit intelligence.

An amplifier increases the amplitude of a signal.

A rectifier changes alternating current to pulsating direct current.

A filter attenuates undesired frequencies and passes desired ones or direct current with a minimum of attenuation.

21. What is meant by amplification, modulation, detection, attenuation?

Amplification is the process of increasing the amplitude of a signal.

Modulation is the process of varying the amplitude, phase or frequency of an emitted signal. It is generally done for the purpose of transmitting information.

Detection is the process of extracting the information conveyed transmitted by a modulated radio signal.

Attenuation is a decrease in amplitude.

22. What is the purpose of a radio-frequency choke? An audio-frequency choke? A filter choke?

A radio frequency choke opposes the flow of radio-frequency currents and passes audio-frequency and direct currents without an appreciable attenuation.

An audio-frequency choke opposes the flow of audio-frequency currents and passes direct current.

A filter choke is a form of an audio-frequency choke and is used to help smooth the direct-current output of a rectifier.

23. How is the actual power input to the tube or tubes supplying energy to the antenna of an amateur transmitter determined?

Power input is the product of the d-c plate voltage and plate current (in amperes) of the final amplifier stage. Example: a stage operating with a plate voltage of 500 and a plate current of 100 milliamperes (0.1 amperes) has an input of fifty watts.

24. Why are a rectifier and a filter required in the plate power supply system of an amateur transmitter when operated from alternating current?

F.C.C. regulation #12.132 requires that the plate power of an amateur transmitter operated on a frequency lower than 144 mc. must be "adequately-filtered" direct current. A rectifier changes alternating current to pulsating direct current, and the filter smooths out the pulsations to deliver an essentially "pure" direct current to the transmitter.

25. What is a frequency multiplier?

A frequency multiplier is a device which delivers radio-frequency power at an integral multiple of its input frequency.

26. What are the undesirable effects of overmodulation in radiotelephony?

Overmodulation generates spurious sidebands and produces a signal that occupies more than its fair share of the radio spectrum. It causes unnecessary interference, and the spurious sidebands may extend outside of an authorized amateur band.

27. What is meant by a "parasitic" oscillation?

A parasitic oscillation is one that is not necessary (and usually detrimental) to the proper operation of a piece of radio equipment. It may occur at any frequency, but is usually far from the desired frequency.

28. What is the purpose of a key-click filter, and when should it be used?

A key-click filter is used to reduce or eliminate spurious radiations caused by keying a transmitter. It is used when such radiations cause unnecessary interference.

Letters And General Comments

Rich, W5IGU, sends in a little news about his son Lowell.

"Between December, 1951 and March, 1952, Lowell, WN6UBW, worked twenty-six different Novices; twenty-five states confirmed; VE1, 2, 3, and 7; WH6AJT, a Novice in Hawaii; and T12FG, and KZ5LM. All this work was done on 27 mc., with a folded dipole antenna

(Continued on page 78)

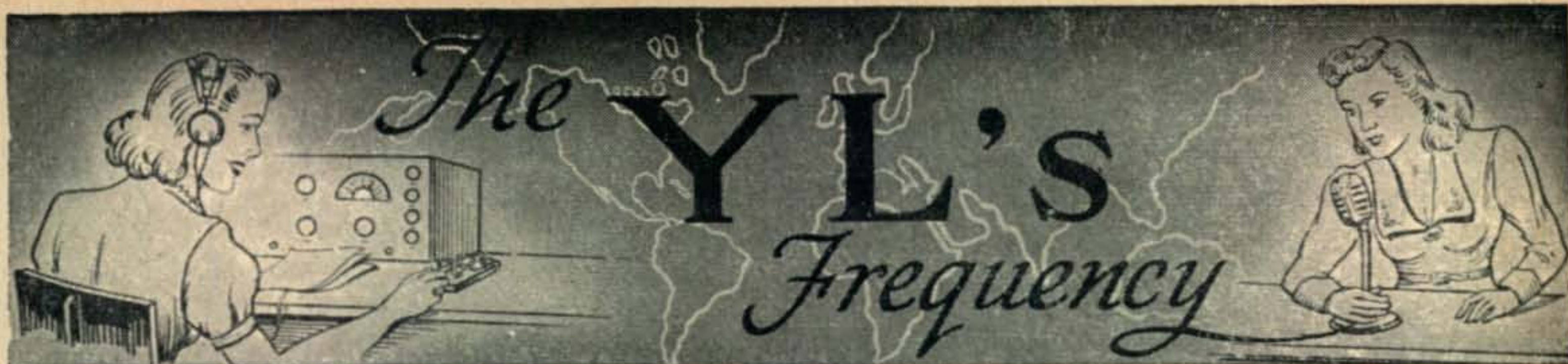

Monitored by LOUISA B. SANDO, W5RZJ

959C—24th Street, Los Alamos, N. Mexico

November again and time for another YLRL contest—the 13th Anniversary Party. Details are given below. Come on and join the fun. Any and all YLs are invited to participate, but only members of YLRL are eligible for awards. Note beginning and ending hours are your *local* time.

YLRL Nets

The YLRL nets are again being activated, and

-
- New England—75-meter phone on 3900 each Wednesday at 0700 EST—NCS is W1SCS.
 - Mid-Atlantic—75-meter phone on 3900 each Wednesday at 0800 EST—NCS is W4CWV.
 - Mid-West—75-meter phone on 3900 each Wednesday at 0900 EST—NCS is W8ATB.
 - Northwest—75-meter phone on 3900 each Monday at 1500 PST—NCS is W7HHH.
 - California—75-meter phone at 1300 PST.
 - All—80-meter CW on 3610 each Wednesday at 2100 EST—NCS either W9JTX or W3JSH.
 - All—40-meter CW on 7040 each Friday at 1900 PST—NCS is W7NOB.
 - All—20-meter phone on 14240 each Thursday at 1400 EST—NCS may be W1MCW, W4OBY, W6HUA or W6NLM.
-

The newly activated YLRL nets, recently announced by Veep W3JSH.

All YLs are invited to join, whether or not members of YLRL.

If interest warrants, sectional Novice nets may be scheduled. Please advise V.P. W3JSH if they are desired.

Flying YL

Ham radio and flying—what better combination of hobbies could one ask for! Rather unusual to find both of them in a YL, too, but that's just the way W1UPZ, Helen Wright, of Brookline, Mass., spends her free time.

Helen says she had been interested in ham radio since high school days, but it was during a wartime training course with the Massachusetts Women's Defense Corps Communication Section that she first got started in radio. Though she found code rather a stumbling block, she got a commercial phone permit, and also assembled her own transmitter (then put in mothballs but recently restored to operation).

In the summer of '42 Helen was appointed assistant director of radio communications for the Massachusetts Committee on Public Safety. This involved coordinating the work done in the various state regions and organizing new classes. During this time she operated in WERS on 2-meter mobile for the town of Brookline. At this time she became interested in aviation and made several student flights until civilians were grounded by government regulations on civilian flying within 45 miles of the coast.

In '45 Helen joined the faculty of Boston University, College of Business Administration, as assistant in the radio department where she operated the console controls for student productions.

Then the aviation bug bit again and in '47 during a vacation she enrolled in the student program at

Some of the ZS gang. Taken at a YL party, the YL's are comfortably outnumbered by OM's! Left to right, seated: ZS6GH, VK6ND, ZS6KK, HO and WV. Standing: ZS6SB, J, JJ, HZ, YL and XY. Photo by ZS6WW.



YLRL 13th Anniversary Contest

DATES: Phone—November 29-30
CW—December 6-7

HOURS: Start—November 29 & December 6
7 a.m. local time.
End November 30 & December 7
7 p.m. local time.

FREQUENCIES: All bands. Net frequencies are 3610, 3900, 7040 & 14,240 kc. It is suggested 14,150 kc. and Novice frequencies of 3740-3750 kc. be monitored, calling on the hour for WN contacts.

ELIGIBILITY: Only YLRL members eligible to compete for awards. However, all YL's are invited to participate and submit logs.

EXCHANGE: RS report (phone) or RST report (CW) and name of state, U.S. possession (KL7, KH6, etc.), VE district, or country.

OPERATING: Call "CQ YLRL." Skeds and crossband operation permitted. CW stations work only CW stations, and phone stations work only phone stations.

SCORING: (1) 10 points for each YLRL member station worked, multiplied by the number of different states (Md. & D.C. count as one state), U.S. possessions, VE districts and countries (except W and VE). Each station, state, possession, etc., will count once only, regardless of the frequency band. (2) 1 point for each non-member YL station worked during the contest period—these points to be added to total after multiplying. Report and state must be exchanged on these contacts also, but these states, etc., will not count as multipliers.

AWARDS: Highest phone score—Cup donated by WIMCW, now held by W3UUG for the second year. Highest CW score—Cup donated by W4HWR, now held by W1FTJ for the second year. These cups are awarded on a yearly basis. A member winning the same cup three times gains permanent possession. 2nd & 3rd place awards for both phone and CW to be donated. A certificate for high score in each U.S. district and country.

Logs must be postmarked not later than Dec 13, 1952, and mailed to YLRL Vice President Dottie Wickenhiser, W3JSH, 1112 State Ave., Coraopolis, Pa. All participants are requested to submit logs whether competing or not.

information officer for the Massachusetts Wing.

Once more radio came to the forefront when, in '51, she joined the Brookline Civil Defense Organization, becoming really active when she got her Novice call of WN1UPZ. And to date she is the only YL on the CD net, operating the 2-meter rig from CD Hq. At home she uses a modified Stancor 25B, and the receiver is a Hallicrafters S40B. She operates 80 CW and has been helping to set up a local net for Novices on 3725. Now she has made her call permanent by passing the Technician exam.

Helen joined the 99'ers several years ago. This is the international organization of women pilots founded by Amelia Earhart 22 years ago. Very few YLs are 99'ers, and she believes she is the only one in the New England Section.

But Helen is quite a "joining" gal—look at this: She is a member of YLRL (chairman for the New England YLRL luncheon next spring), MARS-AF



Helen Wright, WIUPZ, combines hobbies of flying and hamming.

(AF1UPZ operating on 80 and 2), the Eastern Massachusetts Amateur Radio Assn. (of which she is secretary-treasurer), Brookline CD 2-meter net (NCS), Brookline CD Communications Division (secretary), and the South Shore Radio Club.

In addition, Helen is building her own 200-watt rig. She also has other interests; metalwork, needlework and photography,—though she doesn't spend any time on them right now. But she's keeping busy with a full-time job as well. Gainful occupation is that of secretary and researcher for a genealogical service—rather a far cry from either radio or flying!

Here and There

Most OMs get a kick out of seeing a YL get a ticket of her own. They're glad to give a helping hand, and then cheer when she makes the grade. For instance, this note from W2OGY: "When I got my ticket last year Sigrid Topken got the bug too and because of growing interest and the desire to know what her friends were talking about started work on her ticket. In February of this year she was stumped only by the code, and settled for Novice and Technician on her first try. Now, after long sessions on the air, she has made the grade, and is General Class, W2MVC. About to enter Cornell University as a Junior in the School of Industrial and Labor Relations, she is faced with a 'no transmitters' rule in the dorms, but might be on from the Cornell club station, W2CXM." Hope you will, Sigrid, and thanks to you, Norm, for your interest. . . . W8RGU writes of

(Continued on page 72)

Wiggins' Airways at Norwood, Mass., and obtained a private pilot's certificate a year later, flying throughout all kinds of winter weather. Then, in '47 the CAP beckoned, and she became public

DX



AND OVERSEAS NEWS

Gathered by **DICK SPENCELEY, KV4AA**

Box 403, St. Thomas, Virgin Islands

We welcome the following to the Honor Roll:

KL7PI 39-150

The dust should now be settling on CQ's World Wide DX contest for 1952 as this fracas passes into history. We trust that this year's upheaval was attended by passable conditions on all bands and that some record breaking scores will be in the offing. In any case we can be sure that a rip-roaring time was had by all participants.

DX news of an interesting nature seems to have hit a new low for this writing. We do have, however, a rather large ray of sunshine for DX'ers as per our first item below.

Easter Island

The Radio Club of Chile announces as follows: The DX fraternity may, once again, have one of those rare and ever decreasing opportunities of working a hitherto silent, rare DX spot. This will be none other than "Isla de Pascua" (Easter Island to you) and here's the story.

During the past two years CE3AG has been trying to obtain "shack space" on a Chilean destroyer which makes a yearly visit to Easter Island, that mysterious Chilean possession in the South Pacific about 2100 miles west of Valparaiso. It looks now as if Luis may succeed in his efforts to realize this expedition as he is on the list of a privileged few who may visit that lonely reminder of a vanished race. The date of sailing has not been fixed as yet but will probably take place sometime during December, January or February. Luis is all set, however, and will use the gear at his CE3AX QTH. This consists of a Collins 32V2 transmitter, 75A2 receiver and gasoline power plant. Tentative plans call for a four or five day stay and Luis will operate under the call of CEØAA. This will be the first ticket issued under the new CEØ Easter Island prefix. Luis will be accompanied by LU3CZ, Arnold, who will act as second op. CW and phone will be used and every effort will be made to give all hands a contact.

Special QSL cards will be printed and sent via the RCC, Casilla 761, Santiago, Chile. Those interested in obtaining early and direct QSL's via air-mail are requested to forward one dollar for same. The unexpended balance thus collected will be used by the RCC to establish a permanent ham station on Easter Island. Departure date will be immediately forwarded upon release.

At the Time of Writing

6L6MY (HZ1MY) made a short visit to Qatar August 27th. QSO's totaled about 56. Among the lucky ones were G6YQ, W6ZUI, W6GDJ, W6KYG, W6FSJ, W6QDE, W6TI, W6LW, and W6MHB. . . . Effective immediately Qatar is added to the Country List. It is a "sheikdom" located on the east coast of Arabia. . . . HZ1MY went to VQ6 land Sept. 18/20 signing HZ1MY/VQ6. QSO's were reported by W2JB, TI2TG, W5KUC, W2GVZ, W2LV, W9FID and, yes, KV4AA. . . . No further DX trips are planned by HZ1MY for this year. Next jaunt, in '53, may be to VQ9.

SM5LL informs us that Sam, 4X4BX, planned operation from Rhodes, SV5, and Crete, SV6, sometime in October. . . . W6KIP tells us that ZC2MAC has now been heard from VS7MC. Mac said he has been given the call of ZC2AB, for Cocos, thus, the calls of ZC2AB and ZC2MAC will appear on his QSL's which should all be on their way by now. . . . HR1AT has been heard again with a fb signal. Oscar has a new 813 final, 001 2300z. . . . IIAHK plans another San Marino jaunt for the first



Proving that the license plate fad extends to Haiti, we see here Henry Birmingham, HH1HB, pausing for photo in the streets of Port-au-Prince. (Photo courtesy of W2VIA.)

week in December. The new prefix of 9A1 will probably be used. . . . VR4AE has been active giving QTH as Honiara, Guadalcanal, 7/14 mc. . . . W7BD reports strong signals from B1AB, Box 34, Taichung, Formosa while W4CEN reports HU7AB, Kaitex Airport, China.



One of the much sought for stations is shown above. This is FY7YB operated by Hermann Ravin, Cayenna, French Guiana. Power is 40 watts. (Photo courtesy of W9AND.)

7AB is also reported S9 at VS6CM. . . . HB1JJ/HE was again active in Liechtenstein Aug. 20th to 30th. . . . From K2BU, FF8JC is again active in Dakar. Jack plans a 400 watt signal in October. . . . CN8GK (W6KYT VP7NZ) will be active in Fr. Morocco for the next six months. QSL via W6NZ. . . . CP1BX, 001, 2000/2400z, VFO, ex op at VE5GO, now VE7ZZ, says he seems to be the only CP that is active on 14 CW now that CP1BK is headed for west coast USA. Ted is chief of the civil aviation mission sent to Bolivia by the CAA and runs 50 watts to an 807. Antenna is three wave V beam N/S. He expects to be there two more years. Ted was W6RIG, '39 to '41. See QTHs. . . . A further note on HZ1MY/VQ6. While Dick signed HZ1MY, without the VQ6 suffix, probably for the benefit of DX hogs, he assured W2PF, and others, that he was in VQ6 land, for sure. G6YQ reports he worked hundreds of Europeans and W's. . . . VQ5CL has been active on 014, 1930z. See QTH's. . . . FG7XA has been active 018 and 090 2000/2300z. . . . GM3CSM rec'd card from VS9AW, who is ex G3GUK, the QTH read: R.A.F. Salalan, Aden Command, Saudi Arabia. VE3KF advises that the RSGB is counting VS9AW as a new country (Separate from Aden or Oman) (?). . . . VE3KF also says that HB9AW (FO7AW ?) ops from FM7AW 14100 and that YA3VB is one of HZ1MY's proteges and has been heard on the band. He should be on about every three days and then for only two hours starting around 1500z. . . . VE3VO puts in a fine signal from Nottingham Island NWT. Mickey will be there a year and uses a rhombic. VE1BV/VE8, Cec, was also worked from same station. QSL via VE1FQ. . . . ZK1BC did a fine job on his last minute DX spurt during Sept. Bob left ZK1 for ZL around Oct. 1st. W6MUR has placed order for 1000 QSL's for ZK1BC. . . . W2QHH has forwarded 160 meter xtls to VP2MD, CT2BO (1994), and FP8AP (1914). PJ2AA, V5BF, VP5FR, VP1AA and TI2PZ have also rec'd 160 xtls and we hope to see them on the band this winter. . . . From F9RS via W1NWO we hear that new regulations in Andorra forbid the granting of licenses to foreign or native hams for some time to come. This leaves PX1YR, Yves Ramond, as the only PX hope. He will be on 14-mc phone from Sept. with VFO. . . . ZS6BW says YA3XY was a phony operating from an aircraft.

Backfires

Our first prize, a blown out 807, goes to a W6 heard calling "CQ SS" five minutes after the Sweepstakes were over. Upon being advised of this our friend wanted to know if there was any law against calling CQ South Shetlands!!

Our second prize, a rusty grid cap, goes to one VQ7BW (Heard by W4CEN) working a ZL and giving his QTH as Box 99 UPO, Russian Somaliland—some fun!!

Exploits

W7AMX jumps to 235 with 20 additions including such as ZC2MAC, VS5ELA, VR3C and FL8MY. Nice gg Art. . . . Jim, W9LI, goes to 147 with 16 additions. He is slowed down a bit by TVI. . . . W5MPG ups to 193 with VR8C and F9QV/FC. Rex still chases JY1AJ Frank, W6SYG, keeps close to the head of the column with 237. The last two being FL8MY and VS5ELA. . . . Ray, W6BUD, is now going strong with a Viking exciter pushing the PP 250TH's and adds ten to reach 193. . . . W1NWO still retains lead in the 36 A3 column adding FL8MY and YU3AC. This brings Willard to 196. Close on his heels is W1MCW. Lou added C3AR and VS2CY bringing her to 36-195 A3. . . . W6MX has 228 confirmed with cards from EA9DC and FL8MY. Art seeks a CR5 and a ZS8. . . . Loo, W3LE, has been working such as MB9BJ, HZ1SD, ZD4AX, FP8AJ and a flock of TA's. He advises QTH given on TA3AA and TA3GCN is "351 Ataturk Bulvari, Ankara, Turkey". Ed, at TA3AA, is ex J5VQG/W0VQG/QX3BD/W1VQG/W0VQG/D4 while TA3GCN is stateside W8GCN. (Other op at TA3AA is Andy, W6OME). . . . W3MAL up to 87 with his 25 watter with PJ2AD. Ray moved to Ohio in Sept. . . . KP4KD upped to 192 with LZ1KAB upon his return home after a four month stateside trip where W4DYX, W4IEN, W4BOR, W1IKE, W5GG, W3NCJ, W3EGI, W2PUG, W3QHD and W1AW were visited. Ev has just completed WAC on 21 with KG4AF, ZC4RX, LU3EL, ZL4FO, ON4HC and OQ5BQ giving him WAC on all bands 35 through 28. . . . W6TI goes to 210 with VP2KM. We can't add 6L6MY as yet Horace. . . . W9FKC goes to 201 with HI6EC, ZK1AA, KJ6AR, YI3BZL and LZ1KAB. We've been putting Mike down as W9KFC, guess we had W4KFC on our minds—sri. . . . W1APA rises to 135 with KC6QY, ZB1AH, HR1RL and FQ8AG. Gil suffers from TVI and lack of zones 22, 23 and 39. He is recuperating from an auto accident on Aug. 18th and doing nicely. . . . W3GAU returns his list with 52 additions. This puts Joe on 235. . . . Wally, ZS6A, ups to 164 with nine additions. . . . G8IG goes to 203 CW and 175 A3 with FP8AK, ZD9AA and FB8BB. . . . SM5WI submits list of 49 new ones shooting Harry up to 196. . . . OZ7BG added LU4ZI making Eric 167 while VK2ACX benefited from the VS1/2 split to the tune of 223. . . . DL1FF reaches 217 with 4W1MY, ZC2MAC, KC6DX and VS5ELA. . . . Andy, W6ENV, tacks on FL8MY and VS5ELA and is right up there with 245. . . . W1RAN, Ned, advances to 135 with ZP6CR and ZK1BC. . . . Ron, G4CP hops to 232 with such as 4W1MY, FL8MY, VK1BS, ZC2MAC and VS5ELA which takes care of all the latest ones. . . . W4ESP A3'ed to 159 with EA9DC, EA0AB, VQ1RF, ZK2AA, etc. . . . W0ANF reached 138 A3 with EA9DC, YI3BZL, FP8AK and VP5BP while W7ENW made it 178 with PJ2AA and ZP5AY. . . . W6MHB comes through with an overdue list of 23 additions putting him on 183. . . . Bill, W2HAZ, ups to 112 with FP8AP.

F9AH rec'd card from 4W1MY giving him 159 for 173. . . . VK3KX nabbed VSELA and EA6AM. . . . W8EKK,



Armand Mallebranche, HH2X, Port-au-Prince, Haiti, is shown at the mike. He is President of the Amateur Radio Society of Haiti. (Photo courtesy of W2VIA.)

the

VHF

Edited by
W. E. (BILL) McNATT, W5FEW
6614 Plaza Drive, Houston 21, Texas

news

Two-Meter DX Madhouse In September!

The most intensive, extensive, and comprehensive opening ever observed by radio amateurs on 144 mc. occurred on September 7, 8, and 9, 1952. So many first interstate contacts occurred so rapidly that we—as well as you—still aren't sure just exactly "who did what!" And, it will be appreciated, very much, if you'll let us know promptly where errors or oversights exist in the following reports.

It is quite certain, however, that sharp-shooting two-meter DX men made the best of the biggest v.h.f. opening to occur in nearly two years, when W2BAV's terrific signal swept the east, midwest and "northern" southlands (southern Oklahoma and "northern" Texas) in the early fall of 1950! WØEMS, Adair, Iowa; VE3BPB, Lambeth, Ontario; WØIFS, Plymouth Township, Minnesota; W9FAN, Sheboygan, Wisconsin; W2NLY, South Plainfield, New Jersey; W1PBB, Monroe, and W1HDQ, Canton, Connecticut; W1RFU, Indian Orchard, Massachusetts; WØKYF, University City, Missouri; W5RCI, Marks, Mississippi; W4HHK, Collierville, Tennessee; and many others, made v.h.f. history!

Thanks, again, to W9WOK, W2NLY, W9ZHL, W5JTI, WØTKX and VE3BPB for their "flash" reports, which enabled us to insert the last-minute bulletin in the October column. Thanks to the gang, whose reports follow, for the detailed stories.

It appears that WN9RXS, Chicago, and W1RFU made the first Illinois to Massachusetts contact on two. W1HDQ and W9FVJ picked off the first Connecticut to Illinois QSO on two meters.

W9WOK monitored both tropospheric and auroral propagation, practically all night, September 8 and 9. John observed mild aurora at 1:45 AM to 3:50 AM, CDST, on the 9th. A mild aurora also existed on

September 7th, and peaked at about 6 PM, but no stations were heard on either 6 or 2. W9WOK worked W8EP, Terra Alta, West Virginia, for state #17, and called and called W1RFU and W1PBB! W2UK, New Brunswick, New Jersey, and W4AO, Falls Church, Virginia, were also worked at W9WOK.

The frequency and geographical coverage intensity of the opening was recorded deftly by W9WOK, who monitored TV channels, as well as 6 (no activity) and 2 meters, and logged 24 TV stations in 10 states on 11 channels, covering channels 2 through 13, completely, in Illinois, Indiana, Wisconsin, Michigan, Ohio, Iowa, Missouri, Minnesota, Pennsylvania, and Tennessee!

The only Texas station involved in the opening—that we have been notified of—was W5JHX, Dallas, who worked WN9SDH, Sheboygan, Wisconsin on September 8, according to W9PK! Jack also reports, in these columns, that W9BPV, Armington, Illinois, worked W5UBK, New Mexico!

Because of the preponderance of 2-meter reports, we're putting the 420 mc. and 220 mc. reports "up front" in this issue. You will notice that W1HDQ and W8BFQ now hold the 220 mc. DX Record! The Texas gang, "dethroned," is again ready to secede, tidelands oil fields or none, hi!

New 220 Mc. DX Record:

On September 9th, W1HDQ, Canton, Connecticut, arose at 0630, and—after morning schedules with W2UK and W2QED—he heard 2-meter signals from Margaret, W8BFQ, coming through. This was the chance both had been waiting for, for more than a year. So, Ed got hold of her son on 2 and arranged for her to go to 220.

Ed says, "I heard her 220 mc. signal here, S1-5, at once, so I changed to 220 (after a mess of connection troubles with the 220 rig) and we made it 2-way, a solid QSO on voice, for a new record! Changed back to 2, hoping to make a 420 check, but the 2-meter signal was nearly out by then (around 9:30 a.m.) Margaret



The Chicago Area VHF Picnic was well attended by more than 21 two-meter hams and their families. (W9NW Photo)

did hear W2QED on 435 mc., however, which is very good news." (Well, the Texas gang had the 220 mc. record for a while, anyway! Hi!—VHF Ed.)

W4HHK has notified W5AJG, W5AXY, W5BDT, W5FSC, and W5ONS that W5RCI, W4UDQ and W4HHK are set up to keep schedules on 220. Present lineup is: W5RCI, Marks, Mississippi, 220.2 mc., 16-element beam, 829B final, crystal converter to an HRO. W4UDQ/W4HHK, Collierville, Tennessee, 220.725 mc., 32-element beam, 6J6/HFS/NC188, receiver and 832A final. Rex, "DB", and Paul propose the following schedules, subject to approval of the W5s:

Texas stations call on 220—0730 to 0740 CST

Texas stations call on 220—2100 to 2100 CST

Call Texas stations on 220—0740 to 0750 CST

Call Texas stations on 220—2110 to 2120 CST

W5RCI, Marks, Mississippi, says he hasn't heard any DX on 220 yet, but is still trying. He has just about finished the new p.p. 826 final.

420 Mc.

On the morning of her record-setting 220 mc. QSO with W1HDQ, Connecticut, Margaret Roberts, W8BFQ, Everett, Ohio, heard W2QED, New Jersey, on 435 mc., September 9th, according to Ed Tilton, W1HDQ. This represents 420 mc. DX of about 460 miles!

"Still no activity in these parts on 420. I hear W0DDX talking about it but that is all," says Harry, W0INI.

W5AXY and W5BDT, Austin, and W5AYU, Houston, made the first Austin-Houston contact on 430 mc. on the morning of August 24th with good readable signals both ways. The distance is about 150 miles. Lee and Penn had been reading W5AYU's signals for some time, but W5AYU had not been able to hear them.

New Jersey Report

W2NLY, Plainfield, New Jersey, worked W9FAN 10:40 PM, September 8, for the first New Jersey to Wisconsin contact on 2 W0KYF for first New Jersey to Missouri QSO; and W0EMS for first New Jersey to Iowa QSO. Jim also worked WN0GUD, Conway, Iowa. He heard 36 W8s, W9s and W0s! He pulled switches at about midnight, as he had to go to work the next day! This brings W2NLY up to 22 states, 7 call areas VE1 and VE3.

W2NLY had just gotten the 48-element beam modified and back up in time for his DX! He was running 125 watts input. "Say, I need Texas! What say, gang?" says Jim.

Terre Haute Tips

W9ZHL, Terre Haute, Indiana, on September 7, heard or worked W4CVQ, W0OAC, W5RCI, W4HHK, W0BBM and WN4UDQ, after getting on the band late.

Donald L. McCaskell, W9OCA

1922-1952

Don McCaskell, W9OCA, of Watertown, Wisconsin, was fatally injured while witnessing a stock car race in Edgerton, Wisc., early this September. As an uncontrollable car left the track and rushed toward his sideline position, Don sought refuge by dashing between two parked vehicles, where he was ultimately crushed as the careening racer smashed into the vehicle which shielded him.

Don McCaskell was assistant secretary-treasurer of the Watertown Building and Loan association, to where he had returned after five years of service in the Navy in the Pacific. His untimely death on his 29th year came as a severe shock, for both his friends and relatives in Watertown, where he was well loved and respected, and for his friends among the six-meter gang, in which he had been active for several years.

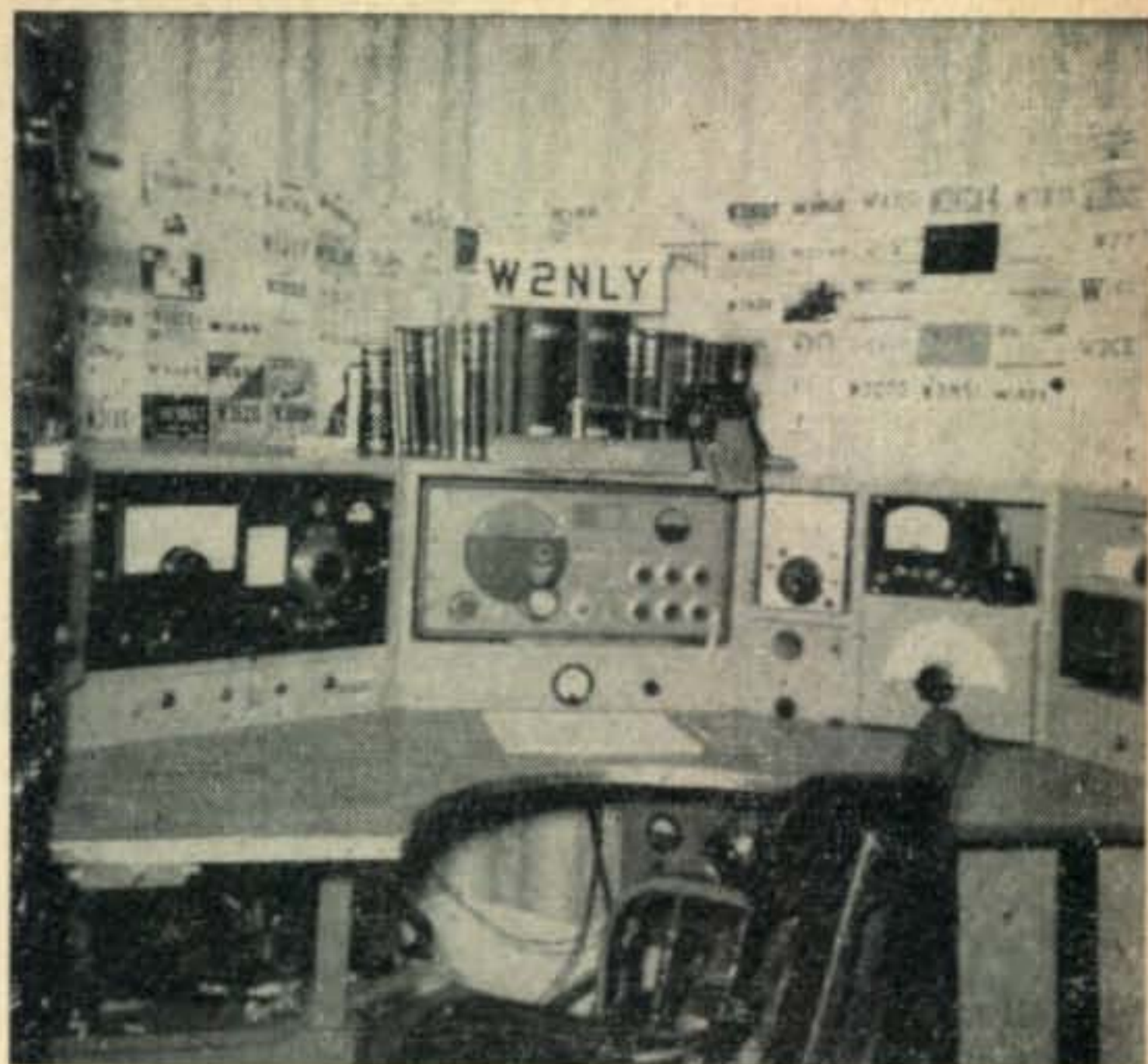

W2NLY's operating position. Neat style; neat QSOs; neat DX!

On September 8, Charles heard or worked WN9QEP, WN0GUD, W0ONQ, W9KCX, W9UED, W0TMI, W0PLJ, W9DGD, W0DDF, W9FVJ, W0EMS, W0DDX, W0INI, W8BQR, W9DDG, W9YHA, W8DJF, W8HUX, W0KYF, W9PNK, W3RUE, W9BOV, W8DX, W8BFQ and W9UCH. On September 9, W9ZHL didn't get on until late, and heard only W9EGH and W8EGX.

"Don't think I ever heard so much DX, but I just couldn't hear the W1 and W2 stations!" says W9ZHL, "I even heard a Dallas station being called on the 8th!"

Connecticut Comments

W1HDQ was on all evening, September 8th. Ed heard the W2s go after the W9s and W0s, early in the evening, but didn't hear a peep beyond Pennsylvania until after 11 PM.

"I raised W9FVJ, Toledo, Illinois, on a CQ, for what I believe to be the first Illinois-Connecticut QSO on 2; phone, too, and good," Ed reports. "I'd been hearing W0EMS for a few minutes before, and continued to hear and call him for about 3 hours, to no avail. Heard him work dozens of stations, including W1PBB, only about 30 miles south of me, and when he asked W1PBB if I was on (after I had called him for 2 hours!) I figured I'd never make it. And, I didn't! Only other DX worked was W9EGH, for his first Connecticut contact."

Finally, after a half-hour more of "nothing" coming through, Ed compared notes with W1PBB and W1RFU. Neither of them was hearing anything, either. So, W1HDQ figured that even the Middle West had gone to bed, and so did he, just after 0300 EDT. At 0318 W1RFU worked W0EMS, for the first Massachusetts-Iowa 2-meter QSO, and the best DX reported this year!

"The band stayed open for about 3 days. It was the longest and best opening I've ever experienced, way ahead of the big W2BAV western opening that you woke me up for in 1950," Ed reports. "If Bill, W2BAV, had been on that night, he'd have worked the West Coast, I guess! Never heard anything even remotely resembling it, here, before. Also, worked W4CVQ the night of the 9th, so I now have 18 states. The state totals around the country are really something, now!!

Mississippi Marks

W5RCI, Marks, Mississippi, reports that the September 7th opening started when he signed with the boys in Memphis and called a CQ. The first QSO was with W9UED; it seems that Rex can work Chuck just about any night. His signal was a little above normal. From then on, W5RCI worked W9LEE for the first Wisconsin-Mississippi contact, W9JBF, for the second Wisconsin QSO and W9ZHL, Terre Haute, for Rex's first Indiana contact. . . . W9BPV, W9POV, WN0GUD, W0EMS, W9KPS, W9LF, W9MBI, W9EQC, W9PK, WN9REM and W9TQ were also worked. . . . Around 1 AM, W4HHK had a contact with W8BFQ, and told her W5RCI was on. Paul arranged for Rex to call Margaret and W5RCI tried for at least 25 minutes to contact her. W5RCI could read Margaret about 25% on phone, and could have read her solid on CW.

The following contacts not only were new states for W4HHK, but are, to the best of our knowledge, the first two-way contacts on two meters between Tennessee and these states: W9LEE, Wisconsin, 2215 CST, September 7th. W0DVV, Kansas, 0032 CST, September 8th. W0QXR, Nebraska, 0023 CST, September 8. W0OAC, Minnesota, 0043 CST, September 8th.

W4HHK says that W9JBF was contacted before W9LEE and would have been the first Wisconsin contact but for the fact that they lost each other, and the contact was incomplete! W0QXR, Omaha, Nebraska, was a real struggle to work. His phone signal was too weak to read, and he had no means of keying. Paul begged and pleaded that he key the rig some way. . . . with the B plus switch, antenna relay, anything. . . . and he finally came through on slow . . . very slow CW.

"I still wonder how he did it," says Paul, "The Nines and Zeros up that way deserve a lot of thanks, for they were grand fellows, helping me get lined up with those rare contacts in Kansas, Nebraska, and Minnesota!"



Leo Heuer, W9OKF, Park Ridge, Illinois, offers a smiling challenge to any new odds, whether in ham radio or in physical endurance. Read "In And Around Chicago." (W9NW Photo)

As for propagation, W4HHK observed that conditions seemed best through Illinois, Iowa and Wisconsin. W8BFQ must have been on the eastern edge, because Margaret's signal was only of fair strength . . . nothing more. Some of the Illinois and Iowa stations nearly pinned the meter at times.

Rex got to bed about 2:15 AM and arose next morning about 6:45. He didn't hear anyone for about 10 minutes, so called a CQ. W9LF came back, and following the CQ with Elmer, Rex worked W0EMS and W0IHD.

The 2-meter score for W5RCI is now 14 states and about 790 miles.

Tennessee Topics

W4HHK says, "It all began Sunday night, September 7, just after an unsuccessful 220 mc. schedule with the Texas gang. Not hearing W5RCI on after the schedule, 'DB' (the XYL) suggested we listen on 144. My only feed-line was on the 220 antenna, but we put it on the two meter converter . . . tuned the band, and there was W5RCI working a Wisconsin station! This was too much for me . . . so I enlisted the aid of W4TIN, who was visiting in the shack, and up the 75 ft. tower we went!"

Several hours later, when the smoke had cleared, these stations and states had been worked by W4HHK, from September 7, 1952, 2205 CST, to September 8, 1952, 0132 CST: W9BEQ, Ohio; W9BPV, W9EQC, Illinois; W9JBF, Wisconsin; W9KPS, Illinois; W9LEE, Wisconsin; W9LF, Illinois; W9LJV, Wisconsin; W9MBI, W9PK, WN9QEP, WN9REM, WN9RXS, Illinois; W9TQ, W9YYY, Wisconsin; W9ZHL, Indiana; W0BIP, Iowa; W0DVV, Kansas; W0EMS, WN0GUD, W0HVF, Iowa; W0OAC, Minnesota; W0ONQ, Missouri; W0QXR, Nebraska; W0TMJ, W0YRX, Missouri.

Paul had come home from work in the afternoon with the idea that an opening to the west or southwest might occur; the weather map looked promising. About the time he found the band already open on Sunday night, Paul and "DB" observed there was a light fog coming in, a rare thing around Collierville; it—the fog—was still present Monday morning.

As a result of the opening, W4HHK now has 19 states. The rig is still 300 watts input to p.p. 4-65A's; a 5-over-5 Yagi, 80 feet up, and a crystal converter to an NC183 receiver.

Kansas City Notes

W0MNLQ wasn't too active on the band, this summer, but he did catch the September 8th opening. Some of the gang in Illinois and Ohio worked some W5s, but nothing was heard from W5-land in Kansas City. W4AO was Jim's longest haul, but he heard W2NLY and what he thinks was W2ORI. Also heard: W8WRN in contact with W4JDN/8.

"They were even talking about me and my signal, but—just my luck—I couldn't make contact, so that makes another state missed: W2NLY, New Jersey. Anyway, I finally did get Ohio, as well as Pennsylvania and Virginia", says Jim. On the smaller opening of August 23, W0MNLQ added Minnesota, Arkansas, and Michigan for a total of six new states this year. Total: 17 states, 7 call areas, and the longest distance still 1098 miles, made with W2BAV in 1950. . . . W0DDX, W0DVV, W0ONQ, W0LFW, W0TMJ, W0INI, W0TOQ and W0ELL were active in the September 8th opening. Ed, W0ELL, moved from Denver and is living in Prairie Village, Kansas.

"The opening was the usual back side of a 'high' for us with the center of the high about over Boston," W0MNLQ comments. "Radiosonde reports from Ft. Leavenworth, Kansas, all the way east to Washington, D. C., showed a layer at about 5000 ft. or lower, mean sea level. Toledo and Albany, New York, didn't report, although I know it was OK around, Toledo, since I worked W8DQR and also W8BFQ at Everett. No W1s were heard. Although the W8s in Ohio and Michigan reported VE3s rolling in, nothing was heard of the Canadians out here."

Jim adds that nothing has been heard, so far, from the west. Also, nothing has been heard from Oklahoma or Texas. W0MNLQ has had schedules with W5UZW, near Oklahoma City, with no success. He does set into the Abilene and Salina, Kansas, area now and then, however. The gang out in central Kansas is still active. W0DSR, Greenleaf, Kansas, is on intermittently and, believe it or not, W0QXR, Omaha, gets on once in a while! Not often enough to satisfy the gang over east, though. They all sure want Nebraska! There are rumors that two stations are on 2 in South Dakota, but, so far, the Kansas City gang hasn't heard them, and neither has the Iowa gang.

W0MNLQ is going to become a W5, about November 1st. "Braniff" is moving the office to Dallas! "I'll have to start all over again on two, darn it," says Jim. "I intend to contact W5AJG; maybe he can put me next to a good location!"

Ohio Observations

September 7, 8 and 9th of the year 1952 will go down in VHF-UHF history for Ohio, W8WRN reports. He missed the 7th deal; couldn't hear through the noise, and went to bed too early! W8CPA tried to raise Ken ovr the landline, but no response. Tsk, tsk!

Stations heard or worked on Monday, September 8, between 8:15 PM and 11:15, EST.: W3FPH, W3RUE, W3LWN, W3QKI, W4JDN/8, W4KZF, W4PCT, W5??? at 8:23 on 144.43, W9UED, W9EGH, W9BPI, W9DVG, W9KPS, W9UGD, W9YHA, W9NVK, W9FAN, W9MBI, W9EQC, W9UJM, W9JGA, W9DDG, W9WOK, W9GDM, W9POW, W9YYY, W9BPV, W9LF, W9FVJ, W9ORZ, W9LJV, WN9SDH, WN9RNE, WN9RXS, W0HAQ, W0TMJ, W0INI, W0EMS, W0KYF, W0MNLQ, (very good), W0LFW, W0DSR, W0DVV, WN0GUD, W8RFQ, W8DX, W8EDS, W8ZPH, W8KAY, W8FMW, W8LPD, W8BLN, W8FQK, W8DQR, W8SDJ, W8EP, WN8HRI, WN8HPB, WN8HQK and WN8HQX. The Wisconsin boys were the strongest. W0MNLQ was very good!

Tuesday, September 9th, 7:15 to 9:30 AM: W9WOK, WN9REM, W8BFQ, W8IEE, W8NNF, W8EP, W8GNN, W4AO, W0EMS, WN0GUD. W4AO was 10 db over S9 and W0EMS was running 20 db over S9, looking for W1HDQ! (Ed was QRL with W8BFQ, making a new 220 mc. DX Record!—VHF Ed.)

From 5:00 to 11:15 PM: VE3BPB, VE3BAA, VE3AQQ, W1HDQ, W1PBB, W2NLY, W2PV, W2AZL, W2UK, W2BE, W2TSY, W3RUE, W3FPH, W3LWN, W3OMY, W3LVD, W3PQY, W3OZD, W3QBF, W3PYW, W3LST, W4PCT, W8BFQ, W8EP, W8LPD, W8UEY, W8YIA, W8FMW, W8SOJ, W8KAY, WN8HQK, WN8JHS, WN8KQV, W9EGH. W2NLY was in all evening, giving a lot of the boys their New Jersey contact! Jim peaked

(Continued on page 66)

Ionospheric Propagation Conditions

Forecasts by GEORGE JACOBS, W2PAJ

3620 Bedford Ave., Brooklyn 10, N. Y.

The CW period of the *CQ World Wide DX Contest* will be conducted over the weekend of November 1-3. Last month's column was devoted to a propagation analysis for the contest period, and the tables appearing in that issue can be used for the CW contest period. This month's analysis describes general propagation conditions expected throughout the month of November and if desired can be integrated with the tables appearing last month to give an up to the minute picture of shortwave conditions.

In November, the seasonal propagation trend in the Northern Hemisphere causes an increase in daytime MUF's and a further decrease in the nighttime MUF's. This means that more DX may be expected on both 10 and 15 meters than during the summer and early fall months. On 20 meters, signals will be somewhat stronger, but the band will be open a shorter period of time on most circuits than during the summer months. Continued improvement on 40 and 80 meters should be noticed on many circuits and some 160-meter DX may be possible towards the end of the month on some circuits.

A note to you fellows who live North of latitude 35 and conduct local night-time nets on 75-meter phone. Towards the end of November you'll experience some difficulty keeping contact with net members within the radius of just a few miles. The reason for this is that on a good many nights the vertical incidence MUF will drop below 3.8 mc., after 8:30 P.M. local standard time. I suggest you give some consideration to the 160-meter band or the VHF bands for your local network operations.

Ionospheric Storms

Throughout this series of articles we have frequently made reference to normal and disturbed shortwave radio propagation conditions. Normal propagation conditions are said to exist when the characteristics of the ionosphere behave according to certain known solar relationships. Every shortwave radio propagation path will have its own diurnal (night and day) characteristics which changes month-by-month and year-by-year throughout the sunspot cycles. These changes for the most part correspond to the position of the sun in relation to the earth, as the earth rotates around the sun. This is due to the fact that it is believed that ultraviolet radiation from the sun is predominantly responsible for the formation of the ionized layers that make DX transmissions possible. As the distances and angles of the sun to the earth's plane of rotation vary, so will vary the characteristics of the ionosphere. These cyclic ionospheric characteristics can be predicted with a good degree of accuracy. It is these normal characteristics that determine the general trend of shortwave radio conditions for any particular period. The disturbed characteristics of the ionosphere are responsible for modifying this general trend. These transient disturbances cause deviations from the typical normal characteristics for any given circuit.

Ionospheric or propagation disturbances are quite often referred to as magnetic storms. Although the

exact relationships are not yet completely known, it is believed that these storms are related to the presence of gaseous eruptions on the sun, commonly referred to as sunspots. These disturbances generally produce varying effects on the ion density of the various ionospheric layers, and, as well, upset the earth's magnetic field. The frequency of occurrence of ionospheric disturbances is believed to vary with sunspot activity, or the number of sunspots that appear on the face of the sun. If this is so, it is quite significant to Amateurs. Presently we are entering the low period of sunspot activity. Considerably fewer sunspots are observed on the sun today than have been within the past few years. This may mean that the pattern of very frequent severe ionospheric disturbances noticed during the Fall, Winter and early Spring months of 1950 and 1951 will not repeat itself this year. If such is the case, even though conditions on the higher frequen-

Periods of disturbed conditions in November are expected as follows: Nov. 1-3, 6, 7, 20-23, 27-29.

cies may become poorer with considerably less DX activity on 10 and 15 meters during the low period of sunspot activity, the lower frequency activity on 20, 40 and 80 and 160 may improve over what it has been for the past few years. The reason for this would be, along with the above mentioned factor, the decrease in ionospheric disturbances attributed to decreased solar activity. This apparently appears to be the case so far this year. Considerably less ionospheric disturbances have been recorded this Fall than during the Fall of 1950 and 1951.

(An unexpected moderate to severe ionospheric disturbance was observed starting on September 6th. This period corresponds to two cycles (54 days) before the CW contest period. If this disturbance recurs for the next two cycles it may affect DX.)

General Propagation Conditions

November, 1952

This month's analysis is based upon a predicted smoothed 12-month running average Zurich sunspot number of 38, centered on November, 1952. Forecasts are based upon an assumed effective radiated CW power of 150 watts. Analyses are based, in part, upon data appearing in CRPL Series D, Number 96, "Basic Radio Propagation Predictions", issued by the National Bureau of Standards, Washington, D. C.

EUROPE

On most days peak daytime MUF's should approach 26 mc., which means that on propagationally good days, the MUF should peak over 28 mc., and some 10-meter openings can be expected, especially to South and West Europe. Less ten-meter openings will occur than for the corresponding period last year. This is due to lower sunspot activity this year, with the minimum not yet expected until 1954. . . . Plenty of activity is expected

(Continued on page 76)

EAST COAST TO:
(Centered on
Washington, D. C.)

	10 Meters	15 Meters	20 Meters	40 Meters
	<u>ALL TIMES IN G M T</u>			
Scandinavia	1330-1600 (1)	1300-1630 (2-3)	1200-1830 (2-3)	2230-0830 (2-3)
Great Britain & Western Europe	1330-1700 (1-2)	1230-1800 (3-4)	1130-1730 (3) 1730-2100 (3-4)	2130-0900 (3-4)
Balkans	1300-1600 (1-2)	1200-1700 (2-3)	1130-1700 (2) 1700-1900 (3)	2100-0730 (2-3)
Central Europe	1400-1730 (1-2)	1230-1830 (3-4)	1130-1300 (3) 1300-1730 (2-3) 1730-2000 (3-4)	2200-0700 (3-4)
Southern Europe & North Africa	1300-1800 (2-3)	1200-2000 (3-4)	1100-1300 (3) 1300-1800 (2-3) 1800-2200 (3-4)	2130-0800 (3-4)
Central and South Africa	1300-1600 (1-2) 1600-1830 (2-3)	1130-1730 (1) 1730-1900 (2) 1900-2100 (3)	1030-1630 (1) 1630-0000 (2-3)	2200-0330 (2)
Near & Middle East	1300-1530 (1-2)	1200-1600 (2)	1100-1600 (1) 1600-1800 (2-3)	2230-0400 (2-3)
Central America & Northern South America	1330-2100 (3-4)	1200-2000 (3-4) 2000-2330 (4-5)	1200-2000 (3) 2000-0030 (4-5) 0500-0700 (1-2)	2230-1300 (4-5)
South America	1300-1830 (3) 1830-2030 (3-4)	1130-2000 (2-3) 2000-2230 (3-4)	1100-1230 (2-3) 1230-2100 (1-2) 2100-0030 (3-4) 0400-0700 (1-2)	2200-1000 (3)
Hawaii	1730-2300 (2-3)	1700-2200 (1-2) 2200-0030 (3)	1500-1700 (2-3) 1700-2200 (1-2) 2200-0200 (3-4)	0400-1400 (3-4)
Australasia	2100-2300 (1)	1400-1700 (2) 1930-0000 (1-2)	1200-1500 (2-3) 1500-2200 (1) 2200-0200 (2)	0400-1200 (2)
Guam & Pacific Islands	2100-2230 (1)	2030-2330 (2)	1330-1600 (2) 1900-0000 (1) 0000-0130 (2-3)	0600-1300 (2)
Japan	Nil	2130-2300 (1-2)	1330-1530 (0-1) 2100-0100 (2)	0500-1200 (1-2)
India	Nil	Nil	1200-1530 (1-2) E 1330-1530 (0-1) A 2300-0000 (0-1) A	2200-0100 (0-1)
Philippine Islands & East Indies	Nil	Nil	2130-2330 (1)	Nil
West Coast, USA	1900-2200 (0-1)	1800-2100 (2) 2100-2230 (3)	1430-1830 (2-3) 1830-2200 (2) 2200-0000 (4)	0200-1300 (3-4)

CENTRAL USA TO:
(Centered on
St. Louis, Mo.)

	10 Meters	15 Meters	20 Meters	40 Meters
	<u>ALL TIMES IN G M T</u>			
Great Britain & West Europe	1430-1700 (1)	1330-1800 (2-3)	1200-1630 (2) 1630-2000 (3)	2200-0900 (3)
Central Europe	1500-1700 (0-1)	1400-1730 (2-3)	1230-1630 (2) 1630-1900 (3)	2230-0200 (3) 0200-0700 (1-2) 0700-0800 (2)
Southern Europe & North Africa	1430-1800 (2-3)	1300-1930 (3-4)	1130-1300 (3) 1300-1800 (2-3) 1800-2130 (3-4)	2200-0800 (3-4)
Central & South Africa	1400-1700 (1-2) 1700-1900 (2-3)	1200-1800 (1) 1800-1930 (2) 1930-2130 (3)	1100-1800 (1) 1800-2100 (2-3) 2100-0100 (3)	2300-0330 (2)
Central America & Northern South America	1500-2130 (4)	1300-2100 (3-4) 2100-2330 (4-5)	1200-1400 (3-4) 1400 2000 (3) 2000-0100 (4-5) 0630-0800 (1-2)	2300-1330 (4-5)

CENTRAL USA TO:
 (Centered on
 St. Louis, Mo.)

	10 Meters	15 Meters	20 Meters	40 Meters
<u>ALL TIMES IN G M T</u>				
South America	1400-1930 (3) 1930-2130 (3-4)	1300-1430 (2-3) 1430-2000 (2) 2000-2300 (3-4)	1130-2200 (2) 2200-0100 (3-4) 0300-0700 (2)	2300-1000 (3)
Hawaii	1800-2300 (2-3)	1630-2200 (3) 2200-0100 (4)	1530-1800 (2-3) 1800-2300 (1-2) 2300-0300 (4)	0400-1500 (4)
Australasia	2100-0000 (1-2)	1500-1730 (2) 1730-1900 (1) 1900-0130 (2-3)	1400-1630 (2-3) 1630-0000 (1) 0000-0300 (3)	0500-1400 (2-3)
Japan	2130-0000 (1)	2100-0030 (2)	2030-2300 (2-3) 2300-0000 (1-2) 0000-0200 (3)	0600-1400 (2)
India	Nil	Nil	1330-1530 (2) AE 2330-0100 (1-2) A	2230-0100 (0-1) E 0600-1200 (0-1) A
Philippine Islands & East Indies	Nil	2130-2330 (1-2)	2100-0000 (1) 0000-0100 (1-2)	0930-1230 (0-1)

WEST COAST TO:
 (Centered on
 Sacramento, Calif.)

	10 Meters	15 Meters	20 Meters	40 Meters
<u>ALL TIMES IN G M T</u>				
Europe	Nil	1500-1730 (1-2)	1430 1700 (1) 1700-1900 (2-3)	0000-0830 (2)
South Africa	1630-2300 (1-2)	1500-1900 (0-1) 1900-2200 (1-2) 2200-0000 (2-3)	1330-2030 (0-1) 2030-2230 (1-2) 2230 0200 (2-3)	0000-0430 (1-2)
Central America & Northern South America	1530-1800 (3) 1800-2230 (3-4)	1430-0000 (4-5)	1330-2230 (3-4) 2230-0230 (4-5) 0700-0900 (1)	0130-1400 (4-5)
South America	1530-2300 (3-4)	1400-2100 (3) 2100-0000 (3-4)	1300-1400 (3) 1400-2300 (1-2) 2300-0300 (3-4) 0700-1000 (1-2)	0200-1130 (3)
Hawaii	2130-0030 (1-2)	1800-2300 (3-4) 2300-0100 (4-5) 0100-0230 (2-3)	1700-2300 (3-4) 2300-0300 (4-5)	0300-1100 (4-5) 1100-1600 (2-3)
Australasia	2200-0230 (2-3)	1700-0200 (2-3) 0200-0330 (3-4)	1600-1800 (3) 1800-0200 (2) 0200-0630 (3)	0600-1500 (3)
Japan	2200-0000 (1)	2130-0130 (2-3)	2100-0130 (2) 0130-0400 (3-4)	0700-1700 (3-4)
Philippine Islands & East Indies	2230-0130 (1-2)	2130-0300 (2-3)	1700-1930 (1-2) 2130-0300 (1-2) 0300-0500 (2)	1100-1400 (1)
Marshall Islands	1930-0130 (3)	1900-0300 (2-3)	1830-0230 (2-3) 0230-0400 (3)	0600-1430 (3)
Guam & Pacific Islands	2100-0100 (3)	2000-0100 (2-3) 0100-0300 (3-4)	1930-0200 (2) 0200-0430 (3)	0730-1600 (3)
East China (HongKong)	2300-0100 (2)	2200-0230 (3)	2130-0130 (2-3) 0130-0430 (3-4)	1000-1430 (3)
India	Nil	2130-0230 (0-1)	0030-0330 (2)	0800-1400 (1)

Symbols for Expected Percentage of Days of Month Path Open:

(0) None (1) 10% (2) 25% (3) 50% (4) 70% (5) 85% or more

Special Note: The letter "A" appearing after the expected percentage figures is used to denote that the azimuth of signal arrival will probably be best over the "Asiatic Path." The letter "E" denotes an azimuth favoring arrival over the "European" path.

CQ**The Radio Amateurs' Journal***The Year Round Christmas Gift—*

BECAUSE—CQ is the only publication devoted entirely to Ham radio that is able to obtain top-notch material from the four corners of the earth.

BECAUSE—CQ regularly prints departments written by experts on such fields as DX, Propagation, VHF, Teletype and Novice activities.

BECAUSE—CQ in 1952 printed more wordage, more feature articles of first-rate material and more pages than in either 1950 or 1951. CQ is growing and 1953 will be an exceptional year both in Ham radio and in editorial content of the magazine that covers the entire field of Ham endeavor.

In May 1952, CQ introduced a new concept into Ham publications—the "SPECIAL ISSUE." There are more to come. February 1953 CQ will feature a "SPECIAL ISSUE" on the subject of DX with articles on every facet from "The Certificate Seeker's Directory" to feature material on high power and big antennas. And then in May, another "SPECIAL ISSUE" on mobile operation. You will not want to miss either one—and the easiest way to do that—

Subscribe now by using this handy envelope



P.S. Not shown in the regular subscription rate chart is our "Buddy Rate" of \$5.00 a year for yourself and some one overseas. Why not remember that fellow over there who would like to see CQ just as much as you would? This special rate saves you \$2.00 over the straight subscription price.

CQ Magazine

67 West 44th Street
New York 36, N. Y.

DX and OVERSEAS

(from page 57)

Endorsements to the HONOR ROLL which appeared in the
September issue

W1FH	40-250	W3DKT	39-207
W3BES	40-245	F9BO	39-204
W6ENV	40-245	W9FKC	39-201
G6ZO	40-241	W2BJ	39-197
W6SN	40-240	SM5WI	39-196
W2BXA	40-239	VK4FJ	39-193
W3JTC	40-238	W5MPG	39-193
W3KT	40-237	KP4KD	39-192
W8NBK	40-237	W5FFW	39-188
W6AM	40-237	W9HUZ	39-187
W6SYG	40-237	GM3CSM	39-186
W3EVW	40-236	W4RBQ	39-184
W8BHW	40-235	W6WO	39-166
W7AMX	40-235	KL7PI	39-150
W3GAU	40-235	W2HMJ	38-202
W2AGW	40-232	W0TKK	38-182
W6AMA	40-232	W2GVZ	38-169
PY2CK	40-232	OZ7BG	37-167
W6MX	40-232	F9AH	37-157
G4CP	40-232	WIAPA	37-135
W7GUI	40-227	W4EPA	37-134
VK2ACX	40-223	W4HA	36-192
W7BD	40-222	W9LI	36-147
W6GDJ	40-218	KG4AF	35-169
DL1FF	40-217	W1RAN	35-135
W6VE	40-213	W2HAZ	35-112
W6TI	40-210		
W6RBQ	40-209		
W5EPZ	40-206		
W0ELA	40-203		
G8IG	40-203		
W6IBD	40-202		
W6BUD	40-193		
W6MHB	40-183		
W7ENW	40-178		
ZS6A	40-164		
W5ASG	39-234		
W2NSZ	39-229		
W2WZ	39-225		
W1JYH	39-216		
W1GKK	39-211		
4X4RE	39-210		
W9LNM	39-209		

PHONE ONLY

VQ4ERR	39-216
PY2CK	39-214
G8IG	39-173
F9BO	39-158
W2BXA	38-196
W1NWO	36-196
W1MCW	36-195
W4ESP	36-159
W4HA	35-164
W3EVW	35-157
W0ANF	35-138
W3KT	34-157
W2ZVS	34-129

The next complete HONOR ROLL will appear in the
January issue

Here and There

VK4QL, DX editor WIA news, now pulls up stakes and goes to VK2QL while Pat, VK3YP, moves to VK4 to fill the gap. . . . OQ5LL dropped in on W4KIX, W5FXN and W5UJ. Andre sails for home on Sept. 22nd. . . . W9PQL/MM and KP4SX visited KV4AA while W2CTO, K2BU and W2MLO had a get together. . . . KH6ADY/KV4AF/W1IAV is now K2BCK, Red Bank, N. J. Ted will visit KV4 land in October. . . . W5MIS enjoyed six weeks vacation in Canada, VE6AO was visited. . . . From W6FSJ we hear that VR1B leaves on three months' holiday to VK. He will return about Jan. 1st. . . . W2UNR has been traveling to VE7 and KH6. Hal returns Nov. 1st. . . . W3EQA/4 and W3KEW/4 were on the air from Kitty Hawk, N. C. during vacation. . . . W6LW lets us know that old VQ2JS is now VE6NL while KH6ES tells us that old VQ4ALF is presently operating from MF2AG (Trieste). . . . From W6AM we hear that W6EAY is the new Editor of the So. Cal. DX bulletin. Eric is doing a fine job on same. . . . F7AW writes that all F7's are American GI's stationed in France. Military personnel anticipating ham operation from F must present their W-ticket, or photostatic copy thereof, which is forwarded with application. It may take up to six months for the

ticket to come through. Ford also says please QSO F7's in English and don't ask them to QSP any messages to Aunt Minnie in Paris as all traffic handling is forbidden. The 20 odd NATO hams now stationed with SHAPE will soon be operating from their club station with the call sign F7AA. . . . We are glad to hear "old faithful" Mick ON4QF active again after a six months' QRL layoff. Mick still hopes to set up shop in a certain rare DX spot. . . . G8PX has been touring Scotland with AP58. . . . G4FN uses a 132-foot wire buried six inches in the ground. Results have been fair on all bands from 1.8 to 14. . . . W6PBI is now out of hospital and going strong. . . . From W6ALQ we hear that F7AT (DL4FA PX1AR) is now W6RDI. . . . W9GNU, Tav, says if any VQ1RF cards are missing you may obtain same by sending QSO details to W5HBM. . . . W3LE worked 5A3TA showing that Tripolitania has advanced from 5A2 calls. See QTH's. . . . W0TKX expects to be QRT a spell while moving to a QTH with definite antenna possibilities. . . . G8IG is active again in a new QTH after an eight month QRX. . . . CP1BX bought CP1BK's rig. . . . WIDEP moves to new QTH. . . . W7OYJ is now W4WHK. W4JUJ rec'd WACO (Cuban) certif No. 64.

HZ1AB is ex-W6VUO and is active daily 16/19z around 040, A3 195. . . . W1CWX collected card from MD6BZL/P (Y13BZL) while G6YQ rec'd one from 4W1MY. . . . We are glad to hear W3IL on again after recent illness. . . . W6NTR reports ZC2MAC's relief operator is not a ham. . . . W9EXP now ops from K5FAB New Mex. . . . KH6ARA may set up shop in KS6. . . . EK1CW is now CN2AP. . . . A new Chilean district division will be put into effect in '53. CE1 to CE6 will be about the same with some CE6 changing to CE7. Most of the present CE7 will change to CE8 (Magallanes province). The present CE7Z—, Antarctic stations will change to CE9 and, as stated, CE0 will be Easter Island. . . . From SWL John Gaynor we hear that there are no privately owned LZ stations. LZ1 denotes southern Bulgaria while LZ32 is north. First examinations for Class A licenses will take place in October. Power limits are as follows: Class A at 250 watts, Class B at 50 watts, Class C at 10 watts. Classes A and B may work all bands but Class C is limited to 3.5 mc. LK1KAB's operating hours are 0700/1000 and 1800/2100z daily except Sunday. CW, 14 and 7 mc. . . . From W5ALA we hear that W5ARV took over the W5 QSL bureau from W5AJG on Aug. 25th.

We regret to report the passing of W9LM, Hal Leighton. Hal succumbed to a heart attack on Sept. 4th. He was well known throughout the DX fraternity. . . . Also to be remembered is our old friend VR5GA who passed away on August 23rd. (From KH6OR and WGB)

QTH COLUMN

KG6IG	Chichi Jima, Bonin Is. via Navy 905 Box 22 c/o PM San Francisco.
CN8MM	P. O. Box 2060, Casa Blanca, French Morocco.
KP4JE	(New QTH) Box 176, St. Just, Puerto Rico.
VQ5CL	Box 231, Kampala, Uganda.
HZ1AB	APO 616 E c/o PM NY.
VE8VO	Nottingham Island NWT. via VE1FQ.
OX3BQ	APO 121 c/o PM NY.
VP8AN	Argentine Island, Antarctica via P. O. Port Stanley, F. I.
DJIAC	Kathe Behrens, Luebeck, Nettelbeckstr. 23, Germany.
IRTS	Irish QSL Bureau, via EI5Z, 23 Orwell Gardens, Rathgar, Dublin, Eire.
CPIBX	Ted Westlake, US Embassy, La Paz, Bolivia.
5A3TA	"Mel" APO 231, Box 372, c/o PM NY.
TA3MP	"Meade" APO 206 A, c/o PM NY.
W5's	W5 QSL Bureau. Will A. Shaw, W5ARV 1610 Eighth Ave., Fort Worth, 4, Tex.

Thanks to W6BYH, W2HAZ, W3LE

W5CKY says: Famous last words of 1953 (If FCC calling freqs. go through) "PLEASE FOLLOW ME TO 14070 KCS OM, THIS FREQUENCY IS FOB USA CALLING ONLY!!!"

S8, here. 8EP was running S8, while working north. The Maryland boys were in very good, also. W2UK was 2 S-units above my high noise level, W8WRN reports.

Wednesday, September 10: 6:45 to 8:30 AM: WN4VLA 10 db over S9, W8SFG, W9EQC, W8BFQ, W8EP, WN8HOH. Conditions were down, this AM at W8WRN. PM hours, quiet here. WN8HRI was in, solid S9. W8LPD was 25 db over S9.

W8WRN still looks S.W. in the AM—mostly on Tuesday, Wednesday, Thursday and Sunday, around 7:45 on Sunday. The rest of the days, at about 7:00 AM. Frequency, 144.67. W8BFQ has been on also, so beam to Columbus when conditions look good. W8BFQ is on the low end.



The late Don McCaskell, W9OCA (ex-W9NJT)—second from the left—as he enjoyed a VHF picnic with W9PK (left), W9ALU, and W0HAQ (right) in 1949, near Chicago.

Minnesota Minutes

When the band opened on August 23rd, W0IFS and W0OAC alerted several others shortly after the first DX, about 1915 CST. The band remained active until about 0145 the next morning, when activity died off, but it was still open, as early morning QSOs indicated, until about 0800, W0IFS worked W5RCI at 2229 with signal reports of S4 to 5, for the first Minnesota to Mississippi 2-meter QSO! Russ also worked W0KYF, University City, Missouri, at 2133 CST, and a number of W8 and W9 stations, according to W0TKX. . . . W0JHS worked a different Missouri station (call not available) and someone in Indiana for two new states. . . . W0OAC worked W0INI, Missouri, about 0145 on August 24th. He worked W8MRK, Michigan, W0DVV, Kansas, and had a total of 22 QSOs outside of Minnesota.

Now for the big openings: W0QIN, who has been around VHF long enough to know what he hears, reports that two meters was wide open for aurora all Sunday afternoon, September 7th, with exceedingly weak phone carriers heard via this mode. (See W9WOK's note in the first part of the column.—VHF Ed.) Nobody seemed to realize it, as no C.W. was heard, no QSOs were made, and no stations were identified during the afternoon.

W0OAC phoned long distance, September 7, to W0QXR, Omaha, Nebraska, to alert him for the opening and, while W0QXR got on the air and worked about everything heard, Joe didn't hear him! And, nobody from around has yet worked Nebraska!

Note: This date, on W0TKX's propagation chart, shows as being 27 days after a slight magnetic disturbance, and the F2 layer MUF to the south was extremely high on Sunday, as often occurs near the times

when Aurora is prevalent (remember HC2OT?).

Sunday evening, W0QIN heard amazingly strong signals, mostly from W9s. These were via direct propagation, and mostly phone. W0QIN heard W8RUE, but didn't stay up until the band closed. He reports having had difficulty raising the eastern stations, who were calling W1 and W2 stations, so that Minnesota was off the backs of many W8 and W9 beams!

W0TKK continues, "W0QIN said that these openings (first of the strong-signal type ever reported in Minnesota, as far as I know) were similar to six meter openings. Some areas would come through and then give way to other areas. This does not mean that W0QIN thinks it was sporadic-E propagation—he said it sounded 'similar'. My own opinion is that, while latter is nearly out of the question, the concurrent magnetic disturbance and the aurora can not be disregarded in analyzing this opening. The weather was undoubtedly conducive to good tropospheric conditions, and I rather suspect that meteorological discontinuities joined with some stray ions to give these results. At what height the ions were, where they were from, etc., I leave to the analysts. The sporadic-E, as we know it, could scarcely have produced Minnesota-Illinois QSOs on 144 mc. without hitherto unknown densities. The aurora did not garble the phone signals, nor noticeably distort beam headings, if it was responsible. Openings like this one have occurred on Six, the Aurora and Es propagation media combining to give clean, steady signals, but this so-called 'Es' may have been entirely different from the normal Es, as known on six."

"W0OAC now apparently leads the 2-meter men in Minnesota with his total of 11 states and 5 call areas (too bad he missed that W5, which would have made 6 areas). Joe bought a new crystal-controlled converter around the middle of August and as soon as he hooked it up, things started popping. After the 23rd of August, things were reasonably quiet until September 7th, at W0OAC. He stayed on until after midnight, knocking off W8 and W9 stations and culminating the session with his W4HHK QSO in the wee hours of September 8th. The next night was much the same, with W3QKI providing the nightcap. Also W2UK, New Jersey, was heard on the new converter. Most of the DX again came after midnight (morning of the ninth.) The evening of the ninth was good, again, with lots of W8s, W9s and a few W3 stations heard, but nothing new worked. Conditions since then have been above normal, but nothing really exceptional has been heard," says W0TKX.

W0IFS lives at Plymouth Township, west of Minneapolis, and uses 20 elements and 75 watts. W0QIN is at Edina, south of town, using twin-fives and an 829B. W0OAC is using 16 elements and an 829B I believe. W0JHS has 12 or 16 elements. W0OAC is at White Bear Lake, north of St. Paul and W0JHS, Champlin, is also north of the twin cities. There is no point in tuning two meters in the city, as no DX has ever been heard right in town. That's one reason W0TKX moved to the suburbs after hearing his "dead" 2-meter converter perform out at W0QIN's QTH!

Among others present at the division convention were Managing Editor Perry Ferrell, W0QIN, W0QHC, W0OUE, W0URQ, W0JHS, W0CJS, W0BJV, W0GPQ, W0ANU, W0ATD and W9RQM. Perry's tape recording of 2-meter aurora, and discussion of propagation, made a big hit with everyone, including mostly non-vhf spectators!

"Canadian Capers"

"It was at VE3BQN's 'Do' that Les, VE3AIB, threw this at me. He said, 'You are about the only guy who is on 2 with any consistency, so how about dropping Bill a few lines each month?' I guess my jaw dropped a few yards and he took that for a sign that I was willing, so he said, 'Thanks!' and here I am!" announces VE3DIR. (Welcome!—VHF Ed.)

VE3BQN's "Do" was held at Ted's QTH on Friday, 16th of August. Although the turnout was good, it was not as good as expected. In the last two years, at least half a dozen W2s attended, but—this year—it was strictly VE3s. However, next year, Ted hopes to have it on a Saturday evening, so that perhaps some W2, W3 and W8 operators can attend.

It is surprising how many stations are on at 1230 AM, when I got on the air. Heard W8BFQ working a W9 the other night, but I couldn't hear him, so—our W9 friends—there is at least one VE3 on at 1230 AM, and up to 2 AM, sometimes, if things look promising. I call CQ to the east, southeast, south, southwest and west in that order on 144.5 mc. from 1230 on, and I am

(Continued on page 68)

SHURE MICROPHONES



from SHACK to CAR!

In the Shack . . .

This sturdy Controlled Reluctance unit is designed to handle the most severe requirements of amateur broadcasting, paging, and dispatching systems. It provides high speech intelligibility, makes your messages instantly understood. The "Dispatcher" has a 2-conductor shielded cable, and is wired to operate both microphone and relay circuits. Firm downward pressure on the grip-bar locks the switch. The "Dispatcher" is immune to severe conditions of heat and humidity. Output is 52.5 db below one volt per microbar. High impedance. Furnished with 7-foot cable.

In the Car . . .

A high-quality carbon microphone specially designed for mobile equipment. Used throughout the world for Ham, Police, Fire, and Transportation Services—more than all other makes combined! Rugged, dependable unit with clear, crisp voice response and high output. Fits snugly into palm of hand. Heavy duty switch for push-to-talk performance. Furnished with bracket for wall mounting; plus coiled-cord cable. Output level: 5 db below 1 volt for 100 microbar speech signal. 70 to 80 ohms impedance.



Model 520SL
List Price \$35.00



"100 Series"

MODEL	SWITCH ARRANGEMENT	CABLE	CODE	LIST PRICE
101C	Two Wire Relay Switch normally open. (No microphone switch)	Standard Coiled Cord 11" retracted; 5' extended	RUCEG	\$27.50
101E		Tinsel Coiled Cord 11" retracted; 5' extended with Amphenol MC4M Connector	RUCAD	\$32.50
102C	Relay normally open. Microphone switch normally open.	Standard Coiled Cord 11" retracted; 5' extended	RUCEM	\$27.50
102E		Tinsel Coiled Cord 11" retracted; 5' extended with spade lugs	RUCAF	\$30.00

Microbar = one dyne per sq. cm.



SHURE BROTHERS, Inc. ★ **Microphones and Acoustic Devices**

225 West Huron Street, Chicago 10, Illinois

Cable Address: SHUREMICRO

(from page 66)

looking for W9s and W1s and W8EP, too, if he is ever around, VE3DIR reports. ('Smoke' will get into your ears, soon!—VHF Ed.)

VE3BUO, VE3ATP and VE3TC have RTTY on 2 meters, if any of the boys are interested, but, all they can get to copy is commercial stuff and each other. If we are not careful, they will be selling it for want of activity! (Egad!—VHF Ed.)

Indications of special effects on 2 were in evidence on September 7th, when the W3s in Erie were heard working W0s, but not a thing was heard of the W0s here. But when I got in at 1230 AM, Monday, the band was alive with all sort of things! I started off to work W9LF on CW, but the QRM from W0EMS put W9LF out of the picture, so I had to wait until 3:30 AM before I could work W9LF, and then we did it on phone. Being cut short for time, we picked our states we wanted and tried to pick them off that way," says VE3DIR.

"We hit four new states: Illinois, Wisconsin, Connecticut and Iowa. All had very good phone signals, in fact W9DDG, Sheboygan, Wisconsin, had an S9 plus signal here! We heard, but could not raise, W0TMJ in Missouri, a W0 in Minnesota, and W9MFH (?) in Indiana for a total of three missed! (W9EGH?—VHF Ed.)

"Tuesday evening was not quite so good as Monday. The opening took a turn further south. When I called CQ Maryland on CW, at 1230, I was besieged by W4s in Virginia and, by 1:00 AM, I had been called and worked by four W4s and a W3 in southeast Pennsylvania. However, we got our Maryland contact, W3PYW; W4CVQ, North Carolina, and W8EP, West Virginia, finishing up with 3 more new states. Called W4PCT, Kentucky, for about 30 minutes on CW, but I guess he passed out of the picture.

"VE3AQQ was being called madly by W4CVQ but unfortunately, Jake and Sid never did hook up. VE3AIB worked 5 new states to bring his total to 17 states.

VE3BQN worked 6 new ones to bring him up to 13. VE3DAA worked quite a few new ones. VE3BQN is getting some good equipment together on 220 mc!" concludes VE3DIR, who now has 17 states.

What seems to be the first Ontario to Iowa 2-meter

contact is reported by Ralph Dierlam, VE3BPB, Lambeth, Ontario. "On Sunday, September 7th, about 9:45 EDST., I was happy to hear and work W0EMS, Adair, Iowa, about 715 miles from Lambeth. He was running about Q4, S5/4."

"I never heard so many VE3s working W0s as I did on September 8th." VE3BPB continues. "Band was wide open to the west and Nines were rolling in. My working W0EMS the night before sure was nothing compared with what the gang did. Milwaukee, Wisconsin signals were up to S9, at times, and—while I didn't work WN0GUD, darn it,—nearly everyone else did!"

Missouri Monitoring On Two

On the night of August 23, W0IHD, Overland, Missouri worked W0JHS, Champlin, Minnesota, and Charles was his first Missouri contact.

"I clinched the state of Minnesota contact by working W0OAC at White Bear Lake, also," says W0IHD.

"We had some good openings in August, for the band was open here on August 18, 19, 22 and 23rd."

As for activity in the St. Louis area, W0IHD reports one new station is on 2 meters. . . . W0ETJ has moved back from Iowa and operates from Elsberry, Missouri, only on week-ends due to his travelling throughout the week. He is on with an AX-9908, clamp-tube modulated, temporarily. . . . W0EV has his equipment at Cedar Hill from his University City location (W0VMY) and has rigs on 2 and 6. . . . W0YRX and W0IHD have new 6BQ7 converters working, and W0IHD is building a 6-meter transmitter and converter. . . . W0KYF has a new 16-element beam under construction. . . . W9UED, who moved from West Frankfort to Belleville, Illinois, last year, had to start all over again on his states-work-on-2, and has knocked off 14 states this year with his 829B-90-watt transmitter, 16 element beam, and 6J4-6BQ7 converter! WN0FCX still holds down the middle of the band at 146.782, and needs contacts. W0VMU added Indiana to his states worked score during the August 23rd opening, but he couldn't hear Minnesota.

In conclusion, Charles says, rightfully, that the mid-west gang is going to miss W9SUV! Russ moved to California shortly after the Turkey Run affair. Someone got their signals mixed up and failed to pick up

(Continued on page 70)

Phone or CW?

Many of us at Electro-Voice are radio amateurs—some are old timers, others only recently were Novices. Of course, as one of the world's largest microphone manufacturers, we believe in radiophone operation—but not without proficiency in cw, too. We think this is a sound approach for every Novice or potential Novice—for each method of communication is important, each can be fun. Code is essential for many types of communication. Your first real responsibility as an amateur is to be versatile, which means among other things, a good "brass pounder." After you have your regular license, when the urge to operate phone can be satisfied, we say take the same pride in your phone signal that you now must cultivate in your fist. Then you will be well started if you make your microphone selection ELECTRO-VOICE. It is an investment in equipment that will give you years of excellent communication performance with any station you construct today or in the future. There is an E-V mike for every need (such as the 915, 630 or 950)—backed by 25 years of experience in engineering and manufacturing. Write for our general catalog.

W8HCW

Electro-Voice

405 CARROLL STREET • BUCHANAN, MICHIGAN

Export: 13 E. 40th St., N.Y. 16, U.S.A.

Cables: Arlab

Two Grand Old Names in the Ham World...

HARRISON and Hallicrafters

For 20 years Hallicrafters has been developing and making consistently better and better equipment for Amateur, Commercial and Military use, and ... for 27 years Harrison has been bringing you the fine products of Hallicrafters and all the other top quality manufacturers — economically, quickly, dependably, and in the friendly helpful manner that will always make you glad you remembered —

HARRISON HAS IT!

NEW!

HT-20 TRANSMITTER



The worthy successor to the world-famous HT-9! Output 100 watts AM phone, 115 CW. 1.7 thru 30 mc continuous bandswitching coverage. Completely shielded and filtered — to live with TV with pleasure!

Order Yours Today! \$449.50

hallicrafters

POPULAR S-38C RECEIVER

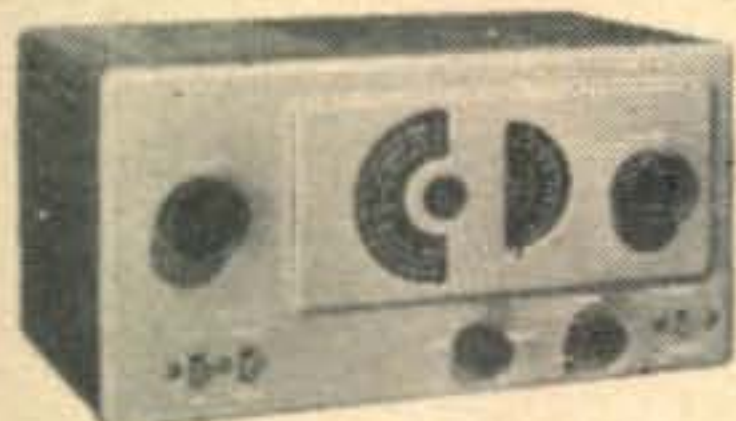

Lowest priced communications receiver that amazes even the experts! Covers broadcast band and everything up to 32 mc. Switch for code signals. Built-in PM speaker. Headphone tip jacks. For 115V., AC or DC. \$49.50 (Vibrapak adapter for 6V. DC operation. \$11.20)

FAMOUS SX-71



Ask the Ham who has one! Dual conversion with 3 IF stages. Built-in NBFM. Crystal filter. Covers 538 to 35 mc, and 46 to 56 mc. 11 tubes plus VR and rectifier.

One of the Best! \$199.50

Speaker in matching cabinet —
For S-76 and SX-71.....\$19.95

S-40B ... HAM AND SWL FAVORITE



Improved version of one of the amateurs' favorites! Covers broadcast band and all to 43 mc. Tuned RF stage, two IF stages, speaker, noise limiter, bandspread, CW BFO, etc. 7 tubes plus rectifier. An FB set! \$99.95

DOUBLE CONVERSION S-76

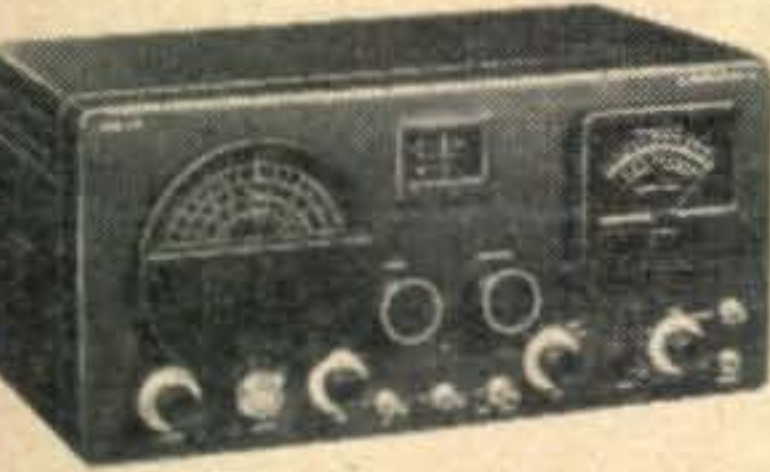

All the good "big" sets use dual conversion. Here's one at a popular price! 50 kc second IF give extremely sharp selectivity. Covers 540 to 1580 kc, 1.72 to 32 mc. 9 tubes plus VR and rectifier. \$169.50

Glad to Help You!...

Since 1925, I've been extending a helping hand to beginners (and OT's too!) seeking information or gear for their shacks. Whenever you have a question, just ask me, or any of the other active Hams in my New York and Jamaica stores. You can always be sure of a dependable, unbiased answer. To all newcomers — welcome to our hobby, and good luck on your exam.

73, *Dil Harrison* W2AVA

DO YOU RECEIVE THE HARRISON HAM-A-LOG?

Articles - New Gear - Bargains
Club Notes - Ham Kinks
A postcard puts your name
on the mailing list ... FREE!
Send It Today!
NOVICES! Ask for Special
Novice Edition

HARRISON RADIO

225 Greenwich St. • N. Y. 7, N. Y.

BARclay 7-7777

JAMAICA BRANCH: Hillside Ave. at 172nd St.

FOR YOUR
SHOPPING AND
PARKING EASE!
OPEN NITES
New York —
Wednesdays
Jamaica — Fridays
'TIL 9

2 meters



the NEW
GONSET
"COMMUNICATOR"
A complete 2 meter station

FEATURES

2E26 FINAL AMPLIFIER CRYSTAL CONTROL
COMPACT-10 1/4" x 9 1/4" x 7 15 WATTS INPUT

Superhetrodyne receiver is complete with 6BQ7 Cascode rf stage, 3 stages if, and employs the famous GONSET NOISE CLIPPER circuit. Receiver has an edge-lit calibrated tuning dial and all transmitter-receiver controls are located on front panel. No external meter required. Transmitter employs 8 mc. crystals for stability. Modulator can be used for P.A. system, for emergency and CD work. The husky AC-DC transformer type power supply weighs 7 lbs. alone. Under ideal conditions of terrain and weather, a range of over 100 miles may be expected. A truly fine communications station complete with 19" whip antenna ready for local operation.

available for commercial frequencies (AM or FM) on special order

803 S. Main St.
Burbank, Calif.



\$189.50

(less microphone
and crystal)

Write today for information

IDEAL
FOR
AMATEUR
CIVIL
DEFENSE
COMMERCIAL
ACTIVITIES
AIRPORT
UNICOM
C.A.P.
FIXED-MOBILE

(From page 68)

Russ, so he missed out on Turkey Run!

WØINI, Pleasant Hill, Missouri, reports that the August 23 opening lasted until 2:00 AM. Harry got four new states that night: Wisconsin, Mississippi, Arkansas, and Minnesota! On September 8th, he heard everything east to Pennsylvania and north to Canada, including a VE3, but couldn't raise him. The band was still open to Chicago and Ohio when WØINI signed at 11:30 PM. Harry worked W3LWN, Sigel, Pennsylvania, and W8ZND, Detroit, Michigan, for states 11 and 12. WØINI now has W3, W5, W8, W9, and WØ.

"I heard one of the Kansas City stations calling W2BYM, but I couldn't hear the W2," Harry reports. "Heard Iowa, Wisconsin, Michigan, Ohio, Pennsylvania, Indiana, Illinois, Kansas and Missouri. Pretty good for one evening on 144!"

Ft. Worth-Dallas Report

W5HD reports that W5HCH is rebuilding. . . . W5OTV raised his antenna higher, with a resultant increase in strength of signal. . . . W5PKZ will be on 2, in the near future, from Brownswood. . . . W5CVW is slow in getting his new modulator finished and is on 10 mobile only from his "baby Cadillac" (Henry J). (Maybe Bill is spending too much time at the boat club like he was recently when the band was romping and stomping. What about it Bill?—W5FEK). . . . (Willie, where the hexx ya' been?—VHF Ed.) The three musketeers from Dallas, W5AJG, W5HHU and W5ABN are blasting through regularly on 2. . . . W5APW, Chico, has 522 on 2, and has worked into "Cowtown" several times, but W5HD has yet to work him, so Les needs more proof. That makes all three West Gulf Division director candidates, W5CA, W5BHO, and W5APW, active on two. . . . Line noise has been so bad at W5HD that only S9 signals can be copied. (Les must not have any trouble on 75 as we hear him regularly.—W5FEK). . . . W5CEL, Terrell, is still using p.p. 65A, 200 watts modulated by 805's, class B.

Two Meter Report From Houston

Two meters is still stinko on the gulf coast, with no major openings recorded in several months. Even regulars like W5BDT, and W5AXY, Austin, W5ONS, Victoria, W5IVU, Edna, and W5QIO, Beaumont, have difficulty in working through very consistently. With the first good "norther" yet to arrive, we are hoping that conditions will change for the better. September and October are usually two of our best months.

New ones in Houston on 2 are: WN5WTN, WN5URT, W5RPH, W5GYK and W5UPR. W5SUM, Shreveport, Louisiana, made his first contacts into Houston on August 14th.

Turkey Run Topics

Margi Bowman, W9GLW-XYL, summarizes the 1952 Turkey Run VHF Meeting. As usual, there were a lot of the old faces missing, but a nice amount of new ones (and several "young'uns," which the band needs badly), gave us our same total attendance, 77, as last year!

Actual statistics for what they're worth: 50 hams at the '51 picnic didn't appear at the '52 affair; there were 42 newcomers in '52, who hadn't been there before (at least in the 3 years I've kept records), compared to 26 from '50 not present at '51, and 36 newcomers, that year!

On Saturday night, W9GLW had 18 people (all W8s, except Clint, W8INQ's "YF," and me) and Taffy (W8BFQ's blond cocker) in the living room; or in the basement "radio room"!! The gang QSO'd over mobiles, W8BLN and WN8HOH, and really made the "welkin", or sumpin', ring! Boy, was it hot!! The Speedway Water Works worked overtime, pumping aqua to W9GLW's house!! Could entice but a few of 'em with cokes and beer after their hot drive—it was "Water-Boy!!" Margaret and Jerry drove in the W8LMW, Anne, and W3GAB, Ben, who are building a radio "home" to enjoy after their retirement from the nursery business for one purpose only, radio!

The picnic drew quite a nice number of WNs and "youngish" hams, even a very unusual trio: W9NJS, WN9PKS and WN9PKU, triplets, 16 years old, from Kentland, Indiana, who had their QSL cards pinned to their pockets! The usual horseplay occurred when "somebody" wrapped W3LWN's overripe banana as a prize, and labeled WN8HOH's. . . . 829-final as the Grand First Prize! W8SDJ hit the jackpot, and got a big ribbing when he won 2 (or more) 6-inch antennas and mounts. The wags expect him to "fancy-up" his bicycle with a mobile rig!

(Continued on page 72)



LEO I. MEYERSON W6GFO
CU ON 10-20 & 75 METERS

A CHICKEN IN EVERY POT... A NATIONAL RECEIVER IN EVERY "SHACK"

NOW is the time to trade for a new receiver or transmitter. Our stocks are complete — our prices are LOW. TAILOR-MADE TERMS — LIBERAL TRADE-INS — COMPLETE STOCKS — PERSONALIZED SERVICE. We Finance Our Own Paper — No Red Tape — No delays. Special Attention Given To Foreign Orders. Deal with WRL — "One of the World's Largest Distributors of Amateur Radio Transmitting Equipment."

JUST OFF THE PRESS

LEO GIVES BEST DEAL ON . . .

National RECEIVERS

HRO-SIXTY RECEIVER AUTOMATIC DUAL CONVERSION



EASY
PAYMENTS

\$483⁵⁰

(less speaker)

The NATIONAL HRO-60 is the last word in modern receivers, offering many outstanding features: Dual conversion automatically switched in and out. High frequency oscillator and first mixer now have current regulated filament circuits. High frequency oscillator is also voltage incorporated. Edge lighted, direct frequency reading scale, with one range in view at a time; Three I. F. stages at 456 kc employing 12 permeability tuned circuits on all bands, plus one I. F. stage at 2010 kc on all freq. above 7mc; Built-in power supply; Sensitivity 1 mV or better for 6 db sig/noise ratio; Micrometer logging scale; Provision for crystal calibrator unit operation from front panel; S-meter amplifier; High fidelity push-pull audio with phono jack.

SEE IT, HEAR IT, COMPARE IT!

NATIONAL RECEIVERS AND ACCESSORIES

NC-125 RECEIVER	\$149.50
SW54 RECEIVER	\$ 49.95
SELECT-O-JET (#2 or #3)	\$ 28.75
NFM-83-50 ADAPTER	\$ 17.95
SPEAKER (for HRO-60 or NC-183D)	\$ 16.00

**FREE
1953
WRL
CATALOG
SEND
TODAY!**



RADIO REFERENCE MAP

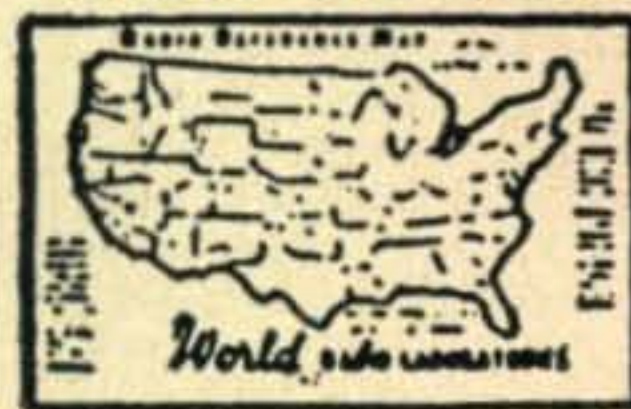

25c
HANDY
WALL
SIZE

New Log Book

25c

Full column log listing all FCC required into . . . accommodates 1,525 stations. "Q" signals, phonetic alphabet, amateur international prefixes.



NATIONAL



NC-183 D RECEIVER

Dual conversion on the three highest ranges plus every feature you want in a truly modern receiver!

(LESS SPEAKER) **\$369.50**

WRITE FOR DETAILED SPECIFICATION EQUIPMENT SHEETS

**WRITE
WIRE**

**PHONE
7795**



World Radio Laboratories, Inc.
744 West Broadway
Council Bluffs, Iowa

C-11

Please send me:

- New Log Book
- Free Catalog
- Radio Map
- SW-54 Info
- NC-183 D Info
- HRO-60 Info
- NC-125 Info
- Used Equipment List

Name _____

Address _____

City _____ State _____

THE VHF NEWS

(From page 70)

W9JGA gave this description of W9KOW's 5-room home: 1-Library, 2-Operating room, 3-Cataloging of stock, 4-Warehouse and 5-Antenna loft.—Where does he wash his hands?! (Convenient holes in the roof; lots of rain in Evanston!—VHF Ed.)

In And Around Chicago

Ken Caldwell, W9NW, reports that summer activity was a bit low due to hot weather, vacation trips, etc.

Twenty-seven 2 meter hams and families enjoyed a get-together and picnic at Thatcher Woods on August 24th. This picnic was suggested and plugged, largely, by Leo Heurer, W9OKF. Yes, Leo now has his general class license! The gang is grateful to Jim Kastrup, W9JGA, who gets Leo down to the picnic and back to Lake Zurich. Leo now lives there, temporarily. The transportation for Leo was an open truck borrowed from WN9QHK and converted for the purpose with a steel bed spring and a stretcher! Leo enjoyed himself, although it was a bit of a trip considering the circumstances. He's still in the cast!

Attending the picnic were: W9BUK, W9CX, W9ENK, W9FI, W9GBB, W9GDM, W9GZH (Hobart, Indiana), W9JGA, W9KCW, W9KDX, W9KJU, W9NVK (Racine, Wisconsin), W9NW, W9OKF, W9OTR, W9PEN, W9QM, W9QJO, W9QXP, W9SJK, W9WOK, WN9OVL (Hammond, Indiana), W9PUW, W9RNE, W9SEF, W9TOY (our new XYL on 2—XYL of W9ENK) and WN9TTI (newcomer on 2).

W9GBB, W9KJU, W9QM and W9QJO arrived late and missed the picture!

W9PK, Downers Grove, says the daily schedule with W9TQ goes on and on without a miss after nearly a year. W9LJV joins in nearly every day, and W9LUQ, Fon du Lac, WN9SDH, Sheboygan, are worked several times a week, during the day. A schedule is again being attempted with W8MRK, Muskegon Heights, Michigan,

with fair success.

"Naturally, I am missing most of the better openings due to working nights," Jack bemoans. On August 23rd, solid contacts were had with W0MVG and W0PKD, Kansas, and W0ZEY, Missouri. Later, I heard W5UBK, Albuquerque, New Mexico, working or calling another W5! I swung the beam on Texas and Oklahoma to peak him, not knowing he was in New Mexico, and I lost him! (Walt, WN9REM, gave me his QTH from his new call book, later.)

First Texas-Wisconsin two meter QSO: WN9SDH, Sheboygan, Wisconsin, to W5JHYX, Dallas, Texas on September 8, 1952.

WN9RUD, "Jim", W9PVN, "Dick", W9ONG, "Bill" and W9ONM, "Earl", are all located in the Madison, Wisconsin area and are active on the 2 meter band. The fellows would like to work out some schedules with other 2-meter stations.

THE YL'S FREQUENCY

(From page 54)

a very active YL in the person of WN6GKO, Lillian Mae Malm. Lillian is working on her General Class, with special interest in going mobile. . . . The ham picnic in Detroit in August brought together these YLs: W8SPU, ATB, FPT, GYU, IDR, ZGT, HUX and HWX.

ZS News

An FB letter from ZS6GH with very special news of herself. Diana has recently (August) become engaged to ZS6J, Reg Green. Says Diana, "He has his DXCC so I must get mine before we get married, which will be in the summer (Feb. or March, '53.) Now I will have to teach him to cook, hi, so I can use that super 10-meter beam of his to work all my friends in the U. S. A."

Diana writes of two other ham romances. Joycelyn,

(Continued on page 74)

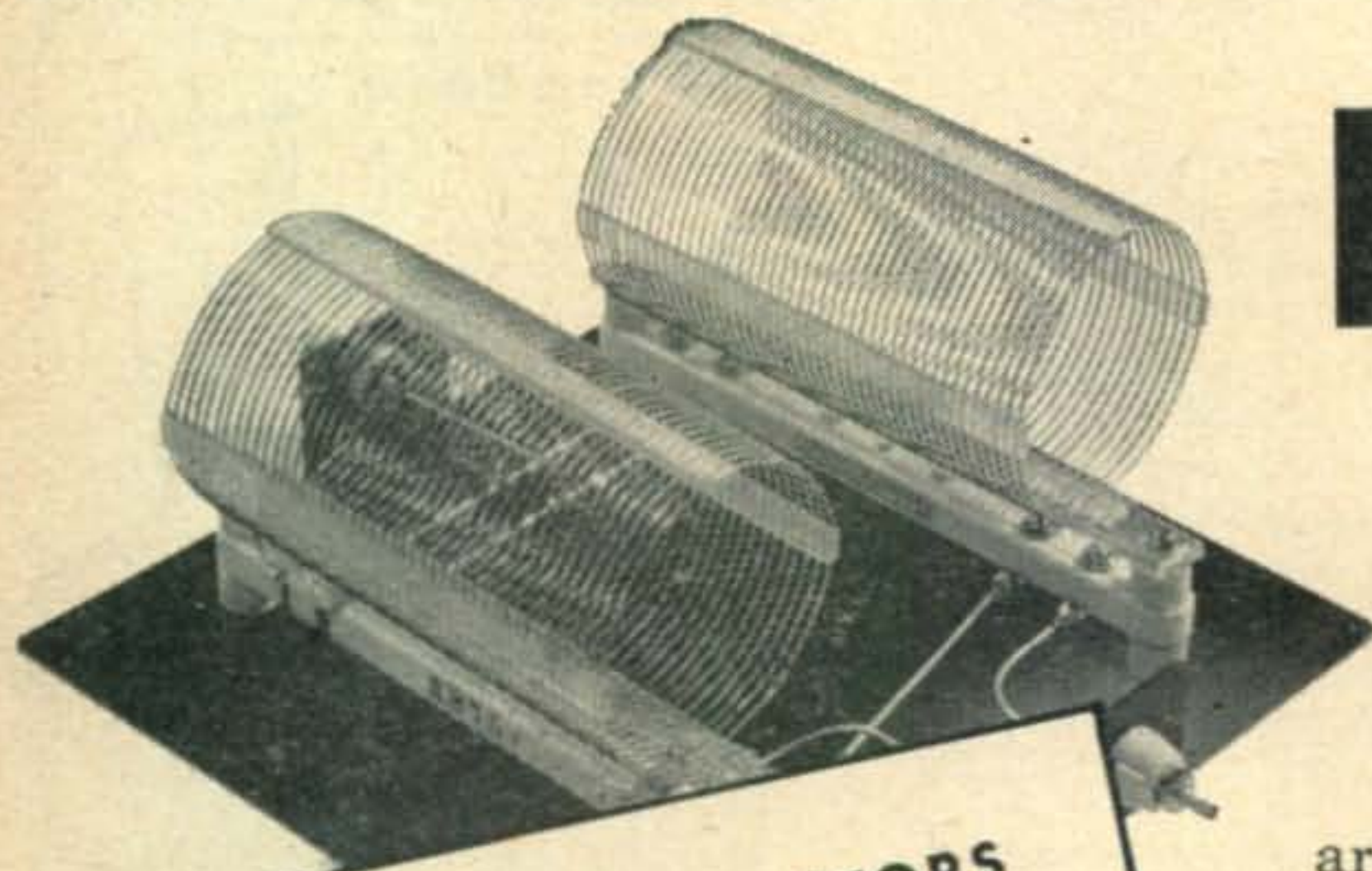

B & W BALUN INDUCTORS
Type 3975

Price: \$4.65 each coil

These sturdily-built air-wound coils can be connected to match 75 ohm unbalanced transmitter outputs to 75 and 300 ohm balanced antenna feed lines.

BALUN COILS!

These bifilar balun inductors are specially designed for use with Collins 32-V series and similar transmitters—see "The Impedance Matcher" as described in CQ Magazine for May 1951. Two coils mounted on an 8" square plate serve as a compact, highly efficient all-band (80-10 meters) unit for matching feed line systems to both transmitters and receivers. Full instructions included with each inductor.

B & W

BARKER & WILLIAMSON, Inc.

237 FAIRFIELD AVE., UPPER DARBY, PA.

HARVEY



AUTHORIZED DISTRIBUTORS

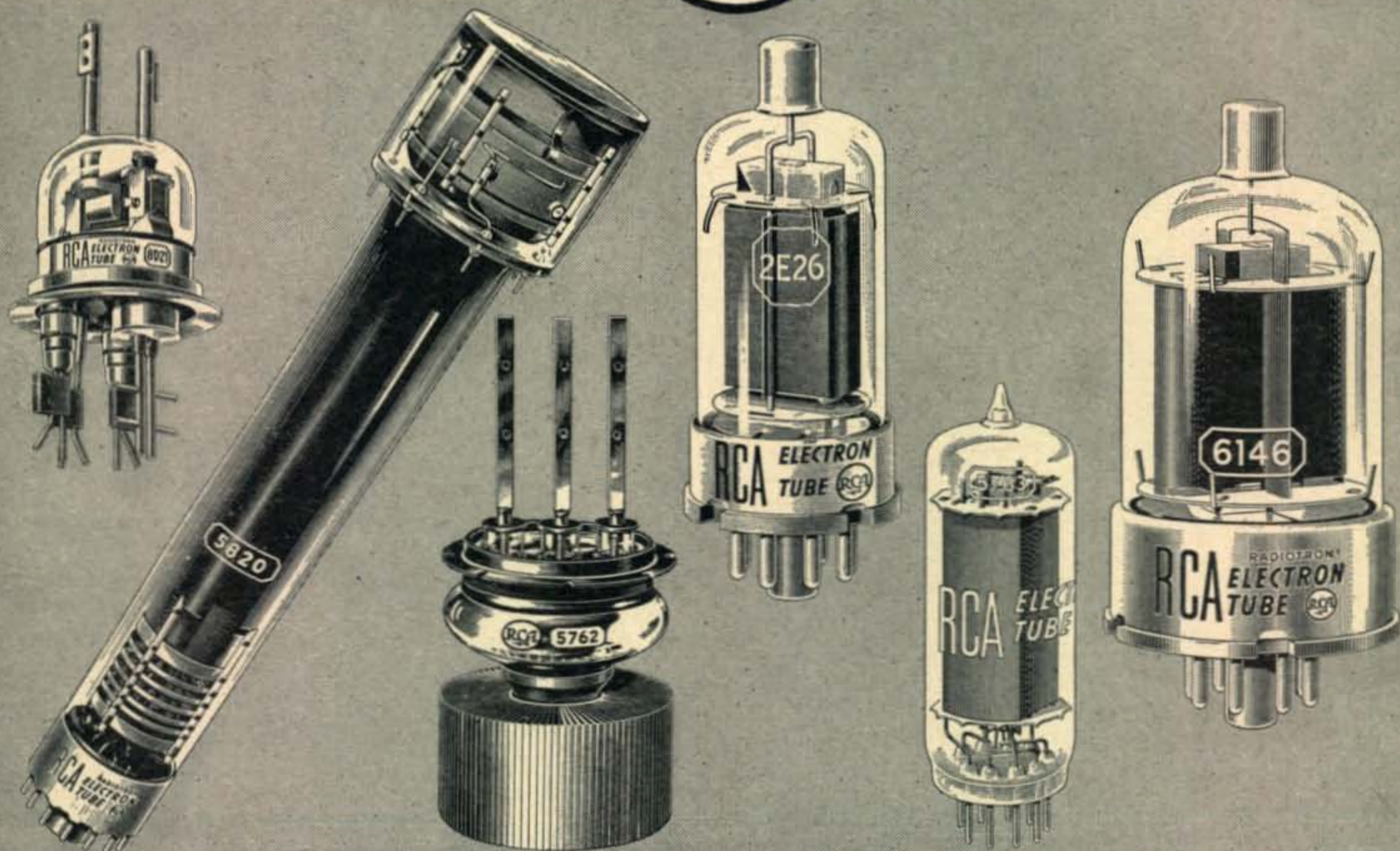

RCA Tubes and Harvey Service... For Double Dependability!

HARVEY's line of RCA tubes is so complete, that HARVEY can fill virtually any requirement . . . right from stock . . . and deliver at almost a moment's notice.

This is particularly important to AM, FM, and TV Broadcasters, Industrial and Commercial users, Amateurs, and Service-Technicians, all of whom depend on tubes for sustained operation of important electronic equipment.

*Write, Wire, or Phone,
for
Prompt Harvey Service.*

Telephone



LUXEMBERG 2-1500

HARVEY

RADIO COMPANY, INC.

103 West 43rd St., New York 36, N. Y.

ZS2JG (ex-ZS5MT), has announced her engagement to ZS8B, and Yvonne, ZS6WV, became engaged to ZS6XY.

"Some rare YL DX the girls can look out for," continues Diana, "are Mrs. Paddy Beckerling, ZS7F, and Mrs. Marie Schonken, ZS3H. Now all we need are YLs in ZS8 and ZS9 to complete the nine ZS divisions. When Joycelyn marries ZS8B, she will be a ZS8, too.

"ZS6AFI, Kath, has three other hams in her family, namely her OM, ZS6AFH, her son, ZS6AHC, and her brother-in-law, ZS6JW. Quite a record for a ZS6 family.

"ZE1JE, Molly, whom I met in Rhodesia, has worked 102 countries so will be applying for her DXCC soon.

"Incidentally, a new YL club has been formed here called the S.A. Women's Radio Club. ZS2AA, Iris, is the organizing president; ZS5KG, Muriel, is organizing vice president, and ZS6KK, Marie, and myself are joint secretaries. Marie and I also run the bi-monthly maga-

zine called 'Y.L. Beam.' We have 25 operators as members, which is quite good for ZS-land.

"I am still in the same job, and spend my life adding up pounds, shillings and pence. I wish I had to use the decimal system instead of dividing by 12 for shillings and then by 20 to get pounds. There are 240 pence to the pound.

"33 from ZS6Gallivanting Ham—will have to change this to ZS6Good Housekeeper—hi!"

Last Minute Item

Once again we are very happy to be able to make this announcement for W5RZJ and WN5UCZ. At 5 P.M. on September 24th, Thaddeus Parker Sando, a 6 pound, 12 ounce jr. op., making the score now one and one, arrived to join the Sando Family.

(Our most sincere congratulations.—Staff, CQ.)

Till next month, 33, W5RZJ.

GOING MOBILE? PE-101C DYNAMOTOR

For 6 Volt Conversion (See August '52 CQ).....\$3.95

AERIAL WIRE—Phosphorus Bronze #16 Stranded, 200 lb. test. Weatherproof. 150 ft. on Reel. RL-3 with Clips\$1.50

TELEPHONE WIRE: 3 Cond. copper & steel, 525 ft..\$4.75

DYNAMOTORS:

DYNAMOTOR and BLOWER: 9 Volts DC input; output 450 Volts 60 MA. 4500 RPM. At 6 Volts DC input; output 260 Volts 65 MA. 3000 RPM.....\$4.95

Input:	Output:	Stock No.:	Price:
14 V. DC	600 V. 300 MA.	BD-86	\$ 9.95
12 V. DC	220 V. 70 MA.	DM-24	6.95
12 V. DC	220 V. 100 MA.	DM-18	4.95
14 V. DC	375 V. 150 MA.	DM-375	8.95
14 V. DC	330 V. 135 MA.	DM-330	7.95
14 V. DC	500 V. 500 MA.	PE-59	14.95
12 or 24 V. DC	275 V. 110 MA.	USA/0516	3.95
12 or 24 V. DC	440 V. 200 MA.		
	225 V. 100 MA.	D-104	14.95
12 or 24 V. DC	500 V. 50 MA.	USA/0515	3.95
12 V. DC	250 V. 50 MA.	DM-25	8.95
28 V. DC	250 V. 60 MA.	DM-32 (Used)	2.95
28 V. DC	250 V. 60 MA.	PE-86	5.95

JUST WHAT YOU NEED...

Standard Test Leads 4" x 1 1/2" Prods. Pair 39c—3 f/\$1.00
Phone Plug—Nickel Plated, Screw Terminals. Ea.: 39c—3 f/\$1.00

Instrument Knobs—Bar, Octagon, Rd., Set Screw, Skirts, Asst.10 f/\$1.00

Line Cord—Bro. Rubber 7 Ft., Molded Rubber Plug. Ea. 29c—4 f/\$1.00

Line Cord—Black Rubber 6 ft., Angle Molded Plug. Ea.: 39c—3 f/\$1.00

POWER SUPPLIES: VIBRATOR TYPE—6 V. DC input; output 230 V. DC 50 MA.—not filtered—w/Tube. Ideal for command receiver operation as receiver is filtered internally. Size: 4 1/2" x 4 1/4" x 3 1/2".....

PE-157 POWER SUPPLY—2 V. Vibrator Supply, operates from BB-54 2 V. Battery mounted in Case. Output voltage 1.4 V. 1/2 Amp 125 V. 50 MA. Less Battery, Speaker & External Power Cord—with Vibrator.....\$4.95

BB-54 2 Volt Dry Battery.....\$2.95

ADDRESS DEPT. CQ ● **ALL PRICES ARE F.O.B., LIMA, OHIO** ● **25% DEPOSIT ON C.O.D. ORDERS**

COMM. TRANSMITTERS With Tubes & Crystals

BC-457 Transmitter—4 to 5.3 MC.—Used.....	\$ 8.95
BC-458 Transmitter—5.3 to 7 MC.—Used.....	7.95
BC-459 Transmitter—7 to 9 MC.—New.....	22.95
T-20/ARC-5 Transmitter—4 to 5.3 MC.—New.....	12.95
BC-456 Modulator—New.....	\$5.95
Transmitter Rack—Single.....	\$1.50
Rec. Rack—Dual.....	\$1.50
Modulator—Mtg.....	1.50
Trans. Dyn.—Used.....	2.95



ANTENNA EQUIPMENT

MP-132 MAST BASE—(Illustrated) 1" heavy coil spring, 2" insulator. Overall length: 11 1/4". Weight: 2 3/4 lbs. Price.....\$3.95

MP-48 MAST BASE—Insulated type with heavy coil spring. Requires 1 3/8" mounting hole. Weight 11 lbs.....\$4.95

MAST SECTIONS FOR ABOVE BASES:
Tubular steel, copper coated, painted, in 3 ft. sections, screw-in type. MS-53 can be used to make any length with MS-52-51-50-49 for taper. Any section.....50c each
Larger Diameter Sections: MS-55-54.....\$1.25 each

TRANSFORMERS AND CHOKES:

TRANSFORMERS—110 V. 60 CYCLE PRIMARIES	
6.3 V. 1 Amp.	\$1.25
24 V. 1/2 Amp. ..	1.50
6-24- or 30 Volt 8 Amp.	5.95
Two 12 V. 4 A. windings, gives 12 V. 8 A. or 24V. 4 A.	5.95
440 VCT/70 MA—5 V. 2 A.—6.3 V. 4 A.	3.35
700 VCT/200 MA—6.3 V. 4 A.—6.3 V. 4 A.—5 V. 3 A.	4.95
490 VCT/60 MA—5 V. 2 A.—6.3 V. 4 A.—6.3 V. 2 A.	3.25
460 VCT/90 MA—5 V. 3 A.—6.3 V. 4 A.	3.75
325-0-325 V. 50 MA—6.3 V. 2.5 A.—6.3 V. .6A. (Rect. 6 x 5) Half Shell—2 7/8" x 3 5/8" x 3"—No. T-23-28	2.75
175-0-175 V. 40 MA—6.3 V. @ 2.4 A.—6.3 V. @ 6 A. Halfshell 2 5/8" x 2-3/16" x 2 3/8"—No. 7-23-40	1.75
350-0-350 V. 90 MA—6.3 V. @ 3 A.—5 V. @ 3 A. Upright—3 1/4" x 3 1/4" x 3 1/4".....	3.25

CHOKES

5 Henries—150 MA. 85 ohms DC—Res. Cased.... 1.95

FAIR RADIO SALES • • 132 SOUTH MAIN ST. LIMA, OHIO

STATEMENT REQUIRED BY THE ACT OF AUGUST 24, 1912, AS AMENDED BY THE ACTS OF MARCH 3, 1933, AND JULY 2, 1946 (Title 39, United States Code, Section 233) SHOWING THE OWNERSHIP, MANAGEMENT, AND CIRCULATION OF CQ, published monthly at New York, N. Y. for October 1, 1952.

1. The names and addresses of the publisher, editor, managing editor, and business managers are: Publisher, Sanford R. Cowan, 1620 Ocean Ave., Brooklyn 30, N. Y.; Managing Editor, Oliver P. Ferrell, 67 West 44th St., New York 36, N. Y.; Business Manager, Sanford R. Cowan, 1620 Ocean Ave., Brooklyn 30, N. Y.

2. The owner is: (If owned by a corporation, its name and address must be stated and also immediately thereunder the names and addresses of stockholders owning or holding 1 percent or more of total amount of stock. If not owned by a corporation, the names and addresses of the individual owners must be given. If owned by a partnership or other unincorporated firm, its name and address, as well as that of each individual member, must be given.) COWAN PUBLISHING CORP., 67 West 44th Street, New York 36, N. Y.; Sanford R. Cowan, 1620 Ocean Ave., Brooklyn 30, N. Y.

3. The known bondholders, mortgagees, and other security holders owning or holding 1 per cent or more of total amount of bonds, mortgages, or other securities are: None.

(Signed) S. R. COWAN, Publisher

Sworn to and subscribed before me, this 8th day of September, 1952.

HARRY N. REIZES, Notary Public

BEST BUYS from your 1953 ALLIED CATALOG

FOR THE NOVICE!

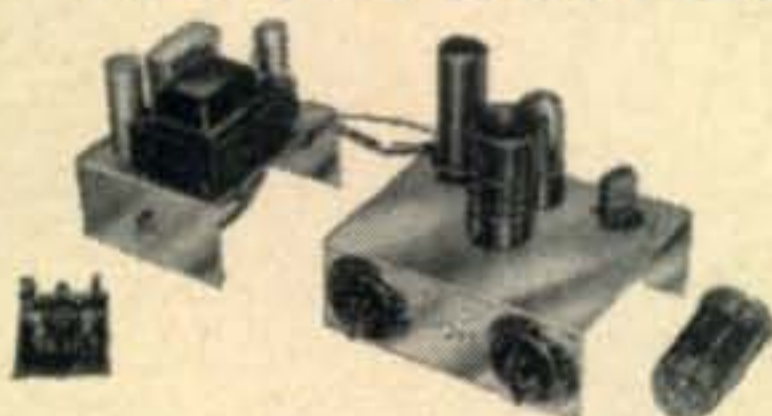

New Philmore Transmitter Kit

Low-cost, 2-band 25-watt CW transmitter. Covers 80 and 11 meters. Uses 6V6 osc., 6L6 power amp., 5Y3 rect. Transmitter and power supply on separate chassis for easy construction and flexibility. Pi-network matches any single-wire antenna. No meters required; uses plate current indicator bulb for tuning. With all tubes and parts, punched chassis, coil forms, coil winding data, hand key, instructions. Less hook-up wire, solder and crystal. Size: Transmitter, 7x5 1/2 x 6 1/2"; power supply, 4 3/4 x 5 1/2 x 6". For 110-120 volts, 60 cycles. AC. Shpg. wt., 6 lbs. 83-556. NET..... \$29.40

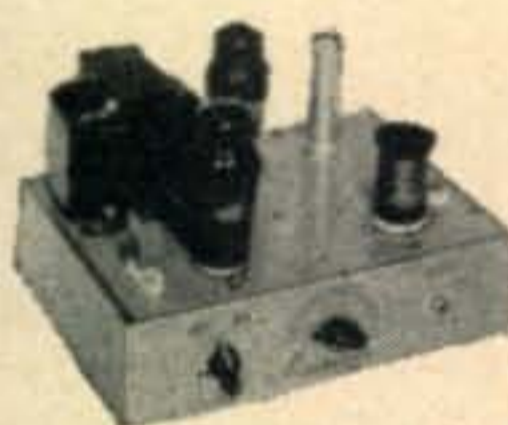

NEW Meissner 2-CW Transmitter Kit

20-watt novice transmitter kit for 20, 40 and 80 meters. Quickly and easily built. Crystal controlled 6L6; rectifier is 5U4G. Designed to operate with folded dipole antenna; instructions also for use with random-length antennas. Has terminal strip at rear to permit metering plate current. Overall size: 6 3/4 x 10 1/8 x 7 1/8". With 80 meter coil, punched chassis, all parts and instructions; less crystal and tubes. For 110-120 volts, 60 cycle AC. Shpg. wt., 7 1/2 lbs. 83-524. NET..... \$24.45

83-522. 20 meter coil. 83-523. 40 meter coil. NET EACH \$2.94
Tubes: 5U4G, \$0.84, 6L6G, \$1.79

Popular "JK Stabilized Crystal"

Type H-43. Popular Amateur type for 3.5 to 4.0 mc., for transmitters above. X-ray oriented, optically lapped and carefully stabilized. Rectangular case holder with 3/4" spacing. Low drift 1 cycle/mc/°C. Size, 1 1/8 x 1 3/8 x 1 1/4". Specify frequency. 99-270. Only... \$2.80

ICA CODE PRACTICE RECORDS

Consists of 5 vinylite 78 rpm records with code recorded on each side. Speed progresses from 2 to 15 words-per-minute in 10 lessons—soon the beginner can copy code with ease. Includes record album and instructions. Shpg. wt., 6 lbs. 89-950. NET..... \$10.73

NOVICES: You'll find everything you need to get started in your ALLIED Catalog.



Here are just a few of the hundreds of "buys" you'll find in your 1953 ALLIED Catalog. For ALL the new gear, for ALL the best values, get and use this 236-Page Buying Guide...

SEND FOR IT!

Great Buy!

NEW ELECTRO-VOICE 208 CARBON MIKE



Ideal Amateur microphone at low, low cost! Fine for mobile operation. Noise-cancelling single-button, carbon differential type. Maximum intelligibility under conditions of extreme noise. Blast-proof, water-proof and shock-resistant. Response: 100-4000 cps. Output: -50 db. Press-to-talk switch. Supplied with 5 ft. cable. Size, 2 1/4 x 1 1/2 x 1 1/8". Shpg. wt., 8 oz. 99-587. List, \$16.50.

Only \$9.70

ANTENNA VALUES!

Amphenol Folded Di-pole



New folded dipole antenna kit. Features high-strength laminated "T" block to insure permanent positive contact to transmission line. Copper-clad steel conductors. Complete with 75 feet standard 300-ohm twin-line feeder. Ready-cut to low end of Amateur band for easy trimming to any frequency. Shpg. wt., 4 lbs. 98-318. 10 Meter (18 ft. length). Only \$5.23
98-319. 20 Meter (35 ft. length). Only \$5.88
98-320. 40 Meter (68 ft. length). Only \$7.64
98-321. 80 Meter (134 ft. length). Only \$11.02

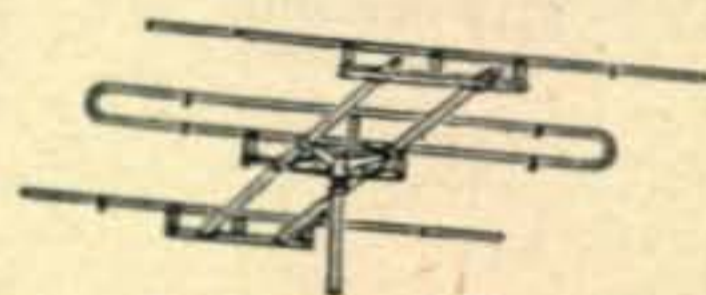

Hy-Lite 3-Element Rotary Beam

Ruggedly constructed; quickly and easily assembled. Elements are high grade telescopic 3/8" and 3/4" aluminum tubing. Elements have locking clamps to secure setting after tuning. Strong aluminum castings support adjustable reflectors, directors and elements. Crossarms are 1" aluminum tubing. Complete with 6' mast, less transmission line. Shpg. wt., 28 lbs. 97-496. 10 Meter (matching 52 ohm coax). Only..... \$42.40
97-497. 20 Meter (T-match, 52-300 ohms). Only..... \$64.95

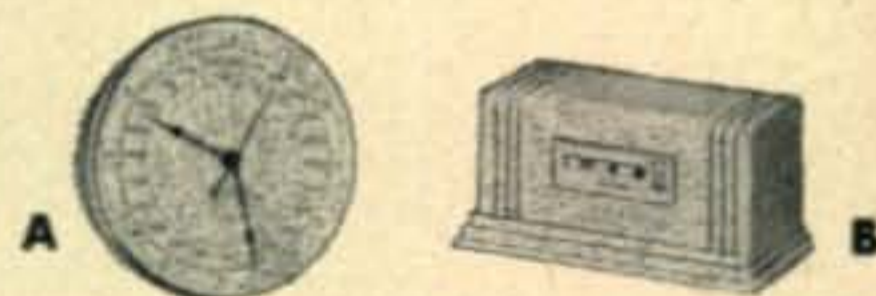

AMATEUR STATION CLOCK VALUES

Fig. A. 24-Hour Amateur Station Wall Clock. Marked in 24-hour time (0000-2400). 10" dial with sweep-second hand; 6" inner dial shows time directly in all world time zones. Self-starting. For 110-120 volts, 60 cycle. AC. Shpg. wt., 3 lbs. 78-325. NET, including excise tax..... \$15.00

Fig. B. 24-Hour Numeral Desk Clock. With seconds scale calibrated in 5-second intervals. Ivory plastic case. 4x7 3/4 x 4". Self-starting. For 110-120 volts, 60 cycles AC. Shpg. wt., 3 lbs. 78-341. NET, including excise tax..... \$8.77
78-340. As above, in ebony plas. case. NET, including excise tax..... \$8.77

SEND FOR YOUR FREE 236-PAGE ALLIED CATALOG

Refer to your 1953 ALLIED Catalog for all your electronic needs, including complete stocks of station equipment and supplies. Save time, effort and money at dependable ALLIED RADIO... If you haven't a copy of our 1953 catalog, write for it today.

order from **ALLIED RADIO**

833 W. Jackson Blvd., Chicago 7, Ill.

NEWCOMER'S BUYWAY

"The Dispatcher"

Here's a Controlled Reluctance microphone assembly designed to handle the most severe requirements of radio amateur rigs. The "Dispatcher" is supplied with two-conductor shielded cable, and it's wired to operate both microphone and relay circuits. This field-proved unit is used extensively in police, railroad, airport, and all

emergency communications work where dependability is vital. Of special interest to "Hams" is the large, easy-to-use grip-bar and positive action of the heavy-duty switch. Firm downward pressure on the grip-bar locks the switch—so you can "yackety-yack" all night without lifting a finger! The "Dispatcher" is immune to heat and humidity and will stand up under rough usage. It is manufactured by Shure Brothers, Inc., 225 West Huron Street, Chicago 10, Illinois. It's a high-impedance unit with a high output level of minus 52.5 db. Lists at \$35.00. See the "Dispatcher" at your Distributor for further details, or write Shure Brothers, Inc., 225 West Huron Street, Chicago 10, Illinois.

Pardon us a minute, Old Timer, while we have a word with the Novice

Welcome to the ranks! We know you're anxious to get going. So here's some sensible advice about getting started without giving away your shirt. You can get a rig on the air for less than 30 bucks—page 40 of the new 1953 ALLIED Catalog shows you how! You'll want this Free 236-page catalog—the most



complete buying guide to *everything* in Amateur radio—the *one reliable* Ham Shack supply source for thousands of Old Timers. It's packed with full selections of quality receivers, transmitters, station gear—everything you need, at money-saving low cost, to start your station and operate at top efficiency. Choose, too, from the world's largest stocks of parts, tubes, kits, tools and books. You can count on ALLIED for fast, dependable shipment, the best time payment terms

in Ham history, and practical help from old-time Hams. Have *all* the advantages enjoyed by thousands of amateurs over the past 30 years. Send today for your FREE copy of the 1953 ALLIED catalog. Write ALLIED RADIO CORP., 833 W. Jackson Blvd., Dept. 16-L-2, Chicago 7, Ill.

(From page 10)

I sincerely believe that a letter to you is due him—and I wish that he would be thanked—not only by me, but many others. Keep up the excellent work.

E. A. Knapp

Cleveland, Ohio

"JUST WHAT I NEEDED - "

(From page 41)

which the dial can be read. Accuracies of a kilocycle or so should be readily achieved at 3500 kilocycles, with correspondingly greater errors possible on the higher frequencies, covered by harmonics of the oscillator. On the other hand, the monitor will enable you to hear exactly how the signal sounds in the other fellow's receiver. As in looking at a mirror, you can decide for yourself if you like what you see.

PROPAGATION

(from page 61)

on 15 and 20 meters, but with the 20-meter band going "dead" earlier than during September and October. . . . Decreased ionospheric absorption and generally lower atmospheric noise levels will permit improved DX activity over all dark paths on 40 and 80 meters. . . . After about the middle of the month, there is a fairly good possibility that 160-meter signals will break through on some nights. Because of more auroral zone penetration, European circuits to the Pacific Coast will be considerably poorer than those to Eastern and Central USA.

SOUTH AMERICA

Propagation control points for these circuits fall in or near tropical areas which are characterized by a more highly ionized ionosphere than more Northern regions. These North-South circuits are characterized by high maximum usable frequencies. Ten and fifteen meters are expected to provide good solid circuits almost daily. . . . Very good DX conditions should prevail on 20, although signals may be weak during the afternoon. . . . Night-time DX conditions on 40 and 80 meters are also expected to be very good with strong signals during many nights. Some 160-meter openings should be possible to Central America.

Propagation conditions favor Latin American countries north of the Equator, since the Summer season, with its higher noise levels and solar absorption, is approaching for the countries south of the Equator.

AFRICA

Fairly good conditions should exist from Eastern and Central sections of the USA to all areas of Africa, with some fair openings also expected to the Pacific Coast. Ten meters should provide some daylight activity. Conditions on 15 meters are expected to be quite good to North Africa, fairly good to Central and Western Africa and fair to South Africa. . . . On 20 meters, signals from North Africa are expected to be strong. Circuits from Central and South Africa will be much weaker because of increased ionospheric absorption and increased atmospheric noise levels at the African end of the circuit. . . . Forty and 80 meters are expected to have good openings on North African paths during the dark hours. As the circuits become more Southerly, conditions on 40 and to a greater extent 80, will become erratic and considerably poorer than the North African circuits.

Although the Propagation Tables are based upon the short, direct great circle radio path, on some occasions Pacific Coast stations may hear the South Africans coming around the long way, on 20 and 40 meters, with the Australasians.

AUSTRALASIA

The propagation control points for these circuits fall in areas where the ionosphere is relatively highly ionized.

(Continued on page 78)

PLATT BARGAIN PAGE

Now you can shop at either of **PLATT'S TWO GREAT STORES!** New Branch Store is at 159 Greenwich St., N.Y.C. Main Store is at 489 Broome St., N.Y.C. (Send all mail orders here.)

20 LBS. ASSORTED RADIO PARTS



\$2.79

You won't want to pass up this bargain — **SO HURRY!** — order now while it lasts!

CD 307A CORDS
with PL 55 Plug and JK 26 Jack, long cord.



SPECIAL 79c

TURBO AMPLIFIER

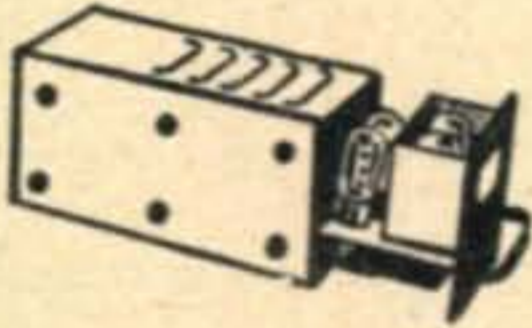

4 tube Amplifier used by U. S. Air Force. 115 V. input at 400 cycles. Without tubes—

BRAND NEW SPECIAL \$119

NOW! Fill Your Battery Only Twice a Year with Automatic Battery Filler



Made by leading Detroit Auto Mfr. Doubles battery life over ordinary care, prevents battery breakdowns, fits all cars, instantly installed.

ONLY 89c COMPLETE

ARMY TEST UNIT 1-236

Meter is contained in a metal box 5 1/4" long x 3 3/4" wide x 3 1/4" deep. Comes complete with test leads and instruction book. Can be used for testing between AC and DC measuring resistances of circuits, checking fuses and testing capacitors.

SPECIAL! \$4.19



NEW! COMMERCIAL MOBILE EQUIPMENT

Now Being Manufactured by Platt Manufacturing Co.

Have many new features. Latest design, compact, easy to handle. Excellent price. Write for data and price.

MINIMUM ORDER \$2.00
Immediate Delivery — Send 25% deposit on C.O.D. orders. All shipments F.O.B., N.Y.C. (N.Y.C. residents add sales tax to your remittance.)



FIELD TELEPHONES

Army surplus, completely reconditioned and electrically tested, using 2 flashlight cells and a pair of inter-connecting wires. **GUARANTEED—like new.**

ONLY \$20.95

PRE-AMPLIFIER—MODEL K-1



The K-1 is used to amplify output level for microphones and phonographs. Operates on 24-28 VDC, can be converted to 110 AC. Comes complete with PL 55 plug and 2-foot 119-B cord, 2 terminal blocks and instruction book.

BRAND NEW SPECIAL! \$3.95

PE 98 12 VOLT DYNAMOTOR

Excellent condition. **SPECIAL! \$39.95**

MULTITESTER FOUNDATION BIAS METER 1-97A

Contains a zero center 3 1/2" round Marion voltmeter calibrated 0-100 volts each side. Movement is one mill each side of center. The unit is mounted in a steel box 7"x5"x4 1/2" and contains 8 contact push button, line cord dual 100 MFD at 200 V DC condenser, a potentiometer 6 1RC 1% wire wound non-inductive resistors; one 400 ohm, two 2500 ohm, one 5000 ohm, one 10,000 ohm, one 15,000 ohm. Excellent for building a zero center multimeter with ranges of 1, 10, 100, 1000 volt.

Complete Brand New \$5.95



HEADSETS

- HS-33 low impedance with cord and plug, used, fine condition **\$2.79**
- HS-23 high impedance, **BRAND NEW** with ear pads **4.95**
- HS-33 low impedance, **BRAND NEW** with ear pads, cord and PL54 plug. **5.39**
- CD-307A Cords, 6 ft. **NEW** .89
- H-16/U, high impedance. Includes two receiving units **3.95**
- HS-16 high impedance—used. **2.49**



TUBES

- IB22 69c
- 1B23 \$3.75
- 2B22 49c
- 2C22 14c
- 2C26 9c
- 2C26A 9c
- 3B22 \$1.19
- 3BP1 \$3.29
- 3C24 98c
- 3D6 39c
- 3DP1 \$1.79
- 7C4 39c
- 10Y 19c
- 12K8Y 39c
- 15R 39c
- 39/44 29c

BRAND NEW! JAN! BOXED!

- 100R 49c
- 114B 29c
- 215A 9c
- 221A 29c
- 804TH \$5.95
- 316A 29c
- 371B 29c
- 388A 59c
- 471A \$1.19
- 532A \$1.19
- 722A 99c
- 801A 19c
- 826 39c
- 841 29c
- 848 17c
- 864 19c

TUBES

- 954 13c
- 1616 49c
- 1610 19c
- 1625 29c
- 1626 19c
- 1629 22c
- 1630 39c
- 1633 29c
- 7193 19c
- 9002 69c
- 9006 19c
- E1148 49c
- HY615 11c
- RK34 99c
- VR92 14c
- VT127 15c

ELECTRIC MEGAPHONE SYSTEM

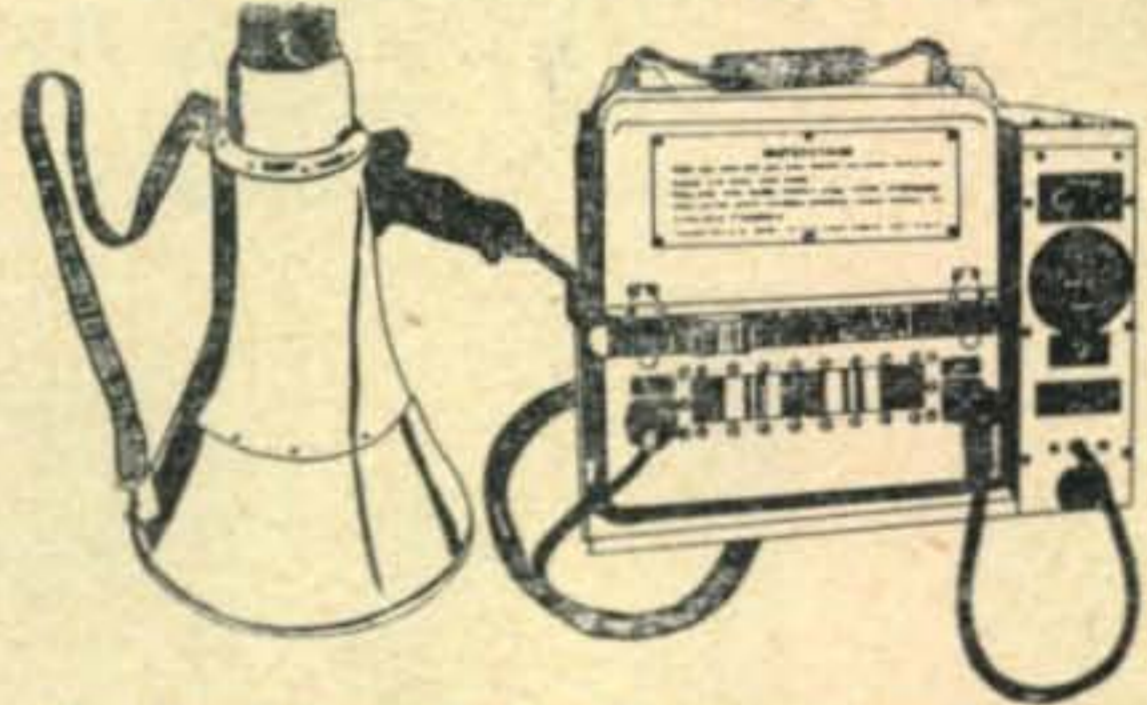

For Rural Areas, Hotels, Steamers, Ball Parks, etc. U.S. NAVY Type PAE-1 designed for voice reinforcement in much the same manner as, but to a greater degree than, the familiar acoustic megaphone. Consists of Megaphone Unit (which combines a microphone and reproducer in a single assembly), Portable Amplifier which electrically amplifies the output signal of the microphone section of the megaphone and feeds this amplified signal to the reproducer section, Charging Rack for re-charging the self-contained storage battery of the portable amplifier. **BRAND NEW!** Demonstration given at either **\$149.50** of Platt's Stores. . . .



SCR-274N COMMAND and ARC-5 EQUIPMENT

RECEIVERS	Used	Excellent Used	New
BC-453—190 to 550 KC	\$29.95		\$49.95
BC-454—3 to 6 MC...		12.95	19.95
BC-455—6 to 9 MC...	9.95	11.95	16.95
TRANSMITTERS			
A-958—2.1 to 3 MC..			29.95
BC-458—5.3 to 7 MC..	7.95	9.95	17.95
ARC 5-T-A—3 to 4 MC.		24.95	34.95
BC-459—7 to 9.1 MC..			24.95
T-15 ARC 5-500 to 800 KC			29.95
ADDITIONAL EQUIPMENT			
BC-456 Modulator	2.49	2.95	5.95
BC-450 Control Box (3 Receiver)	1.49	1.95	2.75
BC-451 Control Box (Transmitter)	1.29	1.79	2.39
BC-442 Relay Unit (ANT) Plugs: PL-147, 148, 151, 152, 153, 154, 156—EACH	2.39	2.89	3.69
Flexible Shafting with gear to fit receivers		1.25	
3 Receiver Rack	1.79	2.29	2.98
2 Transmitter Rack	1.69	2.39	3.97
Single Transmitter Rack			3.97
DM-32 Dynamotor for Command Set		3.95	5.95
Mounts for 2 Trans. Rack, 3 Rec. Rack, Modulator, Antenna and Relay Unit		1.95	

PLATT ELECTRONICS CORP.

DEPT. C, 489 BROOME ST., NEW YORK 13, N. Y.

PHONES: WO 4-0827 and WO 4-0828

On the Beam

with the **NEWEST** and **BEST BUYS** . . .

HUDSON
RADIO & TELEVISION CORP.

**Headquarters
for RCA**

and **ALL Standard
Electronic Equipment for
Amateur and Industry!**



beam power tubes

The Best Your Transmitter Can Use

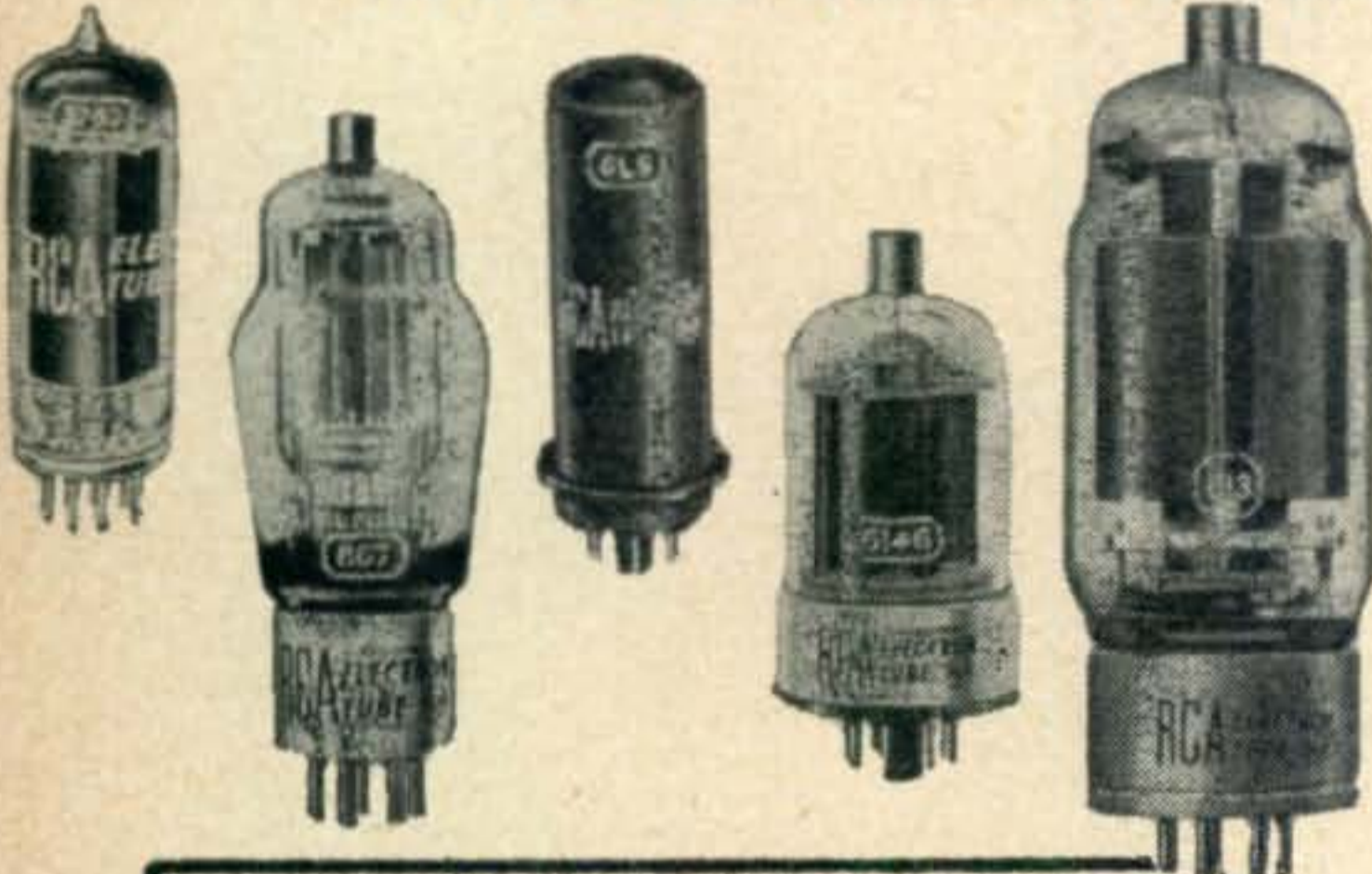

COMPLETE STOCKS ALWAYS ON HAND!

FOR FAST SERVICE on RCA TUBES, TEST INSTRUMENTS, BATTERIES, PARTS . . . Call Hudson your complete, dependable source!

Get the **GREAT NEW 1953
HUDSON CATALOG**

and Latest **JAN** Cross-Reference **GUIDE**

FREE!



Everything in electronics at your fingertips in this greatest of all 1953 HUDSON CATALOGS! Over 196 pages of everything in Radio, TV, and Industrial Electronics. The World's Finest High Fidelity, Test Equipment, Audio Equipment, and the latest in Ham Gear, etc. The most complete buying guide of its kind. INCLUDES the latest JAN CROSS-REFERENCE GUIDE and all types of fully approved JAN type components with interchangeability charts.

Select from the largest stocks of all standard makes at **LOWEST PRICES!**

Send for your Free Copy Today!

One Call for All!

HUDSON
RADIO & TELEVISION CORP.

Write or come in and chat with **BOB GUNDERSON**, W2J10 at our uptown store Thursdays. Downtown Sats.

Uptown (Dept. Q-10) Downtown

48 WEST 48th ST. • 212 FULTON ST.

New York 36, N. Y. • Circle 6-4060 • New York 7, N. Y.

Open daily until 6 P.M. Thursdays Til 9 P.M.

(from page 76)

and therefore MUF's are relatively high on these circuits. However, it is springtime "down under" right now, and Summer is approaching there, with its higher solar absorption and increased atmospheric noise levels. All this means that while the MUF's are high, so are the LUHF's (lowest usable high frequency), and the overall usable band of frequencies may be somewhat limited. Good ten-meter openings are expected to Western USA, with some openings extending into the Central and possibly the Eastern area. . . . Fifteen meters may be the most active band for DX on these circuits. This band falls between the MUF and LUHF for a good number of hours each day. . . . High absorption will keep signal levels down on 20, but some good openings are expected to the Pacific Coast and on many days will extend to all areas of the USA. . . . Conditions on 40 will be no better than fair, with some openings expected on ionospherically quiet days. . . . Only a limited amount of 80 meter activity expected.

ASIA

Circuits from the Near and Middle East to Eastern USA pass through the same great circle paths as do most Central European signals. Because of the longer distances involved, signal intensities are considerably lower. Some 10, 15, 20, 40 and possibly 80-meter openings expected but openings may be erratic, characterized by fading and weak signals. Conditions from this area of Asia to the Central and Western sections of the USA will in general be poor. . . . Far East circuits should be fair on 20 to the East Coast with the possibility of some 15 meter openings. . . . Better conditions should exist to the Central and Western areas, with openings possible on all bands 10 through 80, from most areas of the Far East to the USA, Pacific Coast.

NOVICE SHACK

(from page 52)

in the attic, sixty watts input, and a HQ-129X receiver. Lowell is now W5UBW and still works 27 and 28 mc. exclusively, and he would like to hear more Novices on 27 mc."

Richie, WN4WJD, gets right to the point. "I have a few words of defense for the so-called "cheap" receivers so hotly denounced by WN4USM in the August issue. Of course, you cannot expect the performance from an S-38B or SW-54 than you would with a 75A2 or an HRO. But, with a little patience a lot of fun can be had with one of these little jobs. I know—I have tried it. If it had not been for the S-38B, I would never have become interested in ham radio, and I am sure there are many other hams who could say the same. I don't have anything against the HQ-129X (I really wouldn't mind having one myself), but I think it is unfair to say that a person may become discouraged using the small receivers. On the contrary, I think they have interested more people to become hams than they have turned away."

Richie is looking for a Novice QSO in Rhode Island. His frequency is 3748 kc., if you can help him.

Pete Stanck writes, "Dear Herb, Thanks for printing my plea for help with the code. It was answered by two members of Hamfesters Radio Club, Dick, WN9ORA, and Claude, WN9SSJ. It is amazing what you can do with the proper help. Before Claude and Dick started helping me, my receiving speed was zero, and I could send about two words a minute. I was not worried about the technical end of the examination.

Well, the boys gave me my first lesson four days ago, and I have just come from passing my Novice examination! It seems incredible, but I'll swear on a stack of bibles that it took only four days to bring my speed up from zero to five words per minute. Thanks."

Ladd, W9CYD, has been kept busy answering letters from Novices and prospective Novices as a result of his offer in the Novice Shack to help anyone to become a ham. He said, "I sure was surprised by the number of letters I got, but I was glad to get them, and I hope I was able to help." Ladd repeats his offer of help to anybody who wishes to obtain an amateur license. His address is Ladd J. Smach, W9CYD, 6145 West Eddy St., Chicago 34, Illinois. Telephone: Palisade 5-7867.

(Continued on page 80)

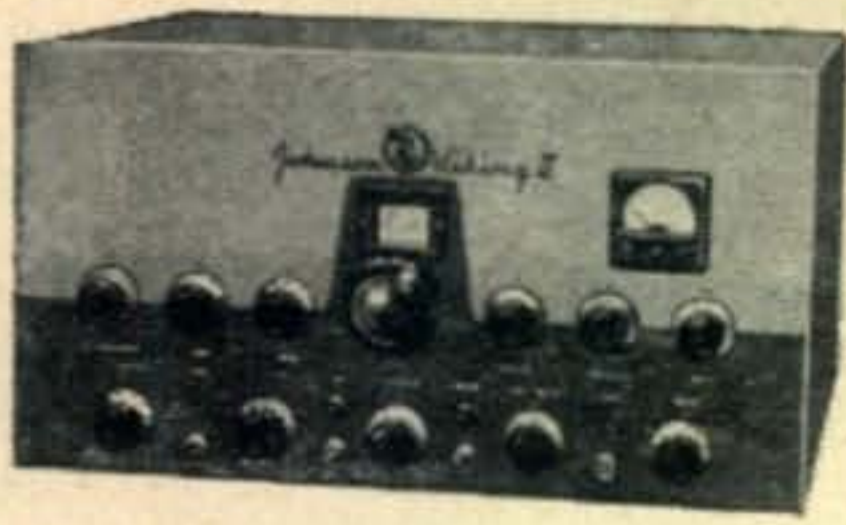

THE NEW VIKING II 100-WATT PHONE-CW TRANSMITTER KIT. Features effective TVI suppression. Kit complete with tubes. Only \$279.50.

MASTER MOBILE UNITS

- All-band center-loaded antenna for 75-20-10, specify coil wanted, less mount.....\$8.75
 100-96S. Stainless Steel 96" threaded whip \$5.25
 9-96T. Silicon-Chrome 96" threaded whip \$3.75
 100-60S-60". "All-Band" top section only \$4.95
 132. Tapered spring universal body mount. \$8.75
 132X. Heavy-duty universal body mount. \$9.85
 132J. Junior model universal body mount. \$4.17
 140. Tapered spring bumper mount.....\$6.55
 140X. Heavy-duty bumper mount\$7.65
 140J. Junior model bumper mount.....\$4.17



B&W BALUM INDUCTORS
Type 3975

- Match 75 ohm unbalanced outputs to 75 and 300 ohm balanced feed lines

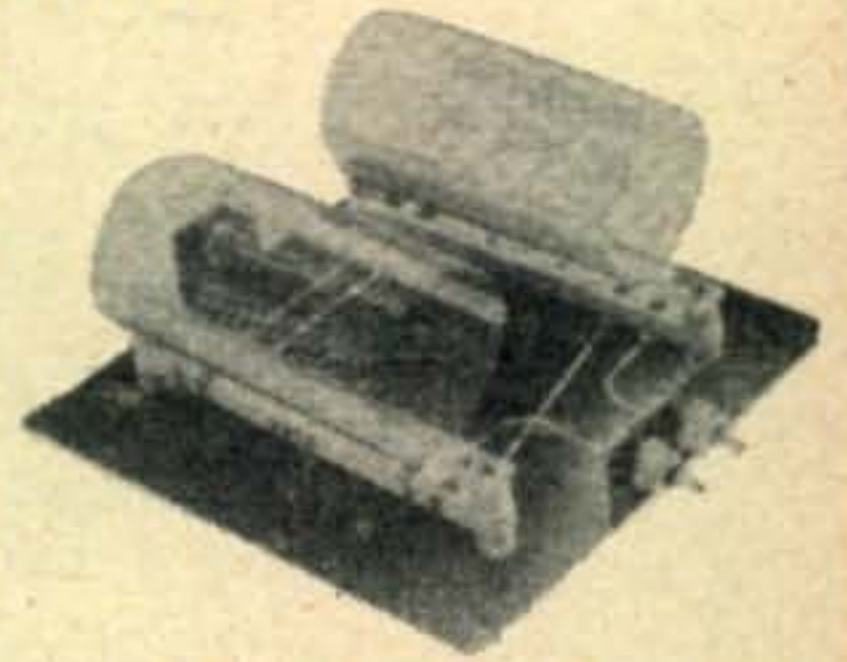

Two of these sturdy bifilar air-wound balun inductors serve as a compact, highly efficient multi-band (80 to 10 meters) unit for matching feed line systems to both transmitters and receivers. Specially designed for use with Collins 32-V series and similar transmitters. Full instructions with each inductor.

Ea. less base

\$4.65

DOW CO-AX RELAY

FOR 52 OHM LINE

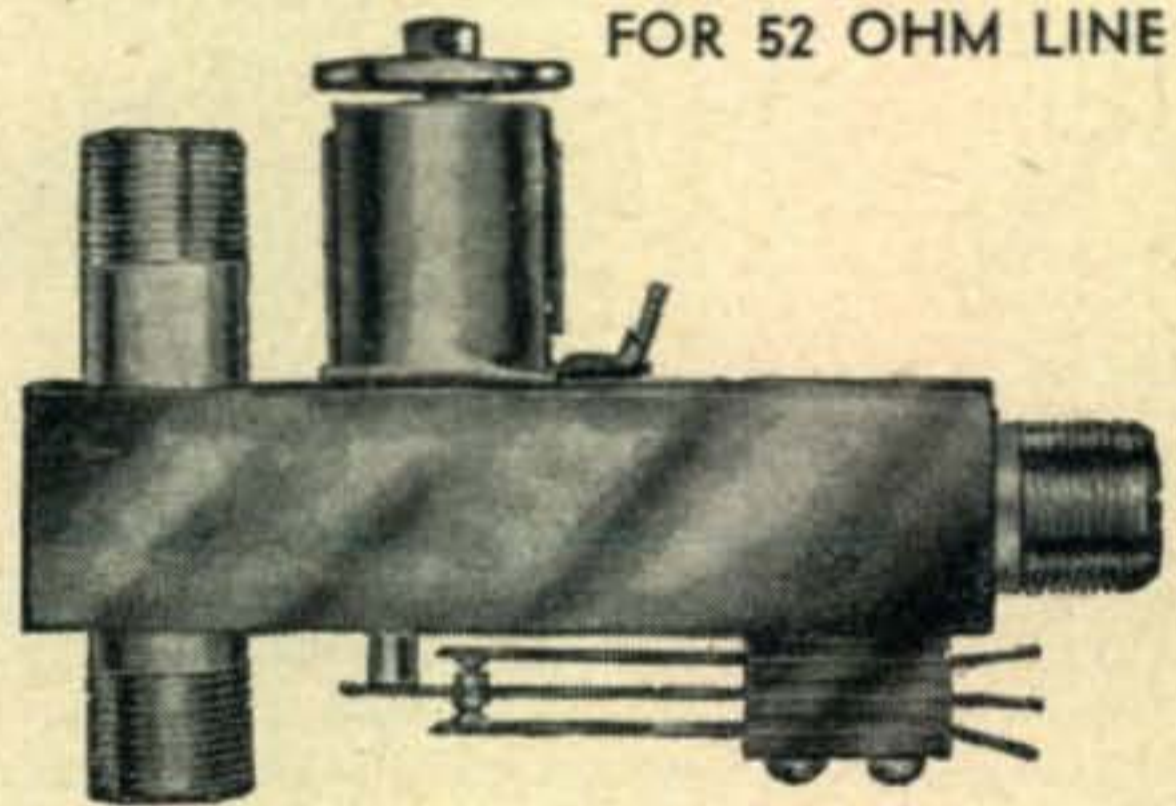

\$12.50

ELMAC-A54

Under-dash Mobile Xmtr.
Measures: 7 1/2" x 7 1/2" x 12"
Weights: 14 1/2 lbs.

For Carbon Mike Input... Net \$139.00
 For Dynamic or Crystal Mike, Net 149.00
 Power Supply, 110 volts AC, Net 39.50



ELDICO TR-75-TV

TRANSMITTER KIT



This is an ideal unit for the novice. Very simple to assemble. New, revised circuit to aid in the elimination of TVI. Uses 6L6 oscillator—807 amplifier combination Pi-network output. Husky power supply delivers 600 volts to the 807. Complete . . . including a punched chassis and shielded cabinet. Unbelievably low priced at.....\$59.95

MD-40 modulator kit for above \$34.95
 WD-40P as above
 but with power supply . . . \$44.95

MORROW CONVERTERS



The latest in Mobile Converters . . . Easy to operate . . . Sturdy construction for long, trouble-free service.

- Model 2BR for 10-75 meters, net \$54.95
 Model 2BRLN for 10-75 meters, net \$49.95
 Model 3BR for 10-20-75 meters, net \$64.95
 Model 3BRLN for 10-25-75 meters, net \$59.95

GRID DIP OSCILLATOR

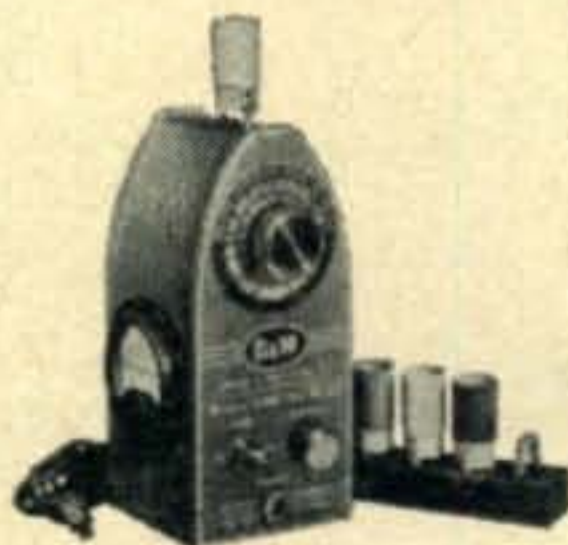

B & W
model 600

\$48.00

WIRELESS RADIO COMPANY

"SUPPLYING AMATEUR RADIO EXCLUSIVELY"

117 12th ST. N.E.

Phone 5-6503

CANTON 4, OHIO

ARROW has CAMBRIDGE THERMIONIC COILS IN STOCK

These coils, now gaining wide popularity among hams throughout the country, are made by the famous Cambridge Thermionic Corporation.

LS3 STANDARD WINDING SLUG-TUNED INDUCTORS

1 mc. .91¢ 10 mc. .84¢
5 mc. .87¢ 30 mc. .84¢

ALSO AVAILABLE FROM STOCK

LS4 LS3 LSM LST
CTC Ceramic and Phenolic
Coil Forms for High
Frequency Use.

ARROW ELECTRONICS, INC.

Dept. C-11
82 CORTLANDT ST., NEW YORK 7, N. Y., DIGBY 9-4714



(from page 78)

Bob, WN9SQP, reports that he has retired his BC-454 receiver in favor of an S-38B. He took his General Class license examination two weeks ago and is now sweating it out. . . . Hugh, WN3TLU/5, reports that he is waiting with what patience he can muster for the authorization of Novice operation on 7 mc. So are many others. . . . WN8KAO reports on another Novice "first." Don writes, "I claim to be the first Novice to operate portable in Canada. We went on our vacation to Sparrow Lake, Ontario, the week of August 17. While there, I operated as WN8KAO/VE3, working ten states and Ontario. I was running seventy watts input to an 807. Antenna was a 150-foot piece of wire, and the receiver a BC-348P.

"At home I run seventy-five watts input to a half-wave doublet and, in four months, I have worked thirty-three states. I am sixteen years old and a senior in High School.

Other Novices who are vacationing in Canada and would like to operate portable there may get the necessary authorization by writing:

Telecommunications Division
Department of Transport
Ottawa, Ontario, Canada

Give your name, address and call letters, and tell where and on what dates you wish to operate in Canada. By return mail, you will receive two copies of an application blank to be filled in. Return them both to the Telecommunications Division. After being checked, one will be certified and returned to you. It and your F.C.C. license will be your authorization to operate in Canada. Allow enough time for processing, several weeks at least, to be safe.

Canadian amateurs may receive similar authorization to operate in the United States by writing to:

Authorization Analysis Division
Federal Communications Commission
Washington 25, D. C.

They would be wise to write a few months in advance for authorization, allowing time for F.C.C. processing.

Incidentally, when U. S. stations operate in Canada, they are governed by Canadian regulations, and when Canadian amateurs operate in the States, they are governed by U.S.A. regulations.

73, Herb, W9EGQ

High Fidelity Reception with ESPEY AM/FM CHASSIS

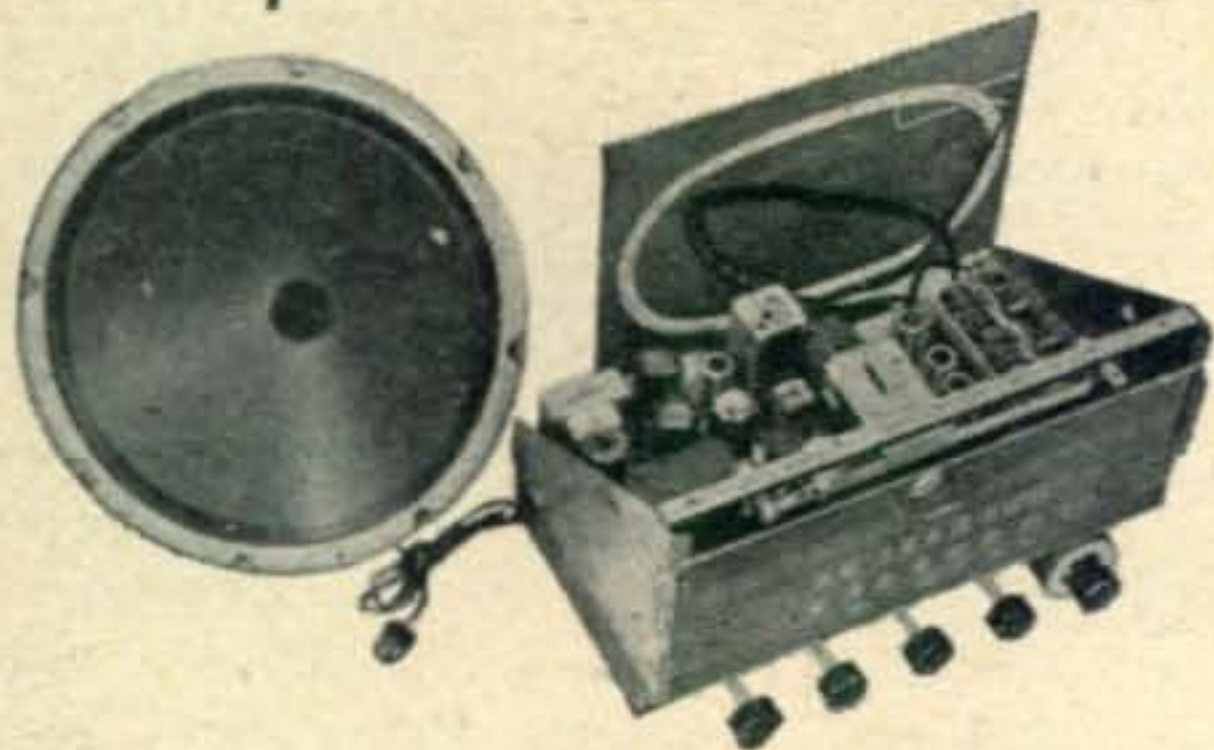

Model 511-C, supplied ready to play. Fully licensed under RCA and Hazeltine patents. Equipped with tubes, antenna, speaker, and all necessary hardware for mounting.

NEW FEATURES—Improved Frequency modulation circuit, drift compensated • 12 tubes plus rectifier, and pre-amplifier 12AT7 tube • 4 dual purpose tubes • High quality AM-FM reception • Push-pull beam power audio output 10 watts • Switch for easy changing to crystal or variable reluctance pick-ups • Multi-tap audio output transformer supplying 3.2-8-500 ohms.

Write Dept. CQ-11 for literature and complete specifications on Model 511-C and others.

Makers of fine
radios since 1928.

ESPEY
TEL. TRefalgar 9-7000
MANUFACTURING COMPANY, INC.
528 EAST 72nd STREET, NEW YORK 21, N. Y.

POWER SUPPLY

(from page 30)

rear of the chassis, and run the green and yellow lead to terminal 12. One wire from L1 and the red lead of C1 are now connected to pin 2 of V1. Connections to this pin may be soldered. The red and yellow lead of T1 is now connected to one lug of a terminal strip placed on the right front mounting screw of T1. The black leads from C1 and C2 are connected to this tie point, and a wire is run from there to terminal 14. Resistor, R2 is connected from this tie point to one lug of a terminal strip placed on the left front mounting screw of T1. From this tie point, a wire is run to terminal 15, and a jumper is run to another lug on this same strip. Resistor, R1 is connected from here to a previously unused lug on the first terminal strip. The red lead from C2 and the remaining lead from L1 are run to this tie point, and a wire is run from there to terminal 16. Now all four tie points may be soldered. Two black leads remain unused on T1. These will be connected later.

Now the low voltage supply may be wired. First, connect the two green leads from T2 to pins 2 and 7

(Continued on page 82)



Just Arrived!

- and of course you'll see it

at **TERMINAL!**

The NEW Hallicrafter Transmitter

A versatile, completely TVI-proof transmitter with commercial performance at amateur prices! Complete bandswitching 10 to 160 meters. 10-position crystal selector switch. Spurious radiation at least 90 db. below full output. Pi network output for 50 ohm coax with special low pass filter. OUTPUT of 115 Watts CW or 100 Watts phone at continuous operation rating. Provision for external VFO and many other new features.



HT-20 complete with all tubes **449⁵⁰**

We regularly stock the complete line of Hallicrafter receivers.

The NEW Johnson Viking II Kit

All the features of the famous Viking I plus TVI suppression in a special copper plated cabinet, up to 180 watts input to two 6146 final amplifier tubes and with many other new features making this the most outstanding transmitter kit ever offered!

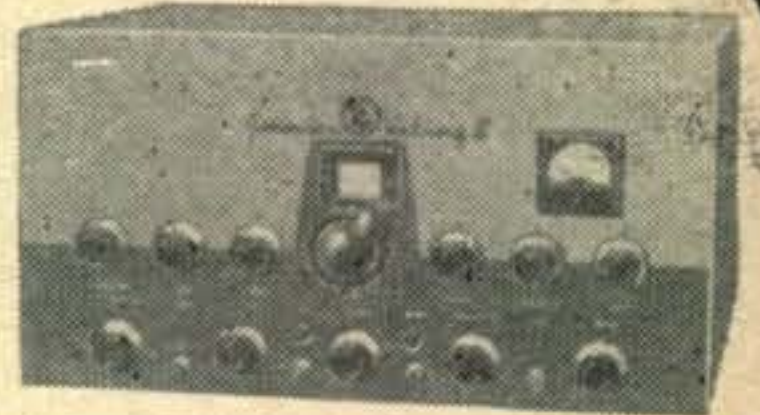

- Viking II complete with all tubes..... \$279.50
- Viking II complete with tubes, wired and air tested 324.50
- Viking VFO Kit, worthy companion to the Viking II 42.75
- Viking Mobile Kit, up to 60 Watts input for that rig-on-wheels 99.50
- Viking Low Pass Filter, 4 section, 75 DB Att., handles a KW 16.50
- Viking TVI Kit, everything to TVI-proof the Viking I 24.75

New NATIONAL HRO-SIXTY



Here's the latest and the greatest of the famous NATIONAL HRO series! Features dual-conversion plus 12 permeability-tuned IF circuits! Many, many other newly designed features to make this the outstanding communications receiver value of the year!

483⁵⁰

Matching Speaker \$16.00

NC 183 D . . . \$369.50 Matching Speaker . . \$16.00

SW-54 Built-in Speaker \$49.95

We regularly stock all National receivers, accessories and parts

ELMAC 50 WATT TRANSMITTER



Fills a long-felt need for a moderately priced mobile transmitter with a real SOCK—or for a low-power regular or stand-by fixed station transmitter. 10, 11, 20 & 75 meter with crystal or with direct-reading VFO on all bands. 50 Watts input, hi-level plate modulation, built-in Pi antenna Network, compact measuring only 7 1/2" x 7 1/2" x 12" complete with tubes.

- A-54 for carbon mike..... \$139.00
- A-54H for hi-imp. mike..... 149.00
- 110 VAC power supply..... 39.50
- 6 VDC dynamotor supply..... 87.50
- Electro-voice 210 carbon mike..... 16.50
- Electro-voice 600D dynamic mike..... 23.10

New SONAR 3-BAND RECEIVER



The complete 4-watt output receiver (not a converter) which has created such a sensation among the "mobile" gang! Covers 10-11, 20, 75 and 80 meters. Ten slug-tuned circuits, 8 tubes, with 500 KC IF's to give better than 1 micro-volt sensitivity. Exceptional selectivity. Built-in BFO and ANL. Full 180° electrical bandspread easily read on accurately calibrated full-view dial. Requires 250 volts at 80 Ma.

Complete with tubes, plugs and mounting bracket less power supply and speaker. **89⁹⁵**

— Preview — The NEW GONSET 2-Meter XMTR-RECEIVER



A complete 2-meter fixed-portable unit, the new GONSET provides an ideal unit for home, mobile and portable use!

- Crystal-control, 12-Watt xmtr
- TVI-proof
- Super-het receiver
- Small size: 8 1/2 x 10 1/4 x 6 D
- Universal power supply, 110 VAC—6 VDC
- Uses either crystal or carbon mike
- Needs only mike and antenna to go on air

189⁵⁰

Open Thursday Evenings till 9 P.M.
Ample Free Parking After 6 P.M.

Terminal Radio Corp.

New York's Dependable Radio Supply House

85 CORTLANDT ST., NEW YORK 7, N.Y.
phone: WOrth 4-3311



PIONEER CHASSIS PUNCHES

Cut     HOLES
ROUND • SQUARE • ANGULAR • KEYED

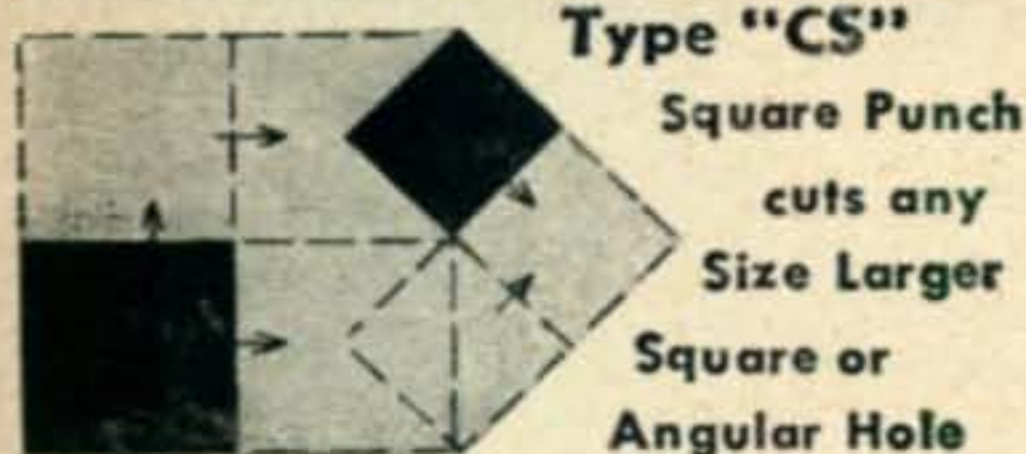

Type "CS"

Square Punch

cuts any
Size Larger

Square or
Angular Hole



★
For mounting IF's, Terminal Strips, Sockets,
Plugs, Meters, Controls, Xfrmers, Switches,
Panel Lites, Etc.

■ SQUARES		● ROUNDS		Simple Hand Wrench Screw Action		
5/8	\$2.95	1/2	\$1.95			1 1/4
1 1/16	\$3.25	5/8		1 3/16		
3/4	\$3.50	1 1/4		1 1/2		
7/8	\$3.85	3/4		2 1/4		
1	\$3.95	7/8	\$2.15	1 3/8	\$2.60	
● KEYED		1		1 1/2		\$2.95
1 1/4	\$3.50	1 1/16		1 1/2		\$2.95
		1 1/8		2 1/4		\$5.65

"AT YOUR FAVORITE DISTRIBUTOR"

PIONEER TOOL CO.
LOS ANGELES 16, CALIFORNIA

Keep Your
Shack Neat

with a

BOUND VOLUME

You'll appreciate the handy convenience of
this compact volume of the 1951 issues of

CQ . . . handsomely
book-bound in tan
colored cloth . . .

distinctive gold foil
lettering embossed
in a black panel strip

. . . available NOW!

\$7.95

in U. S., Canada and
Pan-American
Union. Others,
\$1.00 more.

CQ MAGAZINE

67 West 44th Street New York 36, N. Y.

(from page 80)

of the socket for *V2*. Run a lead from *pin 2* to *terminal 5*, and a lead from *pin 7* to *terminal 7*. The green and yellow lead of *T2* is connected to one lug of an eight-lug terminal strip mounted on the two inboard screws of *T2*. A wire is run from this lug to *terminal 6*. These wires may now be soldered. It is inadvisable to cut this green and yellow lead or the corresponding lead of *T1*. These leads are called centertaps. They are composed of two wires in the same insulation. The unwary constructor might assume these are just two leads leads supplied for convenience and cut one away from the other. This will cause an open circuit in the filament winding because these two leads are the connections from the two halves of the filament winding. The leads can be cut if shortening them is necessary. If so, they must be cleaned and soldered together carefully, because the full filament current will flow through the junction of these wires. The red wires of *T2* are connected to *pins 3* and *5* of *V2* and soldered. The red and yellow lead of *T2* is run to a lug of the terminal strip and a lead is run from there to *pin 2* of *V4*, thence to *terminal 4*. The negative lead to *C3* is connected to the same lug to which the red and yellow lead of *T2* was tied. Now the wires may be soldered on this tie point. One black lead of *L2* is soldered to *pin 8* of *V2*. The positive lead of *C3* is connected to an unused lug of the eight-lug strip. The other black lead of *L2* is connected to this lug, a wire is run from the lug to *terminal 1*, and *R3* is connected from this lug to *pin 5* of *V3*. Solder the wires to this lug. A lead is run from *pin 5* of *V3* to *terminal 2*, and *R4* is connected from *pin 5* to *pin 1* of *V3*. Wires are run from *pin 2* of *V3* to *pin 5* of *V4* and from *pin 1* of *V3* to *pin 6* of *V4*. Resistor, *R5* is connected from *pin 6* to *pin 2* of *V4*, and a lead is run from *pin 5* of *V4* to *terminal 3*. Solder the wiring to the sockets of *V3* and *V4*.

Again two black leads have been left hanging, this time off *T2*. These wires, and the black wires of *T1* are the primary, or 110-volt, a-c leads for the two transformers. These should be the only wires remaining on the transformers. Mount an eight-lug terminal strip on the inside of the back of the chassis. Run one black lead from each of the transformers to one lug of this strip and connect a wire from this tie point to *terminal 9*. One black lead remains on each transformer. These are connected to separate lugs on the terminal strip. Mount *S1* and *S2* on the panel, arranged so that in the *ON* position, the toggles are up. A wire is run from *S1* to the lug to which the black lead from *T1* was attached, and a wire is run from *S2* to the lug to which the black lead from *T2* was attached. Connect a lead from the unused lug of *S1* to one side of *Fs1*, and another from the other side of *Fs1* to *terminal 10*. Connect a wire from the unused lug of *S2* to one side of *Fs2*, and another from the

(Continued on page 84)

CQ RADIO AMATEURS' JOURNAL

YOURS for the ASKING

76 PAGE ANTENNA CATALOG SECTION
as reprinted from Radio's Master

AM-FM-TV Antenna, Boosters, Accessories
Catalogs the products of 32 leading Antenna and Accessory Manufacturers.

FREE!
See Coupon

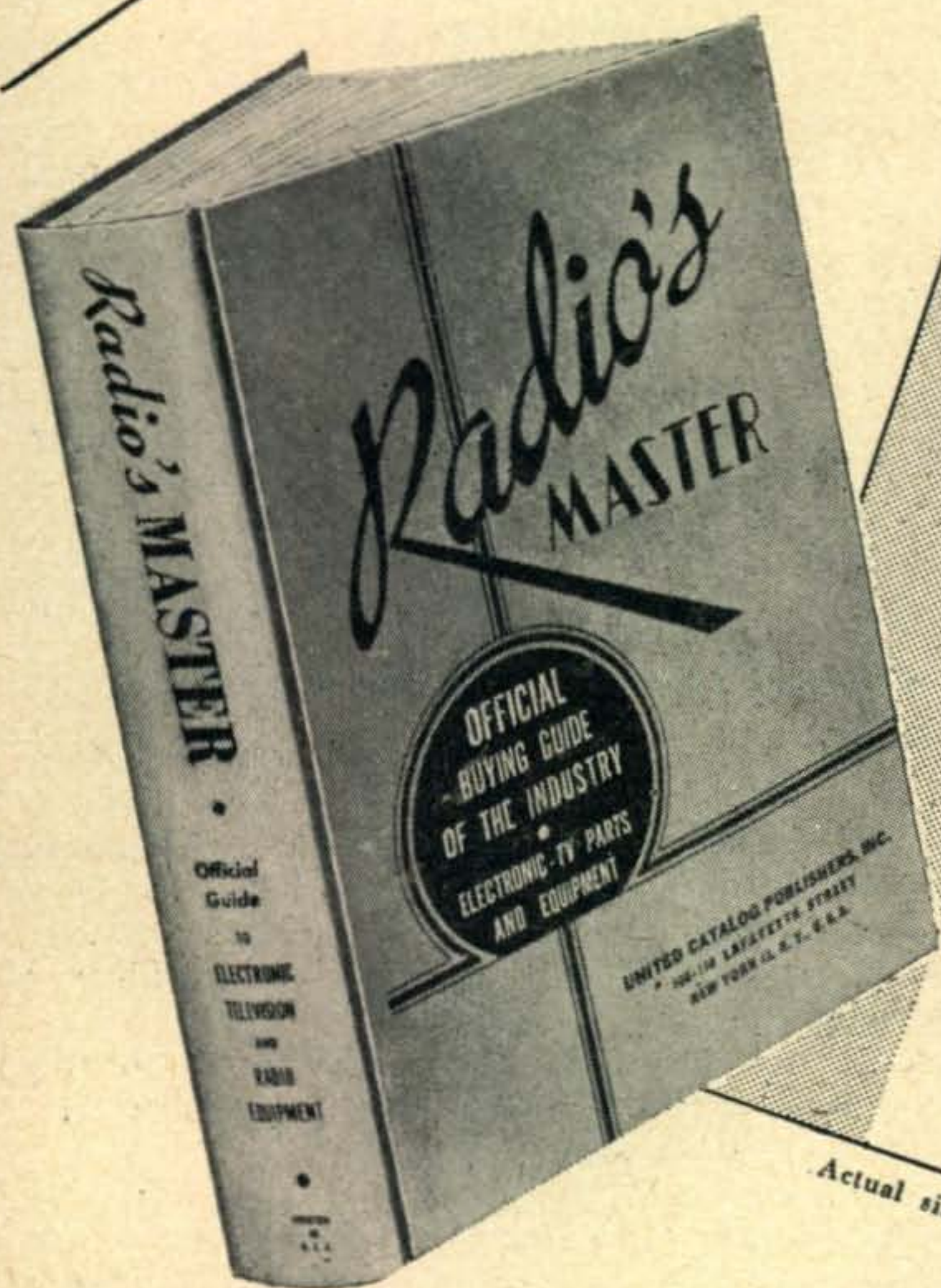

Represented in RADIO'S MASTER 76 page ANTENNA and ACCESSORIES Booklet are the products of the following manufacturers:

- Alliance Manufacturing Co.
- Alproco, Inc.
- American Phenolic Corp.
- Baker Manufacturing Co.
- Birnback Radio Co., Inc.
- Blonder-Tongue Labs., Inc.
- Brach Mfg. Corp.
- Columbia Products
- Cornell-Dubilier Elec. Corp.
- Electro-Voice, Inc.
- Hi-Lo TV Antenna Corp.
- Incline Corporation of Amer.
- J.F.D. Manufacturing Co., Inc.
- LaPointe Plascomold Corp.
- Master Mobile Mounts, Inc.
- Mostey Electronics
- Peerless Products Industries
- Penn Television Products Co.
- Premax Products
- Radelec Manufacturing Co.
- Radiart Corporation
- Radio Corporation of Amer.
- Radio Merchandise Sales, Inc.
- Regency Division
- Walter L. Schott Co.
- South River Metal Prod. Co.
- Spirling Products Co., Inc.
- Technical Appliance Corp.
- Tei-A-Ray Enterprises, Inc.
- Telex, Inc.
- Tricraft Products

Actual size 8" x 10 1/2"

CQ subscribers will receive without cost or obligation, a complete 76 page catalog section as reprinted from the Industry's Official 1220 page Radio's Master, 17th edition.

Whether you buy, sell or specify, you will find this handy Antenna booklet extremely helpful for quick reference. It catalogs in detail the products of the leading Antenna and Accessory manufacturers with complete descriptions, specifications and illustrations.

This offer is made possible by a special arrangement between CQ Magazine and the publishers of RADIO'S MASTER. Fill in the coupon NOW to get your copy. →

CLIP AND MAIL TODAY

CQ MAGAZINE 67 West 44th Street, N.Y. 36

Please send me, without cost or obligation, the 76 page ANTENNA and ACCESSORY Booklet reprinted from Radio's Master.

Name

Address

City Zone State

6-Band Bandswitching Mobile

Choice of 2 Bands, 4 Frequencies
and Antenna Switching While in Motion



BABCOCK MOBILE D-X MITTER

- 35-50 watts input to 6146 final.
- High Band 14-30Mc, Low Band 3.5-7.3Mc.
- 2 crystal frequencies each band.
- Complete metering including watts output.
- Small, compact, 5"x8"x7".
- Ham Net, \$99.50, including tubes.
- Slug-tuned antenna loading coil with switching relay, \$15.00
- Power supply \$67.50 or use PE-103.

For Further Details See Your Jobber
or Write for Illustrated Folder

Babcock Radio Engineering, Inc.
7942 Woodley Ave., Van Nuys, Calif.

TELEPHONE EQUIPMENT & PARTS

New TS9 handsets with flip switch in handle.....ea.	\$6.50
TS 15 handsets with rubber cord PL55 & 68 plugs.....ea.	8.00
TS 13 handsets with PL55 & 68 plugs.....ea.	8.00
Reconditioned TS9 handsets.....ea.	4.95
New W. E. F1W handsets with rubber cord & PL47 plug.....ea.	6.95
New Transmitter & receiver units (Like and interchangeable with W. E. HA1 & F1 elements).....ea.	1.00
New High impedance receiver units (Flts W. E. Holtzer mobot Conn. handle) 350 ohms.....ea.	1.00
Used Am. Mike high imp. receivers.....ea.	0.90
New A.E. & Amer. Mike Transmitters.....ea.	1.50
Reconditioned & Tested EES telephones.....ea.	20.00
Reconditioned & Tested Sound Power field telephones 101A.....ea.	25.00
New W.E. UA38 & B-365 relays.....ea.	1.95
New CKG relays 1000 Ohms 3b & 3 Makes.....ea.	1.95
New W.E. 3A varistors.....ea.	0.90
Upright desk telephones (For extensions, intercoms, etc.) reconditioned.....ea.	3.95
Upright desk telephones reconditioned like new with dial & ringer, box complete.....ea.	9.00
Reconditioned wall telephones with ringer.....ea.	7.50
Like new desk with ringer dial blanked new housing Federal #803.....ea.	14.50
Reconditioned W.E. 302 desk telephones dial blanked.....ea.	14.50
Used BD 57A switchboards #60 jacks, 26 cords W/P147 plug.....ea.	15.00
Reconditioned BD 71 switchboards.....ea.	25.00
Operator head & chest set HS18 (Single receiver double receiver).....ea.	6.50
New RM29A remote control units export packed, carrying bag.....ea.	14.00
W.E. Transmitters D-96554.....ea.	0.90
Used switchboards BD129 good condition.....ea.	25.00
New Telephone cords.....3 Conductor—ea.	0.40
.....4 Conductor—ea.	0.60
New 4 1/2 foot rubber cords with PL47 plug rubber jacketed.....ea.	0.96

EASTERN TELEPHONE CO.
323 Vanderbilt Ave. Brooklyn 5, N.Y.

(from page 82)

other side of $Fs2$ to terminal 8. Solder these connections associated with the primary circuits and the wiring is completed.

Testing

It is now possible to hook 110 volts a-c across terminals 8 and 9 and across terminals 9 and 10, throw the switches, and check the power supply for proper operation. It is also possible that something is improperly connected and that sparks may fly. The writer recommends checking the various terminal block connections for continuity to each other and to ground before applying power, in order to forestall this danger. Resistance from any terminal to ground should be infinite. If any terminal has a low resistance to ground, the constructor has probably used one of the grounded lugs on a terminal strip, rather than the ungrounded lugs, for a tie point. Resistance between terminal block connections will be evident from an examination of the wiring diagram. The resistance of $R1$ should appear between terminals 15 and 16, as will the resistance of $R2$ between terminals 14 and 15. Similarly, resistances between terminals 1 and 2, and terminals 2 and 4 should equal the values of $R3$ and the sum of $R4$ and $R5$, respectively. Terminals 5, 6, and 7 should have very low resistance from one to the other, as should terminals 11, 12, and 13. Very low resistance should appear between terminals 9 and 10 when $S1$ is in the ON position, and low resistance will appear between terminals 8 and 9 when $S2$ is in the ON position. Continuity should not appear from one filament supply to the other, from one plate supply to the other, from either filament supply to either plate supply, or from terminal 9 to either of the plate and filament supplies. A continuity check of this kind is a good idea before applying power to any unit for the first time, whether the unit be a transmitter, receiver, or power supply.

If the continuity check has been satisfactory, 110 volts a.c. may be applied to the power supply unit. Unless a remote switching circuit is to be used, a jumper should be connected from terminal 8 to terminal 10. Then 110 volts applied across terminals 9 and 10 will supply primary voltage for both supplies. D.c. voltage outputs should be approximately equal to those shown in Tables I and II, for a given current drain. Moderate variations in voltage are probable. Aside from normal production differences in transformers, the principal reason for such variations will be found to be fluctuation in line voltage. We used an auto-transformer to set the primary voltages to 110 during the voltage-current runs. Obviously, 120 volts or 100 volts applied to the primaries will increase or decrease output voltages shown by several per cent.

Cost Figures

The two power supplies, less tubes, cost within a couple of cents of thirty dollars. The low voltage

(Continued on page 86)



It's R9 Plus . . . when using a "VAARO ANTENNA"

Presents: The first all band switching mobile and marine antenna system 2Mc to 30Mc. Completely weather proof in high seas or rainy mobile days, available with or without capacity hat.

100

"Hi Gain Capacity Hat" corrosion proof in various colors to match your car, very light weight, fits all whips.

101

"Hi Gain Capacity Hat" corrosion proof anodization in bright attractive colors to match your car, complete with Hi Q Transparent buterate weather proof shield, fits all whips.

102

"Hi Q Junior" air wound medium power All Band Switching coil, completely weather proof, no change of loading in rain or snow, fits all whips.

103

"Hi Q Master" air wound high power weather proof coil, operate all bands in your car without inconvenience of coil changing or other unpleasant operations, one second band switching, fit all whips.

104

New all fiberglass amateur 104 civil air patrol or marine whips and new stress designed base section 106 for use with above units. Completely corrosion and weather proof. No insulators or springs required. "Bumper Mount" completely new design, don't chop holes in your new car, heavy construction and corrosion proof, lends beauty to your installation, designed to fit any bumper, special bumper curvature insert furnished, no drilling or machining necessary to install just bolt on.

105



VAARO ELECTRONIC ENGINEERING COMPANY, BOX 5035 LONG BEACH, CALIFORNIA.

Please send me C.O.D.—F.O.B. CHECK ANY OF THESE:

VAARO 100	<input type="checkbox"/>	\$ 3.95	VAARO 104	<input type="checkbox"/>	\$6.25
VAARO 101	<input type="checkbox"/>	5.95	VAARO 105	<input type="checkbox"/>	9.25
VAARO 102	<input type="checkbox"/>	8.95	VAARO 106	<input type="checkbox"/>	7.95
VAARO 103	<input type="checkbox"/>	14.95	SEND LITERATURE	<input type="checkbox"/>	

NAME

ADDRESS

CITY STATE

BOUND To Give Greater Value

By keeping your copies of "CQ" in a BINDER, you have the finest reference library on ham radio right at your finger tips.

This handsome, red fabricord, steel reinforced binder holds a full year's copies of "CQ." Each magazine can be inserted or removed at will.

Price **\$2.50** postpaid*

*(Foreign Orders add 25c per binder)



CQ Magazine
67 West 44th St., New York 36, N. Y.

Enclosed find \$..... for binders

Name Call

Address

City Zone State

Year to be stamped Heading: CQ. Plain



***MONOSET** (magnetic) ***DYNASET** (dynamic)

The modern styling, dependability and superior performance of these under-chin TELEX headsets have made old fashioned headphones obsolete. With more highs and lows of both music and speech, they are the delight of radio and TV monitors.

Wearing a lightweight TELEX headset with no pressure on the ears and all background noise blocked out, you're all set for hours of traffic, DX or just plain chewing the rag. You'll never again wear an old fashioned headphone after you try one of the fatigue-free, featherweight TELEX headsets.

*Trade Mark



***TWINSET**

This lightweight 1.6 oz. TELEX Twinset pipes signal directly into the ear, blocking out background noises and banishing listening fatigue. Magnetic.



For complete information on any of the above headsets, write

TELEX

ELECTRO-ACOUSTIC DIV.
Department 15-C • St. Paul 1, Minn.
In Canada
ATLAS RADIO CORP., Toronto

TELEX
HEARING AT
ITS BEST

GREENWICH SPECIALS

815—P.P. Beam Pow. Ampl. 75 watts on 2 meters—slight corrosion, or loose bases, electrically perfect. Hundreds sold in our store. only 89c ea.
HF Oscillator Assembly—Calibrated in megacycles on dial. Consists of Condenser, Coil, Ceramic Trimmer—F B for wave-meter, absorption marker, VFO, etc. . . 69c ea. 8 for \$2.00
NATIONAL—Condenser Assembly—PW-4—4 section condenser. Double section each side complete. . . . Special \$8.95
PW-28—Single each side—complete. Special \$6.95
DYNAMOTOR—DM-19-G—input 12VDC—output 500VDC 200MA—Complete w/filter & shock mounts. . . NEW \$18.95
F19/UPR Wave Trap—used to determine frequencies of signals from 80-300MC. Housed in beautiful black crackle cab. 4 x 4 x 4—New with Navy Instruction Book. \$2.95
RG59/u—Hanks from 50-200 ft. Most with PL-259 plug on each end—as they come. 3c ft. incl. connect.
HAMMARLUND Split Stator Variable Condensers—1000V gap. 25 MmFD each Sect.—\$1.49; 50 MmFD each Sect.—\$1.79; 100 MmFD each Sect.—\$1.99.

GREENWICH SALES CO.

59 CORTLANDT ST.
NEW YORK 7, N. Y.

ADDRESS CHANGE . . .

Subscribers to CQ should notify our Circulation Dept. at least 5 weeks in advance regarding any change in address. The Post Office Dept. does not forward magazines sent to a wrong destination unless you pay additional postage. We cannot duplicate copies sent to your old residence. Old and new addresses MUST be given.

CQ Magazine

67 WEST 44th STREET NEW YORK 36, N. Y.

(from page 84)

supply accounts for about seven and a half dollars of this total. If it is not required, the cost will decrease by that amount. The high voltage rectifier tube costs less than a dollar, while the rectifier and voltage regulator tubes for the low-voltage supply cost about four dollars. These figures are for first quality, new tubes.

A careful investigation of the surplus market will show that the power supply cost can be reduced considerably. Some advertisers offer transformers, chokes, and oil filled condensers at comparatively low prices. Much of this equipment is of highest quality. However, as was mentioned earlier, we restricted ourselves to the use of standard components.

Modifications

Some amateurs will require higher voltages than that furnished by the 400-volt supply. This power supply can be modified to furnish up to about 700 volts. Either the *Thordarson T-22R36* or the *Stancor P-6170* transformer delivers 600 volts each side of centertap at 200 ma., as well as the required filament voltages. The *P-6170* has an additional 6.3-volt winding which, when placed in series with the first 6.3-volt winding, will give 12.6 volts which is required for some surplus equipment. Either of these transformers may be substituted electrically for the *Triad R-21A*. With choke input, these transformers will supply about 500 volts d.c. at 200 ma. The 5U4G rectifier tube should stand up under this load, but the filter condenser will be operating in excess of its ratings. An oil filled 800- or 1000-volt, 2 μ f. or larger, condenser is preferable. If a condenser-input filter is used, these transformers will supply about 680 volts d.c. at 100 ma., and about 640 volts at 150 ma. The 5U4G might stand up in this service, but its use is not recommended. A 5R4GY may be substituted directly for the 5U4G, and will handle the voltage. The 5R4GY is rated at 150 ma. maximum with condenser input, so the current drain is limited to somewhat less than the transformer rating. The power capability is still considerably beyond the Novice input limit. Oil filled condensers rated at 1000 volts will be required if these transformers are used with a condenser-input filter. Capacities of 2 μ f. or more will be satisfactory.

It is evident that a chassis as large as the one we used is not required for this power supply unit. There is lots of blank space left on the chassis. If only the high voltage supply is required, the chassis could be as small as 6x9x3 inches.

Mitchell Replacements:

For L1—Chicago R-7200, Stancor C-1416, or Halldorson C5032 or 5033.
For L2—Stancor C-1002, Halldorson C5015, or Chicago R-1365.
For T1—Halldorson P9404, Chicago PV-200, or Stancor PC8412.
For T2—Chicago PV-70A, Stancor PC8407, or Halldorson P9212.

2nd Lt.
Joseph C. Rodriguez
U.S. Army
Medal of Honor



SIXTY YARDS TO GO. From atop the hill, near Munye-ri, Korea, the enemy suddenly opened up a withering barrage. The squad was caught; Red mortars began zero-ing for the kill. Lieutenant Rodriguez (then Pfc., with only seven months service) broke loose and dashed up the fire-swept slope, throwing grenades. Disregarding the fire concentrated on him, he wiped out three foxholes and two gun emplacements. Alone, he accounted for 15 enemy dead, led the rout of the enemy, and saved the lives of his squad.

"When you have to take chances to reach an objective, that's O.K.," says Lieutenant Rodriguez. "But when you can find a surer

way, so much the better. That's why I was glad when I heard that people like you own *nearly 50 billion dollars* in U. S. Defense Bonds. I believe that a strong, *peaceful* America is our objective. And the *sure* way to reach it is through backing *our* strength with *your* strength by investing in United States Defense Bonds *now!*"

★ ★ ★

Now E Bonds earn more! 1) All Series E Bonds bought after May 1, 1952 average 3% interest, compounded semiannually! Interest now starts after 6 months and is higher in the early years. 2) *All maturing E Bonds* automatically go on earning *after maturity*—and at the new higher interest! Today, start investing in better-paying Series E Bonds through the Payroll Savings Plan!

Peace is for the strong! For peace and prosperity
save with U.S. Defense Bonds!

The U.S. Government does not pay for this advertisement. It is donated by this publication in cooperation with the Advertising Council and the Magazine Publishers of America.



YOU CAN TALK TO THE WORLD!

PREPARE FOR F. C. C. NOVICE

FULL PRICE
\$26⁹⁵

AMATEUR RADIO LICENSE

Be a "Ham" in a Few Days
No Experience Needed
The "Hobby with a Future"

SEE YOUR
RADIO SUPPLIER

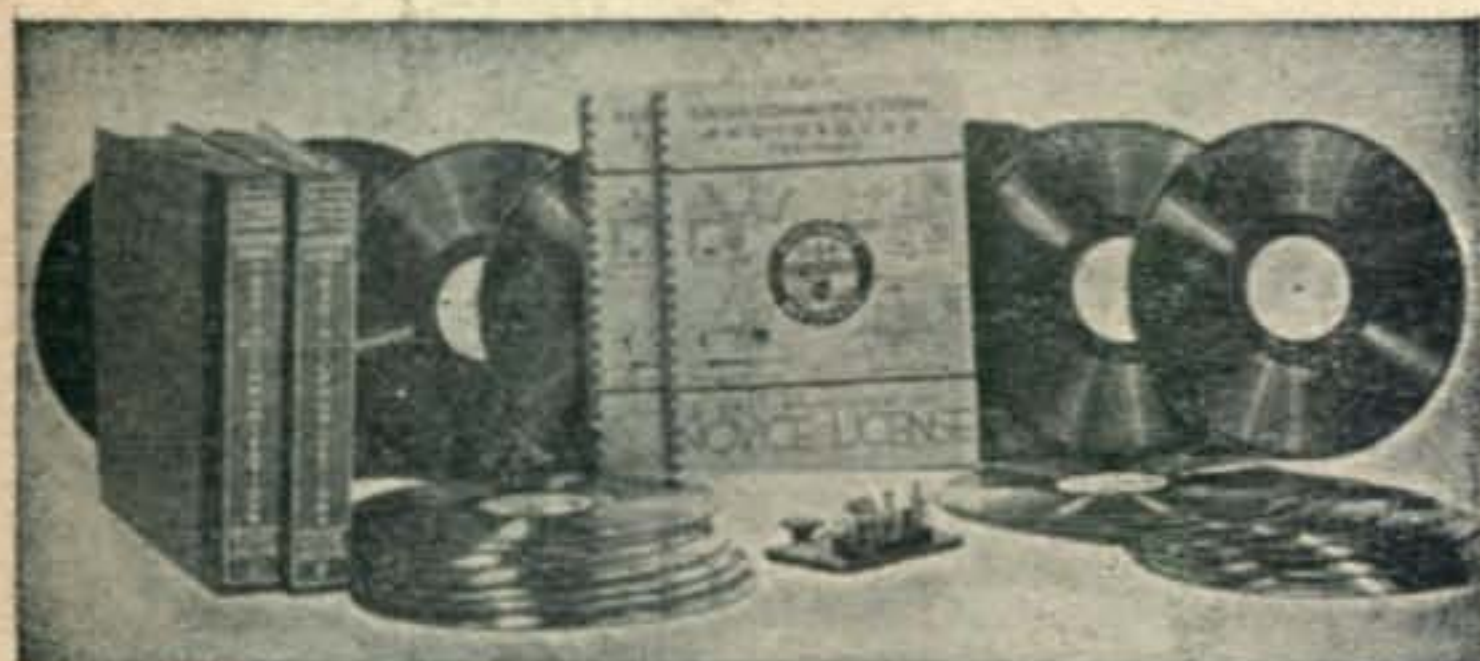

YOU GET AND KEEP: 36 4-min. code recordings (alphabet thru 6 wpm)
• 2 12-record albums • Telegraph Key • Tone Record for Sending Practice • Instruction on Sending, Radio Theory, FCC Regulations and On-The-Air Operating Procedure explained by Pictures and 12 recordings • Pre-FCC Exams graded FREE. All Lessons and Records sent at ONE TIME.

GET ON THE AIR THE SHORT-CUT PHOTOSOUND WAY. You LOOK at pictures, you LISTEN to recordings, YOU LEARN WITHOUT EFFORT! Repeat to your heart's content.

SIMPLE STEP-BY-STEP INSTRUCTIONS to assemble your own Ham Station. Send your voice over land and sea. Make world-wide friends. Act in national emergencies. Start this fascinating, practical hobby TODAY!

ALSO AVAILABLE FROM YOUR RADIO SUPPLIER:

E. T. I.'S RECORDED RADIO CODE COURSE
(alphabet thru 20 words per minute)

MAKE up to 7,500⁰⁰ in RADIO-TV per yr.

Write for FREE Information on:

PHOTOSOUND Home Study Courses for:

- ADVANCED AMATEUR LICENSE PREPARATION
 COMMERCIAL RADIOTELEPHONE AND
RADIOTELEGRAPH LICENSE PREPARATION

ELECTRONIC TECHNICAL INSTITUTE Dept. CQ11

970 W. Manchester • Inglewood, Calif.

AMAZING NEW VIBROPLEX

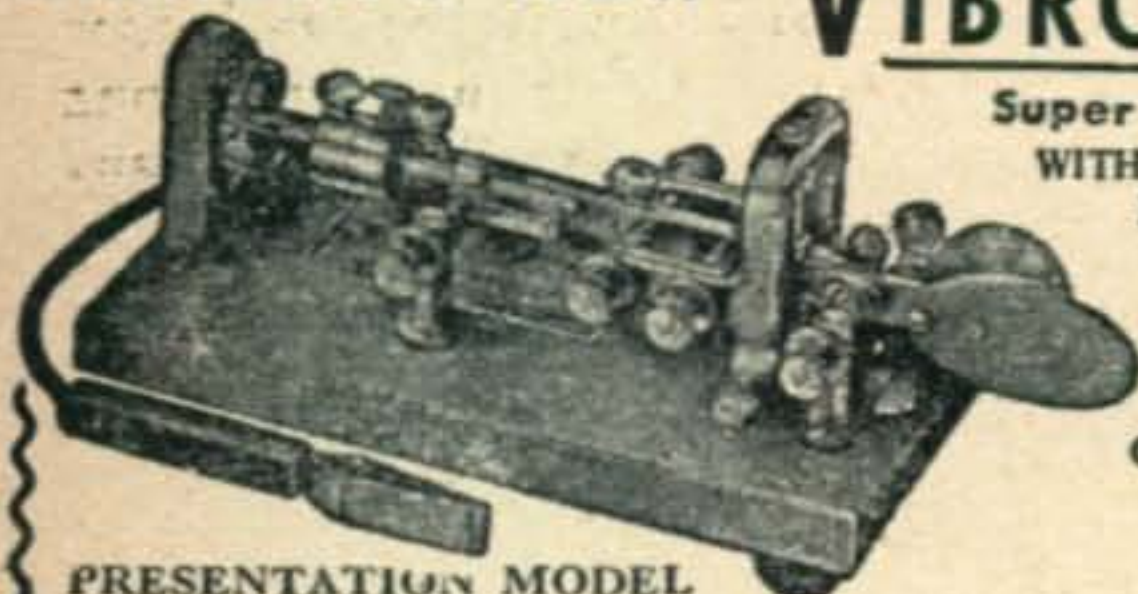

Super Deluxe
WITH ADJUSTABLE
MAIN SPRING
AND OTHER
GREAT
FEATURES
24-K
GOLD-PLATED
BASE TOP

PRESENTATION MODEL

\$29.95

Vibroplex presents the first really speed control key. An adjustable main spring permits operator to send slower or faster as desired. No more muddy signals... no sacrifice of signal quality. Suits any hand or any style of sending. Free of arm tension. Sends easily as pressing a button. Praised by operators and beginners alike. Try this new Vibroplex key! You'll be delighted. Other new popular Vibroplex keys from \$12.95 up. At your dealer or
THE VIBROPLEX CO., INC. 833 Broadway, N. Y. 3, N. Y.

6146

(From page 46)

in the lead to the tap on coil *L1*. Then adjust condenser *C2* for a dip in the plate current. Also tune in the signal around 24 mc. that should show up in your receiver. Once the crystal is oscillating the frequency as observed on the receiver should not vary appreciably when tuning *C2*. If it does vary the tap on *L1* is too close to the plate end of the coil and should be moved towards the crystal end. If the stage refuses to oscillate with a good crystal the tap is too close the crystal end and should be moved further up the coil towards the plate.

After disconnecting the temporary arrangement outlined above plug in all the tubes and measure

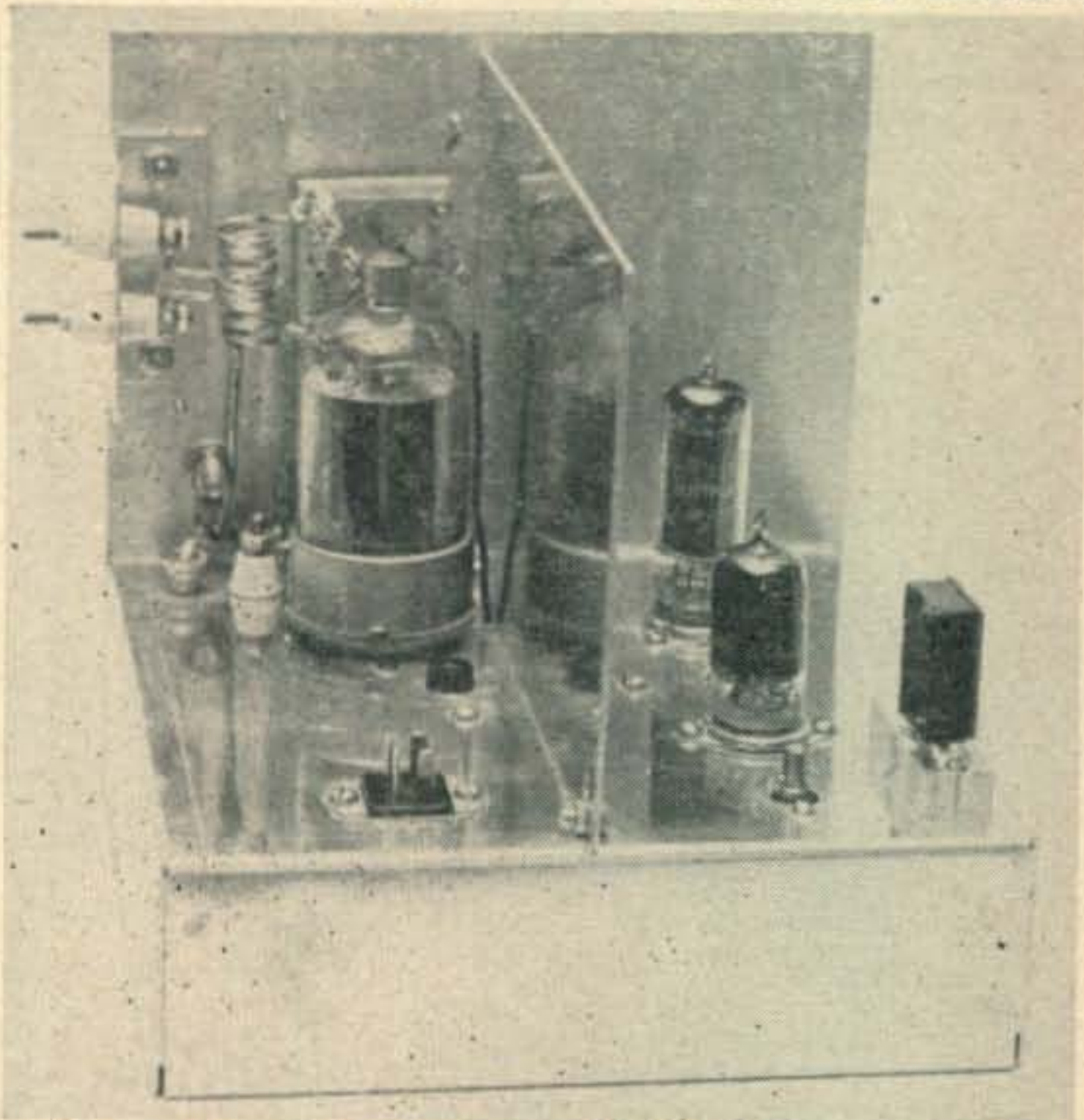

A rear view showing the shield between the final amplifier and doubler stages.

the resonant frequencies of the *LC* circuits in the 12AU7 plate and the 6146 plate and grid. If they are too far out adjust the coils till they peak up near the appropriate multiple of our 8-mc crystal.

Now connect an 0-10 milliammeter into the tip jacks *J1*. Disconnect the plate and screen voltages on the 6146, but apply about 250 volts to the 12AU7 and the 5763. Adjust *C2*, *C4* and *C7* for a maximum reading (grid current). It is not advisable to adjust *C2* unless absolutely necessary. This condenser should be set so that the oscillator will start off everytime that power is applied to the transmitter.

When the circuits have been aligned the final amplifier grid current should be about 1.6 ma. This will drop the very slightest amount when plate voltage is applied to the plate of the 6146 tube.

It was found that the grid to plate capacitance of the final stage was effectively "negative" and additional capacity was added to neutralize the final.*

* This process is detailed in the very handy booklet released by Eimac as their Application Bulletin No. 8. It is entitled, "The Care and Feeding of Power Tetrodes." See particularly page 18 and figure 82.

COIL TABLE

- L1—18 turns #16, 1/2" dia., close wound, tap 5 turns from xtal
 L2—4 1/2 turns #14, 1/2" dia., 1/2" winding length
 L3, L5, L6—Ohmite Z-144 choke
 L4—4 turns #14, 1/2" dia., 1" winding length
 L7—6 turns #14, 1/2" dia., 1" winding length, 1/4" space for L9.
 L8—2 turns #14, 1/2" dia.

A wire was brought through the chassis from the grid side of the 6146, as shown in the photograph.

The final plate voltage should not exceed 300 volts. Adjust the loading to bring the plate current up to about 140 ma. with a 200 milliammeter inserted in J2. With the plate voltage applied it may be necessary to retouch the tuning of C4 and C7. With everything working properly a dummy load consisting of a 25-watt lamp should light to full brilliance. If the builder wants to key this transmitter it will be necessary to place some fixed bias in series with R8 and then key the oscillator and doubler stages.

30- TO 50-WATTER

(from page 19)

drive for the 2E26, so R4, which is the drive control, is adjusted for 6 mils of drive under load on all bands. Because of the great band spread on this band, the drive drops off when going from one extreme end of the band to the other, so I adjusted C18 for maximum drive at 3.9 mc. since I am mostly interested in the phone end of the band. To work the low end of the band, a readjustment of C18 will be necessary.

To tune up Band #3, the 40-meter band, again set C5, 12, 17 to minimum capacity and adjust C2 till a beat note is heard at 7.4 mc. Proceed to calibrate at 25 kc. intervals down to 7 mc. The 40-meter band will occupy 70 divisions of the dial. After calibrating the dial, set to 7.15 mc. and adjust C19 for maximum drive on the 0-15 ma. meter, with R4 full open. A maximum of 10 mils should be noted; however with the final loaded, the drive should be adjusted to 6 mils. The drive on this band will remain constant over the entire band from 7 to 7.3 mc. with no readjustment of C19 necessary.

On Band #2, the 20-meter band, again set C5, 12, 17 to minimum capacity and adjust C3 so a beat note is heard on the frequency meter at 14.5 mc. Proceed to calibrate the dial at every 50 kc. interval. The 20-meter band will occupy 65 divisions of the dial. Set the main dial at 14.2 mc. and

COLUMBIA

GEM OF THE SURPLUS!

TUNING UNIT FOR BC-375 TRANSMITTERS

Do not specify frequency.

- SPECIAL **\$1.95**
 ARC-4 or 223-A VHF TRANSCEIVER: F.B. for all 2-meter use. With tubes and crystal, less dynamotor. Excellent condition **\$32.50**
 TV POWER TRANSFORMER. Used. As is **.95c**
 BLADE TYPE VHF ANTENNA: 100-156 mc. With co-axial plug at base. Used **\$1.95**

BEST BUYS IN BATTERIES!

- EXIDE: 24 V. for aircraft. NEW, orig. box. **\$15.95**
 NAME BRAND Aircraft btry. 12 V. 35 amp @ 5-hr. rate. NEW **\$12.95**

BC-223 25 W. TRANSMITTER: With all SO-75-40 etc. motor tuning units **\$39.95**

New, in orig. box. Only **\$39.95**

12 and 24 V. POWER SUPPLY for above. Brand new.

Terrific for marine or ham transmission **\$24.50**

APN-1 UHF TRANSCEIVER: Excellent for all high frequency work. F.B. for 420 MC. Complete with all tubes, wobulator and schematic. Excel. cond. **\$17.50**

HS-33 600 OHM HEADSET. Low imp. Good cond. .. **\$3.95**

PE-101 DYNAMOTOR: 12 or 24 V. input, 400 V. @ 130 ma. output. See Aug. 1952 CQ for conversion to 6 V. Mobile. BRAND NEW, boxed. **\$4.95**

HS-23 4,000 OHM HEADSET. High imp. Now. **\$4.95**

BC-728 PORTABLE RADIO RECEIVER. 4 push-buttons.

2-6 MC. Less btry. and antenna. Fair cond. **\$15.95**

TBY WALKIE-TALKIE TRANSCEIVER: Good for parts or foundation. As is **\$6.95**

T-23 VHF TRANSMITTER: 100-156 MC. Ex. cond. **\$37.50**

PSSST! See our ad p. 67 Sept./52 CQ for more dope!

SELL OR SWAP YER RADIO GEAR! We buy everything you have to sell in new or used radio equipment. AND WE PAY TOP \$\$\$\$\$\$\$\$\$! Tell us what you have to sell—or what you want to swap. WRITE RIGHT TODAY!

ALL ORDERS F.O.B. LOS ANGELES

25% deposit required. All items subject to prior sale.

COLUMBIA ELECTRONICS SALES

524 S. SAN PEDRO ST., Dept. LS, LOS ANGELES 13, CAL.

A Completely NEW COAXIAL RELAY

for
52 and 72-ohm
lines

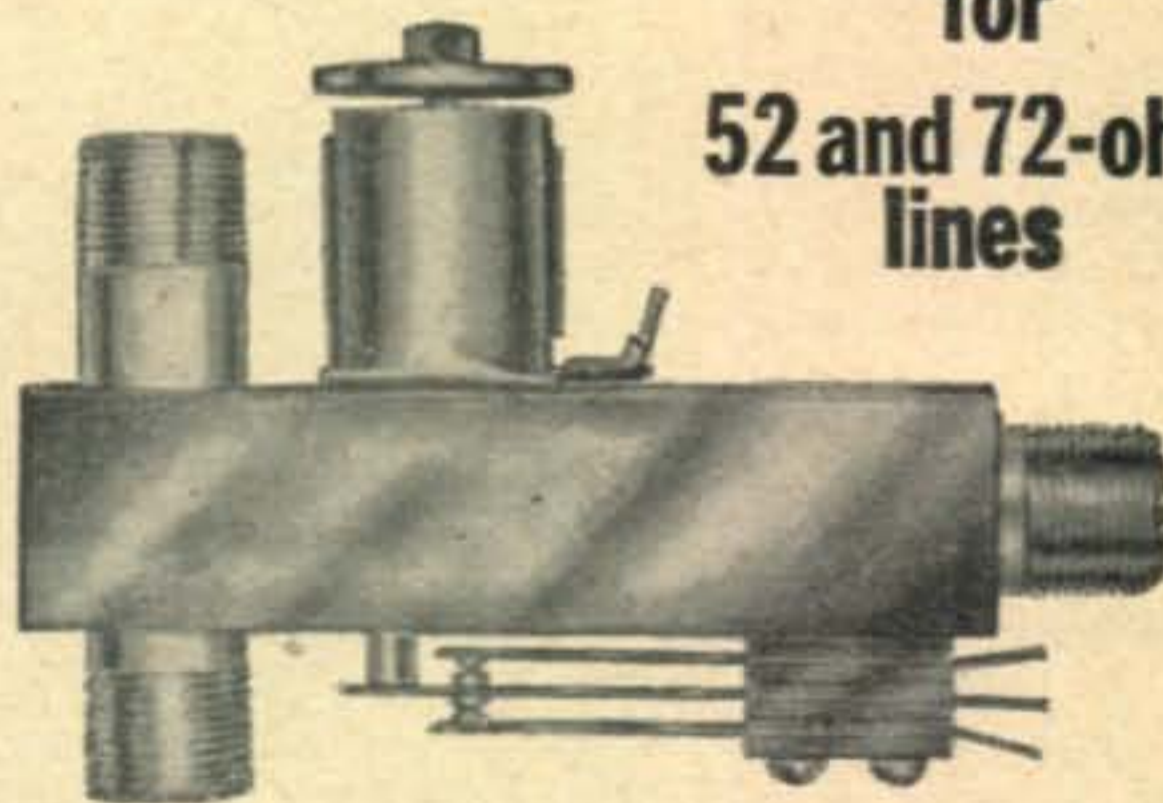

Has been proven to handle 1000 watts at 100 mc. Both a.c. and d.c. models available. The magnets have been greatly improved and are guaranteed to be free of hum or chatter.

- 6, 12, 24, 117 volts a.c. model **\$10.50 net**
 6, 12, 24 volt d.c. model **\$ 9.50 "**
 Antenna shorting connector **\$ 1.00 "**
 External SPDT switch **\$ 1.00 "**

DEALER INQUIRIES INVITED

DOW-KEY CO., INC.
Warren Minn.

EASY TO LEARN CODE

It is easy and pleasant to learn or increase speed the modern way—with an Instructograph Code Teacher. Excellent for the beginner or advanced student. A quick, practical and dependable method. Available tapes from beginner's alphabet to typical messages on all subjects. Speed range 5 to 40 WPM. Always ready, no QRM, beats having someone send to you.



ENDORSED BY THOUSANDS!

The Instructograph Code Teacher literally takes the place of an operator-instructor and enables anyone to learn and master code without further assistance. Thousands of successful operators have "acquired the code" with the Instructograph System. Write today for full particulars and convenient rental plans.

INSTRUCTOGRAPH COMPANY

Dept. C., 4701 SHERIDAN RD., CHICAGO 40, ILL.

WANTED IMMEDIATELY for CRITICAL DEFENSE NEEDS TUBES-CRYSTALS-END EQUIPMENT

OAS/VR75	3C23	125C7M	833A,884
OB3/VR90	3E29,829B	FG17,32,33	927,1000T
OC3/VR105	4C35	100TH	1614,2050
1N21.A,B	5C22	FG104,172	5725
1N23.A,B	5R4GY	250TH,TL	5727
1N25,26	6AC7M	304TH,TL	5749
Xtals: 100Kc,	6AG7M	368AS	5750
200Kc, 1000Kc	6B4G	450TH,TL	5751
2D21	6C21	KU627	5654,5670
2K25, 723AB	6L6M	726C	5686
2J & 4J Magnet-	6SC7M	750T	5726
rons, Klystrons	7C7	807,810	5814
	7AG7	811,813	9001,2,3

All Army-Navy Gear: AN, ART, BC, 1, PE, PU, RA, SCR
TG, TS. WAVE GUIDES: PL & UG CONNECTORS
TURN YOUR SURPLUS INTO SPOT CASH & SERVE
YOUR COUNTRY'S NEEDS AS WELL
Send Lists & Prices—Immediate Reply! Dept. C.

"TAB" 111 Liberty St., N. Y. 6, N. Y.
That's a Buy! Phone WOrth 2-7674

WANTED

WE NEED YOUR SURPLUS
ELECTRONIC EQUIPMENT

WE PAY TOP \$\$\$ FOR:

- RADIO RECEIVERS
- TRANSMITTERS
- ARC-1
- ARC-3
- ART-13
- CONTROL BOXES
- INDICATORS
- CLAMPS
- PLUGS
- CORDS
- RELAYS
- TELEPHONE MATERIALS
- AN CONNECTORS
- WE BUY ANYTHING!

WRITE, WIRE TODAY! TELL US WHAT YOU HAVE
TALLEN CO., Inc., Dept. CQ
159 Carleton Ave. Brooklyn 5, N. Y.

Master Mobile

ACCEPTED APPROVED

FOR EVERY TYPE OF OPEN OR
CLOSED MOBILE VEHICLE

Master Mobile Mounts, Inc.

P. O. BOX 1817 · LOS ANGELES 36, CALIFORNIA
WAREHOUSE AND SHIPPING ADDRESS: 1306 BOND STREET

adjust *C20* for maximum drive on the 0-15 ma. meter. You should note a drive of 8 to 10 mils, with *R4* full out.

To calibrate *Band #1*, the 10-meter band, again set *C5, 12, 17* to minimum capacity and adjust *C4* till a beat note is heard on the frequency meter at 30 mc. Proceed to calibrate the dial at 50 kc intervals. Again, the entire 100 divisions of the dial is used for the 10-meter band. Set the dial at 29 mc. and adjust *C13* and *C21* for maximum drive, with *R4* full out. You should note 6 to 8 mils. Here again as on 80 meters, the band spread is so great, the drive to the final will drop off when going from one extreme end of the band to the other. I adjusted *C13* and *C21* for maximum at 29 mc. since I was mostly interested in operating in the phone section of the band.

The fundamental frequency of the frequency determining coils (that's the grid coils of the Clapp oscillator) are as follows: *L1*, 1.25 to 2 mc.; *L2*, 3.5 to 4 mc.; *L3* and *L4*, 7 to 7.5 mc. On the 80, 40 and 20-meter bands, the second *7C5* doubles the fundamental frequency to run the final as a straight amplifier. On 10 meters, we double in the plate of the oscillator to 20 meters, then in the second *7C5* we double again to 10, and again we run the final as a straight amplifier.

Now then, with the VFO section all calibrated, aligned and adjusted, connect a dummy antenna or a 40-watt lamp to the antenna terminal and get set to fire up the final. Place *SW1* and *C28* to maximum capacity. Now turn the *Transmit/Standby/VFO* switch to *Transmit*. Adjust *C27* for minimum, as shown on the 0-100 ma. meter, and then readjust *C28* and *SW1* for maximum loading, always returning for final adjustment to *C27*. See to it that under maximum loading, *R4* is adjusted for 6 mils of drive on all bands.

Changing of bands and frequency is only a matter of seconds. The number of controls to operate the transmitter is kept to a minimum. The transmitter is very simple to tune, and its reaction is the same on all bands. Once the band has been selected and the frequency set, it is only necessary to set the antenna loading control to maximum capacity and then adjust the plate tuning for a dip, and you will get a very pronounced dip, all the way down to 20 mils. Then you advance the loading for maximum (maximum capacity), always retuning the plate for minimum. Once maximum loading is reached, the plate dip will be small, but still pronounced.

Check each band carefully and when satisfied all is okay, get the scope out and check the modulator. Just follow the instructions in the handbook, and if you have wired it correctly, you should experience no trouble with the modulator.

When the modulator has been checked, and found satisfactory, you are ready to go on the air, ready to load into any antenna on any band. You will be amazed at how simple and versatile this little rig is to operate, and unless my bet is wrong, it will give you much joy and satisfaction for a long time to come.

When this rig was designed, the 6146 had not been announced. A 6146 can be substituted for the 2E26 with no tube socket or other circuit changes. The power supply is capable of handling the extra current drain caused by heavier antenna loading. I am now using a 6146 and the only changes I made was to change the plate meter from a 0-100 to a 0-200ma. I am now loading up this little rig to 150 ma. or 60 Watts input. The 20 watt modulator is doing a good though not 100%, job modulating it.

COME ON-A MY HOUSE

(from page 38)

another frequency in the band.* When the crystal is reinserted in its holder the transmitter will immediately go back on the crystal frequency. Don't try to use a lot of hand-me-down tubes in this rig. You don't have to hand pick the tubes, but they should be good, especially the push-pull 12AT7 tripler and the 832. With only three tubes you don't have any grid drive to spare. Should you experience downward modulation you will find it is undoubtedly due to less than 1 milliamper drive on the 832. By retuning and peaking all stages the drive on the final should be about 1 1/4 mils.

A shielded pair of wires is used for the antenna relay where it passes through the transmitter chassis. This prevents any r.f. pick-up which would then be radiated outside of the chassis via these wires. When picking your crystal I wish to warn you about choosing a frequency near 222 mc. If you are surrounded by television receivers, and channel 7 is used in your area, you may find yourself in the sound of this channel on nearby receivers that use the standard 21.25-mc i.f. You see, 222 mc. is the image frequency of channel 7 on such receivers and because of their poor image rejection this happens. It is not due to any fault in your transmitter. Perhaps this is a case that you can refer to your local TVI Committee for study.

In the circuit diagram C17 is shown as a 500 µf. 25-volt condenser. Do not use a condenser with less than 150 µf. capacity at this point or you will experience motor-boating trouble in the modulator.

Come on fellows, get out the drill, file and soldering iron and build this economical rig and get back in the fun with no interruptions from TVI complaints. The following stations vertically polarized are now active in the New York-New Jersey Metropolitan Areas: W2DZA, W2IQQ, W2KQ, W2QOX,, W2BQK, W2OHI, W2BVJ, W2ESW, W2IHM, W2HRN, W2KON and W2LWN. They give you lots of fun."

* This probably indicates that the 832 final amplifier is "taking off". A good reason for using a fixed bias high enough to cut off the tube, since in the absence of drive, and even with neutralization, the plate current starts climbing. Tech. Ed.

BUY OF A LIFETIME!
TRIED AND PROVEN THE WORLD OVER

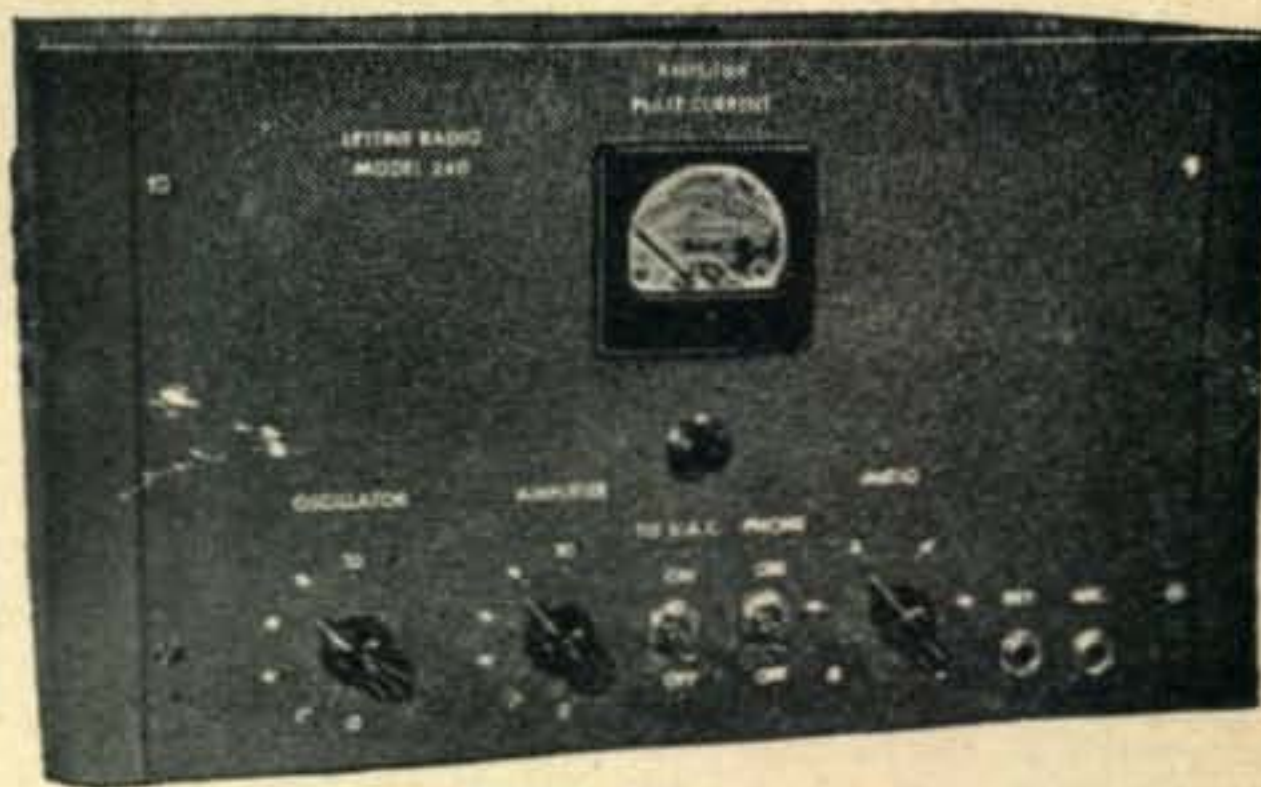

LETTINE MODEL 240 TRANSMITTER WITH MOBILE CONNECTIONS AND A.C. POWER SUPPLY

This outstanding transmitter has been acclaimed a great performer throughout the world. It is excellent for fixed station, portable or mobile operation. Even if you have a transmitter of your own you can't afford to miss this wonderful buy, direct from our factory, ready to operate.

The 240 is a 40 watt Phone-CW rig for 160 to 10 meters, complete with: (8 x 14 x 8) cabinet, self contained A.C. power supply, MOBILE connections, meter, tubes, crystal and coils for 40 meters. Tubes: 6V6 osc., 807 final, 6SJ7 crystal mike amp., 6NT phase inverter, 2 61.6's mod., 5U4G rect. Weight 30 lbs. TVI instructions included. 90-day guarantee. Price \$79.95.

\$25. deposit with order—balance C.O.D.

80, 20, 10 meter coils \$2.91 per set. 160 meter coils \$3.60. Also for CAP, Broadcast, MARS, Marine, State Guard.

LETTINE RADIO MFG., CO.

62 BERKELEY STREET VALLEY STREAM, N. Y.

LEARN CODE AND THEORY FOR AS LOW AS \$6⁹⁵

ECONOMICAL HOME STUDY PARE YOU TO COURSES PRE-PASS AMATEUR AND COMMERCIAL CODE EXAMS, AND AMATEUR THEORY EXAMS THE EASY, FAST WAY. BEAT THE ADVANCED CLASS DEADLINE (closes Dec. 31.)



78 RPM

3 "AMECO" COURSES AVAILABLE:

- #1—NOVICE CODE COURSE. You get and keep 10 recordings (alphabet through S W.P.M.) in an album. Includes typical F. C. C.-type code exams. Free instruction book on learning how to send and receive code the simplest, fastest way; plus charts to check your receiving accuracy all for the low price of only\$7.95
- #2—SENIOR CODE COURSE. You get and keep everything given the Novice Course except that you get 22 recordings (alphabet through 18 W.P.M.), plus typical F. C. C.-type code exams for General class and 2nd class commercial telegraph licenses. All this for only.....\$12.95
- #3—COMPLETE RADIO THEORY COURSE. A complete, simplified home study theory course in radio, covering the Novice Technicians, conditions, 1 general, and advanced classes—all under one cover—with hundreds of typical F. C. C. type questions to prepare you for license exams. No technical background required. You also get, FREE, one year of consultation and a guide to setting up your ham station. All for the amazingly low, low price of \$6.95

ORDER NOW!

ALL COURSES HAVE MONEY-BACK GUARANTEE OR WRITE FOR FREE INFORMATION DEPT. C-11

AMERICAN ELECTRONICS CO.
1451Q Wilkins Ave., N. Y. 59
Tel. No. DAYton 9-4815

75-150 WATT TRANSMITTER

complete with tubes, power supply, crystal, meters—all parts. Tubes: 5U4G rectifier, 6AG7 oscillator, and 807-807 power amplifier. All bands from 160 through 10 meters.
Complete Kit ..\$49.95
Wired & tested..\$64.95
Write for information

Dixon Electronics Co.13444 W. McNichols Rd.
Detroit 35, Mich.**WE WANT . . .**

SURPLUS TEST EQUIPMENT, TRANSMITTERS, RECEIVERS, RADAR EQUIPMENT, NAVIGATIONAL AIDS; MARINE & AIRBORNE EQUIPMENT; TUBES. BE SURE TO NAME YOUR PRICE AND FURNISH FULL DETAILS. WRITE NOW TO:

RADCOM ENGINEERING CO.

8 LIVINGSTON ST., NEWARK 3, N. J.



Large, bright red letters are clearly read across the room. Fine for MOBILE or FIXED STATION. Black wrinkle case 5" x 2 5/8" x 1". Uses screw base pilot lamp.
Price\$1.50 P.P.

HAWKINS NAME PLATE CO.

3208 E. 56th N., KANSAS CITY 16, MO.

8 WIRE CONTROL CABLE

Two No. 16, Six No. 20 tinned, stranded, copper, rubber insulated coded leads. Waterproof rubber jacket. Woven copper armor shield overall. Wt. 16 lbs./100 ft. Lengths to 400 ft. LOW PRICE FOB warehouse. Minimum order 100 ft. Shipment is made by Railway Express—shipping charges collect. **5c ft.**

TRANS-WORLD RADIO-TELEVISION CORP.
6639 S. ABERDEEN ST. CHICAGO 21, ILL.
Phone: AUstin 7-4538

We Carry a Complete Line of Amateur Equipment including:

National • Hallicrafters
E. F. Johnson Co. • Bud • Barker-Williamson, etc.

VARIETY ELECTRIC CO., INC.

468-470 Broad St.

Newark 2, N. J.

UNIVERSAL SUPPLY KIT

Delivers 230V @ 40MA DC. From 110/220VAC, 60 CY. Kit consists of 1 Transformer, 1-5 HY @ 40MA Choke, 2-8MFD @ 450 V Filter **\$3.95**
Cond. 1-6X5 Tube. A Great Buy at Only..

Send M.O. or Check. Shp. Chgs. C.O.D.

COMMUNICATIONS EQUIPMENT CO.

131 Liberty St., Dept. Q-11

New York 7, N. Y.

"Why do you INSIST on a HALLICRAFTERS RECEIVER Leo?"

"Because HALLICRAFTERS gives me the most for my MONEY"

WORLD RADIO LABORATORIES
744 WEST BROADWAY
COUNCIL BLUFFS, IOWA
WRITE for FREE CATALOG

MIDGET ANTENNA

(from page 41)

If a variable condenser, and a surplus rotary variable inductor are used for the L-network, an excellent match can be obtained to the coaxial line. However, for everyday use the 3:1 v.s.w.r. on the line will cause no harm, even with the legal input to the transmitter. I have operated the whip with and without the L-network and can notice little difference in overall operation.

Results

A vertical antenna produces quite different results when compared to the usual half-wave horizontal dipole on the 80-meter band. First of all, it is much better for contacts with mobile stations, since it has a vertically polarized field. Mobile signals will really stand out and attract attention when the midget ground plane is used. Local signals—those within 10 miles or so—will appear louder because of the strong low-angle lobe of the vertical radiator. From about ten miles away, out to about 350 miles, the vertical is slightly weaker than a good, high horizontal dipole. The horizontal dipole radiates considerable amounts of high angle energy which is reflected to earth by the ionosphere to fill in this region. At about 400 miles distant the two antennas are about equal in radiation intensity, and beyond this distance the ground plane rapidly becomes the more effective of the two. For DX work it is unbeatable. A fat S9 plus 20 db was obtained by W6FHR using this antenna on 80-meter phone from a KL7 on Attu Island, just a stone's throw from Siberia. Since Louie was only running 120 watts, and competing in the usual pile-up on a good DX station, this speaks well for the antenna.

On an "A-B" check against a good dipole, DX signals were readability 5 on the vertical and absolutely unreadable on the dipole. CN8BG was readable on the west coast as early as 5 p.m. using the vertical. (Bet the use of the vertical won't get you a QSL from CN8BG—Ed.)

The vertical is more sensitive to static and QRN in general than a horizontal antenna, a good indication that it is really outperforming a horizontal antenna. A few qualms were experienced by the author when the vertical was first used regarding the possibility of local TVI caused by blocking of the TV sets by the stronger ground wave. This however, has failed to materialize, and either antenna may be used with satisfactory results as far as the neighbors are concerned.

All in all, the operation of the midget ground plane has been very satisfactory. It permits 80-meter phone operation without the use of a full dipole. It is red-hot for contacts with mobile rigs. The radials, made of bell-wire, are unobtrusively wrapped around the eaves of the house and through the hedges. All that can really be seen is the un-

guyed whip. All of which led the XYL to remark, "Well, if that little thing is so good, why don't you take down that horrible tower and beam? It makes our house look like a power station!"

TWO-METER CONVERTOR

(from page 26)

number of turns on the i-f link. Of course, there's a chance that the i-f receiver is on the bum—they often get pretty bad before trouble is noticed. Another quick check—remove the antenna feed line from the converter and short-circuit the co-ax fitting right at the connector—there should be quite a noticeable increase in the output noise level of the i-f receiver when the converter input is shorted. (Of course, to show up these changes in noise to best advantage the AVC should be off.) When the antenna is reconnected the noise level should come up and the character of it should change. It should consist largely of man-made noises—ignition and the like, or hissing precipitation static; in any event, the antenna noise level should be higher than the noise level of a pure 75-ohm resistor!

The foregoing alignment procedure did not specify whether the oscillator should be tuned on the high side or the low side of the band. It really makes little difference, except for the class of stations that will be heard on the image mode. If no trouble is experienced due to images, don't worry. But if they have you bothered, try rotating the oscillator trimmer to the point where a second noise peak is obtained—on the opposite side of the signal frequency band. Of course, it will then be necessary to recalibrate the dial; which can probably best be done by marking the dial setting of stations of known frequency until enough points have been taken to establish a smooth scale.

The r-f input coil is non-critical, but no doubt some would like to know how to check its tuning. It can best be checked by removing the tap completely from the coil. Then check the output noise level of the i-f receiver as the input coil turns are spread or squeezed. There should be a definite *dip* in noise level when the coil is tuned to resonance. (A better way of checking this tuning is with a "test wand" which has an iron slug in one end and a copper slug in the other.) The optimum location for the tap point depends on the impedance of the feed line looking back toward the antenna. We preferred to use a standard 75 ohm resistor (part of our noise generator) as an input load during the final tests, and we've spent considerable time trying to make the antenna feed line look like 75 ohms. As a result, we don't dare change the setting of the input tap after locating its position using the noise generator. The converters seem to be consistent enough and sufficiently non-critical that if you locate the tap as shown in the coil table you'll be durned near right—if your antenna looks like 75 ohms. If it doesn't—well, that's another article!

ATTENTION MOBILE HAMS

COMPLETE MOBILE PACKAGE — NOTHING ELSE TO BUY. OUTSTANDING MOBILE SIGNALS USE MOTOROLA EQUIPMENT—BACKED BY YEARS OF COMMUNICATION EQUIPMENT EXPERIENCE — WORLD'S LARGEST PRODUCER OF 2-WAY MOBILE EQUIPMENT.

A mobile transmitter with a double feature FM or AM at flip of the switch, the MOTOROLA FMT-30-DMS 27-30 MC. . . **\$130.00**

P-7253 spring base rear-mount antenna. . . **\$23.13**

MOTOROLA P-69-13 or 18-ARS receiver with special noise limiter for use

with any converter having 1440-3000 KC. **\$60.00**

New Gen-set Tri-Band Spread Converter **\$47.60**

3-30 famous Gen-set converter complete to connect to the P-69-13 or 18-ARS receiver **\$44.75**

P-327-E Fire wall loud speaker **\$7.50**

The above comes complete with all necessary accessories and mounting hardware. Order direct or through the Motorola National Service Organization member in your area.

NOTE: This Receiver and Transmitter is equipment which has been returned from the field, modified and rebuilt for Amateur Service.

For further information write to:

MOTOROLA INC.

Amateur Sales Dept. CQ November

1327 W. Washington Blvd., Chicago 7, Ill.

Attention: Harry Harrison, W9LLX
Telephone—TAYlor 9-2200, Ext. 161

**RADIO
EXPERIMENTERS:**

\$1.79

**MIDGET
ELECTRONIC**

POWER SUPPLY KIT

110 VOLT FILTERED DC at 40MA

Here at a Big Saving you get Top Quality basic components for a Power Supply with many applications . . . for Mike or Phono Pre-Amp, Midget Radios or Audio Amplifiers, Photo Cell equip., Garage Door Openers, Code Practice Oscillators, TV Boosters, Test Equipment, etc.

Kit consists of a compact, fully enclosed Power Transformer, pri: 117 V. 60 cycle AC 110 V @ 40 MA. H.V. Sec., and 6.3 V @ 1 amp. for filament. A 35 MA-130 V. Selenium Rectifier and a 16 Mfd-150 V. DC wkg-225 V. peak electrolytic Filter Condenser . . . both very compact and easy to mount with the tinned wire leads. Wt. 1½ lbs.

You Get All Above
No. 14B993. PER KIT **\$1.79**

Include allowance for postage if shipment by parcel post is desired.

BURSTEIN-APPLEBEE CO.
Dept. M, 1012-14 McGee St.
Kansas City 6, Mo.

I enclose \$.....for.....Power Kits.

Send me FREE your 1953 Catalog No. 531.

Name.....

Address.....

City.....State.....



FREE!
**BIG 1953
RADIO
CATALOG**

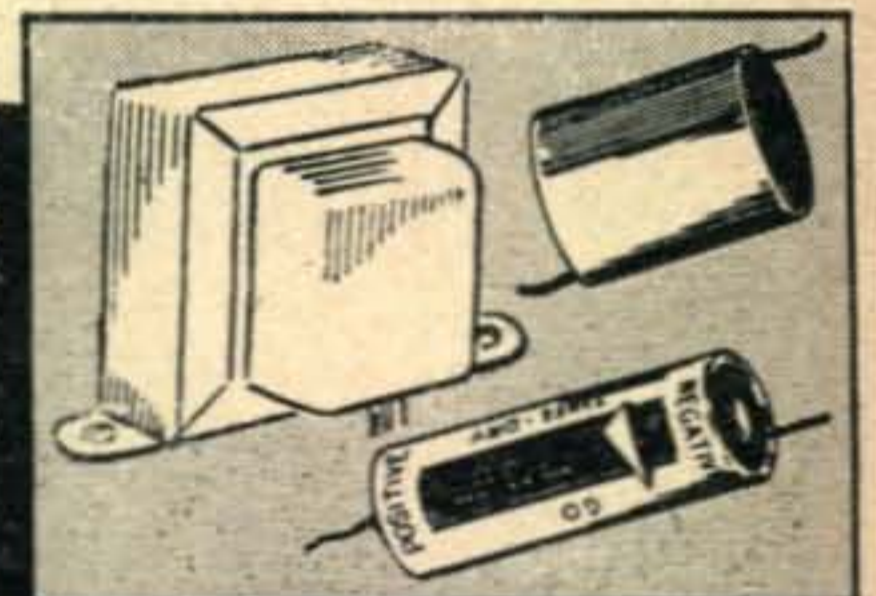



ADVANCE RELAYS

designed for
your application

Soundly engineered and built to famous standards of performance—you can install these outstanding relays in your rig with complete confidence.

ADVANCE offers a complete line of Time Delay, Overload, Antenna and Keying Relays with wide variations of types for special applications. Your inquiry will receive prompt and courteous attention.

Illustrated are
Coaxial & 300
ohm line relays

ADVANCE RELAYS

ADVANCE ELECTRIC & RELAY CO.
2435 North Naomi Street • Burbank, California

CRYSTAL CONTROLLED CONVERTERS

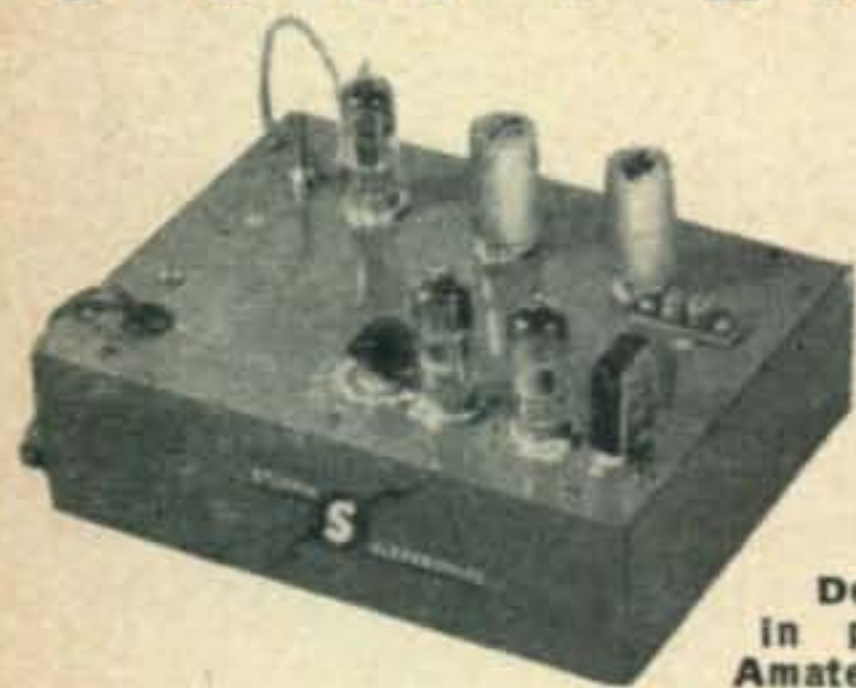

MODEL
RC-1A
\$45.00

Net

Designed for the ultimate in performance on any one Amateur Band, these converters have been widely accepted and very popular, giving all the benefits of dual conversion at lowest prices.

Available for immediate delivery on all amateur bands 20, 15, 10-11, 6, 2. Specify by adding Band to model number.

FEATURES:

- Two Band-pass 6BQ7 R. F. Stages.
- Built-in transformer type pwr. sup.
- Good signal to noise ratio. High gain.
- Crystal controlled for maximum Stability.
- Not a Kit—completely wired & tested.
- Ruggedly built—RMA guarantee.
- 2 1/4" x 6" x 8"—4 lbs. Complete with tubes and crystal.

IMMEDIATE DELIVERY—For free literature write Dept. C

SYLVAN



ELECTRONICS
LABORATORIES, INC.

393 NORTH PEARL ST. ALBANY, N. Y.

Classified Ads

Advertising in this section must pertain to amateur radio activities. Rates: 25c per word for insertion for commercial advertisements. 5c per word for non-commercial advertisements by bona fide amateurs. Remittance in full must accompany copy. Phone orders not accepted. No agency or term or cash discounts allowed. No display or special typographical ad setups allowed. "CQ" does not guarantee any product or service advertised in the Classified Section. Closing date for ads is the 25th of the 2nd month preceding publication date.

SALE 75A1 Rec. \$250.00, also NC 183 \$200.00 with speaker. Both receivers perfect and look like new. Ray Ruggiero, 626 7th Ave., S.E., Cedar Rapids, Iowa.

HARVEY WELLS TBS-50C, TBS-50D and APS-50, normally available for immediate delivery from stock. We trade and offer terms. Write W1BFT at Evans Radio, Concord, N.H.

BC610 parts wanted. Give price and condition first letter. LI Radio Company, Box 474, Montrose, Pa.

DON'T FAIL! Check yourself with a time-tested "Sure-check Test," similar to the FCC tests. Novice \$1.50, General, \$1.75, Advanced, \$2.00. Amateur Radio Supply, 1018 Seventh Ave., Worthington, Minn.

FOR SALE OR TRADE BC-221 with p/s built in. R-9er with 10 mtr. coll. Hallicrafters Panadaptor SP44. Want tape recorder. W8JBH, P.O. Box 87, Franklin, W. Va.

QSL's. TOP quality at fair prices. Samples? Write W9BHV QSL Factory, 855 Burlington, Frankfort, Indiana.

QSL's-SWL's. Super-gloss, 10 colors, four card stocks, seven styles. Samples 10c. Almar Printing Service, Dept. 10B, Farragut, Iowa.

WANTED—Top prices paid—Navy selsyns 1DG, 1F, 1G, 1CT, 5DG, 5F 5G, 5CT and BC-348, BC-221, AN/ART-13 AN/ARC-1, AN/ARC-3, RTA-1B, etc. Lectronic Research, 719 Arch St., Phila., Pa.

FOR SALE: 32V2. Highest bidder. D. Newberry. 4656 Pinewood Rd., Jacksonville, Fla.

BARGAINS: New and reconditioned Collins, Hallicrafters, National, Hammarlund, Johnson, Elmac, Gonset. Harvey-Wells, Morrow, RME, Miller, Meissner, others. Reconditioned S88 \$29.00, S40A \$69.00, S40B \$79.00, SX43 \$119.00, S76 \$129.00 SX71 149.00, SX42 \$199.00, SX62 199.00, NC173 \$139.00, HRO5TA1 \$159.00, NC183 \$199, HRO5OT \$249.00, HRO5OT1 \$299.00, HQ129X \$139.00, SP400X \$259.00, RMES4 \$69.00, RME45 \$89.00, Lysco 600 \$99.00, Lysco 600S \$129.00, Collins 82V1, Collins 32V2, 75A1, 75A2, Viking 1, Harvey-Wells Bandmasters, Elmac A54, Meissner EX VFO \$59.00, many others. Shipped on trial. Terms. List free. Henry Radio, Butler, Mo.

SELL: Signal shifter de luxe 20 thru 160, FB condx. \$35.00. Bargain list, fone CW parts, free. Moving. W4EMJ, 6298 15th Road North, Arlington 13, Va.

QSL CARDS? "Unbeatable" Samples 25c. Sackers, W8DED, Holland, Michigan.

WANTED: Navy Selsyns. 1G, 1F, 1CT, 1DG, 5DG, 5F, 5CT, 6G, 7G, etc. Top prices paid. Electro Sales Co., Inc. 110 Pearl St., Boston 10, Mass.

1-KW FINAL AND PARTS for 1/2 KW power supply. Highest offer. W4NHX, Box 1667, University, Virginia.

QSLs! Interesting Samples 10c. Tooker, Lakehurst, New Jersey.

SELL: Transmitters, receivers, tubes, crystals, microphones, dynamotors, etc. Fredrick H. Wise, W8LGK, 324 Chestnut St., St. Marys, Penna.

KP-81, Navy VFO, ART-13, TS-34/AP scope. Sig. Gen. I-198-8, 110 V AC Selsyns, BC-603, 683, 442. KW tank cond. & Fil. xformer, tubes parts. Sell or trade for SX-71, NC183, professional tape or sound equipment. For details write W6DDI, 200 -4th, Petaluma, Calif.

COLLECTOR'S ITEM—H. Pieper Leige Damascus steel double-barrel hammer shotgun. Patent 83, April 1881. With shell loading rig in felt lined wooden case. Want trade on Viking 1. W4PXT, Savannah, Georgia.

MAP PINS, round head colors, red, blue, green, yellow, orange, brown. One buck brings fifty, Robest Products, 701 Dewey, Harvard, Illinois.

WANTED: 6 and 2 meter transmitter. Preferably high power. Must be a good rig. Box 1723, Havana, Cuba.

FOR SALE: 310-B Collins exciter \$180. W6GTM 4834 Utah Street, San Diego 16, Calif.

FOR SALE: Snoopers (Aug.-Sept. CQ) Custom Built by W7HEA. Bishop's Radio Service, 207 E. Toppenish Ave, Toppenish, Wash.

BARGAINS: EXTRA SPECIAL! Motorola P-69-13 Mobile Receivers \$29.50; Globe King \$315.00; HT-9 \$199.00; HRO-50 \$275.00; Lysco 600 \$109.00; HRO-7 \$199.00; Collins 75A1 \$275.00; HRO-5T \$175.00; SX-71 \$159.00; SX-42 \$199.50; SX43 \$129.00; HRO-Senior \$119.50; RME 2-11 \$99.50; RME-45 \$99.00; Meissner EX Shifter \$59.00; S-40A or SX-16 \$69.50; VHF-152 \$59.00; HF-10-20 \$59.00; Globe Trotter, \$79.50; Meissner Signal Calibrators \$24.95; MB611 Mobile Transmitters \$19.95; 90800 exciter \$29.50; RCA Chanalyst \$69.50; XE-10 \$14.95; Gonset 10-11 converter \$19.95; and many others. Large stock trade-ins: Free Trial. Terms finances by Leo, W0GFQ. Write for catalog and best deal to World Radio Labs, Council Bluffs, Iowa.

STILL AVAILABLE: May "Mobile" 1952 issue, 50c. CQ DX Zone Map, \$1.00 postpaid anywhere. Dept. M, CQ Magazine, 67 West 44 St., New York 36, N. Y.

10, 15 & 20 METER BEAMS, aluminum tubing, etc. Perforated aluminum sheet for shielding. Radcliff's, Fostoria, Ohio.

WANTED: Scott Philharmonic all-wave broadcast receiver in good condition. Workshop or Johnson 20 meter beam. Please give full description and price. R. A. McNeill, VE5RQ, Box 472, Yorkton, Saskatchewan, Canada.

HQ-129X Receiver. Very clean, \$150 f.o.b. Chicago. Crum, W9LC 751 N. Central Avenue, Chicago 44, Illinois.

FOR SALE: RME 45 and Speaker, Fair Shape, \$50; Millen Exciter 90800, Coils, Power Supply, Table Rack, Good Shape, \$50; Eico Signal Generator 320, Good Shape, \$15. Louis Weinstein, W2AJU, 260 Parkside Ave., Bklyn. 26, N. Y.

WANTED: APN-4, APN-9, ARC-3, ARC-1, SCR-694, BC-1306, PE-237, PE-103, ART-13, TCS, BC-348, BC-342, BC-312, BC-221, RA-84, RA-62, APR-4, BC-611, BC-721, LM, DY-17, DY-12, TS and I-test equipment, tubes, radar, technical manuals. Arrow Appliance, Box 19, Boston, 1, Mass. Lynn 8-8100, Richmond 2-0916.

SELL: Model 21A teletype midget tape printer \$45.; Teletype multiplex perforated tape transmitter, \$30. Will trade. Want War surplus transmitters, receivers, test equipment, technical manuals. Tom Howard, W-1-AFN, 46 Mt. Vernon St., Boston 8, Mass.

DXers! "Hams Interpreter"—ham words and phrases translated into 7 languages—\$1.00. For SWL's, "World Radio Handbook"—complete information on international stations, \$1.50 "How to Listen"—for SWL Novices, 30c. World Radio Publications, 1000 Connecticut Ave., Washington 6, D. C.

SWAP: 5 place Stinson airplane, 300 H.P., licensed to April 1953, for Collins 75A and 32V or equivalent. C. W. Baldwin, Three Rivers, Clay, New York.

100 KC STANDARD CRYSTAL RCA No. VC5M guaranteed. Crystal, special 3 pin socket and circuit—\$4.25 postpaid. Crystal Research Products, Dumont, New Jersey.

300 WATT TRANSMITTER, BC-348Q receiver, other equipment and parts—\$875. Bring truck. W6RXA, 939 Palm Drive, Colton, Calif.

WANTED: ART-13 TRANSMITTER and any or all accessories. State price and condition. Write C. Porter, 8545 11th Ave., Silver Springs, Md.

for the high- power man!

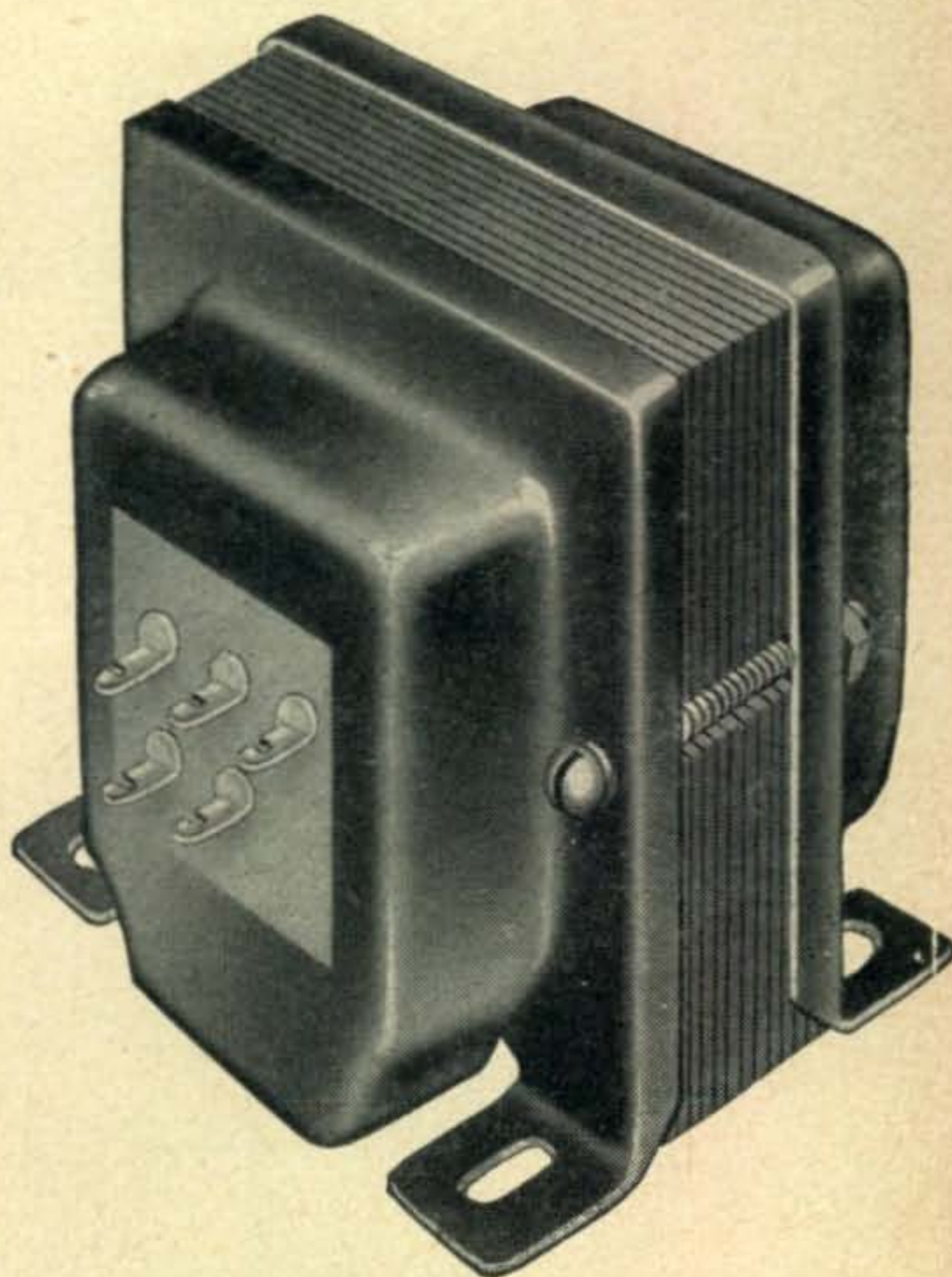

MERIT HIGHPOWER Filament Transformer P-2943

Designed for highpower use in both Amateur and industrial applications.

Specifications: Sec. Volts, 5—Sec. Amp., 30—Insulation Volts, 3000—Center tapped with primary taps for 110-115-120 volts, 60 cycles—Dimensions, 3 $\frac{7}{8}$ H. x 3-3/16 W. x 4 $\frac{3}{8}$ D.—DL Mounting . . . Will handle a pair of 250 TH's . . . 4—250 A's . . . 4—125 A's . . . 4—400 A's, etc.

Net Price — \$6.60

Merit Transformer Corporation
4427 North Clark Street
Chicago 40, Illinois



CURTIS BROWNE ADVERTISING

SPECIAL

HALLICRAFTERS
SX71-576

Write for liberal
trade-in offer.

FILAMENT TRANS.
6V at 3 Amps.,

\$1.45

LOOK — NO HANDS!

Head & Chest Set consisting of Single Button Carbon Microphone with Chest Plate, Switch, Straps, and Pair of Earphones. Ideal for Mobile Operation. Can be used less earphones . . .

Only **\$1.95** complete
ATRONIC CORP., DEPT. C-23
1253 Loyola Ave., Chicago 26, Ill.



NATIONAL

- **P**roven
- **D**ependable
- **Q**uality



XR-50



XR-1

XR-2



XR-4

XR-5

XR-6



XR-3

BAKELITE COIL FORMS

National mica-filled bakelite coil forms have been designed for the widest and most efficient electronic applications. They may be grooved, drilled and wound to meet any specifications. Available with 4 or 5 prongs or without prongs. XR-50 is permeability tuned coil form with iron slug. Write for drawings and specifications.

National



EST. 1914

NATIONAL COMPANY, Inc.
MALDEN, MASSACHUSETTS

CQ Ad Index

Advance Electric & Relay Co.	94
Allied Radio Corp.	75, 76
American Electronics Co.	91
American Phenolic Corp.	10
Arrow Electronics, Inc.	80
Atronic Corp.	95
Babcock Radio Engineering, Inc.	84
Barker & Williamson.....	6, 72
Bliley Electric Company.....	11
Bud Radio, Inc.	9
Burstein-Applebee Co.	93
Collins Radio Company.....	14
Columbia Electronics Sales.....	89
Communications Equipment Co.	92
Dixon Electronics Co.	92
Dow-Radio, Inc.	89
Eastern Telephone Company.....	84
Eitel-McCullough, Inc.	12
Electronic Technical Institute.....	88
Electro-Voice, Inc.	68
Espey Manufacturing Co., Inc.	80
Fair Radio Sales.....	74
General Electric Co.	1
Gonset Company.....	70
Greenwich Sales Co.	86
Hallicrafters Company	Cover 2
Harrison Radio Corp.	69
Harvey Radio Company, Inc.	73
Harvey-Wells Electronics	8
Hawkins Name Plate Co.	92
Hudson Radio & TV Corp.	78
Hughes Aircraft Company	7
Instructograph Co.	90
Lettine Radio Mfg. Co.	91
Marmax Electronics	5
Master Mobile Mounts, Inc.	90
Merit Transformer Corp.	95
Millen, James Mfg. Co.	4
Motorola, Inc.	93
National Company, Inc.	96, Cover 3
Petersen Radio Company, Inc.	2
Pioneer Tool Co.	82
Platt Electronics Corp.	77
Radcom Engineering Co.	92
RCA Tube Dept.	Cover 4
Shure Brothers, Inc.	67, 76
Sylvan Electronic Laboratories	94
Tab	90
Tallen Company	90
Telex, Inc.	86
Terminal Radio Corp.	81
Trans-World Radio-TV Corp.	92
Vaaro Electronic Engineering Co.	85
Variety Electric Company	92
Vibroplex Co., Inc.	88
Wireless Radio & Television.....	79
World Radio Laboratories, Inc.	71, 92

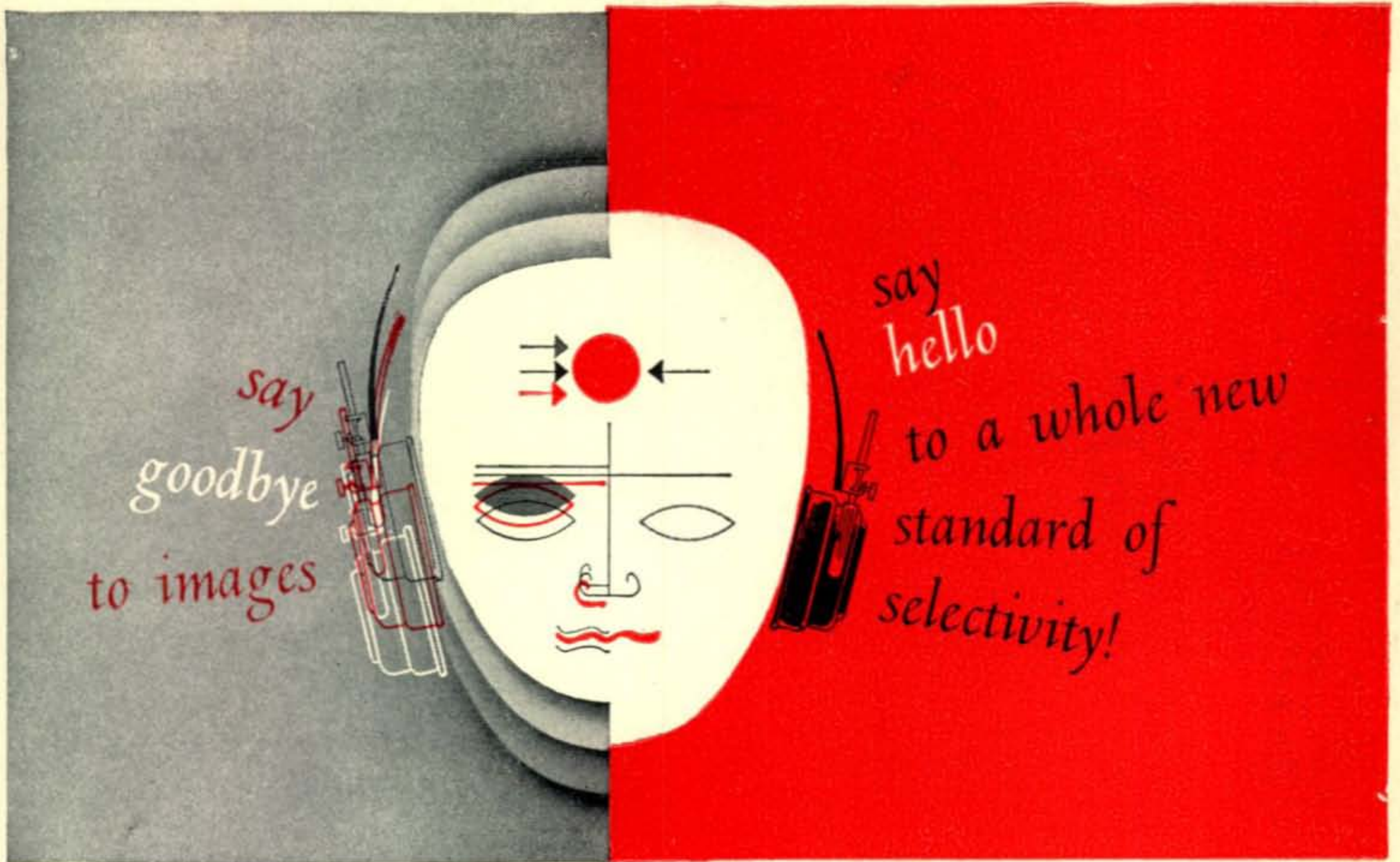

THE NEW
HRO *Sixty*
 IS HERE!

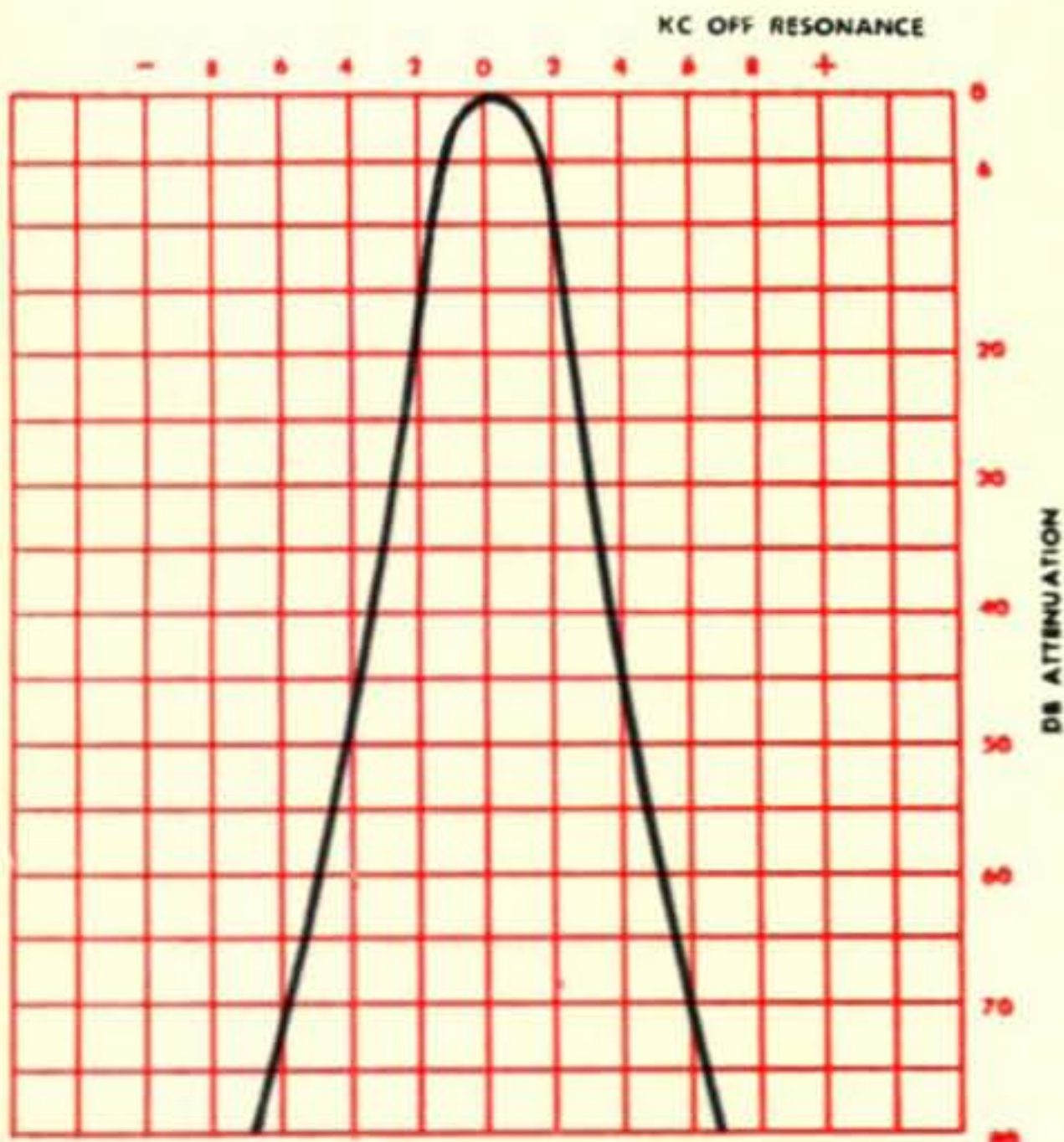

**Without using crystal filter!*



Dual Conversion! 12 Tuned I. F. Circuits!

Here now — the HRO Sixty — latest and greatest of a great series! Now, in addition to all the wonderful features of the HRO-50T1, you get *dual conversion* on all frequencies above 7 mcs. *plus* 12 permeability-tuned circuits in the 3 456-kcs. I. F. stages! Other new features include current-regulated heaters in the high-frequency oscillator and the 6BE6 mixer. High-frequency oscillator and S-meter amplifier are voltage regulated.

Be sure to see and hear the ultimate — **the HRO Sixty!**





RCA Receiving Tubes useful in Amateur Transmitters

RCA Type Number	RF Service					AF Service		
	VFO	Xtal OSC	Frequency Multiplier	Buffer	Final	Voltage Amplifier	Driver	Modulator
6AG7	6AG7	6AG7	6AG7	6AG7	6AG7			
6F6		6F6	6F6	6F6	6F6			6F6
6J5						6J5	6J5	
6J7						6J7		
6L6		6L6	6L6	6L6	6L6		*6L6	6L6
6N7			6N7					6N7
6S7J						6S7J		
6SL7-GT							6SL7-GT	
6SN7-GT						6SN7-GT	6SN7-GT	
6V6-GT		6V6-GT	6V6-GT	6V6-GT	6V6-GT			6V6-GT
†5879						5879		
6AF4	6AF4							
6AK6	6AK6	6AK6	6AK6	6AK6				
6AQS								6AQS
6C4	6C4	6C4	6C4			6C4	6C4	
6J6	6J6	6J6	6J6	6J6	6J6			
12AX7						12AX7		

Octal-Base Types

Miniature Types

*Triode Connected

†Special Type

An RCA Guide for low-power-level planning

This suggested list of RCA Tubes is prepared for your convenience in selecting small-size tube types for economical low-power-level applications.

All of these tubes are widely proved, and are used extensively in amateur equipment. They provide efficient operation ... require little chassis space ... and are inexpensive!

You'll find the table handy. Save it for future reference.

TUBES FOR THE PROFESSIONAL—PRICED FOR THE AMATEUR



The dependability of commercially proved RCA Tubes costs you no more. Buy genuine RCA Tubes and you buy the best. See your local RCA TUBE DISTRIBUTOR.

TMK. ®



RADIO CORPORATION of AMERICA
ELECTRON TUBES
HARRISON, N. J.