

# CQ

# RADIO

DECEMBER  
1952

# FOR HOURS'

CO  
12-26-27  
B JULY 54  
ANDERSON-BOHY  
1909 3RD AVE. SO  
ANKA, MINN. 55001



# Finally! No More TV Interference Problems!

## The New Hallicrafters HT-20 is T.V.I. proofed!\*



\* T. V. I. PROOFED—means that this transmitter has circuitry specifically designed to eliminate spurious and harmonic energies that result in television interference.

Here's the news you've been waiting for—a medium power transmitter (100 watts) that solves the problem of television interference once and for all. The Hallicrafters HT-20 is the answer. Completely tested in the lab and in the field, here is a transmitter that is truly T. V. I. Proofed.\*

This is not simply a revamped design, but completely new circuitry to meet this problem. Physically, too, the entire transmitter is new from the massive, two-piece, completely rigid chassis to the electrical air cooling system of the final amplifier tube.

See this newest Hallicrafters—get the complete story of the finest transmitter, dollar for dollar, on the market today. Or write Hallicrafters direct for full details.

### Check these features!

- 100 watts carrier power with high level (Class AB2) modulation on any band.
- Continuous coverage, with overlapping bands, from 1.7 to 30 mc.
- Compact, efficient design. Amazing for its power. The HT-20 is 20½" long, 11¾" high and 16¾" deep.
- Weight of transmitter, in cabinet, 105 pounds.
- All transformers and chokes operate "cool"—maximum temperature rise of 40 degrees. This means fewer replacements, long operating life.
- Operates equally well from relay rack or in cabinet on table top.
- Uses 117 volts, 60 cycle AC.
- Moderate cost.

# hallicrafters

# CQ!

**Less than five weeks remain to  
nominate your candidate for . . .**

## THE EDISON RADIO AMATEUR AWARD

December is the final month in which you may recommend a radio amateur for the Edison Radio Amateur Award. Nominating letters must be postmarked not later than December 31, 1952.

To review the facts which your nominating letter should contain, also the terms of the Award itself, please see the Edison Award announcement that appeared on this page in the October issue.

Then mail your letter to the *Edison Award Committee, Tube Department, General Electric Company, Schenectady 5, New York.*

**GENERAL  ELECTRIC**

166-1B12



# MERRY CHRISTMAS

B I L L P E T E R S E N , W Ø J R Y



**PETERSEN RADIO COMPANY, Inc.**

2800 WEST BROADWAY, COUNCIL BLUFFS, IOWA

# CQ RADIO AMATEURS' JOURNAL

VOL. 8, NO. 12  
DECEMBER, 1952

## EDITORIAL STAFF

OLIVER P. FERRELL  
MANAGING EDITOR

TECHNICAL EDITOR  
E. M. BROWN, W2PAU

## DEPARTMENT EDITORS

Herb Brier, W9EGQ	Novice
Wayne Green, W2NSD	Teletype
George Jacobs, W2PAJ	Propagation
W. E. McNatt, W5FEW	VHF-UHF
Louisa B. Sando, W5RZJ	YL
R. C. Spenceley, KV4AA	DX

## CONTRIBUTING EDITORS

Herb Becker,	W6QD
Frank C. Jones,	W6AJF
G. F. Montgomery,	W3FQB
William I. Orr,	W6SAI
W. M. Scherer,	W2AEF

## DRAFTSMAN

Thomas Smith, W2MCJ

## BUSINESS STAFF

S. R. COWAN,	Publisher
S. L. CAHN,	Adv. Director
H. N. REIZES,	Adv. Mgr.
D. SALTMAN,	Prod. Mgr.
R. CAMPBELL,	Edit. Prod.
H. WEISNER,	Circ. Mgr.

Branch Offices: Ted E. Schell, 112 West 9th Street, Los Angeles 15, Calif. Vandike 8921.  
Foreign Subscription Representatives: Radio Society of Great Britain, New Ruskin House, Little Russel St., London, WC 1, England. Technical Book & Magazine Co., 297 Swanston St., Melbourne C1, Victoria, Australia.

CQ - (title Reg. U.S. Pat. Office) - is published monthly by Cowan Publishing Corp. Executive and Editorial offices, 67 West 44th Street, New York 36, N. Y. Phone MUrray Hill 7-2080. Reentered as Second Class Matter February 6, 1951 at the Post Office, New York, N. Y. under the Act of March 3, 1879. Subscription rates in the U.S.A and Possessions, Canada & Pan American Union, 1 year \$3.00, 2 years \$5.00. Elsewhere, \$4.00 per year. Single copies 35 cents. Printed in U. S. A. Entire contents copyright 1952 by Cowan Publishing Corp.

## Cover

Looking up into the tower and rotary beams at W5DMP, Baton Rouge, La. This station, operated by Francis L. Pullen, ex-5JE and 5ZAB, is undoubtedly, from a construction viewpoint, one of the most outstanding stations in the country. A full description is planned for an early issue. The tower shown on the cover is 84 feet high, the entire top section rotating, with the 4-element, 20-meter beam mounted on a 28-foot boom, and a 3-element, 10-meter beam mounted on a 14-foot boom.

## FEATURE ARTICLES

- The True-Matcher**  
*Capt. R. R. Hay, USN, W4LW* .....12
- Further Experiments with Screen Modulation**  
*Frank C. Jones, W6AJF* .....17
- Operation Phone Patch**  
*Robert C. Miedke, WØRSL* .....21
- W5TJE 'Patch**  
*Jones P. Talley, W5TJE* .....22
- More on the PE-101-C**  
*Gordon H. Millar, W9KUZ/8*.....25
- Getting on Novice Phone**  
*E. Miles Brown, W2PAU, and Edwin T. Kephart, W2SPV* 28
- Progress?**  
*N. C. Holman, ZS5GO* .....56

## Departments

- Shack and Workshop** .....16, 24
- The YL's Frequency** .....27
- Amateur Teletype** .....32
- DX and Overseas News** .....36
- The VHF News** .....40
- Ionospheric Propagation Conditions** .....43
- The Novice Shack** .....46

## Miscellaneous

- Scratchi** ..... 4
- Zero Bias** .....11
- Private Life of CQ** .....26
- Classified Ads** .....68, 69
- Yearly Index to CQ** .....70, 71
- Advertising Index** .....72

Designed for

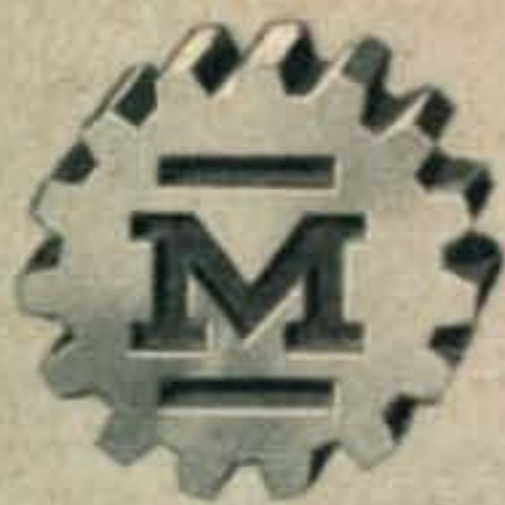

Application

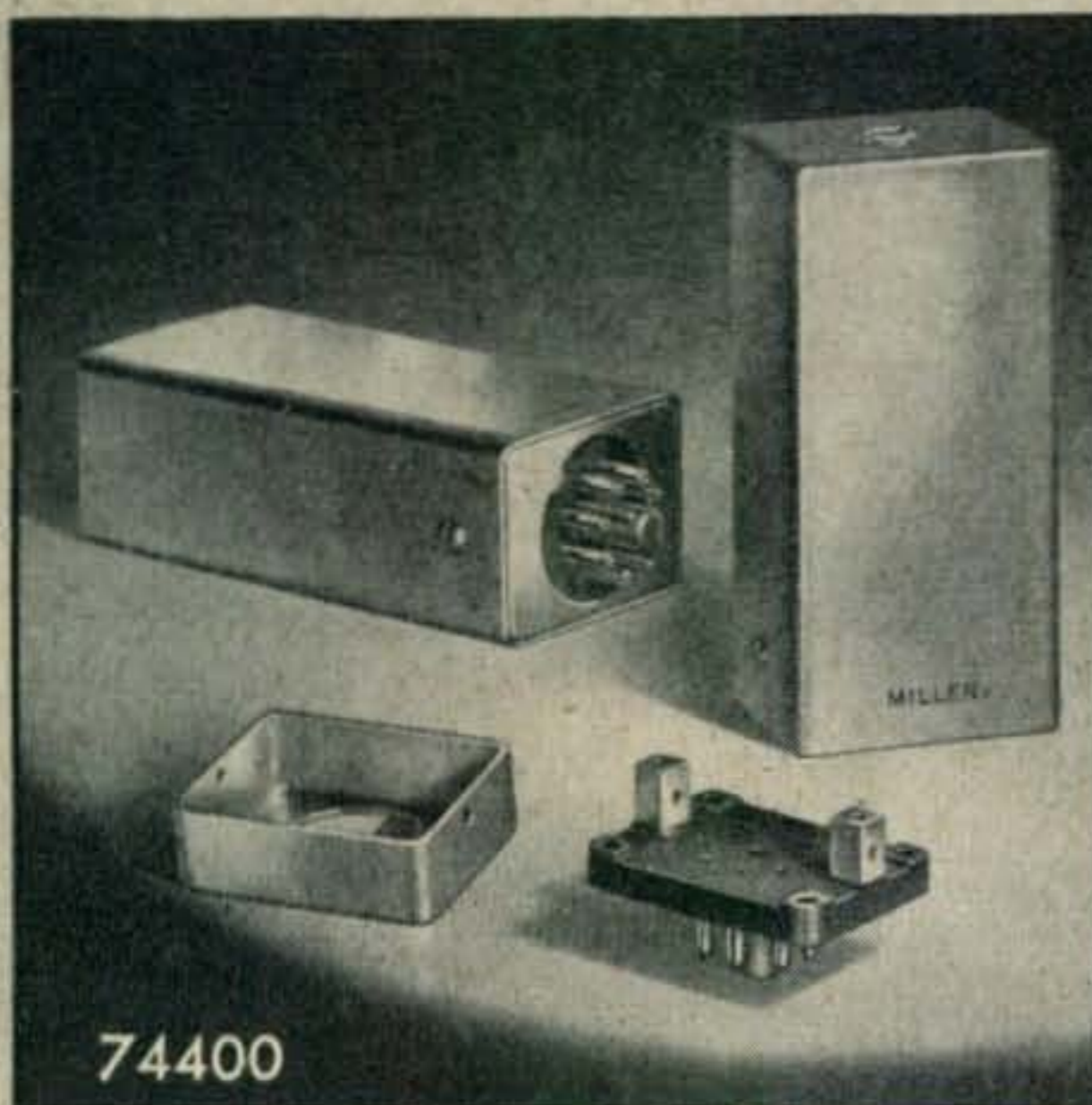

The No. 74400

### Shield Can with Octal Plug-Base

The versatile No. 74400 unit comprises an extruded rectangular aluminum shield  $1\frac{1}{16}''$  x  $1\frac{7}{8}''$  x  $4\frac{1}{2}''$ ; a low loss brown phenolic octal plug base to fit, and a base shield to further extend the shielding. Designed for mounting filters, tuned circuits, relays, IF transformers, audio components, complete midget amplifiers or other circuits, etc.

**JAMES MILLEN  
MFG. CO., INC.**

MAIN OFFICE AND FACTORY  
**MALDEN**  
MASSACHUSETTS



Feenix, Ariz

Dear Hon. Ed:

Merry Noel, Hon. Ed., and are you for a white Xmas wishing? As all smart gentlefellows know, Sandy Claws season are abouts at hand, and Scratchi's Xmas problem are completely out of same. The same it is every Xmas—money. Every year I hoping for radio equipment. I even rite long letters to Hon. Relatives, wishing them cheer, and explaining how Scratchi madly needing new kilowhat final tooob, or sum such thing, and every year same Hon. Relatives are sending me nekties, handkercheeves, and tubsful of shaving lotion. Of that stuff are having enuf to smelling up hole state of Arizona.

My luck are so bad that if Sandy Claws did show up with a new sooper receiver for me he'd probably get stuck with it in the chimney and leave it there, so I'd be having to work it by remote control. Oh, ahkayshunly I getting radio stuff for Xmas, like time grate ant on Hon. Grandfather's side sending me receiver—the kind with exposed coil, four clips and a cristal with cats-whisker. She evidently thinking it latest piece of radar geer, as she riting me later and asking if I discovering any new planets with it—you think she kidding me, Hon. Ed?

At any rates, now have sure-fire skeem for razing sum money, so can go out and for myself buying radio now. I espeshully needing sum 21 megacackle coils, as that are only band Scratchi not bootlegging on yet.

What it is, Scratchi starting new business, and on acct. you being big man in magazeen field and loaded down with bux, I giving you first chance to be a customer. (Also seeing as how you a Hon. Editor, maybe I talking you out of free ad in Hon. Rag.)

You are reeding, I am surely, ads in magazeens which say "Surprize Your Friends this Xmas with a Bushel of Peeches from Georgia, the Peech State"; or, "Sending Out Rhode Island Turkey for Xmas Presents this Year"; or, "Giving a Crate of Oranges from the Sunshine State for Xmas so Your Friends Having Sunshine the Year Round." Well, Scratchi's slogan this year are: "Make This a Cactus Jooce Xmas—Give S-9 Cactus Jooce from the Cactus State and Spread a Little Liquid Sunshine." (I calling it S-9 Cactus Jooce because it reely boosts your input.) Now, aren't that a reel slicky idea? If it catching on, I having enuf money to buying for life—maybe longer.

Shurely, Hon. Ed., you are wanting to make your Xmas shopping easy. All you having to do is sending me a list of your friends and five bux for each name and I seeing that a nice five gallon jug

# NOW

# OHMITE<sup>®</sup> OHM'S LAW CALCULATOR

## WITH PARALLEL RESISTANCE AND SLIDE RULE SCALES!

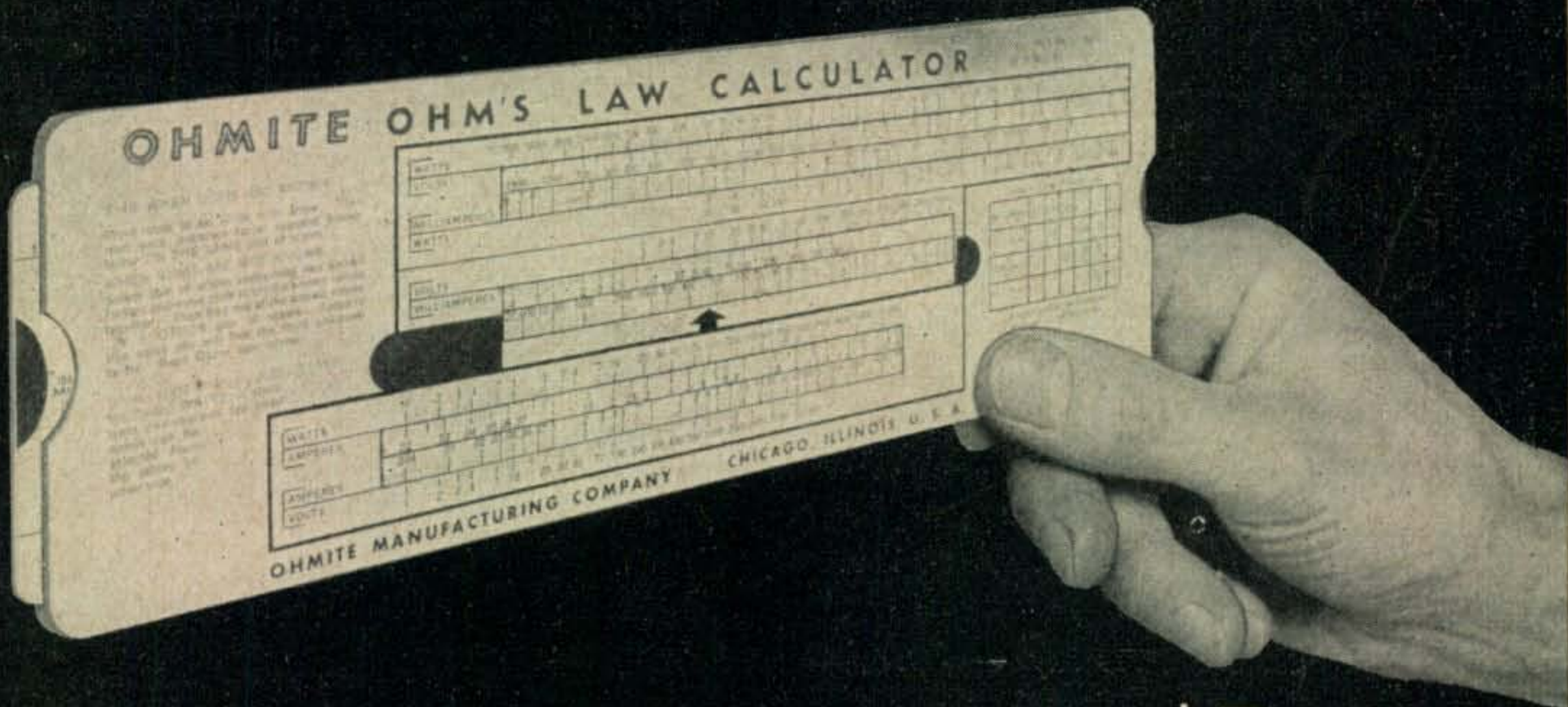

## IN DURABLE VINYLITE - \$1.50

**ONLY ONE SETTING REQUIRED** to solve any Ohm's law and many parallel resistance problems—simply, quickly, accurately. Covers a range of values encountered in electronic and moderate power applications.

**HANDY POCKET SIZE**—Only 9" x 3", it fits neatly into the pocket. Can be carried anywhere. Slide rule scales multiply, divide, and find squares and square roots. Durable vinylite lasts for years and years—remains dimensionally stable.

THIS POPULAR AID FOR ENGINEERS, EXPERIMENTERS, STUDENTS  
ALSO AVAILABLE IN 25c VARNISHED CARDBOARD MODEL

## Be Right with OHMITE<sup>®</sup>

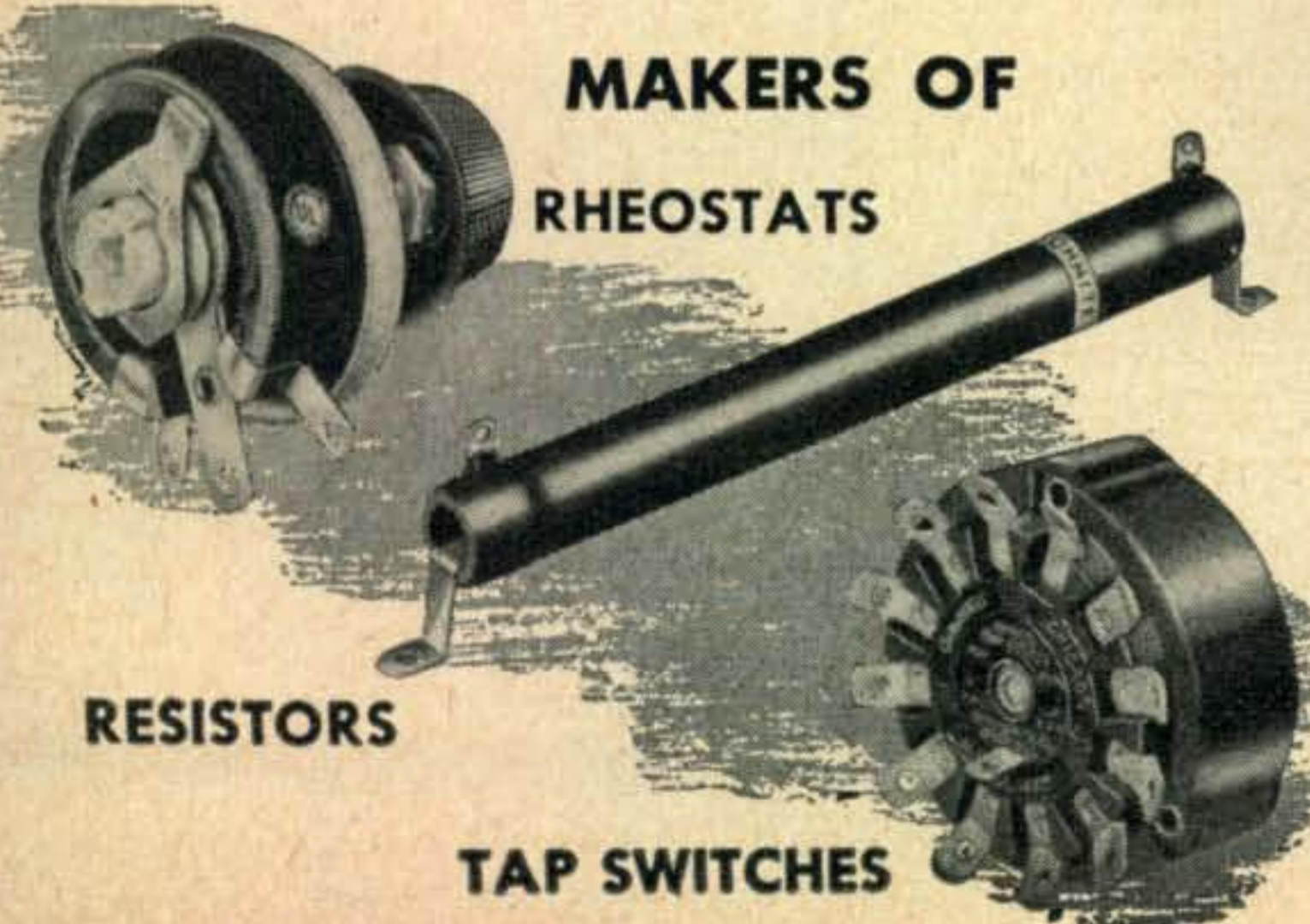

MAKERS OF  
RHEOSTATS

RESISTORS

TAP SWITCHES

### SEND FOR

Ohmite Mfg. Co.  
4831 Flourney St.  
Chicago 44, Ill.

Send my new OHMITE calculator. I enclose check or money order for:

- VINYLITE @ . . . . . \$1.50
- CARDBOARD @ . . . . . 25c

Name \_\_\_\_\_

Address \_\_\_\_\_

City \_\_\_\_\_ State \_\_\_\_\_

**B&W****MODEL 600**

# Dip Meter



- ★ Frequency Range—1.75 to 260 MC. in 5 Bands
- ★ Adjustable Sensitivity Control
- ★ Wedge-shaped for Easy Access in Hard-to-get-at Places
- ★ Rust Proof Chassis, Sturdy Aluminum Case
- ★ Monitoring Jack and Diode Switch
- ★ Powered by 110 V. A.C. Line

PRICE

**\$48<sup>00</sup>**  
net

## A HIGHLY USEFUL INSTRUMENT FOR THE

*Amateur • Engineer • Service Man  
Laboratory Technician • Experimenter*

The New B & W Model 600 Dip Meter provides you with a convenient means of doing the job in a minimum of time with dependable accuracy.

It is an extremely sensitive and reliable piece of test equipment having innumerable uses in the Ham Shack, Service Shop, Electronic Laboratory, or Production Plant.

Armed with this versatile and indispensable instrument, you eliminate the guess-work during measurement of—tank circuit frequencies, antennas, feed line systems, parasitics, and other pertinent tuned circuit characteristics, with speed and accuracy.

The handy instruction manual furnished with each instrument covers full information on how to use the Model 600 as an Absorption Meter, Auxiliary Signal Generator, R. F. Signal Monitor, and several special applications as well. See it at all leading electronic parts distributors throughout the U. S. A. and Canada; or write for descriptive bulletin.

**BARKER & WILLIAMSON, INC.**

237 Fairfield Avenue • Upper Darby, Pa.

of S-9 Cactus Jooce are on your friends doorstep on Xmas day. For another buck will putting name or call letters on the jug in floorescent paint.

To making it easier for you, just riting me check for 1000 bux, and if you can't thinking of 200 friends, I'll sending jugs to people you not knowing. Buleeve you me, when they getting fancy dubble-handled jug of genuwime aged in the sun Arizone S-9 Cactus Jooce from you, they'll be your friend for life—maybe longer.

Scratchi shure hope that idea going over in tramendus way, as I not only needing new radio geer but having to replace sum I have just to making cactus jooce. You see, are finding that copper tank coil just rite or getting most out of cactus—and how. Hon. Brother Itchi's barn you should seeing, piled high with barrels and jugs of cactus jooce. Wowie!! are that stuff powerful. One day resently when examining stock are noticing that one barrel are starting to smoke, and are getting it diluted with water just in time so it cooling down. This Arizona cactus jooce are so strong it can almost electing its own president.

This year are going to be a marry one for Scratchi and no lye. I don't care if Sandy Claws and Hon. Reindeer not even bothering to buzzing the place, as I'll be rolling in the clover. So, whaddayu saying, Hon. Ed. (The checkbook are in upper right drawer of your desk.) Make this an easy Xmas—get your shopping done in one fell swoop. And—excoosing me please, Hon. Ed., heering sirens. I'll be rite back.

Well. . . I'm back. . . and I'm broke. Putting away that checkbook. Hackensake! There was a hot time in the old barn tonite, and when I say old barn, I mean barn what used to be. Old S-9 Cactus Jooce are going off-scale and burning down the barn. Of all the. . . I'll be a. . . Well—back to riting letters to relatives asking for radio stuff for Xmas.

Respectively yours,  
Hashafisti Scratchi

P. S. With my usual luck, about Dec. 26 I'll be rolling in shaving lotion. Wanting sum at one bux a bottle to making Hon. Office smelling. . . sweet, that is?

H. S.



"White Man heap crazy; radio transmitter no better than old pine logs!"



# Introducing... Bliley **FUSED QUARTZ** Ultrasonic Delay Lines

**LONG DELAY TIME WITH EXTREMELY HIGH STABILITY UNDER TEMPERATURE VARIATION...**

**FUSED QUARTZ** ultrasonic delay lines offer decided advantages when it is necessary to delay pulsed or pulse modulated signals for a precise time interval. Bliley, long recognized as the leading manufacturer of precision quartz crystals, is now prepared to **DESIGN** and **CUSTOM BUILD** this new electronic tool for your individual application.

In fused quartz delay lines electrical energy is converted into sound energy, passed through the fused quartz, and re-converted into electrical energy by means of piezoelectric quartz transducers which are bonded to either or both ends of the line. Delay time or transit time in the fused quartz, can be held to close tolerance by utilization of proper techniques.

**STABILITY**  $\pm .2\%$  between  $-35^{\circ}\text{C}$  and  $+85^{\circ}\text{C}$ . For example, a 1000 microsecond delay line will change less than  $\pm 2$  microseconds over this ambient range.

**DELAY TIME** values from 5 to 1500 microseconds are feasible depending upon related end use requirements.

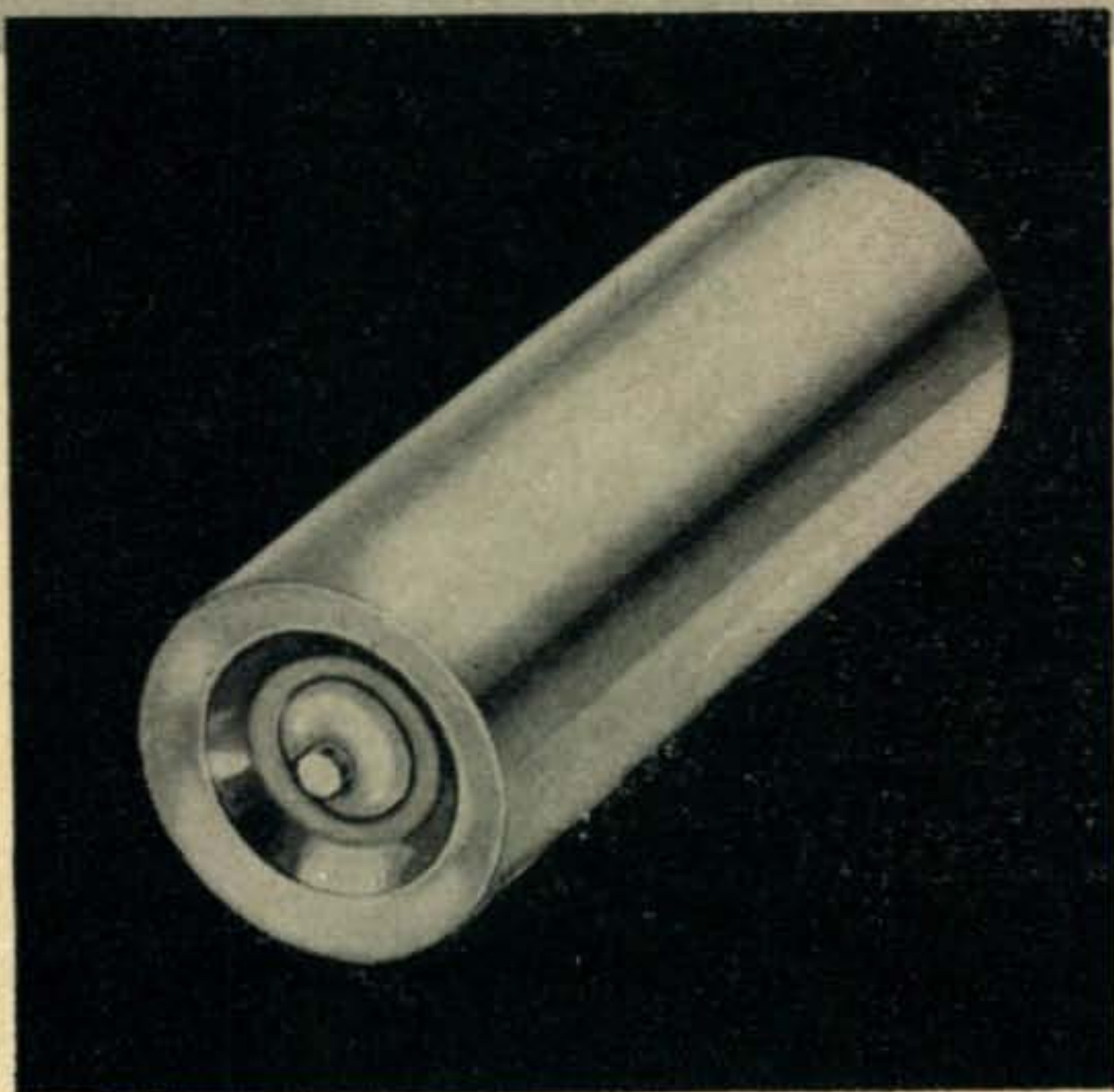

**PHYSICAL SIZE** In the range 5-50 microseconds cylindrical shaped lines are employed, as indicated in the accompanying illustration. Other configurations may be used to meet requirements up to 1500 microseconds. For example, a 15 microsecond (reflection type) delay line including an hermetically sealed case would be a cylinder approximately 2" long x 1" diameter.

**FREQUENCY RANGE** is 5-100 mc with delay time values as indicated above.

**Inquiry INFORMATION** Please include, if practicable, information concerning the general function of the delay line in your end use application. In any event, it is necessary to consider the following conditions:

- |   |   |
|---|---|
| (a) delay time                              | (e) attenuation of spurious responses below main signal |
| (b) frequency (carrier) and pulse frequency | (f) normal operating temperature                        |
| (c) attenuation at mid-band                 | (g) service temperature range                           |
| (d) bandwidth at 6 db down points           | (h) dimensional limitations (if any)                    |

Technical Bulletin No. 45 giving more complete details will be furnished upon request.

**BLILEY ELECTRIC COMPANY** UNION STATION BUILDING **ERIE, PA.**

# ***SELECTIVITY...***

## ***in a Communications***

The selectivity curves shown here tell the story of a new concept in receiver performance. The Mechanical Filter recently developed by Collins and incorporated in the 75A-3 receiver represents an entirely new approach to the attainment of selectivity. Using resonant mechanical elements rather than tuned electrical circuits, the Mechanical Filter gives a close approach to the ideal rectangular selectivity curve. Each 75A-3 receiver has plug-in provisions for two Mechanical Filters. A 3 kc Filter is standard factory equipment and when still greater selectivity for CW operation is desired, the 1 kc plug-in unit is available as an optional accessory. With both the 1 kc and 3 kc Filters in the receiver, a switch on the front panel provides instantaneous choice of selectivity characteristics. When required, the crystal filter may also be switched into the circuit to notch out interfering signals and heterodynes.

The nearly flat top and sharp cutoff at the sides of the selectivity curve of the 3 kc Mechanical Filter permit all AM signals to be tuned so as to accept the carrier and either one of the sidebands at will, while the other sideband is rejected. Thus much distortion due to fading is eliminated, and susceptibility to interference is greatly re-

duced. Alternatively, both AM and SSSC signals may be received with carrier supplied by the BFO; and the ideal selectivity curve of the Mechanical Filter permits full advantage to be taken of the benefits of local carrier reinsertion.

Because of the Mechanical Filter's straight-sided selectivity curve, the 75A-3 receiver can be tuned near a strong signal without responding to that signal. As the receiver is tuned across the band, signals suddenly appear and disappear. This is because of the absence of broad skirts which "drag out" the tuning of conventional receivers.

All of the proven features of the 75A-2 have been retained in the 75A-3. These features, such as crystal controlled front-end, highly stable variable frequency oscillator, and accurate dial calibration, to name but a few, combine with the new Collins Mechanical Filter to give unequalled performance.

Whether you ragchew, handle traffic, or work dx, here is the receiver for solid contacts. The straight-sided, flat-topped, selectivity curve and the excellent frequency stability of the 75A-3 make it a natural for the single-sideband operator.

**The Mechanical Filter** is a resonant mechanical device that is coupled into the receiver's 455 kc IF strip by means of magnetostriction. As shown here, it consists of three general sections: an input transducer, a mechanically resonant section consisting of a number of metal disks, and an output transducer. A 455 kc electrical signal applied to the input terminals is converted to a 455 kc mechanical vibration at the input transducer. This mechanical vibration travels through the resonant mechanical section to the output transducer, and is converted to a 455 kc electrical signal

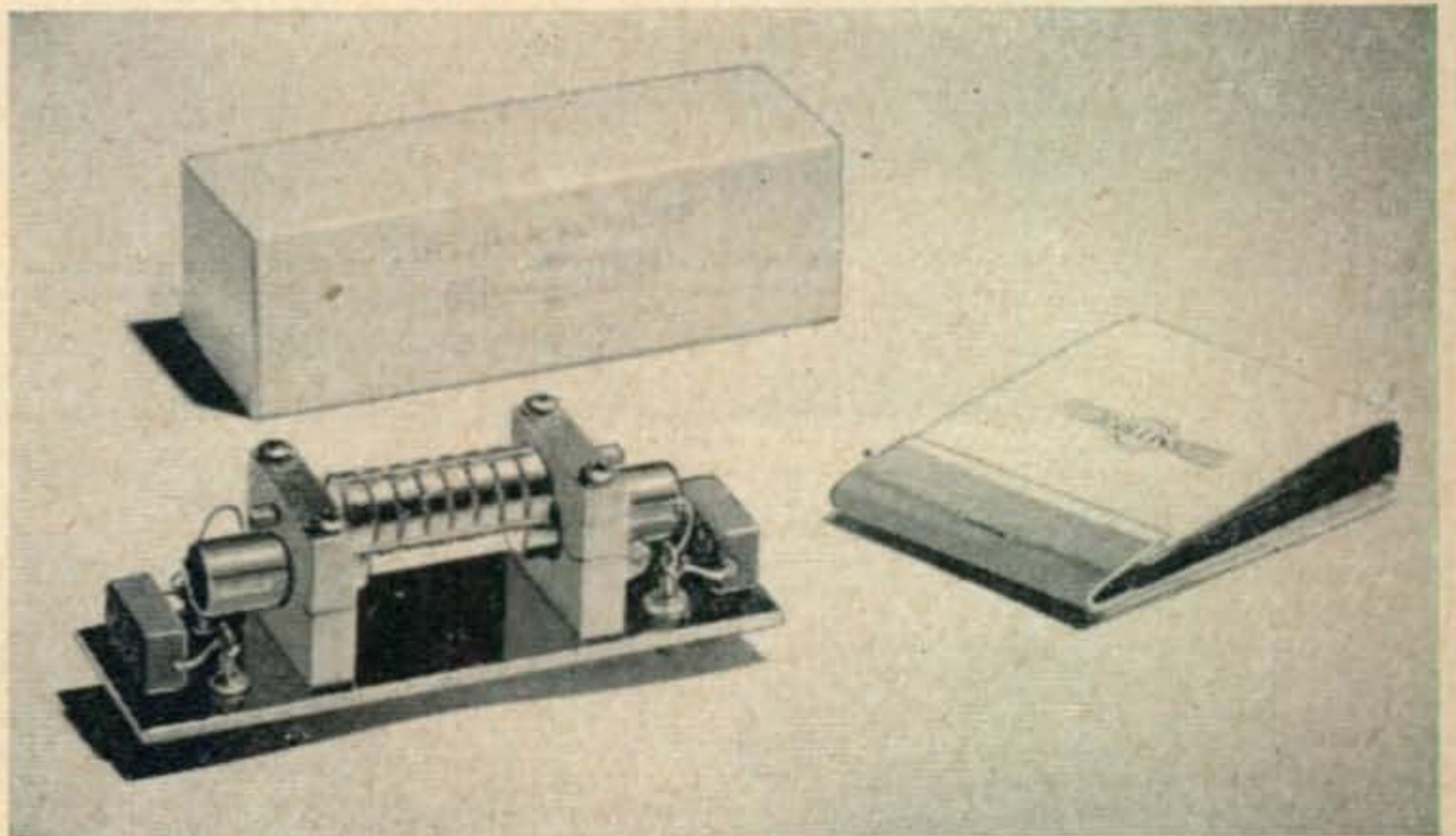

which appears at the output terminals. The Mechanical Filter is enclosed in a hermetically sealed case and requires no adjustment.

# never before achieved

## Receiver

**The Collins 75A-3 with Mechanical Filter.** A 3 kc Mechanical Filter is installed at the factory. The Filters are plug-in units, and a 1 kc Mechanical Filter may be installed at any time.

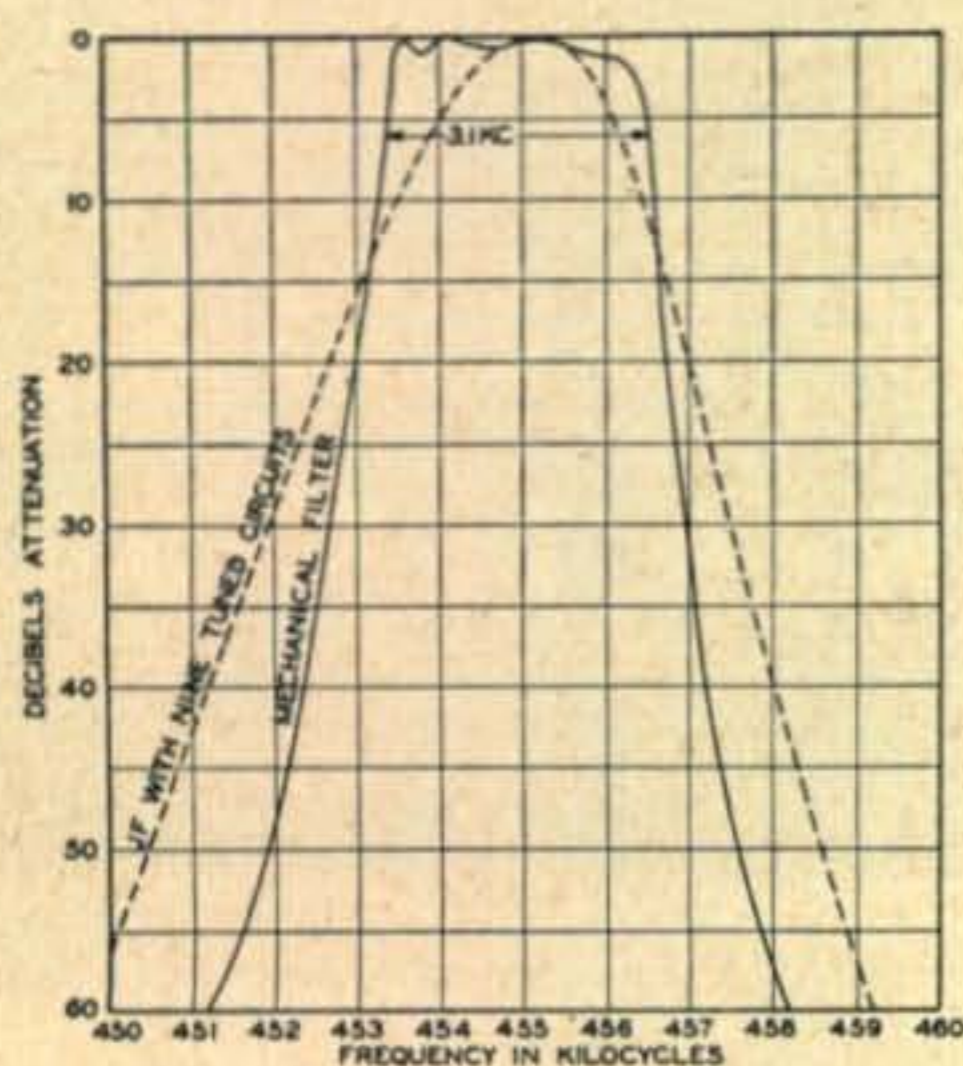

The curves above show a comparison between the selectivity curve of a good IF strip using nine tuned circuits, and typical selectivity available in a Collins 75A-3 receiver incorporating a 1 kc and a 3 kc Mechanical Filter. When both Mechanical

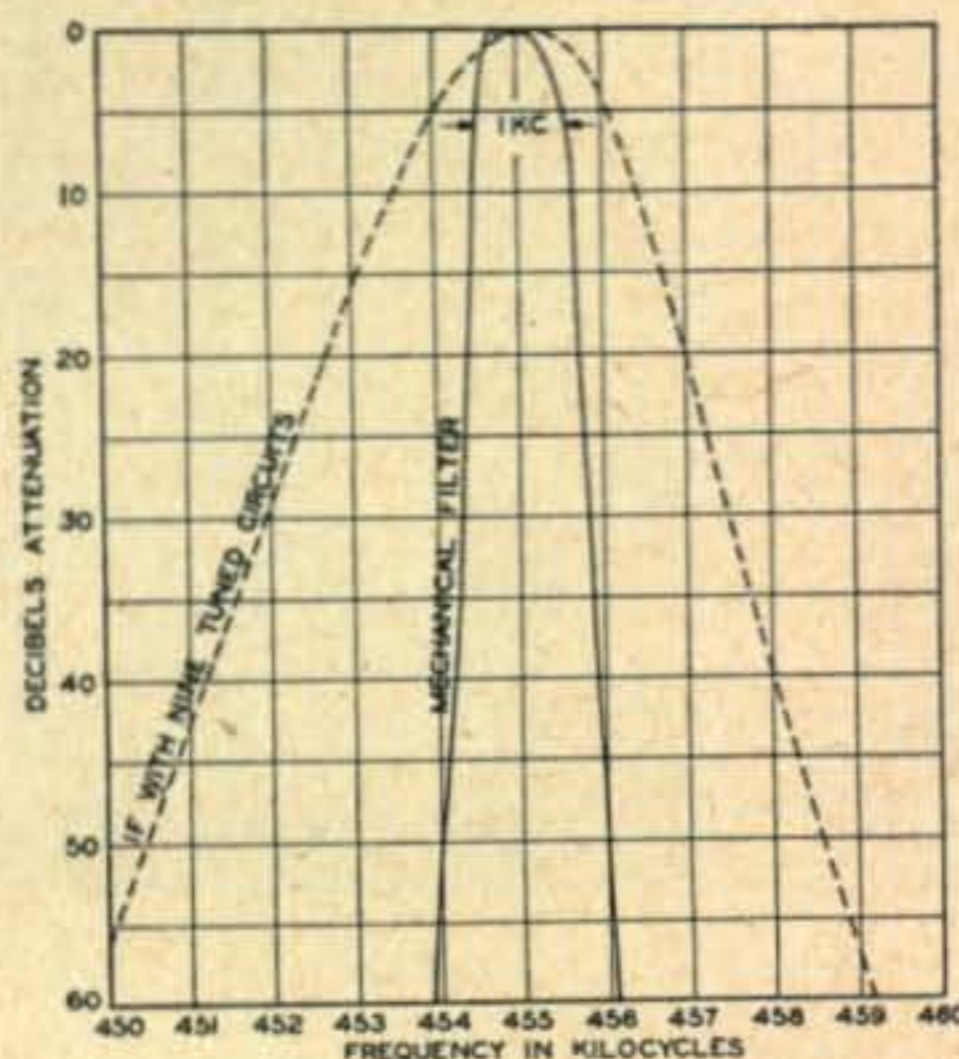

Filters are installed in the receiver, either one may be selected at the flip of a switch. These curves show performance without the crystal filter. When required, the crystal filter may be called into play to phase out unwanted signals or heterodynes.

### ATTENTION 75A-2 OWNERS

75A-2 owners can return their receivers through the Distributor to be modified at the factory to incorporate the new Mechanical Filter arrangement. Modifications can be made, effective immediately, and will consist of the installation of a 3 kc Filter, minor repairs and complete realignment of the equipment. Modification, F.O.B. Cedar Rapids ..... \$125.00

### Net Domestic Prices:

75A-3 receiver including 3 kc Mechanical Filter ..... \$530  
 1 kc Mechanical Filter plug-in unit, \$75  
 10-inch speaker in matching cabinet, \$20  
 8R-1 plug-in crystal calibrator ..... \$25  
 148C-1 plug-in NBFM adapter .. \$22.50

For the best in amateur radio, it's . . .



**COLLINS RADIO COMPANY, Cedar Rapids, Iowa**

11 W. 42nd St., NEW YORK 36

1930 Hi-Line Drive, DALLAS 2

2700 W. Olive Ave., BURBANK

# Amateurs' Choice



*Eimac* RADIAL-BEAM  
POWER TETRODES

Five Top Tetrodes

**4-65A**

**4-125A**

**4X150A**

**4-250A**

**4-400A**

Write our Amateur's Service Bureau  
for information about these tubes.

**Eimac offers** for the amateur radio operator's use five top radial-beam power tetrodes proved by years of commercial and amateur application. Economy and dependability are the results whenever Eimac tetrodes are employed. Not only are they money savers through long life, low driving power and simple circuit design, they also minimize TVI worry. And for outstanding performance you can't beat the high power gain, ruggedness and stability of Eimac tetrodes. At any practical power or frequency range there is an Eimac radial-beam tetrode to do the job.

*Eimac*  
TUBES

**EITEL-McCULLOUGH, INC.**

**SAN BRUNO, CALIFORNIA**

Export Agents: Frazar & Hansen, 301 Clay St., San Francisco, California

# Season's Greetings

from The Staff



W2MCJ



W6SAI



W2PAU



W6QD



W2AEF



W5FEW



O.P.F.



W9EGQ



W2NSD



W2PAJ



W3FQB



KV4AA



W5RZJ

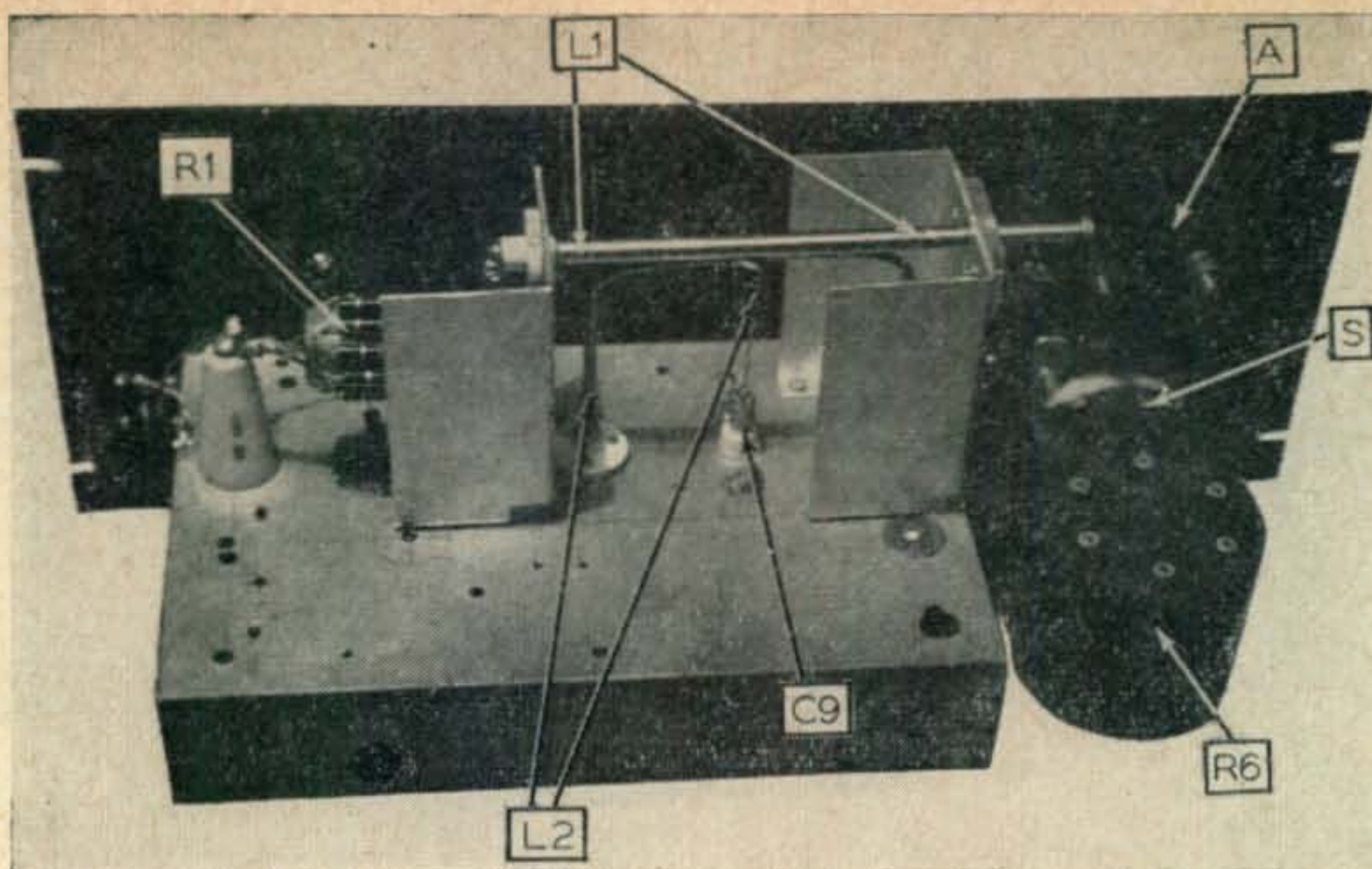

This is a device that the amateur radio operator inserts in the coaxial line after it leaves the transmitter. In sequence it samples the magnitude, phase and power of the energy in the transmission line. By coordinating these measurements the antenna can be loaded with utmost efficiency.

# the True - Matcher

Capt. R. R. HAY, U.S.N., W4LW

610 North Buchanan St., Arlington 3, Va.

CQ is proud to be able to bring to its readers this article on the application of a device that has only recently been brought to the attention of radio amateurs. At the time this is being written it is the only practical circuit combining an impedance magnitude indicator, phase-angle indicator and output meter. This is not for the perfectionist, it is for everyone interested in putting the maximum power of his transmitter into the antenna.—Editor.

Many devices have been used in amateur radio to match transmitters to their antenna loads; Impedance bridges, r-f ammeters, and similar devices all supply valuable information. Not one of them, however, is capable of telling the whole story.

The device to be described in this article is an amateur radio adaption of a unit designed by Mr. Virgil True of the Naval Research Laboratory. It was originally intended to drive an automatic antenna tuning system, but furnishes valuable visual information for any antenna system. The *True-Matcher* furnishes the following information:

- Indicates when the load impedance is of the desired magnitude, or if it is too high or too low.
- Indicates when the load is non-reactive, or if it is capacitive or inductive.
- When the load has been adjusted to the

desired value and is non-reactive, indicates the power output.

The essential components of the *True-Matcher* are a magnitude indicator, a phase-angle indicator, and an output section containing an r-f ammeter and a dummy antenna. This particular version was designed for use with a 73-ohm line and for maximum power output of 100 watts.

The theory of the magnitude and phase-angle indicators was described in Mr. True's article in the December 1951 issue of *Electronics* (page 98). Consequently, space will not be taken here to discuss it. Rather, emphasis will be placed on specific problems of construction and use.

## Magnitude Indicator

An inspection of the circuit diagram of the magnitude indicator (left side of *Fig. 1*) will disclose a resemblance to the "Micro-Match." A distinguishing difference is the addition of a second crystal detector. This provides a means for identifying the polarity of the output voltage. Resistance, *R4*, balances the indicator for zero reading of *G1* when the load is 73 ohms, non-reactive.

The resistor, *R1*, is made up of ten composition resistors in parallel. The photograph, *Fig. 2*, shows that these resistors are mounted on the outside of a coil form one inch in diameter and one and one-half inches long. Condenser crystal *C4* and *X2*

are placed inside this form and the connection to R2 is brought out at right angles to the axis of the form.

The assembly, R1, C4, and X2, is supported at one end by a stand-off insulator and at the other end by RFC2. The galvanometer, G1, is located externally and connected to the indicator through J2. The following components are mounted below the chassis; X1, R3, R4, RFC1, C3, C5, and C6.

**Phase-Angle Indicator**

The inductance, L1, consists of a brass rod 1/4" in diameter and 5 1/2 inches long, suspended between feed-through insulators at opposite sides of a shield box. The diameter of this rod is not critical, although its size will affect the capacitive coupling between L1 and L2. Sampling loop, L2, is mounted with the two vertical legs through feed-through insulators in the chassis. The horizontal portion is placed below and parallel to L1 to provide inductive coupling with the latter. Spacing between L1 and L2 is approximately 1/16". The legs of L2 are threaded, where they pass through the chassis feed-through insulators and are held in position by nuts above and below the insulators. By adjusting the position of the nuts, the spacing between L1 and L2 may be varied. On high power applications, the spacing should be increased to

avoid voltage breakdown and to reduce the maximum current through galvanometer, G1. About 3/16 inch should be adequate for high power. A center-tap connection is taken off L2. This center tap is connected to C9 above the chassis and to RFC3 below the chassis.

L1, L2 and C9 are mounted above the chassis; all other components are mounted below the chassis. The galvanometer, G2, is also mounted in the operating position on the indicator panel. Resistor, R7, limits the maximum current through G2 when large values of reactance are encountered.

The 1N38 crystals were selected for use in the phase-angle indicator because their high value of back resistance made it easier to zero the indicator. If only 1N34, or similar crystals are available it is suggested that each crystal be shunted by a resistor of about 220,000 ohms as recommended by the General Electric Co.

**Output Section**

The output section consists of an r-f ammeter, a low-loss switch and a dummy antenna of 73 ohms. The dummy antenna is used for calibration of the magnitude and phase-angle indicators as well as for tuning and testing the transmitter. The co-ax fitting, J3, is provided for connection to a 73-ohm line.

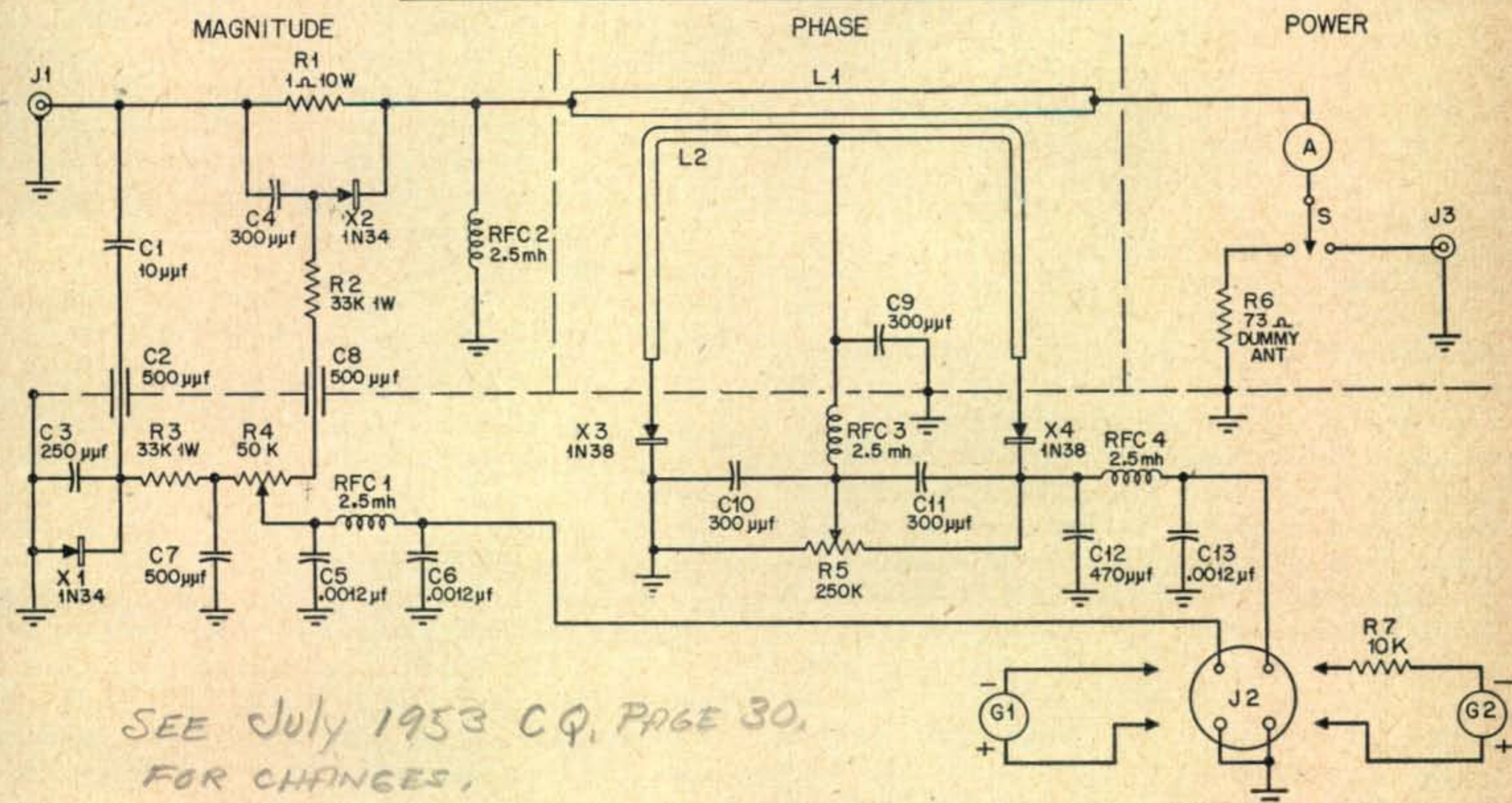

- C1—10  $\mu$ fd. ceramic condenser
- C2, C8—500  $\mu$ fd., feed-through type, ceramic condenser
- C3—250  $\mu$ fd., silver mica condenser
- C4—300  $\mu$ fd., ceramic condenser
- C5, C6, C13 — 1200  $\mu$ fd. ceramic condenser
- C7—500  $\mu$ fd., ceramic condenser

- C9, C10, C11—300  $\mu$ fd., silver mica condenser
- C12—470  $\mu$ fd., ceramic condenser
- R1—1 ohm, 10w. non-inductive resistor (ten 10-ohm, 1w. composition resistors in parallel)
- R2, R3—33,000 ohm, 1w.
- R4—50,000 ohm

- R5—250,000 ohm potentiometer
- R6—Ohmite, D-101, 73 ohm dummy ant.
- R7—10,000 ohm 1/2w. resistor
- L1—1/4" brass rod, 5 1/2" long
- L2—1/8" brass rod, bent in "U" shape, with legs 2 1/2" long, center portion 4" long

- X1, X2—1N34 crystals
- X3, X4—1N38 crystals
- RFC1-4—2 1/2 mh. chokes
- G1, G2—75-0-75  $\mu$ a. galvanometers
- A—0.2 r-f ammeter
- S—s.p.s.t. low-loss switch
- J1, J3—co-ax connectors
- J2—4 prong socket

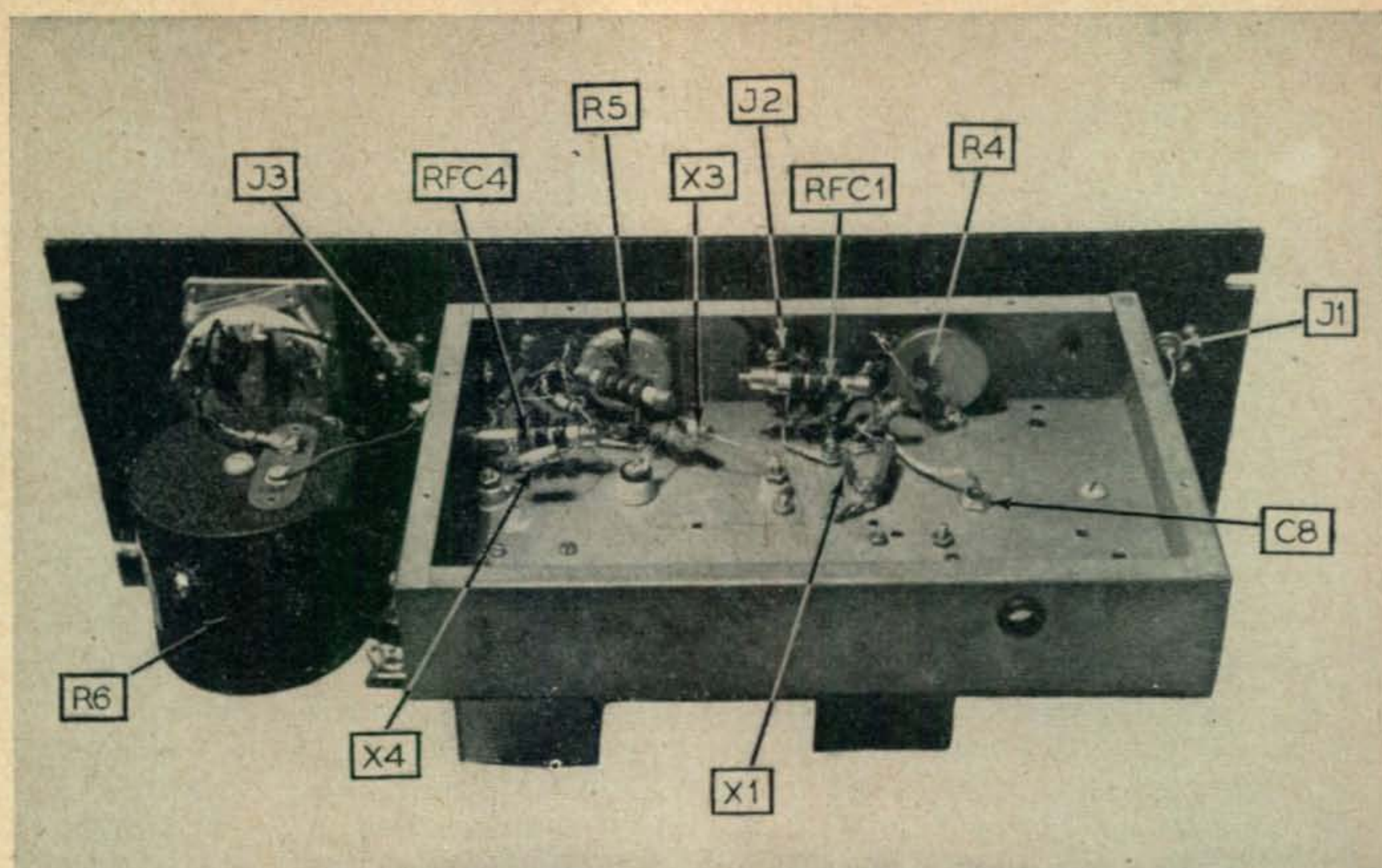

Under chassis view of the True-Matcher.

#### Initial Adjustment and Calibration

The following discussion assumes that all components of the *True-Matcher* have been assembled, a transmitter has been connected to the input and an antenna coupler to the output.

First, throw switch *S1* to the dummy antenna. Next, energize the transmitter (preferably on its lowest frequency) and adjust for maximum current in the r-f ammeter. Check normal power output by referring to *Fig.3*, power vs. r-f current.

The first calibration adjustment is zeroing the galvanometer *G1* by means of the potentiometer, *R4*. The magnitude indicator is now balanced for a non-reactive load of 73 ohms. A lower load impedance will now cause the meter needle to swing right and a high load will cause it to swing left. The meter face may be marked (+) and (-) to indicate this. If a further refinement is desired, the zero point on the meter scale may be marked "73 ohms." Other points on the scale may be calibrated by placing known, non-reactive loads at the output of the *True-Matcher* and observing the reading.

Zero adjustment of the phase-angle indicator is made by means of the potentiometer, *R5*. When the meter has been zeroed, the phase-angle indicator is balanced for a non-reactive load. A capacitive load will cause the meter needle to swing left; an inductive load, to the right. The face of the meter may be marked "C" and "L", accordingly.

When using the dummy antenna at frequencies above 4 mc., due consideration must be given its reactance. The *True-Matcher* was designed for a 73-ohm load in preference to 52 ohms because the dummy antenna for the former value displayed better reactance characteristics. The 73-ohm, *Ohmite D-101*, dummy antenna begins to have appreciable inductive reactance above 4 mc. The total impedance rises 10% at about 32 mc. In contrast,

the total impedance of the 52-ohm *Ohmite D-101* rises about 40% at the same frequency. *Fig. 4* shows 73-ohm dummy antenna characteristics.

The effective resistance of the dummy antenna also rises with an increase of frequency. This fact must be taken into consideration when taking power measurements. The broken line on *Fig. 3* shows the effect of frequency upon power consumption by the dummy antenna.

Once adjusted, both the phase angle indicator and the magnitude indicator should be stable and reliable without further re-adjustment.

#### Additional Notes

The *True-Matcher* may be used with 52-ohm line by substituting a 52-ohm dummy antenna and adjusting the potentiometer, *R4*, for zero reading of the galvanometer *G1* as in the case of the 73-ohm line. When a 52-ohm line is used, it is also advisable to increase the size of the r-f ammeter to 3 amperes. The *True-Matcher* can be adapted for use with 75-ohm or 300-ohm balanced line by use of a pair of *B&W* type 3975 *BALUN* coils. However, it is preferable to use coaxial line to the antenna tuner and to design the latter for the desired balanced line.

Although this *True-Matcher* was specifically designed for low power application, the same principles are adaptable for high power operation. In fact, Mr. True's original design was for use with a transmitter of 400 watts output. Critical values for high power are resistor, *R1*; the r-f ammeter, *A*; the galvanometers, *G1* and *G2*; and the dummy antenna *R6*.

When *R1* is made up of one-watt resistors it will handle an output of 500 watts into a 52-ohm line, or 700 watts into a 73-ohm line. If a greater margin of safety is desired, *R1* should be constructed with 2-watt composition resistors.



The r-f ammeter should have a full scale reading of at least double the normal operating current. For a 52-ohm line and a transmitter with an output of 750 watts, this would require a 10 ampere meter. A compromise measure would be to use the ammeter only for calibration at low power and to leave it out of the circuit during adjustment of the antenna coupler. In addition, dummy antennas suitable for high power applications are quite expensive. Therefore, it is quite likely that the calibrating and testing will be done at low power in order to permit the use of the 100-watt size of dummy antenna.

If the operator can procure a high wattage dummy antenna resistor it will become necessary to consider some protection of the galvanometers, *G1*

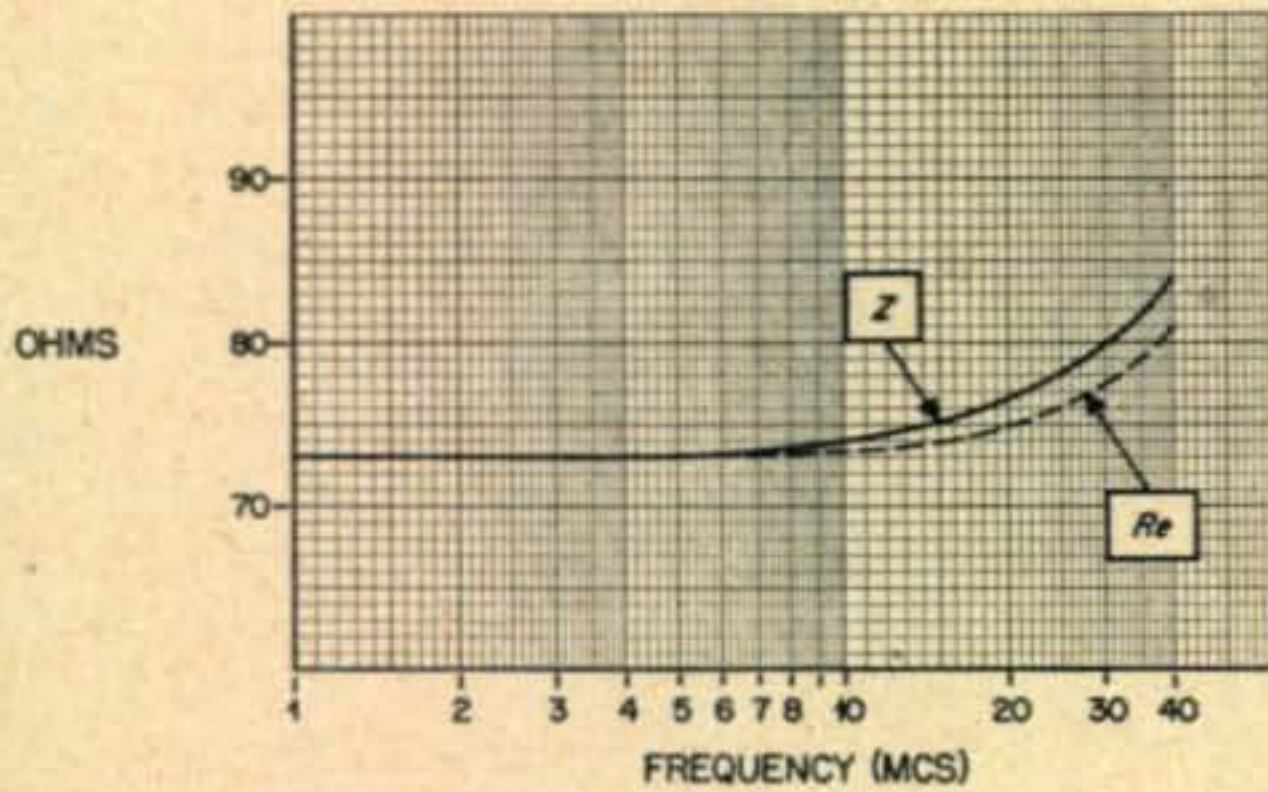

Fig. 4. Variation of impedance and effective resistance with frequency, for the Ohmite D-101, 73-ohm dummy antenna resistor.

and *G2*. While the Marion Company manufactures a special null indicating meter for this type of application (sensitive near the zero point, but will stand high current at the extremes of the scale) they may not be available to amateurs. Regular galvanometers may be protected by using series resistances or diode clippers, or both. A series resistance of about 150,000 ohms should give adequate protection for the 75  $\mu$ a. meters at high power.

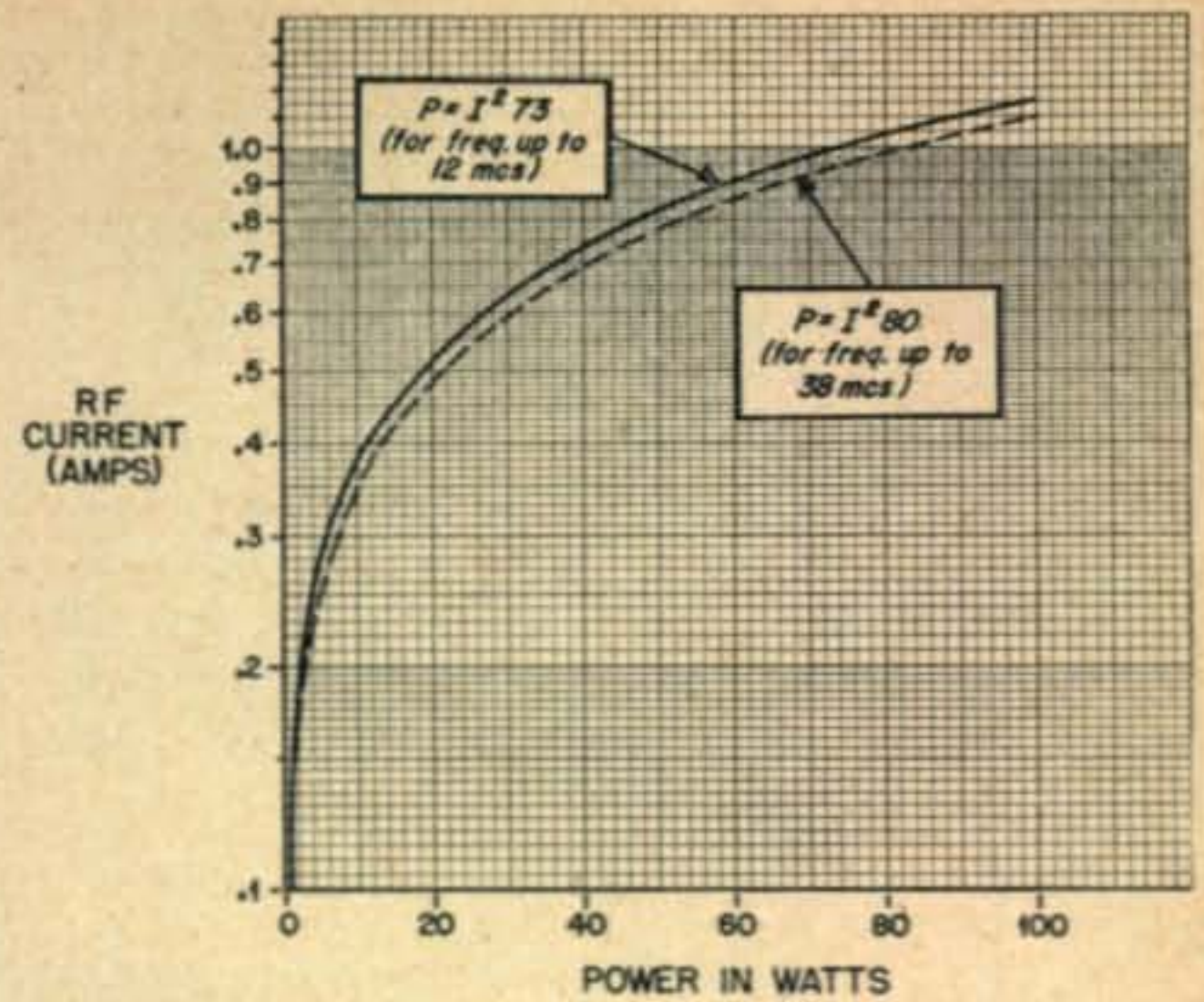
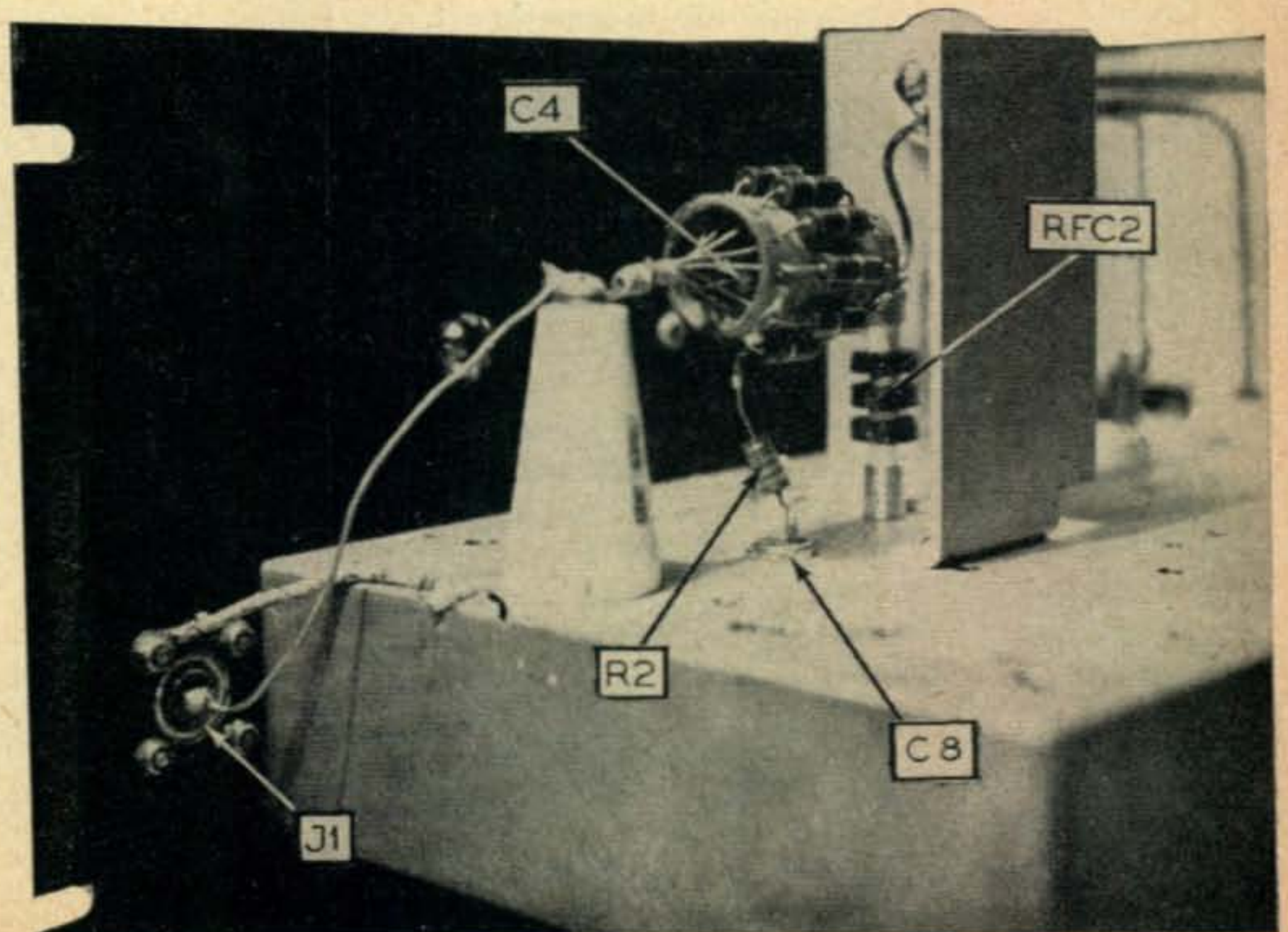

Fig. 3. Power vs. r-f current in an Ohmite D-101, 73-ohm dummy antenna resistor.

### Operation

To use the *True-Matcher* to best advantage, it is necessary to provide an antenna tuner which is adjustable both for reactance and impedance magnitude. *Figure 5* is a suggested tuner for matching an end-fed, half-wave antenna. The condenser provides the magnitude adjustment and the variable inductance takes care of the phase adjustment. Suggested values for an 80-meter, half-wave antenna are 150  $\mu$ f. and 25  $\mu$ h. After the transmitter has been tuned for optimum operation into the dummy antenna, the switch *S1* is thrown to the antenna tuner connection. From this point, the transmitter should not be retuned. Adjustments should now be made to the antenna tuner to bring both galvanometers of the *True-Matcher* to zero reading. When this has been done, both the transmitter plate milliammeter and the r-f ammeter should read the same as they do when the dummy load is being fed.

Fig. 2 Detail photograph of the magnitude indicator showing the resistor network, *R1*.



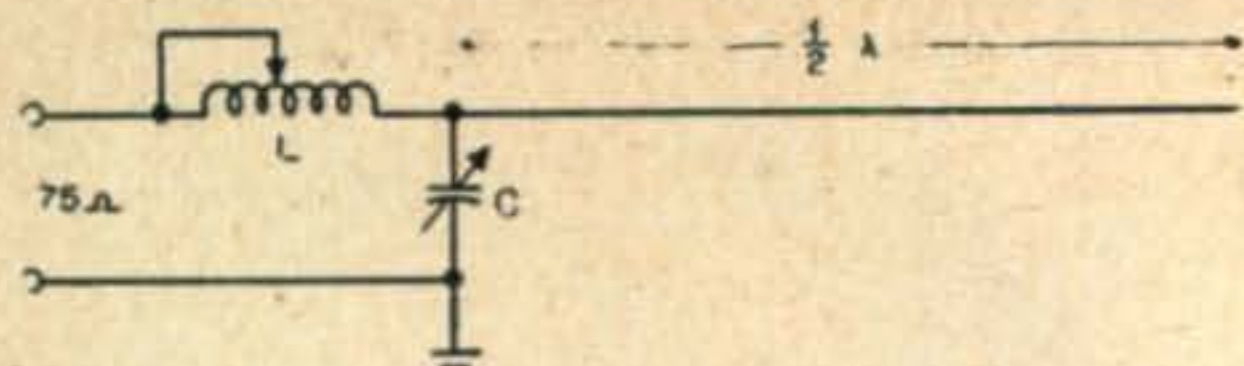
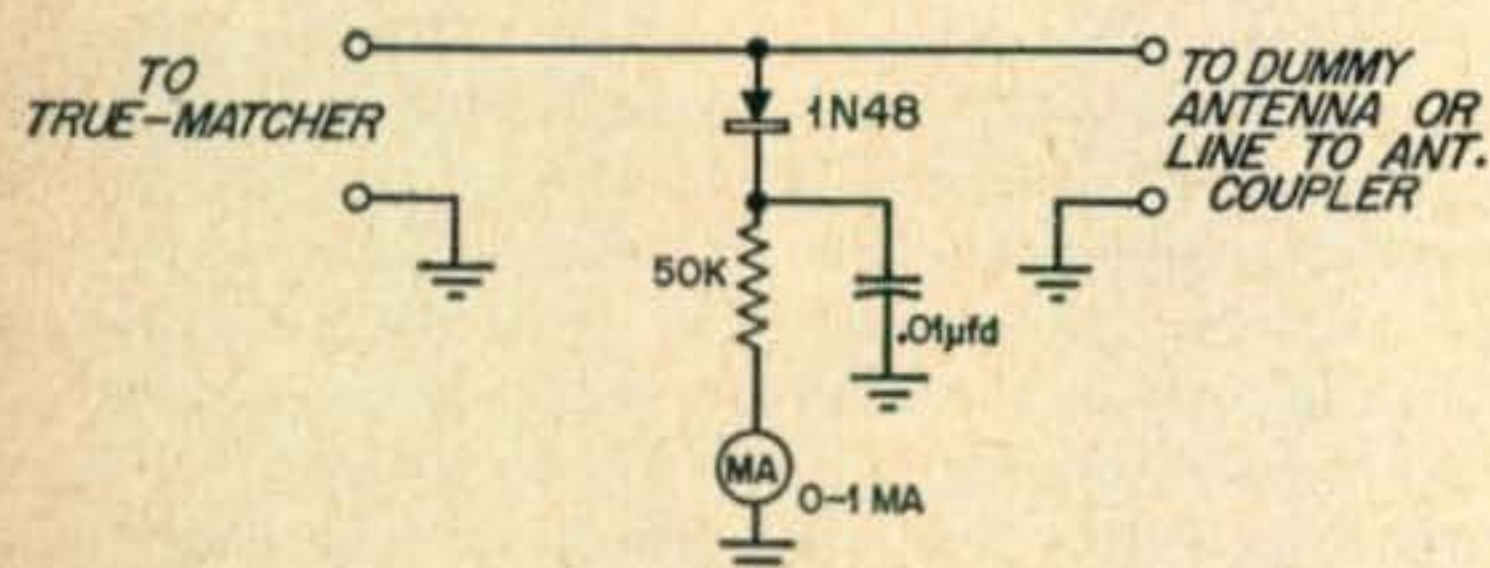

Fig. 5. Suggested L-section tuner for matching a 73-ohm line to an end-fed half-wave antenna. The value of the L-network can be about 250  $\mu\mu\text{fd}$ . and 10 microhenries. Further design data for suitable matching sections may be obtained from the article of coupling circuits in the May, 1952, issue of *ELECTRONICS*.

At some points in this tuning procedure, it will be apparent that the phase and magnitude control are interacting. At others, the phase adjustments may be made with very slight effect on that of the magnitude and vice versa.

Not only is it feasible to have the *True-Matcher* connected during normal operation, but it is highly desirable to do so in order to monitor the operation of the transmitter. The galvanometers, *G1* and *G2* may be located at any convenient point and connected to the *True-Matcher* by means of a 3-wire line. It is usually most convenient to locate *G1* and *G2* where they can be readily seen from the antenna tuner.



Suggested r-f indicator that should be applicable over a wide range of powers. This indicator has not been tested at W4LW, but it is offered for the benefit of those who would like to experiment.

The *True-Matcher* provides the last touch of refinement which will enable the amateur operator to deliver all available power to the antenna system.

#### BIBLIOGRAPHY

"Automatic Impedance Matcher," Virgil True, page 98, *Electronics*, Dec. 1951.

"An Automatic Antenna-Tuning Omt.," Naval Research Laboratory Report 3755, 2 November 1950.

"An Automatic Antenna Tuner for a 35-Foot Whip Antenna," Naval Research Laboratory Report 3888, 20 November 1951.

"A Phase-Angle Detector for R. F. Transmission Lines," R. G. Mezger, *QST*, July 1952.

"Automatic Tuning of the Antenna Coupler," Walter A. Knoop, *QST*, August 1952.

"Ohmite Dummy Antenna Resistors," Bulletin 136A, Ohmite Mfg. Co.

## Inside the

## Shack and Workshop

### Crystal Calibration with a BC-211

I have found that to get an accurate check of almost any fundamental crystal frequency in common use by the amateur, to within one kilocycle, one merely clamps one pin of the crystal holder to the antenna binding post on a BC-211 and grounds the other pin. Make sure that the grounding jumper is very short. Then turn the "Calibrate" switch to "Xtal" and calibrate the BC-211 to somewhere near the suspected frequency of the crystal. Turn the "Calibrate" switch off and slowly rotate the dial near this frequency. At the same time, scratch or tap lightly on the case of the frequency meter. Do this with the audio gain turned fairly well up and as the crystal frequency is approached the noise in the headset will increase. Finally with the frequency meter tuned to the crystal frequency the noise of the scratching will be very loud. As soon as this peak of noise has been found it is best to recalibrate the meter and then relocate the crystal frequency. You will find that the noise frequency will be less than 500 cycles from the true crystal frequency if your measurement has been made carefully.

Glenn H. Thomas

### Series to Parallel Switching

In order to obtain the greatest flexibility in your antenna tuner, or any other similar circuit, you will require some arrangement to switch from series to parallel with a minimum of effort. Various schemes have been proposed that work electrically, but from an operating point of view leave a lot to be desired.

For the generally employed balanced condenser arrangement, I have found that the circuit shown in the left hand part of the drawing to be the easiest to manipulate. All that it requires is a double-pole single-throw knife switch. When the switch is open

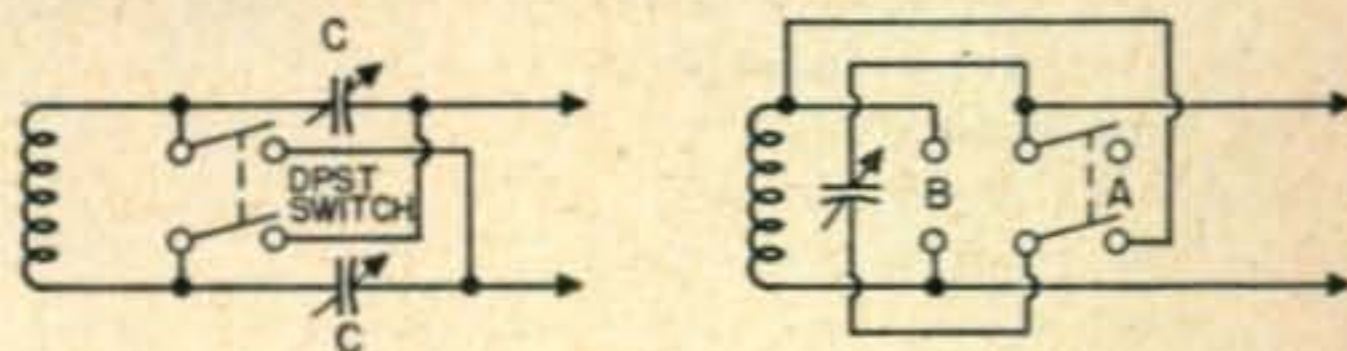

a condenser is in series with each end of the coil, and when it is closed the condensers are in parallel.

If only one variable condenser is to be used the circuit in the right hand part of the drawing seems to work. It uses a double-pole double-throw knife switch. Position "A" shows the circuit is series tuned and position "B" puts the circuit in parallel tune.

William Vissers, W2RN

# Further

# Experiments

# with Screen Modulation

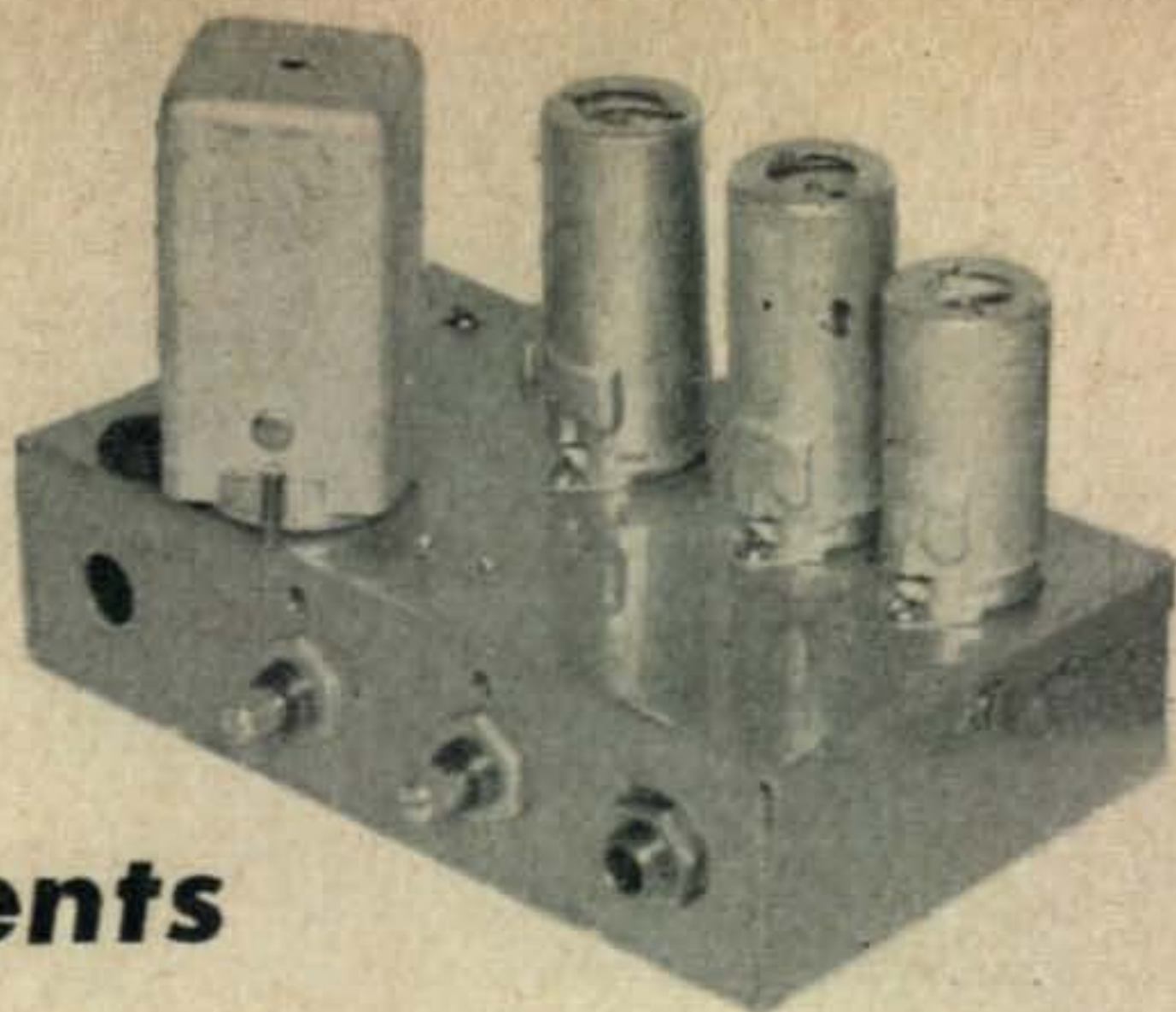

FRANK C. JONES, W6AJF

Contributing Editor, CQ

In the October issue we mentioned that feature articles on the new methods of screen modulation were forthcoming. This is another in that series. It describes a variety of applications based upon the latest developments. Earlier material by the very well-known W6AJF appeared in the January 1952 issue.—Editor.

Since the description of my early screen grid modulators, several more have been developed at W6AJF. Three of the new ones described here show worthwhile improvements in modulation capability and voice quality. It is natural that progress should be made in the form of better quality, greater degree of modulation and simplicity of circuit design as more time and effort are expended on this subject.

One common fault of screen modulation has been the tendency toward negative peak clipping when the operator starts pushing the modulation level upward to "get out" better. Nearly all controlled-carrier systems of the "instantaneous control" type have the fault of practically no negative peak modulation. Operators often try to achieve compensating results by using excessive positive peak modulation. The usual radio receiver will produce less audio output from a 100% positive peak modulated wave with no negative peaks than from a normal 80 or 90% plate modulated signal. If the positive peaks are raised to much greater values than 100%, the negative peaks can remain unmodulated and the radio receiver audio output will be large, though somewhat distorted; a better-sounding signal than this can always be had by using symmetrical modulation in which both positive and

negative cycles are applied to the radio frequency carrier.

Controlled-carrier systems which run with very low resting carrier output are hard to receive unless the AVC system is cut off and manual gain control is used. The time constant of the AVC system will not function properly with fast carrier buildup and receiver output will be quite distorted. With manual gain control only, the controlled-carrier signal will produce high audio output in the receiver. However, when the received signals are fading badly, the signal may drop down below audibility as it fades. Another point against highly controlled-carrier signals is the fact that receiver ignition noise limiters will not function without a large carrier signal component at the second detector input.

In the search for a system which would have the simplicity of screen modulation and economy of controlled-carrier, a circuit was developed which retains the good points of each system. A cathode-follower type of modulator was chosen since it would function most satisfactorily with the non-linear load of a class C r-f amplifier circuit. This type of load could cause severe distortion since the load impedance varies greatly over each audio cycle. The cathode follower, using a small power tube, or two in parallel, has a very low output impedance so the modulation quality should be better than with a normal plate-output triode or pentode screen modulator.

A cathode follower tube requires a large grid driving voltage, which is sometimes a difficult problem. This peak audio voltage may have to be several hundred volts to modulate some large screen

grid r-f tubes. However, a variation of about 250 volts, peak value, will produce ample modulation for most r-f amplifiers. The cathode follower modulator requires a little more peak voltage on its grid than it delivers at its cathode to drive the grid with such a large signal, using reasonably low driver plate voltage supply, or transformer coupled amplifier stages are required. Examples of both systems are shown here.

The circuits to be described differ from previous screen-grid modulators primarily in the use of a carrier-setting control, which permits adjustment of the resting carrier level, and in the use of a negative-peak limiter, which prevents accidental over-modulation of the transmitter on negative peaks. The peak limiter can be adjusted to prevent any negative excursion of the cathode-follower screen-modulator control grid voltage, which automatically insures against cutting off of the screen-grid voltage of the modulated stage. Or, if so desired, the limiters can be set up to "squeeze" the negative peaks while leaving the positive peaks of modulation untouched.

The circuits shown in *Figs. 1* and *2* were built into a 13/4 x 19 inch relay rack panel unit to screen modulate a pair of 4-125A tubes operating in the two-meter band. Both units produced identical results, the difference being in the choice of negative peak clippers and output tubes. A pair

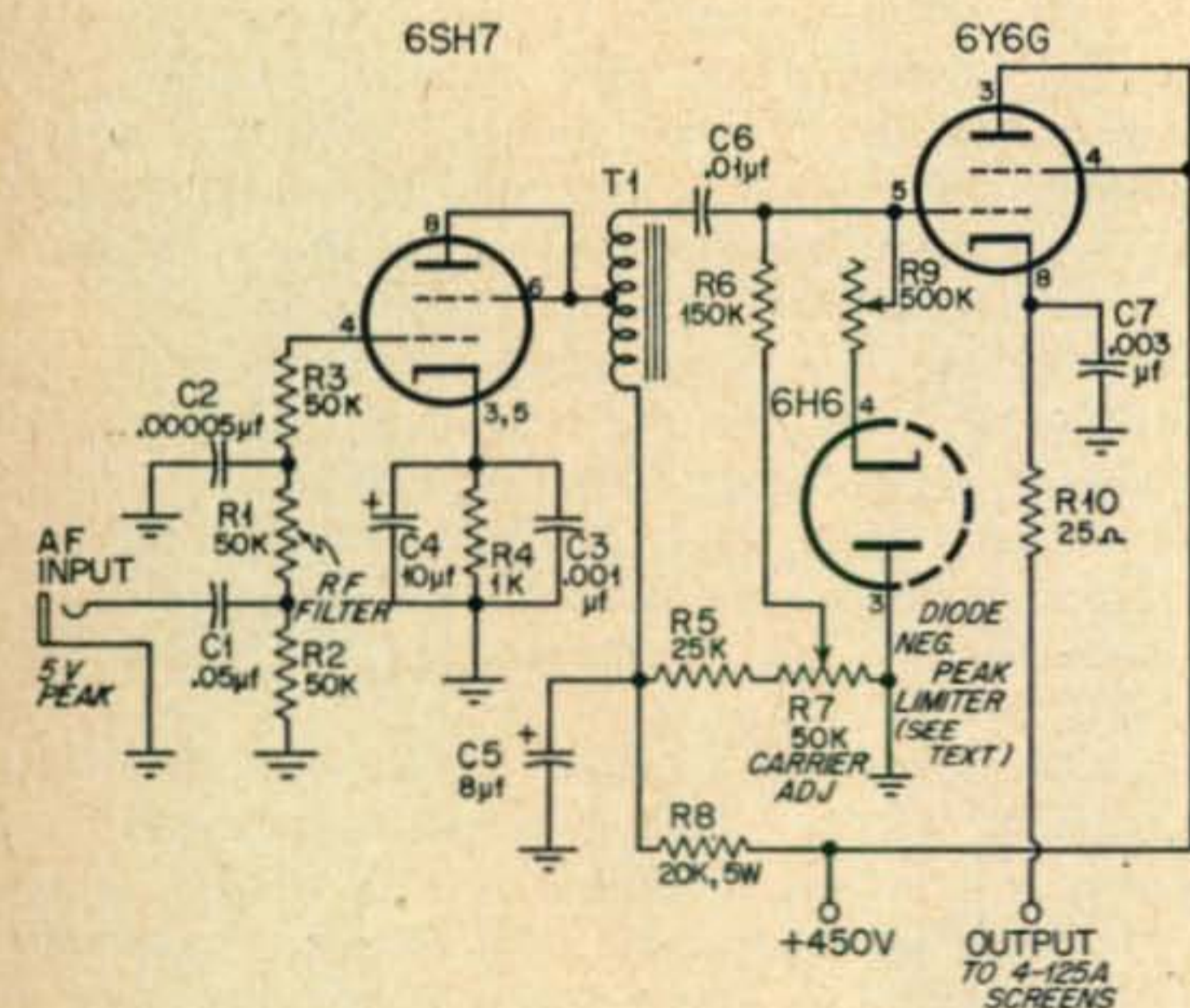

Fig. 1. This circuit has been used to modulate a pair of 4-125A's in the two-meter band.

R1, R2, R3—50,000 ohms, 1/2w.  
R4—1000 ohms, 1w.  
R5—25,000 ohms, 1w.  
R6—150,000 ohms, 1/2w.  
R7—50,000 ohm potentiometer  
R8—20,000 ohms, 5w.  
R9—500,000 ohm potentiometer  
R10—25 ohms, 5-10w.

C1—.05  $\mu$ fd.  
C2—50  $\mu$ fd. mica  
C3—.001  $\mu$ fd. mica  
C4—10  $\mu$ fd.  
C5—8  $\mu$ fd.  
C6—0.01  $\mu$ fd.  
C7—0.003  $\mu$ fd.  
T1—20,000 to 20,000 ohm interstage (See text)

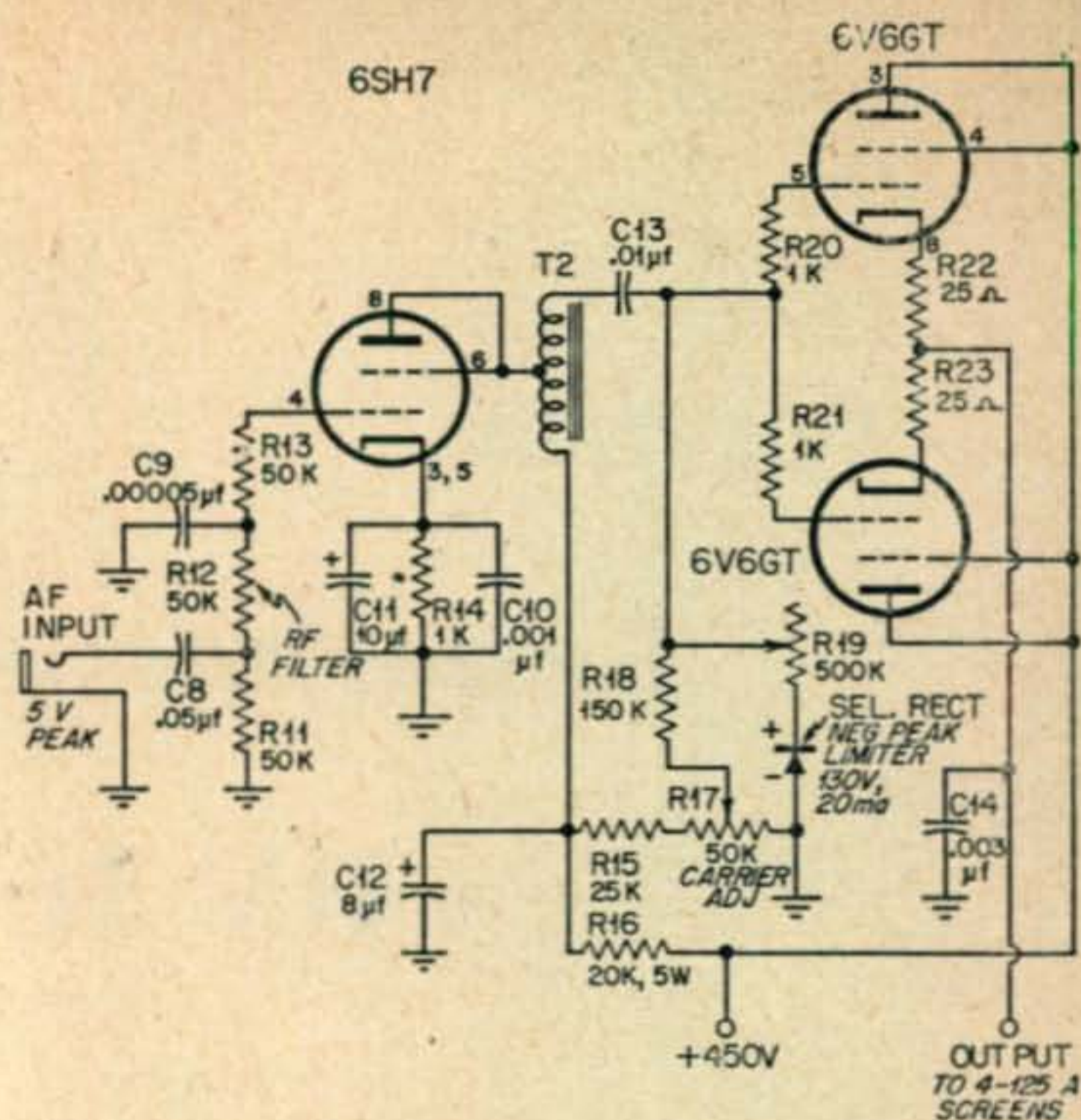

Fig. 2. Somewhat similar to Figure 1, but using a selenium rectifier as a negative peak clipper. As mentioned in the text below this drawing, a germanium diode crystal rectifier has not been successfully employed in this circuit.

R11, R12, R13—50,000 ohms  
R14, R20, R21—1,000 ohms  
R15—25,000 ohms  
R16—20,000 ohms, 5w.  
R17—50,000 ohm potentiometer  
R18—150,000 ohms  
R19—500,000 ohms  
R22, R23—25 ohms

C8—0.05  $\mu$ fd.  
C9—50  $\mu$ fd.  
C10—0.001  $\mu$ fd.  
C11—10  $\mu$ fd.  
C12—8  $\mu$ fd.  
C13—0.01  $\mu$ fd.  
C14—0.003  $\mu$ fd.  
T2—20,000 to 20,000 ohm interstage (See text)  
Selenium rectifier

of 6V6GT tubes in parallel require a little less peak driving voltage. This means a more critical adjustment on the negative peak clipper, however, in some cases a 6Y6G tube with its lower amplification constant, can not be driven far enough negative to fully modulate the r-f tubes on that portion of the audio cycle.

In *Fig. 1* a 6H6 diode was used as a negative peak clipper and in *Fig. 2* a miniature 20-ma type of 130-volt a-c, selenium rectifier was used as the diode. A germanium diode crystal is not satisfactory, since in this modulator the peak inverse voltage rating must be well over 250 volts. The 6H6 tube and 130-volt selenium rectifiers meet this requirement. However, the back leakage current in the higher current-rated types of selenium rectifiers was excessive, and they were not satisfactory. Any triode tube can be connected as a diode with the grid tied to plate. This system is to be recommended in preference to selenium rectifiers unless the new miniature types rated at 5, or 10, or 20 milliamperes happen to be available. These units have pig-tail leads and insulated cartridge housings. They require no heater power and can be mounted in very small spaces.

### Limiting Action

In all of the circuits shown here, it will be seen that a resistor is connected in series with the negative peak clipper. This is shown as a variable potentiometer in two of the circuits. A small fixed resistor can be used if its value is chosen for the particular transmitter application. To select the best setting of the limiter resistance an oscilloscope test should be made since the optimum value of this resistor depends on many other circuit conditions. The correct value is that which permits only 90% to 100% negative peak modulation. Over 100% negative peak modulation results in modulation splatter, which should, under all circumstances, be avoided. An oscilloscope can be used in the conventional manner by connecting the vertical plates to an r.f. tuned circuit or pick-up loop coupled to the antenna feeders, using either a trapezoidal pattern or "sine-wave" envelope pattern. A "tail" on the trapezoidal pattern, or bright dots on the saw-tooth sweep pattern indicates negative peak clipping in the modulated r-f stage. Negative peak limiting should always be done in the a-f section of the rig in order to prevent splatter. By using the proper value of diode series resistance negative peaks will not be able to produce clipping in the r-f tube even at full talking level.

conduct. 100% modulation on negative peaks can be approached, but not exceeded.

It isn't possible to accomplish 100% modulation with some types of r-f screen-grid tubes since they require less than zero screen voltage for zero r-f output. Assuming that the r-f tube output is zero at zero screen voltage, the modulator tube would have a 450-volt drop across it at this point and its grid would have to be 50 to 120 volts negative to cathode depending on the tube amplification constant. The resistor in series with the diode prevents cutting off the negative peaks sharply at the point where the diode starts to conduct and so permits the a-f voltage to drive the modulator tube grid somewhat negative. The final result is a fine sounding phone signal with no splatter but very heavy modulation when these adjustments are correctly made with the aid of an oscilloscope.

The r-f amplifier can be made to exceed 100% modulation on positive peaks by utilizing very heavy antenna loading in order to extend the "linear" screen voltage r-f output characteristic. The oscilloscope again is indispensable in determining the point at which positive peak flattening or overload occurs. A higher than normal d-c plate voltage is needed for permitting larger percentages of positive peak modulation. As in plate modulation,

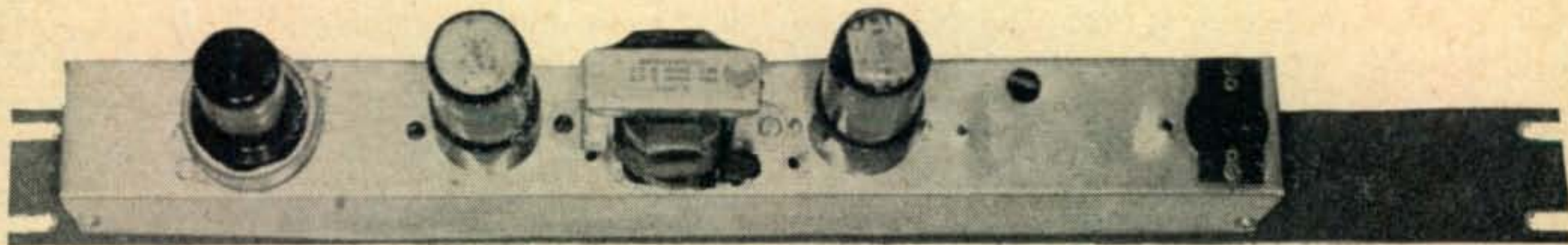

Working model of the modulator shown in Figure 2. It was used experimentally to modulate a pair of 4-125A's and has provisions for setting the level of the resting carrier. It uses a negative peak clipper circuit.

### Setting the Carrier Level

Another refinement in these modulator circuits is a potentiometer for adjusting the carrier level for proper modulation. In *Figs. 1 or 2* the triode connected modulator tubes act as series gates in the 450-volt screen supply to the 4-125A tubes. For best modulation the actual d-c voltage on the 4-125A tube might be set at about 170 volts. This would be the modulator tube cathode to ground d-c voltage. There would be a 280-volt drop across this tube at about 10 to 15 ma. to the 4-125A screens. This would mean that the control grid bias required to pass this current through the modulator would be perhaps 40 volts negative with respect to cathode, which is actually positive with respect to ground. A potentiometer across a 150- to 300-volt source can thus be used as a C-bias supply for the cathode follower tube. In this theoretical example a 40-volt "negative" bias would be  $170 - 40 = 130$  volts positive with respect to ground. Adjustment of this potentiometer readily sets the d-c screen voltage to any desired value for the r-f tubes. The grid voltage of the modulator can thus swing more than 130 volts negative without cutting of the screen-grid current to the r-f stage. At the 130-volt level the diode starts to

the r-f grid drive and d-c bias must also be increased. A carrier shift indicator will show an increase of carrier if more than 100% positive peak modulation is employed, but this may be entirely permissible providing 100% negative peak modulation is never exceeded and the point of positive flattening of peaks is not reached.

### General Construction

In *Figs. 1 and 2* a 6SH7 triode connected tube was used as a driver stage since it required less a-f voltage from an external microphone amplifier. A 1:1 ratio, 20,000-ohm to 20,000-ohm, interstage transformer was connected as a 2:1 set-up impedance by connecting the primary in series aiding to the secondary. An ordinary interstage 2:1 or 3:1 turns ratio transformer may be used here with separate primary and secondary connections, providing the primary inductance is at least 15 to 20 henries. Two small replacement a-f transformers tested had from 2 to 5 henries primary inductance and the result was loss of low speech frequencies and a peculiar effect of downward indication of antenna current on low speech sounds and very good upward indication on "S" sounds and whistles. A reasonably high inductance transformer or

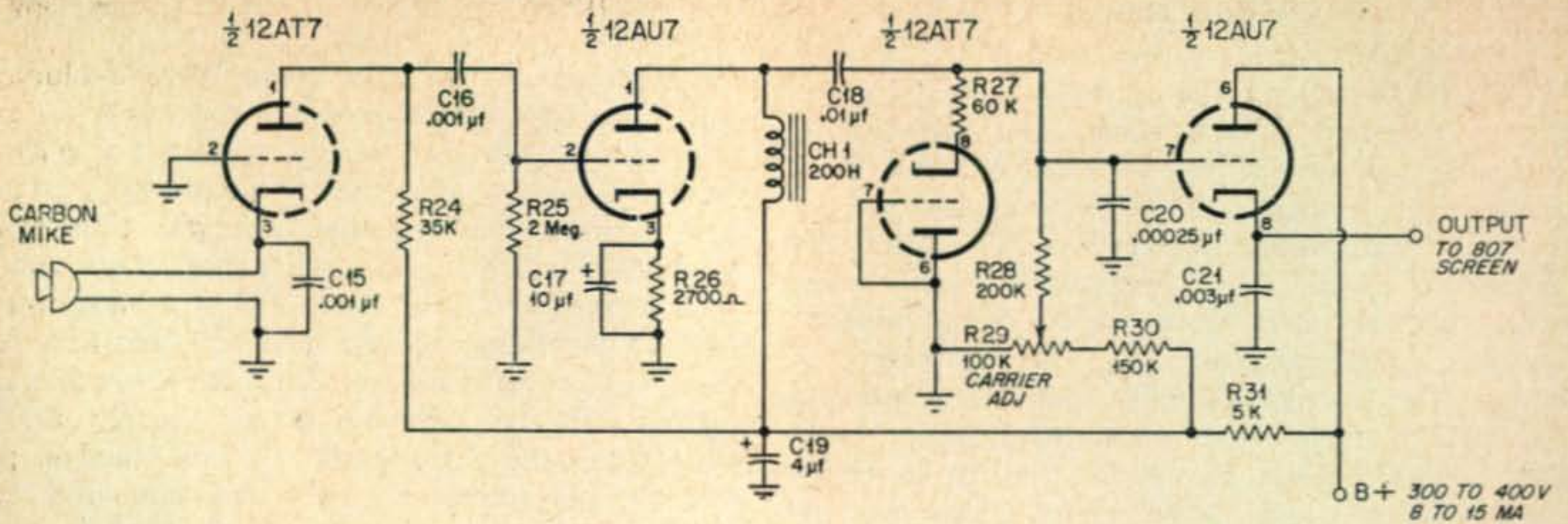

- R24—35,000 ohms
- R25—2 megohms
- R26—2,700 ohms
- R27—60,000 ohms
- R28—200,000 ohms
- R29—100,000 ohm potentiometer
- R30—150,000 ohms
- R31—5,000 ohms
- C15, C16—0.001 µfd.
- C17—10 µfd.
- C18—0.01 µfd.
- C19—4 µfd.
- C20—250 µµfd.
- C21—0.003 µfd.
- Ch1—impedance coupler, 200 h.

Fig. 3. This circuit was designed to modulate a portable transmitter using an 807 in the final.

plate choke is necessary for good results.

In the unit described, the maximum width of the a-f transformer had to be less than 1 5/8 inches because of space requirements, so the arrangement shown was used. Even with a grounded secondary and separate primary connection, a grid blocking condenser is needed for proper operation of the diode limiting and grid biasing circuits, so an auto-transformer connection (with resulting higher step-up ratio) might as well be used.

The modulator shown in Fig. 3 was built for use in a portable transmitter having an 807 tube in its final amplifier. A 12AT7 high-mu and a 12AU7 medium-mu twin triode were connected as shown to meet all the requirements listed in preceding paragraphs. The cathode driven half of the 12AT7 furnishes carbon microphone current and provides

a gain of about 30 to the grid of the second section of this tube. A high inductance choke (over 100 henries) in the 12AT7 plate circuit serves as an impedance coupling unit in order to obtain over 200 volts peak-to-peak output to drive the 12AU7 cathode follower modulator tube. Half of the 12AU7 was used as the limiting diode with a fixed 60,000-ohm series resistor for this particular 807 stage. This series resistor should preferably be adjusted by using a small 100,000- or 200,000-ohm potentiometer. A 100,000-ohm potentiometer was used as a carrier adjustment across part of the B-supply as previously described.

The modulator shown in Fig. 4 was used to

(Continued on page 62)

Fig. 4. A second modulator for portable transmitters used this circuit. The power required by either modulator on this page is very small.

- R32, R35—2 megohms
- R33, R34, R37, R40, R45—50,000 ohms
- R36—400,000 ohms
- R38—1 megohm potentiometer
- R39—100,000 ohm potentiometer
- R41—2,000 ohms
- R42—500,000 ohms
- R43—150,000 ohms
- R44—100,000 ohms
- C22, C26—0.001 µfd.
- C23, C27—50 µµfd.
- C24, C29, C30—0.01 µfd.
- C25—4 µfd.
- C28—10 µfd.
- C31—0.005 µfd.
- Ch2—impedance coupler, 200 h.
- Selenium rectifier

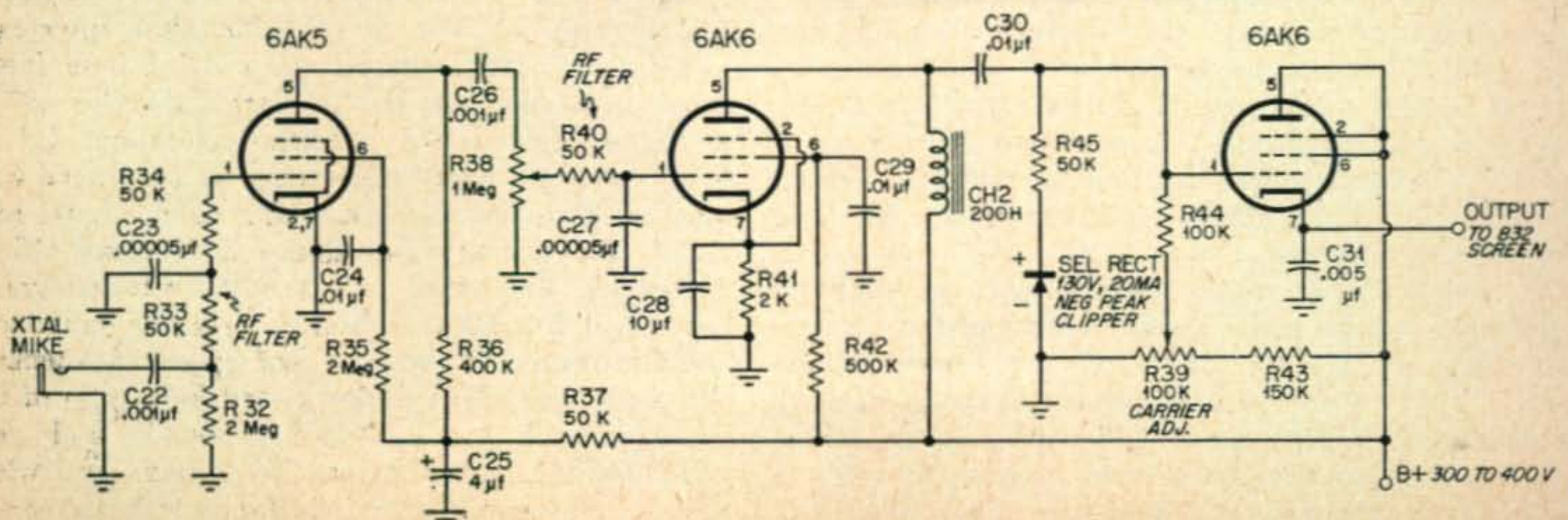

# Operation

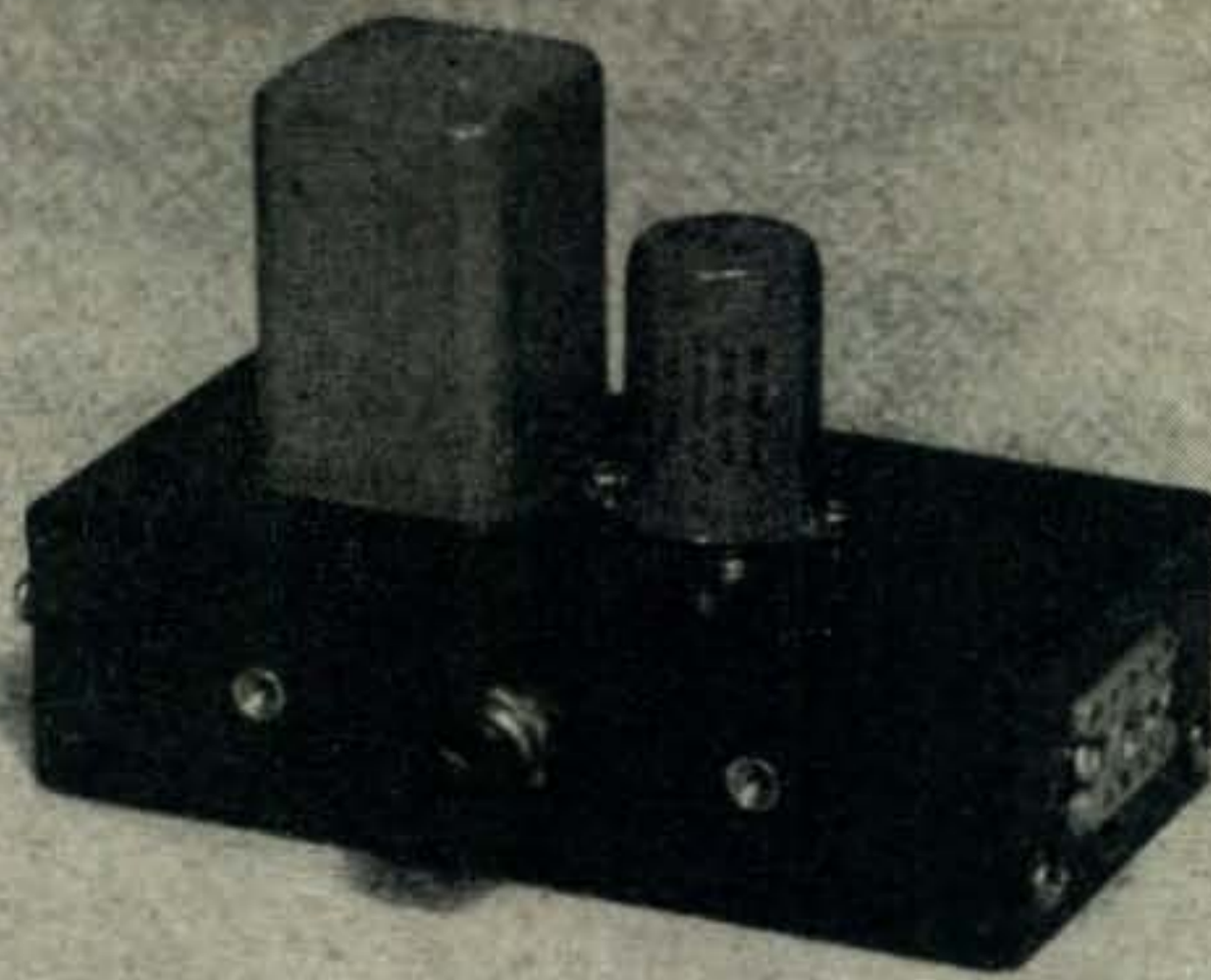

## Phone Patch

ROBERT C. MIEDKE, WØRSL

3140 Carroll Drive SE, Cedar Rapids, Iowa

While use of the phone-patch is not permitted in some localities and suffers restrictions in others, its use is becoming steadily more popular. Without any doubt the phone-patch has been of greatest benefit to our servicemen stationed both overseas and at distant camps in the United States. Just listen on the phone bands for a few hours and see how many servicemen get to talk to their sweethearts, wives or families through the help of the radio amateurs with phone-patch connections. This one service alone should prove its value to the public.

As a result of listening to numerous patches, it was decided that one should be available here. After searching the literature, the advantages and disadvantages of several systems were considered and the following requirements set up:

1. It must have a normal "phone" position which connects the local phone to the incoming line only.
2. It must have a "receive" position which connects the local and remote phones to the radio receiver output.
3. It must have a "transmit" position which permits equal transmitter modulation from both the local and remote phones.
4. It must permit dialing in any position.

With these four major requirements in mind, the phone-patch shown in *Figure 1* was built.

In the "phone" position the local phone is connected to the incoming line only. This permits normal phone operation. The phone patch itself is plugged directly into a base board jack type outlet. This outlet was installed by the telephone company right alongside the operating position. This installation is made when you tell the company that you want to move the phone from room to room.

Obviously, it now becomes quite easy to "break into" the telephone lines without embarrassing after effects. In this area the red wire is common and the green wire is the lead that should be "broken."

In the "receive" position the local phone is again connected to the incoming line, and is also connected through a 2  $\mu$ f. condenser (*C1*) and a step-down transformer (*T2*) to the radio receiver output. The condenser is necessary to permit dialing. A high impedance transformer was used so as to avoid loading the telephone line; however, the ac-

The use of "phone patches" by radio amateur operators continues at a steadily increasing rate. Fortunately, these same amateurs have, in most cases, shown considerable discretion and to our knowledge no difficulties with either the telephone companies or the FCC have arisen.

As we indicated in the January issue ("Phone Patch, page 17) the telephone companies have filed a "tariff" with the FCC that strictly prohibits the use of foreign attachments on telephone lines. However, the telephone companies have been most liberal in their views, especially since the present use of "patches" appears to be confined to CD work and directly relaying conversations that would otherwise be impossible at no loss to the telephone companies.

We therefore introduce two additional circuits which have been used with success and have caused no interference on the telephone lines.

—Editor

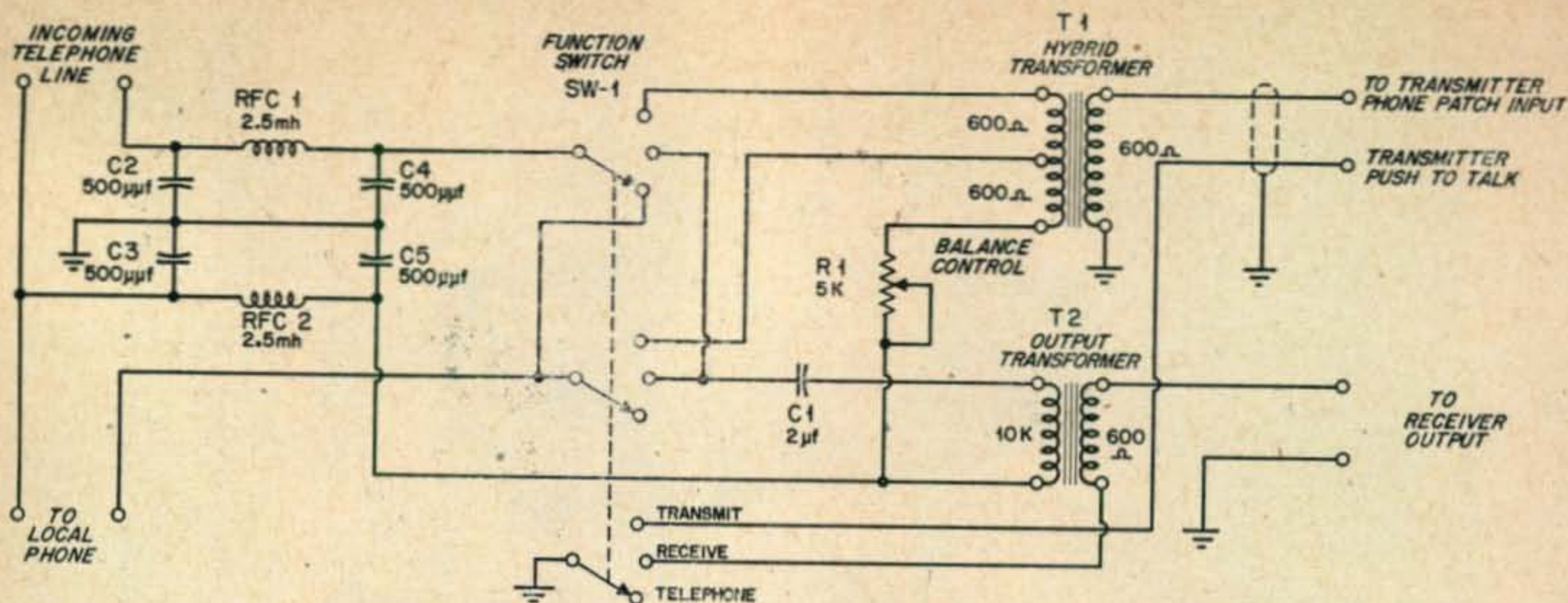

Fig. 1. In the circuit by WØRSL the telephone line must be "broken." The text explains how this may be accomplished without attracting unnecessary attention. The ganged switch must be a "make-before-break" type. The transformers are discussed in the footnote at the bottom of this page.

tual value is not critical. The receiver gain control should be set for a comfortable level in the local phone, remembering that the audio level at the remote phone will be a little lower because of line losses. Care should be taken not to overload the phone line. A visual line level indicator was not considered necessary as you have a constant aural indication in your local phone.

In the "transmit" position the local and remote phones are connected through a hybrid transformer (*T1*) and a balancing control (*R1*) to the transmitter phone-patch input circuit. The connections as shown in *Fig. 1*, permit adjusting the level from the local phone to equal the level from the remote phone so that both parties modulate the transmitter equally. Briefly, the balanced or hybrid transformer permits the signal from the remote phone to be fed straight through to the transformer, while the signal from the local phone, which is fed into the center of the transformer, can be adjusted by the balancing control.<sup>1</sup> This adjustment has very little effect on the level from the remote phone. Normally, the voltage produced by the remote phone is considerably below the level produced by the local phone, thus requiring equalization. Usually the balance control can be set for an average difference between remote and local phone levels with very little need for further readjusting. For a more complete discussion of the hybrid transformer, see pages 312-318 of *Communications Engineering* by W. L. Everitt.

A push-pull output transformer can be used instead of the hybrid at some sacrifice in balance; the better balance being required where there is a greater difference in levels between the two phones.

1. The hybrid and output transformers are both surplus items in this model. However, the hybrid may be a UTC type LS-140, or LS-142, or a CTC type BO-1 or BI-5 (or equivalent). For the output transformer something similar to the CTC type COC-2 might be used. Neither transformer is very critical and replacement should not be a problem. The only question that may arise is the setting of the null. With some of the better hybrid transformers the null will be very sharp and can only be set when using an audio oscillator.

The output impedance of the hybrid transformer should be determined by the transmitter phone-patch input impedance and need not be 600 ohms as indicated in *Fig. 1*. As a matter of fact, a step-up here is desirable where low levels are encountered from the phone line. The circuit has been tested with a transformer having two balanced 600-ohm primary windings and a 20,000-ohm secondary winding. In this case, the transmitter phone-patch input impedance was raised to 20,000 ohms with a definite increase in modulation level. The transmitter phone-patch input impedance should not go too high because of the possibility of hum pick-up.

One further point should be considered. The rotary "function" switch should be of the shorting type where the rotor makes with the second contact before breaking with the first. This is necessary to permit dialing in any position or switching from one position to another after the phone has been taken off the hook.

The photograph shows a model built here for use with an external "function" switch. The "function" switch was mounted on a control panel at the operator's position while the unit shown was mounted behind the control panel.

## W5TJE 'Patch

JONES P. TALLEY, W5TJE

6622 Potain Avenue, Dallas 17, Texas

So you are thinking about building a phone patch? Okay, brother ham, lend an ear. Some ten months ago we decided W5TJE should be equipped to answer calls "CQ Dallas, with Phone Patch." But when we had it finished we found it was installed for two purposes—first for any emergency situation that might arise, and, second, for the exclusive use of military personnel outside the continental limits of the United States. It is a grand feeling to be able to let some serviceman or woman talk to loved ones back home. The time, trouble



and cost of construction were wiped off the ledger on the first patch.

We read all available articles and talked to every ham we could find who had a patch. To make the long story short—we were not impressed, except with the apparent complexity and prohibitive construction cost of existing circuits.

We went off in a dark corner and thought about the deal and said, "Nuts, we've been in commercial radio for nearly 15 years—why can't we design one that will do the job?—no tubes—no power and low cost." *Figure 1* shows the result. It is an audio type of patch and since it is common knowledge that for maximum transfer of energy, at minimum distortion, all impedances must be matched, we consider this to be the success secret of the W5TJE Phone Patch.

**The Circuit**

Now, let's take it apart and explain why we did it this way. The r-f chokes are to keep the r.f. signal out of the patch. We chose Z-28's because we operate 10 meters only—choose the right choke for the band(s) you operate. *Switch 2* (a, b) is just a convenient way to disconnect the patch from the line. We used a rotary switch in order to keep the front panel balanced in appearance. Capacitors C3 and C4 are r.f. by-pass condensers and should have very short leads. Capacitors C1 and C2 are for blocking to keep from loading down the telephone lines. The value of .025  $\mu$ f. was chosen after considerable experimenting. This value was found to pass the maximum signal with the smallest amount of line noise. It was found that without blocking condensers, the transformer—even when matched to the line—would drop the dial tone by fifty per cent. The transformer is a completely shielded type and is very necessary because of stray r.f. Resistors R1 and R2 are loads for the transformer and also center-balance it to ground. *Switch 1* (a through f) is a three-deck ganged rotary to make all necessary circuit changes.

The circuitry in the secondary side of the transformer may look rather odd at first glance. It was evolved due to stray r.f. getting into the transmitter (*Viking 1*) speech amplifier. It is essential that the audio and r.f. grounds be kept separate. We originally channeled r.f. to ground in the primary side and found it could return to the output lead through the capacity of the shield to inner conductor. By-pass condenser, C-5, and the insulated microphone connector resolved this dilemma.

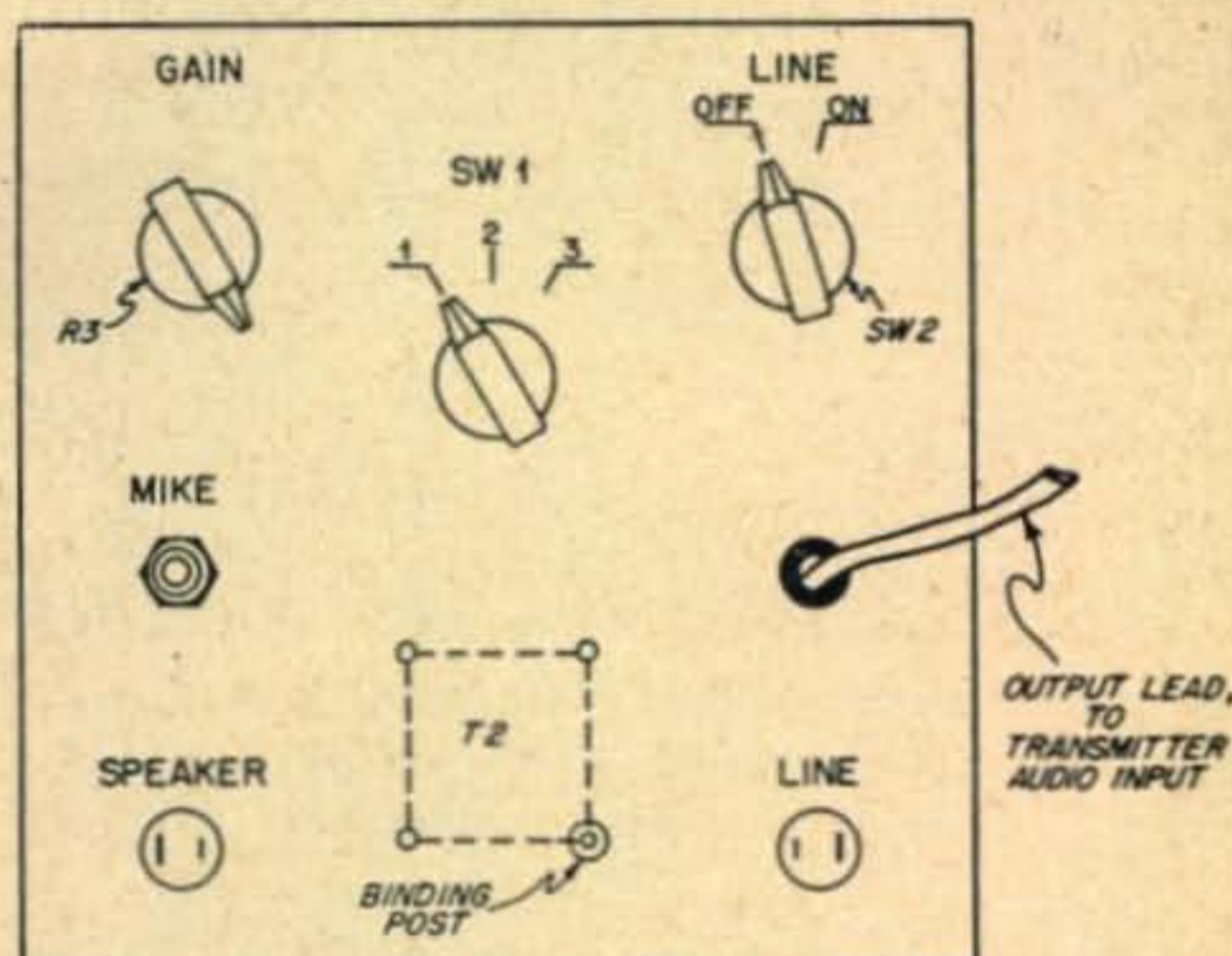

Fig. 2. Front panel view of the phone patch.

The receiver output to the phone line is very simple. Our SX-71, having a 500-ohm output, made the job easy. You may modify the circuit to fit your equipment. Change the value of R4 to match the receiver output impedance. A WORD OF CAUTION: do not feed more than 3 milliwatts of power into the telephone line. If you do, the phone company will descend upon you with great ire, as you will be causing cross-talk in their cables. Use a bit of care and monitor the level in your telephone—keeping it to approximately the level of the regular voice and no louder than your party needs to read the signal.

**Construction**

In the matter of construction, we put ours in a

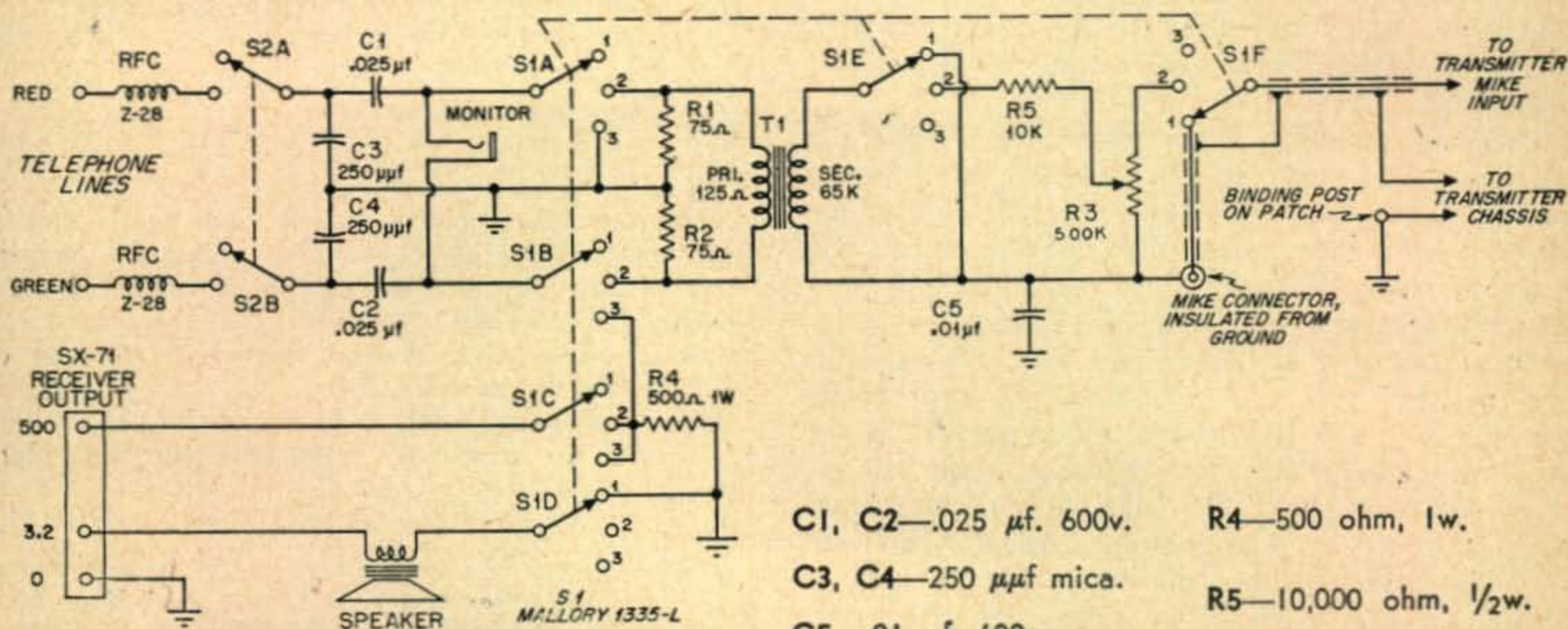

Fig. 1. Wiring schematic and parts list of the W5TJE phone patch. The only critical component is the transformer T1 which must be a step-up of about 1 to 5000. It must be well shielded to prevent accidental hum pickup.

- C1, C2—.025  $\mu$ f. 600v.
- C3, C4—250  $\mu$ f mica.
- C5—.01  $\mu$ f, 600v.
- R1, R2—75 ohms, 1/2w.
- R3—500,000 ohm potentiometer
- R4—500 ohm, 1w.
- R5—10,000 ohm, 1/2w.
- T1—Kenyon type T-3 or possibly UTC HA-101



The 'patch' is conveniently mounted just above the operating position and within easy reach of the telephone and transmitter.

6 x 6 x 6 inch metal box. The entire patch was mounted on the front panel, making installation much easier, and, if and when repairs are necessary, there will be no blistered fingers from soldering irons in tight corners. *Figure 2* shows the front panel layout. You will find the monitor jack missing—it was added later, being mounted on the operating desk. A jack is very convenient and will enable you to monitor both sides of the patch with a pair of high impedance phones. Take it from us, you can get extremely tired holding the phone to your ear on an hour long patch.

It is advisable to keep all leads inside the patch as short and direct as possible, especially the r-f choke leads to the input plugs. Before connecting the patch to the phone company lines, read the caution at the top of this article! With permission, attach it to the red and green wire of the base plug, leaving the yellow wire untouched. If no base plug is available, connect to the red and green wire on the induction transformer connections marked *L1* and *L2*.

The patch is very simple to operate. *Position 1* of *Sw-1* has your regular station mike going through to the rig. *Position 2* has the patch connected to the transmitter and *Position 3* has the station receiver routed to the phone line. In operation our recommendation is: do not use your telephone for a mike—there is a vast difference in level between your phone and that of your patch "party," and with the patch party gain adjusted for 100% modulation, you will considerably exceed it on your local phone. Just flip the switch and use the station mike. The gain control, *R3*, on our patch is approximately one-half open for 100% modulation of the rig. The quality of the patch should be very good and should begin to approach that of the station itself, when you consider the frequency-response of the phone. For best results, the transmitter speech equipment should preferably go out to 3000 cycles before cut-off, especially

when the patch is used by a feminine voice.

We are now experimenting with induction couplers that will require no connection whatsoever to the telephone. The work isn't sufficiently advanced at this time to make any comments—but when and if it's a success, you will read of it in *CQ*.

So there you are, brother and sister hams, good luck to you and I only hope you derive as much satisfaction from the patch as I have. "CQ Dallas with Phone Patch"—Oh-oh, gotta go. 73.

Inside the

## Shack and Workshop

### Another Foolproof Control Switching

The system of control switching that I have shown in the schematic is about the one obvious method when the requirements of "filaments on first and off last" are considered. Strangely enough I could not find it mentioned in the amateur literature, or even in past issues containing *Shack and Workshop* items.

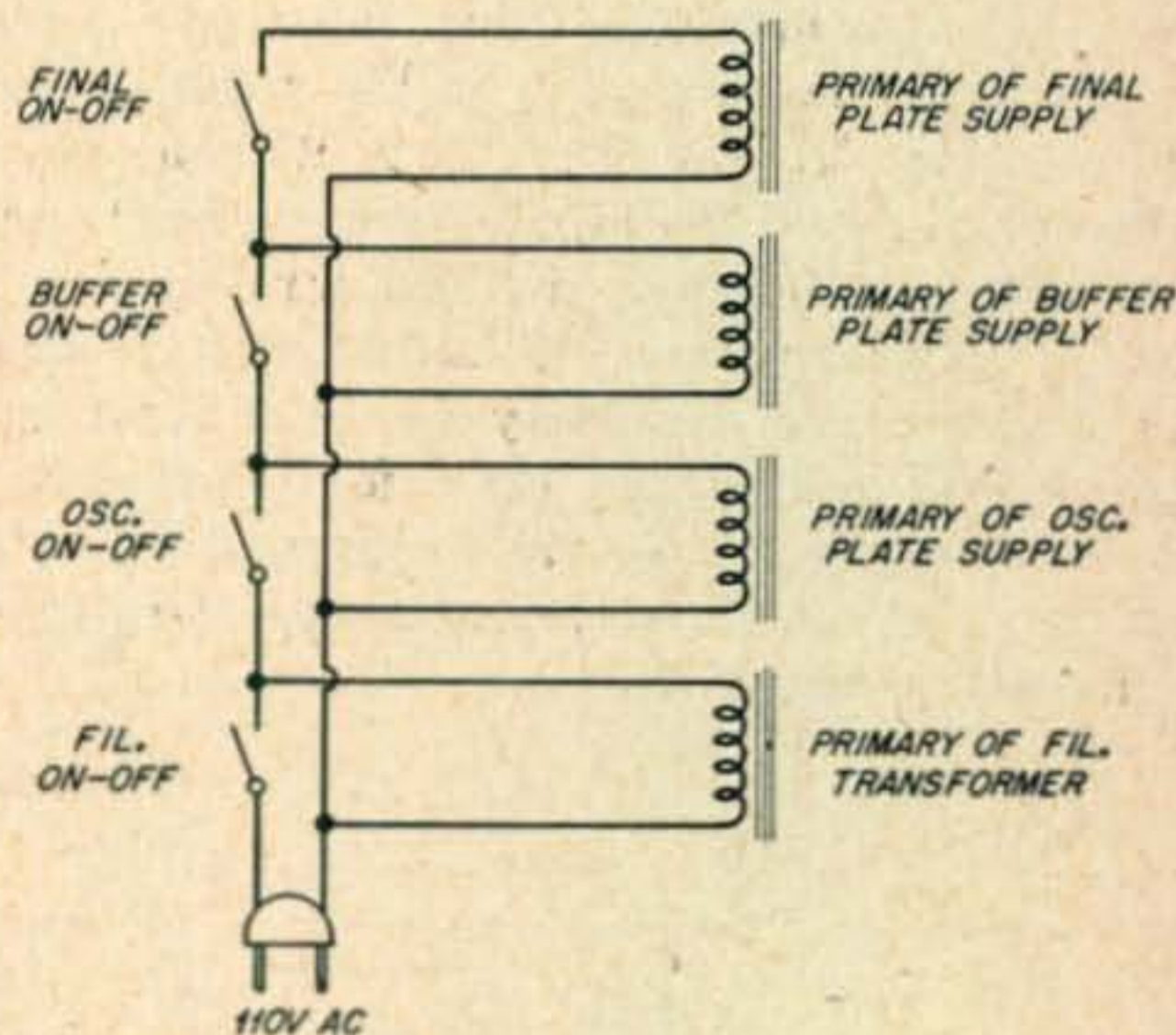

The only part of the circuit that needs special attention are the switches. The maximum current carrying capacity of the switches must not be exceeded. It is however easy to see that the circuit can be adapted to any situation, including the use of relays with 110-volt coils.

If a time delay relay is to be used it should be wired into the filament circuit with the first plate supply switch in the controlled circuit.

Sam D. Bradley, W5SMB

Your S & W Editor still needs more good ideas for this column. Don't let your nifty stunts go to waste. Rough sketches of circuits are satisfactory, and if you have photos of the idea—send them along. Each idea is worth \$2.50 in cash—or a year's subscription to *CQ*. All S & W contributions should be addressed to Shack & Workshop Editor, c/o *CQ Magazine*, 67 West 44th Street, New York 36, N. Y.



## More on the PE-101-C

GORDON H. MILLAR, W9KUZ/8

13615 Archdale Rd., Detroit 27, Mich.

Since the publication of "Converting the PE-101-C Dynamotor" (August, 1952) the author has been swamped with inquiries from the mobile gang. As a result, the Editors have requested that W9KUZ/8 let down his hair on the subject. The following material is abstracted from his notes.—Editor.

The original article appears to have raised four points that many of the possible users feel have been insufficiently explained. These points are:

1. The long end bell will not fit the gear end when cut to the size of the shorter end bell.
2. There is some question about the ability of the lower winding to carry the full current load.
3. Some fellows insist that the battery switching relay will soon destroy itself.
4. Where can I get a PE-101-C?

#### Point 1:

The job of cutting the long end bell to reduce the overall size of the dynamotor when the reduction gear is removed is in itself a little tricky. In order to do a first-class job a jig of some kind should be made or allowances during measurements made for error. To report my experiences, three methods in all have been employed. The first was to clamp the end-bell in a vise and saw off the unwanted section with a hack-saw and then straighten out the end on a sheet of coarse emery paper until it was square. With this method allow about one-half inch for error as it is difficult to get the saw to cut exactly square.

The second method was to chuck the end bell in a lathe and use a sharp cut-off tool to remove the unwanted section. This seems to work fairly well, but once again extreme care must be used and a very slow cut made or there is danger that the end-bell will collapse.

A third method proposed by a prospective user is to turn a wooden plug just large enough to fit inside of the end bell. This stiffens up things considerably and either of the above methods may then be applied with increased possibility of a good job.

With respect to the size of the long end bell when cut down. May I first comment on the proposed test of

placing the short end bell on the gear end and thus proving that the long end bell when cut to the size of the short end bell will not fit due to the fact that the armature shaft on the gear and protrudes about  $\frac{3}{8}$ " further than does the shaft on the short end. This is NOT a valid test. The long end bell has in it a sort of door like affair. There are two general types of doors, but the type shown in Fig. 1 of the article is by far the most prevalent. This door provides a good  $\frac{3}{4}$ " additional clearance for the shaft. When cutting the long end bell, remove the door and mounting ring, and then cut the bell the same length as the short bell. I believe the difficulties encountered by some builders must be due to the fact that they measure the long end bell from the outside edge of the door. This is an error. Measure from the surface of the door mounting ring. If this is done correctly no trouble will be encountered.

I must admit that this point was not made clear in the article for which the author expresses his sincere apologies. In self defense, however, reference is made to Fig. 3 in the article. If the long end bell shows up longer (neglecting the door) than the short end bell I will consume said unit independent of salt, pepper or other flavoring.

As an afterthought the way to do the job and eliminate further argument might be to add an extra inch to the measured value and then cut off a little at a time until the end-bell fits. This seems like the hard way, but it will result in the same dimensions.

#### Point 2:

After re-reading the article as it appeared in CQ I honestly believe that this point should have been explained further.

To start with the lower winding is indeed in series with the upper and as such carries the current of both windings. Considering, then, the current the lower winding would normally carry in the original installation, one would get 135 mills plus 20 mills or a total of 155 mills. It must be remembered, however, that this is a continuous rating. May I repeat—CONTINUOUS. This implies twenty-four hours a day. If ratings on commercial dynamotors are examined it will be found that intermittent ratings are roughly twice the continuous ratings. As a result neglecting for the moment that this

is a piece of surplus Army and Navy equipment a safe estimate of the rating on the lower high-voltage winding would be 310 mills. With 150 mills in the upper winding and 125 in the lower a load of only 275 mills is imposed on the lower winding. If the fact is considered that Uncle Sam demanded units which were greatly underrated the surface has not even been scratched with regard to the possibilities of this unit.

Our original concern was not for the lower winding. As mentioned, twice the value of a continuous rating seems to be a good value for ham work. Even with this, however, the upper winding comes a long way from running a transmitter with only 40 mills available. When the fact is considered that the upper winding is as capable as the lower, new light is thrown on the subject. If the writer may go even further out on a limb already a little shaky, may the comment be made that considering the relationship between intermittent and continuous ratings the dynamotor is not in the least bit overloaded but is actually running well within its capability.

In addition the authors ran tests on the units under the conditions of voltage and current tabulated in the article. A continuous test was run for a period of thirty minutes and no heating (the only destructive effect which need be considered under these conditions of operation) was noticed which would in any way become excessive. As a parting comment the measured efficiency was 62%, which is not too bad.

#### Point 3:

This is indeed a valid argument. As anyone knows, neglecting line losses, two batteries in parallel will share the current load imposed on them. Consider what happens when the engine of the car is started. If the current drawn by the starting motor is in order of 150 amps, which is a reasonable value, and the load is shared equally by the two batteries, relay 2 which is rated at only fifteen amps now suddenly must carry about seventy-five amps. This point delayed the building of the first unit for some weeks. The solution, however, came about of its own free will. If the auxiliary battery is connected into the system with fairly long cables as is usually the case, the cables apparently introduce enough resistance into the circuit to throw almost the entire starting load of the engine onto the original car battery which is connected to the starting motor by a short length of heavy cable.

There is no doubt that the heavier relay 2 is, the less chance there is for failure. An alternate solution for the doubting Thomas in the crowd is to provide the auxiliary battery with a relay which will disengage the battery as the starting motor is energized. This is felt to be an unnecessary gadget.

If the two batteries used are of different age and strength better operation with less chance for failure will be obtained if the stronger of the two batteries is used as the regular battery and the weaker of the two used as the auxiliary battery.

#### Point 4:

At the time this is being written (October 10) the following houses are advertising that they have PE-101-C dynamotors for sale:

Fair Radio Sales  
132 South Main Street  
Lima, Ohio

R W Electronics  
1712 S. Michigan Ave.  
Chicago 16, Ill.

Columbia Electronic Sales  
522 South San Pedro  
Los Angeles 13, Calif.

G. L. Electronics  
905 S. Vermont Ave.  
Los Angeles 6, Calif.

Arrow Sales, Inc.  
7460 N. Varna  
North Hollywood, Calif.

Possibly there are a few that we have missed, and if so we apologize for not mentioning them in the above list.

In closing we would like to indicate that the old adage about eating the pudding still applies. To date five of these units are in operation around Madison. They belong to W9GWK, W9RBI, W9IHB, W9PVN and W9WFZ. None of them have ever given any trouble.

# The Private Life of CQ

## Those Hamfest Announcements

A few weeks ago we were pleased to receive the following letter:

Tri-State Amateur Radio Society  
Evansville, Indiana

Editor, CQ:

The members of the Tri-State Amateur Radio Society have asked me to express their appreciation to you for publishing the notice of our Hamfest in the September issue of CQ. Our attendance was considerably larger than last year in spite of inclement weather and we attribute the increase to the published notice.

/s/ Fred Sawyer, W9FJI  
Secretary

The receipt of this letter emphasized that advance Hamfest publicity must be carefully considered when the plans are being made by the convention committee. It has been our experience that during last spring and summer only 30% of the Hamfest announcements could be used in CQ, because few people seem to take in consideration the advance makeup of the amateur radio magazines.

PLEASE—if you want an announcement of your Hamfest to appear in the proper issue of CQ be sure and send it in at least two months in advance. Don't, as so many have done in the past, send us a notice only three weeks before the Hamfest and then be offended because the announcement did not appear. The closing date for such material is the 20th of the second preceding month, but the earlier you have it in our hands the better chance it has of appearing.

## Re: Another Standard of Comparison

CQ readers who are interested in constructing the exceptional mobile receiver described by Bill Scherer, W2AEF in the November, 1952 issue may obtain a supplement sheet on this unit by writing the CQ Editorial office. This sheet contains all the data on errors and corrections in the printed schematic, places where you can purchase the necessary components and dope on possible substitutions.

## Where Are You?

Will Mr. R. L. Douglas please step forward and identify himself. His *Shack and Workshop* contribution appeared in a recent issue. We have no address to which we can forward his CQ subscription.



Monitored by LOUISA B. SANDO, W5RZJ

959-C 24th Street, Los Alamos, N. Mexico

The nature of the mail this month makes us feel as though we were doing a Dorothy Dix column. But it's all interesting—see if you don't agree.

From an OM in Ohio we received the following:

"This probably is an unusual type of letter, but it is not intended as a joke.

"Would there be any way that single hams of either sex could find out who single hams of the opposite sex might be in order that possible friendships might be started without the very uncertain method of chance contacts and possible rather personal questions?

"I'm 27 years old and don't find it difficult to get a date if I'm willing to shelve my rather technical interests for the evening. I've tried to cultivate an interest in my hobby by posting a notice in a social club I belong to asking anyone interested if they'd like to contact out of town families or servicemen with free messages. The notice acts like poison.

"Possibly a notice to the effect could be run in CQ with the first contact by mail through a central address to avoid embarrassment. Subsequent contacts would be direct and, presumably, by radio.

"Despite all the standing jokes, there are quite a few men, myself included, who would like to meet a nice girl and get married, but who believe in looking for the right girl and not pick the first skirt that passes. Naturally, I'd like a companion who at least doesn't dislike my hobby—and preferably one who enjoys it.

"Any suggestions?"

Such a situation as he describes apparently does exist. We will not give here the call of the ham who wrote this letter, but if any YLs are interested in corresponding with him or contacting him on the air, drop your column editor a note, or postal; if you want to enclose a letter we'll be glad to forward it.

### "Operation Ruby"

A letter from WØAUH, calls attention to a situation where hams can help:

"I write this letter for the sole purpose of asking what, if anything, can be done to help the person mentioned in the following quoted letter. I personally feel it our duty to help her in our own hams' way to finding desired friends beyond the family circle.

"The following letter was lifted from the *Denver Sunday Post*, Sept. 21st, in Jane Sterling's column: 'Dear Jane: I have a sweet invalid sister who has been in a wheel chair her entire life. She is now 36 years old. She has taught our whole family patience, tolerance and shown us the beautiful side of life. We do everything we can for her, but it suddenly dawned on me the other day that it would certainly be thrilling for her to hear from your kind readers, even if it's just a postal card. We try so hard to think of different things to cheer her up, but it's almost impossible after 36 years. Her address is: Miss Ruby Snyder, Box 95, Route 1, Hayden Lake, Idaho.

"After reading that letter it occurred to me that I had read of a similar account given in one of the late issues of CQ. I found the article as well as the picture in the June '52 issue of CQ, but know nothing about how WN7RHM, Illeana Schumacher, became interested in ham radio. But since she did, and with the able help of all those people, she is one of us now.

"Now you may ask, what is he driving at? It is this: Could someone be contacted to help the Snyders assist Ruby in obtaining at least a Novice license? With that coveted ham ticket, Ruby not only would be receiving her 'postals' (QSLs) but finding new friends via amateur radio with a whole new world unfolding before her as we have

(Continued on page 52)

These YL's gathered at Lynfield, Mass., for a luncheon meeting: Left to right, front row: WIMWI, SVN and HIH. Second row: WNIURS, WNIUYH, WITRE, FTJ, RYJ, QON, MCW and BCU.

(Photo by WIUPZ.)



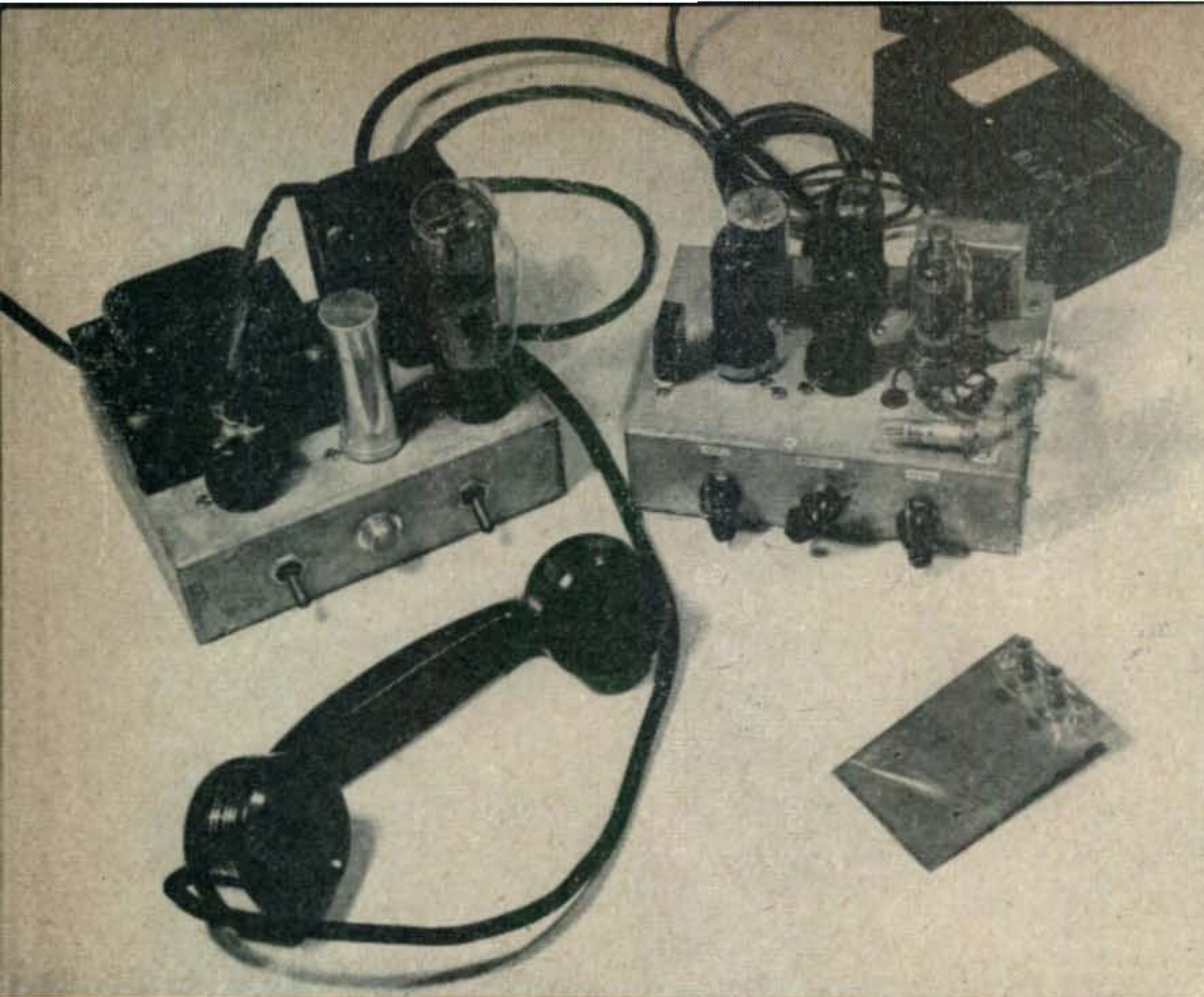

The complete 144-Mc phone transmitter can be built on two relatively small chassis. Power supply is at the left and the transmitter ending in a 2E26 is at the right. The VOM is used to check the final amplifier grid current.

# Getting on Novice Phone

E. MILES BROWN, W2PAU, and EDWIN T. KEPHART, W2SPV

c/o CQ Magazine, 67 West 44th Street, New York 36, N. Y.

## PART I OF TWO PARTS

This transmitter easily satisfies two requirements. It is simple enough for the Novice who wants to mix a little phone operation with his CW and it is efficient enough for the old-timer who would like to take a crack at 2 meters. An interesting part of the circuit is use of the "gating modulation" system described in the September issue.—Editor.

The Novice, when browsing through a radio magazine, often encounters an article describing a piece of equipment he'd like to build. But many of these articles consist more of a theoretical discussion of the subject than a how-to-build-it constructional treatment. A certain "know-how" seems to be expected. "Old Timers" usually spent considerable time in constructional endeavors. It was customary for a ham to start out by building a simple two-tube "blooperdyne" receiver and a one-tube transmitter. He gradually progressed to more complex circuits, and developed a technique of construction which could be applied even to v-h-f circuits. With the Novice it is different. If he is content to operate only on CW, he can work on 80 or 11 meters where it isn't too hard to get along with easy-to-build equipment. But if he wants

to try 'phone operation he must look to the two-meter band.

V-h-f circuits are supposed to be harder to build and get working than low-frequency circuits. Perhaps the biggest reason for this superstition is that the effects of wiring capacitance and inductance are more apparent at the v.h.f. bands. In the construction of an 80-meter rig short wiring is desirable—in a two-meter rig it is a MUST. For example, in an 80-meter rig the cathode leads to a tube may be several inches long, maybe passing through jacks for metering purposes. But we can't get away with this on two meters. Cathode leads must be short, even to the point of bending the tube socket terminals closer to the chassis to shorten the lead length. When bypassing a terminal to ground, the leads of the condenser must be so short that the condenser body is pulled tight against the terminal, whereas on the low frequencies one can use large mica condensers or even paper tubulars. Such units are a common cause of trouble on two meters and it is wise to use smaller physical size low-inductance disk capacitors for coupling and bypassing.

Feeling that many Novices have been confronted

with the problem of building a rig for 2 meters, and lack the know-how required for successful v.h.f. construction, your authors designed a 5-tube two-meter low power phone transmitter. The rig has been purposely kept as simple as possible, and every effort was made to hold the price down; however, quality has not been sacrificed through the use of inferior components.

**COIL DATA**

- L1-7 turns, 5/8" diameter, 16 turns per inch (B & W Miniductor #3007)
- L2-7 turns, 1/2" diameter, 16 turns per inch (B & W Miniductor #3003)
- L3-5 turns, 5/8" diameter, #12 AWG (see text)
- L4-2 turns, 5/8" diameter, hookup wire (see text)

**Getting Started — The Circuit**

Let's start with the schematic circuit diagram, shown on Fig. 1. For constructional purposes, the schematic as printed in a magazine is often too small for one to work from. Let us re-draw it. This will help us to better understand the wiring of the rig and saves the magazine from mutilation. Re-draw the circuit exactly as printed but make it larger—the larger the better—working on a piece of wrapping paper. Start with the tubes, drawing them in and numbering all socket terminals, next the resistors, condensers, coils, etc. Check your drawing against the original to be sure you have made no mistakes. Now let's look the circuit over and see what makes it work.

Tube, V-1 (6AG7), is a crystal oscillator. This

- R1, R4, R7, R10—100,000 ohm, 1/2w.
- R2—68,000 ohm, 1/2w.
- R3—47,000 ohm, 1/2w.
- R5—1,200 ohm, 2w.
- R6—1,000 ohm, 2w.
- R8—25,000 ohm (IRC Potentiometer, type Q)
- R9—1,000 ohm, 1/2w.
- R11—2,200 ohm, 1/2w.
- R12—100 ohm, 1/2w.
- R13—1 megohm, 1/2w.
- C1—50 μmf. (Hammarlund HF50)
- C2—35 μmf. (Hammarlund HF35)
- C3—30 μmf. (Hammarlund HF30X)
- C4, C5, C6, C7, C8, C9, C12, C13, C14, C15—1,000 μmf. disc ceramic (Sprague High-K, Erie Style 811, or Centralab Type DD Hi-Kaps)
- C11—10,000 μmf., disc ceramic (Sprague High-K, etc.)
- C10—25 μfd. 25v. electrolytic (Cornell Dubilier Blue Beaver)
- T1—1 to 3 step up interstage transformer (Stancor A-63-C)
- J1—open circuit jack

- J2—closed circuit jack (Mallory A2A)
- P1—power socket (Amphenol 86RPC4)
- S1—crystal socket (Millen 33102)
- RFC1—see text
- RFC2, RFC3—Ohmite Z-144
- Chassis 5 x 7 x 2 (Bud C8 629)
- Crystal—8 mc., range, 1/18th of desired output frequency
- Neon lamp socket (Dialco #705)
- Neon lamp, #51 (GE #NE51)
- Power supply cable plug, transmitter end (Amphenol 78PF4)
- Power supply cable plug, power supply end (Amphenol 78PM4)
- Grid clip (National #24)
- 4 lug terminal strip (Cinch Jones #2004)
- 1 lug terminal strip (Cinch Jones #51F)
- V1, V2—6AG7
- V3—2E26
- V4—6V6
- V5—6SN7GT

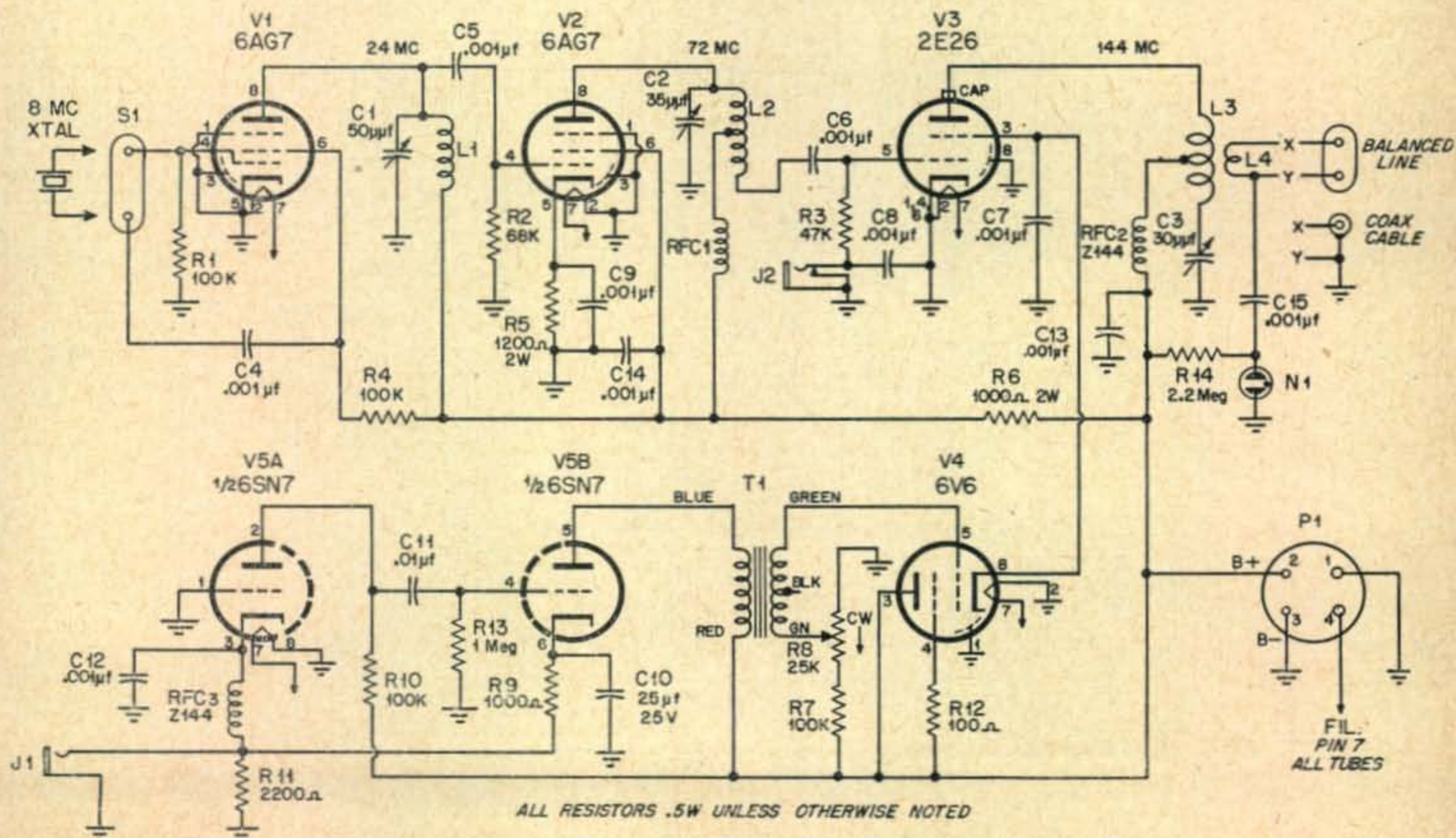

Fig. 1. Wiring schematic of the Novice phone transmitter.

particular circuit is a modification of the Pierce oscillator circuit. The grid and screen grid act as a triode oscillator controlled by the 8 mc. crystal and the plate tank circuit ( $L1, C1$ ) is tuned to the 3rd harmonic or 24 mc. This energy is fed to the grid of  $V2$  (6AG7) through coupling condenser ( $C5$ ). This tube is a frequency tripler stage, the plate tank circuit ( $L2, C2$ ) resonating at 72 mc. You will note that this LC combination is slightly different from the customary tank circuit found between two stages. In this form, it acts as a low-pass filter peaking at 72 mc. Choke,  $RFC1$ , is used to keep the r.f. out of the power supply. The tuned circuit also acts as an impedance matching network between the plate of  $V2$  and the grid of  $V3$  (2E26). This circuit is another form of the pi-coupling network in which the input capacitor consists of  $C2$  plus the 6AG7 output capacitance. The output capacitor consists of the input capacitance of  $V3$  (2E26) plus wiring strays. The 2E26 receives its r-f energy through  $C6$ . This is the final power output stage of this rig and is also a frequency multiplying stage, with its plate tank circuit resonating at 145 mc. (This tank circuit is another form of a pi-network, sometimes referred to as a "series tuned tank.") The two-meter signal is coupled from the final tank coil to the antenna by means of an output link coil  $L4$ . A

neon lamp  $N1$  acts as a r-f power output indicator. Resistor,  $R14$ , supplies the necessary "keep alive" voltage for  $N-1$  while r.f. is coupled to  $N1$  via  $C15$ .

Modulation is accomplished by applying audio frequency voltage to the screen-grid of the final stage. The screen-grid voltage of  $V3$  is supplied only through  $V4$  (6V6). Those familiar with such circuits will recognize that  $V4$  is acting as a "cathode follower" amplifier.<sup>1</sup> Tube  $V5$  (6SN7) is a dual triode speech amplifier with the microphone connected in series with the first cathode. No microphone transformer or microphone battery is necessary. The cathode looks like a low impedance and the cathode currents of  $V5$  pass through the mike. We can connect the mike in series with the cathode because the current will not exceed a safe level for the mike button. Resistor,  $R11$ , is shunted across the microphone to provide a cathode return for  $V5$  when the microphone is removed. Audio voltage is fed to the grid of  $V4$  through  $T1$ . This transformer, having a step-up ratio of 1 to 3 gives us the required high a.f. signal voltage at the grid of  $V4$ . The resting carrier level control,  $R8$ , provides a controllable positive bias on the grid of  $V4$ . If the grid of  $V4$  is driven positive a greater amount of current flows through  $V4$ . This increase

<sup>1</sup> See also "A System of Gating Modulation," C. O. Bishop, CQ, Oct. 1952, page 19.

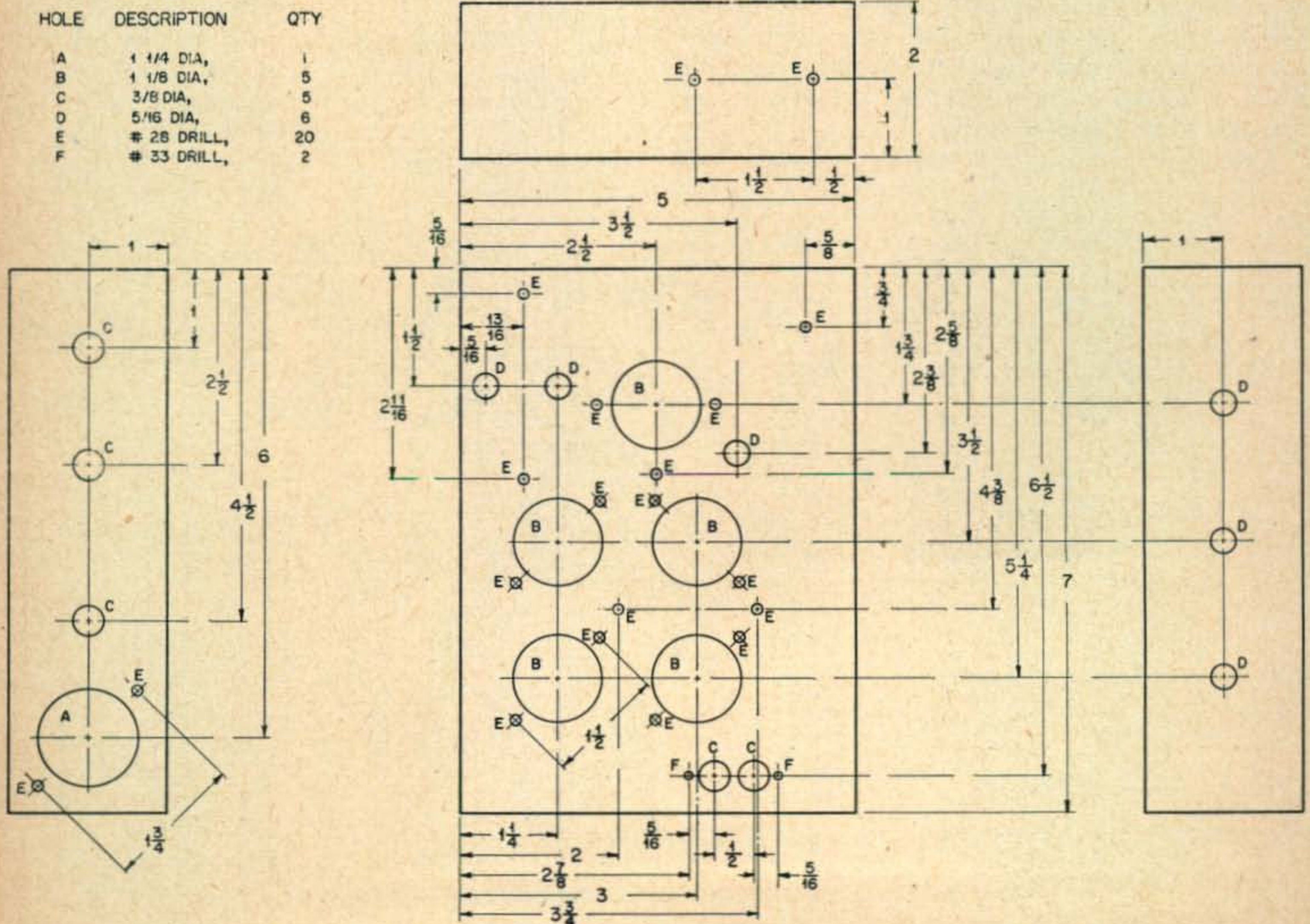
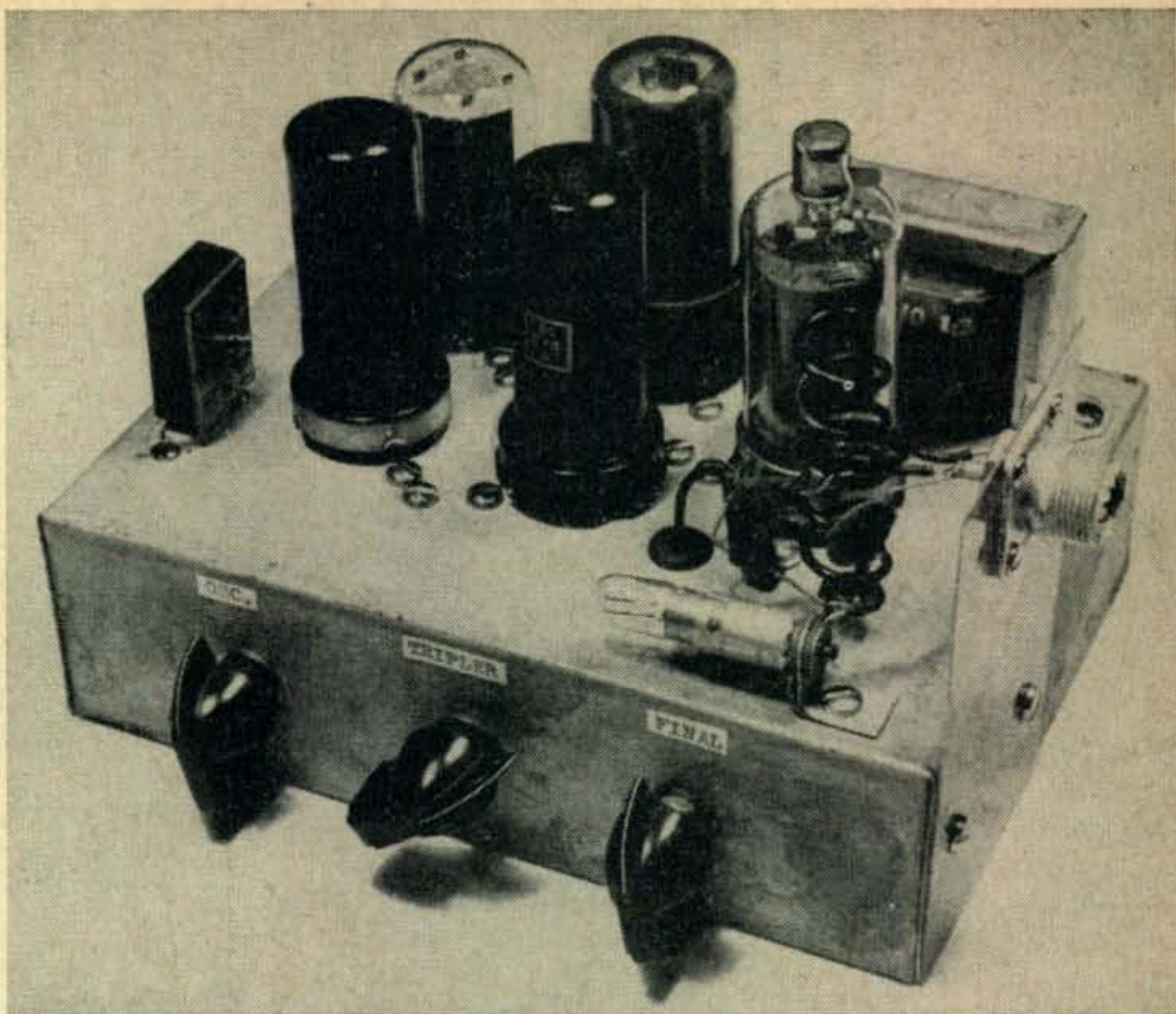

Fig. 2. Chassis layout diagram to be used if the instructions given in the text are followed. The rear skirt is at the left, front skirt at the right and right hand side at the top.



When viewed from the front the two metal 6AG7 tubes and the 2E26 are in the foreground with the 6SN7 and 6V6 in the rear. The output coil L3 is suspended between the plate cap of the 2E26 and the tuning condenser beneath the chassis. It passes through a rubber grommet in a 5/16-inch hole. This hole is not shown in Fig. 2 since it should be drilled when the exact position of C3 has been determined.



of current raises the cathode voltage of  $V_4$ , and the screen voltage of  $V_3$ . It is this varying screen voltage which performs the modulating task for  $V_3$ . So much for the theory section. If one requires more information relative to a particular part of this transmitter he may find the same by referring to one of the various radio handbooks on the market.

### Construction

In order to build this transmitter, there are several tools that are required. We are going to need something to cut our tube socket holes in the chassis along with several drills (size #33, #28, 5/16", 3/8"), screwdriver, pliers, diagonal wire cutters, soldering iron (a pencil type with a heavy tip will do), rule, square, knife, hammer, centerpunch and a small file. If one does not have access to chassis punches (1 1/8", 1 1/4", and 5/8"), a circle cutter (Fly Cutter) will do. If you do not have the tools with which to do the chassis work, you may have it done by your local tinsmith, garage or machine shop.

Figure 2 is a chassis layout and drilling plan for the transmitter. This layout applies *only* if the parts in the parts list are used and no substitutions are made. We would prefer that no substitutions be made—the parts listed are available on the market. The suggestion, "use this, it is just as good!" often leads to the constructor's despair.

We chose to use a Bud # CB629 chassis. This is a zinc electro-plated chassis measuring 5 x 7 x 2 inches with a turned-in bottom edge. Do not use a painted or anodized chassis, as it is difficult to effect a good ground connection on these surfaces. When you buy the chassis don't unwrap it—lay out your drilling pattern on the paper wrapper. If it has been unwrapped, re-cover the chassis with wrapping paper securing it with *Scotch Tape*. Make your layout with a sharp pointed pencil, marking all hole sizes. When you have finished marking, try fitting the parts to the layout drawing, and,

when satisfied, center punch all marks to be drilled. Proceed to drill right through your layout paper. If you are using chassis punches, drill 3/8" holes for the punches if using a "fly cutter", drill the right size pilot hole. Leaving the paper on for layout purposes keeps the chassis clean; if a mistake is made during layout, the chassis can be repapered.

(Continued on page 67)

HOLE	DESCRIPTION	QTY
A	5/8 DIA	1
B	1/2 DIA	2
C	# 28 DRILL	6
D	# 33 DRILL	4

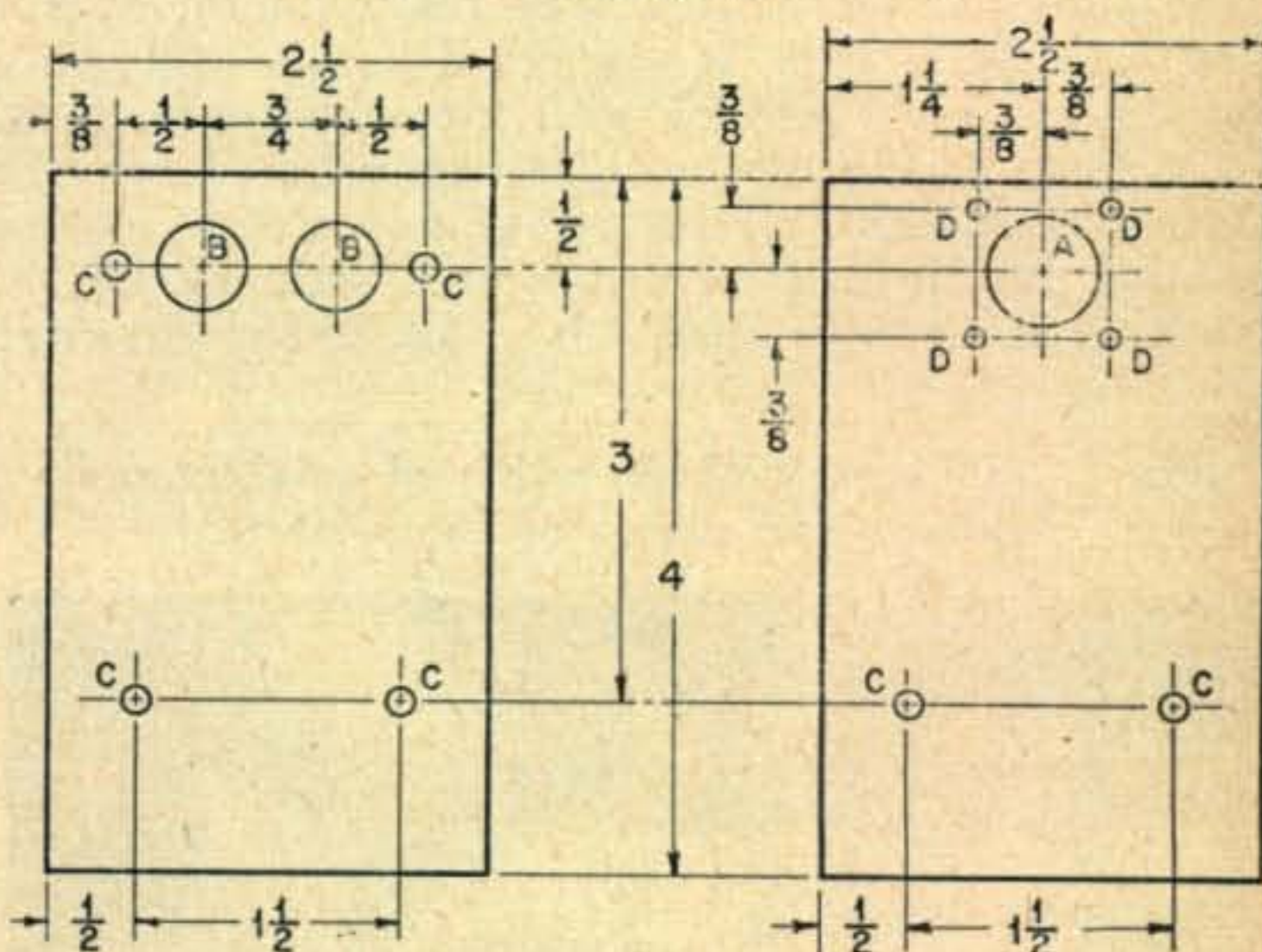

Layout of the antenna terminal bracket. If the antenna is to be fed with 300-ohm lead prepare the bracket shown on the left. It will fit a National FWG terminal strip. The bracket on the right is for a co-ax connector such as the Amphenol 83-1R. The bracket should be made from rather sturdy metal, or might even be cut from quarter-inch thick polystyrene. The antenna coil L4 is soldered directly across the connector and pushed into the middle of coil L3.

# Amateur Teletype

As Reported by WAYNE GREEN, W2NSD

1379 East 15th Street, Brooklyn 30, N. Y.

More and more stations are getting on the air with RTTY every month. The threatened activity in Dayton has burst with W8PTF working W4PCI (Covington, Ky.) regularly on two meters and getting a big bang out of it. They expect to work W8WJC, up near Cleveland, as soon as their work schedules permit. Jerry has been figuring in the news due to his recent RTTY contact with W9TQ (Milwaukee) on two meters. W9DDG up in Sheboygan copied both sides of this QSO but missed out since Vic, W9TQ, thought he had gone to bed.

Boston is going strong on both two and six meters . . . Holyoke is stepping up activity . . . New York is going strong. Say, maybe I should shine the spotlight on myself (with modesty), and mention that W2NSD is putting out a better two-meter signal now that he has his . . . no, now that I have my rig up in the pent house on Fifth Avenue. I generally leave the printer on every Tuesday and Thursday all day and may soon have it on all the time (as soon as I put in the W6AEE auto-start circuit described on page 36). This change has put me in touch with a lot of the local gang and has even gotten me a couple of contacts with W2JAV, a hundred miles off.

W4OLL sent through a message via MARS saying that the MARS now has a weekly F.S.K. schedule on 3497.5 kc. for one hour on Saturday nights from 1700-1800 EST. This might make something interesting for you gentlemen to monitor in order to check your equipment . . . WØHFU is finally about ready to put Minneapolis on the air. There has been a lot of interest up there for some time, but not much activity.

A letter just came from W2RTW (Elmira, N. Y.) that is fairly typical. It was typed by his XYL since he was too busy playing with the teletype to do it. "I've been having too much fun to write—I received all my equipment several weeks ago and of course on the day it arrived I couldn't wait to try it. Hooking it up was some job. Talk about haywire!

John E. Williams, W2BFD, father of amateur radio teletype and source of our printers.

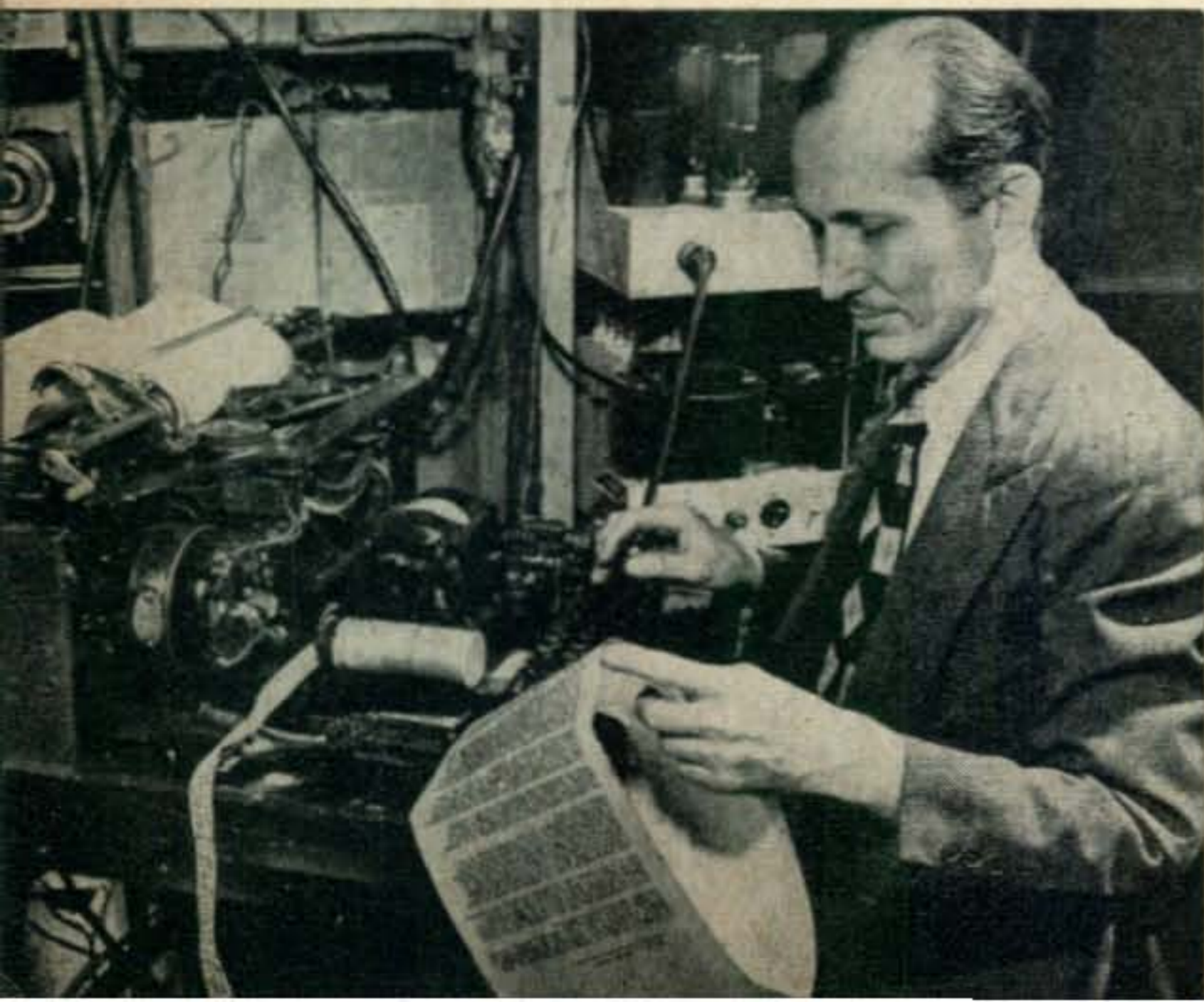

## An RTTY PARABLE

Once upon a time, so the fable goes, there was a traffic expert named, Mr. Friendly. He was "high brass" in a club interested in all types of vehicular traffic. Mr. Friendly was the precise sort of gentleman and often collected many facts and figures.

It was brought to his attention one day, by a group of about 400 people, that a certain road could be made a direct line between two great cities. At the present time there was no road capable of handling really high speed traffic. Present traffic, such as it was, went via devious routes, or if it tried the direct route it soon found that it was impassable.

Mr. Friendly, a methodical soul, set up a tent by the side of this proposed route and started to count the traffic. The first day he saw an A-1 team of oxen wallow belly-deep in the mud and finally struggle through. They were followed by a pair of VHF grasshoppers that jumped off in the general direction. Mr. Friendly never found out what happened to them.

On the second day, a horse and cart eleven meters long started down the road, but finally gave up in disgust. Then on the third day, Mr. Friendly discovered a trail near the direct route. He conveniently pointed it out to the man who came speeding along at 65 miles an hour. Much to the driver's consternation he found the trail filled to capacity with Novices just learning to creep and walk.

Thereupon Mr. Friendly reported that he had made a comprehensive personal study of the situation and had arrived at three conclusions, namely:

- (1) There was insufficient volume of traffic to warrant a high speed road and his count confirmed this assumption.
- (2) The high speed equipment was not sufficiently familiar to the rest of the club members.
- (3) The Novice trail could be widened and could then accommodate all those who wanted to speed along at 65.

Mr. Friendly then retired to his "club" and sold his tent.

I had the wires strung all over the place. Having no diagram of any kind I just put the wires where I thought they ought to go and, believe it or not, it worked right off, amid much sparking and flashes. It printed! A generous application of condensers and resistors eliminated the sparks. I can copy the commercials (get the weather and news almost every day), but am too far from any ham activity right now. I am anxiously awaiting 40 meter operation."

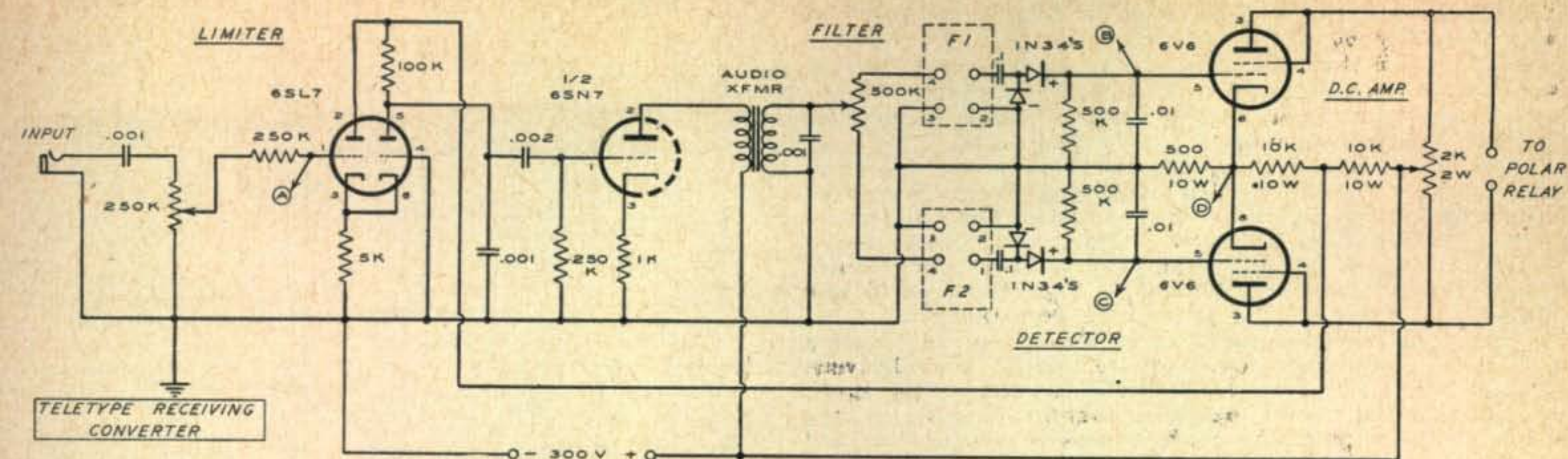

Fig. 1. The original teletype receiving converter unit designed by Merrill Swan, W6AEE.

**Receiver Stabilization**

One of the more difficult problems that comes with the shift of RTTY to the lower frequencies is that of drift. The only receiver that I have heard about that is stable enough is the Collins 75A. Since we all can't afford that, we must turn elsewhere for a solution to the problem. Actually it isn't very difficult. The receiver drift usually is a combination of the local oscillator drift and the b.f.o. drift. The use of an external oscillator to provide a beat with the incoming signal makes the b.f.o. unnecessary and greatly reduces the local oscillator drift problems since the signal will be perfectly readable as long as it stays within the i.f. pass-band. The external oscillator must, of course, be stable. I would recommend a crystal unit that is left on all the time. This is a logical method since the teletype stations will be operating on fixed frequency channels. A very stable VFO would be more flexible and shouldn't be too difficult to build. Some sort of attenuation for the injection voltage should be built in so that the signal from the oscillator can be adjusted to the same order of magnitude as the incoming signal. This means that it will be necessary to build the oscillator in a well shielded box and that all of the TVI prevention methods should be lavished on both it and the power leads coming from it. If you manage to make a unit such as this and get it working how about sending me the details on it?

**W6AEE Teletype Terminal Equipment**

This simple unit is all that is necessary to operate your teletype printer through your regular station equipment for the AFSK bands (two, six, and eleven meters). For the low frequency bands an FSK exciter is also necessary (such as the one described in the October column). This design would seem to be about the ultimate in simplicity without sacrificing performance. The circuit has been boiled down to four tubes for the receiving converter (or perhaps I should say three and a half tubes), one half for the audio oscillator, one for the auto-start (yes, this even has auto-start), an oscilloscope, and two rectifiers. The special parts necessary, the filters and audio oscillator transformer, are readily available in the surplus market, dwindled as it is. If you were not dead broke back in 1948 you probably already have the units these components are pirated from. Certainly one of your friends will have them.

This unit was born on the west coast as the result

of about thirty Model 12 teletype machines finding their way into amateur hands back some four years ago. Merrill Swan, W6AEE, faced with the printer and no place to plug it into the station receiver, looked through all of the technical publications he could get a hand on: no information. Investigation of the printer disclosed that d.c. keyed on and off was necessary for operation. The problem then was to get this keyed d.c. from the two standard teletype tones: 2125 and 2975 cycles.

This called for a selective amplifier to separate the two tones, rectify them, and use the resultant voltage to operate a relay which would key the d.c. to the printer. Many of the teletype gang have been through the gamut of methods for separating the two tones: WØHZR tried several different R/C type filters, as did W2BFD and W6AEE. W2HQ and W3ODF have R/C filters in their present converters, though I believe that they are the only ones now using this system. The others all came to the conclusion that the L/C type filter section gave better performance and freedom from trouble. The W2BFD converter, described in the November 1946, CQ, uses two L/C filter sections for each tone channel made from 50L6 audio output transformers. Since this circuit is still being built by quite a few of the new teletype stations these filter units are available commercially made, \$16 for the set of four. The W4OLL converter, September 1952, CQ, used L/C filters made out of toroid coils. These filters suffer only from being a bit difficult to make. The W6AEE modification of the filter units from the 733D surplus receiver presents one of the quickest sources of teletype filters. With this unit, you may get on the air with teletype for under \$75!

**Limiter**

As you may be aware, it is quite necessary to provide a constant signal amplitude for operation of the rectifier and d-c amplifier circuits in the converter. To accomplish this, a 6SL7 with a fairly low value of plate voltage and a common cathode resistor (with grounded grid in the second section) is used, thereby providing limiting on both positive and negative peaks. Doubt has been expressed as to the validity of using such a limiter due to the possibility of generating harmonics in the pass-bands of the filters. I have not

1. J.N. Brown, "A Teletype Receiving Adaptor," CQ, Sept. 1952, p30: "It is a fact that in any system limiting will in effect destroy the dynamic range of the tone selecting filters."

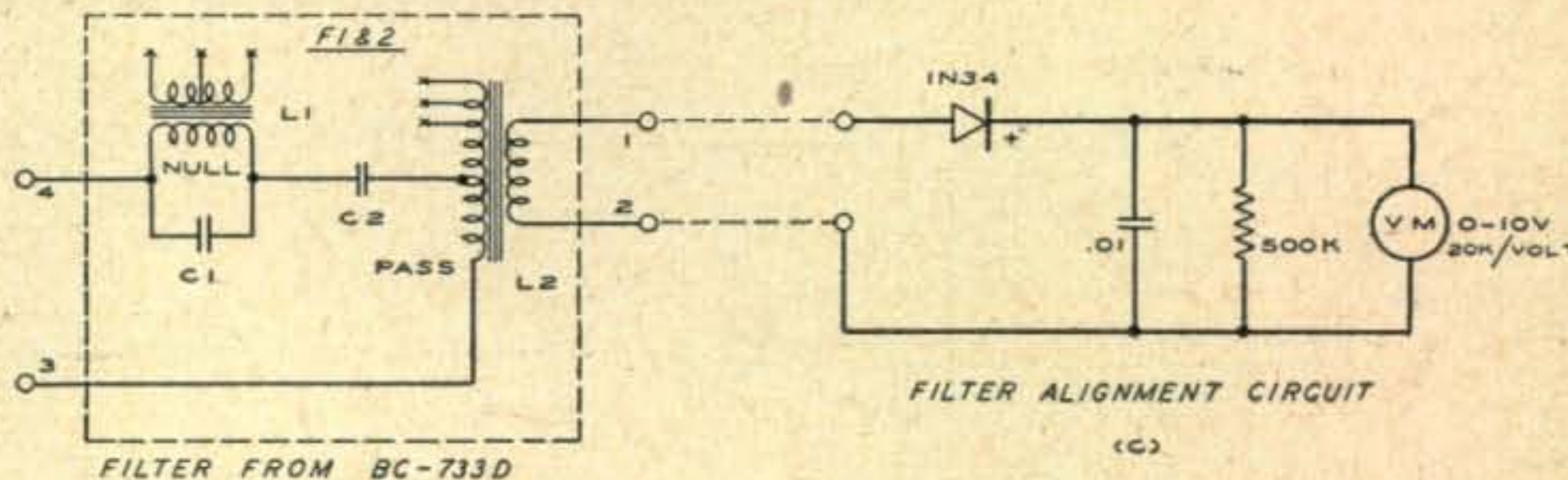
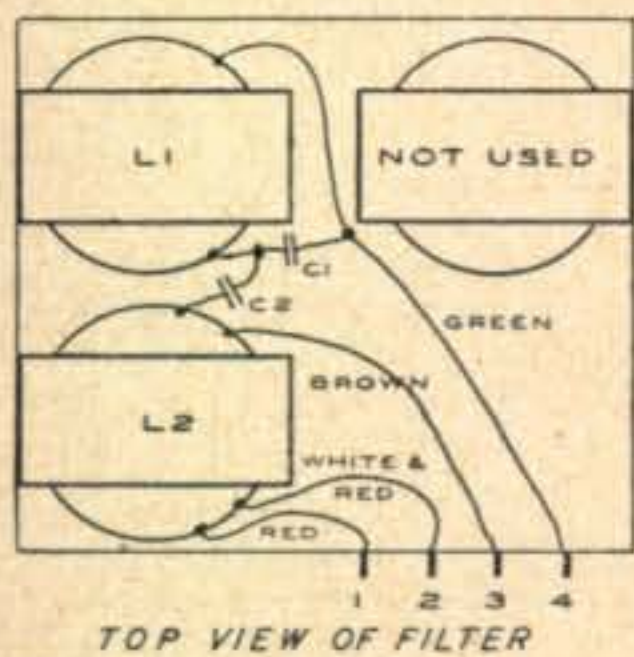

Filter from BC-733D  
 F1 2125 J C1-.001 C2-.005  
 F2 2975 J C1-.00075 C2-.01  
 (B)

Fig. 2. Pictorial (A) and schematic (B) diagrams of the W6AEE modification of filter units found in the BC-733D and R89/ARN5 receivers. The test circuit (C) is used in the alignment of the modified units.

found this to be true. The action of this circuit provides approximately 60 db of limiting. It is not (of course) to be assumed that this gives A.V.C. action, since limiting could have been provided by only adding two more tubes and a small interstage transformer. In favor of simplicity the limiter was used.

The capacitors used between the limiter and the amplifier stage, in conjunction with the shunt capacitors and the capacitor across the secondary of the transformer which feeds the two filters, provide some band-pass action. A normal band-pass filter would require three toroids (or coils) and three capacitors, so it was dropped in favor of the above R/C combination.

Since the incoming signal is frequently a combination of mark and space tones, noise, QRM, and heavens knows what else, it is advisable to remove as much of the superfluous as possible, thereby simplifying the task of the filters. The more expensive commercial and military installations use rather elaborate filters to remove all but the 2000 to 3000 cycle range.

### Auto-Start

Additional "equivalent filter action" is obtained by use of the auto-start feature (Fig. 3). This version of the auto-start circuit is truly automatic in that it can be actuated by any signal that is above the noise level and requires no time clock or additional equipment. Also, it provides freedom from miscopy due to phone QRM or multiple reception of teletype on the same frequency.

Basically, it is very similar in action to the voice operated transmitter control which is used for single sideband operation. D.c. from the two filtered signals is connected to a potentiometer. The arm of this potentiometer is connected through a 10-megohm resistor to the grid of a 6SQ7. Across the grid to cathode is connected a 1.0 ufd. condenser in parallel with 5-megohm resistor. The cathode is biased above ground to a value such that with noise only being received no plate current flows. When a 2125 cycle mark signal is received, a positive bias is applied to the grid, causing the relay in the plate circuit to close, furnishing 110 v.a.c. to the teletype motor. The 5-megohm resistor across the 1.0 ufd. capacitor will discharge and cause the relay to drop out if a space signal is longer in duration than the "letter" character which has five space pulses. To determine the correct value of this resistor for a given capacitor, hold the "letters" key down when transmitting and lower the value of the resistor from 5 megohms until the relay opens and then add a small amount of resistance (10K-50K). After this adjustment, tune in a phone station and it will be found that the signal will not operate the relay. When a phone station interferes with the teletype signals no cutoff of the auto-start will be observed until the phone signal becomes stronger than the teletype or causes more than an equivalent amount of "space" signal. When this occurs the auto-start will shut off your printer.

### Amplifier and Filters

Following the limiter, a single stage class A amplifier is used to build up the level of the signal. The plate

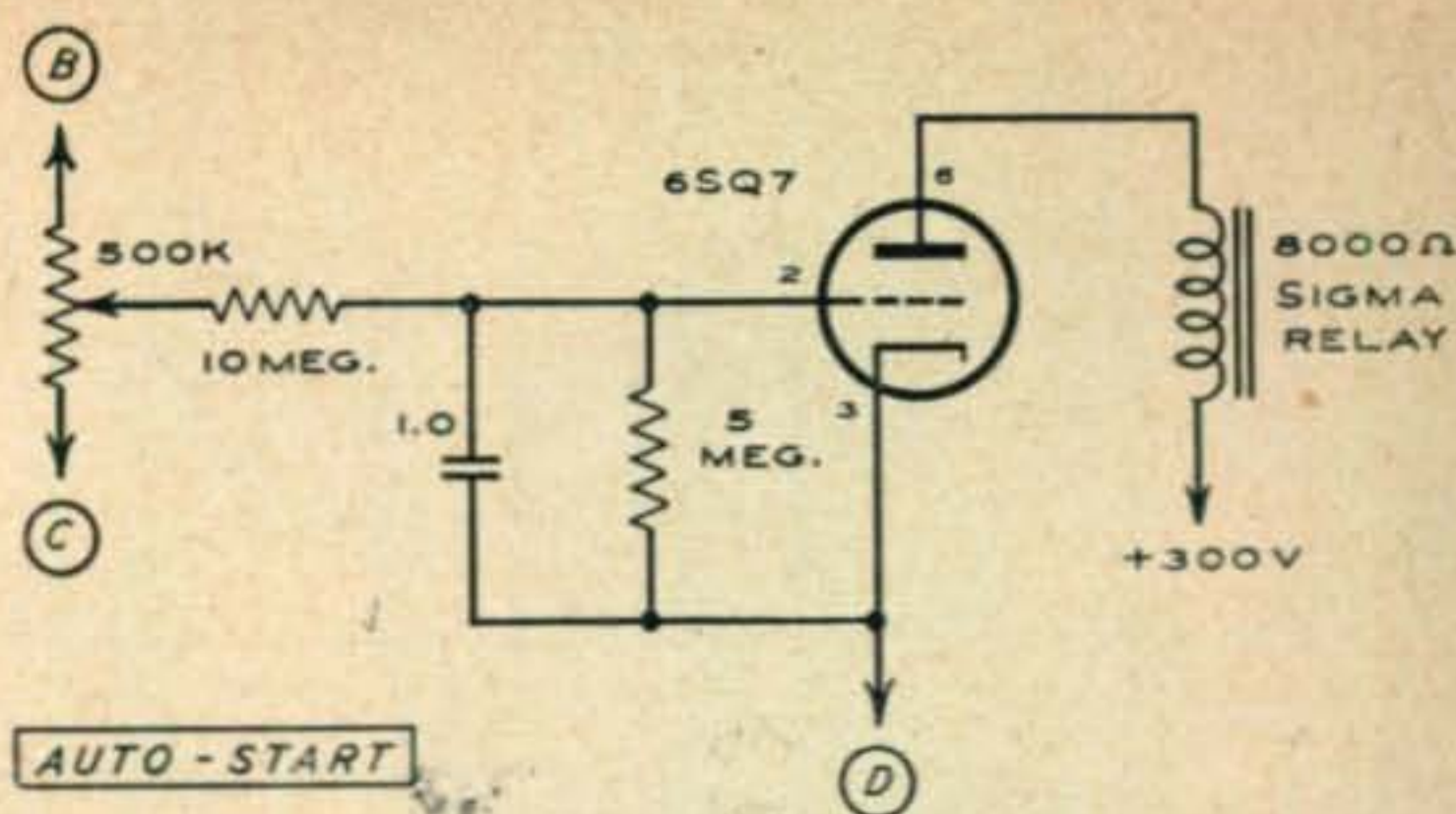

Fig. 3. The fully-automatic auto-start circuit. Its "equivalent filter action" precludes breakup and miscopy due to phone QRM and other spurious interference.

circuit is coupled through a standard audio transformer to the two filters, thereby providing the proper impedance match between the 6SN7 amplifier and the filters. The potentiometer is for balancing the input to the two filters. Since one filter is frequently more efficient than the other it would be wise to have some compensating control.

The filter units were removed from one of the glide-path receivers which are still available in some places as surplus. They are the 90- and 150-cycle filters found in the BC-733D and R89/ARN5 receivers. To modify the filter units to the new frequency the following procedure was used: Remove the top cover by using a small bladed screwdriver and hammer. This is easily done if you start along one side and pry the cover from the case. When all four sides are loose, break the bakelite terminal block loose from the cover. Next, heat the case in a warm oven. When the wax flows, pour it into a can and save it. After cooling the filter cut the capacitors loose from the inductors. Some models of these filters have three coils, others only two coils. In either case, only two coils are to be reused. Viewing the open side of the filter, with the terminals next to the viewer (Fig. 2a), retain the two coils on the left. The coil on the upper right can be discarded. Capacitors to tune to the new frequencies (values in Fig. 2b) should be put in place of the removed condensers. Next, loosen the four screws which hold the core of the inductors. Using the test set up shown in Fig. 2c, and an audio source of 2125 and 2975 cycles, proceed to spread the core apart until the desired frequency is obtained. A small air gap gives a lower frequency and a large gap a higher frequency. It is easier to adjust the "pass" frequency first (L2), then connect the parallel tuned coil-capacitor next (L1) for the null frequency. Then recheck for the peak and readjust if necessary.

To go into maddening detail: Connect a source of 2125 cycles to the input of the first filter unit and tune L2 for a maximum reading on the meter. Change the input to 2975 cycles and adjust L1 for a minimum

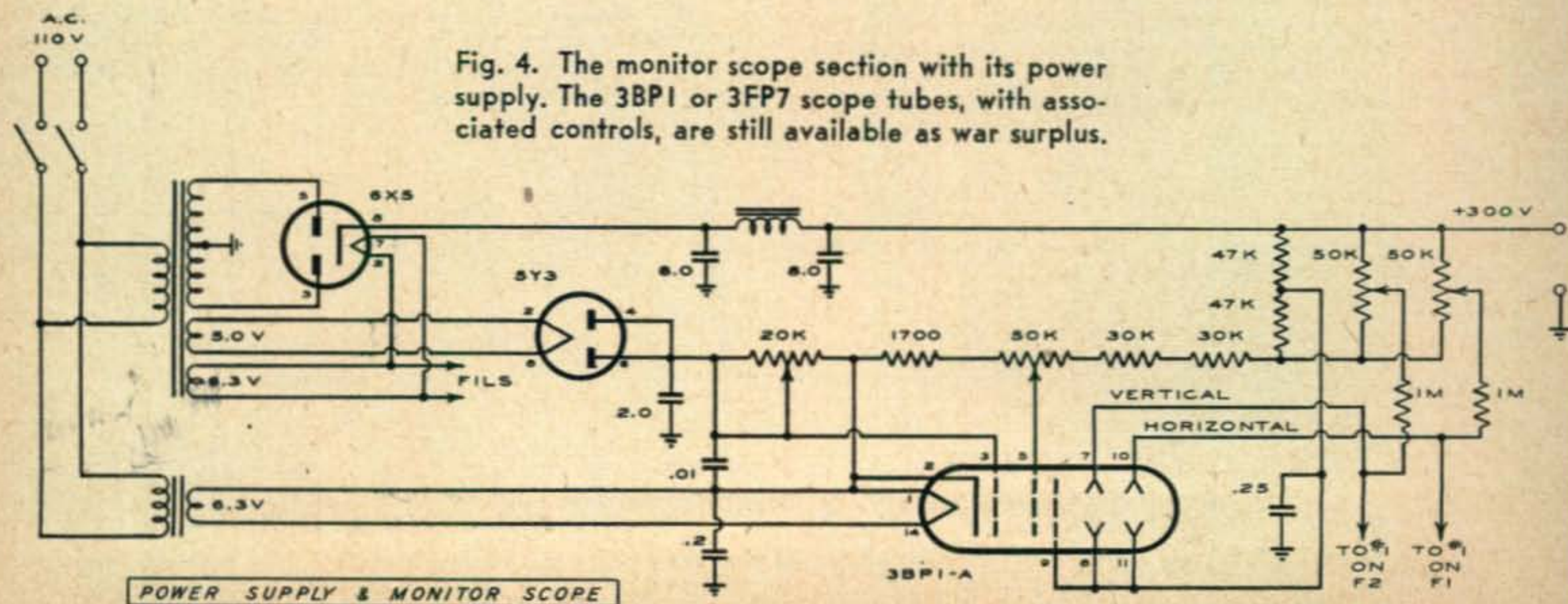
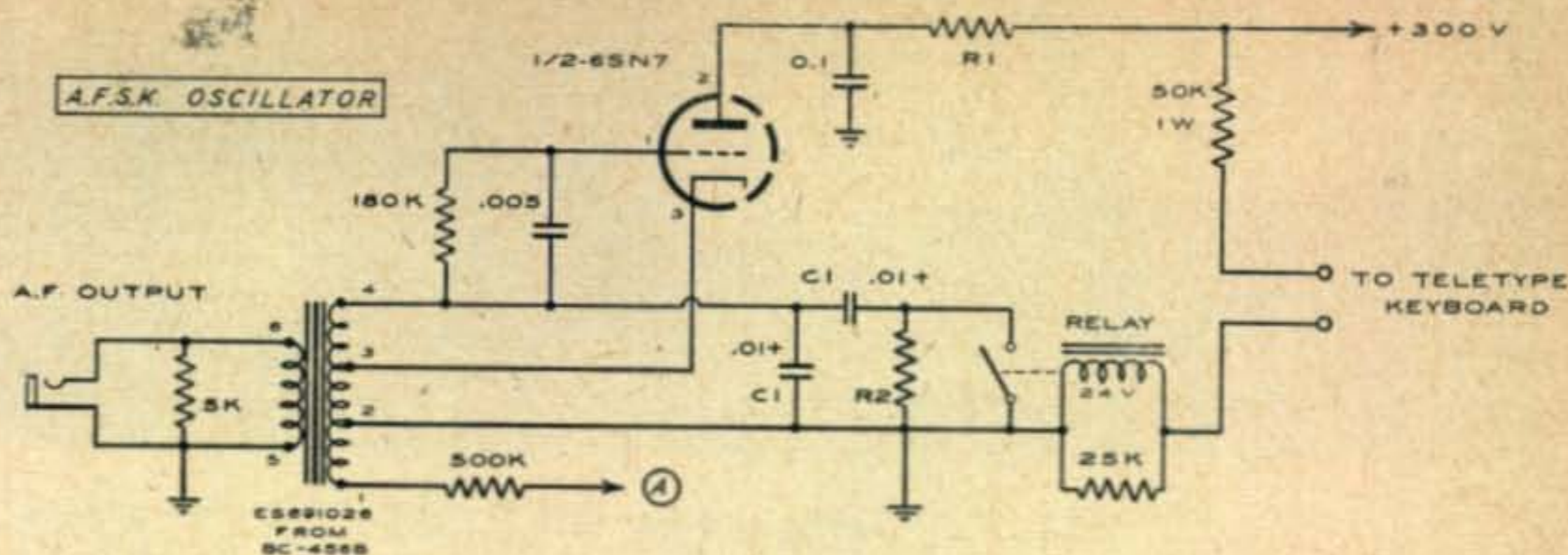

Fig. 4. The monitor scope section with its power supply. The 3BP1 or 3FP7 scope tubes, with associated controls, are still available as war surplus.

Fig. 5. The tone oscillator circuit. The output is fed to the converter for local copy or to the transmitter modulator for AFSK operation.



reading. Recheck L2 on the lower frequency and then L1 on the higher frequency for they will have a tendency to interact. With the second filter start with 2975 cycles and adjust L2 for maximum; change to 2125 cycles and adjust L1 for minimum. Repeat a few more times.

While all this adjusting may sound a bit difficult, anyone who can neutralize an r-f amplifier should find it simple. Mica or hard cardboard should be placed in the air gaps of the two inductors and then the four bolts tightened. Again, recheck the response of the filters. Next, heat the wax and pour it over the coils and capacitors. When cool, check the response again. If necessary, final adjustments can be made by loosening the screws and opening or closing the coil gaps as needed. Finally, clean the covers with a coarse file or rasp and resolder them in place.

### Rectifiers

The rectifiers used in this unit are of the 1N34/1N38 germanium variety. The purpose of these units is to furnish a voltage (d.c.) to the next stage which is proportional to the audio voltage coming from the filters. To provide a greater value of d-c for a given signal a simple voltage doubler circuit is used.

### D. C. Amplifier

The outputs of the two rectifiers are both positive in polarity. With no signal the cathode bias on the 6V6's provides almost plate current cutoff. Proper d-c bias adjustment is obtained from the 2000-ohm potentiometer in the 6V6 plate circuit. The circuit can be adjusted by putting a meter across the polar relay terminals and, with no signal input, adjusting for zero voltage.

If you desire to install a meter permanently across the polar relay to indicate the mark and space signals it is best to use a zero-center meter. An 0.5 ma. each side of center, together with a 50,000-ohm series resistor, will do nicely.

There are several available polar relays which will work in this circuit. The W.E. 215A normally comes with the teletype machine and is ideally suited for this application. The Wheatstone relay ditto. The W.E. 239 relay is available from a leading supply house (Herbach and Rademann, Philadelphia, Penn.) for about \$4 and is quite satisfactory. Some adjustment of the relay may be necessary to get perfect copy. The letters "R" and "Y" are usually sent alternately to make this adjustment.

### Tone Oscillator

The transformer for this circuit can be taken from the war surplus SCR-522, the ARC-5, or the 274N sets. The cost of the 274N modulator (BC-456) units is still about two dollars. This transformer is used for tone generating in this equipment. The two .01  $\mu$ fd. condensers in the diagram are approximate. A capacity decade is very handy for adjusting the tone oscillator. First adjust the oscillator for 2975 cycle output, then close the tone keying relay and vary the other condenser for 2125 cycle output. The relay that comes with the 274N modulator will do nicely for the keying relay. Adjust the contacts for 0.005" to 0.010" clearance. Any small relay will do the job if this one is not handy. The output of the oscillator is fed to the converter for local copy and to the transmitter modulator for AFSK operation.

### Oscilloscope

All that is necessary to add the 'scope is an additional tube and a few resistors and capacitors. This additional tube (5Y3) is a negative voltage source for the 'scope. With the values shown in Fig. 4 there is +300 volts from

Front, top and rear views of the complete assembled W6AEE receiving converter.

the "B" supply, plus approximately -420 volts ( $1.414 \times 300$ ), giving 720 volts—quite adequate for the 3BP1 or 3FP7 type scope tube. These are still available, as surplus, for two to three dollars. Focus, brightness, and centering controls are provided. Voltage, adequate to give approximately two inches peak-to-peak deflection, is available from the output of the filters (terminal #1 on the filters). The ease with which FSK signals can be tuned in makes this circuit important for any teletype converter unit.

### Construction

In order to keep the original idea of a simple unit, a chassis 4" x 3" x 17" was chosen. A standard 4 $\frac{3}{4}$ " x 19" panel mounts the unit for either relay rack use or for under the model 12 teletype stand. The tone oscillator keying relay and auto-start relay are mounted inside the chassis. Terminal strips are provided to enable changes or additions to be made easily.

The input of the converter is designed for high impedance and if the audio output of your receiver is low impedance it will be necessary to use an additional step-up transformer.

### Power Supply

Any small power transformer should work well. Plan on using a unit that has about 650 volts (c.t.) at 70 ma. The UTC R-11 is used in the pictured unit. Any filter choke that will handle 70 ma. can be used.

There you have the information on one of the simplest teletype converters I have yet seen. This whole thing should take only a few hours to put together. Thus, with a \$55 printer and a \$20 converter, you are on the air with teletype. Incidentally, machines are still available. The demand has increased lately quite a bit, but even so there seems to be no great difficulty in getting them.

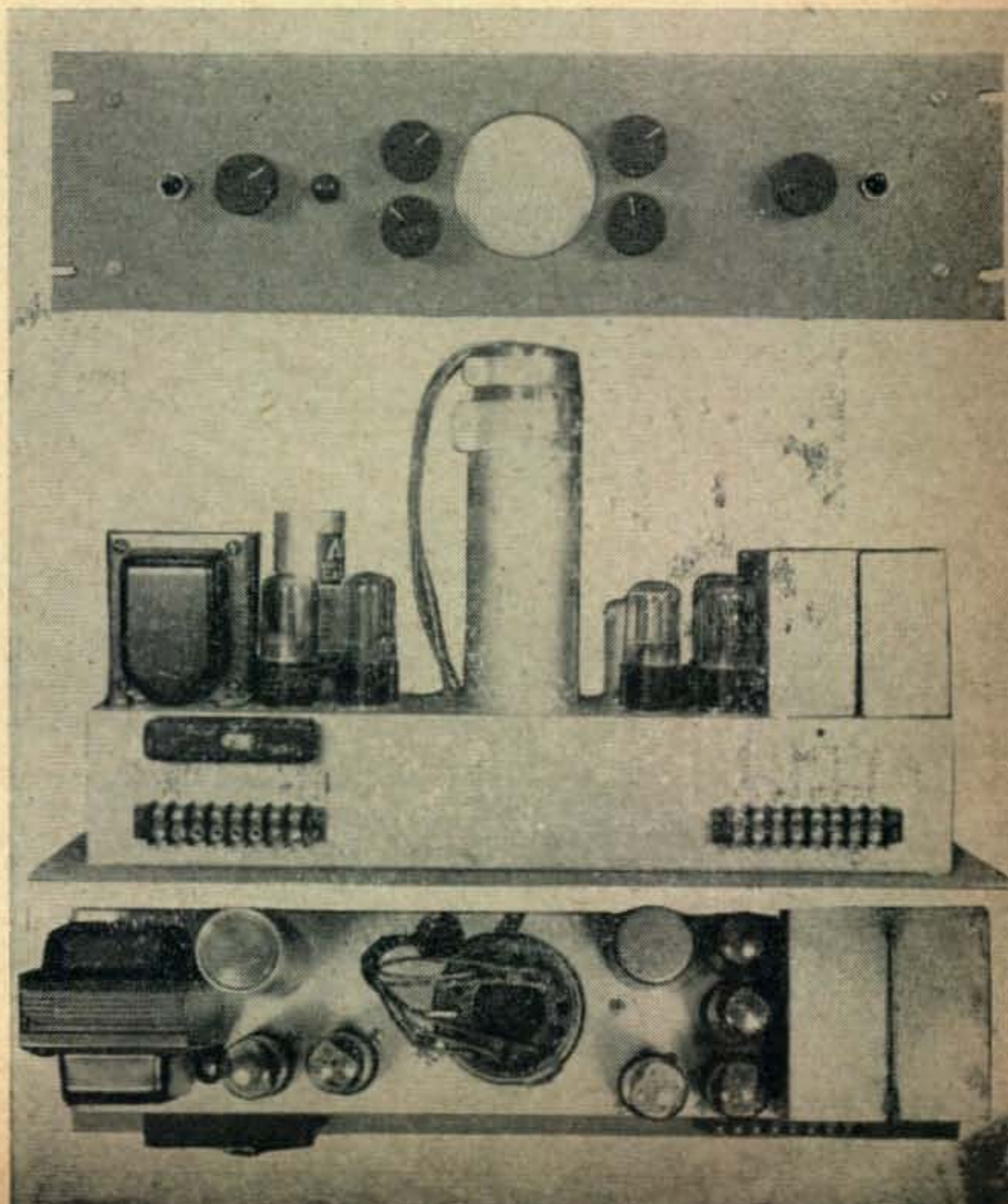

# DX



## AND OVERSEAS NEWS

Gathered by **DICK SPENCELEY, KV4AA**

Box 403, St. Thomas, Virgin Islands

Our heartiest congratulations to the following on achieving WAZ:

No. 282 VK2AM Lee Cuffe 40-151.

We also welcome the following newcomer to the Honor Roll:

GM2DBX 36-156 Phone.

\* \* \* \*

The advent of ZD7A, St. Helena, touched off one of the biggest dogfights your narrator has been privileged (?) to hear. With all the stateside kilowatts beamed on ZD7 and with KV4 right in line you could practically light a neon bulb off of any piece of metal down here. Unfortunately, all that has been said in the past about calling rare DX on his frequency, and appeals to this effect by ZD7A, went unheeded by hundreds of stations including, I am sorry to say, a great number of experienced DX'ers who certainly should have known better. KP4KD counted over eighty stations, in a two-hour period, calling him on or so near his frequency that efforts to pull him in were impossible. DX hogs gave no respite while ZD7A was in actual QSO but called continuously. ZD7A's attempts to contact W8DDS were violated in this manner. My sympathy sure went out to Russ who was probably so mad at the time that you could have lit a cigarette off him. As ZD7A was a fairly slow operator this made things doubly difficult. Faster operation would have eaten into the pileups in a much shorter time with a resultant lessening of the QRM. This, of course, is no slam at

ZD7A whose efforts are certainly appreciated in the face of what might be described as "overwhelming odds" during the first days of operation. Arthur did have the field buffaloed for a while by hopping back and forth from 008 to 076 but the masterminds soon caught up with that and QSY'ed right along with him.

We have always maintained that a DX station in such a position would immeasurably facilitate things by requesting calls 30 or 40 kc. up or down from his operating frequency and repeating this request after each QSO. Somebody, some day, we hope, will try it!!

As 1952 staggers to a close we can look back on a very successful DX year. To the following stations who played a big part in making this so, thanks for your efforts:

VQ1RF (VQ4RF, VQ4CO,  
W5HBM and VQ3KIF)  
ZS2MI Van  
FD8AA/FD8AB  
EA9DC (EA8AW)  
2C2AB/ZC2MAC (VS7MC)  
FL8MY/4WIMY/6I6MY/VQ6MY  
(HZIMY/W6MLY)  
VS5ELA (WØELA)  
FP8AI through FP8AQ  
ZD7/ZD7B (ZS6GV)  
VR4AF/YJIAB (VK2QZ)  
LB6XD, FB8BB, VK1BS, C3AR,  
KS6AA, VP5BH, ZK1BC,  
KC6QY and others.

### At Time of Writing

ZD7A appeared on the scene on October 11th as mentioned. We hear that he may also put in some operating time at ZD8. In any case he was due to sail for England on or about November 3rd. Among the many contacting St. Helena we note the following few: CX1FY, W1BUX, LU7CD, W6GPB, W3BES, W8DDS, W5ASG, W2ATE, W6GDJ, W2BXA, W1ME, W1FH, W6CUQ, W3GAU, KG4AF, W5MPG, W7VY, W6AM, VE2NI, KP4CC, KP4JE, W2APU, LU6AJ, W5CKY, W2HUQ, W2NSZ, CE3AG, W8JIN, W4TO, W1HX, W6SN, W8PQQ, and VE4RO. See QTH column.

YJ1AB has been active recently on 7020 and 7030. VK2QZ, ex VR4AF, is at the key. Bob maintains skeds with VK at 0800 and 1000 GMT. All QSL's should go to the address listed in the QTH column.

HZ1MY writes that there will be no more DX stops for him, with the possible exception of another short stop at Qatar, until next spring when he plans to set up shop at CR8 and YA3. He also has a VQ9 trip in the making for next year, but he will not be on that trip personally. All QSL's for FL8, 4W1, 6L6 and VQ6 have been answered, to date, as received so if you have not received your card at date of reading it is suggested you forward him another one at once. Dick intends to close these logs very shortly. Only about fifty per cent of the cards for all



(Photo Courtesy of No. Calif. DX Club bulletin)

W6MHB, Johnny Beck (40-184) is pictured above with his neat layout. The finals run from 300 to 450 watts on 3.5, 7, 14, 21 and 28 mc. Antennas, located on a hill 500 ft. from the transmitter, include a small rhombic on Europe, a four-section 8JK, and ground planes on 80 and 20.

## 1953 160-METER DX TESTS

This will announce the 1953 series of "Top Band" 160-meter DX tests arranged by the English and the East Coast U.S.A. Amateurs. All 160-meter stations are invited to participate.

*Main Tests*—Jan. 11th and 25th, Feb. 8th and 22nd.

*Preliminary Test*—Dec. 28th.

*Times, each date:* From 0500 GMT to 0800 GMT.

W and VE stations call CQ DX on the hour and each succeeding ten minutes thereafter. DX stations will call W and VE at five minutes past the hour and each succeeding ten minutes thereafter. G stations are mainly found between 1775 and 1795 kcs. It is expected that there will be South American, African, New Zealand and much European DX on the air. Let's all join in and make these tests a success. Reports from W and VE stations should be sent to W1BB while DX stations may send their reports to Austin J. Forsythe, 49 Victoria Street, London SW1, England.

QSO's have been received.

HZ1MY says his method of calling from VQ6 worked out very well and will probably be followed in other DX spots. He doubts if he could hold up again under the barrage of calls hurled at him when operating from 4W1MY. To dispel any doubts that Dick has not actually visited these spots we were sent a notarized statement which reads as follows:

"Jedda, Saudi Arabia, Oct. 6, 1952. To whom it may concern. This is to certify that on the following dates I operated the amateur radio station HZ1MY of G. R. McKercher in his absence and contacted him at FL8MY on May 23, 1952, 4W1MY on July 10, 1952, FL8MY on July 25, 1952, 6L6MY on August 26, 1952 and VQ6MY on September 18, 1952. He was at the following locations on the dates stated. Djibouti French Somaliland May 23, 24, 25, July 25, 26, 27. Sana Yemen July 10, 11, 12. Dukhan Qatar August 26, 27. Hargeisa British Somaliland Septmeber 18, 19, 20. For any further verification I may be contacted at the following address: Mr. Andrew J. Andreou (Chief Operator Saudi Arabian Government Radio-Station) Post Box 147 Dejedda Saudi Arabia—Signed A. J. Andreou."

SV5, SV6. As stated in Nov. CQ we regret to advise that 4X4BX was unable to obtain permission from the Greek government for this operation and was forced to call it off. Sam has not given up, however, and will endeavor to get the necessary OK via diplomat channels some time next year.

ZC5VR, we are advised by VK4FJ, is active on 14-mc phone, 14284, he is located in Sandakan, British North Borneo, where he works as an electrician. He skeds VS1EZ. Status of his prefix is not quite clear to us as Sandakan is the capital city on the Borneo east coast and should come under a VS4 call. See QTH's.

OQ0. ., OQ5RA advises that Belgian Congo officials have agreed on a change of prefix of the trust territory of Ruanda Urundi from OQ5 to OQ0. The International Bureau at Berne will be so informed. We trust this action will favorably influence the listing of Ruanda Urundi as a separate country. Presently active there are OQ5CZ and OQ5DZ.

CE0AA, CE3AG wishes to advise that, if and when, this radio expedition goes to Easter Island, as set forth in Nov. CQ (this may be influenced by the recent Chilean Presidential election), the following operating procedure will be maintained: CE3AG will take care of the CW end and transmit on the low ends of the 7-, 14-, 21- and 28-mc bands. CE3CZ, Arnold, will handle the phone end preferably on 14,100 and 28,100 kc. Do NOT call CE0AA on his own frequency. The operator will indicate what part of the band he wishes to receive

answers on (10U, 15U, etc.). All QSO's will be of the contest type, confined to a simple RST report. Additional remarks may be sent with your QSL. Plans are made to have CE0AA on the air 24 hours a day to give all a chance to QSO during their short stay.

MP4BAF has been heard in Qatar on 7048 (Oct.) while MP4HBK holds forth in Trucial Oman, A3, 14120 . . . VQ2JW is operating from Barotseland, a province in VQ2 land which 2JW says should be counted separately. . . VP2AJ has been heard active on A3 around 14182 while VP2MD skeds his brother, VP6JV, 7045, 1215 z. . . From W8PQQ via SM5ARP we hear that VQ4CO will be active at VQ1CO, Zanzibar, during December. . . ZS6ZU/Marion Island has been reported by KG4AF,14131, A3. QSL to home QTH. . . Burt also reports VK1RR, Macquarie Is. is on each day 0530z, 046.

There will be increased ham activity in VP7, we are told by W4COK, with construction of Air Force installations on Grand Turk Island, Bahamas. Licenses have been granted W ham by the VP7 govt. with the very kind help of VP7NM. Future plans call for like installations on ZD7. . . VK9YT ops from New Ireland. He counts same as New Guinea. . . VS6CG advises there will soon be a VS4 active (ZC5VR ?). . . VK4FJ is getting QSL from AC4NC with assist from VU2JG. AC4NC visited Calcutta week of Oct. 10th.

Notes from F9RS: Chandernagor is now, officially, a dependency of India so FN8AD, located there, must be looked on as a 'pirate' with no value for certificates. The Indian towns of Pondichery, Karikal, Mahe and Yanaon remain in the French Union with the (possible) prefix of FN8 but there is no ham activity there at present. . . FF8PJ is again QRV. . . FR7ZA is active, usually on 14050 CW and 14150 A3. He looks for east coast U.S.A. QSO's from 1130 to 1300 GMT. . . Five FB8's, BA BB BC BE and BH, are now active. Two others will be on soon. . . F08AD skeds W6VFR and W6UHA on Sats. A3 380. . . 3A2's AH AJ and AU are on 14-mc phone. . . The calls of FD8AB and FG7XA are being pirated. SAB is in France on vacation while 7XA is QRT (Oct.) but should be active now. . . DL0 calls are German Club Stations. . . The pneumatic raft "Heretique" with Dr. Bombard, mentioned in previous issues, will carry no radio. Original plans called for communication between an HB9 station and the raft (3A8D) whereby the raft would answer with a 'dot' for yes and a 'dash' for no. Dr. Bombard seeks to prove that one may exist on products of the sea only and hopes to reach U.S.A. (Seems to us that it's hard



Above we see Dick McKercher, Jedda, Saudi Arabia, better known as HZ1MY FL8MY 4W1MY VQ6MY W6MLY—Nuff Sed!!



Pictured above are the North California DX Club Committee, host, this year for the annual No. and So. Calif. DX Club conference. Standing (L to R) W6WB (40-224), W6TI (40-213) Chairman, W6TT (40-229). Sitting (L to R) W6ATO (40-165), W6DZZ (40-229) Pres. No. Cal. DX Club Inc. This get-together promises to be a gala event and will be held at the Californian Hotel, Fresno, Calif. on Saturday and Sunday, January 17th and 18th, 1953. All WAZ and DXCC Amateurs throughout the world are invited to attend. Reservations may be made to the No. Calif. DX Club, W6TI Chairman, P. O. Box 75, Oakland, Calif.

enough to exist on land.)

Notes from the West Gulf Bulletin: VQ8AL, via W5NMA, says, There are five licensed stations in Mauritius. VQ8AD is on very little on account of QRL. VQ8AE has closed down. VQ8AF is mostly interested in CW traffic with Chagos Islands. VQ8AY has also closed down. This leaves VQ8AL as the only ham operating regularly from VQ8 land. . . .From W5ALA: VP5BF (Turks and Caicos) is on 020 or 074 from 1500/1600z each Sunday. He skeds W4LVV. . . .From VE3KF: ZD9AA operates 21 Mc. each day around low end 1600z.

"SOS SOS de KW6BI," greeted the ears of W6LW at 0330z Sept. 15th. Roy established contact at 0348 and received first news of the devastating typhoon which swept over Wake Island on that date. KW6BI (W6WYK), Merle Russ of Redwood City, Cal., a radio technician for PAA, was operating his rig from an abandoned pill-box with his emergency generator located in another. His equipment was later inundated as waves swept over the island. Thus, again, Ham Radio was on the job and news of this disaster was forwarded to Naval Authorities a full-eight hours ahead of other sources, a fact which was probably instrumental in an earlier initiated rescue operation. Nice going Merle!!

From the L.A. Times: "Trieste Rado Ham Tunes in Barbados Uncle by Chance: Rome, Sept. 30 (AP) U.S. Army Sgt. Joe S. Martin, operating from AG2AB, contacted VP6SD in Barbados, B.W.I. 'Say' he asked VP6SD, 'do you know any Martins there? I was born in Port of Spain, Trinidad, but a lot of my relatives are in Barbados!' The Barbados operator turned out to be Syd Martin, the sergeant's uncle. They hadn't seen each other in 22 years!!"

**Exploits**

W6AM upped to 238 with ZD7A while W6SN also nabbed him for 241. . . .W6GDJ goes to 221 with such

as FB8BB, FR7ZA and ZD7A. . . .W1FH rolls on to 251. . . .W3GAU hits 327 with MP4KAE. . . .VQ6 gave W2AGW 233. . . .VE4RO finally latched on to HI6EC, this with ZD7A, YJ1AB and EA9DC gave

*the DX GRAB BAG*

A resume of DX stations recently worked or heard from North America. Times are GMT and abbreviated frequencies 14 Mc.

C. W.		VU2JK	021	0239
AP2N	028 0205	YU1BX	060	1300
CR7LU	025 1325	ZB2A	011	2045
CR5AD	012 1800	ZE4JE	024	1330
CR7CH	150 1400	ZP6CR	012	2400
C3AR	080 1410	ZD2DCP	026	2155
CE7ZS	7035 0335	ZS7D	083	1343
CR7BC	7038 0443	ZP5AY	090	1315
DU1GT	040 1305	ZB1JZ	028	1930
DU1AP	030 1310	9S4AL	052	1520
ET2KZ	090 2125	3A2AF	068	1300
EA8BK	057 1835	FM7WF	142	2132
EA8BF	7003 2330	FR7ZA	145	2130
F9QV/FC	068 2110	FB8ZZ	200	1315
FQ8AG	089 2040	GD6IA	177	1730
FM7WF	125 0100	GD3UB	200	1600
FB8BH	140 0245	HI6EC	200	0220
FF8GP	055 2038	IS1AY	310	1350
FQ8AR	024 2040	KT1LU	324	1745
FR7ZA	121 1625	KW6BC	218	0320
FB8BB	023 1332	KB6AO	223	0612
FB8BE	040 1450	LB6XD	020	2225
FP8AP	062 1230	MF2AA	105	2035
FF8AG	018 2100	MI3KE	180	1845
FF8AJ	100 2113	MI3US	181	2150
FB8ZZ	051 1315	MP4KAC	137	1725
FB8BI	050 1327	OD5AB	300	0453
FA910	048 1300	OQ5BG	190	2226
FM8AD	7030 0430	TA3AA	310	1454
HZ1AB	062 1615	VS1EZ	135	0748
JY1AJ	057 2045	VQ4DQ	123	1855
KA2US	110 0150	VQ5CY	135	1330
KA2AA	082 0500	VP2AJ	180	2240
KM6AX	080 2010	VP5BF	106	2105
LZ1KAB	7035 0500	VK9DB	170	1320
LB6XD	020 2145	VP2SE	195	2315
LU4ZI	045 1310	VQ4ERR	125	2115
MB9BJ	072 1305	VP2LE	184	1235
OQ5CZ	053 1935	VP2AF	182	1125
OD5AB	090 0200	VP1SJC	135	1325
SP5AB	015 2040	VQ8AL	340	1320
ST2GL	021 2100	VP2DC	195	2200
TF3MB	052 2115	VK9FN	195	1330
TA3AA	028 1840	YI3BZL	123	1630
UA2KAW	067 1135	YJ1AC	318	0550
UG6KAA	065 1158	ZK2AA	195	0610
VP8AN	047 1300	ZS3F	121	1320
VQ4FCA	197 1855	XZ2KN	310	1300
VP8AP	010 0030	ZS7C	290	1240
VP5BF	078 1615	ZD6RD	191	1330
VK6SA	7005 1215	ZM6AA	317	0645
VQ3BM	055 1300			
VS9AW	148 1720			
VK9DB	089 1320			
VS6AE	060 1415			
VP3VN	085 0030			
VP8AE	100 1835			
VQ2AH	089 1840			
VP1AA	000 2355			
VS7GV	049 1216			
VP8AU	050 0005			
VP2MD	074 0150			
VP2MD	7045 1200			

PHONE

AG2AB	100	1130
CR6AT	120	2155
CS3AC	324	1330
CR6BX	195	2315
CR7AG	218	1302
EL9A	325	1923
FI8AA	210	1355
FF8AR	140	2120
FF8AS	305	2115

Thanks to the West Gulf Bulletin



George 233. . . . LU6DJX adds 12 to put Alfredo on 229 . . . . ZL2GX comes up to date with 13 more, making Jock 228. . . . W6PB adds 11 setting Dan on 221. . . . KH6IJ adds VS5ELA, LB6XD and FB8ZZ for 218. . . . Guy, W6DLY ups to 216 with MP4BBD, FR7ZA and VS5ELA. . . . W6TI reaches 213 with VQ6MY and MP4BBD. . . . W6EPZ hooked HE1JJ/HE and FD8AB for 208. . . . I1XK comes up to date with 27 additions to reach 167. . . . W5ASG leads the 39-zoners with 236 after hooking VQ6MY and ZD7A. . . . W2NSZ follows closely behind with ZD7A and 230. . . . AL, W2WZ ups to 226 with ZD7. . . . W9LNM reaches 213 with LZ1KAB, KJ6AR and VQ6MY. . . . Norm, W1HX goes to 211 with I5PR, ZD7 and ZK1BC. . . . W5MPG adds such as LB6XD, ZD7 and VQ6 to reach 199. . . . VK4FJ adds JY1AB, VP5BH, CR6BZ and VQ6MY putting Stan on 197. He still seeks card from VP2LE. . . . W5FFW hits 194 with six additions. . . . KP4KD adds overlooked Palau for No. 193. . . . SM7MS adds Zone 39 and five new ones for 164. . . . KL7PI comes up with three more to reach 153. . . . W9NZZ makes it 146 with such as 3V8AN, VQ5CL, VQ6MY, KC6DX and ZD4BH. . . . W2GVZ elevates to 171 with VQ6 and ZK1BC. . . . TF3SF brings his list up to date putting him on 145. . . . OZ7BG adds C3PG, KC6QL and VP8AP giving Eric 170.

W1APA adds LU4ZI for 136. . . . W5JUF sends new list with 200 CW and 165 phone. . . . ZL1QW adds ten giving Alec 134. . . . KG4AF nipped ZK2AA and VK9YT. This gives Burt 172 for about a year's operation. . . . W2ZVS adds 11 to reach 140. . . . W1RAN snagged C3PG for No. 137. . . . W0GBJ goes to 116 with FP8BX, KM6AX and KX6AL. . . . S. Willard, W1NWO keeps a firm grip on the 36-zone phone group adding VS2, ZD7, CE7ZM and VQ6 for an even 200. . . . Mrs. Lou, W1MCW keeps close by with ZD7 and VQ6 for 197 A3. . . . New list brings W5JUF's phone total to 35-165. . . . W5ASG tags right along with FB8ZZ and GD3UB for 35-162 A3. . . . An error on our part kept YV5AB at 34-129 A3. Correct total is 34-139 A3. Sorry . . . . W2ZVS adds VP7NM on the mike for 129. . . . ZL1HY is up to 230 CW with such as VP8AU, FL8MY and VS5ELA. Daves ZD7A made it 242, 227 confirmed, for W1ME. . . . W1DIT got No. 143 with ZK1BC. . . . W8PQQ was first CW QSO at HZ1MY/VQ6. . . . W3AS rec'd. WBE No. 1708 and WAVE No. 95. . . . W9FID just got his DXCC with 207. All on 14 Mc. . . . W6GDJ nabbed VQ8AL on CW 14150. . . . W2CTO nailed LB6XD for No. 187. . . . V87NG, says W4BRB, needs North America on 3.5 to complete WAC on that band. He will be on 3510 nightly between 0100 and 0200z. . . . 9S4AX plans 3.5 activity on 3502 and 3560. . . . W6LW nabbed VQ5AU



Needing no introduction to DX'ers is Norm Young, W1HX, Melrose, Mass. Norm is just about to flip the switch and give ZD7A a call.

who sports a rhombic with 75 watts. . . . W1DSF hooked with two J's to reach 32-118. . . . G3AAM reports CR9AF active on 7 Mc. . . . W3OP has 200 cards out of 201 and seeks missing one from MD4BPC '49.

YS10 keyed with FB8BE, VS5ELA, C3AR, VP2MD and ZS2MI. . . . GD3UB, via W1BUX, wants it known he will be on 1800 kc. each Tuesday 0500z. . . . W3JSH added LZ1KAB, F9QV/FC and CR6BZ. Nice going Dottie. . . . W6PCK has worked 35-148 all on 28 phone . . . . KA9AA is W4VE. He is now active on Hokkaido Island, Japan. See QTH's. . . . Latest worked at W4KE are W5AGB/FM, 5A2TZ, ZK1BC, TG9LC, SL3AU, KA9AA, CP1BX and ZB2A. . . . Bud, DL4LQ, is doing OK with six watts with TF5TP, LZ1KAB, KV4AA, HZ1AB, SU7NS and ZS6RY to mention a few. . . . K2BU got a few new ones in MP4BBD, ZK1BC, HZ1MY/VQ6, VQ4DO and 3V8AN. This gives Ken 141. . . . W6ZZ reaches 123 with KC6QL and CE7ZQ. Miles is going strong on 21 Mc. with KH, VK, ZL, KP4, CE, KZ5, OA4, LU and KV4 contacts. . . . Note: Please resubmit contacts with 6L6MY for credit on Honor Roll. (exception W6TI).

**Here and There**

VE2LI, (ex-G5LI) visited W1BUX. . . . W6GHU is now W7GHU. W6GAL is also in Tucson. . . . F7AW

(Continued on page 65)

Endorsements to the HONOR ROLL which appeared in the September issue .

W1FH	40-251	KP4KD	39-193
W6SN	40-241	SM7MS	39-164
W6AM	40-238	KL7PI	39-153
W3GAU	40-237	W9NZZ	39-146
W2AGW	40-233	W2GVZ	38-171
VE4RO	40-233	TF3SF	38-145
LU6DJX	40-229	OZ7BG	37-170
ZL2GX	40-228	W1APA	37-136
W6GDJ	40-225	W5JUF	36-200
W6PB	40-221	ZL1QW	36-134
KH6IJ	40-218	KG4AF	35-172
W6DLY	40-216	W2ZVS	35-140
W6TI	40-213	W1RAN	35-137
W6EPZ	40-208	W0GBJ	35-116
W6MHB	40-184		
I1XK	40-187		
VK2AM	40-151		
W5ASG	39-236	PHONE ONLY	
W2NSZ	39-230	W1NWO	36-200
W2WZ	39-226	W1MCW	36-197
W9LNM	39-213	GM2DBX	36-156
W1HX	39-211	W5JUF	35-165
W5MPG	39-199	W5ASG	35-162
VK4FJ	39-197	YV5AB	34-139
W5FFW	39-194	W2ZVS	34-129

The next complete HONOR ROLL will appear in the January issue

**DIPLOMA DO MUNDO PORTUGUES (D.M.P.)**

Worked Portuguese World—W.P.W.

This will be awarded to any amateur showing proof of contact with at least one of each of the following:

- CT1 Portugal
- CT2 Azores
- CT3 Madeira
- CR4 Cape Verde
- CR5 Portuguese Guinea
- CR6 Angola
- CR7 Mozambique
- CR8 Goa, Damao, Dui.
- CR9 Macau
- CR10 Portuguese Timor

Send cards to "Rede dos Emissores Portugueses, Travessa Nova de S. Domingos, 34, I. Lisbon, Portugal.

the

# VHF

Edited by  
W. E. (BILL) McNATT, W5FEW  
6614 Plaza Drive, Houston 21, Texas

# news

## W5RCI-W5AXY Take 220 Mc. DX Record!

On Sunday morning, October 5th, shortly before 0800 CST, W5RCI and W4HHK discovered the two meter band was open to Texas. Swinging into action, Paul and Audie contacted the Texas stations on two-meters and asked them to switch to 220 Mc.

At about 0807 CST, W4HHK heard a weak carrier on 220 Mc., thought to be that of W5AXY (600 miles), but not positively identified. At about 0830 CST, W5AXY, Austin, was copied on 220 by W4HHK, at a distance of nearly 600 miles. W5BDT and W5RCI got hooked up on 220 Mc., with some effort, for a new 220-mc DX record of about 525 miles! W5RCI is on 220.2 Mc. with p.p. 24Gs and W4HHK is on 220.05 Mc.

At 0900 CST, W4HHK had to leave for work, *very* reluctantly, having made no contacts on 220 . . . and with W5BDT's 220-mc signal still coming through . . . weak, but readable!

At W5RCI, reception of W5AXY's phone signal was weak; *CW would have done the trick*, but it was no go on phone! When this was taking place—the opening, that is—the leading edge of a cold-front formed a line running from Tennessee to northern Texas. This front passed Memphis about 0930 CST. It was about this time that W5RCI noticed 220 and 144 Mc. dropping off. W5AJG was known to have been on 220 during the opening, but was not heard by W4HHK. That night, no signals were heard from Texas on 144 or 220 by either W5RCI or W4HHK.

"Tell the v.h.f. gang to please use CW when the going gets rough!" W5RCI and W4HHK plead.

## Two-Twenty In Texas

Waldo, W5FEK, says that it looks like one end of the 220-mc record returned to Texas with the W5RCI, Marks, Mississippi—W5AXY, Austin, Texas contact, after the record was held briefly by W1HDQ and W8BFQ. Too bad, Ed! But, Texas just had to take the record out of Yankee-land again.

With W5FSC down for rebuilding and W5ONS, W5AXY and W5BDT with their beams locked on Mississippi-Tennessee, 220 activity in South Texas has been rather skimpy.

The hard-luck guy is W4HHK, who *almost* had one end of the record, had to leave for work before he could make the Texas contact! But, we still insist that Paul will be one of the next 220-mc record holders.

## 420 Mc. Notes

First 420 Mc. contact between Houston and Victoria was made on October 1st, by W5AYU and W5ONS, a distance of 90 miles. Signals were good for over two hours that night, ending when W5AYU had insulator trouble. Lee was using a 4X150A running the legal limit, and Herb was running about 10 watts to an AX-9903 tripler. W5ONS uses a converted BC-788 receiver, while W5AYU has a very hot home-spun converter.

W5PKJ, Houston, is the latest convert to 420 Mc., keeping nightly schedules with W5AYU. Whitey uses a converted BC-645.

W9PK, Downers Grove, Illinois, has the APS-13 going and W9LDS has been worked crossband with good signals. W9MBI, Coleta, loaned Jack his old, tunable 420-mc converter and schedules will be set up soon. Clair is on 434.04 and W9PK will be on 432.9 Mc. Jack has a 16-element beam 45-feet high for 420 Mc. Both stations have 220-mc gear in the planning stage.

W2QED, Seabrook Farms, New Jersey, reports the following eastern stations active on 420 Mc.: W3GGR, W3KFM, W3RE, W3AIR, W3BSV, W3JPX, W3RKQ, W4ODG, W4VVE, W2BLV, W2TP, W2EH, W2HEK, W8BFQ and W1HDQ. Ken should know—he worked all of them one or more times during September for a total of 70 contacts 5 call areas, 15 different stations and 8 v.h.f. contest contacts!

## Seabrook 144 Mc. Story

"Here's my end of the terrific September opening," writes W2QED. "It was just by accident that I caught it. I got on the air to check a new converter I had built for another ham, and the first thing I heard was W2UK calling a W9. So, I swung my beam west and, first crack, worked W0TMJ in Missouri, just 40 miles east of Kansas City. I followed that with W4BCT in Virginia; W3FPH in Pennsylvania, north of Pittsburgh, then W9DDG in Wisconsin; W0EMS, Iowa; W4AO, Virginia; W8SRW, Ohio; W8SFG, Ohio; W9ECH, Indiana; W0GUD, Iowa; W9EQC, Illinois; W9GLW, Indiana, and W9LF, Illinois. By this time it was 4 A.M. and I was dead tired. I had worked 6 new states bringing my total to 18. My best DX was Adair, Iowa, approximately 1,022 miles, and I had a total of seven sections having added two new ones.

"I was on early the morning of the 9th and worked W1HDQ, Connecticut, W8BFQ, Ohio, and my last far west contact was W9FVJ, Illinois, at 11:02 A.M. When I first came on at about 7 A.M., W0EMS was still coming through until he had to leave for work.

"That night, I worked VE3AQQ for my first VE3, then W8HUX, Ohio and W2DXZ, Niagara Falls. After

midnight, on September 10th, VE3BQN, VE3AIB, W2ORI, W2OQW and W3RUE. By this time, it was 3 in the morning and I had to get some sleep. However, later in the morning, at seven, I worked W2UK, New Jersey, W1PBB, Connecticut, W8SFG, Ohio and W8BFQ, Ohio. Then started the heart breaker. We switched to 420 and W8BFQ heard me, S-1/2, but I couldn't hear her low-powered tripler. They (Margaret and Jerry) had had the bad luck to break the AX-9903 in the 420 final and had no replacement! However, in hopes of conditions improving, we checked every half hour and although her two-meter signal was running 9-plus, the 420 signal stayed stable, until the last time she could hear me on 420, at 11:06 A.M. She was still coming in on two until 12:30 P.M. After that, two was out, also. That night, 420 was good up and down the coast and I worked W4VVE in Virginia for the first time. Two was also good but I didn't work much, as I spent most of the time on 420 Mc. and worked W4CVQ at 1:47 on the morning of the 11th."

### Virginia V.H.F.

The opening of September 9th was the best ever observed in Virginia, according to W4UMF. W4AO worked Iowa, Missouri, Illinois, Indiana, Michigan, and Wisconsin. W3AIR worked all of these except Missouri and Indiana (with only 7 watts output!), and W4UMF managed to snag Michigan and Illinois.

"All in all it was a lot of fun. The band didn't really open until after midnight and was open until noon of the next day. As a consequence of the late opening, many of the locals had gone to bed. The following night the band was red hot to VE3. Most of the local fellows worked into Canada and W4CVQ, in North Carolina, also got into the act and gave the boys all up and down the coast and over into VE3 land their 1st North Carolina contact.

"A lot of fellows missed a Virginia contact in these openings because they forgot their b.f.o.'s. We were all using CW as well as phone, down here. Even if they can't use CW themselves, they should tune with their b.f.o., for a lot of boys with 522s were rolling in here and didn't even hear us calling them on CW with 100 to 1000 watts! Even if the local QRM was bad at their end, they should have heard some of our calls. Almost all of the stations around here have and use CW. So, fellows looking for Virginia should use their b.f.o.'s!" Tom advises.

W4SRD should be given the order of the "Faithful Few". He has done more than anyone else in this area to keep up activity on the band, according to W4UMF. W4UBY, with his 100 watts and a "Brownie Beam" on a 60-foot tower, has been getting out very well, recently. . . W3GKP is back on with low power and a 20-element beam. . . W3RE is also back. Robbie has his 32-element beam up and is running 500 watts or so, again. . . W4AO's stacked rhombics are working out very well. . . W4UMF is running 100 watts to a 20-element double "Brownie Beam" now, and is getting out pretty well despite a poor location. The northeast is by far his poorest direction; so, Tom has worked no W1s as yet. He'll try to get them on aurora. W4UMF has worked 11 states this summer, with W9EQC at 600 miles as best DX.

### In And Around Chicago

Illinois-Wisconsin v-h-f men enjoyed a nice picnic on September 29th at W9IMQ's home. A nice crowd of 50 or 75 hams attended. They came from as far as Sheboygan. Some of the Wisconsin boys were WN9SDH, W9FAN, W9TQ, W9LJV and W9UJM, according to W9NW.

W9QM, on 2-meters, during the summer, picked up Minnesota, Iowa, Missouri, Wisconsin, Illinois, Indiana, Michigan, Ohio, Pennsylvania, West Virginia and Ontario, Canada.

Lyman is on 144.1-mc AM with 60 watts, and 144.2-mc NBFM with 120 watts. The antenna is a 5-over-5 Riverside beam, 45-feet high. "The Minnesota boys, 'Five of them' QSL 100%; also, Iowa," says W9QM. W9CPF is trying hard to get all set for 2-meter AM, as is W9UDT. W9IWE is back on 2-meters, using NBFM and a 5-over-5 Riverside beam.

W9PK reports that from September 1st to 6th, nothing unusual occurred—just the regular schedules with W9TQ and W8MRK, plus a few local contacts. On September 7th, nice contacts were had with WNØGUD, W8BFQ and W4HHK. Paul gave a bunch of the guys a new state. Shortly after midnight, W5RCI was

worked for Jack's first W5. Both Paul and Rex were worked by W9TQ, which is not too bad a haul! September 8th and 9th produced the following: W3RUE, W4AO, W8EP, W8BFQ, W8ZEJ, W2UTH, W8JVP, W3WBM, VE3AQQ, and after midnight, W3QKI. All these were phone QSOs. W8EP was worked again by W9PK on the morning of the 12th at 8 AM. Things went along normally until September 27th when W8OQ, W3QKI, W8FQK, VE3BMB and W8KAY were worked. During the W8KAY contact, the fellows checked for aurora, and it was there as it had been for the last four days, but signals were extremely weak. The balance of the month was normal. During the September VHF QSO Party, W9PK had 66 contacts in 5 sections, which is believed to be high for Illinois.

### Indiana Incident

On the nights of September 29, 30 and October 1, 2 and 3, under the cover of darkness and with the help of Norm's sis, W9EWO was boxed up and stored in trunks and slowly moved out of the dangerous "Tennessee Valley." If one looked real close and was careful not to be shot with an arrow, scouts could be seen on almost every house. Some were on the cones and others could be seen on the chimneys—still others could be seen perched high up on a long pole! Real "cloak and dagger" stuff!

"Due to complaint on complaint, and call after call about TVI, I sold the shack and the lot that it was on, so I am no longer on the air," explains W9EWO, Lebanon, Indiana. "I have everything boxed up and stored here at my mother's home. I hope to be back on the air in December, but don't know if I can make it. I now have 40 acres on U.S. 52, northwest of Lebanon, but don't have any buildings on it, yet. During my week off, am going to start the shack and get my 2-meter antenna up, but don't think I can get the building done in 6 days time, hi!"

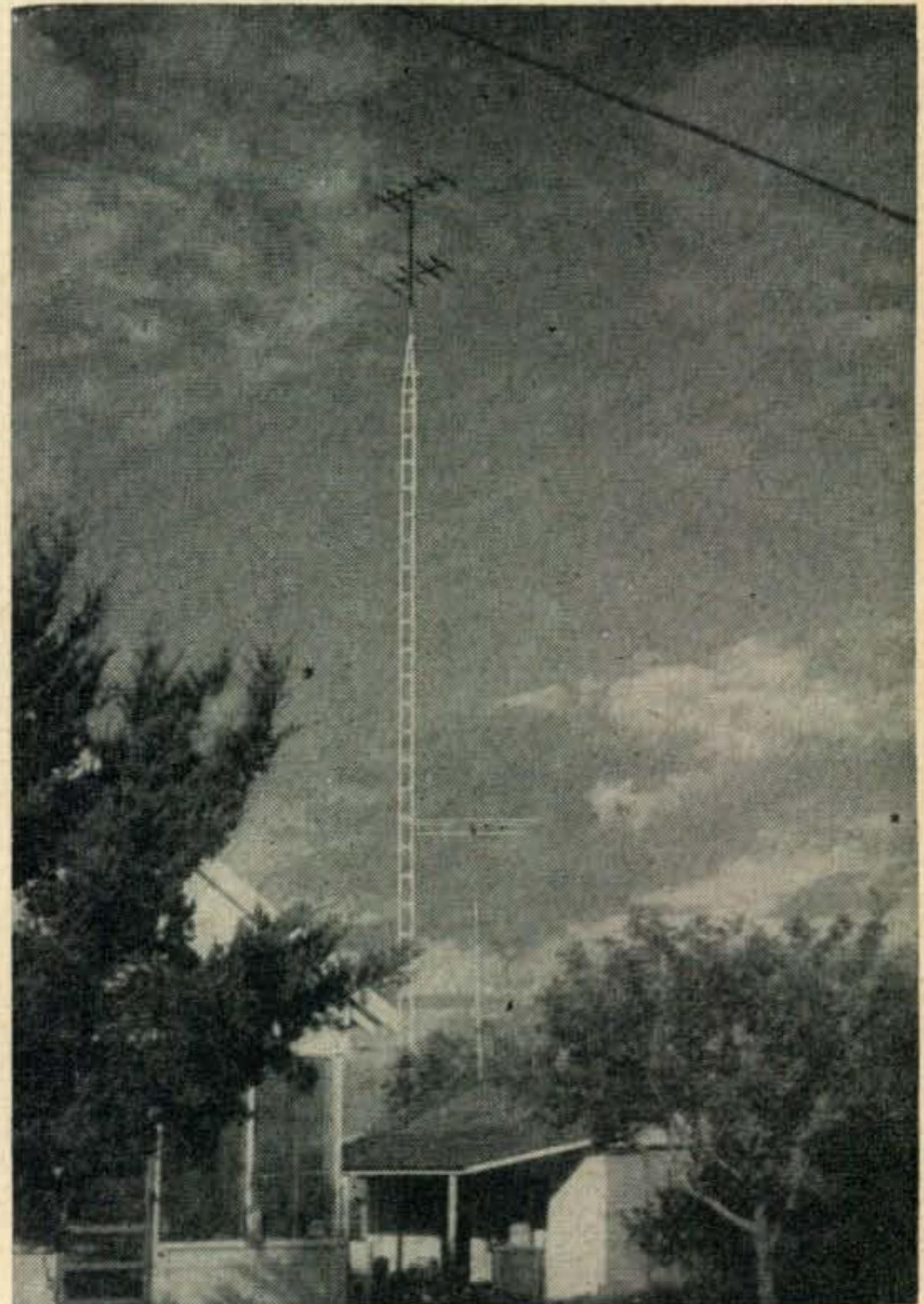

An Edna, Texas landmark is the 60-foot tower of W5IVU. Hank Dittrich has his own version of "Brownie's Twin-5 Beam" designed to match a 52-ohm coaxial cable. W5IVU runs 90 watts to an 829B and uses a 6BQ7 converter for receiving. His is one of the most outstanding signals on the Gulf Coast.

## W9WOK Aurora Observations

My pet peeve for the month of September is that possibilities for aurora contacts were very great. For example: I personally monitored aurora reflections on signals just outside the six-meter band on 11 days out of 30 possible days. Reflections in many cases were also heard on 2-meters; however, with the east-west openings, beams are not oriented to the north. As previously reported, there was an aurora during the "Madhouse"; however, I could get no cooperation in getting a contact to tie it down, but thanks to W3QKI, we tied one down during the tropospheric opening of September 27th and 28th. I was monitoring reflections on the low side of six during this opening and finally nailed W3QKI on phone at 12:50 p.m. CST, September 28, and had him turn his beam north, resulting in an aurora contact with signals reaching a peak of S-4. We both worked at it with the beams north for a while, but gave up trying to attract attention of other stations and concluded with another aurora contact before turning beams back on each other. The pity of the whole thing was that I wasted about three hours CQ-ing into the north prior to attracting W3QKI by phone. The same amount of effort and time was required to crack the aurora of September 29th when VE3AIB answered one of my CQs at 9:25 p.m. CST. Reports were 532 (his) and 555 (mine). Incidentally, there was a mild tropospheric opening at this time with best DX heard here being Ohio.

The aurora dates include September 7, 8, 9, 10, 11, 13, 25, 26, 27, 28 and 30. I have interested myself in the openings that the rest of the boys have not stumbled into, such as the September 25th opening. The auroras have been either not visible, or barely visible here.

I don't mean to imply that we generally experience simultaneous aurora and tropospheric propagation, but that aurora openings have been so frequent that when a tropospheric opening gets the boys on the air, we can tie down the auroras. The significant thing to recognize is that unless the boys do something about smoking out these possible aurora openings by monitoring another service (monitoring WWV is elementary and unsatisfactory, and not used at all here) we will continue to miss more than 90% of the aurora openings, as I am convinced we have done in the past. For all I know, there have been other dates during September for aurora, but as I mentioned, these are the only ones I have personally observed.

Aurora dates for the first 2 weeks of October included October 2, 3, 4, 5, 6, 10, 11 and 12, which means that it was open for six-meters on these dates and probably most of them for two-meters. On October 2nd, I heard W9EGH and W8DX keying and apparently working at about 6:30 p.m., but heard no more, and made no contacts. At 12:01 p.m., October 5th, I worked W2ORI but heard no others in nearby states or districts, either on CW or phone. Reports were RST 555 on the second contact which ended at 12:48.

The main difficulty is getting activity at the right time as my findings are that generally, the best aurora period is from 12 midnight to 4 a.m. W9WOK observes. W2ORI would not schedule, but I am sure I could have worked him on two-meters on 75% of the dates mentioned above. The condition at sunset is just a tease as compared to the early morning hours!

## Ohio Aurora

W8UEY reports from Alliance, Ohio, that aurora was good on 2-meters from 2025 to 2135 EST on the night of September 25th. He didn't work a soul, but heard strong signals from the following during the period: W1PBB, W1PHR, W2NLY, W2AZL, W2RPO, W2OPQ, W3LZD, W2ORI, W8RMH, W8DX, W9EGH and W9MAL—all on CW. Some signals were breaking through after 2135, weaker and for only a short time.

## Texas Two-Meter Topics

W5TFW has a new rig with an 829B final on 2. It's much better than the old rig. . . . We also have another addition to the 2-meter gang: W5CZ, Homer, of Lake Charles, Louisiana. . . . WN5UJP has lost his "N".

W5TFW had a terrible time working W5PMM during the contest but finally did make it. Conditions were not good at all, then. Next morning, the band opened up to Houston and Victoria!

On the morning of October 2, the band was open east to west. W5TAF, W5FEK, W5QIO and W5ONS were worked at W5TFW. John heard W5NZX, and then

worked W5TKF off the back of the beam; signals were very good from both directions. In the evening, W5TFW worked W5QFA, Corpus Christi, and W5PMM. W5QFA was outstanding and really gave the band a working over.

**October 4, night:** Stations heard; W5VPA/5, WN5WTN, W5SVB, W5QME, W5JBW, W5NZX, W5TAF, W5QIO, W5QFA, W5CZ, W5FEK and W5HEM. W5QFA again had the outstanding signal, and was making up for lost time.

**October 5, morning:** The band was open to the north, west and east with W5PMM, W5VY, W5QIO and W5ABN worked at Port Neches. The band was open all around with quite a bit of activity. W5ONS, W5RPT, W5AXY worked W5RCI, Marks, Mississippi, on 2. W5AXY and W5RCI contacted on 220 Mc.

**October 6, morning:** W5TAF and W5QIO were worked; the band was going out as a cold wave was coming in.

## "Gopher Network" Organized in Texas

Organization of the Gopher Network in south Texas has started with W5IVU of Edna as net control, according to W5FEK, Houston. This net, composed of two-meter hams, is dedicated to the purpose of tearing down everything that is held "sacred" by other networks! One of the many requirements, which vary from day to day, is that each member "insult" every other member at least twice during each transmission. To make things interesting, at roll-call time, every member reports in at the same time on different frequencies! A member is kicked out if he misses one drill, which are held at any time two members can get together, but may kick himself in the next time he hits the air and can get the members in good standing to listen to him. There will be ten charter members, and certificates appropriate for the dignity of the net are being prepared. The charter members' certificates will all bear the number 1 so that no one's feelings will be hurt.

It seems that W5IVU has held a lot of trouble with gophers and finally has admitted that the gopher is smarter than he is, so the president of the net is A. Gopher. Every member is a vice-president. Nomenclature suitable for such a net is used. For example, coffee is "stump squeezings", a piece of equipment is a "gismo": nothing ever works, it "gins"; a conversation is a "filibuster." R. I.s are "snoopy stations," and when a member can't take it any longer or wants to quit, he is "unwound." By-laws are very flexible—any member can change them at any time without the consent of any other member. We will report further developments from time to time.

Organizers of the network are W5IVU, W5ONS, W5TAF and W5FEK. The "Gophers" are dedicated to more contacts on two-meters. After the 10 charter members are lined up, if that many "zanies" can be found who want to have anything to do with such a motley crew, ten contacts with ten members is all that is required, to join.

## Houston Highlights

After a very disappointing summer, two-meters on the Gulf Coast came to life between October 1 and 5, with signals from Collierville, Tennessee, to San Antonio and Austin, Texas, being heard and worked in the Houston area, W5FEK reports. Among the many stations participating were W5TAF, W5PMM, W5RCP, W5ON, W5VHF and W5FEK, Houston; W5TNK and W5UUK, LaPorte; W5CZ, W5UJP, Lake Charles, Louisiana; W5VY and W5UB, San Antonio; W5RAL, New Braunfels; W5JBW, Maplewood, Louisiana; W5QME and W5QIO, Beaumont; W5BDA/5, Seabrook; W5AXY and W5BDT, Austin; W5AJG, Dallas; W5MWW, New Boston; W4HHK, Collierville, Tennessee and W5JTI, Jackson, Mississippi.

W5GYP, Edinburg, Texas, expects to be on two with 300-400 watts in the near future. He reports receiving many stations during the first of October opening. Edinburg is in the lower Rio Grande Valley, and Otto will have one of the southernmost two-meter stations in the United States. This scribe (W5FEK) believes that contacts on 144 can be made regularly into the valley, as almost the year around we have nightly coastal inversions. Many of GYP's contacts would be largely over water. The general trend of thinking among the valley hams is that two-meters is no good down there, but

(Continued on page 58)

# Ionospheric Propagation Conditions

Forecasts by GEORGE JACOBS, W2PAJ

3620 Bedford Ave., Brooklyn 10, N. Y.

The winter solstice will occur on December 22nd. This is the day on which the distance between the sun and the earth is less than at any other time of the year. This astronomical phenomena will have its effect upon shortwave DX conditions. Since the sun is nearest to the earth during this period intense ultraviolet radiation from the sun will sweep across the ionosphere, more intense than at any other time during the year. This intense radiation will result in a very strong *daytime* ionosphere that will be able to reflect much higher daytime frequencies than during the other months of the year.

In addition to being nearest to the earth at the time of the winter solstice, the sun, as viewed from the northern hemisphere will be furthest in the southern skies. This means that the zenith sub-solar point, or that point on earth that is directly beneath the sun, when the sun is directly overhead, is further south than during the summer and fall months. In the northern hemisphere, as we all know, this results in longer hours of darkness and less hours of daylight. During the hours of darkness ultra-violet radiation from the sun can not reach the ionosphere, and it starts to de-ionize or become weaker. Since the longest periods of darkness in the northern hemisphere occur during the winter solstice period, the nighttime ionosphere will de-ionize to its weakest point during this period. Therefore, during December and January, while daytime usable frequencies on most circuits are at their highest values of the year, nighttime MUF's are usually at their lowest yearly levels.

Moderate to severe ionospheric disturbances expected Dec. 18-20, and 23-27 with the possibility of unstable conditions on Dec. 3 and 6-8.

To amateurs this simply means that 10- and 15-meter activity should reach its yearly peak on daytime circuits, and 20- and 40-meter DX possibilities will decrease on many nighttime circuits.

Nighttime solar absorption and atmospheric noise levels in the northern hemisphere generally decrease during the winter solstice period, while 80- and 160-meter DX possibilities are usually at their best during this period.

The forecast for December is for DX possibilities on all bands from 10 meters to 160. The predicted smoothed monthly sunspot number for December is 40. The sunspot count is still going down, with the minimum believed to be at least a year off.

In using this month's "Propagation Tables" remember that 80- and 160-meter openings will occur during the hours shown for 40-meter openings, but usually less frequently.

## General Propagation Conditions—

December 1952

### EUROPE

Erratic 10-meter openings expected on some days from eastern and possibly central U.S.A. Conditions more favorable to southwest Europe than other areas. . . Good DX openings expected to all areas of Europe from eastern and central U.S.A. on 15 meters with occasional openings to the Pacific Coast area. . . Daytime conditions on 20 meters expected to be fairly good, with the band going out considerably earlier than during the summer and fall months. . . Fair DX conditions expected for 40 with this band also going out quite a bit earlier than during the fall months. . . When forty goes out to be sure to check 80 and possibly 160 meters as the MUF may not be as high as 7 Mc., but may be high enough to permit 80- and 160-meter transmissions.

### SOUTH AMERICA

Good DX conditions expected on all amateur bands, ten through eighty meters with some 160-meter openings possible to Central America countries. The 10-, 15- and 20-meter bands can be used for daytime circuits, and the 40- and 80-meter bands for night-time circuits. North-south circuits are little, if any, affected by ionospheric disturbances. During such disturbances when circuits passing through or near the auroral zones are not coming through it may still be possible to work the South Americans.

### AFRICA

Fair 10-meter possibilities from eastern and occasionally central U.S.A. to North Africa, with openings also possible to Central and South Africa. . . Some fair to good 15- and 20-meter openings expected from most areas of the U.S.A. to all areas of Africa. . . Some 40-meter night-time openings expected from Africans north of the Equator to most areas of the U.S.A. Exceptionally good night-time conditions expected on 40 and 80 meters from eastern U.S.A. to North Africa, with the possibility of 160-meter openings on propagationally quiet nights.

### OCEANIA

Ten-meter DX favors West Coast QTHs, with only a rare opening possible to central and eastern U.S.A. . . Slightly better possibilities for all areas on 15 and 20 meters, with good circuits expected on these bands from West Coast to Oceania. . . Some 40-meter openings possible, but not too much for 80- or 160-meters since it is summer time "down under" and local atmospheric noise levels are quite high.

### ASIA

An occasional opening expected on 10 meters from west coast U.S.A. to the Far East, and possibly a rare one from east coast U.S.A. to the Middle East. . . Conditions somewhat better on 15 and 20 meters, with some fairly good night-time 40-meter circuits expected from west coast to Far East. Because so many of these Asiatic circuits pass through or near the auroral zones, Asia becomes quite a difficult area to work from many sections of the U.S.A.

As another year draws to a close, W2PAJ wishes every one everywhere a very Merry Christmas and a very Happy New Year, and may 1953 be filled with rare DX contacts despite the disappearing sunspots.

**EAST COAST TO:  
(Centered on  
Washington, D. C.)**

	10 Meters	15 Meters	20 Meters	40 Meters
<u>ALL TIMES IN G M T</u>				
Scandinavia	1330-1530 (0-1)	1330-1600 (2)	1200-1730 (2-3)	2200-0800 (1)*
Great Britain & Western Europe	1400-1630 (1-2)	1300-1730 (3-4)	1200-1600 (3) 1600-2000 (3-4)	2200-0900 (3-4)
Balkans	1330-1530 (1)	1300-1630 (2-3)	1200-1600 (2) 1600-1800 (3)	2200-0500 (2-3) 0500-0900 (1)*
Central Europe	1330-1530 (1-2)	1300-1600 (3)	1200-1600 (2-3) 1600-1800 (3-4)	2200-0700 (2-3)*
Southern Europe & North Africa	1300-1730 (2-3)	1200-1900 (3-4)	1130-1600 (3) 1600-2030 (3-4)	2130-0830 (3-4)
Central & South Africa	1400-1600 (1-2) 1600-1830 (2-3)	1200-1630 (1) 1630-2000 (2-3)	1130-1800 (0-1) 1800-2200 (2-3)	2200-0530 (1-2)
Near & Middle East	1300-1500 (1)	1230-1530 (2)	1200-1700 (1-2)	2200-0200 (2-3) 0200-0500 (1)
Central America & Northern South America	1600-2030 (3)	1300-2000 (3-4) 2000-2230 (4)	1230-2000 (3) 2000-2330 (4-5)	2200-1200 (4-5)
South America	1300-2000 (2-3)	1200-2000 (2) 2000-2200 (3)	1130-1300 (2-3) 1300-2000 (1-2) 2000-2300 (3-4) 0500-0700 (1)	2200-0900 (3)
Hawaii	1830-2200 (2-3)	1700-2130 (1-2) 2130-0000 (3-4)	1600-1900 (2-3) 1900-2200 (1-2) 2200-0130 (3-4)	0330-1430 (3-4)
Australasia	2100-2300 (1)	1430-1700 (1-2) 1930-0000 (1-2)	1300-1500 (2) 1500-2200 (1) 2200-0130 (2)	0600-0900 (1) 0900-1300 (1-2)
Guam & Pacific Islands	2130-2300 (1)	2130-2330 (2)	2000-2200 (1-2) 2200-0130 (2-3) 1100-1300 (1)	0700-1300 (2)
Japan	Nil	2130-2300 (1)	2100-0100 (2)	0800-1200 (1)
Philippine Islands & East Indies	Nil	Nil	2130-0030 (0-1) 1100-1300 (1)	Nil
West Coast, USA	1730-2200 (1-2)	1600-2100 (2-3) 2100-0000 (3-4)	1400-2100 (2-3) 2100-0000 (4)	0100-1300 (3-4)
India	Nil	Nil	1300-1500 (1)EA	2200-0100 (0-1)E 1200-1400 (0-1)A

**CENTRAL USA TO:  
(Centered on  
St. Louis, Mo.)**

	10 Meters	15 Meters	20 Meters	40 Meters
<u>ALL TIMES IN G M T</u>				
Great Britain & Western Europe	1500-1630 (1)	1400-1730 (3)	1300-1700 (2) 1700-2030 (2-3)	2300-0400 (2-3) 0400-0830 (1)* 0830-1000 (2)
Central Europe	1500-1630 (1)	1400-1700 (2-3)	1330-1830 (2-3)	2200-0600 (1-2)* 0600-0900 (2)
Southern Europe & North Africa	1400-1730 (2)	1330-1900 (2-3)	1200-1700 (2-3) 1700-2100 (3)	2230-0830 (3-4)
Central & South Africa	1400-1700 (1-2) 1700-1930 (2-3)	1230-1700 (1) 1700-2030 (2-3)	1200-1830 (0-1) 1830-2300 (2-3)	2300-0530 (1-2)
Central America & Northern South America	1600-2100 (3)	1330-2100 (3-4) 2100-2300 (4-5)	1300-2000 (3) 2000-0030 (4-5)	2300-1330 (4-5)
South America	1400-2100 (3)	1300-2030 (2-3) 2030-2230 (3-4)	1200-1400 (2-3) 1400-2100 (1-2) 2100-0000 (3-4) 0500-0700 (1)	2300-1000 (3)

**CENTRAL USA TO:**  
(Centered on  
St. Louis, Mo.)

	10 Meters	15 Meters	20 Meters	40 Meters
<u>ALL TIMES IN G M T</u>				
Australasia	2230-0000 (1-2)	1500-1730 (2) 1730-1900 (1) 1900-0100 (2-3)	1430-1730 (2-3) 1730-2230 (1-2) 2230-0300 (3)	0600-1400 (2)
Japan	Nil	2230-0000 (1-2)	2100-2330 (2-3) 2330-0130 (3)	0600-1400 (2)
India	Nil	Nil	1300-1500 (1)AE 2300-0030 (0-1)E	2200-0100 (0-1)E 0600-1300 (0-1)A
Philippine Islands & East Indies	Nil	2230-0130 (0-1)	2200-0100 (1) 1200-1500 (1)	Nil

**WEST COAST TO:**  
(Centered on  
Sacramento, Calif.)

	10 Meters	15 Meters	20 Meters	40 Meters
<u>ALL TIMES IN G M T</u>				
Europe	Nil	1530-1700 (1-2)	1500-1630 (1) 1630-1830 (2)	2300-0830 (0-1)*
South Africa	1700-2230 (1-2)	1430-1800 (1) 1800-2100 (2) 2100-0000 (2-3)	1400-2000 (1) 2000-2200 (2) 2200-0200 (2-3)	2300-0400 (1)
Central America & Northern South America	1600-1900 (2-3) 1900-2200 (3-4)	1500-2300 (4-5)	1400-2200 (4) 2200-0130 (4-5)	0200-1400 (4-5)
South America	1530-2300 (3)	1430-2200 (2-3) 2200-0000 (3-4)	1400-2200 (1-2) 2200-2330 (2-3) 2330-0200 (3-4) 0700-1000 (1)	0100-1100 (3)
Hawaii	2000-0000 (2-3)	1900-2300 (3-4) 2300-0000 (4-5) 0000-0130 (2-3)	1800-2200 (3-4) 2200-0230 (4-5)	0230-1030 (4-5) 1030-1600 (2-3)
Australasia	2200-0200 (2-3)	1900-2100 (2-3) 2100-0000 (2) 0000-0230 (3)	1600-1900 (3) 1900-0200 (1-2) 0200-0430 (3)	0600-1430 (2-3)
Japan	2230-0100 (2)	2200-0000 (3) 0000-0200 (3-4)	2100-0100 (2-3) 0100-0330 (3-4)	0600-1700 (3-4)
Philippine Islands	2300-0100 (2)	2200-0230 (2-3)	2130-0300 (1-2) 0300-0400 (2)	0900-1500 (2)
Marshall Islands	2000-0100 (3)	1930-0230 (2-3)	1830-2200 (2-3) 2200-0330 (3)	0630-1500 (3-4)
Guam & Pacific Islands	2100-0030 (3)	2000-0200 (2-3) 0200-0330 (3-4)	2000-0200 (2) 0200-0400 (3)	0800-1630 (3)
East China (Hong Kong)	2300-0100 (1-2)	2230-0200 (3)	2200-0200 (2-3) 0200-0330 (3-4)	0900-1500 (3)
India	Nil	0130-0300 (0-1)	0130-0330 (1-2)	0900-1500 (1)

Symbols for Expected Percentage of Days of Month Path Open:

(0) None (1) 10% (2) 25% (3) 50% (4) 70% (5) 85% or more

Special Note: The letter "A" appearing after the expected percentage figures is used to denote that the azimuth of signal arrival will probably be best over the "Asiatic Path." The letter "E" denotes an azimuth favoring arrival over the "European" path.

\* Indicates 80-meter band will be as good as, or better than, the 40-meter band. For other 80-meter predictions, subtract 1 from rating for 40 meters. In general, except for those circuits marked by asteriks, the 80-meter band should open 1/2 hour after and go out about 1/2 hour before the 40-meter band.



Conducted by HERB BRIER, W9EGQ

385 Johnson St., Gary, Ind.

Shown in the photograph on this page is the "Ameco" home study course designed to help prospective amateurs pass the Federal Communications Commission amateur license examinations. It is offered by *The American Electronics Company*, 1451 Wilkins Ave., New York 59, N. Y., and is available from them or through amateur parts distributors. The complete course, as pictured, consists of the *Senior Code Course* and the *Amateur Radio Theory Course*. Also available is the *Novice Code Course*.

#### Code Course

The *Novice Code Course* (price \$7.95) consists of five, standard 78 r.p.m. phonograph records in an album, and an instruction book. Side #1 of the first record introduces the alphabet, numerals, and simple punctuation. Each character is sent at a speed of 3½ wpm, with ample space between them to allow the student to write down the letters they represent or to try to imitate them with his own key. Subsequent lessons increase in speed one-half word per minute each, until the tenth one, which is straight English words sent at a speed of 7½ wpm.

The *Senior Code Course* (\$12.95) contains the above material, plus six additional records, designed to carry the student to eighteen wpm.

Chapter I of the instruction book, furnished with either course, introduces the code, describes its advantages, and sets forth common-sense suggestions for learning it. One is to practice regularly, but not too long at any one time. Another is not to study

when not feeling well or not "in the mood." I agree whole-heartedly that you should not try to learn the code when you are actually under the weather. There are also times when one just cannot learn, no matter how hard he tries. On the other hand, pointless waiting for just the right mood would be foolish.

The average code student has one thing in common with a nine-year-old boy taking piano lessons. They both can think of hundreds of reasons for skipping practice "just this once"—not being in the mood is a perfect one. Actually, it is surprising how often this feeling disappears after a few minutes of concentration. It works something like shovelling snow off of a sidewalk. Even if you are not wildly enthusiastic about the job, firmly grasping a snow shovel in both hands and going through the motions gets the snow shovelled.

Chapter II of the instruction book discusses how code characters are formed and feeds them to the student a few at a time.

Chapter III does its best to kill the popular fallacy that one can send better and faster than he can receive. It then proceeds to give full instructions on how to learn to send well.

Chapter IV treats the recorded lessons individually, telling the aim of each and how best to use it. The text of each is also printed to aid in checking progress.

An interesting feature of the code courses is that they contain replicas of the F.C.C. tests, both at the speed they are sent during the test and two



The "Ameco" Combination Senior Code and Theory Course reviewed in the text. The eleven record code course is designed to bring the student's copying speed to eighteen w.p.m. The theory course covers the preparation for all grades of amateur technical examinations up to the Advanced Class license.



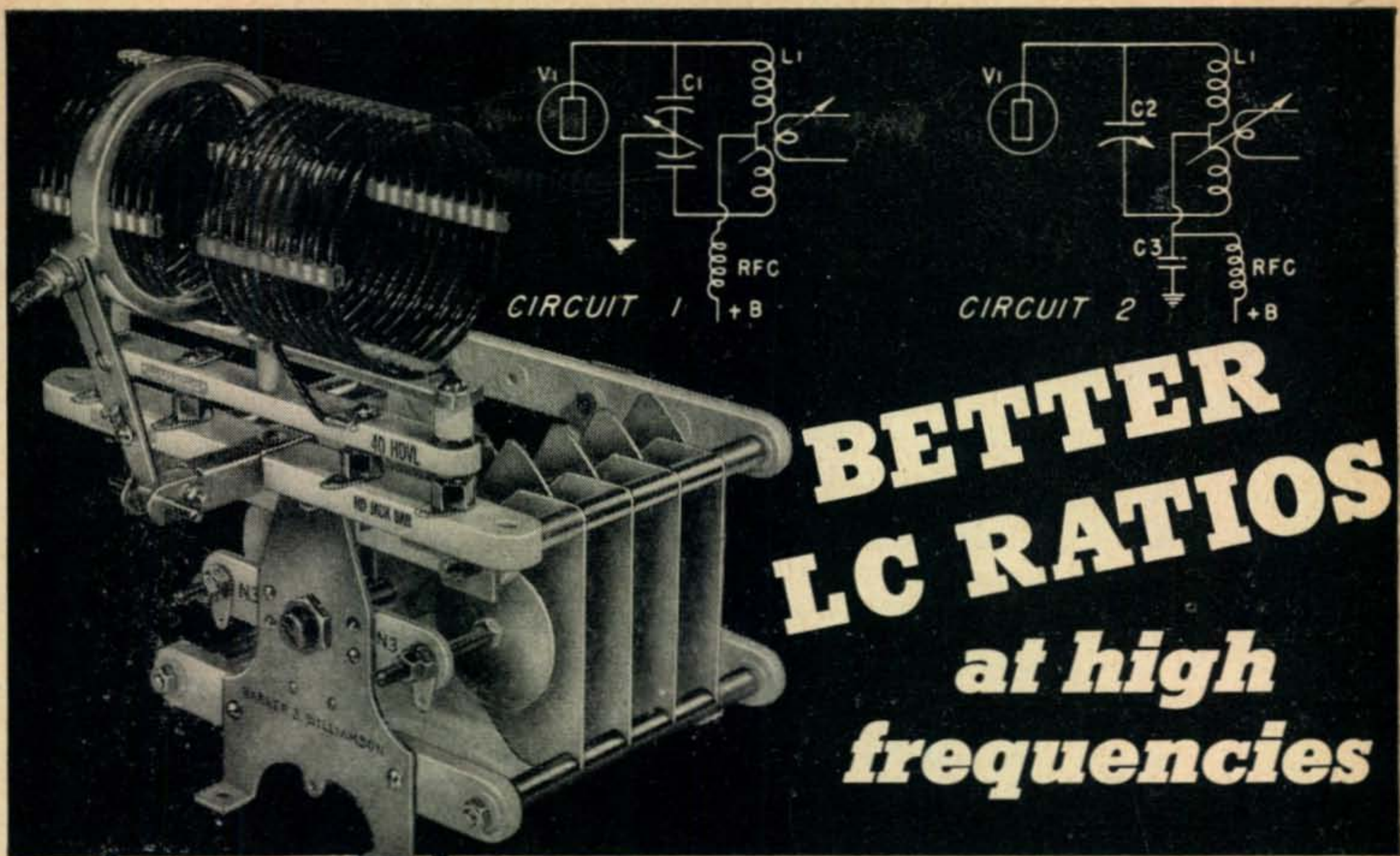

**... with beam power tubes**

B&W Types CX and JCX Butterfly Variable Capacitors with coils integrally mounted pave the way for increased efficiency in single-ended circuits.

Using B&W capacitors and coils with either fixed or variable center links in a split-circuit arrangement as shown above, effective tube capacity is reduced 75%, while circulating current and coil losses are cut to a minimum. All beam power tubes from an 807 up may be used in this manner with smaller losses, greater output and ease of operation.

Single or twin vacuum condenser mounting brackets are available for low-frequency tuning range extension. Rear end plates have provision for built-in neutralizing capacitors thus keeping grid and plate leads uniformly short. Type CX capacitors are normally supplied with air-gap spacings of .500", .375" or .250". Standard plate thickness is 1/16" but 3/32" plates can be supplied on order.

These popular B&W units are featured by leading distributors. See them today—or write for Catalog and Bulletin 547.

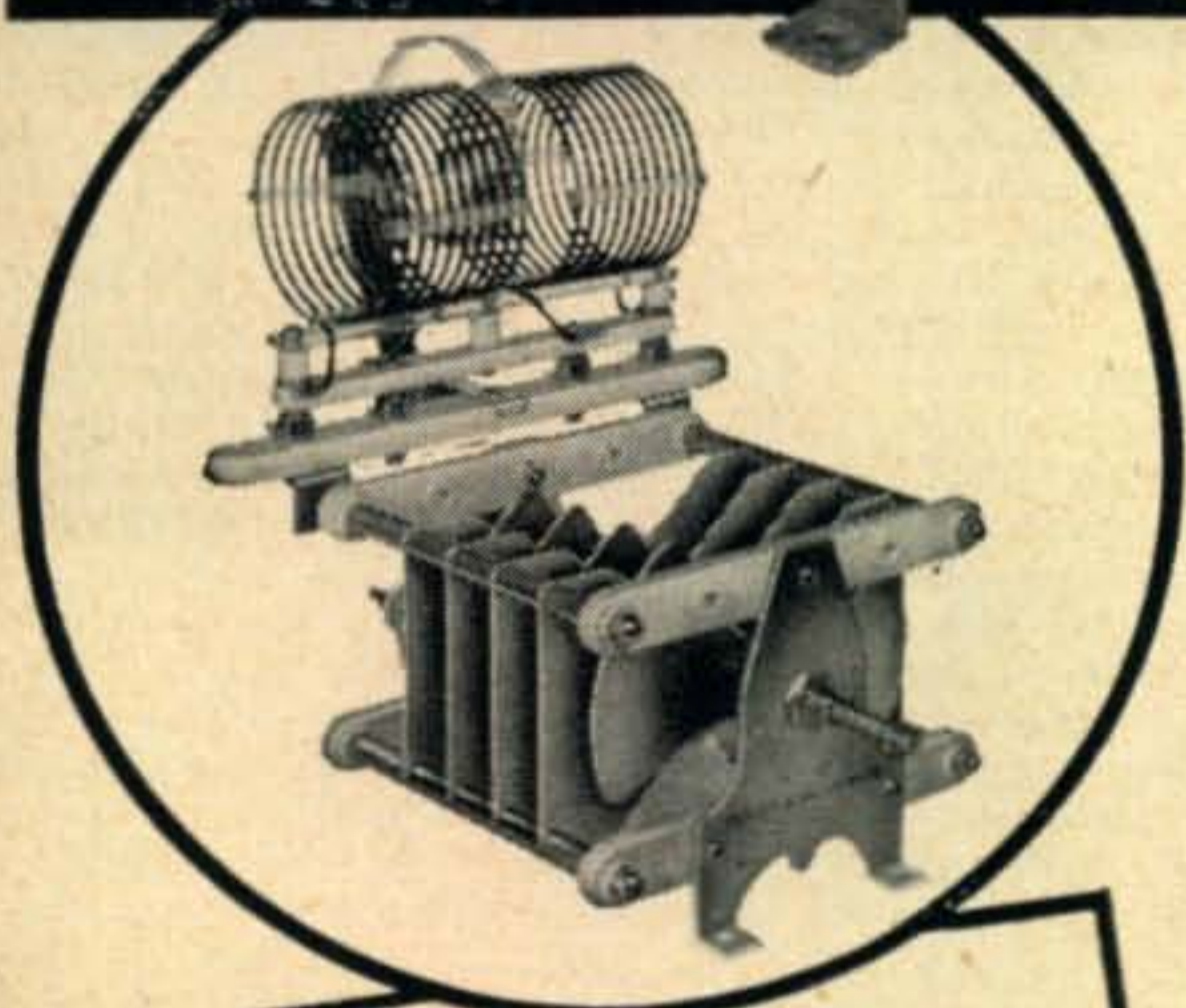

Other features of B&W integral coil-condenser combinations are:

- Greater coupling efficiency.
- Easily mounted Faraday Shielded Links.
- Short R-F paths.
- Simplified conversion to push-pull.
- Compactness with a minimum of leads.

**Barker & Williamson, Inc.**

237 Fairfield Ave., Upper Darby, Pa.





The husband and wife station of Frank and Dena Krosley, WN5VAX, WN5VBG, Lindsay, Okla. Receiver is an NC-125, and the transmitter utilizes an 807.

wpm faster. They give an excellent idea both of the speed of the test and the type of material that must be copied. Simple, five-letter English words sent at five wpm for the Novice and Technician licenses, and English words, numerals, and simple punctuation sent at thirteen wpm for the General Class one.

Practicing until one can copy the higher speed sample test without error will provide a welcome cushion to take care of the inevitable slight loss in speed one suffers while taking the test, because of nervousness or excitement.

In addition to the sample amateur code tests, the *Senior Course* also contains a replica of the Second Class Commercial Radio Telegraphy examination, which is mixed letters, numerals, and punctuation, sent in five-letter groups at a speed of sixteen wpm. Probably few Novices would be interested in this examination, but the last five lessons, all being such mixed groups, are excellent practice material for bringing one's copying speed above the average. I am sure that anyone who could copy the last one, recorded at eighteen wpm, could copy straight text at speeds well in excess of twenty wpm.

### Theory Course

The "Ameco" Amateur Radio Theory Course (\$6.95) is a book of approximately 300 pages. It starts with the assumption that the student knew nothing about radio and then carries him through elementary theory and the function of individual parts, such as resistors, condensers and coils, up to a good general knowledge of amateur radio.

The avowed purpose of the course is to prepare the student to pass the FCC technical examinations for any amateur class license up to and including the Advanced Class license. To do so, it is divided into three sections, each complete with study guide. The sections are further sub-divided into chapters, accompanied by multiple-choice practice questions. Questions similar to those asked in the official examinations are especially marked.

A few of the subjects covered thoroughly enough for the purpose are antennas, vacuum tubes, transmitters, receivers, keying, modulation, calculations used in the examinations, amateur regulations, etc.

Typical FCC examination questions for the several classes of amateur licenses complete the course. Correct answers for all the questions asked in the book are part of the study guides. The purchase price also entitles the student to a one-year consultation service.

Some readers may wonder whether the material covering the Advanced Class license is now of any particular value, as the license will not be issued after December 31, 1952. Yes, it is. Mastery of the information presented is almost a necessity to the correct operation of any amateur phone transmitter. Furthermore, the examina-

tion for the new Extra Class license covers everything covered in this course and more. And who knows, the FCC might change its mind again.

### Comments

Two thoughts occur to me regarding the "Ameco" code course. I doubt that anyone could bring his actual copying speed up to the maximum on the records without additional practice material. By constant repetition, the student is almost certain to memorize the records well enough to anticipate what is coming next.

This is not particularly a defect in the course. All recorded code courses operate under a similar handicap unless a tremendous number of records or tapes are available. The important thing is for the student to realize he might be memorizing the records and to use any other code practice material he can find. Actual over-the-air copying is especially good.

Referring to Chapter II of the instruction book, it seems unnecessary to teach the code by means of dits and dahs on the printed page, at the same time warning the student to look at the page as little as possible to avoid learning it visually instead of aurally, when record No. 1 shows exactly how it sounds without recourse to printed symbols. As the code is received by ear, this seems to me to be the better way to learn it. However, this is a matter of opinion, and I do not doubt that one will learn the code by following the method outlined in the instruction book.

### Letters and General Comments

Occasionally I get letters from Novices who forget to include their call letters or who sign them so hastily that I have to guess at their names or calls. So that you will get credit when I use an item about you in the column, please write your call letters and name clearly. I do not always guess correctly.

Speaking of call letters, I wonder if Novices with Q in their calls have as much trouble with it as I do. A large percentage of my letters and QSL (confirmation) cards come addressed to W9EGO. If W9EGO suspects that there is someone "bootlegging" his call, because he gets DX cards now and then through the QSL bureau from stations he never worked, this may ease his mind. Also, in a recent month, both CQ and QST mentioned me by call letters, but they were not mine.

"Dear Herb. Thought you would like to know of a Novice husband and wife team down here in Oklahoma. My call is WN5VAX, and the XYL (wife) is WN5VBG. Also, my brother, WN5VCK, and his XYL, WN5VAU, are another team. My sister, her husband, and their two children are all hams too. Sort of runs in the family.

"We haven't worked many states so far, but we have had a lot of enjoyment from the contacts we have made. We have only one "gripe" about the 3.7 mc. Novice band—and that is about these "old time" hams (running 100 to 900 watts) getting right in the middle of it and running the poor Novice (with his low power) right out of the picture. Wouldn't be so bad if they would be working another Novice, but for two of them to hold a long-winded QSO right in the middle of that oh-so-narrow fifty kilocycles allotted to the Novices makes it mighty tough going. Give the Novice a chance, we say"—Frank and Dena Krosley, WN5VAX and WN5VBG.

This was delayed somewhat, but is still worthwhile.



Leonard Ross, WN6SJR (talking into mike), and two unidentified hams. Leonard is seven years old and one of the youngest hams ever licensed.

# Harvey ...FOR THE MOST COMPLETE STOCKS OF COMMUNICATIONS EQUIPMENT

## The New GONSET "COMMUNICATOR"

A complete two-way station for 2 meter band operation. Suitable for mobile or fixed location use. Receiver is a sensitive superheterodyne with built-in noise clipper circuit and 6BQ7 Cascode rf stage. Transmitter uses 2E26 in final 15 watts input. Employs 8 mc. crystals for stability, and has a range of over 100 miles. Operates on either 110 volts AC or 6 volts DC. Weight approx. 16 pounds. Complete with Tubes (less crystal and microphone) .....\$189.50



## GONSET "SUPER 6"



### Six Band Amateur Converter

A compact converter covering 10, 11, 15, 20, 40, and 75 meter phone bands. Also covers 6 mc. (49 meter) and 15 mc. (19 meter) short wave broadcast bands. Uses 6CB6 low noise rf stage, with panel controlled antenna trimmer, 6AT6 triode mixer, 6C4 modified Clapp oscillator, and 6BH6 if stage. Complete with Tubes.....\$52.50

## GONSET CASCODE PRE-AMPLIFIER FOR 2-METER RECEIVERS

A wide-band cascode type pre-amplifier designed to increase gain, signal-to-noise ratio, and to improve overall performance. Signal gain of unit is 10 db. over the entire 2-meter band, with a noise level of 5 db. Uses 6BQ7 tube. Complete with Tube.....\$19.95

Complete Line of GONSET EQUIPMENT In Stock for Immediate Delivery

## The New HALLICRAFTER

### HT-20 Transmitter



A completely TVI-proofed transmitter with complete bandswitching from 10 to 160 meters. Power output 115 watts CW or 100 watts on phone. TVI radiation is at least 90 db. below output. Has provision for external VFO head, plus many other new features. Complete with Tubes.....\$449.50

HARVEY Carries a Complete Line of Hallicrafter Communication Equipment Always in Stock for Immediate Delivery.

## SONAR MOBILE Rcvr. Model MR-3



Complete coverage for 10-11-20-75 meters. 8 tubes, 4.5 watts audio output. Uses: 12AT7 RF stage and B.F.O., 6U8 oscillator, mixer, (2) 6CB6 I.F. stages, 6AL5 2nd detector and noise limiter, 6AT6 1st audio, 6AQ5 audio output, OB2 voltage regulator. 1 Microvolt signal produces 0.5 Watt audio output. A.N.L. and B.F.O. are push-button operated. Requires 250 Volts at 60 to 80 mils. Size: 4 1/8" x 5 1/8" x 5 1/8". Complete with tubes... less power supply and speaker.....\$89.95

## The New SONAR Transmitter



### Model SRT-120

For mobile and fixed location operation. Has band-switch for 80, 75, 40, 20, 15, and 10 or 11 meters, plus spare position for any future band. Has provision for two crystals or external VFO head. Final amplifier employs the new AmpereX 9903/5894A tube. Power input is 120 watts on CW, and 100 watts on phone. All circuits metered. Power requirements: 600 volts dc at 350 ma, and 6.3 volts at 6.4 A. Complete with Tubes.....\$198.50 External VFO Head..... 16.50

## The New COLLINS 75A-3 Receiver



### With Mechanical Filter

The familiar Model 75A-2, redesigned and modified to provide for the use of mechanical filters. Supplied with one 3 KC filter, and facilities for two additional. A 3-position front panel switch permits selection of filter desired.

with speaker \$550.00  
Additional Mechanical Filters:  
1 KC and 6 KC.....each 75.00  
COLLINS 75A-2 still continues in popularity.....with speaker 440.00

## New Deluxe Transmitter Kit JOHNSON VIKING II

100 WATTS ON PHONE  
130 WATTS ON CW

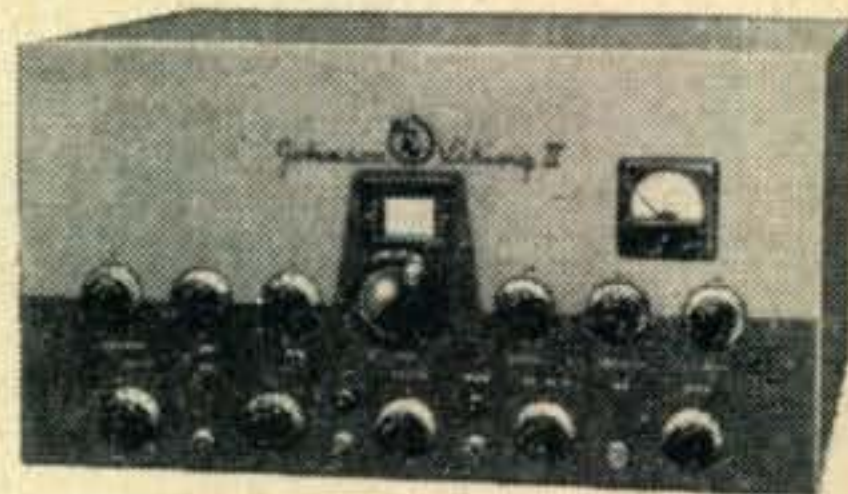

Every desirable feature has been included in this outstanding transmitter: BAND-SWITCHING to all amateur bands, from 160 through 10 meters... TVI suppression... 100% AM modulation... PARALLEL OUTPUT 6146 tubes... PUSH-PULL 807 MODULATORS. Supplied complete with pre-punched chassis, copper-plated steel cabinet, tubes, hardware, assembly instructions, and all necessary parts and components. ....\$279.50

Viking II complete with tubes, wired and air tested..... 324.50  
Viking VFO Kit, worthy companion to the Viking II..... 42.75  
VFO Kit—wired and tested (with tubes) ..... 62.75  
Viking Mobile Kit, up to 60 Watts input for that rig-on-wheels ..... 99.50  
Viking Low Pass Filter, 4 section, 75 DB Att., handles a KW..... 16.50  
Viking TVI Kit, everything to TVI-proof the Viking I..... 24.75

## Brand New Specially Priced DYNAMOTORS

CARTER	Input Voltage	Output Voltage	Output Current in ma.	SPECIAL PRICE
	5.5	600	270	\$35.00
	5.8	375	325	35.00
	5.8	600	175	29.50
	12.3	375	325	39.50
WESTINGHOUSE				
	5.8	375	325	35.00
	6.0	600	270	35.00
	5.75	410	275	35.00

Complete Line in Stock CAMBRIDGE THERMIONIC COILS For Immediate Delivery

VISIT THE AUDIOTORIUM. Come in and visit our new sound department... all these items and many more on display at all times.

NOTE: In view of the rapidly changing market conditions, all prices shown are subject to change without notice and are Net, F. O. B., New York City.



# Harvey RADIO CO., INC.

103 W. 43rd St., New York 36, N. Y. • LUxemberg 2-1500

"Hi Herb. Am trying to start a Novice Net in Iowa. Would interested Iowa Novices please drop me a line"—Fred Warren, WNØKAK, Cambridge, Iowa.

Around the first of August, the Associated Press released a story about Leonard Ross, seven years old, passing the Novice examination in Los Angeles. Here is the story, as Leonard writes it: "Dear Herb. I just got my call letters yesterday. They are WN6SJR. I passed the examination two months after deciding I wanted to become a ham. My cousin, Dick Somers, W6NSV, and



Attractive station of Sid Fleischer, W6QZR, Los Angeles, Calif. Transmitter is the popular 6AG7-6L6 combination, running thirty watts input. Receiver is an S-38B. Sid is a member of the Crescent Bay AREC net, and has just received his General Class license.

my brother, Dan, WN6SDW (who is thirteen), helped me.

"I have also obtained my Commercial Third-Class Radio Phone license. I haven't gotten my station together yet, but Dan is using an RME 45 and a transmitter he built himself. I'll send you a QSL card when

I get them"—Lennie, WN6SJR.

Lennie is a good typist and his family reports that he can work mathematical problems faster in his head than they can on paper. This does not surprise them, because he mastered basic arithmetic when he was three years old. And Perry Ferrell, Managing Editor of CQ has informed me that Lennie has written an article meriting editorial consideration. (Honest, Mr. Ferrell, I think he will be better as Technical Editor than as Novice Editor.)

"Hi Herb. I am now W6QZR, with a General Class License. I am now on forty meters and have added some states to my "DX" list. 73" Sid, W6QZR.

"Dear Herb. I wish to add my call to the list of those who have graduated from the Novice ranks. My Novice call, received when I was thirteen years old, was KN2AJD. Louis, W2LYL, who is fourteen, also just graduated from the Novice Class"—Richard Smith, K2AJD.

"Dear Herb. My name is Jim Rose, and my call is KN2AZA. I am fourteen years old and run nineteen watts input. I have been licensed for two months and have had about 100 contacts in five call areas, nine states and Canada.

"I didn't know what selectivity was until I scraped together enough money to buy a used HQ-129X receiver. You know, I often wondered how fellows my age could afford these big receivers. I am glad that I earned all the money I spent on my station.

"What do other hams with younger brothers and sisters do when they start raising the roof during a QSO? I have lost several stations, because of this"—Jim, KN2AZA, Hamburg, N. Y.

"Hi Herb. Just received my General Class Ticket. While I was a Novice I worked thirty-five states and Hawaii. The transmitter is 6L6-807, 35 watts input, and the receiver is an S-40B. 73"—Don, WØKBD.

**Question Box**

Q. I have been interested in amateur radio for some time. I am going to buy a small Hallicrafters receiver next month. I am in the Air Force, and I wonder if a loop of wire around the wooden barracks will work as an antenna.—A/3C Ronald J. Lamb.



**It's R9 Plus . . .  
when using a "VAARO ANTENNA"**

Presents: The first all band switching mobile and marine antenna system. 2Mc's to 30Mc's Completely weather proof in high seas or rainy mobile days, available with or without capacity hat.

**100**

"Hi Gain Capacity Hat" corrosion proof in various colors to match your car, very light weight, fits all whips.

**101**

"Hi Gain Capacity Hat" corrosion proof anodization in bright attractive colors to match your car, complete with Hi Q Transparent buterate weather proof shield, fits all whips.

**102**

"Hi Q Junior" air wound medium power All Band Switching coil, completely weather proof, no change of loading in rain or snow, fits all whips.

**103**

"Hi Q Master" air wound high power weather proof coil, operate all bands in your car without inconvenience of coil changing or other unpleasant operations, one second band switching, fit all whips.

**104**

New all fiberglass amateur 104 civil air patrol or marine whips and new stress designed base section 106 for use with above units. Completely corrosion and weather proof. No insulators or springs required.

**105**

"Bumper Mount" completely new design, don't chop holes in your new car, heavy construction and corrosion proof, lends beauty to your installation, designed to fit any bumper, special bumper curvature insert furnished, no drilling or machining necessary to install, just bolt on.

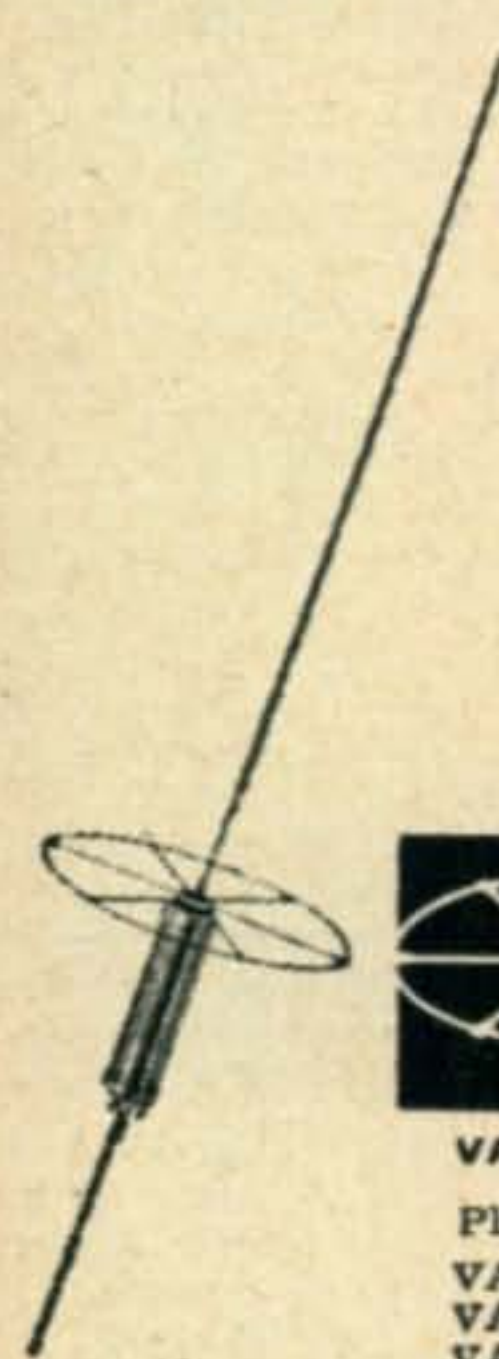

VAARO ELECTRONIC ENGINEERING COMPANY, BOX 5035 LONG BEACH, CALIFORNIA

Please send me C.O.D.—F.O.B. CHECK ANY OF THESE:

VAARO 100	<input type="checkbox"/>	\$ 3.95	VAARO 104	<input type="checkbox"/>	\$6.25
VAARO 101	<input type="checkbox"/>	5.95	VAARO 105	<input type="checkbox"/>	9.25
VAARO 102	<input type="checkbox"/>	8.95	VAARO 106	<input type="checkbox"/>	7.95
VAARO 103	<input type="checkbox"/>	14.95	SEND LITERATURE	<input type="checkbox"/>	

NAME .....

ADDRESS .....

CITY ..... STATE .....

*Best buy of any season!*  
**JOHNSON AMATEUR EQUIPMENT**



**VIKING MOBILE KIT**

Plenty of power and audio gain. Amplifier input 30 to 60 watts, 100% AM modulation. Band-switching (7.5, 20 and 10 meters), VFO provision, dash mounting. Antenna loading problems solved. "cut and try" eliminated. Easily accessible—illuminated meter—clearly marked dials.

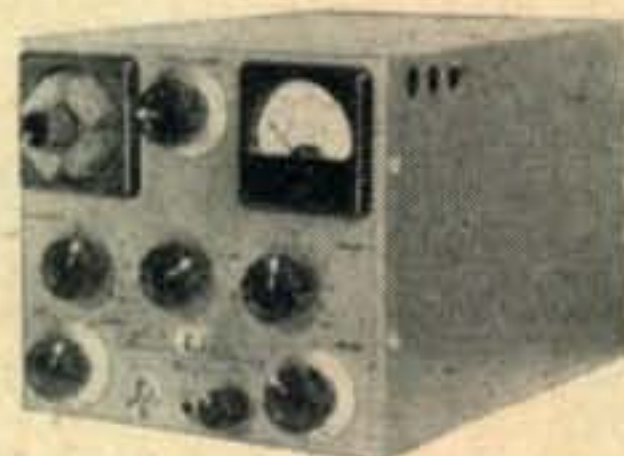

240-141 kit complete, less tubes, microphone, power supply and antenna.

AMATEUR NET **\$99.50**



The JOHNSON Viking II is an expertly designed transmitter, furnished unassembled, but complete. All amateur bands from 10 to 160 meters, 100 watts phone output, 130 watts CW. Includes all necessary parts, hardware, tubes, wiring harness, cabinet, and step by step instructions. 240-102 Viking II kit with tubes, less crystals, key and mike

- TVI Suppressed
- Dual Power Supplies
- Instant Bandswitching
- VFO Input Provision

AMATEUR NET **\$279.50**

**VIKING I TVI SUPPRESSION KIT**

All necessary shields, chokes, capacitors, and hardware to shield the Viking I and suppress harmonic radiation. Designed for easy installation and accessibility. 250-21 only \$24.75 AMATEUR NET

**JOHNSON KEYS**

Semi-automatic, standard, and practice keys. Semi-automatic models adjustable from lowest to highest speeds. Standard and practice keys feature coin silver contacts and operate with a light keying touch.

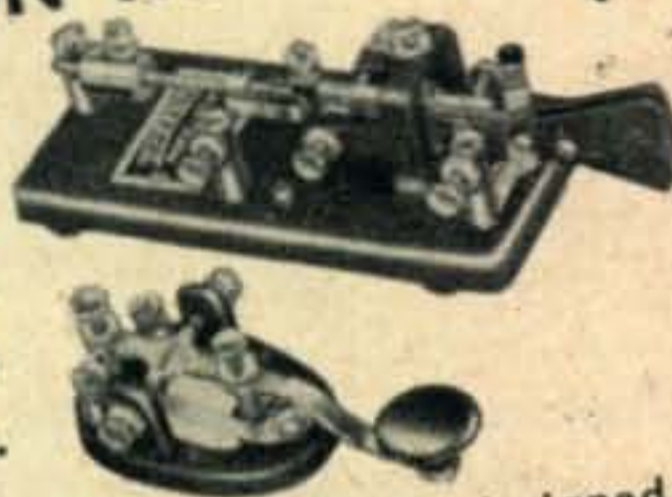

All models well designed and will provide years of dependable service.

**\$1.45 to \$21.00**

**VIKING VFO KIT**

Accurately calibrated for all amateur bands from 10 to 160 meters, vernier tuning, clean keying, and perfect "break-in" on all bands. Excellent stability. Rigid construction, temperature compensated ceramic padders. Assembly is simple. Kit complete, less tubes.



240-122 VIKING VFO KIT.

AMATEUR NET **\$42.75**



**E. F. JOHNSON COMPANY**

CAPACITORS, INDUCTORS, SOCKETS, INSULATORS, PLUGS, JACKS, DIALS, AND PILOT LIGHTS

220 SECOND AVENUE SOUTHWEST • WASECA, MINNESOTA

## NOVICE SHACK

(from page 50)

A. Yes. It will not be as effective as high, carefully-constructed, outside antennas, but it will work. Many amateurs use indoor antennas with excellent results.

Q. I have a supply of 1/4-inch elements from old TV antennas. Could I use them for the 145-mc beam described in the July "Novice Shack?" Please tell me how to stack two or four of these antennas.—Charles Cranfill.

A. I can see no objection to using the TV antenna elements in the array. As for stacking, you can mount two of the arrays 1/2-wave apart, connecting the two radiators together by means of a spaced line, transposed once. Connect feed line to lower radiator. For a more-elaborate stacked antenna, I suggest that you refer to past issues of CQ, or to the handbooks.

Q. To solve a friendly argument, does CW break-in operation require separate receiving and transmitting antennas?—Bill Kloss.

A. Usually, yes; however, the Army has some equipment in which the antenna change-over relay is keyed. This system is limited to slow sending speeds. Another system uses a time-delay system to turn off the receiver and switch the antenna to the transmitter as soon as the key is pressed. A time-delay circuit then holds the relays in for a predetermined time after the key is released. The simplest break-in systems, however, use separate antennas for the receiver and transmitter.

That is about it for this month. Keep writing. And don't forget pictures. 73, Herb, W9EGQ.

## YL'S FREQUENCY

(from page 27)

already experienced in our own radio contacts. "I intend 'dropping a line to Ruby' and explain amateur radio to the best of my ability. It would be nice if some of the girls who read the "YL's Frequency" would bombard her likewise.

"No, I am not a YL—hi! Have had my ticket since 1939, with the first call being W7HKE.

"It might be that Bea, W7HHH, or Mary Ann, W7FWR, or some of the other YLs could be of assistance in finding someone to help out in 'Operation Ruby.'"

Thank you OM—and how about it YL's?

### YL Get-Togethers

A group of W1 YL's gathered at the Towne Lyne House at Lynfield, Mass., on Sept. 20th, for luncheon and ragchewing. The gals discussed plans for a local YL club for Boston and vicinity. See the photo for those who attended.

A couple of other occasions brought the YL's together in New England. A hamfest at Burlington, Vt., drew WIUFM, UET, FTJ, RNF, OAK, RYJ, WNIVVS, WN1UNF, and VE2HL.

Fifteen YLs attended the New Hampshire State convention at Nashua the end of September: W1QJX, OAK, UFM, FTJ, FOF, TRE, UPZ, QJY, QON, MJE, SVN, UBM, RYJ, WNIVOS and WN1UFO.

A ham picnic at Findlay, Ohio, in September drew these YLs: W8SPU, VE3AJR, W8IAA, WN8JCR, W8HUX and W8HWX.

The Hudson Division Convention held at Albany,



### PE-101 DNAMOTOR

F. B. for 6 v. mobile. See the dope in this issue of CQ. These units are brand new and boxed. Ea. **\$4.95**

### TUBES! SPECIALS XMAS SPECIALS!

6J5 .. \$0.50	6AG7 \$1.25	304TL \$8.95
6AC7 .. .79	801 .. .49	829B .. 8.95
1L4 .. .50	803 .. 3.50	1629 .. .19
1S5 .. .50	807 .. 1.49	1626 .. .19

1,000's of other tubes. Tell us your needs.

### CO-AXIAL CABLE—100 Ft. Lengths Only

RG8U: New, not surplus. 52 ohm. 100 Ft. .... \$13.95  
 RG11U: 72 ohm. 100 Ft. .... 7.95  
 CO-AX CABLE: Like RG-54. 100 Ft. .... 3.95  
 PLASTIC CONTROL KNOBS: For Command Receiver. With any purchase of \$3.00 or over. get them at only 25c ea.  
 ARC-4 OR 233-A VHF TRANSCEIVER: 12 or 24 V. For Novice, 2 meter, CD or CAP. All tubes, excel. cond.  
**SPECIAL \$32.50**

BC-625 TRANSMITTER: Part of SCR-522. Freq: 100-156 MC. Less tubes. A real HOT BUY. ONLY **\$13.95**

BC-624 RECEIVER: Part of SCR-522. Freq. 100-156 MC. Less tubes. ONLY **\$19.75**  
 THE PAIR AT SPECIAL LOW PRICE **\$29.95**

APN-1 UHF TRANSCEIVER: Excellent for all high frequency work. F.B. for 420 MC. Complete with all tubes, Wobulator and schematic. Excel. cond. .... **\$17.50**

### WET CELL BATTERIES

24 V. EXIDE AIRCRAFT. Now, orig. box. .... **\$15.95**  
 12 V. 37 amp. @ 5-hr. rate. NEW. .... **12.95**  
 4 V. For TBY Transceiver. NEW HOT! .... **\$4.95**  
 T-23 VHF TRANSMITTER: 100-156 MC. Excel. cond. .... **\$37.50**  
 FL-8 FILTER: Used. .... 89c New. .... **\$1.99**

Santa says: "For Christmas cheer, Treat yourself to COLUMBIA gear. Their stuff is clean, their prices low— But most of all—they need the dough!"

### TUNING UNIT FOR BC-375 TRANSMITTERS

Contains \$10.00 worth of knobs, switches, condensers, coils, mica-capacitors and vernier dial. Do not specify frequencies.

SPECIAL **\$1.95**

### ARC-5 OR 274-N TRANSMITTERS

2.1-3 mcs.	Brand new, orig. box	\$19.95
4-5 3 mcs.	Used, less crystal	6.95
5.3-7 mcs.	Used, less crystal	5.50
7-9.1 mcs.	Used.	12.50

### ARC-5 OR 274-N RECEIVERS

.19-.55 kr.	Excel. cond.	\$14.95
1.5-3 mcs.	Brand new	24.50
3-6 mcs.	Less tubes	6.95
3-6 mcs.	With tubes	10.95
6-9.1 mcs.	Like new	14.95
6-9.1 mcs.	Used	7.95

RACK FOR DUAL TRANSMITTER (274-N) ... **2.95**  
 RACK FOR DUAL TRANSMITTER (ARC-5) ... **3.95**  
 TRIPLE RECEIVER RACK ... **5.00**  
 BC-442-A ANTENNA RELAY with 50 mmfd. condenser. Excel. cond. .... **3.95**

**XMAS \$\$\$**

Make extra gift dough NOW by rushing us your new and used radio gear. We buy it fast at peak-high prices. **WRITE TODAY!**

### BEST BUYS IN HEADSETS!

HS-30, used	\$1.49
HS-23, 4,000 ohms, new, boxed	4.50
HS-33, used, good condition	3.50
CD-307 HEADSET EXTENSION CORD	75c

ALL ORDERS F.O.B. LOS ANGELES

25% deposit required. All items subject to prior sale

**COLUMBIA ELECTRONICS SALES**

524 S. SAN PEDRO ST., Dept. LS, LOS ANGELES 13, CAL.



LEO I. MEYERSON W0GFQ  
CU ON 10-20 & 75 METERS

## A CHICKEN IN EVERY POT... A NATIONAL RECEIVER IN EVERY "SHACK"

NOW is the time to trade for a new receiver or transmitter. Our stocks are complete — our prices are LOW. TAILOR-MADE TERMS — LIBERAL TRADE-INS — COMPLETE STOCKS — PERSONALIZED SERVICE. We Finance Our Own Paper — No Red Tape — No delays. Special Attention Given To Foreign Orders. Deal with WRL — "One of the World's Largest Distributors of Amateur Radio Transmitting Equipment."

**JUST OFF THE PRESS**

LEO GIVES BEST DEAL ON ...

### **National RECEIVERS**

#### **HRO-SIXTY RECEIVER AUTOMATIC DUAL CONVERSION**



EASY  
PAYMENTS

**\$483<sup>50</sup>**

(less speaker)

**FREE  
1953  
WRL  
CATALOG  
SEND  
TODAY!**



#### **RADIO REFERENCE MAP**



**25c**  
HANDY  
WALL  
SIZE

#### **New Log Book**

**25c**

Full column log listing all FCC required into . . . accommodates 1,525 stations. "Q" signals, phonetic alphabet, amateur international prefixes.



The NATIONAL HRO-60 is the last word in modern receivers, offering many outstanding features: Dual conversion automatically switched in and out. High frequency oscillator and first mixer now have current regulated filament circuits. High frequency oscillator is also voltage incorporated. Edge lighted, direct frequency reading scale, with one range in view at a time; Three I. F. stages at 456 kc employing 12 permeability tuned circuits on all bands, plus one I. F. stage at 2010 kc on all freq. above 7mc; Built-in power supply; Sensitivity 1 mV or better for 6 db sig/noise ratio; Micrometer logging scale; Provision for crystal calibrator unit operation from front panel; S-meter amplifier; High fidelity push-pull audio with phono jack.

**SEE IT, HEAR IT, COMPARE IT!**

#### **NATIONAL**

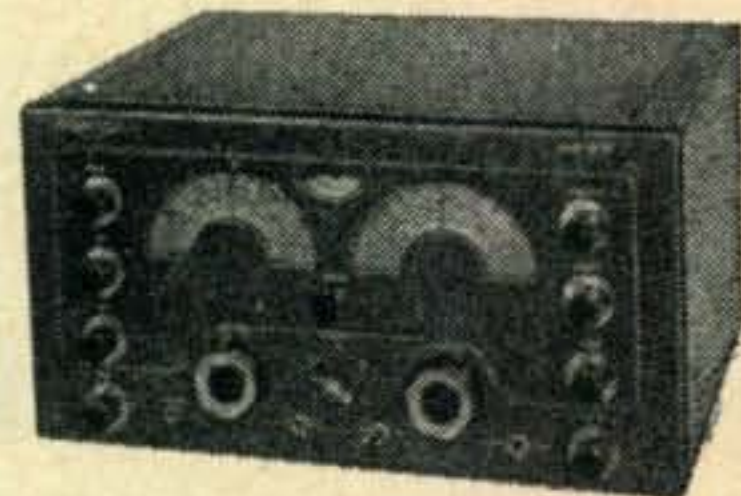

#### **NC-183 D RECEIVER**

Dual conversion on the three highest ranges plus every feature you want in a truly modern receiver!

(LESS SPEAKER) . . . \$369.50

#### **NATIONAL RECEIVERS AND ACCESSORIES**

NC-125 RECEIVER .....	<b>\$149.50</b>
SW54 RECEIVER .....	<b>\$ 49.95</b>
SELECT-O-JET (#2 or #3) .....	<b>\$ 28.75</b>
NFM-83-50 ADAPTER .....	<b>\$ 17.95</b>
SPEAKER (for HRO-60 or NC-183D) .....	<b>\$ 16.00</b>

WRITE FOR DETAILED SPECIFICATION EQUIPMENT SHEETS

**WRITE  
WIRE**

**PHONE  
7795**

**World Radio**  
LABORATORIES COUNCIL BLUFFS, IOWA



World Radio Laboratories, Inc.  
744 West Broadway  
Council Bluffs, Iowa

C-12

Please send me:

- New Log Book
- Free Catalog
- Radio Map
- SW-54 Info
- NC-183 D Info
- HRO-60 Info
- NC-125 Info
- Used Equipment List

Name \_\_\_\_\_  
Address \_\_\_\_\_  
City \_\_\_\_\_ State \_\_\_\_\_

N.Y., was a three-day affair held during October 3-5. These YLs attended: W2ZPR, EJJ, BNC, RUF, BTB, EEO, EWO, WLC, WN2ONC, VE2HI, W1BCU, W1FTJ, and W3JSH. Many of the YLs won prizes, among them WN2ONC, a *Viking I* kit, and W1FTJ,



Francine Mertens, ON4MF

a TV lamp. We hear the women's auxiliary of the Albany club put on a very nice time for the YL's and XYL's with a fashion show and luncheon, card and beano games, and a tour of the State Capitol.

#### Here and There

We hear from W6WRT that Lou Willomitzer, W6VWR, will continue to be confined for quite some time to a tuberculosis sanitarium. Letters and cards to cheer her along the way may be sent to Lou at Pottenger Clinic, Monrovia, California. . . . From W8GJX, Helen, we hear that her latest book, "Sim Barton," will be published before Christmas. Helen says it is the story of a girl radio operator trying to break into the man's game of commercial operating on the Great Lakes freighters—with a love story thrown in for good measure. We hear that even M-G-M is taking a look at the book—wouldn't it be nice to have a YL break into the movies. . . . A year ago on Sept. 18th W8HUX, Marvel, received her call, so this Sept. 19th she took off again for Detroit. Before the day was over she learned she had passed the Advanced Class exam. . . . W8HWX, Lillian, had her call a year on Sept. 21st, and three days later she and her OM also made the trip to Detroit, and passed the Advance Class. Lillian's OM has had his call since '39, but couldn't let her get ahead of him. . . . W1UBM, Norma Jean, recently got her RCC certificate—her qualifying QSO lasted 3½ hours!

A note from WN9URE telling us she's been on the air since August—but she's lonesome. Seems she's the only YL operator in her home town, among some 25 OM operators, and the only YL within an area of a hundred miles. She'd very much like to have letters or cards (or QSOs) from some other YLs. Her address: Mary Gourley,

RFD #6, Madison, Ind. . . . W8ATB and her OM are just back from a month's vacation trip through the Northwest. Along the way Esther met these YLs: WØKOY, Inga; W7JWC, Manilla; W7HHH, Bea; W7MUT, Sister Charlotte; W7NH, Nellie; and W9AYX, Jackie. The Stuewes were operating 75-meter mobile and had lots of fine QSOs. In addition to their hamming, they took in all the main points of interest along the way and returned with some twenty rolls of colored film.

Don't forget the YLRL 13th Anniversary Party. The phone contest is scheduled for Nov. 29-30, CW on Dec. 6-7. Full details appeared in this column last month.

#### Belgian YL

ON4MF, Francine Mertens, at Brussels, is the first YL we've come across in Belgium. Francine was an SWL with the call ONL193 from 1934 until April of 1950 when she got the call ON4MF. She had a license for CW only at first and in April, 1951, got her phone license. "I worked on 7 and 3.5 Mc. For over two years on CW only," writes ON4MF, "but now since May I am on 3.5, 7 and 14 Mc., on CW and phone. Have had over 1500 QSOs, and worked 58 countries, 17 on phone. Today (written in July) I worked my first W station on phone and it was W1MCW, a YL, too. So I was very pleased and proud of myself—hi! On CW W3SJH, a YL also, has been coming in quite nicely and we have enjoyed our QSOs very much."

The transmitter at ON4MF is VFO, running 35 watts and uses a Hertz antenna. Receiver is a BC342N.

Francine is president of the SWL section of the Belgian radio club, UBA. She adds, "I am working each month for the DX program we have at OTC Leopoldville, Belgian Congo. Our radio club, UBA, has each month a program especially reserved for our members and hams from around the world. Each recording is done by hams so each month I must collect recordings, text, or interviews and give them to our manager for the DX program."

Francine is a single gal and holds down a full-time job with the R.A.F. working in operations control center. She says it is very interesting and she is one of 20 girls so employed, the first YLs ever to be working for the army in Belgium.

#### BK

To each and all of you, Season's Greetings, and we'll look forward to hearing from you during the coming year. 33, W5RZJ.

#### 75-METER SSB ROSTER

Anyone who thinks that SSB is unpopular would do well to scan the roster of 225 active 75-meter stations just prepared by W2SHN, W3ASW, W9DYV and W3KPP. The roster contains the QTH, name and call of SSB advocates in Canada, Hawaii and the United States. Contact W3KPP for information on distribution.



- 1220 pages
  - 80,000 items
  - 8,000 illustrations
  - 8" x 11" — 5 lbs.
- Publisher's price  
\$6.50—your price  
through your regular parts distributor . . . . . \$195

#### The right part when you need it for service

This permanent, hard cover Official Buying Guide of the electronic-TV parts and equipment industry with its comprehensive detailed index, eliminates the need for maintaining files of small catalogs and manufacturers' literature. *Radio's Master* catalogs 90% of TV and electronic equipment. Not merely part number listings — complete descriptions, specifications and illustrations written and compiled by each manufacturer. Enables you to make comparisons or substitutions right now!

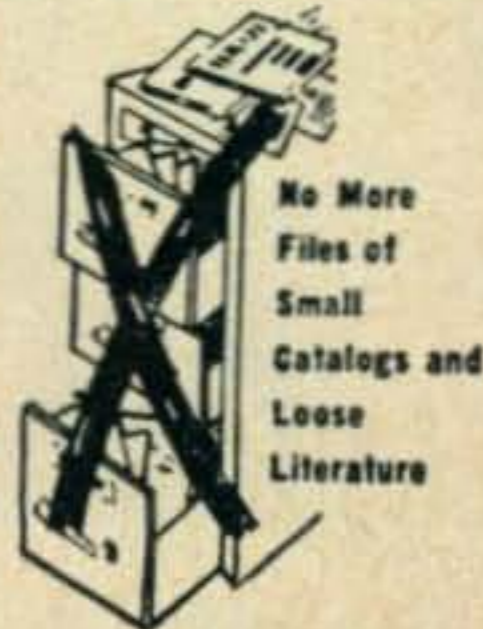

UNITED CATALOG PUBLISHERS, INC.  
110 Lafayette St., New York 13



to the **E. E. or PHYSICS GRADUATE**

with experience in

## **RADAR OR ELECTRONICS**

*Hughes Research and Development Laboratories, one of the nation's large electronics organizations, is now creating a number of new openings in an important phase of its operation.*

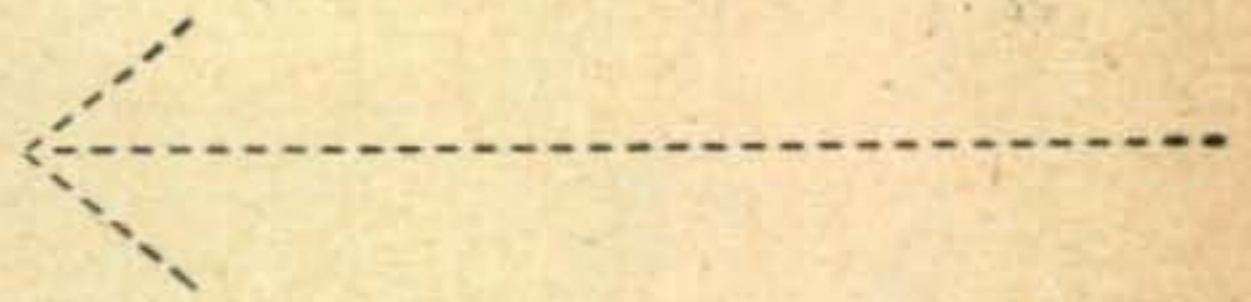

*Here is what one of these positions offers you:*

### **THE COMPANY**

Hughes Research and Development Laboratories is located in Southern California. We are presently engaged in the development of advanced radar devices, electronic computers and guided missiles.

### **NEW OPENINGS**

The positions are for men who will serve as technical advisors to the companies and government agencies purchasing Hughes equipment. Your specific job would be to help insure the successful operation of our equipment in the field.

### **THE TRAINING**

Upon joining our organiza-

tion, you will work in our Laboratories for several months until you are thoroughly familiar with the equipment you will later help the Services to understand and properly employ.

### **WHERE YOU WORK**

After your period of training (at full pay), you may (1) remain with the company Laboratories in Southern California in an instruction or administrative capacity, (2) become the Hughes representative at a company where our equipment is being installed, or (3) be the Hughes representative at a military base in this country—or

overseas (single men only). Compensation is made for traveling and for moving household effects, and married men keep their families with them at all times.

### **YOUR FUTURE**

You will gain all-around experience that will increase your value to the company as it further expands in the field of electronics. The next few years are certain to see a large-scale commercial employment of electronic systems—and your training in the most advanced electronic techniques now will qualify you for even more important positions then.

### **HOW TO APPLY**

If you are under thirty-five years of age, and if you have an E. E. or Physics degree, with some experience in radar or electronics,

write to:

## **HUGHES**

**RESEARCH AND DEVELOPMENT LABORATORIES**

*Engineering Personnel Department*

**CULVER CITY, LOS ANGELES COUNTY, CALIFORNIA**

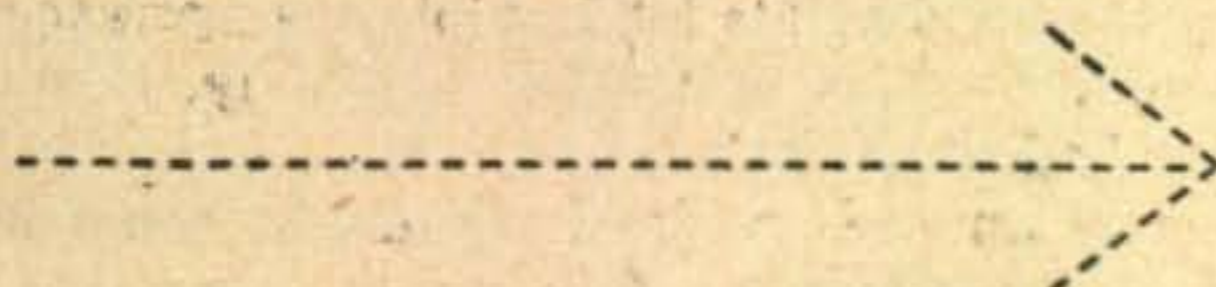

*Assurance is required that relocation of the applicant will not cause disruption of an urgent military project.*

## Bend an ear this way, OM—here's a bright new kind of Xmas giving....

Maybe you didn't know—but we've had a smart gift idea going here at ALLIED for a couple of years. It's our Ham XMAS Gift Certificate—and we'll make it out for you to give to any buddy—in any amount from five bucks to a couple of grand.



Whether you're giving an ALLIED gift certificate to a pal, or buying equipment yourself, you can count on us for money-saving low prices. We've been told it's a pretty swell idea. Any one who gets an ALLIED Xmas Gift Certificate will have himself a gala time making his selections from the 236-page 1953 ALLIED Catalog. It's packed with the world's largest stocks of station gear—at

quick, dependable action and the kind of practical help you want. Here's our holiday best to you: P. S.—For a copy of our 1953 catalog, write ALLIED RADIO CORP., 833 W. Jackson Blvd., Dept. 16-M-2, Chicago 7, Ill.

## Master Mobile

ANTENNAS MOUNTS

### NEW MASTER DELUXE

#### 2-METER COAX ANTENNA—MODEL NO. 214

MASTER MOBILE'S engineers have designed a Superior New, Ruggedly Constructed, Vertically Polarized, Coaxial Antenna in the frequency range of 140 to 170 Megacycles.

**Features:** Completely waterproofed • furnished with approximately 10 ft. of 72 OHM Coax Cable • smart design enhances the appearance of any vehicle • very attractive highly polished chrome finish • delivered complete—ready for quick, simple installation.

**Mounting Types:** Type 1, on side—with 2 brackets furnished—as shown. Type 2: on master mount (No. 132X or 140X). Mounts sold separately. Complete Antenna: Featured at **\$15.95** Net Plus Postage. Approx. Ship. Wt.—3 lbs.

Master Mounts: No. 132X **\$9.85** No. 140X **\$7.65**

**2-METER STANDARD MODEL—NO. 114**  
COAX VHF ANTENNA • At a Popular Price FOR OPEN TYPE VEHICLES using 140 MC to 165 MC. Mounts any convenient place with standard MASTER MOUNTS. Baked enamel finish. With 10' Coax Cable and 18" Adjustable Section. NET—ONLY \$9.95.

At Leading Distributors or Write

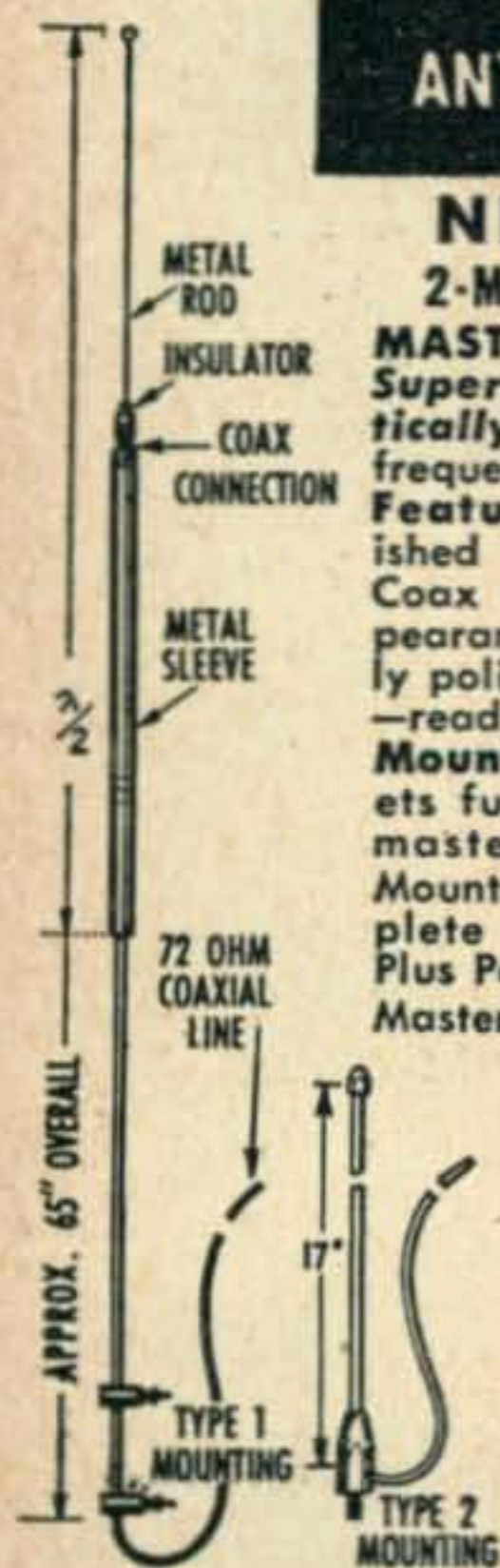

Master Mobile Mounts, Inc.

P. O. BOX 1817 • LOS ANGELES 36, CALIFORNIA  
WAREHOUSE AND SHIPPING ADDRESS: 1306 BOND STREET

## Progress?

N. C. HOLMAN, ZS5GO

The story below attracted our eye in the August issue of "Radio ZS", Capetown, South Africa. We reprint it here in hopes that our readers may also find it a clever bit of whimsy.—Editor.

We are apt to assume that every new discovery in radio, and every new technique, must necessarily be better than the previous ones. Perhaps, however, we ought to judge each item on its own merits, and not be influenced too much by the order in which the inventions were made.

Suppose, for instance, that the beam aerial had been discovered first, and then some ingenious chap had discovered that one could get out just as well on a mere 66-foot wire, this is how he would describe his invention.

"Here at last is what we have all been waiting for. An antenna that will get out equally well all round, so that one can work in any direction without having to turn a wheel. S9 reports from Honolulu and New Zealand. Round table QSOs at last a possibility. And you don't have to be a plumber and a steeplejack to build this antenna, nor does it need a tower. . . ."

Supposing the metal tube had been invented first, just think what good advantages would be claimed for the glass tube: "No more doubt as to whether a valve is burned out or not, as you can see that the filament is alight. Even if the name is scrapped off, you can still identify the tube. Heating no longer a problem, as the heat is radiated through the glass. Warning of overloading is given by a visible blue glow which can also be used as a tuning indication. Altogether, an important advance in design. . . ."

If the carbon microphone had only just been invented, think what a stir it would cause: "Amazing simplicity, nothing in it but a pinch of carbon dust. Make it yourself from scrapings from an electric motor brush. High gain-speed amplifier unnecessary. Pleasant mellow tone. Indestructible by heat or shock. Will soon be put on the market at a price under a dollar. A specially valuable feature is that if ever it loses sensitivity, a smart tap on the table will restore it to normal."

Think of the good points for headphones—privacy power amplifier stages unnecessary, quality, if the loudspeaker had come first.

In the final analysis, radio itself might come in for a bit of re-valuation. We might hear that: "Reading a paper before the Assembly of the S.A.R.L., Mr. Spoo of the U.S.A., stated that all radio problems had at last been solved. Atmospheric, wipe-out conditions, the frequency allocation problem, fading, secrecy, interference, would give us no more trouble. The daring tech-

(Continued on page 58)

**AT ANY PRICE...you couldn't  
ask for more  
in a....  
MOBILE  
TRANSMITTER!**

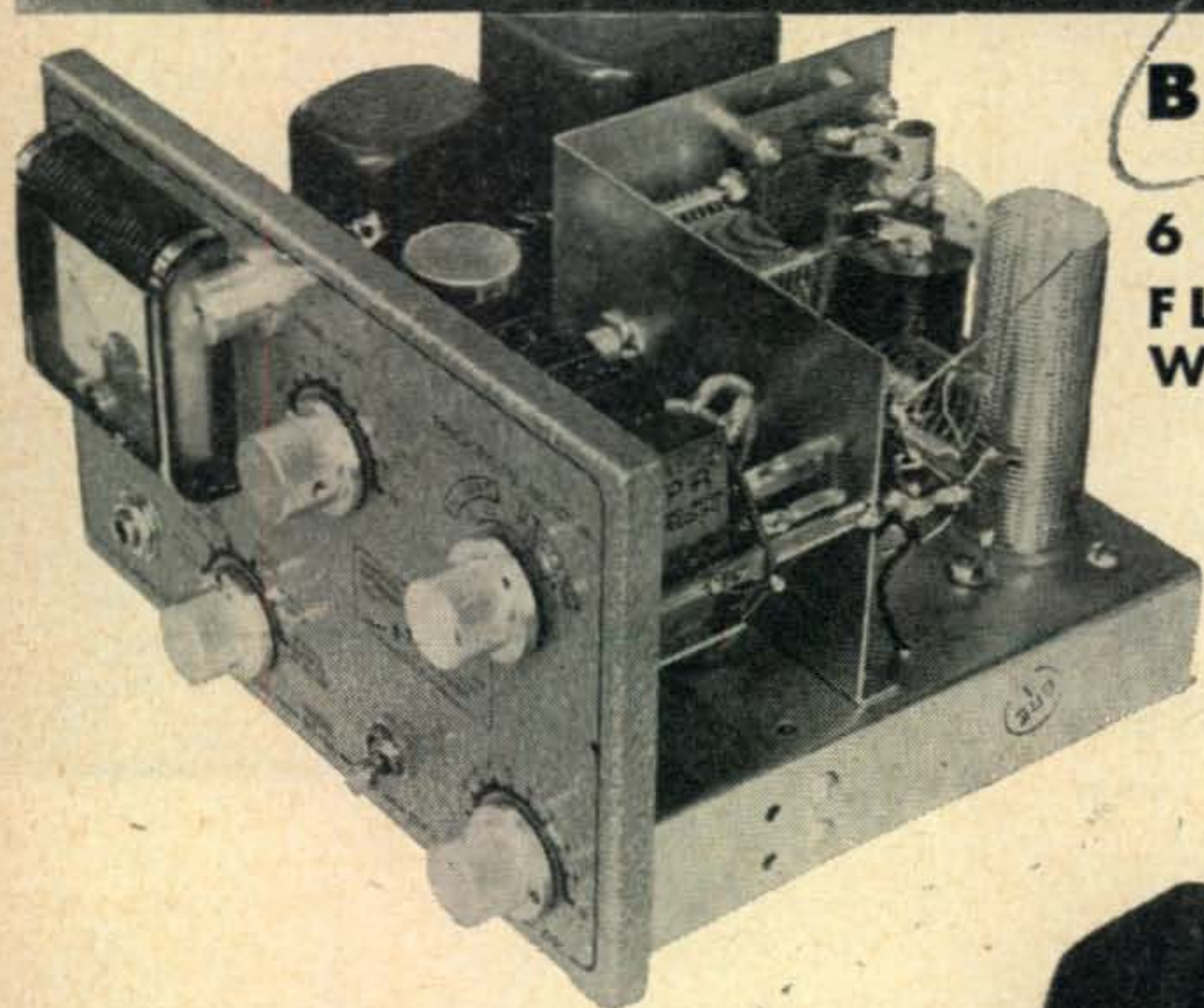

## **BABCOCK MOBILE D-X MITTER**

**6 Band—Band Switching  
FLICK ONE SWITCH...  
WHILE IN MOTION...**

- 2 Bands
- 2 Frequencies per Band
- 2 Band Antenna

**HIGHEST** quality throughout with standard "name brand" parts marks the Mobile D-X Mitter. Small—5" high, 8" wide, 7" deep, for mobile or home use, absolutely guaranteed.

### **COMPLETE METERING**

New Simpson meter reads Plate V, Osc. Pl. Ma, Mod. Pl. Ma, Final Grid Ma, Final Pl. Ma, Watts output into 52 ohms.

### **POWER SUPPLY UNIT**

PS 4A 6VDC Dual vibrator power supply with vibrators, plugs and tubes...\$67.50

**ONLY  
\$99.50  
HAM NET**

**Priced to Gain  
Volume Sales Among  
Discriminating  
Ham Ops**

**PRICE INCLUDES TUBES**

Write for Free Literature and name of your nearest dealer.

# **BABCOCK**

**RADIO ENGINEERING, INC.**  
7942 Woodley Ave., Van Nuys, Calif.

## The Newcomer's Buyway

### "The Dispatcher"



Here's a Controlled Reluctance microphone assembly designed to handle the most severe requirements of radio amateur rigs. The "Dispatcher" is supplied with two-conductor shielded cable, and it's wired to operate both microphone and relay circuits. This field-proved unit is used extensively in police, railroad, airport, and all emergency communications work where dependability is vital. Of special interest to "Hams" is the large, easy-to-use grip-bar and positive action of the heavy-duty switch. Firm downward pressure on the grip-bar locks the switch—so you can "yackety-yack" all night without lifting a finger! The "Dispatcher" is immune to heat and humidity and will stand up under rough usage. It is manufactured by Shure Brothers, Inc., 225 West Huron Street, Chicago 10, Illinois. It's a high-impedance unit with a high output level of minus 52.5 db. Lists at \$35.00. See the "Dispatcher" at your Distributor for further details, or write Shure Brothers, Inc., 225 West Huron Street, Chicago 10, Illinois.

### The Box of 1000 Uses

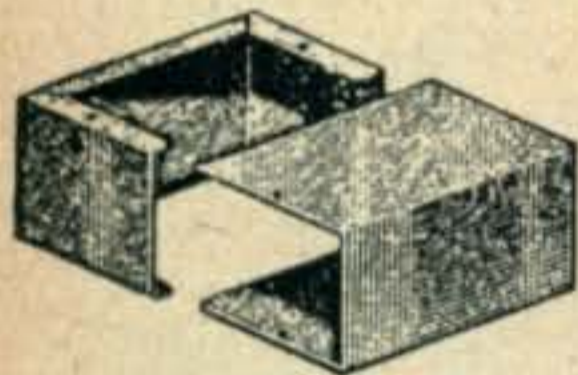

There are thousands of uses in the fields of radio and electronics for these new boxes. They are made from heavy gauge aluminum. The design of the box permits installation of more components than would be possible in the conventionally designed box of the same size. It is of two piece construction, each half forming three sides. The flange type construction assures adequate shielding. Available in etched aluminum finish and gray hammerloid finish.

Catalog Numbers		Length	Width	Height
Grey	Etched			
CU-2100	CU-3000	2 $\frac{3}{4}$ "	2 $\frac{1}{8}$ "	1 $\frac{5}{8}$ "
CU-2101	CU-3001	3 $\frac{1}{2}$ "	2 $\frac{1}{8}$ "	1 $\frac{5}{8}$ "
CU-2102	CU-3002	4"	2 $\frac{1}{8}$ "	1 $\frac{5}{8}$ "
CU-2103	CU-3003	4"	2 $\frac{1}{4}$ "	2 $\frac{1}{4}$ "
CU-2104	CU-3004	5"	2 $\frac{1}{4}$ "	2 $\frac{1}{4}$ "
CU-2105	CU-3005	5"	4"	3"
CU-2106	CU-3006	5 $\frac{1}{4}$ "	3"	2 $\frac{1}{8}$ "
CU-2107	CU-3007	6"	5"	4"
CU-2108	CU-3008	7"	5"	3"
CU-2109	CU-3009	8"	6"	3 $\frac{1}{2}$ "
CU-2110	CU-3010	10"	6"	3 $\frac{1}{2}$ "
CU-2111	CU-3011	12"	7"	4"
CU-2112	CU-3012	17"	5"	4"
CU-2113	CU-3013	10"	2"	1 $\frac{5}{8}$ "
CU-2114	CU-3014	12"	2 $\frac{1}{2}$ "	2 $\frac{1}{4}$ "
CU-2115	CU-3015	4"	2"	2 $\frac{3}{4}$ "
CU-2116	CU-3016	4 $\frac{1}{4}$ "	2 $\frac{1}{4}$ "	1 $\frac{1}{2}$ "

See them at your Bud Distributor.

## BUD RADIO, INC.

2118 EAST 55th ST.

CLEVELAND 3, OHIO

## Progress?

(from page 56)

nicians of his native land, throwing aside all preconceived notions of the principles of radio communication, and after many years of research, had succeeded in dispensing entirely with the carrier wave. The audio signal itself, using trifling power, is conveyed by a fine conductor (or "line" as they propose to call it) right into the receiving station.

## Physician and Dentist Directory

A second edition of the "Directory of Physician and Dentist Amateur Radio Operators" is planned for publication early in 1953. This directory is compiled and edited by Arthur W. Woods, M.D., W4GJW. Doc reports that the first edition, listing about 220, was a big success, as many of the gang found it quite useful.

To insure the greatest accuracy and coverage in the second edition, W4GJW requests that all Doctor and Dentist amateurs QSL him for identification. He will then send an application to be filled out for listing in the directory.

W4GJW can be reached at the Woodward Building, Birmingham, Ala.

## VHF News

(from page 42)

no one has made any serious attempt to find out. We believe Otto will prove them so wrong.

W5FSC has sold his two-meter surplus 829 rig and was off the air for a time. Mut, Bud will have a new one, ending up with a pair of 4-125A's. He should be back on the air by Christmas. Bud is also increasing power to his 220-mc set-up, planning on a pair of 4-65A's in the final. This six-meter rig will retain their present 35Ts. Common modulators and power supplies will be used, and all equipment will go into one six-foot rack . . . W5FEK is in the midst of a building program which will net him a 10' x 16' workshop, in addition to enlargement of his house. Grace gets a covered wash-house out of the deal!

New stations in the Houston area are: W5RCP, W5YAU, W5RPH, who is the son of W5QKF of Corpus Christi, W5URT, W5GYK, W5UPR, W5TSF, WN5WZF and WN5WTN.

(Continued on page 60)



**BOB HENRY**  
gives the best  
trade-ins  
the easiest  
credit terms

on new **Hallicrafters**



**MODEL HT-20** . . . T.V.I. proof 100 watt AM-XW transmitter with all spurious outputs at least 90 db. below full rated output. All stages metered; single meter with eight position meter switch; output tuning indication. Frequency range of 1.7 Mc to 30 Mc continuous on front panel control. Provisions for external VFO. Seven tubes plus five rectifiers. For 117 V. 60 cycle. **\$449.50**



**MODEL SX-71** . . . Double super-heterodyne circuit plus built-in Narrow Band FM reception. Temperature compensated, voltage regulated. 5 position band selector for 538-1650 Kc, 1600-4800 Kc, 4.6-13.5 Kc, 12.5-35 Mc, 46-56 Mc. 11 tubes plus voltage regulator and rectifier. **\$224.50**

Choose from our complete stock of new Hallicrafters receivers and transmitters. Prompt delivery plus 90-day FREE service. I have a payment plan for you. Write, wire, phone or visit either store today! Export orders welcome.



**MODEL S-76** . . . Dual conversion (1650 Kc and 50 Kc). Four bands 538-1580 Kc, 1720 Kc to 32 Mc. 5 position selectivity. Sensitivity 2 microvolts or better with 5 watt output. 9 tubes plus regulator, rectifier. **\$179.50**



**MODEL SX-62** . . . AM, CW or FM with continuous coverage from 540 Kc to 109 Mc in six bands and 27-109 Mc FM. Fourteen tubes plus regulator, rectifier. \$299.50. Other popular Hallicrafters models: S38B \$49.50; S-72 \$109.95; S-72L \$119.95; S-40B \$119.95.

Butler 1, Missouri  
Phone: 395

**HENRY RADIO STORES**

11240 Olympic Blvd.  
LOS ANGELES 64  
BRadshaw 2-2917

"LARGEST DISTRIBUTORS OF SHORT WAVE RECEIVERS"

# A Completely NEW COAXIAL RELAY

for

52 and 72-ohm  
lines

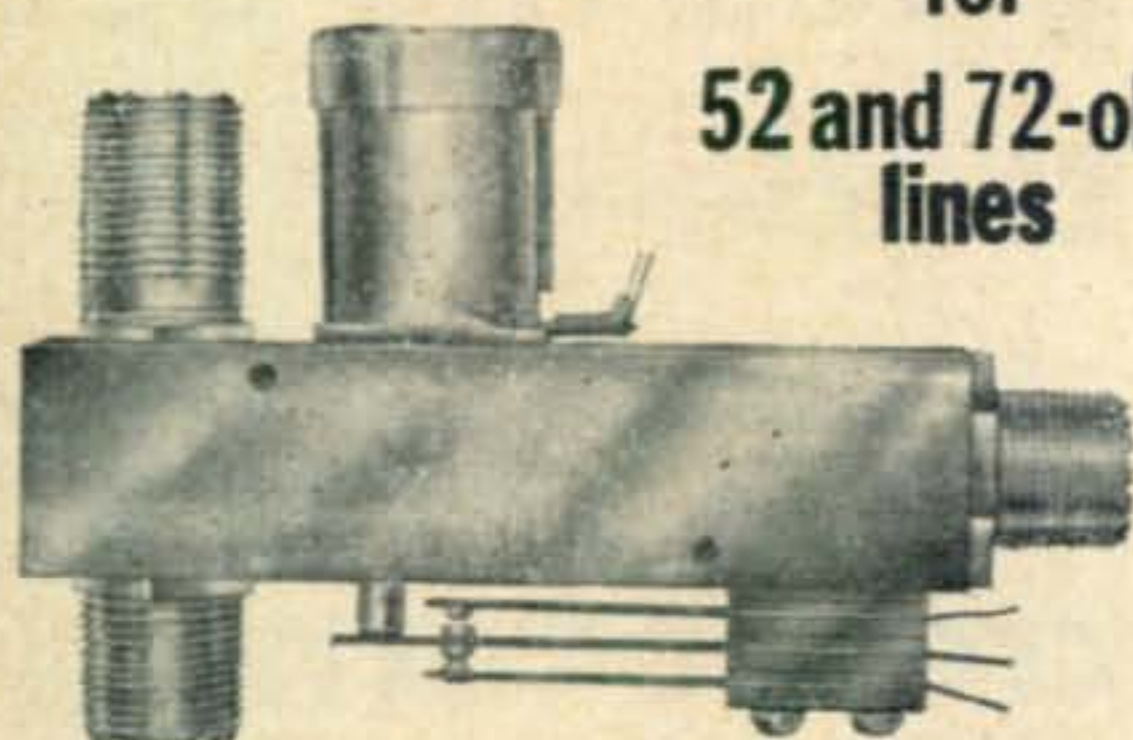

Has been proven to handle 1000 watts at 100 mc. Both a.c. and d.c. models available. The magnets have been greatly improved and are guaranteed to be free of hum or chatter.

6, 12, 24, 117 volts a.c. model .....	\$10.50	net
6, 12, 24 volt d.c. model .....	\$ 9.50	"
Antenna shorting connector .....	\$ 1.00	"
External SPDT switch .....	\$ 1.00	"

DEALER INQUIRIES INVITED

**DOW-KEY CO., INC.**  
Warren Minn.

(from page 58)

Hold on to your hats! W5FEK, that old two-meter die-hard, is operating a little "six-bits!" (75-meter phone!—VHF Ed.) We bought us a rocking-chair at a bargain price, so we had to take advantage of it and go on 75! We are still having a hard time convincing a lot of boys that we are actually on the d.c. bands. If we can get three converts to v.h.f. it will be worth the effort!

W5IVU, Edna, reports skunk trouble in addition to his usual complaints about gophers. Seems as though a young civet cat has decided to make his home under Hank's house, and it is reported that the sales of Air-wick have jumped in Edna.

## Two-Meter RTTY Troubles

The "other side" of the interference problem might well be appreciated after reading the following report from a prominent eastern 2-meter ham. "We have been having a little trouble with stations located adjacent to the two-meter band. The first one noticed was on 148.0347 Mc. Trouble started when modulation was applied to the carrier, and the sidebands started spreading down into the band. As they were using a modulation frequency close to 2 kc., or a sub-harmonic thereof, the RTTY gang had trouble. Their necessarily broad-band auto-start receivers picked up the sidebands; the modulation tone was close to the auto-start-actuating 2125 cycle signal. Result: lots of false starts and missed starts, and a general feeling among the boys that maybe we'd better move the RTTY calling frequency! But, the cause of the trouble was definitely the presence of sideband energy inside our bands—not inadequate ham receiver selectivity. W2JAV and others brought up the matter with the FCC, and Phil was told that the trouble was due to 'inadequate selectivity'; nevertheless someone's conscience must have hurt because the modulation was removed and all we have had to contend with lately has been a nice steady CW carrier on that frequency, 24 hours a day! Makes a dandy beacon, so long as they leave it that way. It is pretty well established that this station is located at an airport on Long Island, and is operated by the CAA or similar agency for v.h.f. multiplex relay work. The signal is vertically-polarized and is normally detectable without much trouble in this neighborhood (approximately 100 miles away) and, under open-band conditions, it rises to over S9.

"That was bad enough, but on the evening of August 11th, 1952, we had a pretty fair band opening to the north and northwest, and I personally experienced a hekkuva lot of trouble with a signal on about 143.967 Mc. (These frequencies were measured, using a secondary standard which produces 10-kc harmonics across the band, and an audio b.f.o. for interpolation; probably OK to better than 10 p.p.m.). This one was modulated by sub-carriers spaced almost exactly 10 kc., which carried RTTY signals. I could count at least 5 sidebands on each side. This is especially bad, since those RTTY-modulated sub-carriers fell right in the low end of the band, pretty much ruining the lowest 100 kc.—DX Alley! My bearings on this were roughly to the northeast, and it was strong either on vertical or horizontal. Although it is normally too weak to give us much trouble, when an opening occurs, it's right in there. As I write this letter the darned thing is cleaning out about 50 kc. of the band!

"You might be able to do some good via your column. Official Observers who are equipped to make good measurements on two meters are too scattered to do much good. It will require action on the part of the devotees of the band to track down the location of the station, the extent of the QRM, and then push the case right to the FCC for action. We'll get action, if we do it correctly. Why not report these interlopers on the 144-mc band to your VHF News column readers? Perhaps you have among your fans some influential men of the FCC who might just possibly be guided in future allocations by experiences in this instance.

"I hope that the particular cases described above will be taken care of by the time you could get anything about it in your column, but there will be other such cases. The hams should establish and maintain their would say if I happened to plunk a solid carrier right rights in cases like these. Now, I wonder what 'they on top of one of their channels—inside the band!"

*Keep Your  
Shack Neat  
with a*

## BOUND VOLUME

You'll appreciate the handy convenience of this compact volume of the 1952 issues of CQ . . . handsomely book-bound in tan colored cloth . . . distinctive gold foil lettering embossed in a black panel strip . . . available NOW!

**\$7.95**

in U. S., Canada and  
Pan-American  
Union. Others  
\$1.00 more.

**C Q M A G A Z I N E**  
67 West 44th Street New York 36, N. Y.

**GOING MOBILE ?**

For 6 Volt Conversion.

**PE-101C DYNAMOTOR**

See August, '52 and this CQ Issue...\$3.95



**ANTENNA EQUIPMENT**

**MP-132 MAST BASE**—(Illustrated) 1" heavy coil spring, 2" insulator. Overall length: 11 1/2". Weight: 2 3/4 lbs. Price.....\$3.95  
**MAST BASE**—Insulated type with heavy coil spring and 5 inch dia. insulator. Requires 1" hole for mtg. Weight: 9 lbs. ....\$5.95  
**MAST SECTIONS FOR ABOVE BASES:**  
 Tubular steel, copper coated, painted, in 3 ft. sections, screw-in type. MS-53 can be used to make any length with MS-52-51-50-49 for taper. Any section.....50c each  
 Larger Diameter Sections: MS-55-54.\$1.25 each

**DYNAMOTORS**

**DYNAMOTOR and BLOWER:** 9 Volts DC input; output 450 Volts 60 MA. 4500 RPM. At 6 Volts DC input; output 260 Volts 65 MA. 3000 RPM.....\$4.95

Input:	Output:	Stock No.:	Price:
14 V. DC	600 V. 300 MA.	BD-86	\$ 9.95
12 V. DC	220 V. 70 MA.	DM-24	6.95
12 V. DC	220 V. 100 MA.	DM-18	4.95
14 V. DC	375 V. 150 MA.	DM-375	8.95
14 V. DC	330 V. 135 MA.	DM-330	7.95
14 V. DC	500 V. 500 MA.	PE-59	14.95
12 or 24V.D.C.	275 V. 110 MA.	USA/0516	3.95
12 or 24V.D.C.	440 V. 200 MA.		
	225 V. 100 MA.	D-104	14.95
12 or 24V.D.C.	500 V. 50 MA.	USA/0515	3.95
12 V. DC	250 V. 50 MA.	DM-25	8.95
28 V. DC	250 V. 60 MA.	DM-32 (Used)	2.95
28 V. DC	250 V. 60 MA.	PE-86	5.95

**COMMAND TRANSMITTERS With Tubes & Crystals**

BC-457 Transmitter—4 to 5.3 MC.—Used.....	\$ 8.95
BC-458 Transmitter—5.3 to 7 MC.—Used.....	7.95
BC-459 Transmitter—7 to 9 MC.—New.....	22.95
T-20/ARC-5 Transmitter—4 to 5.3 MC.—New.....	12.95
BC-456 Modulator—New.....	\$5.95
Transmitter Rack—Single.....	\$1.50
Rec. Rack—Dual.....	\$1.50
Rec. Dyn.—Used.....	\$2.95
Modulator—Mtg.....	1.50
Trans. Dyn.—Used.....	2.95

ADDRESS DEPT. CQ

ALL PRICES ARE F.O.B.,

**RECEIVERS—TRANSMITTERS:**

TA-12B TRANSMITTER with Tubes—Used.....	\$39.95
MP-28 BA Power Supply & Modulator f/TA-12B—New	\$29.95
R1/ARR-1 Receiver—easily converted to 220' MC. (see R.N. Jan. '49). Complete with Tubes—New..	\$ 4.95
RA-10 DB Receiver—24 Volts with Tubes and Dynamotor—Used.....	\$29.95

**TRANSFORMERS AND CHOKES:**

TRANSFORMERS—110 V. 60 CYCLE PRIMARIES	
6.3 V. 1 Amp. ....	\$1.25
24 V. 1/2 Amp. ....	1.50
6-24- or 30 Volt 8 Amp. ....	5.95
Two 12 V. 4 A. windings, gives 12 V. 8 A. or 24V. 4 A. ....	5.95
440 VCT/70 MA—5 V. 2 A.—6.3 V. 4 A. ....	3.35
700 VCT/200 MA—6.3 V. 4 A.—6.3 V. 4 A.—5 V. 3 A. ....	4.95
490 VCT/60 MA—5 V. 2 A.—6.3 V. 4 A.—6.3 V. 2 A. ....	3.25
460 VCT/90 MA—5 V. 3 A.—6.3 V. 4 A. ....	3.75
325-0-325 V. 50 MA—6.3 V. 2.5 A.—6.3 V. .6A. (Rect. 6 x 5) Half Shell—2 7/8" x 3 3/8" x 3"—No. T-23-28 .....	2.75
175-0-175 V. 40 MA—6.3 V. @ 2.4 A.—6.3 V. @ 6 A. Halfshell 2 5/8" x 2-3/16" x 2 3/8"—No. T-23-40 .....	1.25
350-0-350 V. 90 MA—6.3 V. @ 3 A.—5 V. @ 3 A. Upright—3 1/8" x 3 1/8" x 3 1/8".....	3.25

**CHOKES**

5 Henries—150 MA. 85 ohms DC-Res. Cased.....\$1.95

**AERIAL WIRE**—Phosphorus Bronze #16 Stranded, 200 lb. test. Weatherproof. 150 ft. on Reel. RL3 with Clips .....

**TELEPHONE WIRE:** 3 Cond. copper & steel, 525 ft...\$4.75

**PE-157 POWER SUPPLY**—2 V. Vibrator Supply, operates from BB-54 2 V. Battery mounted in Case. Output voltage 1.4 V. 1/2 Amp. 125 V. 50 MA. Less Battery, Speaker & External Power Cord—with Vibrator.....\$4.95  
**BB-54 2 Volt Dry Battery**.....\$2.95  
**POWER SUPPLY No. 3 f/Mark II No. 19 Radio Set.** 12 or 24 V. Two PM Dynamotors: 500 V. 50 MA.; 275 V. 110 MA.—New .....

**FAIR RADIO SALES**

132 SOUTH MAIN ST. LIMA, OHIO

**BOUND**

To Give Greater Value

By keeping your copies of "CQ" in a BINDER, you have the finest reference library on ham radio right at your finger tips.

This handsome, red fabricord, steel reinforced binder holds a full year's copies of "CQ." Each magazine can be inserted or removed at will.

Price **\$2.50** postpaid\*

\*(Foreign Orders add 25c per binder)

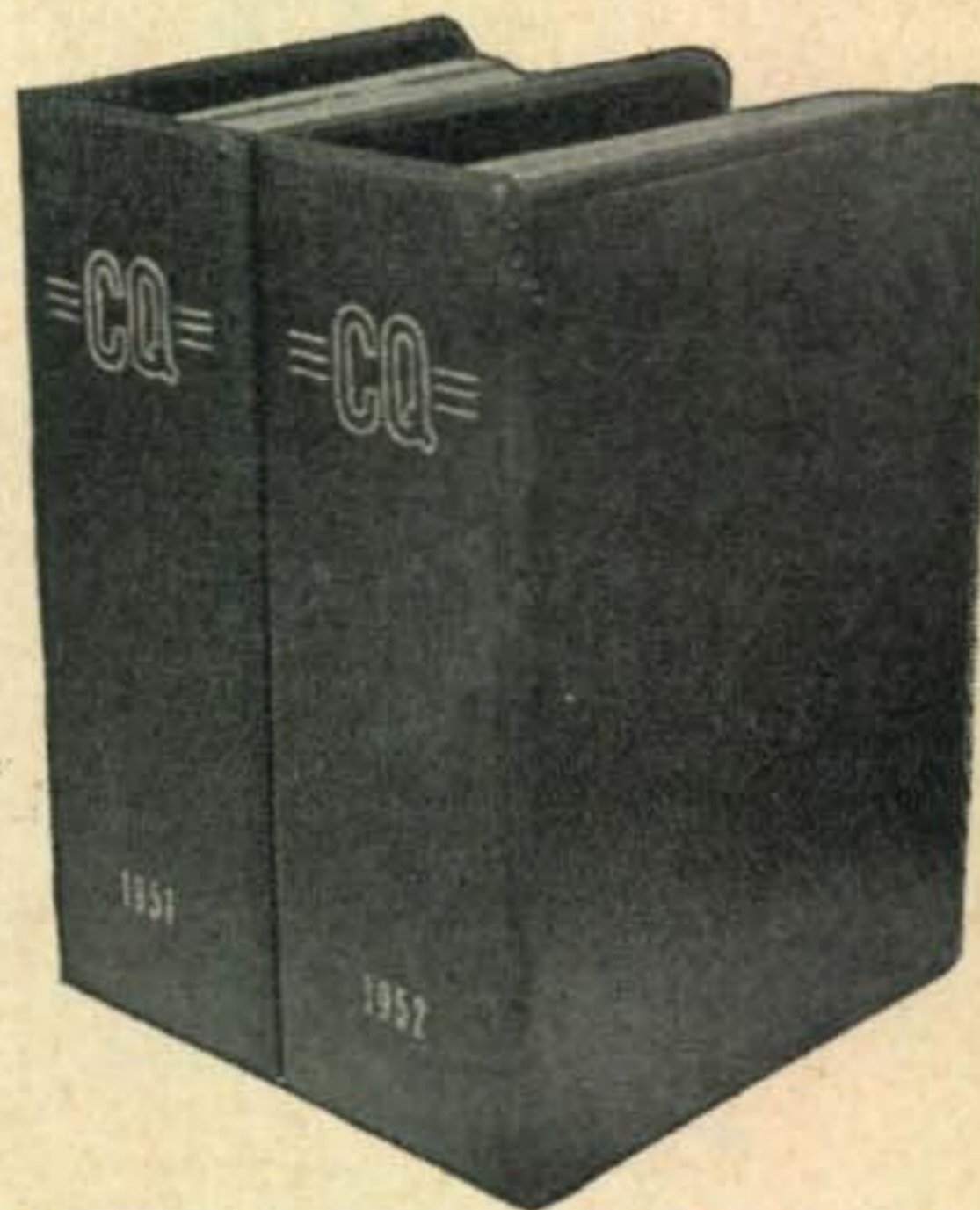

CQ Magazine

67 West 44th St., New York 36, N. Y.

Enclosed find \$..... for ..... binders

Name ..... Call .....

Address .....

City ..... Zone ..... State .....

Year to be stamped ..... Heading:  CQ,  Plain

## ATTENTION MOBILE HAMS

COMPLETE MOBILE PACKAGE — NOTHING ELSE TO BUY. OUTSTANDING MOBILE SIGNALS USE MOTOROLA EQUIPMENT—BACKED BY YEARS OF COMMUNICATION EQUIPMENT EXPERIENCE — WORLD'S LARGEST PRODUCER OF 2-WAY MOBILE EQUIPMENT.

A mobile transmitter with a double feature FM or AM at flip of the switch, the MOTOROLA FMT-30-DMS 27-30 MC. . . **\$130.00**

P-7253 spring base rear-mount antenna. . . **\$23.13**

MOTOROLA P-69-18 or 18-ARS receiver with special noise limiter for use

with any converter having 1440-3000 KC. **\$60.00**

New Gon-set Tri-Band Spread Converter **\$47.60**

3-30 famous Gon-set converter complete to connect to the P-69-13 or 1-ARS receiver . . . . **\$44.75**

P-327-E Fire wall loud speaker . . . . **\$7.50**

The above comes complete, with all necessary accessories and mounting hardware. Order direct or through the Motorola National Service Organization member in your area.

**NOTE:** This Receiver and Transmitter is equipment which has been returned from the field, modified and rebuilt for Amateur Service.

For further information, write to:

### MOTOROLA INC.

Amateur Sales Dept. CQ, December

1327 W. Washington Blvd., Chicago 7, Ill.

Attention: Harry Harrison, W9LLX  
Telephone—Taylor 9-2200, Ext. 161

## WANTED

WE NEED YOUR SURPLUS  
ELECTRONIC EQUIPMENT

WE PAY TOP \$\$\$ FOR:

- |                   |                 |
|-------------------|-----------------|
| • RADIO RECEIVERS | • RELAYS        |
| • TRANSMITTERS    | • TELEPHONE     |
| • ARC-1           | • PLUGS         |
| • ARC-3           | • CORDS         |
| • ART 13          | • MATERIALS     |
| • CONTROL BOXES   | • ON CONNECTORS |
| • INDICATORS      | • WE BUY        |
| • CLAMPS          | • ANYTHING!     |

WRITE, WIRE TODAY! TELL US WHAT YOU HAVE

TALLEN CO., Inc., Dept. CQ

150 Carlton Ave.

Brooklyn 5, N. Y.

## RIDER · TEK-FILE

The EASY way to  
service tv  
receivers!

NOW packs 1-60



JOHN F. RIDER

Publisher, Inc.

480 Canal Street, New York 13, N. Y.

## SCREEN-GRID MODULATORS

(from page 20)

screen modulate an 832 portable two-meter transmitter. The 6AK6 tube draws little heater current and does an excellent job of screen modulating an 832. A second 6AK6, connected as a tetrode voltage amplifier, drives the cathode follower 6AK6. A 6AK5 tetrode speech amplifier completes the tube line-up for crystal microphone input. A 6C4 triode cathode driven tube could have been used with a carbon microphone. However, the writer did not have another such unit available for this set. The 832 tube supplies enough r-f output on two meters to light up a 6-watt lamp to good brilliancy. The power requirements for either of these two portable modulators were from 5 to 15 ma. from the 300- to 400-volt supply, so nearly all of the power supply current is available for the r-f tubes.



This is the model of the circuit described in conjunction with Figure 3. It was used to modulate a portable transmitter with an 807 in the final amplifier.

The plate circuit efficiency of any screen-modulated stage ranges from 30 to somewhat over 40% in most cases. Higher values generally mean that modulation capability is considerably reduced because of either too high a d-c screen voltage or too light an antenna load. The antenna loading must always be together than the value at which maximum antenna current occurs.

To those who might want to use one of the suggested circuits to modulate a tube requiring abnormally high screen grid voltage, a word of warning: The cathode of the cathode follower stage must swing instantaneously up to the screen voltage required for maximum positive peak output. This

(Continued on page 65)



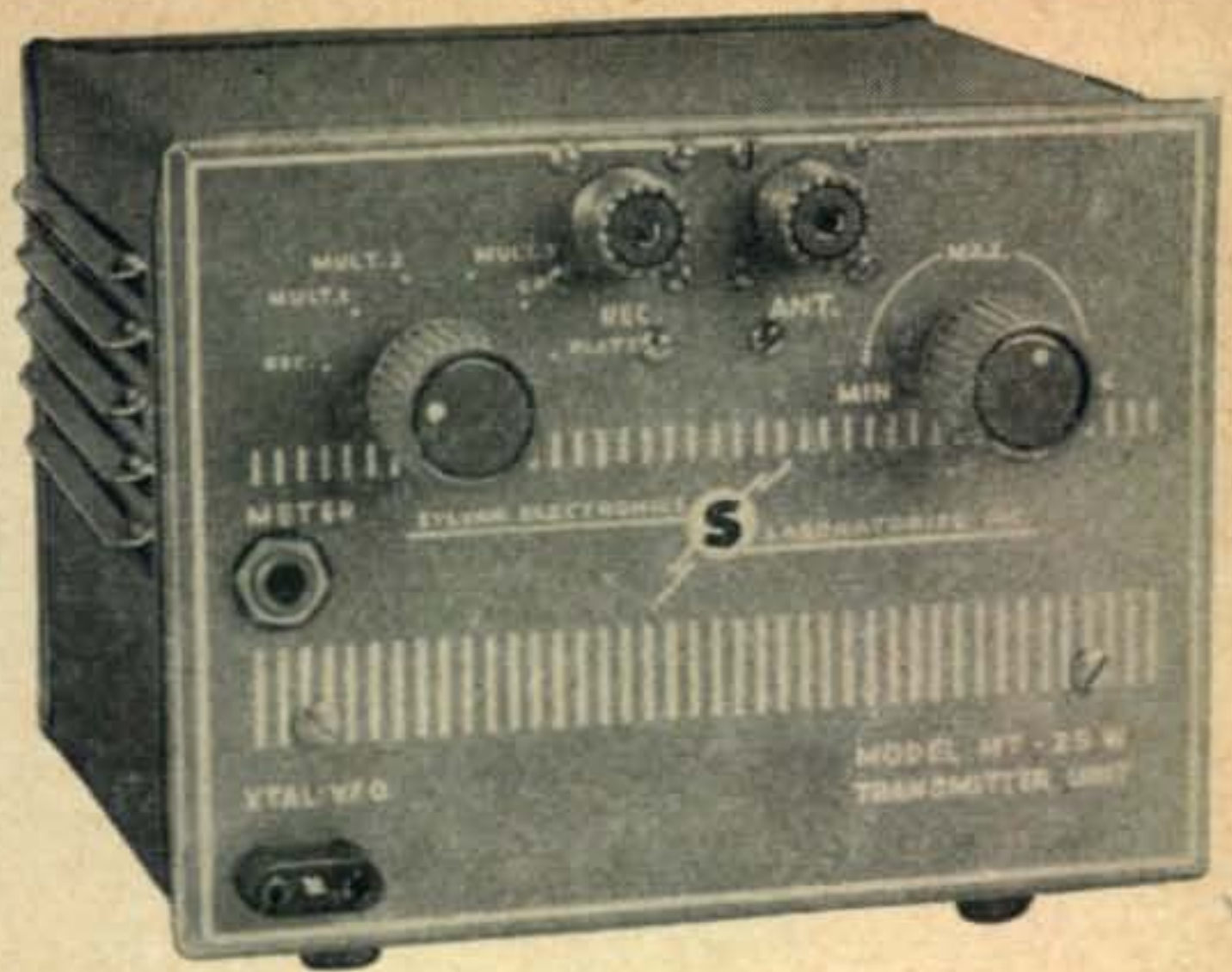

THE



MOBILE

# SYLVAN

# TWINS

## ARE HERE

**MODEL CR-9**

DUAL - CONVERSION RECEIVER

**MODEL MT-25W**

25 WATT TRANSMITTER

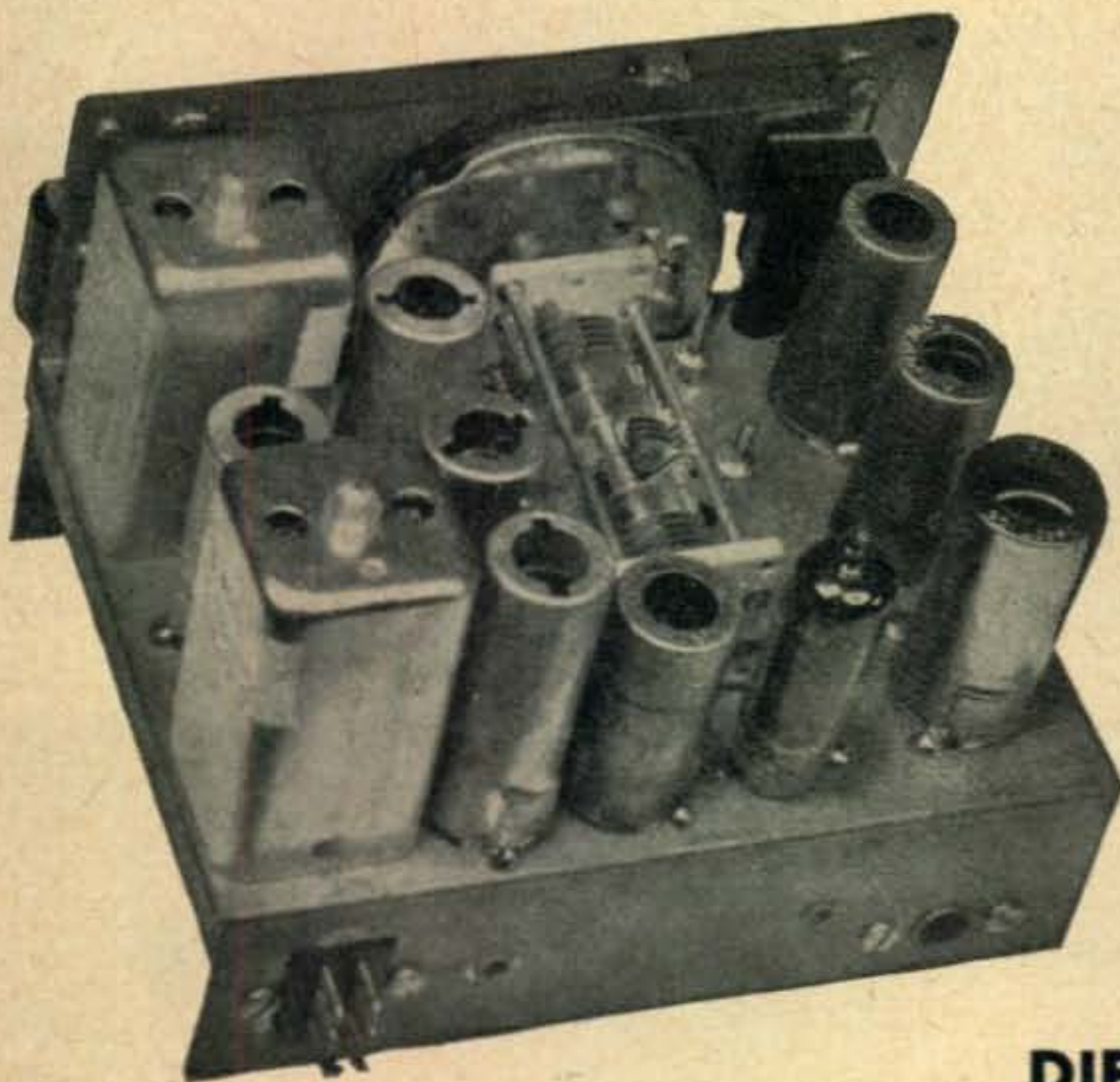

**YOU  
CAN  
SEE  
THE  
DIFFERENCE**

**SEE THEM AT YOUR DEALER • TRY THEM AND BE CONVINCED**

WRITE FOR FREE LITERATURE TO DEPT. C-12

THREE MODELS  
2-6-10, 11 MTRS  
YOUR COST  
**\$99<sup>50</sup>**  
NET COMP.



THREE MODELS  
2-6-10, 11 MTRS  
YOUR COST  
**\$79<sup>50</sup>**  
NET  
Kit of tubes \$22.25

**CQ****The Radio Amateurs' Journal***The Year Round Christmas Gift—*

**BECAUSE—CQ** is the only publication devoted entirely to Ham radio that is able to obtain top-notch material from the four corners of the earth.

**BECAUSE—CQ** regularly prints departments written by experts on such fields as DX, Propagation, VHF, Teletype and Novice activities.

**BECAUSE—CQ** in 1952 printed more wordage, more feature articles of first-rate material and more pages than in either 1950 or 1951. CQ is growing and 1953 will be an exceptional year both in Ham radio and in editorial content of the magazine that covers the entire field of Ham endeavor.

In May 1952, CQ introduced a new concept into Ham publications—the "SPECIAL ISSUE." There are more to come. February 1953 CQ will feature a "SPECIAL ISSUE" on the subject of DX with articles on every facet from "The Certificate Seeker's Directory" to feature material on high power and big antennas. And then in May, another "SPECIAL ISSUE" on mobile operation. You will not want to miss either one—and the easiest way to do that—

*Subscribe now by using this handy envelope*



P.S. Not shown in the regular subscription rate chart is our "Buddy Rate" of \$5.00 a year for yourself and some one overseas. Why not remember that fellow over there who would like to see CQ just as much as you would? This special rate saves you \$2.00 over the straight subscription price.

**CQ Magazine**

67 West 44th Street  
New York 36, N. Y.

## SCREEN-GRID MODULATORS

(from page 62)

voltage may exceed the rated heater-cathode voltage for the particular modulator tube in use. Although most tubes will stand more than the rated heater-cathode voltage, it might be desirable to provide a separate insulated filament transformer winding for the modulator tube. This winding can be left "floating" or one side can be connected to the cathode to insure maintenance of low voltage from heater to cathode.

## DX NEWS

(from page 39)

was advised by the French R.I. that lots of F7 calls are being bootlegged. . . From W8HEV we hear that KW6AW (ex-W6VKR) is headed Alaska way. QTH Box 888, Fairbanks. . . KZ5SX was QRT a month while changing QTH's in Ancon C.Z. . . VQ2AB will return to VQ2, from G land by Xmas. . . W6MUR was QSO'ed at WØLLN during Bill's recent eastern trip. . . W6KIP will QRT for job in Death Valley. Luck Alex. . . W9KFO is now W7SFA. . . G3AAM says G2BXP was the only G to nab YA3VB recently. . . OQ5LL arrived back in the Congo after a three-month stateside visit. Andre wishes to send 73's to all the hams who made his stay such a pleasant one. . . ZL2RC goes to England next year via U.S.A. and hopes to drop in on some of his many friends here. . . W1ZD sports a new Collins KW-1. . . W6EAE QSY'd two miles to new QTH and Bill is now on top of the hill instead of at the bottom.

After summer layoff the '52 contest champ W5ENE is now on making up for lost time. . . PZ10Y has been reported active again. . . ZK1BC left for NZ on Oct. 17th. QSL's may be obtained from W6MUR. This leaves ZK1AB, 7 Mc., and ZK1AZ T6 as the only active ones on Cook. . . OQ5RA regrets he missed on the CQ contest. He had to journey to the east coast Congo towns of Matadi, Boma and Banana. . . PAØGF is old PJØX, remember? . . . PAØRLF is ex-PK2ZZ. . . K2BCK (KH6ADY) dropped in on KV4AA. . . W1RY turned up after a 2-year TVI layoff. . . VE2NI sports a new 14-mc beam. . . Lou, W4PKI, is selling rig and getting married. He'll be back. . . A last minute report from TI2TG reports SV5UN on 7010 around 0030z and later. . . W4CEN reports VS9AD (Aden) on 14100. . . G5LH seeks QSL from VP5BL. . . That grand old DX man, CE3DZ, will not be with us much longer so drop him a line or look for him on the low end of 20.

From W4KE we hear that VE6NL is ex-VQ2JS/-ZS1FA/ZS6PF/ZS4DR. He will stay one year in Canada then go to VK, ZS6 and then back to VQ2 to stay. . . ZL2GX has 39 two-way A3 cards for WAZ but can't get that one from Zone 17 nohow. . . G3GRL's shack burned to the ground mysteriously taking along with it cards for 99 countries confirmed. Only thing salvable was a 6 ft. steel rack. Very tough Johnny. . . Karl, HB1JJ/HE, says all Swiss stns operating in HE must use the HB1-/HE call. He has received QSL's for HE1BQ, HE1AA, HE1EC and HE1LAB which are all pirates as far as he knows. . . CP1BK arrived in Los Angeles around Nov. 23rd. Hanks car will bear additional plates of CP1BK so give him a CQ on your klaxons. . . Y13BZL's activities have now ceased but the station will carry on as a club effort signing YI2AM. Other stations active in Iraq are YI2FD and YI3WH. . . ST2HK (ex-VQ4HK) is active on CW 020 and 030, 22 watts. . . YU1AD say the Russian "WSEM" is a CQ for UA, OK, SP, YO and LZ stations only. Mirko adds that all the ZA signals you have been hearing are strictly phonies.

A swell time was had by all at the 2nd informal get-together of the Mass. DXCC Club. Held at Cambridge, Mass. on October 16th. Of the sixty odd members attending were such well known calls as W1FH, W1HX, W1HE, W1QF, W1NWO, W1JOJ, W1HA, W1PKW,

## TWIN-LEAD folded dipole



## Buy the kit and assemble your own HAM ANTENNA

Tested — tried and proven components from which to build your HAM ANTENNA—complete with full instructions for assembly. Build for permanence and performance with quality components.

complete  
kit . . .

- 2 lengths of #16 copper-clad steel conductor twin-lead—cut to band length.
- 1 75-foot length of standard 300 ohm twin-lead for lead-in.
- 1 high strength laminated "T" block.
- Assembly and installation instructions.

Cut to 10, 20, 40 and 80 Meters

We all strive for the best in transmission and reception characteristics—now with the Amphenol Amateur Antenna Kit you are assured of the BEST. Designed by electronics engineers for the most efficient service.

amateur net as low as  
**\$535** for 10 meters

see your **AMPHENOL**  
radio parts distributor

AMERICAN PHENOLIC CORPORATION

# METERS

## WESTON • SANGAMO

ALL NEW. ALL D.C. 2" SQUARE



0-5 Ma	} \$3.29 EACH or 3 for \$9.00
0-15 Ma	
0-50 Ma	
0-100 Ma	
0-200 Ma	
0-300 Ma	
0-2 Ma \$3.95	0-500 Ma

### Mfg'rs Inquiries: Lots Over 100

Cash with order. Prices subject to change without notice. California orders please include 3 1/2% Sales Tax. Approximate postage 25¢—Excess will be refunded. What Have You in Surplus? Submit

### L. A. HAM SHACK

1306 BOND ST., at PICO, LOS ANGELES 15, CALIF.

"Why do you INSIST on a HALLIDRAFTERS RECEIVER Leo?"

"Because HALLIDRAFTERS gives me the most for my MONEY"

**WORLD RADIO LABORATORIES**  
744 WEST BROADWAY  
COUNCIL BLUFFS, IOWA  
WRITE for FREE CATALOG

### UNIVERSAL SUPPLY KIT

Delivers 230V @ 40MA DC. From 110/220VAC, 60 CY. Kit consists of 1 Transformer, 1-5 HY @ 40MA Choke, 2-8 MFD @ 450 V Filter Cond. 1-6x5 Tube. A Great Buy at Only **\$3.95**

Send M.O. or Check. Shp. Chgs. C.O.D.

**COMMUNICATIONS EQUIPMENT CO.**

131 Liberty St., Dept. C-12

New York 7, N. Y.

We Carry a Complete Line of Amateur Equipment including:

National • Hallicrafters  
E. F. Johnson Co. • Bud • Barker-Williamson, etc.

**VARIETY ELECTRIC CO., INC.**

468-470 Broad St.

Newark 2, N. J.



### MEASURING DEVICE

This Calibrated Capacitor enables you to accurately measure

- Capacity
- Inductance
- Distributed Capacity
- Mutual inductance, Q and other measurements.

Price \$5.65. Write for information.

**P. E. HAWKINS CO.**

3208 E. 56 St. N.  
Kansas City 16, Mo.

### 8 WIRE CONTROL CABLE

Two No. 16, Six No. 20 tinned, stranded, copper, rubber insulated coded leads. Waterproof rubber jacket. Woven copper armor shield overall. Wt. 16 lbs./100 ft. Lengths to 400 ft. LOW PRICE FOB warehouse. Minimum order 100 ft. Shipment is made by Railway Express—shipping charges collect. **5c ft.**

**TRANS-WORLD RADIO-TELEVISION CORP.**

6639 S. ABERDEEN ST. CHICAGO 21, ILL.

Phone: AUstin 7-4538

W1RAN, W1BFT, W1FTJ, W1MUN, W1LMB, W1BIL, W1MIJ, W1KKP, W1ZW, W1HRI and YLs W1MCW and W1FTJ. It was decided at the meeting to change the club name which will now be "The New England DXCC Club."

Forty-eight DX'ers attended the DX Breakfast at the Southwest Division Convention held on October 12th in San Diego, Calif. W6BZE, Conducting; W6AM, Chairman; W6QD, Contest, and W6ENV DX Data. DX Conditions were reported in person by OA4AB, PK1VHN and JA2BA.

Effective October 15th, 1952 a new list of "prohibited" countries has been released by the FCC. These include the following:

Austria (except OE13's)	Laos
Cambodia	Thailand
Indonesia	Viet Nam
	Iran

### 21 MC.

This band continues to show promise and anything can happen if you stick around and wait for the openings which seem to be occurring much more frequently. Here are some scores toward a 15-meter DXCC. Let's have yours:

W4COK 51	DL7AP 37	G8OJ 31	W3AYS 16
G8KP 50	KV4AA 37	CE3AG 27	G3ABG 16
G3GUM 47	G6GN 36	G5BZ 26	VK4FJ 13
G2VD 45	W4KRR 33	GC3EML 26	G5FA 10
G6QB 42	W2WZ 33	G3FXB 21	G2DHV 6
G2BJY 41	KP4KD 32	G3AJP 21	W5ADZ 5
GW3AHN 41	W6VX 32	TA3AA 20	W8EKA 4
	W6DFY 31	W5FCD 17	

### QTH COLUMN

KH6ARA	Pat Miller (ex W2AIS), 283 Awakea Road, Lanikai, Oahu, Hawaii
KA9AA	Fred Westervelt (ex W4VE), KA9AA APO 309 c/o P.M. San Francisco, Cal.
ZD7A/ZD7B	Arthur Hemsley (ZS6GV), Box 103, Lambton, Germiston, South Africa
W4AZK	Dave Traer, 621 SE 8th St., Hialeah, Fla. (New QTH)
CR6BZ	Box 378, Luanda, Angola, Africa
VS9AW	H. J. Wheeler (ex G3GUK), Salalah, Aden Command, Saudi Arabia
ZC5VR	Vic Randall, c/o Post Office, Sandakan, Br. North Borneo
YJIAB	Doctor Robert Black (VK2QZ, VR4AF), 36 College St., Sydney, NSW., Australia
CE0AA	Eastern Island, QSL to RCC, Casilla 761, Santiago, Chile
ITIAGA	Via Granatelli II, Palermo, Sicily
FF8AP	Louis Maurel, Box 6020, Dakar, French West Africa
FF8AS	J. Payen de la Garanderie, Poste Restante, Aerodrome de YOFF, Senegal, FWA.
ZP6CR	P. O. Box 3081, Sao Paulo, Brazil
ZS7D	Post Office, Elembe, Swaziland, Africa
ex KS6AA	Art Fillebrown, 316 Auwinala Road, Lanikai, Oahu, T.H.
YI2AM	Via RSGB

Thanks to W5FXN, W4KE, WIFH, W3JSH, VK4FJ, F9RS, W1RAN and TI2TG.

A Reminder—European DX Contest:

Dec. 6 0001z/Dec. 7 2359z C. W.

Dec. 13 0001z/Dec. 14 2359z Phone

Heartiest Season's Greetings and DX to one and all  
Dick KV4AA

## NOVICE PHONE

(from page 31)

Mount sockets *V1*, *V3*, *V4* and *V5* with the center hole key slots to the front of the chassis and *V2* with the key to the back using 6-32 machine screws  $\frac{1}{4}$ " long. It is a good idea to purchase a quantity of 6-32 machine screws, nuts, and #6 lockwashers when purchasing the rest of the parts. They are quite reasonable by the gross; some distributors package them in jars or plastic boxes which provides a convenient way of storing them. Mount *C1*, *C2*, and *C3* along the front edge of the chassis with the stators vertical and toward the "output" end of the chassis. Now, mount the power socket *P1*, jacks *J1* and *J2*, and potentiometer *R8* along the rear. Mounting positions for these parts may be better understood by referring to the photograph of the underside of the chassis, *Fig. 2*. Install rubber grommets in the two  $\frac{5}{16}$ " holes under transformer *T1* and the two  $\frac{5}{16}$ " holes on the top near front of chassis, one above *C3* and the other adjacent to the single insulated terminal. Mount the crystal socket with 4-40 x  $\frac{5}{8}$ " machine screws. Next, mount 4-point tie strip and ceramic pillar under the chassis, and *T1*, neon lamp socket and single tie point on top of chassis. With all the parts mounted, with the exception of the antenna terminal, we are now ready to think about wiring the rig.

The authors are great believers in colored wire. It makes the tracing of a circuit or trouble shooting so much easier when one knows that all filament leads are one color, the grid another, the plates a third color and so on. If you do not have wire on hand for the building of this rig, we would recommend you purchase an assortment of colored wire. *Belden Mfg Co.* makes up an assortment consisting of six 25-foot rolls of hook-up wire which will fill the bill nicely. It is sold under *Belden #8865*. If you do not wish to buy 6 rolls at a time, you can buy only the number you feel you need, adding to your stock at a later date. You will also need some bare hook-up wire around 20 gauge. *Birnbach* sells bare tinned solid hook-up wire in 25' coils under their catalog number 1421.

Along with the wire, you will need some solder. By all means do not use acid-core solder or solid solder and soldering paste. You are looking for trouble if you do! Both are corrosive, and even though they make soldering easier, trouble is sure to develop later. Use only rosin core solder. You will experience no difficulty if your connections are clean before you start. It is best not to depend on solder alone to make a connection; twist your leads or wrap them around their lugs or tie points to make firm mechanical connections, then solder.

### END OF PART I

The second part of this article will appear in the January issue. It will contain the details on a step by step wiring procedure and a section on how to tune up the transmitter and get it on the air.



## EVERY ONE A GEM!



**PHONOGRAPH KIT!** All the basic parts for solid efficiency. With 110-V. Motor for 78 rpm, Crys. pick-up arm assembly & PM 6" Speaker! H'dware included! Specially priced **Only \$4.50**  
**HEAD-PHONES!** HS-30. Lightweight rubber plugs fit the ears like modern hearing-aid! Comp. w. connecting cable. **Only \$2.25**  
**NAVIGATIONAL BEARING INDICATOR!** 1-82F P/O Radio Compass SCR-269-F. Not many at this price . . . **Only \$6.50**  
**40-METER CERAMIC COIL-FORM!** UR-10A National 20-40, with porc. RF Coil, mounting-strip & 5 banana plugs. Complete with chart for determining the correct coil-form & turns of wire per calculated capacity. And look at the Price! . . . **Only \$1.00**  
**RESISTORS—VARIOHM SLIDE-CHANGE, POWER-WIRE WOUND!** Use for bleeders on voltage dividers. New Reduced Prices!

2000 OHMS . . . \$1.45      10,000 OHMS . . . \$1.65  
 35,000 OHMS . . . \$2.75

**INSTRUMENT BINDING-POSTS.** Nickel plated. Holds wires up to S-12. Thumb-screw & drilled hole for banana plug!  
**Only \$1.80 Dozen**

**7-HENRY FILTER CHOKE.** For Receiver power-supplies & low-powered Xmitters. Christmas Priced! . . . **Only \$1.10**

**TELEGRAPH KEY—J-47.** Longlife construction. Solid brass parts on hard rubber base. Priced less than sanity! **Only .75**

### CAPACITORS

BT. Oil Imp., 200 vdc, .1.1.1 mfd. Sangamo #5002RS **\$2.52**  
 Dry Elect., 15 vdc, 500 mfd. C-D #FV-1505 . . . . . **1.75**  
 Dry Elect. 250 vdc, 12 mfd. Solar #D-12-250 . . . . . **1.25**  
 Dry Elect. Tub. 6 vdc. 2000 mfd. C-D #BRH-620 . . . . . **2.45**  
 Dry Elect. Tub., 15 vdc, 500 mfd. C-D #BRH-155 . . . . . **1.75**  
 Dry Elect. Tub., 25 vdc, 250 mfd. C-D #BRH-2525 . . . . . **1.60**  
 Dry Elect. Tub. 250 vdc, 8 mfd. C-D #BRH-825 . . . . . **.75**  
 Oil Filled, 1500 vdc, 1 mfd. Solar #XGX15-1 . . . . . **6.80**  
 Oil Filled, 1500 vdc, 5 mfd. C-D #TJU-15005 . . . . . **5.00**  
 Plastic, Paper, Tub. 600 vdc, 2 mfd. Sangamo #30612 . . . . . **.70**  
 Oil Filled, 4000 vdc, 1 mfd. C-D #TJU-40010 . . . . . **33.50**

**SUPERHET CRV-46151 RECEIVERS!**  
**FREQUENCY RANGE 195 to 9050 KC!** MADE BY RCA TO SERVICE SPECIFICATIONS. Sold less tubes and dynamotor but with FULL INSTRUCTIONS FOR CONVERTING TO AC OPERATION! Hams will know the real value of this wonderful set! . . . . . **COLD-WAR PRICE! ONLY \$22.75**

### CASH FOR CHRISTMAS!

**DID YOU KNOW THAT RADCOM PAYS THE HIGHEST PRICES IN AMERICA FOR GOOD SURPLUS EQUIPMENT, TUBES & PARTS? HERE ARE THE KIND OF THINGS WE'RE PAYING GOOD MONEY FOR, RIGHT NOW:—**

TCS-7 and up, SCR-274N, BC-696, SCR-399 EQUIPMENT JB-70, JB-60 BC-939A, BC-610E, RA-63, EE-8, BC-614E, PE-95, PE-197, TRAILER K-52 CORDS, LS-3, SCR-508, BC-604, BC-603, FT-237, CRYSTAL SETS, SCR-506, BC-653A, BC-652A, DM-40A, FT-253A, BC-658A, BC312, 342, 348 RECEIVERS, SCR-522 EQUIPMENT, RA-34 RECTIFIERS, R89/ARN-5A, MN-62, SCR-211, I-208 & BC-211 TEST EQUIPMENT, SELSYNS, GN-45 GENERATORS & OTHERS, 5-KW GAS GENERATORS—PE-75, PE-95, PE-197, PLUGS & CONNECTORS, 4J-52, 720AY & OTHER MAGNETRONS, SCR-300, BC-1000, TUBES—GENERAL & SPECIAL PURPOSE (IN LOTS), TECHNICAL MANUALS.  
 Just Tell Us What You Have—You'll Get A Prompt Answer, And A Prompt Cash Settlement!

"EARL WHITE AND HIS MERRY MEN WISH YOU ALL A RIGHT MERRY CHRISTMAS AND A HAPPY NEW YEAR."

## RADCOM

ENGINEERING COMPANY

8 LIVINGSTON ST., NEWARK, N. J.      Bigelow 2-6666

## EASY TO LEARN CODE

It is easy and pleasant to learn or increase speed the modern way—with an Instructograph Code Teacher. Excellent for the beginner or advanced student. A quick, practical and dependable method. Available tapes from beginner's alphabet to typical messages on all subjects. Speed range 5 to 40 WPM. Always ready, no QRM, beats having someone send to you.

### ENDORSED BY THOUSANDS!

The Instructograph Code Teacher literally takes the place of an operator-instructor and enables anyone to learn and master code without further assistance. Thousands of successful operators have "acquired the code" with the Instructograph System. Write today for full particulars and convenient rental plans.



## INSTRUCTOGRAPH COMPANY

Dept. C., 4701 SHERIDAN RD., CHICAGO 40, ILL.

# LEARN CODE AND THEORY FOR AS LOW AS \$6.95

ECONOMICAL  
HOME STUDY  
COURSES PRE-  
PARE YOU TO  
PASS AMA-  
TEUR AND  
COMMERCIAL  
CODE EXAMS,  
AND AMATEUR  
THEORY EXAMS  
THE EASY, FAST WAY.  
BEAT THE ADVANCED CLASS DEADLINE  
(closes Dec. 31.)



## 3 "AMECO" COURSES AVAILABLE:

- #1—**NOVICE CODE COURSE.** You get and keep 10 recordings (alphabet through 8 W.P.M.) in an album. Includes typical F. C. C.-type code exams. Free instruction book on learning how to send and receive code the simplest, fastest way; plus charts to check your receiving accuracy all for the low price of only .....\$7.95
- #2—**SENIOR CODE COURSE.** You get and keep everything given the Novice Course except that you get 22 recordings (alphabet through 18 W.P.M.), plus typical F. C. C.-type code exams for General class and 2nd class commercial telegraph licenses. All this for only .....\$12.95
- #3—**COMPLETE RADIO THEORY COURSE.** A complete, simplified home study theory course in Radio, covering the Novice Technician, Conditional, General and Advanced classes—all under one cover—with hundreds of typical F. C. C.-type questions to prepare you for license exams. No technical background required. You also get, FREE, one year of consultation and a guide to setting up your ham station. All for the amazingly low, low price of \$6.95

ALL COURSES HAVE MONEY-BACK GUARANTEE

ORDER NOW!

WRITE FOR FREE INFORMATION DEPT. C-12

**AMERICAN ELECTRONICS CO.**  
1451 Wilkins Ave., N. Y. 59  
Tel. No. DAYton 9-4815

## NOVICE BARGAINS

**ARC-4 XMTR-RECVR.** Readily convertible to 2 meter operation. We furnish schematic and conversion instructions, including specs for 110 VAC power supply. **ARC-4 with ALL tubes.** (A real bargain. The surplus cost of these tubes is over \$30.00!) **\$37.50**

12/24 v Input dynamotor for above, **EXCELLENT...\$9.50**

**4-5.3 COMMAND XMTR.** Convertible to 80 meter CW Novice operation. With schematic and step-by-step conversion instructions. Excellent used, with all tubes.....**\$8.95**

**5.3-7 COMMAND XMTR.** Also convertible to Novice operation with two more steps. With instructions. Excellent used, with tubes.....**\$7.95**

**TELEGRAPH KEY J-43** New, heavy contacts, **ONLY \$1.25**

**PE-101-C DYNAMOTOR.** NEW, While they last. **\$4.00**

**A VIBRATOR BUY.** 6 or 12 volts, self-rectifying, hermetically sealed. Can take high overloads. With socket and schematic. Specify input voltage.....**BRAND NEW, Only \$8.95**

**R.F. AMMETER.** 0-4 amps, thermocouple type, 2" round. Has 1" scale-spread between 1 & 3 amps. **NEW ONLY \$3.95**

## TRANSFORMER SPECIALS

**THERMADOR 5A-1225 POWER TRANSFORMER.** PRI: 115 v, 50/60 cy, SEC: 600-440-0-440-600 v, 250 ma; 6.3 v, 3 A; 6.3 v, 3 A, 5.0 v, 3 A. Type "A", fully enclosed. Ideal for average ham rig. We furnish schematic. New manufacture, guar. 1 year. Ship. wt. 17 lbs. **Only \$10.80**

**THERMADOR 5A-7220 POWER TRANSFORMER.** PRI: 115v, 50/60 cy. SEC: 370 V CT, 250 ma. 6.3v, 3A, 6.3v, 3A, 5.0v, 3A. Same as above, ship. wt. 12 lbs. **Only \$7.95**

**12 V FILAMENT XFORMER** or line voltage booster. PRI: 110 v, 60 cy.; SEC: 9 to 13 volts in 1 volt steps at 3 A. Free schematic shows many uses.....**NEW \$1.89**

**6 V VIBRATOR TRANSFORMER.** Non sync, two outputs: 345 v, 145 ma for plates; 15 v for bias.....**NEW \$1.89**

**OUTPUT TRANSFORMER.** 5000 ohms input to TWO outputs, 300 ohms or 3.5 ohms. Use as output for 12A6, 6V6, etc. or to match speaker or headset. **NEW, potted, shielded 79c**

**THERMADOR SMOOTHING CHOKE 7A-1225,** 12 H. 250 ma. ....**\$6.90**

**THERMADOR SWINGING CHOKE 7A-5250,** 5 to 30 H. 250 to 25 ma. (Shipping wt. on these chokes—11 lbs.) **\$6.90**

Send for our Free Catalogue

**G. L. ELECTRONICS, Dept. A**  
905 S. VERMONT AVE., LOS ANGELES 6, CALIFORNIA  
All Prices FOB Los Angeles, Calif. Buyers add Sales Tax

## CLASSIFIED ADS

**BARGAINS:** New and reconditioned Collins, Hallicrafters, National, Hammurlund, Johnson, Elmac, Harvey-Wells, Babcock, Gonset, Morrow, RME, Millen, Meissner, others. Reconditioned S38 \$29.00, S40A \$69.00, S40B \$79.00, SX43 \$119.00, S76 \$129.00, SX71 \$149.00, SX42 \$199.00, SX62 \$199.00, Meissner EX \$59.00, Lysco 600 \$99.00 NC57 \$69.00, NC173 \$139.00, HRO5TA1 \$159.00, HRO7 \$179.00, HRO5OT \$249.00, HRO5OT1, HQ129X, SP400X, HF-10-20, VHF152A, RME84, RME45, Collins 32V1, 32V2, 75A1, 75A2, Viking I transmitters, HT9s, many others. Shipped on trial. Terms. List free. Henry Radio, Butler, Mo.

**TRADE** Portable typewriter, good condition, for used recvr or transmitter. Manchik 3135 Godwin Terrace, Bronx 63, N. Y.

**MERRY XMAS AND A HAPPY NEW YEAR FROM WØCVU.** 40 Years on the air from same QTH, Cedar Rapids, Iowa, since 1913.

**BARGAINS: EXTRA SPECIAL!** Motorola P-69-13 mobile receivers \$29.50; Globe King \$315.00; HT-9 \$199.00; HRO-50 \$275.00; Lysco 600 \$109.00; HRO-7 \$199.00; Collins 75A1 \$275.00; HRO-5T \$175.00; SX-71 \$159.00; SX-42 \$199.50; SX-43 \$129.00; HRO-Senior \$119.50; RME 2-11 \$99.50; RME-45 \$99.00; Meissner EX Shifter \$59.00; S-40A or SX-16 \$69.50; VHF-152 \$59.00; HF 10-20 \$59.00; Globe Trotter \$79.50; Meissner signal calibrators \$24.95; MB611 Mobile Transmitters \$19.95. 90800 exciter \$29.50; RCA Chanalyst \$69.50; XE-10 \$14.95; Gonset 10-11 converter \$19.95; and many others. Large stock trade-ins: Free Trial. Terms financed by Leo, WØGFQ. Write for catalog and best deal to World Radio Labs., Council Bluffs, Iowa.

**FOR SALE:** HRO receiver (pre-war) including speaker and power supply, coils. \$95. John H. Graham, 610 West 139 Street, New York 31, N. Y.

**SELL:** Signal shifter de luxe 20 thru 160, FB condx. \$35.00. Bargain list, fone CW parts, free. Moving. W4EMJ, 6298 15th Road North, Arlington 13, Va.

**WANTED:** Navy Selsyns. 1G, 1F, 1CT, 1DG, 5DG, 5F, 5CT, 6G, 7G, etc. Top prices paid. Electro Sales Co., Inc. 110 Pearl St., Boston 10, Mass.

**1-KW FINAL AND PARTS** for ½ KW power supply. Highest offer. W4NHX, Box 1667, University, Virginia.

**WANTED—Top prices paid—Navy selsyns 1DG, 1F, 1G, 1CT, 5DG, 5F 5G, 5CT and BC-348, BC-221, AN/ART-13 AN/ARC-1, AN/ARC-3, RTA-1B, etc.** Lectronic Research, 719 Arch St., Phila., Pa.

**FOR SALE:** Snoopers (Aug.-Sept. CQ) Custom Built by W7HEA. Bishop's Radio Service, 207 E. Toppenish Ave., Toppenish, Wash.

**DXers! "Hams Interpreters"—ham words and phrases translated into 7 languages—\$1.00.** For SWL's, "World Radio Handbook"—complete information on international stations, \$1.50 "How to Listen"—for SWL Novices, 40c. World Radio Publications, 1000 Connecticut Ave., Washington 6, D. C.

**FOR SALE:** Best offer takes! Like new (2) 152 to 162 megacycle communications receivers: Indoor and auto model. Original cost \$125. Private party. Call MO 6-1000, ext. 139 after 9 P.M.

**FOR SALE:** Millen 90881, 500 watt amplifier. Excellent condition. \$55. WØABS, West Plains, Mo.

**FOR SALE:** Morrow 2BR ten and seventy-five meter converter, new, \$40. 60 watt 10 meter mobile xtmr with dynamotor power supply, best offer over \$60. 425 volt 375 ma. 6 volt input dynamotor, \$35. 300 watt phone and C.W. rig, \$250. Slightly used Meissner Signal Shifter with NBFM mod., \$60. W4OSN, 7136 Lone Oak St., Spartanburg, S. C.

**VTVM—STANDARD MODEL** with large meter and capacity range. A-1 condition with operating instructions. \$42 PP. Jim Stormont, Jr., Ligonier, Pennsylvania.

**WANT:** ARC-3, ARC-1, ART-13, APR, APN, ARR, TCS, RAO, DY-12, DY-17, DY-21, SCR-694, BC-1306, PE-237, GN-58, GN-45, TRC, FRC, GRC, BC-639, RA-42, RA-34, RA-62, BC-639, BC-342, BC-312, BC-348, BC-221, BC-610-E, BC-610-E, BC-614, BC-729, BC-939, Pan-adaptors, Teletype equipment, parts, relays 215, 255; Technical Manuals. Arrow Appliance, Box 19, Boston 1, Mass. Lynn 8-3100.

**FOR SALE—SRT-75** Sonar xmitter. Complete in cabinet with latest VFX 680 unit. Coils for all bands. Best offer over \$160.00. Gonset 10-11 converter, good condition. \$25. Sonar SR9 10-11 meter receiver, brand new, \$55. A. E. Clarke, W2PDH, 44 Lewis Lane, Syosset, L. I., N. Y.

10, 15 & 20 METER BEAMS, aluminum tubing, etc. Perforated aluminum sheet for shielding. Radcliff's, Fostoria, Ohio.

NOVICES! You too can work foreign DX, W.A.S.! Simple sure-fire instructions, \$1.00. Rush order today. You will be delighted. Jim, WN6MYP, Box 604, Stockton, Calif.

BC-610C XMTR, 614E SPEECH AMP., Coils and tuning units for 10-20-40-75 meters. Best offer over \$300.00. Full set Rider service manuals will go for best offer. K. H. Logan, 76B Whiting Ave., Turner City, Albany, Ga.

SELL OR TRADE—Mark II B-19 "tank" transmitter/receiver—80/75, 40, 2 meter phone/cw with well-built 110 volt/60 cy AC power supply. Novice 80 meter converted BC-458. 10 meter converted T20/ARC-5. HD 15 by 800 ma. choke. 28 volt 5 amp DC selenium rectifier and transformer. All excellent; reasonable. K2AZR, 2395 Lake Park Terrace, Scotch Plains, N. J.

TELETYPE MACHINE, Model 26, perfect condition, will trade for Model 14 tape printer or Model 14 transmitter distributor. Will trade Model 26 machine for teletype parts and incomplete machines. Also have all kinds of radio equipment to trade for teletype and carrier current equipment. Or will buy outright. Chas. Patrick, W6OZE, 402 North Lucia, Redondo Beach, California.

RADIO AMATEUR and commercial license preparation. International morse code transcribed on magnetic tapes, recording wire and long playing microgroove discs. Disc-A-Method Recording Company, 317 E. 48 St., N.Y.C.

SELL Model 21A teletype tape printers: Multiplex 1A tape transmitters; 12,000 ohm relays for W-2-BFD control panels, #12 page printers, tables, distributor motors. Will trade. Want: war surplus communications & test equipment. Tom Howard, W-1-AFN, 46 Mt. Vernon St., Boston 8, Mass.

WANTED: ART-13 Transmitter and any or all accessories. State price and condition. Write C. Porter, 8545 11th Ave., Silver Springs, Md.

QSL's. TOP quality at fair prices. Samples? Write W9BHV QSL Factory, 855 Burlington, Frankfort, Ind.

BC610 parts wanted. Give price and condition first letter. L I Radio Company, Box 474, Montrose, Pa.

QSL CARDS? "Unbeatable!" Samples 25c. Sackers, W8DED, Holland, Michigan.

30 WATT NOVICE TRANSMITTER complete. 80 meters. \$23.95. William Purdy, W2LFJ, 215 Fobes, R.D. 1, E. Syracuse, N. Y.

WANTED: APR-4, other APR-, APS-, APT-, ARC-1, ARC-3, ART-13, BC-348, BC-221 etc.; TS-12, 13, 35, 120, 146, 155, 173, 174, 175, 323, other "TS-"; particularly microwave equipment. Spectrum Analyzers; G-R, Ferris, L&N; 723A/B, 3C22, all tubes; manuals, meters, parts, cable. Littell, Farhills Box 26, Dayton 9, Ohio.

QSL's-SWL's. Super-gloss. 10 colors, four card stocks, seven styles. Samples 10c. Almar Printing Service, Dept. 10B Farragut, Iowa.

WANTED Teletype Keyboard for type 12 printer. W6QEO, Sacramento, Calif.

600 WATT PHONE, de luxe, all bands 80 to 10, KW coils, TW-75s, modulator TZ-40's, built-in scope, separate calibrated VFO with frequency standard, separate high quality speech amplifier, overload protection, 115/230 volt input, complete with dynamic mike, cables, meters, etc. Sacrifice, \$400.00. Write for further description. Wm. Sloat, 1316 Patrick Henry Dr., Apt. 102, Falls Church, Virginia.

QSL's! Excitingly beautiful! None better at our prices! Samples 10c. Tooker, Lakehurst, New Jersey.

FOR SALE: Original model "Jewel from Junk Box" transmitter illustrated and described Nov. issue, complete with tubes and 40 meter coil, express collect for \$39.50 (less than replacement cost of components). W4QAG, 105 North 1st St., Seneca, S. C.

ALMOST ANYTHING you need for ham radio at bargain prices. List. Stamp. Indicate your needs. WØFIR, 5049 Murdoch St., St. Louis 9, Missouri.

SONAR used equipment available, MB-26 transmitter, two meters, \$45.00; SRT-75 all-band 75 watt transmitter \$89.50; AMP-50 75 watt amplifier with ten meter coils, \$29.50; VFX-680 NBFM/CW exciter \$39.50; MB-611 NBFM 10 meter transmitter, \$19.95; XE-10 NBFM exciter, \$29.50; other brands and items available; write for latest list to W1BFT, Evans Radio, Concord, N. H.

TWO DRAKE LOW PASS FILTERS 300 ohm, 10-160, good condition. Browning Pre-selector 160-10; Hallcrafters 5-10 receiver, with Gonset noise clipper. W8KJ.

## BUY OF A LIFETIME!

TRIED AND PROVEN THE WORLD OVER



### LETTINE MODEL 240 TRANSMITTER WITH MOBILE CONNECTIONS AND A.C. POWER SUPPLY

This outstanding transmitter has been acclaimed a great performer throughout the world. It is excellent for fixed station, portable or mobile operation. Even if you have a transmitter of your own you can't afford to miss this wonderful buy, direct from our factory, ready to operate.

The 240 is a 40 watt Phone-CW rig for 160 to 10 meters, complete with: (8 x 14 x 8) cabinet, self contained A.C. power supply, MOBILE connections, meter, tubes, crystal and coils for 40 meters. Tubes: 6V6 osc., 807 final, 6SJ7 crystal mike amp., 6NT phase inverter, 2 61.6's mod., 5U4G rect. Weight 30 lbs. TV1 instructions included. 90-day guarantee. Price \$79.95.

\$25. deposit with order—balance C.O.D.

80, 20, 10 meter coils \$2.91 per set. 160 meter coils \$3.60. Also for CAP, Broadcast, MARS, Marine, State Guard.

## LETTINE RADIO MFG., CO.

62 BERKELEY STREET VALLEY STREAM, N. Y.

## 75 AND 80 METER CRYSTALS

IN REGULAR FT243 HOLDERS



First quality guaranteed active oscillators made to Signal Corps specs. . . every one brand new and tested! Better get plenty while available . . . we doubt this lucky buy can be repeated.

Available in following frequencies:

3525 KC No. 15A1173	CHOICE
3655 KC No. 15A1174	EACH
3700 KC No. 15A1176	
3735 KC No. 15A1177	79c
3980 KC No. 15A1178	

You can easily change frequency if necessary by following crystal grinding instructions in any handbook.

Assortment of 4 Crystals—Our choice from above.

No. 17B818. Per Asst. . . . \$2.45

Include allowance for postage if shipment by parcel post is desired.

**BURSTEIN-APPLEBEE CO.**  
Dept. M, 1012-14 McGee St.  
Kansas City 6, Mo.

I enclose \$ ..... for .....

Send me FREE your 1953 Catalog No. 531.

Name.....

Address.....

City.....State.....



**FREE**

**BIG 1953**

**RADIO**

**CATALOG**

# Index to CQ

Issues of Vol. 8, Nos. 1 through 12, for the year 1952.

## Antennas, Transmission Lines, Masts, etc.

Balun - Theory and Design (Smith, J. R.) ..	Feb., 24
Center Loaded Antenna (Uryniak) .....	May, 63
Ground Plane Matching Network (Orr) .....	July, 39
How to Build an 80-Meter Midget Antenna (Orr) ...	Nov., 31
Maintaining Mobile Antenna Resonance (Scherer) ..	July, 41
Measurements on a 75-Meter Mobile Antenna-- (Wagener) .....	May, 41
My Mobile Antenna (Spatola) .....	July, 37
Pair of Phased Ground Planes on 40 Meters-- (Lawton) .....	Feb., 30
Safety Methods for the Erection of Beam Poles-- (Kurtz) ..	Mar., 11
"True-Matcher" (Hay) .....	Dec., 12
"V" Array With Controllable Directivity (Seilkop) ..	Sept., 33
42-Foot Rooftop Tower (Clement) .....	Oct., 49

## DX

CQ 1952 World Wide DX Contest .....	Aug., 22
CQ's 1951 DX Contest (Phone Results)-- (Becker & Elsner) .....	Sept., 16
CQ's 1951 DX Contest (CW Results) -- (Becker & Elsner) .....	Oct., 22
PU Expedition (Schoening) .....	Mar., 18
Road to Zanzibar (Featherstone) .....	Apr., 52

## Editorials

A Few Words About ARRL Directors (Ferrell) .....	Oct., 11
A Report to Amateurs (Ferrell) .....	June, 11
Emergency Calling Frequencies (Anderson) .....	Sept., 9
Industry and the Amateur (LeKashman) .....	Aug., 11
JTAC Ideal Approach to Allocation (Ferrell) .....	Nov., 13
Operation - Good Will (Sterling, G. E.) .....	Feb., 11
Regarding Priority Order M-85 (Ferrell) .....	Jan., 11
"Special Mobile Issue" (Ferrell) .....	May, 15
Wanted: Favorable National Publicity (Ferrell) ...	Mar., 9
The "MARS" (Maj. C. C. Mack & Capt. L. A. Peterson) .....	April, 9

## Meters and Measurements

"Just What I Needed (Saltmarsh) .....	Nov., 39
Silicon Crystal Noise Generator (Orr) .....	June, 25

## Miscellaneous

Adventure in Podunk (Clark) .....	Aug., 24
Author! Author! (Floyd) .....	Oct., 13
BCI and the BCL (Tierney) .....	Jan., 23
Codetyper .....	Mar., 52
CQ Tests the 6155 .....	Apr., 26
Get Your Circuits Untangled (Willcockson) .....	Jan., 39
IPOIO (Diven) .....	Apr., 49
MARS Teletype Operations .....	Jan., 54
Men of Radio - Part I - (Wellman) .....	Jan., 36
Men of Radio - Part II - (Wellman) .....	Mar., 20
Men of Radio - Part III - (Wellman) .....	July, 33
Men of Radio - Part IV - (Wellman) .....	Aug., 36
Mobile Catalog .....	May, 74
Name Change for MARS .....	Oct., 69
NARC Comments on Docket 10073 .....	Jan., 56
Progress? (Holman) .....	Dec., 56
PU Expedition (Schoening) .....	Mar., 18
The Worm Turns (Mrs. Ol' Joe) .....	Feb., 35
Word From MARS .....	June, 58

## Modulators and Modulation

Further Experiments with Screen Modulation -- (Jones) .....	Dec., 17
More Modulation Per Dollar (Lee) .....	Aug., 19
Operation Phone Patch (Miedke) .....	Dec., 21
'Phone Patch (Littler) .....	Jan., 17
Rothman System of Modulation (Rothman) .....	Apr., -21

## Some Experiments with Screen Grid Modulation --

(Jones) .....	Jan., 13
System of Gating Modulation (Bishop) .....	Oct., 19
Useful Diode Modulator (Weitbrecht) .....	Apr., 18
W5TJE 'Patch (Talley) .....	Dec., 23

## Mobile and Portable

Center Loaded Antenna (Uryniak) .....	May, 63
Converting the PE-101-C Dynamotor (Millar & Wollin) .....	Aug., 25
Getting the Most From Your Mobile (Brier & Scherer) .....	May, 17
Junk Box Jewel (Gwyn) .....	Nov., 45
Low Pass Mobile TVI Filter (Zucker) .....	May, 43
Maintaining Mobile Antenna Resonance (Scherer) ..	July, 41
Measurements on a 75-Meter Mobile Antenna .... (Wagener) .....	May, 41
Mobile With the ARC-5/SCR-274 (Lee) .....	May, 55
Mobileer and the Law (Hindin) .....	May, 35
"Mobileer" VFO (Andrews) .....	Sept., 11
More on the PE-101-C (Millar) .....	Dec., 25
My Mobile Antenna (Spatola) .....	July, 37
Problem of Ignition Radiation (Goffe) .....	May, 51
Triple-Band Crystal Controlled (Nakamura) .....	May, 65
W2AEF Mobile Special (Part I) (Scherer) .....	May, 24
W2AEF Mobile Special (Part II) (Scherer) .....	June, 17
"28-9" (Smith, J. R.) .....	May, 47
4 on 1 Converter (Cruiser) .....	May, 38

## New Products

Hypass Capacitors (Sprague) .....	Oct., 75
20-Watt Novice Kit (Meissner) .....	Oct., 75

## Novice

All-Purpose Novice Power Supply (Mitchell) . . .	Nov., 27
Foolproof 11-80 Novice Transmitter-- (Kirchhoff & Bulkeley) .....	Jan., 19
Getting on Novice Phone (Kephart) .....	Dec., 28
How to Build an 80-Meter Midget Antenna (Orr) ...	Nov., 31
Junk Box Jewel (Gwyn) .....	Nov., 45
Old One-Two (Mitchell) ...	Mar., 38
Putting the 6146 on Two Meters (Morris) .....	Nov., 43
Two-Meter Converter- The Easy Way (Brown, E.M.)	Nov., 20

## Power Supplies

All-Purpose Novice Power Supply (Mitchell) ... .	Nov., 27
--	----------

## Propagation and Predictions

How's Your Geology (Licastro) .....	Sept., 37
Effects of Planetary Positions on Radio Signals-- (Nelson) .....	Mar., 16

## Radiotelephony

Come On-a My House On 220 Mc. (Heubner) .....	Nov., 34
Complete 144-Mc. VFO with NBFM (Bulkeley & Kirchhoff) .....	Feb., 19
Emergency Converter-Transmitter for 10 Meters (Smith, H. B.) .....	Mar., 33
Getting on Novice Phone (Kephart) .....	Dec., 28
Mobile With the ARC-5/SCR-274 (Lee) .....	May, 55
'Phone Patch (Littler) .....	Jan., 17
Useful Diode Modulator (Weitbrecht) .....	Apr., 18
W2AEF Mobile Special - Part I (Scherer) .....	May, 24
W2AEF Mobile Special - Part II (Scherer) .....	June, 17
W5TJE 'Patch (Talley) .....	Dec., 23
Your Deluxe 3Q- or 50-Watter (Dell) .....	Nov., 15
"28-9" (Smith, J. R.) .....	May, 47

## Radioteletype

Teletype Receiving Adaptor (Brown, J. N.) .....	Sept., 25
---	-----------



Useful Diode Modulator (Weitbrecht) ..... Apr., 18

## Receiving

Modified Single-Sider (Long) ..... Jan., 33  
 Noise Limiter for Everyone -Part I - (Grenfell) ... July, 24  
 Noise Limiter for Everyone -Part II - (Grenfell) .. Aug., 33  
 Second Guessing the Experts on the HQ-129X  
 (Santangelo) ..... Apr., 24  
 Teletype Receiving Adaptor (Brown, J. N.) ..... Sept., 25  
 "The Snooper" - Part I - (Bishop) ..... Aug., 13  
 "The Snooper" - Part II - (Bishop) ..... Sept., 14  
 Triple-Band, Crystal Controlled (Nakamura) ..... May, 65  
 Two-Meter Converter -The Easy Way (Brown, E. M.) Nov., 20  
 4 on 1 Converter (Cruser) ..... May, 38

## Shack and Workshop

January, page 32  
 Installing the FS-135-C Calibrator  
 Simple, Single Switch Sequence Control

February, page 50  
 Push Button VFO Setting  
 Simple R-F Meter  
 Souping Up the T-17

May, pages 23, 34, 40, 45 and 64  
 Mobile Crystal Switching  
 Another T 17 Conversion  
 TS-13 Mike Conversion  
 Low Cost Push-To-Talk Relay  
 75 Meter Antenna Loading  
 Power Supply for Under-the-Dash Mobile  
 Dis-Assembling The Mobile Antenna

July, page 38  
 A Lazy Man's Screen Modulator  
 Improved S/N with FL8

August, pages 28 and 61  
 Modified Crystal Holder  
 Neon Bulb Holder  
 Series/Parallel Tuner  
 Spot Frequency Checker  
 Safety Power Supply

September, pages 36 and 40  
 Grid-Block Keying  
 Air Wound Coil Form  
 Simple 10-Meter Converter

October, pages-55 and 62  
 Improving the Stability of H-F Oscillator  
 A Combination Mobile Antenna

December, page 16 and 24  
 Crystal Calibration with a BC-211  
 Series to Parallel Switching  
 Another Foolproof Switching Control

## Television Interference

One-Element Vacuum Tube Transmitter (Rand).... July, 20  
 Low Pass Mobile TVI Filter (Zucker) ..... May, 43  
 20-Meter Injun Chaser (Smith) ..... Feb., 15

## Theory

Noise Limiter for Everyone - Part I - (Grenfell) .. July, 24  
 Noise Limiter for Everyone - Part II - (Grenfell) .. Aug., 33

## Transmitting

An Outboard VFO (Taylor) ..... Oct., 53  
 Come On a My House On 220 Mc. (Heubner) ..... Nov., 34  
 Complete 144-Mc. VFO with NBFM  
 (Bulkeley & Kirchhoff) ..... Feb., 19  
 Emergency Converter-Transmitter for 10 Meters  
 (Smith, H. B. ) ..... Mar., 33  
 Foolproof 11-80 Novice Transmitter  
 (Kirchhoff & Bulkeley) ..... Jan., 19  
 Getting on Novice Phone (Brown & Kephart) ..... Dec., 28  
 High Power Final Amplifier for 144 Mc.  
 (Bulkeley & Kirchhoff) ..... June, 28  
 Junk Box Jewel (Gwyn) ..... Nov., 45  
 Mobile With the ARC-5/SCR-274 (Lee) ..... May, 55

"Mobileer" VFO (Andrews) ..... Sept., 11  
 "Modern" Heterodyne Exciter (Wherry) ..... July, 13  
 Old One-Two (Mitchell) ..... Mar., 38  
 Operation Phone Patch (Miedke) ..... Dec., 21  
 Phone Patch (Littler) ..... Jan., 17  
 Putting the 6146 on Two Meters (Morris) ..... Nov., 43  
 Simple Overload Circuit (Johnson, R. W. ) ..... Oct., 21  
 Simplified Keying Monitor (Waterloo) ..... June, 34  
 Useful Diode Modulator (Weitbrecht) ..... Apr., 18  
 Very Electronic Key (Montgomery) ..... Mar., 14  
 W2AEF Mobile Special (Scherer) -Part I ..... May, 24  
 W2AEF Mobile Special (Scherer) -Part II ..... June, 17  
 W5TJE Patch (Talley) ..... Dec., 23  
 Your Deluxe 30- or 50-Watter (Dell) ..... Nov., 15  
 20-Meter Injun Chaser (Smith, H. B. ) ..... Feb., 15  
 "28-9" (Smith, J. R. ) ..... May, 47  
 50 Watts on 420 Mc. (Bucksbaum) ..... Apr., 13

## V.H.F. and U.H.F.

Come On-a My House on 220 Mc. (Heubner) ..... Nov., 34  
 Complete 144-Mc. VFO with NBFM  
 (Bulkeley & Kirchhoff) ..... Feb., 19  
 Getting on Novice Phone (Kephart) ..... Dec., 28  
 Putting the 6146 on Two Meters (Morris) ..... Nov., 43  
 Two-Meter Converter -The Easy Way -  
 (Brown, E. M. ) ..... Nov., 20  
 50 Watts on 420 Mc. (Bucksbaum) ..... Apr., 13

## War Surplus Conversion

Converting the PE-101-C Dynamotor  
 (Millar & Wollin) ..... Aug., 25  
 Mobile With The ARC-5/SCR-274 (Lee) ..... May, 55  
 More on the PE-101-C (Millar) ..... Dec., 25  
 On 15 Meters -QUICK! (Lem) ..... Aug., 42

## Monthly Columns

DX and Overseas News - R. C. Spenceley - Jan., 27;  
 Feb., 40; Mar., 25; Apr., 37; May, 77; June, 44;  
 July, 47; Aug., 47; Sept., 45; Oct., 45; Nov., 55;  
 Dec., 36.

Ionospheric Propagation Conditions -George Jacobs -  
 Jan., 41; Feb., 47; Mar., 41; Apr., 27; May, 76;  
 June, 39; July, 29; Aug., 43; Sept., 41; Oct., 31;  
 Nov., 61; Dec., 43.

Mobile Corner - R. V. Anderson - Jan., 51; Feb., 38;  
 Mar., 29; May, 82.

The Novice Shack - Herb Brier - Jan., 24; Feb., 36;  
 Mar., 23; Apr., 30; May, 83; June, 36; July, 43;  
 Aug., 51; Sept., 48; Oct., 56; Nov., 49; Dec., 46.

Teletype - Wayne Green - Feb., 26; Apr., 33; June, 48;  
 Aug., 29; Oct., 37; Dec., 32.

VHF News - W. E. McNatt - Jan., 46; Feb., 43;  
 March, 44; Apr., 41; May, 86; June, 51; July, 50;  
 Aug., 54; Sept., 52; Oct., 41; Nov., 58; Dec., 40.

YL's Frequency - L. B. Sando - Jan., 44; Feb., 33;  
 Mar., 30; Apr., 47; May, 81; June, 42; July, 27;  
 Aug., 40; Sept., 31; Oct., 35; Nov., 53; Dec., 27.

## Corrections

To:

Foolproof 11-8 Novice Transmitter	Mar., 56
Low Pass Mobile TVI Filter	June, 69
Mobile With The ARC-5/SCR-274	June, 69
Outboard VFO	see (Jan. 1953)
4 on 1 Converter	June, 69
"28-9"	June, 69



# NATIONAL

- **P**roven
- **D**ependable
- **Q**uality



## GRID AND PLATE CONNECTORS

High-quality grid and plate connectors of both the insulated ceramic (meeting JAN-1-10 specifications) and the non-insulated spring clip types for use on tubes having contacts of 1/4", 3/8" and 9/16" diameters. All lugs are designed to provide strong mechanical connection. Write for drawings.

### National



EST. 1914  
**NATIONAL COMPANY, Inc.**  
 MALDEN, MASSACHUSETTS

## CQ Ad Index

Allied Radio Corp.	58
American Electronics Co.	68
American Phenolic Corp.	65
Atronic Corp.	72
Babcock Radio Engineering, Inc.	57
Barker & Williamson	6, 47
Bliley Electric Company	7
Bud Radio, Inc.	56
Burstein-Appiebee Co.	69
Collins Radio Company	8, 9
Columbia Electronics Sales	52
Communications Equipment Co.	66
Dow-Radio, Inc.	60
Eitel-McCullough, Inc.	10
Fair Radio Sales	61
General Electric Company	1
G. L. Electronics	68
Hallicrafters Company	Cover 2
Harvey Radio Company, Inc.	49
Hawkins, P. E. Co.	66
Henry Radio Stores	59
Hughes Aircraft Company	55
Instructograph Co.	67
Johnson, E. F. Co.	51
L. A. Ham Shack	66
Lettine Radio Mfg. Co.	69
Master Mobile Mounts, Inc.	56
Millen, James Mfg. Co., Inc.	4
Motorola, Inc.	62
National Company, Inc.	72, Cover 3
Ohmite Manufacturing Company	5
Petersen Radio Company, Inc.	2
Radcom Engineering Co.	67
RCA Tube Dept.	Cover 4
Rider, John F. Publisher, Inc.	62
Shure Brothers, Inc.	58
Sylvan Electronic Laboratories	63
Tab	72
Tallen Company, Inc.	62
Trans-World Radio-TV Corp.	66
United Catalog Publishers	54
Vaaro Electronic Engineering Co.	50
Variety Electric Company	66
World Radio Laboratories, Inc.	53, 66

### SPECIAL

**HALLICRAFTERS**  
 SX71-576

Write for liberal  
 trade-in offer.

**FILAMENT TRANS.**  
 6V at 3 Amps.,

**\$1.45**

### LOOK — NO HANDS!

Head & Chest Set consisting of Single  
 Button Carbon Microphone with Chest  
 Plate, Switch, Straps, and Pair of  
 Earphones. Ideal for Mobile Operation.  
 Can be used less earphones . . .

Only . . . . . **\$1.95** complete

**ATRONIC CORP., DEPT. C-24**  
 1253 Loyola Ave., Chicago 28, Ill.

### WANTED IMMEDIATELY . . .

for **CRITICAL DEFENSE NEEDS**

**TUBES - CRYSTALS - END EQUIPMENT**

OAS/VR75	3C23	12SC7M	833A,884
OB3/VR90	3E29,829B	FG17,32,33	927, 1000T
OC3/VR105	4C35	100TH	1614, 2050
1N21,A,B	5C22	FG104,172	5725
1N23,A,B	5R4GY	250TH,TL	5727
1N25,26	6AC7M	304TH,TL	5749
Xtals: 100Kc,	6AG7M	368AS	5750
200Kc, 1000Kc	6B4G	450TH,TL	5751
2D21	6C21	KU627	5654, 5670
2K25, 723AB	6L6M	726C	5686
2J & 4J Magnet-	6SC7M	750T	5726
rons, Klystrons	7C7	807,810	5814
	7AG7	811,813	9001,2,3

All Army-Navy Gear: AN, ART, BC, I, PE, PU, RA, SCR,  
 TG, TS. WAVE GUIDES: PL & UG CONNECTORS.

TURN YOUR SURPLUS INTO SPOT CASH & SERVE  
 YOUR COUNTRY'S NEEDS AS WELL. . . .

Send Lists & Prices—Immediate Reply! Dept. C.

**"TAB"** 111 Liberty St.  
 New York 6, N.Y.  
 That's a Buy! Rector 2-6245

all new and  
**TERRIFIC**

**183 D**



**DUAL CONVERSION! 12 TUNED I.F. CIRCUITS! 1 M.V. SENSITIVITY ON 6 METERS!**

National proudly announces a brand-new receiver—the NC-183D—every feature you want in a truly modern receiver! Dual conversion on the three highest ranges (including 6, 10, 15, 20 and 40 meter ham bands) no “birdies”! Steep-sided skirt selectivity with 3 I.F. stages (16 tuned circuits on the 3 high bands—12 on all other bands, compared to 6 normally used) plus a new crystal filter. Approximately 1 microvolt sensitivity on 6 meters for a 10db signal-to-noise ratio! New, indirectly-lighted lucite dial scales! New miniature tubes for improved sensitivity! Bandspread on all bands, including new 15-meter band! New bi-metallic, temperature-compensated tuning condenser for drift-free operation! *Plus* all the time-tested features of the famous NC-183!

**\$36950**  
Less Speaker

**FIRST** .....

**IN COVERAGE!**

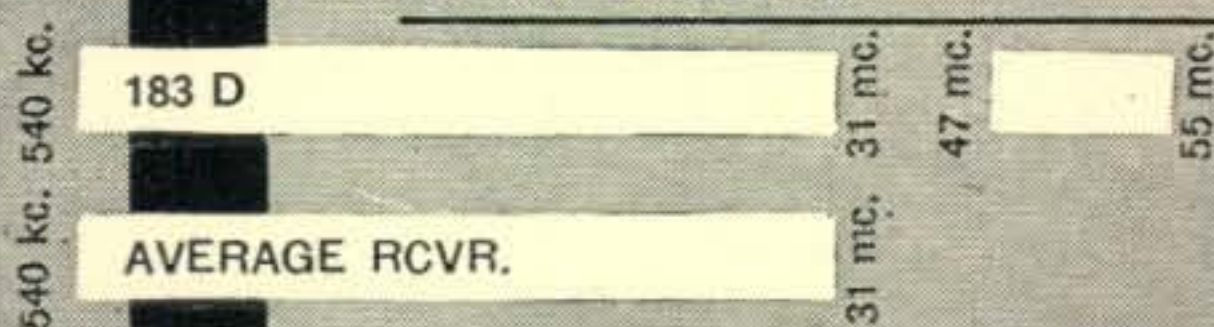

**IN SELECTIVITY!**



**IN BANDSPREAD!**

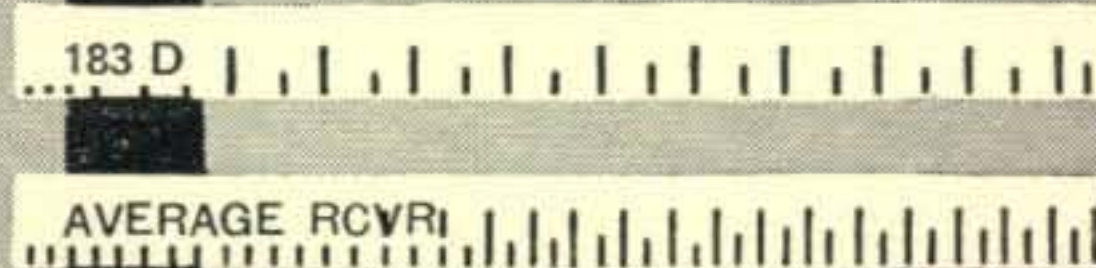

**National**  
©  
EST. 1914  
**NATIONAL COMPANY, Inc.**  
MALDEN, MASSACHUSETTS



Merry Christmas

and good hunting in

1953

*from the Hams of the  
RCA Tube Department*