

CCQ

FEBRUARY
1953

RADIO AMATEURS' JOURNAL

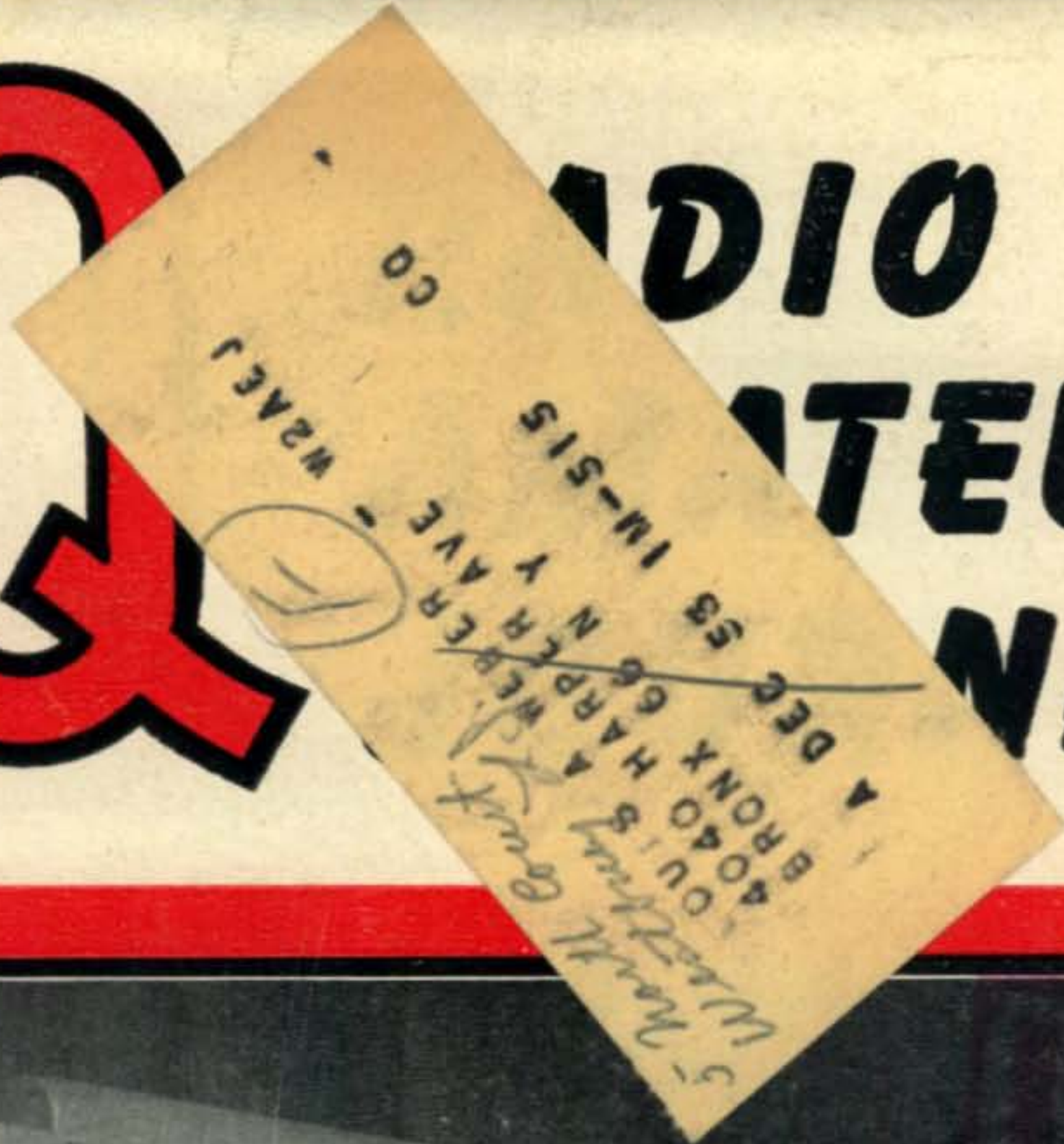

FEATURE DX ISSUE

1953 LAZY KILOWATT
VERSED IN DX
CERTIFICATE SEEKER'S DIRECTORY
THE STORY OF RV2
EVOLUTION OF A 40-METER BEAM
THE DX MAN'S ZOO
THE Gs' POINT OF VIEW

35c

Finally! No More TV Interference Problems!

The New Hallicrafters HT-20 is T.V.I. proofed!*



* T. V. I. PROOFED—means that this transmitter has circuitry specifically designed to eliminate spurious and harmonic energies that result in television interference.

Here's the news you've been waiting for—a medium power transmitter (100 watts) that solves the problem of television interference once and for all. The Hallicrafters HT-20 is the answer. Completely tested in the lab and in the field, here is a transmitter that is truly T. V. I. Proofed.*

This is not simply a revamped design, but completely new circuitry to meet this problem. Physically, too, the entire transmitter is new from the massive, two-piece, completely rigid chassis to the electrical air cooling system of the final amplifier tube.

See this newest Hallicrafters—get the complete story of the finest transmitter, dollar for dollar, on the market today. Or write Hallicrafters direct for full details.

Check these features!

- 100 watts carrier power with high level (Class AB2) modulation on any band.
- Continuous coverage, with overlapping bands, from 1.7 to 30 mc.
- Compact, efficient design. Amazing for its power. The HT-20 is 20½" long, 11¾" high and 16¾" deep.
- Weight of transmitter, in cabinet, 105 pounds.
- All transformers and chokes operate "cool"—maximum temperature rise of 40 degrees. This means fewer replacements, long operating life.
- Operates equally well from relay rack or in cabinet on table top.
- Uses 117 volts, 60 cycle AC.
- Moderate cost.

hallicrafters

**Now G-E 5-STAR
HIGH-RELIABILITY TUBES
... for
FULLY DEPENDABLE
C. D. EQUIPMENT!**



SPECIALLY DESIGNED AND BUILT, G-E 5-Star Tubes will help keep you on the air unflinching. They're shock-proof . . . extra-dependable . . . long-lived . . . with far fewer shorts and heater failures than standard receiving tubes.

MIAMI, FLA., POLICE, in a two-year test of G-E 5-Star Tubes for emergency communications, needed to replace *only 1 percent* —proof of superior tube reliability!

AIRLINES INSIST ON 5-STAR TUBES for passenger safety. Unattended communications relays, because of these tubes, can function for long periods without maintenance. New military electronic equipment owes much of its dependability to 5-Star tubes.

SEE YOUR G-E TUBE DISTRIBUTOR for complete facts! Every socket where you plug in a 5-Star Tube, is one more step toward *assured* operation of your C.D. system in the event disaster should occur. *Tube Department, General Electric Company, Schenectady 5, New York.*

STANDARD TYPES	REPLACE WITH THESE 5-STAR TYPES
2C51	*GL-5670—h-f medium-mu twin triode.
2D21	GL-5727—thyatron.
5Y3-GT	GL-6087—full-wave rectifier.
6AK5	GL-5654—sharp-cutoff r-f pentode.
6AL5	GL-5726—twin diode.
6AQ5	GL-6005—beam power amplifier.
6AS6	GL-5725—dual-control sharp-cutoff r-f pentode.
6AU6	GL-6136—sharp-cutoff pentode.
6BA6	GL-5749—remote-cutoff r-f pentode.
6BE6	GL-5750—pentagrid converter.
6C4	*GL-6135—medium-mu triode.
6SK7	GL-6137—remote-cutoff r-f pentode.
12AT7	GL-6201—high-Gm medium-mu twin triode.
12AU7	*GL-5814—medium-mu twin triode.
12AX7	*GL-5751—high-mu twin triode.
12AY7	*GL-6072—low-noise medium-mu twin triode.
.....	GL-5686—beam power amplifier.

**Slight electrical difference*

● **SUB-MINIATURE G-E 5-STAR TUBES,** as well as regular 5-Star types, are listed in new Booklet ETD-548-A, which contains a reference table of ratings and characteristics. Ask your G-E tube distributor for a copy, or write direct to General Electric at the address given at the left.



ELECTRONIC TUBES OF ALL TYPES FOR THE RADIO AMATEUR

GENERAL  ELECTRIC

QSY WITH PR



The old refrain on phone bands these days: "Sorry, old man, an S9 plussity-plus from Barbwire, Nebraska, is kicking you all over the place. Can you move a few kay-cees lower?" The answer to that is: "Sure can!" You will enjoy all the advantages of having "your spot" with crystal control, and yet dodge QRM if you buy three PRs. Spot your main fre-

quency ... get PR CRYSTALS, say 7 kcs. each side of your spot. See your jobber! All PRs are unconditionally guaranteed.

20 METERS, Type Z-3, \$3.75 • 40, 80 AND 160 METERS, Type Z-2, \$2.75

PR

Crystals

Since  1934

USE  AND KNOW WHERE YOU ARE

PETERSEN RADIO COMPANY, INC.
2800 W. BROADWAY • COUNCIL BLUFFS, IOWA

EXPORT SALES ONLY: Royal National Company, Inc., 75 West Street, New York 6, N. Y., U. S. A.

CQ RADIO AMATEURS' JOURNAL

VOL. 9, NO. 2
FEBRUARY, 1953

EDITORIAL STAFF

MANAGING EDITOR
OLIVER P. FERRELL

TECHNICAL EDITOR
E. M. BROWN, W2PAU

DEPARTMENT EDITORS

Herb Brier, W9EGQ	Novice
Wayne Green, W2NSD	Teletype
George Jacobs, W2PAJ	Propagation
Louisa B. Sando, W5RZJ	YL
R. C. Spenceley, KV4AA	DX

CONTRIBUTING EDITORS

Herb Becker,	W6QD
Frank C. Jones,	W6AJF
G. F. Montgomery,	W3FQB
William I. Orr,	W6SAI
W. M. Scherer,	W2AEF

DRAFTSMAN

Thomas Smith, W2MCJ

BUSINESS STAFF

S. R. COWAN,	Publisher
S. L. CAHN,	Adv. Director
H. N. REIZES,	Adv. Mgr.
D. SALTMAN,	Prod. Mgr.
R. CAMPBELL,	Edit. Prod.
H. WEISNER,	Circ. Mgr.

Branch Offices: Ted E. Schell, 2700 West 3rd St., Los Angeles 5, Calif. Dunkirk 2-4889.

Foreign Subscription Representative: Radio Society of Great Britain, New Ruskin House, Little Russel St., London, WC 1, England.
Technical Book & Magazine Co., 297 Swanston St., Melbourne C1, Victoria, Australia.

Scandinavian Representative: Intrapress, 17 Nordre Paradiesvej, Holte, Denmark.

CQ - (Title Reg. U.S. Post Office - is published monthly by Cowan Publishing Corp. Executive and Editorial offices, 67 West 44th Street, New York 36, N. Y. Phone MURRAY HILL 7-2080. Reentered as Second Class Matter February 6, 1951 at the Post Office, New York, N. Y. under the Act of March 3, 1879. Subscription rates in U. S. A. Possessions, APO & FPO, 1 year \$3.00; 2 years \$5.00; 3 years \$7.00. Elsewhere add \$1.00 per year for postage. Single copies 35 cents. Printed in U. S. A. Entire contents copyright 1953 by Cowan Publishing Corp. CQ does not assume responsibility for unsolicited manuscripts.

FEATURE DX ARTICLES

The 1953 Lazy Kilowatt <i>Lawrence LeKashman, W9IOP</i>	12
The DX Man's Zoo.....	17
The Story of RV2 <i>M. Roland d'Assignies, FO8AD</i>	21
The Evolution of a 40-Meter Beam <i>Hal Leighton, W9LM</i>	23
More on the T2FD <i>Capt. G. L. Countryman, W3HH</i>	28
The Gs' Point of View <i>L. H. Thomas, G6QB</i>	31
The Certificate Seekers' Directory <i>H. S. Bradley, W2QHH</i>	34
Versed in DX <i>G. Franklin Montgomery, W3FQB</i>	42
A VK's Point of View <i>Flt. Lt. F. T. Hine, VK2QL</i>	43
No Clicks — No Backwave <i>Keith S. Williams, W6DTY</i>	60

Departments

Ionospheric Propagation Conditions (W2PAJ).....	45
DX and Overseas News (KV4AA).....	48
The Novice Shack (W9EGQ).....	52
The YL's Frequency (W5RZJ).....	56

Miscellaneous

Scratchi	4
Guest Editorial <i>George E. Sterling, W3DF</i>	9
Present and Prophetic	65, 66
Amateur Teletype Comes of Age (W2NSD).....	71
Classified Ads	78, 79
Advertising Index	80

Designed for



Application

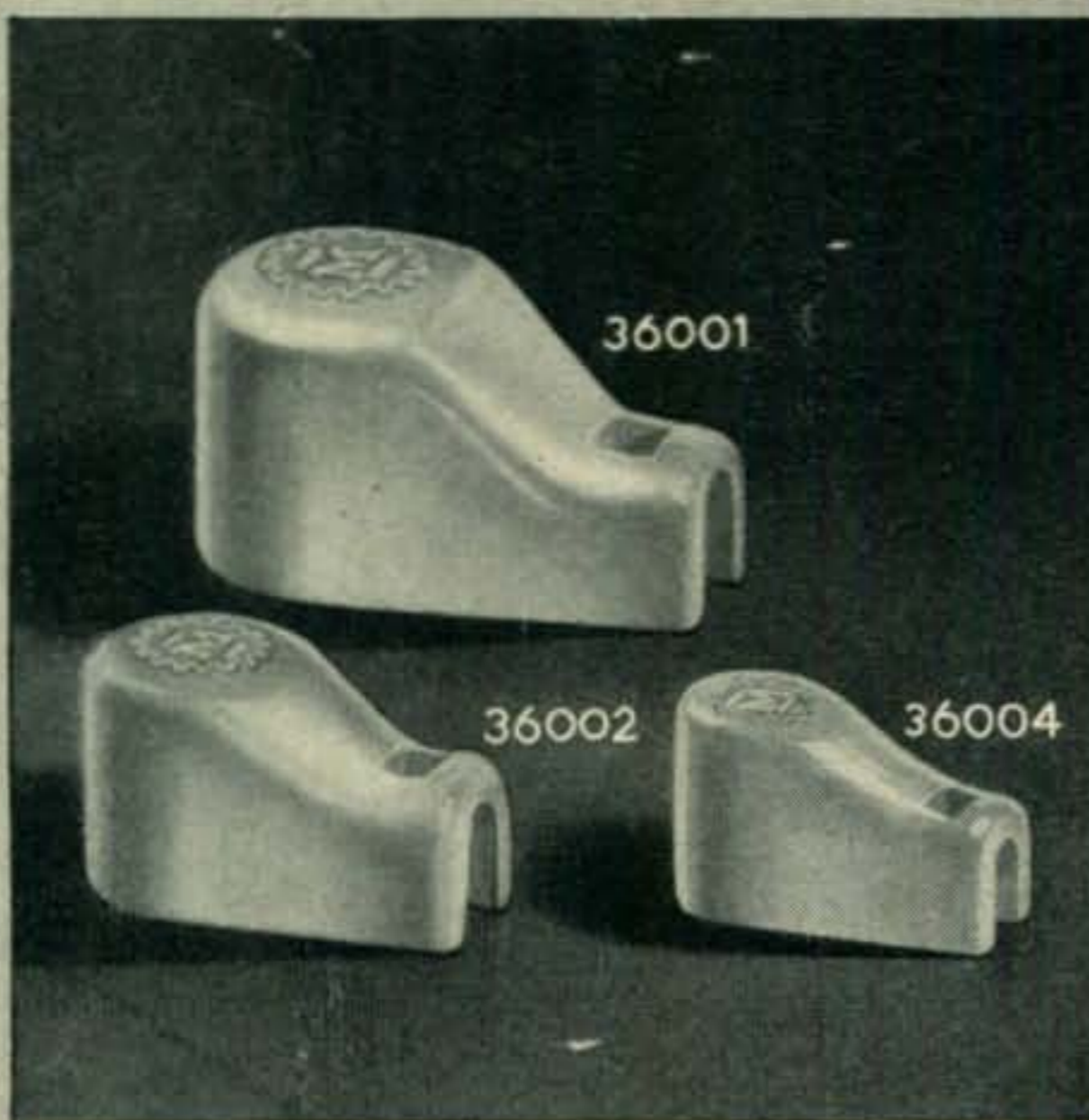

36000 SERIES

Ceramic Plate or Grid Caps

A new addition to this series of exclusive Millen "Designed for Application" products is the 36004 for use on tubes with $\frac{1}{4}$ " diameter contacts. Efficient, compact, easy to use and neat appearing. Soldering lug and contact one-piece. Lug ears annealed and solder dipped to facilitate easy combination "mechanical plus soldered" connection of cable. No. 36001 for $\frac{9}{16}$ " tube terminals. No. 36002 for $\frac{3}{8}$ ". No. 36004 for $\frac{1}{4}$ ".

**JAMES MILLEN
MFG. CO., INC.**

MAIN OFFICE AND FACTORY
**MALDEN
MASSACHUSETTS**



Feenix, Ariz.

Dear Hon Ed:

If Scratchi's signals you resently not heering, or if meloudious voice of Scratchi's haunting the ham bands you are missing, this is to letting you know that your Hon. Receiver are still probably in 1/c shape—it are just that Scratchi have being conspickyewus by his absence on the air. Also, if you are thinking that sum stewpendus thing to Scratchi are happening, you are rite. I are not only without ham license but are not daring to bootlegging, if you can imagine Scratchi in that predickaments. And all this because I wanting to work sum red hots DX!

It all starting cupple weeks ago when I deciding that even though Hon. Sun Spots are making it tuff for sum amchoors to working DX, that this are not going to stop good old geenyus Scratchi. So, are selling car and investing many bux in high power toobs, big transformers, eleventeen miles of wire and everything else needed to putting rock-crusher whammer-bammer signal into all zones. From all this I building sooper-doooper sooper-power rig. Talking about your California kilowhats—Hah! I having Arizona kilowhat. Can't telling you how much power I running to final (not wanting to write anything discriminating) but driver stage using water-cooled toobs with air-cooling fans.

After rig finished I putting up vee-beams, rom-bics, long-wire arrays, and all kinds antennas pointing every which-way. Having reel antenna farm, even though putting up stuff only on short ten foot poles (not having any long ten foot poles). Figuring that with power I using antennas not needing be too high off ground, but just high enuf so RF voltages not arcing backs to ground.

The first week Scratchi are using the Rock Crusher the results are sensayshunal. Wowie!! How that signal were getting out—Hon. Ed., you wouldn't believing it. Sum of the DX I talking to not believing it either—my signals so strong they think I bootlegging in there home town. (I thinking of renaming the rig Old Limburger—what a signal it put out.) I even talking to amchoors what using cristal sets for receivers. That are the life. Call 'em, get 'em. Call 'em, get 'em. Boy oh boy.

It are just at this time that big catastrophy are happening to Feenix. We are having snow storm. Maybe you not heering about it, as Chamber of Commerce trying to keep it mum, but big snow we having anyway. When snow finally stopped snowing there are at least one inch on the ground. When I seeing it I quick-like running to telyfone calling amchoor friend of mine named Mac, to

(Continued on page 6)

ANTENNAS *Master Mobile* MOUNTS

All the prime requisites of a reliable, long lasting mobile antenna system are incorporated into **MASTER MOBILE MOUNTS** through scientific engineering, high quality of materials and workmanship...AND THE PRICES ARE RIGHT.

MOUNT SPECIFICATIONS: Packaged and sealed at factory. Ship. wt. Approx. 3 lbs.

Model	TYPE (All types are tapped for 3/8", 24 thread stud fitting on Antenna end)	Net Price
126	Body Mount—Straight Spring—Swivel Base	\$ 8.75
126X	Body Mount—Heavy Duty—Straight Spring—Swivel Base	9.40
126C	Body Mount—Straight Spring—Swivel Base—With Coaxial Connector	8.75
126XC	Body Mount—Heavy Duty—Straight Spring—Swivel Base—With Coaxial Connector	9.40
132	Body Mount—Double Tapered—Spring Swivel Base	8.75
132X	Body Mount—Heavy Duty—Double Tapered—Spring Swivel Base	9.85
132C	Body Mount—Double Tapered Spring—Swivel Base—With Coaxial Connector	8.75
132XC	Body Mount—Heavy Duty—Double Tapered Spring—Swivel Base—With Coaxial Connector	9.85
132S	Body Mount—Stainless Steel—Double Tapered—Spring Swivel Base	10.75
132XS	Body Mount—Heavy Duty Stainless Steel—Double Tapered—Spring Swivel Base	11.85
132SC	Body Mount—Stainless Steel—Double Tapered Spring—Swivel Base With Coaxial Connector	10.75
132XSC	Body Mount—Heavy Duty Stainless Steel—Double Tapered Spring—Swivel Base—With Coaxial Connector	11.85
138	Bumper Mount—Straight Spring	6.55
138X	Bumper Mount—Heavy Duty—Straight Spring	7.65
140	Bumper Mount—Double Tapered Spring	6.55
140X	Bumper Mount—Heavy Duty—Double Tapered Spring	7.65
140S	Bumper Mount—Stainless Steel—Double Tapered Spring	8.65
140XS	Bumper Mount—Heavy Duty Stainless Steel—Double Tapered Spring	9.65
142	Bumper Mount—Less Spring, with Insulators for Direct Mounting by Series	3.25
	Bumper Mount—100 Antennas or 92 Extension and 106 Antennas	

ALL BAND MOBILE ANTENNA



WHIP ANTENNA SPECIFICATIONS:

Postage rate 10 lbs. minimum. 3 lbs. on all other whip antennas.

MODEL	Overall Stainless Steel Length	Base Specifications	Net Price
100-60S	60"	Threaded 3/8" Stud to fit all Mounts	\$4.95
100-72S	72"	Threaded 3/8" Stud to fit all Mounts	4.95
100-78S	78"	Threaded 3/8" Stud to fit all Mounts	5.00
100-86S	86"	Threaded 3/8" Stud to fit all Mounts	5.15
100-90S	90"	Threaded 3/8" Stud to fit all Mounts	5.20
100-96S	96"	Threaded 3/8" Stud to fit all Mounts	5.25
106-60S	60"	Plain End 3/16" Dia. (Fits Model 92 Ext.)	4.15
106-72S	72"	Plain End 3/16" Dia. (Fits Model 92 Ext.)	4.15
106-78S	78"	Plain End 3/16" Dia. (Fits Model 92 Ext.)	4.20
106-86S	86"	Plain End 3/16" Dia. (Fits Model 92 Ext.)	4.35
106-90S	90"	Plain End 3/16" Dia. (Fits Model 92 Ext.)	4.40
106-96S	96"	Plain End 3/16" Dia. (Fits Model 92 Ext.)	4.50

SILICON-CHROME WHIP ANTENNAS—Fits all Master Mounts. Finest Cadmium Plated.

SERIES 9— with 3/8" 24 thread studs:

Model No.	Overall Length	Net Price
9-60T	60"	\$2.97
9-72T	72"	3.24
9-84T	84"	3.30
9-86-T	86"	3.60
9-96T	96"	3.75

NEW 8 SERIES—without studs:

Model No.	Overall Length	Net Price
8-60	60"	\$2.82
8-72	72"	3.08
8-84	84"	3.13
8-86	86"	3.42
8-96	96"	3.55

COAXIAL CONVERSION KIT

No. 118. Fits all No. 132 and 132J Models. Net \$1.00

SEPARATE SPRINGS FOR ANTENNA MOUNTS

100 Regular, Net \$4.50 100X—Heavy Duty, Net \$5.50 100S—Stainless Steel, Net \$5.50

EXTENSIONS— Model 90, 26" Net \$3.25 Model 92, 18" Net \$3.25 Model 94, 36" Net \$4.25

ALL BAND MOBILE ANTENNA—Center-loaded antenna comes with one coil—20, 40 or 75 meters. Change coils to any band 80 through 20...For 10 meter operation, short coil in use. Fits any MASTER MOUNT or 3/8" SAE thread, Hammertone or Chrome finish (if available). Height: 8' 10". Weight: 28 oz. Shipping weight: 3 lbs. PRICE: \$8.75. Specify freq. coil desired. Less spring mount. Extra coils—20, 40 or 75 meters: Net \$3.30.

CIVIL AIR PATROL ANTENNA—2374, 3507.5 or 485KC. With coil, less mount. Net \$9.95
Extra Coils—2374 KC. Net \$3.60

*X—Heavy Duty, C—Coaxial Type, S—Stainless Steel.

TWO METER COAX ANTENNAS

NO. 214—MASTER DE LUXE—a superior new, ruggedly-constructed, vertically polarized antenna with frequency range of 140 to 170 MC. Completely waterproofed. Attractive, highly polished chrome finish enhances appearance of any vehicle. Furnished with approx. 10' of 72 Ohm Coax Cable. **MOUNTING TYPES:** Type 1—on side with 2 brackets furnished—NET: \$15.95
Type 2, MASTER MOUNT (No. 132X or 140X). Mounts sold separately. Complete antenna: \$17.45
Adjustable mounting—adjusts to 17"

NO. 113—MASTER VHF ROOF TOP ANTENNA—for police, fire, taxi cabs and amateurs using 140 MC to 165 MC. Stainless steel wire with threaded fitting—easily replaced or changed without disturbing mounting. Comes with 10' Coax Cable. NET: \$3.96.

NO. 114—MASTER COAX VHF ANTENNA—for open type vehicles, convertibles, station wagons, fire trucks, taxis and amateurs using 140 MC to 165 MC. Design permits mounting on any convenient place by use of any Master's Standard Mounts. Supplied with 18" adjustable section and 10' of Coax Cable. NET \$9.95.



No. 118



MODEL 100 100X

Series 106 100

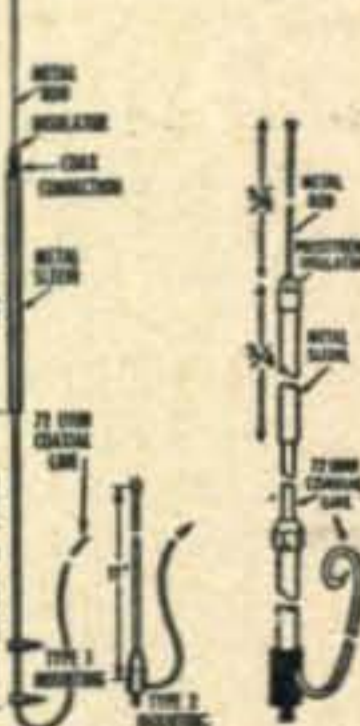

NO. 214 114 113
Inquiries invited on MASTER LINE of MARINE & FIXED ANTENNAS

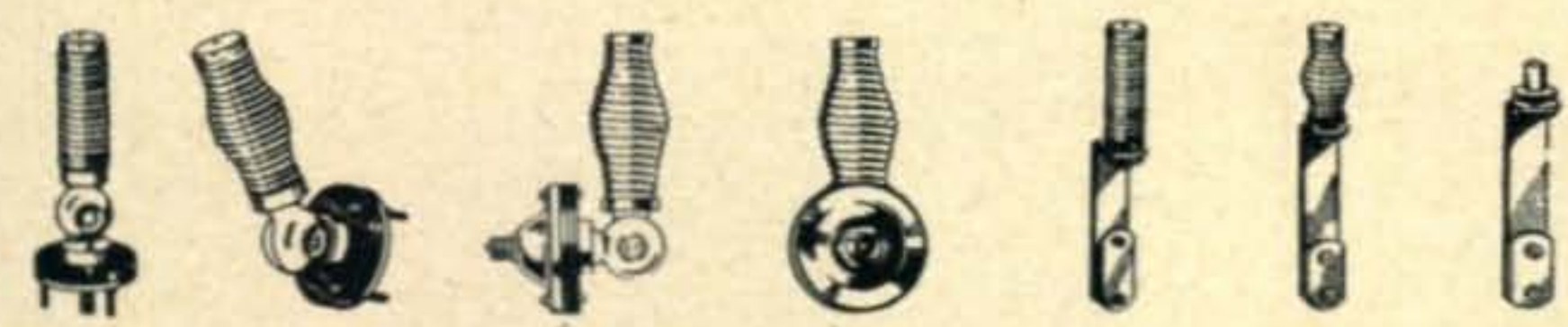

MODEL 126 MODEL 132 MODEL 132C (COAXIAL TYPE) MODEL 138 MODEL 140 MODEL 142

ORDER FROM YOUR DEALER OR WRITE. Dealer Inquiries Invited

Extension Model 92

Master Mobile Mounts, Inc.

All Prices Shown Are Amateur's Net
P. O. Box 1817 • Los Angeles 36, California
Warehouse & Shipping Address: 1306 Bond St., L.A. 15.

New Heathkit GRID DIP METER KIT



Complete unit easily held and operated with one hand.

MODEL GD-1
SHIPPING
WT. 4 LBS.

\$19⁵⁰



A valuable addition to any ham shack.

The INSTRUMENT FOR HAMS — has numerous transmitter applications such as pretuning, neutralization, locating parasitics, correcting TVI, adjusting antennas, design and many others.

Receiver applications include measuring C, L and Q of components — determining RF circuit resonant frequencies, etc.

Covers the 80, 40, 20, 11, 10, 6, 2 and 1 1/4 meter bands. Complete coverage from 2-250 MC.

Easy one hand, one unit operation. Convenient thumb wheel drive of tuning condenser leaves one hand free for making circuit adjustments. No tuning head and meter with connecting cable to worry about. *It's compact — case only 2 1/2" wide x 3" high x 7" long.*

All plug-in coils (rack included) are wound and calibrated—no coil winding, drilling, punching, forming or painting to do — all fabrication is complete, and the kit goes together smoothly and easily.

The 500 microampere Simpson meter movement and sensitivity control allow operator to set instrument for easy detection of dips on all ranges. Instrument is transformer operated for safety. You'll like the appearance of this kit with its baked enamel panel and crackle finish cabinet.

Please include postage to cover parcel post and insurance for 4 pounds.

HEATH COMPANY
BENTON HARBOR 6,
MICHIGAN

(from page 4)

telling him he owing me a free lunch including strawberry shortcake for desert. He betting me I never using those snow tires I buying! Amidst all my merriment, I not realizing that the trap are closing on poor old Scratchi. Next day after snow I are knee-deeps in trubble.

I'll bet you thinking that FCC are getting wind of Old Limburger and seeing me about it? Nope, you are rong. Not the FCC. No indeedy. Ever heering of the FBI? Well, it NOT meening Fine Business Indeed. It all happening faster than hundred amp short circuit. I are on air in shack when two fellows walked in, flashed sum badges, asked if I was Hashafisti Scratchi, found out I was, put me in there car, and whisked me to the nearest FBI office. Gracious to goodness, that are putting me in reel sweat, being clutched by FBI. Scratchi are old hand at visiting local jales here and there (in cases of mistaken identity or sumsuch thing), but when FBI cum after you it different matter. Sacremento! Just thinking of it again putting cold shivers up and down spine.

First thing happening are lots of questions. I are never knowing I knew so much about myself. When they got through they could have ritten biography of me with no trubble. Funny thing, tho, during all these questions I can't figuring out what I been doing rong. How can I confessing if not knowing what to confessing to? Certainly FBI not interested that I running measly hundred thousand whatts to final. In factly, I can't even seeing what they getting at when showing me a nice big fotograf. I can seeing it taken from airplane, and it showing big, fancy patterns in snow. Patterns are big arrows, sum figures that look like "22 miles" and sum other misterious numbers.

Howsomever, the more I looking at fotograf, the more familiar it looking. Sacremento!! Finally it cuming to me. It are fotograf of my antenna sitem! Yep, there are the rombic, there are three of the vee-beams. I telling this to FBI, but explaining I not sure till I see antennas again, so they rushing me out to ranch, tires screeching, sirens screaming. I going out to antennas and finally seeing what are so confusing. Under every piece of wire in antennas are ten-foot wide strip of bare earth where snow having been melted away. Evidentally are using so much power in final that RF from antenna melting snow on ground in nice patterns. Power loss in feeders also meening feeder lines melting nice figures in snow.

After explaining hole thing to FBI men, and they happy that I not doing anything rong, they telling me that pilot of commercial airplane noting pattern in snow, and seeing big arrow pointing to secrut government factory few miles away. Airplane pilot telling FBI he spotting spy in desert, so FBI rushing out to catching spy. Only not catching spy, catching Scratchi with too much power in antenna. Woosh! That were a close call!

FBI say they not going to tell FCC but they taking my license away for awhile, just for causing them so much trubble. Hon. Ed., you thinking I be in bad if FBI finding out that my license not valid, on acct. it already expired?

Respectively yours,
Hashafisti Scratchi

Specify *Bliley*... For 22 Years The Foremost Name In Crystals

★ ★ ★

AMATEUR

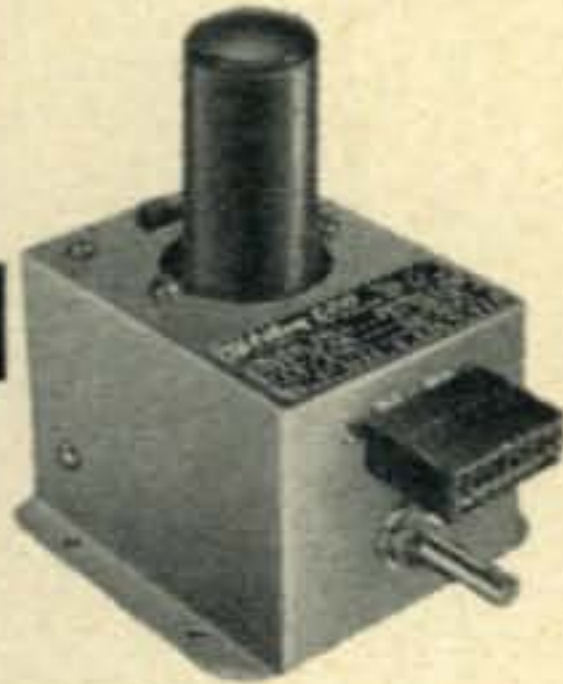

Types AX2 and AX3, designed especially for this service, bring price and precision together in the ham bands. Bliley's packaged oscillator, Model CCO-2A, is a favorite for 2-6-10-11 meter home built rigs. Price and details are given in Bulletin 44.

SHIP-TO-SHORE



Types MC7, SR5 and SR8 are suggested for shipboard dependability. Price and details given in Bulletin 44.

BROADCAST



Types BC46T, MO3B, TC92 are first choice for automatic temperature control in AM, FM and TV transmitters. Consult Bulletin 43 for basic details.

SPECIAL PURPOSE



Types SR10 and MC9 provide wide range frequency choice for TV service, diathermy and citizens band. Request Bulletin 44 for price and description.

COMMUNICATIONS



Type BH6A is the predominant choice for land mobile and airborne applications. Consult Bulletin 43 for basic information.

STANDARD



Types KV3, MC9, SMC100 and MS433 cover reference frequencies from 100 kc through 10.7 mc. Price and "stock tolerances" given in Bulletin 44.

MILITARY



For reference in this broad category, see the "Specification Index for Military Crystal Units" in Bulletin 43.

ULTRASONIC DELAY LINES



Custom built fused quartz delay lines provide high stability and precision time intervals for manipulation of pulsed or pulse modulated signals. Consult Bulletin 45 for technical information.

FREQUENCY STANDARDS



Model BCS-1A is a high stability instrument for precision reference at 100 kc. Ideal choice for research and development laboratories. Descriptive information given in Bulletin 43.



Bliley
CRYSTALS

BLILEY ELECTRIC COMPANY
UNION STATION BUILDING • ERIE, PENNSYLVANIA

W1FH reports on Eimac 4-250 A's...



In a recent letter
Charles Mellen says:

I've been enjoying the operating convenience of Eimac's 4-250A tetrodes for two years. The elimination of hi-power driving stages and the resultant ease with which TVI problems were solved have made my operating that much more a pleasure.

*73 es dx
Chas Mellen
W1FH-*

DX CENTURY CLUB AWARDS
Honor Roll

W1FH249*
Radiotelephone
W1FH222*

WAZ HONOR ROLL
W1FH40-251*

*First Place



EITEL McCULLOUGH, INC.

SAN BRUNO • CALIFORNIA

Export Agents: Frazar & Hansen, 301 Clay St. San Francisco, Calif.

Guest Editorial

Regulatory Powers and the Amateur Radio Service

Commissioner GEORGE E. STERLING

Federal Communications Commission

By a strange coincidence it was one year ago that W3DF discussed on these very pages, the necessity of maintaining "Good Will" in handling TVI complaints. This year we are reprinting a portion of his talk before the New York Radio Club on December 8, 1952.

The particular portion that we selected concerns the reasons "why" the FCC now asks for individual opinions on proposed rules and regulations. Many Hams say, "Let's go back to the old days." Others say, "The FCC is trying to undermine the ARRL." Still others, we are ashamed to say, denounce the FCC without attempting to visualize the possibility that there is a second side to the question.

This other side does exist—keep it in mind and use it to the advantage—not the detriment of amateur radio.

—O. P. F.

"Something has been added to the laws regulating all government agencies within the last six years whereby each and every individual, if he chooses, may make his views known to the federal regulatory bodies when they find it necessary to make new rules or modify those rules in existence and those regulatory bodies must give consideration to those views. This was done by Congress in 1946 when it passed the Administrative Procedure Act. The stated purpose of the Administrative Procedure Act is significant. I quote it:

"To improve the administration of justice by prescribing fair administrative procedure."

This legislation was the outcome of thirteen years of discussion and controversy to enact some comprehensive administrative procedure for federal regulatory agencies. An analysis of the provisions of the Act reveals that it restates certain general principles and requirements which the courts in their review of administrative action hitherto imposed on agencies, or which some agencies in the exercise of their own powers have pursued.

"In all fairness it should be stated that before the passage of the Administrative Procedure Act the Federal Communications Commission practice as it pertained to publication of rules, opinions and orders and making available public records were in substantial conformity with the requirements of the new law.

"Except possibly the requirement of publication of proposed rules in the Federal Register, the other greatest requirement of interest to the amateur fraternity is that relating to procedures. The Act in discussing the deposition of comments on proposed rules states:

After notice required by this section, the agency shall afford interested persons an opportunity

to participate in the rule making through submission of written data, views, or arguments with or without opportunity to present the same orally in any manner; and, after consideration of all relevant matter presented, the agency shall incorporate in any rules adopted a concise general statement of their basis and purpose.

So it can be clearly seen that each amateur regardless of age, race or sex is provided by law the opportunity to voice his or her views as it concerns any proposed rule making on the part of the Commission. This right imposes a responsibility. Amateurs or others must express their views either pro or con. This procedure makes it exceedingly important for those in favor of a proposal to speak their minds. For instance, should the majority favor and be silent and the minority oppose and be vocal, the Commission under this procedure would be forced to adopt the views of the minority unless there were sufficient reasons to the contrary.

"It has been interesting to follow the reactions of the amateur fraternity resulting from proposed rule making on the part of the Commission and the advantage they have taken to voice their approval or opposition to proposed rule making.

(Continued on page 65)

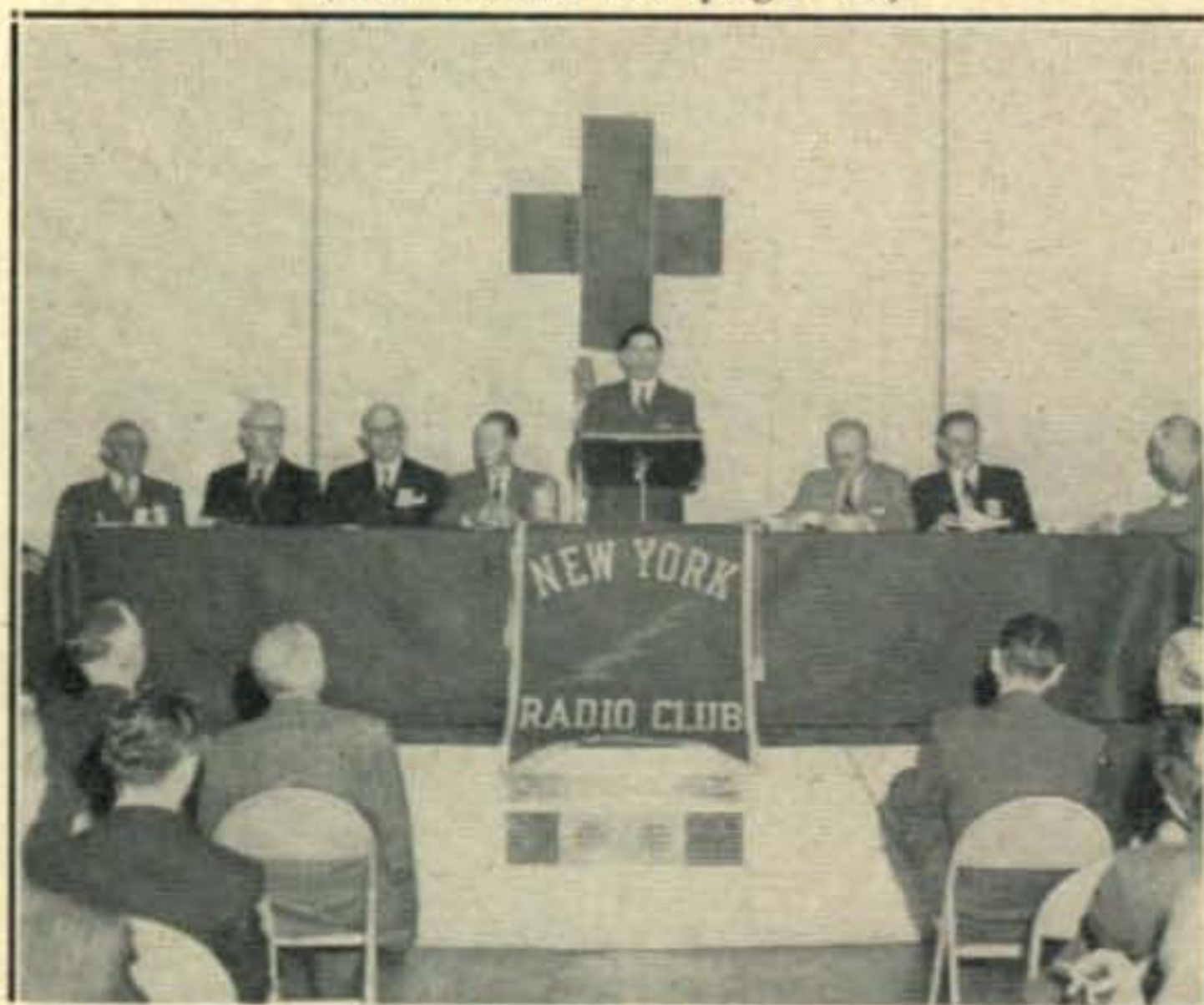
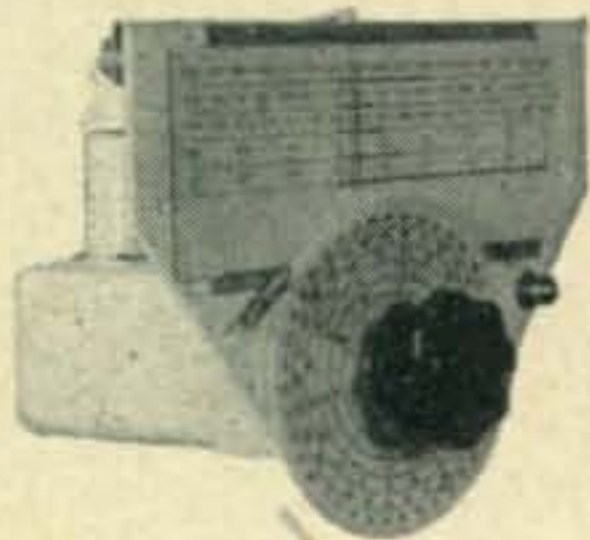

Photo Courtesy W2LRP

Present at the December 8th meeting of the New York Radio Club were, from left to right: W2VOU, W2ZE, W2KH, W3DF, George Sterling, FCC Commissioner; W2CYK, W2DW, W2BW, and W2ATT. At this meeting Commissioner Sterling presented an important address relating to FCC Administrative Procedure, pertinent sections of which are quoted in the adjoining text.

COLLINS

Leading Manufacturers



70E-8A Permeability Tuned Oscillator — The versatility, accuracy, stability and voltage coefficient that distinguish good v.f.o. are standard in the 70E-8A. Every component is highest quality — meets strict specifications. 16 turns of the vernier dial cover the linear range of 1600 kc to 2000 kc. Use in exciter or measuring instruments for truly professional performance. You can depend on it to give you long service free from trouble.



32V-3 VFO Transmitter — A controlled bandswitching, gang-tuned amateur transmitter. Rated at 150 watts input on CW, 120 watts phone, this little receiver-size rig has the kick of a kangaroo, and its excellent audio provides extraordinarily good readability. The 32V-3 covers the 80, 40, 20, 15, 11 and 10 meter ham bands. It is thoroughly filtered and shielded to minimize the possibility of TVI.



KW-1 Transmitter — Engineered for maximum power allowed by your license. Its input is a full 1000 watts on phone and CW. The entire transmitter, including power supply, is integrated in attractive cabinet. Complete bandswitching of the exciter, driver and power amplifier by a single control on the front panel. It covers bands 160 through 10. TVI reduction is accomplished by well engineered shielding and filtering. It's as easy to handle as the 32V-3.

AUTHORIZED COLLINS DISTRIBUTORS

ALABAMA

BIRMINGHAM
Ack Radio Supply Co.
2205 Third Ave., N.

ARIZONA

PHOENIX
Radio Parts of Arizona
214 S. 11th St.

TUCSON
Elliott Electronics, Inc.
Box 5081
418 N. Fourth Ave.

ARKANSAS

LITTLE ROCK
Carlton Wholesale Radio

ARKANSAS-TEXAS

TEXARKANA
Lavender Radio Supply
Co., Inc.
520 E. Fourth St.
P. O. Box 596

CALIFORNIA

BURBANK
Valley Electronics
Supply Co.
1302 W. Magnolia Blvd.

LONG BEACH
Scott Radio Supply
266 Alamitos Ave.

LOS ANGELES
Henry Radio
11240 W. Olympic Blvd.
Kierulff & Co.
820-830 W. Olympic
Blvd.

Radio Products Sales,
Inc.
1501 S. Hill St.

OAKLAND
Electric Supply Co.
140 — 11th St. at Madison

SAN DIEGO
Western Radio & TV
Supply Co.
1415 India St.

SAN FRANCISCO
San Francisco Radio &
Supply Co.
1282-1284 Market St.

COLORADO

DENVER
Radio Products Sales Co.
1237 Sixteenth St.

CONNECTICUT

NEW HAVEN
Dale-Connecticut, Inc.
140 Ferry St.

DELAWARE

WILMINGTON
Radio Electric Service Co.
of Pa., Inc.
S.E. Corner Third &
Tatnall Sts.
Wilmington Electrical
Spec. Co., Inc.
405 Delaware Ave.

DISTRICT OF COLUMBIA

WASHINGTON
Electronic Wholesalers,
Inc.
2345 Sherman Ave., N.W.

FLORIDA

JACKSONVILLE
Kinkade Radio Supply
1402 Laura St.

MIAMI
Electronic Supply Co.
61 N.E. 9th St.
Walder Radio &
Appliance Co.
1809 N.E. 2nd Ave.

TAMPA
Kinkade Radio Supply
402-04 W. Fortune St.

GEORGIA

ATLANTA
Specialty Distributing Co.
425 Peachtree St., N.E.

AUGUSTA
Specialty Distributing Co.
644 Reynolds St.

ILLINOIS

CHICAGO
Allied Radio Corp.
833 W. Jackson Blvd.
Newark Electric Co.
223 W. Madison St.

PEORIA
Klaus Radio & Electric
Co.
707 Main St.

ROCK ISLAND
Tri-City Radio Supply Co.
1919 Fourth Ave.

INDIANA

FT. WAYNE
Ft. Wayne Electronics
Supply, Inc.
223 E. Main St.
INDIANAPOLIS
Graham Electronic
Supply, Inc.
102 S. Pennsylvania St.

LAFAYETTE
Lafayette Radio Supply,
Inc.
627 Main St.

MUNCIE
Muncie Electronics
Supply, Inc.
305 N. Madison

SOUTH BEND
Radio Distributing Co.
432 Carroll St.

IOWA

COUNCIL BLUFFS
World Radio Laborato-
ries, Inc.

744 W. Broadway
DES MOINES
Radio Trade Supply Co.
1224 Grand Ave.

KANSAS

TOPEKA
The Overton Electric Co.,
Inc.
522 Jackson St.

KENTUCKY

LEXINGTON
Radio Equipment Co.
480 Skain Ave.

LOUISVILLE
Universal Radio Supply
Co., Inc.
533 S. Seventh St.

LOUISIANA

NEW ORLEANS
Radio Parts, Inc.
807 Howard Ave.

MARYLAND

BALTIMORE
Kann-Ellert Electronics,
Inc.
9 South Howard St.

MASSACHUSETTS

BOSTON
DeMambro Radio Supply,
Inc.
1111 Commonwealth Ave.
Radio Shack Corp.
167 Washington St.

MICHIGAN

DETROIT
M. N. Duffy & Co.
2040 Grand River Ave., W.

MISSOURI

BUTLER
Henry Radio Co.
211 North Main

KANSAS CITY
Radiolab
1612 Grand Ave.

ST. LOUIS
Walter Ashe Radio Co.
1125 Pine St.

MINNESOTA

DULUTH
Lew Bonn Co.
228 E. Superior St.
Northwest Radio
123 E. First St.

MINNEAPOLIS
Lew Bonn Co.
1211 La Salle Ave.

ST. PAUL
Lew Bonn Co.
141-147 W. Seventh St.
Hall Electric Co.
566 N. Robert St.

NEW HAMPSHIRE

CONCORD
Evans Radio
10 Hills Ave.

NEW JERSEY

ATLANTIC CITY
Radio Electric Service Co.
of Pa., Inc.
452 N. Albany Ave.

CAMDEN
Radio Electric Service Co.
of Pa., Inc.
513-15 Cooper St.

of Amateur Radio Equipment



75A-3 Receiver — Makes use of the new Collins mechanical filter which represents an entirely new approach to the attainment of selectivity. The 75A-3 is a double conversion superheterodyne for top performance on the 160, 80, 40, 20, 15, 11 and 10 meter bands. Only the band in use is shown on the slide rule dial — accurately calibrated directly in 1/10 mc. Vernier zero set control is on front panel.

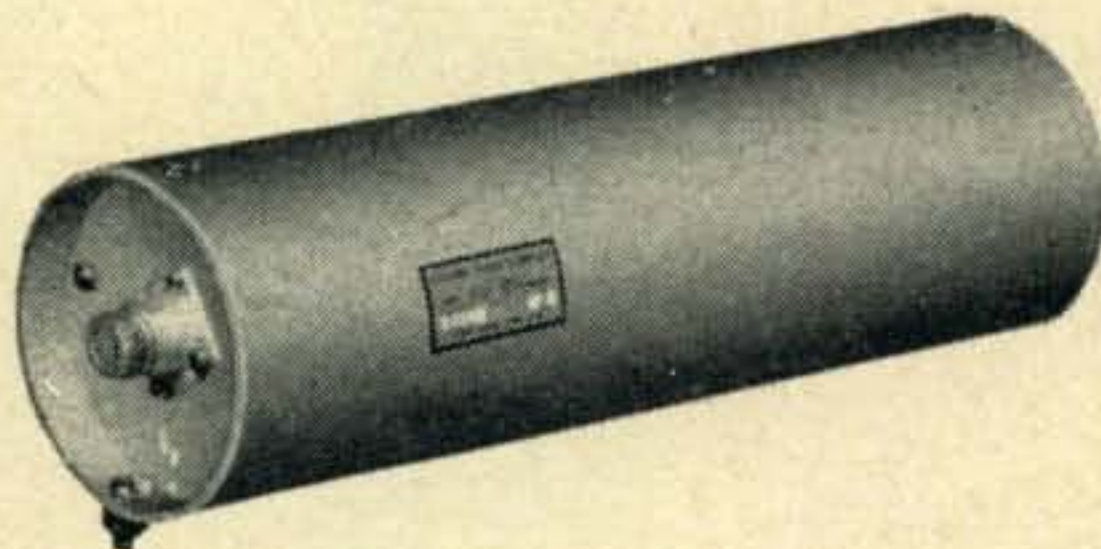

35C-2 Low-Pass Filter — Designed to reduce harmonic radiation. Can be used with any 52-ohm-output transmitter though especially built for use with Collins 32V-3 (left). 35C-2 has coaxial fittings to make installation easy. Provides about 75 db attenuation at television frequencies with an insertion loss of only .18 db. The filter's three sections are individually shielded and the use of low-loss capacitors insures excellent performance under all conditions.

AUTHORIZED COLLINS DISTRIBUTORS

NEW YORK

ALBANY
Ft. Orange Radio Distributing Co., Inc.
642-644 Broadway

AMSTERDAM
Adirondack Radio Supply
P. O. Box 88
32 Guy Park Ave.

JAMAICA
Harrison Radio Corp.
172-31 Hillside Ave.

NEW YORK
Harrison Radio Corp.
225 Greenwich St.
Harvey Radio Co., Inc.
103 W. 43rd St.

NORTH CAROLINA

GREENSBORO
Johannesen Electric Co., Inc.
312-14 N. Eugene St.

OHIO

CINCINNATI
Steinberg's Inc.
633 Walnut St.

CLEVELAND
Radio & Electronic Parts Co.
3235 Prospect Ave.

COLUMBUS
Thompson Radio Supplies
182 E. Long St.

DAYTON
SREPCO, Inc.
314 East Leo St.

SPRINGFIELD
SREPCO, Inc.
119 W. Main St.

TOLEDO
Selectronic Supplies, Inc.
1013 Jefferson Ave.

OKLAHOMA

TULSA
Radio, Inc.

OREGON
EUGENE
United Radio Supply Co.
179 W. Eighth St.

PORTLAND
Pacific Stationery Wholesale Radio Dept.
414 S.W. Second Ave.
United Radio Supply Co.
22 N.W. Ninth Ave.

PENNSYLVANIA

ALLENTOWN
Radio Electric Service Co. of Pa., Inc.
1042 Hamilton St.

EASTON
Radio Electric Service Co. of Pa., Inc.
916 Northampton St.

JOHNSTOWN
Cambria Equipment Co.
17 Johns St.

PHILADELPHIA
Radio Electric Service Co. of Pa., Inc.
3412 Germantown Ave.
Radio Electric Service Co. of Pa., Inc.
5930 Market St.
Radio Electric Service Co. of Pa., Inc.
N.W. Corner 7th & Arch Sts.

PITTSBURGH
Cameradio Co.
1211 Penn Ave.
The Tydings Co.
5800 Baum Blvd.

RHODE ISLAND
PROVIDENCE
W. H. Edwards Co.
94 Broadway

SOUTH DAKOTA

ABERDEEN
Burghardt Radio Supply
P. O. Box 342

WATERTOWN
Burghardt Radio Supply
P. O. Box 41

TENNESSEE

CHATTANOOGA
Curle Radio Supply
439 Broad St.
Specialty Distributing Co.
709 Chestnut St.

JACKSON
L. K. Rush Co.
P. O. Box 1418

MEMPHIS
Lavender Radio Supply Co., Inc.
1014-16 Union Ave.
W & W Distributing Co.
639 Madison Ave.

TEXAS

AUSTIN
The Hargis Co.
P. O. Box 716
706 W. 6th St.

CORPUS CHRISTI
Electronic Equipment & Engineering Co.
805 S. Staples St.

DALLAS
Crabtree's Wholesale Radio
2608 Ross Ave.

EL PASO
C. C. McNicols
811 Estrella

HOUSTON
Busacker Electronic Equip. Co.
1721 Waugh Drive

SAN ANTONIO

Amateur Headquarters & Supply
P. O. Box 5086
Beacon Hill Station

TYLER
Lavender Radio Supply Co., Inc.
503 E. Oakwood

UTAH

OGDEN
Iverson Radio Co.
265 — 25th St.

VIRGINIA

NORFOLK
Radio Equipment Co.
821 W. 21st St.

WASHINGTON

EVERETT
Pringle Radio Wholesale Co.
2514 Colby Ave.

SEATTLE
Western Electronic Supply Co.
717 Dexter

SPOKANE
Northwest Electronic Co.
N. 102 Monroe St.

TACOMA
C & G Radio Supply Co.
2502-6 Jefferson Ave.

WISCONSIN

MADISON
Satterfield Radio Supply, Inc.
326 W. Gorham St.

MILWAUKEE
Central Radio Parts Co.
1723 W. Fond du Lac Ave.

For the best in amateur radio, it's . . .



COLLINS RADIO COMPANY, Cedar Rapids, Iowa

11 W. 42nd St., NEW YORK 36

1930 Hi-Line Drive, DALLAS 2

2700 W. Olive Ave., BURBANK

The 1953 Lazy Kilowatt

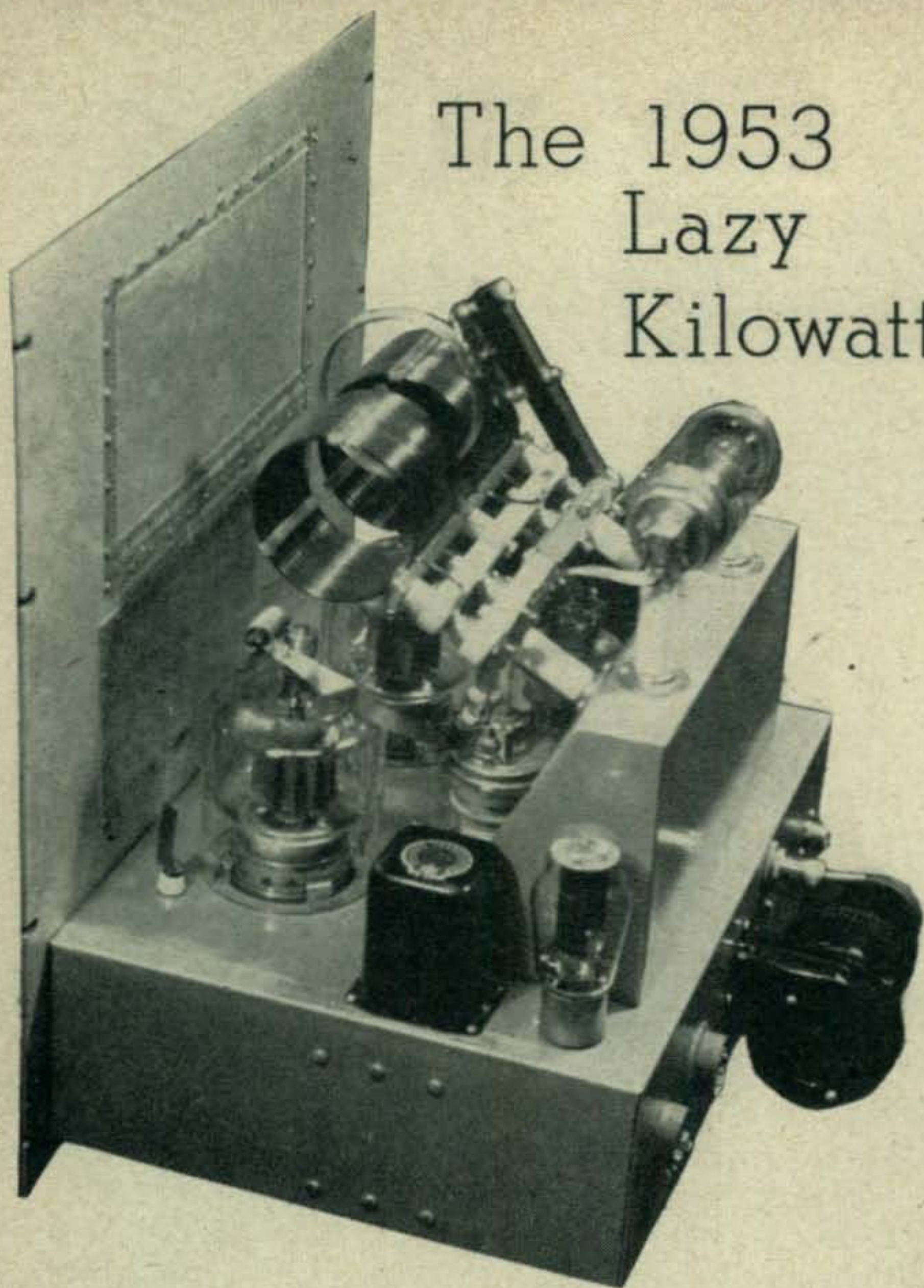

The original "Lazy Kilowatt" designed by W9IOP, served as a prototype for many of the power amplifiers used by our leading DX men. The new "1953 Lazy Kilowatt" has been completely modernized. It incorporates the variable vacuum capacitor tuning and single coil band changing from the front panel. The "1953 Lazy Kilowatt" can be duplicated in any average ham shack.

—Editor

LAWRENCE LeKASHMAN, W9IOP

c/o Electro-Voice, Inc., Buchanan, Michigan

Transmitter design for low-frequency operation is not violently susceptible to technological changes in the art. Yet, somewhat to the dismay of the amateur (and perhaps his family too) the rig to "end them all," in but a few years, is outmoded for one reason or another. Since the war this obsolescence factor has been accelerated tenfold by TVI problems. Thus, the "Lazy Kilowatt," pride and joy of 1947, was due for a complete redesign, perhaps, even sooner than now.

Design Objectives

The objectives of the original "Lazy Kilowatt" design are still essentially the goal of this transmitter: A final amplifier capable of handling comfortably the legal power limit on all amateur bands through 10 meters. To this was added the desire for maximum flexibility without incurring complex circuitry, and cleanliness of design to minimize TVI. The considerably different looking

power amplifier of the "1953 Lazy Kilowatt," is one approach to the design problem that has met and passed exhaustive tests.

Several general considerations should be pointed out. The electrical design is comparatively straightforward. While there is a wide divergence of opinion as to the relative merits of parallel vs. push-pull operation . . . pi coupler finals vs. conventional LC . . . in practice the design previously used in the "Lazy Kilowatt" proved so trouble-free that it was decided to retain the same basic circuitry. After all, most of the power amplifier modifications currently under review vary in degree only, and are not fundamental design innovations. The degree of mechanical complexity was kept as small as possible in order to permit duplication by the average amateur. There are no limits to what can be done with machine shop facilities, if available —this transmitter represents a compromise be-

tween extremes. Certain items may have to be fabricated in an outside shop, but not many.

Defining Flexibility

It is important to know what a piece of equipment will do before deciding to build it. The "1953 Lazy Kilowatt" will permit a cool kilowatt input from 3.5 to 30 Mc. Only the tank coil must be changed and this is done with a minimum of inconvenience through a front panel door. The final may be removed for servicing without undoing any screws or bolts other than those on the front panel. Power and antennas to the final amplifier are brought in using plugs for quick disconnect. The co-ax line is fed through the shield frame using one of the *Es-on* co-ax bushings. This bushing precludes the use of a co-ax connector, and if your local distributor doesn't handle *Es-on*, you can bend a clamp or use a connector. The important thing is to ground the co-ax shield where it passes through the shield frame.

All components that have a finite life, i.e., tubes, capacitors, etc., are of standard brands and widely available. There are no close tolerances to which one must adhere in construction. A diagram of the superstructure for supporting the tank coil and vacuum padder is illustrated; this is the only part calling for fairly close tolerances.

A word about the components selected. A kilowatt amplifier, if properly built, is not a "five and dime" project. The economy of sacrificing any design feature to cut cost is considered inadvisable. Thus, de-luxe features such as the special *Eimac* sockets, while initially costing more, can contribute to longer tube life, and in this manner amortize the slightly higher cost.

The most perplexing single problem in the trans-

mitter design is that of fitting all the components on or into a single chassis. Overall chassis size limits are determined by the rack enclosure, in this instance a 13" x 17" x 5" deep chassis was absolutely essential to locate all the sub-mounted components. This is clearly shown in the photographs.

The amplifier deck houses, in addition to the power amplifier, the bias supply and filament supply. Normally, these components would present no space problem, but the addition of a TVI filter on every lead entering or leaving the chassis quickly consumes most of the open space.

Reasonable care in parts placement is the principal building precaution. The only sub-assembly requiring work is the super-structure supporting the tank coil and the 80-meter vacuum padder. Placing the face of the superstructure at an angle positions the tank coil for convenient handling through the front panel door. The vacuum padder is held by regular clips which are available at most jobbers for this purpose. To these clips are fastened 6" lengths of flexible braid terminating in regular Mueller No. 27 copper test clips. When operation on 80 is desired, the clips are secured to the tank coil mounting bar. Thus, a simple, virtually fool-proof method of switching in the padder is available. When not in use, the clips are secured on the vacuum padder clip, ready for instantaneous use.

The r-f amplifier tubes selected for the final were *Eimac* 4-250A's. They were chosen because of the low driving power requirements of tetrodes, and the fact that their low grid-plate capacitance allows considerable simplification of the associated circuit and driver stage. Operating with 2500 volts on the plate, and a driving power of slightly more than 10 watts, a kilowatt is a modest load for a

Bottom view of the 1953 Lazy Kilowatt. Of particular interest is the 2" Y carrying air from the blower to the air-sockets. To the left is the bias supply plate and filament transformer. On the right is the 4-250A filament transformer. The gear drive for the vacuum variable capacitors is just below the apex of the blower ducts. The components not easily identified by their appearance are the various filters for TVI protection. The grid tuning unit is brought out through the front panel using a Millen right-angle drive.

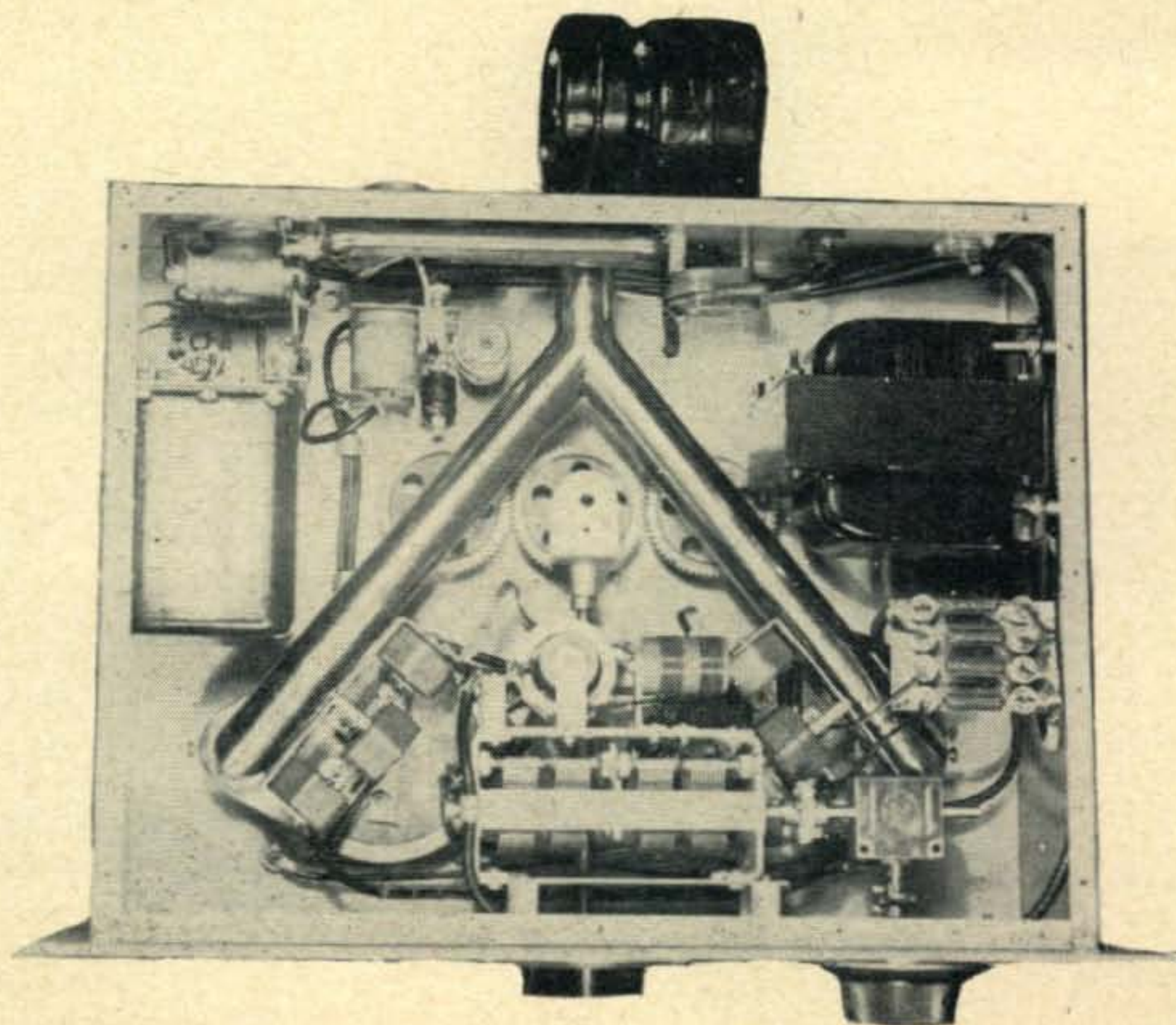

Superstructure for mounting plate coil assembly and vacuum padder. The material is $\frac{3}{32}$ " sheet metal. Dimensions should be held within $\frac{1}{2}$ ".

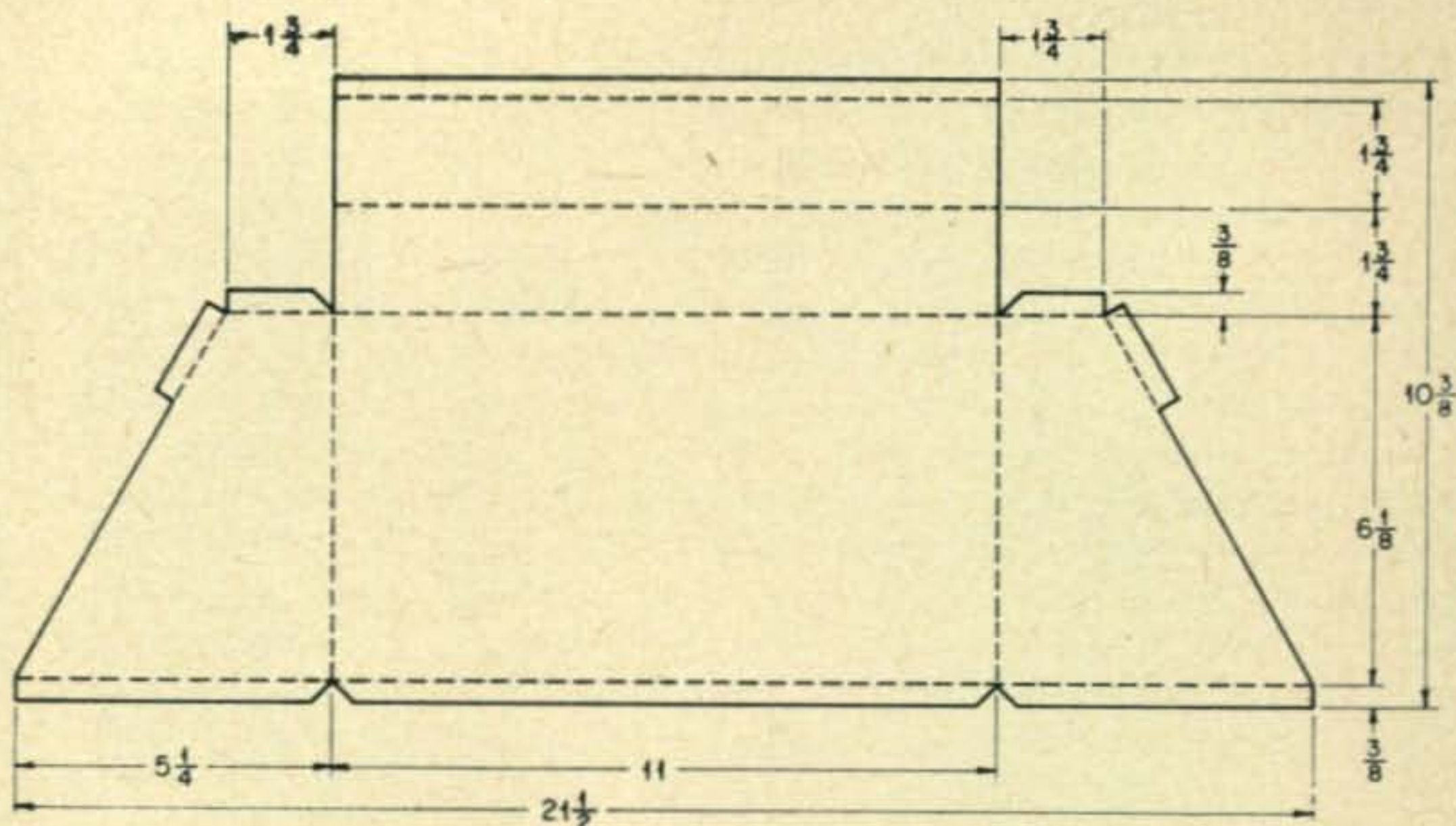

pair of these tubes to handle.

In order to simplify the cooling problem of *Eimac* tetrodes and assure adequate air flow to the various seals, the *Eimac* air-system socket was developed. The air-system socket includes a socket to hold the tube and to make the necessary base connections, and a complete air cooling system. The air enters the bottom of the socket through a 2-inch duct, cools the base terminals and flows through the base of the tube. From there it is guided by the socket chimney past the glass envelope, and is directed against the heat dissipating connector at the plate terminal. A minimum quantity of air is used effectively to cool the tube adequately under the most severe requirements of the 4-250A ratings. The very fancy duct in the bottom of the chassis is constructed from two pieces of 2-inch copper pipe joined together in a "Y," feeding the blower. The bypass condensers for the filament leads and screen are fastened directly to the bottom of the socket. The ground con-

nections are then secured to a strap formed as a broad "U," which, in turn, is grounded to the chassis.

The grid circuit of the final amplifier employs the *National* type MB-40L multi-band tank. Designed specifically for use in grid circuits where the power input does not exceed 20 watts, it is more than adequate to take care of the pair of 4-250As. The tuning range is from 3.2 to 34 Mc. It is possible to tune any of these frequencies simply by turning the knob to the proper setting. No plug-in coils or even bandswitching is necessary. The input is in the form of an electrostatically shielded coupling coil. The shield is grounded to the capacitor frame and becomes grounded to the chassis when the capacitor frame is grounded. This assists in reducing capacity coupling at harmonic frequencies.

The main tuning control is a *Beckman* Model "W" Duodial, Type 15. Delivering a turn ratio of 15:1, it is just about ideal for an *Eimac* vacuum variable capacitor that has a tuning ratio of 17:1. The inner, or primary scale, shows directly the position of the condenser while the outer scale indicates one of the seventeen 360 degree turns to which it should be set. The Model "W" Duodial is designed for mounting on $\frac{1}{2}$ " -32 bushings. This means that since the dial is mounted directly on the front panel, a bushing to go through the chassis and front panel must be provided. For correct operation of the dial, the shaft and bushing extensions beyond the front of mounting panel must be within certain limits. Three special fiber washers, which may be inserted behind the panel to adjust the length, are supplied. Therefore, the bushing should be obtained slightly longer than the total thickness of the panels it must pierce. It should then be adjusted finally with the washers. This is important, because the operation of the Duodial is dependent on this panel bushing.

The tuning capacitor is the *Eimac* VVC2-60-20, a variable vacuum capacitor consisting of two single units in a gang mounting. A word about this type of capacitor is probably in order since they are relatively new in the ham field. The use of a vacuum for the dielectric permits close spacing

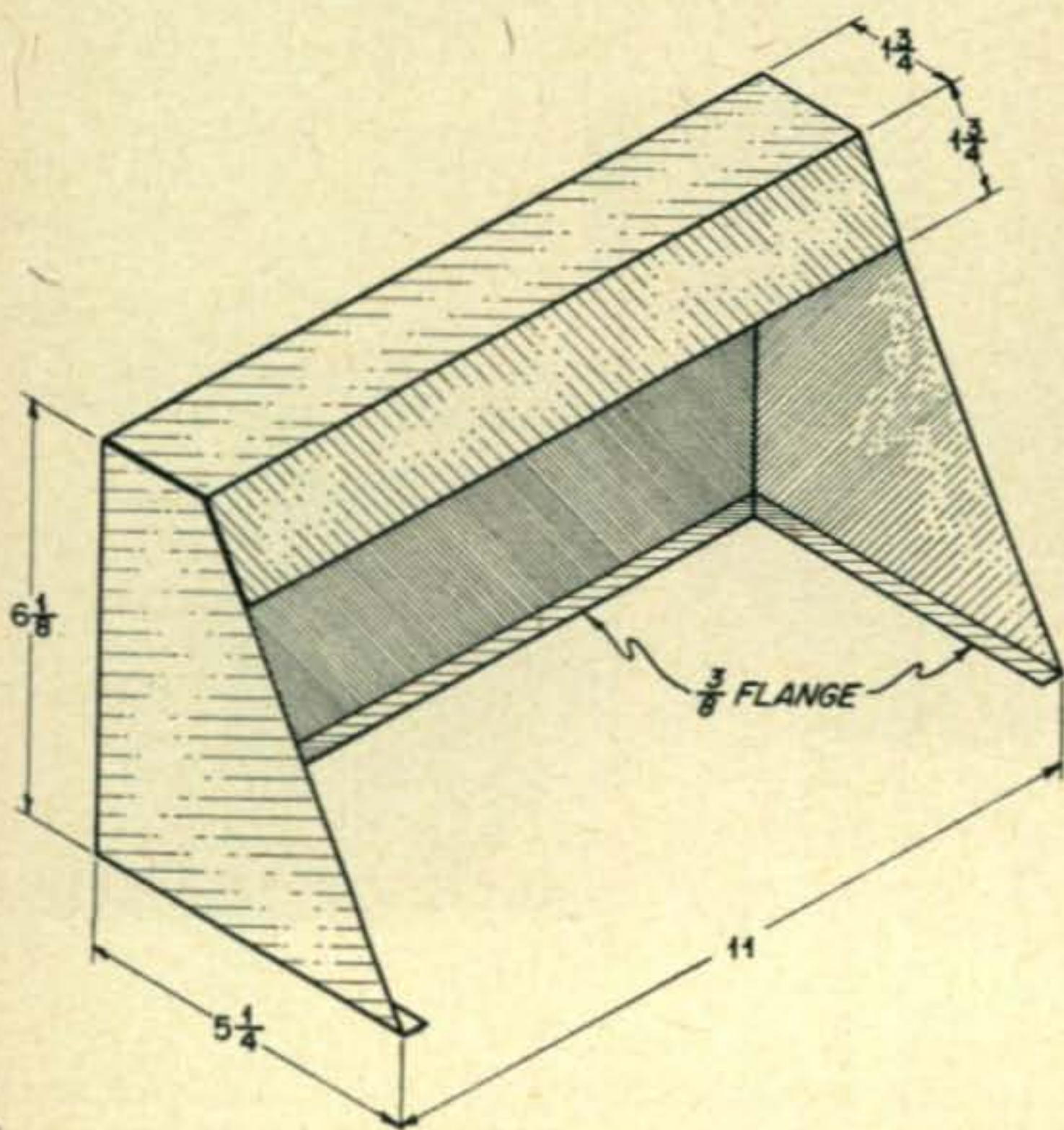

The completed structure as shown here, is bolted to the chassis, and both units are painted to give a finished appearance. Naturally, all major mechanical work should be completed at this stage.

of the electrodes, permitting concentrated capacitance at high voltage. The basic capacitor unit has an r.f. peak voltage of 20,000 volts—more than adequate for any amateur service. Multiple unit capacitors include a single mounting plate, gear train, and a single tuning shaft. One end of each unit capacitor mounts on the common plate, and one end is free. Thus, the multiple capacitor may be connected with the units in parallel, or as two series capacitors for "split-stator" work. The capacitance variation is linear with respect to shaft rotation, the complete range being covered in seventeen revolutions of the shaft. A return to previously indexed settings is positive.

The VVC2-60-20 is employed in the "Lazy Kilowatt" in such a manner that one side of the capacitor is grounded. Thus, the mounting plate can be fastened directly to the chassis. Four eyelets to accommodate 8-32 machine screws are provided on the mounting plate. The other end of the capacitor is secured with two fuse-type clamps and connected by copper straps to the coil jack bar.

An adjustable link control was not brought through the front panel because the particular requirements of our type of operation indicated little need for it. In other words, after using the rig for a short time, the setting of the adjustable link becomes almost automatic. For varying power, it has been my practice to generally raise or lower plate voltage. For someone who desires to duplicate the "1953 Lazy Kilowatt" with a front panel control for the link, it will be necessary to add a right angle drive supported by a bracket on the chassis. Loading on all bands is adequate when using a three turn link.

To facilitate changing the final amplifier plate coil, a door measuring 6 x 11 inches is cut from the front panel. It will take an extra panel to fabricate the door, since the piece removed will probably get pretty well chewed up. A little time and patience will make possible a neat job on aluminum panels. To prevent r.f. leakage around the opening, Eimac pre-formed contact finger stock is used. While designed initially as a means of making connections to coaxially constructed tubes, it is equally ideal for electrical "weather-strip." The top and sides of the opening use Eimac type 17/32. The bottom piece, however, which is slightly larger to cover the door hinge, is Eimac type 31/32. The door hinge is a piece of piano hinge, available at any hardware store.

Shielding, to provide protection against TVI, is essential. There are innumerable ways of constructing a shield. In this instance, $\frac{3}{4}$ inch angle was welded together to form a box which fits over the top of the chassis. Small 4/32 bolts at frequent intervals secure the box to the front panel and chassis. By countersinking flatheads and touching up the heads with paint, a job can be done which is not objectionable in appearance. To provide access for tube changes or simple servicing, the back of the shield is removable. The opening on the front panel, measuring 11 x 4 inches, directly before the

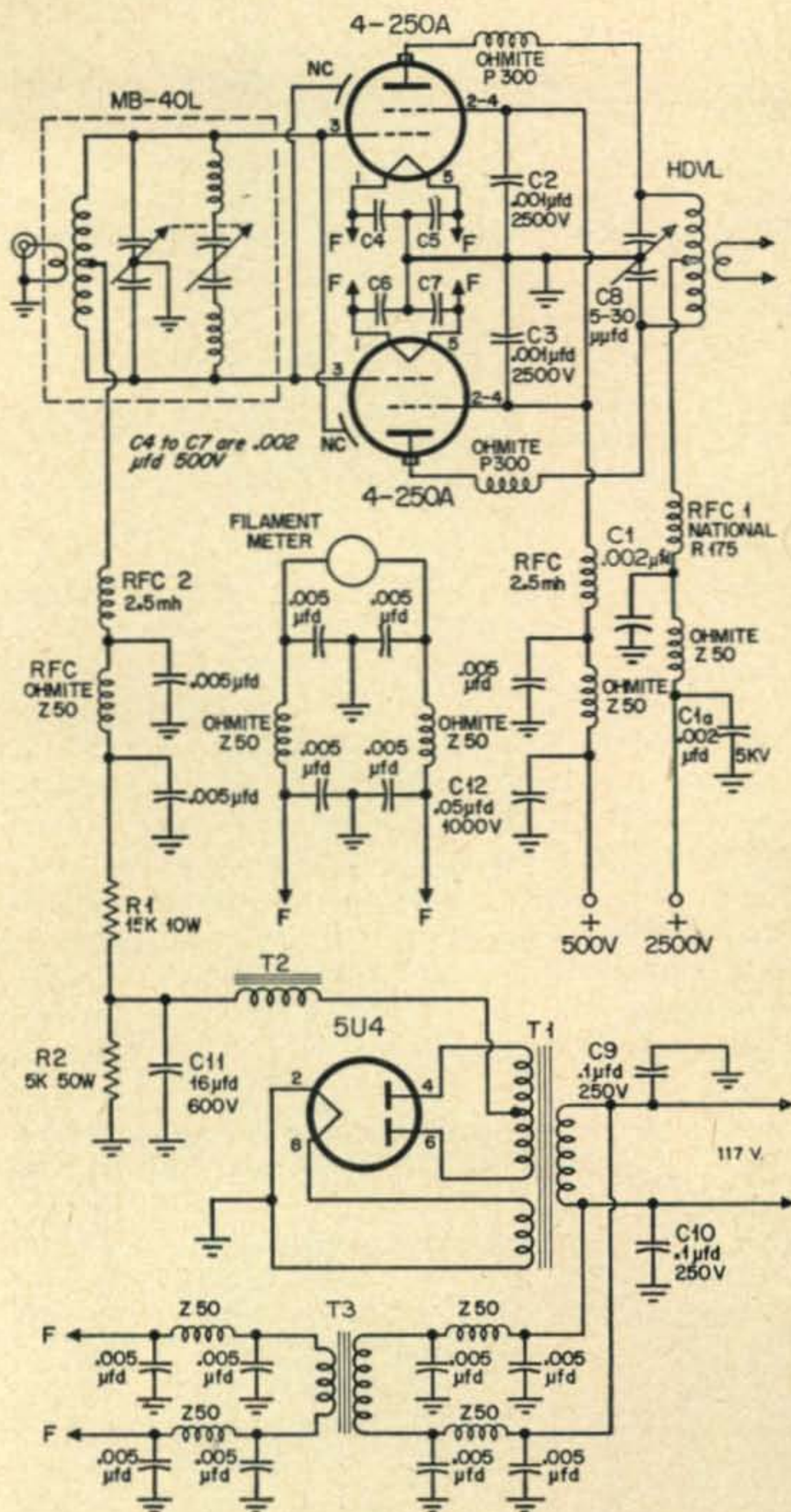

- | | |
|--|---|
| C1, C1 _a — 0.002 μ fd., 5000v. mica | T1 — -180v. bias, Chicago Transformer IBS-150 |
| C2, C3 — 0.001 μ fd., 2500v. mica | T2 — bias filter reactor, 15h., 55 ma., Chicago Transformer RS-1555 |
| C4, C5, C6, C7 — 0.002 μ fd., 500v. mica | T3 — 5v., 30 amp., Chicago Transformer F-530 |
| C8 — 5-30 μ fd. split stator, Eimac VVC2-60-20 | Grid tuning unit — National MB-40L |
| C9, C10 — 0.1 μ fd., 250v. Sprague Hypass | Neutralizing tabs — 2" x 5/8" |
| C11 — 16 μ fd., 600v. | Tube sockets — Eimac air system sockets |
| C12 — 0.05 μ fd., 1000v. Sprague Hypass | Final amplifier coil — B&W type HDVL |
| R1 — 15,000 ohms, 10w. | Base assembly and swinging link — B&W 3766 |
| R2 — 5,000 ohms, 50w. | |
| RFC1 — National R-175 | |
| RFC2 — 2.5mh. | |

Also required are fifteen (15) 0.005 ufd. mica condensers and nine (9) Ohmite Z50 r-f chokes. These are not identified by parts number in the above diagram.

tubes, provides an observation point for the plates, is decorative, and also allows for additional ventilation. This is a piece of the same perforated metal used on the shield. Perforated steel was used because it would take plating (and plating facilities were available), although aluminum of this same character is available from local mill supply houses.

TVI

Filters on the a-c line feeding the bias supply, filament transformer and r-f filters are assembled from conventional components, observing present TVI reduction standards. To facilitate mounting, $\frac{1}{8}$ " brass sheet was cut up to support the filter components in the most convenient manner. Filter details are indicated on the circuit diagram.

South Bend, the home QTH, probably represents as poor a TV location as generally found. About 90 miles from Chicago, the principal source of local TV, the residents use thoroughly souped up, complex installations. On-the-air tests were conducted using a 136 ft. end-fed Zepp, one end on my 65 ft. TV tower, the other end on a neighbor's 65 ft. TV tower three houses away. W9JDS resides three houses away in the opposite direction, so a sympathetic and cooperative local test location is available. On 3.5 Mc. and 7 Mc., at 1 kilowatt input, there is no discernible trace of interference;

On 14 Mc., at W9JDS, there is a trace of TVI when his TV antenna is pointed at my house; when pointed at Chicago, due west, there is no TVI. On the TV set of the non-amateur neighbor, there is no trace of TVI except when operating on 20. On this band there is serious channel 4 interference only. A few scattered complaints have come in from various parts of the neighborhood; however, without exception, a high-pass filter cleaned up the difficulty. It is difficult to pin-point any one factor contributing to the comparatively clean operation, but summing them up, the precautions incorporated include: shielding and filtering of all leads, vacuum variable tuning capacitors giving an extremely short path to ground for harmonics, and, of course, a TVI-proof exciter—the "Gold Plated Special."

Operation

Upon completion of the wiring, the circuit was double checked, and a-c power applied. Excitation was applied on each band and grid tuning function checked. Neutralization was performed on the highest operating frequency, 30 Mc., and rechecked on 3.5 Mc. Initial checks for neutralization were made with a standard commercial grid-dip oscillator, but after applying d.c., the "feel" of the tuning wasn't precisely right. A recheck of the neutralization with a sensitive laboratory quality *Measurements* g.d.o. confirmed our suspicion that the tubes were still out of neutralization. As in all power-sensitive high-gain tubes, stable operation demands careful neutralization. Using the *Measurements* instrument and following conventional procedure, the neutralizing tabs were easily adjusted to give apparently perfect neutralization.

Ohmite P300 parasitic suppressors were placed in each 4-250A plate lead, simply because past experience had shown them to be important for completely stable operation. A reasonably positive indication that these suppressors are not overworking was the fact that the paper labels on the P300s have shown no discoloration after many grueling operating sessions on all bands.

With plate power applied, one of those all too infrequent occurrences resulted—normal operation was observed on all bands. No further "debugging" was required.

On-the-Air Performance

Nothing speaks more eloquently for an amateur's transmitter than his log. In the first week of operation, contacts were made on all bands with extremely good reports. WAC was made on both 7 and 14 Mc. Typical reports in Europe averaged S7 to S8. These contacts were made from one of the worst ham locations in continental United States (frankly admitted by all W9's) and would indicate performance to be normal or better.

Of added interest is the effect on u.h.f. television. WSBT (South Bend, channel 34) has been operating for several weeks, permitting a number of tests under varying conditions. In no case has there been any indication of interference . . . a good omen for all areas to be serviced with UHF TV.

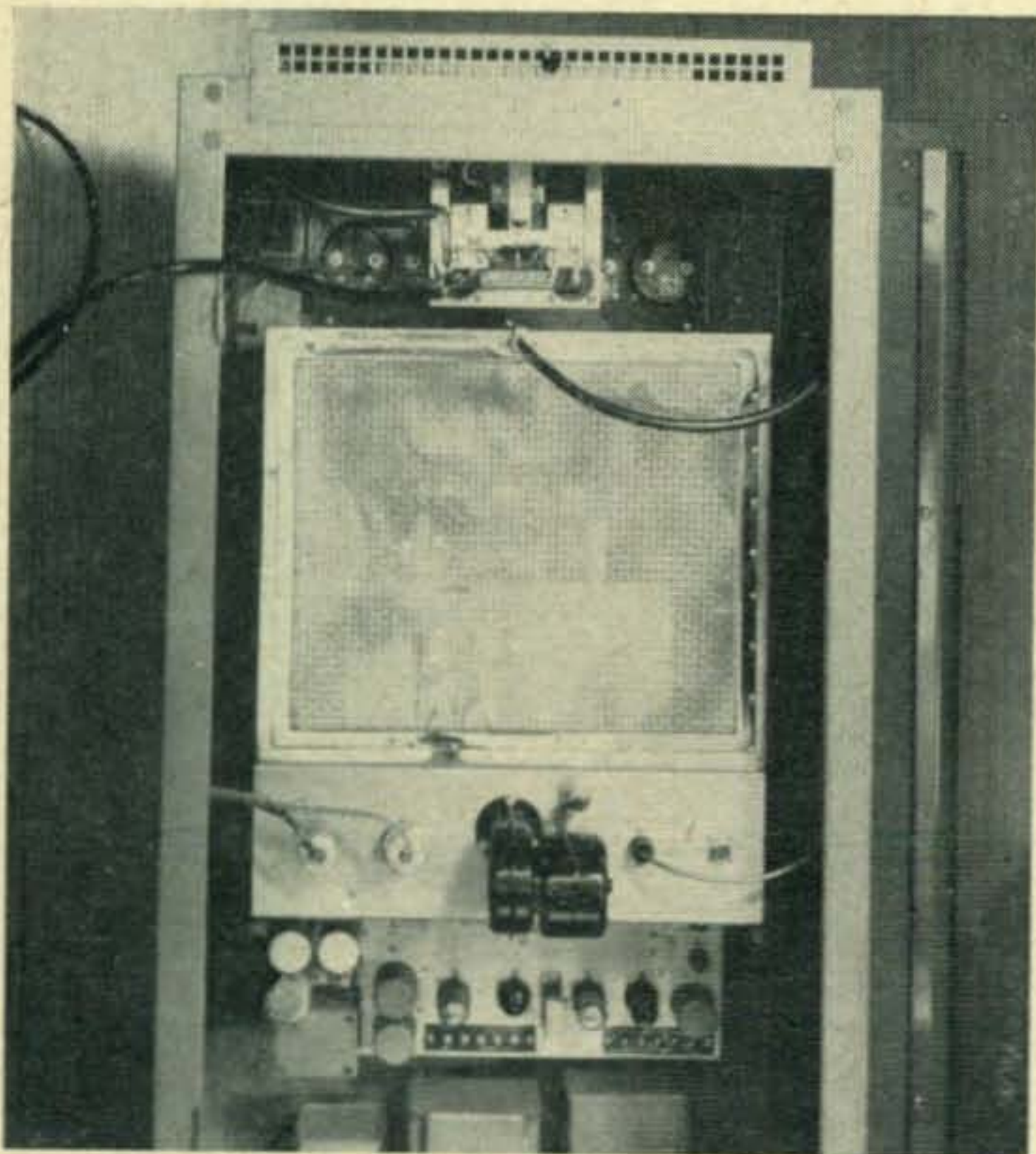

Rear view of the 1953 Lazy Kilowatt. Snug is the ideal expression for the complete shielding job. The connectors on the chassis rear, from left to right, are a.c. input; filament and screen meter leads; a.c. input from the blower; high-voltage input; grid excitation input. Note that the meters are unshielded, the result of tests which proved this satisfactory. Directly below the final amplifier is a limiting and clipping amplifier for 'phone, and below this is the PA screen supply. The bottom shield of the amplifier is a piece of perforated metal secured with self-tapping screws every two inches.

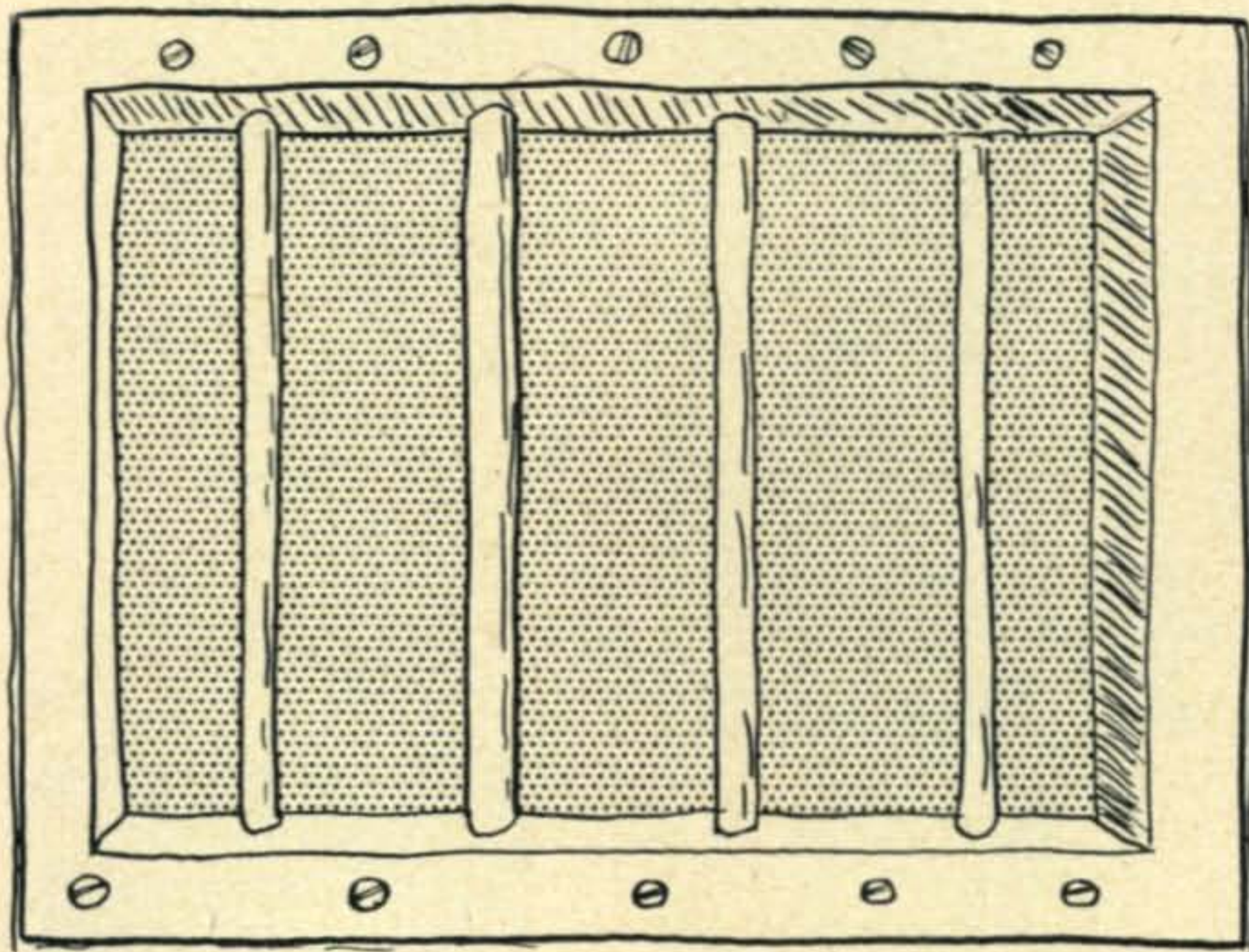

THE DX MAN'S ZOO

For the 1951 ARRL National Convention DX Meetings, Larry LeKashman, W9IOP, and Herb Becker, W6QD, prepared a booklet called, "The DX-Man's Zoo."

So popular was this spoofing of that special breed called the DX-man, that we recently asked Larry to gather some new material for this "DX Feature Issue."

Obviously, any similarity between those pictured herein and our many DX-ers is coincidental and naturally, it is all in fun.

The photographs are from the C. Emerson Brown Collection at the American Museum of Photography, Philadelphia, Pennsylvania.





"CQ DX"

75-meter phone man hears that the Europeans are coming through.



"I know I owe you a QSL,
but don't worry, I haven't
forgotten."

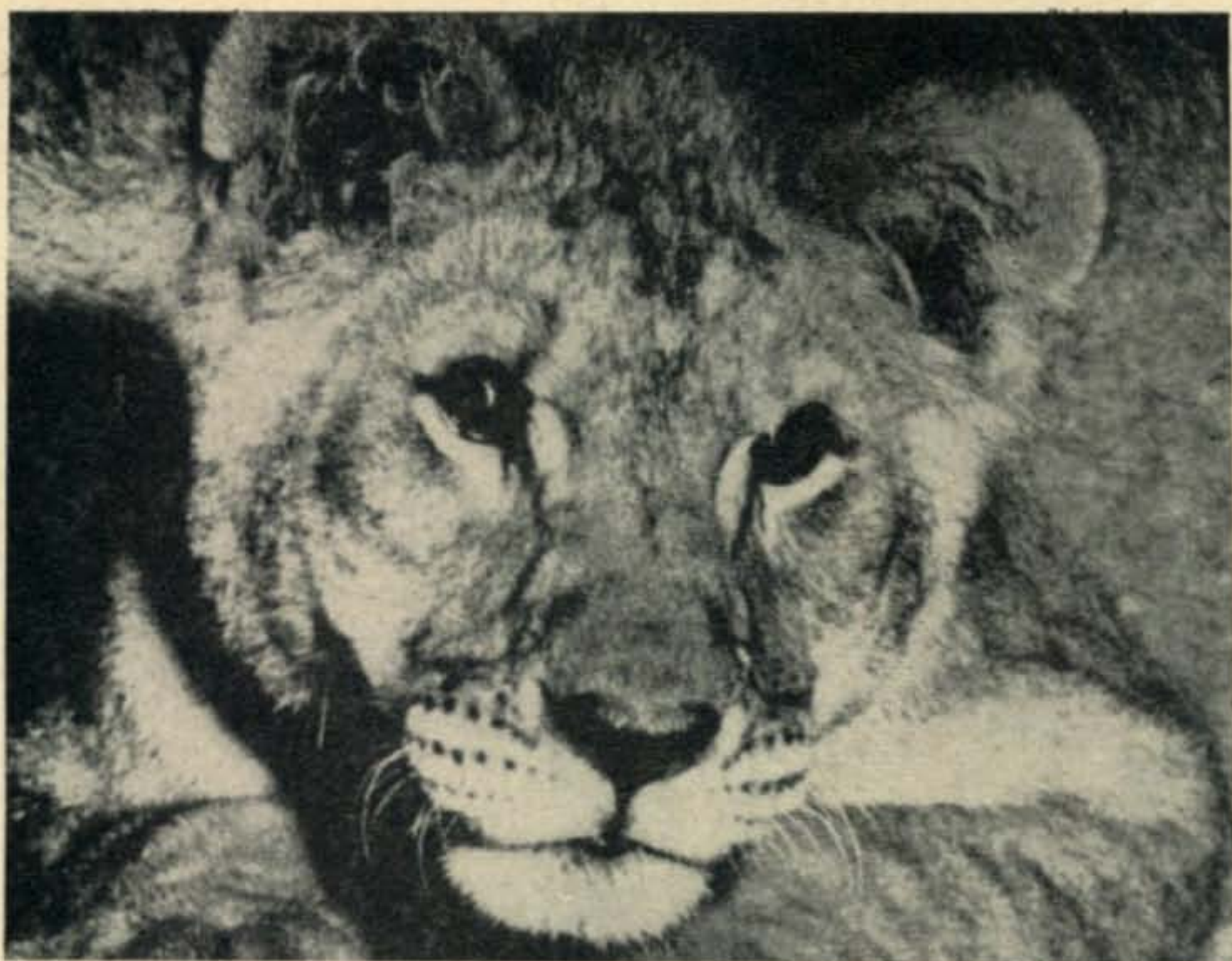

"Gee, and I could'a sworn he came back to me."

Leading DX man modestly discusses his latest QSL's.



"Ready or not, your dinner's on the table!"

DX man emerging into
sunshine.



"You know, I'm one of
the biggest DX men!"

"Why didn't someone tell
us about the Brunei ex-
pedition?"

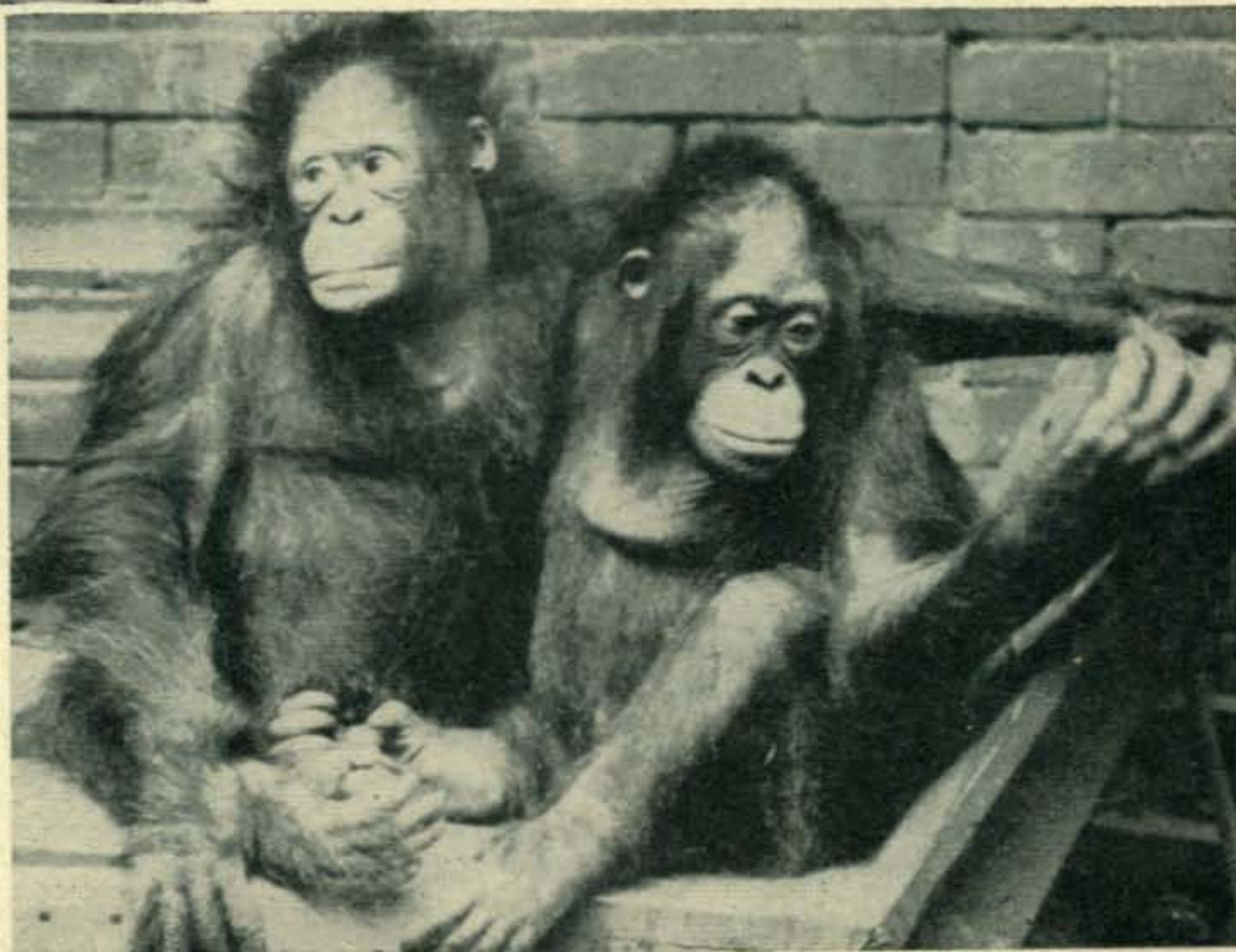

Roland d'Assignies seated at the operating position of FO8AD, Rapa Island, 800 miles south of Tahiti.

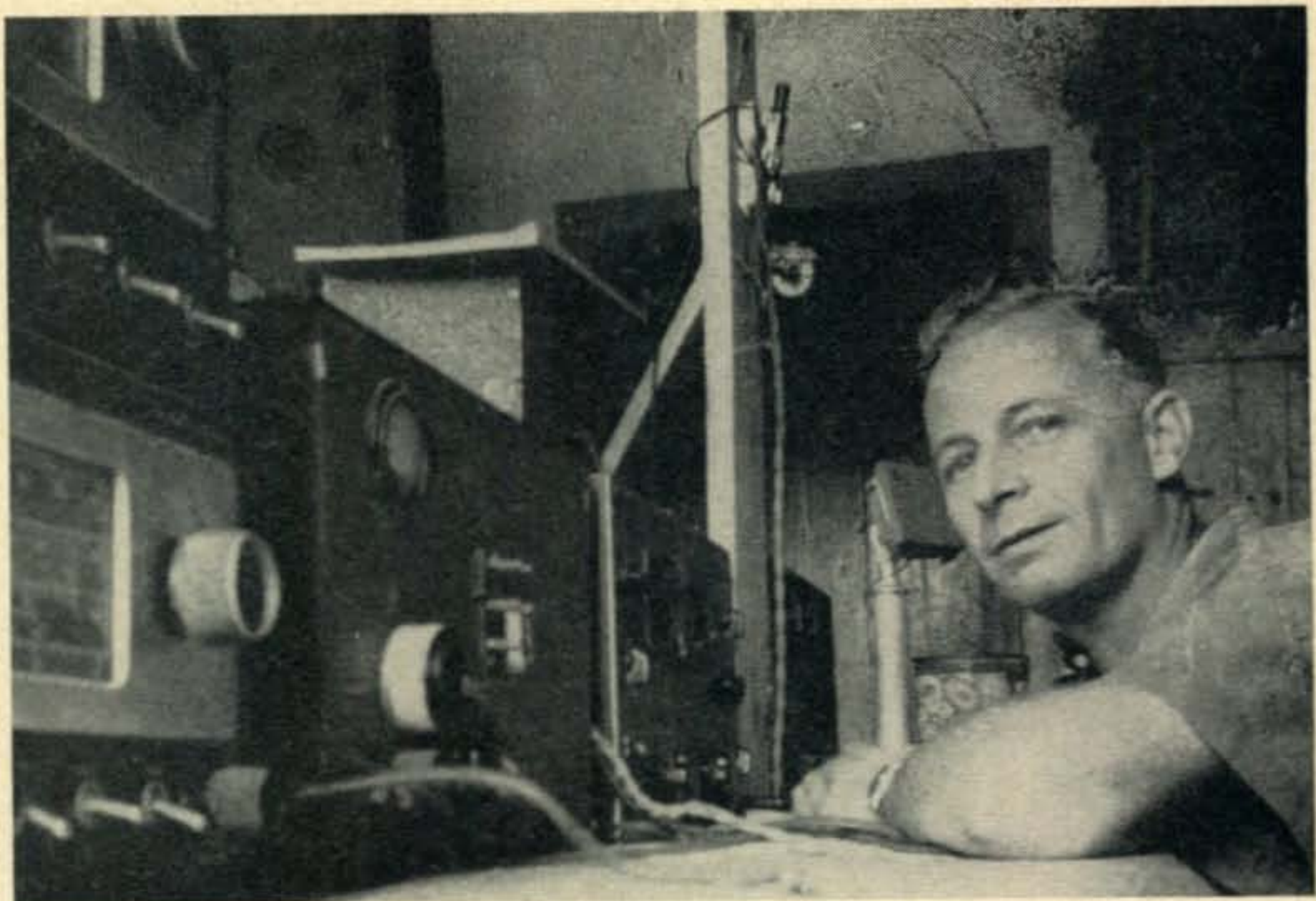

The Story of **RV2**

M. ROLAND D'ASSIGNIES, RV2/FO8AD

Rapa Island, via Tahiti, EFO

Most amateurs have dreamed of living on a tropical island and being rare DX to the entire world. This is the story of one amateur who has realized that dream and is now FO8AD.—Editor.

The seed that was to produce RV2 almost a quarter of a century later was sown in France in 1923-4, during my training with the French Signal Corps. However, by 1939 this interlude in my life was just a memory. By then I was Sales Inspector for the British-American Tobacco Company, and my duties took me all over the South Pacific. When the war started I was in Tahiti, and was immediately inducted into the French Signal Corps.

My war service was in the jungles of French Indo-China. Our radio equipment was meager and mostly obsolete. It was amazing to be able to work 1200 miles through the jungle with a Hartley oscillator and a super-regenerative receiver. As the years in the jungle passed, it became my dream to retire to some remote Pacific isle to operate my own little radio station and live out my life in peace. I wanted no more war!

I was discharged from the Corps in 1946 in Tahiti, from where I had been inducted. The more I thought of the fighting that was still going on in Indo-China, the better I liked Tahiti. Finally, I made the most important decision of my life. I terminated my connection with B.A.T. and chose the lonely island of Raivavae in the Austral Group as my future home.

In preparation, I purchased an *Echophone* a-c/d-c receiver, a 6L6 tube, and as many small parts as possible, including a doorbell transformer. Most important, I obtained an *Onan* 500-watt, gasoline-powered generator and a provisional radio station license. My call was RV2, and I was authorized to operate a ten-watt station on 7 Mc. in order to transmit meteorological messages to the French Navy.

On Raivavae, I located eighty feet from a lagoon facing North America and set up my station. It was built around the 6L6 in a Hartley oscillator and the *Echophone* receiver. For the next seven months, I experimented with antennas and spent hours listening to amateurs on the 7- and 14-Mc bands.

CQ de RV2

Finally, on the night of Oct. 31, 1947, I got up courage enough to put my transmitter on 14 Mc. and call a very nervous CQ. When I finished, I listened on my own frequency, half hoping that no one had heard my call. Instead, I was positively frightened by what I heard. It seemed that everybody in the world was calling RV2! Hesitatingly, I answered W6VFR, the loudest and clearest station calling. Marv surprised me by speaking French, which helped to put me at my ease. At last I was truly a radio amateur! Since then, amateur radio has been the bright spot of my life. I still hold a weekly schedule with W6VFR when conditions permit.

RV2 Goes On Phone

Later, I was determined to go on phone. First, I had to construct a microphone. I filled a small can that had contained soluble coffee with crushed carbon from an old battery. Next, I made a diaphragm from a piece of tin, supported and insulated with a washer cut from an automobile tire inner tube.

I connected the microphone and two torch cells into the grid circuit of the 12SQ7 audio tube of the *Echophone* and put the bell transformer in the 50L6 plate circuit as a modulation transformer. This allowed me to modulate the 6L6 about fifty per cent, with eight watts of carrier power.

On 7 Mc., the phone signal was not too bad, but on 14 Mc., both quality and frequency modulation were terrible. Nevertheless, I managed to work many U.S.A. and other DX stations on phone. How they were able to understand me was always a source of amazement to me.

Some time later, I received a great surprise in the form of a package from W6SAI and W6VFR. It contained a beautiful, beautiful, thirty-five watt, crystal-controlled transmitter, complete with several crystals and a supply of spare parts. Immediately I put it on the air. What a thrill to have a T9X signal, instead of a T5 one that drifted hither and yon as the wind played with my antenna. Still, it was like breaking with an old love to discard the faithful Hartley, after all it had done for me.

Back To Papeete

Soon afterwards, I returned to Papeete and

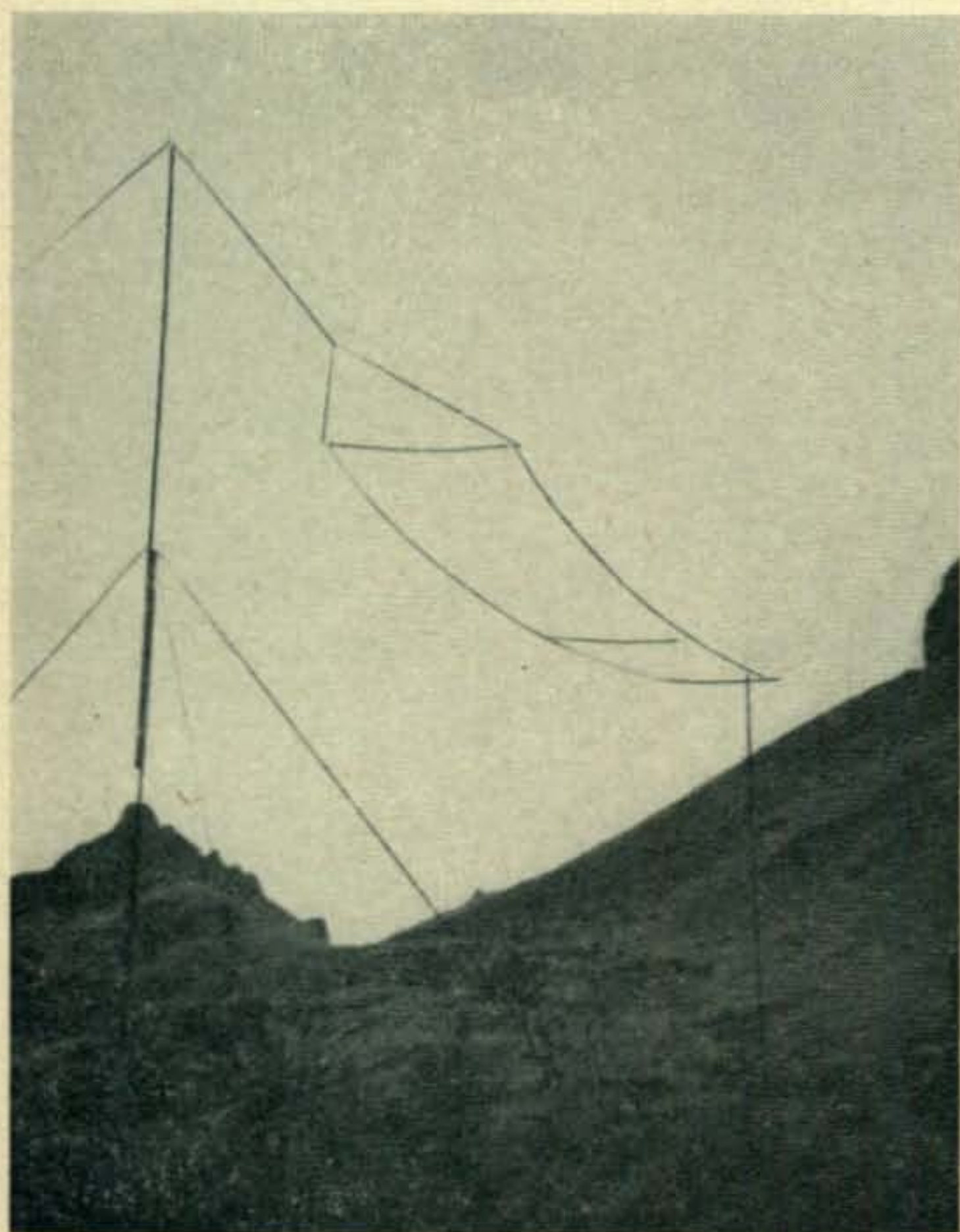

FO8AD's two-section 8JK 14-Mc beam fed with a 115-foot feedline to keep it clear of Government antennas. The best DX is towards South America.

established a radio repair shop—not from choice, but one must live—and I was now the father of a new daughter. Between customers, I operated under my new call of FO8AD. Conditions were not very good, because my antenna location was not favorable, and the noise level was high from the sparking of electric motors on all sides of me. Still I managed to have many fine contacts.

Two things that helped a lot were my good fortune of obtaining a tropicalized *HQ-120X* from U.S. Navy surplus and receiving a complete, two-section 8JK beam antenna from my W6 friends. But life in Papeete was not like on Rai-vavae. So, upon hearing that the French government wanted a radio operator and meteorological observer for a station to be established on the island of Rapa, 800 miles south of Tahiti, I immediately applied for the post. My application was accepted.

Radio To The Rescue

The journey to Rapa was almost disastrous. The motor in our boat failed on the open sea, and we were blown far off our course by high winds. I hooked up an *ATR* generator to the battery to power my little transmitter and called the Papeete Coast Guard for aid. They sent a plane to drop us food and water. Finally, we were blown and drifted to the island of Raiatea, which is northwest of Tahiti. From there, we were towed back to Papeete. Once repairs had been made, we set off again for Rapa, arriving, this time, without incident.

Rapa

Rapa is the farthest south of any island in French Oceania. Its exact location is latitude 27° South, and longitude 144° West. To me it is the most beautiful of the group. Also, its climate is cooler and less humid than Tahiti's. Oranges, perfumed bananas, coffee, vegetables, and the native fruit, taro, grow in large abundance. There are many coconut trees, but they seldom bear fruit. Raspberries are so plentiful as to be almost a menace.

The people are a mixture of Polynesian and almost any other race you care to mention. They are happy and cheerful and very superstitious. Many of their superstitions center around the twenty fortified mountain tops on the island. Who fortified them and for what purpose are real mysteries.

Every Saturday, there is a big dance, strictly chaperoned by the women of the village. The most popular dances are European, and music is supplied by guitars. The clergyman, a Polynesian, who lived for fifteen years in San Pedro, California, is an accomplished guitarist, specializing in American cowboy songs.

Supplies and mail reach Rapa three times a year on the small schooner, the *Fleur de l'Ocean*. Itinerant vessels also stop there occasionally.

My equipment on Rapa consists of three fifty-

(Continued on page 66)

The Evolution of a 40

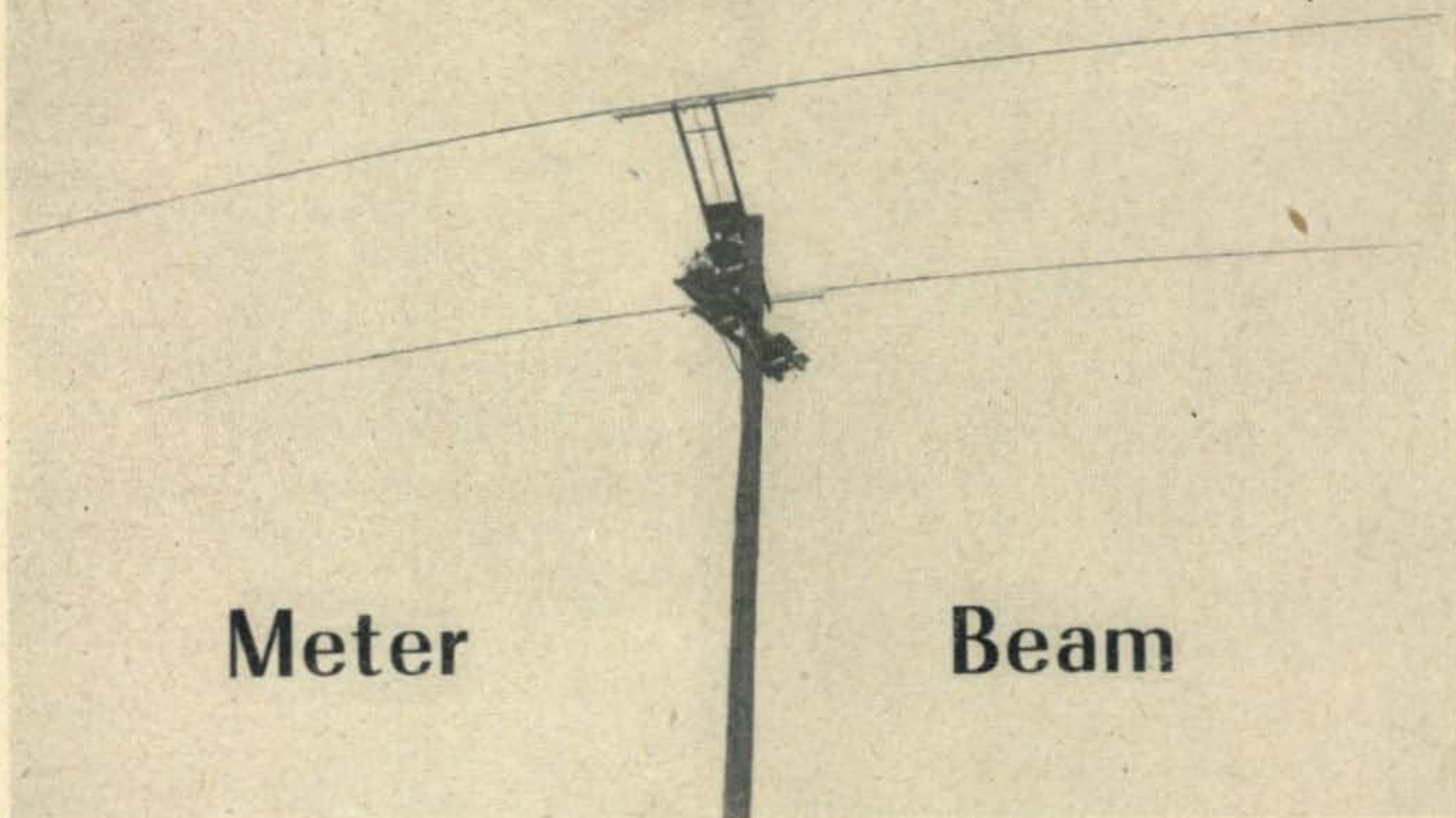

Figure 1: W9LM's two-element, 7-Mc rotary beam described fully in the accompanying article. Sixty-seven feet from the ground, its trim, low-wind-resistance construction makes it hard to believe that each element is sixty-seven feet long. Work? More than one European amateur accused W9LM of being a bootlegger in Europe, because no 7-Mc, U.S. amateur could be that loud!

The Late HAROLD H. LEIGHTON, W9LM

To our knowledge, this is the first complete article on the design and construction of a forty-meter rotary beam to appear in an amateur publication. We doubt that rotary beams will ever exceed the number of doublets in use on forty meters; nevertheless, W9LM's results indicate that one has a definite place on the DX man's antenna farm—Editors.

The statement, "The antenna here is a rotary beam," does not create much of a stir on 14 and 28 Mc., but try it on 7 Mc. some time. The 7-Mc. antenna at W9LM is a two-element rotary beam! It is sixty-seven feet high, and each element is sixty-seven feet long!

The evolution of the array is a story in itself. My primary interest in amateur radio is working DX. For the 1948 DX tests, my 3.5- and 7-Mc antenna was a sixty-seven foot vertical, backed up by a 400-foot square, chicken wire, ground system. On 3.5 Mc., results with this antenna were excellent. On 7 Mc., they were disappointing.

In 1949, I used two sixty-seven foot verticals fed in or out of phase. On 7 Mc., they were obviously $\frac{1}{2}$ -wave long, while on 3.5 Mc., they acted as $\frac{1}{4}$ -wave, top-loaded verticals, with maximum current at the tops of the elements. This combination slightly outperformed the previous antenna on 7 Mc., but was inferior to it on 3.5 Mc. This was rather surprising, because the 3.5-Mc

angle of radiation should have been lower than from the previous antenna.

For the 1949 Field Day, I put up a 3.5-Mc, $\frac{1}{4}$ -wave, vertical antenna, with sixteen, $\frac{1}{4}$ -wave radials forming a ground plane. It worked so well that I constructed a similar one for 7 Mc. This proved to be the best DX antenna to that date. Many DX contacts were made with it throughout the summer.

About this time, I discovered in an antenna handbook, a table showing the angle at which 7-Mc European signals were received on the East Coast. I believe it was originally published in the *Proceedings Of The I.R.E.* The table indicated that the signals arrived at angles between eleven and thirty-five degrees. Significantly, however, only one per cent of the time was the angle as low as eleven degrees.

Correlating this table with my experiences seemed to indicate that too low an angle of radia-

The manuscript for this article was received some eight months before the sudden and unexpected death of the author. We are pleased to publish this to perpetuate the memory of well-known and universally admired radio amateur.

tion for good DX results was possible on the 3.5- and 7-Mc amateur bands. The 7-Mc $\frac{1}{2}$ -wave verticals and the $\frac{1}{4}$ -wave, top-loaded, 3.5-Mc verticals were just undershooting the DX. Conversely, the $\frac{1}{4}$ -wave ground planes did a better job because of their radiation at higher angles.

I began thinking "horizontal." Having a sixty-foot telephone pole available, I could erect a horizontal doublet, $\frac{1}{2}$ -wave high. Such an antenna has its maximum radiation broadside to the element and vertically around thirty-two degrees, with considerable radiation down to and below twenty degrees.

I constructed a self-supporting, $\frac{1}{2}$ -wave element and hoisted it and a rotator to the top of the pole, in order to run some comparative tests between it and the ground plane. Both antennas were fed with RG-8/U cable; consequently, it was possible to switch instantaneously to either. Power input was 900 watts.

Comparing The Horizontal And The Vertical Antennas

Although fading characteristics were often different on the two antennas, there was little to choose between the vertical ground-plane and the $\frac{1}{2}$ -wave doublet for working DX. DX stations did usually report a difference of an S-unit or so in signal strength as the horizontal antenna was swung from broadside to put the end on them. On U.S.A. signals, however, directional effects were seldom noted.

After several months spent in comparing the two antennas and observing how the horizontal rode the winds, another sixty-seven foot element was assembled and spaced one-tenth of a wavelength from the radiator. Three lengths of RG-8/U in parallel were used to feed the beam. Without

changing coupling to the final amplifier, input dropped to 600 watts with the beam, compared to 900 watts with the vertical.

In spite of the power difference, DX reports invariably favored the beam. They varied from, "Signals are slightly louder with the beam," to "Signals more solid on the beam," to a scattering of reports, "Signals three S-units stronger with the beam." On receiving, every DX signal that could be heard using the vertical could be heard better with the beam. On the other hand, many signals, audible on the beam, were completely inaudible on the vertical.

I took down the 7-Mc vertical!

Constructing The Forty-Meter Beam

Beam elements are constructed of telescoped lengths of 24ST aluminum-alloy tubing and are each sixty-seven feet long. They are similar, except that the radiator is split in the center for connection to the feed line, while the parasitic element is unbroken. Measured sag at the ends of the elements is less than one foot.

Each half of the radiator consists of a nine-foot length of $2\frac{1}{4}$ -inch tubing, with $\frac{1}{8}$ -inch walls, a twelve-foot length of two-inch tubing, with $\frac{1}{16}$ -inch walls, and a $14\frac{1}{2}$ -foot length of $1\frac{1}{2}$ -inch tubing, with 0.035-inch walls. The first six feet of the $1\frac{1}{2}$ -inch tubing is reinforced by another length of the same tubing. The reinforcing tube is split down one side on a circular saw, slipped over the other piece, and held in place with a hose clamp.

The various lengths of tubing are joined by splitting the larger-diameter tubing at one end for a distance of one foot with a hack saw, and telescoping the next-smaller diameter tubing into it. Shims are used where necessary to insure a firm fit. As many aircraft-type radiator hose clamps as will fit within the length of the slit are used at the joints to eliminate any possibility of them later working loose.

The parasitic element is constructed as above, except that its center section is a single, eighteen-foot length of the $2\frac{1}{4}$ -inch tubing.

"No Oxide" compound, obtained from the *Aluminum Corporation of America*, is applied to the aluminum surfaces before joining, to inhibit corrosion and to insure good electrical contact. This compound is used for the same purpose on exposed switches and conductors in electrical power stations.

The hose clamps used throughout are cam-operated, aircraft-type, radiator hose clamps. They are obtainable in automobile supply houses and war surplus stores. I have used them for over six years in beam construction and have yet to have one fail.

Connections to the radiator are made by means of two six-inch lengths of thin brass tubing with an inside diameter of $2\frac{1}{4}$ inches. The tubing is split for a distance of an inch at one end. Then, it is cadmium plated, inside and out, and driven over the center ends of the radiator, split end first. Both the brass and aluminum were coated with *No Oxide*. A hose clamp around the split end

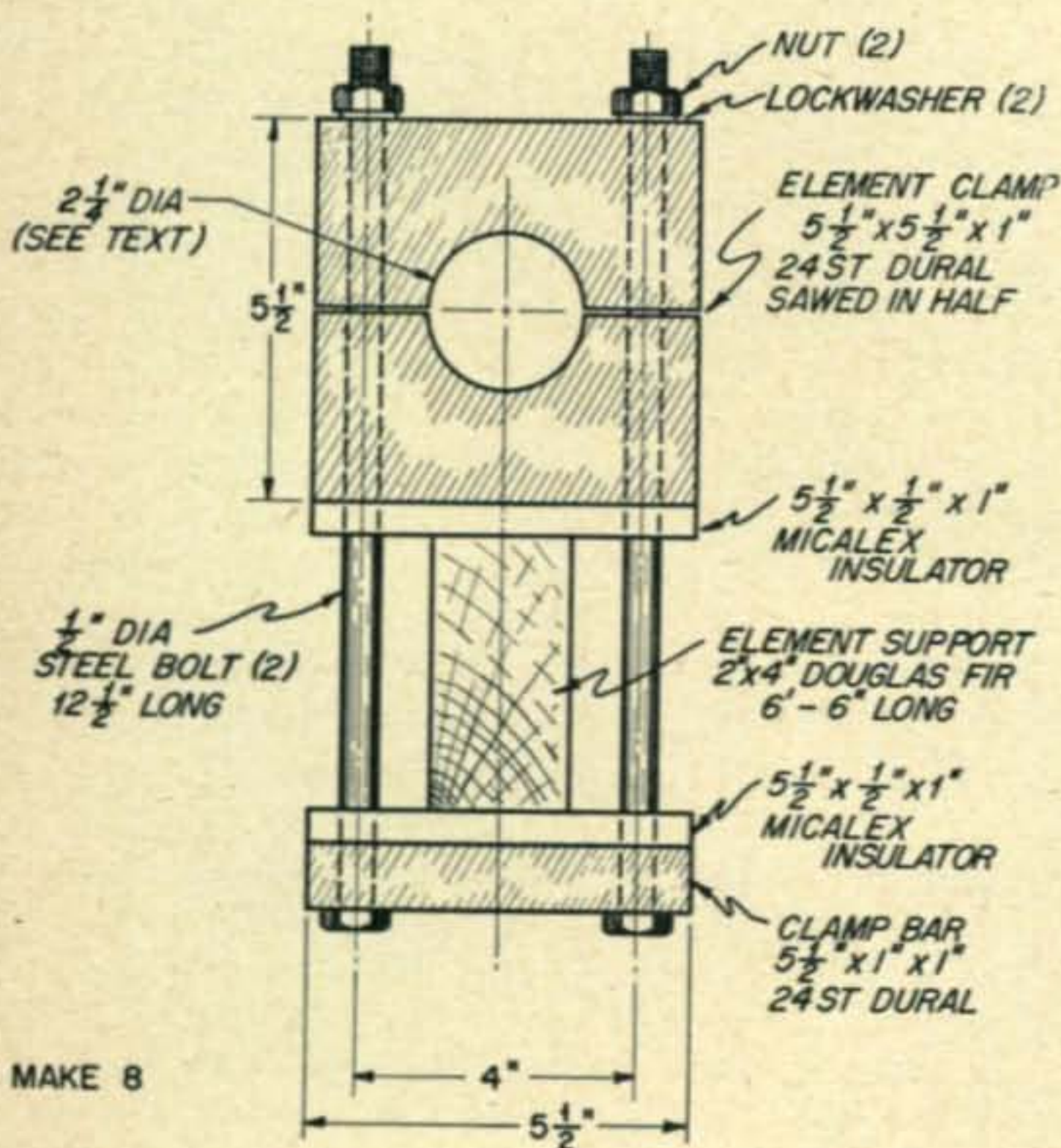

Fig. 2. End view of one of the element clamp assemblies. The text on the opposite page describes their construction in the home shop.

holds each brass sleeve in place. Feeder connections are made by soldering to the brass.

Mounting The Elements

Element supports are six and one-half foot lengths of clear, selected, Douglas Fir, two inches wide and four inches high. The cross-section dimensions are actual measurements, not nominal lumber sizes, in which actual dimensions are appreciably less.

Figure 2 illustrates the method of mounting the elements to the cross arms. Blocks of 24ST dural, 5½ x 5½ x 1 inches, are bored horizontally to accommodate the elements and drilled vertically on four-inch centers to pass ½-inch bolts. The blocks are then sawed in half across the holes. A piece of dural, 5½ x 1 x 1 inches, and two pieces of micarta, 5½ x 1 x ½ inches, also drilled on four-inch centers for ½-inch bolts, complete each clamp. Eight clamps are required.

A detail drawing of the construction of one side of one of the elements is shown in Fig. 3.

To mount the elements, slip a strip of dural and a strip of micarta over two, 12½ x ½-inch bolts. Place four of these assemblies in line on a flat surface. The outer pair should be six feet two inches apart and the inner ones seven inches each side of a center line. Center one of the Fir cross pieces on them. Then slip another piece of micarta and the bottom half of a bored block over each pair of bolts. Lay an element in place, put the remaining halves of the blocks in place, and tighten up with a nut and lock washer on each bolt.

Space the halves of the radiator element; so there is a gap of 1½ inches in its center.

The holes in the inner dural blocks are bored to hold the elements firmly in place, but those in the outer pair are drilled a trifle oversize. This reduces vibration in the elements by decreasing torsional stresses at the outer clamps under temperature changes and when the wind blows.

There is little r-f voltage near the center of a ½-wave element; therefore, the insulation provided by the micarta is more than adequate.

The Support And Rotator

An unguyed, seventy-five foot, class-two, telephone pole supports the array. It is about twelve inches in diameter at the base and tapers to six inches at the top. Between nine and ten feet of the pole are set in the ground, with 4½-cubic yards of concrete poured in a three-foot ring around it. W9LM is located in a low-lying area, and it is not unusual for the ground under the antenna to

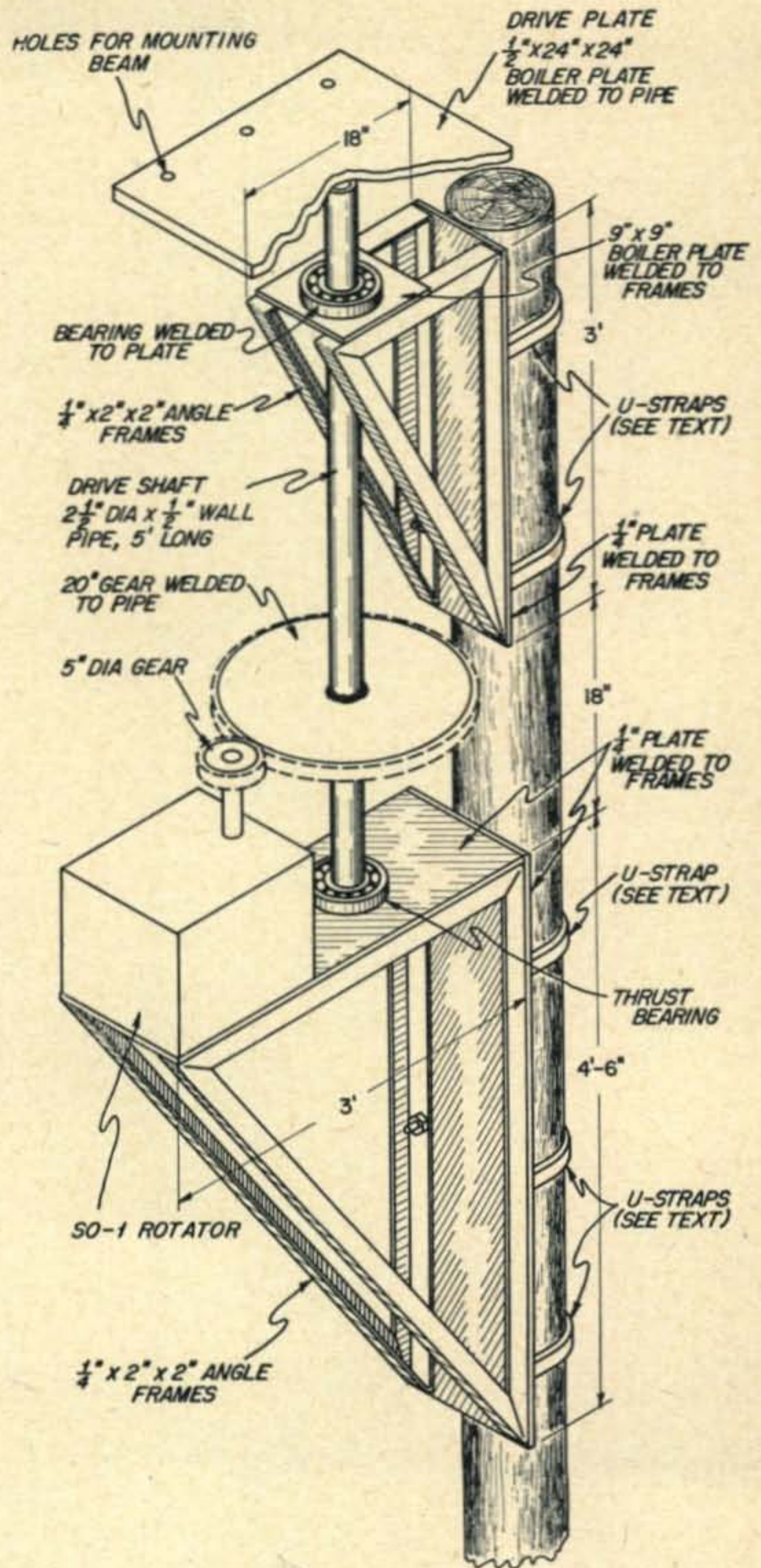

Fig. 4. Construction of the platforms to support the rotator, shaft bearings and drive shaft. All principal metal joints are welded.

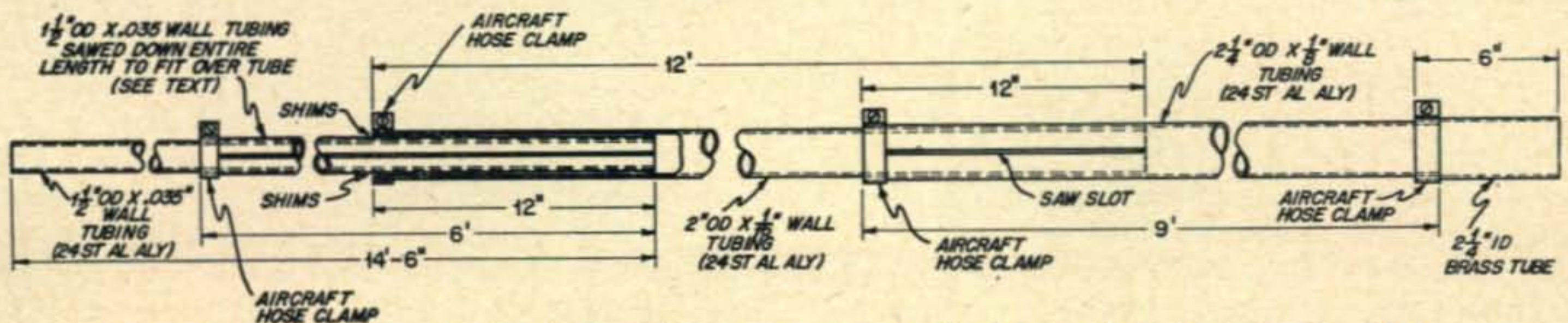

Fig. 3. In order to obtain the rigidity necessary at 40-meters, the elements should be constructed as shown above. This is one side of the radiator. The director/reflector does not have the six-inch brass tube at the right, but is continuous and unbroken.

be under a few inches of water for weeks at a time. The weight and area of the concrete has prevented any trouble from the resulting soft ground. In the more than three years the 7-Mc

beam has been up, it has withstood wind and sleet storms that have taken down many 14- and 28-Mc arrays, commercial radio towers and hundreds of miles of utility wires.

Rotation is accomplished with a *surplus* SO-1 radar antenna rotator. The prongs originally used to support the radar antenna were removed and replaced with a gear. It is five inches in diameter and one inch thick. This gear meshes with another twenty-inch gear welded on the beam drive shaft.

A platform, 4½ feet from the top, supports the rotator. Another platform at the top of the pole supports the top bearing for the drive shaft. The drive shaft is a piece of pipe, five feet long and 2½ inches in diameter, with ½-inch walls.

Figure 4 gives details of the construction of the platforms. The shelf upon which the rotator and the shaft thrust bearing set is a three-foot piece of

2½-inch diameter drive shaft. This plate will later support the beam. Slip the upper bearing, already welded in the center of a nine-inch square piece of boiler plate, over the shaft. Next, weld the twenty-inch gear, which is driven by the gear on the rotator, in a position to correspond with the latter gear. Completing the shaft is the rotating part of the thrust bearing at the bottom.

Assembling The Beam On Top Of The Pole

The metal pieces are quite heavy; therefore, they were pulled up individually with the aid of a block and tackle and a Jeep. (See Fig. 5.) After the platforms are in place and the rotator mounted, the drive shaft is pulled up. Once it is set truly vertical, with its gear meshed with the one on the rotator, the top bearing plate is welded into place and the thrust bearing bolted down.

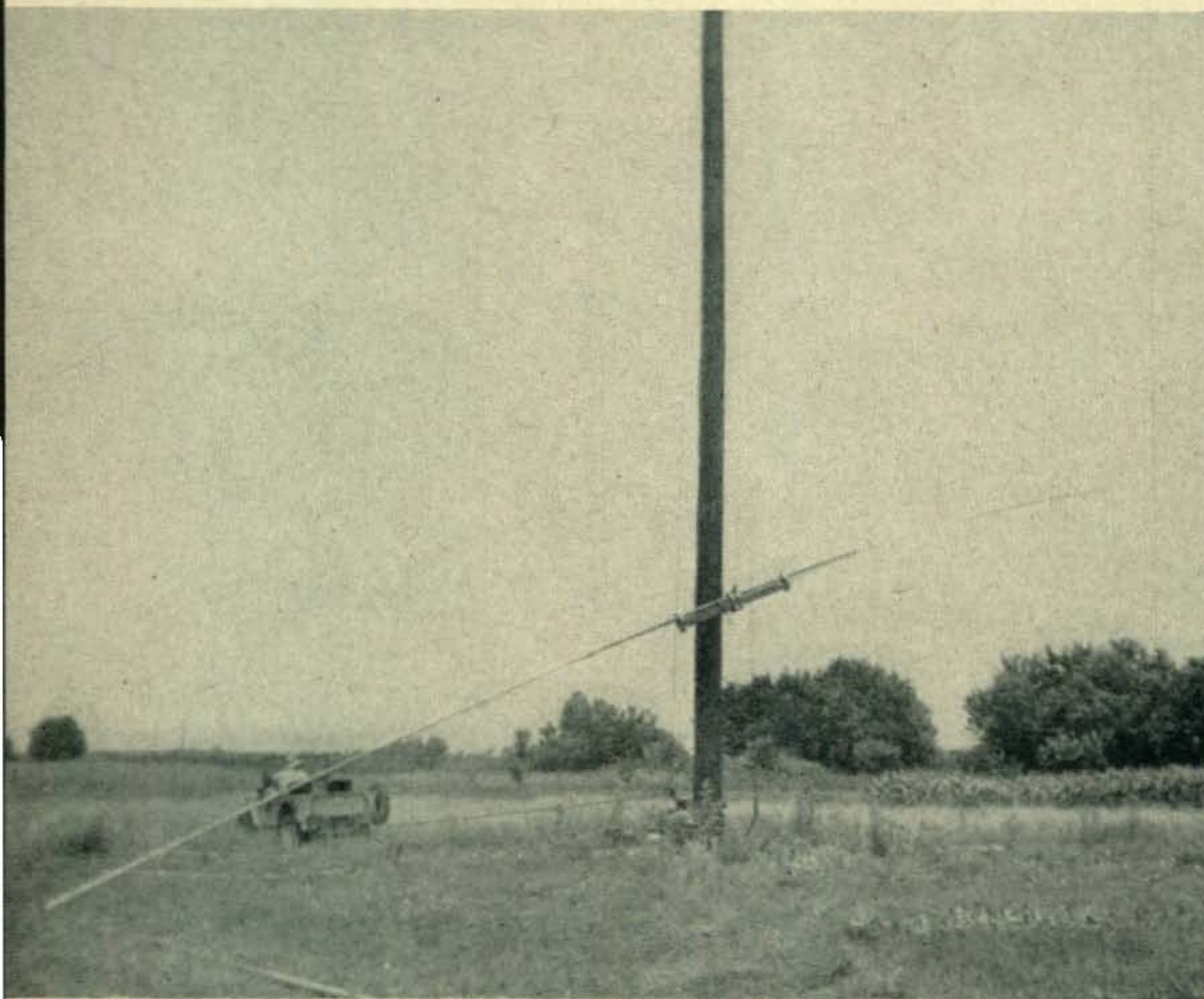

Figure 5: This picture serves the dual purpose of showing the construction of the sixty-seven foot, self-supporting element and the method of getting the various components to the top of the telephone pole. Hal, W9LM, is driving the Jeep. John, W9APE, is perched on top of the pole, thirty feet above the top of the picture, waiting for the element to reach him.

¼-inch plate the width of the rotator. It is welded to a triangular frame constructed of 2 x 2 x ¼-inch angles, which extends down the pole for 4½ feet. Another ¼-inch plate, 4½ feet long, is welded across the vertical angles for maximum strength. The entire structure is fastened to the pole by means of three U straps bent from lengths of 1½ x ½-inch stock. Half-inch bolts, welded to the ends of the U's, join the U's to the platform.

The upper framework is similar to the lower one. It is nine inches wide and extends out from the pole 1½ feet and down it three feet. Two U-brackets are used to fasten the framework to the pole, and the bearing plate, which is nine inches square, is not welded across the top until later.

To prepare the drive shaft, weld a two-foot square of ½-inch boiler plate across the top of the

The first step in assembling the beam itself is pulling up the two lengths of selected, Douglas Fir forming the boom. They are 14½ feet long and have a full 3 x 4-inch cross section. They are bolted edgewise to the plate welded on the drive shaft, using ½-inch bolts. Then, two-foot lengths of 1 x 12-inch lumber are temporarily nailed across the boom to make a floor safe to walk on.

An eighteen-inch spacer of ½-inch pipe is bolted between the 3 x 4's with a 25 x ½-inch bolt about a foot and a half from each end. The previously-assembled elements are then pulled up, and maneuvered into position, and bolted to the boom fourteen feet apart.

After the elements are in place, three RG-8/U cables in parallel are soldered to the radiator. Finally, the temporary "flooring" is removed from

Figure 6: When your taste runs to forty-meter rotaries, it helps when your house is the only one as far as the eye can see. The other antennas visible are ten- and twenty-meter rotaries.

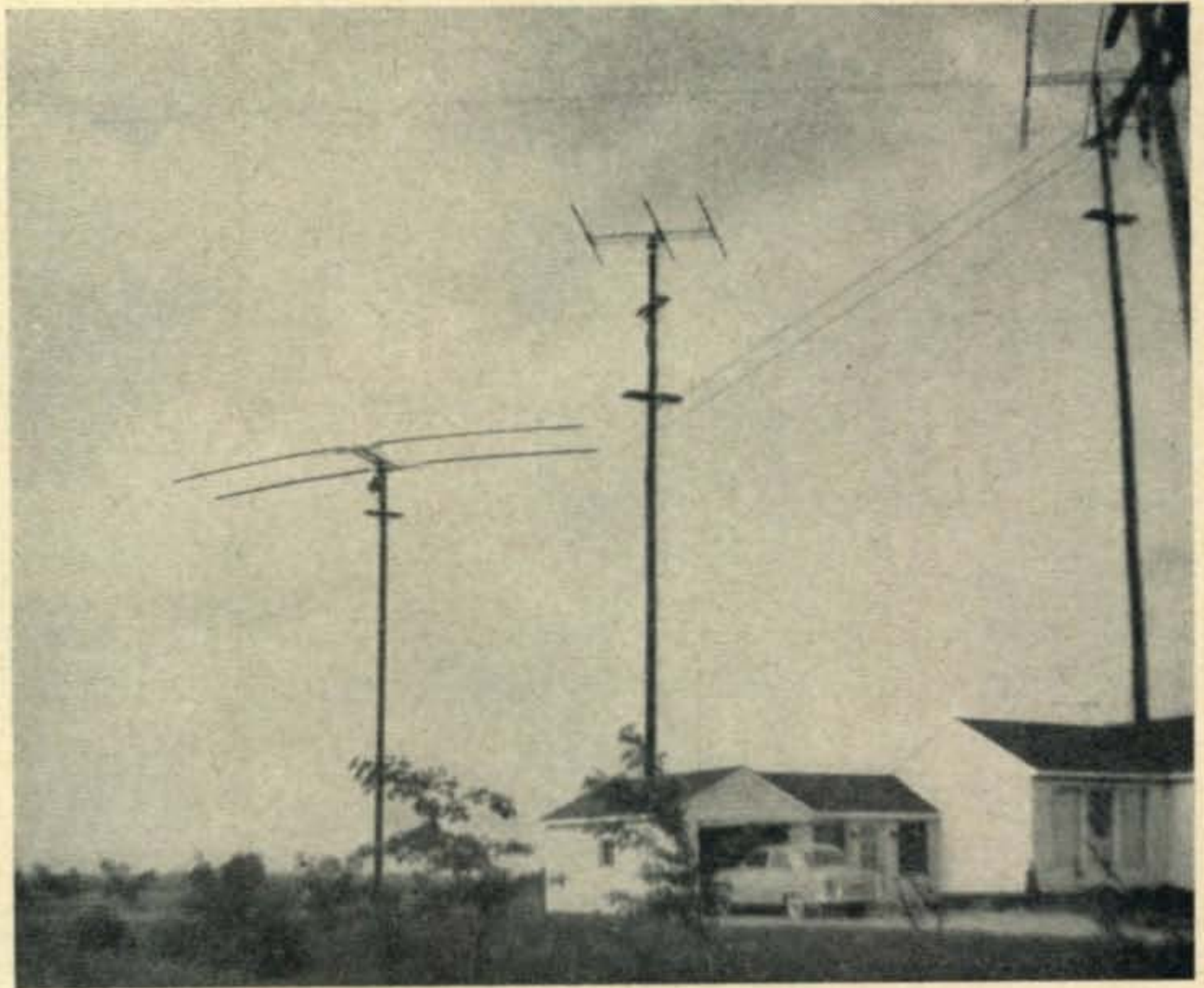

the boom, and the beam is completed.

The net impedance of the paralleled RG-8/U cables closely matches the nominal impedance of a two-element beam. Their length is made an integral multiple of a half wavelength ($\text{Length (ft.)} = 492/\text{Freq. (Mc.)} \times 0.66$); so that the same load is presented to the transmitter as is present at the radiator.

John Cotter, W9APE, did the work on the pole, while I was the ground flunkie and drove the Jeep. It took John only two hours to assemble the beam on top of the pole, although it took somewhat longer to do the iron work. Of course, all holes were already drilled, because the beam had been first assembled on the ground for that purpose.

Results And Conclusions

Tests on the low-frequency end of the band with VK5JE and G5WI brought forth S8 reports on the nose and S3-4, but unreadable, reports from the ends and back of the beam. This indicates the beam's directivity on DX when transmitting. When used for receiving, directivity is about the same as that exhibited by a good two-element array on 14 Mc.

The array also exhibits fair directivity on U.S.A. signals around noon, but shows very little directivity on them in the early evening. Furthermore, it seems to reduce the strength of U.S.A. signals

(Continued on page 72)

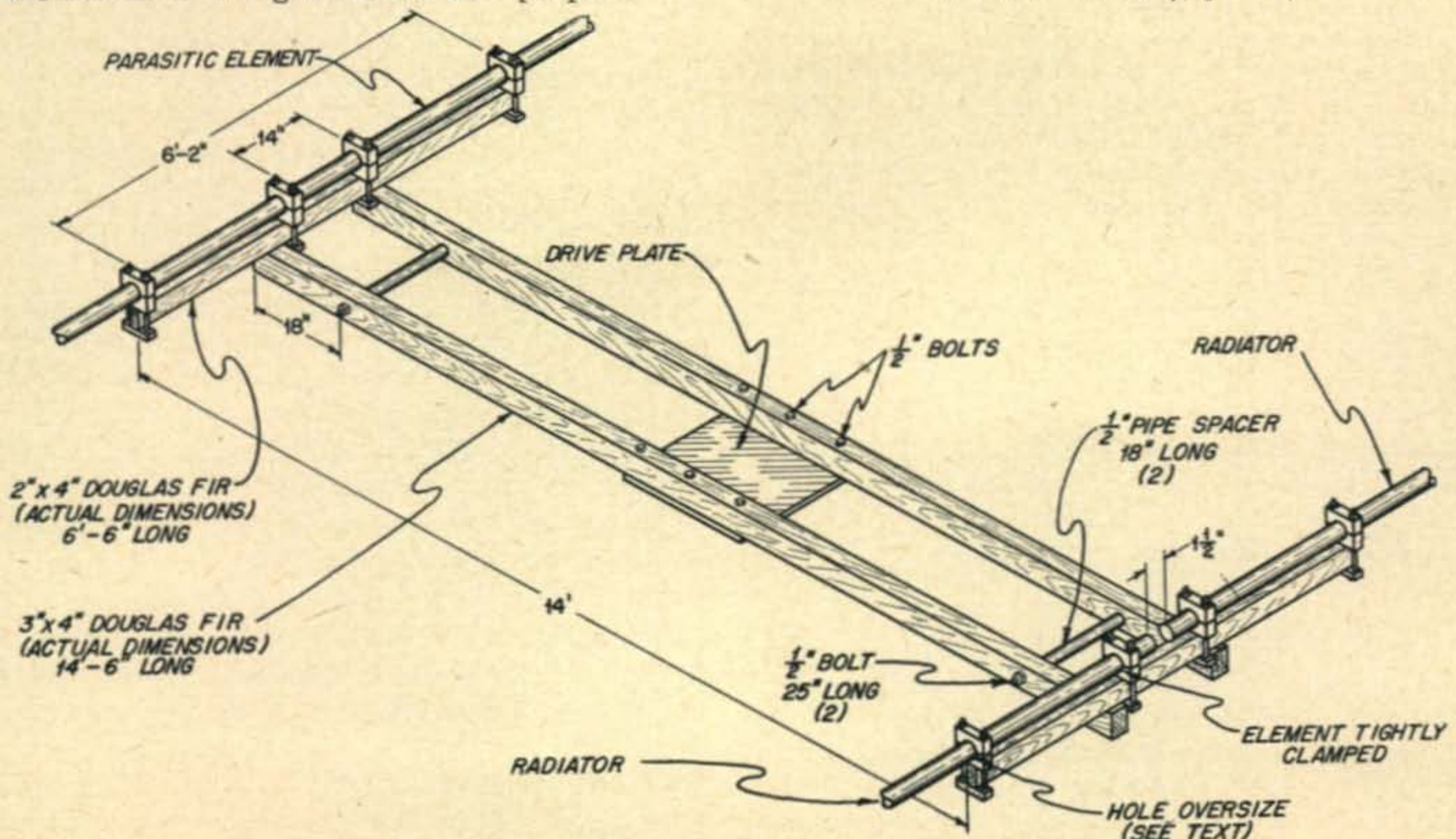

Assembled drawing of the W9LM 40-meter rotary beam antenna. The parasitic element is quite responsive to frequency change. It reacts as director on the low end of the band and as a reflector on the high end of the band.

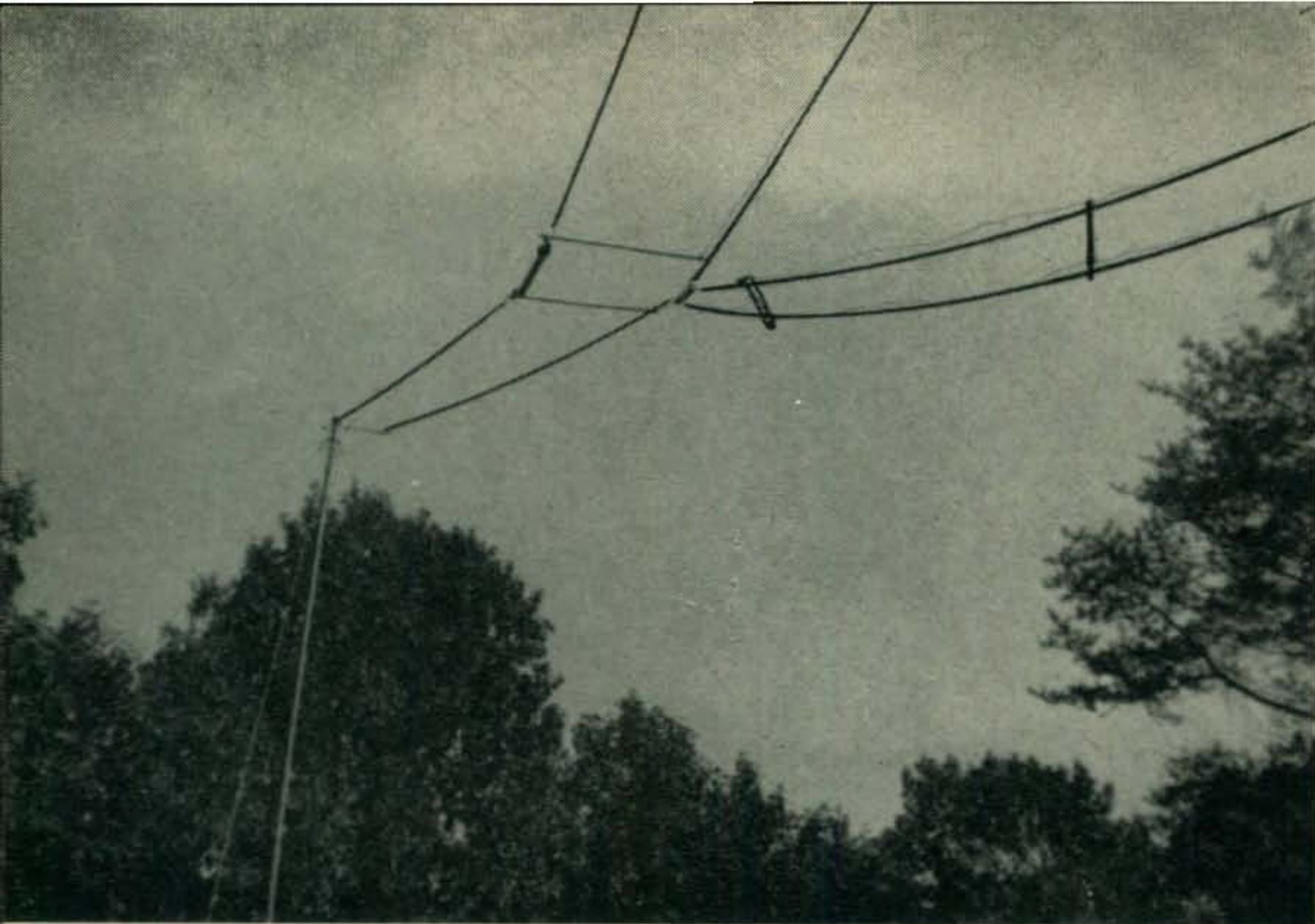

There is certainly nothing fancy or difficult in erecting a T2FD. This is the author's antenna. The peculiar photographic angle is due to the slope (coming towards the reader) of the antenna.

More on the T2FD

CAPT. G. L. COUNTRYMAN, U.S.N., W3HH

309 Windsor Street, Silver Spring, Maryland

While the average citizen walking down the street thinks and talks a lot about the weather, the average amateur radio operator is generally most concerned about his antenna. It, like another invaluable item, comes in an infinite variety and will probably never cease to attract interest and discussion.

About a year ago, CQ printed a little article on a type of folded dipole called the "T2FD." It was, in every sense of the word, a "sleeper." Those who put it up were amazed by its ability to load on three or more amateur bands. Others acclaimed its omni-directional properties, while a third group insisted that it radiated most of its energy at the most favorable vertical angles of radiation. Oddly enough, there still seemed to be some theory-bound skeptics who insisted that it couldn't work. For the benefit of those few, and for the fellows who haven't tried this unusual antenna, we append a few comments.—Editors.

"While looking for a compact antenna for my small backyard . . . I decided to give it a try.

"I put one up for 40 meters and the first night I worked all but the 6th district. Next night I thought I would see what would happen if I tried to load it on 80 meters. On first CQ I got a 579X report with only 40 watts input!"

W8IKB

"Saw your antenna just as I was about to put up the Zepp I use during the winter. Gave your plan preference and the next day . . . I casually asked for a report . . . and got 40 over S9 with doubts about my 450 watts. They said that the kilowatts were generally S6. This was on 75-meter phone.

"Next morning I tried 10-meters and heard more

DX than on a beam at this location. In general, the T2FD surpasses anything I have used on 75-meter phone which included long wires up to 500 feet, center-fed and end-fed Zepps, and shortened center-fed Zepps with long feeders."

W0MIO

"I assisted VE1UL while erecting a T2FD and he found it to be one of the best antennas he had used."

VEIKQ

Several years ago the author experimented with a terminated, tilted, folded dipole that offered possibilities for ham use. The initial data appeared in QST for June 1949 on page 54. Apparently very few hams read the article, or, if they did, skimmed over it lightly. Certain communication services took it seriously, however, and the author continued to have excellent results with the system. Another article made its appearance in the November 1951 issue of CQ, and there is no doubt that this article was not only read, but that many brother hams went to the trouble of erecting a T2FD, and reporting its excellent performance.

Since then, more than a year has elapsed, and the mail continues to roil in. This article is now being published in self defense, as there is no time to answer the many letters. Most of these fall into two categories. First are the letters reporting excellent results with this "all-wave" omni-directional antenna. Next come the questions, and they all follow a general pattern. Here are the answers to the questions most frequently asked:

Question: Is the use of a non-inductive terminating resistor necessary?

Answer: No. However, if you use a wire wound resistor, the antenna is not aperiodic and will resonate at some frequency. The difference is that with a wire-wound resistor it will be necessary to use some form of antenna coupler depending on your installation, and the coupling will probably be different for the various bands. With a non-inductive resistor the system is aperiodic and one coupling method will be satisfactory for all bands. This advantage is offset to some extent by the fact that the resistance value is fairly critical and it is convenient to adjust a wire-wound resistor with slider. Sprague makes a non-inductive "Kool-Ohm" in a 120-watt size that will handle an input to the final of 350 watts. Rhombic non-inductive terminating resistors in larger wattage ratings are still available, now and then, at surplus outlets.*

T2FD Basic Design Data

(See Fig. 4)

1. The length of each leg from the center is equal to 50,000 divided by the lowest desired operating frequency (in kc.) and then multiplied by 3.28. The answer is in feet.
2. The spacing between radiating wires is equal to 3000 divided by the lowest desired operating frequency (in Kc.) and then multiplied by 3.28. The answer is in feet.
3. The sloping angle for a nondirectional pattern should be of the order of 30 degrees.
4. The terminating resistor should be non-inductive and have a rating equal to 35% of the transmitter input power. For further details see the text.

Question: Must the resistor be exactly the same resistance as the feed line impedance?

Answer: No. The value of the resistor is quite critical for optimum results, especially as the impedance of the feeder decreases. For example, with a 600-ohm line (No. 12 wire spaced 6 inches), a value of about 650 ohms seems best although operationally a 600-ohm resistor appears to be entirely satisfactory. When using 300-ohm twin-lead, the optimum resistance is 390 ohms, which results in a tremendous gain, approximately 30 db, over a 300-ohm resistor, although any value from 375 to 400 ohms gives excellent operational results. With 450-ohm line, a 500-ohm terminating resistor will be satisfactory. With lines of lower impedance including coaxial cable, reports indicate that for optimum results the value of the resistor is critical within about 5 ohms, although the author has used only open lines and twin-lead in his work.

* The PHOTOCON SALES (417 N. Foothill Blvd., Pasadena 8, Calif.) have advised us that they have the following available from stock, as this is being written.

300-ohm G.E. globar resistor (200-watt rating)
new at \$1.50 each.
600-ohm G.E. globar resistor (100-watt rating)
new at \$1.00 each.

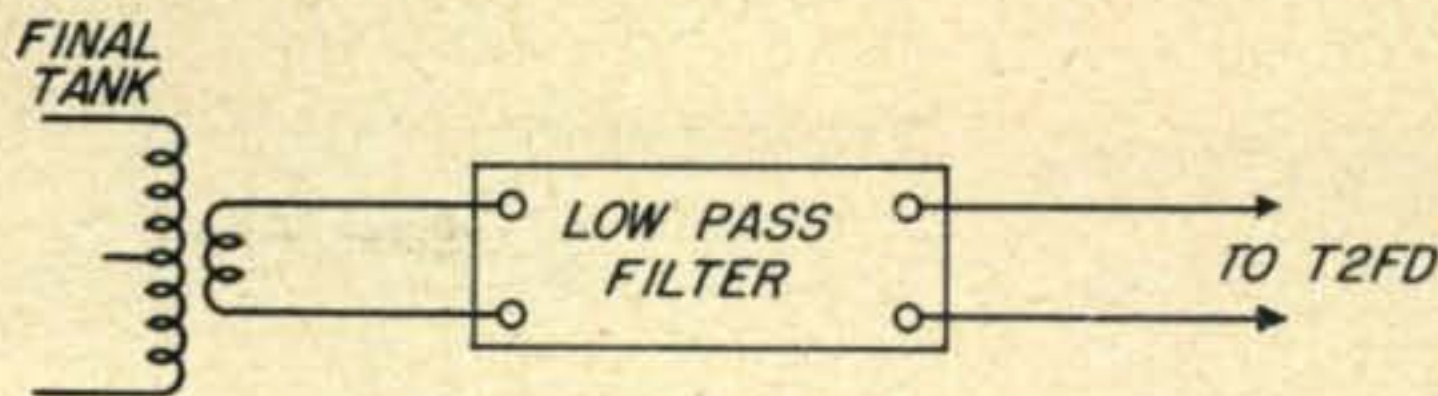

Fig. 1. The T2FD may be coupled to the final with a simple link. The use of a low-pass filter to prevent TVI is recommended.

Question: Is the antenna equally good on receiving and transmitting?

Answer: Definitely, provided the optimum resistance value is established and used. Rush Drake, W4ESK, reported that during the 1951 CQ DX Contest he "couldn't hear 'em on 80" with a hastily erected T2FD, but he had made no effort to establish an optimum value for the terminating resistor, and used the antenna only a few hours. (It's interesting to note that he won the contest!)

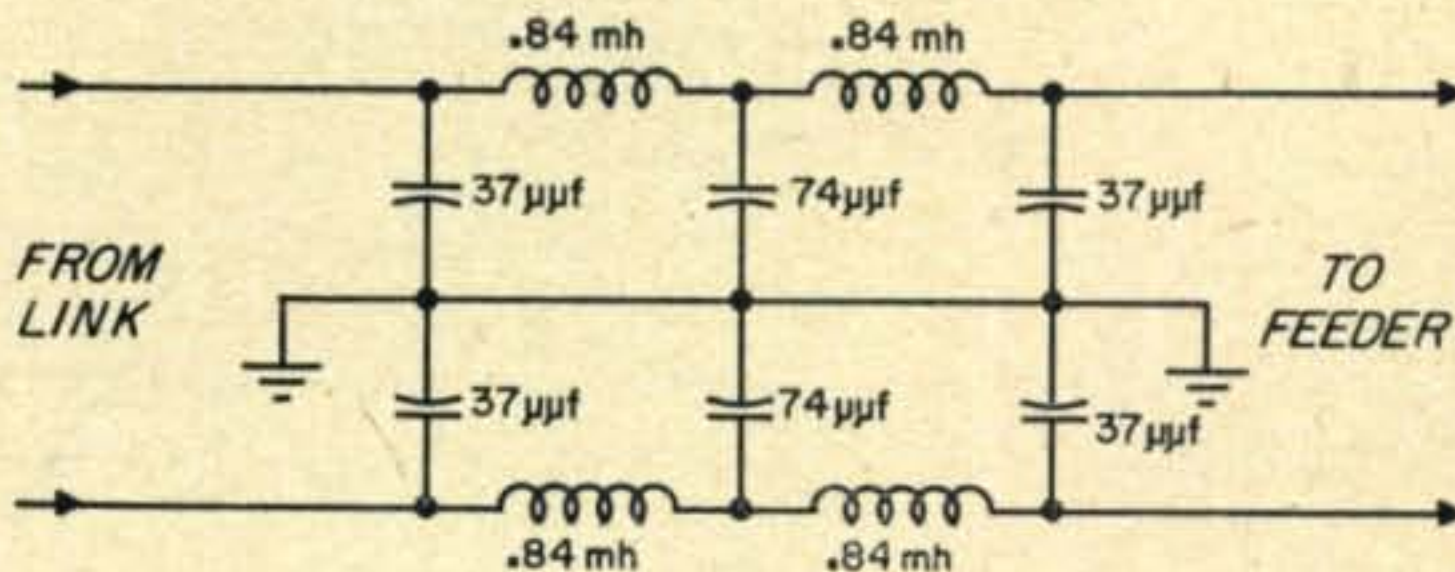

Fig. 2. This simple filter, when inserted as shown in Figure 1, has worked very well with 600-ohm lines.

Question: How is the transmission line coupled to the final amplifier?

Answer: If a non-inductive resistor is used, a simple link (Fig. 1) is all that is required. Remember that you must couple at your line impedance, otherwise your antenna will not load properly. For a 600-ohm line, a 3-turn link should be used for 20 meters and a 6-turn link will be a good match at 40 and 80. The B & W plug-in links are perfect in this application.

Question: How about TVI?

Answer: That's a good question! The usual precautions regarding parasitics, shielding, feedback into the a-c line, etc. should be taken. A low-pass filter in the line is best for all-band operation. If you operate on one band the half-wave "Harmoniker" type is better, but if you are on only one band, why worry about the T2FD? Figure 2 shows a simple low-pass filter satisfactory for 300- to 600-ohm lines. Low-pass filters are available commercially for all line impedances.

Question: Should the two antenna wires be side-by-side or one over the other?

Answer: This is immaterial, although it usually is easier to erect them side-by-side, in the same plane as the surface of the earth.

Construction Notes

Now for some helpful hints. The best connectors for the round end terminals of a resistor approxi-

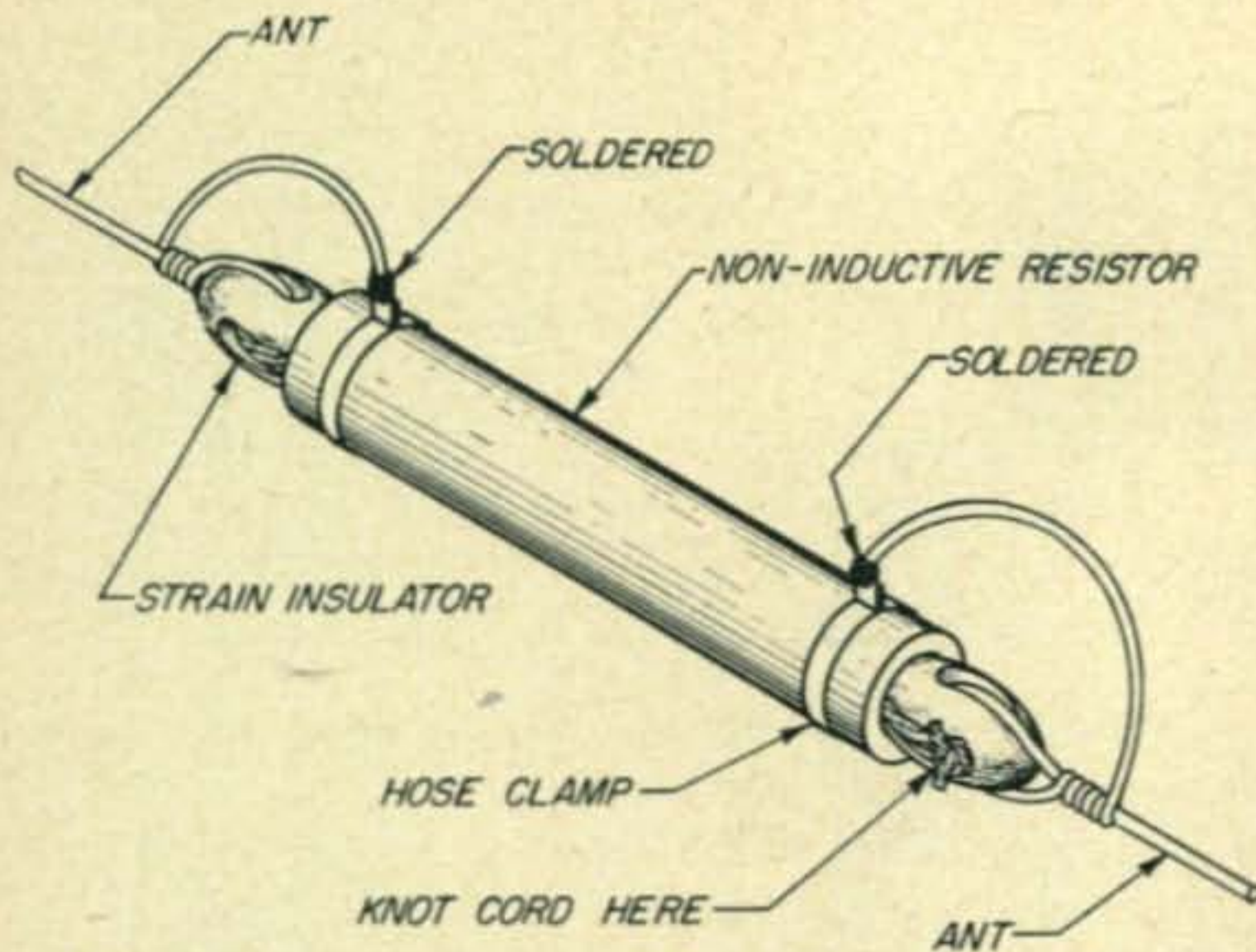

Fig. 3. A very easy method of mounting the terminating resistor is shown above. Note that two egg type insulators are tied together with a short length of heavy cord. This cord runs down the hollow center of the terminating resistor. The radiating wires are attached to the insulators and short jumpers brought over to the resistor terminals.

mating one inch in diameter are ordinary hose couplings, available in any hardware store for a dime. They won't rust and no soldering to the resistor is necessary, although the antenna should be soldered to the connectors.

No strain should be placed on the resistor. If it is hollow, and it usually is, a stout cord, similar to a venetian blind cord can be passed through it and a strain insulator used at each end, as shown in Fig. 3. Use spreaders at each end of a heavy resistor. A $\frac{3}{8}$ -inch diameter wood dowel is fine. Wipe them with oil before installing. A threaded $\frac{3}{16}$ -inch diameter brass rod is ideal for the high end and it serves both as a spreader and connector for the two antenna legs. At the low end it is usually easier to attach insulators to a short pole

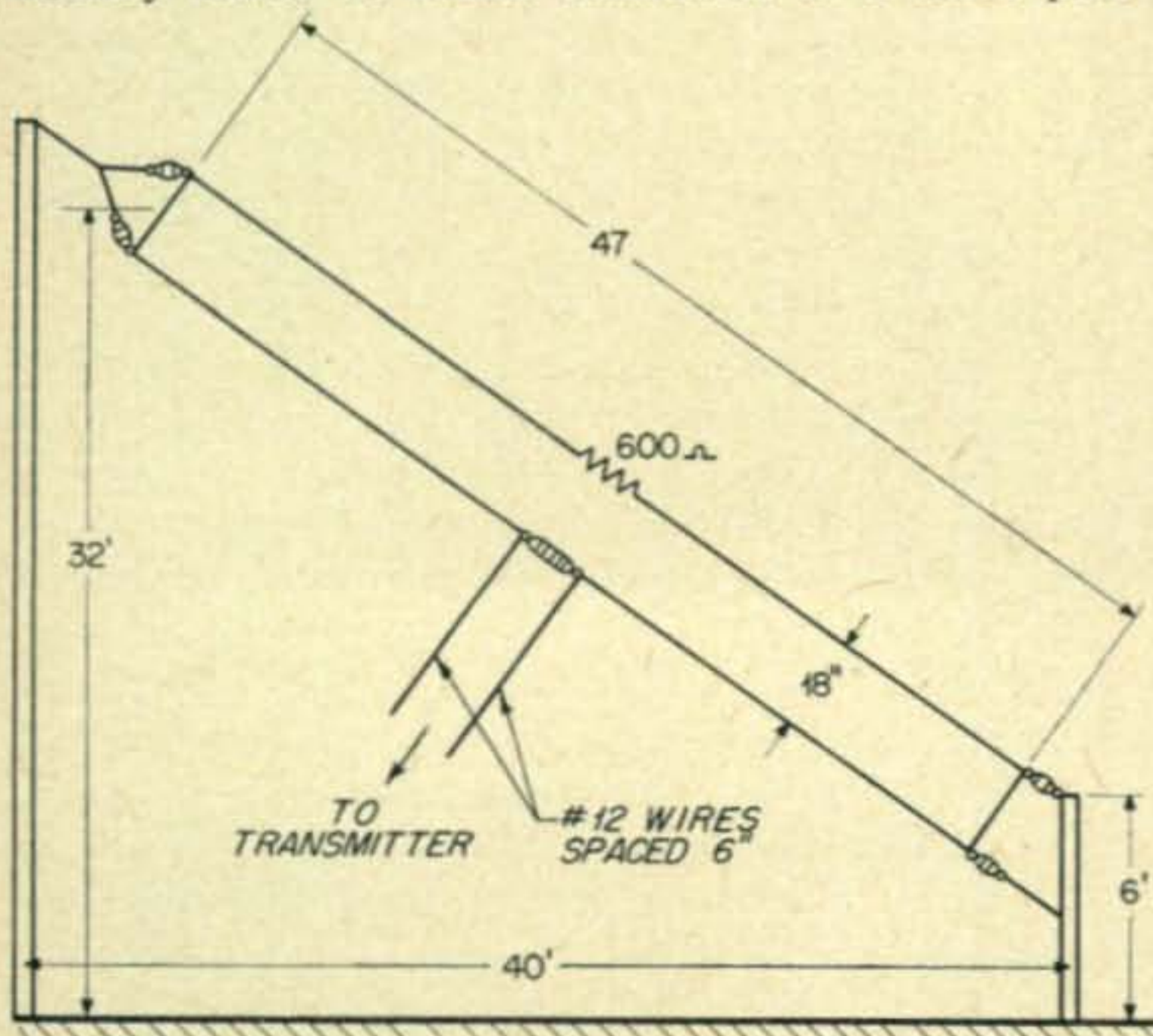

Fig. 4. This drawing represents the antenna that appears on the opening page of this article. Although it was cut for the 40-meter band it has been used on 80 meters with only a small power loss.

or building (far enough apart to give the proper separation) and solder a connecting wire between the two antenna legs.

Further experimenting indicates that formulas for length and spacing previously published for the lowest frequency to be used remain the best. However, with negligible operational loss an antenna cut for 40 meters will, for example, load perfectly on 80. Figure 4 shows the installation the author has used for some time on 20, 40 and 80 with excellent results. On 40, the band for which the antenna is cut, the T2FD is definitely superior to a "center-fed Zepp" for DX. Reports average two S-figures higher from Europe, South Africa and Australia even though the loading to the final amplifier is slightly less than with the tuned-feeder current-fed antenna used as a "standard."

There is a "mental hazard" with the T2FD that is hard to overcome. Upon seeing an antenna with one end only six feet from the ground (in contrast to the usual "higher the better" skywire), one experiences a natural reaction to the effect that "It won't get out." Don't be fooled. The T2FD will hold its own with other omni-directional antennas and normally out performs any of them when properly loaded.

This may be a good place to mention that the long-haired gents still cast a jaundiced eye at the "squashed rhombic." Admittedly it is theoretically inferior but it may be time to overhaul some of our theory! The U. S. Air Force finds it acceptable at Pacific Bases; the British RAF are well satisfied; our Navy uses it at certain locations; Japanese domestic communications on Kyushu use it exclusively, and some 200 Hams have taken the trouble to express to the author the excellent results they have obtained. It's not a "cure all" but if you want a simple unostentatious skywire, which requires little space, that will put out in commendable fashion on 3 or 4 ham bands and is omni-directional, you can't do better than put up a T2FD some Sunday afternoon.

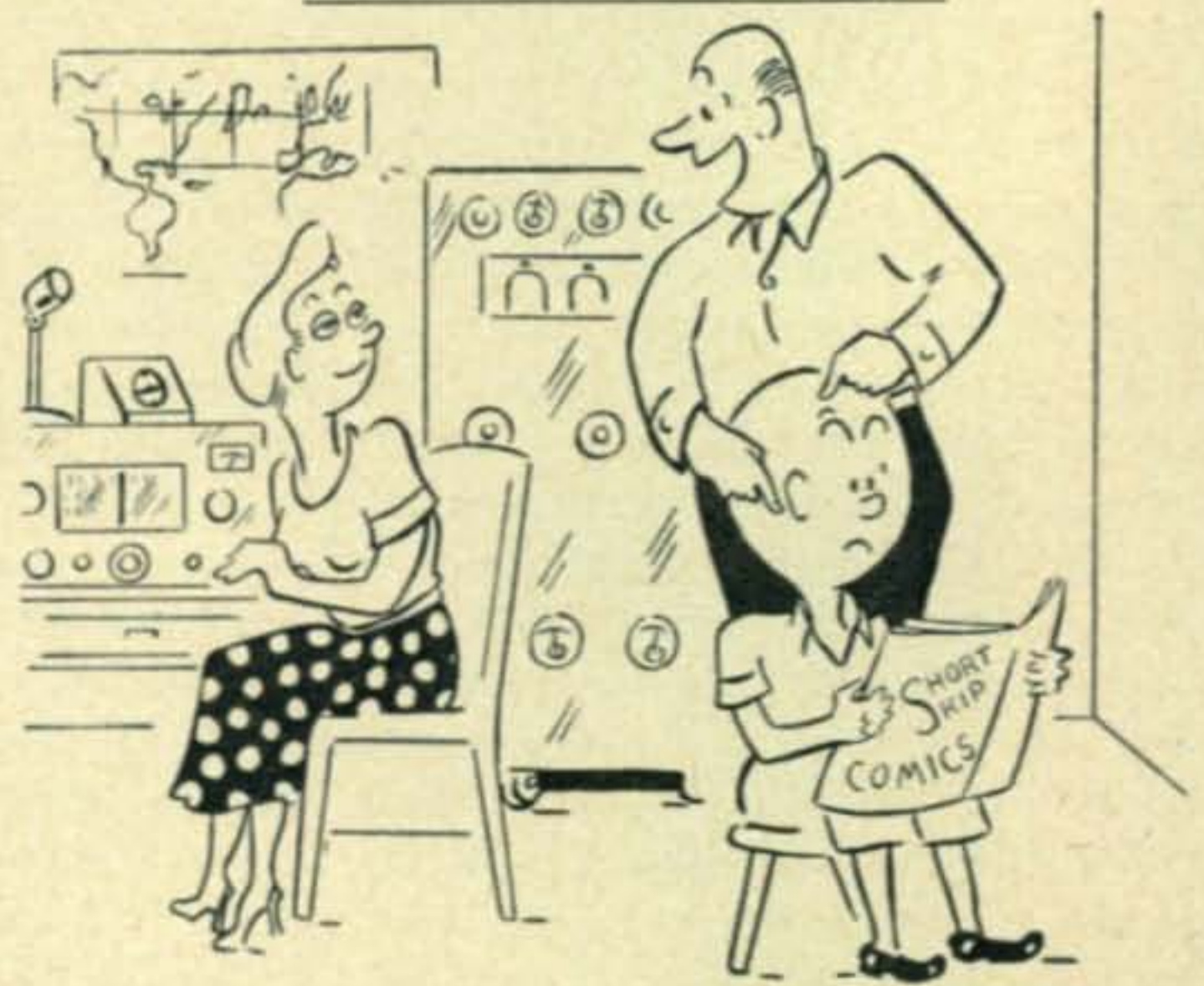

"No, look here, dear. Here we are in the U.S.A. We must beam further to the south hit the VKs down here."

The

Gs'

Point of View



L. H. THOMAS, G6QB

Assistant Editor, SHORT WAVE MAGAZINE

When we decided to put together a "Feature DX Issue," we invited G6QB to prepare for us a post mortem on DX as viewed by our British colleagues. Undoubtedly, you will also find his DX summary as interesting as we have here.

Our thanks to G6FO, Editor of our British contemporary, for the use of the photographs originally printed in SHORT WAVE MAGAZINE.—Editor

We all take our DX in different doses, out of different bottles and from different directions. So the writer need make no apology for the fact that this brief review of post-war DX is written from the only point of view which he really knows—that of the British operator. DX-chasing is really a hobby within a hobby, and for every thousand Hams in the world there are probably only twenty or so whose entire interest lies in chasing those elusive ones. We DX-hounds all speak the same language—we all have the same problems (within limits). Therefore the slight English accent that you will notice hereafter merely means that we, on this side, must perforce have a slightly different slant on the business.

In actual fact the only differences between the DX problem seen through American or British eyes are those of "power" and of "location." The first one is dictated by our maximum power limit of 150 watts input; the second by the fact that our main QRM troubles come from foreign countries and not from our own people. This has implications which are not too obvious, and will be dealt with later.

Post-war activity in the British Isles started rather slowly in January 1946, when licences were re-issued. All of our gear had been impounded by the GPO (British licensing authority—*Ed.*) at the outbreak of war (or, at least, the vital parts of it!) and this was not returned in any particular

hurry. So those stations that managed to put out a signal in January 1946 had mostly built something new, and in a rush. Licences then were for 100 watts only, so most of the signals heard on 10 emanated from a pair of 807's.

Conditions were so fantastically good at the time that worldwide DX was worked at once. The writer's own station, using two crystals, two 6V6 doublers and a pair of 807's feeding a simple full-wave antenna, was only representative of many, but 50 or more countries were worked in a very few weeks, one of the very first being G6CU/ZC2, who put the Cocos Is. on the map in a big way.

The U.S. Forces also co-operated wonderfully, and the 10-meter band was full of signals from Guam, Saipan, Tinian (what a T5 from W6PUZ!), Midway, Wake, Okinawa and all points east. Just for the historical interest, outstanding signals of those early days of 1946 were W4YA ("on the Burma Road"), XU1YO, W6PUZ/Tinian, W6NFL/J5 (Okinawa), W2OAA/J8 (Korea), and a whole bunch on Guam including W6QKB, 3FQB, 2LRI, 9DPZ and many others. Over here the DX timing was such that all these fellows came in between 0930 and 1200 GMT, the Stateside W's being absent until noon. Once they arrived (if the North Atlantic path was good) the other DX could be disregarded; Europe was still DX for all W districts, and any European showing his nose was swamped in quick time by a wolf-pack of the type now reserved for ZD7 and suchlike.

After a while the VK's and ZL's started coming in here, also during the mornings, and of course South America and South Africa, as always, were there practically all day. The Asians such as VS1, VU, VS9 and the rest tended to get mixed up with the Stateside signals in the early afternoons, but otherwise we had the world on tap throughout the daylight hours.



The neat layout of Andrew Sinclair GM3EST, which is single-switch controlled and equipped for full break-in working on CW. The rack on the right ends with an 813.

It wasn't long before the country-chasing habit came into prominence, and one of the leaders in the race, needless to say, was G6ZO/I, busy putting Italy on the map. CR9AG, VQ6MI and VS4JH were three nice ones that arrived that spring, and 10 meters carried all the DX until June 30, 1946, when we were licensed for *Twenty* as well, and the power limit raised to 150 watts (tetch out that 813!)

Early Days on Twenty

Now the competition started in earnest, since the mass of W's were audible from 1200 until after dark, and were packed into two narrow bands (phone and CW) instead of being spread throughout the two-megacycles width of the old ten-meter band. And an important turning-point in DX technique was now reached—the universal adoption of VFO procedure. On 10 one could get along quite well by using three or four crystals; in fact the phone-worker's only concern was to keep clear of QRM, and a CQ anywhere in the band would produce an answer from almost anywhere in the U.S. band. But now, on 20, the CW man had to call the DX on its own frequency; if he didn't, someone else did, and the other fellow was usually the one that got the prize.

Even on phone, the QRM situation rapidly became so bad that crystals weren't much use unless one had dozens of them. So we went right into the

VFO era, from which we have never recovered! Calling on the DX frequency was all very well if there were only three or four of you; but if a G station called a JA, or a KG6, or a VK at the time when the band was also open between the States and the DX, all he could hear on the frequency after a short call was a noise like a thousand mad Highlanders playing the bagpipes (no offence, GM's!) and often the DX station was never heard again.

This was the first serious impact of the high-powered W's (and particularly the *California kilowatts*) on the 150-watt G station, and, at first, it hurt. Later, as the DX stations grew wiser and found that they had worked 140 or 150 countries own frequency, it became obvious that crafty behavior was worth hundreds of watts; the 150-watter using his head could beat the kilowatter who just barged in and called.

Nowadays, unless we meet with a DX station who doesn't really know his stuff, we feel that anyone with a reasonable signal has almost an equal chance, and we are no longer afraid of the forest of rotary beams that is said to occupy the western coast of the U.S.! For we occasionally get through—sometimes by waiting in the queue and sometimes even by jumping it.

With the opening of *Twenty* and the 1947 conditions, anything was possible. Stations who had never dreamed of making a DXCC before the war found that it did not pay to reply to stations on their without even trying very hard. More and more countries came on the air, and eventually it became obvious that the goal for the really keen DX man was not one hundred but *two hundred* countries.

New ones that arrived in 1947 (meaning those that we can't remember hearing in the pre-war years) were such spots as VR1, VR3, KW6, KJ6, VR6, KS6, ZM6, not to mention stray ones such as ZD1, ZD3, ZD6, ZD8, FD8, FE8 and the like. And the twenty odd countries represented by the USSR also became fair game for all and sundry (The really rare ones like Andorra still remained in the future, for the DX-pedition craze had not yet started.) One or two, now considered easy, like VP7, EL, CP and ZP had been rare or absent



Neil Baskerville (G3GUM) and his home-brewed rig, including the receiver. Note the old-timer QSL's on the left—relics of Neil's days as an SWL.

in pre-war years; ZK1 showed up, VK1's were another excitement, VK9 (Norfolk Island) caused a fine dogfight—and so it went on.

Country after country was added to the list of possibles, and every one, on its first appearance, caused the now-familiar dogfight, with no quarter given or received. So yet another modification of technique appeared. The knowing ones cut out their CQ's altogether, and only worked "bread-and-butter DX" when they merely wanted to chew the fat; the rest of the time they really *listened*, ready to pounce. For if you were the first Ham to hear the new country's first call, the chances are that you would get him right away. As soon as your QSO finished (if not before) the pile-up would start—and it would continue until the best part of 500 keen DX chasers had come away with an exchange of RST's. By this time the DX man had probably expired.

So most of the top scorers became miracle-men, in the eyes of the average ham—they only appeared when a rare piece of DX was around. And the second level of DX-ers listened round for these miracle men! (If you want rare DX, listen until you hear W1FH, or W6VFR, or G6ZO, or F8EO . . .) These "parasitic" tactics paid off, too—provided you could hear the fellow.

By the end of 1947 quite a list of WAZ's was getting together; and remember that before the war there were only *three* stations in the world to make WAZ—ON4AU, J5CC and the late G2ZQ. AC4YN and AC4RF had been doing their stuff, aided handsomely by C8KY, C8YR, C8LS and a few others in Zone 23. No other Zone presented any great difficulty except, perhaps, Zone 19. The stations were there, but the QSL's were not—always.

Our own log shows a total of 171, in 40 Zones, by the end of 1947, but probably quite a few scores of 200 had been clocked up by then.

Conditions hardly fell off in 1948, although 1947 was certainly the peak year. Techniques remained about the same, our 150-watters dodging the kilo-



The compact layout at G3BRV, operated by Ron Bennison. All bands from Ten to one-sixty are covered by the home-built gear on the table. G3BRV is interested in key-punching but not in DX "for its own sake"!

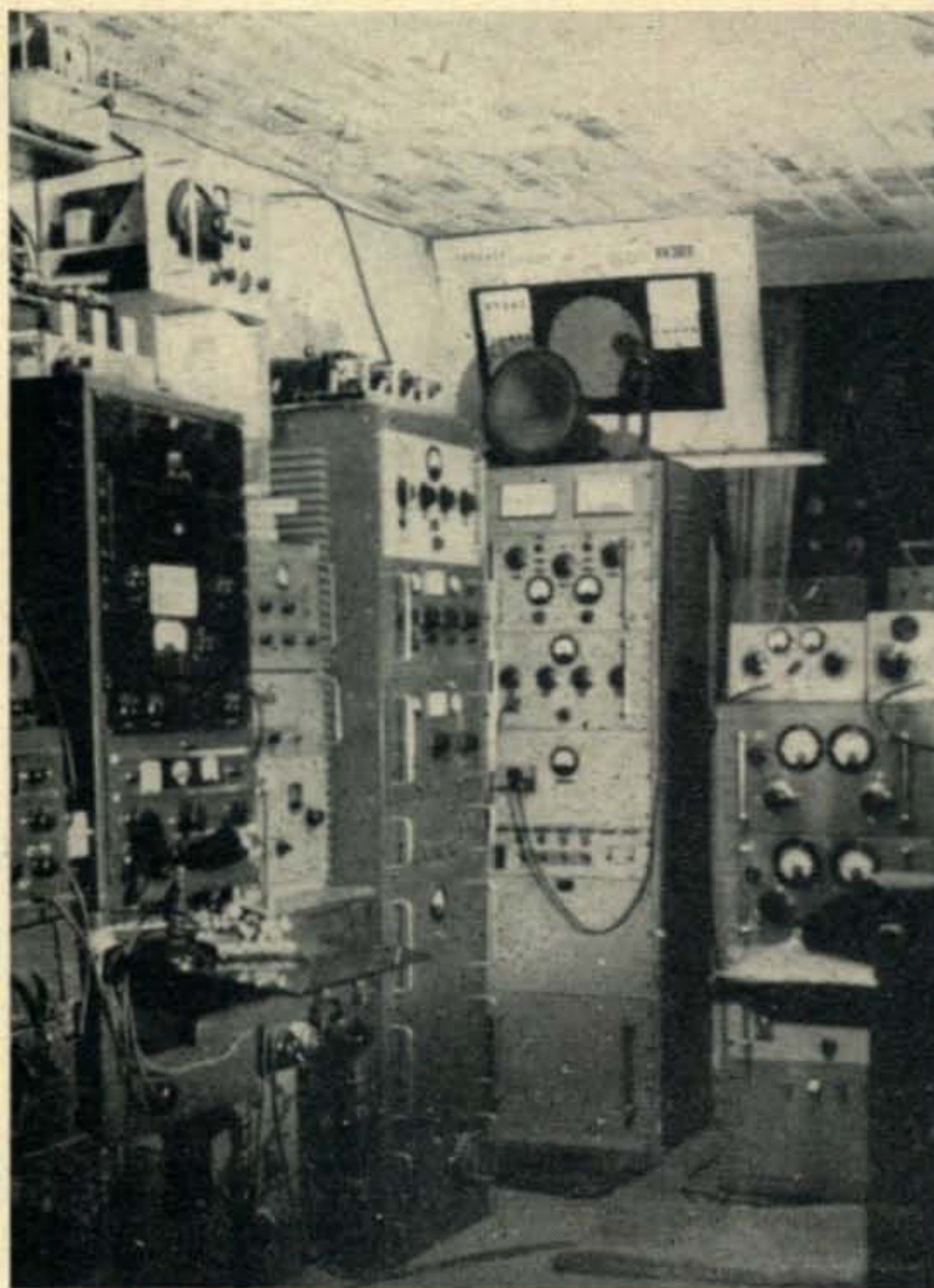

Just a corner of the shack of GW3FSP, a well-known DX-er on all bands, including 160. Separate transmitters for all bands down to two meters are used, with a very effective antenna farm which includes three 270-foot zepps.

watt brigade whenever they could. (After all, given a similar antenna they were only about one S point down, and with a *better* antenna they could compete almost on equal terms.) More and more new countries arrived each month, and QRM on *Ten* and *Twenty* reached saturation.

The LF Bands

Hams being what they are, there were always plenty of them willing to brave the terrors of the other bands, doing things the difficult way. And so the cult of 7 Mc. and 3.5 Mc. grew up once more. Not everyone wants to work new countries all the time, and several fellows were found who would derive more excitement from working a VK or a W6 on *Eighty* than from unearthing something brand-new on *Twenty*.

Round about the end of 1948, we were pretty surprised in the U.K. to find VK5KO coming through on *Eighty* at about 1900 GMT—all in among the local European QRM. If you could hear him, you could work him, and better still, you could work ZL's in the mornings. So 80-meter DX took a bigger lift than it had done even in the pre-war years, but we found new hazards and new difficulties up there. (The principle difficulty, of course, was the appalling strength of local stations chasing the

(Continued on page 74)



The Certificate Seekers'

H. S. BRADLEY, W2QHH

66 Lebanon St., Hamilton, New York

Looking for new worlds to conquer? We suggest that you read W2QHH's article. His list of awards to be won by the amateur is undoubtedly the most complete ever compiled.—Editor.

About the Author

One expects something unusual in a station capable of working 215 countries. And W2QHH, operated by H. S. "Howy" Bradley, is unusual enough to interest old-timers and Novice alike.

W2QHH is located in the village of Hamilton, N. Y., the home of Colgate University, 150 miles northwest of New York City. The village is situated in the Chenango Valley, and Howy says that being surrounded by high hills does not improve it as a DX location. He should know, but his post-war total of thirty-nine zones and 214 countries—213 confirmed—is no mean feat from any location.

Equipment

A VFO, high power, and high-gain antennas always help in establishing a high DX rating; in view of which, a look at W2QHH's equipment is enlightening. The transmitter is a crystal-controlled *Millen 90800*, covering 1.8 to 30 megacycles. Power input averages thirty-five watts. The receiver is a *Collins 75A-1*, supplemented by a *National SW3* for the 1.8 mc band and as a monitor.

Antennas are two end-fed, 135-foot wires, about thirty feet high for frequencies from 3.5 megacycles to 30 megacycles, and a 270-foot one, twelve feet high, bent in a semicircle, used on the 1.8-mc band. An indoor, close-spaced 28-mc beam is also available, but is so inefficient that it is seldom used, except as a receiving antenna. Indoor receiving antennas are used almost exclusively in order to reduce noise pickup from a nearby power plant and high-voltage lines.

The Operator

Such simple equipment and a noisy location do not usually add up to an outstanding DX record. The man who first said that any ham station was ten per cent equipment and ninety per cent operator might have been talking about W2QHH. Howy Bradley is married and has a junior operator, aged eleven. He is employed as a postman and reports that walking twenty miles a day delivering mail is not the best preparation for staying up late to work DX. His hobbies, other than amateur radio, include hunting, fishing, trapping, and playing softball. He is also an avid stamp collector, specializing in United States, Canadian, and Newfoundland postals.

Howy was first licensed in 1933, receiving the call W8JIW, which he held until the FCC rear-

ranged the call areas several years ago, when he was assigned W2QHH. Howy's election to membership in both the A-1 Operators Club and the First-Class Operators Club, plus being awarded a Public Service Certificate, indicates the quality of his operating. Possession of a thirty-five-wpm code certificate indicates, too, that it is not necessary to slow down for him.

W2QHH's interest in four and five band contacts with rare DX stations has resulted in many "firsts." One he is especially proud of is with TA3GVU, worked on 3.5, 7, 14, 27, and 28 megacycles. His ultimate goal is a four band DXCC, and he is well on his way. The score to date stands at 213 countries on 14 Mc., 106 on 28 Mc., 96 on 3.5 Mc., and 96 on 7 Mc. The relatively low 40 meter total is explained by limited activity on that band prior to 1951.

High power (thirty-five watts) operation is a comparatively new development at W2QHH. Before acquiring the *Millen* transmitter in 1950, power input never exceeded twenty watts. Some of his rarest countries, including fifty-three on 3.5 mc, were worked with from ten to seventeen watts input. Even today, 1.8 mc input runs considerably below thirty-five watts. Nevertheless, he has worked thirty-seven States,

Directory

GW, GD, VP4, VP9, KG4 and KV4 on that band.

Awards

Howy's collection of rare DX awards is probably the world's most complete. It includes WAC/YL and the only WAS/YL certificate yet to be issued and the first four band WAS, WPR 225, Empire-DXCC, AAA, and WAA certificates awarded to a United States amateur.

In addition to working DX, W2QHH keeps traffic schedules with isolated areas, often being the only means of communication between men stationed in them and their families in the States. And although primarily a c.w. man, W2QHH occasionally operates 1.8- and 28- mc phone.

Howy would also like to take this opportunity to acknowledge the many thanks due fellow amateurs for items of equipment in use at W2QHH, and to the DX fraternity here and abroad who have so kindly lent a helping hand in making these QRP achievements possible.

In reply to the question of how to work DX with low power, Howy says his method is just to keep calling them until they come back, saying nothing about the "know-how" required to sneak his call through while competition is hopelessly interfering. His reports average considerably below those received by the KW boys, but he occasionally surprises himself (and them) by getting a better one. As might be expected, W2QHH firmly believes that all Hams would be better off with a 100-watt power limit.

—W9EGQ

The Directory

Many amateurs have earned one or more of the certificates, such as WAC, WAS, WAZ, and WBE, offered by *QST*, *CQ*, and the *RSGB* in recognition of outstanding work by radio amateurs. Some amateurs have earned all of them. Doing so is a real achievement, but does not leave them, like Alexander the Great, with no new worlds to conquer. They can still work towards having the certificates endorsed for a specific band or mode of communication. For example, 3.5-megacycle WAC Certificates are almost as rare as hams who admit they have good locations. Nine 50-megacycle WAS certificates have been issued to date, and several amateurs are approaching the halfway mark towards one on 144 megacycles. An impossible goal? Maybe, but that is what they said about WAS above 50 megacycles not too many years ago.

In addition to these awards, other amateur organizations throughout the world offer certificates of their own. These less publicized awards are particularly interesting to the low-power man, because they often place a greater premium on

A Comprehensive Listing of Current DX Awards

skill and perseverance than on signal strength. On the other hand, they are still a very real challenge to the high-power man.

Working several KP4 stations is not too difficult for a high-powered station, but power is not much help in gathering twenty-five or fifty QSL cards for a WPR-25, or WPR-50 certificate, awarded by the Puerto Rican Amateur Radio Club to stations submitting proof of contact with twenty-five or fifty KP4's. And each time another twenty-five-contact sticker is affixed to one's certificate, he feels a great sense of achievement. (W2QHH should know. He is currently working for his 250 contact sticker.—*Editor*)

Many of the certificates in the following list are extremely rare. Several have been earned by only one amateur in the *world*, others have yet to be earned by the first United States Amateurs.

Most of the awards have certain rules in common. Most will be endorsed for single-band work, or for phone or CW. The latest official country list, as published in *CQ* and *QST*, determines what is or is not a country. All contacts must have been made from within 150 miles of the point from which the original one was made. Unless otherwise stated, stations contacted must be "land" stations, not maritime-mobile, etc., to be counted towards an award.

Many of the awards specify minimum reports, usually RST338 for CW and R3 S3 for phone.

Always send evidence by first-class, registered mail, and enclose sufficient postage for its return by the same means. This is especially important for mail to South America.

Decision of the Award Committee of the sponsoring organization is final in any question concerning the award.

(No claim is made here for the accuracy of all details pertaining to the requirements outlined below. We wish to thank the many clubs and other organizations that cooperated in the preparation of this material. Where and whenever possible the information has been verified and is correct as of this writing—*Editor.*)



ALL AFRICA AWARD (AAA): South African Radio League. Awarded to any amateur who is a member of an organization affiliated with the IARU, submitting proof of contact with the nine ZS call areas (ZS1 to 9) and twenty-five additional countries on the *African mainland*. Islands are excluded, and all contacts must have been made since November, 1945. Special endorsement for contacts with all of the possible forty-one countries on the African continent.

Send QSL cards and a list of claimed contacts to: SARL, Postbox 7028, Johannesburg, Union of South Africa. Enclose fifty cents, if not an SARL member. No. 1 for "W" went to W2QHH.

BRITISH EMPIRE TRANSMITTING AWARD (BERTA): Radio Society of Great Britain. Awarded to any amateur submitting proof of contact with at least fifty countries and specified call areas of the British Commonwealth. The countries that apply towards this award are all British nations appearing on the official list, plus VO1 and VO6, with Canada, Union of South Africa, and Australia divided into their call areas. Contacts with mobile stations are permitted if their

exact location is shown on the QSL card.

Send proof to RSGB, New Ruskin House, 28-30 Little Russell St., London, W. C. 1, England. Enclose fifty cents if you are not an RSGB member.



DIPLOME Des PROVINCES de FRANCE (DPF): Réseau des Emetteurs Francais. Awarded upon proof of contact with sixteen of the seventeen French provinces. Contacts must have been made since January 1, 1951, and must be all CW or all phone.

French Provinces: Alpes, Alsace-Lorraine, Auvergne, Bourgogne, Bretagne (French zone of Germany), Champagne, Corse, Franche-Comte, Gascogne, Ile-de-France, Languedoc, Nord, Normandie, Poitou, Provence, Touraine, and Ville de Paris.

Send proof of contacts and three International Postal Reply Coupons to: R. E. F. (DPF), 72 rue Marceau, Montreuil-sous-Bois (Seine), France.

DIPLOME de L'UNION FRANCAISE (DUF): Réseau des Emetteurs Francaise. Awarded in steps. Completion of the first three earns the letter *D* in blue, the letter *U* in white, and the letter *F* in red (The French National colors) and comprise the "Certificate of Honor." Completing the last step earns the "Certificate of Excellence," and a silver medal and bar suitably engraved with recipient's call letters and the award number.

Requirements for stations outside of Europe are:

- (1) Contacts with four French Empire stations in three continents.
- (2) Contacts with ten French Empire stations in four continents.
- (3) Contacts with twenty French Empire stations in five continents.
- (4) Contacts with thirty French Empire stations in six continents.

All contacts must have been made since April 1, 1946.

The first three awards are issued free. The last requires a fee of 700 francs (about \$3.25). United States and Canadian amateurs may submit applications for DUF via ARRL.

COLUMBIA: The Radio Club del Atlantico presents a certificate to stations working ten HK1's. Send proof to: Galo Dugand, HK1DZ, Apartado Nacional 134, Baranquilla, Colombia.

DX CENTURY CLUB (DXCC): American Radio Relay League. Awarded upon proof of contact with one-hundred or more countries. After original award has been made, endorsement stickers will be issued for each additional ten confirmations.

In addition to credit granted on the receipt of written proof, DXCC credit is allowed for contacts made in ARRL DX competitions under certain circumstances. Sufficient other confirmations must be available so that credit for contacts will bring the total to one hundred or more. Before requesting this service, inspect contest results, published each year in QST. If the station is not listed, he did not submit a log, and verification is impossible. If it is listed, forward the usual data on the contact. Under no circumstances is such confirmation possible until contest results have been published in QST. Both a post-war and an all-time DXCC award are available. Send proof, with a list of contacts to: The American Radio Relay League, Inc., 38 LaSalle Road, West Hartford 7, Conn.



EMPIRE DX CERTIFICATE (EDXC): Radio Society of Great Britain. Awarded to RSGB members submitting confirmations of contacts with one-hundred or more British Commonwealth call areas. Fifty of the contacts must have been made on fourteen megacycles, and the rest on the other amateur bands. See BERTA for additional information.



FLORIDA: The Rebel Radio Club, West Palm Beach, offers an enscribed coconut to the first amateur in each country to work five members of the club. It has already been awarded for USA and England, but the club might carry out its promise (threat) to send a live alligator to the first station to work ten of its members. (Simi-

lar awards—apparently sans alligator—are also being offered by the Corpus Christi, Nashville and Orlando Amateur Radio Clubs. If these, and any other clubs offering such certificates will write to me, I will attempt to prepare a supplement to this Directory.—W2QHH.)

HELVETIA 22 (H22): U. S. K. A. Awarded to stations submitting proof of contact with HB stations in each of the twenty-two Swiss cantons. Stations in Europe must work two each, the rest of the world, only one each. All contacts must have been made since April 15, 1948. Send confirmations to: Traffic Manager, USKA, Postbox 1367, Berne, Switzerland.

ISRAELI: The Israeli Amateur Radio Club operating through 4X4BX has announced an award calling for sixteen different 4X4 contacts with at least one of them on 80, 40, 20 and 10 meters.

MARITIME-MOBILE CLUB: Honorary membership in the Maritime-Mobile Club is granted upon proof of contact with thirty MM stations accompanied with a list of the contacts. Send to: John McKinley, W3OB, 1317 Orange-wood Ave., Pittsburgh, Penna.

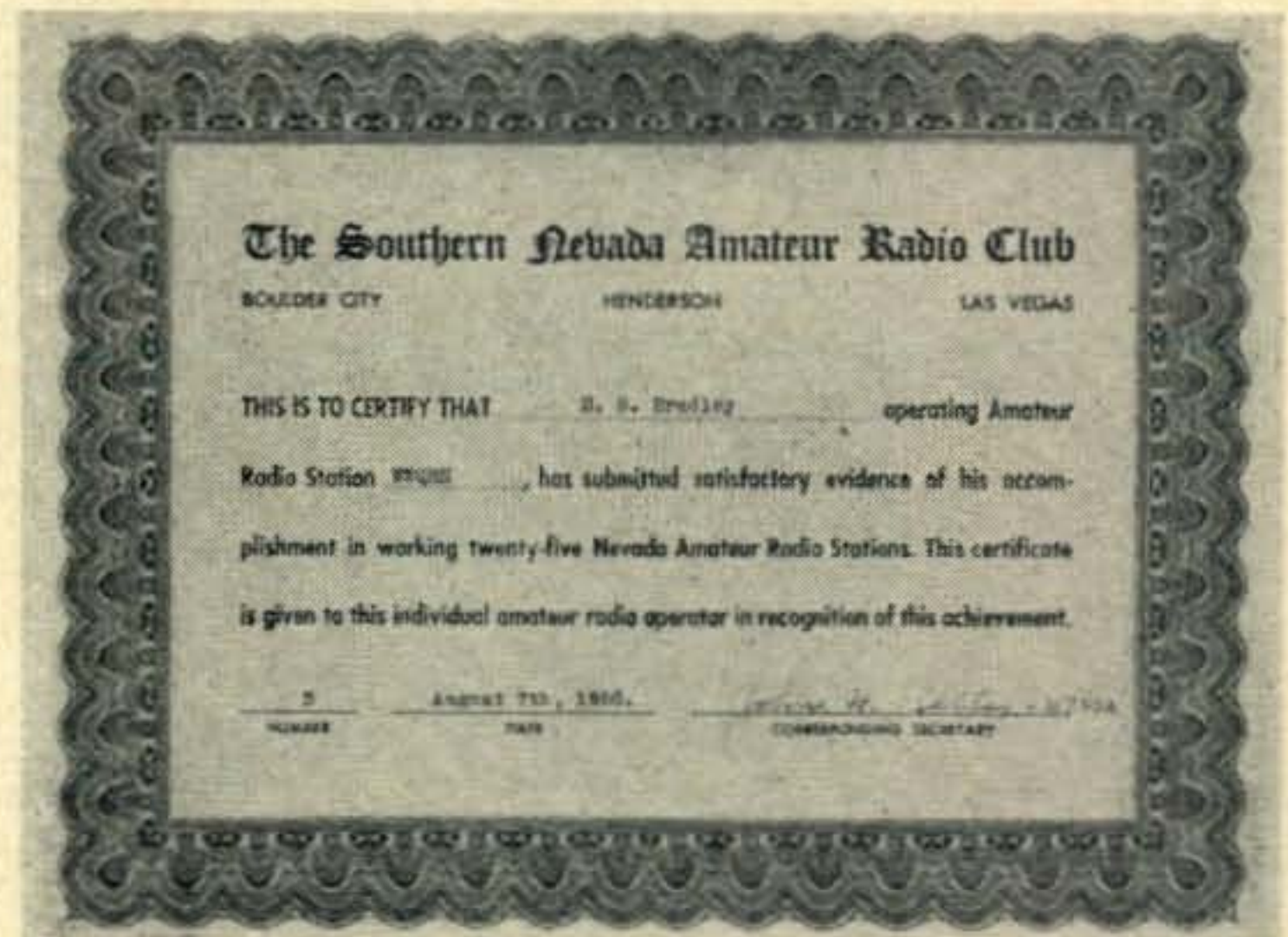

NEVADA: The Southern Nevada Radio Club awards a certificate to any amateur submitting proof of contacts with twenty-five Nevada stations. Send cards to W7NNA, the club secretary.

PANAMA: The Liga Panamena de Radio Aficianados awards a certificate for twenty HP contacts. Send proof to: LPRA, Apartado 1616, Panama City, Republic of Panama.

RAMEY AIR FORCE BASE, PUERTO RICO: Ten contacts with KP4's on Ramey AFB will earn a certificate. Send proof to: Secretary, Ramey Amateur Radio Club, Box 120, APO 845, Postmaster, N. Y.

SOUTH AFRICA AND AUSTRALIA: The radio clubs of Pietermaritzburg, Union of South Africa, and Moorabbin Radio Club (VK3) offer friendship awards with their members. Ask VK3's, and VK4's and ZS5's for details.

SWITZERLAND: The amateurs in the canton of Aargau award a special cartoon certificate to amateurs submitting proof of contact with a minimum of forty-five European countries. This is a "friendship" award. Ask HB9CA, EU, IR, JJ, KB, KC, LK, MQ, or NQ for details (see illustration of this award at the top of the next page overleaf).



SHORT WAVE MAGAZINE AWARD: SW MAGAZINE (London) offers a difficult-to-obtain certificate. Contact requirements are:

- 1.7 Mc: three continents and fifteen countries.
- 3.5 Mc: five continents and forty countries.
- 7 Mc: all continents and forty countries.
- 14 Mc: all continents and 180 countries.
- 28 Mc: all continents and ninety countries.

Send list of the 405 contacts to SW Magazine, whose DX committee will request certain cards for checking. Failure to produce them will result in disqualification. SW Magazine will also now certify proof of contact with at least twenty countries on four different bands. Address: Short Wave Magazine, 53 Victoria St., London, England.



WORKED ALL AMERICA (WAA): Liga de Amadores Brasileiros de Radio Emissao. Awarded upon proof of contact with forty-five of more of the fifty-seven countries in North and South America. Send confirmations to: LABRE, Caixa Postal 2353, Rio de Janeiro, Brazil.

WORKED ALL ARGENTINA DISTRICTS (WAA): Radio Club Argentino. Awarded on proof of contact with twenty-five LU districts. Districts are identified by the first letter following the numeral in LU calls, thusly: A, B, C, City of Buenos Aires; D, E, Province of Buenos Aires; F, Santa Fe; G, Chaco and Formosa; H, Cordoba; I, Misiones; J, Entre Rios; K, Tucuman; L, Corrientes; M, Mendoza; N, Santiago del Estero; O, Salta; P, San Juan; Q, San Luis; R, Catamarca; S, La Rioja; T, Tujuy; U, La Pampa; V, Rio Negro; W, Comodoro Rivadavia; X, Santa Cruz, Fuego; Y, Chubut; Z, Shetlands, Orkneys, and Polar areas.

Radio Club Argentino also awards a certificate upon proof of contact with the twenty-one American republics: Argentina, Bolivia, Brazil,

Chile, Colombia, Costa Rica, Dominican Republic, Ecuador, Guatemala, Haiti, Honduras, Mexico, Nicaragua, Panama, Paraguay, Peru, Salvador, Uruguay, U.S.A., and Venezuela. We also understand that there is an award given for contacts with 100 different LU stations. Send your proof for either award to R. C. A., Av Libertador G1, San Martin 1850, Buenos Aires, Argentina.

WORKED ALL BRAZIL (WAB): L.A.B.R.E. Awarded upon proof of contact with each of the twenty Brazilian states, the federal district in which Rio de Janeiro is located, counting as a state. Address: LABRE, Caixa Postal 2353, Rio de Janeiro, Brazil.

WORKED ALL BRAZILIAN DISTRICTS (WABD): L.A.B.R.E. awards a certificate upon submission of QSL proof from each of the nine PY districts. Address above.

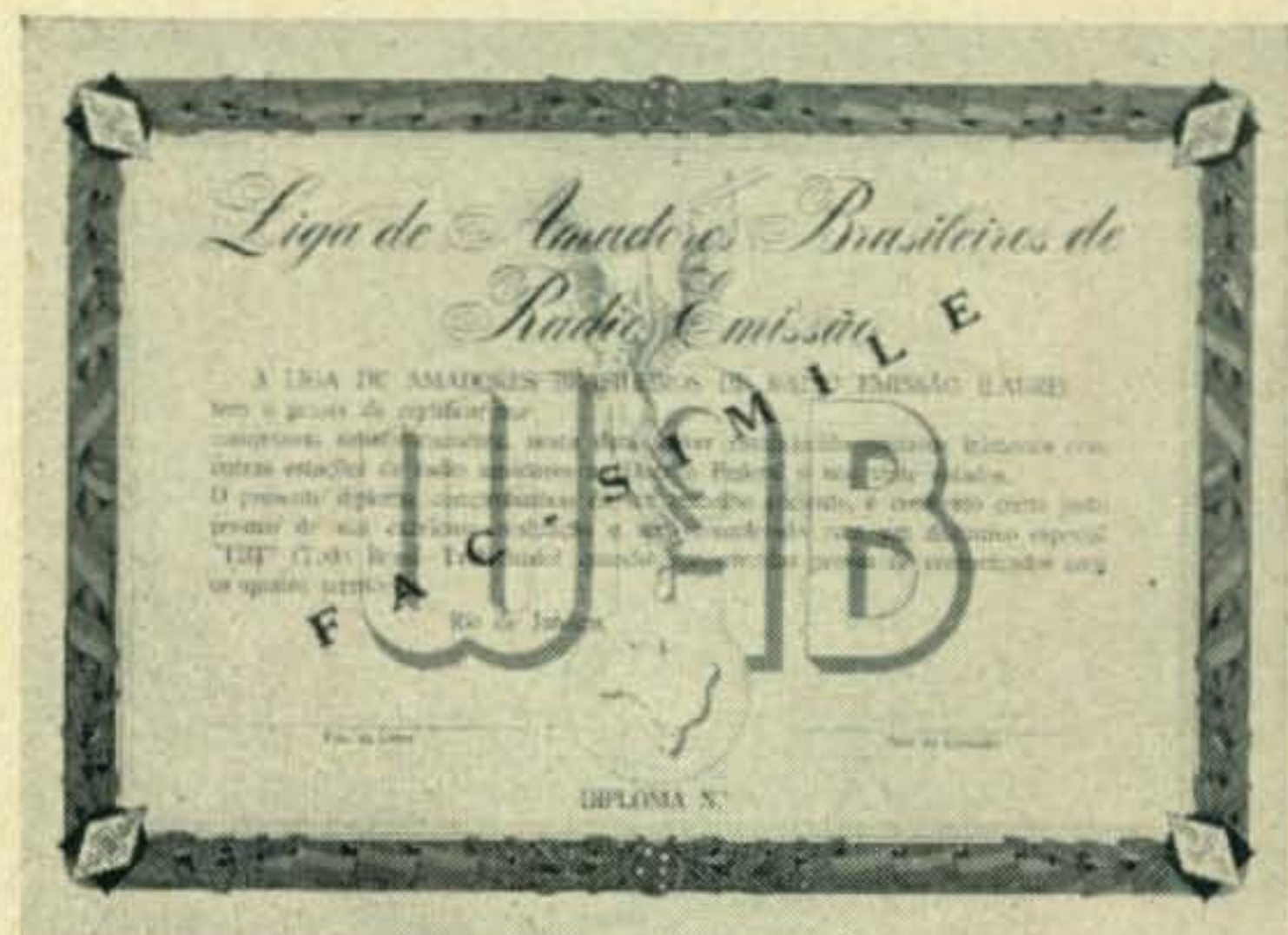

WORKED ALL BELGIAN PROVINCES (WABP): U.B.A. Awarded for contact of each of the Belgian Provinces on two bands. Further, the Bruges Club offers a certificate for working ten of its members. Send the necessary confirmations (18 provinces) to: UBE, Boite Postale 634, Bruxelles, Belgium.

WORKED ALL CONTINENTS (WAC): International Amateur Radio Union. Awarded to members of an affiliated organization who submit proof of contact with the six continents. USA and Canadian amateurs send proof to ARRL, 38 LaSalle Road, West Hartford 7, Conn. Applicants in countries where there is no IARU affiliate also send their proof to ARRL with ten International Postal Reply Coupons or fifty cents, U.S.A. money.

WAC/YL: Awarded by YLRL upon proof of contact with a station operated by a licensed YL in each of the continents. Verify address with WIFTJ or W5RZJ, YL editor of CQ, and send confirmations to: Custodian of Certificates, YLRL.

WORKED ALL CALIFORNIA COUNTIES (WACC): Oakland, California, Radio Club. Awarded upon proof of contact with each of the fifty-eight California counties. Mobile contacts may be counted. Send proof to: Oakland Radio Club, 906 Fallon St., Oakland, Calif.

WORKED ALL CUBAN DISTRICTS (WACD): A.R.A.V. Awarded upon contact with seven Cuban call areas. CM4 is not required, and CM9 is not classed as a district. Send proof to A.R.A.V., Apartado 136, Santa Clara, Cuba.



WORKED ALL CHILE (WACE): Radio Club of Chile. Awarded upon proof of post-war contacts with seven Chilean call areas. Send confirmations to: RCC, Casilla 761, Santiago, Chile.

WORKED ALL CX (WACX): The Radio Club of Uruguay is now granting an award for proof of QSO with each of the CX States (Departamentos). QSL proof should be forwarded to Casilla 37, Montevideo.

WORKED ALL EUROPE (WAE): D.A.R.C. Awarded in three grades as per the following table:

- WAE—Third Class: forty European countries and one hundred points.
- WAE—Second Class: fifty European countries and 150 points.
- WAE—First Class: fifty-five European countries and 175 points.

To the fifty-six European countries on the official list, the D.A.R.C. adds Sicily, the Dodecanese Islands, European Turkey and Pelagic Is. Stations outside of Europe compute points on the basis of two per contact on 1.7 and 3.5 Mc., one point per contact on 7, 14, and 28 Mc., and three points per contact above 30 Mc.

WAE-Second Class entitles the winner to a one-year subscription to *DL-QTC*, and WAE-First Class bestows the subscription and honorary membership in D.A.R.C. Six International Postal Reply Coupons are required for the first two awards, and eight for the third. Send proof to: D.A.R.C., Box 585, Stuttgart, Germany.

WORKED ALL ITALY (WAI): *Selezione Radio (Milano)*. Awarded upon proofs of contacts with each of the following eighteen Italian regions: Abruzzi, Calabria, Campania, Emilia, Lazio, Liguria, Lombardia, Lucania, Marche, Piemonte, Puglia, Sardinia, Sicilia, Toscana, Trieste, Umbria, Veneto, Venezia Tridentina.

All contacts must have been made since January 1, 1950. Send proof and three postal reply coupons to: *Selezione Radio (WAI Award)*, Casella Postale 573, Milano, Italia.

WORKED ALL JAPANESE DISTRICTS (WAJD): Far Eastern Amateur Radio League. Awarded upon proof of contact with seven or more of the nine JA call areas. Send confirmations to FEARL, APO 500, c/o Postmaster, San Francisco, Calif.

WORKED ALL PACIFIC (WAP): New Zealand Amateur Radio Transmitters. Awarded

upon proof of contact with thirty of the Oceania countries on the official country list. All contacts must have been made since November, 1945. Send proof to NZART, Box 498, Wellington, N. Z.



WORKED ALL STATES (WAS): American Radio Relay League. Awarded upon proof of contact with each of the forty-eight states. Send confirmations to ARRL, 38 LaSalle Road, West Hartford 7, Conn.

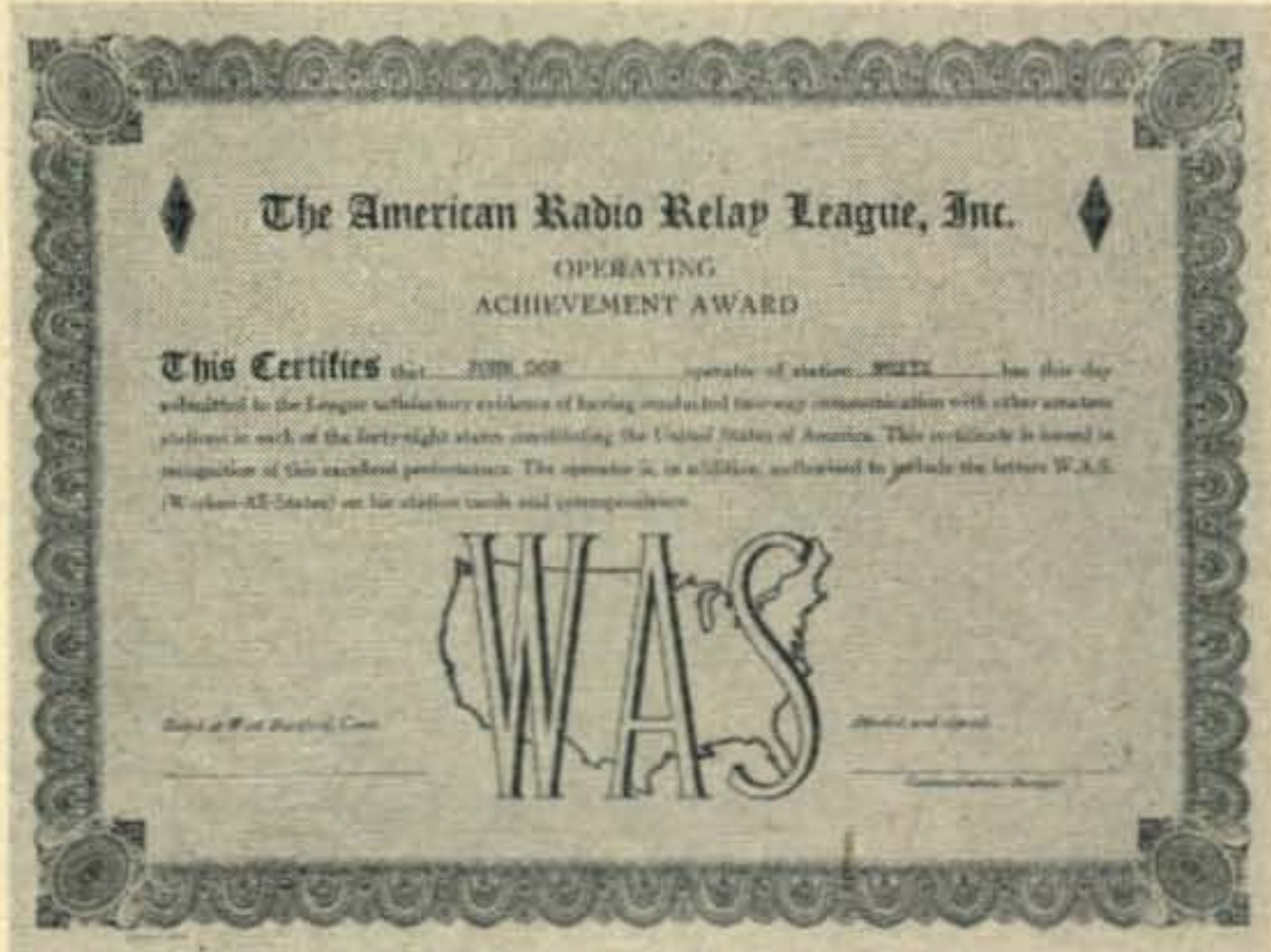

WAS/YL: YLRL. Awarded upon proof of contact with stations operated by licensed YL's in each of the forty-eight states. Send confirmations to: Custodian of Certificates, YLRL, after querying W1FTJ or W5RZJ, YL Editor of *CQ*, for latest address.

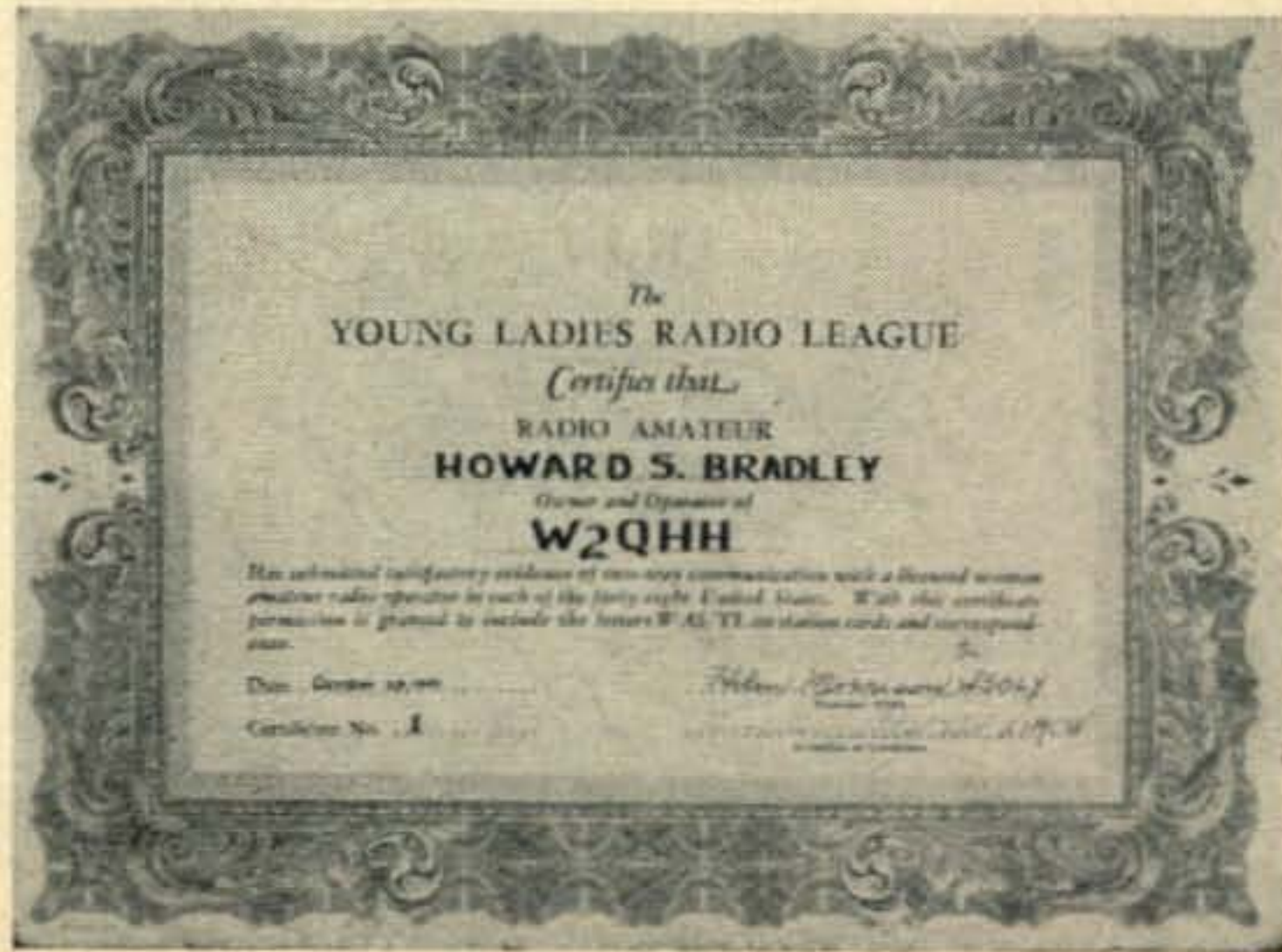

WORKED ALL SWEDEN (WASM): Swedish Sending Amateurs. Awarded upon proof of post-war contacts with the seven SM call areas. SM8 is maritime-mobile, and is not counted in the award. Stations outside of Europe must work one station in each call area. Those in Europe must work two. Send proof with ten International Postal Reply coupons to: SSA, Stockholm 8, Sweden.

WORKED ALL ZONES (WAZ): CQ. Awarded upon proof of contact with the forty DX zones of the world, plus a list of the stations worked. Stations submitting lists of zones and countries worked are eligible for listing in CQ's monthly "Honor Roll." Currently, a minimum of thirty-two zones are necessary to achieve "Honor Roll" listing. Report forms available upon request, accompanied by a self-addressed, stamped envelope. Send confirmations only when applying for WAZ certificate. Address all communications to: CQ, Cowan Publishing Co. Inc., 67 West 44th Street, New York 36, N. Y.



WORKED BRITISH EMPIRE (WBE): The counterpart of the WAC award, the difference being that the stations on each continent must be in the British Commonwealth. Send proof to RSGB (address with BERTA award).

WORKED CANAL ZONE (WCZ): Canal Zone Amateur Radio Association. Awarded for working twenty-five KZ5 amateurs post-war. Stickers for fifty and 100 contacts also available. Confirmations not required, but full data on each contact must be given to aid KZ5 log checking. Send information to: CZARA, Box 407, Balboa, Panama Canal Zone.

WORKED EAST AFRICA (WEA): Radio Society of East Africa. Contacts with a VQ3, three VQ4's, and a VQ5 in a calendar year earns a special, photographic souvenir card. The card for each year contains a picture of a different East-African scene. Five such cards, plus a VQ1 contact, earns the WEA Award. QSL cards need not be sent, unless requested. Send details, with \$1.00 for award, to: RSEA, Box 1246, Nairobi Kenya Colony, East Africa.

WORKED FAR EAST (WFE): This is an other award from Short Wave Magazine. Proof of QSO must be shown with 18 of the 23 recognized countries in the Far East. These include; C, C3, C9, CR9, CR10, DU, FI, HL, HS, JA,

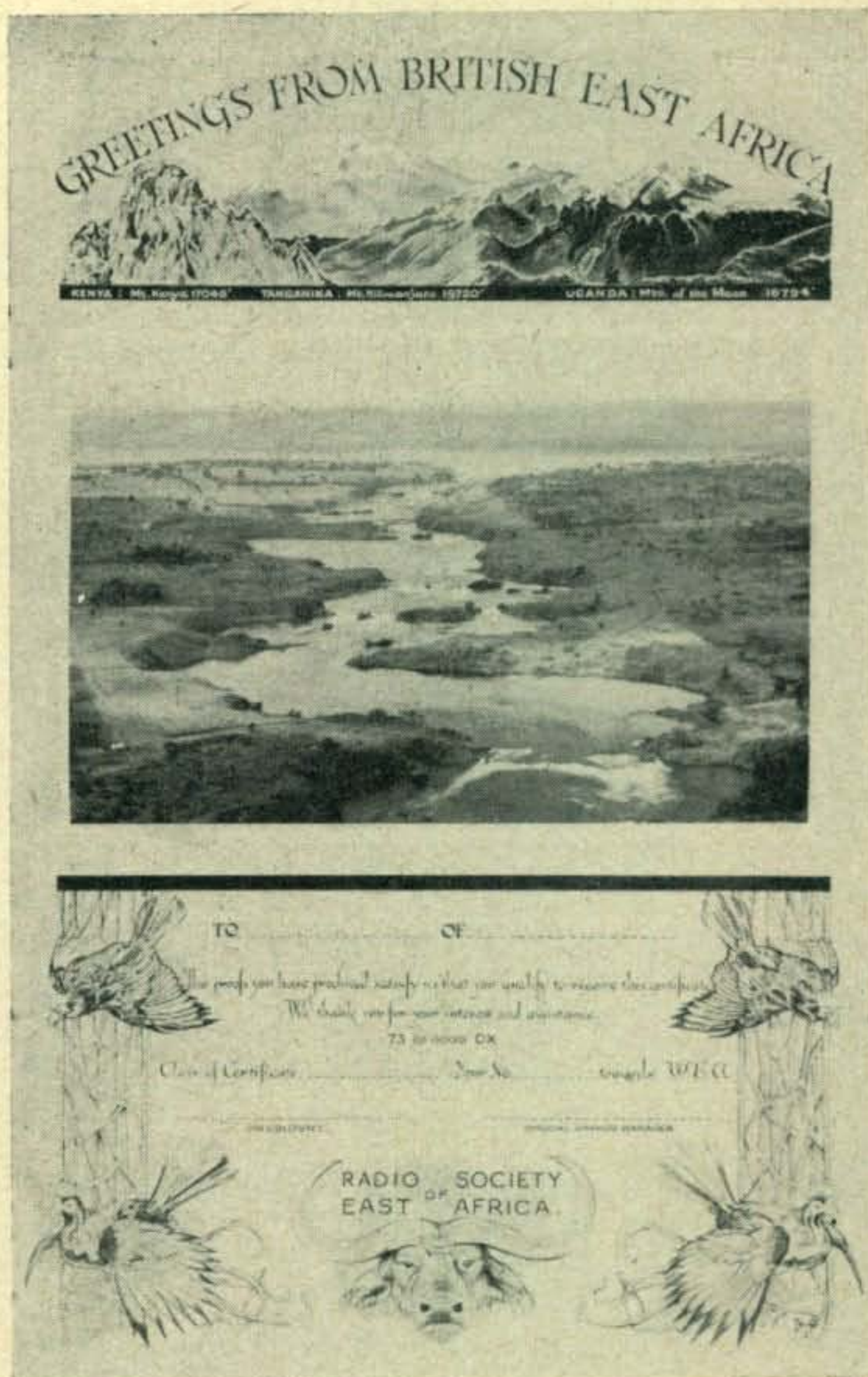

KR6, PK1-2-3, PK4, PK5, PK6 (except N Guinea), UAØ (zone 19 only), VS1, VS2, VS6, XZ and both VS5 areas (Brunei and Sarawak). Address: *Short Wave Magazine*, 53 Victoria Street, London, England.

WORKED FIVE JA STATIONS (WFJS): Far Eastern Amateur Radio League. Awarded upon proof of contact with five JA stations since January 1, 1949. Send to: FEARL, APO 500, c/o Postmaster, San Francisco, Calif.

WORKED HC: Guayaquil Radio Club. Awarded upon proof of post-war contacts with five of the seven HC call areas. Send confirmations to: Guayaquil Radio Club, Casilla 784, Guayaquil, Ecuador.

WORKED NORTH AMERICAN CALL AREAS (WNACA): Is yet another *Short Wave Magazine* certificate for non-North American amateurs. It requires QSL cards from the ten W call areas, 9 VE calls (Yukon and N.W.T. separate), VO, VO6 and KL7. Address with the WFE award requirements.

WORKED NEW HAMPSHIRE (WNH): The Concord Brasspounders, Box 312, Concord, N. H., offer an award to anyone working ten counties in that state. Details from address above.

WORKED PUERTO RICO-25 or 50 (WPR-25, WPR-50): Puerto Rico Amateur Radio Club. Awarded upon proof of contacts with twenty-five or fifty KP4's respectively. The same station may be worked a maximum of three times for this award: fixed, mobile, and portable. Send

confirmations to: PRARC, Postbox 3533, San Juan, Puerto Rico.

WORKED PORTUGUESE WORLD (WPW): This award is given by the REP for proof of contact with CT1, CT2, CT3, CR4, CR5, CR6, CR7, CR8, CR9, and CR10 since July 29, 1947. Address: R.E.P., Travessa Nova de S. Domingos, 34-1 Lisbon, Portugal.

Other Certificates

A-1 OPERATOR CLUB: American Radio Relay League. Membership is based on high operating ethics and skill, and is achieved upon being nominated by two members.

BRASS POUNDERS LEAGUE (BPL): American Radio Relay League. Issued to stations reporting a message total of 500 or an originated-delivered total of 100 in one month. One point is earned each time a message is originated, received, relayed or delivered.

CODE PROFICIENCY: American Radio Relay League. Awarded to anyone submitting correct copy for one minute of any of the International Morse code test runs transmitted monthly by W1AW, W6OWP, and WØTQD. Speeds start at ten WPM and increase in five-WPM increments to thirty-five WPM. A certificate is issued for the highest speed copied, and higher-speed stickers may be earned in subsequent transmissions.

FIRST CLASS OPERATOR CLUB: *Short Wave Magazine* (London). Similar to the A-1 Club, membership is achieved upon nomination by a club member and approval by three others.

MILITARY AFFILIATED RADIO SYSTEM (MARS): Department of Defense. Handsome membership certificate signed by Chief Signal Officer of the Army or Air Force, is issued to United States Amateurs who qualify. Details may be obtained by writing to: Military Affiliated Radio System, Pentagon Building, Washington 25, D. C., indicating whether you are interested in Army or Air-Force affiliation.

OBS, OES, OO, OPS, ORS and RM, ARRL "field" appointments, are available to league

members interested in various phases of amateur radio. Details in *ARRL Handbook*.

OLD TIMER'S CLUB: ARRL. Available to anyone who now holds a valid amateur license and held one twenty years ago. Lapses are permissible. Send brief history to: ARRL, 38 LaSalle Road, West Hartford, Conn.

PUBLIC SERVICE: If one does meritorious work during any public disaster or emergency, and accounts of his work reach the proper authorities, he will be pleasantly surprised to receive his "Public Service Certificate." This one will undoubtedly give the greatest degree of satisfaction.

RAGCHEWERS CLUB (RCC): ARRL. Talk to a member of the RCC over the air for a half hour and, if both he and you drop ARRL a postal card about it, you will be issued a membership certificate.

NET CERTIFICATES: Most of the amateur nets meeting regularly issue membership certificates. Some are relatively easy to obtain. Others require regular reporting and high-quality operating over a period of months to obtain. The NCS or Net Manager will supply details.

The Final Certificate

After acquiring all of the above certificates there must be something left to do, and a slightly embittered member of the NZART has come up with the following suggestions:

WAT (Worked All the Time): Must have missed every opening on 6 meters by being at work.

WAB (Worked All Bands): Must have worked Benny Goodman, Stan Kenton, both Dorseys, etc.

WAWA (Worked All Worked-Alls): Must have at least 100 "Worked All . . ." certificates.

WOOPY (Worked Out of Back Yard): Issued by the **LIBRE** (leaked into broadcast receivers everywhere). Submits proof of contacts within 100 yards.

A shot of W2QHH at the operating position. Or in other words — "A Wife's Eye View of a DX Man!"



Versed in ^{DX} DX

DX DX

DX

DX

DX

DX

DX

(Concerning Certain Rueful Aspects of Long-Distance Working)

G. FRANKLIN MONTGOMERY, W3FQB

Contributing Editor, CQ

Glad To See You Again

Consider, if you will, the morality
Of the practice of plurality.
I am speaking of the chap who insists on working
8X2BA over and over again, just for the fun
of it,
While I have yet to raise even one of it!
(I hesitate to gripe,
But I suspect that you, as well as I, Sir, or Madam,
as the case may be, are only too familiar with
this type.)
My man's passion seems to be
Sending, at considerable length and preferably QSZ:
*That he received the card all right, and fine
Business, because that makes it 209
Confirmed; that he has raised his beam one more yard
And can 8X2BA notice the difference, and would he
like another card?*
And so *ad nauseum*,
With scarcely a pauseum.
Meanwhile, I sit and try to keep my head
And wish, fervently, that he would, for once,
drop dead.

Pse QSL

That DX station five kc
Below us really is S-three,
Yet everybody gives him eight.
Will none among us set him straight?
(*Not me.*)

Seventy-Five

Have you heard of the man in Cologne
Who entered the contest on phone,
Where the awful attrition
Of oral transmission
Abraded his gums to the bone?

To Fall and Winter

The DX contests come again;
The first is drawing nigh.
All hail the time to ascertain
How far the signals fly.
But pardon me if I refrain
With glee from jumping high;
This time, to make it very plain,
I do not care to try.
Remembering the sleepless nights,
The somewhat less than sane
Procedures during calling fights,
The key clicks, and the pain
Of newly lost new countries, I
Propose to pass this contest by.

Call Me If You Hear Anything

I confess that I am baffled
By plans for countries rare
That become completely snaffled
Whenever I am there.
Let Larry call to tip me
On a sked for Urdo-Zoppen;
If I'm on time at two a.m.,
Exactly nothing happen.
But if I fail to make the grade,
It guarantees the prize,
And Larry will have had it made
With fourteen other guys.

How Is Your Standing-Wave-Ratio?

Although I have put in many a long and tedious
hour working on this beam,
It would seem
That no amount of diddling
The dipole lengths and other kinds of fiddling
(Matching stubs and such)
Is getting me much.
According to the last report
My gallon still sounds like a quart.

A VK's

Point of View

Flt. Lt. F. T. HINE, VK2QL

R.A.A.F., Penrith, N.S.W., Australia

In order to round out the "Feature DX Issue," we requested the DX Editor of *AMATEUR RADIO*, the publication of the Wireless Institute of Australia, to summarize DX-ing from "down under." His refreshing account is sure to hold your interest.—Editor.

To compile an article on the Australian aspect of DX-ing that will interest the readers of *CQ*, and at the same time not offend my VK colleagues has presented quite a problem. Rather than look with a critical eye upon DX practices and such, I am going to relate some of the early history of DX-ing from VK-land in hopes that it will recall pleasant memories to those that took part, and will be of interest to the "young squirts" in Ham radio.

Many fellows have forgotten that the licensed power input has never been very high in Australia and for many years before World War II, a maximum of 25 watts was enforced. Gradually we were permitted to increase to 50 watts, and at the present time are permitted 100 watts. Still, the VK boys managed to work their share of real DX although various beam arrays and commercial equipment were unknown. Practically everything in the station was home constructed.

The improvement in equipment available a couple of years before the War helped the VKs, although the final amplifier in most transmitters consisted of receiving type tubes. In 1937, for example, the better than average transmitter used a 53 or 59 as an oscillator, a 46 as a double and another 46 as the final amplifier modulated with a 2A3 or 45. Not impressive, but adequate under the right conditions.

The "Old-Timers"

There are still a number of the "old-timers" of amateur radio active in Australia. One easily recalls

VK2CM, VK2NO, VK2NS, VK5JT and VK7BQ, who have also used the prefix of A and OA long before VK became "official."

VK2CM in April 1923 was the first Australian to hear American signals. In the same year he worked New Zealand on 200 meters using a power of 0.0037 of a watt. The following year on 86 meters, communication was established with G2OD on CW, and, in 1926, on phone. In 1925, VK2CM was the first Australian to work South Africa on 20 meters.

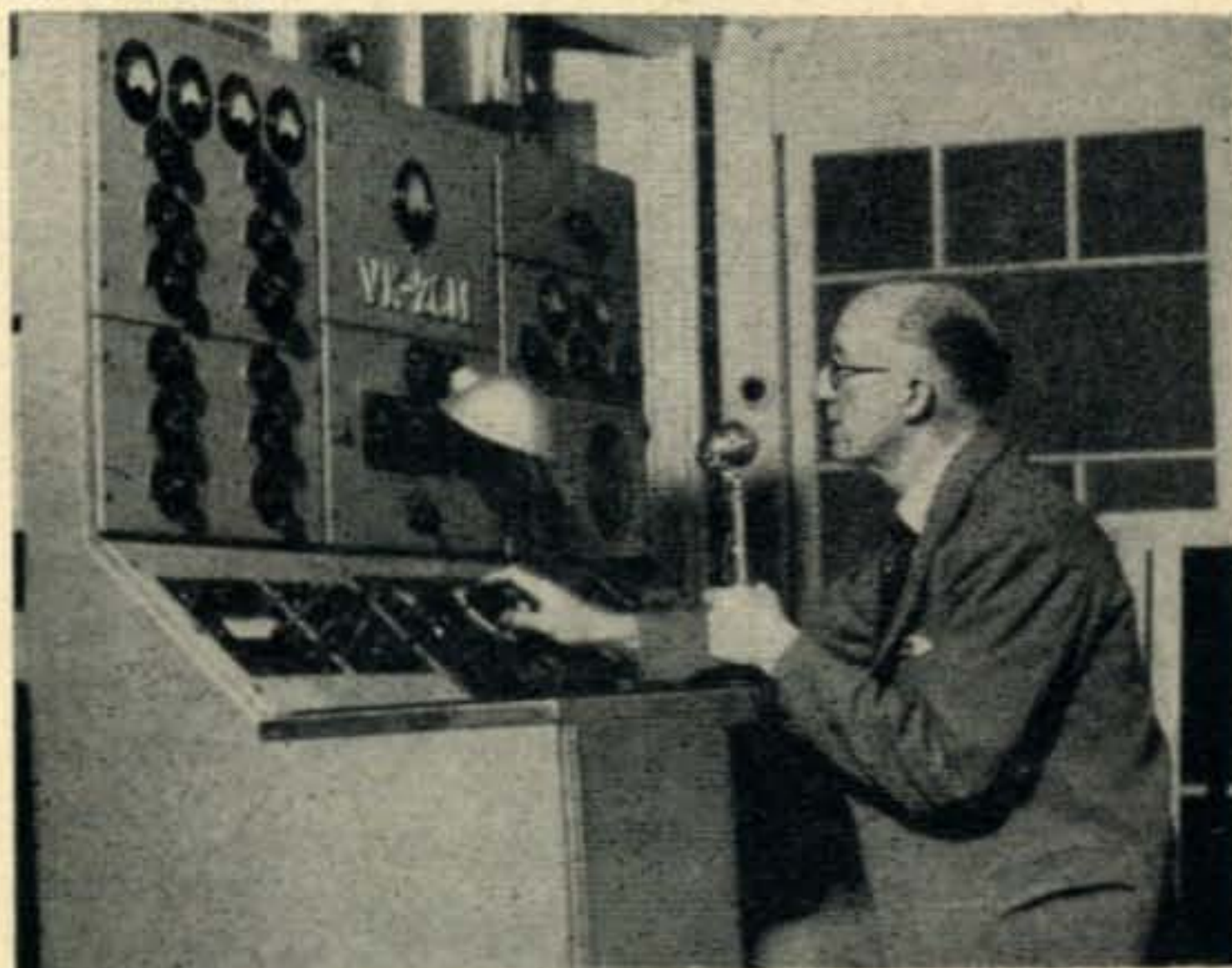

This is the No. 1 Australian amateur; Charles D. Maclurcan, VK2CM as seen in his 1953 shack. The receiver is a National HRO and to the left are the 6-meter converter and "R9-er." Below the meters on the top left section are separate finals for the transmitters which vary from 807's to 829's and 813's. Class AB2 807's are used in the modulator. A surplus "Command" unit is built into the right-hand panel as a VFO from 80 through 10 meters.



The author takes a little time out while in VK4. During the two and one-half years as VK4QL a total of 181 countries were worked, 39 Zones, WAS, and a WAC in 23 minutes. All of the DX bands were used.

Probably one of the first amateur mobile marine stations in the world went on the air in 1924. In February of that year A2CM and A2DS made a trip to the Pacific coast of the U. S. A. in the S.S. *Tahiti*. Using low power on 200 and 185 meters, they were able to maintain contact with 2CM's home in Sydney and 6AKW in California.

VK2NO commenced playing with radio in 1911. In the early 20's you Americans will recall his signal as G6XG, the first G to work across the Atlantic Ocean on 90 meters and a power of 10 watts. In 1925, Don came to Australia and at one time operated from the Northwest as VK6NK. VK2NO made our first VK interstate QSO on 6 meters by working VK3MJ in 1947. Don is still greatly interested in v.h.f. and television, but finds time to work the DX bands.

VK7BQ considered the old 31-meter band (amateur allocation in the mid-twenties) a good DX band, and between 1925 and 1930 Len worked 35 countries. When considered in the light of lack of activity and poor equipment, this was quite an accomplishment. In those days, Australian amateurs were permitted to use the 200 to 250-meter broadcast band to radiate entertainment programmes. VK7BQ was a very active participant and his low power transmissions were often heard in New Zealand. VK7BQ remains active on all bands, up to and including our band at 576 Mc.

From 1931 to shortly before the war, a strange call frequented the amateur bands. It was that of VKZ located at Alice Springs in the heart of Australia. The operator of this station was Joe Kilgariff, now signing VK5JT. VKZ was primarily issued for contacting expeditions operating in the heart of Australia. The first transmitter was

purchased from one of the returning expeditions, and used batteries and a 210 in the P.A. On one occasion a transmitter using a 201A tube operated from a few dry cells managed to get an emergency call over 900 miles on 40 meters.

Calls which come to mind in the pre-war period are, amongst many, VK2YI, 2HZ, 2EO, 2DG, 2QL, 2XU, 2YC, 2TI, 2AGU, 3YL, 3MR, 4AP, 4HR, 4EL, 4EI, 6SA, 6JE, 7CW, 7JB, 7YL, 7LZ and 7CK. VK2HZ later became famous for his exploits of putting together radio receivers while a prisoner of the Japanese . . . VK7CK used to obtain his power from a waterwheel and generator combination . . . Wonder how many will remember the strange "unofficial" calls that appeared on 14 Mc. during this period? T4TWO who sent a well designed hand-made QSL. B4UP, PMZ on an expedition in which one of the members was murdered by natives . . . VK2DG made the first pre-war DXCC while VK2QL, 7JB, 7LZ and 7AB were among the few to reach the astounding total of "90 countries worked!"

DX Conditions

There is considerable variation in the DX conditions throughout Australia from north, south, east to west. A good illustration was the operation of VK5NR on 10 meters from central N.W. Australia. Shortly after we resumed activities, this station could not hear a single North American signal for weeks during the time that the Australian east coast boys were working them right and left. But then, in the evening hours, VK5NR would work the Europeans when they were inaudible on the East Coast. After a couple of months, however, the positions completely reversed themselves, although 5NR could still work the Europeans as well.

In the years preceding the war, the east coast stations found it very difficult to raise South Americans or South Africans; a QSO with one of these continents being one of great rejoicing.

(Continued on page 66)



Here is VK2DG, who has won many sections of the VK/ZL contests, the latest being the CW section of the 1951 Jubilee Contest. With 185 countries confirmed VK2DG also holds the first VK/WAS, DXCC, WAJAD, WASM and WAZ.

Ionospheric Propagation Conditions

Forecasts by **GEORGE JACOBS, W2PAJ**

3620 Bedford Ave., Brooklyn 10, New York.

This February's issue of CQ is the "Feature DX Issue." The following is an analysis of DX conditions expected during the month of February.

GENERAL PROPAGATION CONDITIONS FOR FEBRUARY, 1953:

The following is a brief description of expected short-wave propagation conditions for Amateur circuits from the United States to the five major areas of the world. For specific times of band openings for any particular circuit refer to the **Propagation Charts**. Basic propagation data used in this analysis appears in the Series D Publications of the National Bureau of Standards, entitled "**Basic Radio Propagation Predictions**," and is based on a predicted smoothed sunspot number of 29, centered on February, 1953. Notice that all times are now given in **LOCAL STANDARD TIME**.

Dependent upon observations made during December and early January and based upon certain recurrence tendencies, the most probable period of ionospheric disturbances during February are the 1-2, 5-6, 8, 16-19, 21-26, and 28. February, therefore, will be a month of prolonged ionospheric disturbances.

Europe:

Daytime usable frequencies are going down in accordance with seasonal characteristics, no ten meter openings expected and fewer 15 meter openings than during the winter months. The twenty meter band will improve somewhat on these circuits from what it had been during the winter, with the band remaining open noticeably longer. Not much change in 40 and 80 meters, with both bands supporting some good openings during the dark hours. On some nights, especially during disturbances, the MUF will drop below 7 Mc., and signals will not be heard on 40 meters, although they may be coming through on 80. Possible 160 meter openings on propagationally quiet nights. These circuits considerably favor East Coast and Central USA QTH's.

South America:

Good 15 and 20 meter openings expected during daylight hours from all areas of the USA to all areas of Latin America. Occasional 10 meter openings also possible. Good conditions are forecast, during the dark hours, for 40 and 80 meters, favoring countries North of the Equator. Good 20 meter conditions are expected from shortly before sundown through the early evening hours, with exceptionally strong signal strengths noticed. Some 16 meter openings possible, especially to Central America.

Africa:

During the daylight hours an occasional 10 meter opening to Central and South Africa possible. More frequent 15 meter and quite regular 20 meter openings expected especially to North and Central Africa. Some fairly good nighttime 40 meter openings expected and some occasional 80 meter openings also possible. On quiet nights, the 160 meter band may open between Eastern USA and North Africa.

Australasia:

Conditions on these circuits tend to improve as we approach the equinoctial period (March-April). An occasional 10 meter opening from West Coast, USA, with some 15 and 20 meter openings expected from all areas of the USA. During February 40 meters may be the best band for DX to Australasia, and openings are expected from all areas of the USA during the night hours. Some openings may occur on 80 meters, with these paths favoring West Coast QTH's.

Asia:

No 10 meter openings expected. Conditions on 15 meters, generally poor but some openings expected to the Far East. In general, because of higher absorption due to the long distance of the paths and auroral zone penetration, DX Conditions on these circuits are poor. Some openings should be possible, on 20 and 40 meters, to certain areas of Asia from certain areas of the USA during ionospherically quiet periods (WWV N 7 or better). Not much expected for 80 meters on these circuits.

Post Analysis Of CQ DX Contest:

Shortwave radio conditions during the recent CQ DX Contest were very much as predicted. A general consensus of world-wide observations indicates that the phone period of Oct. 25-27 was somewhat erratic, with conditions being good on the 25th and becoming slightly disturbed on the 26th and 27th with conditions varying between poor to fair on some circuits and fair to good on many others—overall rating generally fair. In general, conditions during this phone period were noticeably better than they were during the previous two contests.

A moderate to severe ionospheric disturbance was noticed during the CW period of the contest, and to quote a European friend, conditions were quite "poorish." Overall ratings for the first and second were poor, becoming fair on the third.

ALL TIMES IN E S T

EAST COAST TO:
(Centered on
Washington, D. C.)

	10 Meters	15 Meters	20 Meters	40 Meters
Scandinavia	Nil	1000-1200 (0-1)	0700-1400 (2)	1700-0400 (2)*
Great Britain & Western Europe	Nil	1000-1330 (2)	0700-0930 (3-4) 0930 1500 (2-3) 1500-1600 (3-4)	1600-2300 (3-4) 2300-0430 (2-3)*
Balkans	Nil	0930-1200 (1)	0700-1300 (2) 1300-1400 (2-3)	1530-2100 (2-3) 2100-0100 (2)*
Central Europe	Nil	0930-1300 (1-2)	0700-0800 (3-4) 0800-1300 (2-3) 1300-1430 (3-4)	1600-2100 (3) 2100-0330 (1)*
Southern Europe & North Africa	Nil	0830-1500 (2-3)	0630-0800 (3-4) 0800-1330 (3) 1330 1700 (3-4)	1630-2200 (3-4) 2200-0400 (2-3)
Central & South Africa	1100-1400 (1)	0800 1430 (1) 1430-1600 (2-3)	0700-1500 (0-1) 1500-1800 (2-3)	1700-0000 (2)
Near & Middle East	Nil	0930-1200 (0-1)	0630-1200 (0-1) 1200-1300 (1-2)	1700-2300 (1-2)
Central America & Northern South America	1100-1600 (2)	0900-1600 (3-4) 1600-1700 (4-5)	0700-1000 (3-4) 1000-1700 (3) 1700-2100 (4-5) 0100-0400 (1)	1800-0700 (4-5)
South America	0900-1600 (2-3)	0800-1330 (1-2) 1330-1730 (3)	0700-1630 (1) 1630-1930 (3-4) 0100-0300 (1-2)	1830-0500 (3-4)
Hawaii	1400-1700 (1)	1230-1800 (1-2) 1800-1900 (2-3)	1100-1800 (1-2) 1800-2130 (3)	2200-0800 (3-4)
Australasia	Nil	1700-2000 (1)	0800-1000 (2) 1000-1900 (0-1) 1900-2100 (1-2)	0100-0730 (2)
Guam & Pacific Islands	Nil	1630-1830 (1)	0900-1100 (1) 1500-1900 (1) 1900-2030 (1-2)	0100-0700 (2)
Japan	Nil	1700-1830 (0-1)	1600-2000 (1-2)	0100-0700 (1-2)
Philippine Islands & East Indies	Nil	Nil	Nil	0330-0700 (0-1)
India	Nil	Nil	0800-1000 (0-1)E	1700-2130 (1)E
West Coast, USA	Nil	1300-1500 (2) 1500-1700 (3)	1000-1730 (2-3) 1730-1900 (4) 1900-2000 (2)	2000-2300 (4-5) 2300-0800 (2-3)*

ALL TIMES IN C S T

CENTRAL USA TO:
(Centered on St. Louis,
Missouri)

	10 Meters	15 Meters	20 Meters	40 Meters
Great Britain & Western Europe	Nil	0930-1230 (1-2)	0700-1400 (2-3) 1400-1500 (3)	1630-2000 (2-3) 2000-0330 (1-2)*
Central Europe	Nil	0900-1200 (1)	0700-1230 (2) 1230-1330 (3)	1530-1900 (2) 1900-0230 (1-2)*
Southern Europe & North Africa	Nil	0800-1330 (2-3)	0600-0730 (3) 0730-1300 (2-3) 1300-1600 (3-4)	1600-2300 (3) 2300-0300 (2)*
Central & South Africa	0900-1400 (1)	0630-1430 (1) 1430-1600 (2-3)	0530-1400 (0-1) 1400-1730 (2-3)	1700-2300 (1-2)
Central America & Northern South America	1030-1500 (2)	0800-1500 (3-4) 1500-1700 (4-5)	0630-0900 (3-4) 0900-1600 (3) 1600-1900 (4-5) 0100-0300 (1)	1730-0700 (4-5)

ALL TIMES IN C S T

CENTRAL USA TO:
(Centered on St. Louis,
Missouri)

	10 Meters	15 Meters	20 Meters	40 Meters
South America	0900-1500 (2-3)	0730-1600 (1-2) 1600-1800 (3)	0600-0730 (2-3) 0730-1600 (1-2) 1600-1930 (3-4) 2330-0230 (1-2)	1730-0500 (4)
Hawaii	1300-1700 (1)	1200-1730 (2-3) 1730-1900 (3-4)	1100-1800 (2) 1800-2000 (3-4)	2100-0730 (3-4)
Australasia	1730-1830 (0-1)	1500-2000 (1) 0930-1200 (0-1)	0800-1130 (2) 1130-2000 (1) 2000-2130 (1-2)	0100-0700 (2-3)
Japan	Nil	1630-1830 (1-2)	1530-2000 (2-3)	0030-0500 (3) 0500-0800 (2)
India	Nil	Nil	0700-1000 (0-1)E 1900-2100 (0-1)A	1700-2030 (1)E 0500-0700 (0-1)A
Philippine Islands & East Indies	Nil	Nil	1600-1900 (0-1)	0300-0800 (1)

ALL TIMES IN P S T

WEST COAST TO:
(Centered on
Sacramento, Calif.)

	10 Meters	15 Meters	20 Meters	40 Meters
Europe	Nil	0900-1100 (0-1)	0800-0930 (0-1) 0930-1130 (1-2)	1700-0000 (1)*
South Africa	1000-1400 (0-1)	0800-1300 (0-1) 1300-1500 (1) 1500-1630 (2)	0600-1200 (0-1) 1200-1500 (1-2) 1500-1800 (2)	1700-2200 (1)
Central America & Northern South America	1000-1500 (2-3)	0700-1500 (3-4) 1500-1700 (4-5)	0600-1500 (3-4) 1500-1800 (4-5) 0000-0300 (1)	1700-0500 (4-5)
South America	1000-1500 (2-3)	0700-1400 (2-3) 1400-1800 (3-4)	0600-1400 (1-2) 1400-1600 (2-3) 1600-1830 (3-4) 2300-0100 (1)	1800-0400 (3-4)
Hawaii	1130-1800 (1-2)	1000-1200 (3) 1200-1800 (4-5) 1800-1900 (2-3)	0900-1700 (3-4) 1700-1930 (4-5)	1900-0500 (4) 0500-0800 (2)*
Australasia	1600-1830 (1)	1200-1800 (1) 1800-1900 (2)	0700-0900 (0-1) 1100-1830 (1) 1830-2000 (2-3)	0000-0600 (2-3)
Japan	1500-1700 (0-1)	1400-1700 (2-3) 1700-2000 (3)	1300-1800 (2-3) 1800-2100 (3-4)	2200-1100 (3-4)
Phillipines & East Indies	Nil	1500-1830	1330-2100 (1-2) 0900-1100 (1)	0300-0600 (1-2)
Marshall Islands	1330-1730 (2-3)	1200-1730 (1-2) 1730-1830 (2-3)	1100-1800 (1-2) 1800-2000 (2-3)	2300-0700 (3-4)
Guam & Pacific Islands	1400-1600 (1-2)	1300-1900 (2-3)	1200-1300 (2) 1300-1800 (1) 1800-2000 (2-3)	0000-0800 (3)
East China (Hong Kong)	Nil	1500-2000 (3)	1400-1900 (2) 1900-2030 (3)	0200-0600 (2-3)
India	Nil	Nil	1730-1900 (1)	0300-0600 (0-1)

Symbols For Expected Percentage of Days of Month Path Open:

(0) None (1) 10% (2) 25% (3) 50% (4) 70% (5) 85% or more

*Indicates conditions on 80 meters will be as good as, or more favorable than on 40 meters. In general, 80 meter band should open about an hour after and go out about an hour earlier than the 40 meter band.

A - appearing after percentage figures, denotes favorable great circle path arrives over "Asiatic" route,
E - indicates signal will arrive over the "European" path.

DX AND OVERSEAS NEWS

Gathered by DICK SPENCELEY, KV4AA

Box 403, St. Thomas, Virgin Islands

Comments Requested

For quite some time it has become increasingly apparent that the possibility of securing QSO's in Zones 16, 17, 18 and 19 was becoming steadily reduced. These are the Zones that are coming under the Soviet orbit, the "WSEM" group.

Rather than reduce the requirements necessary to obtain a WAZ Award, I have given considerable thought to the possibility that CQ would establish an entirely new DX award using a somewhat more equitable basis in view of current world conditions. I am also of the opinion that such an award should be an all-band affair, and that if adopted it would be more indicative of DX achievement while, at the same time, encouraging all-band operation.

Scoring in the new DX Award would be according to the following outline. One point would be allowed for each country and one point for each zone on each of the five major DX bands. The bands would be 80, 40, 20, 15 and 10 meters.

Neglecting Zones 16, 17, 18 and 19 and the countries contained therein, this gives a possible total of 36 Zones and, roughly speaking, 255 countries on

each band. Or, a total of 180 Zones and 1275 countries on all five DX bands for a grand total of 1455 points.

It might be possible to establish certificate awards on such a point basis starting at about 300 points. This represents an average of 50 countries and 10 Zones worked on each of the DX bands, and should be within reaching distance of many DX-ers. A new "Honor Roll" would be established and the minimum requirement for entry could be 150 points, equivalent to contacts in 20 countries and 10 Zones on each band. For the really top-notch DX men, certificates could be made available for 500, 750 and 1000 points. These could be named "ABC-Z 300, ABC-Z 500, ABC-Z 750 and ABC-Z 1000." The letters representing "All-Band Country-Zone Award."

Until necessitated otherwise, the Honor system would prevail and QSL's would not be involved. Contacts would date from the close of World War II and, although this would require considerable digging back into your old station logs, this should not be too difficult, and could easily be accomplished on some rainy Sunday afternoon.

In G6QB's DX column in *Short Wave Magazine*, a Four-Band DX table is printed. This is for countries only and for the 80, 40, 20 and 10 meter bands. According to all reports and what information I have at hand, this method has proven to be quite workable in Europe and there seems to be little reason to suspect that the incorporation of "Zone" points and the addition of the 15 meter DX band would not greatly enhance the over-all plan.

Should present WAZ holders tend to take a dim view of these changes, it should be pointed out that they would be among the leaders in any new type of story, and would also have plenty of elbow space to keep on going. The WAZ certificate would naturally be continued, but listings would probably be cut back severely to make room for the new type of scoring.

As I have indicated above, this brain wave is a result of many requests, and it is being printed in the hopes of obtaining your reactions and suggestions, especially from those who would go all out in the quest of DX. Please drop us a card or letter on the subject and if the replies are favorable, we shall attempt to go to work and develop the idea to a final working plan.



Active on all bands is YUIAD of Belgrade, Yugoslavia. Mirko runs 250 watts to an 813 and has worked 191 countries including 61 on 3.5 Mc. alone. Two ground plane antennas are used on 14 and 21 Mc. and a vertical dipole on 28. Mirko's smooth fist is helped by the W6DPU el-bug which may be seen at lower left.



Fjalar (Ed) Lindstrom, OH2RY, Lohja, Finland, is no stranger to the DX fraternity. Ed is shown here with the 100-watt rig. He is now building an 813 final and plans all-band operation. Ed's score is 39 zones and 183 countries.

At Time Of Writing

14-Mc DX has been very good in the morning hours for the Caribbean and southern W4 areas with such prefixes as VK, VU, VS7, VS2, AP2, CR9 and VS6 putting in very good signals between 1030 and 1400 GMT. Around 1300 the band opens for the Persian Gulf section with strong phone signals from such as MP4KAC, MP4HBK, YI3BU and VS9AW. Twenty pulls a sharp fade-out during local darkness in the Northern Hemisphere and is generally useless. This does not apply to the Southern Hemisphere where conditions seem excellent after dark.

CE0AA, Easter Island. Luis, CE3AG/CE3AX, advises that he should know definitely, by January, whether or not, and on what date, he will be able to set up shop on Easter Island (Isla de Pascua). It is expected this will be some time in early 1953.

CE0AB, Easter Island. Very promising news on Ham activity at this spot also comes from CE3AG who states as follows: A ship, sponsored by the Explorers Company of the island, will be leaving Chile after December 4th. On board will be Fernando Cadiz, the Administrator of Easter Island, and a "Lettine" transmitter of forty watts power which covers the 3.5, 7, 14 and 28-Mc bands. This transmitter should be in operation in January 1953, and will be on the air for the entire year and, possibly, two additional years. This station has been licensed as CE0AB. First QSO's will probably be on phone, but Fernando, who is an old CW man of the 30 WPM variety, has promised to brush the cobwebs from his CW operating and give CW men their full share of QSO's. CE0AB speaks Spanish, English, French and Portuguese in addition to the Easter Island lingo, so world-wide phone contacts will be no problem. CW operation will be concentrated on the frequencies between 14000 and 14015 with xtal control. An SX-42 receiver, now on the island, will take care of the incoming signals. Fernando has been thoroughly briefed on Ham operating by Luis and will take along such helpful literature as the Callbook, Handbook, QST and CQ. Easter Island has a cable service to the Chilean mainland and it has been arranged to transmit the station logs of CE0AB to CE3AG by this method, thus, QSL's will be greatly expedited considering postal service to Easter is once per year. To defray costs of equipment and cable service it is requested that all QSL's sent to CE3AG for CE0AB be accompanied by one dollar. This will climax a three-year effort of Luis to put Easter Island on the air. We wish all parties success.

VK2LN, Lord Howe Island. From VK3CX and "The Pacific Island Monthly," we hear that there is an active Ham on Lord Howe Island under the call of VK2LN. He is quite active on 7 Mc. This island, with an area of five square miles, is a dependency of New South Wales and is located 436 miles Northeast of Sydney. Its radio status, as far as we can determine, is the same as any VK2.

ZC5VS, North Borneo. This station has been contacting West Coast stations on 7020 around 1600 GMT. W7RT tells us that ZC5VS will receive a visit from Fung, VS6CG, on Dec. 16th. He will bring his DX QSL's plus a batch of ZC5VS cards. Hugh has been promised an all-band transmitter and should be able to get on all bands at time of reading. We are counting

on him to make good use of 14 Mc. ZC5VS is Chinese and works at the Sandakan Airport. QSL's may go via VS6CG or direct to: T. S. Hugh, Box 136, Sandakan, British North Borneo.

OQ0, Ruanda Urundi. OQ5RA informs us that the new prefix, OQ0, is now official and a photostatic copy of the document is on its way to KV4AA. This will affect OQ5DZ, OQ5CZ and OQ5AV who operate in that "Trust Territory." Ruanda Urundi has its own postage stamp issues and we hope to have it entered as a separate 'radio' country.

VK1HM, Cocos. From ZS6BW, W5ASG and The West Gulf Bulletin we hear that VK1HM should now be active on Cocos Island. He is located at an AIR radio station which will be permanent.

VS9AW, Sultanate of Oman. The operator of this station leaves around mid-December. Unconfirmed reports have it that VS9AS will take over.

Through courtesy of W6YYN/1, W1NWO and the West Gulf Bulletin we list the following which was tabulated from confirmations credited to DXCC members. While the below may not be the latest word or even a complete listing we feel that it will go far to unravel the tangled Antarctic QTH business: (*denotes phone operation)

Antarctica

- VP8's: AJ*, AN, AM*, AK*
- CE7's: (Now CE9) ZG*, ZH*, ZJ*, ZQ*, ZN*, 8AS*
- LU's: 2ZJ, 3ZB, 5ZB*
- LA4QC, W3LYK/*

South Georgia

- VP8's: AD*, AR, AT, AU*

South Orkney

- VP8's: AP*, AZ*
- LU's: 1ZA*, 2ZA*, 4ZA*, 8ZA*

South Shetland

- VP8's: AK*, AO, AD*
- LU's: 3ZI*, 4ZI*, 7ZI, 9ZI, 1ZC*, 7ZC*

Falklands

- VP8's: AB, AD, AI*, AM, AP*

Heard Island

- VK's: IF*, IHV, IPG*, IRA*, INL*, IVU*, IYG, 3OY, 3ACD.

Macquarie Island

- VKI's: AD*, BS*, RB*, RD*, RF.

Strangely enough no QSL's have been received from VP8AE and his QTH is not definite. Each heading, above, is counted as a separate country.

MP4BAU, Qatar, returned from leave in England around Nov. 6th and has been handing out contacts on 7015 between 0030 and 0200 GMT. .W1DR nabbed SV5UN, 14345, A3, 1505 GMT. .B1AB, Formosa, has been on 14048 1100 GMT. .4UAG, Karachi, and 4UAS, Kashmir, have been very active near 14080 1130 GMT. . . OY3IGO promises to be on 14060 every Saturday at 2200, GMT, and other weekday nights whenever able. Ingvar runs 450 volts to a pair of 1625's. Should any QSL's be missing let him know and he will send another along. .OQ5RA and OQ5CP QSO'ed one RD6RR who gave his QTH as "New Siberian Island" and said QSL via Box 88, Moscow. hm-m-m. .VK5BY nabbed PK3CW who said his name was Ron in Sorong, Neth. New Guinea, and that he was leaving for VK land very shortly. .VK3CX ponders one ZB3A. He also heard ZL1PO calling ZM2CB (?). .KG4AF and W2MOJ scored with PX1YR, Andorra, 14 Mc. We sure hope Yves can get more consistently.

W6UXX/MM seeks licenses which would enable him



Photo Courtesy of W1MUN

Seen above are some of the 50 New England DXCC members who attended the recent get-together at Cambridge, Mass.



At W6NIG's shack (Joe Johnson, Vallejo, Calif.) we see (left to right) DX'ers W6NIG, Joe; W6GIZ, Dan; W6MVQ, Dick; and W6MEK, Frank. Looks like they all have just worked a couple of new ones!

to operate from FO7/Clipperton Is., Galapagos Islands (HC8) and Cocos Island (TI9). Evan visits these spots fairly frequently. In November he QSO'ed KH6UL, W5IZW, W6RRO, W6BTX and W6EET/Mobile while laying off Clipperton Island one quarter mile!!! This was on 28-Mc phone using three (count 'em) watts. He may be contacted at home QTH in callbook.

Exploits

ZS2AT rises to 159 with six additions which include ZC2MAC, AC3PT and UM8KAA. . . . KG4AF makes it 177 with OD5AB, MP4BHK, HC8GI and FG7XA. . . . W6TI knocked off ZD7A putting Horace on 214. . . . Ian, GM3CSM climbs to 188 with HZ1MY/VQ6 and VP5BH (Caymans). . . . DL1FF welcomed QSL's from FN8AD, FB8ZZ, FB8BB and ZK2AA. Armin also added LB6XD and ZD7A to hit 219. . . . Egon, 4X4RE, makes it 215 with VQ6MY, SV5UN, ZD7A, FO8OC and MP4BAM (Qatar '49). . . . W1BFT goes to 162 with EA9DC, LU4ZI and VQ5CL. . . . W6MX's new list, plus ZD7A, puts him 'way up there' with 235. . . . W1HA comes up to date with 15 additions to reach 187. . . . W3DKT added VP8AU and ZD7A for 209. . . . W6GDJ snagged LZ1KAB for his 226. . . . W3JTC soared to 240 with ZD7A and MP4BAU. . . . ZD7A gave W2AGW his No. 234 while W1FH stayed out in front with MP4BAU for 252! ! . . . W8KIA kept up to date with ZD7A, LB6XD and 4W1MY. Glenn now has 232. . . . WØRBA comes up to date with nine additions for 157. . . . W5ASG adds ZS9G, CR4AC and ZD7A to his phone total for 165. . . . VK4FJ pulled in ST2HK, ZS5VR and HB1JJ/HE to reach 199. . . . W7ENW goes to 180 with FR7ZA and LZ1KAB while MP4BAU helped W1HA to reach 196. . . . G6ZO eases to No. 242 with ZD7A who also helped W8HFE to his 207. . . . OE1FF is back in the race and adds CR7AD, VS1CX, VQ4DO, F18YB and FG7XA to reach 141. . . . W6TXL added FB8BB and 5A3TU for 145. . . . LU5AQ ups to 128 with EAØAC, VP3VN, ZS2MI, KM6AX, VP4LZ, VK1JC and KAØIG. Only 92 pasteboards in tho. . . . W5MPG nabbed MP4KAC 14135 1420 GMT and reports him there every day. . . . W2QHH added EA9AP on 3.5 Mc. for 96 on that band! ! . . . VK3CP hooked ZK1AZ, CR9AF and ZK1AZ, all on 7 Mc. . . . W7RT added ZC5VS and PJ2CE to reach 139. . . . W2ESO nabbed MP4BAU and LU4ZI on 7 Mc. . . . W5YIG nabbed KV4AA with a two week old ticket. Yas suh! . . . VQ5AU parceled out QSO's to W5AVF, W2BUV and W9YFV. . . . W2CTO skeds ZD6HN, Sundays, 2000 GMT, 001. . . . W2MOJ reports CR8LI at 1207 GMT S8! . . . W2LCB keyed with ZS2CR, 7029, ZS9I, 7031 and ZL1CI 3.5 Mc. . . . HH2FL helped VK2VN, VK3CX and VK3KB, FL has been on each day around 1130 GMT, 14 Mc CW. . . . W1BLF phoned with VS9AW, MP4KAC, MP4HBK, MP4BBI, VS7PW and OD5AB. . . . W7HXG ups to 179 with a flock of new ones which include ZD7A, VK1BN, FY7YB, LB6XD, LZ1KAB and VQ4DO. . . . W2QHH just rec'd. the first H22 (Swiss) Certificate awarded outside of Europe. . . . W6RW nabbed VP8AP on 3.5 Mc. . . . To come back to Howy again. W2QHH finally snagged FB8BB for No. 213. 35 watts is tops at the Bradley homestead y'know. . . . VE3XO pulled in LZ1KAB for 159 along with WAJAD, BERTA and DUF-1 and 2 Certifs. . . . KP4KD snuk up on MP4BAU for Ev's No. 196 and so added a new one for 3.5 Mc with GI5UR. . . . WØRBA was very happy to add Zone 34 to his collection

which now totals 39. 5A3TZ was on the other end. . . . W9ESQ has 109 on 7 Mc. with 87 confirmed. Some late ones were LU4AAE, KG6FAB, VP4LK, HR2ZE, OK1MB and YU3AIJ. Lou vacationed on 14 Mc. a bit and came up with TG9AQ, VK1JC, OQ5RA, CX6AD, ZP6CR, KA3RN, FY7YB and VE8ML. The VE8 is located at the ALERT weather station near the North Pole. . . . Our regular report from W4KE tells of contacts on 7 Mc. with HH2LD, FFAG, EA8BF, PJ2AD, 5A3TR, VK6SA, VP6UN, ZE3JP and EA1AB. 14 Mc. accounted for TG9RB, 5A3TU, KX6AI, YU1AD, AA3AA, GD3UB, OQ5CP and GC4LI. . . . K2BU upped to 144 with ZD7A, ZS3Q and LB6XD. Ken advises the VP8AP has an order in for 750 QSL's and hopes to answer all cards received in the very near future. . . . OE1FF completed his WAS with QSL's from W7GWD and W7LEE (Our little item on these missing ones brought action, but fast. Tks.). . . .

21 Mc.

Conditions have not shown any marked improvement since last writing, although activity continues to increase. VQ4HJP, ZS3K and VQ2DT put in such strong and consistent signals from Africa that it seems probable that any station in that area would do the same, so let's hear from VQ5, CR7, CR6, etc. . . . G3GUM added HE9LAA and TI2TG to rise to 55. . . . W4COK nabbed SU1FX, VQ2DT and CP1BX to increase his lead to 64 countries. Bill moves back to W2COK in December ('52). As our listing of countries is just on the basis of general interest we shall continue his totals from W2 land. . . . KP4KD spurts ahead to 50 with T12TG, CM9AB, CT3AV, VP9BG, 4X4RE, YU3BC, VQ2DT, VK3NM and EA9AP. . . . VK3CP nabbed XZ2KN A3 and says VK's work into Europe between 0930 and 1330 GMT. . . . W1RY, a relative newcomer, worked 37 countries in the CQ DX contest and then went on to add five more putting him on 42. . . . YN1AA expects to be on 21 when new receiver arrives. . . . TI2TG goes to 38 with such as OD5AB, A3, LA9T and OA4C. . . . W4KE keyed with LU9AX, LU1EK, FA9UO, KZ5DE, FF3AG, G3AWZ, PY6DU and ZS5MP.

Here And There

W9GDI is on again after years layoff. New QTH is Park Forest Ill. . . . G3DCU and G3FNJ parted in London 18 months ago. They recently met again as VK2AWU and ZC4RX on 21 Mc. . . . K2BCK got a phone call from KC6QL from Pittsburgh. KC6QL will soon be permanent at KH6QL. . . . CM9AA received a Jr. Op. on Dec. 6th. Congrats Phil!! . . . W6WVU/1 is active in Rhode Island. Walt will be there 2 years with USN. . . . KV4AA climaxed six months work, moving 60 ft. to new shack. The new final with PP 4/125A's runs up to 800 watts. . . . FQ8AS, Toto, has been very active. He is the son of FQ8AG. See QTH's. . . . YN1AA visited W1BTE. He is now back in YN and will be active all bands. . . . W2AOX paid his annual visit to KV4AA. W8EWS and XYL also dropped in. . . . W7KVU moved to Ramsay, Montana after a stay in Portland Ore. John will take care of any missing Montana QSL's covering his former operations there. . . . W3AS submits info on WAVE certificate. Applicants must show proof of contact with two different VE stations on two different bands with each Canadian Province. Yukon and NWT count with VE7 and, apparently, VO counts with the Maritime provinces. A fee of twenty-five cents must accompany QSL's which go to VE3AUQ. . . . WOELA finally received VS5ELA QSL's from printer and first batch of 200 went out on week of Dec. 14th. Clyde advises he finally got his transmitter back. This was lost during his Brunei trip. It showed up at Travis AFB, California after being flown in from Korea by airlift. . . . VK9XX is now in South Africa under the call of ZS5XX he will be remembered also as VK2XX. . . . ZM6AA received a Johnson Viking transmitter from a US film Company on location in Samoa. ZM6AC is only other active station there. . . . VK3CX advises that a periodical called "The Pacific Islands Monthly" devotes a page each month to Pacific Ham activity. Notes may be forwarded to ex ZK1AC, VR2AK, P.O. Box 5179, Wellesley Street, Auckland, N. Z. . . .

W3FMC just returned from South America where new Electronics Co. was being set up. . . . PJ2CB visited TI2TG. . . . W3JNN has a new 3-element wide-spaced beam 62 feet up. Pushed by the PP 813's it does OK. . . . W8PQQ offers to QSL to anyone who has missed cards resulting from contacts with PX1AR, 3A2AC, 7B4QF or F7AR. . . . WØTKX is on from new QTH with better antenna possibilities. Bob traded his 4/125A's for a pair of 6146's and now runs 100 watts. . . . W4AIX is now going strong in new QTH 2200 ft. up. Smitty is ex W9NRB/9AIX. . . . Congrats to George, KP4BJ, on arrival of Jr. Op. . . .

OQ5CP seeks QSO with North Carolina and Tennessee to complete his WAS (Thanks to W4RG).

OQ5CP may be found on 14030, TS. . . **W6ALQ** lost his beam and other antennas in recent gale. . . **DL1IB** is none other than old **YM4AA/YM4ZO** of contest fame. . . **VK4FJ** seeks QSL's from **VP2LE** and **VP5BH**. . . **W7ENW** would appreciate a card from old **KC6WA**. . . Jim, **WØRBA**, had just about given up hope of a QSL from **W6ATB/KC6** when he QSO'ed **W6ATB/AM** flying

quencies with a power limit of 200 watts daytime operation and 75 watts at night. **D. Puerto Rico, KP4**, and the Virgin Islands, **KV4**, also move to the 'east coast' frequencies with an increased power input of 500 watts daytime and 200 watts at night.

QTH COLUMN

Honor Roll		Endorsements	
W1FH	40-252	W1ZL	39-196
G6ZO	40-242	KP4KD	39-196
W3JTC	40-240	GM3CSM	39-188
W6MX	40-235	ZS2AT	39-159
W2AGW	40-234	WØRBA	39-157
W6GDJ	40-226		
DL1FF	40-219	W1HA	37-187
W6TI	40-214	W1BFT	37-162
W7ENW	40-180	OE1FF	37-141
		KG4AF	35-177
W8KIA	39-232		
4X4RE	39-215		
W3DKT	39-209	PHONE ONLY	
W8HFE	39-207	W5ASG	35-165
VK4FJ	39-199	WONCG	35-149

Last complete HONOR ROLL appeared in the Jan. issue. Next complete HONOR ROLL will appear in the May issue.

8000 ft. over Roanoke, Va. 'Twas the same gentleman and he promised to come through. . . **KH6ARA**, ex-**W2AIS**, now works as Chief Engineer of **KHBC**, Hilo. See QTH's. . . **W2BBK/FP8AK** and **W2ZBO/FP8AQ** seek aid for the widow of **FP8BX**, who passed away last year, and her two wonderful children. No public assistance is available in **FP8** land and this family is penniless. Contributions should be sent to **FP8AP**, P. O. Box 192, St. Pierre and Miquelon, N.A.—Let's do our best to help gang! . . . **DL1FF** seeks confirmations from **HL1US**, **VP2AA**, **PK6FS**, **ZD1SS**, **VP8AD** and **UA1KEC**. . . **VQ4RF** offers to replace any missing QSL's for **VQ1RF** (Zanzibar) contacts. Send IRC coupon. (Thanks **W3LE**) . . . **GM3CSM** seeks QSL from **DU1MB**. . . **G5PS**, Hamish, survived the recent railroad disaster in England with minor bruises and shock. The whole side of his coach was ripped off by the Liverpool-Manchester express. . . **G3EDW** is now **VQ2W**. . . **VE2BV** should be on from new QTH by now. . . **G3HS/AP5B** will be soon adding a new call. See QTH's. . . **HZ1MY** was slated to have spent Xmas with **ZS6BW**. . . **VP8AE** leaves So. Orkneys in December ('52) and **CE7ZU** leaves the Antarctic in Feb. . . **AP2R**, Roy, is ex-**G3GJQ**. He will be there two years and has been active each day around 1230 GMT near 14090. See QTH's. . . **W6ITA** has been running 15 watts while rebuilding for **TVI**. . . From **W6TMP** we hear that **VP8AU** and **VP8AT**, on So. Georgia, request that their QSL's go only via **R5GB**. . . For **VP8AP**, see QTH's for correct address.

We regret to report the passing of **W9GA** in Chicago. John will be deeply missed.

A recent election of Brazil's **LABRE** resulted as follows: President—**PY1ADA**; Vice-President—**PY1BBF**; Director-Secretary, **PY1AXP**; Director-Treasurer, **PY1ACJ**; Director-Communications, **PY1ARM**; Technical Director, **PY1AQM**; Director-Military Reserves, **PY1AF**; Director-General Service, **PY1AZA**.

160 Meters

A reminder: Trans-Atlantic tests will be held Feb 8th and 22nd 0500/0800 GMT. Overseas listeners please note the following changes in frequencies and power limits which were effective Dec. 15th 1952:

- A. Amateurs in the States of Minnesota, **WØ**, Iowa, **WØ**, Missouri, **WØ**, Arkansas, **W5**, and Louisiana, **W5** have moved to the "east coast" frequency bands of 1800/1825 and 1875/1900 KC. Power limits: Daylight 500 watts. Night 200 watts.
- B. Amateurs in the States of Florida, Alabama and Mississippi are now permitted nighttime operation with same power limits as above.
- C. Amateurs in the states of Texas, Oklahoma and Kansas move to the "east coast" fre-

- AP2R** ex **G3GJQ**, Roy, Royal Pakistan Air Force. Via **R5GB**.
- AP5B/G3HS** (New QTH, No call yet) **D. T. Boffin**, Officers Mess, 3 **GHQ** Signals Regt. **FAYID**, M.E.L.F. 17.
- FQ8AG and FQ8AS** Box 138 Brazzaville, French Equatoria' Africa.
- JA3AB** **D. Fujimoto**, 339 Shinmachi, Shimoda Chiuri, Kamigyo, Kyoto, Japan
- KH6ARA** (New QTH) **Pat Miller**, Box 942, Hilo, Hawaii.
- KL7AMA** Box 2319, Ketchikan, Alaska.
- R.E.F.** (Reseau des Emetteurs Francais) (New QTH) 3, Avenue Hoche, Paris (8e)
- VE2BV** (New QTH) 65 Summerhill Ave., Valois Montreal 33, Canada
- VP8AP** **John A. Brown**, Box 243, Port Stanley Falkland Is. via Montevideo.
- VQ2W** 584168 A.P.O. **Munro**, A.J. Officers Mess, (ex **G3EDW**) **RAF Thornhill**, Gwelo, Southern Rhodesia.
- VQ4HJP** (New QTH) P.O. Box 311, Nairobi, Kenya.
- VS1** QSL Bureau P.O. Box 176, Singapore Malaya.
- VS7WB** 40 Jayaratna Road, Negombo, Ceylon
- YI3BU** Via **YI3ECU**
- ZBICG** **RAF Officers Mess**, Luqa, Malta.
- ZC5VS** **T. S. Hugh**, Box 136, Sandakan, Br. North Borneo. (or via **VS6CG**)
- ZP9AY** ex **ON4AP**, **Roberto**, Capitan Miranda Near Encarnacion, Paraguay. Via **RCP Louis**, c/o United Nations, Srinagar, Kashmir. Via India.
- 4UAS** **John Jacobs Jr.** QSL via **W6FJB**, 353 Dwight Ave., Riverside, Calif.
- 5A3TR** **Gerald Fries**, QSL via **W6PCS**, 2239 Simpson Ave., Fresno, 3, Calif.
- 5A3TU**

Thanks to **W3AS**, **W4COK**, **W7RT**, No. Calif. Bulletin and **F.O.C. Bulletin**



Photo Courtesy of **W1MUN**

Snapped at the recent New England **DXCC** meeti were **DX**'ers (left to right, top) **W1FH**, **W1JCX** and **W1NWO**. Left to right, sitting, are shown the only two N.E. **DXCC** **XYL**'s. **Dot Evans**, **W1FTJ**, and **Lou Littlefield**, **W1MCW**.



Conducted by HERB BRIER, W9EGQ

385 Johnson Street, Gary, Ind.

The *Bud, GM-79 Gimix* pictured on this page is a calibrated absorption wavemeter, so called because its operation depends upon it absorbing a small amount of power from the circuit whose frequency or wavelength is being measured. It consists of a coil, a variable condenser, and a pilot bulb in series. Across this combination is a 1N34 crystal diode and a phone jack, also in series. In addition, there is a toggle switch across part of the coil. In one switch position, the "Gimix" covers the 3.5- and 7-Mc bands. In the other, it covers the 14-, 21-, 27-, and 28-Mc bands.



Bud GM-79 Wavemeter reviewed in this month's column. It sells for approximately nine dollars.

In operation, the coil of the wavemeter is placed near the coil of a tuned circuit carrying radio-frequency power. The "Gimix" variable condenser is then tuned to resonance as indicated by the brightest glow from the pilot bulb. A glance at the dial calibration will then show the output frequency of the circuit being tested.

Always use the minimum coupling that will permit the bulb to glow at resonance. This minimizes the interaction always present when two coupled circuits are tuned to the same frequency.

Using A Wavemeter, Etc.

Probably the most valuable function of a calibrated wavemeter in an amateur station is to assure that the transmitter will actually operate in its prescribed band. Most transmitter tank circuits are capable of being tuned over a wide range of frequencies. The output tank of a typical 3.7-Mc transmitter, for example, usually tunes to 3.7 Mc. with the condenser near maximum capacity and may double or even triple this frequency (second and third harmonics) when set near minimum capacity.

Having been forewarned, you can avoid trouble by always tuning to resonance at the point requiring the most capacity. You could, that is, if you were sure that the stage was actually capable of tuning to 3.7 Mc. Suppose it is a new transmitter, and you could not duplicate the specified coil-condenser combination exactly. A nearly-identical substitute might be just enough different to prevent reaching 3.7 Mc. As a result, the lowest frequency on which you could achieve resonance would be 7.4 Mc.

A pi network is also easy to tune to the wrong harmonic. With one antenna, correct tuning might occur with the input condenser near maximum capacity and the output condenser near minimum. With another antenna, the condenser settings might be reversed. With either, there will probably be another pair of settings which will tune the amplifier and load the antenna—outside the band.

Should you choose the wrong settings, you would undoubtedly discover your error after several hours of futile calling. In a week or so, a letter from the FCC asking you to explain why you were transmitting in a commercial band, would probably prove it.

On the higher frequencies, it is just as easy to tune a frequency multiplier to a lower frequency

(Continued on page 54)

What do you want in a MICROPHONE?

Check the features and characteristics for which E-V microphones have become favorites in every field. Then take your choice, and know you can expect performance that is guaranteed by E-V research-engineering. Here are 9 models of today's most complete microphone line.

950 CARDAX ▶

High level cardioid crystal microphone with dual frequency response for high-fidelity sound pick-up or for extra crispness of speech. Overcomes feedback and background noise. Wide range response. "On-Off" switch. Metal Seal crystal. List, \$42.50



◀ 630 DYNAMIC

Popular high fidelity high output dynamic. Response 60-11,000 cps. Omni-directional. Exclusive Acoustalloy diaphragm. Extra rugged. Tilttable head. "On-Off" switch. Available in high or low impedances. Model 630. List, \$42.00



◀ MERCURY

Model 611 Dynamic and Model 911 Crystal. Smart design. Rugged and dependable. Response 50-8000 cps. High output level. Omni-directional. Tilttable head. "On-Off" switch. Available in high or low impedances. List from \$25.50 to \$35.50

208 MOBILE ▶

Small size, high output, single-button carbon microphone for maximum intelligibility. Close-talking, noise-cancelling Differential* type. High articulation. Blast proof, water proof, shock resistant. Comfortably hand-held. Press-to-talk switch. Panel mounting. bracket. List, \$16.50



600-D and 210 ▶

Dynamic and Carbon high articulation mobile microphones. Give high intelligibility speech transmission. Light weight, yet extra rugged. Easily held in hand. Press-to-talk switch. Model 600-D. List, \$38.50 Model 210. List, \$28.50



◀ CENTURY

Low-cost all-purpose Crystal, Dynamic and Ceramic models. Can be used in hand, or on stand. Remarkable performer. Satin Chrome finish. In high and low impedances. List from \$11.25 to \$18.50 Model 415 Desk Mount lists at \$1.70



◀ H-51/U HANDSET

Virtually indestructible. Transmits speech clearly and intelligibly under high ambient noise conditions. Noise-cancelling second order differential carbon microphone, 600 ohm receiver, black nylon handle, push-to-talk switch. 10" long. Weighs 1 lb. List, \$180.00

636 SLIMAIR ▶

Slim, versatile dynamic of exceptional quality. High-fidelity response 60-13,000 cps. Output -55 db. Acoustically-treated grille head stops wind and breath blasts. Acoustalloy diaphragm. Tilts 90°. "On-Off" switch. High or low impedance selection. List, \$70.00

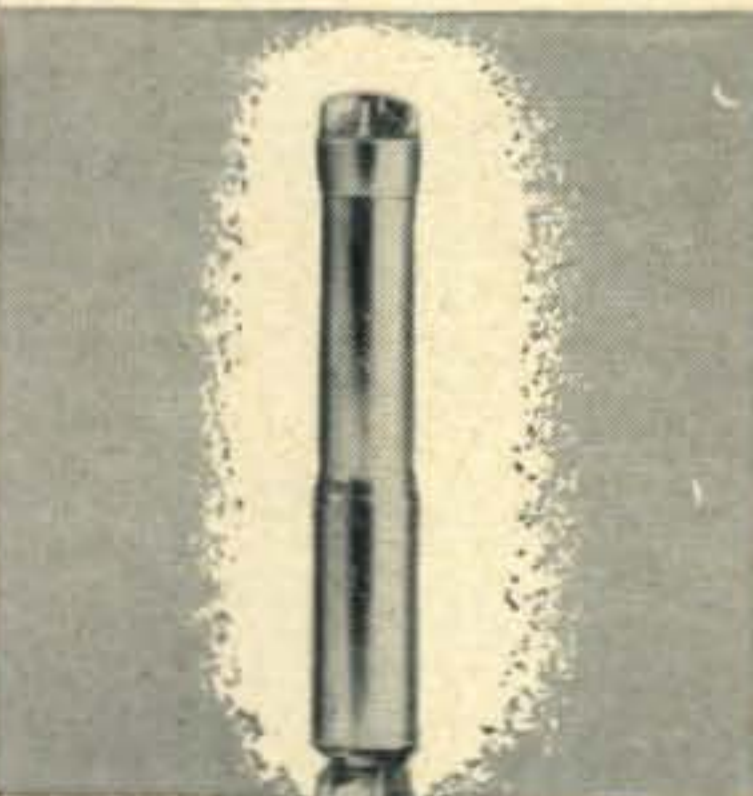

TOUCH-TO-TALK ▶

Model 428 "Break-in" Touch-to-Talk Stand with locking feature. Fits any microphone with standard 5/8"-27 thread. Lever-type switch gives finger-tip relay operation or microphone "On-Off." Single-pole double-throw. List, \$14.00



MICROPHONES • PHONO-CARTRIDGES
HIGH FIDELITY SPEAKER SYSTEMS
TV ACCESSORIES • PA PROJECTORS

See your E-V Distributor or Write for Bulletins

Crystal mikes licensed under Brush patents. E-V Pat. Pend.

Electro-Voice INC.

404 CARROLL STREET • BUCHANAN, MICHIGAN
Export: 13 East 40th Street, N.Y. 16, U.S.A. Cables: Arlab

*Patent No. 2,350,010



It really doesn't take a transmitter like this to work DX. The rig is W2LCK's, and the operator is KN2CDN, his wife. Power is limited to seventy watts on 3.7 Mc. and ten watts on 145 Mc., when she is operating.

than desired. Almost as if to help me write this review, W9MIF, a local amateur, telephoned me this morning to get on 14-Mc phone and tell W9—, who was calling "CQ 20-meter phone," that he was actually on 7,110 Kc. Unfortunately, the lad was within the 14-Mc skip zone; therefore, W9MIF made a long-distance phone call to give him the information. A fine example of the true Ham spirit, incidentally. It is fairly common, too, to hear stations in the high end of the 14-Mc band blithely calling "CQ ten-meter phone."

A conventional monitor or frequency meter (or a receiver used as a monitor) will seldom give a positive indication that a transmitter stage is tuned to a wrong harmonic. The very strong signal from the transmitter usually generates an audio beat note in them wherever fundamental, harmonic, or image frequencies of the transmitter and monitor coincide. For this reason, it is necessary to have some idea of the proper dial settings to be sure the transmitter is on the desired frequency.

This is where a wavemeter like the "Gimix" shines. Simply couple it loosely to the tank coil and tune it for maximum glow of the indicator bulb. Then refer to the wavemeter calibration to determine the approximate frequency.

Note that the "Gimix" is designed to show in which band your transmitter is emitting power. A frequency meter/monitor should be used to measure the exact frequency.

Other Uses

The "Gimix" may be used as a neutralizing indicator. Also, it will reveal spurious oscillations in a transmitter anywhere within its frequency range. In addition to the pilot-bulb resonance indicator, a low-range milliammeter or microammeter may be plugged into the phone jack for greater sensitivity.

High sensitivity is seldom required in a wavemeter. However, by using the meter and coupling an antenna to the "Gimix" through a few turns of

wire wrapped around the coil, the unit becomes a field-strength meter, useful in antenna experiments. Substituting a pair of phones for the meter makes the "Gimix" an audio monitor, useful around a phone station.

There is one absolute must in using a wavemeter around a transmitter. It is usually necessary to put it close to components which have dangerous high voltages on them. Be extremely careful not to touch any of them.

Working DX

At first, I had intended to devote the *Novice Shack* of this "Feature DX Issue" of *CQ* to the same subject. On second thought, I changed my mind. The technique is the same whether you are a Novice or an Extra Class licensee. It might as well be admitted, however, that the Novice is at a disadvantage in working foreign DX.

New Novice Band

Effective February 20th all Novice licensees will be permitted to operate in a new band situated between 7175 and 7200 kc.

This band has been provided by the FCC in order to further encourage Novice operation. Using these frequencies the Novice will be able to make DX contacts and to work over much greater distances. Further details in my next column.

W9EGQ

Probably more than anything else, it takes patience to work new countries and new states. Patience to comb the band listening for them, and once a new one has been found, to call it after its every CQ or signoff with other stations, until you finally work it. Your confirmed DX man thinks nothing of stalking a rare one for months before finally working it.

Letters and General News

Bill, W9PAS, Dyer, Indiana, is the father of a rather unusual radio family. Bill, Jr. WN9RWN, who is 23 years old, is studying radio at Valparaiso Technical Institute, and has a Commercial First Class Telephone
(Continued on page 72)



KN2BHV, New York City, operated by "Fritz" Hess. He is a firm believer in the desirability of home-built transmitters. The SX71 in the picture indicates he favors commercial receivers.

to the **E. E. or PHYSICS GRADUATE**

with experience in

RADAR OR ELECTRONICS

*Hughes Research and Development Laboratories,
one of the nation's large electronics organizations, is now
creating a number of new openings
in an important phase of its operation.*

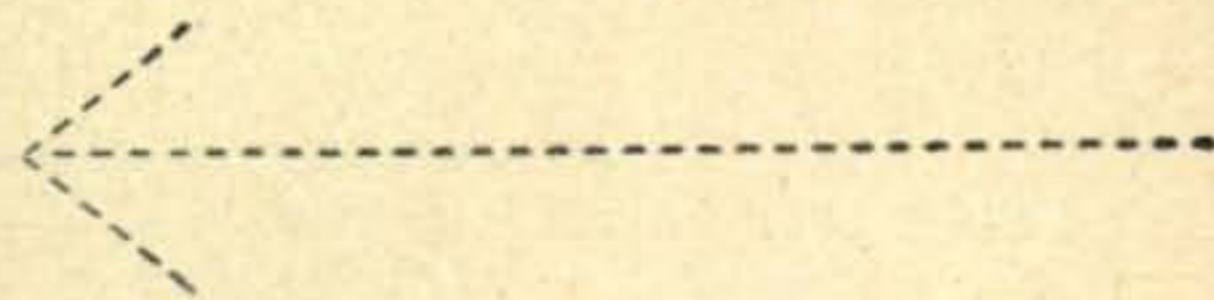

Here is what one of these positions offers you:

THE COMPANY

Hughes Research and Development Laboratories is located in Southern California. We are presently engaged in the development of advanced radar devices, electronic computers and guided missiles.

NEW OPENINGS

The positions are for men who will serve as technical advisors to the companies and government agencies purchasing Hughes equipment. Your specific job would be to help insure the successful operation of our equipment in the field.

THE TRAINING

Upon joining our organiza-

tion, you will work in our Laboratories for several months until you are thoroughly familiar with the equipment you will later help the Services to understand and properly employ.

WHERE YOU WORK

After your period of training (at full pay), you may (1) remain with the company Laboratories in Southern California in an instruction or administrative capacity, (2) become the Hughes representative at a company where our equipment is being installed, or (3) be the Hughes representative at a military base in this country—or

overseas (single men only). Compensation is made for traveling and for moving household effects, and married men keep their families with them at all times.

YOUR FUTURE

You will gain all-around experience that will increase your value to the company as it further expands in the field of electronics. The next few years are certain to see a large-scale commercial employment of electronic systems—and your training in the most advanced electronic techniques now will qualify you for even more important positions then.

HOW TO APPLY

If you are under thirty-five years of age, and if you have an E. E. or Physics degree, with some experience in radar or electronics,

write to:

HUGHES

RESEARCH AND DEVELOPMENT LABORATORIES

Engineering Personnel Department

CULVER CITY, LOS ANGELES COUNTY, CALIFORNIA

*Assurance is required
that relocation of the applicant will not cause
disruption of an urgent military project*





Monitored by LOUISA B. SANDO, W5RZJ

959-C 24th St., Los Alamos, New Mexico

Well, we asked for it—now we're getting it! Here's one response to our December column from an OM in Indiana:

"Dear Miss Dix: (Oops, wrong heading)

"Read your interesting column in Dec. CQ. I always read it even though I'm an OM. The guy in Ohio didn't have an original idea—I've just taken longer to write. I think it is rather a hopeless method, however. I've been on the air for 2½ years, and in that time I've talked to only one YL (a Sister in a Catholic school), and a few XYLs who got interested in Ham radio after meeting their OMs. If there are any unattached YLs on the air, I guess I need a new receiver—I don't hear 'em.

"I had a better idea. (???) Decided to operate 10 meters—cause a little TVI—get acquainted with all the neighbors—maybe find a YL who would get interested in Ham radio. And so? Yep, no TVI. Of course I'm a farmer, and no neighbors with TV sets within half a mile. That's why no TVI, I suppose. I TVI my own set, but that doesn't help!

"Seriously though, I'm 30, blond, 6'2", 155# (yeah, I'm starvin'—I need a good cook), operate all bands occasionally (160 through 2), have mobile station (with car attached). Modern grain farm; no livestock. Need some spare time to operate Ham radio!"

"Oh, well, it's a hopeless case—I'll go quietly.

"73—(name furnished on request) "

Any YLs interested in arranging a sked? Let us know and we'll give you his call, or forward mail if you prefer.

YL's Gatherings

The YLs already are planning get-togethers for '53. The New England YLRL luncheon is scheduled for April 11th, while the W9 district girls will hold their second annual YL convention in May in Mishawaka, Ind. More details on both of these later.

The YLs of LARK held their first Christmas party on December 13th at the QTH of W9FZO, with OMs joining them for the occasion. There was square dancing, Ping-pong, a grab bag of radio gadgets, and a late evening supper. Those attending: W9LDC, KXL, FSS, FZO, RQF, LOY, JIO, BCB, MYC, SSK, SJR, MND and SYX. It also was a farewell party for W9KXL, Bobby, whose Navy OM, W9LDC,

has been transferred to Norfolk, Va. Two of the YLs also were celebrating receipt of their Advanced Class licenses—W9LOY and MYC.

February brings up the YL-OM Contest, this year's to be the fourth annual such event. The dates are February 28th-March 1st. To make it even more interesting this year, additional cups will be awarded to the high scorers. Here are the details.

4th Annual YL-OM Contest

START: FEBRUARY 28— 6 p.m. EST

END: MARCH 1 —12 midnight EST

ELIGIBILITY: All licensed OMs

YLRL members only eligible to compete

EXCHANGE: QSO number, RS or RST report, State, U. S. possession, VE district or country—except W-VE

SCORING: A—10 points for each station worked, YL to OM, or OM to YL only, multiplied by number of different States, U.S. possessions, VE districts or countries—except W-VE.
B—Stations and multipliers count once only regardless of band or mode of operation.
C—For phone only or CW only awards: 10 points for each station worked, YL to OM, or OM to YL only, multiplied by number of different States, U.S. possessions, VE districts or countries—except W-VE. Stations and multipliers count once only regardless of frequency band.

OPERATING: Any or all bands may be used. Phone—Call CQ YL-OM contest

CW—OMs call CQ YLRL

YLs call CQ OMs

YLs on CW are encouraged to operate near the net frequencies of 3610, 7040 and 14,150 kc.

(Continued on page 58)

USE OHMITE®

WHERE *DEPENDABILITY* COUNTS!



Rheostats

Available in 10 sizes from 25 to 1000 watts. Ceramic and metal construction. Vitreous enamel locks windings in place. Metal-graphite brush provides smooth, gliding action.

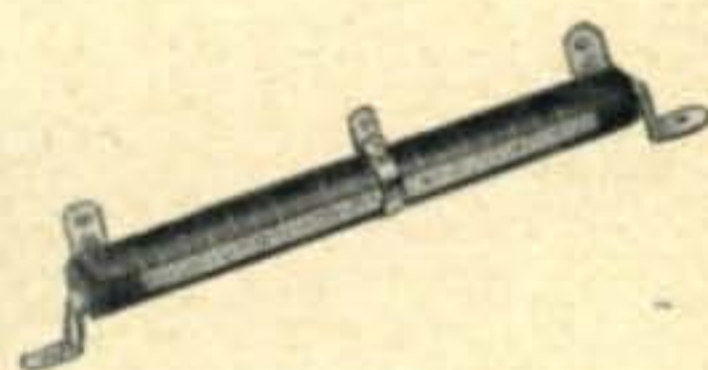

Dividohm® Adjustable Resistors

These wire-wound, vitreous-enameled resistors, with one or more adjustable lugs, provide odd resistance values. Stock units made in 10, 25, 50, 75, 100, 160, and 200-watt sizes.

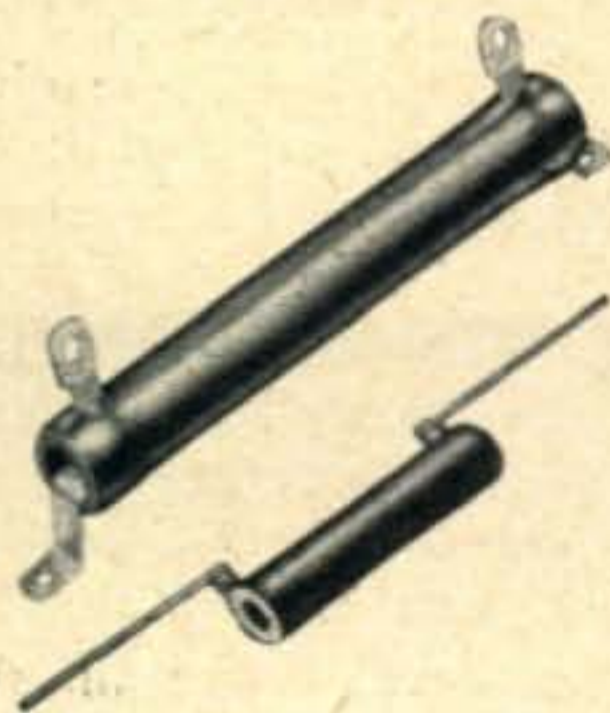

Fixed Resistors

These wire-wound, vitreous-enameled units provide utmost dependability and long life. Eight sizes: 5, 10, 20, 25, 50, 100, 160, and 200 watts. Tolerance $\pm 10\%$.

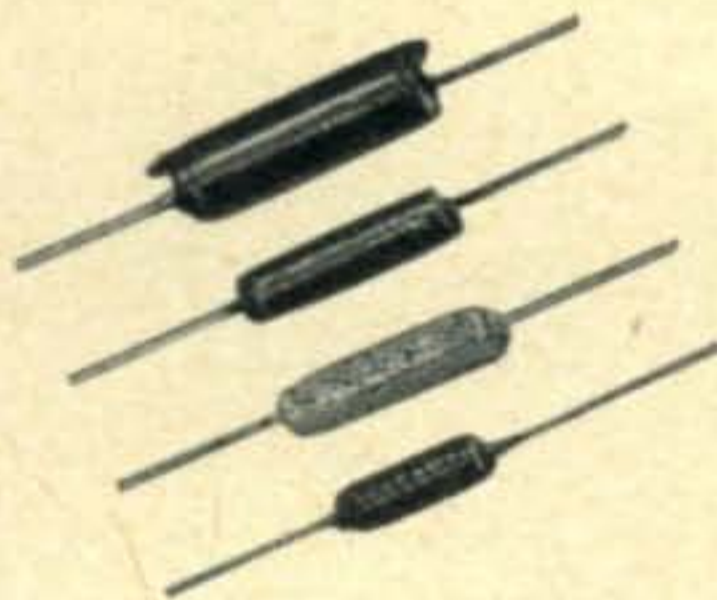

R. F. Chokes

Single-layer-wound on low power-factor steatite or bakelite cores. Seven stock sizes for all frequencies, 3 to 520 mc. Two units rated 600 ma; all others rated 1000 ma.



Dummy Antenna Resistors

For loading transmitters or other r.f. sources. Vitreous-enameled. Practically non-reactive within their frequency range. In 100 and 250-watt sizes, 52 to 600 ohms, $\pm 5\%$.

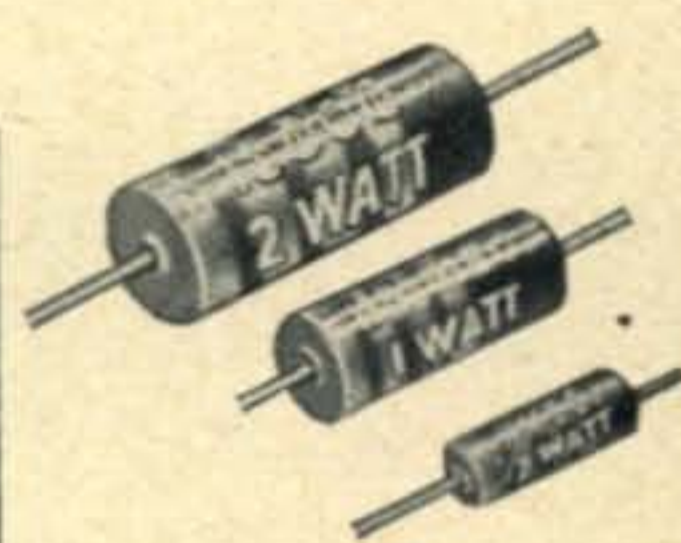

Little Devil® Composition Resistors

Tiny insulated composition units. Three sizes: $\frac{1}{2}$, 1, and 2 watts—in all RTMA resistances. Tolerances $\pm 5\%$ and $\pm 10\%$. Available only from Ohmite distributors.

OHMITE MANUFACTURING CO.

4830 Flournoy Street, Chicago 44, Illinois

Write for Stock Catalog



Be Right with **OHMITE®**

RHEOSTATS • RESISTORS • TAP SWITCHES

YL Century Certificate

The YLRL will now award the YL Century Certificate to any amateur in the world who submits confirmation of contacts with stations operated by 100 or more different licensed women amateur radio operators. Space does not permit including the rules at this time; look for them in this column next month.

- AWARDS:**
- Highest OM combined score—cup donated by W8UDA, now held by W1BFT.
 - Highest YL combined score—cup donated by W1BFT, now held by W4SGD.
 - Highest OM phone to YL phone only*
 - Highest YL phone to OM phone only*
 - Highest OM CW to YL CW only*
 - Highest YL CW to OM CW only*

*Cups to be awarded by YLRL

2nd & 3rd place winners in all categories to receive certificates.

The cups are awarded on a yearly basis, with a three-time winner obtaining permanent possession.

- LOGS:** All participants, whether competing for awards or not, are requested to submit logs, to be postmarked not later than March 7, 1953, to Dorothy K. Wickenhiser, W3JSH, 1112 State Ave., Coraopolis, Pa.

Hale W6VWR

It is with heavy heart that we have to record the following. On December 17th, the key of W6VWR, Louise Willomitzer, was stilled forever in this world. Louise, in her early forties, was a victim of cancer and had been very ill for many months. Louise became interested in amateur radio in 1941, via the AWVS classes in New York City where W6NAZ, Lenore, was her instructor, and received her amateur operator's license in 1942. A superior CW operator, she turned from activities that were more important to her personally to help her country by taking a position as code operator at Governor's Island for the Signal Corps. Then, after moving to California after the war, she finally got W6VWR on the air with the help of Clara's (W6TDL) OM. Louise thoroughly enjoyed what time she could spend on 40 meters but soon she accepted the job of secretary-treasurer for YLRL for the 1947-48 term and devoted all of her leisure time and much of her not-to-be-spared time to this work. She spent countless hours organizing the YLRL files, writing hundreds of letters and assisting in the publication of the YL Callbook.

YL Of The Month

Our YL of the Month this time, appropriately enough, is very much of a DXer. Though she has had an amateur license only a little over a year, Marion Wagner, W5UCQ, has worked over 100 countries and is now only awaiting the QSL's to apply for her DXCC. Marion also is deep in DX as secretary of the West Gulf DX Club, having been elected to that post at a meeting of the club last April in Shreveport, La. "And believe it or not," says Marion, "these DX boys really do have the correspondence, too!"

Official publication of the West Gulf DX Club is known as "The DX Bulletin" and Marion and her OM, W5KUC, get this out bi-weekly. It consists mostly of letters from members all over the world and the latest DX information.

Marion received her general class ticket on the 14th of November, 1951, and passed her Advanced Class on the 14th of November, 1952—no grass growing under her feet! She operates on most of the ham bands as both she and her OM like to make use of all their privileges. And with their set-up this is readily possible.

Their station consists of four 1-kw transmitters, each ending up with a pair of 250TH's in the finals, on each of the bands 10 through 80 meters, either phone or CW. All transmitters are controlled from the operating position—Marion's OM is an electronics technician for the Navy and he likes everything operated from one position. Their receivers are an HRO-60 and an HF-10-20 into a Super-Pro. The antennas are three rhombics, five wavelengths to a leg on 20 meters; a 2-element helical beam, and a quarter-wave vertical for 75 meters.

Yes, the Wagner's live on a farm—one they chose so they could put up the antennas they wanted. It's about seven miles north of Honey Grove, Texas. It's also a good place for their jr. op, Joe, aged six, to run off some of his energy.

33 es CUL—W5RZJ



DXer's W5UCQ, Marion Wagner, and her OM W5KUC, give their jr. op a chance at the mike.



HARVEY FIRST TO STOCK... FIRST TO DELIVER

NATIONAL NC-183D RECEIVER

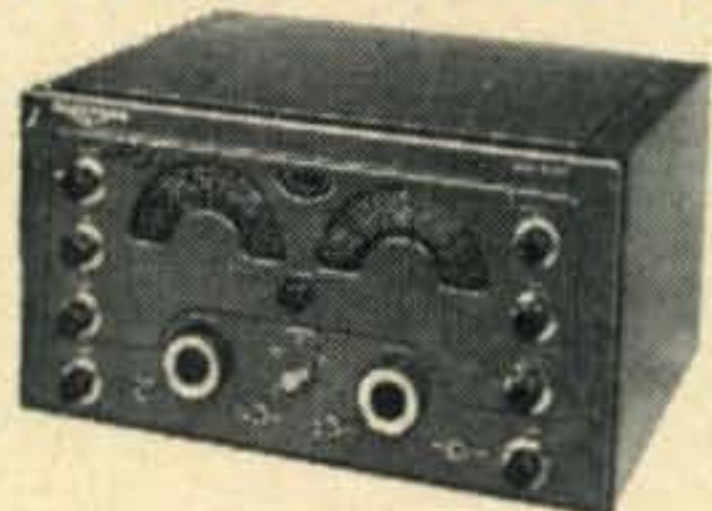

Has everything you want: 3 stages of IF . . . 15 meter band spread . . . 6 meter band . . . dual conversion . . . 2 stages of RF . . . broadcast band . . . push-pull audio output . . . sharper, narrower IF . . . sensitivity better than 1.5 microvolts . . . exclusive full adjustable automatic noise limiter . . . and many other exclusive features. Finished in smooth gray enamel. Supplied complete with all tubes.

NC-183DT Table Model
(with speaker)\$385.50
NFM-83 Narrow Band FM Adaptor 17.95

ELDICO TR-75-TV



TRANSMITTER KIT

This is an ideal unit for the novice. Very simple to assemble. New, revised circuit to

aid in the elimination of TVI. Uses 6L6 oscillator—807 amplifier combination PI-network output. Husky power supply delivers 600 volts to the 807. Complete . . . including a punched chassis and shielded cabinet. Unbelievably low priced at . . .

\$64.95
MD-40 modulator kit for above... 49.95
MD-40P as above.
but with power supply..... 59.95

SUPERIOR POWERSTATS

Smooth, efficient voltage control, 0-135 volts output from 115 volt AC line. Models also for 230 volt input. Write for free literature. Models for table and panel mounting.



Type 10, 1.25 amps.....\$ 8.50
20, 3 amps..... 12.50
116, 7.5 amps, table mtg..... 23.00
116U, 7.5 amps, panel mtg... 18.00
1126, 15 amps..... 46.00
1156, 45 amps..... 118.00

Complete Stock Always On Hand For Immediate Delivery

Complete Line in Stock
CAMBRIDGE THERMIONIC COILS
For Immediate Delivery

NOTE: In view of the rapidly changing market conditions, all prices shown are subject to change without notice and are Net, F. O. B., New York City.

The New HALLICRAFTER



HT-20
Transmitter

A completely TVI-proofed transmitter with complete bandswitching from 10 to 160 meters. Power output 115 watts CW or 100 watts on phone. TVI radiation is at least 90 db. below output. Has provision for external VFO head, plus many other new features.

Complete with Tubes.....\$449.50

HALLICRAFTER "CIVIL PATROL" S-81 AND S-82



A compact, low-cost, FM receiver covering police, fire, taxi, telephone, railroad, and other industrial frequencies. Ideal for civilian defense and emergency communications. Has built-in PM speaker and phone tip jacks. Operate on 105/125 volts 50/60 cycle AC or DC.

Supplied complete with tubes.
S-81 VHF FM 152-173 mcs.....\$49.50
S-82 HF FM 30-50 mcs..... 49.50

Central Electronics Units Increase Phone Power 8 Times With SINGLE SIDEBAND VIRTUALLY ELIMINATES TVI

MULTIPHASE EXCITER MODEL 10A—Switchable single sideband with or without carrier. Double sideband AM. Phase-Modulated Break-in CW. Output approximately 10 peak watts 160 to 20 meters, reduced on 15 and 10. Voice operated break-in. With coils for one band:

Wired and tested.....\$139.50
Additional Coils per band..... 3.95

SIDEBAND SLICER MODEL A—Receiver adapter. Selectable single sideband reception of SSB, AM, PM and CW. Reduces heterodynes and interference at least 50%. For receiver IF, 450-500 kc.

Wired and tested.....\$69.50
PS-1 PLUG-IN prealigned 90° phase shift network and socket.....\$7.50

The New SONAR Transmitter



Model
SRT-120

For mobile and fixed location operation. Has band-switch for 80, 75, 40, 20, 15, and 10 or 11 meters, plus spare position for any future band. Has provision for two crystals or external VFO head. Final amplifier employs the new Amperex 9903/5894A tube. Power input is 120 watts on CW, and 100 watts on phone. All circuits metered. Power requirements: 600 volts dc at 350 ma, and 6.3 volts at 6.4 A.

Complete with Tubes.....\$198.50
External VFO Head..... 16.50

HARVEY IS YOUR COLLINS HEADQUARTERS

The New 75A-3 Receiver



With Mechanical Filter

The familiar Model 75A-2, redesigned and modified to provide for the use of mechanical filters. Supplied with one 3 KC filter, and facilities for one additional. A 2-position front panel switch permits selection of filter desired.

with speaker \$550.00
1 KC Mechanical Filter..... 75.00
COLLINS 75A-2 still continues in popularity.....with speaker 440.00

COLLINS 32V-3 Transmitter

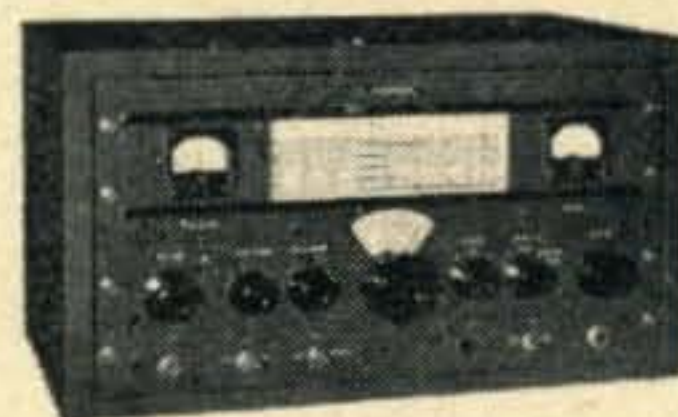

A VFO controlled bandswitching, gang-tuned amateur transmitter. 150 watts input on CW and 120 watts on phone. Covers 80, 40, 20, 15, 11 and 10 meter bands.

Dimensions: 21 1/8" wide, 12-7/16" high, 13 7/8" deep.
Complete with tubes.....\$775.00



Harvey RADIO CO., INC.

103 W. 43rd St., New York 36, N. Y. • LUxemberg 2-1500

NO CLICKS - NO BACKWAVE

KEITH S. WILLIAMS, W6DTY

355 Laurel Street, Oxnard, California

Described in this article are the experiments by W6DTY in overcoming signal feed-through when using the W2RYI method of obtaining "clickless" keying. The author shows that only a slight modification is necessary in the original circuit.—Editor.

In an attempt to find a simple method of keying an 807 buffer stage, a screen keying circuit was finally developed which eliminated clicks completely without the use of click filters. This circuit design also precludes radiation of back-wave during key-up periods, thus minimizing the effects of signal feed-through, which has always been a serious obstacle to the use of screen keying systems.

In *CQ* for May, 1948, Mack Seybold, W2RYI, presented an excellent idea in his article, "Clickless Keying Using VR Tubes." Since that time I have used several variations of his keying system with generally good results. However, the problem of key clicks was still present to some degree or other in all these variations except when keying the screen grid. With this arrangement clicks were non-existent and no filters of any kind are required. However, in spite of the fact that screen voltage is reduced to zero and the screen effectively grounded when the key is up, some small amount of plate current continues to flow and, with continuous excitation to the control grid, a small signal is fed through to the plate tank. This signal is coupled to the following amplifiers and eventually shows up as back-wave, which can make keying difficult to copy.

Shortly after W2RYI's article appeared, a variation of his screen keying circuit was tried (*Fig. 1*). The transmitter in use employed a continuously running oscillator, and the keyed stage was followed by a final power amplifier, biased to cut-off. With this arrangement key clicks were completely eliminated, but the strong back-wave due to signal feed-through was very objectionable, and the screen system was discontinued in favor of cathode keying, which, in spite of the VR-tube screen circuit, again resulted in clicks with the usual filtering difficulties.

Since it has recently become very important to eliminate clicks, not only from the standpoint

of pleasing fellow Hams, but in order to simplify TVI reduction, I again went back to screen keying in an attempt to do this, and, at the same time, find a simple means of preventing signal feed-through with key-up. The method which did the best job is shown in the circuit of *Fig. 2*. It is identical with the circuit of *Fig. 1* except for the change of the value and position of one high-value carbon resistor. The present rig consists of a low power oscillator and multiplier stages, running continuously, feeding a screen-keyed 807 which drives a class-B push-pull 812 final amplifier. Smooth keying is obtained, with neither clicks nor back wave. With adequate shielding, the oscillator is barely audible in the station receiver, and is not heard at all at any distance from the station.

Theory

The basic screen keying circuit, utilizing VR tube screen voltage control, is shown in *Fig. 1*. With excitation being continuously supplied to

(Continued on page 62)

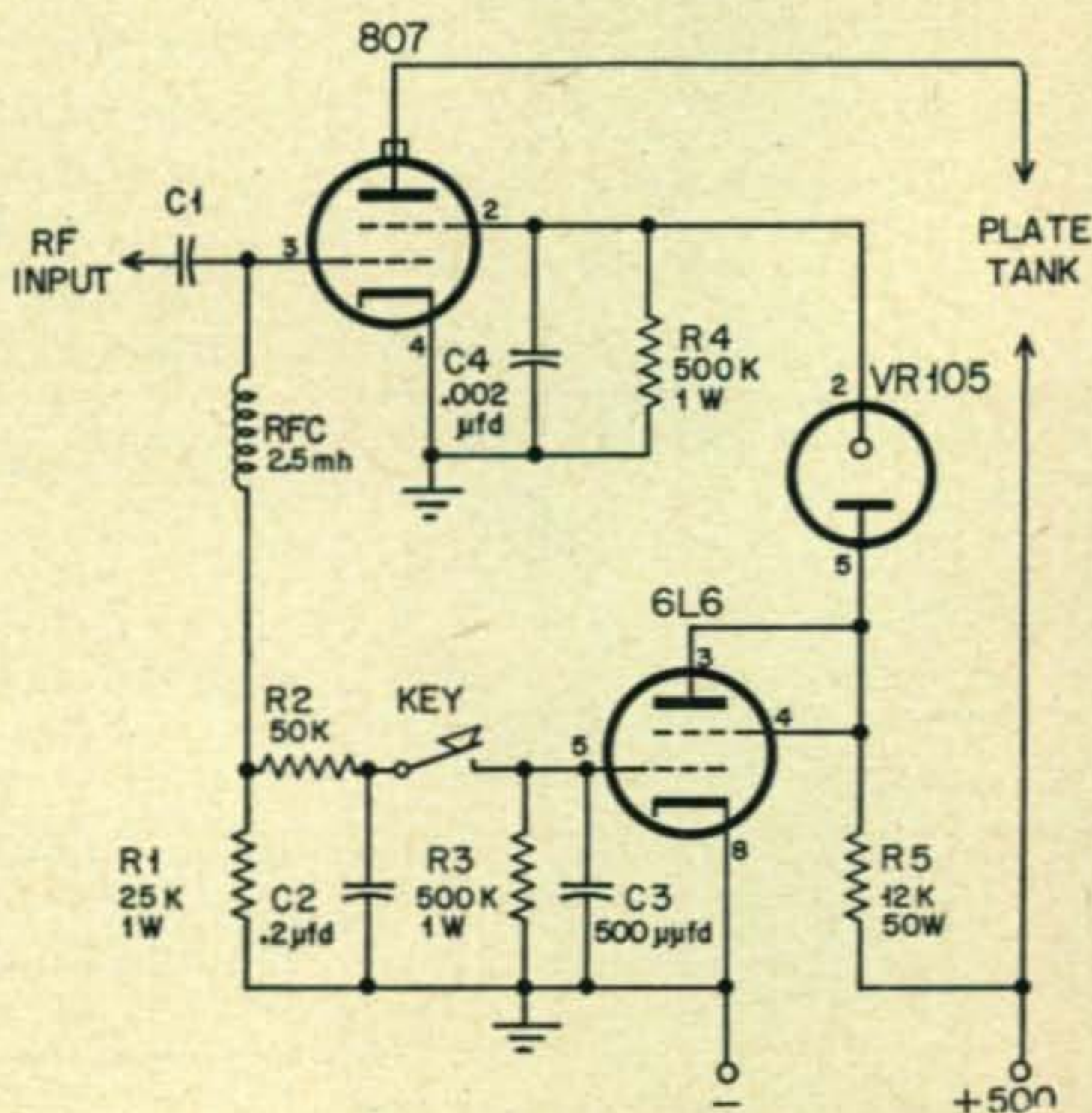

Fig. 1. This is the method of obtaining control-tube bias from the amplifier grid current. The revised circuit appears on page 63.



LEO I. MEYERSON WØGFQ
CU ON 10-20 & 75 METERS

GET ON THE BEAM IN '53 WITH A NATIONAL RECEIVER

Any experienced ham will tell you that you'll save time and money if you deal with WRL, the world's largest distributor of amateur radio transmitting equipment. WRL offers the most liberal trade-in allowances on all types of used equipment—the most flexible time payment plan—as little as 15% down—no interest charges if bill paid within 60 days. NO RED TAPE—all credit arrangements strictly confidential. Special attention given to foreign orders. Deal with WRL—the world's most personalized radio supply house.

LEO GIVES BEST DEAL ON . . .

National RECEIVERS

HRO-SIXTY RECEIVER AUTOMATIC DUAL CONVERSION

EASY
PAYMENTS

\$483⁵⁰

(less speaker)



The NATIONAL HRO-60 is the last word in modern receivers, offering many outstanding features: Dual conversion automatically switched in and out. High frequency oscillator and first mixer now have current regulated filament circuits. High frequency oscillator is also voltage incorporated. Edge lighted, direct frequency reading scale, with one range in view at a time; Three I. F. stages at 456 kc employing 12 permeability tuned circuits on all bands, plus one I. F. stage at 2010 kc on all freq. above 7mc; Built-in power supply; Sensitivity 1 mv or better for 6 db sig/noise ratio; Micrometer logging scale; Provision for crystal calibrator unit operation from front panel; S-meter amplifier; High fidelity push-pull audio with phono jack.

SEE IT, HEAR IT, COMPARE IT!

RADIO REFERENCE MAP



25c
HANDY
WALL
SIZE

New Log Book

25c

Full column log listing all FCC required into . . . accommodates . . . 525 stations. "Q" signals, phonetic alphabet, amateur international prefixes.



NATIONAL

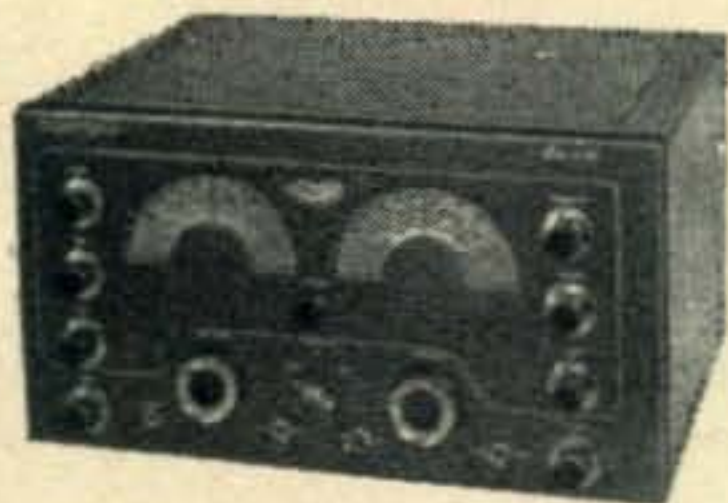

NC-183 D RECEIVER

Dual conversion on the three highest ranges plus every feature you want in a truly modern receiver!

(LESS SPEAKER) . . . \$369.50

Get Your New Copy



NATIONAL RECEIVERS AND ACCESSORIES

NC-125 RECEIVER	\$149.50
SW54 RECEIVER	\$ 49.95
SELECT-O-JET (#2 or #3)	\$ 28.75
NFM-83-50 ADAPTER	\$ 17.95
SPEAKER (for HRO-60 or NC-183D)	\$ 16.00

FREE
1953
WRL
CATALOG
SEND
TODAY!

WRITE FOR DETAILED SPECIFICATION EQUIPMENT SHEETS

WRITE
WIRE

PHONE
7795

World  *Radio*

LABORATORIES

COUNCIL BLUFFS,
IOWA

World Radio Laboratories, Inc.
744 West Broadway
Council Bluffs, Iowa

C-2

Please send me:

- New Log Book
- Free Catalog
- Radio Map

- SW-54 Info
- NC-183 D Info
- HRO-60 Info
- NC-125 Info
- Used Equipment List

Name _____

Address _____

City _____ State _____

(from page 60)

the control grid through $C1$, grid current flow through the regular grid bias resistor, $R1$, results in a voltage negative with respect to ground at the grid end of $R1$. When the key is up, the 6L6 control tube grid is at ground potential by way of $R3$ and the 6L6 draws heavy current through $R5$, the screen dropping resistor. This results in a voltage at the plate of the 6L6 which is too low to ionize the VR-105. The VR-105, therefore, is the equivalent of an open switch in the 807 screen lead and the screen is at ground potential via $R4$. Plate current in the absence of screen voltage is reduced almost to zero. Now, when the key is closed, the negative bias developed across $R1$ by grid current flow is applied to the 6L6 grid, cutting off the 6L6 control tube. The voltage at the 6L6 plate rises above the firing voltage of the VR-105, thus closing the screen circuit. Screen voltage is then normal for the 807 and normal plate current flows. The value of the dropping resistor, $R5$, will be less, of course, than would be required ordinarily, because 105 volts of the necessary drop from full B-plus will appear across the VR tube.

Key clicks, using the circuit of *Fig. 1*, will be completely absent, with no click filter required in the key leads. This is due to the fact that no current is broken by the key. There is also a lag in rise and decay time of applied screen voltage, introduced by the ionization and de-ionization characteristics of the VR gaseous regulator tube.

Now we have eliminated key clicks, and have a keying system that will follow high speed keying, and the additional virtue of no hazardous voltage at the key itself. However, considerable back-wave will be radiated in the key up condition because some small amount of plate current continues to flow, even with the screen at zero potential. At W6DTY the 807 plate current under these conditions was in the neighborhood of five milliamperes, with 500 volts on the plate, and, with continuous grid excitation, a small signal at the operating frequency was therefore present in the 807 plate tank. This signal was coupled to the grids of the push-pull triode final. Even though it was not sufficient to produce any final grid current indication it did cause the 812's to draw about 20 milliamperes of plate current. The signal, appearing in the 812 plate tank, was then coupled to the antenna, and resulted in a strong back-wave when the key was open.

It was desired to retain screen keying because of its ability to completely eliminate clicks, using the VR-tube screen circuit. Something had to be done, however, to prevent radiation of back-wave when the key was up. The solution lay in putting negative bias on the screen of the 807, and the most convenient source of bias was furnished by the control tube grid current.

One simple change in the circuit of *Fig. 1* results in a screen keying system that suppresses both clicks and back-wave, and does a beautiful job of both. Referring to *Fig. 2* we will see that $R4$ has been increased to one megohm in value

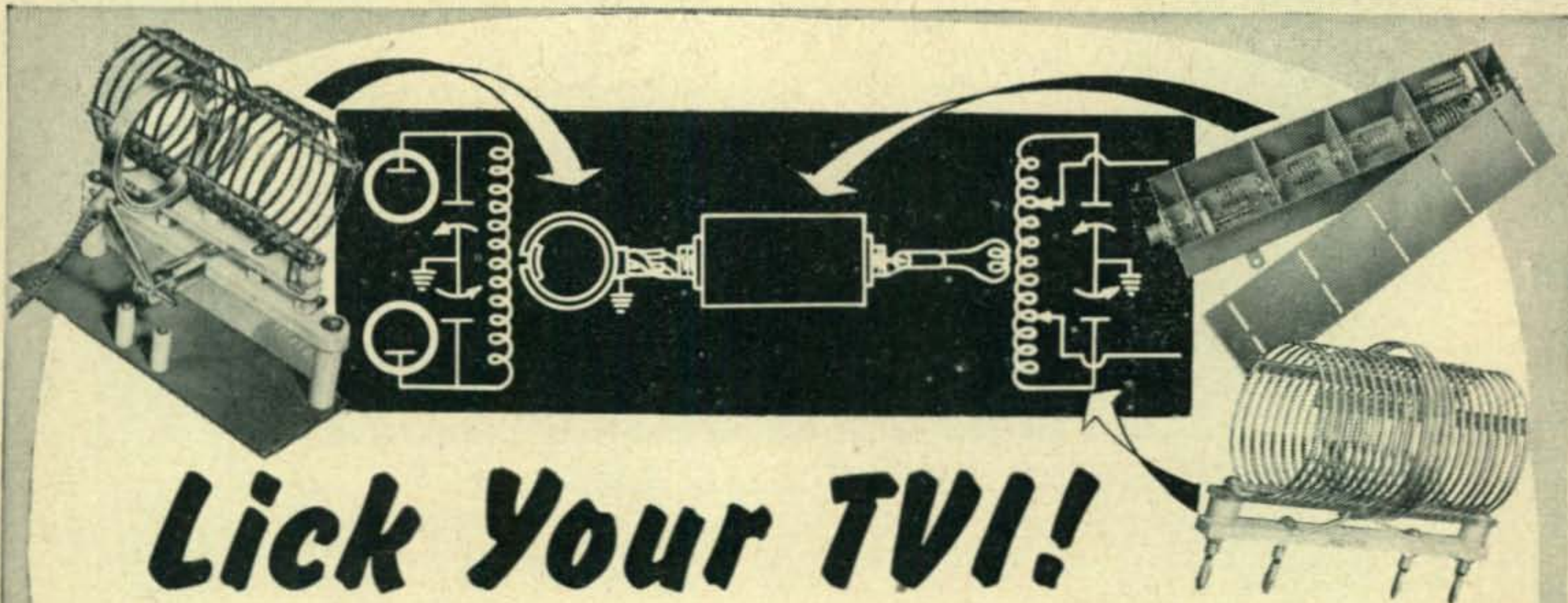

Lick Your TVI!

Most cases of TVI caused by harmonics and spurious radiations can be reduced to a negligible minimum.

In planning a new rig, the best bet, of course, is to use precision-made B&W components—from oscillator to final including antenna coupler. Filtering and shielding recommendations in our "Filter Facts" booklet show what to do, how to do it.

Should your present rig be

of fairly good design, a few minor changes as outlined in "Filter Facts" plus installation of B&W low-pass filters and Faraday shielded links will effectively throttle TVI. Many hams have proved it!

Send 15c today for a copy of "Filter Facts" giving details on how to lick your TVI and get silent rigs back on the air!

B&W Low-pass Filters, Models 52, 75 and 300 Amateur net \$27.00.

B&W

BARKER & WILLIAMSON, Inc.
237 Fairfield Ave. Upper Darby, Pa.

and removed from ground. This resistor is now connected between the control grid side of the key and the 807 screen grid. When the key is up, the VR-tube is de-ionized, cutting off the normal positive screen voltage, and the bias developed across grid resistor $R1$ is applied to the 807 screen through $R4$. This negative screen bias cuts off plate current completely so that no signal is present in the 807 plate tank and none is fed through to the antenna to cause a back-wave. When the key is closed the VR-tube fires, positive screen voltage is applied to the 807, and a normal dot or dash is transmitted. The one megohm resistor, $R4$, which may be a half-watt carbon unit, is high enough in value to prevent any appreciable disturbance to normal operating voltages when the key is closed. Voltage distribution is such that there is no danger of shock if you get across the key leads.

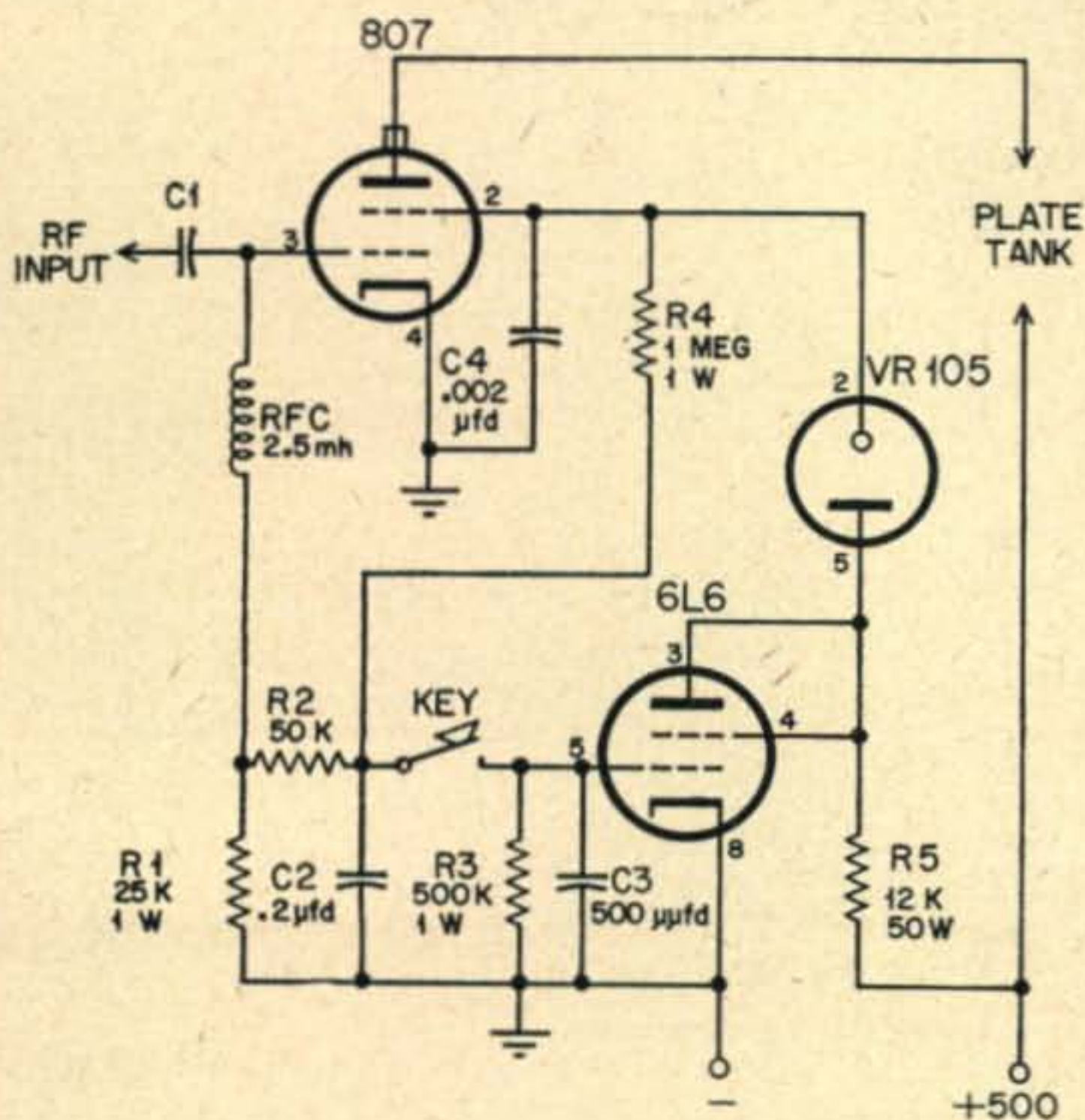

Fig. 2. A modified W2RY1 circuit shown above will virtually eliminate both clicks and backwave. The only significant circuit change has been an increase in the value of $R4$ and its connection to the control grid side of the key.

Operators who like the smooth, chirpless c-w signals that amplifier keying provides, particularly on the 20-, 15- and 10-meter bands, will find the circuit described above to be the answer. Its advantages, again, are: (1) complete elimination of clicks without the necessity for click filters, (2) screen keying without back wave, and, (3) no current at the key contacts, and no shock hazard. This same system could be applied to most of the screen grid tubes ordinarily used as buffer amplifiers in amateur transmitters.¹

1. Some of the newer tubes, such as the 6146, are not as readily susceptible to screen grid control as some of the older pentodes. This also applies to some extent to the 2E26.—Tech. Ed.

TWIN-LEAD folded dipole



Buy the kit and assemble your own HAM ANTENNA

Tested—tried and proven components from which to build your HAM ANTENNA—complete with full instructions for assembly. Build for permanence and performance with quality components.

complete
kit . . .

- 2 lengths of #16 copper-clad steel conductor twin-lead—cut to band length.
 - 1 75-foot length of standard 300 ohm twin-lead for lead-in.
 - 1 high strength laminated "T" block.
- Assembly and installation instructions.

Cut to 10, 20, 40 and 80 Meters

We all strive for the best in transmission and reception characteristics—now with the Amphenol Amateur Antenna Kit you are assured of the *BEST*. Designed by electronics engineers for the most efficient service.

amateur net as low as
\$535 for 10 meters

see your **AMPHENOL**
radio parts distributor

AMERICAN PHENOLIC CORPORATION

FIELD TRANSMITTER SET

COMPLETE WITH KEY, HEADPHONES, CARRYING CASE & SHOULDER STRAP

POWERED BY 2 SMALL CELLS
SIGNALS SEVERAL MILES
REMOVABLE FROM CASE
FOOLPROOF, READY TO OPERATE

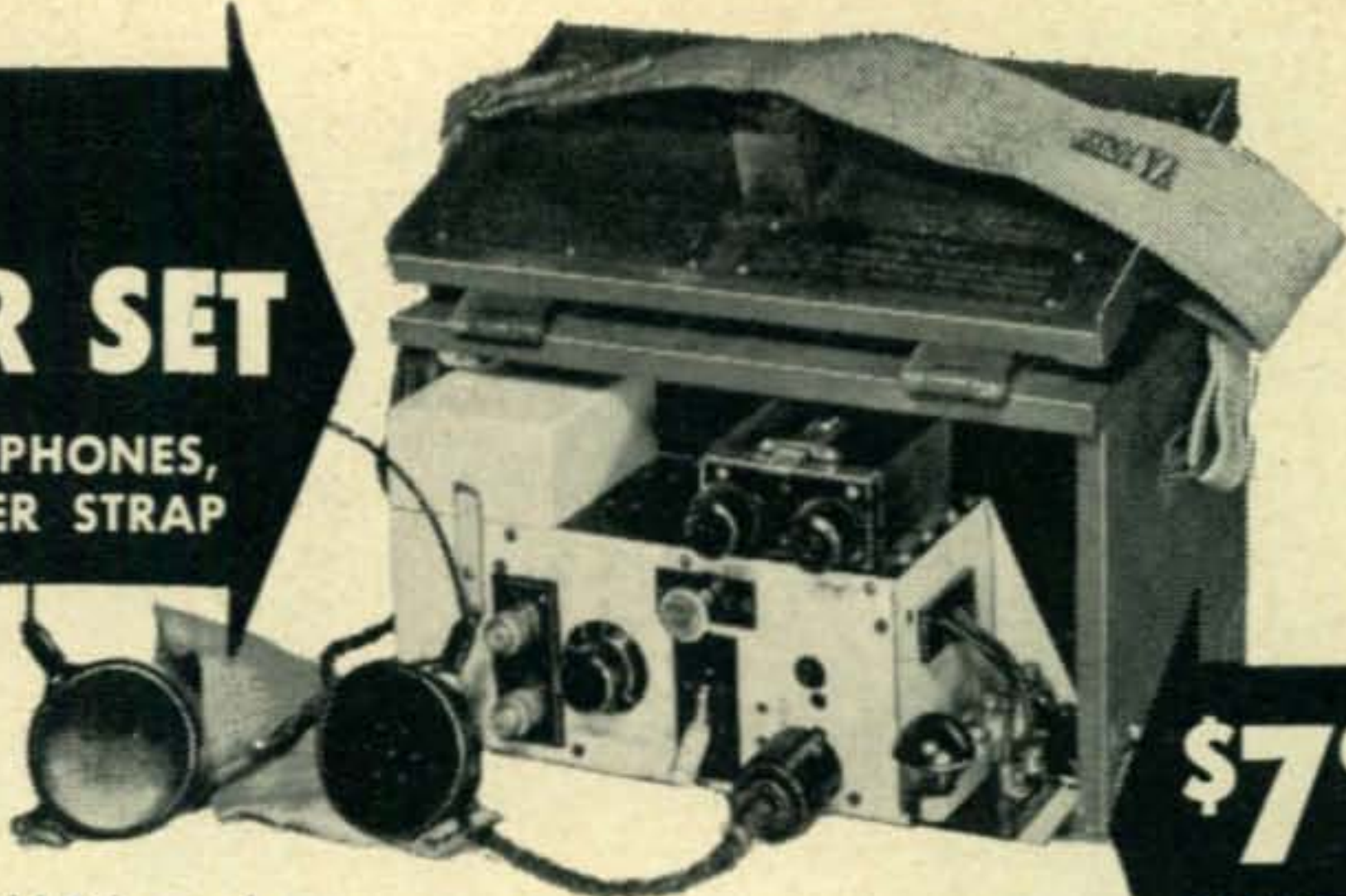

\$7.95

2 FOR \$15

Here's the famous Fullerphone C.W. Field Telegraph Transmitter at a sensationally low price. Sends signals up to several miles on only two small dry cells. Ideal for hams, scouts, rangers, etc. Rugged, foolproof, easy to set up and operate. Removable from sturdy wood case 11" x 6½" x 6¾", for permanent operation. Makes ideal code practice unit by itself, has extra jack for two sets of phones. Get two for complete point-to-point communications system. Wt. 20 lbs.

FULLERPHONE TRANSMITTER, less batteries.
Each . . . (Two For \$15) \$7.95



HS-33 HEADPHONE SET

The lowest price ever on these fine, low impedance headsets. Brand new, complete with light weight, comfortable ear pads, and PL-354 plug.
HS-33 HEADPHONES\$4.49



T-17B TYPE HAND MIKE

You'll never get a chance to repeat this buy! Famous press-to-talk T-17B type hand microphone. New; complete with 6 ft. cord and connector.
HAND MIKE SPECIAL\$1.29

SP-AIR-ES, INC. OF CALIFORNIA

3108 Valhalla Drive Dept. R-2
Burbank, California

KLEIN ELECTRIFYING BARGAIN!

THYRATRON REMOTE CONTROL

THE NEW WONDER OF ELECTRONIC CONTROL CAN BE YOURS FOR PRACTICALLY NOTHING
SERVICEMEN — HOBBYISTS — HAMS
EXPERIMENTERS — RADIO SCHOOLS

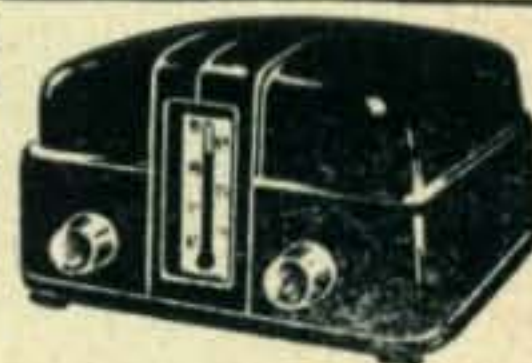

1.95

add 35c for handling and postage

Here's the chance of a lifetime to own a genuine 110V AC Thyatron Electronic Remote Control of your own at a fraction of its regular price! This mighty handful (only 5 3/4" x 5" x 3 1/4") of miracle control can be made to perform hundreds of practical, fascinating feats of remote control. A complete schematic showing the circuit is included with each unit.

It's a steal! Buy it just for the parts alone. Take it apart. See what you get: over 30 components such as Cabinet, Condensers, Resistors, Transformer, Controls, Dial Assembly, Control Relay, etc. Valuable parts galore that you can so easily use in any other radio, amplifier, etc.—or for experimenting. How can you lose? These parts are certainly worth FIVE TIMES this amazing low cost. The relay alone is worth more than the price we're asking for the entire unit. Besides, consider the filament transformer, condensers, resistors (many of them 1% precisions). No matter how you use it, here's a great Klein Bargain.

PRECISION THYRATRON CIRCUITRY

These amazing Thyatron thermostatic controls can easily and quickly be modified by you for electronic remote control of: Transmitters, Turn radio and TV on and off, Open and Close Garage Doors from your car, Remote control of Appliances, Machinery, Power Tools, Remote Controls for Model Railroads, Planes, Boats, Trucks, Burglar, Fire, Temperature and Rain Alarm Systems, Poultry Brooder Controls, etc., etc.

MANUEL KLEIN CO.

92A Chambers Street New York 7, N. Y.

REctor 2-6460



- 1220 pages
- 80,000 items
- 8,000 illustrations
- 8" x 11" — 5 lbs.

Publisher's price \$6.50—your price **\$1.95**
through your regular parts distributor

The right part when you need it for new gear or replacements

This permanent, hard cover Official Buying Guide of the electronic-TV parts and equipment industry with its comprehensive detailed index, eliminates the need for maintaining files of small catalogs and manufacturers' literature. *Radio's Master* catalogs 90% of TV and electronic equipment. Not merely part number listings — complete descriptions, specifications and illustrations written and compiled by each manufacturer. Enables you to make comparisons or substitutions right now!



UNITED CATALOG PUBLISHERS, INC.
110 Lafayette St., New York 13

GUEST EDITORIAL*(from page 9)*

"The Detroit Amateur Radio Association in their September blast at the Commission concerning Docket 10237 made this statement, "And every new burst of so-called thought from the FCC is now accompanied by a snide invitation to file comments in five copies."

"Now as a matter of fact the procedural rule 1.764 is not new, it has been on the books for many years. In response to an inquiry from an amateur on this subject, the Commission stated as follows:

'In the first place, Section 1.764 of the Commission's Rules requires that an original and 14 copies of such papers be filed, but permits the Commission to call for a smaller number, or even a larger number of copies, if necessary. In view of the fact that many amateurs must resort to handwritten copy work, the Commission reduced the number of copies in amateur proceedings to five, but in rule-making proceedings pertaining to other radio services, an original and 14 copies is required.

Rule making is a docket procedure requiring two identical docket folders, one kept in a public reference room and available for general inspection, and the other used by Commission personnel engaged in rule work; thus, only three copies remain for distribution to Commissioners of whom there are seven, and who personally pass upon all Notices of Proposed Rule Making and finalization of rules. Often it is necessary for other Commission personnel to examine comments without waiting until the docket becomes available. Accordingly, an original and 14 copies is not excessive.

'Although the Commission is not required to consider any material not submitted in the form and with the number of copies required, in cases where only one letter or copy of letter is filed in a rule-making proceeding, the Commission's staff makes the necessary number of copies. However, the Commission does not have a staff of typists available for that purpose and copy work of this nature done by the staff necessarily diverts man-power which would otherwise be employed, thus retarding the prompt dispatch of Commission business.'

"The point I want to make is, you have a responsibility to respond to rule making and I urge you to do so. Send in your five copies so that your views will be duly considered along with those of other amateurs when the matter is brought to the Commission for final decision."

NEW F. C. C. DEFINITION!

Every ham in the country knows what F.C.C. stands for. That's right! It means:

Fastest
Cash
Communication

That's what YOU will get when you sell your new or used radio gear to Columbia. Have you something to sell? Fine! Make your own appraisal and we'll make a quick, clean deal F.C.C.—For Cold Cash!

REMEMBER! We've got the biggest stock of new and used radio parts in the U.S.! Tell us your needs. You'll be surprised at our low, LOW, LOW prices!

COLUMBIA ELECTRONICS SALES

522 S. San Pedro St., Los Angeles 13, Calif.

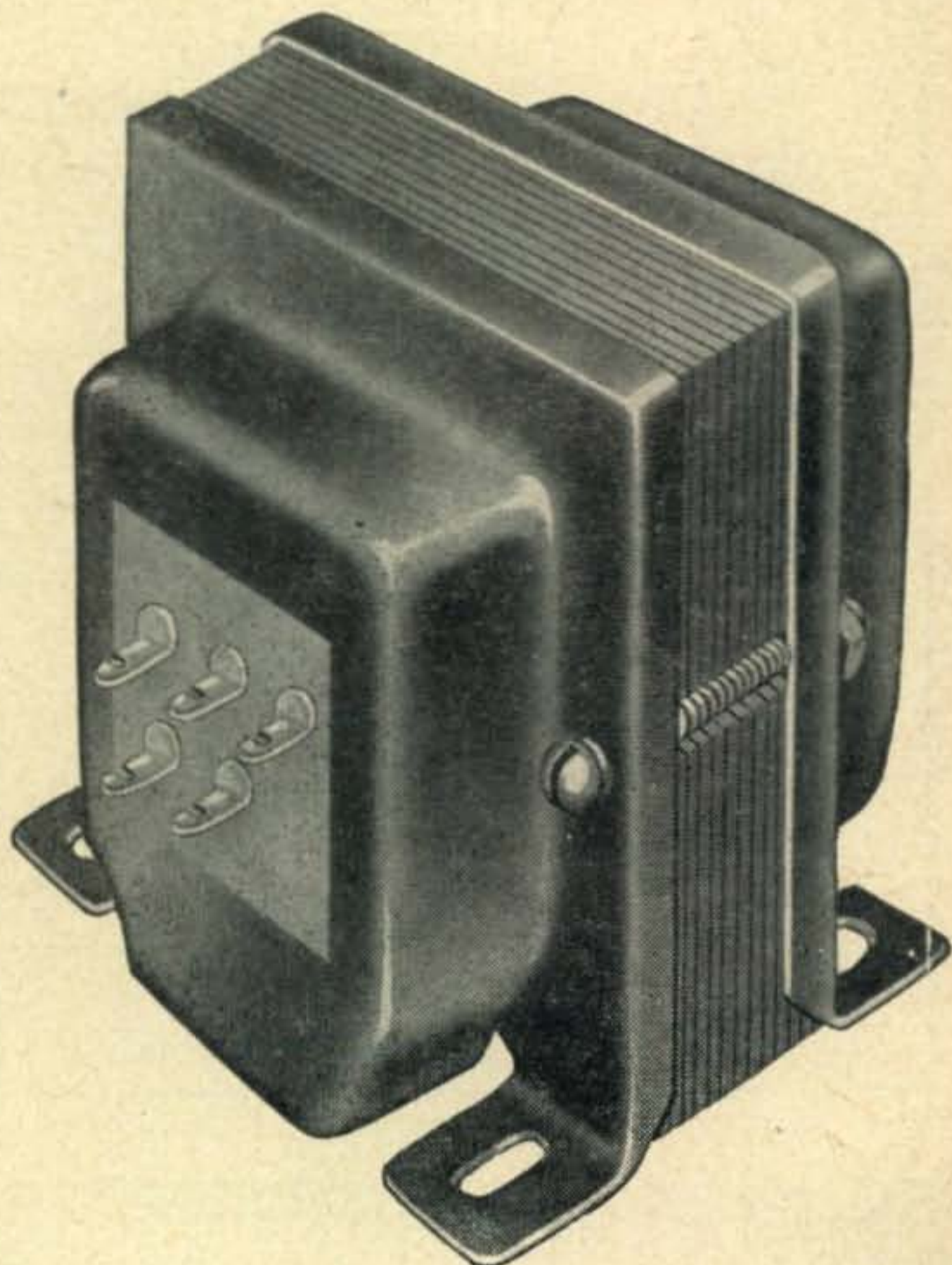
for the high-power man!**MERIT HIGHPOWER
Filament Transformer P-2943**

Designed for highpower use in both Amateur and industrial applications.

Specifications: Sec. Volts, 5—Sec. Amp., 30—Insulation Volts, 3000—Center tapped with primary taps for 110-115-120 volts, 60 cycles—Dimensions, 3 $\frac{7}{8}$ H. x 3-3/16 W. x 4 $\frac{3}{8}$ D.—DL Mounting . . . Will handle a pair of 250 TH's . . . 4—250 A's . . . 4—125 A's . . . 4—400 A's, etc.

Net Price — \$6.60

Merit Transformer Corporation
4427 North Clark Street
Chicago 40, Illinois



BURTON BROWNE ADVERTISING

THANKS TO VAARO IT'S R9+



\$8.95

OPERATE ALL BANDS
WITH ONE COIL —
TWO SECOND BAND
SWITCHING.

- Highest "Q" possible — therefore highest gain
- Absolutely no corrosion
- All weather proof shield
- All new VAARO glass construction
- Fits all whips
- All fittings chromed brass
- Available with or without complete VAARO glass antenna, capacity hat or other accessories.

COMPLETE MARINE, AMATEUR, POLICE,
AND C.A.P. ANTENNA UNITS AVAILABLE.
WRITE FOR LITERATURE



VAARO ELECTRONIC ENGINEERING COMPANY,
BOX 5035 LONG BEACH, CALIFORNIA

Present and Prophetic

Lawton - Fort Sill Hamfest

The Lawton-Fort Sill Amateur Radio Club is having their 5th annual banquet and hamfest during February 15, 1953, at 1:30 p.m., at the "Old South Cafeteria", Lawton, Okla. All hams, and their XYL's, are invited to attend. Preregistration will be \$1.75 per person or \$2.00 at the door. Preregistration and door prizes will be awarded. Send your preregistration to the Lawton-Fort Sill amateur club, P.O. Box 892, Lawton, Okla.

RV2 STORY

(from page 22)

watt amateur transmitters and two 200-watt government ones. Power is supplied by five-kilowatt generators. My 8JK amateur antenna is fed with 115-foot feeders, because I must keep it clear of the government antennas.

DX is not as good here as one might expect. Only South American stations come in really well. I am always interested in working France and French North Africa, but conditions seldom permit it. Part of the trouble is probably the present stage of the sunspot cycle. At any rate, FO8AD is always looking for contacts with old or new friends.

Two old friends I must mention are Don Carlos, HC1FG, Quito, and Ike, W9RUK, Chicago. I have had many wonderful contacts with them both. Ike did an excellent bit of emergency work one night by relaying an urgent message to a hospital in France for me.

Some day, I hope to visit many of my amateur friends throughout the world. Until then FO8AD is always QRV to QSO you.

VK's POINT OF VIEW

(from page 44)

However, at the present time, with the efficient use of good equipment, we are able to take more advantage of the ever-changing band conditions, instead of being victimized by them.

Nevertheless, keep in mind that Australia is a big place and don't expect to work every district during one opening. On the other side of the ledger

Proven Performance

ANNOUNCING the NEW

SONAR PHONE PATCH

MODEL
PP-24



- Break-In Operation
- Extremely Compact
- Operates with Any Rig
- Minutes To Install
- Totally Shielded — No Hum

\$19⁵⁰
HAM
NET

Immediate Delivery — At Your Dealer
WRITE FOR LITERATURE

SONAR
RADIO CORPORATION

3050 West 21st St.

Brooklyn 24, N. Y.

The Newcomer's Buyway

"The Dispatcher"



Here's a Controlled Reluctance microphone assembly designed to handle the most severe requirements of radio amateur rigs. The "Dispatcher" is supplied with two-conductor shielded cable, and it's wired to operate both microphone and relay circuits. This field-proved unit is used extensively in police, railroad, airport, and all

emergency communications work where dependability is vital. Of special interest to "Hams" is the large, easy-to-use grip-bar and positive action of the heavy-duty switch. Firm downward pressure on the grip-bar locks the switch—so you can "yackety-yack" all night without lifting a finger! The "Dispatcher" is immune to heat and humidity and will stand up under rough usage. It is manufactured by Shure Brothers, Inc., 225 West Huron Street, Chicago 10, Illinois. It's a high-impedance unit with a high output level of minus 52.5 db. Lists at \$35.00. See the "Dispatcher" at your Distributor for further details, or write Shure Brothers, Inc., 225 West Huron Street, Chicago 10, Illinois.

BUD Antenna Tower

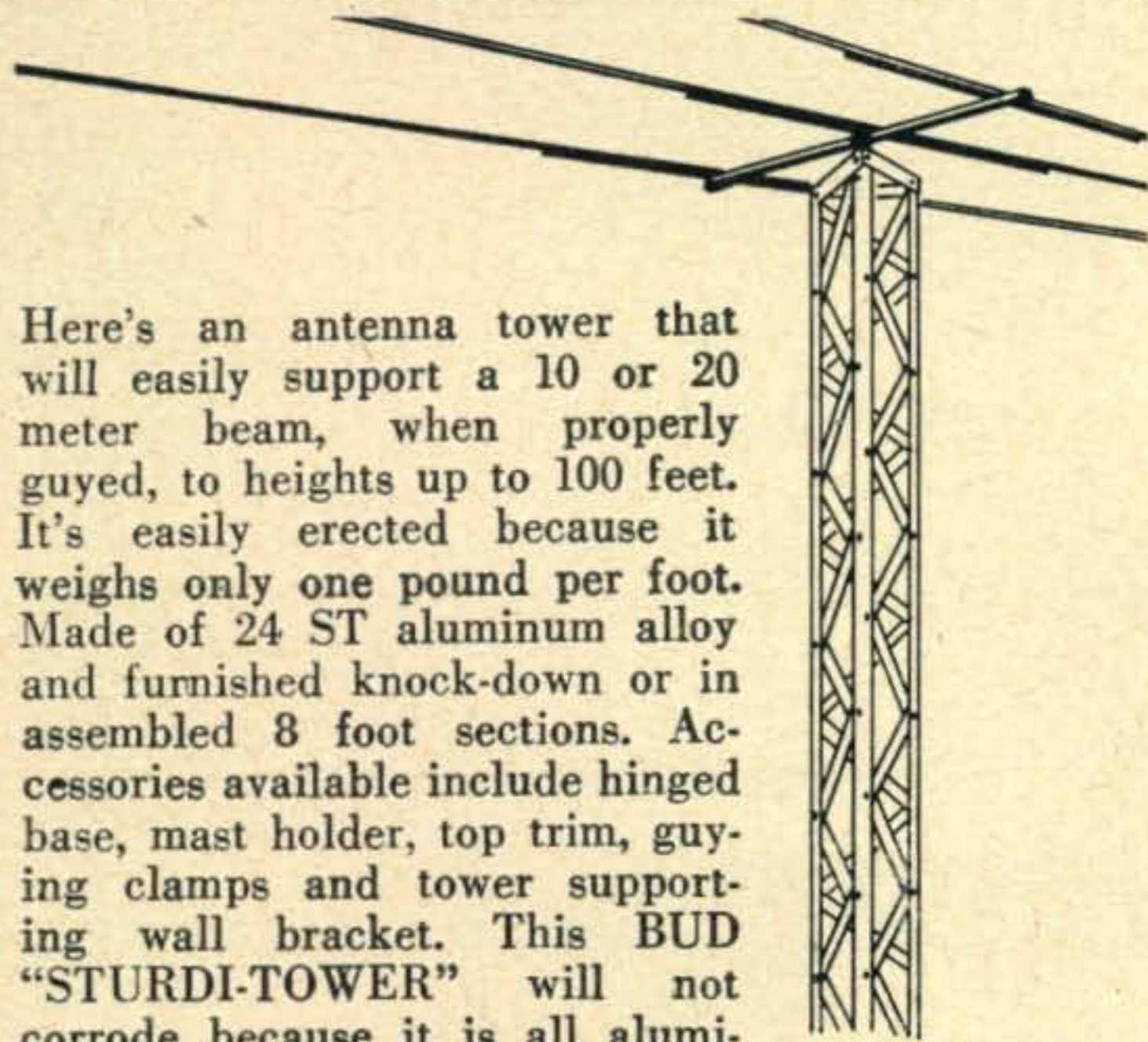

Here's an antenna tower that will easily support a 10 or 20 meter beam, when properly guyed, to heights up to 100 feet. It's easily erected because it weighs only one pound per foot. Made of 24 ST aluminum alloy and furnished knock-down or in assembled 8 foot sections. Accessories available include hinged base, mast holder, top trim, guying clamps and tower supporting wall bracket. This BUD "STURDI-TOWER" will not corrode because it is all aluminum including the hardware. The BUD "STURDI-TOWER" will give a lifetime of service at a moderate cost. See it at your BUD distributor today or write for literature.

BUD RADIO, INC.

2118 East 55th Street

Cleveland 3, Ohio

ATTENTION MOBILE HAMS

COMPLETE MOBILE PACKAGE — NOTHING ELSE TO BUY. OUTSTANDING MOBILE SIGNALS USE MOTOROLA EQUIPMENT—BACKED BY YEARS OF COMMUNICATION EQUIPMENT EXPERIENCE — WORLD'S LARGEST PRODUCER OF 2-WAY MOBILE EQUIPMENT.

A mobile transmitter with a double feature FM or AM at flip of the switch, the MOTOROLA FMT-30-DMS 27-30 MC. . . **\$130.00**

P-7253 spring base rear-mount antenna. . . **\$23.13**

MOTOROLA P-69-18 or 18-ARS receiver with special noise limiter for use

with any converter having 1440-3000 KC. **\$60.00**

New Gon-set Tri-Band Spread Converter **\$47.60**

3-30 famous Gon-set converter complete to connect to the P-69-13 or 1-ARS receiver **\$44.75**

P-327-E Fire wall loud speaker **\$7.50**

The above comes complete with all necessary accessories and mounting hardware. Order direct or through the Motorola National Service Organization member in your area.

NOTE: This Receiver and Transmitter is equipment which has been returned from the field, modified and rebuilt for Amateur Service.

For further information, write to:

MOTOROLA INC.

Amateur Sales Dept. CQ, February

1327 W. Washington Blvd., Chicago 7, Ill.

Attention: Harry Harrison, W9LLX
Telephone—Taylor 9-2200, Ext. 161

Here's a two-way resolution that will keep you operating at peak all year long . . .

If you resolve to order your supplies from us at ALLIED—we'll prove we're keeping a resolution we made more than a quarter of a century ago. We'll give you every buying advantage: the squarest



deals you can make on trade-ins (just try us); a real break on time payments; fastest delivery; Ham-to-Ham personal help. So resolve right now to do your ordering from the 236-page 1953 ALLIED Catalog. It's packed with the world's largest stocks of quality station gear—at money-saving low prices. You can count on us for everything you need to keep operating

at peak—and we'll save you money and time. P. S.—For a copy of our 1953 catalog, write ALLIED RADIO, 833 W. Jackson Blvd., Dept. 16-B-3 Chicago 7, Illinois.

Next Month — —

When you see this cover keep in mind that CQ will contain as its feature article a full description on how to use one of the most important receiver developments in the post-war era.

The Collins Mechanical I-F Filter

The Technical Editor of CQ, W2PAU has designed two adapters using the Collings Filter that enables it to be inserted in many 455 kc. i-f communications type receivers to afford an unbelievable improvement in selectivity.

Also in this issue, W4OLL will introduce the first part of his valuable series of articles on single-sideband operation. This series will summarize the present state of the SSB art. It will include (in this part) the reasons "why" so many Hams are switching to SSB. This, and latter installments, will supply all of the necessary details for getting on the air.



Each Month - -

CQ contains top quality informative and constructional articles of interest to every amateur. CQ is moving ahead—there is no slackening in its pace—your subscription will not only ensure you of every single issue, but it will help us to continue to bring you the "best" material in any amateur radio publication.

3 years	\$7.00
2 years	\$5.00
1 year	\$3.00

[Foreign Subscriptions \$4.00 per year]

CQ MAGAZINE

67 West 44th St., New York 36, N. Y.

CQ-2

Enclosed find \$..... for a year subscription

to be sent to:

New

Renewal

Name

Call

Address

City

Zone

State

(from page 66)

we know that having a rare DX call in the Southern hemisphere does not automatically indicate that you can always be heard. Witness the visit of WØELA to VS5 and his reported disappointment with results. Many times I have heard VK1 call CQ in vain.

Heard Island

They tell me that a standing joke in the U. S. A. is the fellow that got a "heard card from Heard Island!" Well, be that as it may, a station in Zone 39 was of great interest around the world. VK2PG was there as VK1PG. John reports that the island is entirely volcanic and has no natural vegetation. The island's scientific staff is changed each year and generally have no outside contact with the rest of the world except via radio. During his sojourn, John had VK1YG and VK1HV as company; together they made about 500 contacts with VK1PG working 75 countries.

Radio reception at Heard Island is severely influenced by magnetic storms and auroral activity. At times there existed a complete radio "blackout,"

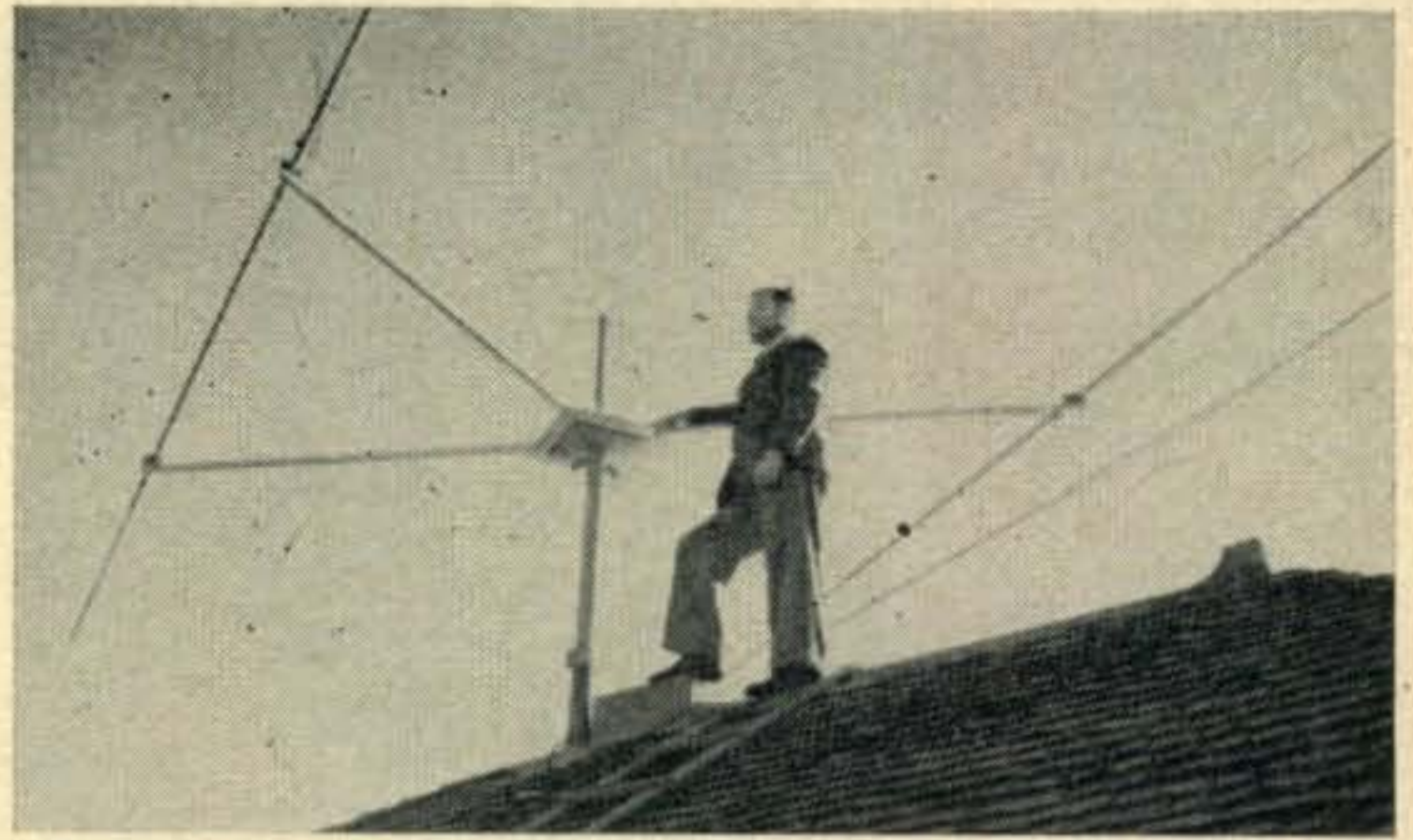

Don, VK2NO surveys the terrain from the rooftop of VK2CM. The beam is a two-element rotary of the G8PO type which is somewhat like the 8JK except that it has electrically reversible phased elements for a controllable front-to-back ratio.

varying from 2 to 10 days in duration. Amateur activity was limited to about 3 hours per day, the remainder being occupied with commercial and official traffic.

The power at Heard Island was 25 watts, and

SAVE 5%* By Stating You Ordered From This CQ Ad!

* ON ORDERS RECEIVED DURING FEBRUARY 1953

ANTENNA EQUIPMENT



MP-132 MAST BASE—(Illustrated) 1" heavy coil spring 2" insulator. Overall length, 11 1/2". Weight: 2 3/4 lbs. Price.....\$3.95
MAST BASE—Insulated type with heavy coil spring and 5 inch dia. insulator. Requires 1" hole for mtg. Weight: 9 lbs.\$5.95
MAST SECTIONS FOR ABOVE BASES:
 Tubular steel, copper coated, painted, in 3 ft. sections, screw-in type. MS-53 can be used to make any length with MS-52-51-50-49 for taper. Any section50c each
 Larger Diameter Sections: MS-55-54. \$1.25 each

GOING MOBILE?

For 6 Volt Conversion, See details in August & December, '52, CQ issues **\$4.95**

PE-101C DYNAMOTOR

RECEIVERS—TRANSMITTERS:

TA-12B TRANSMITTER with Tubes—Used.....\$39.95
MP-28 BA Power Supply & Modulator f/TA-12B—New.....\$29.95
R1/ARR-1 Receiver—easily converted to 220 MC. (see R.N. Jan. '49). Complete with Tubes—New ..\$4.95

DYNAMOTORS

DYNAMOTOR and BLOWER: 9 Volts DC input; output 450 Volts 60 MA. 4500 RPM. At 6 Volts DC input; output 260 Volts 65 MA. 3000RPM.....\$4.95

Input	Output:	Stock No.:	Price:
14 V. DC	600 V. 300 MA.	BD-86	\$ 9.95
12 V. DC	220 V. 70 MA.	DM-24	6.95
12 V. DC	220 V. 100 MA.	DM-18	4.95
14 V. DC	375 V. 150 MA.	DM-375	8.95
14 V. DC	330 V. 135 MA.	DM-330	7.95
14 V. DC	500 V. 500 MA.	PE-59	14.95
12 or 24V.D.C.	275 V. 110 MA.	USA/0516	3.95
12 or 24V.D.C.	440 V. 200 MA.		
	225 V. 100 MA.	D-104	14.95
12 or 24V.D.C.	500 V. 50 MA.	USA/0515	3.95
12 V. DC	250 V. 50 MA.	DM-25	8.95
28 V. DC	250 V. 60 MA.	DM-32 (Used)	2.95
28 V. DC	250 V. 60 MA.	PE-86	5.95

AERIAL WIRE—Phosphorus Bronze #16 Stranded, 200 lb. test. Weatherproof. 150 ft. on Reel. RL3 with Clips\$1.50
TELEPHONE WIRE: 3 Cond. copper & steel, 525 ft. \$4.75

COMMAND TRANSMITTERS With Tubes & Crystals

BC-457 Transmitter—4 to 5.3 MC.—Used.....\$ 8.95
 BC-458 Transmitter—5.3 to 7 MC.—Used..... 7.95
 BC-459 Transmitter—7 to 9 MC.—New..... 22.95
 T-20/ARC-5 Transmitter—4 to 5.3 MC.—New.... 12.95
 BC-456 Modulator—New.....\$5.95 Used 2.95
 Transmitter Rack—Single.....\$1.50 Dual 2.00
 Rec. Rack—Dual \$1.50 Modulator—Mtg. 1.50
 Rec. Dyn.—Used \$2.95 Trans. Dyn.—Used..... 2.95

PE-157 POWER SUPPLY—2 V. Vibrator Supply, operated from BB-54 2 V. Battery mounted in Case. Output voltage 1.4 V. 1/2 Amp. 125 V. 50 MA. Less Battery, Speaker & External Power Cord—with Vibrator.....\$4.95
 BB-54 2 Volt Dry Battery.....\$2.95
POWER SUPPLY No. 3 f/Mark 11 No. 19 Radio Set. 12 or 24 V. Two PM Dynamotors: 500 V. 50 MA.; 275 V. 110 MA.—New\$12.95
PE-104 Vibrator Unit f/BC-654.....\$10.95
550C Vibrator f/PE-104—New.....\$ 1.95
VB-16 Vibrator f/PE-237—SCR-694—New.....\$ 4.95

TRANSFORMERS AND CHOKES:

TRANSFORMERS — 110 V. 60 CYCLE PRIMARIES:
5 Volt CT-25A — 10,000 V. Ins. OPEN FRAME—
 6" x 5" x 4 1/2"\$7.95
 6.3 V. 1 Amp.\$1.25 24 V. 1 Amp. 1.95
 24 V. 1/2 Amp. 1.50 24 V. 6.5 Amp. .. 5.95
6-24- or 30 Volt Amp. 5.95
440 VCT/70 MA — 5 V. 2 A.—6.3 V. 4 A. 3.35
490 VCT/60 MA—5 V. 2 A.—6.3 V. 4 A.—6.3 V. 2 A. 3.25
460 VCT/90 MA—5 V. 3 A.—6.3 V. 4 A. 3.75
325-0-325 V. 50 MA—6.3 V. 2.5 A.—6.3 V. .6A.
 (Rect. 6 x 5) Half Shell—2 7/8" x 3 3/8" x 3"—No. T-23-28 2.75
175-0-175 V. 40 MA—6.3 V. @ 2.4 A.—6.3 V. @ 6 A. Halfshell 2 5/8" x 2-3/16" x 2 3/8"—No. T-23-40 1.25
350-0-350 V. 90 MA—6.3 V. @ 3 A.—5 V. @ 3 A. Upright—3 1/2" x 3 1/2" x 3 7/8"..... 3.25

CHOKES

5 Henries—150 MA. 85 ohms DC-Res. Cased.....\$1.95

ADDRESS DEPT. CQ

ALL PRICES ARE F.O.B., LIMA, OHIO

25% ON C.O.D. ORDERS

FAIR RADIO SALES

132 SOUTH MAIN ST. LIMA, OHIO

L. A. HAM SHACK SELLS FOR LESS



METERS—WESTON -SANGAMO
ALL NEW - ALL D. C. - 2" SQUARE
0—5 Ma } \$3.29
0—15 Ma } EACH
0—50 Ma } or
0—100 Ma } 3 for
0—200 Ma } \$9.00
0—300 Ma }
0—500 Ma }

0—2 Ma \$3.95

Mfg's Inquiries: lots over 100

Voltmeter, 2" sq.—0 to 20 Volts.....\$3.29
DC Voltmeter, 2" sq.—0 to 300 Volts w/Ext. resistance.
Complete \$3.95.....3 for \$9.95
RF Ampmeter, 2" sq.—0 to .5 Amp.....\$3.95
Ampmeter, 2" rd.—0 to 50 Amps.....\$3.29
Ampmeter, 2" sq.—0 to 50 Amps.....\$3.29
3 for \$9.00
3" Round Meters, DC. All New, 0—15, 0—30, 0—300
Mills. \$4.95 Each.....3 for \$11.95
Milliammeters, 2 1/2" rd. 0—30 Mills. Each.....\$3.95
Milliammeters, 2" rd. 0—50 Ma. 0 to 5 Ma. movement.
Each \$3.29.....3 for \$9.00
Thermocouple, 2" rd. 350 Milliamp. HF.....\$3.29



"S" METER, Illuminated face. Full scale reading of 5 ma. A standard value for most "S" Meter Circuits. 2 3/8". Black face. New.....\$2.49
Amp Meter, No. 60-0-60. New \$1.29

COMMAND AND/OR ARCS TRANSMITTERS and RECEIVERS

3-6 MC Receiver.....Used \$6.95
New \$17.95
6-9.1 Receiver.....Used 7.95
New 12.95
Triple Receiver Rack.....\$1.95
V.H.F. ARC5 Transmitter or Receiver, Complete w/tubes
Used \$24.95
New
4-5.3 MC Transmitter with tubes.....\$ 8.95
5.3-7 MC Transmitter with tubes.....6.95
7-9.1 MC Transmitter with tubes.....9.95 \$19.95
3-4 MC Transmitter with tubes.....18.95
28V Receiver Command Dynamotors .. 1.95

MODULATORS

BC-456 with Tubes, less dyn.....2.95
MD-7 Modulator Dynamotor, 28V.....3.95
BC-433 Receiver—with tubes.....24.95
MN-26C Compass Receiver.....24.95 \$39.50
MN-26Y Compass Receiver.....24.95 39.50
BC-357 Marker Beacon Rec. W.O. Tube.....5.95

CIVIL AIR DEFENSE or 2 METERS

522 Trans.-Receiver, W/tubes, Good, used.....\$69.50
Modulation Transformer, BC-375.....New 2.49
BC-306 Antenna Loading.....New 1.95
FL8 Filters—A's, B's, C's.....New 1.95
FL5 Filters.....New .95
Hand Keys—J-38.....New 1.19
Heineman Circuit Breakers 115 V., 20 amp. 1.39
115 V., 5 amp. .97

TRANSFORMERS

12V 24V 2am 110V primary.....\$2.95
Code Tapes for TG-10 15 rolls. New.....7.95

DYNAMOTORS

PE-101C.....New \$ 4.95
PE-103 New Case.....29.95
PE-73 29V @ 20 amps. output 1000V @ .350 amps.....New 9.95
PE-77 14V @ 40 amps output 1000V @ .350 amps.....New 24.95
RL-42B Antenna Reel Ass. Less wire.....New 9.95

OIL CONDENSERS — STANDARD MAKES — NEW

2 mfd 600V \$ 0.49
4 mfd 600V 1.39
1 mfd 1000V .69
3 mfd 4000V 7.95
.5 mfd 2500V 1.49
10 mfd 600V 2.95
2 mfd 2500V 3.95
2 mfd 2500V 3.95
2 mfd 7500V 29.59



HEAD SETS

HS-30.....New \$1.95 HS-23.....Used \$2.95
Matching Transformer for HS-30......69
MIKE CHEST SET "F-1" button.....New 2.95
Cash with order. Prices subject to change without notice.
California orders please include 3 1/2% Sales Tax. Please include approximate postage—Excess will be refunded. What Have You in Surplus? Submit

L. A. HAM SHACK

1306 BOND STREET, at PICO
LOS ANGELES 15, CALIFORNIA

(from page 69)

40 meters was not tried due to poor conditions. No signals were heard on 10 meters. During the period of April to September, the VK, ZS and W signals were the main stations heard, from 0200 until 1600 GMT. From October through March the Europeans were heard. DX activity on 20 meters peaked in November and December, with the band staying open almost 24 hours per day. South America was always difficult to contact.

One complaint that the Australian Ham has had, is that should a license be terminated, especially by a fellow Ham joining the "silent keys," the call was soon re-issued. Consequently, many DX calls are now held by others, in many cases amateurs quite new to the game. We have frequently noted that overseas stations are unaware that their DX pal in Australia has passed on, and are either offended or embarrassed by the actions of the new party holding the call. Through the efforts of the W.I.A., this situation is gradually being improved.



This is VK1FG at Heard Island, Antarctica 1950. The rig was a pair of 807s modulated with 6L6s. The receiver was an Eddystone (British) 680.

I would also like to point out that Australian Hams are not permitted to handle third party traffic. Many of our friends in U.S.A., who were out here during the war, have been disappointed when they found we would not handle their messages to VK-acquaintances. Sorry, but regulations are regulations and we want to keep our hobby going.

DX-ers in Australia, like most countries, can be divided into a number of classes or types. There are those who like to work as many countries as possible on low power and a simple antenna; those who try to work as many with higher power and bigger antennas; the certificate hunter; or the one like VK4EL who runs a marathon sked with a particular DX station, in this case G5ZA (600 QSOs). Finally, we come down to the "proowler" (like VK2QL) who listens around the bands for something tasty or an old DX pal, often without using the transmitter. It's amazing how dead a band can seem until something good in the way of DX shows up. Maybe I'll see you!

Amateur Teletype Comes of Age

WAYNE GREEN, W2NSD

1379 East 15th Street
Brooklyn 30, New York

It was a merry Christmas indeed for those interested in teletype. The new FCC regulations culminated two years of waiting, hoping, planning, and construction. Up to now the active teletype stations have been stuck way up on two meters and the stations outside of the big cities have either had to interest another local amateur or else sit and wait for new legislation. No wonder the excitement is so high.

The new regulations (amended section 12.82 [a]) say, in essence, that the RTTY stations must sign their call letters both in CW and RTTY. This will make it possible for all listening to effortlessly identify the station as amateur, although it will raise hob with the printers, until we can put in some circuits to disable the machines while c.w. is being sent or received. This will probably be only a temporary difficulty, since the FCC states quite clearly that these rules are open for revision if they do not work out right.

Section 12.111 has been amended to allow FSK (type F-1 emission) in the bands: 3500-3800 kc; 7000-7200 kc; 14000-14200 kc; and 14300-14350 kc.

The Amateur Radio Teletype Society has tentatively decided upon the following calling frequencies for the new bands: 3620 kc., 7140 kc., and 14340 kc. The mark frequency will be considered the channel frequency and the space signal will be 850 cycles lower. Another recommendation is that we adopt the use of the letters, "RY" when calling "CQ"; "RY" is much more recognizable, in code, than "CQ." Since many of the machines do not unshift on space please remember to send a "LTRS" pulse whenever shifting to lower case.

The FCC went into rather exacting detail as to the standards to be used for RTTY transmission. Fortunately these standards are exactly those that have been in use, and will, therefore, be a matter of little concern except to those who might wish to do some experimenting with narrower frequency shifts or some such. The new section 12.107 sets the deviation for both FSK and AFSK at 850 cycles, with a maximum of plus or minus 50 cycles. Our present, self adopted, tolerance of plus or minus ten cycles is far more satisfactory and will no doubt remain the standard. This new section also sets a high limit on the audio tones used with AFSK of 3000 cycles. This permits us to keep the present tones of 2125 and 2975 cycles.

All in all, though there are some parts of the rules that will cause annoyance, most of them are just what the doctor ordered. They go into effect February 20, 1953, so get that diode modulator into the VFO and clean up the clicks from the printer.

THE CONVERTER THAT OPENED UP THE 2 METER BAND



PRESENTS:
**THE NEW CASCODE, CRYSTAL
CONTROLLED, CONVERTER**

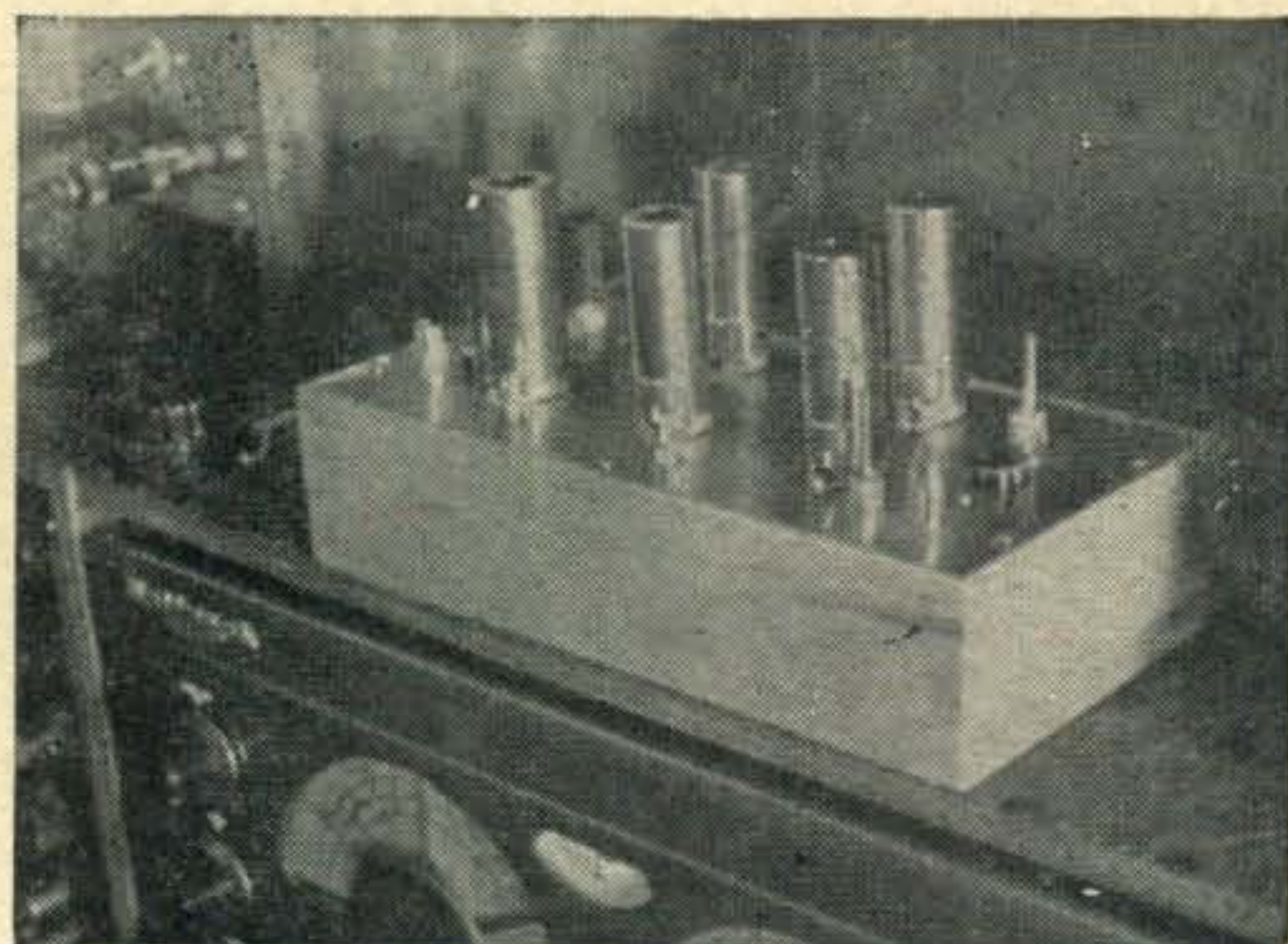

PROVIDES:

- HIGH SENSITIVITY—R.F. input less than 1 micro-volt for 20 db thermal noise quieting. Absolute sensitivity better than .1 micro volt. Gain approx. 30 db.
- LOW NOISE FIGURE—approx. 4 db.
- 6 MC Pass band at 6 db down points. May be peaked to favor any portion of the band.
- COMPLETELY STABLE—C.W. on 144 mc. NO mechanical modulation, PURE D.C. Note. No drift.
- 9 TUNED CIRCUITS—High Image rejection.
- SILVER PLATED RF INDUCTORS—Non-critical slug tuned multipliers.
- I.F. OUTPUT AT 14 MC—Permits direct calibration of rec'vr dial.
- RUGGEDLY BUILT—Suitable for mobile applications
- USE WITH ANY COMMUNICATIONS RECEIVER—Availability with output at I.F. Frequencies 6-10mc, 8-12 mc, 10-14mc, 12-16mc, 14-18mc. We recommend use at I.F. output 14-18mc.
- COPPER PLATED CHASSIS, FINISHED IN SATIN WHITE NICKEL. Low circulating chassis current, maximum resistance to tarnish.
- COMPLETELY SHIELDED—Heavy tin plate lining in hardwood instrument case. Available in Mahogany, Birch, Oak, Walnut, Korina.
- Available (SPECIAL ORDER) FOR 220 MC and other CD or industrial frequencies.
- USES 6BQ7, 2—6CB6 or 6AK5, 2—6J6 tubes.

ORDER DIRECT—COMPLETE WITH PLUGS, TUBES
AND CRYSTAL\$42.50

F.O.B. Hackensack, N.J.

The Equipment Crafters

a division of

TELEVISION INDUSTRIES, INC.

222 RIVER STREET

HACKENSACK, N.J.

SUPER SENSITIVE RELAY SCOOPS!

BK-7, fully enclosed and adjustable. Single pole, double throw, fully adjustable contacts with dial calibrated spring. Will operate as low as 1/2 ma! In plastic case, 1 1/2" x 3" x 1" deep **Only \$1.95**

SENSITIVE RELAY. Closes at 4 to 5 ma. (Extra set of SP/ST contacts for additional sequence, close at 6.5 ma.) Coil 6000 ohms. Sensitivity easily altered by bending limit arm or changing spring. Only 1 1/2" x 2 1/8" x 1 5/8" overall. Dozens of applications and offered at a "stock up" price. Removed from clean equipment. **98c EACH, 3 for \$2.75**

12 CHANNEL T-V TUNER

Complete front end, famous make "Silver Circle." Furnished with original factory instructions, less tubes. Dozens of uses; receivers, converters, etc. The TV bargain of the year for builders, amateurs, students. These are factory rejected for minor damage. **ONLY \$1.93 each, 3 for \$5.00**

6 V VIBRATOR TRANSFORMER. Non sync, two outputs: 700 VCT, 145 ma for plates, 15 v for bias. Using 5U4G can deliver 320 V at 130 ma. NEW **\$1.89**
With 6 V vibrator **2.89**

12V FILAMENT XFORMER or line voltage booster PRI: 110 v 60 cy.; SEC: 9 to 13 volts in 1 volt steps at 2 A. Free schematic shows many uses **NEW \$1.89**

OUTPUT TRANSFORMER, 5000 ohms input to TWO outputs, 300 ohms or 3.5 ohms. Use as output for 12A6, 6V6, etc. or to match speaker or headset. NEW, potted, shielded **79c**

NOVICE BARGAINS

ARC-4 XMTR-RECVR. Readily convertible to 2 meter operation. We furnish schematic and conversion instructions, including specs for 110 VAC power supply. **ARC-4 with ALL tubes**. (A real bargain. The surplus cost of these tubes is over \$30.00) **\$37.50**

12/24 v Input dynamotor for above, **EXCELLENT.. \$9.50**

4-5.3 COMMAND XMTR. Convertible to 80 meter CW Novice operation. With schematic and step-by-step conversion instructions. Excellent used, with all tubes. **\$8.95**

5.3-7 COMMAND XMTR. Also convertible to Novice operation with two more steps. With instructions. Excellent used, with tubes. **\$7.95**

Send for our Latest Flyer

G. L. ELECTRONICS, Dept. A

905 S. VERMONT AVE., LOS ANGELES 6, CALIFORNIA
All Prices FOB Los Angeles, Calif. Buyers add Sales Tax

BUY OF A LIFETIME!

TRIED AND PROVEN THE WORLD OVER



LETTINE MODEL 240 TRANSMITTER WITH MOBILE CONNECTIONS AND A.C. POWER SUPPLY

This outstanding transmitter has been acclaimed a great performer throughout the world. It is excellent for fixed station, portable or mobile operation. Even if you have a transmitter of your own you can't afford to miss this wonderful buy, direct from our factory, ready to operate.

The 240 is a 40 watt Phone-CW rig for 160 to 10 meters, complete with: (8 x 14 x 8) cabinet, self contained A.C. power supply, MOBILE connections, meter, tubes, crystal and coils for 40 meters. Tubes: 6V6 osc., 807 final, 6SJ7 crystal mike amp., 6N7 phase inverter, 2 6L6's mod., 5U4G rect. Weight 30 lbs. TVI instructions included. 90 day guarantee. Price **\$79.95**.

\$25. deposit with order—balance C.O.D.

80, 20, 10 meter coils \$2.91 per set. 160 meter coils \$3.60
Also for CAP, Broadcast, MARS, Marine, State Guard, Novice

LETTINE RADIO MFG., CO.

62 BERKELEY STREET VALLEY STREAM, N. Y.

40-METER BEAM

(from page 27)

in the evening, obviously a help in copying DX.

When conditions are good, it is not unusual to raise a European station around midnight, exchange reports with him, and be kept busy for the next couple of hours answering calls from other Europeans wishing reports. Stations running as low as five watts input have been worked. I am often accused of being a bootlegger, located somewhere in Europe, "because no W, let alone a W9, could be that loud."

A number of RST559 reports have been received from Australia the long way around at 4:00 p.m. The beam permitted me to run up the highest W9 score on 7 mc. in the 1950 and the 1951 *CQ World-Wide DX Contests*. (Hal was modest. His score in the 1951 contest was the highest W9 score on all bands—Editor.)

In operation, if the coupling to the final amplifier is adjusted for an input of 750 watts at 7000 kc., it increases to a kilowatt at 7100 kc. and starts dropping off again toward 7200 kc. Over this range of frequencies, it is unnecessary to retune the final amplifier to retain resonance. This is probably because the various reactances introduced into the tank circuit over this range of frequencies balance out. Between 7200 and 7300 kc., however, even a small shift of frequency requires retuning the final amplifier.

The parasitic element acts as a director between 7000 and 7100 kc., and as reflector between 7200 and 7300 kc.

All-in-all, I would recommend a similar 7-Mc. array as an excellent DX antenna for anyone who has the room for it. Constructional difficulties are not excessive for the results obtained.

NOVICE SHACK

(from page 54)

Institute, and has a commercial First Class Telephone license. Jack, 21, is W9PFZ; Paul, 17, is W9PKG; Mike, 15, is WN9TNI; Richard (about 13) is ready to take his Novice and Technician examinations. Penny, 10, is studying for hers. Mom, Revelda, studies spasmodically for her license, but she believes one of the family should retain a slight hold on her sanity. Oh yes, Gael, 5, recognizes CQ and a few other code combinations.

All this concentrated radio activity takes place on a farm upon which only Hams and antennas are raised. At last count, there were seven antennas covering every band from 1.8 to 148 Mc. Receivers include two HRO's and two BC-348's, among others. Transmitters? You name it; they probably have something similar. To summon the clan from the remote areas of the farm, there is an automobile horn connected to a telegraph key at the house. Seeing this gadget work amazes visitors to this unusual home more than anything else.

Well I did it again! "Dear Herb, I sure do thank you for putting my letter in the *Novice Shack*. Just wanted to inform you that I am a BOY, not a GIRL"—Penny (boy), WN4WYA

Fritz, KN2BHV, and I have been discussing the merits of kits versus building a rig from the ground up. He says, "I still think it is infinitely better to build a rig from scratch. Your comment on cutting holes in sheet iron is well taken here, 'cause I've never used

a steel chassis. Aluminum is my building material. My present 80-meter transmitter was built on a 7x13x3 inch chassis, with all holes, including tube-sockets, meter holes (phew!) and other large holes made with a hand drill and a pocket knife! The training one receives doing this manual labor is, I think, very valuable.

"Too, by shopping around, you can save quite a bit on a part here and there. (Not so easy when you have to buy all your parts by mail—Herb). Two days ago I started construction on a 145-Mc transmitter ending up in an 832A, and using Rothman modulation. 73"—Fritz, KN2BHV.

WNØLJQ speaks his piece very forcibly. "Dear Herb, I am slightly hot under the collar about one of the letters in the **Novice Shack** that runs old-time Hams into the ground. I don't know about other Novices, but fifty to seventy-five per cent of my contacts are with the 'big boys.' I enjoy all of them. It is surprising how they will help you all they can. I know I would not be a Ham if it wasn't for the assistance of WØCIH, one of the old timers. Long may they live!"—George, WNØLJQ.

"Dear Herb, Would you please print this and get me some help learning the code? I am thirteen years old"—Davis Wilson Murphy, 417 Oak St., Greenville, Alabama.

W3TMZ, writes, "Dear Herb, I now have my General Class license, a new rig, with a 6146 final running forty watts and a BC-312 receiver. Jay, WN3URW, who is twelve years old, lives next door to me. Keep up the good work in the **Novice Shack**. 73"—Jack, W3TMZ.

"Dear Herb, I would like to back up Richie, WN4WJD, 100 per cent. I think that the S-38 and the SW-54 just can't be beat for the money. Furthermore, I know several fellows with more expensive receivers who do not know

how to use them. Therefore, we fellows with cheap receivers often get more out of them than those with expensive ones.

"I have twenty-six states confirmed, including California, on the 3.7-Mc band. So if that is not a nice record for an S38B receiver, a ten-watt, 6AG7 transmitter, and a $\frac{1}{4}$ -wave antenna, I don't know what is"—Ron, WN8KYD. "P.S. I am seventeen and a Senior in High School."

"Dear Herb, I am thirteen years old. I need some help in becoming a Ham. Can you print my plea?"—Harry Bluestein, 288 So. Long Beach Ave., Freeport N. Y.

"Moose," WN9SWM, conducts the Indiana Novice Net on 3715-3720 Kc. every morning at 6:00 AM, CST. Moose is a Junior in high school. His 6L6 running at twenty watts has worked thirty-five states, and VE2, 3, and 4. He welcomes visitors to his fine backyard shack. . . . Bob, WN9SWC, runs seventy-five watts and has fifteen states. . . . Ray, WN9SYG, is sixteen, runs nine watts and has worked ten states. . . . Wally, WN9NPJ, is fourteen, runs forty watts, and has five states. . . . Harold, WN9NQX, is the newest of Martinsville, Indiana gang. He operates WN9SWM. All these lads have one thing in common. They want to work more YL's.

WNØMMM writes, "Dear Herb, I got my license exactly thirty days after taking my examination. Your review of the **Philmore** Novice Kit transmitter sold me on it. My first contact was with W5UJW/O. We talked for two hours"—Dub.

WN5WUL writes, "I whole-heartedly agree with Richie, WN4WJD, about the so-called cheap receiver. In a month and a half, I have worked fifteen states with
(Continued on page 74)

15 WATT POWER AMPLIFIER UNIT

Brand New



Model F Power Amplifier Unit manufactured by Personal Music Company, Newark, New Jersey. Formerly sold to jobbers at \$129.50 each.

Chassis size 11 $\frac{1}{2}$ " x 17 $\frac{1}{2}$ " x 2 $\frac{1}{2}$ " high (with cover 11 $\frac{1}{2}$ " x 17 $\frac{1}{2}$ " x 7 $\frac{1}{2}$ " high). Net weight about 50 lbs. Gray crackle finish.

OUR PRICE BRAND NEW **\$35⁰⁰**
COMPLETE

This amplifier delivers 15 watts of undistorted audio power with excellent frequency response. The tube line-up is 1—2D21, 1—6AL5, 1—6SJ7, 1—6SN7, 2—6L6G's, 1—5U4G. The total power drain is 300 watts from the 110 V. 60 cycle AC power source. Treble, bass, vernier volume and master volume controls are provided. This amplifier is beautifully designed and is sturdily constructed with the best of components. It can be used for continuous day and night service. Deluxe features such as high—low AC line switch, AC line fuse,

good ventilation of chassis and cover, external carrying handles, lock and key, and heavy duty AC line cord are provided.

You can use this unit for microphone, phonograph, or radio input or fix it for combinations of such inputs. It will make an excellent foolproof and trouble-free unit for dance bands, lecture halls, schools, sports events, for rental purposes, for inner-office communication. It will handle a number of loudspeakers. Originally sold for \$129.50.

40 West
South Street

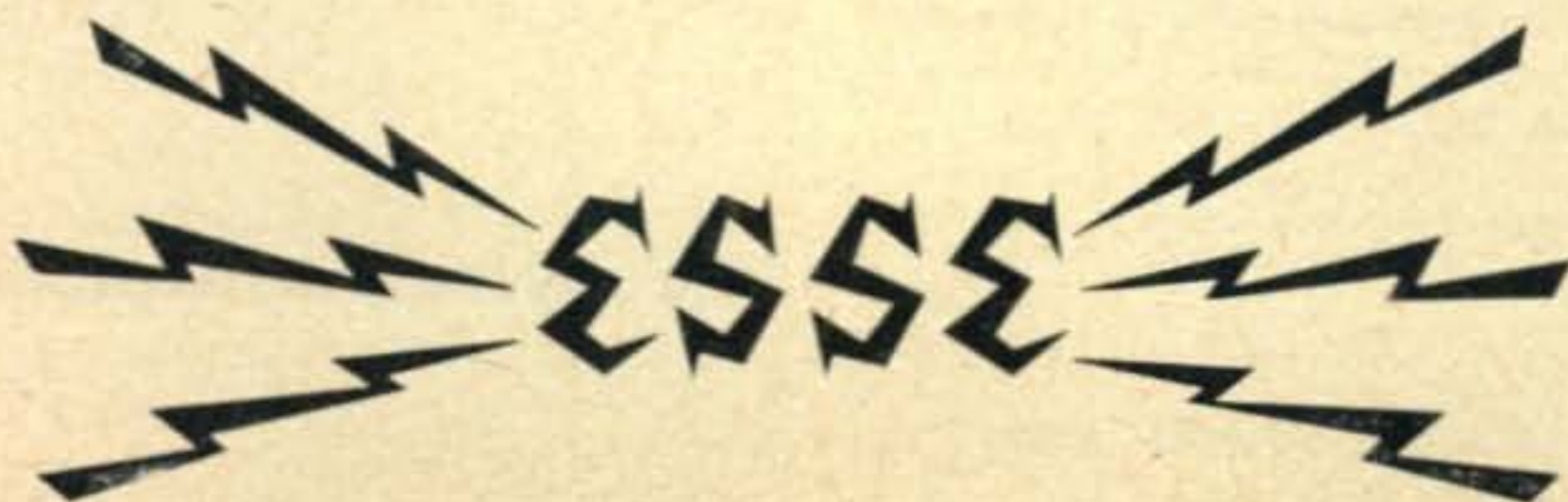

Indianapolis 4,
Indiana

EASY TO LEARN CODE

It is easy and pleasant to learn or increase speed the modern way—with an Instructograph Code Teacher. Excellent for the beginner or advanced student. A quick, practical and dependable method. Available tapes from beginner's alphabet to typical messages on all subjects. Speed range 5 to 40 WPM. Always ready, no QRM, beats having someone send to you.

ENDORSED BY THOUSANDS!

The Instructograph Code Teacher literally takes the place of an operator-instructor and enables anyone to learn and master code without further assistance. Thousands of successful operators have "acquired the code" with the Instructograph System. Write today for full particulars and convenient rental plans.



INSTRUCTOGRAPH COMPANY

Dept. C., 4701 SHERIDAN RD., CHICAGO 40, ILL.

WANTED

WE NEED YOUR SURPLUS
ELECTRONIC EQUIPMENT

WE PAY TOP \$\$\$ FOR:

- | | |
|-------------------|-----------------|
| ● RADIO RECEIVERS | ● PLUGS |
| ● TRANSMITTERS | ● CORDS |
| ● ARC-1 | ● RELAYS |
| ● ARC-3 | ● TELEPHONE |
| ● ART-13 | ● MATERIALS |
| ● CONTROL BOXES | ● AN CONNECTORS |
| ● INDICATORS | ● WE BUY |
| ● CLAMPS | ● ANYTHING! |

WRITE, WIRE TODAY! TELL US WHAT YOU HAVE
TALLEN CO., Inc., Dept. CQ
159 Carlton Ave. Brooklyn 5, N. Y.

GET CASH NOW!

Sell Us Your Surplus Test Equipment, Transmitters, Receivers, Radar Equipment, Navigational Aids; Marine & Airborne Equipment: Tubes and Manuals. State price and full description. *Top Prices Paid!*

Always Right With Earl White

RADCOM Engineering Co.

8 LIVINGSTON ST. NEWARK 3, N. J.

Telegraph WUX, Newark, N. J.

Phone Bigelow 2-6666

75-150 WATT TRANSMITTER



Including power supply, tubes, crystal — all parts. Operates on all bands from 160 to 10 meters. Two 5U4G rectifiers, 6AG7 oscillator and 807-807 power amplifier. TVI proof except on 10 meters. Kit with instructions \$49.95. Factory wired & tested \$64.95.

Send post card for free information

DIXON ELECTRONICS CO.

13444 W. McNichols Rd.

Detroit 35, Mich.

MEASURING DEVICE

This Calibrated Capacitor enables you to accurately measure ● Capacity, 3 mmf to 50 mfd ● Inductance ● Distributed Capacity ● Mutual inductance, Q and other measurements. Price \$5.65. Write for information.

P. E. HAWKINS CO.

Kansas City 16, Mo.
3208 E. 56 St. N.



(from page 73)

my S38C and seventy-five watts input. I can't see why anyone can complain about a receiver like that"—Tom.

WN6TKD says, "Dear Herb, I built the Philmore Novice Kit Transmitter after reading the August Novice Shack and it works fine. My receiver is homemade, and it isn't so hot, but I hope to have a better one soon."—Ron.

Send information on your high school or junior high school radio club to Willis C. Brown, Room 3643, U. S. Office of Education, Washington 25, D. C., to be included in a list being compiled. Include name of club and school, address, name of president, number in club, special exhibits, demonstration, and other pertinent information. In return, you will receive a copy of the list to aid you in contacting other similar clubs. See you next month. 73, Herb, W9EGQ

G's POINT OF VIEW

(from page 33)

same DX as you were!)

Certain characters established reputations as 80-meter stalwarts and proceeded to make WAC's, both on phone and CW. Mention the band almost anywhere in the world, and the call-signs of a faithful few stations will spring to mind. There should really be a club for the 80-meter fanciers, because, once bitten, they stay bitten—and hard!

The QRM Band

Time was when *Forty* was one of our best DX bands, and, of course, it still could be. But no W Ham can imagine what the band is like for us without taking a trip to Europe and listening for himself. Political reasons were responsible for handing out 7200-7300 kc. to broadcasting soon after the war; later on, the 7100-7200 section became filled with them. Nowadays, the only section of the band usable for DX work in Europe is the bottom end—roughly 7000-7050 kc. And even inside this minute slice we have pirate broadcasters, jammers, jingle-bells and heaps of miscellaneous seaweed that beggars description.

Add to these sad facts the further one that certain European countries still tolerate amateurs who regard a wobbly T4 tone, complete with whiskers, chirp and key-clicks, as one of the latest scientific achievements of the century—and spare a sigh of sympathy for us. (Some of the above-mentioned transmissions have grid modulation applied to them as well. They are then far more effective than the current Russian jammers.)

Notwithstanding all this, one or two G's have worked more than 100 countries on *Forty*, and one outstanding short-wave listener has heard 178 on the band! Real DX work is best carried out at night (between midnight and 0500 for preference), but there is a good patch between 1700 and 1900 GMT, when the Far East and Australasia often break through. The European QRM is still in full cry, though, and selective eardrums with built-in crystal filter and phasing control are an essential.

A very interesting development of this band was

opened up by persistence on the part of some W6's and some G's, who were convinced that long-way-round working should be possible at about 1430 GMT during the months of December, January and February. It was tried out in 1950, and it worked: excellent signals came over here from W6DFY, 6GAL, 6EBG, 6FSJ, 6OEG, 6MHB, 7OY and 7VY—to mention the first to arrive in the winter of 1950-51. Receiving these signals through European QRM in mid-afternoon took some doing, but it was possible, and several good QSO's were made. They were definitely over the long path, with no other DX coming in but an occasional VS2 or VS6.

At about the same time of year the ZL's were outstanding round about 0800-0900 GMT, the VK's showing a preference for the early evenings. All these events go to show what a wonderful band *Forty* could be if someone had the necessary powers to sweep away the garbage. Meanwhile many of us over here use it as much as we can, especially during the hours when skip is long and the local QRM not too hot; hence many hundreds of fine contacts with East Coast W's, KP4, KV4 and so on round about the midnight hour.

If you have had the patience to read all the foregoing, you will probably have the extra amount to spare for us when your calls go unanswered; it isn't the fault of your rig, but merely the unfair opposition you have to contend with on this side. We are told that your own QRM on *Forty* is just nothing to it!

The Solar Cycle

The past five years have given us a chance to observe the sunspot cycle in action in a more complete way than we ever had before the war. In the 30's, as fast as conditions fell off someone produced a better receiver, better transmitter, better antenna system, and so offset the loss of DX. But we are not in a position to advance so quickly now, and huge numbers of hams are doubtless using the same gear now as they were in the peak year of 1947. So we have gone round half the cycle, from the days of easy DX on *Ten* to the days of fighting for it on all bands and nothing below *Forty* at night!

This has shown up the value (or, for us, *potential* value) of the LF bands, and *Forty* and *Eighty* have done much to keep the DX tradition fully alive through the lean years. Even the Ham who likes to do things the hard way—and most genuine Hams do!—has not been capable of maintaining DX work on a band as dead as *Ten*; however, he has been able to make some almost impossible DX conquest on *Forty* and *Eighty*.

The "Top Band"

One-sixty is known with some affection as "the Top Band" to its many devotees over here, where we have the use of 1715-2000 kc. with a maximum input of *ten watts*. So it is an ideal beginners'

(Continued on page 76)

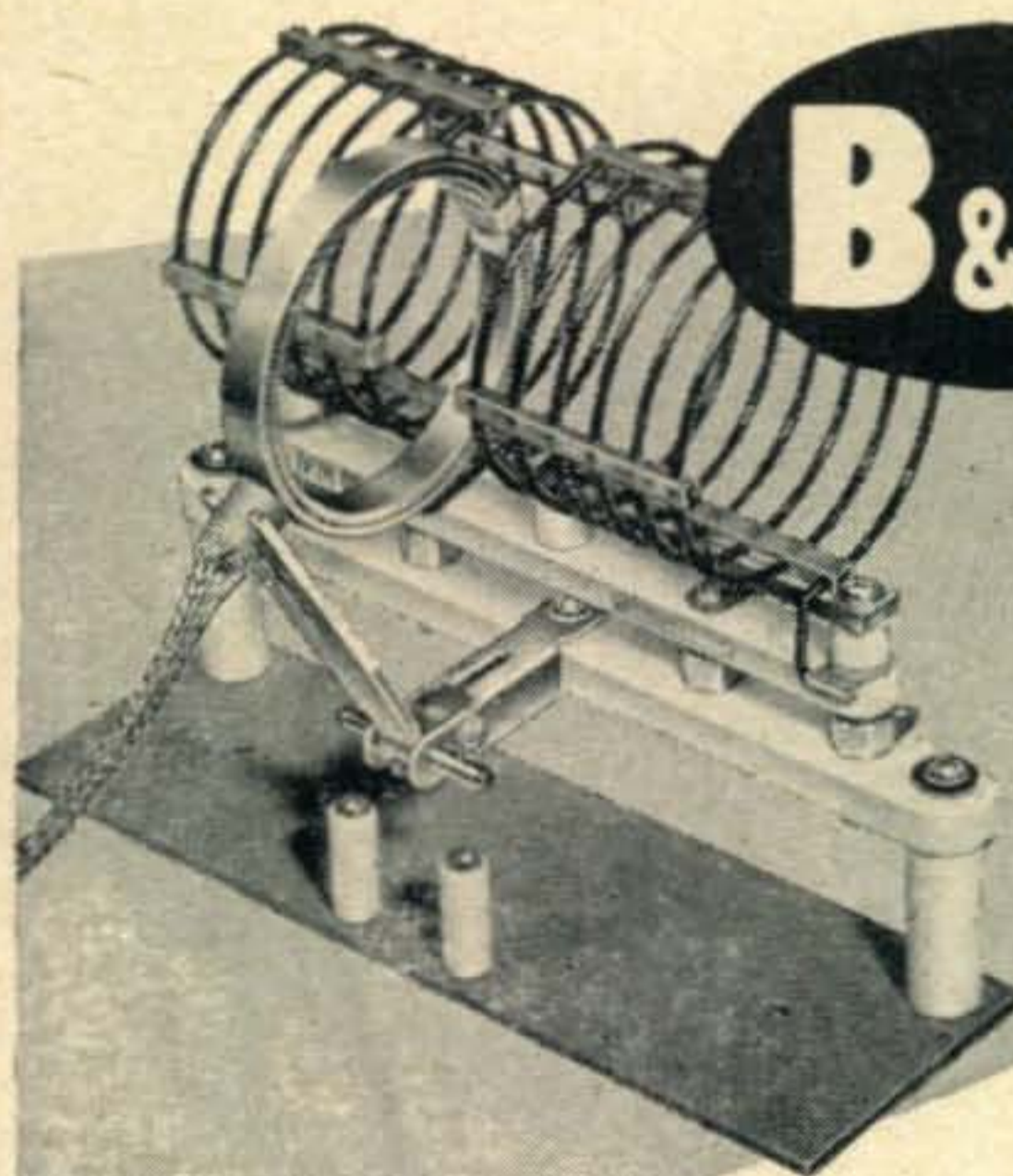

B&W

FARADAY SHIELDED LINKS

... for reducing TV and BC interference

B&W Faraday Shielded Links are highly effective in reducing harmonic or spurious signal radiations, normally transferred by capacity coupling, and which are always present with an open wire link. They're easily adapted to all conventional link-coupled circuits and with external antenna units, or in conjunction with harmonic suppression filters of either the low-pass or band-pass type. Available for B & W Series HDVL, TVL, TVH, and BVL coils. Write for Bulletin 605.

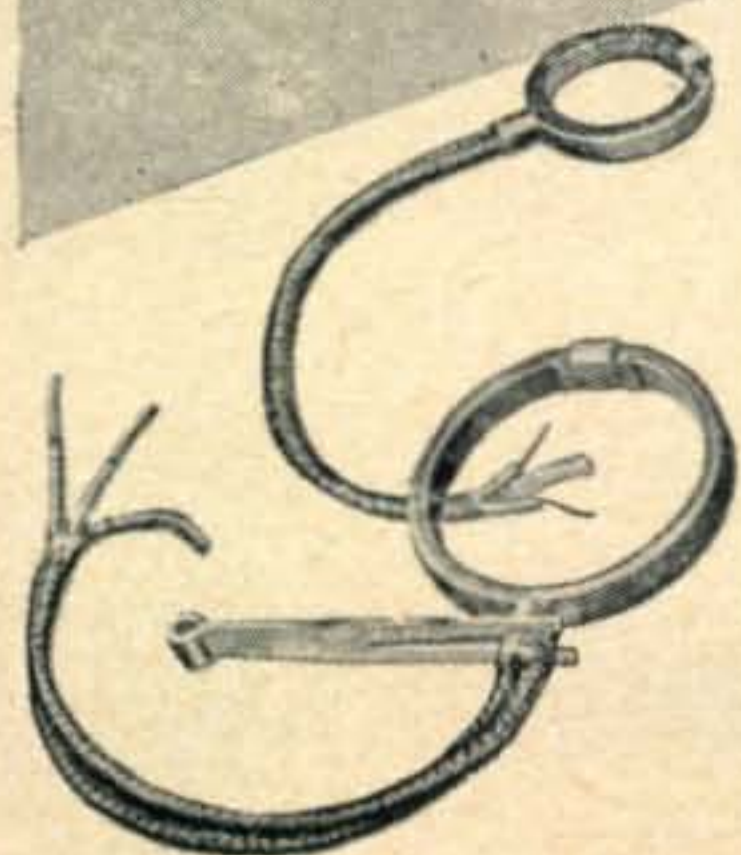

BARKER & WILLIAMSON, INC.

237 FAIRFIELD AVE.

UPPER DARBY, PA.

HERE ARE REAL BUYS

Panels removed from Eniac type computer contain at least 2 dozen low loss sockets and loaded with valuable components. No junk.

Each 98c. 3 for \$2.50

Modulation transformer pair of 807's to 807 cased, 40 in stock to close out Only \$2.50 each
 RG59/U coax, 150 to 300 ft. lengths, special 3c ft.
 C. D. condenser, 1 mfd 1000 vdc, special 3 for \$1.00
 Doing any TV work? Complete line fully guaranteed, ind. boxed tubes at low, low prices. Price list on request.

Sample Listing			
5U4G .55	6BQ6 .90	19BG6G 1.40	
6BG6G 1.25	12AU7 .75	6BQ7 1.10	
1B3GT .75	12AT7 .85		

GREENWICH SALES CO.

59 Cortland St. New York 7, N. Y.

GET YOUR COMMERCIAL TICKET EASIER WITH . . .

RADIO OPERATOR'S LICENSE Q AND A MANUAL
 (4th Edition)
 by Milton Kaufman
 Covers Elements 1 through 8. Complete discussion of answers to every technical question in the F.C.C. Study Guide! Used by over 50 leading schools. Only \$6.60 at jobbers, bookstores or direct from—



JOHN F. RIDER Publisher, Inc.
 480 Canal Street, New York 13, N. Y.

SPECIAL

HALLICRAFTERS SX71-S76

Write for liberal trade-in offer.

FILAMENT TRANS.
 6V at 3 Amps.,

\$1.46

LOOK — NO HANDS!

Head & Chest Set consisting of Single Button Carbon Microphone with Chest Plate, Switch, Straps, and Pair of Earphones. Ideal for Mobile Operation. Can be used less earphones. Shpg. Wt. 3 lbs.

Only **\$1.95** complete
ATRONIC CORP., DEPT C-26
 1253 Loyola Ave., Chicago 28, Ill.

FLEXIBLE SHAFTS 2c INCH

MC 215 (All Lengths in Inches)				
34	135	163	186	260
MC 124 (All Lengths Shown in Inches)				
23	61	120	175	
29	65	140	205	
39	103	161	241	
52	114	166	348	

Send Check or M.O. Ship. Chgs. C.O.D.

COMMUNICATIONS EQUIPMENT CO.

131 Liberty St., Dept. Q2 New York 7, N. Y.

We Carry a Complete Line of Amateur Equipment including:

National • Hallicrafters
 E. F. Johnson Co. • Bud • Barker-Williamson, etc.
VARIETY ELECTRIC CO., INC.
 468-470 Broad St. Newark 2, N. J.

8 WIRE CONTROL CABLE

Two No. 16, Six No. 20 tinned, stranded, copper, rubber insulated coded leads. Waterproof rubber jacket. Woven copper armor shield overall. Wt. 16 lbs./100 ft. Lengths to 400 ft. LOW PRICE FOB warehouse. Minimum order 100 ft. Shipment is made by Railway Express—shipping charges collect. **5c ft.**

TRANS-WORLD RADIO-TELEVISION CORP.
 6639 S. ABERDEEN ST. CHICAGO 21, ILL.
 Phone: AUstin 7-4538

(from page 75)

band, but also an ideal rag-chewing ground for Old Timers and beginners alike. After dark our 10 watts will cover the whole of the U.K. with ease, and also—surprisingly—much greater distances. Stations consistently worked from here with 10 watts and a reasonable antenna include OH3NY, OH7OH, ZC4's, CN2, many OK's and, formerly OZ's (not now licensed for this band).

The Transatlantic Tests organised by the *Short Wave Magazine* in 1950, 1951 and again this year produced many contacts with East Coast W's, in spite of our flea-power limitations, although it was obvious that only those with real antenna systems could hope to succeed. (GW3ZV had up 1800 feet of wire for some of these tests!) W9's were heard consistently; KV4AA got across on quite a few occasions; and even HC1JW was heard several times. The first logging of WØ on the band was carried off by SWL G. C. Allen, an Old Timer at the game, who heard WØTQD and had confirmation in due course.

The ultimate DX was, of course, finally achieved after much careful planning between GW3ZV and ZL1AH. This necessitated careful choice of dates, times and frequencies, and was one of those many things that no one but an amateur would have attempted—because anyone else would have known that it was impossible. It came off, with full credit due to both stations, and surely represents the ultimate in DX working—right round the world on One-Sixty.

The Present Day

So we arrived at the state of affairs in which no one could find any new DX to work unless someone went some place and provided a signal, and so the DX-pedition craze was born. It is hard to say who started the fashion, but one of the very early ones on this side was 3A2AB, operated in Monaco by DL4FS. Since then Monaco has become almost commonplace, but at that time it had never been worked legitimately by anyone in the world.

W6SAI's work at FP8AC also caused a terrific stir over here, and the concerted effort at 7B4QF was another one that set the bands off. Since then we have had so many that there is no point in listing them all—EA9DC, VS5ELA, FL8MY, HC8GRC and the like were all world-famous for a brief period, and introduced new countries to the amateur world which otherwise would have remained blanks on everyone's list.

Unfortunately the appearance of one of these rare ones brings out all that is worst in human nature (and that's saying plenty). Operating becomes chaotic from the very first CQ, and the wolf-pack crowds in ever closer. It is then entirely up to the DX man himself to control the riots; he is the supreme master of the situation, if only he has the know-how and the operative ability. Some of them have, fortunately; others, however, have been quite

incapable of handling things and have even packed up in disgust.

So may we appeal to anyone thinking of a DX-pedition to ask himself "Can I crack the whip and make the boys behave?" If the answer is *No*, he should take someone with him, who knows the answers. A few simple rules are all that are necessary—Don't call on frequency; don't call until you hear an SK (and that implies that the DX man mustn't send SK until he really means it—some of them have been shocking in this respect); call on any frequency that may be specified—but you know them all.

One of the snags, over here, is that even if the DX says, slowly and clearly, "Do *not* call on this frequency; call on 14025 to 14050 and listen on this frequency," or something like that, swarms of Lids with the wobbly T4 already mentioned will sit right on his frequency and call blindly. Some of them may still be doing it two hours after he has gone to bed. No one can really cope with these manifestations, and they are one of the reasons why we don't *all* work every new piece of DX that shows up. Four or five European countries are notorious for this sort of madness.

What we really want is a university course for would-be skippers of DX-peditions, including some rapid-QSY technique to dodge these blind callers; however, we're not giving all the possible tricks away in case we ever manage to go on one of these cruises ourselves. (Sufficient to say that we would have the boys hopping around, but no *permanent* QRM!)

The Future ?

Where do we go from here? There are not many countries left for the top-scorers to work, and no one thinks that inter-planetary DX will become the rage in our lifetime. Some would say "Why worry about country-chasing anyway? If a G can make his signals hit New Zealand, California and Chile he knows they cover the world, so why worry about all the other ports of call?" Probably the answer is just that any hobby needs some competitive aspect to inject the necessary life to keep it progressive. Many fine Hams are not interested in contests, country-chasing or anything of the sort; yet, the fact remains that many *are*. Those who indulge in constant competition, whether friendly or cut-throat, are largely responsible for the development of communication techniques, snappier operating, cleaner signals and all the rest.

Let us always remember, though, that ham radio is a fine hobby but a very bad master. The essential thing about a hobby is that one can spend just as much, or as little, time and money on it as one wishes to, and if you don't want to get up early in the morning, no one compels you to do it until the hobby has become an obsession and therefore the master.

(And now for a couple of nights with some "wakey-wakey pills" to find those new ones on *Forty!*)

Now
PL-4D21
POWER TETRODE



125 WATT PLATE DISSIPATION.
FULL RATINGS TO 120 Mc.
HIGH OVERLOAD CAPABILITIES.
AVAILABLE IMMEDIATELY.

For data, Write:

 **PENTA LABORATORIES INC.**
216 North Milpas Street
SANTA BARBARA, CALIFORNIA

**more
dough**

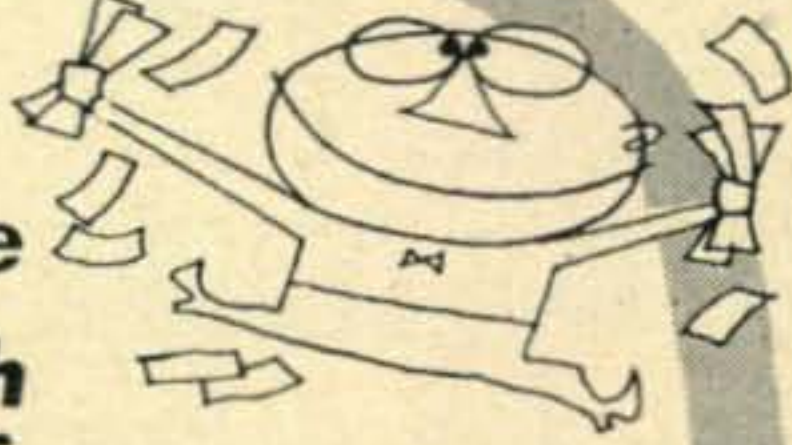

from Generous Joe!

JOE POSSNER Needs Your Equipment for New Operation. Your MONEY rushed by return mail! No Red Tape!
Just write one letter: List items, EXACT condition, price you want!

ALL QUERIES ANSWERED IMMEDIATELY
You Get More Because We Have No Stock.
We Will Swap - Tell Us What You Want.
Equipment - Relays - Switches
Condensers

POSSNER ELECTRONICS
(formerly Electronics Sales Co.)

Dept. C-1

1208 Venice Blvd., Los Angeles 6, Calif.

- 4 E 2 - - - - - \$8.75
2 MTR—4 ELEMENT YAGI
- 8 E 2 - - - - - \$20.50
2 MTR—TWO 4 ELEMENT YAGI
- PD 3 E10 - - - - \$24.95
PLUMBER'S DELIGHT
INCLUDES T MATCH
10 MTR—3 ELEMENT
CLOSE SPACED
- 3 E 10F - - - - - \$42.40
FOLDED DIPOLE
10 MTR—3 ELEMENT
CLOSE SPACED
- 3 E 10T - - - - - \$41.80
INCLUDES T MATCH
10 MTR—3 ELEMENT
CLOSE SPACED
- 3 E 15T - - - - - \$59.00
INCLUDES T MATCH
15 MTR—3 ELEMENT
- 2 E 20T - - - - - \$47.95
INCLUDES T MATCH
20 MTR—2 ELEMENT
- 6 E 10-20T - - - \$98.95
STACKED 10-20
3 ELEMENT
INCLUDES 2 T MATCHES

Complete catalog on request: Dept. C-1

**HY-LITE
BEAMS**
**HY-LITE
BEAMS**
**HY-LITE
BEAMS**
**HY-LITE
BEAMS**
**HY-LITE
BEAMS**

HY-LITE Antennae INC.

Makers of Fine Antennas for AMATEUR · FM · TELEVISION

241 EAST 137th ST., N.Y.C. 51, N.Y.

**A Completely NEW
COAXIAL RELAY**

for
**52 and 72-ohm
lines**

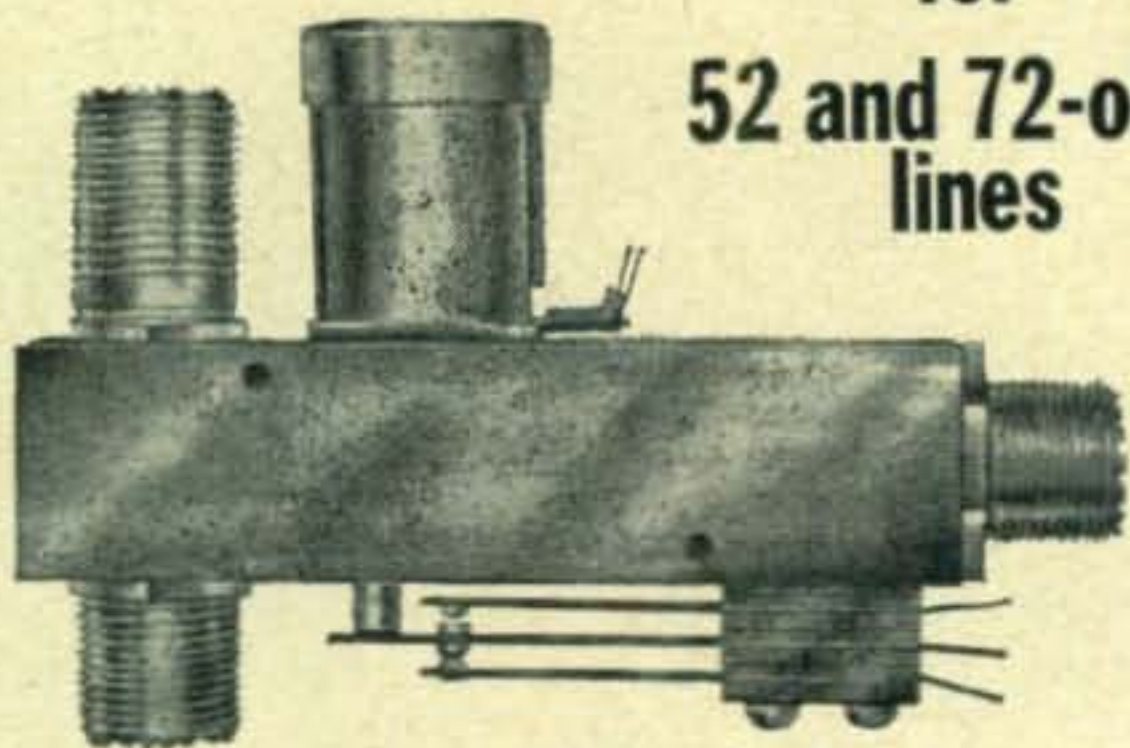

Has been proven to handle 1000 watts at 100 mc. Both a.c. and d.c. models available. The magnets have been greatly improved and are guaranteed to be free of hum or chatter.

- 6, 12, 24, 117 volts a.c. model \$10.50 net
- 6, 12, 24 volt d.c. model \$ 9.50 "
- Antenna shorting connector \$ 1.00 "
- External SPDT switch \$ 1.00 "

DEALER INQUIRIES INVITED

DOW-KEY CO., INC.
Warren, Minn.

Classified Ads

Advertising in this section must pertain to amateur radio activities. Rates 25c per word per insertion for commercial advertisements. 5c per word for non-commercial advertisements by bona fide amateurs. Remittances in full must accompany copy. Phone orders not accepted. No agency or term or cash discounts allowed. No display or special typographical ad setups allowed. "CQ" does not guarantee any product or service advertised in the Classified Section. Closing date for ads is the 25th of the 2nd month preceding publication date.

DXers! "Hams Interpreters"—Ham words and phrases translated into 7 languages—\$1.00. For SWL's, "World Radio Handbook"—complete information on international stations, \$1.50. "How to Listen"—for SWL Novices, 40c. World Radio Publications, 1000 Connecticut Ave., Washington 6, D. C.

RADIO AMATEUR and commercial license preparation. International morse code transcribed on magnetic tapes, recording wire and long playing microgroove discs. Disc-A-Method Recording Company, 317 E. 48 St., N.Y.C.

QSL's. TOP quality at fair prices. Samples? Write W9BHV QSL Factory, 855 Burlington, Frankfort, Ind.

BC610 parts wanted. Give price and condition first letter. L I Radio Company, Box 474, Montrose, Pa.

VOLT-OHM-MILLIAMMETERS: Pocket Size AC/DC Ranges 750 v., 150 v. and 15 v.; 150 ma. and megohm—\$8.75. W2OXR, R. Gross, 11 Belmont Terrace, Staten Island, 1, New York.

DON'T FAIL! Use the time-tested "Surecheck Test." Novice, \$1.50; General, \$1.75. Amateur extra available soon. Amateur Radio Supply, 1013-7th Ave., Worthington, Minn.

RADIOMEN—Tour the country. Complete trailer radio shop, best instruments, living quarters. First \$1200 takes. Reason—sickness. Fred Lines, W6NRV, 2826 Waverly Drive, Los Angeles 39, Calif.

QSLs—100 2-colors \$2.00, 3-colors \$3.00. Remit with order. Processed same day. CPS, Box 157, Bladenburg, Maryland.

SCR 522, original condition. Will sell or swap. How much or what have you? W2KNQ, R. D., Hewitt, N. J.

QSL CARDS?? Unbeatable variety, samples 25c. Sackers, W8DED, Holland, Michigan.

WANTED: Navy Selsyns. 1G, 1F, 1CT, 1DG, 5D, 5DG, 5F, 5CT, 6G, 7G, etc. Top prices paid. Electro Sales Co., Inc., 110 Pearl Street, Boston 10, Mass.

TWO USED TELEVISION RECEIVERS, 7" \$35, 10" \$50. Ideal TVI monitor, many other uses around shack. W4API, 1420 South Randolph, Arlington, Virginia.

WANTED: APR-4, other APR-, APS-, APT; ARC-1, ARC-3, ART-13, BC-348, BC-221 etc.; TS-12, 13, 35, 120, 146, 155, 173, 174, 175, 323, other "TS-"; particularly Microwave equipment, Spectrum Analyzers; G-R, Ferris, L&N; 723A/B, 3C22, all tubes; manuals, meters, parts, cable. Littell, Farhills Box 26, Dayton 9, Ohio.

QSLs! Interesting Samples 10c. Tooker Press, Lakehurst, N. J.

BARGAINS: EXTRA SPECIAL: Motorola P-69-13 mobile receivers \$29.50; Globe King \$315.00; HT-9 \$199.00; HRO-50 \$275.00; Lyseo 600 \$109.00; HRO-7 \$199.00; Collins 75A1 \$275.00; HRO-5T 175.00; SX-71 \$159.00; SX-42 \$189.50; SX-43 \$129.00; HRO-Senior \$119.50; RME 2-11 \$99.50 RME-45 \$99.00; Meissner EX Shifter \$59.00; S-40A or SX-16 \$69.50; VHF-152 \$59.00; HF 10-20 \$59.00; Globe Trotter \$79.50; Meissner Signal Calibrators \$24.95; MB611 mobile transmitters \$19.95; 90800 exciter \$29.50; RCA Chanalyst \$69.50; XE-10 \$14.95; Gonset 10-11 Converter \$19.95; and many others. Large stock trade-ins: Free Trial. Terms financed by Leo, WØGFQ. Write for catalog and best deal to World Radio Labs., Council Bluffs, Iowa.

SELL—Hammarlund Super-Pro SP-400-SX receiver. Excellent condition. Power supply and speaker. \$250. F.O.B. Ray Warner, W7JU, 539 Birch St, Boulder City, Nevada.

SELL—Collins 231-B transmitter. Complete cool KW. 1.75 mc to 21 mc. Bandswitching or autotune. CW and AM phone. New spare tubes included. \$400. Worth more in components. No crating. Bring truck or trailer. Ray Warner, W7JU, 539 Birch St., Boulder City, Nev.

LIQUIDATION OF COMPLETE ELECTRONIC STOCK LABORATORY and testing equipment of highest quality. No war surplus in this stock. Few used items. Electronic gear from smallest to large commercial size. This opportunity is your dream come true. Must hurry. Send 10c for airmail inventory and prices. Industrial Electric Co., Fallon, Nevada.

BARGAINS: New and reconditioned Collins, Hallcrafters, National, Hammarlund, Johnson, Elmac, Harvey-Wells, Babcock, Gonset, Morrow, RME, Millen, Meissner, Lysco, Workshop, Hy-Lite, others. Reconditioned S53 \$49.00, S40A \$69.00, S40B \$79.00, S76 \$129.00, SX71 \$149.00, SW54 \$35.00, NC57 \$69.00, NC125 \$124.00, NC173 \$139.00, NC183 \$199.00, HF-10-20 \$49.00, VHF152A \$59.00, RME45 \$89.00, HRO5TAI, HRO7, HRO5O, HRO5OT1, HRO6O, HQ129X, SP400SX, SX42, SX62, SX43, Collins 75A2, Collins 32V1 transmitter \$395.00, Viking transmitter \$199.00; others. Shipped on approval, terms, list free. Write. Henry Radio, Butler, Mo.

WANTED: commercial panadapters. Collins 32V2. No junk. Have cash or choice trade items. Thomas Dale, Box 868, Portsmouth, N. H.

SELL: BC-429 surplus receiver-tube, extra coil: \$15.00. BC-430 surplus transmitter-tubes, coils \$15.00. PS225 28 v. dynamotor \$4.95. Buy all and get cables, control boxes, terminal box free. Ship F.O.B. Write Wendell Carvan, Route 1, Oakland, Miss.

"QSL's—SWL's NEW! Better than ever! The 1953 line of Almar QSL, SWL cards. Samples 10c, Almar Printing Service, 602 Barker Bldg., Omaha Nebraska.

ANTENNA TROUBLE? Send \$1.00 for solution (money back guarantee) to manufacturers of the famous custom built "Challenger"—"Invader"—"Conquerer" antenna systems—literature available. "Antenna Inc., Box 149, Wakefield, Rhode Island.

10, 15 & 20 METER BEAMS, aluminum tubing, etc. Perforated aluminum sheet for shielding. Radcliff's, Fostoria, Ohio.

POWER SUPPLY, 750-900 volt 200 ma rack mounting, Toledo, Ohio. TA. 1-1211. W8HRP.

SELL: TELETYPE EQUIPMENT, motors, parts. **WANT:** BC-610-E, BC-614-E, APR, APN, ART-13, BC-348, BC-312, RA-62, RA-34, BC-1306, PE-237, GN-58, Technical manuals, test equipment. Tom Howard, W-1-AFN, 46 Mt. Vernon St., Boston 8, Mass. Richmond 2-0916.

TRADE HENSOLDT 7 x 42 roof prism binoculars with case, good condition, for receiver. Arnold Tudor, 121 E. Warren St., Lebanon, Ohio.

WANTED: BC-610-E, BC-614-E, BC-939, ARC-1, ARC-3, APR-4, APN-9, APR-5AX, ART-13, ATC, DY-17, DY-12, TCS, SCR-694, PE-237, BC-1306, GN-58, SCR-284, PE-103, PE-104, GN-45, BC-348, BC-342, BC-312, BC-221, BC-639, Panadapters, teletype, RA-34, RA-42, RA-62, technical manuals, Signal Corps supply catalogs, TS, I, test equipment, Selsyns, tubes. Arrow Appliance, Box 19, Boston 1, Mass. Lynn 8-3100, Richmond 2-0916.

TROUBLE OBTAINING HAM PARTS or equipment? Why not try a parts distributor who specializes in catering specifically to radio amateurs, and who employs licensed, active amateurs to serve you? We trade and offer terms. Write W1BFT at Evans Radio, Concord, N.H.

NEW REGENCY TV booster, \$10. WØHLS.

FOR SALE: BC-453, good condition, with tubes, \$25. WN9UYE, 7850 Cressett Drive, Elmwood Park 35, Illinois.

SELLING, Temco 100 watt xmtr daily on 75; DM-36 HF converter; Collins 310B3 exciter—xtmr. W2JIL, Box 746, Brooklyn, N. Y.

NOVICE: Sell new 50 watt c.w. transmitter for 40 and 80 meters; very compact, \$40.00. Also new assembled Eico VTVM, \$40.00. Sell or swap four new 815's. Bobby Francisco, Glade Spring, Virginia.

SELL: BC 610E with following: BC614E speech amp.; D-104 microphone, new; 18.2 amp. Transtat. Converted BC696 and BC459 VFO's, with power supplies, DB22A, SP44 Panadapter, 3 element, all aluminum 20 meter beam, 3 element all aluminum 10 meter beam. 30 ft. beam rotating tower and controls. Everything above is operating now. What am I offered? W3KRQ, Route 3, Danville, Penna.

TRADE BC221N AC and modulation built in excellent condition for 16 or 17 inch TV receiver or chassis with Standard Coil tuner, complete, in good condition. L. F. Hay, W7JWD, Battle Ground, Washington.

RADIO Surplus Buys

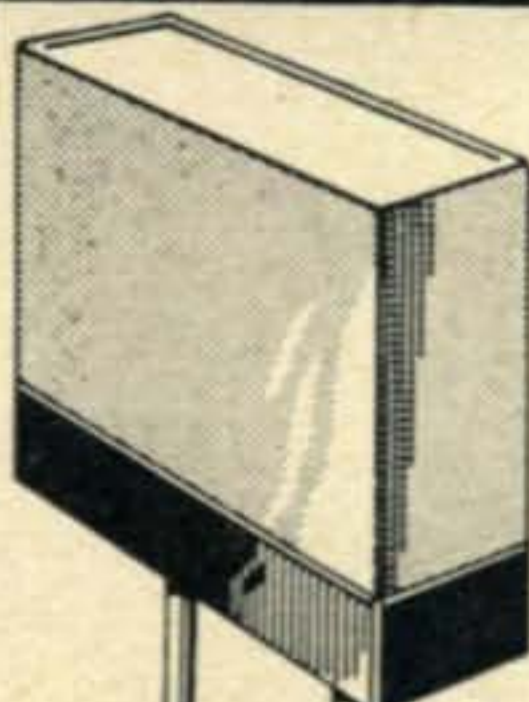

CRYSTALS

... in FT 241-A Holders— $\frac{1}{2}$ " Pin SPC. Marked 54th OR 72nd Harmonic MC Freq. Listed below by fundamental frequency with fractions omitted.

500 KC Crystals ea. **\$1.95**
 1000 KC Crystals ea. **\$3.95**

370	407	444	476	509
372	408	445	477	511
374	409	446	479	512
375	411	447	480	513
376	412	448	481	514
377	413	450	483	515
379	414	451	484	516
380	415	452	485	518
381	416	453	486	519
383	418	454	487	520
384	419	455	488	522
385	420	456	490	523
386	422	457	491	525
387	423	458	492	526
388	424	459	493	527
390	425	461	494	529
391	426	462	495	530
392	427	463	496	531
393	429	464	497	533
394	430	465	498	534
395	431	466	501	536
396	433	468	502	537
397	434	469	503	538
398	435	470	504	540
400	436	472	505	
401	437	473	506	
402	438	474	507	
403	440	475	508	
404	441			
405	442			
406	443			

\$1.00 EACH

10 for \$8.00, Postpaid

FOLLOWING CRYSTALS AVAILABLE IN FT 243 HOLDERS $\frac{1}{2}$ " PIN SPACING

3500	5035	7350
3590	5127.5	7450
4165	5285	7750
4280	5587	7875
4335	5660	8006.7
4350	5730	8025
4370	6073.3	8200
4440	6075	
4445	6140	
4540	6150	
4580	6350	
4620	6525	
4635	6700	
4710	6875	
4880	6975	
4980	7075	
4995	7150	

\$1.00 EACH

11 for \$10.00, Postpaid

PLEASE ENCLOSE FULL AMOUNT WITH ORDER
 QUANTITIES AVAILABLE
 WRITE FOR YOUR REQUIREMENTS

C & H SALES CO.

BOX 356-FQ EAST PASADENA STA. • PASADENA 8, CALIF.

LEARN WITH AMECO COURSES

BECOME A RADIO AMATEUR

Simple, Low Cost, Home - Study Courses prepare you to pass F.C.C. Code and Theory license examinations. Write for details and receive free sample of F.C.C. type questions and answers for all amateur examinations.

AMERICAN ELECTRONICS CO.

1451 Wilkins Ave. (Dept. C2) New York 59, N. Y.



NATIONAL

- **P**roven
- **D**ependable
- **Q**uality

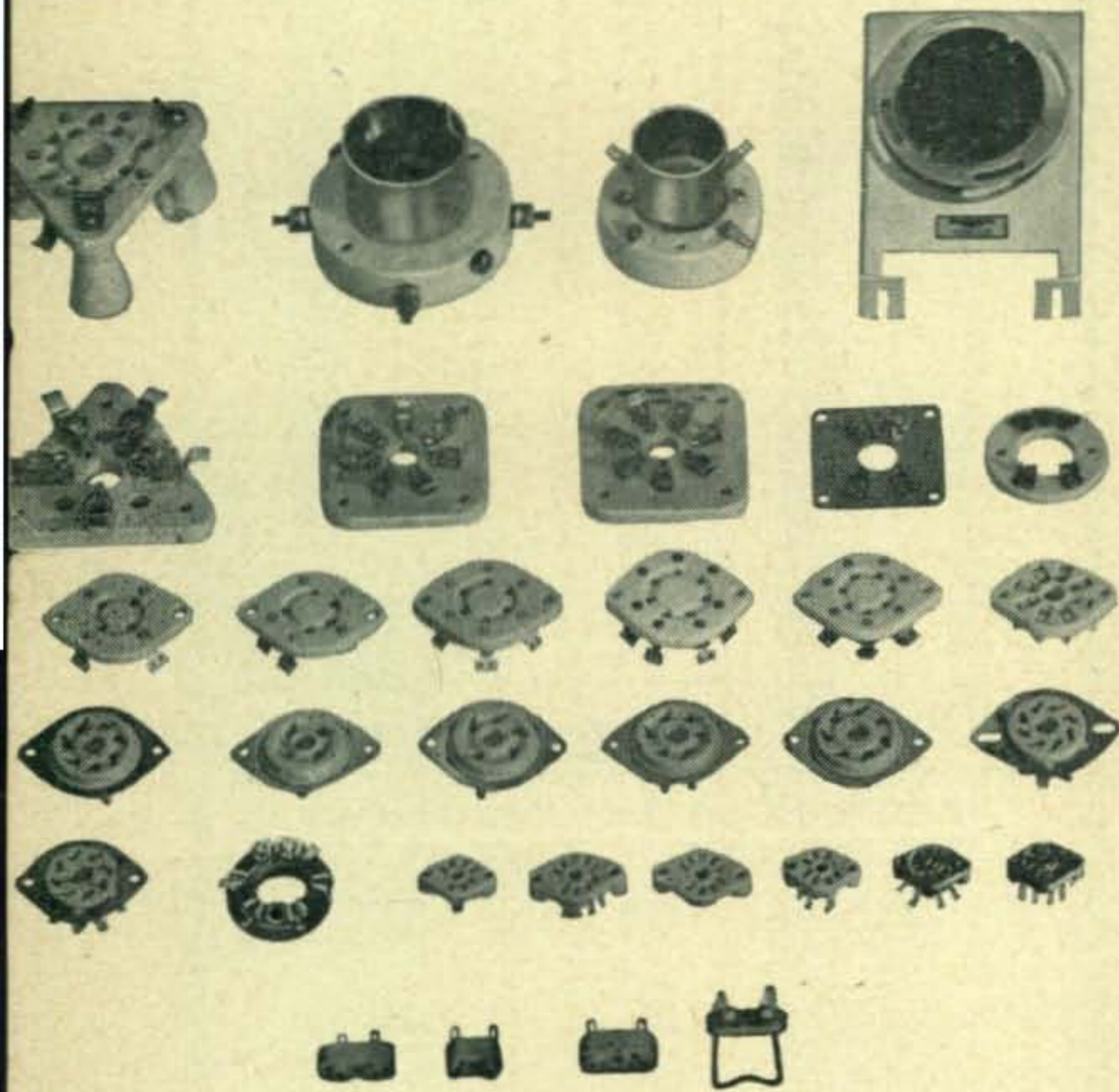

COMPLETE LINE OF SOCKETS

There is a National socket made for every popular tube type and for every circuit application. All feature low-loss electrical characteristics, firm tube support and easy, secure mounting. They are recommended wherever the highest quality is required. Write for drawings and specifications.

National



EST. 1914

NATIONAL COMPANY, Inc.
MALDEN, MASSACHUSETTS

CQ Ad Index

Allied Radio Corp.	67
American Electronics Co.	79
American Phenolic Corp.	63
Atronic Corp.	76
Barker & Williamson	62, 75
Bliley Electric Company	7
Bud Radio, Inc.	67
C. & H. Sales Co.	79
Collins Radio Company	10, 11
Columbia Electronics Sales	65
Communications Equipment Co.	76
Dixon Electronics Company	74
Dow-Key Company, Inc.	78
Eitel-McCullough, Inc.	8
Electro-Voice, Inc.	53
Esse Radio Company	73
Fair Radio Sales	69
General Electric Company	1
G. L. Electronics	72
Greenwich Sales Co.	76
Hallicrafters Company	Cover 2
Harvey Radio Company, Inc.	59
Hawkins, P. E. Co.	74
Heath Company, The	6
Hughes Aircraft Company	55
Hy-Lite Antennae, Inc.	78
Instructograph Company	74
Klein, Manuel Co.	64
L. A. Ham Shack	70
Lettine Radio Mfg. Co.	72
Master Mobile Mounts, Inc.	5
Merit Transformer Corp.	65
Millen, James Mfg. Co., Inc.	4
Motorola, Inc.	67
National Company, Inc.	80, Cover 3
Ohmite Manufacturing Company	57
Penta Laboratories, Inc.	77
Petersen Radio Company, Inc.	2
Possner Electronics	77
Radcom Engineering Co.	74
RCA Tube Dept.	Cover 4
Rider, John F. Publisher, Inc.	76
Shure Brothers, Inc.	67
Sonar Radio Corp.	66
SP-AIR-ES, Inc. of Calif.	54
Tab	80
Tallen Company, Inc.	74
Television Industries, Inc.	71
Trans-World Radio-TV Corp.	76
United Catalog Publishers	64
Vaaro Electronic Engineering Co.	66
Variety Electric Company	76
World Radio Laboratories, Inc.	61

WANTED IMMEDIATELY
for CRITICAL DEFENSE NEEDS
TUBES - CRYSTALS - END EQUIPMENT

OAS/VR75	3C23	12SC7M	833A,884
OB3/VR90	3E29,829B	FG17,32,33	927, 1000T
OC3/VR105	4C35	100TH	1614, 2050
1N21,A,B	5C22	FG104,172	5725
1N23,A,B	5R4GY	250TH,TL	5727
1N25,26	6AC7M	304TH,TL	5749
Xtals: 100Kc.	6AG7M	368AS	5750
200Kc., 1000Kc	6B4G	450TH,TL	5751
2D21	6C21	KU627	5654, 5670
2K25, 723AB	6L6M	726C	5686
2J & 4J Magnet-	6SC7M	750T	5726
rons, Klystrons	7C7	807,810	5814
	7AG7	811,813	9001,2,3

All Army-Navy Gear: AN, ART, BC, I, PE, PU, RA, SCK, TG, TS. WAVE GUIDES: PL & UG CONNECTORS. TURN YOUR SURPLUS INTO SPOT CASH & SERVE YOUR COUNTRY'S NEEDS AS WELL. . . . Send Lists & Prices—Immediate Reply! Dept. C.

"TAB" 111 Liberty St.
New York 6, N.Y.
That's a Buy! Rector 2-6245

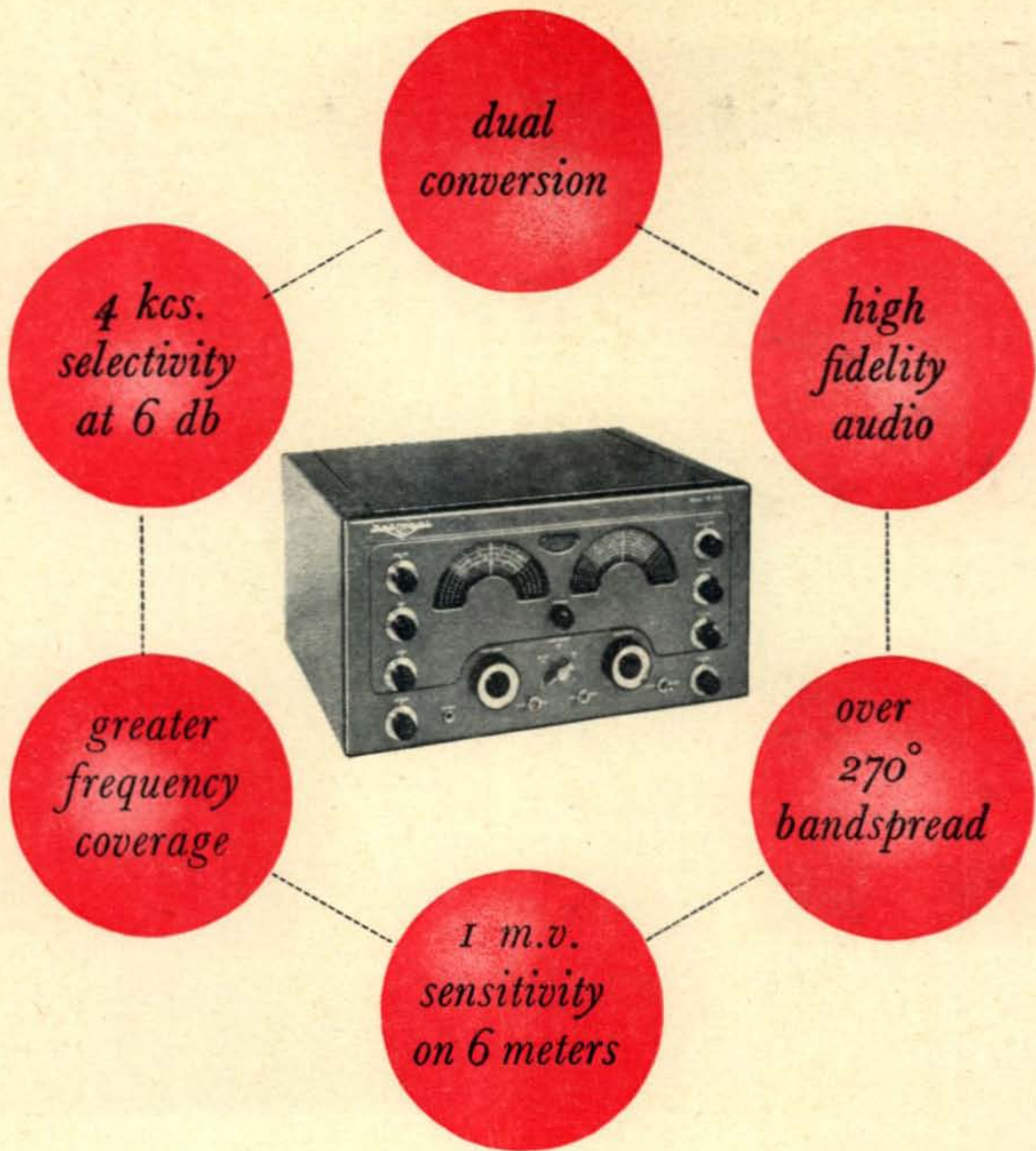

NC-183D

THE ONLY RECEIVER WITH ALL THESE FEATURES FOR LESS THAN \$500!

Dual conversion on the three highest ranges! Twelve tuned I. F. stages (16 on the three high bands)! Perfect separation of phone signals only 4 kcs. apart! One microvolt sensitivity on 6 meters! Audio essentially flat to 13,000 c.p.s.! Exceptional coverage — from 540 kcs. to 31 mcs. and 47 mcs. to 55 mcs.! Bandspread scales that are a pleasure to read!

No other receiver selling for less than \$500 can give you all these features! **\$369⁵⁰***

(less speaker)

*slightly higher west of the Rockies



"Ether buster"



...penny pincher

500 watts input*

...4 watts drive!

Here's a real champion when it comes to circuit simplicity, operating convenience, high power, and economy. For high-power work . . . for full input up to 30 Mc with a 6L6 driver, RCA 813 delivers *more watts per dollar than any other amateur beam power type in its class.*

The low driving power required at the grid of this "ether buster" also allows you to simplify the design of the exciter circuit, thereby making it easier to minimize TVI.

Get an RCA 813 for your new high-power final. Your RCA Distributor carries them in stock.

(ICAS ratings) **It's a "power house"**
500 watts input on CW
400 watts input on phone

*CW rating, ICAS

Suggested user price \$18.00

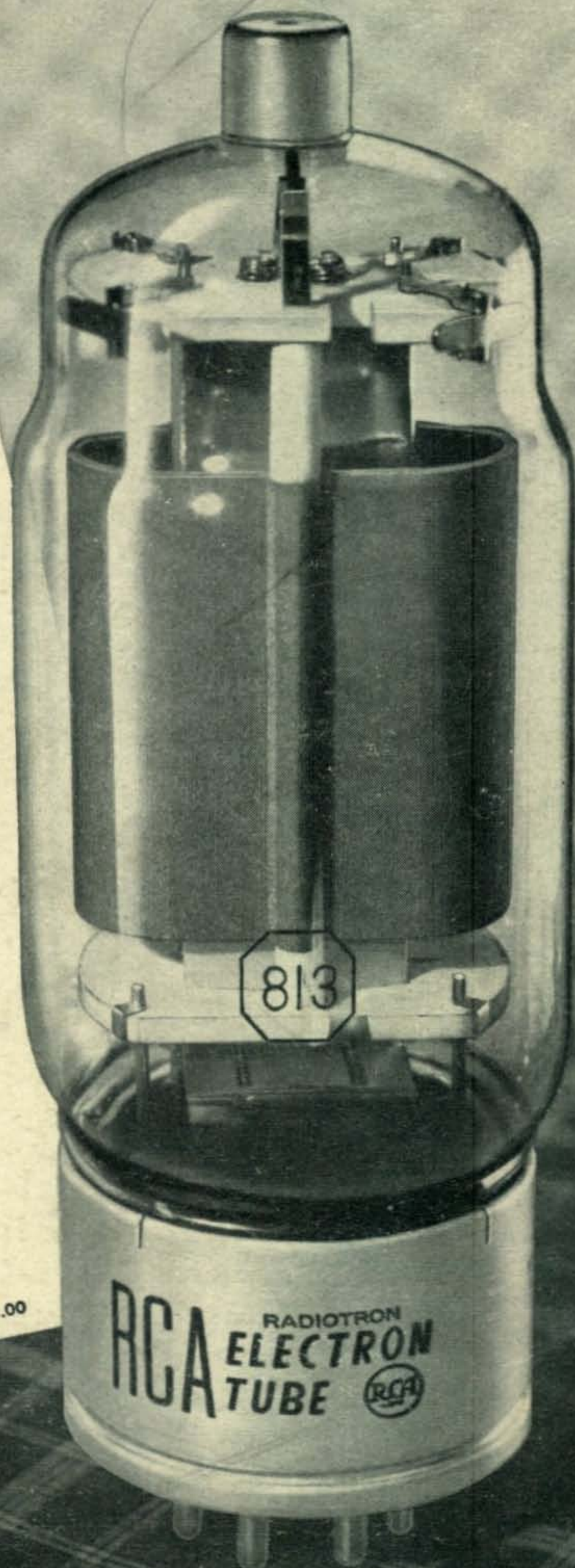

RADIO CORPORATION of AMERICA
ELECTRON TUBES

HARRISON, N. J.