

CQ

RADIO AMATEURS' JOURNAL

APRIL
1953

A 1M 515
L A WEBER-W2AEJ
CO DEC 53
WESTBURY LI N Y



'I said Tune, not turn!!'

Standard of Excellence



SINCE 1934

20 METERS, Type Z-3, \$3.75 • 40, 80 AND 160 METERS, Type Z-2, \$2.75

PR *Crystals*

Since  1934

USE **PR** AND KNOW WHERE YOU ARE

PETERSEN RADIO COMPANY, INC.
2800 W. BROADWAY • COUNCIL BLUFFS, IOWA

EXPORT SALES ONLY: Royal National Company, Inc., 75 West Street, New York 6, N. Y., U. S. A.

- Save space . . .
- Increase rectifier life . . .
- Get top dollar value!

Use G-E GERMANIUM DIODES

THINK OF THE SPACE SAVED when you use diode rectifiers approximately 1/2" long, 1/4" diameter! Think of that worry-free feeling that comes from knowing these tiny marvels can give you 10,000 hours and more of reliable service!

DIODES ARE SELF-HEALING when temporary over-voltage occurs. They stand up under shock and vibration. They have no filaments to heat, so power drain is less. You get no filament hum!

YOUR G-E TUBE DISTRIBUTOR is your best source for germanium diodes, for General Electric makes and markets more diodes than any other manufacturer. Huge G-E production by the most modern methods assures dependable performance—packs extra value into thrifty G-E prices.

CHECK THE LIST BELOW for popular G-E types. There are many more available. Then see your distributor for further information, including descriptive diode Bulletin ECG-3B. Or write *Tube Department, General Electric Company, Schenectady 5, New York.*

● made by the world's largest producer!



TYPE		USE	INVERSE VOLTAGE		RECTIFIED CURRENT (IN MA)			
RTMA	G-E		PEAK	CONTINUOUS OPERATION	OPERATING	PEAK	SURGE, 1 SEC.	MAX INV. AT -50 V
1N48	G5	General	85	70	50	150	400	.833
1N52	G5D	General	85	70	50	150	400	.15
1N63	G5E	General	125	100	50	150	400	.05
1N64	G5F	*Video Det.	20	—	—	—	—	.25 at -1.3 v
1N65	G5G	General	85	70	50	150	400	.20
1N69	G5K	General	75	60	40	125	400	.85
1N70	G5L	General	125	100	30	90	350	.30
1N72	G7	**U-h-f	2	—	25	75	—	—
1N81	G5P	General	50	40	30	90	350	.01 at -10 v

Now

another G-E "first"—Diffused-junction Germanium Rectifiers! Hermetically sealed against humidity and dust . . . extremely small and compact . . . with high output ratings, low leakage loss. Your G-E tube distributor has them!

1N91	4JA1A1	General	100	30	150	470	25 amp	—
1N92	4JA1A2	General	200	65	100	310	25 amp	—
1N93	4JA1A3	General	300	100	75	230	25 amp	—
1N94	4JA2A4	Line volt. rect'r	400	185	500	1570	25 amp	—

*Tested at 44 mc for rectifying efficiency.

**Tested at 500 mc as a low-noise mixer.

GENERAL ELECTRIC



Available in seven sizes, covering a range of 3 to 520 megacycles. Two sizes rated at 600 ma, others at 1000 ma. Single-layer wound on low power-factor plastics or steatite cores. Moisture-proof coating.

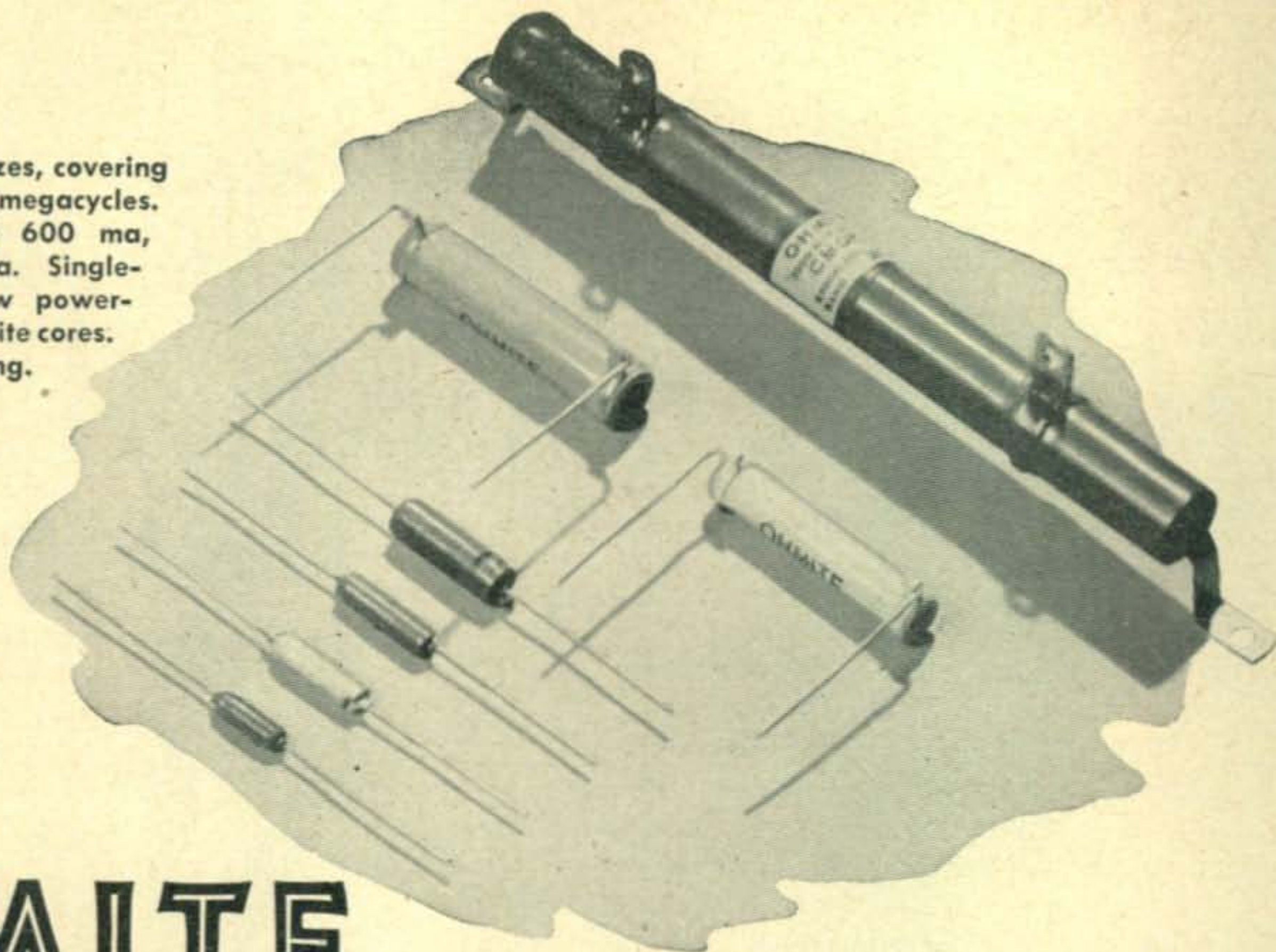

OHMITE®

"FREQUENCY-RATED" PLATE CHOKES

IT'S EASY TO SELECT THE RIGHT UNIT

You can be sure that the plate choke you use is "matched" to the particular frequency you need, with Ohmite Frequency-Rated Chokes. These plate chokes have had their frequency characteristics accurately predetermined for excellent performance at the rated frequencies.

Ohmite plate chokes are invaluable for a multitude of TV, radio, and electronic applications. For instance, they can be used with suitable trimmer capacitors for tuned wave traps—series, parallel, or combination type—to reduce TV interference. Adaptable to either 300 or 72-ohm input.

OHMITE CHOKE	mmf at 3.5 Mc	mmf at 7 Mc	mmf at 14 Mc	mmf at 21 Mc	mmf at 28 Mc	mmf at 50 Mc	mmf at 56 Mc
Z-28	98	25	6.2				
Z-50		74	19	8.2	4.6		
Z-144			72	32	18	5.7	4.5
Z-235				6.9	39	12	9.7
Z-460						51	40

The above table shows the approximate capacity necessary to resonate OHMITE Frequency-Rated Chokes at various frequencies for tuned wave traps.

write for Bulletin 133

OHMITE MANUFACTURING COMPANY

4831 Flournoy St., Chicago 44, Ill.

OHMITE

RHEOSTATS • RESISTORS • TAP SWITCHES • CHOKES

CQ RADIO AMATEURS' JOURNAL

VOL. 9, NO. 4
APRIL, 1953

EDITORIAL STAFF

MANAGING EDITOR
OLIVER P. FERRELL

TECHNICAL EDITOR
E. M. BROWN, W2PAU

DEPARTMENT EDITORS

Herb Brier, W9EGQ	Novice
Wayne Green, W2NSD	Teletype
George Jacobs, W2PAJ	Propagation
Louisa B. Sando, W5RZJ	YL
R. C. Spenceley, KV4AA	DX

CONTRIBUTING EDITORS

Herb Becker,	W6QD
Frank C. Jones,	W6AJF
G. F. Montgomery,	W3FQB
William I. Orr,	W6SAI
W. M. Scherer,	W2AEF

DRAFTSMAN

Thomas Smith, W2MCJ

BUSINESS STAFF

S. R. COWAN,	Publisher
S. L. CAHN,	Adv. Director
H. N. REIZES,	Adv. Mgr.
D. SALTMAN,	Prod. Mgr.
R. CAMPBELL,	Edit. Prod.
H. WEISNER,	Circ. Mgr.

BRANCH OFFICES

California: Ted E. Schell, 2700 West 3rd Street, Los Angeles 5, Calif. Dunkirk 2-4889.
Mid West: Harold F. Mann, 333 No. Michigan Avenue, Chicago 1, Illinois. Franklin 2-7100.
Foreign Subscription Representative; Radio Society of Great Britain, New Ruskin House, Little Russel St., London, WC 1, England.
Technical Book & Magazine Co., 297 Swanston St., Melbourne C1, Victoria, Australia.
Scandinavian Representative: Intrapress, 17 Nordre Paradsvej, Holte, Denmark.

CQ—(title Reg. U.S. Post Office)—is published monthly by Cowan Publishing Corp. Executive and Editorial offices, 67 West 44th Street, New York 36, N. Y. Phone MUrray Hill 7-2080. Reentered as Second Class Matter February 6, 1951 at the Post Office, New York, N. Y. under the Act of March 3, 1879. Subscription rates in U. S. A. Possessions, APO & FPO, 1 year \$3.00; 2 years \$5.00; 3 years \$7.00. Elsewhere add \$1.00 per year for postage. Single copies 35 cents. Printed in U. S. A. Entire contents copyright 1953 by Cowan Publishing Corp. CQ does not assume responsibility for unsolicited manuscripts.

FEATURE ARTICLES

The G-String <i>Major Walter White, Jr., K2CHF</i>	13
Project CONELRAD	17
A CONELRAD Alarm System <i>Athan Cosmas, W2PKD</i>	18
Getting Started on Single Sideband, Part II <i>Jack N. Brown, W4OLL</i>	19
Mobile Corner (The Phil-Mont Mobile Radio Club)	25
"What's the Percentage?" <i>William I. Orr, W6SAI</i>	33
Some Practical Results on the Question of Antenna Height <i>Leroy May, W5AJG</i>	38
A Crystal-Control Adapter for the BC-696 <i>Henry R. Greeb, WØFVD</i>	54

Departments

Amateur Teletype (W2NSD)	28
The YL's Frequency (W5RZJ)	31
Ionospheric Propagation Predictions (W2PAJ)	41
DX and Overseas News (KV4AA)	44
The Novice Shack (W9EGQ)	48

Miscellaneous

Scratchi	6
Zero Bias	11
Present and Prophetic	16
Ontario Section QSO Contest	16
Book Reviews	52
A Lament to CQ from an XYL <i>Helen Ferguson</i>	60
New Parts and Products	66
Classified Ads	70, 71
Advertising Index	72

QRK?*

ALWAYS TOPS WITH A hallicrafters

You'll have the best QRK 100 watts can give with Hallicrafters HT20 transmitter—and you'll *listen* to more and hear it better on a Hallicrafters receiver. You be the judge—you hear the difference!

It's value like this—and more of it dollar-for-dollar in every price class—that has made Hallicrafters equipment the unchallenged first choice of the world's most critical expert, the Amer-

ican amateur operator for 19 years.

Hallicrafters equipment is designed specifically for the ham operator—planned to meet his problems—planned to fit his pocketbook. The measure of Hallicrafters success is in the reputation this group of experts extends to this equipment. And that reputation is unchallenged in the field. You can *hear* the answer every night of the year on the air—just listen!



◀ **Top Selectivity—Low Price! Model S76**
—Dual Conversion Super with 50 kc amplifier for tops in selectivity, 500 C.P.S. at 6 db down—3.5 kc at 60 db down. Giant 4-in. "S" meter. 540-1580 kc, 1.72-32 Mc in 4 bands. 1 r-f, 2 conversion, 2 i-f stages. 5 pos. selectivity. Phono input jack. 3 watt output. **\$179.50**

A Ham's Dream! Model SX71—Com. ▶
Rcvr. especially designed for top ham performance. Double conversion, built-in NBFM limiter stage. 538 kc to 35 Mc, 46-56 Mc in 5 bands. Temp. Comp., voltage reg. 1 r-f, 2 conversion, 3 i-f stages. Xtal. filter, 4-pos. selectivity, 18½" x 8⅞" x 12" deep. Ship. wt. 51 lbs. 115V, A.C. 11 tubes, reg. rect. **\$224.50**





◀ **Model S-40B**—Covers Broadcast Band 540-1700 kc and three short-wave bands. 1.7-43 Mc. One r-f, two i-f stages. Electrical bandspread tuning. Switches for automatic noise limiter, code reception and three-position tone control. Code pitch control. Built-in PM speaker. 115 V, A.C. Only **\$119.95**

TVI Suppressed 100 Watter—Model HT20 ▶

Here's the transmitter you've been waiting for! Continuous coverage from 1.7 Mc to 30 Mc. Full band switching, no more plug-in coils; choice of 10 crystals. Shielded, filtered r-f compartments plus low-pass 52 ohm co-axial line output filter assures at least 90 db suppression of all harmonics above 40 Mc. Only **\$449.50**



◀ **Matched Speaker, Model R46**—The perfect speaker for SW. Includes transformer of 500/600-ohm input. Voice coil impedance 3.2 ohms. 10" cone. Black finish. 15" x 10⁷/₈" x 10⁷/₈" deep. Only **\$19.95**

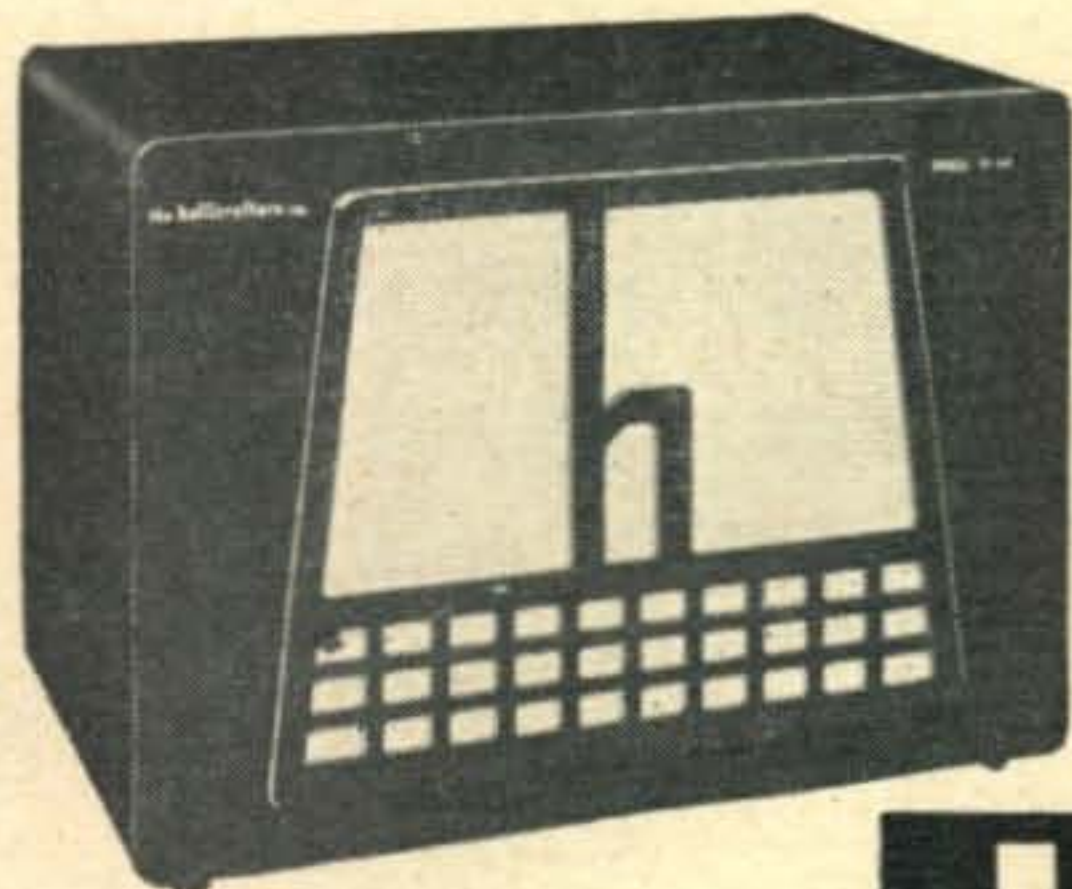

✻ QRK—International "Q" Signal for—"What is my readability?"

hallicrafters

Chicago 24, Illinois

*World's Leading Exclusive Manufacturer of Communications,
High-Fidelity, Precision Radio and Television*

Designed for



Application

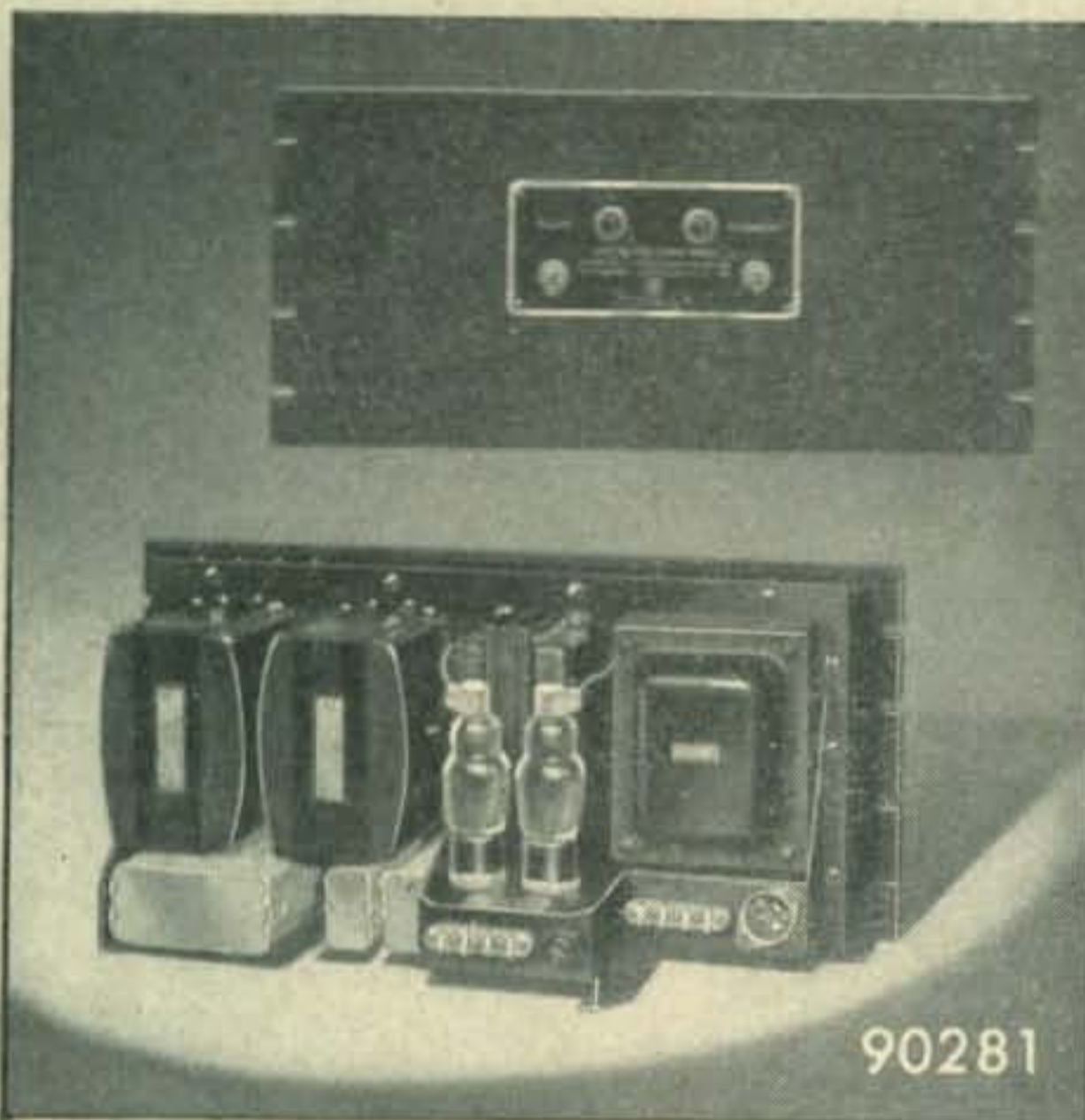

The No. 90281

High Voltage Power Supply

The No. 90281 high voltage power supply has a d.c. output of 700 volts, with maximum current of 250 ma. In addition, AC filament power of 6.3 volts at 4 amperes is also available so that this power supply is an ideal unit for use with transmitters, such as the Milen No. 90800, as well as general laboratory purposes.

The power supply uses two No. 816 rectifiers and has a two section π filter with 10 henry General Electric chokes and a 2-2-10 mfd. bank of 1000 volt General Electric Pyranol capacitors. The panel is standard 8 $\frac{3}{4}$ " x 19" rack mounting.

**JAMES MILLEN
MFG. CO., INC.**

MAIN OFFICE AND FACTORY
MALDEN
MASSACHUSETTS



Feenix, Ariz.

Dear Hon. Ed:

For the last few years Scratchi have been working with a practically useless reseever. You would hardly bulleeving it if you saw it. The glass on the tooning dial are broken and the vernear dial are rusted, so I tooning reseever by moving the little dial pointer by hand. Are no dial lite on acct. using dial lite socket to plugging in six-volt soddering iron. This are becaws I smart gentlefellow and knowing that needing soddering iron each time I using reseever. Volume control too noisy to using (after all, it a Scratchi control, are it not?) so putting pot across speaker to controlling loudness.

Band-change switch work so hard I are leaving off knob and using cressent rench on shaft when wanting to change bands. BeeFO switch not working, so wiring it into AVC on-off switch. Not needing any AVC anyway, on theery that speaker cone so cracked that it can't making too much noises even when set wide open. Despite all this, I still not too mad at reseever until last nite, when as trying to change bands with rench, braking shaft of band-switch, leaving it half-way between two bands. Now getting both eighty and forty meter bands at same time. This are just to much, even four long-suffering Scratchi.

Next day I spending in deep thought, try to figyour way to raising cupple hundred bux to bying new reseever. Not getting very far until I thinking what radio club would do in same spot. Yessirree! Why not holding a Hamfest? Scratchi's private Hamfest!

Saying are next to doing, so sitting rite down and making out invitashuns and sending them to all amchoors in Arizona and all members of 6-meter Bootlegger Club. Are even asking for RSVP (reserving seats very promptly). Next day having posters made, saying "Come One, Come All to Scratchi's Hamfest, Prizes Galore, Free Food and All the Cactus Jooce You Can Drink." "Total Price \$1.00."

The Hams in the state thought hamfest big bargain, as the next to weeks I receiving hundreds requests for tickets. Sum amchoors even QSP there one bux along. Not to be caught short-footed, I are rushing plans for the hamfest. Borrowing sum extra barrels and making up nice big new batch of aged-in-wood cactus jooce. (By making it ahead of time, are giving it chance to aging for cupple weeks, so it

(Continued on page 8)



HARVEY FIRST TO STOCK... FIRST TO DELIVER

ELDICO TR-75-TV



TRANSMITTER KIT

This is an ideal unit for the novice. Very simple to assemble. New, revised circuit to

aid in the elimination of TVI. Uses 6L6 oscillator—807 amplifier combination PI-network output. Husky power supply delivers 600 volts to the 807. Complete . . . including a punched chassis and shielded cabinet. Unbelievably low priced at . . .

\$64.95

MD-40 modulator kit for above... **49.95**

MD-40P as above

but with power supply..... **59.95**

SONAR



Model SRT-120

Transmitter

For mobile and fixed location operation. Has band-switch for 80, 75, 40, 20, 15, and 10 or 11 meters, plus spare position for any future band. Has provision for two crystals or external VFO head. Final amplifier employs the new Amperex 9903/5894A tube. Power input is 120 watts on CW, and 100 watts on phone. All circuits metered. Power requirements: 600 volts dc at 350 ma, and 6.3 volts at 6.4 A.

Complete with Tubes..... **\$198.50**

External VFO Head..... **19.50**



The New Model DB-23

RME PRESELECTOR

Radically new in design, the DB-23 increases communications receiver efficiency by providing an average overall gain on all amateur bands from 3.5 through 3 mc. of approximately 25 db. Controls include: 'on/off' band selector and antenna peaking. Band selector, when set at 0-position, provides through-coupling of antenna to receiver directly. Employs unique 3-tube, broad-band, low noise circuit. Power supply is self contained.

Dimensions: 5" high, 7 3/8" wide, 6" deep. Cabinet: Blue-gray steel.

Complete with tubes..... **\$49.50**

GONSET "COMMUNICATOR"

A complete two-way station for 2 meter-band operation. Suitable for mobile or fixed location use. Receiver is a sensitive superheterodyne with built-in noise clipper circuit and 6BQ7 Cascode rf stage. Transmitter uses 2E26 in final 15 watts input. Employs 8 mc. crystals for stability, and has a range of over 100 miles. Operates on either 110 volts AC or 6 volts DC. Weight approx. 16 pounds. Complete with Tubes (less crystal and microphone)..... **\$199.50**



Also available for commercial or airport Unicom applications.

With crystal..... **\$299.50**

SUPERIOR POWERSTATS

Smooth, efficient voltage control, 0-135 volts output from 115 volt AC line. Models also for 230 volt input. Write for free literature. Models for table and panel mounting.



Type 10, 1.25 amps.....	\$ 8.50
20, 3 amps.....	12.50
116, 7.5 amps, table mtg.....	23.00
116U, 7.5 amps, panel mtg.....	18.00
1126, 15 amps.....	46.00
1156, 45 amps.....	118.00

Complete Stock Always On Hand For Immediate Delivery

FOR YOUR SPECIAL NEEDS

Harvey Carries Complete Stocks for Immediate 'Off-the-Shelf' Delivery

SINGLE SIDEBAND EQUIPMENT

By Central Electronics, Eldico, Millen and others.

All makes and types

TRANSISTORS, GERMANIUM DIODES, SUBMINIATURE TUBES, ETC.

SPRAGUE NON-INDUCTIVE RESISTORS

For Rhombic Antenna Termination, and other applications.

CAMBRIDGE THERMIONIC COILS

Brand New WESTON RF AMMETER

Model 425

3 1/2" dial, non-glare glass. Range: From 0 to 2.5 amps.

Special..... **\$8.95**



The New ELMAC PMR 6-A

Portable Mobile Receiver

A complete 10-tube dual conversion, communications receiver. Provides coverage of 6 bands from 10 to 80 meters as well as broadcast and 160 meter band.

Other features include: High Selectivity . . . Built-in noise limiter . . . Built-in BFO . . . Thermal-Compensated Oscillator . . . Panel-controlled A V C 'on/off' switch. Designed for 50-ohm antenna.

Power requirements: 6 volts AC or DC at 3.3 Amps. and 250 volts DC at 90 mA.

Dimensions: 4 1/2" high, 6" wide, 8 1/2" deep.

Weight: 6 1/2 lbs.

Complete with tubes..... **\$134.50**

Brand New Specially Priced DYNAMOTORS

CARTER	Input Voltage	Output Voltage	Output Current in ma.	SPECIAL PRICE
	5.5	600	270	\$35.00
	5.8	375	325	35.00
	5.8	600	175	29.50
	12.3	375	325	39.50

WESTINGHOUSE	Input Voltage	Output Voltage	Output Current in ma.	SPECIAL PRICE
	5.8	375	325	35.00
	6.0	600	270	35.00
	5.75	410	275	35.00

QUANTITIES LIMITED — Subject to Prior Sale

We reserve right to ship either brand.

NOTE: In view of the rapidly changing market conditions, all prices shown are subject to change without notice and are Net, F. O. B., New York City.



Harvey RADIO CO., INC.

103 W. 43rd St., New York 36, N. Y. • LUxemberg 2-1500

New Heathkit GRID DIP METER KIT



Complete unit easily held and operated with one hand.

MODEL GD-1

SHIPPING
WT. 4 LBS.

\$19⁵⁰



A valuable addition to any ham shack.

The INSTRUMENT FOR HAMS — has numerous transmitter applications such as pretuning, neutralization, locating parasitics, correcting TVI, adjusting antennas, design and many others.

Receiver applications include measuring C, L and Q of components — determining RF circuit resonant frequencies, etc.

Covers the 80, 40, 20, 11, 10, 6, 2 and 1 1/4 meter bands. Complete coverage from 2-250 MC.

Easy one hand, one unit operation. Convenient thumb wheel drive of tuning condenser leaves one hand free for making circuit adjustments. No tuning head and meter with connecting cable to worry about. It's compact — case only 2 1/2" wide x 3" high x 7" long.

All plug-in coils (rack included) are wound and calibrated—no coil winding, drilling, punching, forming or painting to do — all fabrication is complete, and the kit goes together smoothly and easily.

The 500 microampere Simpson meter movement and sensitivity control allow operator to set instrument for easy detection of dips on all ranges. Instrument is transformer operated for safety. You'll like the appearance of this kit with its baked enamel panel and crackle finish cabinet.

Please include postage to cover parcel post and insurance for 4 pounds.

HEATH COMPANY
BENTON HARBOR 6,
MICHIGAN

(from page 6)

getting old, tangy flavor.)

Next are digging up the prizes. That statement are so close to the truth it painful, Hon. Ed. Hah! Not catching Scratchi going out and spending lotsa bux on prizes. No indeedy. Not when my basement are nee-deep in radio stuff. My XYL-to-be, Lil, and I are keeping busy one hole day just dusting off old junk-box parts and sorting them. I even painting sum of the cabinets so surplus stuff looking like new. When getting through are having prizes worth about \$5000 (if considering what the Hon. Government paid for them originally).

For a few moments I thinking of giving my re-seever away as a prize, but deciding against idea. as having even grater idea. Selling chances at ham-fest, winner having privilege of carting it away or having the fun of using an axe on it. I even planning on taking cupple chances so maybe winning and using Hon. Axe myself.

So, as the fickshun riters say, the day of the ham-fest dawned brite and clear. By ten ayem Hon. Brother Itchi's ranch are full of parked cars, with more arriving all the time. I are exuberate! I standing guard at gate collecting the one bux per person and riting out stubs for prize drawing. I had worried sum about not having any speshul program or tecknickel talks, but Itchi telling me not needing same on acct. free cactus jooce taking care of that. He are so rite! By noon everybuddy having so much funs that I not even bothering to bring out the food.

That afternoon after I counting the money and sticking it between the 866 tooobs in my rig for safe-keeping, I going out to mingle with crowd. I finding that cactus jooce are holding out okeh, but to playing safe I dyelooting it a little bit—about two to one.

Just then Hon. Brother Itchi calling me into house and raising big fuss about the broken vases, overturned chairs and the stewpendus mess in general. I telling him not to worry, as I will pay him for brakage, on acct. I are loaded. I have no more gotten this out from Hon. Mouth when Itchi and I heering tremendus crash. We rushing out back door just in time to see my new forty over twenty over ten over six over two rotary been going down through roof of barn. Hokendoke!! What a catsatrope. Sum of the hamfest amchoors had been trying to clime guv wires on beam and they braking one of them. Whooeey! Cattle are running around bellowing like mad and Itchi hopping up and down like modulashun pattern on o-silly-score. He are yelling so loud that all the amchoors are deciding that hamfest had better being over. and they all scrambling like sixty.

After they leaving I looking at mess of barn, and reelizing that I may have been loaded with bux a few minutes ago, but now my wad is shot. (Bux shot, getting it, Hon. Ed?) Now not only broke but still having all that junk-box equipment on acct. hams not staying for prize drawing.

Hon. Ed., can I intrust you in my my Hon. Reseever for your Hon. Museum?

Respectively yours,
Hashafisti Scratchi



LEO I. MEYERSON W6GFO
CU ON 10-20 & 75 METERS

PARDON OUR PRIDE

but we are mighty happy to say that we have the most satisfied customers.

Ask the fellows who deal with me. They'll tell you WRL allows more on trade-ins—WRL's large volume of sales means faster turnover and greater savings. We finance our own paper—there's no red tape. We accept low down payments—name your own terms. WRL buys more equipment—WRL sells more equipment. We offer the most personalized service anywhere.

LEO GIVES BEST DEAL ON . . .

NATIONAL RECEIVERS

HRO-SIXTY RECEIVER AUTOMATIC DUAL CONVERSION

EASY
PAYMENTS

\$483⁵⁰

(less speaker)



The NATIONAL HRO-60 is the last word in modern receivers, offering many outstanding features: Dual conversion automatically switched in and out. High frequency oscillator and first mixer now have current regulated filament circuits. High frequency oscillator is also voltage incorporated. Edge lighted, direct frequency reading scale, with one range in view at a time; Three I. F. stages at 456 kc employing 12 permeability tuned circuits on all bands, plus one I. F. stage at 2010 kc on all freq. above 7mc; Built-in power supply; Sensitivity 1 mv or better for 6 db sig/noise ratio; Micrometer logging scale; Provision for crystal calibrator unit operation from front panel; S-meter amplifier; High fidelity push-pull audio with phono jack.

SEE IT, HEAR IT, COMPARE IT!

RADIO REFERENCE MAP



25c

HANDY
WALL
SIZE

New Log Book

25c

Full column log listing all FCC required into . . . accommodates . . . 525 stations. "Q" signals, phonetic alphabet, amateur international prefixes.



NATIONAL

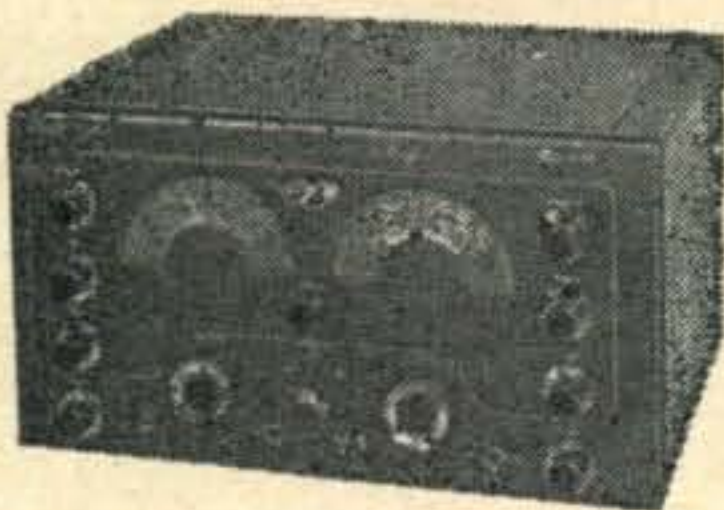

NC-183 D RECEIVER

Dual conversion on the three highest ranges plus every feature you want in a truly modern receiver!

(LESS SPEAKER) . . . \$369.50

Get Your New Copy

NATIONAL RECEIVERS AND ACCESSORIES

NC-125 RECEIVER	\$149.50
SW54 RECEIVER	\$ 49.95
SELECT-O-JET (#2 or #3)	\$ 28.75
NFM-83-50 ADAPTER	\$ 17.95
SPEAKER (for HRO-60 or NC-183D)	\$ 16.00

FREE
1953
WRL
CATALOG
SEND
TODAY!



WRITE FOR DETAILED SPECIFICATION EQUIPMENT SHEETS

WRITE
WIRE

PHONE
7795

World Radio

LABORATORIES

COUNCIL BLUFFS,
IOWA

World Radio Laboratories, Inc.
744 West Broadway
Council Bluffs, Iowa

C-4

Please send me:

- | | |
|---|--|
| <input type="checkbox"/> New Log Book—25c | <input type="checkbox"/> SW-54 Info |
| <input type="checkbox"/> Free Catalog | <input type="checkbox"/> NC-183 D Info |
| <input type="checkbox"/> Radio Map—25c | <input type="checkbox"/> HRO-60 Info |
| | <input type="checkbox"/> NC-125 Info |
| | <input type="checkbox"/> Used Equipment List |

Name _____

Address _____

City _____ State _____



TYPICAL OPERATION

(Frequencies below 120 mc.)

Radio Frequency Power Amplifier and
Oscillator Class C Telegraphy or FM
telephony (key down conditions, one
tube)

D-C Plate Voltage	2500 volts
D-C Screen Voltage	350 volts
D-C Grid Voltage	-150 volts
D-C Plate Current	200 ma.
Driving Power	3.8 watts
Plate Power Input	500 watts
Plate Dissipation	125 watts
Plate Power Output	375 watts

Write our Amateurs' Service Bureau for a free copy of the information filled 28 page booklet, "Care and Feeding of Power Tetrodes".

*An Eimac trade name

Quality screen-grid tubes became popular eight years ago when Eimac introduced the 4-125A radial-beam power tetrode to the electronic industry. Since that time thousands of engineers and amateur radio operators have used the Eimac 4-125A in a wide variety of applications and have consistently received outstanding, dependable performance. This versatile tetrode contains the *pyrovac** plate, controlled emission grid wire, low inductance leads, thoriated tungsten filament, and input-output shielding. All of these advanced features are found only in Eimac tubes. Add to this, high power output with low driving requirements, simple circuit design that minimizes TVI, low grid-plate capacitances, and ability to withstand heavy momentary overloads, and you have the Eimac 4-125A — quality tetrode in the 125 watt field.

EITEL-McCULLOUGH, INC.
San Bruno, California

Export Agents: Frazar & Hansen, 301 Clay St., San Francisco, California

Eimac
TUBES



Eternal darkness

will not halt the progress of our brother Hams who are sightless. The Braille Technical Press, available to all blind Hams, radio technicians and students, needs your financial support. Won't you help a friend to help himself?

The Braille Technical Press publishes the only electronics journal in braille every month and devises and develops precision auditory test equipment such as: volt-ohm-ammeter, VTVM, impedance bridge, grid dip oscillator, field strength meter, antenoscope, capacitance checker, S meter for communications receivers and many others.

Contributions are tax deductible.

Send contributions to:

Bob Gunderson, W2JIO, Editor
The Braille Technical Press, Inc.
980 Waring Ave., New York 69, N. Y.

A MECHANICAL FILTER FOR YOUR 75A-2!

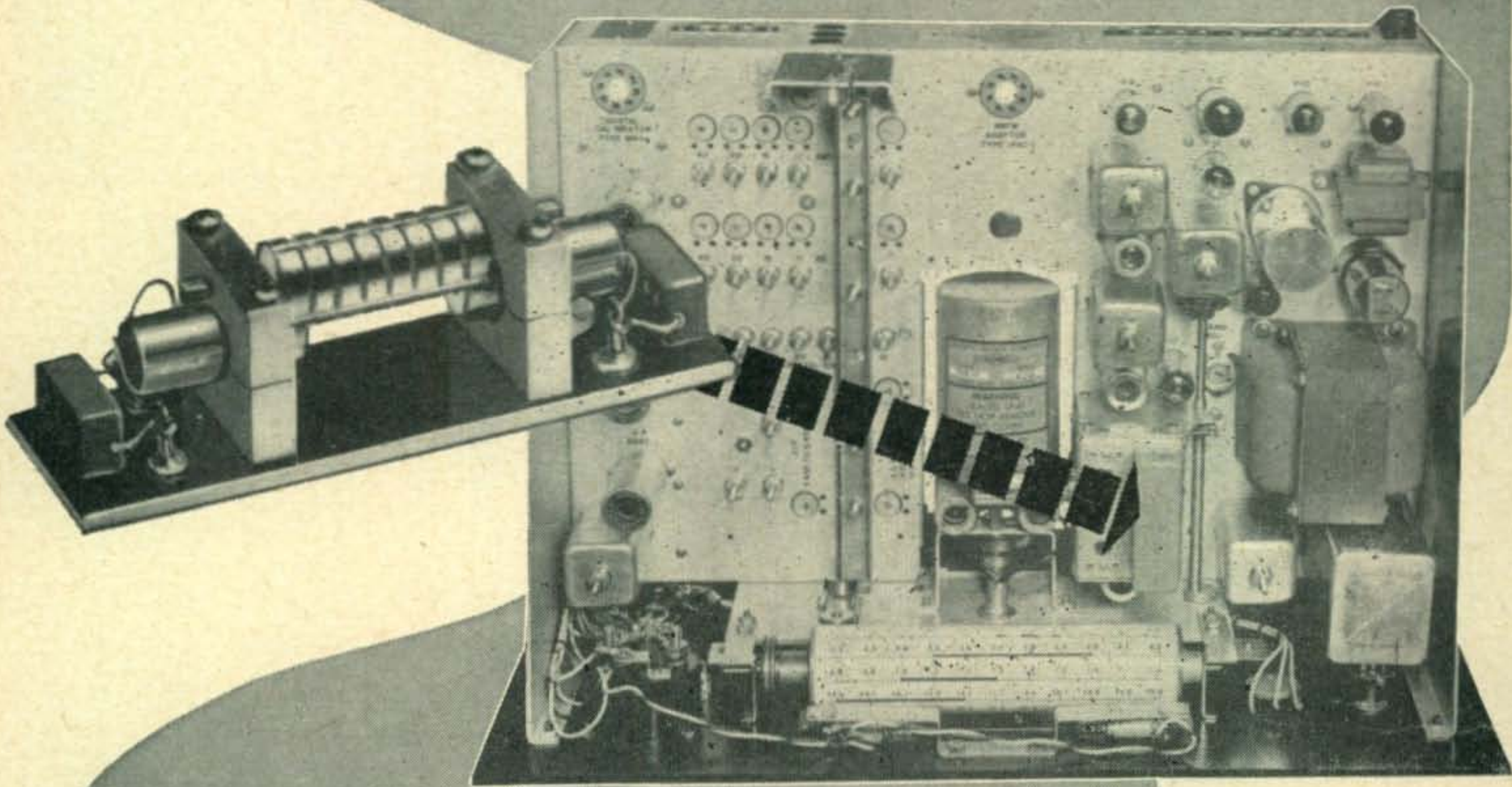

Your Collins distributor has a kit that will enable you to convert your 75A-2 into a 75A-2A — the equivalent of our new 75A-3!! Or, if you prefer, your distributor will make arrangements for you to return your receiver to Collins. We will make minor repairs and completely realign your 75A-2 in addition to converting it into a 75A-2A.

The type number "75A-2A" indicates that the receiver was once a 75A-2 but has been converted and is now the same as the new 75A-3 — including mechanical filter!

Whether your 75A-2 is brand new or several

years old, it can share honors with the 75A-3 as the world's most advanced ham receiver.

Conversion kit, complete with a 3 kc plug-in mechanical filter and instructions

Net domestic price \$100.00

Factory modification, including minor repairs, complete realignment, and installation of a mechanical filter conversion kit complete with a 3 kc filter

Net domestic price \$125.00

Type F455B-08 — 800 cycle mechanical filter plug-in unit

Net domestic price \$ 75.00

COLLINS EQUIPMENT IS A GOOD BUY — FOR THE PRESENT AND FOR THE FUTURE. SEE YOUR COLLINS DISTRIBUTOR TODAY.

For the best in amateur radio, it's . . .

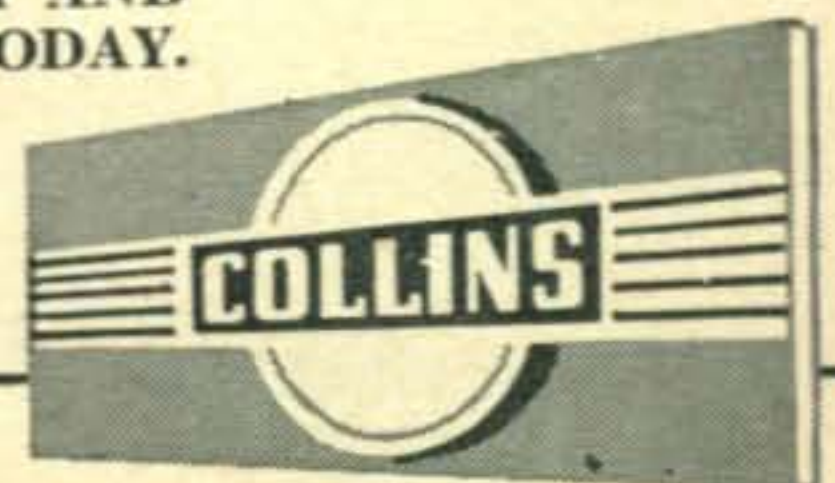

COLLINS RADIO COMPANY, Cedar Rapids, Iowa

11 W. 42nd St., NEW YORK 36

1930 Hi-Line Drive, DALLAS 2

2700 W. Olive Ave., BURBANK

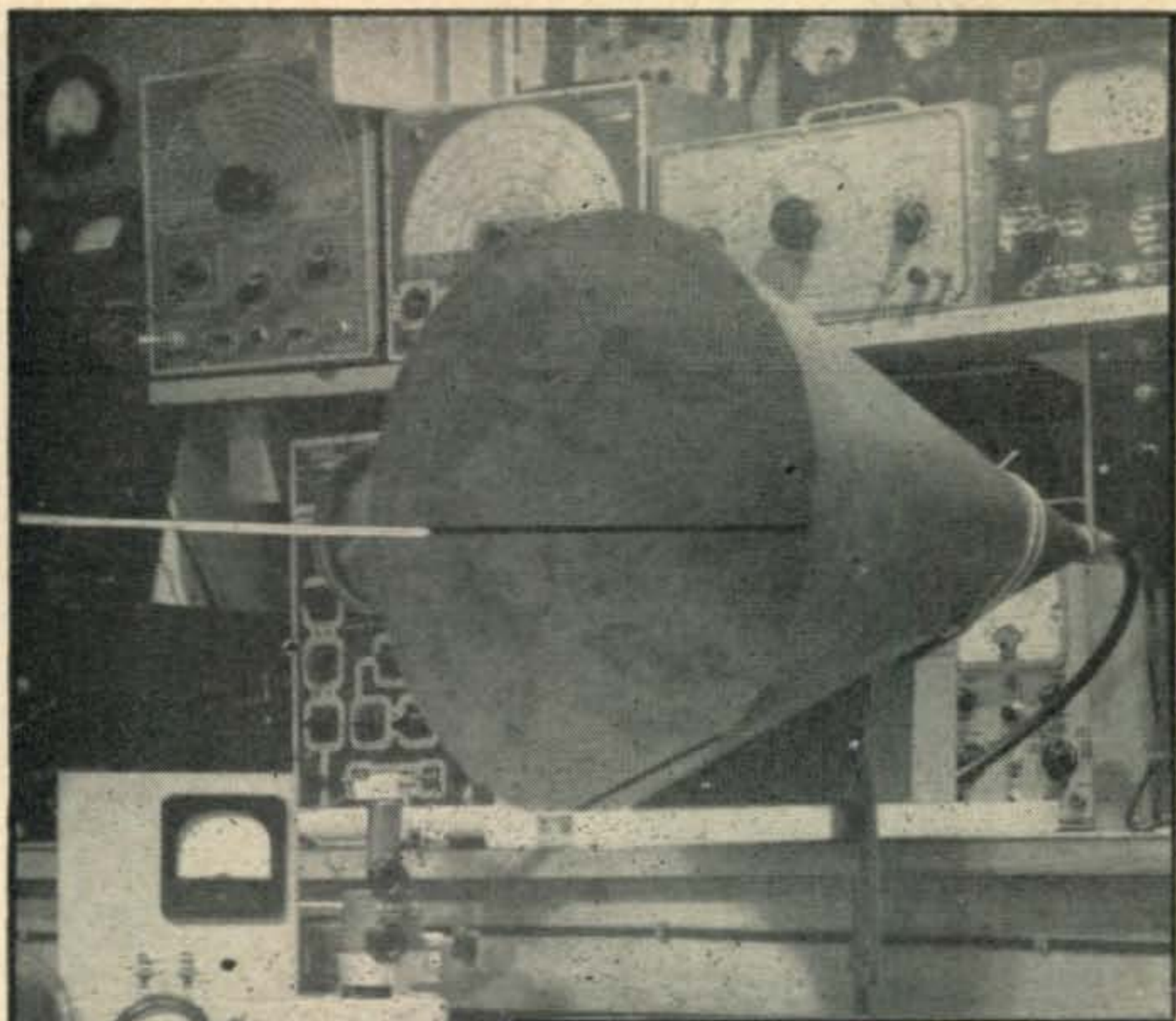

Fig. 2. Experimental setup used by the author showing the u-h-f oscillator connected to one end of a Surface Wave Transmission Line by means of a short length of coaxial cable. Microwaves are effectively "launched" down the center conductor.

Courtesy, Signal Corps, U.S. Army

The G-String

MAJOR WALTER WHITE, JR., K2CHF

167 Hunting Lane, Fair Haven, N.J.

Continuing the long line of research and developmental work performed by radio amateurs is this story on the use of a Surface Wave Transmission Line. Better known as SWTL, or "G String," it was developed around 1950 by Dr. Georg Goubau of the Signal Corps. In 1951 considerable attention was given this development through the medium of military publications, scientific press and newspapers. The details of the amateur development contained herein are unclassified, and for the most part the result of independent experiment conducted from research material available to the general public. Nevertheless, this is the FIRST application of the SWTL in the amateur field.—Editor.

The SWTL is a single conductor form of waveguide which can be cheaply produced, and which is certainly quite simple to install. It has much less attenuation than coaxial cable—becoming comparable to the attenuation of a standard waveguide.

Following the initial release of published material in 1951 the SWTL did not come to my attention again until the summer of 1952. At that time, I was in the process of constructing a u-h-f transmitter and I felt that a G-String would make an ideal

transmission line between the antenna and transmitter.

Many months of mathematical computations and predictions preceded the initial experiments on my SWTL. This part of the story can be briefly stated from the "Non-Resident Conference Course" prepared by the Civilian Components Department, The Signal School, Fort Monmouth, New Jersey. I quote in part,

"Dr. Goubau and his associates noted that, in coaxial cables, as the diameter of the outer conductor increases, with the frequency being fixed, wave propagation becomes possible by *modes*, i.e., by particular types of wave patterns in the electro-magnetic field. This, of course, is a well-known principle. Each of these wave patterns, or modes as they are called, has its own particular method of propagation.

"The scientists concluded that if we can produce the wave mode, or pattern, which will transmit the signal wave over the center conductor of a coaxial cable whose outer

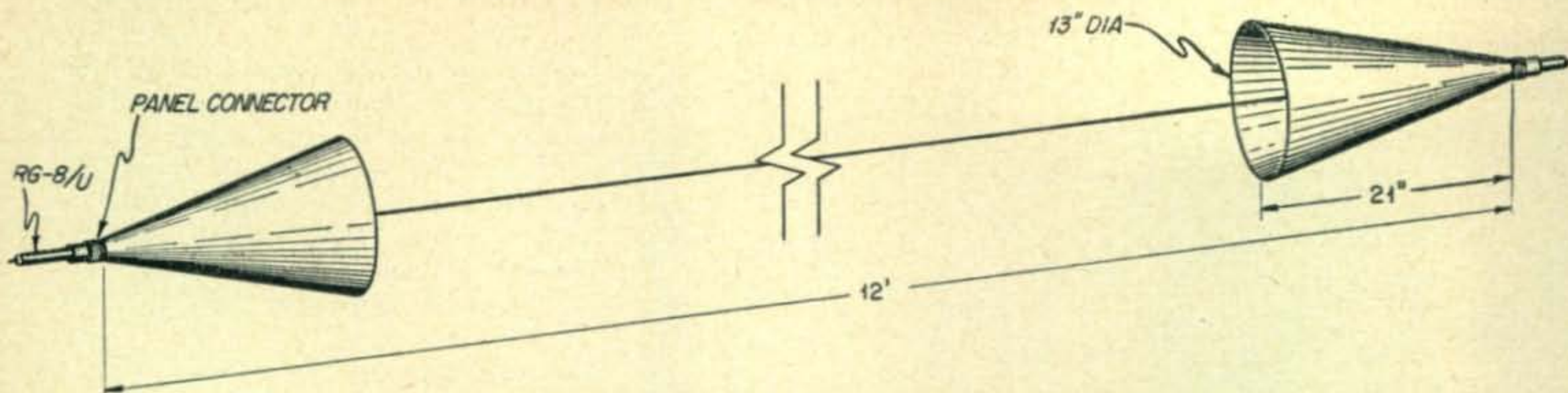

Fig. 1. Working arrangement of a simple "G-String."

conductor has an infinitely large diameter and at the same time keep the radiation losses down to a reasonable value, then our problem of a low-loss, low-cost transmission line is solved."

Primarily, the G-string is useful as a transmission line when it is not feasible to place the oscillator/transmitter in close proximity to the antenna system. Figure 1 is a schematic drawing of a simple type of this system being used by the author at the present time. Note that the G-string consists of

nothing more than a copper wire connected to the inner conductor of a coaxial panel connector about which is placed a cone whose open end is directed towards the running end of the copper wire. The identical arrangement is used at the far end of the line. Figure 2 shows the transmitting, or "launching device," used to feed the SWTL and parabolic antenna. My experimental line is twelve feet long since I was only concerned with a line on which experiments could be conducted. Successful lines have been constructed in lengths of 100 and 120 feet. Eventually I hope to be able to use a vertical line, at such time as my rig can be completed and used for practical local communication (see Fig. 3).

The line itself consists of No. 12 or 14 enameled copper wire. The thickness of the enamel coat on the wire is quite important. This generally differs with each manufacturer. The minimum thickness desired is 0.0015-inch. For frequencies in the neighborhood of 2000 Mc., the dielectric coating will confine the u-h-f field closer to the wire if it is thicker.¹ If the experimenter has facilities for handling plastics, a polyethylene coat 0.015-inch in thickness will serve very nicely. A liquid plastic employing a catalyst such as the commercial product "Plastidur" might be employed successfully in treating limited amounts of transmission line. Wire having a coating 0.015-inch thick is not available commercially.*

The temporary arrangement shown in Fig. 2 in which the insulating precautions mentioned above have not been considered will result in small additional losses, although no attempt has been made to evaluate them. Losses will also result in connection with lines having kinks, bends and sagging because of excessive length. In the latter case, waxed twine may be used to support the line at critical points along its length.²

The connector, an Amphenol 83-1R, which is the panel connector used on the launching device, will not withstand any great strain. On long lines a different system is recommended. Dr. Goubau, in a

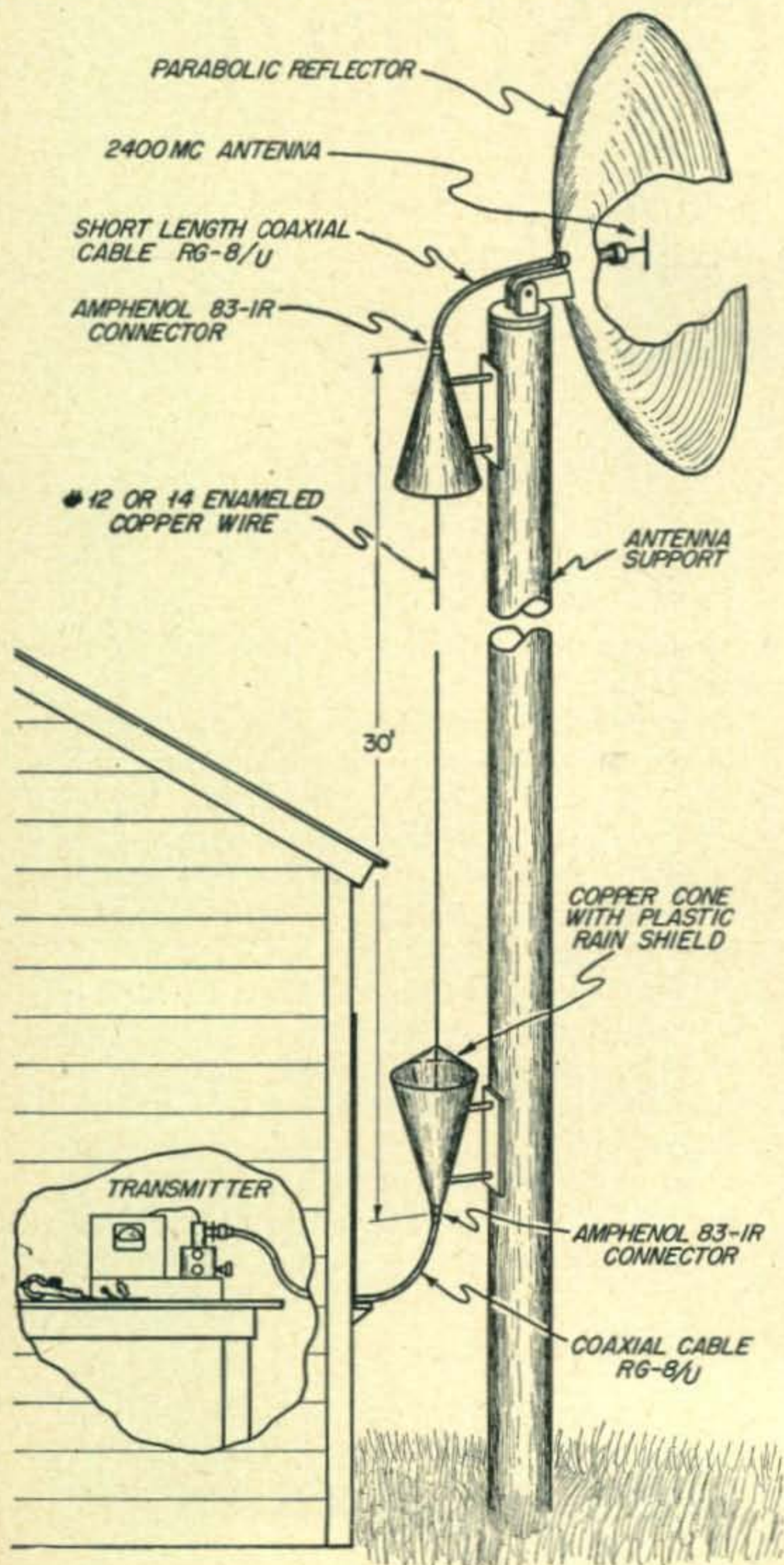

* If it is desired to utilize liquid plastic, the following procedure is recommended. Make a solution of liquid plastic in the quantity desired. In mixing such a solution, 70 drops, or 5 cc., of catalyst should be added to every ounce of "Plastidur" (by weight). Quantities of mica flour can be added to the mixture given above if a plastic with improved dielectric constance is desired.

Fig. 3. The plan of K2CHF is to use the SWTL to feed his 2400-Mc antenna. A system of this nature will have approximately one-eighth the loss of coaxial cable.

letter to the author, suggested another arrangement, as follows:

'As the connector does not stand much pull . . . the wire is fastened to the center conductor of a rigid coaxial line section, which is shorted on one end. The other end is continued by the surface wave line as shown in the cross-sectioned sketch [Fig. 4].'

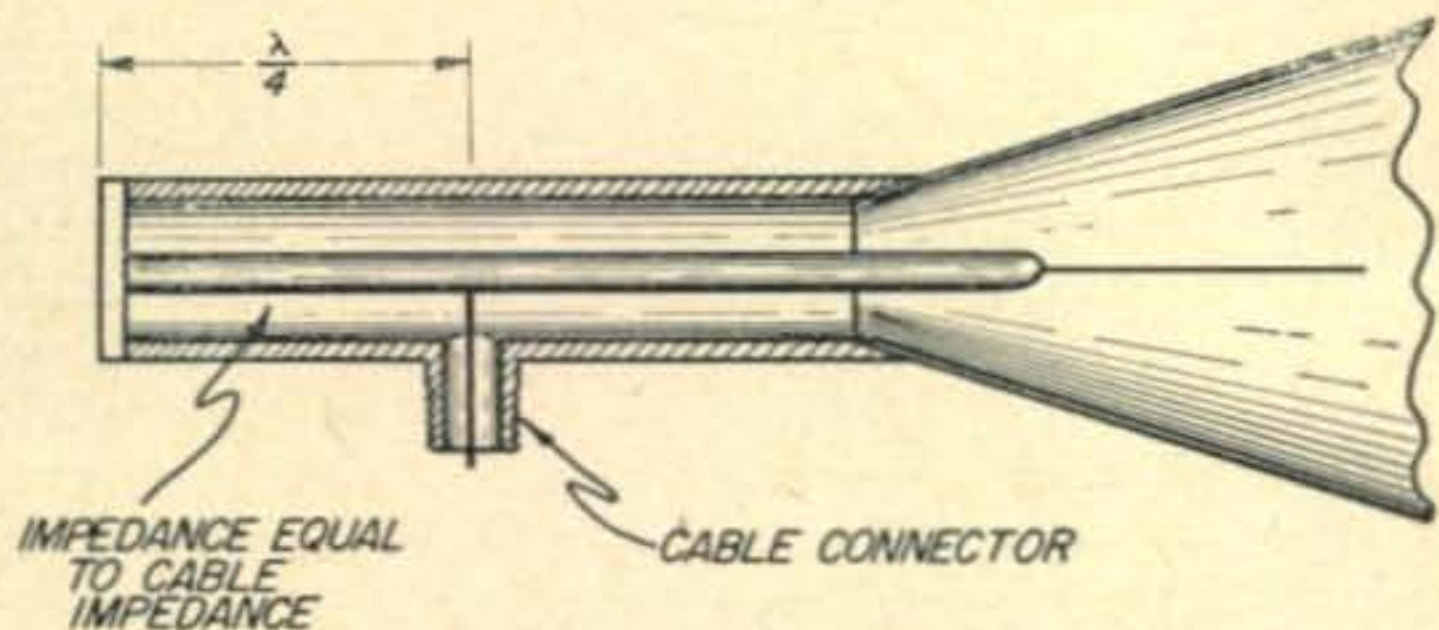

Fig. 4. Launching method suggested by Dr. Goubau in place of the Amphenol 83-1R connector. The quarter-wave matching section can be made tunable.

In addition to the losses mentioned previously, other losses may occur in the *G-string*. These are: (1) conductivity loss in the wire, (2) loss in the dielectric coat, and, (3) loss caused by particular excitation of the radiating modes effected through the launching device.

These losses are treated in detail in the paper entitled, "Single Conductor Surface-Wave Transmission Lines," by Georg Goubau in the *Proceedings of the I.R.E.*, Vol. No. 39, No. 6, June 1951. The information contained therein treats these losses in detail, and also contains important design information.

Figure 5 compares the losses in the *G-string* with those of a rectangular hollow waveguide having the internal dimensions of 3 x 1 inch. Fig. 6 compares losses in a coaxial cable, RG-8/U.

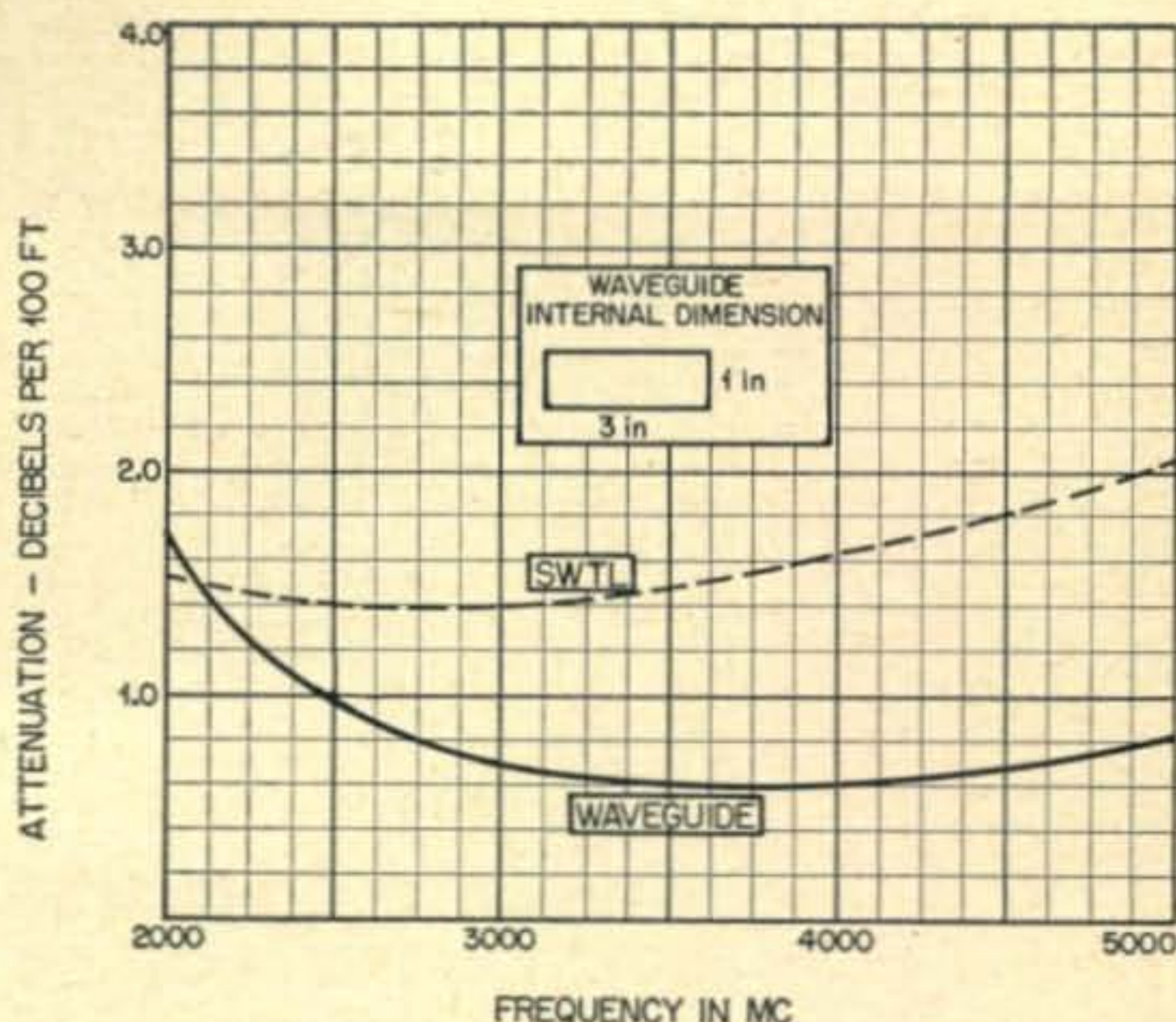

Fig. 5. Comparative curves of the attenuation in a standard copper wave guide, plotted as a function of frequency, versus attenuation in a "G-String."

Courtesy, Department of Non-Resident Instruction, The Signal School, Fort Monmouth, N.J.

Notwithstanding the fact that the *G-string* used by the author does not have a dielectric coating, a meter held near the line gives no indication of loss due to radiation until it is within one or two inches of an imaginary line which is in prolongation of the outside edges of the two cones. With the 12-foot line, only a very slight difference has been noted in energy readings taken at the antenna with and without the SWTL connected to the system. The reason for the small loss is due to the corrosive film on the bare wire, which appears to the wave as a partial dielectric. Dr. Goubau once stated that the single wire would not be a guide if the conductivity were infinite and the surface perfectly clean and smooth.³

A *G-string* utilizing cones having a diameter and

Fig. 7. Major White (while A4UEK and Chief of Third Army MARS) and Capt. Robson (at the right) measure the frequency of the u-h-f oscillator during preliminary experiments.

(Reprinted from the MARS Bulletin, Vol. III, No. 7, July, 1952, Headquarters Third Army, Fort McPherson, Georgia.)

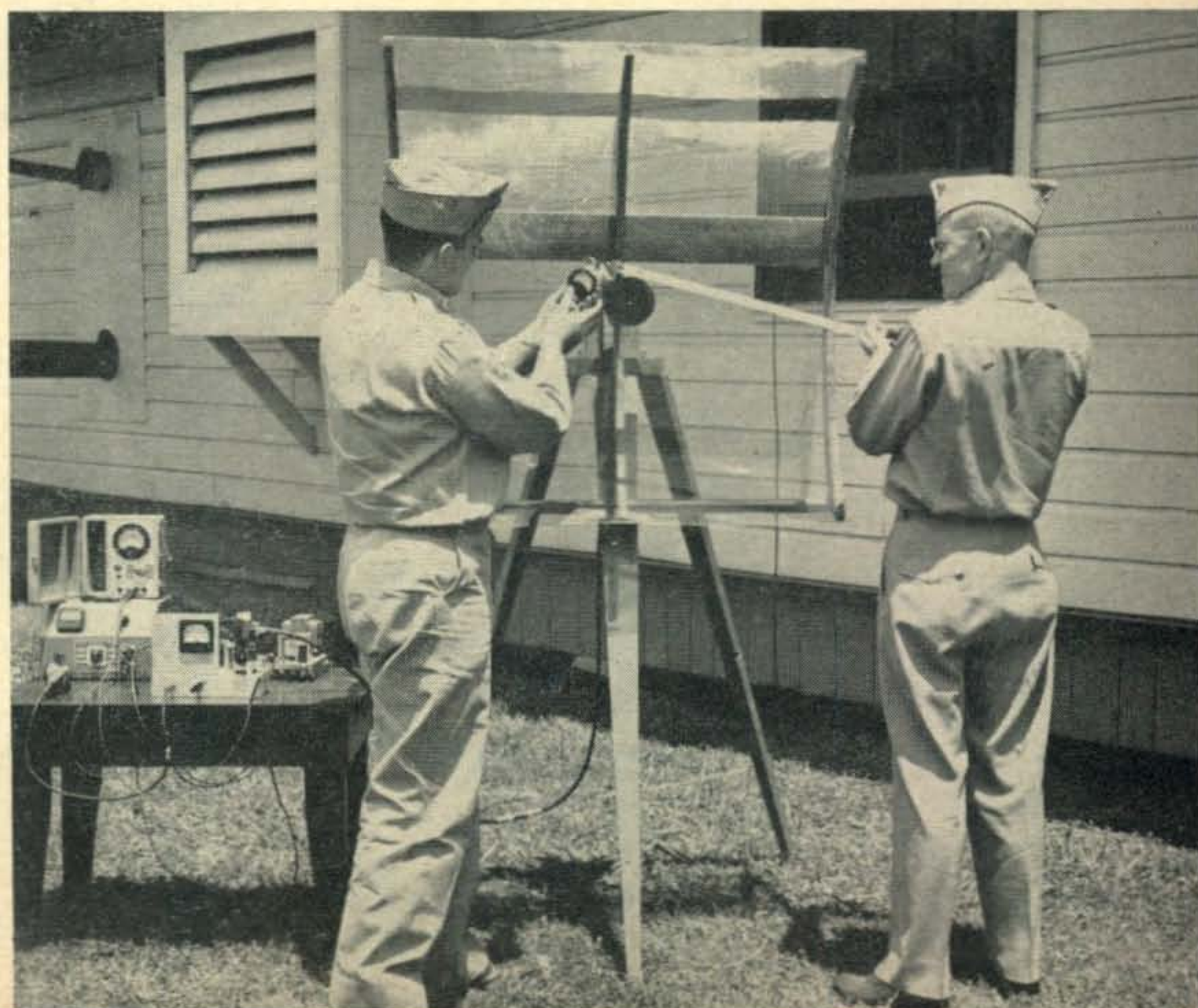

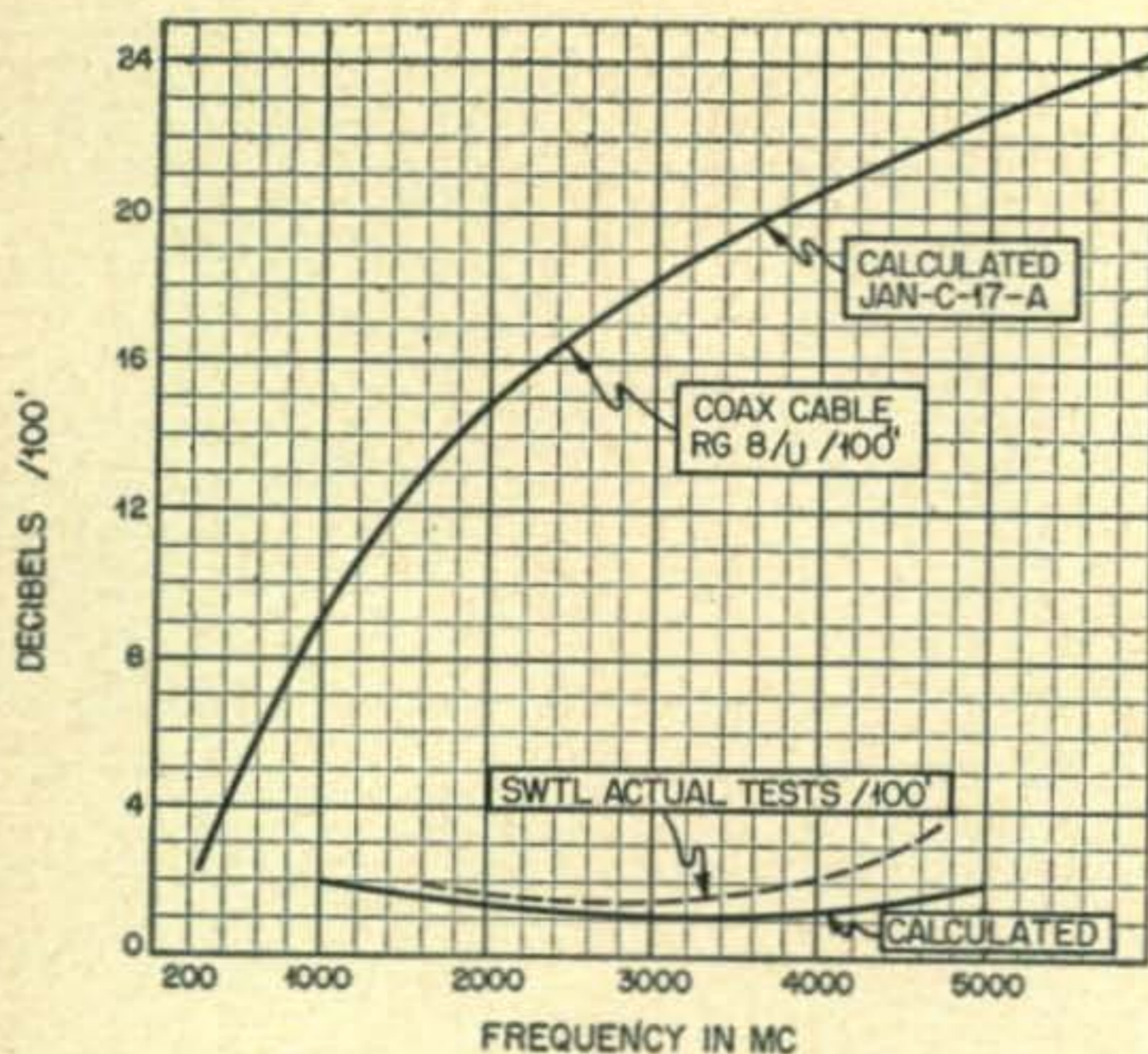

Fig. 6. Comparative curves for losses in the u.h.f. spectrum with coaxial cable and SWTL.

length of 13 and 21 inches respectively, is suitable for experiments in the 2400-Mc amateur band. Fabrication of the cones is relatively simple. After the metal has been rolled into a cone having the specified dimensions, the small end is prepared for soldering. Small nuts and bolts are used to hold the side of the cone together rather than soldering it together permanently. This was felt necessary in order to study the effects of varying the cone diameters. When it is desired to use the line solely as a transmission line, the cone may be permanently brazed or soldered along the seams.

Before placing the apex of the cone on the panel connector, run the wire, after stretching it to remove the kinks, through the cone and solder the end of the wire to the inside conductor of the panel connector. When this has been made fast, place the end of the panel connector firmly against the outer diameter of the cone and solder in place. The same procedure is employed at the opposite end of the line.

Suitable mountings are required to support the cone and provide proper tension on the line. Such a support may be made of pine or other wood boiled in wax, or plain wood on which stand-off insulators have been fastened to support the cone.

The experiments conducted in these tests use a *DeciMeter* model DM 240-A transmitter as shown in Fig. 7. Future articles will cover the construction of this transmitter, and receiving equipment for the 2400-Mc. amateur band.

Experimenters will find considerable satisfaction with the study of such a line, and I firmly believe that fellow Hams requiring a transmission line for their u-h-f rig. will find the *G*-string superior to coaxial cable. Such a line is the answer to the problem of low loss and low price.

1. Correspondence from Dr. Georg Goubau.
 2. Goubau, "Single-Conductor Surface Wave Transmission Lines," Proc. I.R.E., Vol. 39, No. 6, June 1951.
 3. Ibid.
- see also: "Surface Wave Transmission Lines," Civilian Components Dept., The Signal School, Fort Monmouth, N.J.

Present and Prophetic: The Delaware Valley Hamfest

The 9th annual Old Timer's Nite Round-Up and banquet, sponsored by the Delaware Valley Radio Association, will be held on Saturday evening, April 25th, in the Grand Ballroom of the Hotel Stacy-Trent, West State and Willow Streets, in downtown Trenton.

A turkey dinner will be served promptly at 6:30 p.m. in the hotel ballroom, and the program will include personalities prominent in early radio and wireless history. Bring along your oldest amateur and commercial licenses, as awards will be made to those holding the earliest dates. A special award will go to the "Grand OM" whose radio operating experiences date back to the earliest days of wireless. W2ZI's now famous collection of old time wireless gear will be on display, as usual.

Tickets, at \$5.00 per person, are by reservation only, and may be obtained before April 21st from General Chairman, Ed G. Raser, W2ZI, 315 Beechwood Ave., Trenton 8, New Jersey. Late comers who purchase at the door will be assessed \$6.00. Plan to bring along as many guests as you wish; Everyone is welcome. As in the past, the party will be *stag*.

3rd Annual

Ontario Section QSO Contest

A QSO Contest between Ontario Section amateurs, sponsored by the Ontario Phone Club, will be held on two consecutive Sundays, April 26 and May 3, 1953 from 1000 to 2200 EST each period. The purpose of the Contest is to enable CW and phone operators to become familiar with both types of operating. Two awards will be made. The c-w award will be known as the "Sparton Radio Trophy" and the phone award will be known as the "Columbia Record Trophy." Both trophies, donated by Sparton of Canada, will be suitably engraved with the winner's call and the year of presentation. Permanent possession of the trophy will be given to the station winning it on three occasions.

Following are the rules: The Contest call is 'CQ VE3', Frequencies from 3500 kc. to 3725 kc. will be allotted for CW operation, 3500 kc. to 3800 kc. for CW-to-phone operation, 3725 kc. to 3800 kc. is allotted to phone-to-phone operation, 3765 kc. is allotted to mobile phone stations. No multipliers will be used and one point per contact for phone-to-phone, phone-to-CW and CW-to-phone, provided the contacts are made in the portion of the band designated above. Exchanges will be: Contest number, Call, Report and Time. Any station may operate phone and CW, provided his operation takes place in the proper portion of the band. Stations may be worked only once regardless of type of emission. One contestant cannot win both trophies. Judges of the contest will be the Contest Committee, contest logs should be sent to S. Moir, P.O. Box 191, Simcoe, Ontario, up to midnight May 16th, 1953. After the winners have been selected, the remaining contestants who submit logs shall be eligible for a draw prize.

Project

CONELRAD

The material appearing on these two pages devoted to CONELRAD may come as a shock to many of the CQ readers. It is, unfortunately, no "April Fool's Joke." I personally urge each and every reader to carefully study this preliminary report on Project CONELRAD. Subsequent reports will be devoted to the dissemination of data on approved plans for the alerting and operation of amateur stations during a "Radio Alert."

The editors of CQ will also be pleased to receive "ideas and suggestions" on methods of interrupting amateur transmissions coincident with the announcement of a CONELRAD "Radio Alert."

o. p. f.

Now that the furor concerning FCC dockets 10073, 10173, 10188 and 10237 is a matter of history, everyone can turn their attention to one of the most important problems facing amateur radio operation—Project CONELRAD.

Conforming with the present-day practice of euphonizing lengthy titles, CONELRAD is the project name for "Control of Electromagnetic Radiation." This program was initiated by an Executive Order (No. 10,312) issued by the President of the United States on December 10th, 1951. In this order the President indicated that the FCC was to prepare and, to the extent necessary, put into effect plans with respect to radio stations in order to minimize the use of electromagnetic radiation, in the event of attack or imminent threat thereof. It was felt that radio transmissions of almost any nature could serve as an aid to the navigation of hostile aircraft, guided missiles and other devices capable of direct attack upon the United States.

Almost all of the CQ readers are familiar with the fact that aircraft flying at high altitudes must depend almost solely upon some means of radio navigation. Obviously, if the United States were to be attacked, what would be more natural than the attacking force attempting to use radio stations for D.F. purposes near their target area? In order to prevent the use of these stations, three alternatives present themselves. It would be possible, as soon as the air raid is expected, to take all radio stations

immediately off the air. It would also be feasible to devise some means of preventing the identification of certain radio stations, or to improvise a means of rendering the D.F. of certain stations, or areas, as being "unreliable."

For ordinary D.F. purposes radio stations operating in the range 100 to 2000 kc. and 30 to 200 Mc. are most suitable; however direction finders are available for the 2 to 30-Mc range and can be used to obtain valuable navigational information.

The 100- to 2000-kc range and the 30- to 200-Mc range include a major portion of all broadcasting assignments. To furnish Civil Defense information to the public during periods of impending Air Attack, it is essential that large numbers of broadcast stations remain on the air. Thus the FCC, in cooperation with Air Defense Command of the U. S. Air Force, has devised a plan to minimize the navigational aid that may be obtained from these stations.

Amateur Stations Must Go Off

All amateur stations will be expected to leave the air as soon as a threat of air attack has been established. Regardless of the technical aspects of amateur operation, the cessation of operation during a "Radio Alert" is not optional—it is a definite MUST!

In accordance with the usual FCC practice in matters pertaining to amateur radio, a conference was called on February 10th by Ralph J. Renton, W4CU, National Supervisor of CONELRAD, in the FCC Washington offices. Attending this meeting were representatives of the radio amateur organizations and press. The purpose of the meeting was to set up tentative proposals for participation in the radio amateur CONELRAD project. In other words, how were radio amateurs to be alerted and how were amateur stations to act during a "Radio Alert."

It is to be emphasized at this point that the discussions during this meeting were directed towards forwarding to the FCC a proposal, which would be later handed down as a "Rule" governing the participation of amateurs in CONELRAD. The responsibility for ascertaining the presence of a "Radio Alert" will be placed solely upon the individual amateur. It is expected that in the interests of his country's welfare, the amateur will provide himself with a means to interrupt his activities during the threat of an air attack.

How To Know When To Go Off

At the first sign of a "probable" air attack, the United States may be placed under a WARNING YELLOW. When the attack seems imminent, the situation will be changed to a WARNING RED. At some period between these two "warnings" all radio stations will be notified of a "Radio Alert." The usual broadcast station procedure will be to interrupt their carrier for 5 seconds, it will then be returned to the air for 5 seconds, and interrupted a second time for 5 more seconds. The carrier will be returned to the air with a 1000-cycle tone modulation warning signal for a 15-second period. At the completion of the tone signal the broadcasting station will then notify its listeners of the imminent air attack. After this notification certain broadcast band stations will shift frequency to either 640 or 1240 kc. Such "clusters" of broadcasting stations may then operate in a non-cyclical sequence for random periods varying generally from 5 to 40 seconds. This "sequential mode" of operation will be used in order to reduce, or completely destroy, the effectiveness of any D.F. using broadcasting stations. Note particularly that all broadcasting stations that remain on the air will be shifted to either of these two frequencies.

The operation of the "clusters" will be such that as one station goes off the air and another station comes on, there will be no appreciable "lost-air" time, or carrier signal overlap. All stations will be broadcasting the same program. Since, in the larger cities, the location of the broadcasting station transmitters may be separated by as much as 35 or 40 miles, the use of these stations for D.F. even at fairly short range is effectively minimized. Civilian Defense organizations and others, however, may keep in touch with the status of the over-all picture by monitoring the one "selected" frequency in their area. Provisions have been made so that citizens in the metropolitan area may continue to receive air raid instructions with a minimum of broadcast interference, although high-altitude aircraft will undoubtedly find these two frequencies an unbelievable hodge-podge of broadcast carriers.

The simplest method for the radio amateur to determine the presence of the "Radio Alert" is to provide himself with a means of monitoring broadcast stations in his area. A simple device, such as shown below by W2PKD, may be used to "silently" monitor a broadcast station for the "Radio Alert" carrier interruption. Many similar devices automatically come to mind, and the one shown below is a good example of an optimum design.

In review, within the very near future it is expected that the FCC will announce a new Docket, providing for inclusion in the current amateur Rules and Regulations an expression of the individual responsibility to provide a means of ascertaining the presence of a "Radio Alert."

All amateurs should accept this Docket as a positive indication that their country is interested and working to minimize possible loss of life and property should we be attacked from the air.

A CONELRAD Alarm System

ATHAN COSMAS, W2PKD

As indicated herein under certain conditions in the Air Defense Program all broadcast stations will be required to notify their listeners of a "Radio Alert." For obvious and similar reasons, all Ham transmitters must be ready to leave the air.

An inexpensive broadcast receiver can be used for "silent" monitoring of a selected broadcast carrier, and with a few simple circuit modifications, provide for simultaneous cut-off of an amateur transmitter. The diagram shown in Fig. 1 may be connected to any simple superheterodyne receiver.

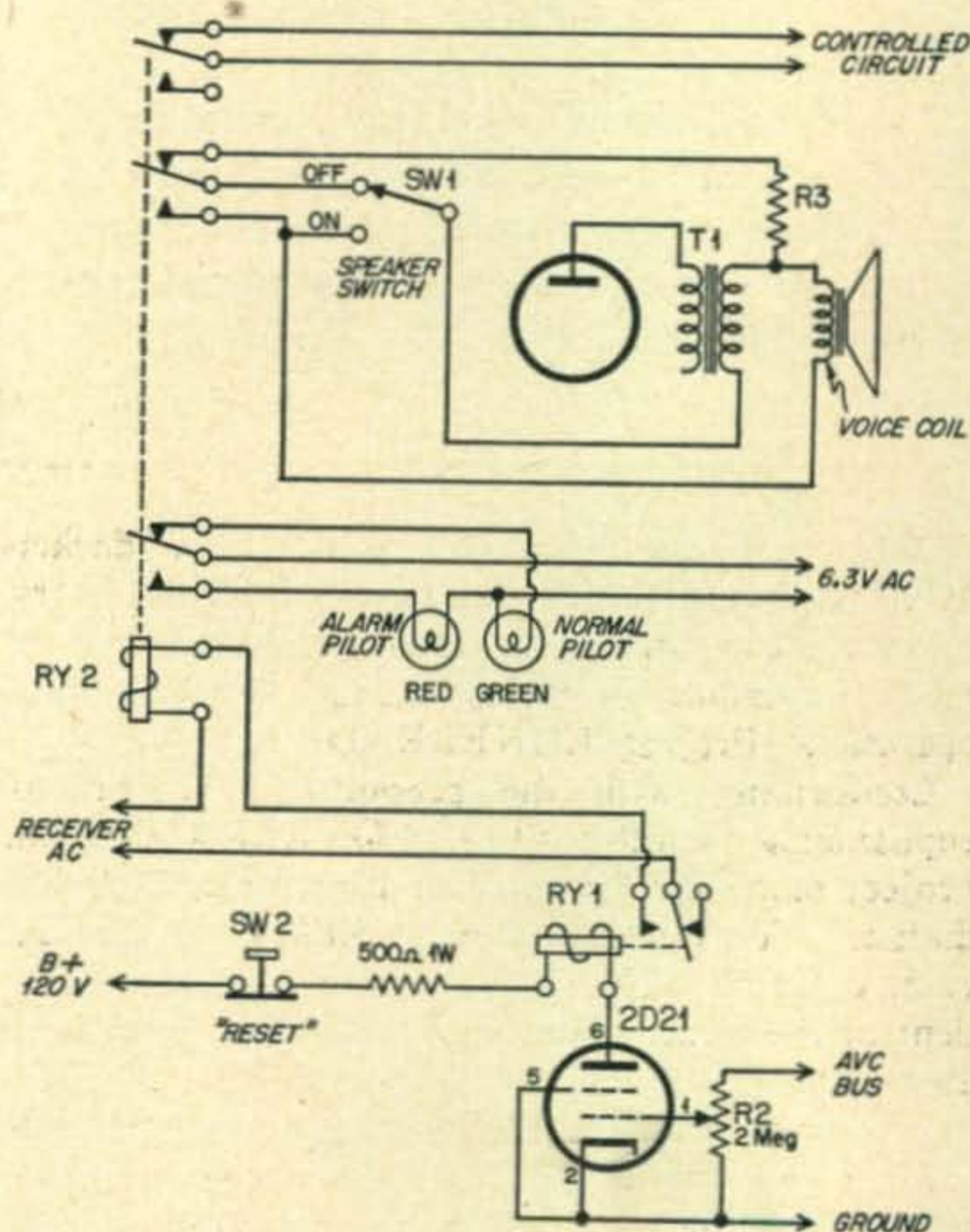

Fig. 1. Wiring schematic of a thyatron controlled CONELRAD alarm device.

A small voltage taken from the a-v-c bus of the receiver places a bias on the grid of the 2D21 thyatron. A sudden loss of signal will remove this bias, allowing the thyatron to conduct. The flow of current will cause RY1 to function and its contacts will complete a circuit to the winding of RY2 with the following results:

- 1: The green or "normal" pilot lamp will go out; the red or "alarm" pilot lamp will come on.
- 2: The speaker will be connected back into

(Continued on page 57)

Getting Started on Single Sideband

JACK N. BROWN, W4OLL

412 Spring Street, Herndon, Va.

The second installation of this series covers the two methods of SSB generation; (1) the filter method and, (2) the phase-shift method. Examples of both exciters are described in sufficient detail to permit the amateur to construct them from this text. The mechanical filter recently announced by the Collins Radio Company and described in the March issue of CQ is used in an experimental model.—Editor.

PART II

As in the receiving adapters described in last month's installment of this series, there are two methods of generating a single-sideband signal available. The older method in use for many years is the filter method. The other system which has become popular in the last few years is the phasing method. I do not intend to further the friendly feud of filter versus phasing that many of the boys have indulged in. Each has its own points and careful work will produce a satisfactory signal using either system. Conversely sloppy workmanship will yield a sloppy signal with either system.

I would like to spend a little time dealing with each system, outlining what takes place, so that the beginner can better understand what he is trying to do when he tackles an SSB exciter.

The Filter Method

As we saw in *Part I* of this series an AM signal is composed of a carrier (occupying no bandwidth) and two sidebands. The sidebands are like the carrier, in that they are actual r-f signals distributed either side of the carrier in the spectrum. The sideband components corresponding to the lower audio modulating frequencies are close to the carrier, and the higher audio frequencies are proportionately farther away from the carrier. The two sideband signals are identical, in that they carry the same intelligence. The filter-type of SSB exciter must separate these two sidebands, transmitting one and attenuating the other. The matter of carrier suppression is secondary, and can be accomplished with relative ease. It is not feasible, from a practical standpoint, to accomplish the filtering process at the final operating frequency for these reasons: First, finding circuit components to separate the sidebands, whether coils and condensers, or crystal filters, would be an almost impossible job. Second, if we wished to move

frequency, all the circuit components would have to be retuned for the new set of conditions. There is, however, an easier way. Generate the SSB signal at some lower fixed-frequency, and then heterodyne it up with conventional mixers to the desired frequency. This procedure solves both problems for us, in that it makes our filtering problems simpler, and because the VFO can be used as the heterodyning oscillator to put us anywhere in a particular Ham band.

The first filters built for this purpose were in the higher audio frequencies, i.e., from about 10 kc. to 25 kc. Direct heterodyning into amateur bands from this low frequency is not practical, because, when two signals are mixed (or heterodyned), the output products are the original signals and the sum and difference of these original signals. If we heterodyned to 4.0 Mc., for example, the tuned circuits would not allow the original 25-kc signal to appear in the output, but the original mixing oscillator near 4.0 Mc. would be present and both the *sum* and *difference* of the two signals would appear in the output. This would give us a steady carrier and an upper-sideband 25 kc. above this carrier and a lower-sideband displaced 25 kc. lower than this carrier. This is undesirable, to say the least. Thus it was necessary to first heterodyne the 25-kc SSB signal up to about 450 kc., so that normal i-f transformers could discriminate between the various products of mixing, and select the desired one. Then it was necessary to heterodyne once more into the desired amateur band, making this last mixing-oscillator variable for v-f-o control of the output signal. The first transmitters described for amateur use utilized this system.^{1,2,3} They were a little complex in adjustment, number of tubes, and tuned circuits used; however, they produced a very high degree of sideband attenuation. The advent of crystal filters for amateur use,^{4,5} made possible the generation of

1. Nichols, "A Single-Sideband Transmitter for Amateur Operation," QST, Jan., 1948, p. 19.
2. Berry, "A Filter Design for the Single-Sideband Transmitter," QST, June, 1949, p. 29.
3. Mann, "An Inexpensive Sideband Filter," QST, Mar., 1949, p. 21.
4. Edmunds, "A Crystal-Filter SSB Exciter," QST, Nov., 1950, p. 11.
5. Weaver and Brown, "Crystal Lattice Filters for Transmitting and Receiving," QST, June, 1951, p. 48, and Aug., 1951, p. 52.

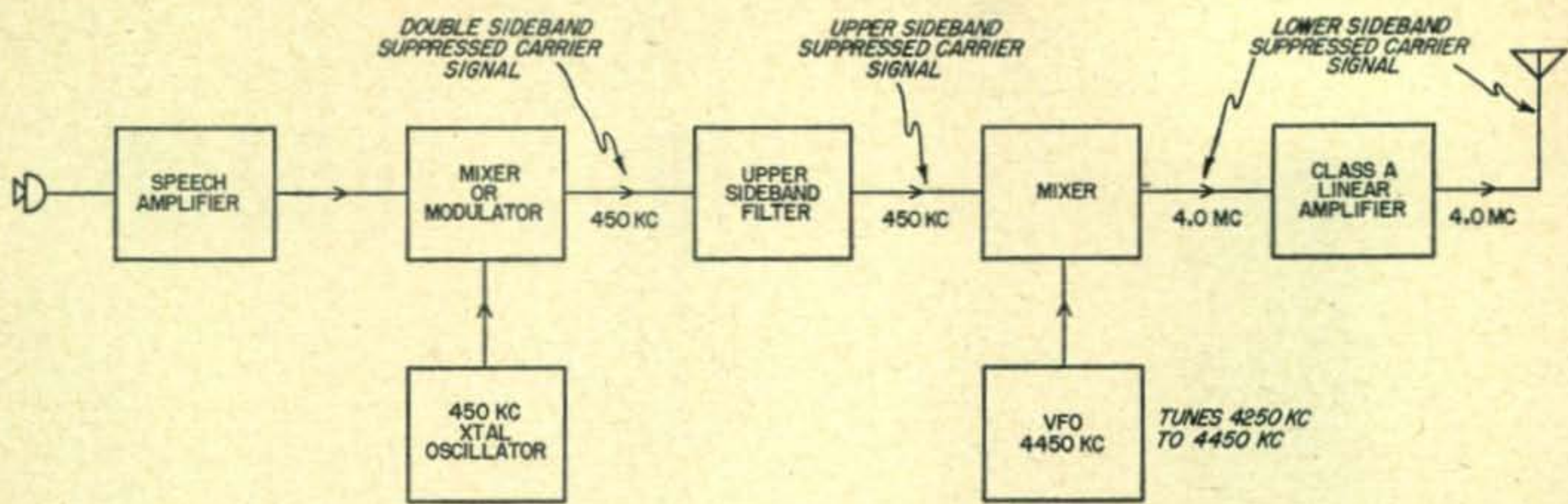

Fig. 1. This is a block diagram of a simple crystal filter SSB exciter.

SSB signals in the region of 400 to 500 kc. This eliminated the necessity of the extra heterodyning operation.

The sideband filter, whether at 25 kc. and made of toroid coils and condensers, or at 450 kc. and made of quartz crystals, must have certain characteristics to be acceptable for use. The filter, whether bandpass, or high-pass or low-pass in nature, must be capable of separating the sideband components close to the carrier on the high-frequency side from those close to the carrier on the low-frequency side. This dictates a sharp drop-off in the filter response characteristic, or, as the boys say, a good skirt response. (*This is not to be confused with a YL's answer to a wolf whistle!*) We cannot obtain practical filter characteristics with a vertical drop-off, so we must be content with an attenuation of from 30 to 60 db. in about 600 cps. We can help this situation by moving our carrier frequency part way down this slope of the filter characteristic. We accomplish two things by doing this: (1) We attenuate the useless, power-wasting, low speech frequencies below about 400 cps and (2) allow the filter to be more effective on the portion of the undesired sideband nearest the carrier. A good rule of thumb to follow in placing the carrier on the slope of a filter is to put it about 20 db. down on the response of the filter characteristic. This should result in the transmission of few frequencies below 500 cps. If the carrier is so placed and the speech response is not up to maximum until you reach a frequency of 700 or 800 cps, the filter skirt is *not* steep enough, and measures must be taken to correct this. The commercial standard for a *good* sideband filter is 80 db. drop in the filter skirt in 1 kc.! This is a bit more than required for amateur use, but it will give you something to shoot for!

The high-frequency response of the filter characteristic and speech amplifier need only be enough for good speech intelligibility. This means that frequencies above 3000 cps should be attenuated, first of all, to conserve spectrum space, and to result in a pleasant sounding signal. Since we have eliminated the low-frequency speech components, cropping the high frequencies will produce a balanced-sounding signal that will be more intelligible.

The only thing remaining now is to heterodyne the 450-kc SSB signal up to a desired frequency in an amateur band. Refer to *Fig. 1* for a block diagram of a simple crystal-filter SSB exciter. You will note that an *upper-sideband* signal is generated in the filter, and when it reaches the 4.0-Mc band it has changed into a lower-sideband signal. How come? Take a pencil and figure it out for yourself. Take 450 kc. as a suppressed-carrier frequency, and 452 kc. as being the frequency of an upper-sideband resulting from a 2000-cps input tone. If we use the difference-mixture of these frequencies, and a 4350-kc v-f-o voltage, do the following: (1) Subtract 450 kc. (*carrier*) from 4350 kc. Result—3900 kc. carrier frequency; (2) Subtract 452 (*sideband*) from 4350 kc. Result—3898 kc. sideband frequency. So, in the 75-meter band our sideband is *lower* in frequency than the carrier—a lower sideband. Simple, no?

Heterodyning

This section applies to the phasing type of exciters as well as to the filter exciters. Heterodyning, or mixing, as it is more commonly known, is the process whereby two r-f voltages of different frequencies are combined in a non-linear device so that either the sum or difference of the two frequencies is present in the output. Normally, tuned circuits are used to select the mixture product we want. The non-linear device mentioned in the formal sounding definition can be an ordinary vacuum tube, either triode or multi-grid type. Diodes, either vacuum or germanium, also serve as non-linear elements. In the transmitter-exciter to be described, both types are used. In mixing in a non-linear device, the output amplitude of the desired product must be in linear amplitude relation with its corresponding input signal. What does this fancy sounding statement mean? It means that when heterodyning an SSB signal from one frequency to another, the output SSB signal must vary in the same proportion, amplitude-wise, as the input SSB signal. To accomplish this, the mixing oscillator voltage must be several times greater than the SSB signal, the usually accepted ratio being ten to one. For every volt of signal, we will require ten volts of mixing oscillator voltage. This

is a safe figure and should eliminate any possibility of signal distortion taking place in the mixer.

Amplifiers

We have dealt briefly with the two systems used in generating a SSB signal. This SSB signal has variations in amplitude of its various r-f components, which means that we cannot use conventional class C amplifiers to amplify it. As we must faithfully reproduce the signal as originally generated, the amplifiers must be linear. Linear amplification, in words of one syllable, means that, if the input voltage doubles in amplitude (from 1 to 2 volts, for example), the amplified output voltage must change in the same proportion (20 to 40 volt increase).

There are various classes of linear amplifiers—depending on how much driving power is used and what amount of grid-bias is used. Class A, AB₁, AB₂, or class B amplification may be used depending on the voltage or power level involved. Ordinarily, class A or class AB₁ amplifiers are used at low levels for high-gain amplification of generated SSB signals. Class AB₂ and B stages are used for power amplification in the high-level final amplifier stages. Amplifiers will be dealt with in more detail in the fourth part of this series. Here, we will be content with only the voltage amplifier stages—class A and AB₁.

Further discussion will be deferred until we cover the sections describing the two specific exciters.

A Crystal-Filter SSB Exciter

As representative of the filter-type exciter, the circuit shown in *Fig 2* was chosen. Basically, the circuit is that of Edmunds⁴, and has long since been nicknamed the "W1JEO filter." The author felt that the original filter has some inherent disadvantages, namely: The alignment was a compromise one, in which *best* sideband suppression did not occur when *best* pass-band characteristics were realized. The slope of the filter characteristic would not be steep enough when the adjustments for maximum undesired sideband suppression were made. Generally, there would also be a large dip in the middle of the transmitted sideband characteristic. Many of the boys using this type of filter had successfully modified it as follows: Following Edmunds' original alignment procedure with the three-crystal filter, as described in *QST*, careful adjustment was made for best pass-band shape, without worrying too much about the suppressed sideband characteristic. Then the frequencies at which humps appeared in the filter characteristic on the suppressed-sideband part of the curve were noted. Additional FT-241 crystals were chosen so that their *series-resonant* frequencies were at the frequencies of worst attenuation. These extra crystals were then connected in parallel with the input crystal (*Crystal "B" in Fig. 2*), with the output crystal (*Crystal "D"*), or both places. As few as two or as many as ten extra crystals have been used. Ken Stiles, W2MTJ, originally conceived these modifications, and suggests that additional

crystals may be used to improve the steepness of the filter cut-off characteristic next to the carrier frequency.

The series-resonant frequency of a FT-241 low-frequency crystal may be determined in the following manner: Connect the crystal in series with the hot lead of a BC-221 frequency meter (or a signal generator) and the input lead of a scope, sensitive r-f vacuum-tube voltmeter, or some other indicating device that will respond to the frequency range of 400 to 500 kilocycles. Slowly tune the signal generator through the range of the crystal, and a sharp kick will be noted on the VTVM or 'scope. This sharp rise indicates the series-resonant frequency of the crystal. Carefully check this peak. Shunt circuit capacity should not move it, so no great care need be taken in circuit arrangement.

One of the local Hams, W4RL, who tried this modified filter scheme, said that he used two additional crystals. One of the crystals was chosen for the channel between the carrier crystal (*Crystal A*) and the rejection crystal (*Crystal B*). The other extra crystal was chosen to be very close to the carrier suppression crystal (*Crystal D*). As in Edmunds' original article, *Crystals A* and *D* are chosen at the carrier frequency. *Crystal C* is the band-pass crystal—used to pass the desired frequencies—and for upper sideband generation is one channel higher than the carrier frequency crystal. *Crystal B* is the lower-sideband suppression crystal and is two channels *below* the carrier frequency crystal.

The above-mentioned modifications will improve the sideband suppression of the W1JEO filter to approximately 40 db., as opposed to the 25 db. available on the unmodified filter.

Circuit Particulars

Certain requirements were outlined for the exciter shown in *Fig. 2*. These were: (1) band switching operation on at least two bands, (2) carrier reinsertion for working the unenlightened, (3) voice control, and, (4) enough output to drive most of the higher-powered final amplifier tubes without an additional amplifier stage.

Referring to *Fig. 2*, we will consider the schematic in logical order. The speech amplifier, *V1a* and *V1b*, is conventional, and has sufficient gain for a high impedance microphone. *V2a*, the mixer portion of *V2*, is conventional also and is pretty much as originally described by Edmunds. However, the carrier crystal oscillator, *V2b*, has been changed to a Pierce oscillator because it was found that the grid-plate type of oscillator used originally was very sluggish. By varying condenser *C9* the oscillating frequency of the carrier crystal may be moved a small amount so that it may be moved into the attenuation notch of the carrier rejection crystal of the filter (*Crystal D*).

Transmitter carrier insertion is accomplished by *V3*, which serves as a conventional amplifier with choke *L2* as plate load. Potentiometer *R15* controls the amount of carrier insertion.

The filter has been discussed previously. It was felt that sideband switching is not normally re-

quired, so only the one sideband filter is shown. You will note that the filter is set up for upper sideband generation. Normally the lower sideband is transmitted on both 75 meters and 40 meters. In order to come out with a lower sideband on the 4.0-Mc band, the VFO must operate *above* the 75-meter band in frequency by an amount equal to the filter carrier-frequency.

This will make our VFO tune the range of approximately 4.25 Mc. to 4.45 Mc. If 40-meter phone is contemplated it will be best to operate the unit in the manner just described. If the filter is set up for lower-sideband generation, and the VFO operated at 3.55 Mc., the second harmonic of the VFO will fall in the 7.0-Mc band. This signal when passed through *V5*, the second mixer used for 40-meter operation, would appear in the output as an undesired c-w signal. The double-tuned transformer, *L3* and *L6*, was used to further attenuate the harmonic output of the mixer and prevent the generation of spurious "birdies." Even if the second harmonic of the VFO is negligible as far as actual radiation is concerned, it would certainly be strong enough to block the local receiver even when not transmitting. It is generally the custom to leave all heterodyning oscillators run when in the stand-by position in order to insure better frequency stability. However, with the VFO at 4.4 Mc., the second-harmonic is at 8.8 Mc. and even the heterodyne-mixture of the fundamental 4.4-Mc voltage and the 3.3-Mc mixing voltage of *V5* will fall well outside the 7.0-Mc band at 7.7 Mc. You can see that this business of heterodyning signals here and there must not be taken too lightly. Always sit down with a pencil and paper and figure out all the possible combinations.

Coil Winding Data

(Fig. 2)

- L1, L2, L7—2.5 mh.
- L3, L6—45 turns, #28 formex on National XR-50 coil form
- L4, L5—3 turn link of insulated wire wound on cold end of L3 and L6
- L8—18 turns #18 formex wire on National XR-50 coil form
- L9—8 turns (insulated wire) wound on cold end of L8
- L10—4.0 mc: 30 turns, #18 on 1 1/2" dia. plug-in form
7.3 mc: 15 turns, #18 on 1 1/2" dia. form
- L11—4 turns, #18 wound on cold end of L10

The BC-457 Command transmitter lends itself nicely for VFO use. It is recommended that not over 150 volts regulated plate-supply be used. This will minimize the drift and will still provide plenty of v-f-o signal for the 4.0-Mc mixer stage.

For 4.0-Mc operation, the mixer stage employing *V5* is not used, as can be seen by the position of switch *S1* in Fig. 2. 40-meter operation makes necessary the changing of *S1*, as already indicated

- R1, R27—250,000 ohm, 1/2w.
- R2, R6—2,7000 ohm 1w.
- R3, R7, R12—47,000 ohms, 2w.
- R4, R11—100,000 ohms, 1/2w.
- R5—22,000 ohms, 2w.
- R8—500,000 ohm potentiometer
- R9, R17, R20—220 ohm, 1w.
- R10, R18, R19, R21, R22—22,000 ohms, 1w.
- R13—120,000 ohms, 1/2w.
- R14—1,000 ohms, 1w.
- R15—20,000 ohms potentiometer
- R16—220,000 ohms, 1/2w.
- R23, R24—100 ohms, 1w.
- R25—6000 ohms, 10w.
- C1—50 $\mu\text{mfd.}$, mica
- C2, C5, C10—1 $\mu\text{mfd.}$, 200v., metallized paper
- C3, C6, C11—0.1 $\mu\text{mfd.}$, 500v., metallized paper
- C4—1 $\mu\text{mfd.}$, 500v., metallized paper
- C7—500 $\mu\text{mfd.}$, mica
- C8, C16, C18, C19, C22, C24, C25, C26, C28, C29, C32, C33—0.1 $\mu\text{mfd.}$, 600v. disc ceramic
- C9—100 $\mu\text{mfd.}$ trimmer
- C12, C13—100 $\mu\text{mfd.}$, mica (matched)
- C14—3 to 30 $\mu\text{mfd.}$ compression trimmer
- C15—47 $\mu\text{mfd.}$, mica
- C17, C20—0.001 $\mu\text{mfd.}$, mica
- C21, C23—140 $\mu\text{mfd.}$ per section, dual section
- C27—120 $\mu\text{mfd.}$, silver mica
- C30—140 $\mu\text{mfd.}$, air variable
- C31—0.005 $\mu\text{mfd.}$, 600v., feed-through ceramic
- T1, T2—455-kc i-f interstage transformer, Meissner No. 165712
- S1a, S1b—d.p.d.t. ceramic wafer switch
- Xtal A, B, C, D—see Edmunds, Nov., 1950 QST
- Xtal 1, 2, 3, 4, 5, 6—see text

Parts List for Fig. 2.

and the changing of plug-in coil, *L10*, in the output stage, *V6*. The second mixer output circuit will be broad enough to cover the 100 kc. of the 40-meter phone band without re-peaking when QSY-ing. The 6SB7Y tube was chosen as the mixer because of its very high conversion-transconductance. This makes for a very "hot" mixer and a minimum of stages.

The choice of the 2E26 as output stage was brought about after hearing the complaints of many of the boys who have experienced trouble "taming down" the 6AG7. The excellent isolation provided by the 2E26 was a "natural." Also the fact that the 2E26 was capable of more output at higher plate voltages made it desirable for driving some of the larger tubes directly, without any additional amplification. The fewer amplifier stages you have to use, the less trouble you are going to have keeping the system linear—and linearity means a clean SSB signal.

One note on construction in the 2E26 stage. Keep the grid circuits below the chassis, and the plate tank coil and tuning condenser above the chassis. Use of the ceramic feed-thru condenser, *C31*, is recommended.

Alignment

After the filter is aligned per the original procedure and preceding suggestions, the following should be done: Using the Ham-shack communications receiver set up the VFO on approximately

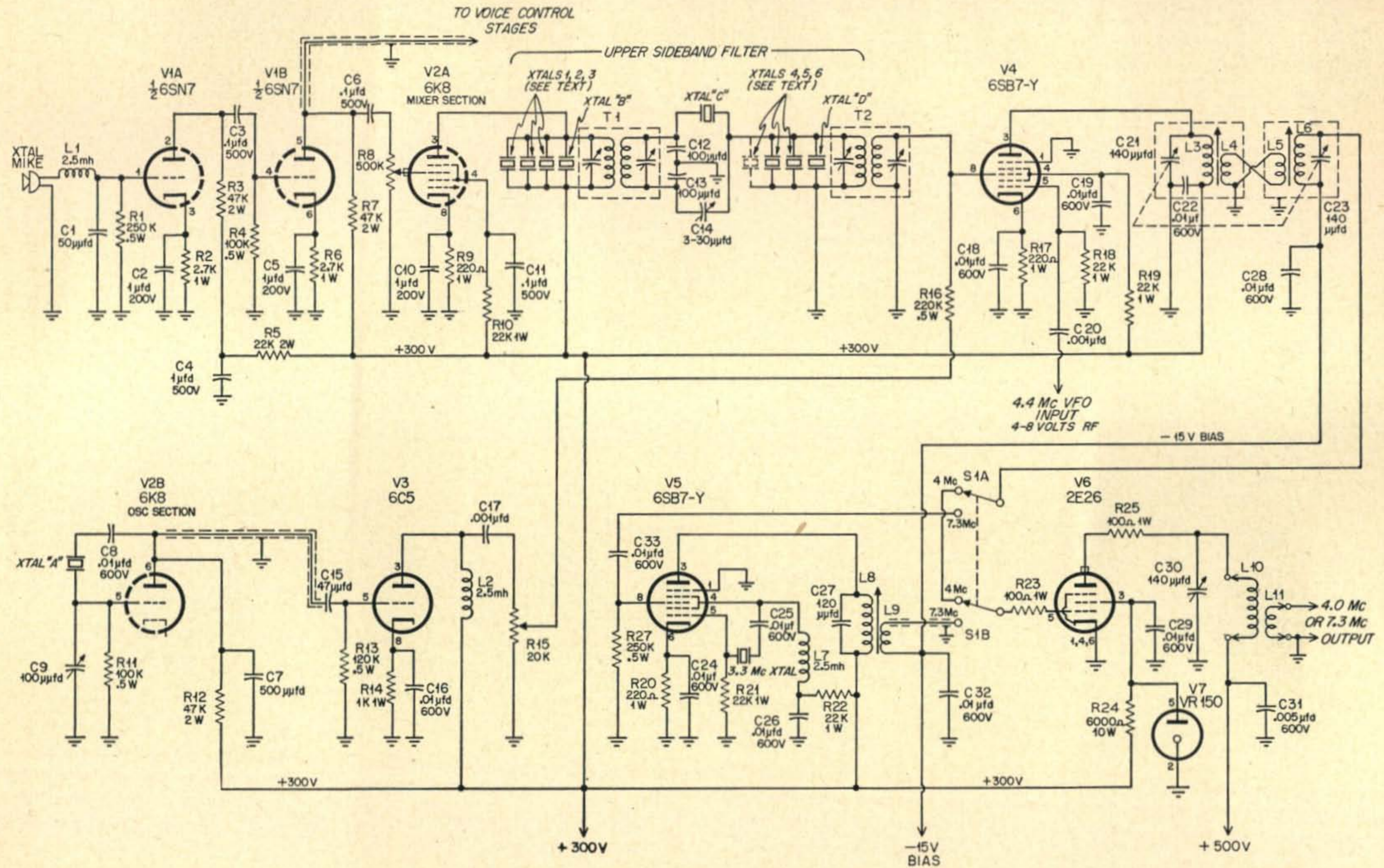

Fig. 2. This is the two-band crystal-type single-sideband exciter as modified by W2MTJ from the original design by WIJEO. The text describes how the modifications in the filter will improve the sideband suppression characteristics by about 15 db.

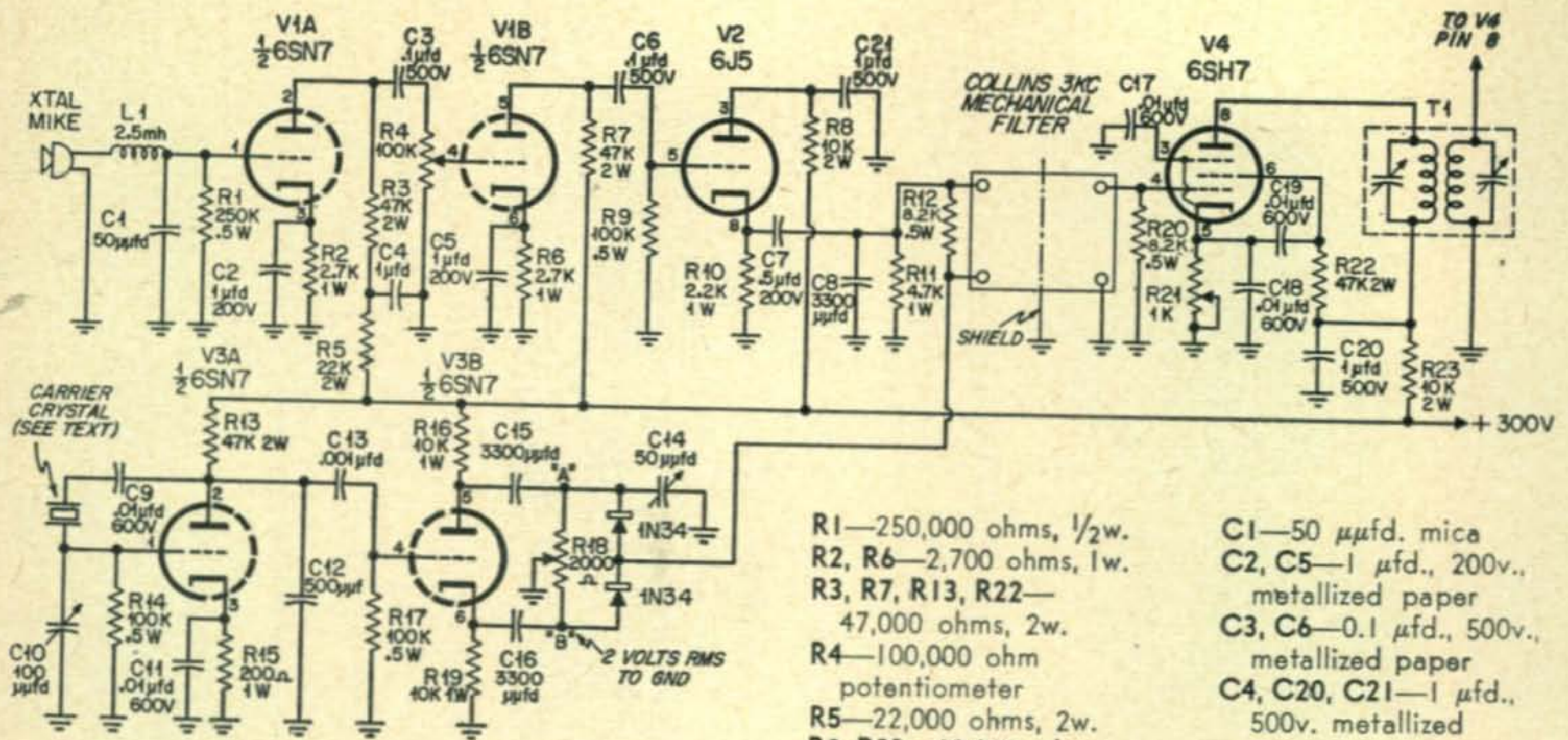

Fig. 3. The exciter shown in Fig. 2 may be adapted to use a COLLINS mechanical i-f filter if the constructor finds the appropriate crystals are not available.

- R1—250,000 ohms, 1/2w.
 R2, R6—2,700 ohms, 1w.
 R3, R7, R13, R22—47,000 ohms, 2w.
 R4—100,000 ohm potentiometer
 R5—22,000 ohms, 2w.
 R8, R23—10,000 ohms, 2w.
 R9, R14, R17—100,000 ohms, 1/2w.
 R10—2,200 ohms, 1w.
 R11—4,700 ohms, 1w.
 R12, R20—8,200 ohms, 1/2w.
 R15—200 ohms, 1w.
 R16, R19—10,000 ohms, 1w.
 R18—2,000 ohm carbon potentiometer
 R21—1,000 ohm potentiometer

- C1—50 µfd. mica
 C2, C5—1 µfd., 200v., metallized paper
 C3, C6—0.1 µfd., 500v., metallized paper
 C4, C20, C21—1 µfd., 500v. metallized paper
 C7—0.5 µfd. 200v. metallized paper
 C8, C15, C16—3,300 µfd., mica
 C9, C11, C17, C18, C19—0.01 µfd. 600v. disc
 C10—100 µfd. variable
 C12—500 µfd. mica
 C13—0.001 µfd. mica
 C14—50 µfd. variable
 L1—2.5 mh.
 T1—455-kc i-f transformer

4.45 Mc. Place *S1* in the 4.0-Mc position. Feed an audio tone into the microphone input, or insert carrier by advancing *R15*. Tune the receiver to the difference-frequency of the low-frequency carrier crystal (*Crystal A*) and the VFO. This should be in the neighborhood of 4.0 Mc. If you are unable to find the signal at this point, lightly couple an insulated wire from the receiver antenna post to the grid of the 2E26, *pin #5*. With the ganged condensers, *C21* and *C23*, set about two-thirds engaged, adjust the slugs of *L3* and *L6* for maximum signal as indicated on the receiver *S*-meter. Disconnect the receiver, use an output indication device (neon bulb or other r-f indicator), and tune the 2E26 plate tank circuit to resonance.

For 40-meter operation, change *S1* to the 7.0-Mc position and plug the 40-meter coil, *L10*, in the 2E26 output. First, tune the receiver to the frequency of the 3.3-Mc crystal to make sure it is oscillating. Then, tune the receiver to the sum-frequency of the 4.0-Mc SSB signal and the frequency of the 3.3-Mc crystal. This should be in the 7.3-Mc phone band. Adjust the slug of *L8* for maximum output signal; then again resonate the 2E26 output tank circuit by adjusting *C30*.

You should now be ready for operation. The unit described should give between 10 and 15 watts output "without a sweat." Properly loaded by an antenna or by a following amplifier, the 2E26 should be perfectly stable and free of regenerative tendencies. If such should not be the case, a swamping resistor should be placed across *L10* to discourage self-oscillation. The exact value of this resistor will depend on how bad a case of instability you are afflicted with. Start with a high value and gradually reduce it until the stage tames down. It is better to be conservative in this matter and over-swamp slightly than to suffer periodic seizures

of instability. Under normal operation the plate current of the 2E26 should kick upward slightly. No grid current should flow in this stage, however.

Using The Mechanical Filter

The author is well aware that at some future date the surplus low-frequency crystal market will probably "dry up." This being the case, I would like to show how the new Collins 3-kc mechanical filter may be used in an SSB exciter. Figure 3 shows the modifications necessary to transform the exciter just described to use the mechanical filter.

I cannot deal with the theory of operation of a mechanical filter, because of space limitations. Let's let it rest by saying that mechanical equivalents of high-Q electrical tuned circuits are used to select the desired frequencies and reject the undesired ones. It really works and works very well. Take a look at the characteristic in the current advertising by the Collins Company. Referring to Fig. 3, *V1a* and *V1b* are the conventional speech amplifier stages used previously. *V2* is a cathode-follower used to feed the carrier-cancelling balanced modulator composed of the two 1N34 diodes. The particular modulator circuit used is the series-diode modulator described by Berry.⁶ The crystal oscil-

6. Berry, "The Series Balanced Modulator," QST, Sept., 1952, p. 46.

(Continued on page 61)



H. P. BOHLANDER, W3VVS

for the

PHIL-MONT MOBILE RADIO CLUB

Five charter members met in December 1949 to organize the *Phil-Mont Mobile Radio Club*. The purpose in organizing a mobile club was to create interest in amateur mobile operations in the Philadelphia-Montgomery County (Pennsylvania) area. The three years which followed have seen the growth of an active mobile club, dedicated to public service, and numbering 35 active club members with approximately the same number of associated members. Many mobile Hams in "transient status" have attended the club meetings while in the Philadelphia area.

From the very beginning it became apparent that a common "net" frequency would be necessary, and since "surplus" crystals were available in quantity, a club frequency of 29.493 megacycles was chosen. In mobile net operations, it became evident that crystal switching for rapid QSY was necessary in order to handle traffic without hindering net operations. An alternate frequency of 29.626 megacycles was chosen. In this manner, net control can direct the mobile stations concerned to QSY and handle traffic directly without relay through the net control station.

Although the majority of club members operate 10-meter mobile, we have members who operate 160-, 75-, 20-, and 2-meters. Perhaps the reasons for the

majority of members operating on 10-meters is due to the availability of commercial converters at reasonable cost, and the possibility of DX as well as local contacts. Six meters, which should be a good bet for mobile operations, was passed up for lack of local interest and activity in that band. Two meter operation has been attempted by some, but the mobile-to-mobile operation is not too successful in the greater Philadelphia area. Mobile-to-fixed station operation is successful, however.

Communication in the 10-meter band for mobile operation in this area has proven to be quite successful, and reliable ground-wave communication can be had over distances of up to 30 miles. By seeking the "ideal" location, the distance of point-to-point communication can be increased.

When the 10-meter band opens, it is bound to have an adverse effect upon mobile net operations, however, the QSY feature of the mobile stations is an assist to the problem. When such measures fail, the mobiles move closer together so that readability is again restored in spite of the QRM from distant stations. Under such conditions of operation it may be necessary for a message to be relayed through several mobile stations.

In many of the activities in which communication plays a part, there is need for a small, portable unit

Interior of the Phil-Mont Communications trailer with W3QFY at the mike.

(All Photos by W3CTT)





Phil-Mont's entry for the World's Smallest Mobile.

which can be transported to locations not accessible by automobile. This problem was solved by W3JLE, who constructed a "walkie-talkie." Since batteries are the source of power for such equipment, a compromise must be reached between power output, size, and weight. The power input of this particular unit is 375 milliwatts; nevertheless, it provides a communication link which is reliable up to approximately three miles.

The services which the *Phil-Mont Mobile Radio Club* render are varied and interesting. Twice the club has been called upon to assist in the marshalling of the New Jersey State Firemen's Association Parade at Trenton, N. J. This parade each year has consisted of over 100 bands, together with fire trucks and various apparatus. Mobile units located at the main approaches to the city of Trenton contact the parade units as they arrive, report arrival of the unit to net control, and then direct the unit to its proper position in the line of march. Mobiles then are dispersed throughout the length of the parade to "pace" the parade and maintain liaison as the parade progresses. These parades often take four and one-half hours to pass the reviewing stand.

The Lansdale (Pa.) Mardi Gras during the Christmas Season is usually marshalled and "paced" by *Phil-Mont* mobiles, as is the Glenside (Pa.) Fourth of July Parade.

Although parades come in for their share of club activities, Civil-Defense is always utmost in the mind of those who participate, and such mobile net activities provide many problems which are met and solved, placing the mobile Ham in a better position to cope with a possible emergency or disaster.

In January of 1951, the members of the *Phil-Mont Mobile Radio Club* participated in a network telecast over a local TV station. This Civil Defense program was given approximately one and one-half minutes on the *Camel News Caravan* with John Cameron Swayze. Many Hams must have viewed the

program as the mail response proclaiming approval came from all parts of the country. Ten mobiles took part in the demonstration from various locations in the area, with net control being located near the studios. A telephone patch carried the audio to the studio. One mobile on location in South Philadelphia was surprised, after having reported into the net control his position, to find the neighborhood flocking to his car saying they had just heard him on television! (Via the network, of course.)

July of 1951 gave the mobile club members a chance to try out direction finding equipment, another interesting phase of mobile operation. The *Bartol Research Foundation* sent aloft a meteorological balloon equipped with scientific instruments to record data taken while in the upper atmosphere. The balloon was equipped with a small 72-Mc transmitter by which the balloon's course could be plotted. Mobile d-f equipment took many forms, from converted TV front-ends, to super-regenerative receivers. Folded dipoles were used as the receiving antennas. W3PMD acted as net control, and W3QV, also a fixed station, coordinated reports and maintained liaison via telephone with the *Bartol Research Foundation*.

The *Phil-Mont Mobile Radio Club* assisted the Civil Air Patrol during one of their recent drills in checking flight procedures. Twelve mobiles positioned themselves at airfields throughout the immediate Pennsylvania and New Jersey area to report to net control the arrival and departure of participating aircraft which were not radio equipped.

A communications survey was made of Civil Defense of Bucks County, Pa. The *Phil-Mont Mobile Radio Club* communications trailer was placed at C-D Headquarters and mobiles travelled the entire county to assist in the plotting of "dead" areas.

Picnics at nearby parks are a family affair and take place several times each year. Two events which also are family affairs, are the boat races and the model airplane meet. The Delaware Regatta is an annual affair with the *Phil-Mont* net control station, W3RQZ, being located near the starting line. Liaison is maintained with the U. S. Coast Guard, and if any of the mobiles spot floating debris along the race course, the Coast Guard quickly removes it. Mobiles are stationed along the river as far north as Trenton, N. J., ready to report accidents, or notify the finish line of the location of a disabled boat, so that a car and trailer can be sent to retrieve the boat and driver.

The jointly sponsored Navy-Plymouth Dealers Model Plane Show at the Naval Air Development Center, Johnsville, Pa., offers another opportunity for an all-day outing. Each mobile receives a map of the area divided into grids. The *Plymouth Dealers* provide trucks to retrieve the models. A Navy "K" ship circles the area and advises Navy-Radio when a model is caught in a thermal. Navy-Radio has an intercom to our net control station, W3RQZ, which previously has been located in an unused "tower" on top of the hangar. Our net control can also spot models leaving the area from this vantage point. Mobiles are vectored to areas near the field, and when the model lands and is in sight, a request is made by the mobile for a retriever truck to rendezvous at a given location. The truck is then dispatched by net control to the exact location of the model. Only two or three of the

many models participating in these meets were lost because of such operations, and these models were found and returned to the Navy several weeks later. One mobile chased a plane for four miles before realizing it was a Piper Cub!

The mobile Ham's home station allies itself with mobile activity in many cases. Several members have vertical antennas and fixed frequency receivers operating such as to "guard" the net frequency. The drooping ground plane antenna fed with 50-ohm coaxial cable seems to work the best, with a coaxial antenna fed with 70-ohm line being second. An "eight-ball" mount, less spring, placed in the roof of the house, with eight-foot lengths of No. 12 wire drooped to follow the slope of the roof, works very well. A variation of this antenna is that of placing the antenna on a mast and guying it from four directions, breaking the guys with insulators to form the ground radials.

Fixed-frequency receivers are basic, either crystal controlled, or conventional superheterodyne circuits. The receivers are purposely made "broad" so as to receive stations near the club frequency. Time clocks are also used in some installations to control the receivers. Several systems of squelch have been employed, all of which have been taken from recently published articles. Crystal-controlled low-power transmitters complete the setup. Any mobile needing assistance, or desiring a QSO can usually get an answer in this area.

A great deal of the local interest in mobile operation can be attributed to the 24-hour guard station which until recently was manned under the call of W3CLM at one of the local BC stations by licensed amateurs who were willing to assume secondary duties as monitors.

Hidden transmitter hunts are a semi-annual affair. D-f equipment has been improved to such an extent that the transmitter is usually found well within the two hour period. Equipment most commonly used consists of a co-ax loop and t-r-f stage coupled to the mobile converter, or a folded dipole. The latter is somewhat bulky and difficult to handle in traffic. An S-meter is an additional refinement.

Once each month a news letter called "The TVI Retreat" is mailed to all club members. This paper contains news of interest to all the members and

consists largely of news contributions from the members themselves. In conjunction with this effort, a Technical Data Sheet is issued periodically at club meetings. These data sheets usually contain information based upon our mobile experience and are primarily of interest to the mobile Ham. Such subjects as noise limiters, elimination of tire static, etc., are presented. A recent data sheet catalogued noise elimination data by make and model of automobile.

Early in 1951 the need for a trailer equipped for communications was seen, and the first step was taken when the wheels, springs, and front axle of a 1933 Chevrolet were obtained. Members donated channel steel, two tires, tubes, and construction was begun. W3QQH, W3AAG, W3PMD, W3QFY, W3KCG, W3VVS, and others assisted in the construction and painting.

The trailer was designed to provide an operating position and convenient overhead stowage for all accessories, cables, etc. Benches over the fender wells serve to seat personnel, and are boxed in to provide additional storage space.

The main transmitter, a 50-watt converted police rig, was installed on the operating shelf but was later moved to the floor at the front of the trailer. Two antenna systems are used for the 10-meter band. A drooping ground plane antenna is built into the roof of the trailer using a standard mobile mount, and ground radials within the trailer framework run from the base of the antenna mount to each corner, then bend down the cornerposts for the remainder of length.

Antenna connections, a-c mains, a-c emergency power, remote control, and telephone circuits terminate in waterproof junction boxes located at the forward corners of the trailer. A 500-watt a-c alternator driven by a four-cycle, one-cylinder gasoline engine supplies emergency power. A line-monitoring a-c meter can be switched to either a-c main or emergency power, and the transfer to either power source can be made by a manually operated change-over switch. The emergency supply can be started remotely from battery, or by hand.

If when operating on a-c mains, the power should fail, the lighting circuit drops out and a 6-volt

(Continued on page 68)

Some of the members gather outside the trailer at a recent CD exercise. Standing (l. to r.) W3CTT, W5NYA, W3QFY, W3VVS, W3GIF, W3UXP, W3AAG, W3QQH, W3NIP, W3UIX and W3HYU. Kneeling (l. to r.) W3EXY, W3IM, W3SGR, W3JGB, W3IW, W3FFP and W3PXY.



Amateur Teletype

As Reported by
WAYNE GREEN, W2NSD

1379 East 15th Street
Brooklyn 30, New York

I'm not really complaining, but since the announcement of the opening of the L-F bands for RTTY, it seems as if everyone was hearing about teletype for the first time. My poor old mailman has been having a time of it. I sure am glad that I got most of the dirty work done while there was less pressure and got just about all of the necessary information for understanding teletype in print in the past issues of this column. For your reference interest here is a recap of the semi-startling data has been set forth within these musty pages.

The first column, December 1951, went into tedious detail while trying to explain just how a teletype impulse is made up (the teletype code), and what basic pieces of equipment are needed for RTTY operation. The February 1952 column discussed tape equipment and gave a diagram of the model 12 printer, complete with an involved electron-by-electron account of how the darn thing worked. The April 1952 Column was no better, except that it featured info on the VT Keyer for the printer to quiet its operation, and a complete diagram of tape equipment interconnections. This issue also had a fine article by Bob Weitbrecht giving data on FSK'ing oscillators. Cleverly hidden among the pages of the June 1952 *CQ* was the usual column, containing info on FSK'ing an xtal oscillator, model 21A printers, and polar



W1BGW, Jack Berman, enthusiastically reading copy from W2NSD.

relays. The August column went back to brass tacks again and gave block diagrams of complete teletype systems and other basic data. It also discussed the various types of printers and the differences between them. September 1952 *CQ* had the W4OLL converter which many have since constructed. October 1952 saw RTTY on the front cover; the Collins FSK oscillator and shack photos inside. The December column featured the W6AEE converter, easily one of the simplest to appear in print. January 1953 and we are back on the cover again, that lovely picture. Inside is all sorts of data, but that was only a few months ago, so you should still remember all that.

Since there are universal reports of an outstanding increase in interest in RTTY I suppose it would not be considered off base to devote some space to the fanning of this flame. What can I say that I haven't already said? Not much, I guess, so, if for some reason you don't meticulously recall the past Teletype columns, you might thumb back over the array of trivia and see what encouragement you can find. Certainly some of the tremendous enthusiasm that the active teletypers have must have seeped into the column somewhere. And I notice, in looking over the mail, that just about all of the early settlers on the TT channels are still there and are having more fun than anybody.

These stations may be heard on FSK RTTY

W1BGW	K2WTW	W4VMS	W6FLW	W9THE
W2NSD	W3PYW	W6AEE	W6CAP	W0BP
W2PAT	W3PKF	W6CMQ	W7VS	W0UVL
W2PAU	W3LMC	W6RZL	W7LU	W0LHS
W2JAV	W3ODF	W6OWP	W8RMH	W0HKE
W2PXR	W3ERS	W6ITH	W8DLT	W0UYL
W2MYL	W4FJ	W6MSG	W9TCJ	VE2AKT
K2WAN	W4OLL	W6SCQ	W9ZBK	VE3AXX
	W4SQF	W6IZJ	W9UAU	

Calling All Equipment

Teletype equipment is in short supply, as you might well imagine. If you have any such equipment lying around that you don't figure to use why not drop me a line and describe it. I can then forward the information to whoever needs the equipment and who is fairly near to you.

FSK'ing Your Oscillator

This circuit, Fig. 1, sent in by W6ITH, might be called a crystal-crystal FSK circuit in that it uses a small crystal diode to vary the capacity across the quartz crystal, thus shifting its frequency. This circuit has certain disadvantages, thereby limiting its usefulness. The germanium diode won't stand heat and can't be used in a xtal oven if such thing is used. If the oven is not used trouble may be encountered with excessive drift—excessive for RTTY anyway. Then, too, few 80-meter xtals will give enough shift on the fundamental for the full 850 cycles so that it is generally necessary to use 160-meter xtals for 3.6-Mc operation. Most 40-meter xtals give no difficulty in this matter. Then there is the problem of variable output. Often the xtal will have much less output on one frequency than the other and it will be necessary to have an overdriven stage to even out this variation.

Even with these limitations the circuit is indeed handy and can be installed in a few minutes in most xtal oscillators.

MISC. FSK, TSK TSK

There are innumerable (almost) methods for achieving FSK, many of which can be used with your existing oscillator. Before plunging into such a conversion it would be considerate of the fellows who are going to try to decypher your signals if you would make sure that your oscillator is satisfactorily stable. It is quite a feat to keep from drifting the few cycles necessary to louse up RTTY reception. Please consider this a formal request for information as to how you managed to make your oscillator stable.

Slight digression: The W2NSD method of oscillator drift cure. Millen Vari-Arm division. Starting confidently

with the assumption that there would be little drift of the VFO, providing that it was at a steady temperature and had unchanging voltages applied to all tube elements, it was only (only!) necessary to achieve this delicate condition to prove or disprove the assumption. The temperature problem was the easiest to solve: turn on the VFO an hour before using. There are probably many other ways to handle this problem, but I was in my usual hurry and thought less of future time squandered on waiting for the thing to warm up than of present time spent in building an oven or some such contraption. Voltage stabilization I handled the same way: brute force, no finesse. I hooked in an outboard VR-150 to keep the oscillator plate voltage semi-put, but the thing still drifted northeast about 200 cycles when I threw the transmitter on the air. Aha! The filament voltage. Sure enough, there was about five volts change in the line voltage whenever I turned on the 4000-T's. Solution: small relay and auto-transformer to increase the line voltage five volts to the VFO when the transmitter high voltage is turned on. The same voltage is good medicine for the receiver and frequency meter. The result of all this effort is a pretty stable VFO. Listen for it on 3620 kc and see for yourself.

Another FSK method that has been used successfully is even simpler than most of the previously diagrammed methods: keying a change in voltage on one of the elements of the oscillator tube. This is for use with VFO's, of course, and presupposes mastery of the stability problem, which can be conquered, but seldom is. If your oscillator tube is a pentode, you can put a small potentiometer in series with the screen resistor, and have the polar relay short out the potentiometer for the mark pulses. The potentiometer can be adjusted for 850 cycles shift, and will probably give this range, if it is about 5000 ohms.

W2PAU found that, though his VFO was very stable under normal operating conditions, it afforded the full 850 cycles shift on 80 meters when the plate voltage was changed from 50 to 200 volts. Thus, with the expenditure of a small pot in the oscillator B plus lead and a pair of wires going to the teletype transmitting distributor (or polar relay), FSK was accomplished. And the frequency went lower on space, as it should . . .

W4OLL Crystal Stretcher FSK Oscillator

This circuit was diagrammed in part in the June 1952 CQ, page 49, and rather complete instructions were given there for tuning it up. The FSK diode is added in this diagram so that you won't even have to experiment with the values of condensers and chokes. The crystal affords stability, L1 allows the base frequency to be shifted as much as 3 kc. at 2 Mc. When the oscillator has been adjusted according to the instructions in the June CQ, you can set the "mark" condenser for the channel desired, and adjust the "space" condenser for 850 cycles shift. Says W4OLL: "I find that the shift stays put and doesn't drift once it is set up."

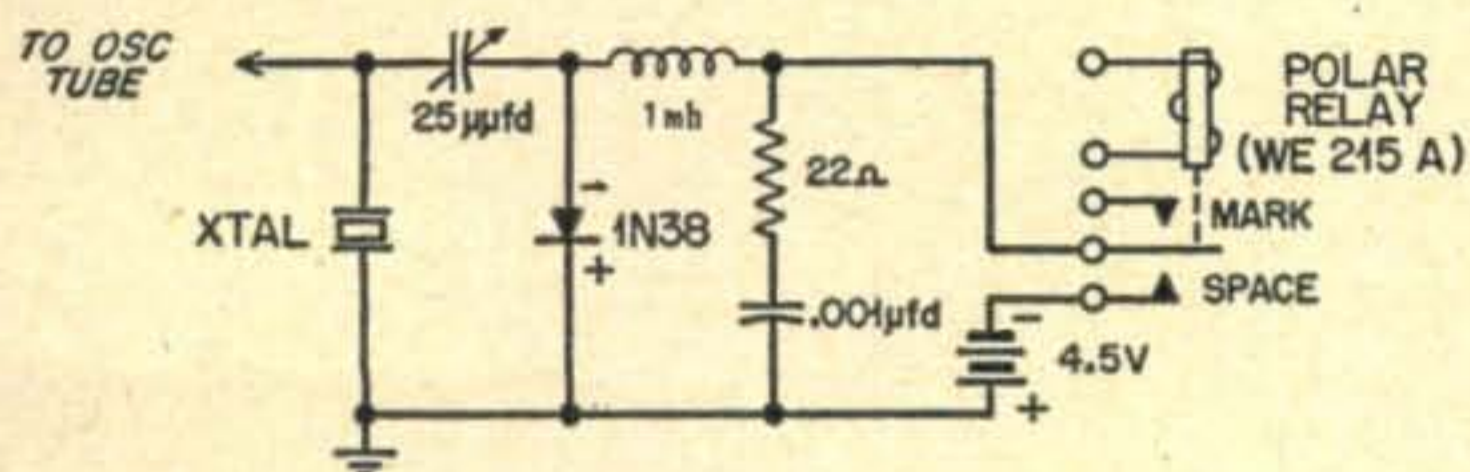

Fig. 1. W6ITH's crystal-crystal f-s-k circuit.

Use "Space" for Identification

Since a great number of the TT stations have built-in auto-start circuits which turn on the printer when a mark signal is received and turn it off on the space signal, there have been many requests that one more "standard" be set up for FSK operation. When using straight CW emission for purposes of identification, as prescribed by the FCC, send on the space frequency; thus you will not be starting printers willy-nilly and causing misprinting with every thump of the key. If the printer has not been shut down the space pulses will at least keep it quiet.

Let's See, Is Space High or Low?

Somehow there is still some confusion about whether to send the space pulses higher or lower than the mark pulses in FSK. The August '52 Teletype column, page 29, went into exasperating detail on this subject and explained, complete with a chart, why the space signal is sent lower than the mark. LOWER-LOWER-LOWER.

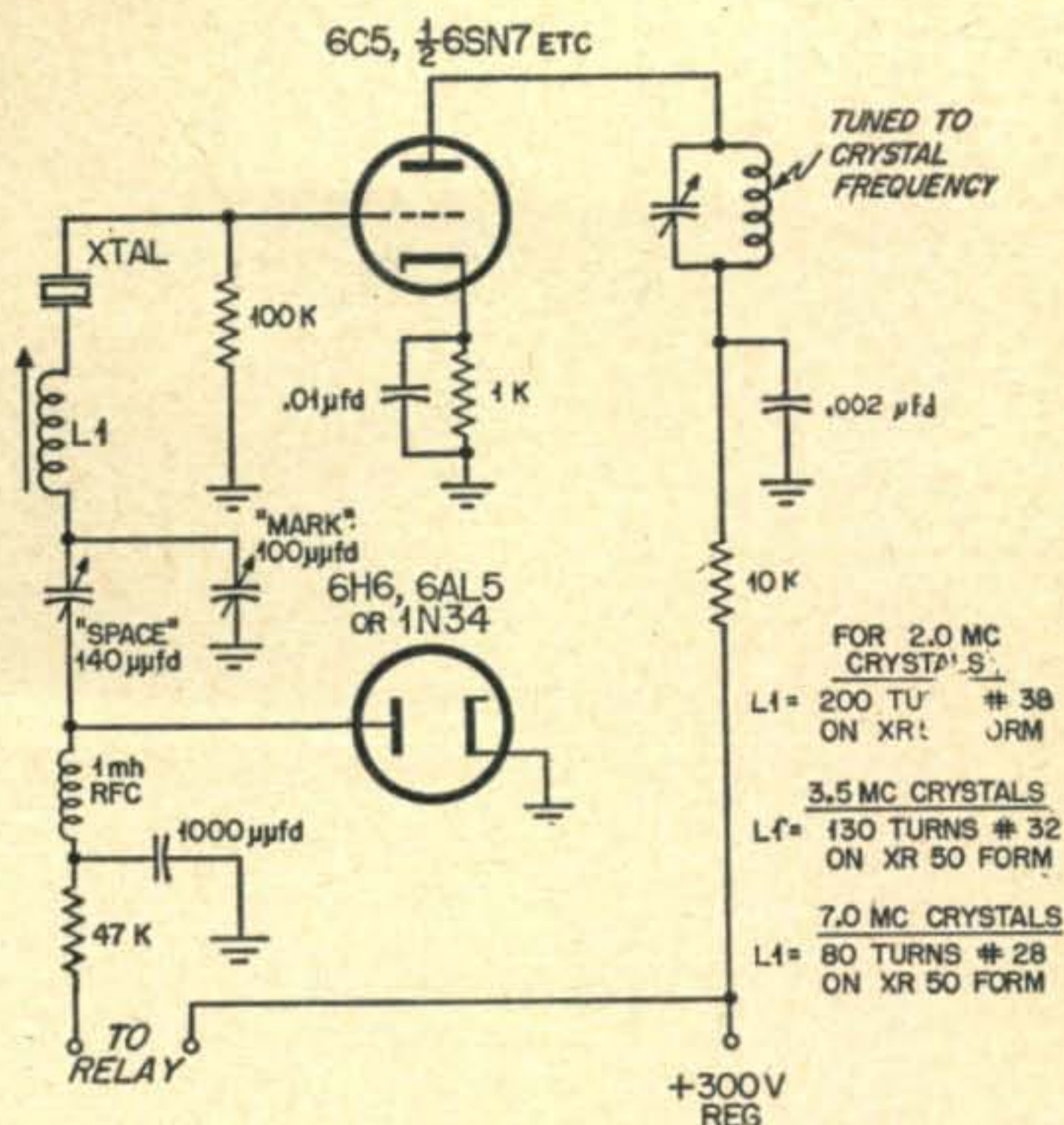

Fig. 2. The W4OLL crystal stretcher circuit.

Space — lower, got that? Naturally, there is puzzlement on this point since with AFSK it is the opposite and most of the present FSK'ers are graduates of the VHF school of space-high. You might say: LS/MFT. Low Space Makes Fine Teletype.

A Letter from WOBP

"Amateur radio teletypists, as an active minority, are to be congratulated on their victory. The FCC states, 'comments were filed by some 266 individuals, amateur radio clubs and other organizations,' and that 'a large majority were in favor of adoption of the proposed amendments.' A bare majority would be 134. But Docket 10073 concerned a number of non-related, very heated questions on radically new ideas, such as: (1) 40-meter phone, (2) new identification rules, (3) novice operation not only in a new band but the first band of world-wide range, (4) F-1, frequency shift keying, new to amateur radio also, and (5) teleprinter standards. Probably many letters had axes to grind on only one or two of these five points. In the absence of a difficult tabulation of all letters, one might guess there were 60 letters in favor of F-1, 50 were in favor of amateur teletype with gripes against 'the severity of technical requirements,' and perhaps 10 were against the 'jingle bells' in any band so thusly you achieve the 'large majority' the FCC relies upon. If you have ever been a lobbyist or have tabulated responses to appeals to 'write your Congressman' you know that 50 out of a possible 500, or 10%, is phenomenally high. Had 10% of the hundred thousand American amateurs responded to these issues which affected most of them, the FCC would have been deluged with 10,000 letters instead of 266! To those who gripe now in true democratic fashion and who did nothing when they had the chance, I dedicate my suburban farm 'Belly Acres.'

Beyond the fine technical articles that have appeared on the subject of amateur radio teletype from time to time, RTTY Hams should bow to the east and thank the following four persons: (1) John Williams, W2BFD, 'granddaddy of the TT'ers' and procurer of equipment; (2) Wayne Green, W2NSD, who made personal sacrifices of time and money for the 'Teletype Bulletins,' as well as his fluent writings in CQ; (3) Perry Ferrell, Managing Editor of CQ for his vision and championing the cause of the underdog before his thousands of readers; and (4) Bob Weitbrecht, W6NRM, now W9TCJ, who (either like gallant Lochinvar from out of the West, or Oliver Twist who called for more) had the audacity to instigate Docket 10073 by suggesting amateur frequency shift teletype on all CW frequencies, which idea many of us got behind and pushed to a very successful conclusion after we were shown the light.

"Radio amateurs, particularly the newer ones, are inclined to regard their hobby like that of model airplanes. True, it has the same room for individual genius craftsmanship, basement reclusion or more extrovert contests. But on full scale both are subject to national

and international regulations. Our main difference is that we have very valuable rights which deny commercial interests from using what we hold. The commercial value of a hundred kilocycles inside any amateur band is worth as much as the next hundred kc. outside, but it is wondered if amateurs ever evaluated this. Perhaps it was the January 1926 FRC conference when RCA made the statement that each short wave frequency was worth a million dollars. We (QST) questioned this afterward and the answer was, in effect, 'A high speed transoceanic station should earn the annual interest on that sum!' Get the idea? Giving the ARRL due credit for a valiant fight, a few thousand Hams could not hold the frequencies 7000-8000 or 14000-16000 kc. after 1928. The question of occupancy is important. Assuming technical advancements permit assignments every 2 kc., like devalued dimes in a rack, then, by 1926 values, amateur teletype has just received frequencies commercially worth \$373,000,000.00! Fantastic? Any Hams want to solicit funds to purchase a single channel next to our 80-40-20 meter bands from the vested interests? But our present interest is to show occupancy, and Hams were especially vulnerable on part of 40 meters before now. The grants for F-1 seem very generous in view of the probable immediate use, but future use will determine the ability to have and to hold, so, "Start 'em Printin'."

"Technically our equipment at this point is far from perfection. True, fairly decent copy may be made from beamed commercials of many kilowatts and no interference, but Ham radio is something else. We must be versatile to cover many frequencies, quickly and with stability never required before. Our ears ignore interference that operates our relays. So we sharpen our filters, radio and audio, down to so few cycles that we get ringing, or tuning becomes a nightmare and drifting transmitters are definitely out. We should be able to

RTTY Calling Frequencies

"Mark" Channels

3620 kc.

7140 kc.

14,340 kc.

Send "Space" low

utilize a.v.c on F-1 to easily combat fading, but many of our receivers cut this out when the b.f.o. is switched on, or it feeds into the front end of the i.f. to bat down the sensitivity, or the beat note changes with strength. In our transmitters we try many crystals and find many that will not shift enough on 80 meters and the power varies from mark to space. The v.f.o. meets this objection, but in terms of absolute cycles drift it leaves much to be desired on 80, let alone 40 and 20, so we go back to crystals on 40 and 20, adding a stage so overdrive will even up excitation variations. Preliminary tests between WØHZR and WØBP produced unacceptable results both ways, so both stations rebuilt both transmitters and receivers! Serious consideration is being given to sawing the Model 12 in half and making the printer portion work from an on-the-air monitor receiver, but out of respect for old age and lack of time this has not been done yet. Parts are being assembled for a crystal controlled high frequency converter to work into a tunable low frequency selective receiver. In the end RTTY (like love) will find a way. Standing up in a hammock is very unstable! Gotta find the best way.

Operating Hints And Suggestions

"Put a beat frequency knob on the receiver that means something. Start with a sanded scrap piece of aluminum under a large bar knob. Re-learn what you have forgotten about CW reception, that is, where zero beat really is and how the b.f.o. produces tones of equal volume each side of this spot. Then, by WWV, also mark 440 and 600 cycles each side of zero and, if you are any judge of musical harmonics and distance, make pencil marks at 880, 1200, 1320, 1760, 1800, 2200, 2400, 2640, 3000, etc. By this means, or better audio standards if you

have them available, place an ink mark at the mark frequency of 2125 cycles and the space frequency of 2975 cycles on each side of the zero. Better not engrave or stamp the panel until you are sure which side of zero you want and if you like the position and bandspread. But it is certain that once you get the hang of tuning in a station to zero beat by the tuning knob and then swinging the b-f-o bar knob from zero to 2125, which still keeps the station tuned to resonance, you will be quickly sold on this rapid audio standard which is good for any band. By way of further CW refresher, the wrong way is to disregard the b-f-o knob and tune the receiver to produce the desired tones. Recollect that the commercials may take days or months setting up a communication circuit, but you want to do it in seconds. The calibrated b-f-o knob is a valuable and cheap gimmick to make this possible.

"Little glory goes with trying to force copy on the wrong frequency at the wrong time of day for that season and distance.

"Be judicious in cluttering the bands with "RY" or taped general calls. Years ago phonograph records were outlawed for similar abuses. Conversely, do not idle on mark or space lest you get a ticket for illegal AØ. Sometimes a phone Ham stops for a breath and teletypists should be allowed similar intervals of AØ, but not much longer.

"Fortunately the originally proposed Morse identification every 30 seconds did not survive the violent opposition. The present rules call for such identification every ten minutes during communication and at the start and finish of every transmission of three minutes or less. Since neither the mark nor the space frequency were specified for the A-1 Morse identification either can be keyed. It is therefore proposed that the lower, or space, frequency be keyed for this A-1 identification because with slight mechanical or electrical bias of the teletype receiving relay toward the space side there should be little misprinting, spoiling of copy, or waste of paper as the relay would only be pushed harder against the contact by the keying. Originally a diabolical impulse suggested the typed letters 'QFCC' or 'ZFCC' to mean, 'The misprints you are about to receive are due to International Morse Code identification sent in compliance with FCC regulation 12.82(a)(2). Shut off your printer!' But out of deference to elimination of the 30 second rule this is not suggested. The double standard of requiring two types of emission every three or ten minutes is still a damnable nuisance not required of any other type of service.

"A code wheel with the station call letters transmitted periodically is not sufficient to comply with 12.82(a)(2), as identification must also include the call sign of the station called or communicated with.

"To sum up, we have received valuable frequencies which present a challenge. Our equipment and technique must deviate from commercial standards especially to combat interference from stations separated only a few feet or cycles. Selectivity, flexibility, and stability are not brothers. It looks like the field can surely use adroit amateurs and aspirin."

Boyd "BeeP" Phelps-WØBP—

The 3 AM Opening

February 20th, probably saw more Hams awake in the early morning hours than ever before in history, including the SS Contests. It was a four way band opening, what with the new 40 meter phone band, the general class availability of 20 and 75, the new 40 meter Novice band, and RTTY. I, too, was there. After knocking off a couple of local quickies on 40 phone I went down to 3620 and worked W9TCJ, Bob Weitbrecht, on RTTY. The contact was perfect, solid copy both ways, and we were both pretty excited about it. W4OLL was on there, too, but was too close for either of us to get good copy. I heard Bob work W4OLL, W2PAU, and just before I went to bed at 5 a.m., W2JAV. The next evening I had about five minutes before dinner was ready and I had a quick but solid QSO with W4OLL. Looks like we are going to be doing fine on the low frequencies.

Even these short bouts with the low frequencies clearly demonstrated to me the advisability of following the instructions in WØBP's letter about the b.f.o. knob. Also I intend to install the W9TCJ receiver remote tuner (April 1952 CQ) and a pair of 6E5's to indicate the mark and space voltages (RTTY Bulletin #20). I already have my hand key mounted on the side of the printer so that it is not necessary to move to send the hated A-1 identification. Actually, the CW has been helpful to me for the identification of weak and fading signals, but I expect that a reduction of the noise generated by the printer would remove this problem.



Monitored by LOUISA B. SANDO, W5RZJ

959-C 24th Street, Los Alamos, New Mexico

Remember the letter from the OM in Indiana that we published in the February *CQ*? Here's the response of one W1 YL:

"Say, what is this, a joke? Does that OM from Indiana actually exist? Is he kidding? You must be literally swamped with replies! Frankly, in these 48 States of ours, I can't believe there is an unattached farmer of 30 with an interest in Ham radio. If so, 'guess I need a new receiver—I don't hear 'em!' "

Indeed he does exist—and he's answering all mail. "Don't know what I'll get into," he tells us, "but I can hope anyway—hi!" Any more letters for Bill? We'll be glad to forward them.

As to the Ham in Ohio, whose letter appeared in the December *CQ*, his situation apparently has changed for the better for he writes, "I'm going steady with further plans not too far off. She didn't know anything about Ham radio when we met but she's taking 8 WPM now." That's the way to do it, Jack—radio license before the marriage license—hi!

Needed, Sunshine Shower

A card from W8FSM informed us that W8NAL has been hospitalized for the past year and a half. A note to Carmella brought this quick response: "I have been a patient here since Jan. 22, 1951, and I am most grateful to God for the way I have regained my strength and good health. Although I have come a long way, my stay here is not over, nor do I know what the future holds for me. I don't know if Frank explained my condition. I had contracted tuberculosis and my doctor missed it in checking my X-ray during my 6-month check-up, resulting in allowing it to gain a good start before my next X-ray showed it up. I really had a battle on my hands, lost weight and weighed 115 lbs. when I entered the hospital. I now weigh 180 lbs. so you can see I have come a long way even though I am not completely recovered. This week they started treatment on me in preparation for surgery. I expect to undergo surgery very soon as it will shorten my stay here. It gets so tiresome staying in bed day after day.

"I would like very much to hear from the gang, but please advise them I may not be able to answer their letters. You may inform the YLs that I spend my time flat on my back—'bed-rest' they call it—and writing while lying on your back is very tiring. I shall answer all mail after my surgery if everything works out as planned. Sure would like to hear from the Cleveland AARS gang. I last heard of them two years ago when I had a small Navy surplus converted job on the air.

"Regarding my rig—no, I do not have it here as they do not allow radio of any kind, with one exception; They have their own radio receiving system here that we may listen to with phones (not much good at its best). Wouldn't it be something to have a 10-meter CW rig here? I may try and have them grant me permission to operate one after my surgery—it would surely be great for a morale booster.



W3NNS and W3QZ tie the wedding knot with the help of W3QPQ (left) and W3PWQ (right).

"Thanks again for your QSL—it is the first I have heard from a Ham while here."

How about it gang? (We won't say YLs for we hope some of the OMs will drop her a card, too.) You may address her: Carmella Cicerello, W8NAL, Molly Stark Hospital, Canton 1, Ohio.

God speed, Carmella—may you soon be back at your rig again.

Ham Wedding

Last month we had the opportunity to congratulate W3NNS and W3QZ on their marriage. Now here are more of the details. The event took place on Dec. 6th, and, as you can see from the picture, it was an all-Ham affair. W3QPQ, Jeanette, is Anabel's sister. Anabel's wedding presents were a diamond and a beautiful rhombic antenna. She will soon be operating phone and CW on all bands from their QTH at Forty Fort, Pa. W3QZ has his own kilowatt rig at his office, and has built his wife a beautiful console set in two windows with a gorgeous view across the valley. This sounds like an FB set-up, and we can see where W3NNS will spend many happy hours.

Last month we congratulated W1FTJ on receiving WAS/YL certificate No. 2. We should have added that Dot was the first YL to win the award—W2QHH, Howy, made certificate No. 1. We asked Dot for her list of YL QSL's, and here they are, by state:

Ala.	W4HWR	Maine	W1MCW	Okla.	W5IKC
Ariz.	W700H	Mass.	W1ZR	Ore.	W7LKG
Ark.	W5LVT	Mich.	W8WUT	Pa.	W3FXZ
Calif.	W6NAZ	Minn.	W0JMI	R.I.	W1HUH
Colo.	W0EVT	Miss.	W5ROB	S.C.	W4GUZ
Conn.	W1KUI	Mo.	W9OWQ	S.D.	W0ZWL
Del.	W3KOG	Mont.	W7FTX	Tenn.	W4LVM
Fla.	W4PPQ	Md./D.C.	W3CDQ	Tex.	W5IZL
Ga.	W4NMS	N.H.	W1MUW	Utah	WN7RRM
Idaho	W7MUT	N.J.	W2FKA	Va.	W4CWV
Ill.	W9CHD	N.Y.	W2NAZ	(W3JTQ at mike)	
Ind.	W9JTX	Nebr.	W0SHF	Vt.	W1MVX
Iowa	W0NXW	Nev.	W7QJH	Wash.	W7JWC
Kans.	W0AGA	N.M.	W5DRA	W. Va.	W8EVR
Ky.	W9ZTU	N.C.	W4SGD	Wis.	W9AYX
La.	W5MZI	N.D.	W9NBX	Wyo.	W7HDS
		Ohio	W8SJF		



W8EVR, Bera Furbee, YL of the Month.

With all the interest in YL/CC, we also asked Dot how many YL's she has worked altogether, and the answer (in early February—she's probably worked more by now!) is 226 different YLs! That is, she has QSLs from 226 different YLs—she has worked 28 additional YL's from whom she's waiting to receive QSL cards. Can any one beat this record?

W1HHH, Bea, says she has QSLs from at least 185 YL's, and we know several of the OM's are going after the YL/CC. If you are interested in this award, check this column in the March issue for rules. Send your cards to YL/CC Custodian, Dot Dickey, W7GLK, 615 Siskiyou Blvd., Ashland, Oregon. Dot, by the way, has had her ticket since 1938. She is Advanced Class and works 160 through 10. She has an ARRL CPA for 30 wpm and has been NC for the 80-meter YL net. Her OM is W7FRO.

Also from Bea we learn that she has made her 44th state toward WAS/YL. She still needs Nevada, Colorado, Rhode Island and Delaware. "I have found several names of YL ops in all these states but Delaware. Is there a law against YL ops in Delaware? Hi! There used to be one there and I missed her by about 10 minutes one day. When I wrote her a short time later, she'd moved." Can anyone help Bea?

New call for Maxine, ex-W0CCK, is W5YRT. "Ain't it erful!" says Maxine—but she's already giving it a workout on 75 phone. W5YRT is the second YL in Tyler, Texas—also the second Maxine; the other one is W5VSN. . . . From W0RAW, Bertha, a nice note from their portable 5 location at Port Lavaca, Tex. Bertha says she and her OM, W0FXW, have been to California several times, "but we like it better here." Hi! They are right on the coast and plan to spend the summer there. They operate 75 phone mostly, and hope to get on 40. . . . W9QYG, Verona, and OM, Vern, W9QXZ, are now operating portable 5 from Albuquerque, N.M., where they are staying temporarily for their daughter's health. They are on 160 and 10 phone with a VIKING II and also on 40 and 80 CW.

The Ladies Amateur Radio Klub of Chicago, has an-

nounced it will issue a certificate of achievement to any amateur who works ten members of LARK. The members may be worked on all bands. Send members' call, and date and frequency of each QSO to W9MYC, Gladys Jones, 4232 Hampton Ave., Western Springs, Ill., for your certificate. Starting in February the LARK changed their weekly 10-meter net to Wednesday, at 1400 CST, except the first week of each month. In order to accommodate the members who work, that week's net will remain at the old time of 2200 CST on Tuesday. . . . A reminder of the spring luncheon meeting of the New England YL's which is to be held on Saturday, April 11 at 1 p.m. Place: The Smith House, 500 Memorial Drive, Cambridge, Mass. Anyone wishing transportation from downtown Boston should contact W1UPZ, Helen, who is chairman of the affair. She also will supply any further details you may wish. Tickets are \$2.10 each for the luncheon. . . . The W9 district YL's second annual convention is to be held in May in Mishawaka, Ind. Details in the next issue, but anyone wishing further information at this time can contact W9LRT, Julie, who is this year's chairman.

YLRL

A query from W0MJK on how to join the YLRL reminds us that it is time to repeat this information for newcomers to the game, or any other YLs interested. YLRL is the Young Ladies Radio League, an international club of YL operators. YLRL publishes a bi-monthly news bulletin, YL HARMONICS, and sponsors various operating contests and YL nets. Dues are \$1 a year (75c. if you join now for the remainder of 1953) and cover the cost of HARMONICS, mailing, contest trophies, etc. Any licensed YL operator is eligible and invited to join YLRL. You may write to this column editor for application cards, or directly to YLRL Secretary Peg Wells, W1BCU, Woodland Rd., Foxboro, Mass. . . . While we're on the subject, those of you who already are members of YLRL, don't forget that 1953 membership fees became due on January 1st. If you haven't already done so, get yours in the mail now.

YL of the Month

Rather few and far between are the YL's in the State of West Virginia, so this description of the setup at W8EVR may be of some help to you who are working toward WAS/YL. W8EVR is Bera Furbee of Belle, W. Va., and she has been on the air since the Fall of '49. It was in October that she flew to Washington, D. C., and got her ticket, and three days after getting on the air, worked W2QHH, Howy, to complete his WAS/YL—the first one issued. She also supplied W1FTJ's W. Va. contact for WAS/YL No. 2.

Bera tells of a couple of other YLs now on the air in West Virginia, so you can be looking for them, too: W8HLF, Arlie Hager, XYL of W8VPO, works 40 CW. Then there is WN8IES, Pauline, whose QTH is Weston, W. Va.

It all started for Bera, when her OM became enthusiastic about Hamming and she promised to help him learn code, though the whole business was "pure Greek" to her. They both joined the Charleston Amateur Radio Club and almost immediately the OM's started urging Bera to try for a ticket since there was then no licensed YL operating in the State. Six months later she got it—but it was another year before her OM went on the air as W8GEC.

W8EVR started out on 40 CW. Made WAS in seven months, RCC in three months, joined MARS in Dec. '50, and got her Class A in '51. Now she works mostly phone, being active in the W. Va. phone net on 75 meters and the general coverage CD net also on 75, and in MARS on 4025 and 4085 kc.

Bera says she is too busy, however, to spend much time operating these days—and here's why: She is an assistant director of the Roanoke Division, PAM for the W. Va. section of the Roanoke Division, and secretary-treasurer of the Charleston Amateur Radio Club.

And of course, she has other hobbies as well, having raised and shown dogs for about 18 years, during which she finished about 25 champions. Breeds include smooth fox terriers, English springer spaniels, and cocker spaniels, though now she has only cockers. She also raises fish and African violets, and writes tall tales for a hunting and fishing association.

The setup at W8EVR consists of a 32V2 and an NC183 with an R9'er. She has a beam for 10 meters and half-wave dipoles for 20, 40 and 80. Incidentally, if you work Bera or her OM, Ben, you'll receive an FB QSL card showing them as "just a couple of genuine W. Va. hill billies!"

33—till next month, W5RZJ

Here is the "modulation oscilloscope" sitting atop a neat looking transmitter at W6VRR. (Photo by W6RDR)



"What's the percentage?"

WILLIAM I. ORR, W6SAI

Contributing Editor, CQ

In conjunction with the anticipated publication of several 'phone transmitters, the staff feel that the description of a device to measure percentage of modulation is definitely called for. This easily constructed instrument can do the job with a minimum of extra components, and best of all, it does not need a high voltage power supply; it 'steals' it from the transmitter—Editor.

A famous philosopher once remarked that an over-modulation indicator would never become a popular piece of amateur equipment, unless it was designed to work in conjunction with a *receiver* instead of with a *transmitter*!! Use of a good over-modulation indicating device should be mandatory in many phone stations, but until such time as a receiver-operated over-modulation suppressor should become readily available, the following equipment design is offered to the readers of CQ.

A Simple 'Scope

The most painless way of observing the behavior of a phone transmitter is through the use of a 'scope coupled directly to the transmitter. So-called "on the air" checks, during which you ask Joe, "How's my modulation?" are practically useless. Unless Joe is plenty smart, knows his receiver, and knows just how to examine your signal, he will tell you that you "sound just fine, OM." (Even though you may be 100 kilocycles broad!) No sir;

your best friend is your own judgment when you can answer "How's my modulation?" by having your own inexpensive oscilloscope modulation checker.

Preliminary Design

The appearance of the 5BP1 'scope tube on the surplus market for a few dollars makes the cost of building an oscilloscope very modest, indeed. The 'scope to be described uses just such a tube, and the instrument may be employed with any phone transmitter using plate modulation and an operating potential of 1000 volts or more on the modulated stage.

The 5BP1 is a five-inch cathode ray tube with a short persistence screen. Its operation is very simple in this little 'scope: Modulated r-f energy from the transmitter is applied to one set of deflection plates of the 5BP1 while audio voltage from the modulator of the transmitter is applied at the same time to the other set of plates. The 5BP1 produces an instantaneous picture of the relationship of the audio voltage to the r-f voltage. If all is well, this picture will be the well-known triangle at 100% modulation (*Fig. 1*). This is exactly the picture we need for adjustments on the transmitter. Furthermore, if we apply a sine-wave signal to the transmitter we can obtain a reference pattern which may be used to observe how different adjustments affect the modulation of the transmitter.

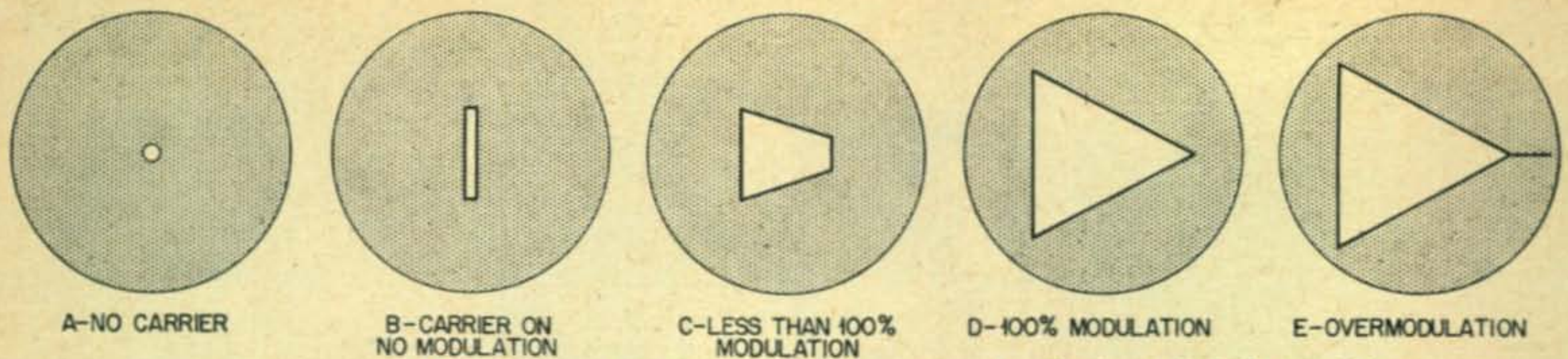

Fig. 1. These are a few of the conditions that may be observed with the aid of this modulation oscilloscope. Various other articles and books have been printed illustrating the identification of modulation defects from the appearance of the trapezoidal patterns.

The Circuit

Fig. 2 shows the circuit necessary to do the job. The 5BP1 tube receives its filament voltage from a small transformer (T1); its plate voltage is stolen from the transmitter. Since the total current drain is only a milliampere or two the transmitter power supply will suffer no pain. R1 and C2 constitute a simple filter which irons out any ripple in the power supply. The focusing voltage (425 volts) and the brilliance voltage (20 volts) are both obtained from the transmitter supply by the bleeder string, R1 through R7.

The comparison audio voltage is dropped to the correct value by means of a second bleeder string, R8 through R12. Condenser C1 is a high voltage blocking condenser. The width control (R12) is part of this bleeder string. The audio voltage is applied in correct proportion to the first set of deflection plates in the 5BP1 tube.

Note that the width and focus controls are at va-

rious high potentials above ground. They must be well insulated from the chassis of the scope. The filament circuit is also "hot" by about 50 volts.

The r-f signal stolen from the transmitter is applied to a tuned circuit, L-C, resonated to the operating frequency of the transmitter. The r.f. is applied in "push-pull" to the second set of deflection plates of the 5BP1. Since all the deflection plates must operate at the same d-c potential level, L-C must operate at the full value of the tube voltage. Care must therefore be given to the insulation of the coil and condenser. The remaining condensers insure that the r-f does not go wandering about in the innards of the scope.

Mechanical Layout

There are two possible and highly practical layouts for the scope. The first layout is to use a commercial cabinet, such as the Bud CA-1126 amplifier chassis and dust cover, with the tube mounted

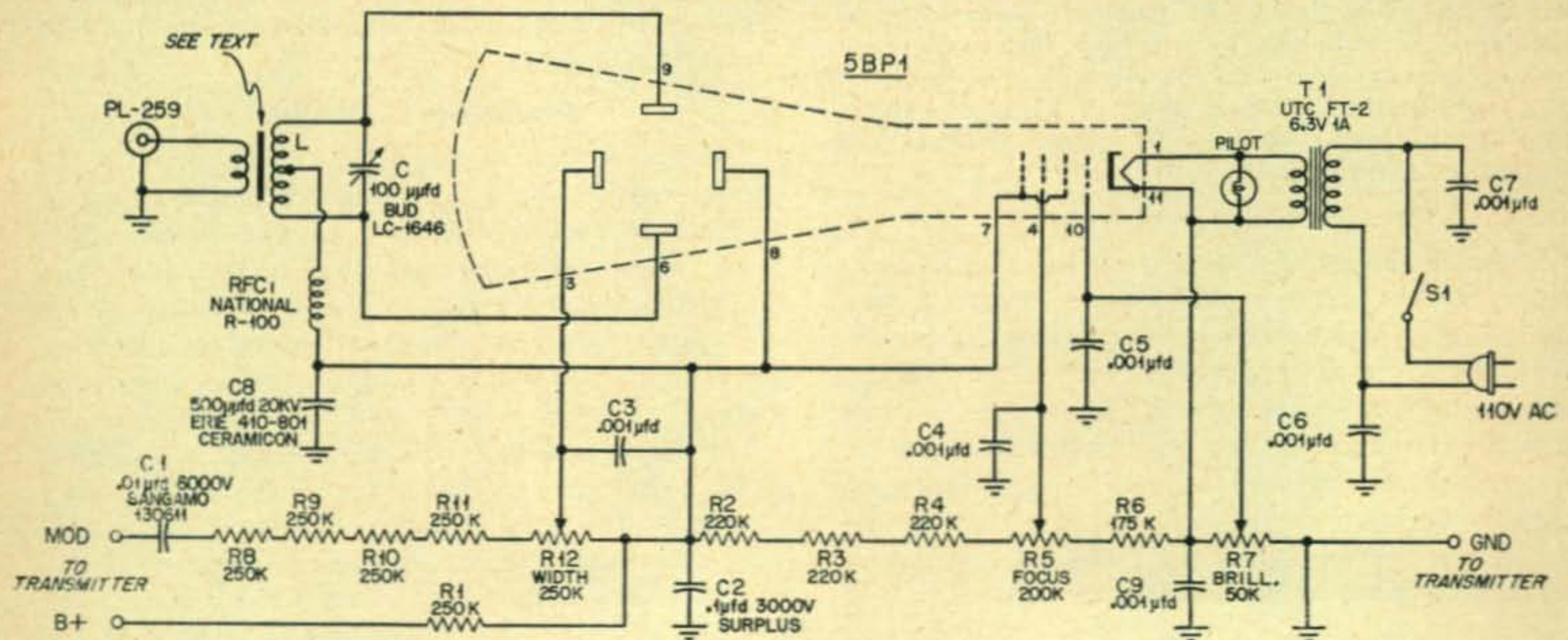

ALL BYPASS CONDENSERS ERIE CERAMICON 801-001 UNLESS NOTED
RESISTORS, IRC TYPE BTB 2 WATT INSULATED COMPOSITION TYPE
POTENTIOMETERS, CENTRALAB "BLUE SHAFT" TYPE, C1 TAPER
SOCKET FOR 5BP1, MAGNAL SIZE EBY S-20-11
SAFETY TERMINALS—MILLEN 37001

Fig. 2. Wiring schematic and parts list.

- | | | | |
|---|---|--|--|
| C—100 μ fd. variable,
Bud LC-1646 | C3, C4, C5, C6, C7,
C9—0.001 μ fd.
mica | R1, R8, R9, R10, R11—
250,000 ohms, 2w. | R7—50,000-ohm
potentiometer |
| C1—0.01 μ fd., 6000,
volts working,
Sangamo 130611,
or equivalent. | C8—500 μ fd. 20,000
volts working,
Erie 410-801 | R2, R3, R4—220,000
ohms, 2w. | R12—250,000-ohm
potentiometer |
| C2—0.1 μ fd., 3000
volts working | L—see text | R5—200,000-ohm
potentiometer. | T1—filament
transformer,
UTC FT2, or
equivalent |
| | | R6—175,000 ohm, 2w. | |

lengthwise (Fig. 3). All controls are mounted on on the chassis base, and connections to the 5BP1 tube are made with high voltage insulated wire, run through a large grommet at the rear of the chassis.

A second layout (known as the cheap and dirty approach) makes use of the black-crackle aluminum box from the war surplus *Antenna Loading Unit BC-306A*. Luckily, this box is just the right length for a 5BP1 tube! The 5BP1 mounts lengthwise in the box, the erstwhile bottom of the *Tuning Unit* now becoming the front panel of the modulation oscilloscope. The fluorescent face of the cathode ray tube projects through a hole cut in the "bottom" of the box. The tube socket is mounted in the "top" of the box. A *Bud CU-883 Utility Cabinet* is placed over the back of the socket as protection against shocks. This arrangement provides a rugged and neat package at a low price.

This layout is shown in Fig. 3. All components are mounted inside the box and no chassis is used. The two holes for the 5BP1 (socket hole and face hole) must align axially with each other so that when the box is assembled the tube may be placed in the socket by inserting it through the face hole in the front of the box. This face hole is cut slightly larger than the tube to allow room for a shock ring to be placed around the tube. This ring is made of a length of plastic tubing that is slit lengthwise and slipped over the rim of the panel hole, thus providing a soft shoulder against which the tube may rest. The various controls are located symmetrically in the corners of the front panel. The potentiometers are mounted near the rear of the box on insulated brackets and are connected to the panel knobs with short lengths of $\frac{1}{4}$ " bakelite shafting and shaft couplers. Typical mounting brackets for the potentiometers are shown in Fig. 4.

To prevent the a-c field of the filament transformer from affecting the picture, the transformer is mounted behind the 5BP1 tube on the outside of the box.

Using a Commercial Chassis

For a more finished appearance the *Bud CA-1126* chassis and dust cover should be employed. The parts layout in this case will be considerably different, since the components may be mounted on the underside of the chassis, rather than hung inside a box as in the case of the previously described BC-306A cabinet. If you do not mind the extra cost, the *Bud* box adorned with a pair of handles from an extinct TU-5B tuning unit makes a very professional appearing job.

A glance at Fig. 5 showing the underside layout of the chassis, will give you a pretty good idea of how the assembly should be handled.

Referring to Fig. 5: All panel controls are mounted on two bulkheads. These bulkheads are just long enough to reach from side-to-side of the chassis, and should be about $\frac{1}{8}$ " thick. They may be made of micarta or bakelite. They are fastened to the side of the chassis with small angle

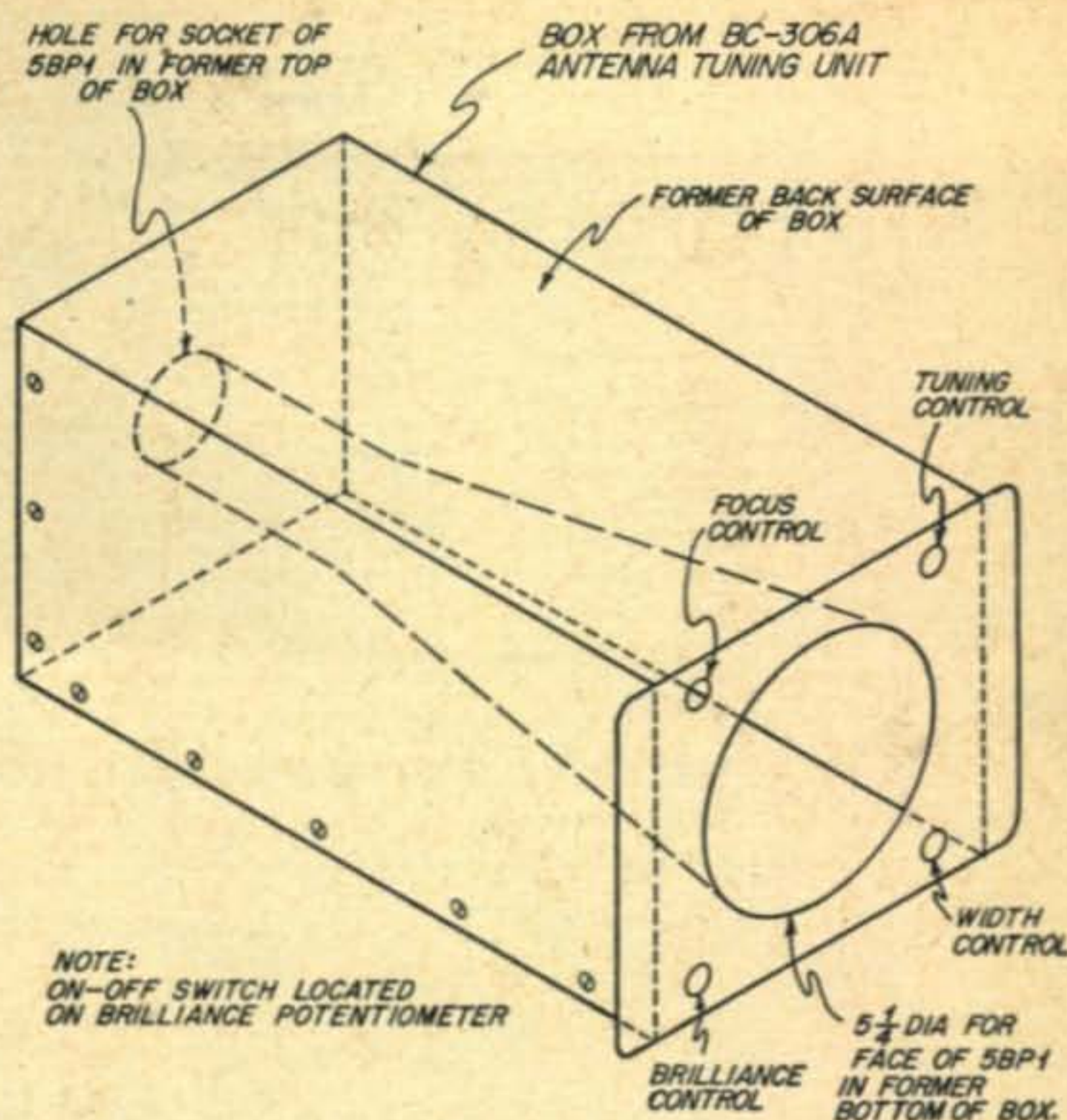

Fig. 3. This is the approximate layout using a surplus cabinet from a BC-306A unit.

brackets of the ten cent store variety. *Bulkhead #1* mounts *R7*, *R12* and *C*. These three controls are spaced $2\frac{1}{2}$ " center-to-center, leaving just about one inch between the outside controls and the edges of the bulkhead. *Bulkhead #2* is the same size as #1 and mounts *R5* and *S1*. These two controls are mounted $2\frac{1}{2}$ " apart leaving $2\frac{1}{4}$ " between the controls and the outside edges of the panel. Three additional holes must be drilled in line with the controls of *bulkhead #1* to allow their shafts to pass through *bulkhead #2*. Metal shaft couplers and bakelite extension shafts are put on all controls. One-inch knobs are used on *R7*, *R12* and *C*. Pee-wee $\frac{1}{2}$ " knobs are used on *R5* and *S1*. They provide ample manipulation space for the controls on the front panel.

The modified *MCL* coil is mounted on the side of the chassis just behind *C*. Directly behind it is

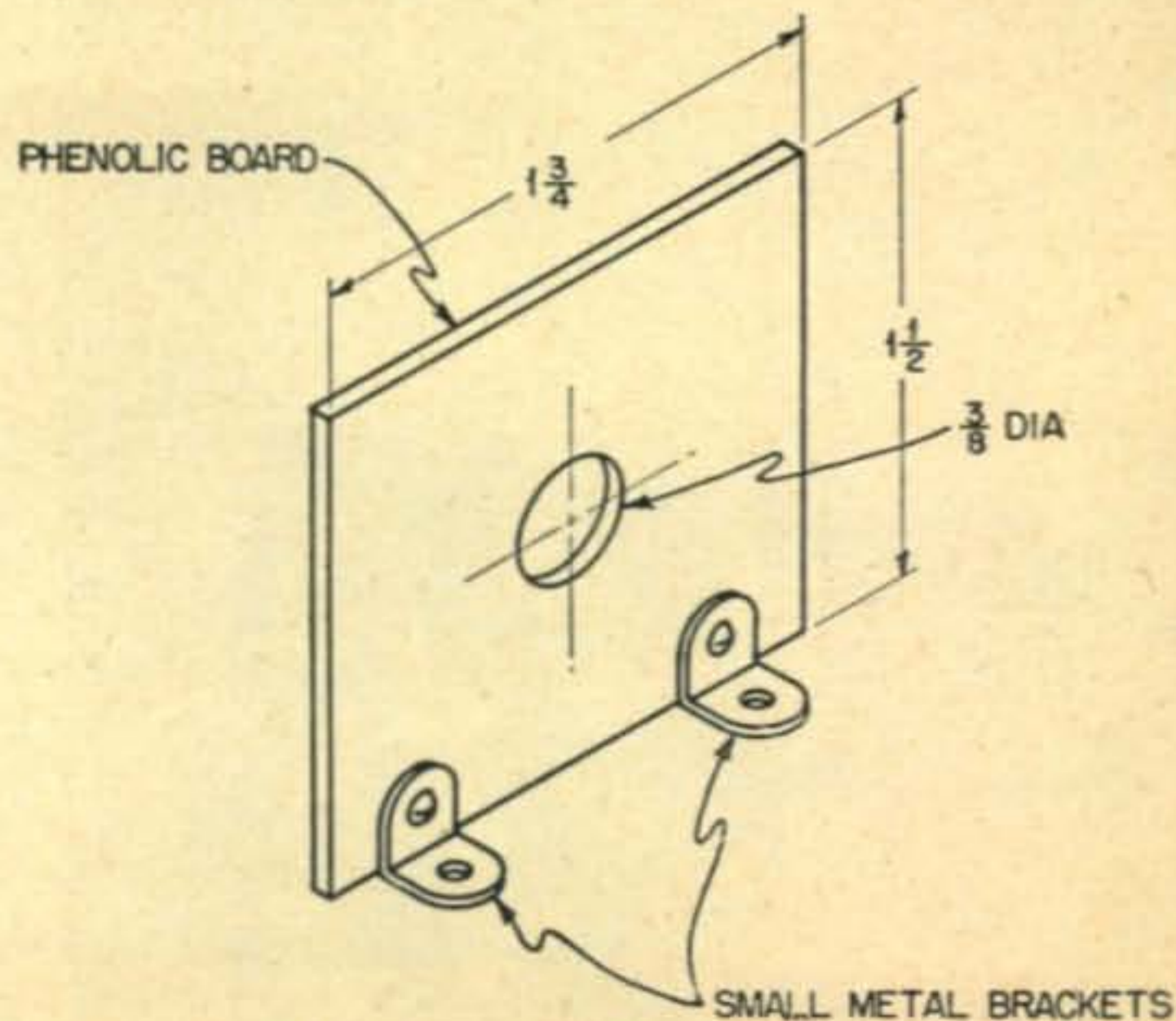

Fig. 4. Insulated potentiometer mounting bracket. If the BC-306A cabinet is used several of these are required for the potentiometers.

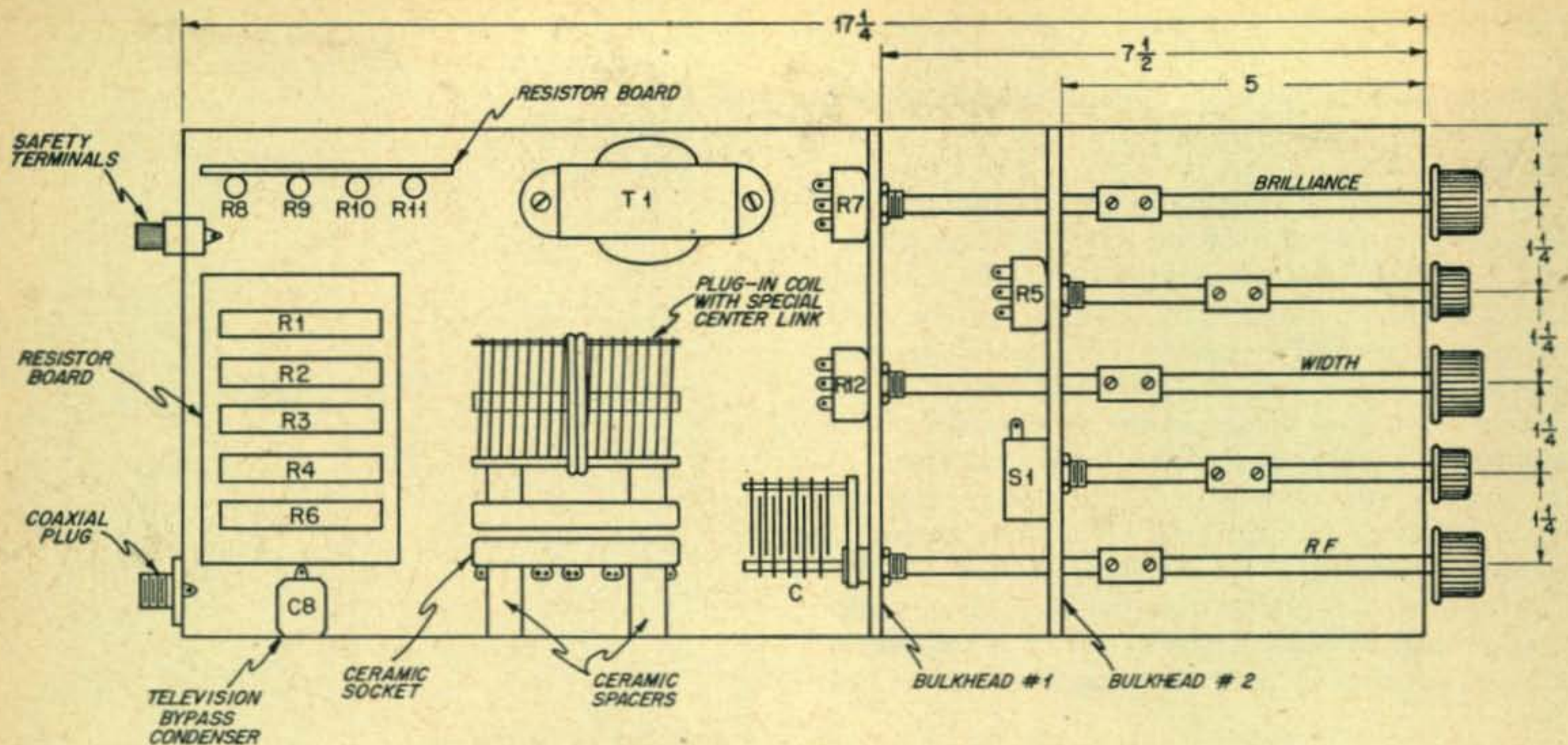

Fig. 5. Bottom view of the chassis layout using a BUD model CA-1126 chassis.

the 20-kv television type high voltage bypass. The SO-239 coaxial receptacle is mounted on the rear chassis wall behind the bypass condenser; the filament transformer directly behind control $R7$. The remaining space beneath the chassis is taken up with the two resistor boards. The placement of these boards will depend slightly upon the physical size of the boards. From a layout point of view, it is best to make the boards out of small pieces of micarta or bakelite. The terminal boards available on the market have too many mounting lugs located in the wrong places. These boards, as well as the ceramic coil socket, should be mounted on short ceramic insulators to space them away from the metal chassis. $C2$ can be a base mounting, metal can type condenser and may be placed in any free space that is left.

Figure 7 shows a disassembled view of the scope from the side. The CU-883 box is bolted to the chassis at the rear, with the length of the box run-

ning vertically. The cathode ray tube socket is mounted on the rear wall of the box, and a hole is cut into the front wall of the box large enough to clear the neck of the cathode ray tube. The box contains no parts; it merely serves as a support for the 5BP1 socket. The placement of the box on the chassis is determined by the length of the cathode ray tube and by the distance it projects out of the front end of the case. In my case, the face of the tube projects out from the case about $\frac{1}{2}$ ". The tube is $16\frac{1}{2}$ " long from the face to the bottom of the base; therefore, the mounting socket must be 16" back from the front edge of the scope face. A split piece of insulating tubing is ringed around the front mounting hole for the 5BP1 as a protection against shocks.

It should be noted that condenser $C3$ should be mounted on the 5BP1 socket directly between pins 3 and 8.

Safety First!

These general remarks apply to either of the two types of construction.

1. The tuned circuit is as hot as a bandit's pistol—some one thousand to two thousand volts above ground. A few important steps must be taken to protect the operator and the scope itself from the effects of a flashover from the hot coil to the link or to the chassis. A standard 25-watt plug-in coil may be used for L, such as the B&W MCL series coils. The coil should be mounted in a ceramic socket that is fastened to the wall of the chassis with two ceramic insulators, about one inch tall.

A flashover from the coil to the link would burn out $R1$ and $RFC1$. It is mandatory that

Fig. 7. View of the oscilloscope showing the mounting of the tube. The face projects through and is supported by the front of the chassis cover. The r-f choke which is visible in the photograph was used merely for tests and is not required in actual operation.

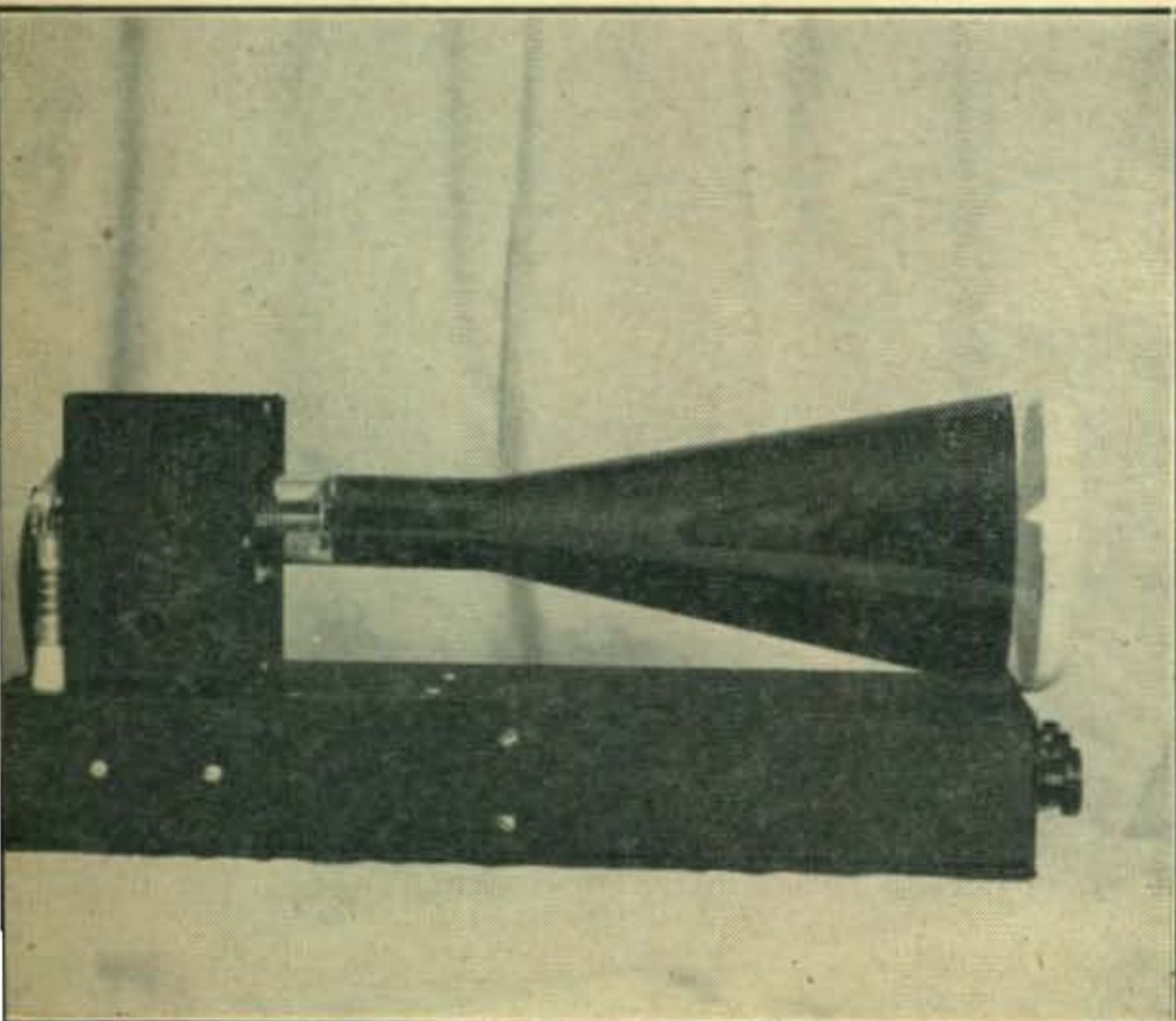

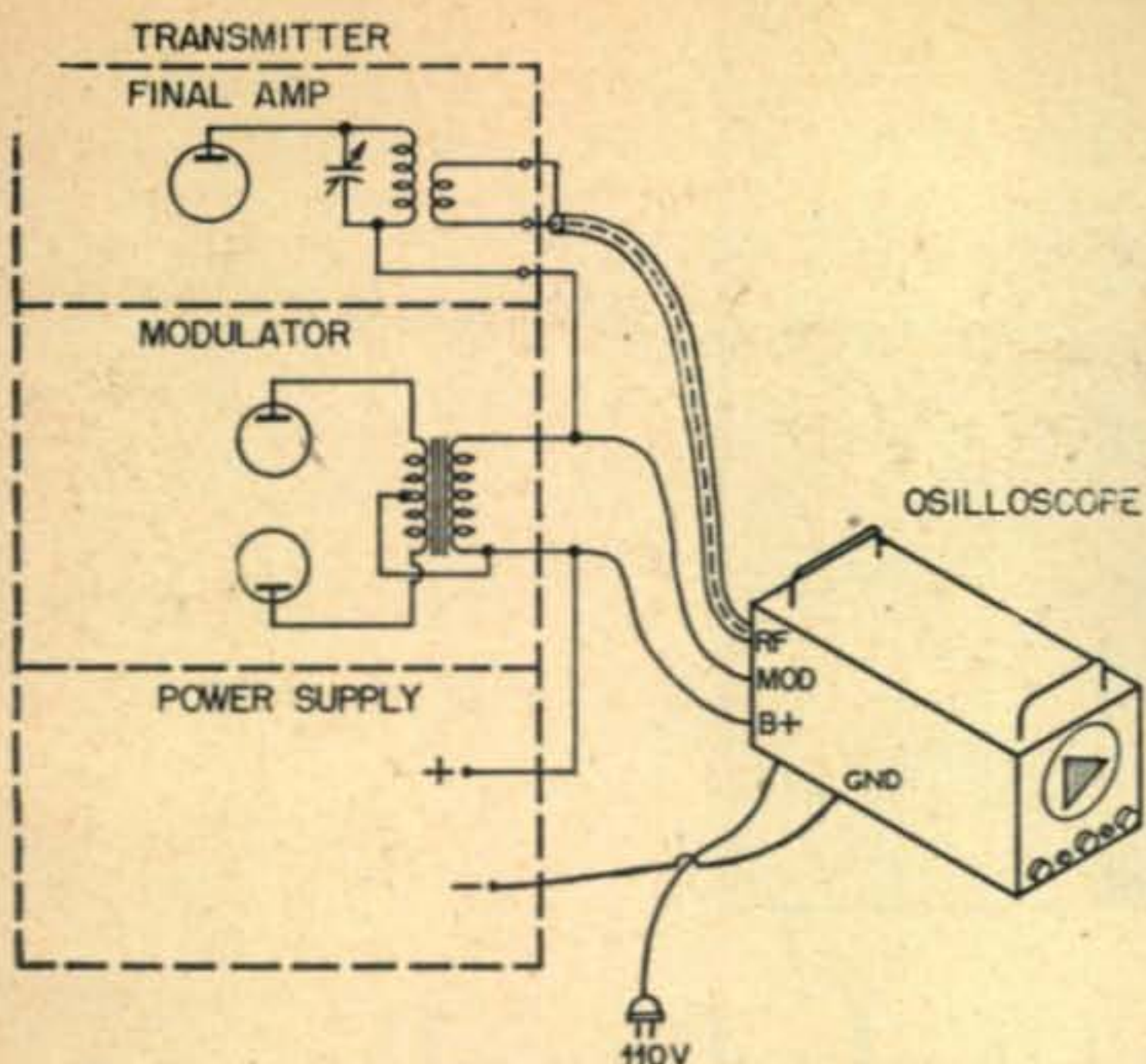

Fig. 8. Simplified sketch of the method of using the modulation oscilloscope.

one side of the link be grounded for safety's sake, so a slight modification of the coil is necessary in order to protect these other components. The center link of the MCL coil should be removed and a substitute link made from a length of the 8869 high voltage wire. The new link is wound over the center of the coil in place of the old link, and cemented into place.

- 2 The voltage dividers are mounted on phenolic boards that are spaced away from the chassis on ceramic insulators. All high voltage wires passing thru the chassis should go thru heavy rubber grommets so that the wires cannot chafe on the edges of the hole. As a last protection, Millen 37001 Safety terminals should be used for high voltage connections.

Operation of the Oscilloscope

When the unit is completely wired, a high reading ohmmeter should be used to trace out the circuits to check for wiring errors. 110 volts a.c. should then be applied to the filament primary circuit and the unit turned on. If the tube and pilot lamp light, the scope is ready for preliminary adjustment.

The two high voltage leads to the transmitter should be connected across the secondary of the modulation transformer, as shown in Fig. 6. The lead marked "B Plus" should go to the power supply side of the modulation transformer, and the lead marked "Modulation" should go to the side of the transformer connected to the modulated r-f stage. These leads may be permanently attached to the transmitter. Be sure the transmitter is OFF when these connections are made! The "Ground" lead is clipped to the "B minus" of the transmitter. (Fig. 8).

Next, a short length of coaxial line such as RG-59/U or RG-8/U with a matching PL-259 plug on one end is connected to the SO-239 receptacle on the scope. A small two turn link is placed at the other end of the line and loosely coupled to the final amplifier plate circuit of the transmitter. The transmitter is now turned on, applying the full plate voltage to the scope. The

Focus, Brilliance and Tuning controls of the scope are adjusted to produce a vertical line on the tube about two inches in height. If the line is not high enough, a bit tighter coupling to the plate coil of the transmitter may be indicated. It may also be necessary to rotate the socket of the 5BP1 tube slightly to position the line vertically with respect to the cabinet of the scope. When measured with a vacuum-tube voltmeter or a high resistance voltmeter the voltage on the arms of the *Focus* and *Brilliance* controls should be in the region of 400 volts and 20 volts respectively. If the line is fogged or seemingly out of focus, it may be that r.f. is appearing in places where it should not be. If the bypassing in the circuit is carefully followed, this should not happen. In one instance, a particular scope utilizing a slightly different layout from those shown needed a $2\frac{1}{2}$ mh. r-f choke and a 100- μ fd 3000-volt mica bypass condenser connected as a filter in series with the lead from the *Width* control to pin 3 of the 5BP1. This is something to keep in the back of your mind if you run into any r-f troubles.

With some audio applied to the transmitter (a whistle will do), *R12 (Width)* is adjusted until the familiar trapezoidal pattern appears. By adjusting *R12, C*, and the link coupling to the transmitter, an excellent pattern can be obtained. The scope may be left connected to the transmitter as a permanent part of the station equipment.¹

Interpretation of the scope pictures that may be obtained under various conditions cannot be covered in this short article. The various handbooks cover this subject, as do many technical books on oscilloscopes. The reader is referred to these publications for additional information.²

1. For operation of the oscilloscope at plate potentials of less than 2500 volts, it is necessary to remove the dropping resistor, *R1*.
2. An article by J. H. Owens, W2FTW in the Jan.-April, 1948 issue of the "RCA Ham Tips" shows a number of patterns similar to those obtainable with this unit. These were published in conjunction with the "RCA 'Ray Gun Monitor.'"—Tech. Ed.

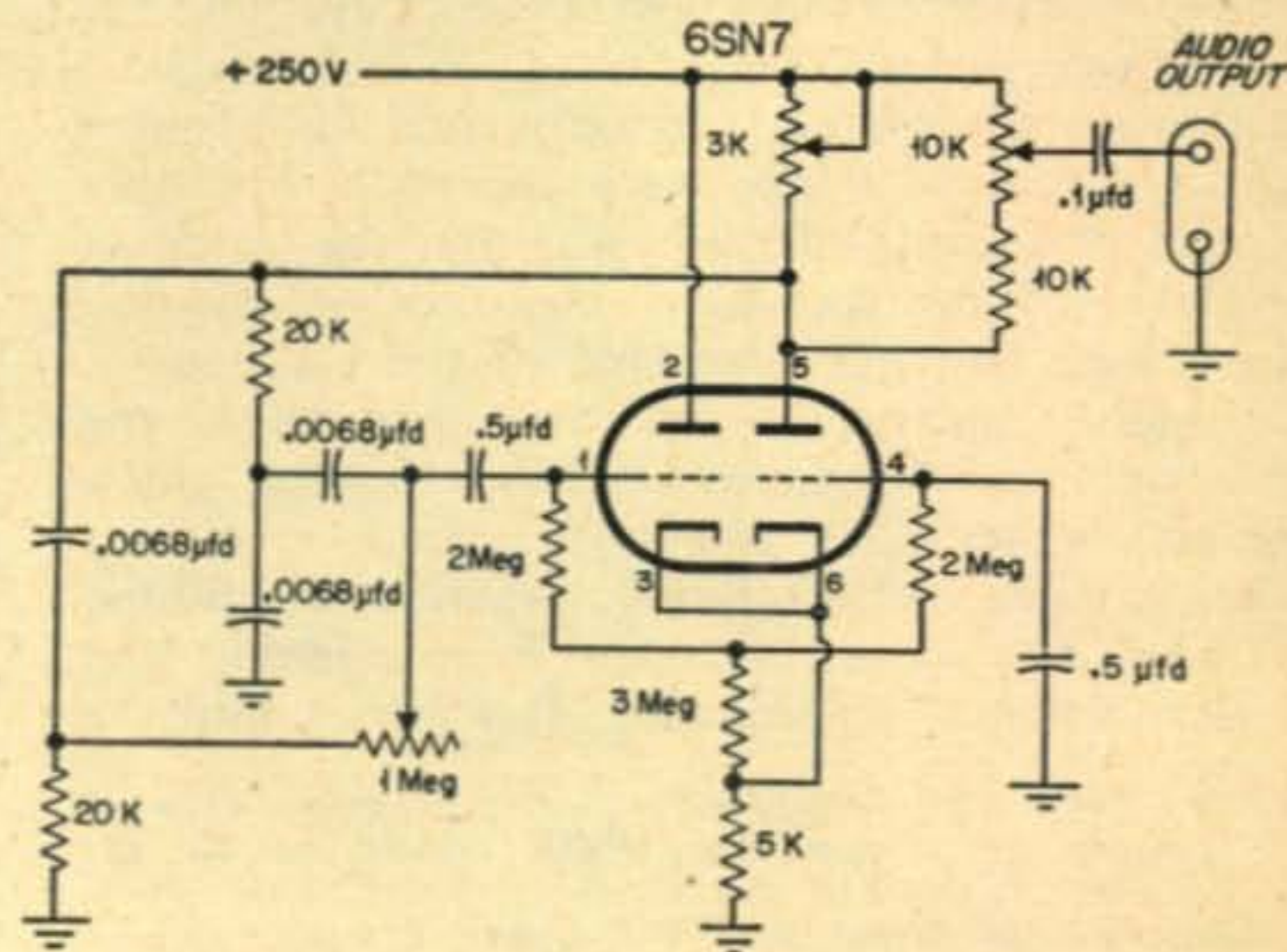

In order to obtain an audio signal of constant amplitude a simple sine-wave oscillator is needed. The circuit shown above is reprinted from the RADIO HANDBOOK (12th and 13th Editions, by permission, Editors and Engineers, Ltd.). The 1-megohm control varies the frequency, the 10,000-ohm potentiometer controls output level and the 3000-ohm potentiometer adjusts output for best low frequency waveform.

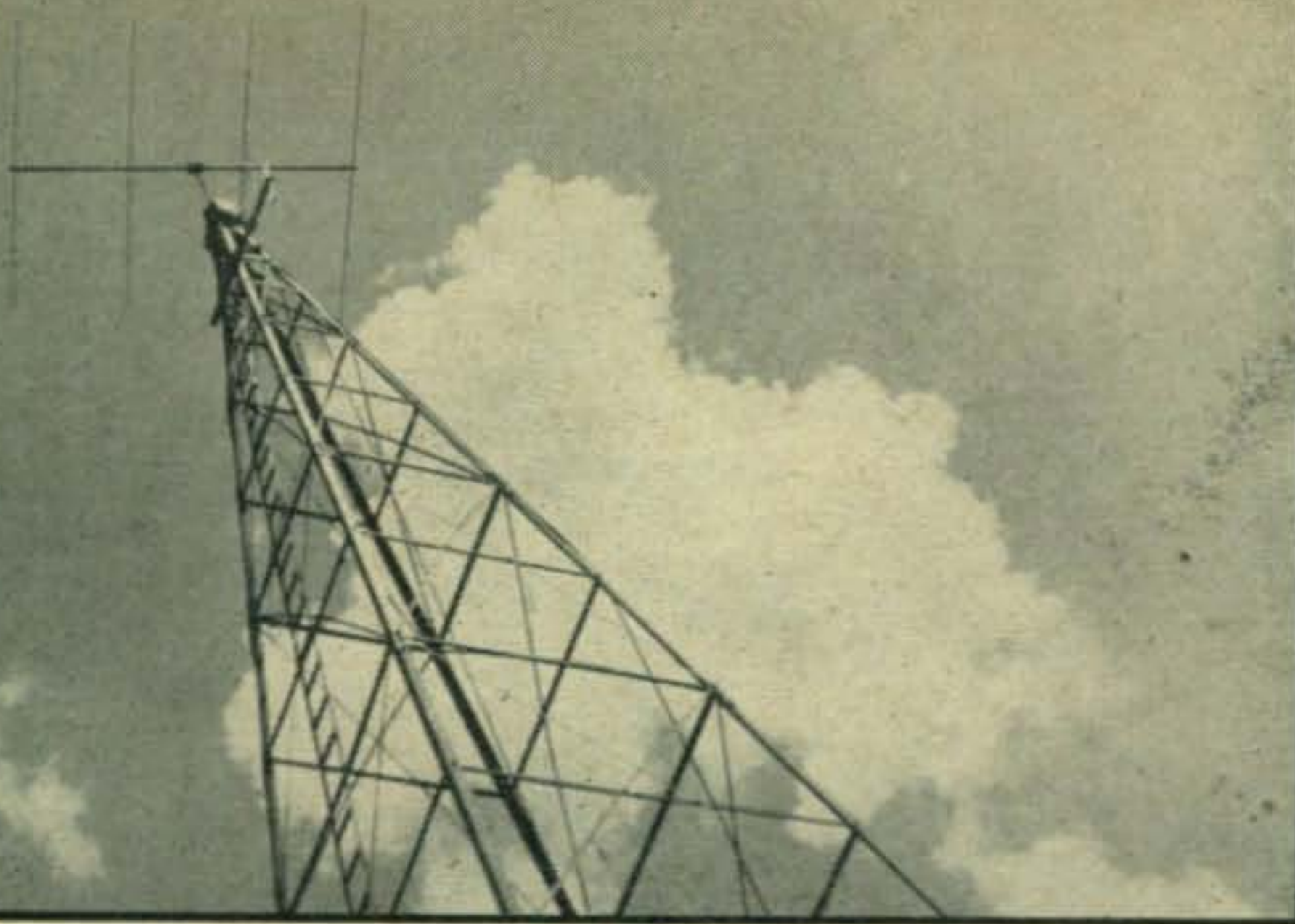

Looking Up

Some Practical Results on

LEROY MAY, W5AJG

9428 Hobart Street, Dallas 18, Texas

It is difficult for me to believe that over four years have elapsed since W5AJG put these data in my hands for analysis. Even so, I am glad it has been completed since it contains information of value to the average amateur. The results are probably applicable to every band above 7.0 Mc. even though they were obtained at 50.0 Mc. and via sporadic-E propagation.—Editor

During the latter part of the sporadic-E¹ DX session in 1941, W5AJG made simultaneous transmissions a few hundred kilocycles apart in the old 56-megacycle band. The two transmitters had power inputs of 30 and 250 watts. They were fed to separate antennas—the higher power going to an antenna about 75 feet above ground level and the lower power to an antenna about 35 feet high.

Although this system was only used for about a month several odd things were observed. Probably the most interesting of these was that the signal of the lower antenna was sometimes received by skip DX stations stronger than that of the high power (and higher antenna). On the other hand, the higher antenna seemed to be able to reach out a little bit further.

The postwar period found us with the 50-mc band and a renewed interest in continuing the high/low antenna experiments. It was not until the

summer of 1948 that we found ourselves ready to go again. A different approach was used—our rig consisted of a single 250-watt transmitter and emphasis was placed on the strength of received signals. Naturally, it was assumed that the superior receiving antenna would work better on transmitting as well. This proved fairly correct in practice and simplified the bookkeeping of the data.

The Equipment

Two identical 4-element horizontal all-metal beams were employed. The spacing between each element was 0.2 wavelength. A "T" match was used on the radiating element, with two-wire open feedlines coming down into the shack. The higher beam was again 75 feet above ground level; the lower, 35 feet. Both were rotatable and seemed to be sufficiently separated to rule out any interaction effects.

Each antenna was fed through individual coupling networks, with a relay providing rapid switching of either antenna to the transmitter or receiver. In this way, it was possible to change beams many times during a single transmission and thus minimize the fading effects, etc. Due to the separate coupling networks associated with each antenna, the transmitter fed the same amount of power into each antenna, and looks into a purely resistive load in either relay position.

The receiving lineup consisted of an *R9-er* type antenna matching pre-amplifier ahead of an *RME VHF-152A* converter, the latter being fed into an *SX-43* receiver. The S-meter on the communications receiver was carefully calibrated so that each S-unit increase in signal level was equal to 6 db. Inasmuch as the period of the tests was rather short,

1. The term Sporadic-E refers to a singular type of ionospheric phenomenon which occurs during the summer months in the northern hemisphere. It is during this period that TV, 5 and 6 meter signals are propagated. The effect is also popularly referred to as "short skip" on 10 meters.

Sporadic-E occurs at a more-or-less constant height of about 75 miles above sea level. For further information see "The Air Force Interest in Sporadic-E Ionization," Gerson, CQ, June, 1950, page 17.—Ed.

Looking Out



the Question of Antenna Height

it is felt that the receiving equipment maintained a fairly high order of accuracy. All observations were made in the range 50.0-50.5 mc.

Topography

Many who read this are going to question the results on the basis of my antenna site. Admittedly, I have what would be considered a fairly good v.h.f. location. The general topography is shown in Fig. 1. Note that the ground slopes away in all directions since W5AJG is located on a slight hill, generally taking about one mile for a drop of about fifty feet. Beyond a four mile radius the terrain is quite flat. An overwhelming percentage of observations were made in the first quadrant.

The Tests

There are undoubtedly some 6-meter operators who will recall having heard W5AJG ask for comparative reports during the summer of 1948. After the first 150 contacts however, this procedure was discontinued, as it became apparent that reciprocal conditions existed, except in a few rare and unstable cases. All in all, 350 good observations were made and recorded in the following form.

JUNE 28

0834	CST	Heard	W4FBJ	L6
0854	"	"	W8CMS	L12
0907	"	"	W4EQM	L12
0914	"	"	W9ALU	L12
0921	"	"	W4LNB	L12

Fig. 1. W5AJG has been fortunate in the choice of a site that is slightly higher than any ground within the first ten miles from the antenna. Most of the skip DX worked on 6 meters has been in the first quadrant (north through east). It is difficult to determine if the lake behind the antenna has any effect on the angle of radiation. The view from the top of the tower shown at the top of this page is towards the west.

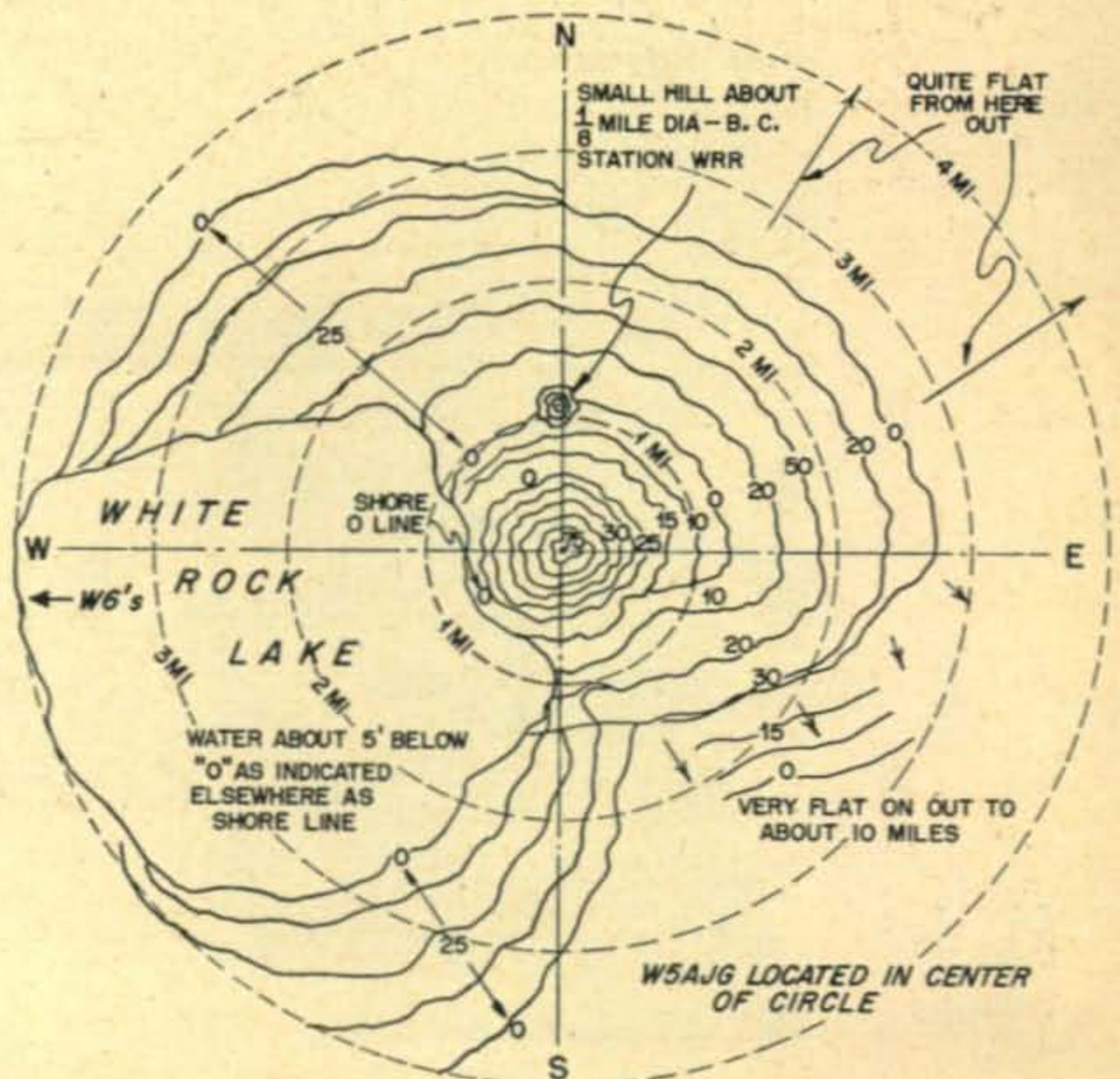

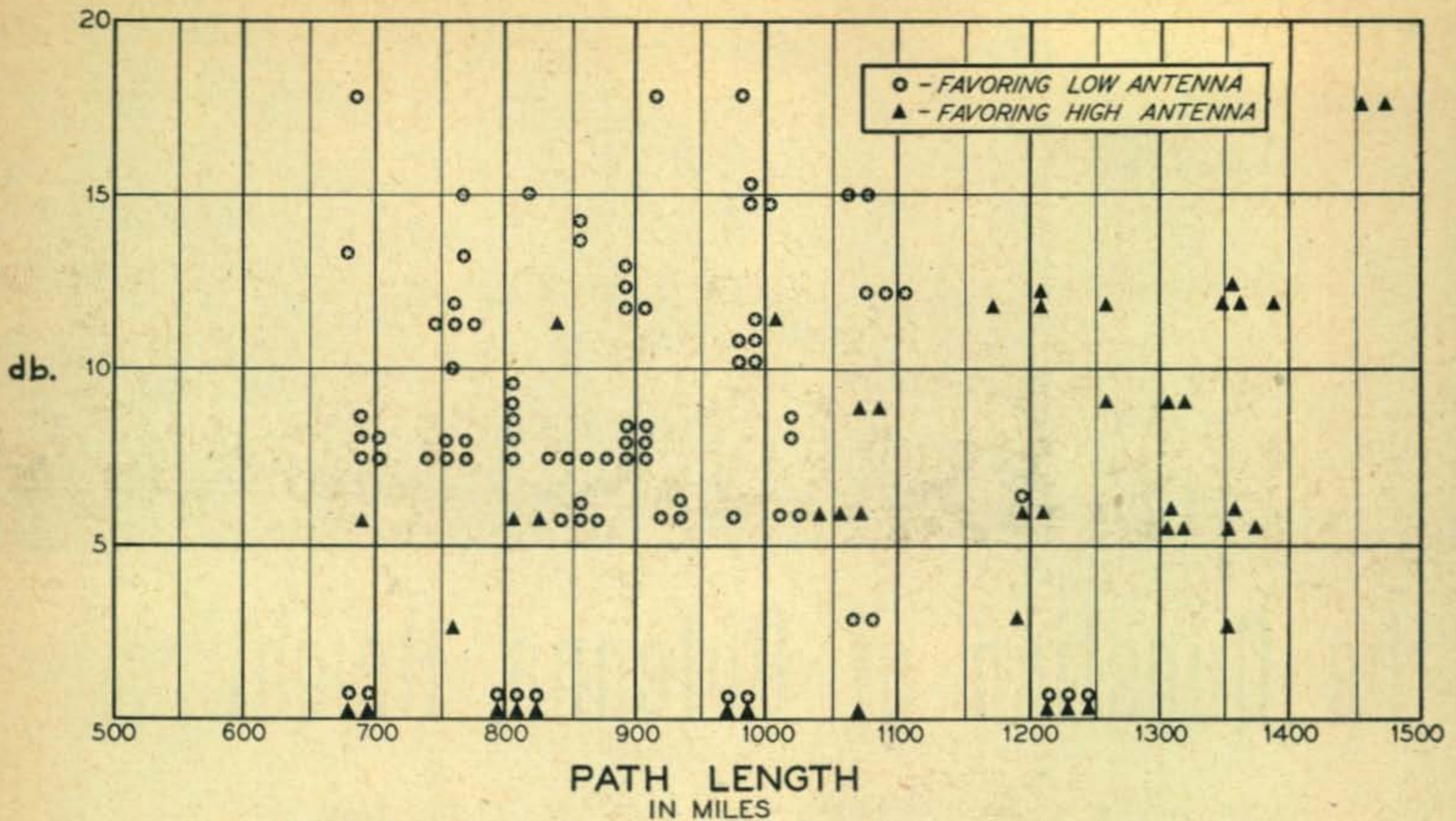

Fig. 2. Rough plotting method used after the mileage between the terminals had been worked out. "Non-standard" reports (i.e., observations favoring the high antenna in the predominantly low antenna readings) may be due to a change in layer height.

The "L" denotes that the lower antenna was favored by about 12 db. in the last four cases, and only 6 db. in the first test. In other instances these reports might be reversed, and favor the higher antenna.

The information obtained in this fashion was roughly plotted as shown in Fig. 2, after the mileage or path length between W5AJG and the station in question had been worked out. The mileages are within plus or minus fifteen miles, depending upon the QTH of the DX station in relation to his announced location.

Final Results

After a sizable quantity of the reports had been broken down in the manner shown in Fig. 2, the

next step was to draw a "mean average value." The results of this are shown in Fig. 3.

Note particularly in the graph (Fig. 3) that the field strengths of the two antennas are approximately equal at about 1125 miles. Below this distance the field strength of the lower antenna was definitely stronger. As a matter of fact, we can also see from the graph that it had two pronounced minor lobes; one returning the signal at about 730 miles and a second at about 960 miles.

On the other side of 1125 miles we cannot help observing the superiority of the higher antenna. At about 1275 miles this antenna was emitting a 10

(Continued on page 69)

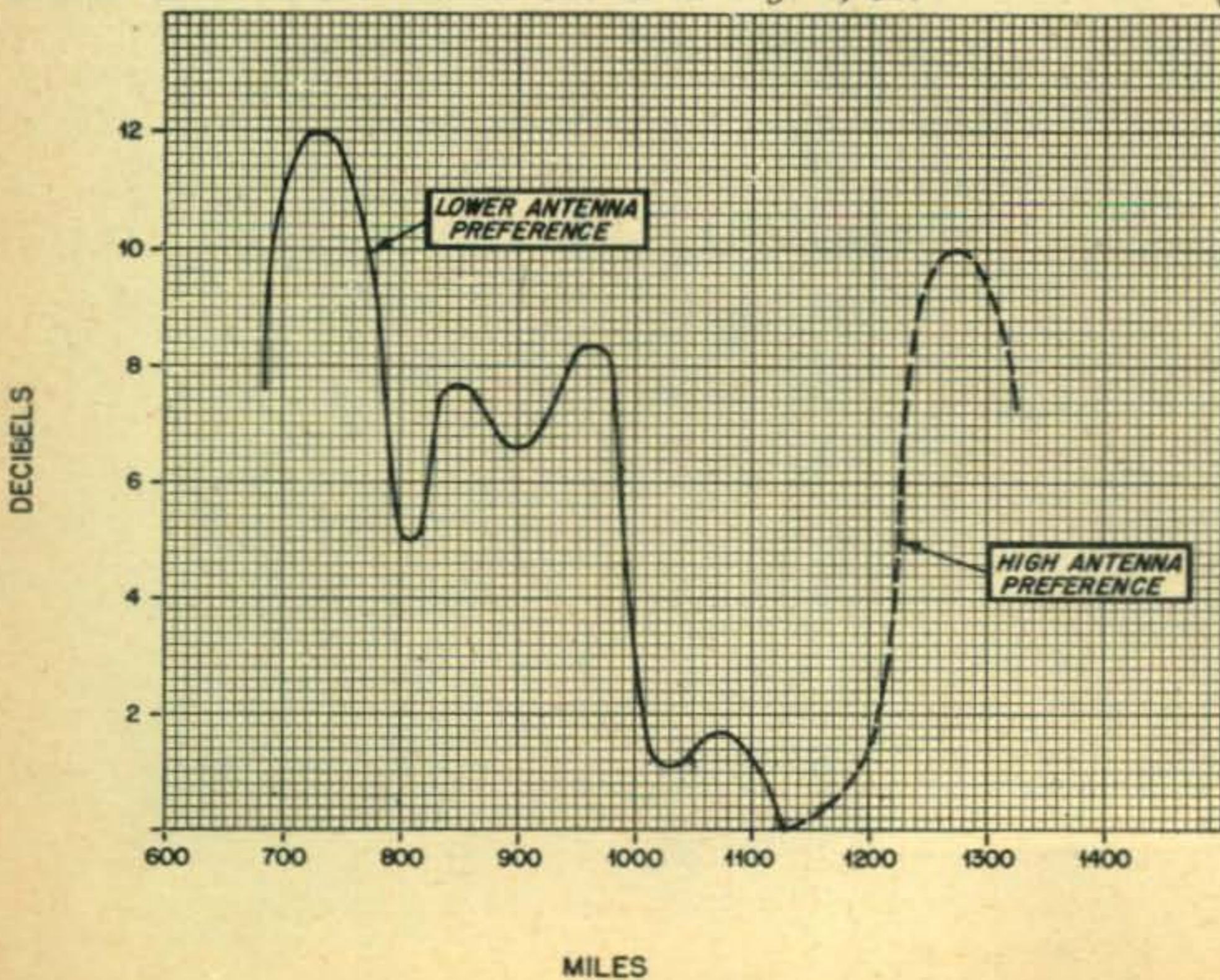

Fig. 3. The final plot of 350 observations clearly shows the advantage of great height (electrical wavelengths) above ground for extreme first-order skip DX. The "bumps" in the graph (low antenna) represent the lobe pattern of the antenna.

Ionospheric Propagation Conditions

Forecasts by **GEORGE JACOBS, W2PAJ**

3620 Bedford Ave., Brooklyn 10, New York

April is a month of changing radio propagation conditions. It marks the transition period between winter and summer conditions. Twenty meters will remain open for considerably longer periods during the daytime hours, and forty meters will remain open for DX considerably longer through the night hours than during the winter months. An increase in atmospheric noise levels will be noticed, especially on the eighty-meter band.

As we approach the summer months, nighttime usable frequencies become higher. During April, local 75-meter phone networks will not be disrupted by the MUF dropping below 3.8 Mc. as often happened as early as 1830 throughout the winter months. During undisturbed periods the 75-meter phone band should hold up for local nets until at least 2230 local time.

Most probable days for ionospheric disturbances during April are 1-3, and 16-28. A period of good propagation conditions is expected during April 5-10.

In January's column, I requested readers to let me know what they would like to see in subsequent columns. By the time I had written this month's column, I had received 35 letters from interested readers. A tabulation of their suggestions follows:

Eight letters requested more discussion on propagation theory—how to draw MUF curves, how to predict ionospheric disturbances, etc.

Seven readers requested that additional propagation charts be included, centered on such areas as Texas, Georgia, Mexico City, England, Italy, Peru and Puerto Rico.

Six letters requested extraordinary or rare DX circuits analyzed each month.

Six requested forecasts each month for 80, 75 and 40 meter propagation conditions for those readers not interested in DX.

Four wanted a discussion of the sun-spot cycle. One requested a discussion of aurora propagation.

One requested a discussion of VHF propagation. One asked for a discussion on antenna design, taking into account propagation parameters. One requested that periods of good conditions, as well as disturbed conditions, should be forecast.

All in all I found these letters extremely interesting—and they certainly gave me plenty of food for thought. Each letter received will be answered personally, and I will also try to get as much of the requested information as possible in future columns. Please continue to send in your letters and comments.

Fifteen Meter Phone

The past year has been a period of new band openings. Last month we discussed the new forty-meter phone band and now we shall discuss the new fifteen-meter phone band. The opening of this band to phone comes at a time when fifteen-meter DX conditions are seasonally poorer. While not much DX is expected to Europe, some very good openings should be possible on north-south paths. Signals should be strong enough on many days, on these paths, to permit good low-power phone (100 watts or so) QSO's. Domestically, for the next few months, the normal skip will be further out than 1600 miles, and trans-continental phone QSO's should be possible on a good number of days. The frequency of occurrence of Sporadic E (short skip) openings increases during the spring and summer months. Extremely strong

signal levels are generally associated with these short skip openings, and good phone QSO's should be possible. The skip will be shorter on fifteen meters than on ten, but longer than the short skip distance on twenty.

Next fall and winter, fifteen meters should be an outstanding band for low power phone DX possibilities. Throughout this discussion the emphasis is placed on low power because ionospheric absorption is lower on fifteen meters than on twenty or forty meters. This means, it takes considerably less power on fifteen meters to produce strong signal levels. It can be shown that, on many DX circuits, 100 watts on fifteen meters will do the job of over 500 watts on twenty meters. General fifteen-meter propagation conditions were discussed fully in this column for July and August, 1952.

General Shortwave Propagation Conditions For April, 1953

The following is a brief discussion of predicted short-wave propagation conditions for amateur circuits from the United States to the five major areas of the world. For specific times of band openings on any particular circuit refer to the "Propagation Charts." Basic ionospheric data used in this analysis appear in the Series D Publications of the National Bureau of Standards, entitled "Basic Radio Propagation Predictions," derived from a predicted smoothed sunspot number of 24 for April, 1953.

Europe

Daytime MUF's are decreasing in accordance with seasonal propagation conditions. No ten-meter openings are expected, and fifteen meters will not open to Western and Central Europe again until late in October. There may be an occasional fifteen-meter opening to South Europe from Eastern U.S.A. on propagationally good days (WWV 7 or better). . . DX conditions for Europe are improving on twenty meters, and the band will remain open considerably later in the afternoon than during the winter months. Fairly good openings should be possible throughout the month from all areas of the U.S.A. to Europe. . . Although nighttime absorption and atmospheric noise values are increasing, forty meters is still expected to support some good openings on these circuits during the dark hours. . . Eighty meters is becoming quite noisy, and openings will be fewer and signals weaker than they were during the winter months.

South America

Some ten-meter openings are expected during the daylight hours from all areas of the U.S.A. to most countries of Latin America. In fact, Latin American circuits will be the only consistent DX on ten meters for the next few years. . . Ionization should be strong enough to permit good daily fifteen-meter openings throughout the daylight hours. . . Twenty meters should open shortly after sunrise, with signals becoming weak or fading out completely during the late morning and early afternoon hours, becoming stronger again in the late afternoon. This band should remain open until late in the evening on most days, and well past midnight on some days. Signals will be extremely strong after sunset. . . Good DX conditions are expected on forty, especially to countries north of the equator. . . Fair conditions are expected on eighty meters, with high atmospheric noise levels limiting the DX use of this band on many nights.

(Continued on page 66)

ALL TIMES IN E S T

EAST COAST TO: (Centered on Washington, D. C.)	10 Meters	15 Meters	20 Meters	40 Meters
Scandinavia	Nil	Nil	0900-1300 (1) 1300-1600 (1-2)	1900-0100 (1-2)
Great Britain & Western Europe	Nil	Nil	0800-1330 (2-3) 1330-1630 (3-4) 1630-1730 (2)	1800-2200 (3-4) 2200-0200 (2-3)*
Balkans	Nil	Nil	0900-1330 (1) 1330-1700 (2-3)	1930-2100 (2) 2100-2330 (0-1)*
Central Europe	Nil	Nil	0800-1230 (2-3) 1230-1730 (3-4)	1800-2130 (3-4) 2130-0000 (2)*
Southern Europe & North Africa	Nil	1300-1600 (0-1)	0700-1300 (3) 1300-1800 (4)	1700-2100 (3-4) 2100-0000 (1-2)*
Central & South Africa	Nil	1100-1400 (1-2) 1400-1630 (2-3)	0600-1230 (0-1) 1230-1600 (2) 1600-1930 (3)	1800-2330 (2-3)
Near & Middle East	Nil	1300-1500 (0-1)	1900-1300 (1) 1300-1630 (2-3)	1900-2230 (2)
Central America & Northern South America	1300-1700 (1-2)	0930-1500 (3-4) 1500-1830 (4-5)	0700-0900 (3-4) 0900-1600 (3) 1600-2100 (4-5)	1900-0630 (4-5)
South America	1200-1600 (1-2)	0900-1500 (1-2) 1500-1900 (3-4)	0600-0800 (2) 0800-1600 (1) 1600-2100 (3-4) 2100-0200 (1-2)	1900-0500 (3-4)
Hawaii	Nil	1300-1900 (1-2) 1900-2030 (2-3)	1030-2100 (1-2) 2100-2330 (3-4)	2230-0730 (3)
Australasia	Nil	1600-2000 (1-2)	0800-1100 (2) 1400-2000 (0-1) 2000-2300 (2)	2330-0700 (2-3)
Guam & Pacific Islands	Nil	1700-1900 (0-1)	0900-1000 (1) 1700-2100 (1) 2100-2300 (2)	2300-0630 (2)
Japan	Nil	Nil	0800-1000 (1) 1900-2300 (1-2)	0130-0700 (1-2)
Philippine Islands & East Indies	Nil	Nil	0900-1100 (1)	0100-0600 (1)
India	Nil	Nil	1330-1800 (1)S 0700-1000 (0-1)L	1400-2100 (1)
West Coast	Nil	1300-1900 (1-2)	1000-1800 (2) 1800-2000 (4) 2000-2130 (2)	2100-0200 (4-5) 0200-0630 (2-3)*

ALL TIMES IN C S T

CENTRAL USA TO: (Centered on St. Louis, Mo.)	10 Meters	15 Meters	20 Meters	40 Meters
Great Britain & Western Europe	Nil	Nil	0700-1330 (2) 1330-1630 (3)	1800-2100 (2-3) 2100-0130 (1-2)*
Central Europe	Nil	Nil	0700-1300 (2) 1300-1700 (3)	1730-2100 (2-3) 2100-2300 (1-2)*
Southern Europe & North Africa	Nil	1200-1500 (0-1)	0700-1300 (3) 1300-1700 (3-4)	1730-2000 (3-4) 2000-0130 (2)*
Central and South Africa	Nil	1000-1400 (1-2) 1400-1530 (2-3)	0500-1300 (0-1) 1300-1600 (2) 1600-1830 (3)	1830-2300 (2)
Central America & Northern South America	1200-1600 (1-2)	0930-1500 (3-4) 1500-1830 (4-5)	0600-0830 (3-4) 0830-1500 (3) 1500-2030 (4-5) 2030-0100 (1)	1830-0530 (4-5)
South America	1100-1700 (1-2)	0800-1500 (2-3) 1500-1830 (3-4)	0600-0800 (2-3) 0800-1500 (1-2) 1500-2100 (3-4) 2100-0130 (2)	1800-0400 (3-4)
Hawaii	Nil	1200-1800 (2-3) 1800-2000 (3)	0900-2000 (2) 2000-2330 (3-4)	2200-0730 (3-4)

ALL TIMES IN C S T

CENTRAL USA TO:
(Centered on
St. Louis, Mo.)

	10 Meters	15 Meters	20 Meters	40 Meters
Australasia	1600-1900 (1)	1400-1900 (1) 1900-2100 (2)	0800-1100 (2) 1400-1930 (1) 1930-2300 (2)	2300-0700 (2-3)
Japan	Nil	1600-2000 (1)	0800-1000 (1-2) 1400-1700 (0-1) 1700-2200 (1-2) 2200-0000 (2)	0200-0700 (2)
India	Nil	Nil	0900-1130 (1-2) 2000-2200 (0-1)	0430-0600 (1)S 1800-1930 (1)L
Philippine Islands and East Indies	Nil	1500-1900 (0-1)	0730-1200 (1-2) 1200-1900 (0-1) 1900-2030 (1)	0200-0600 (1-2)

ALL TIMES IN P S T

WEST COAST TO:
(Centered on
Sacramento, Calif.)

	10 Meters	15 Meters	20 Meters	40 Meters
Europe	Nil	Nil	0700-1400 (1-2)	1800-0000 (0-1)
South Africa	Nil	1100-1400 (1) 1400-1700 (2)	0800-1300 (0-1) 1300-1600 (1-2) 1600-2000 (2-3)	1700-2300 (1-2)
Central America and Northern South America	1300-1600 (1)	1000-1400 (3-4) 1400-1800 (4-5)	0530-1400 (3-4) 1400-2000 (4-5)	1830-0400 (4-5)
South America	1200-1400 (1)	0800-1430 (2-3) 1430-1830 (3-4)	0530-1500 (1-2) 1500-1630 (2-3) 1630-2030 (3-4) 2030-0130 (1-2)	1900-0300 (3-4)
Hawaii	1400-1800 (1-2)	1100-1600 (3-4) 1600-1830 (4-5) 1830-2000 (3-4)	0800-1800 (3-4) 1800-2100 (4-5) 2100-2230 (3-4)	2030-0400 (4-5) 0400-0630 (3)
Australia	1400-1900 (2-3)	1200-1400 (1-2) 1400-1800 (1) 1800-2000 (1-2)	0700-0900 (1) 1100-1200 (1) 1200-1900 (0-1) 1900-2200 (1-2)	0100-0400 (2)
New Zealand	1300-1800 (1-2) 1800-1930 (2-3)	1200-1800 (2) 1800-2000 (2-3)	1100-1800 (1) 1800-2200 (2-3)	2200-0500 (3)
Japan	Nil	1600-2100 (2-3)	0730-1200 (1-2) 1200-1900 (2) 1900-0000 (3-4)	0030-0500 (2-3)
Philippine Islands and East Indies	Nil	1500-2030 (1-2)	0730-1100 (2) 1300-1430 (1) 1430-2100 (0-1) 2100-0000 (1-2)	0300-0430 (1-2)
Malaya	Nil	1600-2000 (1)	0800-1130 (2) 1400-1530 (1) 1530-2130 (0-1) 2130-2300 (1)	0500-0700 (1)
Marshall Islands	Nil	1200-1700 (2-3) 1700-2000 (3-4)	1000-1900 (2) 1900-2230 (3)	2300-0600 (3)
Guam & Mariana Islands	Nil	1330-1900 (2) 1900-2000 (2-3)	0700-0900 (2) 1100-1300 (2) 1300-1900 (1) 1900-2300 (2-3)	0100-0600 (3)
Hong Kong, Formosa and Macao	Nil	1700-2000 (1-2)	0700-0930 (1-2) 1200-2000 (1-2) 2000-2330 (2-3)	0300-0600 (1-2)
India	Nil	1700-2100 (1)	0700-0830 (1-2) 0830-2200 (0-1) 2200-2300 (1)	0400-0700 (1)

Symbols for Expected Percentage of Days of Month Path Open:

(0) None (1) 10% (2) 25% (3) 50% (4) 70% (5) 85% or more

* Indicates conditions on eighty meters may be as good as, or more favorable than on forty meters.

L Indicates long great circle path

S Indicates short great circle path

DX



AND OVERSEAS NEWS

Gathered by **DICK SPENCELEY, KV4AA**

Box 403, St. Thomas, Virgin Islands

With Spring coming more attention can be given to antenna problems. Best bets on 14, 21 and 28 Mc. are the rotary beams, while the ground plane set-ups are making a big reputation for themselves on 7 and 3.5 Mc. On 160 the cry goes out "The longer the long wire the better."

The DX speed merchants may say "Oh, why did I work all that stuff in such a hurry?" Yup! The bottom of the barrel can get pretty monotonous.

The advent of 7 and 21-Mc phone should give the A3 enthusiasts a lusty shot in the arm, while embryo DX kings will emerge as the result of Novice space on 21 Mc.

How about a little jaunt to Clipperton, The Seychelles or Tannu Tuva, gang?—Afghanistan, The Comoros or Albania will do as second choice!!—All tied up? Too bad—Oh well, DX thinks I'm dead too.

At Time of Writing

G6ZO recently visited EA4BH who stated that EDZ1/ECZ1, Cabo Juby, Rio de Oro, is a commercial aviation



Photo courtesy of SM5RM

Seated at the neat station of Vic Persson, SM5KP we see the "contest champ," Sam Monastirsky, 4X4BX. The genial gent on the left is Olof Fridman, SM5RM. Sam spent three weeks in Stockholm in January during an extensive European swing.

station who is doing a little Hamming on the side and QSL's will probably not be forthcoming. (W8DMD made one up and got the op to sign and return it—a buck was enclosed.) EA4BH hopes to visit Rio de Oro, no date given, and will be on the air with EAØBH.

VP2LC/Mobile is now active on the island of Tortola, British Virgin Islands. Ivan is on phone only, using 12 watts on 7 and 3.5 Mc. He is awaiting a new call for this QTH which is administered from Antigua, B.W.I. and, thus, comes under the Leeward Island status. See QTH's.

Notes from F9RS: FR7ZA is spending a holiday in France. .FB8ZZ departed from New Amsterdam Island on Jan. 15th. QSL's will be coming soon. .FQ8AE left France and will be setting up shop in FK8-land. Missing QSL's via F9RS. .FQ8AP is very active in new QTH, 0600/0800 GMT, 15 watts but good antenna. See QTH's. .PX1YR, Andorra, has been heard on 7 and 14 Mc., CW, 35 watts input. Yves will soon have a new phone xmtr. .CN2, Tangiers, is a new country for the DUF award. .FF8AR is now FF8AV. .FY7YB is very QRL but gets on the air each Sunday 1130/1300, 14100, A3. .OH8OG, located at Sodankyla, North of the Arctic circle, is country No. 46 for the WAE award. .FQ8AL runs 15 watts xtl on 14080 or 14100 from Tchad.

From W5AVF we hear that there will soon be another active ZS9 on the air in the person of Mrs. ZS9I who has just passed her exams for the license. ZD9AA shuts up shop in April and may QSY to ZS2MI, Marion Island. Red will be replaced by an active Ham on ZD9.

W6UXX/MM, Evan, will be supplied with a QRP layout by W6KYG and chances are very good that he will be heard from a very rare spot at any moment. W6UXX has also applied for a TI9 license and TI2TG advises that this has probably been granted, thus clearing the way for Evans' operation on Cocos. The call will be TI9UXX.

We have been notified that the Swiss Contest H-22 CW section will begin on April 18th at 1300 GMT, and will end at 1900 GMT on April 19th. Our thanks to W2DKF.

W6KYG reports the advent of FO8AI. This station is located on Hivaoa Island in the Marquesa group which, as far as we know, comes under the FO8 status. FO8AI was worked 14045 xtl 2400 GMT. QSL via W7FNK.

Definite dope on CEØ, Easter Island, activity should soon be on hand. CE3DZ has advised that there will be no action there until around the middle of March.

VP8AP states that VP8AE is active from his (VP8AP's) old QTH in the South Orkneys while VP8AN operates from Argentine Island, Antarctica. The latter station is not on very frequently due to a shortage of lubricating oil but a relief ship should have taken care of this by now. .FU8AA, New Hebrides, has been active around 14025 T9C VFO. .LZ1DP advises that the YO stations have now been forbidden to contact any one outside of the "WSEM" group. .WØUQV/WØAIW/WØFNO & Co., who will be remembered for last summer's FP8 operation, are casting about for new worlds to conquer. TI9 is a possibility if they can all arrange vacations for the same time. .ST2AR opened up on Jan. 30th from Khartoum. He is ex-G4AR. See QTH's. .PZ1AL, Gene, has been heard knocking them off on 14005 around 2230 GMT. .W8CIR reports a CP phone possibility in CP5AB. He is ex-LU9DBF

and was worked on 14280 at 2000 GMT. .CR8NMC, A3, 14117, was worked by W5BGP and W5KUC on Jan. 11th, 1520 GMT, long path. .ZD7A is still visiting England and there is a possibility that he will go to ZD8 (Thanks to W5ALA). .From W2AGW via F8PQ and F18AC we hear that all F18's coming through will be phonies and the new prefix will be 3W8, as of Feb. '53.

Below are listed Argentine stations located in the Antarctic Zone for 1953 (Courtesy LU5AQ): (QSL's go via Radio Club of Argentina).

SOUTH ORKNEY ISLANDS (Laurie Island)
LU's—IZA, IZG, IZM, 2ZM, 3ZM, 4ZM, 5ZM.
SOUTH SHETLAND ISLANDS (Decepcion Island)
LU's—IZC, 8ZI, IZO, 2ZO, 3ZO, 4ZO, 5ZO, 6ZO.
PALMER ISLANDS, MELCHOIR ARCHIPELAGO (Observatory Island)
LU's—IZB, 5ZH, 7ZH, 8ZH, IZN, 2ZN, 3ZN, 4ZN, 5ZN.
ARGENTINE CONTINENTAL ANTARCTICA, GRAHAMLAND (Gen. San Martin Base)
LU's—IZD, 3ZD, IZJ, IZP.

Exploits

PY2CK zooms to the top of the phone list with VP1AB, VQ6MY, ZD7A, FL8MY and 4W1MY giving Jaime 39-219. His CW total goes to 239 with VK9GM, LB6XD and YJ1AB. .Andy, W6ENV, hits 246 with ZD7A. .G6ZO adds two, VS9AW and MP4BAM (Qatar) to reach 244. .W7DL, Bob, comes up to date with a list containing 49 additions to put him on 225. .W6GDJ pulled in OD5AB for number 227. .Maxine, W6UHA, submits 30 new ones to rise to 209 and then took over bookkeeping chores for the OM, W6TS, who goes to 225 with the help of such as ZP4BB, ZC2MAC, ZS2MI and FB8BB. .W1ZL ups to 198 with FB8BE. .W5MPG reaches 206 with VK9GM, I5GO and VP8AT. Rex welcomed cards from FG7XA, ZD9AA, ZD6DU, ST2GL, MP4KAC, VR4AE, CR4AD and CE7ZC, to mention a few, and states that a boat left VP8AT on Jan. 28th with a stack of QSL's aboard. .W9NZZ ups to 151 with 9S4AL, FQ8AP, VP5BH, FB8BB and 5A3TZ. .W3OCU adds ZS2MI, ZS8MK, FR7ZA, VS2CE and FL8MY to reach 224. .We list W2BJ at 198 with ZD7A and HZ1MY/VQ6. .ZS2AT comes up to date with 12 additions for 171. .Buck, W4RBQ, edges upward with FB8BB, VP8AP and VP8AT for 187. .W5KUJ keyed with OY3IGO, ZC4IP and MP4BBD to hit 181.

KG4AF goes to 180 with ZS9I, VS9AW and FB8ZZ. Burt leaves KG4 around August. .W2ZVS nabbed FB8BE and VQ3KIF for 143 and 4 while W6ZZ went to 125 with ZS3K and YS10. .W4AIX nabbed 28 zones and 79 countries since going on the air Oct. 18th, '52. Smitty is ex-W9NRB. .VP8AP has now added Ala, S. C., S. D. and Nev. and now only needs Utah for WAS. .W8WZ pulled off a five band QSO with LU1EP on Feb. 8th repeating a performance of 1938 when Doc was W8OFN. Starting at 1235 EST the last QSO on 3.5 Mc. was made at 2035. .W3OFM/VO hopes to get his VO permit renewed to take part in ARRL contest. See QTH's. .VK3XO nabbed FB8BE for No. 159. .VK3KB added EA9AX. .W4TO received QSL from MP4BAU and advises that AP5B is now SU1HS. Buck will handle QSL's for SU1HS. .W5WUW's third DX QSO was KV4AA. .W1CWX exhibits cards from FM7WH and LZ1KAB while W6BYH nabbed ZC5VS 1520 GMT, 7018. .OQ5CZ made W2CTO, KV4AA and W1CWX very happy. .W1DSF finally collected enough cards for DXCC. .W9FID got card No. 210 from LB6XD/LB8CH. .W8EKK added ZD7A and ZD9AA and rec'd. QSL from VP8AP. .Heard on a 7-Mc roundtable were W8PQQ, W6SAI and W9SRB/6. These gents may be remembered as 3A2AC, 3A2AF and 3A2AB, respectively. .W8ZY added YJ1AB and MP4BAU. .According to CE3DZ the three LZ stations now active are: LZ1KAB, 50 watts; LZ1AA, 50 watts, and LZ1KNB, 10 watts. All in Sofia. .DL7AA advises that a DL station will be active from HE on all bands. .VK5HI rose to 157 with MF2AG, C3BG, FN8AD and TS5IV. .W2EQG gathered in WAVE (Canadian) Certificate No. 96. .G6GN hooked ZD4AF, KP4JE, ZS1BK, FF8AG, KL7AJH and ZS5LB/MM on 7 Mc. The last being at ZD9. .W8HEV and W8YIN heard I1AHR/9A2 A3, 14150 on Feb. 11th. This probably represents I1AHR's jaunt to San Marino originally planned for December. .W6NZW nabbed TA3AA for No. 121.



At one time swinging your beam up north meant running into the signals of Fred Whiteside, W5AGB/FM, later KF3AA. The top view shows Fred at the operating position and the bottom photograph shows Dave Reynolds, the culinary expert (at the right), and Fred outside the "shack" they built with snow blocks and cargo drop chutes. The antennas consisted of a rhombic on Alaska, a family of Vee beams for 360 degree coverage, a three-element for 20, a ground plane for 20 and a 75-meter doublet buried in the snow. More news on Fred in the text.



Up on Eighty

The very tight and interesting race for first DXCC honors between W4BRB and W2QHH has been watched for some time and has been climaxed in a dead-heat between the two contenders. We are not quite sure, at present, whether the honors will go to the first one to present QSL's confirming DXCC or whether the actual time of QSO of No. 100 will be the winner. At any rate a big hand should go to both these stations. .W2QHH nabbed his century by QSO'ing 5A3TU on Jan. 30th and, with that behind him, ended a long and remarkable run of QRP operation by acquiring a VIKING transmitter so, henceforth, Howy will be in the 100-watt class. .Gene, W4BRB, who is also widely known for his 3.5-Mc activity, had 99 countries on Jan. 25th plus three doubtful ones, namely; ZB1AJX, OQ5BC and PZ1LZ from which no QSL's had been received. On Feb. 3rd. Gene worked VQ3KIF for No. 100 (for sure). Since then he has gone on to add EL2P, 9S4AX, LU4ZI, ZS9I and FF8AG which gave him a running start towards No. 200!!!

Eighty, in addition to the stations mentioned above, has been "real hot" with VP8AP working TI2PZ, SM6ACO, G5VB, VE1JD, FA8IH and DL1FF. .W6IBD knocked off VS6CG. .W2BBK nabbed VK5JE. .W2GGL keyed with FF8AG, TA3AA and SP3PL and W6ZAT, along with W6SAI, got 5A3TU. Other signals of note emanated from the fists of YN1AA, TA3AA, VP5BF and ZS3K.



One of the best signals from down-under comes from VK3XO. Lee Paul is an old-timer, having been active since 1919. An 807-807-813 rig may be seen on the right, with the home-brew, 19-tube, double conversion receiver in the center. The antenna is a three-element beam on a 40-foot tower.

160 Meters

The TRANSATLANTIC TESTS continue and we report as received from W1BB and others:

QRN was accented on the Jan. 11th test but, otherwise, conditions were excellent. A new record was made when W1BB worked OH3NY for the first W/OH QSO and went on to work G5RI, G5JU, GW3FSP, G6GM, G3PU, G3FGT and EI9J. . . W2QHH, with 16 watts input, nabbed G5RI and EI9J. . . W1LMU, also 16 watts, received an RST of 569 from G5RI. . . Paddy, EI9J, received special permission from his Government to operate on 160 for the TESTS only. . . G2NU says W1LYV peaked 599 at times while W1BB and K2ANR were 589. . . W9PNE did a fine job working G5RI, G2FGD, GW3FSP, G3PU and G6GM. He also added EI9J. . . EI9J was heard by W5ENE.

The January 25th TESTS were marked by generally poor conditions. No DX was heard out W9/WØ way. . . W1BB managed to work EI9J, G6GM and G3PU. Conversely it was one of the best nights at KV4AA who QSO'd W2EQS, W1BB, W3EIS, W1QJM, W9PNE, WØNWX, VE1HJ and W9NH.

On the Feb. 8th TESTS QRN predominated over all areas, and every few stations stayed on to work DX. W1BB worked EI9J and G6GM and received reports of 159 and 269 which gives an idea of the terrific QRN. KV4AA nabbed VE1EA, W1LYV, W2EQS and W3EIS.

W1BB has received encouraging reports from operations with his 257-foot vertical, Kytoon-supported antenna, but to date weather and wind velocity have been such that tests under ideal conditions have been impossible. Stew is still waiting for that calm, moonlit, crisp DX night when the wind won't drag it over to a 45-degree angle. . . W6KIP maintains a watch in his new Death Valley QTH. Alex has heard all W dists, but worked no DX as yet. He is on 1901 or 1999 kc. . . EI9J was country No. 10 for W1LYV. . . WØNWX QSO'ed ZL1NX on Dec. 28th. ZL1NX runs 50 watts with a 300-foot long wire. . . W2HCW uses a 66-foot base loaded vertical for 160 meters. His signals average S7 at KV4AA. . . G6GM recently celebrated his 68th birthday. Congratulations, and FB on 160. . . After working unaccounted W's on other bands G8KP hooked W2EQS for his first on 160. . . First two DX contacts for GI2ARS were W1LYV and W2EQS. . . VP4LZ, ex-W1EEC, is rockbound on 1982 kc., recent QSO's have been with W2QHH, W2EQS and KV4AA. . . A report from Matti, OH3NY (Feb. 1st), states the following stations were heard between 0607/0631 GMT: KV4AA 339, W1BB 449, W2HCW —, W3EIS 459. OH3NY holds forth on 1790 Mc. . . A report from John Hall, BSWL-2323, lists the following as heard between Jan. 1st and 18th: Phone: W2HCW, W2RYJ. On CW: VE's 1EA, 1HJ, 1YW, 2AIE, 3AAZ; W's, 1AYG, 1BB, 1LYV, 1QCA, 1QJM, 1DWO, 1HSC, 1RQR, 1LMU, 1SS, 1BEZ, 1TCR, 1WPN, 2AMC, 2BMC, 2WH, 2WWP, 2HCW, 2JPW, 2KNZ, 2EQS, 2TRK, 2QOS, K2ANR, 3AVL, 3EIS, 3RGQ, 3TBG, 3FUP, 3HL, 3FNF, 4POB, 4IRN, 4DTB, 4VUA, 4VFL8, 8NJC, 8DNB, 8HMF, 8SYJ, 8BKH, 8GDQ.

(Continued on page 62)

Prefixes by Zones for WAZ

- 1—KL7, VE8.
- 2—VO6, Northeast and North Central Canada.
- 3—VE7, W6, W7 (Wash., Ore., Ida., Utah, Nev., Ariz.).
- 4—VE3/4/5/6, W4 (Ky. Tenn., Ala.), W5, W8 (Except West Va.), W9, WØ.
- 5—FP8, VE1/2, VO1/5, VP9, W1/2/3, W4 (Fla., Ga., S.C., N.C., Va.), W8 (W. Va.).
- 6—XE, XE4 (Revilla Gigedo Is.).
- 7—FO7 (Clipperton Is.), HP, HR, KS4, KZ5, TI, TI9, VPI, TG, YN, YS.
- 8—CO/CM, FG7, FM7, HH, HI, KG4, KP4, KV4, PJ (St. Martins), VP2, VP5, VP6, VP7.
- 9—FY7, HK, PJ2, PZ, VP3, VP4, YV.
- 10—CP, HC, HC8, OA.
- 11—PY, ZP.
- 12—CE, CEØ.
- 13—Antarctica, CX, LU, VP8 (All).
- 14—CT1, CT2/CS3, DJ/DL, EA, EA6, EI, F, G, GC, GD, GI, GM, GW, HE, HB, LA, LX, ON, OY, OZ, PA/PI, PX, SM, ZB2, 3A2, 9S4.
- 15—HA, I, IS, IT, FC (Corsica), MI/9A1 (San Marino), OE/OE13/MB9/FKS8, OH, OK, SP, Trieste (I/AG2/MF2), UP, UQ, UR, YU, ZA, ZBI.
- 16—UA1/3/4/6, UB, UC, UN, UO.
- 17—UA9, UH, UI, UJ, UL, UM.
- 18—UA9/Ø (Eastern Siberia).
- 19—UAØ (Western Siberia).
- 20—JY/ZCI, LZ, OD5, SVI to Ø, TA, YK, YO, ZC4/MD7, 4X4.
- 21—AP (West), EP/EQ, HZ, MP4 (All), VS9, YA, YI/MD6, 4WI.
- 22—AP (East), AC3, Bhutan, CR8, FN8, Laccadive Is, Maldiva Is, Nepal, VS7, VU.
- 23—AC4, C8 (West China), Mongolia, Tannu Tuva.
- 24—C (Eastern China), C3 (Formosa), C9 (Manchuria), CR9, VS6.
- 25—HL, JA/KA, KR6.
- 26—HS, XZ, 3W8 (FI8), Andaman Is.
- 27—DU, KAØ, KC6, KG6.
- 28—CRIØ, Indonesia (PK1 to 7), VR4, VK9 (Papua, New Guinea), VS4/ZC5, VS5, VS1, VS2.
- 29—VK6 (Western and North Central VK), ZC2, ZC3.
- 30—VK2/3/4/5/7, VK1 (Macquarie Is.).
- 31—KB6, KH6, KJ6, KM6, KP6, KW6, KX6, VR1, VR3.
- 32—FK8, FO8, FU8/YJ, KS6, VK9 (Norfolk Is.), VR2, VR6, ZKI, ZK2, ZL, ZM6.
- 33—CN2, CN8, CT3, EA8, EA9 (inc. Rio de Oro, Ifni), FA, KT1.
- 34—SU/MD5, ST, 5A1/2/3.
- 35—CR4, CR5, EL, FD8, FF8, ZD1/2/3/4.
- 36—CR6, FE8, FQ8, EAØ, OQ5, OQØ, VQ2, ZD7, ZD8.
- 37—ET, FL8, CR7, 16/MI3/MD3, I5/MD4, MS4, VQ3/4/5/6, VO1, VS9 (Socotra Is.), ZD6.
- 38—ZS1 through ZS9, ZE, ZD9, Marion Is.
- 39—FB8 (Madagascar), FR7, VQ8, VQ9, Amsterdam Is, Kerguelen Is, Heard Is.
- 40—LB5 (Jan Maven Is.), Spitzbergen, TF, OX, UA (Franz Josef Land).

FREQUENCY CONTROL FOR MILITARY APPLICATION



MIL CRYSTAL UNIT	BLILEY CRYSTAL HOLDER	FREQUENCY RANGE MEGACYCLES	OPERATING TEMPERATURE RANGE (Centigrade)	FREQUENCY TOLERANCE OVER OPERATING RANGE
CR-15	AR	0.080 - 0.19999	-40° to +70°	± .01%
CR-16	AR23W	0.080 - 0.19999	-40° to +70°	± .01%
CR-18	BH6A	0.8 - 15.0	to +90°	± .005%
CR-19	BH6A		-55° to +90°	± .005%
CR-23	BH6A	10.0 - 75.0	-55° to +90°	± .005%
CR-24	BH7A	15.0 - 50.0	-55° to	± .005%
CR-27	BH6A	0.8 - 15.0	to +80°	± .002%
CR-28	BH6A		+70° to +80°	± .002%
CR-29	AR23W	0.080 - 0.19999	+70° to +80°	± .002%
CR-30	AR23W	0.080 - 0.19999	+70° to	± .002%
CR-32	BH6A	10.0 - 75.0	to +80°	± .002%
CR-33	BH6A		-55° to +90°	± .005%
CR-35	BH6A	0.800 - 20.0	+80° to +90°	± .002%
CR-36	BH6A	0.800 - 15.0	+80° to +90°	± .002%
CR-37	BH9A	0.090 - 0.250	+70° to +80°	± .02%
CR-42	BH9A	0.090 - 0.250	+70° to +80°	± .003%
CR-44	BH6A	15.0 - 50.0	+80° to +90°	± .002%
CR-45	BH6A	0.455	-40° to +70°	± .02%
CR-46	BH6A	0.2 - 0.500	-40° to +70°	± .01%
CR-47	BH6A	0.2 - 0.500	+70° to +80°	± .002%

BULLETIN NO. 43 CONTAINS A QUICK REFERENCE INDEX FOR MILITARY TYPE CRYSTAL UNITS---SENT UPON REQUEST

Bliley CRYSTALS

BLILEY ELECTRIC COMPANY
UNION STATION BUILDING, ERIE, PA.

MILITARY SPECS
+ DEPENDABLE QUALITY
+ RELIABLE DELIVERY
+ LONG EXPERIENCE (22 years)
Bliley CRYSTALS

NOVICE SHACK



Conducted by HERB BRIER, W9EGQ

Forward all mail to 385 Johnson Street, Gary, Ind.

Many readers probably remember the discussion of a few months ago about the relative merits of communications receivers. It started with one Novice saying that it was a waste of money to buy one of the cheaper receivers, because the results were so poor. This brought many, many letters from other Novices on the subject, and a representative selection was later printed in the *Novice Shack*.

The consensus of the majority of the letters was that the expensive receiver would do more than a cheaper one, though you could have a lot of fun and make many successful contacts with the latter. A point made by several was that knowing how to use a receiver had much to do with the results obtained. This is especially true of the more elaborate receivers.

This condition is not peculiar to communications receivers by any means. For example, for the Novice photographers, where the only adjustments possible are to wind the film and push the shutter release, one usually gets pretty good pictures. However, a Novice photographer may possess an expensive camera, with many fine adjustments, and yet take pictures that look like the interior of a coal mine during a power failure or of three ghosts wrapped in a sheet hiding in a snow-drift. Yet, the second camera is capable of taking excellent pictures under conditions where the first one would be useless.

Getting The Most From Your Receiver

Probably the first step in getting the full performance from your receiver is to read the instruction

book packed with it. Too often, the only time it is consulted is to identify the antenna and speaker terminals. Actually, a modern communications receiver is a complicated piece of equipment and merits at least as much care in tuning as you exercise in tuning your transmitter.

"You can't work 'em, if you can't hear 'em," is an old chestnut, but its truth is demonstrated every day. Very often, I hear Novices and other amateurs call CQ and have several stations call them, only to have them call another CQ—often before the replying stations have finished. It is also common to hear a station call and *raise* another one, without apparently ever knowing that his call had been answered. Because of the crowded condition of the amateur bands, a certain amount of this is inevitable, but you can minimize it by utilizing the full capabilities of your receiver.

Unfortunately, some instruction books are rather skimpy. Be that as it may, here are a few suggestions for adjusting and tuning a communications receiver to supplement the instruction book.

Allow the receiver to warm up thoroughly to minimize drift. Set it for phone operation. Beat oscillator off. Automatic Volume Control on. R-f gain control well advanced and the audio Volume Control moderately retarded.

If the receiver covers the broadcast band, turn the band switch to it, because broadcast stations are not likely to sign off right in the middle of your adjustments. Also, fading is usually less severe than it is on the higher frequency bands.

Tune in a fairly weak station for the clearest, most understandable quality, which should correspond to the maximum deflection of the S-meter—if any. Now shut off the AVC and play with the r-f gain and the audio volume controls. You will discover that you can regulate the volume from the speaker with either control. In general, maximum sensitivity occurs with the r-f gain well advanced and the audio control retarded. However, strong signals will easily overload or "block" the receiver.

Blocking is evidenced by the modulation becoming distorted, the volume from the speaker decreasing when the gain control is advanced above a certain critical setting, and the signal occupying more than its normal space on the dial. This spreading is the most serious problem to an amateur, because it is responsible for many strong signals being accused of being unduly broad.

Try setting the r-f gain control just below the



This is the compact station of W5VNT, operated by ex-Novice Rice Tilley, Jr. The QTH is Fort Worth, Texas. Equipment consists of a National NC-125 receiver and Viking II transmitter.

blocking point on a weak signal and then tune to a strong signal and note how broad it seems. Probably it will be impossible to read the stations on either side of the strong signal, because of the "splatter." Then, reduce the setting of the r-f gain control to eliminate the blocking, and advance the audio control to keep the speaker output the same. The chances are then excellent that you will be able to copy the adjacent-channel stations without difficulty.

I have devoted quite a bit of space to proper setting of the receiver volume and gain controls, because many Novices do not realize their importance. Note particularly that the signal that you are trying to copy may be too weak to block the receiver, but another one on a frequency considerably removed from it may cause all the trouble. Do not make the mistake of believing that is strictly a phone man's problem. It is not. However, some operators believe that turning on the AVC eliminates the trouble when receiving phone signals. The AVC action does help eliminate the blocking, but when a weak signal is being received, the r-f gain of the receiver becomes automatically high, and a strong signal spilling over from an adjacent channel can take control of the a-v-c circuit and swamp out the weak signal.

Setting The Beat Oscillator Pitch Control

After playing around with the volume controls, tune in the weak signal again, with the AVC off and the gain control retarded to eliminate any trace of blocking. Then turn on the receiver beat oscillator. Without touching any other receiver control, adjust the BFO pitch control for the most pleasing heterodyne tone from the speaker. If the note is not as well rounded as you think it should be, try decreasing the r-f gain and increasing the audio gain. The beat oscillator effectively modulates the incoming signal; therefore too much signal for the available oscillator output will result in a weak beat note.

In adjusting the pitch control, you will discover that there are two settings that will give the same beat note. Half way between them will be a setting producing no beat note ("zero beat"). Either setting may be used, but note the position of the other one for future reference.

Once the pitch control is adjusted, it will normally seldom require readjustment, unless you desire to change the beat note. Now slowly tune the receiver tuning dial. If you turn it one way, the beat note will gradually increase in frequency until it becomes inaudible. Turning the dial in the opposite direction will cause the beat note to decrease to zero and increase again to the **original pitch**.

The ratio of the signal strengths of the two beats depends on the selectivity of the receiver and the frequency of the beat note selected. The higher each is, the greater the ratio. With a cheaper receiver or a *surplus* one, like the BC-455, there may be almost no difference. In a receiver with high selectivity, however, the difference may be several S-units. A receiver in which it is pronounced is frequently called a "single signal" receiver.

Now, if you turn the pitch control to the "other side" of zero beat, the position of the strong and weak beat notes will be reversed with reference to the carrier frequency.

Naturally, it is desirable always to use the stronger beat note. A way to do this automatically is to set the pitch control always to the same side of the zero-beat position. Then always tune the receiver in

the direction so that the louder beat note is always heard first.

In a basic superhet without a crystal filter, these complete the preliminary adjustments, except for setting the band switch and the band-set dial to the appropriate positions for the band to be covered. Signals are then tuned in by careful adjustment of the band-spread condenser.

Adjusting the band-spread dial is somewhat of an art in itself. It should be tuned *slowly*, so that a desired signal is not inadvertently passed over. Yet, it should not be tuned so slowly that it takes five minutes to cover a small segment of the band. The usual tendency is to tune too rapidly, but I have seen one or two Novices go to the other extreme.

As the tendency is to work stations on or very near your own frequency, it is natural to tune around it first. Nevertheless, many Novices miss contacts by not tuning a reasonable distance either side of their frequencies. How much is a "reasonable distance" depends largely on how crowded the band is at the time. I suggest a minimum of twenty kc.



Yes, believe it or not, the station of WN4WKL and W4UVM, Fred Wimberly, Senior and Junior, respectively. Lt. Col. Wimberly will soon leave for another command and W4UVM will keep the home station going.

The Crystal Filter

The more the communications receiver costs, the more likely it is to have a crystal filter. The idea is to utilize the extremely high Q of a quartz crystal, ground to the intermediate frequency of the receiver, to increase selectivity. A good one effectively widens the amateur bands an almost unbelievable amount. Strangely enough, many amateurs never use theirs. There are several commonly advanced reasons for not doing so.

Some of them are: I always lose the station I am trying to copy when I switch in the crystal. . . .It cuts down the strength of signals too much. . . .It is too hard to tune the receiver with the crystal in the circuit. . . .I don't like the way signals sound with it in the circuit."

Such complaints indicate two things: One, that the crystal does increase the receiver selectivity greatly, and, two, that the operator does not know how to take advantage of it.

The way to avoid losing a station when switching in the crystal filter is to leave it in the circuit all the time in the first selectivity position until the going gets really tough. Doing this affords the further advantage of allowing one to get used to how the receiver acts with the crystal in the circuit, at times when one's entire attention is not concentrated on trying to copy through heavy interference.

The complaint that a crystal filter reduces the sensitivity of a receiver is largely psychological. The filter in most modern receivers actually increases the receiver gain slightly, except possibly in the maximum-selectivity position. However, the reduced band width so cuts down background noise and interference that it seems that the gain has been reduced. Even if the crystal filter should reduce the gain somewhat (as it does in the BC-348, similar surplus receivers, and in some of the older commercial models), the loss can easily be overcome by advancing the volume control a trifle. Here again, keeping the crystal always in the circuit eliminates the necessity of making mental adjustments each time it is switched in and out.

As for a crystal filter making a receiver harder to tune, this may be true with inadequate band spread. Usually, however, all that is necessary is to tune more carefully. This is surely not too much to pay for more successful contacts.



Will this be the youngest Novice licensee? The one-year old son of Robert Askley is getting off to an early start.

A crystal filter does have a tendency to change the sound of a receiver somewhat. The background noise takes on a ringing sound. The change is usually slight, except in the maximum-selectivity position. Often, when the ringing is objectionable, it is the result of too much gain ahead of the crystal. Try reducing the r-f gain a little and advancing the audio volume control.

Adjusting The Crystal Filter

As I have tried to imply, one of the most important requirements in using a crystal filter is to become thoroughly familiar with its operation. Tune in a broadcast signal as outlined earlier, then cut in the crystal filter. You will immediately notice that you must tune much more accurately in order to understand the modulation on the signal. Also, you will probably notice that as you advance the selectivity control, the apparent signal strength drops off, as far as the ear is concerned, but the S-meter remains right up there. This is because the extremely high selectivity is actually cutting the power out of the modulation sidebands.

Play around with the "phasing control." It is interesting to note how adjusting it will modify the crystal selectivity curve, as evidenced by having to reset the main dial a trifle to keep the signal in tune. As soon as you have the "feel" of the crystal's operation, especially the phasing control, turn on the beat oscillator and adjust the pitch control as already described.

With the crystal in the circuit, the signal on the other side of zero beat will be much weaker. Also by adjusting the phasing control, it is possible to reduce the strength of any desired beat note to practically zero, by getting it in the so-called rejection notch. This is a very handy feature. With it, you can frequently remove an interfering signal.

About the only thing left to do at this point is to tune the receiver down in the Novice bands and try the crystal filter on some real interference. I have a hunch you will be able to find some. Oh yes, many old-timers are convinced that any signal is easier to copy through a pair of phones than over a loud speaker. I am one of them.

Letters and General News

W8KYD writes, "Hi Herb. Thought I'd write to tell you that I knocked the N out of my call. I have worked thirty-one states and VE2, VE3, with eleven watts input to a 6AG7 oscillator feeding a $\frac{1}{4}$ -wave antenna. The receiver is an S-38B"—Ron, (age 17).

Here is a lad with rare good judgment. How about giving him a hand? "Dear Herb, I have been reading CQ for many years and think it is about the best magazine on the market today. I am an SWL and would like to become a Ham. I would like you to print part of this letter and get me some help with the theory. I know the code and can draw all the diagrams in the License Manual, but that theory has me stopped. I am twenty-six and a veteran. Do you think I am too old to start learning code and theory, hi?"—T. G. (Tom) Thompson, Box 347, New Addition, R.F.D. #1, Knoxville, Maryland.

WNØNAE writes, "Dear Herb, I think W9SQP is right in not hearing anyone on 27 Mc. The only ones I know who are up there are myself with an HT-17 with twenty-five watts input, and WNØMZX, with a TR-75TV2. I think we had better be getting more Novices on 27 Mc., when the band is open, or we will lose the band. I just got my license two weeks ago, but I have been listening in the Novice Bands for over a year. I think if more Novices would send slower and smoother, instead of fast and rough, they would get a lot more contacts. Oh yes, my receiver is an S-41G. and WNØMZX has an S-40."—James Boyer . . . From WN5WMN, "Dear Herb, I read about Mickey, W5UTE, in the January column, and I thought I'd write you another letter from Mississippi. When I went down to take my Novice examination in Jackson, I met Mickey, and he is really FB. The age here is fifteen. I am waiting for my General Class ticket. When I get it, I will be on twenty and forty meters. On eighty, I have worked twenty-six states with a twenty-watt rig. My mother will soon be a Novice. She will really enjoy it."—Charles, WN5WMN.

WN4YRF says, "Dear Herb, I got my license on December 5th. I made my first contact the next day with W4UUF. My third one was with WN9USP in Illinois. Since then I have worked twenty-five states. The rig is an Eagle-X, with thirty-five watts input. Antenna is an end-fed Hertz, and the receiver is an S-38B. My big thrill would be to work a W6 or maybe a VE! Besides that I wish the stations I have worked, who have not already done so, would send me their QSL cards. I am fourteen years old, and my brother is W4VZD/5 at the University of Mississippi."—John, WN4YRF. . . So you think you have your troubles? Listen to this. "Dear Herb, I have qualified for both a Novice and Technician license but have not been able to prove to the FCC that I am a citizen of the United States; therefore I have not been granted a license. To while away the time, I build equipment instead of operate and I listen on all bands constantly. I am a Sophomore at the National Central High School and president of the school radio club. I think that doing a lot of listening on the amateur bands will teach you more about operating procedure than reading all the books in the country. But we have lots of kids coming to the club who want to become Hams, but they won't take the time to do a bit of listening. I certainly agree with WN4VKE about the importance of giving honest reports. If someone were to give me a good tone report and I found out that it wasn't true, I'd be so mad I'd like to hit him with something light—like a transmitter. I'd like to exchange letters and pictures with others in the same fix as I am. 73"—Barrie Smith, 1709 W. Stoddard, Spokane, Wash.

WN8KOW describes an antenna that will interest any Novice with limited space. He says, "Dear Herb, my transmitter is a converted Command Set with seventy-five watts input. With it I have worked thirty-nine states, thirty-seven confirmed. This is probably not an outstanding record, but it indicates how my little antenna works. I enclose a picture of it. The antenna itself consists of a bamboo pole, eleven feet long. It is one inch in diameter at the bottom and $\frac{3}{8}$ inches in diameter at the top. Starting at the tip, 150 feet of plastic-covered, "bell" wire is close wound down the pole. Then the winding is continued, but with approximately one-

(Continued on page 52)



opportunities

AT

BELL TELEPHONE LABORATORIES

A career for you with one of the nation's leaders in research and development in communications and military electronics.

ELECTRONIC TECHNICIANS DRAFTSMEN
ELECTROMECHANICAL TECHNICIANS

Openings require previous training at high school, armed service school, or technical institute level and in general 2 or more years of applicable industrial or military experience.

Other positions generally open for experienced Wiremen and Machinists for experimental development work.

Send your name and address for application, telephone collect within 100 miles for information, or visit us Monday through Saturday. Evening interviews arranged.

BELL TELEPHONE LABORATORIES

WHIPPANY, N. J. (Near Morristown)
 WHIPPANY 8-1000 EXTS. 326, 300
 MURRAY HILL, N. J. (Near Summit)
 SUMMIT 6-6000 EXTS. 3259, 3381

Order Yours Now!

VIDEO speed SERVICE SYSTEMS

\$4.95
 POST-PAID

Contains over 600 Service Items representing over 500 of the most-serviced Television models now in use. Over 25 different manufacturers' lines are covered.

The expansion type ring binder (of finest quality) is 9 x 12 inches, holds all 224 pages of VSSS Vol. I, and has room for another year's supply of VSSS Data Sheets. Opens flat for bench use. TVset models and chassis are cross indexed for speedy reference.

Video Speed Service Systems IS GUARANTEED To Simplify Servicing All TVsets

TEAR OFF AND MAIL NOW

RADIO-TELEVISION SERVICE DEALER
 67 West 44th Street, New York 36, N. Y.

Please send me post-paid VIDEO SPEED SERVICE SYSTEMS Volume I as soon as available. Enclosed herewith is my check money order for \$_____for_____copies at \$4.95 each.

Name

Address

City Zone..... State.....



(from page 50)

half inch between turns, to within a few inches of the bottom. About 195 feet of wire are required. As can be seen from the picture, I have the bamboo pole fastened to a stick in ground, giving an over-all height of approximately twenty feet. The antenna is connected to the transmitter through a short length of wire and is tuned by the original antenna network in the transmitter. (A conventional pi-network output tank or link-coupled antenna tuner should also work—Herb.) I have been told that the antenna has $\frac{1}{4}$ -wave characteristics. Of this I am not sure. The only thing I am sure of is the excellent results I have had with it. The antenna is not of my design. W8GNX told me about it. Some one else told him about it. If I had not heard about it, I probably still wouldn't be on the air, because I do not have room for a horizontal antenna."—Bill, WN8KQW.

Bill, W4VUA, has a challenger. W5VNT writes, "Dear Herb, Saw W4VUA's question in January CQ whether any other Novice had had 500 contacts in 4½ months. I haven't had as many contacts as Bill, but I wasn't a Novice as long as he was either. In forty-eight days of Novice operation, I worked 211 separate sta-

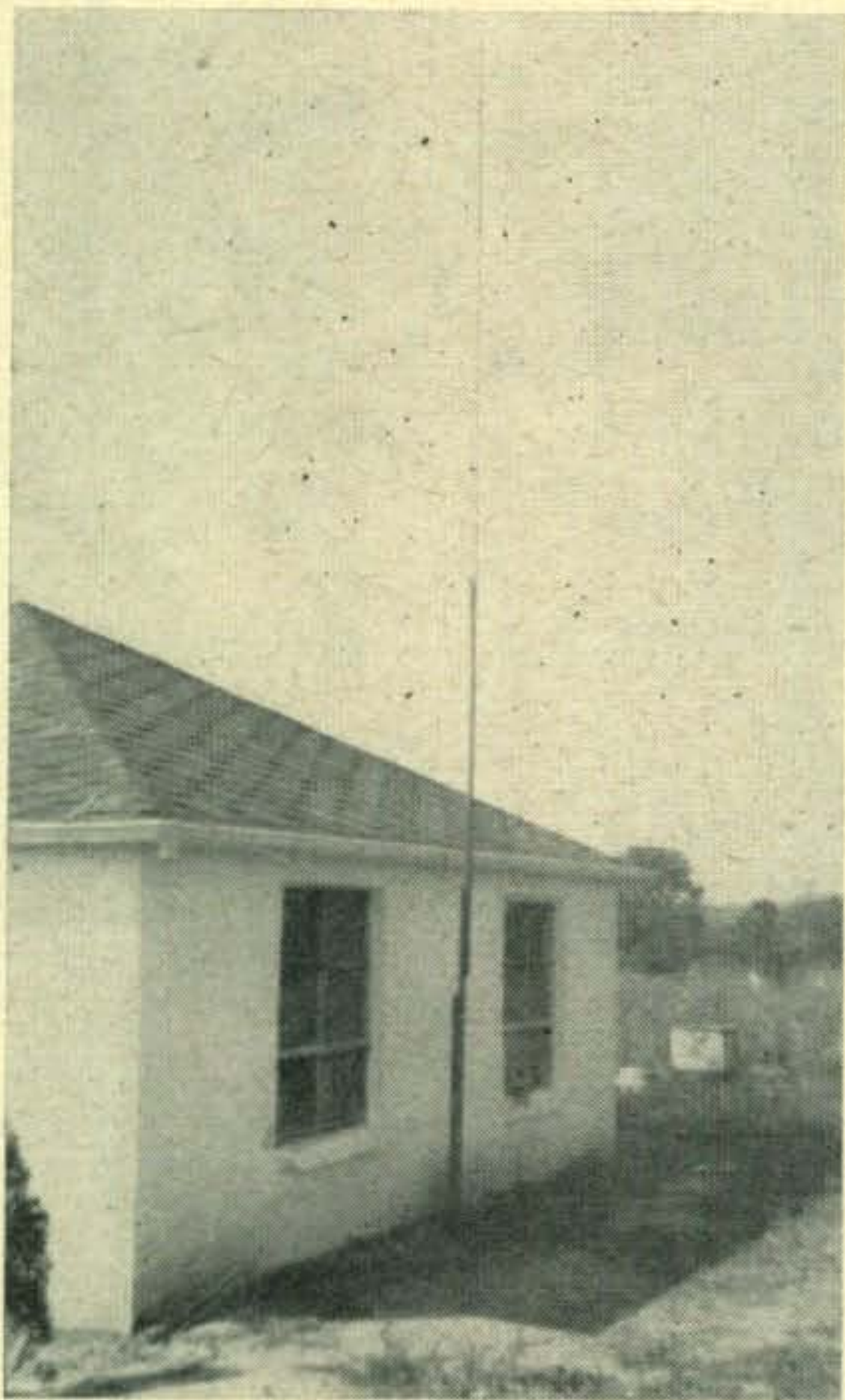

The antenna at WN8QKW is only twenty feet high with the top ten feet consisting of bell wire wrapped around a bamboo pole. Bill has worked 39 States on 3.7-Mc. in a few months.

tions. This figures out to an average of 4.4 contacts a day, compared to W4VUA's 3.6 contacts a day. Bill has me beat on DX and States confirmed, though. My Novice transmitter used an 807 with fifty watts input. I now have a Viking II transmitter and a NC-125 receiver."—Rice, W5VNT.

Fred Haney sends some news from North Carolina, but forgot to include his call. He writes, "I'm not the only WN in Elizabeth City now. After I got my license, Heywood decided to get his. Starting on the code on Monday, he was sending six w.p.m. by Wednesday. Thursday, he studied theory, and on Friday, he, I and another lad went to the FCC office in Norfolk. Heywood passed and received the call WN4YDI. I don't know whether this is a record, but it sure is fast. He is using fifty watts input to a home-brewed transmitter, an indoor antenna, and an S-76 receiver. He is working out quite well. Harris, WN4WGD, is also located in Elizabeth City, but he is not active now. Could you get me the name of some Ham in Salisbury, Maryland? A friend of mine (a YL, hi) moved there recently, and I would like to make a schedule to talk to her through one of the high-power boys here. She is agreeable, if we

can find someone in Salisbury to cooperate."—Fred Haney, c/o WGAI, P. O. Box 426, Elizabeth City, N. C.

WN4WKL writes, "Dear Herb, Most of your publications in CQ are about fathers who are General Class licensees with sons who are Novices. However, in this case, the reverse is true. I am the Novice and got my training from my son. The enclosed picture was taken in our shack at Fort Jackson, South Carolina. Since I am going to the Far East soon, we are to move our rig to Camden, S. C. and hope to continue operation from there soon. 73."—Fred M. Wimberly, Sr., Lt. Col., Infantry, Commanding, Hdq., 13th Infantry, 5th Infantry Division, Fort Jackson, S. C.

A few months ago, I mentioned that many of the cards and letters I received had my call as W9EGO, instead of W9EGQ. I wondered if W9EGO was plagued with cards from stations he had never worked. He is. The other day, I worked K7FAB in Washington, operated by W9EGO. He said he had received quite a number of DX card through the bureau, from stations he had never worked. If it happens to me, it can happen to others; therefore, I suggest that you be especially careful in writing call letters to get them right.

Another suggestion that I want to make is that you include both your address and call letters when you write to the Novice Shack. I have received a number of letters recently with one or the other, or both missing. As a result, I know there must be several Novices waiting in vain for a reply that will never come. Please put the information in the letter as well as on the envelope. I usually discard the envelope, and, unless I notice that the address is missing from the letter, I may inadvertently throw away an address.

Out of space again. Keep writing and sending pictures.

73, Herb, W9EGQ

Book Reviews

Electrical Fundamentals of Communication by Arthur L. Albert, published by McGraw-Hill Book Company, 330 West 42nd Street, New York 36, N. Y. 531 pp. and 363 illustrations, 6¼ x 9. Price \$7.00.

This is the second and greatly revised edition of one of the most frequently used books in our technical radio schools. It is also a fitting companion to the authors other book on radio fundamentals. Having taught school from both of these books I can say without reservation that they represent the best texts for people interested in learning more about radio, but who feel handicapped without college or university training. Anyone with a high school education need have no fear of being swamped with mathematics or non-practical illustrations.

Since it has been some ten years from the publication of the first edition the author has had the opportunity to add that material of greatest importance in the current trend of electronics. Emphasis appears on such subjects as electroacoustics and measuring instrument, while many of the other chapters have been entirely rewritten with greatly improved illustrations, etc.

The current edition contains sixteen chapters and the appendix on natural trigonometric functions. Each chapter has an excellent summary, review questions and number of problems at the end. The answers to the problems are available from the publisher.

o. p. f.

"High Fidelity Simplified" by Harold D. Weiler. John F. Rider Publisher, Inc. 480 Canal St., New York 13, N. Y. 208 pages \$2.50.

This profusely illustrated paperbound book contains a rather complete course in high-fidelity basics which should prove of interest and value to the semi-technically trained man with an interest in the field.

The audiophile who wishes a firm ground from which to argue will find many details in this book with which he can bait and hook fellow (but not so well read) audiophiles.

High fidelity is a rapidly expanding hobby and has its own techniques, circuits, and jargon. The discussions in audio circles over which amplifier or speaker is better than the other is just the same as Ham discussions of which is the better receiver.

W2NSD

The Newcomer's Buyway

"The Dispatcher"



Here's a Controlled Reluctance microphone assembly designed to handle the most severe requirements of radio amateur rigs. The "Dispatcher" is supplied with two-conductor shielded cable, and it's wired to operate both microphone and relay circuits. This field-proved unit is used extensively in police, railroad, airport, and all

emergency communications work where dependability is vital. Of special interest to "Hams" is the large, easy-to-use grip-bar and positive action of the heavy-duty switch. Firm downward pressure on the grip-bar locks the switch—so you can "yackety-yack" all night without lifting a finger! The "Dispatcher" is immune to heat and humidity and will stand up under rough usage. It is manufactured by Shure Brothers, Inc., 225 West Huron Street, Chicago 10, Illinois. It's a high-impedance unit with a high output level of minus 52.5 db. Lists at \$35.00. See the "Dispatcher" at your Distributor for further details, or write Shure Brothers, Inc., 225 West Huron Street, Chicago 10, Illinois.

BUD

HI-PASS FILTER



Eliminates or greatly reduces television interference from short wave broadcasting, amateur radio stations, diathermy and X-ray equipment, automotive ignition systems or other similar sources.

HF-600 High Pass Filter is designed to have a cut-off frequency at 42 megacycles. It is within this range that the majority of the signals causing interference would be received. Since there is no attenuation above 42 megacycles, picture strength or quality is not affected.

The filter is housed in an attractive aluminum case $3\frac{1}{4}'' \times 2\frac{1}{8}'' \times 1\frac{1}{8}''$. See it at

your Bud distributors today or write for literature.

Amateur net \$3.00

BUD RADIO, INC

2118 East 55th Street, Dept. C., Cleveland 3, Ohio

ATTENTION MOBILE HAMS

Complete mobile package—nothing else to buy. Outstanding mobile signals use MOTOROLA equipment—backed by years of communication equipment experience—World's largest producer of 2-way mobile equipment.

A mobile transmitter with a double feature FM or AM at flip of the switch, the MOTOROLA FMT-30-DMS (27-30 M.C.) **\$130.00**

MOTOROLA P-69-13 or 18-ARS receiver with special noise limiter for use with any converter having 1440-3000 K.C. **\$60.00**

100/96" Master Mobile Whip Antenna **\$5.25**
132S Master Mobile Stainless Steel Spring—Double Tapered **\$10.75**
New Gon-set Tri-Band Spread Converter **\$47.60**
Gonset "Super 6" Converter **\$52.50**
P-327-E Fire wall loud speaker **\$7.50**

The above comes complete with all necessary accessories and mounting hardware. Order direct or through the Motorola National Service Organization member in your area.

NOTE: This Receiver and Transmitter is equipment which has been returned from the field, modified and rebuilt for Amateur Service.

Above units subject to State and Federal Excise Tax where it applies.

For further information write to:

MOTOROLA C & E INC.

AMATEUR SALES DEPT.

1327 W. Washington Blvd. Chicago 7, Illinois

Attention: Harry Harrison, W9LLX

Telephone—Taylor 9-2200 Ext. 161

We don't fix flats or tune up engines . . .

but when it comes to mobile radio gear for that limousine of yours, it'll pay to make ALLIED your headquarters. Amateur mobile enthusiasts all over the country depend on ALLIED for the



finest in mobile radio gear. Because of our wide selection of equipment and large stocks, shooting an order into ALLIED means getting the mobile equipment that you want—when you want it! And of course, you can always count on that famous Ham-to-Ham service—a big reason ALLIED has always been Amateur Radio's leading supply house. So whether you require a tube of

anti-static powder for the spare tire or a complete mobile installation, you can be confident your order will be given our very best. For full details on the finest and latest in Amateur mobile equipment, be sure to go through our big 1953 Catalog and Catalog Supplement No. 133. If you don't have copies, just drop a card to ALLIED RADIO CORP., 833 W. Jackson Blvd., Dept. 16-D-3, Chicago 7, Illinois.

to the

E.E. or PHYSICS GRADUATE

with an interest

or experience in

RADAR or ELECTRONICS

Here is
what
one of
these
positions
offers you

Hughes Research and Development Laboratories, one of the nation's large electronic organizations, is now creating a number of new openings in an important phase of its operation.

OUR COMPANY

located in Southern California, is presently engaged in the development of advanced radar devices, electronic computers and guided missiles.

THESE NEW POSITIONS

are for men who will serve as technical advisors to the companies and government agencies purchasing Hughes equipment.

YOU WILL BE TRAINED

(at full pay) in our Laboratories for several months until you are thoroughly familiar with the equipment that you will later help the Services to understand and properly employ.

AFTER TRAINING

you may (1) remain with the Laboratories in Southern California in an instruction or administrative capacity, (2) become the Hughes representative at a company where our equipment is being installed, or (3) be the Hughes representative at a military base in this country—or overseas (single men only). Adequate traveling allowances are given, and married men keep their families with them at all times.

YOUR FUTURE

in the expanding electronics field will be enhanced by the all-around experience gained. As the employment of commercial electronic systems increases, you will find this training in the most advanced techniques extremely valuable.

How
to
apply

If you are under 35 years of age and have an E.E. or Physics degree and an interest or experience in radar or electronics,

write to

HUGHES

RESEARCH AND DEVELOPMENT
LABORATORIES

Scientific and Engineering Staff
Culver City,
Los Angeles County, California

Assurance is required that the relocation of the applicant will not cause the disruption of an urgent military project.

A Crystal-Control Adapter

for the BC-696

HENRY R. GREEB, WØFVD

R.F.D. #1, Tecumseh, Nebraska

Many Novices possessing "Command" transmitters hesitate to dig into their oscillators to convert them to crystal control. By grounding an unused pin on the oscillator tube socket and using WØFVD's adapter, changing from variable-frequency to crystal control or vice versa takes less than a minute.—Editor.

Wishing to convert a BC-696 to crystal control for Novice operation, I hit upon a very novel way of doing so. A plug-in adapter, using parts costing less than \$3.00, changes the 1626 from a variable-frequency to a crystal oscillator. As it requires no modification of the oscillator, v-f-o operation may be restored in a matter of seconds. *Figure 1* and the picture shows the simplicity of the adapter.

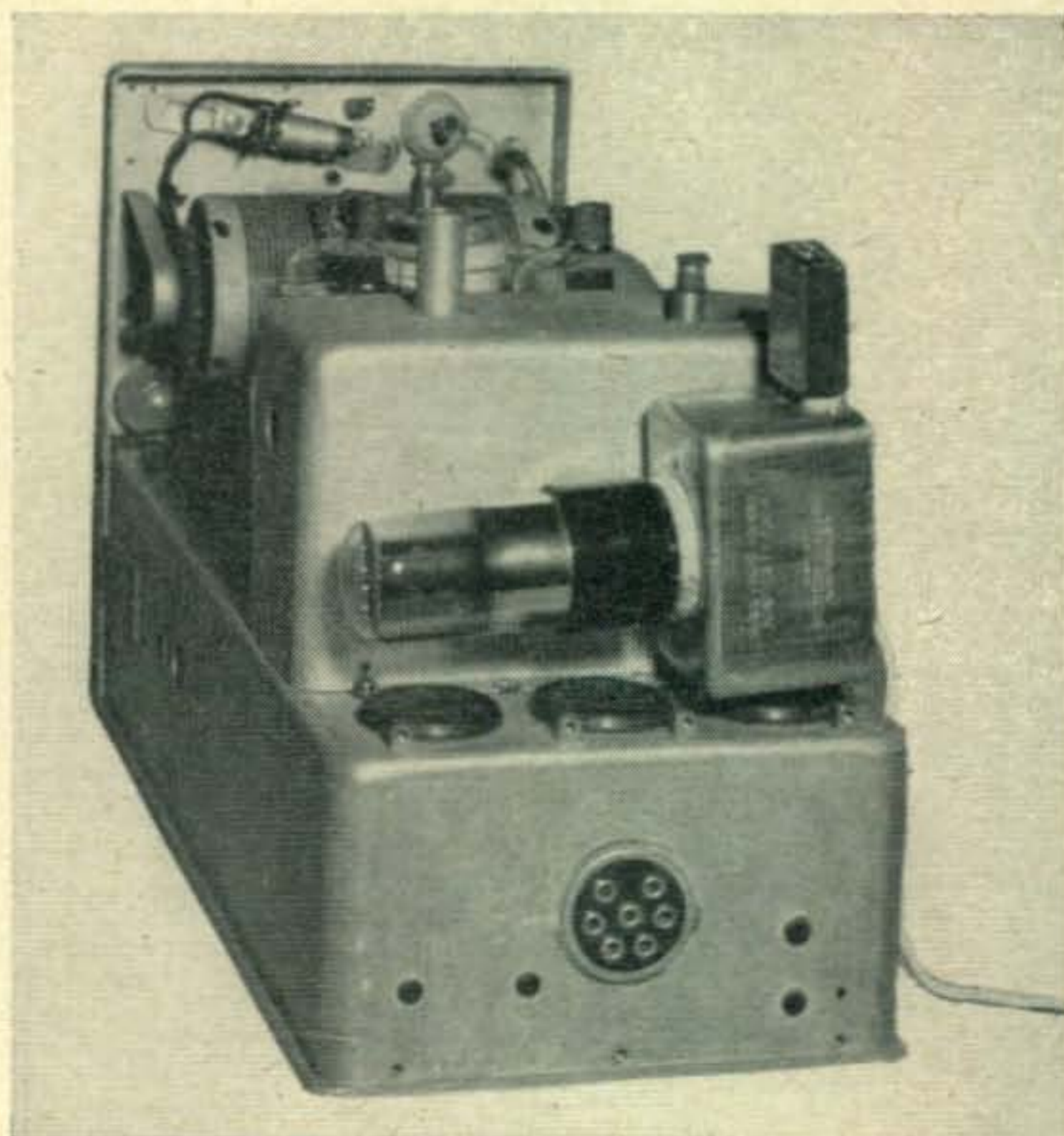

The plug-in adapter is simplicity in itself. The 1626 v-f-o oscillator tube is removed and the adapter with either a 6J5 or 6C5 (for 6-volt operation) is inserted. The calibrating crystal and the 1629 tube are also removed to make room for the adapter. In the above photograph the wire shown leading to the right is a special 6-volt lead used by the author.

This unit was built in an FT-203A adapter from a BC-454. However, a U-bracket, about $1\frac{1}{2} \times 1\frac{1}{2} \times 2$ inches, will work satisfactorily. The parts arrangement shown in the picture utilizes the available space to good advantage. One word of caution is in order. Do not apply too much pressure while drilling the holes, as the thin aluminum is easily bent.

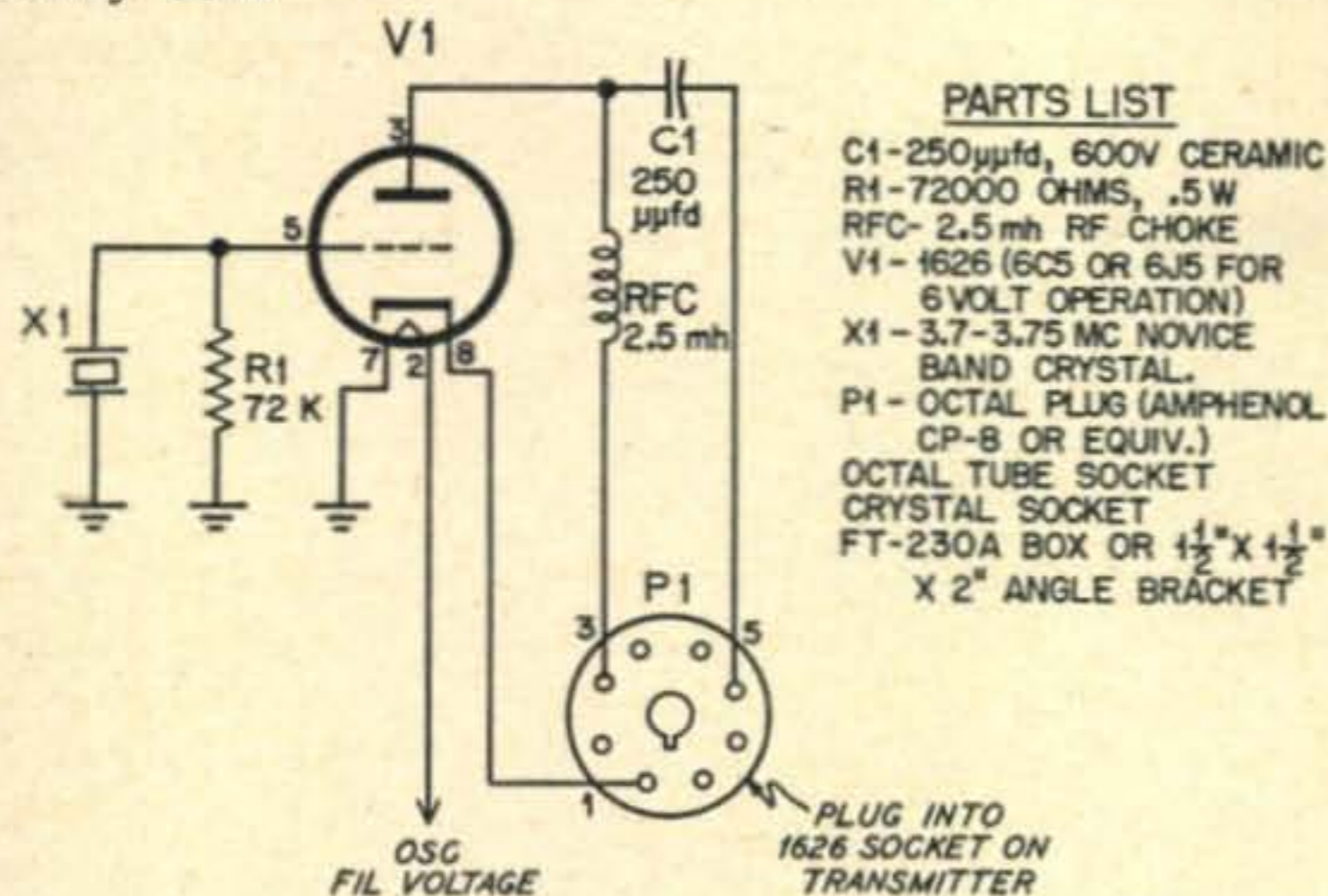

Fig. 1. The wiring schematic reveals that only a very few parts are required. The only circuit change in the Command transmitter is to ground pin #1 of the 1626 socket.

Much of the wiring may be done before the parts are mounted. Mount the tube socket with the keying slot down and the plug P1, with its key to the front.

To prevent possible shorting, insulate the r-f choke, RFC, with a layer of tape before wiring it into the circuit.

The only modification required in the BC-696 itself, besides those usually made for amateur operation, is to connect pin 1 of the 1626 socket to the nearest ground lug.

Remove the 1626 and 1629 tubes and the calibrating crystal from the transmitter. Plug the 1626 and a Novice-band crystal into the adapter, and plug the adapter into the 1626 socket. The unit is now ready for testing.

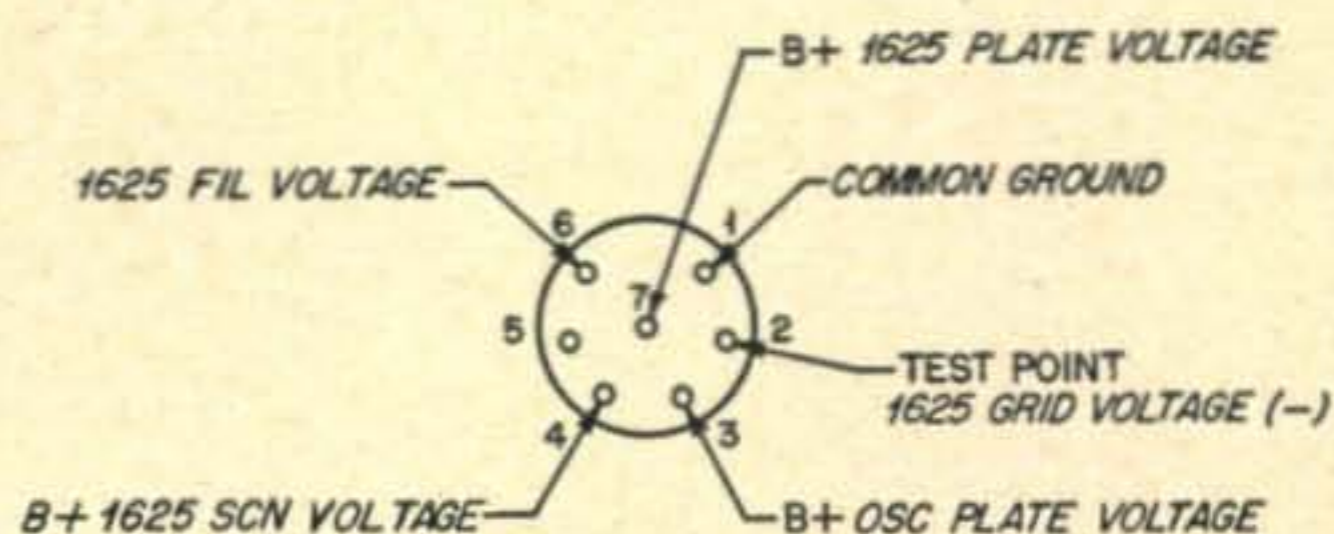

This view of the Command transmitter power plug is shown for reference purposes.

Testing

Apply filament voltage between pin 2 of V1 and ground and to the 1625 filaments. Connect a 100-volt, d-c meter between pin 3 of the power plug on the transmitter, the positive meter terminal to ground and the negative one to the pin.

Set the transmitter dial approximately 100 kilo-

...for heavy duty!

B&W TYPE CX

Butterfly Variable Capacitors

"THE ARISTOCRAT OF ALL VARIABLES"

Perfect electrical and mechanical symmetry.
Short R-F paths.
One unit assembly of coil and capacitor.
Built-in neutralizers optional.
Provides maximum compactness in high-powered final stages.
Extra heavy, highly polished, rounded edge plates.

Mounting brackets for vacuum condensers are available for padding and extending the tuning range for low-frequency operation. Type CX capacitors are supplied with air-gap spacings of .500"—.375"—.250". Standard plate thickness is $\frac{1}{16}$ ", but $\frac{3}{32}$ " plate can be supplied on order. Write for catalog.

B&W products are featured by leading distributors

BARKER & WILLIAMSON, Inc.
237 Fairfield Ave., Upper Darby, Pa.

cycles above the crystal frequency and apply a maximum of 250 volts, d.c., to pin 4 of the power plug. Quickly tune the dial for maximum meter deflection, consistent with the crystal starting every time oscillator plate voltage is applied.

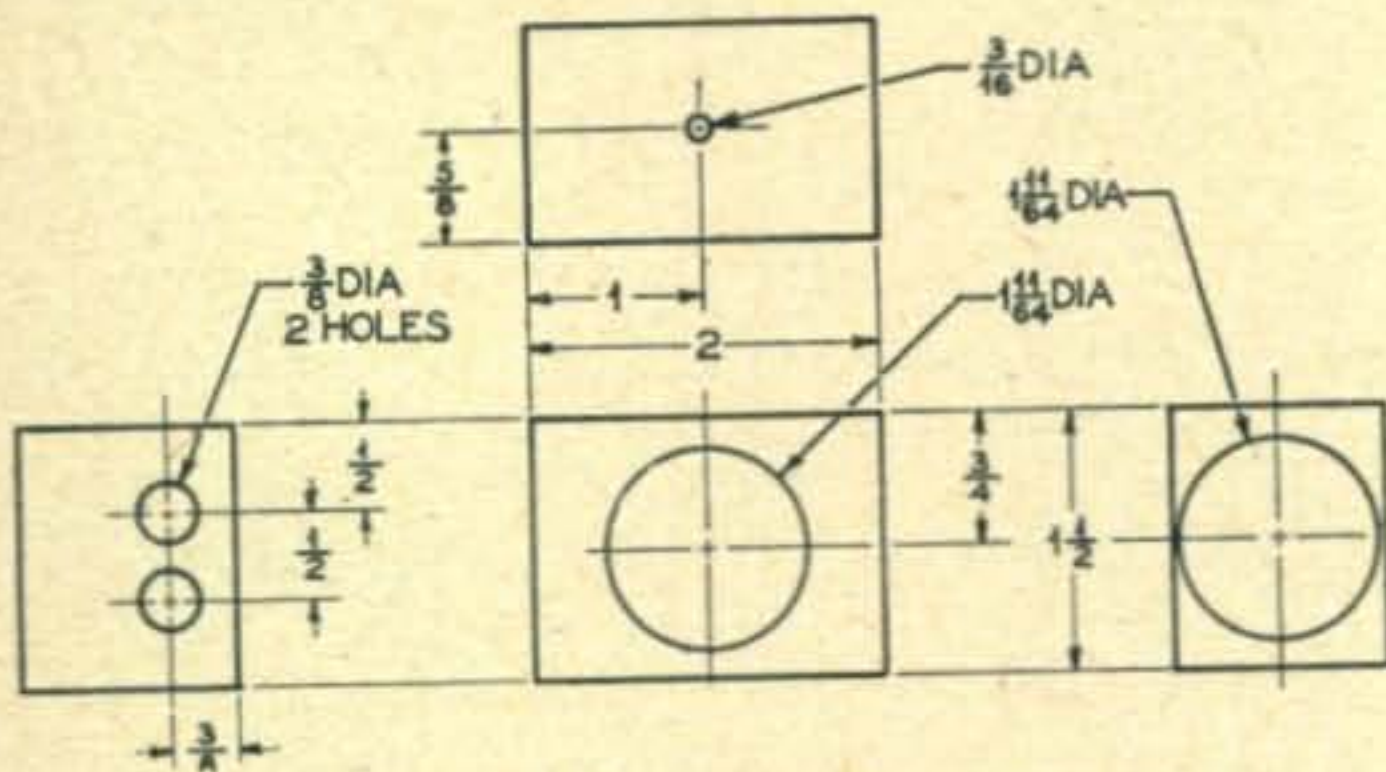

Suggested adapter chassis layout.

Now apply plate and screen voltage to the 1625's and adjust the amplifier padding condenser for minimum plate current. Antenna tuning and loading follow standard procedures described many times in CQ and other publications.*

Several methods of keying have been tried with this transmitter. The most foolproof method was cathode keying of the 1625's. Oscillator plate and amplifier screen keying also works fine, but oscillator tuning becomes rather critical.

* See especially "The Novice Conversion of a Command Transmitter," R. M. Smith, W1FTX, and W. E. Bradley, W1FWH. QST, November, 1951, page 22.

(This adapter should work equally well with a BC-459 and an appropriate crystal on the new 7.2-Mc Novice band. Also, the BC-457 will tune to the 3.5-4.0-Mc band by setting the oscillator and amplifier padding condensers to approximately maximum capacity. Similarly, the BC-458 will cover the 7-7.3 Mc band by decreasing the capacity of the padding condensers somewhat—Editor.)

Please Note!

The CQ editorial offices were astonished a few weeks ago to suddenly note that at least 20% of the incoming mail was misaddressed. A very large group of readers were sending their manuscripts, contributions, complaints, etc. to the old address on Madison Avenue in New York City. Although we have been at 67 West 44th Street for nearly two years, many readers apparently have failed to note that the offices have been moved.

In addition, there is certainly nothing more frustrating for the Managing Editor than to open a completely mis-addressed letter which starts off, "Dear Doc Hayes: I am a constant reader of CQ and follow each issue faithfully" (!!!!).

If you have any reason to send a letter or postcard to CQ, please be sure that it is completely and properly addressed. This will insure prompt delivery to the party for which it is intended. By the way, the Circulation Manager is not responsible for missing manuscripts, nor is the Managing Editor responsible for changing your subscription mailing address!

PE-101C DYNAMOTOR, 6 or 12 VOLT—(Reprints of original CQ conversion articles, Oct. & Dec., '52 furnished). This is the Dynamotor the Hams have been talking about. Easily adapted to supply 625 V. @ 152 MA and 325 V. 125 MA at 12 V.—or 300 V. 90 MA and 160 V. 110 MA at 6 V. (Illustration modified).



Price **NEW: \$4.95**

RECEIVERS—TRANSMITTERS:

- TA-12B TRANSMITTERS with Tubes—Used \$39.95
- MP-28 BA Power Supply & Modulator f/TA-12B—New \$29.95
- R1/ARR-1 Receiver—easily converted to 220 MC. (see R.N. Jan. '49). Complete with Tubes—New \$ 4.95
- RTJ/APN-1 Transceiver—420 MC., complete with Tubes and Dyn.—NEW: \$24.95 USED: \$19.95

TRANSFORMERS AND CHOKES:

- TRANSFORMERS — 110 V. 60 CYCLE PRIMARIES:**
- 5 Volt CT-25A — 10,000 V. Ins. OPEN FRAME—6" x 5" x 4 1/2" \$7.95
- 6.3 V. 1 Amp. \$1.25 24 V. 1 Amp. 1.95
- 24 V. 1/2 Amp. 1.50 24 V. 6.5 Amp. 5.95
- 6-24- or 30 Volt Amp. 5.95
- 440 VCT/70 MA — 5 V. 2 A.—6.3 V. 4 A. 3.35
- 460 VCT/90 MA — 5 V. 3 A.—6.3 V. 4 A. 3.75
- 325-0-325 V. 50 MA.—6.3 V. 2.5 A.—6.3 V. .6A. (Reot. 6 x 5) Half Shell—2 7/8" x 3 3/4" x 3"—No. T-23-28 2.75
- 175-0-175 V. 40 MA.—6.3 V. @ 2.4 A.—6.3 V. @ 6 A. Halfshell 2 2 1/2" x 2-3/16" x 2 3/8"—No. T-23-40 1.25
- 350-0-350 V. 90 MA.—6.3 V. @ 3 A.—5 V. @ 3 A. Upright—3 1/8" x 3 1/8" x 3 7/8" 3.25
- CHOKES**
- 5 Henries—150 MA 85 ohms DC-Res. Cased. \$1.95

- PE-157 POWER SUPPLY—2 V. Vibrator Supply, operates from BB-54 2 V. Battery mounted in Case. Output voltage 1.4 V. 1/2 Amp. 125 V. 50 MA. Less Battery, Speaker & External Power Cord—with Vibrator. \$4.95
- POWER SUPPLY No. 3 f/Mark II No. 19 Radio Set. 12 or 24 V. Two PM Dynamotors: 500 V. 50 MA.; 275 V. 110 MA.—New \$12.95
- PE-104 Vibrator Unit f/BC-654 \$10.95
- 550C Vibrator f/PE-104—New \$ 1.95

ADDRESS DEPT. CQ • MINIMUM ORDER \$5.00 •

RECEIVER AND TRANSMITTER

- RECEIVER BC-229—TRF Receiver with 3 Plug in Coils to cover Freq. Range 201 to 398, 2500—4700, 4150—7700 KC. With 6 Tubes: 1/37—1/38-3/39. Power required: 6 or 12 Volt & 250 Volts. Size: 16" x 8" x 7". Schematic included \$8.95
- TRANSMITTER BC-230—Voice Modulated Trans. with 5 Plug in Coils to cover Freq. Range 2500 to 7700 KC. With 4 Tubes: 2/10y—2/45—& RF Meter 0—1.5 Amps. Power Supply required: 6 or 12 Volt & 350 Volts. Size: 13" x 8" x 7". Schematic included \$8.95
- SPECIAL BUY—BOTH REC. & TRANS. \$15.00



ANTENNA EQUIPMENT

- MP-132 MAST BASE—(Illustrated) 1" heavy coil spring. 2" insulator. Overall length: 11 1/2". Weight: 2 3/4 lbs. Price. \$3.95
- MP-S-33 MAST BASE—Insulated type with heavy coil spring and 5 inch dia. insulator. Requires 2" hole for mounting. Weight: 9 lbs. \$5.95
- MAST SECTIONS FOR ABOVE BASES:**
- Tubular steel, copper coated, painted, in 3 ft. sections, screw-in type. MS-53 can be used to make any length with MS-52-51-50-49 for taper. Any section 50c each
- Larger Diameter Section: MS-54. \$1.25

COMMAND TRANSMITTERS With Tubes & Crystals

- BC-459 Transmitter—7 to 9 Mc.—Used. \$14.95
- BC-456 Modulator—New \$5.95 Used 2.95
- Transmitter Rack—Single \$1.50 Dual 2.00
- Rec. Rack—Dual \$1.50 Modulator—Mtg. 1.50
- Rec. Dyn.—Used \$2.95 Trans. Dyn.—Used 2.95

- AERIAL WIRE—Phosphorus Bronze #16 Stranded, 200 lb. test. Weatherproof. 150 ft. on Reel. RL3 with Clips \$1.50
- TELEPHONE WIRE: 3 Cond. copper & steel, 525 ft. \$4.75

DYNAMOTORS

- DYNAMOTOR and BLOWER: 9 Volts DC input; output 450 Volts 60 MA. 4500 RPM. At 6 Volts DC input; output 260 Volts 65 MA. 3000 RPM. \$4.95

Input:	Output:	Stock No.:	Price:
14 V. DC	600 V. 300 MA.	BD-86	\$ 9.95
14 V. DC	375 V. 150 MA.	DM-375	8.95
14 V. DC	330 V. 135 MA.	DM-330	7.95
14 V. DC	500 V. 500 MA.	PE-59	14.95

PRICES F.O.B. LIMA, OHIO • 25% ON C.O.D. ORDERS

CONELRAD

(from page 18)

the circuit, regardless of the position of the speaker switch.

- The contacts for the external-controlled circuit will open, breaking the a-c line to the Ham transmitter antenna change-over relay, effectively putting the Ham station in the "receive" position.

Naturally, it is conceded that a momentary broadcast carrier break due to overload at the broadcast station will simultaneously cause a break in any transmissions taking place at the Ham station. Since the speaker comes on immediately, the

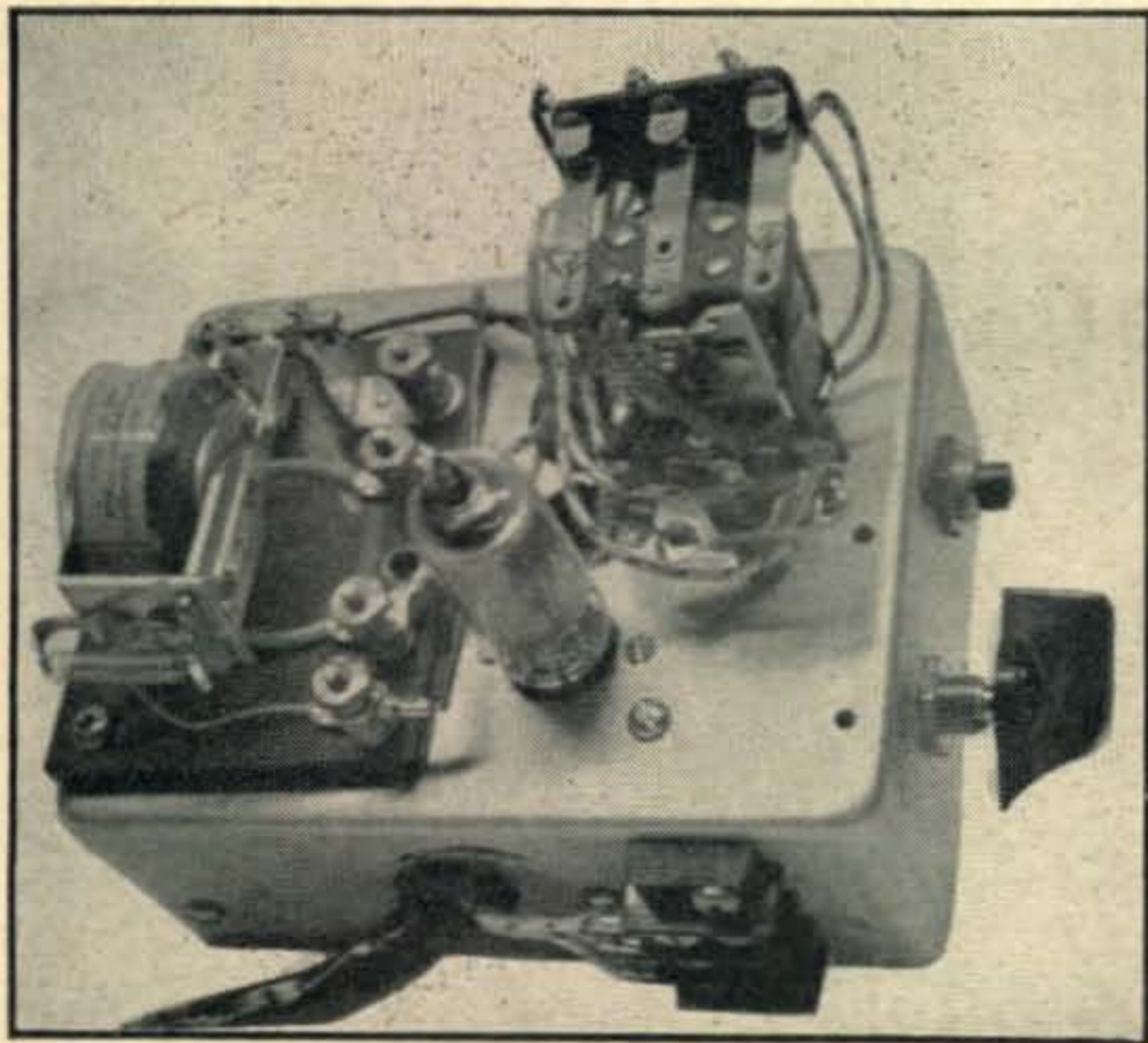

Shown above is a top view of the "alarm" constructed by the author. The reset switch, Sw2, is on the side of the chassis at the upper right. The terminal strip at the bottom permits wiring changes to the controlled circuit. In the photograph below note that the filament transformer is only used because of the 12-volt series of tubes in the broadcast receiver.

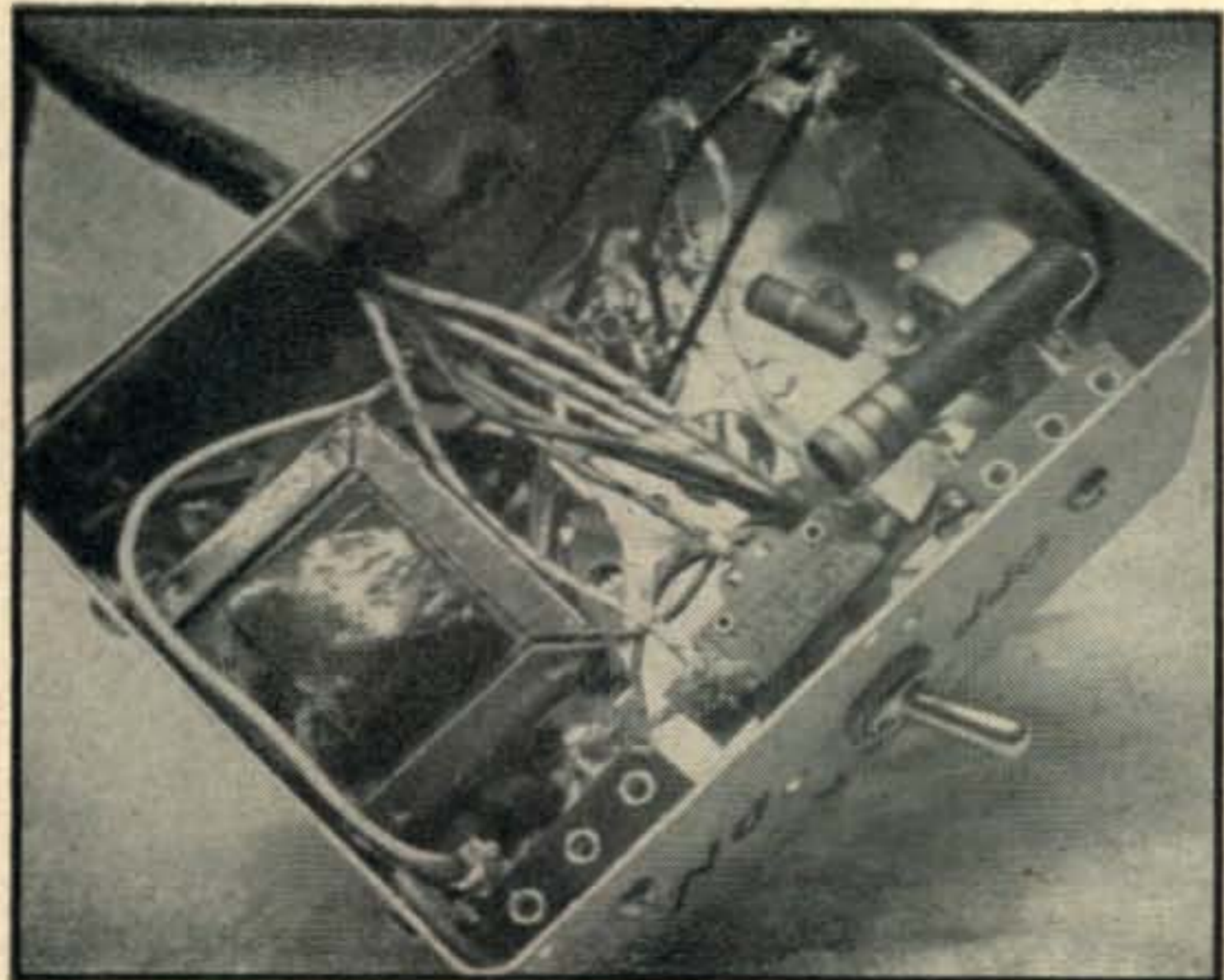

A SENSITIVE RELAY

Closes at 4 to 5 ms. (Extra set of SP/ST contacts for additional sequence, close at 6.5 ms.) Coil 6000 ohms. Sensitivity easily altered by bending limit arm or changing spring. Only 1 1/2" x 2 1/4" x 1 1/4" overall. Dozens of applications, and offered at a "stock up" price. Removed from clean equipment.

ONLY 98c each, 3 for \$2.75

Boxed, reconditioned, like new.....\$1.69

NOVICE BARGAINS

4-5.3 COMMAND XMTR. Convertible to 80 meter CW Novice operation. With schematic and step-by-step conversion instructions. Excellent used, with all tubes.....\$8.95

5.3-7 COMMAND XMTR. Also convertible to Novice operation with two more steps. With instructions. Excellent used, with tubes.....\$7.95

TELEGRAPH KEY J-43. New, heavy contacts. ONLY \$1.25

6-9.1 mc RECVR, excellent, with tubes and schematic \$6.95

LOCAL CONTROL KIT for above. Contains rear plug, front panel adapter parts, and spline tuning knob. ALL FOR \$2.25

THERMADOR 5A-1225 POWER TRANSFORMER. PRI: 115 v, 50/60 cy, SEC: 600-440-0-440-600 v, 250 ma; 6.3 v, 3 A; 6.3 v, 3 A, 5.0 v, 3 A. Type "A," fully enclosed. Ideal for average Ham rig. We furnish schematic. New manufacture, guar. 1 year. Ship. wt. 17 lbs. Only \$10.80

THERMADOR 5A-7220 POWER TRANSFORMER. PRI: 115v, 50/60 cy. SEC: 740 V CT, 250 ma. 6.3v, 3A, 6.3v, 3A, 5. Ov, 3A. Ship. wt. 12 lbs.....Only \$7.95

6 V VIBRATOR TRANSFORMER. Non sync, two outputs: 700 VCT, 145 ma for plates, 15 v for bias. Using 5U4G can deliver 320 V at 130 ma.....NEW \$1.89

With 6 V vibrator \$2.89

12V FILAMENT XFORMER or line voltage booster PRI: 110 v 60 cy.; SEC: 9 to 13 volts in 1 volt steps at 3 A. Free schematic shows many uses.....NEW \$1.89

OUTPUT TRANSFORMER, 5000 ohms input to TWO outputs, 300 ohms or 3.5 ohms. Use as output for 12A6, 6V6, etc. or to match speaker or headset. NEW, potted, shielded 79c

12 CHANNEL T-V TUNER

Complete front end, famous make "Silver Circle." Furnished with original factory instructions, less tubes. Dozens of uses: receivers, converters, etc. The bargain of the year for builders, amateurs, students. These are factory rejected for minor damage.....ONLY \$1.95 each, 3 for \$5.00

Send for our Latest Flyer

G. L. ELECTRONICS, Dept. A

905 S. VERMONT AVE., LOS ANGELES 6, CALIFORNIA
All Prices FOB Los Angeles, Calif. Buyers add Sales Tax

AT ANY PRICE...
you couldn't ask for more
in a MOBILE TRANSMITTER!

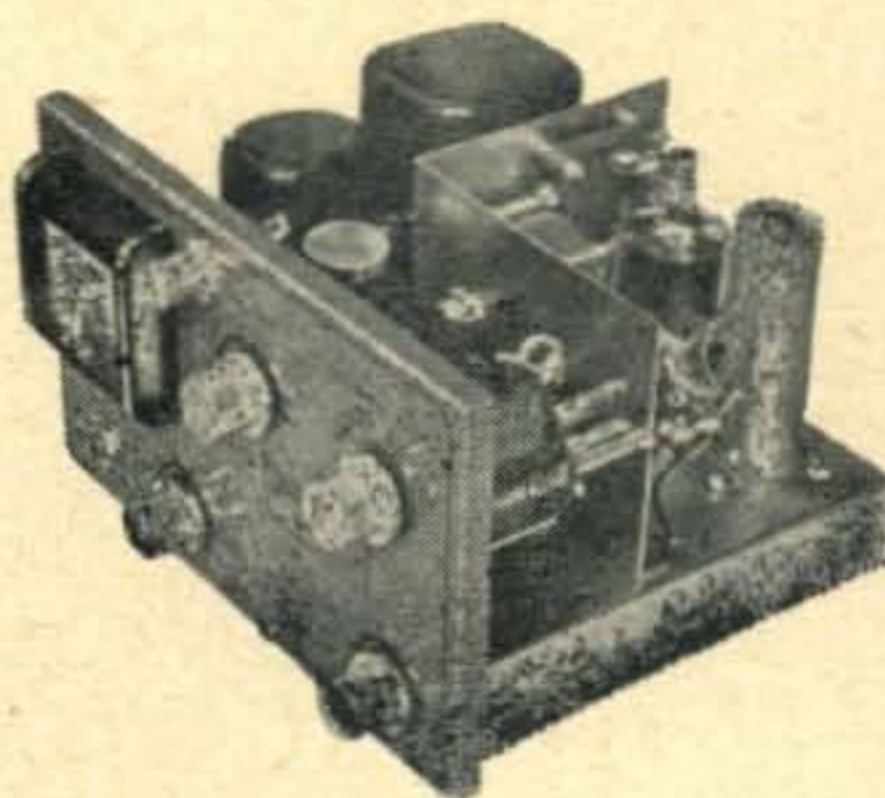

40 WATT BABCOCK MOBILE D-X MITTER

6 BAND—BAND SWITCHING

• 2 Bands (3.5—7.3 mc) (14—30 mc)

• 2 Crystal Frequencies per band

• Instantaneous Antenna Change-over with LS-1 or LS-2 Units into 8 ft. whip

only \$99.50

HAM NET

Priced to Gain Volume Sales among Discriminating Ham Operators

PRICE INCLUDES TUBES

Features:

Finest Components available

6BK5 oscillator

6146 final amplifier

Complete Metering, including Watts output into 52 ohm antenna load

Small Size—5" hi., 8" wi., 7" d.

Readily adaptable to mobile or home use.

ABSOLUTELY GUARANTEED

Write for Free Literature and name of your nearest dealer.

BABCOCK RADIO ENGINEERING, INC.
7942 Woodley Ave., Van Nuys, Calif.

EICO 221 or MERIT M-345 VTVM

4 1/2" meter with adjustable pointer to zero center for TV & FM discriminator alignment. AC-DC Ranges: 0-5/10/100/500/1000 V. 5 Resistance Ranges: .2 ohms—1000 megs. DB scale for audio and gain measurements. Completely wired & tested—ready for use—**SPECIAL**



WHILE THEY LAST!.....\$34.95

HEADSETS

- HS-23 high impedance. BRAND NEW with ear pads\$5.95
- HS-33 low impedance. BRAND NEW with ear pads, cord and PL 54 plug..... 6.45
- HS-33—BRAND NEW—Western Electric 7.25
- CD-307A Cords, 6 ft., NEW..... 1.49
- SPECIAL!**
- HS-16 high impedance—used..... 1.29



Radio City Products

Model 449

VOLTOHMMETER

AC-DC output: 1000 V. ohmage up to 2 megs. In metal case with zero adjusting knob on front panel. Ready for use. **ONLY A LIMITED NUMBER LEFT—SO RUSH! SPECIAL!**\$14.95



TUBES

- 1B2269c
- 1B23 ..\$3.75
- 2B2249c
- 2C2609c
- 2C26A ..09c
- 3B22 ..\$1.19
- 3C2498c
- 3D639c
- 7C439c
- 10Y19c
- 12KSY ...39c
- 15R39c
- 39/44 ...29c

BRAND NEW! JAN! BOXED

- 100R49c
- 114B29c
- 215A09c
- 221A29c
- 304TH \$5.95
- 316A29c
- 388A59c
- 471A ..\$1.19
- 532A ..\$1.19
- 722A99c
- 801A19c
- 82639c
- 84129c
- 84317c

TUBES

- 86419c
- 95413c
- 161649c
- 162529c
- 1626 ... 19c
- 162922c
- 719319c
- 900269c
- E1148 ...49c
- RK3499c
- VR9214c
- VT127 ...15c

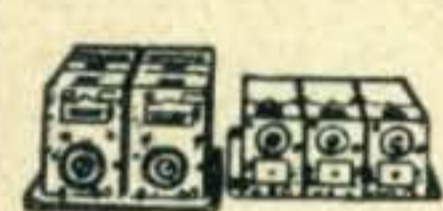

SCR-274N COMMAND and ARC-5 EQUIPMENT

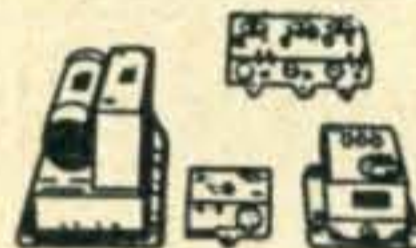

	USED	Excellent USED	NEW
RECEIVERS			
BC-453—190 to 550 KC.....	\$29.95		\$49.95
BC-454—3 to 6 MC.....			24.95
BC-455—6 to 9 MC.....		\$13.95	19.95
1.5 to 3			34.95
TRANSMITTERS			
A-958—2.1 to 3 MC.....			29.95
BC-458—5.3 to 7 MC.....	7.95	9.95	17.95
BC-459—7 to 9.1 MC.....			24.95
T-15 ARC 5—500 to 800 KC			29.95
ADDITIONAL EQUIPMENT			
BC-456 Modulator	2.45	2.95	5.95
BC-450 Control Box (3 Receiver)	1.49	1.95	2.75
BC-451 Control Box (Transmitter)	1.29	1.79	2.39
BC-442 Relay Unit (ANT)....			5.69
Plugs: PL-147, 148, 151, 152, 153, 154, 156—EACH		1.25	
Flexible Shafting with gear to fit receivers			2.69
3 Receiver Rack	1.75	2.29	2.98
2 Transmitter Rack	1.69	2.39	3.97
Single Transmitter Rack			3.97
DM-32 Dynamotor for Command Set.		3.95	5.95
DM-33 Dynamotor for Command Set.		2.95	3.95
Mounts for 2 Trans. Rack, 3 Rec. Rack, Modulator, & Antenna Relay Unit.....		1.95	

MINIMUM ORDER \$2.00. Send 25% deposit on C.O.D. orders. All shipments F.O.B., N.Y.C. (N.Y.C. residents add sales tax.)

PLATT ELECTRONICS CORP.

Dept. C, 489 BROOME ST., N.Y. 13, N.Y.
PHONES: WO 4-0827 and WO 4-0828
BRANCH STORE: 159 Greenwich St., N.Y.C.

amateur will be able to hear if the broadcasting resumes without the 1000 cycle "Radio Alert" tone signal. If the broadcast station continues its scheduled program, the operator can reset and resume normal operation.

Resetting is accomplished through the push-to-break switch, *Sw2*, which opens the plate circuit of the 2D21.

The current path in the 2D21 will open *Ry1* and will drop out *Ry2*. This, in turn, will extinguish the red light and the green light will come back on. The speaker will go off (if the speaker switch, *Sw1*, has been placed in the off position) and the controlled circuit will again function normally.

The voltage applied to the grid of the 2D21 will depend upon the strength of the signal being monitored. The value of *R2* should be set at a point just past the cut-off for the 2D21 thyatron.

The speaker switch, *Sw1*, permits "silent," or aural, monitoring of the broadcast carrier. The resistor, *R3*, should be of a value equivalent to the voice coil impedance in order to provide proper loading of the output transformer when the receiver is used for "silent" monitoring.

The system described has been in use for several months and appears to work in a completely trouble-free fashion.



HE WAS CALLED "OLD MAN"
BUT JUST FOR A YEAR.
THIS YOUNG HAMS DEMISE
DREW MANY A TEAR.
"SISSIES," HE BOASTED,
"I'LL DRAW THE ARC..."
AND HE DID... HIS SHACK'S
NOW PERMANENTLY DARK.



FOLLOW ARROW FOR BIGGEST STOCK AT LOWEST PRICES

- RADAR—TRANSMITTERS
- RECEIVERS — TUBES — PARTS

SURPRISE PACKAGE!

lbs. of good
20 usable radio \$2.95
parts

RT-34/APS-13 420 MC. TRANSCIVER with 5 stages of 30 MC. IF amplifier strip. Less tubes & R.F. section. With dynamotor. **\$6.95**

ARC-4 TRANSCIVER
140-144 MC. Complete with control box, tubes, 12/24 VDC dynamotor with schematic. This is a special reduction for this month only. Like new. **\$32.50**
MT 101 ARC-4. NEW. \$6.00

TUBES: 250TL. \$11.50 250TH. \$14.50

MP-22 MOBILE ANTENNA. MOUNTING RACK
Complete with hardware. New. \$ 3.95

TU-17 TUNING UNIT, (2-3 MC.) For BC-223 Xmtr. Used 2.95

1-70 "S" TUNING METER. New. 2.50

WOBLATOR. See p. 43 Dec. '51 RADIO NEWS 5.95

BC-1023 75 MC. MARKER BEACON RECEIVER.
Complete with tubes mtg. jack, NEW. 10.95

TU-25 TUNING UNIT, (3.5-5.2 MC.) For BC-223 Xmtr. Used 2.95

IN-4A L/R TUNING METER. Used. \$ 3.95

FL-5 RANGE FILTER. 1.25

BC-1033 75 MC MARKER BEACON RECEIVER.
Complete with tubes. P.U.R.

FIELD TELEPHONE, EE-8. Complete BRAND NEW. SPECIAL. ONLY 27.50

TUBES!	TUBES!	5CP1	\$4.95
16JP4 \$19.95	3FP7 \$2.25	5BP4	4.95
16AP4 24.95	304TH 8.95	5FP7	2.25
16DP4 19.95	830-B 2.75	304TL	8.95

TOP \$ \$ \$ PAID FOR NEW AND USED ELECTRONIC GEAR! WHAT HAVE YOU TO SELL?

- HS-18 HEADSET.** 8,000 ohms. New. \$2.45
- HS-23 HEADSET.** High imp. New. 4.95
- HS-30 HEADSET.** Featherweight type. Low imp. NEW. \$2.49 USED. 1.49
- HS-33 HEADSET.** Low imp. New. 6.95
- HS-38 HEADSET.** USED, excel. cond. 1.49
- NEW 3.50
- T-32 DESK STAND MIKE.** Good, used cond. 2.75
- LIP MIKE.** Navy type. New.98

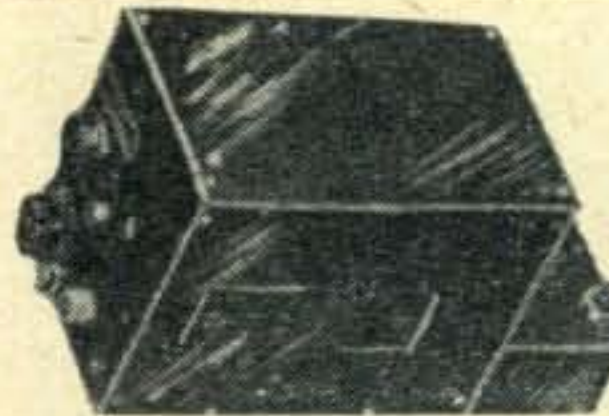

234 - 258 MC RECEIVER

11 tube UHF tunable receiver with schematic **\$17.95**
LIKE NEW \$3.50
Rack \$3.50
Control Box 1.50

BC-709 INTERPHONE AMPLIFIER. With tubes, less batt. With manual. NEW. \$ 3.95

CD-307 EXTENSION CORD. For HS-23-33. NEW .95

RS-38 MIKE. NEW. \$4.95 USED. 1.75

BC-605 INTERPHONE AMPLIFIER. With dual mike input circuit. NEW. 5.95

RM-13 COMPLETE REMOTE CONTROL BOX. For 3 separate transceivers. With handset, decibel output meter and EE-8 ringer unit, 110 V. AC operated. Excel. cond. 29.50

FL-8 RANGE FILTER 1.95

\$5.00 MINIMUM ORDER ACCEPTED. All shpts. F.O.B. whse. Cal. residents add sales tax with remittance, 20% dep. Specify shpg. instructions. Send for FREE Catalogue, No. 112.

ARROW SALES, INC.

Mailing Address: P.O. Box 3878-Q N. Hollywood, Calif.
Office-Warehouse: 7460 Varna Ave., N. Hollywood, Calif.
PHONE: Poplar 5-1810 CABLE ADDRESS: Arrowsales

70% of all CQ readers keep their copies for three or more years.

(reader survey)

Yes—but, how many of those thousands can find just the back issue they want?

Those with a CQ BINDER can!

Why not invest in a CQ Binder and be sure of having at your fingertips one of the finest reference libraries on Ham radio.

Each binder is steel reinforced and bound in a handsome red fabricord. They are designed to comfortably hold a full year's copy of CQ. With a simple operation any desired month may be inserted or removed from the binder.

Price **\$2.50** Postpaid*

*(Foreign Orders add 25c per binder.)

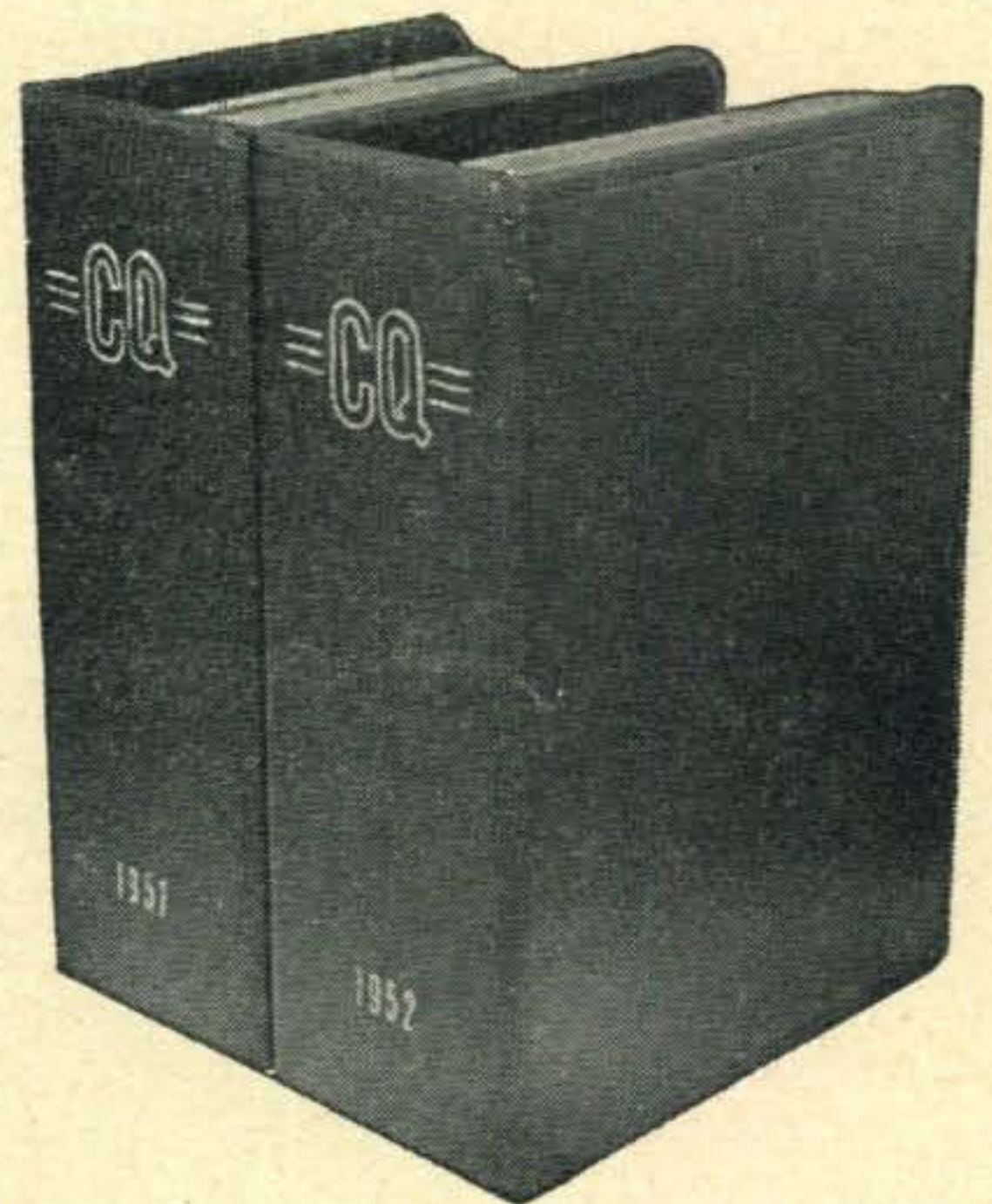

CQ Magazine
67 West 44th St., New York 36, N. Y.

Enclosed find \$..... for binders

Name Call

Address

City Zone State

Year to be stamped..... Heading: CQ, Plain

TWIN-LEAD folded dipole



Buy the kit and assemble your own HAM ANTENNA

Tested — tried and proven components from which to build your HAM ANTENNA—complete with full instructions for assembly. Build for permanence and performance with quality components.

complete
kit . . .

- 2 lengths of #16 copper-clad steel conductor twin-lead — cut to band length.
 - 1 75-foot length of standard 300 ohm twin-lead for lead-in.
 - 1 high strength laminated "T" block.
- Assembly and installation instructions.

Cut to 10, 20, 40 and 80 Meters

We all strive for the best in transmission and reception characteristics—now with the Amphenol Amateur Antenna Kit you are assured of the *BEST*. Designed by electronics engineers for the most efficient service.

amateur net as low as
\$535 for 10 meters

see your **AMPHENOL**
radio parts distributor

AMERICAN PHENOLIC CORPORATION

A Lament to CQ From an XYL

My husband plans a brand new rig
And shows me how he'll work it.
Then you come forth and spoil the jig
By showing a new circuit
You lure the ham by diagram,
Your articles weave magic.
Perhaps you do not givadam
That their effect is tragic.
I realize you are a "must",
Your writers are terrific.
But here is why I get so fussed,
Dear Sir, I'll be specific:

As XYL, I understand
That rigs can never be so planned
They utilize the things on hand
And fire up right on every band,
And that is all there's to it.

Ah, no! the wiring must be checked
Lest labvrinthine maze defect
Deceive the ham, most circumspect,
And leave his fuse-less rig sore-wrecked
And him the time to rue it.

Or else a coil must be rewound
Or this connection sent to ground
Or hidden "finals" (stored) be found
Or fifty dozen hams around
To show how they would do it!

I know the challenge and the charm
Down on this antenna farm.
But life is sweet and life is fair,
For he, at last, gets on the air.

He *would* be on the air, I say,
Tra-la-la-la, Hooray! Hooray!
Except that CQ comes one day
And leads him out to see their way.
CQ, CQ, CQ, CQ-it!

Now, here's a simple thing, he cries,
And kilowatts light up his eyes,
As through your precious mag he flies
To see just how he should revise
The rig he's just completed.

A little circuit change is all.
It's true this chassis is too small.
And, yep, these tubes won't do at all.
We'll give the surplus store a call.
Alas, he's not defeated.

Defeated? Wow! Electrified,
He hies him to the shack
And all because of you, CQ,
He starts his building all anew,
And bids his other rigs adieu.
So, on with the attack!

P. S. I'm told the undertaking
Is most exciting in the making.
Commercially that may be well
But does not please an XYL.

Sincerely,
Helen V. Ferguson
XYL of Fred Ferguson, W6GED

SINGLE SIDEBAND

(from page 24)

lator, *V3a*, is as described previously. The frequency of the carrier crystal should be chosen so that it is 20 db. down the low-frequency slope of the filter characteristic. The low-frequency skirt of the mechanical filter is generally steeper than the high-frequency skirt. This fits in nicely with our plans as we originally wanted to generate an upper-sideband.

Carrier balance is obtained by adjusting *R18* and *C14* for minimum carrier output. It may be necessary to connect *C14* to point *B*, instead of *A*, as shown in the schematic. The carrier amplitude at points *A* and *B* should be 2 volts r.m.s., as measured with the r-f probe of a VTVM. The amplitude of the audio voltage across the cathode follower load, *R10*, should not exceed 0.2 volts r.m.s.

The i-f amplifier, *V4*, is necessary to make up the insertion loss (26 db.) of the mechanical filter before going into the mixer as described in *Fig. 2*.

The particular circuit parameters shown were tried by the author and worked "first crack out of the box." If carrier insertion is desired, the arrangement shown in *Fig. 2*. is recommended, rather than unbalancing the diode modulator.

Exciter alignment procedure using this filter is exactly the same as that described for the crystal-filter exciter.

End of Part II. The next part of this series appears in the June issue. A Mobile SSB transmitter is to be featured in the May issue.

75-Meter SSB Roster

The February 1st roster of active Single-Sideband 75-meter phone stations reflects the tremendous increase in activity. The latest roster reveals that at least 328 stations have equipment and are active. This is an increase of 103 stations over the earlier list compiled by W2SHN, W3ASW, W9DYV and W3KPP. Contact W3KPP for information on distribution.



15 WATT POWER AMPLIFIER UNIT

Brand New

Model F Power Amplifier Unit manufactured by Personal Music Company, Newark, New Jersey. Formerly sold to jobbers at \$129.50 each.

Chassis size 11½" x 17½" x 2½" high (with cover 11½" x 17½" x 7½" high). Net weight about 50 lbs. Gray crackle finish.

OUR PRICE BRAND NEW **\$35.00**
COMPLETE

This amplifier delivers 15 watts of undistorted audio power with excellent frequency response. The tube line-up is 1—2D21, 1—6AL5, 1—6SJ7, 1—6SN7, 2—6L6G's, 1—5U4G. The total power drain is 300 watts from the 110 V. 60 cycle AC power source. Treble, bass, vernier volume and master volume controls are provided. This amplifier is beautifully designed and is sturdily constructed with the best of components. It can be used for continuous day and night service. Deluxe features such as high—low AC line switch, AC line fuse,

good ventilation of chassis and cover, external carrying handles, lock and key, and heavy duty AC line cord are provided.

You can use this unit for microphone, phonograph, or radio input or fix it for combinations of such inputs. It will make an excellent foolproof and trouble-free unit for dance bands, lecture halls, schools, sports events, for rental purposes, for inner-office communication. It will handle a number of loudspeakers. Originally sold for \$129.50.

40 West
South Street



Indianapolis 4,
Indiana

DX NEWS

(from page 46)

9NH, 9CZT, 9PNE, 9FIM, 9MFV, ØFXV, ØNWX, and KV4AA. John adds that ZB1BJ and HA5BT are active around 1790 and looking for DX QSO's. This will show that it's not too hard to "get across" for those giving 160 a whirl!!

Down on Fifteen

Conditions continue "fair" on this band with consistent openings to Europe and the U. S. East Coast in the mornings and activity on the rise. Phone and Novice allocations on this band will add new interest and we suggest that all hands tune up here in preparation for the time when this band will really come into its own.

New 21 Mc. Standings

G6ZO	66	FA8IH	56	TI2TG	48
G6GN	61	W3AYS	54	PAØKW	47
W1BUX	56	W4KRR	50	KV4AA	46

Here and There

FLASH. . . Word from VK3CX advises that a VK7 Ham is now en route to Christmas Island (Indian Ocean). He expects to commence operations on the 14-Mc band, CW and phone, on April 26th.

From W6TI, W6LW and the No. Calif. DX'er) Western DX came almost to a complete stop when members of the North and South California DX Clubs took over the Hotel Californian, in Fresno, for their 4th Annual DX Conference. This event, on Jan. 17/18th, was attended by 81 which included OZ4FT, 3A2AB and W2WMV/C9. Highlights included the awarding of the DX trophy to the Northern California DX Club, DX Quiz (with W6SA and W6SC tied for the best score), CQ "Honor Roll" discussions led by W6QD, Slides and experiences of W2WMV/C9 in the C9 and C3 countries and a W6WB talk on "L" and "Pi" networks. A vote of thanks goes to W6TI and his FB committee with

special mention of W6TT and W6DUB and their well-organized open houses. Many old friendships were renewed making this event one to be long remembered. Members are looking forward to the Fifth Joint Conference to be held in Fresno on Jan. 16/17th, 1954.



Dimiter Petroff, LZIDP is also Chief Operator at LZIKAB the Sofia Club station.

Fred, KF3AA/W5AGB/Fixed Maritime, has now arrived home on leave prior to taking up his new assignment at Kelly AFB, Texas. He states the call "KF3AA" was assigned to him just before Christmas. This call will also be used by the new radio op on Fletchers Ice Island but Fred doesn't know just how DX minded he is. Over 3000 separate contacts were made from KF3AA/W5AGB/FM with 336 stations in 37 countries.

(Continued on page 64)

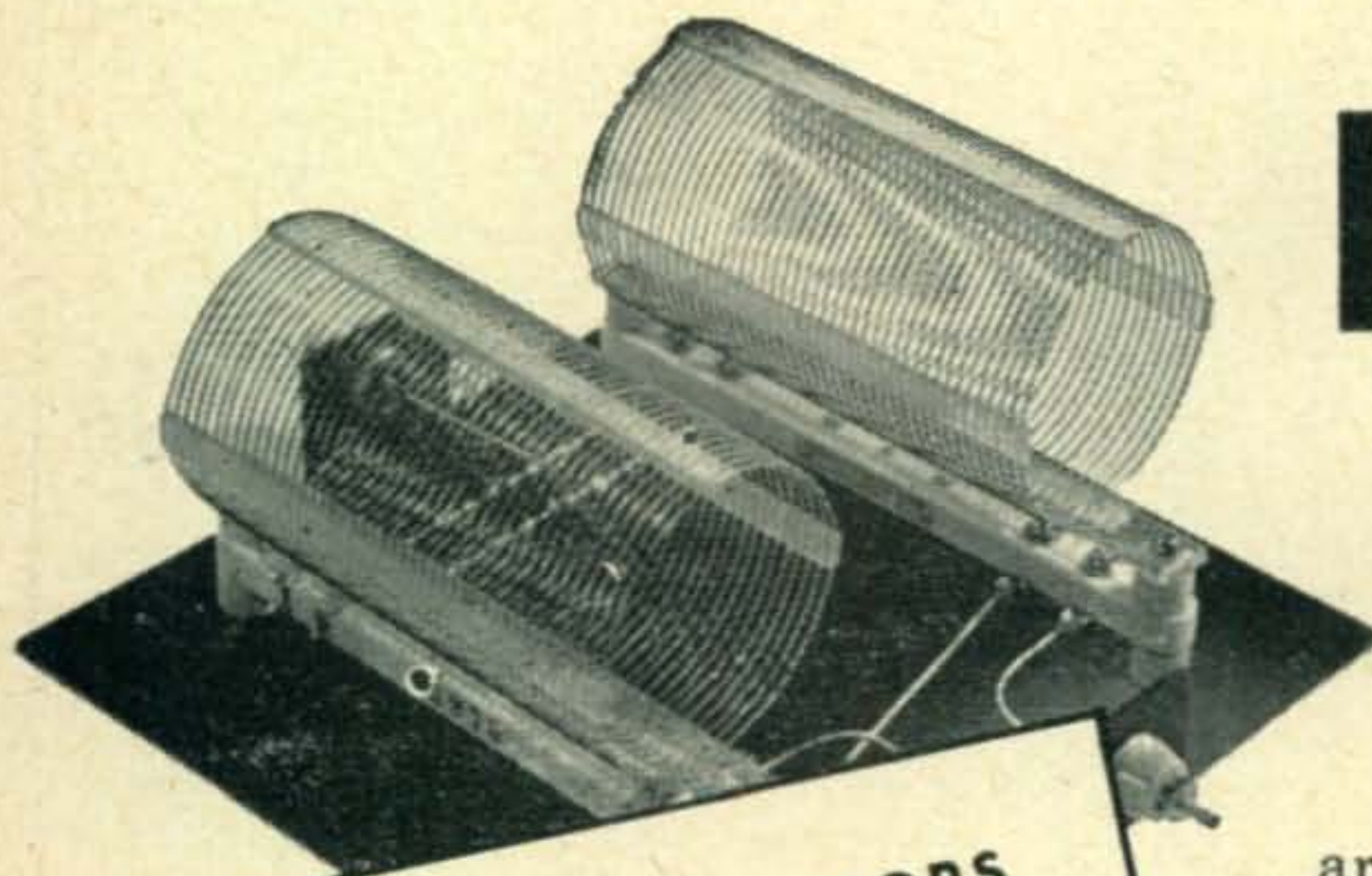

B&W BALUN INDUCTORS
Type 3975

New Low Price
\$3.75 each coil

These sturdily-built air-wound coils can be connected to match 75 ohm unbalanced transmitter outputs to 75 and 300 ohm balanced antenna feed lines.

BALUN COILS!

These bifilar balun inductors are specially designed for use with Collins 32-V series and similar transmitters—see "The Impedance Matcher" as described in CQ Magazine for May 1951. Two coils mounted on an 8" square plate serve as a compact, highly efficient all-band (80-10 meters) unit for matching feed line systems to both transmitters and receivers. Full instructions included with each inductor.

Metal Base Plate & Connectors Not Supplied.

B&W

BARKER & WILLIAMSON, Inc.

237 FAIRFIELD AVE., UPPER DARBY, PA.

On the Way!



\$2.00

POST-PAID
ANYWHERE

To be released within 90 days

Are you thinking about mobile operation?

Are you just getting started with your installation?

Are you an old-timer when it comes to mobile?

Regardless of your status—you will want this completely new authoritative 192-page "Radio Amateurs' MOBILE Handbook."

It is profusely illustrated with scores of schematics, diagrams, charts and photographs. Complete dope on noise reduction in your automobile, installation and mounting problems, all types of power supplies, antennas, test equipment, etc., etc.

A wide variety of transmitters, converters and mobile receivers are described in detail. From low to high power, from a one-tube converter to the advanced and modified version of the W2AE receiver—the "Radio Amateurs' MOBILE Handbook" covers them all.

Advance Orders are now being accepted

Copies will be mailed directly from the CQ Editorial Office—RESERVE YOURS NOW!

CQ MAGAZINE
67 West 44th St., New York 36, N. Y.

Enclosed find \$..... for copies of the Radio Amateurs' MOBILE Handbook at \$2.00 each.

Name Call

Address

City Zone State

PREMAX



Mobile Antennas

For All Regular and Emergency Service

Car-top, Whip, Center-Loaded, Zone and Sector Civil Defense Control . . . a complete line for every purpose including Marine.

PREMAX PRODUCTS Send for
DIVISION CHISHOLM-RYDER CO., INC. Special
Bulletin.

5303 Highland Ave.

Niagara Falls, N. Y.

*Keep Your
Shack Neat
with a*

BOUND VOLUME

You'll appreciate the handy convenience of this compact volume of the 1952 issues of

CQ . . . handsomely book-bound in tan colored cloth . . . distinctive gold foil lettering embossed in a black panel strip . . . available NOW!

\$7.95

in U. S., Canada and Pan-American Union. Others, \$1.00 more.

CQ MAGAZINE

67 West 44th Street

New York 36, N. Y.

(from page 62)

Honor Roll Endorsements and New Members

CW ONLY		PHONE ONLY	
W6ENV	40-246	W9HUZ	39-193
G6ZO	40-244	W4RBQ	39-187
PY2CK	40-239	ZS2AT	39-171
W6GDJ	40-227	W9NZZ	39-151
W7DL	40-225	W1ZD	39-150
W6TS	40-225	W5KUJ	38-181
W6UHA	40-209	KG4AF	35-180
W3OCU	39-224	W2ZVS	35-144
W5MPG	39-206	W6ZZ	35-125
W2BJ	39-198		
W1ZL	39-198		
		PY2CK	39-219

Last complete HONOR ROLL appeared in the January issue.

Next complete HONOR ROLL will appear in the June issue.

Fred wishes to thank W2LXP, KL7AIR, KL7AMJ, KL7AJR, W8UPN, VE8MC, VE8ML, W1BB, W6NCP, W9NZZ and others for their help in handling traffic. Fred hopes that his old QTH will be considered as a new country. Many of his contacts have not yet QSL'ed to Box 143, Oakdale, La. Cards are promised to all those who come through with theirs.

W2BBK and W2ZBO along with W3BXE plan a return trip to FP8 land this summer. Vee beams will be used during their 14-day stay. W2BBK wishes to thank those who contributed (via FP8AP) to the XYL and children of the late FP8BX. Their kindness made Xmas a very happy one for the recipients.

VS7BB, who works with VS7MC ex-ZC2MAC, advises that MAC's new QSL's are now en route from England and will start flowing out upon arrival. .KV4BB, who is participating in the ARRL phone contest, bemoans the fact that VE phones show reluctance to tune the U.S. phone bands for DX contacts. This puts Bill at a decided disadvantage when nearby DX competition can breeze along merrily on the frequencies from 14100 to 14200 mc. . . W6ARI and W6BVM are setting up shop in an abandoned air control tower. .W2SAI entered the March contest with stacked beams on a 100-foot pole for 14, 21 and 28 Mc. Dawson also has ground plane verticals on 75 and 80. All antennas are backed up with a 80 x 45 ft. screen. .W1KY is back on the bands after a year layoff. .W8PQQ and W3MFW sport new ground plane ants. .W2VJN's 30-watter completed a DXCC on 7 Mc. .W2OHF enjoyed a visit to KV4AA. W6DFY is expected to drop over in March while visiting KP4. .KV4AU is now W4YID in Tenn. . . W6FKZ, Roy, is happy to be back on after long layoff. .W2ESO offered to handle QSL's for FM7WD (No answer yet). .W9NN renews offer to help out with QSL'ing for any DX station so inclined. .A new Club Station was opened in the Canal Zone on Feb. 7th. The call letters are KZ5PA which fittingly perpetuate the memory of that FB OM, Arnold Pincus. .W5RLY, New Mex. is Jack of ex-W0NMT. .W6GIF now pounds brass at DI' MW. .Ole, of W0MCF/C3 fame, is now W4YKO. Ole was after KV4AA back in 1946-49—Now he tells me! Ole has several C3 QSL's left if any are missing. He nearly cracked WAZ during operations in Formosa but slipped up on Zone 6. .Tom ex-W4IG/W8BNO/DI'WA is now K2DT. . . Congrats to K2BCK and Betty upon arrival of Y1 harmonic. .W1QF knocked off a 21-Mc WAC recently. Included were TA3AA and TF3MB. .W4LZ, Frank, is now back at the old stand in N. C. .W1AXA is completing new rig with pi-network coupling throughout. This will give Red 10 to 80 in a small package. .Ron, W6ZF/3, leaves Washington, D. C. on April 1st for trip to Ashville, N. C. and then home to Sacramento. .Max, HB9HC, visited W2HWH. . . Dick, HZIMY, has quit Arabia leaving that call with another operator. He will be spending some time with KT1WX in Tangiers. QTH W. F. Wilcox, Camino del Monte 28. Dick advises that logs for VQ6MY, 4W1MY and FL8MY are in the hands of G6LX who will take care of any missing cards. By this time all QSL's for 6L6MY should be on the way. Dick is job-seeking at present. Any takers? .OQ5RA will not be on the air very often due to pressure of work and studies. .W3QAC is old HK3CT. .W5TOE, Ed, is completing a new 4-400 xmtr. .ZL1MP, now in KZ5, writes TI2TG that upon arrival of his Land Rover (English type

Jeep) from ZL he plans to drive up to Warm Springs, Ga. seeking treatment for his arm injured after a polio attack a few years back. He will drop in a see TI2TG on the way . . . W6NZW is handling QSL's for VP6JV. Andy, TA3AA, writes, and we quote:

"Just received CQ and read your column with a great deal of interest concerning poor old ZD7A. In general I have the same kind of difficulty over here. I have tried from time to time by stating, answer 10 up or 10 down, but the gang just doesn't pay any attention to it. One time in particular I was determined not to answer anyone nearer than 10 kc. of my frequency. It took over a half an hour before the gang finally got wise and did start to answer there, but by and large the average Ham just won't do it. Some day they are going to realize that the DX station could probably work them all if they called off the frequency and made short calls. In that light there have been times when things have gone off nicely. For instance, on Sunday, Dec. 28th, for over a period of three hours and fifteen minutes I worked a total of 85 W and VE stations which included a twenty-minute special phone test with W5VSS. It seems the boys were wise that day, really in the groove. As a result I was able to work all that I could hear until the band went on me.

As of Jan. 9th all QSL's received have been answered. Since May 28th '52 we have made about 4500 contacts. . . I've been in W8DDS shoes many times here and when that happens I just pull the big switch and go do something else. Please ask the gang to pay attention to directional or regional CQ's (as) we DX stations also like to work the DX when it is coming through. I am on all bands CW and phone and, in spite of what some of the boys think, we are using a BC-610. It's the rhombic that does the trick."

To the above we add "AMEN" with the slightly bent hopes that various writings on the subject of decent operating ethics may penetrate the craniums of many whose motto seems to be "All's Fair in Love, War and DX."

After hitting a string of VP8's W2ZGB says "how about a VP8 award." Good idea, Gabe, but let's get someone on South Sandwich Is. first. . . Doc, KA9AA, hears lots of stuff on 7 and 3.5 but advises he is not allowed on these bands. KA9AA, who has been bowling them over on 14 Mc. will be on 21 Mc. pending arrival of 21-Mc coils for his HRO-50-1. Doc is increasingly 'sold' on his ground plane antenna which, he says, is at least as good in all directions as a dipole in its best direction. His 50-watt signals seem to bear this out. . . ZS2AT got his QSL to VQ9DB returned by RSGB as "unlicensed". . . Deadline for contributions to this column occurs on the fifteenth of each month. Please airmail your stuff in before that date. 73, Dick.

Latest QSL Addresses

- CP5AB Casilla 496, Cochabamba, Bolivia.
- (ex-LU9DBF)
- CX7AC Manola, Box 37, Montevideo, Uruguay.
- ET3Q Box 1656, Addis Abbaba, Ethiopia.
- FQ8AP and Box 31, Fort Archambault, Tchad, FEA.
- FQ8AL
- FO8AI Via W7FNK.
- PY6FI Jose, Box 533, Salvador, Bahia, Brazil.
- OD5DN Ben, Box 235, Tripoli, Lebanon.
- ST2AR Box 253, Khartoum, Anglo-Egyptian Sudan.
- (ex-G4AR)
- VP2LC/ Alan Humphries, Maya Cove, Tortola, B.V.I.
- Mobile
- W3OFM/VO 'C' Division, Navy 103, F.P.O. New York.
- ZD9AA Via ZSIFD.
- 3A2AX Jean Cessamati, 41 Bis rue Plati, Monaco.

Thanks to: W3AS, W2LV, W6KYG, F9RS and the West Gulf Bulletin.

RADIO Surplus Buys

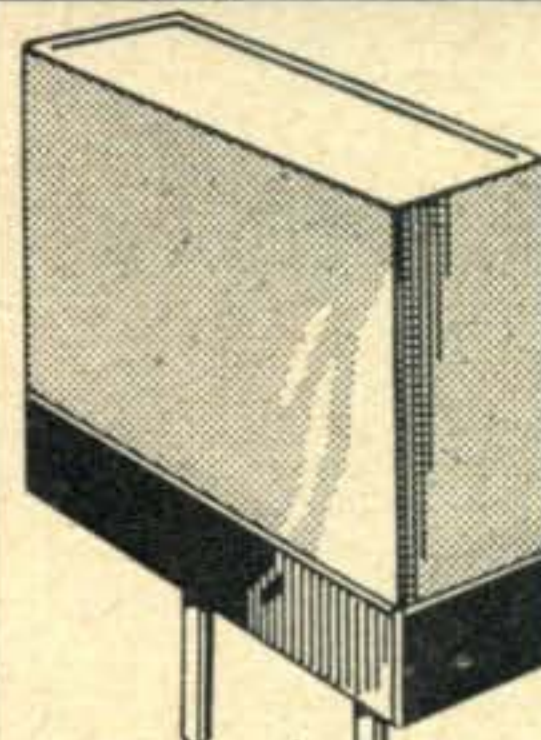

CRYSTALS

. . . in FT 241-A Holders - 1/2" Pin SPC. Marked 54th OR 72nd Harmonic MC Freq. Listed below by fundamental frequency with fractions omitted.

500 KC Crystals ea. **\$1.95**
 1000 KC Crystals ea. **\$3.95**
 200 KC Crystals ea.

370	407	444	476	509
372	408	445	477	511
374	409	446	479	512
375	411	447	480	513
376	412	448	481	514
377	413	450	483	515
379	414	451	484	516
380	415	452	485	518
381	416	453	486	519
383	418	454	487	520
384	419	455	488	522
385	420	456	490	523
386	422	457	491	525
387	423	458	492	526
388	424	459	493	527
390	425	461	494	529
391	426	462	495	530
392	427	463	496	531
393	429	464	497	533
394	430	465	498	534
395	431	466	501	536
396	433	468	502	537
397	434	469	503	538
398	435	470	504	540
400	436	472	505	
401	437	473	506	
402	438	474	507	
403	440	475	508	
404	441			
405	442			
406	443			

\$1.00 EACH

10 for \$8.00, Postpaid

FOLLOWING CRYSTALS AVAILABLE IN FT 243 HOLDERS 1/2" PIN SPACING

3590	5035	7350
4165	5127.5	7450
4280	5285	7750
4335	5587	7875
4350	5660	
4370	5730	
4440	6073.3	
4445	6075	
4540	6140	
4620	6350	
4635	6525	
4710	6700	
4880	6875	
4980	6975	
4995	7150	

\$1.00 EACH

11 for \$10.00, Postpaid

PLEASE ENCLOSE FULL AMOUNT WITH ORDER
 QUANTITIES AVAILABLE
 WRITE FOR YOUR REQUIREMENTS

C & H SALES CO.

BOX 356-FQ EAST PASADENA STA. • PASADENA 8, CALIF.

8 WIRE CONTROL CABLE

Two No. 16, Six No. 20 tinned, stranded, copper, rubber insulated coded leads. Waterproof rubber jacket. Woven copper armor shield overall. Diameter 7/16 inch. Length to 400 ft. Minimum order 100 ft. Prepaid delivery 10¢ ft. made to nearest express or post office, U.S.A. only. **PREPAID**

TRANS-WORLD RADIO-TELEVISION CORP.

6639 S. ABERDEEN ST. CHICAGO 21, ILL.
 Phone: AUstIn 7-4538

WANTED

WE NEED YOUR SURPLUS
ELECTRONIC EQUIPMENT

WE PAY TOP \$\$\$ FOR:

- | | |
|-------------------|-----------------|
| ● RADIO RECEIVERS | ● PLUGS |
| ● TRANSMITTERS | ● CORDS |
| ● ARC-1 | ● RELAYS |
| ● ARC-3 | ● TELEPHONE |
| ● ART-13 | ● MATERIALS |
| ● CONTROL BOXES | ● AN CONNECTORS |
| ● INDICATORS | ● WE BUY |
| ● CLAMPS | ● ANYTHING! |

WRITE, WIRE TODAY! TELL US WHAT YOU HAVE

TALLEN CO., Inc., Dept. CQ

159 Carlton Ave.

Brooklyn 5, N. Y.

WANTED— TUBES YOUR IDLE

Sell me your idle transmitting, special-purpose, receiving tubes including klystrons, magnetrons, etc. Also wanted, other types of military as well as amateur gear. I will pay you spot cash or we can arrange a swap for such equipment as the following:

S-38 Hallicrafter Revr.	\$ 39.95
Morrow Converter #3BR.....	52.00
Jackson Signal Generator, Model #640.....	66.00
115 V. AC Portable Gas Generator.....	135.00
Carter 6V. Dynamotor 600 V. out @ 170 ma.	28.00
Carter 6V. Dynamotor 590 V. out @ 150 ma.	25.00

Above equipment is also for straight sale at the prices indicated. For a fair deal and quick action, write to B. N. Gensler, W2LNI, 136 Liberty St., New York 6, N.Y.—REctor 2-2528



CONSIDER YOUR VISITORS

\$1.50 (less bulb)
at your dealer's.

The "ON THE AIR" Signal Light tells your visitors in a very nice way "The Mike is Alive." Your visitors are sure to appreciate this consideration. For fixed or mobile use.

P. E. HAWKINS COMPANY

3208 E. 56th Street, N. Kansas City 16, Mo.

I'LL PAY MORE FOR ART-13 XMITTERS

Also need late type CFI Units for above, using 2-prong crystals!

I'll pay top \$ for above plus BC-788, I-152 and BC-348 Receivers.

Write: BOB SANETT

5404½ Packard Street

Los Angeles, Calif.

HERE'S YOUR ANSWER TO LOW ANGLE PROBLEM RADIATES GOOD DX SIGS EVERYWHERE, VERTICAL WHIP ANTENNA ASSY for 10, 15, 20, 40, & 80M 9½ ft. \$1.45, 16 ft. \$2.40, 24 ft. \$3.85, 32 ft. \$4.75. LIGHTWEIGHT MOBILE WHIP ANTENNA, threaded molybdenum sections with 3/8" stud to fit standard automobile mounts, complete assembly. 1-12 ft. \$4.95 LINK/BOSCH MOBILE POLICE RECEIVERS, 5 tubes, (RF stage) fixed tunable 2-3 mc, adj. squelch control, W/6 volt power supply, 250V/100 ma. IDEAL/HAM, C.D. MARS & MARINE services. Makes hot recvr W/HF converter, used clean cond. With new 5" PM speaker \$12.95 PE 101-C DYNAMOTOR, NEW. \$3.95 Modified \$7.95 ESSCO ELECTRONICS 58 WALKER ST., N. Y. 13, N. Y.

NEW PARTS and PRODUCTS

A 17-Unit Tool Kit

Just as the v-h-f minded hams sit around and watch tube developments because of TV, the rest of us should keep an eye on the ever-enlarging radio service business. The other day we spotted a 17-unit tool kit that is being marketed by Tele-Scopic Products, Inc., 111 W. 42nd Street, New York 36, N. Y.

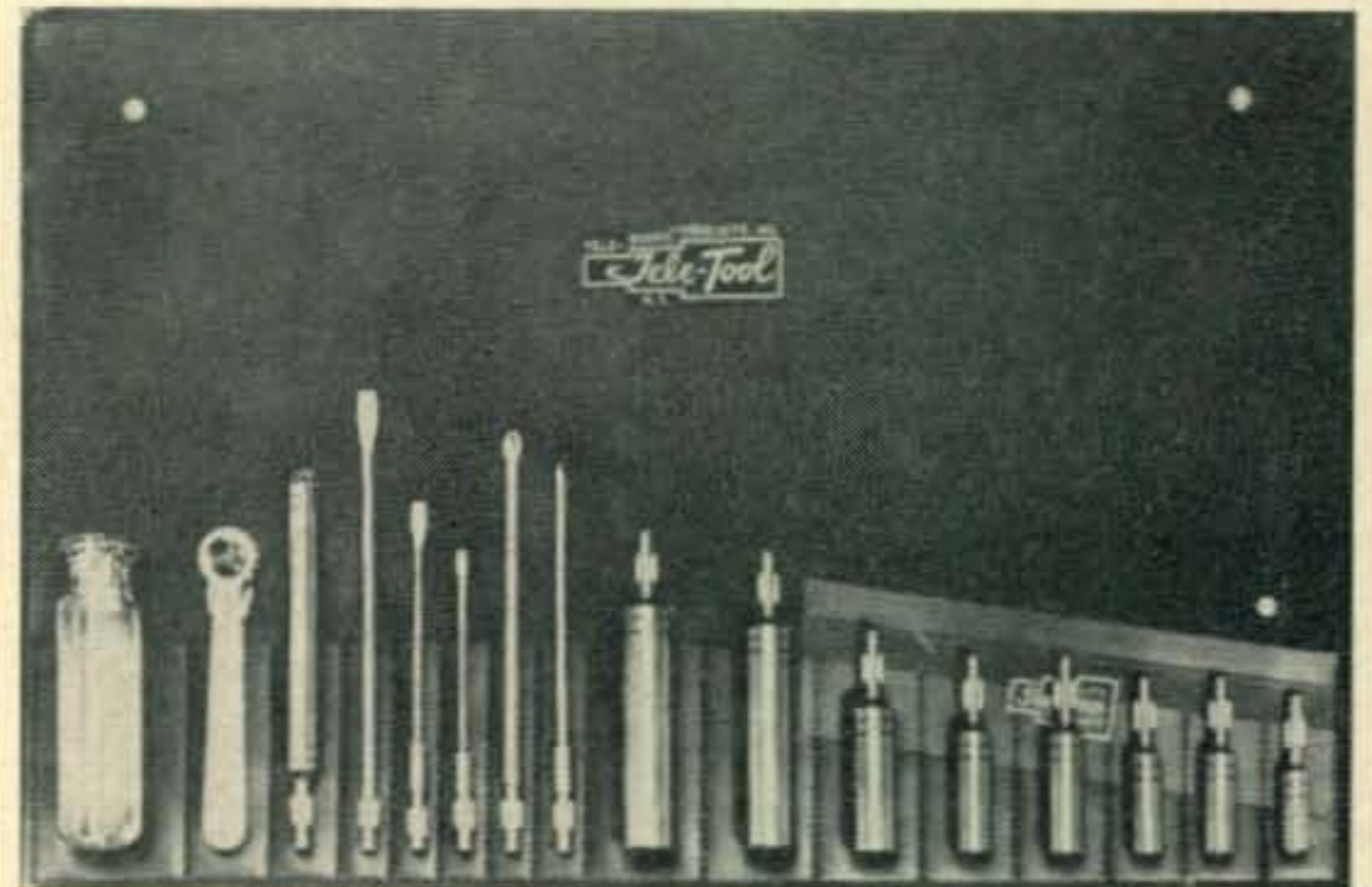

The kit comes in a 16 x 11½ inch strong plastic roll-up container and easily takes the place of 50 different individual tools. It contains two basic handles, one : heavy amber and the other a ratchet wrench. Five screw driver blades are provided with three sizes of the regular flat blades and two sizes in the recessed head. Nine sockets give you a range of from ¼" to 9/16" and permit removal of potentiometers because of their long hollow shafts. An extension shaft is provided for working in those hard to get at places.

The market price of the kit is \$9.95 and may be purchased through your Local distributor.

PROPAGATION CONDITIONS

(from page 41)

Africa

These transmission paths have "control points" in more highly ionized regions than do European circuits, so the MUF for African circuits are generally higher than those to Europe. Although no ten-meter openings will be possible, some fifteen-meter openings should occur during the daytime hours, from all areas of the U.S.A. to most areas of Africa. Signals may be somewhat erratic, with considerable fading. Signal levels will be quite weak when the band first opens, becoming stronger later in the afternoon. Some good forty-meter openings are expected from East and Central U.S.A. to North Africa, with generally fair forty meter DX possible from most other areas of the U.S.A. to most areas of Africa during the evening hours. . . . Some occasional eighty-meter openings are possible on propagationally quiet nights, mainly from Eastern U.S.A.

Australasia

Fairly good possibilities of some ten-meter openings between Australasia and the Pacific area of the U.S.A. Occasionally these openings may extend into some Central areas of the U.S.A. . . . Fifteen-meter openings are expected from all areas of the U.S.A. to Australasia. Conditions will be somewhat erratic, becoming stable late in the afternoon. . . . The twenty-meter band should open early in the morning and remain open until late

(Continued on page 68)

Because of Unprecedented Reader Demand...



"A 1953 Special Mobile Issue"

In the mails, or on your favorite newsstand look for the charming smile of W3MSU

- The "SSB Mobile" for operation on 3999 kc. Uses a 6L46 in the final and has carrier reinsertion facilities. This is one of the outstanding mobile units on the road today! (by W4RKE, W4OLL and W4SIA)
- The "Dial-less VFO" for those who want to keep peace in the family through an inconspicuous mobile set-up. You'll like this idea. (by W1VJV)
- The "TNS" noise silencer and squelching circuit. Unquestionably the best noise silencing two-tube arrangement ever developed—for either mobile or fixed station operation. (by W2AEF)
- The "Care and Feeding of Your Storage Battery" is a timely subject with all of the necessary dope on setting your generator and regulator. By the author who last year told us about ignition interference—W2BGF.
- PLUS articles on antennas, crystal-controlled transmitters, VFO transmitters, loading coils, mobile calibrators and many others—not forgetting all of our regular departments.

Subscription Bonus

While they last—we will send you a free copy of the 1952 "Special Mobile Issue" to keep your files intact, or replace that worn out copy.

SUBSCRIPTION RATES

3 years	\$7.00
2 years	\$5.00
1 year	\$3.00

(Foreign Subscriptions are \$4.00 per year)

CQ MAGAZINE

67 West 44th St., New York 36, N. Y.

CQ-43

Enclosed find \$..... for a year subscription to CQ. Send me the May 1952 Special Mobile Issue FREE!

to be sent to: New Renewal

Name Call

Address

City Zone State

EASY TO LEARN CODE

It is easy and pleasant to learn or increase speed the modern way—with an Instructograph Code Teacher. Excellent for the beginner or advanced student. A quick, practical and dependable method. Available tapes from beginner's alphabet to typical messages on all subjects. Speed range 5 to 40 WPM. Always ready, no QRM, beats having someone send to you.



ENDORSED BY THOUSANDS!

The Instructograph Code Teacher literally takes the place of an operator-instructor and enables anyone to learn and master code without further assistance. Thousands of successful operators have "acquired the code" with the Instructograph System. Write today for full particulars and convenient rental plans.

INSTRUCTOGRAPH COMPANY

Dept. C., 4701 SHERIDAN RD., CHICAGO 40, ILL.

GET YOUR COMMERCIAL TICKET EASIER WITH ...

RADIO OPERATOR'S LICENSE Q AND A MANUAL (4th Edition) by Milton Kaufman Covers Elements 1 through 8. Complete discussion of answers to every technical question in the F.C.C. Study Guide! Used by over 50 leading schools. Only \$6.60 at jobbers, bookstores or direct from—



JOHN F. RIDER Publisher, Inc.
480 Canal Street, New York 13, N. Y.

SPECIAL

HALLICRAFTERS SX71-576

Write for liberal trade-in offer.

FILAMENTTRANS. 6V at 3 Amps.,

\$1.45

LOOK — NO HANDS!

Head & Chest Set consisting of Single Button Carbon Microphone with Chest Plate, Switch, Straps, and Pair of Earphones. Ideal for Mobile Operation. Can be used less earphones. Shpg. Wt. 3 lbs.

Only **\$1.95** complete

ATRONIC CORP., DEPT. C-28
6566 N. Sheridan Rd., Chicago, Ill.

COUPLING SHAFTS 2c/INCH

MC 215 (All Lengths in Inches)				
34	135	163	186	260
MC 124 (All Lengths Shown in Inches)				
23	61	120	175	
29	65	140	205	
39	103	161	241	
52	114	166	348	

Send Check or M.O. Ship. Chgs. C.O.D.
COMMUNICATIONS EQUIPMENT CO.
131 Liberty St., Dept. Q4 New York 7, N. Y.

75-150 WATT TRANSMITTER



Including power supply, tubes, crystal — all parts. Operates on all bands from 160 to 10 meters. Two 5U4G rectifiers, 6AG7 oscillator and 807-807 power amplifier. TVI proof except on 10 meters. Kit with instructions **\$49.95** Factory wired & tested **\$64.95**

Send post card for free information

DIXON ELECTRONICS CO.

13444 W. McNichols Rd. Detroit 35, Mich.

We Carry a Complete Line of Amateur Equipment including:

National • Hallicrafters
E. F. Johnson Co. • Bud • Barker-Williamson, etc.
VARIETY ELECTRIC CO., INC.
468-470 Broad St. Newark 2, N. J.

(from page 66)

in the evening. However, high daytime absorption will generally not permit much DX during the late morning or early afternoon hours. . . .Fair to good conditions are expected on forty meters, with some good openings during propagationally stable periods. . . .Some eighty-meter DX possible, but signal levels may be very weak, and very often below the atmospheric noise levels.

Asia

Long distances, high absorption, and auroral zone penetration make Asiatic DX quite difficult to work from the U.S.A. No ten-meter openings expected. . . .There is a very slight possibility, from the eastern area of the U.S.A., of an occasional erratic fifteen-meter opening to Asia Minor. More frequent fifteen-meter openings should be possible between the western U.S.A. and the Far East, with some of these openings extending to the central area of the U.S.A. . . .Twenty-meter DX conditions are rather good from the western U.S.A. to the Far East, but are no better than fair to the Central and Eastern areas. . . .Not much expected on forty—but some DX openings are possible. . . .Seasonally high noise levels will not permit much eighty-meter DX on these circuits—certainly not to the Eastern and Central areas of the U.S.A.

MOBILE CORNER

(from page 27)

lighting circuit operating on the trailer battery is energized. At the same time the receiver is transferred to a d-c pack which supplies the plate voltage; filaments are switched directly to 6-volts d.c.

Receiving equipment has been the subject of much discussion, but by experience we have arrived at a combination which operates very satisfactorily. A selective receiver is *not* desirable for net operations, as many times the mobile station is not exactly on net frequency. This is due primarily to the differences in crystals (although they may be marked for the same spot frequency) and the circuits in which they are employed. The receiving combination employed is a VHF-152A converter operating into a 6-9 Mc. ARC-5 receiver. A noise limiter has been added to the ARC-5, and the combination provides excellent sensitivity with the desired band width. Of course, this combination is bound to suffer, should the band suddenly open during net operations.

At this point it might be interesting to give a cross-section of the average *Phil-Mont* mobile. A few mobiles are using converted ARC-5 receivers and home built converters, but the majority of mobiles seem to lean toward the commercial models in conjunction with the auto receiver. Transmitters are generally home built, with power inputs ranging from 6 to 25 watts, and a few at 150 watts. Crystal switching for rapid QSY is general, although dash-mounted transmitters usually provide a panel mounted crystal socket to accomplish the same purpose. The oscillator tube employed is generally either the 6V6, 6AQ5, or 6AG7, using a 7-Mc crystal to quadruple to 10-meters. Final amplifier tubes are usually the 6V6, 5763, 2E26, 807, or 6L46. The 6V6, 6AQ5, or 6L6 are the usual choice of modulator tubes.

Carbon microphones of the F-1 type are most commonly used. A program of standardization has been initiated and most of the club mobiles have converted to a standard connection, thus in an emergency any microphone or handset can be used

with any other mobile station in the area, police and taxi included.

Antenna types and locations vary. The location which seems to have the least directional effect is one high on the rear of the body, usually on the left-rear. 50-ohm coaxial cable is used as the transmission line, and if a trunk transmitter is used, and electrical quarter-wave length or as short a length as possible, is best. Dash-mounted transmitters, in general, require approximately three-quarter wavelength transmission lines.

A-c, low-voltage, alternators, with rectifier and regulator belt driven from the engine, will prove most satisfactory for mobile use. The initial cost is high, but in the long run will prove to be an investment which will outlast several cars and may be installed in the new car should you trade. An alternative is a second generator, battery, and regulator specifically for the radio circuits. Otherwise, a heavy-duty battery of the 120- to 130- ampere hour capacity is recommended, and with judicious use of the transmitter and frequent generator inspection, no difficulties should be encountered.

This article has been an attempt to describe some of the phases of mobile radio as enjoyed by members of the *Phil-Mont Mobile Radio Club*. We sincerely hope that you, the reader, have received some benefit from our experiences. Should you be interested in any particular phase of our operations, or activities, feel free to write the club secretary for details.

ANTENNA HEIGHT

(from page 40)

db. stronger signal than the lower Yagi. This effect was originally difficult to interpret, but was finally resolved through the use of radio amateur data obtained in "Project RASO."²

Comparison With Theory

As mentioned earlier, the data shown in this article applies particularly to single hop transmission via the sporadic-E layer. Regardless of this singular method of obtaining the data, the results are undoubtedly applicable to "short-skip" and E-layer effects on other frequencies. Then, too, it also confirms the theoretical height above ground formulas, since one antenna was approximately $1\frac{3}{4}$ wavelength above ground that the other about 4 wavelengths above ground. For DX it still goes—the higher the better.

2. It was only after a considerable quantity of the RASO 6-meter Project data (under Air Force contracts AF19(122)-72 and AF19(122)-242 with the Air Force Cambridge Research Laboratories) had been analyzed that we were able to obtain any positive results at this range. Records then became available that showed the incidence of "double-hop" or multiple reflections over the paths greater than 1200 miles. Prior to this the small number of readings available were confusing. They showed a preference for the lower antenna where we had been led to suspect that the higher antenna would work out best. It was found that these readings were being taken over two 600-plus mile hops and thus were actually coming in better on the lower antenna.—Ed.

BUY OF A LIFETIME!

TRIED AND PROVEN THE WORLD OVER



LETTINE MODEL 240 TRANSMITTER WITH MOBILE CONNECTIONS AND A.C. POWER SUPPLY

This outstanding transmitter has been acclaimed a great performer throughout the world. It is excellent for fixed station, portable or mobile operation. Even if you have a transmitter of your own you can't afford to miss this wonderful buy, direct from our factory, ready to operate.

The 240 is a 40 to 50 watt Phone-CW rig for 160 to 10 meters, complete with: (8 x 14 x 8) cabinet, self contained A.C. power supply, MOBILE connections, meter, tubes, crystal and coils for 40 meters. Tubes: 6V6 osc., 807 final, 6SJ7 crystal mike amp., 6N7 phase inverter, 2 6L6's mod., 5U4G rect. Weight 30 lbs. TVI instructions included. 90 day guarantee. Price \$79.95.

\$25. deposit with order—balance C.O.D.
80, 20, 10 meter coils \$2.91 per set. 160 meter coils \$3.60
Also for CAP, Broadcast, MARS, Marine, State Guard, Novice

LETTINE RADIO MFG., CO.

62 BERKELEY STREET

VALLEY STREAM, N. Y.

WANTED!

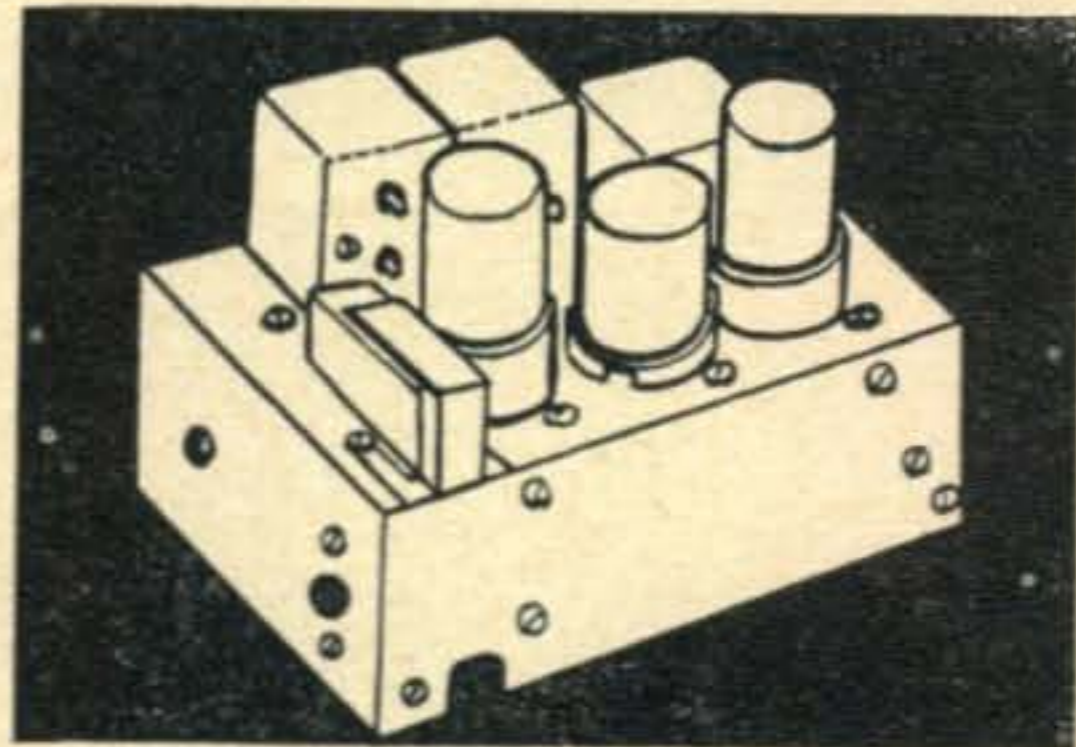

CASH REWARD FOR

ART-13 XTAL CALIBRATORS

ART-13 XMITTERS (or any parts or spares)

BC-348 Q and R

Also need desperately BC-788C, I-152C, R5/ARN-7, APN-9, DY-17.

IF IN YOUR POSSESSION
PLEASE NOTIFY US IMMEDIATELY!

V. & H. RADIO & ELECTRONICS

2033 W. Venice Blvd.

Los Angeles 6, Calif.

Phone Collect: REpublic 3-1127

for a CAREER in communications
... to pass FCC amateur exams

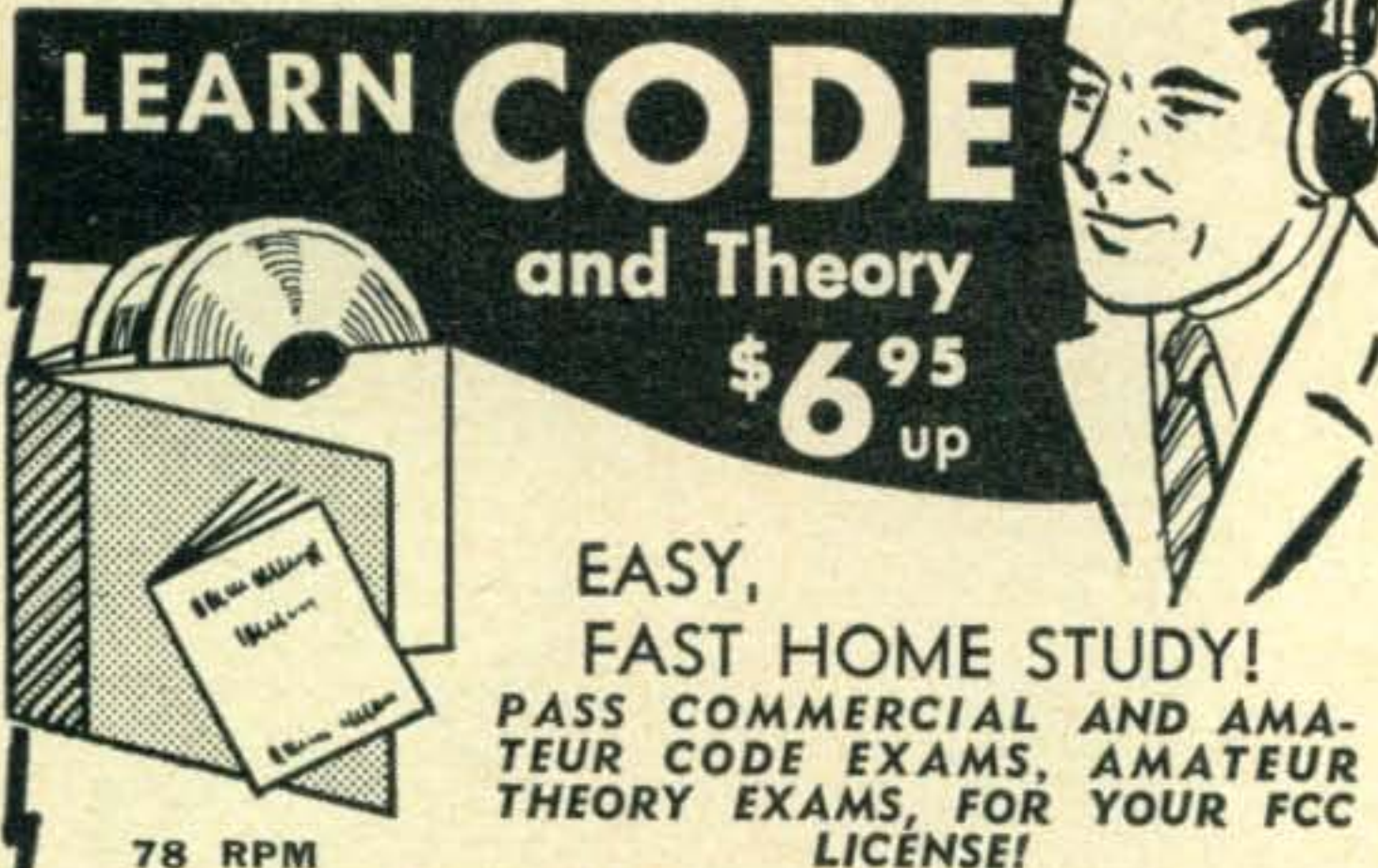

LEARN CODE
and Theory
\$6⁹⁵
up

**EASY,
FAST HOME STUDY!**
PASS COMMERCIAL AND AMATEUR
CODE EXAMS, AMATEUR
THEORY EXAMS, FOR YOUR FCC
LICENSE!

78 RPM

4 AMECO Courses Available:

No. 1—NOVICE CODE COURSE. You get and keep 10 recordings (alphabet through 8 W.P.M.). Includes typical FCC type code exams. Free instruction book on learning how to send and receive code the simplest, fastest way; plus charts to check your receiving accuracy; plus an album; all for the low price of only.....**\$7.95**

No. 2—SENIOR CODE COURSE. You get and keep everything given in the Novice Course except that you get 22 recordings (alphabet through 18 W.P.M.), plus typical FCC type code exams for General class and 2nd class commercial telegraph licenses. All this for only.....**\$12.95**

No. 3—COMPLETE RADIO THEORY COURSE. A complete, simplified home study theory course in radio covering the Novice, Technician, conditional and general classes—all under one cover—with nearly four hundred typical FCC type questions to prepare you for license exam. No technical background required. You also get, FREE, one year of consultation and a guide to setting up your own Ham station. All for the amazing low, low price of.....**\$6.95**

No. 4—NEW ADVANCED COURSE. Prepares Novice operators for the amateur general class and second class commercial license tests. Contains 12 recordings (8 through 18 W.P.M.) PLUS the complete code book—PLUS typical F.C.C. code examinations for general and commercial tests. ALL for only.....**\$6.95**

Dealer Inquiries Invited!**FREE LITERATURE AVAILABLE**

Sold at leading dealers everywhere
or write direct to
Dept. C-4

AMERICAN ELECTRONICS CO.
1203 Bryant Ave., N. Y. 59 • DAYTON 9-4815

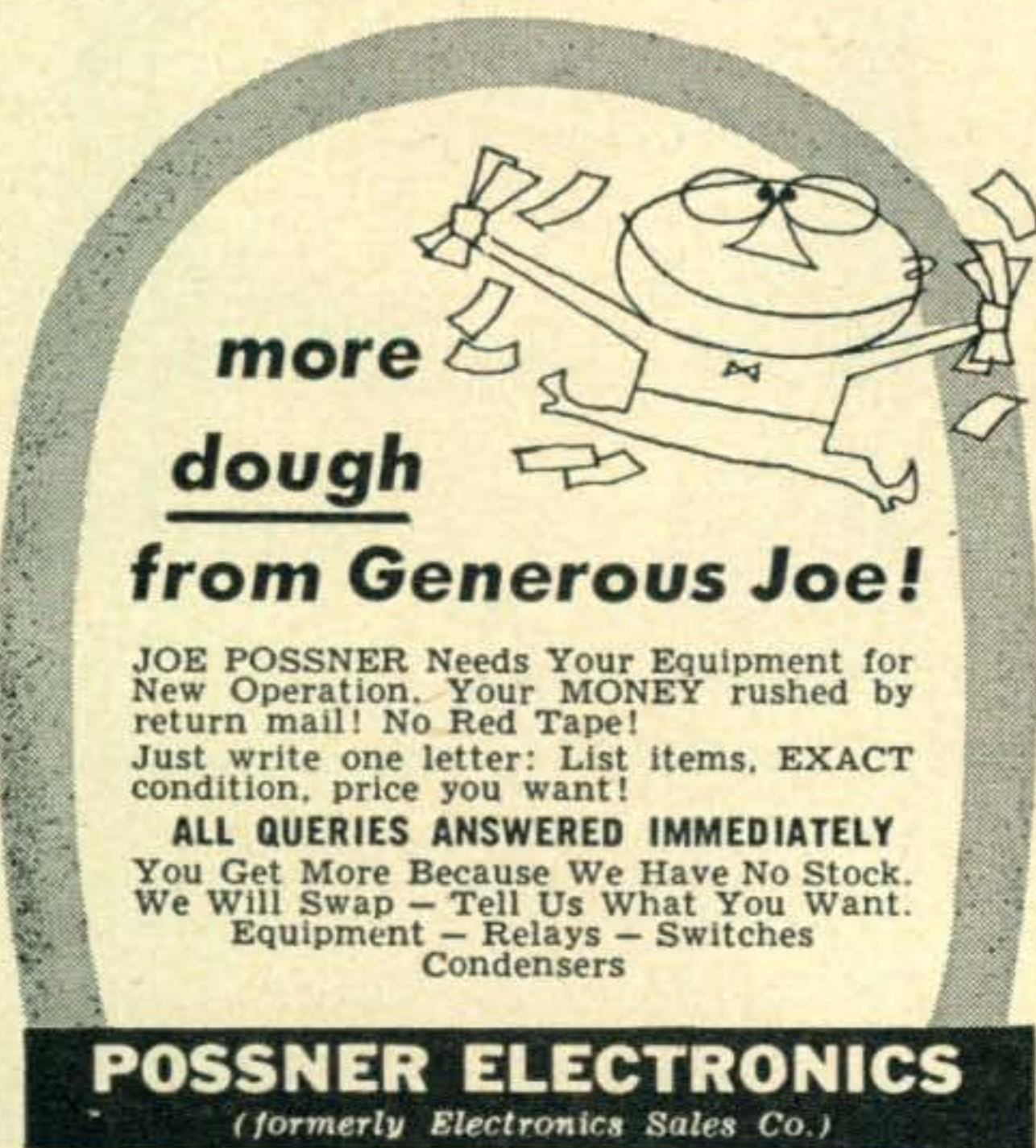

**more
dough
from Generous Joe!**

JOE POSSNER Needs Your Equipment for New Operation. Your MONEY rushed by return mail! No Red Tape!
Just write one letter: List items, EXACT condition, price you want!

ALL QUERIES ANSWERED IMMEDIATELY
You Get More Because We Have No Stock.
We Will Swap — Tell Us What You Want.
Equipment — Relays — Switches
Condensers

POSSNER ELECTRONICS
(formerly Electronics Sales Co.)

Dept. C-2

1223 Venice Blvd., Los Angeles 6, Calif.

Classified Ads

Advertising in this section must pertain to amateur radio activities. Rates 25c per word per insertion for commercial advertisements. 5c per word for non-commercial advertisements by bona fide amateurs. Remittances in full must accompany copy. Phone orders not accepted. No agency or term or cash discounts allowed. No display or special typographical ad setups allowed. "CQ" does not guarantee any product or service advertised in the Classified Section. Closing date for ads is the 25th of the 2nd month preceding publication date.

NOW READY! 1953 DIRECTORY of over 1300 San Diego county hams, cross-indexed three ways, plus many additional features. Accurate, invaluable reference for traffic handling. \$1 postpaid. Coronado Radio Club, Box 277, Coronado, California.

SELL—HQ129X, S40, 630 chassis, HT6 coils, meters, audio amplifiers. W2NBM, John V. Urban, 140-84 Holly Avenue, Flushing, N. Y.

WANTED: APR-4, other APR-, APS-, APT; ARC-1, ARC-3, ART-13, BC-348, BC-221 etc.; TS-12, 13, 35, 120, 146, 155, 173, 174, 175, 323, other "TS-"; particularly MICROWAVE equipment, Spectrum Analyzers; G-R, Ferris, L & N; 723A/B, 3C22, all tubes; manuals, meters, parts, cable. Littell, Farhills Box 26, Dayton 9, Ohio.

TRADE modern firearms for ham gear. Want Viking transmitter and 2 meter gear. L. Miln, 2562 Midvale, W. Los Angeles 64, Calif.

PRECISION AND CUSTOM BUILT ANTENNAS for any band and frequency. Literature on request. Antenna, Inc., Wakefield, R. I.

FREE LIST: Used Collins, Elmac, Hallicrafters, Hammarlund, Harvey-Wells, Lysco, National, RME, Sonar, etc. Lowest prices. Liberal trades. Dossett W9BHV, 355 Burlington, Frankfort, Indiana.

WANTED: BC-348 Receiver. State price and condition. Write R. Wegelin, 410 Cedar St., N.W., Washington, D.C.

WANTED—Top Prices Paid—Navy Selsyns 1DG, 1F, 1CT, 1G, 5DG, 5D, 5CT, 5G, 6G, 7G, etc. and BC-348, BC-221, AN/ART-13, AN/ARC-1, AN/ARC-3, AN/APR-4, Electronic Surplus, Lectronic Research, 719 Arch St., Philadelphia.

WANTED—AN/ARC-1 or AN/ARC-3 or Components. Write J. Durrant, 5526 Parkland Court, Apt. 202, Washington, D. C.

QSLs—Brownie W3CJI, 3110 Lehigh St., Allentown, Pa. Samples free, catalogue 25 cents.

FOR SALE: Two Amertran transformers, 6200 volts C.T. 2KVA—\$45.00 each. Super Pro and power supply, excellent working condition, \$200. Winter, 84-18 87 St., Woodhaven, L. I., N. Y. VI 7-8379.

SELL: BC-788C TRANSCEIVER, converted for 420 Mc operation, good condition, \$20.00. W5TOU, 4585 Fairway, Los Alamos, N. M.

QUALITY QSLs—10c for Samples—W2AOA Print, Box 54, Goshen, New York.

CLEARING OUT accumulated parts and equipment. Xmtrs, receivers, VFO, power supplies, surplus gear, tubes, xformers, etc. Bargain prices. Send for list. Clarence Hartneck, WØGBZ, Lakefield, Minnesota.

FOR SALE BC221 frequency meter with A.C. power supply, original calibration book. Little used, perfect condition. \$95 plus shipping and crating. G. E. Mandell, 247 N. Duke St., Lancaster, Pa.

NEWTYPED: Ten Meter ground plane antenna. Results guaranteed. Kit \$14.95, plans \$1.00. W5UKC, 4402 Sinclair, Austin, Texas.

WANTED: ART-13, ATC, DY-12, DY-17, ARC-3, ARC-1, APR-4, APR-5, PE-237, GN-58, BC-1306, SCR-693, TRC-2, RA-34, RA-62, BC-348, BC-342, BC-312, BC-611, SIG 5 supply catalogs, Test equipment, manuals. Will trade for new Ham equipment. Arrow Appliance, Box 19, Boston 1, Mass. Richmond 2-0916.

\$700 value imported Hertel & Reuss monocular compound microscope with 5X, 8X, and 12X oculars; 10X, 50X, and 100X oil-immersion objectives; right-angled vernier mechanical stage on 360 degree calibrated platform; sub-stage condenser with iris diaphragm shutter, and dark-field condenser. Guaranteed superior condition. Swap for Johnson Viking II with VFO or Collins 32V. All inquiries answered. Capt. Atherton, W4RVE, Crime Laboratory, Cp Gordon, Ga.

QSL CARDS? Largest variety, samples 25c. Sackers, W8DED, Holland, Michigan.

MUST SELL: My Viking I Transmitter and VFO. Guaranteed new condition. Everything complete for only \$250. Burton Byard, W6UFZ, Box 7, Hayfork, Calif.

QSLs! QSLs! for OMs! QSLs for YLs! Printed on beautiful Kromekote stock, and shipped within 36 to 48 hours! Samples 10c. Tooker Press, Lakehurst, New Jersey.

RADIO AMATEUR and commercial license preparation. International Morse code transcribed on magnetic tapes, recording wire and long playing microgroove discs. Disc-A-Method Recording Company, 317 E. 48 St., N.Y.C.

BC610 parts wanted. Give price and condition first letter. L I Radio Company, Box 474, Montrose, Pa.

QSL's—SWL's NEW! Better than ever! The 1953 line of Almar QSL, SWL cards. Samples 10c, Almar Printing Service, 602 Barker Bldg., Omaha, Nebraska.

WANTED: RCH receivers, RBS receivers and SLR receivers, Navy type equipment. Also, I-135 test sets. Write immediately stating condition and best price in first letter. GMEINC, 7315 Varna Ave., North Hollywood, Calif.

DON'T FAIL! Check yourself with a time-tested "Sure-check Test," similar to F.C.C. tests. Novice \$1.50 General \$1.75. Amateur extra \$2.75. Your money back if not satisfied. Amateur Radio Supply, 1013-7th Ave., Worthington, Minnesota.

QSLs! Interesting Samples 10c. Tooker Press, Lakehurst, New Jersey.

TRADE: BC 779A Super-Pro, power supply, and speaker, needs cabinet and some mechanical repairs, for smaller receiver such as S-51, NC 57, S-40. No shipping. Louis Weinstein, W2AJU, 260 Parkside Avenue., Brooklyn 26, N.Y.

10, 15, & 20 METER BEAMS, aluminum tubing, etc. Perforated aluminum sheet for shielding. Radcliff's, Fostoria, Ohio.

BARGAINS: EXTRA SPECIAL: Motorola P-69-13 mobile receivers \$29.50; Globe King \$315.00; HT-9 \$199.00; HRO-50 \$275.00; Lysco 600 \$109.00; HRO-7 \$199.00; Collins 75A1 \$275.00; HRO-5T \$175.00; SX-71 \$169.00; SX-42 \$189.00; SX-43 \$129.00; HRO-Senior \$119.50; RME 2-11 \$99.50; RME-45 \$99.00; Meissner EX Shifter \$59.00; S-40A or SX-16 \$69.50; VHF-152 \$59.00; HF 10-20 \$59.00; Globe Trotter \$69.50; MB611 Mobile Transmitters \$19.95; 90800 exciter \$29.50; XE-10 \$14.95; Gonset 10-11 converter \$17.50; and many others. **WE NEED USED RECEIVERS:** We give highest allowances for S2OR; S-40 A, B; NC-57; NC-100; NC-125; SX-24; SX-25; HQ-129X, and similar receivers. Free Trial. Terms financed by Leo, WØGFQ. Write for catalog and best deal to World Radio Laboratories, Council Bluffs, Iowa.

WANTED: ART-13 Transmitter and Parts. Write B. Spivey, 7013 Rolling Road, Chevy Chase, Md.

CRYSTALS-CABLES, Five PE-103 dynamotor cables with two plugs attached and three BC-223 transmitter cables, one PL-149 plug, \$2.75 each. Miscellaneous commercial crystals for marine frequencies 2000 to 3500 Kc., also aircraft 3105 Kc. and 4500 Kc. T.V. test. All good, accurate low drift crystals in holders, \$3.75 each. In FT-243 holders 7203, 7204, 7295 and 7296 Kc. \$1.80 each. W6KEG, 2142 Parkway Dr., El Monte, Calif.

BARGAINS: New and reconditioned Collins, Hallicrafters, National, Hammarlund, Johnson, Elmac, Harvey-Wells, Babcock, Gonset, Morrow, RME, Millen, Meissner, Lysco, others. Reconditioned S40A \$69.00, S40B \$79.00, S76 \$129.00, SX 71 \$149.00, SW54 \$35.00, NC57 \$69.00, HFS \$99.00, NC125 \$129.00, NC173 \$149.00, NC183 \$199.00, HF-10-20 \$49.00, DB22A \$49.00, VHF152A \$59.00, Gonset Tri-Band \$29.00, HQ129X, SP400X, SX43, SX42, SX62. HRO60, Collins 75A1, 75A2, 32V1, 32V2, Viking I, many others. Shipped on trial. Terms. Write for free list. Henry Radio, Butler, Mo.

SELL: Precision Signal Generator #E-400, new, \$85.00. #21A teletype midget printer, \$50. Teletype tape transmitter, \$35. #12 teletype page printer, receiving distributor, polar relay, table, \$125. **WANT:** ART-13, DY-12, GN-58, APR-4. Tom Howard, W-1-AFN, Box 19, Boston 1, Mass. Richmond 2-0916.

CASH FOR NAVY OR ARMY ORDNANCE: 60 cycle synchros or selsyns. \$35.00 for 1DG, 1D, 1F, 1G, 1CT. \$20.00 for 5D, Sizes 6 & 7. Subject to inspection. Other types advise. **ELECTRO,** Dept. CQ, 58 Eastern Avenue, Boston.

FOR SALE: 304TL Tubes, 4 for \$20.00; factory reconditioned glass watt-hour meters, 4 for \$10.00; 446A tubes, 10 for \$15.00; X400 mercury flashlamp, trigger transformer, in case, \$7.50; FL-8A filters, \$6.00; FL-5F Filters, 2 for \$6.00. Engineering Associates, 434 Patterson Road, Dayton 9, Ohio.

ATTENTION HAMS! Beautiful closely woven cotton Throw Rug in pastel colors with your Call Letters hand painted in large shaded letters. Rugs have beautiful fringe all way round. Fast dyes in the following colors: White, green spray, grey mist, radiant rose, mimosa yellow. We select colors for call letters to match. Sizes 21" x 34," \$5.00 and 30" x 54," \$10.00. Please send money order with order and allow for postage and any sales tax (where tax applies). Be sure to specify color. 73, Chatsworth Mfg. Company, Chatsworth, Ga. Wilbur Jackson, W4AVR.

SALE: HT-9 XMITTER 80, 20, 10 meter coils, \$200. Millen hi frequency xmitter 90810, \$100. D. G. Fuller, 210 Utica St., Tonawanda, N.Y.

ADDRESS CHANGE . . .

Subscribers to CQ should notify our Circulation Dept. at least 5 weeks in advance regarding any change in address. The Post Office Dept. does not forward magazines sent to a wrong destination unless you pay additional postage. We cannot duplicate copies sent to your old residence. Old and new addresses **MUST** be given.

CQ Magazine

67 WEST 44th STREET NEW YORK 36, N. Y.

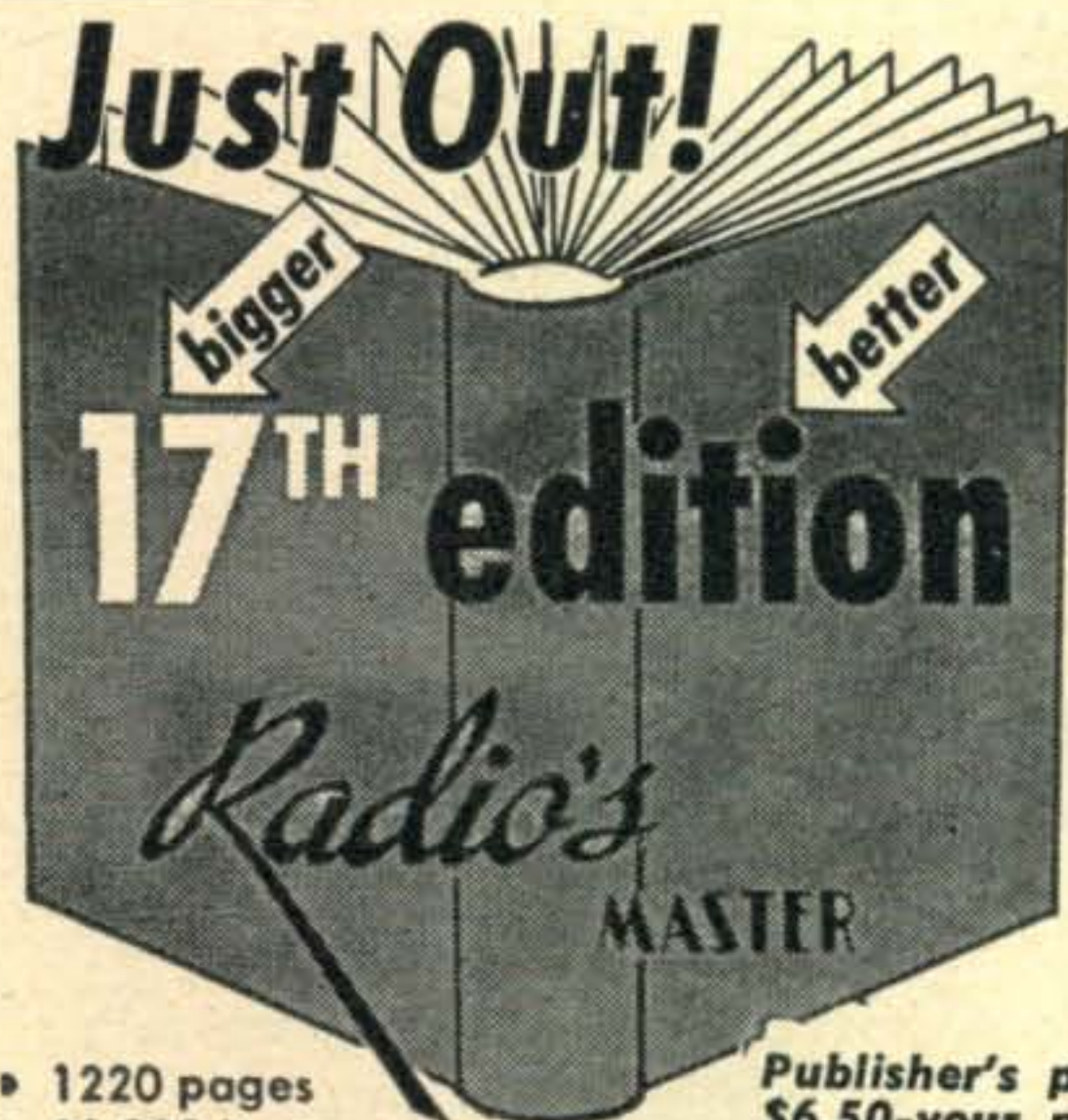

- 1220 pages
- 80,000 items
- 8,000 illustrations
- 8" x 11" — 5 lbs.

Publisher's price \$6.50—your price **\$1⁹⁵** through your regular parts distributor.

The right part when you need it for new gear or replacements

This permanent, hard cover Official Buying Guide of the electronic-TV parts and equipment industry with its comprehensive detailed index, eliminates the need for maintaining files of small catalogs and manufacturers' literature. *Radio's Master* catalogs 90% of TV and electronic equipment. Not merely part number listings — complete descriptions, specifications and illustrations written and compiled by each manufacturer. Enables you to make comparisons or substitutions right now!



UNITED CATALOG PUBLISHERS, INC.
110 Lafayette St., New York 13



NATIONAL

- **P**roven
- **D**ependable
- **Q**uality

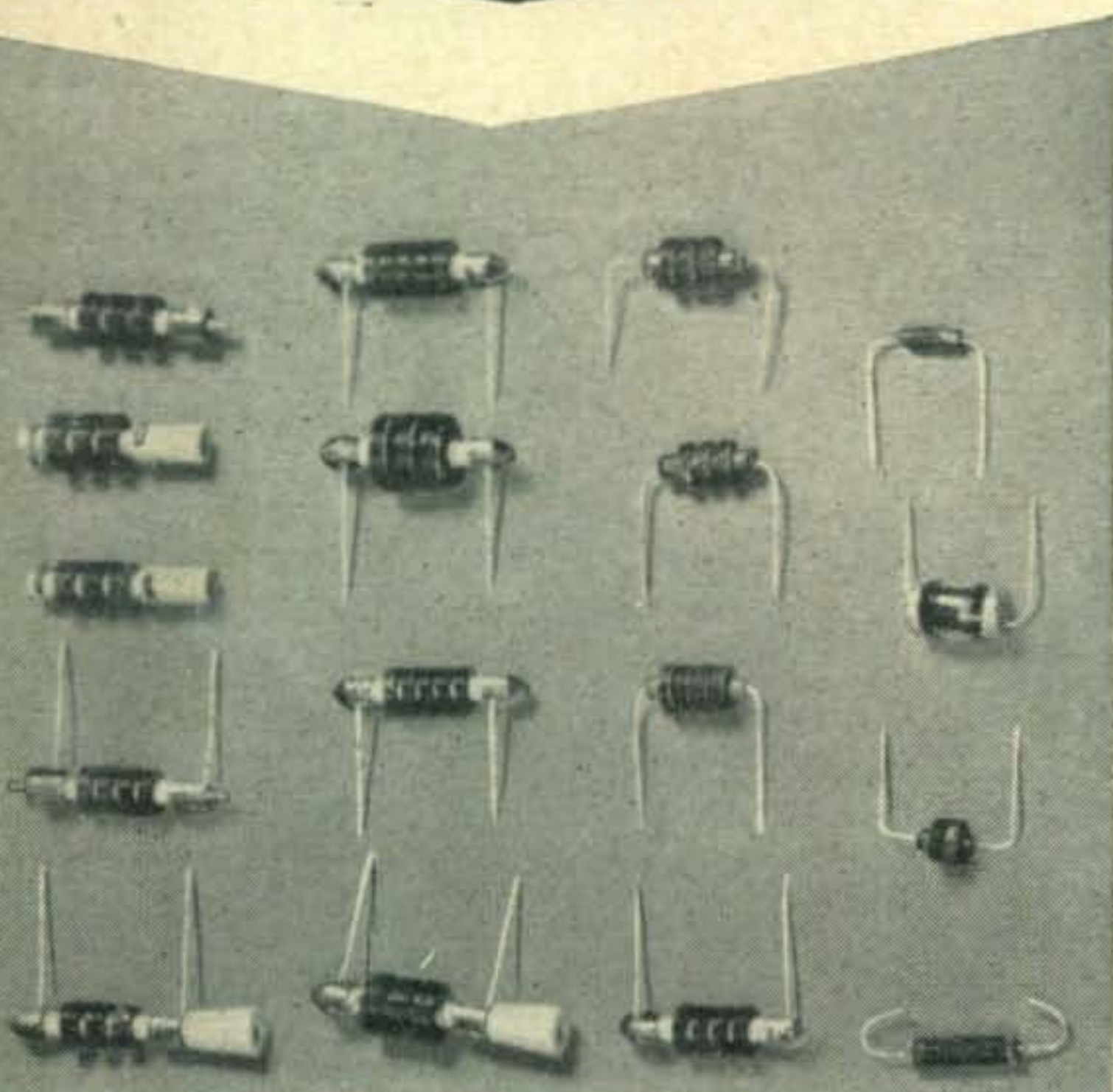

PRECISION-WOUND R. F. CHOKES

National makes a complete line of quality R. F. chokes to meet every electronic need. In addition, National's engineering staff and production facilities are capable of winding chokes to any set of specifications for commercial or military applications. Close tolerances guaranteed. Write for complete information or send specifications.

National



EST. 1914

NATIONAL COMPANY, Inc.
MALDEN, MASSACHUSETTS

CQ Ad Index

Allied Radio Corp.	53
American Electronics Co.	70
Arrow Sales, Inc.	59
American Amphenolic Corp.	60
Atronic Corp.	68
Babcock Radio Engineering, Inc.	57
Barker & Williamson	55, 62
Bell Telephone Laboratories	51
Bliley Electric Company	47
Bud Radio, Inc.	53
C. & H. Sales Co.	65
Collins Radio Company	12
Communications Equipment Co.	68
Dixon Electronics Co.	68
Eitel-McCullough, Inc.	10
Esse Radio Co.	61
ESSCO	66
Fair Radio Sales	56
General Electric Company	1
Gensler, B. N.	66
G. L. Electronics	57
Hallicrafters Company	4, 5
Harvey Radio Company, Inc.	7
Hawkins, P. E. Co.	66
Heath Company	8
Hughes Research and Development Co.	54
Instructograph Company	68
Lettine Radio Mfg. Co.	69
Millen, James Mfg. Co., Inc.	6
Motorola, Inc.	53
National Company, Inc.	72, Cover 3
Ohmite Manufacturing Co.	2
Petersen Radio Co., Inc.	Cover 2
Platt Electronics Corp.	58
Premax Products	64
RCA Tube Department	Cover 4
Rider, John F. Publisher, Inc.	68
Sanett, Robert	66
Shure Brothers, Inc.	53
TAB	72
Tallen Company, Inc.	66
Trans-World Radio-Television Corp.	65
Variety Electric Company	68
V & H Radio Supply Co.	69
Video Speed Servicing Systems	51
World Radio Labs Inc.	9

WANTED IMMEDIATELY

for **CRITICAL DEFENSE NEEDS**

TUBES - CRYSTALS - END EQUIPMENT

OAS/VR75	3C23	12SC7M	833A,884
OBS/VR90	3E29,829B	FG17,32,33	927, 1000T
OC3/VR105	4C35	100TH	1614, 2050
1N21,A,B	5C22	FG104,172	5725
1N23,A,B	5R4GY	250TH,TL	5727
1N25,26	6AC7M	304TH,TL	5749
Xtals: 100Kc,	6AG7M	368AS	5750
200Kc, 1000Kc	6B4G	450TH,TL	5751
2D21	6C21	KU627	5854, 5870
2K25, 723AB	6L6M	726C	5886
2J & 4J Magnet-	6SC7M	750T	5726
rons, Klystrons	7C7	807,810	5814
	7AG7	811,813	9001,2,3

All Army-Navy Gear: AN, ART, BC, I, PE, PU, RA, SCR, TG, TS. WAVE GUIDES: PL & UG CONNECTORS. TURN YOUR SURPLUS INTO SPOT CASH & SERVE YOUR COUNTRY'S NEEDS AS WELL. . . . Send Lists & Prices—Immediate Reply! Dept. C.

"TAB" 111 Liberty St.
New York 6, N.Y.
That's a Buy! Rector 2-6245



IN THE ROYALTY OF RADIO *The HRO Sixty* IS THE KING OF RECEIVERS

National



\$483.50* (less speaker) SLIGHTLY LESS THAN THE CROWN JEWELS!



National Company, Inc., Malden, Massachusetts

(*slightly higher West of the Rockies.)

30TH EDITION • 1953

The radio amateur's handbook

THE STANDARD MANUAL OF AMATEUR
RADIO COMMUNICATION

100% Beam Power

IN the High-Frequency and VHF Transmitter chapters of the new 1953 Radio Amateur's Handbook, all of the 30 transmitting type tubes illustrated in rf applications are beam power types.

Why beam power?

Beam power tubes . . . an original RCA development . . . offer better results with fewer stages, tubes, and components. Beam power tubes require less driving power—enable you to work exciter circuits at lower power levels (a big step forward in TVI reduction). Beam power tubes have higher perveance—make it possible to get high plate input with lower plate voltage.

Take advantage of the features of beam power tubes when you design that new transmitter. Your **RCA Tube Distributor** carries a complete line of RCA Beam Power Tubes in stock.



RADIO CORPORATION of AMERICA
ELECTRON TUBES

HARRISON, N. J.