

# CQ

FEBRUARY  
1954

# RADIO AMATEURS' JOURNAL

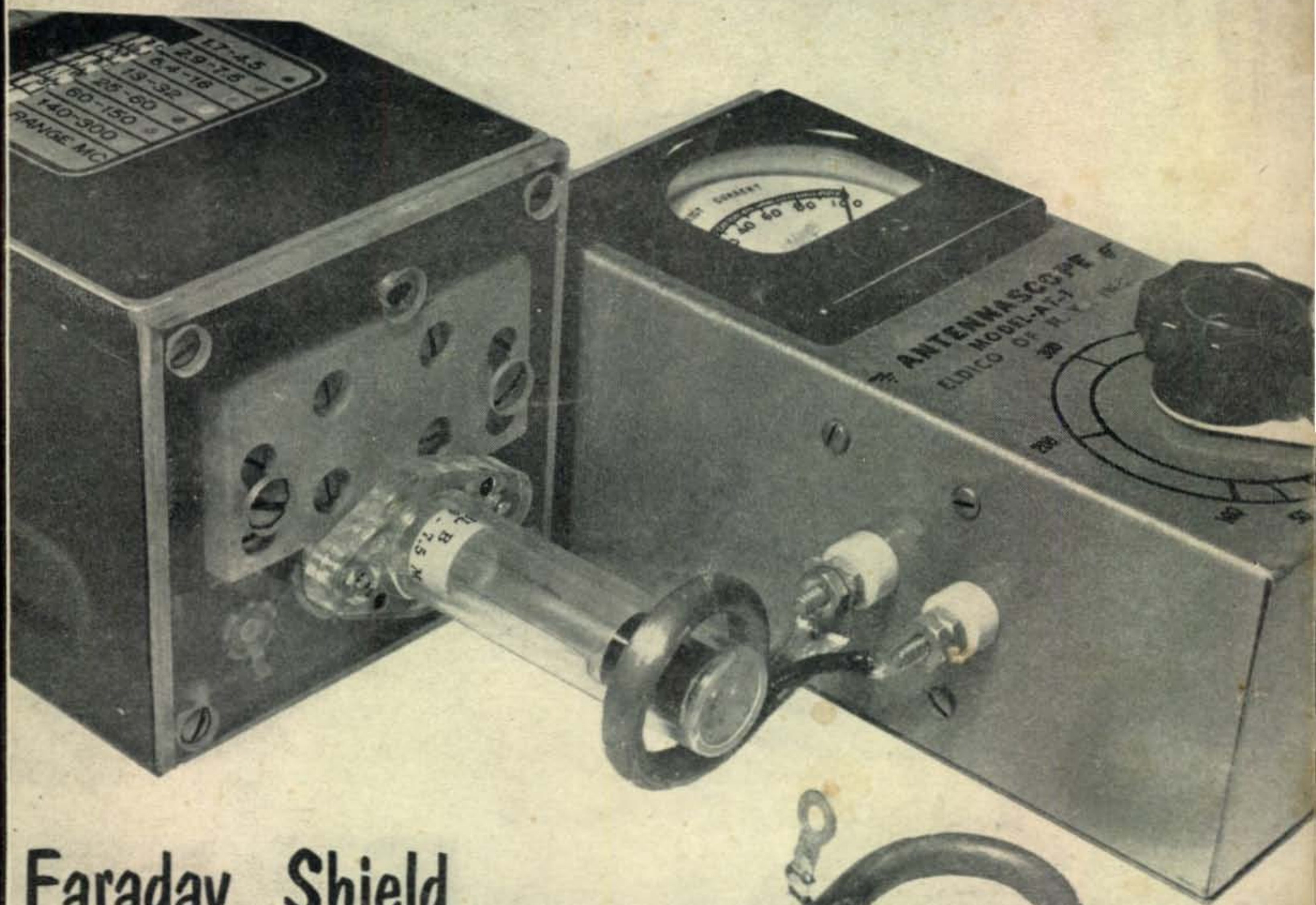

Faraday Shield  
for the

## ANTENNASCOPE

(see page 52)

# Just plug it in

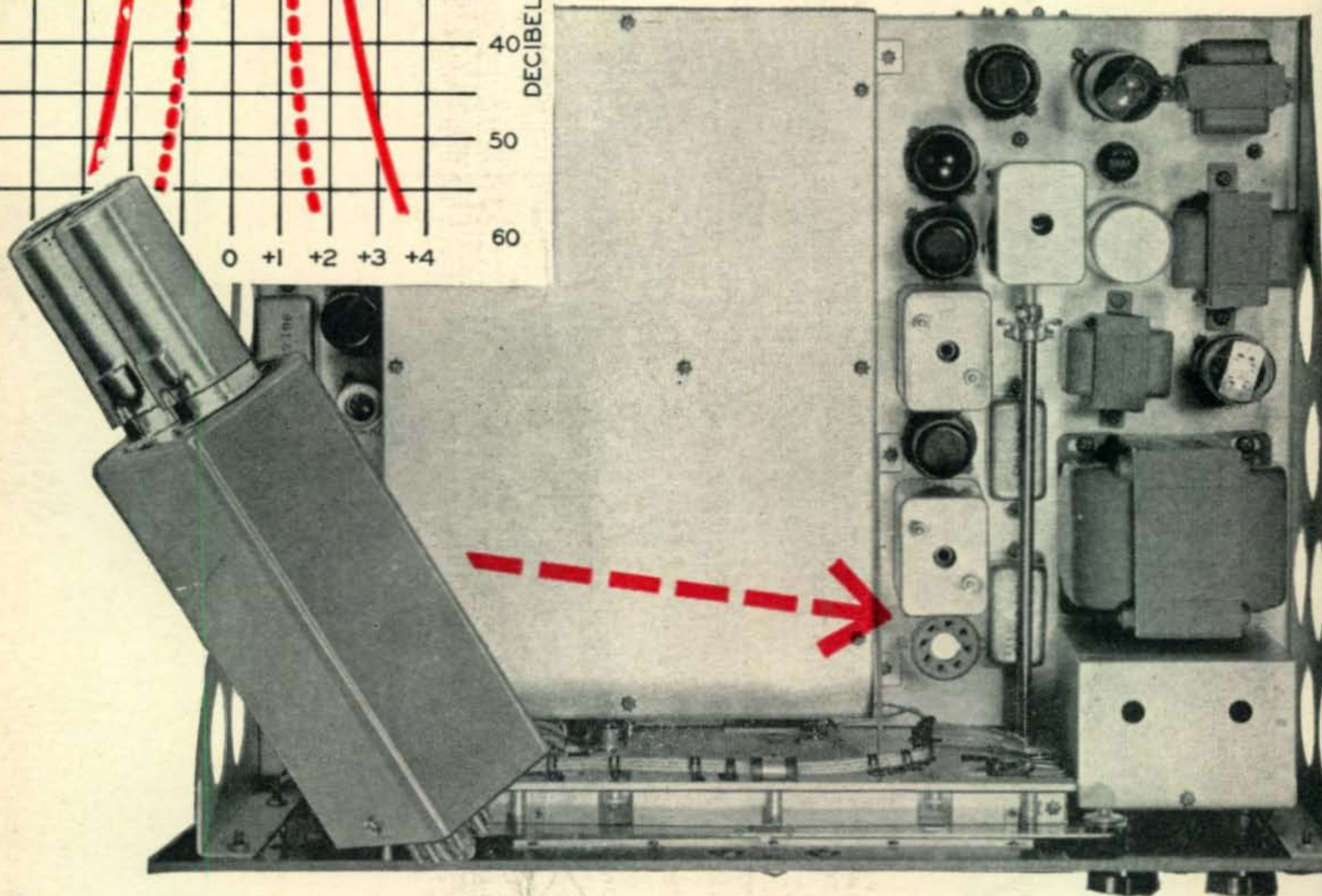
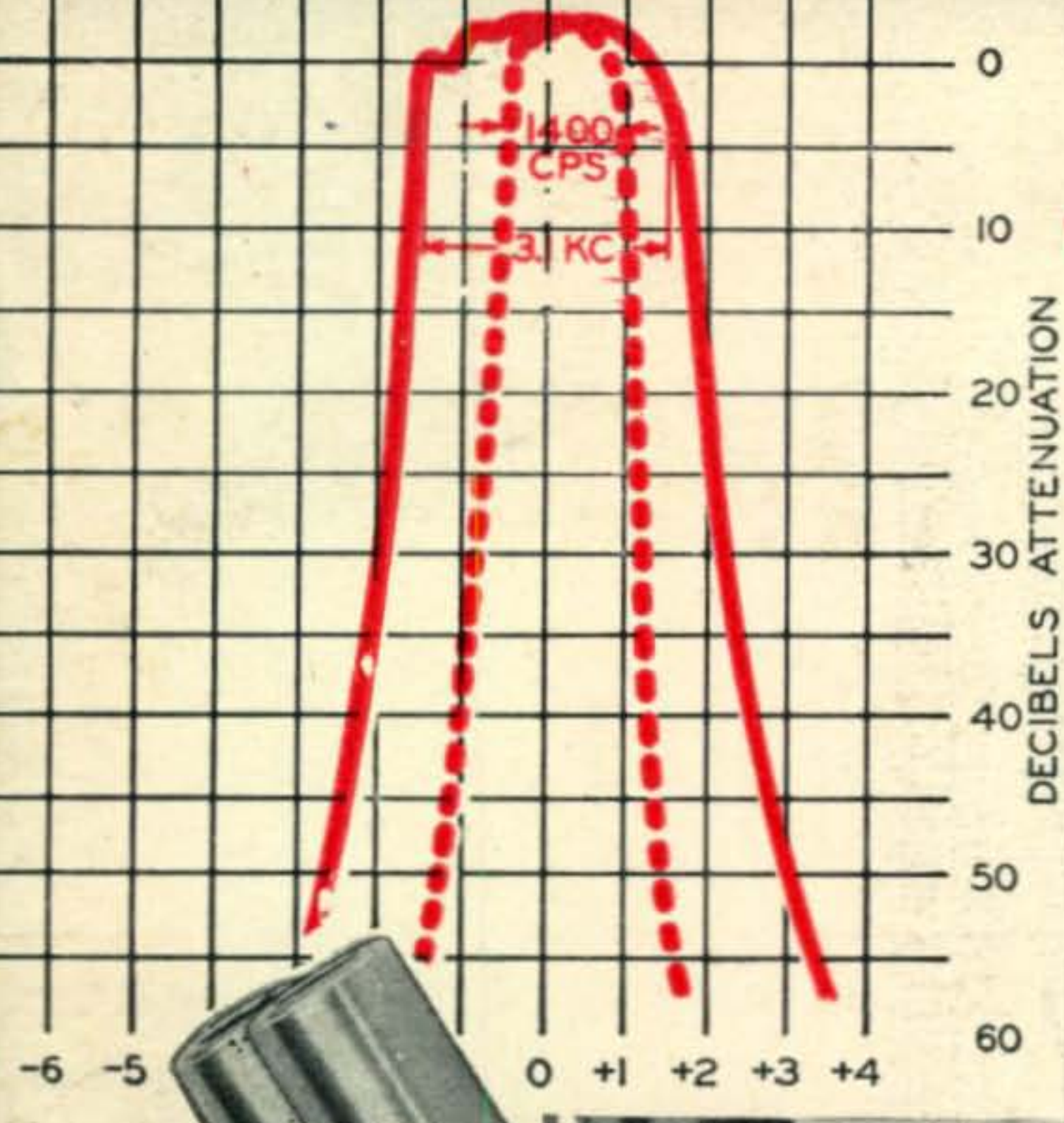

## A Mechanical Filter for Your 75A-1!

IN A MATTER OF SECONDS your 75A-1 can be converted to incorporate the revolutionary new Collins mechanical filter! Just unplug the first 500 kc IF tube and plug in your choice of either the 1400 cycle or 3.1 kc unit. The 353C series plug-in adapter units for your 75A-1 will be available at your Collins distributor soon — contact him now for early delivery.

**75A-2 OWNERS:** Your Collins dealer now has 75A-2 mechanical filter conversion kits in stock. The 75A-2 kits are designed to be permanently wired into the set and include sockets for two plug-in mechanical filters. A type F455B-31 3.1 kc filter is included with each kit and a type F455B-08 800 cycle filter may be added at any time.

- Type 353C-14 Plug-in Adapter, complete with 1400 cycle filter for 75A-1. . . . . \$ 75.00
- Type 353C-31 Plug-in Adapter, complete with 3.1 kc filter, for 75A-1. . . . . \$ 75.00

- Mechanical Filter Conversion Kit for 75A-2, complete with F455B-31 3.1 kc Filter. . . . \$ 80.00
- Factory conversion of 75A-2, including installation of mechanical filter kit, minor repairs, and realignment. . . . . \$105.00

- Plug-in filters for converted 75A-2's and new 75A-3's:
- F455B-08, 800 cycle. . . . . \$ 55.00
  - F455B-31, 3.1 kc. . . . . \$ 55.00
  - F455B-60, 6.0 kc (available now) . . . . \$ 55.00

- Solder Terminal Filters:
- F455A-08, 800 cycle. . . . . \$ 55.00
  - F455A-31, 3.1 kc. . . . . \$ 55.00
  - F455A-60, 6.0 kc. . . . . \$ 55.00

NOTE: 353C-14 and 353C-31 Adapters incorporate 500 kc solder terminal filters; they are designed for the 75A-1 receiver and will not operate in the 75A-2 or 75A-3.

**COLLINS RADIO COMPANY, Cedar Rapids, Iowa**

11 W. 42nd St.  
NEW YORK 36

1930 Hi-Line Drive  
DALLAS 2

2700 W. Olive Ave.  
BURBANK



HOW **Go Mobile with Confidence!**



**NEW**  
**BABCOCK**

**MOBILE D-X MITTER**

Model MT-5B • 6 Band Bandswitching

*Luxury Quality!*

*Professional Performance!*

*Low Cost!*

**5 NEW FEATURES**  
**HAVE BEEN ADDED**

- 1** NEW, exclusive clear-vision Meter with D'Arsonval Movement, providing most complete metering of all circuits.
- 2** Uses tubeless VFO which may be simply built from plans in instruction book.
- 3** NEW, extremely effective Crystal Oscillator Circuit using 6CL6 tube.
- 4** VFO-XTL Crystal Switch and VFO Connector now located on panel.
- 5** Alternate 6 and 12 volt wiring depending on power plug connection.



A beauty—more than meets every demand! Designed for amateur use but built to most exacting commercial standards, with the rare skill and meticulous care that identifies world-renowned Babcock master craftsmanship.

Vibration-proof, shock-proof—the same rugged but high performance qualities that go into Babcock airborne and military radio equipment. Every part, every tube tied down to insure a steady, solid signal at all times. New and exclusive *time-tested* features, inside and out, provide the utmost in operating efficiency, simplicity and convenience.

All this, and more, in a sturdy 5x8x7" lifetime gray Hammertone baked enamel case—the smallest, most compact per watt output, most reliable unit available anywhere at any price. Inspect this new D-X Mitter—compare it—you'll never want any other!

Model MT-5B Babcock Mobile D-X Mitter, includes tubes, Ham Net ..... \$119.50  
 Babcock PS 4A 6VDC Dual Vibrator Power Supply, includes vibrators, plugs, tubes.  
 Ham Net ..... \$67.50

Contact your nearest dealer or write direct for full details.

Manufactured and Fully Guaranteed by  
**BABCOCK RADIO ENGINEERING, INC.**  
 7942 Woodley Ave. • Van Nuys, Calif.  
 Export Dept., Frazar & Hansen, Ltd., 301 Clay St.,  
 San Francisco, Calif., USA

IF A FINER SET IS EVER BUILT, IT WILL CARRY THE NAME...





## Heathkit AMATEUR TRANSMITTER KIT

MODEL AT-1

**\$29<sup>50</sup>**

SHIPPING  
WT. 16 LBS.

Range ..... 80-40-20-15-11-10 meters  
6AG7 ..... Oscillator - Multiplier  
6L6 ..... Amplifier - Doubler  
5U4G ..... Rectifier  
105-125 volts AC 50/60 cycles 100 watts  
Size — 8 1/8" high x 13 1/8" wide x 7" deep

Here is the latest Heathkit addition to the Ham Radio field, the AT-1 Transmitter Kit incorporating many desirable design features at the lowest possible dollar-per-watts price. Panel mounted crystal socket, standby switch, key click filter, AC line filtering, good shielding, etc. VFO or crystal excitation-up to 35 watts input. Built-in power supply provides 425V @ 100MA. Amazingly low kit price includes all circuit components, tubes, cabinet, punched chassis and detailed construction manual. (Crystal not supplied.)

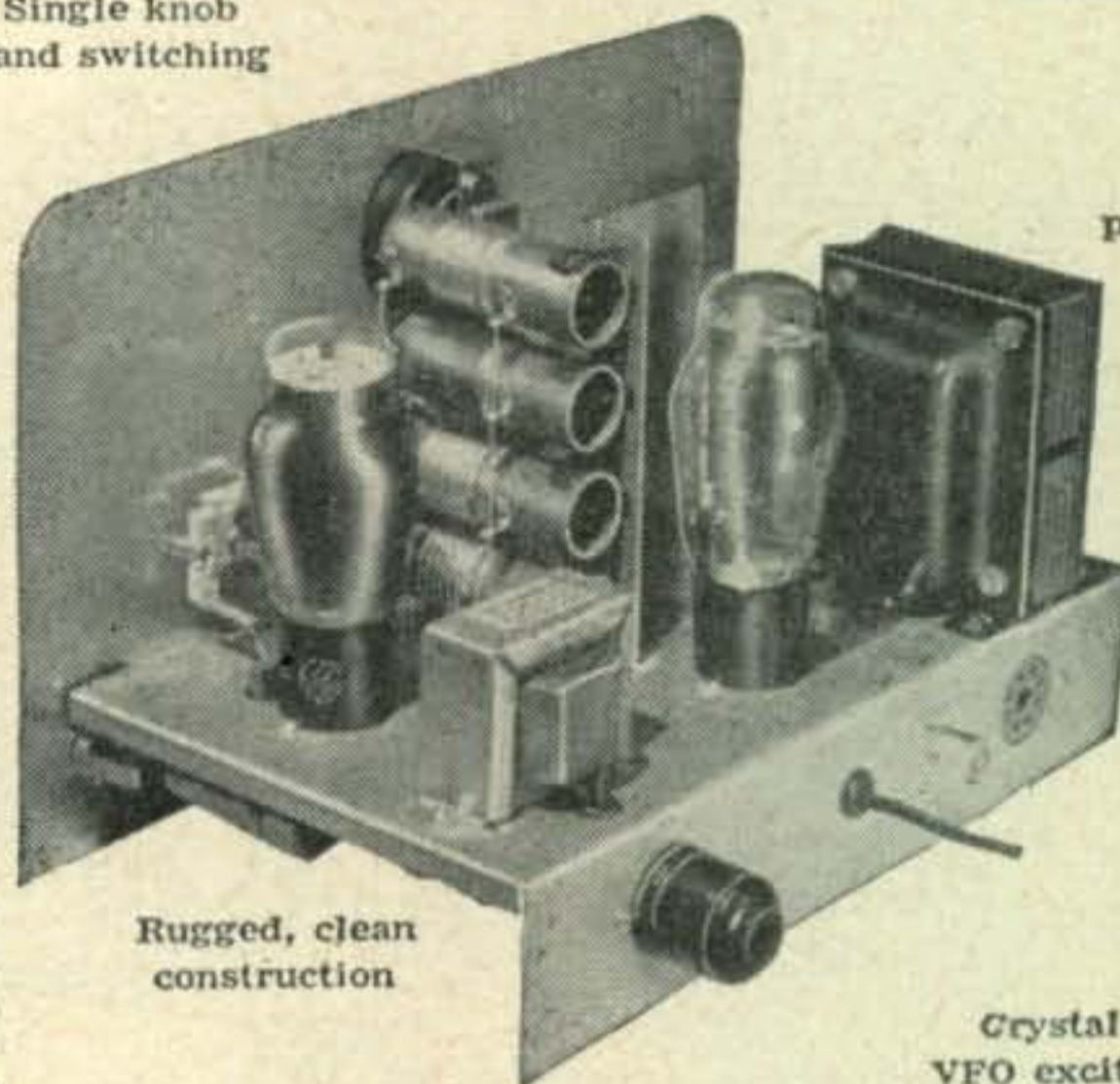
Single knob  
band switchingPre-wound coils —  
metered operation52 ohm  
coaxial outputBuilt-in  
power supplyRugged, clean  
constructionCrystal or  
VFO excitation

## New HEATHKIT COMMUNICATIONS RECEIVER KIT

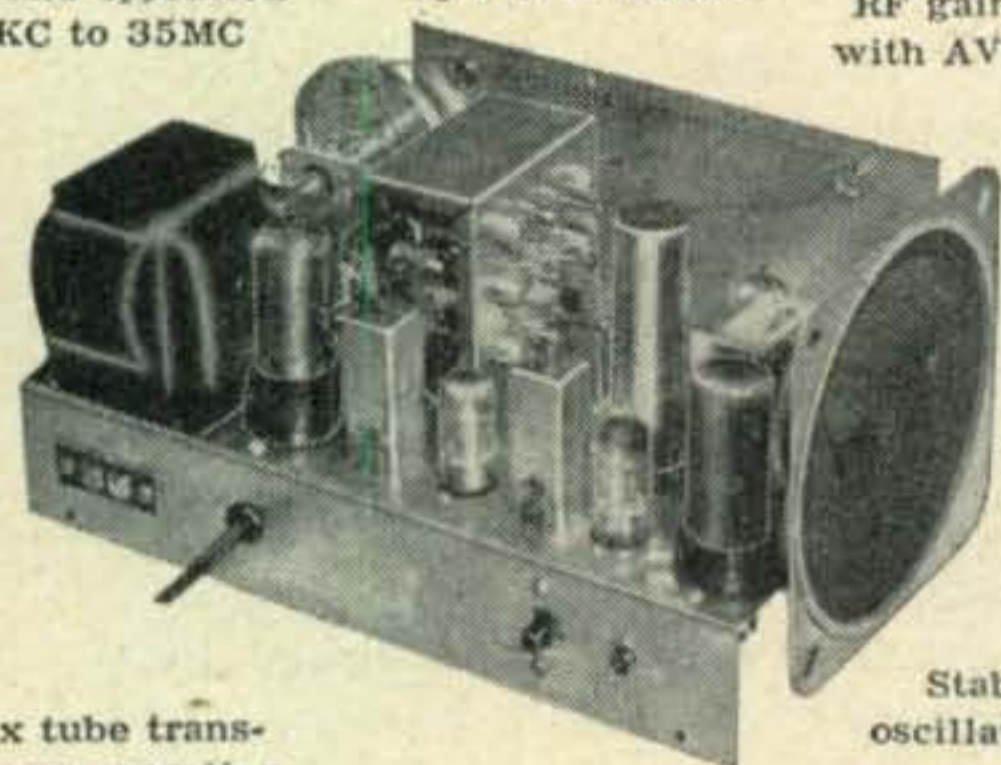
Four band operation  
535KC to 35MCElectrical band  
spread and scaleRF gain control  
with AVC or MVCSix tube trans-  
former operationNoise limiter —  
standby switchStable BFO  
oscillator circuit5 1/2" PM speaker —  
headphone jack

Range.....535KC to 35MC  
12BE6.....Mixer oscillator  
12BA6.....IF amplifier  
12AV6.....Detector - AVC - Audio  
12BA6.....BFO oscillator  
12A6.....Beam power output  
5Y3GT.....Rectifier  
105-125 volts AC 50/60 cycles  
45 watts

A new Heathkit AR-2 Communications Receiver. The ideal companion piece for the AT-1 Transmitter. Electrical band spread scale for tuning and logging convenience. High gain miniature tubes and IF transformers for high sensitivity and good signal to noise ratio. Construct your own Communications Receiver at a very substantial saving. Supplied with all tubes, speaker, circuit components, and detailed step-by-step construction manual.



MODEL AR-2

**\$25<sup>50</sup>**

SHIP. WT. 12 LBS.

CABINET

Proxylon impreg-  
nated fabric cov-  
ered plywood cabi-  
net. Ship. wt. 5 lbs.  
No. 91-10. **\$4.50**

## THE IMPROVED Heathkit GRID DIP METER KIT

- Pre-wound coil kit
- Range — 2MC to 250MC
- Meter sensitivity control
- Compact one hand operation
- Headphone monitoring jack
- Transformer operated

The invaluable instrument for all Hams. Numerous applications such as pre-tuning, neutralization, locating parasitics, correcting TVI, etc. Receiver applications include measuring C, L, and Q of components, determining RF circuit resonant frequencies, etc. Thumbwheel drive for convenient one hand operation. All plug-in coils are wound and calibrated (rack included). Headphone panel jack further extends usefulness to operation as an oscillating detector.

MODEL  
GD-1A

**\$19<sup>50</sup>**

SHIP. WT. 4 LBS.

**HEATH COMPANY**  
BENTON HARBOR 6, MICHIGAN

Two additional plug-in coils are available and provide continuous extension of low frequency coverage down to 355KC. Dial correlation curves included. Shipping Wt. 1 lb. **\$3.00** Kit 341.

# CQ RADIO AMATEURS' JOURNAL

Vol. 10, No. 2  
FEBRUARY, 1954

## EDITORIAL STAFF

MANAGING EDITOR  
OLIVER P. FERRELL

TECHNICAL EDITOR  
E. M. BROWN, W2PAU

## DEPARTMENT EDITORS

Herb Brier, W9EGQ	Novice
Wayne Green, W2NSD	Teletype
George Jacobs, W2PAJ	Propagation
Louisa B. Sando, W5RZJ	YL
R. C. Spenceley, KV4AA	DX

## CONTRIBUTING EDITORS

Frank C. Jones,	W6AJF
G. F. Montgomery,	W3FQB
William I. Orr,	W6SAI
W. M. Scherer,	W2AEF

## DRAFTSMAN

Thomas Smith, W2MCJ

## BUSINESS STAFF

S. R. COWAN,	Publisher
S. L. CAHN,	Adv. Director
H. N. REIZES,	Adv. Mgr.
D. SALTMAN,	Prod. Mgr.
R. CAMPBELL,	Edit. Prod.
H. WEISNER,	Circ. Mgr.
E. HARMAN	Ass't Circ. Mgr.

## BRANCH OFFICES

California: Ted E. Schell, 2700 West 3rd Street, Los Angeles 5, Calif. Dunkirk 2-4889.  
Mid West: Harold F. Mann, 333 No. Michigan Avenue, Chicago 1, Illinois. Franklin 2-7100.  
Cleveland: Richard E. Cleary, Commercial Bank Bldg., Berea, Ohio. Telephone BE 4-7719.  
Foreign Subscription Representative; Radio Society of Great Britain, New Ruskin House, Little Russel St., London, WC 1, England.  
Technical Book & Magazine Co., 297 Swanston St., Melbourne C1, Victoria, Australia.  
Scandinavian Representative: Intrapress, 17 Nordre Paradisvej, Holte, Denmark.

CQ—(title Reg. U.S. Post Office)—is published monthly by Cowan Publishing Corp. Executive and Editorial offices, 67 West 44th Street, New York 36, N. Y. Phone MURRAY Hill 7-2080. Reentered as Second Class Matter February 6, 1951 at the Post Office, New York, N. Y. under the Act of March 3, 1879. Subscription rates in U.S.A. Possessions, APO & FPO, 1 year \$3.00; 2 years \$5.00; 3 years \$7.00. Elsewhere add \$1.00 per year for postage. Single copies 35 cents. Printed in U.S.A. Entire contents copyright 1954 by Cowan Publishing Corp. CQ does not assume responsibility for unsolicited manuscripts.

POSTMASTER: SEND FORM 3579 to CQ, 67 WEST 44th ST., NEW YORK 36, N. Y.

## FEATURE ARTICLES

<b>The Command Set Roundup</b> <i>Herb Brier, W9EGQ</i> .....	13
<b>Design of a Screen Supply</b> <i>William I. Orr, W6SAI/FP8AC</i> .....	20
<b>Spurious Emissions</b> <i>Capt. E. H. Conklin, USN, W3VQ</i> .....	26
<b>A Six Band Mobile Antenna</b> <i>Hartland B. Smith, W8VVD</i> .....	28
<b>The Cool Persian</b> <i>G. F. Montgomery, W3FQB</i> .....	32
<b>Test Equipment in the Ham Shack (Part III)</b> <i>Howard Burgess, W5WGF</i> .....	50
<b>Faraday Shield for the Antennascope</b> <i>Elbert Robberson, W2FRQ</i> .....	52

## Departments

<b>DX and Overseas News (KV4AA)</b> .....	33
<b>The Novice Shack (W9EGQ)</b> .....	37
<b>Ionospheric Propagation Conditions (W2PAJ)</b> .....	40
<b>What's New in Ham Radio</b> .....	42
<b>The VHF-UHF News</b> .....	44
<b>The YL's Frequency (W5RZJ/Ø)</b> .....	47

## Miscellaneous

<b>Snorlock Ohms</b> .....	6
<b>Zero Bias</b> .....	11
<b>Errata: "Versatile 70 Watts"</b> .....	25
<b>WAZ Honor Roll</b> .....	36
<b>Broad Band</b> .....	56
<b>Advertising Index</b> .....	80

Here are  
**31 REASONS WHY THE...**

*is the hottest*

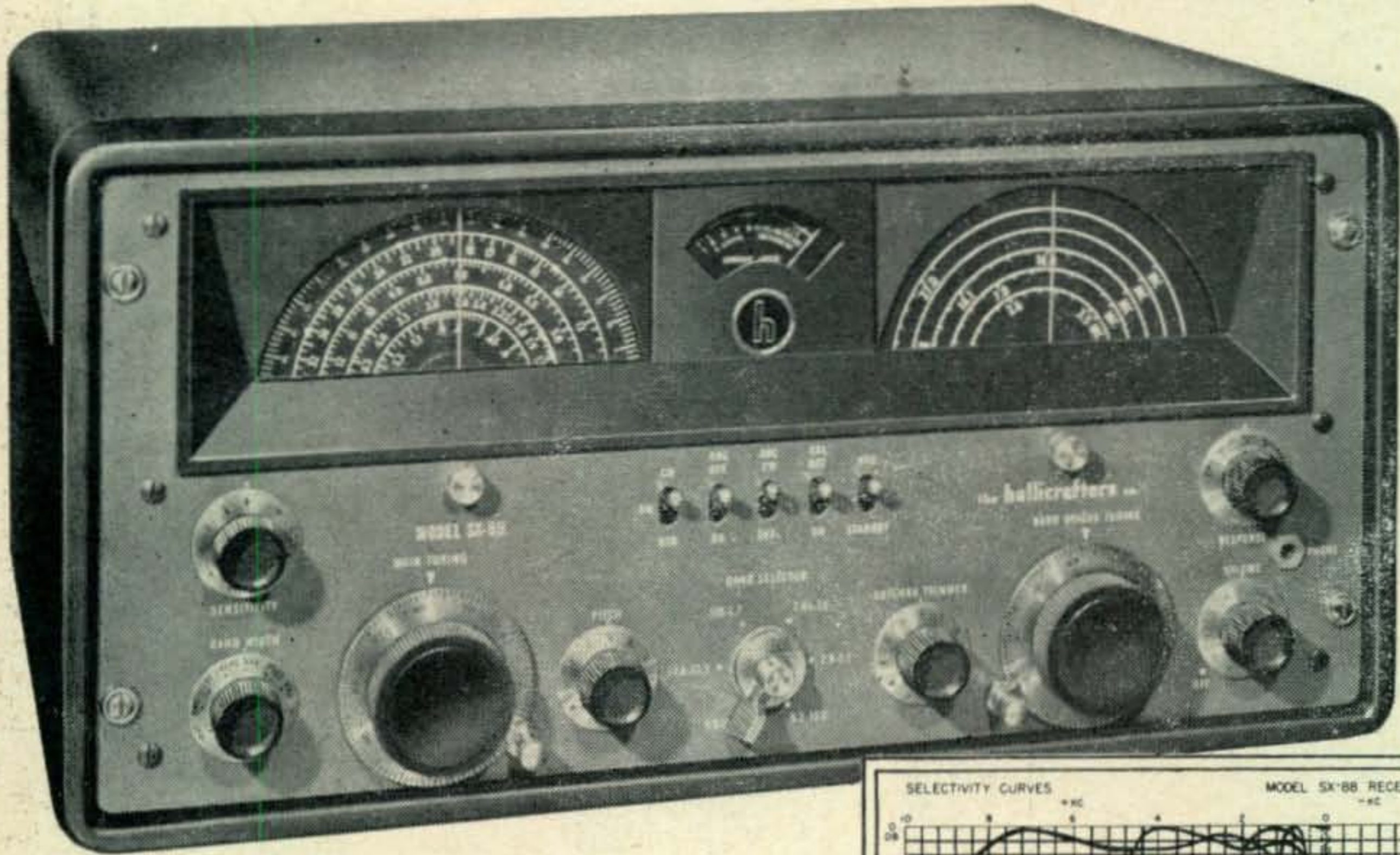

**SELECTIVITY**—For the first time, selectivity from 10 kc to 250 cycles in six steps. Compare with ANY other receiver!

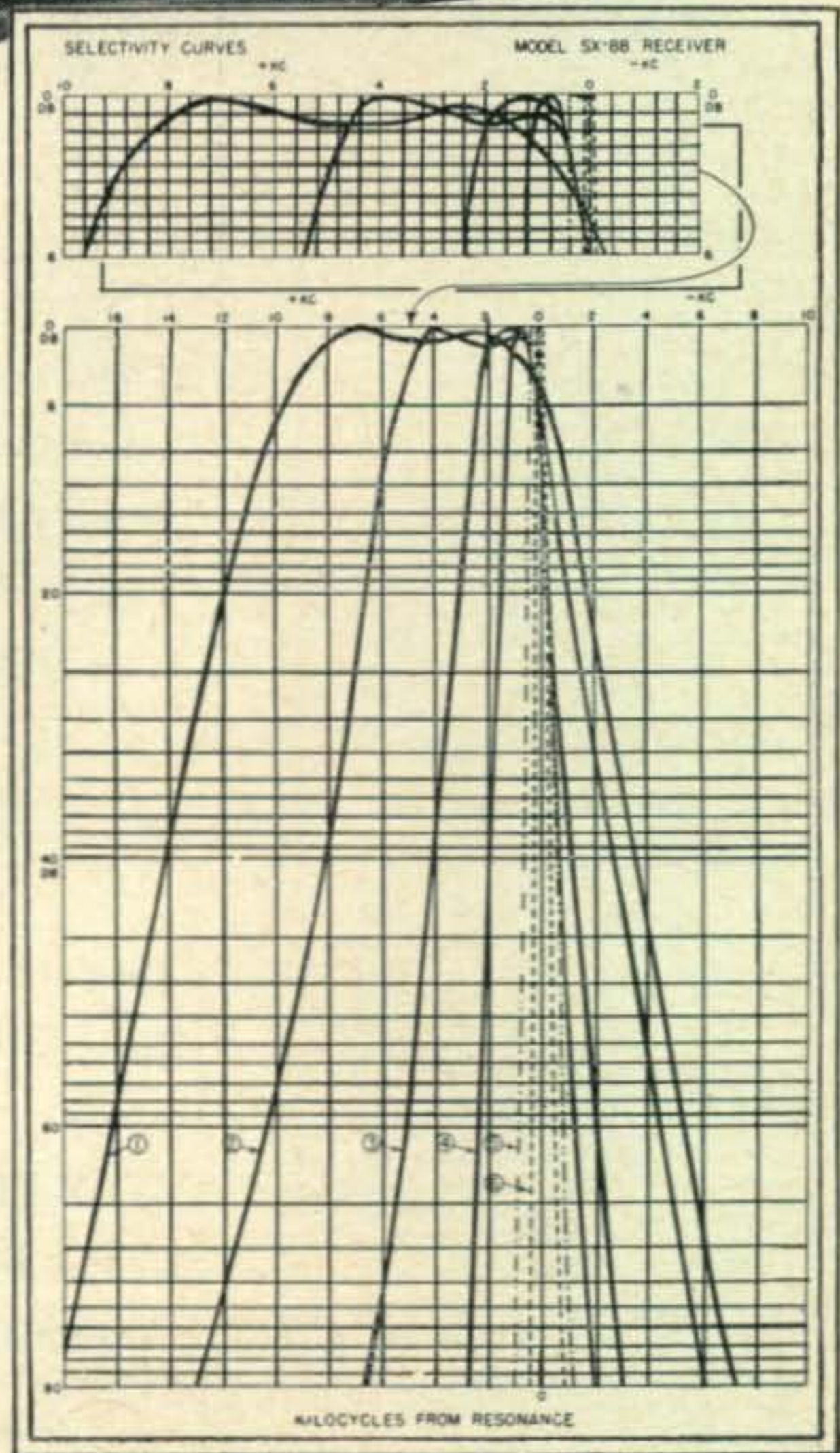
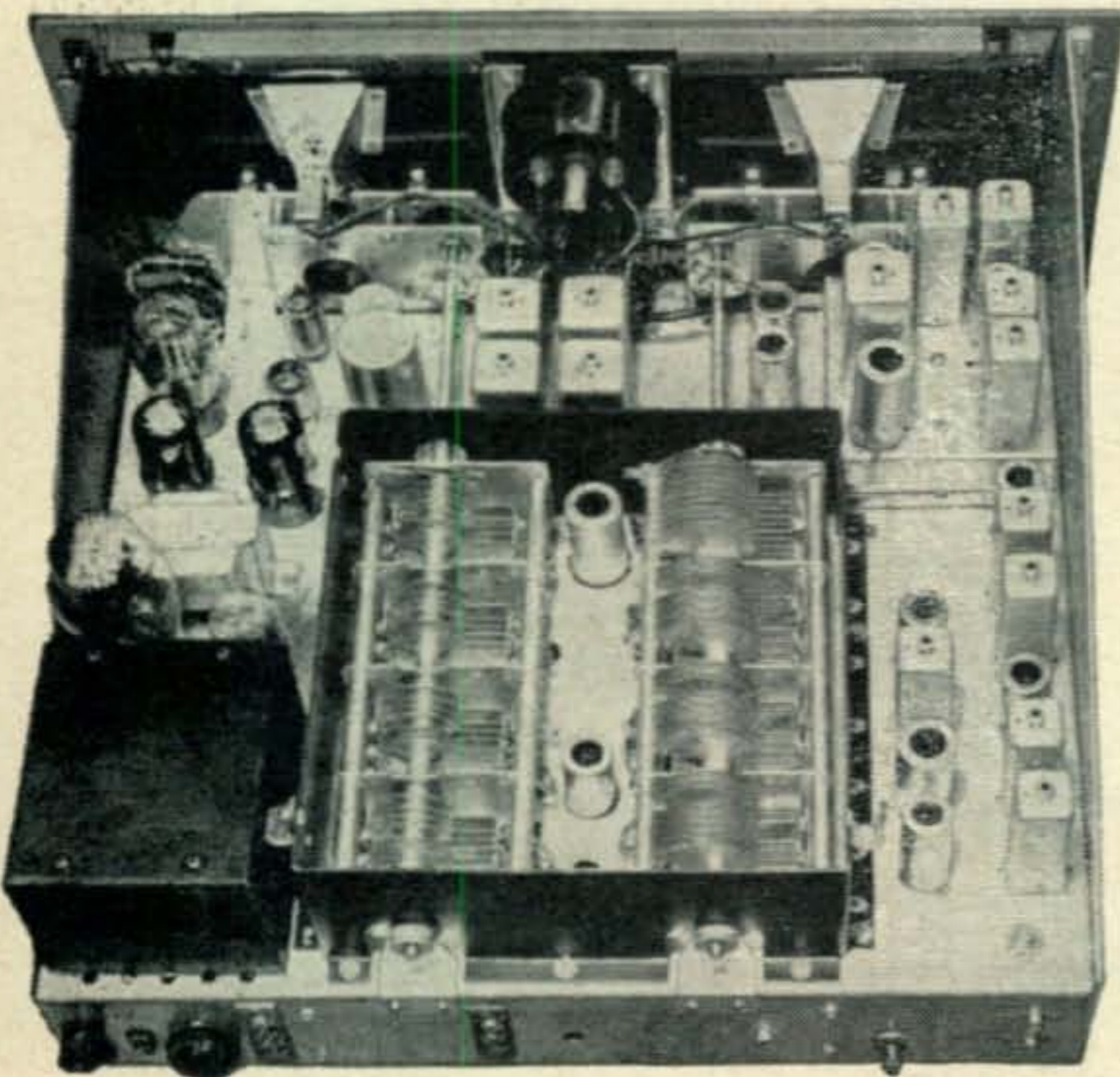

# hallicrafters SX-88

## ham news in years!

1. Heavy gauge steel welded chassis for mechanical stability.
2. Full precision gear drive for main and band spread tuning.
3. Six position Band Width Control (selectivity) from 250 cycles to 10 kc.
4. 10 watt inverse feed back and push-pull audio output.
5. Exalted B. F. O. for tops in single side band reception.
6. Buffer amplifier in B. F. O. circuit.
7. Antenna trimmer.
8. Amplified and delayed A. V. C.
9. Built-in 100 kc calibration crystal.
10. Second conversion oscillators crystal controlled.
11. Inertia tuning (fly wheels both dials).
12. Full frequency coverage from 535 kc to 33 mc.
13. Calibrated electrical band spread 160, 80, 40, 20, 15, 11, and 10 meters.
14. Logging scales on each tuning shaft.
15. Dial locks on each tuning shaft.
16. Tuning dial indicators resettable from front panel for maximum calibration accuracy.
17. Auxiliary A.C. socket on rear of chassis.
18. Illuminated band-in-use indicator.
19. Illuminated S meter.
20. Dual S meter calibration: S units and microvolts.
21. Auxiliary power socket plus .6 amps at 6.3 volts and 10 ma at 150 volts for accessories.
22. Standard 8 $\frac{3}{4}$ " by 19" panel for rack mounting if desired.
23. 50 kc i.f. output jack via cathode follower for teletype converter, etc.
24. Five position response control (tone control).
25. Two r.f. stages (Bands II to VI).
26. 17 tubes plus voltage regulator, ballast tube and rectifier.
27. Automatic noise limiter circuit.
28. Phono Jack.
29. Audio output transformer for 3.2, 8, 500/600 ohm loads.
30. Fuse for overload protection.
31. Auxiliary sensitivity control permits monitoring of local transmissions in standby position.

# hallicrafters

*World's Leading Manufacturer of Communications and High Fidelity Equipment, Radio and Television*

4401 West Fifth Avenue, Chicago 24, Illinois • Hallicrafters Ltd., 51 Camden Street, Toronto, Canada

Designed for



Application



39016

**A Really NEW  
FLEXIBLE COUPLING  
No. 39016**

Incorporating features which have long been desired in a flexible coupling. No Back Lash—Higher Flexibility—Higher Breakdown Voltage—Smaller Diameter—Shorter Length—Higher Alignment Accuracy—Higher Resistance to Mechanical Shock—Solid Insulating Barrier Diaphragm—Molded as a Single Unit.

**JAMES MILLEN  
MFG. CO., INC.**

MAIN OFFICE AND FACTORY  
**MALDEN**  
MASSACHUSETTS



# Snorlock



## Who Zero-Beated Sir Obie?

The great detective Snorlock Ohms and his physician-friend, Watts Gnu, were ushered into wealthy and eccentric Sir Obie Quiet's sumptuous Ham shack. Pierced through Sir Obie's leopard skin jacket were: (1) an oriental dagger, (2) an occidental hatchet, (3) a knife, and (4) a series of bullet holes oddly reminiscent of the schematic diagram of an inductance coil.

Snorlock stroked heavy chin whiskers, disturbing a robin that had laid three eggs. "This," he announced, "looks like murder."

"Astounding perception!" echoed Watts. "But now I see he's been knifed in the abdomen."

"Alimentary, my dear Watts, alimentary."

"But who could have done so heinous a deed?" inquired the butler. "I trust, sir, that you will not be influenced by mystery story writers and say 'the butler did it'."

The detective fastened gimlet eyes upon the menial, then returned the eyes to his sockets. Without a word, he strode to Sir Obie's 45-tube Ham receiver and observed the frequency on the slide-rule scale. It read 14,000½ kilocycles. "The person who last worked Sir Obie on 20-meters is the murderer," he announced.

Watts' upper plate fell with a *clack*. "B-b-but," he spluttered like a short-circuited rectifier tube, "we already have full evidence of the foul deed here." He pointed to the lethal instruments. "Do you mean to imply he was murdered *over the air*?"

Snorlock smiled as one does to a six-year-old who does not know the Einstein theory. "Look," he said, removing the dead man's jacket, "not a mark on the body. The killer employed a ruse—rubber weapons of the same type used by television comedians . . . Yes, you are right. We shall learn that Sir Obie was done away via 20-meter Ham radio."

"But-b-but how?" spluttered the butler, like two rectifier tubes in short circuit.

"Tell me," evaded Snorlock, "was Sir Obie impressionable—did he respond to suggestion?"

(Continued on page 8)





*Bliley* TYPE  
**AX2**

RANGE (kc)	TOLERANCE (kc)	PRICE
1803-1822 1878-1897 1903-1922 1978-1997	±1	\$3.75
3500-3997	±5	\$2.95
7000-7425 8000-8222	±5	\$2.95
12500-13615 14000-14850	±30	\$3.95

On crystals supplied to the tolerance above, the nameplate frequency is calibrated to ± .002% in factory test equipment. The drift is less than .0002% per °C.



*Bliley* TYPE  
**AX3**

RANGE (kc)	TOLERANCE (kc)	PRICE
24000-24333 25000-25500	±5	\$3.95

Specially designed third overtone crystal produced for the Bliley CCO-2A oscillator. On crystals supplied to the tolerance above, the nameplate frequency is calibrated to ± .003% in factory test equipment. The drift is less than .0002% per °C.

*Bliley Crystals* **FOR 23 YEARS**  
**TOP AMATEUR CHOICE...**

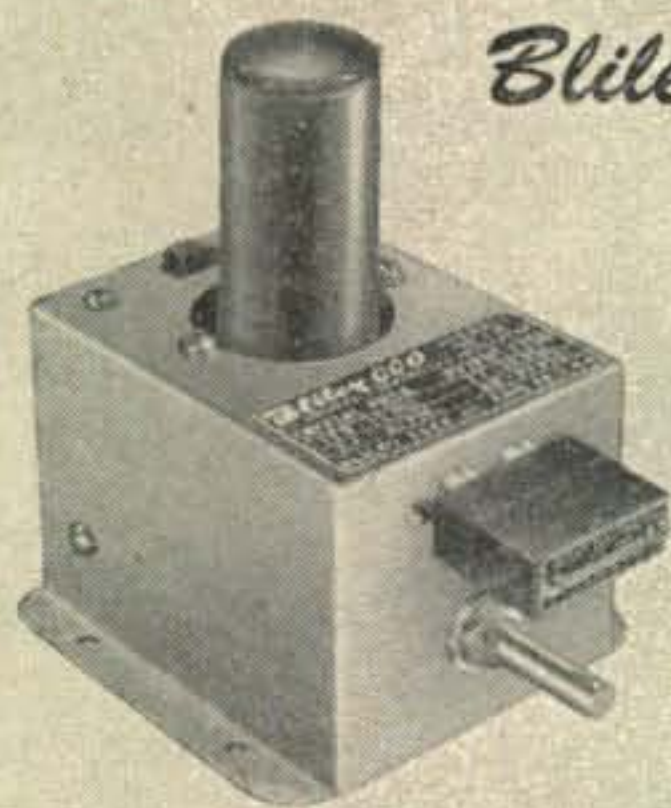

*Bliley* TYPE **CCO-2A**

This famous packaged oscillator unit was designed and engineered to utilize the many advantages of crystal control on 2-6-10-11 meters. With the CCO-2A, output is obtained directly on 6-10-11 meters; operation on 2 meters requires only a tripler stage.

Specified for 10 meters and 11 meters is the Bliley type AX2. For 6 meter operation, use Bliley type AX3. On 2 meters, select an AX3 crystal which will triple to the desired transmitting frequency.

PRICE: \$11.95 (Less Tube and Crystal)



*Bliley* TYPE **MC9**

**SPOT FREQUENCIES**  
*for* **NET OPERATION**

RANGE (kc)	TOLERANCE (kc)	PRICE
ANY SPECIFIED FREQUENCY BETWEEN 3000-10000	±.03%	\$4.80

On crystals supplied to the tolerance above, the nameplate frequency is calibrated to ± .002% in factory test equipment. The drift is less than .0002% per °C.



You will find these famous Bliley amateur products described in Bulletin 44-A—now available at your favorite distributor of amateur equipment.

**BLILEY ELECTRIC COMPANY**

UNION STATION BLDG., ERIE, PENNSYLVANIA



(from page 6)

"Very much so, sir," said the butler. "Once he was hypnotized into believing he was a dipper. All evening he dunked his head in a pail of water. Another time he was led to believe he was a fog horn. He kept us all up with the most fearful sounds. Still another time, he was hypnotized into believing he was an old-fashioned farm pump. He'd fill his mouth with water and then have me pump his arm. It was, well, decidedly unsanitary."

"Who," queried Snorlock, "was this person who exerted so great a power over Sir Obie's mind?"

"The eminent Sir Hypp Noah Twist. The two were great friends. Sir Hypp was also a radio Ham, and—good heavens!! You don't believe—?"

"I do," returned Snorlock. "Sir Hypp, the hypnotist, performed the foul deed by suggestion via radio. Sir Hypp was envious of the frequency used so successfully by Sir Obie. He, too, wanted to live, to breathe the rarified atmosphere of twenty meters' kilowatt corner, 14,000½ kilocycles. How he must have wanted to work DX on that coveted band edge. But always occupying the favorite corner was his hated rival, Sir Obie. There was only one thing for the mentally distorted hypnotist to do. Eliminate Sir Obie!"

Watts coughed. "I say, old man, you'll excuse my obtuseness, but I still do not know how Sir Obie met his end."

Snorlock gazed blandly at the three-element beam outside. "It's as elementary as that rotary beam. Sir Hypp hypnotized our defunct friend into believing he was a bleeder resistor. Note the power burns on the finger ends of Sir Obie's hand."

"By Jove—electrocuted!" exclaimed Watts. "I see—Sir Hypp zero-beated on Obie's frequency and gave him the business."

"But I'm still in the dark," said the butler, who had forgotten to take off his sun glasses.

"Elementary," explained Snorlock, "our friend met his end by his own hand. Sir Obie was hypnotized into believing he was a bleeder resistor. The natural location for a bleeder resistor is across the power supply. Well, when Sir Obie shunted his fingers across 1200 volts—you see the result." He glanced dramatically at the supine figure. "This case is closed," he ended.

As casually as any private eye of the movies, Snorlock removed an old pipe from a voluminous pocket, tamped in a pound of his own formula "Stencho No. 69," ignited the portable furnace with a small blow torch, and staggered away, coughing violently.

### New Work by

### MOBILE HANDBOOK Author

Undoubtedly many of CQ's readers follow the field of aviation as a second hobby, or perhaps as a livelihood. The hobby of aviation also has a following among the staff of CQ. A recent letter from W6SAI, William I. Orr (Author of the *Radio Amateurs' Mobile Handbook*, and Contributing Editor of CQ) reports that he has just completed two interesting sections for a new book in the aviation field: *YEAR's Pictorial History of Flight*. The book (published by the editors of *YEAR*, the *Annual Picture History*, Los Angeles 25, Calif.—\$7.95) tells the complete history of aviation in some 1250 pictures and 75,000 words of text, and is now on sale in bookstores. W6SAI wrote the sections on guided missile development, and aircraft of the future. Noting the intriguing information regarding interplanetary flight in this book, we wonder who will be the first Ham to make a two way contact with a moon expedition.

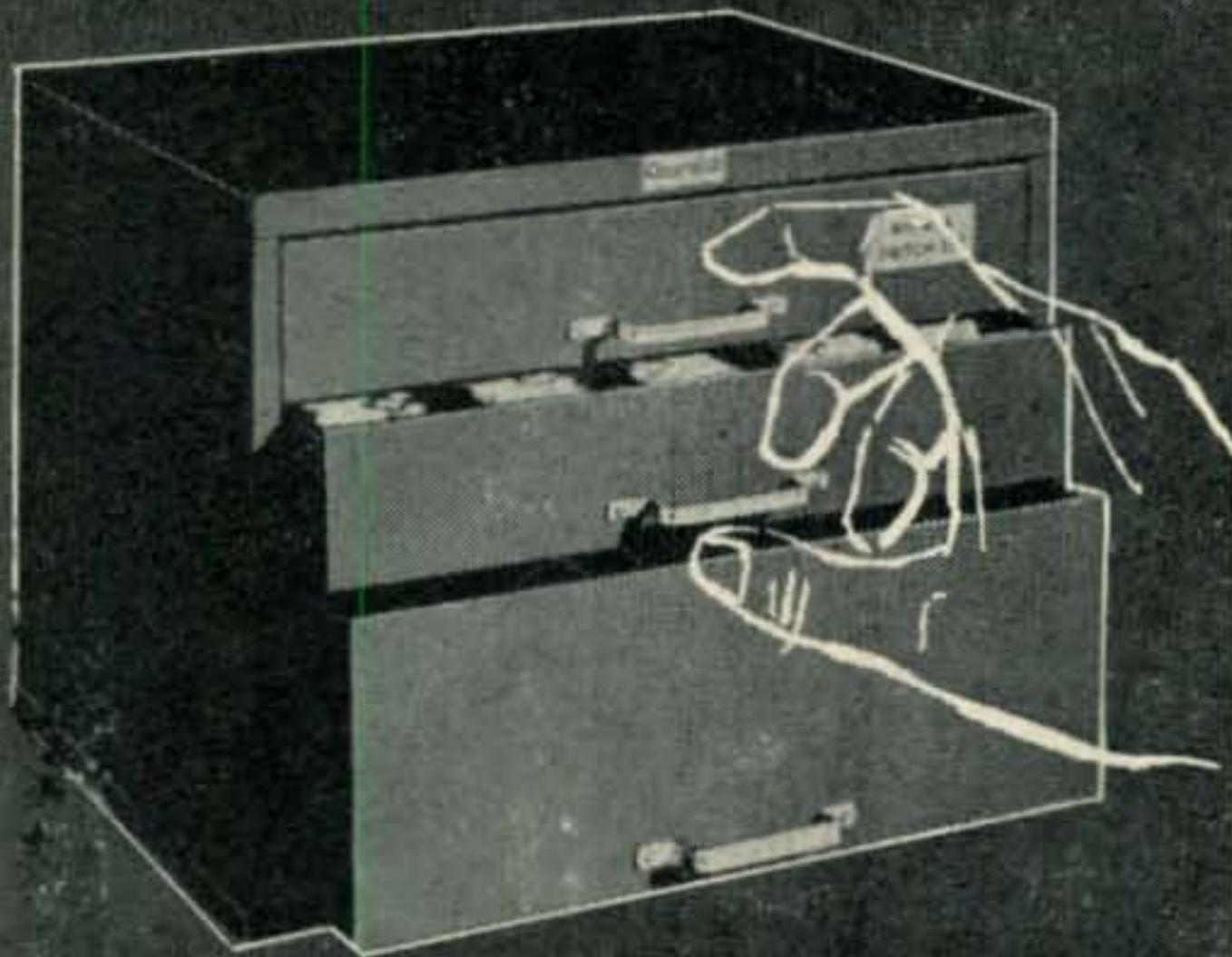

*Everything you need*

at your fingertips — in

# Centralab

## Rotary Switch Kits

Centralab Switch Kits contain *all* the parts you need to assemble almost any standard or special switch for low-power application—stock sections, indexes, and hardware. There are four different kits packed in attractive steel cabinets:

**(1) Kit No. 414 for Phenolic Switches.**

With this kit, you can build any of Centralab's standard, 1400 Series, stock rotary switches or 31 special switches of from one to ten sections. Send for bulletin 42-138.

**(2) Kit No. 419 for Steatite Switches.**

With this kit, you can build any of Centralab's standard, 2500 Series, stock rotary switches or 27 special switches of from one to ten sections. Send for bulletin 42-138.

**(3) Kit No. 2000 for Miniature Steatite Switches.**

**(4) Kit No. 1500 for Phenolic Selector Switches.**

Your Centralab distributor can furnish kits and kit replacements from stock. You pay only for parts — there's no charge for the cabinet. Get your kits soon.

Send coupon for Centralab Catalog 28 and bulletin.

# Centralab

CENTRALAB, A Division of Globe-Union Inc.  
911B E. Keefe Ave., Milwaukee 1, Wis.

Send me the material I have checked:

Catalog 28       Bulletin 42-138

Name \_\_\_\_\_

Address \_\_\_\_\_

City \_\_\_\_\_ Zone \_\_\_\_\_ State \_\_\_\_\_

# SINCE WORLD WAR I

Working with spark . . . CW . . . phone . . . mobiles . . . as equipment progressed, the radio amateurs of this continent have, since World War I done a magnificent job of serving their communities when emergencies demanded a functioning standby communications system. The value of their contribution can never be fully measured, nor fully recognized.

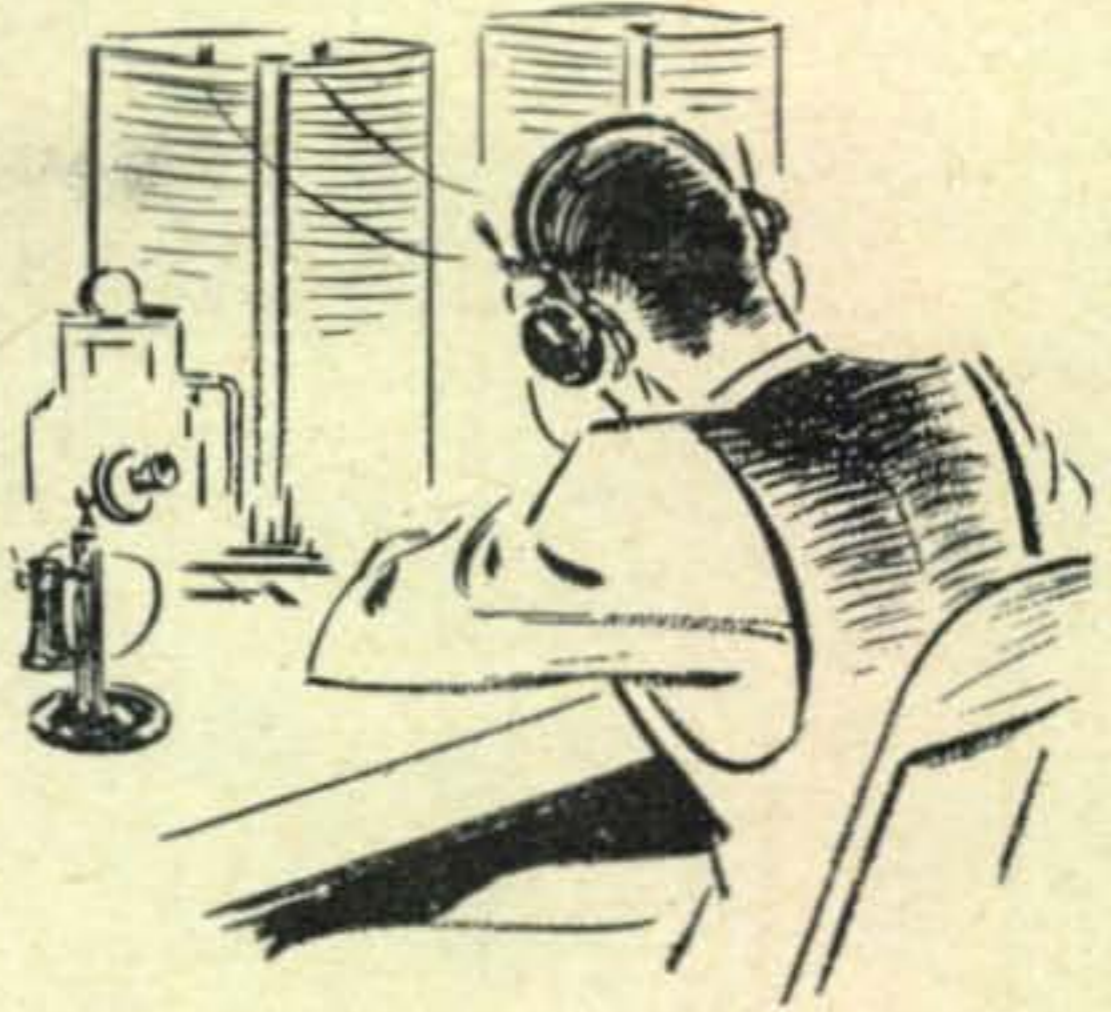

**P18A  
P23A**

Full range of amateur frequencies. Holders have .09 pins, spaced  $\frac{1}{2}$  inch — to fit FT-243 sockets. P18A and P23A hermetically sealed, filled with dry nitrogen; silver-plated.



**P3A**

# SINCE WORLD WAR II

Pan-El Crystals, made to a precision that is measured in Cycles rather than Kilocycles, were first produced in 1942. Our engineers have developed a process that assures long-term stability. You can count on Pan-El Crystals to keep you on the nose for years to come.

**PRICES** If your dealer does not stock Pan-El Crystals, write us and we will see you are served. In Boston area, see Radio Shack Corp.

80 meter band (P18A or P3A Holder)	\$2.75
40 meter band (P18A or P3A Holder)	2.75
(to the nearest 5 kc)	
20 meter (3d overtone) (P23A Holder)	3.75
27.255 (3d overtone) (P23A Holder)	3.95
10 meter (3d overtone) (P23A Holder)	3.95
(to the nearest 10 kc)	



QUANTITY PRODUCERS OF STANDARD AND SPECIAL

# Control Crystals

PAN-ELECTRONICS CORPORATION • 901 West Peachtree Street, N.E.

Atlanta, Georgia



## Eimac designed,\* Eimac produced ...for Eimac QUALITY

Included in the incomparable list of Eimac developed electron-power tubes, which range to 9600mc and 25 kw power output, are six favorites of Amateur Radio Operators. Application-proved in many types of commercial and military service, the 4-65A, 4-125A, 4-250A, 4-400A and 4X150 radial-beam power tetrodes and 4E27A radial-beam power pentode possess the inherent features of Eimac multi-grid tubes—high power gain, minimized neutralization needs, and on-the-air economy. Mobile or shack, 2mc or 420mc, CW or phone, there's a tube in the Eimac Amateur's Big Six to do the job for you with a wallop. When visiting your distributor ask for Eimac—the mark of excellence in electron-power tubes.

Write our Amateur Service Bureau  
for further information.



**EITEL-McCULLOUGH, INC.**  
SAN BRUNO, CALIFORNIA

### \*Eimac developed electron-power tubes

4-65A	75TL
4-125A	100TH
4-250A	100TL
4-400A	152TH
4-1000A	152TL
4PR60A	250TH
4W20,000A	250TL
4X150A	304TH
4X150D	304TL
4X150G	450TH
4X500A	450TL
4X500F	592/3-200A3
4E27A/S-125B	750TL
3K20,000LA, F, K	1000T
3K50,000LA, F, K	1500T
3W5000A3	2000T
3W5000F3	2-25A
3W10,000A3	2-50A
3X2500A3	2-150D
3X2500F3	2-240A
3X3000A1	2-2000A
3X3000F1	250R
25T	253
35T	8020(100R)
35TG	KY21A
75TH	RX21A

# Zero Bias...

If we had been a newspaper - - -

## ARRL Executive Committee Meets

HARTFORD, Conn., Sept. 28 (CQ)—The Executive Committee of the American Radio Relay League was in session today for a total of 52 minutes. This was one of their shortest meetings on record, although they considered the nomination petitions of 31 candidates in the forthcoming ARRL Directors election.

Six candidates were declared ineligible. Five petitions were denied because of insufficient continuity of membership and one because of an occupation in radio manufacturing.

The committee also affiliated 15 radio clubs with the ARRL and held an extensive discussion on the performance of the ROWH ceremonies at various Hamfests.

Attending the committee meeting were Messrs. Budlong, Houghton, Dosland and Noble. Absent were Roberts, Handy and Groves. Committee actions were unanimous.

## ARRL Ordered to Show Cause

HARTFORD, Conn., Oct. 28 (CQ)—The Honorable Judge Charles S. House of the Hartford County Superior Court today granted a "show cause" order to the Rock Creek Amateur Radio Association against the American Radio Relay League.

The Rock Creek Association from Kensington, Md. has petitioned the court to hear arguments on the interpretation of Article 12 of the recently approved bylaws of the ARRL. The Rock Creek Association is said to be acting in behalf of three candidates declared ineligible on Sept. 28 by the ARRL Executive Committee for the office of Director of the Corporation.

## Budlong Accepts Summons

HARTFORD, Conn., Nov. 2 (CQ)—The Secretary of the American Radio Relay League, A. L. Budlong, today is reported to have accepted the summons issued by Judge House of Hartford County Superior Court on the suit of the Rock Creek Amateur Radio Association.

The Rock Creek Association has filed in behalf of James W. John, W3OMN; John W. Gore, W3PRL and Paul M. Bossoletti, WØGZD. The plaintiffs claim that the "intent and spirit" of the ARRL Articles of Association has been violated. The Ex-

ecutive Committee of the ARRL recently declared the plaintiffs ineligible to be candidates for the office of Director and Vice-Director of the corporation.

A hearing has been set for Nov. 12 before Judge Louis Shapiro in the Hartford County Superior Court.

## Rock Creek Plaintiffs Must File

HARTFORD, Conn., Nov. 12 (CQ)—The Superior Court today instructed the plaintiffs in the suit of the Rock Creek Amateur Radio Association against the American Radio Relay League to file written memorandum in support of their claims.

The ARRL was instructed to file a reply brief within one week thereafter.

## Around the Courts

(A Gossip Column)

HARTFORD, Conn., Dec. 4—The suit of the Rock Creek Amateur Radio Association against the American Radio Relay League, a well-known local organization, resulted in a little conclave in Judge Shapiro's chambers this morning . . . The attorney for the plaintiff wanted the League held in Contempt of Court because they had not filed their reply brief until November 25 . . . However this was set aside and the League apparently agreed to set the elections aside should the Rock Creek Association finally win the suit.

HARTFORD, Conn., Dec. 28—Rumor has it that the American Radio Relay League yesterday replied to the brief filed by the Rock Creek Amateur Radio Association on December 18th . . . The latter group now represents John W. Gore, W3PRL who was in Hawaii on business when his ARRL membership dues fell due in September 1950 (the ARRL only accepts year-by-year membership) and is now claimed to have a 30 day lapse in membership, and Paul M. Bossoletti, WØGZD who also suffered a comparable lapse in membership . . . the plaintiffs stated on Dec. 18th that the wording of Article 12 of the ARRL By-Laws was such that any four year period of "continuous" membership should suffice. Gore has been a League member since 1930 and Bossoletti since 1943 . . . Just for the record, that disputed Article states, "No person shall be eligible for the office of Director, Vice-Director or President who has not been a member of the league for at least four years or who does not hold a valid authorization as a radio amateur . . ." To this columnist the League's By-Laws really have a loop-hole!!!

o. p. f.

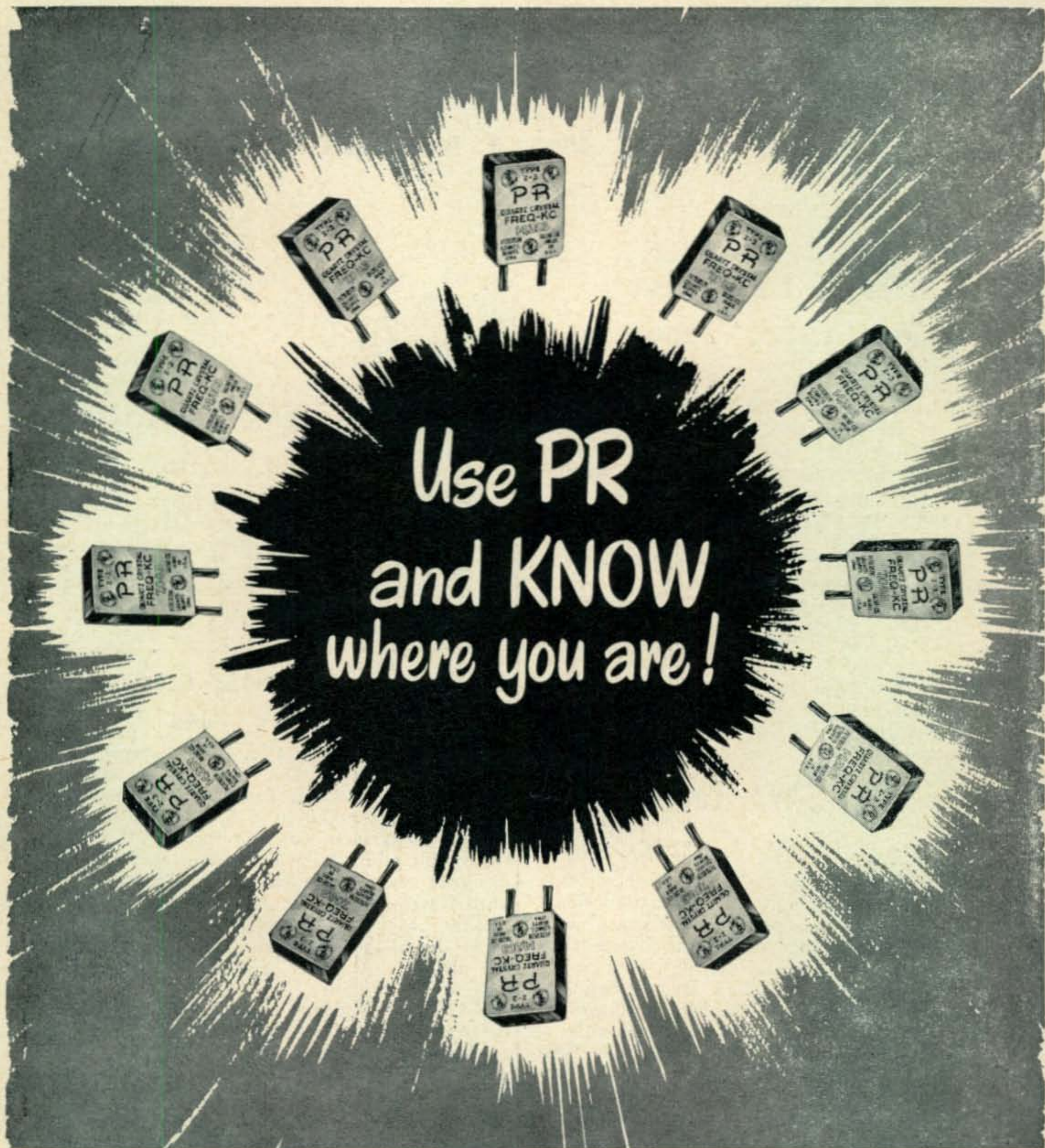

20 METERS, Type Z-3, \$3.95 • 40, 80 AND 160 METERS, Type Z-2, \$2.95

# PR Crystals



USE **PR** AND KNOW WHERE YOU ARE

PETERSEN RADIO COMPANY, INC.  
2800 W. BROADWAY • COUNCIL BLUFFS, IOWA

EXPORT SALES: Royal National Company, Inc., 75 West Street, New York 6, N. Y., U. S. A.

# the COMMAND SET ROUNDUP



HERB S. BRIER, W9EGQ

Undeniably the Most Popular Items of War Surplus Gear were the "Command Set" Receivers and Transmitters. Because of the Tremendous Interest They Still Have for Many of Our Readers We Take Pleasure in Presenting a Final-Final Conversion Article

In spite of the many articles published about "Command Sets" in the past several years (*See bibliography*), there remains an insatiable appetite among new amateurs for conversion data on the *BC-274N* and *ARC-5* equipments.

Information on the following points is in demand:

1. Basic conversion data.
2. Power supply requirements.
3. Simple modification to crystal control for Novice use.
4. Modifying 4-5.3 Mc. (*BC-457*) and 5.3-7 Mc. (*BC-458*) units to cover amateur frequencies.
5. Transmitter de-TV'ing information.
6. Receiver data.

This "final-final" article will attempt to assemble the above information in one place for the benefit of all concerned.

### The Basic Transmitter Circuit

Although they have different nomenclatures and cover different frequency ranges, all "Command" transmitters utilize the basic circuit shown in *Fig. 1*. A 1626 variable-frequency oscillator drives an amplifier, consisting of a pair of 1625's in parallel. A 1629 "magic eye" tube, in conjunction with a quartz crystal, serves as a frequency calibrator.

A roller-type antenna coil, adjusted by means of a thumb wheel through the front panel permits using almost any *non-resonant* length of wire as a *Marconi* antenna. Antenna coupling is varied, also from the front panel, by a pivoted link coil inside the amplifier coil.

Rated transmitter input is about 90 watts on CW and half that on 'phone. All tubes have 12.6-volt filaments wired in series-parallel and operated from a 25-volt (nominal) d.c. source.

The two important differences between the

*BC-* and *ARC-5* model transmitters are in the method of plate feed to the 1625's and the power sockets on the rear. In the *ARC-5*'s, an r-f choke feeds the voltage directly to the plates, and a 0.0004- $\mu$ fd. blocking condenser keeps the d-c voltage off of the tank coil. In the *BC*-models, the plate voltage is fed through the 1625 tank coil. This difference has no practical effect on the operation of the transmitters.

Of more immediate importance are the differences in the power sockets, which are noted in *Fig. 1*.

### Adapting The Transmitters

Few amateurs have 25 volts of d.c. available; therefore it is necessary to modify the filament circuit of the transmitters for a-c operation. Either 12.6 or 25 volts may be used. For 25-volt operation, the modification entails three steps:

1. Remove the two resistors (*R70* and *R77*) connected to *pin 8* of the 1629 tube socket. Replace them with a single 2500-ohm,  $\frac{1}{2}$ -watt resistor connected between *pin 8* and the chassis (ground).

2. Jam both relays (*K53* and *K54*) closed.

3. Mount a key jack in the lower right-hand corner of the front panel. Disconnect the 1625 cathodes from relay *K53* and the 51,000-ohm resistor (*R75*) across it. Connect the cathodes to the jack through a 50-ohm, two-watt resistor. Bypass the cathode of each 1625 tube (*pin 6*) to the metal shell of the tube socket with .005- $\mu$ fd., 600-volt, disc ceramic condensers (*Centralab DD-502*). The 50-ohm resistor eliminates the effect of having the "dots" on a slightly different frequency than the "dashes," as sometimes happens when a "bug" key is used.

Operating the filaments on twelve volts requires one additional step:

4. Ground *pin 7* of the remaining 1625 socket (one is already grounded). Tie *pin 1* of the two sockets together and to *pin 2* of the 1629 socket. Remove the 126-ohm resistor (*R71*), which is connected across *pins 2* and *7* of the 1629 socket and mounted on the rear chassis wall. Transfer the wire connecting *pin 7* of the 1629 socket and the oscillator coil terminal strip to *pin 2* of the socket. Ground *pin 7* of the socket, and connect *pin 2* to the filament terminal on the power socket (*pin 6* on *BC*-models and *pin 5* on *ARC-5*'s.)

This completes the basic conversion.

### Power Supply

The power supply shown in *Fig. 2* will furnish all power for 75-watt operation of the "Command" transmitters. This level probably represents the best compromise between power output, signal quality, and power supply cost.

Oscillator plate voltage is relatively critical for best results. Approximately 200 volts gives essentially "zero-drift" operation. Either higher or lower voltage causes a frequency drift in one direction or the other. Actually, optimum voltage varies from transmitter to transmitter, but is usually quite close to 200 volts. Fortunately, a deviation of ten or fifteen volts does not degrade performance appreciably. Regulation of the oscillator plate voltage is highly recommended. Two VR-105 tubes in series may be used, between B+ and ground, as shown.

Six hundred volts a-c on the plates slightly exceeds the 550-volt maximum rating of the

5U4G rectifier tube, but such operation does not apparently reduce tube life, especially if the maximum current drawn does not exceed 200 milliamperes. Because the 5U4G is being slightly overloaded, fusing the primary circuit of the transformers is a wise precaution so that, should the tube arc over at the end of its useful life, the fuse and not the transformer will blow.

The transformer, *T1*, in the parts list is one of the very few available stock items that delivers sufficient plate voltage for our purpose and has two 6.3-volt filament windings that may be connected in series to provide 12.6 volts to light the tubes in the transmitter. Transformers with only a single 6.3-volt winding may be used in conjunction with an additional 6.3-volt, two-ampere filament transformer. Connect its primary in parallel with the primary of the plate transformer, and connect the two 6.3-volt windings in series.

The most desirable filter condenser for the power supply is an oil-filled, 1,000-volt unit,

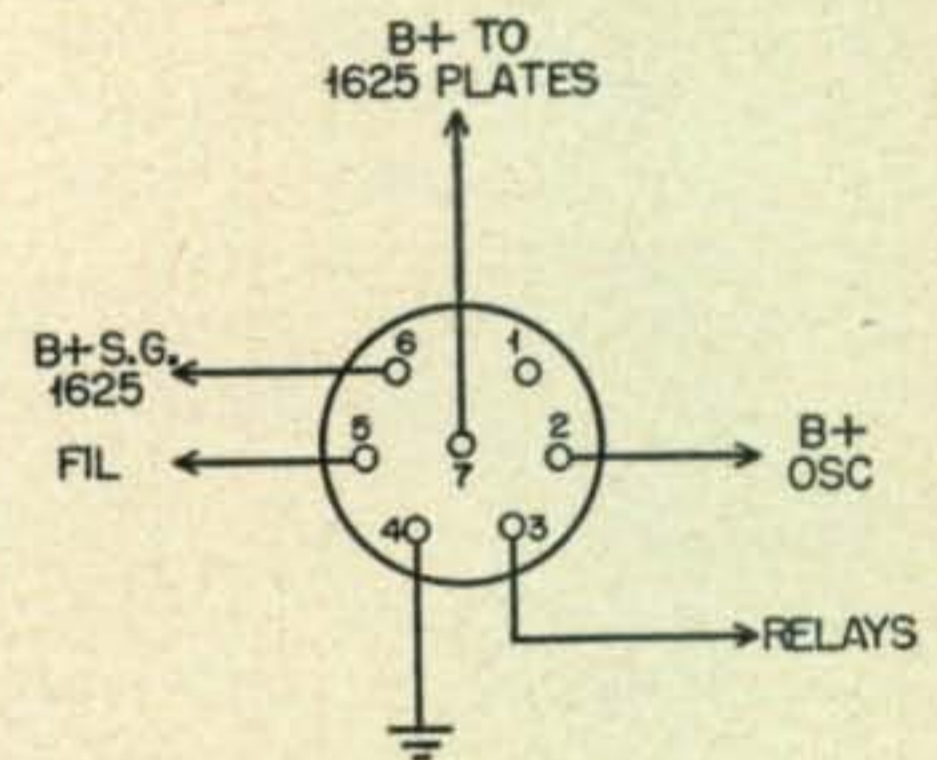

ARC-5 Power Plug Connections.

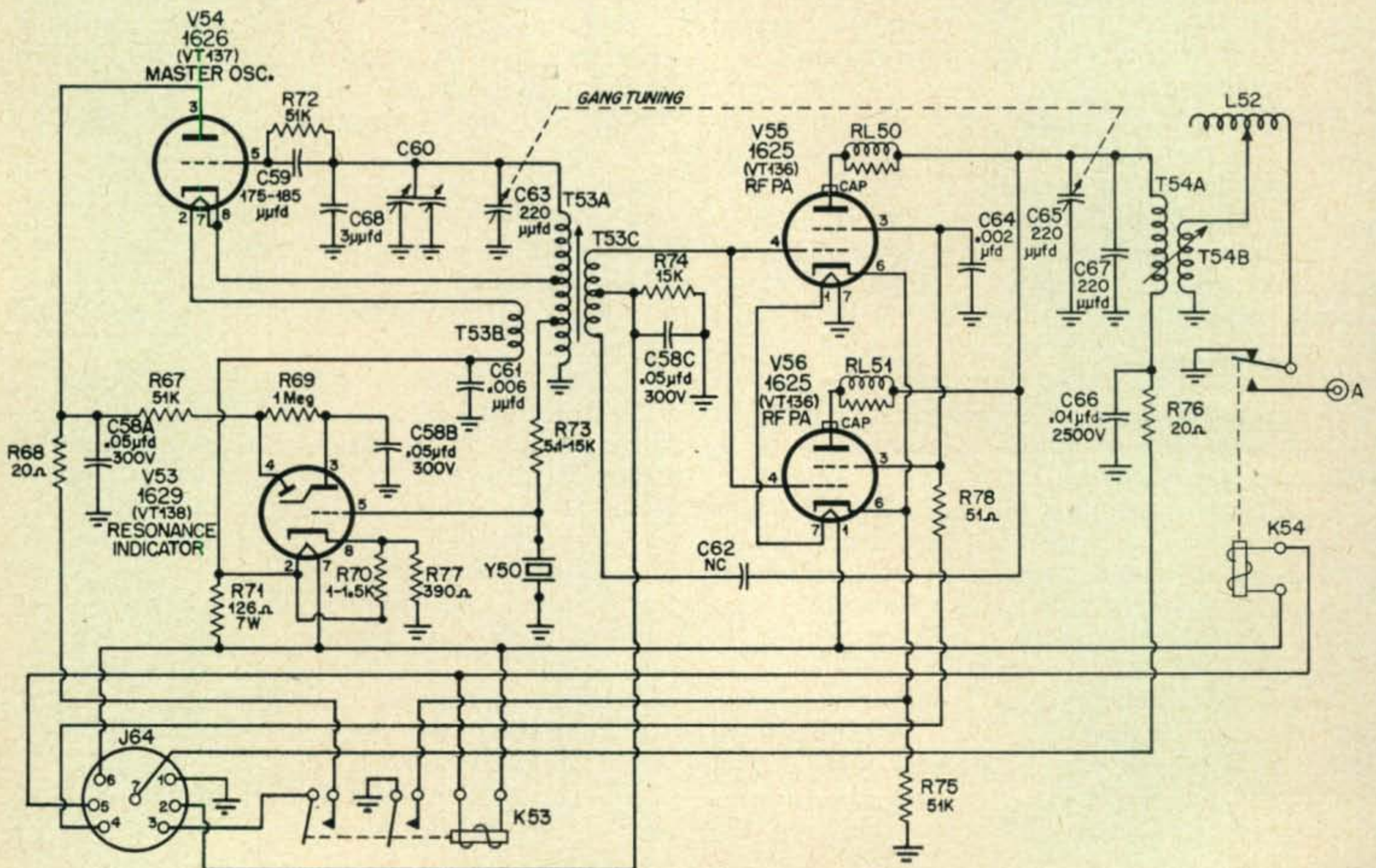

Fig. 1. Typical Command Set transmitter wiring schematic with power plug connections for the "BC-" series.



with a capacity of 4.0  $\mu$ fd., or more. However, where economy is important, two 8.0 or 16.0- $\mu$ fd. electrolytic condensers connected in series may be used, with 100,000-ohm 1-watt resistors across each one to equalize the voltage drops.

Probably the easiest way to bring power to the transmitter is through a five-conductor cable soldered directly to the transmitter power socket and terminated in a five-prong male plug for connection to the power supply. Proper terminals to use on the power socket are shown in Fig. 1.

To connect the cable to the transmitter, bare and tin about  $\frac{1}{2}$ -inch of each conductor, and solder them into the appropriate terminals of the power socket. Fasten the cable to the back of the transmitter with a clamp to prevent straining the connections.

### Operating and Tuning Up A Command Transmitter

Operating a "Command" transmitter differs little from operating any other transmitter, except in the use of the crystal calibrator, which works in this manner: Normally, the "eye" of the 1629 tube is nearly closed, but when the 1626 oscillator is tuned to the frequency of the calibrating crystal, the "eye" opens to its full width. The transmitter dial reading should then be the same as the frequency marking of the crystal. If it is not, the calibration is corrected by inserting a screwdriver through the slide-covered opening in the transmitter cover and adjusting oscillator condenser C68.

Calibrating crystals of other frequencies can be substituted for the one furnished with the transmitter by plugging them into pins 1 and 3 of the crystal socket.

To load a random length end-fed antenna, connect it to the antenna terminal and ground the transmitter case. Set the link coupling control to about half scale and rotate the antenna loading coil for maximum 1625 plate current, re-adjusting C65 as necessary to keep the 1625 tank circuit tuned to resonance. Adjust coupling to draw the desired plate current.

Antenna lengths that are an integral multiple of  $\frac{1}{4}$ -wave long may be difficult to load, unless a 100- $\mu$ fd. variable condenser is available. Connect it in series with the antenna for lengths an odd multiple of a quarter-wave, and between the antenna terminal and the case for lengths that are multiples of a half-wave.

A center-fed doublet using a low-impedance line may be loaded by setting the rotary inductance to minimum inductance and connecting one antenna lead to the antenna post and the other to ground (chassis). Although this theoretically unbalances the antenna system, there does not seem to be any difference in results, on 3.5 and 7 Mc. If insufficient loading is obtained, even with the coupling control set to maximum, a few turns of well-insulated wire may be wound around the bottom (cold end)

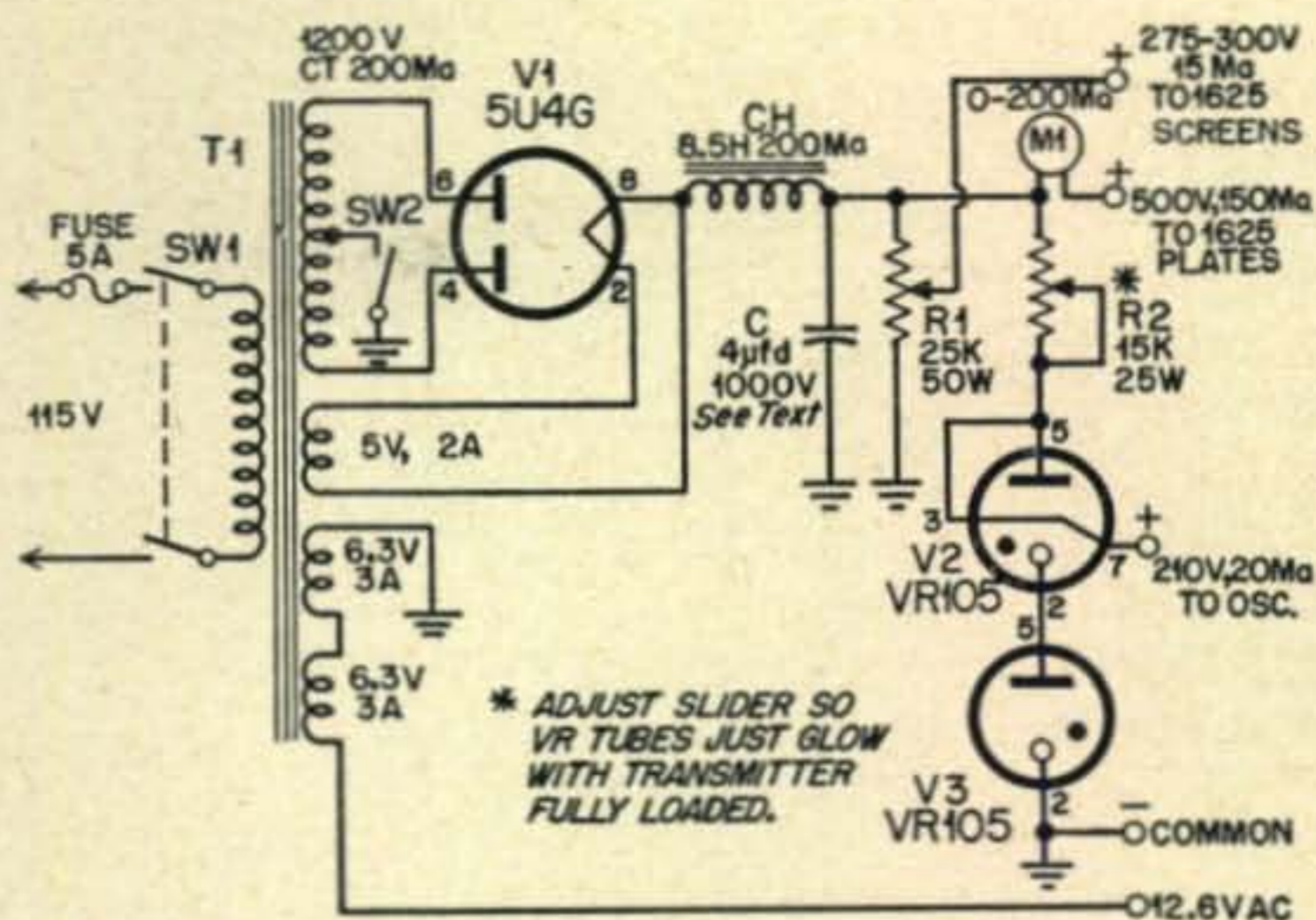

- T1—Power transformer, 1200v., 200ma., ct.; 5v., 3amp.; 6.3v., 3amp.; 6.3v., 3 amp. (Stancor #8414 or equiv.)  
 Ch—8.5h., 200ma. (Stancor #C1721 or equiv.)  
 C—4  $\mu$ fd. 1000v., oil filled (Cornell-Dubilier TJU, or equiv.)  
 R1—25,000 ohms, 50w. with slider (Ohmite 0585 or equiv.)  
 R2—15,000 ohms, 25w. with slider (Ohmite

- 0387 or equiv).  
 SW1—d.p.s.t. toggle.  
 SW2—s.p.s.t. toggle.  
 Fuse—5amp.  
 V1—5U4G  
 V2—OC3/VR105  
 V3—OC3/VR105  
 M1—200ma. milliammeter (Triplett 227T or equiv).  
 Chassis—10 x 17 x 2" 3 octal tube sockets.  
 Note: meter may be mounted on power supply chassis or at transmitter.

Fig. 2. Parts list and wiring schematic of a power supply suitable for use with the Command Set transmitters. Although the rectifier tube is slightly overloaded no damage should result if the primary of the transformer is fused. The oscillator voltage must be regulated for v-f-o operation.

of the 1625 tank coil and connected in series with the link.

### Crystal Control

There are two methods of modifying "Command" transmitters for crystal control, which is mandatory for Novice operation. One is to rewire the oscillator for crystal control.<sup>32</sup> The other is to build a plug-in adapter.<sup>21</sup>

An adapter has the advantage that the transmitter is easily restored to variable frequency control by unplugging it and inserting the regular oscillator tube. The diagram (Fig. 3) is a modification of the previous adapter,<sup>21</sup> using a 12A6 tetrode in place of the original triode, since it is a more vigorous oscillator with "sluggish" crystals. However, the triode circuit also works well and uses fewer parts. To use the latter, omit C2, C3, C4, R2, and RFC2, and connect pin 8 of the tube socket directly to the common ground point.

There are no special precautions required in constructing the adapter, except to position the octal plug so that the oscillator tube extends horizontally over the crystal and 1629 tube sockets when the adapter is plugged into the 1626 socket. Ground pin 1 of the 1626 socket to use the adapter and connect the external filament wire from the adapter to the "hot" side of the filament supply. Apply not more than 250 volts to the oscillator B+ pin on the power socket. The voltage need not be regulated.

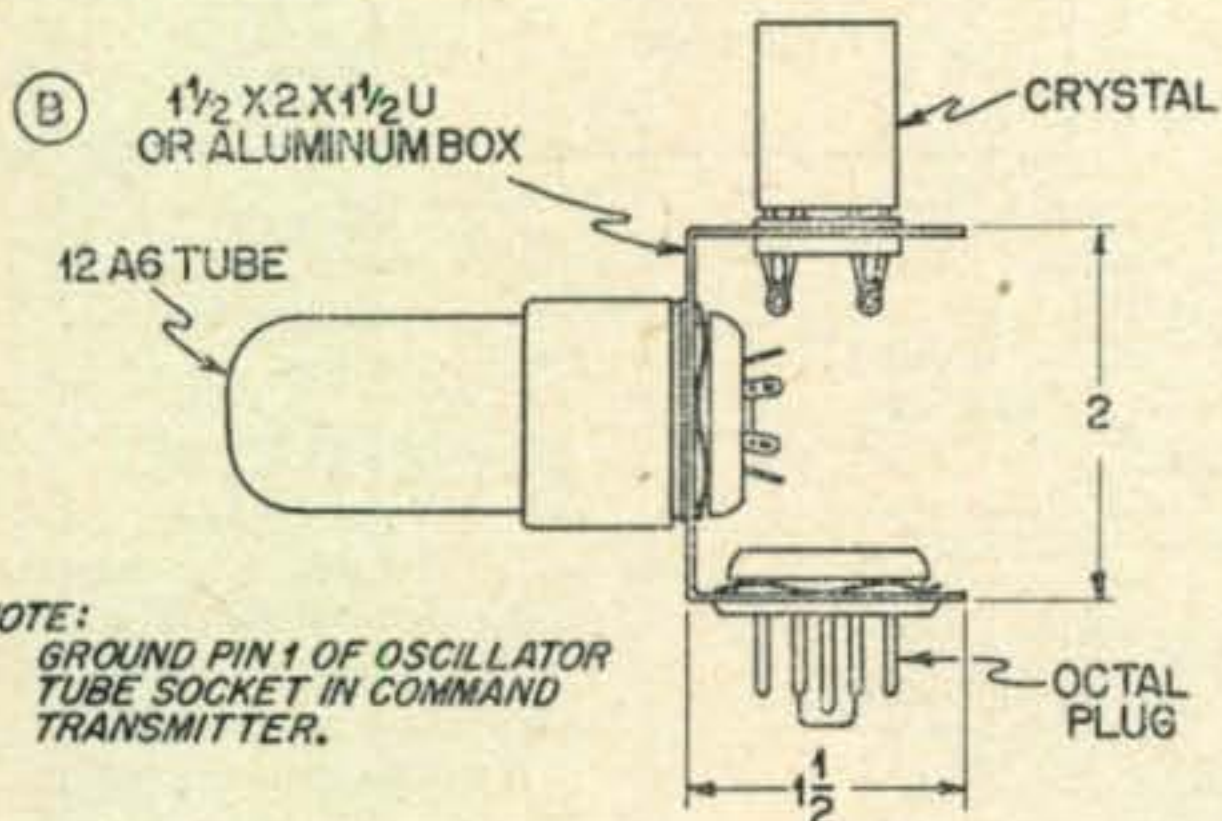
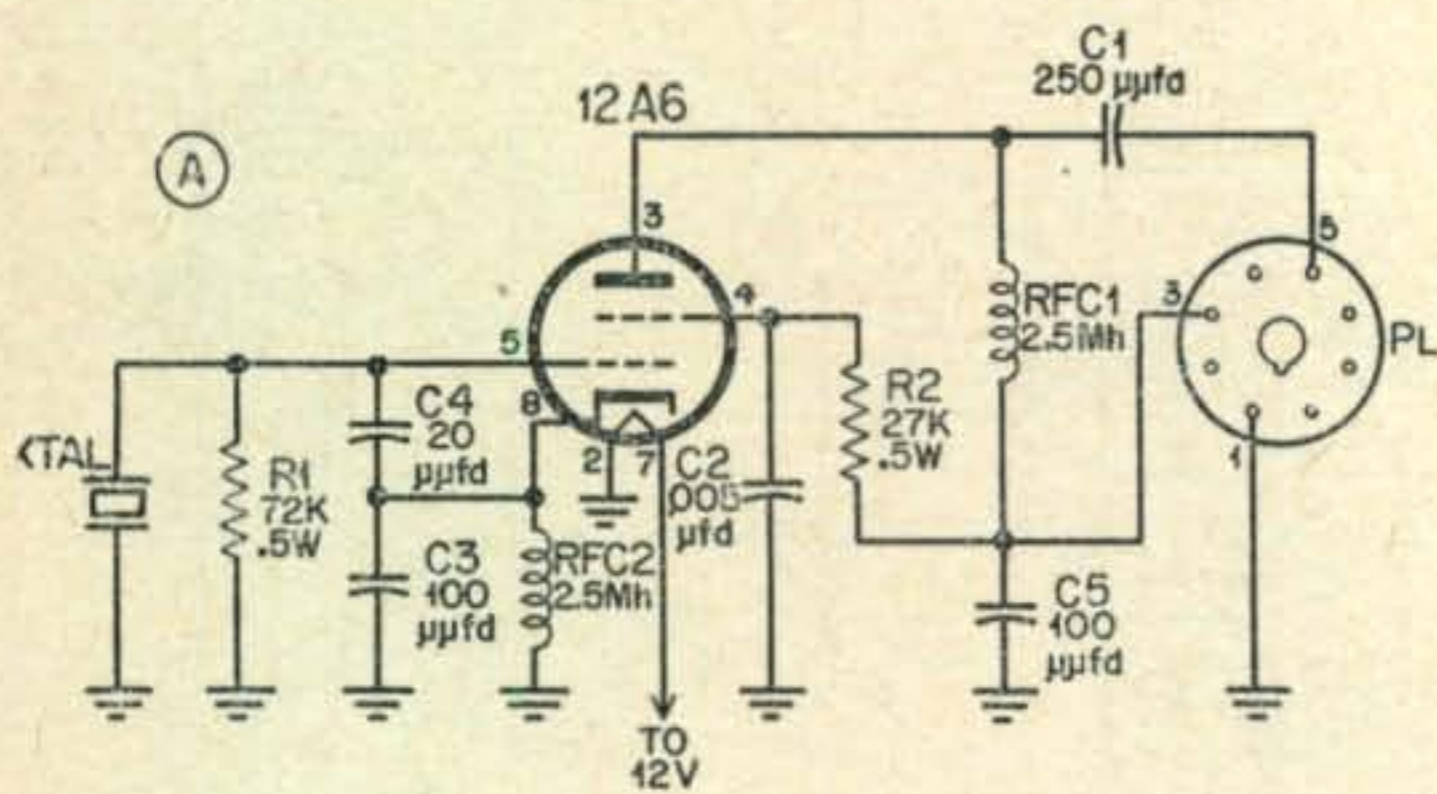

NOTE:  
GROUND PIN 1 OF OSCILLATOR  
TUBE SOCKET IN COMMAND  
TRANSMITTER.

C1—250  $\mu\text{f}$ d. 600v.  
ceramic.  
C2—.005  $\mu\text{f}$ d. 600v.  
ceramic.  
C3, C5—100  $\mu\text{f}$ d. 600v.  
ceramic.  
C4—20  $\mu\text{f}$ d. 600v.  
ceramic.  
R1—72,000 ohm  $\frac{1}{2}$ w.  
R2—27,000 ohm  $\frac{1}{2}$ w.  
RFC1, RFC2—2.5 mh.  
r-f chokes  
PL—Octal plug, male

(base of metal tube or  
Amphenol CP8).  
VT—12A6 or 1626  
(see text).  
Xtal—3.5 or 7 Mc.  
crystal.  
Built-in U bracket  
bent of aluminum or  
aluminum box approx.  
 $1\frac{1}{2} \times 1\frac{1}{2} \times 2$ ".  
To use adapter, ground  
pin 1 of 1626 tube in  
transmitter.

Fig. 3. This adapter may be used with any Command transmitter by following the instructions given in the text on the previous page. A partial structural view is shown in "B" and a schematic (parts list above) is shown in "A."

Without plate or screen voltage on the 1625's, adjust the main transmitter dial until the oscillator functions smoothly. Then apply voltage to the 1625's and resonate the 1625 tank circuit by adjusting C65. Antenna tuning and loading are described previously.

#### Utilizing the BC-457 and BC-458

So far, it has been assumed that 3-4 Mc. or 7-9.1 Mc. transmitters, which cover the 3.5 and 7-Mc., amateur bands, respectively, are available. However, 4-5.3 Mc. and 5.3-7 Mc. units are more plentiful and can be modified to cover these and other bands quite easily.

To cover the 3.5-Mc. band with a 4-5.3 Mc. BC-457 unit, set the oscillator padding condenser C60 (under the oscillator coil shield) to maximum capacity and re-resonate the 1625 stage with C65. The oscillator coil shield must be in place while this is being done.

The easiest way to cover the 7-Mc. band with a 5.3-7 Mc., BC-458 unit is to decrease the capacity of both padding condensers just enough to permit covering the entire band. A better way is to short out three turns from the top of each coil, before adjusting the padders.

By shorting out the top turn on each coil,

removing two rotor plates from each of the ganged condensers, and judiciously juggling the setting of the coil slugs and padders, it is possible to make the 7-Mc. band start at 6.0 on the dial and end at 6.3, giving direct frequency calibration by mentally adding 1 to the dial reading<sup>19</sup>.

#### Covering Other Bands

Modifying the frequency range of "Command" transmitters to cover other bands requires changes ranging from working on the coils to completely rebuilding the unit. Some of the more-successful methods will be described briefly in the following few paragraphs, with full details to be found in the reference articles.

**160 Meters:** If the scarce 2.1-3 Mc. BC-456 transmitter is available, set the padding condensers to approximately maximum capacity.<sup>16</sup> Otherwise, the coils of one of the higher-frequency units may be rewound. A new oscillator coil contains 36 turns of #20 enameled wire, with the cathode of the 1626 connected to the eighteenth turn. The 1626 filament wires (pins 2 and 7) are cut completely free of the oscillator coil. Disconnect the neutralizing condenser from the oscillator coil and move R74 and C58C to that terminal. Set oscillator padder to maximum capacity. Rewind the amplifier coil with  $34\frac{1}{2}$  turns #18, enameled wire. Tune to resonance with C65.<sup>22</sup>

**20 Meters:** The simplest method of covering 14 Mc. with a "Command" transmitter is to use a 7-9.1 Mc. BC-459 unit. Disconnect tuning condenser C67, and use C65 to tune the 1625 stage as a 14-Mc. doubler. Disconnect neutralizing condenser from the oscillator coil. Move R74 to that terminal. Replace C58C with an 0.002- $\mu\text{f}$ d. mica condenser.<sup>26</sup> A much better method is to insert a frequency multiplier between oscillator and revamp the amplifier.<sup>28</sup>

**15 Meters:** With a 7-9.1 Mc. BC-459 unit, add a frequency multiplier between the oscillator and amplifier. Rewind the amplifier coil to have 5 turns, double spaced.<sup>18</sup>

The conversions using an added multiplier stage may have it installed in the space originally occupied by the 1629 calibrator tube socket.

**10 and 6 Meters:** Operation on these bands requires practically a complete rebuilding job. The process has been described fully in several articles.<sup>3, 15, 16</sup>

#### Adding Another Stage To The Command Transmitter

Installing an untuned stage between the oscillator and the amplifier of a "Command" transmitter reduces reaction, resulting in better keying, which is discussed a bit later, and eliminates the possibility of frequency modulation when the 1625's are amplitude modulated for 'phone work. Also, as mentioned above, an extra frequency multiplier is usually required to operate the amateur bands above 7.3 Mc. Figure 4 is a suitable circuit for either application.

A 2.5 mh. r-f choke acts as the plate load impedance when the stage is to be used as an isolating stage, and a slug-tuned coil is substituted for the choke when a frequency multiplier is required. The switch and coil shown in the dashed lines permits using the stage for either purpose. Of course, for this feature to be of any value, a similar switch must be added to the 1625 tank circuit. Then one transmitter may be used on two adjacent bands.

Rewire the crystal socket for the tube, mount the coil on a scrap of metal in place of the 1629 tube socket, and mount the switch on the rear or side lip of the chassis.

The simplest modification of the 1625 tank circuit for two-band operation is to mount another switch on the side of the chassis behind  $C_{65}$  and  $C_{67}$  (See Fig. 1 and bottom photograph) and wire it so that when it is open,  $C_{67}$  is out of the circuit. Resonance is obtained on the new frequency near minimum capacity of  $C_{65}$ . It is convenient to add an external shaft and dial to  $C_{65}$  for adjustment.

Alternatively, the switch may be mounted above the chassis and used to short out the top half of the turns on the amplifier coil  $T_{54}$ . Resonance on either band will then occur at approximately the same setting of  $C_{65}$ , depending upon how accurately the tap is placed. Ganged tuning of the oscillator and amplifier is retained. Also a more favorable L/C ratio in the tank circuit for harmonic discrimination is obtained.

#### De-TVI'ing The Command Set Transmitter

"Command" set transmitters are notorious TVI producers. However, there are tremendous differences in the TVI produced by apparently identical units. Some are very nearly "clean," and others are just the contrary. Also, the oscillator of one may be full of TVI, with the amplifier relatively clean, or vice versa, or both stages may contribute their share to the overall confusion.

The first step in de-TVI'ing the transmitter is to improve the effectiveness of the bypassing under the chassis, and to cool off the power and key leads. The ingredients required are a handful of 0.005- $\mu$ fd. disc ceramic condensers and about five feet of shielded wire. Carry out as many of the following steps as are necessary to clean up your troubles:

1. Bypass to ground each of the following points: screen grid of each 1625 (*pin 3*), plate of 1626 (*pin 3*), target of 1629 (*pin 3*), the centertap of the 1625 grid coil, and the point where the filament voltage is fed into the oscillator coil. Disconnect and remove the three-section, 0.05- $\mu$ fd. condenser ( $C_{58}$ ) mounted on rear lip of the chassis.

2. Replace the leads from the power socket to the various points within the transmitter with shielded conductors, grounding the shield wherever possible throughout its length, especially at each end. At the same time, short-

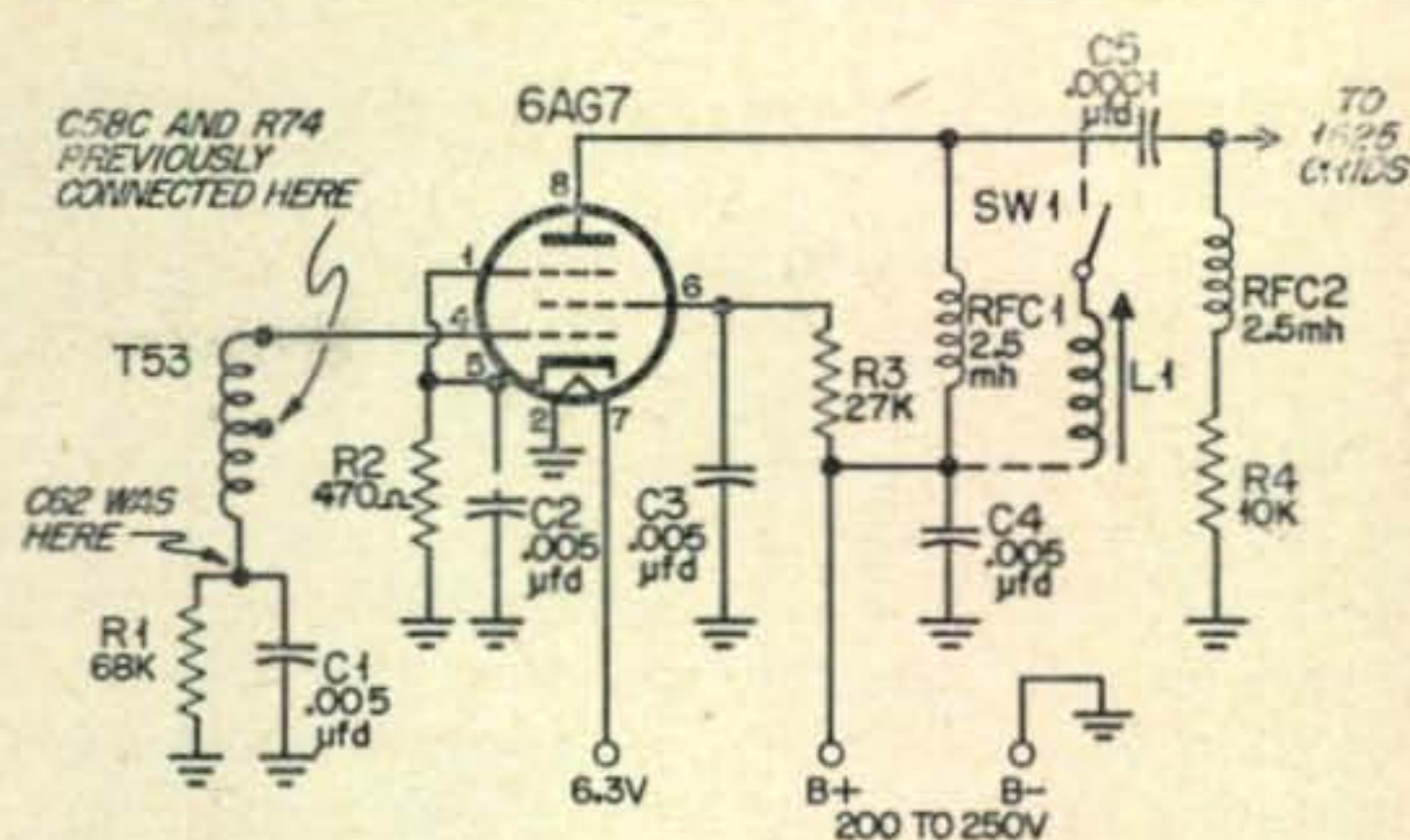

$C_1, C_2, C_3, C_4$ —0.005  $\mu$ fd. 600 v. disc ceramics.

$C_5$ —0.0001  $\mu$ fd. mica or ceramic.

$L_1$ —Wound on National XR-50 or equiv. slug-tuned forms 7 Mc. 20 T. #20, enam. close wound. 14 Mc. 10 T. #20, enam. spaced to occupy  $\frac{1}{2}$  inch. 21 Mc. 7 T. #20, enam. spaced to occupy  $\frac{1}{2}$  inch. (One only required.)

$R_1$ —68 K,  $\frac{1}{2}$ w.

$R_2$ —470 ohms, 2w.

$R_3$ —27 K, 1w. (May be varied to adjust excitation to 1625's).

$R_4$ —10 K,  $\frac{1}{2}$ w.

$RFC_1, RFC_2$ —2.5 mh. 50 ma. radio-frequency chokes.

$SW_1$ —S.p.s.t rotary switch, preferably ceramic insulated (Centralab 2043 or equiv.) A similar switch is used in the 1625 stage, described in text.

Fig. 4: Diagram of an isolating stage or frequency multiplier which may be substituted in the frequency calibrator stage space of "Command" transmitters. Referring to Fig. 1, the wire between the oscillator coil ( $T_{53}$ ) and the 1625 grids is removed from the grids and connected to pin 4 of the 6AG7 socket, and the output of the 6AG7 connected to the 1625 grids. Other changes required are to remove the 1625 neutralizing condenser ( $C_{62}$ ) and disconnect  $C_{58}$  and  $R_{74}$  from the oscillator coil terminal strip. Connect  $R_1$  and  $C_1$  to the terminal to which  $C_{62}$  was previously connected. When only an isolating stage is required,  $L_1$  and  $SW_1$  are omitted, and when only a frequency multiplier is required,  $L_1$  is substituted for  $RFC_1$ ,  $SW_1$  again being omitted

en all ground leads as much as possible and remove unused components and conductors. In low TV-signal areas, it is also desirable to bypass each terminal of the power socket with an 0.005- $\mu$ fd. disc ceramic condenser. The important point in installing these bypasses is to keep their lead length to an irreducible minimum.

3. With the bottom plate in place, the bottom of the transmitter is quite well shielded, even though there is a theoretical possibility of r-f leakage along the crack between the edges of the chassis and the plate. Use all screws and press the plate firmly into place while tightening them.

4. Another good method of improving the shielding is as follows: Remove the rotary antenna coil and cover the holes in the front panel with a piece of scrap aluminum. Next, bend a piece of bronze screening, 12 x 15 inches, into a trough to fit inside the cover. Then solder another piece across the open back of the trough. When the cover is screwed into place, the screen is clamped firmly between it and the chassis. Pay particular attention to the openings near the rear of the cover at the bottom. They may be sealed off by soldering the edge of the screening at this point.

5. Other methods of improving the shielding of the cover include backing up the ventilating louvres with perforated sheet metal and sealing the tube-access openings on the top with electronic weatherstripping.<sup>44</sup>

6. Undoubtedly the most efficient way to keep harmonic energy out of the antenna circuit is to substitute a coaxial fitting for the original output terminal and feed the antenna through a low-pass filter, in conjunction with an antenna tuner if necessary. Any conventional link-coupled antenna tuner may be used. Also, by remounting the original rotary coil on a small metal base and link coupling it to the transmitter, it will function in much the same fashion as it did before being removed from the transmitter.

After the coil is remounted, close wind a three-turn link of stiff, well-insulated wire (about #16) of a diameter just sufficient to slip over the rotary coil. Slip the link coil over one end of the rotary coil, with the link fitting between the coil and the rod upon which the roller slides. Terminate the link winding in a coaxial cable chassis fitting mounted on the base on a small angle plate. The fitting serves the dual purpose of supporting the link winding and bringing r-f power from the transmitter to the tuner.

Ground the end of the rotary coil under the link winding and connect the roller to the antenna. Adjustment and limitations of the loading coil will be as already described, but with the possibility of inserting a low-pass filter in the link line for further attenuation of harmonic output from the transmitter.

#### Alternate Keying Methods

The problem of which is the best method of keying "Command" transmitters has caused more hair tearing than any other question. When operated conservatively, excellent keying can be obtained on 3.5 Mc., and good keying

on 7 Mc. On the higher frequency bands, however, keying is seldom better than passable, unless a frequency multiplier has been inserted between the oscillator and power amplifier in the course of the modification, and if only the 1625's are keyed.<sup>18, 28</sup>

In our opinion, on 3.5 and 7 Mc., straight cathode keying of the 1625's is as good as any type, and better than some. It suffers the disadvantage of not permitting "break-in." Keying the oscillator permits "break-in" operation, but almost invariably accentuates chirps. Expedients used to permit oscillator keying include keying the B- lead of the power supply,<sup>31</sup> keying oscillator B+ and amplifier screens simultaneously through a relay,<sup>14, 31</sup> and replacing the jumper between pins 7 and 8 on the 1626 socket with a 0.002- $\mu$ fd. condenser and connecting pin 8 to the key jack through a 2.5-mh. r-f choke.<sup>13</sup>

#### Modulation

The transmitters work well on phone at inputs of approximately fifty to sixty watts. In fact, many amateurs run considerably higher power than this on phone, without too much trouble. For an input of fifty watts, any modulator capable of delivering twenty-five watts of audio power may be used. Assuming a 1625 tube plate voltage of 500 volts and a total current of 100 milliamperes, the modulation transformer should be capable of matching the plate load impedance of the modulator tubes to a 5000-ohm load. The screens of the 1625's should be modulated as well as the plates. This is most easily accomplished by feeding the screen voltage through a 10-henry, 50-milliamperere filter choke, which will allow them to be self-modulated.

#### Command Receivers

The most commonly available "Command" receivers are the BC-453, covering 190-550 kc; the BC-454, covering 3-6 Mc; and the BC-455,

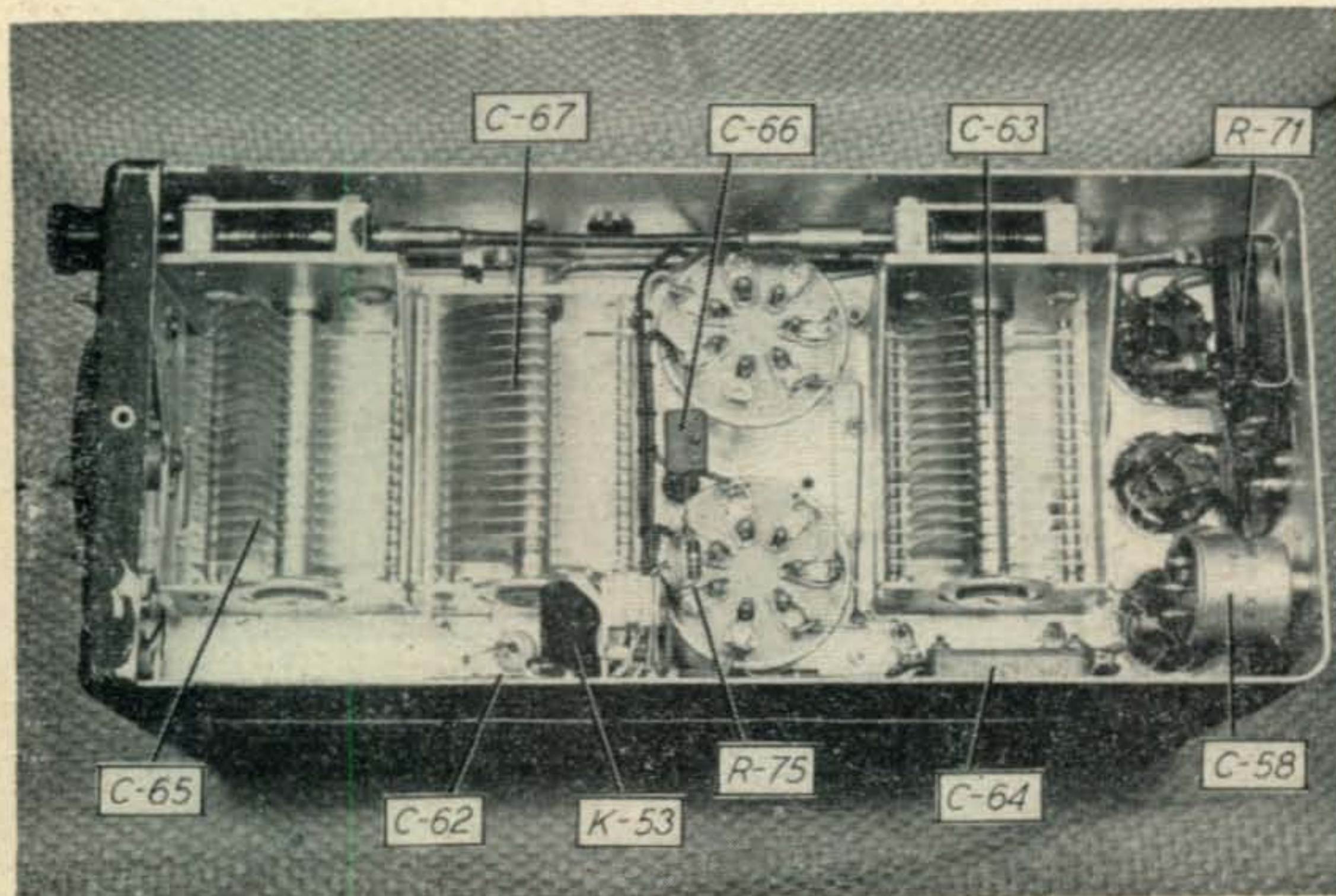

Bottom view of the typical Command type transmitter.

covering 6-9 Mc. They all use the same, basic, six-tube circuit, with the filaments of the 12.6-volt tubes wired in series-parallel for operation from twenty-five volts.

As in the case of the transmitters, there are both *BC*- and *ARC-5* models, but the only important difference between them is that the *ARC-5* receivers use a 12SG7 tube in the second i-f stage, while the *BC* models use a 12SK7 tube.

The receivers are quite sensitive and stable, but the two units that cover the amateur 3.5 and 7-Mc. bands leave much to be desired from the selectivity standpoint. Nevertheless, they make excellent "first" or standby receivers. The bibliography contains many references to articles describing how to cover these and other bands with "Command" receivers.<sup>2, 6, 8, 9, 17, 19, 20, 33, 35</sup>

The *BC-453*, 190-550 kc., receiver has proved to be an extremely useful gadget around many amateur shacks. It uses an 85-kc., i-f amplifier, which is very selective. By tuning the main dial to 455 kc., the standard intermediate frequency of most communications receivers, and using a wire connected to the antenna post of the *BC-453* with the other end wrapped loosely around the lead from the last i-f transformer in the communications receiver, the combination becomes an extremely selective "dual-conversion" receiver.<sup>25</sup>

Some amateurs however, just take the i-f transformers from the *BC-453* to build a selective i-f channel in less space.<sup>24, 27</sup>

### Modifying The Receivers

To use the receivers in amateur service entails adding a gain control, a beat-oscillator switch and a phone jack, and building a power supply.<sup>2, 35</sup> Also, as it is easier to obtain 12.6 volts than twenty-five volts, it is usually necessary to rewire the filaments in parallel for twelve-volt operation. When this is done, the six-volt equivalents of the original tubes may be substituted and the receivers then operated from a six-volt filament source.<sup>3, 17, 19, 38</sup>

The logical place to mount the new gain control, phone jack, and beat-oscillator switch is on the front panel in the space occupied by the adapter box. Remove the screws holding the box in place. Unplug it and remove the aluminum box holding the socket into which the adapter plugged. Mark the wires that were connected to *pins 1, 4, and 5*. Remove the rest. Cover the hole in the panel with a flat piece of aluminum upon which is mounted a midget, 25,000-ohm wire-wound potentiometer, flanked by a s.p.d.t. toggle switch and a small phone jack.

Ground the middle terminal of the potentiometer and one terminal of the switch to the ground lug of the phone jack. Connect the *No. 1* wire to the *left-hand* terminal of the potentiometer (viewed from the back with terminals down), wire *No. 5* to the switch, and wire *No. 4* to the phone jack.

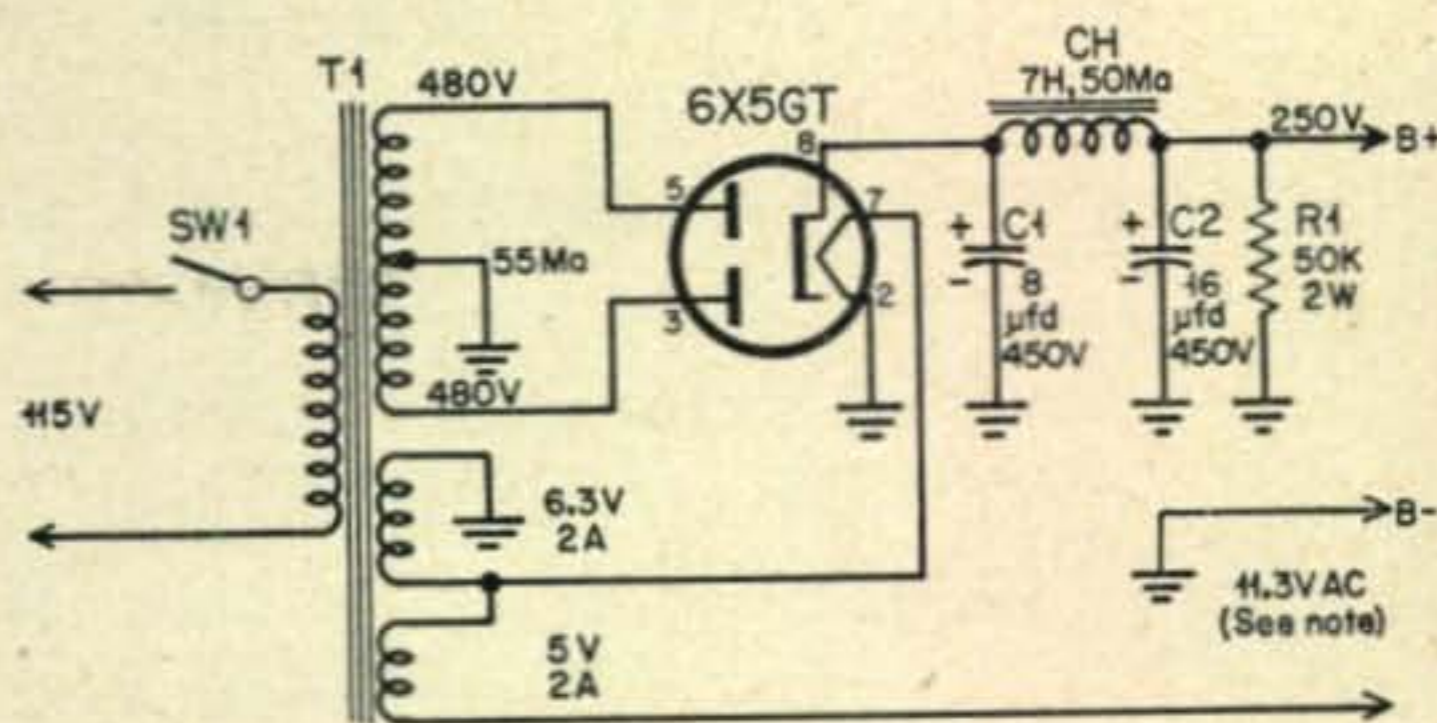

NOTE: REVERSE CONNECTIONS TO ONE FILAMENT WINDING, IF THIS VOLTAGE IS VERY LOW.

T1—Power transformer. 480v., 55ma., c.t., 5v., 2amp.; 6.3v., 2amp. (Stancor PC-8402 or equiv.)

Ch—7 h., 50ma. filter choke. (Stancor C-1707 or equiv.)

C1, C2—dual 8 µfd., 450v. electrolytic.

R1—50,000 ohm, 2w.

SW1—s.p.s.t. toggle.

Octal tube socket

6X5GT tube

7 x 7 x 2" chassis

Additional receiver conversion parts:

25,000-ohm, wire-wound pot. small size.

S.p.s.t. toggle switch.

Single-circuit phone jack.

Fig. 5. Wiring schematic and parts list of a power supply unit suitable to operate the Command Set receivers.

To rewire the filaments of tubes, ground one filament pin of each tube socket and connect the other filament pins of each socket together and to *Pin 2* of the three-terminal plug at the rear of the receiver. *Pins 2 and 7* are the filament terminals on all tubes, except the 12SR7 and 12SG7, on which they are *pins 7 and 8*.

Connect power to the three-terminal plug thusly: B— and one side of the filament circuit to *pin 1*; twelve volts, a.c., to *pin 2*; and 200 to 250 volts, d.c., at fifty milliamperes, to *pin 3*.

WARNING! Do not apply more than 250 volts to the receiver; otherwise there is danger of blowing some of the condensers in it.

Figure 5 is the diagram of a power supply suitable for use with "Command" receivers. It is conventional, except for the 6X5 rectifier tube and the use of two filament windings connected in series to operate the tubes in the receiver. The total of 11.3 volts is a little low, but it will satisfactorily operate the receiver.

Obviously, this article just scratches the surface of the vein of information available on the use of "Command" equipment, but we hope that, combined with the bibliography, it serves a useful purpose.

### Bibliography

1. "Converting the SCR-274N for VFO Operation on FM or AM," L. W. May, Jr., W5AJG, CQ, May, 1946, p. 18.
2. "Converting the BC-274N Receiver," Russell F. Sievert, W8OZA, CQ, November, 1947, p. 24.
3. "Mobile With the SCR-274N," George M. Brown, W2CVV, CQ, January, 1948, p. 22. (A 28-Mc. conversion.)
4. "Variations in the Modifications of the SCR-274N Transmitters," E. B. McIntyre, W3KHJ; Edwin W. Hannum, W2VNU/8; Vince Dawson, W0ZJB, CQ, July, 1948, p. 42.
5. "Bandspreading the SCR-274N," E. Henrich, W8OVL, CQ, August, 1948, p. 23.

(Continued on page 60)

# Design of a Screen Supply

By WILLIAM I. ORR, W6SAI/FP8AC

Contributing Editor, CQ

In This Extensive Treatment of an Important Subject the Well-Known Author of the "RADIO AMATEURS' MOBILE HANDBOOK" Discusses the Development of Tetrode Screen Voltage Supplies

There's no doubt about it. The swing is to the use of low-drive pentodes and tetrodes in the final stages of amateur and commercial transmitters. Low grid drive requirements and the ease of applying anti-TVI measures make these high gain tubes attractive to the builders of new equipment. The inherent crankiness of some of the old style pentodes is absent in the newer versions, which are rugged, reliable and efficient.

Unfortunately, the tube designers have yet to produce a tetrode transmitting tube that does not require a source of screen voltage. This abruptly confronts the all-triode man with a unique new problem: How best to get a screen voltage source for a tetrode?

## Various Screen Supplies—Good and Bad

The wrong type of screen supply can lead to many operating headaches, and may under certain circumstances, lead to the destruction of the tube itself. For purposes of illustration, let us assume that we are going to use a single 4-250A tube in the final stage, running at 3000 volts and 330 ma. for an input of 990 watts on CW. According to the data sheets on this tube, the maximum screen dissipation for this service is 35 watts. If the power dissipated by the screen exceeds this figure, the temperature of the screen will become excessive, and there is danger that the heat generated will warp the fragile screen structure, causing it to short to the grid or plate of the tube. Such an accident as this can happen in the wink of an eye, when the screen dissipation is allowed to exceed the maximum level during tuning operations, or by carelessly applied screen voltage.

There are two popular types of screen supplies in common use: (1) The supply wherein the screen voltage is obtained from the plate circuit high voltage supply by means of a suitable dropping resistor, and (2) the separate low voltage screen supply. Let us examine each type of supply and judge their respective merits and deficiencies.

## The Series Resistor Supply

The 4-250A screen requires 500 volts at a current of about 45 ma. for c-w operation. Proper operation of the 4-250A may be had with screen currents of 25 to 60 ma. with equal values of grid drive. Unfortunately, the screen is op-

erating very near the point of maximum dissipation when a current of 60 ma. is drawn, leaving very little "margin for error." It is better to operate the screen at a lower value of current, and accept the fact the tube is slightly harder to drive. The difference in driving power is less than 10%, in any case.

To drop 3000 volts to 500 volts at a current of, say 45 ma. requires a 55,000-ohm resistor, capable of dissipating 110 watts. As long as the 4-250A remains in a static operating condition of 990 watts input, everything will be fine. But suppose the exciter of the 4-250 is keyed, or the input to the tube is changed slightly during a quick QSY? If the tube has the correct cut-off bias (120 volts) and the exciter is keyed, the screen current will drop to zero with no excitation. The voltage drop across *R1* will therefore be zero, and the screen voltage will be 3000 volts! This is six times the recommended maximum screen voltage. Undoubtedly the tube, and *C1*, the screen bypass condenser, will suffer drastically!

When the input to the tube is varied slightly, as by tuning changes, the screen current will also vary. In fact, the screen current meter of a tetrode is the most sensitive indicator of proper tube operation. If the stage is loaded too heavily, the screen current will drop. If the loading is too light, the screen current will be excessive. A change in plate current of 50 ma. will often double or halve the screen current. A

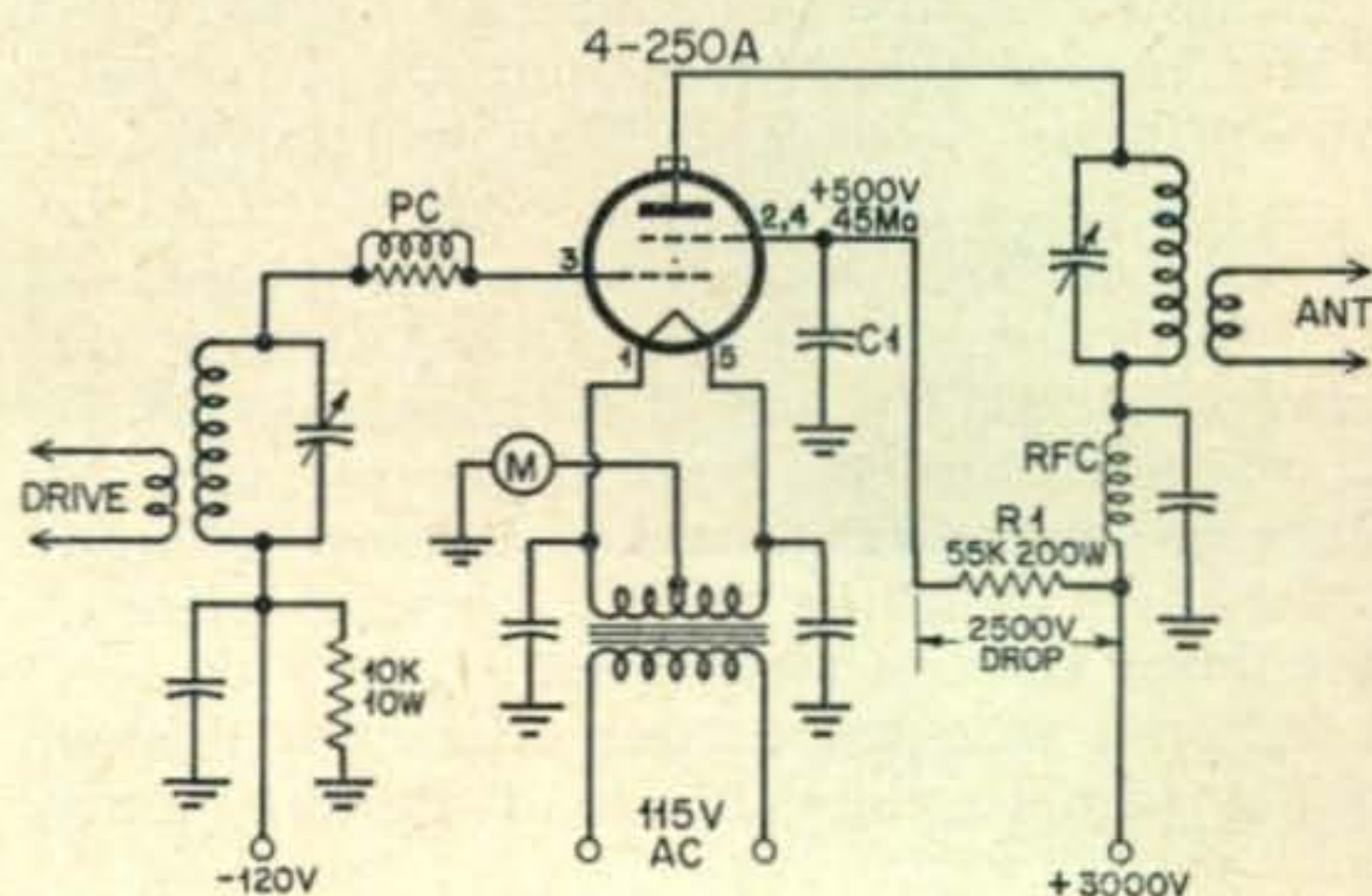

Fig. 1. This is the basic circuit of a 4-250A tube operating with a series screen supply for C-W operation. The voltage shown are those when excitation is applied to the tube.

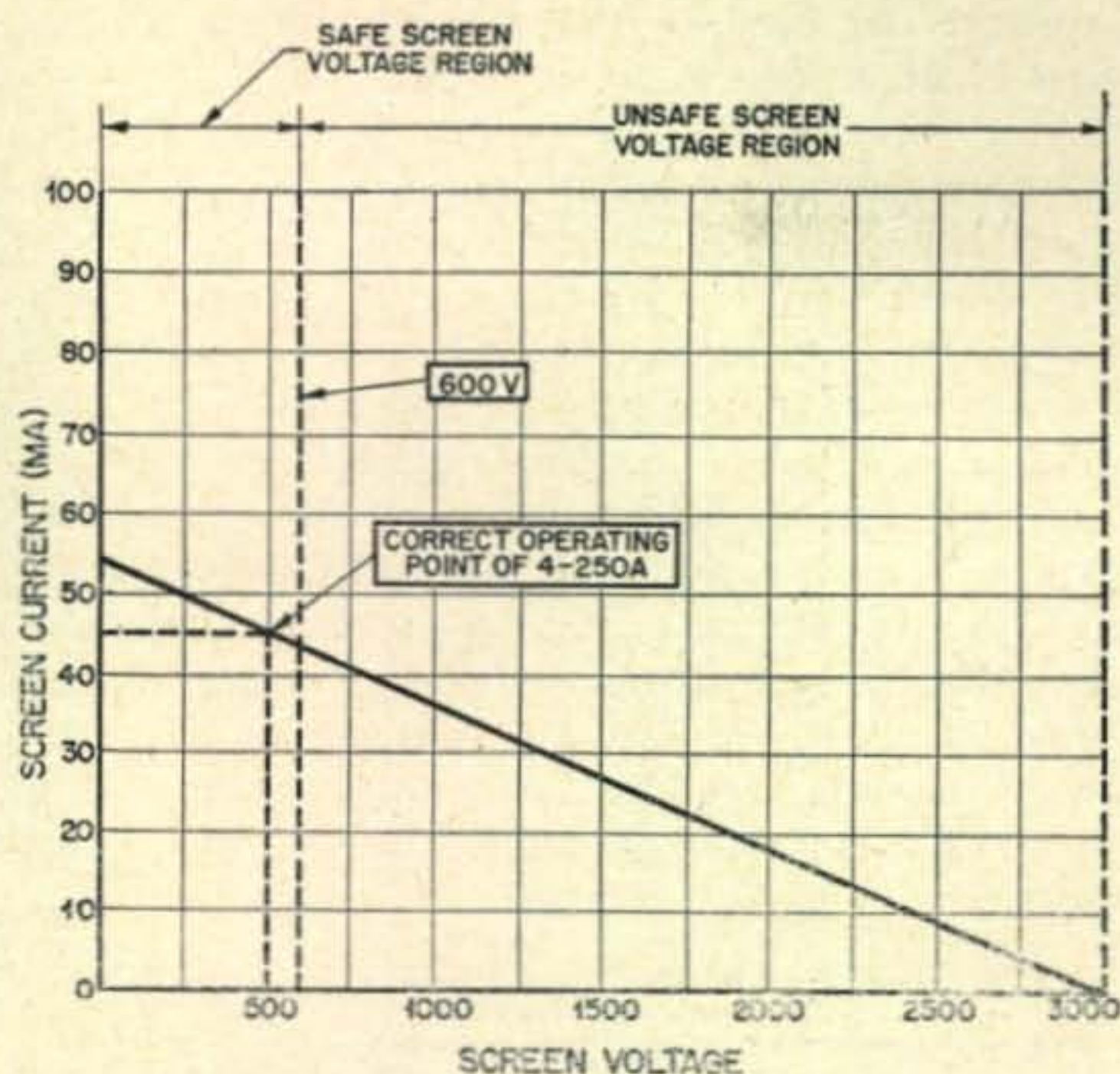

Fig. 2. Plot of screen voltage as a factor of screen current for the basic circuit in Fig. 1.

graph of screen voltage plotted against screen current for the circuit of Fig. 1 is shown in Fig. 2. It can be seen that the screen voltage is extremely sensitive in terms of screen current, and therefore very dependent upon antenna loading, grid drive, and other circuit parameters. If the screen current should drop from 45 ma. to 30 ma. (which it could easily do with a slight change in antenna loading) the screen voltage would soar to 1300 volts! In fact, a drop of screen current from 45 ma. to 40 ma. would boost the screen voltage to 750 volts. Such a current sensitive screen supply is much too dangerous to use on large, expensive transmitting tubes, as the chance of damaging the screen is great.

On the other hand, when the screen current is excessive, the screen voltage drops quickly. 10% excessive screen current will drop the screen voltage to about 250 volts.

A circuit of this type may be used with small tubes such as the 807, where the plate voltage is not much greater than twice the screen voltage, but where the plate/screen voltage ratio is higher, as in the case of the 4-250A or tubes of that type, the circuit is exceedingly impractical—and dangerous to use.

### The Series Resistor/Clamp Tube Supply

To prevent the screen voltage gyrations under "keyed" conditions, a clamp tube may be added to the circuit of Fig. 1. When excitation is applied to the 4-250A, and it is running at 990 watts input, the currents and voltages are as shown in Fig. 3. Resistor bias may be used on the tetrode, instead of a bias pack. The 180-volt bias developed across  $R_2$  by the flow of rectified grid current is applied to the control grid of a tetrode-connected 6Y6 clamper tube. The plate of the 6Y6 is tied directly to the screen of the 4-250A. Under these conditions,

the 6Y6 is biased beyond cut-off and is effectively out of the circuit. When the exciter stages are keyed, and the rectified grid current flow is interrupted, no voltage will be developed across  $R_2$ , and there is no bias on the 6Y6. Consequently it draws a heavy plate current. This current drain boosts the voltage drop across  $R_1$ , and the screen voltage of the 4-250A (as well as the plate voltage of the 6Y6) drops to a very low value. This action protects the screen of the 4-250A tube, as well as  $C_1$ . Thus as the excitation rises and falls, so does the screen voltage, by the action of the 6Y6. This would seem like an ideal arrangement, but it also has some serious drawbacks:

1. If the 4-250A stage has any v-h-f parasitics that would cause it to draw grid current and develop voltage across  $R_2$  during periods of no excitation, there will be no safety action of the clamp tube. In failing to act, the clamp tube could allow damage to the screen of the 4-250A.
2. The clamp tube is essentially a "yes or no" device, either operative or inoperative (just like a switch) and offers no protection to the tetrode under unfavorable operating parameters. If the excitation to the 4-250A remains constant, but because of changes in plate loading, the screen voltage drops to, say, 40 ma., the screen voltage will still rise to 750 volts. It would even be possible for the screen current to drop to an even lower value under excessive antenna loading, and allow the screen voltage to soar to 1500 or 2000 volts. In addition to damaging  $C_1$ , the 6Y6 tube would probably be ruined.

So it can be seen that the clamp tube offers only marginal protection in the best of cases, and may offer no protection to the tetrode at

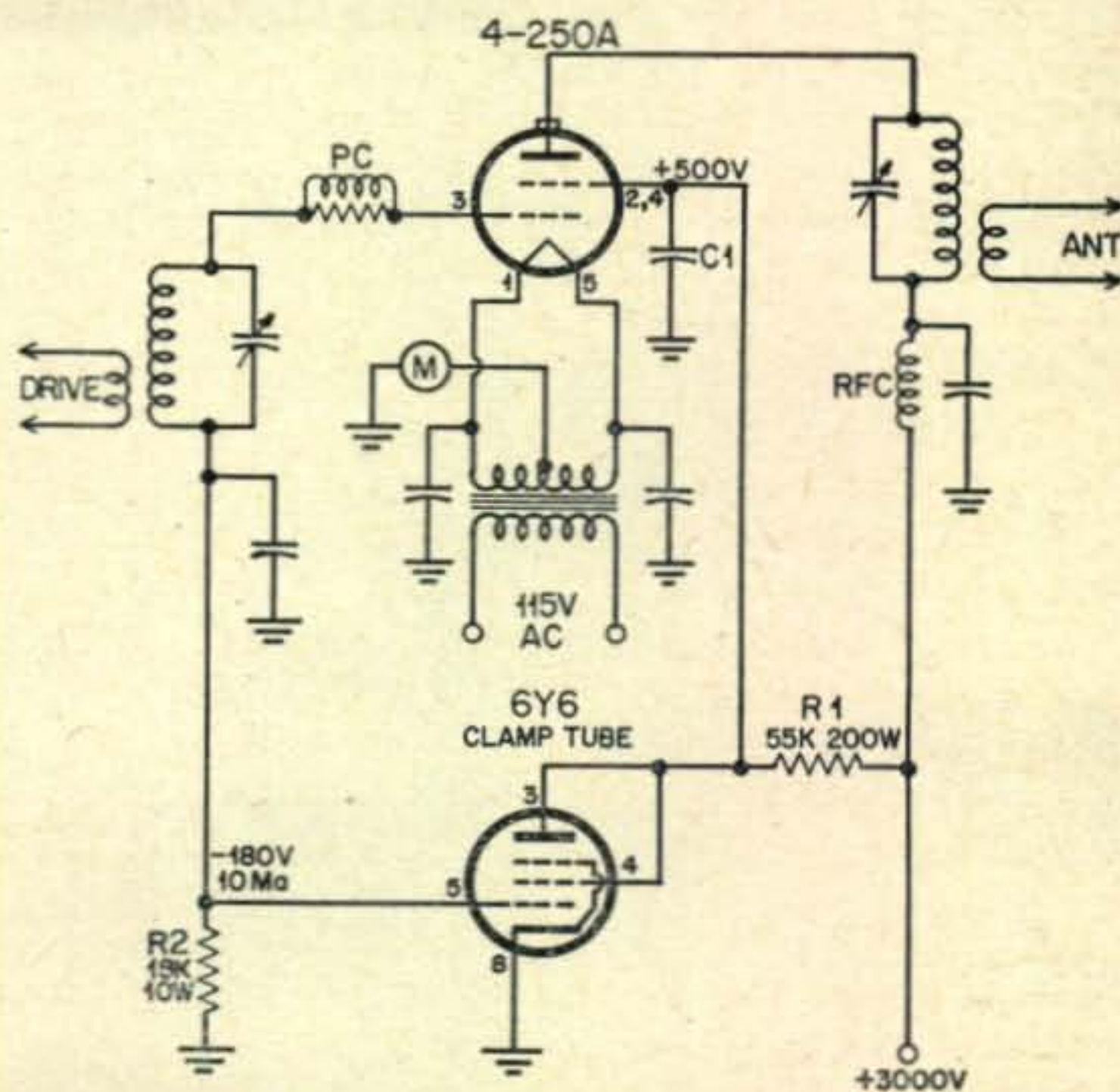

Fig. 3. In this basic circuit the 4-250A tube now has a screen clamper tube across the series resistor supply. The voltages are those that might be expected under normal excitation conditions.

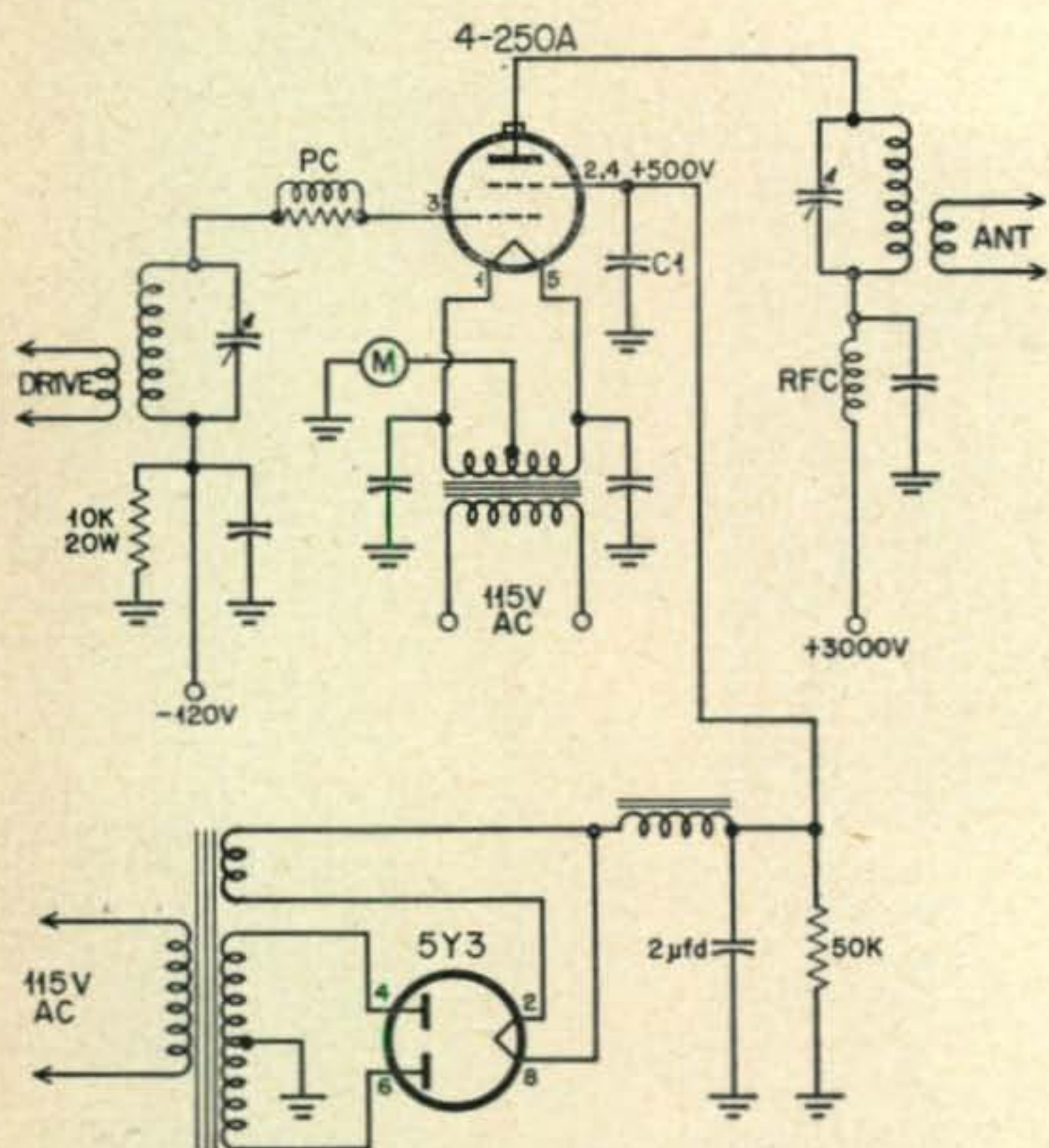

Fig. 4. Another alternative method is to provide screen voltage from a small power supply of reasonably good regulation. The disadvantages are mentioned in the text.

a time when the tetrode may be easily damaged.

### The Low Voltage Screen Supply

A third type of screen supply is the low-voltage (see Fig. 4) power supply, which insures much better regulation than the series resistor type: When the excitation is removed from the tetrode, or the plate loading is changed, the screen current will still fluctuate over a large range. However, because of the better regulation of the low voltage screen supply, as compared to the series resistor supply of Fig. 1, the screen voltage will vary only a small amount, perhaps 30 or 50 volts. This will

eliminate the danger of excessive screen voltage when little screen current is drawn.

Even so, this supply is not fool-proof, and can damage a perfectly good tube. Assume again that our 4-250A is coasting along at 990 watts input, and the overload relay on the high-voltage supply kicks out from an accidental arc-over, or that perhaps an 866 konks out and blows a line fuse on the high-voltage supply. With full screen voltage on the tube, and excitation, but no plate voltage, the screen current rises to perhaps five or ten times its normal value (limited only by the capacity of the screen supply). There is a slightly metallic "ping" as the red-hot screen expands and warps against the grid of the 4-250A, and po-o-o-oo! This process takes about 0.1 second,

TUBE	MAX SCREEN VOLTS	MAX SCREEN DISSIPATION (WATTS)
4-65A	400	10
4-125A	400	20
4-250A	600	35
4-400A	600	35
813	400	20
803	500	30

Table 1. Maximum screen voltage and screen dissipation ratings for various popular transmitting tetrodes and pentodes in r-f service.

much quicker than you can hit the standby switch! If you have one 4-250A in the final it is bad enough; if you have two of them—(censored-Editor).

So it can be seen that none of these commonly used circuits offer 100% protection for the costly 4-250A. Either there is danger of excessive voltage or excessive current during tuning periods, or during keying. What actually is needed is a supply that will limit both current and voltage to the screen circuit. In other words, a wattage limited supply.

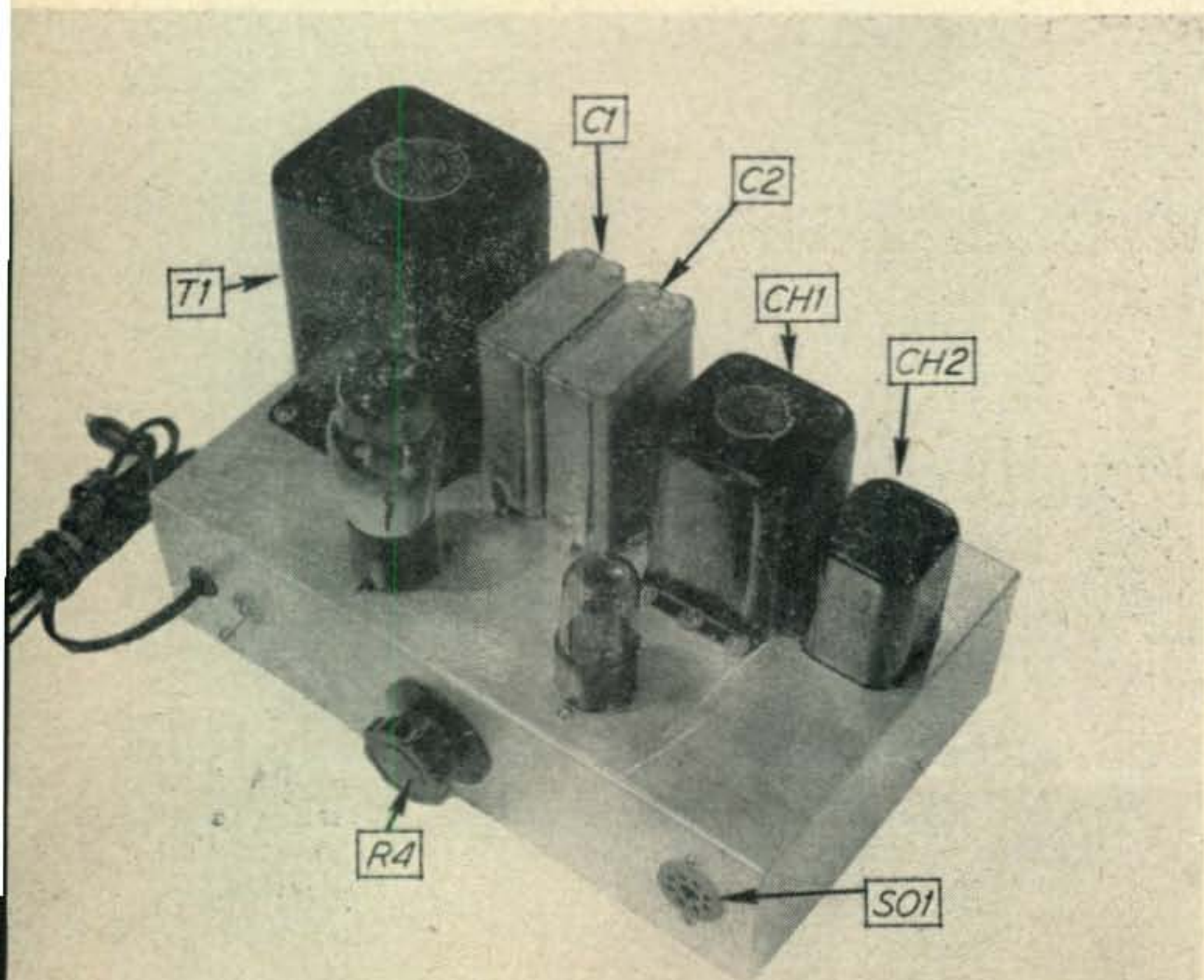

Fig. 5. The wattage-limited supply designed by the author for protection of pentode and tetrode final r-f amplifiers. Although shown here on an individual chassis the idea might easily be incorporated in the regular power supply deck of the transmitter.



### A Wattage Limited Screen Supply

The maximum screen voltage and dissipation ratings of various tetrode transmitting tubes are listed in *Table 1*. If these ratings are always observed, the tube will be protected from screen overloads caused by keying or tuning maladjustment. What is needed is a screen supply of sufficiently poor regulation to allow the screen voltage to drop slowly as the screen current is increased, but at the same time not produce excessive voltage when the screen current is low. The introduction of a small amount of series resistance into a low-voltage supply of good regulation will do the trick. By the proper choice of this series resistor, the maximum wattage output of the supply may be set below the maximum dissipation of the screen grid of the tetrode tube. As the screen current then increases, the screen voltage drops, always keeping the screen dissipation within safe limits. As the screen current drops, the screen voltage rises, but not to excessive values. In this way the transmitting tube is adequately protected in all cases. The wattage output of the supply may be changed as desired by varying the series resistor.

A supply of this type, combined with a safety bias supply is illustrated in *Fig. 5*, and the schematic is shown in *Fig. 6*. This supply is intended for use (as shown) with a single 4-250A or 4-400A, and will deliver 500 volts at 45 ma., or a maximum of 35 watts power. The actual voltage, current and wattage curves are shown in *Fig. 7*. When two 4-250A tubes are used, *T1* and *Ch1* must be increased in size (see parts list) and *R1* decreased in value. If smaller tubes such as 813's or 4-125A's are used, *T1* and *Ch1* remain as shown, and *R1* is in-

creased in value, since these tubes have less allowable screen dissipation.

To permit proper operation of *R1*, condenser input is used in the supply, and a power transformer with a 900-volt c-t winding is used. The number of small transformers that will deliver 600 volts out of a condenser input filter at load currents up to 100 ma. is limited. Our recommendation is the *Chicago Corp.* line of *PSR* transformers for this application. If the supply is for one tetrode, with a screen current of 60 ma. or less, the *PSR-85* transformer may be used. For two tetrodes, and a maximum screen current of 120 ma., the *PSR-120* transformer may be used. The current ratings of the transformers as given in the catalog are for continuous duty with reactor-input filter systems. Approximately the same ratings seem to apply under intermittent operation when a condenser input filter system is used.

A separate 6X5 half-wave rectifier is used as a bias supply, delivering about -130 volts. If a different value of bias is required, *R2* and *R3* may be changed in value. *R3* is the grid bias resistor for the tetrode tube, and its value may be computed from the tube data sheets. Once *R3* is determined, *R2* may be adjusted to pro-

- |   |  |
|---|--|
| C1, C2—4.0 $\mu$ f.d., 600-volt, oil filled, Cornell Dubilier TJH-6040.           | R1—2000 ohms, 50 watts with slider.  |
| C3, C4—8.0/8.0 $\mu$ f.d., dual unit with separate negative leads, Sprague TU-88. | R2—6000 ohms, 20w., fixed.   |
| C5—0.001 $\mu$ f.d., ceramic, Erie 801-001.                                       | R3—10,000 ohms, 20w., fixed.   |
| C6, C7—0.001/0.001 $\mu$ f.d., dual unit, ceramic, Erie 812-001.                  | R <sup>1</sup> —35 ohms, 50w., Ohmite Model J.   |
| C8, C9—same as above.   | R5—200,000 ohms, 1w.   |
| Ch1—12 henries at 85 ma., Chitran #RS-1085.                                       | S1—S.p.s.t. switch   |
| Ch2—15 henries at 40 Ma., Chitran #RS-1540.                                       | So1—8-prong octal socket.  |
|   | T1—900 volts, c.t., 105 ma., 5 volts at 2 amps., 6.3 volts at 3.5 amp., Chitran PSR-105. |

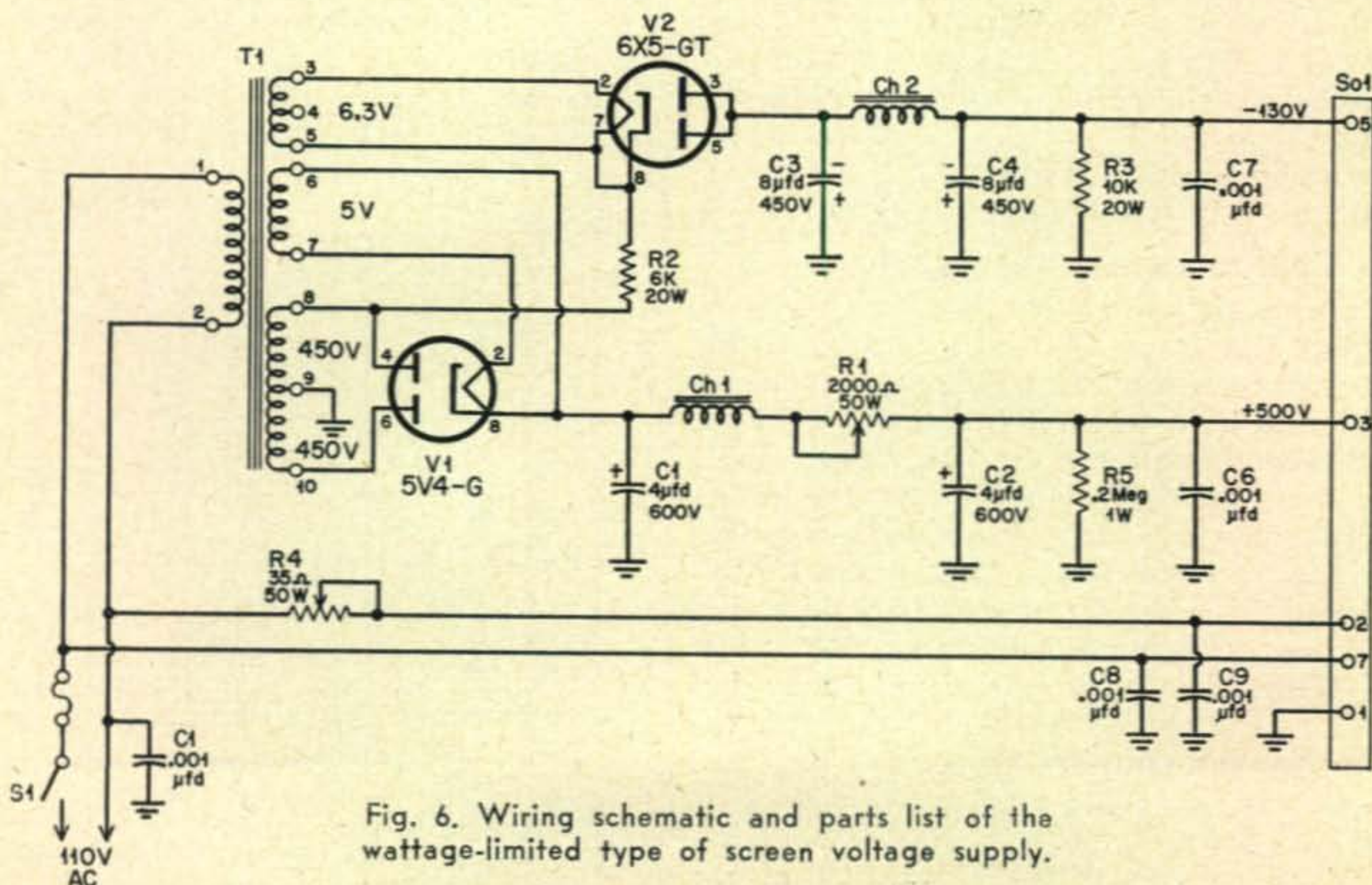

Fig. 6. Wiring schematic and parts list of the wattage-limited type of screen voltage supply.

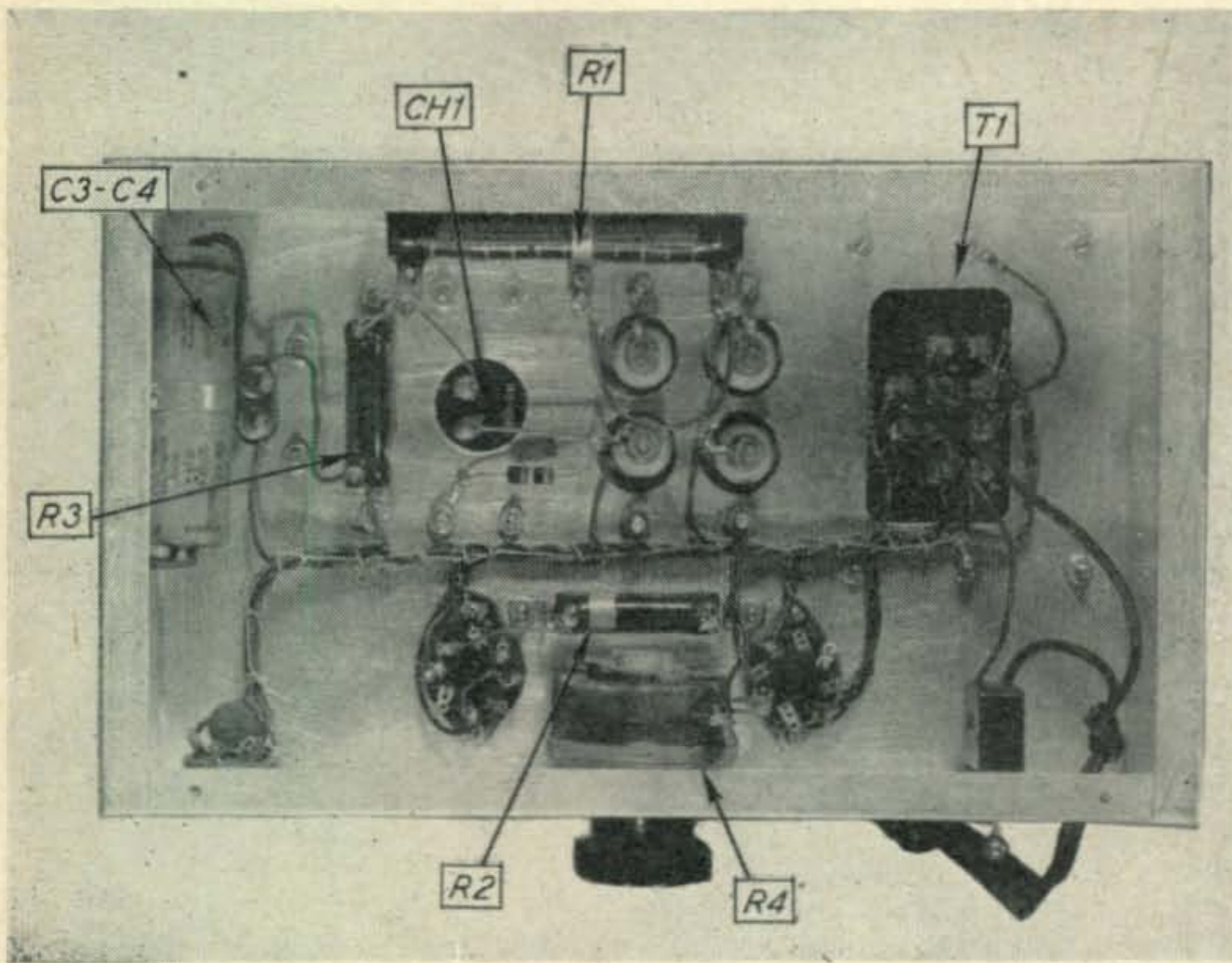

Fig. 8. Under chassis wiring view of the supply. Note particularly that C3/C4 is a dual unit with separate negative leads. This condenser is used in the bias supply and has the positive leads grounded.

vide the correct cut-off bias to appear across  $R3$ .

It is necessary that the bias voltage be applied to the 4-250A at the same time, or slightly before the screen voltage is applied. A 5V4-G cathode type rectifier is therefore used for the screen supply, making its warm-up time approximately equal to the 6X5 tube in the bias supply. Actually, the 6X5 warms up quite a bit faster than the 5V4-G, since the filament voltage on the 6X5 tube is about 6.8 volts. No harm is done to the 6X5 by this high filament voltage, as it is well within the 10% variation limit set by the manufacturer.

It is convenient to have the filament voltage of the 4-250A controlled by the same switch that controls the above voltages, so 110 volts is brought out through two prongs of the power plug to be applied to the filament transformer of the 4-250A. Rheostat  $R4$  is mounted on the supply to adjust the filament voltage to exactly 5.0 volts.

The wattage limiting resistor  $R1$  is a 50-watt type, with an adjustable slider.

### Construction of the Supply

The supply is easily constructed upon a 12x7x3-inch aluminum chassis. The placement of parts is not critical. Good 600-volt oil condensers should be used for  $C1$ , and  $C2$ .  $C3$  and  $C4$  are the condensers for the bias supply, and may be a dual unit *with* separate negative leads. (Remember, positive leads grounded, negative leads to each side of  $Ch2$ !) Condensers  $C6$ - $C9$  are to prevent r-f from wandering back into the supply. They are mounted directly on the pins of  $So1$ . The wiring for the supply may be laced and run down the center of the unit as shown in the photograph.

### Testing the Supply

When the supply is wired, it should be carefully checked before voltage is applied to it.

Be sure of the correct polarity of  $C3$  and  $C4$ . Insert the 5V4-G and the 6X5 tubes in their sockets and turn on the primary switch. Plus 600 volts (without load) should be measured from *pin 3* to *pin 1* of  $So1$ , and minus 130 volts from *pin 5* to *pin 1* of  $So1$ . Adjustment of  $R1$  and  $R2$  will set these voltages correctly. For tubes other than 4-250A's, consult the chart in *Table I*. To plot the output wattage of the supply, various values of 50-watt resistors, ranging from 500 to 10,000 ohms should be placed across *pins 3* and *1* of  $So1$ , and the voltage across, and current through these resistors measured. A chart such as shown in *Fig. 7* may be made up from these measurements.  $R1$  may then easily be set to limit the maximum wattage delivered by the supply.

### Operation of the Supply

Operation of the supply is easy! Just hook it up and forget it. The correct voltages will come on an instant after the tetrode filament is warm. The tetrode is fully protected, and if

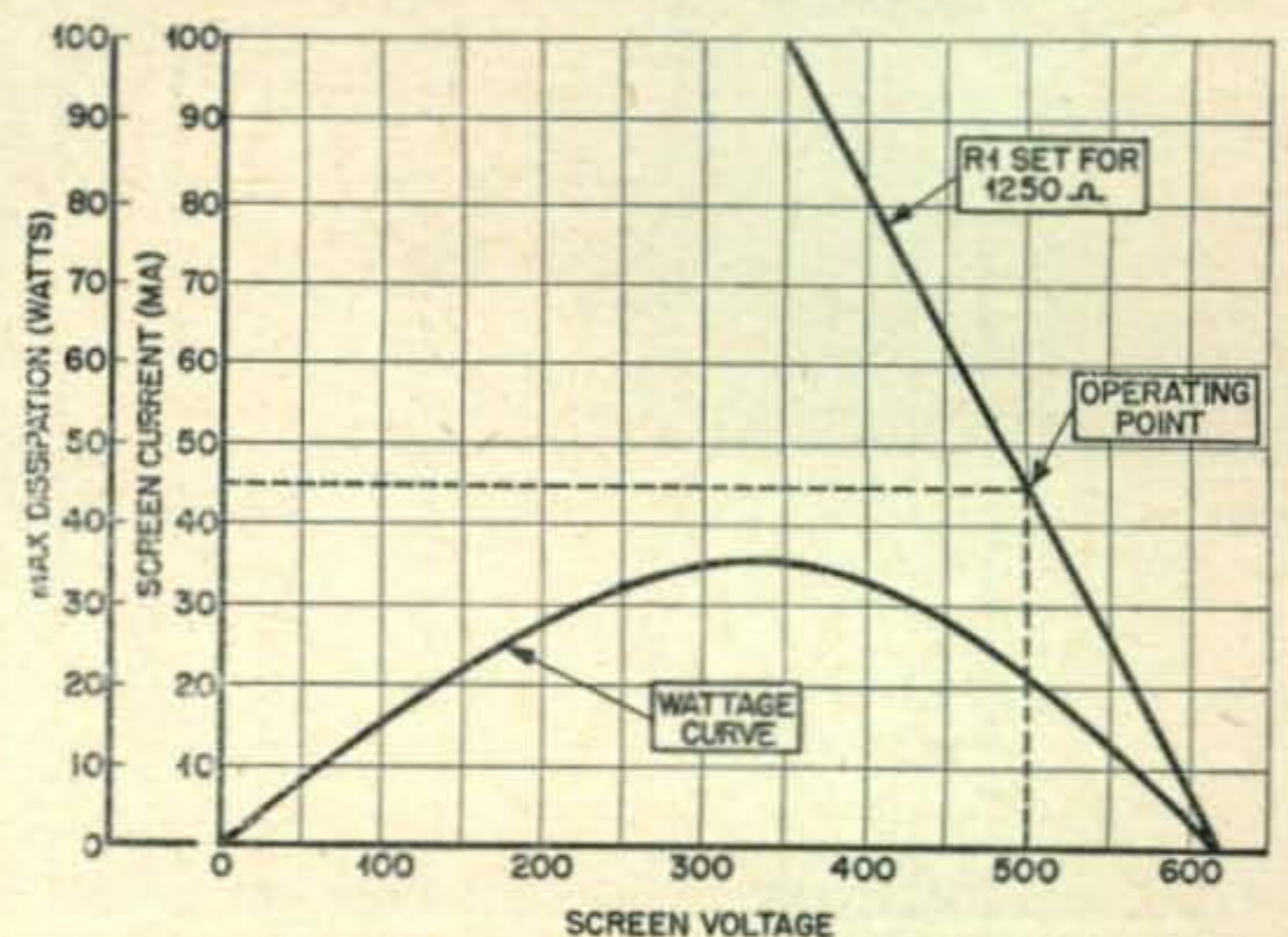

Fig. 7. Plot of voltage, current and wattage of the safety screen supply. All values are dependent on the setting of  $R1$ .

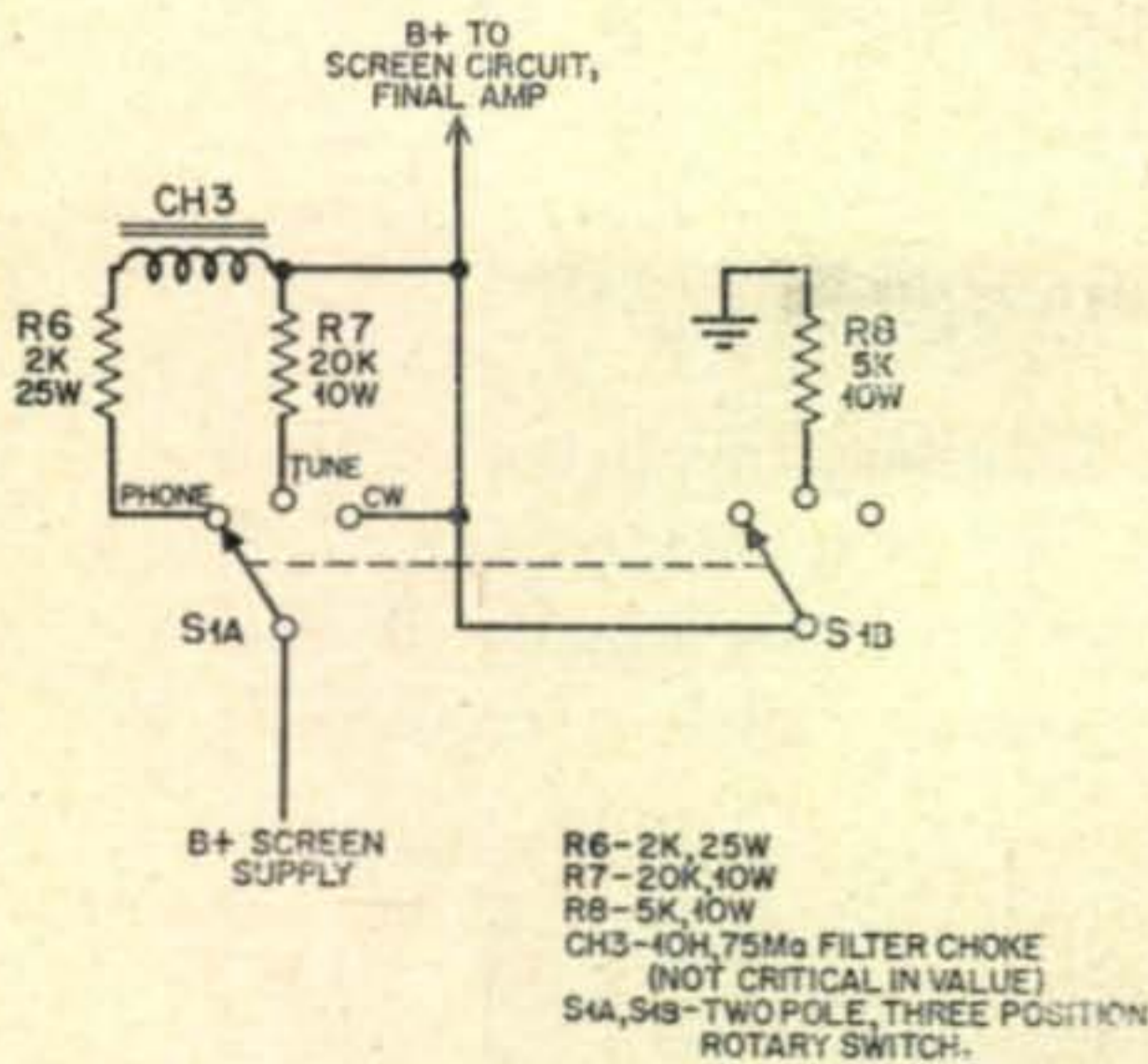

Fig. 9. To permit phone operation with the safety screen supply it is necessary to add a choke in the screen lead to the final amplifier tetrode. Provisions are made to switch it out of the circuit for C-W operation.

something happens to blow the fuse of the bias supply, the filaments of the tetrode go off, too. After it is installed, you can forget it is around!

### Phone/CW Switching Circuit.

The safety screen supply may be used for phone operation by the incorporation of a selector switch, as shown in Fig. 9. An extra position on the switch will also permit a "tune-up" or QRP position, whereby the final stage may be run at reduced input for tuning, or cross-town QSO's.

In the "phone" position of S1, a series modulation choke, Ch1 and dropping resistor R1 are introduced in the screen circuit. R1 drops the screen voltage by about 80 volts at a screen current of 40 ma. An additional 20 volts drop is introduced by the d-c resistance of Ch1, making the applied screen voltage 400 volts, which is

the correct amount for 4-250A or 4-400A tubes. R1 may be increased in resistance for those tubes requiring a lower value of screen voltage for modulated operation.

No audio power need be applied to the screen circuit. Ch1 isolates the screen circuit from the filter and bypass condensers in the screen supply, and allows the screen of the pentode tube to "float" at an audio potential determined by the modulation level of the plate of the tube. This results in a very linear form of plate modulation, and requires no audio power to be supplied to the screen. The normal amount of audio power is coupled to the plate circuit of the pentode tube, as in any normal form of plate modulation.

When S1 is turned to the center, or "tune" position, a series resistor R2 is added to the screen circuit, and a shunt resistor R3, is placed from screen to ground. This drops the screen voltage to the region of about 80 volts. The final amplifier may be tuned, or low power run to the transmitter for local QSO's without danger of tube overload. Changes in the value of R3 will vary the "tune" screen voltage.

For straight c-w operation, with full screen voltage, S1 is thrown to the "CW" position, and full screen voltage is applied to the pentode tube.

### Attention:

### Hamfest Publicity Committees

The Editors of CQ must candidly report that the publication of Hamfest and convention notices has been pretty much of a catch-as-catch-can proposition throughout the past several years. Practically all notices that were received were set in type. However, space allocations during the "make-up" of the magazine often as not dictated that a large number of such notices would be dropped.

Frequently notices about Hamfests were received too late to be included in the proper issue. The length of the announcements varied over extremely wide limits while many were garbled in hopes, we assume, that the Editors would straighten them out and make them readable. The end result of the handling of the convention and Hamfest announcements was a feeling by many groups of being "slighted."

To apply a little practical psychology and to make these announcements somewhat more valuable we are bringing to the attention of Hamfest and Convention Publicity Committees that notices will only be published in 1954 in the "Classified Ads" section of CQ.

A special insertion rate has been prepared and is 25 words for \$1.00 and 25 to 50 words for \$2.00. No special discounts will be granted for fractional ads. All convention or Hamfest ads will appear under a special heading. Address your announcements to: Classified Ads, CQ Magazine, 67 West 44th Street, New York 36, N.Y.

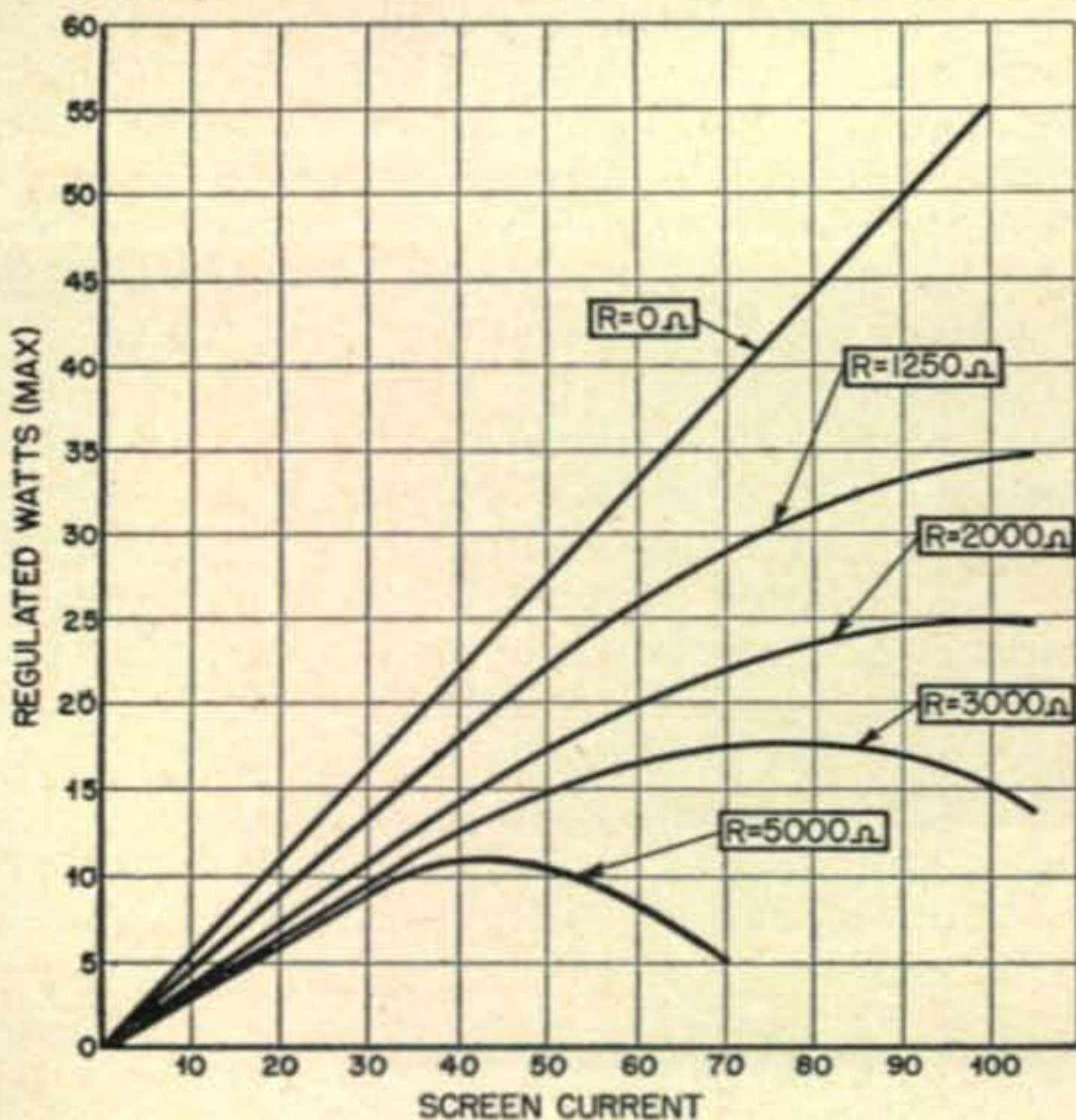

Fig. 10. Wattage ratings (approximate maxima) of the screen supply with various values of R1.

### Re "Versatile 70 Watts"

There is an errant connection in the power supply schematic on page 21 (December, 1953 issue). The junction of cathode (pin 7 of the 6X4) and filament (pin 4) should not be there. Pin 4 is connected to I1 as shown, but not to pin 7 or the resistor network R27 and R28. We hope all of the readers caught this in wiring up the transmitter.

# Spurious Emissions

CAPT. E. H. CONKLIN, USN, W3VQ

7200 Clarendon Road, Bethesda 14, Maryland.

If you are Sitting Down to Design Your Rig this is the Article to be Read before Working out the Oscillator Stage. A Well-Known Author Tells Us the Why of Spurious Beats and What Can be Done About Them on a Fundamental Basis

The vastly increased use of very-high and ultra-high frequencies in recent years has placed great emphasis upon the emission of clean signals. By this is meant the emission of the desired frequency without considerable power being expended in various spurious frequencies which are likely to interfere with other services.

Some studies have been made of the methods by which v-h-f and u-h-f power may be obtained from a string of multipliers, or similar devices usually required in order to obtain satisfactorily high stability of the output frequency, as contrasted with the generation of the output frequency without multiplier stages. In one such test, it was found that a transmitter with a multiplier of, let us say, 24 times, would produce not only the harmonics of the output frequency, but also to some extent *all* the harmonics of the original crystal or master oscillator frequency. Similarly, a companion receiver using a crystal-controlled oscillator would respond not only to the image frequencies, but also to other spurious frequencies resulting from the production of other than the desired crystal harmonic in the oscillator chain.

Figure 1 illustrates the type of output that might be produced by a multiplier string in a transmitter. Some of the predicted harmonics may fail to show up unless the measuring equip-

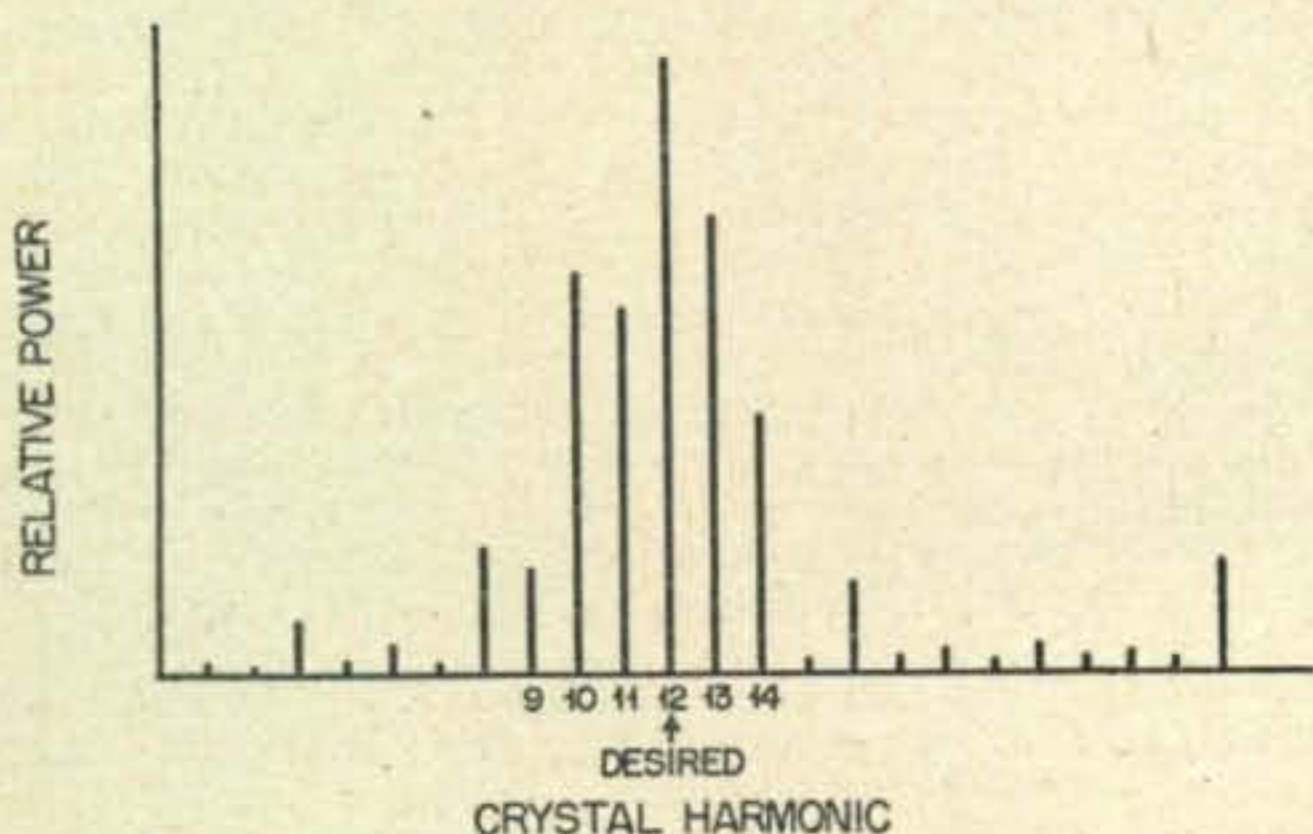

Fig. 1. Possible spurious emissions from a transmitter where the twelfth harmonic is the desired frequency. As explained in the text, these spurious emissions may result from coupling between the oscillator and the second or third multiplier stage rather than the stage directly following the oscillator.

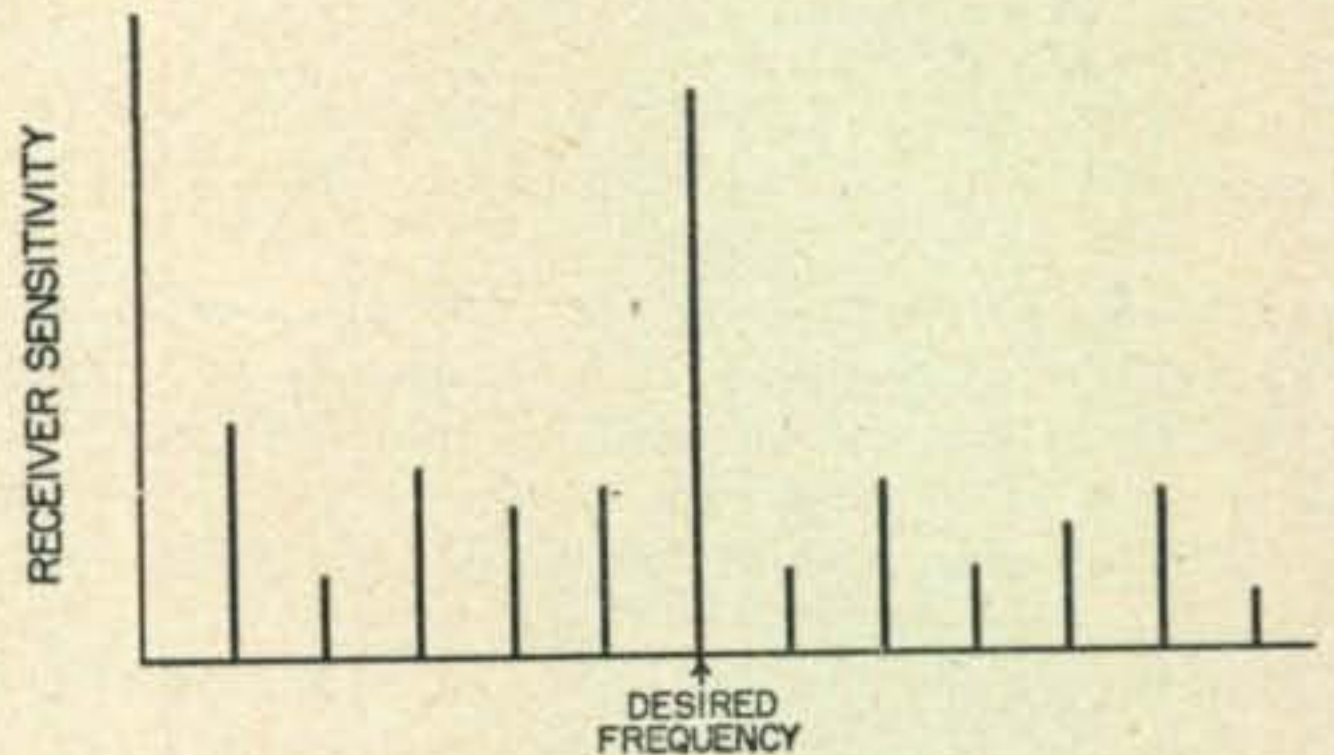

Fig. 2. Spurious beats in a crystal controlled receiver. These are undesired products of the crystal multiplier and are exclusive of images.

ment is capable of measuring spurious emissions that are more than 120 db. down from the desired output frequency.

Similarly, Fig. 2 shows the type of response that might occur in a receiver using several stages of frequency multiplication in order to produce the first-detector injection voltage.

## Harmonic Relationship

One of the first questions that arises in a study of the spurious emissions in a transmitter, or spurious responses in a receiver, is in relation to the method by which the undesired frequencies are produced. Frankly, some of them may not be analyzed readily, but most of them can be related to some cause. For example, if we have a desired multiplication of 12, we might wonder how the 11th and 13th harmonics of the oscillator appear in the output when the numbers 11 and 13 cannot be factored, and therefore must be direct crystal harmonics without benefit of multiplication. The answer to this may lie in a study of Fig. 1, which shows that the amplitudes of many of the spurious emissions produced from the oscillator frequency are of irregular magnitude; that is, a crystal harmonic that should appear in the output may not be measurable, but, on the other hand, a harmonic that should not be strong may be excessive.

One may suspect, therefore, that the spurious frequencies are produced not only by the generation of harmonics of the oscillator itself, but also by leakage of the oscillator output into

other stages of the multiplier or into the final amplifier, where this power may modulate the frequency existing in that circuit. In short, the multiplication by 12 may produce output at the 11th and 13th harmonics simply by oscillator power getting into the final amplifier inductively or through circuit components, thereby producing the desired frequency plus or minus the modulating frequency. (*The output circuit of the first multiplier stage may be sufficiently "broad" so that the signal output of this stage is effectively amplitude modulated at the fundamental frequency. During subsequent frequency multiplication the "sideband" frequencies maintain their original separation from the carrier—Tech. Advisory Ed.*) The 10th and 14th harmonics may also be present due to this same leakage.

If such is the case, what are some of the factors that contribute to the creation of spurious frequencies in the output, and what are the methods by which these difficulties might be overcome?

### What Can be Done about Them?

From the above discussion it is apparent that extensive shielding of stages, even to the point of filtering the power leads entering the shields, and the use of individual shield boxes with one-point grounds, may reduce unintentional modulation caused by electromagnetic or electrostatic coupling or by power being transmitted through leads or chassis. But even when this is done, spurious frequencies may still appear in the output, although the pattern may be changed.

Taking the most simple situation of an oscillator followed by a doubler and a final amplifier, the most probable spurious emissions are at the frequency of the oscillator, the harmonics of the amplifier, and the undesired third harmonic of the oscillator. Let us disregard the harmonics of the amplifier itself, as this problem has been treated adequately in the past. We may expect to reduce the direct coupling of the oscillator to the final amplifier and to the antenna by the shielding mentioned earlier, by neutralizing the doubler, by using a push-push circuit, by using adequate screening in the tubes themselves, and by using adequate selectivity in the tuned circuits following the doubler tube, which should discriminate to some extent against the oscillator frequency. Inasmuch as the oscillator frequency is considerably removed from the output frequency, this discrimination may be sufficient.

The third harmonic of the oscillator, however, will not be as far, percentage-wise, from the desired output frequency as is the fundamental of the oscillator; the third harmonic, therefore, may be transmitted through the tuned circuits at a somewhat stronger level than is the oscillator fundamental. Hence it is already apparent that good shielding, good filtering, and

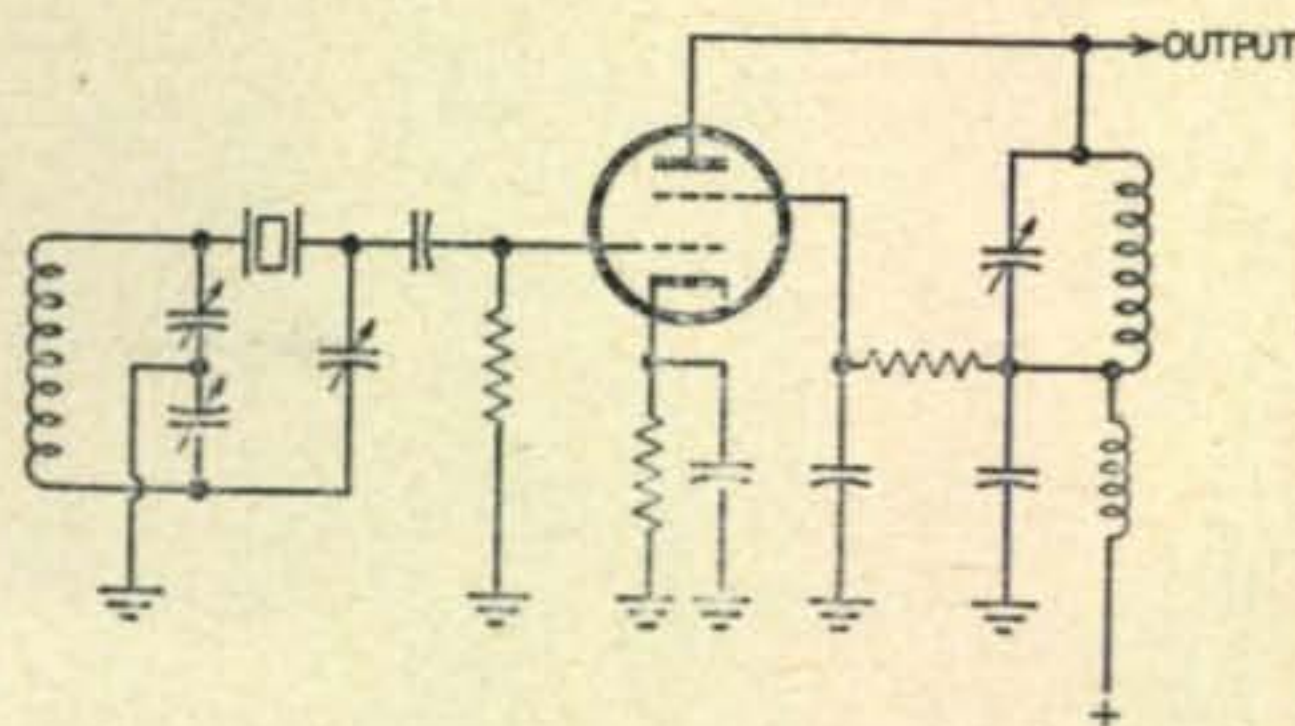

Fig. 3. Basic tri-tet oscillator circuit. This circuit will not create power at the crystal fundamental.

screening within tubes themselves may be required to control undesired spurious emissions. Also, tuned circuits should be selective and there should be an adequate number of them; or means such as tapping plates and grids down on the tuned circuits and inductive or link coupling should be employed to reject frequencies that differ from the output frequency.

### Choosing the Multiplication Factor

Now let us apply this simple thinking to a long multiplier string. First, we should start with an oscillator that operates on the highest possible frequency, producing no power below that frequency.\* Second, we should select a multiplier that can be factored into the lowest digits. That is, we certainly would not select 17 which can be factored only into 17 and 1, nor 19 which can be factored into 19 and 1. The most desirable multiplications would be 20, which can be factored into  $2 \times 2 \times 5$ , or 18 which can be factored into  $2 \times 3 \times 3$ , or, still better, 16 which can be factored into  $2 \times 2 \times 2 \times 2$ . The latter is preferable because only doubling is required, and tripling and higher factors are eliminated. That means that every stage in the multiplier string has the greatest possible separation between the driving frequency and the desired frequency, or between the next higher harmonic and the desired frequency. Obviously, it is not desirable to use a multiplier of 4 or any other figure which in itself can be factored into smaller numbers.

Separation of the desired harmonic of the oscillator from the desired adjacent harmonic, as mentioned above, is facilitated by the use of a higher frequency oscillator and a lower multiplication. This may not be accomplished too effectively by using a type of harmonic crystal that produces some power at the fundamental frequency. A very attractive approach to the problem of not creating any power at the crystal fundamental frequency is contained in a tri-tet oscillator circuit, with a crystal, inserted in the grid as a neutralized crystal filter. In this circuit, crystals in low capacity holders can be

(Continued on page 61)

\* Some harmonic oscillators actually produce signals on the crystal frequency fundamental, although true "overtone" oscillators do not—Tech. Advisory Ed.

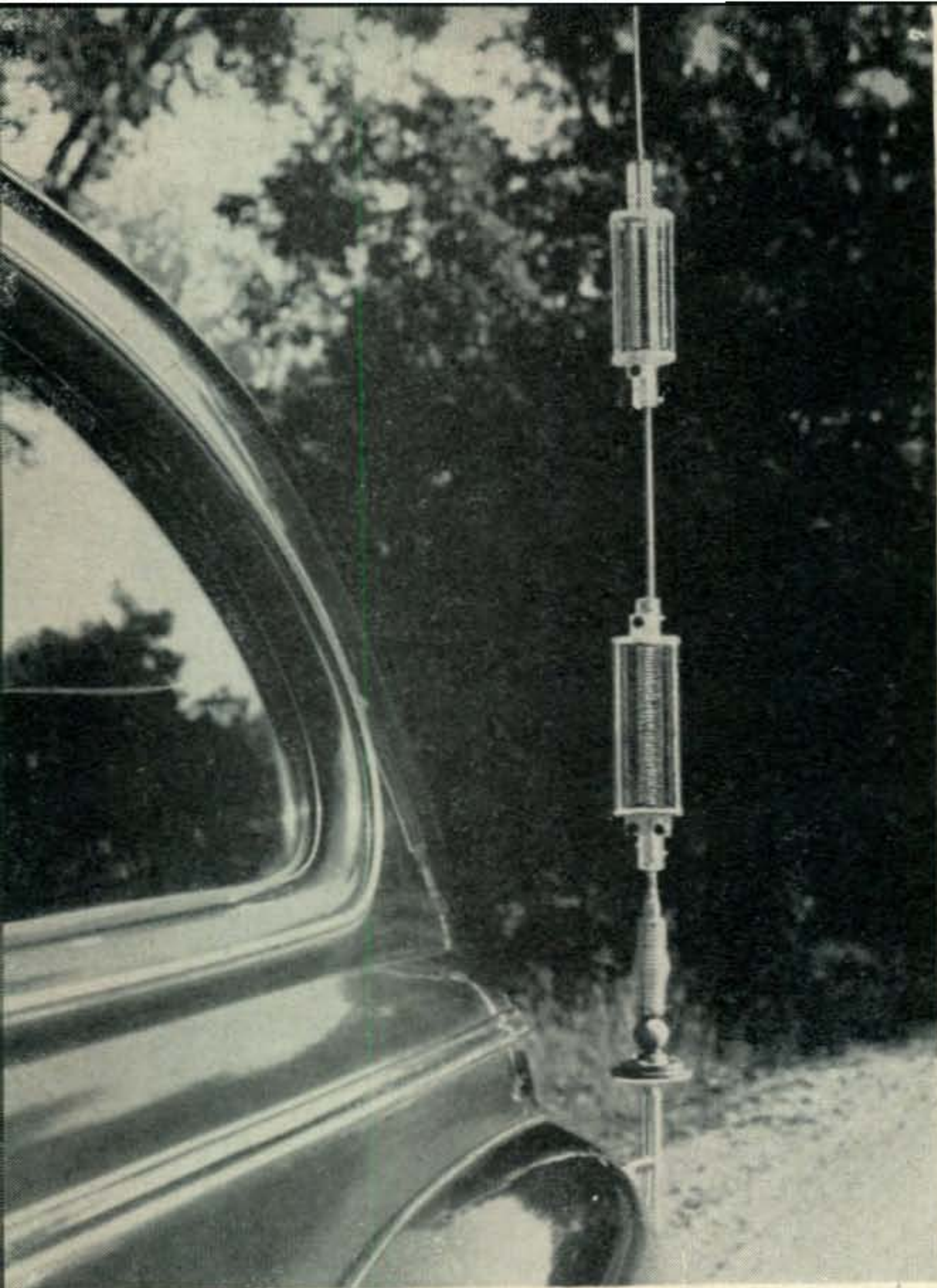

Fig. 1. The two high-Q loading coils shown here are important factors in the operation of this versatile antenna.

# a Six Band Mobile Antenna

HARTLAND B. SMITH, W8VVD

467 Park Ave., Birmingham, Mich.

## In This Article a Well Known Author Describes the Step by Step Construction of a Novel and Efficient Multi-Band Antenna

The number of amateur mobile installations which include band-switching transmitters has recently shown a marked increase. However, despite the ease with which gear of this type can be shifted from one frequency to another most mobileers still operate on only one band. This is true because the process of altering the resonant frequency of a loaded mobile antenna is usually so complicated that the average Ham shies away from the task.

After building a multi-band transmitter and installing it in my car I was faced with this same dilemma. I wanted to work several different bands, but I didn't care to load the trunk compartment with numerous coils and wrenches just so I could change the operating frequency of the antenna.

The most convenient way to have solved the problem would have been to construct an antenna with a remotely operated bandswitch controllable from the driver's seat. Unfortunately, most switching schemes that I could devise put too much metal near the loading coil and seriously reduced its Q. Although not remotely switched, the mobile antenna I finally settled for is relatively inexpensive to construct, works well on all Ham bands from 3.7 Mc. to

29.7 Mc. and can be changed from one frequency range to another with a minimum of inconvenience. It is truly a six-band mobile antenna.

The most efficient mounting position for a mobile antenna is reputed to be in the center of the car's roof. Trees, trolley wires and XYL's, however, make it impossible for the majority of amateurs to utilize such a location. Bumper mounting may be slightly less efficient, but it was decided on because it is certainly much more practical.

Total length, including loading coils, is slightly more than 8 feet. Although a longer antenna would work somewhat better on 75 meters, the 8-foot length was chosen as a good compromise between performance and appearance.

### The Base Sections

As shown in *Fig. 2*, the lower part of the antenna is a 13" length of  $\frac{3}{4}$ " galvanized pipe which is fastened, by means of fiber insulators, to a bumper bracket of aluminum angle. A floor flange on the threaded top of this pipe provides a solid foundation for a body-mount style of antenna spring. Placing the spring

part way up the antenna results in greater mechanical stability, thus reducing antenna sway while the car is in motion. This is an important factor when two loading coils are made a part of the radiating system.

Threaded into the spring is the bottom 4½" of an Army surplus AN-131-A antenna. Although the lower portion of any mobile whip can be used at this point, the section of AN-131-A works out nicely because its fairly large diameter helps to provide good support for the rest of the antenna.

One end of a 12" length of 1" diameter polystyrene rod is drilled to a depth of 2" to accept the short piece of AN-131-A. A 14" section of ⅜" dural tubing is next cut and fitted into a hole drilled for it in the top end of the 12" poly rod. Another poly rod, 11" long, is drilled on the lower end to provide a tight fit with the dural tubing. The top 4 feet of a good spring steel mobile whip is then placed in a hole drilled at the top of the 11" poly rod. To insure that the sections of antenna are held firmly together, a number of 6-32 set screws are placed in holes drilled and tapped for them in the poly rods, as shown in Fig. 5.

The operating frequency of the antenna can

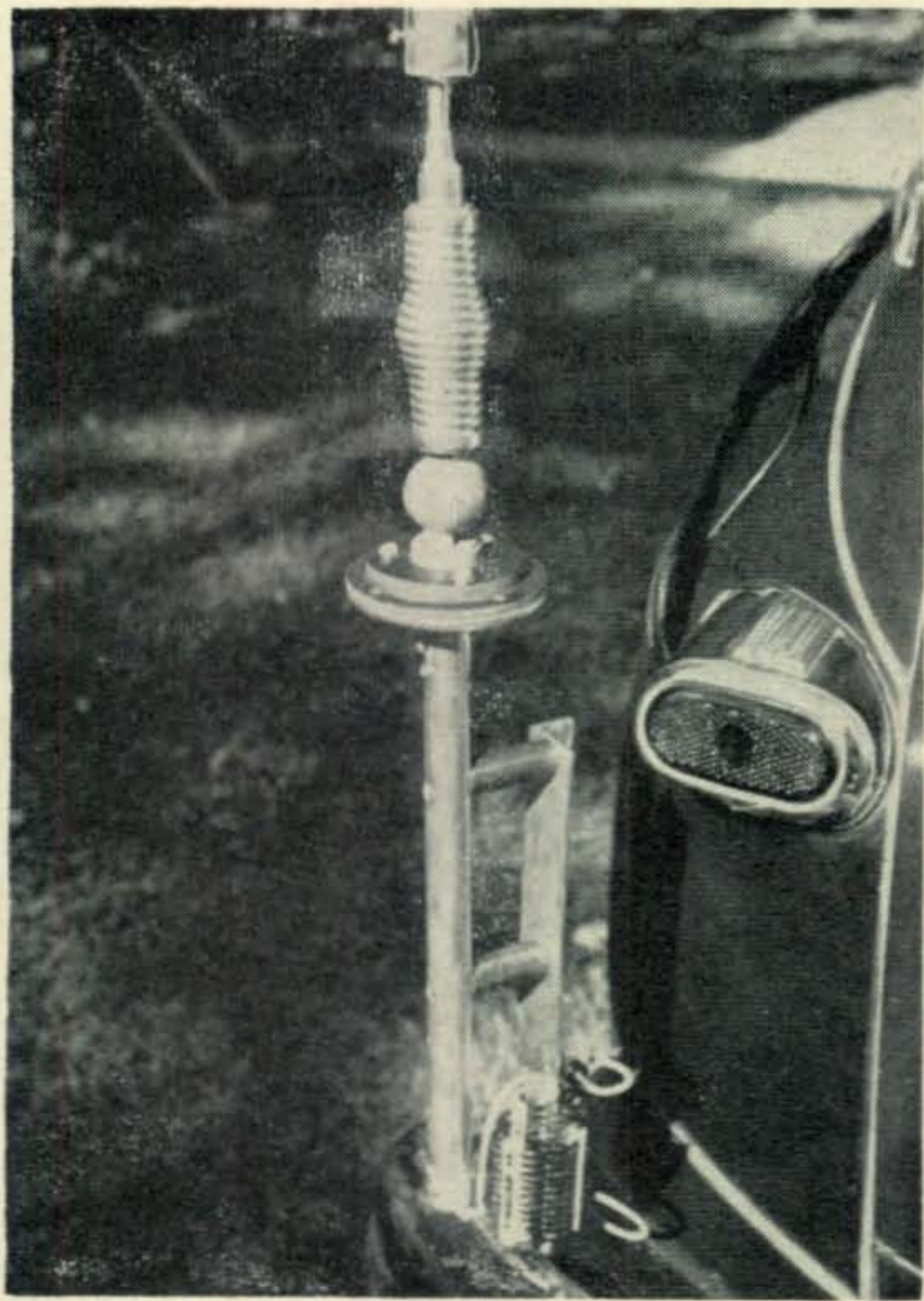

Fig. 2. A floor flange, atop a 13-inch length of ¾-inch galvanized pipe, provides a suitable location for the body mount type of antenna spring. A ¼-inch thick fiber disc acts as a shim between the spring mount and the flange to provide adequate clearance for the stud protruding from the bottom of the mount.

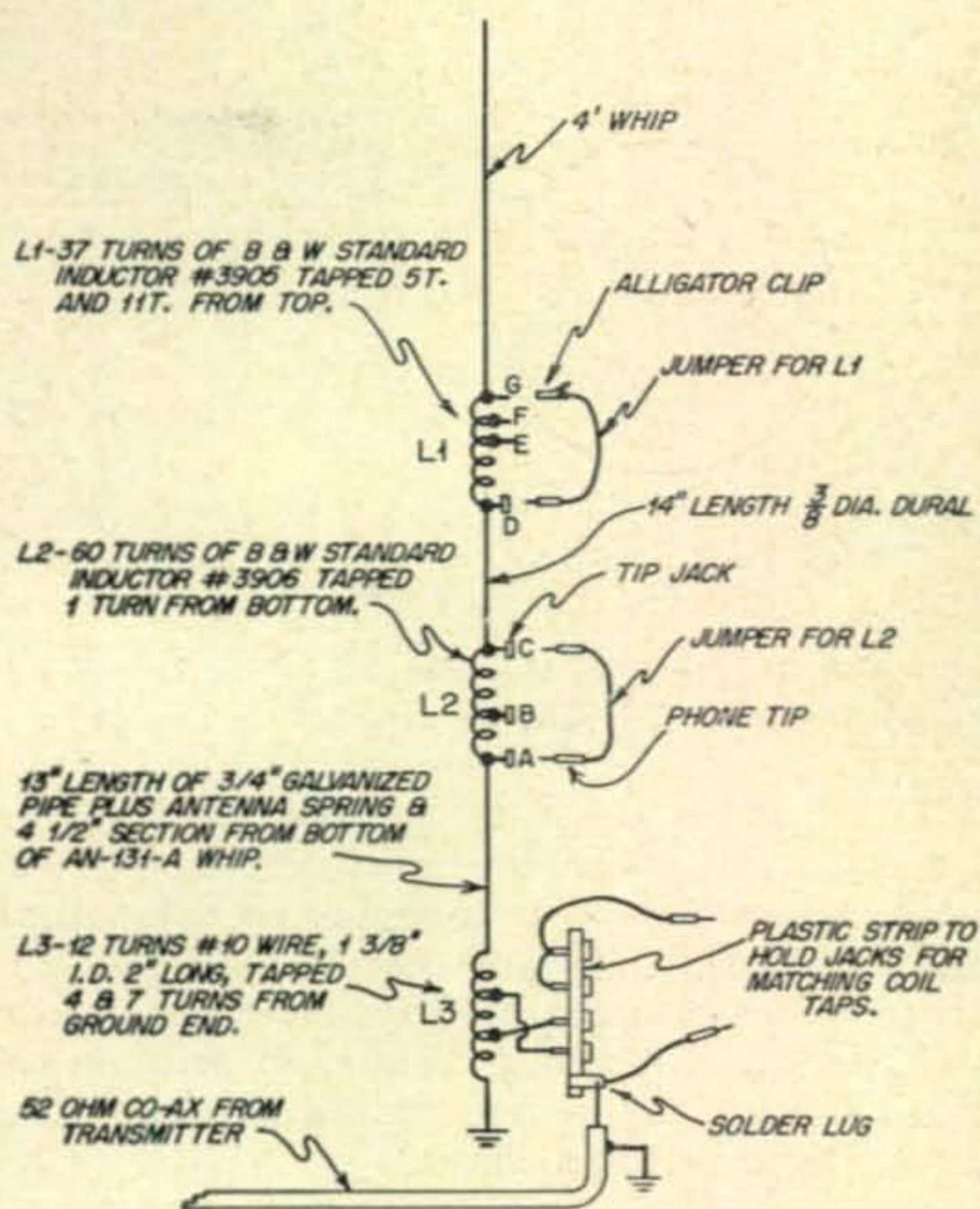

Fig. 3. Wiring schematic of the antenna.

be changed by shorting either  $L1$  or  $L2$  with a couple of 12" jumpers made from test lead wire. One jumper should have phone tips on both ends while the other jumper should have a phone tip on one end and an alligator clip on the opposite end. The jumper with two phone tips is for use with  $L2$ . The one with an alligator clip is for  $L1$ .

### Making the Coil Formers

Four 2 ⅝" diameter discs with 1" center holes are cut from ¼" sheet polystyrene. The discs slip over the poly rods and help to hold the loading coils in place. Holes must be drilled in the discs for the screws that fasten the plastic mounts of the shorting jumper tip jacks. These mounts can be 4 pieces of ¼" polystyrene, ¾" by 1" in size. A hole just large enough to accommodate a tip jack should be drilled in each of these pieces. A smaller hole that can be tapped to take the 6-32 screw which fastens the mount to the plastic disc should be drilled in one edge of each mount. A drop of polystyrene cement put on this edge of the mount, just before it is screwed to the disc will provide a good strong bond between the two pieces of plastic. The tip jacks, by the way, should contain strong springs which firmly grip the tips of the shorting jumpers to provide good, low resistance contacts.

When working with polystyrene, patience is very important. Without it, Ole Man Friction will heat your tools to the point where the plastic melts into a sticky, unmanageable goo. A supply of water should be kept on hand for cooling drills and saws.

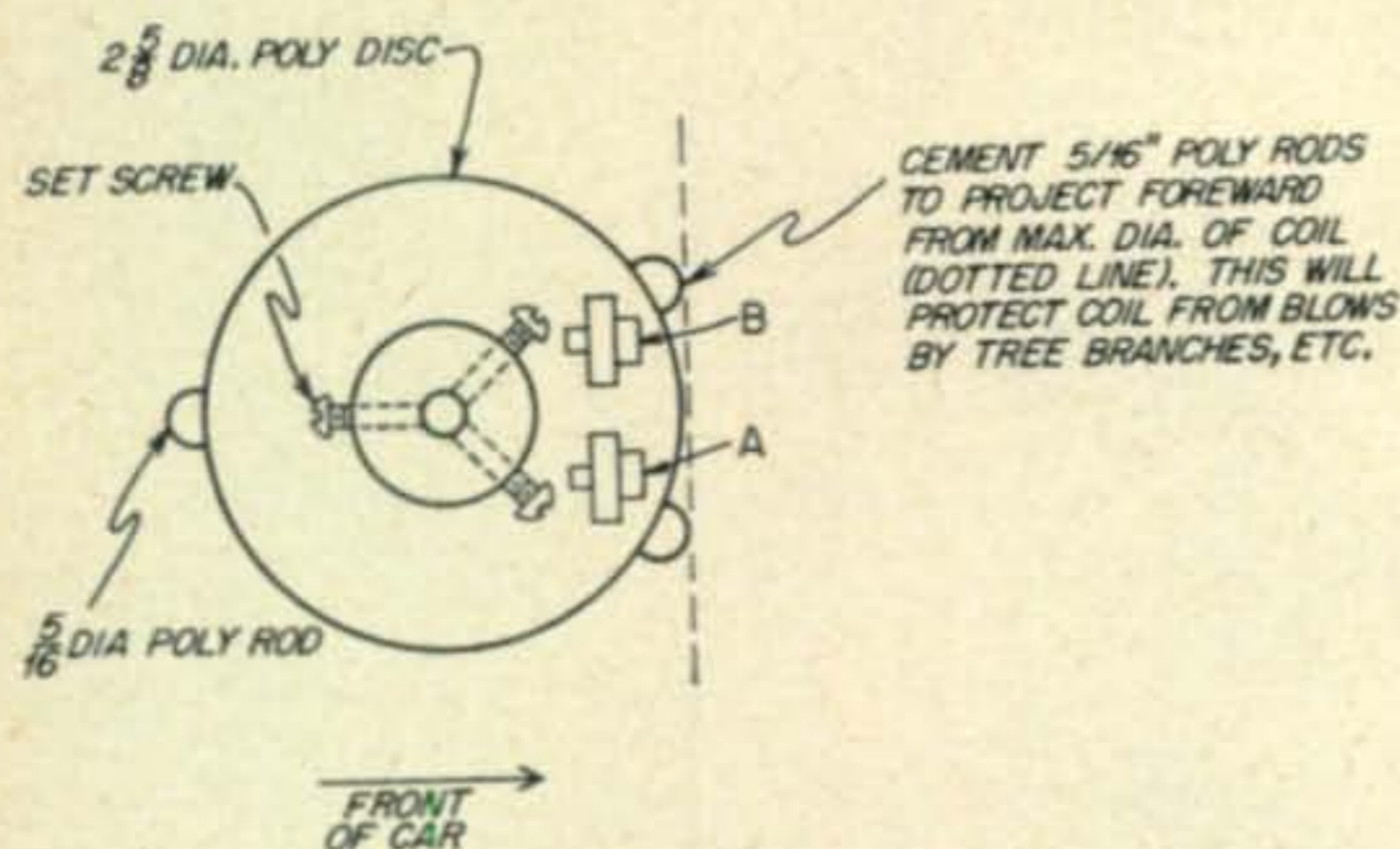

Fig. 5. This is a bottom view of L2 to show the positions of the rods to strengthen the coils.

The loading coils are modified B&W standard inductors. For preliminary tune-up purposes, be on the safe side and leave a few more turns on them than are shown in Fig. 3. The exact inductance required differs with each installation, and it is much easier to prune a coil that's too long than it is to add turns to a coil that's just a little too short.

### Matching the Antenna

Matching the antenna to the coaxial feed line is accomplished by means of a small tapped coil, L3, connected between the base of the antenna and the car body ground. This coil can be closewound with 12 turns of #10 wire using a size D flashlight cell as a form. After the coil is wound, remove it from the battery and carefully stretch it to a length of 2". The coil may then be strengthened, as shown in Fig. 4, by cementing thin plastic strips to it.

The importance of this base matching coil can hardly be overemphasized. It answers the problem of incorrect loading which so often is encountered with pi-network finals operating on 40 and 75 meters. Furthermore, a matching coil makes possible the use of an inexpensive standing wave bridge to correctly resonate the antenna and produce a very low standing wave ratio on the feed line.

As can be seen in the photographs, the matching and loading coils are exposed to the weather. Normal precipitation has had little effect on the antenna and so no protective covering appears necessary for the inductance. It takes a very heavy downpour to put the unit so far out of resonance that it is no longer possible to load the transmitter on 75. Operation on the other bands is little affected by anything short of a deluge.

All exposed metal parts should be protected from the weather. The 3/4" pipe and pipe flange can be given a coat of aluminum paint. The screws, and other pieces of hardware may be protected by spraying them with Krylon. The plating of these items isn't always too good and so the liquid plastic is used to help keep them from rusting.

Do not attempt to tune the antenna by

guesswork. Either a standing wave bridge<sup>1</sup> or an Antennascope<sup>2</sup> must be employed during the process of adjustment if satisfactory performance is to be obtained.

Mount the antenna on the car with the loading coils temporarily held in position between the plastic discs by means of Scotch tape. The discs, in turn, should be taped to the plastic rods to keep them from slipping down during the preliminary tune-up. Once the antenna is working properly, the discs and coils may be permanently cemented in place. At the same time three 5/16" polystyrene rods should be cemented to each coil as shown in Fig. 5 to provide a certain amount of mechanical protection. The rods can be so positioned that they will help to absorb any blow from a tree branch or other obstruction which may be encountered when the car is in motion.

One satisfactory method of antenna tune-up employs a standing wave bridge as shown in Fig. 6. With the antenna temporarily disconnected from the output of the bridge, feed in just enough r.f. to give a full scale reading on the indicator meter. If your mobile rig can't be decoupled sufficiently to prevent overloading the meter, some other source of low power

1. "Bridge Construction," p. 480, The Radio Amateur's Handbook, 30th edition, 1953.
2. Scherer, W. M.: "Building and Using The Antennascope," CQ, September, 1950.

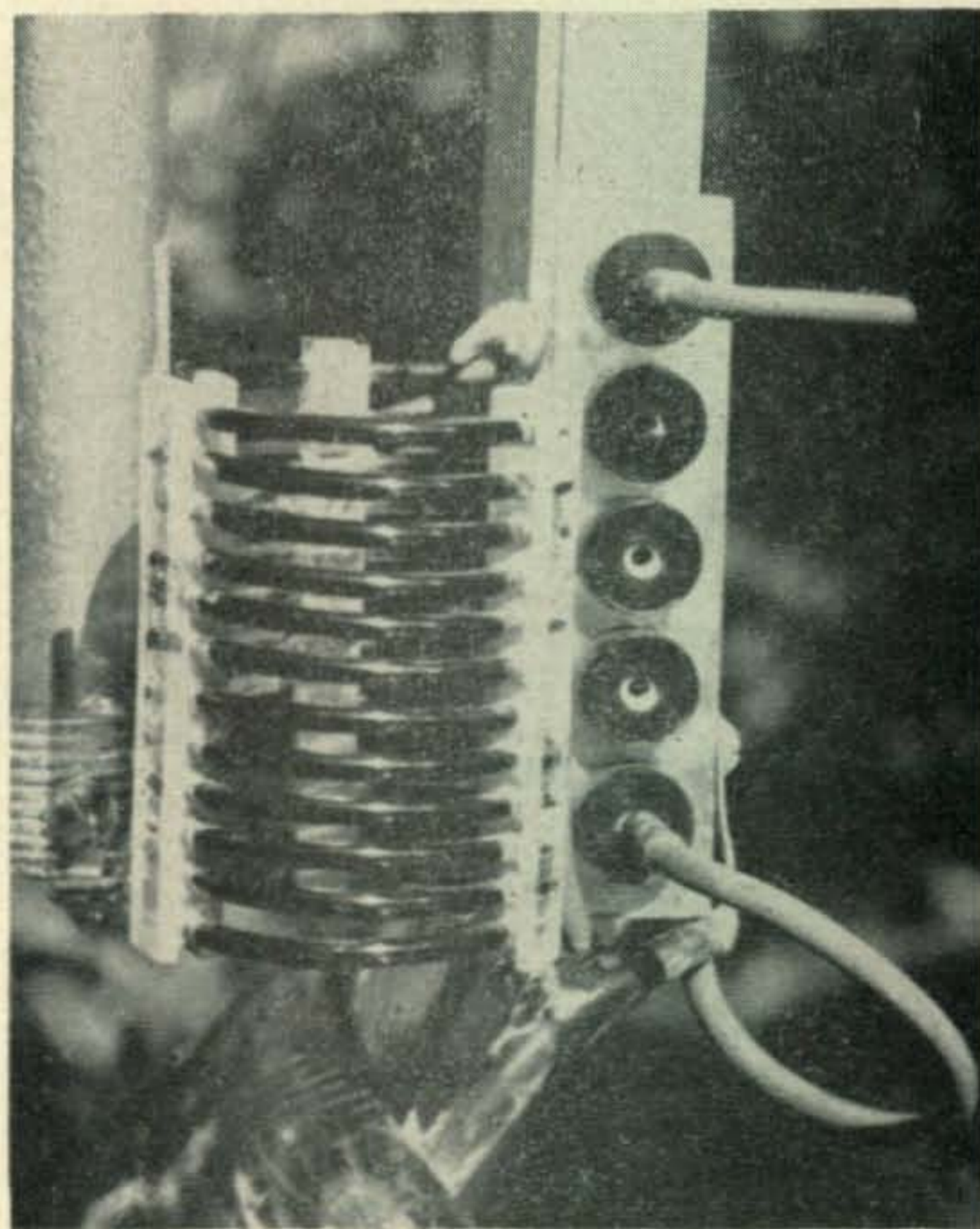
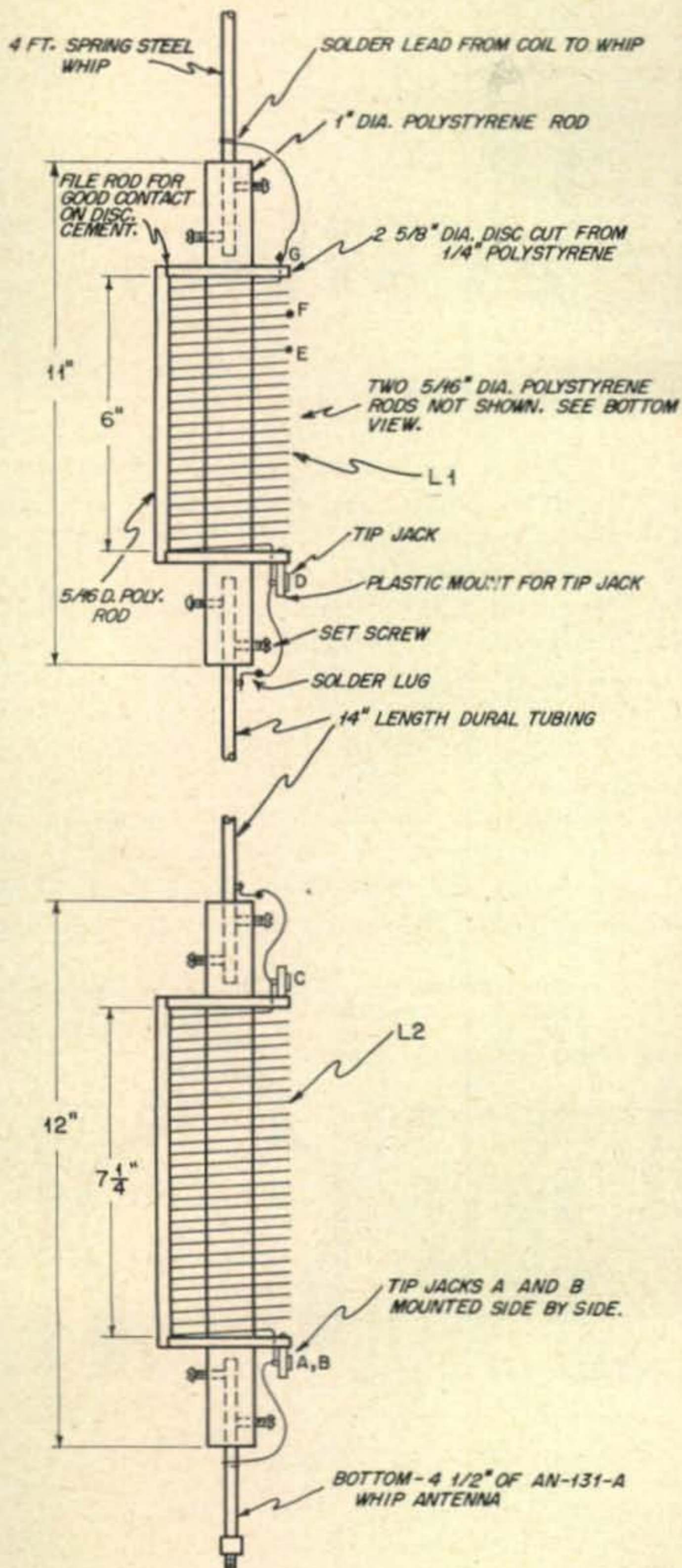

Fig. 4. Careful examination of this closeup will reveal that matching coil, L3, is mounted upside down. The top is grounded to the aluminum angle mounting bracket, while the bottom is connected to the base of the antenna. The center tip jack on the plastic strip to the right of L3 is not used, and so may be omitted by the constructor.





Mechanical assembly details of the antenna.

r.f. will have to be found. In my case, Command transmitters, a BC-458 for 75 and a BC-459 for 40 and 20, were pressed into service. When powered with a small a-c supply, the output from one of these rigs can be made very low by reducing the coupling to minimum and, at the same time, slightly detuning the final plate condenser.

Once the indicator reads full scale, the coaxial lead from the antenna may be attached to the output terminal of the bridge. The meter reading will drop, but it won't go to zero. Short the bottom loading coil,  $L_2$ , and set the matching coil for 40 meters. Plug the jumper with an alligator clip into the jack in the base of the upper loading coil,  $L_1$ . Using the jumper,

start at the bottom of  $L_1$  and short out a turn or two. Note the reading on the standing wave indicator and then short out a few more turns. After several trials, some point will be found where the reading on the meter will drop to zero. This denotes antenna resonance and a correct match between the feed point resistance of the antenna and the coaxial line. If no position can be found where the meter goes all the way to zero, move the 40-meter tap on the matching coil,  $L_3$ , up or down a turn or two and repeat the shorting process on  $L_1$ . When the meter finally reads zero, disconnect the alligator jumper and remove almost all turns which had to be shorted out on  $L_1$ . Then, carefully prune the coil a turn at a time until the antenna is resonant at 7250 kc. as shown by a zero reading on the standing wave meter.

### Tuning Up on 75 Meters

Disconnect the antenna and feed enough power at 3850 kc. to the bridge to produce a full scale reading. Reconnect the antenna and set matching coil,  $L_3$ , for 75 meters. Leave  $L_1$  unshorted, and plug the alligator clip jumper into the jack at the bottom of  $L_2$ . Proceed to tap up on this coil until a resonant condition is noted. As with the 40-meter adjustment, it may be necessary to make a slight change in the position of the matching coil tap before exact resonance can be achieved.

If you wish to operate at a higher frequency in this band, you can tap up one or two turns from the bottom of  $L_2$  and bring this tap out to another tip jack at the coil's base. By plugging a jumper between this tap and the bottom of  $L_2$  the resonant frequency of the system will be raised a number of kilocycles. Another method for QSYing on 75 is to resonate the antenna near the high frequency end of the band. Then a short pigtail may be clipped to the whip where it emerges from the top of  $L_1$ . The added capacity of the pigtail will lower the resonant frequency by a significant amount.

To tune the radiator for 20 meters, disconnect the antenna and feed r.f. to the bridge at

(Continued on page 62)

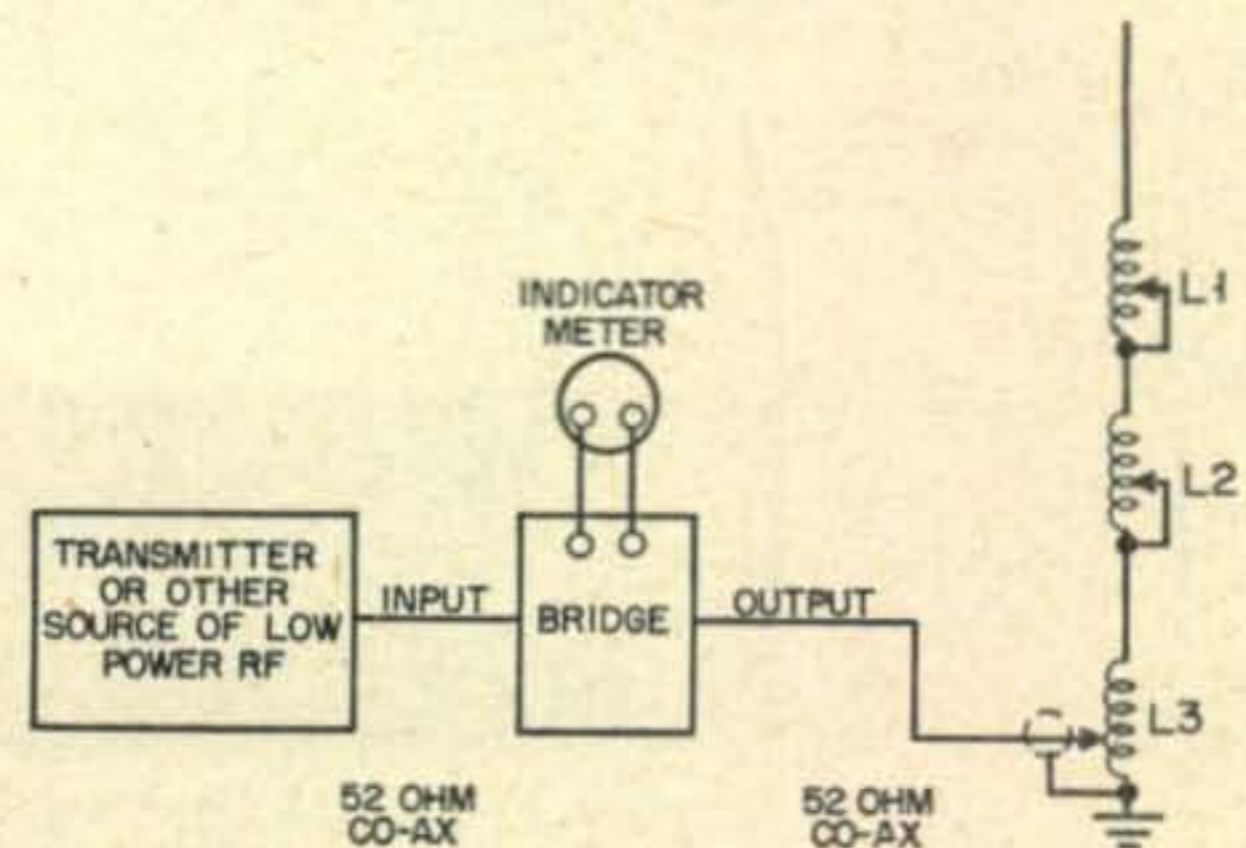

Fig. 6. Block diagram showing the connections to VSWR bridge during the tune-up process.

the

# Cool Persian

G. FRANKLIN MONTGOMERY, W3FQB

Now gather round, Kiddies, and Uncle George will come on with the story of Ali Baba and the forty TV's, or how square a picture can you get?

Once upon a time, in the land of EP, there lived a young cat named Ali Baba. Now Ali's old man was a TV service type, and one day while he and Ali were cleaning up the joint he said, "Kid, there's a real sharp chick over on East Rubaiyat who's been after me to fall by her pad and touch up her horizontal linearity, like, so I'll be cut out for a couple of sets."

"Wild," said Ali, "but what if Mrs. Khayyam rings up about her hi-fi again?"

"Tell her I'm gone," said Mr. Baba.

"Pops, she already knows you're real frantic," said Ali. "I mean, where shall I say you went?"

"Tell her I've goofed," said The Head, "I got no time to dig that old jazz," and modulated out the back way.

Now this was the time of day when Ali was feeling the least, so he decided to take five and pick up on the sounds on a new shortwave a customer had left. Trying to catch something hip, he moved across the 40-meter band in the middle of a CD session. "Man!" said Ali, "Dig

that crazy flute," and right away began to have eyes for Ham radio. In almost no time, Ali had himself a big rig, a super super, and six in phase, rotary like.

One evening after the twenty-sixth call to CE0AA, one of Ali's neighbors fell in. "Look, Jack," he said, "it's Tuesday, and me and the missus likes to catch Milton Bernoulia on Channel 4. Why don't you wrap up them electronics and get lost?"

"You're flipping," said Ali. "All I got here is a cool 807; you can't get TVI'd from that."

"Don't hand me that jive," said Red Eyes. "Besides, I ain't the only one; every cat for

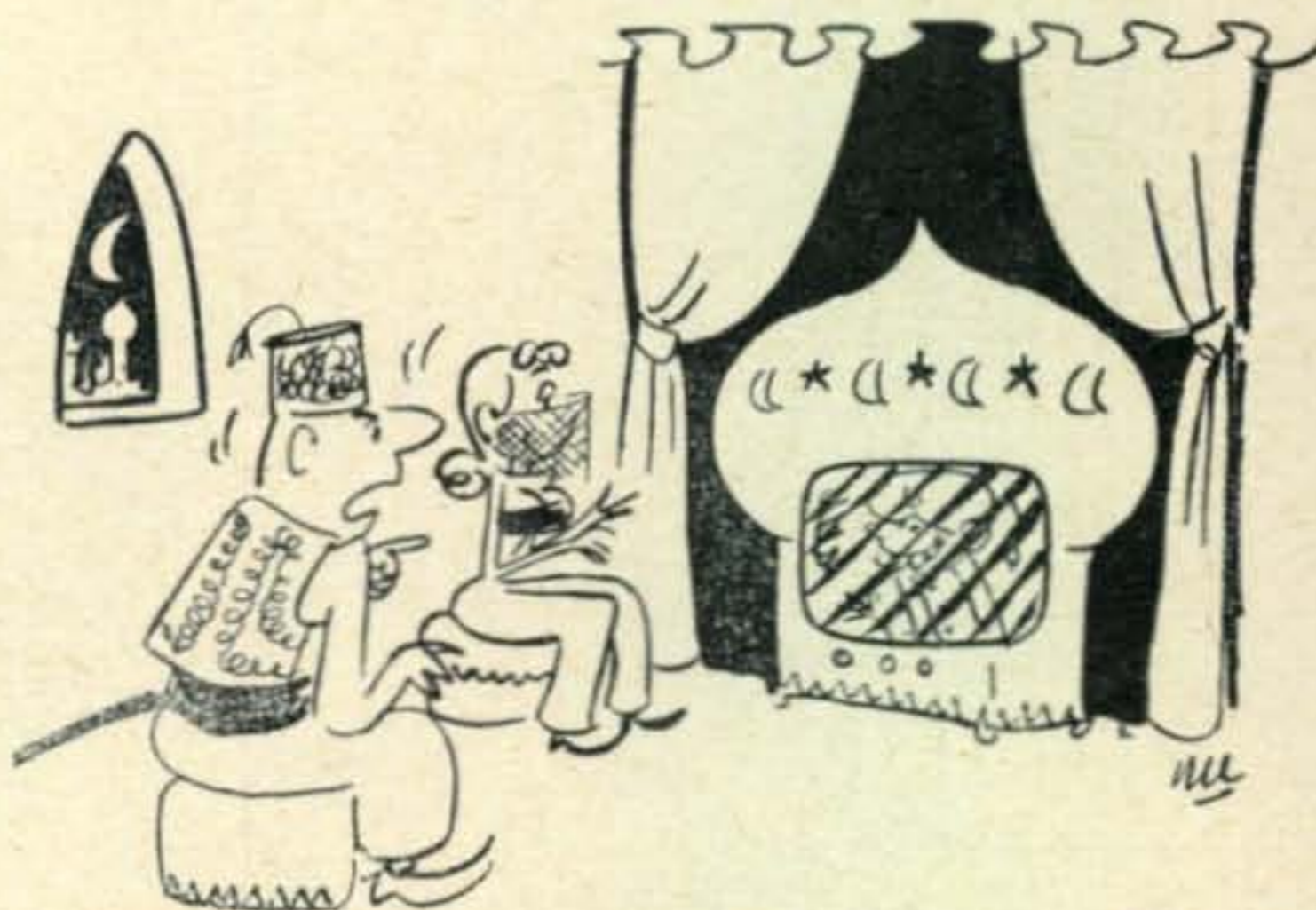

"... me and the missus likes to catch Milton Bernoulia . . ."

blocks around this pad says you been comin' on like Dragnet."

"Now look, Man," said Ali, "let's not get all steamed, like. What do you say we pick up on some juice and gas this thing over?"

"Crazy!" said the neighbor, "Fill me in," and after a couple of tastes he began to see the light. In fact, Ali phrased it so groovy that Old Rasters even put in for his card.

Before long the two of them had all the local squares hip to CW and making with the kilowatts, and the sounds from EP-land began riding out on 20 like Jazz At The Phil. But the most was, that when next November fell by, Ali and the boys made the club award in the Greater Near East Sweepstakes, which was really the end, you know?

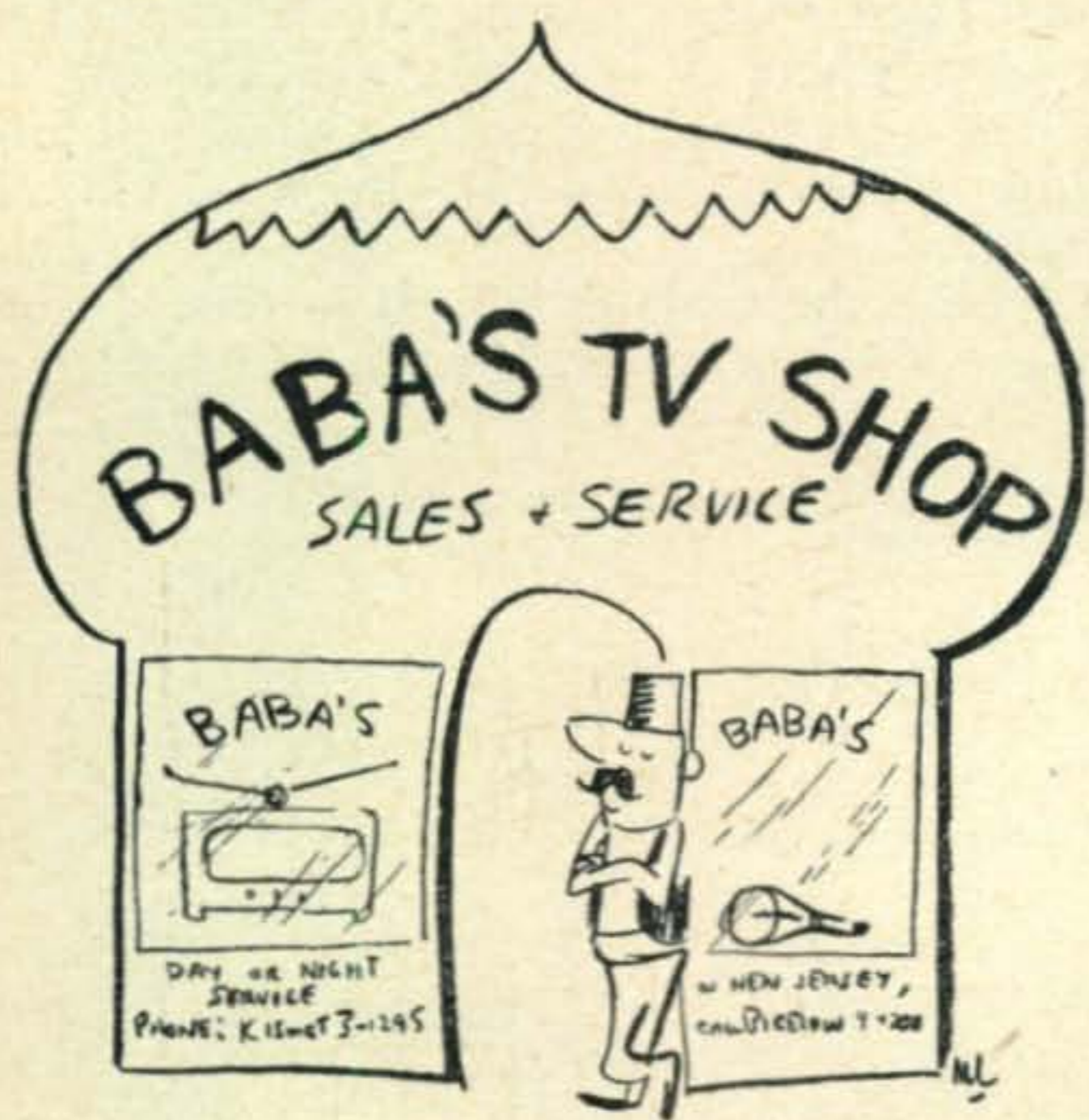

"Now Ali's old man was a TV service type . . ."



Gathered by DICK SPENCELEY, KV4AA

Box 403, St. Thomas, Virgin Islands, U.S.A.

This month we are happy to report quite a number of new WAZ entries. Our heartiest congratulations to the following stations who now enter this "elite" category:

**NO. 293 SM5LL Hilding Anderson 40-**  
**NO. 294 SM5KP Wiktor Persson 40-223**  
**NO. 292 ZS2AT A. Burney Trewin 40-171**  
**NO. 291 G2M1 Arthur Milne 40-202**  
**NO. 295 W8PQQ Albert H. Hix 40-240**

We also welcome the following newcomers to the HONOR ROLL:

**VE3LJ 37-161**  
**W6HJ 35-104**  
**SM5KP 38-199 (Phone only)**

#### Cocos Island, TI9UXX (W6UXX)

The long awaited appearance of Evan, TI9UXX, materialized on November 14 between the hours of 0135 and 1202 GMT. As was expected, due to the necessary briefness of his stay, the time of day spent on the air coupled with the uncertainty of his actual arrival caused many of the DX gang to miss him by a wide margin. Only twenty-nine contacts were made. The lucky ones were as follows: W1WPO, W1YYM, W2BOK, W2DOD, W2ESO, W2FSN, W2GLM, W2HTT, W2UWD, W3VWH, W4IMI, W5QKZ, W5TLY, W6CGQ, W6CYL, W6DFY, W6KYG, W6LW, W6OEG, W6RW, W8BKP, W8NBK, W9ESQ, WØEWF, WØJCT, WØQDF, G2PL, HR1AA and KP4CC.

Here is a brief resume in Evan's own words: "On the evening of November 13 we anchored in Chatham Bay, Cocos. I was unable to get ashore until 0135 GMT on the 14th due to commercial radio schedules. Loading the tarpaulin-wrapped gear on a small skiff (it was raining cats and dogs, of course), I set off for shore, and, with the aid of the ship's searchlight, attempted to locate a sandy beach. Due to high tide this was unsuccessful but I managed to get ashore after a rough landing which thoroughly soaked my key in salt water. Pulling the skiff up as far as possible I tied a long line to the bow and secured it to a tree twenty yards away. Propping the line up with sticks I threw the tarpaulin over it and, with the help of another line, I had a makeshift tent which effectively dripped water inside very nicely. Next, the key had to be dismantled and the base wiring removed. A couple of battery clip leads to the contacts finally made it

workable. Also, I had no means of anchoring the key, which made it necessary for me to answer calls on my own frequency so that I could monitor my transmissions for some degree of accuracy via the receiver.

"At 0446 GMT I called W6KYG on 14,122 kc. as planned, and followed this with a few CQ's with no results. Altho a few phone signals were heard on 20 the band seemed completely dead for CW. I then shifted to 7022 kc., tuning the transmitter to resonance by listening to the receiver, and, with tongue in cheek, called *CQ de TI9UXX* at 0529 GMT. The response was immediate and I logged the following: *TI9UXX de W3VWH your sigs 569 in Pittsburgh OM. The name here is Mort. If I sound nervous it's because this is my first 7 Mc. QSO with my new General Ticket (This boy Mort is going far if his luck holds up!!). QSO No. 2 was with W9ESQ, No. 3 with W2DOD, No. 4 with W6RW and No. 5 with W6CYL. QRM on frequency was heavy but nothing could be done as the 7022 rock was the only one I had along which would perk on 7 Mc. My operating position was extremely cramped and my feet reposed in a puddle of water. Many QRT's were necessary to wipe things dry. Power was furnished by a 6-volt *Auto-Lite* storage battery which read 1.260 at the start and checked in at 1.215 after the operation. Illumination was furnished by a 6-volt 400-ma. pilot light.*

"Came the dawn and I found the tide at low ebb. This forced me to portage the skiff over to a section of beach some seventy-five yards away. I still bear scars from this—!! The ship's motorboat was then sighted; the skipper had been getting worried about me, and I was towed back to the ship, thus ending this Cocos episode." (We understand that Evan will have other chances to repeat this safari so don't give up hope on that TI9 QSO.)

---

**MACQUARIE ISLAND, VK1:** The relief ship "Kista Dan" called at this QTH in December and picked up VK1AF, VK1BA and VK1RL for the homeward trip. At the same time it disembarked VK3ACI, Alan, who will be the only Ham here for 1954. His call is VK1CI.

---

**HEARD ISLAND, ANTARCTICA, VK1:** VK3ADZ and VK2PG are due to depart in January for Heard Island where they will be using the calls of VK1DY and VK1PG. Bill Storer, VK2EG, ex-VK1BS of

*Macquarie, accompanies them and will be dropped at MacRobertson Land which is directly south of Heard Island on the Antarctic Continent. His call will be VK1EG.*

CHRISTMAS ISLAND, ZC3: This QTH has been heard from via the signals of ZC3AB, 14080/14090 kc., 1130 GMT. His name is Dave Laing, ex-VK2DE. QSL's go via Malaya.

TIBET, AC4NC: Chak has been putting consistent signals through to the Caribbean area around 1130 GMT on 14120. He is usually on phone on this frequency but will switch to CW on request for greatly improved readability.

PERSIAN GULF AREA, MP4: Some new activity from Qatar comes from MP4BEN (Dukhan Airport), MP4BUS (QSL via QPC Persian Gulf), MP4QAB and MP4BTF. The last mentioned also operates mobile from Trucial Oman. We understand that MP4BAU, formerly in Qatar, now operates from Bahrein Is. MP4BEN and MP4BUS have been heard around 1330 GMT near 14070. DL4QX nabbed MP4QAH who gives his QTH as Halul Island (60 miles NE of Qatar but not under its jurisdiction), 14142 A3. MP4ABW continues phone activity from Qatar. WØECS reports a QSO with MP4BAU on 7039 at 2345 GMT.

ZC4XP/YP1, YP1AB: *Many stations worked these two during the latter part of November. QTH was not given due to "security reasons." Light may be shed on this in our next issue.*

CRETE, SV9: DL4QX (W6CUF) and SUIBJ plan a trip to SV9 some time in February. Exact date is not yet known so keep your ears open for this one.

ALDABRA ISLAND, SEYCHELLES ISLANDS, VQ7NZK/VQ9NZK: An expedition covering one, or both, of these spots should take place around the middle of February. Plans call for a twelve-day stay.

ALBANIA, ZA: SP3AN reports that a legitimate station signing ZAIKAA will shortly appear from this QTH.

GRENADA, WINDWARD ISLANDS, VP2RO: *G2RO was scheduled to have been on for this spot from Jan. 1 to Jan. 12. Bob made some 300 QSO's as VP7RO and about 600 QSO's as VP1RO. Frequencies most used are 7030 and 14059. QSL's go to G2RO or via RSGB. Bob sails for England on Feb. 9 from Jamaica.*

TRINIDAD ISLAND, PYØ: PY2CK advises that this expedition is shaping up and may occur in January. This QTH is some 900 miles off the east coast of Brazil.

BURMA, XZ2OM: This station advises that he is on each day from 1130 to 1230 GMT, 14022 kc., looking for DX QSO's. The name is Mike.

NORFOLK ISLAND, VK9: VK9GM has been active from this spot and may be found on 7010 or 14022. QSO's have been reported around 0530 GMT on the latter frequency. VK2AOK is also on the island and is active as VK9OK.

SHIP "XARIFA," DI9AA: *This vessel passed through the Panama Canal on December 23 and now operates in the vicinity of Galapagos and Cocos Islands. Permission to land on Cocos has been requested from the TI government and there is a bare possibility that the op of DI9AA may be heard as TI9AA. This underwater photography expedition returns to Germany in March.*

KERGUELEN ISLAND, FB8: Joe, ex-op at FB8ZZ, Amsterdam Is., will sail for Kerguelen in January and will put FB8XX back on the air. As Joe is a rabid DX'er we should all have a very good chance to add FB8XX to our lists.

LUXEMBOURG, LX1AS: OE1FF has been on, from LX1AS, every Saturday from 1300 to 1930 GMT, 14-Mc VFO. He is due to return to Vienna on February 1.

JAN MAYEN ISLAND, LB: LB8YB and LB6IE continue activity from this spot. 8YB may be found on 7020 at about 0200 GMT and on 14039 around 1400 GMT.

#### DX Notes

TI9BR has been QSO'ed on 7008 but says he is in Puntarenas, Costa Rica. He tells of one TI3FR who will be active on Cocos when gear arrives . . . TI9BRA was worked by W4ZAE but no definite dope . . . VP2MD is again active after a physical checkup in VP6 . . . In a letter to LU5AQ; Floyd McCoy, VR6AC says his receiver is up in Balboa . . . ZC3AB runs 40 watts to an 815 . . . SVØWG, Rhodes, was QSO'ed on 7010 at 0100 GMT. Roy says he will not go to Crete . . . IT1AGA is QRV for DX each day between 2300/2400 GMT on 3620 . . . ZC5VS is supposed to be on each day from 1045 to 1230 GMT, 14085 xtl . . . ZL2LB advises that VK9YY also handles QSL's for JZØKF . . . ZC5 calls may be changed to VS4 again . . . All LU-ZS calls emanate from the Argentine Antarctic base at Bahia, Antarctic continent, while LU1ZT is in the South Shetlands . . . ST2UU promises to cover ZD1 and ZD3 when conditions improve a bit. Jim recently picked up a new receiver and scrapped the S-40.

ZS8D was heard recently with Doc, ZS8MK, at the throttle . . . W6MUR picked up C9AA on 7020 . . . HS1CA has been heard on 14050, 1330 GMT . . . Very active at VP4LZ is new arrival, W4HKY. Other ops at VP4LZ, besides Ed, are John, W1EEC; Les, W6AKR; Butch and Carroll . . . FR7ZA was nabbed by W5DJA on 7010 at 2000 GMT . . . AX8BA turned out to be a Ham located in Alice Springs, Central Australia who awaits a new call . . . F18AE has been very active, 14080, 1200 GMT . . . Jim, ST2UU, writes W8JBI that he is thinking of filling up the Dakota with gas and heading for the Comoro Group, FB8. We can't think of a nicer place Jim!! . . . Jeff, YI2AM, wishes it known that he is looking for W's from 1400 GMT on. He is on 'phone around 14145.

#### Exploits

W8NBK, Arkie, went to 243 with EA9DD and TI9UXX . . . EA9DD also helped W6SYG to No. 241 . . . Jayme, PY2CK, added VQ9UU, VU5AB (Car Nicobar), JZØKF and EA9DD to boost his total to 248 while phone contacts with EA9DD, ZC5VM and VU5AB put him way out ahead in the "Phone only" section with 225! . . . Luis, CE3AG, submits EA9DD and CEØAA to reach 234 . . . W6DZZ came up to date with some recent oldies such as FL8MY, VS5ELA, EA9DC and MP4KAE to rest on 229 . . . DL1FF upped to 224 with KJ6AX, ZC5VS, VS9UU, CEØAA and EA9DD . . . Horace, W6TI, pulled

(Continued on page 72)



W6BAX, "Opie" Taylor, San Carlos, Calif. needs no introduction. Licensed in 1927 Opie was one of the top pre-war DX men. The rig, remotely controlled from this position in the kitchen, runs 800 watts to PP 4/125A's assisted by a three element rotary beam. W6BAX sticks to 14 Mc. and his present CW score is 222 countries. The homebrew receiver pictured above has since been replaced with a Collins 75A2. (Photo: North California DX Bulletin)



HRIAT, Oscar Trochez, of Tegucigalpa, Honduras is active on all bands Phone and CW. Set-up runs a Viking VFO-6L6-807 which pushes an 813 to 150 watts. Oscar, who is now acting as HR QSL Mgr. wants it known that he is on every day at the following times: 1900/2000 GMT on 21 Mc., 2000/2100 GMT on 14 Mc. and from 0400/0600 GMT on 7 or 3.5 Mc. HRIAT went on the air in 1947 and has worked 105 countries and about 2000 W's.



Thirty-four certificate holders attended the initial W9-DXCC get-together held in Chicago on December 5th. Standing (left to right) are W9FDX, W9TKV, W9PGW, W9DHT, W9ABB, W9TMU, W9FKC, W9ABA, W9YFV, W9ESQ, W9GRV, W9ALI, W9WFS, W9GIL, W9WKU, W9FID, W9KA and W9NN. Sitting (left to right) are W9IU, W9UM, W9VW, W9UJ, W9KXK, W9HQF, W9GZK and W9QIY. Present but not appearing in the photo were W9TQL, W9JUV, W9UXO, W9CIA, W9GDI, W9FNR, W9MXX and W9LI. The meeting was arranged by W9NN who was ably assisted by W9KA and W9PGW. (Chicago Tribune Photo)



VK4FJ, Roy Baxter, Brisbane, Australia is the man behind one of the most consistent signals from "down under." Roy runs 75 watts to PP807's on 28, 21 and 14 Mc. and 100 watts to an 813 on 7 Mc. The country total at VK4FJ is 207; AC4NC QSL is awaited for WAZ.

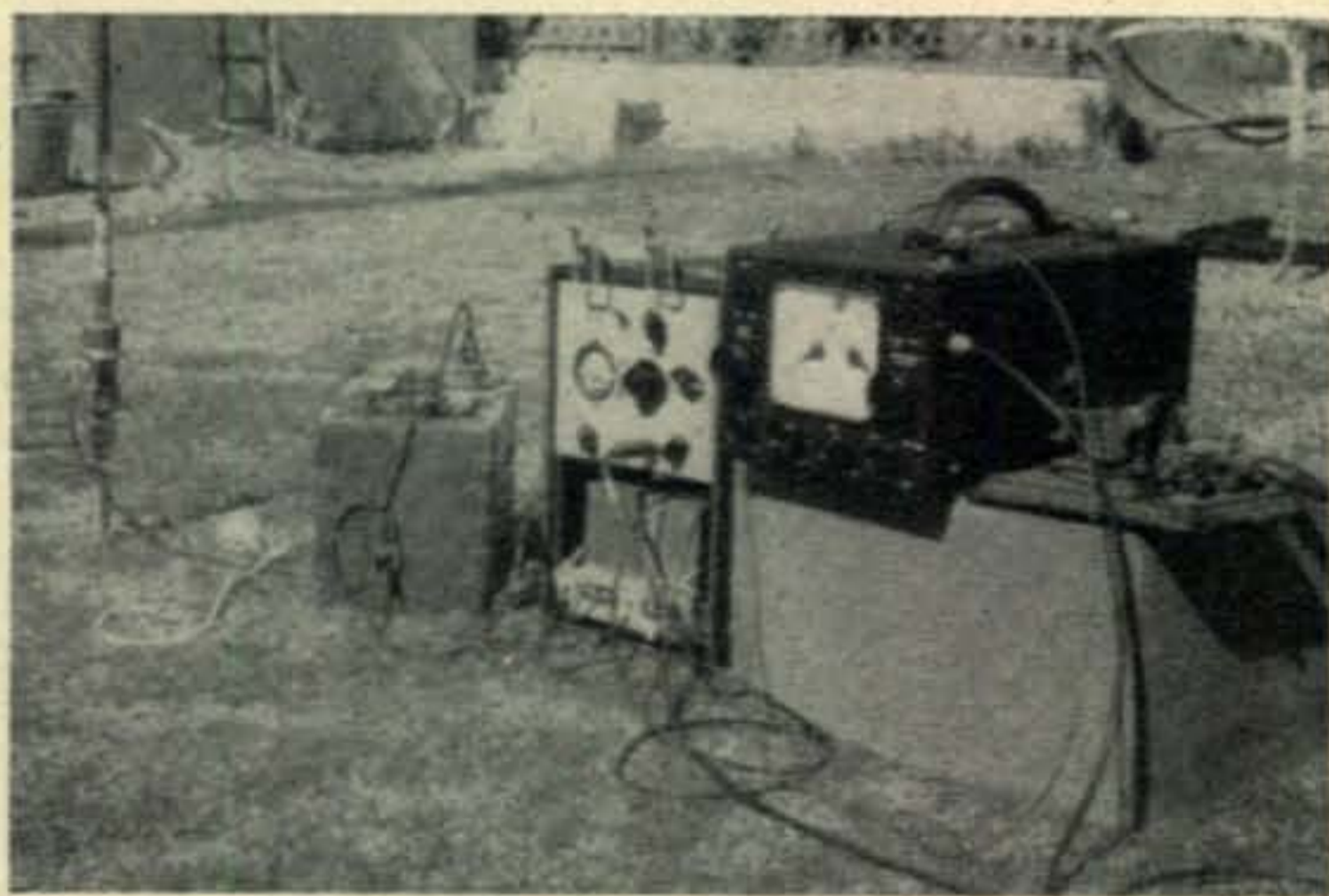

Equipment at TI9UXX: A Hallicrafters S29, a crystal controlled transmitter with a 2E26 final, Vibrapak-powered with a six-volt storage battery. Whip is rigged as groundplane, tuned to 14,100. Entire rig can be assembled or dismantled in five minutes.





Conducted by HERB BRIER, W9EGQ

385 Johnson St., Gary 3, Indiana

One way to increase your enjoyment of amateur radio is to join a radio club. This applies equally to the prospective amateur, the newest Novice and the old timer. Here are a few of the advantages of club membership.

For the prospective amateur, joining a club offers the opportunity to obtain help and encouragement in obtaining a license. Some clubs offer beginner's code and theory classes regularly. In others, individual members take beginners under their wings for private help. At the very least, a couple of beginners may be brought together through the club so that they can help each other.

For newly licensed amateurs the club is a wonderful place to boast about DX contacts and show off the QSL cards to prove them, get tips on how to de-bug their transmitters and to improve their operating techniques. It is also a good place to round up a crew for erecting a new antenna.

For all amateurs the radio club offers an incomparable opportunity to meet and renew acquaintance with local amateurs. This can be very important, because of the many different branches there are to modern amateur radio.

On the air, a CW station seldom works a phone station. Traffic men keep busy with schedules and nets. Single sideband (SSB) stations work other SSB stations. VHF/UHF stations seldom listen below 50 Mc. and so forth. As a result, the users of the different modes of communication have no opportunity to talk to each other over the air. At the club, however, these barriers are removed. Friendly chats and a little inter-denominational missionary work help us all to increase our knowledge of the pleasures and problems of these different phases of amateur radio. This strengthens our fraternal bond.

The radio club is also the ideal place to discuss such things as new FCC proposals, frequency allocations, and political developments that may affect our present enjoyment and the future existence of our hobby. They can be explored thoroughly, voted on, if necessary, and the result of the voting dispatched to the proper people as the majority opinion of the club members. In this manner, most of the misunderstandings and hard feelings and all of the bad publicity engendered by discussing controversial subjects over the air is avoided.

#### Organizing A Radio Club

What do you do if there is no radio club in your area? You organize one—Yes, you! With help, of course, because no one can start a club alone. Actually, there is nothing difficult about the organization. It is maintaining it that requires the effort, which is largely supplied by the few.

In general, there are two types of radio clubs. One is the purely social, informal club in which the members meet at each other's homes, with the host providing entertainment and refreshment at his discretion. The other is more formal, with a constitution,

elected officials and probably a regular meeting place. In addition, it may have some special aim which it sponsors, such as the recruiting and training of new amateurs, participation in contests, or the construction of emergency communications equipment.

The informal club is easy to organize and is usually quite successful when membership is small. Its snugness makes it a very friendly affair. However, it may easily become a "closed corporation." If no effort is made to recruit new members when the original ones drop out or move away, the club just fades away. The formal club requires more effort to organize, but is more likely to be a permanent institution. Formality is almost a necessity when actual or potential membership is large.

The first step in organizing a club is to canvass for new members among all your radio-minded friends and acquaintances and among others they suggest. Practically all of them will be interested in joining a club, but not in organizing it. Keep talking until you have found one or two who will help. You now have an organizing committee.

The committee learns all it can about clubs by visiting others and asking questions. How did they get started? What are their biggest problems? Their most popular activities? Where and how often do they meet? What do their constitution and by-laws cover? It is better to get this information from other radio clubs, but organizational problems run pretty much the same in all hobby clubs, therefore officials of the local photography or stamp collector's club can give you valuable tips.

After the committee has some idea of the problems involved, an organizational meeting can be called. Notify by postal card, telephone, or in person everybody who might be interested, and try to get a small item about the meeting and its purpose published in your local newspaper—which is not nearly as difficult as some people imagine.

At the meeting, such things as the desirability of a club, its aims and purposes are first discussed. Then details—constitution, name, frequency of meetings, officials and their duties, and so forth, are discussed, and temporary officers appointed. Nothing permanent need be decided at this meeting. It is more important that everyone get acquainted and briefed about what must be done. Appoint committees to prepare a constitution, investigate possible meeting places, and select a suitable name. They will report to the next meeting, and their findings will be voted on.

Before the meeting adjourns, the temporary secretary should take the names and addresses of every-

one present, plus the names that they may suggest, in order to notify them, by card, of the date of the next meeting. Undoubtedly the committee members will have more information on the points discussed than anyone else present. In fact, the more pertinent information they can furnish the better, but they should not try to dictate their ideas as club policy. A club is a voluntarily cooperative organization, and its members decide for themselves how it is to be conducted.

### The Club Constitution

An important part of any club is its constitution. It states the Club's aim and purpose, records its name, describes the duties of its officers, and covers similar matters. The bylaws then prescribe practical rules for the actual functioning of the club. A sample constitution and a set of bylaws were printed in CQ for October, 1948.<sup>1</sup> A point worth considering while organizing a club and writing its constitution is the advisability of incorporating it as a non-profit organization for the protection of its members. This is most desirable when group activities are sponsored, which might lead to a law suit against the club in the event of an accident. Incorporation, to be done right, usually requires the services of a lawyer, who can also explain its advantages and disadvantages; therefore, try to include one in your membership. It cuts cost.

### Keeping The Club Going

Once the club is organized there will appear the problem of maintaining it. This, most of all, requires making the meetings interesting enough to make the members want to attend. A few suggestions, therefore, based upon the experiences of different radio clubs, may be helpful.

Oddly enough, holding member interest is easier if meetings are not too frequent. Once a month is usual. More frequent ones keep the program committee hopping to provide suitable entertainment. Suitable entertainment programs include demonstrations of new equipment by club members, dealers, or manufacturer's representatives. Descriptions by members of their experiences in building or using equipment featured in articles in CQ and other magazines may also prove entertaining.

Representatives of local broadcast and TV stations can give very interesting talks about their problems and amusing experiences. They can also often arrange for the club to make a tour of their stations. The larger companies, like General Electric and Bell Telephone, have films on electronic subjects which they will lend to clubs for showing. Your local library probably has a list of many of them, and the secretary of another nearby club can probably suggest other sources. An exchange of speakers between clubs is another possibility.

Club members also appreciate an occasional meeting without any formal program. It gives them an opportunity to visit and become better acquainted with each other.

Serving of light refreshments—coffee and doughnuts, etc.—is another important ingredient of successful meetings. It's not a necessity, but it does seem to produce a more relaxed friendliness among those attending.

Avoid those lengthy business meetings which make a Russian Peace Conference seem short. The average club member is not interested in them. It is expedient to have an executive committee of some kind to take care of routine business.

A final suggestion is to have the secretary mail a reminder to the members a few days before each meeting. It is surprising how many fellows miss meetings through sheer forgetfulness.

### Club Members

The one important qualification for membership in a radio club is interest in radio. Practically, however, age also has some importance. Very young members frequently become bored at adult club meetings, and relieve their boredom by various forms of horseplay, thereby distracting the other members. As a result, some clubs specify that, to be eligible for membership, an applicant must either have a valid amateur license or be at least sixteen years old. Younger applicants are given private help by individual members until they obtain a license.

An even better solution is a special teen-age club. Any adult with the time and inclination can earn the eternal gratitude of the members by sponsoring one.<sup>2</sup>

<sup>1</sup> "Radio Clubs: Making 'Em Work," H. S. Brier, W9EGQ, CQ, October, 1948, p. 32.

<sup>2</sup> "How To Organize A Novice Club," Harold E. Peder-son, W6MRP. CQ, August, 1951, p. 14.

### Letters And General News

Gary, WN0QDP, Winona, Minn., reports for himself and Bill, WN0QDR. "Dear Herb, Bill and I took our exams the same day and got our licenses nine weeks later on the same day. In three months of operating, Bill has worked 36 states and I have 32, plus VE3, VE4, VE5. . . . We both have S-38B receivers and 10-watt, home-made transmitters. Also, we trade between us a 70-watt, 807 transmitter lent to us by ex-Novice W0HAA. Our antennas are various sizes and shapes, but my main one is centered, 3.7-Mc doublet, and Bill's is a 7-Mc end-fed 1/2-wave. . . . I am 16 and Bill is 17, and we are both proud of our 'Minnesota Milliwatts'."

"Salt," KN2DEG, writes, "Dear Herb, I write this letter while listening to the QRM (interference). We have five Hams on our street, myself—KN2DEG, K2DOH, W2QSV, W2NEP, and K2BVE. If that is not enough, K2BWM and K2WLK are a block away! 73 from Ham's Paradise, Montclair, N. J."

Del, W8KJP, reports that, since getting his "General," he has worked 43 states, 6 Canadian provinces, Puerto Rico, Venezuela, and Labrador on 80 meters. In addition, he is a member of 5 traffic nets. He adds as a postscript, "I am 15 years old. We live in a trailer, so I have to do all my operating standing up. 73"

Nick, WN7TSM, 1102 West Broadway, Lewistown, Mont., writes, "Dear Herb, I am 15 years old, and I am especially interested in working W8 and W9 on 7 Mc. I also operate on 3.7 Mc. My frequencies are 7,194 and 3,744 kc. . . . I will be glad to help anyone obtain their Novice license."

Nick, KN4APN, who was having trouble last month, has a better report this time. He writes, "Dear Herb, Thanks for your letter. I really worked checking over the transmitter (6AG7-807) and the antenna, and when I got it all tuned up, I called CQ. It was a noisy night, with a lot of WN's QRM'ing each other. But at least three stations answered my call! So now I am in business after four months of trying. . . . I sure hope that I can help out some new Ham so that he won't get as disgusted as I did. Thanks again."

Marty, W3QXV, writes, "Dear Herb, Our West Catholic High School Radio Club, 49th and Chestnut Streets, Philadelphia, has been reactivated again this year and is going along in great style. Under the leadership of Andy, W3TPC, we have 12 Novices with their shiny new licenses this year. Three of last year's Novices have their Technician licenses and one has his General. . . . The club has acquired its own call, W3WWS, and the gang here would like to work other high school club stations. We operate on 3711 kc. every school day after 2:30 p.m."

Mike, WN9ASK, 513 Forest Ave., River Forest, Ill., writes "Dear Herb, I use a 6AG7-6L6 rig, with 25 watts input, a 7-Mc. dipole, and an S-38C receiver. So far, I have worked 14 states and Canada on 3.7 and 7 Mc. All my reports have been good, and the receiver works well with only a 20-foot antenna. . . . If anyone needs an Illinois contact or card, I shall be glad to make a sked with them. Or I am always ready just to chat. . . . I am 15 years old."

Ed, WN1ZHE, Boston St., Middleton, Mass., writes, "Dear Herb, I would like to hear from anybody who would like to organize a radio club for boys (and girls) up to sixteen years old in or around Middleton, Mass. There are several Hams around town who would like to have a radio club. My transmitter uses a 6L6 with 15 watts input, feeding a 136-foot doublet, and my receiver is an S-40B. I have worked about 100 stations in nine states. I sent cards to all stations worked and have received cards in return from half of them. I am 14 years old."

John, WN8ODQ, Newton, Ohio, writes, "Dear Herb, I have separate 1/2-wave doublets for 3.7, 7, and 21 Mc. and a 12-element, 146-Mc. beam. I have 12 states confirmed out of 14 worked in 360 contacts. I have no complaints about conditions, but I would like to see more activity on 146 Mc."

Donn Kuse, now an "expectant" Novice, says, "Dear Herb, Thanks for printing my letter about the SWL Correspondence Club in the November column. We already have nine members (in November). I'd still like to hear from other SWL'ers who need help in obtaining their licenses. Several of the members have helped me a great deal. My address is: Donn Kuse, 10091 Brecksville Road, Brecksville, Ohio."

### Help, Help!

Our list of those requesting help in obtaining an amateur license contains the following names:

Jim Hollister (18), 661 Lottie, Monterey, Calif.

(Continued on page 70)





The answer to many Novice prayers! Yvonne Heath (16), WN8PBW, Dowagiac, Mich. She is to be found almost every afternoon on her favorite frequency, 3735 kc. Transmitter runs sixty watts to a 6146. Yvonne had a 10-w.p.m. code certificate before her license arrived.



KN2DPQ, Pleasantville, N.J. Transmitter is a TR75 and receiver is an S-40A. Unit on top of receiver is a 146-Mc converter. The one on top of the transmitter is a converted BC-625 (522) transmitter for 146 Mc.

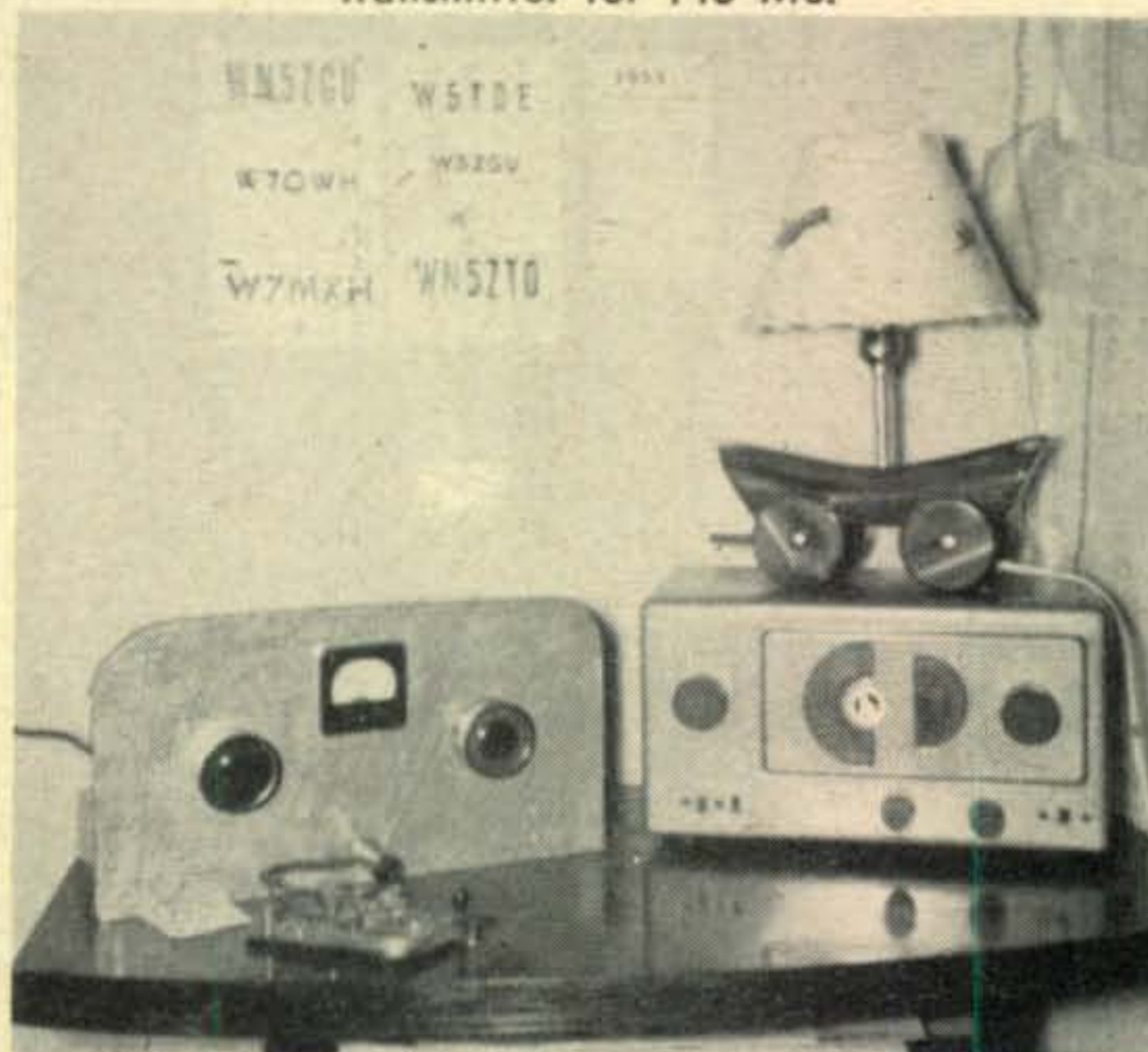

WN5CFZ, Rockdale, Texas, operated by Jim Rogers. The transmitter on the left consists of a 6L6 driven by a 6AG7. The receiver is an S-38C.



John Bowen, WN8ODQ, Newton, Ohio, owns this "all Band" Novice station and 146-Mc rotary beam. The beam tower is fifteen feet high and is mounted on the roof of the house.



Harold Loden operating W5WBU, Carthage, Texas. Running ten watts input, he made 1192 contacts in forty states as a Novice. Harold is the son of a Methodist minister and is a senior in high school.

ALL TIMES IN C S T

CENTRAL USA TO:	15 Meters	20 Meters	40 Meters	80 Meters
South East Asia	Nil	1500-1900 (0-1)	0000-0800 (1)	Nil
Hawaii	1200-1800 (2-3)	1000-1200 (3-4) 1200-2000 (3)	2100-0900 (3-4)	2300-0700 (3-4)
Australasia	1530-1800 (1-2)	0700-1030 (2) 1300-1900 (3) 1900-2100 (1-2)	0000-0800 (3)	0100-0600 (2-3)

ALL TIMES IN P S T

WESTERN USA TO:	15 Meters	20 Meters	40 Meters	80 Meters
Europe & North Africa	Nil	0800-1200 (1)	1700-0100 (0-1) 0100-1100 (1)	1800-2300 (1)
Central & South Africa	1000-1500 (2)	0600-0730 (1-2) 0730-1600 (0-1) 1600-1800 (1-2)	1700-2200 (2-3) 2200-0300 (1)	1800-2200 (1-2)
South America	0900-1400 (1)* 0700-1600 (3-4)	0600-1400 (2-3) 1400-1700 (4) 1700-1900 (2) 2200-0200 (1-2)	1700-0500 (3-4)	1800-0400 (2-3)
Guam & Mariana Islands	1400-1700 (1)* 1300-1900 (3-4)	1230-1800 (1-2) 1800-2100 (2-3)	2300-0830 (3-4)	0000-0800 (2-3)
Okinawa	1430-1830 (2-3)	1400-1800 (2-3) 1800-2100 (3-4)	2300-0800 (3)	0100-0630 (2-3)
Australasia	1500-1900 (1)* 1300-1900 (2-3)	0630-0900 (1) 0900-1700 (2) 1700-2000 (2-3)	0000-0800 (3)	0100-0700 (3)
Japan & Far East	1400-1700 (1)	1300-2000 (3-4)	2100-0900 (3)	0000-0600 (2-3)
Philippine Islands & East Indies	1500-1830 (2)	1400-2100 (1-2)	0100-0700 (1)	0400-0700 (0-1)
Malaya & South East Asia	1600-1900 (0-1)	0900-1100 (0-1) 1500-2000 (1-2)	0300-0700 (1)	0400-0600 (0-1)
Hong Kong, Macao & Formosa	1430-1800 (2)	1400-2000 (3)	0000-0700 (3)	0200-0600 (2)

Symbols For Expected Percentage Of Days Of Month Path Open:

(0) None (1) 10% (2) 25% (3) 50% (4) 70% (5) 85% or more.

\* Indicates time of possible ten-meter opening.

ALL TIMES IN E S T

EASTERN USA TO:	15 Meters	20 Meters	40 Meters	80 Meters
Western Europe	0900-1300 (1)	0730-1300 (3-4) 1300-1500 (1-2)	1600-2000 (3-4) 2000-0600 (2)	1730-0400 (3-4)
Central Europe & Balkans	0830-1230 (1)	0700-1300 (3-4) 1300-1500 (2)	1600-2100 (3) 2100-0430 (2)	1730-0300 (3)
Southern Europe & North Africa	0800-1430 (1-2)	0700-1400 (4) 1400-1600 (2)	1600-2100 (3-4) 2100-0430 (3)	1730-0400 (3-4)
Near & Middle East	0830-1200 (1)	0700-1100 (1-2) 1100-1400 (2-3)	1700-2100 (2-3) 2100-2300 (1-2)	1900-2300 (1-2)
Central & South Africa	1100-1430 (1)* 0700-1030 (2) 1030-1430 (3)	0630-1230 (1-2) 1230-1730 (3-4)	1700-0030 (2-3)	1900-2330 (2)
South America	0930-1500 (1)* 0800-1500 (2-3) 1500-1700 (3-4)	0700-1600 (2) 1600-1900 (3-4) 0100-0300 (1-2)	1800-0400 (3-4) 0400-0700 (2-3)	1900-0500 (2-3)
South East Asia	Nil	Nil	0330-0800 (0-1)	Nil
Australasia	1600-1800 (1)	0700-1030 (2-3) 1030-2000 (0-1)	2300-0100 (2) 0100-0500 (1) 0600-0830 (2-3)	0200-0730 (2-3)
Guam & Pacific	1600-1800 (0-1)	1600-1900 (1) 0730-1030 (1)	2300-0830 (3)	0000-0700 (2-3)
Japan & Far East	Nil	1600-1900 (1-2)	0200-0830 (1)	0330-0700 (0-1)
West Coast USA	1300-1700 (0-1)	1100-1600 (3) 1600-1900 (4)	0800-1000 (3) 1900-2200 (3-4) 2200-0800 (1-2)	2000-0700 (3-4)

ALL TIMES IN C S T

CENTRAL USA TO:	15 Meters	20 Meters	40 Meters	80 Meters
Western & Central Europe	0830-1230 (0-1)	0700-1230 (3) 1230-1400 (1-2)	1600-1800 (3) 1800-0330 (1)	1800-0200 (2-3)
Southern Europe & North Africa	0900-1300 (1)	0600-1330 (3-4) 1330-1500 (1-2)	1600-1900 (3) 1900-0400 (1-2)	1730-0300 (2-3)
Central & South Africa	1100-1400 (1)* 0700-1100 (2) 1100-1400 (3)	0600-1200 (1-2) 1200-1700 (3-4)	1630-0000 (2-3)	1900-2300 (2)
Central America & Northern South America	1000-1400 (1)* 0800-1530 (4) 1530-1700 (1-2)	0630-0900 (3-4) 0900-1430 (2-3) 1430-1900 (4) 0000-0300 (1-2)	1700-0700 (4)	1800-0500 (3)
South America	0900-1500 (1)* 0700-1500 (3) 1500-1700 (4)	0600-0800 (3) 0800-1500 (2) 1500-1900 (4) 2300-0300 (1-2)	1730-0600 (3-4)	1900-0500 (2-3)
Japan & Far East	1430-1730 (0-1)	1400-2000 (2-3)	0100-0900 (1-2)	0200-0700 (1)

# Ionospheric Propagation Conditions

Forecasts by

**GEORGE JACOBS, W2PAJ**

144-40 72nd Ave.,

Flushing, Long Island, N. Y.

## General Propagation Conditions

- 10 Meters**—DX conditions very poor, with only an occasional north-south opening expected.
- 15 Meters**—DX conditions becoming poorer as the spring months approach, but still fair to good during daytime hours to South America.
- 20 Meters**—Best daytime DX band, remaining open a bit longer than during the winter months.
- 40 Meters**—Fair to good nighttime world-wide DX continues, especially during the early evening hours. Conditions improving for DX on this band to Australasia.
- 80 Meters**—Generally fair nighttime DX to many areas. Band becoming a bit noisier towards the end of the month. On many circuits this band will remain open throughout the night, hours, after 40 meters has "dropped out."
- 160 Meters**—Although peak conditions have passed, the band is still quiet enough to permit occasional DX openings to occur. The 160 meter band opens during the "dark hours," approximately during the same times as 80 meters, but on much fewer occasions, with weaker signals.

During February, as the sun continues to travel northward, seasonal propagation characteristics are generally such that in the northern hemisphere daytime usable frequencies are decreasing and nighttime usable frequencies increasing. During February, ionospheric absorption and atmospheric noise levels increase somewhat from the minimum values of the previous months. Towards the end of the month, and continuing through March and April, an improvement should be noticed on all bands on paths going from the mid and higher latitudes of the northern hemisphere to the mid and higher latitudes of the southern hemisphere—for example, from the United States to Australia.

This overall picture of band conditions is intended to indicate qualitative changes in each band from month to month. For specific times of band openings for any particular circuit, refer as usual to the *Propagation Charts* on the opposite page.

This month's *Propagation Charts* are based upon a predicted smoothed Zurich sunspot number of 11 centered on February, 1954. While primarily intended for the month of February, these *Charts* can be used as a guide for working DX up to March 15.

The *Charts* are calculated on a CW radiated power

of 150 watts (See "Ionospheric Propagation Conditions" January, 1954), and are based upon basic ionospheric data published by the National Bureau of Standards, Washington, D.C.

## 1953 In Review

During 1953, the sunspot numbers and associated ionospheric characteristics continued to decrease in accordance with the established cyclic trend.

The monthly average sunspot number for November 1953, as reported by the Zurich Observatory, was 1.4. This was the lowest number recorded for any month since April, 1944, when the number was 0.3 and the lowest number recorded for the month of November since November, 1933 when the count was 0.9. The Zurich monthly average sunspot number recorded during November, 1947, the year of peak solar activity, was 127.4.

This does not necessarily mean that the minimum of the present cycle has been reached. As discussed at length in "DX and The Sun" (CQ July and August, 1953), the sunspot cycle trend is based upon the smoothed sunspot

Periods of good propagation conditions are expected Feb. 1-4 and 22-28. No severe ionospheric disturbances are presently forecast to occur during February.

Up to the minute ionospheric forecasts are now being broadcast over WWVH (N. Pacific) at 9 and 39 minutes past the hour on 5, 10 and 15 Mc., and on WWV (N. Atlantic) at 19.5 and 49.5 minutes past the hour on 2.5, 5, 10, 15, 20 and 25 Mc.

numbers. These numbers are the 12-month averages of the monthly numbers. Since 12 months data is necessary for calculating the smoothed sunspot number, the latest available number is for the month of May, 1953, which has been calculated by averaging the monthly numbers between November, 1952 and November, 1953.

Following are the smoothed sunspot numbers for 1952-1953, and for comparison purposes, those for last year (1951-1952), and for 1947-1948 (sunspot maximum).

	1953	1952	1948		1952	1951	1947
Jan.	23.9	43.3	144.8	July	30.6	67.2	155
Feb.	22.6	42.9	142.8	Aug.	27.8	64.0	151
March	19.8	40.2	140.4	Sept.	27.1	61.2	148
April	18.2	35.7	138.2	Oct.	27.5	59.0	152
May	16.5	33.5	135.8	Nov.	26.1	53.6	149
June	—	32.1	135.3	Dec.	26.0	48.1	149

Figure 1 is a plot of the smoothed Zurich sunspot numbers observed during the present cycle (January 1943-May 1953). The dashed continuation of the graph, starting with June, 1953, is a prediction for the remainder of the present solar cycle. This prediction is an estimate based upon the study of the behavior of the previous ten cycles. The minimum of the present cycle is expected to occur during the fall of 1954 when minimum smoothed

(Continued on page 69)

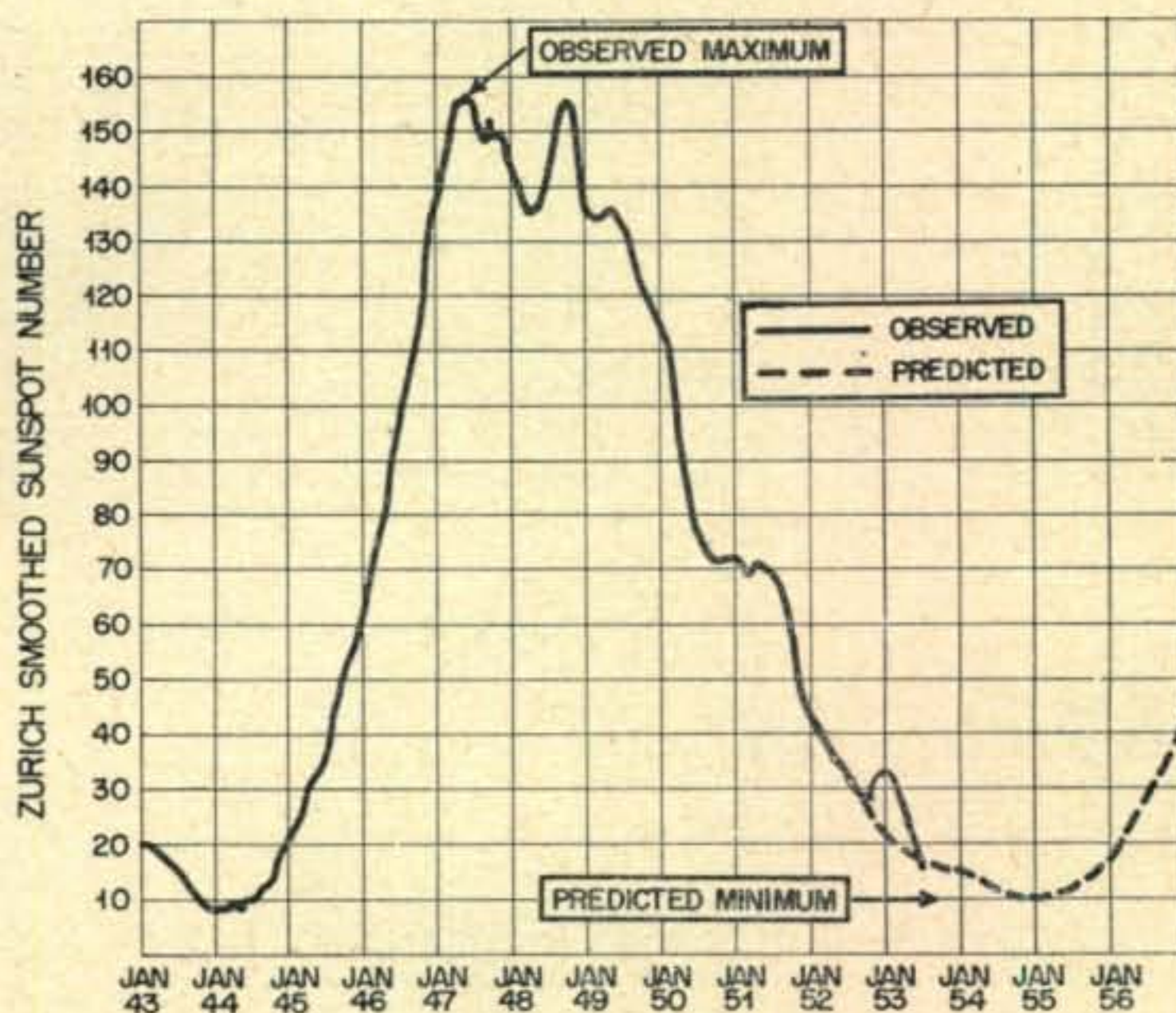

Bringing the sunspot curve from the July issue up to date ("DX and the Sun," page 18) we see the slight hump that centered around January 1953. The curve is now dropping off rapidly.

# What's NEW

# in HAM RADIO

## Parts Products Catalogs

Say That You Saw It In CQ!!

Six new PROTO pliers have been recently marketed by the **PLOMB Tool Co.**, of Los Angeles, Calif.

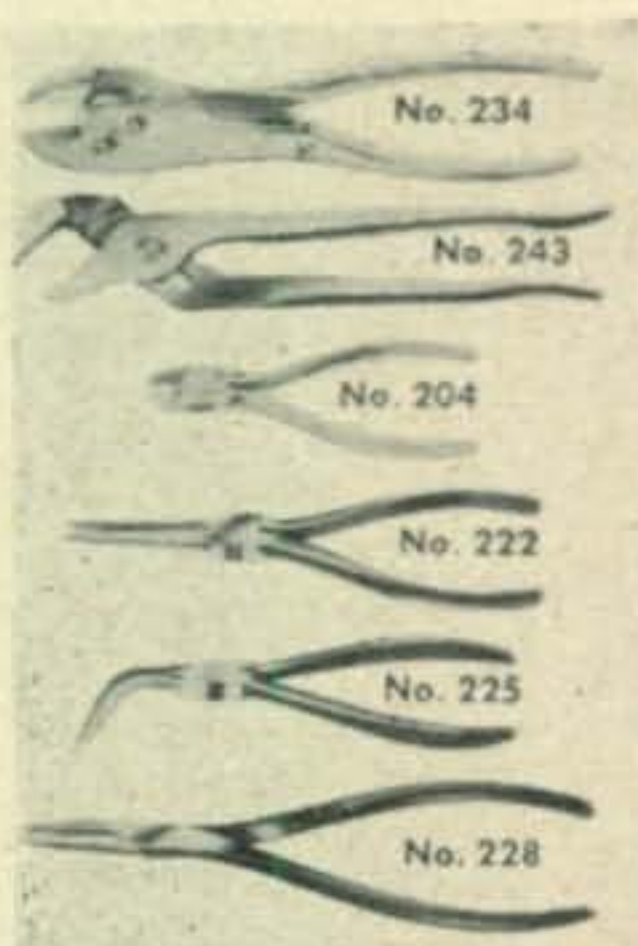

Three precision needle nose pliers, a compound leverage plier, a multiple-groove joint plier, and a diagonal cutting plier are included in this new line. The matched cutting jaws of the diagonal cutters are especially thin, and induction hardened for long wear. Just the ticket for tearing up that surplus gear!

Just off the press is the newest **BUD** Catalog of sheet metal products and electronic components. Well known parts to every amateur that has ever lifted a soldering iron, the complete **BUD** line of products, with concise specifications and information, is shown in this catalog along with suggestions for uses and applications. A "must" in every Ham shack! Copies of the catalog may be obtained by writing to **Bud Radio, Inc.**, Dept. C2, 2118 East 55th St., Cleveland 3, Ohio.

All amateurs interested in mobile communication will welcome the new **Carter Dynamotor Catalog No. 753**, recently published by the **Carter Motor Co.**, manufacturers of dynamotors, converters and "Change-A-Volt" dynamotors. The catalog consists of 28 illustrated pages giving complete electrical and

mechanical specifications on all Carter dynamotors. Of special interest to the technically minded amateur are the performance charts and oscillograph photos of typical dynamotor performance. Described also is the new Carter heavy-duty generator, cataloged for the first time. A copy of the new brochure may be obtained by writing the manufacturer: **Carter Motor Co.**, Dept. 16, 2660 No. Maplewood Ave., Chicago 74, Ill.

The old saying has it that every Ham should have two stations: One that works good, and another that looks good! The **Elgin Metal-**

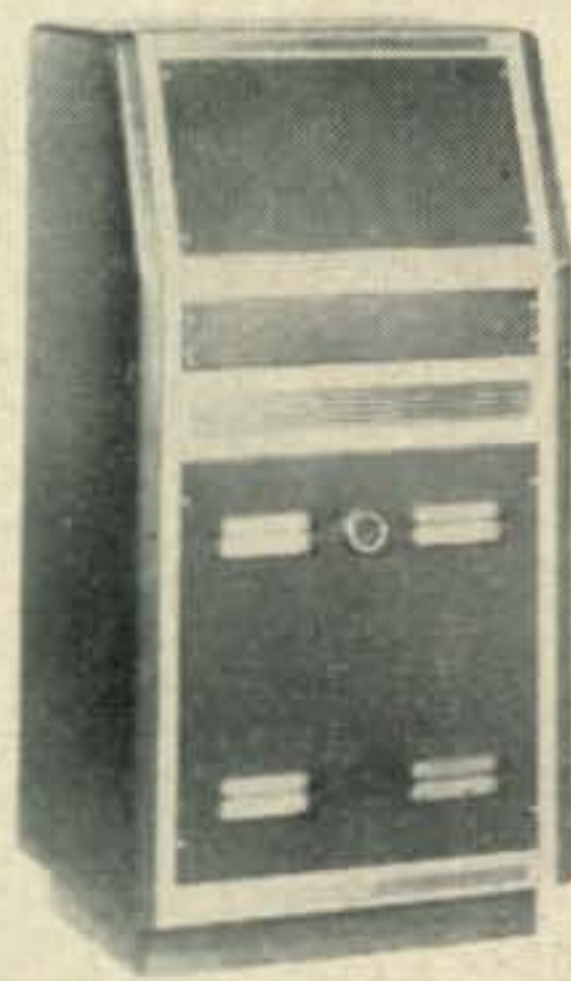

**formers Corp.**, Elgin, Ill. (W9GW, prop.), has introduced a new, standard line of metal enclosures that will do much to hasten the end of "haywire" in the Ham shack. Of particular interest to amateurs is the BU-2121 basic console (illustrated). It measures 21"x48"x21" with standard RTMA and WE mounting holes for 19" relay rack panels. Any number of these units may be locked together to form an attractive console enclosure. With the addition of Elgin's Pedestal Drawer Enclosures and Writing Tops, a three-unit control assembly desk may be built up that could house a complete kilowatt station, occupying the space of an office desk! Attractive enough, too, to go

in the living room, without vexing the XYL! A catalog of the 75 component units of the Emeor System may be obtained from: **Elgin Metalformers Corp.**, 903 No. Liberty St., Elgin, Ill.

Flashovers in that new power supply? Here's the solution. **INSL-X!** It has an extraordinarily high dielectric strength, resists salt spray, moisture, chemicals, corrosion, and hot air (Phone men, attention!). It is a clear, quick-drying liquid plastic, and is available in an easy-to-use aerosol dispenser. Supplied in bulk form for more than 20 years to U.S. government departments, **Insl-X** insulating spray is now available to amateurs, servicemen, and experimenters in this 12-oz. container. Inquiries should be directed to **Insl-X Sales Co.**, 26 Rittenhouse Place, Ardmore, Pa.



All amateurs will be interested in **Centralab's Catalog No. 23**, which contains a complete listing of all the varied Centralab products. Of particular interest to amateurs is the section devoted to the JV-9000 series of rotary ceramic switches, designed to handle 750 watts, and up to 3,000 volts. These switches may be just the thing for that new band-switching final amplifier! Of equal interest is the

line of DD-16 disc ceramics, designed for operation at 1600 volts d.c. These are extremely helpful for TVI by-passing of low voltage leads in transmitters. The "TV" series ceramic condensers are rated up to 30,000 volts d.c., perfect for high voltage by-passing of harmonics. (Two of these condensers in series may be used for transmitters west of the Rockies.) The type 850 Centralab condensers may be used in high-power low-pass TV filters for the big rig, and the FT series are designed for feed-thru condensers to be used in interstage shielding. Obviously, the catalog is indispensable to any amateur contemplating a TVI-housecleaning. A copy may be obtained from your local Centralab distributor, or by writing to Centralab Inc., 900 East Keefe Ave., Milwaukee 1, Wisconsin.

Sylvania Electric Products Inc., keeping pace with the trend to 12-volt automotive equipment has just brought out a complete line of 12 volt receiving tubes.

For the r-f stage, there is either a 12BA6 or a 12BD6. The 12BA6 can also be used in the i-f circuits. The Sylvania 12BE6 is designed for converter service; the new 12AV6 functions as the 2d detector, a-v-c, and audio tube.

The new audio tubes, the 12AQ5 and the 12V6-GT may also be used in r-f circuitry. The popular 28-9 transmitter described in the "Radio Amateur's Mobile Handbook" can be easily adapted for 12 volt operation by using the new 12AQ5.

The new 12X4 rectifier rounds out the complete line of tubes. Next time you go to the local radio emporium, ask about these 12 volt tubes for your mobile equipment!

A lot of sound and fury has revolved about the amazing new transistors, but little has ever brushed off on the lapels of the average Ham. Now that Raytheon has introduced the reasonably priced CK-727 transistor, we think that tremendous reader interest will soon appear in transistors. The



CK-727 has an average noise factor of 13 db., an average power amplification of 37 db., and is darned small, as can be seen from the accompanying photograph.

Full details of the CK-727 are given in a data sheet available from: Raytheon Manufacturing Co., Technical Information Service, 55 Chapel St., Newton, Massachusetts.

VHF men! Now hear this! FRETCO, Inc. has now on the market an open-wire 300-ohm line. While produced primarily for UHF-TV installations, the miniature line is perfect for amateur use on the v.h.f. and u.h.f. bands. Pee-wee polyethylene spacers are used on the line, and the wet or dry losses

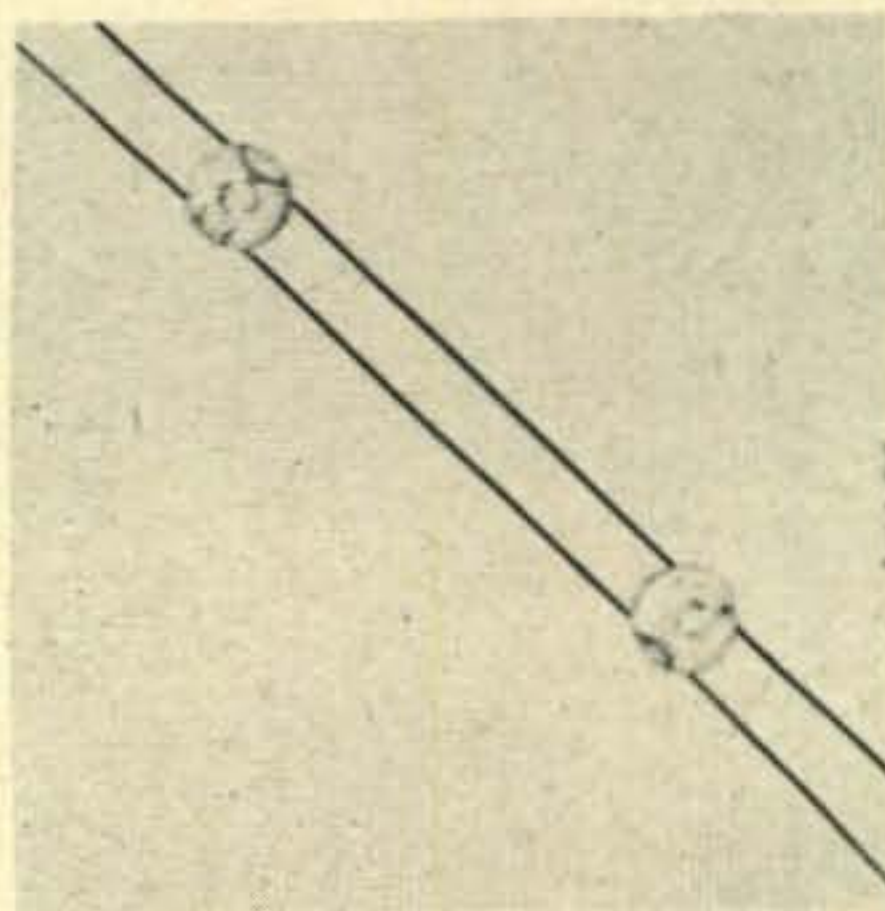

of the line are extremely low. The line is known as "Saucerline" (illustrated) and may be obtained at local distributors. The extremely close spacing prevents power loss and unbalance at high frequencies, and should prove very popular on the 220-Mc. technician's band. Oh yes, the line may be also employed on TV receivers.

After a short whirl at mobile radio, Joe Ham usually finds the weak link in his communication set-up is the car radio! Long on price and short on sensitivity and selectivity, it just doesn't fill the bill. S&W Electronics, 3418 West Pico Blvd., Los Angeles 19, Calif. (The brain-child of W6MVK and W6ZUX) has just announced a special mobile receiver for use with converters—the MOBIL-CEIVER. This compact little unit includes many features found only on high quality communication receivers. Variable i-f selectivity, high-Q 175-kc. intermediate frequency transformers, BFO, separate r-f and a-f gain controls, self-adjusting noise limiter, and special ventilated case are among some of the features that will make the avid Mobileer's eyes light up in anticipation. The MOBIL-CEIVER will work on either 6 or 12 volts, and features a built-in power supply, with provisions for regulated B plus voltage for the converter. The con-

verter may be seen at your amateur supply house, or complete information may be obtained from S&W Electronics.



Have you ever tried to figure the correct value of a negative temperature coefficient condenser to put in your v.f.o. to reduce thermal heating drift? Well, here's an easy way to do it. The Sprague Products Co. has introduced a Capacitor Temperature-Coefficient Slide Rule which substantially speeds and simplifies ceramic capacitor installation problems. Stock values of N750 and NPO type Sprague capacitors may be parallel connected to provide various odd values of temperature coefficient condensers that will correctly fit the particular problem at hand. On the back of the Sprague T-C rule is a key to ceramic capacitor color codes, showing capacitance, tolerance, voltage and temperature coefficient values. The T-C slide-rule is available for 15c, either direct from Sprague Products Co., 85 Marshall St., North Adams, Mass., or through Sprague distributors in all major cities.

How do you like this aluminium mesh grill for the protection of loudspeaker openings? This new ICA product could also be used as a decorative mesh over panel openings as an anti-TV measure—It looks much better than window-screening for this purpose! Finished in a non-tarnishing gold color, it's available in several sheet sizes. The material can be readily cut with a pair of ordinary tinner's

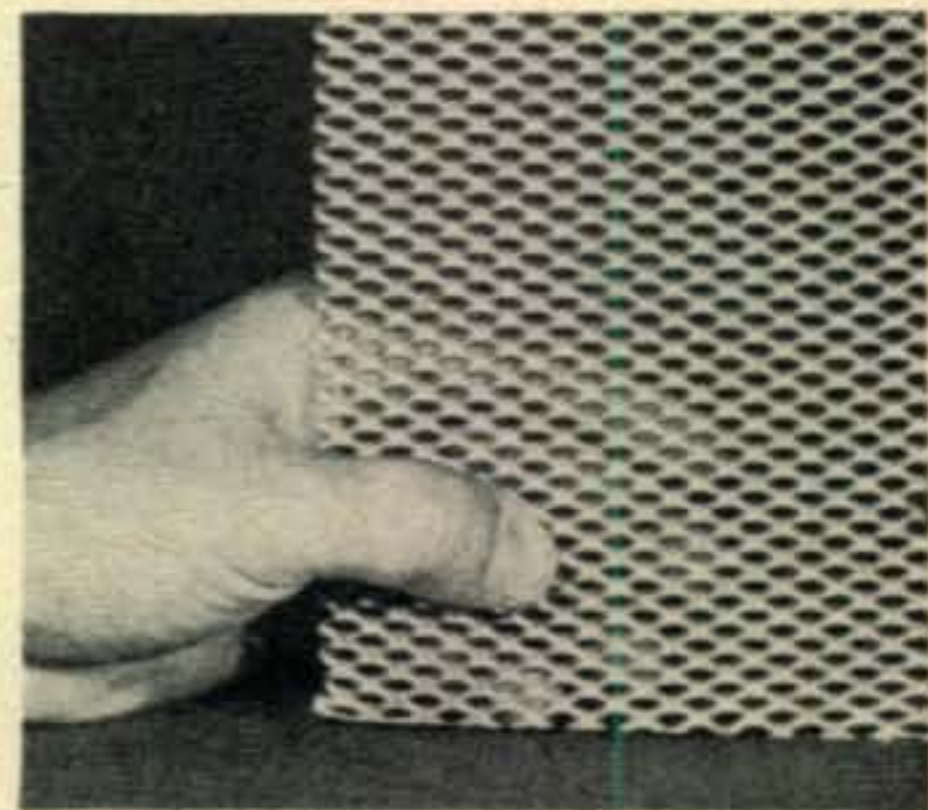

snips. This grill is produced by the Insuline Corporation of America, 3602-35th Ave., Long Island City 1, N.Y., and is available at many amateur supply houses.

# The VHF-UHF News

FURMAN C. COBB

c/o CQ Magazine, 67 West 44th Street, New York 36, N.Y.

The device to be described this month is a 6-meter antenna mounted "booster" or r-f stage. It was designed by Joe L. Pryor, W5MJD (Amarillo, Texas) and has proven to be quite useful in improving his signal-to-man-made noise ratio. Joe seems to be surrounded by lots of power leaks, neon signs, etc. that make the interference problem fairly severe (unless a lot of co-ax cable is used) and this is how he solved it.

The "booster" is a 6BQ7 in a cascode circuit which is broad-banded and covers the entire four megacycles of the 6-meter band without loss of gain. It has a 15 db. stage gain and in every instance worked out better than a pentode r-f stage in the shack with the receiver. A-c power is supplied right to the "booster" which is mounted in a couple of 46-oz. fruit juice cans. A pair of relays on either side of the "booster" switch it out of the circuit when transmitting.

The photographs illustrate the general method of constructing the "booster." Two large juice cans and some galvanized tin are required to fabricate the housing. One can is used whole, while the other is cut and used as an extension housing to mount the relays. The main can has one end cut completely off and the other end is trimmed so that there is a piece about 1/4-inch wide left around the tip of the can. This prevents the chassis holding the r-f stage from slipping all the way through. The other can is cut up and soldered to the main can as shown in Fig. 1.

Obviously, the method of building the mounting for the "booster" will vary from constructor to constructor and I have not gone into too much detail on this point.

The chassis layout may also be visualized from

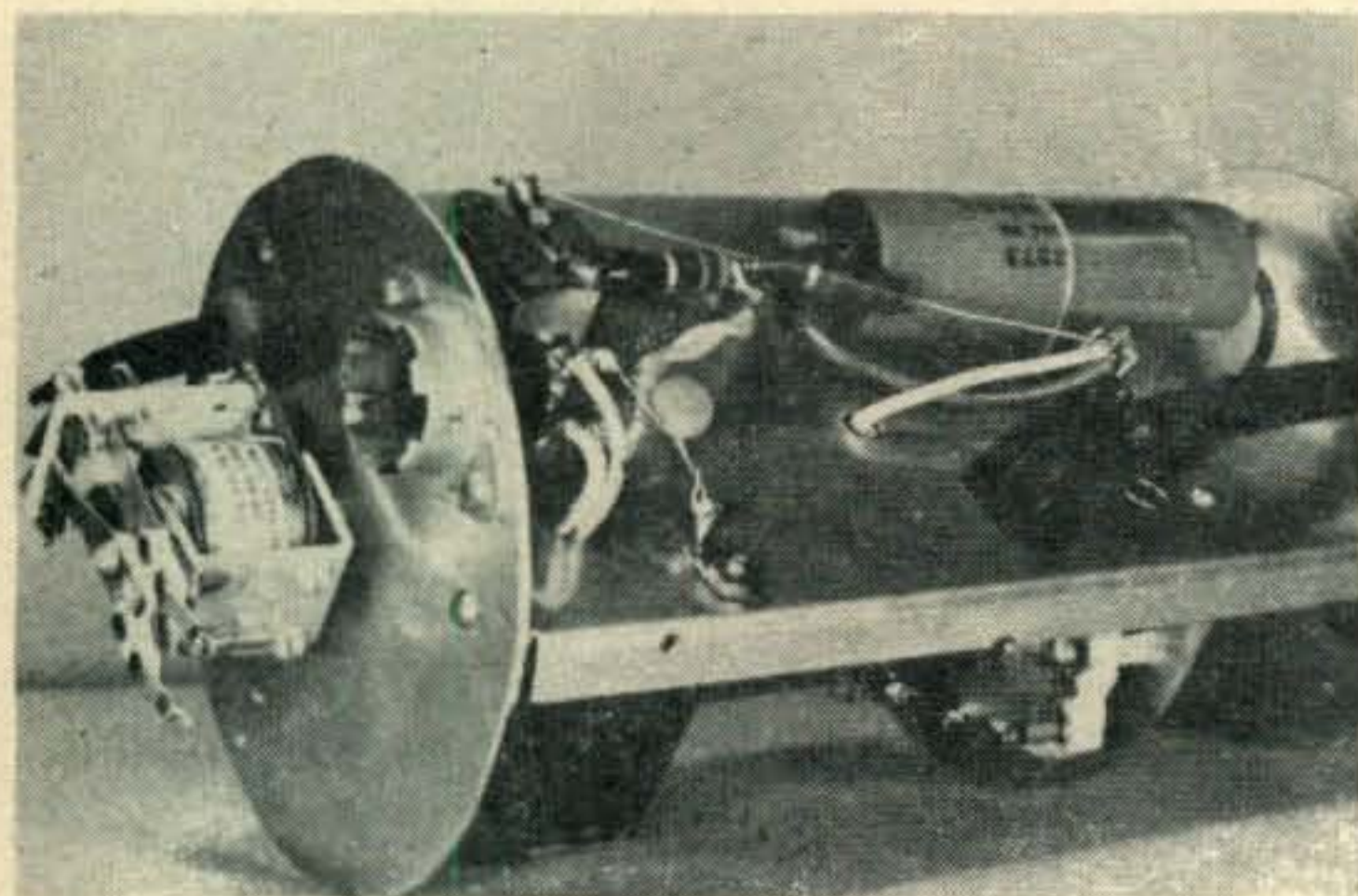

Under chassis view of the antenna-mounted booster at W5MJD, Amarillo, Texas.

the photograph. The tube is mounted so that the input and output circuits are screened from each other by the shield diagrammed in Fig. 1.

Chokes, RFC1 and RFC2 are bi-filar units wound using a 3/16-inch drill as a winding form. They are made by winding two short pieces of #18 enam. wire side by side for 8 turns. The value of the neutralizing condenser, C6, may vary from installation to installation, but will probably be about 1.0  $\mu\mu\text{fd}$ . It can be made from a short piece of 72-ohm twinlead with about one inch of coupling to start

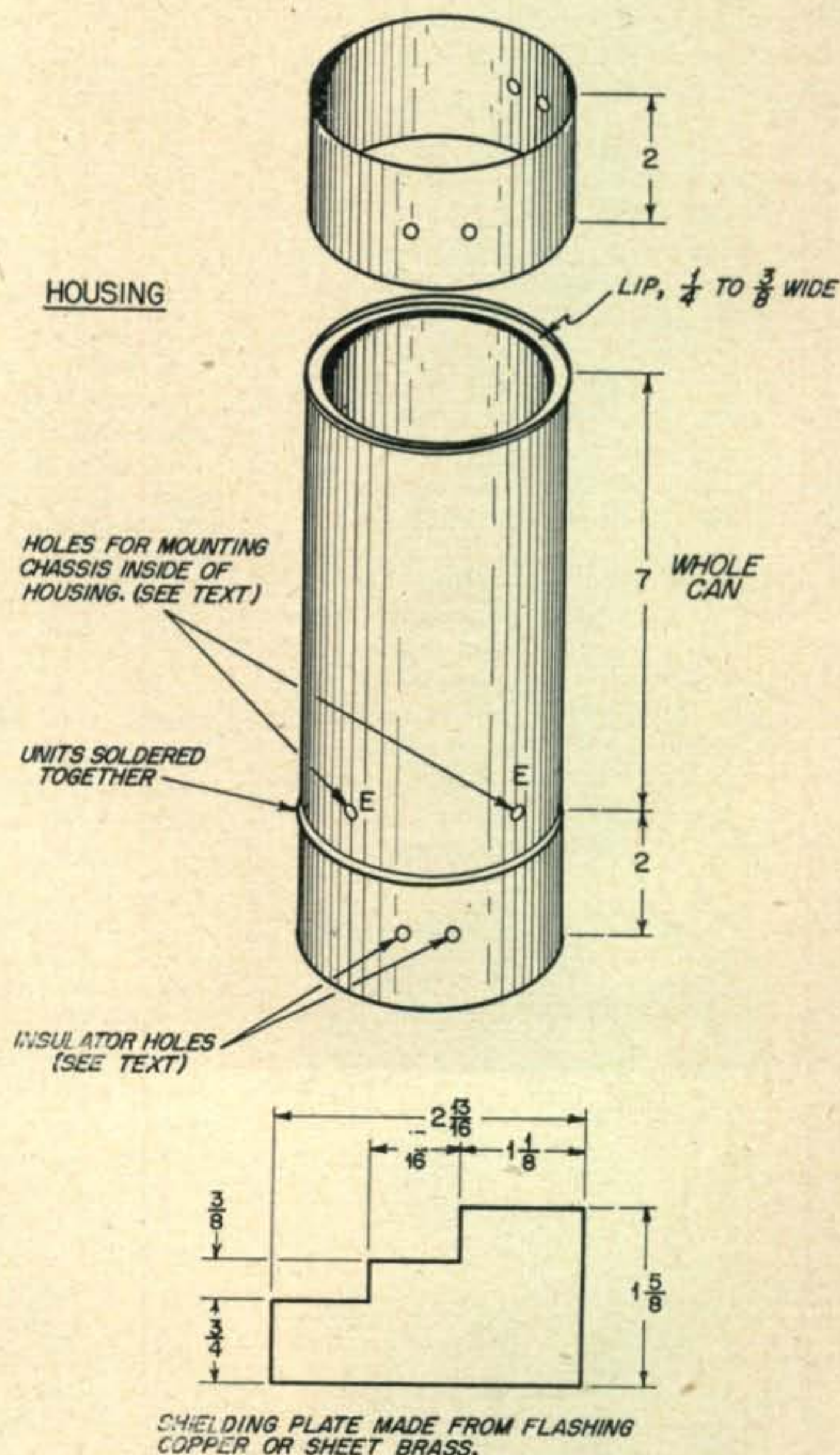

Fig. 1. Details of the "tin can" housing.

with. Coil, *L1*, is very closely coupled to the cold end of *L2* and is tuned to frequency with the antenna attached.

Coil, *L4*, can be made by winding four turns of #24 enam. wire around coil *L3*, just above the tap, or it can be made from a *B&W #3008 Miniductor* if some of the insulating material is filed off on the inside so that it can be slipped over *L3*.

**Tuning Up**

With the power supply diagrammed in the accompanying schematic (*Fig. 2.*) the output voltage should be about 200 before 6BQ7 warmup and about 150 volts after. With a test signal, tune up the cascade on 52 Mc. If the stage is neutralized properly it should be possible to swing the 6-meter receiver from one end of the band to the other and not hear any birdies. The neutralization may also be checked by breaking the high-voltage lead and inserting a 0-15 milliammeter in the circuit. If, when the grid coil is touched the plate current does not remain steady at about 6 or 7 ma., it is a fairly good indication that the stage is not completely neutralized. This may be corrected by changing the position of the tap on *L3* or the capacity of *C6*. The W5MJD unit neutralized with about 3/8-inch of connected 72-ohm twinlead.

No other special precautions were observed by Joe, except to make sure that relays are connected to the send-receive switch in the shack and that the switch is one of those with a spring return. This makes sure that the relays in the "booster" do not

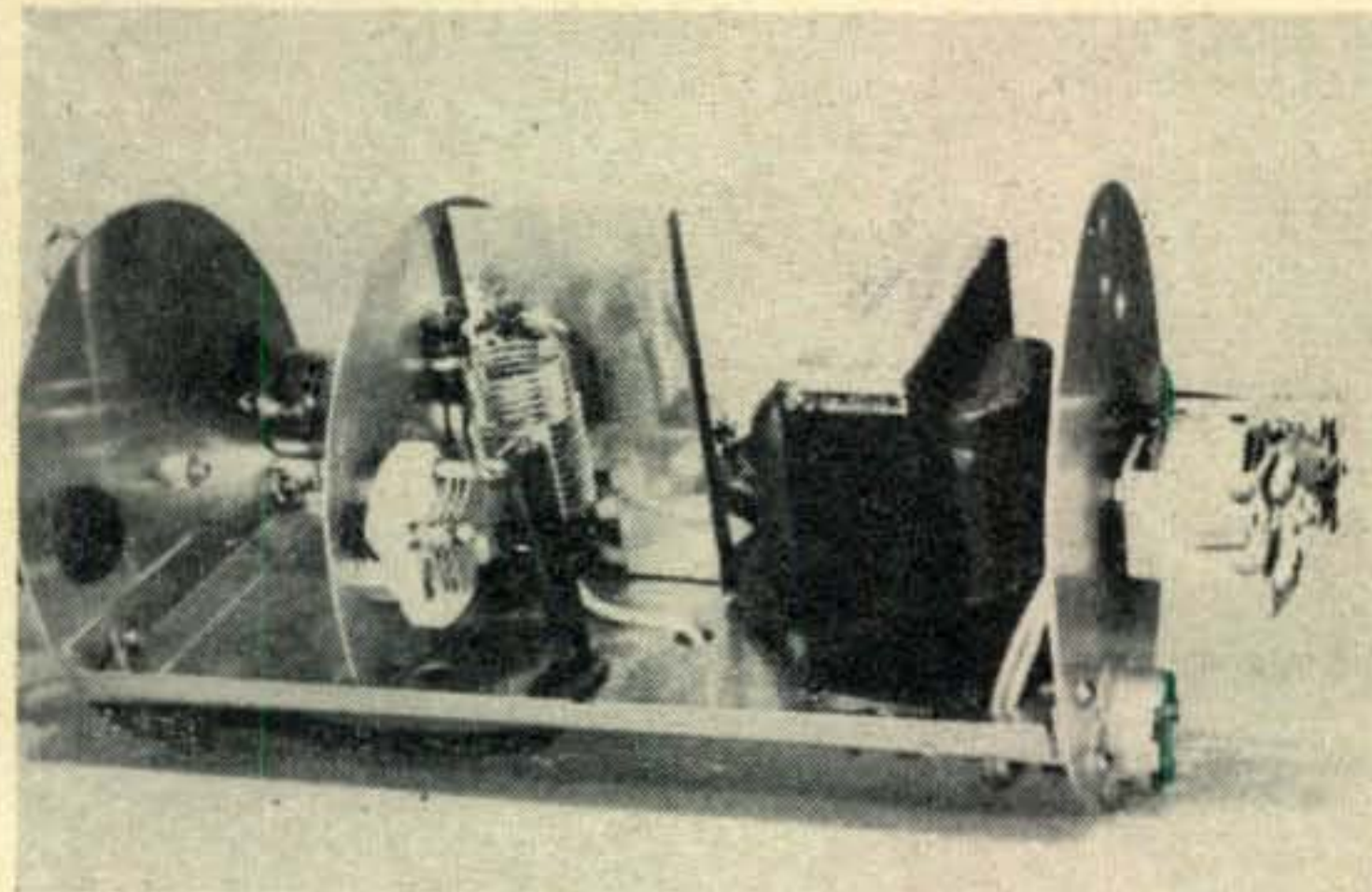

In this view the power transformer (a Merit P-3046) is seen mounted near the base of the 6BQ7. The selenium rectifier is a Federal #1159.

burn up due to an oversight which left them in the "Transmit" position.

**Coil Winding Data**

(50 Mc. Unit)

- L1—6 turns, #20 tinned on 5/8 inch diam., 3/8 inch long, or Miniductor 3007.
- L2—11 turns, #20 tinned on 5/8 inch diam., 11/16 inch long, or Miniductor 3007.
- L3—14 turns, #20 tinned, 1/2 inch diam., 7/8 inch long, tapped 3 turns from C6 end, or Miniductor 3003.
- L4—4 turns of #24 enam. wound around L3, also see text.

**"Microwave Nomograms and Charts"**

This is the title of a little booklet just released by Airtron, Inc., Linden, N.J. We draw the conclusion that it is available upon request at the above address. The booklet contains a series of charts and nomograms developing the art of designing and utilizing waveguide components. Apparently there was such a large call for this type of material that the engineering staff at Airtron, Inc. decided to put this booklet in the hands of those that can use it. The charts contain data on cutoff frequencies, characteristic impedances, waveguide attenuation, waveguide dimensions, etc. For anyone interested in this field (1000 megacycles and up) this booklet should be quite valuable.

**What The Gang is Doing**

R. W. Pullen, W4KPB/Ø (Minot, N. Dakota) brings to our attention that the "skeleton slot" antenna built by G2HCG and described in the November column is not quite comparable to the usual "slot." The latter is a term derived from the waveguide aperture antenna with horizontal polarization. Possibly we did not make this clear, and we stuck to the nomenclature used by G2HCG, although as W4KPB points out it is inaccurate.

V. L. Carr, W1WAS (So. Portland, Me.) asks for further dope on the G5CD helical beam installation which has been sent out to him.

Roy T. Tucker, W8LVF (Columbus, Ohio) has sent in a detailed report on the 144-Mc. FM emergency net in the Ohio state capitol. It appears that a very active organization has been formed to operate on 145.26 Mc. and is now known as the Franklin County Civil Defense Emergency Net. A portion of the net also operates 10-meter AM, but W8CXD, W8KEM, W8KMM, W8WXY and W8LVF try to encourage 2-meter work. Most of this group have their own FM equipment (some of it mobile). The remainder of the FM gear is located in the CD stations throughout the city and county. While some of the FM equipment was purchased by CD funds from General Electric, a lot of the Ham gear has been converted from old commercial taxicab mobile equipment.

This net sounds so interesting we hope to have further details on it within the near future—possibly with conversion data on the commercial equipment.

Amos Hawkins, W8INQ (Zanesville, Ohio) reports that 220 Mc. activity in and around Dayton is quite strong. Most of the fellows are using 832 finals and crystal controlled converters. Since conditions are against using the 220-221 Mc. portion of the band the gang tries to keep above 221. Some of the common frequencies are:

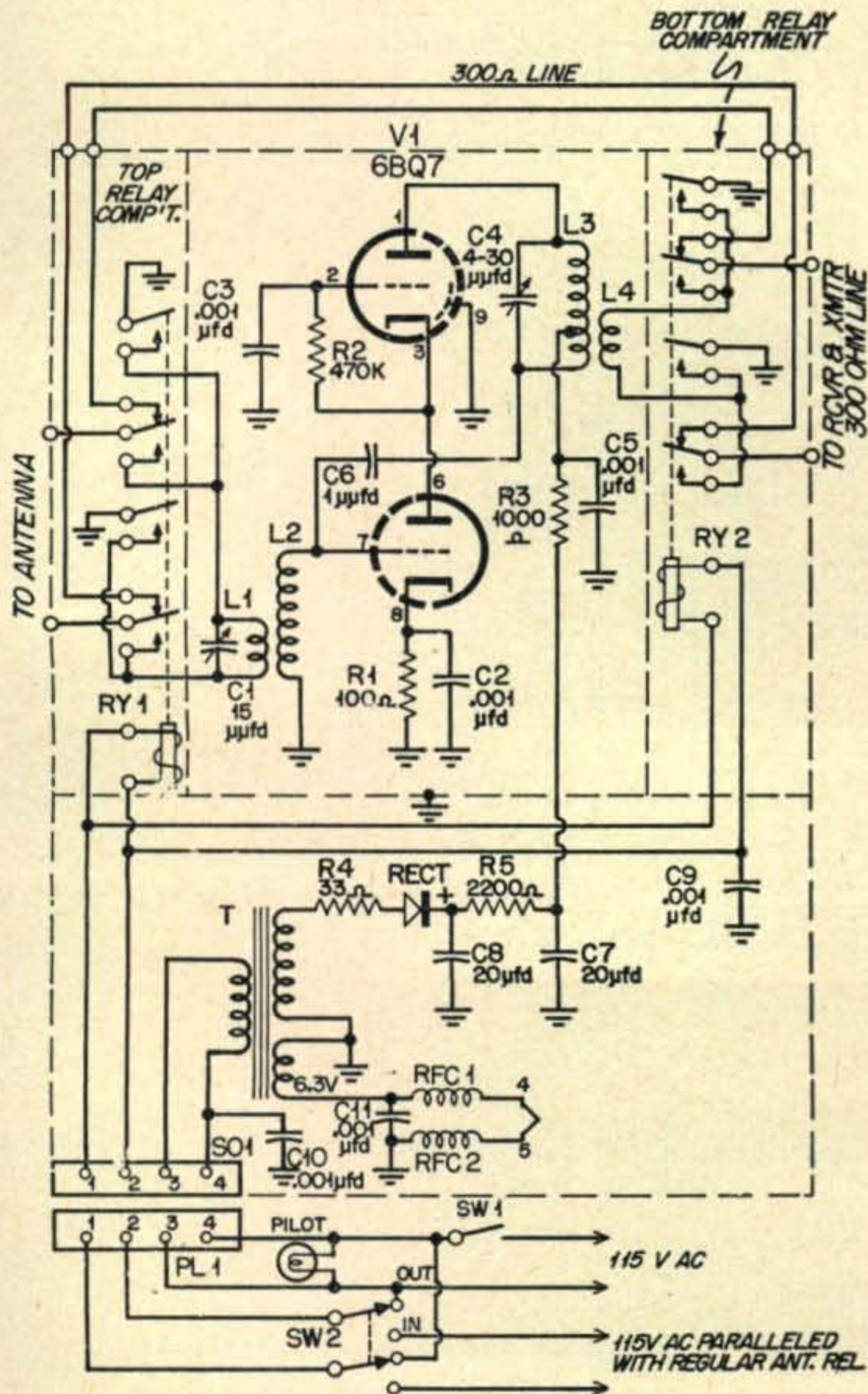
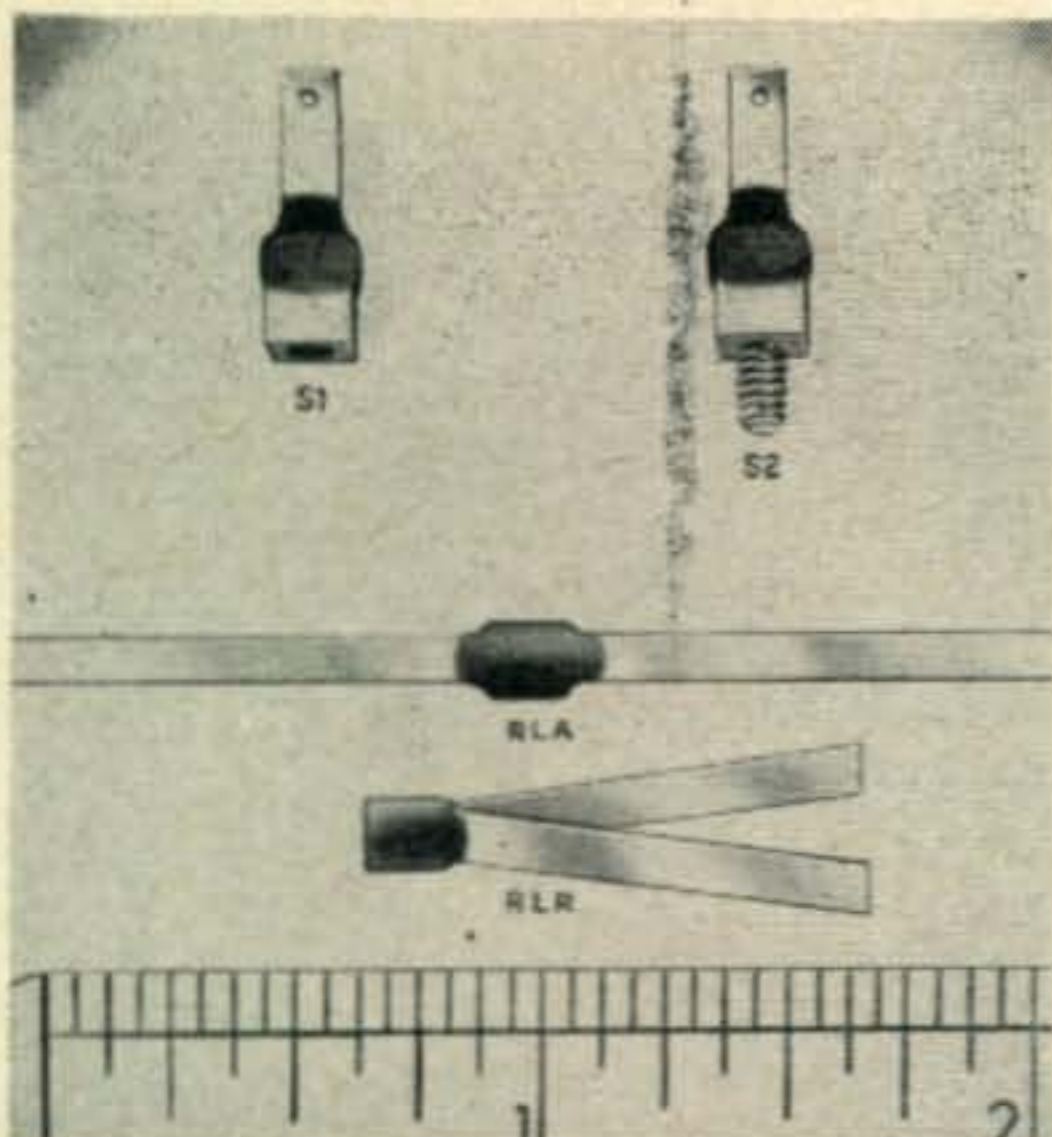

Fig. 2. Wiring schematic of the booster. The two toggle switches are mounted in the shack.



(Newark, N.J.) has introduced some subminiature ceramic capacitors that are really small. The photograph will give you an approximate idea. Type S1 has a female thread (4-40) while type S2 has a male thread with capacities ranging from 2 to 10,000  $\mu\text{fd.}$  (to 2000  $\mu\text{fd.}$  in the standoff unit only). Type RLR and RLA have lead ribbons and body sizes from  $\frac{1}{8}$ " to  $\frac{3}{8}$ " square. They range in values from 4 to 7500  $\mu\text{fd.}$  No doubt about these capacitors reducing inherent series inductance to a minimum for u.h.f. work. We are trying to find out if and when they will be available on the open market from your local parts jobber and distributor.

You fellows that are thinking of 420 Mc., and above, may be interested in seeing some of the new commercially available "G-string" line now being marketed by David Bogen Co. (29 Ninth Ave., New York 14, N.Y.). It has a loss comparable to that described by K2CHF ("The G-String," CQ, April, 1953, page 13) which is about half that of open-wire line and one-third that of the best 300-ohm twin-lead. The line is insulated and comes from the manufacturer with two "launchers." The launchers are supposed to match 300-ohm lines to the antenna and receiver. We must admit it sounds good.

**Standing Waves**

This month we are introducing a few paragraphs on current techniques, news, etc. that are not covered in the remainder of this department. If you like the idea of these short items, please be sure and let us know.

A lot of v-h-f readers have expressed some interest in the appearance on the market of the 6BQ7A. Little definite information is available but the impression is widespread that the 6BQ7 developed a form of displacement on the heater wires which shorted to the cathode. However, these were not entirely caused by thermal expansion of the heater. Reports indicate that the shorts resulted when there was a potential difference of over 100 volts between the cathode and heater. The 6BQ7A has this defect corrected and is also capable of a little more gain . . . Speaking of tubes, we were quite impressed to see the 26-page booklet issued by the **Amperex Electronic Corporation** (230 Dufy Ave., Hicksville, N.Y.) on the 5894/AX9903 tube. It is punched for insertion in a small looseleaf notebook. It contains detailed data on the popular twin-triode with application notes, typical performance curves, special features and a description of the tube construction. If you are thinking of using this tube be sure and get this booklet from the above address. Mention that you saw it in this column.

(Continued on page 59)

W8KJT on 221.8 Mc., W8SVI on 220.0 Mc., W8BMO on 221.9 Mc., W8INV on 221.69 Mc. and W8INQ on 221.4 Mc.

**Additional Dope on the "Twin-5"**

It doesn't seem possible that nearly four years have gone by since the widespread introduction of the W2PAU, or Brownie "Twin-5" antenna. Still a very popular array, it was described in the March, 1950 issue of CQ (the Circulation Manager tells me that back copies are not available) and essentially consists of two 5-element Yagis spaced 81" apart. The matching design pictured in the original article centered around 300 ohms (noted in part 1 of the drawing).

Many 144-Mc. operators however use various forms of co-ax cable, or even 450-ohm open wire line. The diagram below shows the methods of matching into 50-ohm co-ax (part 2), 75-ohm co-ax (part 3) and 450-ohm line (part 4).

By the way, we plan on running some more data on this antenna with particular emphasis on its use at 220 and 420 Mc.

**Some Thoughts on a New Product**

While this may be stealing the thunder from our new section in CQ on "parts and products" I do feel that several items should be mentioned and discussed in this column. For example, the other day I noted that Mucon

1. 300-ohm RIBBON AMPHENOL FLAT WIRE (RECEIVING TYPE)

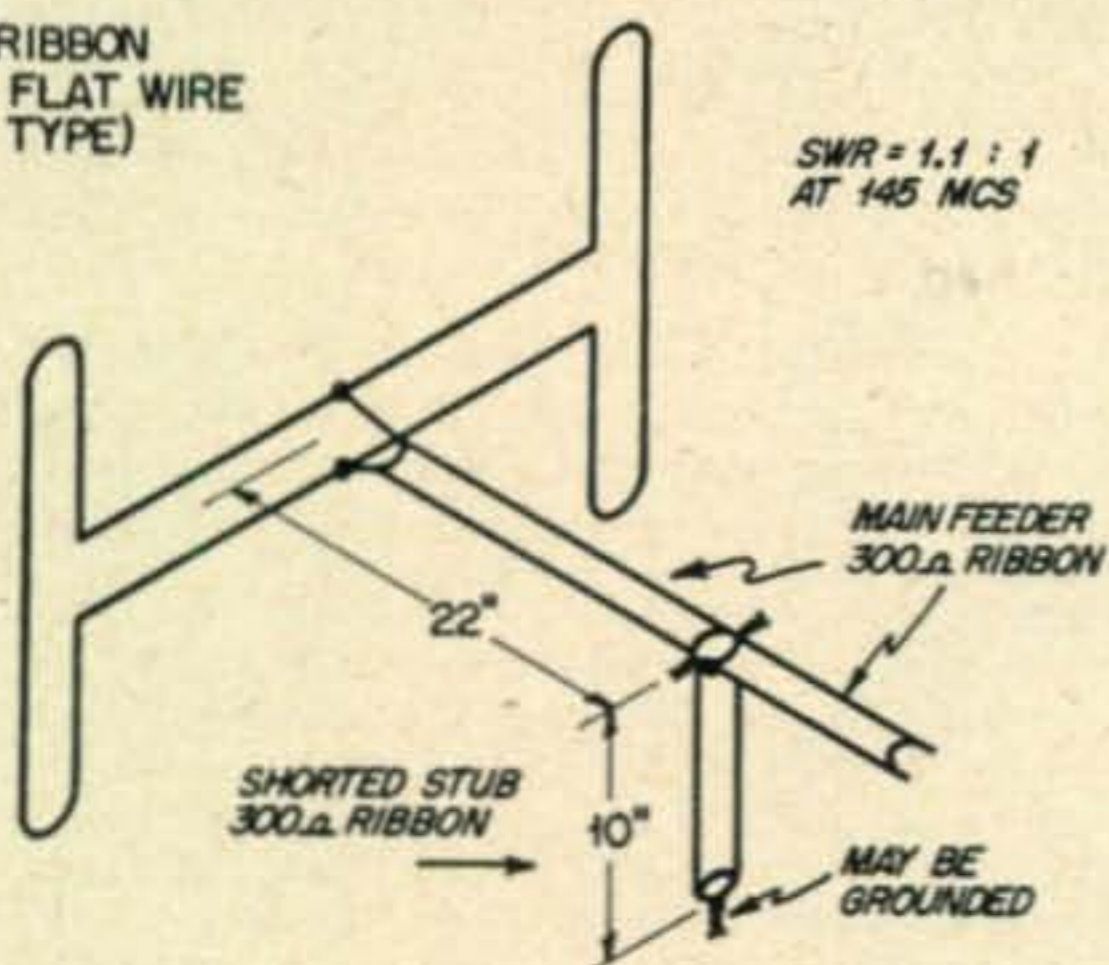

3. 75-ohm CO-AX RG 11/U, RG 59/U, RG 13/U, ETC.

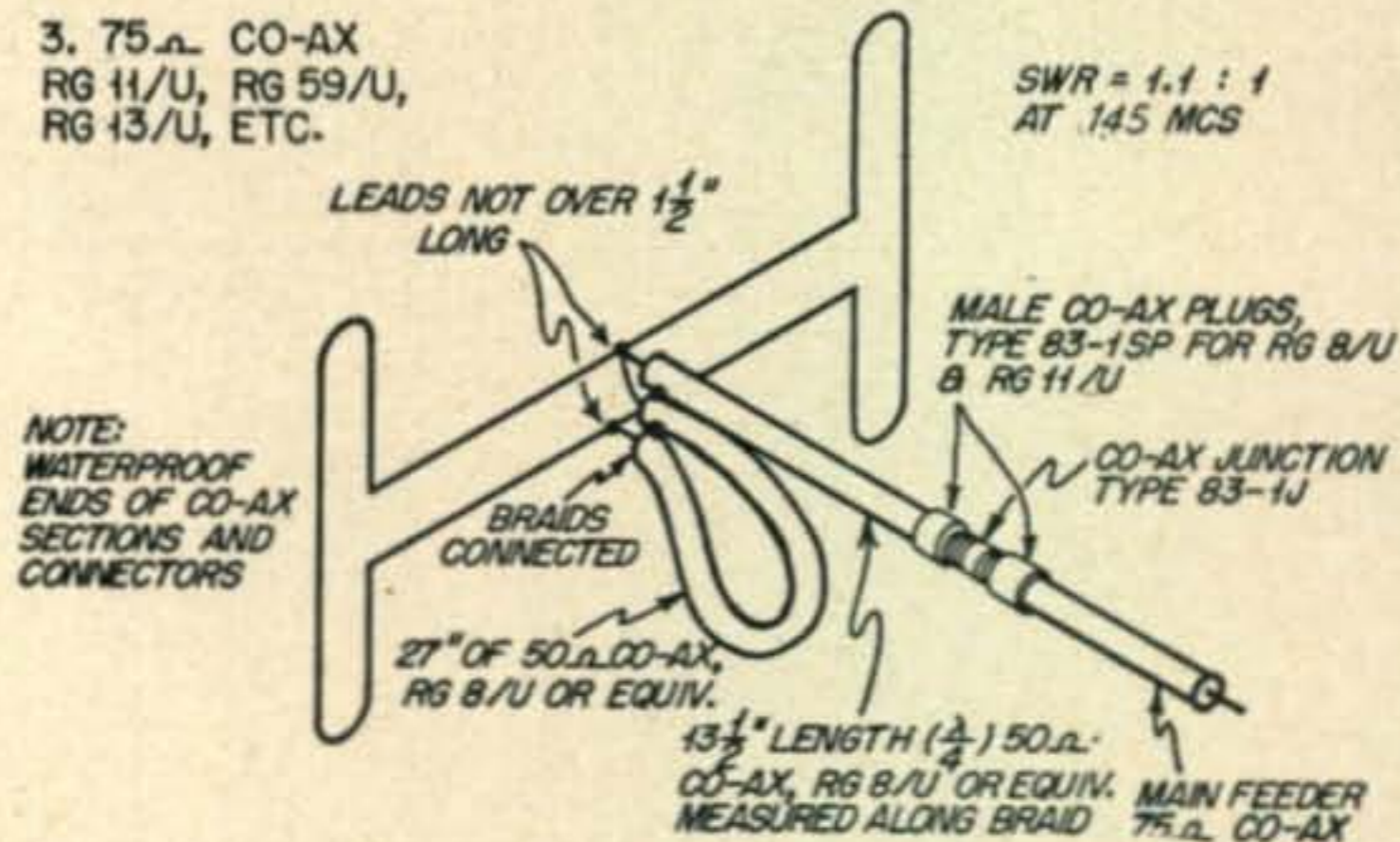

2. 50-ohm CO-AX RG 58/U, RG 8/U, ETC.

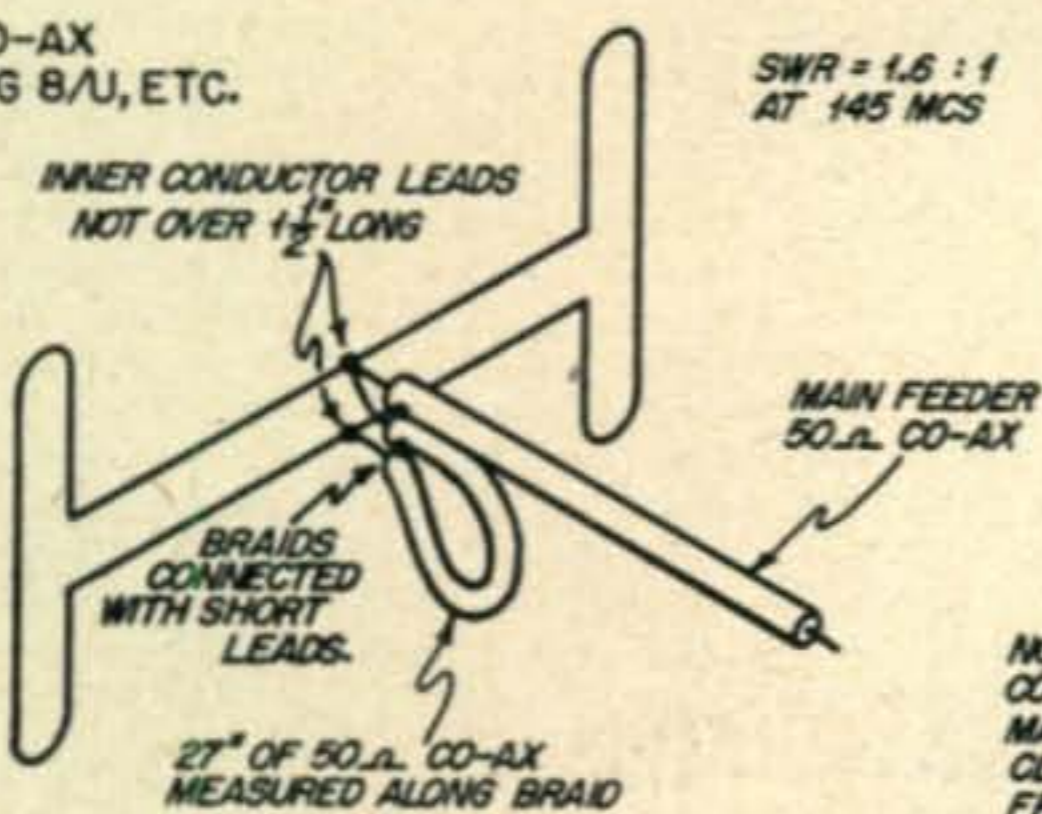

4. OPEN WIRE 450-ohm LINE

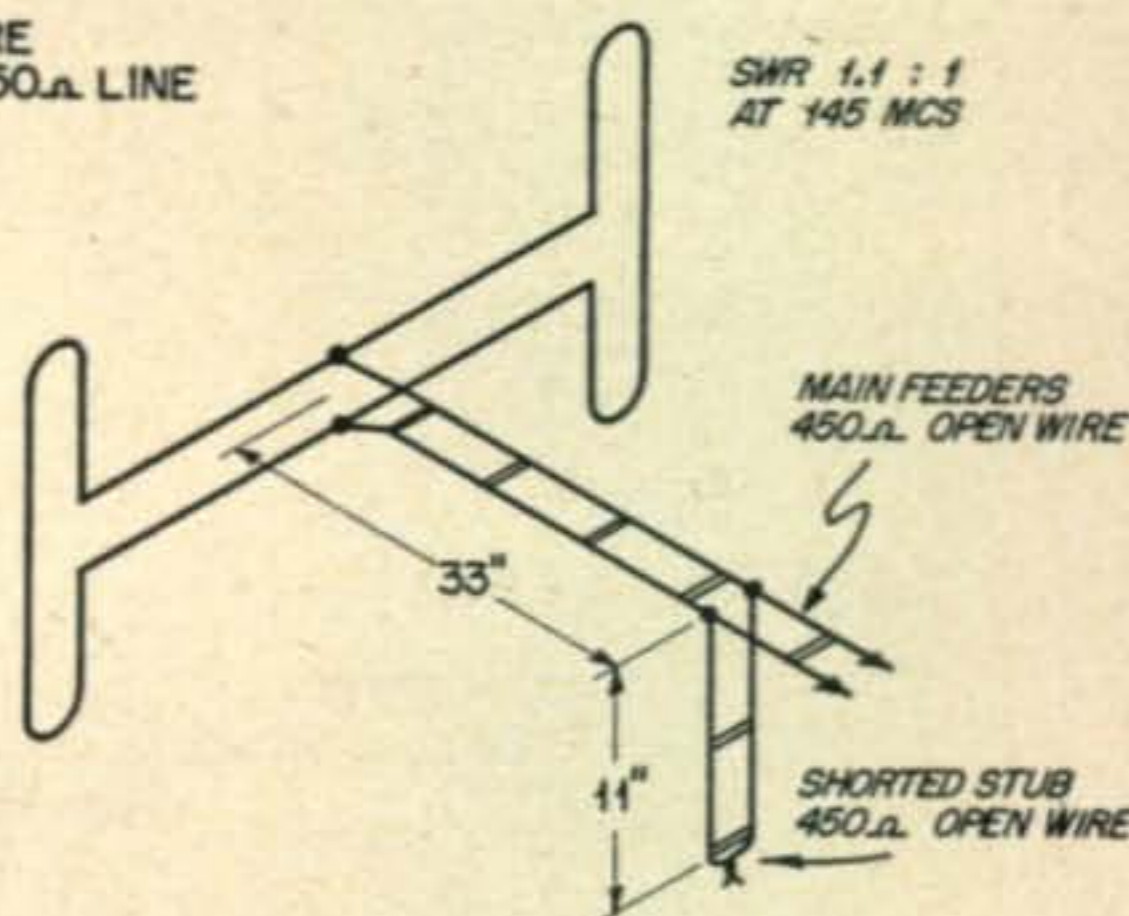

Matching the "Twin-5" to various feedline impedances.





LOUISA B. SANDO, W5RZJ/Ø

General Delivery, Cortez, Colorado

### 5th Annual YL-OM Contest

March is just around the corner, and that means the second big contest of the season for the YLs—and the OMs are included in this one—the *YL-OM Contest*. This will be the fifth annual run-off of this event. Dates have been set for Saturday, March 6, and Sunday, March 7. Here are the details:

- DATES:** Start Sat., March 6, at 1300 EST.  
End Sun., March 7, at 2400 EST.
- ELIGIBILITY:** All licenced OMs, YLs and XYLs.
- FREQUENCIES:** All bands. Cross-band operation permitted.
- PROCEDURE:** Call "CQ YL-OM."
- EXCHANGE:** QSO number; RS or RST report and State, U. S. Possession, VE District or Country.
- SCORING:**
- a—One point for each station worked (YL to OM or OM to YL only.)
  - b—Stations and multipliers count only once, regardless of band or mode of operation.
  - c—Add number of points and multiply by number of different States, U. S. Possessions, VE Districts and Countries worked.
  - d—All phone contestants running 150 watts input or less at all times may then multiply final score by 1.5
  - e—All CW contestants running 150 watts input or less at all times may then multiply final score by 1.25
  - f—Maryland and District of Columbia count as one State.
- AWARDS:**
- Highest OM score—regardless of mode of operation—cup and certificate.
  - Highest YL score—regardless of mode of operation—cup and certificate.
  - Highest OM score—phone to phone—cup and certificate.
  - Highest YL score—phone to phone—cup and certificate.
  - Highest OM score—CW to CW—cup and certificate.
  - Highest YL score—CW to CW—cup and certificate.
  - Second and third highest in each category will receive certificates.
  - Winner of one award is not eligible for any other award.
  - These cups are awarded on a yearly basis with a three-time winner obtaining permanent possession.
- LOGS:** Copies of contestants logs must be postmarked not later than March 27, 1954 and must be sent directly to Ruth B. Siegelman, W2OWL, Vice-President, YLRL; 1414 Wythe Place, Bronx 52, New York. All contestants must fill in their own logs while operating. No help is permitted. Contestants are requested to send in separate phone-to-phone, CW-to-CW, phone-to-CW and CW-to-phone logs. Please state power input, and send copies of logs in, regardless of size of score, to help in cross-checking others logs.

### Meritorious Service

As winter storms wreak their usual havoc, Hams, as usual, come to the rescue by handling emergency traffic. WØKFN, Catharine Tepley, received credit for maintaining emergency communications when her home town of Pipestone, Minn., was cut off on Nov. 20th from the outside world by a sleet storm. All telephone and telegraph lines were out of order from early Friday until late Sunday, Nov. 22. WØKFN's antenna, protected by an evergreen tree, survived the storm. With the first plea for help Catharine contacted W9AAG, who relayed to WØARY, who phoned the telephone company's division headquarters in St. Paul. Thereafter WØKFN and WØBWN in Minneapolis maintained contact, and for three days all emergency messages left Pipestone via Catharine's station.

### Beware!

We all know the potential danger of electricity—and are often warned of it. In fact, most Hams are on the lookout for "hot" gear, but we're not always on the lookout for other trouble spots. W8ATB, Esther, recently suffered a harrowing experience with 117 volts a.c.

She had used her automatic washer but had not turned off the water. She reached to turn it off and at the same time took hold of the sump pump—which had a short in it to the 117-volt line. Both her hands were held fast with current coursing through her body. She was alone in the house, so calling for aid was useless. She managed to kick one a-c plug from the wall socket, but it wasn't the one to the pump. All the time she had been praying for help—and suddenly she was free. She managed to get upstairs to the phone, and later the doctor told her that the only thing that saved her was a strong heart. Esther says that the muscles of her right arm were tied in knots and her left wrist very sore, but both are coming along fine. She also expresses thanks to all those who have sent cards and letters, and warns everyone to "Be careful!"

### Here and There

Speaking of recuperating, we've recently had a couple of letters from W8NAL, Carmella—one just before she underwent surgery (for TB) at Cleveland, and another now that she is back at Molly Stark Hospital in Canton, Ohio. Carmella says she came through surgery in fine shape but needs another six months of strict bed rest after which she can gradually start taking on extra activities. "This means the gang will have to wait a little longer for my replies," she adds. "Since your write-up in CQ I have received scads of cards and letters—from Ireland, Guam, Canada, all U.S. districts but the first and sixth and from many non-amateurs. It's wonderful what one acquires through these FB radio friends—I am proud to be one."



**W5VIL, Gladys Landry, experimenter and UHF enthusiast, is looking for skeds on 220 Mc.**

A note from W2TUK commending the efforts of W2KEB during the Mineola Fair and Long Island Agricultural and Industrial Exhibition. At the amateur radio exhibit Georgianna operated the station, K2DHC/2, every day from opening time to closing time (1 to 11 p.m.) with only time out for dinner. . . . Attending the Oklahoma State Hamfest No. 15, W5CA met YLs W5VBG, SNL and PWN. . . . W7SFR, Lorraine, tells of a big write-up in the *Portland Oregonian* about gals in amateur radio with a full page of pictures, including two NYLON net members, W7NJS, Beth, and W7RVM, Helen. Among the other net members, W7PTX, Betty, is back at Mukilteo. She is a member of MARS. W7GX1, Marge, also a member of MARS, shot a deer during hunting season. W7QYN, Lois, has been waiting for Air Force MARS membership. She checks into the Washington net, is on a 2-meter local net and handles lots of traffic.

According to W6PCN, Peggy, it looks like San Francisco might finally be developing some YL activity. The San Francisco Radio Club, which admitted its first YL in its 25-odd years of existence just about three years ago, now has five licensed YL members. They are W6PHT, Cynthia, who, with her OM, PIH, got their tickets when the Novice license first became available. She's on 75 and 10. W6QMO, Jeri, also came up through the Novice ranks with OM, PHS. Jeri's active on 80 and 40 CW and on 10. She got into club activities the hard way when she handled the cook tent for Field Day. KN6CUT, Myrtle, got her ticket in October after 19 years of exposure to Ham radio, first through her brother and then, with her OM, AHH. She is on 80, and will join Bob on 75 and 10 when she makes General Class. KN6CUV, Lee, whose OM is KN6BZY, will also be on 80 till she gets her general. W6PCN, Peggy, was the first licensed YL in the club and has just finished a year as secretary and editor of the club newssheet. She and OM, GCV, are on 20. They've put up a beam, succumbed to NBFM, and added a phone patch, so they're

handling a load of traffic from Japan and Alaska.

The Long Island Press did a picture story on women radio amateurs on Long Island. YLs photographed were W2JZX, Vi; K2ESO, Lea; W2SUR, Esther; Winnie, XYL of W2UXY; W2IGA, Ruth, and W2MWY, Ann. W2RTZ, Hope, is now at ARRL Hq. as an official log-checker, and hopes to be on the air again soon.

### 220-Mc. Schedule?

W5VIL, Gladys Landry, of New Orleans, La., is looking for schedules on 220 Mc. Yes, she has a Technician's license (May, '52)—and she's putting it to good use. Her transmitter is a modulated tuned-lines oscillator consisting of a 24G with a pair of 6V6's as modulators. The input to the oscillator is 30 watts. Antenna is a horizontally polarized folded dipole fed with 300-ohm twinlead. The receiver is a superregenerative 9002 followed by a 6J5 and a 6V6 audio.

Gladys feels the higher frequencies are a great challenge to Hams and a chance to see if we can do something with those "useless" frequencies. Of course, she's interested in the lower frequencies, too, and has been looking forward to ragchewing on 20. Her OM, W5VUH, got his General Class ticket in July '52. This was one of those cases where the XYL got her ticket first so that her OM would become a Ham. Now they both enjoy it, especially operating mobile with his call. Norm also has built a 500-watt all-band rig for their radio room. Gladys likes to build, too, and has been putting together a transmitter using transistors instead of vacuum tubes—just for the fun of experimenting.

W5VIL first became interested in radio when she worked in the Electronics Department of the Industrial Manager, USN, Eighth Naval District (a ship repair outfit). Her OM is an electronics engineer she met while working for this office. Presently she is the assistant to the Secretary to the Industrial Manager, USN, Eighth Naval District. Gladys also is secretary of the Westside Amateur Radio Club of New Orleans.

### SK

Here we go again—yep, we're moving once more. Been at this QTH 2½ years, as long as we've ever stayed put in one spot. We'll be in the Ø district now, at Cortez, Colorado. And we expect to be a working girl again, too (not that we haven't been right along what with homemaking and caring for the two jr. ops!). At this writing all we can say is that both the OM and yours truly will be working for a new agency, at Towoac, set up to help the Southern Ute Indians.

You know this signature, "33", that we use every month, causes a lot of comments. It is used by all YLRL members as an expression of sisterly affection. After explaining this on the air recently to an OM, W7PJY broke in and quipped, "You mean 33's are half of an 88 (cover the left half of an 8 and you do get a 3)—they leave off the kisses but send the love." Very clever, OM!

So, 33 till next month—W5RZJ/Ø



Members attending one of the summer meetings of the New York City YLRL. Left to right, seated: W2UXM, Sally; K2DYO, Dot; W2TBU, Kit; W2OWL, Ruth; W2EEO, Madeline. Standing: Ruth Schlitt; W2IGA, Ruth; CO2MR, Marie Rose; W2RTZ, Hope; Helen Zuparn; W2VXC, Ethel; W2IQP, Lil.

# for Peak Performance...



**INSIST ON...**

## **OHMITE<sup>®</sup>** **DEPENDABILITY**

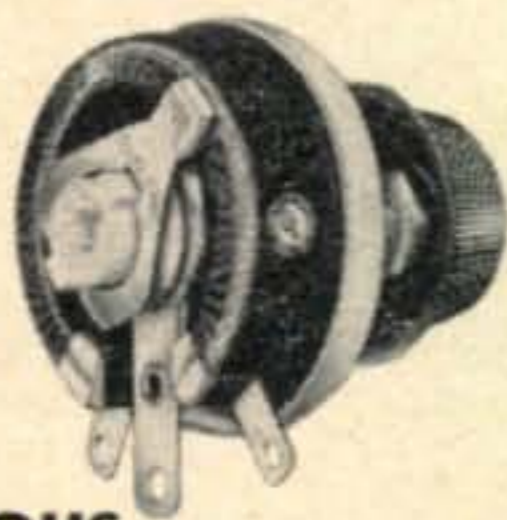

### **VITREOUS ENAMELED RHEOSTATS**

10 Sizes, 25 to 1000 watts.  
Ceramic and metal construction;  
metal-graphite brush.

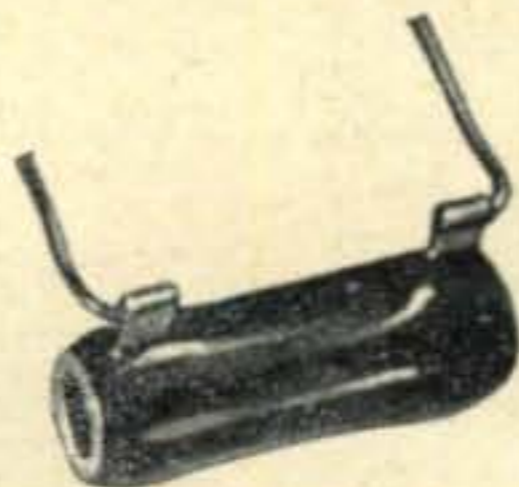

### **BROWN DEVIL<sup>®</sup> FIXED RESISTORS**

Small sizes—5, 10, and 20  
watts. Five larger sizes to  
200 watts.



### **DUMMY ANTENNA RESISTORS**

Practically non-reactive within  
recommended range. 100-250  
Watts. 52-600 Ohms.

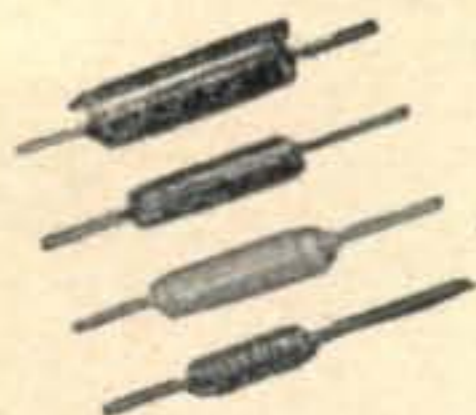

### **FREQUENCY-RATED PLATE CHOKES**

It's easy to select the right  
unit for all frequencies.  
Seven sizes, 3 to 520 mc.



### **DIVIDOHM<sup>®</sup> ADJUSTABLE RESISTORS**

Wire-wound, vitreous-enam-  
eled. Adjustable lugs. Seven  
sizes—10 to 200 watts.

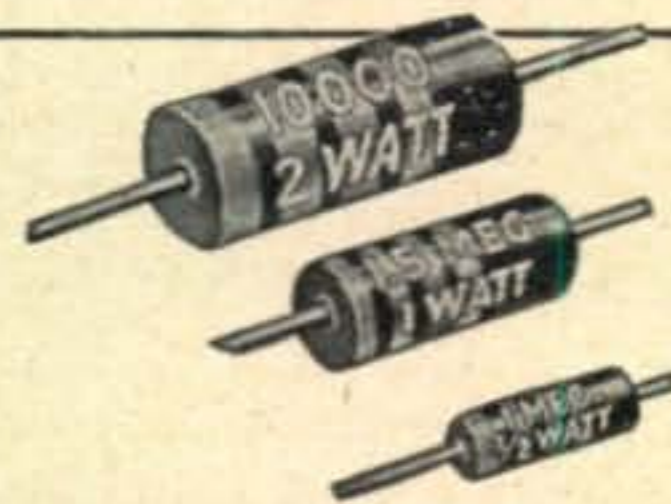

### **LITTLE DEVIL<sup>®</sup> COMPOSITION RESISTORS**

Tiny, rugged, insulated units,  
clearly marked for resistance  
and wattage. 1/2, 1, and 2 Watts.

*Be Right With...*

## **OHMITE**

**RHEOSTATS • RESISTORS • TAP SWITCHES**

**WRITE FOR  
STOCK  
CATALOG**

**OHMITE  
MANUFACTURING CO.**

3638 Howard Street  
Skokie, Ill.  
(Suburb of Chicago)

# Test Equipment..... ... in the Ham Shack

HOWARD BURGESS, W5WGF

925 Adams St., S.E., Albuquerque, New Mexico

(Part III of This Series)

## R. F. Signal Generators

The amateur who builds or repairs his own equipment most certainly needs an r-f signal source for alignment purposes. There are a great many Hams, though, who purchase ready-made gear. Sooner or later, however, the temptation to "peak 'er up just a little" will overcome even the conservative individual and we then have another candidate for a signal generator. It appears to be a common failing among us that some of the most useful tools are the least complicated and the ones we do without. Signal sources seem to fall into this class.

During the past few years the field of signal generators has been developed to the point where a comprehensive discussion of the subject would require volumes. Due to limited space the present discussion will cover only that small portion most suited to amateur radio.

The common r-f test signal generator can be divided into two important parts, the oscillator and the attenuator. The attenuator, in many cases more difficult to construct than the oscillator, will be discussed later. Of course the oscillators used can be divided into two types, the self-excited for general coverage and the crystal for precision spot frequencies.

### Selecting the Oscillator

In selecting a circuit for the self-excited test oscillator any of the basic circuits such as Hartley, Colpitts, Franklin or others may be used. Several versions of these common circuits have appeared in recent years under such names as Clapp, electron-coupled, or other designations. Regardless of many heated discussions in the past, it is generally considered by unbiased workers that given equal treatment, there is little stability difference between the basic circuits.

Having eliminated the question of stability the selection is more or less determined by the physical layout possible with various circuits. It is frequently convenient from a switching standpoint to use a circuit where only one or two terminals need to be switched on the inductor. Other times, selection of specific parts

available such as the tuning condenser will indicate the use of another such as the Hartley circuit.

If one is contemplating the construction or purchase of a signal generator, the mechanical layout of the oscillator should be given considerable attention. This applies to the dial as well as the condenser and bandswitch. A dial or tuning condenser which has backlash or lacks resetability will render the most stable oscillator useless. A desirable type of bandswitching arrangement is the movable coil turret, but because of its cost it is usually out of the average Ham price range.

A good substitute for frequencies below 100 megacycles is the sub-assembly type of construction. In this method a rugged tuning condenser and other oscillator components including a well-made wafer type bandswitch and coils are mounted on a small sub-chassis. With this construction, very short leads are possible and stresses on the main chassis or cabinet are not readily transferred to the oscillator assembly. This also lends itself to better shielding if such is desired.

For the brave few who insist upon building all of their equipment, the two most tedious tasks of a general coverage r.f. generator are

*(Continued on page 64)*

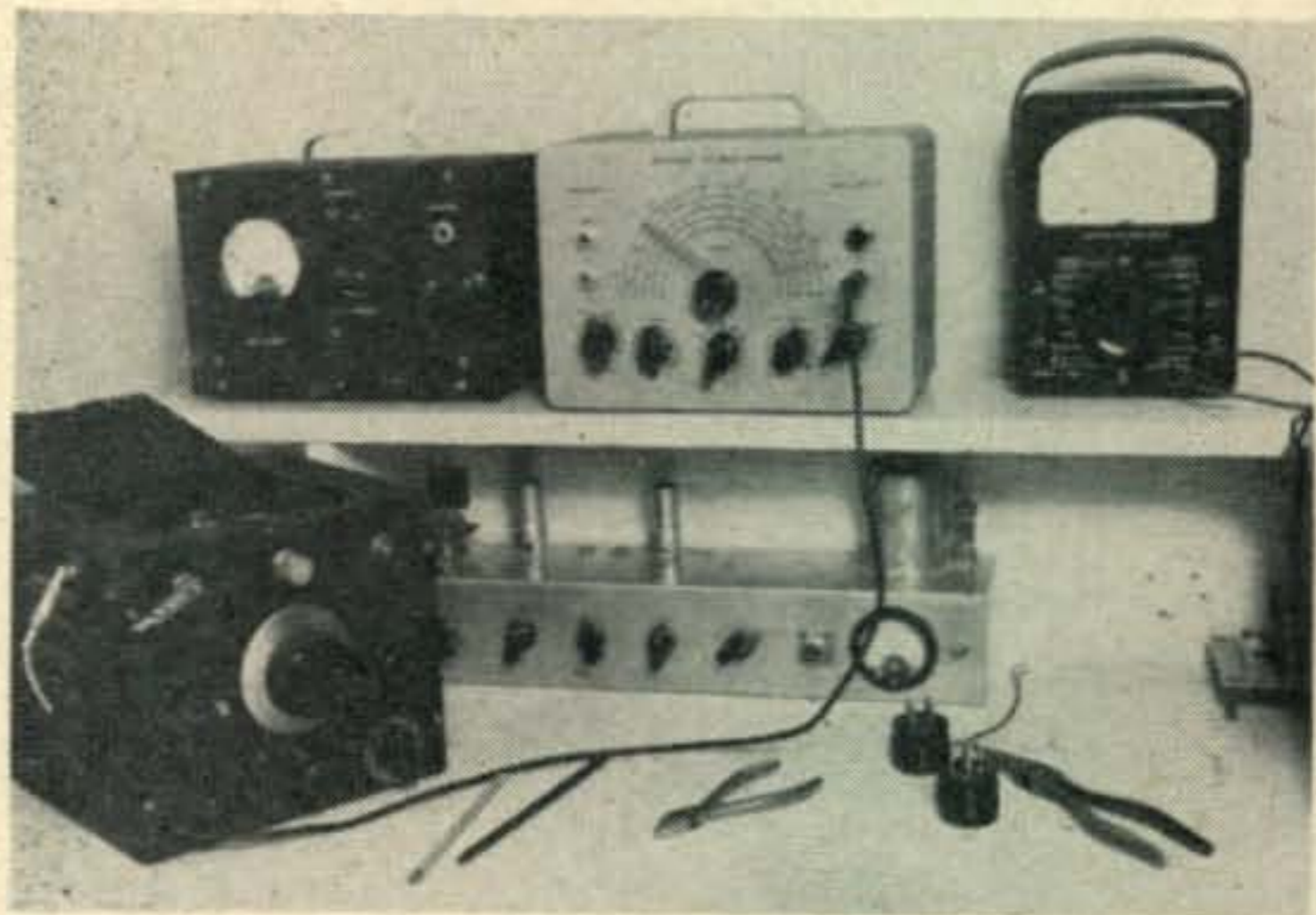

A Heathkit Model SG7 signal generator is used by the author to align a portable receiver. The long chassis under the shelf is a crystal calibrator. A multimeter connected to the output of the receiver is on the right of the generator.

# HARVEY ALWAYS HAS IT...IN STOCK For IMMEDIATE DELIVERY

## The New GONSET COMMUNICATOR II

Built-in Adjustable Squelch and Ear-Phone Jack

An improved model of the popular Communicator, 2-meter station. Cabinet modified to include ventilating screens. Ideal for CD work because of squelch and automatic speaker muting when phones are plugged in. Has receiver dial light, on/off switch and built-in speaker, noise limiter and 19" whip. Takes crystal or carbon mike. Crystal control.



Complete with tubes (less crystal and mike).....**\$229.50**

## New Mobile Receiver GONSET SUPER-CEIVER

Uses any converter as a tuning head. Employs crystal-controlled first IF and dual conversion to 265 kc. Adjustable-pitch BFO; AF, RF and AVC controls; built-in noise clipper and squelch; built-in PM speaker. Furnished with convertible (dual) 6-12 volt pack and tubes.

less converter **\$119.50**

## GONSET "SUPER 6"

Six Band Amateur Converter



A compact converter covering 10, 11, 15, 20, 40, and 75 meter phone bands. Also covers 6 mc. (49 meter) and 15 mc. (19 meter) short wave broadcast bands. Uses 6CB6 low noise rf stage, with panel controlled antenna trimmer, 6AT6 triode mixer, 6C4 modified Clapp oscillator, and 6BH6 IF stage.

Complete with Tubes.....**\$52.50**

## JOHNSON VIKING Mobile Transmitter Kit

A low cost, efficient rig in kit form, ready for quick and easy assembly. 30 watts input at 300 volts... up to 60 watts, at 600 volts. 100% modulated...three stages, 807 output...75, 20, and 10 meters with provision for additional band... crystal control. Other features include: band-switching, gang-tuning, RF fixed bias supply, and metered stages.....**\$99.50**

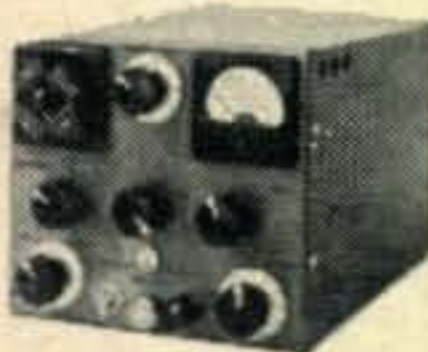

## New SONAR SONAFONE Portable and Marine Radiophone

Model M4W

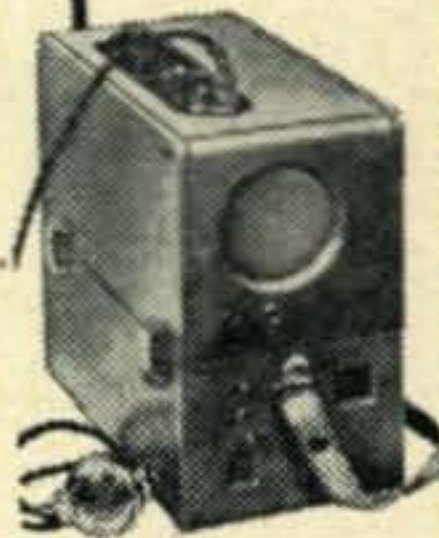

A compact, four channel, 2-way radio telephone. Self powered. Will operate for approximately 20 hours without recharging. Self-contained batteries can be charged from standard household current or from storage battery. Operates on any channel from 2 to 3mc covering telephone, Coast Guard, and two ship-to-ship bands. Has 5 to 50 mile transmitter range. Delivers approximately 3 watts to built-in antenna. Built-in speaker, plus closed circuit jack for use with external trumpet speaker as efficient P.A. system. No written test or technical knowledge required for license. Weighs less than 20 pounds and can be carried like an overnight bag.

Complete with battery, tubes, antenna, and microphone (less crystals).....**\$198.50**

Battery Charger.....**19.95**  
Add Federal Tax..... **6.62**

## The COLLINS 75A-3 Receiver



With Mechanical Filter

The familiar Model 75A-2, redesigned and modified to provide for the use of mechanical filters. Supplied with one 3 KC filter, and facilities for one additional. A 2-position front panel switch permits selection of filter desired.

Complete (less speaker).....**\$530.00**  
Speaker.....**20.00**



## NATIONAL NC-88 World-Master in coverage... World Beater in value

The advanced NC-88 circuit uses 8 high-gain miniature tubes plus rectifier, covers 540kc to 40mc with calibrated bandspread for amateur bands. Built-in speaker; two IF stages; 2 audio stages with phono input and tone control; antenna trimmer; separate high frequency oscillator; sensitivity control; series valve noise limiter; delayed AVC; headphone jack... and other features that add valuable performance characteristics to this popular model.

NC-88 complete with tubes.....**\$119.95**

## COLLINS 32V-3 Transmitter

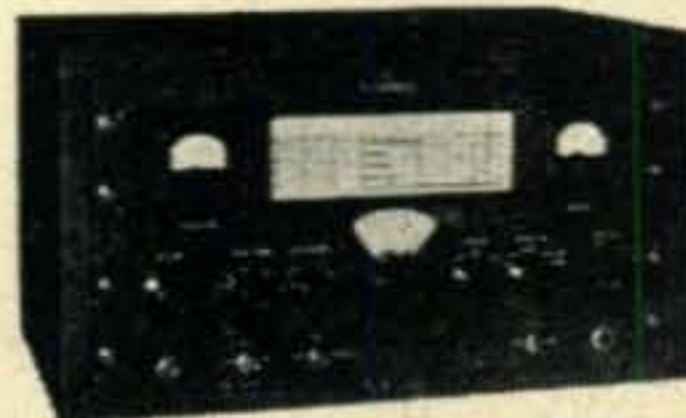

A VFO controlled bandswitching, gang-tuned amateur transmitter. 150 watts input on CW and 120 watts on phone. Covers 80, 40, 20, 15, 11 and 10 meter bands.

Dimensions: 21 1/8" wide, 12-7/16" high, 13 7/8" deep.  
Complete with tubes.....**\$775.00**

## SUPERIOR POWERSTATS

Smooth, efficient voltage control, 0-135 volts output from 115 volt AC line. Models also for 230 volt input. Write for free literature. Models for table and panel mounting.



Type 10, 1,25 amps.....**\$ 8.50**  
20, 3 amps..... **12.50**  
116, 7.5 amps, table mtg..... **23.00**  
116U, 7.5 amps, panel mtg... **18.00**  
1126, 15 amps..... **46.00**  
1156, 45 amps..... **118.00**

Complete Stock Always On Hand For Immediate Delivery

**WE'RE GENEROUS ON TRADE-INS!**

What've you got to trade on this fine equipment? Because of our big outlet in the New York market, we can make you a generous allowance. Send full description.

**Anywhere in The World ORDER BY MAIL DIRECT FROM HARVEY**

NOTE: Prices Net, F.O.B., N. Y. C. Subject to change without notice



# Harvey RADIO CO., INC.

103 W. 43rd St., New York 36, N.Y. • JUDSON 2-1500

# Faraday Shield for the Antennascope

ELBERT ROBBERSON, W2FRQ

44 Sintsink Drive, East, Fort Washington, N.Y.

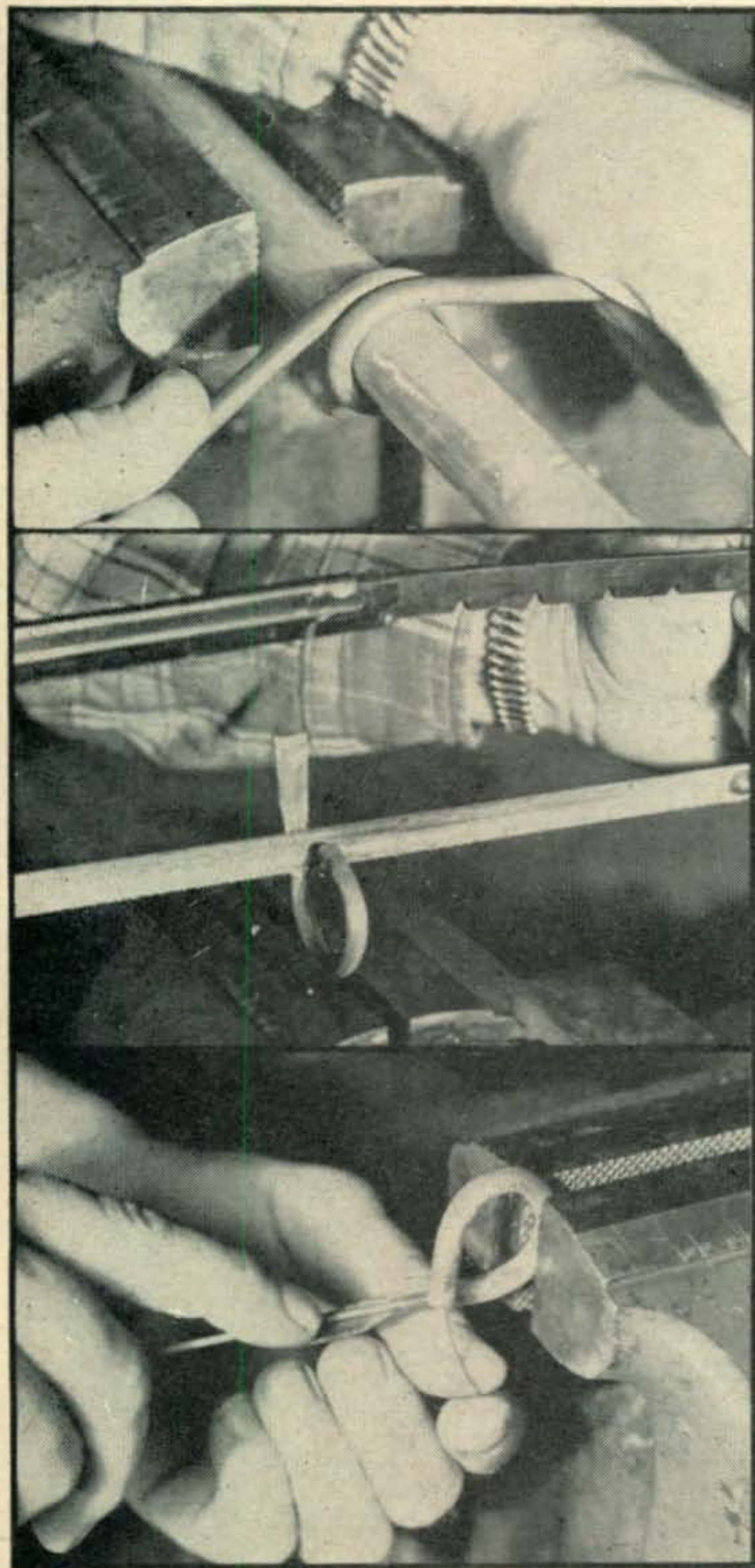

Soft-drawn tubing is bent to diameter, then one end sawed off at point of meeting (top photo). The remaining end is slit and flattened, and the edges smoothed (center photo). Solid wire is then pushed into the tubing, using the straight portion as a guide to prevent compression kinks (bottom photo). At this operation, the end of the tubing is still offset to facilitate insertion of the wire. After the proper number of turns have been pushed through, it is bent back into the main plane of the circle.

Amateurs using that very popular little r-f bridge, the "Antennascope,"<sup>1</sup> sooner or later notice that resistance readings vary with the grid-dip oscillator coupling and the placement of the various items in the test setup. This difficulty is largely due to capacity coupling causing residual current which cannot be balanced out. Such a condition makes it appear that the circuit under test is reactive when it actually may not be, and is, therefore, a source of inaccuracy.

A Faraday shield will cure the fault, allowing the full degree of magnetic coupling while completely eliminating electro-static coupling. Construction is not complicated or difficult.

The first thing to be determined is the minimum number of turns required in the input coil for the particular g.d.o. being used. This can be done with small, bunch-wound coils of insulated wire. The fewest number of turns that will give a satisfactorily high meter indication should be used. With the *Millen* instrument shown in the photograph, four turns are ample from 1.7 Mc. to 32 Mc., and for higher frequencies, two turns give maximum sensitivity. Some instruments require only one turn.

## A Simple Faraday Shield

In this case, a shielded one-turn input coil can very simply be made from a few inches of RG-58/U coaxial cable. One end is skinned, and lugs are put on the shield and central conductor. At the other end, the outer sheath and the braid are cut back approximately  $\frac{1}{4}$ " and the insulation trimmed from  $\frac{1}{8}$ " of the inner conductor. The cable is then bent into a loop which will just slip over the g.d.o. coil, and the sheath marked where the cable end touches. At this point, two girdling cuts should be made through the neoprene cover  $\frac{1}{8}$ " apart, and this little piece removed. This exposes the outer braid, and the end of the inner conductor should be soldered to it at this point. Care should be taken not to melt the dielectric, and the connection should be cooled immediately after the solder has flowed. The loop should be connected to the *Antennascope* input with the braid connected to the ground terminal, then formed so the g.d.o. coil can conveniently be coupled. Place the g.d.o. as far as possible

(Continued on page 54)

<sup>1</sup> W. M. Scherer, "Building and Using the Antennascope," CQ, Sept., 1950, page 13.



LEO I. MEYERSON  
W8GFQ

# NOW ANYONE CAN AFFORD TO BUY FROM WORLD RADIO LABORATORIES

MINIMUM DOWN PAYMENTS — ONLY 10%  
PAINLESS INSTALLMENTS — UP TO 18 MONTHS  
MINIMUM INTEREST RATES — ONLY 1/2% PER MONTH

Get personalized service from WRL — "One of The World's Largest Distributors of Amateur Radio Transmitting Equipment."

LEO GIVES BEST DEAL ON . . .

## National RECEIVERS

### NC-183 D RECEIVER

Dual conversion on the three highest ranges plus every feature you want in a truly modern receiver! (Less Speaker). \$383.50



**\$20<sup>90</sup>** (18 MONTHS)  
\$30.49 (12 Months)    \$38.35 (Cash Down)

### HRO-60 RECEIVER

with AUTOMATIC DUAL CONVERSION

Less speaker . . . \$533.50

**\$29<sup>08</sup>** (18 MONTHS)  
\$42.42 (12 Months)    \$53.35 (Cash-Down)

### Now Available . . . NEW NC-88

only \$129.95  
with Built-in Speaker

**\$10<sup>33</sup>**

(12 MONTHS)

**\$13.00**  
CASH DOWN



A top-notch value for both the novice and experienced amateur! Compare these features: Calibrated bandspread for 80, 40, 20, 15, and 10 meter bands. Advanced A.C. superhet circuit uses 8 high gain miniature tubes plus rectifier. Covers 540 kcs. to 40 mcs. in 4 bands. Tuned R.F. stage — two I.F. stages — two high-fidelity audio stages with phono input and 2-position tone control. Built-in speaker. Antenna trimmer — separate high frequency oscillator. R.F. gain control. Series valve noise limiter. Delayed A.V.C. Headphone jack. And, send-receive switch.

## CHECK OUR GENEROUS ALLOWANCES WE NEED MORE TRADE-INS

### NATIONAL RECEIVERS AND ACCESSORIES

MODEL NO.	12 MONTHLY PAYMENTS	CASH DOWN	CASH PRICE
NC-125 RECEIVER	\$15.89	\$20.00	\$199.95
SW-54 RECEIVER	3.97	5.00	49.95
SELECT-O-JET	2.29	2.88	28.75
NFM-83-50 ADAPTER	1.43	1.80	17.95
SPEAKER FOR HRO-60 OR NC-183D \$16.00			

**FREE**  
1954 WRL  
CATALOG  
**SEND TODAY**



World Radio Laboratories  
744 West Broadway  
Council Bluffs, Iowa

C-2

Please send me:

- New Log Book
- Free Catalog
- Radio Map (25c)
- NC-88 Info
- NC-183 D Info
- HRO-60 Info
- NC-125 Info
- Used Equipment List

Name \_\_\_\_\_  
Address \_\_\_\_\_  
City \_\_\_\_\_ State \_\_\_\_\_

WRITE FOR DETAILED SPECIFICATION EQUIPMENT SHEETS

WRITE  
WIRE

PHONE  
7795

# World Radio

LABORATORIES

COUNCIL BLUFFS,  
IOWA



## WHY BUY 3 COILS WHEN A VAARO VARIABLE

SINGLE UNIT GIVES YOU 75 - 40 - 20 - 15 - 11 and 10 METER BANDS.

Can be INSTANTLY TUNED to ANY DESIRED BAND or FREQUENCY by moving the SLIDER until transmitter loading is obtained. "ALL BANDS IN ONE COIL"

FINEST MOBILE COIL EVER BUILT:

- Factory Pre-tuned.
- No Grid Dipping.
- 3-Second Band Changing.
- Corrosion & Shatterproof Construction.
- No Loose Connections.
- Continuous Coverage from 3750 kcs to 30,000 kcs.
- Highest "Q" Available.
- Fits All Whips & Bases.

V-102—250 Watts Input—

\$17.95 Amateur's Net

V-103—500 Watts Input—

\$19.95 Amateur's Net

COMPLETE ANTENNA from Base Mounting to Whip Tip ALSO AVAILABLE . . .

NEW LITERATURE READY.

AT YOUR DEALERS, or WRITE

VAARO ELECTRONIC ENG. CO.

P.O. BOX 5035 LONG BEACH, CALIFORNIA

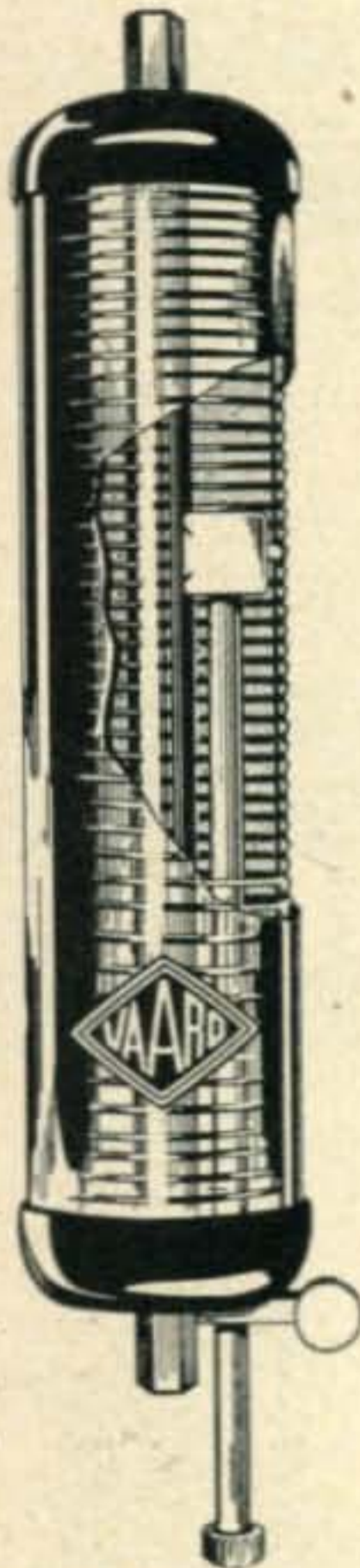

(from page 52)

from the exposed "hot" input terminal.

On the lower frequencies, or with oscillators having a low-Q tank, more than one turn will be required. The required number of turns can be wound inside an incomplete loop of copper tubing which will provide the necessary shielding, as well as mechanical protection to the coil.

A short length of soft-drawn, 1/4" tubing is used. It should be tubing which has not already been bent, since such working hardens the copper and makes short-radius bends almost impossible. Although only about 4" of the tubing will be used, working with a longer piece will make the forming operation easier.

One complete turn is tightly wrapped around a form the size of the g-d-o coil, and the tubing is then cut to size. Slit and flatten the terminal end of the tube, ream off the inner burrs, and file all edges smooth. This is the shield. All that is required now is to get a coil having the required number of turns inside the tube.

Use solid-copper (not stranded) plastic-insulated wire. Number 20 will do for 2 or 3 turns, but #28 gauge will push easier if more turns are needed. On the first pass, push through enough wire for the whole coil.

After the required number of turns are pushed into the loop, the curved end of the loop is bent so it is in line with, and almost

## Engineered BEAMS By GOTHAM 10—20M

All beams use any standard transmission line. Full data supplied with each beam. All GOTHAM beams assemble quickly, are adjustable over the entire band, and can easily be stacked on a single mast. Every beam complete with all hardware, fittings and castings. All aluminum tubing is 61ST6 alloy, with wall thickness of .049".

S202T—Std. 20m 2-E1. T match, \$24.95. 1—12' Boom, 1" Alum. Tubing; 2—12' Center Elements, 1" Alum. Tubing; 4—12' End Inserts, 3/8" Alum. Tubing; 1—T Match (8'), Polystyrene Tubing; 1—Beam Mount.

D103T—DeLuxe 10m 3-E1. T match, \$25.95. 1—8' Boom, 1" Alum. Tubing; 3—6' Center Elements, 1" Alum. Tubing; 6—6' End Inserts, 3/8" Alum. Tubing; 1—T Match (4'), Polystyrene Tubing; 1—Beam Mount.

D203T—DeLuxe 20m 3-E1. T match, \$49.95. 2—12' Booms, 1" Alum. Tubing; 3—12' Center Elements, 1" Alum. Tubing; 6—12' End Inserts, 3/8" Alum. Tubing; 1—T Match (8'), Polystyrene Tubing; 1—Beam Mount.

### NEW 2 METER BEAM KIT

Contains, 1-12' Boom, 1" alum. Tubing; 2-12' lengths 3/8" alum. tubing, also 7 hanger fittings. A great buy in a 2 meter beam kit. . . . . \$9.95

HOW TO ORDER: Remit by check or money-order. We ship immediately by Railway Express, charges collect; foreign shipments cheapest way. 10 day unconditional money-back guarantee.

**GOTHAM HOBBY** 107 E. 126 Street  
New York 35, N. Y.

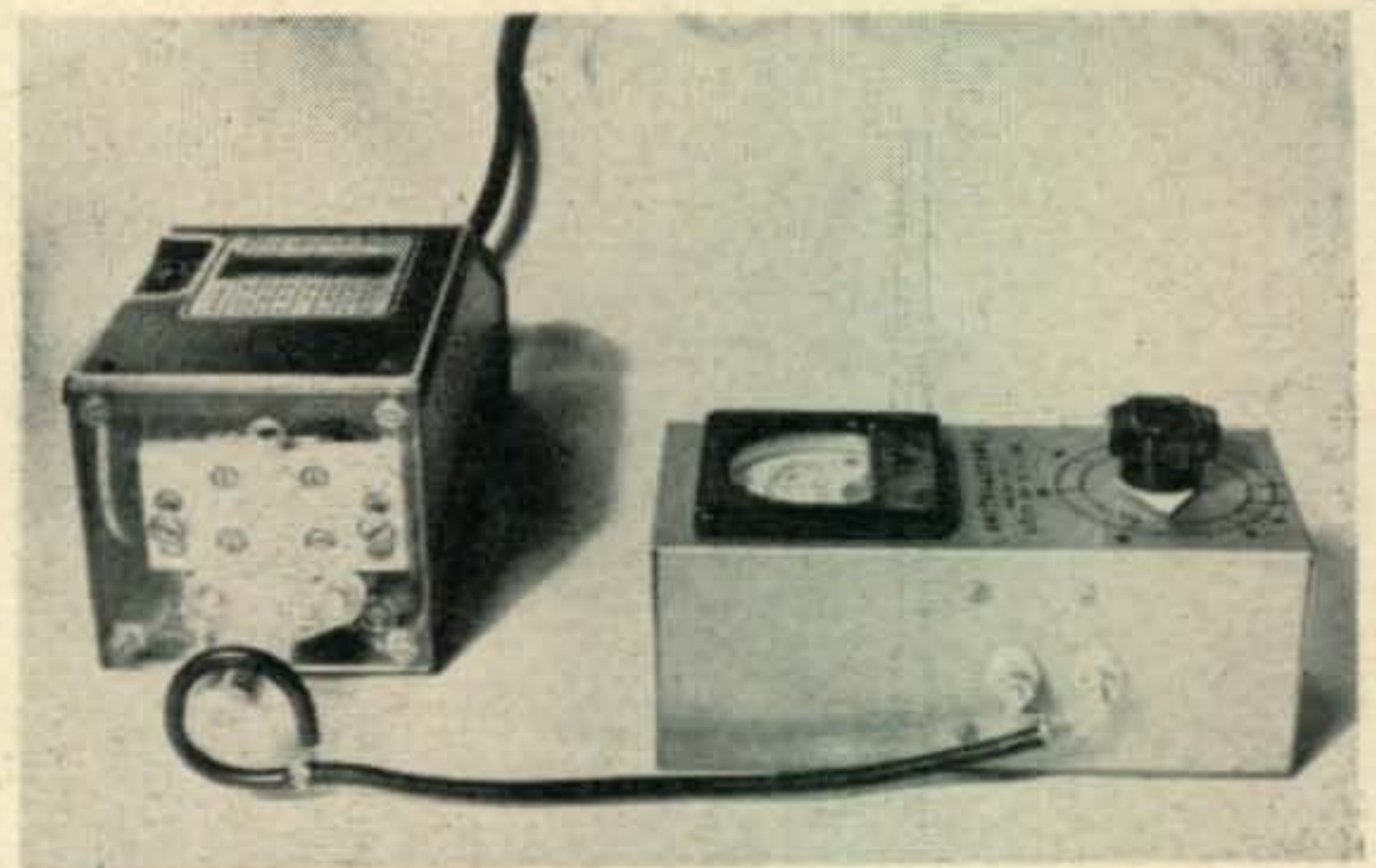

1. A one-turn shielded loop of RG-58/U may be ample for the higher frequencies, depending upon meter sensitivity and the Q of the g-d-o output circuit.

touching, the end of the opening in the straight portion. Gently take up on the wire as required so that it is all inside the shield, and push small pieces of spaghetti over the ends to prevent cutting the insulation. One end should be soldered to the terminal, or ground end, of the copper tubing, and the other fitted with a lug. Drill a hole in the flat end with a #25 drill, bend as shown in the photograph, and the assembly is ready to connect to the Antennascope. Make certain, of course, that the shield is connected to the grounded-input terminal. Operation should now be free of any irregularities due to capacitive coupling.



# ESSE SPECIALS

## 20 WATT AMPLIFIER: Brand New

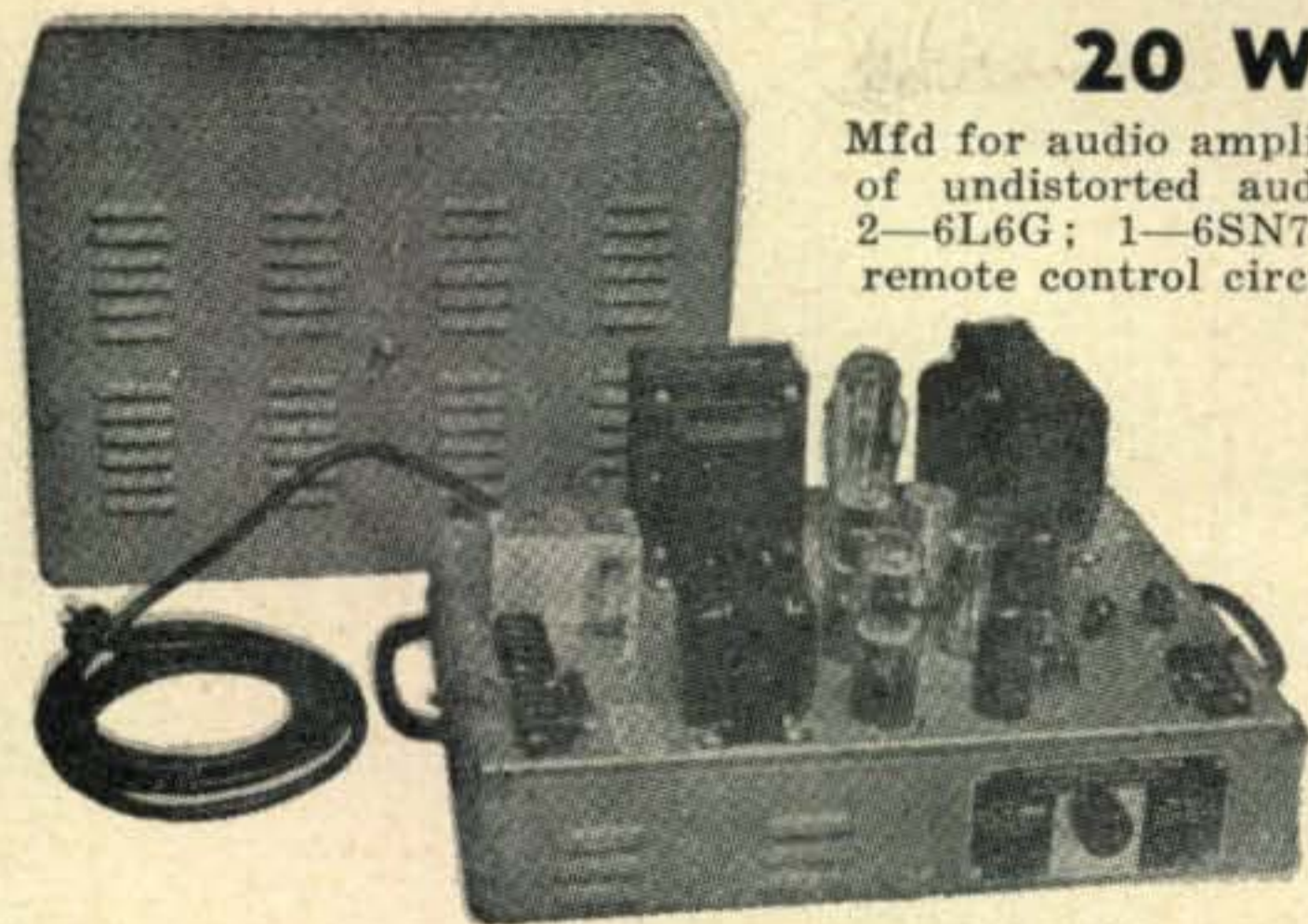

Mfd for audio amplifier in Measured Music Systems. Amplifier delivers 15 watts of undistorted audio or 20 watts maximum. Tubes used and included are 2-6L6G; 1-6SN7; 1-6SJ7; 1-5U4. Also 1-6AL5 and 1-2D21 used in remote control circuit. Treble, bass, vernier volume and master volume controls are provided. Sturdily built for continual operation in beautiful gray crackle cabinet 17" x 9 3/4" x 12 1/2" with carrying handles and key lock cover. Unit is foolproof and trouble free, ideal for use in skating rinks, dance halls, etc. Has Phono and 600 ohm line inputs. Circuit diagram provided with each unit. Original Manufacturer's price on this item understood to be \$129.50. Your price, brand new with all tubes, for 110-120 V. **\$24.95**

Can be supplied for 110 V. **\$5.00** extra  
25 cycle operation.....

## M-1 SERVO UNIT FOR BEAM ROTATION

Unit has self-contained hydraulic pump actuated by 27 V.—11 Amp. 1/5 hp. motor which pumps oil into either side of hydraulic piston giving better than a 100 lb. torque to cable drum. Unit is reversible by actuation of either of two self-contained solenoid hydraulic valves. Connect by cable around antenna beam for any desired rotation speed. Greater adaptability than any other surplus device on the market. **\$9.95**  
BRAND NEW—Only a few, order early

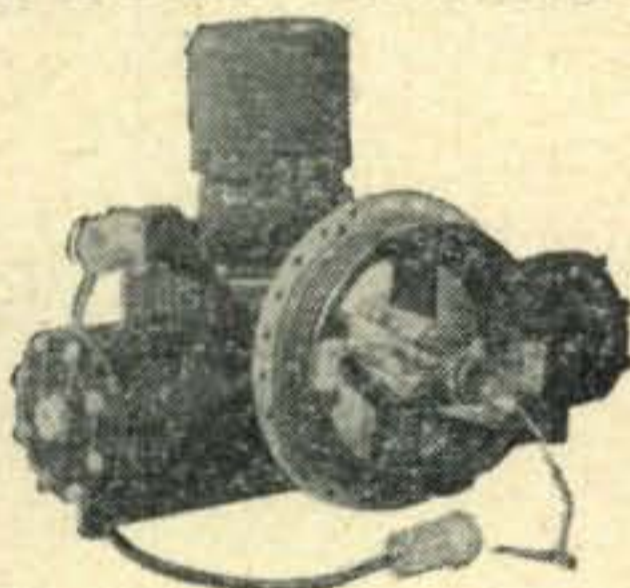

## CAP — 75 meter Mobile ATTENTION! BC-454 RECEIVER — 3-6 Mc.

Here is an ideal receiver for CAP or mobile enthusiast. Excellent sensitivity and frequency stability are found in these receivers. Can be supplied converted for 6 V. filaments or with self-contained 110 V. AC power supply and volume control ready for operation. Used but good. 110 V. **\$17.95**  
Complete .....  
6 V. Conv. **12.50**  
(HV needed)

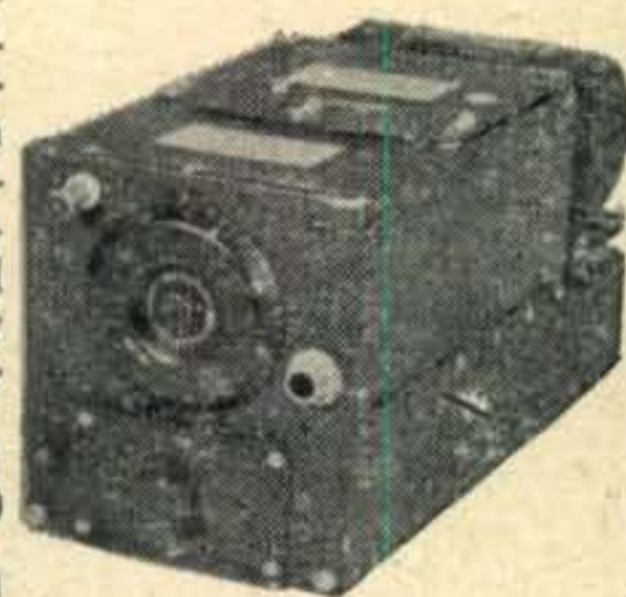

## NEW TUBES - - JAN

10-Y/VT25	\$ .50	956	\$ .35
211/VT-4C	5.00	1619	.50
10E-146/VU111	.50	1625	.50
100TH	5.00	1626	.35
VT-127A	3.50	7193	.25
250TH	15.00	1G6/GT	.50
304TL	7.50	2X2/S79	.72
371B	1.00	3B7/1291	.50
446A (light house)	1.75	3D6/1299	.50
450TH	35.00	3S4/VT174	.50
454	7.50	6B8G	.50
801-A	1.00	6J6	.75
813	9.50	6SF7	.75
826	1.00	7C4	.50
829	7.50	7C5	.75
832	7.50	7Y4	.75
832A	8.50	12A6	.50
GL-846	20.00	12C8	.50
851	25.00	12J5GT	.50
852	12.50	38/VT38	.50
860	3.50	39/44	.50
954	.35	45/VT52	.50
955	.35		

## 115 V. 60 CYCLE SELSYN INDICATOR UNIT & TRANSMITTER

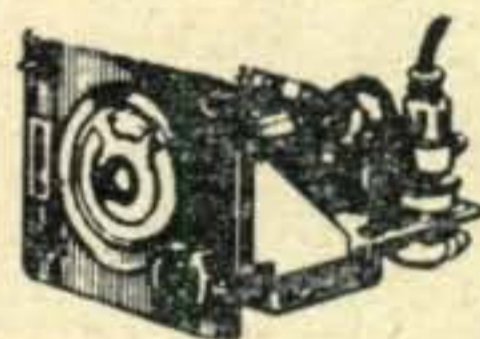

Complete with Selsyn Transmitter & Indicator calibrated from 0-360 degrees. By use of the transmitter on the beam, indicator will show position on rotation, or use for TV antenna rotation by attaching TV antenna to transmitter shaft and setting indicator. (Not large enough for rotation of heavy Ham beams.) Unit has self-contained transformer for illumination of indicator dial. Size 6 3/4 x 6 3/4 x 8 3/8". **\$18.50**  
PRICE, Complete with Transmitter.....

## CO-AXIAL CABLE

RG/8U.....100 ft. ....**\$4.95**  
RG/29U.....100 ft. ....**\$2.95**  
1000 ft. or more, 20% discount

## WANT TO BUY

electronic or hydraulic surplus in quantities. Please advise of any known whereabouts of the above and we will endeavor to negotiate a deal whereupon we will pay the sum of 5% of our purchase price for the information.

40 West  
South Street



Indianapolis 4,  
Indiana

## ARE YOU FEEDING YOUR ANTENNA WITH 300 OHM RIBBON???

These compact, multi-band (80-10 meters), balun coils assure maximum transfer of power between the transmitter and the antenna by serving as an efficient, impedance matching device. Designed for 75 ohm unbalanced power output from such transmitters as the new B&W Model 5100, the Collins 32V Series, the Vikings, and others with Pi-network finals, they will match either 75 or 300 ohm balanced antenna feed lines—AND WITHOUT TUNING or Switching.

B&W TYPE 3975.....\$3.75

net  
each  
coil



### Barker & Williamson, Inc.

237 Fairfield Ave., Upper Darby, Pa.

## CRYSTALS!

**NOTE** Huge Price Reduction  
Free Gift Offer Below!

### COMPLETE SET — 80 CRYSTALS

Ranging from 370-516 Kc., 54th Harmonic.  
INCLUDING 500 Kc. & 455 Kc. crystals.  
Only ..... Per set **\$6.95**

### COMPLETE SET — 120 CRYSTALS

Ranging from 370-540 Kc., 72nd Harmonic.  
PLUS 500 Kc. & 455 Kc. crystals.  
Only ..... Per set **\$9.95**

200 KC. CRYSTAL.....Ea. \$1.75  
500 KC. CRYSTAL.....Ea. .75  
1,000 KC. CRYSTAL.....Ea. 2.75

**FREE** WRIST COMPASS—On request with  
every \$15.00 order for crystals.

GENERATOR: 12 V. 35 amps.  
Used cond. ....Ea. \$3.95

### Miscellaneous Specials

ULTRA-VIOLET COCKPIT LAMP, Used.....\$1.95  
PILLOW SPEAKER, Used.....1.95  
SOUND POWERED 2-WAY COMMUNICATION SET, With  
50 ft. of wire, Palm type, Excel. cond.....\$3.95  
24 V. TRANSFORMER, Pri. 110 V. @ 2 amps. New 1.95  
MICA CONDENSERS 400 Assorted ONLY \$1.95  
(10 to a strip)  
SILVER CIRCLE TUNER, Used.  
Ea.....\$1.25 3 for.....\$2.95  
GUY LINE: Ideal for TV and radio tower. Heavy duty, with  
turnbuckle on one end. New. Approx. 40 ft. length.....\$1.25  
10 Lengths (40 ft. ea.).....9.95

All merchandise sold as is.

WRITE FOR QUANTITY DISCOUNTS!

Items subject to prior sale. Send for FREE Catalogue!

**J. J. GLASS ELECTRONICS CO.**  
1624 S. MAIN ST. LOS ANGELES 15, CALIF.

## Broad Band . . .

### PE-101-C Info

Editor, CQ:

During my recent conversion of the PE-101-C dynamotor to 6-volt operation, I reconnected the low-voltage armature windings from Simplex Lap to Duplex Lap and got the following approximate load readings: high voltage pin M to ground—420 volts at 170 ma. With simultaneous readings of pin M to ground and pin H to ground, the following readings were observed: pin M to ground—400 volts at 140 ma; pin L to ground, 200 volts at 50 ma.

This information may be of some interest to owners of the PE-101-C dynamotor who will want to increase the output with only 6 volts input.

G. M. Higgs, W6AEK

Grass Valley, Calif.

### Bouquets

Editor, CQ:

The article in the October issue by W6SAI on the gamma match is the clearest, most understandable explanation that has come to my attention.

John H. Elder, Jr., W3RSB

Pittsburgh, Pa.

Editor, CQ:

This is the first fan letter I've ever written. Bill's article is the best written and simplest to understand.

Major E. Murrill, W8OK, ex-W6OQ  
Falmouth, Mass.

### Scratchi vs. Snorlock

Editor, CQ:

Where's Scratchi every other month? I liked him very much!

Horace Smith, W9PPD

Hagerstown, Ind.

Editor, CQ:

I want you to know that every single Ham that I've talked to since you quit publishing "Scratchi" has been very disappointed.

Elza Lenn, W7SMB

Tacoma, Wash.

Editor, CQ:

On page 63 of the December CQ, I noticed your question, "What happened to all those that wanted anything but Scratchi?" I doubt if those who wanted anything but, realized how bad something else could be until you published Snorlock Ohms.

I agree with W5PPS, Snorlock is a poor excuse for humor—give him the editorial axe at once.

William C. Ryder, W1JNM

Chatham, Mass.

Editor, CQ:

Snorlock Ohms sort of caught "H" from the Scratchi fans in the latest BROAD BAND section of CQ. The comment seemed so overwhelming and one-sided that I am moved to express my own very enthusiastic vote for your continuing to print the adventures of Snorlock Ohms.

With apologies to the author of Scratchi, I can only say that I have tried and have not succeeded in working up any interest in his articles. I hope you will continue to present them 50-50.

Donald F. Hemenway, W3SQP

Washington, D.C.

### Test Equipment Series Liked

Editor, CQ:

Just to tell you that I am enthusiastic about the series that you have just started on "Test Equipment in the Ham Shack." Just completed reading the first article (December, 1953, p. 23) on tube checker and found it very valuable. I hope the series will contain similar articles on all the other equipment that should be valuable around the Ham shack.

Ralph H. Turner, W8HXC

Oberlin, Ohio

(Continued on page 58)



**FOLLOW ARROW FOR BIGGEST STOCK AT LOWEST PRICES**

- RADAR—TRANSMITTERS
- RECEIVERS — TUBES — PARTS

**C.A.P. SPECIAL BC-625 VHF TRANSMITTER.** With conversion dope. Used. Good cond. . . . \$9.95

**BC-604 30 W.F.M. TRANSMITTER.** For 20-27 MC band. Excel. cond. . . . \$12.95  
**BC-603 RECEIVER.** New 65.00

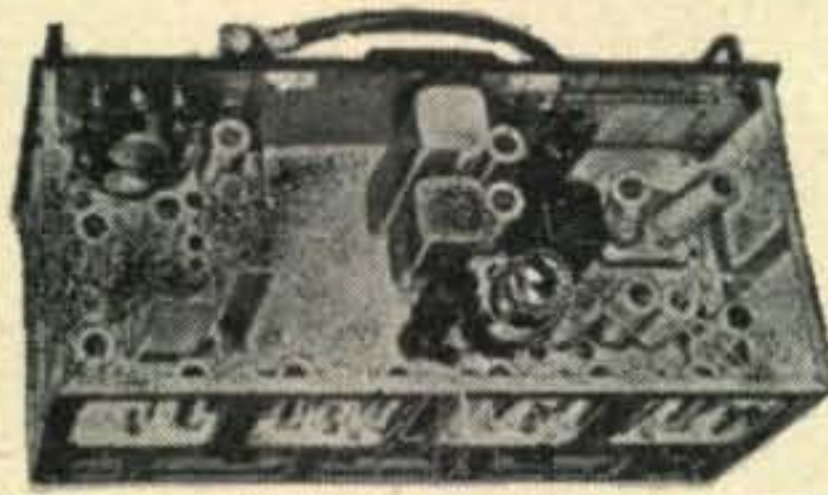

Sensational Buy!

**UHF TRANSMITTER-RECEIVER**

Frequency range 415-420 MC. Receiver uses 13 tubes. 5 Stages of 30 MC. IF amplifier. With schematic. Less dynamotor and tubes. **\$5.95**  
 Excellent condition. Never before offered at this money-saving price!

**COMMAND EQUIPMENT (SCR-274N)**

	Used	New		Used	New
BC-442	ANTENNA RELAY. Less cond.	\$ 1.95	MC-211	90° ANGLE COUPLING UNIT	\$0.95
BC-451	TRANSMITTER CONTROL BOX	1.50	FT-234	MOUNTING RACK for single xmtr	\$2.95
BC-450	3-RECEIVER REMOTE CONTROL BOX	2.95	FT-226	MOUNTING RACK for 2 Command Xmtrs.	3.95
MC-215	MECHANICAL DRIVE SHAFT Per length	2.95	FT-221	MOUNTING PLATE for FT-220	1.50
BC-496	2-POSITION RECEIVER CONTROL BOX	2.95	FT-220	MOUNTING RACK for 3 rec.	2.25
BC-455	6-9 MC RECEIVER. With tubes	9.95	FT-225	MOUNTING PLATE for BC-456	2.25
BC-453	With tubes	19.95	FT-331	MOUNTING RACK for 4 comm. xmtrs.	7.50
BC-454	RECEIVER. 3.6 MC. With tubes	12.95	BC-456	MODULATOR. For SCR-274..	5.50
BC-457	TRANSMITTER. 4-5.3 MC. With tubes	9.95	Complete set of 4 tubes for transmitter		1.25
			BC-458	TRANSMITTER. 5.3-7 MC. With tubes	9.95

HS-18	HEADSET, High imp. New	\$2.45
HS-23	HEADSET, High imp. New	4.95
HS-30	HEADSET, Featherweight type. Low imp. NEW	\$2.49
	USED	1.49
HS-33	HEADSET, Low imp. New	5.25
HS-38	HEADSET, USED, excel. cond.	1.49
	NEW	3.50
H-16U	High imp. 8000 ohms. New	3.95
DESK STAND MIKE.	New	5.95
LIP MIKE.	Navy type. New	.98
TU-17	TUNING UNIT. (2-3 MC.) For BC-223 Xmtr.	2.95
PE-157	POWER SUPPLY. Excel. cond.	12.95
1-70	"S" TUNING METER. New	1.49
WOBLATOR.	See p. 43 Dec. '51 RADIO NEWS	5.95
BC-1023	75 MC. MARKER BEACON RECEIVER. Complete with tubes, mtg. Jack. NEW	10.95
TU-25	TUNING UNIT. (3.5-5.2 MC.) For BC-223 Xmtr. Used	2.95
R-28	ARC-25 2-METER RECEIVER. 100-156 MC. With tubes. Excel. cond.	45.00
PE-101	DYNAMOTOR. New	5.95

**250 TL TUBE**

Limited quantity! Order now!

EACH	\$ 9.95
PAIR	17.00

**Mobile! C.D. Men! C.A.P.!**

**UHF MOBILE DIRECTIONAL ANTENNA.** New . . . 95c  
**SCR-283 TRANSMITTER-RECEIVER.** With dynamotor and tubes. 40, 80, 160-meter. F.B. for mobile. **\$24.50**  
 New  
**DYNAMOTOR SPECIAL.** 9 v. input. Output 450 v. 75 mils. With extended shaft and drive gear on one end. New . . . **\$7.95**

**ARC-4 MOBILE TRANSCEIVER**

140-144 MC. Complete with control box, tubes, 12/24 VDC dynamotor with schematic. This is a special reduction for this month only. Like new. . . . **\$32.50**  
**RS-38 MIKE.** Carbon type for ARC-4. NEW . . . \$4.95  
 Used . . . 2.95

**MOBILE ANTENNA**

Complete 15 ft. Antenna with mounting unit. NEW This month only. . . . \$5.95  
 ADDITIONAL SECTIONS. Each only. . . . .75

**MP - 22 MOBILE ANTENNA**

MOUNTING Per Pair. . . . \$4.95  
 BRACKETS Each . . . 2.95

**Miscellaneous Specials!**

**BROADCAST BAND & AERO**

**MN-26-C** Remote Controlled navigational direction finder and communication receiver. Manual DF in any one of three freq-bands, 150 to 1500 KC. 24 V. Self contained dynamotor supply. Complete installation, including receiver, control box, loop transmission line and flex. shafts.

BRAND NEW. Complete	\$69.50
MN-26-C alone, New	24.95
MN-52 Crank drive, New	2.50

**SCR-625 FAMOUS MINE DETECTOR**

For prospectors, miners, oil companies, plumbers, etc. **\$59.50**  
 NEW. WHILE THEY LAST!

<b>SURPRISE PACKAGE:</b> 20 lbs. Usable radio parts.	\$ 2.95
<b>CD-307 EXTENSION CORD.</b> For HS-23-33. NEW	.95
<b>FL-8 RANGE FILTER</b>	1.95
<b>FL-5 RANGE FILTER, NEW</b>	.95

<b>RA-10 DB RECEIVER</b>	<b>PE-103 DYNAMOTOR</b>	<b>RA-10 FA RECEIVER</b>
New \$39.95	Like new cond. \$24.95	Excel.
Used 24.50		Cond. \$29.95

**EQUIPMENT WANTED**

To meet government and industrial orders we urgently need all types of new and used Test Equipment, Radar, Receivers, and Transmitters. **WE PAY HIGHEST PRICES.** Tell us what you have.

**\$5.00 MINIMUM ORDER ACCEPTED.** All shpts. F.O.B. whse. Cal. residents add sales tax with remittance. 20% dep. Specify shpg. instructions. Send for FREE Catalogue, No. 112. Note: Max. shipping weight by parcel post is 20 lbs.

**UHF TRANSMITTER**

450-710 MC. Tunable Transmitter. 10 W. output. Two 368-A type tubes as push-pull oscillators. Wide band video amplifier. Less tubes, with schematic. Excellent condition. **\$8.95**

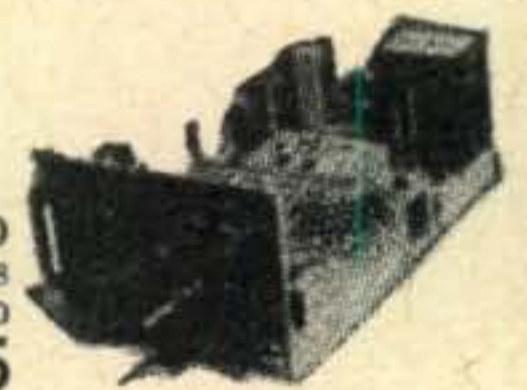

**R. F. MODULATOR**

Complete Tunable 205 MC. Test Set. With 110 V. 60 cps. power supply, 3-stage audio amplifier. Terrific chassis for experimentation. With schematic, like new. . . . **\$9.95**

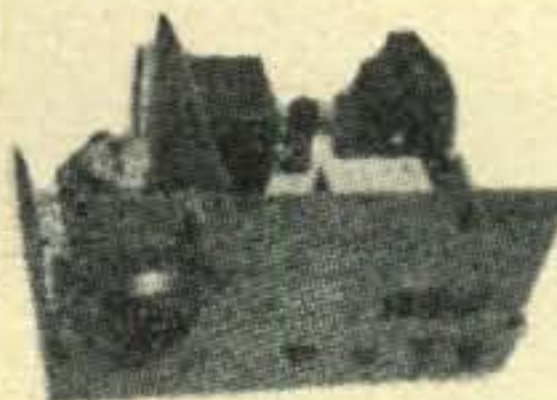

**INTERPHONE AMPLIFIER BC - 709 - B**

A 2-position single stage audio amplifier. Uses 1 tube and operates from self-contained batteries. With Instruction Manual and Schematic. **\$3.95**  
 NEW (less batteries) . . . . .



**TS-10 SOUND POWERED HAND SET**

USED Excellent condition Per PAIR Only . . . . . **\$14.50**

**ARROW SALES, INC.**

Mailing Address: P.O. Box 3878-Q N. Hollywood, Calif.  
 Office-Warehouse: 7460 Varna Ave., N. Hollywood, Calif.  
 PHONE: Pepler 5-1810 CABLE ADDRESS: Arrowsales



## NEW BUD 2-TUBE CODE PRACTICE OSCILLATOR & MONITOR CPO-128

Here is a real money saver! While learning the code it can be used as a code practice oscillator. After the code has been mastered a flip of the switch converts the unit into a fine CW Monitor. It has a 4" built in, permanent magnetic dynamic speaker and will operate up to twenty ear phones. A volume control and pitch control permit adjustments to suit individual requirements. Any number of keys can be connected in parallel to the oscillator for group practice. Operation is possible on 110 volts AC or DC. An external speaker can be plugged in without the use of an output transformer. All controls are on the front of the unit and all jacks in the rear. The unit is 6½" x 5½" x 3½" and is finished in a beautiful grey hammer-tone.

**Amateur net \$15.75**

CPO-130 Earphone model—same as above.

**Amateur net \$14.10**

See these at your distributors today or write for literature.

### BUD RADIO, INC.

2118 East 55th Street

Cleveland 3, Ohio

## Here's a key for CQ and Phone Men . . .



Nope, we're not talking about a telegraph key—we're referring to the key to the fastest, most efficient handling of Amateur orders you'll find anywhere—ALLIED'S 258-page catalog. Whether you need a new tube to keep your Novice-band oscillator perking, or require a modulation transformer for your all-band KW, you'll do better when you order from ALLIED. It's the one sure

way to get what you want when you want it.

Here's why ALLIED is the favorite supply source of the Amateur: 1) The largest and most complete stocks in the world mean immediate availability on *everything*; 2) a staff of experienced Hams with plenty of "know how" understand your problems and are ready always to help you get the best and most for your money; 3) one of the most modern mail order set-ups (now including speedy conveyor belts) assures lightning-fast shipment; 4) top trade-ins, best terms in Hamdom.

Yes, ALLIED'S catalog is the key to your every station need. Every well-equipped shack should keep it handy. If you don't already have a copy, just drop a card to Allied Radio Corp., 100 N. Western Ave., Dept. 16-B-4, Chicago 80, Illinois.

(from page 56)

Editor, CQ:

Just wanted to take my pen in hand and express my appreciation of the article, "Test Equipment in the Ham Shack" by Burgess in the December issue. This is a subject that has always been of very much interest to me, and I am more than glad to see that it is only the first of such a series. Swell!

Everett V. Brant, ex-W8PQH

Detroit, Mich.

### Still More of QSL Percentages

Editor, CQ:

The QSL returns reported by W9HEX (CQ, October, 1953, page 10) and WØKV (CQ, December, 1953, page 11) have prompted me to check on my own.

Although I only operate 160 meters during the daylight and my contacts are subsequently mostly G's, I have achieved, in two years and three months a return of just over 76%. The actual figures were 228 QSL's sent out and 175 received.

And, in writing, I must tell you that the "DX and Overseas News" feature by KV4AA, and "Novice Shack" by W9EGQ are, for me, the main interest in CQ.

F. Allan Herridge, G3IDG

London, England



Editor, CQ:

I was greatly interested in the reaction to my letter in the October issue. My QSL card is shown for the benefit of WØKV and others. Let's see more ideas on the subject.

Al Wessel, W9HEX

Indianapolis, Ind.



Editor, CQ:

Since becoming ON4QX I only work 28, 21 and 14 Mc. DX. I am very sorry to report that only 45% in the world of amateurs send a QSL. Here are my statistics.

CT—10%; PA—80%; F—45%; ON4—52%; LA—3%; W1—70%; W2—11%; W3—68%; W4—60%; W5—80%; W6—71%; W7—98%; W8—40%; W9—60%; WØ—80%; VK—71%; OA—0%; MI—10%; ZL—35%; ZS—8%; OH—90%; DL—90%; HB—30%; I—10%; English Dominions—30%;

French Colonials—80%; and Spanish Colonials—70%.

Why do OA4AK, MI3AB, ZB2A, PY5TQ, ZE5WL and W6KH stay on the DX bands? They promise 100% QSL via bureau. After one year of waiting I send a new QSL direct, no answer. I sent a second with coupon, no answer. A third one with two coupons, a photo of the shack and a series of stamps—no results!

I lose my temperature and courage.

Bob.h.th.Berge', ON4QX

Anvers, Belgium

Editor, CQ:

Below are my results for a year and a half on the air.

W1—67%; W2—100%; W3—92%; W4—90%; W5—85%; W6—91%; W7—89%; W8—97%; W9—89%; WØ—93%; foreign—89%. A total of 502 cards sent for an 89% return.

Don Vandenberg, WØKBD

Colorado Springs, Colo.

**One Less Solution — —**

Editor, CQ:

Just suddenly discovered that the fourth solution from "In a Fit of Pique" (July, 1953, page 28) will not solve the problem. The moveable semaphores cause TV picture flicker by acting as reflectors—the Ham is still blamed.

Egils Evalds

Philadelphia, Pa.

**Fire at World Radio Laboratories**

A serious fire at press time has destroyed the OLD plant of the World Radio Laboratories, Council Bluffs, Iowa. We are informed directly by Leo Myerson that business is continuing as usual from his new ultra-modern building. Slight delays in the delivery of a few items may occur, but all orders will be filled as quickly as possible.

**VHF NEWS**

(from page 46)

**Converter Oscillator Stability**

While building up a 144-Mc. converter similar to the one described by W2PAU (November, 1952, page 21); Ed Stewart, W3DHH encountered an interesting problem on oscillator stability. It was found that weak stations could not be tuned in and strong stations were very hard to peak. After ascertaining that all circuit components were securely mounted and vibration had been minimized, the new VHF-1-D split-stator condenser was investigated. Even considering the fact that it is of excellent workmanship and that the oscillator circuit is theoretically balanced (the rotor carries no r-f current) there is a good chance that frequency jitter and noise may occur. Obviously, this is a borderline critical condition (the extremely high-priced versions get around this through the use of pyrex ball bearings and ceramic shafts) and may not be observable in every case.

The solution to the problem is shown in the accompanying drawing. A brass collar with a brush type contact is slipped on the rear shaft extension. This effectively shorts the inner and outer bearing races with a wiping contact that is independent of the balls.

Weak signals now ride in smoothly as the dial is rotated.

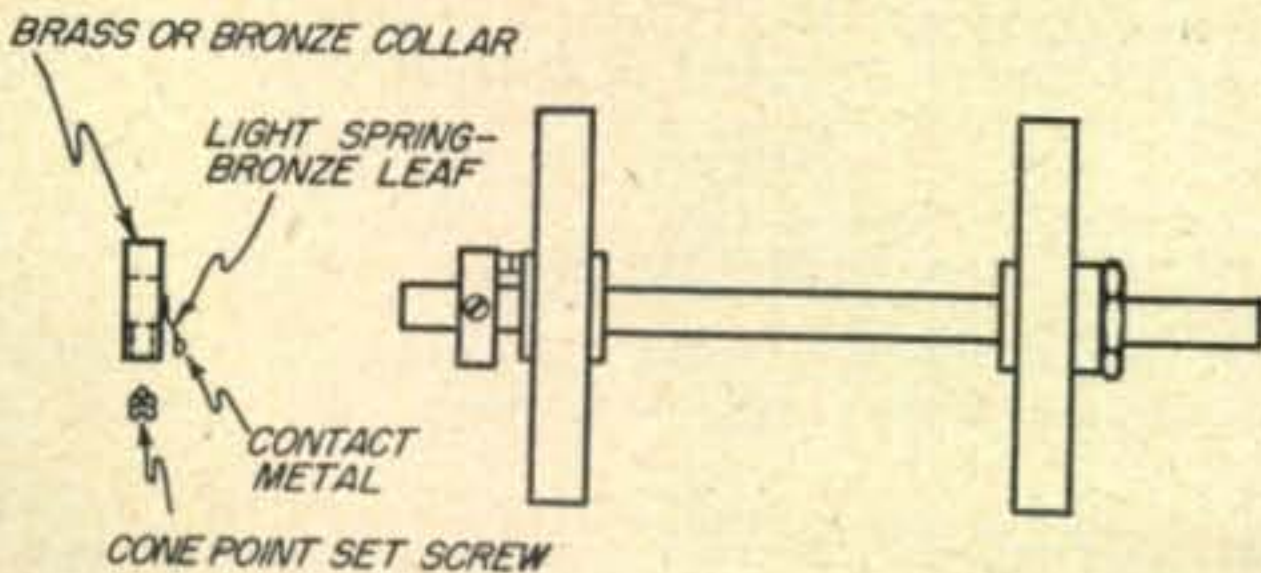

SMALL COLLAR OF NON-MAGNETIC METAL, FITTED TO SHAFT. ADJUST AND HOLD IN PLACE WITH CONE POINT SET SCREW. INSTALL ONE ON FRONT BEARING IF NECESSARY.

*It's a snap!*

to convert controls to switch-types — with

**FASTATCH\***

**Switches**

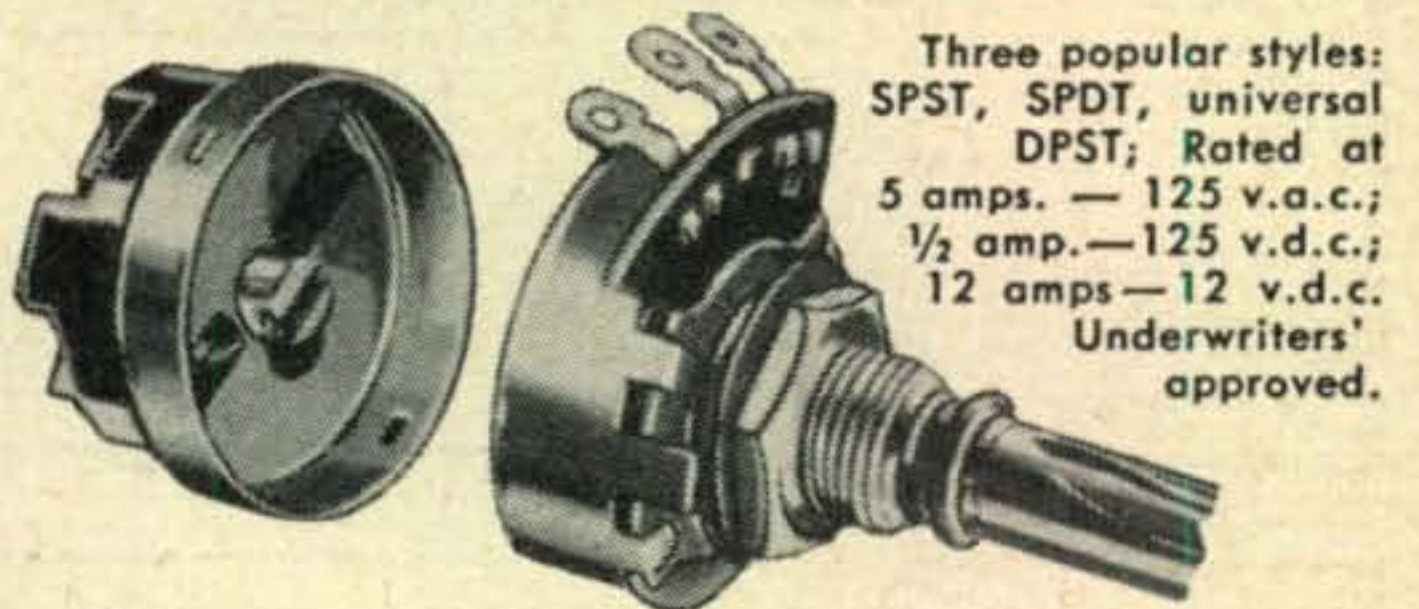

In just seconds, Type KB Fastatch converts any plain-type control with blue-and-white label to a TV-AM-FM switch-type. Snap — and it's on. No ears to bend, no loose parts.

Your Centralab distributor can furnish Fastatch switches from stock. He also has Centralab Blue Shaft Controls from 500 ohms to 10 megs in a wide variety of tapers and tapped units. See him soon.

Send coupon for Centralab Catalog 28.

**Centralab**

\*Trademark

CENTRALAB, A Division of Globe-Union Inc.  
911B E. Keefe Avenue, Milwaukee 1, Wisconsin  
Send me Centralab Catalog 28

Name.....

Address.....

City..... (.....) State.....

## RADIO Surplus Buys

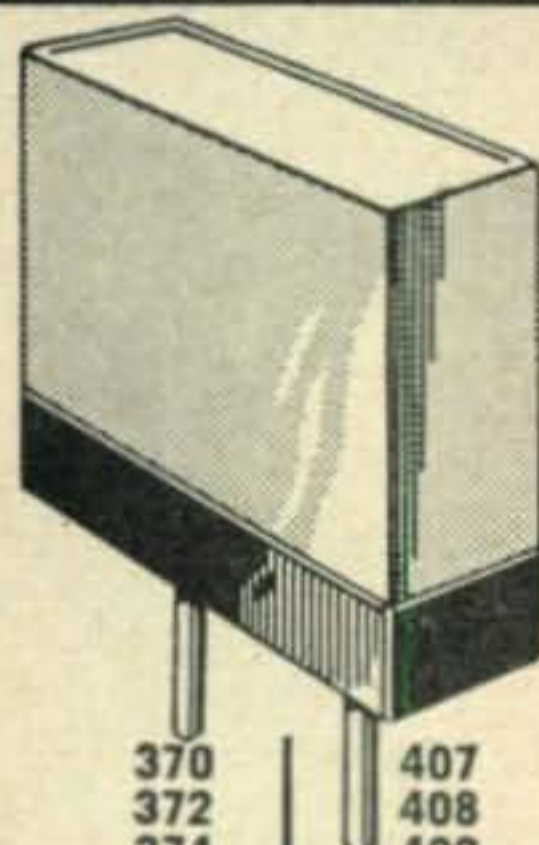

### CRYSTALS

... in FT 241-A Holders - 1/2" Pin SPC. Marked 54th OR 72nd Harmonic MC Freq. Listed below by fundamental frequency with fractions omitted.

500 KC Crystals ..... ea. **\$1.95**  
 1000 KC Crystals ..... ea. **\$3.95**  
 200 KC Crystals

370	407	444	476	509
372	408	445	477	511
374	409	446	479	512
375	411	447	480	513
376	412	448	481	514
377	413	450	483	515
379	414	451	484	516
380	415	452	485	518
381	416	453	486	519
383	418	454	487	520
384	419	455	488	522
385	420	456	490	523
386	422	457	491	525
387	423	458	492	526
388	424	459	493	527
390	425	461	494	529
391	426	462	495	530
392	427	463	496	531
393	429	464	497	533
394	430	465	498	534
395	431	466	501	536
396	433	468	502	537
397	434	469	503	538
398	435	470	504	540
400	436	472	505	
401	437	473	506	
402	438	474	507	
403	440	475	508	
404	441			
405	442			
406	443			

**\$5** Per Doz. Postpaid

PLEASE ENCLOSE FULL AMOUNT WITH ORDER  
 QUANTITIES AVAILABLE  
 WRITE FOR YOUR REQUIREMENTS

### C & H SALES CO.

BOX 356-FQ EAST PASADENA STA. • PASADENA 8, CALIF.

# HEADSET SALE!

HS-33.....\$4.50 each  
 HS-23.....\$4.00 each

### BRAND NEW

TALLEN CO., Inc. Dept. CQ

159 Carlton Avenue Brooklyn 5, New York

### 8 WIRE CONTROL CABLE

Two No. 16. Six No. 20 tinned, stranded, copper, rubber insulated coded leads. Waterproof rubber jacket. Woven copper armor shield overall. Diameter 7/16 inch. Length to 400 ft. Minimum order 100 ft. Prepaid delivery 10c ft. made to nearest express or post office. U.S.A. only. **PREPAID**

TRANS-WORLD RADIO-TELEVISION CORP.  
 6639 S. ABERDEEN ST. CHICAGO 12, ILL.  
 Phone: AUstin 7-4538

## COMMAND SET ROUNDUP

(from page 19)

- "Putting the BC-455 on 10," Everett J. Gilbert. W9MSP, CQ, September, 1948, p. 45.
- "Power-House Portable," Clyde C. Larry, W6GCS, CQ, October, 1948, p. 45.
- "Bandspreading the BC-455," George E. Bidwell. W9FIS, CQ, November, 1948, p. 50.
- "A Double-Conversion Receiver for \$30.00," Allen A. Engelman, W8MYU, CQ, February, 1949, p. 21. (Using BC-453 with converters.)
- "Screen Grid Modulating the Command Rig," Robert Hall, W0CRO, CQ, September, 1949, p. 35.
- "Command Set Special," F. A. Bartlett, W60WP/6, CQ, November, 1949, p. 18.
- "TVI-Proofing the Command Transmitter," Samuel J. Lanzalotti. W2DVX, CQ, March, 1950, p. 19.
- "Modifying the BC-459 for TVI-Free 40-Meter Operation," H. S. Brier, W9EGQ, CQ, June, 1950, p. 27.
- "SCR-274N Transmitter Modifications," James N. Whitaker, W2BFB, CQ, August, 1950, p. 24.
- "At last, A Practical All-Band Heterodyne-Type VFO," L. Denis Shapiro, W2URX, CQ, December, 1950, p. 16.
- "War Surplus for Civil Defense," P. S. Rand, W1DBM, CQ, part 1: April, 1951, p. 11. Part 2: May, 1951, p. 23.
- "Mobile With the ARC-5/SCR-274N," Lt. Cdr. Paul H. Lee, W4RXO, CQ, May, 1952, p. 55. (Correction June, 1952, p. 69.)
- "On 15 Meters—Quick," F. N. Lem, W2CTE, CQ, August, 1952, p. 42.
- "40-Meter Mobile With Your ARC-5," Lt. Cdr. Paul H. Lee, W4RXO, CQ, March, 1953, p. 62.
- "Bandspread Dial for the Command Receivers," Jesse O. Bostwick, W7LDT, CQ, March, 1953, p. 34.
- "Crystal-Control Adapter for the BC-696 A," Henry R. Greeb, W0FVD, CQ, April, 1953, p. 54.
- "Put Your SCR-274N on 160 Meters," Eugene Westervelt, W9DRJ, CQ, June, 1953, p. 55.
- "Easy-Way Heterodyne Exciter, The," Major R. H. Mitchell, W6TZZ, CQ, March, 1953, p. 21. (Converting "Command" receivers to a VFO.)
- "New Simplified Q5-er," Robert H. Weitbrecht, W6NRM/W9TCJ, CQ, July, 1953, p. 25.
- "Lazy Man's Q5-er, The," Technical Topics, QST, January, 1948, p. 40.
- "ARC-5 Transmitter Modifications," T. A. Previtt, W9UKT; John McIntosh, W8ZGO; B. Goodman, W1DX; F. W. Wright, Jr., W2UWK; J. R. Abbott, W6ZOL; Don Imhoff, W8YFS, QST, June, 1948, p. 6.
- "Triple Conversion for the Communications Receiver," William I. Orr, W6SAI, QST, September, 1948, p. 53.
- "Adapting the 274N Series Transmitters for 14 Mc," William I. Orr, W6SAI, QST, September, 1948, p. 31.
- "Crystal-Controlled Plug-In Converter for the Q5-er," John L. Steward, W6UJD, QST, October, 1949, p. 31.
- "Plug-In Exciters From Surplus Transmitters," T. Glade Wilcox, W9UHF; Charles Hoffman, W9ZHL, QST, January, 1950, p. 54.
- "Keying the BC-696," Holland M. Carter, W4ADE, QST, July 1951, p. 41.
- "Novice Conversion of a Command Transmitter," R. M. Smith, W1FTX, and W. E. Bradley, W1FWH, QST, November, 1951, p. 41.
- "Command Set Receiver for 6 and 10," Charles L. Faulkner, W6FPV, QST, September, 1953, p. 22.
- "Conversion Notes on the BC-696A," John T. Frye, W9EGV, Radio News, March, 1948, p. 57.
- "Conversion of SCR-274N Receivers," C. W. Roeschke, W5MLX, Radio News, June, 1948, p. 49.
- "Modernizing The SCR-274N Transmitter," Carl V. Hays, W6RTP, Radio and Television News, January, 1953, p. 50.
- "VFO From Surplus," George F. Marts, W0TDH, Radio Electronics, January, 1949, p. 38.
- Radio Amateurs' Mobile Handbook, by William I. Orr, W6SAI, p. 166.
- Surplus Radio Conversion Manual, Vol. 1, by R. C. Evenson and R. O. Beach.

#### SEE ALSO:

- "Increasing Bandspread on BC-274N Receivers," Arthur Larky, Inside the Shack and Workshop, CQ, June, 1948, p. 28.
- "20 and 40 Meters with the BC-459A," W2VNU/8, Inside the Shack and Workshop, CQ, March, 1948, p. 31.
- "Keying the ARC-5's," Letters by W1RIF and Herbert Batten, CQ, March, 1949, p. 6.
- "SCR-274N Keying Filter," by W6SAL, Inside the Shack and Workshop, CQ, April, 1949, p. 36.
- "Is Your Rig R-f Tight," W2UHH, QST, August, 1953, p. 29.

## SPURIOUS EMISSIONS

(from page 27)

made to control oscillations which take place near a harmonic of the crystal, and are further multiplied in the output circuit of the tri-tet. Frequencies as high as 200 Mc. are obtainable in the first tube using this method, and weak oscillations as high as 50 Mc. are obtained in the oscillator section. The spurious emissions produced by a multiplier string starting with such an oscillator are, of course, not only few in number, but more easily separated from the desired frequency.

Figure 3 shows the basic neutralized tri-tet circuit for this type of operation, usable with low-capacity crystal holders. Circuit constants may be similar to other tri-tet oscillators, depending upon tubes, voltages and frequencies.

### The Butler Oscillator

About 1944, Butler in England and others independently devised a controlled multivibrator type of crystal oscillator circuit somewhat similar to that shown in Fig. 4. The crystal is placed between the cathodes of the two tubes—each being parallel twin-triodes in this particular oscillator. Feedback is adjusted by, and controllable with, capacitor  $C1$ . Increasing the cathode resistors increases power but reduces stability.  $R1$  was not in the original circuit but has been inserted to control any tendency toward spurious emissions.  $C7$  provides degenerative feedback. The output may be taken from

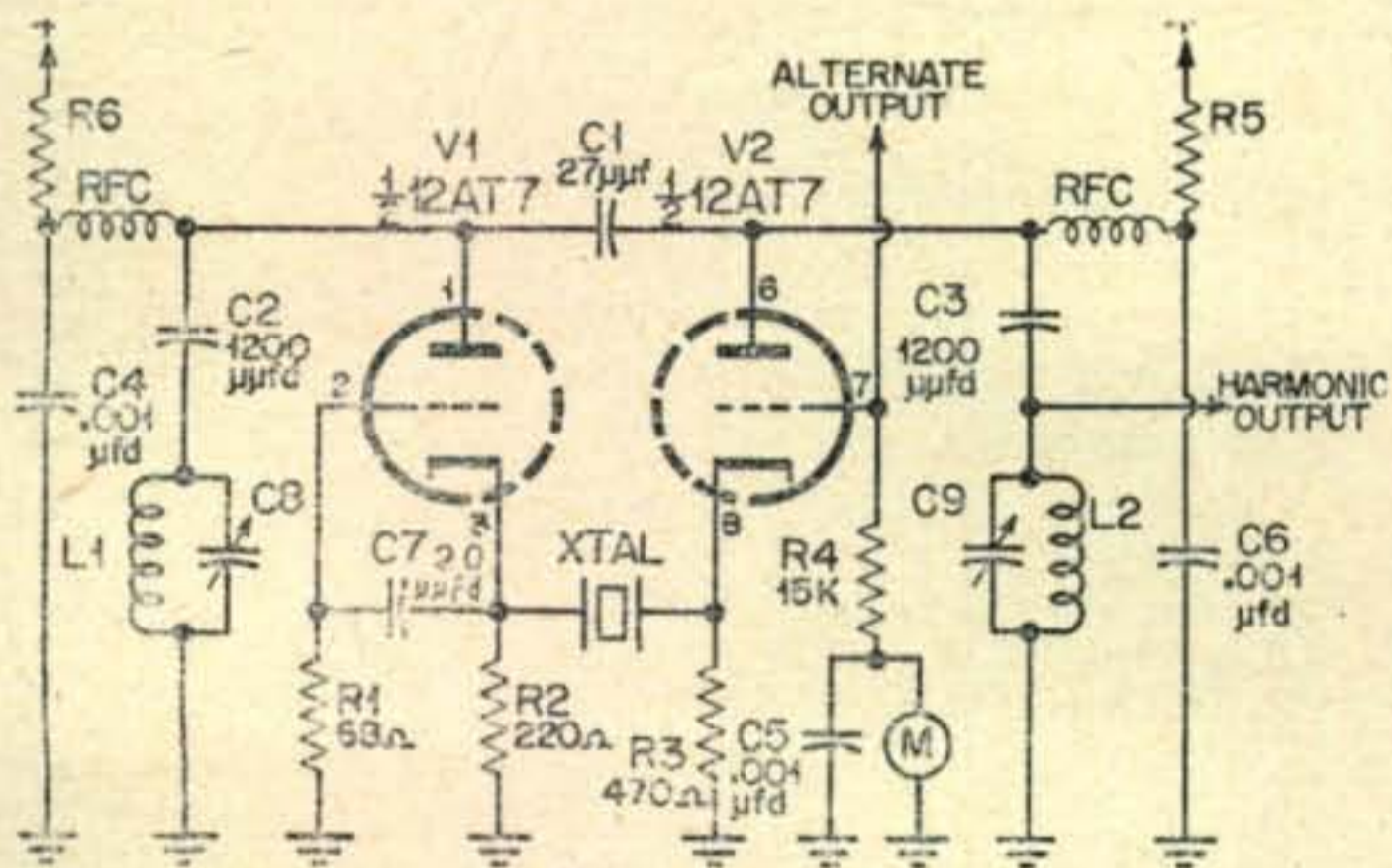
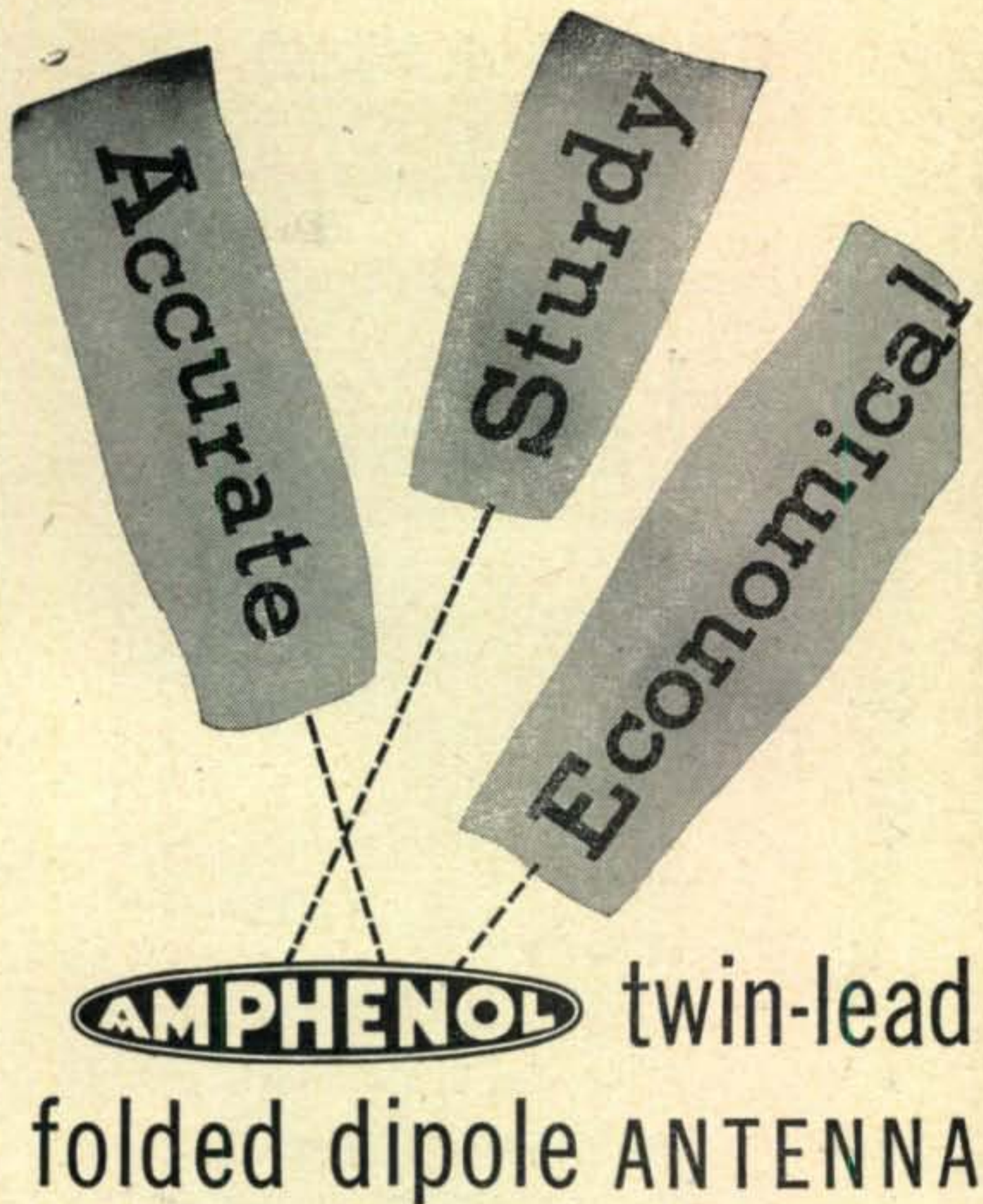

Fig. 4. Wiring schematic of the Butler oscillator. Determine the values of  $R5$  and  $R6$  by experiment. Tune  $L1/C8$  to the crystal frequency and  $L2/C9$  to the harmonic output frequency.

the grid or plate circuits of the right-hand triode. The grid meter shown is an aid to experimentation. The oscillator may be followed by half of another 12AT7 grounded grid amplifier, injecting the drive into the cathode. With another tube as a doubler, 400-Mc. output may be obtained. Like the circuit previously described, the Butler circuit will produce the first, feeble output power on a high frequency, and make the job of separating oscillator-multiplier frequencies from the output an easy one.



The AMPHENOL amateur communications antenna kit has proved to be very popular with amateurs everywhere. They have found the antenna to be economical in initial cost, efficient in operation and sturdy. Utmost accuracy is assured because the amateur cuts the antenna to the specific frequency he desires and does all assembly work himself.

The amateur antenna kit is available in four models: 10, 20, 40 and 80 meters.



The complete kit includes:

- 2 lengths of #16 copper-clad steel conductor twin-lead, cut to band length.
  - 1 75-foot length of standard 300 ohm twin-lead for use as lead-in.
  - 1 high strength laminated T-block.
- Assembly and installation instructions.

#### AMATEUR NET

10 meters	\$5.35	40 meters	\$ 7.80
20 meters	6.00	80 meters	11.25

see your **AMPHENOL** radio parts distributor

AMERICAN PHENOLIC CORPORATION

# EVANS RADIO

10 Hills Avenue  
Concord, New Hampshire

has **hallicrafters**



- 10 Kc to 250 cycles in six steps!
- The most stable receiver made!
- Single Side Band Suppressed Carrier!

**The Hottest Ham News in Years!**

See complete details on pages 4-5

THE HALLICRAFTERS CO • CHICAGO 24, ILL.

## QUARTZ CRYSTALS

Low Frequency — FT-241A for SSB, Lattice Filter etc., .093" Pins, .486" SPC, marked in Channel Nos. 0 to 79, 54th Harmonic and 270 to 389, 72nd Harmonic. Listed below by Fundamental Frequencies, fractions omitted.

49¢ each—10 for \$4.00

370	393	414	436	498	520
372	394	415	437	501	522
374	395	416	438	502	523
375	396	418	481	503	525
376	397	419	483	504	526
377	398	420	484	505	527
379	401	422	485	506	529
380	402	423	486	507	530
381	403	424	487	508	531
383	404	425	488	509	533
384	405	426	490	511	534
385	406	427	491	512	536
386	407	429	492	513	537
387	408	430	493	514	538
388	409	431	494	515	
390	411	433	495	516	
391	412	434	496	518	
392	413	435	497	519	

99¢ each—10 for \$8.00

400	459
440	461
441	462
442	463
444	464
445	465
446	466
447	468
448	469
450	470
451	472
452	473
453	474
454	475
455	476
456	477
457	479
458	480

99¢ each—10 for only \$8.00

CR-1A SCR 522— $\frac{1}{8}$ " Pin, $\frac{1}{2}$ " SP	FT-171B — BC-610 Banana Plugs, $\frac{3}{4}$ " SPC					
5910	7350	2030	2220	2390	3120	3520
6370	7380	2045	2258	2415	3150	3550
6450	7390	2052	2260	2435	3155	3570
6470	7480	2065	2280	2442	3202	3580
6497	7580	2082	2282	2532	3215	3945
6522	7810	2105	2290	2545	3232	3955
6547	7930	2125	2300	2557	3237	3970
6610		2131	2305	2660	3250	3995
		2145	2320	2940	3322	
		2155	2360	3035	3510	

BC 746 TUNING UNITS—  
foundation coils and condensers  
for 80 meter VFO or exciter—  
less xtals ..... 98c



520 TENTH ST., N.W.—Wash., D. C. Dept. C

FT-243—.093" Pin Dia.—  
.486" Pin SPC for Ham and  
General Use

49¢ each—10 for \$4.00

4035	5500	5950	6725	7525	7840
4080	5675	5973	6740	7540	7850
4110	5677	5975	6750	7550	7873
4165	5700	6225	6773	7573	7875
4190	5706	6240	6775	7575	7900
4255	5725	6250	6800	7600	7906
4280	5740	6255	6806	7606	7925
4300	5750	6273	6825	7610	7940
4397	5760	6275	6840	7625	7950
4450	5773	6300	6850	7640	7973
4490	5775	6306	6873	7641	7975
4495	5800	6325	6875	7650	8206
4780	5806	6335	6900	7673	8225
4845	5825	6340	6906	7675	8240
4930	5840	6350	6925	7700	8250
5030	5850	6373	6940	7706	8273
5205	5852	6375	6950	7720	8275
5235	5873	6400	6973	7725	8300
5250	5875	6406	6975	7740	8306
5300	5880	6425	7450	7750	8325
5305	5900	6673	7473	7773	8630
5333	5906	6675	7475	7775	8683
5385	5925	6700	7500	7800	8690
5485	5940	6706	7506	7825	

99¢ each—10 for \$8.00

1015	2605	3995	6575	7273	8175
1110	2738	6000	6600	7275	8200
1150	2785	6025	6606	7300	8340
1525	2895	6050	6625	7306	8350
1915	2940	6073	6640	7325	8375
1930	3005	6075	6650	7340	8380
1940	3010	6100	7000	7350	8400
1950	3202	6106	7006	7375	8425
2065	3215	6125	7025	7400	8430
2105	3237	6140	7040	7425	8450
2118	3245	6150	7050	7440	8460
2125	3250	6173	7073	8000	8475
2140	3460	6175	7075	8006	8483
2145	3500	6200	7100	8025	8500
2305	3540	6440	7106	8040	8525
2320	3590	6450	7125	8050	8550
2390	3640	6473	7140	8073	8575
2415	3680	6475	7150	8075	8583
2430	3720	6500	7173	8100	8600
2442	3735	6506	7175	8106	8625
2460	3760	6525	7200	8125	8650
2532	3800	6540	7206	8140	8700
2545	3840	6550	7225	8150	8733
2557	3885	6573	7240	8173	

add 20c post. for ea. 10  
xtals (or less)

## 6 - BAND ANTENNA

(from page 31)

a frequency of 14,250 kc. Reconnect the antenna and short  $L_2$  with the appropriate jumper. Plug the alligator jumper into the jack on  $L_1$  and set the matching coil,  $L_3$ , for 20 meters. Run the alligator clip up and down  $L_1$  until resonance is indicated by a zero reading on the bridge indicator. As soon as the optimum tap position is located, solder a loop of wire on  $L_1$  at this point. Then, whenever 20-meter operation is desired, the alligator may be clipped to the same spot with no difficulty.

The adjustment for 15 meters is quite simple. Put the matching coil on the 10-11-15 meter position. Remove the bridge from the circuit and feed 15-meter energy directly from the transmitter to the antenna. Find the tap position on the top coil which provides maximum

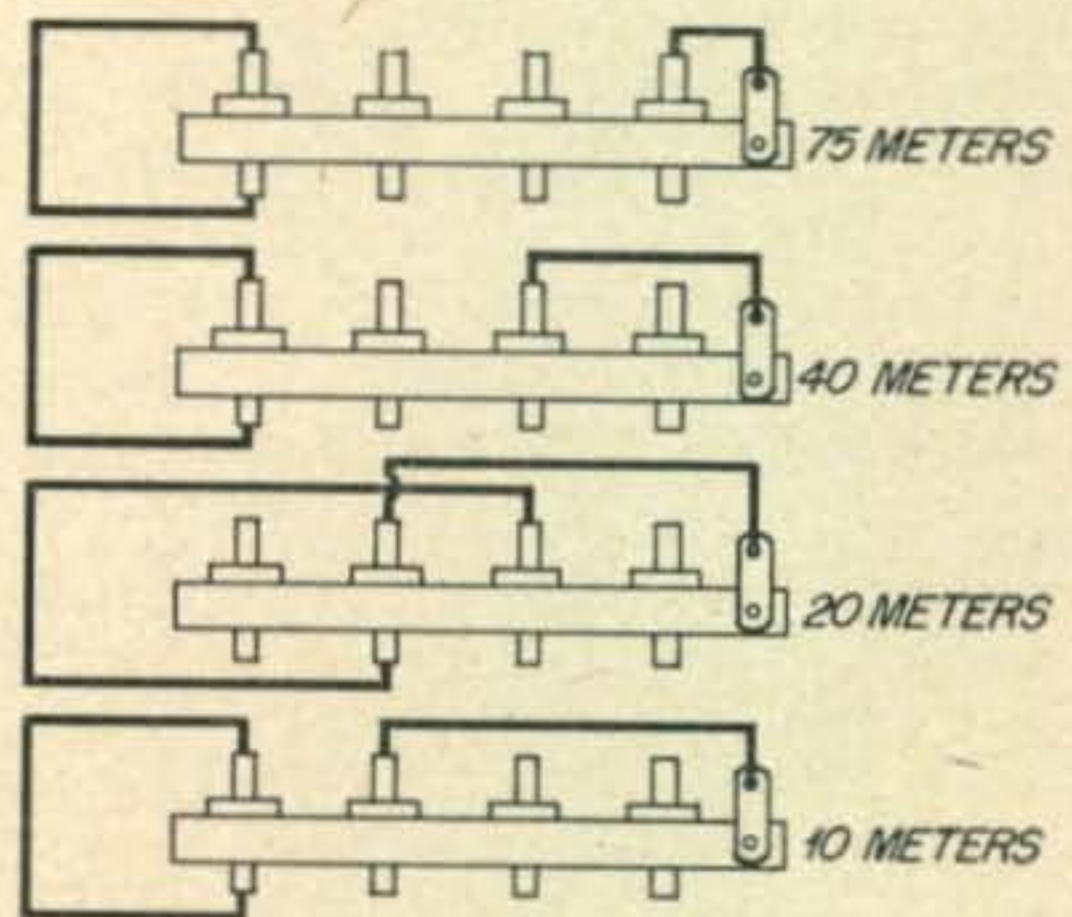

This sketch shows the correct positions of the jumpers on  $L_3$ , the matching coil at the base of the antenna. Compare this drawing with Figures 3 and 4.

field strength as shown on a nearby sensitive field strength meter tuned to 21 Mc. As with the 20-meter tap, solder a loop of wire at this point so that it may be easily identified in the future.

No loading coil adjustment is required for either 10 or 11 meters. On both of these bands  $L_1$  and  $L_2$  are completely shorted out.

A word of caution regarding the foregoing adjustments is in order. Before tuning the antenna make sure that the trunk lid is closed and that the whip is fairly well in the clear—well away from power wires and tree limbs.

Since installing this multi-band antenna, I've overheard numerous comments regarding it and have been asked a great many questions about it. Wide-eyed youngsters inquire if I have TV in my car, while curious Hams are anxious to know if the contraption works.

(Continued on page 64)



## BIGGEST BUY ON MARKET for 2-METER CONVERTER WITH or WITHOUT A. C. POWER SUPPLY

Now you can receive 2 meters on a conventional Short Wave Receiver. Especially designed Push-Pull 6J6 R. F. Amplifier into 6J6 Oscillator-Mixer. Balanced line input, coaxial output. All slug tuned adjustments, high quality components. Output frequency is 21 to 25 MC. Highly stable oscillator.

The Converter is PRE-WIRED excepting the tuned

FOR ADDITIONAL DETAILS REFER TO "VHF-UHF NEWS," DECEMBER ISSUE, THIS PUBLICATION.

circuits . . . Any one with even the slightest experience can complete in a comparatively short time. ONLY AN EXCELLENT BUY OF COMPONENT PARTS ENABLES US TO SELL AT THESE LOW PRICES . . . WITH PROPER ASSEMBLY, WE GUARANTEE SATISFACTORY RESULTS . . . COMPLETE SIMPLIFIED INSTRUCTIONS and ALL necessary components are supplied.

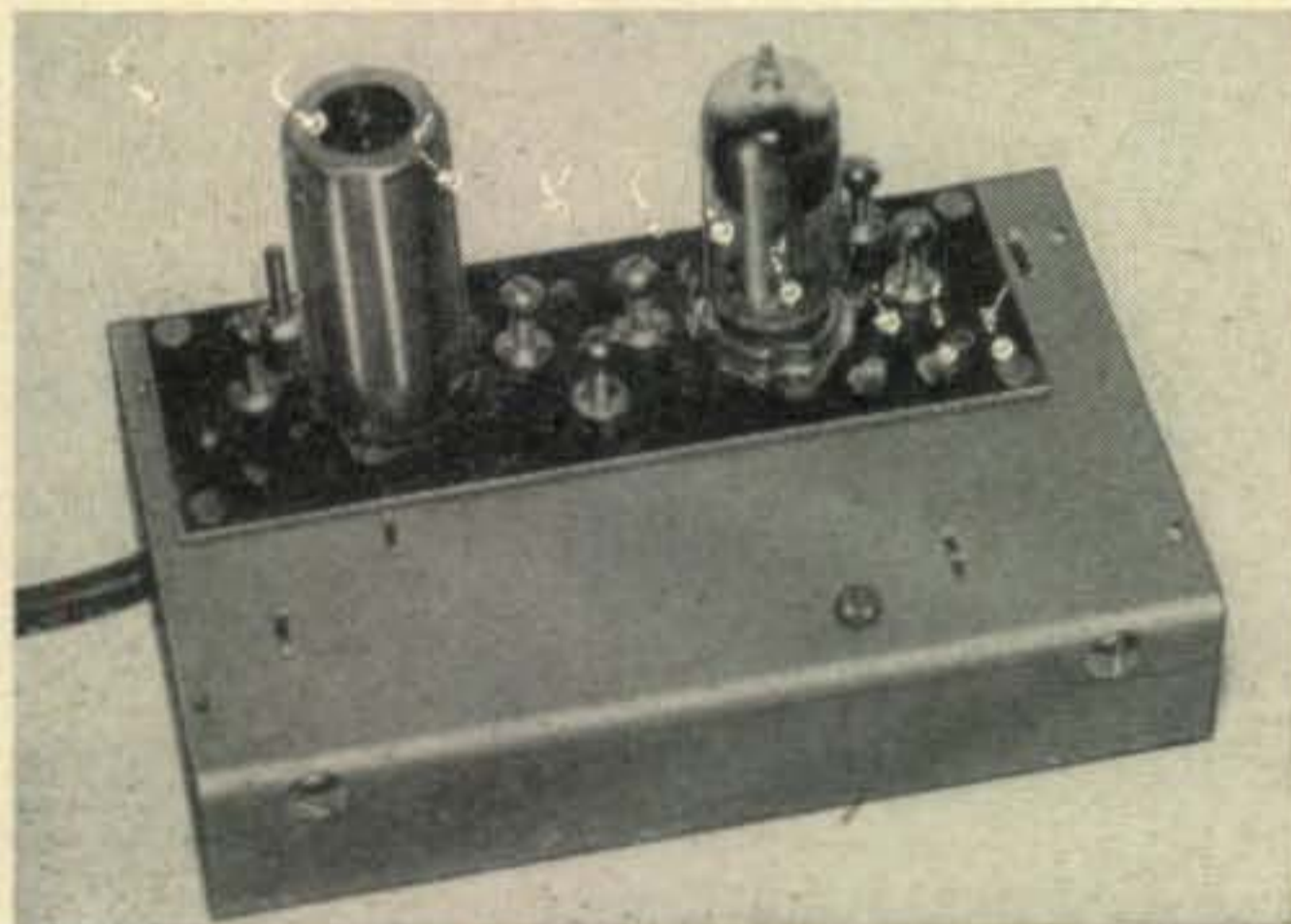

MODEL 1—Without Power Supply

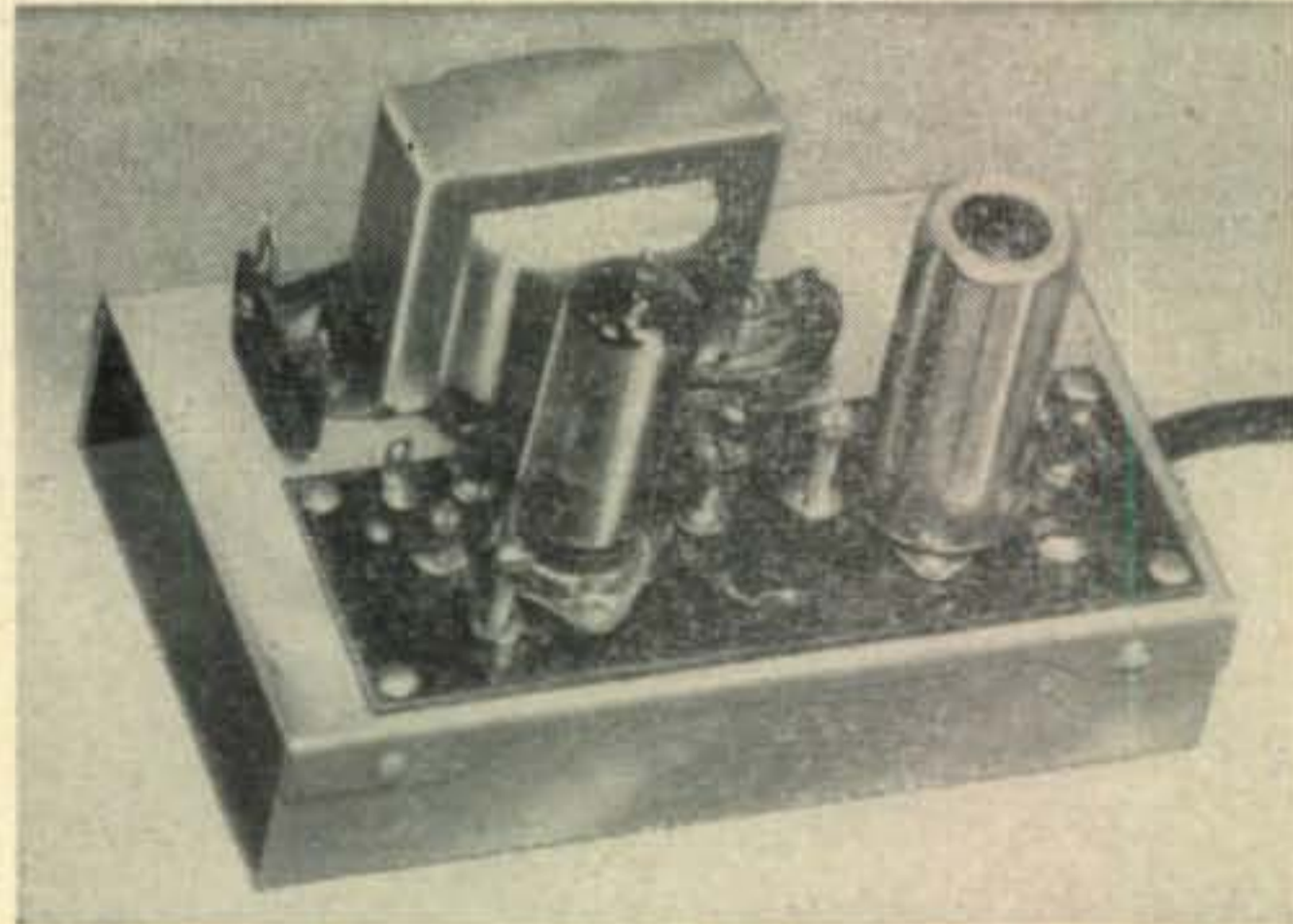

MODEL 2—With A.C. Power Supply

MODEL 1 — \$9.95      MODEL 2 — \$14.45  
6J6 Tubes (each unit requires 2)—\$1.25 NET EACH

WE PAY POSTAGE ANY PLACE IN U.S. Send Check or Money Order. No C.O.D.'s. California orders add 3% Sales Tax.

### K & L RADIO PARTS CO.

PRospect 0553

1406 VENICE BLVD., LOS ANGELES 6, CALIF.

● COMING SOON: VFO—FOR 2 METERS. HIGHLY STABLE. REASONABLY PRICED.

## HERE IS AN EFFECTIVE HIGH PASS FILTER TO SUPPRESS TELEVISION INTERFERENCE!



The Regency Model HP-45 High Pass Filter is a constant "K" type filter with a cut-off frequency of approximately 45 mc. in a 300 ohm balanced line.

Attenuation at 29 mc. is approximately 20db. At frequencies of 14mc. and below, the attenuation is 40db. or more.

Signals above 55mc. are passed through the filter without loss. Simple to install—full instructions included with each unit.

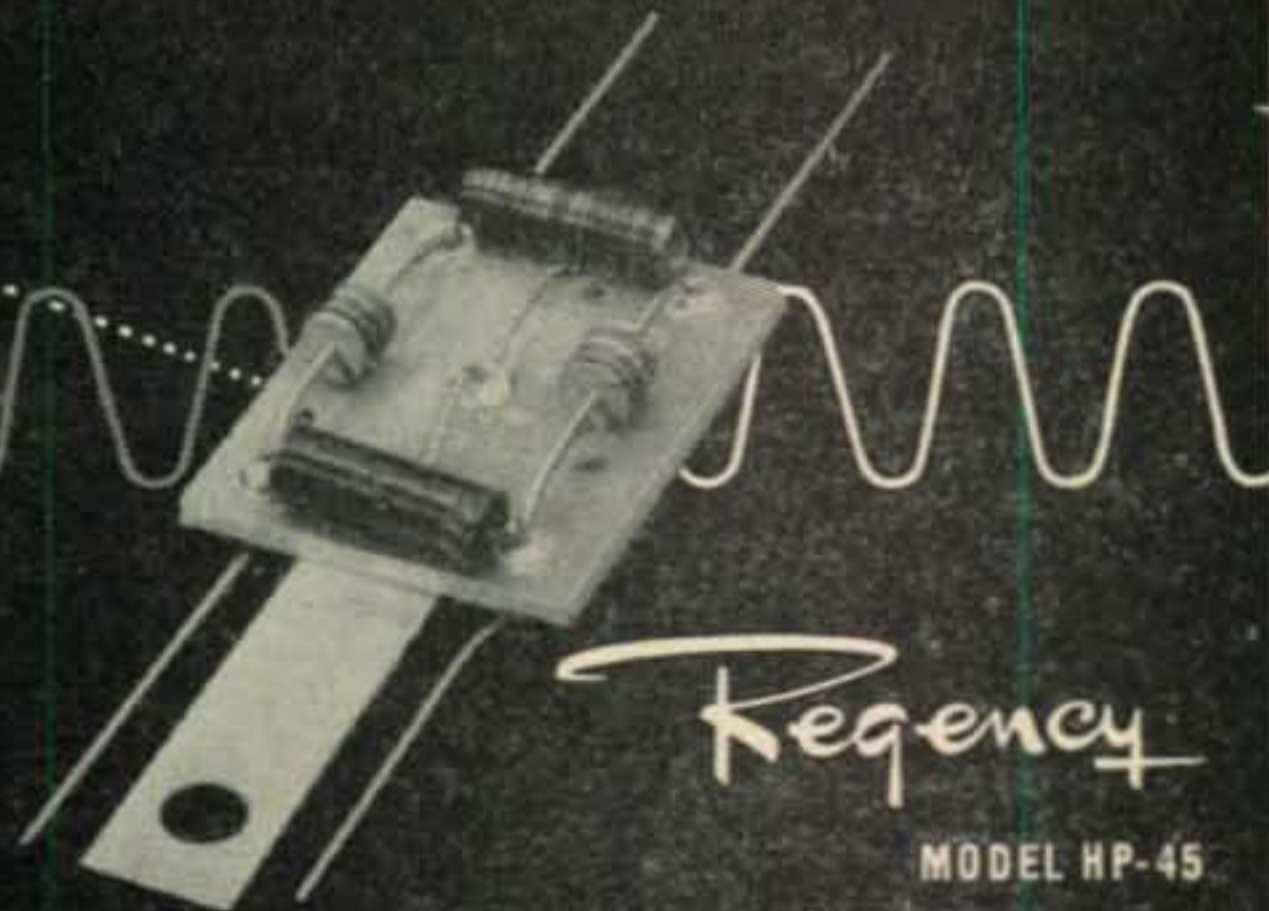

*Regency*

MODEL HP-45

REGENCY Division of I.D.E.A., Inc., Indianapolis 26, Ind.

AMATEUR NET, ONLY 99c

## HELP WANTED

This established radio & television manufacturing firm in Western New York has openings for:

Test Engineers  
Technicians  
Trouble Shooters  
Aligners

Applications should contain details of past experience. Write

Personnel Manager, H. E. Dudley  
STROMBERG-CARLSON COMPANY  
Rochester 3, New York

## Memo

Before you buy or trade, be sure to get our prices.

We stock all the leaders, including Hallcrafters, National, RME, Hammarlund, Elmac, Babcock, Gonset and a host of others.

You just can't beat buying from an old time and active Ham.

Fast four-hour shipping service. Trades accepted, and time payments if you wish.

### M. H. DOSSETT CO.

*"You always get more—  
From a Ham Parts Store"*

855 Burlington Ave., Frankfort, Ind.

**R.C. & L.F. HALL, INC.**

Radio & Television Parts

Distributors of Electronic Equipment Supplies

HOUSTON GALVESTON TEXAS CITY BEAUMONT  
 1301 Polk at Caroline 4414 Broadway 523 7th Ave. 1135 Park  
 Phone: Capital 9731 Phone: 3-1656 Phone: 4-7740 Phone: 5-7577

has **hallicrafters**



- 10 Kc to 250 cycles in six steps!
- The most stable receiver made!
- Single Side Band Suppressed Carrier!

**The Hottest Ham News in Years!**

See complete details on pages 4-5

THE HALLICRAFTERS CO • CHICAGO 24, ILL.



**110V, AC POWER SUPPLY FOR ANY 274-N RECEIVER**

Just plug it into the rear of your 274-N RECEIVER . . . any model. Complete kit and black metal case, with ALL parts and diagrams. Simple and easy to build in a jiffy. Delivers 24 volts plus B voltage. No wiring changes to be made. Designed especially for the 274-N receiver. **Only \$8.95.**

Filament trans. for 274N receivers. Pri. 110V, 60 cy. AC. Sec. 24V @ .6A. An excellent buy at **\$1.95 ea.**

**SPLINED TUNING KNOB FOR 274N RECEIVERS**

An exclusive O-R item manufactured for us. Fits BC-453, BC-454 and other 274N receivers. This is a really hard-to-obtain item. **Only .89c ea.**



**OFFENBACH-REIMUS**

1564 Market Street, San Francisco, Calif.

**LEARN WITH AMECO COURSES**

**BECOME A RADIO AMATEUR**

Simple, Low Cost, Home-Study Courses prepare you to pass F.C.C. Code and Theory Examinations for Amateur license and Code for Commercial license. . . . . Sold at leading distributors or write for information to

1203 Bryant Ave. **AMERICAN ELECTRONICS CO.** (Dept. C-2) New York 59, N. Y.

(from page 62)

Despite a transmitter input of only 15 watts, the antenna does a good job on the bands for which it is designed. Most contacts made on 75 are of a ground wave nature with reports equal to or better than those given nearby mobiles employing single-band commercially built trans-

FREQ. KCS	L1	L2
3850	NO JUMPER	NO JUMPER
3950	NO JUMPER	JUMPER FROM A TO B
7250	NO JUMPER	JUMPER FROM A TO C
14250	JUMPER FROM D TO E	JUMPER FROM A TO C
21350	JUMPER FROM D TO F	JUMPER FROM A TO C
27000	JUMPER FROM D TO G	JUMPER FROM A TO C
28750	JUMPER FROM D TO G	JUMPER FROM A TO C

Loading coil tap positions for various frequencies in the six amateur bands.

mitting antennas. When conditions have been favorable, satisfactory 75 meter QSO's have been made at distances up to 250 miles.

Almost all 40-meter contacts are with stations more than 300 miles away. Reports have ranged from S5 to S9. Although not too much 20-meter operation has been attempted, a number of excellent ground wave contacts have been made. Little skip has so far been worked. It seems as though every time I try 20 it is either dead or else is loaded with DX. Neither condition is good for long haul mobile work.

At those times when 15 and 10 are open, QSO's via skip can be had with little difficulty. Due to lack of activity on the band, no 11-meter work has, up to now, been attempted.

If you've been looking for an inexpensive, efficient and highly versatile mobile antenna—one which can be constructed with ordinary hand tools—this 6-band job should adequately meet your requirements. Build it and enjoy the fun denied those unfortunate fellows whose antennas restrict them to one narrow segment of the radio spectrum.

**TEST EQUIPMENT**

(from page 29)

the coils, for overlapping bands, and the calibration. The coil winding problem can be reduced somewhat by the use of a circuit such as that shown in Fig. 1. With this type of circuit the coils require no taps or secondaries, which makes pruning easy. For the low ranges almost any pie or bank wound r-f chokes may be used as tuning coils. To isolate the output and give greater stability the oscillator may be followed by a cathode-follower type amplifier.

**Calibration**

Even though we have reduced the headache of coil winding, calibration is still a difficult

job, unless one has at his disposal a frequency standard of some sort or at least a crystal calibrator. Of course, spot checks can be made by listening on a receiver and beating the generator with stations of known frequency. When calibrating the lower frequencies, such as those below the broadcast band where stations are few, harmonics of the generator can be checked against the broadcast band. For example, if we think the oscillator is in the frequency range below the broadcast region we can look for strong harmonics between 550 and 1600 kc. If a strong signal is found at 600 kc., and in tuning higher another is found at 800 kc., and the next at 1000 kc., it is a pretty safe bet that the generator is on 200 kc. Or if signals are found at 600 kc., 900 kc., and 1200 kc. the generator is very likely on 300 kc. The distance between the strong signals in kilocycles will be the fundamental frequency of the oscillator. When checking in this manner several points should

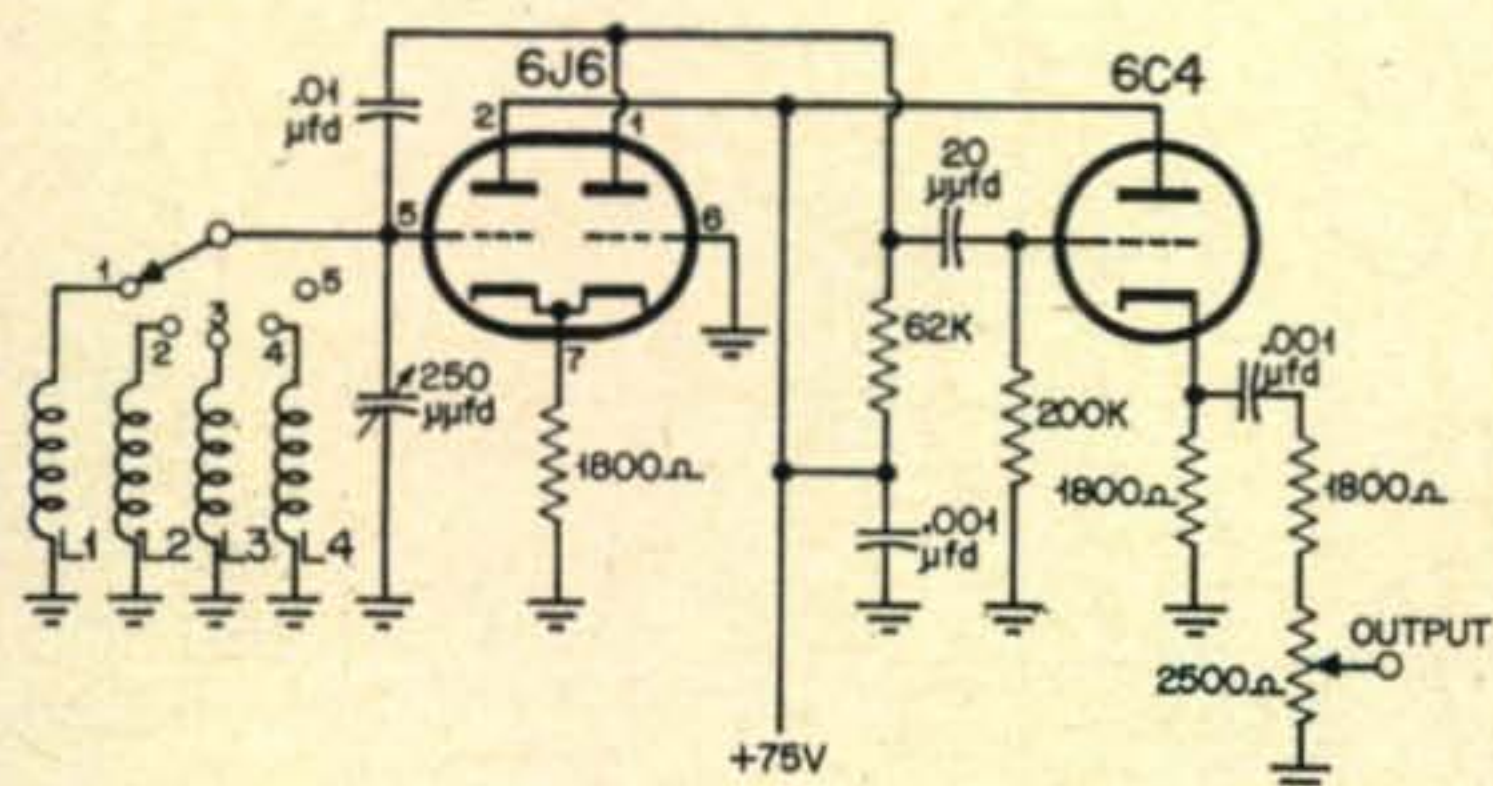

Fig. 1. This is an elementary type of signal generator circuit which has been designed to reduce the coil winding problems.

be tuned each time to avoid errors. This method of calibration is tedious but in due time a fairly complete chart can be filled in.

A useful gadget around the Ham shack is a simple crystal calibrator. Such an instrument is equally useful whether one buys or builds a signal generator, as it is an excellent means of calibrating a new instrument or recalibrating one that has aged. The circuit shown in Fig. 2 will operate with any crystal from 100 kc. to 10 Mc., or higher. The circuit can be changed from a Colpitts to a Pierce by means of the switch depending upon the type of crystal used. The trimmer can be used to zero-in crystals when checked against WWV. Also some crystals will require adjusting of this capacitor to obtain oscillation. The newcomer should be reminded though that when harmonic or overtone crystals are used they will probably oscillate on their fundamental rather than their marked frequency. Crystals below 10 Mc. will usually oscillate at their marked frequency.

The Ham with a box full of surplus crystals can find a multitude of uses for them. Wide

(Continued on page 66)

# Here's the new SHURE SLIM-X

## All-Purpose Crystal MICROPHONE



MODEL 777  
List Price \$21.00  
MODEL 777s (with switch)  
List Price \$23.00  
(Price includes cradle  
for mounting on stand)

Its Versatility and "Hand-a-Bility"  
give you an ideal low-cost  
all-purpose microphone

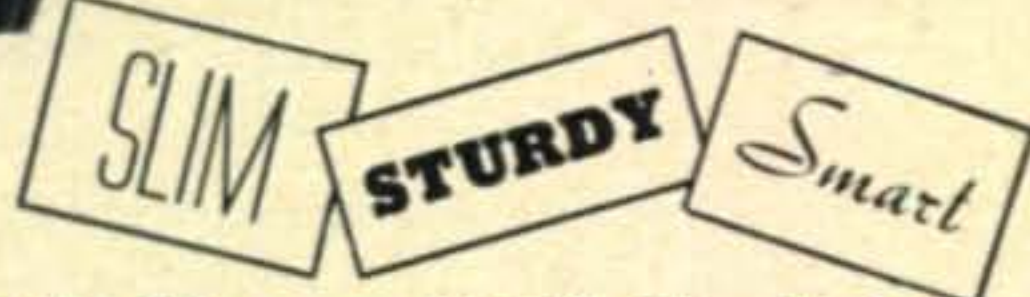

**LIGHT!** The new "777" Slim-X Microphones are rugged little microphones weighing only 6 ounces! They are designed for good-quality voice and music reproduction. Their versatility and "hand-a-bility" make them ideal for use by lecturers, announcers, instructors, and Hams; for audience participation shows; carnivals; panel and quiz shows; and use with home-recorders. When mounted on either cradle or swivel, the "777" can be removed in a flash (no tools necessary)—simply by lifting it out of the holder. This makes it an ideal "walk-around" hand-held microphone.

**TECHNICAL INFORMATION:** Smooth frequency response—60 to 10,000 c.p.s.; special-sealed crystal element—for long operating life; high impedance; 7' single-conductor cable, disconnect type. Dimensions: (Microphone only) Length, 4½"; Diameter 1". *Finish:* Rich satin chrome overall.

**NOTE:** Lavalier cord for suspension of Microphone around neck is included.

### ACCESSORIES FOR "777"

**MODEL S38 STAND** is a heavy die-cast base. Includes metal screw machine stud for connecting microphone adaptor to stand base.

List Price: \$3.30

**MODEL A25 SWIVEL ADAPTOR** features a long-life, high-quality swivel connector. Is lined with a long-life nylon sleeve—for noise-free and scratch-free insertion and removal of microphone.

List Price: \$5.50



On S38  
Desk  
Stand



On Floor  
Stand



With  
Lavalier



On S38 Desk Stand  
With A25 Swivel

## SHURE BROTHERS, INC.

Manufacturers of Microphones and Acoustic Devices  
225 W. Huron St. • Chicago 10, Ill. • Cable Address: SHUREMICRO

# NEW MOTOROLA

## Home Unit Monitor Receiver

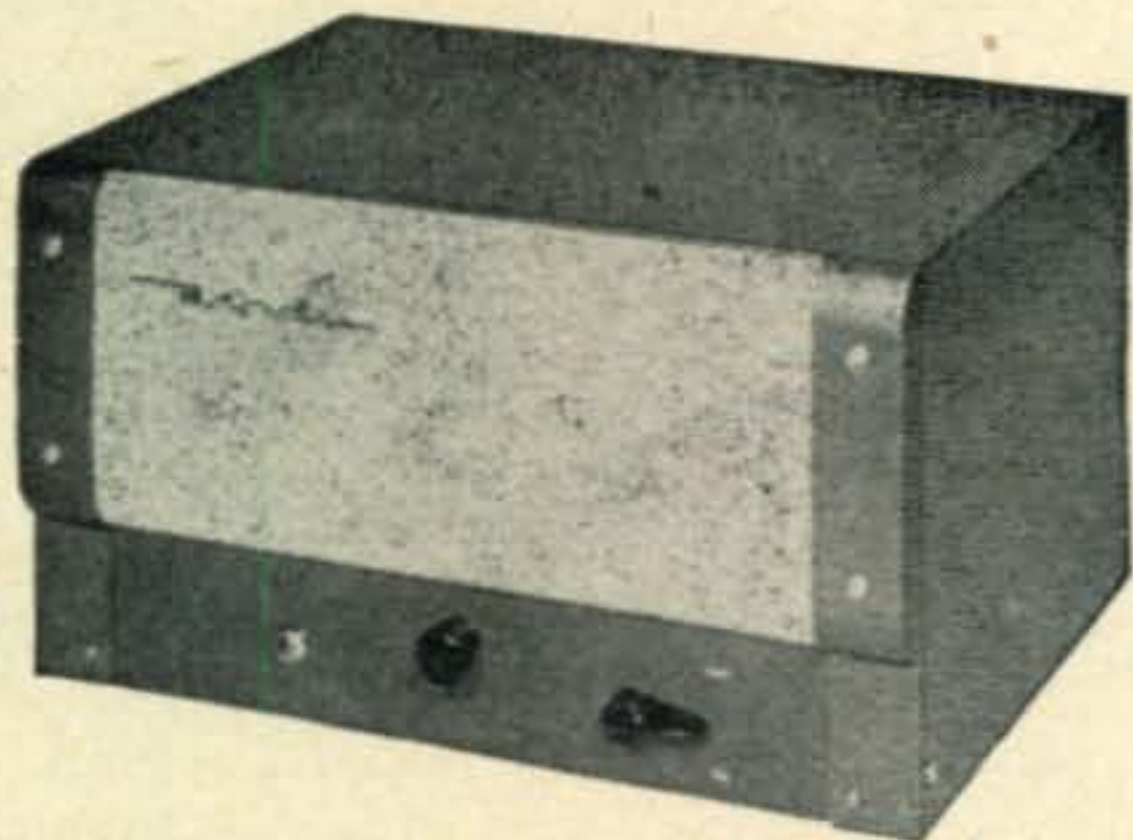

Now available—the new Motorola Monitor or Alert Receiver, for operation in the 25-50 mc. and 152-174 mc. ranges. Optional selective signaling, emergency 6 VDC power supply, and red-yellow-blue-white light alert cabinet attachments. Ideal for amateur, as well as public safety, civilian defense, industrial and commercial radio systems.

For further information write to:

# Motorola®

Communications & Electronics, Inc.

Amateur Sales Dept. - CQ - 2

1327 W. Washington Blvd., Chicago 7, Illinois

Attention: Harry Harrison, W9LLX, Tel. TAYlor 9-2200—Ext. 161

## SAVE! CLOSE OUT SAVE!

# COMMAND SETS

Buy While They Last . . .

And Save

## 274N and ARC - 5 EQUIPMENT

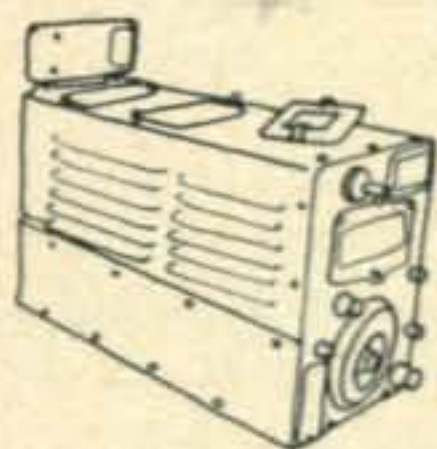

TYPE	Rev.	Freq.	Condition	Price
BC-453	Revr.	190-550 Kc.	Used, with tubes . . .	\$14.95
			As is, less tubes . . .	12.95
BC-454	Revr.	3-6 Mc.	Used, with tubes . . .	8.95
			As is, less tubes . . .	4.95
BC-455	Revr.	6-9 Mc.	Used, with tubes . . .	7.95
			As is, less tubes . . .	4.95
BC-456	Modulator		Used, with tubes . . .	3.95
			As is, less tubes . . .	2.95
BC-696	Xmtr.	3-4 Mc.	Used, with tubes . . .	14.95
			As is, less tubes . . .	8.95
BC-457	Xmtr.	4-5.3 Mc.	Used, with tubes . . .	6.95
			As is, less tubes . . .	3.95
BC-458	Xmtr.	5.3-7 Mc.	Used, with tubes . . .	6.95
			As is, less tubes . . .	3.95
BC-459	Xmtr.	7-9.1 Mc.	Used, with tubes . . .	9.95
			As is, less tubes . . .	5.95
BC-450	3 Revr. control box		Used . . . . .	1.49
BC-451	Xmtr. control box		Used . . . . .	1.49
3 Receiver rack			Used . . . . .	1.49
2 Transmitter rack			Used . . . . .	1.49

Specify first and second choice—274N or ARC-5 Equipment.

CASH WITH ORDER. Include 3½% sales tax with California orders—plus approximate postage. Excess will be refunded.

## SAM'S SURPLUS

1306-A BOND STREET

LOS ANGELES 15, CALIF.

(from page 65)

coverage can be had with just a few, as the crystal diode element in the output will generate strong harmonics. A crystal in the 10-megacycle region with proper coupling to a receiver can produce usable harmonics to 500 megacycles or more. In fact a 7.5 Mc. crystal has been found to give harmonics as high as 1800 megacycles when the plate voltage was raised to 300 volts. However, at this high frequency the harmonics were too close together to be of much value to the average Ham. This oscillator is quite tolerant of plate voltage, and around 100 volts is suggested; however, with an active crystal, operation is possible with as low as 7.5 volts on the plate. For uses where harmonics are not desired, the 1N34 crystal should be shorted out.

### Attenuators

As mentioned earlier the attenuator is no small part of a good signal generator. In the expensive laboratory models the output of the

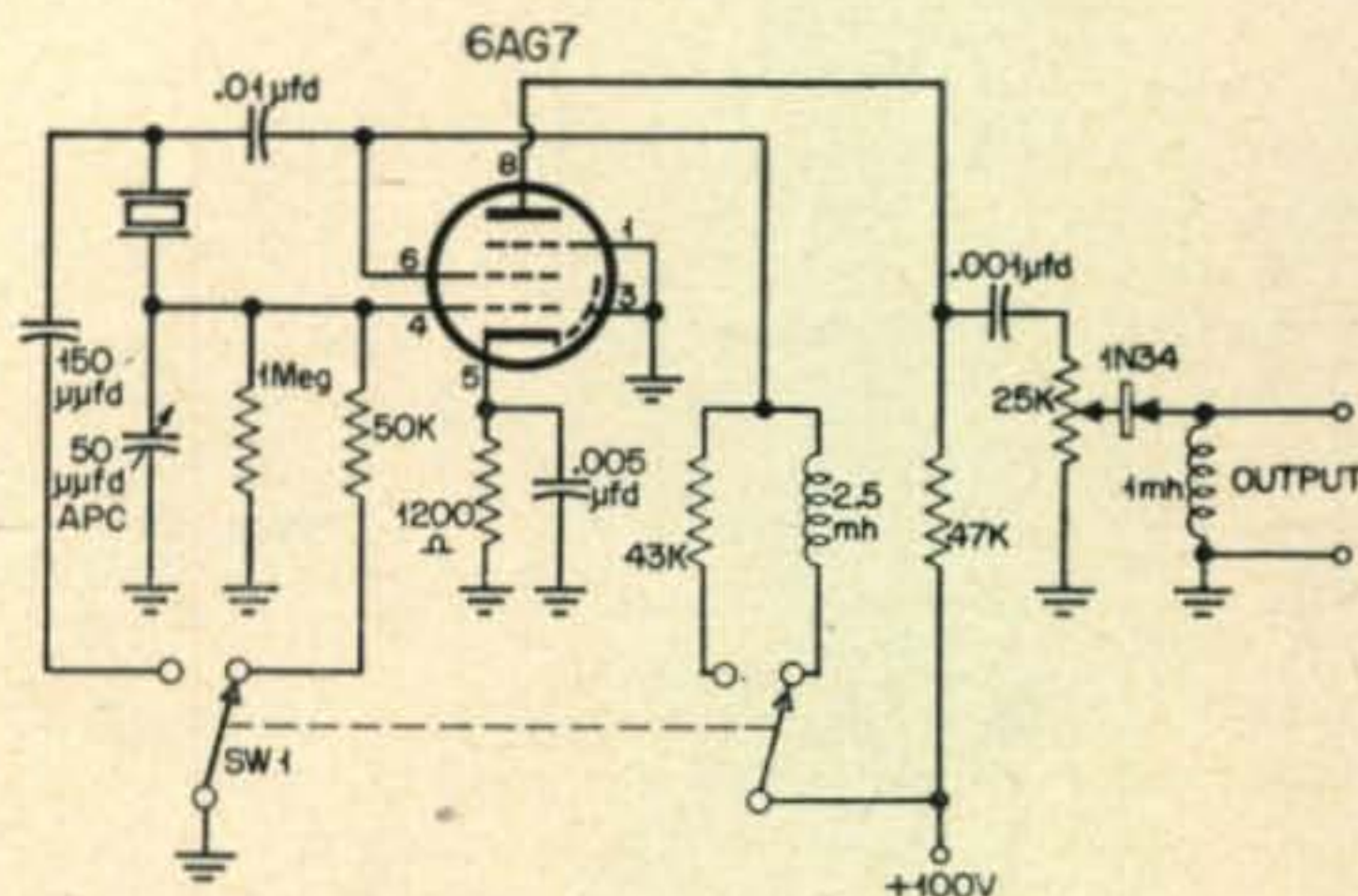

Fig. 2. Crystal calibrator for use with alignment of r-f signal generators. The circuit may be changed from a Colpitts to a Pierce oscillator by switch, Sw1.

generator is fed to an r-f voltmeter with a reference point such as 1 volt on the scale. With the output held constant to this value it is fed to the attenuator. This is just a precision voltage divider which holds its accuracy to high frequencies.

If the oscillator is shielded well enough to prevent a transfer of signal through space or through the associated wiring and IF the attenuator is constructed of resistors which hold their accuracy at high frequencies, the input to the receiver under test can be measured in microvolts or even fractions of microvolts. The second "if" is even more difficult to eliminate than the first. For this reason many laboratory generators which range into the very high frequencies have turned to the mutual inductance type of attenuator, sometimes called "wave guide below cutoff." As shown in Fig. 3, this consists of just a movable coupling coil which travels in a rigid metal tube. As it moves

away from the signal source the induced voltage falls in a logarithmic manner. This resolves the problem into a mechanical one and figuratively speaking it can be calibrated with a ruler.

Because of production costs the ordinary small generator found in everyday usage concerns itself mainly with the problem of reducing the output to a value which will not block a sensitive receiver, rather than that of giving exact output readings in microvolts.

**Use of the Generator**

In using a signal source it must be coupled to the receiver under test. This may take on

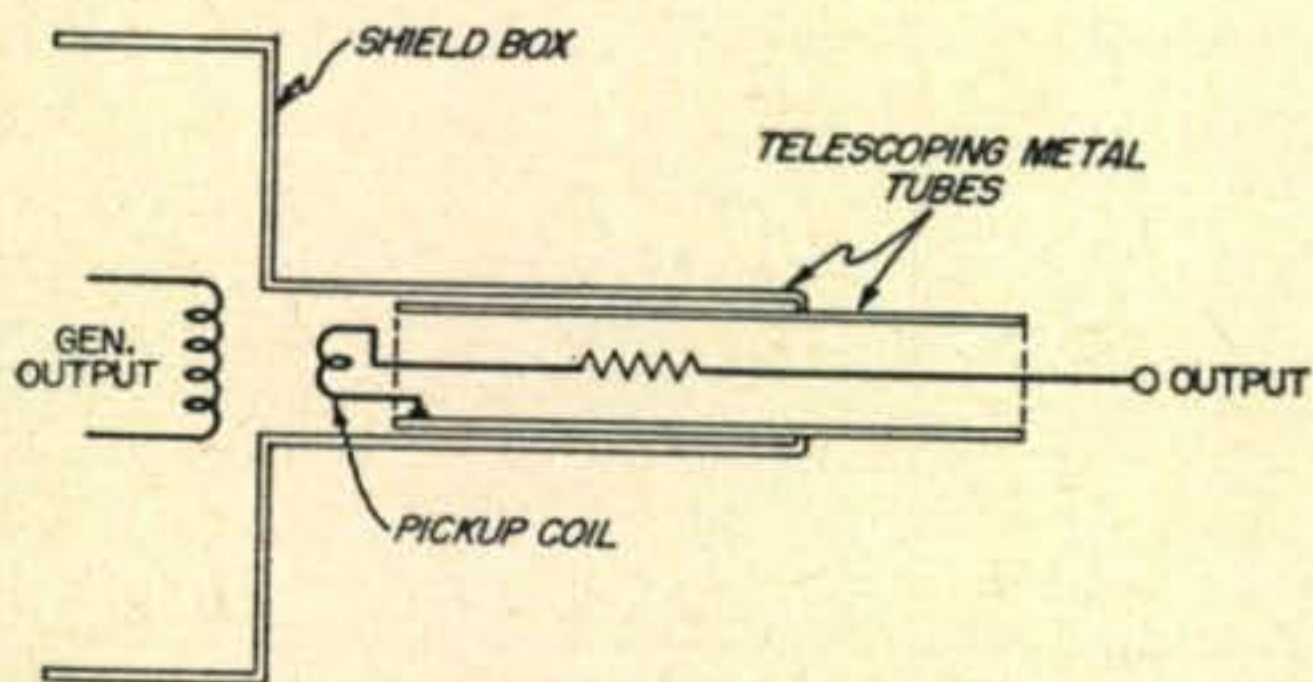

Fig. 3. Mutual inductance attenuator discussed in the text. The output of the r-f signal generator is reduced logarithmically by this method.

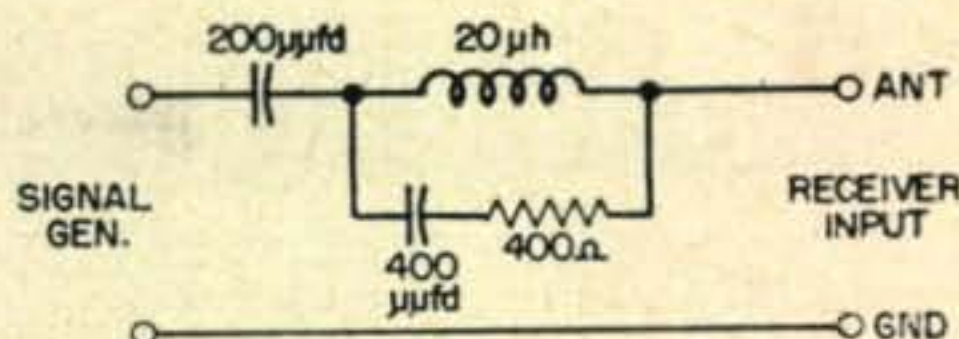

Fig. 4. Standard "dummy antenna" coupling network for use between the signal generator and the receiver or converter.

many variations ranging from a network such as that in Fig. 4 to the mere expedient of separating the units across the room from each other. The network of Fig. 4 has been accepted for general use for connecting a signal generator to a receiver or converter. At lower Ham bands and broadcast frequencies it will simulate a single-wire antenna, and from 7 Mc. through 30 Mc. will approximate a 300 to 400-ohm line such as twin-lead.

Although we are not trying to debunk good practices we have found by actual measurement that very few receivers rated for 300 or 500 ohms antenna input even approach this figure except at a few points through the spectrum. In consideration of this it is sufficient in most Ham usage simply to connect a resistor between the receiver antenna post and the hot

(Continued on page 68)

Low pass filter 36 MC cut-off frequency



Inductance and capacity tuning—neon indicator

52 ohm input coaxial—up to 75 watts input power

Transmitting type variable condenser—tapped inductance.

**MODEL AC-1 ANTENNA COUPLER**

The new Heathkit Antenna Coupler, Model AC-1 was specifically designed to operate with the Heathkit Amateur Transmitter and will operate with any Transmitter not exceeding 75 watts RF input power.

**RUGGED DESIGN** has resulted in a sturdy, well-shielded unit featuring a copper plated chassis and shield compartments. A coaxial 52 ohm receptacle on the rear of the chassis connects to a three section, Pi type low pass filter with a cut-off frequency of 36 MC.

**TUNING NETWORK** consists of a variable capacitance and tapped inductance in an impedance matching unit.

**CAPACITY COUPLED** neon lamp serves as a tuning indicator and will also provide a rough indication of power output.

**\$14.50**

SHIP. WT. 3 LBS.

*Heathkit* **ANTENNA IMPEDANCE METER KIT and ANTENNA COUPLER KIT**

**MODEL AM-1 IMPEDANCE METER**

The Heathkit Antenna Impedance Meter is basically a resistance type standing wave ratio bridge with one arm a variable resistance. In this manner, it is possible to measure radiation resistance and resonant frequency of an antenna, transmission line impedance, approximate SWR and optimum receiver input.

**USE IT ALSO** as a phone monitor or as a field strength meter where high sensitivity is not required.

**FREQUENCY RANGE** of the AM-1 is 0-150 MC and range of impedance measurement 0-600 ohms. The circuit uses a 100 microampere Simpson meter as a sensitive null indicator. Shielded aluminum, light weight cabinet, strong, self-supporting antenna terminals.

**\$14.50**

SHIP. WT. 3 LBS.

Match transmission lines for minimum SWR



Determine antenna resistance and resonance

Contact light weight completely portable

Strong, self-supporting antenna terminals

**HEATH COMPANY**  
BENTON HARBOR 6, MICHIGAN

## Professionally Engineered Amateur Priced



### VALENCO 140 R. F. UNIT

- 180 Watts Max. (140 W. Phone)
  - 3.5 through 30 MC
  - 6CL6-5763-Parallel 6146's
  - Kit or Factory Wired
  - Crystal or Your External VFO
  - Completely Shielded Against TVI
  - Pi Network Output
  - Fixed—Mobile—Novice
- Kit \$74.50 Factory Wired \$89.50**  
for further information write

**VALLEY ENGINEERING COMPANY**  
Box 2, Los Alamos, New Mexico

(from page 66)

lead of the generator, and then ground the generator to the receiver chassis. For receivers with a co-ax input, such as RG-8/U, a 50-ohm size should be used; for those with a 300-ohm input with grounded center tap the signal can be fed between ground and one side through a 150-ohm resistor. These should be carbon resistors.

In many cases coupling with a small mica condenser in place of the resistor will be adequate. The main object is to prevent the low output impedance of the generator attenuator from loading the input tuned circuit to the point where alignment will not remain the same when the generator is removed and the antenna is connected.

The *Heath Company* has attracted considerable attention by their approach to the problem of low cost test equipment by means of the *Heathkits*. Because of this we have been investigating a number of the kits in connection with this series of test equipment for the amateur. For those interested we would like to mention in passing that any statements made have not been influenced by the *Heath Company* as the writer has had no contact with them regarding this series of articles.

The kit which falls under our heading this month is the *Model SG-7*. This r-f generator covers a range from 160 kc. to 52 Mc. on funda-

### BC1267 Transmitter and Receiver

154 to 186 Mcs., 1KW pulse oscillator, superhet circuit, 2 RF stages, and 5 stagger tuned IF's, includes 21 tubes: 2C26(2), 3E29/829B(1), 6AG5(7), 6C4(1), 6E5(1), 6H6(1), 6AK5(3), 6J5(2), 6SN7(1), 6V6(1), 9006(1), can be easily converted to 2-meter converter and outboard amplifier, shipwt.—75 lbs., complete with conversion instructions (NOTE: 3E29/829B is worth \$10.00 alone).

excellent condition **\$14.95** (less tubes) with 21 tubes **\$24.95**

### MONTHLY SPECIAL All 3 Items For \$10<sup>00</sup>

**RT7/APN-1 TRANSCEIVER UNIT**—Used as an altimeter, it may be converted for signaling control circuits, etc. Used, less tubes, as is. **\$4.95**

**RT/34 APS 13 TRANSCEIVER** used as a tail warning radar on 415 MC. Containing a 30MC IF Strip and various other parts, these units have been stripped of RF sections and all tubes, but are an excellent buy if only for parts and IF Strip. Used. **\$4.95**

**R-1/ARR-1**, 220 MC converted with minor alterations becomes a high gain converter with two stages of RF amplification—(complete with diagram). New. **\$4.95**

**BC 906 FREQUENCY METER**—Range 150-225 MC with modification possible for lower frequencies of TV, etc., and uses Battery pack of 1.5 and 45 VDC. **\$4.95**  
LIKE NEW

### TRANSCEIVER

140-144 mc, 2 meter, used, excellent condition, less dynamotor, less tubes, Only. **\$10.95**  
with tubes **\$19.95**

**RW ELECTRONICS**

2432 S. Michigan  
Chicago 16, Ill.

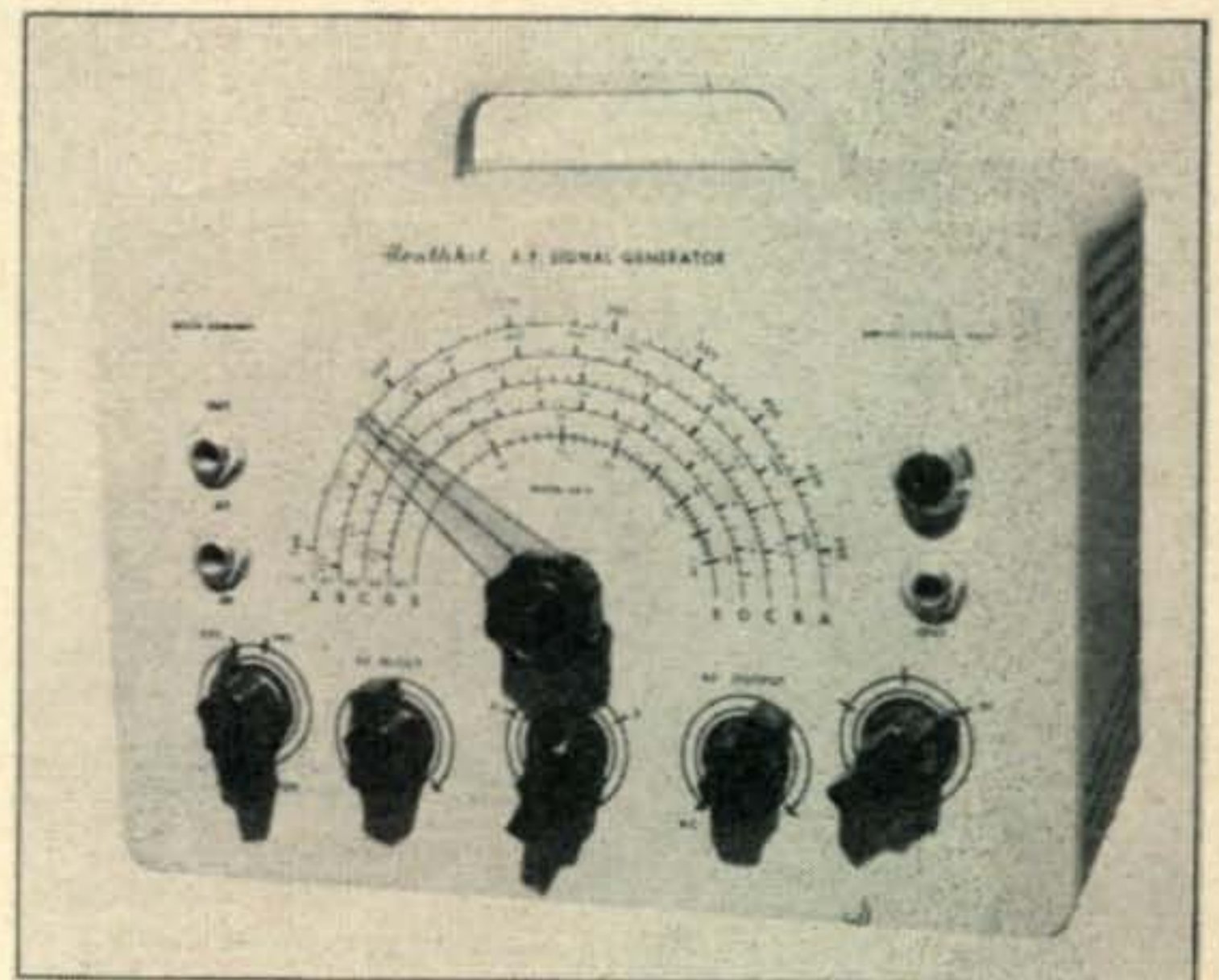

This is the Heathkit Model SG7 generator.

mentals and is calibrated to 156 Mc. If one cares to use a diode crystal across the output, signals far into the kilomegacycle range are available. The calibration is spread over six bands and this combined with a smooth vernier dial affords easy tuning, even on high bands.

For those interested in the circuitry, the oscillator is a 6C4 Hartley. Modulation is accomplished with another 6C4 as an audio oscillator or as an amplifier if external modulation is used. Internal modulation is at 400

cycles. A jack is provided to facilitate external use of this audio if desired, and about 2 volts are available. When modulated from an external source approximately 5 volts are required. By using tubes with low current heaters and a selenium rectifier, heat in the cabinet is kept to a minimum, thus reducing drift. This unit has a power transformer which helps to prevent leakage through the power line.

The output is taken from an attenuator which is of the combined step and vernier type and except on the highest output step at the higher frequencies will have little effect upon

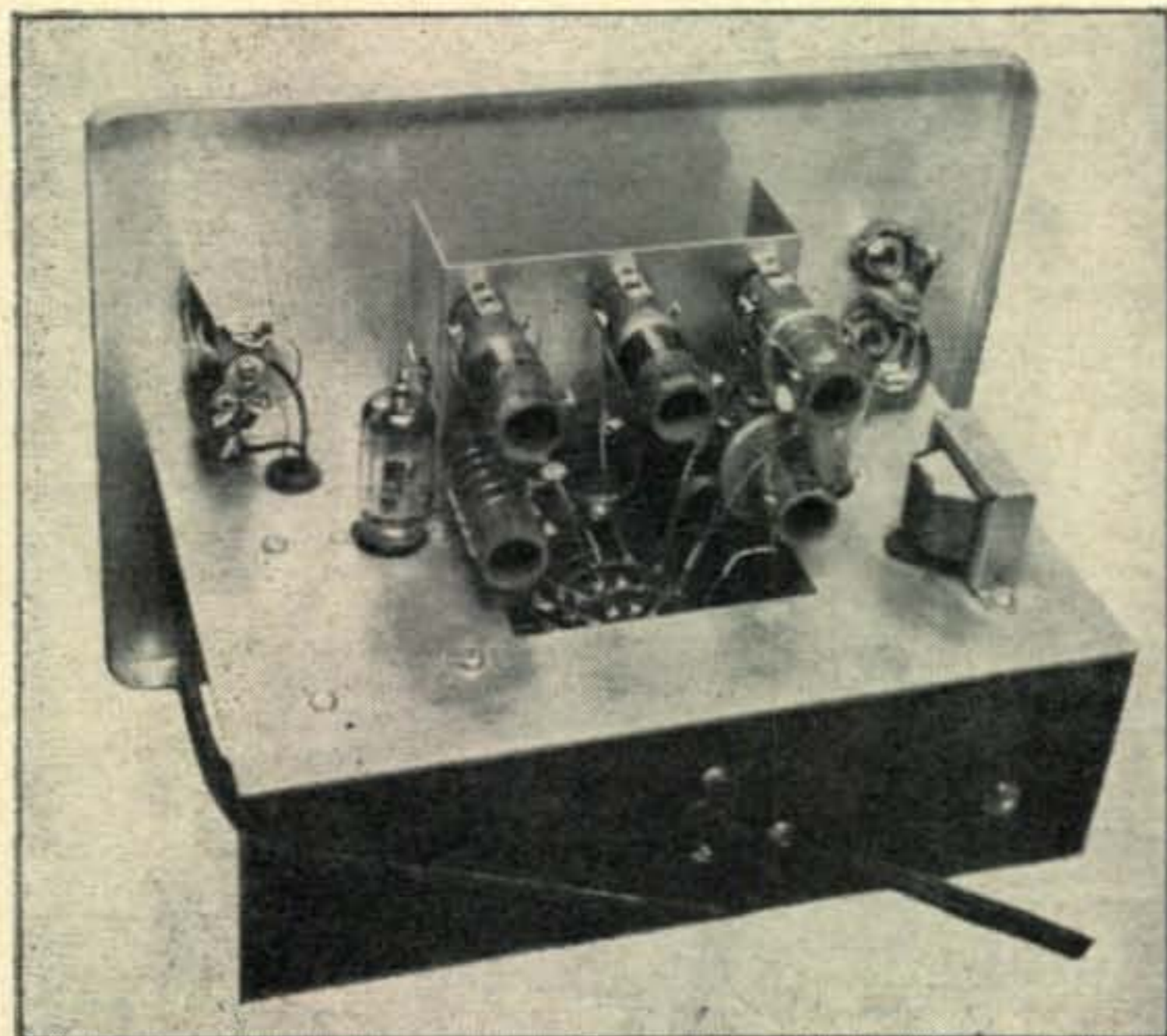

Switch-type construction as used in the Heathkit.

the frequency. There is some r-f leakage through the cabinet on the high bands. However, because of the great increase in price which would be caused by complete leakproof shielding, the present unit seems to be a justifiable compromise.

For those who missed the first of this series, an attempt is being made to present material strictly from the view-point of Ham radio requirements and not from that of the precision laboratory worker. The subject of 'scopes will be next month's attempt to compress a jugful of information into a one-capsule dose.

## PROPAGATION

(from page 41)

sunspot number is predicted to be approximately 6.

During 1953, usable frequencies also continued to decrease with the ten meter band generally useless for ionospheric propagation (except Sporadic E, short skip) and with the 15, 20 and 40 meter band less useful than in previous years.

Ionospheric absorption decreased somewhat during 1953, and this resulted in the nighttime (40 and 80 meter) bands opening earlier than during previous years. For example, the 40 meter band opened between New

(Continued on page 70)

# PRICES SLASHED TO ROCK BOTTOM! COMMAND SETS

by-THE-CARLOAD

SAVE NOW during this  
Market-Busting Sale!

### ARC-5 OR 274N COMMAND SETS

T-20/ARC-5 XMTR 4-5.3 MC Like New.....	\$ 7.50
T-21/ARC-5 XMTR 5.3-7 MC Like New.....	6.95
T-22/ARC-5 XMTR 7-9.1 MC Like New.....	9.95
R-26/ARC-5 RCVR 3-6 MC Used, Xlnt.....	12.50
R-27/ARC-5 RCVR 6-9.1 MC Used, Xlnt.....	7.95
190-550 KC RCVR Used, Good.....	17.95
2.1-3 MC XMTR Used, Good.....	12.95
RC-456 MODULATOR, Used, Good.....	2.95
MD-7/ARC-5 MODULATOR, Used, Xlnt.....	12.95
T-23/ARC-5 XMITTER, 100-156 MC and	
R-28 ARC-5 RCVR 100-156 MC.....pair	79.95
C-30/ARC-5 r-channel control box.....	4.95
R-4/ARR-2 234-258 MC.....	15.95
RCVR RACK, 2-section, \$2.95.....3-section,	2.95
XMTTR RACK, 2-section.....	2.95
BC-442 W/METER & VACUUM COND, New....	2.95
12 V DYNAMOTOR for Command Receivers....	9.95

FULL 10% DISCOUNT ON ANY ORDER  
\$30 OR OVER

### Check This Value in PORTABLE FM XMITTERS & RCVRs

Operate on 6V DC, 34 MC varied either direction depending Xtals. Xmtr and rcvr. has aluminum case with antenna relay. Xmtr. uses 1073.125 KC xtal in osc stage followed by 4 doubler and 1 fin. amp. all using HY-65 tubes. Mike amp. and Pre. Mod. uses 1C7G tubes. Xmtr. stages have metering jacks. Rcvr. is superhet Xtal cont. local osc at 8060 KC. Power Supply on chassis using Carter 6 V gen. output 450 V 250 ma 6V vibrator power supply for receiver. All tubes inst. heating. Included is control box, hand set, 8" speaker and extra mike. Used, not tested.

Complete set only..... **\$39.00**

### 25 WATT PORTABLE FM XMITTER

Model 565A, Power Output 25 watts, Freq. 30-40 megs. xtal controlled. Input voltage 5.6 VDC. Used, not tested. Dynamotor ok and tested. Less speaker, control box, crystals and bottom mounting cover. With tubes and dyns. Rcvr. and Xmitter driver stages use local tubes (705, 7F6, etc.). Xmitter final amplifier is 815 tube. Xmitter dyn; 5.6 VDC at 17.6A input, 500 VDC at 100 ma output. Receiver dyn; 5.6 VDC at 7.6A input 250 VDC at 50 ma output. Meter plugs furnished for tuning xmitter.

Price ..... **\$45.00**

### IMPORTANT

NO ORDER LESS THAN \$10.00. Send full amount of order. Do not send shipping costs. Merchandise will be shipped via Railway Express with shipping costs COD, unless otherwise specified. California orders add 3% sales tax.

### V&H RADIO & ELECTRONIC SUPPLY CO.

Dept. C-Q 2033 West Venice Blvd.  
LOS ANGELES 6, CALIFORNIA  
Phone: REpublic 3-1127

# HOW TO Tackle TVI



PRICE **\$14.85**  
NET

## SQUELCH HARMONIC RADIATION WITH THIS B&W LOW PASS FILTER

- Minimum attenuation of 85db thru entire TV band, more than 100db on Channel #2
- 4 "K" sections, 2 "M" derived end sections
- Insertion loss less than .25db through entire pass band to 30 mc.
- Handles more than 1 KW of r-f power
- Size: Approx. 10 $\frac{3}{4}$ " x 3" x 2"

When your transmitter is equipped with one of these B&W Low Pass Filters, unwanted harmonics causing TVI are reduced by a minimum factor equal to 17,780 to 1. No tuning or adjustments of any kind are necessary to achieve this terrific performance. See one at your B&W dealer today or write for Data Bulletin 425.

Model 425: 52 ohms impedance ● Model 426: 75 ohms impedance

**B&W**

**Barker & Williamson, Inc.**

237 Fairfield Ave., Upper Darby, Pa.

Radio Operators!

**THE GUARDIAN  
SERIES 200  
RELAY...**



*Interchangeable*  
**COIL and CONTACT  
SWITCH ASSEMBLIES**  
Save Time—Cut Costs!

★ Coil assembly includes coil and field piece. Contact assembly consists of switch blades, armature, return spring and mounting bracket. Standard and Midget contact assemblies in either S.P.D.T. or D.P.D.T. are *interchangeable* and can be used with any of 13 coils described below.

### CONTACT SWITCH ASSEMBLIES

CAT. NO.	TYPE	COMBINATION
200-1	Standard 8 amps	Single Pole Double Throw
200-2	Standard 8 amps	Double Pole Double Throw
200-3	Standard Contact Switch Parts Kit with complete assembly and wiring details.	
200-4	Standard 12.5 amps	Double Pole Double Throw
200-5	Standard 8 amps	Four Pole Double Throw
200-M1	Midget 8 amps	Single Pole Double Throw
200-M2	Midget 8 amps	Double Pole Double Throw
200-M3	Midget Contact Switch Parts Kit with complete assembly and wiring details.	

### 13 COILS ASSEMBLIES

A.C. COILS*		D.C. COILS	
CAT. NO.	VOLTS	CAT. NO.	VOLTS
200-6A	6 A.C.	200-6D	6 D.C.
200-12A	12 A.C.	200-12D	12 D.C.
200-24A	24 A.C.	200-24D	24 D.C.
200-115A	115 A.C.	200-32D	32 D.C.
		200-110D	110 D.C.
		200-5000D	for current type

\*All A. C. coils available in 25 and 60 cycles

**GUARDIAN ELECTRIC**  
1604-B W. WALNUT STREET CHICAGO 12, ILLINOIS  
A COMPLETE LINE OF RELAYS SERVING RADIO AMATEURS

(from page 69)

York and Europe as early as 2:30 PM EST during the fall and winter months, with occasional openings noted as early as 12:30 PM EST during late November and early December.

In general, 1953 was a year of continued decrease in the DX potentialities of the amateur 10, 15 and 20 meter bands. Lower usable frequencies and decreased ionospheric absorption averaged out so that DX conditions on 80 and 160 meters are believed to have actually improved somewhat during 1953, with conditions on 40 meters improving during the early evening and early morning hours, but becoming poorer during the late evening hours.

### Post Analysis of DX Contest

A number of reports have been received from CQ readers who used the special September and October predictions during the recent World Wide DX contest. The following from Bill Case, W5FNA, typifies these reports:

"... but your predictions helped make maximum use of the short time available. The predictions were quite accurate, particularly on 21 Mc."

In general, both contest weekends occurred during relatively quiet radio propagation conditions, with the CW weekend actually occurring during a relatively good period.

The October CQ forecast predicted that propagation conditions during the phone period would be normal, but sandwiched in between disturbed periods. The November CQ forecast predicted that the CW contest period would occur during a good propagation period.

Based upon reports received by the Radio Warning Service of the Central Radio Propagation Laboratory, actual radio quality observed during the contest period has been estimated as follows:

October 24—Started poor becoming fair to good.

October 25—Started fair becoming good.

October 26—Started fair becoming poor.

October 31—Started fair becoming good.

November 1—Good.

November 2—Good.

Therefore, unlike the previous three CQ DX contests, significant ionospheric disturbances did not occur during the post World Wide DX contest, and propagation conditions were generally fair or better.

## THE NOVICE SHACK

(from page 39)

Pvt. Ronny E. Harris, RA17393763, Co. D, 1st Inf. Reg't., Ford Ord, Calif.

Johnny Jarvis (14), 610 S. Sunny Slope Ave., West Frankfort, Ill.

James Greer (30), Box 346, Camp Wood, Texas.

Carlton Yaffey (12), 5215 Argall Ave., Norfolk 8, Va. phone: 41586.

Seymour Lanton, 85 Bristol St., Brooklyn 12, N. Y.

Larry Mitchell (16), R.D. #3, Ithaca, N.Y. Phone: 41770.

Bruce Kibler, Jr., Box 201, New Castle, Va.

Bill Heitritter, 1114 $\frac{1}{2}$  Virginia, Sioux City, Iowa. (Also wants pen pals interested in radio.)

### More Letters

Jim Rogers, WN5CFZ, General Delivery, Rockdale, Texas, writes, "Dear Herb, I have been on the air three weeks and four days. I have been able to work only 7 stations in 2 states. I am using an S-38C receiver, a 6L6 transmitter running thirty watts, and a 136-foot folded dipole fed with 300-ohm ribbon. My frequency is 7185 kc. I think that I should have better luck than I have been having. Any suggestions?" (Jim's trouble is probably the result of using a 3.5-Mc. folded dipole on 7 Mc. A folded dipole is essentially a "one-band" antenna, although a 7-Mc. one works o.k. on its third harmonic—21 Mc. Cutting antenna length to sixty-five feet or transferring operations to the 3.7-Mc. Novice band are two solutions. I have received several letters recently from other Novices with exactly the same complaint—Herb.)

Norman, KN6ANE, writes from Placerville, Calif. "Dear Herb, After hearing some of you city fellows complain, I thought I would tell you my troubles. I live in the Sierra Nevada Mountains, where radio recep-

(Continued on page 72)



# Chapter One

## Automotive Electrical Systems

Regulator Adjustment

Batteries

PE-103A

# Chapter Two

## Mobile Power Supply

High Power Supply



# Chapter Three

## Mobile Receivers

Converter Installation

12-Watt Mobile

# Chapter Five

## Mobile Transmitters

"Mobile Special"

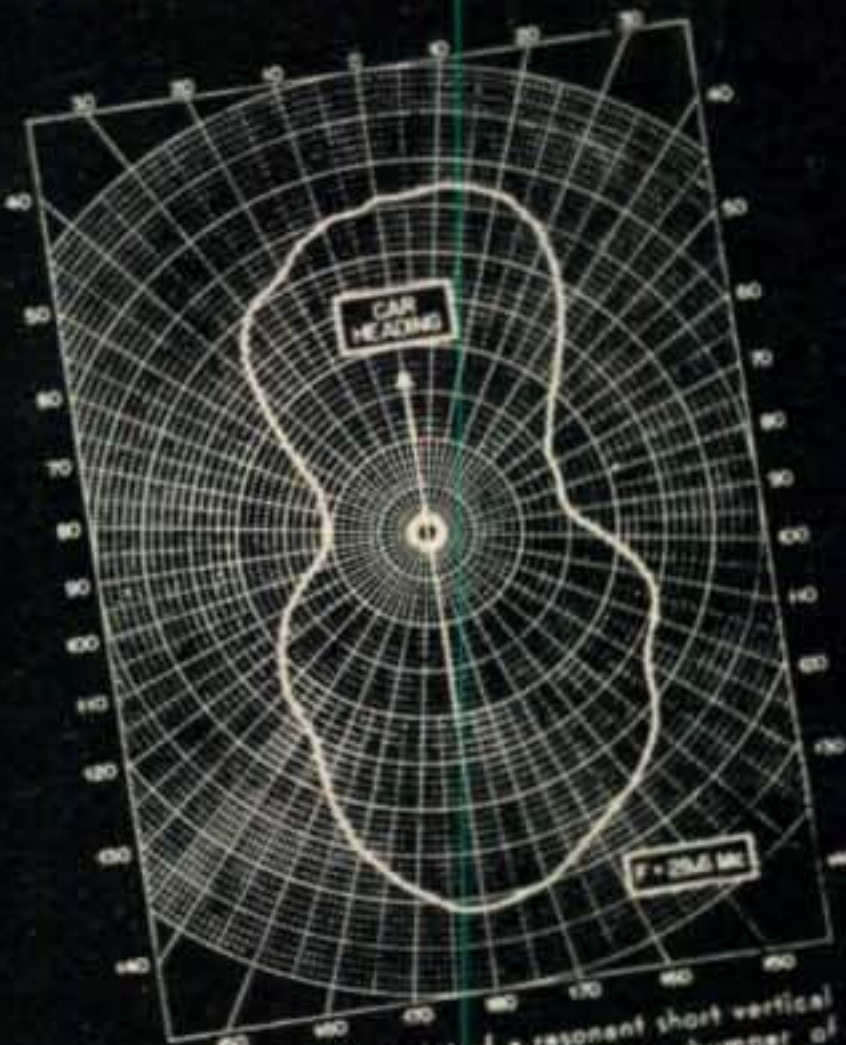

Fig. 5-1-E. Polar plot of a resonant short vertical antenna mounted on the left rear bumper of an automobile.

# Chapter Four

## Noise Suppression

Shunt Limiters

Speech Clipping

# Chapter Six

## Mobile Antennas

Everything in ONE book!



\$2.00 even

Antennas

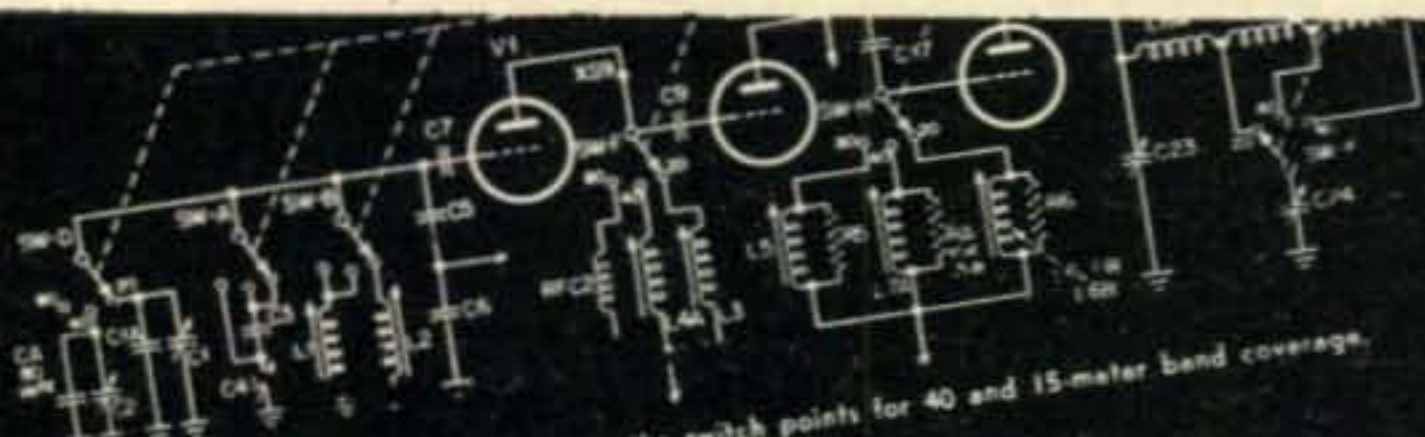

Fig. 5-17-J. Wiring changes to the switch points for 40 and 15-meter band coverage.

Grid Dip Oscillator

Test Equipment

## BUY OF A LIFE TIME!

### TRIED AND PROVEN THE WORLD OVER



#### LETTINE MODEL 240 TRANSMITTER WITH MOBILE CONNECTIONS AND A.C. POWER SUPPLY

This outstanding transmitter has been acclaimed a great performer throughout the world. It is excellent for fixed station, portable or mobile operation. Air wound plug-in coils used for greater efficiency—never obsolete—an outstanding buy, direct from our factory, ready to operate.

The 240 is a 40 to 50 watt Phone-CW rig for 160 to 10 meters, complete with: (8 x 14 x 8) cabinet, self contained A.C. power supply, MOBILE connections, meter, tubes, crystal and coils for 40 meters. Tubes: 6V6 osc., 807 final, 6SJ7 crystal mike amp., 6N7 phase inverter, 2 6L6's mod., 5U4G rect. Weight 30 lbs. TVI instructions included. 90 day guarantee. Price \$79.95.

#### LETTINE VFO & ANT. TUNER NOW IN STOCK

\$25 deposit with order—balance C.O.D.  
80. 20. 10 meter coils \$2.91 per set. 160 meter coils \$3.60  
Also for CAP, Broadcast, MARS, Marine, State Guard, Novice.

### LETTINE RADIO MFG., CO.

62 BERKELEY STREET VALLEY STREAM, N. Y.

#### TO THE E. E. OR PHYSICS GRADUATE WITH EXPERIENCE IN RADAR OR ELECTRONICS

*Hughes Research and Development  
Laboratories are engaged in a continuing program  
for design and manufacture of advanced radar  
and fire control systems in military all-  
weather fighters and interceptors.*

YOU WILL serve as technical advisor in the field to companies and government agencies using Hughes equipment.

TO BROADEN your field of experience in radar and electronics you will receive additional training at full pay in the Laboratories to become thoroughly familiar with Hughes radar and fire control equipment.

AFTER TRAINING you will be the Hughes

representative at a company where our equipment is installed; or you will advise in the operation of Hughes equipment at a military base.

THE GREATEST advancements in electronics are being made in this sphere because of military emphasis. Men now under 35 years of age will find this activity can fit them for future application of highly advanced electronic equipment.

#### HUGHES

RESEARCH AND DEVELOPMENT LABORATORIES

*Scientific and Engineering Staff  
Culver City, Los Angeles County, California*

Assurance is required that relocation of the applicant will not cause disruption of an urgent military project.

(from page 70)

tion at best is poor, and my shack is at the base of a 2000-foot ridge that stops most of my signals. I had to cut down several trees to make room for my antenna, which is 60 feet long and 50 feet high. My rig is a Lettine 240, running 40 watts, and the receiver is a used RME 45. I have made 150 contacts in 5 states on 3.7 Mc. Best DX is 1,000 miles. But, in the winter, I cannot be sure whether I will finish a contact or not, because the power often goes off because of strong wind or snow. I am nineteen and travel 100 miles a day by bus to attend Sierra College. No, I do not have TVI, hi."

Let's squeeze in just one more letter. Gary, WN7UXP, reports, "Dear Herb, I have had my ticket one week now. My first QSO was with KN6AYJ, and my best DX has been W2CJX. So far, I have had 42 contacts in 8 states, 5 confirmed. My transmitter uses 6Y6—6V6—6V6—6L6 at 45 watts input. Antennas are doublets for 3.7 and 7 Mc., and the receiver is an RME 45.

See you next month, and why not drop me a note before then? 73—Herb, W9EGQ."

## DX NEWS

(from page 35)

in EA9DD for No. 219 while W6CYI also added Luis and TI9UXX to reach 216 . . . G8IG added EA9DD for No. 212 while W6BIL hooked CR6AI for his 137th . . . W2NSZ reported CE0AA and EA9DD to reach 232. F18's are still verboten Weldon . . . KV4AA can't kick about November when he finally added KA0IJ along with C3BF, ZC3AB and AC4NC!! . . . Al, W2WZ, went to 231 with LB8YB and W3DPA came up to date to reach 230.

W1JYH goes to 219 with CE0AA and EA9DD . . . Rex, W5MPG, keeps right up to date with VQ9UU, VS9UU, VQ7UU, EA9DD and CE0AA to reach 214 while Roy, VK4FJ, adds CT2BO and EA9DD for 207 . . . Ray, W2BJ, goes to 205 with VQ1NZK and EA9DD . . . W2EMW keyed with EA9DC, VS2CP and VP8AK to raise his total to 198 while Roy, W6LW, goes to 196 with ZS8D and TI9UXX . . . Joe, W6GPB, hits 186 by adding CE0AA, OY2Z and LZ1KDP . . . W9ABA snagged EA9DD and I1BLF/Trieste for 176 while Tom, TI2TG, climbs to 215 with F18AE and ZS9G. The latter gave him 179 on 'phone only . . . Gus, W2HMJ, pushed to 206 with EA9DD while Juan, KP4CC, also added Luis plus TI9UXX for 193 . . . OE1FF grabbed MP4ABW A3 for his No. 145 while Sam, W3AXT, steadily climbs upward with ZK1AB, KB6AY and OE13USA to reach 151 . . . John, W6BYB, enjoyed Oct. with OD5XX, ST2AR, 5A1TM, ZD4BJ, YU1BCD, YN1AA, CT3AB and VQ3EO to reach 157 . . . Mickey, W8YIN, with new El-Bug and beams snagged ET2ZZ, KF3AB, EA6AF, VQ3EO, 3V8AN, VS2DH, ZS9G, LB8YE and EA9DD for 168.

Miles, W6ZZ, is gunning for that KH6-100 Certif. So far 349 QSO's with 132 KH6's but only 73 cards to show for it . . . W7AHX, Geo., nabbed OK1MB, VK9GM, VK9WZ, DU7SV, HP3FL and many others on 7 Mc. while 14-Mc. A3 accounted for such as CR6AI, VP3YG, OX3BD, EL6A, OD5AD, OH2OV, OE13RB, KA0IJ and the usual run of JA's, KA's and ZL's . . . Ev, KP4KD, awaits QSL's from MP4BAU, VS9AP, ZK1AB, OD5BH and VQ1NZK to give him that coveted DXCC-200 . . . Rag, W5TLY, gave his vertical a workout on 7 Mc. and came up with VP2KO, VP4LZ, VP6CJ, VP7RO, VP8AX (Rod, South Shetlands), PJ2AJ, HH2OT, TI9UXX, CX4OW, FK8AO and OK1MB . . . Dave, W1WAI, and his Viking accounted for TF3SG, 9S4BS, ZB1BJ, YV5AB and EA9DD for a total of 55 . . . HR1AT added KR6LP on 14 Mc . . . YK1AH was No. 181 for VK3CX . . . W2DRD nabbed ZS9AA who claimed to be a ship near the South Pole!! . . . AC4NC was heard QSO'ing ZL1BY, VK5MS and ZL2GX . . . FK8AO says best time for FW8AB is on Sundays at 2300 GMT, 14080 . . . W7KVU has been exploiting 3.5 Mc with these results: DL3DU, SP3AN, DL6NR, OK1DC, OK1MQ, G2RU, ZK1BG and, at 1407 GMT, 3510, VU2KL.

W7AAT picked up CR6CS for a new one while LU5AQ went to 163 with such as EA9DD, VR4AE, VK1BA, FK8AO, JZ0KF, VR2BZ and C3BF . . . W4CEN added VK9GM, CR5SP and was the first W to QSO VQ7UU . . . W4ZAE came up with VP2MD, CR6AI,

(Continued on page 74)



**WE LOVE YOU**

**"sing, MOBIL-CEIVER owners"**

**\*VARIABLE SELECTIVITY** is one of the many reasons Mobilers love the new Mobil-ceiver—sharp enough for "75" or broad enough so that they do not disappear on "10" when the motor idles. Here is a complete mobile communications receiver with built-in noise limiter and BFO, when used with any converter.



SEE YOUR DEALER TODAY

**\$89<sup>50</sup>**  
COMPLETE

**S & W Electronics**

MANUFACTURERS OF MOBILE RADIO EQUIPMENT  
3418 W. PICO BLVD. • LOS ANGELES 19, CALIF.

**Don't Pile Them - - - -**



No need to dig into a dusty pile of back issues to find a reference. By filing your copies of CQ in a binder, you keep them neat and clean, and ready for instant use. Save yourself time, money, and headaches.

**File Them!**

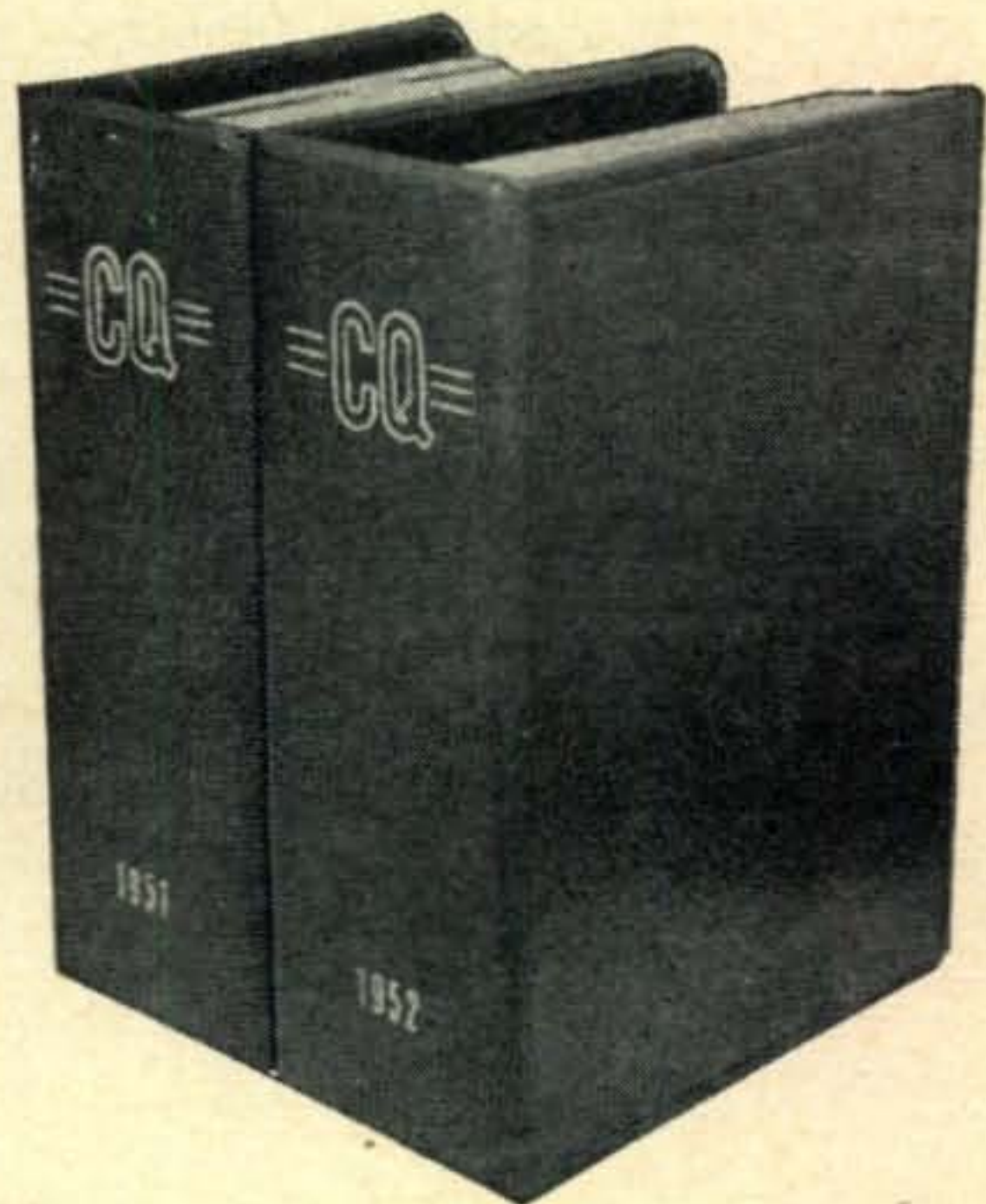

Attractive storage space such as this can be yours for the small cash outlay of \$3.50 per binder. Steel reinforced and bound in red fabricord. Order today with this convenient coupon.

CQ MAGAZINE CQ-2  
 67 West 44th St., New York 36, N. Y.  
 Enclosed find \$ \_\_\_\_\_ for \_\_\_\_\_ Binders  
 Year to be stamped \_\_\_\_\_ Heading:  CQ  Plain  
 Name \_\_\_\_\_ Call \_\_\_\_\_  
 Address \_\_\_\_\_  
 City \_\_\_\_\_ Zone \_\_\_\_\_ State \_\_\_\_\_

# TRANSFORMERS

<b>NEW</b>	<b>GUARANTEED</b>
2500-0-2500 VAC 500 mil Sec. 115/230 volt Prim. Cased.....	<b>\$39.95</b>
1875-1250-0-1250-1875 400 mil 115 volt Prim. Cased.....	<b>\$32.50</b>
1150-0-1150 VAC 300 mil Sec. 115 volt Prim. Cased H.S. ....	<b>\$22.50</b>
750-0-750 VAC 200 mil Sec. 1 6.3 V @ 3 A #2, 5 @ 3 A #3 115 volt Prim. Cased .....	<b>\$ 8.40</b>
600-0-600 VAC 200 mil Sec. 1 12.5 V, 12.5 V @ 2 A. 5 V @ 3 A 115 volt Prim. ....	<b>\$ 7.95</b>
250-0-250 VAC 50 mil Sec. 6.3 V 1 A 24 V @ 1 A .....	<b>\$ 3.95</b>
6.3 VAC @ 10 amps .....	<b>\$ 3.85</b>
2.5 VAC @ 20 Amp 3 K Ins. ....	<b>\$ 3.75</b>

We repair transformers above 500 watt. Get Quote.

Write for prices on complete Power Supplies stationary and Vib. Moble

## POWER-TRAN

115 E. North St. Indianapolis 4, Indiana

(from page 72)

VP1RO, CR7IT and KR6AA to reach 90 . . . W5AVF added LBSYB while VQ2AB was a new one for CP1BX . . . HH2FL was No. 147 for ZL2GS while LU8NA added KA0IJ . . . Harry, W3IL, keyed with VQ3EO and CR6AI . . . OH2RY reached the 200 mark with HH2LD . . . CO2OM, CO2CT and CO2OE all added CE0AA . . . W6LW and W2FMF came up with one AC5AA on 3506 around 0050 GMT hmm-m-m? . . . With assist from LZ1DP, W8PQQ received an overdue QSL from UA1KEC! . . . K6CEF got up a 3-element beam and snagged C3BF, EL7A and DU7SV while VK3JA and VK5DB hooked HK3FF on 090 . . . W0HVN returned to 7 Mc. after a 20-year absence and promptly hooked LBSYB . . . SM8LS, Gunnar, puts S8 sigs into the Caribbean area while sailing from Madras to Calcutta . . . Fung, VS6CG, added CM9AA to his totals . . . VK2QL pulled a three-hour WAC with his 30-watter on Dec. 6 . . . W2FBA's new two-element 7-Mc. beam is getting out nicely. The elements are 55 feet long and driven 135 degrees out of phase . . . Frank, W2WC, added these new ones on 7 Mc: CR4AG, EA9DD, ZK1AB and LB6IE . . .

### Here and There

DL7AH changed QTH from Berlin to Munich but his call will stay the same . . . W8HWZ/6 is now K6CME in Modesto, Calif . . . W1GD, Willis, now may be heard as W1GD/MM on a coastwise tanker . . . VK1EG has had QSL's printed prior to his departure for Antarctica. They will be available from VK4FJ . . . W8HMI has 85 countries since last June and will soon get down to serious business with a new kilowatt rig . . . Ted, CP1BX, closed down for good on Dec. 10 and will be heard next from TI2BX in March. He is chief of the CAA mission in San Jose . . . W6DZZ looks forward to a fine DX future from new QTH overlooking San Francisco Bay . . . W8NBK informs us that EA9DD (EA4BH) has sent out 2247 QSL's which cover things 100% . . . W6JKH/2, Paul, is now K2GFQ and has worked 115 countries from Rye, N.Y. . . . HR1AT received QSL from VQ3EO bearing QTH as follows: Paul Stein, Murongo Mines, 13, Tanganyika. QSL QTH is in the Jan. issue . . . Ron, ZL2RC, was QSO'ed from W4EJN. He will be there until the end of Jan. . . . Jack, ex-VO6X, may now be found behind the key at VE3DSA . . . W4UX is back on the air from Jax. Fla. he has been on at SU1US and HZ1AB . . . K2ECY was OX3BI in '51 . . . The Vicksburg tornado missed W5AVF's home by only three blocks. Fred said it looked like an A-bomb had hit the place!

OH2RY is in a new apartment QTH and plans some nice long VEE antennas when the snow disappears . . . From W6BYH we hear that the Delano, Calif. Club plans an award for working a certain number of Delano stations including the club station K6BLL. 22 members are available most of them working at CBS-KCBB. They include W6's BRP, BVM, BYH, EFV, FHC, GNR, HT, HYK, JOU, ARI, UJZ, WNX, ZVP and ZEK. Officers are Fred Whittaker (W6-to be) Pres., W6ZVP Vice-Pres., W6BYH Sec'y, W6ARI Treas., W6BVM and W6BRP Directors. Members W6MJJ and W6LBN are now in DL4-land and W6IDZ is with VOA in DU-land. The VOA station, KCBB runs a mere 200,000 watts . . . CE0AA/CE3AG states that he has sent QSL's for all those received. This amounted to over 1000 up to Nov. 15. Luis wishes it known that contributions for the purpose of establishing a permanent station on Easter Island are absolutely voluntary. Such contribution will result in a card with photo from CE0AA via airmail. Other QSL's go via bureaus . . . PJ2AA returned to PJ-land in December after a long European vacation . . . ZE3JP will be in England from March to August this year. Dick is very active on 21 Mc. and has completed WAC on all bands from 3.5 to 28 Mc. . . . W6RW suggests separate certificates for each band with DXCC and WAZ. This is a natural for DXCC but would be a bit too tough for WAZ . . . From the So. Cal. Bulletin we see that W6HPV has a new pi-network final underway using a 4-1000A and W6KSF is about to christen a 450TH. W6AM attended a meeting of TG Hams while in Guatemala and had slides taken . . . Upon reading our item that EL2P was off the air due to the death of Jock we received a hasty card from Les, EL2P, who assures us that EL2P is still going strong. Jock used to handle the A3 side at EL2P.

W1WPO, ARRL, advises us that FW8AB, Wallis Island, is attached to FK8, New Caledonia, and is counted as same . . . Tex, KA0IJ, advises that he will change QTH's to KA2-land shortly and will be looking for all

## GET YOUR COMMERCIAL TICKET EASIER WITH...

RADIO OPERATOR'S LICENSE Q AND A MANUAL (4th Edition) by Milton Kaufman Covers Elements 1 through 8. Complete discussion of answers to every technical question in the F.C.C. Study Guide! Used by over 50 leading schools. Only \$6.60 at jobbers, bookstores or direct from—



JOHN F. RIDER Publisher, Inc. 480 Canal Street, New York 13, N. Y.

## EASY TO LEARN CODE

It is easy and pleasant to learn or increase speed the modern way — with an **Instructograph Code Teacher**. Excellent for the beginner or advanced student. A quick, practical and dependable method. Available tapes from beginner's alphabet to typical messages on all subjects. Speed range 5 to 40 WPM. Always ready, no QRM, beats having someone send to you.

### ENDORSED BY THOUSANDS!

The **Instructograph Code Teacher** literally takes the place of an operator-instructor and enables anyone to learn and master code without further assistance. Thousands of successful operators have "acquired the code" with the **Instructograph System**. Write today for full particulars and convenient rental plans.



## INSTRUCTOGRAPH COMPANY

Dept. C., 4701 SHERIDAN RD., CHICAGO 40, ILL.

(Continued on page 76)



# FOUND! The Missing Link

## NEW **B&W** 1-KW BALUNS FILL THE GAP BETWEEN UN-BALANCED FEED LINES AND BALANCED ANTENNA LOADS

YOU DON'T HAVE TO BE AN ENGINEER TO MATCH A COAX LINE TO YOUR ROTARY BEAM

Use these precision-built B&W 1-KW Baluns and take the guess work out of your *beam matching problems* for:

- MAXIMUM TRANSFER OF POWER
- LOW LINE RADIATION ON TRANSMISSION
- HIGH SIGNAL-TO-NOISE RATIO ON RECEPTION

Designed to match pi-network or other low impedance output of any transmitter with power ratings up to 1000 watts to beam type antennas, employing the popular "T" MATCHING SECTION.

Model 700 ..... for 10 meters  
 Model 701 ..... for 15 meters  
 Model 702 ..... for 20 meters

Housed in heavy gauge steel, weather-proofed cases fitted with coax input connectors and ceramic feed-thru output terminals.

**Impedance**—75 ohms unbalanced, to 100 ohms balanced.

**Size**—approx.—3 1/2" x 3 1/2" x 4". **\$16.50**

**Weight**—less than 3 lbs.

GET IMPROVED PERFORMANCE WITH FOLDED DIPOLE ANTENNAS

Use these precision-built B&W 1-KW *single band baluns* for:

- MAXIMUM TRANSFER OF POWER
- LOW LINE RADIATION ON TRANSMISSION
- HIGH SIGNAL-TO-NOISE RATIO ON RECEPTION

Designed to match pi-network or other low impedance output of any transmitter with power ratings up to 1000 watts into half wave folded dipoles using 300 ohm feed lines.

Model 710 for 10 meters | Model 712 for 20 meters  
 Model 711 for 15 meters | Model 713 for 40 meters  
 Model 714 for 80 meters

Housed in heavy gauge steel, weather-proofed cases fitted with coax input connectors and ceramic feed-thru output terminals.

**Impedance**—75 ohms unbalanced, to 300 ohms balanced.

**Size**—approx.—3 1/2" x 3 1/2" x 4". **\$16.50**

**Weight**—less than 3 lbs.

# BARKER & WILLIAMSON, Inc.

237 Fairfield Ave., Upper Darby, Pa.



## TG-34A KEYER

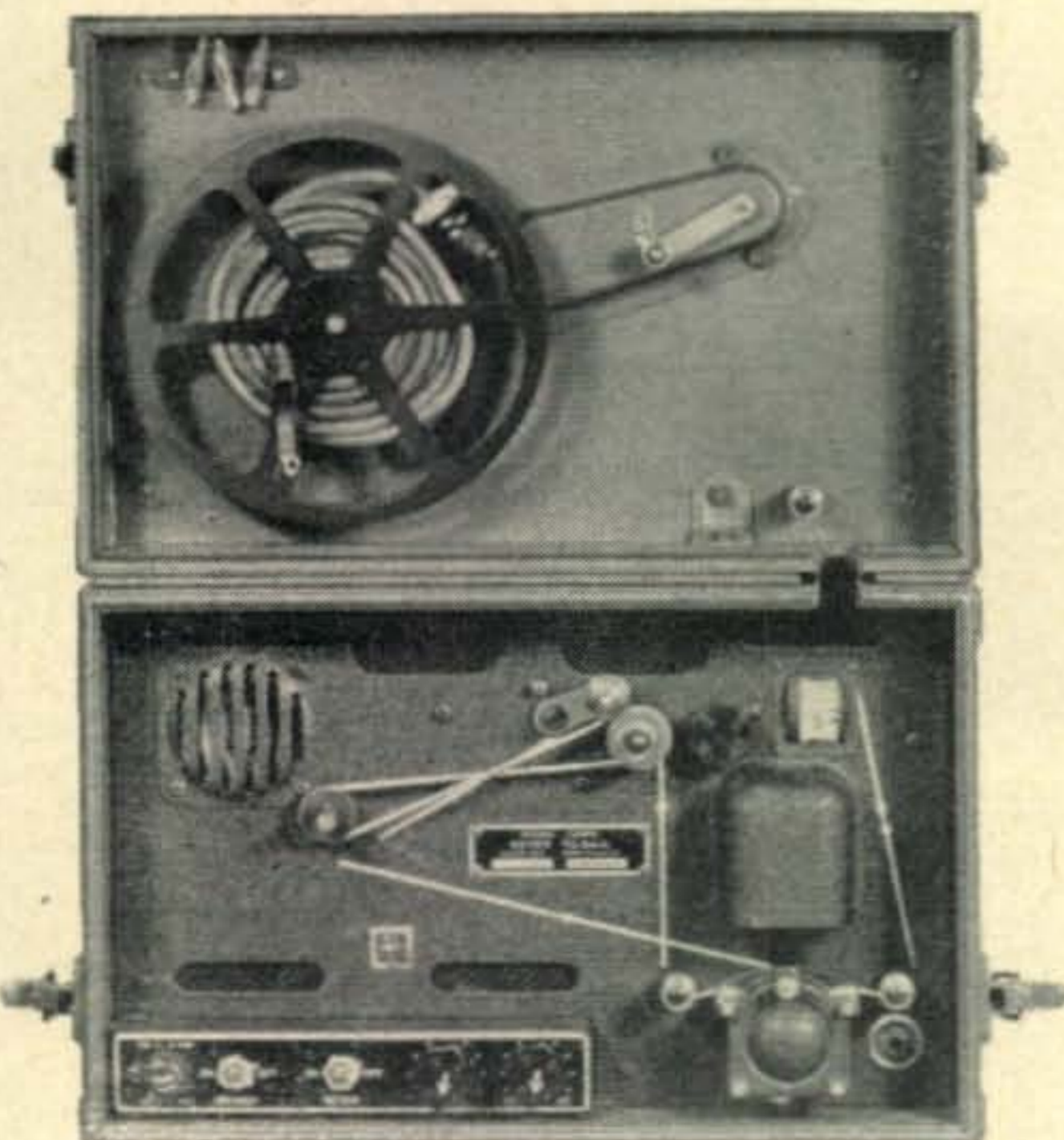

**PORTABLE**—115 or 230 V. @ 50 to 60 cycle—KEYER TG-34A is an automatic unit for reproducing audible code practice signals previously recorded in ink on paper tape. By use of self contained speaker, unit will provide code practice signals to one or more persons or provide a keying oscillator for use with a hand key. Unit is compact, in portable carrying case, complete with tubes, photo cell, and operating manual. Size: 10-9/16" x 10 1/2" x 15-13/16". Shipping weight: 45 lbs. **BRAND NEW**—in original box— **\$24.95**

While They Last. . . . . Only: **\$24.95**  
 ADDRESS DEPT. CQ • MINIMUM ORDER \$5.00

## NEW — LOW — LOW PRICES:

ARC-5 COMMAND EQUIPMENT:		Used:	New:
R-25/ARC-5 Rev.	—1.5 to 3 Mc. No Tubes	\$14.95	
R-26/ARC-5 Rev.	—3 to 6 Mc. No Tubes	7.95	
R-27/ARC-5 Rev.	—6 to 9 MC. No Tubes	6.95	
R-28/ARC-5 Rev.	—100 to 156 MC. No Tubes	12.95	
T-20/ARC-5 Trans.	4 to 5.3 MC.		16.95
T-22/ARC-5 Trans.	7 to 9 MC.	14.95	
274-N COMMAND EQUIPMENT:		Used:	New:
BC-454 Receiver	—1.5 to 3MC.	\$10.95	
BC-455 Receiver	—6 to 9 MC.	9.95	
BC-458 Transmitter	—5.3 to 7 MC.	9.95	
BC-459 Transmitter	—7 to 9 MC.	14.95	
BC-456 Modulator		2.95	
FT-225 Mounting F/BC-456		.50	.95
FT-220 Three Rec. Rack		1.50	2.50
FT-221 Three Rec. Shock		.50	.95
BC-450 Three Rec. Cont. Box		1.50	2.00
BC-451 Trans. Cont. Box		1.00	1.50
PLUG—Male for rear of Rec. or Trans.			.55
DM-32 Dynamotor F/Rec. 24 V.		2.95	6.95
DM-33 Dynamotor F/Modulator & Trans.		2.95	

## DYNAMOTORS:

**HEAVY DUTY MOBILE DYN.**—14 V. input—output: 1030 VDC 260 MA. Tapped 515 V. 215 MA.; @ 6 VDC input—500 V. 175 MA. While they last **\$14.95** **New: \$29.95**

—DM-42: Excel. Cond. . . . . **New: \$29.95**

INPUT VOLTS:	OUTPUT VOLTS:	MA.:	STOCK NO.:	USED:	NEW:
14	1000	350	BD-77	\$22.50	\$39.95
28	1000	350	PE-73	8.95	
12 or 24	500	50	USA/0515		4.95
12 or 24	275	110	USA/0516		4.95
6 or 12	500	160	PE-103	29.95	39.95
12	230	90	PE-133	6.95	8.95

**PE-101 DYN.**—6 or 12 Volt. (Reprints of original CQ conversion articles—Oct. & Dec., '52 issues—furnished.) This is the Dynamotor the Hams have been talking about! Easily adapted to supply 625 V. @ 150 MA. and 325 V. 125 MA. @ 12 Volts—or 300 V. 90 MA. and 160 V. 110 MA. @ 6 Volts. . . . . **NEW: \$4.95**

**COAXIAL CABLE**—RG-8/U (Special) 51.5 ohm. Same size as RG-8U. Prices: 1 to 100 ft. at 8¢ per ft.—100 to 500 ft. at 7 1/2¢ per ft.—500 to 1000 ft. at 7¢ per ft.—1000 ft. Rolls at 6 1/2¢ per ft. RG-34/U—71 ohm, 145 ft. length \$15.00.

PRICES F.O.B. LIMA, OHIO • 25% ON C.O.D. ORDERS

# FAIR RADIO SALES

132 SOUTH MAIN ST. LIMA, OHIO

## Nobody Undersells **COLUMBIA ELECTRONICS!**

**ARC-5 274-N EQUIPMENT!!** We've got the fullest, most complete line—at unbeatable LOW prices! Check with us before you buy!

**SCR-518 UHF ELECTRONIC ABSOLUTE ALTIMETER.** Terrific for conversion to 420 MC and citizen's bands. Consists of transmitter, receiver, indicator, power supply, control boxes, cables with plugs, mounts, etc. Complete and BRAND NEW. Less tubes. Never before priced so low. **ONLY \$19.95**

**SCR-183 12 V. RECEIVER & TRANSMITTER!** Covers aircraft, marine and Ham bands! Complete with 2 coils, control boxes, tuning head, flex cable. Plus 12 V. Dynamotor! Individual parts worth \$25.35. Approx. 25w. output. EXCEL. COND., COMPLETE! Plus schematic. Never before sold at this sensationally low price. **\$12.95**

**MINIATURE 6 V. WET CELL BATTERY.** With 6 V. rev. DC motor. F.B. for R/C boat. 3 1/2 x 2 1/2 x 1 3/4". Battery less motor—\$1.49. With motor **\$2.59**

**APS-13 "TAIL END CHARLEY" TRANSCEIVER:** 420 MC. UHF. 5 stages of 30 MC IF amplifier. Complete but less tubes and dynamotor. With schematic. **\$4.95**

**T-23/ARC 5 VHF 2-METER TRANSMITTER:** Complete with 2-832, 2-1625. **\$24.50**

Best 2-meter deal made! **\$10.95**  
**NEW SOUND-POWERED HANDSETS.** Each. **\$10.95**  
Per Pair—A great value. **19.95**

### THE BIGGEST BUYS FOR A BUCK OR LESS!

**BA-38 "B" BATTERY:** For Handy Talkie, mine detector. 103 1/2 V. New, Post-War late model. Same as XX-69 selling for \$3.75. Grab 'em at our price! **\$1.00**  
3 (THREE!) for only.

**POTENTIOMETER ASSORTMENT:** All good values! Excellent, used condition. **\$1.00**

Some new! 12 for. **\$1.00**  
**CHASSIS:** P/o APG-5. Jammed full of bathtub condensers, resistors, pots, relays, etc! This is clean—NOT corroded junk. ONLY **\$.98**

**12 V. GENERATOR:** Made by Delco-Remy. 25 amp. **\$3.95**  
Used, fair cond.

**RHEOSTATS:** 10 amp. heavy duty. Excel cond. Ea. **\$1.29**

**RS-38 PUSH-TO-TALK HAND MIKE:** Terrific output. Excel. cond. This month reduced to **\$2.79**

**BC-442 ANTENNA SWITCHING RELAY:** Complete with meter & 50 mmfd. vacuum condenser. Excel. condition. A COLUMBIA SPECIAL! Only **\$3.89**

**MD-7 ARC-5 PLATE MODULATOR:** Cases beat but modulation transformer and internal components in excellent condition. Less tubes. **\$5.50**

**6" HEAVY DUTY P.M. SPEAKER:** New. **\$1.69**

**500 KC CRYSTAL:** In 241-A Holder. **.75**

→ **FREE!** CATALOGUE! Just off the press!  
Ask for your copy TODAY!

## COLUMBIA ELECTRONICS SALES

2251-53 W. Washington Blvd., Los Angeles 18, Calif.

## MOBILES! C. D. MEN! CAP!!

IDEAL DYNAMOTOR — CONVERTS EASILY TO SUPPLY UNIT DELIVERING

12 VOLT INPUT OR 6V INPUT

610V @ 150 MA OR 306V @ 90 MA

325V @ 125 MA OR 160 @ 110 MA

BRAND NEW WITH CONVERSION DATA **\$3.75**

Send Check or M.O. Ship. Chgs. C.O.D.

## COMMUNICATIONS EQUIPMENT CO.

131 LIBERTY ST Dept. Q-2 NEW YORK 7, N. Y.

## ADDRESS CHANGE . . .

Subscribers to CQ should notify our Circulation Dept. at least 5 weeks in advance regarding any change in address. The Post Office Dept. does not forward magazines sent to a wrong destination unless you pay additional postage. We cannot duplicate copies sent to your old residence. Old and new addresses MUST be given.

CQ Magazine

67 WEST 44th STREET NEW YORK 36, N. Y.

(from page 74)

the lads from that QTH . . . OE1FF states that the Austrian authorities have received the right to issue licenses at last and calls should be coming through as this is read. In the meantime Club licenses will be issued in which the first letter of the call, after the numeral, will be an "X" such as OE5XG, OE1XA, etc. They do not intend to issue calls which have been used undercover but attempts are being made to change their minds . . . A flash Sou'easter with gusts at 60/70 knots put two feet of water in W1ZL's shack. A little baking put things right again without too much damage done . . . From the FOC Bulletin we note that G3BRV recently operated a rig "steam driven." He was able to QSO eight countries with input varying from one to ten watts. A dinghy hand generator was driven by two 1/4 hp. steam engines purchased from surplus . . . Congrats to F8BS on the arrival of a new Jr. op in October . . . W6GIZ has taken over the writing chores for the North Calif.

## 160 Meters

The February Transatlantic Tests will be held on Feb. 14 and 28 from 0500/0800 GMT. This is being written just prior to the test run of Dec. 20 and we hope to report on them in the March issue . . . We are happy to note top band QSO's as follows: Oct. 16 G6GM/ZL1AH; Oct. 17 G6GM/ZL1AH; Oct. 21 G6GM/ZL3RB; G6GM/ZL1AH. Two further QSO's took place, same stations, on Oct. 22 and 23 . . . G3PU snagged W3RGQ at 0505 GMT on Oct. 4 for what was probably the seasons first W/G QSO. G3PU was on 1840 kc. G3PU also worked W1LYV on this date and G5JU came through with QSO's with W1LYV, W3HL and W3RGQ . . . Oct. 8 accounted for a QSO between G5JU and W3RGQ followed by contacts on Oct. 11 by G3PU with VE1EA, W1LYV and W3RGQ. On Oct. 30 G8JR QSO'ed W3RGQ . . . ZE3JO and ZE3JP are organized on 160 and will be trying hard during the tests . . . KP4KD, EI9J and GC2CNC will be in there . . . VP4LZ will also be active for that South American QSO . . . KV4AA will probably hang out on 1823 kc.

## Fifteen Meters

Conditions remain spotty on this band. Many think this seemingly dead band could be brought to life with a few CQ's. It's a case where everyone is just listening and concluding that the band is dead . . . TI2TG came up with his No. 100 by snagging ZS9G on A3 . . . Ross, W4DOU, A3'd with such as TA3AA, Y13WH, SU1KB, VQ4RF, ZS9G, FF8AP, GD6IA, G3BXI, PAØIDW, F3YE and CR6BX . . . GD6IA reports 96 countries on 15 and G3BXI reports activity from VS6CL, 21,262, VU and CR9 on A3 . . . ZE3JO and ZE3JP are very active here . . . GW3AHN goes to 85 countries while KP4KD reports band as not much good for the Caribbean area in November . . . DX QSO's at W7AHX include (on CW) such as KG6ADY, KX6BF, OQ5CP, CR7AF, XE1OM, KR6AA, CP5EK, VP9BG and KG4AN. On Oct. 24 George nabbed FUSAA at 2117 GMT on 21,092 CW. 7AHX's A3 brought in G3BXI, VK9YT, VP5SC, ZS6ME, KV4BD, ZP5AM and a host of others . . . Miles, W6ZZ, added KW6BB on A3 to reach 60. Other A3 contacts were DU7SV, JA1CO, KX6BB, ZS9G, ZE2JK, KP4TA and many others . . . W1BUX went to 75 with ZD4AB . . . G5BZ goes to 91 for the leading G station but says G2PL is well over the 100 mark.

## LATE ADDRESSES

CE5CT, Box 229, San Martin, Concepcion, Chile.  
HH2OT, Herb, Box 1027, Port-au-Prince, Haiti.  
ex-KAØIJ (1951/2), Larry Arcement, 53 Jackson St., Ocean Springs, Miss.  
KB6AY, Fred Carpenter, Box 1, Canton Island, Pacific.  
KH6ASU/KM6, Box 19, USNS, Navy 3080, F.P.O. Postmaster San Francisco.  
KJ6AZ, Dale, APO 105, Postmaster, San Francisco.  
MP4BEN, Dukhan Airport, Qatar, Persian Gulf.  
MP4BUS, Ummsaid, Via QPC., Persian Gulf.  
SP2KAC, Kadhowski Stanistow, NL Kopevnika 18, Gdansk, Poland.  
TI2BX, (After March 1) Ted Westlake, c/o US Embassy, San Jose, Costa Rica.  
VP1RO/VP7RO etc., Via G2RO or RSGB.  
ZC3AB, Dave Laing, Christmas Island, via Malaya.  
Thanks to No. Calif. Bulletin, W3AXT, W5RX and W4ZAE.

73's Dick KV4AA.

# Sneaking a Look at the Future

## **CQ RADIO AMATEURS' JOURNAL**

The old saw about the Ham who got a "Heard card from Heard Island" may come true in the March issue. Roth Jones, VK3BG has written an excellent account of the Australian Antarctic Expeditions to Heard Island, MacQuarie and MacRobertson Land. It is a photographic story of the hardships in these rare DX spots. Don't miss the famous shot of ex-VK3OY and "friend."

A little further around the corner is the "8PO" antenna that has attracted so much attention in England. Speaking of antennas, the v.h.f. group will want to see details on the "Rocket Quad," and W6SAI will soon describe his "Project Telescope," the antenna tower that helps make peace with the neighbors.

The "bias-shaft" modulator is still in the works and will be featured very soon. W2SPV has finished his new transmitter using the "gating modulation" system with a 5894A final on 2 meters. YUIAD will discuss his break-in keying Johnson "Match-Box" into a fully automatic antenna tuner.

CQ is an investment in your hobby that pays off with a terrific dividend each month—SUBSCRIBE TODAY!

One year: \$3.00 Two years: \$5.00 Three years: \$7.00

Use this coupon to order your copy of the **MOBILE HANDBOOK** Advertised on page 71.

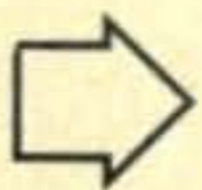

CQ MAGAZINE

67 West 44th St., New York 36, N. Y.

Enclosed find \$ \_\_\_\_\_

for \_\_\_\_\_ copies of The **MOBILE HANDBOOK** at \$2.00 per copy.

and/or for a \_\_\_\_\_ year subscription.

New  Renewal

Name \_\_\_\_\_ Call \_\_\_\_\_

Address \_\_\_\_\_

City \_\_\_\_\_ Zone \_\_\_\_\_ State \_\_\_\_\_

## CLASSIFIED ADS

Advertising in this section pertains to amateur radio activities. The publishers of CQ do not guarantee any product or service advertised in this section.

**RATES:** 25c per word per insertion for commercial ads:

5c per word per insertion for non-commercial ads.

Remittance in full must accompany copy. No agency or term or cash discounts allowed.

**CLOSING DATE:** the 25th of 2nd month preceding publication date.

**WRITE:** CQ Magazine, 67 West 44th St., N.Y. 36, N.Y. Attention, Jeanne C. Gillespie.

### For Sale:

NEW GUARANTEED 4D32 tubes, \$11.00 postpaid. Roy Sawdey, Harper Rd., Solon, Ohio.

TVI MONITOR, compact 7" set \$35. Larger screen, \$40. Want Eldico or Multiphase SSB Exciter. W4API, 1420 South Randolph, Arlington, Virginia.

SELL 32V-1 transmitter \$325. W4GKI, Austin Drive, Columbus, Georgia.

FREE LIST. New and reconditioned receivers, transmitters, etc. A hundred big bargains every month. Highest trade-in allowance. Fast four-hour shipping service. Special Novice department. Write today. Dosssett, W9BHV, 855 Burlington, Frankfort, Indiana.

VX 101 DELUXE transmitter 807 final 4 position crystal as well as VFO. TVI'd, first \$60 takes it. W2NFU, 2 Center Drive, Flower Hill, Roslyn, L.I., New York.

SELL OR TRADE: Boehme automatic perforated tape keyer for Morse code, 7-B, transmitter for teletype, 21A midget tape printer, #12 page printer with keyboard, 32V-3, Hallicrafters S-25, HRO50-1, APA-10, APR-5A, frequency meter, SCR-694-C. Want: BC610 and parts, panadaptor, #15 Printer, ART-13, BC348 or similar receiver, BC221 or LM, technical manual, SIG-5 catalogs. Tom Howard, W1AFN, 46 Mt. Vernon St., Boston 8, Massachusetts. RIchmond 2-0916.

MORROW 3-BAND converter 10-40-75 meters. Two months old, guaranteed perfect. \$40 prepaid. Money order to Robert Lorenz, 2695 Lorian Lane, Salem, Oregon.

REAL BARGAINS: New and reconditioned Collins, Hallicrafters, National, Hammarlund, Johnson, Elmac, Gonset, Babcock, Morrow, RME, Millen, Lysco, others. Reconditioned S38 \$29, S40A \$69, S40B \$79, SX43 \$99, S76 \$129, SX71 \$169, SX42 \$179, SW54 \$35, NC57 \$69, NC125 \$129, NC173 \$149, NC183 \$199, HRO50T1 \$299, HRO60 399, HF-10-20 \$39, VHF152A \$39, HQ129X, 75A1, 75A2, 32V1, 32V2, 32V3, Viking I, many others. Shipped on approval. Easy terms financed by us. Write for free list. Henry Radio, Butler, Missouri.

SELL MEISSNER 150-B with Signal Shifter complete, no reasonable offer refused, FOB, South Bend, Indiana. Robert G. Kasa, W9OGZ, 821-24th Street, South Bend, Indiana.

PAIR OF NEW 814's, never used, \$10. Brand new 813 \$8.50. Globe Scout transmitter complete with coils, \$75. Will ship. Roger Aden, W9UZP, Golden, Illinois.

BALUN COILS, type B & W #3975, mounted on 7 x 9 x 2 chassis and wired for use to match 75-ohms unbalanced to 300 ohms balanced lines, \$12.95; mail orders please include \$1.00 for packing and postage costs. Evans Radio, P.O. Box 312, Concord, New Hampshire.

SELL OR TRADE: Mobile transmitter, Gonset Tri-Band, Argus C-3 camera. Want: press or reflex camera, enlarger. R. Queen, Route 7, Spartanburg, South Carolina.

FOR SALE—complete station consisting of a WRL 50-watt 6-band transmitter, voice and CW, all coils and Novice crystal included, plus antenna tuner and National SW54 receiver, phones and a Triplatt wave meter. \$100.00. Raymond Schmidt, 568 Columbus Avenue, New York City. Phone TR 7-8307.

SELL, Collins transmitter type 32RA in operating condition. Complete with tubes, mike, 20-40-80 coils, phone or CW. \$125. W7IWC, 522 North 120 Street, Seattle, Washington.

BEST OFFER on following new parts: Eimac variable vacuum condenser VVC-60-20, set 10-meter coils for Super Pro, Johnson butterfly condenser CX45B, Eimac 4-65A tube and socket, Astatic DK-1, Bliley CCO, surplus 12-henry 500-mill filter choke and 2-813 tubes. Bob Guercio, 910 South 8th Street, Lawton, Oklahoma.

CLEANING SHACK. DB-20, good condition \$20; BC1206 LF Beacon receiver, new, \$8; BC357-G VHF Beacon receiver, new, \$5; electronic 110-volt DC-AC converter, 200 watts, used, \$15; AN-CRT-3 "Mae West" emergency transmitter, new, \$10. Dynamotors: PE-94A used \$7; PE-86N new \$3; DY-21-ARC, three, new, \$5; DM-21-B, new, \$5. Postage extra. George Jacobs, W2PAJ, 144-40 72nd Avenue, Flushing, 67, New York.

SX-71 LIKE NEW, \$150; BC696-A perfect, \$25; TBY transmitter receiver, 28-80 Mc, some tubes missing, \$20; Wilcox CW3 receiver, \$20; ABK-4 receiver, like new, easily converted 144-220 or 420 Mc., \$15; BC654-A, receiver, 3800-5800 kes., minus case, \$10; PE-101-C dynamotor, brand new, \$3.50. Want: ART-13 transmitter and parts. W1KJO, 29 Pine Street, Bedford, Massachusetts.

BARGAINS: EXTRA SPECIAL: Motorola P-69 series mobile receiver \$19.50; Gonset 10-11 converter \$19.95; DM-36 10 meter converter \$19.50; VHF-152 \$49; HF-10-20 \$49.50; S-40A \$75; RME-45 \$99; RME 2-11 \$99.50; HRO-senior \$99; SX-43 \$119; S-76 \$149; SX-71 \$169; SX-42 \$189; HRO-50 \$275; 75A1 \$275; MB611 mobile transmitters \$14.95; 90800 exciter \$22.50; HT-17 \$32.50; EX Shifter \$69; Globe Scout \$69.50; Globe Trotter \$69; TBS-50D \$99; HT-9 \$199; Supreme AF100 or Temco 75GA \$225; Globe King \$295. Free trial. Terms financed by Leo, WØGFQ. Write for catalog, and best deal, to World Radio Laboratories, Council Bluffs, Iowa.

FOR SALE CLEANING SHACK: ARC5 xmtrs convert to 160M \$10, 2M \$20, BC457 for 80M \$10, BC458-A for 40M \$10, BC459-A for 40M \$12. ARC4 xmtr-receiver for 2M \$25. Preamplifier BC1284-A \$5, AYD3 xmtr-receiver \$5, BC456-A modulators \$3, all complete, some new. Also RCA receiver 15-600 kc. \$5, UTC kw plate transformer \$25. Will ship postage collect. Dan Johnston, Viewmont Terrace, Little Falls, New Jersey.

LOOKING FOR A REAL telephone patch? KWickPatch is the answer. One hand control with real quality. Only \$14.95. Erv Rasmussen, 164 Lowell, Redwood City, California.

MOBILE HAMS. Carter Magmotors model MV280, 5.50DC, 5.8 amps and 200VDC, .080 amps output. Fine for mobile receivers. Just a couple left. \$6.00. Art Winter, 11 Warren Street, New York 7, N.Y. WO 2-7955.

### Wanted:

WE NEED USED RECEIVERS: We give highest allowances for S-20R; S-40A, B; NC-57; NC-100; NC-125; SX-24; SX-25; HQ-129X and similar receivers. World Radio Laboratories, Council Bluffs, Iowa.

NEED: BC348 and BC342 radio receivers. Hoffman, 1406 G Street, N.W., Washington, D.C.

WANT: AN/ARC-1's, AN/ARC-3's, BC610-E's and components. Write—B. Spivey, 7013 Rolling Road, Chevy Chase, Maryland.

WANTED: B&W low pass filter, 150 ohms, model 300, catalog number 417. Will pay cash or trade. WØEHF, 2558 Ida, Omaha, Nebraska.

WANTED: Latest model Pilot Miniature TV receiver. Want best possible condition. Must work perfectly. Write price and description, Bill, K6BSW, 133 North Valley Street, Burbank, California.

WANTED: AN/ART-13 transmitter and/or parts. Robert Wegelin, 410 Cedar Street, N.W., Washington, D.C.

WANTED: RCA 5527 Iconoscope. W4SOD, J. E. Howell, Box 126, Lumberton, North Carolina.

WANTED: Complete equipment or parts of BC610, ART-13, ATC, TCS, RTA-1B, ARC-1, ARN-7, BC348, BC312, BC342, BC221, LM, teletype. Any model Collins receivers or transmitters. Manuals. Test equipment. Will take your old equipment in trade for new amateur equipment. Write or phone Alltronics, Box 19, Boston 1, Massachusetts. RIchmond 2-0048, 2-0916.

WANTED: BC348 receiver and parts. Write, James S. Spivey Co., 1406 G Street, N.W., Washington 5, D.C.

WANTED: Sylsyns and amplidynes. G.E. control transformers, size 5, models 2J5FBI, 2J5D1, 2J5F1 or equivalent. 115/55v. 60. G.E. amplidynes-motor generators, input 115/230v 60-1 ph., output 250 VDC @ .6 amps or larger. Also need Type 5DG synchro differential generators, 6G generators, C78248 synchronous transmitters, electronic tubes, inverters, rate generators, autosyns and any other specialized rotating equipment. Advise quantity available, price and condition. We are interested in any quantity—small or large. Electro Sales Company, Inc., 50-58 Eastern Ave., Boston 13, Mass.



### Surplus Equipment:

HERE IS YOUR CHANCE to own a sensitive Microammeter at a reasonable price. Weston 3" 0-20 microamps. D.C. These have been sold in the surplus market for \$10 each. Now, a limited quantity offer to the amateur field, new and guaranteed \$5.95 each postpaid. Greenwich Sales Co., 59 Cortland Street, New York 7, N.Y.

**SURPLUS BARGAINS.** New oil-filled condensers 2 $\mu$ f. 600VDC 69c—4  $\mu$ f. 600VDC \$1.65—6  $\mu$ f. 400VDC 85c—8  $\mu$ f. 600VDC \$1.85—4  $\mu$ f. 1000VDC \$1.59—12  $\mu$ f. 2000VDC \$8.95—2  $\mu$ f. 4000VDC \$7.95. 200 Asst.  $\frac{1}{2}$  watt resistors, all insulated \$2.50. Postage extra. Request bargain bulletin. Reliance Merchandizing Co., 2217 Arch Street, Philadelphia 3, Pennsylvania.

**SURPLUS SPECIALS!!** RG-8/U cable, 225 ft. \$12.25; RG-59/U cable, 250 ft. \$15.00; coaxial connectors PL-259, 5 for \$2.25; SO-239, 5 for \$2.00; manuals for SCR-522, BC610, BC779, BC848-J, N, Q—\$1.00 each (plus postage). New tubes 1619, 1625, 1626, 1629, 6 for \$1.80; 813—\$10.50, 866A—\$1.48. Postage extra. Request our free bulletin. Want to buy: Selsyns, Synchros, Servo Motors, Amplidynes, surplus tubes, equipment. Lectronic Research, 717 Arch Street, Philadelphia 6, Pennsylvania.

### Positions Offered:

**ELECTRONIC TECHNICIANS:** For permanent positions with Sandia Corporation. Armed Forces acquired radar or electronic experience desirable; trade school certificate with minimum five years' experience. Versatility, capability and willingness to work most essential. Sandia Corporation, a subsidiary of the Western Electric Company, operates the Laboratory under contract with the Atomic Energy Commission in Albuquerque, New Mexico. Excellent working conditions and liberal employee benefits, including paid vacations, sickness benefits, group life insurance, and a contributory retirement plan. No housing shortage in the Albuquerque area. For further information write to: Section 1, General Employment Division, Sandia Corp., Sandia Base, Albuquerque, New Mexico.

### QSL Cards:

QSL Samples, dime, refunded. Gale Press, W1BD, Waterford, Connecticut.

QSL's—SWL's. Excellent quality. Fair prices. Samples 10c. Almar Printing Service, 602 Barker Building Omaha, Nebraska.

QSLs of DISTINCTION. Three colors and up. Uncle Fred, Box 86, Lynn, Pennsylvania.

QSLs—"Brownie" W3CJI, 3110 Lehigh, Allentown, Pennsylvania. Samples 10c with catalogue 25c.

QSL's, SWL's. High quality. Reasonable prices. Free samples. Write Bob Teachout, W1FSV, Box C124, Rutland, Vermont.

QSLs! "America's First Choice" Samples 10c. Tooker Press, Lakehurst, New Jersey.

QSLs??? Samples 20c. Sackers, W8DED, Holland, Michigan.

### Instruction:

**PORT ARTHUR COLLEGE,** Port Arthur, Texas, provides training in radio, radar & television necessary to pass FCC exams for phone and tel. licenses. 12-14 months. Start any level, low tuition with board & room at cost in dorm. Advanced students on-the-job KPAC (5000-watt station) training. Approved for Veterans. Write "Registrar" for catalog and info. New courses start every 5 weeks.

### Miscellaneous:

**REFLECTORIZED Aluminum Call Sign,** Regular \$1.50, Jumbo. \$2.00. Satisfaction—refund, overnight service. Whitley, W2LPG.

**ABSOLUTELY DAZZLING.** The most beautiful call letter plates ever offered. Mounts on auto license or in shack. Brilliant colors laminated in heavy gauge, crystal clear plastic with bright chrome-type border. Large 5 x 11 size with call letters, town and state—\$2.00. Standard 3 $\frac{1}{2}$  x 9 $\frac{1}{2}$  size with call letters only—\$1.50. Specify white or black letters on red, green, blue, yellow, black or white background. No COD. Money cheerfully refunded if not satisfied. Dayton Plastic Products, Riverdale Box 93, Dayton, Ohio.

**CALL LETTERS.** Two inch red reflecting weatherproof letters. Self-sticking to bumpers, windows, signs, chassis. 60c set. No stamps. R. Boyce, 52 Bennett Street, Waltham 54, Massachusetts.

**INCREASE CODE SPEED.** New method. Free particulars. D. H. Rogers, Fourth Street, Fanwood, New Jersey.

**DON'T FAIL** those FCC exams. Use Surecheck Tests. Novice \$1.50, General \$1.75, Extra \$2.00. Amateur Radio Specialties, 1013 Seventh Avenue, Worthington, Minnesota.

10, 15 & 20 METER BEAMS, aluminum tubing etc. Perforated aluminum sheet for shielding. Radcliff's, Fostoria, Ohio.

**FOR DXers—"Ham Interpreters,"** Ham words and phrases translated into seven languages, \$1.00. For SWL's—"World Radio Handbook," complete information on international stations, \$1.50. For SWL Novice—"How To Listen," 40c. World Radio Publications, 47 Mount-haven Drive, Livingston, New Jersey.

**PRECISION and Custom-built ANTENNAS** for any band and frequency. Literature on request. Antenna, Inc. Wakefield, Rhode Island.

The Editor of CQ is still looking for good manuscript material on mobile, SSB, Novice and VHF equipment. Send your ideas and manuscripts to the address on page 3.

**LAPEL PINS**—neat and professional looking—only 35c. Your call engraved in white on black background, plastic,  $\frac{3}{8}$ " x 1". W2SPV, 4309 Willis Avenue, Merchantville, New Jersey.

**RECORDING HAMS**—Join world-wide club; swap tapes, make friends everywhere. Details FREE. P.O. Box 1404-C. San Francisco, California.

**ARE YOU MOVING?** Please allow four weeks for a change of address and be sure to include the old as well as the new address. It saves us time and insures you of getting each copy of CQ!! Circulation Manager, CQ.

# Keep Your Shack Neat

with a **BOUND VOLUME**

You'll appreciate the handy convenience of this compact volume of 1953 issues of CQ . . . handsomely book-bound in tan colored cloth . . . distinctive gold foil lettering embossed in a black panel strip . . . available NOW!

## \$7.95

in U.S., Canada, and Pan-American Union. Others, \$1.00 more.

## CQ Magazine

67 WEST 44th STREET  
NEW YORK 36, N. Y.

inside this package on your Jobber's shelf...  
is the world's **toughest transformer**



**C-TYPE**

With 10" color-coded leads brought out through fibre board base cover. Lead ends are stripped and tinned for easy soldering. Flange-mounted.



there's nothing tougher than  
**CHICAGO'S "Sealed-in-Steel" construction**



**H-TYPE**

Hermetic sealing meets all MIL-T-27 specs. Steel base cover is deep-seal soldered into case. Terminals hermetically sealed. Ceramic bushings. Stud-mounted unit.



**S-TYPE**

Steel base cover fitted with phenolic terminal board. Convenient numbered solder lug terminals. Flange-mounted.

CHICAGO "New Equipment" transformers (available in 3 mountings) feature one-piece drawn-steel cases—the strongest, toughest, best-looking units you can buy. The one-piece seamless design, enclosing an electronically perfect construction, provides the best possible electrostatic and magnetic shielding, with complete protection against adverse atmospheric conditions. For every application: Power, Bias, Filament, Filter Reactor, Audio, MIL-T-27, Stepdown—ask your electronic parts distributor for CHICAGO "Sealed-in-Steel" Transformers—the world's toughest with that extra margin of dependability.

**FREE "New Equipment" Catalog**

Get the full details on CHICAGO'S New Equipment Line—covering "Sealed-in-Steel" transformers for every modern circuit application. Write for your Free copy of this valuable catalog today, or get it from your distributor.



*CQ Ad Index*

Allied Radio Corp.	58
American Electronics Co.	64
American Phenolic Corp.	61
Arrow Sales, Inc.	57
Babcock Radio Engineering, Inc.	1
Barker & Williamson, Inc.	56, 70, 75
Bliley Electric Company	7
Bud Radio, Inc.	58
C & H Sales Co.	60
Centralab	8, 59
Chicago Standard Transformer Corp.	80
Collins Radio Company	Cover 2
Communications Equipment Co.	76
Columbia Electronics Sales	76
Dossett, M. H. Co.	63
Eitel-McCullough, Inc.	10
Esse Radio Company	55
Evans Radio	62
Fair Radio Sales	75
Glass, J. J. Co.	56
Gotham Hobby Corp.	54
Guardian Electric Mfg. Co.	70
Hall, L. F. Inc.	64
Hallcrafters Co., The	4, 5
Harvey Radio Co., Inc.	51
Heath Company	2, 67
Hughes Research & Development Labs	72
Instructograph Co.	74
K & L Radio Parts Co.	63
Lettine Radio Mfg. Co.	72
Millen, James Mfg. Co., Inc.	6
Motorola, Inc.	66
National Company, Inc.	Cover 3
Ohmite Manufacturing Co.	49
Offenbach & Reimus Company	64
Pan-Electronics Corp.	9
Petersen Radio Co., Inc.	12
Power-Tran	74
Radio Corp. of America	Cover 4
Regency	63
Rider, John F. Pub., Inc.	74
RW Electronics	68
Sam's Surplus	66
Shure Brothers, Inc.	65
Stromberg-Carlson Company	63
Sun Parts Distributors, Ltd.	62
S & W Electronics	73
TAB	80
Tallen Company, Inc.	60
Trans-World Radio-TV Corp.	60
Vaaro Electronic Engineering Co.	54
Valley Engineering Company	68
V & H Radio Supply Co.	69
World Radio Labs, Inc.	53

**WANTED IMMEDIATELY  
for CRITICAL DEFENSE NEEDS  
TUBES - CRYSTALS - END EQUIPMENT**

OA3/VR75	3C23	12SC7M	833A, 884
OB3/VR90	3E29, 829B	FG17, 32, 33	927, 1000T
OC3/VR105	4C35	100TH	1614, 2050
1N21, A, B	5C22	FG104, 172	5725
1N23, A, B	5R4GY	250TH, TL	5727
1N25, 26	6AC7M	304TH, TL	5749
Xtals: 100Kc	6AG7M	368AS	5750
200Kc, 100Kc	6B4G	450TH, TL	5751
2D21	6C21	KUG27	5654, 5670
2K25, 723AB	6L6M	726C	5686
2J&4J Magnetrons, Klystrons	6SC7M	750T	5726
	7C7	807, 810	5814
	7AG7	811, 813	9001, 2, 3

All Army-Navy Gear; AN, ART, BC, I, PE, PU, RA, SCR, TG, TS. WAVE GUIDES: PL & UG CONNECTORS.  
TURN YOUR SURPLUS INTO SPOT CASH & SERVE YOUR COUNTRY'S NEEDS AS WELL.  
Send Lists & Prices—Immediate Reply! Dept. C.

**"TAB"**  
That's a Buy!

**111 Liberty St.  
New York 6, N. Y.  
REctor 2 - 6245**

**CHICAGO STANDARD  
TRANSFORMER CORP.**

3501 ADDISON STREET • CHICAGO 18, ILLINOIS





**50** dollars more  
can't buy  
a better receiver!



NC-125  
\$199.95

Before you buy any receiver in the \$200-\$300 price range, compare it with an NC-125 at \$199.95.

You'll find that \$50 more won't buy any important feature, any extra tubes or any better performance! In fact, the NC-125 with auxiliary sockets, tone control, extended coverage and large dial, has extras that more expensive receivers lack.

And — the NC-125 is the *only* receiver at any price with the famous Select-O-Ject circuit for truly amazing selectivity.

**AVAILABLE FOR IMMEDIATE DELIVERY**

Write for complete specifications



**national**

NATIONAL COMPANY INC., MALDEN, MASS.

# For steady signals

—design with modern V-R\* tubes



**F**REQUENCY STABILITY  
—the basis of a steady signal from any VFO  
—starts with good dc voltage regulation for the oscillator tube. For dc voltage regulation of the oscillator power supply in modern transmitters (or receivers), RCA offers a choice of V-R tubes. These tubes stabilize the dc operating voltage and maintain it—*virtually independent of load current and moderate fluctuations in line voltage.*

For compact designs, use the modern miniatures pictured here. The RCA-OA2 holds dc operating voltage at approx. 150 volts. The RCA-OB2 holds dc operating voltage at approx. 108 volts. (Both tubes stabilize their output voltages over a range of 5 to 30 ma.)



For technical data on RCA V-R's—including the OA3, OC3 and OD3, write RCA, Commercial Engineering, Section B15M, Harrison, New Jersey.



**RADIO CORPORATION of AMERICA**

ELECTRON TUBES

HARRISON, N. J.

Maximum over-all length of tubes is 2 $\frac{5}{8}$ "



#### NOVICE NOTE:

\*Higher voltages can be regulated by connecting two or more V-R (voltage regulator) tubes in series. To determine the proper value of series resistance necessary for your operating condition, see the published data on RCA V-R tubes.