

October 1960

50¢

CQ

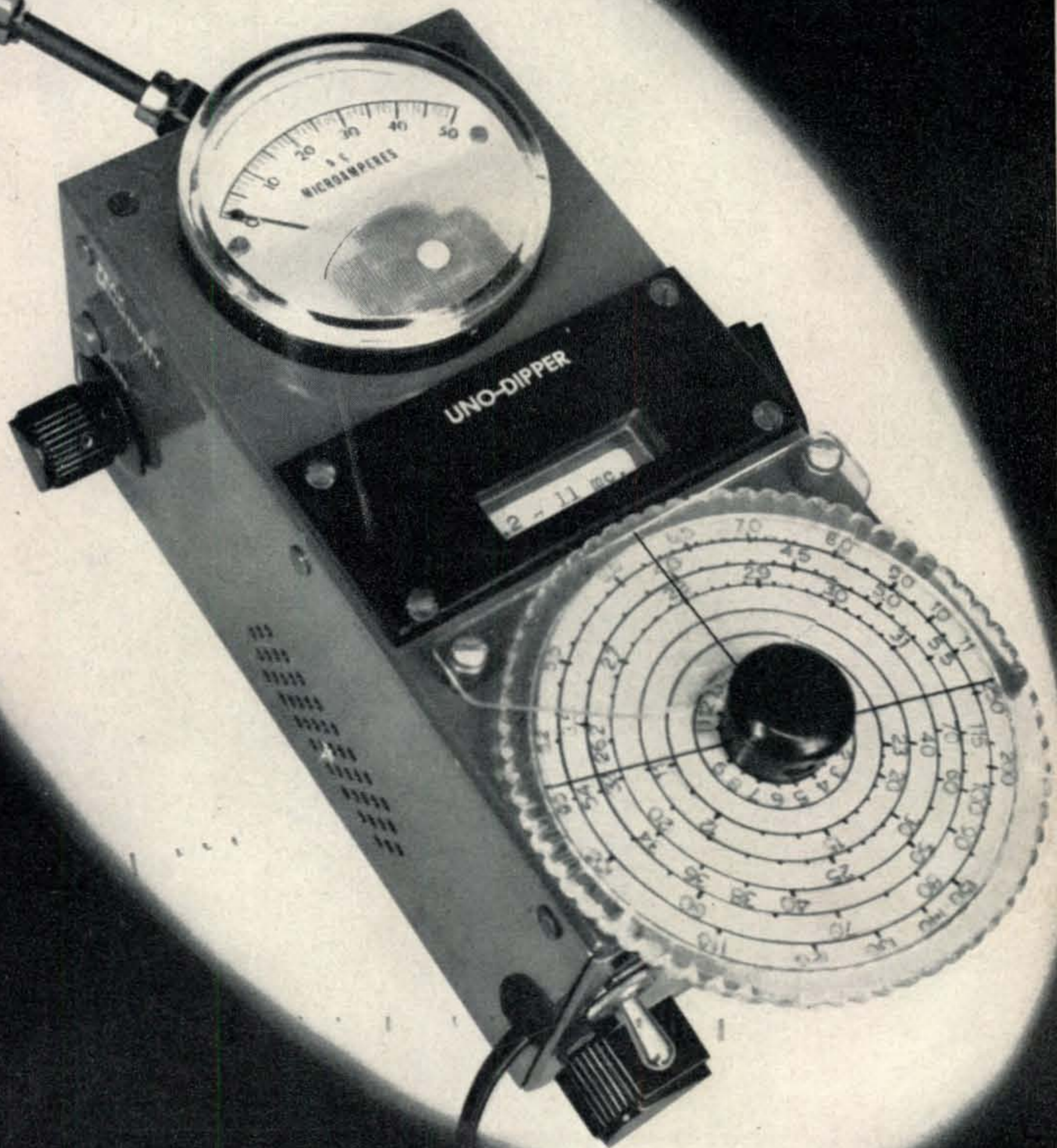

The Radio Amateur's Journal

ersary
aternity

WRL

For 25 years, WRL has been a name respected throughout Hamdom for personalized service, quality merchandise and a reputation for sincere and continual interest in the Amateur Radio Fraternity — World Radio Laboratories... *"the house the hams built!"*

AN ANNIVERSARY MESSAGE

Leo I. Meyerson, WØGFQ

Our Silver Anniversary year is a time to re-evaluate our policies and to restate our purpose of service to Amateur Radio enthusiasts around the world.

Whatever you need, you will find at WRL. You will always find the greatest trade values, maximum budget payment plans, and responsible personalized service from one of our 23 hams.

Our Reconditioning Department will continue to offer the finest used gear at tremendous savings with guaranteed factory-new operation.

In fact, when you are in need — whatever your ham requirements may be — write to WRL — write to World Radio Laboratories, *the house the hams built!*

Leo I. Meyerson, President

SAVINGS UP TO 50% at WRL on Reconditioned Equipment

WRL's huge Reconditioned Equipment Department carries more than 1000 items continually in stock, with turnover of nearly 500 pieces each month. Whenever you buy from WRL's reconditioned department, you are assured that your gear has been thoroughly checked, repaired, aligned and tested by the five-man technician team at WRL. In short, this equipment will operate as if it came directly from the factory line. With the great demand and subsequent turnover, new lists must be prepared each month. Send for your free lists today.

CELEBRATING

25

YEARS OF SERVICE

Silver Anniversary **FREE CATALOG**

Over 200 Pages of excellent bargains for the novice, the technician and the advanced amateur. Fully illustrated. Includes the complete service story on World Radio. Send for your FREE copy now!

WRL WORLD RADIO LABORATORIES

3415 WEST BROADWAY • PHONE 328-1851
COUNCIL BLUFFS, IOWA

LEO: PLEASE SEND: FREE CATALOG LATEST RECONDITIONED EQUIPMENT LISTS, AND COMPLETE INFO ON THE COLLINS LINE.

NAME: _____ CALL: _____

ADDRESS: _____

CITY & STATE: _____ C-10

For further information, check number 3 on page 126.

the full
kw on
ng on
n two
s from
1 kw
3.
onsole
Re-
other
te op-
system
es, or
nation

er-
op-
pen
ice
en-
ed
nd
C,
nd
el-
out
60
crystals and bandswitch positions
bands. Easily moved between
Weights only 16 pounds.



Celebrating Our 25th Anniversary Of Service to the Ham Fr

COLLINS S/LINE

Finely finished in blue-gray tones, Collins S/Line gives your ham shack a modern and distinctive decor. Controls and meters on the panels provide you with maximum operating convenience and efficiency.

Inside each unit you'll find the latest circuitry, the careful craftsmanship and quality components that make Collins S/Line truly a system engineered single sideband radio station.

From microphone to antenna, the S/Line operates as an integrated high powered SSB ham station. With Collins 75S-1 Receiver you get SSB, CW and AM reception on all amateur bands between 3.5 and 29.7 mc. The 75S-1 can cover the entire HF spectrum between 3.5 and 29.7 mc by selecting the appropriate HF beating crystal.

The 32S-1 Transmitter, with an input of 175 watts PEP on SSB and 160 watts on CW gives you strong, clear signals.

Add the 30S-1 Linear Amplifier

and you can operate at the legal limit on SSB, and 100 watts CW. Front panel switching on the 30S-1 lets you operate on SSB power levels; 100 watts the exciter alone, or the meter average input for SSB. Collins 312B-4 Speaker Console integrates the Transmitter, Receiver, Linear Amplifier and accessories into one complete operating unit.

See this complete exciting system at World Radio Laboratories. Write for additional information on the Collins S/Line now.

30S-1 Linear Amplifier \$1,556.00
\$155.60 down, \$68.00 per mo.

75S-1 Receiver \$520.00
\$52.00 down, \$24.00 per mo.

312B-4 Control Console \$195.00
\$19.50 down, \$13.00 per mo.

32S-1 Transmitter \$666.00
\$66.60 down, \$29.00 per mo.

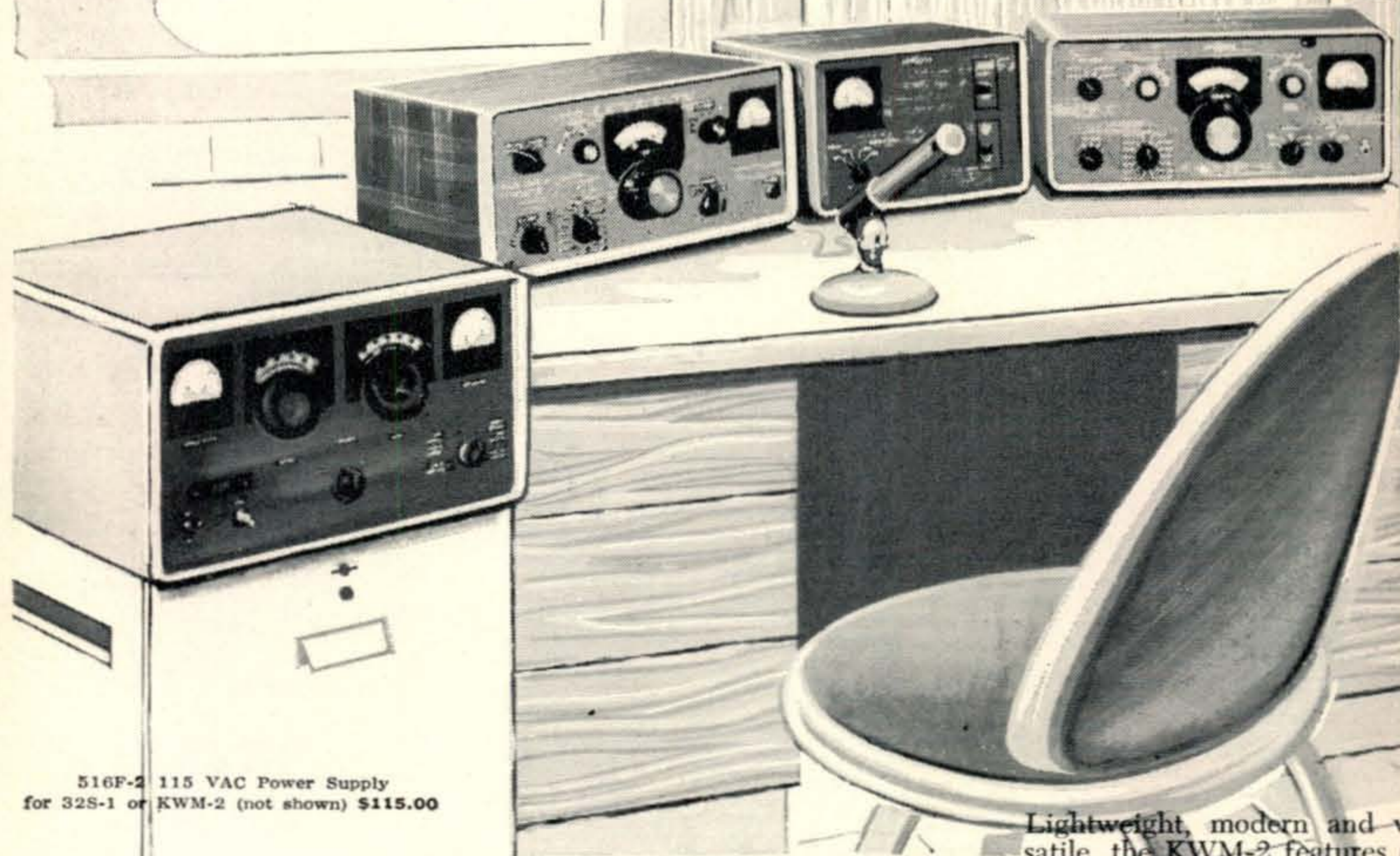

516F-2 115 VAC Power Supply
for 32S-1 or KWM-2 (not shown) \$115.00

COLLINS KWM-2



KWM-2, \$1150.00 \$115.00 down \$50.00 per mo.

Mobile or Fixed Station SSB Transceiver

Lightweight, modern and versatile, the KWM-2 features operation on all bands between 3.4 and 29.7 mc, either voice or CW. Filter type SSB generation, crystal controlled double conversion, VOX, a speaker anti-trip circuits, AL permeability-tuned VFO and RF inverse feedback for excellent linearity. RF power input is 175 watts PEP on SSB, 160 watts CW. Crystal sockets, provided for twelve 200 kc mobile and fixed stations.

COLLINS KWM-2

two hamshacks—one transceiver

Out of your ham shack and into your mobile unit is a quick and easy operation when you own a Collins KWM-2 Mobile Transceiver.

The KWM-2 connects instantly to the power supply, antenna, antenna selector and car radio speaker when it is slipped into its specially designed mobile mount.

Just plug in one of Collins Mobile Microphones and you're on the air ready to work any of the amateur bands between 3.4 and 29.7 mc.

To experience versatility, mobility and fixed station performance plus Collins craftsmanship and advanced design, try the KWM-2 at any of the 103 Collins Distributors.



COLLINS RADIO COMPANY • CEDAR RAPIDS, IOWA • DALLAS, TEXAS • BURBANK, CALIFORNIA

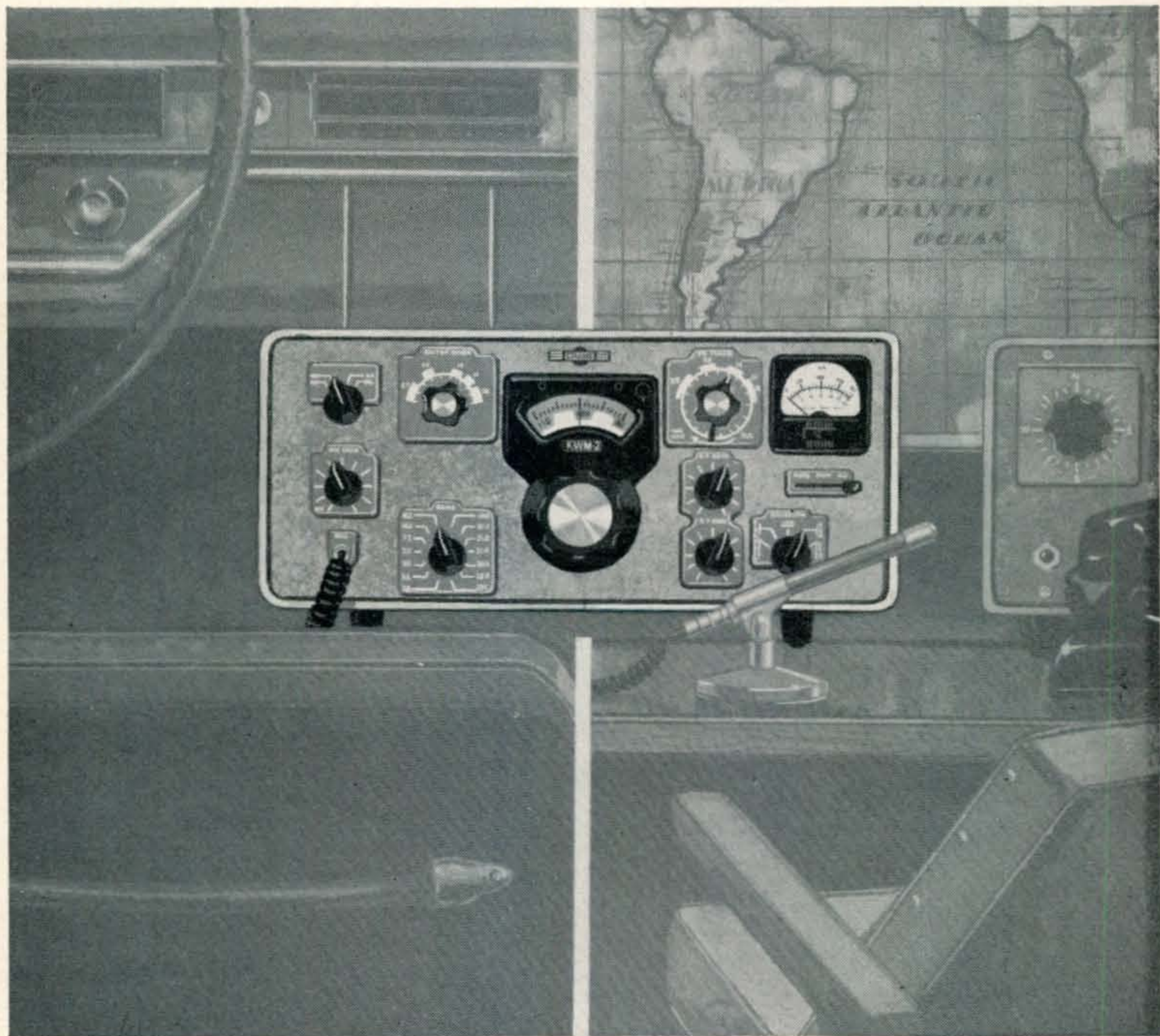

For further information, check number 2 on page 126.

ONLY THE BEST IS GOOD ENOUGH!

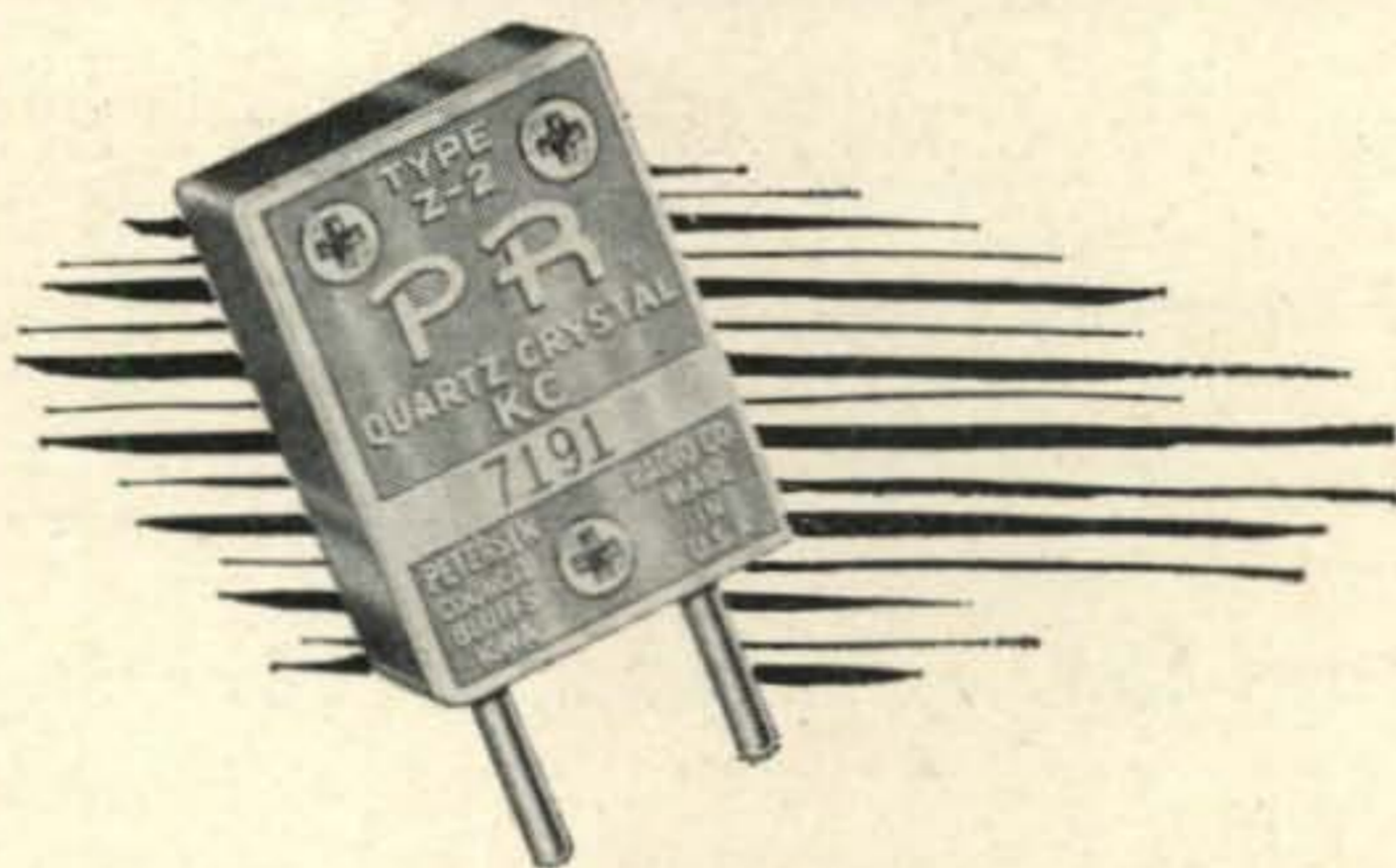

In many respects, Crystals are like "diamonds." You can buy them from six-bits up. It may be difficult to tell quality from a distance, but measured under close-up of performance, accuracy and stability . . . quality stands out. After all, your frequency control is the heart of your transmitter. When you trust your frequency to PR you know where you are . . . today, tomorrow and years from now. This is worth

a great deal. In the long run the money you put in a crystal is not important . . . because even quality PRs cost little. When you buy a PR from your jobber you can get the exact frequency you want (integral kilocycle) within amateur bands, at no extra cost. You can be where you want to be . . . not within 5, 10 or 15 KC., but **JUST WHERE YOU WANT TO BE!** That means a lot.

40 and 80 Meters, PR Type Z-2....\$2.95

Citizens Band, Type Z-9R.....\$2.95

PR

Crystals



USE **PR** AND **KNOW** WHERE YOU ARE

PETERSEN RADIO COMPANY, INC.
2800 W. BROADWAY • COUNCIL BLUFFS, IOWA

EXPORT SALES: Royal National Corporation, 250 W. 57th Street, New York 19, N. Y., U. S. A.
For further information, check number 5 on page 126.

October, 1960 • CQ • 1

CQ—The Radio Amateur's Journal

October 1960
vol. 16, no. 10

300 West 43rd Street, New York 36, N. Y.

Uno—Dipper	Frank Hatanaka, W9BEZ	40
The Electronic Phone Patch	Cmdr. Paul Lee, W3JHR	48
An S.S.B. Ten Meter Mixer	Ed Marriner, W6BLZ	49
K6BX Pleads Guilty!	Carole Hoover, K9AMD	50
A Crystal-Controlled Frequency Coupler	Henry Elwell, W2JKH	52
The Elimination of Stray R.F.	L. G. Jakubec, Jr.	56
Four Tubes—Two Meters S.S.B.	Don Stoner, W6TNS Les Earnshaw, ZL1AAX	58
Spanish-American Ham Relations		61
A \$.98 Bug	Stanmore Cooper, K4DRD	62
CQ Reviews The Transcon Transistorized Power Supplies		63
VHF Contest Results		64

DEPARTMENTS

Announcements	20	Letters To The Editor	10	Semiconductors	82
Classified	120	MARS Bulletin	14	Sideband	89
Contest Calendar	94	New Amateur Products	100	Space Communications	86
DX	65	Novice	78	Surplus	80
Editorial	11	Propagation	92	VHF	72
Ham Clinic	69	RTTY	84	YL	98
Ham Headlines	16				

Branch Advertising Offices:

William A. Ayres, The William A. Ayres Co.,
233 Sansome Street, San Francisco 4, Calif.
YUkon 6-2981

Fred Frisenfeldt, The William A. Ayres Co.,
1709 West 8th Street, Los Angeles 5, Calif.
HUBbard 3-2777

publisher S. R. Cowan
production manager Bill Gardner, Jr.
circulation manager Harold Weisner, WA2OBR
editorial production Robert Jordan
advertising representative Jack Schneider, WA2FPE
advertising representative Dick Cowan, WA2LRO
classified advertising Kathi Gerace
draftsman Mike Dominguez

CQ—(title registered U. S. Post Office) is published monthly by Cowan Publishing Corporation. Executive and editorial offices at 300 West 43rd Street, New York 36, N. Y. Telephone JUdson 2-4460. Second-class Postage paid at New York, N. Y.

SUBSCRIPTION RATES: U. S. A. and Possessions, APO, FPO, Canada and Mexico; one year \$5.00; two years \$9.00; three years \$13.00. Pan-American and foreign: one year \$6.00; two years \$11.00; three years \$16.00.

FOREIGN SUBSCRIPTIONS: Great Britain: RSGB, New Ruskin House, Little Russell St., London WC 1, England. Australia: Technical Book Co., 297 Swanston St., Melbourne C 1, Victoria, Australia.

Printed in U. S. A. Entire contents copyright 1960 by Cowan Publishing Corporation. CQ does not assume responsibility for unsolicited manuscripts.

Postmaster: Send Form 3579 to CQ, 300 West 43rd Street, New York, N. Y.

Hallicrafters Quality...

(at down-to-earth prices)



Today . . . you can be on the air with single sideband! This is the combination whose price makes it possible—whose performance makes it a great new experience.

HT-37 Transmitter \$450.00 A precision-engineered CW/AM/SSB transmitter with the same power, rugged construction, and long-term frequency and carrier suppression stability as the famous HT-32. Sideband suppression 40 db. at 1000 CPS. Power rating: 70-100 watts P.E.P. output CW or SSB. 17-25 watts carrier on AM phone. 3rd and 5th order distortion products down 30 db. Instant CW CAL signal from any transmission mode. Ideal CW keying; full voice control system. 52-ohm pi network output for harmonic suppression.

For further information, check number 6 on page 126.

SX-111 Receiver \$249.50 Here's a CW/AM/SSB receiver with the essential performance characteristics of the renowned SX-101. CW/AM/SSB reception; complete coverage: 80, 40, 20, 15 and 10 meters in 5 separate bands, 6th band tunable to 10 Mc. for WWV. Upper/lower sideband selection; sensitivity: 1 microvolt on all bands; 5 steps of selectivity: 500 to 5000 cycles. Dual conversion, crystal controlled 2nd converter, famous Tee-Notch filter, built-in crystal calibrator. Separate AM and SSB detectors.

Also shown: The Stradivarius of electronic keyers—HA-1 T.O. Keyer—\$79.95; and the R-48 Speaker—\$19.95.

the new ideas in communications are born at . . .



Export Sales: International Div.,
Raytheon Mfg. Co., Waltham, Mass.
Canada: Gould Sales Co., Montreal, P.Q.

hallicrafters

Chicago 24, Illinois

Designed for



Application

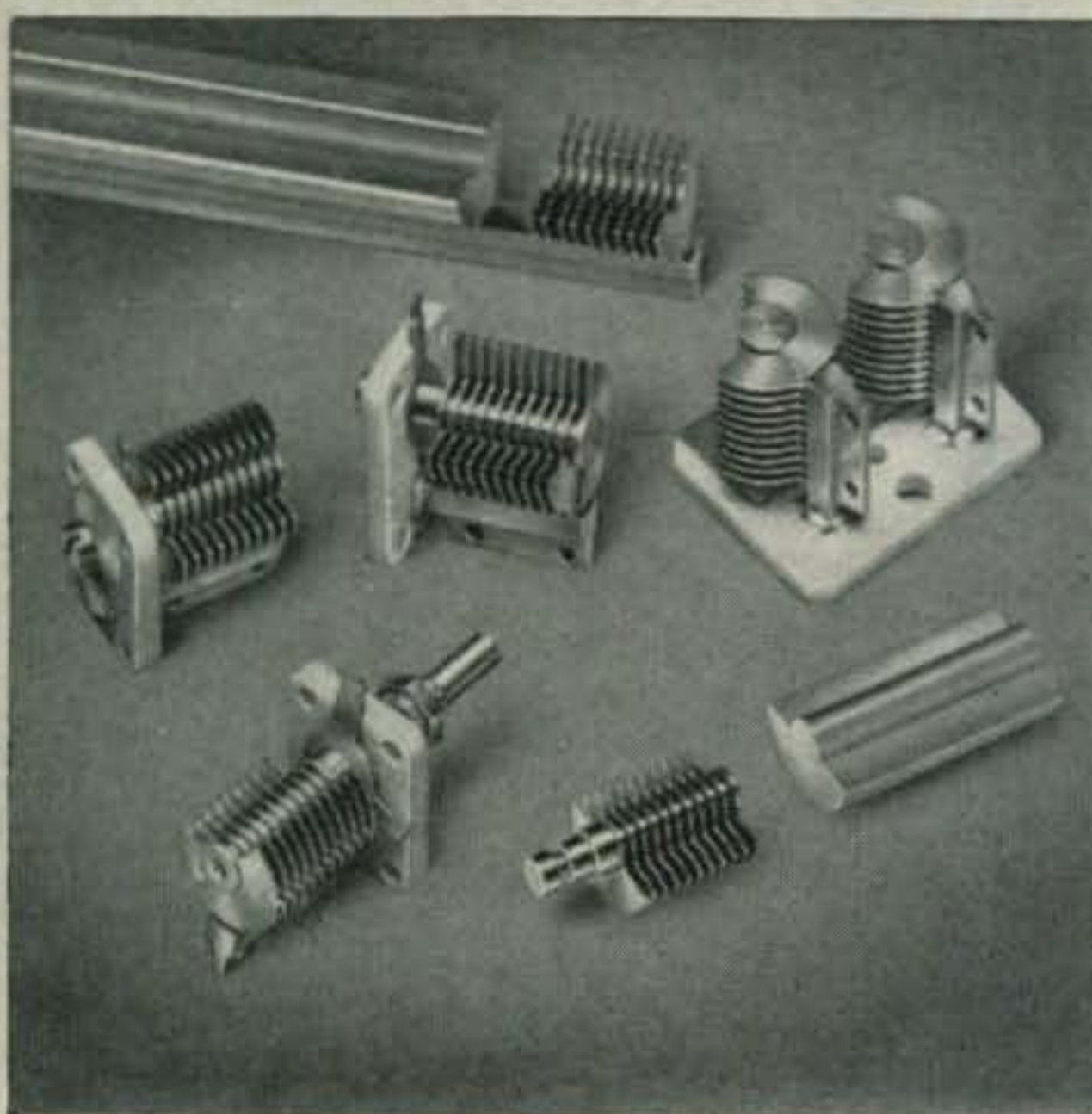

**NO. 25000 SERIES
HIGH Q MINIATURE
VARIABLE AIR CAPACITORS**

High Q at high frequencies. Rotors and Stators precision machined from extruded solid brass. Terminal integral part of Stator block. Shaft an integral part of Rotor. Screw-driver slot adjustment or $\frac{1}{8}$ " extended shaft for knob. Only 6 parts to a complete Capacitor. Stock sizes 15, 25 & 35 mmfd. single or dual units.

**JAMES MILLEN
MFG. CO., INC.**

MAIN OFFICE AND FACTORY
**MALDEN
MASSACHUSETTS**



Barry Briskman, K2IEG	<i>managing editor</i>
Arnold S. Trossman, W2DTJ	<i>associate editor</i>
Lee Aurick, W2QEX	<i>technical editor</i>
<i>department editors</i>	
Frank Anzalone, W1WY	<i>contest calendar</i>
Ken Grayson, W2HDM	<i>surplus</i>
Bob Brown, K2ZSQ	<i>vhf</i>
George Jacobs, W3ASK	<i>propagation</i>
Byron Kretzman, KØWMR	<i>rtty</i>
Urban Le June, Jr., W2DEC	<i>dx</i>
Marvin Lipton, VE3DQX	<i>ham headlines</i>
Louisa Sando, W5RZJ	<i>yl</i>
Charles Schauers, W6QLV	<i>ham clinic</i>
Don Stoner, W6TNS	<i>novice & semiconductors</i>
Irv Strauber, K2HEA	<i>sideband</i>
Dot Strauber, K2MGE	

CQ, the Radio Amateurs' Journal is published for active hams by active hams. CQ endeavors to be a true and honest reporter for those interested in the hobby. Suggestions for improvement are welcomed.

Manuscripts submitted to CQ should be typewritten, double spaced on 8½ by 11 inch paper with adequate margins on both sides of the typewritten copy. Photographs and drawings should be clear and contain adequate explanations. All manuscripts should be accompanied by an envelope and sufficient postage for its return.

CQ CERTIFICATES:

The WPX Award is granted for two-way contact with certain number of amateurs in different prefixes of the world. Full details are contained in the WPX Record Book which is available for 15¢ from CQ. Application forms are free.

The WAZ Award is granted for contacting all of the amateur zones of the world. Current standings of amateurs awarded WAZ will be found in the DX column. A DX Zone map of the world is available free from CQ. Send stamped envelope.

Special SB Certificates are available from the Sideband Department for operators providing proof of contact (QSL cards) with stations in 50, 75 and 100 countries using two-way sideband. Send cards directly to the SB Editor.

TECHNICAL INFORMATION:

CQ's 15-year cumulative index may be obtained free from our circulation department by enclosing a stamped, self-addressed envelope (8¢). Most back issues are available at \$1 from us. Check our "Back Issue" ad for details on those not available.

THIS MONTH'S COVER:

How many times have you placed a hot soldering iron on an unused coil of your grid-dipper? Between dropping the coils, stepping on them or losing them, they pose quite a problem around the shack. Locating on elusive parasitic or pruning a coil can also be a problem requiring constant plugging and unplugging of coils.

We feel that the description of the *Uno-Dipper* beginning on page 40 of this issue will change the concept of the most widely used accessory in hamdom.

← For further information, check number 7 on page 126.

on the air tonight



HAMMARLUND HX-500 TRANSMITTER

Tonight, and every night to come, more and more Hammarlund HX-500 SSB transmitters will be operating and serving as the topic of conversation. This new transmitter is rapidly setting the standards by which all other transmitters will be judged.

Loaded with new features, designed to provide the finest performance, and built to the fine traditions of Hammarlund craftsmanship, the HX-500 is your best buy in the fine transmitter field...

Write today for complete details... **\$695⁰⁰** amateur net.

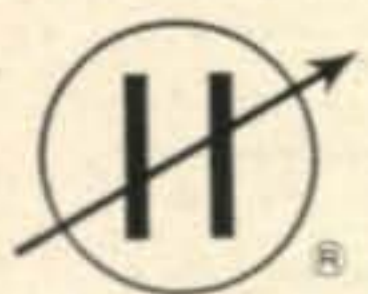

Established 1910

HAMMARLUND

A DIVISION OF
TELECHROME

HAMMARLUND MANUFACTURING COMPANY, INC., 460 W. 34th ST., N. Y. 1, N. Y.

Export: Rocke International, 13 E. 40th St., N. Y. 16, N. Y. Canada: White Radio, Ltd., 41 West Ave. N., Hamilton, Can.

For further information, check number 8 on page 126.

October, 1960 • CQ • 5

“Phase detector of the Moving Target Indicator receiver misaligned on the FPS-3...realignment procedure must be followed.”

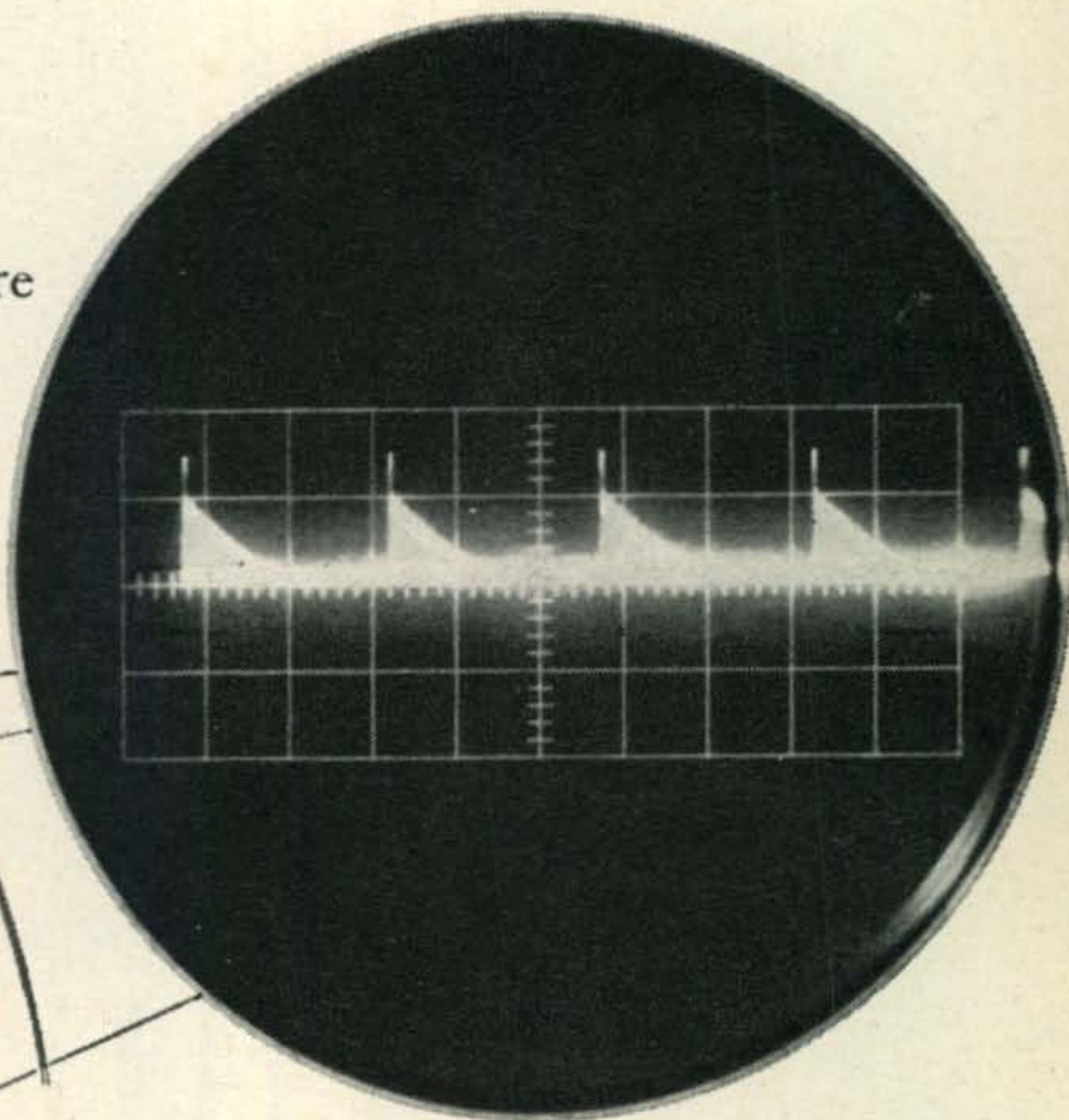

YOU MAY HANDLE A SITUATION LIKE THIS...

If you measure up to the Aerospace Team

This man is on a team. And the situation facing the team is a moving target. Mission? Intercept same. This man is an expert. He was given thorough training in his specialty. Now he is a skilled technical specialist with an assured future. He is a man who measured up to the requirements of the Aerospace Team ...a man you can depend on.

Are you that man? If you have what it takes, an exciting and interesting career may lie before you. You will be eligible for valuable

training for a key job in the rapidly unfolding age of air and space travel. Also, there will be the opportunity to further your formal education, perhaps even win a college degree—with the Air Force paying a substantial part of your tuition costs.

If you are interested in a career of steady advancement, solid security...a career where you will handle situations of increasing responsibilities, we of the Air Force would like to talk to you. Just clip and mail this coupon.

U.S. AIR FORCE

There's a place for tomorrow's leaders on the Aerospace Team

PASTE COUPON ON POSTCARD AND MAIL TO:
Airman Information, Dept. MC010, Box 7608, Washington 4, D. C.

Please send me more information on my opportunities in the U.S. Air Force. I am between the ages of 17-27 and reside in the U.S.A. or possessions.

Name _____

Address _____

City _____ Zone _____ County _____ State _____

FROM HEATH ... 9 NEW RADIO AMATEUR KITS



GC-1
\$99.95
\$10.00 dn.,
\$9.00 mo.



TEN-TRANSISTOR "MOHICAN" GENERAL COVERAGE RECEIVER KIT (GC-1)

An excellent portable or fixed station receiver! Many firsts in receiver design for outstanding performance . . . ten transistor circuit . . . flashlight battery power supply . . . ceramic IF transfilters. The amazing, miniature transfilters used in the GC-1 replace transformer, inductive and capacitive elements used in conventional circuits; offer superior time and temperature stability, never need alignment and provide excellent selectivity. Other features include telescoping 54" whip antenna, flywheel tuning, tuning meter, large slide-rule dial and attractive, rugged steel case in gray and gray-green. Covers 550 kc to 30 mc in five bands. Electrical bandspread on five additional bands cover amateur frequencies from 80 through 10 meters. Operates up to 400 hours on 8 standard size "C" batteries. Sensitivity: is 10 uv, broadcast band; 2 uv, amateur bands for 10 db signal to noise ratio. Selectivity: 3 kc wide at 6 db down. Measures only 6½" x 12" x 10". 20 lbs.

Heathkit XP-2: plug-in power supply for 110 VAC operation of GC-1. (optional extra). 2 lbs. \$9.95



HD-20
\$14.95

100 KC CRYSTAL CALIBRATOR KIT (HD-20)

Align or check calibration of your communications gear with this versatile ham aid. Provides marker frequencies every 100 kc between 100 kc and 54 mc. Transistor circuit is battery powered for complete portability. Accuracy is assured by .005% crystal furnished. Measures only 2½" x 4½" x 2½". 1 lb.

7 more kits on following pages



HEATHKIT® . . . WORLD'S FINEST HAM GEAR



KL-1
\$399⁹⁵

\$40.00 dn.
 (Write for time
 payment details)

"CHIPPEWA" KILOWATT LINEAR AMPLIFIER KIT (KL-1)

Here is a top-quality kilowatt rig with all the features you've been looking for. Operates at maximum legal power input on all bands between 80 and 10 meters, in SSB, CW or AM linear operation. Premium tubes (4-400A's), forced air cooled with centrifugal blower. Grid neutralized, continuous plate current monitoring, extensive TVI shielding. Features both tuned and swamped grid circuits to accommodate all popular exciters. Operates class ABI for SSB and AM linear service and high efficiency class C for CW service. Convenient panel controls include power switch, tune-operate switch, HV on/off switch, final bandswitch, meter switch, grid bandswitch, grid tuning, mode switch, plate tuning, plate loading and bias adjust. Accessory connectors are provided on the rear apron of the chassis for complete compatibility with all control circuitry in the Heathkit "Apache" Transmitter. Two meters provided; one monitors final plate current; the other indicates switch selected readings of final grid current, screen current, and plate voltages. Send for complete specifications now. 70 lbs.

A PERFECT COMPANION FOR THE "CHIPPEWA" KILOWATT POWER SUPPLY KIT (KS-1)

Ruggedly constructed for heavy-duty use in medium to high power installations, the KS-1 fills the requirements of a top-notch power supply with economy and safety. Features an oil-filled hermetically sealed plate transformer, "potted" swinging choke input filter and 60-second time delay relay. Line filters minimize RF radiation. Maximum DC power output is 1500 watts. Nominal voltage output, 3000 or 1500 volts. DC current output, average 500 ma, maximum 1000 ma. Control circuitry is arranged to allow remote installation. The KS-1 employs two 866A half-wave mercury vapor rectifiers in a full-wave, single-phase configuration. Power requirements: 115 V, 50/60 cycles, 20 amperes; 230 V, 50/60 cycles, 10 amperes. 105 lbs.

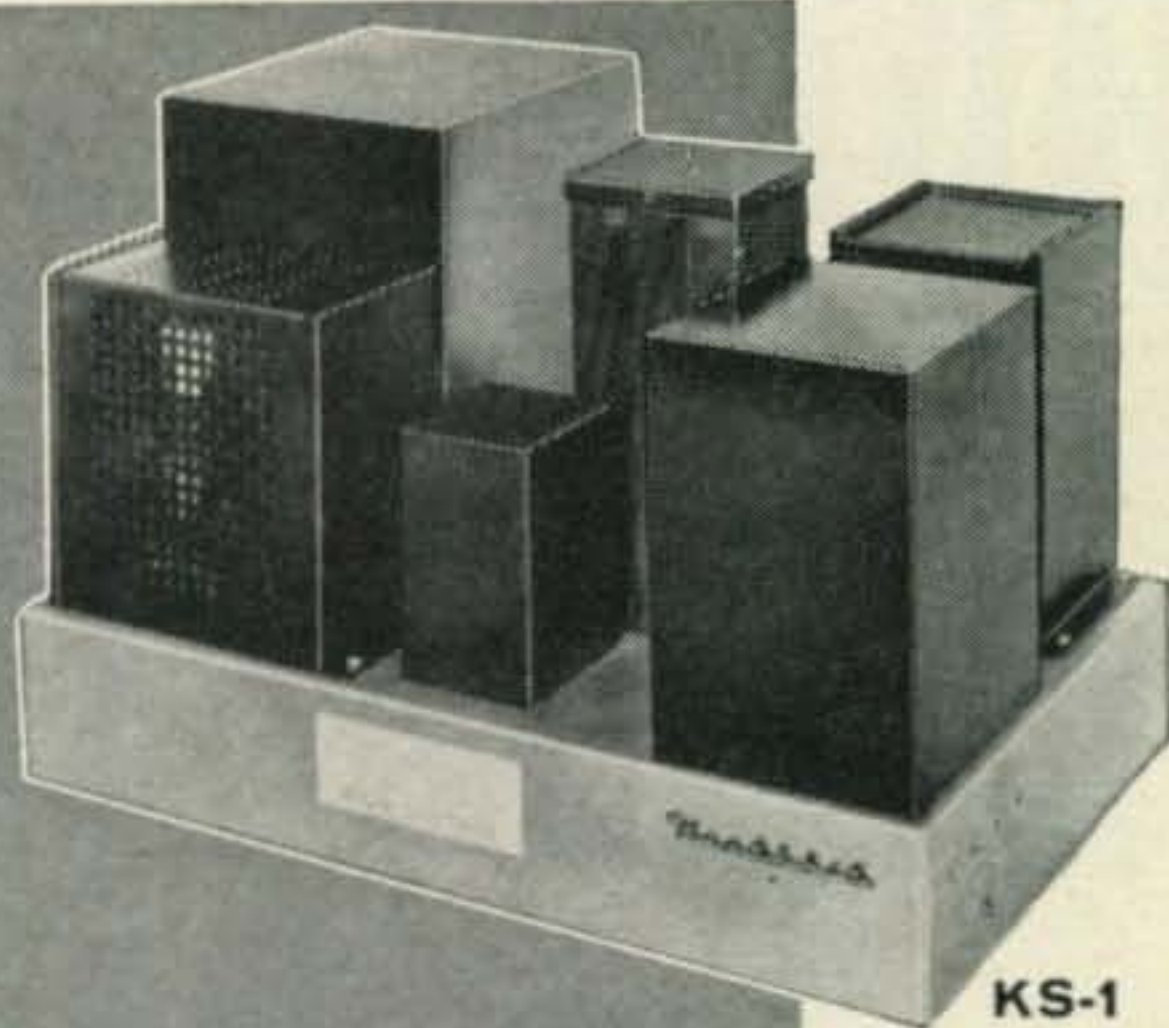

KS-1
\$169⁹⁵

\$17.00 dn.,
 \$15.00 mo.

XC-6
\$26⁹⁵

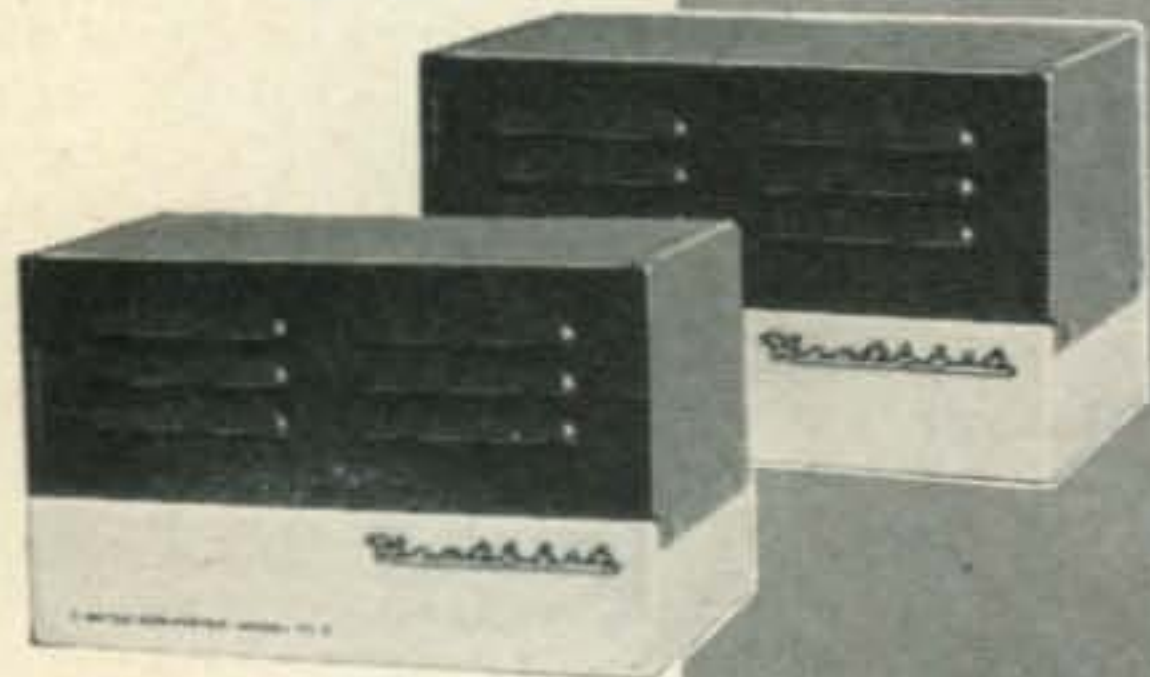

XC-2
\$36⁹⁵

6-METER CONVERTER KIT (XC-6)

Extends frequency coverage of the Heathkit "Mohawk" and most other general coverage receivers into the 6 meter band. Converts 50-54 mc signals to 22-26 mc. 3-tube circuit provides two RF stages and low-noise triode mixer. Calibration accuracy assured by .005% overtone crystal supplied. Provision for external RF gain control. 6 lbs.

2-METER CONVERTER KIT (XC-2)

This top-quality 2-meter converter may be used with receivers tuning any 4 mc segment between the frequencies of 22 and 35 mc when appropriate crystal is used. Converts 144-148 mc signals to 22-26 mc with .005% overtone crystal supplied. High quality parts used throughout. Silver plated chassis and shields. 7 lbs.

IN KIT FORM TOPS IN TRANSMITTING POWER

TWO BRAND NEW MODELS HEATHKIT 10 & 6 METER TRANSCEIVER KITS

Complete ham facilities at low cost! The new Heathkit transceivers are combination transmitters designed for crystal control and variable tuned receivers operating on the 6 and 10 meter amateur bands (50 to 54 mc HW-29 and 28 to 29.7 mc for HW-19) in either fixed or mobile installations. Highly sensitive superregenerative receivers pull in signals as low as 1 microvolt; low power output is more than adequate for "local" net operation. Other features include: built-in RF trap on 10 meter version to minimize TVI; adjustable link coupling on 6 meter version; built-in amplifier metering jack and "press-to-talk" switch with "transmit" and "hold" positions. Can be used in ham shack or as compact mobile rigs. Not for Citizen's Band use. Microphone and two power cables included. Handsomely styled in mocha and beige. Less crystal. 10 lbs.

VIBRATOR POWER SUPPLIES: VP-1-6 (6 volt), VP-1-12 (12 volt), 4 lbs. Kit; \$8.95 each, wired; \$12.95 each.



HW-19 (10 meter)
HW-29 (6 meter)
\$39⁹⁵ each



HD-19
\$34⁹⁵

HYBRID PHONE PATCH KIT (HD-19)

Add the thrill of phone patching to your ham hobbying, while rendering valuable public service during emergencies and in countless other instances. The HD-19 puts a top-flight phone patch in your ham shack at the lowest price anywhere! Features: voice control (VOX) or manual operation; large, easy to read VU meter for continuous monitoring of output to 600 ohm line; specially designed hybrid transformer providing better than 30 db isolation between receiver and transmitter circuit; separate receive and transmit gain controls. Switched circuitry allows VU meter to be used as null depth indicator. Provides effective match for 3 to 16 ohm speaker impedance. 4 lbs.

ORDER DIRECT BY MAIL OR SEE YOUR HEATHKIT DEALER*

*The convenience of Local Heathkit Sales and Service costs but a few dollars more.

HEATH COMPANY

a subsidiary of
DAYSTROM, INCORPORATED

Benton Harbor 12, Michigan

All prices and specifications subject to change without notice. Please include postage on orders to be shipped parcel post. 20% deposit is required on all C.O.D. orders. All prices are NET F.O.B. Benton Harbor, Mich., and apply to Continental U.S. and Possessions only. Dealer and export prices slightly higher.



FREE CATALOG!

Describes over 150 easy-to-build electronic kits in HI-FI, Test, Marine, and Ham radio fields. To get yours, fill in this coupon and mail today!

NAME _____

ADDRESS _____

CITY _____ ZONE _____ STATE _____

ITEM	MODEL	PRICE

For further information, check number 10 on page 126.

**Get This
Handy
POCKET
ELECTRONICS
DATA GUIDE**



free

Puts all the commonly used conversion factors, formulas, tables, and color codes at your fingertips. Yours absolutely free if you mail the coupon below. No further obligation!

**Cleveland Institute Training
means BETTER JOBS . . .**

OUR TRAINEES GET JOBS LIKE THIS:

"Since enrolling with Cleveland Institute I have received my 1st class license, and am now Chief Engineer of Station WAIN. Thanks to the Institute for making this possible." L. M. Owens, Columbia, Ky.

EMPLOYERS MAKE OFFERS LIKE THESE:

RCA has positions for technician, field engineers & instructor technicians to install, maintain, & teach military radar, communications, and fire control equipment. Company benefits.

**A Commercial FCC License . . .
YOUR GUARANTEE OF SUCCESS!**

The Master Course in Electronics will provide you with the mental tools of the electronics technician and prepare you for a 1st Class FCC License (Commercial) with a radar endorsement.

**MONEY-BACK
GUARANTEE!**



Mail Coupon
Today and Get
All 3 Books
FREE



Cleveland Institute of Electronics
Carl E. Smith, Consulting Engineer, President
Accredited by the National Home Study Council
Desk CQ-69, 4900 Euclid Avenue, Cleveland 3, Ohio

Please send Free Booklets prepared to help me get ahead in Electronics and a free copy of your "Pocket Electronics Data Guide." I have had training or experience in Electronics as indicated below:

- | | |
|---|---|
| <input type="checkbox"/> Military | <input type="checkbox"/> Broadcasting |
| <input type="checkbox"/> Radio-TV Servicing | <input type="checkbox"/> Home experimenting |
| <input type="checkbox"/> Manufacturing | <input type="checkbox"/> Telephone Company |
| <input type="checkbox"/> Amateur Radio | <input type="checkbox"/> Others |

In what kind of work are you now interested?.....

In what branch of Electronics are you interested?.....

Name..... Age.....

Address.....

City..... Zone..... State.....

**Letters
to the Editor**

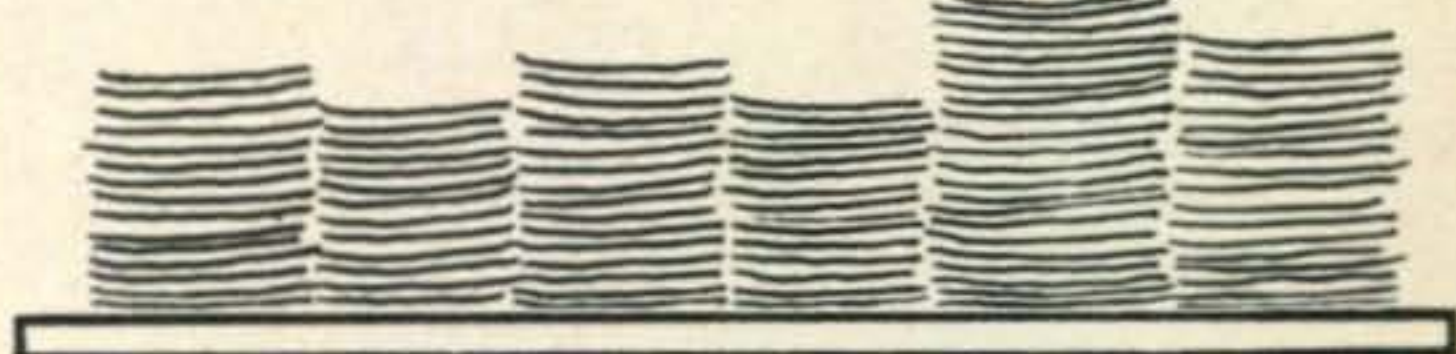

Rocky Rockey

Editor CQ:

Directed and dedicated to my neighbor to the north and to all holders of an amateur license.

In many years of "Hamdom" I have never seen one letter destroy the true meaning of the term "Hobby" than that displayed in the August CQ Journal and composed by C. F. Rockey!

Why publish an article such as his? Why tear down what has taken years to build? Education is a good thing to come by in any sense. Education however, is only a part of what many have found to be a most wonderful hobby in years gone by. In these so called atomic days, we are so concerned about keeping up with the Jones' that we seldom take time to relax. You know C.F., talking to one another can be quite *educational too*.

Everyone should hold an Extra Class License, huh? In two more years some other know-it-all will suggest that all hams be holders of a First Phone. Then what? Well, I'll tell you; the bands will be vacant of conversation. There are not that many engineers interested in holding a ham license.

In effect you are saying that all hams should develop into engineers. Make only the Extra Class renewable? Bah! Humbug! Give a guy a chance Mr. Rockey. An amateur photographer is not a professional. A doctor who plays golf once a week is not a pro. An amateur rail-roader is not an *engineer*. Get the idea?

Mr. Rockey, you have apparently decided (for all of us) that amateur radio is only to educate people. Granted, that it is one purpose but there are others; many others.

So you have had your license for 25 years. Soooo what? Just because you consider yourself an intellectual in electronics gives you no right whatsoever to slam the various organizations which have devoted their time and interest in setting up the present rules.

A body of people suggest, or make a motion to a board, it is then acted upon in an orderly way. But for any one individual to take it upon himself to sound off in judgment of the present rules and regulations, is to harrass the very minds of people capable of taking away all privileges granted to us in ham radio. We are having a hard enough time keeping the ham frequencies presently alloted to us. To make everyone an Extra Class Ham would cut the amateur body in half, to say the least. The less hams the less strength.

Would you rather operate under the present conditions or not operate at all? United we stand . . . divided we fall.

Make only the Extra Class License renewable? OK Sir. If you are going to be a Class "A" operator, let's do it right. My profession is as a Staff Announcer in Chicago and Network Television. You improve your diction on the bands, Mr. Rockey, and I'll work on my calculus.

R. D. Lashbrook, K9GWC
Skokie, Illinois

Editor, CQ:

I was very much interested in the letter from Mr. C. F. Rockey, W9SCH, ("Letters" August 1960, p. 11) in regard to stricter requirements for amateur licenses. While I am quite willing to agree on some of his points, particularly the limitation on power to 200 watts or less, I cannot agree that amateur radio should become a club restricted to Electronic Engineers and Radio Technicians. This, to me, makes about as much sense as limiting drivers licenses to automobile designers and licensed mechanics, or the enjoy-

In Our Opinion

On the eve of the historic completion of "Project Moonbounce", *CQ* received word of Sam Harris's resignation as contributing editor of *CQ*'s V.H.F. column and his acceptance of the post of V.H.F. editor for *QST*.

Sam and his colleagues of the Rhododendron Swamp V.H.F. Society, laboriously planned and executed "Project Moonbounce" which, ushered in a new era of world wide communications. Through his devoted efforts, east and west coasts were linked via a reflection from the moon. No longer can microwaves be considered as limited to line of sight communications. On the contrary . . . communications, accomplished by means of the h.f. portion of the spectrum, using ionospheric propagation techniques may, eventually, become as obsolete as the rotary spark!



Sam Harris, W1FZJ

W1FZJ's services with *CQ* extended from July 1955 when, at that time he was W8UKS/1. We will miss Sam at *CQ*! We are thankful, however, that his contributions to amateur radio will continue, and that the v.h.f. community will *not* lose a favorite son.

We congratulate the American Radio Relay League on their excellent choice and wish continued success to Sam and the R.S.V.H.F.S.

Occupying the position formerly held by W1FZJ will be Bob Brown, K2ZSQ. Bob, v.h.f. enthusiast extraordinary, should be well known to many v.h.f.'ers through his own publication *The VHF Amateur*. We hope our readers will

extend Bob a cordial welcome, and provide the cooperation which he deserves in taking on this great task.

Mightier Than The Sword . . .

Peace is everybody's business—and especially the ham's who can, through world-wide contacts help create goodwill and increase international understanding. His DX contacts, it must be remembered, are not the only ones listening!

Scattered all over the world are thousands of people in every land who listen to amateur radio conversations. Be careful of what you, the American amateur, say!

Be courteous; respect the personal beliefs of others even though they do not coincide with yours; but never be afraid to speak the truth!

We know, that there are some hams in countries throughout the world who, like their fellow citizens, are led to believe many things which are not true. If you are asked by any of them for information, be certain to set the record straight *only* if you have the facts!

One evening not too long ago, we heard two American hams discussing the U2 and RB-47 incidents on 20 meters. Never once did they mention the fact that only a handful of Soviet citizens know that the USSR's agents: 1) stole the secrets of the atomic bomb; 2) that hundreds of Soviet agents are active, and many have been apprehended in Europe; 3) that a Russian Army Colonel is presently in a U.S. penitentiary after being lawfully convicted of spying in the United States, *ad infinitum*.

We wonder who on the globe was listening the night that these two guys were bandying the subjects around on 20 meters without making the slightest effort to tell the other side of the story!

In America we have free speech, but when radio amateurs use it, let's remember that others are listening; let's make certain that we have our facts straight. For those listening, whomever they may be, they must know the truth.

Yes, amateur radio is a mighty instrument of global communication—use it well—use it for friendship but steer away from controversial subjects when you do not have enough facts to present both sides of the story.

Remember: the world is listening! Make your words count.

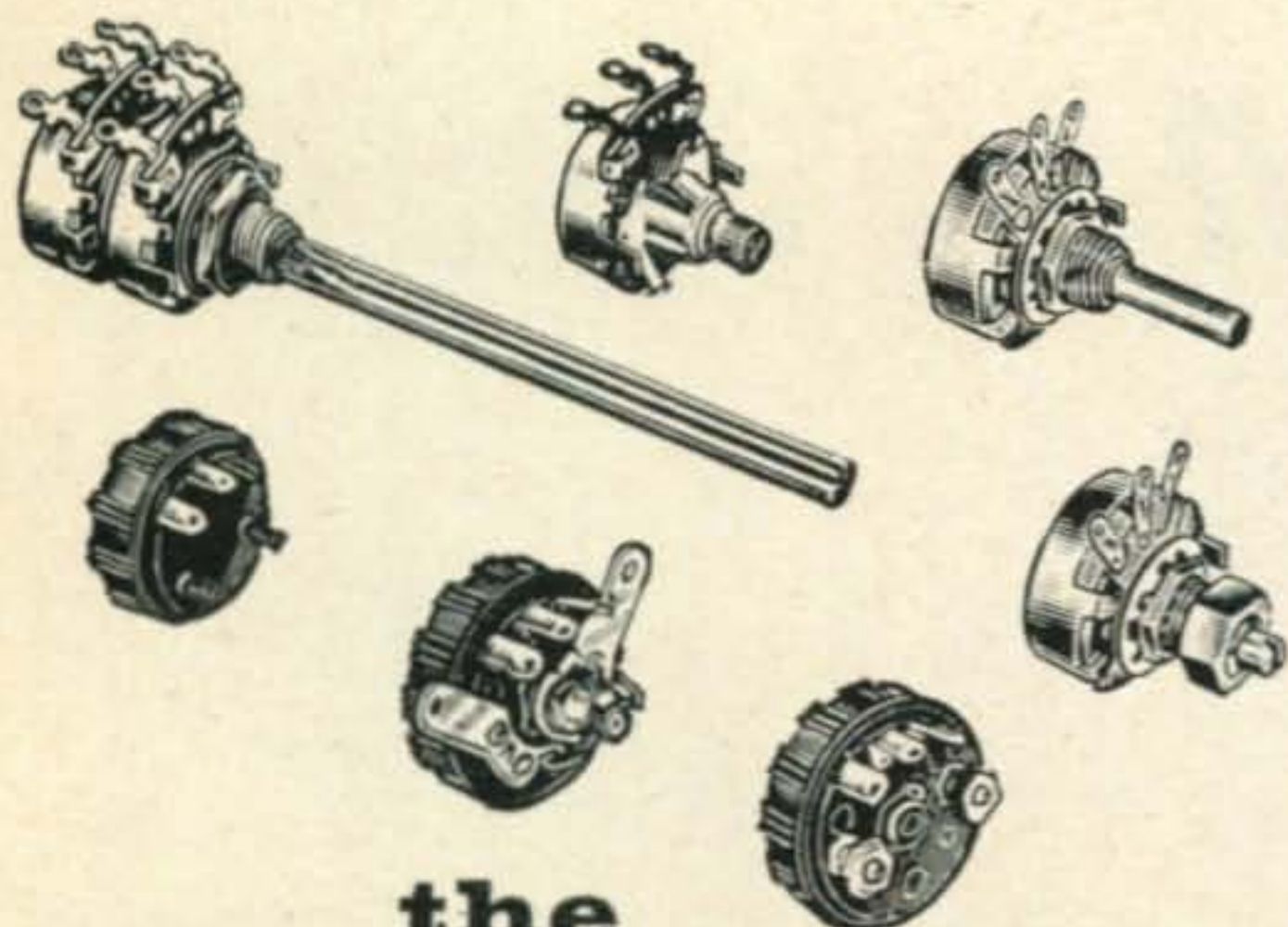

**the
VARIABLE
RESISTOR**

**you need is carried
by your**

Centralab

distributor

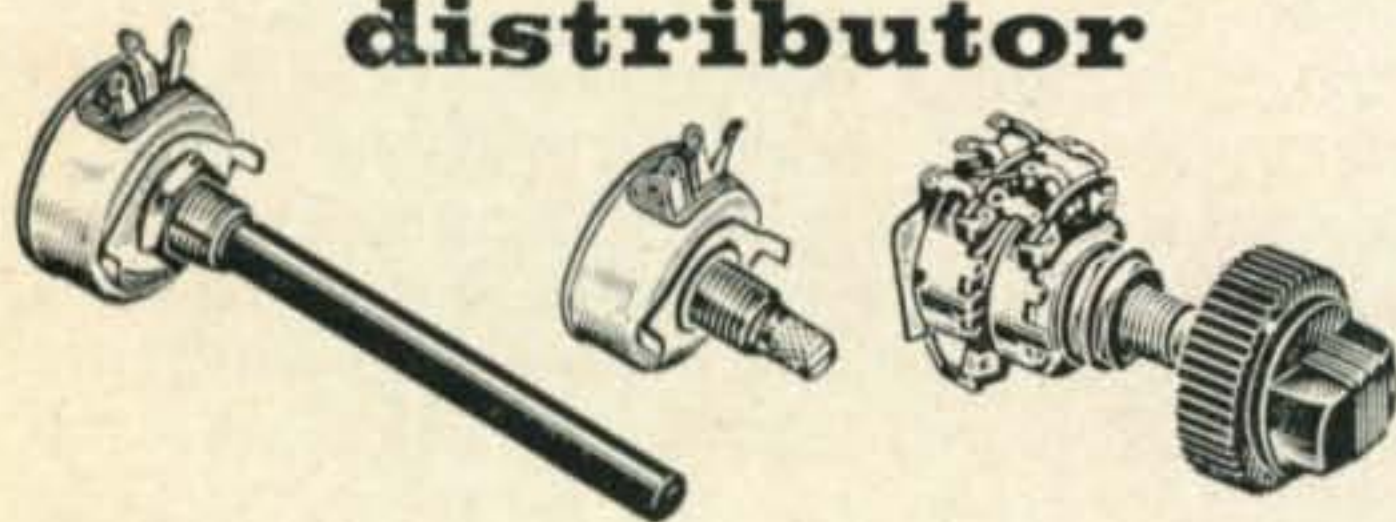

You'll find the variable resistor you need in the extensive CENTRALAB line. For every ham application, you can always depend on CENTRALAB (as do countless industrial and military users).

Miniature, sub-miniature, ultra-miniature units—wirewounds and composition—all are available from your distributor's stock. And they're all listed in CENTRALAB's Catalog 31. If you don't have this catalog, write us or ask your distributor for a free copy.

All CENTRALAB products are listed in *The Radio-Electronic Master*.

Centralab
B-5923

For further information, check number 11 on page 126.

ment of Hi-Fi to composers and concert pianists.

I got my first ticket in 1921, when hams of necessity made their own gear, and while there have been breaks in my ham career due to circumstances beyond my control, I have found my knowledge of the fundamentals of radio and the ability to send and receive Morse code of the greatest value to me (and I hope others) during my time in the service in World War II. On the other hand, I have neither the time nor the ability to build complicated, modern radio equipment. Am I to be denied a pleasant, interesting hobby because I might not be able to take my transmitter and receiver apart and get them together again?

Charles C. Pyne, K1DLF
4 Mansion Road
Marblehead, Massachusetts

QRM Generators

Editor, CQ:

Regarding Frank Wilson's sentiments on contests ("Letters" Aug. 1960, p. 11); let me add a hasty "amen."

Nothing disgusts me more than these senseless QRM contests. I believe a great portion of the participants get into the miserable mess out of simple self defense, "If you can't like em, jine em." I for one, refuse to join anything so outlandishly juvenile. In fact, I have frequently wondered if such contests might not be construed as willful interference, unnecessary and illegal.

At least they might restrict the thing to 160 meters and leave the regular bands free for normal people and normal activities.

Amos R. Utterback, W9FB
Route 7, Valparaiso,
Indiana

Status Quo

Editor, CQ:

The membership of this Club, have, for several months, been besieged by Amateur Radio Operators in the United States primarily, but world wide in general, who want to know why the congestion on 20 meters, from 14.325 mc to 14.350 mc is occupied in great part by Okinawa Stations, when the band is open to the States.

A ruling of the Tri-Service Amateur Radio Board in the Ryukyu Islands published in a directive dated 1 October 1950 is as follows:

"All 3A3a (single sideband) radio telephone stations operating in the 14 mc band are restricted to that portion of band between 14325 kc and 14350 kc while handling message traffic or phone patch traffic."

It will be noted that double side band and amplitude modulated signals are not so restricted! KR6 Stations are also restricted from the 20 meter band between 14.2 and 14.3 mc.

The Okinawa Amateur Radio Club passed a Resolution to the Tri-Service Amateur Radio Board asking that these restrictions be rescinded. This request was summarily refused. At present this is our status quo, which is latin for the mess we're in.

George F. Kendrick, KR6IM
Secretary, Okinawa Amateur Radio Club
APO 331, San Francisco, Calif.

Re: Box-Tops

Editor, CQ:

It would seem that John Halser, K9MTM, protests too much on page 14 of CQ for August. If he obtained his Conditional Class License seven years ago while in military service, fine! He's lucky; during my five years in service (1941-1945), ham radio was closed down most of the time.

But why does John still operate with a Conditional License? It was a five year license, and must have expired two years ago. His residence is Milwaukee, Wisconsin, which is a quarterly examining point of the F.C.C.; accordingly, he was ineligible for renewal of a Conditional Class License. An amateur obtaining a Conditional Class License does not have to be re-examined when he moves into a regular examination area (Sec. 12.44b); but F.C.C. Regulations say at Sec. 12.67 (c) that "Renewal applications shall be governed by applicable rules in force on the date when application is filed".

Also, did John give that friend of his the Novice code test? F.C.C. regulations (Sec. 12.44 (c)) say that the code test must be given by an examiner who is "the holder of

operation: 40 meters!

Not working 40 meters? We suggest you give this band serious thought! There's fine "rag-chewing" and good DX to be found on 40. You'll enjoy this fun-filled band even more with efficient, maintenance free Mosley antennas. DX-Rated for top performance.

40-D DIPOLE LOADING COIL

Make an inexpensive, fine performing dipole transmitting and receiving antenna at about $\frac{1}{2}$ the length of a full size dipole—just 37 feet! Only one coil necessary. Rated to a full KW.

Amateur Net \$7.95

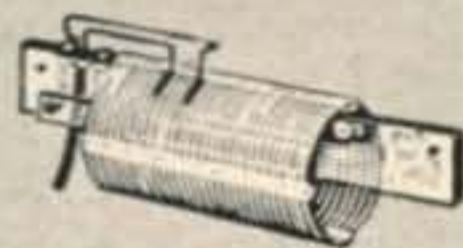

TD-2 TRAP DOUBLET

Resonates at 40 and 75/80 meters providing a typical figure eight, $\frac{1}{2}$ wavelength pattern at each resonant frequency. Overall length is 114 feet, 11 inches. Mosley "Sr." traps are aluminum enclosed and are frequency stable through wide climatic conditions. End insulators are high grade ceramic. Center connector securely holds No. 14 copper-weld wire. Rated to 1 KW. A complete antenna ready to go!

Amateur Net \$37.75

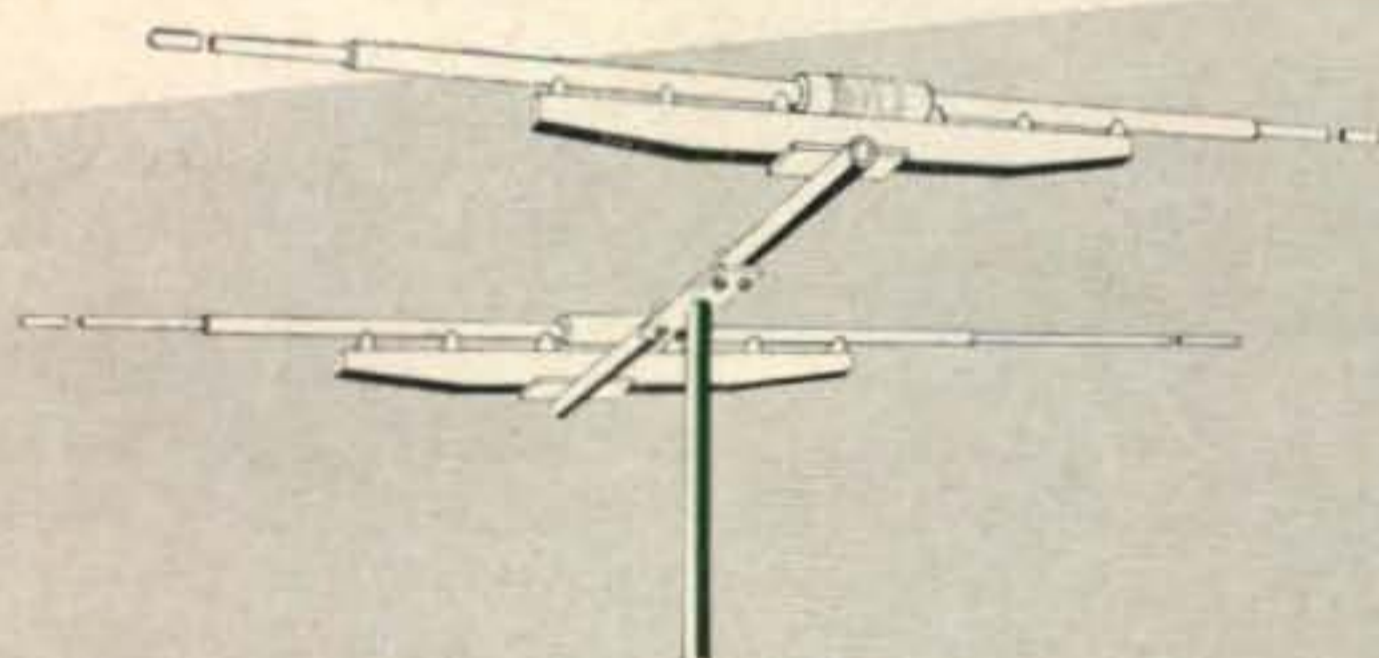

VPA-40-2 "Vest Pocket" BEAM

Ideal for low cost 40 meter operation - and this wonderful little DX antenna is only the size of an ordinary 20 meter beam! Rated to in excess of 1 KW.

Amateur Net \$74.95

TA-20-40 THE BIG SIGNAL BEAM FOR 20 AND 40 METER OPERATION

For those radio amateurs who will not accept less than the finest . . .

Performance to satisfy the DX enthusiast!

Built for operation at maximum amateur legal power. Frequency stability under all weather conditions. Tilting head included for ease of installation. Fully rust and corrosion proof - guaranteed! Holes are factory pre-drilled and elements color coded. Just one coaxial feed-line needed. Assembled weight with tilting head, 150 pounds.

Amateur Net \$337.50

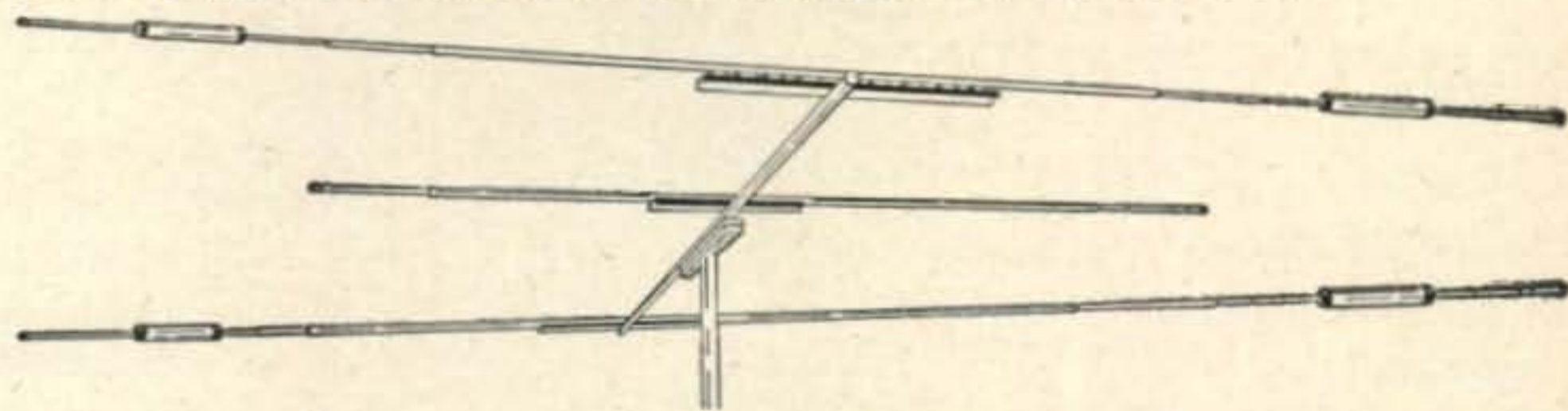

Mosley Electronics, Inc.

4610 N. Lindbergh • Bridgeton, Missouri

Mosley Dipole Connectors and Insulators are available to make it easy for you to construct your own 40 meter antenna using the 40-D Dipole Loading Coil.

For further information, check number 12 on page 126.

LET GEORGE DO IT!



Instead of singing our own praises, we're going to let George Bonadio do it. George Bonadio — W2WLR — of 373 East Avenue, Watertown, New York is a recent purchaser of a Turner 250. Here's the letter he wrote to The Turner Microphone Company.

Gentlemen:

Here are some comments on my new Turner 250 Hi-Z Dynamic mike. I copied these direct quotations out of my logbook:

'broadcast quality' 'smooth as can be'
'best quality I've ever heard from you'
'sounds beautiful' 'sounds just like you'
'very good' 'very normal — kinda refreshing'
'you've got very good audio'
'excellent' 'beautiful audio'
'nice signal, nice tone' 'modulation sounds
real fine. I appreciate one that does.'

I've left on the whole 20 feet of mike cord so I can roam as far as the bed or the back porch and operate.

I'm a gadgeteer myself, but can't figure out a happier set of switching controls than those on the 250 mike-stand. It's very handy. My compliments for a job well done.

Sincerely,
George Bonadio, W2WLR (160-10)

P.S. I wish everybody I worked on phone used one.

THE TURNER 250, FOR "BROADCAST QUALITY"

More versatile, convenient and easy to operate than any other amateur microphone. Has exclusive 3-way switching arrangement. Wired to operate both relay and mike circuits at a touch.



For more information write:

THE TURNER MICROPHONE COMPANY
925 17th Street N.E.,
Cedar Rapids, Iowa

For further information, check number 13 on page 126.

an Extra Class, Advanced Class, or General Class license".

Let's hear more from K9MTM! Perhaps he threw away his box-tops and earned his General or Extra Class!

George H. Goldstone, W8MGQ
2609 W. Thirteen Mile Road
Royal Oak, Michigan

Series Modulation

Editor, CQ:

I was interested in Mr. Baird's fine article on "Series Modulation" in June 1960 issue of CQ, page 64.

He suggests using a small 6 volt glass storage battery to handle the 6.3 volt, 2.5 ampere heater requirements of the 6AS7G. For mobile operation there is an equivalent tube, the 7105, that uses a 12.6 volt, 1.25 ampere filament that can be connected right across the 12 volt battery. It has the further advantages for mobile use of having a smaller bulb, and of being ruggedized to take the normal shock and vibration of mobile equipment.

David M. Sanger, W2MNV

QRT vs. PEP

Editor, CQ:

I am a Novice with a lot to say. Right now I am a BCL because my one and only crystal frequency happens to be in what the s.s.b.'ers consider the phone portion of the 40 meter band. Just because my receiver does not have 500 cycle selectivity I am forced to QRT when the PEP boys start gabbing.

I have seen letters bearing a similar tale of woe and I doubt if this one will do any more good than the aforementioned letters seem to have. But maybe the OO's will wake up and do their job. I wonder how many Novices QRM the phone band?

So how about it fellows? Please lay off us poor, QRP, rock bound Novices.

Terry King, WV6IJE
1789 Jeffery Court
Santa Clara, Calif.

Mid-west MARS Conference

Over a hundred USAF-MARS members participated in the first Mid-west MARS Conference, held in the Officer's Club, Richards-Gebaur AF Base, Missouri, on 21 August 1960.

Key personnel present included the Chief, MARS, USAF; the MARS Directors of Continental Air Command, Air Defense Command, Air Materiel Command, Military Air Transport Service and the Central Technical Net; State Co-ordinators from Indiana, Illinois, Iowa, Nebraska, Missouri and Kansas; Directors of Forbes and Schilling AFB's and the 33rd Air Division; as well as 4 Zone Directors and numerous Net Managers and NCS.

Capt. Bernard Yoffee, the new Director of ConAC, answered many questions concerning the assumption, by ConAC HQ, of the entire civilian MARS program. Subjects covered included administration, supply, correspondence, frequencies, points and many others.

Don Meserve, W1FL-AFØWYK, State Co-ordinator of Kansas, who organized the Conference, acted as MC and Panel Moderator. He opened the meeting by introducing Lt. Col. Zed W. Barnes, Deputy Chief of Staff, Communications-Electronics of the 33rd Air Division, who welcomed the conferees and wished them success in their efforts. Plans are now being made to hold a similar meeting in the summer of 1961.

from **EICO**® .. a completely new

CITIZENS BAND TRANSCEIVER

that meets
FCC regulations*

*EICO premounts, prewires, pretunes, and seals the ENTIRE transmitter oscillator circuit to conform with FCC regulations (Section 19.71 subdivision d). EICO thus gives you the transceiver in kit form that you can build and put on the air without the supervision of a Commercial Radio-Telephone Licensee!

#760:
117 VAC
Kit
\$59.95
Wired
\$89.95



Kit **\$69.95**
Wired **\$99.95**
#761: 117 VAC & 6 VDC
#762: 117 VAC & 12 VDC
incl. mtg. bracket (Pat. Pend.)

designed
by Hams...
for Hams...

to the highest
Ham standards

Highly sensitive, selective SUPERHET (not regenerative) receiver with 5½ dual function tubes and RF stage. Continuous tuning over all 23 bands. Exclusive Super-Hush® noise limiter. AVC. 3" x 5" PM speaker. Detachable ceramic mike. 5 Watt xtal-controlled transmitter. Variable "pi" network matches most popular antennas. 12-position Posi-Lock® mounting bracket. 7 tubes and 1 xtal (extra xtals available). Covers up to 20 miles. License available to any citizen over 18 — no exams or special skills required; application form supplied free. Antennas optional.

Additional crystals \$3.95 each.

Most EICO distributors offer budget terms.



NEW! 60-WATT CW TRANSMITTER #723
Kit \$49.95 Wired \$79.95
Ideal for novice or advanced ham needing low-power, stand-by rig. 60W CW, 50W external plate modulation. 80 through 10 meters.



COLOR & MONO DC-5MC LAB & TV 5" OSCILLOSCOPE #460
Kit \$79.95 Wired \$129.50



90-WATT CW TRANSMITTER* #720 Kit \$79.95 Wired \$119.95
*U. S. Pat. No. D-184,776
"Top quality" — ELECTRONIC KITS GUIDE. Ideal for veteran or novice. 90W CW, 65W external plate modulation. 80 through 10 meters.



5" PUSH-PULL OSCILLOSCOPE #425 Kit \$44.95 Wired \$79.95



HIGH-LEVEL UNIVERSAL MODULATOR-DRIVER #730
Kit \$49.95 Wired \$79.95
Delivers 50W undistorted audio. Modulates transmitters having RF inputs up to 100W. Unique over-modulation indicator. Cover E-5 \$4.50.



PEAK-TO-PEAK VTVM #232
Kit \$29.95 Wired \$49.95
VACUUM TUBE VOLTMETER #221
Kit \$25.95 Wired \$39.95

RF SIGNAL GENERATOR #324 (150kc-435mc)
Kit \$26.95 Wired \$39.95
TV-FM SWEEP GENERATOR & MARKER #368
Kit \$69.95 Wired \$119.95

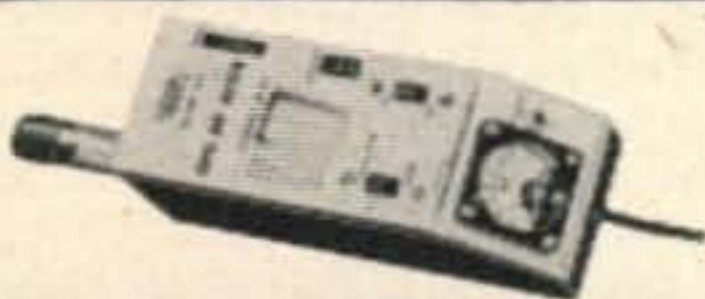

GRID DIP METER #710
Kit \$29.95 Wired \$49.95
Includes complete set of coils for full band coverage. Continuous coverage 400 kc to 250 mc. 500 ua meter.



DYNAMIC CONDUCTANCE TUBE & TRANSISTOR TESTER #666
Kit \$69.95 Wired \$109.95
TUBE TESTER #625
Kit \$34.95 Wired \$49.95

EICO®

33-00 Northern Blvd.,
Long Island City 1, N. Y.

EICO, 33-00 N. Blvd., L.I.C. 1, N.Y. Show me how to save 50% on 72 models of top-quality: Ham Gear Test Instruments Hi-Fi Send free Short Course for Novice License. Send free catalog and name of neighborhood EICO distributor.

Name..... CQ-10

Address.....

City.....Zone.....State.....

Add 5% in the West.

For further information, check number 14 on page 126.

FIELD STATION ENGINEERS

Several qualified engineers will be selected to join in a program which is advancing the state-of-the-art of

IONOSPHERIC PHYSICS *and the study of* BACKSCATTER PHENOMENA

Background in these areas will be developed through a training program in our Electro-Physics Laboratories, located in Bladensburg, Maryland. Engineers selected will become part of a team extending experiments of the Research and Development Department to the field, in both Domestic and Overseas assignments, and will have ample opportunity to develop technically.

*They will possess a combination
of the following requirements:*

- ✓ BSEE, or equivalent consisting of combined civilian or military technical school plus work experience.
- ✓ Presently employed as a Field Engineer or Project Engineer.
- ✓ A good command of some of the following:
 - RADAR, preferably High-Power
 - HF Long-Distance Communications Systems
 - Tropospheric or Ionospheric Scatter Systems
 - Meteor-Burst Communications Systems
 - Propagation Prediction—computation of propagation for long-distance communications
 - Ionospheric Sounder Operations
 - RDF Systems
 - Doppler RADAR Systems
 - Amateur Radio Enthusiast
- ✓ FCC License, 1st or 2nd Class.

Applications Are Also Being Accepted For

SENIOR SCIENTISTS ENGINEERS (All Levels) ELECTRONIC TECHNICIANS

*for permanent assignment at our Electro-Physics
Laboratories in Bladensburg, Maryland.*

Please Send Resume To:

Professional Employment Dept.

ACF ELECTRONICS DIVISION
ACF INDUSTRIES
INCORPORATED

RIVERDALE, MARYLAND

ham headlines

MARVIN D. LIPTON, VE3DQX
311 ROSEMARY ROAD
TORONTO 10, ONTARIO,
CANADA

114 Bootleggers Caught in '59

(Yarc-Mitter, Yonkers, N. Y.)

Investigation of unlicensed radio operation for "beating the bookies" at racetracks continues. Ingenuity is necessary to apprehend such operators because the small transmitters are well hidden, are moved continuously in a crowd, and are on the air only momentarily. One operator found guilty of so disseminating racetrack information in Florida was sentenced to pay a fine of \$260 or spend 60 days in jail.

Types of unlicensed operation of radio transmitters are many and varied. In Portland, Ore., a young radio enthusiast attached a 60 foot antenna to a small wireless oscillator and got into trouble. A cannery on an island off Washington State used unlicensed radio equipment for communications with its fishing boat. A Georgia county sheriff operated an unlicensed highway radar device because its salesman said no license was required. In a California city an electronic technician operated an unlicensed mobile transmitter in the amateur service while driving to and from work. Illegal stations uncovered during the year numbered 114 (exclusive of booster stations), which was 28 less than 1958.

Cuban Radio Ops Arraigned

(Florida Skip, Miami)

The Federal Communications Commission and the U.S. Department of Justice found a hidden radio transmitter on the Florida Keys at Tavernier. It had been using 7010 kc to transit information to Cuba, antagonistic to that government. The clandestine operating had been observed by the Miami detachment of the FCC. Two Cubans were subsequently arraigned in Miami, Fla., bond set at \$5000 each for violations, Sec. 301 and 318 of the Communications Act which requires station and operator licensing.

The daily transmissions used tape recordings in Spanish.

An appeal was made to report any other illegal operations of the Florida Skip and the CD Bulletin).

Radiation Hospitalizes Six

(QLF, Lockport, N. Y.)

Six civilian radar technicians were hospitalized and three others were being kept under observation after exposure to radiation from high frequency klystron tubes. The nine technicians were identified as employees of the General Electric Co. and the Philco Corporation. They were repairing Air Force radar equipment utilizing the klystron tube.

The Air Force said the men came in contact with X-rays when a lead shield which covers the klystron tube was taken off to correct a malfunction.

The radiation was first detected after the technicians began experiencing nausea and headache while their condition became progressively worse. Three were treated and released at a hospital but were told to appear for weekly check-ups. The remaining six, who were exposed to the tube for a longer period, remained at the hospital for more than three months.

The Air Force revealed that the men were not seriously disfigured by their exposure but each was "well tanned". Some of the six retained at the hospital are reported as having developed a mild bone cancer.

The klystron tube is used as the local oscillator in high frequency radar units.

Radio Ham in Honduran Invasion

(Metro Modulator, Toronto)

Miami ham operator Charles Schiffer said he plans to radio his friend, Irving Vosbrink to find out how things are going in the invasion of U.S. held Great Swan Island by 13 Hondurans in a banana boat.

POWER... PACKAGED FOR TODAY'S AMATEUR



LPA-1 GROUNDED GRID LINEAR AMPLIFIER
NET PRICE \$375.00 COMPLETE WITH TUBES

LPS-1 POWER SUPPLY
NET PRICE \$205.00 COMPLETE WITH TUBES

Power—a full kilowatt with this smartly designed, excellently styled version of the famous B&W linear amplifier family! New compactness . . . takes up no more space on your table than a receiver. New features . . . for greater performance and flexibility than ever before.

Separately housed LPA-1 R. F. section employs two Type 813 beam power tetrode tubes, connected as high-Mu triodes in a grounded-grid circuit. Blower, filament and bias supply are included in this section.

High voltage power supply unit LPS-1 may be remotely located. Switching control panel is removable for convenient installation at the operator's location. Circuit consists of a full wave single phase bridge rectifier, using four Type



LPA-MU MATCHING UNIT \$36.00
LPA-MU-2 \$36.50

816 mercury vapor rectifier tubes. R. F. filtering protects tubes and prevents mercury vapor hash radiation.

The LPA-1 can be driven by most exciters in the 100 watt class, such as the B&W 5100/5100B series, Vikings 1 and 2, Valiant, Collins 32V, KWM-1, 32S-1 series, Heath DX100 and others.

A compact impedance matching unit, the B&W LPA-MU, is separately available. It provides for operation with fixed output exciters such as the Hallicrafters HT 32 Series and similar types. A similar unit, the LPA-MU-2, is also available for use with the B&W L-1000-A and L-1001-A.

Your local distributor should have these advanced units *now* . . . see them soon.

Send for this illustrated brochure in full color giving specifications and detailed descriptions of the new B&W LPA-1, LPS-1 and LPA-MU.



Barker & Williamson, Inc.

Bristol, Penna.

OTHER B&W AMATEUR EQUIPMENT: Transmitters AM-CW-SSB • Single Sideband Generators • Single Sideband Receiving Adapters • Dip Meters • Match Masters • Frequency Multipliers • Low-Pass Filters • T-R Switches • R.F. Filament Chokes • Transmitting R.F. Plate Chokes • Audio Phase Shift Networks • Band Switching Pi-Networks • Cyclometer-type Counters • Antenna Co-axial Connectors • Baluns • Variable Capacitors • Fixed and Rotary Type Coils

For further information, check number 15 on page 126.

EFFICIENCY EXPERTS!

Built for DC to DC mobile power supplies, these small, encapsulated, toroidal transistor power transformers by Triad offer efficiencies of 85 to 90%.

Center tapped output windings are provided so that two simultaneous voltages may be used. Typical units are listed below. Our new brochure TY-67 has circuit schematics for 26 Triad transistor power transformers, plus complete electrical and mechanical data. Ask your distributor for a free copy, or write us direct.



TRIAD TRANSFORMER CORPORATION

A DIVISION OF LITTON INDUSTRIES

4055 Redwood Avenue, Venice, California
350 North Briant Street, Huntington, Indiana

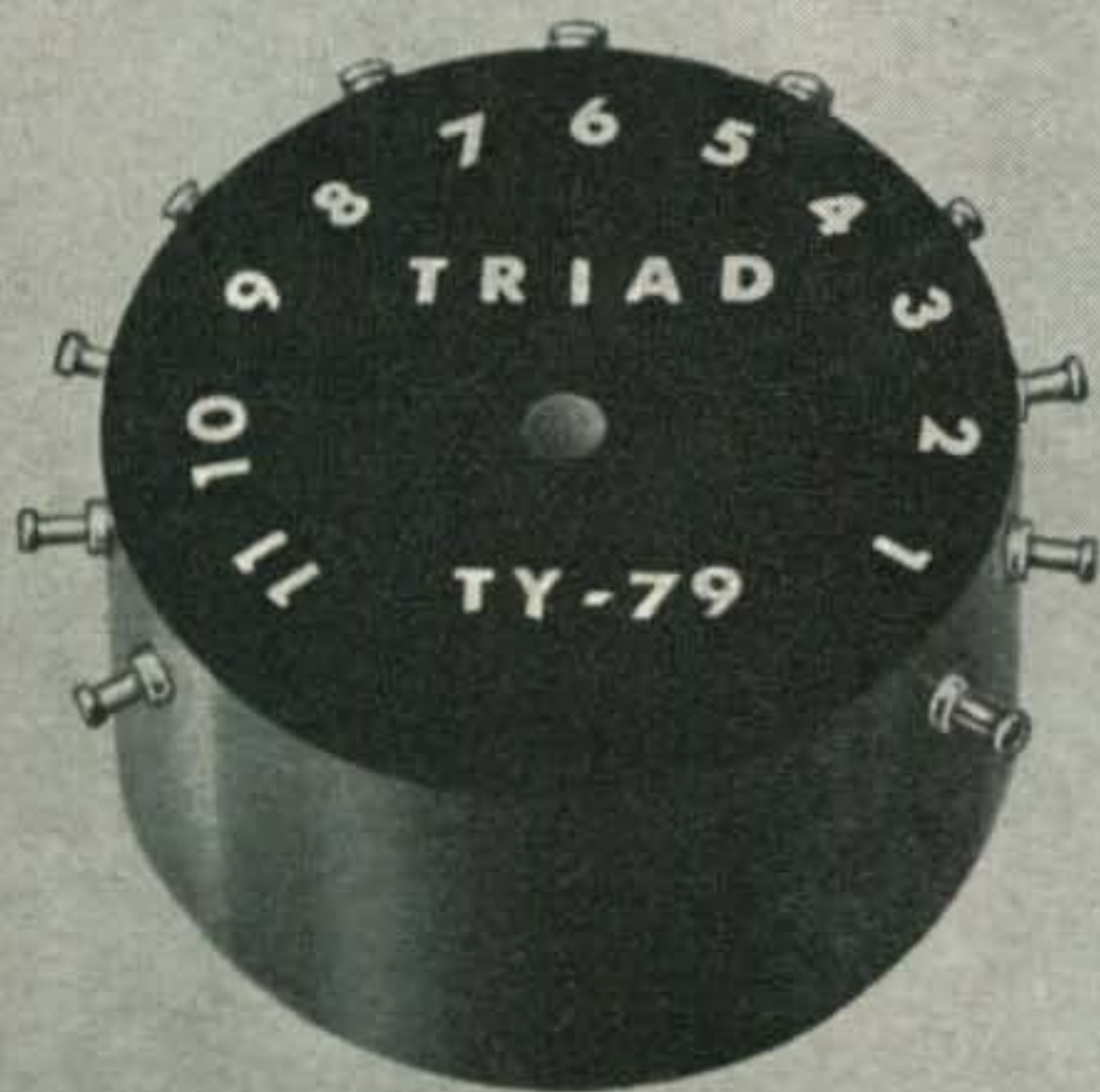

Type No.	D.C. Source Volts	D.C. Volts Out of Rectifier	D.C. Ma. Max.
TY-78	12.6	250/125	100
TY-79	12.6	300/150	200
TY-80	12.6	325/162.5	150
TY-81	12.6	375/187.5	200
TY-82	12.6	450/225	150
TY-83	12.6	500/250	200
TY-84	12.6	600/300	200
TY-99	6.3	300/150	100
TY-100	6.3	325/162.5	150
TY-101	6.3	375/187.5	200
TY-102	6.3	450/225	150

For further information, check number 16 on page 126.

Schiffer said, Vosbrink radioed him that the Hondurans landed on the island, took a census, sang the Honduran national anthem, and staked a flag claiming the two-mile-long island as Honduran property.

The U.S. claim on the island, about 50 miles off the Honduras coast, goes back to 1863, but Honduras has frequently disputed it. The U.S. has 13 Americans there, including Vosbrink, manning weather stations of the Federal Aviation agency and the U.S. weather bureau.

Vosbrink said the Hondurans were unarmed and their invasion was peaceful.

"He said the Hondurans gathered in the mess hall and read some documents and said they were going to build a school." The language barrier, Schiffer said, prevented Vosbrink from getting a full fill-in on their plans.

Schiffer said communications between him and Vosbrink broke down before he was able to learn how the invasion concluded.

Call Book Exchange

(Loudspeaker, San Gabriel Valley, Calif.)

If you have an expired *Call Book* (must be under 3 years old) and would like to see a fellow ham overseas receive it, then follow the directions below:

As a gesture of good will and American friendship for overseas radio amateurs, K6BX, Clif Evans, has established a central clearing office for information: First, for American Amateurs who desire to mail their "expired" copies of *Call Book Magazines* to overseas hams who would appreciate receiving the *Call Book*, and secondly, for overseas amateur friends who desire to be placed on the mailing list for the gift of one of those expired but usable books.

This is a person-to-person friendship project and books will be mailed directly from the American Ham offering it. The names and calls of individual overseas hams rather than Clubs is desired.

Names or lists of names should be air mailed to K6BX, Clif Evans, Box 385, Bonita, Calif. USA.

This would be an excellent way to dispose of your expired *Call Books*. Why not write to K6BX and ask him for the name of an overseas ham.

Editorial Comment

(Auto-Call, Washington, D. C.)

Operation "Suicide"

What is undoubtedly the most asinine, as well as the most dangerous, of all the hairbrained schemes ever thought up to plague amateur radio has been proposed by the International Center, Albany, New York. Briefly, it proposes that on a certain date all amateur stations start "broadcasting" a message to foreign listeners. The text of the message would be supplied by the International Center and would be of a highly political nature.

If an enemy of amateur radio had schemed for years to dream up a plan to guarantee the certain death of amateur radio, he could not have compounded a more nefarious plot.

In the first place, the FCC prohibits broadcasting by amateur stations. In the second place, engaging radio amateurs in a propaganda dissemination program can lead only to antagonizing a block of nations. At international conferences, amateur radio needs every friendly vote it can muster. To deliberately alienate a group of nations that have in the past been friendly to the institution of amateur radio can be classified as only one thing: "Suicide".

Any amateur radio operator who takes part in this illegal and ill-advised activity will be doing a great and irreparable disservice to amateur radio.

Project Hope

(DARA QMN Bulletin, Detroit, Mich.)

Our attention has been directed to a very worthy effort that may put a DX station in orbit within the next year. We refer to "Project HOPE". And what is Project HOPE?

The four letters in HOPE stand for this: Health Opportunity for People Everywhere. You may have read about the project in *LIFE Magazine*, where it obtained much of its impetus. The project involves use of a fully equipped and staffed hospital ship—which has been provided by the U.S. Navy. (Formerly the ship "Consolation", perhaps some of our readers wounded in World War II traveled upon it). The ship will travel from country to country, (but only where it is asked), bringing the skill and techniques de-



NEW!

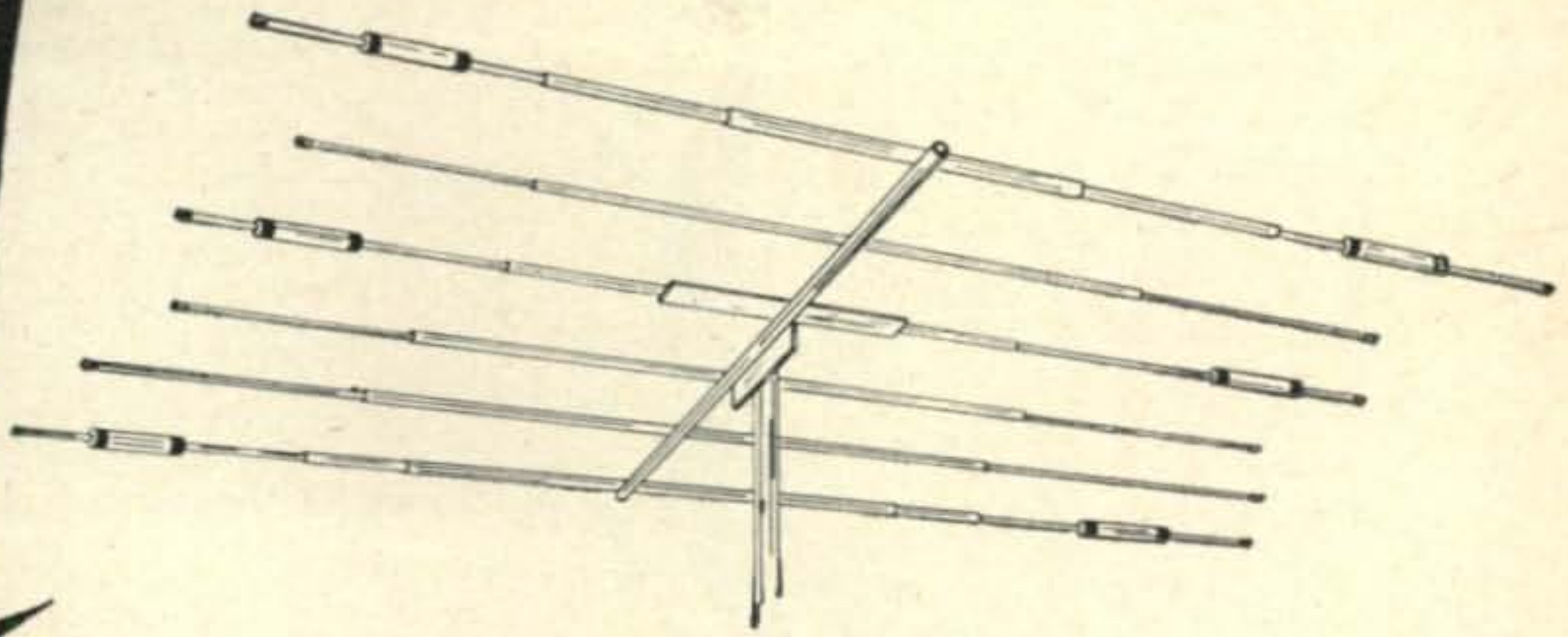

TA-36 by Mosley

for 10 • 15 • 20

The new clean-line design TA-36 . . . the three band beam that will give your signal that DX punch!

This wide spaced, six element configuration employs

- 4 Operating Elements on 10 Meters**
- 3 Operating Elements on 15 Meters**
- 3 Operating Elements on 20 Meters**

Automatic bandswitching is accomplished by means of exclusive design high impedance, parallel resonant "trap circuits". Built for operation at maximum legal amateur power. Low SWR with high gain and front-to-back ratio. Traps are weather and dirt proof offering frequency stability under all weather conditions.

All heavy wall 6061-T6 aluminum - the finest aluminum alloy for antenna construction! Boom measures 2" OD by 24' by 1/8" wall, elements measure 1 1/8" to 5/8" in diameter with center sections of double thickness aluminum to reduce sag . . . fully rust and corrosion proof - Guaranteed!

Before you buy any beam - Check Construction Features!

See your nearest amateur equipment dealer or write for literature describing the TA-36 . . . the newest member of the Mosley TrapMaster family of fine amateur antennas.

Amateur Net \$129.50

Mosley Electronics, Inc. 4610 N. LINDBERGH BLVD.
BRIDGETON, MISSOURI

WEST COAST BRANCH
1406-08 South Grand Avenue
Los Angeles 15, California

INTERNATIONAL DIVISION
15 Moore Street
New York 4, New York

For further information, check number 17 on page 126.

October, 1960 • CQ • 19



WITH THE **Hy-gain** roto-brake

16" diameter Great Circle Indicator multi-colored world map makes a decorative as well as practical unit for your ham shack. Countries and call areas outlined and labeled. Moving wedge of light 10° wide at perimeter shows beam width and direction at every moment. Circumference calibrated in 1° units. Available centered on West Coast, Midwest or East Coast. Compass rose available for other countries.

**1000 IN. LBS. ROTATING POWER
5 INCH TONS BRAKING POWER**



**\$19995
Complete**

Attractive, wrinkle-finish roto-brake control box for mounting under operating desk . . . Master on/off switch, rotation control lever and fuse. Furnished with 10' connecting cable.

Roto-Brake utilizes high carbon machined steel gear and rack, reinforced aluminum castings and massive construction throughout . . . Powerful torque motor starting torque motor assembly. Limit switches at due North prevent continuous rotation . . . Safety switch on brake allows motor to be energized only after brake is released. Mounts in steel tower with 10-18" inside clearance . . . Kits available for side mounting on small towers and pole or pipe masts.



**SEE YOUR NEAREST DISTRIBUTOR OR
WRITE DIRECT TO**

Hy-gain antenna products

1135 NO. 22ND • LINCOLN NEBRASKA

**ASK FOR OUR FREE NEW
COMPLETE ANTENNA CATALOG**

For further information, check number 18 on page 126.

20 • CQ • October, 1960

veloped by the medical and health professions of our country to the various countries needing their help.

Project HOPE is a project not of our government, but a project of the people of the United States, who want to help people of other countries. It will be an expensive project; even with donation of the use of the ship, it will take at least \$3,500,000 for the first year.

Would you like to help? Contributions in any amount are welcomed. They should be sent to Project HOPE, Box 9808, Washington 15, D.C.

While at this point it is not definite, we are advised by Ralph Charbeneau, W8OLJ, that ham radio equipment will no doubt be installed aboard the "HOPE", enabling the U.S. personnel aboard to talk to homes and families from Southeast Asia, the first area to be visited. Hams will have another unique opportunity to show that they render a very real communications service, where no other exists.

Announcement

Editors of amateur radio club publications are invited to send a monthly copy of their papers to me (QTH at head of column) to be considered for inclusion herein. I'll also be happy to tell editors how they might join a free amateur paper news service through which they can secure interesting copy for their periodicals.

144 MC Band Converter, CQ, August 1960

John Specialny, W3HIX, author of "A Transistorized Converter For The 144 MC Band", August 1960, page 40, informs us that transistors T1694, T1695 and T1696 are now discontinued and are replaced by T1832, T1859 and T1833 respectively. Also, if 3 ma is desired at the collector of the r.f. amplifier the values of R_1 and R_2 should be interchanged.



Syracuse V.H.F. Round-Up

The sixth annual Syracuse V.H.F. Round-Up, sponsored by the Syracuse V.H.F. Club, will be held October 8, 1960 at Three Rivers Inn, located eight miles north of Syracuse on route 57, exit 38.

Registration starts at ten AM for the Early Birds and for others at twelve thirty PM. Pre-registration only 5.50. For tickets and information contact Bill Burns, 779 Fay Rd., Syracuse 4, New York.

Northeastern DX Association

The Northeastern DX Association will hold its annual dinner and meeting on 8 October 1960 at 7:30 PM at the Hot Shoppes Restaurant and Towne House Motel in Albany, New York. Dinner tickets are \$5.00 and any active DXCC holders are welcome. Motel reservations will be made in advance for out of town visitors. All reservations must be made before 1 October 1960. A DXpedition movie will be shown as part of the program. Menu includes a choice of Roast Beef or Turkey. Please state choice when making reservations. Address all correspondence and reservations to NEDXA c/o K2UVU, 117 Shaker Road, Albany 11, New York.

New York Ham Convention

One of the largest and most elaborate ham conventions ever planned will be held at the Statler-Hilton Hotel in

COMMUNICATOR IV

GONSET'S VHF STATION "PACKAGE"...



"IV"... newest member of a family of champions... size of a lightweight... wallop of a heavyweight...

Now... "IV" offers you... More carrier power... 20 watts input power • More talk power—10 watts of audio, integral high-level clipping and audio shaping allow high modulation percentages • Simple, non-critical tuning... broadband driver stages—no panel controls. Only PA "Tune" and "Load" adjustments with panel meter to assist. Six crystal channels, (6 or 8 mc crystals) selectable by switch... provisions for external VFO • And a really fine receiver. Continuously tunable 143.7-148.3 megacycles... latest low-noise frame grid VHF tubes (6ER5's) used in RF and Mixer stages. Noise figure of 4-5 is exceptional for equipment of this general type... opens up real possibility for weak signal DX reception • Unit is exceptionally compact... only 5"H, 9½"W, 13"D, weighs only 21.8 pounds. Strap handle on side facilitates carrying • Universal mounting bracket is optionally available... allows simple under-dash mounting.

Contributing further to excellent performance... High stability—crystal controlled 1st conversion • Low image—triple conversion, 455 kc 3rd I-F • Muted standby—adjustable squelch—noise limiter • Panel speaker—earphone provisions... Tuning meter—gives relative signal strength • Universal power supply—12V DC transistorized, (negative ground) and 117V AC. Change from one to the other merely by using proper cord.

For further information, check number 19 on page 126.

COMMUNICATOR IV FOR CIVIL DEFENSE APPLICATIONS



Communicator IV has been certified to ODCM (FCDA) as meeting applicable specifications under ODCM Item No. U-70 and will qualify for matching funds but only when supplied with #3361 C-D kit. (shown). Kit contains yellow C-D canvas carrying case, telescoping antenna, C-D decals, right angle coax connector and crystal certificate. (In lieu of crystal)

AVAILABLE SOON:

COMMUNICATOR IV MODELS FOR 50 AND 220 MCS

GONSET

GONSET

Division of Young Spring & Wire Corporation
801 SOUTH MAIN ST., BURBANK, CALIFORNIA

EXPORT SALES: WESTREX CORP., 540 WEST 58TH STREET, NEW YORK 19, N.Y.



CITIZEN BAND CLASS "D" CRYSTALS

All 22 Frequencies in Stock

3rd overtone, .005% tolerance—to meet all F C C requirements. Hermetically sealed HC6/U holders, $\frac{1}{2}$ " pin spacing—0.050 pins. (.093 pins available, add 15¢ per crystal).

**\$2.95
EACH**

The following Class "D" Citizen Band frequencies in stock (frequencies listed in megacycles): 26.965, 26.975, 26.985, 27.005, 27.015, 27.025, 27.035, 27.055, 27.065, 27.075, 27.085, 27.105, 27.115, 27.125, 27.135, 27.155, 27.165, 27.175, 27.185, 27.205, 27.215, 27.225.

Matched crystal sets for Globe, Gonset, Citi-Fone and Halli-crafters Units . . . \$5.90 per set. Specify equipment make.

RADIO CONTROL CRYSTALS IN HC6/U HOLDERS

Specify frequency, $\frac{1}{2}$ " pin spacing . . . pin diameter .05 (.093 pin diameter, add 15¢) . . . \$2.95 ea.

FUNDAMENTAL FREQ. SEALED CRYSTALS

in HC6/U holders
From 1400 KC to 4000 KC .005% Tolerance . . . \$4.95 ea.
From 4000 KC to 15,000 KC any frequency
.005% Tolerance . . . \$3.50 ea.

SEALED OVERTONE CRYSTALS

Supplied in metal HC6/U holders
Pin spacing .486, diameter .050
15 to 30 MC .005 Tolerance . . . \$3.85 ea.
30 to 45 MC .005 Tolerance . . . \$4.10 ea.
45 to 60 MC .005 Tolerance . . . \$4.50 ea.



QUARTZ CRYSTALS FOR EVERY SERVICE

All crystals made from Grade "A" imported quartz—ground and etched to exact frequencies. Unconditionally guaranteed! Supplied in:

FT-243 holders Pin spacing $\frac{1}{2}$ " Pin diameter .093	MC-7 holders Pin spacing $\frac{3}{8}$ " Pin diameter .125
DC-34 holders Pin spacing $\frac{3}{4}$ " Pin diameter .156	FT-171 holders Pin spacing $\frac{3}{4}$ " Banana pins

MADE TO ORDER CRYSTALS

1001 KC to 2600 KC: .01% tolerance \$2.00 ea. .005% tolerance \$2.75 ea.	2601 KC to 9000 KC: .005% tolerance \$2.50 ea. .005% tolerance \$3.00 ea.
--	---

Specify holder wanted

Amateur, Novice, Technician Band Crystals

.01% Tolerance . . . \$1.50 ea.—80 meters (3701-3749 KC), 40 meters (7152-7198 KC), 15 meters (7034-7082 KC), 6 meters (8335-8650 KC) within 1 KC
FT-241 Lattice Crystals in all frequencies from 370 KC to 540 KC (all except 435 KC and 500 KC) . . . 50¢ ea.
Pin spacing $\frac{1}{2}$ " Pin diameter .093
Matched pairs \pm 15 cycles \$2.50 per pair
200 KC Crystals, \$2.00 ea.; 455 KC Crystals, \$1.50 ea.; 500 KC Crystals, \$1.50 ea.; 100 KC Frequency Standard Crystals in HC6/U holders \$4.50 ea.; Socket for FT-243 crystal 15¢ ea.; Dual socket for FT-243 crystals, 15¢ ea.; Sockets for MC-7 and FT-171 crystals 25¢ ea.; Ceramic socket for HC6/U crystals 20¢ ea.

Write for new free catalog #860 complete with oscillator circuits

ASK YOUR PARTS DEALER FOR TEXAS CRYSTALS
See big red display . . . If he doesn't stock them, send us his name and order direct from our Florida factory.

RUSH YOUR ORDER TO OUR NEW PLANT

Use coupon below for 1st Class shipment.

TEXAS CRYSTALS

Dept. C-100, 1000 CRYSTAL DRIVE, FORT MYERS, FLORIDA
For extra fast service, Phone WE 6-2100

**ATTACH THIS COUPON TO YOUR ORDER FOR SHIPMENT VIA
1ST CLASS MAIL AT NO EXTRA COST**

TERMS: All items subject to prior sale and change of price without notice. All crystal orders must be accompanied by check, cash or M.O. with **PAYMENT IN FULL.** No COD's. Dept. C-100

New York on October 15th. The Convention will run from 9 AM until the banquet at 7:30 PM. This is going to be one of the busiest days in ham history with a complete program of talks and discussion groups on almost every specialized ham interest. There will be exhibits by just about every manufacturer in the ham field, plenty of space for rag chewing on your favorite subject, prizes by the gross, and a huge capping banquet with Jean Shepherd K2ORS as Master of Ceremonies and a feature talk by Bill Orr W6SAL.

Tickets may be purchased at the door or from *HARC Convention*, Box 971, New Rochelle, N.Y. Send \$9 for a combination Banquet and General Admission ticket or \$1.50 for General Admission only (50¢ less for YL's and XYL's).

Testimonial Dinner For Dr. George W. Bailey

The Single Sideband Amateur Radio Association will join the Quarter Century Wireless Association at its annual dinner on October 14th in sponsoring a testimonial for Dr. George W. Bailey, W2KH, Executive Secretary of I.R.E. and former President of A.R.R.L.

This affair will be the opening event of the *Hudson Division A.R.R.L. Convention*. The dinner will be held at the Shelburne Hotel at Lexington Avenue and E. 37th Street, New York City.

Tickets can be obtained by contacting Fred Huff, W2AMB, at 8712 31st Avenue, Jackson Heights 69, New York.

Other convention events will be held on Oct. 15th at the Statler-Hilton Hotel at Seventh Avenue and W. 33rd St., N.Y.C.

S.S.B. Program For Hudson Division ARRL Convention

Arrangements have been made to present an outstanding s.s.b. forum at the *Hudson Division ARRL Convention* sponsored by HARC. It will be held on October 15, from 2 to 5 PM at the Statler-Hilton Hotel, Seventh Ave. and W. 33rd St., N.Y.C.

The moderator will be Ed Piller, W2KPQ, President of the SSB Amateur Radio Association. The program will include:

"Various SSB Applications For the New Beam Deflection Tube" by Harold Vance, Sr., K2FF, Manager Sales Engineering, RCA Tube Division.

"SSB From A to B" by Dorothy Strauber, K2MGE, and Irv Strauber, K2HEA, Editors of *The Sidebander* and the *CQ SSB Column*.

"Details of Design and Quality Control of Transistorized Mobile SSB Equipment" by Fritz Franke, Assistant to the President. The Hallierafters Company.

"Larson E. Rapp Goes SSB" by Marty Bettan, K2JKX.

North Penn A.R.C.

The following have been elected officers of the North Penn Amateur Radio Club for the fiscal year June 1, 1960 to May 31, 1961:

President: Major M. R. Jones W3DHJ
Secretary: Carolyn B. Currens W3GTC

Please address all communications to the Secretary.

Signal Seekers Award

The "Signal Seekers" is a club established for fun and service in the Whittier California area. The club was organized in 1958. We meet the second and fourth Saturday of each month.

The purpose of the club is to better qualify the members in operating the amateur mobile radio for civil defense and disaster work, thereby aiding the community.

First a transmitter hunt — sometimes one — sometimes many depending on what the hidden transmitter decides upon. After the hunt we take turns serving coffee and donuts and have a business meeting.

We have decided to give a certificate to anyone meeting the requirements. Any station working four member stations from outside Los Angeles or Orange county, or visitors to Southern California working four members from anywhere qualify.

Okinawa Cotton Pickers

A new certificate is being offered from KR6 land! In Zone 25, by staying in a *roundtable* type QSO for three hours with at least three of the charter members of the Okinawa Cotton Pickers Club, the certificate is won. For



KOLLET KNOBS

DIODE CLIPS

BATTERY HOLDERS

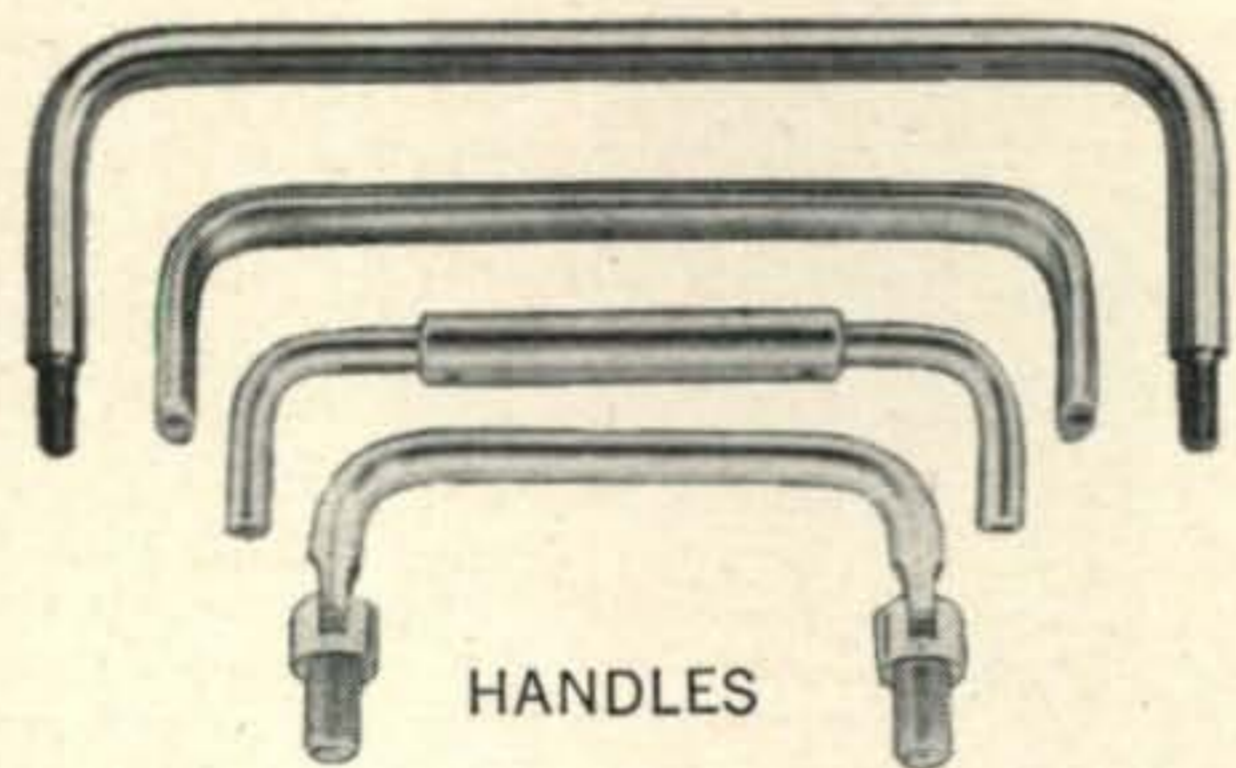
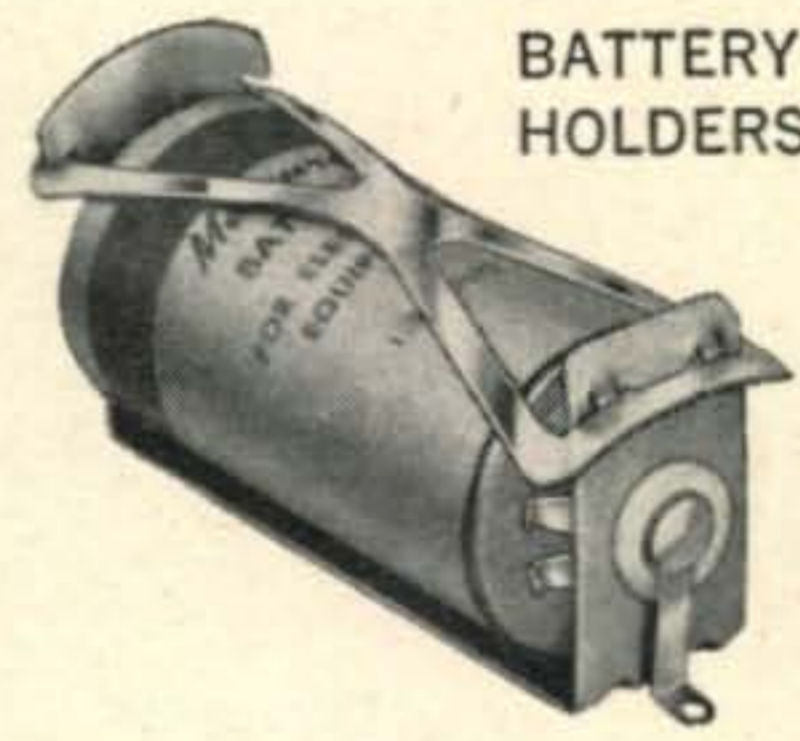

HANDLES

PLUGS AND JACKS



TUBE CLAMPS

Everything you need QUALITY GUARANTEED!

You can do a neat, professional job on your rigs with dependable CAMBION® components . . . they're *all* unconditionally *quality-guaranteed*. Each tailored to your needs, too. Take a look at these versatile features in CAMBION's complete line of panel hardware:

- **Kollet Knobs** — with built-in gripping power, skirts and indicating lines optional, available for shafts $\frac{1}{8}$ " or $\frac{1}{4}$ ", ten code colors.
- **Diode Clips**—7 different types, including spring-loaded units, rivet-mounted and Teflon-insulated clips. Holds fragile pigtail leads from .005" to .085".
- **Handles** — 36 type and finish combinations. Fixed, full-folding and 90° folding types.
- **Tube Clamps** — 4 types for tube base diameters from 1.136" to 1.377".

- **Mercury Battery Holders** — vibration-proof. Suitable for all types of circuits.
- **Plugs and Jacks** — 35 types. Perfect electrical connections and lasting low-resistance contact.

For best results, choose CAMBION components. For detailed information on any product, write Cambridge Thermionic Corporation, 451 Concord Avenue, Cambridge 38, Massachusetts.

At your Authorized
CAMBION Distributors



CAMBRIDGE THERMIONIC CORPORATION
CAMBION®
The guaranteed electronic components

For further information, check number 21 on page 126.

NOW AT LAST! FOR THE PORTABLE OR FIXED DX MAN Revolutionary! New!

K&S Power-packed portable yagies featuring the amazing new **ADD AN ELEMENT** series. Power gains from 9 to 15 DB. Two models for six meters: **THE SUPREME 466** a powerful, portable 4 element parasitic array which easily augments to a 5 or 6 element long-yagi. Actually three antennas for the price of one, start with four elements and add elements 5 & 6 as your pocketbook permits.

Completely collapsible to 44x8 inches with all 6 elements. Absolutely no tools needed to assemble **complete antenna** in two minutes. Constructed from durable, light weight (air-craft aluminum) can be used as permanent installation. (approx. wt. 10 lb. with 6 elements) Telescopic 5/8 to 1/2 inch elements on approx. 20 Ft. max. length boom. Each beam pretuned and matched for 52 ohm coax. (Gamma match positions for 4, 5 & 6 elements. UHF connector on boom).

THE DELUX 466 model, similar to the Supreme, except the elements are non-telescopic, this model folds to 72x8 inches.

AMATEUR NET

	Part No.	Supreme	Part No.	Delux
Four element yagi with one mast section on boom	S46P	\$24.95	D46P	\$21.95
Convenient roll type carrying case	SecP	1.95	DecP	2.95
Fifth element, boom section and support	S56E	6.95	D56E	5.95
Sixth element and boom section	S66E	6.50	D66E	5.50
Complete six element package with case	S66P	38.50	D66P	34.50
44 and 72 inch mast sections	S44M	1.50	D72M	1.95
Car window mount for rotating all portables	CWAM	7.95		

Prices subject to change without notice.

Also a special for the mobile amateur **THE MOBILER 36** a compact three element six meter beam which folds to 5 ft. Part No. MO36, Amateur net, \$9.50.

Not forgetting the two meter portable man. **K&S** offers **THE KING 82** an eight element yagi spaced for maximum gain on a 10 ft. boom. Completely collapsible to 34 x 6 inches which includes one mast section fixed to boom. Part No. K82P, Amateur net, \$19.50.

K&S also specializes in fixed, max forward gain parasitic arrays for the VHF amateur. **220, 144** and **50 Mc WIDE SPACED YAGIES** matched for 52 ohm line, available on a per element basis. Order by element and specify approx. operating frequency.

From 4 to 16 elements @ 220 Mc \$1.50 per element
From 4 to 12 elements @ 144 Mc 1.75 per element
From 3 to 8 elements @ 50 Mc 4.75 per element

Special boom design permits expansion of any **K&S** fixed VHF beam to it's maximum length. For all models order expansion kit **FBK** @ \$2.50 plus the cost of each remaining element at the original low per element price given above.

These yagies are designed for grouping matching harnesses available for two bay stacked or 4 bay stacked side by side groups instructions accompany each harness:

Freq.	Part No.	2 bays stacked	Part No.	4 bay stacked side by side
220 Mc	2220	\$4.50	4220	\$ 8.50
144 Mc	2144	6.50	4144	12.50
50 Mc	2500	9.50	4500	17.50

At lower frequencies **K&S** offers **CUSTOMIZED DXers** max. forward gain beam antennas for 10, 11 (citizen band) 15 and 20 meters.

Specify your needs, **K&S** will design and manufacture a customized beam antenna to fit **YOUR STATION** and **POCKETBOOK**.

All Prices FOB Factory

K & S ELECTRONICS, INC.

421 East 37th Street • Paterson, N. J.

any area outside of Zone 25 it will take a thirty minute roundtable QSO with at least three of the charter members. The charter members are: KR6CR, IC, ID, DZ, GR, KF, and HS.

The charter members operate 10, 20, and also 15 meters a.m. The sideband boys will not be left out. KR6CR, KR6IC, KR6GR, and KR6DZ operate 15 and 20 meters on sideband and are willing to QSO with any certificate seekers on these portions of the bands.

Many of these certificates have been issued at the time of mailing. IRC's appreciated to defer the mailing costs but are not necessary.

Miami Valley V.H.F. Club of Ohio

October 1, 1960 is the date for the V.H.F. Fall Fun-Fest of the Miami Valley V.H.F. Club. The program includes tech talks, hidden transmitter hunts on 50, 144 and 420, morning and afternoon programs for XYL's, door prizes, and a big banquet with more prize drawings. Time is provided for eye-ball QSO's; there are favors for the ladies, and every one attending will receive a "door prize". The banquet speaker will be Mr. A. L. McIntosh, W3ZM, of the U.S. Army Frequency Engineering Service. Mr. McIntosh was senior U.S. Spokesman at the Geneva Conference.

Registration is \$1.50, banquet tickets are \$3.50 each. Banquet tickets must be ordered by September 29 (include payment) from Mr. E. Gillespie, K8MDX, 1351 Alcott, Dayton 6, Ohio. The V.H.F. Fall Fun-Fest will be held at the Engineer's Club, 110 E. Monument Ave., Dayton, Ohio.

Great Grand Mothers Award

We are looking for Great Grand Mothers with a ham ticket.

The awards are ready and waiting. The requirements are easy: A Great Grand Mother must contact another Great Grand Mother.

So far we have four Great Grand Mothers but we are only getting started. Contact Grace McCormack, W7GWG at 1428 E. 20th Ave., Eugene, Oregon for more information.

Tufts Seeks Information

When the Tufts University Amateur Radio Society celebrates its fiftieth anniversary next year, we would like to have our records, which are now either sketchy or non-existent due to changes in location and membership, complete. We are requesting information on the activities, operating, happenings, locations, QSOs, members, alumni, nature of equipment, etc. and on the existence, condition, or fate of logs, records, QSLs, etc. of the Society and W1KN from 1911 to present, especially before World War II. Communications may be sent to W1KN, 40 West Hall, Tufts University, Medford 55, Mass.

Sunshine Certificate

Hey! you certificate hounds, we've got a new and nice one for you to try for. We don't believe it rains in Washington as much as you think it does, so for contacting any 10 club members while it's raining here and forwarding their calls, date, and time worked to the Tacoma Amateur Radio Society; 949 So. Cushman, Tacoma 5, Wash.; our secretary will send our *Sunshine* certificate along to you. Club frequencies are 29.4 mc and 51 mc.

KZ5 Certificate

A KZ5 certificate shall be issued by the Canal Zone Amateur Radio Association upon written application listing contacts with 25 different KZ5 amateur radio stations. The application shall include the date, time, call sign, name, and vicinity of the local amateur radio stations, as well as the name, call sign, and address of the applicant. A contact shall consist of at least two acknowledged transmissions by both the applicant and the KZ5 amateur radio station, respectively.

KZ5 certificates bearing appropriate seals shall be issued upon written application listing contacts with 50 and 100 different KZ5 amateur radio stations, containing the specified information. However, if the records reveal that a KZ5 certificate has already been issued, only the seal may be forwarded for attaching to the certificate, unless issuance of a new certificate bearing the seal seems advisable.

Applications may be forwarded to Gloria M. Spears, KZ5GS Secretary, Canal Zone Amateur Radio Association, Box 407 Balboa, Canal Zone.

For further information, check number 24 on page 126.

THE BROADBAND TWINS

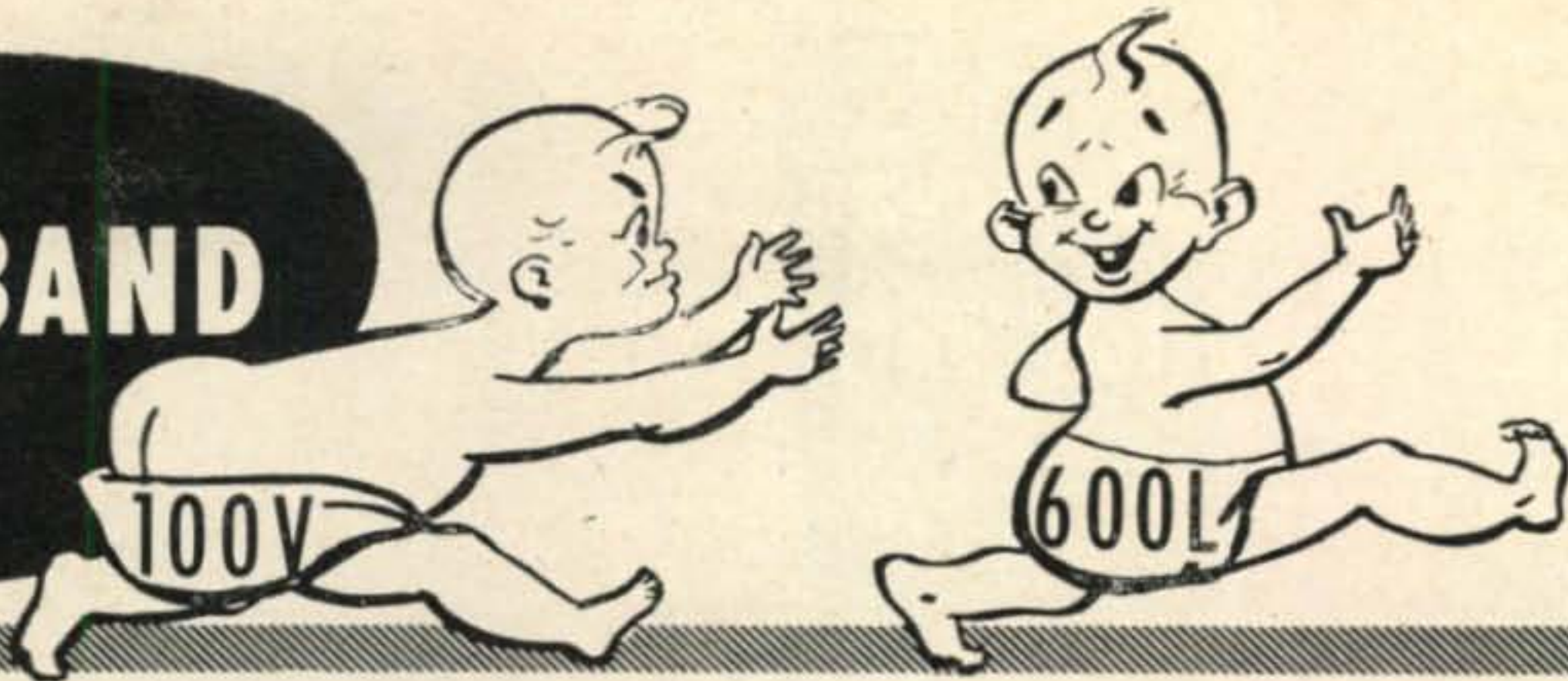

**THE REVOLUTIONARY NEW 100V
EXCITER-TRANSMITTER**

NO TUNING (except VFO), uses famous CE BROADBAND system. PRECISION LINEAR VFO—1KC Calibration. Single Knob Bandswitch 80 thru 10. SSB—DSB—AM—PM—CW and FSK. RF Output adjustable 10 to 100 Watts PEP. Meter reads Watts Input, Amps Output and Carrier Suppression. 2" RF Scope. Speech Level and Load Mismatch Indicators. Audio Filter — Inverse Feedback — 50 db Carrier and Sideband Suppression.

PRICE \$795.00



**FAMOUS MODEL 600L
BROADBAND LINEAR**

NO TUNING CONTROLS — CE BROADBAND Couplers in HIGH EFFICIENCY CLASS AB² using single 813. Easily driven to 600 Watts PEP Input 160 thru 10 by a 20A or 100V. Built-In HEAVY DUTY POWER SUPPLY — 45 MFD PAPER Capacitor. Meter reads WATTS INPUT, GRID DRIVE, RF AMPS, and SWR. Completely shielded — TVI suppressed — parasitic free. REMEMBER there is LESS than ONE S UNIT difference between the 600L and a 2 KW PEP job. PRICE \$495.00

MODEL 20A



**THESE MULTIPHASE EXCITERS
PIONEERED AMATEUR SSB**

MODEL 10B — 10 watts PEP. Plug-in coils 160 thru 10 meters. Perfect voice control on SSB—DSB—AM and PM — CW breakin: Carrier and calibrate level controls. 40 DB suppression.

Wired \$179.50 Kit \$139.50

MODEL 20A — 20 watts PEP. Bandswitched 160 thru 10 meters. SSB—DSB—AM—PM and CW. Magic eye monitors carrier null and peak modulation. Ideal for driving AB¹, AB², and most Class B linears.

Wired \$279.50 Kit \$219.50

MODEL 10B



MODEL GC-1. Gated Compression Amplifier. Connects between receiver and speaker. Automatically brings all received signals to same level—no blasting. Compensates for receiver AVC deficiencies. Compresses a 40 db increase in level to less than 3 db. Magic Eye continuously monitors compression value. Keep peace with your family and neighbors — buy a GC-1.

KIT . . . \$49.50 Wired . . . \$59.50

MODEL MM-2. 3" RF analyzer scope for use on SSB—DSB—AM—PM and CW. MONITORS RECEIVED AND TRANSMITTED SIGNALS thru new electronic switching circuits. NO TUNING — BROADBAND response 1MC to 55MC at power levels of 5 watts to 5 KW. SIMPLE CONNECTIONS. Built-in 1KC oscillator for exciter alignment. Plug-in IF adapters available for 450-500 KC, 80 KC and 50 KC.

IF adapter RM-455 or RM-80 or RM-50 \$9.95
MM-2 (less adapter) wired \$149.50
Kit \$119.50



WRITE FOR INFORMATION ON THE COMPLETE MULTIPHASE LINE.



Central Electronics, Inc.

1247 W. Belmont Ave.

Chicago 13, Illinois

A SUBSIDIARY OF ZENITH RADIO CORP.

**MULTIPHASE
THE OVERWHELMING
CHOICE OF HAMS
EVERYWHERE**

For further information, check number 23 on page 126.

You haven't really known
mobile operation until
you've used the

TRANSQUELCH



Size 3" x 3" x 3 1/4" **\$23⁹⁵**

Incorporates "The only completely transistorized noise clipper squelch device produced to work with the new hybrid tubes — a natural complement to your mobile converter." Only two connections to the pot of your broadcast receiver. No cutting of any broadcast receiver circuitry.

**CIRCUITRY IS AN EXCLUSIVE
NORTHEAST DESIGN WITH
COMPONENTS SPECIALLY
DESIGNED FOR THIS PURPOSE**

Get your literature now describing the exciting new TRANSCON products. Each one engineered to give you more and better QSO's.



TRANSCON DIVISION
NORTHEAST TELECOMMUNICATIONS, INC.
Plantsville, Conn.

For further information, check number 24 on page 126.

26 • CQ • October, 1960

QSL contest

Winner this month is **Abe Robie, ZS6AQP**, of Johannesburg with a multicolored item. The black stock is silkscreened with brown, red, yellow, white and grey. A free year subscription of *CQ* to Abe for a very fine card.



Runners Up



HAVE RIG — WILL TRAVEL
QSO K2TRZ
MANHASSET, L.I., N.Y.



DX-100 VOX, CQ, August 1960

With regard to "DX-100 VOX", *CQ*, August 1960, page 54, the d.c. resistance of the relay coil should be 10K. A suitable resistor (R_3) in series with the relay should provide a total of 10K. If the relay seems to hold in too long, reducing the value of C_1 will probably correct the situation.

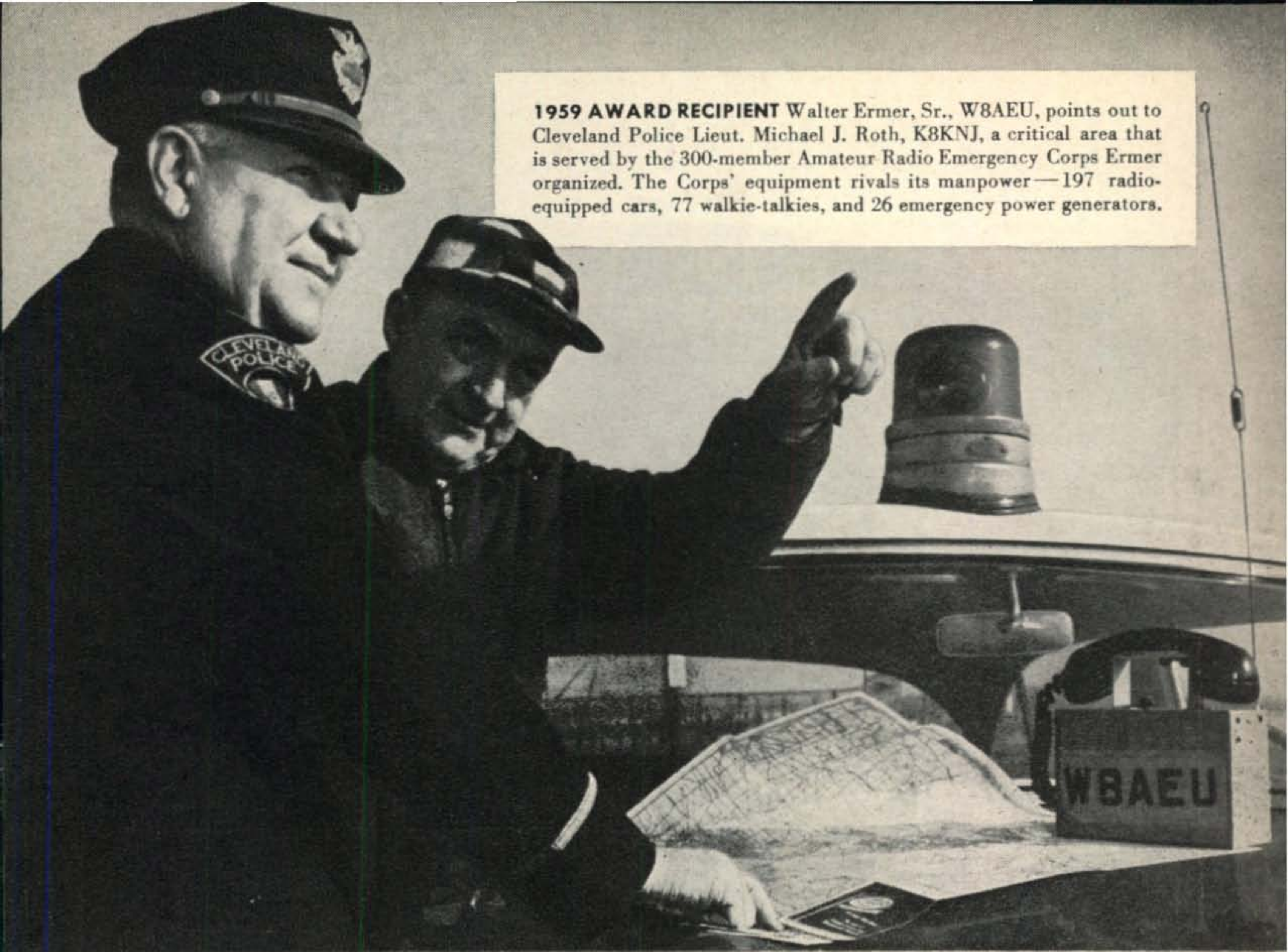

1959 AWARD RECIPIENT Walter Ermer, Sr., W8AEU, points out to Cleveland Police Lieut. Michael J. Roth, K8KNJ, a critical area that is served by the 300-member Amateur Radio Emergency Corps Ermer organized. The Corps' equipment rivals its manpower—197 radio-equipped cars, 77 walkie-talkies, and 26 emergency power generators.

Nominations Open for 1960 Edison Award

Eight previous annual Edison Radio Amateur Awards have honored hams who rendered important public service. The ninth Edison Award, for 1960, will follow the same distinguished pattern as its predecessors.

A panel of impartial judges—all men of national standing—will select the Award recipient, from a group of candidates made up entirely of

names which you and others submit by letter.

You will help raise the stature of *all* radio amateurs by naming a suitable candidate for the acclaim, trophy, and gift that go with the Edison Award. See rules below for help with your nominating letter! Mail it to *Edison Award Council, General Electric Company, Electronic Components Division, Owensboro, Kentucky.*

RULES OF THE AWARD

WHO IS ELIGIBLE. Any man or woman holding a radio amateur's license issued by the F.C.C., Washington, D.C., who in 1960 performed a meritorious public service in behalf of an individual or group. The service must have been performed while the candidate was pursuing his hobby as an amateur within the limits of the United States.

RECIPIENT OF THE AWARD will receive the Edison trophy in a public ceremony in Washington, D.C. Expenses of his trip to that city will be paid.

\$500 GIFT. Recipient will be presented with a check for this amount in recognition of the public service which he has rendered as a radio amateur.

WHO CAN NOMINATE. Any individual, club, or association familiar with the public service performed.

HOW TO NOMINATE. Include in a letter a full description of the service performed, as well as the candidate's name, address, and call letters. Your letter of nomination must be postmarked not later than January 2, 1961.

BASIS FOR JUDGING. All entries will be reviewed by a group of distinguished and impartial judges. Their decisions will be based on (1) the greatest benefit to an individual or group, (2) the amount of ingenuity and sacrifice displayed in performing the service. Edison Award judges will be:

E. ROLAND HARRIMAN, Chairman, The American National Red Cross.

ROSEL H. HYDE, Commissioner, Federal Communications Commission.

GOODWIN L. DOSLAND, President, American Radio Relay League.

Recipient of the Award will be announced on or before Thomas A. Edison's birthday, February 11, 1961.

Employees of the General Electric Company may nominate candidates for the Edison Radio Amateur Award, but are not permitted to receive the Award.

GENERAL  ELECTRIC

624-401

CUSTOM STYLED GIFTS

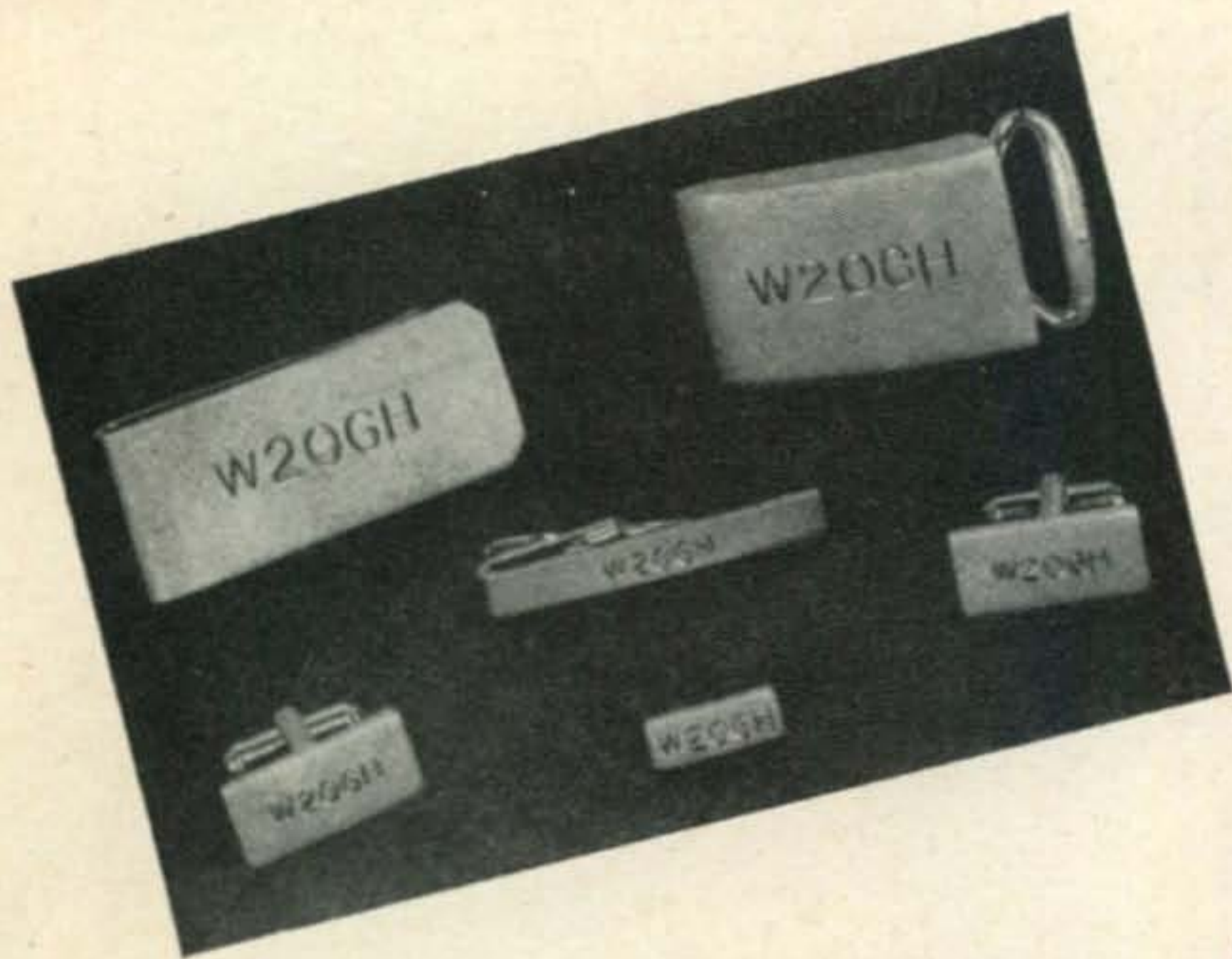

The Finest in Ham Jewelry

A complete line of personalized jewelry handsomely engraved with your call letters, name or initials. All items available in choice of gold plate or silver plate. Mark appropriate box on coupon. Sandblast finish insures long wear.

Money Clip....\$3.50*	Tie Bar.....\$2.50*
Cuff Links..... 3.50*	Tie Tack..... 2.50*
Buckle..... 3.50*	Lapel Pin..... 2.50*

Match Books
Personalized with your call letters, name or initials. 50 books of matches attractively packed in a reusable clear plastic drum. Attractive Gold, Silver, Green, Red metallic colors and White letters.

\$2.95 postpaid.

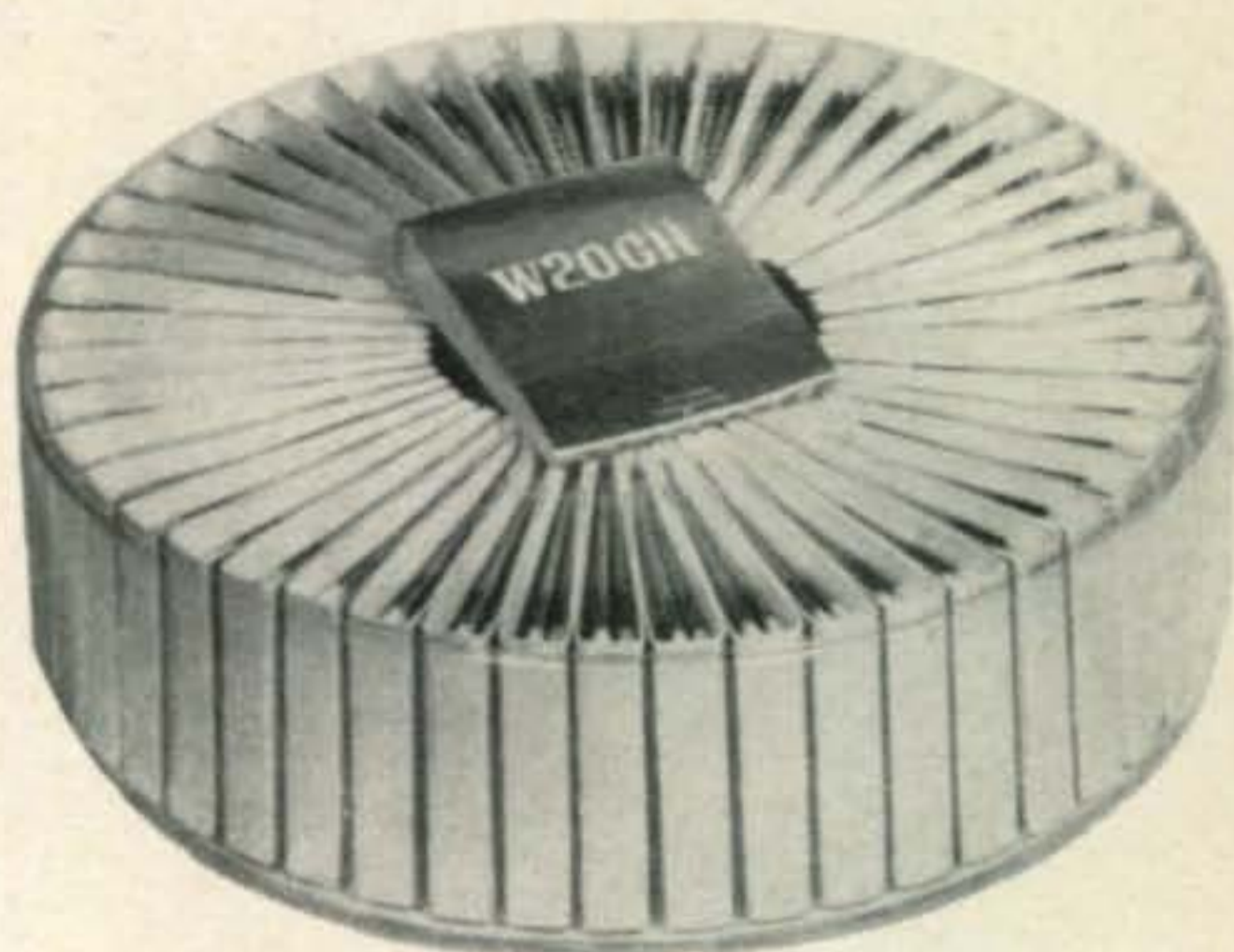

Hostess Set

50 each, beverage and luncheon napkins and guest towels. Personalized with your call letters, name or initials. Attractive Gold and Silver scroll border design, gift boxed.

\$4.95 postpaid.

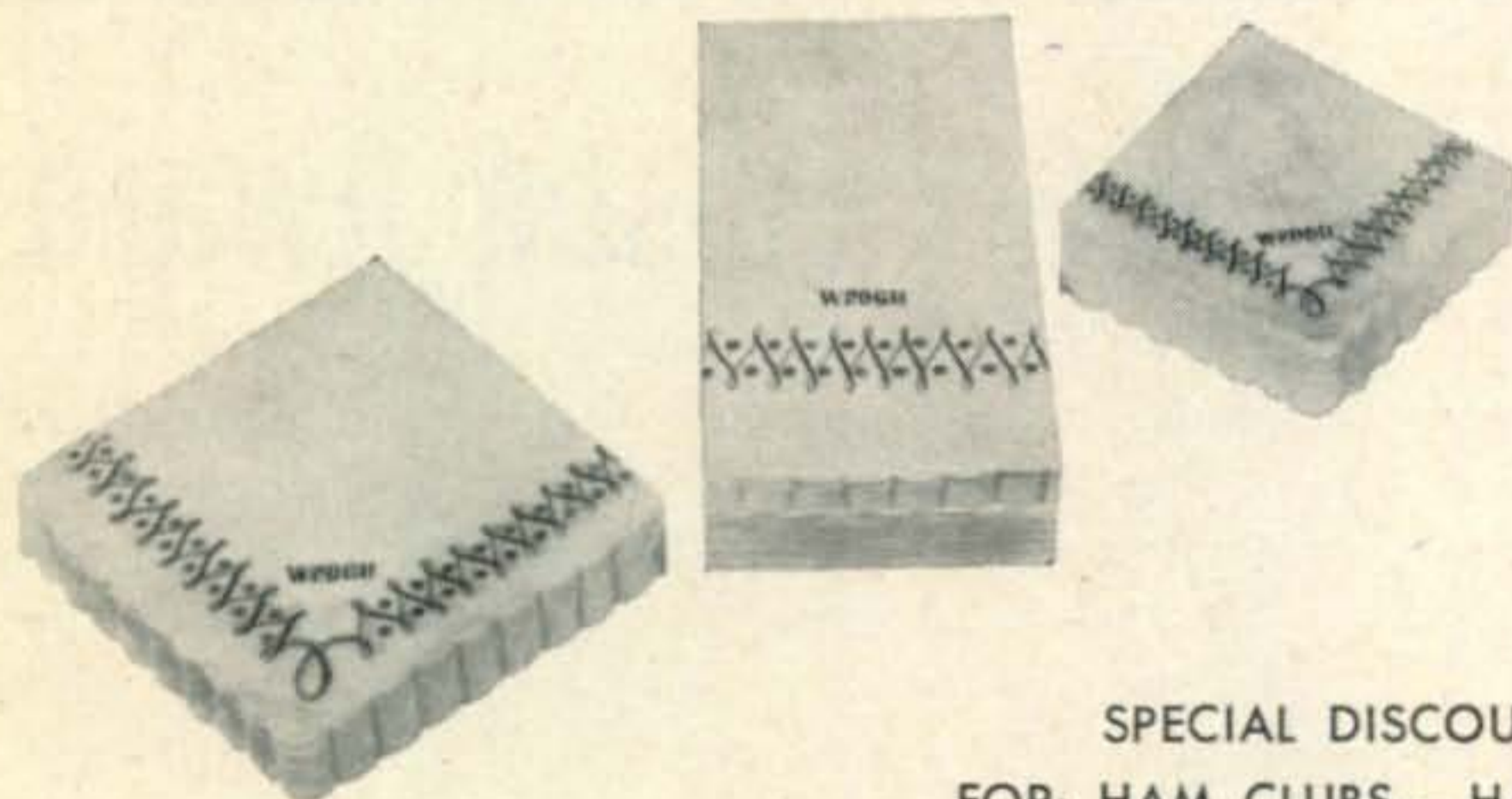

SPECIAL DISCOUNTS ON QUANTITY ORDERS
FOR: HAM CLUBS — HAMFEST PRIZES — MANUFACTURERS
WRITE FOR FULL DETAILS, SPECIFYING YOUR PARTICULAR NEED

*Add 10% Federal Excise Tax to all jewelry.

Hewlett Sales Co.		CQ 10	
Box 600CQ		SIRS: My check (money order) for \$..... is enclosed. Please send	
300 West 43rd St.		Money Clip	G <input type="checkbox"/> S <input type="checkbox"/> Buckle
New York 36, N.Y.		Cuff Links	G <input type="checkbox"/> S <input type="checkbox"/> Tie Tack
		Match Books	Gold <input type="checkbox"/> Silver <input type="checkbox"/> Green <input type="checkbox"/> Red <input type="checkbox"/> Hostess Set <input type="checkbox"/>
NAME or INITIALS.....		CALL.....	
ADDRESS.....			
CITY.....		ZONE STATE.....	
Add 10% Federal Excise Tax to all jewelry.		New York City residents add 3% Sales Tax.	

POWER

- where you want it!

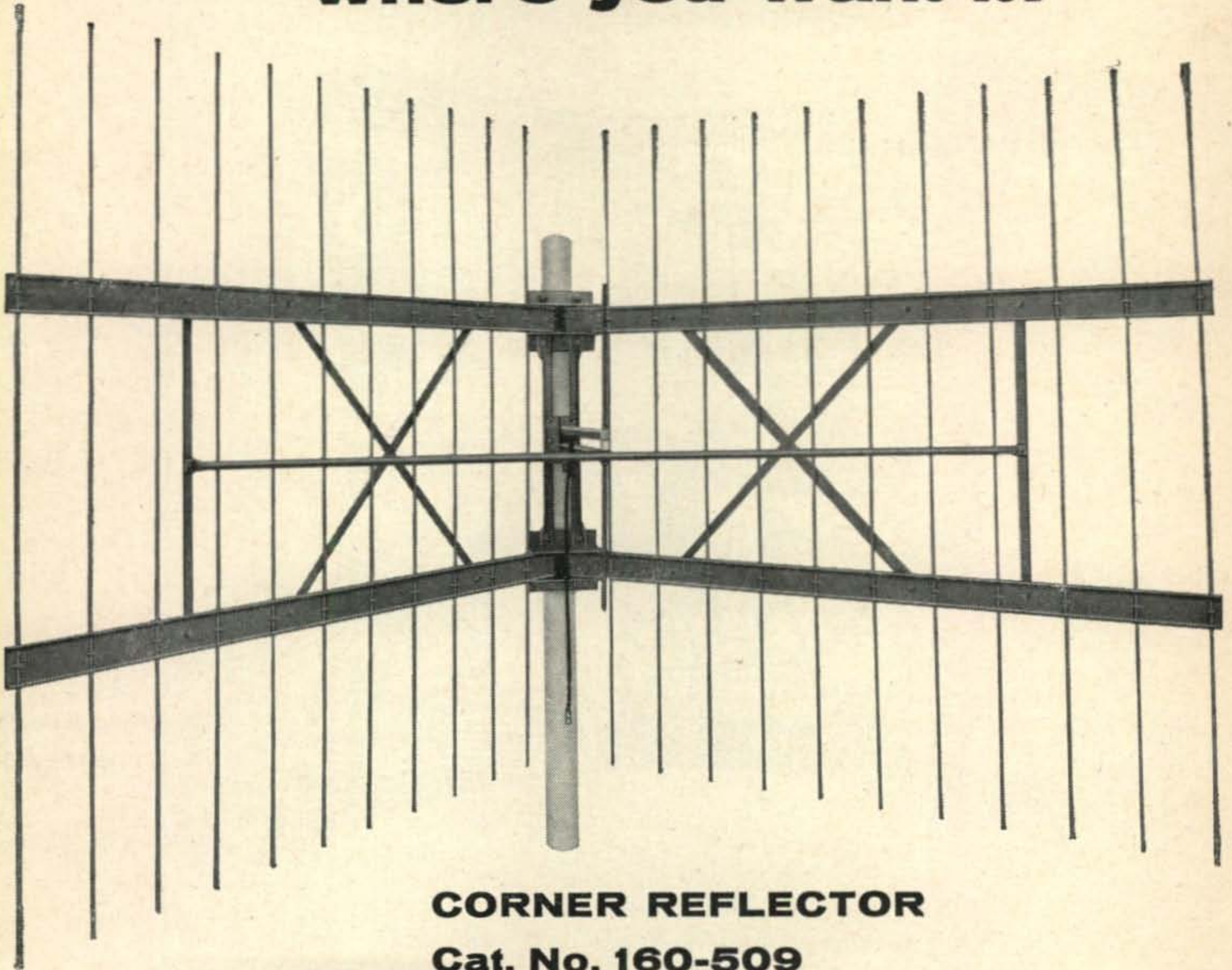

CORNER REFLECTOR
Cat. No. 160-509

SPECIFICATIONS

Electrical

- Frequency range 144-174 Mc
- Forward gain 10 db
- Nom. input impedance . . 50 ohms
- Front-to-back ratio 20 db
- Maximum power input . . 500 watts
- VSWR 1.5:1
- Bandwidth $\pm 3\%$

Mechanical

- Reflector (size per side) 6' x 6'
- Reflector material
High strength
aluminum alloy
- Radiating element material
Copper alloy
- Rated wind velocity 100 MPH
- Weight 75 lbs.

Communication Antenna Systems for American Business

Communication Products Company, Inc.

MARLBORO

NEW JERSEY

For further information, check number 26 on page 126.

Random Thoughts — — — —

From the Boys in the Back Room



We find that every once in a while it pays to sit down, away from the office clamor, and just do a little self examination. In our particular case this involves a round table pow-wow between editorial, advertising, and circulation departments to decide how to further improve *CQ* in the interests of our readers.

Now and then a brainstorm materializes into reality. In the months ahead you'll see interesting columns on space and satellites, a fabulous contest for circuit builders, and a series of articles so hot that we can't let the cat out of the bag until it's ready.

Incidentally, you may have noticed a vast improvement recently in *CQ*'s overall feature articles. We're paying top prices for good articles, and the new editors are taking great pains to answer all correspondence, not a small task, by any means. These efforts have been rewarded by a noticeable upturn in both circulation and advertising.

So, there you have it. Our main objective is to keep ham radio the great and pleasant hobby it's always been. If any reader has a suggestion toward that end, or for improvement of *CQ*, we welcome all letters.

Best 73

Dick, WA2LRO

ANTENNAS
SINCE
1921

telrex LABORATORIES

Communication and TV Antennas

ASBURY PARK 25, NEW JERSEY, U.S.A

DESIGNERS AND MANUFACTURERS OF COMMERCIAL SERVICE "BEAMED-POWER" ARRAYS

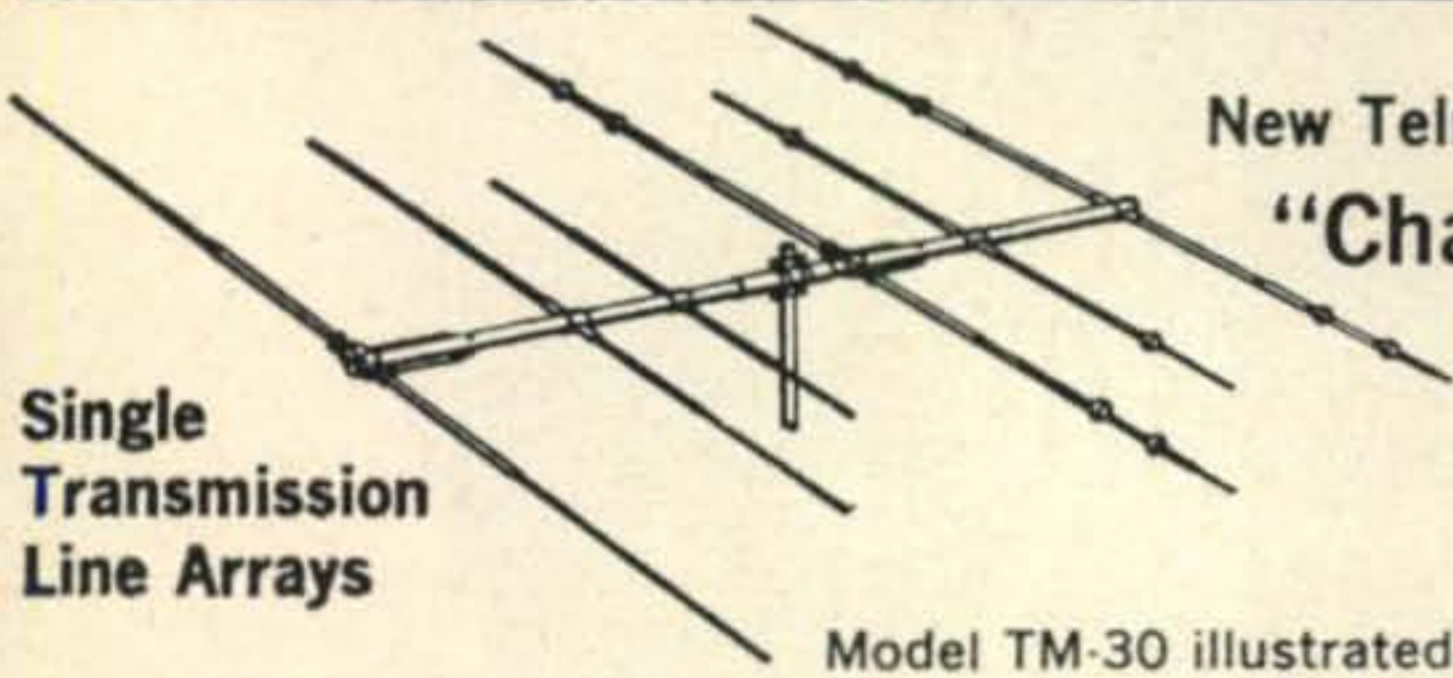

Single
Transmission
Line Arrays

Model TM-30 illustrated

26 pounds of educated aluminum—Telrex "Tri-Band" is World Renowned for performance, excellence and value.

New Telrex "Challenger"

Model TC-88
"Tri-Band"
\$99.75

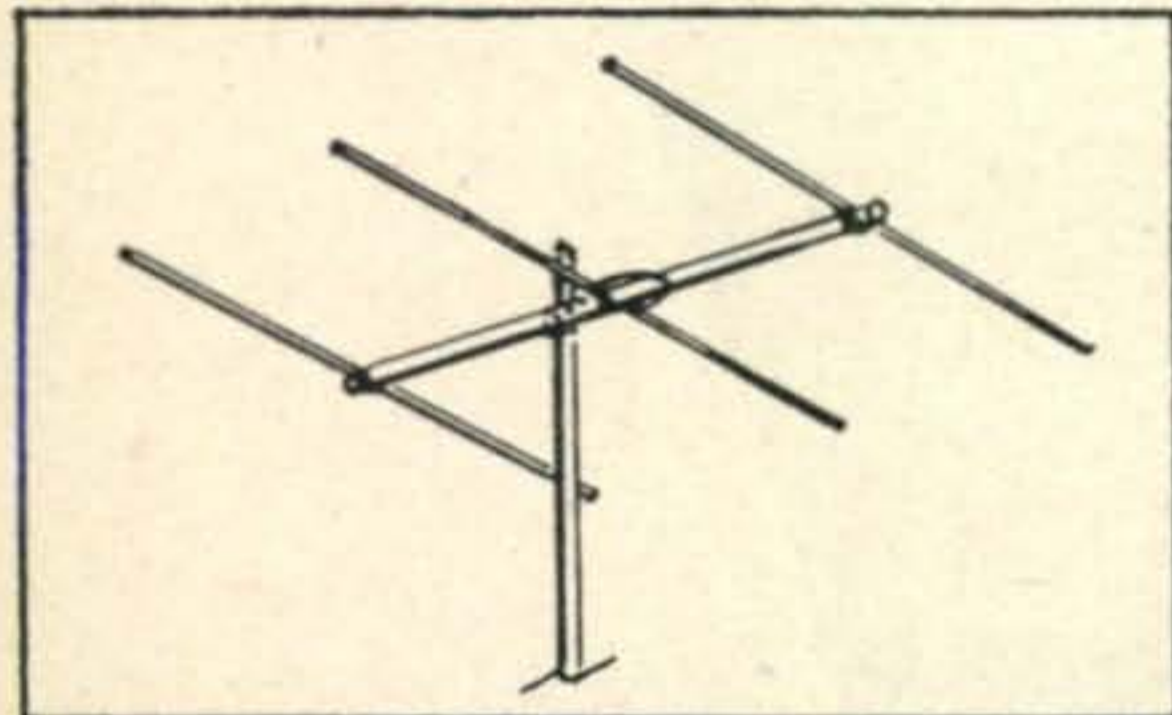

Model 2M-3C \$6.95

2 Meter Arrays

Telrex offers 12 models in the 2-meter band. Prices range from \$6.95 to \$115.00.

- Model TC-99 \$159.50
- Model TM-30 \$328.00
- Model DP-3 \$38.50
(10-15-20 Meter Dipole)
- Model DP-4 \$175.00
(10-15-20-40 Meter Dipole)

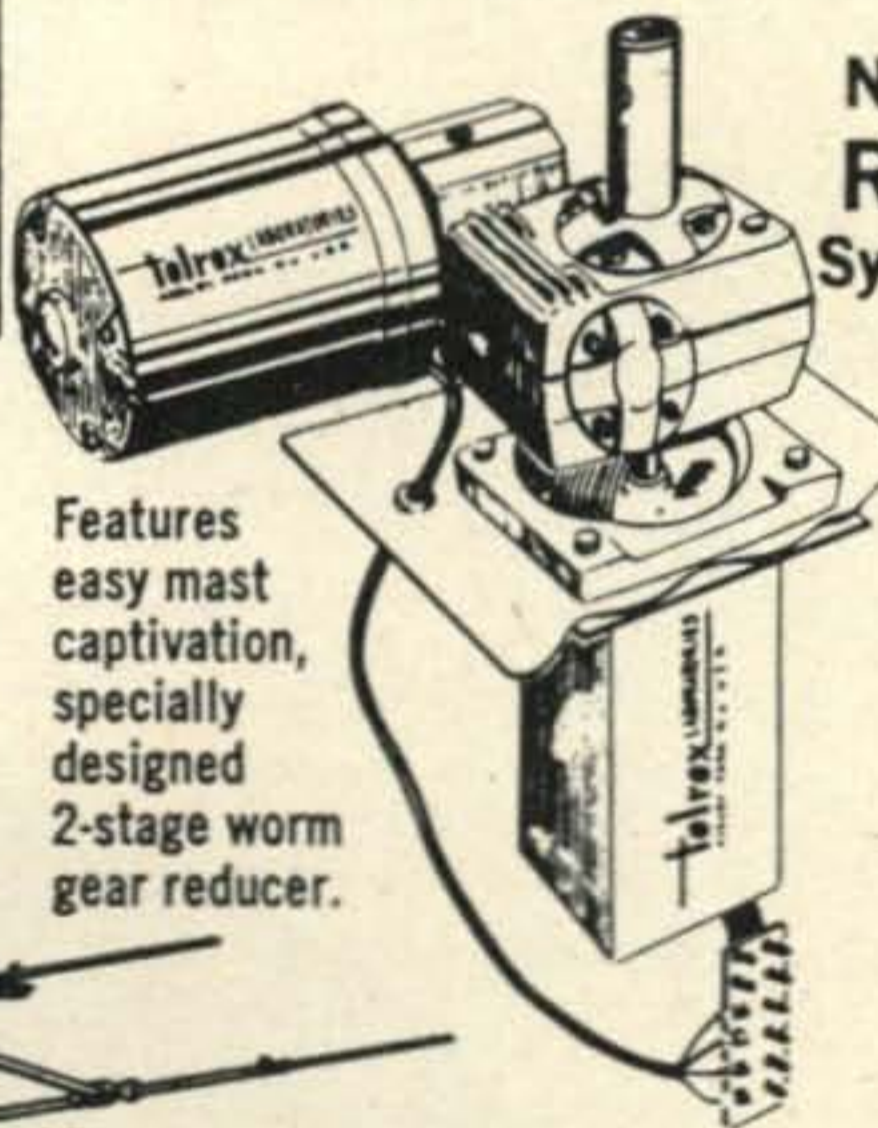

New Telrex ROTATOR/INDICATOR System Model 175-RIS \$198.50

Features easy mast captivation, specially designed 2-stage worm gear reducer.

Designed to out-perform and outlast any other beam rotator in its class. Will hold and rotate beams in winds up to 110 mph. Control Housing is Telrex quality thru-out. Black japanned aluminum housing. Tri-colored azimuth rose and reciprocal readings. Has sel-syn indication and limit of rotation circuitry.



Also available—Extra Heavy Duty Rotator Models

New Telrex "CHRISTMAS TREE" 3-Band System

By far the most powerful and practical 3-element "Tri-band"® System... guaranteeing no compromise, 3-band performance and reliability—rain or shine! "Balun" feed and optimum antenna design assures... maximum gain, and impedance bandwidth, plus pattern symmetry with minimum TVI, BCI and harmonic radiation qualities not possible with so-called "Tri-banders".

World's Finest, Most Practical Communication System Featuring "Beamed-Power" and "Balanced-Pattern"

New Telrex "SPIRALRAY"

\$19.50

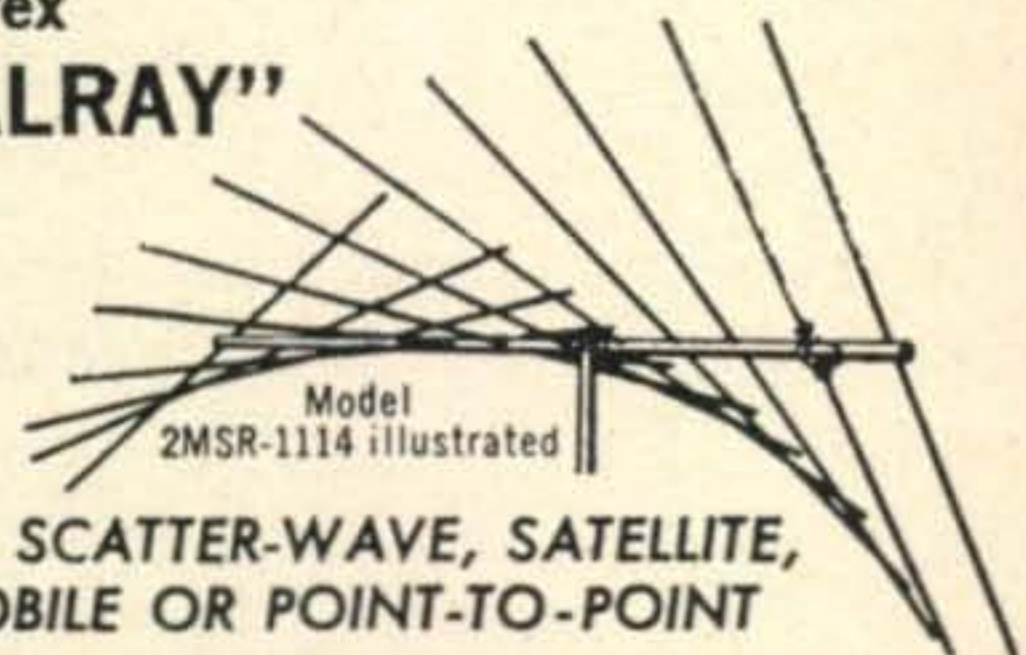

Model 2MSR-1114 illustrated

FOR SCATTER-WAVE, SATELLITE,
MOBILE OR POINT-TO-POINT

Extremely high-gain, high signal-to-noise, practically no fade, all radiation planes—horizontal, vertical or oblique! 50, 108 and 144 megacycle models available.

All prices FOB Asbury Park, New Jersey, subject to change without notice

For further information, check number 28 on page 126.

**IMPROVE
SPEECH
INTELLIGI-
BILITY
AND
CUT
THROUGH
QRM**

SHURE *Ranger*

MODEL NO. 405T

**controlled magnetic microphone
with transistor amplifier**

All the advantages of controlled magnetic microphone construction—ability to withstand hard usage and extremes of climate and weather conditions—are yours in this sturdy, reliable microphone. The Ranger 405T has a flat frequency response characteristic (200 to 4000 cps), controlled to provide maximum speech efficiency.

It is ideally suited for SSB-AM transmission. Fits naturally and comfortably in the palm of the hand . . . takes up minimum space in mobile or fixed-station equipment. Equipped with heavy-duty push-to-talk switch.

Shure Brothers, Incorporated
222 Hartrey Ave., Evanston, Ill.

\$29.10
Amateur
Net



**MICROPHONES, HIGH FIDELITY
AND ELECTRONIC COMPONENTS**

For further information, check number 29 on page 126.

HIGH POWER IN SMALL PACKAGES

A COMPLETELY NEW DESIGN CONCEPT IN MOBILE COMMUNICATIONS . . . Here is a LINEAR AMPLIFIER package that takes low exciter power, converts it to 1000 watts PEP and delivers the RF directly into a conventional whip antenna.

The DM1000A is a single tube liquid cooled Linear Amplifier operating in Class AB₂. Cooling is accomplished by a small amount of recirculating coolant. Pump and heat exchanger are an integral part of the base and no external liquid connections are required. Normally supplied in a passive grid configuration, it is also available as a grounded grid amplifier where use of more exciter power is desired. The output circuit is unique—there is no tank tuning in the ordinary sense. The antenna working through the ground system provides the required capacity. Peak antenna adjustment is made possible through use of a Jennings variable vacuum capacitor. The Amplifier is sufficiently broadband to cover a wide range without retuning and with little attenuation. A conventional 96-inch whip antenna is satisfactory on all frequencies. The system requires no base loading and puts the RF power where it is most useful. Multiband operation from 6 to 60 MC is attained through easily interchangeable plug-in units.

The DMP1012A is a highly efficient solid state inverter that operates from a 12 volt DC source and supplies the plate, screen and bias voltages for the DM1000A. It is capable of 1000 watts output ICAS and has many applications. Test points are provided as part of the inverter for monitoring plate voltage, plate current, screen voltage and bias.

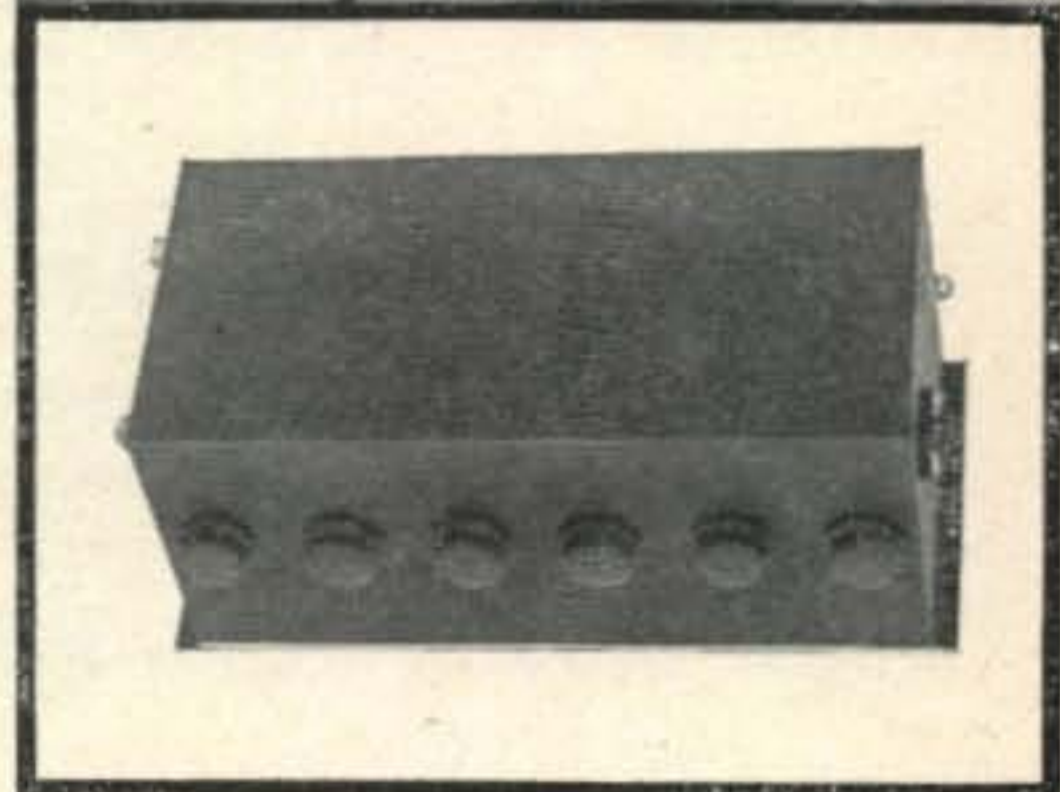
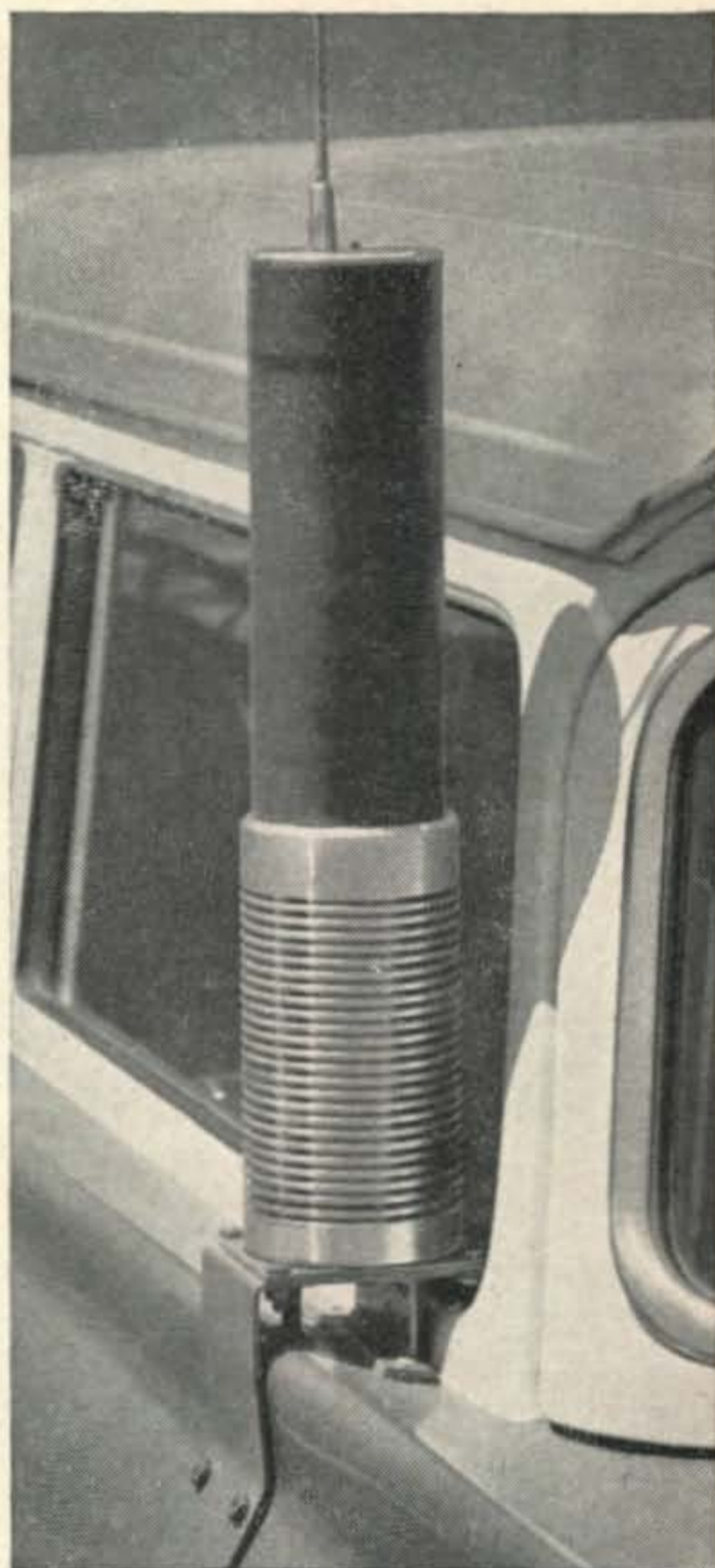

TECHNICAL INFORMATION

DM1000A Linear Amplifier	DMP1012A Inverter
Plate: 2500V.	Output: 2500V. at 400MA
Screen: 350V.	350V. at 100MA
Bias: -60V.	-40 to -80V. adjustable
RF Bandwidth: Flat for 100KC at 7MC.	Input: 11 to 13V. DC
Frequency Range: 6-60MC with plug in units.	Efficiency: 85% at 1 KW
Excitation: Any good exciter providing a peak signal of 80 volts.	
High power exciters should be terminated in characteristic loads.	

PRICE AND ORDERING INFORMATION

Complete package consisting of DM1000A Linear Amplifier, DMP1012A DC to DC Inverter and all power and signal cables for normal installation \$995.00
 Additional plug-in units DM1000A \$ 27.50 each

The package consists of a Linear Amplifier model DM1000A, a DC to DC inverter model DMP1012A and all power and signal cables necessary for normal installation.



Contact your nearest dealer or write:

YUBA-DALMOTOR DIVISION
 1375 El Camino Real, Santa Clara, California
YUBA CONSOLIDATED INDUSTRIES, INC.

For further information, check number 30 on page 126.

THIS BEAM THINKS IT'S A PIPELINE

THE NEW MODEL TB 1000-4 10-15-20 Meter Antenna

- Famous Hornet Quality
 - Rated at Maximum Legal Power
 - Four Elements On Each Band
- Model TB 1000-4 Cash Price, Only \$119.50

YOU WILL THINK SO TOO!

The four triband elements, in operation on each band make the difference —
A Powerful four element punch!

NOW AT YOUR DEALERS!

World famous Hornet antennas are now available from dealers. See your dealer today for the model of your choice, or order direct from Hornet.

THE NEW MODEL TB 750

This husky antenna replaces Hornet's famous Model TB 600, and is now rated at 750 watts AM or SSB.

Model TB 750 Cash Price, Only \$69.95

THE NEW MODEL TB 1000 offers top performance in three element design.

- Famous Hornet Quality
- Rated at maximum legal power

Model TB 1000 Cash Price,
Only \$89.75

ALL MODELS . . .

- Are Pre-tuned and Easy to Install
- Have Custom Fittings of Cast Aluminum
- Use a Single 52 ohm Coaxial Transmission Line
- Have completely weather-sealed Frequency-Dividers*
- Have Elements of 6061-T6 Aluminum

All Prices F.O.B. Dealers Store or Factory

Model TB-500
Cash Price
Only \$59.75

WRITE FOR
FREE
ILLUSTRATED
CATALOG

THE BEAM WITH A STING

HORNET
Antenna Products Co.

P.O. BOX 808 • DUNCAN, OKLA.

*Pat. Pending.

MAIL YOUR ORDER TODAY — 10 DAYS FREE TRIAL

HORNET ANTENNA PRODUCTS CO.
P.O. Box 808, Duncan, Okla.

- Please ship one Model _____ Hornet tribander. Cash price in full is inclosed.
- I wish to purchase one Model _____ Hornet tribander, and would like to use your time-payment plan.

NAME _____ My Call Letters Are _____

ADDRESS _____

CITY _____ STATE _____

ABSOLUTELY NO RISK ON YOUR PART

For further information, check number 31 on page 126.



CRYSTAL FILTER-TYPE SIDEBAND—Exclusive high frequency bandpass crystal filter gives you more than 60 db of unwanted sideband and carrier suppression! Select upper or lower sideband instantly with front panel "mode" switch.

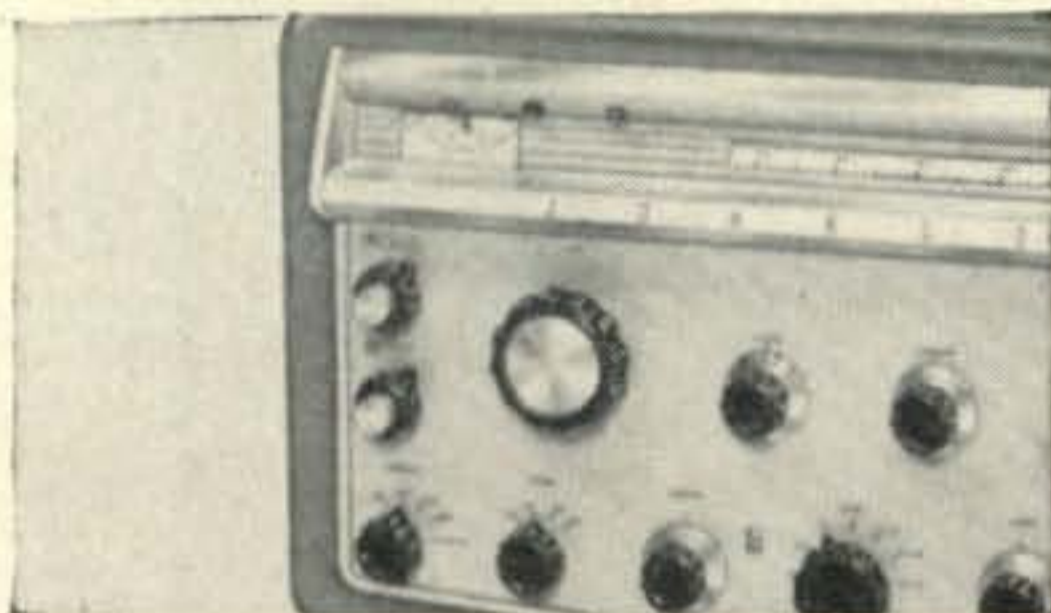

SIMPLIFIED OPERATION—Unique design and circuitry make the "Invader" and the "Invader-2000" extremely easy to tune and operate! Tune for maximum on the meter and you're ready to go—just a few front panel controls give complete flexibility!



FREQUENCY CONTROL—Instant bandswitching coverage of the full 80, 40, 20, 15 and 10 meter bands... no extra crystals or retuning required. Highly stable, built-in VFO is differentially compensated and factory adjusted for maximum stability—exclusive "keep warm" heater element keeps VFO at operating temperature even with equipment turned off... NO WARM-UP DRIFT!



Write today for your free 8-page "Invader" brochure—complete with detailed specifications and photographs!

Here's the transmitter with the sharp, penetrating signal you've been waiting for—plus more exclusive operating and convenience features than any other Transmitter/Exciter on the market today! The "Invader" offers instant bandswitching, full bandspread coverage 80 through 10 meters—no extra crystals to buy—no retuning necessary! Rated a solid 200 watts CW and SSB input; 90 watts input on AM! Final amplifier utilizes a pair of 6146's in parallel, bridge neutralized. Unwanted sideband and carrier suppression is 60 db or better! Exclusive RF controlled audio AGC and ALC (limiter type) provide greater average speech power—high gain push-to-talk audio system has plenty of reserve gain for either crystal or dynamic microphones. VOX and anti-trip circuits are extremely smooth in operation—built-in anti-trip matching transformer—adjustable VOX time delay circuit. Mixer-type shaped keying is crisp, sharp—click and chirp free. Single knob wide range pi-network output circuit. Fully TVI suppressed. Blocking and operating bias provide noise-free T-R switch operation. Heavy duty power supply is completely self-contained. The "Invader" may also be used as an exciter for the Viking "Courier", "Thunderbolt", or the Viking "Kilowatt". Dimensions: 11 5/8" high x 21" wide x 17 1/2" deep. Compact, heavy duty power supply with swinging choke circuitry gives excellent voltage regulation—supplies all necessary high and low voltages. Power Requirements: 325 watts, 105-125 V AC 2-wire, 50-60 cycle.

Cat. No. 240-302-2 . . . Viking "Invader" wired and tested with tubes, crystals, less key and microphone.

Amateur Net \$619.50

VIKING "INVADER" HI-POWER CONVERSION—Take the features and performance of your Viking "Invader" . . . add the power and flexibility of the unique Viking "Hi-Power Conversion" system . . . and you're "on the air" with the "Invader-2000"—a solid 2000 watts P.E.P. (twice average DC) input* SSB, 1000 watts CW and 800 watts input on AM! Completely wired and tested—includes power supply, new front overlay panel, extra knobs, additional meter, necessary tubes—everything you need to convert your "Invader" into the power-packed "Invader-2000". All you need is a small wrench and a screwdriver—no soldering necessary—complete the entire conversion in just one evening!

Cat. No. 240-303-2 . . . Hi-Power Conversion, complete **Amateur Net \$619.50**

Available completely factory wired and assembled, the "Invader-2000" offers all of the fine features of the "Invader" plus the added power and flexibility of an integral linear amplifier and remote controlled power supply. Here's desk-top operating convenience unsurpassed by any other high power transmitter . . . 2000 watts P.E.P. (twice average DC) input on SSB, 1000 watts CW, and 800 watts AM input! Final amplifier employs two rugged, high efficiency, low replacement cost Type PL-175A pentode tubes in parallel . . . features a ganged tank assembly that provides exceptionally uniform "Q". RF stages are cut off automatically on stand-by and key-up—wide range output circuit (40 to 600 ohms adjustable) will match virtually any antenna system. Push-pull fan assembly draws air through the chassis, effectively cooling components as well as filament and plate seals for extended tube life. Heavy duty, multi-section power supply uses 866A High Voltage Rectifiers. Screen supply employs a 5U4GA rectifier and uses heavy bleeder and high filter capacity for excellent dynamic screen voltage regulation in Class AB₂ operation. An OC2 bias regulator provides regulated bias for the two PL-175A final amplifier tubes. Dimensions: 11 5/8" high x 21" wide x 17 1/2" deep. Power Supply: 11 1/4" high x 19 3/4" wide x 14 1/2" deep. Power Requirements: 1600 watts, 105-125 V AC 2-wire; or 210-250 V AC 3-wire, 50-60 cycle.

Cat. No. 240-304-2 . . . Viking "Invader-2000" wired and tested with remote power supply, tubes, crystals, less key and microphone.

Amateur Net \$1229.00

FIRST CHOICE AMONG
THE NATION'S
AMATEURS



Viking

ANTICIPATED DELIVERY—LATE FALL

E. F. JOHNSON COMPANY • WASECA, MINNESOTA

Viking transmitters and accessories. 1st choice of amateurs the world over



NEW... FOR 10 METERS

10-Meter Messenger

Ideal for fixed or mobile operation, new 10-meter "Messenger" is a compact 10-tube (including rectifier) crystal-controlled transceiver! Superhet receiver of excellent sensitivity and selectivity—very effective ANL, AVC, and Squelch circuit. 10 watts input delivers a solid signal. Wide range pi-L network output circuit—self-contained power supply. Pre-tuned for 20 to 29.7 mcs—covers any 5 frequencies within a 300 kc segment of the 10-meter band. Compact... lightweight... easy to install. 5 $\frac{5}{8}$ " high, 7" wide, and 11 $\frac{3}{8}$ " deep. For 6V D.C. and 115 volts A.C., 12V D.C. and 115 volts A.C., or 115 volts A.C. only. Complete with tubes, microphone, power cords, and crystals for one frequency covering 29,640 kc, national calling and emergency frequency. For complete details write for specification Sheet 737.

Cat. No.	Amateur
242-201... 115 V only	\$129
242-202... 115 V & 6 V	\$139
242-203... 115 V & 12 V	\$139

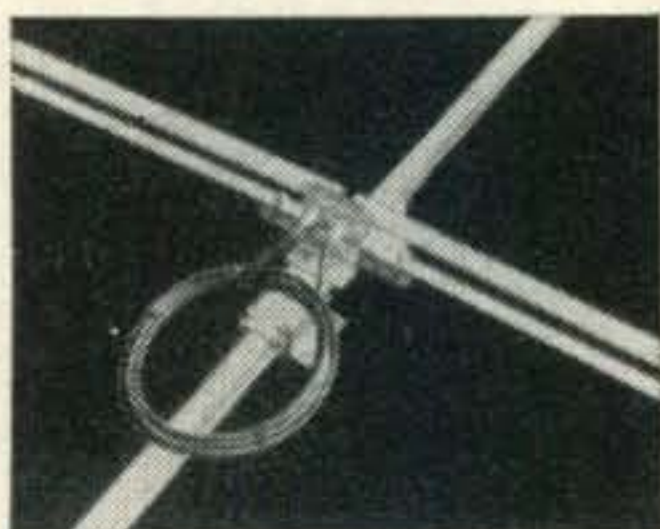
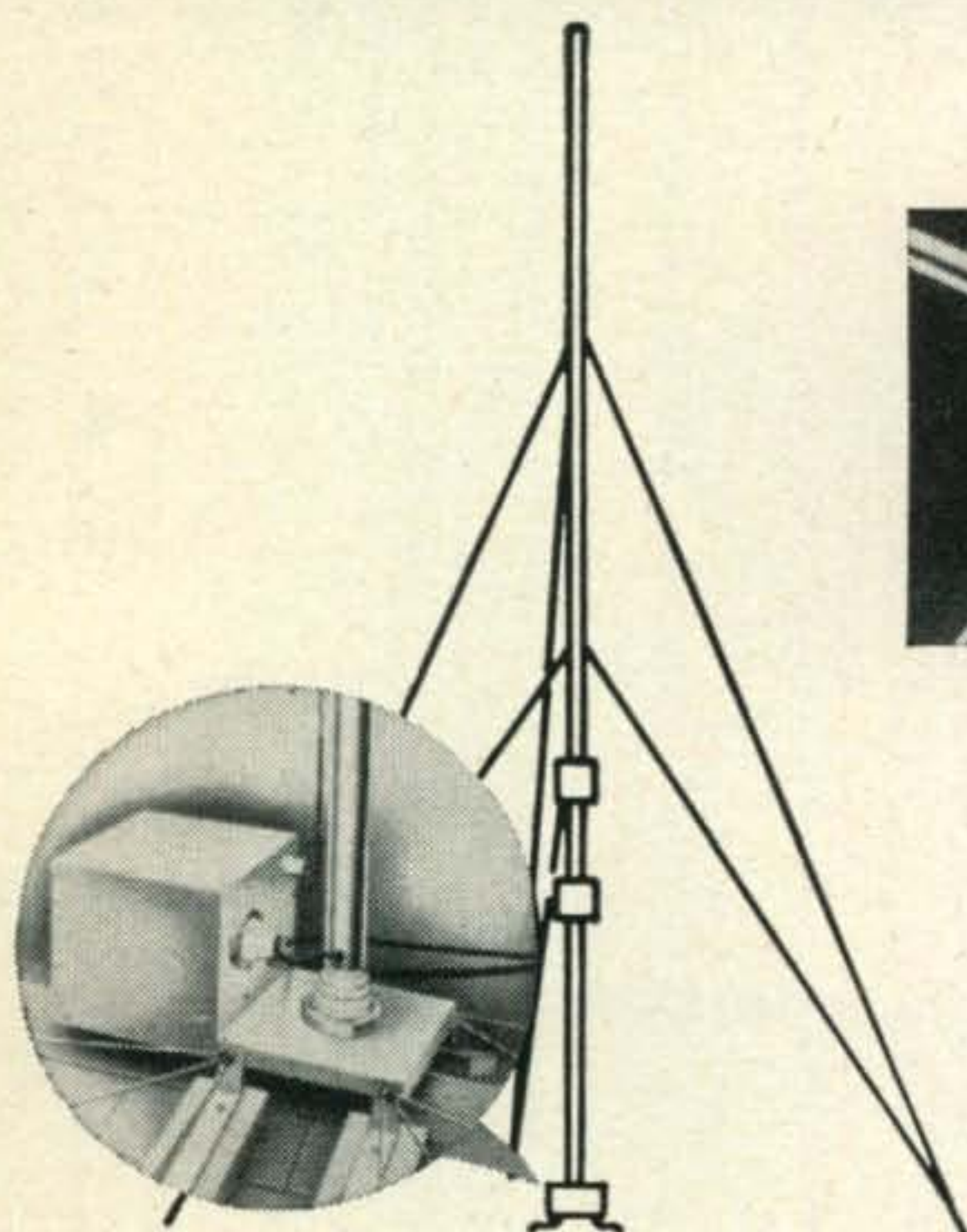

138-420-3

137-102

PRE-TUNED BEAMS—Rugged semi-wide spaced beams—pre-tuned for 20, 15, and 10 meters. Approximately 9.0 db gain over a tuned dipole—greater than 27 db front to back ratio with 1.5:1 SWR. With 3 element beams, boom and balun. For 52 ohm coaxial transmission line.

Cat. No.	Amateur
138-420-3... 20 meter beam	\$139
138-415-3... 15 meter beam	\$119
138-410-3... 10 meter beam	\$ 79

"MATCHSTICK"—A fully automatic bandswitching vertical antenna system—may be mounted on roof top, ground, or in any limited space location. Completely pre-tuned—low SWR on all bands 80 through 10 meters. Low vertical radiation angle for DX. Impedance: 52 ohms. Complete with 35' mast, base tuning network, relays, control box and 9 Dacron guy ropes.

Cat. No. 137-102... "Matchstick"..... Amateur Net \$129

"MATCHBOXES"—Provide completely integrated antenna matching and switching systems for kilowatt or 275-watt transmitters. Bandswitching 80, 40, 20, 15, and 10 meters. No "padding" coils or "load-tapping" necessary.

275 Watt "Matchbox"—Designed to match a 52 ohm coaxial line to reactive and nonreactive loads ranging from 25 to 1500 ohms for balanced lines; and 25 to 3000 ohms for unbalanced lines. For transmitters with a maximum power input of 275 watts.

Cat. No.	Amateur
250-23-3... With directional coupler and indicator	\$89
250-23... Less directional coupler and indicator	\$54

Kilowatt "Matchbox"—Handles unbalanced line impedances from 50 to 2000 ohms, and balanced line impedances from 50 to 1500 ohms. For transmitters with a maximum power input of 1000 watts.

Cat. No.	Amateur
250-30-3... With directional coupler and indicator	\$149
250-30... Less directional coupler and indicator	\$124



250-30-3



250-23-3

COMING SOON... the all new Viking filter-type sideband transmitter with 60 db sideband suppression

Crystallography at its Finest



CRYSTALS

AMATEUR TYPES

H43 or H73 low drift fundamental oscillators. Will withstand high drive conditions.

1800 to 3000 kc ± 2 kc	\$2.95
3000 to 9000 kc ± 5 kc	2.95
9000 to 15000 kc ± 10 kc	3.95

H173 plated, high stability oscillators.

1800 to 3000 kc ± 2 kc	\$4.95
3000 to 9000 kc ± 5 kc	4.95
9000 to 21 mc ± 10 kc	4.95
21 mc to 40 mc ± 15 kc	4.95
40 mc to 54 mc ± 25 kc	5.95
54 mc to 75 mc ± 100 kc	7.95

Special close tolerance crystals for the amateur.

H43 or H73 1800 kc to 18 mc	\$4.80
H173 1800 kc to 75 mc	7.95

MARINE CRYSTALS

Type H-4 or H-7 marine tolerance high drive crystals.

Frequency range 2 mc to 7 mc \$4.95

AIRCRAFT CRYSTALS

All types available. State holder size, pin dimensions, and spacing, equipment model and manufacturer, crystal frequency and channel frequency. If receiver, specify IF frequency.



H-73 or H-7 (FT-243).
Dia. .093" Pin Spacing

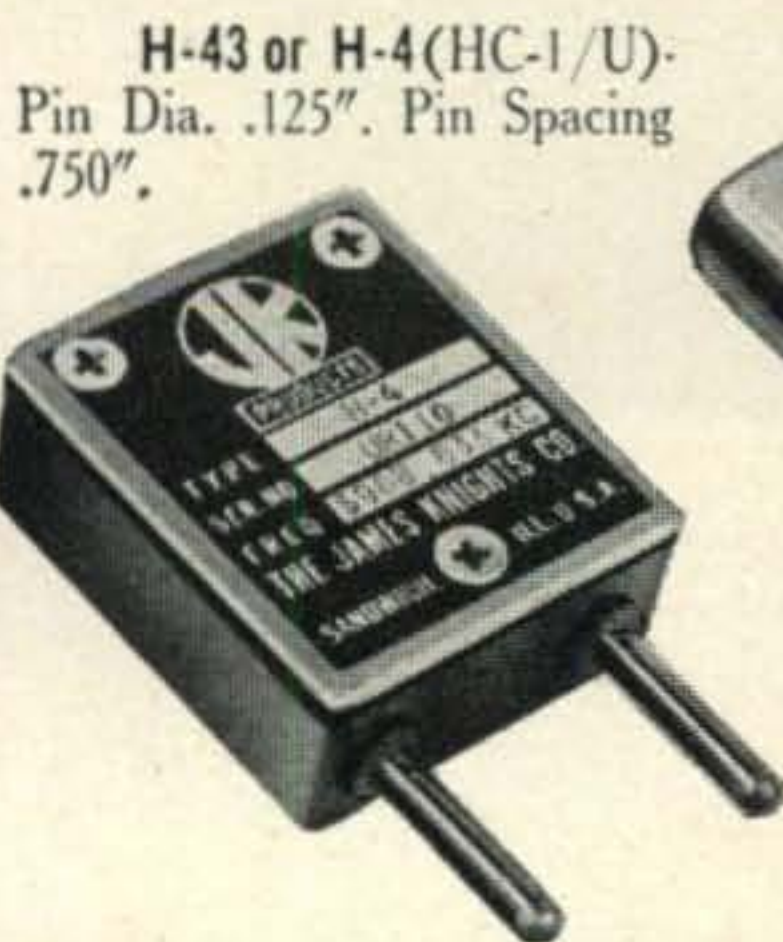

H-43 or H-4 (HC-1/U).
Pin Dia. .125". Pin Spacing .750".

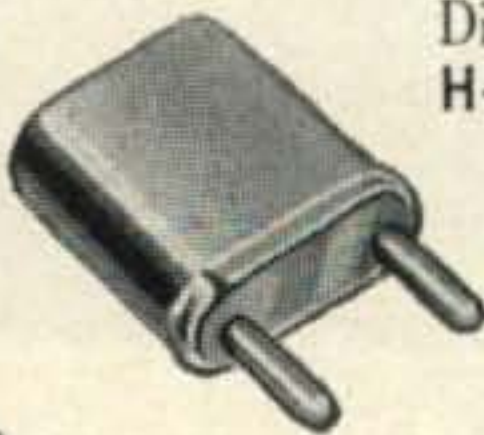

H-173 or H-17 (HC-6/U). Pin Dia. .050". Pin Spacing .486".
H-17L (HC-6/U Except .093" Pin Dia.)
H-17W (HC-6/U With Wire Leads)



H-3 (HC-18/U Except .039" Pin Dia.) Pin Spacing .192".
H-3W (HC-18/U) With Wire Leads

H-17T (HC-13/U). Pin Dia. .050". Pin Spacing .486".
H-17TL (HC-13/U Except .093" Pin Dia.)



CITIZENS BAND

Standard Transmitter Crystals. Type H-17 (HC-6/U) standard load, .005% tolerance. Crystal on any FCC channel frequency. \$2.00

Standard Receiver Crystals. Type H-17 (HC-6/U), standard load. Crystal 455 KC lower than FCC channel frequency. $\pm .005\%$ tolerance. \$2.00

Special Transmitter Crystals. Type H-17 (HC-6/U), with pins, or H3W (HC-18/U) with wire leads. Standard load, crystal on $\frac{1}{2}$ or $\frac{1}{3}$ FCC channel frequency. Give holder, load, frequency, and make of equipment. Also includes control frequencies of 26.995, 27.095, 27.145, 27.195, and 27.255 MC. $\pm .005\%$ tolerance. \$2.95

Special Receiver Crystals. Same holders and loads as special transmitters crystals but crystal frequency for IF other than 455 KC lower than channel frequency. Give holder, crystal frequency, load, IF frequency, and make of equipment. $\pm .005\%$ tolerance. \$2.95

MARS AND CAP

Type H-7 available on assigned frequencies. Calibrated to $\pm .005\%$.

Frequency Range 2 mc to 10 mc \$4.80

TV & MARKER CRYSTALS

Calibrated $\pm .005\%$	
Type H7, 3 mc to 18 mc	\$4.80
Type H17, 4 mc to 30 mc	7.95
Type H17, 3579.545 kc	4.80
Type H173, 1000 kc	7.95
Type H17TL, 100 kc	6.95

All prices postage paid. Send cash, check, or M.O. No COD's. Distributor inquiries invited.

For further information, check number 32 on page 126.

THE JAMES KNIGHTS COMPANY
Sandwich, Illinois

SSB

A totally new concept in transmitter design — FILTER-TYPE

TRANSMITTER / EXCITER / AMPLIFIER



"INVADER"

*A superbly engineered SSB Transmitter/Exciter
... add hi-power conversion for 2000 watts P.E.P.
(twice average DC) in put SSB!*

Here is the most versatile . . . most advanced SSB Transmitter/Exciter/Amplifier package ever designed for the amateur service! Excitingly different—from exclusive filter-type circuitry to distinctive front panel and cabinet design—the Viking "Invader" and the "Invader-2000" offer flexibility and performance for a lifetime of operating pleasure.

"HI-POWER CONVERSION"



"INVADER-2000"



The world at your finger tips!



VIKING "KILOWATT" AMPLIFIER—The only power amplifier available which will deliver full 2000 watts SSB* input, and 1000 watts CW and plate modulated AM. Continuous coverage 3.5 to 30 mcs. Excitation requirements: 30 watts RF and 10 watts audio for AM; 10 watts peak for SSB.

Cat. No.	Amateur Net
240-1000 ..Wired and Tested.....	\$1595.00
251-101-1 ..Matching desk top, back and 3 drawer pedestal, FOB Corry, Pa.	\$132.00

*The FCC permits a maximum of one kilowatt average power input for the amateur service. In SSB operation under normal conditions, this results in peak envelope power inputs of 2000 watts or more, depending upon individual voice characteristics.



"RANGER" — 75 watts CW and 65 watts phone input. Bandswitching 160 through 10 meters. Built-in VFO or crystal control. With tubes.

Cat. No.	Amateur Net
240-161-1 ..Kit	\$229.50
240-161-2 ..Wired	\$329.50



"VALIANT"—Instant bandswitching 160 through 10. 275 watts input CW and SSB (P.E.P. with aux. exciter) 200 watts phone. With tubes.

Cat. No.	Amateur Net
240-104-1 ..Kit	\$349.50
240-104-2 ..Wired	\$439.50



"FIVE HUNDRED" — 600 watts CW input; 500 watts phone and SSB (P.E.P. with aux. SSB exciter). Bandswitching 80 through 10. With tubes.

Cat. No.	Amateur Net
240-500-1 ..Kit	\$749.50
240-500-2 ..Wired	\$949.50



"THUNDERBOLT" AMPLIFIER—2000 watts P.E.P.* input SSB; 1000 watts CW; 800 watts AM linear. Continuous coverage 3.5 to 30 mcs. With tubes.

Cat. No.	Amateur Net
240-353-1 ..Kit	\$524.50
240-353-2 ..Wired	\$589.50



"6N2"—Instant bandswitching coverage of both 6 and 2 meters. Power input rated at 150 watts CW, and 100 watts AM phone. With tubes.

Cat. No.	Amateur Net
240-201-1 ..Kit	\$129.50
240-201-2 ..Wired	\$169.50



"6N2" THUNDERBOLT AMPLIFIER—Input rated 1200 watts P.E.P.* SSB and DSB, Class AB₁; 1000 watts CW, Class C; 700 watts AM linear, Class AB₁. Continuous coverage 6 and 2. With tubes.

Cat. No.	Amateur Net
240-362-1 ..Kit	\$524.50
240-362-2 ..Wired	\$589.50

"COURIER" AMPLIFIER — Class B linear rated 500 watts P.E.P. input with auxiliary SSB exciter; 500 watts CW; 200 watts AM. Continuous coverage 3.5 to 30 mcs. With tubes.

Cat. No.	Amateur Net
240-352-2 ..Wired	\$289.50



New Catalog

Your complete guide to amateur radio's most exciting equipment. Write today for your free copy.



FIRST CHOICE AMONG
THE NATION'S
AMATEURS



Viking

E. F. JOHNSON COMPANY • WASECA, MINNESOTA

For further information, check number 33 on page 126.

Uno-Dipper

A New Approach To An Old Accessory

Frank Hatanaka, W9BEZ, ex-W7HUK

1340 West Byron
Chicago 13, Illinois

Although the author insists this unit is an experimental prototype, we can not help but marvel at the skill and ingenuity with which he planned and executed this project, a band switch grid-dipper. It is even more startling to find that no special tools were used in his apartment QTH.

For the past few years, until the construction of the *Uno-Dipper*, the author had been poring over many articles on grid-dippers, hoping that someone would come up with a unit which was entirely self contained; the main idea being to eliminate the separate set of coils. But alas, after all this waiting, I felt that perhaps it was not feasible. Yet, I see similar ideas put into practical form; like an "all-wave" receiver employing band switching and its input utilizing a single antenna which, performance wise, may not measure up to a receiver with plug-in coils (which perhaps used more than one antenna for maximum efficiency). Yet the former still did a satisfactory job. By following a similar line of thought, it appeared to be a challenge worthwhile investigating since the shack was sadly in need of a dipper anyway. So before you turn your back on another of seemingly endless ar-

ticles on grid-dipper, here is another approach which may arouse your interest.

General Description

The *Uno-Dipper* is enclosed in a gray aluminum case, $6\frac{7}{8} \times 3\frac{1}{2} \times 3\frac{5}{8}$ inches and weighs about $3\frac{1}{2}$ lbs. Range covered is from 3.4 to 250 mc, in eight bands plus four spare bands which are indicated in the window next to the dial. Both the window and dial are illuminated. The pickup coil or link coupler is movable, and extends out some $4\frac{1}{2}$ inches.

The bandswitching unit is a salvaged Standard Coil TV tuner. From previous knowledge of u.h.f. construction practices it was felt unwise to use conventional bandswitching, the usual rotary-wafer switch. This will result in extraneous peaks and dips because the switch can appear quite reactive on some of the ranges. The efficient TV turret tuner solves most of these problems.

Construction

A local surplus store had some of these tuners which were in fair shape for the purpose and available for about \$2.00. Make certain that all the required parts are there, such as all 12 pairs of clip-in coil strips (drum strip) with coil forms, and make sure you have clean contact terminals, and smooth switching action. This doesn't

Top view of the dipper. Just above the calibration knob is the escutcheon which covers the turret and allows the band in use to be viewed through the window. Both the FREQUENCY dial and BAND window are lighted by an internal pilot light. The meter is a Triplett, type 221-PL. Zero adjust pot R_{10} is mounted on the right side of the case next to the meter.

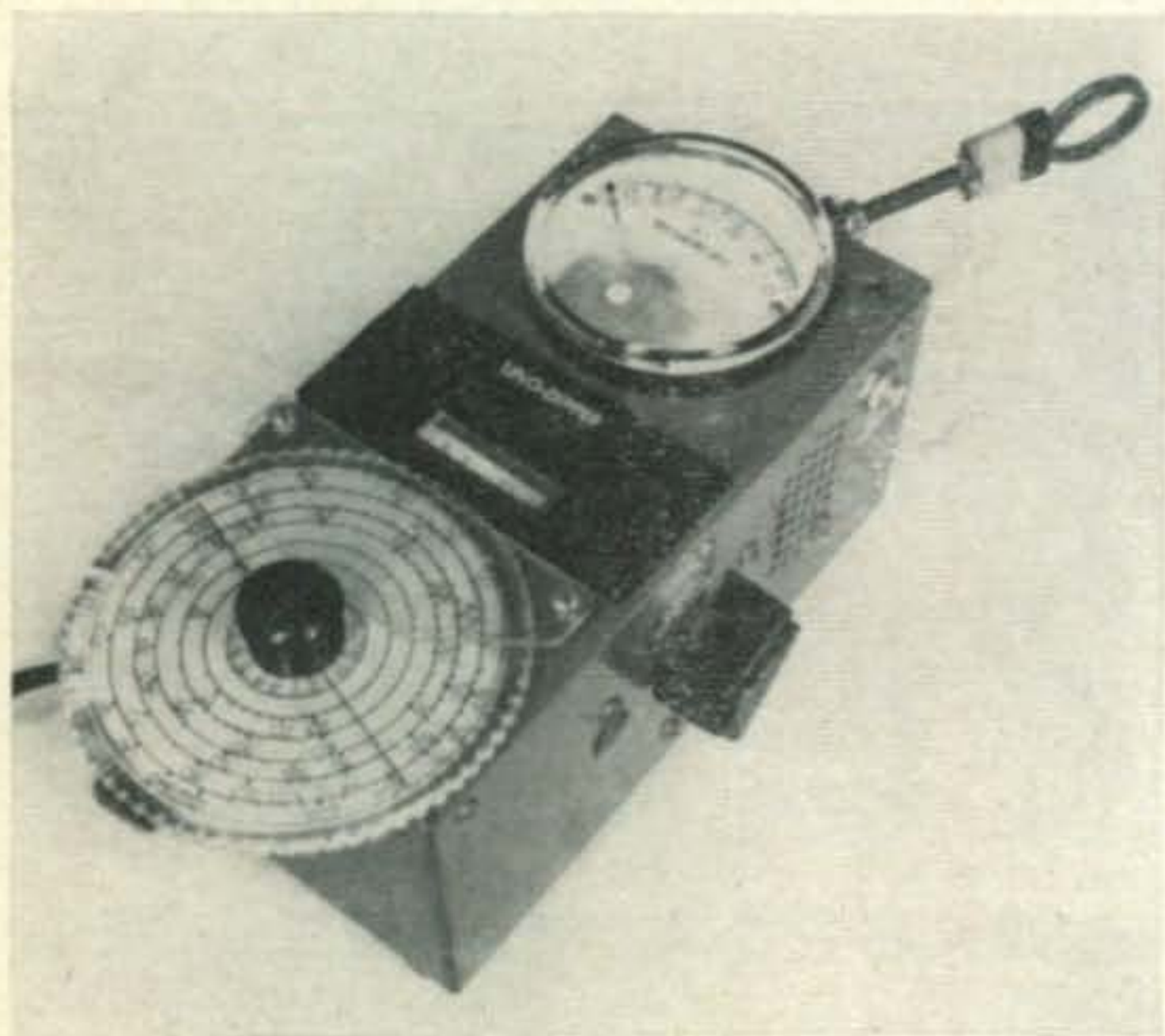

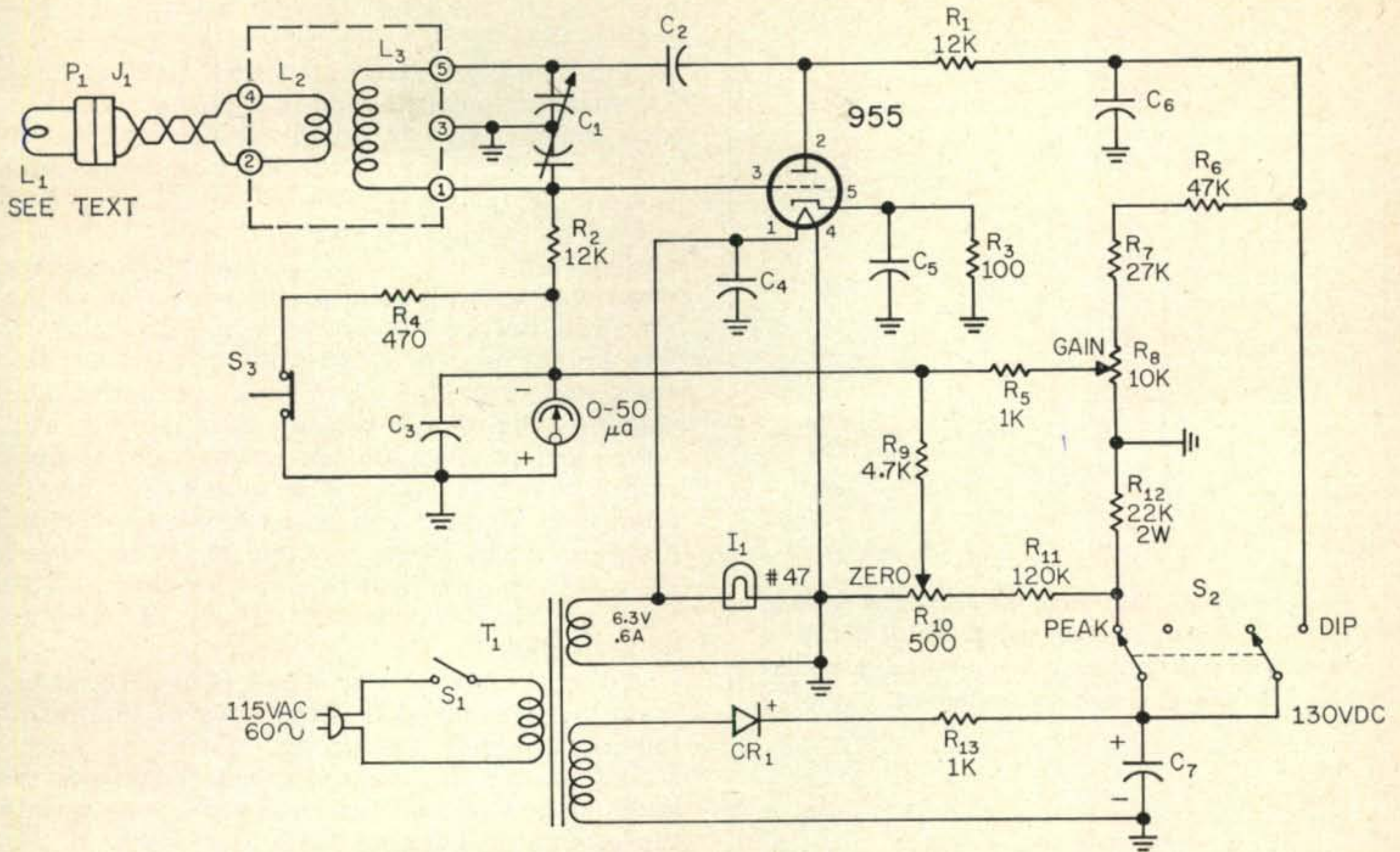

Fig. 1—Circuit of the Uno-Dipper. All resistors are 1/2 watt unless otherwise specified.

- C₁—50-50 mmf Hammarlund HFD-50
- C₂—100 mmf Disc Ceramic
- C₃-C₆—.001 mf Disc Ceramic Erie Type ED
- C₅—47 mmf tubular Erie type 1K
- C₇—20 mf 150 w.v.d.c. C.B. BBR
- CR₁—Selenium Rectifier, Sarkes Tarzian Type 50
- I₁—#47 Pilot Light

- S₃—Normally Closed Pushbutton Switch, Switchcraft Type 102
- T₁—Power Transformer, 125 v. 15 ma d.c. 6.3 v. 0.6A Stancor PS 8415
- J₁—Crystal socket Cinch Jones 2KM
- P₁—Line Plug, Millen 37412

mean that you will be using all the coils but since the tuner housing is divided into two parts, (antenna and mixer-oscillator) personal preference as to housing size and ease of dismantling may dictate the choice of the particular section you'd want to use. This tuner had a socket to mount a 6J6 and another to take a 6CB6, 6AG5, or a 6BC5.

Turning this unit upside down reveals the two sections. One of them must be eliminated. Unfortunately, the rear antenna section which is the smaller of the two was not used because it entailed more complicated dismantling techniques, although, if one truly desires that section in the interests of a more compact unit, it could be done.

The drum is removed by lifting the front and rear wire springs which clamp down the shaft. All parts including sockets, resistors, capacitors, chokes, etc., were removed. One and 13/16 inches of the rear section housing was hacksawed away as shown in fig. 2. This wall is then brought forward to form the rear wall of the front section. After aligning this rear wall with the front section, remove all burrs and scrape the edges of the wall and the edges of the front section clean down to bare metal but do not solder them together yet. Remove the outer sleeve of the concentric shaft (the fine tuner)

COIL TABLE

Frequency Range	L ₃ Pins 1 and 5	L ₂ Pins 2 and 4
3.4 to 5.5 mc	85μh and 10 mmf see text	30t #30 enam. scramble wound
4.9 to 11.5 mc	220t #34 close wound	17t #20 close wound
10.6 to 25.0 mc	96t #29 enam. close wound	9t #20 Nylonel close wound
19.0 to 45.0 mc	51t #26 enam. close wound	10t #26 enam. close wound over center of L ₃
32.0 to 75.0 mc	27t #20 enam. 8 turns close wound on each end, space wound in center	11t #26 enam. interwound on L ₃
49.0 to 115.0 mc	14t #18 enam. double spaced	7t #20 enam. interwound over L ₃
100.0 to 250.0mc	#14 enam. 1 15/16" long	#14 enam. 1 5/8" long
26.0 to 31.0 mc	22t #24 Nylonel space wound	11t #26 enam. interwound on L ₃ 100 mmf from 1 to 3 100 mmf from 5 to 3

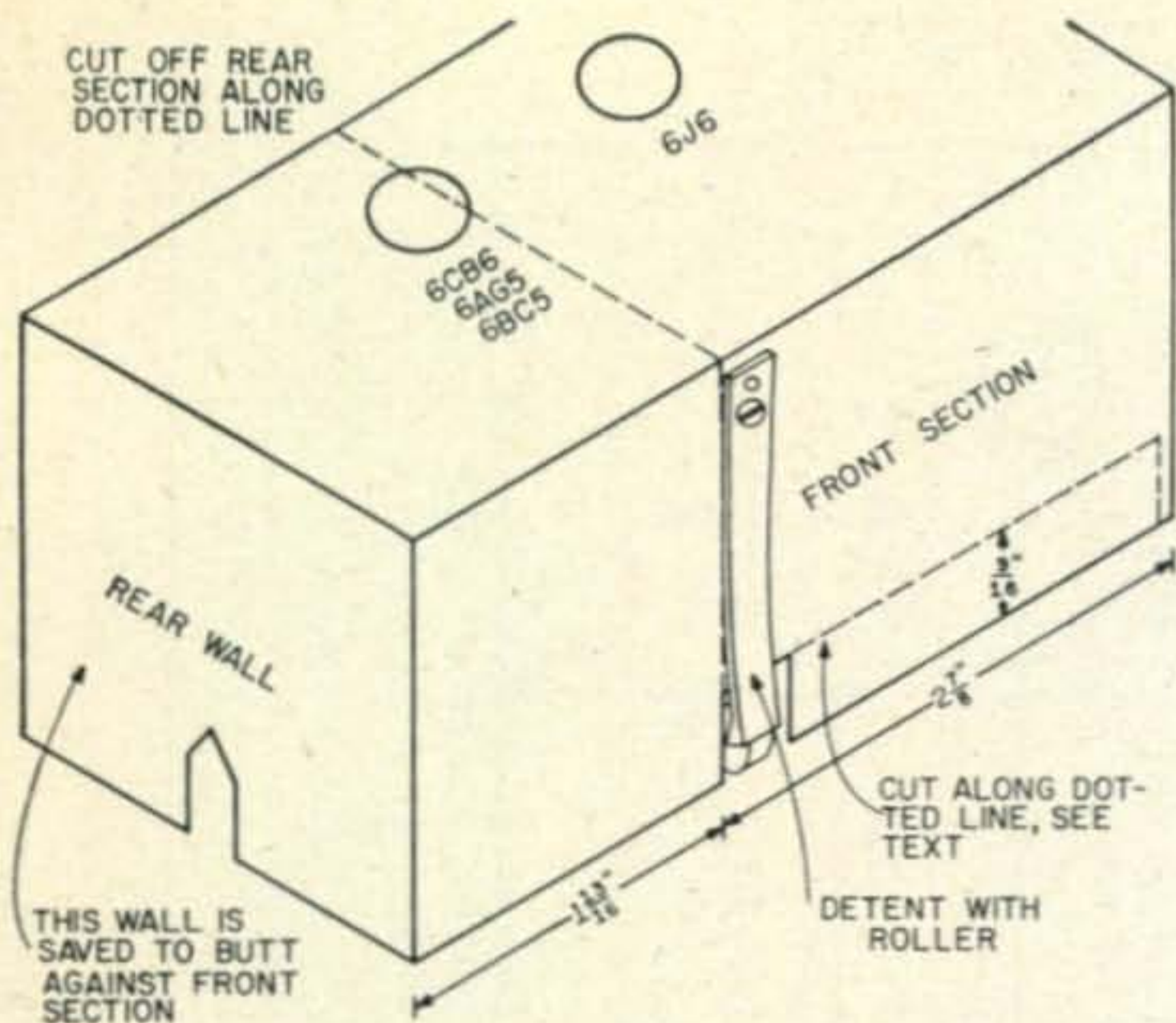

Fig. 2—Drawing illustrating the method of forming the basic chassis used for the dipper. If the same tuner cannot be obtained the same basic modification should be performed.

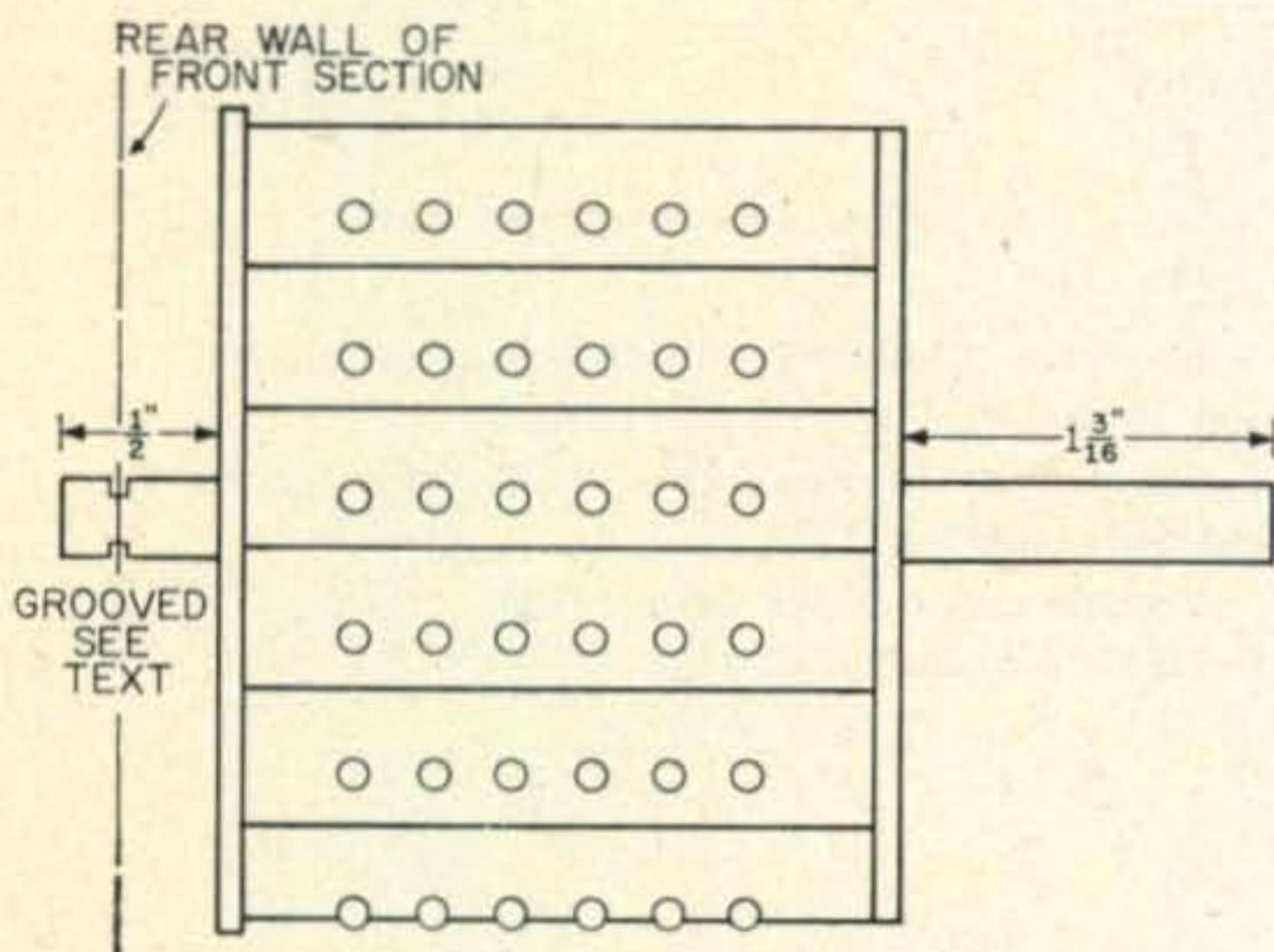

Fig. 3—The TV turret is modified to fit the chassis fabricated as in fig. 2.

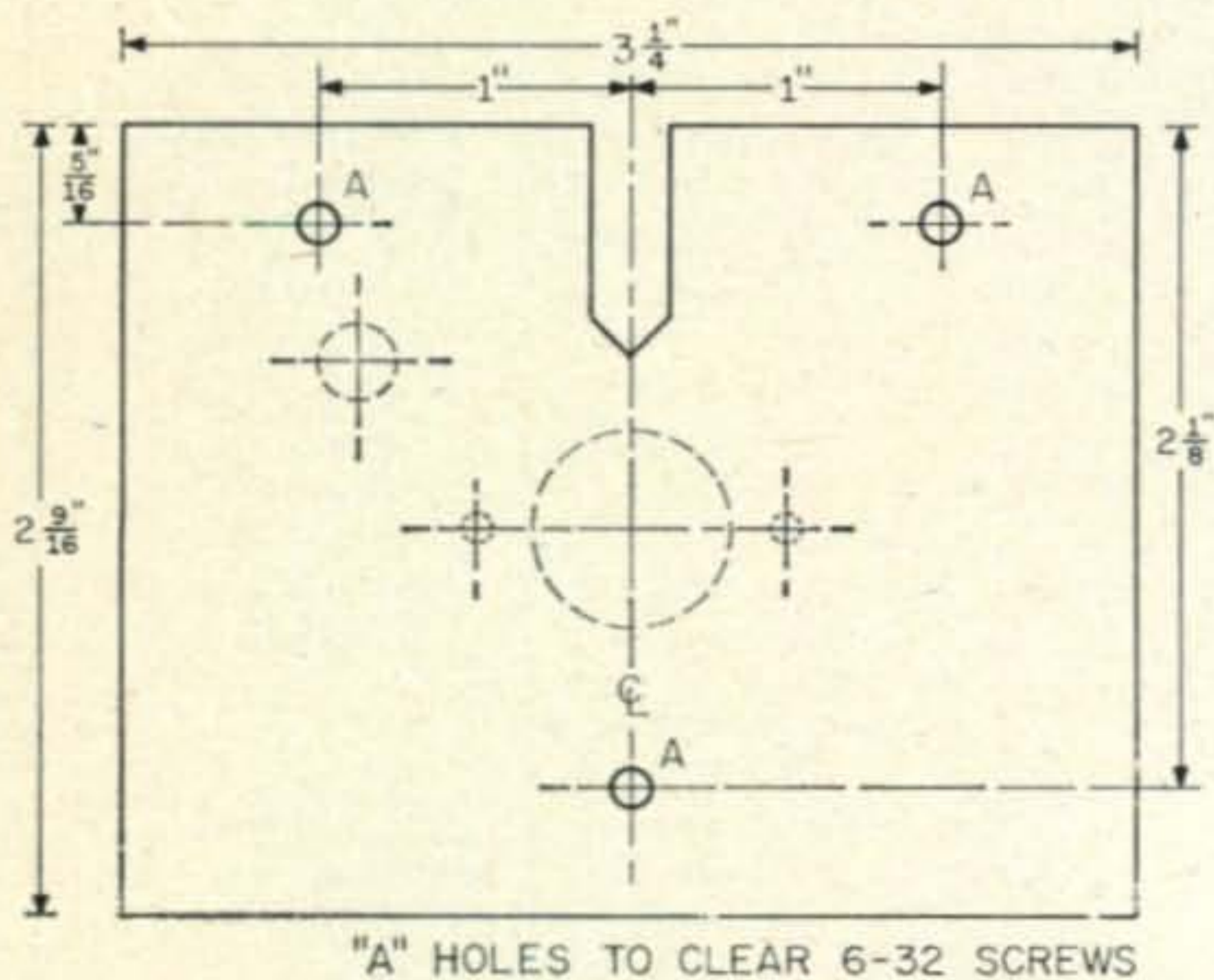

Fig. 4—Tuner front plate. Holes marked "A" are locations for the brass standoffs mentioned in the text.

and saw off the shaft leaving a length of $1\frac{3}{16}$ inches. (See fig. 3.) All strips on the rear portion of the drum are removed which then exposes the rear section of the shaft, a part of which is also sawed away as shown in fig. 3. This remaining rear portion of the shaft must ride on a slot in the rear wall. But to do so, a groove, similar to that on the rear end of the shaft, already cut off, must be sawed into the shaft at a point where it will meet the new position of the rear wall. Before this groove is cut into the shaft, line up the rear wall carefully to see that the front and rear slots are in line and commence soldering the rear wall to the front section wall with a high wattage soldering iron. If only a small iron is available, solder it in spots just to give it temporary support and heat the edges over the flame of a gas stove, flowing on more solder. Be careful not to heat the bakelite finger strip. Once this has cooled off, remove the residue with alcohol.

A section next to the detent is now removed from the housing so that the body of the meter may occupy that area. In fig. 2, with the detent facing you, and located to the left, the portion of the housing wall to the detent's right is removed, the amount depending upon the depth of the meter used. In our case, it was cut off, even with the upper edge of the detent roller, which seems sufficient for most meters. The top of this unit now becomes the bottom, from here on.

Now remove all drum strips from the front section except one for purposes of contact alignment. Also temporarily remove the detent spring. Rather than adhere strictly to the dimensions, drop the shaft partly into the front slot of this housing and rest the rear end of the shaft upon the slot of the new rear wall. Make sure that the drum strip is in line with its mating contacts (finger strips) in the housing. Twirl the shaft to note where a groove should be cut into the shaft. (See fig. 3.) If this shaft could be mounted in a lathe or a slow-speed drill, the groove could be controlled easily, but since most of us are not so equipped, a vise and a hacksaw will do a satisfactory job, surprisingly enough. The depth of the groove should be about $1/32$ inch every 45 degrees, or it may be easier to make grooves every 90 degrees and then make cuts in between. Now that there are eight grooves forming a rough octagon, trim these cuts with a curving motion of the saw to obtain a $3/16$ inch diameter groove, such that it will ride freely in the slot of the rear wall. The groove then should be given a few final strokes with the edge of a flat jeweler's file until it rolls smoothly in the slot. Attach the detent spring and roller and check the switching action.

Referring to fig. 4, holes "A" are drilled into the front part of the housing to mount three $1/4$ " brass standoffs which in this case were already internally tapped with 6-32 threads. Mount these three standoffs to the housing with 6-32 screws, $5/32$ inch long. Actually, this modification of the housing takes no more than three hours but it certainly would be nice to have a commercially

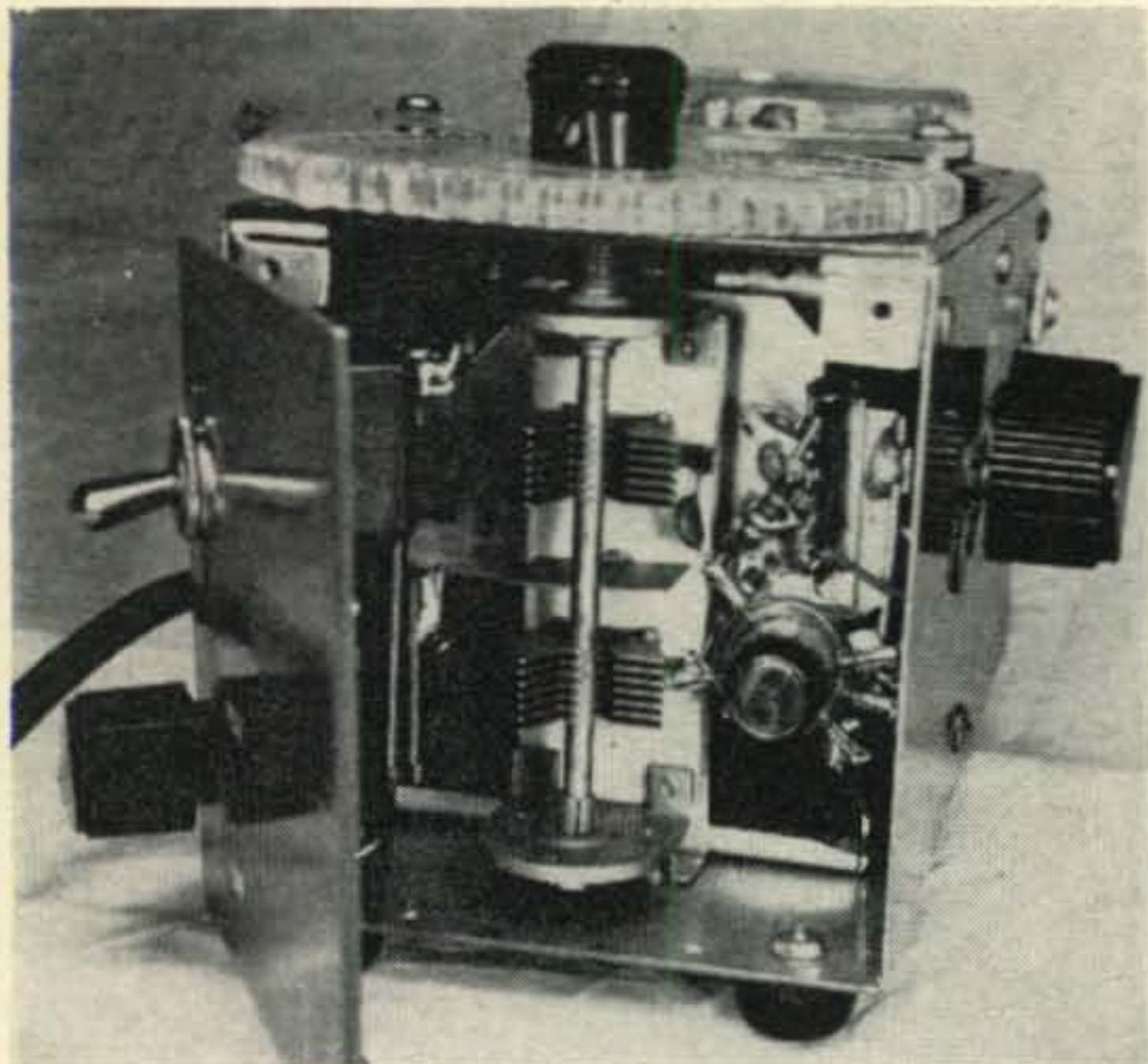

View of the dipper with the bottom plate partially removed showing the method of mounting the variable capacitor and the 955. The ON-OFF toggle switch and PEAK-DIP switch are mounted on the removable plate. Bandswitching is accomplished with the large knob on the right.

available unit, since it could be used for so many types of related r.f. work.

Since this housing already contained a socket for a 6J6, use of a 6J6 was given consideration, but the configuration, which would have resulted in a larger-sized unit, discouraged a move in that direction. Therefore, to keep size to a minimum (after experimentation with other tubes and circuits) a 955 acorn tube was chosen, which is popular in many grid-dip circuits.

Figure 5 shows mounting plate A. This plate mounts the Hammarlund HFD-50 variable capacitor. When mounting this plate, position it so that the center line coincides with the center line of the carrying case rather than the tuner housing itself, since this may vary with individual installations. Align the bottom of the plate with the bottom of the tuner. In the photograph, you will note that a tube socket is not used, mainly to conserve space as well as to reduce circuit inductance and stray capacity. Instead of solder-

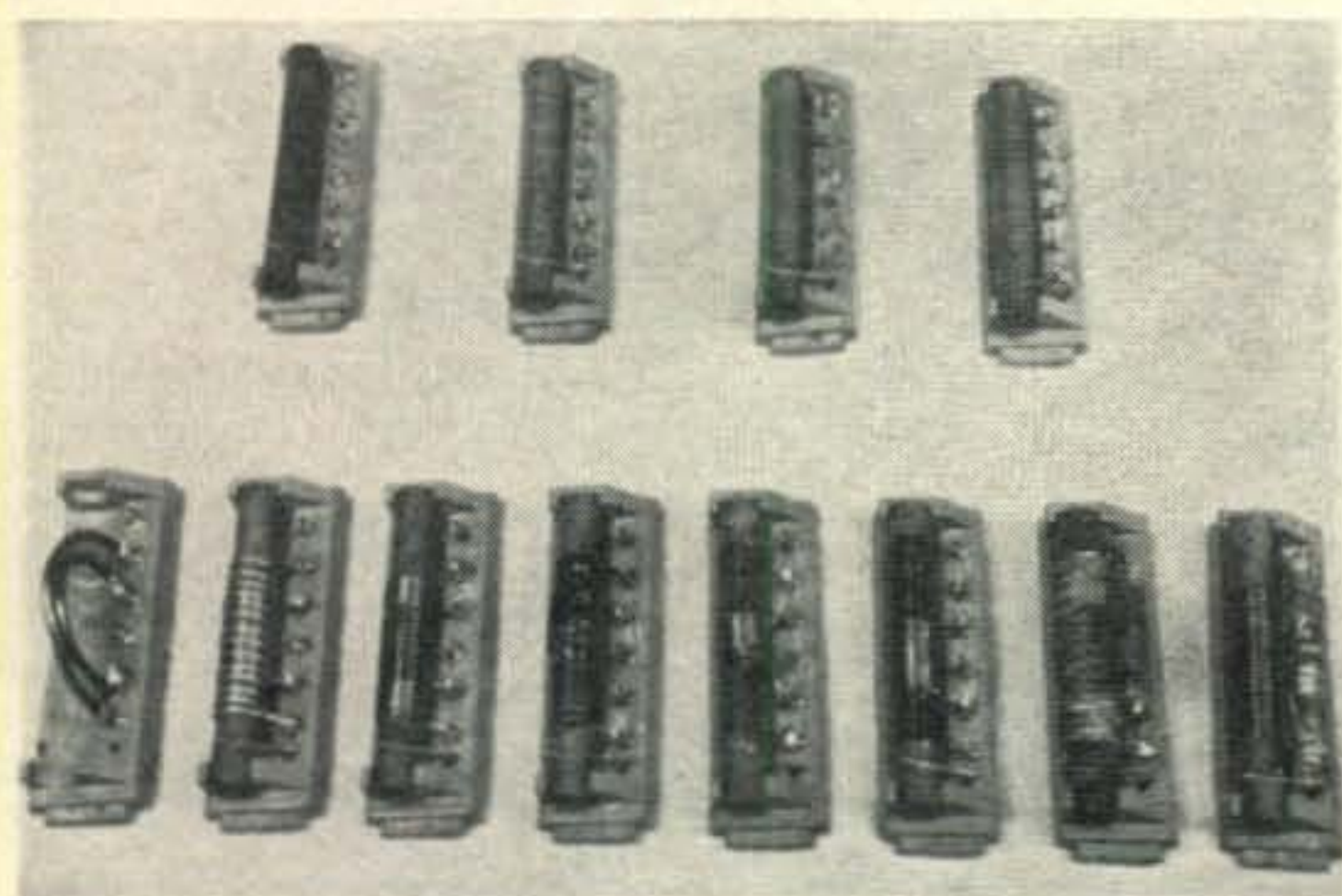

A view of the converted TV tuner inductors. The coil on the bottom right, as explained in the text is for 10 meters as well as the citizen's band. The four forms at the top are spares.

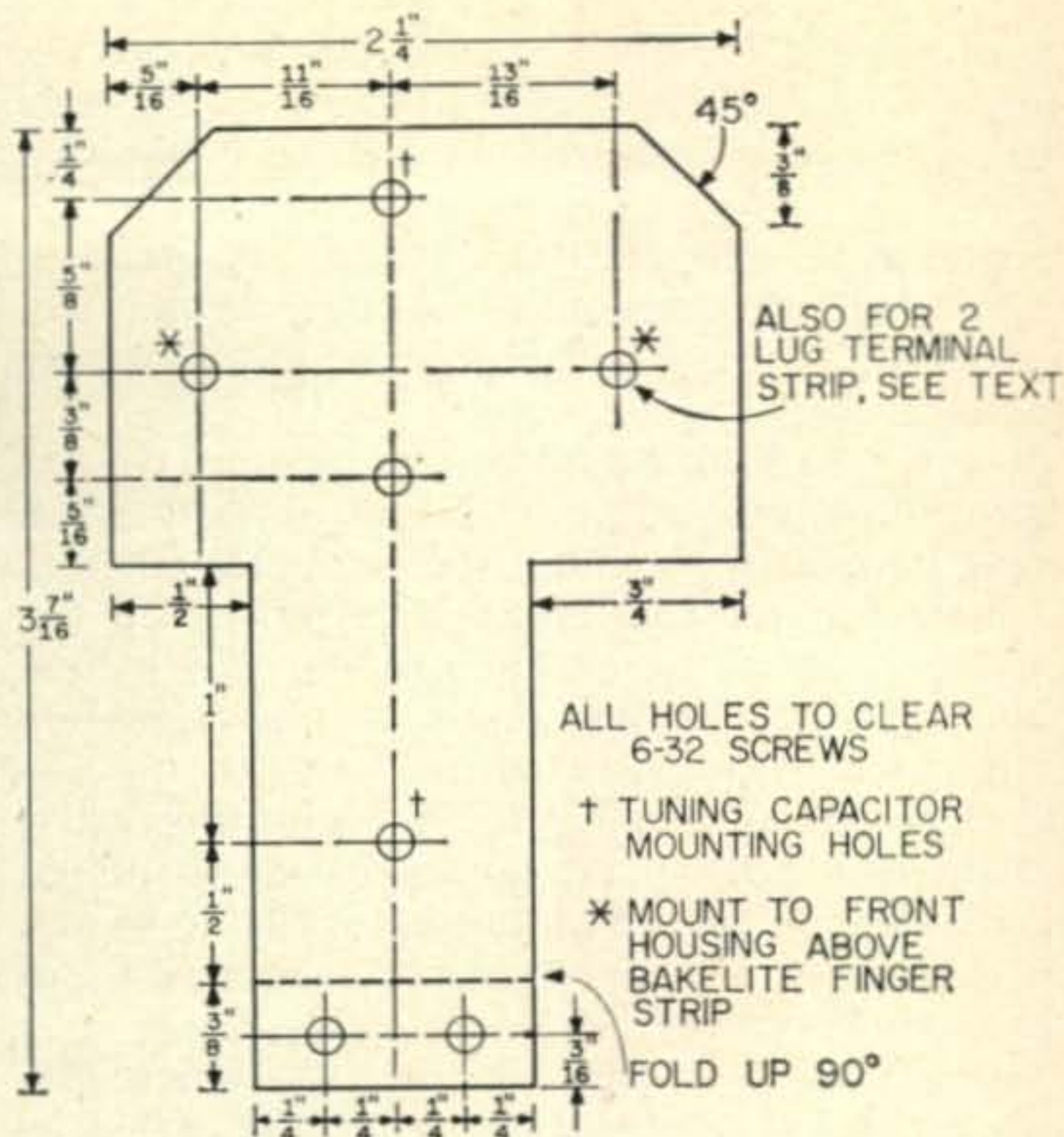

Fig. 5—PLATE A—This plate mounts the main tuning capacitor for the dipper. In this case the dimensions fit the Hammarlund HFD-50.

ing directly to the 955 tube pins, a lug is inserted into each pin before mounting the tube in place. These lugs may be obtained from an old miniature tube socket which is wedged in a vise and carefully crushed to free the lugs. The grid lug is soldered directly to the lower section of the variable capacitor and a piece of #14 bus-wire is brought from this point to finger-strip lug #1, which, for purposes of orientation we'll designate as the lug at the farthest right, (see fig. 6). The plate-blocking capacitor is mounted between the plate of the tube and the righthand lug of the upper section of the variable capacitor. From the same section, (this time the left-hand lug) a piece of #14 bus-wire is extended to finger-strip lug #5 behind plate A. The lug at the extreme left will remain unused. A ground lug is attached to the center of this mounting plate to where the plate shield, separating the two capacitor sections is tied. A 2 lug terminal strip is mounted directly above the 955, where

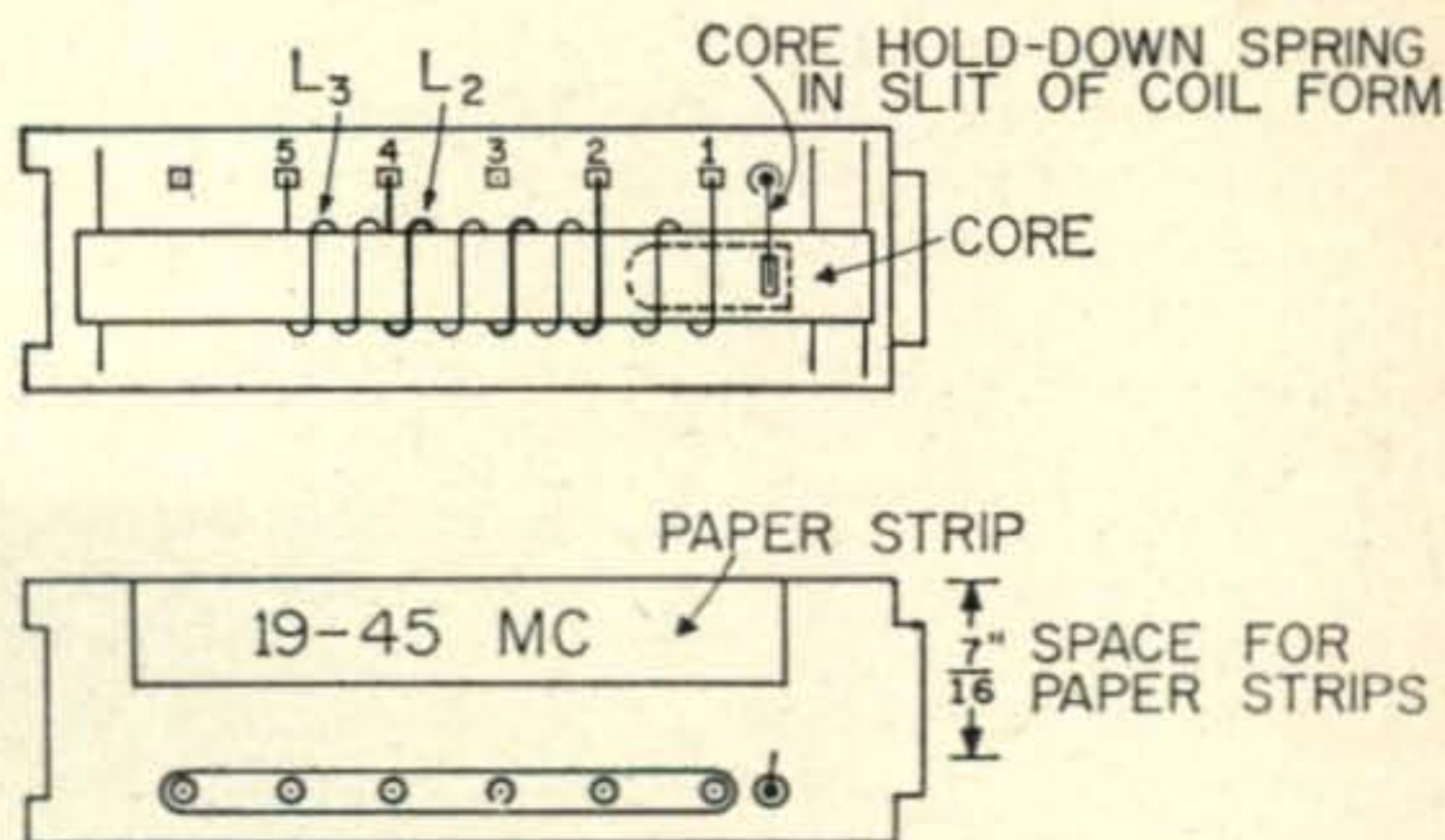

Fig. 6—Drawing illustrating the points used when fabricating the coils. All coil winding data may be found in the Coil Table.

C_3 , C_6 , R_1 and R_2 are attached. Capacitor C_3 is grounded at the above mentioned ground lug, while C_6 is grounded directly to the point supporting the terminal strip. These two capacitors are of the button variety, but if cost is a factor disc type may be used (good to 250 mc), provided shortest possible leads are maintained, in keeping with good high frequency wiring practice.

In order to limit extraneous peaks and dips to a minimum, it is imperative that point-to-point wiring be used throughout the oscillator section. A single lug terminal strip is mounted on the housing close to the cathode of the 955, which is the center pin of the three, on the right side of the tube. Mount the ground end of C_4 , C_5 , and R_3 with a solder lug to the mounting screw and the hot side of the heater to the insulated lug. The toggle switch on the left is the AC switch and below it is the PEAK-DIP switch both of which are mounted on a removable panel.

On the opposite side of the unit, where the link-coupler shaft emerges from the panel, is the compartment which contains the power transformer, potentiometer, S_3 , a 3 lug terminal strip, and other components which take care of the power to the 955 and the microammeter. Above these parts and on the top panel is located the 0-50 microammeter. A sensitive meter was chosen, since, as seen on the schematic, there are two coupling points; one between L_1 and the external circuit being "dipped" and the other being between L_2 and L_3 . Tight coupling is employed between L_2 and L_3 at a point of zero r.f. potential or nodal point of L_3 . This enables a coefficient of coupling as high as possible. This is the one drawback to this method of coupling. Because the sensitivity of the unit is reduced, one must resort to a very low range meter. Full sensitivity, however, is not really necessary, although at first you will probably have to couple closer to get a reading. As the circuit shows, the meter is shunted with R_4 in series with S_3 . With S_2 in the DIP position in almost all cases it will not be necessary to depress S_3 .

Switch S_3 , labeled PEAK SENSITIVITY is located on the left side next to the meter. This was labeled in this manner so it would be used only on PEAK position rather than in DIP as mentioned previously. Just below it is the GAIN control, R_8 . The ZERO ADJUST potentiometer, R_{10} (screw driver adjust) is mounted on the opposite side and just below it and slightly to the left is the selenium rectifier, CR_1 which is not visible in the photographs.

Since no enclosure of the proper size was available, a part of the high-voltage housing from an old TV set was used as the basic frame. This made the unit almost half an inch wider than needed. A pair of aluminum angle brackets with ends folded 90 degrees are mounted along the top of the frame to support the top and end panels. These strips are 4-40 tapped and can be identified from the photographs.

A pilot light is located just behind mounting plate A and its lamp assembly is supported on

the aluminum angle bracket on the right side.

Eight coils and four spares are shown in the photograph. The inductor at the left is for the highest band and the inductor second from the right is for the lowest. In all cases except one, the original TV coil form is used. The coil at the extreme right is the bandspread coil for 10 and 11 meters as well as the citizen's band.

Coil L_2 is either interwound or wound around the center portion of L_3 . For the highest band, L_2 and L_3 consist of a pair of hairpin loops. The low frequency coil was obtained from a permeability-tuned car radio. It used 7-44 Litz wire and measured 85 microhenries. Its diameter was larger than the other forms, so it was slipped over the existing form and cemented in place. The iron core from the radio is not used.

The cores which tuned the original TV coils were used here for purposes of realignment as the unit ages. This is set so that the edge of the coil lines up at the halfway point of the core. The cores are reached from the right side of the unit through a hole drilled to the left of the RANGE SELECTOR knob. Normally, this hole remains covered with a $\frac{3}{8}$ " metal cap.

In the tuner housing, behind the drum, C_7 , the electrolytic is mounted on a terminal strip and nestles comfortably in the space which would otherwise be wasted.

Construction of L_1

The link coupler (L_1) consists of two turns of #14 tinned wire close-wound to form a 1 inch diameter ring. Before winding this coil, slip on a close fitting piece of tubing about $6\frac{1}{4}$ inches long so that the turns do not short together and to offer some protection when probing in high voltage circuits. This wire is then inserted into a line plug used for 300 ohm transmission lines and soldered. The body of this plug as can be seen from the photographs is cut down, mainly to reduce its size. The plug is then inserted into a mica-filled crystal socket which has a center mounting hole that is very carefully enlarged to accommodate a $\frac{3}{16}$ inch hollow fiber rod 2 inches long. A slit is sawed down this end of the rod about $\frac{1}{2}$ inch and the two tinned ends of a pair of twisted wires, preferably *teflon* insulated, are fed through the opposite end of the rod and the ends are fed through the slits and are soldered to the lugs of the crystal socket. The other end of the rod is next slipped into a Millen differential coupler. Since the set screws are liable to dig into the fiber rod, a thin sheet of metal sleeve should be slipped in between the rod and the coupler. To obtain a greater swing of the coupler without abrading the insulated wires, the center ring, upon which the shaft coupler pivots must have the hole reamed out and beveled. This differential coupler is now placed over a hollow $\frac{1}{4}$ inch brass rod which mounts on the front plate by means of another plate which is $\frac{3}{4}$ inch square. This is labeled plate "B" in fig. 7. This latter plate has a hole through its center and the brass rod is press fitted and firmly soldered in place. It is mounted with 4-40 screws

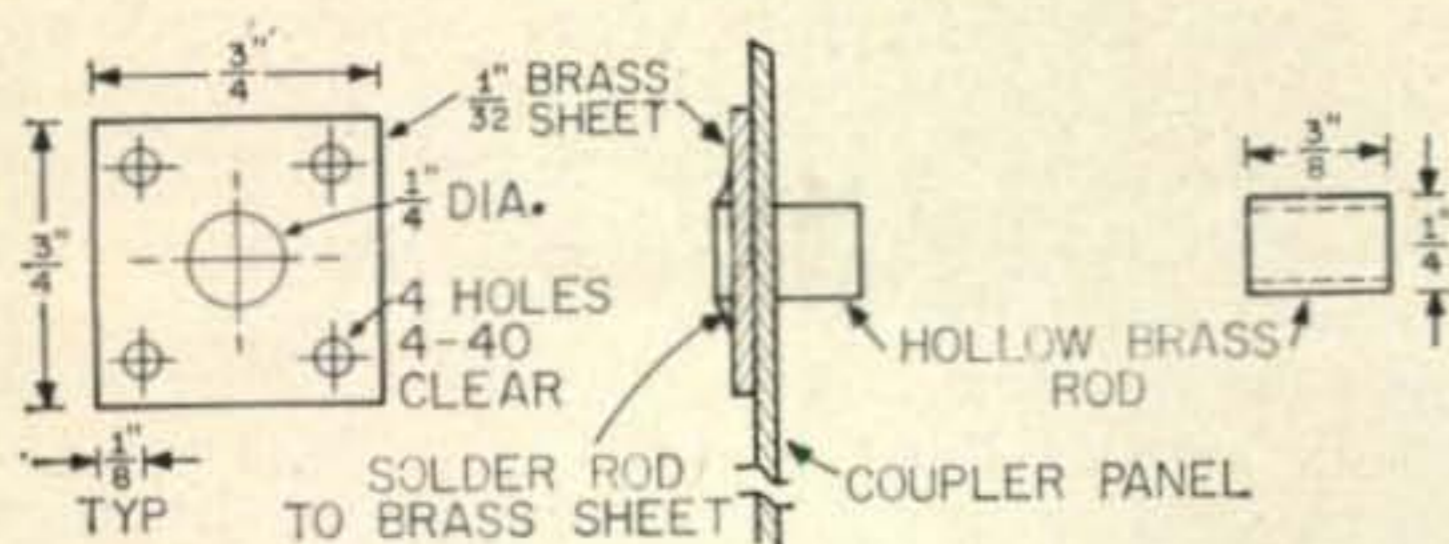

Fig. 7—PLATE B—This plate and bushing are used to hold the Millen universal coupling which connects L_1 to the rotary turret.

from the inside, with the hollow brass rod inserted through the panel to accept the shaft coupler. The loop coupler may then be easily swung through a 90 degree arc either vertically or horizontally.

Tilt Base

To further enhance its flexibility, the forward part of the dipper can be raised by locking in place a "V" leg made from a coat hanger which is supported by two bakelite strips. The top end of the "V" each has a couple of ears extended outward to fit into the bakelite pads. The hole in each strip, has added to it, a vertical and a horizontal groove so that in some applications the leg is pushed forward and locked in the vertical grooves.

Plastic Dial Assembly

To obtain the material for the dial, one must use a bit of diplomacy, regardless of marital status. Helena Rubinstein face powder comes in a clear, round, plastic container which is $3\frac{1}{2}$ inches in diameter and the *Uno-dipper* happens to be the same dimension. (And it's ribbed too!) Since the "hand is quicker than the eye," quickly dispose of the contents and scale off $\frac{3}{16}$ inch all around the circumference. Heat up her favorite knife until it starts to show color and start slicing carefully just above the $\frac{3}{16}$ inch mark. Once this disc drops off, file down carefully to the $\frac{3}{16}$ th mark, taking care not to slip. Use a fine file for the last filing. Next, take some abrasive such as Simoniz cleaner and give it a final polishing. (Rubbing compound is too coarse). Turn this disc upside down so that space for the paper dial is underneath. Take either tracing paper or bond paper and cut a disc $3\frac{1}{16}$ inches in diameter. Draw a line across the center with a sharp pencil of medium hardness, or, if preferred it can be inked. Depending upon the number of bands required, take a compass and construct circles around the center. In our case, six circles, spaced $\frac{5}{32}$ of an inch gives us space for twelve bands in 180 degree arcs plus space for calibration numbers around the knob edges. Another plastic disc, $\frac{1}{32}$ inch thick and also $3\frac{1}{16}$ inch in diameter is slipped in underneath the paper to give it support and to prevent dirt from seeping in along the edges. A $\frac{1}{4}$ inch hole is drilled in the center of all three discs to accommodate the tuning capacitor shaft. The particular knob used here came from a surplus WW II tuner and it had a metal skirt which was affixed

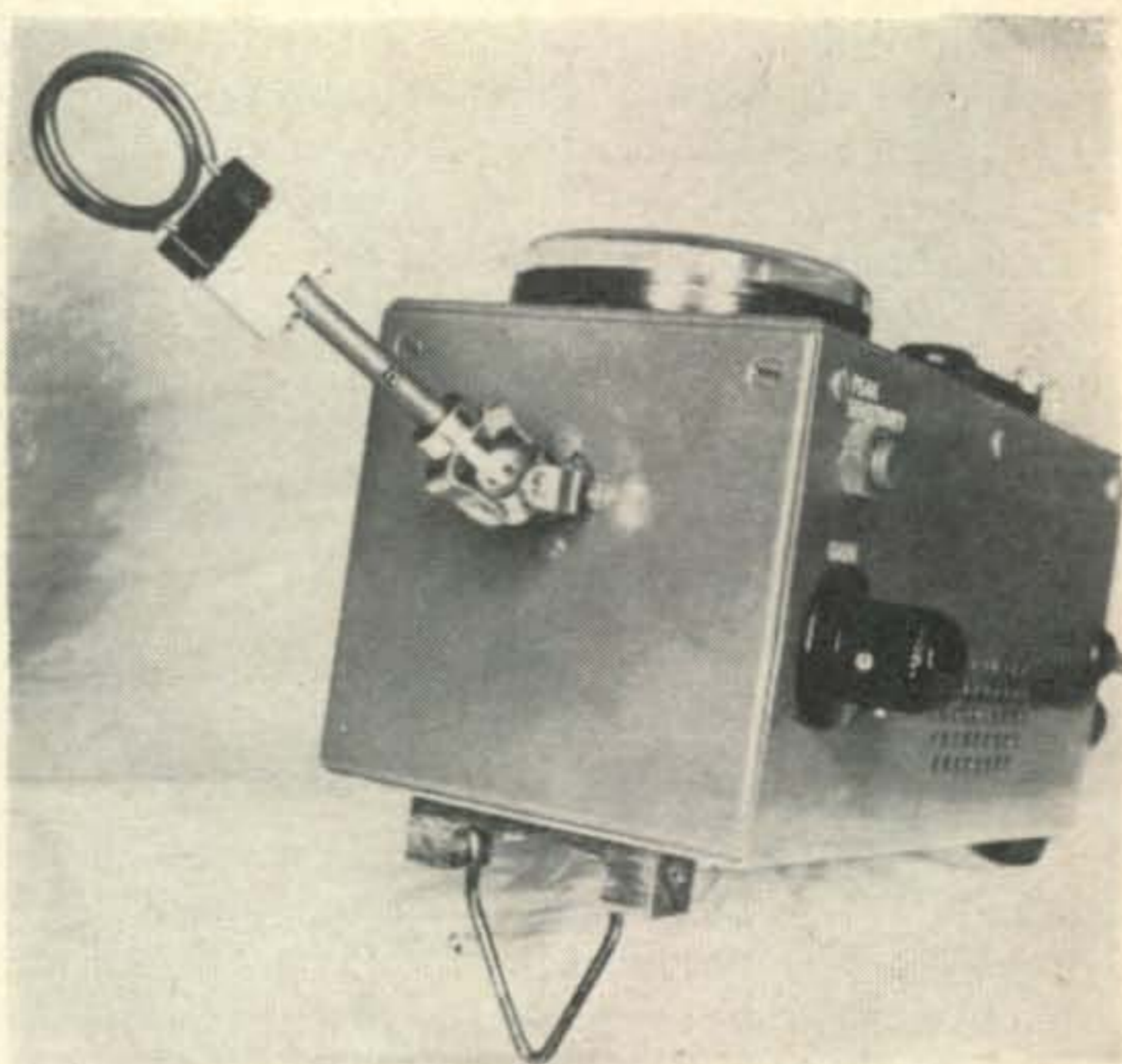

Top view showing details of the pick up loop and "V" shaped foot. The two turn link is soldered to a slightly cut down Millen 37412. In order to prevent abrasion of the pick up wires passing through the universal coupling, (Millen 39005), the center joint of the coupling is bevelled to allow the wires to pass freely. The "V" shaped foot provides a tilt base for the dipper and folds up when not in use. Mounted on the side of the cabinet is S_3 the push button PEAK SENSITIVITY control and below it is the GAIN control R_8 .

to the knob by means of three little self-tapping screws 120 degrees apart. These screws were used to support the three discs for the dial.

The cursor above the dial is made from a $\frac{1}{16}$ inch clear plastic, $3\frac{1}{4} \times 1\frac{3}{16}$ inch with an angle cut out on two sides as seen in some of the photographs. A hairline on the underside of the piece is scribed on carefully. This is mounted on $\frac{1}{4}$ inch brass standoffs.

Escutcheon

Just above the drum, between the meter and the dial is added a $\frac{1}{4}$ inch black bakelite escutcheon which is beveled, smoothed down with rubbing compound and finished off with Simoniz cleaner. A thin plastic window is wedged in from the bottom and cemented in place.

Similarly, a thin piece of plastic is wedged in and cemented to keep the dust out of the aperture of the panel underneath the calibrated dial. This is where the light from the pilot light will show through, to light the portion of the dial being used.

The window of the black bakelite cover is also lighted and shows the band in use. Eight adhesive-backed paper strips were typed for each tuning range. In applying these paper strips in the right sequence, it must be remembered that the active coil is not the one seen through the window but is the third coil from where the finger strip is located.

With a flick of the wrist the required band may be selected while probing; moving the gain control with the left thumb while shifting the

dial with the right thumb. As a typical example, one's eyes are usually shifting between the probe and the meter. With this layout, the probe and meter are almost next to each other. This seems more desirable than the usual dipper, where the meter is located farther apart from the coil probe.

No phone jacks were used here nor were any "do-all" features included since the primary objective was to check the feasibility of this method of grid-dipping, although if one prefers, the circuit may be modified to suit individual requirements.

Increase Frequency Coverage

Originally it was considered to extend the frequency range to around 400 *mc* but for most purposes 250 *mc* was felt sufficient. By the same token, for the home constructor this would have entailed more difficulties. But yet, if one wants to attempt a turret arrangement which would result in shorter grid and plate leads, he may use a 5703 sub-miniature tube which is half the cost of a 955 and actually takes up less space, even though a tube socket is used. Resistor R_3 , in this case, should be changed to 220 ohms.

Since the turret tuner takes up much of the space, a smaller one with perhaps a different configuration might be used, if there are any in existence, as previously mentioned. This will also tend to reduce the weight. Not all surplus stores may handle this type of tuners but a local TV repair shop may have some just gathering dust. In the Chicago area, one should inquire at Elston Electronics Co., 7644 N. Milwaukee, Niles 48, Illinois, as they have different models on hand. In case this particular type tuner is unavailable, one can use tuners of other configurations but modified in the same manner as described here. This *Uno-Dipper* being a prototype, does not necessarily mean that one should follow this layout explicitly but that one should leave room for desired modifications. As mentioned previously, this model was primarily built to prove feasibility. It does not infer that it is the ultimate design.

Maintenance

If in time, symptom of dirty contacts show up, a commercial contact cleaner fluid may be applied to the finger-springs as well as to each drum strip contact with a clean cloth. This procedure, however, will rarely be necessary. To get at these points, lift off the black bakelite cover. The finger-springs may be reached by removing three or four drum strips.

Calibration Chart

A dial calibration chart is not included here because home constructors may want to deviate somewhat from this article. When calibrating, it appears helpful if each band were color-coded to quickly determine the range or part of the range you are seeking to use. For a calibrating source, a receiver or a signal generator may be used.

There are a couple of places where some coil interaction does occur but it is so slight as to be unappreciable. In case of excessive interaction, one may try using every other drum strip. This may prompt the use of a larger diameter coil but the increase in Q is not appreciable enough to be worth while, and here again the danger of even greater interaction may occur. By using every other drum strip, one may have to resort to a variable capacitor which has more capacity so that similar band coverage is obtained.

If most of the ranges show a marked decrease in grid current on the very high end of the band, this is probably due to capacity unbalance of a few mmf but may be large enough to decrease the feedback ratio appreciably. Since this is a small part of the entire variable capacitor, its effect is negligible toward the maximum capacity end. To determine the side with less capacity, touch the lug of each capacitor with an insulated screwdriver and see which side causes the grid current to increase. Once this is found, solder to it a small piece of thin brass sheet and bend it toward the nearest ground point until maximum grid current is obtained.

Applications of the grid-dip oscillator are so varied that they all cannot possibly be covered here. The reader should refer to past articles on same.^{1, 2}

Hindsight

Since this uses a link coupler, methods of link coupling may differ somewhat depending upon the individual case. That is, you cannot link couple into another link or a low impedance pick-up coil as you would with an ordinary dipper. For example, if one wants to use a test instrument which has a pick-up coil which requires energy from a grid dipper, then you would have to couple an absorption frequency meter (L/C tank) between the dipper link coupler and the pick-up coil of the test instrument. The dipper is first tuned to the required frequency and then the L/C tank is tuned to this frequency, absorbing some of the dipper energy. The input to the test instrument is adjusted by adjusting the coupling points to the L/C tank. Otherwise the use of the dipper is similar to the conventional types. The plane of the link is vertical but if in practise, a horizontal plane is required, tilt the unit about 45 degrees until it rests on the RANGE SELECTOR knob. In some applications, it may be desirable to add a coupler locking feature. Or perhaps when the unit is not in use, some means could be employed whereby the coupler could be folded back out of the way and locked. Along this line, originally a BNC 90 degree receptacle (UG-535/U) was used along with a coaxial cable but it appeared too reactive for this purpose. The 2 turn link is used as a universal coupler so at the lower frequencies it becomes a little less sensitive but still usable.

¹Bane, C.F., "About Grid Dip Oscillators", *CQ*, March 1947, p. 13

²Brown, M.E., "Subject: Grid Dippers", *CQ*, January 1953, p. 12

This photograph shows the major mechanical components of the *Uno-Dipper*. At the left is the 0-50 μ a meter, escutcheon and calibration dial. Next, is the meter mounting bracket, plastic plate and mounting bracket. Both aluminum angle brackets are visible, with the pilot light mounted on the bracket to the right. Taking up the major portion of the cabinet is the modified TV tuner. The top and bottom panels lay in their respective places. The power transformer can be seen mounted behind the tuner. At the far right is the "U" shaped cabinet with some of the controls already in place.

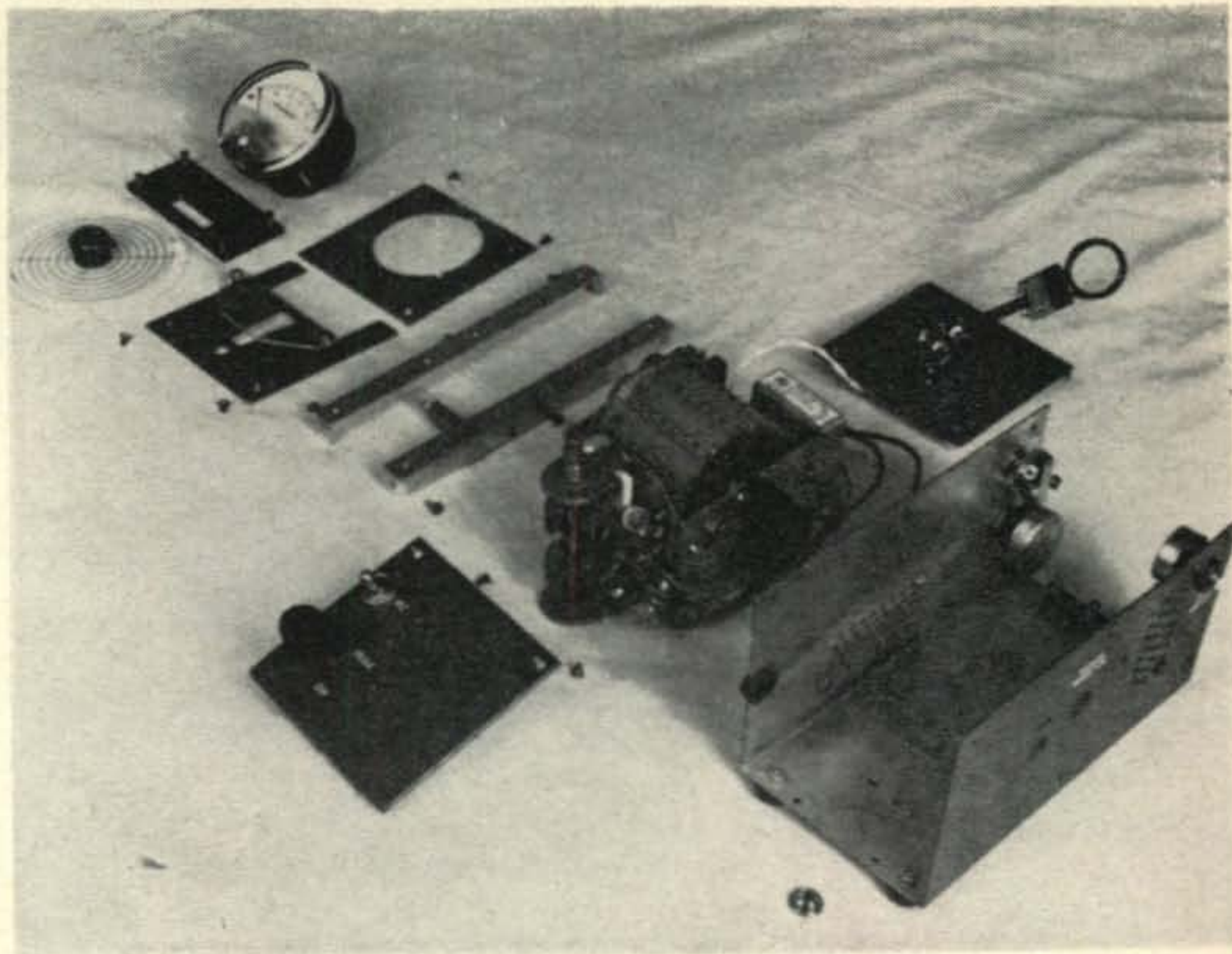

For the microammeter, it is suggested that a meter which is not too well-damped be used. Since some of them contribute most of the weight, perhaps a miniature variety, as used in some dippers be used, except it involves sacrificing some resolution. When switching to PEAK or absorption meter position, many grid-dip meter pointers slam against the stop. The zero-adjust control, R_{10} is added here so that the pointer will "coast" to zero. Another consideration is, that when band-switching, the pointer has a tendency to hit the stops as most dippers do. To avoid this, the grid current is adjusted toward the center portion of the meter scale and then band-switched. Another alternative would be to first switch S_2 to PEAK and then band-switch. Then too, a silicon diode scheme across the meter might be a worthwhile feature to add.

The *Uno-Dipper* cabinet is painted gray with a zinc chromate undercoating. The ventilation holes on the sides are the original holes from the TV set and are not necessary. The complicated cabinet was due to a lack of a proper size box. The aluminum panels need not be 1/16 inch thick. The black bakelite cover is necessary as a separate piece to gain entry into the tuner housing to change the drum strips.

By now it must be quite apparent to the reader that by eliminating the coils we have eliminated such problems as the "parasite coil set," lost, damaged or dropped coils. Of course, this does not hold true if you drop the *Uno-Dipper*!!

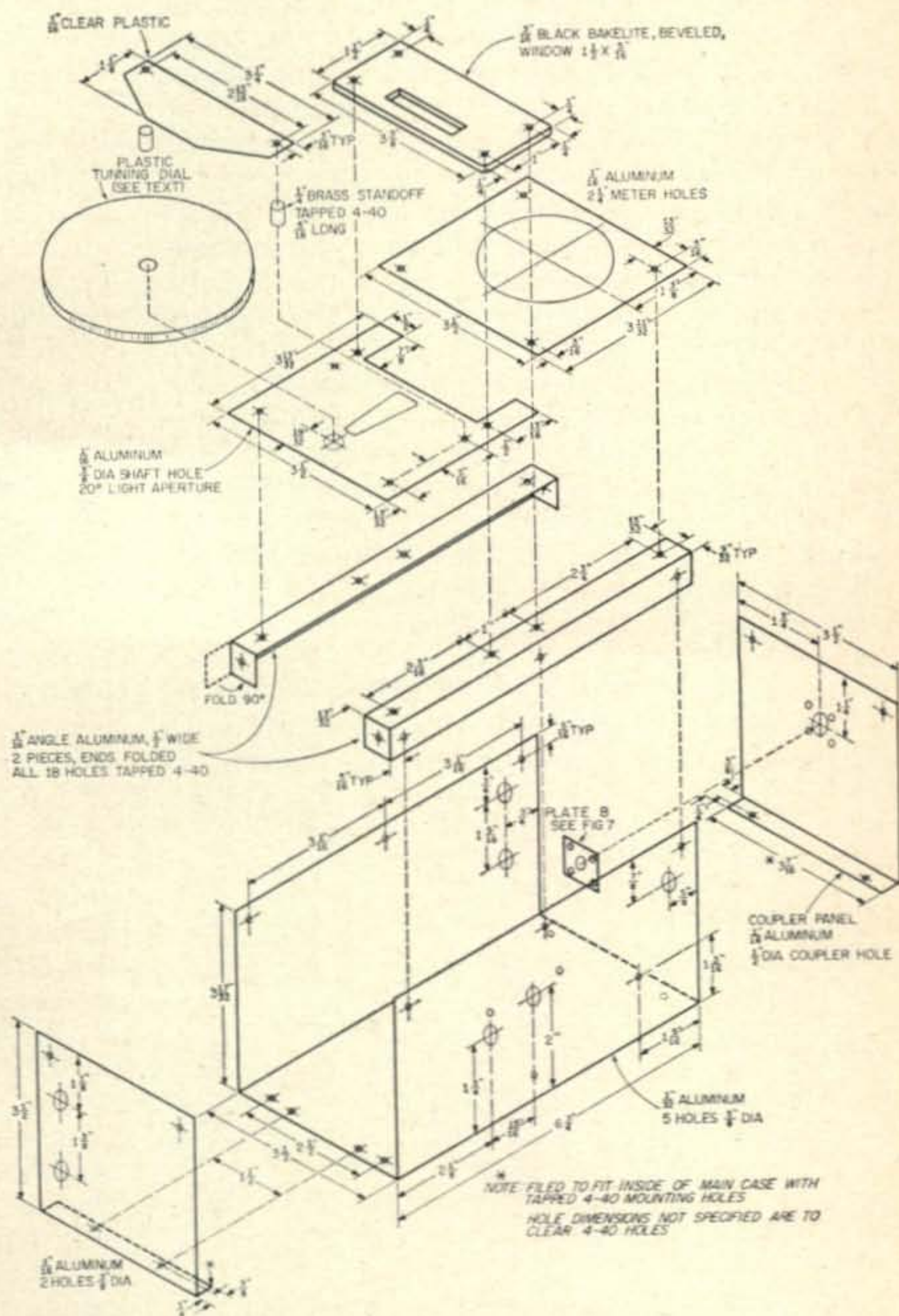

Fig. 8—Exploded view of the mechanical details. The pilot light mounts on the right hand aluminum angle bracket.

The Electronic Phone Patch

Commander Paul H. Lee, USNR, W3JHR

5209 Bangor Drive
Kensington, Md.

Here is a simple, single tube phone patch circuit which can be powered from your receiver. It matches the phone line nicely, it's not frequency sensitive and has no tuning controls.

Since I modernized my operation by converting to single sideband, I have been looking for a good phone patch which would operate automatically without throwing any switches, and which would permit the party on the telephone line to operate the VOX control of the transmitter. This requirement dictates a high degree of suppression of *unwanted* received signals in the transmitter input. I have tried various hybrid schemes involving the use of transformers, but have found that such circuits are quite audio-frequency-sensitive, and also that the balance varies between local and long-distance calls. This state of affairs prevents using this type of circuit for VOX operation.

It seemed to me that I could devise some sort of electronic *nulling* circuit using vacuum tubes which would not be frequency-sensitive, and which would provide freedom from variations in loading caused by different lengths of telephone circuits. A circuit involving a cathode follower output seemed like a good bet for accomplishing the latter objective.

Circuit Description

The circuit of fig. 1 is the result of much experiment, trial and error. In this circuit, the

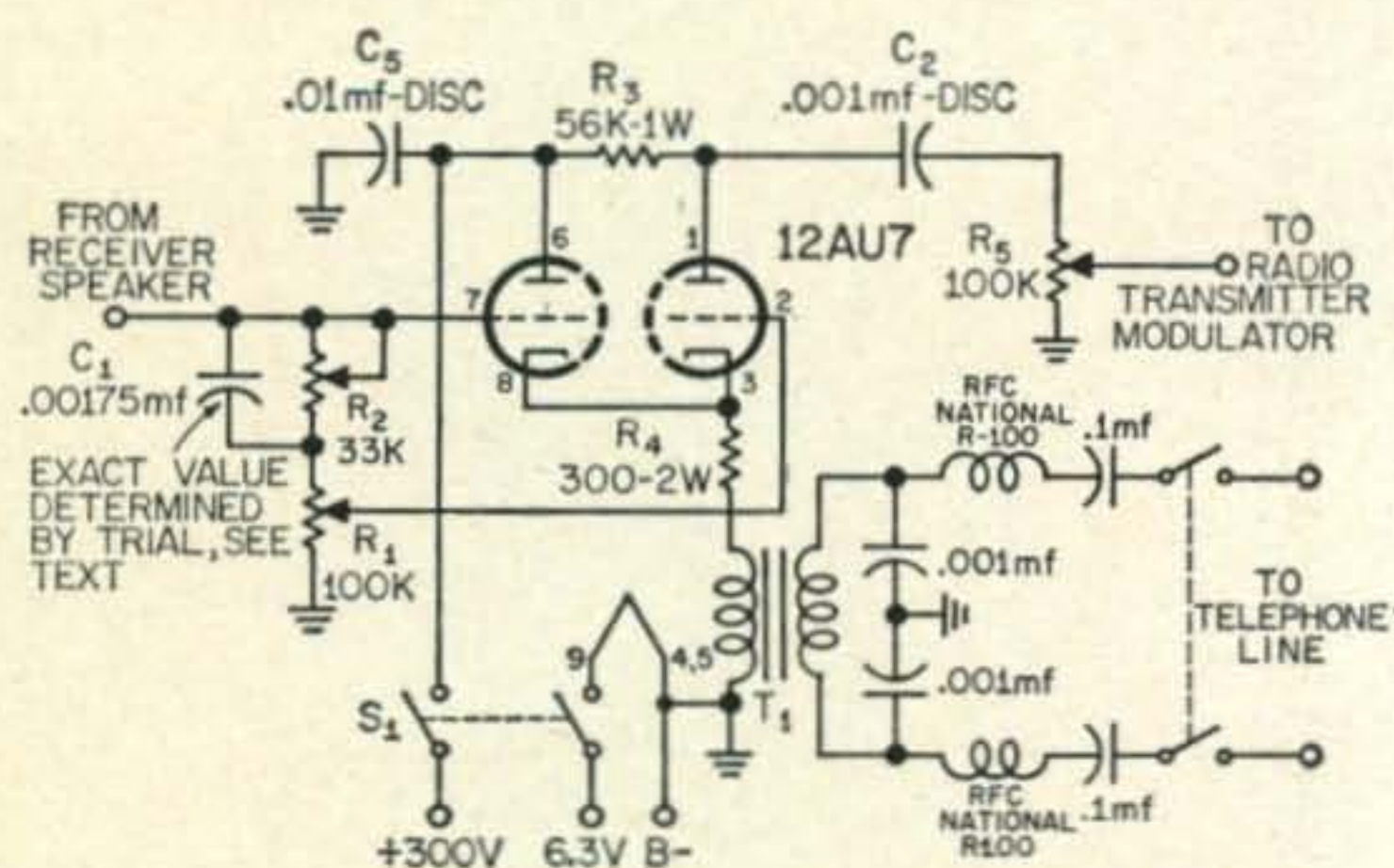

Fig. 1—Schematic of an electronic phone patch. Resistors are $\frac{1}{2}$ watt unless otherwise specified. Transformer T_1 is a 500/500 or 600/600 ohm line transformer. S_1 and S_2 are dpdt switches.

first section of a 12AU7 dual-triode tube is used as a cathode follower, driving the second section through a common cathode impedance. The grid of the second triode section is returned to a potentiometer R_1 . By adjustment of R_1 , the grid of the second triode is supplied with a voltage which is in phase with and equal to the voltage at its cathode, when there is any incoming signal from the receiver.

Therefore, a *nullled* or minimum output of incoming signal exists across plate load R_3 , but an actual amplified output exists across the cathode load impedance consisting of R_4 and the line transformer. Also, any signal coming from the telephone line is coupled into the cathode circuit and appears as an amplified output across R_3 . The telephone line signal does not feed back to the receiver, however, due to the isolation provided by the triodes.

Inasmuch as no transformer is perfect with respect to leakage reactance, a slight amount of compensation must be included in the circuit to balance out this effect. This compensation is provided by capacitor C_1 , whose value will depend only upon the leakage reactance of the transformer used. In my case, the value of C_1 which gave the best null, was found to be 0.00175 mf, made up of several smaller values in parallel.

The two capacitors C_3 and C_4 should be a good grade of paper capacitor, to keep the patch from giving any unwanted *dc* path across the telephone line which would cause relays at the central office to lock in.

Construction

The patch unit is built in a small aluminum box, which is then mounted on the side of my operating desk. Connections to receiver and transmitter audio jacks are made by means of shielded patch cords. The various controls on the patch are at the top of the box. The switch opens the plate and filament supply circuits. The patch can easily be powered from the station receiver. In my case, I simply ran a *shielded*

[Continued on page 114]

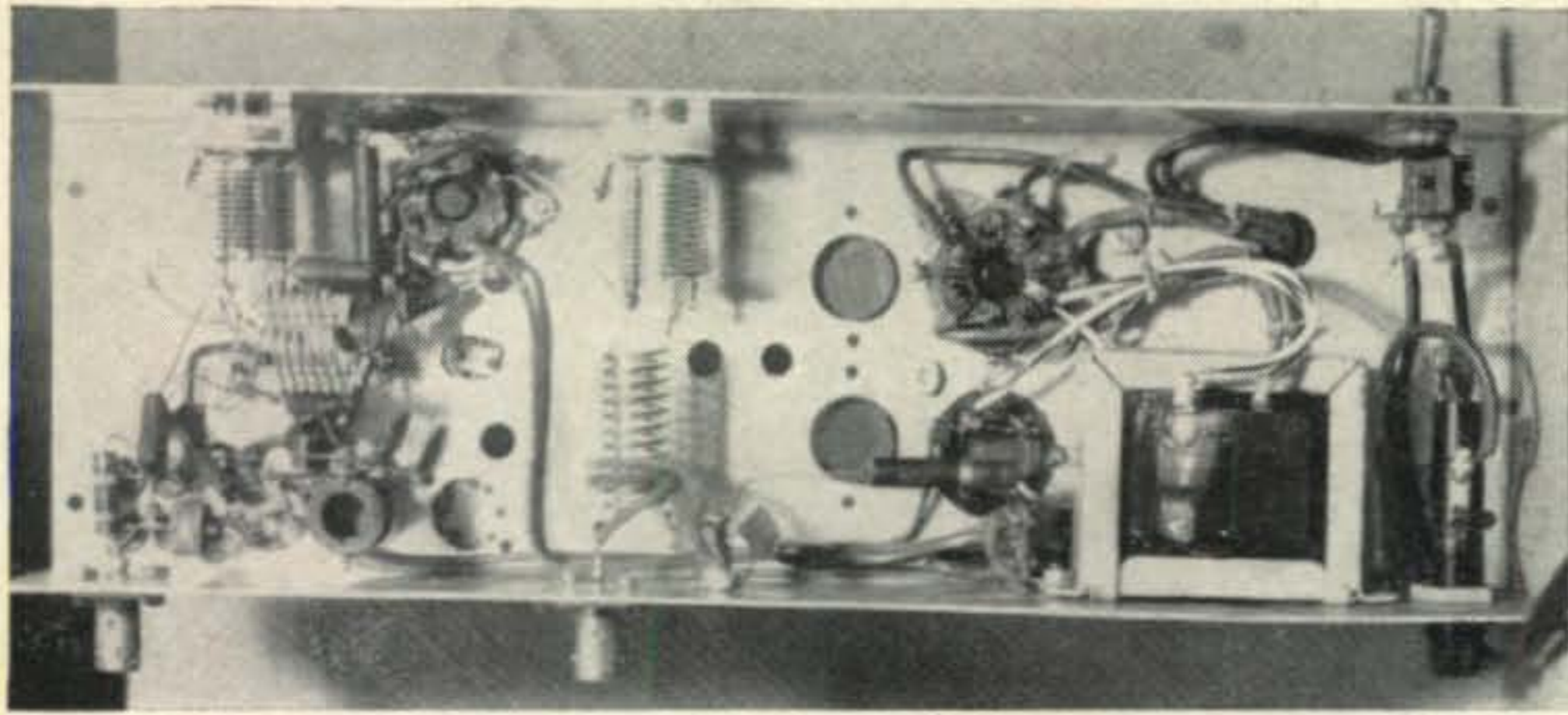

Bottom view of the 10 meter mixer. J₁ exciter input is mounted at the bottom left and J₂, RF out is almost in the center. L₁ can be seen mounted on the main chassis between the BNC coaxial connectors.

An S.S.B. Ten Meter Mixer

Ed Marriner, W6BLZ

528 Colima Street
La Jolla, Calif.

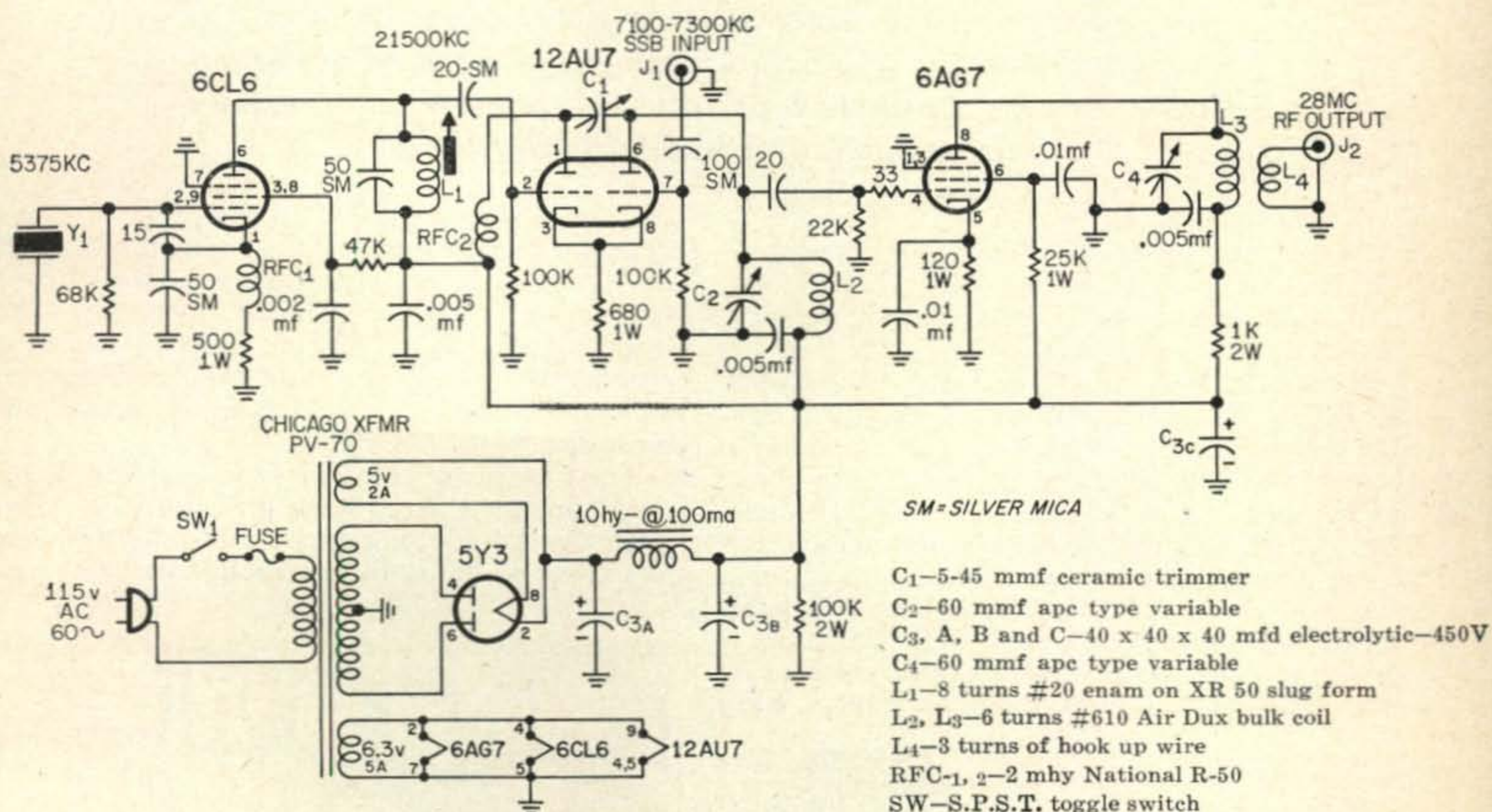

Fig. 1—Schematic of an SSB Ten Meter Mixer. All resistors are 1/2 watt unless otherwise specified. All fixed capacitors are silvered mica with the exception of the decimal values which are disc ceramic.

Ten meters, let's go! Here is a simple mixer using surplus parts that will put the 10B or 20A owners on ten meters in a hurry. Stop procrastinating, this circuit is easy, no fuss, its wonderful. Just leave the 10B on forty meters all of the time and feed it into this mixer. With a flick of a switch you can work either band immediately, no tuning involved. It is also much more of a stable system than trying to build a *vfo* and multiplier to inject at high frequency into the 10B.

The 6CL6 crystal oscillator quadruples using a 5375 kc surplus crystal to obtain output at 21500 kcs. This frequency when mixed with 7100-7300 kc from the 10B exciter will give you output from 28600-28800 kc with enough power to drive a pair of 6146's class AB-1, or it will drive 4-6AG7's in grounded grid operation.

Construction

The only critical placement of parts is to keep the 6CL6 output coil far enough removed from the grid to prevent self oscillation. If it is close to the grid pin a small shield can be placed between the plate and grid across the socket of the 6CL6.

Wire the 6CL6 crystal oscillator circuit first and obtain a 21500 kc output. Next wire the mixer and when it is finished couple a field strength meter close to the coil. Tune in the 21500 kc signal and carefully tune C₁ which is the small condenser between the plates for a minimum of signal. There will also be a signal at 26875 kc which we can't do anything about unless a 10750 kc crystal was used in a doubler

[Continued on page 114]



K6BX Pleads Guilty!

Carole F. Hoover, K9AMD
401 East Wood Street
Hillsboro, Illinois

In Clif's own words: "Too many people think of amateurs as the 'boy' down the street who possibly causes a bit of TVI now and then . . . so amateurs gaining recognition of various achievements constitute a perfect vehicle to tell the true story to the public and the world at large . . ."

Would you believe that one man is responsible for hundreds of hams losing sleep, meals, and sometimes wives because they spend so much time at their stations? Whether or not you're a believer, it's true, and Clif Evans, K6BX, of Bonita, California, is the guy behind the 8-Ball! As the new editor of the unique *Directory of Certificates and Awards*, Clif is proud to be the founder of the Certificate Hunters' Club (CHC). Although the average amateur has a big job working 100 different countries for a single award, (DXCC issued by the American Radio Relay League) a basic CHC certificate is given only to those whose awards number at least twenty-five. Colorful gold seals mark addi-

tional attainments up to a staggering total of 100 different certificates. Amazing as it may be over fifty have already qualified including Jim Ringland, W8JIN, of Cincinnati, Ohio, who sent proof of his 131 achievement awards representing countless contacts with countries throughout the world.

The Certificate Hunters' Club and the *Directory* combined, keep Clif busy until 2 A.M. almost every morning answering some sixty letters received daily. Begun about two years ago



The author, K9AMD wraps a *Callbook* which will be sent to Margery Snyman, ZS1RM, of Strand, South Africa. This is the 1st YL-to-YL exchange in the *Callbook* program begun by Clif Evans, K6BX, to promote friendship between amateurs of the world.



A candidate for the Certificate Hunters' Club is Stan Surber, W9NZZ, of Peru, Indiana. Stan holds dozens of Brass Pounder Awards, the Edison Award, and countless other confirmations of his service to ham radio, the United States government, and many countries of the world. Stan has kept daily skeds for years with the Arctic out-post stations.

by William Clark, W3RPG, the Directory is quite a challenge even for a journalist. Ex-Navy Commander, and avid DXer Evans intends to keep it going as a service to fellow hams. Included is information on how to get 350 awards from over 50 countries on six continents, and the data is revised constantly to keep subscribers up to date.

"Considering the cost of postage and paper, I'm running in the red," says K6BX, "but all I hope to do is break even some day. It's definitely not a commercial venture."

Another K6BX project causing comment far and near is the Goodwill-Callbook program he started about a year ago. Acting as a clearing house, he solicits names of U.S. hams who have callbooks to discard. He then sends them the address of an overseas amateur who finds it next



An Honorary Member of the Certificate Hunters' Club, F. E. Handy, W1BDI, representing W1AW and the ARRL, is shown signing the A-1 Operator Award of K9AMD.

to impossible to get a book. So far, some 1100 have been placed in far away countries and the demand is great.

"I have over 230 letters requesting callbooks right now," Evans said, "and I get 20 more every week. Anyone with a book issued within the last three years can make another ham very happy for only the cost of postage."

With barrels of correspondence, Clif receives many letters bearing foreign stamps which he feels are too valuable for the wastebasket. As a result, the Shriner's Crippled Children's Hospital in Los Angeles now has a thriving stamp club

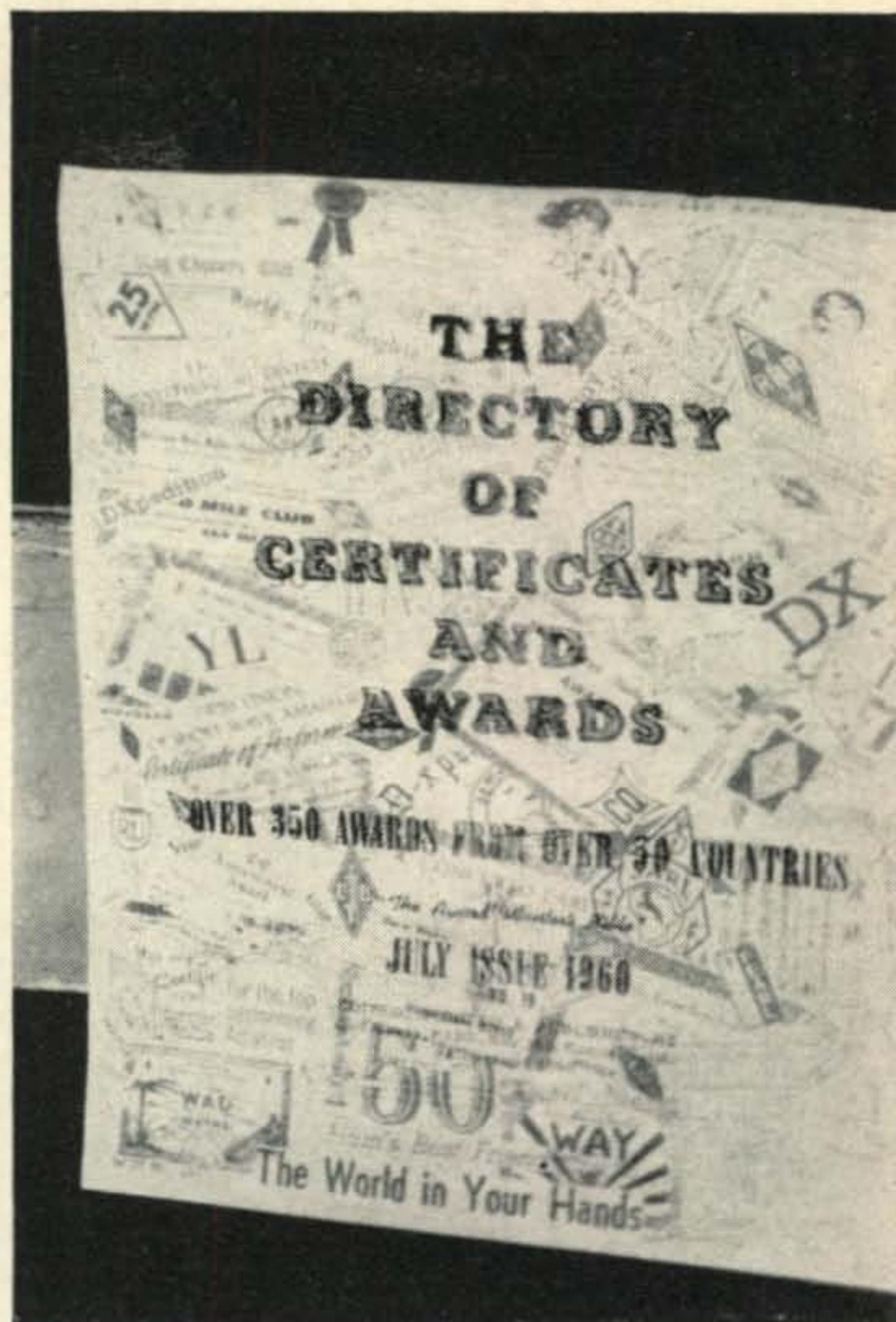

Shown here is the cover of *The Directory of Certificates and Awards* begun by Bill Clark, W3RPG, about two years ago and now edited by Clif Evans, K6BX, who hopes to maintain it as a service to hams and not as a money-making venture.

and Clif invites any DXer to send their stamps along, too.

With the first issues of his *Directory of Certificates and Awards* now in the mail, the Callbook Service and Certificate Hunters' Club to maintain, Clif Evans dares to ask for more letters and suggestions from his readers. Completely dedicated to his hobby of ham radio, K6BX needs more than 24 hours in his day. ■



Becoming one of the most sought after awards currently being issued is the "Certificate Hunter's Award". Just one of Clif's "babies".

A Crystal-Controlled Frequency Coupler

Henry G. Elwell, Jr., W2JKH

392 Lafayette Ave., Westwood, N. J.

The age of push buttons is here! Following the publication of his article "A Crystal Synthesizer 3.000 to 3.999 Mc." many enquiries were received concerning its use on other bands. With this unit it is possible to produce output every 1 kc on bands other than 80 meters. Stepping relays, not often found in amateur gear also makes this unit quite unique.

A Frequency Coupler may be defined as a component of a transmitter which is driven by a master oscillator and provides driving power to an amplifier operating on a different output frequency, not necessarily harmonically related. The device described in this article and in use at W2JKH is actually a "converter", but the use of the latter word almost automatically infers receiver use. Therefore, the term Frequency Coupler is used herein to describe a frequency conversion unit in a transmitter.

The Frequency Coupler described, is used between a Crystal Synthesizer¹ operating from 3.000 mc to 3.999 mc, and amplifiers operating in the 3.5, 7, 14, 21, 28, and 29 mc bands. It may, however, be used with any master oscillator of comparable tuning range to replace multi-band harmonic generators of the doubling, quadrupling, etc. type. Such a device described here is essential for multi-band use of an SSB exciter.

Novel Features

Two relatively novel features are introduced in this design as far as published amateur constructed equipment is concerned:

1. Use of rotary stepping relays for automatic band-switching.

2. Series mixing of two frequencies at a common electrode.

With all the rotary stepping relays on the surplus market, it is surprising the limited use to which they have been put in amateur service. The stepping switch is ideal for remote switching, and when activated by a push button, produce instantaneous band selection in less than one second.

A second feature permits coupling to a high impedance output of a master oscillator which may use an untuned buffer output stage with an *rf* choke for a plate load. Conventional methods of parallel mixing at the grid, or mixing one signal in the grid and one in the cathode circuit were unsatisfactory.

Block Diagram

Figure 1 indicates in block diagram form the basic plan of the Frequency Coupler. It consists of a triode crystal oscillator, a frequency doubler, and a mixer stage. Subminiature tubes are used in the first two stages, and a 6AR6 tetrode is used, as a mixer, to produce reasonable output. Table A shows the frequencies at which the various stages operate. Crystal frequencies were se-

¹Elwell, Henry G., "A Crystal Synthesizer 3.000 to 3.999 Mc," *CQ*, Nov. 1959, p. 34.

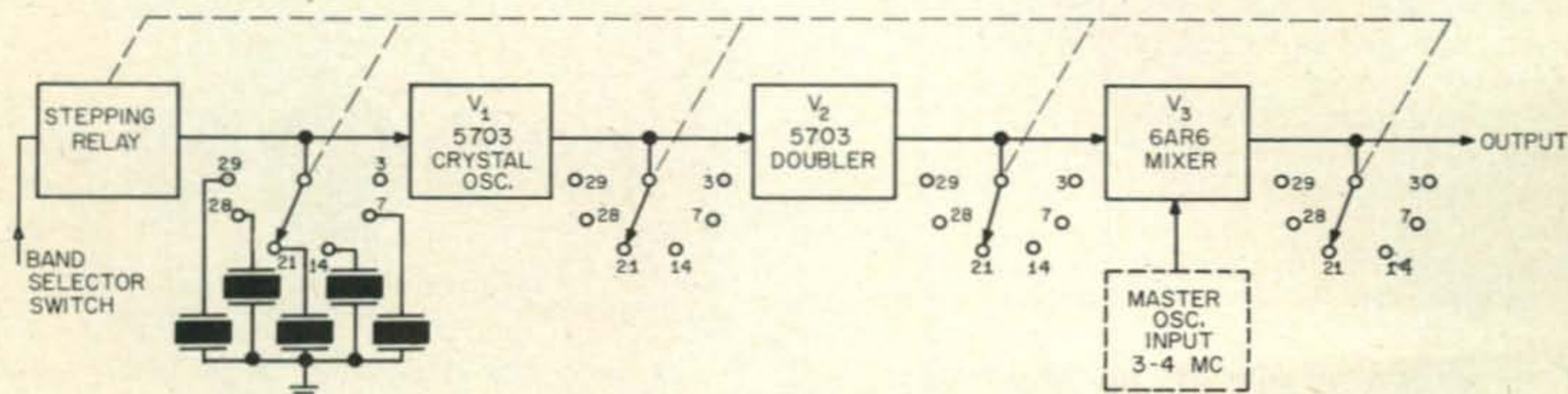

Fig. 1—Block diagram of the Frequency Coupler showing relationship of stepping relay to band-switching. The master Oscillator was described by the author in a previous article.

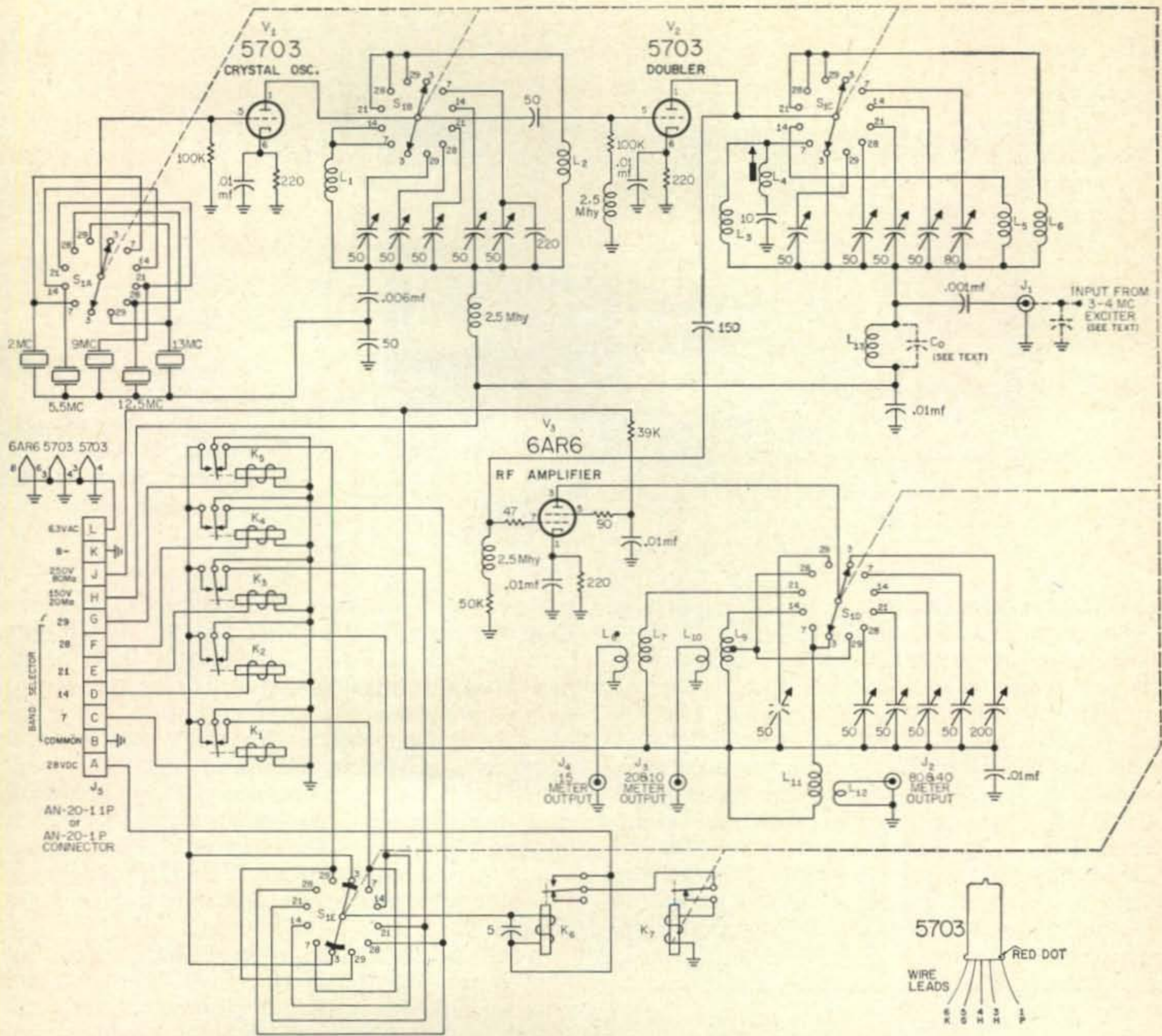

Fig. 3—Schematic of a crystal controlled frequency coupler, which, when used in conjunction with a crystal synthesizer will give 1 kc steps on all amateur frequencies 80 through 10 meters. Switches S_{1a} through S_{1d} are two pole 6 position non-shorting type. S_{1e} is of the shorting variety.

lected so that doubling in the second stage would take place for each band.

Table A

Switch Position	Crystal or V_1 Plate Mc	V_2 Plate Mc	V_3 Plate Mc
3	none	none	3-4
7	2	4	7-8
14	5.5	11	14-15
21	9	18	21-22
28	12.5	25	28-29
20	13.0	26	29-30

Circuitry

Figure 2 shows the schematic of the Coupler which is relatively conventional and a discussion of it can be limited.

The crystal oscillator, V_1 , is of the triode type with additional feed-back provided by returning the low voltage end of the crystal to a capacitor voltage divider in the plate circuit. This circuit

has been found to produce oscillations even with low activity crystals. The plate tank circuit switching was selected to minimize the number of coils used. A common coil is used for the 7, 14 mc outputs and one for the 21, 28-29 mc outputs; variable capacitors are then switched in for each band. The use of a type 5703 subminiature tube operating at 150 plate volts was found to be satisfactory.

The same arrangement is used in the second stage, V_2 , which is always operated as a doubler to provide best output without requiring neutralization. A series trap circuit tuned to eliminate an 8 mc harmonic is required when using the 7 mc output.

C_0 and L_{13}

Series mixing of the crystal controlled frequency and the frequency from the master oscillator takes place in the grid of the mixer stage, V_3 , utilizing the tuned circuits of V_2 and the input coil L_{13} . Inductance L_{13} is tuned to approximately 3.5 mc by the distributed capacity of the coax cable connecting the Coupler from the

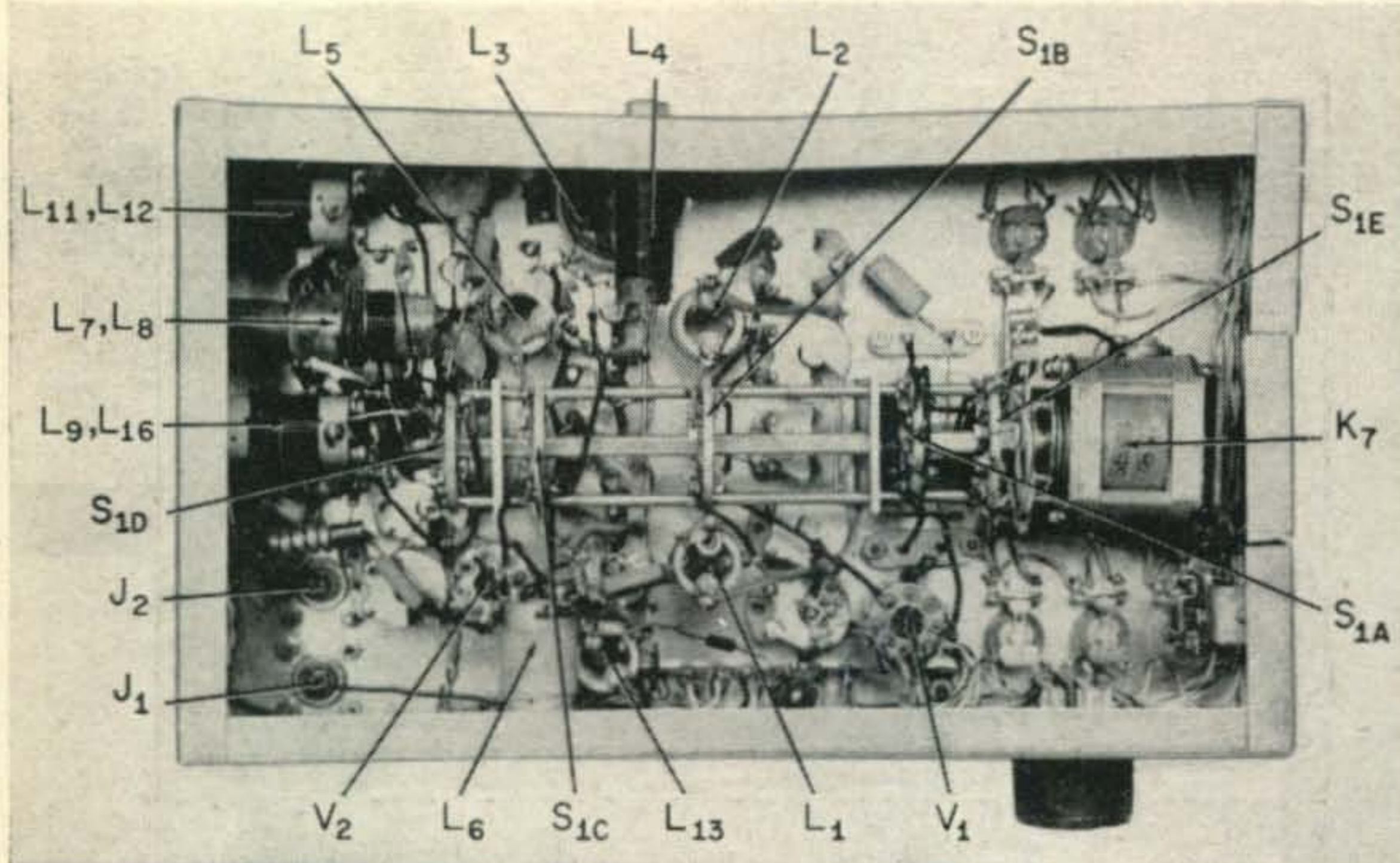

Under chassis view of the frequency coupler showing parts location and method of linking the stepping relay to the switch shaft.

master oscillator. If desired, a variable capacitor, C_0 , may be added to facilitate tuning.

The mixer and output stage, V_3 , utilizes common tank coils where possible, and are linked coupled to separate coax connectors. The arrangement used at W2JKH was selected because the outputs will go to different output amplifiers as indicated. It can be seen that the mixer stage is used as a straight through amplifier on 80 meters. The stage draws approximately 80 ma at 250 volts. Suppressor resistors in both the control and screen grid are required for stable operation. Table B shows the suggested coils dimensions.

Table B

Coil	Diameter Inches	Wire size	Number Turns
L ₁	3/4	26	40
L ₂	3/4	20	18
L ₃	1 3/8	24	27
L ₄	5/8	26	87*
L ₅	3/4	20	29
L ₆	3/4	20	14
L ₇	3/4	20	8
L ₈	3/4	20	3
L ₉	3/4	20	14 tap at 5
L ₁₀	3/4	20	3
L ₁₁	3/4	20	30
L ₁₂	3/4	20	3
L ₁₃	3/4	sufficient turns to resonate with coax cable, see text.	

*Slug tuned.

Rotary Stepping Relay

The rotary stepping relay, K_7 , requires special treatment as little use of it has been found in amateur publications. The rotary switch is a solenoid which produces rotary motion. It has a built in switch which is normally closed, and is in series with the excitation to the solenoid. When energized, the solenoid rotates a shaft to

the extremity of motion, 30 degrees, at which time the switch opens the circuit. A latching arrangement maintains the output shaft at its new position, but a spring pulls the solenoid to its unenergized position. If excitation is still applied to the circuit, a 30 degree rotation will again be imparted to the output shaft. This will continue to rotate the output shaft at about 60 rpm in 30 degree steps until the main circuit is opened. Therefore, the secret of operating a stepping relay is to rotate it until it reaches a set of open contacts; you are then on the band desired.

It will be noticed from fig. 2 that a relay, K_6 is in series with the built in switch of the stepping solenoid K_7 . Although a make before break switch is used in S_{1e} , the solenoid would not rotate the five ganged switches to a full 30 degrees before it became de-energized due to the opening of S_{1e} . The relay with a condenser across its coil permitted a time delay so that the solenoid rotated to its full 30 degrees before breaking. Putting a large condenser across the solenoid did not produce satisfactory results. The writer would appreciate comments on the experiences of others on this matter.

Herbach and Rademan, Inc. of Philadelphia advertise as catalog TM7565 a 28 volt rotary stepping relay containing wafer switches on a 7" actuating rod, and a 12 volt relay all mounted on a bakelite board in a diecast chassis for \$2.95. This should do nicely for K_6 and K_7 .

Since the surplus market is full of 28 vdc relays, shop around. However, *Herbach and Rademan* also list as catalog TM9137 an assembly of 9,28 vdc relays, seven of which are *spdt* for \$4.95 which should ideally fit the requirements for K_1 through K_6 .

Switching Sequence

Reference to fig. 3 will indicate how a particular switching sequence takes place. Briefly, with no band selecting switch closed, or just the 3 mc one, (which goes nowhere), the circuit is as shown and nothing happens; K_7 open circuited.

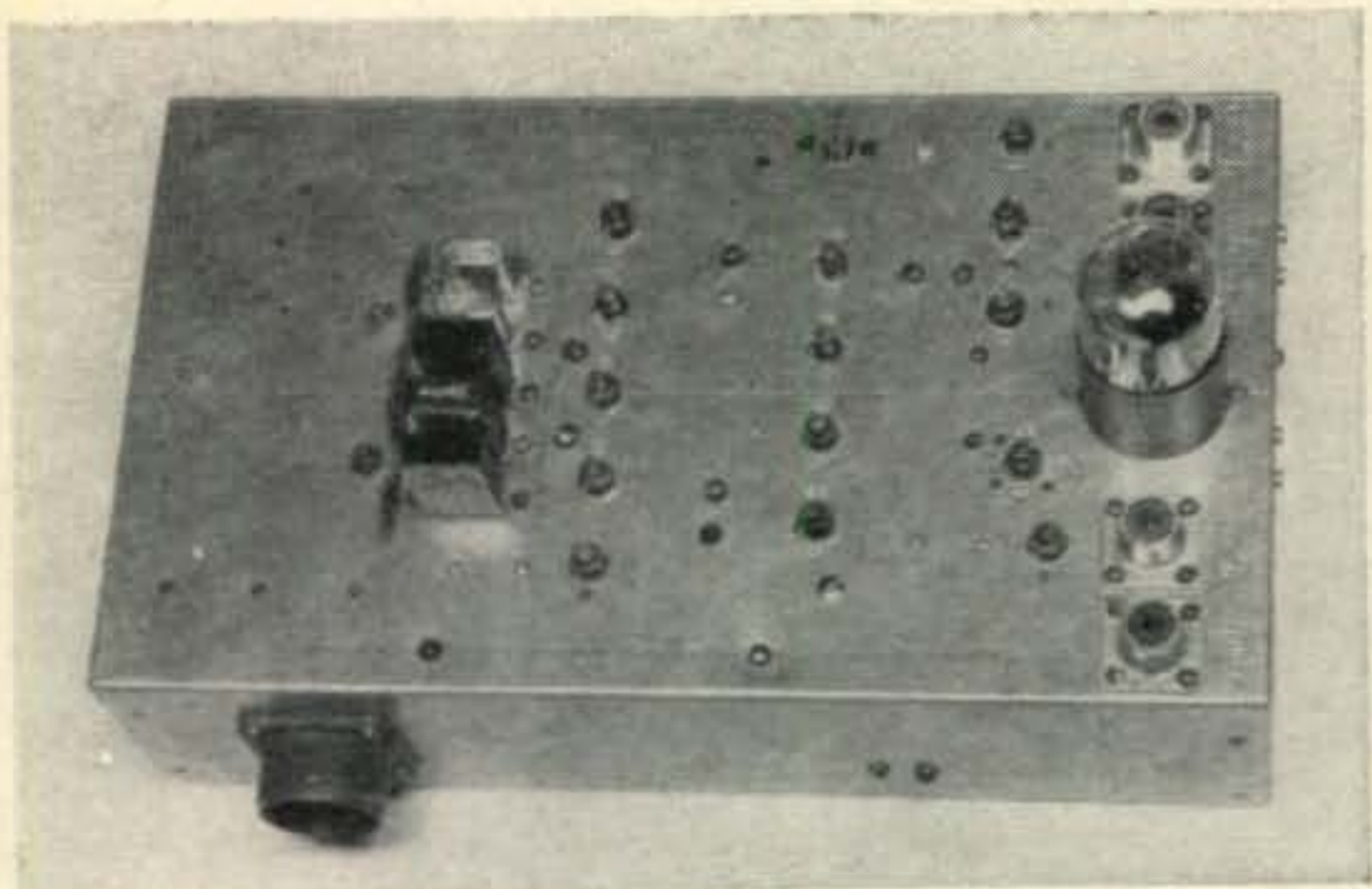

Top of the frequency coupler showing crystal and capacitor arrangement. The AN connector, J₅, supplies power and switching signals from the push-button consol. The coaxial connectors are, from bottom to top, J₁ master oscillator input, J₂ 80 and 40 meter output, J₃ (partially hidden by the 6AR6) 20 and 10 meter output and J₄ 15 meter output.

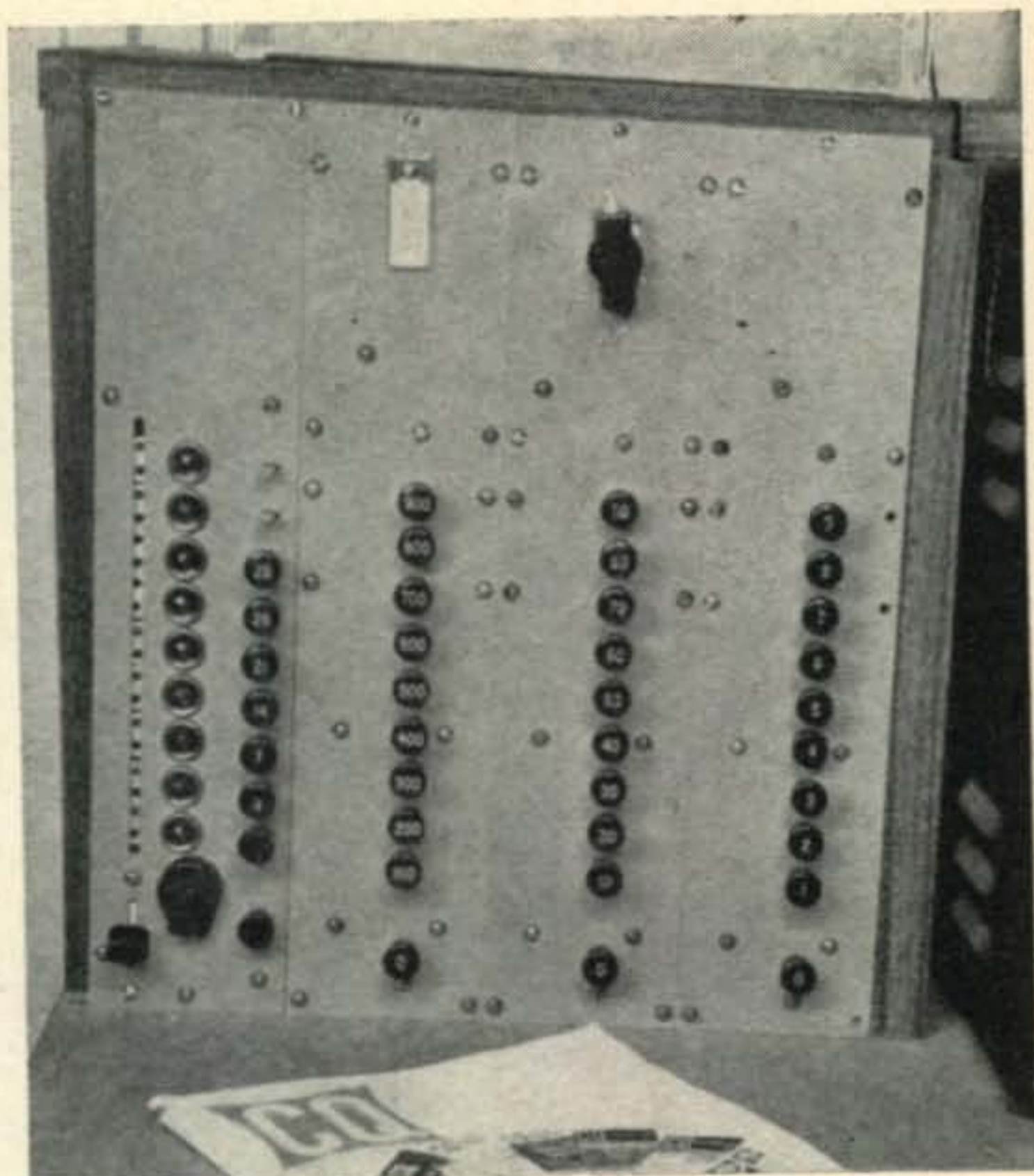

Push button consol at W2JKH. By actuating appropriate buttons, choice of frequency is made instantaneously. For example; $7+100+20+8=7128$ kc.

If the previous condition had been 7 mc, (see dotted connections in fig. 3), and the 3 mc band was selected, relays K₁-K₃ would be unenergized thereby grounding the end of the solenoid, K₇, and the solenoid would step around through the 14 mc, 21 mc, etc. until the switch S_{1e} reached the 3 mc band. This position would be open, and the switch would stop. Other switch positions are similar. With the arrangement shown, five relays select six bands; any surplus 28 volt relay may be used. If found desirable, single pole, double throw toggle switches could be used in place of the push button-relay combination. Incidentally, a second set of contacts on each push button, not shown, applies 115 vac to the system

and to the appropriate final amplifier when any button is pushed initially energizing all equipment.

Tuning

Tuning of the unit is straightforward. On any given band, the sequence of tuning is as follows:
1. V₁ tank tuned to produce less than maxi-
[Continued on page 104]

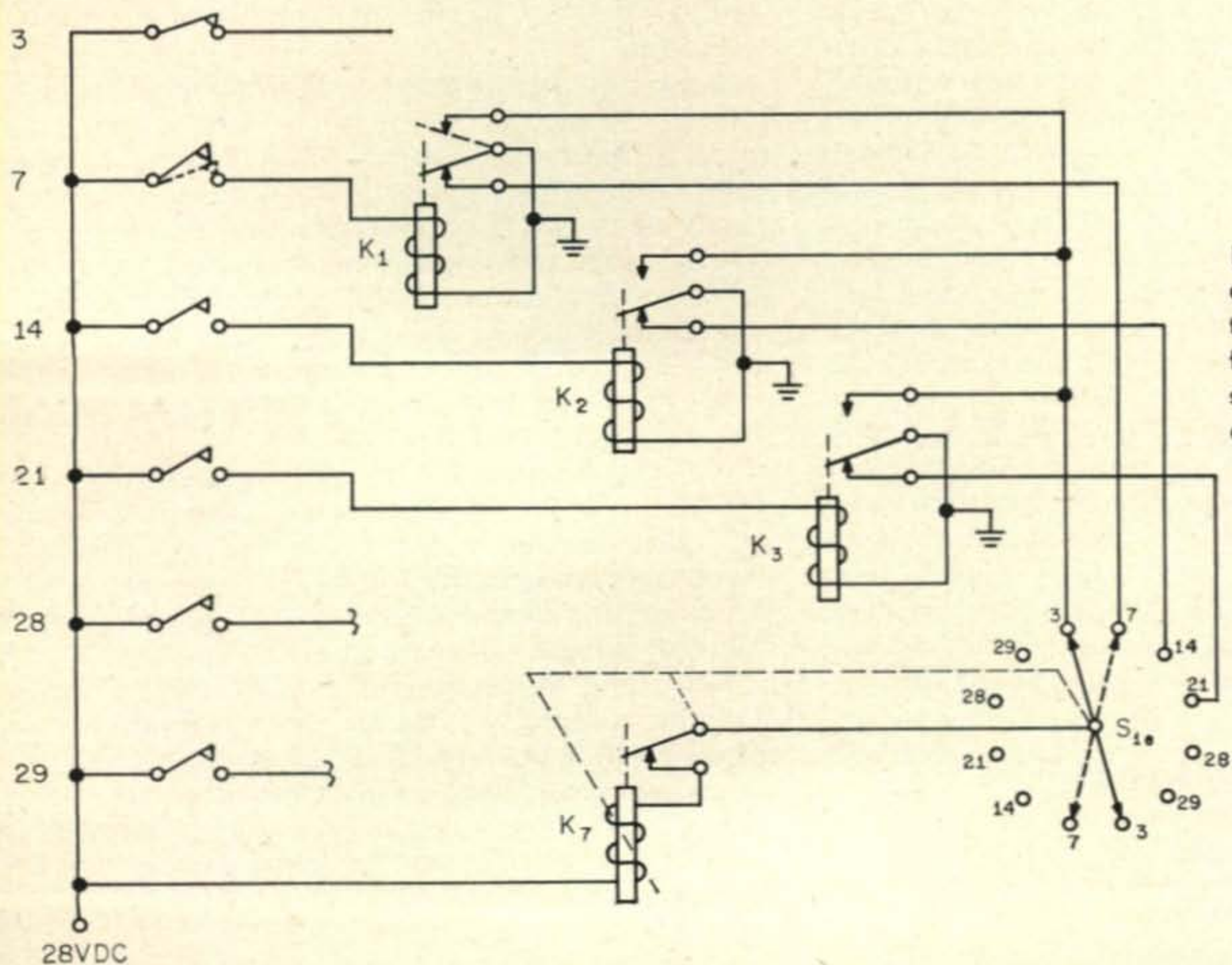

Fig. 3—Simplified breakdown of switching system and stepping relay functions. The spst switches are push buttons at the W2JKH installation.

The Elimination of Stray R. F.

L. G. Jakubec Jr.

18413 Friar Street
Reseda, Calif.

A discussion of basic proven techniques for the suppression of r.f. interference. Treated are, grounding, bonding and shielding techniques as well as design methods. A refresher for the old timer and good introduction for the newcomer.

During the past few years, numerous articles have appeared in the various electronic and communication trade journals, concerning stray *rf*, or radio frequency interference. On the whole, these articles have dealt with specific problems or particular equipments. It is not my intention to duplicate these previous endeavors, but rather to discuss basic, proven suppression techniques, many of which have been overlooked or disregarded of late.

Interference Defined

Basically, radio interference may be defined as any undesired conducted or radiated electrical disturbance which interferes with the operation or dependability of communication or other electronic equipment. More and more complex amateur stations are appearing on the scene, many of which contain *vhf* or *uhf* phone installations, RTTY, FAX, or in some instances, stations incorporating several of these installations. With the rapid increase of activity and interest in these regions, home designed, engineered, and built equipment is often the rule rather than the exception. Designing units with interference reduction in mind is of the utmost importance, both from the standpoint of compliance with FCC regulations, and equipment compatibility within your own station. Interfering with your neighbors TV is a problem, but interfering with the operation of your own rig is nothing less than a catastrophe! (The FCC has recently been subjected to increasing pressure regarding the elimination of non-military generated radio interference).

Grounding, Bonding and Shielding

Without a doubt, the most important single consideration in *rf* interference reduction is the proper application of grounding, bonding and shielding techniques.

All ham shacks have a ground of one type or

another. Unfortunately however, many of these represent a suitable ground plane in name only. A waterpipe connection or a four foot rod, driven into the earth, will seldom be sufficient above 30 *mc*. It is recommended that a "star" or "grid" ground similar to that suggested by C. J. Schauers, (*CQ*, Feb. 1958), be employed wherever possible. This ground must then be brought into the station, via the largest cable practical, and attached to the various pieces of gear. The important point is to, insofar as possible, maintain an equipotential ground throughout the equipment. A solid strap of .030" copper affixed to the wall behind your equipment will serve as a convenient equipment tie point to ground.

Each equipment chassis should then be *individually* bonded to this tie point via short lengths of .015" solid copper strap. Many instances have been noted where the primary ground bus consisted of a #12 conductor, and connections thereto were accomplished using #18 or #20 hookup wire. Oftentimes this will result in higher *rf* radiation levels due to the increased, relatively high impedance, radiating surfaces.

As an example of conductor impedances, a one foot length of #12 AWG has a *dc* resistance of but 0.0015 ohms, however represents an *rf* impedance of approximately 18 ohms at 10 *mc*. The ideal ground bus is short, wide and thin, presenting maximum possible mass, and constructed of a metal high on the relative conductivity table.

Returning to equipment chassis, bond straps shall be soldered to the copper tie point, but may be nut, bolt and lockwasher connected to the equipment. This connection at the equipment chassis however must be void of paint or other protective finish, and present a clean metal-to-metal contact between the bond strap and equipment case.

Where shielded leads are employed, either in

an offensive or defensive nature, similar treatment should be given shield terminations. That is to say, shield terminations should maintain minimum length pigtailed of $\frac{1}{2}$ inch length or less where possible. The following four general rules are considered to be sound shielding philosophy.

1. Conductors carrying *rf* currents should have shields terminated to ground at both ends.
2. Low-level signal leads should have shields grounded at the termination end only.
3. Shields should not be used for signal returns.
4. All shielded conductors should be insulated to prevent intermittent contact between the shield and chassis.

Design Techniques

Observation of home designed and fabricated equipments has revealed that in many instances little or no consideration has been given to *rf* interference reduction. The intrepid audiophile, building a hi-fi, carefully isolates filament leads for the prevention of 60 cycle hum. Why then do we often route a low level signal lead in close proximity to high energy or pulse type leads?

Reducing the possibility of such circumstance is easily accomplished. The first step in equipment design is the determination of theoretical performance and the drawing of a schematic. After this has been accomplished, carefully

evaluate the diagram lead by lead, noting the nature, type, and level of signals anticipated on each. Separate high and low level energy conductors and provide them with as much physical isolation as practical. It may be desirable to shield particularly susceptible low level circuits such as a receiver's first *rf* stage etc.

Good practice must be observed in lead dress, decoupling, and capacitor lead length. Many a resonant circuit has been developed by inadvertently combining the correct amount of capacitance with a particular lead length. (As an example, a 180 mmf capacitor with $\frac{1}{2}$ inch total lead length, will be series resonant at approximately 106 mc). A good rule of thumb is short, direct connections.

Optimum enclosure design must also be practiced in the development of home brew equipment. The practice of building modulators, converters etc., on open chassis, and leaving them in this condition, is to be avoided. If a unit develops *rf* the enclosure will serve to contain it. Conversely, if the equipment is susceptible to extraneously generated noise, the cabinet will help in a protective manner.

Here again, the grounding and bonding practices previously outlined must be kept in mind. Chassis must be effectively bonded to their respective cabinets or shielding efficiency will be severely impaired.

General Suppression Techniques

Interference reduction must be considered
[Continued on page 104]

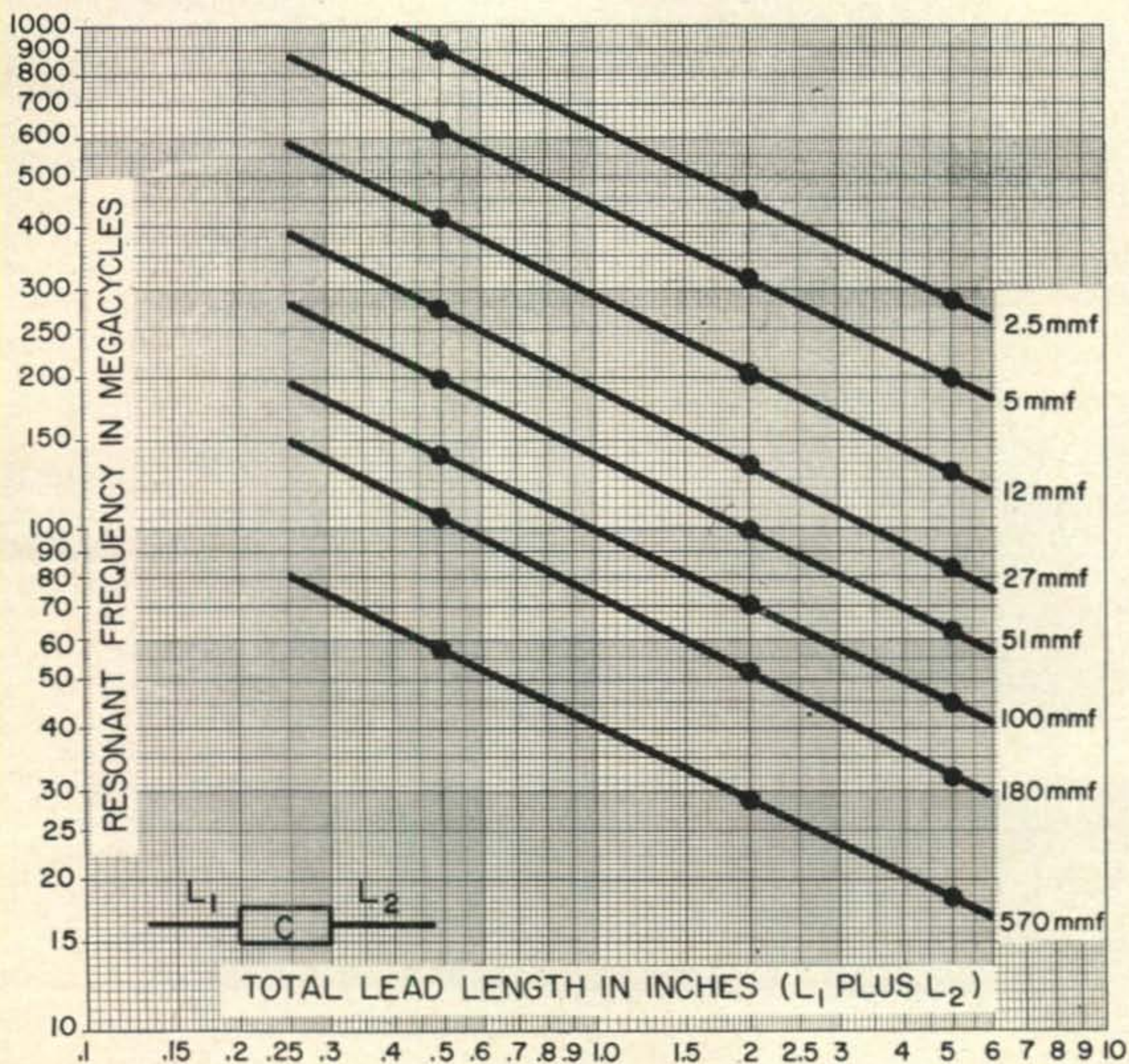

Fig. 1—A series resonant circuit may be formed by a capacitor and its own lead length, with the lead length acting as the inductance. This chart will help you determine the resonant frequency of various combinations.

Four Tubes—Two Meters—S.S.B.

Donald L. Stoner, W6TNS

Box 137
Ontario, California

Lester A. Earnshaw, ZL1AAX

Box 51
Warkworth, New Zealand

A double barreled scoop, the "Two By Four" presents an ultra-simple method of getting 100 watts on two meters SSB with only four tubes. In addition a vhf version of a ZL linear is described for the first time in CQ.

Those of you operating *vhf* sideband have already discovered there is an acute shortage of information telling one just how to go about firing up a two meter SSB rig. Tube and circuit losses at *vhf*'s make it difficult to assess requirements, and unless one is clairvoyant, the finished chassis will have many unwanted holes and mutilated wiring as testimony to the alterations that have taken place. Before the "Two By Four" was actually built, mock-ups were constructed on an old chassis and the true worth of the various mixers and amplifiers determined.

What Was Required

The existing low frequency exciter was a phasing rig not unlike the *Central Electronics 10A* and it was considered economical to make use of this to drive a suitable heterodyne unit to 144 *mc*. The circuit of fig. 1 is the final result and was derived only after much alteration and experimentation. Its name is really a misnomer for it uses five tubes. However, one is a clamp tube and it is hardly fair to include this in the two meter generation complement anymore than say rectifiers and VR tubes.

Any exciter delivering from three to ten watts on 14 *mc* will drive the "Two By Four" to full output on 144 *mc*. Input to the 5894 is dependent upon plate voltage and will be between 60 and 100 watts. Efficiency is very good, especially with the higher plate voltages.

Circuit Description

A 130 *mc* carrier is mixed with the 14 *mc* exciter to produce 144 *mc*. An International overtone crystal on 43.333 *mc* is used with a 12AT7 oscillator. An 8.66 *mc* crystal may be used on its 5th overtone but the higher frequency crystal is recommended for it gives the circuit a "sure-to-work" ability and also allows one to use the 14 *mc* *vfo* readings merely by adding another 4. For example, 14 *mc* = 144 *mc*, 14.3 *mc* = 144.3 *mc*, and so on.

The 43.333 *mc* oscillator output is tripled in the other half of the 12AT7 to 130 *mc* and fed to the control grid of the EL84/6BQ5, where it mixes with 14 *mc* to obtain the required 144 *mc* output.

The 14 *mc* signal is fed into the screen of the EL84 and the plate circuit is tuned to the sum frequency. Series tuning is employed for greater efficiency and output. The fixed 100 *mmf* capacitor across the 14 *mc* coil is mounted right on the socket of the mixer tube, between pins 3 and 9. The EL84 is link coupled to the 832 (which is operated strictly Class A), and this stage is inductively coupled to the 5894 *vhf* linear amplifier. The 5894 is operated as a ZL linear to avoid the necessity for regulated screen and control grid supplies. Also, this method of operation allows a change to class C condition merely by "winding in" carrier. The circuit then behaves as a clamp tube controlled class C amplifier. CW keying is effected by keying the SSB exciter.

The clamp tube is an EL84, operated as a pentode and *not* as the customary triode. A triode in this position cannot be made to hold the 5894 screen voltage down to the required figure and at the same time allow it to rise to the required value when signal is present. It is important that the screen voltage of the EL84 not be allowed to

This view shows the EL84 mixer tube in the left hand lower compartment, the grid coil and line to the 832 and in the right hand compartment—the 832, the plate circuit compartments and the 5894 screen dropping resistors. In the upper compartment is the 5894, the EL84/6BQ5 clamp tube and the tuned lines. The 12AT7 overtone oscillator and tripler tube are behind the lower EL84/6BQ5.

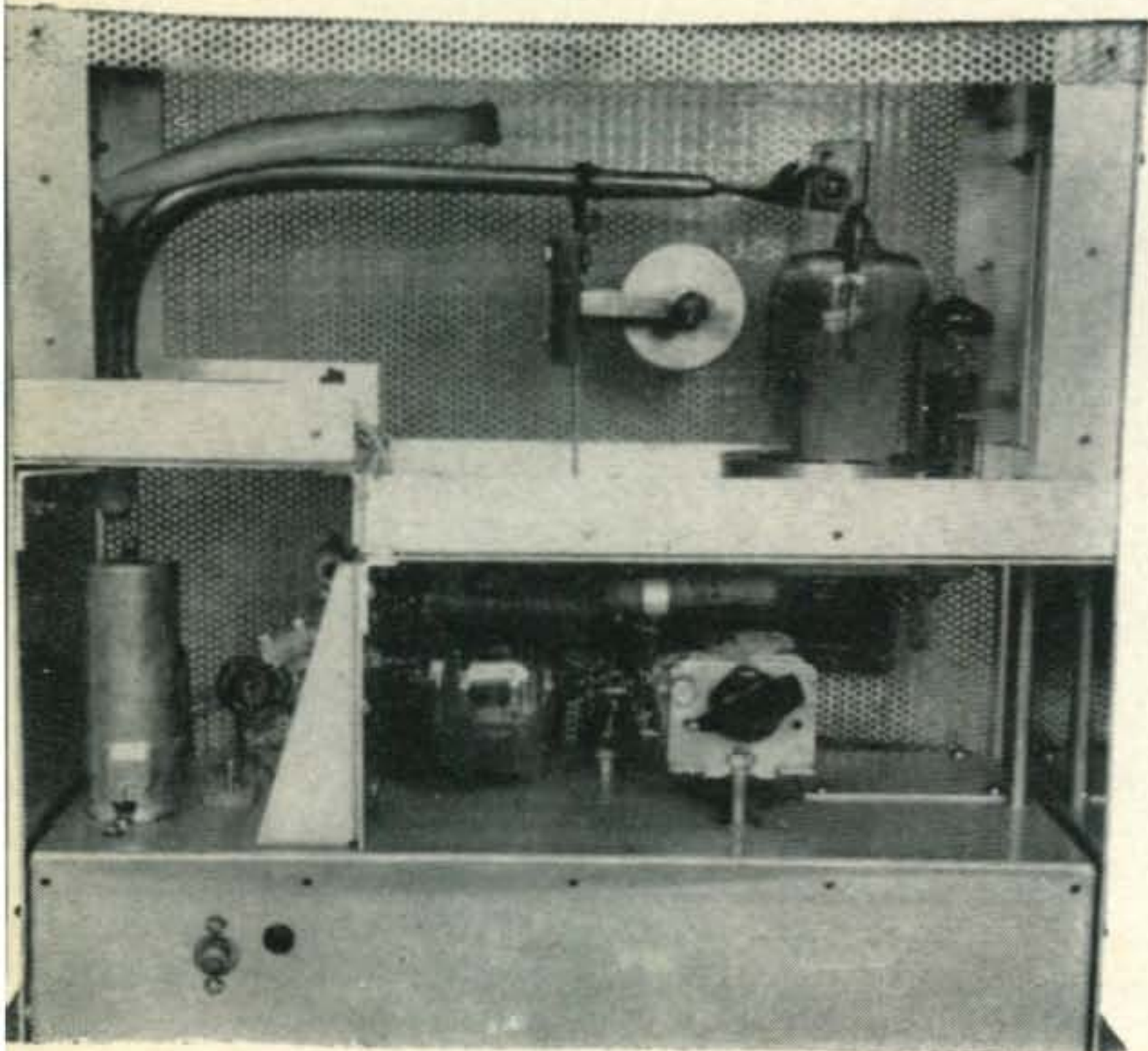

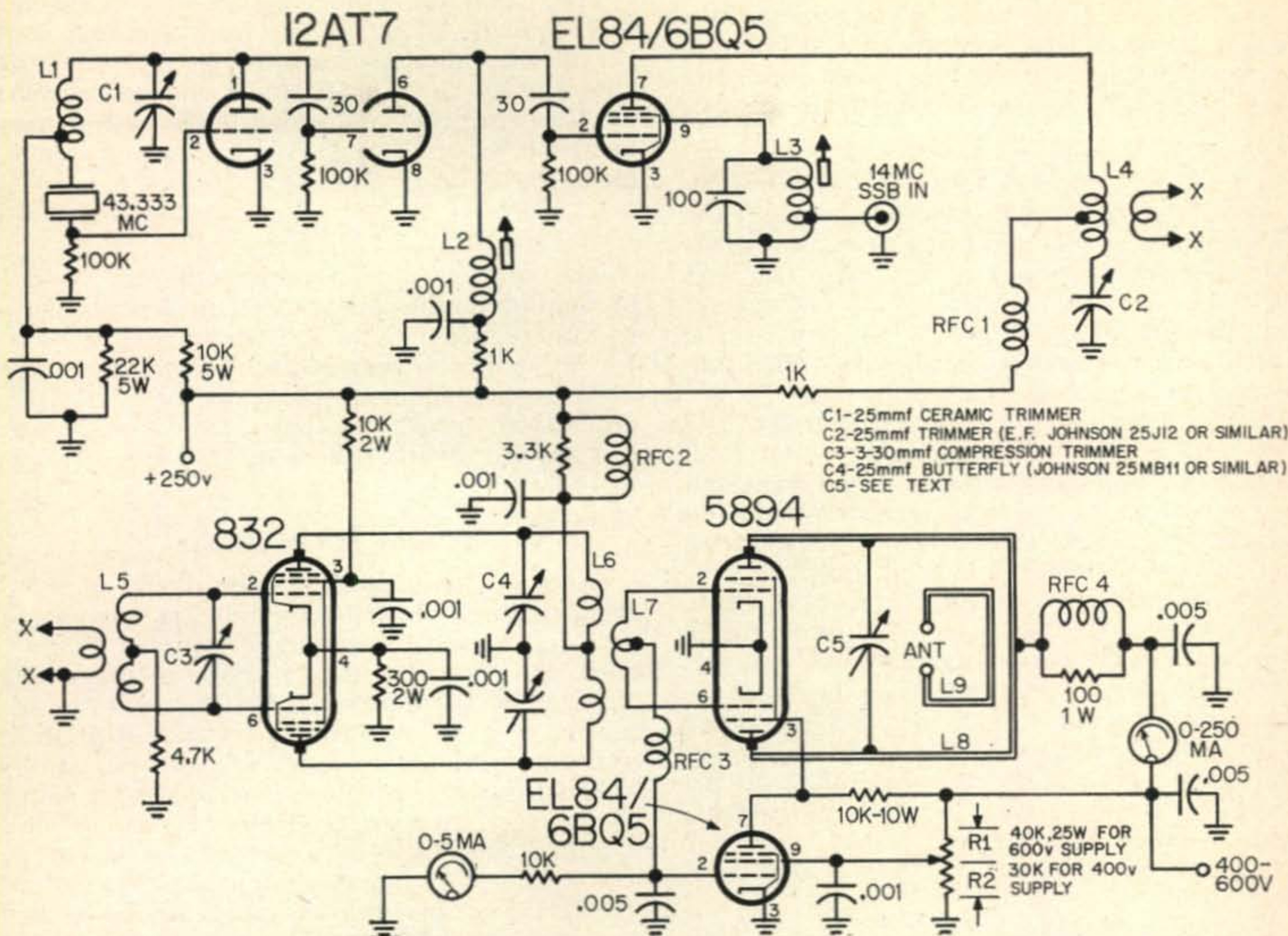

Fig. 1—Schematic diagram for the "Two By Four". With a 600 volt supply, the slider is set to make R2 approximately 7K. With a 400 volt supply, it would be approximately 7K. With a 400 volt supply, it would be approximately 9K (see text for final adjustment). Typical figures for a 600 volt supply are: 5894 idling screen voltage = 37 volts, clamp tube screen voltage = 84 volts, peak plate current CW = 240 ma., SSB = 200 ma.

Parts List

- L1—5½ turns, #18 enam., ½" dia., ¾" long, tap at ½ turn from bottom.
- L2—2 turns, #18 enam., on ¼" slug tuned coil, winding length ¾".
- L3—10 turns, #22 enam., on ½" slug tuned coil, winding length 1", tap at 2 turns from bottom.
- L4—4 turns, #18 enam., ½" in diameter, ⅝" long, tap at center. Link is 2 turns small hookup wire inserted in the center.
- L5—2 turns, #18 enam., ½" diameter, ½" between turns, centertapped. Link is 2 turns inserted at center.
- L6—2 turns, #18 enam., ⅞" diameter, ⅝" between turns, centertapped.
- L7—3 turns, #18 enam., ⅝" diameter, placed be-

- tween turns of L6. Adjust for max transfer of *rf*.
- L8—Plate lines of ¼" copper tubing, see text for details. Polish and coat lines with clear lacquer.
- L9—See text.
- R1, R2—40K, 25 watts for 600 volt supply. 30K for 400 volt supply.
- RFC1—Fill ½ watt high value resistor with #34 enam. wire.
- RFC2—Fill 3.3K, 2 watt resistor with #22 enam. wire.
- RFC3—28 turns, #34 enam. wire wound on ½ watt resistor, wound in two pies, one at each end of resistor.
- RFC4—Fill 2 watt high value resistor with #22 enam. wire. Parallel 100 ohm, 1 watt resistor.

vary and the voltage divider figures were carefully chosen to meet this requirement.

Construction

Two of these units have been built, each by different persons and with different physical layouts. The experienced constructor may vary this layout to suit both components and location preferences, but care must be taken to prevent feedback and self oscillation of the two amplifier stages. These are high gain stages and require only a "smell" of *rf* to begin oscillating. Properly built, the stages should show *no* sign of oscillating. Even the 832 stage, which is not neutral-

ized, cannot be made to "take off" no matter where the grid and plate capacitors are set.

Construction of the unit, as can be seen from the photograph, is on the two storied principle. This provides a compact unit only 10½" long, 10½" high, and 5" deep. The bottom chassis is two inches deep. On the left hand end of the bottom chassis (from front to back) will be found the EL83, 12AT7, and crystal, in that order. A partition, the width of the chassis, supports the 832 at ¾" from the left hand chassis edge. This partition is ¾" high. The 832 plate tuning capacitor is mounted just ½" from the right hand edge of the chassis (from

edge to shaft). The second deck is stepped to allow easy removal of the EL84 and 12AT7 tubes, without being faced with a major dismantling project. The portion of the deck holding the 5894 is 3" above the lower deck. The 5894 grid coil is positioned between the two halves of the 832 plate coil.

Tank Coils

The 5894 tuned lines are 9½" long from the plate pins to the supporting strip at the other end. The vertical portion is 2¼" high. The lines are made from copper tubing ¼" in diameter and are spaced 1⅛" center to center. The ground ends are soldered into holes drilled into a small piece of brass measuring 1½" × ¾" and are supported by a standoff insulator. The "hot" end of the ¼" lines are cut about 1½" short of the tube pins, are split at the ends, and have pieces of ⅜" wide copper strap soldered into the slits. These pieces form a flexible connection between the tubing and the plate connectors. The plate connectors are homemade from pieces of ¾" wide by 1½" long copper strip bent double and shaped about a nail just a little smaller in diameter than the pins. By squeezing the copper with the vise, just short of the nail, the copper will be made to hug the nail tightly. The nail is then removed, and the pieces drilled and bolted to the connecting straps. The nut should be "done up" so that the copper fits the pins tightly thus carrying away heat from the pins.

The tuning capacitor is "manufactured" from an old *National* neutralizing capacitor having circular discs 1⅜" in diameter. The capacitor is connected exactly 2¾" back from the plate pins. The actual connection between the capacitor and the lines is made with flexible braid removed from a piece of coax cable. It is important that no mechanical stress be placed on the 5894 plate pins and the form of construction shown was chosen to prevent this.

A 300 ohm link was made from #12 copper wire, insulated with spaghetti to prevent accidental contact with the lecher lines. This link is supported by two feedthrough insulators which may be seen in the photograph. A 70 ohm link will be approximately 2" long.

Clamp Tube

The EL84/6BQ5 clamp tube is located on the same deck as the 5894, and is in the right-rear corner. Its associated components are fixed to tie strips on the underside of the top deck. Construction of the whole unit is such that the lower deck may be built and operated before the top deck (with the 5894) is added. The top deck may be built later and dropped into place as a complete unit.

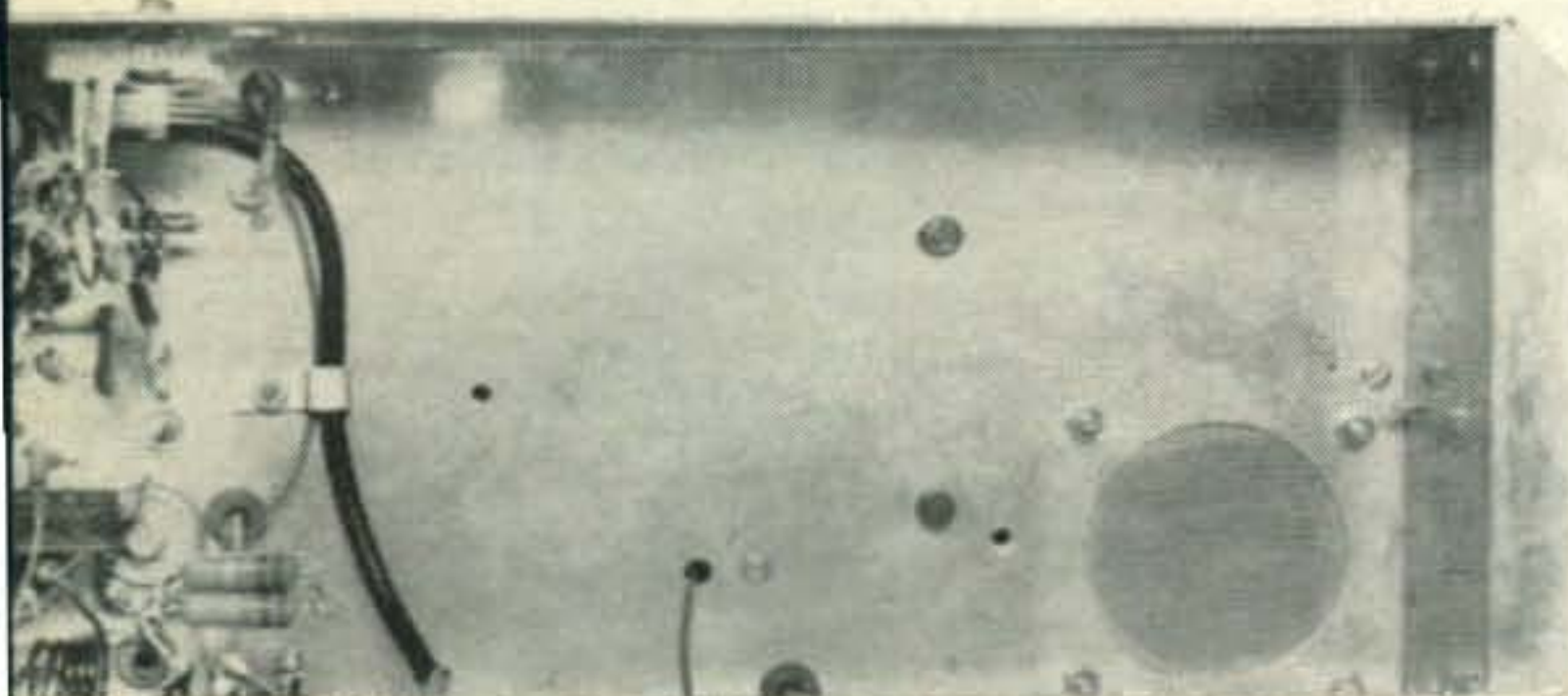

TVI

The "Two By Four" has been completely TVIproofed. All *ac* and *dc* leads entering the chassis pass through feedthrough type capacitors. The B+ lines, heater lines, and miscellaneous leads are run in shielded wire. Liberal use has been made of angle stock and perforated metal.

Controls

The controls are all preset but may be brought out to the panel if desired. In particular, if wide frequency excursions are to be made, the 14 *mc* input coil may require a small trimmer fitted to the panel, and paralleled with the 100 mmf fixed mica. All other circuits are broad and require no adjustment in the range of 144 to 144.5 *mc*.

Beware the RF Choke

Considerable trouble was originally experienced with *rf* chokes resonating at unwanted frequencies, and the attendant spurious oscillations. For example, the *rf* choke in the plate of the EL84 resonated with the 25 *mmfd* tuning capacitor at 14 *mc*. The mixer output at this frequency was surprisingly high and the cause of much head scratching, particularly in view of the fact the carrier balanced out just as it should. Suspicions of something being wrong were confirmed when the output increased after the 43.333 *mc* crystal was removed! The choke was rewound and also series connected with a 1K resistor. In a like manner, the *rf* choke in the plate circuit of the final resonated with the choke in the grid circuit and set up an excellent tuned plate-tuned grid oscillator. A 100 ohm resistor in parallel with the plate choke cured this one.

Adjustment

A calibrated grid dip oscillator is essential. Particular care must be taken to see that the coils are on the *right* frequencies. There are many unwanted products present in this, as in all mixers. For example, the 14 *mc* signal, when beat with the 130 *mc* oscillator, not only produces a signal at 144 *mc* but also an image at 116 *mc*.

If the second half of the 12AT7 is tuned to the 2nd rather than the 3rd harmonic of the oscillator, signals will be produced on both 72 and 100 *mc*. The fourth harmonic will produce a signal at 159 *mc*. Also present at the mixer plate circuit will be strong 130 *mc* components. These signals are not hazards if you are aware of them.

[Continued on page 102]

Underside view of the lower chassis. The patch in the right lower corner covers an unwanted hole in the chassis. L1 is in the lower left hand corner, L2 is in the center. The picture shows four turns on this coil, but it was reduced to two turns after the photo was taken. L3 and C2 are in the top corner of the chassis. The coil L3 is at right, in the upper corner.

Spanish-American Ham Relations

By CQ's European Correspondent

ALTHOUGH the many American hams stationed in Spain are not yet allowed to operate their private stations, they are, nevertheless, paving the way for this eventuality by demonstrating to the world-at-large how international friendship is obtained and maintained . . . and that operating reciprocity is a good thing.

The Spanish - American Amateur Radio (SARA) Club of Madrid was activated last year under the leadership of Stan Parrish, W5QGL. Its membership is composed of both active and inactive Spanish and American hams. All the American hams have become members of Spain's URE (Union de Radioaficionados España), an organization similar to the ARRL.

John Barrows, K1ECT is president of the SARA of Seville, another very active group. John assisted at the June hamfest in Madrid along with Enrique Gallego, EA4EF, acting President of the URE.

During the hamfest, silver cups were presented to six SARA members for their outstanding performance in handling over 6000 messages during the Agedir earthquake disaster in March of this year. These fine hams are: Carlos Panero, EA4HC; Bill Wright, CN8GJ; John Irons, K5MKH; Jack Wingfield, K4TUI; B. Welch, MARS and George Sharpe MARS.

Bob Nerger, K6HRC, Secretary of SARA, Madrid, read letters from President Eisenhower and Generals Curt Lemay and Butch Griswald wishing the group continued success in their international amateur activities.

Guests of the hamfest who were very pleased with the way in which it was conducted were: General Panero, Commander of Blindada Herman Cortes, Badajoz, Spain; General Anguls, Commander of the Spanish Army Communications Division; General Sarmiento, retired Commander of Spanish Army communications; Commander Perry, USN representing Commander Nav Comm Fac, Morocco and Lt. Cunningham, USN acting for the commander

Back row; l. to r. Bill Wright, CN8GJ first ham into the Agedir disaster area; Commander Perry, USN who presented four of the silver cups on behalf of SARA of Madrid; Jack Wingfield, K4TUI; Carlos Panero, EA4HC; John Irons, K5MKH. Front row; l. to r. Stan Parrish, W5QGL, President of SARA of Madrid; General Panero, Spanish Army; General Anguls, Commander of Spanish Army Communications; General Sarmiento Ret. Commander of Spanish Army Communications; Enrique Gallego, EA4EF, Acting President of URE.

Nav Acts Spain. Luis de Guzman, EA4CX, Vice President SARA, Madrid acted as master-of-ceremonies and alternated between Spanish and English so that all members could understand what was happening.

Hams visiting Madrid are invited to get in touch with K6HRC at Torrejon Air Base and let him know you are in the area; he will be glad to invite you to one of SARA's meetings. ■



On behalf of the SARA of Madrid, General Panero presents his son Carlos, EA4HC with a silver cup for his outstanding work during the earthquake at Agedir in March 1960.



Display of electronic equipment seen by Spanish Amateurs at the Hamfest.



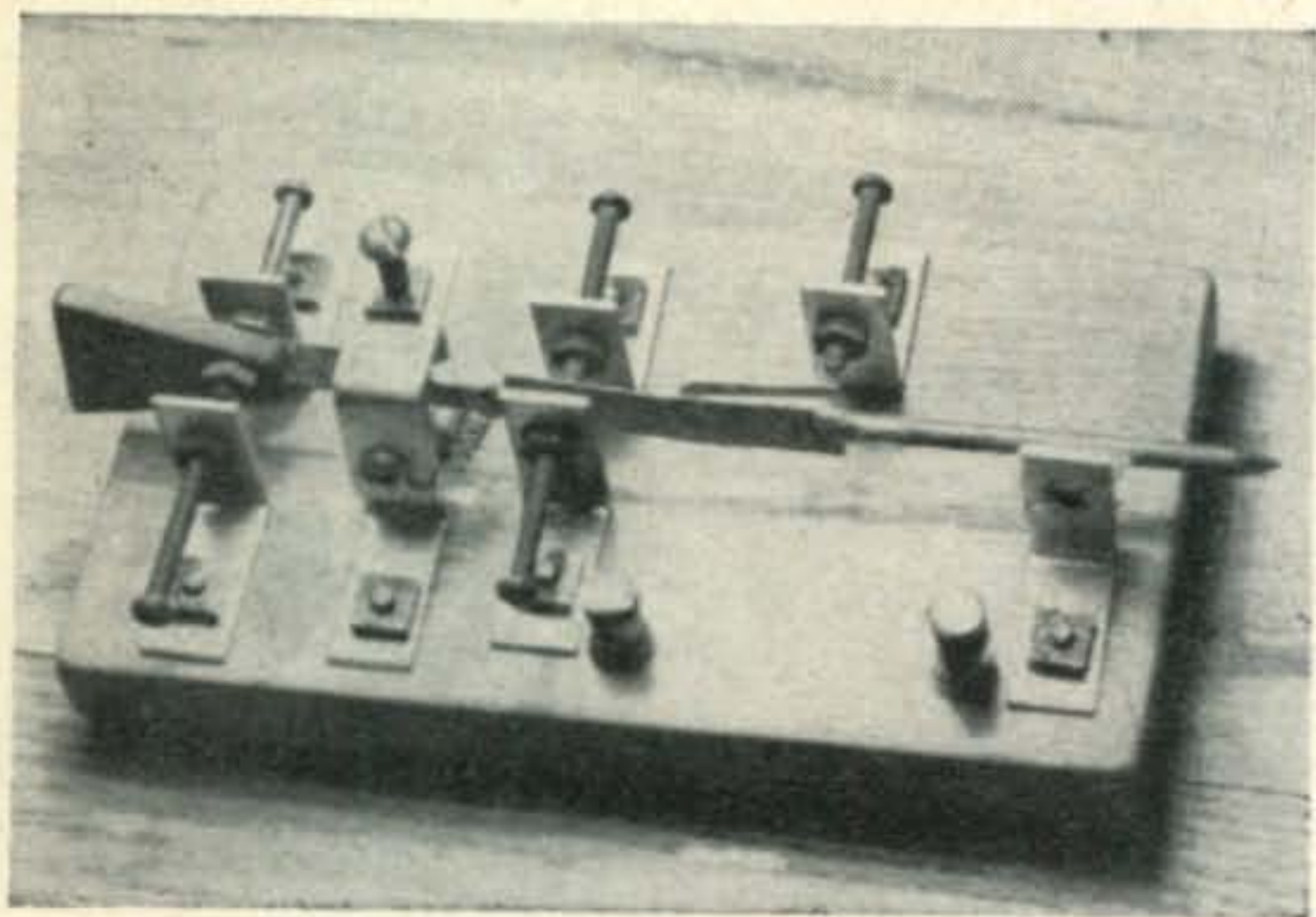

This semi-automatic key is built on a $6\frac{1}{4} \times 3\frac{1}{2} \times \frac{3}{4}$ inch block of wood. The addition of rubber feet should keep it from sliding on the operating table.

"A \$.98 Bug"

Stanmore C. Cooper, K4DRD

2314 Lake Shore Boulevard
Jacksonville 10, Florida

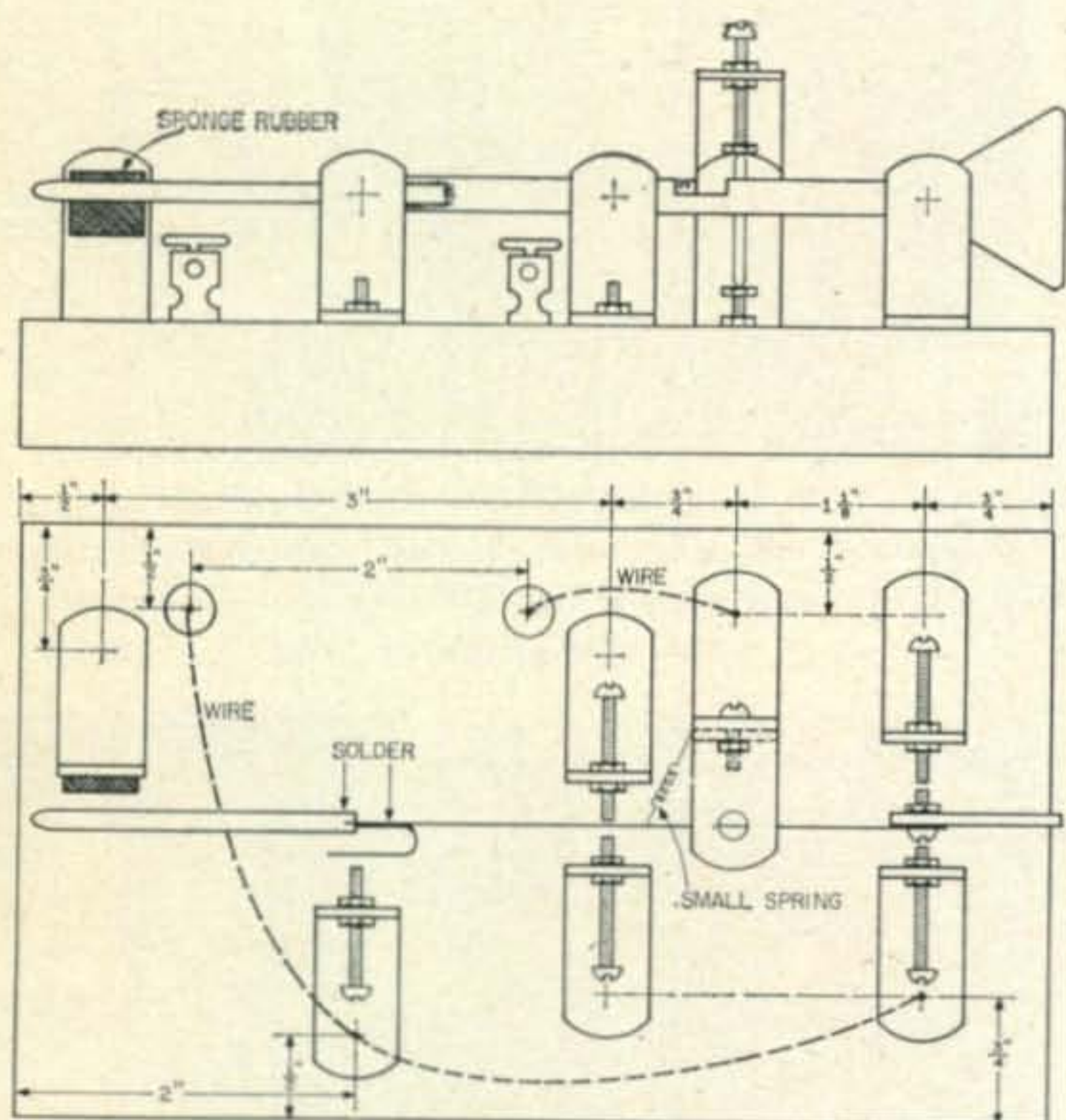

Fig. 1—Dimensions and layout of a homebrew "bug". If your time is cheap, the cost can be kept under a dollar.

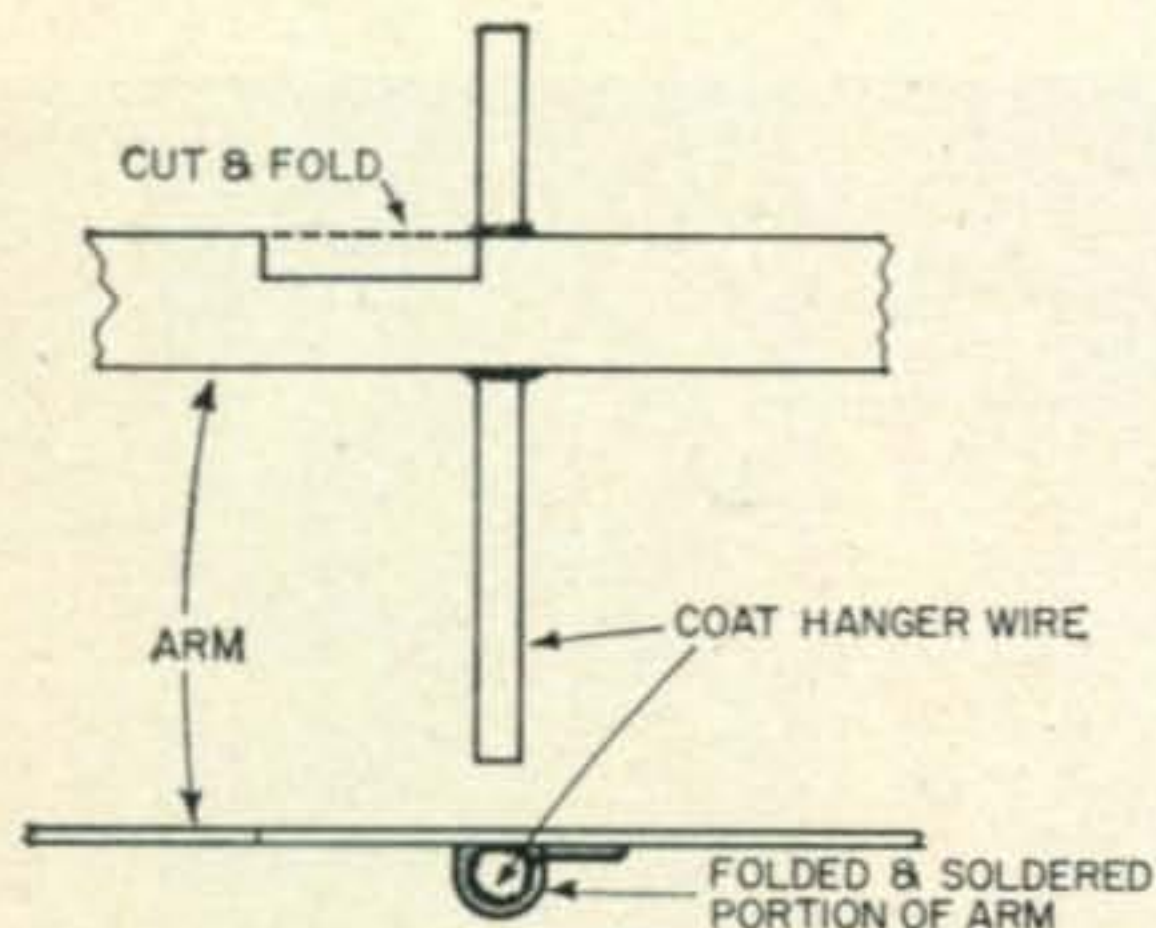

Fig. 2—Side and top detail of pivot construction.

Many of the younger members of our fraternity have undoubtedly heard bugs on the air and dreamed of the day when they could afford to make sufficient monetary sacrifices to finance such an investment themselves. It wasn't too long ago that I was in the same predicament. The problem was solved, however, when I suddenly got the bright idea to build one out of scraps and thus do away with any cost or at least, make it quite negligible. I arrived at my goal and found that the product was quite favorable in comparison to commercial apparatus selling for ten and fifteen dollars.

The key to be described has been in use at K4DRD for several years (three to be exact), and has faithfully performed throughout many enjoyable QSO's.

Numerous hams refused to believe it was home brew. In this article I shall briefly describe the construction and operation of the bug.

Construction

The base is a scrap of wood $6\frac{1}{4} \times 3\frac{1}{2} \times \frac{3}{4}$ ". I gave it several coats of varnish before mounting the parts.

The basic unit of construction as can be seen in fig. 1 is a 1" brass angle bracket picked up at a local hardware store. Eight of these brackets are required. Seven are secured directly to the base with 1" 6-32 screws and nuts. These screws were inserted from the bottom of the base through pre-drilled holes. This was done so that connections could be made by means of solder lugs, etc. The eighth bracket was bolted to one of the base mounted brackets in order to form the pivot.

The binding posts were requisitioned from the rear panel of a vintage 1920 BC receiver. They can be found in just about any self respecting junk box.

[Continued on page 102]



With the advent of semiconductors capable of handling considerable power, one of the more conspicuous advantages that has accrued to hams has been in the area of transistorized supplies that eliminate the need for bulky and inefficient dynamoters. Most recent additions to the number of units now available are the PS-300, PS-425, and PS-600 manufactured by Transcon Div., Northeast Telecommunications, Inc.

These high-efficiency units are each housed in a black-anodized drawn-aluminum case measuring $5 \times 3 \times 3\frac{1}{2}$. Weights, and output ratings are shown below. All require 12 volts d.c. input.

Model	DC Output Voltages	Total Power Output (max.)	Weight
PS-300	300 @ 100 ma 150	30 watts	1 lb. 7 oz.
PS-425	425 @ 150 ma 212	63.75 watts	2 lb.
PS-600	600 @ 200 ma 300	120 watts	1 lb. 15 oz.

The supplies are rated for continuous duty and are designed to operate, under full load, at over 80% efficiency.

Transcon Transistorized Power Supplies

Lee Aurick W2QEX,
Technical Editor; CQ

Relay and Protective Diode

Several unique features recommend themselves in the design of these rugged units. A master control relay is an integral part of each supply. This relay serves two important functions: (a) provides low current remote control of the supply, and (b), protects the transistors from catastrophic failure in the event that the polarity of the battery leads is inadvertently reversed.

The two higher voltage units use dual voltage doubler windings with series output to provide 425 and 600 volts d.c., respectively. The PS-300 uses only a single voltage doubler.

In all models, a protective diode is used in series with the coil of the master control relay. Only when battery polarity is correct will the diode conduct and permit the relay to close. If voltage of incorrect polarity is applied, the diode will not conduct, and the relay will not close. The transistors are thus protected from the certain destruction that would otherwise result.

Installation

The aluminum housing is completely isolated from the circuitry and this feature permits the supplies to be used in any vehicle regardless of which battery terminal is grounded.

It is suggested that the supplies not be mounted in an enclosed area, or over the engine block.

[Continued on page 102]

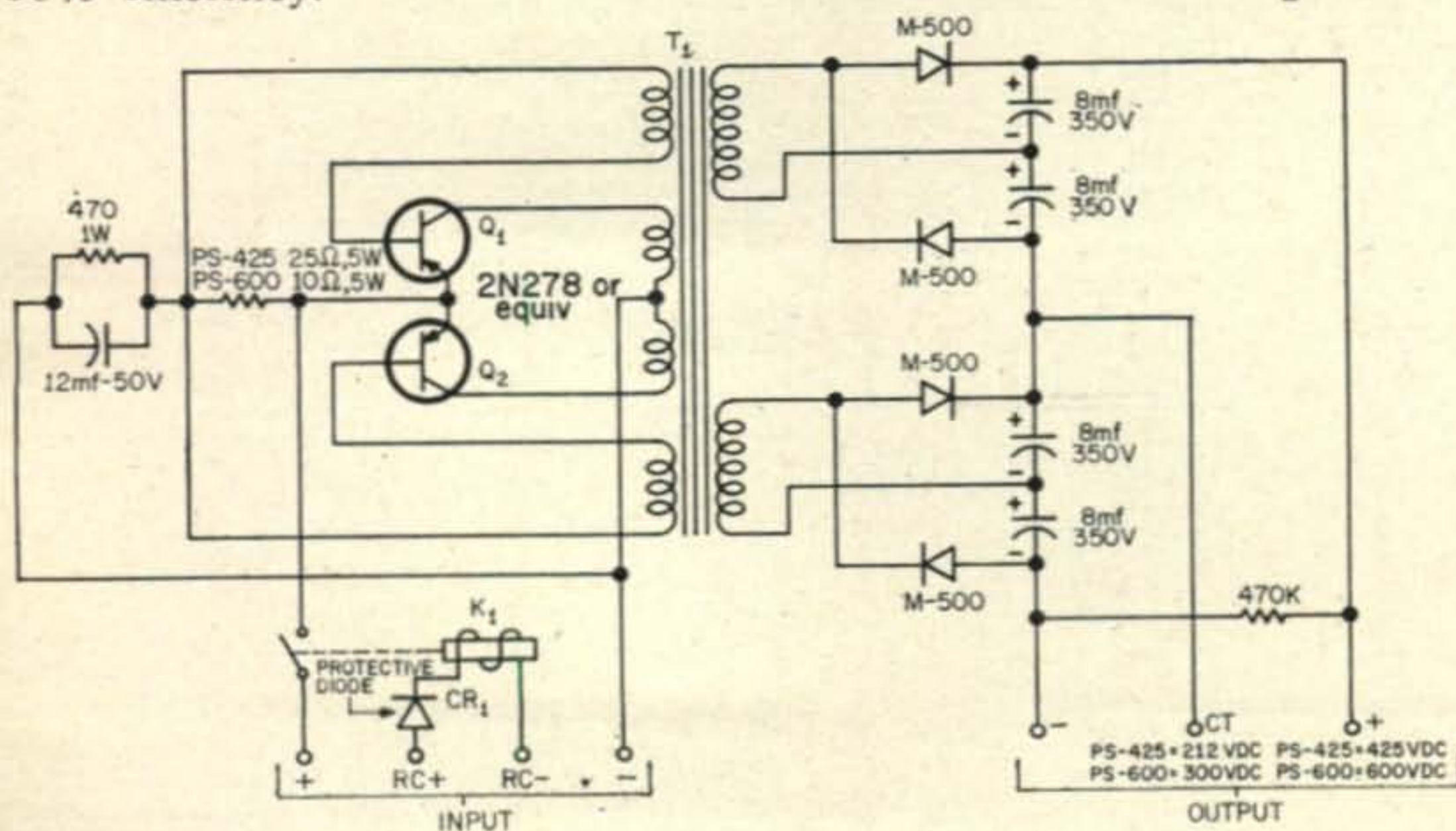

Fig. 1—Schematic of the Transcon Transistorized power supplies. The protective diode is explained in the text.

Results, CQ WW-V.H.F. Contest—August 29 and 30, 1959

DUe to circumstances beyond our control the final tabulations of the August 1959 V.H.F. contest were delayed until now. Our sincere apologies to all those who took part, and every v.h.f. enthusiast may rest assured that we will list future results as soon as possible.

All those who received scores in excess of two million points will receive a plaque. To the top scorer, WINBN/1, the Merrimack Valley Amateur Radio club, we present a trophy in honor of the highest score submitted. Congratulations to all those who won, and for those who took part we can promise a bigger and better contest next year.

6 Meter Plaque Winners	
WINBN/1	4,872,000
W8TO/8	4,770,200
W9YCR/Ø	4,021,920
K2ZSQ	3,888,000
W3JMY	3,035,520
K9MMH	2,884,200
W3BKF	2,737,920
K1BSM	2,504,160
K1DIT	2,007,360
K2CVG/2	2,402,400
K2VIX	2,383,680
K2SKB/2	2,285,280
W8RKX/8	2,227,200
K9GFQ	2,117,280
K2GLI	2,086,560
W8UUM	2,060,800
K2RRM/2	2,056,320

2 Meter Plaque Winners	
K2OIQ/2	3,136,320
K1CRQ	2,962,300
K2KJI	2,736,000
WA2GVT	2,024,640

6 Meters

Station	Score	Station	Score
K7GAT	13,050	K2VIX	2,383,680
K5IPL	8190	K2SKB/2	2,285,280
K5AZH	4500	K2RRM/2	2,056,320
WA6BZA	206,080	K2OIQ/2*	1,633,920
K6UMM*	399,360	W2KVA*	1,596,000
W6SDW*	372,600	K2CBA	1,200,960
K6VDK	105,060	WA2FMF*	1,116,720
W1HMW	184,800	K2ERQ*	877,800
K3AZH	72,540	K2YGL	257,040
W3LML	7600	K2SQB	198,220
K4PPS	132,000	W2MTA	152,750
K4UGA	104,060	W2SHE	49,920
K4QHN	57,200	W2EZL	22,848
K4PDL	52,470	K2CUQ	20,240
K5AWT/4	1,385,160	W2EMW	680
K4KLD	32,400	W8TO/8*	4,770,200
K9DTB	399,960	W8RKX/8	2,227,200
K9DWR	14,700	W8UUM*	2,060,800
W9DJ	960	K8III*	1,603,920
K9MMH	2,884,200	K8CRF	470,400
K9GFQ	2,117,280	K8GVM	10,920
K4BPY	14,300	W3JMY	3,035,520
K5AEY	104,000	W3BKF	2,737,920
W3JTE/5	60,480	K3BDR*	786,240
W1NKA	739,500	K3ATX	720,720
K3HCE	166,400	W3ZOR	599,760
K3DQA	135,850	W3KWH*	481,140
W1NBN/1	4,872,000	K3GZU	406,640
K1BSM	2,504,160	K3HRF	163,200
K1DIT	2,007,360	W3FEY	114,840
W1DXS	158,300	W3LDA	92,400
K1BXA	78,490	K3IPM	12,800
W1KSZ	3000	W3NAV	3000
K8KEQ	228,800	K1DFU	13,000
K8ICZ	222,376	W4VIW	5200
K8HWW	92,400	K4OSF	1,597,440
W9YCR/Ø	4,021,920	K5SPO	957,600
KØSBJ	132,480	K5BDL	660,480
WØYTB*	10,920	W5HXW	561,600
K1IZM/1*	1,338,624	K5MDZ	497,640
W1VEX	408,000	K5STI	446,760
K2ZSQ	3,888,000	K5TXX	393,120
K2GLI	2,086,560	K5PWX*	252,000
W2AFU/2	1,458,240	K5BBG	234,400
K2PSQ*	527,000	K5RAK	208,560
WA2BDP	133,380	K5TIQ	202,020
K2ZDY/M	1440	K5UFW	195,840
K2CVG/2*	2,402,400	K4KVE	187,720
		K5JKQ	82,680
		K5TKR	79,800
		K5WPD	75,012
		K5OQE	72,000
		K5KDY	49,350
		K5JFY	48,960
		K5BQA	46,000
		K5CER	44,720
		W5FFS/5	36,000
		K5MTK	31,500
		K5GHR	30,720
		K5SXU	14,400
		K5KWB	12,000
		W5AQS	11,960

Station	Score	Station	Score
K5OCS	10,000	W4YOP	560,120
K5PIG	9660	K4UKQ	374,220
K5PWD	5770	K4RTG	37,400
K5UGQ	3900	K4LZP	37,120
K5QAN	3840	K7VXR/7	109,980
W5AHG	3520	K7BBO/7	85,500
W5FEG	1360	K9JSA	486,000
K5TZL	740	W9YLL	483,600
K5MLN	400		
W1EXZ	720		

2 Meters

Station	Score	Station	Score
W6ASH	1,558,480	W2AFU/2	1,541,760
W6SDW*	695,520	WA2CZS	1,422,720
K6UHS*	537,600	K2YIB	764,400
W6GDO	444,400	K2LYU*	580,750
WV6FZA	393,040	WA2CNC	442,200
WA6EEO	319,200	K2DI/2	382,774
K6TBS	205,800	W2AJY	141,900
WV6FBO	179,140	K2AZJ	5040
WA6AYC	113,600	K2OIQ/2*	3,136,320
W6GQZ	108,800	K2LIO*	1,781,760
K6KOP	72,600	K2GXJ/2	440,000
WV6DQI	3840	K2GSF	376,320
K1CRQ	2,962,300	W2ATC	154,040
K1AFR	290,365	WV2GQV	143,360
KN1IWM	94,080	WA2EZD	106,020
W1NLM	39,780	K2MMX*	58,080
K2PJT/4	2200	K2YAZ	54,000
K9HMB	375,820	W2IN	33,600
KN9TWV*	91,200	WV2HEM	5850
K9LLU	74,250	K2RNX/2	1800
KN9RVG	39,060	W8SFG*	254,800
K9DTB	5600	W8LCA	77,490
W9DYX	600	KN8MFPZ	48,360
K9MRI	77,280	W3ICU/3	1,115,520
W1LMZ	526,500	K3DSN	289,380
K1AII/1*	1,455,440	W3NAV	15,120
K1AIC/1	627,640	KN3JFY	11,520
K1JVA	210,600	W3FJV	960
W1NYL	118,800	K1CRN	1,092,240
W1AQE	73,260	KN1KPB	164,160
W1AHE	35,100	W3MSR/4	140,600
W1BDF/1	3024	KN7HNI	720
W8VRH	62,400	W9TQ	2754
W8BGZ	50,160	VE3AIB	245,280
K2KJI	2,736,000	VE3BBD	174,420
WA2GVT*	2,024,640	VE3DVV	52,800
W2HDL	1,542,240	VE2TT	26,112
		WE7ANK	1600

*Multi-Operator

220 mc

Station	Score	Station	Score
K42FY	160	W8PT	2800
K9DWR	20	W2AFU/2	720

DX DX DX DX DX DX DX DX

Urban Le Jeune, Jr., W2DEC

416 North 15th St., Kenilworth, N. J.

The following certificates were issued between July 10th and August 10th, 1960:

WAZ		
1397	K2QHL	Robert B. Tuttle
1398	WØDVZ	Dave Carpenter
1399	KØGXR	Fred A. Minnis
1400	F2BS	Jean Mahias
1401	XE1PJ	Arnold G. de Jager
1402	OH2LX	Vaino K. Virtanen
1403	W9GRF	Fred W. Shields
1404	UB5CI	
1405	W4SHX	Charles J. Hinkle
1406	KH6DKA	Wm. S. Haddon
1407	DL1YQ	Dr. A. J. Haberstein
1408	UQ2AN	Bruno J. Greiza
1409	DL1BS	Kuno Huber
1410	K9HOL	Jack Kurtz

All Phone WAZ

63	UQ2AN	Bruno J. Greiza
64	G3FPQ	D. L. Courtier Dutton

CW WPX

130	W2SAW	A. N. "Sax" Ringler
131	LU8EN	Hector Soula
132	SP6FZ	Jan Ziembicki

Phone WPX

19	I1CBZ	Lt. Col. Giovanni Sapino
20	W9WHM	John R. Leary
21	W3AYD	Michael Solomon

SSB WPX

34	YV5FK	Gregorio Marin Yebenes
35	W2GNQ	Dr. Joseph A. Anderten

In the August list, WAZ #1372 was erroneously credited to Larry Eisler, SVØWQ; it should have read SVØWP.

WPX Honor Roll

CW WPX

W2HMJ	560	W5AFX	407	WØPGI	353
W6KG	517	W3OCU	405	HB9TT	351
W5KC	483	W8JIN	403	W5DA	351
K6CQM	455	W5LGG	401	K2PFC	350
W1NLM	455	W2MUM	400	VK3KB	350
W8KPL	453	K2UKQ	380	W1IJB	349
W2EQS	443	K4JVE	377	W9IU	344
W9YSX	433	WØQYE	377	IT1AGA	330
K5LIA	425	W9DYG	367	W6YY	330
OK1MB	428	W4AZK	365	W2NUT	329
W1EQ	427	W9QGR	361	DL1QT	328
K6SXA	424	SM5AJU	359	WØSNL	327
W8PQQ	418	VE3DIF	357	LU8EN	326
W3BQA	415	DL7CS	356	DL3RK	324
W9UXO	414	KL7MF	356	W6UNP	322
W8LY	413	W5OLG	356	K9EAB	319
W2PTD	411	W2GVZ	355	EA4CR	318
W4OPM	411	K9AGB	354	G3EYN	318
W6WO	409	W5AWT	353		

Phone WPX

W8WT	495	W8PQQ	327	DL3TJ	305
G3DO	448	W9WHM	323	SM3BIZ	304
CT1PK	430	W5ERY	315	F8PI	302
PAØHBO	363	W3AYD	314	PY1NC	302
PY2CK	354	I1CBZ	312	W9UZC	302
5A5TO	353	W3DJZ	306	W9PQA	301
W9YSQ	352	ZP5CF	306	VE1ADE	300

SSB WPX

K2MGE	263	K9EAB	204	VE3MR	164
MP4BBW	257	W4OPM	183	YV5FK	162
W8PQQ	250	K2HEA	181	TG9AD	160
W1GR	245	W6BAF	170	W8YIN	157
TI2HP	231	DL4AS	166	W1TYQ	155
HB9TL	221	W8BKO	166	WØCVU	155
W3MAC	212	W2JXY	165	W3VSU	154

Letters

The following letter is from Bryan, G3OFI, MP4TAE, MP4MAB, MP4QAO, MP4BDA, and MP4MAB/4W1 via the West Gulf DX Bulletin.

"... VS9AZA was a pirate and therefore no cards forthcoming. This was checked personally with the Aden license authorities by Rudy, W3ZA. MP4DAA may be reached via G2SB as in call book.

VS9OA's QTH is c/o R. A. F., Masira Island, Sultanate of Muscat and Oman, B.F.P.O. 63.

Can we please once and for all clear up the VS9O/MP4M situation. The situation is as follows: The person in charge of radio license in the Arabian Gulf is Her Britannic Majesties Political Resident in the Persian Gulf (to give him his full title). His jurisdiction covers the Independent Sheikdom of Bahrain, Qatar and the Trucial States and the Sultanate of Muscat and Oman (which includes Masira Island and an area to the east of the Aden Protectorate called Hadraumaut, which was formerly part of Aden). Amateur licenses for all of the area are issued from the British Political Residency, P. O. Box 3, Bahrain by a Mr. Garth on behalf of the HBM's Political Resident. The aforementioned Mr. Garth checks with the British Political Agent in each territory before issuing a license for that territory. The authorities in Aden have no powers, radio licensing or otherwise in these areas. The correct call for the entire Sultanate of Muscat & Oman is MP4M. The stations who signed VS9O and ZB2A/VS9 operated without permission and were deported by the RAF by request of the Sultan!

The stations signing VS9OA, OC and OM are also unlicensed and operate from the RAF base only with the permission of the RAF commander who has no license issuing power. Despite frequent request, the VS9O stations have not applied to the authorities for permits possibly because they do not hold sufficient qualifications to obtain a proper license. All the above information can be checked by writing to the proper authorities at the box no. given above. The latest license holder is Rudy, OD5CT, W3ZA, who has been issued the call signs MP4BDD, 4MAG, 4TAI and 4QAQ for operation in the

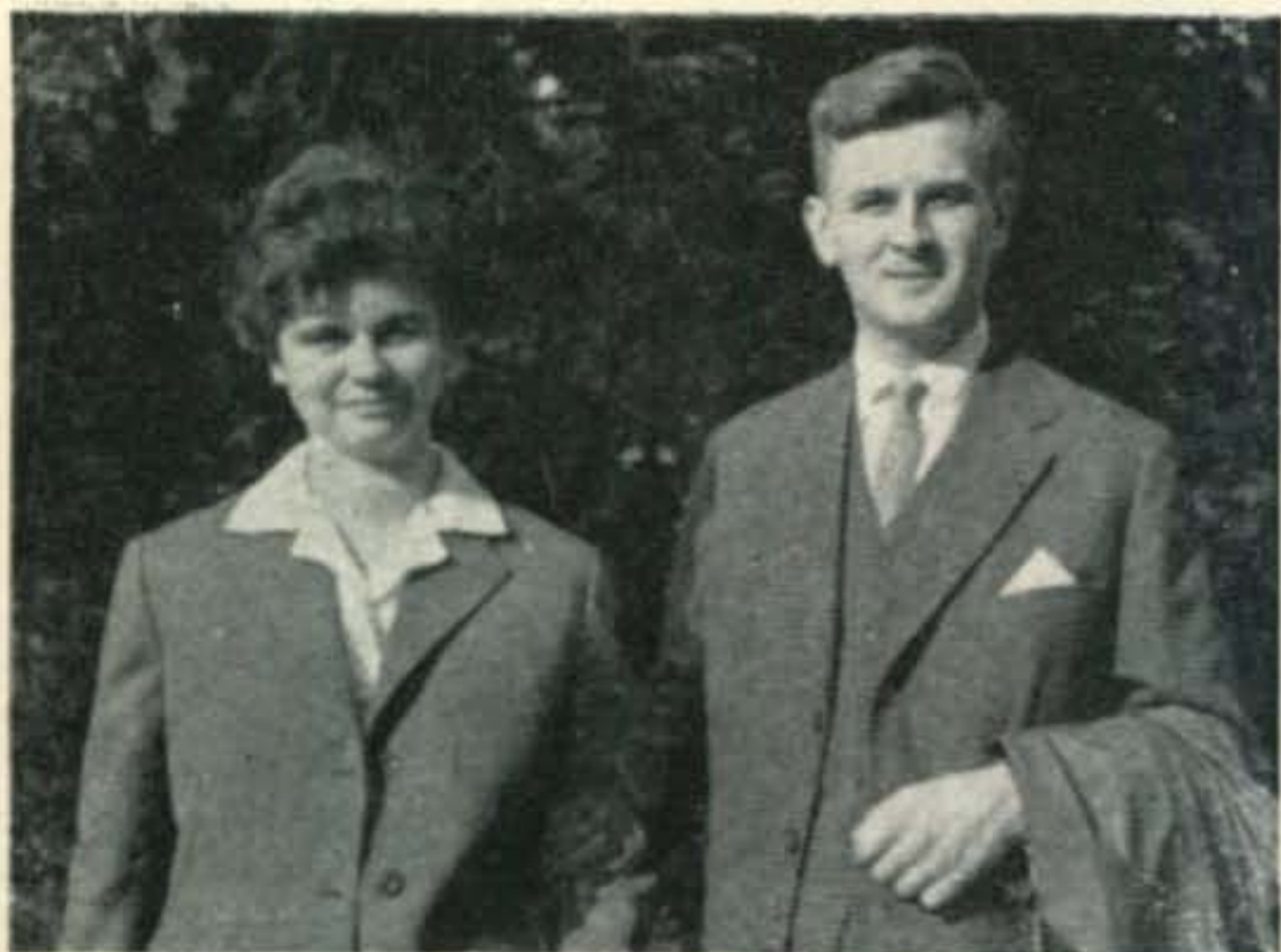

This good looking couple is Sophia, SP5YL and Chris SP5HS. (Tnx K2UKQ)



YV5FK and his very neat station in Caracas. Gregorio as you will notice received on SSB WPX certificate this month.

Gulf during the fall this year.

Finally, I am hoping to visit Qatar, the Trucial States, the Sultanate of Muscat and Oman and Possibly Yemen again.

73, BRYAN A. BISLEY, G3OFI"

EP Iran — K4ORQ/EP is helping W2AYN and W3ZA dish out EP QSO's. His QTH is Box 951, Tehran, Iran.

FB8 Comoros—Andre, FB8CD, should be pulling the big switch about this time. He may be reached at F2LI in France.

FL8 French Somaliland—Rundy is planning a trip to French Somaliland from December 8th to 12th. The call will be FL8ZA on all bands, c.w. and s.s.b. (Tnx WGDXC)

FQ8 French Equatorial Africa—FQ8AF has left FQ8 land and is going to France. Gus will really be missed in future contests. He may go to FK8 land in the future. He may be reached via REF in France. (Tnx W2HTI)

TF Iceland—TF2WFF, who is K4APM state-side, is active on 14.030 c.w., 21.030 c.w., 14.186 s.s.b. and 24.245 s.s.b. with weekend operation commencing at 2100 GMT, Friday preferred. QSL's may go to his home QTH or to TF2WFF 667A.C. & W Squadron, Box 174, APO 81, N. Y., N. Y. Tnx W1WQC)

VR1 Ellice Island—VR1D will be on the following crystal frequencies 14110, 14136, 14160

and 14190. He will also have a beam. (Tnx WGDXC)

VS9 Aden—Ray, VS9ARF, is the new QSL manager for all VS9 stations. VS9AHM, the old manager, is heading back to England.

XE4 Socorro Island—VE7ZM will be joining the group that will be going to Socorro during January. S.s.b. frequency will be 14180.

YA1 Afghanistan—YA1AO is teaching several young Afghan boys radio and they are very interested in ham radio. It would be greatly appreciated if a few handbooks could be sent to them.

ZA Albania — ZA2BAK has been heard in Europe on 14 mc c.w. using low power. He seems to know DM2ACB who was licensed as ZA2ACB a few years back.

ZC5 British North Borneo—ZC5AE has been active on 14 mc c.w. daily mornings, U.S. time. (Tnx KØDQI)

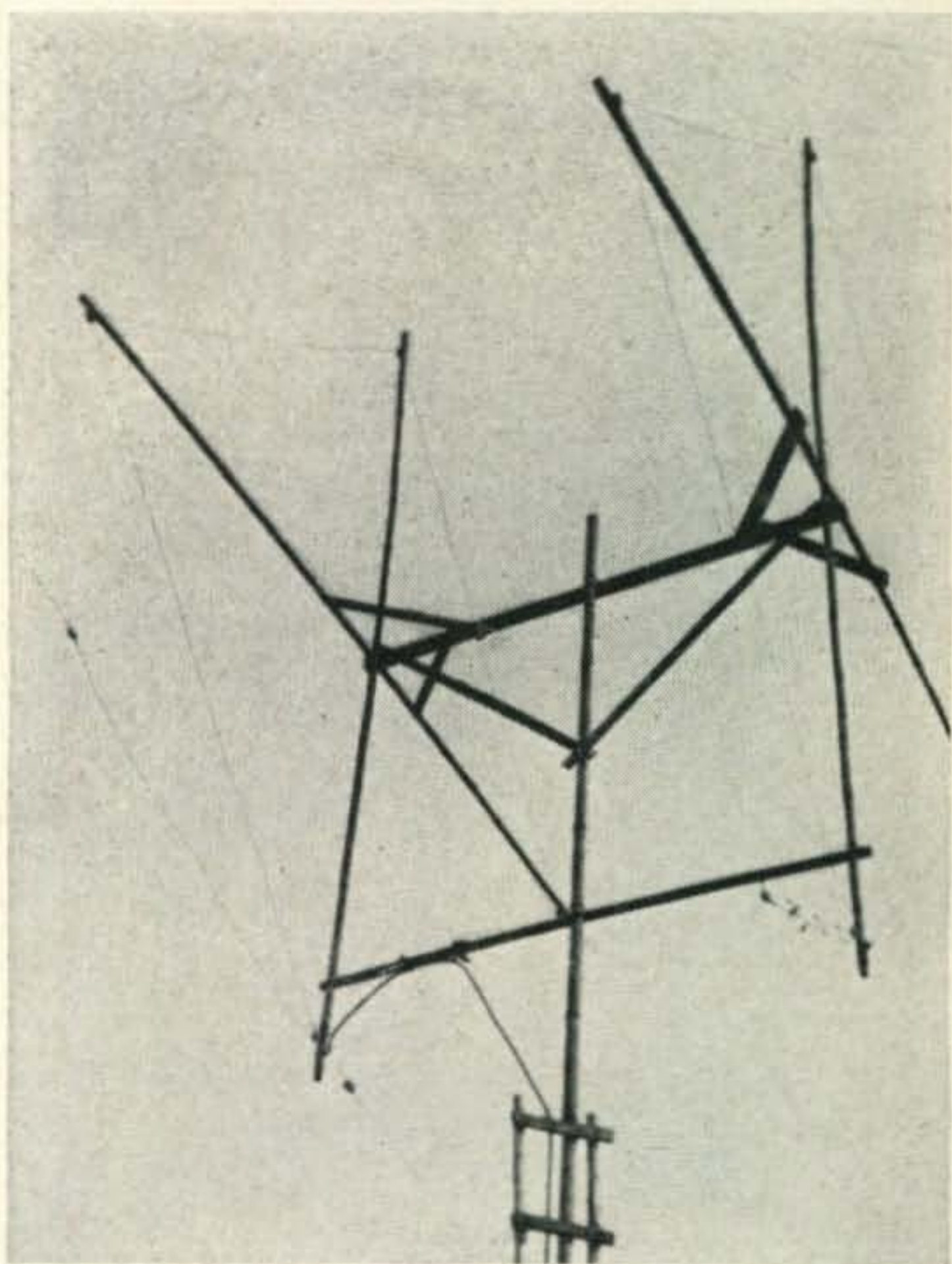

Antenna at used JA2XW



The rig of Kim JA2XW. K2OLG who sent in these photos has worked Kim from his 30 watt mobile rig on 10 meters.



Two of the most popular HB9's on the air, HB9ZE on the left and HB9ZV. (Tnx K2UKQ)

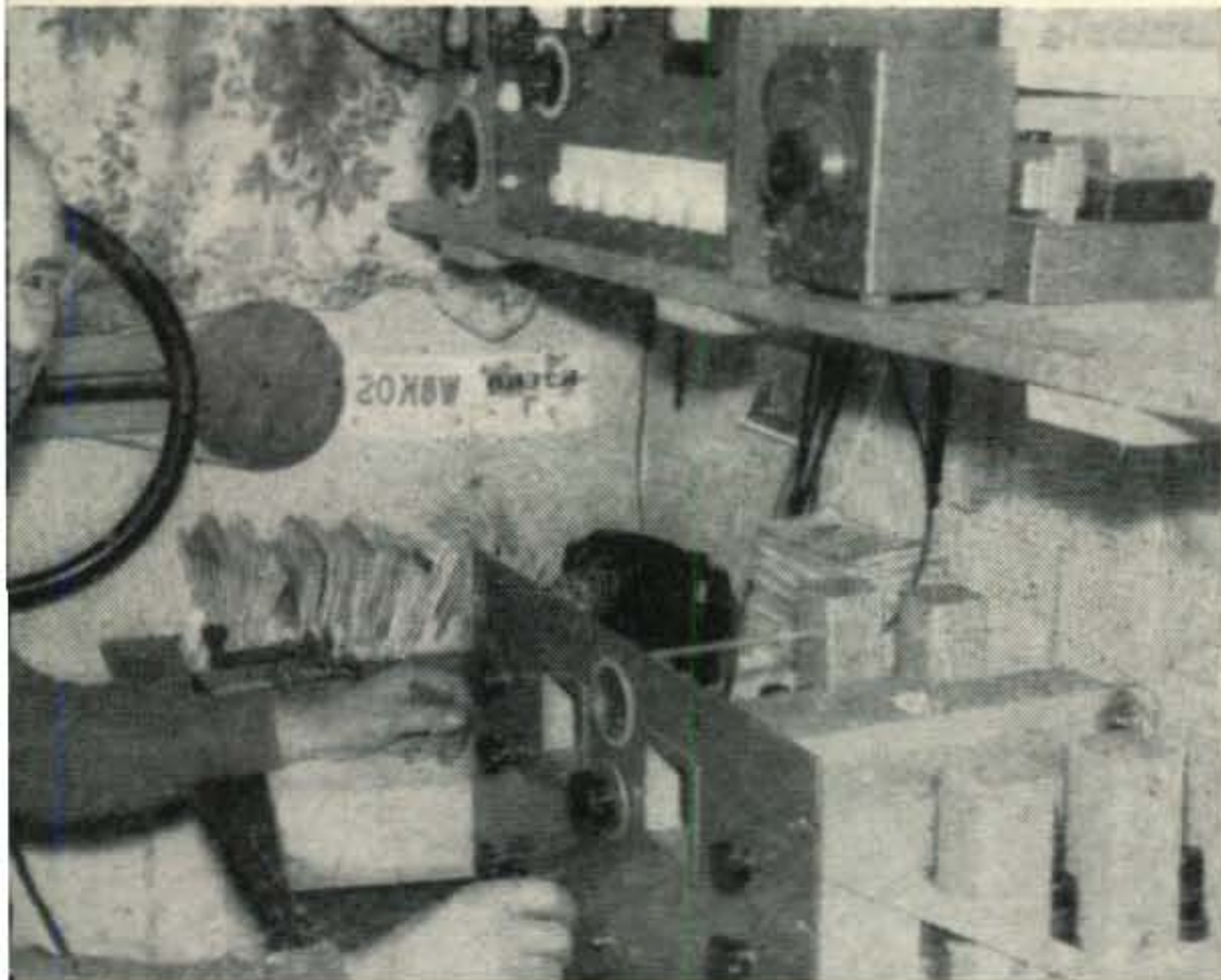

Two of the fellows from down under that keep things jumping when the band is open to ZL land. ZL3IS and Charlie, ZL1ALG in the usual order. (Tnx W2DEO and K2UKQ)

Two of the "big guns" from down W5 way, Bob W5UX and Jack, W5PM. Bob, W5UX has an 80 foot pole with a three element beam in the back yard. Jack as you may know is Sec-Treas of the West Gulf DX Club. (Tnx K2UKQ)

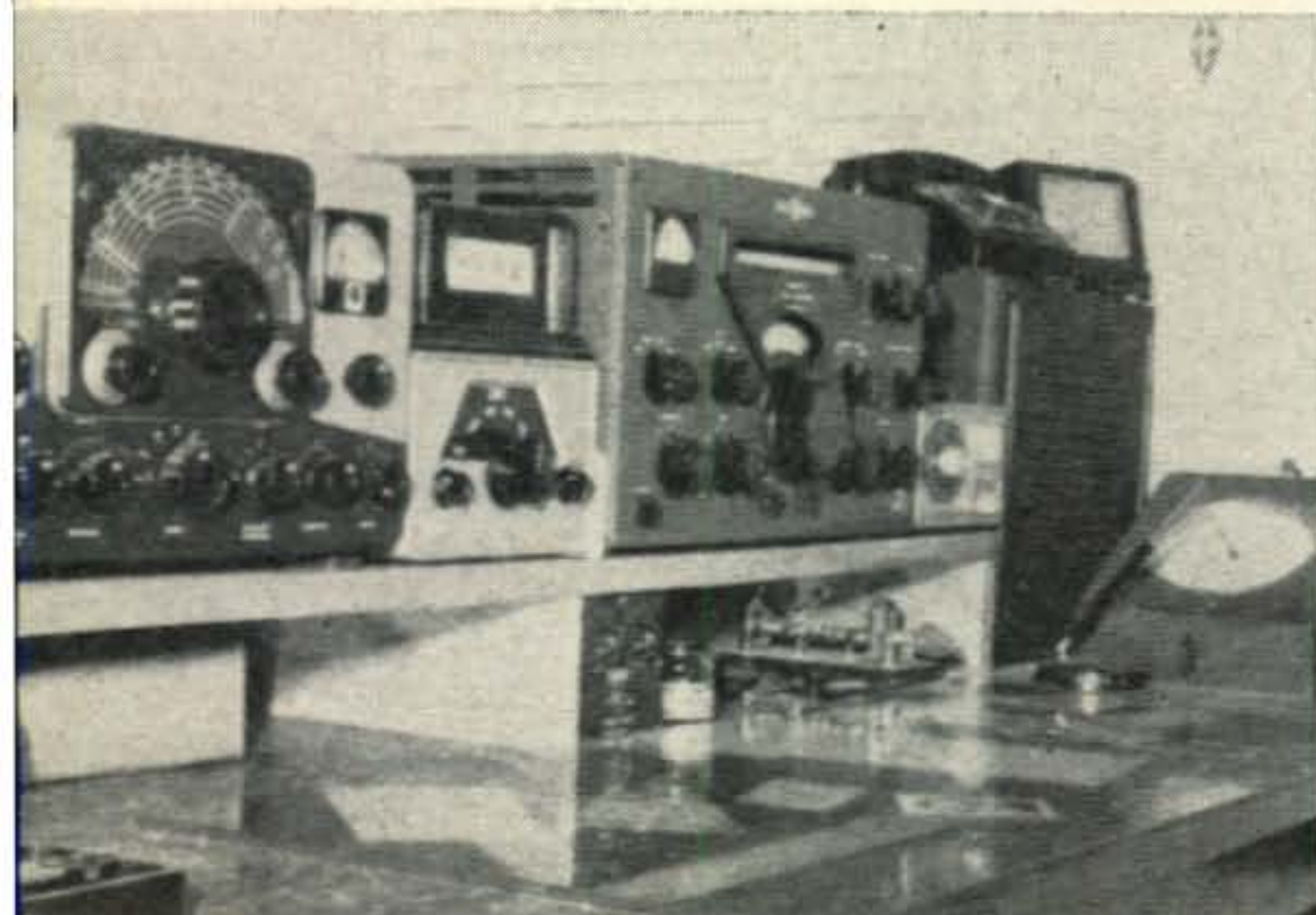

ZD2 Nigeria — ZD2JM will be stationed in Lagos, Nigeria for the next three years. He will operate with 15 watts using 3-807's to a G5RV dipole receiving on a Regifon. His new QTH is: John Macintyre, c/o Assistant in Chief (Radio) Posts & Telegraphs Hdqtrs. Lagos, Nigeria. Stateside QSL's should go directly to K9EAB with SASE. (Tnx K9EAB)

ZS9 Bechuanaland—Lambert, ZS6IF, will be operating as ZS6IF/9 from November 5-14 on 7005, 14010 and 21015 *kc.* (Tnx WGDXC)

9N1 Nepal—Glen, 9N1GW, should be going to East Pakistan about the time you read this. He will have a KWM-1 with DX adapter and a 2 element beam. He had to call off the AC5 portion of the trip because it would involve a 12 day hike over very rugged country to get in and, of course, a 12 day hike out again, and at present, he doesn't have the time to devote to such a trip. (Tnx WGDXC)

9U5 Ruanda Urundi — Many stations are active in their local evening hours around 17-2200 GMT on 21 *mc.* Two of the most active are 9U5VS, Raymond, on 21270 and 9U5DM on 21120. (Tnx WGDXC)

Only air mail should be used for Ruanda Urundi as there is no other form of mail service at present. Also, the OQ5 (9Q5) QSL bureau has been dissolved and cards should be sent to the ON4 Bureau (Tnx W2HTI)

W4BPD DXpedition — The future itinerary of the W4BPD trip will be more or less as follows:—

Oct. 1-3	ST2AR—possible operation
Oct. 3-6	ETE3CE—possible operation
Oct. 6-16	Kenya with VQ boys
Oct. 17	Leaves for the Seychelles with WØAIW, WØMAF and WØUQV
Oct. 20-22	Operates as VQ9HB on Seychelles
Oct. 23	Platte Island, VQ9
Oct. 24	Coetivy Island, VQ9
Oct. 25-30	Algalega Island, VQ8 (a new DXCC country)
Nov. 1-2	Farquhar Island, VQ9
Nov. 3-4	Madagascar, to meet FB8BC
Nov. 5	Isle Glorieuses (FB8)
Nov. 6-10	Astove Island, if new country is given—shorter time if not
Nov. 7-21	Aldabra Island, VQ7
Nov. 22-25	Comoro Island (Here the others leave for home leaving Gus alone)
Nov. 26-27	FB8BC, Madagascar
Nov. 29-Dec. 5	Tromelin Island (if money is left for transportation)
Dec. 5-8	Reunion Island, FR7ZD
Dec. 8-12	Mauritius, VQ8
Dec. 12-20	St. Brandon I. VQ8B
Dec. 20-24	Motor trip thru VQ3, VQ4, VQ5, 6O1 and 6O2
Dec. 25	French Somaliland, FL8
Jan. 1-14	Big try for Kamarau Island, VS9 (another new one)

Jan. 15

Gus leaves for New York and home

Certificates

Award—"Hunt The Hunters".

By—The Certificate Hunters' Club (CHC).

QTH—c/o Sect'y, Clif Evans, K6BX, Box 385, Bonita, California.

Requirements—Confirmed contacts with 25 or more CHC members after their date of joining the Club shown on Club Roster.

Application—Send list, 25 QSLs, \$1.00 or 10 IRCs to K6BX, Box 385, Bonita, California.

Comment—CHC membership is expected to exceed 100 by the end of 1960. Honorary members also count. CHC membership list will be published quarterly in the Directory and Directory News Letter-revision Service. Free list for SASE.

The first 50 club members are as follows:

K6BX	VE2AFC	SM5BPJ	K2CPR
W1AW	W2QHH	K6OQD	YV5FK
W8JIN	W6NWI	W8KPL	WØIUB
W3RPG	W9YNB	W3DKT	F9IL
K2QXG	K2PFC	W2SAW	W8IBX
W4ML	K9EAB	W2PTD	DL1QT
W8QHW	WØCVU	W6FGJ	W2FLD
W6CHY	KP4KD	W1BB	KØGIC
K4DKE	W2TP	K4RNS	ZL2AFZ
K6EIE	ZL2GX	W2GVZ	XE2AE
W6YC	W5AWT	W5NXF	W2DEC
W8WT	F9MS	W3OP	K2TGH
W2DTJ	F3DM	W5LGG	

Bits and Pieces

—Everyone will be glad to hear that OQ5IE and OQ5GU are safely out of the Congo. They may be reached at 58 Chaussee de Dudzele, Brugge, Belgium—XS5A has been heard on 14 *mc* c.w. Says he is in Shensi province in China! —W8EWS is handling all Yasme QSL after HKØAA—VS6EN is ex G3JZI—W2TR was heard in England on 160 in August! Better get your long wires ready men—among the better ones worked on s.s.b. by K2TDI recently are PJ2MC, CT3AV, PX1PF, HB1TU/FL, UB5FJ and 9Q5GA, all with 30 watts — It looks as though the v.h.f. men have done us in, on July 17th, W1FZJ worked W6HB on 1296 *mc* via moon bounce. The distance, a little over 500,000 miles! Congratulations Sam and to the boys of W6HB.—The Amateur Radio Mobile Society has been formed in England. This is an international club which offers certificates, among other things, to promote mobile operation. Details may be obtained from G3HTC.

QTH's

9U5KU	P. O. Box 76, Kitega, Ruanda, Urundi.
UA9KOG	P. O. Box 44, Novosibirsk, Central Siberia
VR4CW and	Box 49, Honiara, Guadalcanal, British Solomon Isl. Prot.
VR4JB	Charlie Morris, Post and Telecomms Dept.,
ZD1CM	New England, Freetown, Sierra Leone
9Q5US	Frenchy c/o American Embassy, Leopoldville
OD5CT	via W2JXH

[Continued on page 104]



ham clinic

CHARLES J. SCHAUERS, F7FE/W6QLV

C.Q. Magazine, 300 West 43rd St., New York 36, N. Y.

Noise And How To Fight It

At least one full page of *CQ* would be required to list all the electrical devices that can and often do create radio and TV interference or unwanted *noise*.

Although electrical manufacturers do consider noise in the design of their products and adopt every available means to suppress it; electrical equipment does age and develop troubles which inevitably lead to noise production.

No receiver (TV or radio) on earth is completely noise-free—yet, what counts in any r.f. receiving setup is the amount of usable signal in proportion to the amount of unwanted noise. In other words, if our *wanted* signal is stronger than our *unwanted* noise, we communicators will seldom have too much trouble.

A high signal-to-noise ratio is hard enough to achieve with modern techniques, let alone trying to combat noise produced by malfunctioning electrical equipment.

The following do produce noise when not functioning properly: neon lamps and signs; heating pads; electric motors of all kinds; kitchen appliances (toasters, broilers, mixers etc.); house wiring (both internal and external); oil burner ignition systems; power company transformer installations; shop equipment of all kinds, including arc welding equipment; high tension power line corona; poor or very loose ground connections; defective switches and relays of all types; defective tubes (especially those whose elements become shorted); internal meter arcing; improperly shielded and/or suppressed TV and receiver oscillators; diathermy equipment; X-ray equipment; refrigerators of all

kinds; antenna installations (*at the receiving station or nearby*); and small components such as resistors, capacitors, coils, diodes etc.

Noise is either *conducted, radiated or both*. It can travel through a complicated wiring system or arrive via any antenna system.

Sporadic or steady, noise can be specific in frequency or it can be *aperiodic* (having no discernible single frequency characteristic).

Often, the type of noise sound heard via a good receiver will enable one to determine "roughly" what may be causing it. For example, we all know (those of us who operate on 6, 10, 15 and 20 meters) how noise caused by an automobile ignition system sounds. When the car engine is idling we hear a distinctive, "puck, puck, puck. . . ." As the engine speeds up our "pucks" increase in number.

The only really effective way to eliminate ignition noise is at the source. Of course, those of us who have noise limiting circuitry in our receivers are able to attenuate the "pucks" to where they are not annoying.

Noise from electrical motors is usually characterized by a steady high pitched whine. This is also true of generators.

Neon lamps and other "high-voltaged" devices will usually radiate a noise that is characterized by its "hash" or aperiodic type sound. Again, suppression is only effective right at the source.

A defective "pole pig" (power line pole transformer) will usually create a combination of sounds from a distinct crackle to a high frequency type hash. The noise is much stronger in wet or very humid weather. If loose connections are not the cause nor can the trouble be pinpointed to an internal leak, replacement may be indicated.

Diathermy and X-ray equipment are troublemakers when not operating properly. The former throws out a "good" r.f. type of noise which



Sprague Electric Co. interference locator.



Stoddart Aircraft Radio Co. interference locator.

usually does have a specific frequency, while the latter sounds like an old spark transmitter—its signal is full of harmonics and hash.

Vacuum cleaners are the bane of the amateur's Saturday morning contacts! Locating this offender is not difficult because it makes a mechanical as well as electrical noise. The most effective cure is to connect two .1 *mf* capacitors in series and put the combination directly across the brushes of the motor. The center tap of the two condensers is connected to the vacuum cleaner frame. If this measure does not work, it may be necessary to install a brute force filter consisting of two coils in series with each line (leaving the condensers already connected) and then connect a like combination on the point side of the coils. (See the *ARRL Handbook*)

The location of a noise producing source is not always a simple matter; this is why such companies as the *Stoddard Aircraft Radio Co., Inc.* of Hollywood, California and the *Sprague Electric Company* of North Adams, Mass. (among others) specialize in the production of interference location and measuring equipment.

It must be remembered that an interference that will effect low frequency reception may not have any effect on frequencies at very or ultra high frequencies, and vice-versa. This is the main reason why much interference location equipment has been designed to cover a very wide range of frequencies.

The Stoddard Aircraft Radio Co.'s type NM-52-A pictured here operates in the 375 *mc* to 1000 *mc* regions and is capable (in addition to locating noise sources) of supplying accurate information for frequency conservation and allocation studies, spectrum signatures, antenna propagation studies, field intensity survey, r.f. energy surveillance and monitoring, and verification of the electronic compatibility of modern weapons systems (missile firing and guidance), computer, telemetering and communications; the measurement of all rotating electrical devices, transmitting and receiving equipment, or any system or equipment capable of producing unwanted radiated or conducted electrical disturbances.

The Sprague Model 500, also pictured here, covers 550 *kc* to 220 *mc* and is especially designed for interference location.

Both of these equipments incorporate a very sensitive receiver, directional antennas (chosen for a given band), output indicators and other special features to do the jobs for which they are designed.

You will no doubt realize when you glance at the pictures of these two selected pieces of equipment that the location and pin-pointing of r.f. interference is no minor field.

The radio amateur can make up his own "interference locator" by using a portable radio receiver and a directional antenna; both of which must be capable of covering, frequency-wise, the bands in which you are interested. Now with h.f. transistorized receivers on the market these can be used very effectively in many cases

to locate noise produced by nearly any electrical device.

But here is another thing to remember; most electric power and telephone companies in nearly every city in America have a special "interference location section." If you should have noise which may be caused by telephone or power systems, contact them for assistance. By using instruments like those described here, their technicians can quickly locate the trouble and correct it.

If you are not familiar with an appliance (refrigerator, sewing machine, electric mixer, stove, neon assemblies etc.) and it is a noise producer, it is better to call in an experienced service man (who may also be a ham, and have a quick solution).

Most noise can be filtered or shielded out of any electrical device *at the device*. Using a brute-force filter at a receiver is not often too effective but will help in many cases. Choosing the correct filter and/or shielding often requires the services of an expert, for it is very possible to affect the efficiency of a device by using the wrong "corrective" measures.

Some causes of noise and/or interference are very simple and can be corrected simply. For example, a radio-taxi dispatcher in one of our large cities was continually experiencing a nerve-wracking noise which opened the station receiver's squelch. No matter how he tried to adjust it, he could not cut out the interference with the squelch control without over-desensitizing the receiver. A little investigation disclosed that one cab contained a mike with a defective switch that closed and opened intermittently as the cab bounced around the city!

Another case: a ham was experiencing an intermittent clicking noise in his receiver. He tried and tried to find it. One day when in QSO he wanted a drink of water and went to the kitchen to get it—(meanwhile leaving his receiver on loud so that he would not miss what his contact was saying). All of a sudden he heard the refrigerator click on and the noise covered up his contact. He pulled the refrigerator power cord and the noise stopped. He solved the problem by rubbing graphite on the refrigerator compressor belt and carefully *grounding* the refrigerator motor and compressor. (Sometimes it is necessary in like cases to install a "belt contact brush." This is nothing more than a grounded wiping finger of metal which contacts the revolving belt.)

If you have a noise problem, describe it in a letter to HAM CLINIC; maybe we can help you.

Observation (On Building Kits)

A number of my friends have brought their newly assembled *inoperable* kits to me to trouble-shoot. In nearly every instance, I have found that *careless* soldering, reading tube pin numbers wrongly or using a wrong resistor i.e., a 2.2K for a 22K was the cause of their trouble.

Ever try to trouble-shoot someone else's kit blunders? It isn't an easy task!!!

Observed: the new-comer in set construction tries to work too fast and is not always careful enough.

Advice: take your time! Check off each step in the book before you do it, then check it again after you have done it—after you have ascertained you have done EXACTLY what the instruction told you to do. Insufficient heat applied to a connection results in a cold connection. Be sure to HEAT-SINK the connection ends of small resistors and condensers—too much heat and you'll wonder where the VALUE went!

After you have finished your whole wiring job, CHECK it against the schematic and circuit diagrams. The first will educate you; the second inform you of your mistakes.

BE CAREFUL where high-voltage is involved. Take no chances! Keep one hand behind you and make certain you are not a "circuit return"!

Simple 50 MC Rig

As promised, fig. 1 shows the diagram of the simple 50 mc rig which has created so much interest and which elicited so many requests for diagrams.

With only three tubes, this little rig has a big voice. An ideal modulator for it is contained in my article "VW Special" in the December 1957 issue of CQ; or you can use any transistor modulator capable of 12 watts or so output.

To tune it, insert the crystal, adjust L₁ for 25 mc output; adjust coupling between the second 6C4 and the 2E26 for maximum grid current (around 2½ mils). Resonate the 35 mmf final condenser, and load with the final 140 mmf condenser. A milliammeter may be inserted in the final plate for a final current meter reading. After tune-up neither the grid milliammeter or the final milliammeter are necessary IF you stick to one frequency . . . to save space these were eliminated in the original model which was built into a chassis smaller than a cigar box.

Good luck with it!

Questions

BC779 Rec.—"What's the input antenna im-

pedance of the BC-779 receiver?"

115 ohms.

Easy on 10—"Tell me, what is the easiest way to get on 10 meters; the only band in which I'm really interested? I want a mobile installation and I do not want to spend days making it."

I'd suggest you look into the *Transcon 10*. It is a complete transmitter-converter unit with power supply. I would say that it would take about 2 hours to make a good installation including antenna. Write *Arrow Electronics*, 65 Cortlandt St., N.Y. 7, N.Y., for more complete information on this fine little piece of gear.

Trap Leak—"I have a trap antenna and when the weather swings to rain I obtain erratic loading readings. What could be the cause?"

You may have a leaky trap (s). Also, you may have water entering your coax. Check the antenna with a good high range ohmmeter (at the transmission line end) when the weather is wet and when it is dry. A low reading when wet will indicate moisture infusion. Also disconnect the coax and check it; then re-check the antenna itself with the coax disconnected. Be sure, if you use the *Mosely TA33J* that the trap vent holes are OPEN, and that they are on the bottom and not the top.

Panadaptor Conversion—"I too have a Hallicrafter's SP44 panadaptor and enjoyed K2DHA's fine article in the June issue of CQ adapting it for 1650 kc output. Would it not be simpler though to convert the panadaptor itself?"

This can be done but is a difficult design task. The SP44 was designed for 455 kc i.f. operation and full 200 kc sweep. To get the gain you need at frequencies above 20 meters (going into a 1650 i.f. stage) would require at least 2 more tuned circuits. Then you would run into the band-width problem.

Linear Supply—"What is the most practical way to get high filtering capacity for a linear power supply for proper dynamic stability? The d.c. voltage will be around 1200 volts."

Try four 100 mf electrolytic capacitors rated

[Continued on page 97]

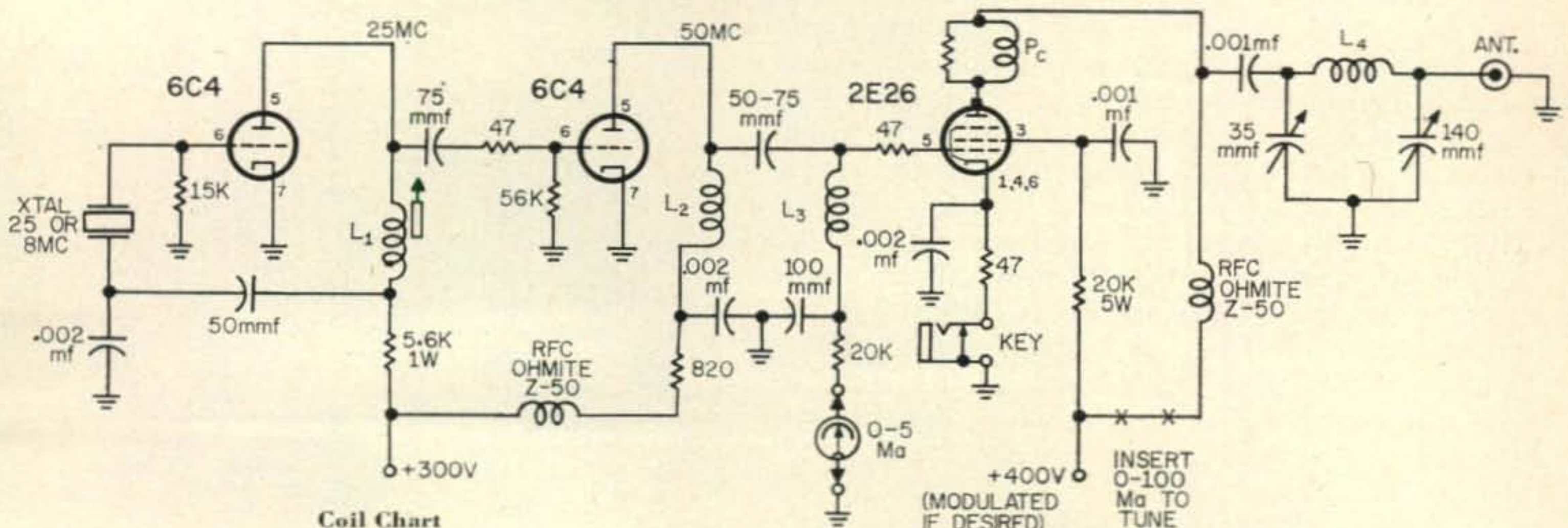

Coil Chart

L₁ 23t #30 enam. on ⅜" slug tuned form
L₂ Air-dux #516T ⅜" long, ⅜" dia. (use 6t)
L₃ Air-dux #516T. Use 6½ turns (#20 enam. may be used for L₂ and L₃ if #516T is not used)

L₄ 4t #18, ¼". Air-dux 608T
PC 2½t #18 spaced 1½ times wire diameter on 10 ohm ½ watt resistor.

Fig. 1—Circuit of a simple 50 mc rig of extreme simplicity.

VHF

50mc. 144mc. 220mc. 420mc. and above

BOB BROWN, K2ZSQ
67 RUSSELL AVENUE
RAHWAY, NEW JERSEY

You no doubt have noticed the new call at the head of this month's column. I'm happy to greet you as the new VHF Editor of *CQ*. Some readers already know me from *The VHF Amateur* and I sincerely hope all you fellows will bear with me on this new venture.

We are all sorry to see my esteemed predecessor, Sam Harris, W1FZJ, leave his post after so many years of service. He will be sorely missed. We are happy to report, though, that Sam is taking over W1HDQ's position at *QST* through their VHF column. No doubt you have seen his first contribution by now. Again, Sam, our thanks for a job well done.

As for me, perhaps a bit of an introduction is in order. My first encounter with v.h.f. was right from the start through Carl, W2AZL, who conducted my Novice examination. Since that day I've been fascinated by every facet of v.h.f. work and have sampled a bit of each. I've spent the last three years or so operating 6 meters. At the present my true love is propagation and its effects on v.h.f. bands. I especially enjoy straight ground wave work and may be found just about all the time on the low end of the 50 mc band with the beam toward the New England or Washington, D.C., area. At the present I'm running about 150 watts with plans for throwing the rig on 2 meters. Before very long I hope to be operating all v.h.f. bands with a respectable set-up.

One thing I hope you will bear in mind is that this is really *your* column and I must rely on you, the reader, for information—Anything you can contribute will be most appreciated. Make sure all your letters, pictures (don't forget 'em!), etc., reach me by the 5th of the month. A great many of the boys have expressed a desire to have a section set aside for schedules. Fine! I would really like to see this and I'm sure it would benefit all concerned. And how about your club's activities? Practically every little tidbit has value; send it in! The new address is at the head of this column. As mentioned earlier, this is *your* column. Now let's get down to the matters at hand.

KH6UK — W6NLZ

Yessir, they've done it again! Got a line from Tommy, KH6UK, regarding his 432 mc skeds with W6NLZ . . .

"Just a line to let you know that W6NLZ

received my 432 mc transmissions on July 20, loud and clear, peaking 30 db above the noise. Signals were in and out for several hours starting around 1700 HST. They were in again but much weaker on July 21 for about 2 hours starting at 1600 HST. A defective antenna relay at my end prevented the signals of W6NLZ from being heard at my QTH so no QSO took place. This was a new one and did not occur to me that it might be giving me trouble, so I was checking everything else like mad. There is no activity out here on these frequencies so no signals are on the air to check the receiving set-up with. Tests continue and we are hoping, hi. Will keep you informed." *You do that Tommy, and we're just as anxious to see you make it as you are. Maybe by the time this is in print you will have made it. Keep with it!*

Flash! KL7FIC—Heard in W1!

I just got word today from Art, K1AII, that on the Aurora of August 15th and 16th, *KL7FLC* was heard by *W1GEF* and an unidentified VE2.

This constitutes the first break-through from Alaska to W1-land in many a year. We are now in the process of contacting the parties con-

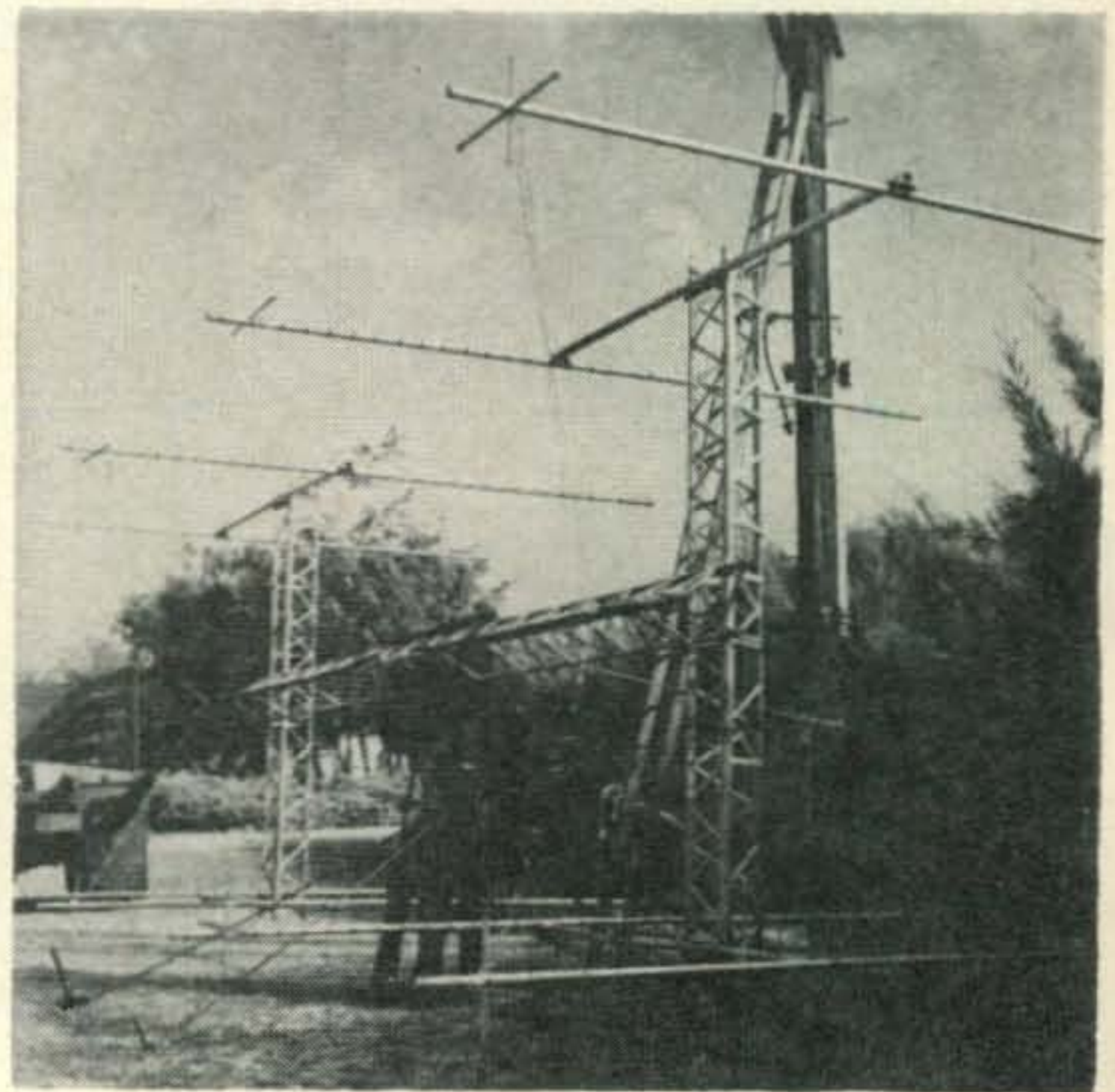

This antenna farm belongs to Tommy, KH6UK, and shows his 432 mc array on the ground for repairs. Yes, this is the very same set-up that just broke through to W6NLZ in California!

cerned and checking to see who else might have heard KL7FLC. He is located, by the way, on Ice Floe Charlie (hence the letters "FLC") T3 off the coast of Alaska. The call of KG1FN had to be changed due to a drift of the floe which brought it into Alaskan waters.

Anyone else who hears KL7FLC is urged to contact me immediately for inclusion in this column. Keep on the lookout next aurora session. Maybe you can get Alaska yet!

Contests

I know you were all very happy, to at last see the results of the August 1959 CQ VHF Contest. The plaques and certificates are going out and by this time we trust all have received theirs. My congratulations to the winners! In spite of past delays in printing contest results, we'll be back on schedule very soon and will have them in print a lot sooner than before. Be looking for you in the April v.h.f. contest!

6 Meter Contest!

A contest to end all contests is being conducted by the Clegg Laboratories Radio Club of Morristown, New Jersey. The contest is open to all 6 meter enthusiasts nationwide. Rules are as follows:

1. Contest starts at 2200 GMT November 1, 1960 and ends at 2200 GMT January 30, 1961.
2. Object of the contest is to attain the highest possible number of points in the time allotted.
3. Points are determined by counties worked. Each county worked for the first time in the contest scores 1 point. An additional 1/2 point may be added for the same county worked between 50.0-50.1 mc on c.w. Both stations in the QSO must use c.w. Another 1/2 point may be added for a two-way sideband QSO with the same county. Conclusively, it is possible to get 2 points with the same county utilizing all modes.
4. Each entrant must keep a log during the contest showing the QSO exchange material necessary—Call, Handle, QTH, County, and Signal Report. All times in the log must be in GMT. It is recommended that your log be sent in every month during the three month period, but not required.

5. In your monthly log submission, you should nominate one outstanding candidate in the contest in your call area on the basis of operating technique, procedure, etc. Monthly winners (in each call area) get 5 extra points to add to their final score plus a \$20.00 gift certificate.

6. All logs should be mailed to: Clegg Laboratories Radio Club, Box 641, Morristown, N.J.

Prizes will be offered to the first 25 station to get 50 points; First 15 stations to get 75 points; first 10 stations to get 100 points; and to the first 5 stations to get 125 points.

To the station who gets the highest point total by 2200 GMT January 30—goes a Clegg Mercury transmitter. Second prize is a Crystalplexer. Third prize is a \$100.00 gift certificate. Fourth prize to tenth prize will be gift certificates to



OM Fumio, JA2GR, the first Japanese station contacted by LU3DCA on 6 meters.



Michael Czysch, at the operating controls of LU3DCA. Mike's station is completely homemade from the transmitter through converter and receiver. Aren't very many like this boy around anymore!

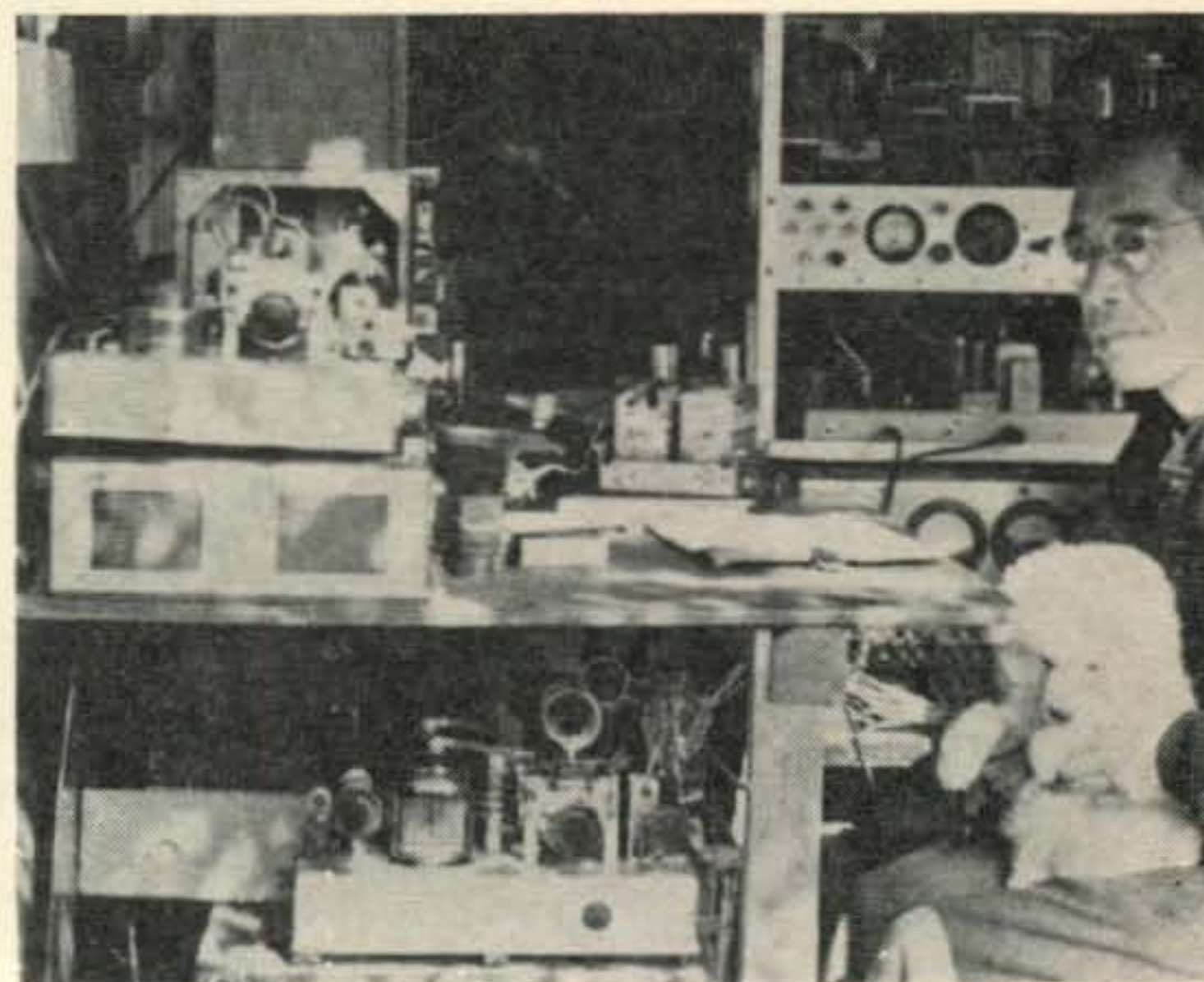

This is OM Katsumi, JA6JY, a very active v.h.f.'er.

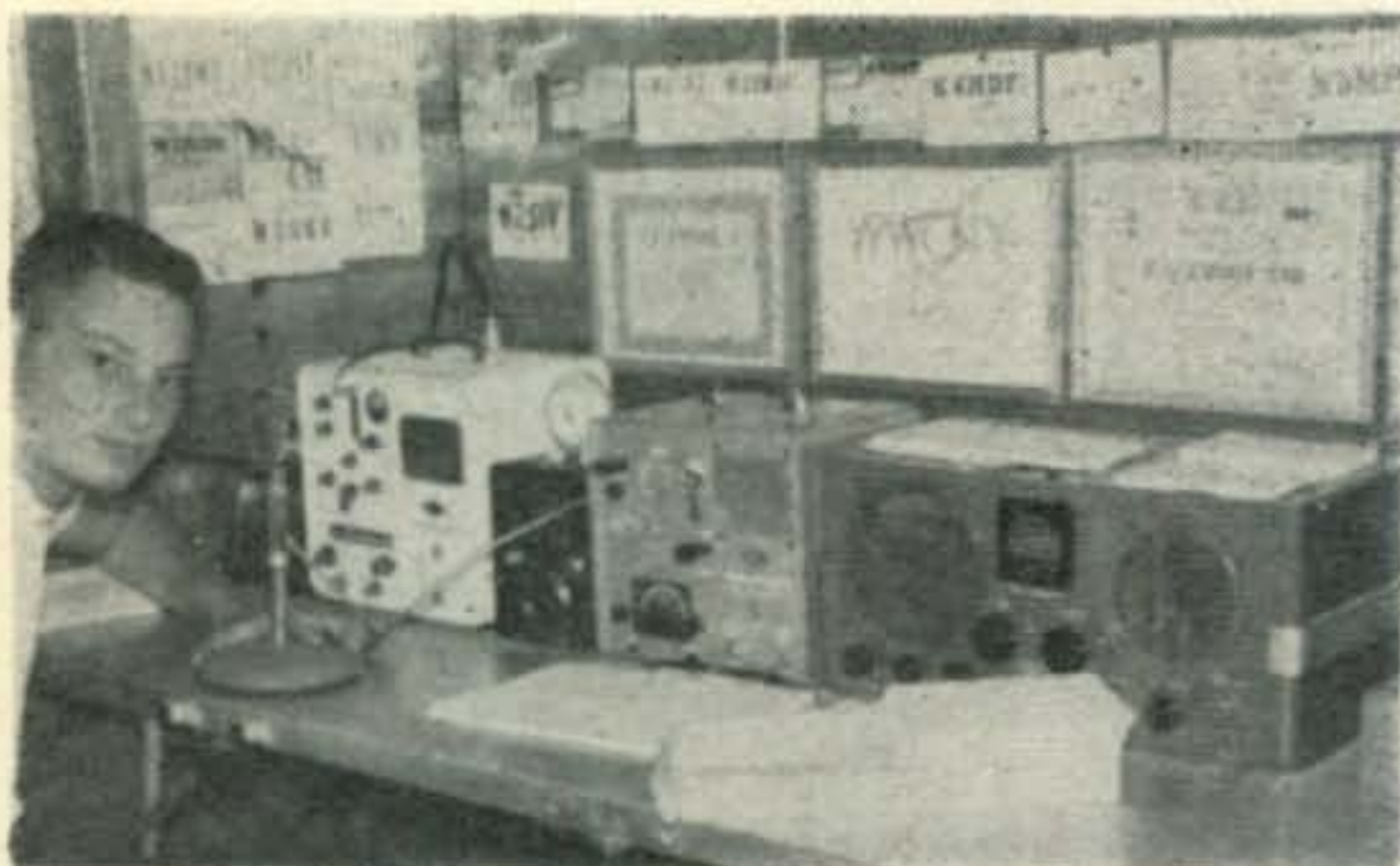

Stu, K2RPZ, at the controls using his new Gonset II on 2 meters.



K7ILB braves the chilly night wind under an Indian blanket calling "CQ 6" while K7HRW looks on. See Curly's letter (K7HRW) in this month's column.

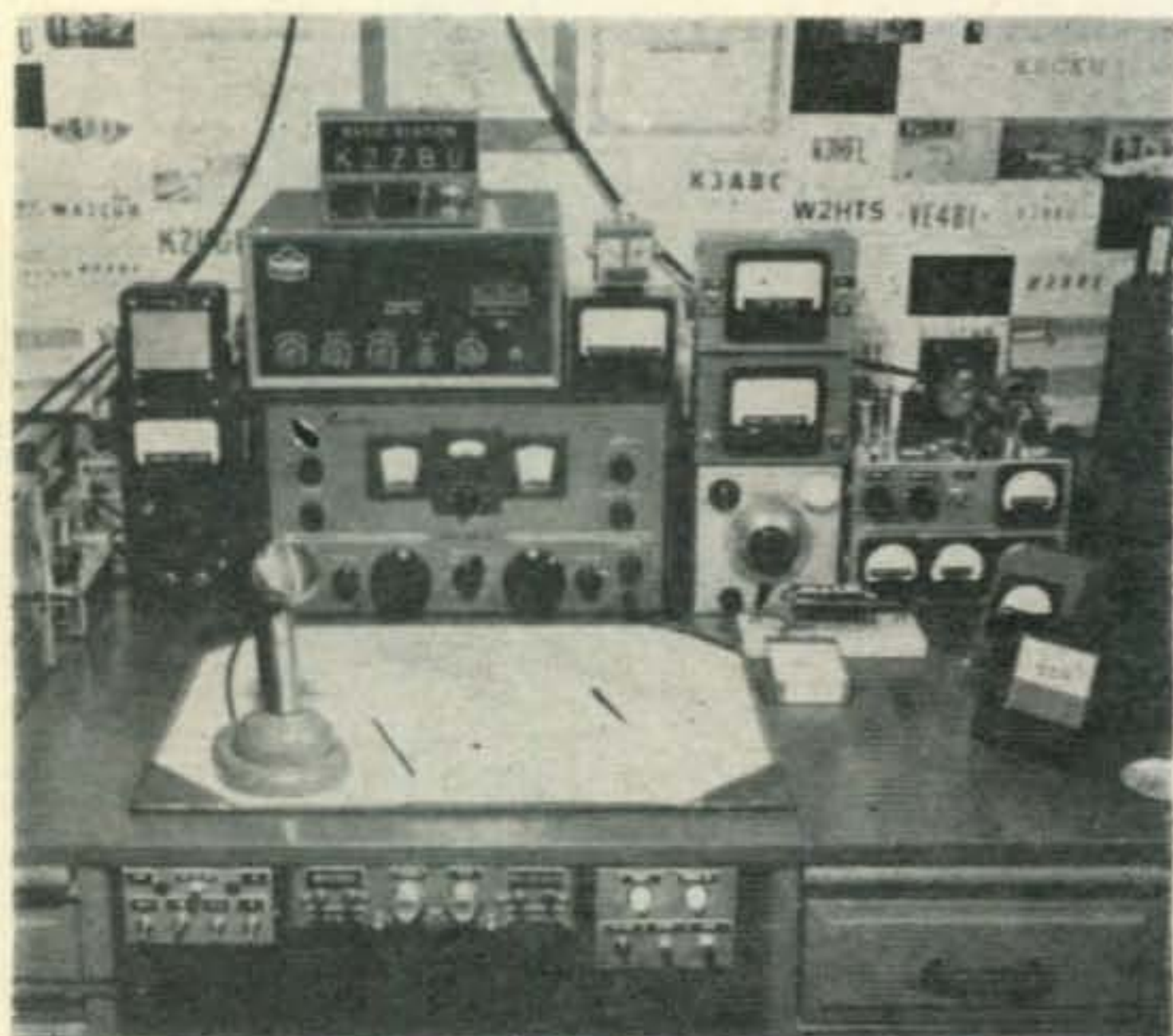

Wow! How would you like to sit down at this vhf rig! This neat shack belongs to Gordon, K2ZBU.

major radio supply houses. Total value of prizes —\$1,300.00!

More about this and other contests next month. Meanwhile, make plans to get started! Those prizes can't be beat, and *you* can do it. Mark your calendar for November 1st—2200 GMT!

VHF Hamfests

October 1—This is the date for the VHF Fall Fun-Fest of the Miami Valley VHF Club in Ohio. The program includes tech talks, hidden transmitter hunts on 50, 144 and 432, morning and afternoon programs for XYL's, door prizes, and a big banquet with more prizes and drawings. Time is provided for eye-ball QSO's, there are favors for the ladies, and everyone attending will receive some sort of "door prize." Registration is \$1.50, banquet tickets are \$3.50 each. Write now to Mr. E. Gillespie, K8MDX, 1351 Alcott, Dayton 6, Ohio. Fun-Fest will be held at the Engineer's Club, 110 E. Monument Ave., Dayton, Ohio.

October 8—What can be said about the "One and Only"—The Syracuse VHF Roundup? I can add nothing to this already world-famous annual event. I intend to be there and will be looking forward to meeting you. For tickets write to K2TXG, 317 Clover Ridge Drive, Syracuse 6, N.Y. Act now!

Condolences

We are all familiar, I'm sure, of the contributions of F. E. Ladd, W2IDZ. We regret to announce the passing of his son, Harold W. Ladd, on August 10. The accident occurred when the well of a radar mast was being lowered aboard the submarine Trigger. He was crushed below decks by the well. The Ladds reside at Bowers Place, Denville, New Jersey. Our sincere condolences.



Partial view of set-up at W1BU.

Opinions—C.W.

At this time I'd like to express my views on the 50-50.1 and 147.9-148 mc c.w. subbands as viewed several months ago through *The VHF Amateur* and bring them up to date a bit. . . . Well, for several months now we've had our new c.w. segments in effect. Some opinions praised the action, some were indignant. First off, I think we'll all agree that the 50.0-

50.1 allotment is a long-awaited, long hoped for segment. At last we have a portion exclusively for A1—to the triumphant joy of our loyal aurora men. The a.m. QRM problem has ceased, at least in the first 100 kc. Quite a number of newcomers have already taken advantage of the new segment, increasing the c.w. population on six meters. I feel that although our record-breaking DX season is long gone (here in North America, at least) the sub-band should be used to the best of our individual capacity. Let's make the best of what we have. If we can show, and I think we can, that the segment will be used to our advantage daily, we'll have a much better opportunity for further "legislation" with much less opposition. It took years to get this c.w. segment where we wanted it. Don't make the FCC regret it.

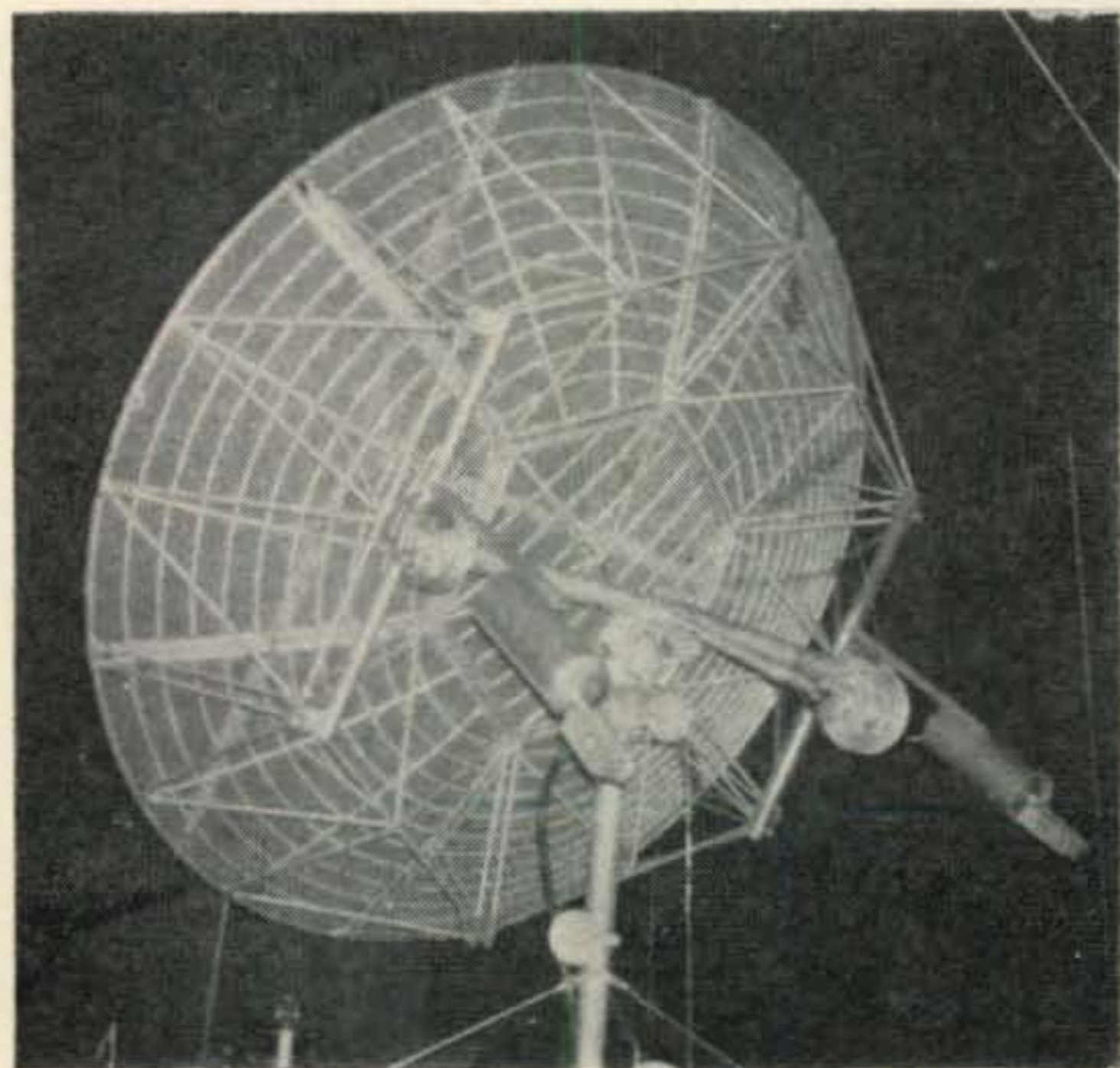

This view is Sam Harris's (W1FZJ) 18' parabolic for moonbounce used in the W1BU-W6HB 1296 moonbounce contact announced last month. Photo by W1EGE.

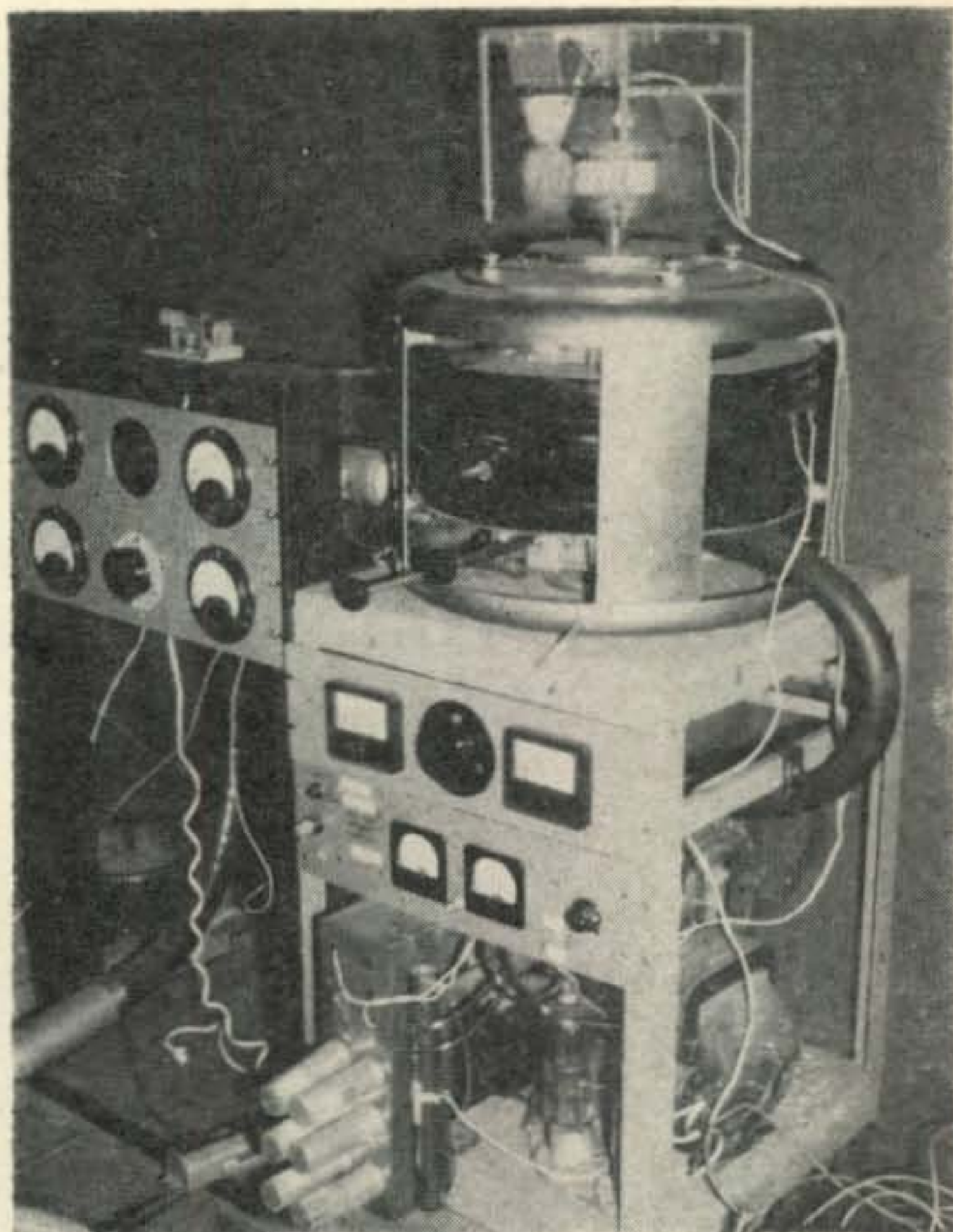

Final 1296 amp and power supply at W1BU used to break through to the West Coast via moonbounce.



Just had to steal this one—couldn't resist it. This is, believe it or not, K3EGP's QSL card! Some rig, eh?



Some of the gang at the East Coast VHF Society's Annual Picnic and Hamfest in Saddle Brook Park, New Jersey, on August 14. The center of attraction of this group is the "talk-in" station for mobiles on route.

Now the other side of the story; 2 meters. I've found that the almost unanimous opinion of all 144 mc men has been that the 147.9-148.0 sub-band will probably be ignored. It's going to take a lot more "doing" to get what we want, but don't give up. I hope that the new segment, already received with utter displeasure and disappointment, will not remain for long. Keep after it boys, and sooner or later we'll have that first 100 kc.

WAC—50 mc Crossband

W2ESZ passes along an interesting tidbit on a new group whose chief goal is to enable complete crossband QSO's between 6 meter operators and lower frequency DX.

Over the past two months this plan has been set into operation. This is *not* the same type of crossband as the EI2W-G3EHY to W, 10 to 6 meter operation of a year or so ago. Rather it is for six meter 'ops to have their sigs piped into a 20 or 15 meter kw and on across the world. Copy back in reverse.

First attempt was between K1FCF (low-frequency) and WA2IQJ (on six). Contact was a success. Since then there have been numerous contacts between W2 and K6-KH6-JA2-KC4, etc. The man behind the whole scheme is John Cuches, Sr., W2ESZ, mentioned above, who resides in Middle Village, L. I. For those within phoning distance you might try DA 6-1446. John will fill you in on the details on how you can be "connected" with a DX station re six meters.

Another facet now in the planning stages is the type mentioned above that was haphazardly carried out years ago. These 10 to 6 meter QSO's are still possible and John will try to set up skeds for you if you're interested.

Mailbag

Anchorage, Alaska: From the famous pen of Jack, KL7AUV, comes:

"For the first time since the last of January 1959, I made another contact with the States. Wednesday evening I had a rather poor fone patch with W7RT, through KL7CC here in Anchorage. 'Ole John said Es was rampant, and could we make some skeds! I agreed, wholeheartedly, and advised him I would be on from 0300 to 0430 GMT last night, Thursday (July 13) tonight Friday, and Saturday. The exchange of information was not too good, but I think that data was gotten across." *Good for you!*"

"Thursday I fired up the keyer at 0300 GMT and gave it a try. Well, there was no sign of John, but at 0350 there was K6ZEH, loud and clear at the bottom of the band. Slow QSB of

Here's a shot of Gordon, K2ZBU's 6 meter antenna set-up. Wonder what those other "do-dads" are?

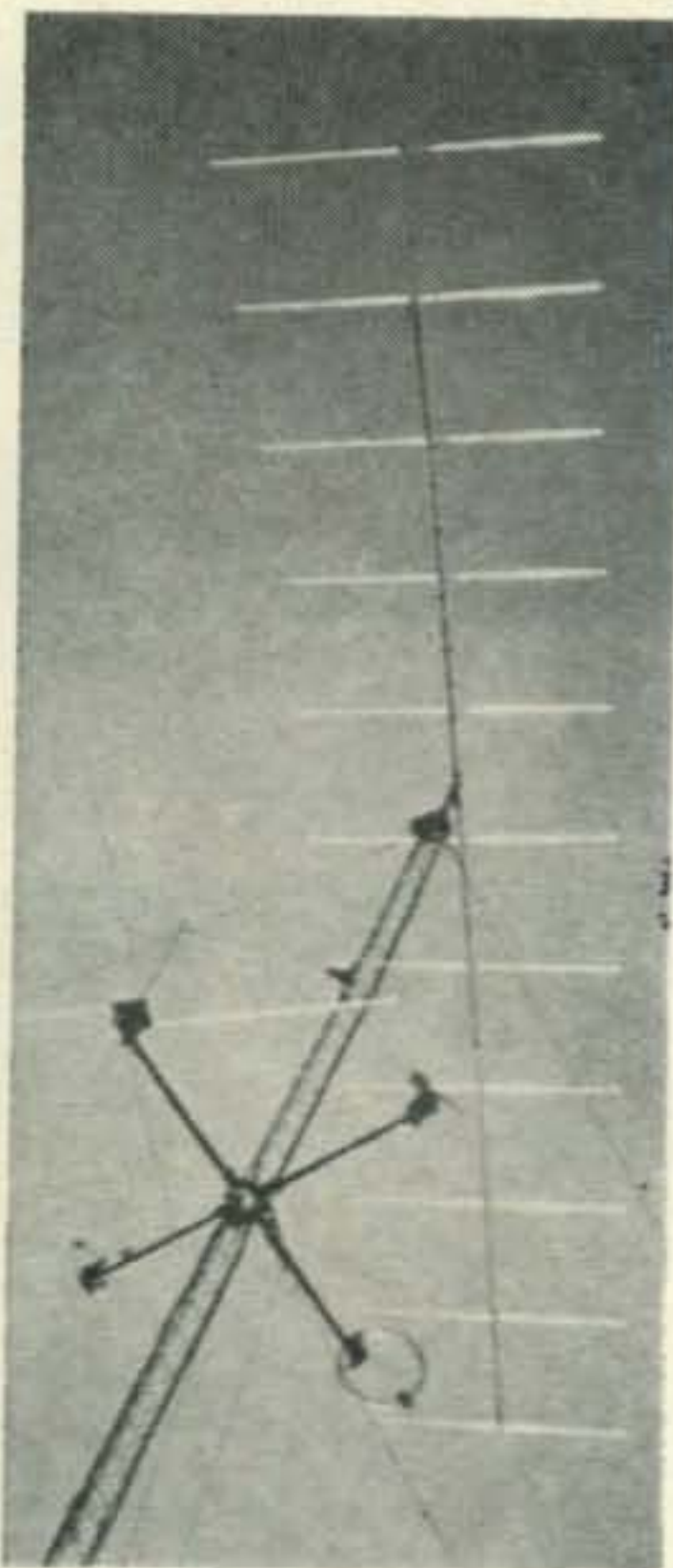
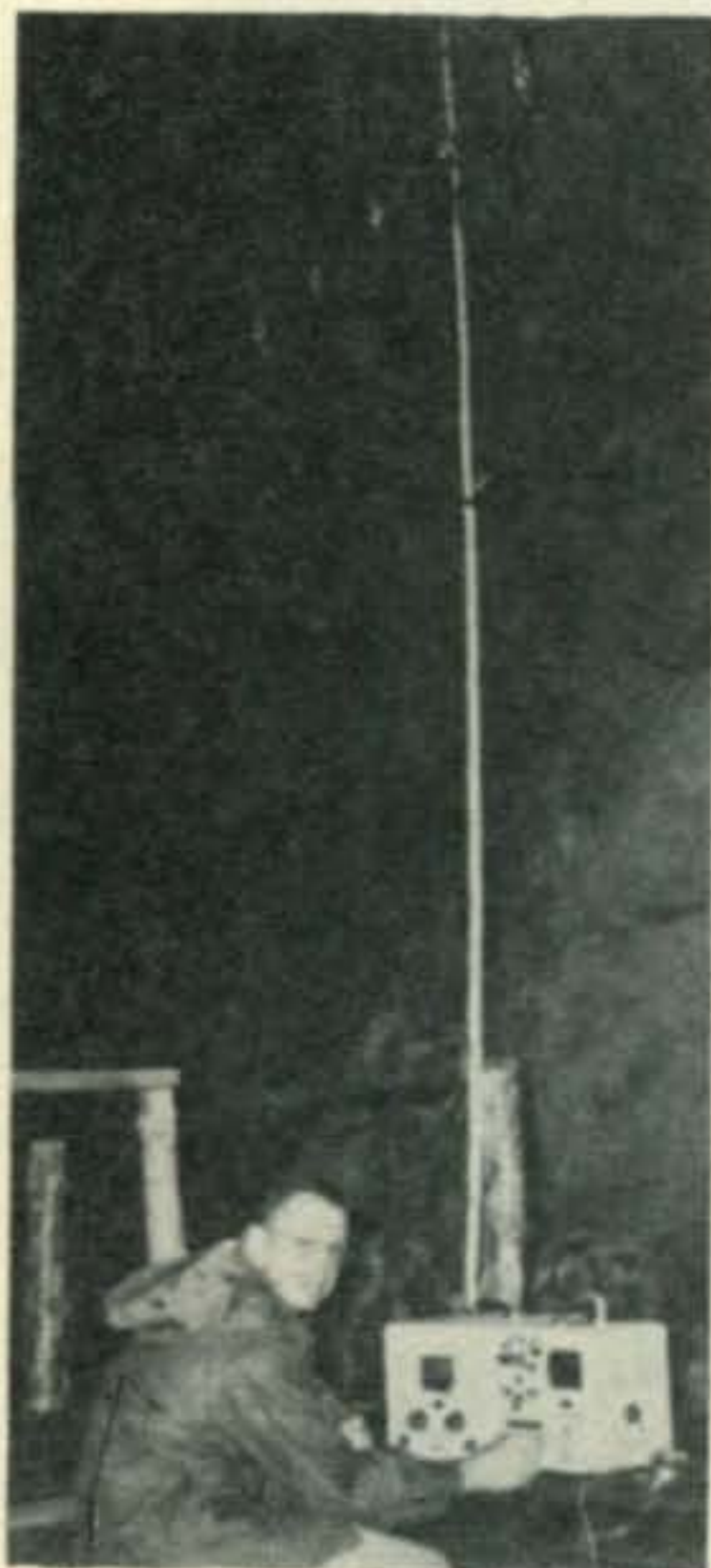

'Ole John, W7MAH, tunes up for a DX call on two meters with a Communicator and linear on Slide Mt., Nevada—9,000 ft!

course, but a fairly good signal, raising to about an S7 off and on. At almost the same moment I heard her, the phone rang, and Margie (KL7BLL) relayed the information that it was Norma, and she was hearing me also. By the time this was relayed to me in the basement I had already called her and we had a short exchange over about eight minutes. Guess we were both shook a little, but we managed to get in a short exchange with W6FZA, Allan, before we signed and I went back to looking for W7RT. Never did hear him, but I did hear a couple of short bursts of steady carriers just above 50.1." *Real fine, Jack! Glad to hear you're back at it making those DX contacts once again after all that work on null periods. How about a try at quadruple skip Sporadic E for us East Coaster's?*

Euclid, Ohio: Howard Perkins, K8EUX, sent in a long letter regarding stations worked on Es along with the following:

"On August 2, we experienced a "one way" skip in here . . . Heard W4NZI, K4BMW, K4PQU/M, K4TOK and W4OYZ. They were working 2's and VE 3's. *Don't I know it!*"

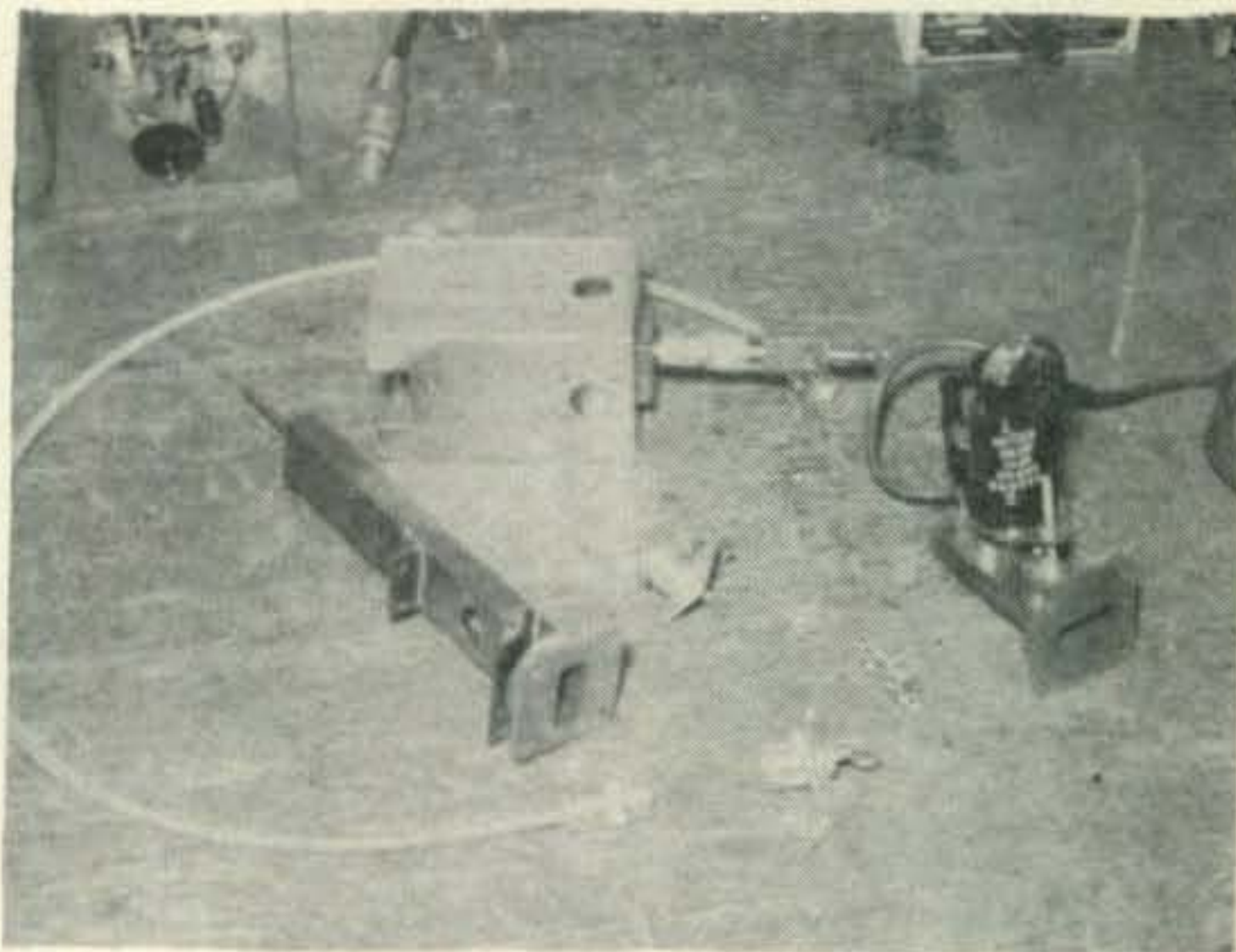

John's at it again! This is his new 1296 mc paramp.

On August 3—Very good skip to the East at 1050 to 1230 EST. Worked three new states with K1MUC, K1BGB, K1NLK, in Mass., KILSA in R.I., and K1LW/1 in Maine. *Congratulations!* Heard K1CPL, K1OIG, K9JCA, W2IDM. *How'd that K9 get in there?* Around noon time the skip shifted to Mid-West. Heard W5BWS, KØVLZ, KØVLT, KØWLB, Kansas, KØPYB, Mo.

"August 7—Weak one way skip in with W5BGA, K5HVC, K5PIB, and K5YAW. Texas boys were working WØ land." *Thanks for the report, Howie. Keep 'em coming.*

Wilkes-Barre, Pennsylvania: This one comes from Bill Evans, W3JMP:

"I do a lot of portable work in the summer-time from Electronics Height, which is a mountain about 2000 feet above sea level 5 miles east of here. *Wish I had that elevation!*"

"I use a Hy Gain 5 element beam 25 feet

above the ground up there and most of the time run a Communicator III on 6 meters with a gasoline driven a.c. generator to power supply. *Sounds like a DXpedition!*

"I try to get up on the mountain in the evenings on the weekends (about 7 PM to 2 AM EDT). Possibly once every two weeks, or better than that if I can manage it." *Have heard you in there, Bill, and I assume quite a number of the boys have worked you. We'll be looking for the 'ole W3JMP/3 signal.*

Reno, Nevada: Boy, here's a rare one! "Curly" Silva, K7HRW, comes through with this one . . .

"Just a line to let you know there is a little activity on 6 meters in Nevada. Just about every day at 1230 and 1830 PDST, without fail, you'll

Here's the woman of the cameo herself, Marie Gilmartin, WA2AKM, of Boonton, N.J. Her daughter, 16, is WA2GTV.



find K7HRW, and K7ILB (ex K2YEB), chewing the rag at 50.1. Also if and when he gets a chance, our high power s.s.b. friend John, W7MAH, chimes in with a few well chosen words. We always monitor and usually work this frequency, but are all v.f.o. controlled."

"There have been other marginal openings into the Dakotas, Nebraska, and Iowa. Have heard from most sections except the one, twos, and threes, but we're waiting. Stations heard most frequently with potent signals here are W5SFW, K5IQL, and KØEIC." *Same here, Curly.*

"Power here in Reno ranges from 50 watts to 250 on a.m. and c.w., and up to 350 watts s.s.b. with W7MAH at the switch. Antennas range from 4 element to 6, 25 feet to 70. Altogether, there are 8 hams here in Reno on 6, but all are not too active."

"W7MAH, K7ILB, and I have recently ventured to Slide Mt., 9,000 ft. elevation, near Reno, to try and work some DX. *With that elevation what else could you work!* We have managed to work into 6 land both on 6 and 2 meters, but are still not satisfied with the location." *Maybe not, but I know about 2,000 other v.h.f. men who'd like to trade QTH's! Keep us posted, Curly.*

Tulsa, Oklahoma: Our wandering friend, "T.R." Bishop, K3DKV/5, writes . . .

"At this writing I am in W5 land, all ready to leave for Japan. Got my order about two weeks ago and this moving has been a mess. If you would like, I'd enjoy giving you a report from Japan. *Would I?!!* I understand v.h.f. is

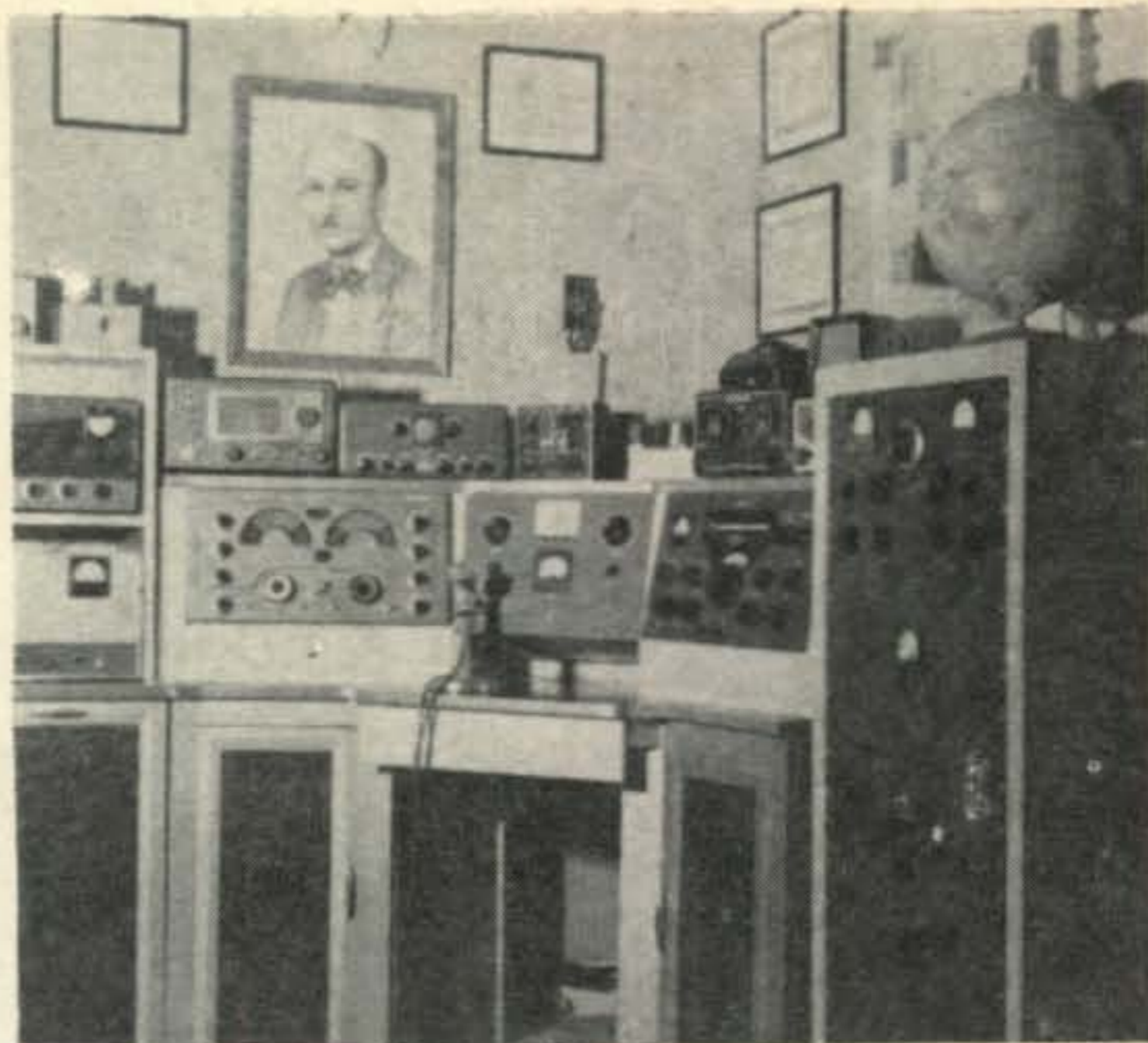

This elaborate station belongs to Frank Greene, K5IQL, of Roswell, New Mexico. How'd you like to man that rig?

considered the very best over there. *The way I hear it, it's not so bad here either—hi.*

"On the trip down here I worked the following stations which I am sure will be very familiar from the recent band openings. They are as follows: W3FUZ, K4VZO/8, K8QPA, K8OMI, K8HAZ, K8HNU/8, W9DZC, K9QDP, K2-QHH/Ø, KØLLU, W5ICZ, K5HXQ, and K5VIT. My whole trip was made more enjoyable and a lot easier going through the big cities.

"I would like to thank all my friends in 2 and 3 land for the very nice fellowship and all the help they have given me in the last three years. Will be looking for a real wild ground wave from KA8 land to you." *That would really have to be some ground wave! Thanks for the report, "T.R.", and do send us a letter on your activities in Japan.*

Encinitas, California: From that sunny land and George Strang, K6MLH, comes this short note . . .

"I am especially interested in u.h.f. If you have any information constructionwise on 1215 and 2300 mc transmitters and oscillators please inform me." *Well, George, I think the best bet would be to have some of the boys contact you direct. How about it fellas? K6MLH's mailing QTH is 1372 Hymettus Avenue, Encinitas, California.*

Mount Airy, Maryland: Ralph Pickett, W3-JWY, comes through with another "shorty."

"I have been having my usual good time on the 6 meter band, meeting a lot of nice folks. As you know, the band openings have been great and I have had the pleasure of working into Argentina three times; also a number of contacts into Cuba, Newfoundland, etc. *Congratulations!*

You may put me down as having worked two more states to bring me up to a total of 42.

[Continued on page 108]



Novice

by DONALD L. STONER, W6TNS
P.O. Box 137, Ontario, Calif.

From time to time, I run across a good bargain; something which will appeal to budget conscious Novices. Recently I ordered, from the Government Printing Office, a book titled *Basic Electricity* which is part of the Navy training course and carries the catalog number NAVPERS 10086. The handbook includes such subjects as "Fundamental Concepts of Electricity," "Batteries," "The Simple Electric Circuit," "D.C. Series and Parallel Circuit," "Direct Current Compound and Bridge Circuits," "Electrical Characteristics of Conductors," magnetism, inductance and capacitance, instruments, d.c. motors and generators, a.c. theory, alternators, transformers, motors, and many-many more subjects. The book is loaded with useful information and runs 684 pages long. At the end of each chapter is a quiz to test your knowledge of the subject and the answers are given at the end of the book. Also included is useful information on color codes, resistance, abbreviations, symbols, and wire sizes. As I said before, the book is a bargain and is priced at \$2.25. You can order it by the title and number D 208.11:E1 2/3/956 from the U.S. Government Printing Office.

K6ATX Does It Again!

Those of you who have been with me these past few years may remember my telling you about Walker A. Tomkins, K6ATX, writing a mystery with an amateur radio flavor, titled *SOS at Midnight*. Now, Tommy has done it again with his latest *CQ Ghost Ship*. I didn't think it possible, but K6ATX has outdone himself with this new book. The hero, Tommy Rockford (who also holds the call K6ATX- hi) heads for what looks like a nice summer vacation with his uncle, who is a private investigator for the Neptunian Marine Casualty Insurance Company. Their vacation spot in Washington State abounds in odd characters, not to mention quite a few amateurs. A transmitter hunt sponsored by the local hams turns into a game of hide and seek with a group of smugglers. The end is as exciting as anything you're likely to read in a Perry Mason mystery and I'm not going to give it away like the book jacket does. If you buy a copy, hide the jacket; you'll enjoy the thrilling conclusion much more! Tommy's new book, *CQ Ghost Ship* is at leading bookstores and sells for \$2.95.

A Novice Kilowatt

Bob Heselberg, 3328 Sunset Dr., Tacoma 66, Washington has a typical problem. He writes, "I have a small Ameco AC-1, and an 807. I want to mix them up and come out with a "Novice Kilowatt." I was wondering if you would tell me how to do it." I imagine many Novices have low power c.w. rigs and would like to add an amplifier for more punch. Well Bob, I have not tried the circuit shown in fig. 1, but it is pretty much standard and should work for you too. The power transformer is anything you can scrape up with more than 400 volts each side of center. A transformer out of an old RCA 10" television set makes a real beauty. The coils are the Bud plug in type for the 75 watt power

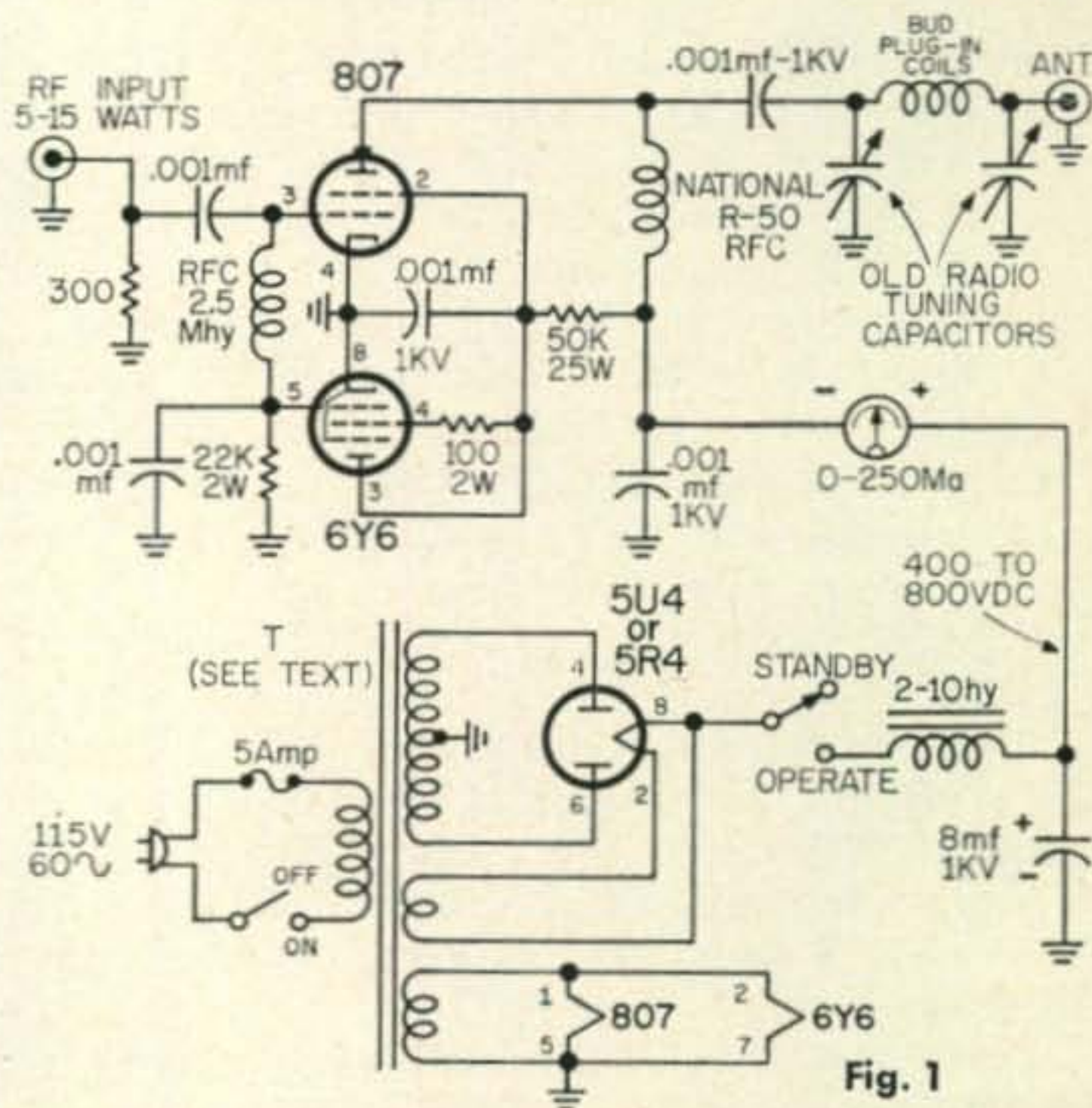

Fig. 1

level. The two tuning capacitors can be salvaged out of an old radio. No neutralization is required because the resistor "swamps" the grid circuit. A 6Y6 tube is used as the clamper. The r.f. drive from the rig makes the grid of the 807 draw current and provides bias. When your key is up there is no bias on the tube and ordinarily it would draw excessive current. However, in this circuit, there is also no bias on the clamp tube and it draws heavy current. This shunts some of the voltage away from the screen of the 807 and greatly reduces its plate current, thereby protecting the final amplifier. Give it a whirl, Bob, I think it is just what you are looking for.

Who's DX?

Want to correspond with a dog-xray station? I received a nice letter from Mats Gunnarsson, SM7BUA, Snapphanevagen 14A, Hesselholm, Sweden, requesting pen pals. Mats operates on the 40 meter band with a 5 watt rig and has worked 266 stations in 18 countries.

Our friend Tom, KR6ZT, the Okinawa Novice, has shed the "N" (only in this case it is a "Z") and graduated to the General class amateur ranks. Tom now holds call letters KR6KP. Look for him still operating on the Novice bands.

Earlier we published the address of Jimmy, LA6CF/MM, in California. If you would like to meet him when he arrives in the States, drop him a line to LA6CF/MM, M/S Bonneville, Overseas Shipping Co., 310 Sansome St., San Francisco, Calif.

Don, WA6ENG/JA1, 500 Shimo Ochiai 1-Chome, Shinjuku, Tokyo, Japan, writes to report reception of the following stations in JA-land; June 1, 0950-1000 GMT: KN5ZRC, WH6DRB, KN7KSK. June 4, 1000-1200 GMT: KN5CGN, WH6DRT, WV6JAD, JMR, KDO. June 15, 0840-0900 GMT: WH6DOI, DRB, WV6KJI. June 16, 0800-1110 GMT: KN4PNM/KL7, WH6DPN. June 21, 0745 GMT: WV6KJA. June 26, 1130-1140 GMT: WH6DNO, KN7LPA. June 27, 1129 GMT: WV6LRL. June 30, 1126 GMT: WH6DJV.

Help Wanted

The following stations have requested help with their licenses. Can you give them a hand?
W4- Roger Rozelle, 164 King Springs Road, Smyrna, Georgia, Phone HE 5-9586.
WØ- Wallace Schulz, RR2 #44, Parkston, S. Dakota, WA 8-3942.

Letters

Bill Dillon WV6LGE, 2032 Saipan Dr., San Diego 14, Calif. turns on the power switch this month. Bill operates mostly 40 meters (7170 kc) but occasionally migrates to 80 and 15 with his Globe Scout 65 and Hallicrafters S-38. He lives in an apartment so he must resort to a 35' wire strung up in this room. He is also building a transistor c.w. rig from *P.E. Mag.*

Another Bill, namely Opdyke, KN3KHK, 710 Devonshire Rd., Takoma Park 12, Md., has dropped his "N" by the time you read this. He plans operation on the general bands with his DX-20 and NC-109, with DB-23 pre-selector. Bill's antennas include a 150' long wire, a 40 meter Dipole, a 3 band vertical, and a three element beam up 45'. His DXCC stands at 71 worked and 52 confirmed but would like skeds with KL7 and KH6 to obtain pen pals. Stations needing Md. should drop him a line for a sked.

Phil Coley, KN4MPE, 2006 Twain Rd., Greensboro, N.C., is a "regular." His awards include WAS, WAC, RCC and CP-15. His DX includes such goodies as CR6, UP2, LZ1, UN1, CP3 and so on, far into the nite. Phil just re-

[Continued on page 110]



Morris S. Burton, K5WZT (Wonderful Zone—Texas), 2717 Crest View Avenue, Tyler, Texas, has just graduated from the Novice ranks. In the 7 months he operated as a KN5, Morris worked 524 QSO's and wound up with a WAS of 41/41. He has a word of advice to the "older" fellows—"Come on in—you will get the needed experience and make many enjoyable contacts".



Meet Freddie Crawford, KN5CWR, 1030 Church St., Aloo, Oklahoma, who plinks away with a DX-20 and AR-88. After 3 weeks his WAS stands at 20/28. Fred will sked anyone needing Okla., and would like skeds with 4, 7, Ø districts and the new states KH6 and KL7.

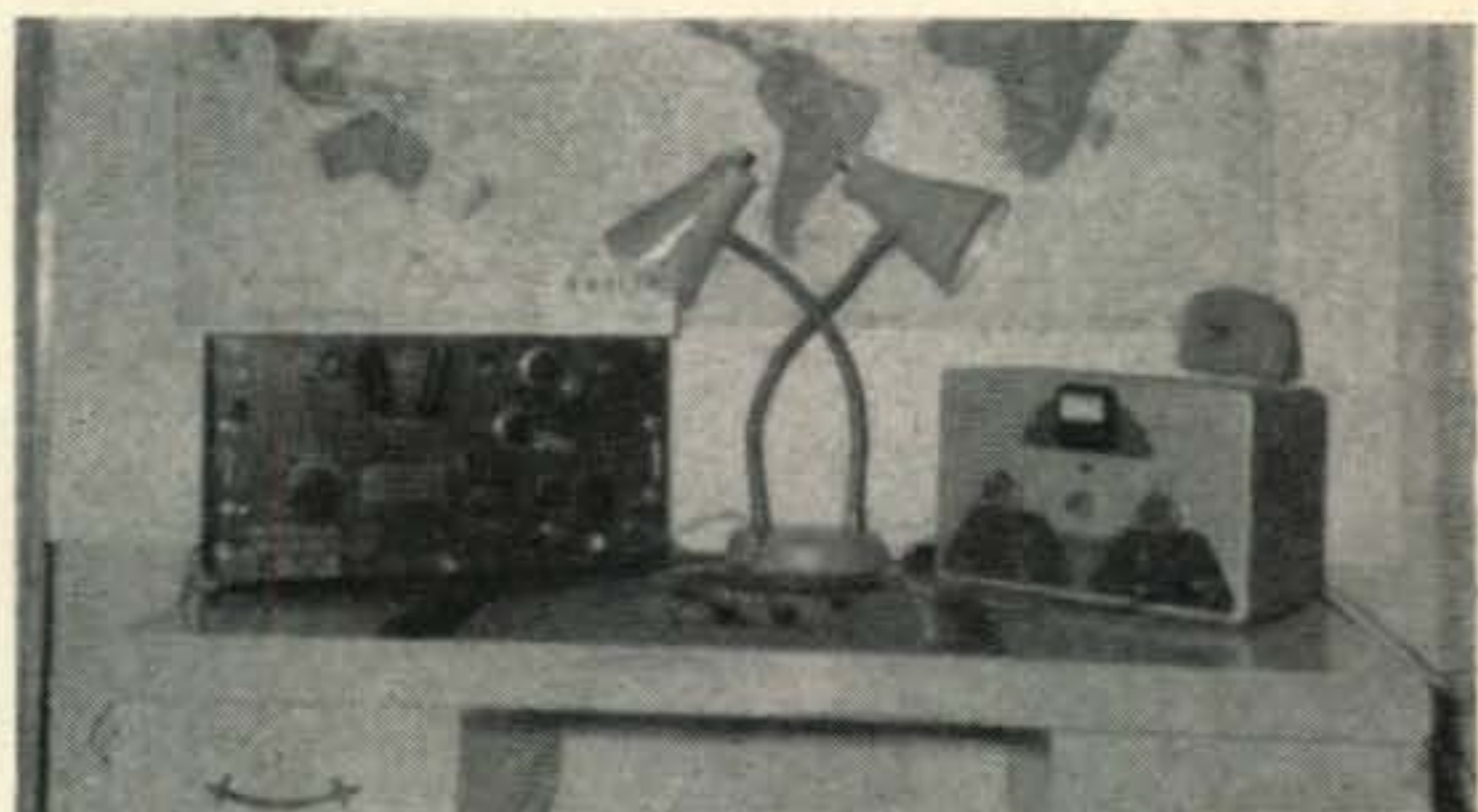

This station belongs to Bud ?, KN4???, of 3331 N. E. 13 Terrace, Pompano Beach, Fla. Not shown is a 3 element Hornet beam on a 30' tower. Bud extended the range of his BC-312 up to 15 meters which allowed him to work such stations as G3CAZ, LJ1, MUO, F2LR, UC2AX, OK1KGG, and CR5AR!



by **KEN GRAYSON, W2HDM**
 Care of CQ 300 West 43rd Street,
 N. Y. C. 36, N. Y.

With the six meter band as popular today as ten was a few years back, there is a need for a good six meter converter for the mobile operator. This month's little gem was found at Meshna's for four and a quarter and cost about another five dollars in parts for the conversion. The conversion results in a crystal controlled converter with (using the auto radio) a one megacycle segment of the band. Any segment can be used, depending upon your needs, and choice of crystal. We haven't been able to discover the unit from which this pre-amplifier is designed to work, but it was made by Motorola and it is built beautifully. Cabinet dimensions are 7 $\frac{1}{4}$ " long, 2 $\frac{3}{4}$ " high and 2 $\frac{1}{8}$ " wide.

Begin the conversion by first buying the unit and examining what you have bought! The 5840 tube should be found close to the front of the unit, in a combination tube shield, mounting bracket, supporting the tube in its socket, since this tube is of the sub-miniature type. Take care when removing or replacing this tube, since the base pins are somewhat fragile. It is necessary to remove the following parts, but do so carefully so as not to damage from beyond what has to be, since they will be used again: Terminals 202, 203, 204 and 205. Capacitors 210, 211, 214, 218, 221, 224, 226, 230, 232. Resistors

204, 205, 206, 208, 09, 210 and 211 and tube sockets 202 and 203. The stand-off insulator at the junction of L-209, L-208 and C-226 should be kept, but remove L-208, 209 and 210. By removing the single screw under the chassis you can remove Z-204, 205 and 206. Remove the wiring going to these coils and reassemble Z-204 where Z-206 was previously. Remove the coil shields from where Z-204 and 205 were by careful prying and filing, with a small file, around the bottom rim. The L-bracket on the V-203 shield can be removed as can be the V-202 spring clamp. Chances are, it will be impossible to locate the mating plugs for the output and input coax connectors, so remove all three and substitute the RCA phono-jack type instead of P-201 and 202. BNC types could be used if an additional expense is not objectionable. Remove all wires connected to C-205, 215, 216, 225 and 233. Remove R-207 and the standoff it is mounted on and relocate the two red wires to C-233. Connect C-220 and 206 by a wire. Mount one standoff previously removed into the hole left by the removed rivet on the V-203 shield bracket. Mount a 7 pin socket in the hole left vacant after removing Z-204, with pins 1 and 7 parallel to the edge of the chassis. Use a mounting screw with a soldering lug under the

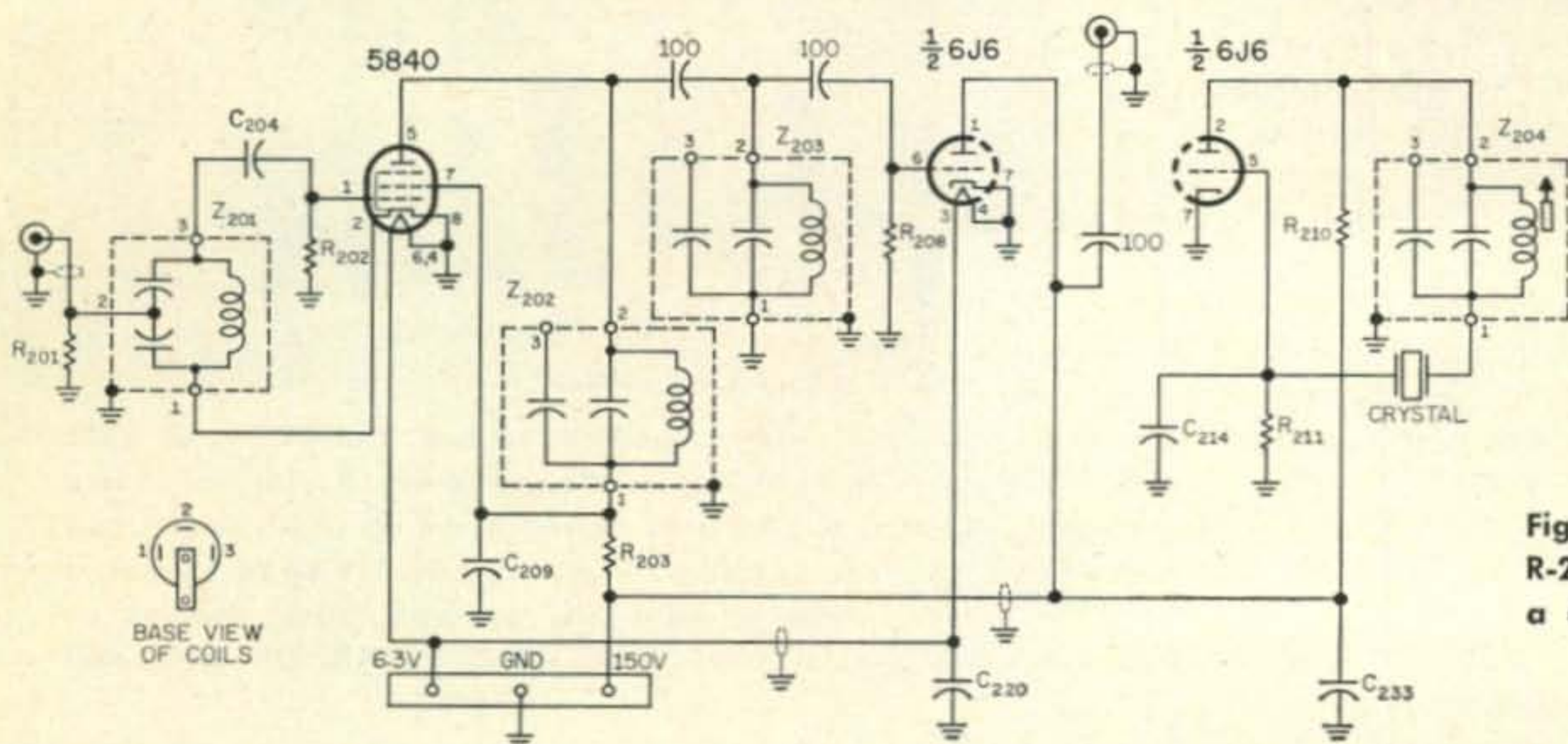

Fig. 1—Circuit of the R-257/U modified to a 6 meter converter.

nut. When mounting this socket enlarge the hole of Z-204 to about $\frac{3}{4}$ inch. Use spacers to drop the socket about $\frac{1}{4}$ inch under the chassis to allow clearance for the shield. Solder pins 4 and 7 to the solder lug on the tube socket. Mount a crystal socket where Z-205 had been.

A matching plug for the power connector can be purchased as a Continental Connector Corp. type 14-20 S with shield, or you can run the power leads out separately if you so desire, thereby saving about three dollars. You may also mount any other type of socket you choose for power leads. The red wire is 150 +, the brown is 6.3 volts (filament) and the black is common ground.

The wiring of the unit is the next step and shouldn't take too long. Remove the lead from R-202 and C-205 junction and connect to any convenient ground point. Ground pin 1 of Z-203. Connect a 100 mmf capacitor between pin 2 of Z-202 and pin 2 of Z-203. Connect pin 3 of 6J6 to C-220. Wire in a 1 megohm resistor (R-208) between pin 6 of the 6J6 and ground and connect a 100 mmf capacitor between pin 6 of 6J6 and pin 2 of Z-203. From pin 2 of Z-204 connect a wire to pin 2 of the 6J6 and a 10K resistor (R-210) to C-233. One terminal of the crystal socket goes to pin 1 of Z-204 and the other to pin 5 of the 6J6 socket. Pin 5 of the 6J6 also has a 1.5K resistor going to ground (R-211) and a 24 mmf capacitor (C-214). From pin 1 of the 6J6, run a small wire to the small insulated standoff. Connect a 100 mmf capacitor to the output r.f. connector from this small standoff. Connect R-206 (15K) between pin 1 of 6J6 and the large insulated standoff. Capacitor C-226 is connected between this standoff and ground. Run a wire from this same standoff to C-233.

Adjustments

For the fifty megacycle band the crystal used should be 8225 kc which will produce an output of 650 to 1650 kc for 50 to 51 mc. The oscillator frequency will be 49.45 mc, and the fifth harmonic of the crystal is being used. Z-204 should be adjusted for maximum output in a receiver capable of picking up the oscillator, or for maximum signal from the converter when using a receiver tuned to a station. A grid-dip oscillator can be used for this purpose very nicely if no station can be heard or if a signal generator is not available. The signal should be free from shifting or should be stable once adjusted. The set should be tapped or jarred for this check and should any change be noted, Z-204 should be readjusted for oscillator locking. Z-201, 202 and 203 should be staggered tuned for best results but this is not easy to do without a signal generator. Use a grid dipper if you have one, or if not, follow this procedure. With the converter picking up a signal somewhere in the middle of the band covered (say 50.5 mc) peak Z-201, 202, 203 for maximum signal output to the receiver. Now, tune the receiver and try to pick up a station about 50.1

mc. Peak Z-201 for maximum signal on this station, and reset the receiver for a signal at about 50.8 mc adjusting Z-202 for maximum output. That's about all there is to it.

Make sure you connect the set with some care and use shielded wire for your input and output leads, and power leads, for maximum noise reduction.

The converter can be wired to Ten meters, if desired, the only differences being that there should be a jumper on TB-201 for ten meters and connect pins 2 and 3 of each of the coils Z-202, 203 and 204 together to themselves, and not to each other. A crystal of 6850 kc (fourth harmonic) will put you in at 28 and 29 mc, while a crystal of 7050 kc will put you in at 28750 to 29700 kc. In any event, the only parts you will have to buy are one seven pin socket (without shield base), a solder lug, a crystal socket and crystal, a 6J6 tube and three 100 mmf capacitors (preferably mica).

AN/APS-4 Indicator

We just got word from Rex Radio, New York City, that they have the APS-4 indicator and amplifier with a conversion sheet for a transmitter monitor for four-fifty plus postage. This seems like a fine buy and since the scope can fit right into the average transmitter like a meter, it may be worth while looking into. The conversion seems simple enough even for a beginner, but it does require a power supply source, such as is probably found in the transmitter you already have.

Mail

We have a request from Bill Feyes, 417 Westinghouse Avenue, Wilmerding, Penna. for info on the TBS equipments. Dick Grimshaw, 3255 Polk Street, Omaha 7, Nebraska wants any conversion info for the AN/VPC-2 equipment originally used as f.m. on 30 mc.

John Eigenbrod, 207 W. King St., Waynesboro, Penna. needs a conversion of the BC-AS-229 transmitter to crystal control and a Selectoject circuit for the receiver. William Hawthorne, 1283 Pinecrest Avenue, Daytona Beach, Fla. is in need of a manual and information on the R-44/ARR-5 receiver. Arvid Evans, RR-1, Midvale, Idaho is in need of a handbook and operating manual for the MN transceiver and for the GF-11 to 10, 15 and 20 meters. J. Reginald Myers, MD, 138 E. Main St., Everett, Penn. is looking for a manual for the X-19 Hickok Microvolt Generator. James DeVita, 200 Boylston St., Watertown, Conn. is in need of all information available on a Meissner 150B Transmitter. Mr. Victor Long, 602 Willowbank, Bellefonte, Pa. wants a handbook for the RBC-1 (Navy) receiver.

H. W. Gould, 368 Stewart St., Morgantown, W. Va. wants a manual for the RDZ-1 Navy receiver. Paul Gregory, 99 Botsford Rd., Seymore, Conn. would like any information on the AXT-2 or AXT-3 equipments. Bob Jensen, 5109 Bond Avenue, Drexel Hill, Pa. wants a conversion of the TBS-5 transmitter, and a complete manual as well. Harry McClellan, 117 Kingston, Louisville 14, Kentucky wants a manual on the RT-77/GRC-9. Harry McGaughy is looking for info on a TS-306/ARW. His address is 303 W. Bay Dr., Olympia, Washington. Darrell Johnson, c/o TV Workshop, Calhoun Road, Ostrander, Ohio, is looking for manuals on the Navy MN equipment. Raymond A. Robertson (RA-12574945), Company "D", 32nd Sig. Bat. (Corps) APO 175, N.Y., N.Y., is in need of conversion info and manuals on the BC-610, BC-614, BC-924-A, O-165 and the PE120.

73, Ken, W2HDM



semiconductors

How would you like to "get your feet wet" with transistor circuits by building a "can't miss" three transistor converter? The circuit shown in fig. 1 was designed by Texas Instruments and is intended for mobile use.

The transistorized 20 meter shortwave converter is designed to be connected between the automobile antenna and antenna lead. Referring to fig. 1, you will note the 20 meter whip antenna connects to a low impedance point on coil L_1 , resonant at 14 mc by the 50 and 180 mmf capacitors. Base bias is fed to the bottom end of the tuned circuit to prevent unnecessary loading. An RC network in the emitter of the amplifier stage stabilizes it from the effects of temperature drift. The amplified signal appears across L_2 , where it is coupled to the mixer transistor, along with the oscillator energy. Bias is provided by the 39K and 2.7K resistor, and the 1K resistor in the emitter stabilizes the stage. The oscillator, which operates on 13.6 mc is a common base overtone circuit, with feedback between a tap on the coil and the emitter. Energy from this stage mixes with the incoming signal to produce an i.f. between 550 and 1550 kc . With a 13.6 mc crystal, the converter will receive the frequencies between 14.1 and 15.1 mc . The transistors for this simple converter are available at most TI distributors and are not expensive. The coils used are Air Dux or B&W type.

Speaking of Texas Instruments, your conductor has been playing with some high power-high frequency TI types. In particular the TI 2N1046 is a little beauty. Although it was originally intended for core driver service in computers, it has an alpha of around 15 mc and is packaged in the diamond case shape. To test the power gain of this transistor, the circuit shown in fig. 2 was constructed. The drive source was a Millen grid dip meter, with a loaded power output of roughly 30 milliwatts. A #49 pilot lamp, coupled to the coil, will show no indication of r.f. The dipper was coupled to a 4 turn base link as shown in fig. 2, and an r.f. output of more than 2 watts (2.15) was indicated. These measurements were made at 4.0 mc , and were then repeated at 7.5 mc . The output appeared to fall off about 10% but this could be due to less r.f. from the dipper. It does indicate, however, that the 2N1046 should operate at 20 meters. From these tests, and a glance at the specifications, it appears that one-half watt of drive would kick the collector current of a class B (push-pull) stage to 10 amperes or more. In s.s.b. service on 80 and 40, the 2N1046 push-pull class B stage should deliver approximately 100 watts PEP to a load.

Let's go from very high power to very low. The circuit shown in fig. 3 is for a 2 meter transmitter which appeared in the Yugoslav ham magazine *Radio-Amateur* and was ex-

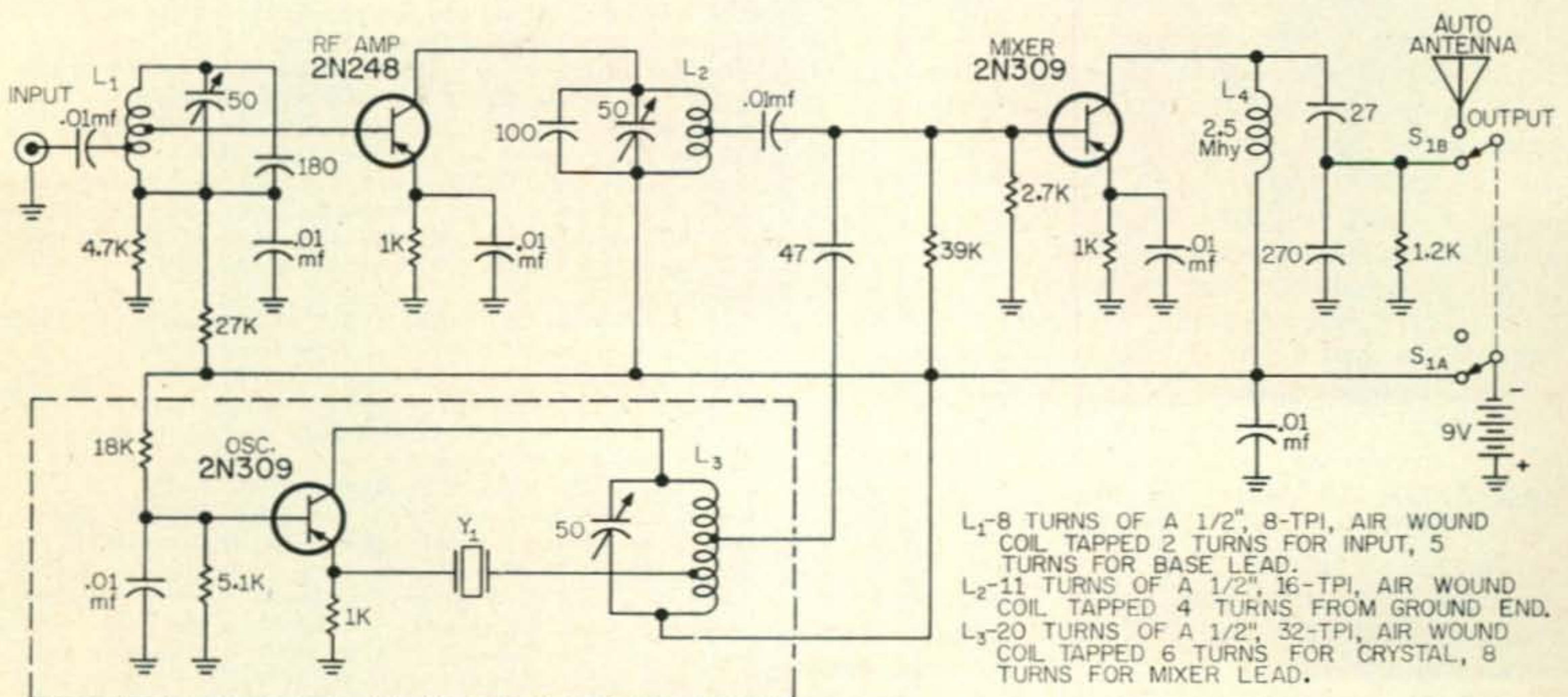

Fig. 1—Schematic diagram for the Texas Instruments transistorized 20 meter converter.

tracted from the German magazine *Funktechnik*. The article translates something like this: An OC614 transistor oscillates on 72.2 mc. Feedback is between emitter and collector through a 5th harmonic crystal. The 470 ohm resistor in parallel with the crystal prevents unwanted oscillations due to the holder capacity. Feedback is controlled by the trimmer which is critical. Potentiometer "P" optimizes operation of the amplifier. Its setting should avoid exceeding the dissipation of the transistor. The method of modulation is primitive, but it works. Modulation is applied to the base of the oscillator. A crystal microphone is used. Coil L_1 is 5 turns, 10 mm. diameter and 1 mm. between turns, coil L_2 is 1 turn 10 mm. diameter, L_3 is the same as L_2 , and L_4 is 2 turns centertapped. Amateurs wishing to experiment with this circuit can obtain 5th overtone crystals from International Crystal. The OC transistors are distributed in this country under the name "Amperex".

Semiconductor News

The Centralab TA-12B is an ultra-miniature 4-stage transistor amplifier which supersedes the earlier TA-11 used in the radar speedmeter. This amazing circuit recently won a Certificate of Excellence in the Miniaturization Awards Competition conducted by Miniature Precision Bearings, Inc., of Keene, New Hampshire.

General Electric has just announced price reductions for their line of Silicon Controlled Rectifiers, up to 51%. Silicon Controlled Rectifiers convert alternating current to d.c. but the amount of power fed to the load can be controlled like the thyatron.

International Rectifier Corporation is now marketing a new line of silicon diodes between 300 and 750 ma, and 100 to 500 p.i.v. The units have a low leakage current and operate over the range of -65°C to $+165^{\circ}\text{C}$. The latest issue of IR's *Rectifier News* describes the Tyros 1 Weather Satellite system and the uses of zener diodes as filament voltage regulators in a.c. applications (good v.f.o. data), in addition to specifications on their new miniature diffused junction silicon rectifiers (X5 series). Experimenters who are working with zener diodes should investigate IR's series of EZ zener units. Although they are not hermetically sealed, their performance seems to be excellent and the cost is considerably less than other units. For more information request bulletin SR-257.

Pacific Semiconductors Inc., are now offering a new series of tiny 500 and 750 milliwatt zener diodes. If you use these devices, drop a line to their new offices at 12955 Chadron Ave., Hawthorne, Calif.

Philco Corporation is using a new technique for etching their MADT devices, known as ETL-etching by transmitted light. Essentially, ETL consists of etching the germanium blank under white illumination coming from the side of the wafer *opposite* to the side being etched, instead of applying both light and etch jet from



President Haggerty of Texas Instruments seated at the console of the IBM Model 7070 all transistorized computer.

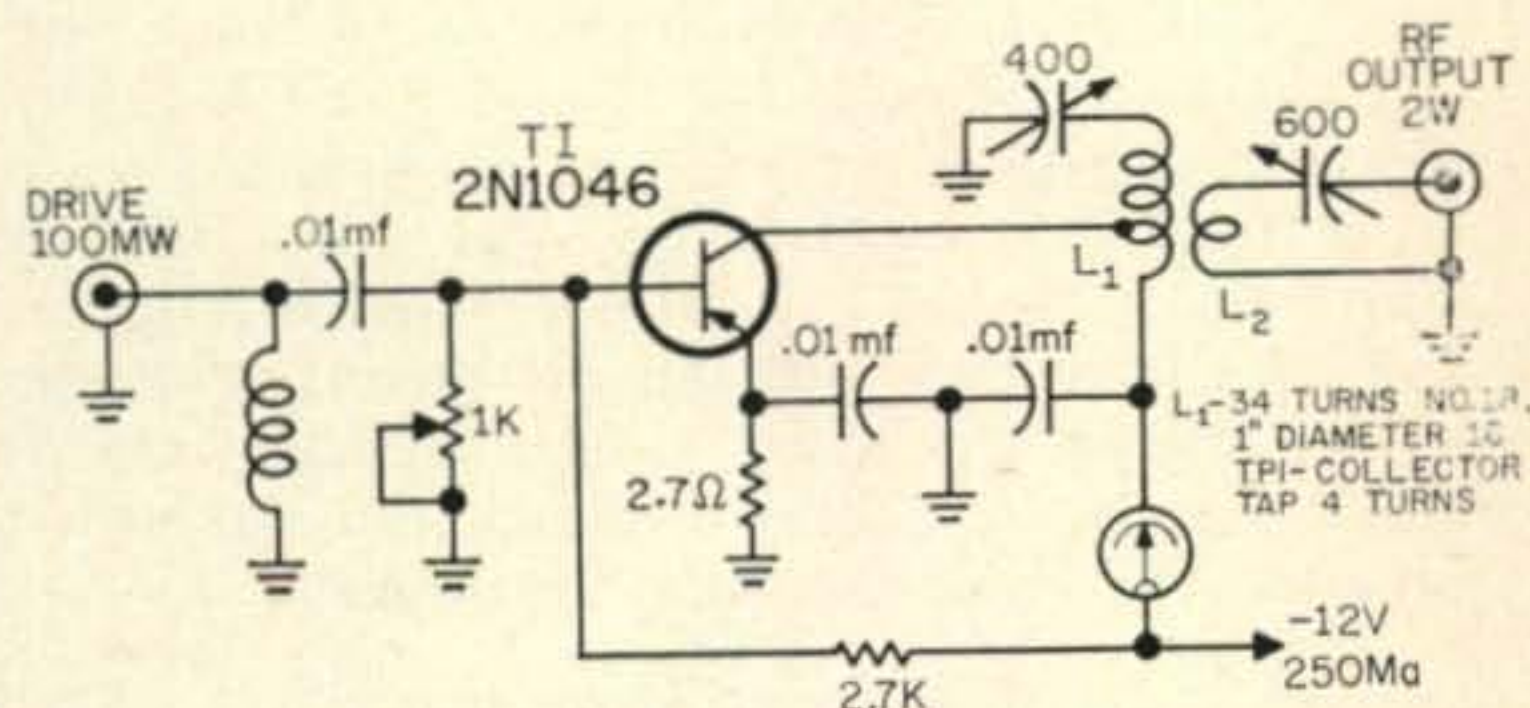

Fig. 2—Linear amplifier for 40 and 80 meters.

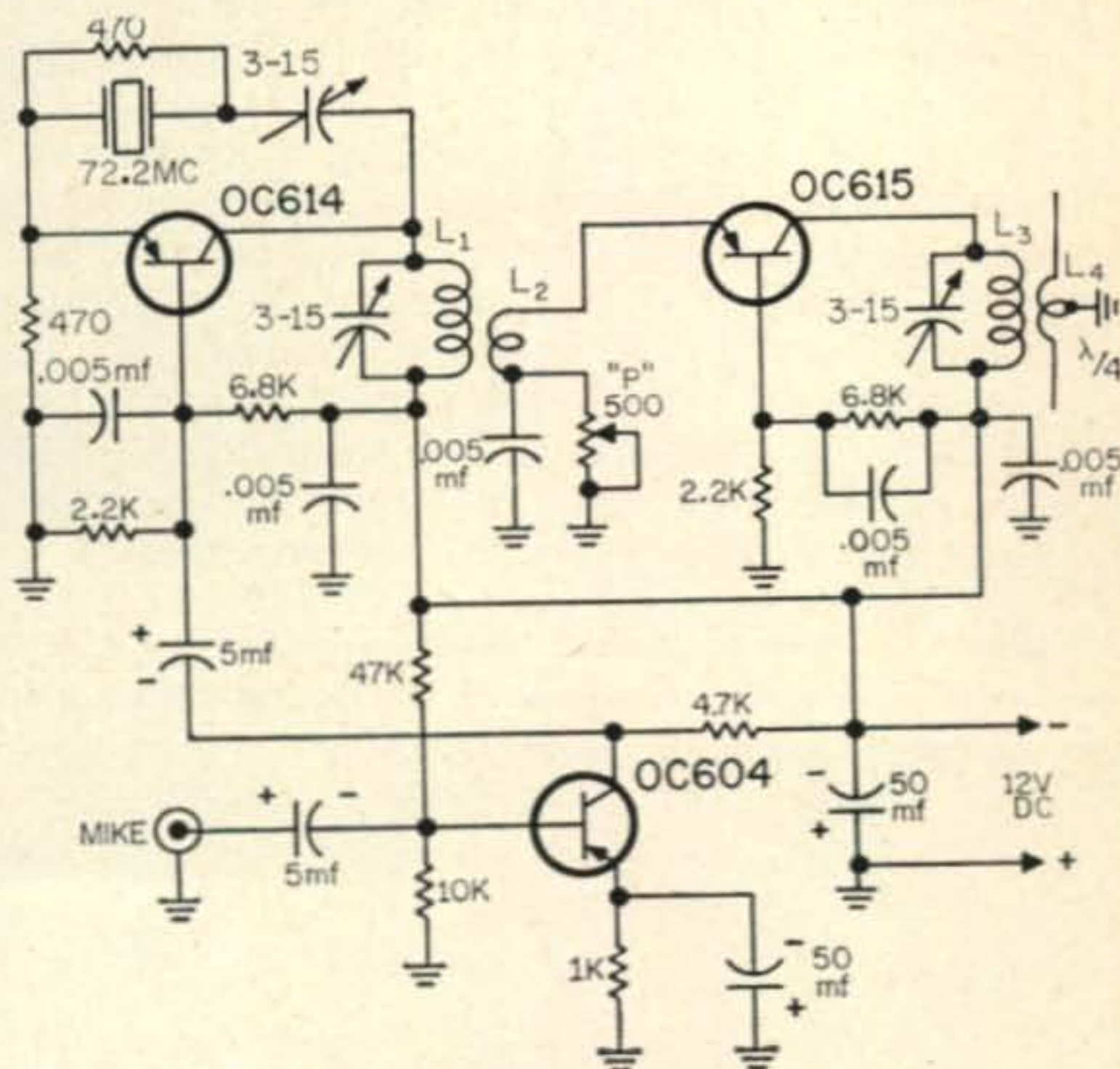

Fig. 3—Two meter transmitter.

the same side. The catalytic action of the intense light coming through the blank makes it possible for the first time to etch flat-bottomed pits with diameters as large as 0.115 inches. The ETL. [Continued on page 125]

RTTY

CATS Meeting

Chicago Amateur Teletypers Society, October 9, 1960
At Hallicrafters, 5th Ave. & Kosner, Chicago
Contact Ray Morrison, W9GRW, 8029 Keeler Ave., Skokie, Ill.
Meeting 10 A.M., Model 28 as Door Prize, Dinner, 8 P.M., \$4.25

Byron H. Kretzman, KØWMR

108 W. Teresa Drive
West St. Paul, Minn.

Starting with the June (1960) issue, this column has been devoting most of its space to the newcomer, or to the radio amateur just getting interested in this particular mode of transmission. The June column very briefly outlined the set-up in a typical, new, RTTY station. The July column explained some of the terminology and technical aspects of the FCC Rules as applied to RTTY equipment. The August issue pictured and described in general terms the various page-printer machines most likely to be found in an RTTY ham shack; and, the September issue did the same honors for tape equipment.

This month we will try to acquaint you with some of the more common circuits that are connected to the station v.f.o. to obtain frequency-shift-keying (FSK). It should be kept in mind that the object here is to move the r.f. carrier back and forth 850 cycles in accordance with the make-and-break of the keyboard circuit. Keep in mind, also, that if we multiply our v.f.o. four times, we also multiply our shift the same number of times. For example, if we are operating on 20 meters with an 80 meter v.f.o., the actual shift of the v.f.o. is only 212.5 cycles. In other words, be sure you check the amount of shift on the band in which you operate.

FSK Requirements

First of all, let us look over some of the technical requirements which must be met: It is very desirable, particularly for the newcomer, that the v.f.o. shift right-side-up when connected directly to the keyboard. That is, when the keyboard circuit is closed (*mark*), the emitted frequency should be higher than when the keyboard circuit is open (*space*). This eliminates the obvious but impractical method of using the keyboard to switch a capacitor across part of the v.f.o. *L/C* circuit. It is naturally desirable, also, to keep the machine some distance from the v.f.o. It therefore becomes necessary to de-

W4RWM, Daytona Beach, Florida, operated by Fred W. DeMotte, Secretary-Treasurer of the Florida RTTY Society.

vising some method that will allow direct current, keyed by the machine's keyboard, to indirectly shift our v.f.o.

Another consideration is the stability of the v.f.o. We require the same order of stability as if we were on s.s.b., with the *additional* requirement that the v.f.o. be capable of being shifted in a stable recurring manner between two frequencies only a few hundred cycles apart. So, we must start out with an exceptionally stable v.f.o. to begin with, than add an FSK circuit which will not reduce the stability, and last but not least, have an amount-of-shift adjustment that is smooth and that is capable of being reset to several desired values, depending upon how many times we multiply in the associated transmitter.

FSK Circuits

Figure 1 is the schematic diagram of probably the most widely used FSK circuit in amateur RTTY, the dual diode keyer. It is shown applied to a typical Clapp v.f.o., in this case as used in the popular Heathkit DX-100 transmitter. Note that the keyboard circuit is above ground. The 1 Megohm shift-adjust pot is of the linear variety. Values are not critical. 2.7K ohms can be used instead of the 3K ohms shown, and 51K can be used in place of the 50K indicated. Note, though, that if excessive voltage is applied (through the 50K resistor), the shift might reverse when the pot is turned too far. Carefully check, too, to make sure that the entire keyboard circuit is above ground, and if the *R/C*

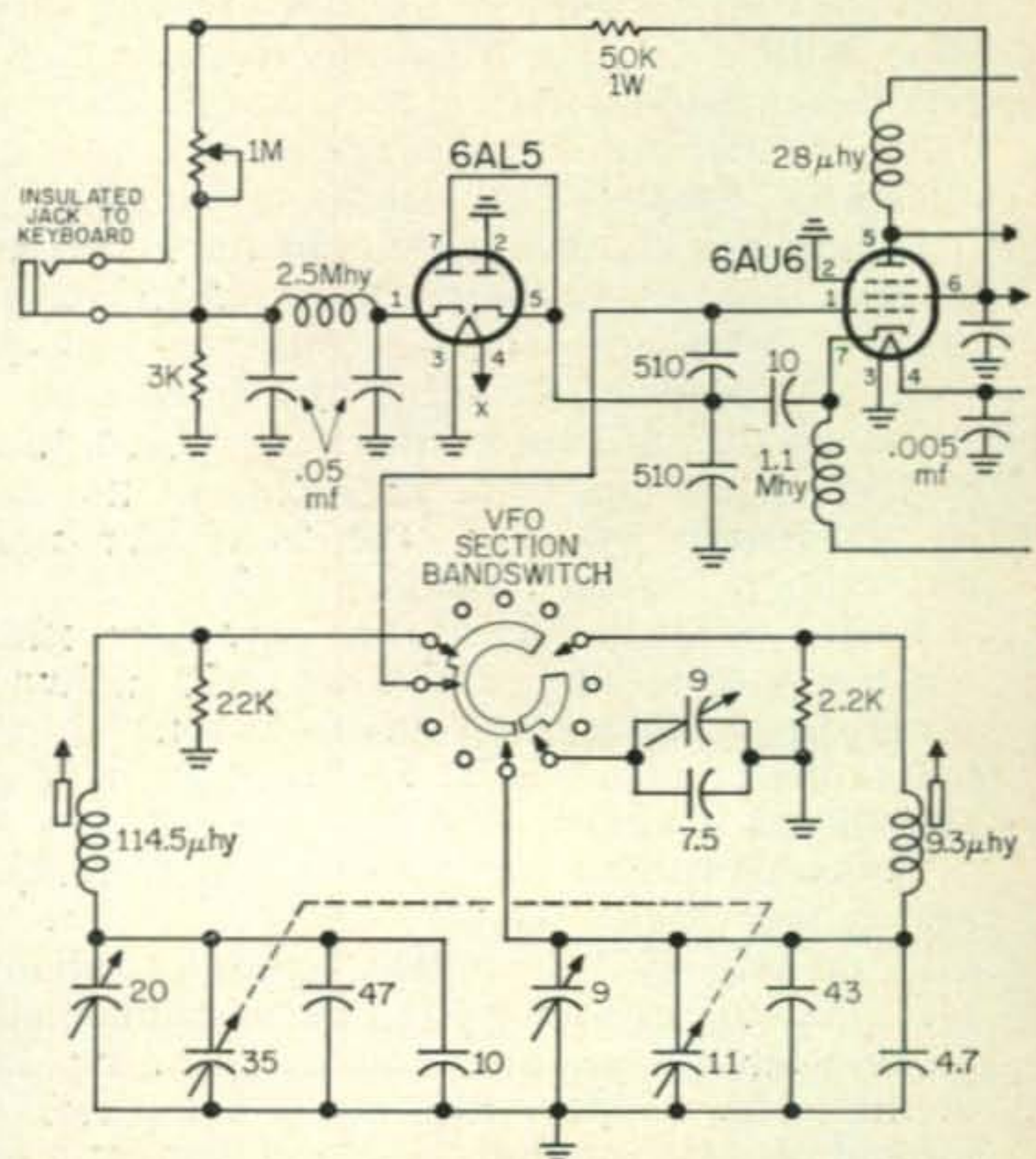

Fig. 1—DX-100 FSK Circuit of W6AEE.



spark suppressor circuit is still connected across the keyboard contacts, disconnect it.

You can substitute a 6H6 for the 6AL5, or if you are looking to save space, use a pair of Texas Instruments 601-C diodes. Don't try to use ordinary germanium diodes in this circuit—their leakage is too high. This application of the dual diode keyer was devised by W6AEE. The original work was by W6ZH and was described in April 1953 *RTTY*.

Figure 2 is an FSK circuit worked out by Frank Kline, WØACV. Designed to key right-side-up, it is a simple diode switch, with the diode switching in and out the shift-adjust capacitor C_2 . The main feature of this circuit is that it puts high voltage on the keyboard contacts. This makes any slight variation in contact resistance of no consequence and helps to keep them clean. Another feature is that one side of the keyboard circuit can be grounded. Like the W6AEE circuit, it can be connected to the midpoint of the two padding capacitors across the *L/C* circuit, or by using certain values of C_1 and C_3 as an r.f. voltage divider it can be directly connected to the top side of your *L/C* circuit. Simply start with a given value of C_1 , say 10 mmf, then add C_3 until you get a variation in shift of no more than 900 to 1,000 cycles as C_2 is varied. If you get too much range of shift you will find that it will key up-side-down with minimum settings of C_2 .

Figure 3 is the schematic diagram of the FSK circuit that Al Hourigan, K9CNG, uses on his CE 458 VFO in conjunction with his CE 20A exciter. Many letters have come in requesting information on frequency-shifting this particular v.f.o. Note that a polar relay is used. (the coil bias and loop connections are not shown) This is so that the keying can conveniently be turned over as required, depending upon which band you use. If you don't understand this right away, get out your pencil and do a little arithmetic. You will quickly see what happens. On some bands you heterodyne the 9 mc crystal plus the v.f.o. frequency (or one of its harmonics) while on other bands the output is 9 mc

minus the v.f.o. frequency. Therefore, even if you shift right-side-up on one band, you will have to turn something over at some time in order to send *mark* as the higher radio frequency on all bands. The polar relay, plus an ordinary s.p.d.t. toggle switch makes this "turning over" real easy.

Tune in next month and we will explain not only just what a polar relay is, but how to adjust it as well. Polar relays are very useful devices around an RTTY shack. While this month we have shown its use in transmitting, it is also used many times in receiving, and sometimes for both purposes in a local loop to simplify operation when several pieces of equipment are available.

Around the World

W3KOL is on 80 with a DX-100 and a Model 15. W4KLT is FSKing a Heathkit VFO. W5HZU made the W2JAV TU (April 1958 *CQ*) with built-in 'scope. Listen for W6CG, DX Editor of *RTTY*, sending NCARTS and ARRL Bulletins on 21,090 kc Saturday mornings at 10 A.M. PDST. W7JMS is in Japan and will be on 20 as KA2LB. W7WWG reports activities of the Portland, Oregon RTTY group, including a meeting at W7LI August 11th.

VE6VK offers to swap a 2-A perforator, with power supply, for either a 2.1 kc or a 3 kc mechanical filter. G6CL has forwarded a most interesting paper presented for the RSGB before the IARU June 13-17 by G2UK of the British Amateur Radio Teleprinter Group. Outlined are the technical standards for RTTY in the United Kingdom; which, except for the use of International Alphabet No. 2 and the International machine speed of 66 words-per-minute, are similar to American standards.

Comments

We have had a most interesting idea forwarded to us. A certain RTTYer, who must be nameless for obvious reasons, has access to professional tape recording equipment. This fellow

[Continued on page 113]

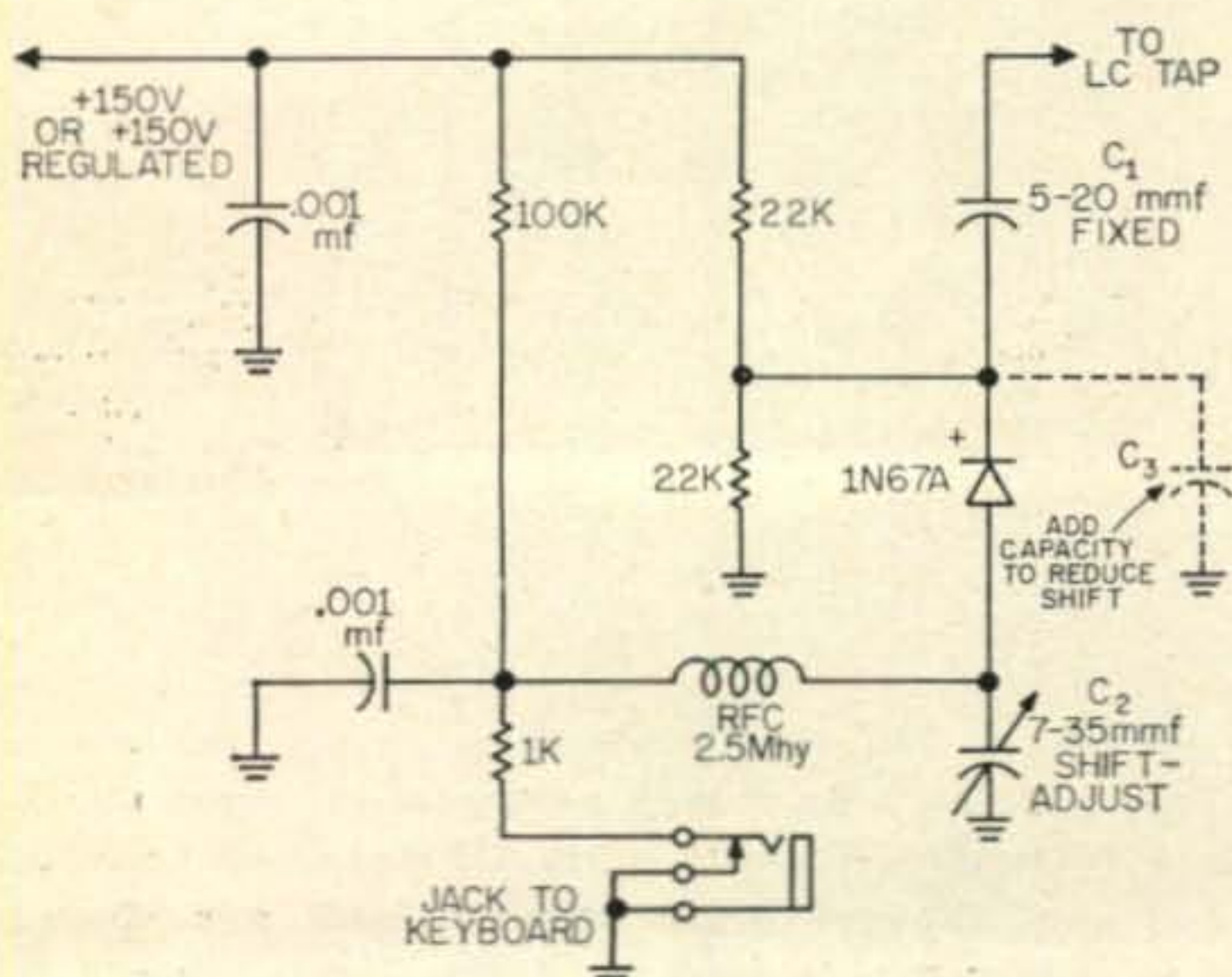

Fig. 2—Diode Switch FSK Circuit of WØACV.

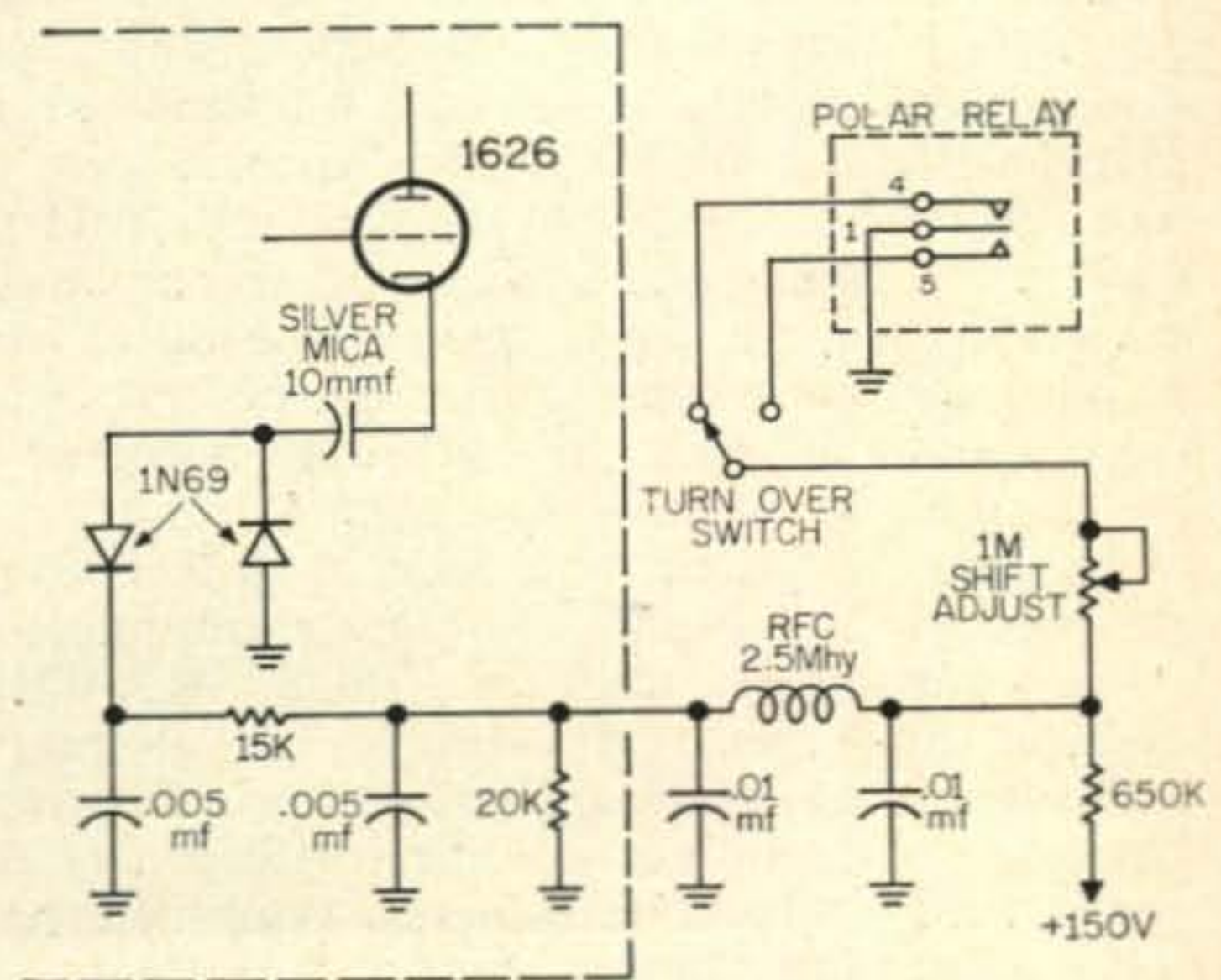

Fig. 3—CE 458 VFO FSK Circuit of K9CNG.

Space Communications

GEORGE JACOBS, W3ASK

11307 CLARA STREET
SILVER SPRING, MARYLAND

Amateur Moonbounce Successful

Amateur radio communications using the moon as a passive relay is now a reality! On July 21, 1960 the first successful amateur radio two-way QSO took place as a result of moon reflected signals. This historic contact, on 1296 *mc*, was between members of the Eimac Gang Radio Club of San Carlos, California (W6HB) and the Rhododendron Swamp VHF Society (W1BU/W1FZJ) of Medfield, Mass.

After months of personal effort by the various radio amateurs concerned with this project, test signals were transmitted in both directions on Sunday, July 17th. The equipment was then refined and adjusted to optimum performance, and the first successful two-way QSO was made Thursday morning, July 21st, between 7:30 and 8:00 A.M., PST. The first transmission was from west (W6HB) to east (W1BU), followed immediately by an east-west transmission to complete the first amateur coast-to-coast communication using the moon as a relay point.

Just as it ushered in the age of telegraphy more than a century ago, the first message transmitted by means of the moon relay was: *What Hath God Wrought*. Painfully sent at slow speed (one second dots and three second dashes) by George Badger, W6RXW, this historic message was received at W1BU by Sam Harris, W1FZJ. The initial signal and subsequent transmissions varied in strength from "just in the noise level to perhaps two decibels out of the noise." Occasional bursts of signal strength were noted up to six decibels above the background noise.

Similar equipment was used at both ends of the moon-relay circuit. The power amplifiers of both transmitters used an Eimac 3K2500LX ceramic and metal klystron for developing a kilowatt of r.f. power at 1296 *mc*. Receivers consisted of a slightly modified Microwave Associates MA2-1000 Parametric Amplifier having a noise figure of less than two decibels. The intermediate frequency (29.5 *mc*) output was

passed through a low noise amplifier into a Collins 75A-4 receiver employing a 500 cycle mechanical filter. The output of the receiver was applied to earphones or a tape recorder through a 100 cycle filter.

Parabolic antennas were used at both ends of the circuit. An eighteen-foot mesh-type dish provided W1BU's signals with a gain of 35 decibels, and an eight-foot steel dish lined with aluminum foil to improve reflectivity was used at W6HB. The dish antennas were laboriously hand-tracked to follow the ever-moving moon.

While the great circle distance between W6HB and W1BU is approximately 2700 miles, the distance actually travelled by the signal from the earth to the moon and back totaled nearly 480,000 miles. Traveling at the speed of light, it took the signal nearly 2½ seconds to traverse the circuit, causing a time lag of this magnitude between reception and transmission.

It's not only the great distances involved that has made a moon relay circuit so difficult to establish. The moon's diameter is 2160 miles, and viewed from the earth (at distances varying between approximately 221 and 253 thousand miles) this diameter subtends an angle of only

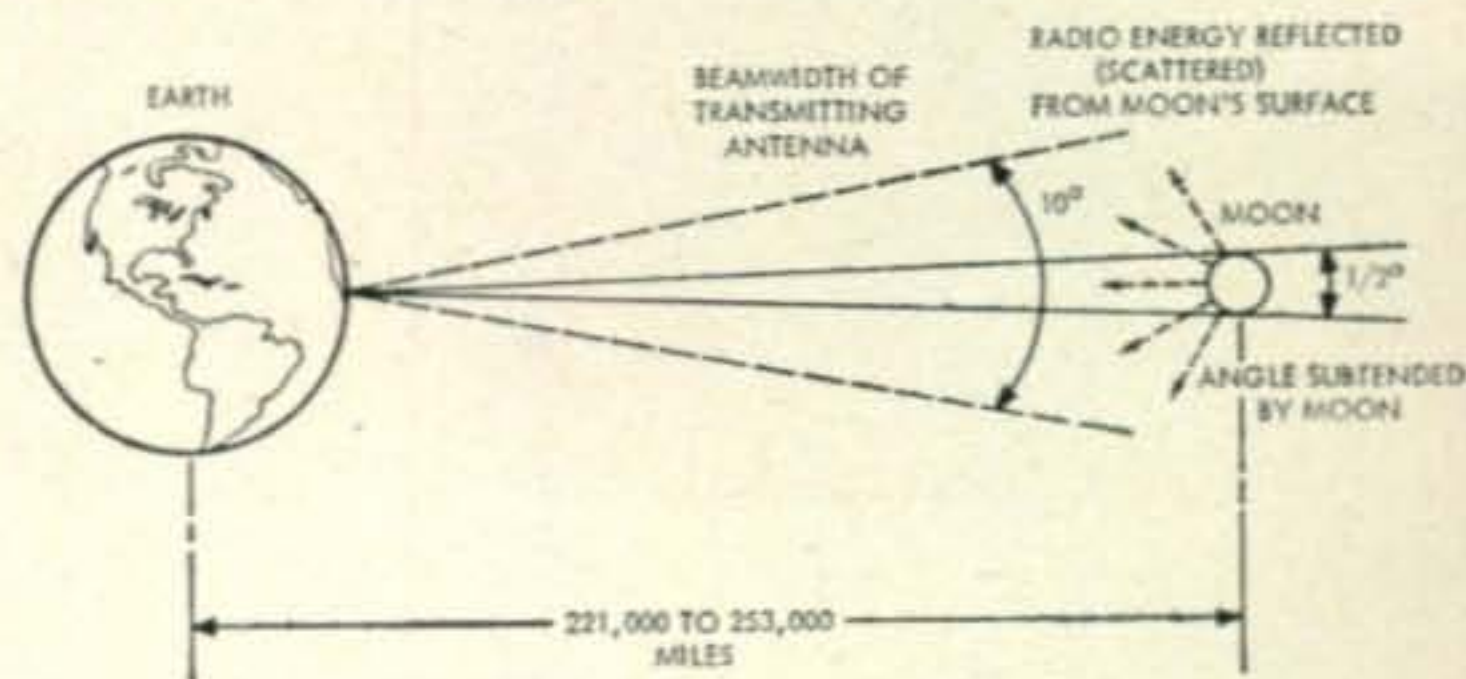

Fig. 1. The earth-moon-earth circuit. The moon intercepts only a small portion of the radio signal transmitted from the earth. Of that small amount, only about 15% is scattered back into space. Only a minute fraction of the original energy is scattered back in the direction of the earth.

Lunar And Space Probes

Name	Launched By	Launch Date	Status
Pioneer IV	US	3 Mar 59	Orbiting sun
Lunik I	USSR	2 Jan 59	Orbiting sun (1st space probe)
Lunik II	USSR	12 Sep 59	Hit Moon—13 Sept 1959

Burned-Up Objects

Object	Name	Launched By	Launch Date	Burn-Up Date
1957 ALPHA 1	Rocket Body	USSR	4 Oct 57	1 Dec 57
1957 ALPHA 2	Sputnik I	USSR	4 Oct 57	Early Jan 58
1957 BETA	Sputnik II	USSR	3 Nov 57	14 Apr 58
1958 GAMMA	Explorer III	US	26 Mar 58	28 Jun 58
1958 DELTA 1	Rocket Body	USSR	15 May 58	3 Dec 58
1958 DELTA II	Sputnik III	USSR	15 May 58	6 Apr 60
1958 EPSILON	Explorer IV	US	26 Jul 58	23 Oct 59
1958 ZETA	Atlas	US	18 Dec 58	21 Jan 59
1959 BETA	Discoverer I	US	28 Feb 59	Early Mar 59
1959 GAMMA	Discoverer II	US	13 Apr 59	26 Apr 59
1959 EPSILON 1	Discoverer V	US	13 Aug 59	28 Sep 59
1959 ZETA	Discoverer VI	US	19 Aug 59	20 Oct 59
1959 THETA	Lunik III	USSR	4 Oct 59	Apr 60?
1959 KAPPA	Discoverer VII	US	7 Nov 59	26 Nov 59
1959 LAMBDA	Discoverer VIII	US	20 Nov 59	8 Mar 60
1960 DELTA	Discoverer XI	US	15 Apr 60	26 Apr 60
1960 EPSILON 2	Rocket Body	USSR	15 May 60	17 Jul 60

Objects In Orbit

Object	Name	Launched By	Launch Date	Period (Mins.)	Inclination	Apogee Perigee (statute miles)	Transmitting mc freq.
1958 ALPHA	Explorer I	US	31 Jan 58	107.9	33.22	1200 214	
1958 BETA 1	Rocket Body	US	17 Mar 58	138.3	34.26	2685 407	
1958 BETA 2	Vanguard I	US	17 Mar 58	134.0	34.26	2460 401	108.022
1959 ALPHA 1	Vanguard II	US	17 Feb 59	125.5	32.86	2050 349	
1959 ALPHA 2	Rocket Body	US	17 Feb 59	129.6	32.89	2280 346	
1959 DELTA	Explorer VI	US	7 Aug 59	Position Uncertain			
1959 EPSILON 2	Capsule	US	13 Aug 59	99.8	78.94	805 120	
1959 ETA	Vanguard III	US	18 Sep 59	129.8	33.33	2318 318	
1959 IOTA 1	Explorer VII	US	13 Oct 59	101.2	50.31	673 344	19.9904
1959 IOTA 2	Rocket Body	US	13 Oct 59	101.1	50.30	667 343	
1960 ALPHA*	Pioneer V	US	11 Mar 60	311.6D	3.35	.9931AU .8061AU	
1960 BETA 1	Rocket Body	US	1 Apr 60	99.1	48.41	467 429	
1960 BETA 2	Tiros 1	US	1 Apr 60	99.2	48.41	468 429	107.997
1960 GAMMA 1	Rocket Body	US	13 Apr 60	94.5	51.99	418 199	
1960 GAMMA 2	Transit 1B	US	13 Apr 60	95.6	51.28	444 238	
1960 GAMMA 3	Metal Object	US	13 Apr 60	93.6	51.29	384 177	
1960 EPSILON 1	Sputnik IV	USSR	15 May 60	94.0	64.89	405 181	
1960 EPSILON 3	None	USSR	15 May 60	94.1	64.89	420 172	
1960 EPSILON 4	None	USSR	15 May 60	94.0	64.89	410 176	
1960 EPSILON 5	None	USSR	15 May 60	92.4	64.89	314 176	
1960 EPSILON 6	None	USSR	15 May 60	92.4	64.89	311 176	
1960 EPSILON 7	None	USSR	15 May 60	91.9	64.89	283 176	
1960 EPSILON 8	None	USSR	15 May 60	92.5	64.89	316 176	
1960 EPSILON 9	None	USSR	15 May 60	92.6	64.68	326 176	
1960 ETA 1	Midas II	USSR	24 May 60	94.4	33.00	319 300	
1960 ZETA 2	Metal Object	US	24 May 60	94.1	33.00	307 292	
1960 ETA 1	Transit 2A	US	22 Jun 60	101.7	66.77	651 389	54; 162; 216; 324
1960 ETA 2	Greb	US	22 Jun 60	101.7	66.77	651 389	108.00
1960 ETA 3	Rocket Body	US	22 Jun 60	101.4	66.77	640 383	

*Aphelion, perihelion in astronomical units, inclination to ecliptic.

The above listing is a summary of the satellite and probe launchings since October 4, 1957. Data for Echo I will be given net month.

one-half degree (see fig. 1). Most of the energy radiated from even the finest designed antennas used by radio amateurs (having beamwidths as narrow as ten degrees, or so) misses the moon completely and passes by it into space. Of the small amount of energy that may strike the moon, almost 85% would be absorbed by the roughness of the moon's surface. The remaining 15% would be scattered over the heavens. The earth subtends only two degrees when viewed from the moon (the earth's diameter is approximately ten times greater than the moon's), so only a minute fraction of radio energy leaving the earth is ever reflected back to it by the moon. In spite of these overwhelming difficulties, the earth-moon-earth circuit *can* be made to function by radio amateurs, as proven by the historic W6HB-W1BU QSO.

The only other moon relay communications circuit known to be in operation links Washington, D.C. with Hawaii. The circuit is operated in the 435 to 445 mc range by the U.S. Navy.

ZEEEX
 W3ASK
 TO RADIO PROPOGATION EDITOR
 CQ MAGAZINE

THIS IS A SAMPLE OF A TELETYPE MESSAGE
 TRANSMITTED BETWEEN WASHINGTON D C AND
 HONOLULU HAWAII VIA THE 400MCS NAVY MOON
 RELAY SYSTEM

GEORGE JACOBS



Fig. 2. Message sent by W3ASK via the U.S. Navy's moon relay system. On July 21st, 1960 the first successful amateur radio two-way moonbounce QSO was held between W6HB and W1BU.

Using 400 megawatts of effective radiated power, concentrated in a 1.5 degree beam automatically tracking the moon, the circuit accommodates four two-way multiplexed teletype-writer channels or one two-way radiophoto or facsimile channel. Recently, the circuit has also been used experimentally for two-way voice communications.¹

Now that it has been proven that amateur radio moon relay communications is possible, what lies ahead for this exciting new mode of communications?

Certainly, this successful attempt at using the moon as a signal reflector will stimulate efforts to improve amateur-built equipment for further moonbounce communications. Communications between continents and across oceans, presently limited to the h.f. bands, may soon be possible on u.h.f. Looking to the immediate future, the W6HB/W1BU path will be tried again, using single sideband instead of c.w. It is also planned to use the moonbounce equipment in attempts to reflect signals from the giant 100-foot diameter balloon-type, Project Echo satellites.

Unlimited possibilities come into view in this new field of amateur space communications, as once more the radio amateur blazes a trail of progress through his constant urge to experiment.

The Editor wishes to express his appreciation for the assistance given by Bill Orr, W6SAI, in the preparation of this article.

Objects In Orbit

Thanks to the National Aeronautics and Space Agency (NASA), the following "satellite situation report" is made available to readers of this column. The report lists vital statistics for those objects that are presently in orbit and those which have already "burned-up".

Radio signals are still being received from some objects in space, and their transmitting frequencies are shown in the report. It is interesting to note that the transmitter in Vanguard I, launched March 17, 1958, is still on the air. This transmitter is solar powered, and it is expected to transmit for decades, perhaps centuries.

The report reflects data computed and compiled by the National Space Surveillance Control Center, Bedford, Massachusetts through early August, 1960. Amendments to this report will appear regularly in this column.

In signing off this second column in this new field of Space Communications, the Editor again wants to emphasize reader participation, and comments, suggestions, observations, questions and news-worthy items are requested.

73, George, W3ASK

¹Jacobs, G., "Navy's Moon Relay System Demonstrated", *CQ*, April, 1960, p. 86
 For further information concerning moonbounce see also: Orr and Johnson, *VHF Handbook*, Radio Publications, Wilton; Conn., Harris, F. S., "Project Moonbounce", *CQ*, Aug. 1960, p. 96

sideband
sideband
sideband

SIDEBAND

Irv and Dorothy Strauber, K2HEA/K2MGE

12 Elm Street, Lynbrook, New York

Myron's signal—he's found the winning combination!

Myron and his charming XYL, Ginny, are in the throes of planning a new home and Myron complains that he now has little time to spend on the air but note his standing on the Honor Roll. We have no doubt that through blueprinting and bricklaying, through painting and papering, W4IYC will always find just enough time to catch each new country as it appears.

Adding new "Worked 100" Certificates to their walls this month were YV5AFF, W3GHD, and W9ROU (now WA6IPG) while a certificate for "Worked 50" was mailed to WØLBK. VE6-VK earned the "Worked 125" sticker to add to his certificate. Congratulations to Susana, YV5-AFF, who is the very first YL outside of the States to earn the "Worked 100" Certificate; we hope to bring you a photograph and more information on this outstanding YL DXer.

It obviously bears repeating over and over that you must include a listing of your DX worked on SSB when submitting your cards. Another reminder here that forms are available from us for these listings—just send a large, stamped, self-addressed envelope and they shall be rushed to you.

Roberto Castro, TI2RC

The world of amateur radio was shocked and saddened to learn of the untimely passing of Roberto Castro, TI2RC, on August 1, 1960. While moving some heavy equipment in his radio shack, Bob suffered a heart attack and the resultant fatal complications were more than even modern medical science could overcome.

All who knew Bob—and his friends were legion—knew that he was an A-1 operator. Although he was an avid DXer and one of the top

SSB DX HONOR ROLL			
W4IYC	214	4X4DK	150
T12HP	210	ON4DM	150
W6UOU	210	W8YIN	148
VQ4ERR	202	W1OOS	147
W8EAP	200	K2HEA	146
W8PQQ	200	W2FXN	142
W6PXH	192	W5KFT	138
W2JXH	190	VE3ES	136
PY4TK	186	W3VSU	136
W6RKP	181	W7DLR	135
WØQVZ	181	KØCTL	135
W6BAF	180	W4OPM	129
K2MGE	179	XE1AE	125
K9EAB	175	K8RTW	125
W6WNE	173	VE6VK	125
TG9AD	172	W6VUW	120
WØCVU	164	W1DCE	118
W2TP	159	W6UPP	118
MP4BBW	159	W2MAF	117
W2LV	159	W9ROU	114
K2FW	153	W3GHD	113
W3MAC	152	W4UWC	112
K6LGF	152	W1JSS	110
K6ZXW	151	W4ANE	110
W5IYU	150	W2ATJ	109

Myron, W4IYC, finally found the time to assemble his additional 114 cards and wound up not only with Certificate #6 for "Worked 200 Countries" but also as top man on the DX Honor Roll. Myron, who has held his license since 1923, switched to sideband in 1952 and "got tangled up in the DX business," not only as an ardent DX chaser but also as QSL manager for Paul Stein's DXpedition across in Africa in 1958 and VQ4ERR's DXpedition to Zanzibar and the Seychelles last year. And an excellent job he did, with the help of the Richmond ARC.

As can be seen in his photograph, Myron's equipment consists of an Eldico 100F driving the Johnson Viking Kilowatt, 75A-4 and 75S-1 receivers, and, way out back, a W3DZZ beam for the higher frequencies as well as a 70 foot vertical for 40 and 80. It all sounds pretty usual, doesn't it, but just try and break through



Jimmy, GM3CIX, operator of the first station in the United Kingdom to earn the "Worked 100" certificate.



Budd, K2PMA, and BILL, K1DTA, finally get to meet each other after many 75 meter contacts.



Paul, BV1USC, who is responsible for some of the fine contacts out of Formosa. (Photo—courtesy of DL4DP).

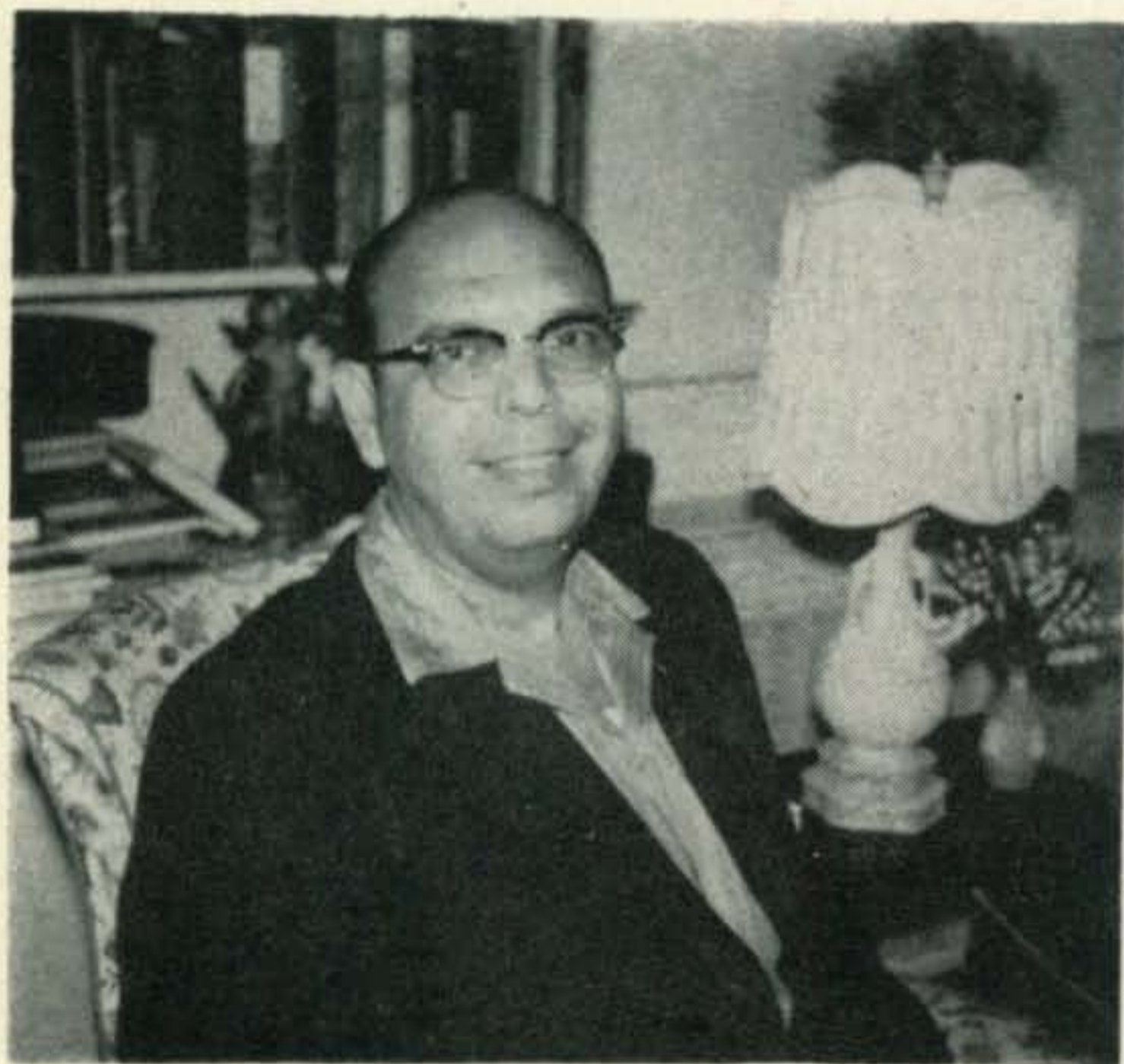

Tony, KP4RD, one of the most ardent sideband enthusiasts in Puerto Rico.

Myron, W4IYC, the newest member of the "Worked 200" Inner Circle.



men in working SSB DX, he was never that fanatic about a new country that he did not stop to pass the information along to others and even help them by arranging schedules. He never let his keen interest in DX warp his enjoyment of ragchewing and many a log book has recorded a lengthy QSO with TI2RC. There are many sidebanders on the air today—particularly in the Latin American countries—who owe their interest in SSB to the help given them by Bob.

To his widow, Maria Elena, to his mother and father, to his daughter and son-in-law and to his grandchild, we extend our sincere sympathy and that of the world of amateur radio.

It is with the deepest regret that we remove the call of TI2RC from our SSB DX Honor Roll. However, his call will be perpetuated in the "TI2RC DX Honor Trophy." The trophy will be provided by Bob's good friend, Humberto, TI2HP, and will be awarded each year to the DXer who, in the opinion of a special committee, has best emulated the high principles of good manners and good DX operating so long exemplified by Roberto Castro, TI2RC. We'll bring you more details about this in the next issue.

Suppression

Ever get a report of poor unwanted sideband suppression or of insufficient carrier suppression? Ever get mad about it? Ever do anything about it? *Need you do anything about it?*

We've heard reports being given like so; "you're 50 over 9, old man, but your other sideband—just about S 9." This is said in a commiserating tone—as if you've said a dirty word or forgotten to identify after ten minutes! Actually, you're doing quite well with 50 db of suppression, either of unwanted sideband or carrier! If everyone on the air suffered from the same trouble, we'd all be happier.

The point of all this? Merely, there exists a great deal of misunderstanding about the standards of good sideband. We all read the ads and nod knowingly about given ratings of commercial rigs and then proceed to forget that we must understand our equipment in order to preserve the capabilities the manufacturers put into it at the factory.

First, we must remember what a lot of us don't take time to think about; SSB doesn't mean that we have only one sideband, that the carrier is removed and that the unwanted sideband is completely inaudible. Quite the contrary! When you receive a signal that hits your S meter at 50 db over 9, the unwanted sideband may be anywhere from 15 db over S 9 to S 9 and still be within acceptable standards. The carrier may be S 9 and yet be quite good sideband. Remember, these two characters are only *suppressed*—not eliminated! Of course, the more suppression the better, but no one has yet found a way to eliminate either. With low power, of course, the "Unbearables" are not noticed, but put a kilowatt on the end of that beautiful sounding exciter and the "Unbearable"

bles"—the carrier and the unwanted sideband put in an appearance!

Distortion Products

Along with the signal, your linear will amplify the unwanted and the distorted—and what it does to the latter is something you don't really want to hear!! Most of us worry about carrier and sideband suppression but few of us give but passing notice to one of the worst offenders—the odd order distortion products, such as the third and fifth. Third order products, one of the principal distortion components encountered in linear amplifiers, are mentioned in the ads and are one of the least understood technical terms by most of the readers. The linear amplifier has little trouble with second order distortion products or any even numbered order, as these products will normally fall outside of the tuned passband and will be suppressed accordingly. Odd order products, on the other hand, are close to the desired frequency band and many of the products actually fall in the desired passband. Third Order Intermodulation Distortion (TOID) is generated whenever there are two frequencies in the passband whose frequencies are so related that the second harmonic of one will mix with the other to give a third frequency inside of the desired passband.

The first and most important means of reducing this type of distortion is the careful selection of a tube with a good plate characteristic. The designer then chooses the operating conditions for low order curvature. The manufacturer has done this for us, but this is only half the battle! With all the engineering and all the money that has been poured into the design of the rig, a loose hand on a "buck" control can louse up the whole deal!

Not all of us have r.f. feedback built into our rigs to help keep this distortion down, but all of us have "anti-gain control" built in, if we will only take the trouble to use it! The amplitude of the distortion and the adjacent channel interference created by the distortion products can be controlled *by you*, by limiting the input signal amplitude so that the operation of the final tube is always over its linear operating characteristic. The final should be driven with sufficient signal and yet not be overdriven to cause excessive intermodulation distortion. A scope is most useful in determining this operating point and a simple monitor adaptor may be made in no time at all. (See SSB Column, April 1960 page 78).

So keep in mind our Third Order Intermodulation Distortion friends when you are on the air—they thrive on open gain controls!

Remember, "TOID" IS FOR THE BOIDS!!!

How To Get QSL Cards And Save Money!

As many an avid DXer has discovered, there's a big jump between working a new country and getting it confirmed. When the DX bug first bites, we feel that all we have to do is encircle "Pse QSL" and a card will be immediately forthcoming. We fail to realize that this plea is

repeated on thousands and thousands of cards received by the DX station; it doesn't take long for it to lose its effectiveness (if it ever had any). After a little more DX experience (and a poor return of cards), it suddenly dawns on us that the DX station has absolutely no use for another W or K card. So, to make matters easier, we enclose IRCs and possibly a self-addressed envelope. In many cases, this does the trick—*partly* eliminating the expense to the DX station and increasing the convenience of his returning a card. Notice that we say "partly" eliminates the expense. Just lately, we have been made aware that sending IRCs does not accomplish the purpose. In a letter from Robby, VQ4ERR, and in conversation with John, ZE4JN, both these gentlemen have established the fact that we and the DX stations are not getting our money's worth from International Reply Coupons.

As the face of the coupon indicates, each is good *only* "for a postage stamp or postage stamps representing the amount of postage for an *ordinary single rate* letter destined for a foreign country." (Also see "Letters" page 12, August CQ). As you know, here in the States, we pay 15c for an IRC; our DX friends receive a stamp in return worth often less than half that amount! Using Kenya as an example, we have to send 5 IRCs (worth 75c here) in order to receive a card by airmail. Many amateurs, not realizing the situation, send random numbers of coupons—two, three, four—and request an Air Mail reply. What is the DX station to do? Send the card by ordinary mail for which he has received too many coupons—or send the card by Air Mail for which not enough postage was supplied, causing a great drain on his pocketbook?

There are two solutions to this problem: either send the DX station a \$1 bill which is only slightly more excessive than sending sufficient IRCs for Air Mail postage if such is desired (and who among us likes to wait months for that rare card?); or send along an air mail stamp from

[Continued on page 116]



Gibby, W8IJ, Lou, W2CLD, and Fritz Francke of Hallicrafters make a real happy triangle for our camera.



PROPAGATION

George Jacobs, W3ASK
11307 Clara St., Silver Springs, Md.

General Forecast

Maximum usable frequencies (MUFs) continue their seasonal rise on paths to most areas of the world during the daylight hours of October, while night time MUFs decline. Atmospheric noise levels (static) and ionospheric absorption generally continue to decrease during October, while much fewer sporadic-E short-skip type openings are likely to occur as compared with the summer months.

The best band for DX during most of the daylight hours is expected to be 10 meters, with 15 meters becoming optimum during the late afternoon hours. Twenty meters is forecast as the best band for DX openings to most areas of the world from a few hours before, until a few hours after, sunrise and sunset. During the hours of darkness, 40 meters is forecast as the best band for DX propagation conditions.

This month's column contains Short-Skip Propagation Charts, and charts centered on Hawaii and Alaska, for October and November, 1960. DX Charts for October appeared in last month's column; next month's column will contain DX Charts for November and December.

CQ DX Contest

The phone section of the CQ World-Wide

DX Contest will be held from 0200 GMT October 29th to 0200 GMT October 31st. General worldwide shortwave radio propagation conditions are expected to be seasonally normal on October 29th and 30th, but are predicted to become moderately disturbed by the 31st. The disturbance is likely to have an adverse influence on reception during the last few hours of the phone section and possibly somewhat longer. DX Propagation Charts for use during the phone section of the contest appeared in last month's column. Propagation Charts for the c.w. section (to be held from 0200 GMT Nov. 26th to 0200 GMT Nov. 28th) will appear in next month's column.

Solar activity during the 1960 CQ WW DX Contest is expected to be considerably lower than during any of the contests held since 1955. Although some good DX openings are forecast, general propagation conditions should be noticeably poorer on the 10 and 15 meter bands as a result of the decrease in solar activity. On the other hand, night time conditions on both 40 and 80 meters may be somewhat improved over previous years. All-in-all, final scores during the 1960 Contest are expected to be at

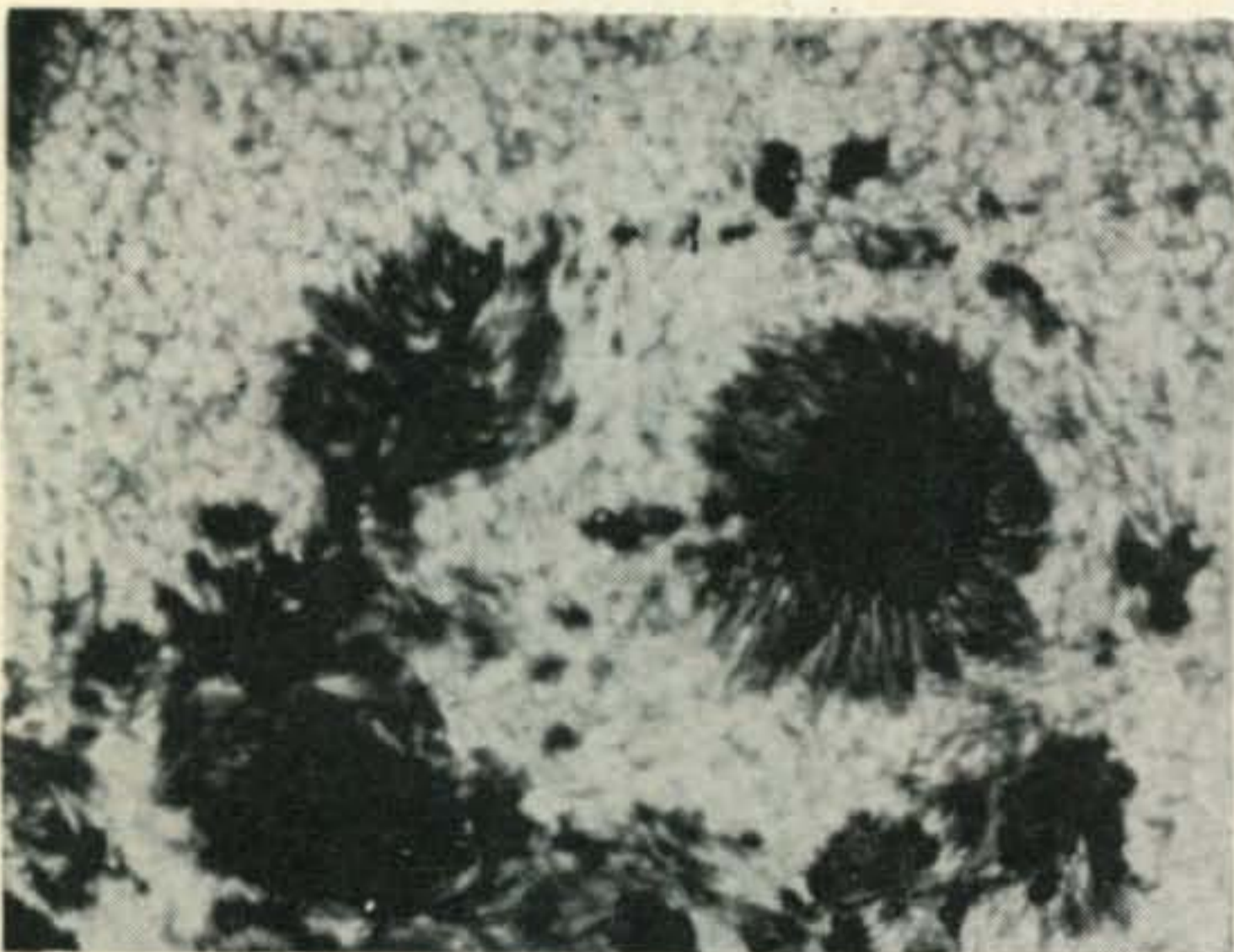

Fig. 1—Active group of sunspots photographed with unprecedented sharpness from an unmanned balloon at 80,000 feet on August 17, 1959. This particular spot group produced a magnetic storm on earth the day before the flight, causing major disturbances in long-range radio communications and a brilliant aurora throughout the night. (Official National Science Foundation Photo).

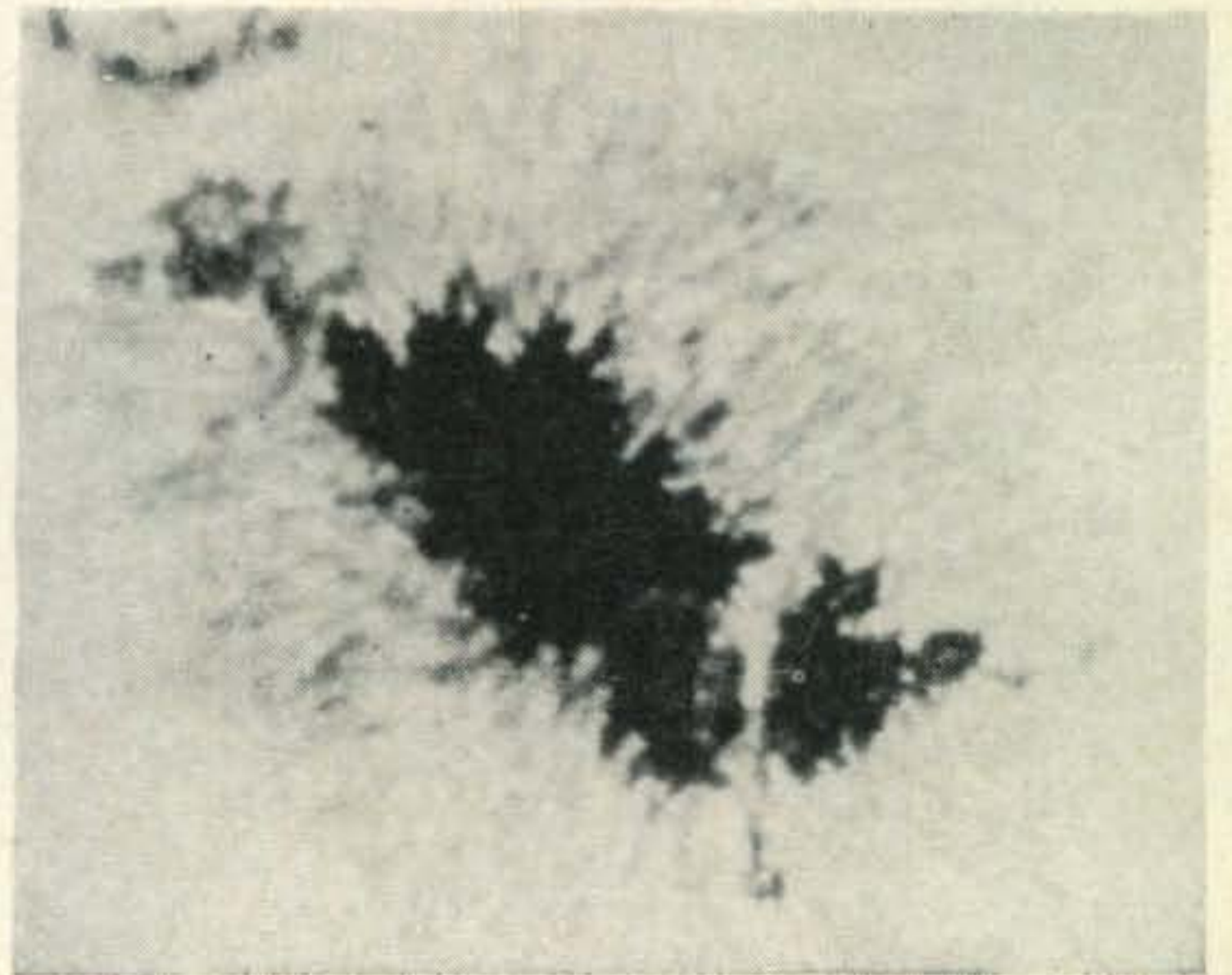

Fig. 2—White dots in center of sunspot are shown clearly for the first time in this photograph taken 80,000 feet above the earth by Stratoscope 1 balloon-borne telescope. Less than 200 miles in diameter, these dots are believed to be gaseous columns rising from the sunspot area as a result of convection. The long diameter of the umbra (black area) is roughly the diameter of the earth. (Official National Science Foundation Photo).

least somewhat lower than the record breaking scores compiled during the contests of the past four years.

Sunspot Number

The Zurich Solar Observatory reports a monthly mean sunspot number of 119 for July, 1960. This results in a 12 month running smoothed sunspot number of 128 centered on January, 1960. Based upon the current rate of decline in solar activity, a smoothed sunspot number of 103 is predicted for October, 1960.

Sunspot Close-Up

The National Science Foundation has recently released striking solar and sunspot photographs taken from an unmanned balloon 80,000 feet above the earth's surface. High above the dust layers and other optically disturbing regions of the earth's atmosphere, the balloon-borne telescope and automatic camera system (called Stratoscope I) produced the clearest photographs ever taken of the sun's surface and the areas immediately surrounding sunspots.

Stratoscope I, consisting of an automatic camera system and a 12 inch solar telescope equipped with a photoelectric mechanism for constantly tracking the sun, made four successful flights during the summer of 1959. The balloons were launched from Lake Elmo, Minnesota as part of a solar research project jointly supported by the National Science Foundation and the Office of Naval Research. In charge of the project was a Princeton University astronomy team headed by Dr. Martin Schwarzschild.

Figure 1, the most highly defined photograph of the sun taken to date, was snapped by Stratoscope I on August 17, 1959.

The granular characteristics of the sun's surface, and the *penumbra-umbra* composition of sunspots can be seen clearly in the photograph.

The *penumbra* is the raised, luminous region surrounding the dark inner depression called the *umbra*. In large sunspots of the type shown in fig. 1, the *umbra* may have a depth of several thousand miles. The *umbra* appears dark against

[Continued on page 117]

FORECAST INDICES

Circuits forecast to open:

- (1) Less than 7 days during each month of forecast period.
- (2) Between 8 and 13 days during each month of forecast period.
- (3) Between 14 and 22 days during each month of forecast period.
- (4) On more than 22 days during each month of forecast period.

Where two indices are shown within a parenthesis the first applies to the forecast for the shorter distance range, the second to the forecast for the longer distance.

A - A. M. P - P. M. N - Noon M - Midnight

See "Last Minute Forecast" in text for the relationship between the Forecast Indices and the day-to-day propagation conditions expected during the month.

* Indicates expected times for 80-meter openings from Alaska and Hawaii. On nights when atmospheric noise conditions are exceptionally quiet, 160-meter openings are likely to occur during these same periods.

The CQ Short-Skip Propagation Charts are based upon a CW effective radiated power of 75 watts from a half-wave dipole antenna, a half-wave above ground. The charts are valid through November 30, 1960. These forecasts are based upon basic propagation data published by the Central Radio Propagation Laboratory of the National Bureau of Standards, Boulder, Colorado.

CQ SHORT-SKIP PROPAGATION CHART

OCTOBER-NOVEMBER, 1960

ALL TIMES IN LOCAL STANDARD TIME

Band (Meters)	DISTANCE IN MILES			
	50-250	250-750	750-1300	1300-2300
10	NIL	NIL	10A - 5 P (1-3)	7 A - 10A (1-3) 10A - 5 P (3-4) 5 P - 6 P (1-2)
15	NIL	8 A - 12N (0-1) 12N - 4 P (0-2) 4 P - 6 P (0-1) 6 P - 10P (0-1)*	7 A - 8 A (0-1) 8 A - 12N (1-4) 12N - 4 P (2-4) 4 P - 6 P (1-4) 6 P - 10P (1-2)*	7 A - 8 A (1-2) 8 A - 6 P (4) 6 P - 8 P (2-3) 8 P - 10P (0-1)
20	10A - 5 P (1)*	8 A - 5 P (1-4) 5 P - 7 P (0-3) 7 P - 8 A (0-2)*	8 A - 5 P (4) 5 P - 7 P (3-4) 7 P - 12M (2-3) 12M - 8 A (2)	8 A - 11A (4) 11A - 3 P (4-3) 3 P - 10P (3-4) 10P - 12M (3) 12M - 8 A (2)
40	6 A - 8 A (3) 8 A - 7 P (4) 7 P - 10P (3) 10P - 3 A (1-2)*	6 A - 8 A (3) 8 A - 10A (4) 10A - 4 P (4-3) 4 P - 7 P (4) 7 P - 10P (3-4) 10P - 3 A (2-3) 3 A - 6 A (0-2)	6 A - 8 A (3) 8 A - 10A (4-2) 10A - 2 P (3-2) 2 P - 4 P (3) 4 P - 7 P (4) 7 P - 3 A (3-4) 3 A - 6 A (2-3)	6 A - 8 A (3-1) 8 A - 10A (2-1) 10A - 2 P (2-0) 2 P - 4 P (3-1) 4 P - 3 A (4) 3 A - 6 A (3)
60	7 A - 1 P (4) 1 P - 4 P (4-3) 4 P - 4 A (4) 4 A - 7 A (3-4)	5 A - 7 A (4-3) 7 A - 9 A (4-2) 9 A - 1 P (4-1) 1 P - 4 P (3-0) 4 P - 6 P (4-2) 6 P - 5 A (4)	4 A - 7 A (3-2) 7 A - 9 A (1-0) 9 A - 4 P (0) 4 P - 6 P (2-1) 6 P - 10P (4-2) 10P - 4 A (4)	4 A - 7 A (2) 7 A - 4 P (0) 4 P - 6 P (1) 6 P - 8 P (2-1) 8 P - 10P (2) 10P - 4 A (4-3)
160	5 A - 7 A (4-3) 7 A - 9 A (3-1) 9 A - 5 P (2-0) 5 P - 8 P (4-2) 8 P - 5 A (4)	4 A - 6 A (3-2) 6 A - 9 A (1-0) 9 A - 5 P (0) 5 P - 8 P (2-1) 8 P - 4 A (4)	4 A - 6 A (2-1) 6 A - 5 P (0) 5 P - 8 P (1-0) 8 P - 11P (4-1) 11P - 4 A (4-3)	4 A - 6 A (1) 6 A - 8 P (0) 8 P - 11P (1) 11P - 4 A (3-2)

* Predominantly Sporadic-E type opening.

HAWAII

(TIMES GIVEN IN HAWAIIAN STANDARD TIME)**

To:	6/10 Meters**	15 Meters	20 Meters	40/80* Meters
Eastern USA	9 A - 12N (1)** 6 A - 8 A (1) 8 A - 11A (2) 11A - 2 P (4) 2 P - 4 P (2) 4 P - 5 P (1)	5 A - 6 A (1) 6 A - 8 A (3) 8 A - 11A (2) 11A - 1 P (3) 1 P - 3 P (4) 3 P - 4 P (3) 4 P - 6 P (2) 6 P - 7 P (1)	1 P - 3 P (3) 3 P - 8 P (4) 8 P - 10P (3) 10P - 12M (2) 12M - 5 A (1) 5 A - 7 A (2) 7 A - 1 P (1)	4 P - 7 P (1) 7 P - 1 A (4) 1 A - 3 A (2) 3 A - 1 A (2)*
Central USA	9 A - 1 P (1)** 6 A - 7 A (2) 7 A - 8 A (3) 8 A - 2 P (4) 2 P - 4 P (3) 4 P - 5 P (2) 5 P - 6 P (1)	6 A - 7 A (2) 7 A - 9 A (4) 9 A - 1 P (3) 1 P - 4 P (4) 4 P - 6 P (3) 6 P - 9 P (2) 9 P - 10P (1)	6 A - 8 A (3) 8 A - 1 P (2) 1 P - 4 P (3) 4 P - 10P (4) 10P - 1 A (3) 1 A - 6 A (2)	5 P - 7 P (2) 7 P - 3 A (4) 3 A - 5 A (2) 8 P - 3 A (3)*
Western USA	11A - 2 P (1)** 6 A - 8 A (2) 8 A - 2 P (4) 2 P - 3 P (3) 3 P - 4 P (2) 4 P - 5 P (1)	6 A - 8 A (2) 8 A - 4 P (4) 4 P - 5 P (3) 5 P - 7 P (2) 7 P - 8 P (1)	6 A - 9 A (4) 9 A - 3 P (3) 3 P - 6 P (4) 6 P - 7 P (3) 7 P - 10P (2) 10P - 12M (1)	6 P - 8 P (2) 8 P - 5 A (4) 5 A - 7 A (2) 8 P - 4 A (3)*

*** Hawaiian Standard Time is equal to:

Eastern Standard Time minus five hours;
Central Standard Time minus four hours;
Mountain Standard Time minus three hours;
Pacific Standard Time minus two hours.

ALASKA

(TIMES GIVEN IN ALASKAN STANDARD TIME)**

To:	10 Meters	15 Meters	20 Meters	40/80* Meters
Eastern USA	9 A - 11A (1) 11A - 2 P (3) 2 P - 4 P (2) 4 P - 5 P (1)	6 A - 8 A (1) 8 A - 12N (2) 12N - 3 P (3) 3 P - 5 P (2) 5 P - 6 P (1)	5 A - 7 A (2) 7 A - 1 P (1) 1 P - 3 P (2) 3 P - 5 P (3) 5 P - 7 P (2) 7 P - 8 P (1)	7 P - 5 A (1)
Central USA	9 A - 1 P (1) 1 P - 4 P (2) 4 P - 5 P (1)	6 A - 9 A (1) 9 A - 1 P (2) 1 P - 4 P (3) 4 P - 6 P (2) 6 P - 7 P (1)	7 A - 9 A (2) 9 A - 3 P (1) 3 P - 4 P (2) 4 P - 5 P (3) 5 P - 7 P (2) 7 P - 8 P (1)	9 P - 6 A (1)
Western USA	11A - 2 P (1) 2 P - 4 P (2) 4 P - 5 P (1)	8 A - 11A (1) 11A - 1 P (2) 1 P - 4 P (3) 4 P - 6 P (2) 6 P - 7 P (1)	6 A - 8 A (1) 8 A - 10A (3) 10A - 2 P (2) 2 P - 6 P (3) 6 P - 8 P (2) 8 P - 9 P (1)	10P - 6 A (2) 1 A - 5 A (1)*

** There are four different time zones in Alaska. The chart is based on standard time in the zone from Skagway to 141 degrees west longitude. Time in this zone is equal to:

Eastern Standard Time minus four hours;
Central Standard Time minus three hours;
Mountain Standard Time minus two hours;
Pacific Standard Time minus one hour.

CONTEST CALENDAR

by Frank Anzalone, WIWY
14 Sherwood Road, Stamford, Conn.

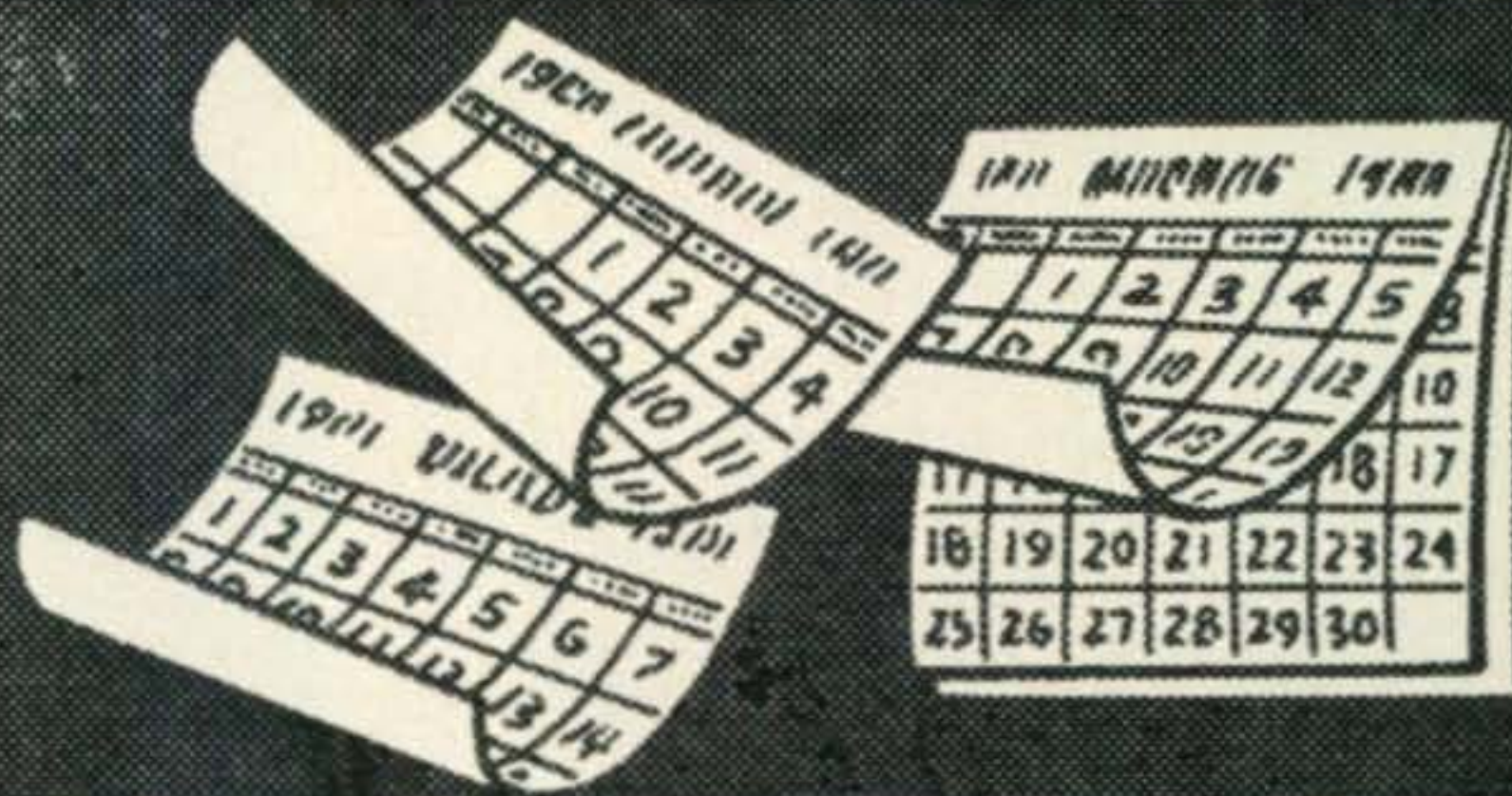

September	24-25—S A C Phone
September	24-25—Marc VE/W
October	1- 2—VK/ZL Phone
October	8- 9—VK/ZL CW
October	22-23—Boy Scouts
October	29-31—CQ WW DX Phone
November	12-13—ARRL SS
November	19-20—ARRL SS
November	26-28—CQ WW DX CW
December	3- 4—RSGB 21/28 Phone

S A C

Phone

Starts: 15.00 GMT Saturday, September 24th.
Ends: 18.00 GMT Sunday, September 25th.

The c.w. portion is already past history and its doubtful if you will receive this issue in time for the phone section. However this can serve as a reminder to get your log off before October 15th to: SSA Contest Manager, Karl O. Friden, SM7ID, Box 2005, Kristianstad 2, Sweden.

MARC VE/W

Starts: 18.00 EST Saturday, September 24th.
Ends: 24.00 EST Sunday, September 25th.

Rules for this one were in last month's Calendar in case you receive this issue in time to take part in this Canadian/US party.

Your log must be mailed no later than October 12th to: Gordon H. Webster, VE2BB, 69 Pine Beach Blvd., Dorval, Quebec, Canada.

VK/ZL

Phone

Starts: 10.00 GMT Saturday, October 1st.
Ends: 10.00 GMT Sunday, October 2nd.

C.W.

Starts: 10.00 GMT Saturday, October 8th.
Ends: 10.00 GMT Sunday, October 9th.

This contest is alternately sponsored by the W.I.A. and the N.Z.A.R.T. This year the New Zealand boys are taking over. Since the rules vary according to the organization that is running the affair, it would be advisable to check back to the July Calendar and review the rules.

Mail your logs to: The N.Z.A.R.T., Box 489, Wellington, N. Z. They must be in the hands of the Contest Committee before January 20, 1961.

Boy Scouts

This is not a contest but an event to promote contacts between Scouts of different countries. If you are in the Boy Scout's organization or have ever been associated with the Scout movement you can join the activity starting at 00.00 GMT Saturday, October 22nd. The party ends 24 hours later.

CQ WW DX

Phone

Starts: 02.00 GMT Saturday, October 29th.
Ends: 02.00 GMT Monday, October 31st.

C.W.

Starts: 02.00 GMT Saturday, November 26th.
Ends: 02.00 GMT Monday, November 28th.

For the uninitiated few who are not familiar with the rules of our World Wide DX Contest, we refer you to the August issue of *CQ*, page 67.

There is still time to get log sheets but you will have to act fast. Send sufficient postage for 1st class mail if you need them for the phone contest.

Once again we call your attention to the rule change in Par. VIII #7 and Par. X #3, which applies to multi-operator stations. The change simply means that multi-operator stations will only be judged on an all band score, regardless of how many bands are used. Single band competition is now reserved for single operator stations only.

We also want to call the attention of DX Clubs to the rules regarding club competition.

1. Only DX Clubs affiliated to a national body are eligible for an award.

2. In order to be eligible for the *CQ* Plaque an officer of the Club must submit a list of its participating members and also their claimed scores.

Don't leave all the work for your committee. Our patience grows thin after going through a few hundred logs. You are expected to figure your score and check your log for duplicate contacts. Be sure to sign the pledge that all rules have been observed. (See sample report sheet.) And *Print* your name and address.

And last but not least, be sure to send us your log, regardless of how few contacts you may have made. It's very important to us.

ARRL 55

No need to explain this one. *QST* will have all the info. There's a big week-end of C.W. coming up at the end of the month.

RSGB 21/28

Starts: 07.00 GMT Saturday, December 3rd.

Ends: 19.00 GMT Sunday, December 4th.

It's the world working the British Isles on phone in this one. Rules are the same as in previous years but your attention is called to the additional bonus of 50 points for each additional ten G3 stations worked, irrespective of band.

1. *Exchange*—RS report plus the usual progressive three figure serial number starting with 001. Only one contact on each band (21 & 28 mc) may be made with the same station. Cross-band contacts are not allowed.

2. *Scoring*—For Overseas stations: Each contact with a British Isles station will count 5 points. In addition, a bonus of 50 points may be claimed for the first contact with each British Isle country-numeral prefix, e.i. G2, G3, G4, G5, G6, G8, GB, GC2, GC3, GC4, GC5, GC6, GC8, GD2, GD3, GD4, GD5, GD6, GD8, GI2, GI3, GI4, GI5, GI6, GI8, GM2, GM3, GM4, GM5, GM6, GM8, GW2, GW3, GW4, GW5, GW6, GW8. A total of 37 possible 50 pointers on each band. A further 50 point bonus can be scored for each additional ten G3 stations worked, irrespective of band.

3. *Final Score*—The final score therefore will be the total contact points plus the bonus points and the special bonus.

4. *Reporting*—Logs must be clearly written or typed on one side of the paper only. Show in this order: Date, time in GMT, station worked, serial nr. sent and received, band, bonus points and contact points.

Sign the usual declaration that you were operating within the limits of your license and that your log is correct and true.

5. Certificate will be awarded to the leading station in each country and each call area in the following countries: VE, VK, W/K, ZL and ZS. Stations in the British Isles also compete for the Whitworth Trophy, which will be awarded to the top station.

Your log must be postmarked not later than December 19th and goes to: The RSGB Contest Committee, New Ruskin House, Little Russell Street, London, W.C. 1, England.

Ed Note

Tony Susen and the gang at W3HAO have generously offered to donate a Cup for one of the Multi-operator divisions. That now completes the awards list in our World Wide DX Contest and now there is an award for each division. Single band, All bands, Multi-operator single transmitter and Multi-operator multi-transmitter; both Phone and CW, eight Trophies in all. Plus the *CQ* plaque for Club honors. Without a doubt the most attractive display of prizes of any DX contest in the world.

It seems that W3FFQ did not get the credit

due him for being the highest U.S. station on 21 mc c.w. in our last contest listings. His score of 83,512 should have appeared in the Continental Leaders box instead of W8UPN who received a score of 78,304.

Results 1960 WAEDC Contest

Continental Leaders

Europe	DL1KB	254,483
No. America	K2DGT	186,715
Africa	FA9UO	65,952
So. America	PY1ADA	39,370
Asia	OD5LX	38,935
Oceania	VK2GW	29,522

US Winners & Entries

W1WY	39,312	W3CGS	632
W1BOD	16,677	W3QLW	468
W1HWH	13,584	W4KFC	35,520
W1FZ	4526	W4HTV	32,660
W1CTW	1078	W4YK	8194
W1NLM	150	W4ORT	6963
W1UQP	16	W4KXV	3936
K2DGT	186,715	W4GIE	2750
W2EQS	173,049	K4LNA	900
W2FBS	13,325	W5KC	7400
W2AQT	18,824	W5QF	4256
W2WZ	8073	K5UYF	10
W2DRV	1479	W6UDR	12,408
W2BOT	306	W6PUY	7290
W2KVL	270	W6YMH	5700
W2GPR	144	W6DDO	3450
W2WAS	77	W6KG	1088
K2EKM	16	W6UYZ	588
W3GRF	150,640	W6BIL	435
W3FYS	67,920	K6HYO	35
W3ZAO	65,748	K6BOB	25
W3ARK	30,780	W7AJS	15,264
W3KA	5530	W7PQE	8636
W3MSR	1376	W7CAB	4202
W3FSP	1152	W7BTH	2919

Winners Only

W8RQ	58,050	<i>North America</i>	
W8DUS	17,784	KL7CDF	48,608
W8HUD	10,215	KP4CC	13,034
W8UMR	7644	VE1EK	12,513
K8IUX	1313	VE2NV	8910
W8KC	1200	VO2RH	8330
W8OOR	868	VE3IR	5850
W8YPT	481	VE6VO	348
W8NP	480	XE1PJ	230
W8YGR	273	VE5DZ	36
W8OCO	9	<i>Africa</i>	
W9YNB	12,000	FA9UO	65,952
W9NII	9417	CR6AI	39,300
W9WIO	8140	ZS6IW	25,956
K9PJN	2664	ST2AR	9198
W9KXK	1820	OQ5IG	5712
W9DDP	1206	VQ2RG	4805
W9FYM	836	CR4AH	2125
W9PWM	720	FQ8HA	2120
W9CLH	264	ZS2U	990
W9BGX	32	ZD2GUP	465
W9IOP*	68,120	ZS1O	35
K0SLD	18,669	<i>Asia</i>	
W0MCX	6580	OD5LX	38,935
W0BLZ	2254	YA1AO	38,190
W0VFE	336	JA1VX	5697
*Multi-operator		JA3IS	2816

[Continued on page 118]

Coming next month . . .

1960 ANNUAL GIANT

NOVEMBER ISSUE OF CQ

This annual event has already become a tradition in amateur radio and is eagerly awaited by everyone in the hobby.

Each year we try to out-do ourselves to make the annual bigger and better—and we've done so well with next month's issue that we shudder to think of the job we'll have trying to top it—but we'll worry about that next year. We wish we could give you a list of the contents, but we can't let the cat out of the bag. We can only say that you'll see some of the most luscious, mouth-watering articles of the year on the many subjects of ham radio.

EXTRA SPECIAL ARTICLES for the "do-it-yourselfers", for the antenna men, the dx'ers, the vhf'ers, and the ssb gang, in addition to the usual popular monthly departments. A **BIG BONUS** feature will be a 24 page **SPECIAL DISTRIBUTOR SECTION** printed on a distinctive yellow colored paper, and designed as an index to help you find out in a hurry "who has it" and where he is. This can be used as a year round reference to save you much time and leg work.

If you are a newsstand copy reader, you better make sure your dealer reserves a copy for you (at \$1.00 per copy). Take no chances, they'll be going fast!

ORDER YOURS NOW!

**GLAD YOU LOOKED
THIS WAY . . .**

We used up so many superlatives in the 1960 annual blurb next door that we're almost at a loss for words to use in this ad. Almost, but not quite.

Actually, if you've been reading CQ for the past few months, there isn't much we can tell you that you don't already know. We refer, of course, to the vast improvement you have noticed in the quality of our feature material, the monthly columns, and the over-all "new look" of the magazine. As a publication that's put out by active hams for active hams, we're dedicated to making it and keeping it the best in amateur radio.

So, if you're an active ham and are not yet on our subscription list, you owe it to yourself to give the idea some serious consideration.

A subscription will not only save you money, but will give you the assurance of getting your copy each month and the convenience of delivery right to your door.

How can you hesitate?

**SEND IN YOUR
SUBSCRIPTION NOW!**

CQ MAGAZINE

300 West 43rd St.

New York 36, N. Y.

HAM CLINIC [from page 71]

at 450 volts d.c. in series. Be sure you have the correct bleeder across the combination—preferably a dual resistance section in series. The center of the bleeder will go between the two “upper” and two “lower” capacitors. You can use a combination of a number of oil filled capacitors with high voltage ratings too, but they cost money. (Unless you are lucky enough to pick up some surplus bargains).

Antenna Match—“I built up a beam that is supposed to have an impedance of 52 ohms when adjusted properly. I have some 90 ohm surplus coaxial cable. How can I use it with some sort of matching device so I will have a low s.w.r. with my 52 ohm antenna?”

By using a quarter-wave transformer or “Q” section. See pages 376 and 377 of the 37th Edition of the ARRL *Handbook* for full info.

In your case, you would need a $\frac{1}{4}$ wave matching section (ms) having a characteristic impedance of about 70 ohms. To figure the ms length you must know the velocity factor of your coaxial cable; then the following formula is used: Length of the $\frac{1}{4}$ wave matching section in feet = $246V/f$. Where V is the velocity factor of your coax and f is the center frequency in mc. (246 being a constant.)

VR Checker—“Have a simple VR tube checker circuit handy?”

Yep. See fig. 2. The variac voltage is varied UP. When the VR tube fires, read the milliam-

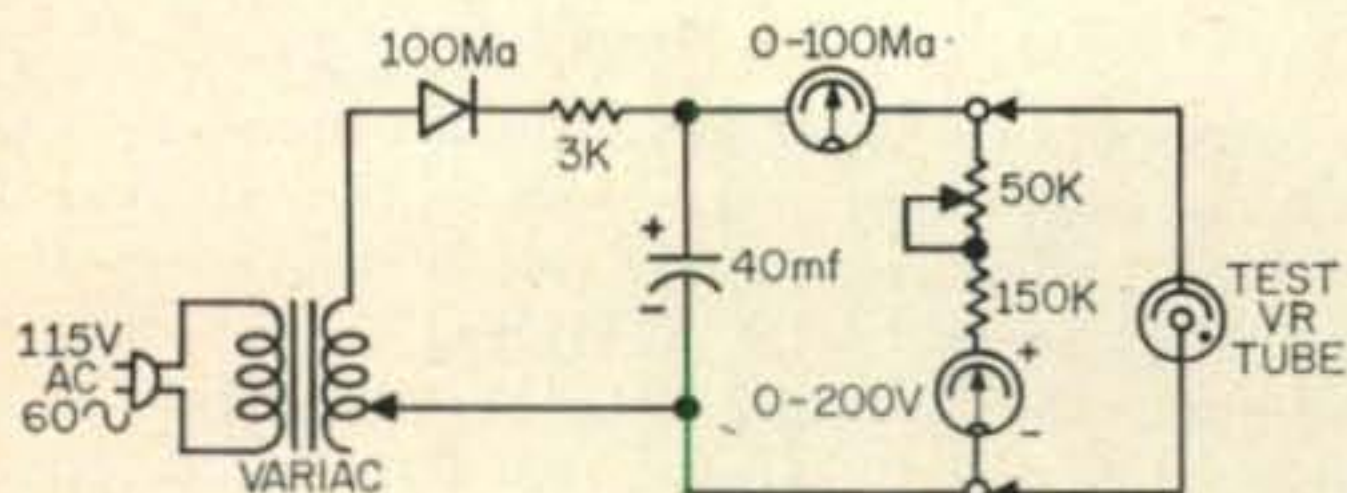

Fig. 2—Simple VR tube tester. The 0-200 v meter is a 1 ma movement with a total of 200k as a multiplier.

meter and voltmeter. Good tubes will fire at their rated voltage and current.

Saving Tip—“I built up a transmitter monitoring device using transistors which require 9 volts, and I have been using a battery for this purpose. But at nearly a dollar a throw, these batteries are expensive. I still want to use a battery because I do a lot of portable work. Any ideas?”

I guess you want me to suggest a substitute. Well, I'd suggest *Lafayette Radio's* #F570 charger and battery assembly that sells for \$2.69 plus postage. The leakproof battery is rated at 9 volts and can be used over and over again. Write them at Jamaica, 33, N.Y.

Book Review

I purchased a copy of “*Transistors in Radio, Television and Electronics*” by Milton S. Kiver,

the editor of *Electrical Design News*. Published by *McGraw Hill Book Co.*, it sells for \$7.50 and I can truthfully say that it IS a book in which the ham will be really interested.

In its 419 fact-filled pages, Kiver covers the theoretical and practical aspects of transistors in his inimitable and very readable fashion.

Although intended as a textbook and aimed toward this objective by the inclusion of “experiment” and question sections, it contains many practical circuits of interest to everyone; is well illustrated and so very easy to understand.

Its 12 chapters are well thought out; and any ham working with transistors could make good use of its contents. Although the transistor data table in the back of the book is too short, this is the only fault I find with this text. In the next issue, I hope he incorporates the transistor charts found in the June 1960 issue of his fine technical journal.

72 and SSB Overseas

(Thanks to Barker and Williamson, Inc.)

As expressed in this column before, many hams overseas who wish to try out s.s.b. are prevented from doing so because of lack of funds. This is understandable.

A good s.s.b. mechanical filter costs more than some hams overseas make in a month; and phase-shift networks cannot be assembled properly because of the lack of good precision test equipment.

But I thought of an approach which is now “paying off” and I hope you too will consider and implement it wherever you can.

The easiest s.s.b. exciter to make is one using a phase-shift network. . . . IF our foreign ham friends can get them. So I wrote a letter to Tom Consalvi, W3EOZ of B&W and asked for his advice in the matter. He suggested that B&W's very simple but very effective phase-shift network, the 2Q4 (Model 350) which is installed in a type 6J5 metal tube envelope would be ideal. (These are used in *Heath's* SB-10).

These wonderful little units sell for \$4.65 and are worth every penny! I designed a transistor exciter around one and it works as well as my two commercial jobs.

So here is the plan: if you run into a foreign ham on the air who signifies his desire to go on s.s.b., why not suggest that you will send him a 2Q4 along with full information? (The 2Q4 is shipped with instructions). You can also tell him that HAM CLINIC will be glad to send him free, any additional information required to get on the air using the 2Q4.

Now let me see some of you “dyed-in-the-wool” s.s.b.'rs do *something* concrete in getting others to use the s.s.b. mode. In the process you will be assisting in the creation of better international good-will and understanding. (SSBARA please copy)

I sent three 2Q4s to Spanish hams. I know they will make good use of them.

[Continued on page 106]

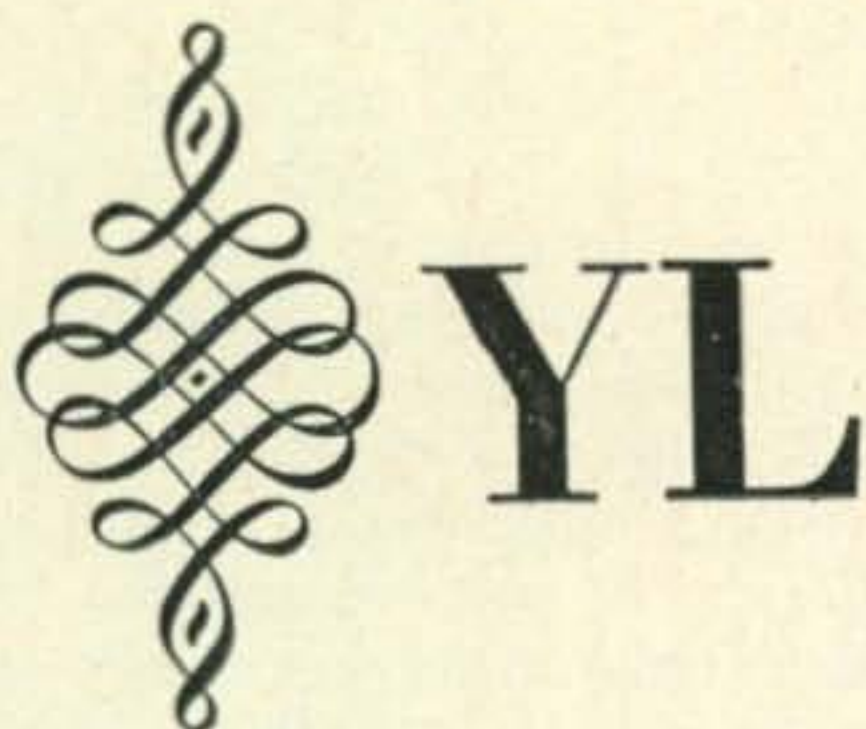

by Louisa B. Sando, W5RZJ
212 Sombrio Drive, Santa Fe, N.M.

YLRL 21st Anniversary Party

- C.W.:** Start Oct. 19, 1960 at 12 noon EST. End Oct. 20, 1960 at 6 P.M. EST.
- Phone:** Start Nov. 2, 1960 at 12 noon EST. End Nov. 3, 1960 at 6 P.M. EST.
- Time:** Work any amount of hours you wish, providing you do not exceed the 30 hours allowed in each section of the contest.
- Eligibility:** All licensed YL and XYL operators throughout the world are invited to participate. YLRL members are eligible for the cup awards, non-members will receive certificates. Only YLRL members are eligible for the Corcoran Award. Contacts with OMs will not count. There will also be a special certificate to the highest scoring Novice operator, and one for the highest scoring Technician operator.
- Operation:** All bands may be used. Cross-band operation is not permitted. Only one contact with each station in each section of the contest will be counted.
- Procedure:** Call "CQ" YLAP."
- Exchange:** Station worked, QSO number, RS or RST report, ARRL section, U.S. possession, VE district or country. Entries in your log should also state the band you were working at time of contacts, power, time of contacts and date.
- Scoring:** (a) C.w. and phone sections will be scored as separate contests. (b) Multiply number of contacts by the total number of ARRL sections, U.S. possessions, VE districts and countries worked. (c) Contestants running 150 watts input or less at all times may multiply the results of (b) by 1.25. (low power multiplier).
- Awards:** Highest c.w. score—gold cup.
High phone score—gold cup.
Top three scores in each contest will receive certificates. Highest c.w. and phone score in each ARRL section, U.S. possession, VE district and country will receive a certificate.
Highest combined c.w. and phone score of YLRL member, will receive Corcoran Award.
- Logs:** Copies of all logs must show claimed score and must be *postmarked* not later than November 19, 1960, and *received* by the Vice President of YLRL not later than Nov. 30, 1960, or they will be disqualified. Send copies of log to: Lillian E. Beebe, W5EGD/3, 923 Kent Ave., Baltimore 28, Md. Be sure zone number is included. No logs will be returned; keep a copy of your log in addition to the one you send in for confirmation.

21st YLRL Anniversary Party

To the right appears the rules for YLRL's 21st Anniversary Party. Note that the c.w. section is being held first this year—on Oct. 19-20. The phone section will be held on Nov. 2-3. Because of so many other contests, dates for the A.P. were moved up this year and also to avoid conflicts the contest will again be held on weekdays. ARRL sections will be used in scoring U.S.A. contacts. Remember, a combined score is required for the Corcoran Award. All YLs everywhere, whether or not members of YLRL, are invited to participate in this contest. Come on, gals—see you in the A.P.

With the Clubs

Members of WHOOT, the Women Ham Operators of Texas, were very active during the 30th annual West Gulf Division convention held in Dallas June 17-19. WHOOT YLs sponsored the licensed YL breakfast, the ladies' coffee and hospitality room and assisted with the luncheon. 38 YLs attended the breakfast and the main prize, an electric roaster, was won by K5KEC. 95 YLs and XYLs attended the luncheon, which featured a color movie on mosaics. (Favors were mosaic ashtrays made by members of WHOOT.) Main prize, a silver tea service, was won by K5QAK, Charlene.

The ALAMO YLs are very sorry to have lost a beloved member, K5PDI, Mary Carmack, who became a Silent Key in June.

Members of the San Diego YLRC held an installation-of-officers luncheon in June with these YLs taking over: President, W6VSL, Barbara; V.P., WA6EVU, Debbie; secy, WA6FTZ, Jeanie; treas., WA6CBN, Dee. W6GGX, Pat, is certificate custodian.

The Los Angeles YLRC also had installation of officers in June. K6BUS, Midge, the club's president, presented incoming president K6-ANG, Billie, with the gavel of olive wood which W6QYL, Martha, brought from Jerusalem. Other officers: V.P., WA6AOE, Maxine; treas., K6OAI, Anita; rec. secy, K6JCL, Jenny; corres. secy, K6LMV, Esther. Member W6NZZ, Evelyn, and her OM are in Europe for a year.

They purchased a Volkswagon and are visiting YL's homes and art museums. Sympathy of all the L.A. YLs, and others as well, goes to Lucille, W6JMS, whose OM Jim, W6DJU, became a Silent Key in June.

New officers for the Chicago YLRL: President, W9GME, Grace; V.P., K9UHD, Esther; secy-treas., K9LIW, Dorothy.

WA6MAO is the official call for BAYLARC, which the YLs were happy to receive in time for Field Day operation. BAYLARC sponsors two nets: 3850 at 1000 on Saturdays and 50.5 at 1930 on Mondays.

At their third annual meeting held at Orlando, the Floridora YLs elected these officers: President, K4RNS; V.P., K4RED; treas., K4HSC; secy, K4OYB; certificate custodian, W3WPD; publicity, K4PPX; directory, K4ANR; historian, W4HRC; membership, W4BIL. The Floridora YLs are busy making plans for their Floridora Week, Jan. 8-15, to help Hams earn the club certificate. The Floridoras have a number of nets going: Sun. 0900 on 7225, K4UIZ NCS; Mon. 0900 on 7225, W4IUR NCS; Fri. 1330 on 7185 (Novice cw net), KN4RDX NCS; plus a 6-meter (Central) net on Thurs., 2000, 50.3, K4ANR NCS; 6-meter (Southern) net on Thurs. 2000 on 50.33, W4LPR NCS, and a Gulf Coast Area 6 meter net with W4BAV as net manager. Floridora member and 4th D/C, W4UF, Dot, left in mid-July for an around-the-world trip.

The Georgia Peaches now have a Directory containing information about all 39 members of their club.

WAYLARC members held a surprise tea for Ethel, K4LMB, in honor of her marriage to W3CN, Tex, and presented her with an azalea shrub for her new home. WAYLARC member W3CDQ, Liz, has been touring in Europe again.

The LARK's contest, coinciding with the YL-OM Contest, provided these winners: Out-of-town—c.w., W6PCA, Opal; phone, K9QGR, Hazel. Local—c.w., K9HGY, Bev; phone, K9IVG Roberta. The club will resume these nets in Oct.: LARK c.w. net, 3.75 mc at 0930 on Tues., W9MYC, NCS; LARKNEST, phone, 29 mc at 2200 Mon., W9BCA NCS.

Here and There

You never know when Ham radio may save a life. KØBFH, Nina, was in QSO with WØVQE when the latter suffered a heart attack. Nina summoned help and he was taken to the hospital.

WØKQD, Irene Craft, was one of five Hams to receive special citations in the 1959 Edison Award program. Irene organized a multi-state radio network for emergency communications.

From K6BX we hear that K6OQD, Jean, became "queen" of the Certificate Hunters' Club by being the first YL to submit evidence of holding 25 amateur awards.

Our sympathy to W1ONV on the loss of his XYL, Lil, on May 25th. Art says some of the old-timers will remember her as 8BPT in Mich.

[Continued on page 119]



Members of the YL Welcome Net (80 meters on Tuesdays) gathered on July 10, 1960, for a picnic at the QTH of NCS W8ATB in Flint, Mich. and decided to make it an annual affair. L. to r., standing: VE3AJR, K8LHF, W8EIR, K8IOP, K8OMH; second row: V8ATB, W8SNB, W8UAP, W8ONI; front row: K8HWC, W8RIR, W8OTK, W8VRH. Also attending, WBQNA.



The four YLs who have served as president of the Floridoras, l. to r., W4UF ('59), W4BWR ('58), W4BIL ('57), K4RNS ('60).



A group of the YLs attending the 10th Annual Midwest YL Convention held at Indianapolis in May. L. to r., W8EIR, W9RTH, W9YWH, W9RUJ, K9RXK.

New Amateur Equipment

Code Practice Oscillator

Electronic Instrument Co., Inc., of 33-00 Northern Blvd., L. I. City, N. Y., has now made available a code practice oscillator. Measuring $6\frac{1}{2} \times 3\frac{3}{4} \times 2\frac{3}{4}$ inches. This transistorized oscillator provides visual as well as aural signals. A three inch speaker produces clear loud signals and a phone jack mutes the speaker for private listening. A pitch control allows the operator a choice of tone ranging from 500 to 2000 c.p.s. By switching the toggle switch, three modes of signaling may be produced. Tone, light and both tone and light. A novel feature included is a "temporary" key which is formed across the contacts, which can be removed and a regular key substituted. The Model 706 can be purchased in kit form or completely wired and tested. For more information circle A on page 126.

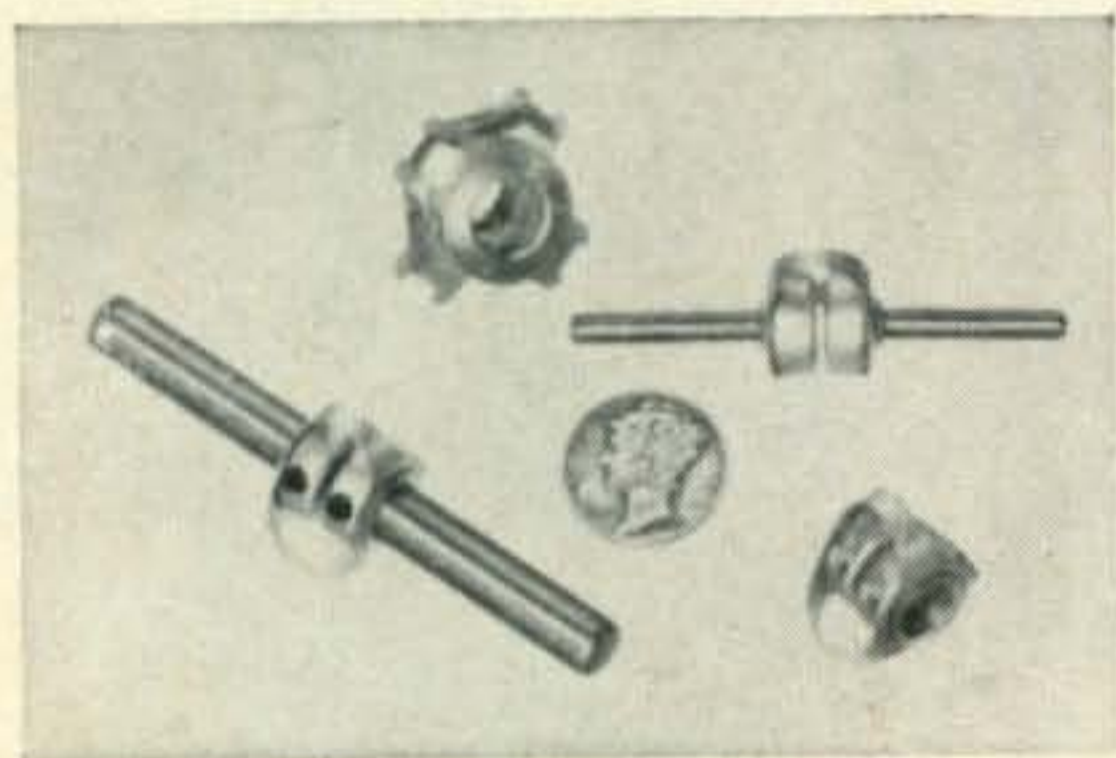

Flexible Coupling

Davale Coupling Co., a division of Davale Tool and Die Company, 147 No. Avenue 18, Los Angeles 31, California has introduced a new line of flexible coupling designed for angular transmission of rotary motion. The unique feature of these couplings is that they are of one piece construction and therefore, there are no parts to wear out. Misalignment allowances are 5° angular or $.020$ " parallel. Models shown with the illustrated shaft, fit sizes from $.120$ to $.250$ " and the others will accommodate shafts from $.120$ to $.375$ ". Three materials can be supplied; brass, beryllium copper, and stainless steel. Torque ratings vary from 6 in. oz. to 150 in. oz. and are available from stock depending on your requirements. For more information circle B on page 126.

Slow Motion Drive

Stratton and Co. Ltd. Eddystone Works, Birmingham 31, England are exporting their Geared Slow Motion Drive Assembly, Cat. No. 898. This vernier dial is ideally suited for v.f.o. or receiver tuning. The reduction ratio is 110 to 1 and provides a seven inch slide rule dial which can be calibrated on five different bands. A small window above the knob provides a logging scale of 500 divisions. A cam is included which allows for zero setting adjustment. British Radio Electronics Limited, 1833 Jefferson Place, N. W., Washington 6, D. C. is the distributor in this country. For more information circle C on page 126.

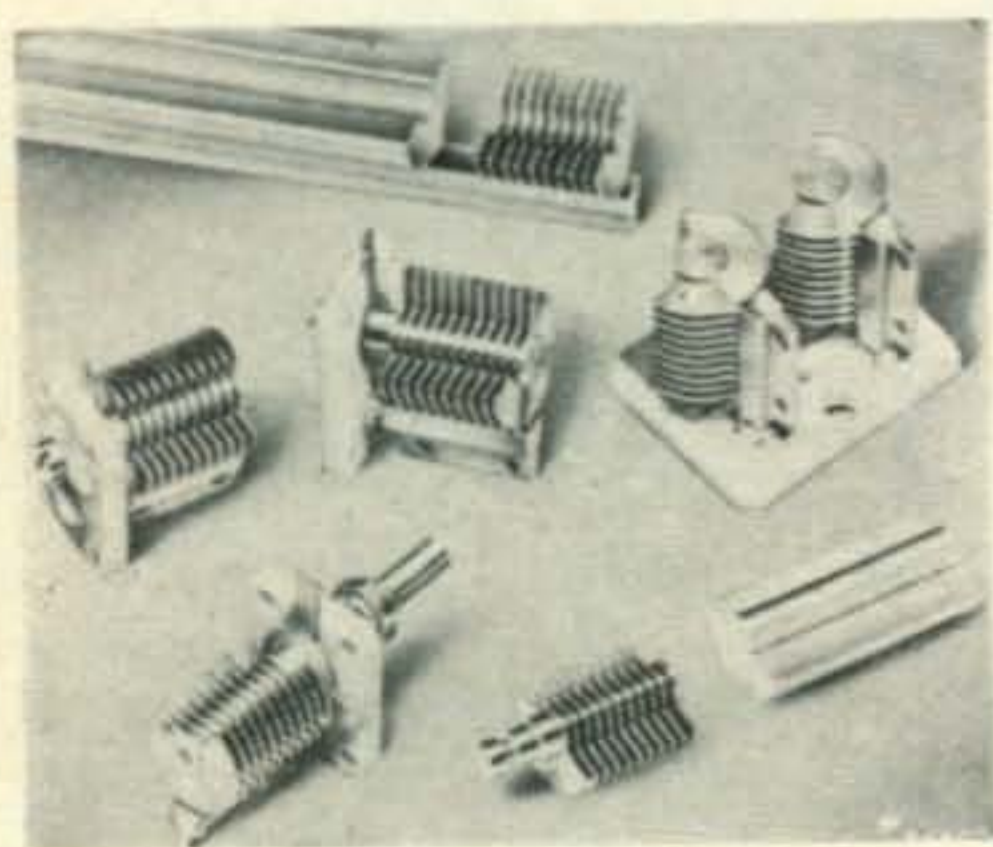
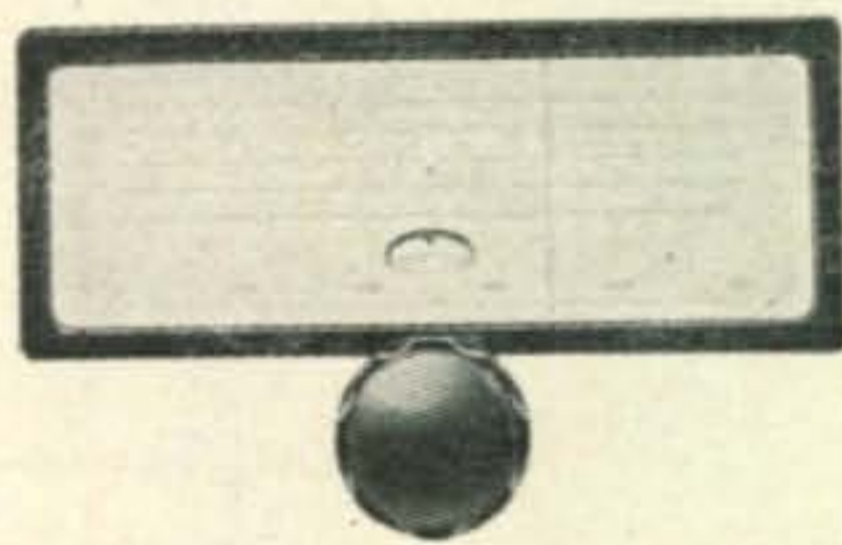

High Q Miniature Capacitors

James Millen Mfg. Co., Inc. has announced a new line of miniature air variable capacitors. The stationary and moveable plates of these capacitors are each machined from a solid piece of extruded brass. Breakage at the stator has been considerably reduced by making the solder lugs an integral part of the unit. These miniature capacitors can be mounted by four $.094$ " diameter holes, or the extend shaft models are available for single hole mounting. Values available are 15, 25, and 35 mmf single or dual units. Circle D on page 126 for more details.

**AGAIN
AVAILABLE
AT**

HARVEY RADIO

TOROID LOW PASS FILTER

Low pass audio filter that contains 5 Toroidal coils in an L/C network — Pass band 300 to 2,500 cps \pm 3 DB — Extremely sharp cut off at 3,200 cycles — Impedance 600 ohm in and out . . .

Weights 3.6 lbs.
Dimensions: $3\frac{3}{8}$ " x $3\frac{3}{8}$ " x 5"



**AN UNBEATABLE
VALUE!
WORTH TWICE
THE PRICE**

- ▶ **Handle up to 25 to 30 watts of audio**
- ▶ **No maintenance**
- ▶ **Better than a Speech Clipper**

You can put it to use in so many ways—

- ★ In single side band applications
- ★ In 500 ohm line from speech driver to modulator
- ★ In 500 ohm receiver output
- ★ As a telephone line filter for broadcast stations

**ONLY
\$9.95**

F.O.B. New York

Take advantage of this sensational *below manufacturer's cost* offer. It's the buy of a lifetime you can't afford to miss. Order by mail today.

Send check
or money order
inclusive of
shipping charges
to

**HARVEY RADIO
CO., INC.**

103 West 43rd Street, New York 36, New York

For further information, check number 36 on page 126.

October, 1960 • CQ • 101

TRANSCON TRANSISTORIZED SUPPLY [from page 63]

In both instances excessive heat could impair transistor operation. Where possible, it is recommended that the supplies be mounted on the "fire wall" where air from the car's air vents may circulate past them.

Connection to the battery should be made as indicated in the instructions, regardless of which side is grounded to the car chassis. Primary leads should be as short and as heavy as possible. Control wiring may be as small as #18, and any convenient length.

In vehicles with the negative terminal grounded, the jumper between RC+ (relay control) and + must be removed and the control device (switch or relay) connected between these two points. In the event of a positive ground installation, the other jumper must be

removed. In any event, the terminal marked CHASSIS GROUND should always be connected to the vehicle through a short length of heavy wire.

The full rated output power is available from either the maximum or the half-voltage terminal. If both output voltages are used simultaneously, the *total* output power must not exceed the indicated rating.

A PS-600 was tested at near full load at temperatures close to the boiling point of water. Obviously, the manufacturer doesn't suggest this rigorous environment for regular use of his product. The information was supplied to advise those amateurs who would like to install their transistorized supplies in the trunk that they need have no fears as to this location for installation. ■

A \$.98 BUG [from page 62]

I got a bit of plexiglass from the High School workshop and fashioned it into a crude paddle by means of a hacksaw and file. The vibrating part of the arm is a thin strip of galvanized roof flashing obtained from the same hardware store where I obtained the angles. The dot contact spring is a slice of mainspring from an old pocket watch which recently headed for the happy hunting grounds. I heated it, let it cool slowly, bent it into the desired "U" shape, heated it again, and finally dunked it into a paper cup full of cold water while still red hot. Heating was done over the burner of a gas kitchen range. The end piece of the vibrating arm (on which the clothespin weight is mounted) is, or was a 2½" nail with the head cut off and a small slit cut

down the middle about ¼" long.

Pivot

The pivot is about the only real tricky part of the construction and its detail is shown in fig. 2.

A small piece of sponge rubber is mounted near the end to absorb the vibration of the arm after the last dot of a series.

When wiring the key, connect one binding post to the screw supporting the pivot angle and the other post to the dot and dash contacts in series.

The little spring between the pivot mount and the vibrating arm makes for a better electrical connection and also returns the arm from the dot side. ■

FOUR TUBES — 2 METERS [from page 60]

The Oscillator—Feedback to sustain oscillation is not normally required with the International crystal. Nevertheless, a small amount of feedback was used, for it was found to produce more reliable starting and higher output. It is stressed that only a *minimum* amount should be used. Excessive feedback will cause severe drift erratic operation and possible crystal damage.

To adjust the oscillator, rotate the trimmer until the crystal stops oscillating, then reverse direction until it starts again. Check that oscillation commences after the crystal is removed for a moment and then replaced. Do not run the oscillator in a non-oscillating state for more than a few seconds as the tripler will then be without bias and will "blush" very quickly. Next, adjust the slug in L2 for maximum signal. Use a crystal diode and multimeter lightly coupled to the coil to obtain this indication. If a *vtvm* rf probe is used, allow for the detuning of the circuit.

The Mixer—Feed in the 14 mc signal and adjust the EL84 plate capacitor for maximum output. *Check that the signal is the correct one!*

It should disappear when the carrier is balanced out and when the crystal is removed.

The Amplifiers—Adjust the EL84 clamp tube screen voltage to give 45 to 55 ma of plate current (5894) without signal. With a plate supply voltage of 400, the EL84 screen voltage should read around 95 volts. For 575 volts, the screen voltage should read around 84 volts. Next adjust the loading by moving the position of the link. With full carrier "wound in", the amplifier should peak up to 240-250 ma when properly loaded. Needless to say the tube should not be held at this level for this is well beyond the ratings. However, the tube should run up to 200 ma without "blushing". On SSB, one ma of grid current, when the amplifier is fully loaded, should produce full output.

The "Two By Four" may be used to drive the antenna directly or alternately, it may be used to excite a linear amplifier. By special license, two of these units are being used in ZL scatter and each unit drives a 4X500A to a full kilowatt input. ■

**"CALL ME
for
Personal Service"**

**"CALL ME
for
Personal Service"**

Bob Henry
WØARA
Butler, Mo.
ORchard 9-3127



ON

Ted Henry
W6UOU
Los Angeles
GRanite 7-6701



**WORLD'S
BEST TERMS**

**Because we finance
our own terms...**

- Only 6% a year finance cost
- 20 months or longer to pay
- Only 10% down (or your trade-in as down payment)
- No finance charges if paid within 90 days
- Reduced charges if paid off ahead of time
- You get more flexibility of financing in the future (such as re-financing) because we handle our own financing

**Collins
S/LINE**



**A-1 Reconditioned
Apparatus**

Nearly all makes and models. Big savings! Ten day trial—90 day warranty. 90 day full trade back on new apparatus. Write for bulletin.

KWM-2 Transceiver	\$1150.00
32S-1 Transmitter	666.00
516F-2 AC Power Supply	115.00
516E-1 12 V DC Power Supply	270.00
75S-1 Receiver	520.00
312B-3 Speaker	29.00
312B-4 Speaker Console	195.00
30S-1 Linear Amplifier	1556.00

Write, phone or visit either store today!
Inquiries & orders from military men
and others outside USA wanted.

Butler 1, Missouri
ORchard 9-3127



Henry Radio Stores

11240 West Olympic Blvd.
Los Angeles 64 Ph. GRanite 7-6701



BIG

TRADE-INS

World's Largest Distributors of Short Wave Receivers

For further information, check number 37 on page 126.

ELIMINATION OF STRAY RF [from page 57]

from each of its two principle mediums of propagation, conduction and radiation. In addition to the grounding, bonding, and shielding techniques previously mentioned, the following general practices may prove worthwhile.

1. AC powerlines should have effective filtering installed. This need not consist of a pi-type filter, but may be an *rf* choke placed in series with each lead, or in the case of high current lines, the application of bypass or feedthru type capacitors.
2. Filament and heater leads should be twisted pair, thus canceling interference fields.
3. Oscillator stages, either transmitter or receiver, must be isolated from other stages.
4. Receiver oscillators and their respective antennas should be separated by one or more stages of *rf* amplification wherever possible.
5. Parasitic suppression devices such as plate and grid resistors and chokes should be employed.
6. Electrostatically shielded power and filament transformers should be used, if available.
7. All B Plus supply voltages should be decoupled. (This is independent of

necessary ripple filtering).

8. Thyatron tubes should be shielded and filament leads decoupled.
9. Suitable R-C networks should be placed across switch contacts.
10. Keying or switching relays should be surge suppressed. A diode placed across the relay coil is generally quite sufficient.
11. RF hash suppression chokes should be placed in the plate and cathode leads of gas tube rectifiers.

Parasitics may be located with a *gdo*, and may oftentimes be corrected with a slight circuit modification. In the few instances where this is not practical however, the application of a series resonant capacitor to ground may eliminate the problem. Figure 1 provides a rapid means of determining capacitor resonant frequencies. (This chart is derived by assuming a capacitor lead inductance of 25 mili-microhenries per inch).

Conclusion

As mentioned earlier, this is by no means a complete or thorough text on radio interference reduction. Nor is it meant to be. Methods of combating cross modulation, intermodulation, parasitic oscillation, and harmonic generation will be found in the handbooks. ■

CRYSTAL CONTROL FREQUENCY COUPLER [from page 55]

imum output to minimize crystal current.

2. V_2 tank tuned for maximum output with master oscillator off.

3. L_{13} adjusted experimentally or tuned with C_0 to produce maximum output at 3.5 *mc* with Coupler oscillator off; this tuning is very broad.

4. V_3 tank tuned for maximum output at mid-point of band in use.

5. L_4 tuned to produce minimum output at 8 *mc*.

Once tuned, operation over any band may be accomplished without further adjustment, and the Frequency Coupler is tucked in an out of the way place at W2JKH.

Proposal

Hindsight being better than foresight, it can now be stated that if it was done over, one stage could probably be eliminated. For example, a doubling crystal oscillator of the Tri-tet variety could have been used with the specified crystals, or more expensive crystals could be purchased with fundamental output at the frequencies V_2 is tuned. However, the circuitry shown is straightforward and has been giving an excellent account of itself. What a nice feeling to push a button and have the Coupler zoom to the wanted band! ■

DX [from page 68]

VQ4RF	via W4MCM
SM3AZI	Ric, Box 303, Gavle, Sweden
9U5JH	Box 76, Kitega, Ruanda, Urundi
VP5VI	Box 215, Kingston, 10, Jamaica
6O1TUF	Box 16, Mogadiscio, Somalia
YV3AS	Box 13, Barquisimeto
TI2LT	P. O. Box 26, San Jose
FG7XH	Box 335, Point-a-Pitre, Guadeloupe
YN6HH	Corinto, Nicaragua
VS6AE	Pat O'Brien, 24-B Carnarvon Rd., 7th floor, Kowloon, Hong Kong
VP8EM	Box 107, Port Stanley, Falkland Islands
ZP5HZ	Mission Radio Station, US Army Mission to Paraguay, c/o US Embassy, Asuncion, Paraguay

OA1W	International Petroleum Co., Talara, Peru
YV5EX	P. O. Box 6269, Caracas
PZ1BF	Box 184, Paramaribo
CP6FJ	P. O. Box 55, Santa Cruz
CR7FN	P. O. Box 1436, Lourenco Marques
H18DGH	Box 99, Ciudad Trujillo
TG9CP	Box 115, Guatemala City
TI2PZ	via KØDQI
TI2WR	via KØDQI
ex FQ8AP	via KØDQI

That's about it for this month. CU agn next month.

73 es DX, Urb, W2DEC

NEW at RADIO SHACK

**Globe
Ham
Equipment
that
Outdates
Them All**

Immediate delivery!
Use handy ordering
coupon below.

Easiest Budget
Payments! Low as \$5
down, take up to
2 years to pay



FREE CATALOG

Radio Shack's 1961
Electronics Catalog
plus all issues for 1
year. Write for it now

RADIO SHACK

America's Electronic
Shopping Center

730 COMMONWEALTH AVE.
BOSTON 17, MASS.

THE GLOBE SCOUT DELUXE TRANSMITTER



**New RELAY CONTROLLED circuitry
for wide flexibility, ease of use**

Streamlined table-top design with 90 watts CW and 75 watts phone input. Bandswitching 80-6 meters, straight thru operation of final on ALL bands; high efficiency, panel adjustment of loading on ALL bands. Pi-net matches 50-300 ohms on 80-10, 50-75 ohms link output on 6 meters. Husky new 7027A modulator tube. Plug in VFO or crystal. Cat. No. 45DX852, shipping weight 36 lbs.

Outstanding power!
Packed with advanced
operating features
◀ **\$159.95** Wired
\$5 down, \$7.50 month



755A VFO for use with Scout.
10-160M bands with output
on 40 and 160M. Cable
drive; 13:1 tuning ratio.
Built-in power supply. Ship.
wt. 9 lbs. \$2 down, \$5 mo.
45DX859—Kit\$49.95
45DX858—Wired ...\$59.95



**The Globe Chief
Deluxe Transmitter**

Kit **\$59.95**
Wired **\$79.95**
\$5 down, \$5 month

Compact, modern, efficient! Self-contained bandswitching (10-80M). 90 watts for advanced CW or novice (at 75W input). Cathode or bias keying. No rewiring for external 755A VFO, UM-1 or SM-90 modulators. Just plug in. Built-in power supply. New design pi-net for wide range matching. 3-color kit diagrams. Cat. No. — 45DX855 — Kit; 45DX854 — Wired. Shipping weight 31 lbs.

**Globe Moline Six
Complete Ham Station**

\$229.95

\$10 down, \$15 month

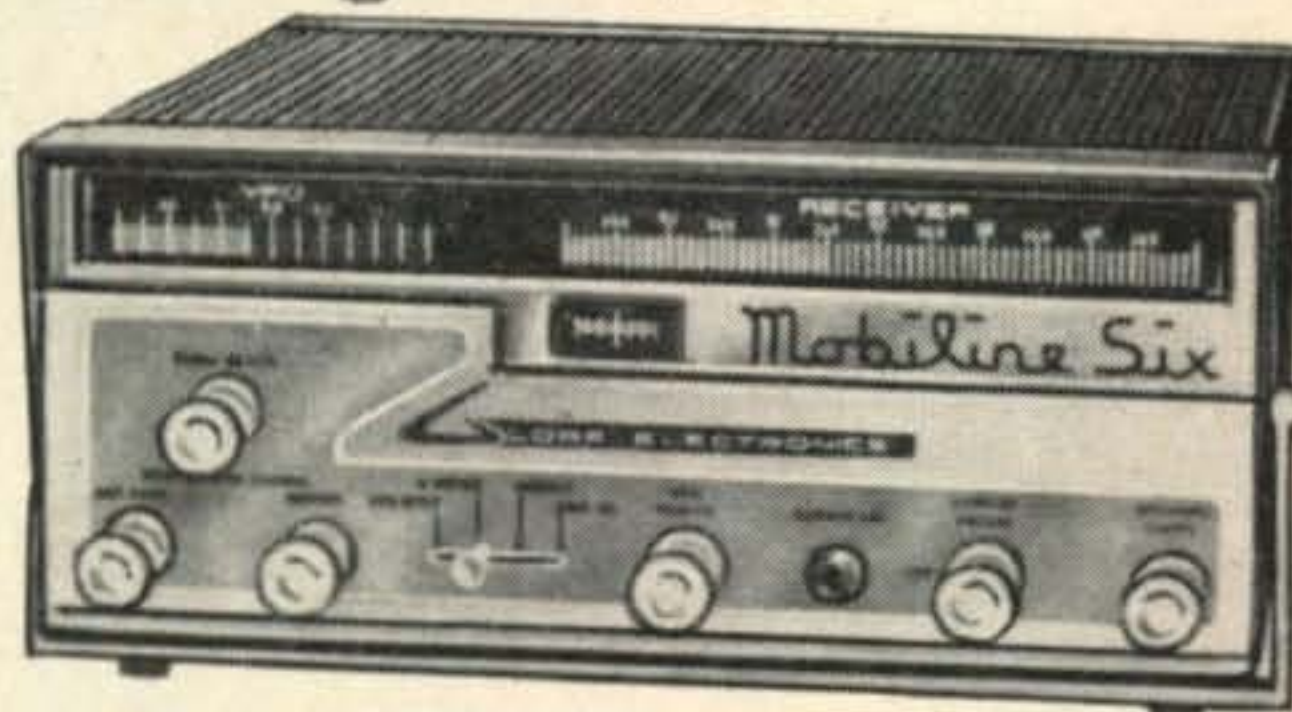

Crystal or VFO controlled with 20 watts input. Compact transmitter and receiver combination for equal 6 meter adaptability to a fixed or mobile installation. Operates from 115v AC, 12v DC or 6v DC, all power-supplied. Only 5x12" size for home or car. 7 tubes including RF stage. Squelch control. Internal VFO voltage regulated and shock mounted. "S" meter, tuning meter, slide rule dial, VFO spotting and Class B modulation. Cat. No. 44DX740. Shipping wt. 22 lbs.

MONEY BACK GUARANTEE

Radio Shack guarantees your complete satisfaction with every item or your money refunded in full. 15-day no-risk home trial on any item.

RADIO SHACK CORP., Dept. 10C
730 Commonwealth Avenue
Boston 17, Massachusetts

ORDERING INFORMATION:
Fill out the order blank below. State
Catalog No., Item, Quantity, Price. All
items shipped express, delivery charges
collect.

Send FREE Radio Shack Electronics Catalog
Please send me the following electronics items:

Cat. No.	Item	Quantity	Price

Name _____
Address _____
City _____ Z _____ State _____

- Check enclosed
 Money Order enclosed
 Ship COD

For further information, check number 38 on page 126.

YOUR QSL CARD

permanently engraved on personal jewelry. Satin Chrome or lustrous gold plate finish. When possible Call Letters will be in a contrasting color to other copy. **BE SURE TO SEND YOUR QSL CARD WITH ORDER.** #C-8 Lapel Pin, #C-9 Tie Tack, #C-10 Tie Clasp \$5.00 plus 50c Federal Excise Tax.



#C-10

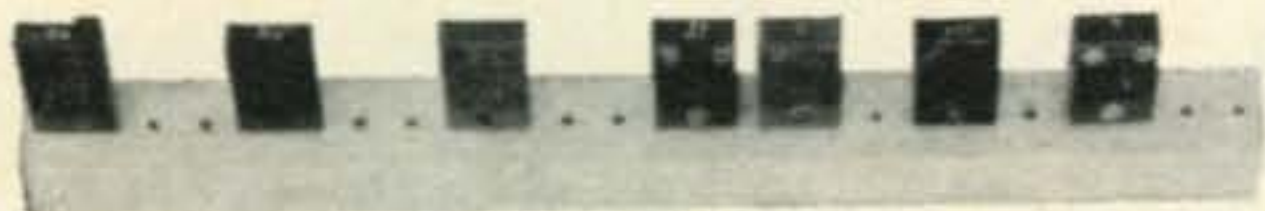

CRYSTAL CADDY #C-56 \$1.00

Do you have to hunt to find your crystals? You need the "Crystal Caddy". It holds up to 12 crystals. Place it right on top of your Xmtr where you can readily read the frequency numbers. You will wonder how you ever did without it.



#C-52



#C-42

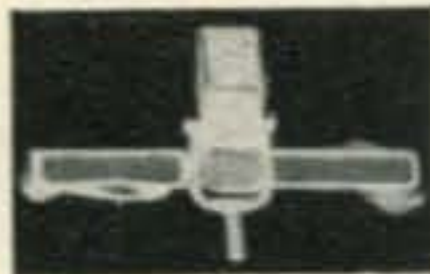

#C-60—#C-37

SILVER-FINISHED JEWELRY WITH ENGRAVED CALL LETTERS

Made up as Tie Clasps, Lapel Pins or Key Chains. Available in Rectangular or Oval Microphone or Telegraph Key designs. May be ordered with or without call letters. \$2. plus 20c FET. Call letters engraved 50c additional. Microphone tie clasps C-37 and C-52 may also have a short name engraved 50c additional.

Deluxe Rhodium Plated Tie Bar with Microphone #C-60 \$3.50 plus 35c FET. Both name and call letters engraved \$1.

HAM LICENSE PLATES

Embossed Steel. Either style \$1.00. Just the thing to attach to your vehicle or dress up the shack.



#C-3 2 1/4" x 7" with letters 1 1/4" high. Suitable for call letters or name up to 7 characters on one line. #C-26 3" x 6" with letters 5/8" high. Suitable for both call letters and name. Up to 10 characters or spaces allowed on each line. Ø is not available for #C-26. Order #C-3 or #C-12.

#C-12 Cast Aluminum \$3.75. Raised letters and border satin polished finish, 2 1/2" x 10", black baked on wrinkle finish. When ordering indicate if mounting holes should be on top or bottom. Also make and year of car.

"Magic Slate"® Paper Saver #C-2 \$1.00

Ideal for transposing the dits and dahs into letters and words. Pick up the transparent film after copying into your log and your copy disappears like magic. No Scrap paper needed and no waste paper basket to empty. Large enough for two or more QSOs. Use it over and over again. Each Magic Slate® Paper Saver is personalized with your call letters. The following log data information is imprinted twice for your log: Time, Call Letters, RST, QTH, Name, Frequency, Address. Available without imprint upon request.

Laminated phenolic call letter and handle lapel pins, bolo (lariat) ties and tie clasps.

Black with White Core. The black surface is engraved exposing the white. Will not rub off, tarnish nor fade. Beveled edge.

Engraved with one or two lines—your handle, call 1" x 1 1/2".

C-32 Lapel pin with safety catch \$1.00

C-61 Lariat (bolo) tie \$2.00

C-31 Tie clasp \$1.00

Engraved with large Call letters only.

C-64 Lapel pin with safety catch 1" x 3" \$1.25

Pure Silk Necktie, Arnel Washable Necktie.

#C-29 Pure Silk Necktie with Silk Screened Call Letters on Microphone design \$5.00, 2 with same call letters \$9.00

#C-78 Arnel washable Necktie with silk screened call letters on microphone design \$4.00, 2 with same call letters \$7.00

Both ties available in NAVY, BLACK, CHARCOAL, MAROON, BROWN, RED, WHITE, BEIGE, LIGHT BLUE or GREY.

#C-1 Personal Printer Rubber Stamp \$1.00

Your Call Letters, name, street address, city and state or any other four lines of copy. In a compact case with self contained ink pad.

#C-63 3" Felt Iron-On Call Letters. \$1.00 per set of 5 or 6 characters. Names available; 20c per letter.

#C-76 1" Felt Iron-on Handle and Call Letters. \$1.00 per set of up to 12 characters. Additional characters 10c each.

#C-25 Complete Ham Map Library \$1.50

Consists of a map of the World and a map of North America, each is 50" x 38" (over 13 sq. ft.). Also included is a 16-page General Atlas of the World showing over 20 maps. The 2 maps and the atlas are printed in 7 colors. All detailed and meticulously drawn.

Dealer inquiries welcome.

Make checks or money orders payable to Chuck Baer. If your QTH is in an area where there is a sales tax it should be included with your remittance. All items shipped prepaid. No C.O.D. As most items are personalized with your call or handle allow 2 to 4 weeks for delivery.

CHUCK BAER K9TVA ENTERPRISES

6429 N. GLENWOOD AVE. CHICAGO 26, ILL.

HAM CLINIC [from page 71]

Most radio distributors carry the networks. If you have difficulty obtaining them, let Tom Consalvi of B&W know.

I have two more 2Q4s which I shall send to the first two foreign radio hams who write to me, after reading this (or having been told about it over the air). Only one requirement to be eligible: let me know what equipment you are presently using.

VE3DIT (Tip Of The Month) (On the Heath OM-1 Scope)

"Having recently cleared up a unique case of trouble in my Heath OM-1 scope, I thought I'd pass my tip along to HAM CLINIC which seems to be read by most active technically minded hams.

"The trouble I experienced with my OM-1 scope manifested itself as spot shape distortion; the spot taking the shape of a very short oblique stroke.

"All pin voltages checked out okeh; tubes substituted; resistance values throughout checked (and verified okeh); and the CRT was good because I checked it out in another scope.

"I checked the filters and everything else imaginable. The only clue was that the spot shape was okeh with both the first vertical and horizontal tubes pulled. So I borrowed another scope and found that a small amount of 60 cycle a.c. was found to be present on the cathodes of the first vertical and first horizontal amplifiers. This a.c. was amplified through each section to give the odd condition.

"I recalled an old problem with oxidization, so I removed the 6 screws holding the printed circuit board, and the board itself was lifted up about an inch. The common or ground strip that edges the board's underside was then cleaned and polished with brass cleaner; the board put back in place with the 6 screws. Lo and behold The trouble disappeared."

Thanks to you "Pat" for your fine tip. Others experienced the trouble too. However, I would suggest instead of brass polish that a good contact cleaner be used. Some brass cleaners promote rather than inhibit corrosion.

Thanks to SARA

My heartfelt thanks to the Spanish-American Radio Amateurs Club of Madrid for making me the first honorary member I sincerely hope that you will eventually receive the well-deserved reciprocal operating priveleges that you are striving for in such a correct and friendly way.

Non-Technical Dept. (Magazines for Friendship)

When I instigated the "magazines for peace and friendship through ham radio exchange" through this column some months ago, I expected those American hams who volunteered to send their old radio-electronics publications

For further information, check number 25 on page 126.



Mail the coupon today for your FREE copy

FREE!

LAFAYETTE RADIO'S 324-PAGE 1961 CATALOG

America's "Electronics Shopping Center"
40 years of servicing the Amateur

HERE IT IS — the biggest, best and most comprehensive catalog you can ask for. Immediate delivery at the lowest, money-saving prices.

- Amateur Equipment • Radio and TV Parts and Tubes • Mobile and Fixed Station Equipment • Stereo Hi-Fi Equipment • PA Systems • Industrial Supplies • EXCLUSIVE LAFAYETTE KITS

SATISFACTION GUARANTEED OR MONEY REFUNDED

EASY PAY PLAN—the simplest, and quickest way to get what you want when you want it. As little as \$2 down . . . up to 24 months to pay.

NEW! LAFAYETTE HE-15A CLASS D CITIZENS BAND SUPERHETERODYNE TRANSCEIVER



Completely
Wired
57.50
5.00 Down

- For Industry, Farming, Business, Pleasure
- 5 Crystal Controlled Transmitting Positions
- Tuneable Receiver Over Full 23 Channel Band
- Complete with Transmitting Crystal for Channel 9
- Planetary Vernier Tuning
- Full-Wave Variable Noise Limiter
- High Output Crystal Microphone
- 5-Prong Microphone Jack for Easy Relay Addition

No examination or technical knowledge required—any citizen 18 years or older is eligible for a license. Simply fill out enclosed FCC application. HE-15A size: 10 $\frac{3}{4}$ "x6 $\frac{7}{8}$ "x5 $\frac{7}{8}$ ". Shpg. wt., 11 lbs.

HE-15A Wired and Tested (less antenna) 5.00 Down Net 57.50
HE-19 Whip Antenna Net 3.95
HE-16 Power Supply for 12 Volts Net 10.95
HE-18 Power Supply for 6 Volts Net 10.95

LAFAYETTE PROFESSIONAL QUALITY COMMUNICATIONS RECEIVER— ENGINEERED FOR THE AMATEUR



KT-200
in Kit Form
64.50
5.00 Down

- Superhet Circuit Utilizing 8 Tubes and Rectifier Tube
- Built-in "S" Meter with Adjustment Control
- Band Spread 80 to 10 Meters
- Covers 455kc to 31 mc
- Variable BFO and RF Gain Controls
- Switchable AVC and Automatic Noise Limiter

HE-10
wired
and tested
79.95
5.00 Down

The Communications Receiver that meets every amateur need — available in easy-to-assemble kit form or factory wired and tested. Signal to noise ratio is 10 db at 3.5 MC with 1.25 microvolt signal. Selectivity is -60 db at 10kc, image reflection is -40 db at 3 MC. 7 $\frac{7}{8}$ "x15"x9". Shpg. wt., 22 lbs.

LAFAYETTE RADIO

Please include shipping charges with order

165-08 LIBERTY AVENUE, JAMAICA 33, N. Y. • OTHER LOCATIONS

NEW YORK, N. Y.
100 6th Avenue

NEWARK, N. J.
24 Central Avenue

BRONX, N. Y.
542 E. Fordham Rd.

PARAMUS, N. J.
182 Route 17

BOSTON, MASS.
110 Federal Street

PLAINFIELD, N. J.
139 W. 2nd Street



CUT OUT
AND PASTE
ON POST
CARD



Lafayette Radio Dept. CJ-6
P.O. Box 190 Jamaica 31, N. Y.

Send me the FREE 324-Page
1961 Catalog No. 610

Name _____
Address _____
City _____ Zone _____ State _____

For further information, check number 39 on page 126.

QUICKLY CUT HOLES

in metal, plastics,
hard rubber...

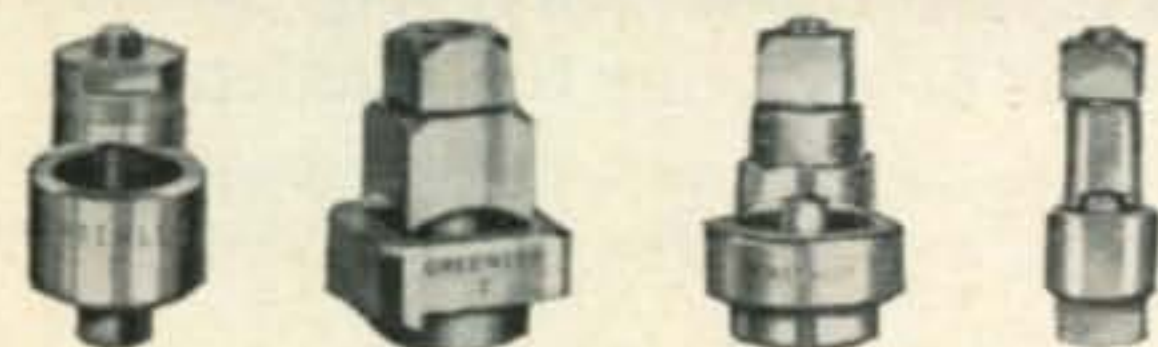

GREENLEE CHASSIS PUNCHES

Make smooth, accurate openings in
1½ minutes or less . . . for sockets,
plugs, controls, meters, panel
lights, etc. Easy to use . . .
simply turn with wrench.

Many sizes and models.

Write for literature.

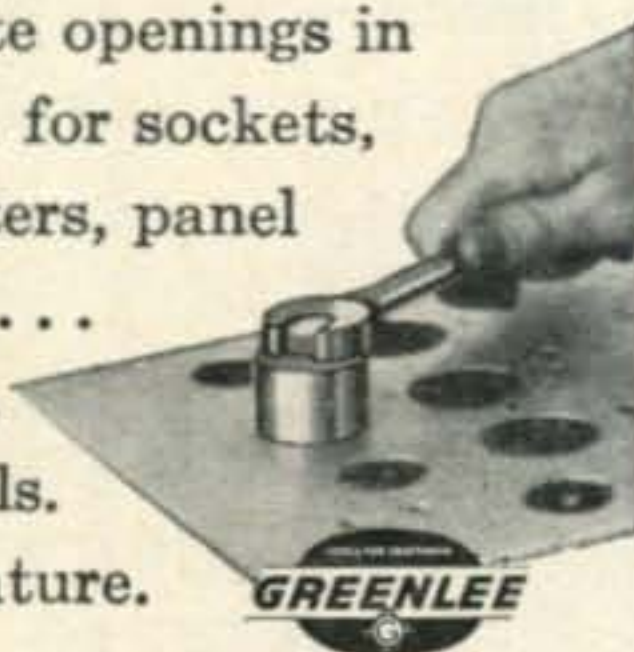

GREENLEE TOOL CO., 1915 Columbia Ave., Rockford Illinois
For further information, check number 42 on page 126.

Reserve your
copy of the

**NOVEMBER
ANNUAL
ISSUE
NOW!**

\$1 at the newsstand, subscribers will receive
their copies at no extra cost.

(especially CQ) to overseas hams to follow through. Some did not.

So those of you who promised to send mags, callbooks etc., will you please fulfill your promise after reading this? Do not lead others to think that your word isn't worth a "plugged nickel."

Thirty

My thanks to you, the readers of HAM CLINIC, for your encouragement and kind words. As I have stated before, we are not "world beaters"; do make mistakes; but do try to do our best. We can learn from you too, if you'll take time out to jot down your trouble-shooting ideas and tech tips and send them to us.

72, 73 and 75, Chuck

VHF [from page 77]

I now have finished with the entire eastern half of the USA." Good work, Ralph, and keep it up. Your signal has become a regular institution. Once in a while, though, see if you can't turn the beam up this way and give some of the New Englanders a new state, hi!

Lethbridge, Alberta, Canada: Seems like we're getting short notes from everywhere this month and R.J. Henry, VE6DB, is no exception:

"I hear the odd K2, W3, and W4's out this way on 6 meters but they seem to be beamed in another direction. Guess we'll have to do something about this, eh?"

"Tell 'em to give us a call now and then and we sure will be glad to try and work them. My frequencies are 50.040, 50.250, and 50.280 mc." Well, seems like you just told 'em yourself! Sure be looking for you!

Villa Park, Illinois: Phil Caruso, K9DTB, writes:

"The worked all states total here is 47 states; I need Nevada, North Dakota, and Hawaii, although I've worked KH6 before. Am running about 80 watts on a.m. and c.w.

"I will be running about 330 watts in a few days on c.w. and s.s.b. I would like to make skeds with anyone about 200 miles away.

"At the present time I run 65 watts on s.s.b. (50 mc). Been working out quite well. On an aurora worked KØDGE, and K9HAE—both had very good s.s.b. signals here." FB Phil! How about some other sidebanders operating v.h.f. dropping a line?

Laramie, Wyoming: Here's a state we'd all like to snag and here is a boy who can tell us all about it, Paul Sandels, K7EMO . . .

"My equipment here on 6 meters is all homebrew; the transmitter is running 28 watts; receiver is a homebrew superhet and the antenna is a homebrew 5 element beam. How about a picture, Paul? Sounds real good! I have no ground wave contacts because there are no other 6 meter stations around.

"My sole ground wave contact was a mobile

Don't miss it! A million have sent for it already! Send for your copy of **Radio Shack's new 1961 Electronics CATALOG**



FREE

Plus a full year's **FREE SUBSCRIPTION** to all other Radio Shack Catalogs as issued

Save up to 50% all year long on the latest and best items in the whole fascinating field of Electronics.

See the world's biggest line of Stereo, Hi-Fi, Ham Radio, Transistors, Test Equipment, Kits and Parts, scores more.

You get fast, accurate service!
 ■ Every order processed the same day received. No delays!

■ You can pay as you earn on Radio Shack's Easy Budget Plan. Low as \$2.00 down.

■ You can open a convenient Monthly Charge Account. "Add-on" orders are easy.

GUARANTEE

Radio Shack guarantees your absolute satisfaction or your money back. 15-day no-risk home trial on any item you order.

MAIL COUPON TODAY

RADIO SHACK CORPORATION Dept. 60K21
 730 Commonwealth Ave., Boston 17, Massachusetts

Without obligation, send your latest Electronics Catalog plus every new issue, hot off the press, for one full year, free and postpaid.

Name _____

Address _____

Post Office or City _____ Zone _____ State _____



RADIO SHACK

Corporation

730 Commonwealth Avenue
 Boston 17, Massachusetts

For further information, check number 41 on page 126.

October is the **Hy-gain** Month
at
Burghardt's

Stan Burghardt

WJBL-TV



"MOST TREMENDOUS VALUE"

Hy-gain's **3-Element Thunderbird**

The new TH-3 is designed and engineered mechanically and electrically to be the finest 3-Element Tribander for 10, 15 and 20M. Overall boom length 14 ft. Longest element 26 ft. All aluminum construction, 2" OD boom and 1 1/4" telescoping to 3/4" OD elements. 100% rustproof. Guaranteed less than 2 to 1 SWR all bands. Designed for 52 ohm coax. Easy to assemble. New solid state "slim traps" are highly efficient, offer minimum windloading. Withstand 1000w CW or AM and 2KW (PEP).



MODEL TH-3

Weights only
29 lbs.

\$89.95

We Also Stock

the **Hy-gain** VERTICALS

- 12 AVS — 10, 15 & 20M.....\$21.95
- 14 AVS — 10-40M\$27.95
- hy-Tower — 10-80M\$129.50

the **Hy-gain** MULTIBAND DOUBLET

- Model 2-BD, 40 & 80M\$34.95
- Model 6-BD, 6-80M\$37.50
- Model 5-BD, 6-40M\$29.95
- Model 4-BD, 6-20M\$21.95

SEND FOR
FREE

Catalog

complete line
of amateur
antenna products



Burghardt
RADIO SUPPLY

P.O. Box 746

Watertown, So. Dakota

Phone 5749

Please Rush —

FREE HY-GAIN CATALOG

ENCLOSED IS MY CHECK FOR \$ _____

AS 10% DOWN PAYMENT ON _____

NAME: _____

ADDRESS: _____

CITY & STATE: _____

For further information, check number 40 on page 126.

who was going through Wyoming; he was from back East. I now have 215 contacts in 2 months and only one was ground wave. I try to catch all band openings, so have the fellows listen for me on 50.38 and 50.34 mc. I will have better equipment on soon. The things I am interested in mostly are construction on 6 meter equipment especially in mobile transmitters." Well, Paul, good to know there is someone out there for contacts. Keep your eye on CQ for things to come in v.h.f. equipment.

Baldwinsville, New York: Gordon Hullin, K2ZBU, writes on activity in the area.

"I'm located 14 miles northwest of the city of Syracuse. It is somewhat of an electronic industry center with several large electronic firms in the area.

"As you would expect because of this there are large numbers of hams on all the bands. I have been active on 6 meters in this locale now for three years. During this time six has become more popular every year. The entire upstate New York area from Buffalo to Albany is well represented on six and activity on 144 and 200 mc is increasing all the time.

"A few of the upstate boys have large antenna set-ups and a few are in the planning stages, but for the most part, beams with 10 to 11 db gain predominate. Checking over my records for the last three years indicates the average power input on 6 meters in upstate New York is under 50 watts.

"With the tremendous activity on six down in New Jersey and the metropolitan New York area, I am surprised to have worked so few from down your way. On ground wave I've worked the following on numerous occasions: W2HTS, W2IDZ, W2LOY, K2RRG, K2HAK, K2VIX, K2HLA, W2OCM, and K2USA." Very interesting, Gordon! Thanks for a very informative report. Keep us posted on the "doings" up that way.

That just about brings us down to the bottom of the stack for this month. Don't forget to send me your letters and pictures.

Till next month,

73, Bob, K2ZSQ

NOVICE [from page 79]

ceived his general ticket so he is starting all over again.

Brian Alsop, WV2KSD, Fox Hunt Lane, Cold Spring Harbor, Long Island, N.Y., has been on for 5 months now and has tallied up 42/39 on WAS, 13/6 on DXCC, and 598 QSO's. He would like skeds with KL7, Montana, Wyo., Utah, N. Mexico, N. Dakota, Okla., and Nevada. Brian's best DX is VE5, KZ5, UA3, WH6 and LA6. His rig is an EICO 720, HQ-110 and a windom antenna.

Bill Albrant, Box 18, Oakridge, Oregon, holds call letters KN7??? and also runs an EICO 720 along with a Knight Receiver, feeding a

[Continued on page 113]



... symbol of
RAD-TEL
FIRST QUALITY

INSIST ON RAD-TEL FOR EVERY
 TELEVISION AND RADIO TUBE NEED

Super-Special! **KIT OF 100**

**Bi-Pass
 CONDENSERS**

Over 50% Are 600V
 Others 400 V And 200V

at LESS
 THAN
 4¢ each

\$3.95

Goodall
 Semi-Molded
 Paper and
 MYLAR

Values
 .001 to 1 mf

Up To 75% Off on BRAND NEW TUBES

GUARANTEED ONE FULL YEAR! You Can Rely On Rad-Tel's Speedy One Day Service!

Not Used — Not Pulled Out Of Old Sets • Each Tube Individually and Attractively Boxed!

Qty.	Type	Price	Qty.	Type	Price	Qty.	Type	Price	Qty.	Type	Price	Qty.	Type	Price	Qty.	Type	Price
—	0Z4M	.79	—	4BZ7	.96	—	6AV6	.40	—	6DE6	.58	—	12AE6	.43	—	12CR6	.54
—	1AX2	.62	—	4CS6	.61	—	6AW8	.89	—	6DG6	.59	—	12AF3	.73	—	12CU5	.58
—	1B3GT	.79	—	4DE6	.62	—	6AX4	.65	—	6DQ6	1.10	—	12AF6	.49	—	12CU6	1.06
—	1DN5	.55	—	4DK6	.60	—	6AX7	.64	—	6DT5	.66	—	12AJ6	.46	—	12CX6	.54
—	1G3	.73	—	4DT6	.55	—	6BA6	.49	—	6DT6	.53	—	12AL5	.45	—	12DB5	.69
—	1J3	.73	—	5AM8	.79	—	6BC5	.54	—	6EU8	.79	—	12AL8	.95	—	12DE8	.75
—	1K3	.73	—	5AN8	.86	—	6BC7	.94	—	6EA8	.79	—	12AQ5	.52	—	12DL8	.85
—	1L6	1.05	—	5AQ5	.52	—	6BC8	.97	—	6H6GT	.58	—	12AT6	.43	—	12DM7	.67
—	1LN5	.59	—	5AT8	.80	—	6BD6	.58	—	6J5GT	.51	—	12AT7	.76	—	12DQ6	1.04
—	1R5	.62	—	5BK7A	.82	—	6BE6	.55	—	6J6	.67	—	12AU6	.50	—	12DS7	.79
—	1S5	.51	—	5BQ7	.97	—	6BF6	.44	—	6K6	.63	—	12AU7	.60	—	12DZ6	.56
—	1T4	.58	—	5BR8	.79	—	6BG6	1.66	—	6S4	.48	—	12AV5	.97	—	12EL6	.50
—	1U4	.57	—	5CG8	.76	—	6BH6	.65	—	6SA7GT	.76	—	12AV6	.41	—	12EG6	.54
—	1U5	.50	—	5CL8	.76	—	6BH8	.87	—	6SK7	.74	—	12AV7	.75	—	12EZ6	.53
—	1X2B	.82	—	5EA8	.80	—	6BJ6	.62	—	6SL7	.80	—	12AX4	.67	—	12F5	.66
—	2AF4	.96	—	5EU8	.80	—	6BK7	.85	—	6SN7	.65	—	12AX7	.63	—	12F8	.66
—	3AL5	.42	—	5J6	.68	—	6BL7	1.00	—	6SQ7	.73	—	12AZ7	.86	—	12FM6	.45
—	3AU6	.51	—	5T8	.81	—	6BN4	.57	—	6T4	.99	—	12B4	.63	—	12K5	.65
—	3AV6	.41	—	5U4	.60	—	6BN6	.74	—	6U8	.78	—	12BA6	.50	—	12SA7M	.86
—	3BA6	.51	—	5U8	.81	—	6BQ5	.65	—	6V6GT	.54	—	12BD6	.50	—	12SK7GT	.74
—	3BC5	.54	—	5V6	.56	—	6BQ6GT	1.05	—	6W4	.57	—	12BE6	.53	—	12SN7	.67
—	3BE6	.52	—	5X8	.78	—	6BQ7	.95	—	6W6	.69	—	12BF6	.44	—	12SQ7M	.73
—	3BN6	.76	—	5Y3	.46	—	6BR8	.78	—	6X4	.39	—	12BH7	.73	—	12U7	.62
—	3BU8	.78	—	6AB4	.46	—	6BU8	.70	—	6X5GT	.53	—	12BL6	.56	—	12V6GT	.53
—	3BY6	.55	—	6AC7	.96	—	6BY6	.54	—	6X8	.77	—	12BQ6	1.06	—	12W6	.69
—	3BZ6	.55	—	6AF3	.73	—	6BZ6	.54	—	7AU7	.61	—	12BY7	.74	—	12X4	.38
—	3CB6	.54	—	6AF4	.97	—	6BZ7	.97	—	7A8	.68	—	12BZ7	.75	—	17AX4	.67
—	3CF6	.60	—	6AG5	.65	—	6C4	.43	—	7B6	.69	—	12C5	.56	—	17BQ6	1.09
—	3CS6	.52	—	6AH6	.99	—	6CB6	.54	—	7Y4	.69	—	12CA5	.59	—	17C5	.58
—	3CY5	.71	—	6AK5	.95	—	6CD6	1.42	—	8AU8	.83	—	12CN5	.56	—	17CA5	.62
—	3DK6	.60	—	6AL5	.47	—	6CF6	.64	—	8AW8	.93	—			—		
—	3DT6	.50	—	6AM8	.78	—	6CG7	.60	—	8BQ5	.60	—			—		
—	3Q5	.80	—	6AN4	.95	—	6CG8	.77	—	8CG7	.62	—			—		
—	3S4	.61	—	6AN8	.85	—	6CM7	.66	—	8CM7	.68	—			—		
—	3V4	.58	—	6AQ5	.50	—	6CN7	.65	—	8CN7	.97	—			—		
—	4BC5	.56	—	6AR5	.55	—	6CR6	.51	—	8CX8	.93	—			—		
—	4BC8	.96	—	6AS5	.60	—	6CS6	.57	—	8EB8	.94	—			—		
—	4BN6	.75	—	6AT6	.43	—	6CU5	.58	—	10DA7	.71	—			—		
—	4BQ7	.96	—	6AT8	.79	—	6CU6	1.08	—	11CY7	.75	—			—		
—	4BS8	.98	—	6AU4	.82	—	6CY5	.70	—	12A4	.60	—			—		
—	4BU8	.71	—	6AU6	.50	—	6CY7	.71	—	12AB5	.55	—			—		
—	4BZ6	.58	—	6AU7	.61	—	6DA4	.68	—	12AC6	.49	—			—		
			—	6AU8	.87	—	6DB5	.69	—	12AD6	.57	—			—		

Not a Kit, but Completely Wired

**STEREO AMPLIFIER
 CHASSIS \$4.95**

- Lots of 3 ea.
- Single, \$5.95 ea.
- Set of tubes: 2-35C5; 1-12AX7; 1-35W4 \$1.15
- Set of 3 grey 1/2" knobs 30c

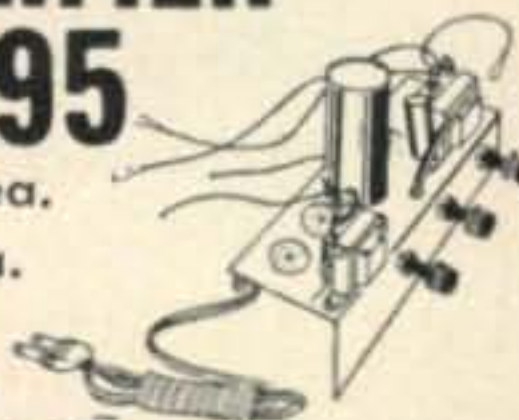

Experimenters! Hams! Rad-Tel Saves You Money On All Your Equipment Needs!

SEND FOR FREE TROUBLE SHOOTER GUIDE AND NEW TUBE & PARTS CATALOG.

RAD-TEL TUBE CO.

55 Chambers St
 Newark 5, N. J.

CQ-1060

TERMS: 25% deposit must accompany all orders — balance C. O. D. Not Affiliated With
 \$1 HANDLING CHARGE FOR ORDERS UNDER \$5. Subject to prior sale. Any Other Mail
 Please add postage. No C. O. D.'s outside continental U. S. A. Order Tube Co.

For further information, check number 43 on page 126.

Directory of Certificates and Awards

Over 350 Awards From Over 50 Countries.

The Directory contains 12 sections listing awards from all continents as well as special awards.

Revision Service includes "write-in" corrections, actual size "paste-ins", "paste-overs", data for supplemental pages, matter for the General Information Section, and when necessary, new pages either for replacements or additions.

Directory Prices:

Directory plus 1-year Revision Service to U.S., Possessions, and Canada:

By Third Class Mail.....\$3.50

(1st Class—add 50¢; Air Mail—add \$1)

Foreign by First Class Mail.....\$4.75

Revision Subscription Prices:

U.S., Possessions & Canada, 3rd Cl...\$1.35

(1st Class—add 50¢; Air Mail—add \$1)

Foreign by First Class Mail.....\$2.10

Edited, Printed & Published By

CLIF EVANS, K6BX

Box 385, Bonita, Calif.

For further information, check number 49 on page 126.

BACK ISSUES FOR SALE \$1.00 per copy

1950—Jan., July, Oct., Nov.

1951—All issues, except Nov.

1952—All issues, except Aug.

1953—All issues, except May, July, Dec.

1954—All issues, except Feb.

1955—All issues, except Nov.

1956—All issues, except April, July

1957—All issues, except Feb. and Nov.

1958—All issues, except July, Sept., Oct.

1959—All issues except Jan.

1960—All issues, 50¢ Per Copy

BC-603 Conversion article (Sept. & Oct., 1958 CQ)

Reprints available at 50¢ per set.

CQ Magazine

300 West 43rd St., New York 36, N. Y.

LOW SPECIAL PRICES

for the BEST, most easily understood of the current Official U.S. Dept. of Air Force Instruction Manuals—Extremely helpful for on-the-job and at-home reading and learning.

ANTENNA SYSTEMS, AF Manual 52-19, 296 pages of the best information ever gathered for any training curriculum. This book is now being used by thousands of Technical Schools and Industrial Training Depts. Govt. List Price \$2.00—Only \$1.75 per your copy.

LEARNER'S GUIDE—ADVANCED CIRCUITS, AF Manual 52-18, 234 pages of Laboratory Material covering the most frequently used Oscillators, Multivibrator and other Generator Circuits, as well as the Test Equipment necessary for Troubleshooting. Govt. List Price \$2.00—All for Only \$1.75 per manual.

POWER PLANT MAINTENANCE—FOR RECIPROCATING ENGINES, AF Manual 52-12, 456 pages of Aircraft Engines Training Materials, including 4 and 5-color, exploded-view diagrams, Information necessary to the Ground Crews, Flight Crews and Administration Groups, Covers: Power Plant, Fuel Systems, Ignitions and Controls, Propellers, Mountings and Inspections. Govt. List Price \$3.25—ONLY \$2.25 per book to you.

ENGINE CONDITIONING FOR RECIPROCATING ENGINES, AF Manual 52-9, 70 pages on final check-outs of Aircraft Engines. Covers: A New Approach To Maintenance, Basic Engine Principles, The Cockpit Check Analysis of Cockpit Check Data, Conditioning of an Engine and the Part of The Flight Crew. Govt. Cat. Price \$1.25—\$1.00 to you.

OPERATION OF AIRBORNE SHORAN, AF Manual 101-6, 120 pages covering the Basic and Operational Procedures of SHORAN Techniques, what it is and how it operates. Govt. Cat. Price \$2.00—ONLY \$1.00 ea. to you.

SHORAN GROUND STATION OPERATION, AF Manual 102-4, over 120—8½"x11" pages with over 6 large pull-out schematics. Includes: Introduction To Shoran System, Theory of Operation Of The Shoran Ground Station, Installation and Operational Procedures of the Ground Station. Govt. Price \$2.00—ONLY \$1.25 each to you.

GET THEM NOW WHILE THEY LAST

COWAN PUBLISHING CORP.

BOOK DIVISION

300 West 43rd St., New York 36, N.Y.

N. Y. City Residents add 3% Sales Tax

NOVICE [from page 110]

doublet on 40 and 15 meters. So far he has worked VE2, 6, and 7, plus XE2, WH6, and has a WAS of 23/17. Bill says if anyone needs Oregon, he's a 100% QSL'er.



Bob Gains, KN4SUN, 120 Roszel Rd., Winchester, Va. operates this impressive set-up and has been on the air for 5 months. So far he has a WAS of 44/39, and has worked PAØ, SP2, UA3, VK3XB, T12, WH6, WP4, YV5, VE's 3, 5, 6, and 7. Bob is very anxious for skeds with Nev., Vt., Wyo., Idaho, N. Dakota, and Alaska. In addition he would like to get in touch with KNØZQD, and KN1OEB (or was it KN1OYJ?).

Daniel Esler, K8RWA, 16881 Cheyene, Detroit 35, Mich., just dropped the "N", but is still an ole timer, having been a wireless operator on board ship from 1914 to 1927! Dan is having a wonderful time with his Valiant, Collins 75A-4, and a beam perched on a 60' tower.

Ed Wojtowicz, 490 Middle Rd., Conneaut, Ohio, is KN8QWY. His ticket is due to expire in Sept., but he has piled up 740 contacts, including VE2,3,6, WH6, and VK3XB on 40 meters with a DX-100 and HQ160. His WAS is 47/47 but he still needs Wyo., N. Dakota, and Alaska.

That caps the letters for this month, fellows. Almost too late for the column this month, Tom Harmon, WØIUB, 5019 Gramar, Wichita 18, Kansas, advises us he is issuing a new award for working United Nations Countries. All it takes for the Novice class is 10 UN countries and 70 for the Class 1 award. Tom says that although the award is not hard to earn, only two Novices have sent in their 10 confirmations (KN2UPD and KN9GVE). If you would like more information on the WUN award, drop a SASE to Tom at the above address. I am going to dig through my QSL's and see if I can come up with 70 of 'em. For now,

Very 73, Don, W6TNS

RTTY [from page 85]

would like to know how many of you other RTTYers would be interested in obtaining a test tape, recorded at 7½ inches-per-second, of the standard audio tones (425, 850, 2125, 2550, 2975 c.p.s.) plus AFSK (2125 and 2975 cps) of

FREE

GIANT 1961 204 PAGE CATALOG

B-A

1961

ANNUAL CATALOG 611

Guarantee

A Complete Buying Guide for Everything in

RADIO TV ELECTRONICS

BURSTEIN-APPLEBEE CO.

Dept CQ, 1012 McGee St., Kansas City 6, Mo.

Send Free 1961 B-A Catalog No. 611

Name

Address

City State

SAVE UP TO
50% ON B-A
SELECTED
KITS

HI-FI AND
STEREO
SYSTEMS &
COMPONENTS

TOP VALUES
IN POWER
AND HAND
TOOLS

30 PAGES
OF BARGAINS
NOT IN ANY
OTHER CATALOG

For further information, check number 44 on page 126.

RECONDITIONED AMATEUR EQUIPMENT

CENTRAL ELECTRONICS.....	600L, rack mounting style, \$325.00
COLLINS.....	32V2, \$325.00; 75A4, \$595.00; 75S-1, \$425.00
DRAKE.....	1-A receiver, \$210.00
GONSET.....	500W linear amplifier, \$125.00; GSB100, \$435.00
GLOBE.....	300A transmitter, \$250.00; DSB-100, \$69.00; Scout 680, \$69.00; Scout 680A, \$89.00; 2 CB-100 Citizens' Banders, \$175.00; CB-100 Citizens' Banders, \$99.00 (New)
HALLICRAFTERS.....	HT-20, \$169.00; HT-32, \$495.00; SX-101 Mark IIIA, \$325.00
HAMMARLUND.....	HQ-160, \$269.00
HEATHKIT.....	DX-100, \$199.00; DX-100B, \$225.00
JOHNSON.....	Kilowatt Matchbox, \$85.00; Viking I, \$129.00; Viking II, \$185.00; Valiant, \$375.00; 500, \$595.00
NATIONAL.....	NC-66, \$69.00; NC-109, \$129.00; NC-98, \$95.00
MORROW.....	MB560 mobile transmitter, \$99.00
PHASEMASTER.....	II side band exciter, \$199.00; Band-hopper VFO, \$89.00
RME.....	4350 receiver, \$159.00

ON ALL ABOVE ITEMS YOU MAY DEDUCT 10 PER CENT FOR CASH AND NO TRADE IN. Send for our new amateur buying guide No. H-60 just released and also our latest listing of top-quality reconditioned gear.

BURGHARDT
RADIO SUPPLY, INC.
WATERTOWN, SO. DAKOTA
 PHONE TURNER 6-5749

For further information, check number 45 on page 126.

NEW IN ALL RESPECTS!

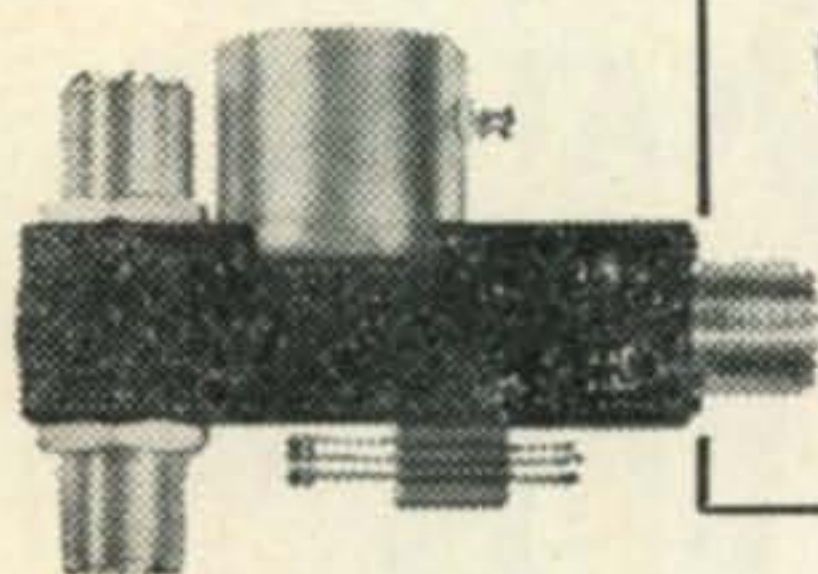

**EPOXY RESIN
USED IN
DK60
SERIES**

COAXIAL RELAYS

For quieter operation and resistance against moisture, all coils are encapsulated in an epoxy resin. Add to this; low VSWR—less than 1.15 at 500 mc.—low losses—high contact pressures—patented receiver protecting connector (optional)—bifurcated DFDT external contacts (optional)—and many other mechanical and electrical features, all of which are found in the NEW Dow DK60 series. \$10.90 to \$14.20.

OTHER FINE DOW-KEY PRODUCTS:

DK60-T2-Transfer two or more antennas—1KW capacity—price (with standard U.H.F. connectors) \$10.90 to \$12.65.

T/R switches—3 models—self powered and non self-powered. Also available for special COMMERCIAL frequencies up to 250 mc. Engineering inquiries solicited, regular models \$12.50 and \$27.75.

We invite inquiries for coaxial relays using types 'N' 'C' 'HN' 'BNC' and 'UHF' connectors.

Catalog sheets available from any of our 700 dealers and distributors in U.S. and Canada or from the main office.

DOW-KEY CO. INC.
THIEF RIVER FALLS, MINNESOTA

For further information, check number 46 on page 126.

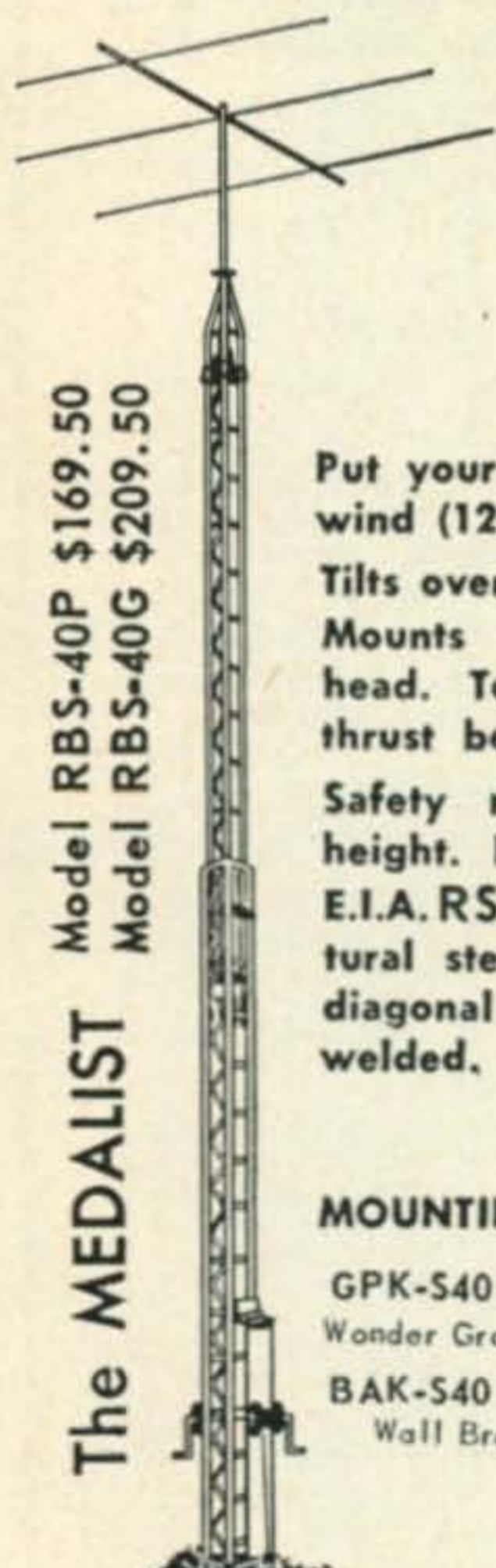

Model RBS-40P \$169.50
Model RBS-40G \$209.50

The MEDALIST

STURDY E-Z WAY TOWERS

Put your Tribander at 41' in 70 mph wind (125 mph cranked down to 24').

Tilts over for E-Z access to array.

Mounts Ham-M Rotor inside tower head. Top radial bushing - vertical thrust bearing.

Safety rest locks tower at desired height. No weight on cables.

E.I.A. RS-222 specs. Heavy wall structural steel tube legs, solid steel rod diagonal & horizontal bracing — arc welded. Sold by Top Flight Distributors Everywhere!

MOUNTING KITS:

GPK-S40 \$75.00
Wonder Ground Post
BAK-S40 \$10.50
Wall Bracket



Write for Catalog 22-1

P.O. BOX 5767 TAMPA 5, FLORIDA

For further information, check number 47 on page 126.

114 • CQ • October, 1960

RY's, the Quick Brown Fox, and reversals (equal length *mark* and *space*) for lining up terminal units, balancing polar relays, etc. This fellow feels that it would be much easier to borrow a tape recorder, if you don't already have one, than a fork standard. If you are interested in making use of such a tape, drop me a post card right away. If the response is sufficient the tapes will be made available.

73, Byron, KØWMR

SSB MIXER [from page 49]

circuit. This would eliminate the problem but who can afford the additional expense of a 10750 kc crystal when the signal is far enough down that it can be tuned out in the 6AG7 final stage.

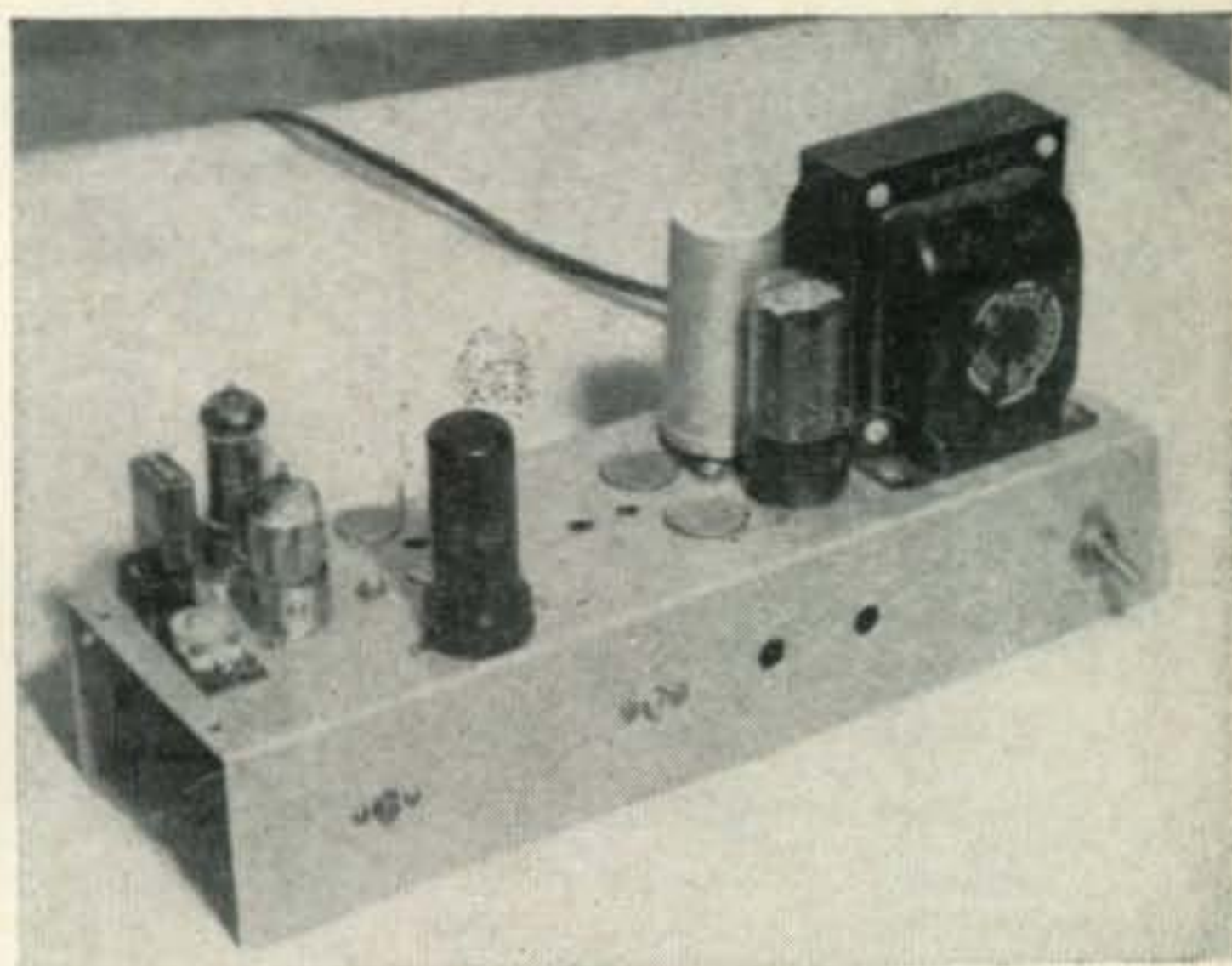

The ten meter mixer chassis showing component layout. The power supply components are at the right and rf circuitry at the left. Front controls are l. to r. C₂ mixer plate tuning C₅ 6AG7 tank (screw-driver adjust), and SW₁, ac on-off.

When you are certain the mixer is working tune it up by peaking C₂ while talking into the microphone. Finish wiring the 6AG7 final stage and peak all controls using a tone or inserted carrier. The 6AG7 should have a 50 ohm resistor on the output if it is not fed directly into another amplifier during the tuning. ■

PHONE PATCH [from page 48]

three conductor cable over to a plug on the rear of the receiver. The shield of the cable must be grounded at each end to prevent unwanted rf pickup in the power leads.

The balance of the patch is easily adjusted by putting a vtvm across the output to the transmitter, feeding an audio tone of about 1000 cycles into the receiver input, and connecting the patch to the telephone line while you have a friend and accomplice across town "hold the line". It may take a few minutes to find the right value of C₁ for the best null, but after this, all is smooth sailing. Simply mark the setting of the potentiometers R₁ and R₂ that gives the best null and lock them in position. You are ready

"RIG-PLAQUE"

W8QMT

ONLY
\$1.50

Custom-Engraved with YOUR CALL!

Dress up your rig with a deeply-engraved 1" x 4" plaque. Thick, handsome, black plastic, white letters. Adhesive backing... sticks anywhere. Specify call letters. Send with check or M.O. Ohio Res. add 3% Sales Tax. \$1.50 Each... 2 for \$2.75 (Same call). Write Now—for Free Catalog other Ham and Home Gifts.

BAY CRAFT GIFTS • P. O. Box 9644 • Bay Village 40, Ohio

COAX DIPOLE DRI-FIT CONNECTOR

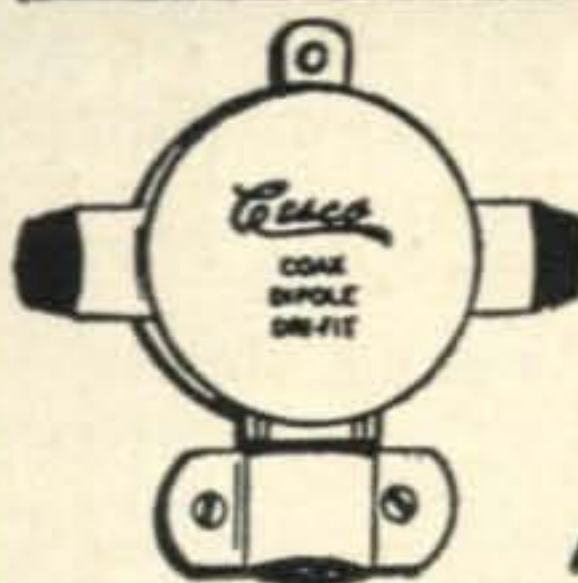

The most ideal connector ever made for dipole antennas. Install in minutes. Completely moisture proof. For use with coax cables RG-8, RG-58, RG-11, RG-59 and 300 ohm twin tubular. Has eye pull up for inverted V's. One piece aluminum alloy construction. Weighs only 2 oz.

Amateur Net \$2.95 ea.

See your Distributor or write

CONTINENTAL ELECTRONICS & SOUND CO.
6151 DAYTON LIBERTY ROAD
DAYTON 18, OHIO

RADIO AMATEUR CERAMIC SPECIALTIES

only **\$5.00**

Postpaid...



Item #M6. This mug is seven inches high, featuring a figurine handle.

Operators individual call sign in fired gold one-half inch letters. First name if desired in half-inch capitol, three-eighths inch lower case letters.

Our familiar Item #M1 still available \$2.75.

MILLWOOD STUDIO
Haverhill St., Rowley, Mass.

FOR SALE

SX-101A	\$ 250.00	6 Mo. Old
HT-32A	\$ 450.00	2 Mo. Old
Viking		
Thunderbolt	\$ 300.00	2 Mo. Old

Total **\$1000.00** for package

At this price freight will be FOB

St. Louis, Mo.

Ronald F. Smetak WØIFL

c/o **MOSLEY ELECTRONICS, INC.**

4610 N. Lindbergh Blvd., Bridgeton, Missouri

NEVER BEFORE A HAM MAP LIKE THIS!

SO BIG! SO BEAUTIFUL! SO ACCURATE! SO FACT FILLED! SO UP-TO-DATE!

KNOW THE ZONES FOR WAZ
KNOW THE CONTINENTS
FOR WAC • KNOW THE
COUNTRIES FOR DX-CC
ETC. • ETC. • ETC.

• NOW ON SALE • BRAND NEW •

We are proud to announce the publication of the long-awaited **AMATEUR RADIO WORLD-WIDE DX & ZONE MAP.**

This new map is complete, accurate and up to the minute with information that every amateur needs.

It contains:

Every prefix, including the newest additions and latest changes, printed in red, right in, or next to, the Country or Island, for accurate identification.

The most authentic Zone Boundaries, including the **ANTARCTIC CONTINENT for the FIRST TIME ANYWHERE!**

Great circle beam bearings for East, Mid-West and Western United States.

Attractively printed on heavy vellum map paper in four colors for easy location of Zones and Prefixes.

Size 36x42 inches for easy, no squint reading from operating position.

Price only **\$3.00** postage paid in the U.S.A. and possessions.

COWAN PUBLISHING CORP.

Map Division
300 West 43rd Street
New York 36, N. Y.

SIRS: My check (money order) for \$_____ is enclosed.

Please send _____ maps to:

(Additional name, or names, enclosed on separate paper.)

Name _____

Address _____

City _____ Zone _____ State _____

New York City residents add 3% Sales Tax

C-10

* TWO-WAY * COMMUNICATION CRYSTALS



**UNCONDITIONALLY
GUARANTEED**

FAST — 24 HOUR SERVICE

American specializes in two-way communications. Frequency correlation data for G.E., Motorola, R.C.A., Collins, Lear, Narco, Hallcrafters, Link, Gonset, Aerotron, Heath, Bendix, Johnson, Globe, U.S. Gov't. and many other companies.

FREQUENCY RANGE	CALIBRATION TOLERANCE	PRICE
2501 KC to 9999 KC	.002%	\$3.00
15 MC to 32 MC TM	.0025%	\$3.00
32 MC to 50 MC	.0025%	\$4.00
10 MC to 17 MC Fund	.002%	\$4.00
2001 KC to 2500 KC	.002%	\$4.00
50 MC to 60 MC	.0025%	\$6.00
1000 KC to 2000 KC	.002%	\$7.50

Write for quantity discounts—

AMERICAN CRYSTAL CO.
P.O. BOX 2366 • KANSAS CITY 42, MO.

LOOK Ma!
NO GUYS

IT'S got

"ITQ"



Write for
FREE BROCHURE

E-Z WAY TOWERS, INC.
P. O. BOX 5491 - TAMPA, FLA.

EASY TO LEARN CODE

It is easy and pleasant to learn or increase speed the modern way—with an Instructograph Code Teacher. Excellent for the beginner or advanced student. A quick, practical and dependable method. Available tapes from beginner's alphabet to typical messages on all subjects. Speed range 5 to 40 WPM. Always ready, no QRM, beats having someone send to you.

ENDORSED BY THOUSANDS!

The Instructograph Code Teacher literally takes the place of an operator-instructor and enables anyone to learn and master code without further assistance. Thousands of successful operators have "acquired the code" with the Instructograph System. Write today for full particulars and convenient rental plans.



INSTRUCTOGRAPH COMPANY

4711 SHERIDAN RD., CHICAGO 40, ILL.
4700 Crenshaw Blvd., Los Angeles 43, Calif.

to go. Do not set your VOX gain on the transmitter any higher than necessary for proper operation. This prevents the VOX from being tripped by telephone line noise, room noise, etc.

Results

The patch gives an excellent nulling action which is quite independent of audio frequency, and it enables me to run "full-automatic" with the party on the telephone line tripping the VOX. It has provided many good contacts for persons overseas since I built it two months ago. It is far superior to hybrid-type units which are frequency-sensitive. I recommend it heartily for all of you who are interested in improving your telephone patch capability. Some ingenious soul may also think of another use or two for this type of circuit in his audio system. ■

SIDEBAND

[from page 91]

the foreign country (not forgetting the self-addressed envelope since stationery is scarce and expensive in many countries).

Regarding the first solution, many amateurs are loathe to act as if they were "buying" QSL cards yet we must admit that U.S. currency is readily acceptable throughout the world. The second solution is less expensive and more practical and is easily arrived at by patronizing local stamp dealers or using a stamp service such as that run by W2SAW. A quick run-down of the listing of available stamps will surprise you—a Kenya Air Mail stamp costs you only 54c, the necessary 5 IRCs 75c; a British Somaliland Air Mail stamp costs you only 59c, the necessary 8 IRCs 90c; a Montserrat Air Mail stamp costs you only 17c, the necessary 3 IRCs 45c, etc. etc.

We suggest you consider this matter of International Reply Coupons very carefully before spending your money and not getting results.

Sideband Around the World

Gus, W4BPD, should be putting quite a number of interesting calls on the air this month. Listen for him from ST2AR, ET3CE, VQ4-land, VP9HB in the Seychelles, VQ9 on Platte Island, VQ9 on Coetivy Island, VQ8 on Algalega Island, and VQ9 on Farquhar Island. Gus has many other new calls on his itinerary, making DX chasing quite active during the coming months. . . . Ian, MP4BBW, finally yielded to the inevitable and put up a beam—what a difference in his signal! . . . VU2NR is planning a trip to the Laccadives with those two famous string-pullers, W3RIS and W7PHO, manipulating the behind-the-scenes activity. . . . Congratulations to Luis, XE1SN, and XYL, and to Ray, SVØWK, and XYL, Roberta; both couples recently welcomed baby sons into their families. . . . Although Fred, KJ6BV, left Johnston Island in July, we hope the promised ham replacements have arrived and have put that spot back on SSB. . . . Bryan, MP4MAB, MP4QAO, /4W1, etc., will start a three month leave in London this month, operating as G3OFI. Bryan then goes to Lebanon for a one year stay. . . . Frank, VQ4RF, has designated W4MCM as his QSL manager for contacts after Aug. 1, 1960. . . . Ray, DL5BK, in Bitberg, provides a new prefix on 2 way SSB. . . . Cal, 5A5TR, was slated to leave Libya at about this time, headed for Algeria where he hopes to get permission to operate with an FA call.

Band Hopping

When you run across Bob, K6LGH, ask him about his

woodworking project. Bob decided that it was just the thing to relax with after flying for the Air Force all day; we're glad, though, that Bob has some time left to do a bit of hamming. . . . Herb, K6MQU, gave us a hot half hour from Palm Springs. With the temperature over the 100 degree mark, Herb, an architect by profession, explained how to insulate houses against high temperatures—we'd like to try the QSO again in January!!! . . . Finally found out how to make real tough concrete for that tower installation, thanks to Bob, W8CTP. It isn't just sand and water—takes chemicals too—which is where Bob comes in. . . . Had a real bang-up time with Dave, W8GWB, and Jim, W2YHM, recalling some of the old-time airplaners. Dave, who flies a B-26 for Bendix Research, filled us in on some of the old time crates while Jim and his buddy, Dick, acquainted us with the Experimental Aircraft Association, a group of flying enthusiasts who build and fly their own planes. . . . Know anybody who wants to get on SSB cheap and easy? Ask Jack, W4PME, who built his exciter for \$1.50 cash plus a used Western Electric filter. We promised not to tell how much the filter costs—it spoils the story! . . . Operating portable/3 from Jessup, Maryland, Bill, W1FAV, puts out a terrific signal on 40 meters with his HT-37/Thunderbolt combo from his motel room. Bill, who hails from Wayland, Mass., gets his rent free, we hear—he keeps the neon motel signs lit in exchange—with r.f.!

6AG7 users—unite on 7204 kc most any evening! With Jack, W2CD, Pete, W3SH, and other 6AG7 users, it can be a fascinating evening! Before we left the frequency, we weren't sure just who was using what where, but a good time was had by all, including Tony, K8AAE; Bill, W2VAV; John, K2LSX; and Art, W4EEU, who never did quite find out what hit him. . . . Chuck, W0CVU, himself passed along this story to us: Chuck had been having trouble with his old prop-pitch rotator and had the whole unit re-worked which made operation possible at any time of the day or night without waking up the whole neighborhood. The new set-up worked beautifully for two weeks, and, after that, only intermittently. It would work for a couple of hours and then not reverse. One night, it would be working fine—the next morning, no results! By this time, Chuck was almost ready to put up a long wire! Finally he had the outside hood covering removed and what did he find? A bird's nest—12 inches high and 10 inches across!! And here was the trouble—when the bird sat on the nest, it exerted just enough pressure on the relay so that the contacts would not pull in! When the bird flew away, all worked fine! Despite Chuck's love for our feathered friends, you can bet that no nests will be built in his rotator from now on. As Chuck mentioned, in the four years during which he had his noisy assembly, not one bird ventured near the unit—just as soon as the new assembly was installed and ran quietly, the birds became so happy, they started raising a family!! . . . Charlie, who was so active from his mobile as K0RDI/9, is now K9LAZ and settled in Indianapolis. . . . Bob, K4AJ, played host to Chester, W0NFA, and XYL, but try as he might to be the perfect host, there was no fighting it—Bob still caught the biggest fish!! . . . A hearty welcome to Curly, W5NZ, in New Orleans, who joined the SSB gang recently. . . . Add another call to our listing of musicians turned ham: W9JJG, Ray, now portable in Kansas City, plays piano and bassoon with the Kansas City Philharmonic. . . . V. Mayree, K5LXA/K4ICA, never ceases to amaze us; she is the epitome of feminine charm and, in addition, blessed with tremendous artistic talent. V. Mayree is an accomplished sculptress and not only forms but also fires lovely porcelain figures with which she has raised thousands of dollars for her pet charities. We hope you have had the pleasure of meeting her on the air.

Do you have another hobby or special talent? Do drop us a line and tell us all about yourself—we'd like to hear from you.

73, Irv and Dorothy

PROPAGATION [from page 93]

the sun's surface because the temperature in the depression, or solar crater, is approximately 1500 degrees F. cooler than at the surface. The light given off by the cooler sunspot area is about

AMAZING NEW VIBROPLEX

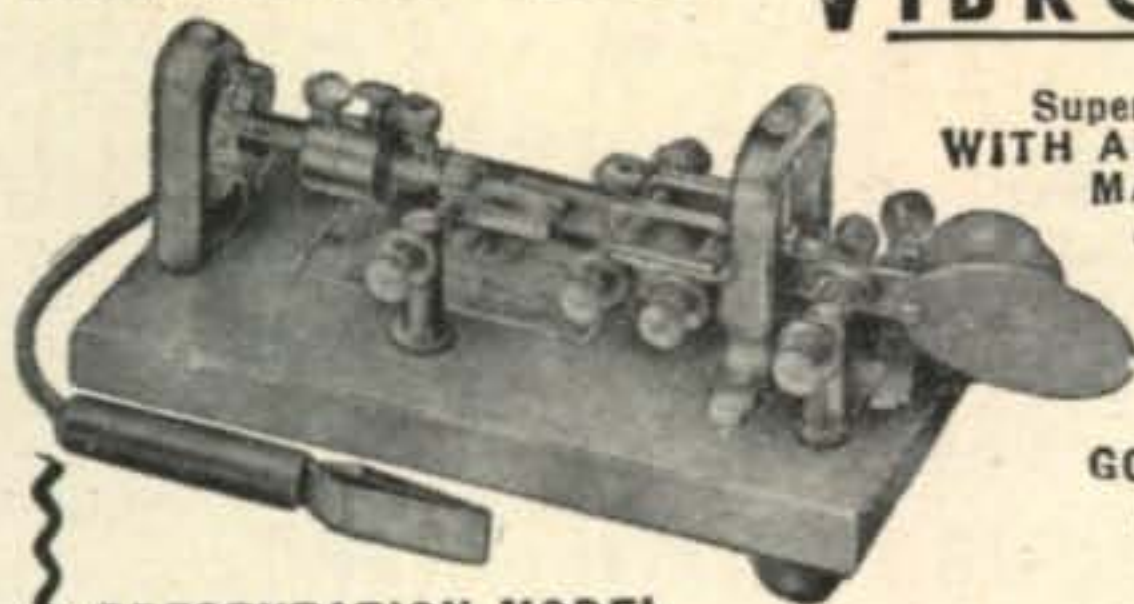

Super DeLuxe
WITH ADJUSTABLE
MAIN SPRING
AND OTHER
GREAT
FEATURES

24-K
GOLD-PLATED
BASE TOP

PRESENTATION MODEL

\$29.95

Vibroplex presents the first really speed control key. An adjustable main spring permits operator to send slower or faster as desired. No more muddy signals . . . no sacrifice of signal quality. Suits any hand or any style of sending. Free of arm tension. Sends easily as pressing a button. Praised by operators and beginners alike. Try this new Vibroplex key! You'll be delighted. Other new popular Vibroplex keys from \$15.95 up. At your dealer or
THE VIBROPLEX CO., INC. 833 Broadway, N. Y. 3, N. Y.

CALL-IDENT TYMETER 10-Minute Station Call Reminder with 24 Hour Tymeter Clock

Model 124 **22.50**

10 minute repeating timer, buzzes warning to sign in your call letters.

Walnut or ebony plastic case. H 4", W 7 3/4", D 4". Wt. 3 lbs. 110V 60 cy. AC. 1-yr. guarantee.

12 Hour System
#112 . . . 17.50

At Your Dealer . . . or WRITE to

PENNWOOD NUMECHRON CO.
7249 FRANKSTOWN AVE. PITTSBURGH 8, PA.



**SEE
PAGE 96**

for some
interesting news.

QUADS by SKYLANE are outstanding performers

- Aluminum alloy end and center spiders
- Aluminum boom with hardwood insert
- Pretuned reflector coils—
- Three bands—10-15-20 meters
- Very low SWR
- High gain and high F/B ratio
- High "area" factor
- Very light—30 lbs.
- Low wind resistance
- Single co-ax feed system

\$59.95 f.o.b.

Ask about the all aluminum, fully weatherproof quad.

SKYLANE PRODUCTS

405 Ban Air

Tampa 10, Fla.

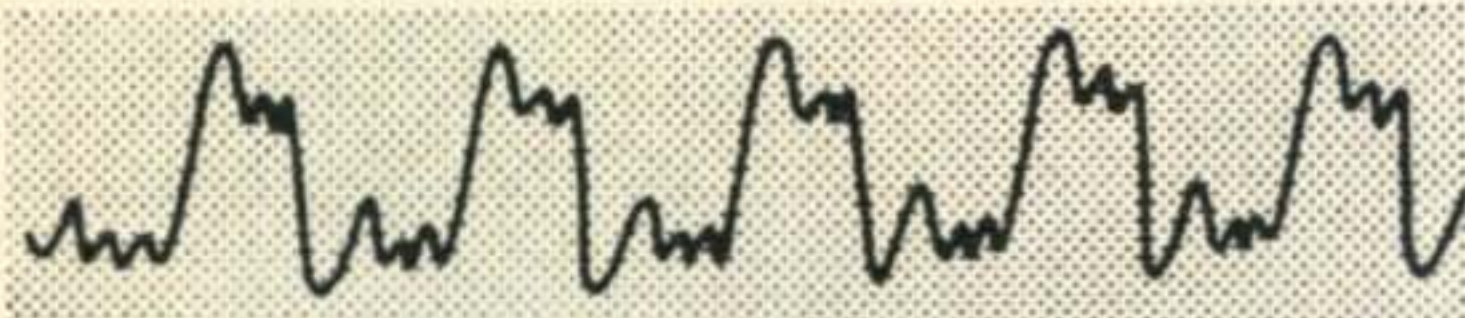

**Add threshold control
to your HQ-170 or
HQ-180 with the NEW**

HAMMARLUND NOISE LIMITER

Just the thing for noisy locations . . . a Lamb-Type noise limiter of improved performance that reduces impulse noise (ignition-type) to a minimum. Complete kit, ready-to-install in about 15 minutes. Available from your Hammarlund dealer, or direct from factory . . .

\$33.50

*Write for complete details

HAMMARLUND
HAMMARLUND MANUFACTURING CO., INC.,
Since 1910 An Affiliate of Telechrome
460 W. 34th ST., N. Y. 1, N. Y.

For further information, check number 62 on page 126.

ARE YOU MOVING?

If you expect to move, and IF you know your new address now, and IF you don't want to miss any issue of CQ here are three things you can do right now!

1. Tear your name and address label off the wrapper of this issue and paste it in this box right over these words, or make a complete and accurate copy of your old address label.
2. Print your name and NEW post office address in the lines below:

(Name)

(Number and street—or Route)

(City)

(Zone)

(State)

3. Cut out this whole box and mail it to: CQ Magazine, 300 W. 43 St., New York 36, N. Y.

HAM LICENSE COURSES

Resident Classes—3 Evenings a Week. Thorough preparation in Code and Theory. Qualifies for NOVICE CLASS in 4 Weeks and for General Class in 2 Months.

Dept. C, DELEHANTY INSTITUTE

117 East 11 St., N.Y. 3—Phone GR 3-6900

TELETYPEWRITER EQUIPMENT Collins 51J Receivers .54-30.5 Mc.

Model #14, 15, 19, 26 & 28 Teletype machines, Telewriter Receiving Converter and others. For general information & equipment list write:

Tom W1AFN, ALLTRONICS-HOWARD CO.
Box 19, Boston 1, Mass. Richmond 2-0048

50% less than the light given off by the surrounding solar surface, accounting for its darker appearance.

Figure 2 was taken by Stratoscope I on Sept. 24, 1959 nearly 80,000 feet above Minneapolis, Minnesota. A special film was used in the telescope-camera during this flight in order to obtain even greater detail in the umbra region of the sunspot. The white dots seen in the center of the umbra are believed to be gaseous columns rising from the sunspot area as a result of convection. The discovery of these white dots as a result of the Stratoscope I flights lends considerable support to present day theories that sunspots, and their electromagnetic effects on the earth's atmosphere, result from some sort of inter-action between masses of gaseous material and the tremendous heat near the surface of the sun.

While much detailed analysis remains to be done of the many photographs taken by Stratoscope I before definite conclusions can be made concerning sunspot characteristics, their great clarity and definition will almost certainly contribute to improved knowledge concerning sunspot behavior, and the influence of sunspots upon shortwave radio propagation conditions.

Last Minute Forecast

The forecast Indices for the month of October, shown in the Propagation Charts by parentheses following the times of openings, are expected to be related to day-to-day propagation conditions in the following manner:

Forecast Indices	Above Normal	Normal	Below Normal	Disturbed
	Oct. 15-17, 25-27	Oct. 1-3, 9-14, 18, 22-24, 28-30	Oct. 19-21	Oct. 4-8, 31
(1)	C	D-E	E	E
(2)	B	C-D	E	E
(3)	A	B-C	D-E	E
(4)	A	A	B-C	C-D

Where:

- A—Excellent circuit, strong steady signals.
- B—Good circuit, moderately strong signals, some fading and noise.
- C—Fair circuit, moderately strong to weak signals, moderate fading and noise
- D—Poor circuit, weak signals, considerable fading and very high noise level.
- E—Circuit out.

73, George, W3ASK

CONTEST CALENDAR [from page 95]

4X4II	2484	ZL2GS	7860
UA9KOG	1078	ZL4GA	696
JA7AD	697	KH6DLF	490
JA2XW	528	South America	
JA0AC	114	PY1ADA	39,370
JA8LN	15	LU5AQ	4082
Oceania		HK3TH	270
VK2GW	29,522	PY2BNX	216
ZL1APM	19,475	VP4LA	135
VK5NQ	14,896	Europe	
VK6RU	13,900	DL1KB	254,483

DL7AA	192,304	CT1KD	34,222
DL7BA	152,877	PAØLOU	30,816
DL7DF	136,755	YU3OV	18,944
DL1JW	136,104	LA6U	14,076
IT1TAI	158,400	TF3AB	11,004
OE1RZ	139,908	YC3WL	10,296
OK1MG	130,556	OZ7BZ	10,045
G2DC	109,494	UR2BU	5,000
HB9UB	80,560	ON4EG	3,861
SM5CCE	51,750	GM8SQ	2,673
SP6FZ	47,594	HA5BI	1,428
F8TM	45,214	CT2BO	1,414
EA1AB	41,140	UC2AR	780
OH5QN	37,536	IIDFB	190

73 for now, Frank, WIWY

YL [from page 99]

in 1930, and as 9FO from 1932-36, as well as at 9USA at the Chicago fair.

Powder Puff Derby

W3GTC, Carolyn, again served as national chairman of the Ham Radio net which had stations located in cities throughout the route of the 14th annual All Woman Transcontinental Air Race (AWTAR). 73 planes completed the flight which began at Torrance, Calif. on July 9, and crossed the finish line at Wilmington, Del. before noon on July 13. W6QPI, Betty, served her 8th year as chairman of the Directors of TAR.

K6CPX, Marian, and Bernie, XYL of K6KNP, operated continuously during the race hours at Torrance. Other YLs assisting included W4WTJ, Betty, at Memphis, Tenn., and K3HOC, Livy, at Wilmington, Del. Stop-over city chairman for other cities: K6JZD, Needles; W7BSO, Prescott, Ariz.; W7REO, Winslow, Ariz.; K5LBM with MARS station K5FIQ at Albuquerque, N.M.; K5LLN with W5WX, Panhandle ARC at Amarillo; W5HXT with W5PAA, Aeronautical Center ARC; W5QHJ at Ft. Smith, Ark.; W4JVM, Chattanooga Frye ARC; W4WRH at Johnson City, Tenn., and K4JQO at Roanoke, Va. Most stations were on SSB.

CQ YL

"CQ YL" is the one and only book devoted to telling the very active part YLs have taken in Ham radio. Twenty chapters, over 500 photos. Order from W5RZJ (address at head of column), \$3, postpaid.

TYLRUN Birthday Party

Nov. 5th is the date set for the 6th get-together of TYLRUN members. This year the ALAMO YLs will be the hostesses and it will be held at the Belvedere Hotel in San Antonio. Registration is \$2.25; send it to K5OPS, Ethel Chastain, 4338 Seabrook, San Antonio by Oct. 25. Make room reservations directly with hotel. Plenty of entertainment is planned for Friday and Saturday and a station will be operating on 3855 & 3880 for convenience of mobiles.

33, Louisa, W5RZJ

THE NEW P & H LA-400-C 800 WATTS PEP SSB LINEAR AMPLIFIER



**NOW 800 WATTS PEP
FOR ONLY \$164.95
THE "BEST BUY" YET**

NEW modern styling! NEW high efficiency 3 element band-switching pi net. Puts more power into any antenna or load from 50-70 ohms. For SSB, DSB, Linear AM, PM, CW and FSK. All bands 80-10 meters. May be driven to 800 WATTS PEP SSB with popular 100 watt SSB exciters. Uses four modified 1625's in grounded grid. On customer's order, will be furnished with 837's. (note: 1625's and 837's are not directly interchangeable, since sockets are different.) Typical P&H Low Z untuned input. TVI suppressed. Parasitic Free. Meter reads grid drive, plate current, RF amps output. Heavy duty power supply using 816's. NEW modernistic grey cabinet measures approx. 9" x 15" x 10½". Panel is recessed. WANT TO SAVE MONEY? BUY IT IN KIT FORM. It's a breeze to assemble and wire. BEFORE YOU BUY — SEE THE NEW LA-400-C AT YOUR DEALERS.

LA-400-C Kit complete with tubes.....\$164.95
LA-400-C Wired and Tested.....\$219.95

P & H ELECTRONICS INC.
424 Columbia Lafayette, Ind

For further information, check number 52 on page 126.

**Cush
Craft**

- 2 Meter with mast
Model # AM-2M \$8.70
- 2 Meter stacked
COMPLETE
Model # AM-22
- 6 Meter with mast
Model # AM-6M
\$12.50
- DUAL HALO with
mast. Mod. # AM-26
\$17.45



PORTABLE 3 EI.
6 meter beam.
(50" x 4" folded)
Model No. A50-3P
\$10.95

CUSHCRAFT

621 HAYWARD ST.
MANCHESTER, N. H.

OCTOBER BARGAINS

- VHF Xmtr. Perfect for 2 mtr and/or 1 1/4 conver. (See conversion info in Sept. '60 CQ, p. 82.) Modern design. Uses two 6201's into single Amperex 6360 twin tetrode. Xmtr only 4" x 4" x 11" H. 3 3/4 lbs. Comp. w/antenna and A & B Battery pack, connection cable, schematic and conversion info. Battery is water-activated \$15.00
- Deluxe BC-640B VHF Xmtr (100 to 156 Mcs.). Unused. Orig. crate. Operates from 110 to 125 or 220 to 250 VAC @ 50/60 CPS (single phase) W/book (includes 2 sets of tubes) \$395.00
- Mobile Xmtr. Uses 5618 crystal oscillator into CBSS 5516 amplifier. Modern design. 7 lbs. net wt., including built-in 6 V. vibrator pwr supply, w/8 silicon rectifiers. Completely enc. in aluminum cabinet (5 1/2"H x 7"W x 8"D). Furn. w/crystal that doubles nr 10 mtr band. Requires slight and easy modification for 10 mtr oper. \$13.95
- Hickok 539A Mutual Cond. Tube Tester. Excellent condition \$115.00
- Sale: HQ-100C with S-100 Speaker \$181.86
HQ-110C with S-100 Speaker \$232.86
HQ-145C with S-200 Speaker \$254.11

WRITE FOR TRADE-IN DISCOUNTS

BRAND NEW IN SEALED HAMMARLUND CARTONS

- Johnson Messenger—Finest Citizens' radio available. Complete 23 channel Citizens' Band coverage. Outstanding voice quality—recognition-intelligibility. Maximum legal power, excellent range, meets all FCC requirements. Three models: for 115 VAC and 6VDC; 115 VAC and 12 VDC; or 115 VAC only. Write for prices.
- MC Jones 600 Watt Dummy Load Resistor 51 Ohms impedance. Freq. range: 0-3,000 Mcs. \$49.95
- LS-13 \$6.95; LS-3 Loudspeaker \$5.95; G.E. Bolometer \$15.00; T-126/ARC-5 Xmtr \$13.50; R-28/ARC-5 UHF Recvr \$12.50; TS-34/AP Scope \$55.00; TS-35/AP (8700 to 9500 Mcs) \$45.00; Gen. Radio VTVM Type 726A \$55.00; LM Freq. Meter (190 to 20,000 KC) \$79.00.
- Dumont Model 224-A (3 Mc) Scope \$135.00
- HQ-129X Receiver @ \$85.00
- RME #HF10-20—Preselector—Like New \$37.50
- Hewlett Packard Audio Generator 200B @ \$60.00
- Deluxe Co-ax Relay 115 V. 60 CPS—
Good up to 2 KW. \$12.50
- Deluxe Co-ax Relay 24 VDC—Good up to 2 KW \$7.95
- Westinghouse Interteen Capacitor
2 Mfd. 5500 VDC @ \$7.50
- Sperry Plate XMFR.—115V/60V Secondary: 540 volts D.C. @ 226 Ma. (conservative stencilled ratings) w/choke input filter—orig. cartons. Test 2100 V.R.M.S. \$5.95
- B&W 850A KILOWATT PI-NETWORK \$35.00
- B&W FC15 15 Amp filament choke for grounded grid \$7.50

KEEP AHEAD OF THE CROWD ON VALUES.

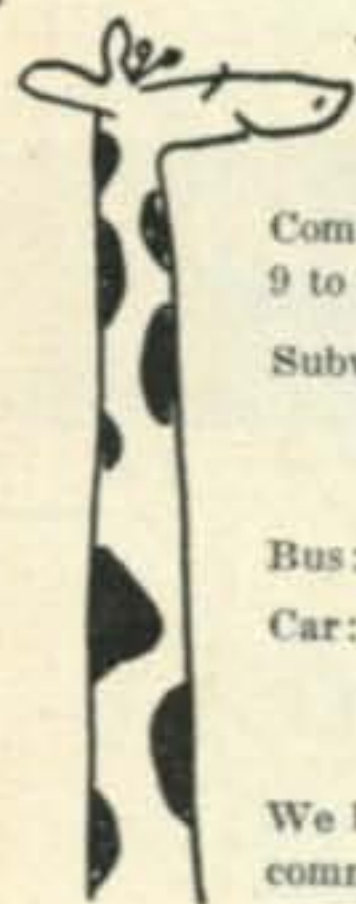

WRITE FOR CATALOG ON TUBES
AND EQUIPMENT . . . FREE.

Come in and browse. We are open Mon. to Fri.
9 to 6. Sat.: 10 to 2 P.M.

Subways: BMT: (Broadway local) to Prince St.
Station—walk 1 block to Spring St.
IRT: Lexington (local) to Spring St.

Bus: Broadway #6 Bus to Spring St.

Car: We are 4 blocks North (uptown of Canal
St.) Parking allowed on Broadway Sat.,
Mon. thru Fri. parking at 501 & 557 B'way.

We buy surplus inventories. Send us list of good
commercial equipment and unused tubes.

BARRY ELECTRONICS
CORPORATION

512 BROADWAY, NEW YORK 12, NEW YORK

(NEAR SPRING ST.), DEPT. C10

Telephone: Walker 5-7000

Classified Ads

RATES: 25¢ per word per insertion for commercial
business organizations.

10¢ per word per insertion for individuals on
a non-commercial basis. Full payment must
accompany order.

MINIMUM CHARGE \$1.00

CLOSING DATE: 20th of the 2nd month preceding
date of issue.

MAIL: Your typewritten copy with full remittance
should be sent to CQ Magazine, 300 West 43rd
Street, New York 36, N. Y.
Attention: Classified Ad Dept.

NOTE: The products and services advertised in this
section are not guaranteed by the publisher of
CQ. Telephone orders not accepted.

FOR SALE

For Sale: TV Cameras, Teletype, Panadaptors, Transmitting Tubes, Transistors, SSB gear. Write for list. Spera Electronic, 37-10 33 Street, L.I.C., N.Y. Stillwell 6-2199.

COLLINS KWM-2 and "S" line IN STOCK at—Purchase Radio Supply, 327 E. Hoover Ave., Ann Arbor, Mich. Ph. NO 8-8696.

ONE THIN DIME brings 50 page eye-popping war surplus electronics catalog. Fabulous bargains. Meshna, Malden 48, Mass.

TOROIDS: Uncased 88 mhy like new. Dollar each. Five \$4.00 PP. DePaul, 309 South Ashton, Millbrae, Calif.

COLLINS 51J-2 \$495. 51J-3 \$675. Both reconditioned. PMO Oscillator \$245. 75A-1 \$259., 75A-2 \$295., 32V-3 \$325., HRO-7R \$95., HQ-145X \$155., HQ-110 \$149. Valiant \$319., Ranger \$198. Gonset III 2m \$209. Panadapter \$89., R-390A/URR, R-274 \$245. NC-183D \$199. Tom W1AFN, Alltronics-Howard Co. Box 19, Boston 1, Mass. (Richmond 2-0048)

PRESERVE YOUR HAM TICKET, Social Security Card, small photo, passes and anything else of value that is wallet-size. We will laminate it in clear plastic, guaranteed for life. Lamination will prevent it from getting torn, soiled or frayed. Send your ticket or anything of value with \$1 in stamps or cash for each item that you want preserved. 24-hour service. Send to C. Lee, P.O. Box 395, Times Square Station, New York 36, N.Y.

Something new and useful for \$1. Flexible holster for soldering gun; fits all types; facilitates work bench storage; easily mounted and no more burned fingers or tabletops. Postpaid, money back guarantee. George Jacobs, 11307 Clara St., Silver Spring, Md.

ANTENNA TROUBLES? Watch Laurel & Hardy erect a roof antenna amid hilarious antics Kraus and Yagi never dreamed of. Low front to back ratio, but loads of laffs for all ages . . . especially the Jr. Ops. 200 ft. 8 mm film. \$5.50 postpaid. Please allow 4 weeks delivery. Send check or M.O. (no cash or COD) to JAGFILMS, 1738-201 St., Bay-side 60, N.Y.

CALL LETTERS may be applied to any surface. 2" sets 60¢, 3" set 80¢. Send to C. Lee, P.O. Box 395, Times Square Station, New York 36, N.Y.

Technical book bargains, all in excellent condition. "Short-wave Wireless Communication" by Ladner & Stoner, 5th Ed. \$4.75. "VHF Techniques" by Radio Res. Lab. 2 Vol. \$8.50. "Higher Math. for Eng. & Phys." by Sokolnikoff, \$4. "Engineering Math." by Sohn, \$3.25. "Handbook of Industrial Electronics Ckts" by Markus & Zeluff, \$4.75. "Airglow and the Aurora," Pergamon Press, \$10. "Solar Eclipses and the Ionosphere," Pergamon Press, \$10. "Advanced Mech. of Materials" by Seely, \$3. "Inorganic Qual. Anal." by Fales & Kenny, \$2. All for \$46 postpaid. George Jacobs 11307 Clara St., Silver Spring, Md.

Johnson Valient—Like new. \$300.00. John Mansheim, 1311 Avenue B, Fort Madison, Iowa.

For further information, check number 53 on page 126.

HAM SHACK NOVELTY: Authentic-looking, two-color certificate claiming tongue-in-cheek ownership of an acre on the Moon's surface. Ideal humorous gift or conversation piece for shack, bar, den or office. With gold seal and name and call inscribed only \$1.00. Six for \$5.00. Send check or M.O. only to—Box DXG, 1738 201st Street, Bayside 60, New York.

FOR SALE: Tickets to The One and Only—Syracuse VHF Roundup, October 8, 1960. Write K2TXG, 317 Clover Ridge Dr., Syracuse 6, N. Y.

Sell: Teletype printers #15—May consider trade on commercial recvrs. Winfred Winkler, 2199 Mark Trail, Decatur, Georgia.

S. W. Converter \$1 Electro. 953—18th Newport News Va. Drucker.

Selling a DX-40 price is \$60. The transmitter is in good condition. Joe Child, Brick Town, New Jersey.

Just completed DXCC. Must sell NC 300, 3el 15 mtr Beam, 250 watt xmtr, two plate xfrms. Inquiries welcome. Walt Berry, 816 2nd Ave. Webster City, Iowa.

Selling Out: Heath mohawk receiver. Excellent condx. Aligned by Heath. Harvey Wells TBS 50D. Heath VFO, D-140 and bug. A. Banaski, 9110 S. Saginaw Ave., Chicago 17, Ill.

HQ-160 Excellent condition, electrically and mechanically, \$270. J.F. Pyryt, 192 Norman Way, Paramus, N. J. CO 1-8655.

COMMUNICATIONS RECEIVERS. Cover 140-425 kes. and 1.7-36 mcs. in four bands. \$124.95 each. Write for further details. Richard Milburn, 5 Briar Lane, Newark, Delaware.

MOBILES: Used motorola FMT-50D 60 watt units convertible to 6 meters, good condition. For information write Mainbrace Co., P.O. Box 53, St. Louis 19, Mo.

National NC-125 perfect condition. \$50.00. George Levy, ES 2-8990.

For Sale: Lettine Model 240 xmtr; Millen R'9er; T-54 TV; and other odds & ends. List furnished. Will consider swap for telescope. B. A. Skurnowicz, Gouldsboro, Penna.

***The VHF Amateur—**At last a magazine for VHF'ers! Don't miss a single issue! \$2.00, year. . . . \$1.00, six big issues. . . . 67 Russell, Rahway, N. J.

SELL: 100V, factory guaranty, \$700.00, KWS-1, modified—\$1,000.00; MM-2 R. F. Analyzer, 455 kc—\$100.00. All F.O.B. Lamb, 1219 Yardley Road, Morrisville, Pa.

"Practice 1st Class Radiotelephone Examinations—Multiple Choice—FCC Type Question". New book with new approach based on latest FCC Study Guide of Element 4. Diagrams, formulas, math the easy way. Send \$3.00 to Hilger Enterprises, Box 2798, Dept. B, Long Beach, California.

SINGLE SIDEBAND GENERATOR as described page 26, August CQ \$75.00 Longhorn Electronics, Inc. Box 157, Wolfe City, Texas.

1,000 W homebrew transmitter. Pair 100 T H final. Complete with modulator, power supply, and speech amplifier. VFO included. \$200.00, F. O. B. Anniston. Selling because of death of husband. Mrs. M. S. Adams, 1400 Glenwood Terrace, Anniston, Alabama.

RECONDITIONED! TERMS! GUARANTEE! Collins 32-V3 \$399.00; KWM-1 \$595.00; KWS-1 \$999.00; 75A4 \$499.00; Central Electronics 10B \$109.00; 600L \$299.00; B-W 5100 \$245.00; Gonset 500W Linear \$149.00; Communicator III-6 \$199.00; Hallicrafters SX-71 \$135.00; SX-88 \$349.00; SX-101 \$235.00; HT-30 \$309.00; HT-32 \$435.00; HT-33 \$429.00; SR34AC \$249.00; Hammarlund HQ-110 \$180.00; SP600JX \$499.00; HQ140X \$165.00; Heath DX-100 \$189.00; SB-10 \$75.00; Apache \$265.00; Johnson Viking II \$169.00; Pacemaker \$295.00; KW final w/desk \$995.00; National HRO60T \$345.00; NC-98 \$95.00; NC-183D \$234.00; NC-300 \$209.00; Regency ATC-1 \$49.50; TMC GPR90 \$355.00; Globe 65B \$65.00; 6 PMC Converter \$17.00; DSB-100 \$74.50; 300-A \$349.00; 500 \$375.00; 755 \$37.00; Leo WØGFQ, Box 919, Council Bluffs, Iowa—World Radio Laboratories.

For Sale: SX-101A \$250.00 6 Mo. Old; HT-32A \$450.00 2 Mo. Old. Viking Thunderbolt \$300.00 2 Mo. Old; Total \$1000.00 for package, all inquiries to Ronald F. Smetak WØIFL, c/o MOSLEY ELECTRONICS INC., 4610 N. Lindbergh Blvd., Bridgeton, Missouri.

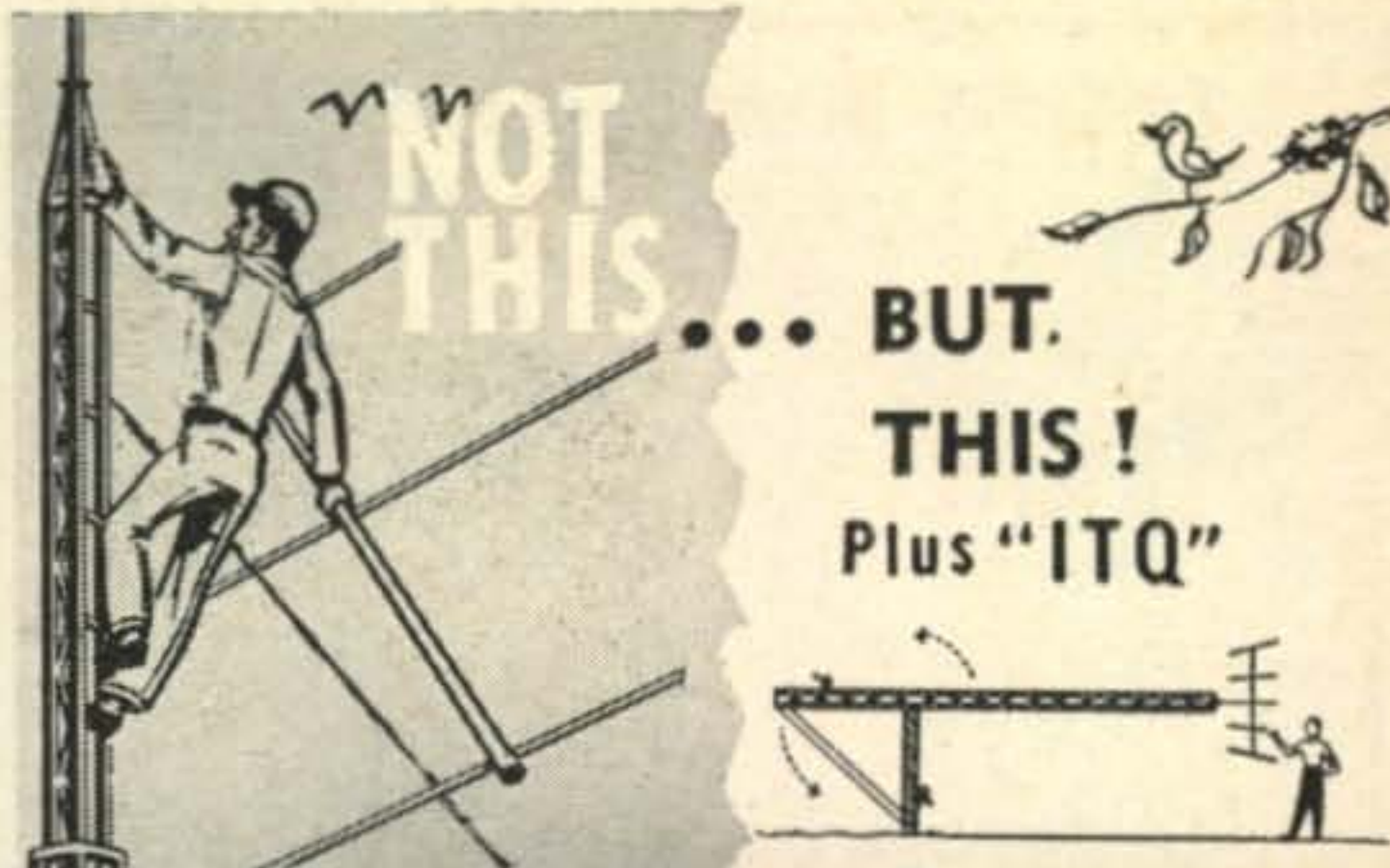

E-Z WAY TOWERS, INC.
P. O. BOX 5491 - TAMPA, FLA.

ALL BAND TRAP ANTENNA!

Reduces interference and Noise on All Makes Short Wave Receivers. Makes World Wide Reception Stronger, Clearer on All Bands!

For ALL Amateur Transmitters. Guaranteed for 500 Watts Power for Pi-Net or Link Direct Feed, Light, Neat, Weatherproof

Complete as shown total length 102 ft. with 87 ft. of 72 ohm balanced feedline, Hi-impact molded resonant traps. (Wt. 3 oz. 1"x5" long). You just tune to desired band for beamlike results. Excellent for ALL world-wide short-wave receivers and amateur transmitters. For NOVICE AND ALL CLASS AMATEURS! NO EXTRA TUNERS OR GADGETS NEEDED! Eliminates 5 separate antennas with excellent performance guaranteed. Use as Inverted V for all band power gain. NO HAYWIRE HOUSE APPEARANCE! EASY INSTALLATION!

80-40-20-15-10 meter bands. Complete \$14.95
40-20-15-10 meter bands. 54-ft. ant. (best for w-w swl's ... 13.95
20-15-10 meter bands. Dual Trap. 24-ft. antenna 19.95

SEND ONLY \$3.00 (cash, ck., mo) and pay postman balance COD plus postage on arrival or send full price for postpaid delivery.

Available only from:
WESTERN RADIO • Dept. AC-9 • Kearney, Nebraska

HAM-SWAP

The ONLY way to buy, sell or swap Ham Gear!
\$1 a year brings you 24 issues of bargains galore—PLUS the "Fastest Way in the World" to profitably dispose of your old or excess parts and equipment. FREE AD certificate and latest edition returned immediately if you send \$1 NOW to:
HAM-SWAP, Inc., 35-D East Wacker Drive, Chicago 1, Ill.

"HOW TO MAKE MONEY IN Mobile Radio Maintenance"

AUTHORITATIVE GUIDEBOOK
ABOUT THE BOOM IN TWO-WAY MOBILE-RADIO:
GIVES FACTS, FIGURES, PAY RATES,
WRITE TODAY!



LAMPKIN LABORATORIES, INC. Electronic Div. BRADENTON, FLA.

Telrex I75 RIS — the finest low cost rotator on the market!

- ★ 2 Stage Boston Gear Reducer
- ★ 1/12 HP. Motor
- ★ Selsyn Indicator

\$198⁵⁰

TELREX LABORATORIES
ASBURY PARK 40, N. J., U. S. A.

HAM SHACK NOVELTY

Authentic-looking, two-color gag certificate claiming tongue-in-cheek ownership of an acre on the Moon's surface. Ideal humorous gift or conversation piece for shack, bar, den or office. With gold seal and name and call inscribed only \$1.00 cash. Six for \$5.00. Send check or M.O. only to—
BOX DXG, 1738—201 St., Bayside 60, N. Y.

FAMOUS BC-645 TRANSCEIVER

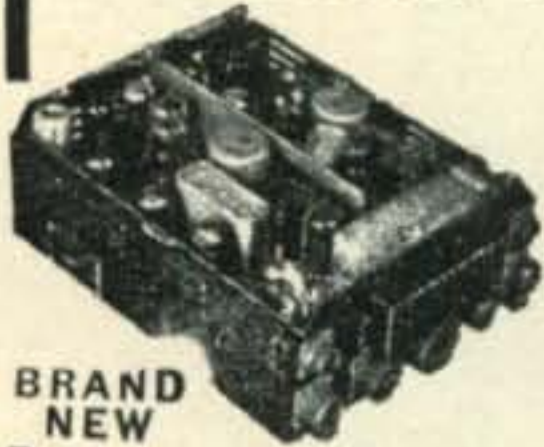

BRAND
NEW

15 Tubes 435 to 500 MC

Can be modified for 2-way communication, voice or code, on ham band 420-450 mc. citizens radio 460-470 mc, fixed and mobile 450-460 mc. television experimental 470-500 mc. 15 tubes (tubes alone worth more than sale price!); 4-7F7, 4-7H7, 2-7E6, 2-6F6, 2-955 and 1-WE-316A. Now covers 460 to 490 mc. Brand new BC-645 with tubes, less power supply in factory carton.

\$19.50

Shipping weight 25 lbs. **SPECIAL!**
PE-101C Dynamotor, 12/24V input \$7.95
UHF Antenna Assembly 2.45
Complete Set of 10 Plugs 5.50
Control Box 2.25

SPECIAL "PACKAGE" OFFER:

BC-645 Transceiver, Dynamotor and all accessories above.
COMPLETE, BRAND NEW,
While Stocks Last **\$29.50**

BC-603 FM RECEIVER

20 TO 27.9 MC. Exc. Used..... **\$14.95**

BRAND NEW **\$16.95**

10 Channel, pushbutton tuning or continuous tuning.
Complete with speaker, tubes, squelch.



12 or 24V Dynamotor for Above
Exc. Used \$4.25 Brand New \$5.50

BC-604 TRANSMITTER — Companion for BC-603 above.
With all tubes. BRAND NEW \$10.95 Used..... \$4.95

SPECIAL! BC-603 FM RCVR CONVERTED FOR ANY FREQUENCY FROM 30 TO 50 MC!

Checked out, perfect working condition, ready for operation. Specify Frequency desired (between 30-50 Mc) when ordering. BRAND NEW..... **\$27.50**

AC POWER SUPPLY FOR BC603, 604

Interchangeable, replaces dynamotor. Has On-Off Switch. NO RECVR. CHANGE NEEDED. Provides 220 VDC @ 80 Ma. 24VAC @ 2 Amps \$10.49
Complete 240-page Technical Manual for BC-603, 604..... \$3.15

SCR-274 COMMAND EQUIPMENT

ALL COMPLETE WITH TUBES

Type	Description	Excel. Used	Like NEW
BC-453	Receiver 190-550 KC	\$12.95	\$14.95
BC-454	Receiver 3-6 Mc	9.45	12.45
P-455	Receiver 6-9.1 Mc	9.95	12.50

110 Volt AC Power Supply Kit, for all 274-N and ARC-5 Receivers. Complete with metal case, instructions **\$7.95**
Factory wired, tested, ready to operate \$11.50

SPLINED TUNING KNOB for 274-N and ARC-5 RECEIVERS. Fits BC-453, BC-454 and others. Only **49c**

BC-457 TRANSMITTER—4-5.3 Mc. complete with all tubes and crystal. Exc. Used \$5.95 BRAND NEW..... **\$8.95**

BC-458 TRANSMITTER—5.3 to 7 Mc. Complete with all tubes and crystal. Exc. Used \$6.95 BRAND NEW..... **\$9.75**

BC-459 TRANSMITTER, 7-9.1 Mc. Complete with all tubes and crystal. Like New \$12.50 BRAND NEW..... **\$13.95**

BC-456 Modulator USED 3.45 NEW 5.95

ALL ACCESSORIES AVAILABLE FOR ABOVE

5-TUBE AMPLIFIER

HOT SPECIAL! Uses 2-6SN7, 2-6H6, 1-6X5. BRAND NEW Only **\$2.95**

DYNAMOTOR ASSEMBLY

Very fine unit, made by Collins Radio. Consists of TWO Dynamotors mounted on filter base.

	INPUT	OUTPUT
Dynamotor #1	12V DC @ 3.8A	220 VDC @ 100 Ma.
Dynamotor #2	12V DC @ 9.9A	400 VDC @ 180 Ma.

BRAND NEW in original packing; shpg. wt. 29 lbs. OUR LOW PRICE only **\$10.95**

MOBILE-MARINE DYNAMOTOR

Model DM35—Input 12V DC. Output: 625 V DC @ 225 Ma. for press-to-talk intermittent operation. Shpg. wt. 14 lbs. OUR LOW PRICE, BRAND NEW **\$8.45**

Please include 25% Deposit with order—Balance C.O.D., or Remittance in Full. 50c Handling Charges on all orders under \$5.00. All shipments F.O.B. Our Warehouse, N.Y.C. All Merchandise subject to Prior Sale and Price Change.

G & G

Radio Supply Co.

Telephone: CO 7-4605

53 Vesey St., New York 7, N. Y.

FOR SALE (Cont'd)

SELL: Eldico SSB 1000 kilowatt linear. Perfect condition, gray cabinet, half original price. \$385. K2CIV Tom Patterson, 50 Crescent Lane, Roslyn Heights, L.I., N.Y.

"Respo-Hams!!" "Polio-Quad Hams!!" Compiling catalog, please send call letters, rig information and bands used to Lamp-K8ABP, 108 N. Center St., Seville, Ohio.

BEGINNERS: Code bothering you? Now learned in one hour. New Method. Quick approach towards your ham ticket. Used in Armed Services, Ham Radio, Scouting. Ketchum's One Hour Code Course \$1.00 postpaid. MONEY BACK GUARANTEE—O. Ketchum, 10125 Flora Vista, Bellflower, California.

FOR SALE: Gotham D104N four element ten meter beam and CDR automatic rotator total cost \$60. Sell both for \$35. Will ship W5HSO Box 307 Belen, New Mexico.

COLLINS STATION: 30S-1, \$1200; 75S-1 with noise blanker, \$490; 32S-1, \$500; 516F-2 AC supply, \$90; 312B-4 console speaker; \$150; Central Electronics, MM-2 scope, \$100; Telrex 'Monarch' tri bander TBS 626, \$205; HAM-M rotor, \$85; Johnson TR switch, \$20; Johnson 52 ohm low pass filter, \$10; Astatic 10D with G stand, \$27. All prices F.O.B. Phoenix, Arizona, K73PD 3850 E. Elm. CR 9-2824. All above equipment in perfect condition. On the air less than 50 hours.

LEARN MORSE CODE IN 30 MINUTES! Thousands have learned to send and receive the Morse Code within Thirty Minutes by this simple new system. Complete Code Kit, only \$1.00. Moneyback Guarantee. Send \$1.00 to CODE, BOX 666, Whittier 47, California.

Sideband specials: HT-37 like new, \$379.95. Apache and SB-10, \$339.95. 20-A, QT-1 and VFO, \$199.95. HQ-180, excellent, \$359.95. National NC-303, \$379.95. Send for list. We buy as well as sell, trade. H & H Electronic Supply, 506 Kishwaukee St., Rockford, Illinois.

FOR SALE: New grounded grid linear filament choke, 30 amps, \$5.50 each. Herb Hoover, K4PIJ, 1126 Elizabeth St., Eau Gallie, Fla.

XTALS—3rd OVERTONE—\$1.25 32.16 MC-32.36, 32.4-32.7 K2OSC—310 Ann St., Harrison, N.J.

COILS: R.F., I.F., Chokes and Toroids wound to your Specifications. Any Quantity. Barrett Coil Company Inc., 1611 West Smith Ave., Orlando, Florida.

BC 620 Trans and rec new boxed in overseas boxes—\$12.95 complete parts for the BC 603 Rec's—Manuals \$1.00 each transformers, chokes, resistors, pots, tubes, dynamotors DM 34—\$4.00 each DM 35—\$5.50 each—MN 5 rec's trans \$45.00. Hundreds of other items send 10¢ to cover mailing etc. of list of parts and also your needs. Special grab bags \$2.00 each. Murray Brother's, 12 Adams Street, Charlestown 29, Mass.

WANTED

WANTED: Military and Commercial laboratory test and measuring equipment. Electroncraft, Box 399, Mount Kisco, N.Y.

WANTED: TELETYPE TG-7 and Model 15 and parts, printers and reperforators, etc.; COMM'NS and REC'V'RS AND XMTRS, e.g. BC-610-E, -I, BC-399A, Collins 51J, 17L3, -4; R-388 and R-390/URR; 18S-2, -3; ARN-14 and -30; APR-9, -10, ARC-21, 27, etc.; APS-31, -33, and TEST EQP'T, with TS- or 1-prefix. We pay freight. AMBER INDUSTRIAL CORP., 75 Varick St., N.Y. 13, N.Y.

WANTED: Teletype printers, perforators, reperforators, transmitter-distributors, test equipment: Model #14, #15, #19, #26, #28, GRC, TT, TGC, GGC, etc. All types Collins receivers, 51J, R-388, R-390, 75A, etc. Cash, or trade for NEW amateur equipment. Write Tom, W1AFN, Alltronics-Howard Co., Box 19, Boston 1, Mass. (Richmond 2-0048). Wanted to buy 1955 Ford auto radio. Will pay cash or trade radio tubes and parts.

ANY TUBES commercial test equipment, broadcasting equipment, any quantity. Diamond, 749 W. End Avenue, New York City.

WANTED for trade registered basset or toy dachshund puppy. Have new 4-1000A, 4X150A, 4-250A, 813's etc. Other dogs considered. Phil Lamarche W9DVM, 6003 Danube Way, Orlando, Florida.

For further information, check number 54 on page 126.

WANTED: Surplus measurement model 78 or 80 signal generators. Also Federal 804 or I-22 or used Motorola two-way equipment. State quantity, price, and condition. **COMMUNICATIONS SERVICE, INC.**, 3209 Canton Street, Dallas, Texas.

QSL

Picture QSL Cards of your shack, rig, home; made from your photograph. 1000 \$12.00. Raum's 4154 Fifth Street, Philadelphia 40.

QSL's-SWL's: That are different colored, embossed card stock, and "Kromekote." Samples 10¢. K8AIA, Box 953, Hamilton, Ohio.

QSL's-10 useable samples 10¢. Back issues CQ, QST, 75¢. Co-op, Box 5938 Kansas City 11, Missouri.

GLOSSY 3-color QLS cards 100-\$4.50. Free sampler. Rutgers Vari-Typing Service, 7 Fairfield Road, New Brunswick, N.J.

QSL's-SWL's: 100 2-color glossy \$3.00; 100 QSO file cards \$1.00; Sample 10¢. Rusprint, Box 7507, Kansas City 16, Missouri.

QSL Cards printed. 24 hours service, send dime for samples. QSL Printing Co., Box 12351, Houston 17, Texas.

QSL's-SWL's, samples 10¢. Malgo Press, 1937 Glendale Avenue, Toledo 14, Ohio.

QSL's-"Brownie" W3CJI, 3110 Lehigh, Allentown, Pa. Samples, 10¢, with catalogue, 25¢.

QSL's four colors glossy stock forty design send \$5 for 200 and get surprise of your life. 48 hour service satisfaction guaranteed, Constantine Press, Bladensburg, Md.

QSL's: Samples, dime. Print Shop, Corwith, Iowa.

QSL'S. Samples Free. Phillips, W7HRG, 1708 Bridge Street, The Dalles, Oregon.

OUTSTANDING QSL's... Dime... Filmmakers. Martins Ferry, Ohio.

QSL's, SWL's, XYL-OM's. (Sample assortment approximately 9 3/4¢). Covering designing, planning, printing, arranging, mailing, eye-catching, comic, sedate, fantabulous, DX-attracting, prototypal, snazzy, unparagoned cards, (Wow!) Rogers KØAAB, 737 Lincoln Avenue, St. Paul 5, Minnesota.

QSL CARDS: Printed in 2 colors on glossy krome kote cards. 2 designs especially for Mobil. \$2.75 for each 100 cards. 5¢ for sample card and brochure. Williams Printing, P.O. Box 2597, Van Nuys, Calif.

QSL's? SWL's? Largest variety samples 25¢ (refundable). CALLBOOKS American \$5.00; Foreign \$3.00. 'Religious' QSL samples 25¢. Sackers, W8DED, Holland, Michigan

QSL'S SWL'S Citizen Band. Nicholas & Son Printery P.O. Box 11184, Phoenix, Arizona. Samples 5¢.

MISC.

dedeeN neM laeR: Due to over 3 years of preparation, a staff of about 25 people is now being organized to delve into all phases of Radio Astronomy, Propagation and Moon Bounce. The experiments are to be conducted in a chosen isolated area, and supported by the staff members. If you are a single male, and feel like expressing yourself, then do not hesitate to mail your qualifications to Radiometric Research, Box 315, Mercury, Nevada.

HIGHLY EFFECTIVE home-study review for FCC Commercial Phone Exams. Free literature. Wallace Cook (CQ10), Box 10634, Jackson 9, Mass.

Ex W5HO-The famous S.S.B. talking dog and Geo. W. Fahrubel now K4DP, 1004 Drake Ave., S.E. Huntsville, Ala.



ONE DOLLAR

Your call letters hand engraved on a 14 carat, gold-plated tie clip for only one dollar, federal tax included. Send one dollar with your call letters, name and address to: Tie Clips, 28 Cunningham Road, Wellesley Hills 81, Massachusetts.

GOOD BUYS - ALL NEW

Extraordinary values await you in government surplus components. Our specialty is components; we have many of those hard to find items that you just won't see advertised elsewhere in surplus materials. Don't buy anything until you have our "Bargain Bulletin"; write for it today, it's free. New material is available to you for mere nickels and dimes on the dollar value. Here are some typical values:

RELAYS, all are beautifully constructed to govt specs.
 13 VAC coil, DPDT + SPDT, 10 amps, ceramic.....1# \$2.89
 12 VDC, 64Ω coil, DPDT, 20 a + SPST, 6 a, cer.....1# \$1.89
 Differential, 2-9000Ω coils, 2-SPDT sect, 2 a.....1# \$3.39
 115 VAC coil, DPDT at 5 amps, hermetic seal.....1/2# \$1.95
 Min. DPDT, 3800Ω coil, 1 amp cont. 28 VDC.....1/2# 89c

AUDIO TRANSFORMERS, a few typical values, many more.
 5 w output, 5KΩ:15Ω, ±1/2 db 16-18,000 cps, per pr 3# \$2.22
 Line match, 15KΩ to 600Ω, 50-10,000 cps, pot.....1 1/2# 69c
 25 w output, 8,000Ω ct, 15/125/250Ω, potted.....4# \$1.95
 Line to v c, Thord. 2-16Ω v c to 500Ω line.....2# \$1.39

PLATE & FILAMENT POWER TRANSFORMERS, 115 volt, 60 cycle.
 720 vet/135 mils, 5/3 and 6.3/3, potted.....12# \$3.79
 490 vet/130 mils, 5/2, 6.3/3, potted.....9# \$3.19
 800 ct/175, 80 v tap, 5/3, 6.3/2.5, 6.3/2.5.....9# \$4.44
 600 vet/350 mils, 12.6 v/11 amps, potted.....18# \$4.29
 Auto, 115 to 230 volts, 90 watts, potted.....7# \$2.29
 HV scope, 4500 volts/5 mils, 10 KV RMS ins.....10# \$1.95

FILAMENT TRANSFORMERS, 115 volt unless otherwise shown.
 5 vet/30 amps, 215/230 pri., 15 KV ins., Chl.....20# \$6.45
 6.3/0.6 potted, uses only 3 sq in chassis areal.....1 1/2# 79c
 6.3/27 amps, four windings, 3 amps are ct.....9# \$3.29

MISCELLANEOUS VALUES, all are outstanding.
 CW "Dream Filter", bandwidth 200 cps down 20 db.....4# \$6.95
 Oil cond., 15 mfd/330 VAC, HV ceramic terms.....3# \$2.29
 BC-610 40 meter coils, C-390-A, three for.....1# \$1.79
 3AP1 cathode ray tubes.....2# \$1.45
 3C24 triodes, Lewis and Kauffman, a pair.....2# \$5.55

and hundreds of other equal values appearing in the "Bargain Bulletin". Write for yours today!

Send adequate postage with orders. We refund any overage. All prices are FOB Sacramento. \$3.00 minimum order please.

JOE PALMER

PO BOX 6188 CCC, SACRAMENTO, CALIF.

For further information, check number 55 on page 126.

GUARANTEED CRYSTALS!

BUY NOW AND SAVE!!

ALL MARINE FREQ.-FT-243, DC-34 Holders. Tol. .005.....\$2.00
 POLICE, C.A.P., CD, MARS. Tol. .01%.....\$1.60
 CITIZENS BAND-11 METERS-.005% TOL.
 26.965 to 27.225 MC, 3rd Over. Herm. Seal. or FT-243.....\$2.50
 13.4825 to 13.6125 MC, 2nd Harm. Herm. Seal. or FT-243.....\$2.50
 6741.25 to 6806.25 Kc, 4th Harm. FT-243 only.....\$2.00

SPECIAL! STOCK CRYSTALS

FT-243 Holders 4035 KC to 8650 KC
 in steps of 25 KC's
 DC-34 Holders 1690 KC to 4440 KC
 steps of 10 KC

SEND FOR FREE CATALOG



NOVICE BAND FT-243 Fund.

80 Met. 3701-3748-Steps of 1 KC. FT-243
 40 Met. 7150-7198-Steps of 1 KC. FT-243
 Dbl. to 40 Met. 3576-3599. Steps of 1 KC. FT-243
 15 Met. 5276-5312-7034-7083 Steps of 1 KC. FT-243

86¢
ea.

FT-243-2 Meters (Steps of 1 KC).....\$.93
 FT-243-6 Meters (Steps of 1 KC).....\$.93
 FT-243-From 3000-4000.....\$.93
 FT-243-From 1005-2999 (Steps of 5 KC).....\$2.39
 FT-241 SSB Low Freq. Xtals 370 to 540 KC
 (Steps of 1.852 and 1.388).....\$.49
 FT-241 SSB Matched Pairs.....\$1.95

Open Friday Evenings until 9 P.M.

Include 5c per crystal for postage (U. S. Only) Calif. add 4% Tax. No. C.O.D'S. Prices subject to change. Ind. 2nd choice; substitution may be necessary. Min. Order \$2.50.

"The House of Crystals"

U. S. CRYSTALS, Inc.

1342 S. La Brea Ave. Los Angeles 19, Cal.

For further information, check number 56 on page 126.

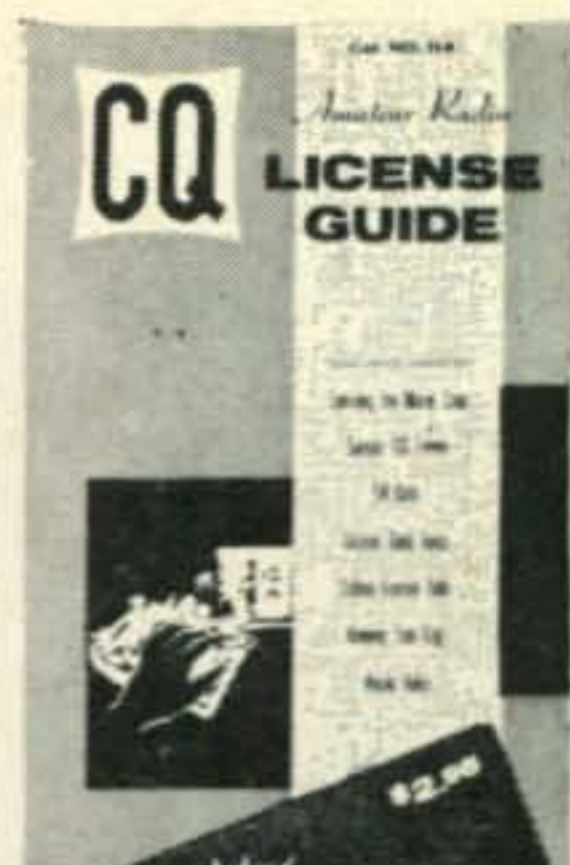

SURPLUS SCHEMATICS
This is a book literally loaded with schematics for all the currently popular pieces of the surplus gear. Most amateurs are well aware of the problems encountered in purchasing seemingly inexpensive surplus units, only to find that no schematic diagram is available. Why knock yourself out when you can have a book with complete coverage on hand in your library? All this for only \$2.50.

SIDEBAND HANDBOOK
Written by Don Stoner, W6TNS, was almost one full year in the preparation of this terrific volume. This is not a technical book. It explains sideband, showing you how to get along with it . . . how to keep your rig working right . . . how to know when it isn't . . . and lots of how to build-it stuff, gadgets, receiving adaptors, exciters, amplifiers. Price, only \$3.00.

LICENSE GUIDE
212 pages of everything the Amateur must have to get his license and progress toward the general class ticket. Plus many additional pages of vital information for the ham operator. All this for only \$2.50.

CQ ANTHOLOGY
Most amateurs do not have a good file of back issues of CQ. So we've looked back through the years 1945-52 and assembled all in one place the articles that have made a lasting stir. The issues containing most of these articles have long ago been sold out. The price is a paltry \$2.00.

CODE RECORD
Learning code is a snap with this record. Speeds from 3 to 16 WPM, depending upon turntable speed. This 12" LP record has on it all you need to learn the code for both the Novice and General License. \$3.50 each.

HAM'S INTERPRETER
Now you can talk in broken French, Spanish, Italian, German, Swedish and Finnish. This handy little book gives all the popular ham conversation in seven languages, including letters and numbers. Only \$1.50 postpaid.

MOBILE HANDBOOK
Anyone who tries to go mobile without getting this book should register for a sanity hearing. Bill Orr, W6SAI has put everything you need to know in this book. Build-its by the dozen . . . solutions to ignition problems, keeping the battery charged, noise . . . only \$2.95 postpaid.

ALL ABOUT MISSILES & SATELLITES
Here's a book, written in down-to-earth language, which answers questions on missile maintenance, fire control, flight control tracking, testing, fuels, payload and many other achievements in rocketry and space for both scientific and military applications. Also, featuring the most up-to-date "Directory of 38 Most Popular Missiles and Their Photos," (supplied by Department of Defense) as well as a "Glossary of Missile Terms." \$1.50 per copy.

HI-FI BOOK
This nifty volume contains the latest dope on amplifiers, pre-amplifiers and equalizers plus a buyer's guide of component manufacturers! Over 150—5½" x 8½" pages of heavily illustrated descriptions covering Hi Fi Audio Components—the greatest publication value in its field today. Only \$2.50 per copy.

TVI HANDBOOK
WIDBM's newly written TVI book (2nd edition) covers all aspects of curing TVI from both the Ham's viewpoint and that of the TV viewer or the TV serviceman. It includes 2- and 6-meter TVI as well as Citizen's Band, Industrial, Medical and Utility TVI. Profusely illustrated with diagrams, photos, charts, tables and FCC regulations pertaining to radio and television interference. Price \$1.75 postpaid, USA, \$2.00 Foreign.

COMMAND SETS
This IS a collection of reprints, containing all of the available information on the conversion of the popular "Command" transmitters and receivers into good ham transmitters and receivers. Invaluable for Novice, Technician, General, Advanced and Extra class operators. 136 fabulous, amazing terrific pages for only \$1.50 postpaid.

BOUND VOLUME
By far the handiest way to keep your library. Why not go first-class? This impressive volume is only \$10.00. We only made a few of them this year, so Don't expect to get one later.

19" GLOBE
Here is a chance to preserve your breath for posterity! This beautiful World Globe, made by Hammond, is a must for every hamshack. Plain for \$19.95 or lighted for \$24.95. The first 10,000 people who jump at this bargain will get a year of CQ at no extra charge.

BINDER
There is no other good way to keep your back issues. Make 'em neat. We supply the binder, with the year embossed in gold, not merely a sticker which will come off later. Specify what year you want stamped on your binder. \$3.50 each.

ATLAS
What! You don't know where Nicobar Island is? Incredible! And with the CQ deal on the Hammond Atlas so reasonable too. This is a reference book that will get good usage around your house if you have any kids. 7 lbs. of colored maps and a gazetteer for only \$12.50 . . . and you get a year of CQ.

LOGS
Log Sheets of the most astounding modern design. Infinitely superior to any others on the market. And they are only \$1 for a pad of 100 sheets. Specify Regular or SSB type.

COWAN PUBLISHING CORP. CQ 10
Book Division
300 West 43rd Street
New York 36, N. Y.

LIGHTED GLOBE	\$24.95	<input type="checkbox"/>
UNLIGHTED GLOBE	19.95	<input type="checkbox"/>
ATLAS	12.50	<input type="checkbox"/>
COMMAND SETS	1.50	<input type="checkbox"/>
MOBILE HANDBOOK	2.95	<input type="checkbox"/>
CODE RECORD	3.50	<input type="checkbox"/>
REGULAR LOG SHEETS (100)	1.00	<input type="checkbox"/>
SSB LOG SHEETS (100)	1.00	<input type="checkbox"/>
HAM'S INTERPRETER	1.50	<input type="checkbox"/>
TVI HANDBOOK	1.75	<input type="checkbox"/>
BINDER—YEAR WANTED	3.50	<input type="checkbox"/>
BOUND VOLUME	10.00	<input type="checkbox"/>
CQ ANTHOLOGY	2.00	<input type="checkbox"/>
MISSILES & SATELLITES	1.50	<input type="checkbox"/>
HI-FI BOOK	2.50	<input type="checkbox"/>
SIDEBAND HANDBOOK	3.00	<input type="checkbox"/>
CQ LICENSE GUIDE	2.50	<input type="checkbox"/>
SURPLUS SCHEMATICS HANDBOOK	2.50	<input type="checkbox"/>

SIRS: My check (money order) for \$ _____ is enclosed. Please send the following items to:

Name _____

Address _____

City _____ Zone _____ State _____

New York City Residents Add 3% Sales Tax

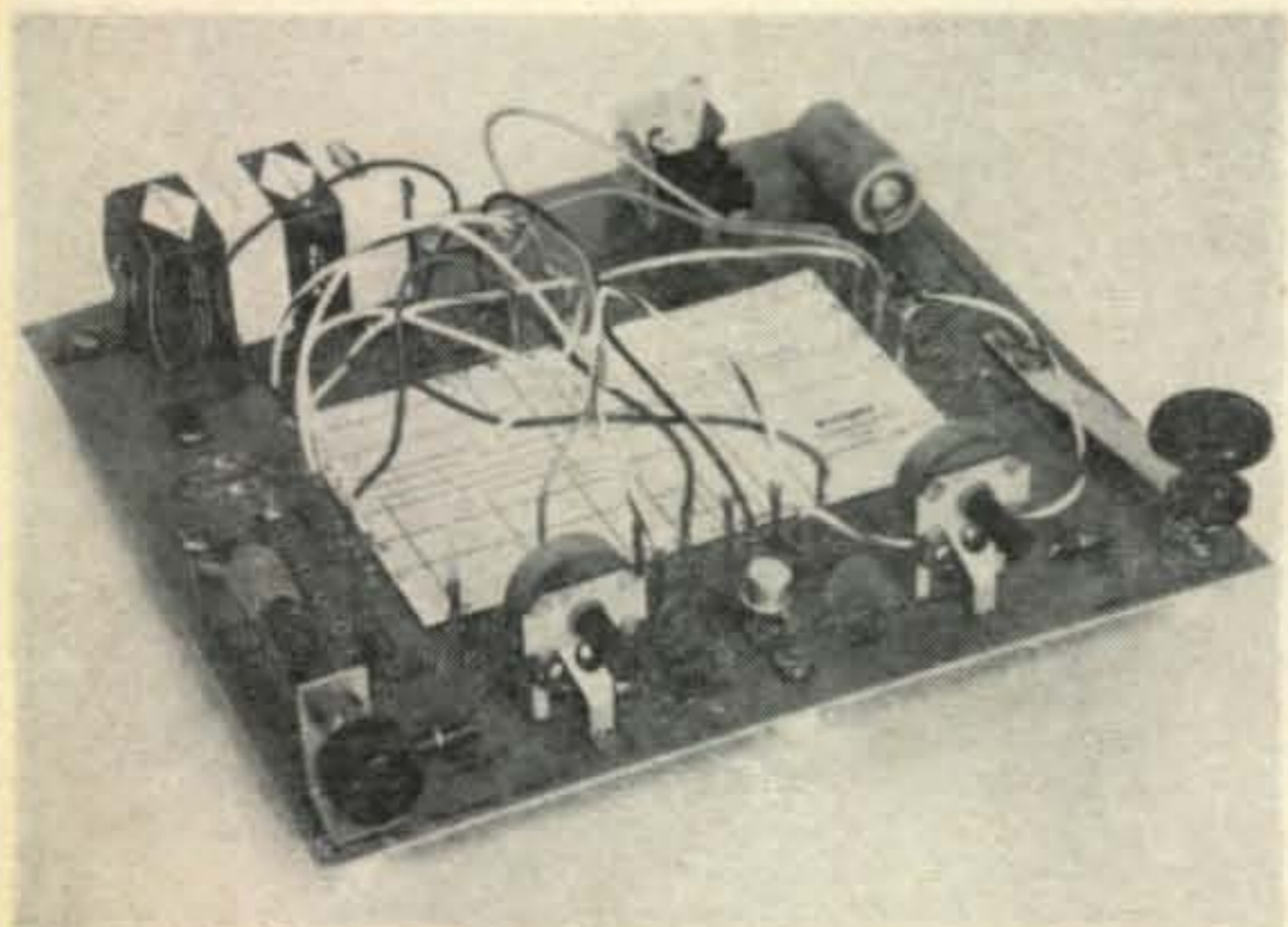

Want to experiment with transistors? Nothing could be more informative than the Knight 10-in-one Transistorized Electronic Lab Kit. With it you can build a radio, light operated relay, wireless broadcaster, code practice oscillator, and many other circuits. The circuit actually plugs in, and the individual cards show you how!

etched pits are flat to within one wavelength of sodium light—and are in mass production.

Radio Corporation of America has cut the price of their 2N1300 transistor by 36%. The new price in 1K quantities is only \$1.60 for a mesa computer transistor! The device is capable of switching in the 5 mc range, bandwidth of 25 mc, and C_u dissipate 150 mw at 25°C. Speaking of switching transistor, RCA is now marketing the fabulous 2N706 and 2N706A which has a gain bandwidth of 400 mc, operates between -65 and +175°C, and has a dissipation of 1 watt at 25°C. This transistor will deliver a good portion of a watt at 144 mc!

Sylvania is now marketing a new series of varactor diodes their type numbers D-4140A to E and D-4141A to E. Intended for parametric applications they go as high at 70 kmc and \$100. For switching applications, they have announced a new NPN germanium alloy transistor, type 2N1605, to complement the PNP 2N404 for symmetrical computer circuits. Of interest to experimenters is the new 2N464 to 467 series of general purpose PNP audio frequency transistors. The units have a 150 mw dissipation rating and are in the \$1.50 to \$2.00 range.

Texas instruments has received the first all-transistorized data processing systems, an IBM type 7070. The new computer which will be used to solve TI's industrial questions can add or subtract 17,000 five-digit numbers per second, remember "instructions", and make 27,700 logic decisions per second. It has more than 500,000 magnetic ferrite cores for memory, can store up to 100,000 digits or letters at a time, and put them to work in six-millionths of a second! Needless to say, the IBM brain uses all TI semiconductors, 41,000 of 'em to be exact!!

73, Don, W6TNS

G4ZU

FAT.

CLIMATIZED BEAMS LESS EXPENSIVE BY FAR YOUR FIRST COST THE LAST

No Traps mean equal results in all climates. Will not break down in tropical heat, arctic blasts or salt water spray.

20/40 Meter Birdcage with New Collapsible, 1 man operated, masts plus low loss cylindrical stubbing. Nine foot turning radius \$94.50

10-15 and 20 Minibeams (Not Miniature). Sturdy low loss construction. High gain 13'6" turning radius \$89.50

Rohn 25G stand up towers. Can be tilted by adding tilt base plate.

30 feet 1 1/4 inch side rails \$ 64.15

40 feet Engineered Amateur top \$ 82.40

50 feet Heavily galvanized steel \$100.65

Rohn 50' Fold Over Mast—Tops in its field. No ladders needed to reach antenna \$186.50

Cornell Dubilier AR22 Rotators \$ 32.75

100 Feet 4 wire cable for AR22 \$ 2.95

Special for October

25' collapsible, telescoping masts \$12.50

30' 16 gauge, steel tubing with clamps, etc. \$16.50

Only a portion of our large stock of accessories.

IMMEDIATE DELIVERY
CREDIT ACCOMMODATIONS

HOUSE of ANTENNAS

1155 East 82nd St.
Chicago 19, Ill.
Tel. SO 8-9282

For further information, check number 57 on page 126.

TS 36 WE-X BAND POWER METER	\$ 14.95
TS 45-X BAND SIGNAL SOURCE	\$ 14.95
TS 76-TEST METER	\$ 9.95
TS 102A-CALIBRATOR	\$ 14.95
TS 173-FREQUENCY METER	\$124.50
TS 196-BRIDGE	\$ 24.95
TS 247-WAVE METER	\$ 14.95
STANDARD LABORATORY RECEIVER APR-4 with 3 Tuning Units. Frequency 38-1000 MC. Checked out.	\$159.50
MEASUREMENTS CORP. 79-B PULSE GENERATOR. Checked out	\$ 39.50
GEN. ELECT. COMPUTER TESTER. New	\$ 29.95
MD 7-MODULATOR with Tubes	\$ 5.95
BC 442-ANTENNA RELAY with Condenser	\$ 2.95
Less Condenser	\$ 1.49
ARC 3-RECEIVER 100-156 MC	\$ 14.95
ARC 3-TRANSMITTER 100-156 MC with 2-832A's	\$ 16.95
WEST. ELECT. SOUND POWER TRANS. New	\$ 1.29
BC 620-TRANSCIVER. Citizens Band FM-20-28 MC	\$ 16.95
METER-3"-0.5 MA. 270° indication By-Pass Shunt and add scale. Excellent condition	\$ 1.29
TELEGRAPH KEY-J47. New	\$ 1.29
ART-13-TRANSMITTER with tubes and meters	\$ 29.95

Send M.O. or check with order
Write for Bargain Flyer

R W ELECTRONICS

2430 S. MICHIGAN AVE.
Phone: CALumet 5-1281

DEPT. CQ
Chicago 16, Ill.

For further information, check number 58 on page 126.

ADVERTISING INDEX

FREE Catalog

OF THE WORLD'S FINEST
ELECTRONIC GOV'T
SURPLUS BARGAINS



MOBILE COAXIAL CHANGE OVER RELAY

Used with SCR-522 and ARA-8
equipment for switching antenna.
Has 24 Volt relay tapped at 12 Volts,
3 ea. SO-239 co-
axial connectors
and power plug.
Mounted in metal
box, size: 3x3½x3".



Antenna Relay No. RE-13/ARA-8,
Price —
Unused **\$4.95**

Connector for power plug.....\$2.00

Address Dept. CQ • All Prices are
F.O.B., Lima, Ohio. • 25% Deposit
Required on C.O.D. Orders.

FAIR RADIO SALES
2133 ELIDA RD. • Box 1105 • LIMA, OHIO

New! Telrex "Spiralray"

Extremely high-gain, high signal-to-noise,
practically no fade, all radiation planes —
horizontal, vertical or oblique! Ideal
for scatter-wave, satellite, mobile or
point to point work! 50, 108 and
144 megacycle models available

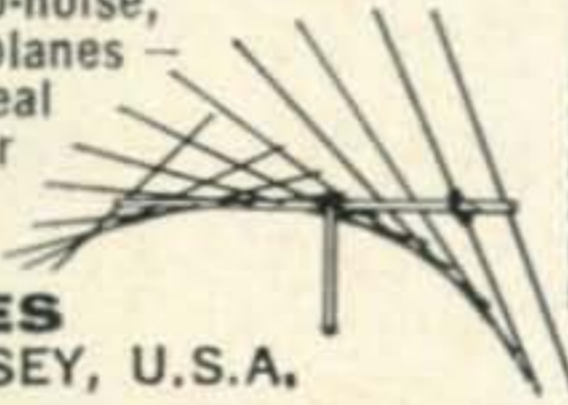

TELREX LABORATORIES
ASBURY PARK 40, NEW JERSEY, U.S.A.

READER SERVICE

CQ Magazine, Dept. RS

300 WEST 43rd STREET
New York 36, N. Y.

Coupon K

Void after

Oct. 25, 1960

Please send me information on your ads in
the Oct. 1960 CQ keyed as follows:

1	2	3	4	5	6	7	8	9	10	A
11	12	13	14	15	16	17	18	19	20	B
21	22	23	24	25	26	27	28	29	30	C
31	32	33	34	35	36	37	38	39	40	D
41	42	43	44	45	46	47	48	49	50	
51	52	53	54	55	56	57	58	59	60	
61	62	63	64	65	66	67	68	69	70	

NAME _____

(Please Print)

Call _____ Engineer

Type of work (specify) _____

ADDRESS _____

CITY _____

ZONE _____ STATE _____

ACF Industries, Inc.	16
Allied Radio Corporation	128
Alltronics-Howard Company	118
American Crystal Company	116
Baer, Chuck	106
Barker & Williamson Incorporated	17
Barry Electronics Corporation	120
Bay Craft Gifts	115
Burghardt Radio Supply	110, 113
Bursteln-Applebee Company	113
Cambridge Thermionic Corporation	23
Centralab	12
Central Electronics Incorporated	25
Cleveland Institute of Electronics	16
Collins Radio Company	Cover II
Communication Products Company, Inc.	29
Continental Electronics & Sound Co.	115
Cush Craft	119
CQ's Classified Ads	120
CQ Gov't. Books	112
CQ Ham Mart	124
CQ November Announcement	96
CQ Subscription Ad	96
CQ Worldwide DX Zone Map	115
Delehanty Institute	118
Dow-Key Company, Incorporated	114
E-Z Way Towers, Incorporated	114, 116, 121
EICO	15
Evans, Cliff	112
Fair Radio Sales	126
G & G Radio Supply Company	122
General Electric Company	27
Gonset Company	21
Greenlee Tool Company	108
Hallcrafters Company	3
Hammarlund Manufacturing Company	5, 118
Ham-Swap, Incorporated	121
Harvey Radio Company, Incorporated	101
Heath Company	7, 8, 9
Henry Radio Stores	103
Hewlett Sales Company	28
Hornet Antenna Products Company	34
House of Antennas, The	125
Hy-Gain Antenna Products	20
Instructograph Company	116
Johnson, E. F. Company	36, 37, 38, 39
K & S Electronics	24
Knights, James Company, The	35
Lafayette Radio	107
Lampkin Laboratories, Incorporated	121
Millen, James Manufacturing Co., Inc.	4
Millwood Studio	115
Mosley Electronics, Incorporated	13, 19
National Radio Company, Incorporated	Cover V
Northeast Telecommunications, Inc.	26
P & H Electronics	119
Palmer, Joe	123
Pennwood Numechron Company	117
Petersen Radio Company, Incorporated	1
RCA Tube Division	Cover VI
RW Electronics	125
Radio Shack Corporation	105, 109
Rad-Tel Tube Company	111
Shure Brothers, Incorporated	32
Skyline Products	117
Smetak, Ron	115
TAB	127
Telrex, Incorporated	31, 121, 126
Texas Crystals	22
Triad Transformer Corporation	18
Turner Microphone Company	14
U.S. Air Force	6
U.S. Crystals, Inc.	123
Vibroplex Company, Incorporated	117
Western Radio Company	121
World Radio Laboratories, Inc.	Covers III, IV
Yuba Consolidated Industries, Inc.	33

NEW POWER CONVERTER

12VDC to 500VDC
up to 200MA
100 Watts; Tap at 250VDC
Type C1250E \$35



Hi efficiency, low ripple, low idle current—Silicon rectifiers! Toroidal HiEff! Magnetal tape wound transformer, fused & short circuit proof, small in size! Quiet! Light weight! C1250EE built, ready to go. Conservatively Rated. Delco Transistors Heavy Copper-Heatsink.

12VDC to 250VDC up to 150MA
Type C1225A \$30

"TAB" GUARANTEED XTALS!

HAM BAND 80 or 40Mtrs... \$1@
NOVICE BAND ... \$1@
CITIZENS BAND ... \$3@
Include 1st, 2nd, 3rd & 4th choice!
On XTALS!
*Postpaid 48 States XTALS Only

DC POWER SUPPLIES for TRANSISTORS!
New low-cost filtered 0.5% Ripple Power Supply. Same as specified in Transistor Manual G.E. Ideal for Powering transistor circuits, small in size!

12VDC at 150Ma-
T12V150M \$ 8
25VDC at 150Ma-
T25V150M \$10
40VDC at 1 Amp-
T40V1A \$19

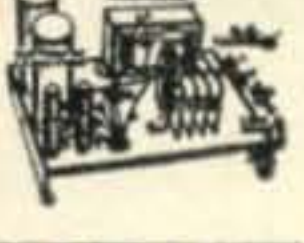

NEW BATTERY CHARGER !!! FOR 2V OR 4V OR 6V OR 12 VOLT BATTERIES, TRICKLE & FULL CHARGE up to 4 AMP

Charges 2-4-6 & 12 volt
batteries.



Built BCK-1 \$13.50

"TAB"—THAT'S A BUY!—BARGAINS!!

AN-ARR2/RCVR less tubes A-1 condn \$1.95
RDZ/USN 200-400 Mes Revs As Is \$25
G.E./YRS-1 Side Band Selector \$45
829B Socket 85¢, 2/\$1.50, 813 Socket \$1
4x150 Ceramic/LORTAL 2 for \$1.00
W.E. 416B Higain—HiMu \$4

Leece Neville Charger Systems
"SILTAB" Silicon Rectifier Replacement
Non-Aging Hermetically Sealed
FOR 6 or 12VDC @ 100A. Type YJ9 \$24
If U Don't See It Write!

NEW "SILICON 750 Ma RECTIFIERS WORKING VOLTS RMS—ACV INPUT! Order 10 or More 750Ma deduct 10%

rms/piv	rms/piv	rms/piv	rms/piv
35/50	70/100	140/200	210/300
19¢	29¢	34¢	43¢
rms/piv	rms/piv	rms/piv	rms/piv
280/400	350/500	420/600	490/700
50¢	62¢	80¢	95¢

rms/piv	rms/piv	rms/piv	rms/piv
560/800	630/900	700/1000	770/1100
\$1.05	\$1.25	\$1.70	\$2.00

Use in Bridge or C.T. up to 1 Amp DC
*Derate 20% for Capacitive input
"TAB" Special General Purpose Silicons
400 PIV @ 300Ma 39¢@, 25 for \$8.00
General Purpose & Replacement
*Silicon 400PIV at 250 Ma Rectifiers
Hi-Temp 100°C at 252V/RMS. Special 2 for \$1, 25 for \$10.

EXPORTERS-OEM-DISTRIBUTORS
Write for Data & Qty Prices
Silicon Orders \$20 shppd prepaid U.S.A.

PROTECT THAT METER "TABISTOR"
LOW LEVEL VOLTAGE
REGULATING DIODES
TG150 1V@100Ma 50¢, 5 for \$2
TM2K 2V@2000Ma 90¢@, 3 for \$2

SELENIUM

PHOTOCELL—

"SUNTAB"®



5AP ROUND 1 1/8" Dia.—250ua \$1.00
10AP ROUND 1 1/2" Dia.—380ua \$1.75
15AP ROUND 2" Dia.—750ua \$3.00
2BP RECT 3/4 x 7/16—75ua70
5BP RECT 1-7/16 x 3/8—200ua \$1.35
10BP RECT 1-11/16 x 3/4—380ua \$1.80
KIT ALL SIX ONE EACH \$7.00

ORDER QTY'S TEN OR MORE
DEDUCT 20%
THIS ITEM SHIPPED POSTPAID
ORDERS \$5 UP.

"TAB"

THAT'S A BUY



"TAB" Tubes Tested, Inspected, Boxed

Six Months Guaranteed! No Rejects!

GOVT & MFGRS Surplus! New & Used
0A270
0A380
0B265
0C370
0D350
0Z480
1A790
1B378
1L482
1R4 5/\$1

6BZ7 1.25
6C445
6C569
6C6 1.08
6C8 1.08
6CB689
6CD6 1.49
6CF685
6CL6 1.40
We Trade!
RK59 1.39
RK60 1.17
HY69 2.20
7581
HY75 5.00
83V95

We Swap Tubes! What Do/U Have?
1R578
1S478
1S568
1T485
1T595
1U4 6/\$1
1U575
IX299
2C39A 9.00
2C40 5.50

Send 25¢ for Catalog!
2C43 6.50
2C51 2.00
2D2165
2E22 1.75
2E24 1.90
2E25 2.50
2E26 2.75
2E30 1.70
2E35 1.60
2K25 9.75

All Tubes Stocked at Low Prices!
2K26 34.00
2K28 30.00
2V3 2/\$1
2X248
3A470
3A5 1.00
3AP1 5.95
3BP1 3.99
3C24 3.50
3D23 3.95

We Buy! We Sell! We Trade.
3E29 6.00
3Q468
3Q586
4-65A 13.50
4-125A 27.50
4-250A 34.00
4X150A 7.00
4X250 36.00
4X500 37.00
5AP1 2.95

Wanted Test Sets and Equipment
5BP1 5.02
5BP4 5.00
5CP1 4.99
5CP7 9.00
5R4 1.00
5T490
5U499
5V489
5Y360
5Z389

Send 25¢ for Catalog!
15GP22 89.00
6A7 1.00
6A899
6AB459
6AC772
6AG565
6AG775
6AK569
6AL559
6AQ566

Top \$\$\$ Paid for 304TL tubes
6AR6 1.95
6AS7 3.49
6AT6 2/\$1
6AU679
6B8 1.35
6BA659
6BE659
6BG6 1.49
6BH679
6BJ672

Top \$\$\$ Paid for XMITR Tubes!
6BK799
6BL7 1.35
6BN469
6BN6 1.08
6BN7 1.99
6BQ6 1.19
6BQ799
6BX7 1.11
6BY5 1.19
6BZ691

TERMS: Min Order \$3—25%
with order F.O.B. New York.
Ten day guarantee, price of
mdse. only. Our 15th year.
Prices shown are subject to change.

111CN Liberty St., N. Y. 6, N. Y. RE 2-6245

SELENIUM F.W. BRIDGE RECTIFIERS

DC AMP	18VAC 14VDC	36VAC 28VDC	72VAC 54VDC	130VAC 100VDC
1/2	\$1.00	\$1.90	\$3.85	\$5.00
1	1.30	2.00	4.90	8.15
2	2.15	3.00	6.25	11.10
3	2.90	4.00	8.60	13.45
6	4.15	8.00	18.75	31.90
10	6.10	12.15	26.30	41.60
12	7.75	14.90	30.95	43.45
20	12.85	24.60		
24	15.00	29.45		

New "TABTRAN" Rectifier Xfms

Sec'd Volts (DUAL) 0-9-15-18-& 0-9-15-18. Series Sec'ds 0-3-6-9-12-15-18-21-24-27-30-33-36 Volts.

Write for Rectifier Catalog
TR4001 @ 1 Amp ea/sec/winding \$5.15
TR4002 @ 2 Amp ea/sec/winding \$7.15
TR4003 @ 5 Amp ea/sec/winding .990
†Wdngs in Series at Ratings shown: Parallel 2X Current. Voltage output. 0-9-15-18

RECTIFIERS 130V/RMS HALF-WAVE

75Ma 49¢, 5 for \$2; 100Ma 59¢, 6 for \$3
150Ma 70¢, 8 for \$5; 250Ma 79¢, 6 for \$4
300Ma 88¢, 5 for \$4; 350Ma \$1.00, 8 for \$7
400Ma \$1.10, 5 for \$5; 500Ma \$1.35, 5 for \$5
This Item P.Pd. 48 states orders \$10.

WE BUY! SELL & TRADE Send 25¢ for Bonus Catalog!

"VACDAC"® SILICON TUBE REPLACEMENTS WITH BUILT IN RF SURGE & SERIES BALANCING PROTECTION

TYPE	VRMS/PIV	AMPS	PRICE
ST866	5000/10400	0.3	\$20.00
ST816	5000/7000	0.3	\$16.00
ST5R4	1900/2800	0.5	\$15.00
ST5U4	1120/1600	0.6	\$ 8.00

HDQTRS. TRANSISTORS & ACCESSORIES

2N441/\$3; 2N442/\$4.50; 2N277/\$4; 2N278/\$5;
2N155/\$1.39; 2N176/\$1.80; 2N177/\$1;
2N178/\$1.75; 2N247/\$1.50; 2N255/\$1.20;
2N270/95; 2N274/\$1.25; 2N408/80;
2N554/\$1.20; 2N578/\$1.80; 2N579/\$2.20.

DIAMOND BASED MICA MTG KIT30
DELCO ROUND BASED MICA MTG
KIT30
DELCO FINNED POWER HEAT
SINK75

Send 25¢ for Catalog

Wanted 304TL Tubes & ALL TYPES!!!

"TAB" FOR THE BEST KITS!

99¢
KITS! Each "TAB" Kit Contains The Finest Selection!!!
Kit 5 Mylex Glass/HF Strips
Kit 35 Precision Resistors
Kit 10 Switches
Kit 75 Resistors 1/2/1/2W
Kit 150 Carbon Resistors
Kit 25 Panel Lamps
Kit 12 Electrolytic Cond's
Kit 15 Volume Controls
Kit 56 Tube Sockets
Kit 65 Tubular Condensers
Kit 500 Lugs & Eyelets
Kit 500 Bathub Oil Cond's
Kit 5 lbs. Surprise Package
Kit 10 Transist Mica Cond's
Kit 3 Phone/Patch Xfms
Kit 3 Phone/Cement
Kit 3 Searchlights
Kit 4 AN/Reflector Lites
Kit 6 Instd Tuning Tools
Kit 2 AN Plugs & cnettrs
Kit 2 Bakelite Panels 6x12"
Kit 5 pcs Wrench Set
Kit 8 pcs Nut Driver Set
Kit 10 ea Phonoplugs & Jacks
Kit 25 ft Lo-Cap Mike Cable
Kit 18' Lo-Cap 2 Cond M-Cable
Kit 20 ft RG59 Coax Cable
Kit 15 ft RG11U Coax Cable
Kit 2 pair S0239 & PL59
Kit 12 Binding Posts Asstd
Kit 5 Phone Jacks Asstd
Kit 3 Phone Plugs Asstd
Kit 3 Long Nose Pliers
Kit 2 Side Cutter Pliers
Kit 2 Xmtr Variables
Kit 5 of 2mfd @ 600wvdc/oil
Kit 5 of 2mfd @ 600wvdc/oil
Kit 5 AN Plugs & cnettrs
Kit 5 Sub-Min Tubes
Kit 40 Standoff Insulators
Kit 35 Power Resistors
Kit 75 Mica Condensers
Kit 5 Crystal Diodes
Kit 200ft Hook Up Wire.
4 Rolls, 50ft/ea. Asstd. Color
Kit 100 Fuses, assorted types
Kit 100 Ceramic Condensers
Kit 5 FT243 Xtal Holders
Kit 5 Microswitches
Kit 10 Wheel Lamps
Kit 3 Transistor Xfms
Kit 8 Xtal Osc-Blanks
Kit 4 Asstd Rectifiers
Kit 12 Alligator Clips Asst
Kit 5 UG/Connectors
Kit 100 Self/Tap Screws
Kit 5 Mycalex Glass/HF Strips
Kit 35 Precision Resistors
Kit 10 Switches
Kit 75 Resistors 1/2/1/2W
Kit 150 Carbon Resistors
Kit 25 Panel Lamps
Kit 12 Electrolytic Cond's
Kit 15 Volume Controls
Kit 56 Tube Sockets
Kit 65 Tubular Condensers
Kit 500 Lugs & Eyelets
Kit 500 Bathub Oil Cond's
Kit 5 lbs. Surprise Package
Kit 10 Transist Mica Cond's
Kit 3 Phone/Patch Xfms
Kit 3 Phone/Cement
Kit 3 Searchlights
Kit 4 AN/Reflector Lites
Kit 6 Instd Tuning Tools
Order Ten Kits We Ship Eleven!!!
ONE EACH ABOVE KIT ONLY

For further information, check number 59 on page 126.

get in on the
VHF fun at

ALLIED-

your best supply source



GONSET COMMUNICATOR IV
2 Meter Transceiver
Stock No. 78 SZ 152 \$369.50

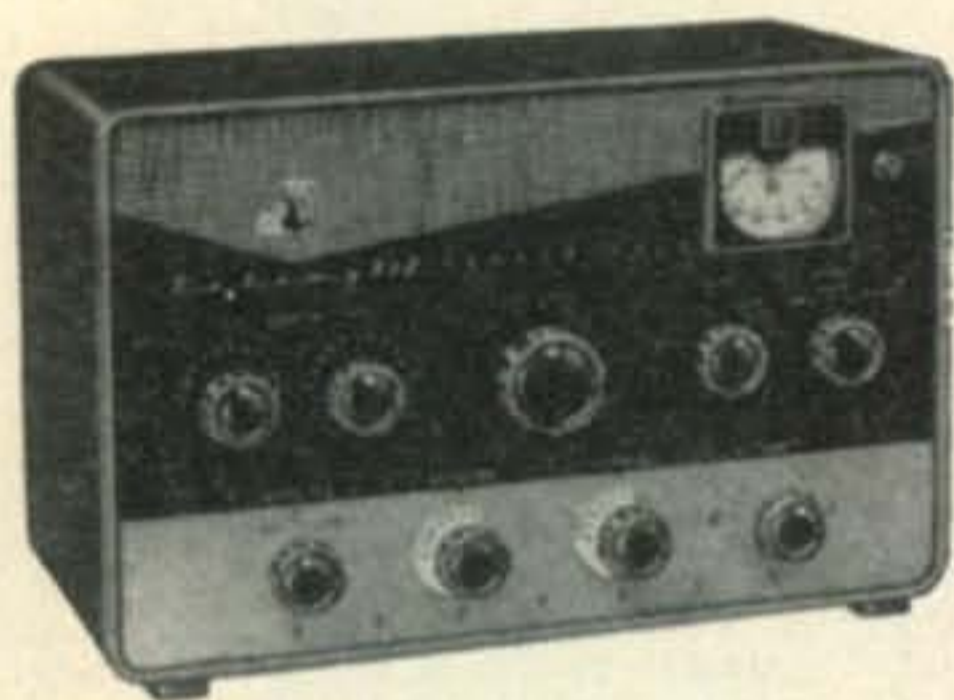

JOHNSON VIKING
"6N2" TRANSMITTER
6 & 2 Meter Transmitter
No. 94 SU 851, Wired . . . \$169.50
No. 83 SU 844, Kit, 129.50



JOHNSON VIKING
"6N2" THUNDERBOLT
K.W. Power Amplifier
No. 77 SZ 840, Wired . . . \$589.50
No. 77 SZ 841, Kit, 524.50



RME VHF-126
CONVERTER
6, 2, 1 1/4 Meter
Tunable Converter
Stock No. 83 SU 598 \$239.00

HERE'S WHY YOU DO BEST AT ALLIED

**IN STOCK FOR
IMMEDIATE DELIVERY**

We also carry a complete line of Tecraft VHF Transmitter-Converters, as well as Hy-Gain, Telrex and Mosley VHF antennas

ONLY \$2 DOWN on orders up to \$50; only \$5 down on orders up to \$200; only \$10 down over \$200. Up to 24 months to pay . . .

FOR THAT BEST DEAL on the new equipment you want, write to Jim Sommerville, W9WHF, c/o Allied, or stop in at our Ham Shack and meet Joe Huffman, W9BHD, Joe Gizzi, W9HLA, Jack Schneider, W8CZE . . .

HAM-TO-HAM HELP—Our staff of 35 Hams will go all-out to give you the help you want, whether you write or call in or visit us in person. You'll like the friendly attention and interest you get *all-ways* at Allied.

See the complete selection of VHF gear in the 1961 Allied Catalog. If you haven't a copy, write for it today.

our 40th year of service
to Amateurs



order from

ALLIED RADIO

100 N. Western Ave., Dept. 16-K
Chicago 80, Ill.

For further information, check number 60 on page 126.

IN PRODUCT DETECTOR

NC 270



Photographed in true color

THE "COSMIC BLUE" NATIONAL'S NEW HAMBAND RECEIVER

This newest and finest precision double conversion amateur receiver with 6 meter coverage, brings you an ease of sideband tuning previously available only in the most expensive equipment. The NC-270 features an exclusive "Ferrite Filter" for instant upper-lower SSB selection, and a degree of selectivity to conquer even the toughest AM and CW signal conditions. The solid $\frac{1}{8}$ " steel panel, ceramic coil forms, double-spaced tuning gang, and full ventilation cabinet combine to give mechanical and thermal stability that will surprise even the most critical operator. Even the color of the NC-270 is outstandingly different, National's new duo-tone "Cosmic Blue." Write for detailed specifications.

Only \$24.99 down*

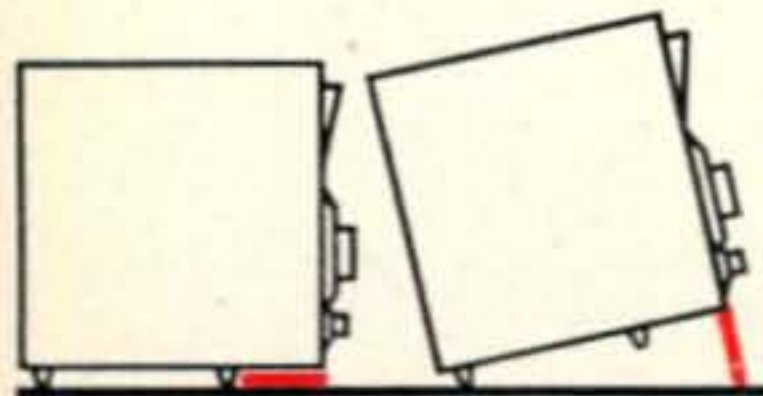

And National Radio's patented "Flip Foot" makes operating the NC-270 so easy.

Suggested cash price: \$249.95. NTS-3 Matching Speaker: \$19.95 (slightly higher west of the Rockies and outside the U.S.A.). *Most National distributors offer budget terms and trade-in allowances.

NATIONAL RADIO COMPANY, INC.



A WHOLLY OWNED SUBSIDIARY OF NATIONAL CO., INC.

MELROSE 76, MASS.

Export: AD AURIEMA, INC., 85 Broad St., New York, N. Y.

Canada: CANADIAN MARCONI CO., 830 Bayview Ave., Toronto 17, Ont.

"FERRITE FILTER" PATENT PENDING

SPECIFICATIONS SUBJECT TO CHANGE WITHOUT NOTICE

For further information, check number 4 on page 126.

90-WATTS **MOBILE**

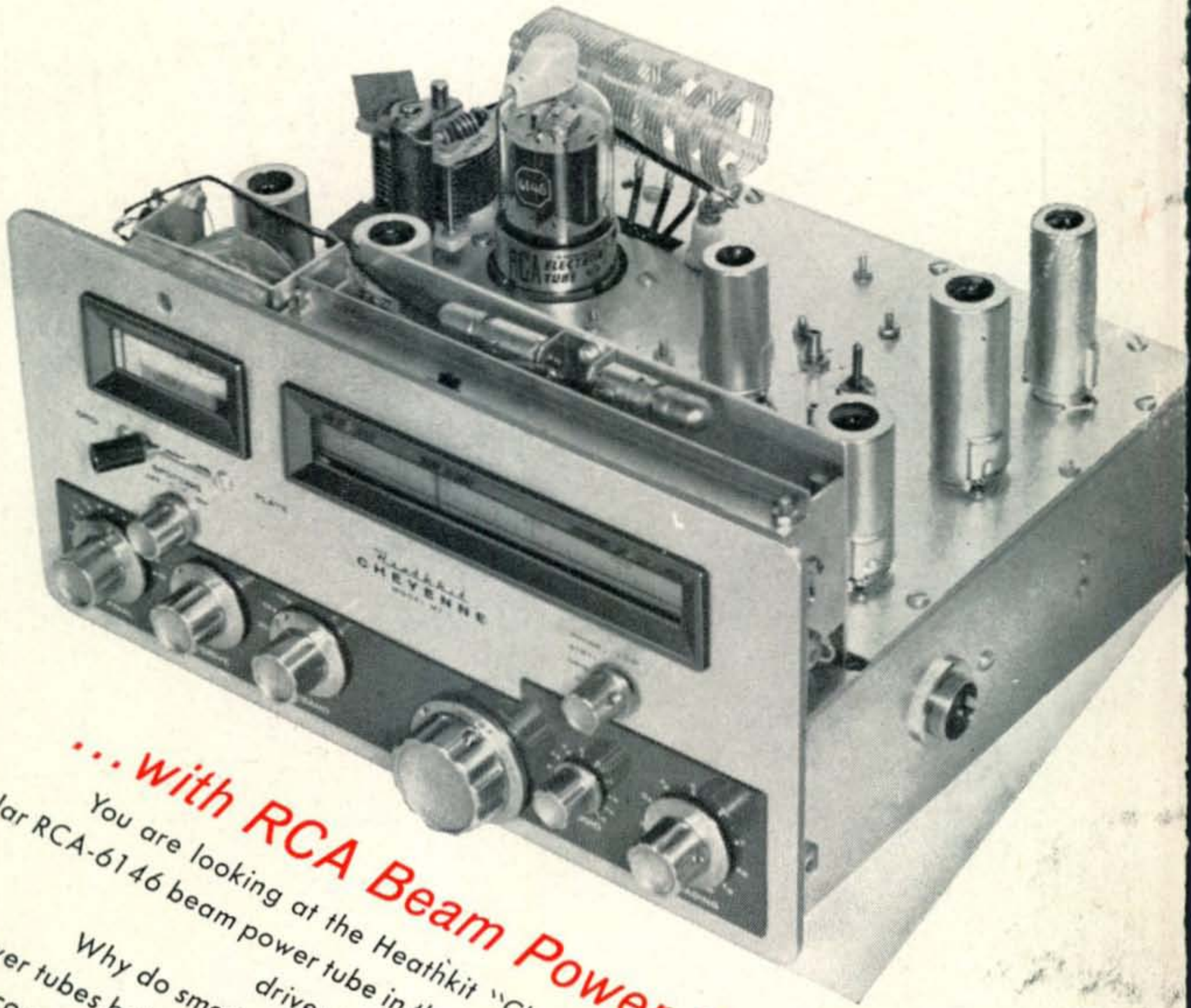

...with RCA Beam Power Tubes

You are looking at the Heathkit "Cheyenne". That's the popular RCA-6146 beam power tube in the final—and an RCA-5763 drives it on "all bands" from 10 to 80.

Why do smart designers choose beam power tubes? Beam power tubes help the transmitter man to shrink a rig down to more compact size. Beam power tubes banish "three-arm" operation—do the job with fewer stages, less expensive components, and fewer controls. Beam power rigs keep more of those transmitter dollars where you want them—in YOUR pocket! Originator of beam power tube design, RCA is proud of the part these tubes have played in the progress of amateur radio.

Your RCA Industrial Tube Distributor is the man to see for RCA Beam Power Tubes. For technical data on any specific RCA Beam Power type, write RCA Electron Tube Division, Commercial Engineering, Section J-15-M Harrison, N. J.



The Most Trusted Name in Electronics
RADIO CORPORATION OF AMERICA