

May 1961

50¢

CQ



W8JIN

**W8JIN Wins 200 Awards -
The Radio Amateur's Journal**



COLLINS S/LINE where beauty is more than skin deep

Finely finished in blue-gray tones, Collins S/Line gives your ham shack the most modern and distinctive decor. Controls and meters on the panels of Collins S/Line provide you with maximum operating convenience and efficiency. But exterior styling is only a fraction of Collins advanced design. It goes deeper. Inside each unit of the Collins S/Line you'll find the latest circuitry, the careful craftsmanship and quality components that make Collins S/Line truly a system-engineered single sideband radio station.

From microphone to antenna, Collins S/Line operates as an integrated high powered SSB ham station. With Collins 75S-1 Receiver you get SSB, CW and AM reception on all amateur bands between 3.5 and 29.7 mc. The 75S-1 can cover the entire HF spectrum between 3.5 and 29.7 mc by selecting the appropriate HF beating crystal.

The 32S-1 Transmitter, with an input of 175 watts P.E.P. on SSB and 160 watts on CW gives you strong, clear signals.

Add the 30S-1 Linear Amplifier and you can operate at

the full legal limit on SSB, and 1 kw on CW. Front panel switching on the 30S-1 lets you operate on two SSB power levels; 100 watts from the exciter alone, or the 1 kw meter average input for SSB.

Collins 312B-4 Speaker Console integrates the Transmitter, Receiver, Linear Amplifier and other accessories into one complete operating unit.

Visit your Collins Distributor and give the S/Line your own thorough inside-and-out investigation. See for yourself, why, when it's Collins S/Line, beauty is more than skin deep.



For further information, check number 1, on page 126

It pays to insist on

PR crystals

STANDARD OF EXCELLENCE SINCE 1934

AMATEUR TYPES

Fundamental, PR Type Z-2

Frequency Ranges in Kcs.: 3,500 to 4,000 (80M); 7,000 to 7,425 (40M); 8,000 to 8,222 (2M); 8,334 to 9,000 (6M).

Rugged. Low drift, fundamental oscillators. High activity and power output. Stands up under maximum crystal currents. Stable, long-lasting; ± 500 cycles.....**\$2.95 Net**

Third Overtone, PR Type Z-9A

Hermetically sealed; calibrated 24,000 to 24,666 and 25,000 to 27,000 Kc., ± 3 Kc.; .050" pins.....**\$4.95 Net**

6 Meters, PR Type Z-9A

Fifth overtone; for operating directly in 6-meter band; hermetically sealed; calibrated 50 to 54 Mc., ± 15 Kc.; .050" pins. **\$6.95 Net**

CITIZENS BAND CLASS "D"

Type Z-9R, Transmitter

FCC assigned frequencies in megacycles: 26.965, 26.975, 26.985, 27.005, 27.015, 27.025, 27.035, 27.055, 27.065, 27.075, 27.085, 27.105, 27.115, 27.125, 27.135, 27.155, 27.165, 27.175, 27.185, 27.205, 27.215, 27.225; calibrated to .005%. (Be sure to specify manufacturer of equipment).....**\$2.95 Net**

CITIZENS BAND CLASS "D"

Type Z-9R, Receiver

Specify I.F. frequency, also whether receiver oscillator is above or below transmitter frequency. Calibrated to .005%. (Be sure to specify manufacturer of equipment.) **\$2.95 Net**

Type Z-9R, Radio Control

FCC assigned frequencies in megacycles: 26.995, 27.045, 27.095, 27.145, 27.195, 27.255; calibrated to .005%. (Be sure to specify manufacturer of equipment).....**\$2.95 Net**

COMMERCIAL TYPES

Commercial Crystals available from 100 Kc. to 70 Mc. Prices on request.

Type Z-1, MARS and CAP

Official assigned frequencies in the range. Calibrated to .005%. 1600 to 10000 Kc.....**\$3.45 Net**

Type Z 1, TV Marker

Channels 2 thru 13.....**\$6.45 Net**

4.5 Mc. Intercarrier,

.01% **\$2.95 Net**

5.0 Mc. Signal Generator,

.01% **\$2.95 Net**

10.7 Mc. FM, IF,

.01% **\$2.95 Net**

Type Z-6A, Frequency Standard

To determine band edge. To keep the VFO and receiver properly calibrated.

100 Kc. ... **\$6.95 Net**



Z-6A



Z-2



Z-9A
Z-9R



Z-1



2XP

Type 2XP

Suitable for converters, experimental, etc. Same holder dimensions as Type Z-2.

1600 to 12000 Kc., (Fund.) ± 5 Kc.....**\$3.45 Net**

12001 to 25000 Kc. (3rd Overtone) ± 10 Kc.....**\$4.45 Net**

ALL PR CRYSTALS ARE UNCONDITIONALLY GUARANTEED.
ORDER FROM YOUR JOBBER.

PETERSEN RADIO CO., Inc. 2800 W. Broadway
COUNCIL BLUFFS, IOWA

EXPORT SALES: Royal National Corporation, 250 W. 57th Street, New York 19, N. Y., U. S. A.
For further information, check number 3, on page 126

CLEAN

SHARP

STRONG



*(or your pet word
to describe SSB
at its very best!)*

CLEAR

*it all adds up to
HAMMARLUND SSB equipment*



HX-500 SSB TRANSMITTER

More talk-power when it really counts! Carrier suppression 50 db or better. Unwanted sideband suppression 50 db or better. 3rd or 5th order distortion down 30 db or better. Spurious frequencies down 50 db or better. T.V.I. proof. Separate dial scale for each band. All crystals included—nothing extra to buy. Frequency readability to 200 cps, or better. Stability after warm-up better than 100 cps. 100 watts output of the best performance you ever heard!

\$695.00



HQ-170 RECEIVER

Tops for reception of SSB amateur bands. Triple conversion. Full dial coverage of 6, 10, 15, 20, 40, 80, and 160 meter amateur bands. Razor-sharp slot filter with up to 60 db attenuation. Exclusive—separate ± 3 KC vernier tuning. Separate linear product detector plus normal diode AM detection. Tuned IF amplifier. Selectable sideband. BFO control. Selectable fast-attack AVC. Crystal calibrator—and everything you need to simplify SSB reception.

\$359.00



HQ-180 RECEIVER

For those that want general coverage and outstanding SSB reception. Triple conversion 18-tube superheterodyne. Frequency range from .54 MCS to 30.0 MCS. Bandspread calibration for 80, 40, 20, 15 and 10 meter amateur bands. High frequency crystal filter. 60 db adjustable slot filter. Exclusive—separate linear product detector plus normal diode AM detection. Tuned IF amplifier. Selectable sideband. And every operational feature you could wish for!

\$429.00



Established 1910

HAMMARLUND

MANUFACTURING COMPANY, INC.,
an affiliate of Telechrome
460 West 34th Street, New York 1, N.Y.

For further information, check number 4, on page 126



The Radio Amateur's Journal

EDITORIAL STAFF

EDITOR

A. S. TROSSMAN, W2DTJ

ASSISTANT EDITOR

RICHARD A. ROSS, K2MGA

TECHNICAL EDITORS

LELAND W. AURICK, W2QEX

IRVING TEPPER

CONTRIBUTING EDITORS

CONTEST CALENDAR

FRANK ANZALONE, W1WY

V.H.F.

ROBERT BROWN, K2ZSQ

PROPAGATION

SPACE COMMUNICATIONS

GEORGE JACOBS, W3ASK

RTTY

BYRON KRETZMAN, KØWMR

DX

URB LE JEUNE, W2DEC

YL

LOUISA B. SANDO, W5RZJ

HAM CLINIC

C. J. SCHAUERS, W6QLV

NOVICE

SEMICONDUCTORS

DONALD L. STONER, W6TNS

SIDEBAND

DOT STRAUBER, K2MGE

IRVING STRAUBER, K2HEA

BUSINESS STAFF

PUBLISHER

S. R. COWAN

ADVERTISING REPRESENTATIVES

JACK SCHNEIDER, WA2FPE

DICK COWAN, WA2LRO

CIRCULATION MANAGER

HAROLD WEISNER, WA2OBR

PRODUCTION MANAGER

CARY L. COWAN

OFFICES

300 West 43rd Street

New York 36, N. Y.

Telephone, JUDSON 2-4460

WEST COAST REPRESENTATIVES

WILLIAM A. AYRES

The William A. Ayres Co.

233 Sansome Street

San Francisco 4, California

YUKON 6-2481

FRED FRISENFELDT

The William A. Ayres Co.

1709 West 8th Street

Los Angeles 17, California

HUBBARD 3-2777

CQ—(Title registered U.S. Post Office) is published monthly by Cowan Publishing Corp. Second class postage paid at Garden City, New York and New York City. Subscription Rates: U.S.A. and Possessions, APO, FPO, Canada and Mexico: one year \$5.00; two years \$9.00; three years \$13.00. Pan-American and foreign, one year \$6.00; two years \$11.00; three years \$16.00. Printed in the U.S.A. Entire contents copyright 1961 by Cowan Publishing Corp. CQ does not assume responsibility for unsolicited manuscripts. Postmaster: send Form 3579 to CQ, 300 W. 43rd St., N. Y. 36, N. Y.

VOL. 17, No. 5

MAY 1961

TABLE OF CONTENTS

A Bandswitching, Low Cost 400 Watt Linear	
<i>Howard L. Morrison, W7ESM</i>	26
A Solid State Signal Source for 144, 432, and 1296 Mc	
<i>Frederick W. Brown, W6HPH</i>	32
A Novel Method of Frequency Measurement	
<i>Calvin Sondgeroth, W9ZTK</i>	34
The Sunspot Story; Cycle 19; The Declining Years; Part II	
<i>George Jacobs, W3ASK and Stanley Leinwoll</i>	36
Updating the 75A-2.....	<i>Donald L. Stoner, W6TNS</i> 44
Adapter for Surplus Tube Testers...	<i>J. R. Throop, WA6CLT</i> 47
A Unique Suppressed Carrier Transmitter	
<i>Robert W. Stolzenbach, W8KP</i>	48
Gamma Matched 160 Meter Vertical	
<i>Katashi Nose, KH6IJ/K1PND</i>	52
W8JIN Makes History on the Ham Bands	
<i>Carole F. Hoover, K9AMD</i>	54
Transmitter Hunts on V.H.F.....	<i>Helen Signorelli, K6KUP</i> 56
Big Things Come from Small Radio Clubs!	
<i>Carole F. Hoover, K9AMD</i>	57
CQ Reviews: The National NC-270...	<i>Lee Aurick, W2QEX</i> 58
Results of the 1960 CQ World-Wide Phone Contest	
<i>Frank Anzalone, W1WY</i>	61
CQ Reviews: The Finco Model A-62 V.H.F. Antenna	
<i>Lee Aurick, W2QEX</i>	98

DEPARTMENTS

Announcements	16	Propagation	76
Contest Calendar	69	RTTY	78
DX	66	Semiconductors	80
Ham Clinic	70	Sideband	91
Ham Shop	120	Space Communications	74
Letters To The Editor	14	VHF	83
Novice	87	YL	96
Zero Bias	7		

Everywhere you turn, there's something

NEW

from **hallicrafters**



HA-2 & HA-6 TRANSVERTERS

Now—go single sideband on VHF!

New transverter converts your present 10-meter station to VHF... AM, CW, SSB, RTTY, FM capability.

Complete, effective, easy to install—Hallicrafter's new HA-2 or HA-6 transverters offer a new approach to Single Sideband on VHF.

All modes of transmission and reception available on your present equipment are useable with these units.

Inputs up to 120 watts to the 5894 final can be obtained by exciters having a capability of 10 to 100 watts.

A nuvistor front end in the receiver section pro-

vides excellent sensitivity and noise figures.

Furnished less power supply. Requirements: 750 volts @ 160 MA; 250 volts @ 70 MA; Minus 60 volts @ 10 MA.

HALLICRAFTERS MODEL P-26 POWER SUPPLY Unit (not illustrated) supplies all voltages; only one supply necessary for operation of either HA-2 or HA-6 when used in stations set up for 2 and 6 meter operations.

The new ideas in communication

Presenting—a new standard of performance for AM, CW, SSB reception

- Band-pass filter front end—equivalent of four tuned circuits preceding 1st mixer.
- Crystal-controlled high frequency oscillator.
- 5 steps of selectivity plus Hallicrafters' exclusive upper/lower sideband selection.
- Linear CTO, direct reading in kc.



SX-115 RECEIVER

The experienced amateur will immediately recognize in the SX-115 a first rate engineering triumph that creates an *entirely new class* of deluxe receiver.

Frequency coverage: Nine 500-kc segments covering 3.5–4.0 mc.; 7.0–7.5 mc.; 14.0–14.5 mc.; 21–21.5 mc.; 28.0–30.0 mc.; (4 segments); and WWV.

Additional features: Highest order of

mechanical and electrical stability; linear tuning; constant tuning rate; separate noise limiters for SSB/CW and AM; dual loop AVC; spurious signal and image rejection better than 60 db. down; sensitivity less than one micro-volt; perfect match for Hallicrafters HT-33 and HT-32 series exciters and transmitters.

For further information, check number 5, on page 126

born at...



hallicrafters

Chicago 24, Ill.

Export Sales: International Div., Raytheon Co., Waltham, Mass. Canada: Gould Sales Co., Montreal, P. Q.

Put your
signal—

WAY OUT YONDER!

—with

STATIONMASTER[®]
Base Station Antenna
Cat. No. 200-509

- FREQUENCY RANGE 144-174 Mc
- OMNIDIRECTIONAL GAIN 5.8 db
- MAXIMUM POWER INPUT 500 watts
- NOMINAL INPUT IMPEDANCE 50 ohms
- BANDWIDTH $\pm 0.3\%$
- VSWR 1.5:1
- RATED WIND VELOCITY 100 MPH
- WEIGHT 30 lbs.
- ELEMENT HOUSING LENGTH 19'



Communication Antenna Systems for American Business

Communication Products Company, Inc.

MARLBORO

NEW JERSEY

ZERO BIAS

THIS month, *CQ* is pleased to announce the inauguration of a new awards program which is aimed at every radio amateur in the world. The new program is entitled the "United States of America Counties Award" (USA-CA) which encompasses every county in the United States and carries with it, a certificate worthy of every effort made to obtain it.

The need has long existed for an award which would serve to better publicize the geopolitical structure of the United States. The award has a scope which reaches into every ham's shack with a challenge of participation and achievement. Regardless of location, call, power, band preference or mode of operation this award belongs to *all* amateurs. DX amateurs all over the world now have a greater purpose in turning their beams towards the United States and thus being less selective than before in answering W/K stations.

The USA-CA provides an incentive for every individual amateur in the U.S. and abroad, and adds significance to every contact and every QSL card, never before realized. It now becomes *imperative* that all U.S. amateurs identify their county on their QSL card.

The challenge this award offers insures its long life and promotes healthy competition. Individual amateurs, as well as club groups now have an opportunity to form DXpeditions to "rare" counties, with little cash or time expenditure.

Much thought has gone into the preparation of the award and no effort has been spared to make the rules as clear and concise as possible. The mechanics of the program are simple. Because the record keeping may become a little unwieldy, *CQ* is making available a record book which will serve to simplify the handling of data. This book will be 8½" × 11" in size and will contain complete rules as well as individual state maps in alphabetical order,

showing county outlines, with appropriate check-off space for counties worked. These booklets will serve as the application form and become the property of *CQ*. It is suggested that duplicate copies be kept for use in later applications for higher awards.

The record book will be quite an adjunct to the ham shack even if it is not used for the program. The Directory of Post Offices, Post Office Department publication #26, shall be the official guide in determining county identity for all contacts. The QTH printed on the QSL confirmation shall apply, unless otherwise stated.

QSL cards will not be required! Certification, however, by two other amateurs, to the effect that the cards are in the possession of the applicant will be required. *CQ* reserves the right to ask for sample cards.

Seven classes of the new award are available: USA-500, contact with 500 different counties; USA-1000, contact with 1000 different counties, 25 different states must be represented; USA-1500, contact with 1500 different counties, 45 different states must be represented; USA-2000, contact with 2500 different counties, all 50 states must be represented; USA-3000, contact with 3000 different counties; and USA-3077-CA, representing confirmation with *all* the counties of the United States of America.

"Mr. Certificate" himself, Clif Evans, K6BX, has been chosen by *CQ* to be custodian for the USA-CA. As many of you know, Clif has been very busy with his *Directory of Certificates* which has won world-wide acclaim in just a few short months. Clif has consented to handle the USA-CA and we feel no other man could better handle the job. His QTH is Box 385, Bonita, California.

Check your cards, check the counties and let us know where you stand.

Amateur Crystals

**1000 KC to
137 MC - .01%
TOLERANCE**

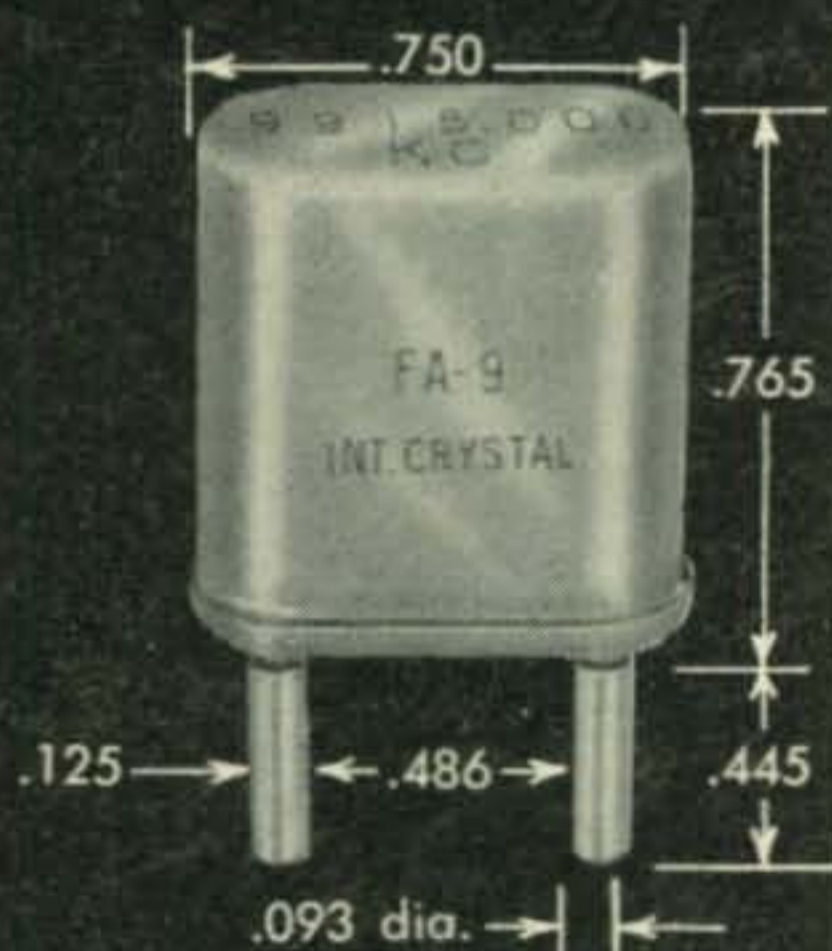
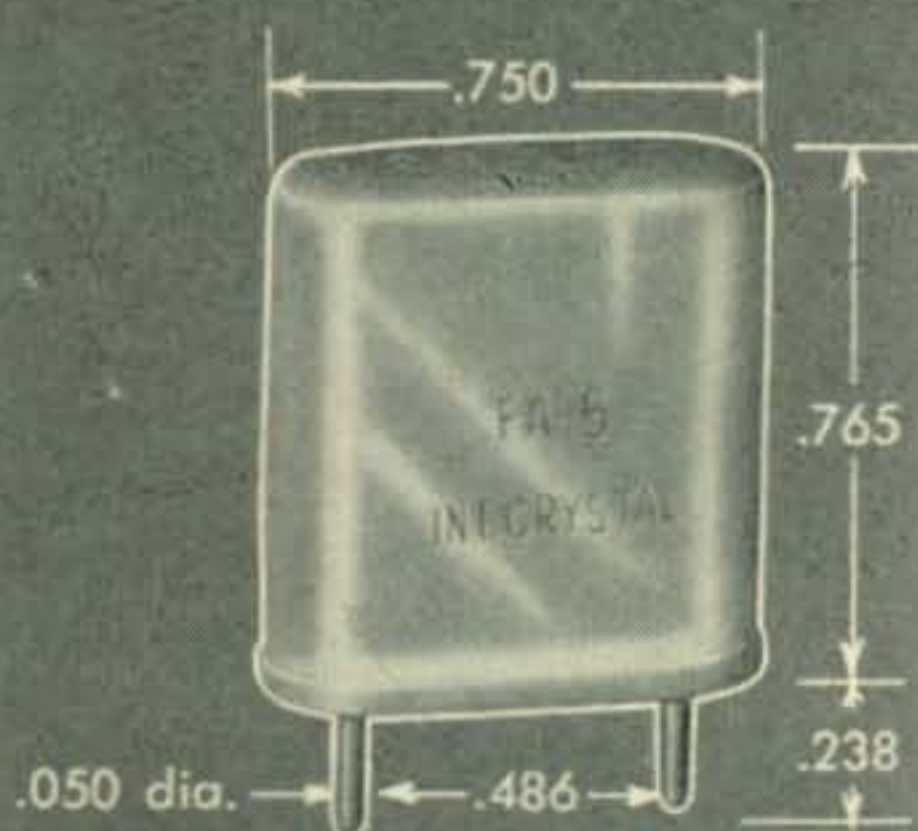

New!
MINIATURIZED
FM-9 SERIES

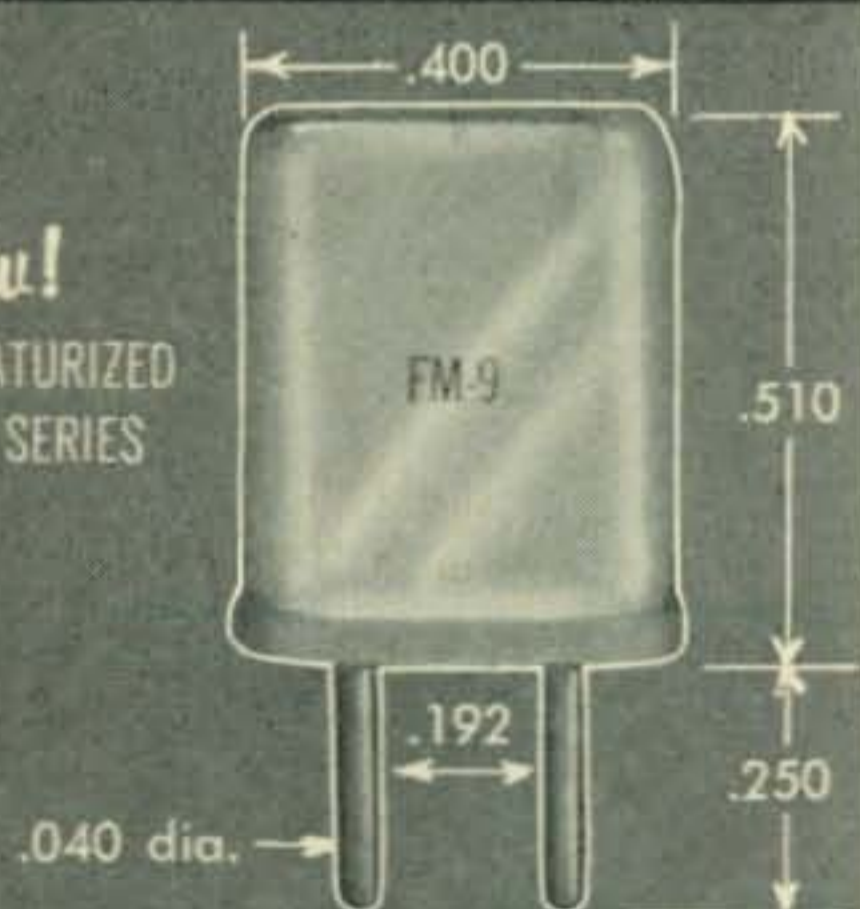

Wire mounted, plated crystals for use by amateurs and experimenters where tolerances of .01% are permissible and wide-range temperatures are not encountered.

Just any crystal in any oscillator will NOT combine to produce spot frequencies. These crystals are designed to operate into a 32 mmf load on their fundamental between 1000 kc and 15000 kc. Overtone crystals operate at anti-resonance on 3rd mode and series resonance on 5th and 7th mode crystals.

- **HOLDERS:** Metal, hermetically sealed. FA-5 and FA-9 are HC/6U pin type while the FM-9 is an HC/18U pin type.
- **FREQUENCIES** (Specify crystal type and frequency when ordering.)

	FA-5 and FA-9	Price	FM-9	Price
Fundamental	1000 - 1499 kc	\$ 5.75	Not available	
	1500 - 1799 kc	\$ 4.95	Not available	
	1800 - 1999 kc	\$ 4.40	Not available	
	2000 - 9999 kc	\$ 3.30	8000 - 9999.999 kc	\$ 5.00
	10000 - 14999 kc	\$ 4.40	10000 - 15000 kc	\$ 5.50
	15000 - 20000 kc	\$ 5.50	15001 - 19999.999 kc	\$ 6.50
Overtone (3rd)	10 - 14.99 mc	\$ 4.40	Not available	
	15 - 29.99 mc	\$ 3.30	20 - 39.99 mc	\$ 5.00
	30 - 59.99 mc	\$ 4.40	40 - 59.99 mc	\$ 5.50
Overtone (5th)	60 - 75.99 mc	\$ 4.95	60 - 89.99 mc	\$ 6.50
	76 - 99.99 mc	\$ 7.15	90 - 100 mc	\$ 8.50
	Not available		101 - 110 mc	\$10.00
Overtone (7th)	100 - 137 mc	\$ 9.35	Not available	

Overtone crystals are calibrated on their overtone frequency. They are valuable for receiver-converter applications and are **NORMALLY NOT UTILIZED IN TRANSMITTERS**, since only a small amount of power is available under stable operating conditions.

- **CALIBRATION TOLERANCE:** $\pm .01\%$ of nominal at 30° C.
- **TEMPERATURE RANGE:** -40° to +70° C, $\pm .01\%$ of frequency at 30° C.
- **DRIVE LEVEL:** Recommended, maximum 3 milliwatts for overtones; up to 80 milliwatts for fundamentals, depending on frequency.

ONE DAY PROCESSING . . .

Orders for less than five crystals will be processed and shipped in one day. Orders received on Monday through Thursdays will be shipped on the day following. Orders received on Friday will be shipped the following Monday.

WRITE FOR 1961 CATALOG FREE!

**INTERNATIONAL
CRYSTAL MFG. CO., INC.**

18 NORTH LEE • OKLAHOMA CITY, OKLA.

For further information, check number 6, on page 126



HERE'S A NEW HEATHKIT® GROUNDED GRID KW LINEAR...JUST \$229⁹⁵

The new Heathkit "Warrior" is a completely self-contained, desk-top kilowatt linear, loaded with special features, at half the cost of comparable units! Compare feature for feature, quality component for quality component, you'll find no shortcuts . . . only the finest watt-per-dollar value in a linear amplifier on the amateur market today!

Maximum power input: SSB—1000 watts P.E.P., CW—1000 watts, AM—400 watts (500 watts using carrier controlled modulation), RTTY—650 watts. **Driving power required:** 50 to 75 watts—depending on frequency. **Output circuit:** Variable pi-network (50 to 75 ohms). **Input circuit:** Broad banded—requires no tuning. **Input impedance:** Approx. 70 ohms. **Band coverage:** 80, 40, 20, 15, 10 meters. **Panel metering:** Switch-selected, grid current, plate current, high voltage and relative power output for ease of loading. **Tube complement:** 4-811A, 2-866A. **Size:** 19½" W x 11½" H x 16" D.

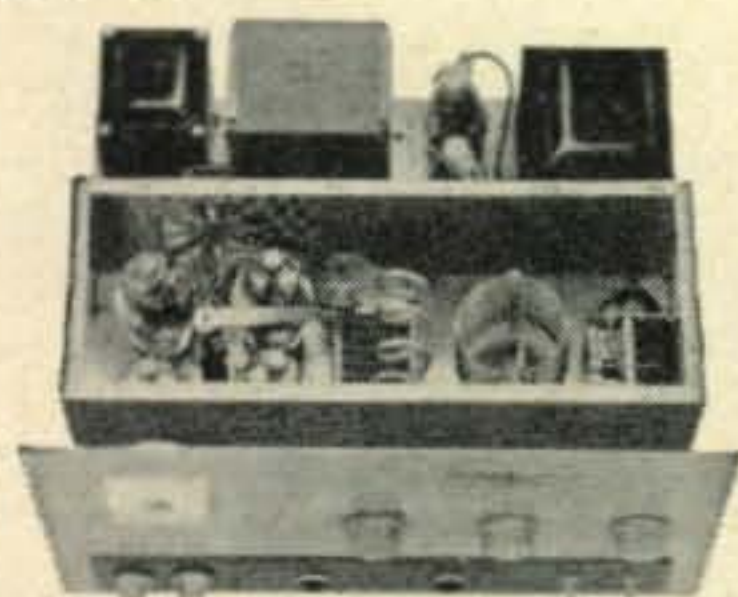

This inside view shows the neat circuit layout and husky components that emphasize quality. Note the internal shielding of plate circuit for maximum protection against TVI.

CHECK THESE FEATURES . . .

Completely self-contained . . . HV, Fil. and Bias supplies built in. *Versatile . . .* May be driven by any 50 to 125 watt transmitter or exciter—no matching or swamping network required.

Efficient . . . Stable grounded grid circuitry allows most driving power to appear in output for up to 70% efficiency.

Oil-filled capacitor . . . And 5-50 henry swinging-choke provide the excellent dynamic regulation required for high peak power output with low distortion.

Inexpensive tubes . . . 4 paralleled 811A's and 2-866A's, forced-air cooled by silent built-in fan.

Stable . . . careful design provides a high degree of over-all stability in conjunction with the grounded grid circuit configuration.

Exclusive . . . Internal RF shielding of plate circuit for maximum TVI suppression.

Interlocked switching . . . prevents accidental application of HV before switching on filament and bias.

Rugged construction . . . 16 gauge steel chassis—1/8" aluminum front panel—welded one-piece cabinet.

Kit Model HA-10 . . . 100 lbs. \$23 dn., \$20 mo. **\$229.95**

Assembled Model HAW-10 . . .
100 lbs. \$33 dn., \$28 mo. **\$329.95**

HEATHKIT® by DAYSTROM

HEATH COMPANY Benton Harbor 12, Michigan



Model DX-60 **\$82⁹⁵**

- Built-in low pass filter
- Neutralized 6146 final amplifier
- Grid block keying
- Handsome low profile styling

more features, better performance in this new Heathkit transmitter

PHONE AND CW TRANSMITTER KIT (DX-60)

Smart modern styling . . . clean, rugged construction . . . and conservatively rated components all add up to ease of assembly, trouble-free operation and fine performance in the new DX-60 Transmitter. Offering far more than any other unit in its price and power class the DX-60 features a built-in *low pass filter* for harmonic suppression, *neutralized final* for high stability, *grid block keying* for excellent keying characteristics and easy access to crystal sockets on the rear chassis apron. A front panel switch selects any of four crystal positions or external VFO. Modulator and power supply are *built in*. *Single knob bandswitching* for 80 through 10 meters and the *pi-network output* provide complete operating convenience. A tune-operate switch provides protection during tuneup and a *separate drive control* allows adjustment of drive level without detuning driver. *Panel meter* shows final grid or plate current. A fine kit for the beginner as well as general class amateur, the DX-60 may be run at reduced power for novice operation. Operates CW or AM phone with crystal or VFO control. Power input is *90 watts peak*, carrier controlled phone or CW. Construction of the DX-60 is a breeze, with its clean circuit layout, pre-cut and cabled *wiring harness* and the complete, informative instructions furnished. The handsomely-styled finished unit measures only 13³/₄" W x 11¹/₂" D x 6¹/₂" H. 29 lbs.

Model DX-60 . . . \$8.30 dn., \$8 mo. **\$82.95**

you get twice as much for your budget



Model HW-20 **\$199⁹⁵**

- Tracked VFO & Exciter Stages for single knob tuning
- 10-watt RF output to antenna—6360 final
- Built-in low pass filter
- Built-in 3-way power supply for 117 VAC, 6 VDC, 12 VDC
- Push-to-talk ceramic element microphone

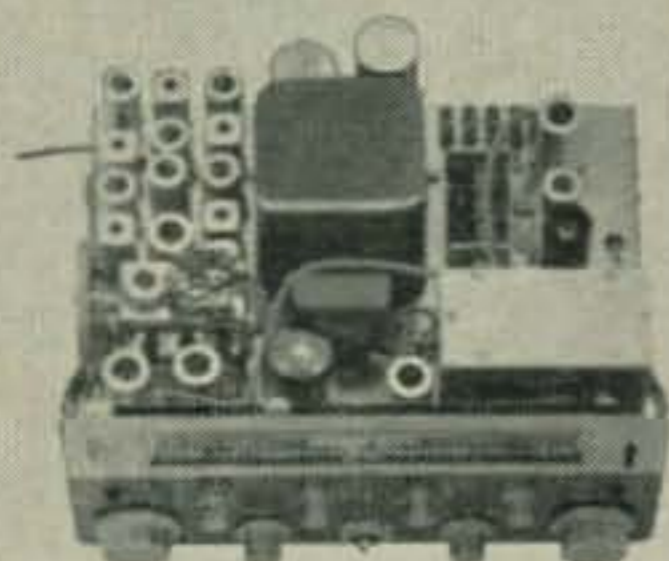

new transceivers for 6 & 2 meter nomads

VHF TRANSCEIVER KITS (HW-10 & HW-20)

"Mobile" or "Fixed", the new "Shawnee" 6-meter or "Pawnee" 2-meter transceivers bring you unprecedented performance, for each is a complete AM & CW Transmitter/Receiver combination with features unmatched at this price . . . just connect an antenna and you are in business! Transmitters feature a *built-in VFO* with all frequency determining components mounted on a "heat sink" plate for temperature stability and *four* switch-selected crystal positions for novice, CAP, MARS or net operation. VFO and all exciter stages are tracked for convenient *single knob tuning* over any 500 kc band segment (greater excursions require simple re-peaking of final). A VFO "spotting" switch is provided to "zero in" signals with transmitter off-the-air. The 6360 dual-tetrode final RF amplifier provides 10 watts of power *output* to the antenna and a built-in *low pass filter* is incorporated to suppress harmonics and other spurious radiation. The *dual-purpose modulator* provides a full 10 watts of audio for high level plate modulation of the final RF amplifier or 15 watts of audio for paging or public address use, selectable with push-pull switch. Superheterodyne receivers feature double conversion with first oscillator crystal-controlled. All oscillators are voltage regulated for stability. A large slide-rule dial and vernier tuning provide more than ample bandspread for both receiver and VFO. RF gain, BFO, ANL, Squelch, AVC on/off and transmitter controls are front panel mounted. *Tuning meter* is automatically switched to read signal strength or relative power output. Units come complete with built-in speaker, heavy duty AC & DC power cables, primary fused relay, adjustable mounting bracket and push-to-talk ceramic element microphone with coil cord & mounting clip. 6" H x 12" W x 10" D. 34 lbs. each.

Model HW-20 (2 meters) . . . \$20 dn., \$17 mo. . . . **\$199.95**
Expected Shipping Date Feb. 25.

Model HW-10 (6 meters) Coming Soon.

Model
HW-29A
\$44.95



Attn. HW-29 owners: Convert your "Sixer" to the new improved "A" model with this easy-to-install conversion kit. Allows use of 8 mc crystal for maximum stability.

Model HWM-29-1 1 lb. \$4.95

lowest cost transceivers on the air

- Operate from low-frequency crystals for greater stability
- Push-to-talk Transmit/Receive switch
- Variable receiver tuning
- Built-In AC power supply—easy conversion to mobile operation, using accessory vibrator power supply

2, 6 & 10 METER TRANSCEIVER KITS (HW-30, 29A, 19)

These three outstanding transceiver models bring you top performance at the lowest prices offered in complete amateur facilities. Each model has a crystal controlled transmitter and tunable, superregenerative receiver with RF preamplifier. Receivers pull in signals as low as 1 uv and the 5 watt transmitters are ideal for emergency work or "local" net operation. Features include push-to-talk transmit/receive switch, metering jack, ceramic element microphone, and two power cables. Less crystal. 10 lbs. each.

- Model HW-19 (10 meter)...\$4 dn., \$5 mo.....**\$39.95**
- Model HW-29A (6 meter)...\$4.50 dn., \$5 mo.....**\$44.95**
- Model HW-30 (2 meter)...\$4.50 dn., \$5 mo.....**\$44.95**

with Heathkit® Amateur Gear

FREE CATALOG

Lists over 200 kits. Send for your free copy today!



MONEY BACK GUARANTEE

Heath Company unconditionally guarantees that each Heathkit product, whether assembled by our factory or assembled by the purchaser in accordance with our easy-to-understand instruction manual, must meet our published specifications for performance or your purchase price will be cheerfully refunded.

ORDER DIRECT BY MAIL OR SEE YOUR HEATHKIT DEALER



HEATH COMPANY
Benton Harbor 12, Michigan

ORDERING INSTRUCTIONS

Fill out the order blank below. Include charges for parcel post according to weights shown. Express orders shipped delivery charges collect. All prices F.O.B. Benton Harbor, Mich. A 20% deposit is required on all C.O.D. orders. Prices subject to change without notice.

Please send the following HEATHKITS:

ITEM	MODEL NO.	PRICE

Ship via () Parcel Post () Express () COD () Best Way
() SEND MY FREE COPY OF YOUR COMPLETE CATALOG

Name _____

Address _____

City _____ Zone _____ State _____

Dealer and export prices slightly higher.

For further information, check number 7, on page 126

Central Electronics

Famous for

DYNAMIC PUNCH



ANNOUNCES
THE NEW
200V
BROAD-BAND
Exciter-Transmitter

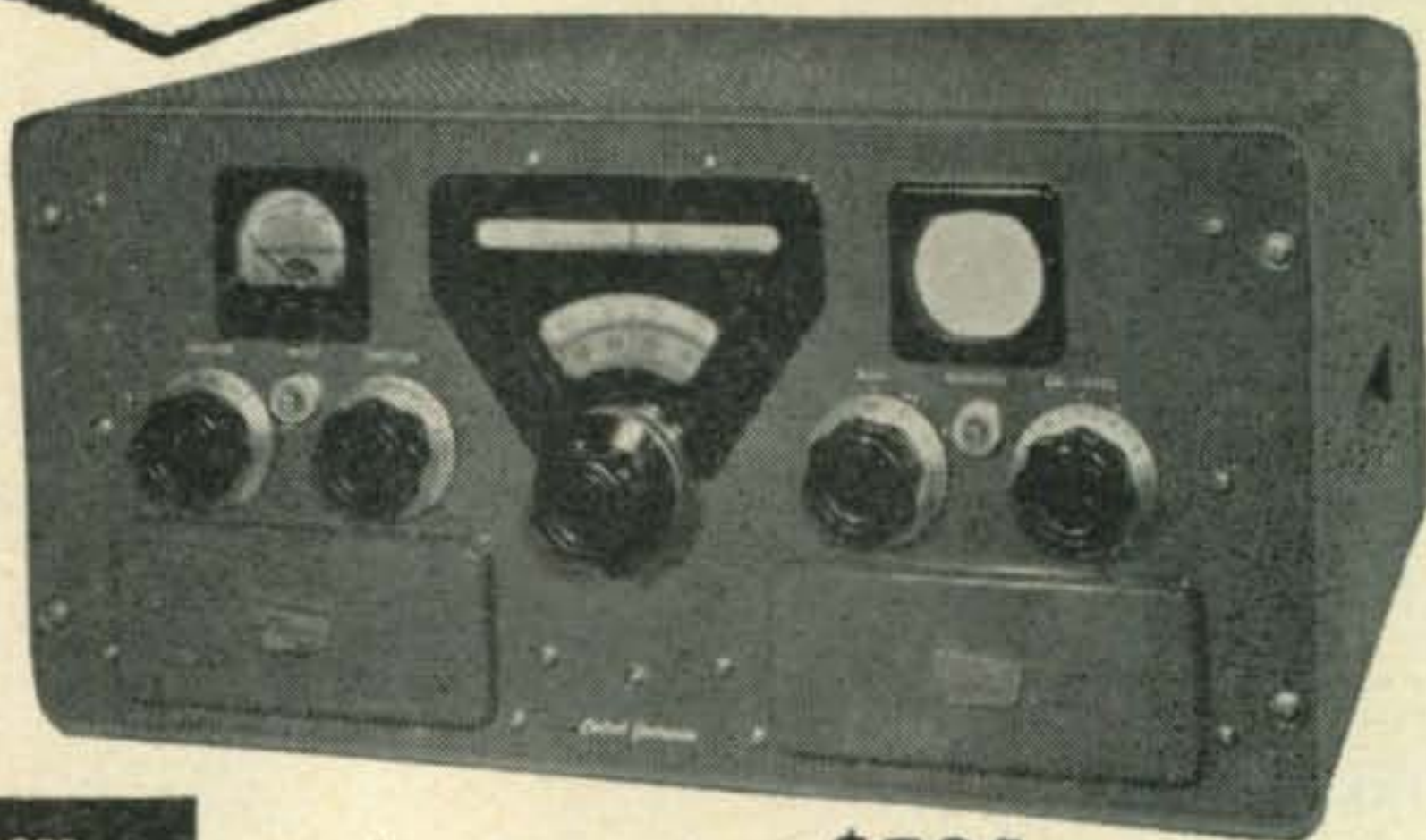

NEW FEATURES IN THE 200V

Amateur net... **\$795**

- NEW! Silicon rectifier power supply. Better regulation. Less heat. Higher voltage. 200 watts PEP input on SSB.
- NEW! Frame grid (6EH7-6EJ7) mixers. Extremely high gain Less heat. Unwanted mixer products down in excess of 50 DB.
- NEW! Temperature compensated crystal oscillator circuits for extreme, long term stability.
- NEW! Increased mike pre-amplifier gain. Compensates for weak voices or low output microphones.
- NEW! Smooth as silk two speed tuning knob with 5 KC per turn vernier tuning ratio.

**PLUS
THESE
ORIGINAL
FEATURES**

- COMPLETELY BROAD-BANDED. You tune only the VFO. Inherently matches output impedances of 50-72 ohms.
- COMPLETE BAND COVERAGE. ALL of the 80-40-20-15-10 meter bands, plus generous overlap and position for extra band.
- INPUT 175 watts on CW, FSK and PM. 100 watts on AM.
- "TAILORED" audio filter-Audio limiter.
- ADJUSTABLE POWER OUTPUT control. 2" MONITORING SCOPE.
- CALIBRATION ACCURACY better than 1 KC.
- UNWANTED SIDEBAND SUPPRESSION 50 DB.
- CARRIER SUPPRESSION at least 50 DB.
- HARMONICS down in excess of 50 DB.
- Third order DISTORTION PRODUCTS down in excess of 40 DB.

THERE IS
NOTHING
FINER THAN
THE
200V

- EASIER TO OPERATE THAN EVER! Choice of USB-LSB-AM-PM CW-FSK at the flip of a switch. Perfected VOX, PTT, CW breakin 4 ways to key.

Available soon - write for literature.

Central Electronics, Inc.

1247 W. Belmont Ave.

Chicago 13, Illinois

A subsidiary of Zenith Radio Corp.



For further information, check number 8, on page 126

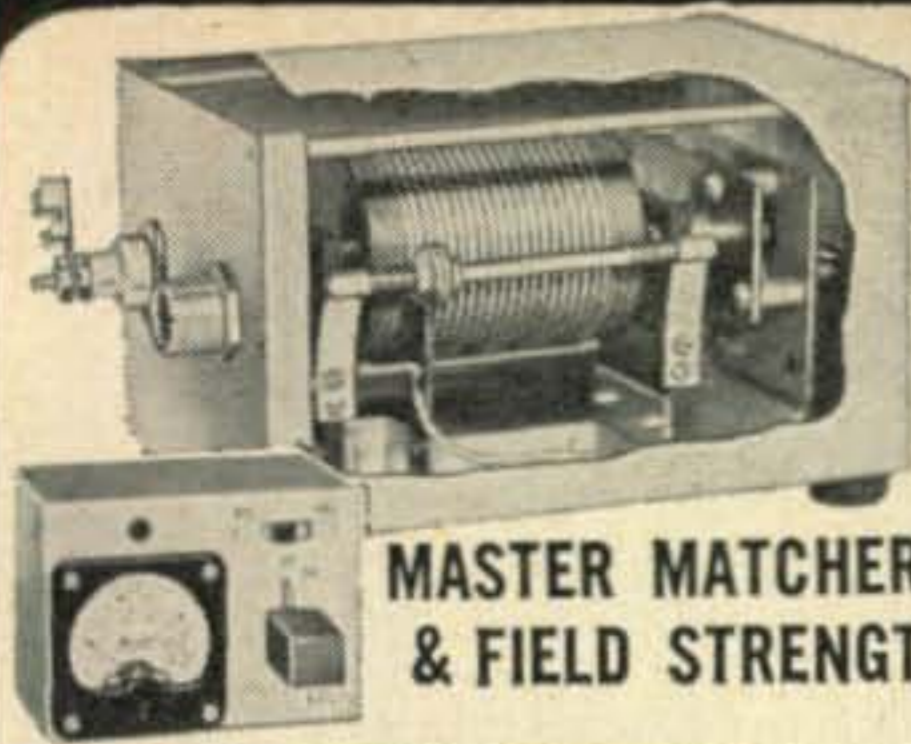

MASTER MATCHER & FIELD STRENGTH METER

6 or 12
volt models

Complete
\$24.95

Automatically
tunes entire
band by re-
mote control.



ULTRA-HI-"Q" COILS FOR 80, 40, 20, & 15 METERS

Your
Choice
\$5.25
ea.

The coil with the highest "Q" ever obtained. Tested and found to have a "Q" of well over 515. Use with 36" base sect. 60" whip. 3" Dia.

NEW! SLIM-JIM ALL-BAND BASE LOADING ANTENNA COIL

96" WHIP

FOR 10, 11,
15, 20, 40, 80
METERS

SIZE 1 3/8" x 19"

Positive action,
just slide whip
in or out to
loading point
and lock nut
into position.

NO.
B-1080
\$17.95

MULTI-BAND ANTENNA COILS

New Plug-in type coils, designed to operate with std. 3' base and 5' whip.

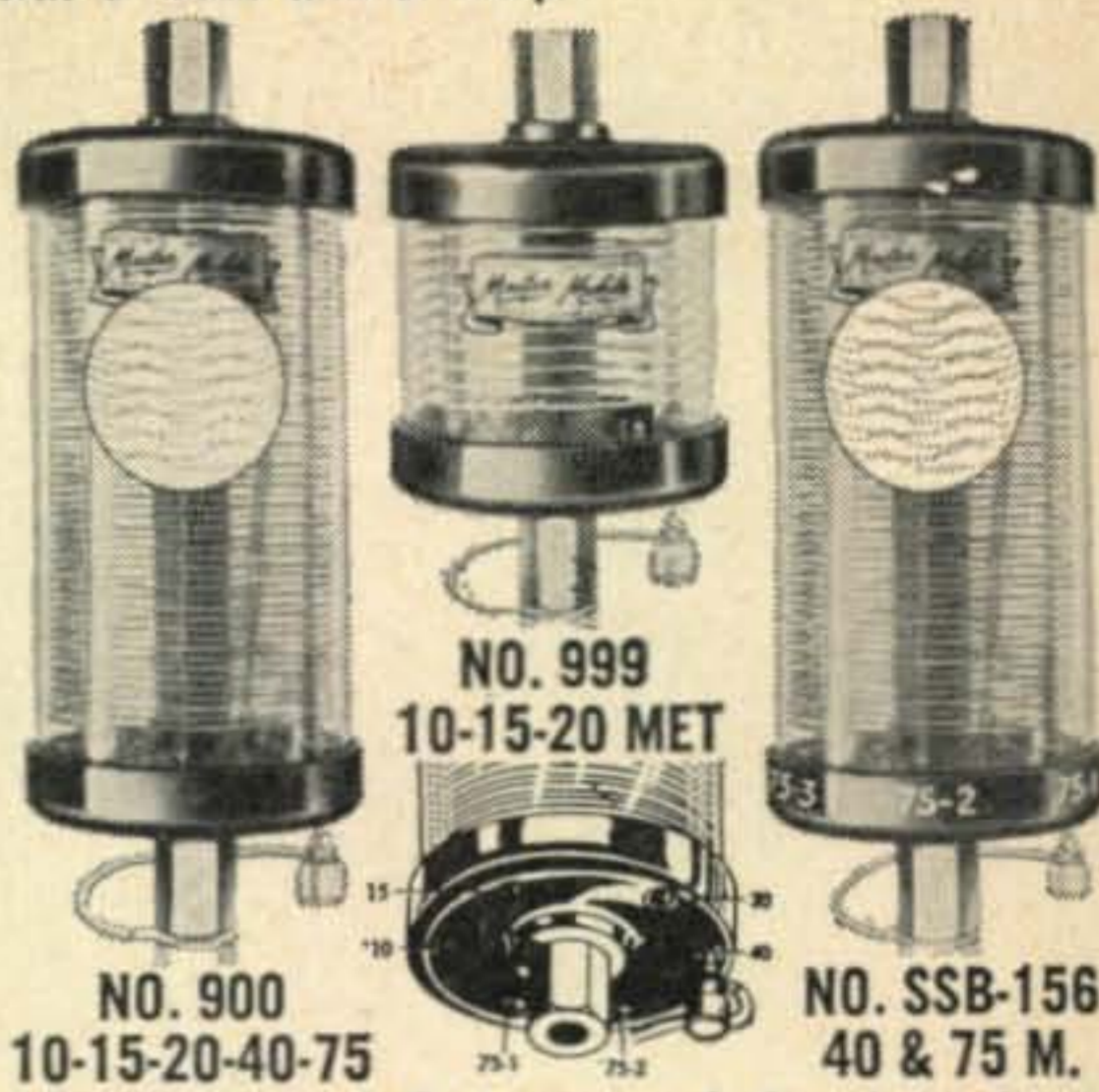

NO. 900
10-15-20-40-75

NO. 999
10-15-20 MET

NO. SSB-156
40 & 75 M.

• Rigidly tested & engineered—found to have "Q" of 525 • Handles 500 Watts input
• Operates into a 52-ohm cable • Positive contact—noise-free, trouble-free operation
• Weathersealed • Factory pre-tuned—no adjustments needed. **YOUR CHOICE EA \$14.95**

FIBRE-GLAS WHIPS

The Feather-
Weight Antenna
with Spring-Steel
Strength!

Completely
weather proof,
breakproof an-
tenna with
special flexibil-
ity that prevents
accidental short-
ing-out against
overhead ob-
structions which
can cause loss of
signal, serious
damage to equip-
ment.

FG-60 60" \$4.95
FG-72 72" \$4.95
FG-84 84" \$5.15
FG-96 96" \$5.25
FG-103 103" \$6.95

Leaders in the Design and Manufacturing of Communication Equipment & Antennas FOR LAND, SEA AND AIR

MONOPOLE ANTENNA

Folded radiating
element for in-
stallation requir-
ing a ground
plane configura-
tion and a wider
useful range.

11 Met. . \$24.50
10 Met. . 24.50
6 Met. . 16.95
2 Met. . 14.95



SR-600

3 ELEMENT 11M. BEAM NO. SR-500

Provides a power gain of
approx. 2 1/2 (8DB)
in forward direction.

THE CITIZEN
SR.

10 to 1 inter-
ference reduction from sides
and rear. VSNR-1. 1 to 1 at band
center when fed with 52 OHM coax. . .

\$36.00

MOUNTS

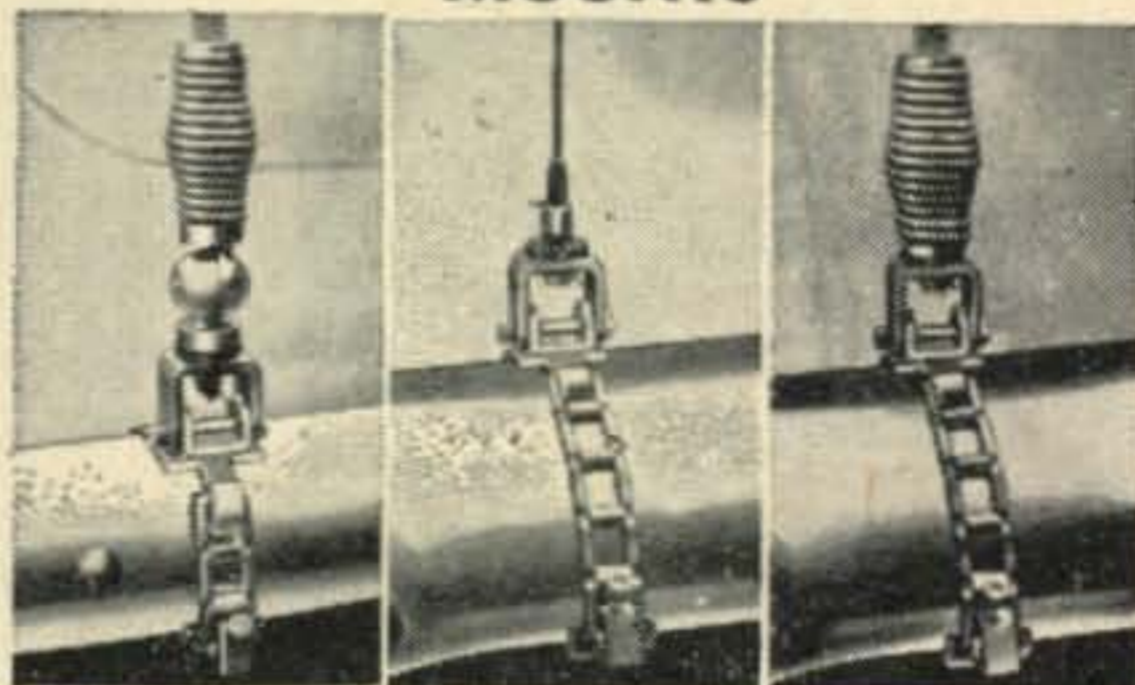

No.444 \$17.80 No.445 \$7.95 No.446 \$13.45
Adjustable to any bumper. No holes to drill.

UNIVERSAL MOUNTS

Heavy-duty communications an-
tenna mounts. Either mount
can be attached through open-
ings as small as 3/16". Re-
ceptacle for spring or whip
with phenolic insulators. 3/8"-
24-thread.

MM530 Deluxe Dbl. SS. \$21.95
MM531 Deluxe Sgl. SS. 11.95
MM520 Dbl. St-Cad. Pl. 7.95
MM519 Sgl. St-Cad. Pl. 4.95

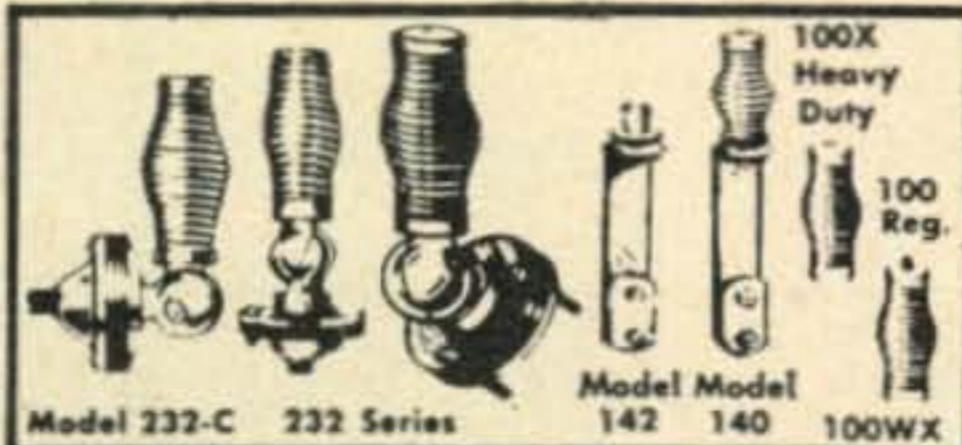

Model 232-C 232 Series Model Model 142 140 100WX

MASTER-MAGIC WAND

New easy-to-install, sin-
gle band, top-loaded
plastic covered fiber
glass antenna provides
maximum performance
at the most useful ra-
diation frequencies.

10 Met.- 5 Ft. L. \$8.95
11 Met.- 5 Ft. L. 8.95
11 Met.-35 In. L. 8.95
11 Met.-45 In. L. 8.95
15 Met.- 5 Ft. L. 8.95
20 Met.- 5 Ft. L. 8.95
40 Met.- 6 Ft. L. 9.95
80 Met.- 6 Ft. L. 9.95

SKYMASTER COAX ANTENNA

Gets your signal
through where others
fail. Concentrates
signals at the lowest
angle, provides
omni-directional pat-
tern for best cover-
age. Matches RG
59/U Cable. SM-700

11 Met. . . \$17.95
10 Met. . . 17.95
6 Met. . . 15.95
2 Met. . . 10.95



MOUNT

Smaller version of
Master Mobile Mounts,
less spring. Swivels,
mounts in all positions.
3/8"-24 thread for
Magic Wand, and all
Master Antennas.

No. J-11 **\$2.95**

11M. CITIZEN BAND ANTENNA

40" base loaded
S.S. whip antenna.
Fitted with a 1/4"
dia. brass slug for
all-purpose
mounts. Low
standing-wave ra-
tio on most of
band when fed
with a 52 ohm
coax.

8B-27 **\$12.95**

WRITE FOR FREE
CATALOG

All products are for Universal Use-Mobile, Home,
Marine, C.A.P., Civil Defense, Emergency, etc.



Master Mobile Mounts, Inc.

4125 W. JEFFERSON BLVD. • LOS ANGELES 16, CALIF.

AT LEADING
RADIO JOBBERS
EVERYWHERE

For further information, check number 9, on page 126

Designed for



Application

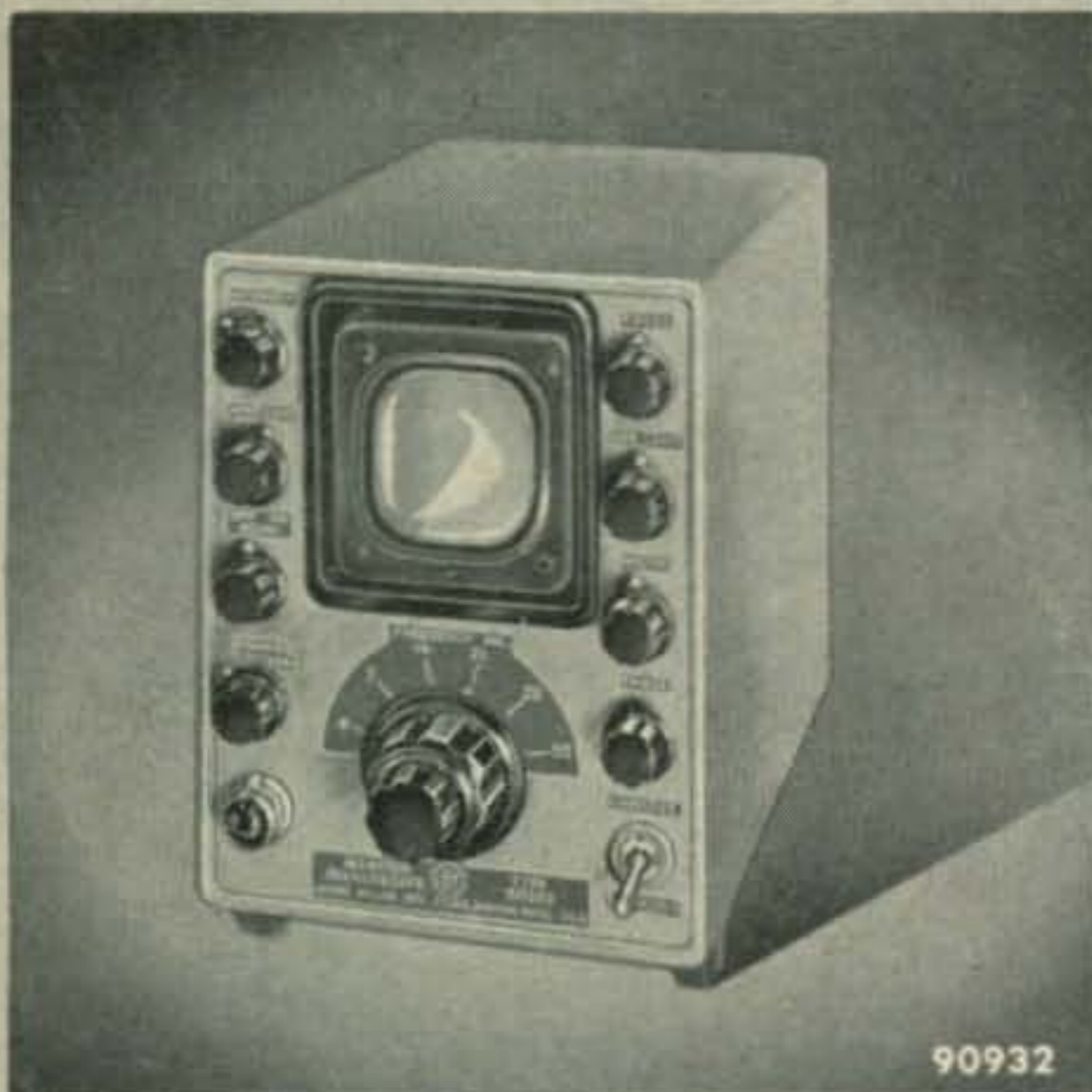

90932

THE NO. 90932 MODULATION MONITOR

The No. 90932 Amateur Band Monitor Oscilloscope is a complete oscilloscope for monitoring the modulated r-f output of a transmitter. Built-in link-coupled tuned circuits cover all amateur bands 3.5 to 54 mc. All circuits and accessories are built in. The monitor will display the r-f envelope and/or the trapezoidal monitoring pattern of single side band transmitters or amplitude modulated transmitters. It shows the linearity or non-linearity of Class-B r-f amplifiers, parasitic oscillation, neutralization, and r-f output.

**JAMES MILLEN
MFG. CO., INC.**

MAIN OFFICE AND FACTORY
**MALDEN
MASSACHUSETTS**



Letters..... to the Editor



10th Anniversary

PROPAGATION Editor, CQ:

Congratulations on your first ten years with CQ.

Working out a continuous monthly propagation chart has been a terrific advantage to a number of us, particularly when it is presented in the concise form that yours is. I've been particularly glad to see the different changes your column has gone through during the past ten years and feel that it now offers about as widely diversified information as can be compiled in the space allotted.

I, myself, operate teletype, s.s.b., c.w. and a.m. phone. The use of the propagation chart allows me to set up schedules on a basis that is reasonably reliable.

Again, congratulations for a job well done and I hope that we are all around to see your next ten year column concluded.

D. E. Chapman, W9DPY
Director Midwestern Eng. Div.
Telechrome Manufacturing Corp.

—This letter is one of many received by W3ASK on the 10th Anniversary of his PROPAGATION section in CQ. We are indeed sorry that we can not print all the letters received.—Ed.

Operating Skill

Editor, CQ:

Having just completed operating in a contest I must take pen in hand to comment on certain items.

I realize that at contest time there is an overload on the frequencies with resulting QRM, but it disturbs me to hear the comments of some amateurs. Many of them have the attitude that "as long as I am not doing it, it should be banned". Time and time again I heard various comments concerning the QRM.

My rebuttable is as follows: Watch out, boys, if you eliminate one phase of amateur radio, the next elimination might be yours.

Remember that amateur radio is only a hobby and it is pursued by participants with various interests. The next time you are QRM'd by someone, remember that *you* are undoubtedly QRMing someone else. Smile and try to show your operating skill by continuing to operate through the QRM. It can be done!

Jack H. Osborne, K6LVD
863 Arbol Verde
Carpinteria, California

Reciprocal Licensing

Editor, CQ:

A big "thanks" to K4KSZ regarding reciprocal licensing (LETTERS, Jan. 1961). As K4KSZ wisely points out, this matter is vital to all hams regardless of whether or not they ever go overseas, or reside in another country.

Those of us stationed in the United Kingdom (there are over a dozen of us at this relatively small A.F. base) can do little at this end until the U.S. offers equal privileges to U.K. amateurs.

The countries in which we are privileged to operate, now steadily dwindle. We have seen them drop from the list one by one. It's time we woke up and got those letters written to our congressman.

Let's all lend active support to reciprocal licensing and write that letter where it will do the most good.

T/Sgt. Duane Eyman, K4RPP, ex-KG1DE, 5A1TN
Howletts,
Willows Green, Essex,
England

For further information, check number 10, on page 126

To the hundreds
of Hams who have
taken the time
to write, we at
EICO can only
say...

FROM THE BOTTOM OF OUR HEARTS, THANK YOU

We promise to continue
to do all in our power
to merit your approval.

Milton Stanley
3909 High View Rd.
E. Peoria, Illinois

Electronic Instrument Co., Inc.
3300 Northern Blvd.
Long Island City 1, N. Y.

Dear Sir:

When I saw your Model 720 Transmitter on display, it looked so good that I decided to purchase a 720 kit. I put it together in five evenings. The instruction book is so well written that any beginner can build this kit with no trouble at all. When I put the 720 on the air for the first time, I called CQ and a station in Munising, Mich. answered me and gave me a 599 report. In two months I had worked 37 states with a single wire antenna about fifteen feet off the ground. All stations worked gave me a good report. I was so pleased that I purchased an EICO Model 730 Modulator. Results were equally good. I have worked 44 states and Canada on phone with the 720 and 730. All reports I get are very good. The clipping level control and the over modulation indicator helps make the EICO 730 Modulator the best buy for the money and I personally believe the EICO 720 Transmitter is the best 90-watt rig on the market. The EICO 720 and 730 together make an all around rig that is hard to beat. I am so well pleased with the quality of EICO kits that I am looking forward to building more of your products. I highly recommend EICO kits to beginners as well as the old timers.

Sincerely,
Milton Stanley
MILTON STANLEY, K9VJH



**90-WATT CW
TRANSMITTER***
#720
Kit \$79.95
Wired \$119.95

*U. S. Pat. No. D-184,776
"Top quality" — ELECTRONIC
KITS GUIDE. Ideal for veteran or
novice. 90W CW, 65W external
plate modulation. 80 through 10
meters.



**NEW!
60-WATT CW
TRANSMITTER**
#723
Kit \$49.95
Wired \$79.95

Ideal for novice or advanced ham
needing low-power, stand-by rig.
60W CW, 50W external plate mod-
ulation. 80 through 10 meters.



**CITIZENS
BAND
TRANSCIVERS**

Single and
Multi Channel Models Available.
From Kit \$59.95 Wired \$89.95

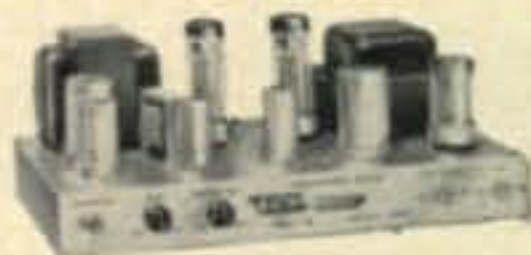

**HIGH-LEVEL
UNIVERSAL
MODULATOR-
DRIVER**
#730

Kit \$49.95 Wired \$79.95
Delivers 50W undistorted audio.
Modulates transmitters having
RF inputs up to 100W. Unique
over-modulation indicator. Cover
E-5 \$4.50.

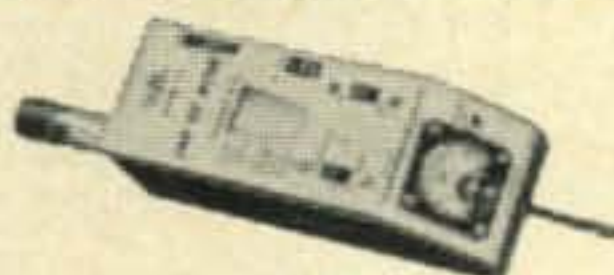

**GRID
DIP
METER**
#710

Kit \$29.95 Wired \$49.95
Includes complete set of coils
for full band coverage. Continu-
ous coverage 400 kc to 250 mc.
500 ua meter.



**PEAK-TO-PEAK
VTVM #232
& *UNI-PROBE®**
Kit \$29.95
Wired \$49.95

VACUUM TUBE VOLTMETER #221
Kit \$25.95 Wired \$39.95

*U. S. Pat. No. 2,790,051



**COLOR &
MONO DC-5MC
LAB & TV 5"
OSCILLOSCOPE**
#460
Wired \$129.50
Kit \$79.95

5" PUSH-PULL OSCILLOSCOPE
#425 Kit \$44.95 Wired \$79.95



**DYNAMIC
CONDUCTANCE
TUBE
& TRANSISTOR
TESTER #666**

Kit \$69.95 Wired \$109.95
TUBE TESTER #625
Kit \$34.95 Wired \$49.95



**RF SIGNAL
GENERATOR**
#324
(150kc-435mc)
Kit \$26.95
Wired \$39.95

**TV-FM SWEEP GENERATOR
& MARKER #368**
Kit \$69.95 Wired \$119.95



3300 Northern Blvd.
Long Island City 1, N. Y.

EICO, 3300 N. Blvd., L.I.C. 1, N. Y.

Send free Catalog & name of
neighborhood distributor.
 Send free "Short Course for
Novice License." Send
36-page **STEREO HI-FI GUIDE:**
25c enclosed for postage
& handling.

Name.....
Address.....
City..... Zone..... State.....

Add 5% in the West.

CQ-5

ENGINEERS: Excellent career opportunities in creative electronics design. Write to the Chief Engineer.

For further information, check number 11, on page 126

How To Get an FCC License (Commercial)



**GET
ALL 3
FREE!**

Just Mail Coupon

YOUR GUARANTEE:

Completion of the Master Course (both Sections) will prepare you for a First Class Commercial Radio Telephone license with a Radar Endorsement. Should you fail to pass the FCC examination for this license after successfully completing the Master Course, you will receive a full refund of all tuition payments. This guarantee is valid for the entire period of your enrollment agreement.

**Investigate our NEW
Training Program In
COMPUTERS,
SERVO MECHANISMS,
MAGNETIC AMPLIFIERS,
and others.**

Get This Handy POCKET ELECTRONICS DATA GUIDE

FREE

Puts all the commonly used conversion factors, formulas, tables, and color codes at your fingertips. Yours absolutely free if you mail the coupon today.

Mail Coupon TODAY!

CLEVELAND INSTITUTE OF ELECTRONICS

Desk CQ-76, 1776 E. 17th St., Cleveland 14, Ohio

Please send FREE Career Information Material prepared to help me get ahead in Electronics.

Name..... Age.....

Address.....

City..... Zone..... State.....

FOR PROMPT RESULTS SEND AIR MAIL

CQ 76



Before the
FEDERAL COMMUNICATIONS COMMISSION
Washington 25, D. C.

In the Matter of
Amendment of Section
12.90 (b) (2) of the Commis-
sion's Rules to permit Maritime
Mobile operation on a World-
Wide Basis in the 14.00-14.35 Mc
Band.

Docket No. 14026

NOTICE OF PROPOSED RULE MAKING

1. The Commission is in receipt of a petition from the Maritime Mobile Amateur Radio Club (MMARC) 1317 Oranewood Avenue, Pittsburgh 16, Pennsylvania seeking to amend the Commission's Rules to permit maritime mobile operations in the frequency band 14.00-14.35 mc on a world-wide basis, i.e. outside the continental limits of the United States, its territories and possessions.

2. The Commission had adhered to a policy, supported by the petitioner, that as a condition precedent to permitting amateur maritime mobile operations on amateur frequencies on a world-wide basis, the frequencies involved must contain no international restriction on their usage. In the 1959 ITU RADIO REGULATIONS Table of Frequency Allocations, footnote 218 governs the use of part of this band as follows:

"218. In the U.S.S.R. the band 14,250-14,350 kc is also allocated to the fixed service".

The petitioner points out that other general explanatory footnotes in these Regulations lead to the conclusion that the above-quoted proviso is not to be regarded as a restriction in other areas, and that elsewhere other than fixed operations are permitted. In other words, this restriction should not be regarded as precluding the availability of the frequencies from 14.00 mc to 14.35 mc for world-wide maritime mobile operations. Perhaps more significantly MMARC has submitted factual data showing that the U.S.S.R. permits its amateurs to operate on the frequencies in question despite the aforementioned footnote. The petition, therefore, seeks amendment of the Commission's Rules to permit amateur operations in the frequency band 14.00-14.35 mc outside the continental limits of the United States, its territories, and possessions. The Commission is of the opinion that the petition merits a Notice of Proposed Rule Making to amend Section 12.90 (b) (2) to read as follows:

(2) When outside the jurisdiction of a foreign government: Operation may be conducted within Region 2 on any amateur frequency band between 7.0 mc and 148 mc, inclusive; and when not within Region 2, operation may be conducted only on the amateur frequency bands 14.00-14.35 mc, 21.00-21.45 mc, and 28.0-29.7 mc. (Region 2 is defined as follows: On the east, a line (B) extending from the North Pole along meridian 10° west of Greenwich to its intersection with parallel 72° north; thence by Great Circle Arc to the intersection of meridian 50° west and parallel 40° north; thence by Great Circle Arc to the intersection of meridian 20° west and parallel 10° south; thence along meridian 20° west to the South Pole. On the west, a line (C) extending from the North Pole by Great Circle Arc to the intersection of parallel 65° 30' north with the international boundary in Bering Strait; thence by Great Circle Arc to the intersection of meridian 165° east of Greenwich and parallel 50° north; thence by Great Circle Arc to the intersection of meridian 170° west and parallel 10° north; thence along parallel 10° north to its intersection with meridian 120° west; thence along meridian 120° west to the South Pole.)

4. The proposed amendment herein described is issued pursuant to authority contained in Sections 4 (i) and 303 of the Communications Act of 1934, as amended.

5. Any interested person who is of the opinion that the proposed amendments should not be adopted or should not be adopted in the form set forth herein, and

NEW! GSB-201

GONSET'S LITTLE POWERHOUSE!



Now at your distributor

RF LINEAR AMPLIFIER

BIG ... with a husky, go-places power rating of 1500 watts PEP ...

SMALL ... only a foot across the front—less than one-and-a-half feet in depth!
No space problem here—these are true “table-top” dimensions.

Fine looking—modern industrial designer styling—finished in durable, attractive light colors. Blends well with existing equipment.

Features and features ...

Full bandswitching 80-40-20-15 and 10 meters • pi network output • stable, efficient grounded grid circuitry • Power input rating: 1500 watts PEP SSB • 1000 watts CW • 400 watts AM • can be driven by exciters in the 65-150 watt category, GSB-100 and similar units • Low cost Type 811A tubes used in amplifier • long life silicon rectifiers replace older vacuum tube rectifiers in high voltage power supply • Antenna changeover relay is built in • panel switch allows tune up at low power • full vision panel instrument is switchable to indicate amplifier plate current or relative RF output • Dimensions, 8½" high, 12⅝" wide, 17" deep.

Model #3340

399⁵⁰

For further information, check number 12, on page 126

GONSET

Division of Young Spring & Wire Corporation
801 SOUTH MAIN ST., BURBANK, CALIFORNIA

EXPORT SALES: WESTREX CORP., 540 WEST 58TH ST. NEW YORK 19, N. Y.

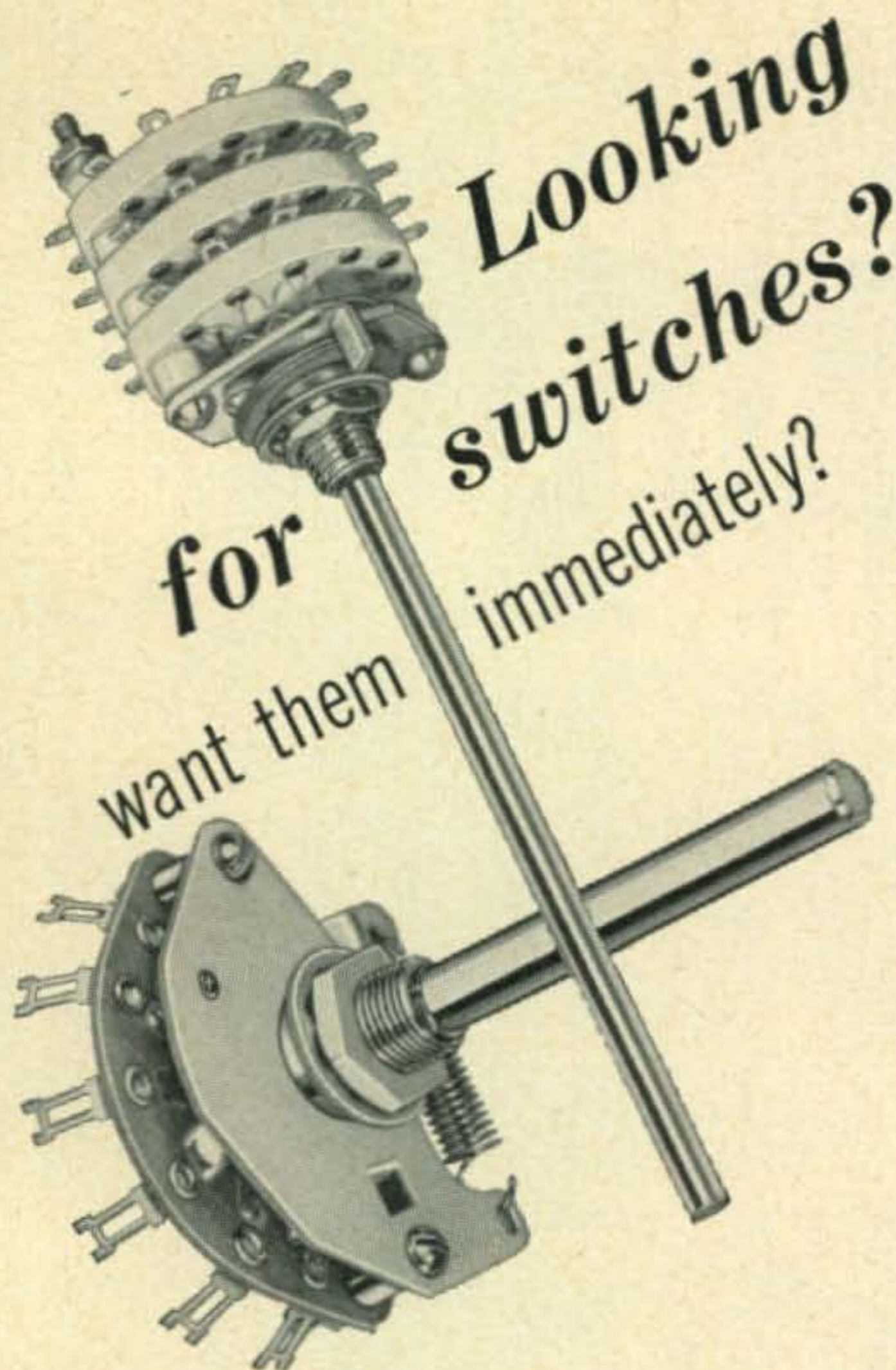

see your
Centralab
 distributor!

Whether you need one switch or one hundred, your best source is your nearby Centralab distributor. He has complete stocks of the complete Centralab line, ready for immediate delivery, *regardless of your quantity requirements.*

For every application in amateur radio—as well as in countless industrial uses—Centralab makes the switch you need: rotary and lever action; ceramic and phenolic; miniature, ultra-miniature, and general purpose.

They're all listed in Centralab Standard Catalog 31; be sure to write for your free copy.

P-6120



THE ELECTRONICS DIVISION OF GLOBE-UNION INC.
 954E EAST KEEFE AVENUE • MILWAUKEE 1, WISCONSIN
 CENTRALAB CANADA LIMITED—AJAX, ONTARIO
 For further information, check number 13, on page 126

any person desiring to support this proposal may file with the Commission on or before June 1, 1961, a written statement or brief setting forth his comments. No additional comments may be filed unless (1) specifically requested by the Commission, or (2) good cause for the filing of such additional comments filed is established. The Commission will consider all comments filed hereunder prior to taking final action in this matter provided that, notwithstanding the provisions of Section 1.213 of the Rules, the Commission will not be limited solely to the comments filed in this proceeding. If comments are submitted warranting oral argument, notice of the time and place of such oral argument will be given.

6. In accordance with the provisions of Section 1.54 of the Commission's Rules and Regulations, an original and fourteen copies of all statements, briefs, and comments filed shall be furnished the Commission.

FEDERAL COMMUNICATIONS COMMISSION
 BEN F. WAPLE
 Acting Secretary

Before the
 FEDERAL COMMUNICATIONS COMMISSION
 Washington 25, D. C.

In the Matter of
 Sections 12.21(d) and 12.44(a)
 of Part 12, Rules governing
 amateur radio regarding
 eligibility for Conditional
 Class licenses. } DOCKET No. 14025

NOTICE OF PROPOSED RULE MAKING

1. The Commission is in receipt of a petition filed by the American Radio Relay League, Inc., (ARRL) Hartford, Connecticut, seeking amendment of the Commission's Rules to permit an applicant living temporarily outside the United States to take an examination for a Conditional Class license even if his residence in the United States is less than 75 miles from a legal Commission examination point.

* * *

4. Hence, the ARRL proposes amendment of Sections 12.21(d) and 12.44(a) of the Rules to add another category to those now eligible to take the Conditional Class examination by mail. It requests that the following language be added to Section 12.21(d): ". . . or any citizen temporarily resident, for a reasonable period, outside the jurisdiction of the Federal Communications Commission and who maintains a legal residence within the United States, its territories or possessions, without regard for the distance of such legal residence from the Commission examination points listed elsewhere in the Chapter. (Note: Nothing in this Section shall be construed as authorizing Commission licensees to operate within the jurisdiction of a foreign government except in accordance with the provisions of Sections 12.90 and 12.91 of this Part.)" The word changes proposed by the ARRL for Section 12.44(a) are substantially the same. The Commission is of the opinion that the term "for a reasonable period" is too indefinite and will impair the efficiency of processing applications as expeditiously as possible. It is proposed, therefore, to substitute the phrase for a period of at least twelve months" in lieu thereof and also to require the applicant to submit sufficient proof of such tenure. This would appear to provide a reasonable and definite standard for qualification for this type of license and would still accomplish the purposes of the League's petition. As a result, the Commission is proposing to amend Sections 12.21(d) and 12.44(a) as set forth in the attached Appendix.

* * *

7. In accordance with the provisions of Section 1.54 of the Commission's Rules and Regulations, an original and fourteen copies of all statements, briefs, and comments filed shall be furnished the Commission.

FEDERAL COMMUNICATIONS COMMISSION
 BEN F. WAPLE
 Acting Secretary

TRANSISTORIZED D. C. POWER CONVERTERS & INVERTERS

These small light-weight units, feature low current drain, high conversion efficiency, ruggedness and no moving parts. They provide trouble free, economical operation of communications equipment and other related devices. Ideal for use in mobile, marine, aircraft, Citizen's Band and amateur equipment.



Precision wound Toroidal Transformers. For use in construction of Transistorized Power Converters and Inverters or as a replacement part. Encapsulated for ruggedness and long life. Easy to install and wire. Designed for operation in ambient temperatures from -55° to 130° C.

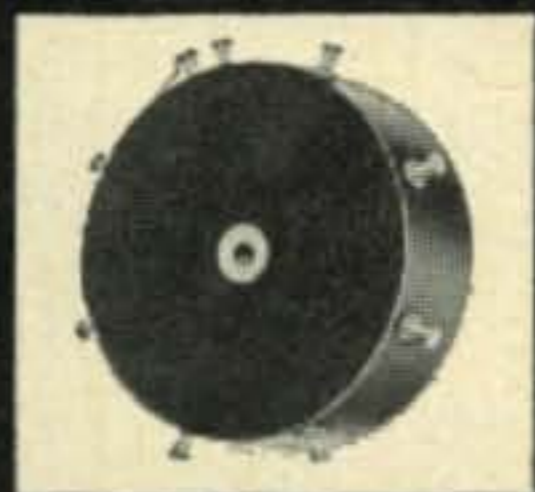

TRANSISTORIZED CONVERTERS AND INVERTERS 12 TO 14 VDC INPUT

MODEL	TPC-25W	TPC-60W	TPC-120W	TPI-25W
RATING	25W	60W	120W	25W
PRICE	\$32.50	\$48.50	\$57.50	\$32.50
OUTPUT Voltage Current	250V 100ma	300/150V 200ma total	500/250/-60V 200/100/10ma	115/26VAC 25W-400cy
INPUT No Load Full Load	0.5 amp 3 amp	1 amp 7 amp	1.5 amp 12 amp	0.5 amp 3 amp
REGULATION Full Load/No Load Full Load/1/2 Load	86% 92%	88% 93%	85% 91%	70% 85%
OVERALL DIMENSIONS Width Length Height	3 in. 4 1/4 in. 3 1/8 in.	4 1/4 in. 5 1/4 in. 3 1/4 in.	4 1/4 in. 5 1/4 in. 3 1/4 in.	3 3/8 in. 5 in. 3 1/4 in.

TOROIDAL TRANSFORMERS FOR 12 TO 14 VDC INPUT

MODEL	TT-25W	TT-60W	TT-120W	TIC-25W
RATING	25W	60W	120W	25W
PRICE	\$8.10	\$11.25	\$15.25	\$14.75
TRANSISTOR POWER RATING	3 amp	6 or 12 amp	12 amp	3 amp
OUTPUT Voltage Current	250V 100ma	300/150V 200ma	500/250/60V 200/100/10ma	26 & 115 VAC 400cy



Barker & Williamson, Inc.

Bristol, Pa.

For further information, check number 14, on page 126



THIS is the microphone for mobile use

THE TURNER 350C

Good performance on mobile operations — citizen's band, 2-way commercial radio and amateur radio — requires a microphone designed for mobile use. Tape recorder type mikes can't do the job. The Turner 350C is a reasonably priced, ceramic microphone especially designed for quality voice reproduction. DPST switch is wired for relay operation with easily reversible terminals to allow modification (if necessary). A wiring diagram is enclosed with each microphone. Hanger button and standard dash bracket are included for mobile rig mounting. Microphone furnished with 11" retracted (five foot extended) Coiled Kord. Response: 80 to 7000 cps. Output: -54 db. List price: \$16.80 complete. See your electronic parts distributor. He has the Turner 350C in stock.

THE **TURNER** MICROPHONE COMPANY
925 17th Street NE
Cedar Rapids, Iowa

For further information, check number 15, on page 126

NEW! VACUUM ANTENNA RELAY

specially designed for amateur kilowatt service

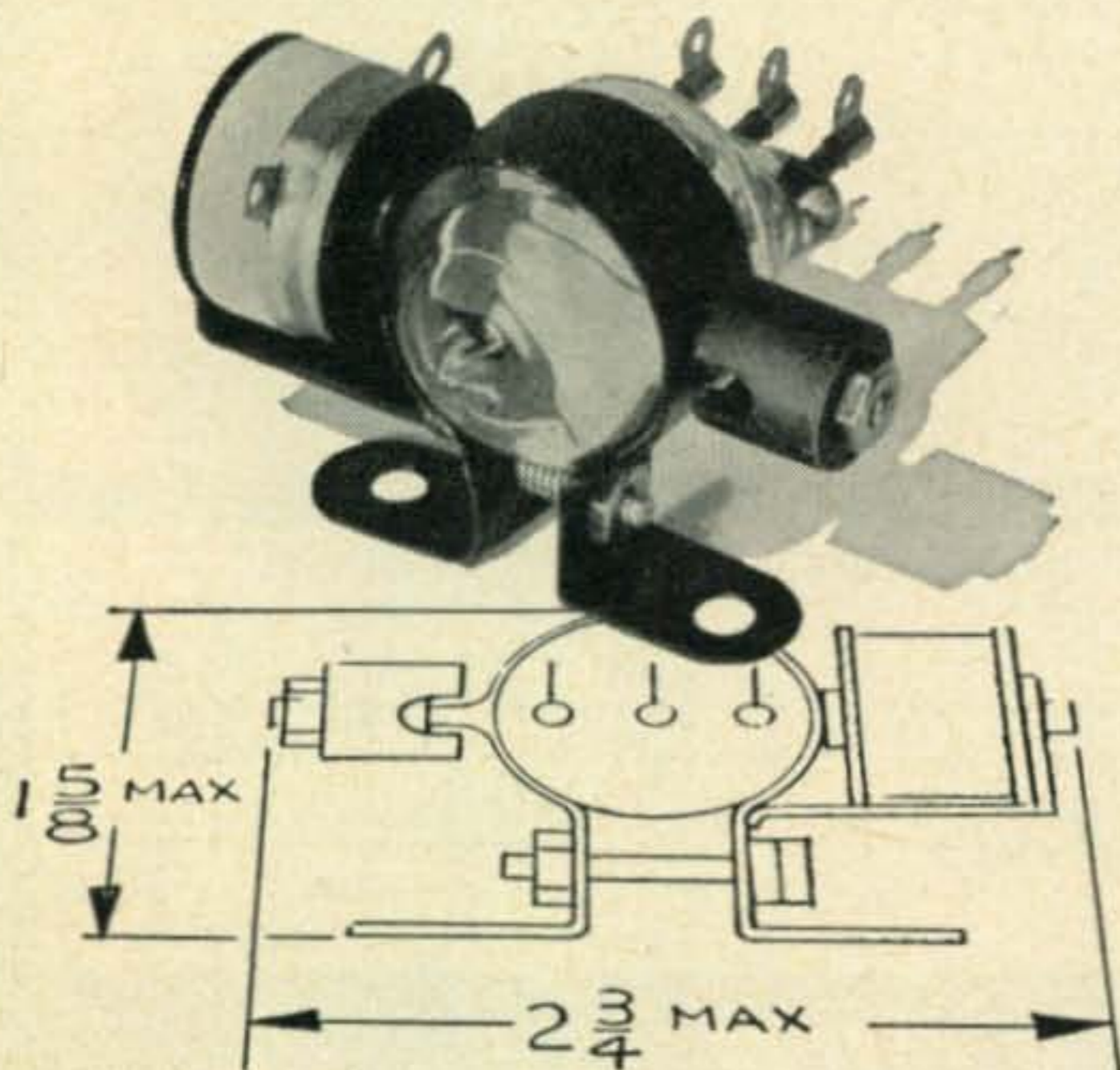

HERE, AT LAST, is a vacuum TR relay engineered for economy, yet offering all the advantages that have made vacuum switches famous. Economy has been achieved through the use of an inexpensive, externally mounted magnet and 28 vdc coil to provide the actuating force necessary for movement of the vacuum enclosed contacts. Vacuum dielectric offers these advantages:

Super clean contacts *that guarantee low unchanging contact resistance.*

High voltage and current ratings . . . *this new Model RP-1 switch has conservative rf ratings of 1 kv and 4 amps rms.*

Small physical size — *should be installed adjacent to the tank coil.*

Silent operation . . . easily mounted.

Amateur Net Price—each . . . **\$32⁰⁷**

Write Jennings today—we will be glad to send further information on the new Model RP-1 relay.

RELIABILITY MEANS VACUUM
VACUUM MEANS **Jennings**

JENNINGS RADIO MFG. CORP., 970 McLAUGHLIN AVE., P. O. BOX 1278, SAN JOSE 8, CALIF.

For further information, check number 16, on page 126

APPENDIX

Part 12 of the Commission's Rules is amended as follows:

- §12.21(d) is amended to read as follows:
§12.21 Eligibility for License

(d) Conditional Class. Any citizen of the United States whose actual residence and amateur station location are more than 75 miles airline distance from the nearest location at which examinations are held at intervals of not more than 3 months for General Class amateur operator license; or who is shown by physician's certificate to be unable to appear for examination because of protracted disability; or who is shown by certificate of the commanding officer to be in the armed forces of the United States at an Army, Navy, Air Force or Coast Guard station and, for that reason, to be unable to appear for examination at the time and place designated by the Commission; or who furnishes sufficient evidence of temporary residence for a continuous period of at least twelve months, outside the continental limits of the United States, its territories or possessions, irrespective of whether his permanent residence in the United States is more or less than 75 miles airline distance from the nearest location at which examinations are held at intervals of not more than 3 months for General Class amateur operator license.

- §12.44(a) is amended by changing the period at the end of subparagraph (3) to "; or" and by adding a new subparagraph (4) to read as follows:

§12.44 Manner of Conducting Examinations

(a)

- If the applicant demonstrates by sufficient evidence that his temporary residence is for a continuous period of at least twelve months, outside the continental limits of the United States, its territories or possessions, irrespective of whether his permanent residence in the United States is more or less than 75 miles airline distance from the nearest location at which examinations are held at intervals of not more than 3 months for General Class amateur operator license.

Lewiston-Clarkston A.R.C.

The Lewiston-Clarkston Amateur Radio Club of Lewiston, Idaho and Clarkston Washington is issuing a certificate in honor of their Centennial Celebration which began May 13th and extends to September 1st, 1961. This attractive Certificate will be awarded to anyone who works an amateur in the Lewiston, Idaho Clarkston, Washington valley. Only contacts between November 1, 1960 and September 1, 1961 count toward the award. No band or mode stipulations are made. QSL cards must be sent to the L-CA.R.C. Inc., P. O. Box 383, Lewiston, Idaho.

Atlanta Radio Club

Thirty two years is a long time to be putting on Ham-fests and this year marks the 33rd time the Atlanta Radio Club will sponsor their gala occasion. Where: The Shrine Temple, Ponce de Leon Ave., N. E., Atlanta, Georgia. When: June 3rd and 4th. What: Dinner, dance and the usual Hamfest activities. Who: Crowds from all over the Southeastern region. Will you be there? Betty Bennett, K4BZE will fill you in, if you write to her at 2651 Volmar Drive, Doraville, Georgia.

The Quad City A.R.C. Inc.

The Quad-City Amateur Radio Club will hold their Hamfest on May 28th, at the Gra Ell picnic grounds, east of Moline, Illinois. Tickets in advance are \$1.50 and can be obtained by writing to Wayne Blick, 2366 30th Street, Moline, Illinois. A penalty of 50¢ will be levied on all amateurs buying tickets at the picnic grounds.

[Continued on page 100]

NOW! TWO ANTENNAS TWO ANTENNAS IN ONE*

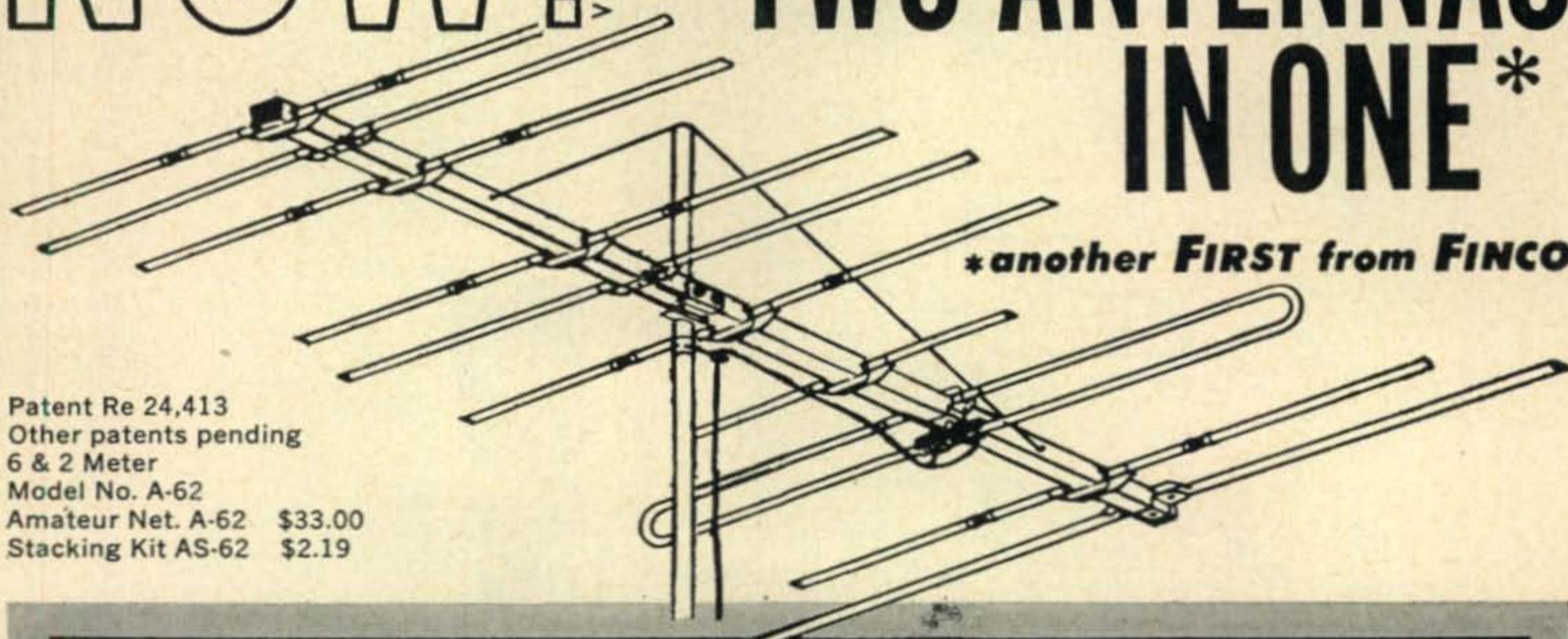

*another **FIRST** from **FINCO**

Patent Re 24,413
Other patents pending
6 & 2 Meter
Model No. A-62
Amateur Net. A-62 \$33.00
Stacking Kit AS-62 \$2.19

Introducing..... THE ONLY SINGLE FEED LINE 6 & 2 METER COMBINATION ANTENNA from **FINCO**[®]

- Heavy Duty Square Aluminum Boom, 10 Ft. Long
- All Elements Are Sleeve Reinforced And Completely Pre-assembled With "Snap-out" Lock-Tite Brackets
- Boom Suspension Rods Are Supplied Completely Pre-assembled, Ready To Be Snapped Into Upper End Of Mast

ON 2 METERS

- 18 Elements
- 1 - Folded Dipole Plus Special Phasing Stub
- 1 - 3 Element Collinear Reflector
- 4 - 3 Element Collinear Directors

ON 6 METERS

- Full 4 Elements
- 1 - Folded Dipole
- 1 - Reflector
- 2 - Directors

OTHER ANTENNAS for the DISCERNING AMATEUR

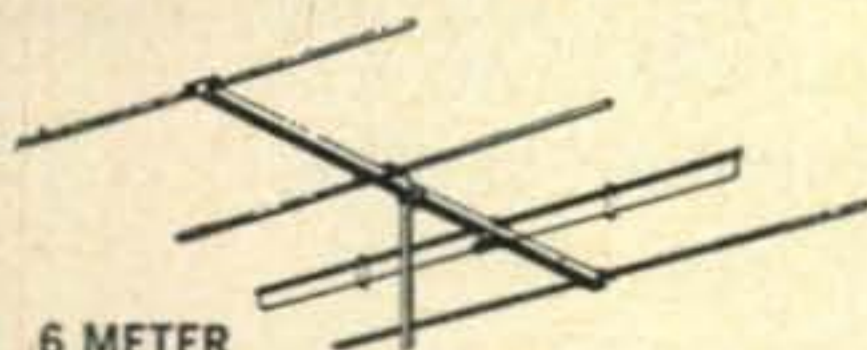

6 METER
4 ELEMENT
AMATEUR NET
A6-4 \$17.16
STACKING KIT
AS-6 \$2.19

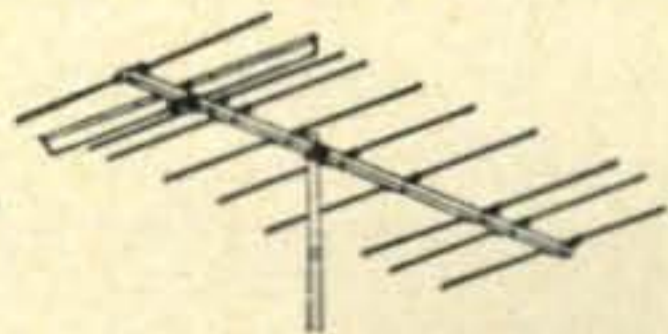

2 METER
10 ELEMENT
AMATEUR NET
A2-10 \$11.88
STACKING KIT
AS-2 \$1.83

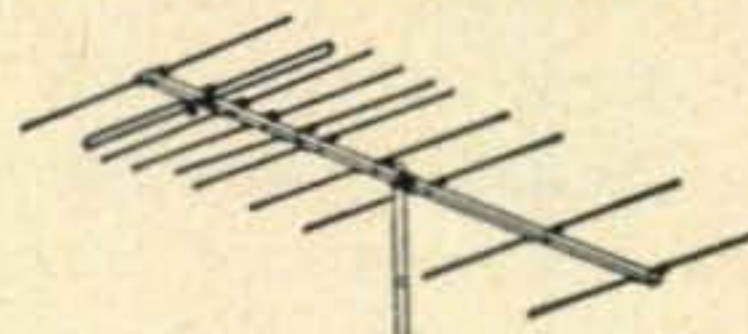

1 1/4 METER
10 ELEMENT
AMATEUR NET
A1 1/4-10 \$11.88
STACKING KIT
AS-1 1/4 \$1.26

See your **FINCO** distributor

or write direct to

THE FINNEY COMPANY • DEPT. 19, 34 W. INTERSTATE ST., BEDFORD, OHIO

For further information, check number 17, on page 126

From the Boys in the Back Room



Amateur radio today is big business. With more than 240,000 Americans holding ham licenses today, somewhere between \$25 million and \$35 million will be spent during the next twelve months on amateur equipment. Where that money will be spent, and how, will naturally be determined by new developments in the industry and by economic trends around the country, and only time will tell.

But, one significant fact stands out: distributors and dealers of amateur equipment throughout the country are crying the blues—and justly so. It's getting more and more difficult for a legitimate dealer to stock ham gear and sell it at a profit. The reasons are numerous.

For one thing, there's a dangerous trend on the part of amateurs to pressure the dealer to cut prices or offer discounts in order to make a sale. A typical situation might find Joe Ham, W2XXX walking into the dealer's store, locating a counterman, and saying something to the effect of, "your competitor down the street will sell me an XYZ receiver for 15% off. Can you make me a better offer?" Unfortunately, too many dealers have found it necessary to do just that if they want the sale badly enough, and sooner or later the word gets around that ham equipment can be bought locally at a nice discount.

Many hams don't realize that by saving a few dollars at the outset on a discount purchase, they're only hurting themselves in the long run. Here's why. A typical amateur receiver or transmitter selling for say \$400 normally nets the dealer approximately a 25% markup or \$100. That markup is legitimate business profit for labor, capital investment, and service. And in the same manner, the manufacturer is also entitled to a normal profit, which in this case will run somewhere around \$50. Thus, a receiver which originally costs \$250 in parts, labor, and engineering sells to the amateur for \$400, and the amateur is getting a pretty fair buy for his money.

Now, if the dealer is pressured into selling this receiver for a discount of say 17%, his markup is only 8% or approximately \$24, hardly enough to make it worth his while. Yet, the dealer is expected to stock a complete inventory of ham gear which requires an investment of tens of thousands of dollars, and is also expected to handle warranty claims, all for a paltry 8% profit. He's better off putting the money in a good real estate or stock investment where his money is safe and his profit as great or greater.

In addition, when the amateur is ready to trade in his receiver for something newer or better, he finds that he doesn't get anywhere near what he thinks is a fair price. It's obvious why; a receiver which can be bought at a large discount brand new, decreases fantastically in value as used gear. And that's only a small part of how the ham is hurting himself by buying at a discount.

The distributor, in order to make a fair profit, is forced by matters to ask the manufacturer for a larger discount, say 33% instead of 25%. And if that happens, the manufacturer, in order to stay in business, must either cut production costs—which invariably result in an inferior product—or he must raise the list price of the unit to allow himself a fair margin. So who's suffered now? Joe Ham. And who's to blame? Joe Ham! It's the old story of being penny-wise and pound foolish.

And the worst part of the picture hasn't been mentioned yet. The ham who can afford to buy the \$400 receiver with a 17% discount can afford to pay full list price, in most instances. It's the younger ham who's looking for a piece of good low-priced used gear that takes it on the chin, because that used gear just isn't around. Why isn't it around? Simple, because the discounting on new gear has dropped the bottom out of the used equipment market to the point where the average old-timer will probably keep that old receiver as a spare, rather than let it go for pennies. And frankly, we can't blame him either.

So, where do we go from here? That depends on the fraternity itself. The problem can only be licked by a voluntary cooperation on the part of the amateurs buying equipment. If you expect to buy new gear and can afford to pay list price without a discount, do so. If you have a piece of good used gear to trade on your new unit, don't let it sit in the attic gathering dust. In the long run, you'll come out ahead, your fellow hams will come out ahead, and the industry which has made our hobby so much more fun will be that much more stable, and that much more inclined to find better and newer items to make the hobby even more enjoyable.

Dick, WA2LRO

"INVADER"

EXTENSIVELY FIELD

here are typical reports:

"Sideband never sounded so good!"

"Excellent penetration and an outstanding signal!"

"Full-fidelity voice reproduction—picks up the lows for that 'natural' sound for the first time!"

"Sideband and carrier suppression is tops!"

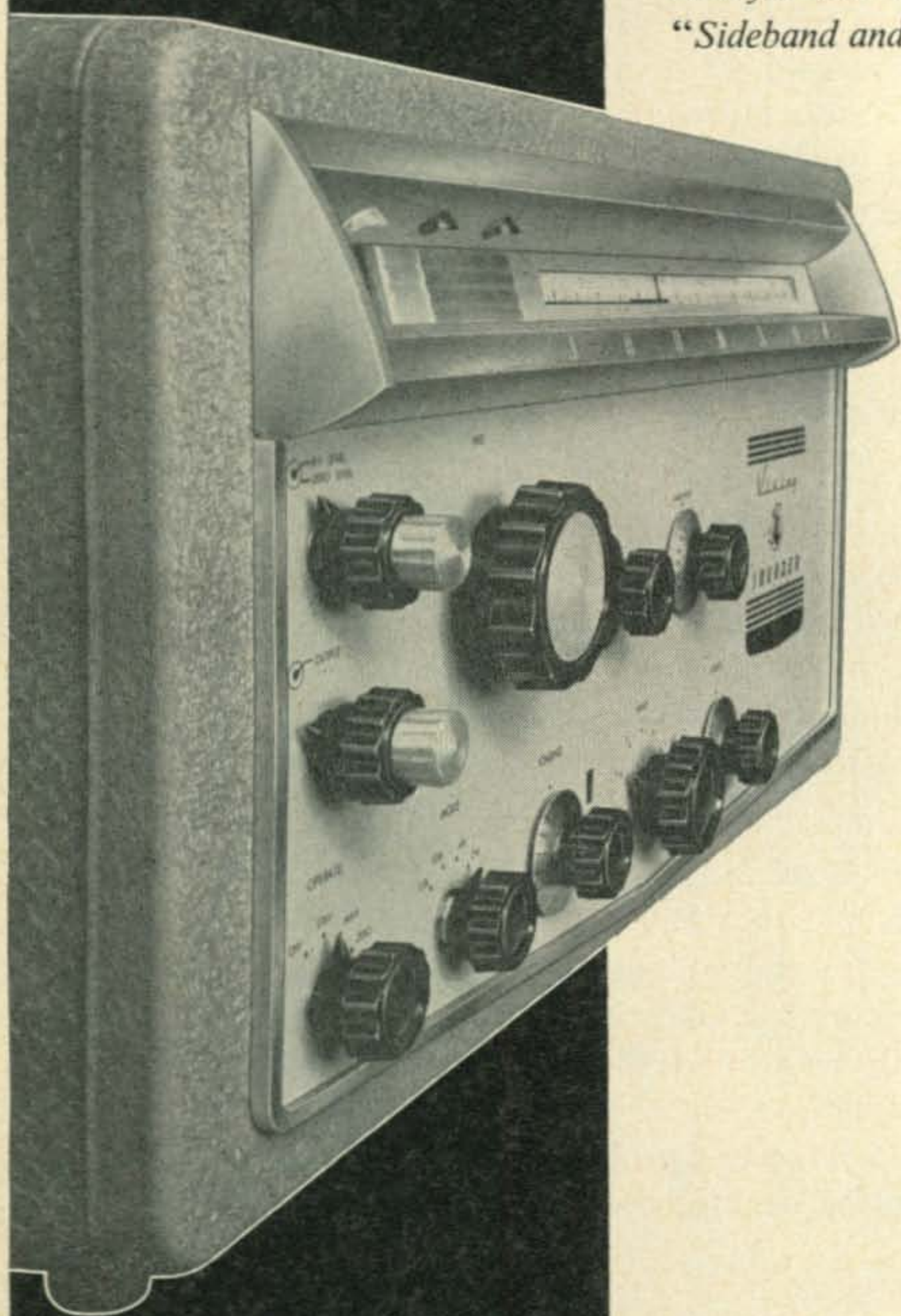

Here's the transmitter with the sharp, penetrating signal you've been waiting for—plus *more* exclusive operating and convenience features than any other SSB Transmitter on the market today! A classic of modern communication equipment design, the "Invader" offers instant bandswitching coverage 80 through 10 meters—no extra crystals to buy—no retuning necessary—delivers a solid 200 watts CW input; 200 watts SSB input; 90 watts input on AM! Unwanted sideband suppression is 60 db or better! Built-in VFO is differentially compensated. Exclusive RF controlled audio AGC and ALC (limiter type) provide greater average speech power—high gain push-to-talk audio system has plenty of reserve gain for either crystal or dynamic microphones. VOX and anti-trip circuits are extremely smooth in operation—built-in anti-trip matching transformer—adjustable VOX time delay circuit. Mixer-type shaped keying is crisp, sharp—click and chirp free. Single knob wide range pi-network output circuit—fully TVI suppressed. Blocking and operating bias for noise-free T-R switch operation.

Cat. No. 240-302-2—Wired and tested with tubes, crystals and crystal filter. **Amateur Net \$619⁵⁰**

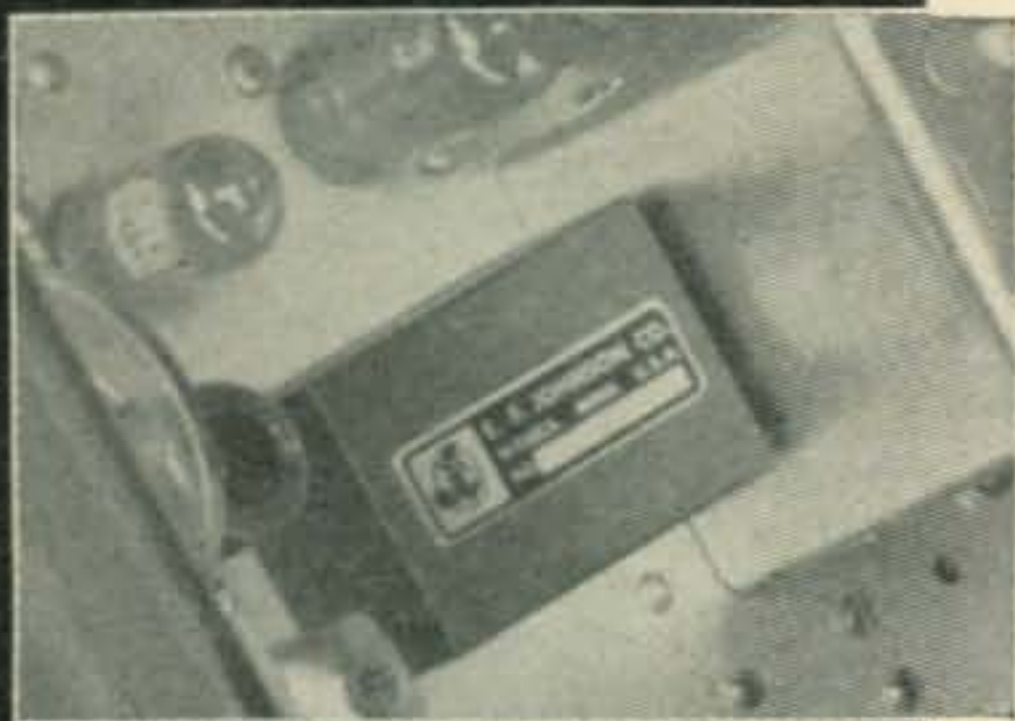

*superior to phasing-type units
. . . obsoletes all other filter types!*

EXCLUSIVE—Now, for the first time, not only **better** audio fidelity—but balanced audio response in a filter-type transmitter. The only equipment on the market using a specially developed high frequency, symmetrical, multi-section band-pass crystal filter for more than 60 db sideband suppression—more than 55 db carrier suppression! Select either upper or lower sideband instantly with a front panel "mode" switch.

the finest SSB signal on the air!

TESTED BY DOZENS OF UNBIASED AMATEURS!

**A BOLD STATEMENT
FROM E. F. JOHNSON CO.**

The sophisticated engineering and styling of the "Invader" is *unmatched* by other equipment within the amateur field—*bar none!*

Long recognized as the "first choice among the nation's amateurs" . . . Viking transmitters achieved popularity in a solid and healthy way. Known the country over as the line that gives you excellent engineering and performance, outstanding dollar value and more features at a popular price . . . the Viking line now achieves a new pinnacle with the introduction of the "Invader" and the "Invader-2000". We feel that the creative and imaginative engineering in the "Invader" sets aside "old fashioned" ideas that a unit is good simply on merit of the manufacturer's name alone! It has to perform—and nothing outperforms the "Invader!"



EXCLUSIVE—When converted to the Invader-2000—the only maximum legal power table-top unit available! (Remote power supply can be placed in any convenient location.)



EXCLUSIVE—The only transmitter with both limiter ALC and audio AGC for an **extra sharp signal!** Reduces overdriving and flat-topping—increases average audio level for greater penetration and the **best signal anywhere!**

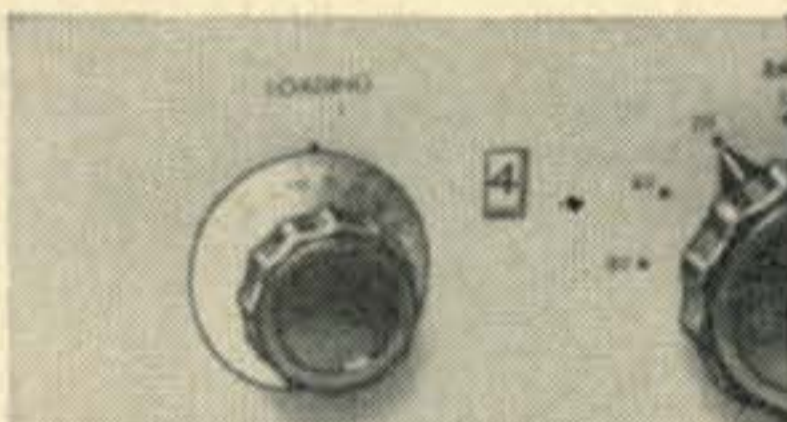

EXCLUSIVE—Single-knob wide range output circuit makes it possible to load into just about any conceivable type of antenna!



EXCLUSIVE—Full-time VFO heater element keeps VFO at operating temperature, even with the equipment turned off! No warm-up drift—rock-solid stability!

add hi-power conversion overnight for an integrated 2000 watt desk-top transmitter!



HI-POWER CONVERSION—Take the features and performance of your "Invader" . . . add the power and flexibility of this unique Viking "Hi-Power Conversion" system . . . and you're "on the air" with the "Invader-2000". Completely wired and tested—includes everything you need—no soldering necessary—complete the entire conversion in one evening!

Cat. No. 240-303-2 . . . Amateur Net **\$619⁵⁰**

INVADER-2000—All the fine features of the "Invader", plus the added power and flexibility of an integral linear amplifier and remote controlled power supply completely wired and tested. Rated a solid 2000 watts P. E. P. (twice average DC) input on SSB; 1000 watts CW; and 800 watts input AM! Wide range output circuit (40 to 600 ohms, adjustable.) Final amplifier provides exceptionally uniform "Q". With multi-section power supply, tubes and crystals.

Cat. No. 240-304-2 . . . Amateur Net **\$1229⁰⁰**

free

**8-PAGE
BROCHURE . . .**

Yours on request . . . complete specifications and photographs on the "Invader" and the "Invader-2000"!

FIRST CHOICE AMONG
THE NATION'S
AMATEURS



Viking

E. F. JOHNSON COMPANY • WASECA, MINNESOTA.

For further information, check number 18, on page 126

A Bandswitching, Low Cost

400 Watt Linear

Howard L. Morrison, W7ESM

9000 S. W. Beaverton — Hillsdale Hgwy.
Portland 25, Oregon

R.f. input of approximately 12 watts is required to drive this unit to 400 watts output. Both driver and power amplifier are running grounded grid and the use of surplus components throughout makes this a rather inexpensive construction project.

ECONOMY was the byword in making this amplifier. A glance at the photographs will show that the chassis-case, band-switches, plate tuning capacitors, and pi-output padding capacitors came from BC-375 coil drawers, which cost \$3.00 each. The filament coils (substituting for the more conventional chokes in grounded-grid amplifiers), the low frequency plate coils, and two of the filament blocking capacitors are familiar Command set items, as is the fixed vacuum padder for the final plate circuit on 80 meters. The 803 used in the output stage is still a surplus buy at \$3.25, and the 814 driver tube is \$1.65. This leaves only the meters, 3 gang pi-output variable capacitor, tube sockets, r.f. chokes, doorknob-type blocking capacitor, pi-output padder switch, small bypass capacitors, assorted hardware, and wire for coils and hookup—and even many of these can be surplus or junk-box items. A significant saving in power supply cost, is that only one high voltage is needed; the 814 operates at the same plate voltage as the 803, and that is the reason for choosing such an “oversize” tube for a driver. The grounded grid circuit with both tubes connected as high- μ triodes eliminates the need for both a screen supply and a regulated bias supply. (Cut-off bias is required during standby in practically all medium and high power amplifiers to prevent shot-noise pickup by the receiver. Here, no current during standby is required, so the bias can be obtained in various ways. For example, the power supply which provides receiver muting and current for operating changeover relays can be utilized if it is operated with its positive side grounded.) Few amplifier arrangements, therefore, can match this one on a watts-per-dollar basis.

Drive Requirements

The drive requirements for this linear are surprisingly low, considering that both stages are run in grounded grid. A home brew s.s.b. exciter

with a peak *output* of about 12 watts drives it nicely on the 15 to 80 meter bands. (Drive requirements for 10 meters have not been determined because I no longer reside near the college ham station for which the rig was built.) The exciter, however, has a pi-output circuit and so can accommodate itself to the higher than 50 ohm input impedance of the linear. If something like a 20-A exciter is used, either more turns must be wound on the exciter's output link or else a simple matching network must be used as shown in fig. 1. A higher powered exciter would probably provide sufficient driving voltage to the 814 even at the usual 50 ohm output impedance. However, if you have an exciter with

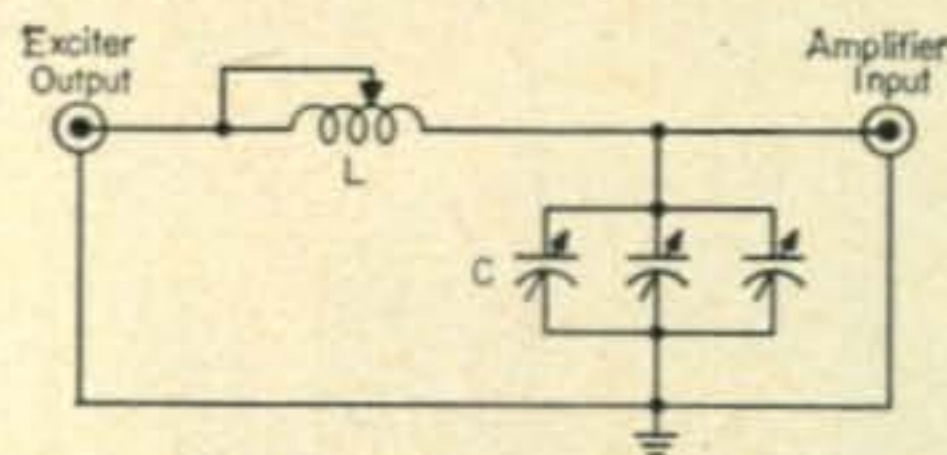
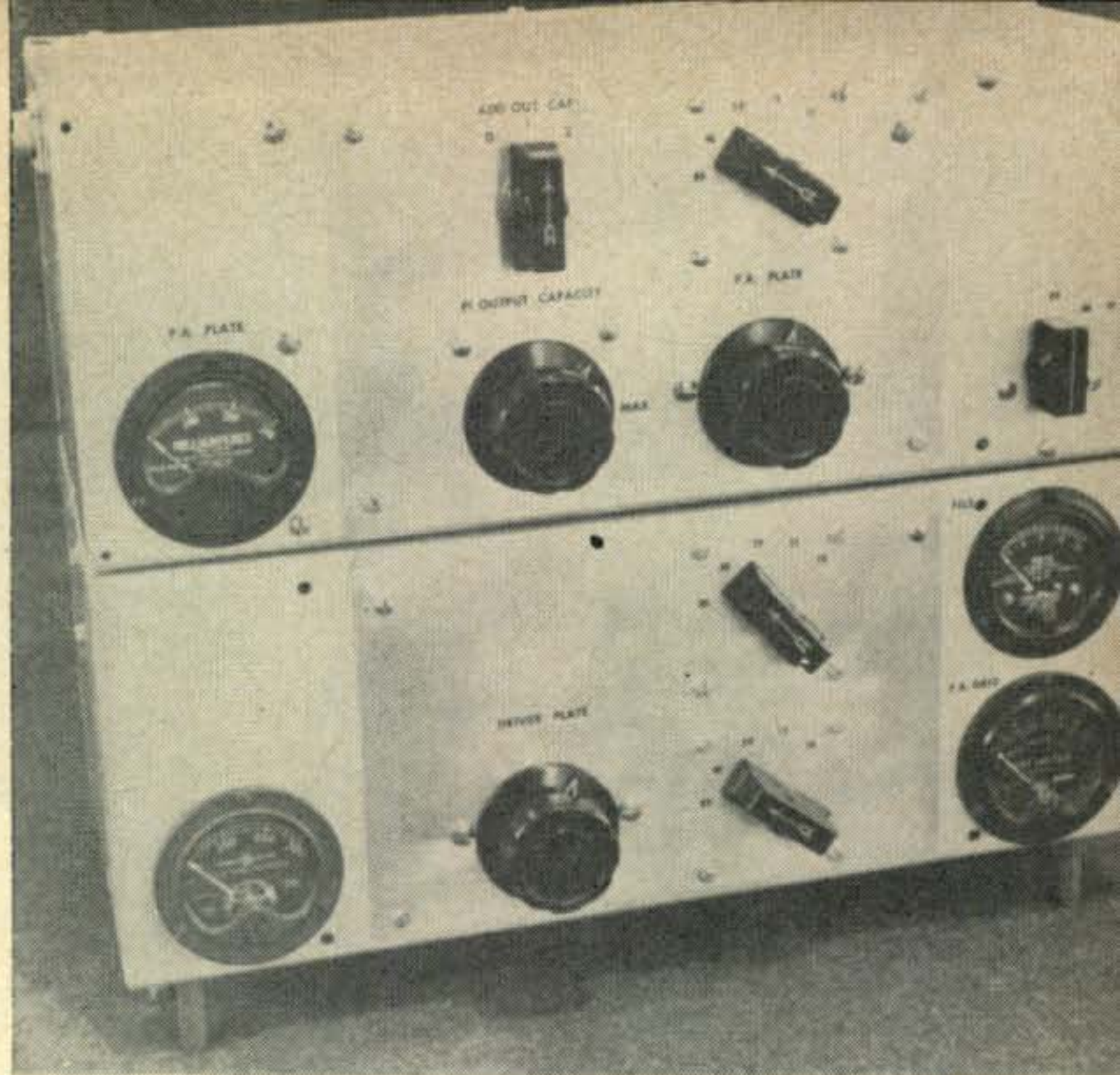

Fig. 1—Suggested matching network for using exciters having low impedance output coils. Inductance L is a $1\frac{1}{2}$ " length of Illumitronic 816A indented-type coil stock or 15 turns of #14, 1" I.D., 2" long, air wound, capable of being tapped with a clip at each turn. Capacitor C should be rated at 300 to 400 mmf per section.

a peak *output*² around 70 watts you could eliminate the 814 stage and drive the 803 directly, again with a matching network as shown in fig. 1. Grounded-grid operation in a linear amplifier has advantages which previous articles in *CQ* have emphasized many times. This amplifier retains these advantages while also overcoming the main disadvantage of high driving power, by the arrangement of two stages operating from a common plate supply. Note also that the number of tuning controls is no more than in a conventional single-stage amplifier with tuned grid cir-

² If such an arrangement were to be used on a.m., the carrier output should be only one fourth this value.

Front view of the ground grid amplifier illustrating the method of stacking two BC-375 tuning units, and the stand-offs used to improve circulation through the cabinet. As explained in the text a filament volt-meter is not required if a 10 volt transformer is obtained. The meter at the lower left monitors the 814 plate current.



cuit. The idea would not be so attractive, of course, if the driver tube had to be purchased at regular net price!

Power Input

The power developed by the 814, which is in excess of its own plate losses and the 803 grid circuit requirements, appears as additional useful output power, as in all grounded grid amplifiers. With 2100 volts (at 190 ma) applied to the 803, the peak input to the final is 400 watts. Since the FCC requires the driver input be added to the final input in grounded grid operation, this then is legally a 500 watt amplifier on c.w. On s.s.b. the input becomes something which depends upon the ballistics of the particular plate milliammeters you happen to be using, the characteristics of the voice talking into the mike, and the setting of the audio gain control. Because of its inherent degeneration, a grounded grid amplifier is notably more tolerant than others to overdrive; however, it is still fairly easy to "flat top" such an amplifier, and you are *strongly* urged

to monitor your output with a scope when operating phone, so as to know just how high you can set that audio gain control without splat-tering!

Circuit

The circuit of the transmitter is shown in fig. 2. It is conventional except for the filament coils substituted for the filament chokes mentioned earlier, and for the switching arrangement for driving the 803. The idea for the filament circuits is to let the filament coils actually become a part, even though a shunted part, of the tank circuit which feeds them. The "cold" ends of the filament coils are bypassed to ground, as

Fig. 2—Schematic of a grounded-grid bandswitching transmitter using surplus components. All capacitors are in mmf unless otherwise noted. Parts marked with an asterisk are explained in the text. Cut-off bias is applied to point A and should be grounded during transmit.

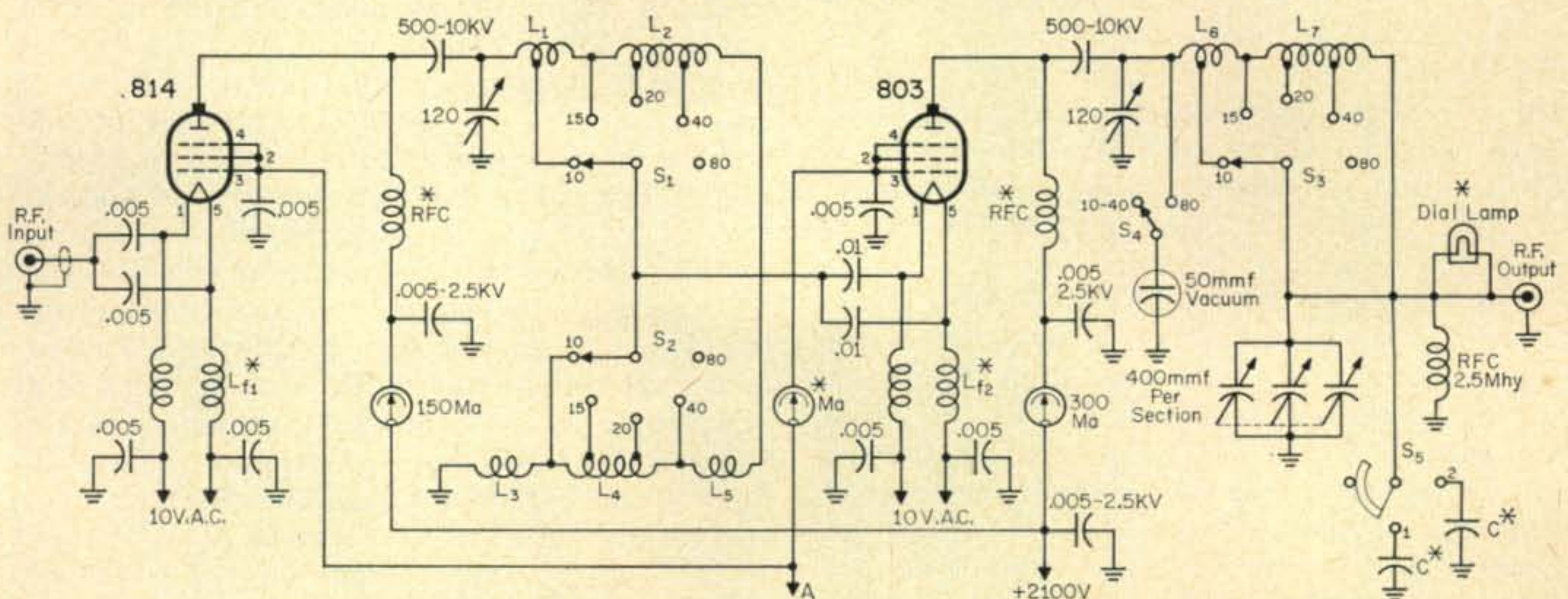

- L₁—7½ turns of #14, ¾" I.D., ⅛" Pitch (the distance from the center of one turn to the center of the next). 10 Meter tap; 4½ turns from plate end.
- L₂—Inductor #6035 removed from a Command set 20 Meter tap; 3⅜ turns from plate end. 40 Meter tap; 8 turns from plate end.
- L₃—2 turns of #14, ⅜" I.D., ⅛" pitch, (See text).
- L₄—7¾ turns of #14, ⅝" I.D., 15 and 20 Meters; ⅛" pitch, 40 Meters; 3/32" pitch. 15 Meter tap at approximately ⅞ turn from ground.

- 20 Meter tap 3 turns from ground end.
- L₅—10 turns of #14, 1" I.D., total length ⅞".
- L₆—8½ turns of #12, ¾" I.D., ⅛" pitch for 10 Meter section; 3/32" pitch for 15 Meter section. 10 Meter tap at 4⅓ turns from plate end.
- L₇—Inductor #6035 removed from a Command set; three turns removed. (See text). 20 Meter tap at 3 turns from plate end. 40 Meter tap at 9 turns from plate end.
- L_{f1}, L_{f2}—Filament coils—(See text).

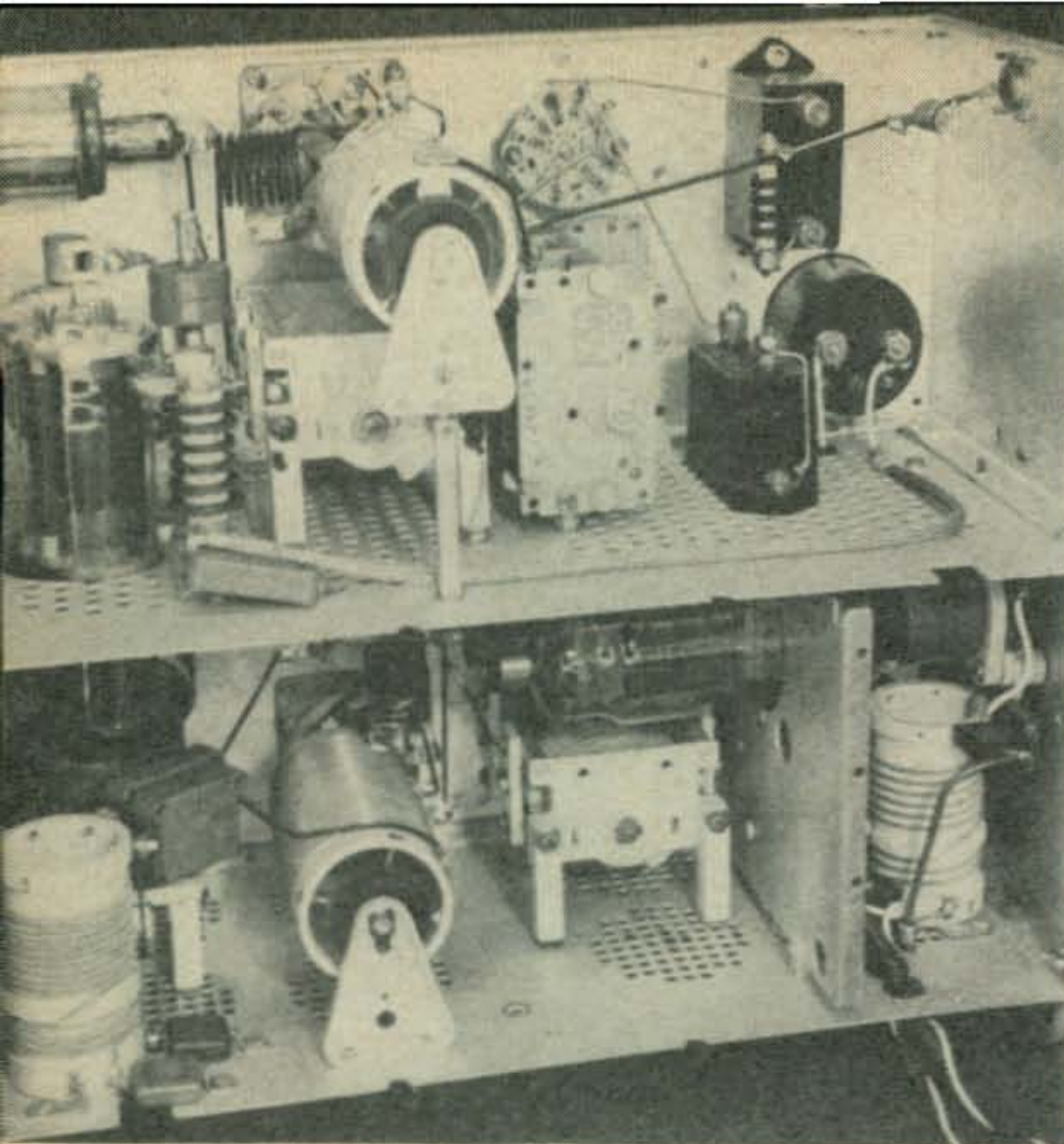

Rear view of the grounded grid transmitter with the Reynolds "Do-It-Yourself" aluminum cover removed. The lower deck houses the entire 814 driver stage and the grid circuit of the 803 amplifier. Two BC-375 tuning unit shields are stacked and provide excellent shielding between stages.

the bottom of any tank circuit, and one ordinary filament transformer is sufficient for both stages. This allows fewer turns to be used than is used in the usual filament chokes for grounded grid operation, and eliminates the need for ferrite cores. The filament coils are bifilar wound on forms that were taken from the plate coils of Command sets. In the rig shown one coil is from a 5.3-7 mc set, and the other is from a 7-9 mc unit. (Both coils could be from either type of set, although the number of turns on L_5 may have to be changed if a coil from a 7-9 mc unit is used for the 803 filament coils.)

The original winding is removed and replaced with two parallel strands of insulated #18 or #19 magnet wire. Single-silk-enamel (SSE) wire was used in the rig shown, but any of the other kinds would be satisfactory, such as single-cotton-enamel, or double-cotton covered. Ordinary enamel is not recommended due to danger of a short if the enamel gets nicked while winding the coils, but the newer type enamels such as *Kovar* would be satisfactory if you don't mind the rather difficult job of scraping off the insulation when making the connections.

In winding the filament coils one of the parallel strands is wound in the groove of the coil form, and the other is wound along the upper side of the former, making as far as the r.f. is concerned, a single coil with a slight spacing between its turns. The terminals of the original command set coil can be unscrewed (if they are heated with a soldering iron while doing it), and repositioned as shown in the photographs.

This type of construction makes easy a circuit modification suggested by K7BYQ and W7EPM,³ which would make life easier for the 803's control grid. The modification is shown in fig. 3. The 803 is a very rugged tube, as Norman McLaughlin proved in *CQ* some years ago. However, control grid current does run very high in this case where a tetrode is connected as a

high- μ triode, and some damage might be done if there is continuous operation with carrier inserted. The use of the modified circuit shown in fig. 3 reduces the likelihood of this type of damage, although it may increase the driving power required.

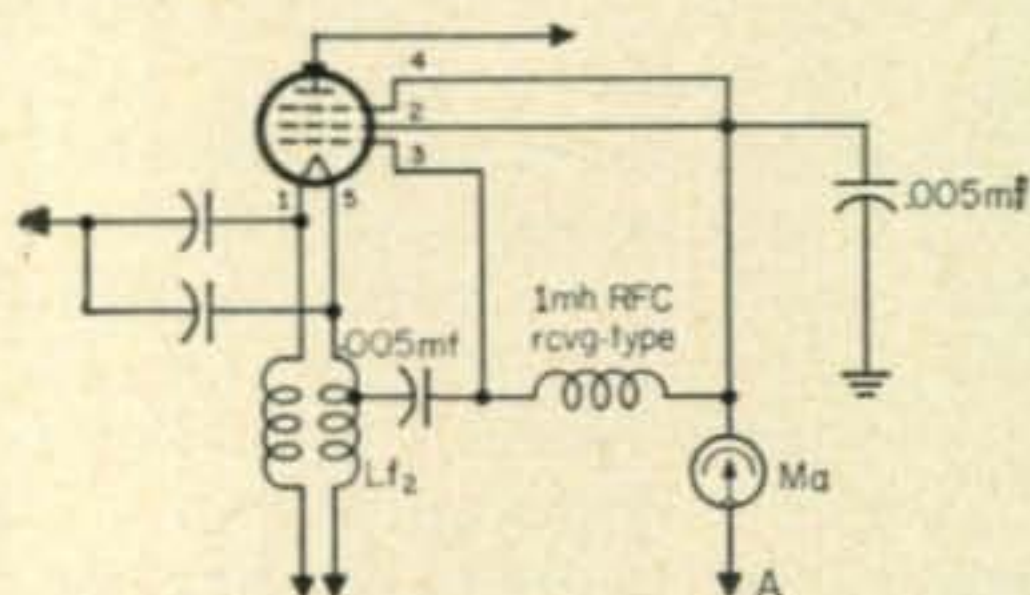

Fig. 3—Suggested modification to reduce control-grid dissipation as was described by K7BYQ and W7EPM. Inductor $L_{1/2}$ should be tapped between one fifth and one fourth the total number of turns down from the filament end. Cut-off bias is applied to point A and should be grounded in transmit.

The second unconventional feature of this amplifier is the method used to obtain driving voltage for the final. It is electrically equivalent to a tap on the driver plate coil, but is much easier to adjust than a tap, and is also better adapted to a bandswitching circuit. A series of small coils, L_3-L_5 , is connected between ground and the lower end of the main driver plate coil, L_1-L_2 . The inductance between ground and the arm of S_2 determines the amount of drive for the 803. Increasing this inductance is equivalent to moving a conventional tap further up on the tank coil; decreasing the inductance is equivalent to moving the tap down. McLaughlin's original article on grounded grid amplifiers in *CQ* stressed the importance of tapping at just the right place. In this amplifier the diameter, wire size, number of turns, and spacing between turns of coils L_3-L_5 , and the taps on L_4 , are things which can be varied to obtain the best position for the equivalent tap. The advantage of having so many variables to play with should be obvious to any ham who has had to deal with ordinary tapped coils. Even the taps on L_4 are less critical than taps on the main tank coil because moving one turn on L_4 has much less effect than moving one turn on the main tank. This arrangement is especially helpful on the higher frequency bands, where an optimum tap on the regular plate coil would be either very difficult

³ Campbell, V. S., & Skeen, W.S., "Grounded Screen-Grid Operation for Tetrodes" *QST*, Nov. 1959, p. 37.

or actually impossible to make because of the mutual inductance between the coil and the lead to the tapping point having more effect than the physical position of the tap itself.

Switches

All of the switches except S_5 came from BC-375 coil drawers. Switches S_1 - S_3 are the single-pole, 6 position ceramic switches common to all the drawers used in the BC-375. In wiring these switches remember that only four of the six positions have leads connected to them, because the 80 meter position has no connection. Switch S_4 , used to connect additional tank capacity for the 803 on 80 meters, comes from the 200-500 kc drawer, although there is a switch in the drawer covering 3.5 mc which would work equally well. If you are going to purchase some coil drawers, one should be in the 200-500 kc range because it not only provides S_4 but also contains many 2500 volt mica capacitors which can be used for bypassing the high voltage and for blocking in the 803 filament circuit. It also contains large mica capacitors which would be satisfactory for padding the pi-output as described below. If coil drawer switches are not available, the switches used must be similar in size and have ceramic insulation. The switch, S_5 , is a receiving type ceramic and is satisfactory so far as contact spacing is concerned because it is located at a low voltage part of the tank circuit; however, its current rating will be exceeded at times. This will not cause trouble provided you remember to *never move S_5 when r.f. drive is applied to the amplifier.* Life would be easier for all the switches if this rule was followed for them too.

Capacitors

The plate tuning capacitors for both the 814 and 803 come from the output sections of two of the high frequency range coil drawers. Capacitors from the oscillator sections of the coil drawers are not recommended because of insufficient capacity and slightly smaller plate spacing. A better operating Q for the 803 tank circuit is obtained for 80 meter operation by connecting a 50 mmf fixed vacuum capacitor from a command set antenna relay unit in parallel with the

main plate tuning capacitor. These items are also still fairly plentiful and cheap.

The pi-output tuning capacitor is a 3 gang, 400 mmf per section capacitor similar to a large-size broadcast receiver tuning capacitor. The midget size capacitors now most widely available would probably be satisfactory for feeding low output impedances (50 ohms or so), but might spark over at medium-high output impedances. A 2 gang variable capacitor can be used if you are willing to sacrifice some convenience in tuning, and use a switch at S_5 with four or five positions so that more fixed padding capacitors can be used.

The output padding capacitors, unmarked in fig. 2, are not critical in capacity. The number used will depend upon the maximum capacity of the variable capacitor and the lowest load impedance on 80 meters that you intend to feed. For 50 ohm loads and higher, the total padding capacity should be at least 1,000 mmf with a 3 gang variable, or 1400 mmf with a 2 gang variable. In order to prevent gaps in the tuning range of the pi-output circuit the maximum capacity of the capacitors connected to any one position of S_5 should not exceed about 80% of the maximum total capacity of the particular variable capacitor used. The capacitors used in the amplifier shown are 720 mmf surplus items. Although the padding capacitors do not have to withstand high voltages, they do have to carry high currents; therefore heavy-duty transmitting type micas should be used. Only the large-case mica capacitors in the BC-375 coil drawers should be used for output padding.

Plate blocking capacitors are the usual television-type doorknobs. The 803 filament coupling capacitors have to carry a moderate amount of r.f. current; those shown are from Command set output tank circuits, but any capacity greater than .003 mf should be satisfactory.

Coils

The 814 filament coil is wound on a form taken from a 7-9 mc Command set, as previously described. The 803 coil is wound on one taken from a 5.3-7 mc set, and both are wound as previously described. The 20, 40, and 80 meter

Top view of the upper half of the amplifier showing parts location. The 803 fits into the large round hole at the right. The vacuum capacitor and its associated switch below the capacitor are used on 80 meters. The rotary inductor, L_7 , salvaged from a Command set, is used as a fixed inductor and L_6 is mounted at the right. Output indicator lamp is shown on the left. The shunt value for the lamp is determined by the length of wire between connections.

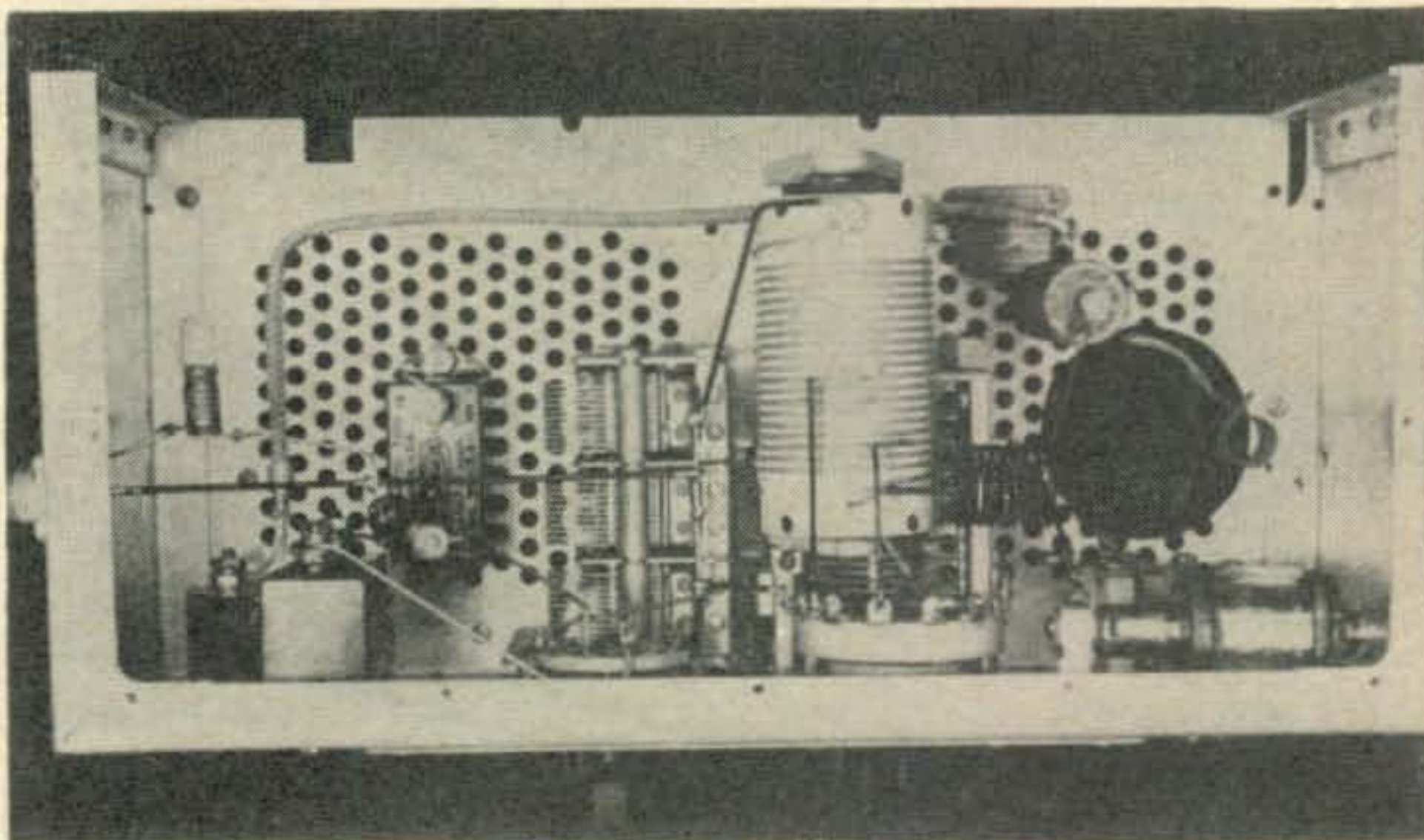

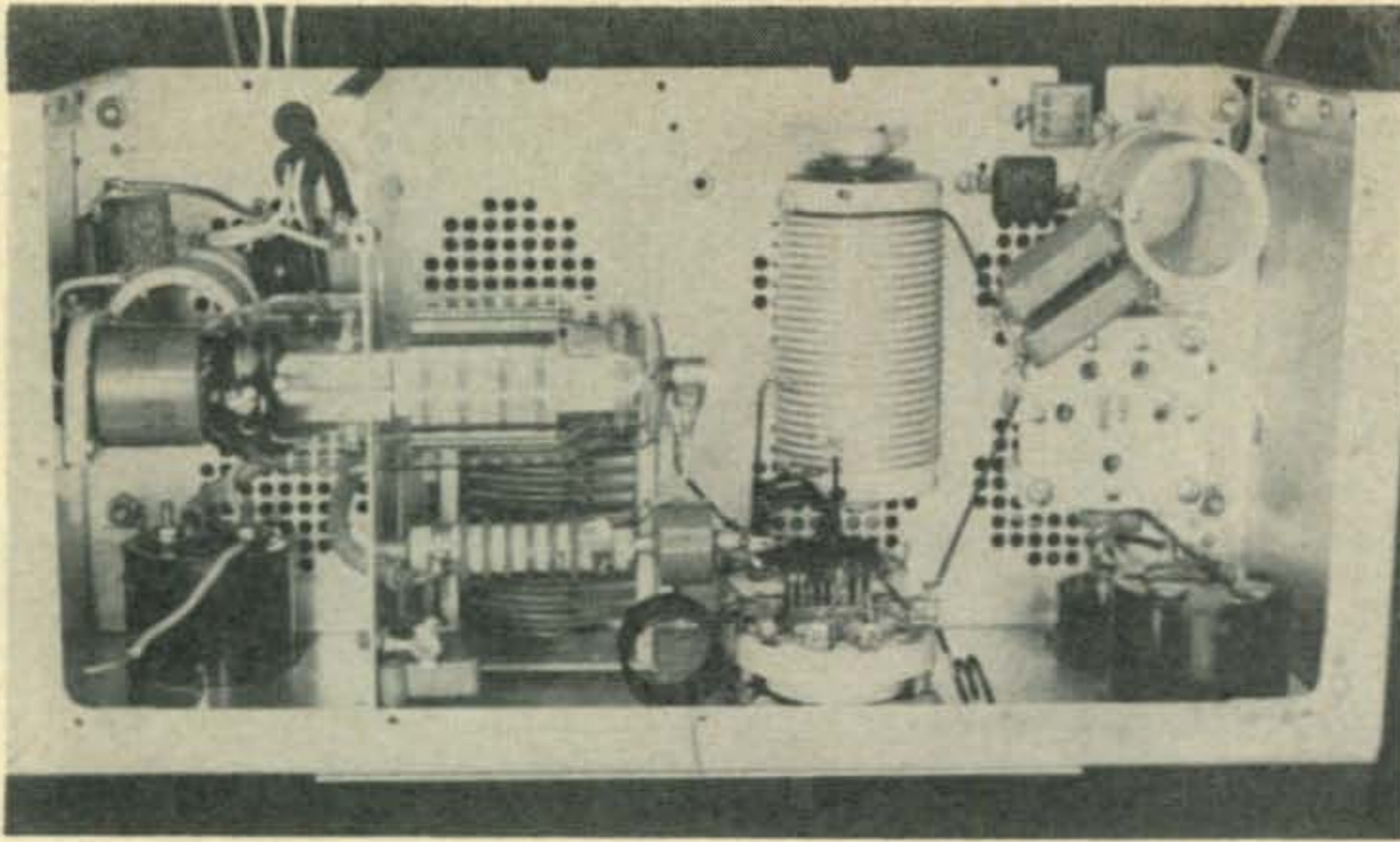

Top view of the driver. The 814 plate and grid connections are well shielded by an aluminum partition and power is supplied by the wires at the upper left. Inductors grouped around the ceramic switch are, left to right, L_5 , L_4 , and L_3 . Inductor L_1 is mounted lower down near L_2 which is a Command set loading coil. The 803 filament inductor and by-pass capacitors are shown at the upper right. The 803 has been removed from its socket.

sections of both plate tank circuits are the antenna loading coils from the same command sets (#6035, common to both sets). These coils are tapped as shown in the pictures and described in the accompanying coil table. The picture of the 803 tank circuit shows three turns removed from the large coil. This is not necessary, but does improve the L/C ratio for the phone end of 80. On the other hand, it may prevent the low end of 80 from being tunable with some types of antenna loads and/or with lower inductance plate r.f. chokes.

Coils L_1 and L_3 to L_6 are air wound; see the coil table for data. The specification for L_3 is tentative only, because I have moved from the college, where the amplifier was built and is now used, before I had sufficient opportunity to test it on ten meters. The spacing between the turns of this coil should be varied for maximum power output, and if this adjustment is not sufficient a coil of different diameter substituted.

The two plate r.f. chokes are modified Hammarlund transmitting chokes (no longer sold), and were used because of their short length plus the fact that they were on hand in the junk box. Since the amplifier was not operated at many frequencies in the 10 and 15 meter bands I can not guarantee the modification for these bands.

For the benefit of those who may wish to modify similar chokes: Remove 25 turns from the first and sixth pies, 35 turns from the second pie, 45 turns from the third pie, 55 turns from the fourth pie, and 39 turns from the fifth pie. Other chokes which should be practical for this amplifier are those used in the output plate circuits of Viking and Valiant transmitters, and probably obtainable on a spare parts order to the E. F. Johnson Co. The National type R154-U is the right physical size, but may possibly develop a hot spot somewhere in the 10 or 15 meter bands; if so, remove turns from the center pie, or pies, until the difficulty is eliminated.

The small choke in the antenna circuit provides a d.c. path to ground for the plate blocking capacitor and serves to prevent shocks from the antenna or antenna tuner when the amplifier is in stand-by condition. It also will drain a rea-

sonable amount of static electricity from the antenna in stormy weather and act as a safety short in case the plate blocking capacitor breaks down. Don't depend upon it as a lightning arrester! Any of the ordinary 1.0 mh to 2.5 mh receiving chokes should be satisfactory here. A National type R-100 is used in the amplifier shown.

Meters

The filament voltmeter shown in the photographs does not appear in the schematic diagram because it is not necessary when a regular 10 volt filament transformer is used. Two 6 volt windings in series were used to supply filament voltage for the rig shown with a rheostat used to reduce the primary voltage; a filament voltmeter was therefore a necessity.

The rating of the grid current meter for the 803 depends upon the grid circuit you decide to use. For the circuit as shown in fig. 2, the meter should be able to handle 150 or 200 ma. If you use the modification shown in fig. 3, a rating of 50 ma should be satisfactory.

A grid current meter is of help in tuning the 814 plate circuit, although the 803 plate current meter can also be used for this purpose. The 814 plate current meter is helpful in indicating grid drive applied to the 814, as well as providing a check on plate dissipation. It does *not* indicate resonance in the 814 plate circuit because the usual rule of "tuning for a dip in plate current" does not apply to grounded grid amplifiers using pentodes connected as high- μ triodes. Similarly, the 803 plate current meter indicates grid drive applied to the 803 as well as plate dissipation, but does not indicate resonance. An indicator of r.f. output is therefore a necessity. R.f. ammeters are fine but expensive, so a simple lamp type indicator is used. A dial lamp is connected in shunt with several inches of the #12 wire output lead. The size bulb and the length of the shunt will depend upon the impedance which the amplifier feeds. A standard brown bead, 6-8 volt dial lamp is suggested as a starting point for experiment. If the shunting length is short and difficult to adjust, used a higher current lamp, such as a blue bead one. If even a long

shunt doesn't provide sufficient lamp glow (as may be the case with output impedances greater than about 100 ohms), use a pink bead, 2 volt lamp. In all cases keep the loop formed by the output lead and the connections to the dial lamp as far from the plate coils as possible, and also keep the plane of the loop horizontal in order to avoid a false indication of output current by reason of direct inductive pickup from L_7 . If you use a Moni-match or other type of output indicator in conjunction with your antenna tuner, no indicator in the amplifier is required.

Construction

The accompanying photographs provide a good idea of the physical construction of the amplifier. Two BC-375 coil drawers provide the main parts of the chassis-cabinet, and a back cover plate made from Reynolds perforated aluminum makes the shielding complete. The front of the chassis-cabinet was the rear part of the original coil drawers. Plates of sheet aluminum cover up the holes that existed there. Since the 803 extends from the bottom to top of the cabinet, the only wire which goes to upper section is the plate voltage lead. It can be seen in one of the photographs coming through a grommet directly below the 803 plate current meter. Be sure to use high voltage-type wire for all the plate voltage leads—not ordinary hookup wire. Having only one wire to disconnect when separating the two sections of the cabinet makes for ease in adjusting coils in the 814 plate circuit. Contrary to what the photographs show, shielded leads are suggested for the filament and plate supply leads coming out near the 814 filament coil, and for the bias lead coming out near the grid meter. The station where this amplifier is used is not very close to any television sets! The rest of the construction, however, is in accordance with the usual anti-TVI principles, so there should be little or no difficulty on this score, unless a parasitic rears its ugly head. None was found, using ordinary tests, in the rig shown. A nearby television set may possibly indicate differently. If so, a conventional parasitic choke and resistor combination could be placed in the plate lead of each tube. Not having tubes in parallel reduces the parasitic problem considerably, as does also the triode connection.

To improve ventilation and also clear space for the filament and bias leads running underneath the bottom plate of the cabinet, tubular spacers are screwed to this plate as shown in the front view photograph.

Power Supply

Only two things need emphasis when considering a power supply for this and similar amplifiers: First, even grounded grid linears need a plate supply having good voltage regulation. This is usually obtained by using mercury vapor rectifiers (or silicon diodes, if you can afford them!) with a single-section filter having a swinging type choke and as much capacity as you can get,

together with as many watts being dissipated in the bleeder as the power transformer is capable of furnishing beyond the requirements of the amplifier. Secondly, adequate safety precautions are a must in power supplies for amplifiers like this. Two or more bleeder resistors in parallel are safer than one; if one opens up the other(s) will safely discharge the lethal power that would otherwise lurk in the filter capacitor.

A fuse or circuit breaker in the plate transformer primary is of course obviously necessary. Also recommended is a d.p.d.t. switch for turning on and off the plate transformer, with a red pilot light connected across the primary and a green one across the second pair of poles; the transformer is definitely off when the green light glows, whereas lack of red light could mean either that the transformer is off or that it is on, and the light is burned out.

Plate voltages as low as 1200 can be used with this amplifier, but the maximum possible input will be proportionately lower. The 803 cannot be made to take more milliamperes at lower voltages.

Life will be easier for the 814 and 803 if provision is made for reducing the plate voltage during initial tune-up. A simple way to do this is to wire three or four 120 volt lamp sockets in parallel and connect the combination in series with one of the leads to the primary of the plate supply transformer. Also connect a single-pole switch in parallel with the lamp sockets. When this switch is closed, full primary voltage is supplied to the transformer; when it is open, reduced values of output voltage are available, depending upon how many and what size lamps are used in the sockets. Start off with 300 watt lamps, one lamp at a time.

Tuning

As mentioned before, the plate current meters cannot be used to indicate tank circuit resonance in this type amplifier. Basically, tuning is done with two rules in mind: 1—Never apply r.f. drive to the amplifier unless the plate voltage is on. (This saves the control grids of the tubes.) 2—*Tune everything for maximum output.*

When first testing the amplifier it is a very good idea to use a dummy load made of incandescent lamps. The resistance of the dummy load should be approximately the same as the load impedance which the amplifier will feed in service, or at least within a two-to-one ratio of that value. The power handling capacity of the dummy should be about 300 watts. Incandescent lamps are not, of course, pure resistances at radio frequencies, but they are entirely satisfactory for dummy loads here because the pi-output circuit is easily capable of tuning out their relatively small inductive reactance. Such lamps are inexpensive and they also allow you to get a fairly accurate measurement of actual r.f. output power when you place them next to similar lamps being run from the power line. Their chief disadvan-

[Continued on page 108]

A Solid State Signal Source For 144, 432, and 1296 Mc.

Frederick W. Brown, W6HPH

Box 78, Star Route
Idyllwild, Calif.

Need a stable, low power signal on 144, 432 or 1296? Presented here is just the thing for you in a battery powered unit utilizing semiconductors throughout.

ANY experimentally inclined amateur sooner or later has need for a stable source of signals for antenna and receiver testing. On-the-air signals have the disadvantage of not being steady in amplitude (if farther away than line of sight) and they have the habit of going off just at the crucial point in the test. Signals supplied by local amateurs suffer from a number of disadvantages. The local may not be available at the desired time, or may not have equipment for the right band. And, of course, he must be in the shack to sign his call every ten minutes while he is transmitting.

After a number of years of imposing on locals, relying on harmonics from the exciter or unstable signal generators, etc., the need for a portable, battery powered, crystal controlled, signal source became painfully clear. Since most of the experimenting at this station is done on the higher frequencies, the device would have to supply usable signals on these bands. At first it might not appear simple to construct a low drain, battery powered unit that would give crystal controlled output at 1296 mc. But the availability of the new semiconductors now makes it relatively easy to build a microwave transmitter that will fit in your pocket and having a total power drain measured in milliwatts.

Described here is a solid state device that provides enough crystal controlled output on 144, 432, and 1296 mc for receiver and antenna measurements. It can be hung up in a tree or placed atop a stepladder without the inconvenience of trailing wires or external power supplies. The unit has proven extremely valuable in u.h.f. receiver and antenna work at this station. As can be seen from the diagram (fig. 1), only two transistors and two semiconductor diodes are used. Power is supplied by 4 penlight cells. These particular transistors (WE 2N559's) were used because they happened to be available. Although they are rather expensive (\$8.40), there are now on the market transistors for less

than \$3 that should work even better than the 2N559. In particular, I would recommend the Philco T-1859 at \$2.79 each.

Diode Frequency Multipliers

Multiplying up to 1296 mc from an 8 mc rock with only two transistors may seem slightly incredible, but is really not difficult. The secret lies in the use of variable capacitance diode multipliers. This type of multiplication will no doubt completely replace vacuum tube multipliers in the future. With ordinary non-linear resistance diode multipliers, it can be shown¹ that the maximum efficiency (ratio of r.f. power out to r.f. power in) obtainable is only $1/n^2$, where n is the order of multiplication. In other words, a tripler using an ordinary diode, driven by 100 mw could supply only 11 mw of third harmonic output. However, with non-linear capacitance diodes (varactors), the picture is much brighter, and it is theoretically possible to obtain 100% efficiency for any degree of multiplication.² In principle we could multiply from 8 mc 162 times to 1296 mc and have as much output as we have available at the fundamental. As might be expected, practical difficulties rear their ugly head and prevent high efficiencies at high orders of multiplication. The principle limitation is varactor diode Q . With presently obtainable diodes it is usually better to multiply through 3 cascaded doublers than to multiply 8 times in one diode. This is because efficiency drops off rapidly with increasing order of multiplication.

The Circuit

Referring to fig. 1, the first transistor Q_1 is a 24 mc overtone oscillator employing an ordinary surplus 8 mc crystal. This drives the diode

¹Page, C. H., "Harmonic Generation With Ideal Rectifiers", *Proc. IRE* vol. 46, pp. 1738-1740, October, 1958.
²Uhlir, Jr., A., "The Potential of Semiconductor Diodes in High Frequency Communications", *Proc. IRE*, vol. 46, pp. 1099-1115, June 1958.

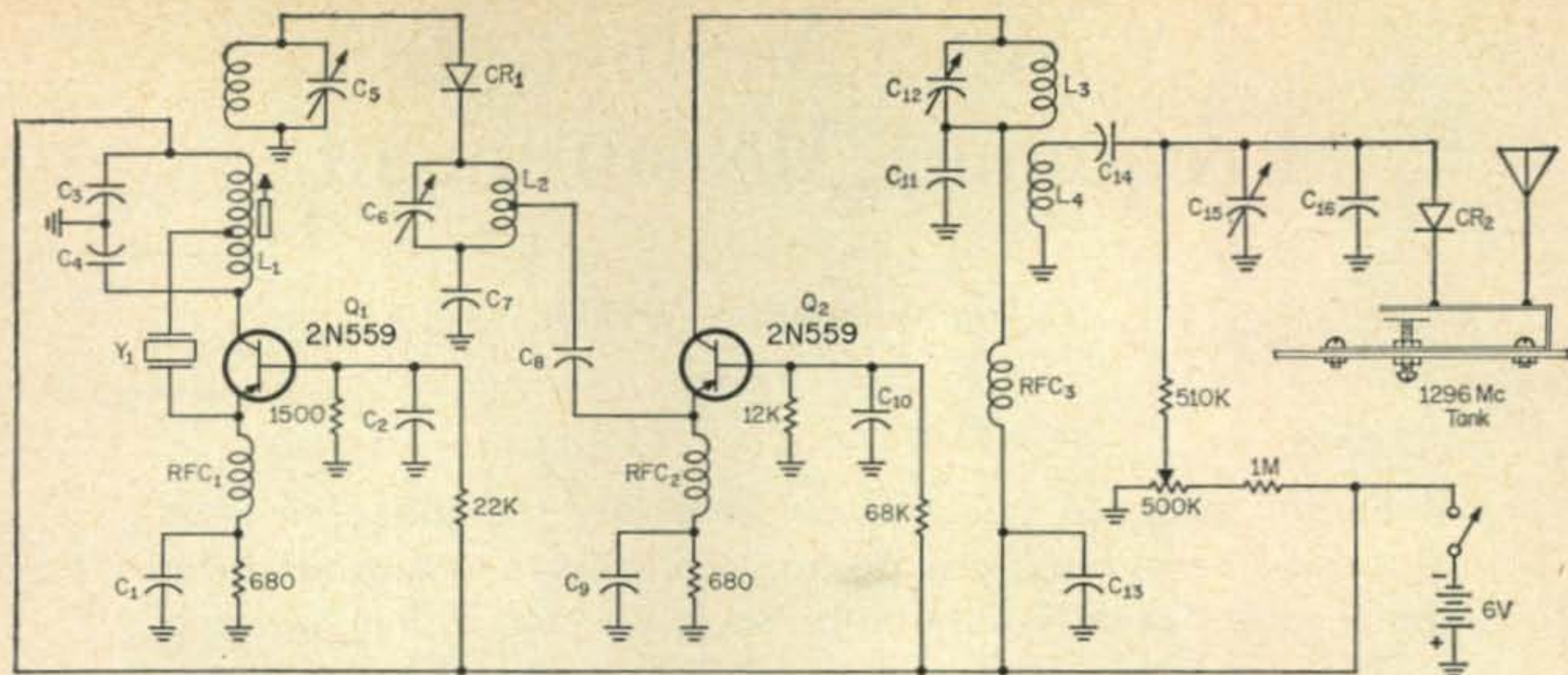

Fig. 1—Circuit of a crystal controlled signal source for 144, 432 and 1296 mc. Details of the 1296 tank are shown in fig. 2. All resistors are 1/4 watt.

- C₁, C₂, C₃, C₇—.002mf ceramic
- C₄, C₁₄—47 mmf mica
- C₅—3-30 mmf compression trimmer
- C₆, C₁₂—25 mmf APC type variable
- C₈—30 mmf ceramic
- C₉—330 mmf ceramic
- C₁₀, C₁₁, C₁₃—500 mmf button bypass
- C₁₅—5 mmf miniature variable Johnson 5M11 or equiv.
- C₁₆—5 mmf ceramic
- CR₁, CR₂—DR303 diodes (General Instrument Corp.)

- L₁—11 turns #26e. close wound on 1/4" slug tuned form. Tap 4 turns from top. Link, 3 turns of #22 hook-up wire
- L₂—3 turns #18e. 1/4" diam., 3/16" long. Tap one turn from lower end
- L₃—3 1/2 turns #18e. 1/4" diam., 1/4" long
- L₄—3 turns #18e. 1/4" diam., 1/4" long
- Y₁—8 or 24 mc crystal
- RFC₁—20 μh video peaking coil
- RFC₂—15 turns #22e. 1/4" diam., air wound
- RFC₃—9 turns #24 e. 1/4" diam., air wound

multiplier CR₁ which multiplies 6 times to 144 mc. The 144 mc signal is then amplified by Q₂ in a conventional grounded base arrangement. The 144 mc output of Q₂ drives CR₂ which multiplies 9 times to 1296 mc.

All components are mounted on a piece of sheet aluminum about 3 1/2" X 10". The "chassis" is mounted upright on a piece of 1/2" plywood which serves as the base. This open type of construction permits radiation from the coils and wiring. Despite the fact that there is no tuned circuit for 432 mc, the output on this band is quite good, adequate for antenna measurements at a distance of 100 feet or so. Details of the 1296 mc tuned circuit are given in fig. 2. It is

Adjustment

Tuning up is very simple: tune everything for maximum output. This can be done by watching the S-meter of your receiver. It is best to adjust L₁ and C₅ using a 24 mc receiver since these adjustments cause considerable frequency pulling at the higher harmonics. The setting of L₁

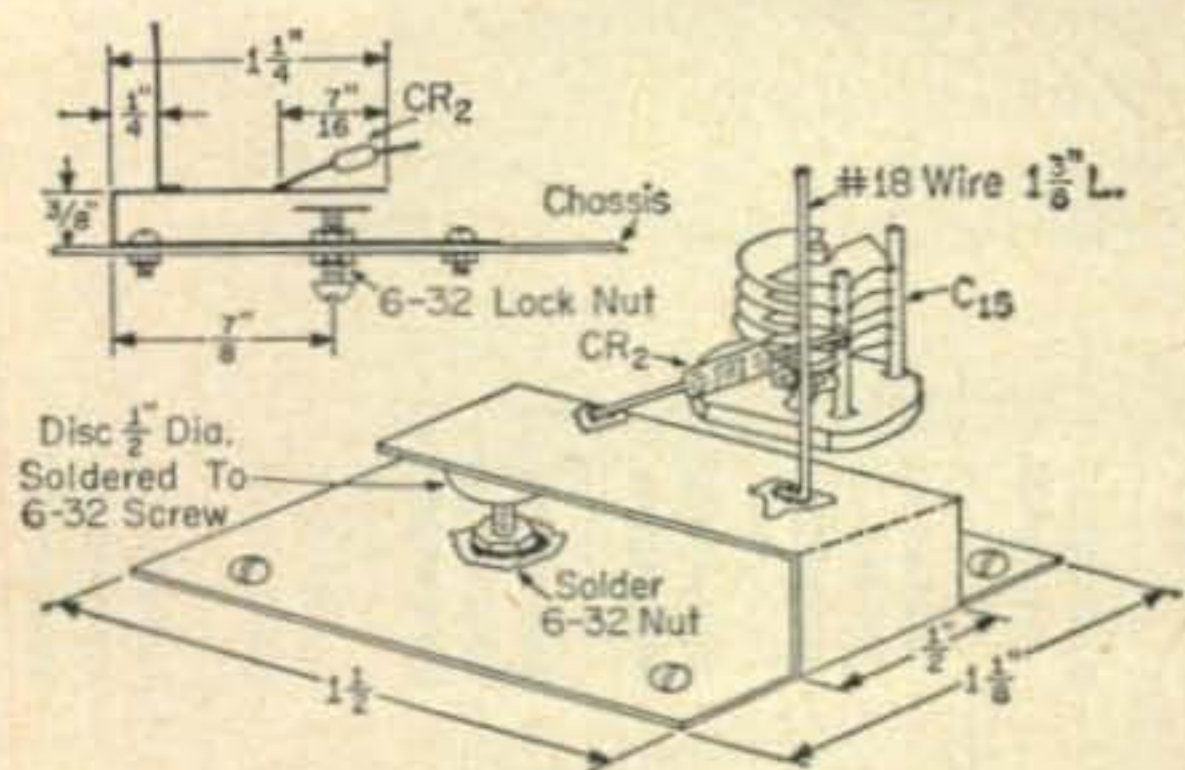
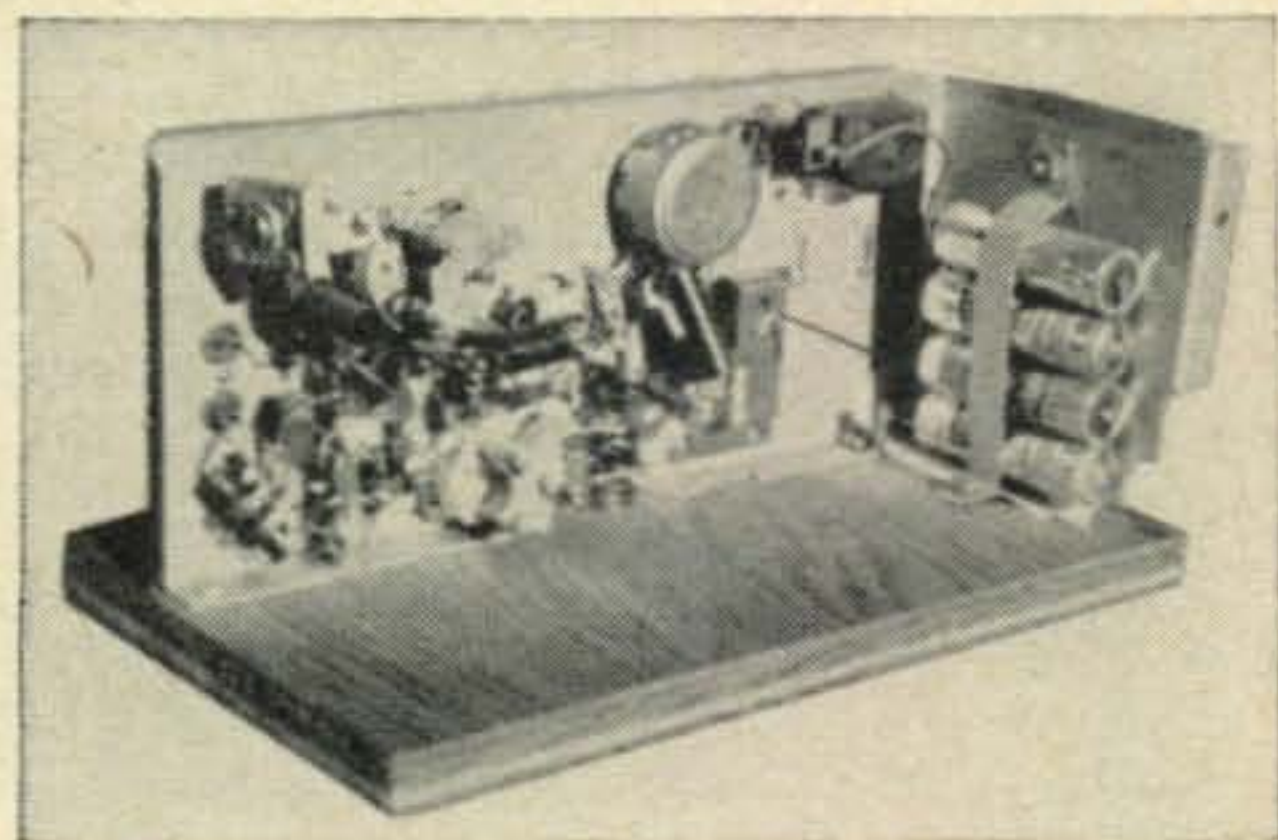

Fig 2—Details of the 1296 tank circuit.

made of flashing copper and is tuned by a 1/2" disc soldered to a 6-32 machine screw. Radiation is enhanced by the short wire soldered to the tuned circuit. d.c. bias on CR₂ is adjusted by the 500K pot. The first multiplier diode is self-biased, because in this case external bias did not significantly increase the output.



Rear view of the solid state v.h.f. signal source. The 1296 mc tank circuit can be seen below and to the right of the potentiometer.

that gives maximum output will probably not permit easy starting of the overtone oscillator and should be detuned slightly to the low frequency side. Capacitor C₅ resonates with the link on L₁ neither to 24 mc or 144 mc, but to some frequency around 130 mc. The reason for this is not too clear, but much experimenting proved it to be the optimum setting.

The device exhibits some directivity and it's best to determine the direction of strongest radiation experimentally. Also, the plane of polari-

[Continued on page 104]

A Novel Method of Frequency Measurement

Calvin Sondgeroth, W9ZTK

R. R. #2
Mendota, Illinois

We don't propose you run out and buy the piece of gear described here, but if you do happen to have one around the shack, give it a work-out and prove to yourself that it can be a pretty useful gadget for measuring drift.

WHEN I recently encountered a v.f.o. which drifted quite seriously, I set out to remedy the situation with various operations on the unit. However before starting to work on this problem, I realized that it would be very helpful to know just how much drift there was and its relationship as a function of time. With this information, I could tell how much improvement was being made as work progressed.

Since I had a 100 kc oscillator in my station receiver, and the receiver itself was quite stable after 10 or 15 minutes warmup, it would be possible to measure the frequency drift by beating the v.f.o. against the frequency standard and measuring the frequency of the audio note coming out of the receiver, further noting its change in frequency with respect to time. With an audio generator, I would have been all set, but such a gadget was not to be found among my test equipment. All seemed lost as far as accurate measurements were concerned, and I was about ready to start guessing at the audio frequencies when I hit on the idea described.

The Instrument

The heart of this system is the instrument used to measure audio frequencies. Although practically never found in the hamshack, it

might be in your living room or den just waiting to be put to use as an audio generator. If there is a piano at your QTH, you are ready to make audio measurements. Don't worry about its vintage or condition, because the overall results with a new baby grand will probably not greatly exceed those obtained with an instrument inherited from the XYL's great aunt Sarah.

When a key on the piano is struck, a certain audio tone is produced and each key produces a tone of different frequency. It doesn't take a Leonard Bernstein to recognize that going from left to right on the keyboard, the tones get higher in pitch or frequency. The frequencies associated with each key are shown in fig. 1. It will be noted that the frequencies at the low and high ends of the keyboard are not indicated. At the low end, they are pretty well out of the range of any speaker a ham is likely to use for the measurements to be described. At the high end it becomes rather difficult to identify the notes, as will be described later. In addition, these tones are fairly far apart, thus limiting the accuracy in the extreme upper register. If desired, the frequencies omitted may be found quite easily since the notes of the keyboard are harmonically related.

A little study of fig. 1 will prove helpful to the non-musician readers. The first note to be

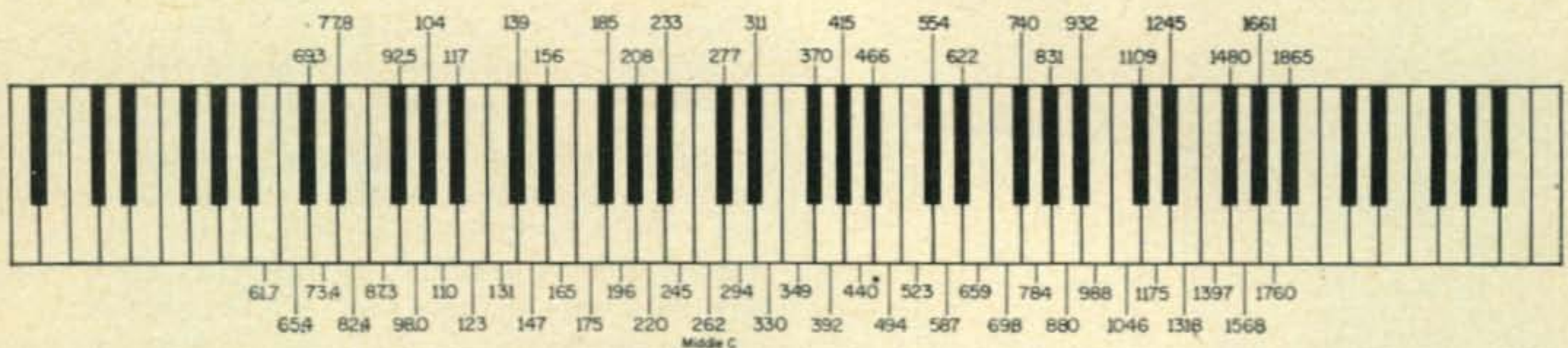

Equal Tempered Chromatic Scale $A_4 = 440$
American Standard Pitch (1936-Am. Std. Assoc.)

*Check With 440 Cycle Note From WWV

Fig. 1—Standard piano keyboard illustrating the tone in c.p.s. obtained from various keys. With this method, the author was able to carefully check the drift of a v.f.o. The text describes the reason for not indicating the frequency at the upper and lower limits of the keyboard.

learned by any student of the piano is Middle C probably because you place yourself in front of this note when beginning to play. This note is shown in fig. 1, and as indicated it produces a tone of 262 cycles per second. (The decimals have all been dropped from the frequencies shown to give 3-place accuracy. The tones are not all even numbers as shown, but this expedient simplifies the arithmetic involved during a long series of tabulations.)

Now in fig. 1 look up the keyboard from Middle C (to the right) and locate the note that produces a tone of 440 c.p.s. This note is A above Middle C or A_4 as shown in handbook charts of the musical scale. It is the note that is used as the basis for tuning a piano in the first place, and the next time you hear a band or orchestra "tuning up" it is a safe bet that the musicians are all playing just this A to get their instruments in tune. A note of 440 c.p.s. such as this can be compared directly with the 440 c.p.s. transmissions from WWV, and it is a good idea to check your piano in this way. If it is out of tune you will undoubtedly find that a note one or two steps higher will be in tune with WWV, and in such a case your readings will have to be adjusted accordingly. The nice part about this is that a piano goes out of tune with all the keys going down in frequency so that they all remain relatively in tune with each other. This adjustment of one or two steps can be made without introducing serious inaccuracies. As a last observation from fig. 1 note that the notes are harmonically related. The "A's" are 110, 220, 440, 880 and 1760 c.p.s. All the other notes are similarly related as a little arithmetic will show.

Experimentation at the piano with your receiver turned on will help clarify the procedure. If your piano is quite far from the hamshack as will probably be the case, it will help to run an extension speaker near the piano so that it can be heard easily. With the b.f.o. on, tune to a signal that you know is fairly stable. Strike different notes on the piano and get used to finding the one that is in tune with the audio note coming from the receiver. From a cold start you can measure the amount your receiver drifts by the change in audio frequency when beating it against some sort of crystal controlled oscillator. (A crystal controlled transmitter or 100 kc oscillator will do.) The difference in frequency between the beginning note and the note found as the receiver finally settles down, is the drift in cycles. A measurement such as this will tell you how long it takes for your receiver to achieve stability, so you can be sure it isn't drifting when checking other devices.

Making Measurements

A good way to make drift measurements is to start as near zero beat as you can determine, and let the unit under test drift from there. If the drift does not exceed 1.5 kc or so, you are in business because this does not exceed the useable range of the piano. If the drift is in excess

of 1.5 kc, it will be necessary to re-zero and start over, adding on the audio frequencies to the last high audio note recorded. If the drift is too extreme or too rapid, start on one side of zero beat and let the unit drift through zero beat. In this manner, a drift of about 3 kc can be recorded without introducing the slight inaccuracy of re-zeroing. This method was used to record the data of fig. 2.

By plotting Frequency vs Time on a sheet of graph paper, you can get a visual record of what your v.f.o. or other oscillator is doing. A curve of my v.f.o.'s drift after some modification is shown in fig. 2. As can be seen, it settles down to a respectable value after about 20 minutes of warmup. For my present purposes this drift is adequate, since I plan to rebuild the entire unit. For those who want to be able to chase a rare one immediately after turning on the rig, this drift would not do.

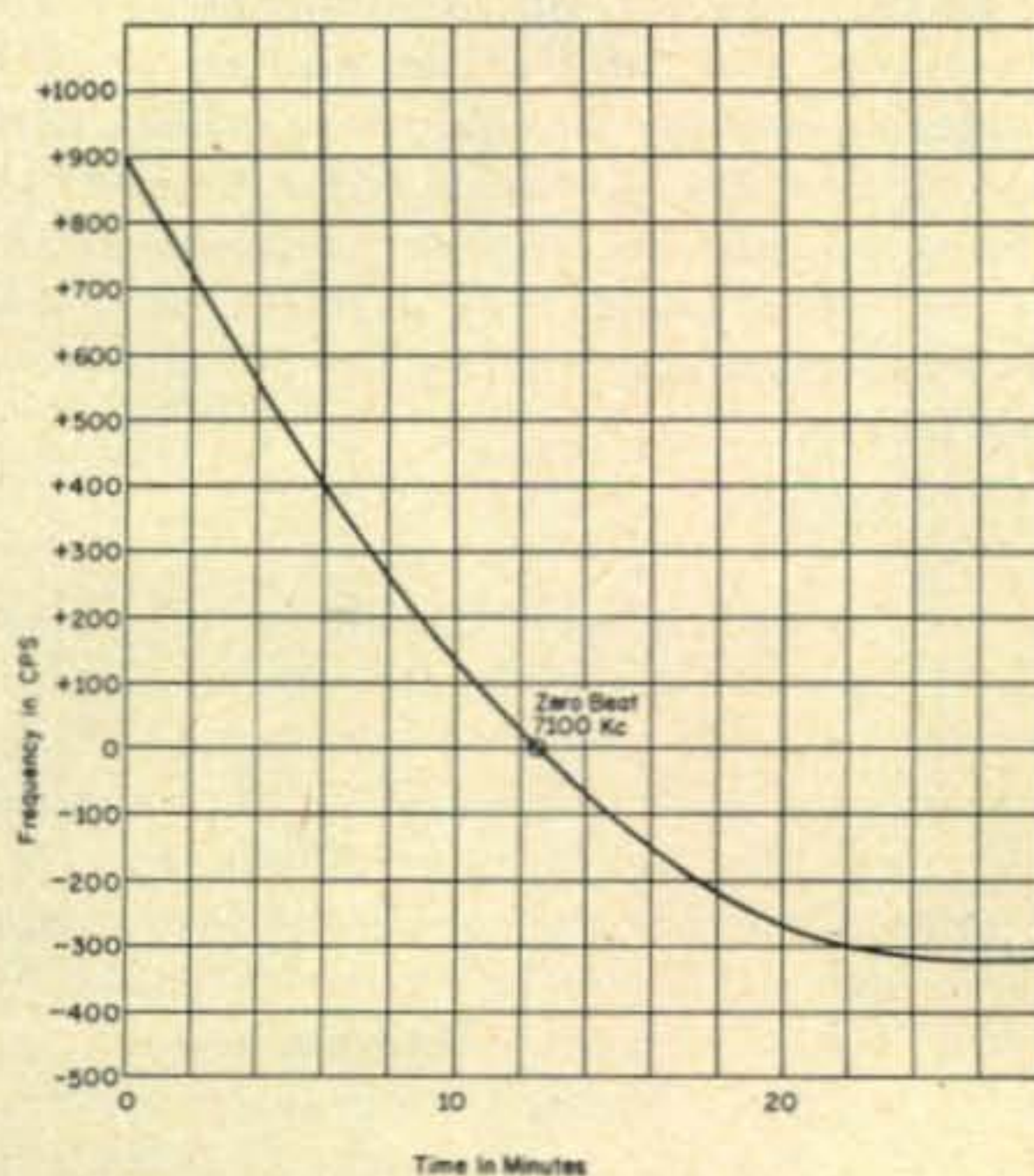

Fig. 2—Drift of W9ZTK's v.f.o using the piano keyboard as a frequency test instrument. See text for full explanation.

Conclusion

Certainly this makes an interesting project, and the system just described can be used to measure frequencies, and particularly changes in frequency, quite accurately. With the proper procedure and by restricting the audio notes to the middle register of the piano, changes in frequency of some 20 cycles can easily be detected; certainly quite accurate for amateur standards. The next time you decide to build that ultra-stable v.f.o., don't run out and buy an audio generator and scope. Persuade the XYL to abandon her Chopin for a few evenings so that you can find out how "ultra" your brain child really is.

I haven't won any Frequency Measuring Tests with this idea, but I certainly know a lot more about what my frequency determining components are doing than before I hit upon this scheme. In a way, it's frightening to know whenever your v.f.o. drifts 20 cycles. Try it and see! ■

The Sunspot Story; Cycle 19

The Declining Years

By George Jacobs*, W3ASK and Stanley Leinwoll†

Part II

IN the initial installment of this special report, which appeared last month, the authors discussed the ionosphere in general; how its several layers are formed by ultraviolet energy radiated from the sun, and how its electrical characteristics vary diurnally (hour-to-hour), seasonally, geographically, and over an approximate 11-year cycle. The 11-year variation in the electrical strength of the ionosphere, which is associated with the number of sunspots appearing on the face of the sun, is perhaps the most important factor affecting the ionosphere's capability to reflect shortwave radio signals.

In this, the second installment of a special three-part report dealing with the present decline in the solar cycle, and its probable influence on propagation conditions in the various amateur bands, the authors discuss sunspots and the sunspot cycle in greater detail. Besides pointing out how sunspots affect the ionosphere and shortwave propagation conditions, the authors give their prediction of solar activity for the remainder of the cycle, which they expect will reach a minimum during early 1965. They also hint that solar activity during the remainder of the present century may remain at relatively low levels.

ALTHOUGH no completely satisfactory theory as to what sunspots are, or what causes them, has as yet been advanced by scientists, numerous scientific studies undertaken during the past fifty years have shown that these large craters on the sun's surface have a direct influence on shortwave radio conditions.

Figure 10 is a recent photograph of the sun taken at the U.S. Naval Observatory in Washington, D.C. The sunspots appear as black spots on the solar surface.

*PROPAGATION Editor CQ, 11307 Clara Street, Silver Spring, Md.

†33 Cranston Road, Franklin Park, New Jersey

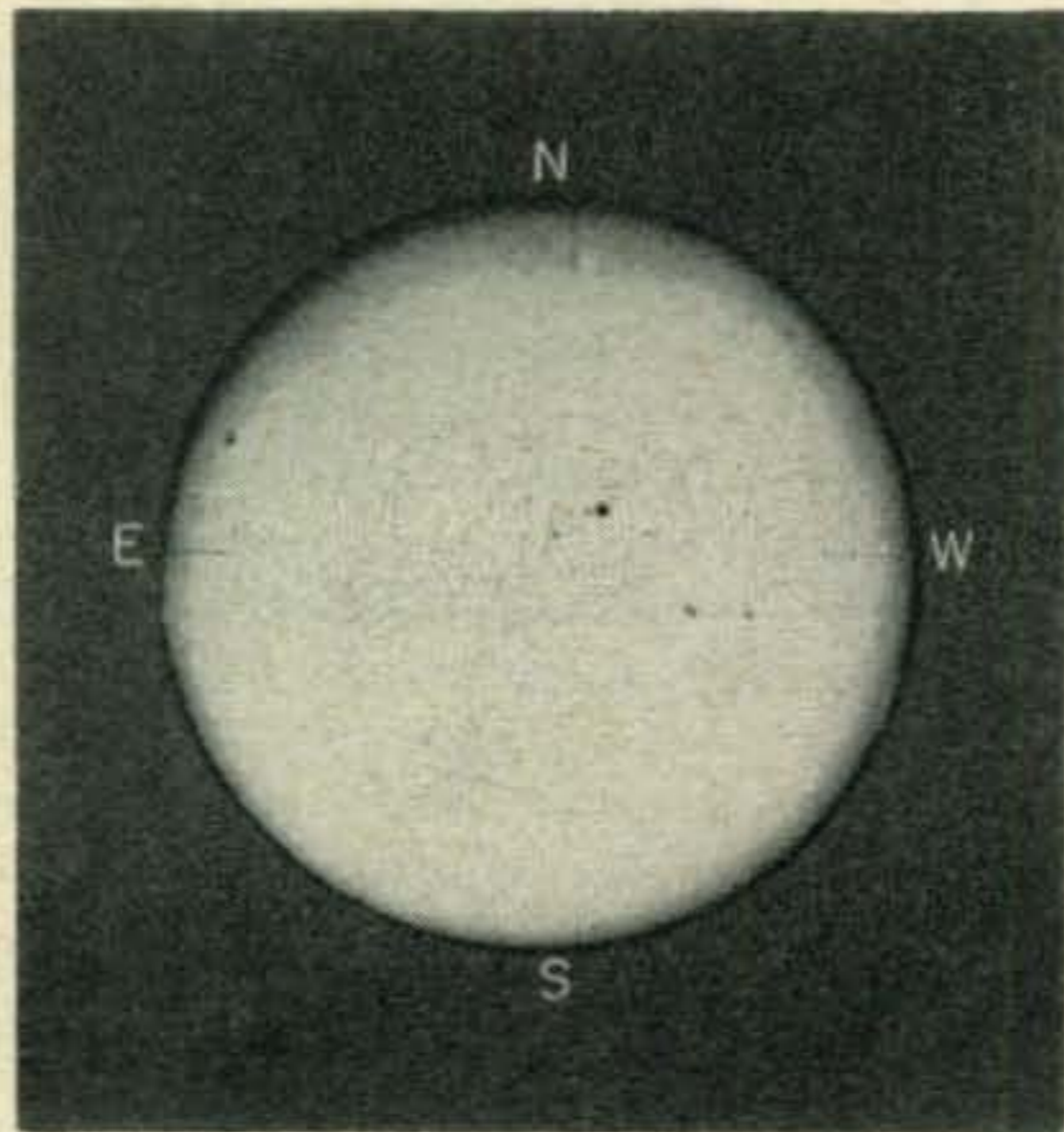

Fig. 10—A large group of sunspots seen recently on the face of the sun. The sunspots move from the east limb of the sun towards the west, as the sun rotates. (Official U.S. Navy Photo)

Figure 11 is a close-up view of a sunspot taken from an unmanned balloon 80,000 feet above the earth's surface. Taken from high above the dust layers and other optically disturbing regions of the earth's atmosphere, this is the clearest picture made to date of a sunspot and its immediately surrounding area⁸. The granular composition of the sun's surface and the *penumbra-umbra* composition of sunspots can be seen in great detail in the photograph. The *penumbra* is the raised, luminous region surrounding the dark inner depression called the *umbra*. In large sunspots, of the type shown in fig. 11, the *umbra* may have a depth of several thousand miles. The *umbra* appears dark against the sun's surface because the temperature in the depression, or solar crater, is about 1500° F cooler than at the surface. The light given off by the cooler sunspot area is about 50% less than the light given off by the surrounding solar surface, and it is darker by contrast.

Sunspots almost always appear in groups. The groups may range in size from small clusters of tiny specks a few hundred miles in diameter, to enormous groups stretching nearly a quarter of a million miles across the sun's surface, and containing individual spots as large as 80,000 miles in diameter . . . an area into which several planets the size of the earth could easily disappear!

⁸This photograph was taken on August 17, 1959 by Stratoscope I, an unmanned balloon containing an automatic camera system and a 12 inch solar telescope. This project was supported by the National Science Foundation and the Office of Naval Research, and was under the direction of Dr. Martin Schwarzschild of Princeton University.

Sunspots, although embedded in the sun's surface, appear to move in an east to west direction as the sun rotates. If a spot is born on the side of the sun out of view from the earth, it will first become visible as it crosses the sun's eastern edge. It will then drift westward across the visible face of the sun, and disappear out of sight behind the western edge in slightly more than 13 days, which corresponds to half the period of rotation of the sun. The spot then enters the hidden side of the sun, where it may remain for the duration of the 27-day solar period.

The lifetime of a sunspot, or sunspot group, varies from a few days to several months. Larger sunspots often are visible during several solar rotations, reappearing at the eastern edge of the sun approximately every 27 days. For this reason, many terrestrial phenomena which are believed to be influenced by sunspots tend to recur at intervals of about 27 days.

While sunspots are under daily scrutiny from the giant telescopes of dozens of solar observatories throughout the world, large ones can often be seen with the naked eye, *provided* that a piece of smoked glass, negative film, or some other suitable ray filter is used to protect the eye from serious damage by the sun's rays.

Occasionally, at sundown, or when haze or light fog obscures the sun's rays, large sunspots may be seen, often accidentally, without the use of a telescope or sun filter. Such was the case in London recently, where the *Daily Telegraph and Morning Post* reported that thousands of persons were able to see two enormous spots on the face of the sun during a foggy sunset. It was, no doubt, due to accidental occurrences of this sort, that history records the sighting of sunspots by the Chinese, Romans, Greeks and Egyptians nearly 2000 years ago.

High Flying Animal or Electro-Magnetic Eruption?

History vaguely records that visual sightings of sunspots before the invention of the telescope, if they drew any explanation at all, were usually thought to be either slow high flying animals, or far away clouds. When the Jesuit friar Joseph Scheiner, one of the first specialists in solar research, saw his first sunspot with an early telescope in 1611, his fellow astronomers called it a stain on the lens of the telescope!

It was in fact Galileo, inventor of the telescope in 1610, who offered the first serious explanation of sunspots. In 1613, he wrote⁹:

"Having made repeated observations I am at last convinced that the spots are objects close to the surface of the solar globe, where they are continually being produced and then dissolved, some quickly and some slowly; also that they are carried around the Sun by its rotation, which is completed in a period of about one lunar month. This is an occurrence of the first importance in itself, and still greater in its implications."

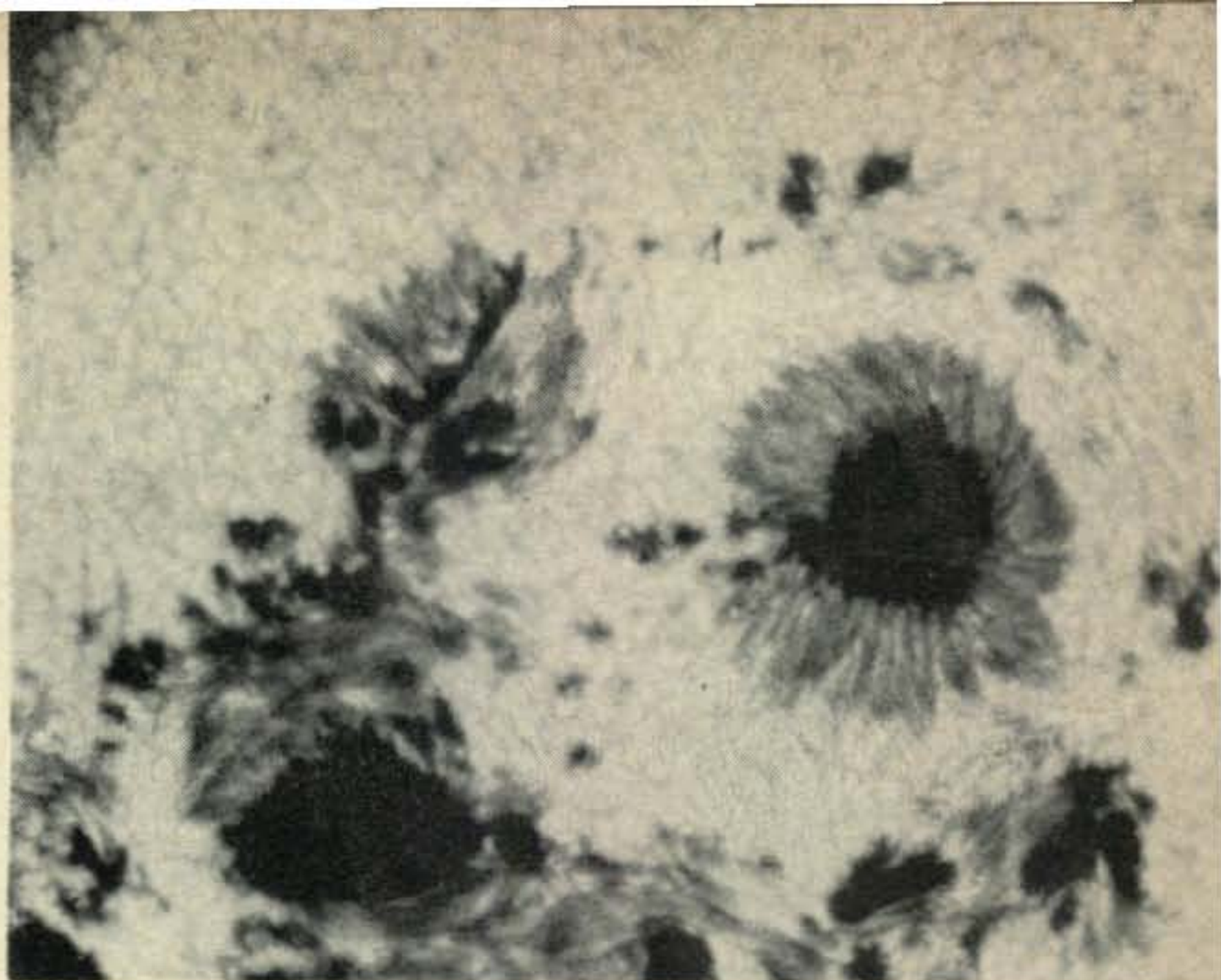

Fig. 11—A large group of sunspots photographed with unprecedented sharpness from an unmanned balloon at an altitude 80,000 feet. The granular composition of the sun's surface can be seen clearly, as well as the raised penumbra surrounding the sunspot, and the darker, depressed region of the spot called the umbra. (Official National Science Foundation Photo)

In this explanation, elementary as it was, Galileo was far nearer the truth than many of his successors, during the next 300 years.

During the 18th and 19th centuries, various explanations were given for sunspots by noted astronomers. Some considered sunspots to be cold mountain peaks towering above the luminous surface of the sun; others, believing that a fiery, luminous cloud surrounded the sun, thought sunspots to be holes in this solar cloud, caused by hurricanes, through which could be seen the cool surface of the sun!

One of the most significant discoveries concerning sunspots took place in 1908. Using his newly invented *spectro-heliograph*, Dr. George E. Hale of the Mount Wilson Observatory in California, photographed certain characteristics of the sun for the first time. From these, he was able to demonstrate that large sunspots are frequently engulfed in whirling masses of gas, or vortices.

Six years later, in 1914, Dr. Hale made another remarkable discovery, proving that magnetic fields, often more powerful than the magnetic field surrounding the earth, occurred at the center of sunspots.

Working with these two important facts, that sunspots are engulfed in whirling masses of gas and are surrounded by magnetic fields, scientists during the past forty years have developed at least a partial explanation for sunspots. Many scientists presently think that sunspots are caused by a strong magnetic field deep within the sun's interior. Tremendous waves of energy generated from this magnetic field eventually break through the sun's surface in a mighty eruption of whirling masses of gas and other electrified material.

The whirlwind of electrified gas produces a strong magnetic field in its center. This imparts a certain amount of rigidity to the cloud of gas,

⁹Galileo, "Three Letters on Sunspots", *Accademia dei Lincei*, Rome, 1613.

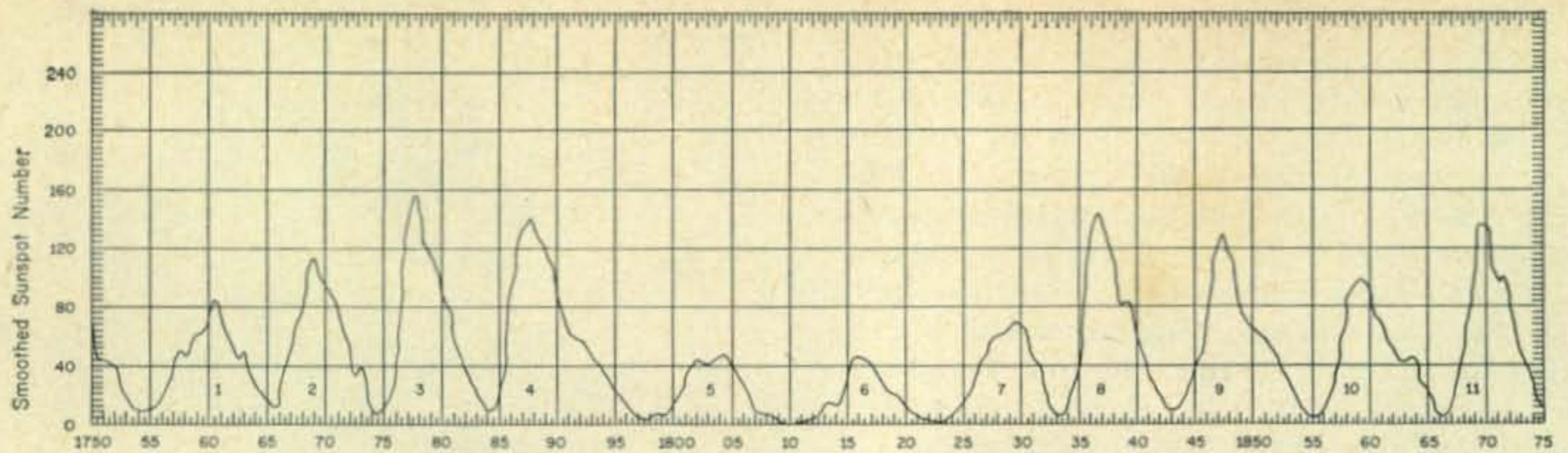

Fig. 12—A plot of all solar cycles recorded since 1750. To date, 18

causing the temperature in the vicinity of the magnetic field to drop below that of the sun's surface, resulting in a darkened area, or sunspot.

The Sunspot Cycle

Sunspots are known to have been observed by the Chinese many years before the birth of Christ. But it was not until 1611, one year after the invention of the telescope by Galileo, that permanent records of sunspot activity began. In that year, Galileo and his contemporaries began to draw pictures of the sun's surface by projecting telescopic views upon a white wall or screen. A number of Galileo's drawings of the solar disk made in 1612 still exist, and these show many large sunspots.

It was not until the middle of the 18th century, however, that many European astronomers independently began keeping sunspot records on a regular basis. To one of these, Hendrick S. Schwabe, a pharmacist from Dessau, Germany who engaged in astronomy as a hobby, goes the credit for the discovery of the sunspot cycle.

With the intellectual curiosity characteristic of a true scientist, Schwabe began his work on the sun in the early part of the 19th century, painstakingly counting the spots he saw with his small telescope, day after day and year after year. After several years he observed that the number of sunspots he saw varied over wide limits in a fairly regular manner. During some years he found the face of the sun almost completely free of sunspots month after month. During other years he saw hundreds of spots day after day. After observing the sun on almost every day that the weather permitted for nearly twenty years, Schwabe concluded that sunspots came and went in a periodic fashion, varying from a minimum, to a maximum, to a minimum again in about a decade's time. He published his findings in 1843.

Sunspot Numbers

Shortly after Schwabe's discovery, the director of the Zürich Solar Observatory, Rudolf Wolf devised a means for all astronomers to describe relative sunspot activity in terms of a common standard. The Zürich Observatory had been recording sunspot data on a regular basis since 1749, and Wolf realized the great importance of having other observatories and astronomers, who used various types and sizes of telescopes, report

their observations according to a common standard.

Wolf called his standard a "sunspot number." The sunspot number is obtained from daily solar observations of individual sunspots and sunspot groups, according to the following equation:

$$R = k (10g + f) \dots \dots \dots (1)$$

- where: *R* is Wolf's relative sunspot number,
- g* is the observed number of sunspot groups,
- f* is the total number of sunspots observed, either individually or in groups, and
- k* is a factor for bringing the observations of many different observers into general agreement, and takes into account the type and power of the telescope used, the viewing conditions, and the individual observer.

The factor 10, which multiplies *g*, was selected by Wolf in order to give greater weight to the large active sunspot groups, which he intuitively judged to be a more important criteria of general solar activity, than to small spots of short duration.

The Zürich Observatory has been publishing daily sunspot numbers, recorded near mid-day, according to equation (1) since 1849. These have now come to be known as the "Zürich Sunspot Numbers," and represent the official sun-

Jan. 1961	Sunspot Number	Jan. 1961	Sunspot Number
Day		Day	
1	128	16	31
2	123	17	43
3	109	18	51
4	84	19	50
5	78	20	45
6	69	21	50
7	60	22	37
8	52	23	27
9	52	24	18
10	49	25	35
11	39	26	48
12	31	27	43
13	28	28	62
14	21	29	68
15	20	30	55
		31	52

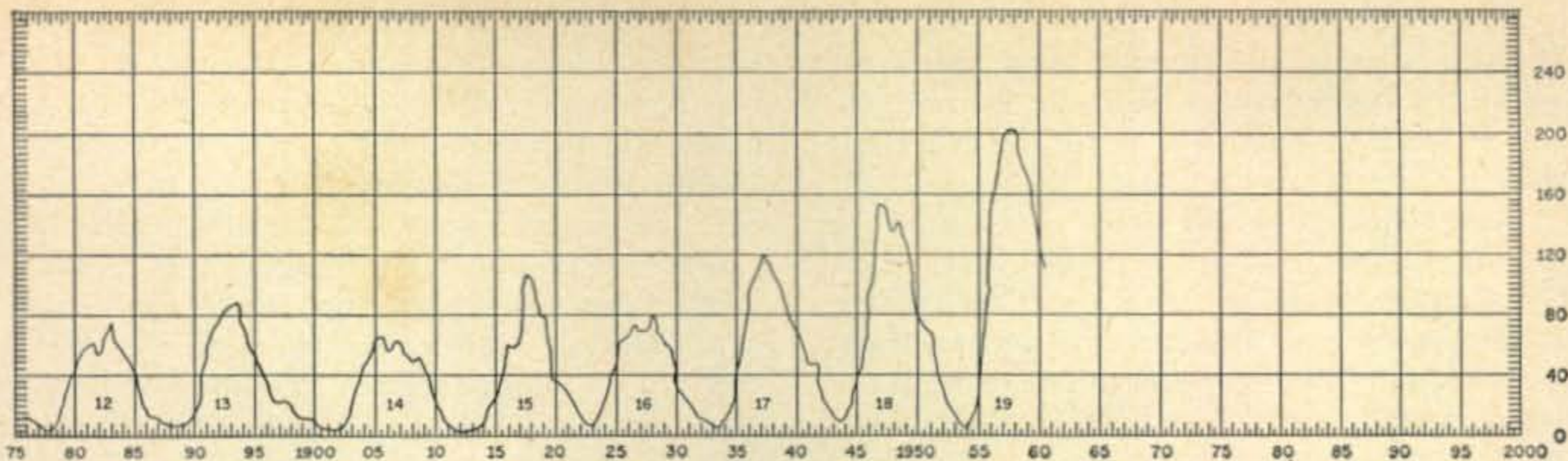

complete cycles have taken place; the 19th is now in progress.

spot count upon which sunspot information is based.

The daily sunspot number is subject to considerable day-to-day variation, and little correlation between the daily sunspot number and general shortwave propagation conditions has been observed. Table 1 shows the variation in daily Zürich sunspot numbers for the month of January, 1961.

During January 1961, the daily Zürich sunspot numbers ranged between 18 and 128. The monthly mean Zürich sunspot number was 53.5. Even the monthly mean numbers, however, are subject to month-to-month fluctuation and do not correlate too well with shortwave propagation conditions. Table 2 shows the variation in monthly mean Zürich sunspot numbers for 1960.

TABLE 2

Month	Sunspot Number	Month	Sunspot Number
January	146	July	122
February	106	August	134
March	102	September	127
April	122	October	83
May	120	November	90
June	110	December	86

Experience has shown that a twelve-month running average, or *smoothed sunspot number*, serves as the best index of general ionospheric and shortwave conditions. The smoothed sunspot number takes into account the monthly Zürich numbers for a twelve month period, tending thereby to give a truer picture of long-term solar activity. It is the smoothed sunspot number, plotted over a long period of time, which exhibits the well known solar cycle variation.

Wolf began publishing daily sunspot numbers in 1849. This effort, since carried out by his successors at the Zürich Observatory, has resulted in a long, unbroken, and very valuable series of solar data of over a century's duration. In addition, Wolf, using the sunspot records of earlier observers, reduced to sunspot numbers, data going back to 1749.

Daily and monthly Zürich sunspot numbers are published by the Zürich Solar Observatory. A complete listing of the daily numbers and the monthly average can be received monthly di-

rectly from the Observatory.¹⁰ This information is also broadcast on the *fourth day of each month* by the shortwave service of the Swiss Broadcasting Corporation.¹¹ Monthly average sunspot numbers and the corresponding smoothed values appear each month in CQ's PROPAGATION column.

Sunspot Cycle Behavior

Figure 12, based on smoothed sunspot numbers observed since 1749, shows the cyclic nature of this solar index. In accordance with the Zürich Observatory's cycle numbering system, the cycle which began in 1755 is shown as cycle 1. Since that time *eighteen* complete cycles have occurred, and the *nineteenth* is now in progress.

Inspection of fig. 12 shows that sunspot activity varies in a periodic manner, resulting in alternate minima and maxima at intervals of several years. The number of years for a complete cycle of activity, from minimum, through maximum, and back to minimum again, varies somewhat with each cycle, but has an average period of 11 years. For this reason, the variation in sunspot activity is called the *11-year sunspot cycle*. It should be noted, however, that no two cycles are exactly alike, and that some cycles have been as short as nine, and others as long as 14 years in duration. The last previous complete cycle, cycle 18, began in February 1944 and ended in April 1954. Cycle 19, the present cycle, began in April 1954 and is still in progress.

The following is a summary of other vital statistics concerning the eighteen complete sunspot cycles observed to date:

1. The minimum sunspot values recorded, range from 0 to 11.2, with 4.8 as the average.
2. The maximum values recorded range between 49 and 159, with 105 as the average. The 19th cycle, now in progress, reached a peak of 201.3 during March 1958. This was the highest maximum ever recorded.
3. The mean sunspot number for an entire cycle, representing the integrated area beneath that

¹⁰The Zürich Observatory, Eidg. Sternwarte, Zürich, Switzerland.

¹¹Scheduled in English to North America on the fourth day of each month at 8:35 and 11:20 P.M. EST on 6165, 9535 and 11865 kc.

cycle, varies between 18.5 and 74.5.

4. The ascending period of each cycle varies between 2.6 and 6.9 years, with the average period of ascent being 4.3 years. The present cycle rose to its maximum in 3.9 years.
5. The descending period from maximum to minimum varies between 4 and 10.2 years. The average value is 6.7 years. The average sunspot cycle is, therefore, unsymmetrical about its point of maximum intensity; with the rising portion more rapid (4.3 years) than the descending period (6.7 years).
6. Cycles with higher maxima rise considerably faster, and descend somewhat more gradually, than less intense cycles. For example, cycles 3, 4, 8, 11 and 18, the highest complete cycles recorded, all rose from minimum to maximum in less than 3.5 years. The present cycle, the most intense ever recorded, rose from minimum to its peak in 3.9 years.
7. The interval between the maxima of two adjacent cycles varies between 7.3 and 17.1 years, with the average period being 10.9 years. This is just about the same as the 11 year period between cycle minima.

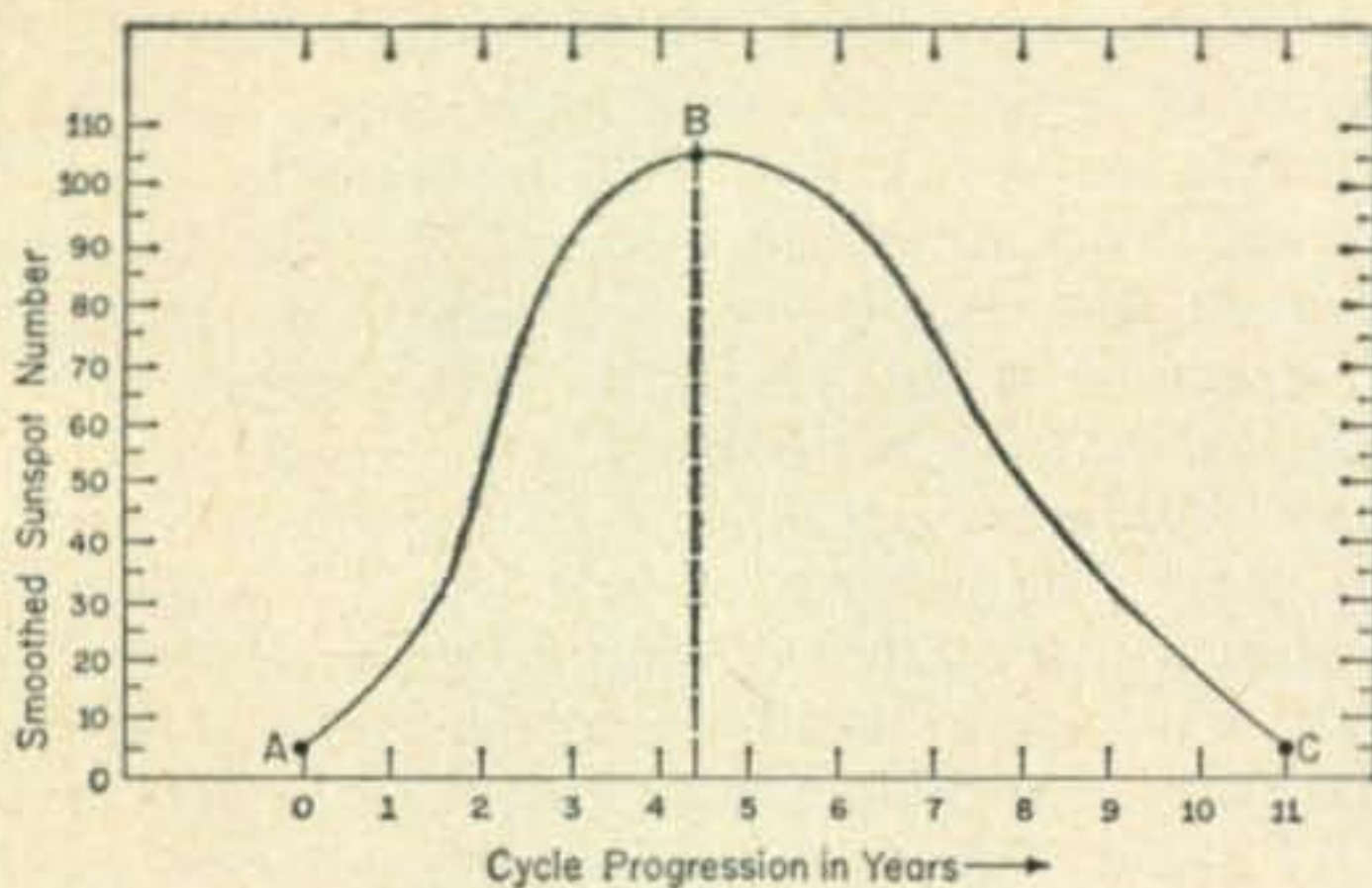

Fig. 13—The average sunspot cycle, based on the characteristics of the 18 cycles which have taken place since 1755. At A, the mean minimum sunspot value is 4.8; at B, the mean maximum value is 104.6, and C is the end of the cycle. The average time interval, AB is 4.3 years; from B to C equals 6.7 years and the overall time interval for ABC is 11.0 years.

Figure 13 shows the average sunspot cycle described by the characteristics summarized above. It must be pointed out, however, that there have been some rather large deviations from these average values in the characteristics of many cycles.

Sunspots and Ultraviolet Radiation

From the radio communication viewpoint, perhaps the greatest discovery concerning sunspots was made during the early 1930's when Dr. Edison Pettit and his associates at the Mount Wilson Observatory found a *direct* relationship between the smoothed sunspot number and the intensity of ultraviolet energy radiated by the sun.

Beginning in 1924, Dr. Pettit undertook daily

systematic measurements of the intensity of ultraviolet radiation emanating from the sun. During the years 1924-1928, he found a steady increase in the ultraviolet level as the smoothed sunspot numbers increased. After 1928, when the cycle began to decline, Dr. Pettit observed a corresponding decrease in ultraviolet intensity.

Dr. Pettit's work in this field, and similar measurements made elsewhere in the world, have led to the conclusion that the intensity of ultraviolet radiation reaching the earth from the sun can be measured by the smoothed sunspot number.

In the first installment of this report it was pointed out that ultraviolet radiation from the sun was mainly responsible for forming the ionosphere. Dr. Pettit's discovery was of paramount importance because in relating the sunspot number to the intensity of ultraviolet radiation, he was also relating it to the intensity of ionization. The smoothed sunspot number is, therefore, *an index of the general level of ionization in the upper atmosphere*. Ionization is greatest when the smoothed numbers are high and when the numbers are low, ionization is relatively weaker. To Dr. Pettit goes credit for giving practical importance to sunspots and the sunspot cycle.

Sunspot Cycle Prediction

Since the discovery of the sunspot cycle by Schwabe in the middle of the nineteenth century, considerable interest has been shown in forecasting the trends of future cycles. Becoming somewhat of a sport for mathematicians, statisticians, and those who have a flare for studying cycles, the methods of prediction have covered a wide range. Until recently these predictions were largely of academic interest, but with Dr. Pettit's discovery of the relationship between sunspot numbers and ultraviolet intensity, the prediction of sunspot activity has assumed considerable practical importance. Later in this report we will show that long range forecasts of shortwave propagation conditions are based upon predicted smoothed sunspot numbers.

Since there is at present no satisfactory theory fully explaining the cause of sunspots or the sunspot cycle, an exact prediction of their future behavior is not possible. However, because of the cyclic nature of sunspots, empirical methods for determining future cycle behavior can be derived from observed patterns of previous cycles.

Based upon a statistical analysis of the basic sunspot cycle characteristics discussed previously, W3ASK, one of the authors of this report, has developed an empirical method for determining future solar activity.¹² Using this

¹²The method is based upon that suggested by M. Waldmeier, Director of the Zürich Observatory, in "A Prediction of The Next Maximum of Solar Activity", *Terrestrial Magnetism & Atmospheric Electricity*, Vol. 51, 1946, p. 270.

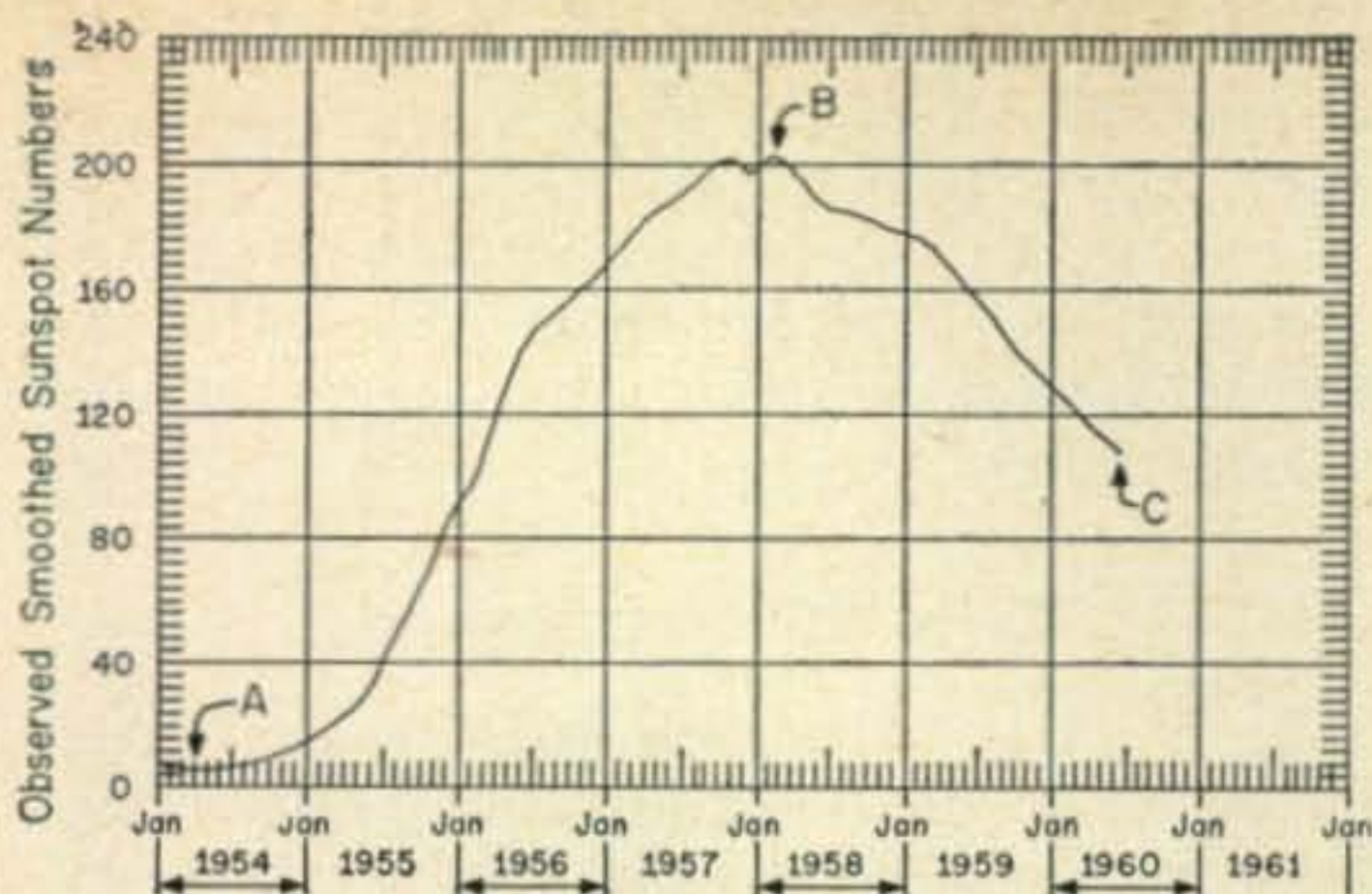

Fig. 14—Progress of Sunspot Cycle 19, April, 1954 through July, 1960. At A, the start of cycle 19 in April, 1954, the smoothed sunspot number was 3. The peak of cycle 19 occurred at B, when the smoothed sunspot number was 201, in March, 1958. At C, the latest value taken July, 1960, the smoothed sunspot number was 108.

method over the past eight years for predicting the smoothed sunspot values appearing monthly in *CQ*'s PROPAGATION column, an overall accuracy of better than 10% has been achieved between predicted and observed values. It was this same method that resulted in the prediction, made in March 1956, that the present cycle would reach its maximum by May 1958, and would be the highest ever recorded.¹³ The peak actually occurred during March 1958, and was of unprecedented intensity! The same empirical method will be used to predict, in this report, the behavior of the remainder of the present cycle.

Cycle 19, Its Past & Present

The year 1958 will go down in scientific history as the year in which the most intense solar cycle ever recorded reached its peak. Rising rapidly from its beginning during April 1954 (with a smoothed sunspot number of 3.3), the present cycle, the 19th recorded since 1755, reached an unprecedented peak of 201.3 during March 1958. The previous record of 158.6 was recorded during May 1778 (cycle 3). The great intensity of the present cycle can be seen from the fact that it rose past the previous level of record high sunspot activity during November 1956, and remained above this level for nearly three years.

As a result of this unusually high level of solar activity, high frequency radio communication conditions were better during the years 1957-1959 than they had ever been in the entire history of radio.

It took 3.9 years for the present cycle to rise from minimum to maximum. This is somewhat

faster than the 4.3 year average ascent time for all previous cycles. While cycle 19 is yet far from completed, the smoothed sunspot numbers have been decreasing slowly, but steadily, from the record maximum of March 1958.

The progress of cycle 19 to date is shown in fig. 14. The latest available smoothed sunspot number, centered on July 1960, and based on the monthly numbers recorded between January 1960 and January 1961, is 108. In just over two years time the present cycle has declined to almost half its maximum value.

Cycle 19, Its Future

According to the empirical prediction method used by the authors of this report, the present cycle should continue to decline steadily until a minimum value is reached sometime between November 1964 and November 1965. The most probable date for the end of the present cycle is May 1965, with a minimum smoothed sunspot value of approximately 5.

Table 3 lists the smoothed sunspot numbers already recorded for cycle 19, and those predicted for the remainder of the cycle. The predicted values are shown also in graphical form in fig. 15.

TABLE 3

Values of smoothed sunspot numbers observed during Cycle 19. *Italic figures indicate values predicted for the remainder of the cycle.*

Year	1954	1955	1956	1957	1958	1959	1960	1961	1962	1963	1964	1965
Month												
Jan	6	14	89	170	199	179	129	<i>89</i>	<i>54</i>	<i>36</i>	<i>20</i>	<i>8</i>
Feb	5	16	92	172	201	177	125	<i>86</i>	<i>53</i>	<i>35</i>	<i>19</i>	<i>7</i>
Mar	4	20	109	174	201.3	175	122	<i>84</i>	<i>52</i>	<i>34</i>	<i>18</i>	<i>6</i>
Apr	3.3	23	119	181	197	169	120	<i>81</i>	<i>51</i>	<i>32</i>	<i>17</i>	<i>6</i>
May	4	29	127	186	191	165	117	<i>77</i>	<i>49</i>	<i>31</i>	<i>16</i>	<i>5</i>
Jun	4	35	137	188	187	161	114	<i>74</i>	<i>47</i>	<i>30</i>	<i>15</i>	<i>6</i>
Jul	5	40	146	191	185	156	108	<i>70</i>	<i>45</i>	<i>29</i>	<i>14</i>	<i>7</i>
Aug	7	47	150	194	185	151	<i>104</i>	<i>66</i>	<i>43</i>	<i>27</i>	<i>13</i>	<i>7</i>
Sept	8	56	152	197	184	146	<i>101</i>	<i>61</i>	<i>41</i>	<i>25</i>	<i>12</i>	<i>8</i>
Oct	8	64	156	200	182	141	<i>98</i>	<i>59</i>	<i>40</i>	<i>23</i>	<i>11</i>	<i>8</i>
Nov	10	73	160	201	181	138	<i>94</i>	<i>57</i>	<i>39</i>	<i>22</i>	<i>10</i>	<i>9</i>
Dec	12	81	164	200	181	133	<i>92</i>	<i>55</i>	<i>38</i>	<i>21</i>	<i>9</i>	<i>9</i>

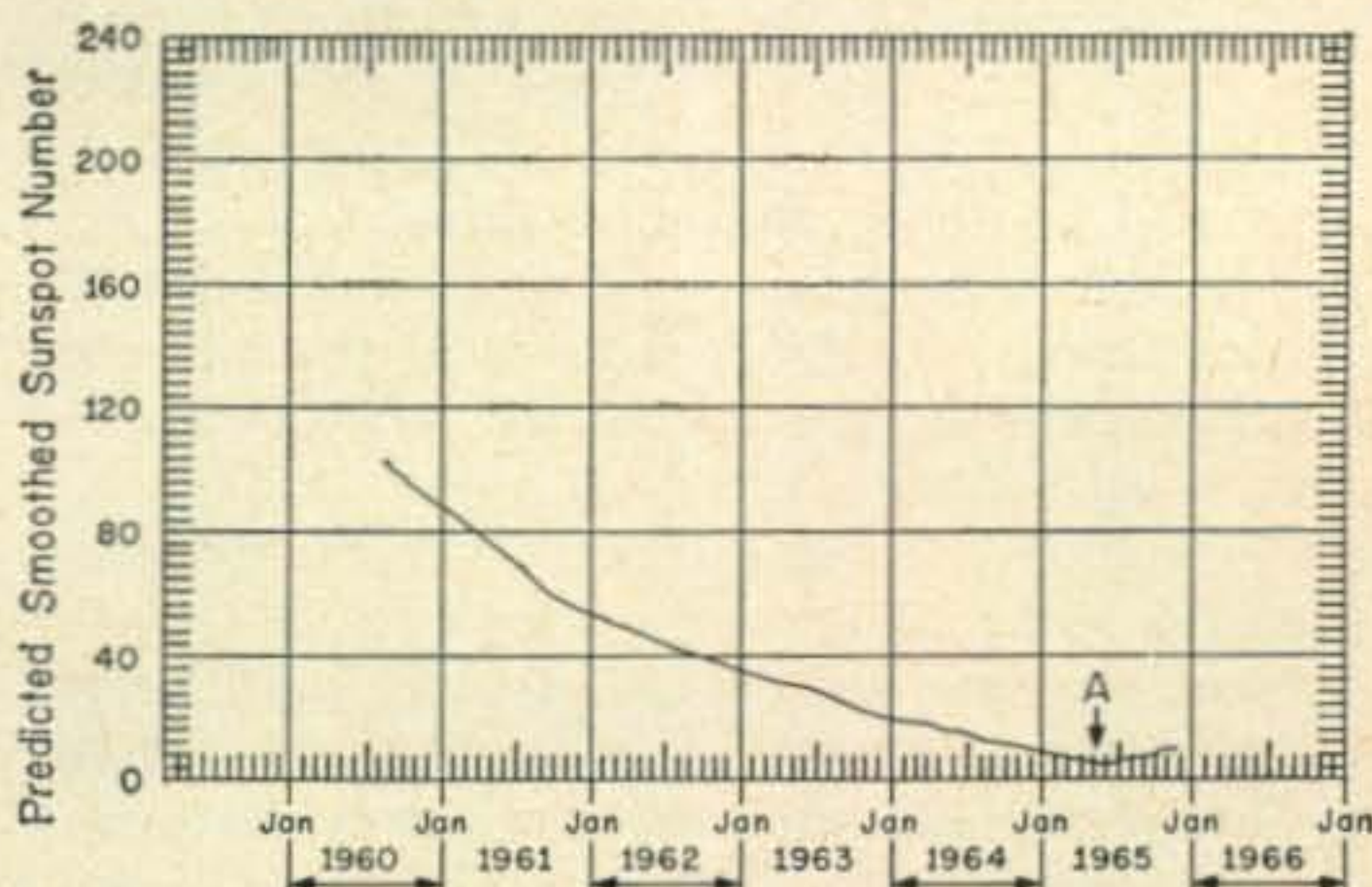

Fig. 15—Predictions for the remainder of Sunspot Cycle 19. The minimum of cycle 19 is predicted to occur sometime between November, 1964 and November, 1965, (A), the most probable date being May, 1965, when the smoothed sunspot number is expected to be 5.

¹³Jacobs, G., "The Sunspot Story; Cycle 19—Once In a Lifetime Conditions", *CQ*, March, 1956, p. 28; June, 1956, p. 24.

The accuracy of short range sunspot predictions generally varies with the phase of the solar cycle, and the number of years in advance for which the predictions are made. During the ascending period of solar activity, accurate forecasts can not usually be made for more than six months in advance. During the descending period, forecasts for several years in advance are often reliable within reasonable limits (less than 20% difference between predicted and observed values). Predictions are more accurate during periods of declining solar activity because sunspot numbers change at a considerably slower rate than during periods of increasing solar activity.

Although present sunspot predictions are based upon empirical methods developed from the behavior patterns of previous cycles, there is an observable pattern on the sun itself that makes it possible to predict the final stage of a cycle with a high degree of accuracy. This is the drift pattern of spots from high solar latitudes towards the solar equator, as the cycle progresses.

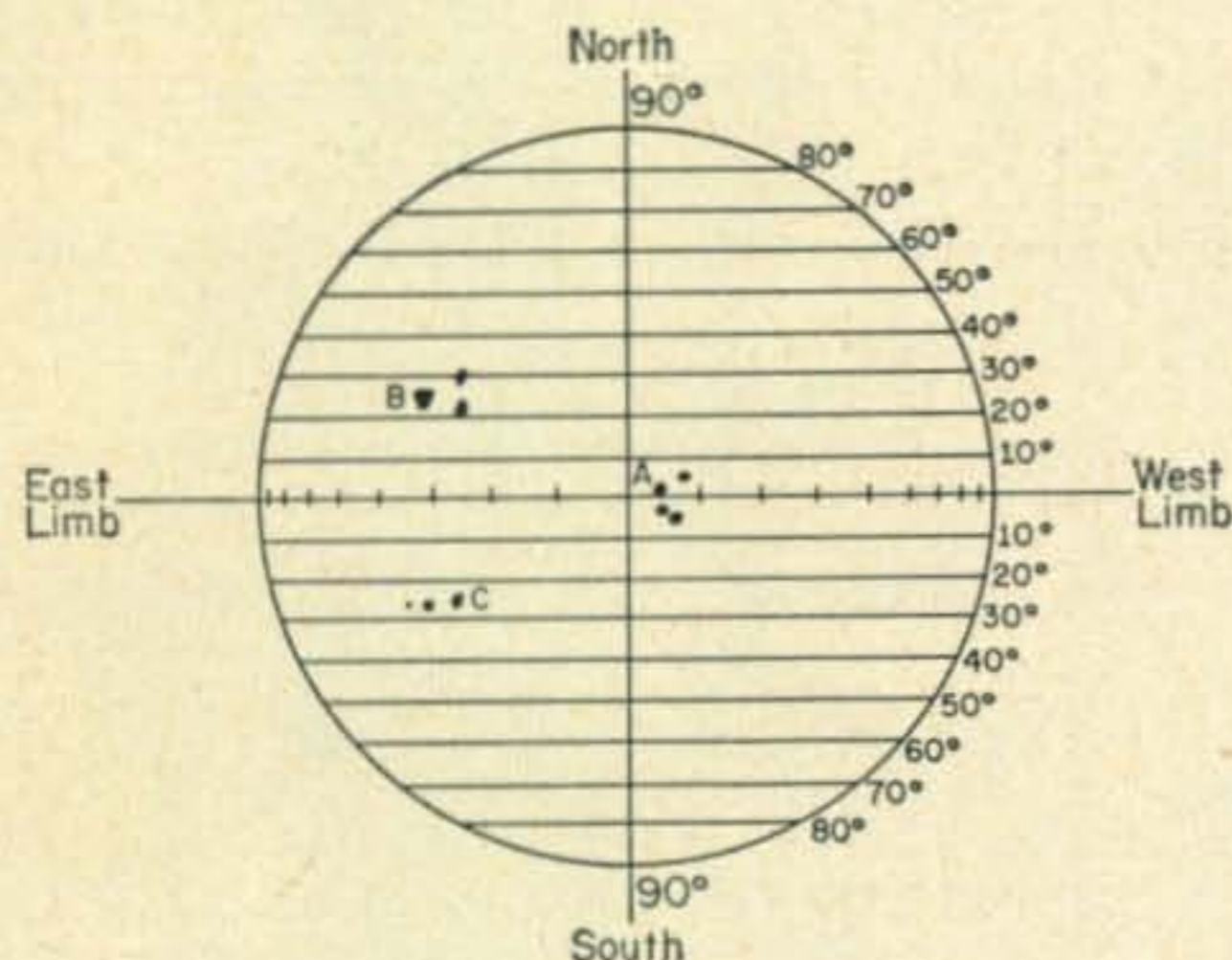

Fig. 16—At the start of a new solar cycle, sunspots first break out in two zones, 25 and 30 degrees north and south of the sun's equator (shown at B and C). As the cycle progresses the spots occur closer and closer to the equator. At A, sunspots are shown breaking out almost on the equator, as the cycle nears its end.

At the start of a new solar cycle, sunspots first break out in two zones, 25 to 30 degrees north and south of the sun's equator (see fig. 16). As the cycle progresses, the zones in which sunspots occur slowly drift towards the equator by about two degrees a year. By sunspot maximum, most spots break out at about 15 degrees, and by the end of the cycle, the sunspots nearly touch the solar equator. For almost a year, both the new and the old cycles overlap, with spots of the new cycle seen in high latitudes, while the few remaining spots of the old cycle break out near the equator. The date usually assigned to the end of the old cycle and the beginning of the new one is when the spots of both cycles are equally numerous.

The latitude drift of sunspots during a cycle is a reliable physical indication of sunspot mini-

mum, and it can also be used as a rough indicator of other phases of the solar cycle. Perhaps, as more data is accumulated from future sunspot cycles, physical laws based on the rate of sunspot drift may replace present empirical methods as a more accurate means for predicting sunspot behavior.

Cycle 20 and Beyond

At the present time, it is generally considered impossible to predict solar activity reliably beyond one cycle. Some solar researchers, nevertheless, have suggested interesting, although speculative, theories concerning long range sunspot cycle prediction.

One of these theories, based on the findings of C. N. Anderson,¹⁴ a leader in sunspot cycle research, suggests the existence of an approximate 169-year cycle which is superimposed on the more familiar 11-year cycle of sunspots. Although admittedly based on fragmentary data (reliable sunspot data is available for only 210 years, hardly enough time in which to establish a 169 year recurrence tendency), Anderson points out the striking similarity that exists between the sequence of maximas of cycles 1, 2 and 3 (with peaks of 87, 116 and 159) and cycles 16, 17, and 18 (with peaks of 78, 119 and 152), and the marked likeness between the corresponding cycles themselves.

TABLE 4

	Cycle Start	Cycle Peak	Max. Sunspot Number
Predicted Cycle 17	1933.3	1937.3	105-125
Observed Cycle 17	1933.8	1937.4	119
Predicted Cycle 18	1944.2	1948.2	145-165
Observed Cycle 18	1944.2	1947.5	152
Predicted Cycle 19	1954.4	1958.5	125-155
Observed Cycle 19	1954.3	1958.2	201
Predicted Cycle 20	1965.9	1970.3	45-65

Table 4 shows the accuracy of Anderson's method, based on the 169-year cycle, in predicting cycles 17, 18 and 19. The predictions for the start and peak of these three cycles were in very close agreement with observed values. The predictions of the maximum smoothed sunspot number for cycles 17 and 18 were also in close agreement with observed values, while the prediction for cycle 19's peak was about 35% low.

According to Anderson's method, the next sunspot cycle, cycle 20, should be a *very weak cycle* (recurrence of cycle 5), with little likelihood that its peak intensity will exceed a

¹⁴Anderson, C. N., "Notes on the Sunspot Cycle", *Journal of Geophysical Research*, Vol. 59, 1954, p. 455.

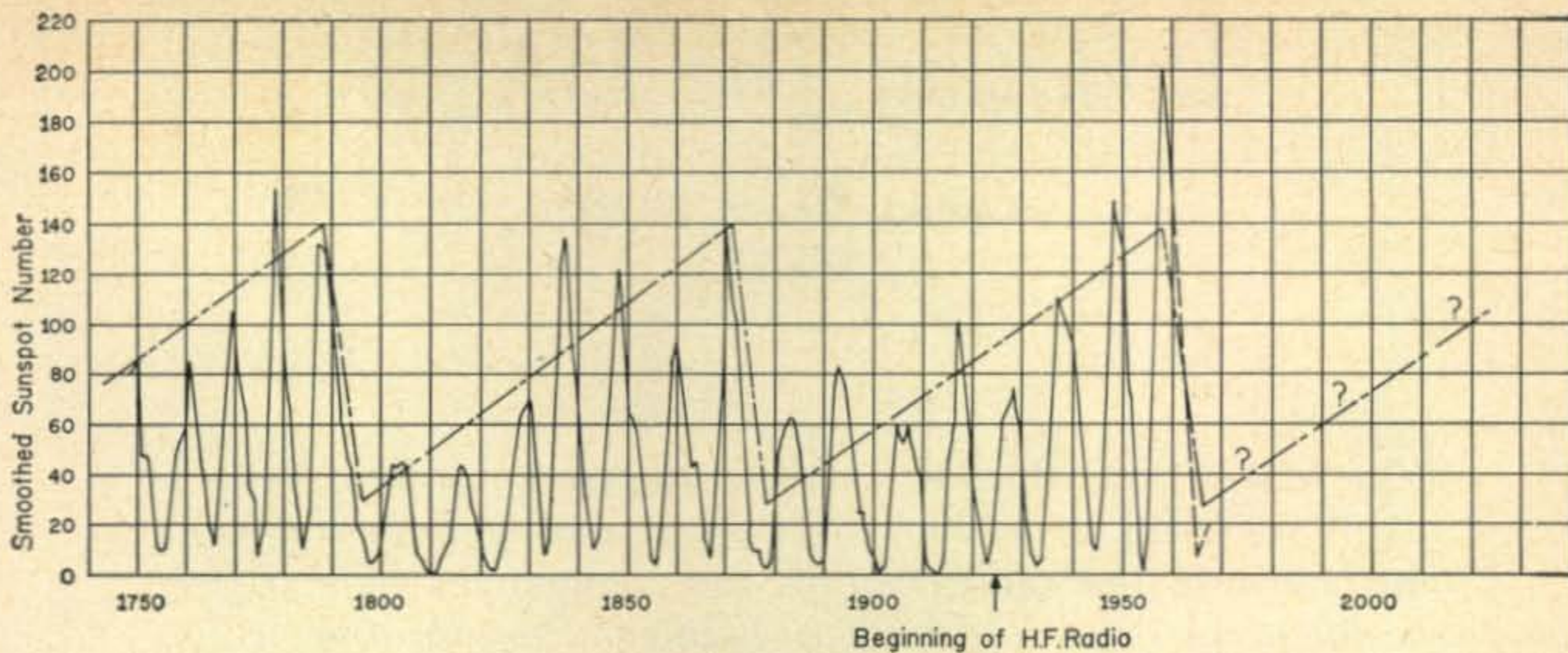

Fig. 17—Based on a saw-tooth recurrence pattern suggested by Dr. S. G. Lutz, solar activity for the remainder of the century is expected to be low.

smoothed sunspot value of 65. Cycle 20 is forecast to begin during December 1965 (which is in very close agreement with the date predicted earlier in this report, based upon another empirical method, for the end of cycle 19), and reach its peak by April 1970.

Using the 169-year cycle approach for predicting further into the future, cycle 20 should be followed by two more low cycles, extending through the year 2005. These would be recurrences of cycles 6 and 7, and their peaks would not be likely to exceed a smoothed sunspot number of 70.

Recently, Dr. S. G. Lutz of Hughes Research Laboratories published a long range solar cycle prediction based on his observations that cycle peaks seem to behave according to a long-term saw-tooth pattern¹⁵ (see fig. 17). According to this approach, the next three sunspot cycles (cycles 20, 21 and 22) should be low cycles, with the smoothed sunspot numbers not expected to exceed a value greater than 75 during the remainder of the present century. This is in very close agreement with the results predicted by Anderson's 169-year cycle method.

Until scientists find a satisfactory physical theory for describing the nature of sunspots, empirical methods similar to Anderson's and Lutz's, although speculative and subject to error, are the only means available for attempting to predict long range sunspot cycle behavior.

Impact On Communications

The sunspot cycle is a reliable index of the ionosphere's capability for reflecting shortwave, or high frequency, radio signals. When the smoothed sunspot numbers are very high, in excess of 125, a wide range of frequencies between about 3 and 50 mc are reflected over great distances. As the cycle declines, the ionosphere's capability to reflect radio waves decreases, and the upper limit of the frequency range reflected decreases accordingly.

Based on experience during the past few sun-

spot minima, the highest frequency normally reflected by the ionosphere during periods of low solar activity when smoothed sunspot numbers are less than 40, is about *one-half to one-third* the value of the highest frequency reflected during the peak of the cycle. Frequencies as high as 50 mc were reflected great distances during the peaks of the two most recent solar cycles. However, reflections rarely took place over 20 mc, and were confined below 14 mc most of the time during the last three periods of minimum solar activity.

The present solar cycle is declining steadily towards a minimum which is predicted to occur sometime between November 1964 and November 1965, with the most likely date being May 1965. There are indications, although considerably less reliable, that the present cycle will be followed by three very low cycles, and that solar activity from 1962 through the remainder of the century may never exceed a smoothed sunspot number of 75, and may remain below a value of 40 for more than half of this time.

Such a state of nature would have a very serious implication for shortwave radio communications in general, and amateur radio in particular! The impact of the predicted decline in solar activity upon conditions in the various amateur bands will be discussed at considerable length in the final installment of this special report, scheduled to appear in next month's issue of *CQ*. ■

A slight error was made in the captions of fig. 8 and fig. 9 of the first part of this series which appeared last month. Below are the correct captions.

Fig. 8—Comparison of diurnal variation in E (dashed curves) and F₂ layer (solid curves) critical frequencies during maximum and minimum sunspot activity. The data shown in the curves marked A were measured near Washington, D. C. during December 1957 when a sunspot number of 200 was recorded. The data shown in curves B were recorded during December 1954 when the sunspot number was 12.

Fig. 9—Variation in the yearly average noon F₂ critical frequencies with the yearly average sunspot numbers over a period of two-and-a-half sunspot cycles. Curve A is a plot of critical frequencies measured near Washington, D. C., and curve B is a plot of sunspot numbers.

¹⁵Lutz, S. G., "An Eventual Communication System", *IRE Transactions of the National Symposium, 1960 On Space Electronics and Telemetry*, 1960, SEC 2-4, p. 1.

Updating The 75A-2

Donald L. Stoner, W6TNS

Box 137
Ontario, California

With newer and "flashier" receivers appearing almost every month we often forget that a fair amount of engineering went into some of the older models too. Sometimes only a few modifications can produce a receiver comparable to or superior to any of the latest models. Described here are such modifications for the popular 75A-2 for s.s.b. use.

The sound of the banging screen door soon followed the entrance of my old friend, Sam Ham. Sam was moving like an irate TVI complainant was right on his heels!

"Look at this flier on the new *Regurgit-Eight* s.s.b. receiver", Sam bellowed in my ear, "This thing is so fancy it even has a sum detector" "Yup, it looks like about the last word in s.s.b. receivers, Sam", I replied trying to share his enthusiasm. I couldn't work up the same fever pitch, however. I was thinking of the price tag, and the last time Sam got a "crush" on a new model receiver. His wife had started a divorce action and named my Allied Radio Catalog as correspondent!

"It sure is a honey, Sam, but what's wrong with your old 75A-2", I said, trying to temper the situation? "Nothing that about 10 years, a product detector and a mechanical filter wouldn't fix", replied Sam, as he thumbed through his check book.

Our conversation took on a confidential tone as Sam and I had a father and son talk about receiver "facts of life". To be brutally frank, 90% of the receivers made today are nothing more than yesterday's newspapers set in a new type face. Each year the companies introduce new gadgets, a different box, and call it a "1960 model", just like the car manufacturers.

"Your old 75A-2 is an exception, Sam. When that job was designed there were only a few hardy souls on s.s.b., yet today it will still outperform most receivers! It's got stability (both mechanical and electrical) and calibration accuracy. The only thing it hasn't got is a mechanical filter and a product detector, and we can fix that situation in short order.

A furrow spread across Sam's brow as I hid his new catalog and replaced it with the 75A-2 schematic.

Filter Modifications

The first step was to decide where to insert the mechanical filter. Between the second mixer and the first i.f. was the crystal filter. This circuitry was retained and the filter was installed between the first (V_5) and second (V_6) i.f. stages. Connected in this manner, the filter determines the maximum selectivity (3.1 kc at 6 db). The crystal filter can still be used for c.w. reception, and provides the minimum bandwidth (200 cycles at 6 db down).

A small diameter, one inch long threaded $\frac{9}{32}$ pillar was fastened to the mounting bolt of T_5 closest to the shield plate. The filter was supported on this pillar (directly above T_4 and T_5) by a $\frac{3}{8}$ " plastic cable clamp. Next C_{108} and C_{109} were disconnected from T_4 and T_5 (see fig. 1) and connected to the end terminals of the filter. A 120 mmf capacitor was soldered across each end of the filter to resonate the transducer coil. The remaining transducer winding lug and the ground lug on the filter can were connected together and grounded to the nearest solder lug. Finally C_{32} was removed (don't forget this step, or the signal will bypass the filter) and the secondary slug of T_4 (bottom) and the primary slug of T_5 (top) were screwed all the way out to shift the resonant frequency outside the i.f. passband. Incidentally, an attempt was made to use these two coils as skirt traps, but a few minutes experimenting proved fruitless.

After the primary of T_4 and the secondary of T_5 was resonated at the i.f., the receiver performed just like a 75A-4, as far as selectivity was concerned (actually the skirts are a little better, due to improved filter design). A.M. stations drop out the passband with a "ker-plunk". Sam complained that the signals sounded bassy, but I demonstrated that it was necessary to tune to

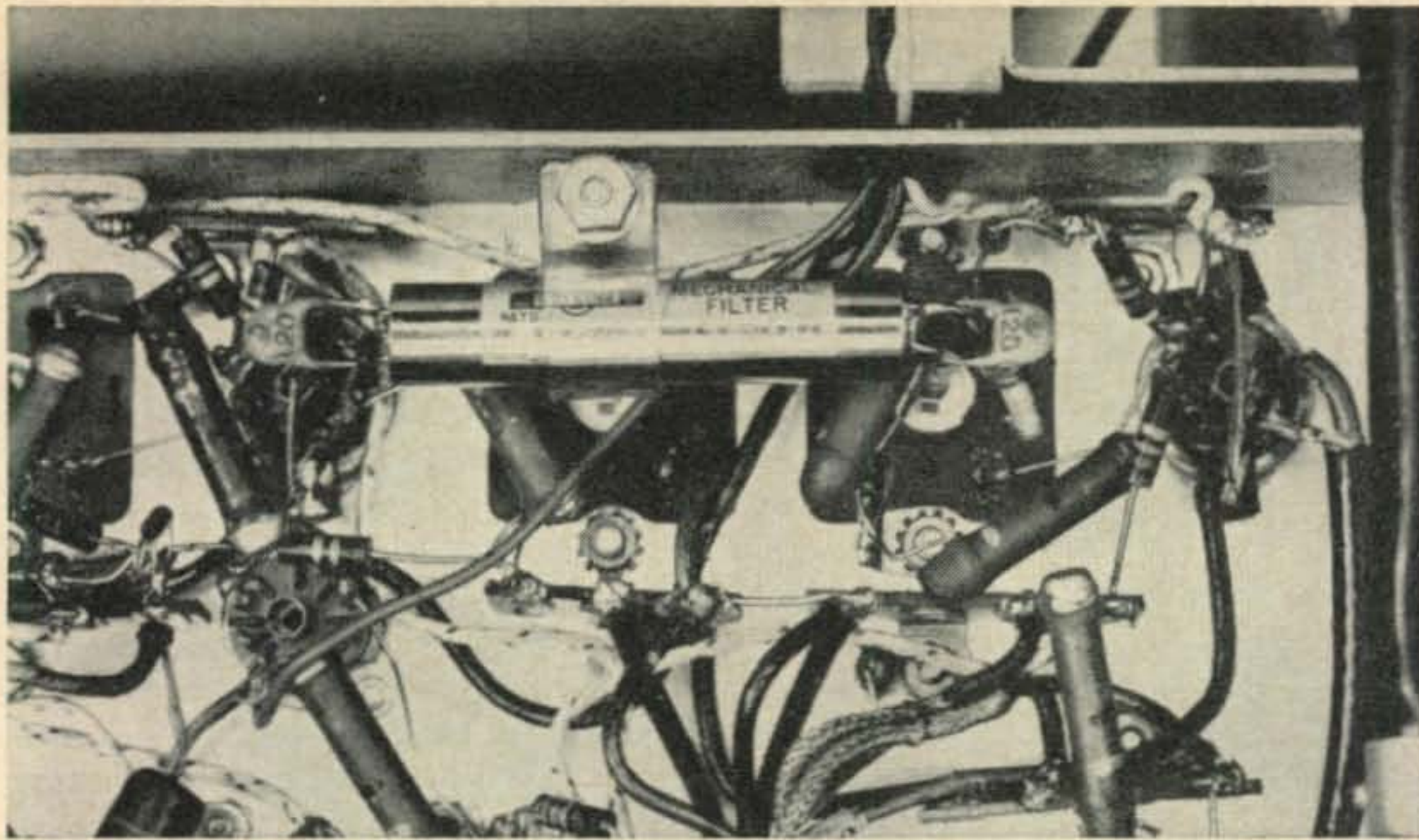

Under chassis view showing the method of mounting the mechanical filter. Check for signal leaking around the filter by disconnecting one end and shorting the terminals. The speaker should be silent, even with full gain.

the side of the station in order to place one-half of the spectrum in the receiver bandpass. This, of course, removes the other sideband, making s.s.b. transmissions out of all a.m. stations. Using this system it was possible to eliminate heterodyne interference by tuning to the other side of the signal, thereby placing the heterodyne outside the receiver bandpass.

nal circuit for comparison. A three-lug terminal strip was mounted under the nut nearest the i.f. section and all connections except the filament were removed from the n.b.f.m. adapter socket. The filament connection is pin 7. The front lug

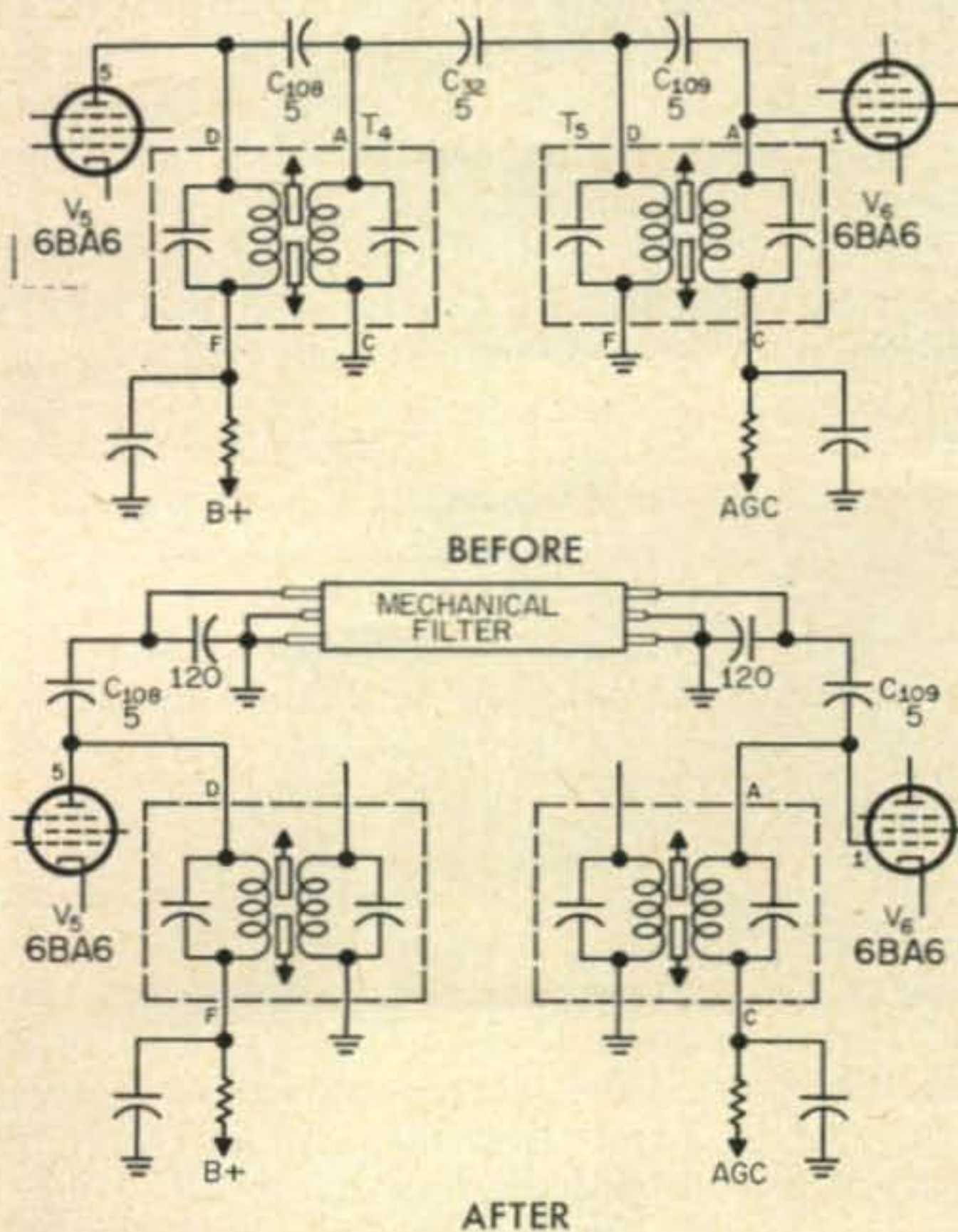

Fig. 1—Circuit modifications for adding a mechanical filter to the Collins 75A-2.

Product Detector Modifications

The next step in our conquest of the 75A-2 was to wire in the product detector circuit. Since Sam had no aspirations to operate n.b.f.m., it was decided to use the narrowband f.m. adapter socket, making it unnecessary to drill any holes in the chassis. A 6SN7 tube was selected since it is an octal type. The final circuit for the product detector is shown in fig. 2, along with the origi-

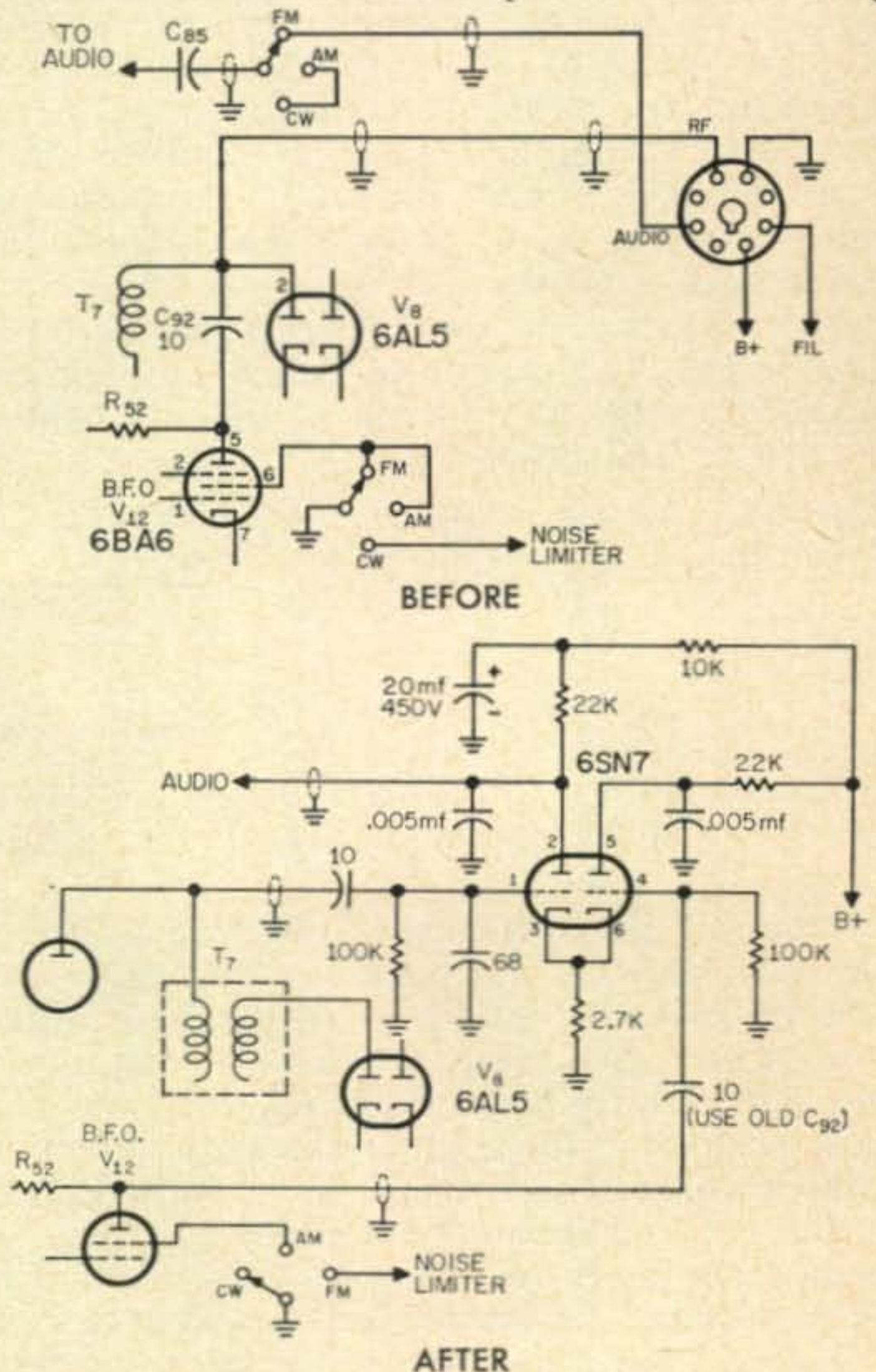
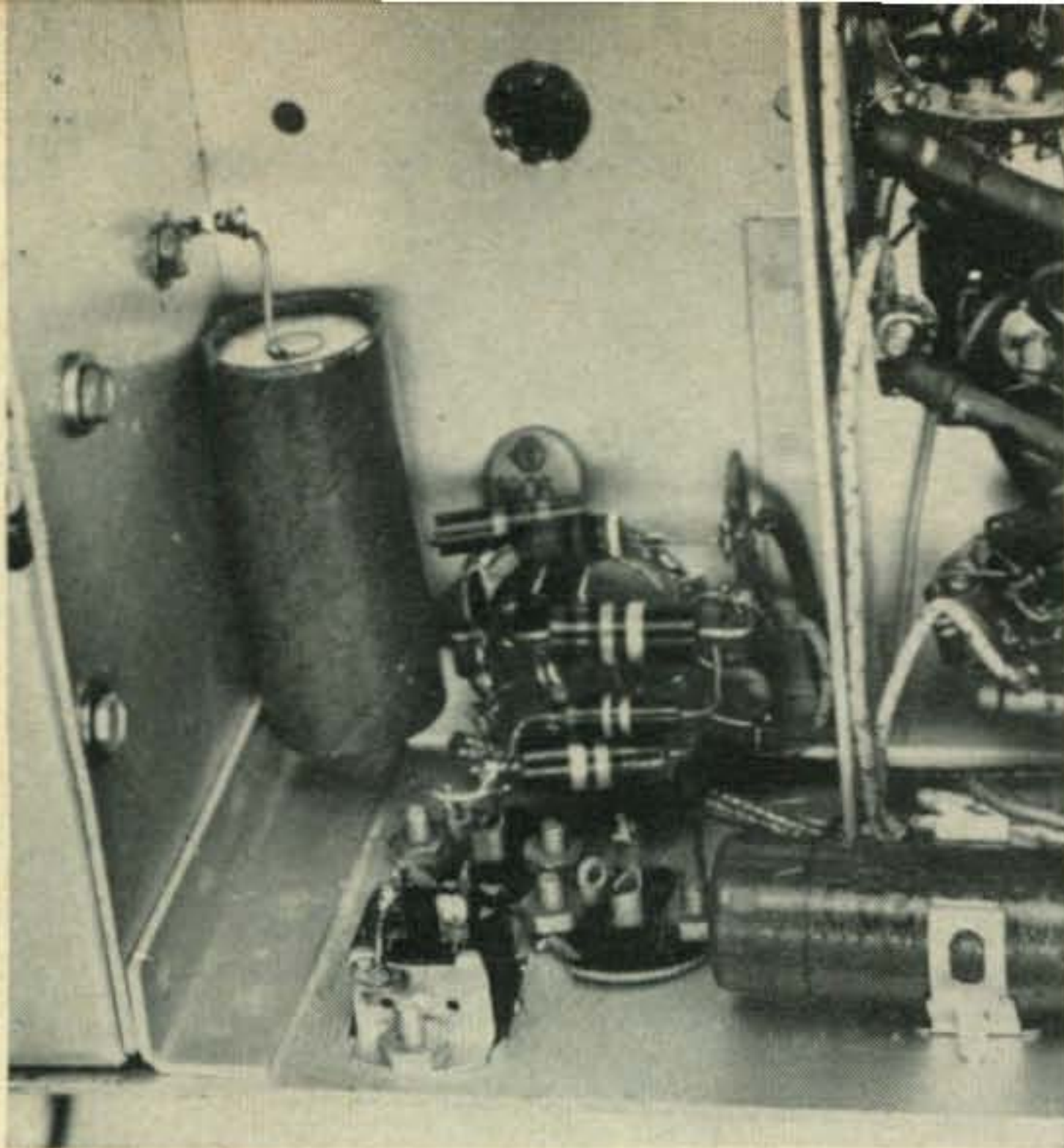

Fig. 2—Modifications to add a product detector to the 75A-2.

of the terminal strip connects to the plate, pin 5 of the b.f.o., tube (V_{12}) through a short length of coaxial cable (use the existing coax connected between the detector and n.b.f.m. socket. Capacitor C_{92} is removed and connected at the product detector end of the coax. The center



The product detector is mounted in the space behind the PTO unit. The connectors on the rear apron were the handiwork of a previous owner and have no bearing on the modifications described in the text.

lug of the terminal strip connects to B plus, originally pin 8 of the n.b.f.m. socket. The rear lug of the strip connects to the plate (pin 5) of the last i.f. amplifier through another short length of coax. Finally, the product detector circuit is wired as shown in fig. 2. To complete the conversion, clip the wire on the CW-AM-FM SWITCH which grounds the screen of the b.f.o. tube on f.m. This section of the switch is closest to the left edge of the chassis, directly behind the first i.f. transformer.

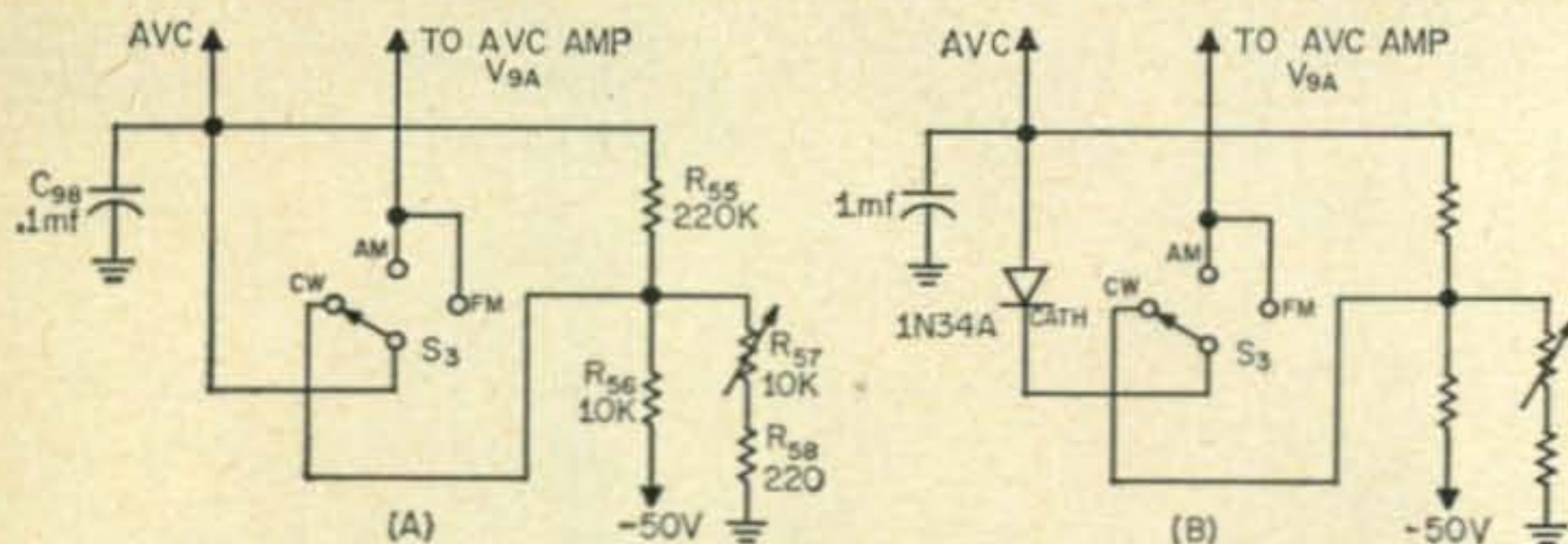

Fig. 3—Modifications to the a.g.c. circuit to eliminate pumping on strong signals. Note that C_{81} in the a.g.c. amplifier circuit must be removed to decrease attack time.

To check the operation of the product detector, switch to the FM position (now SSB) and tune in an s.s.b. station. Turn the b.f.o. pitch knob a little past the panel mark, in the clockwise direction for upper sideband reception. The same position in the counter-clockwise direction is the lower sideband. Once you have the station properly tuned in, pull out the b.f.o. tube, or temporarily short the screen grid to ground. The audio output from the speaker should drop considerably, indicating proper product detector operation.

AVC Improvement

I was just putting the last bolt in the cabinet, when Sam made an observation. "Listen to that 'thump' on s.s.b., every time someone says something". Sure enough, the a.v.c. took so long to build up, that the sudden inrush of r.f. would overload the receiver until the a.v.c. could catch

up. This produced a pronounced tail or "thump" at the beginning of each word. What was needed was an *agc* system which would charge up, or attack quickly, but decay or discharge slowly.

One solution to the problem is shown in fig. 3. A diode was connected in series with the a.v.c. line. When the negative a.v.c. voltage builds up, the diode cathode is more negative than the anode, and the diode conducts. Capacitor C_{98} charges quite rapidly due to the impedance of the a.g.c. line. When the s.s.b. operator pauses for a breath, the a.g.c. voltage on the diode cathode drops to zero, making the anode more negative than the cathode. This condition virtually opens the diode, and the charge on C_{98} slowly leaks off through the back resistance of the diode. Before the charge leaks off completely, the next burst of r.f. causes the diode to conduct and recharges the a.g.c. circuit.

Thus a station which is S9 will hold the meter between S6 and S9 (depending on how fast he talks, and the time constant of the circuit) for his entire transmission. Then when he stands by for an S2 station, the a.g.c. voltage drops to a new low value and averages at that point for the weaker stations transmission. The improved a.g.c. circuit really shows its worth in a round table, for there is no need for constantly readjusting the volume or r.f. gain control. There is a slight thump at the beginning of a transmission (or after a long pause) but this is not objectionable compared to the constant "pumping" action with the original a.g.c. system.

The decay time of the a.g.c. voltage is determined by the capacity of C_{98} and the leakage resistance of the germanium diode. For best

results a diode with very high back resistance should be selected. This will allow the smallest value of C_{98} and provide the fastest attack time. The author used a 1N34A, retrieved from the junk box, and it was necessary to use 1 *mf* at C_{98} to obtain a sufficient decay time. Don't forget to remove capacitor C_{81} , as noted in fig. 3, or you won't be able to make the attack time fast enough.

Sam and I had just finished buttoning up the A-2 for the second time when his wife charged into the shack like Teddy Roosevelt heading up San Juan hill. Her dramatic entrance was followed by a 20 minute tirade about keeping Sam away from home so much of the time, interspersed with comment about my giving him ideas on spending all their hard earned money. As Sam, his wife, and the 75A-2 faded into the evening, I muttered "There ain't no justice". And you know what? There ain't! ■

Adapter For Surplus Tube Testers

J. R. Throop, WA6CLT

3206 Melanie Road
Marina, California

How to extend the usefulness of the I-177 surplus tube tester (or any other tube tester) by use of an outboard adapter.

THE surplus market has a good tube tester available at a reasonable price. It may also be available to those of you who are MARS members. This is the I-177(-) tester in various modifications. The drawback with this and many other tube testers is that it can not be kept up to date. An outboard adapter, MX-949/U (described in the Army Technical Bulletin TB 11-2627-2), is made to extend the utility of the tube tester. Having the basic tester and being unable to locate the adapter, I decided to construct my own following the circuit in the bulletin. Figure 1 is the circuit used.

Adapter Circuit Operation

The circuit is simple, having the same pin numbers of each tube socket connected in parallel and terminated at a banana plug lead. Thus lead #1 connects to pin #1 of all sockets used.

A set of banana jacks are connected by a cable and an octal plug to one of the octal sockets (socket E) on the main tube checker. This cable is wired for a standard tube so that the leads are always connected to the same tube elements. These are marked in fig. 1.

When a tube is to be checked that the main tester will not handle, a tube manual is used to determine the proper socket connections. If pin #1 is the plate then lead #1 should be connected to the PLATE banana jack; the grid pin of the tube connected to GRID jack with its jumper, and so on. The filament voltage should be set to the proper range and the tube plugged into the adapter socket.

Initially a known good tube should be checked with a milliammeter in the plate circuit. The shunt control (labeled "L" on the I-177) should be

[Continued on page 106]

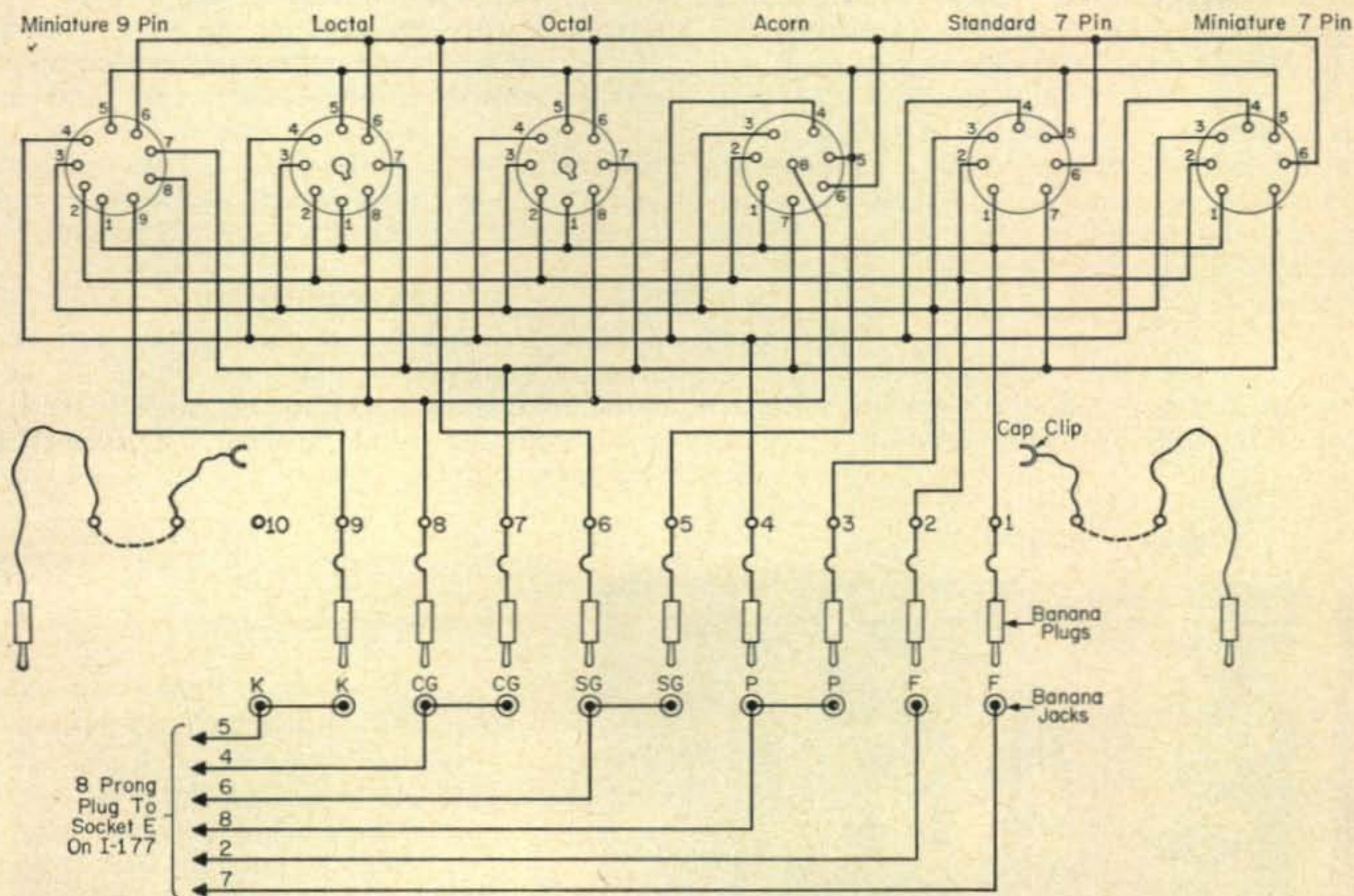

Fig. 1—Circuit of simple outboard adapter that extends the usefulness of outdated tube testers. Set selector switch A to 4 and B to 2 on the I-177 and insert plug in socket E.

A Unique Suppressed Carrier Transmitter

Robert W. Stolzenbach, W8KP

Chief, Scientific Services Branch
USAF Standards Calibration and Certification Division
Dayton Air Force Depot, Gentile Air Force Station
Dayton 20, Ohio

W8KP has constructed an experimental d.s.b. transmitter using a 6AR8 balanced modulator. The entire unit, described here, is nicely packaged on a Command transmitter chassis. The unit is ideal for use as a spare, emergency or mobile transmitter.

MANY writers are hesitant when it comes to writing articles about double sideband transmitters in the present era of single sideband. However, the described transmitter is unique and the author feels sure that many amateurs will be interested and may visualize many applications of the underlying principle.

Comparisons

There are a number of ways to look at suppressed carrier double sideband transmitters. One may compare the system with a.m., in which case it can be shown that for equal tube capacity, the system is equal to or equivalent to approximately two a.m. transmitters operating simultaneously with the advantage of economy and compatibility with single sideband. Or, one may further compare the system with single sideband techniques and observe that for all practical purposes it is only down approximately 3db when received on either of its two sidebands and this at reduced bandwidth. However, the comparison that the writer prefers is that it makes an excellent low cost "second car" and possesses, for emergency or mobile operation the assurance of being heard, regardless of the sideband position of the listener's receiver, plus economy and portability.

Circuit Analysis

As one can see from the schematic diagram the unit is composed of a total of six tubes

(less power supplies). Namely, the oscillator (3-4 mc), using the original 1626 as found in the BC-696 Command transmitter, a 6AR8 balanced modulator, a pair of 6550's (Hi-Fi audio tubes) and finally a pair of 12AX7's for the entire audio system.

The selection of tubes may concern some readers. But let's make it clear that the described transmitter is experimental and was originally intended for single band operation for the purpose of simplifying portable amateur equipment. The 6AR8 was selected to eliminate the necessity for a buffer between the oscillator and balanced modulator and further, that it requires practically no audio power as the audio energy merely deflects the electron beam by electrostatic fields. The 6550's were selected for the final as they are ideal for linear amplifier applications and capable of 100 watts average power in class AB1 operation with 600 volts on the plate. The relatively low plate voltage reduces power supply requirements. It is interesting to note, and possibly you have already guessed, three of the tubes may be transistorized, i.e., the oscillator, and the audio tubes which of course, would further reduce the overall size and weight.

Multiplication

How does the system multiply the reference frequency without a multiplication of the sideband components? The answer to this question is incorporated in the inherent characteristic of

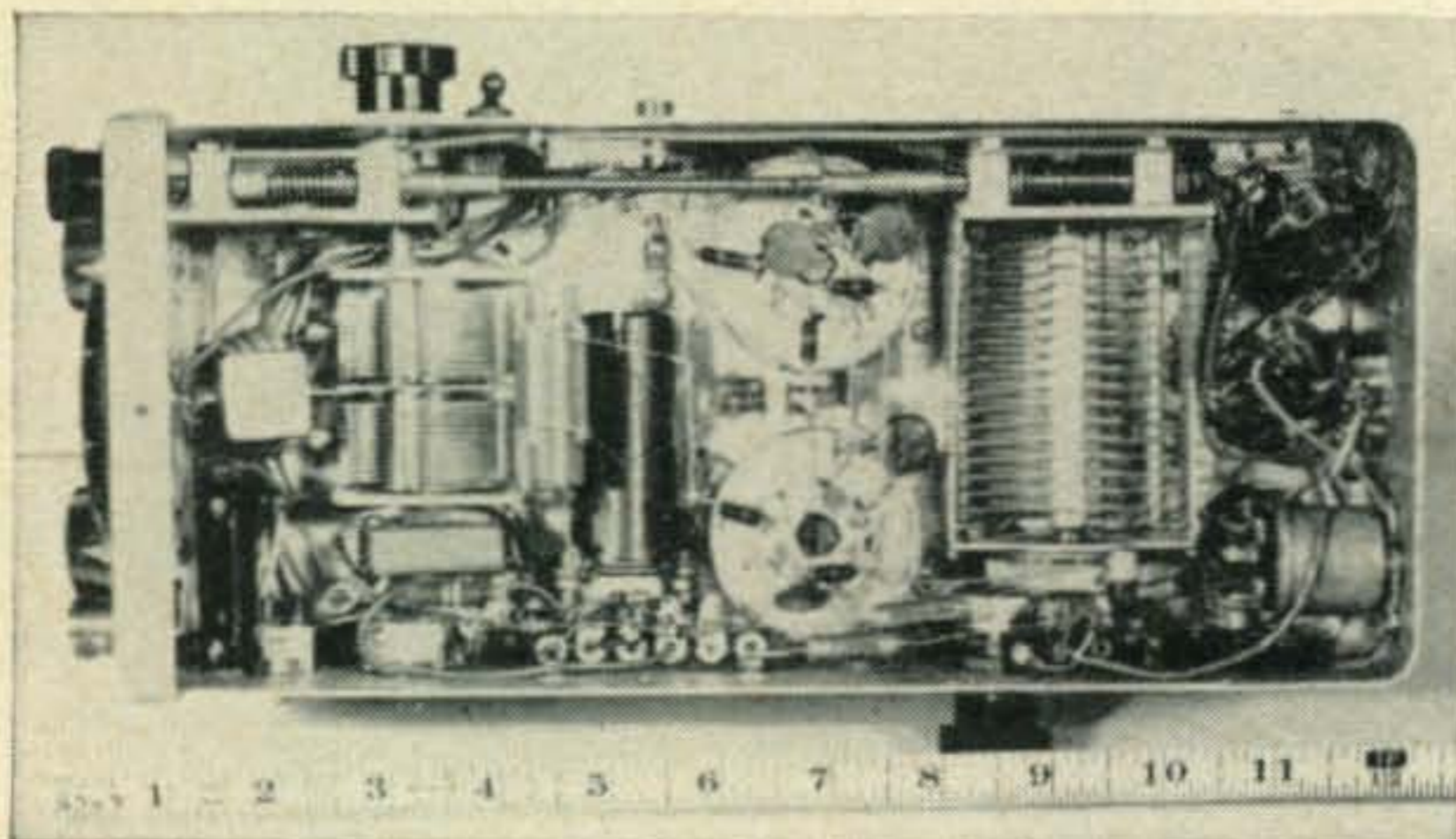

Bottom view shows location of the two gang tuning capacitor for the balanced modulator plate tank on the left. To the right of it is the modulator plate coil, 2 sections of B&W coil stock. The 6AR8, shielded, is just to the right of the coil. The neutralizing capacitor is located between the two 6550 sockets.

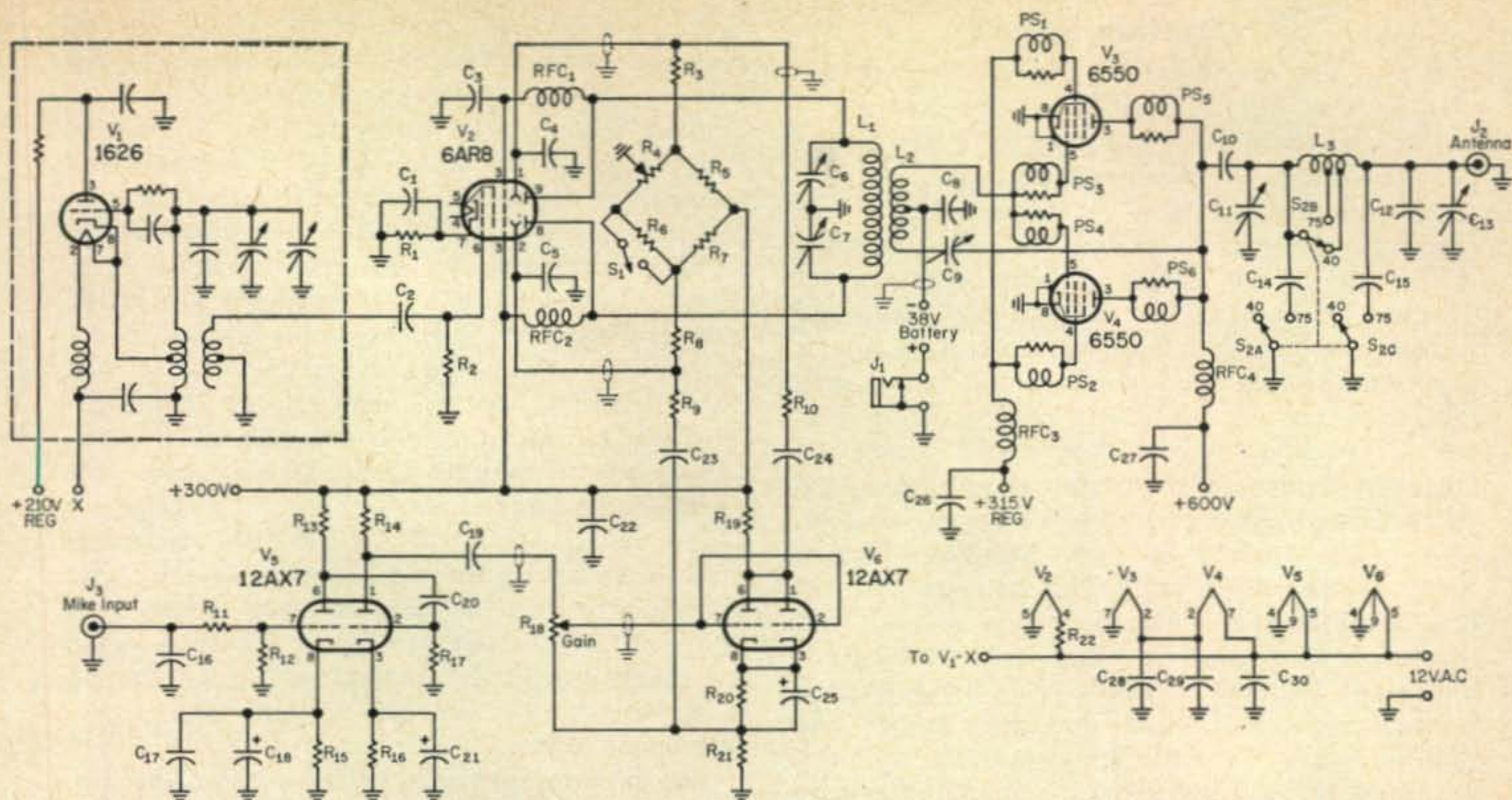

Fig. 1—Circuit of a d.s.b. transmitter built around a Command set. The 6AR8 tank circuit can tune to 80, 40 and is not too efficient from 9 to 12 mc.

- C₁—.01 mf
- C₂—500 mmf
- C₃—.01 mf
- C₄—100 mmf
- C₅—100 mmf
- C₆, 7—420 mmf two gang variable
- C₈—.01 mf
- C₉—1.5 to 5 mmf, Johnson 5M11
- C₁₀—500 mmf
- C₁₁—200 mmf variable
- C₁₂—500 mmf
- C₁₃—200 mmf variable
- C₁₄—100 mmf
- C₁₅—500 mmf
- C₁₆—100 mmf
- C₁₇—.005 mmf
- C₁₈—5 mf, 25 v.
- C₁₉—.005 mf
- C₂₀—.005 mf
- C₂₁—5 mf, 25 v.
- C₂₂—.01 mf
- C_{23, 24}—.0015 mf
- C₂₅—5 mf 25 v.
- C₂₆—.002 mf
- C₂₇—.01 mf
- C₂₈—.005 mf
- C₂₉—.005 mf
- C₃₀—.005 mf

- R₁—390 ohms
- R₂—10K
- R₃—150K
- R₄—5K pot.
- R₅—220K
- R₆—50K
- R₇—220K
- R₈—150K
- R_{9, 10}—10K
- R₁₁—4700 ohms
- R₁₂—1 megohm
- R_{13, 14}—500K
- R_{15, 16}—4.7K
- R₁₇—500K
- R₁₈—500K pot.
- R₁₉—56K
- R₂₀—2.4K
- R₂₁—56K
- R₂₂—21 ohms

- R₂₃—150K
- R₂₄—150K
- R₂₅—150K
- R₂₆—150K
- R₂₇—150K
- R₂₈—150K
- R₂₉—150K
- R₃₀—150K
- R₃₁—150K
- R₃₂—150K
- R₃₃—150K
- R₃₄—150K
- R₃₅—150K
- R₃₆—150K
- R₃₇—150K
- R₃₈—150K
- R₃₉—150K
- R₄₀—150K
- R₄₁—150K
- R₄₂—150K
- R₄₃—150K
- R₄₄—150K
- R₄₅—150K
- R₄₆—150K
- R₄₇—150K
- R₄₈—150K
- R₄₉—150K
- R₅₀—150K

- RFC₁—2.5 mh
- RFC₂—2.5 mh
- RFC₃—5 to 10 μh
- RFC₄—1 mh, 600 ma, National 154-U
- PS₁ to 6—Type used in command transmitter
- L₁—53t, 1/2" diam. B&W (32 tpi)
- L₂—27t, 5/8" diam. B&W (32 tpi)
- L₃—Antenna tuning coil from BC-459
11t for 40M.
16t for 75M.

the 6AR8 Balanced Modulator.

As most amateurs know, the energy delivered from the oscillator tube in the command transmitter represents a considerable power level (3-4 watts). For example, in the original design of these transmitters the oscillator was capable of driving a pair of 1625 (807's) into Class C operation with the 1625's self-biased with a 15K grid resistor. The grid current of the 1625's was well above 5 milliamperes. Let's say for our purpose the value was exactly 5 ma. This value of current through the 15K grid resistor represents 75 volts. So one notes immediately the 6AR8 is being driven into the positive grid area and thus into a form of class C operation. The positive grid current waveform takes on the shape of a pattern some place between an ideal rectified sine wave pulse and a hybrid square wave due to clipping. A Fourier spectrum analysis indicates immediately that the harmonic content increases to relatively large values and almost equals the strength of the fundamental energy on the desired harmonics.

Thus the electron beam of the 6AR8 contains more than a single frequency. In this particular experimental unit the fundamental, 3-4 mc, and the second harmonic 6-8 mc, were very strong while the 9-12 mc energy was lower due to the unfavorable L/C ratio (at these frequencies) in circuit.

Modulation

The reader must keep in mind these frequencies are contained within the beam of the 6AR8 and represents beam intensity. Due to the structure of the tube the audio is applied on two electrodes whose action is purely a deflection technique of the beam similar to the deflection plates of an oscilloscope. They do not change the intensity of the beam but add, through the plate tank of the 6AR8, the audio energy on a one to one basis, simultaneously to each frequency present in the beam. The output circuit of the 6AR8 is used for selecting the desired frequency band.

Construction Details

It was not the intention of the writer to devise another modification for Command transmitters but the chassis lent itself very well to the construction of the experimental transmitter.

The oscillator system is very stable if one regulates the plate voltage. No other changes were made in this section. It may be of interest to some readers that in many of the Command transmitters the oscillator variable capacitor is constructed with invar plates. Invar has a very low temperature coefficient of expansion and while expensive, is ideal for stable oscillators. One may determine if the unit is so constructed by checking the plates with a permanent magnet.

It is worthwhile to select oscillator tubes; many of the 1626's are rather bad drifters; but it is not difficult to find one, out of several, that performs with good stability. The stability is important because in this circuit the reference frequency is multiplied and the higher the multiplication the more important the stability requirement. A 12A6 works quite satisfactorily and the socket connections require only a slight modification. By grounding pin #1 the metal shield of the 12A6 becomes effective and eliminates "hand" effect commonly experienced because of the glass envelope of the 1626's.

The excitation of the balanced modulator (6AR8) is obtained by using one-half of the original excitation coil as may be observed in the schematic.

Balancing

The resistive network composed of 150K, 50K, (normally shorted), 5K (variable), 150K, 220K resistors as shown in the schematic are for the purpose of establishing equal d.c. potentials on the audio deflectors to eliminate the carrier. The variable resistor, 5K, is adjusted for maximum carrier rejection by observing a milliammeter (0-20) connected in series with the

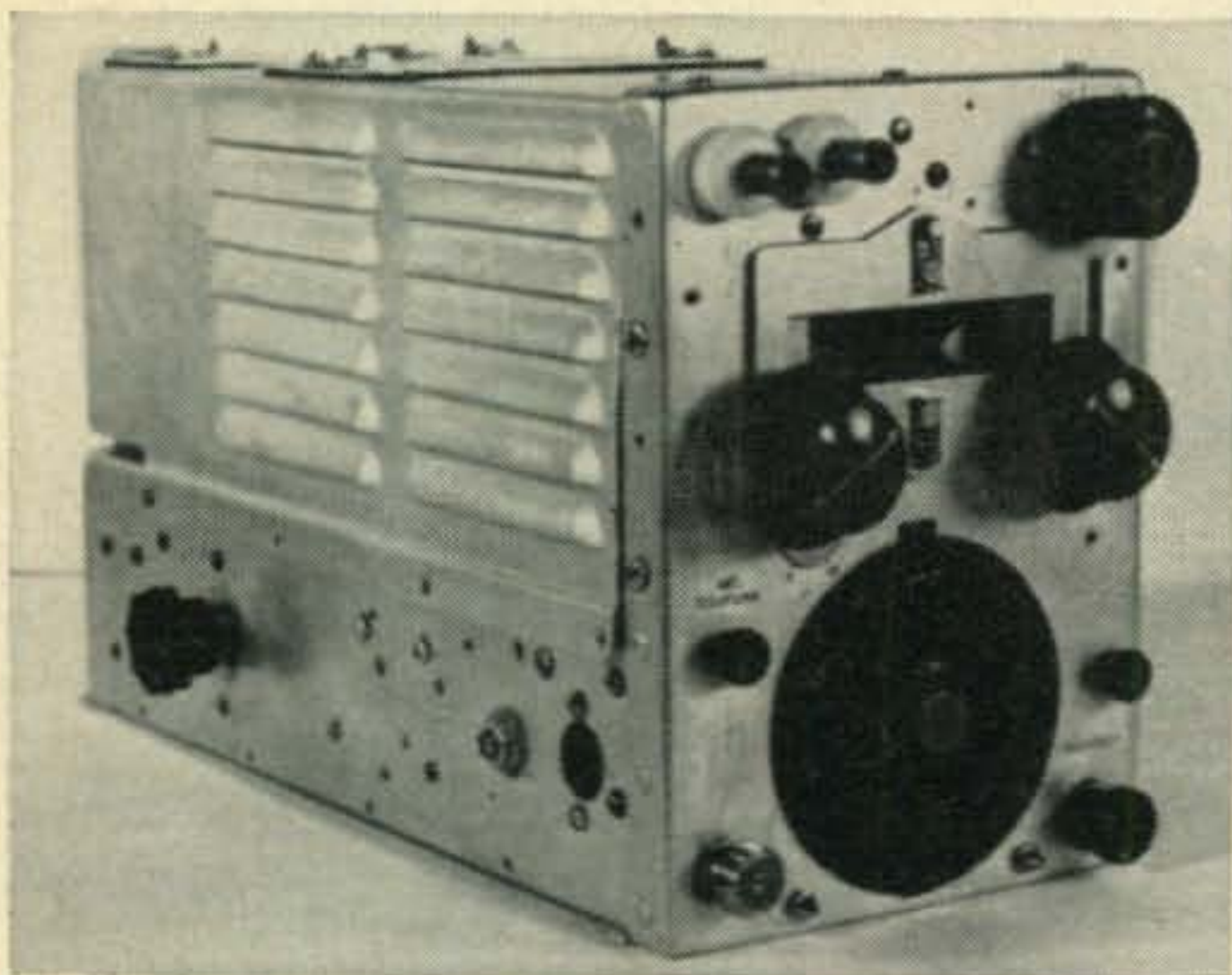

The controls on the side are, from l to r; audio level, carrier rejection and 2 circuit connector for an antenna relay. The front panel controls are; lower right, oscillator tuning; center right, final tank capacitor; upper right, pi-network bandswitch; lower left, mike input connector; center left, loading capacitor; upper left, antenna terminals.

6550's grid return circuit. The 6550's, during this adjustment, have the filaments operating but without control grid, screen or plate voltage applied. The correct setting for the 5K resistor is for a minimum deflection. The experimental transmitter indicated practically zero grid current under these conditions. Greater carrier rejection is possible by the incorporation of a phase adjustment in addition to the amplitude control. However, measurements indicated approximately 40 db rejection of the carrier so a phase adjuster was not incorporated in the experimental transmitter. To this date no listener, during several months on the air tests, was able to report hearing the carrier.

The switch shown across the 50K resistor is used to unbalance the d.c. potential on the audio deflectors to shift the electron beam to one plate of the 6AR8 thereby producing a carrier signal for determining in the correct setting of the pi-network for the antenna system and signal frequency used.

The photographs clearly show the radio frequency transformer that couples the 6AR8 to the Class AB1 6550's linear amplifier. The 5/8 inch B&W Miniductor Coil is carefully slid over the 1/2 inch B&W Miniductor.

As noted in the schematic diagram the linear amplifier operates with 600 volts on the plate, 315 volts on the screen, and approximately 38 volts (negative) bias from a battery source. The fixed capacitors shown by dotted lines in the pi-network are switched into the network when operating on the 75 meter phone band. The values selected are designed for optimum operating condition into a dipole antenna of approximately 75 ohms impedance.

The audio system is self explanatory but for those interested the microphone used was a Model 729 Ceramic Cardioid manufactured by Electro-Voice, Inc.

Balanced Modulator Adjustments

One may quickly observe that the oscillator, balanced modulator and the audio system are working satisfactorily by observing the grid current flow through the grid return circuit of the 6550's. The current is observed with the grid bias, plate and screen voltages disconnected from the linear amplifier and with the switch across the 50K resistor in the open position. The tuning adjustment, under these conditions, for the balanced modulator is for maximum grid current flow. (Approximately 11-12 ma for the 40 meters and 12-13 ma on the 75 meter band.) Following this adjustment, the switch (across the 50K resistor) is closed and the amplitude balance adjustment (carrier rejection) is made for minimum grid current flow. No further adjustments will then be required. If one desires, at this phase of the testing, the signal quality may be checked in a monitoring receiver.

The balanced modulator tank circuit, following its adjustment for maximum grid current flow, will not require further adjustment unless the operator desires to exceed a band area

coverage of ± 5 kc in which case, a slight adjustment will be required and may be made by observing the maximum average plate current reading on the linear amplifier with carrier temporarily inserted.

Neutralization

Before any attempt is made to excite the linear amplifier, it is of utmost importance to adjust the neutralizing capacitor. This adjustment is made using a radio frequency galvanometer (a diode shunted across a sensitive 0-500 microammeter movement) connected across the output terminals of the pi-network (antenna connection). The procedure is as follows: Set the oscillator to 7.25 mc. (Dial setting, 3.625 mc.) Plate, screen and bias voltages are disconnected (short out battery connection points) and, *most important*, the heater circuits to the 6550's must be disconnected.

Just prior to disconnecting the 6550's heater circuit the balanced modulator tank is peaked for maximum drive by checking for maximum deflection with a 0-20 ma meter in the grid return circuit. The pi-network is also adjusted, observing the radio frequency galvanometer for maximum deflection, and at the same time being careful not to damage the movement by excessive deflection. Now disconnect the filaments of the 6550's. The neutralizing capacitor is then adjusted for minimum deflection on the r.f. galvanometer. This adjustment should result in a meter deflection very close to zero. Now check the system by varying the oscillator between 7.2—7.3 mc during which the galvanometer should remain very close to zero. Readjust the balanced modulator circuit to the 75 meter band (3.8—4 mc) and check the neutralization on this band. The system should still be satisfactorily neutralized.

The next step is to replace the heater circuits, plate, screen, and grid voltages. Place a 100 watt lamp across the antenna terminals as a dummy load. With no carrier inserted the idle plate current should be approximately 75 to 85 ma. With carrier inserted the plate current should rise to between 300 to 325 ma. Always check the tuning adjustment (excitation) of the balanced modulator for maximum power output, of course, not to exceed a maximum of 325 ma.

The tuning of the pi-network is conventional. Should minimum plate current and maximum power output not occur at the same point on the tuning dial, the linear amplifier is incorrectly neutralized. Recheck the neutralization procedure and the difficulty will be eliminated.

Frequency Modulation

At this point in the testing program it is advisable to make a check for frequency modulation difficulties. It is doubtful if oscillator pulling will be experienced because of the type of tube structure (6AR8) and technique involved in the modulation process. However, it is advisable to check the loading effect of the power amplifier because of a change of plate current from 85 ma

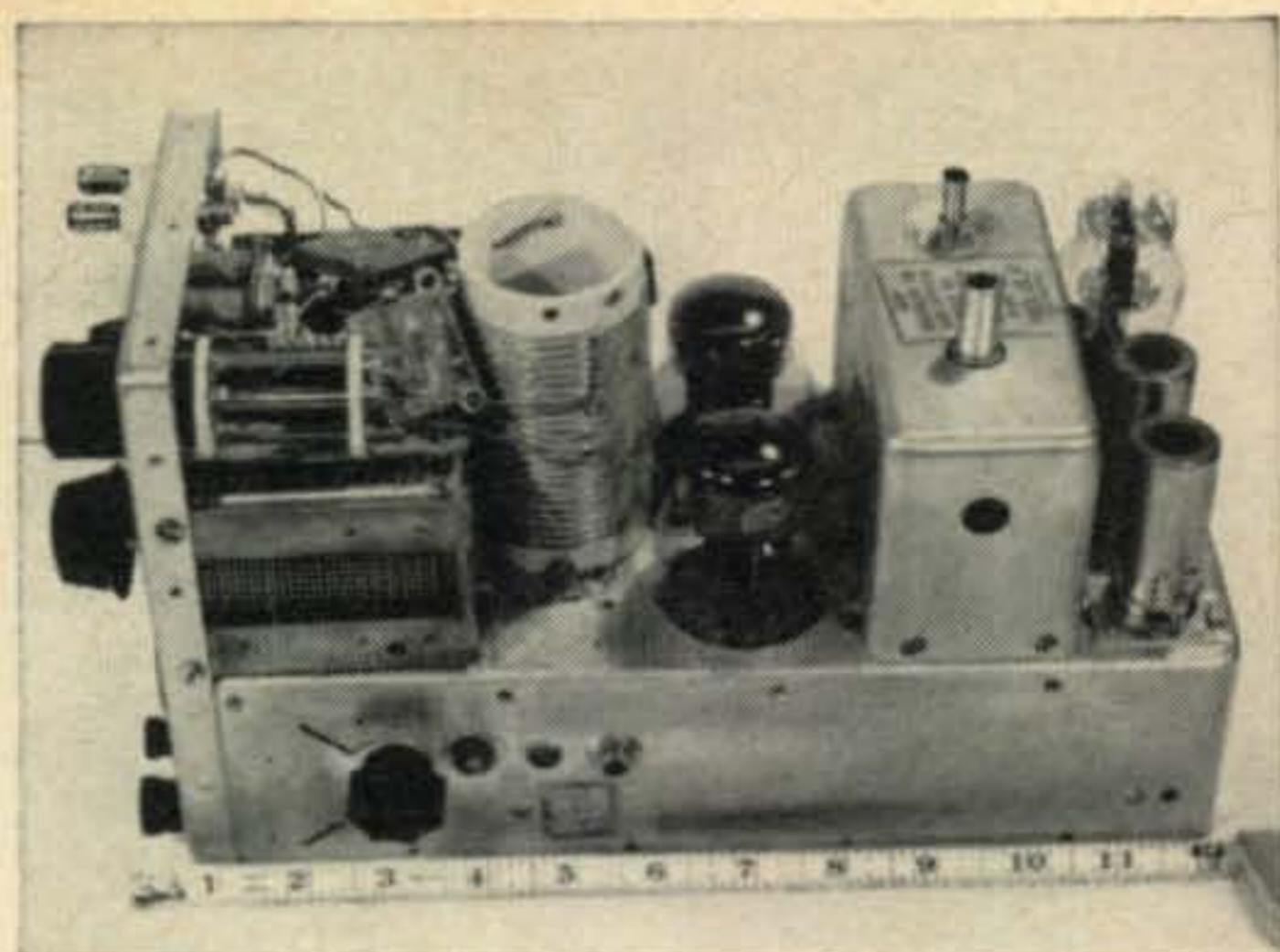

Controls on the side flange are, from l to r; balanced modulator tuning (upper mark is 40 m and lower 75), carrier insertion switch, 6550 grid return jack. Tuning capacitor on the left is for the final and the switch directly above is the bandswitch for the pi-network. The pi-network coil (standing upright) is salvaged from a BC-459. To the right of the coil are the two 6550's. The tubes on the right are from f to b; 12AX7, 12AX7 and 1626. The plate r.f. choke is mounted directly behind the pi-network coil and is not visible.

to 325 ma represents a husky variation in load. This check is accomplished by inserting the carrier, adjusting the transmitter to maximum power output into a dummy load (100 W lamp). With a stable receiver, Zero beat the transmitted signal. Vary the output by varying the drive. Varying drive is accomplished by a slight adjustment of the balanced modulator output tuning capacitor. If no change in frequency is observed everything is satisfactory. Should some deviation be noted, the main power supply is possibly causing trouble through the power mains, affecting the plate voltage to the oscillator. An improved power main or better voltage regulation of the oscillator is required to correct this type of frequency deviation.

Operating

A few words should be mentioned regarding the general operating procedures on the air. While utilizing the 75 meter phone band, the frequency dial is read directly in accordance with its original frequency calibration. After the operator has selected the frequency of transmission (75 meter phone band) and the required switching is accomplished, the class AB1 stage with no grid drive indicates a plate current of approximately 85 ma. Carrier is inserted momentarily and the drive and pi-network are adjusted. The carrier is then suppressed by turning the CARRIER INSERTION switch to the off position. Talking into the microphone circuit then produces the suppressed carrier double side band signal.

The 40 meter operation is similar however, the pi-network components are changed by the pi-network switch for this particular band.

The balanced modulator is tuned to the new
[Continued on page 106]

Gamma Matched 160 Meter Vertical

Katashi Nose, KH6IJ/K1PND

RR 1, Lihue, Kauai, Hawaii

With the decreasing sunspot activity forecast for the next several years, many amateurs are turning their attention to the lower frequency bands, notably 160 meters. Here is a Gamma matched antenna for 160 utilizing the tower or coax feed line as a vertical radiator.

DURING the course of erecting horizontal 160 half wave dipoles at heights commonly available to amateurs, it was noticed that no amount of pruning would bring the s.w.r. down to a reasonable level. This effect was noticed to a lesser extent on 80 meters, whereas a good match was possible every time on the higher frequencies.

On 160 meters, a horizontal dipole 50 feet off the ground is equivalent to a ten meter dipole three feet off the ground, a situation no self-respecting amateur would condone.

The well known effect of height versus center impedance¹ comes into play, wherein the impedance oscillates around the 73 ohm value and

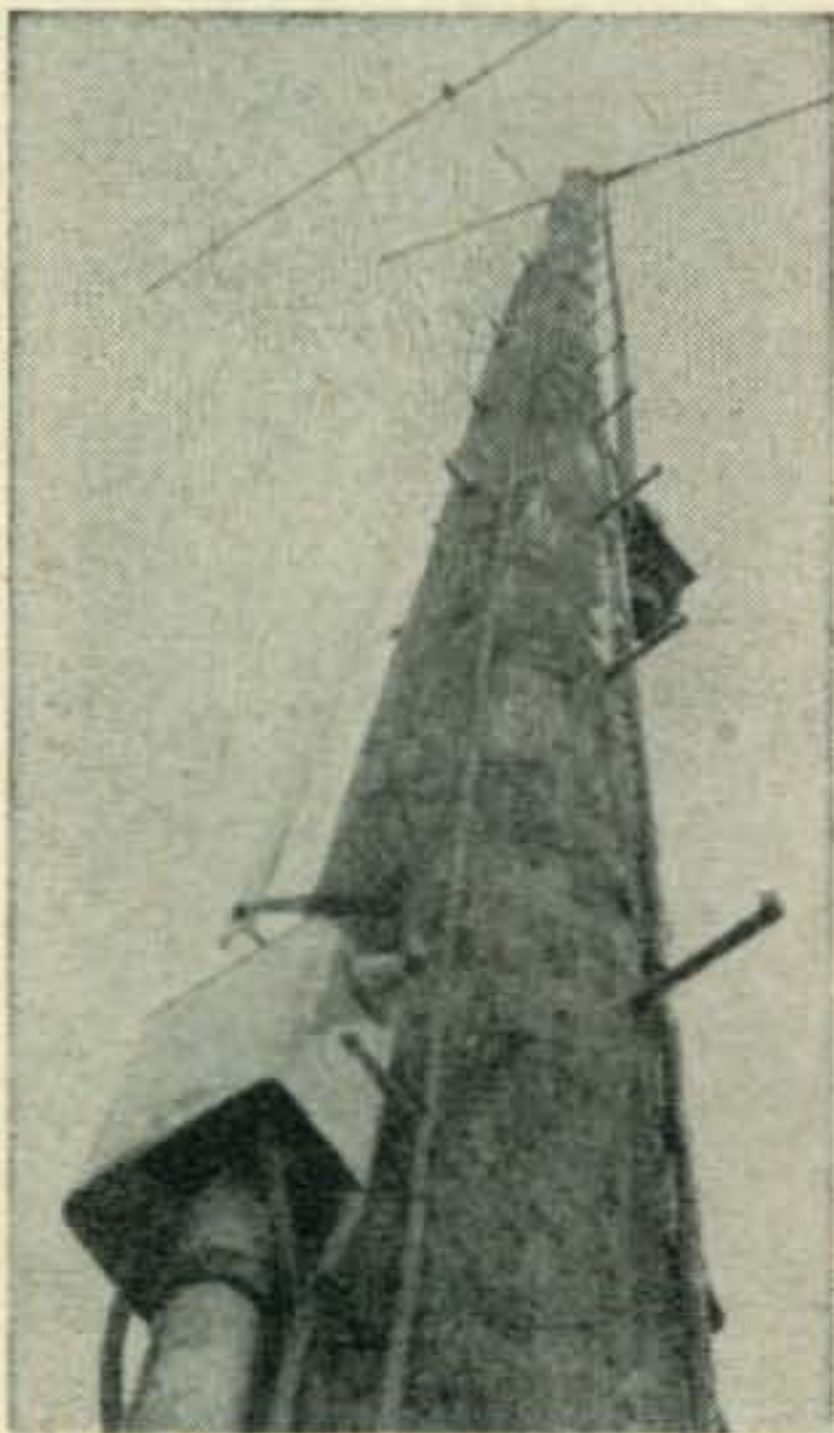

Looking up the gamma matched pole. Conduit may be seen leading into the gamma capacitor housing.

converges on this value at infinite height above ground. Some sort of impedance step down transformer is called for. This can either be a linear transformer or made up of lumped constants, either one of which is a nuisance to hang in the center of a dipole supported at the ends. Moreover, we can't get around the fact that a dipole 1/10 of a wave off the ground is not the

best radiator. An inverted Vee only aggravates the situation as it brings the high impedance ends nearer the ground.

A practical solution is found in gamma matching the tower used to hold up the high frequency beam (10, 20, or tribander etc.). The capacitive hat provided by the beams make the tower into an excellent radiator. This scheme is not new and has been proposed and used many times before, the latest by W9ERU for 80 meters².

A gamma match will match any reasonable length of radiator³. As seen in the photo, on the author's 50 foot pole there is assorted "junk" in the form of control cables, rotator and shaft, 2 meter beam on an offset arm, guy wires, etc. However, as long as the tower or support is reasonably free-standing electrically, the gamma will do the trick.

Top Loading

If guy wires are used, as is likely, they should be broken up with insulators, one near the top and another set near the anchor. If you want more top loading, the top insulator should be at a lower level and vice versa, an action equivalent to varying the length of the radiator.

The ideal situation would be where cables run underground to the tower, in which case you use the full height of the tower as a radiator. However, if you are like most tower owners, control cables and feedline approach the tower at an angle and are attached to the tower at some point above ground level. In this case the portion above the point of attachment to the tower as the radiator as shown in fig. 1 and neglect the lower portion of the tower. In practical situations, the lower portion contributes little to radiation unless it is longer than say $\frac{1}{3}$ the height of the tower.

Construction

The gamma rod may be tubing, angle, stripping or wire of any conductive material. Stand-off insulators should be used to keep rigid spacing between the tower and gamma rod. TV mast standoff insulators make convenient supports.

¹Kraus, J. D., "Antennas", McGraw Hill, pg. 261.
Kasper, H. W., "Added Gain Using Vertical Antennas", CQ, December, 1960, pg. 50.
ARRL Antenna Handbook.

²Hubbell, G., "Feeding Grounded Towers As Radiators", QST June, 1960, pg. 32.

³Nose, K., "Adjustment of Gamma Matched Parasitic Beams", QST March, 1958, pg. 44.

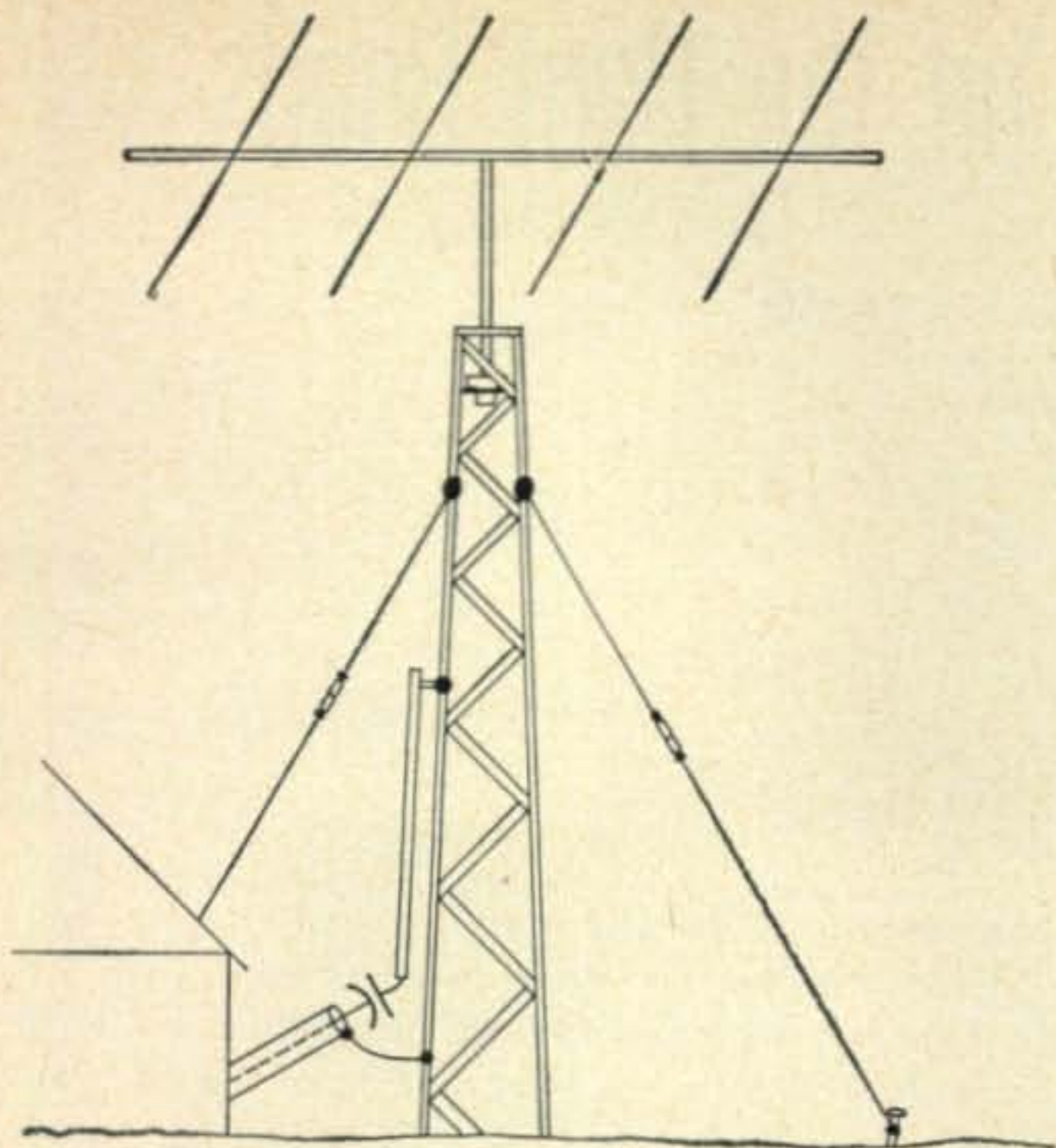

Fig. 1—When the coax and control cables angle up to the tower the coax feed can be attached part way up with no ill effect.

For 160 meters, a 20 foot length of gamma rod spaced 8" from the radiator resonated with a 750 mmf mica capacitor served for a 60 foot mast with a 10 meter four element beam on top. With tribanders, the capacitive hat effect would be greater—equivalent to a longer radiator.

As may be seen from the photograph, it is not necessary to have a metal tower. A wooden pole can be used if the gamma rod is secured to it with standoffs and a separate wire run for the return. It is also possible to cut through the outer sheath of coax running up the pole and connect to the shield as shown in fig. 2. Most amateurs are loathe to cut into the coax, however.

A rectangular gallon oil can is a convenient housing for gamma capacitors, and also serves

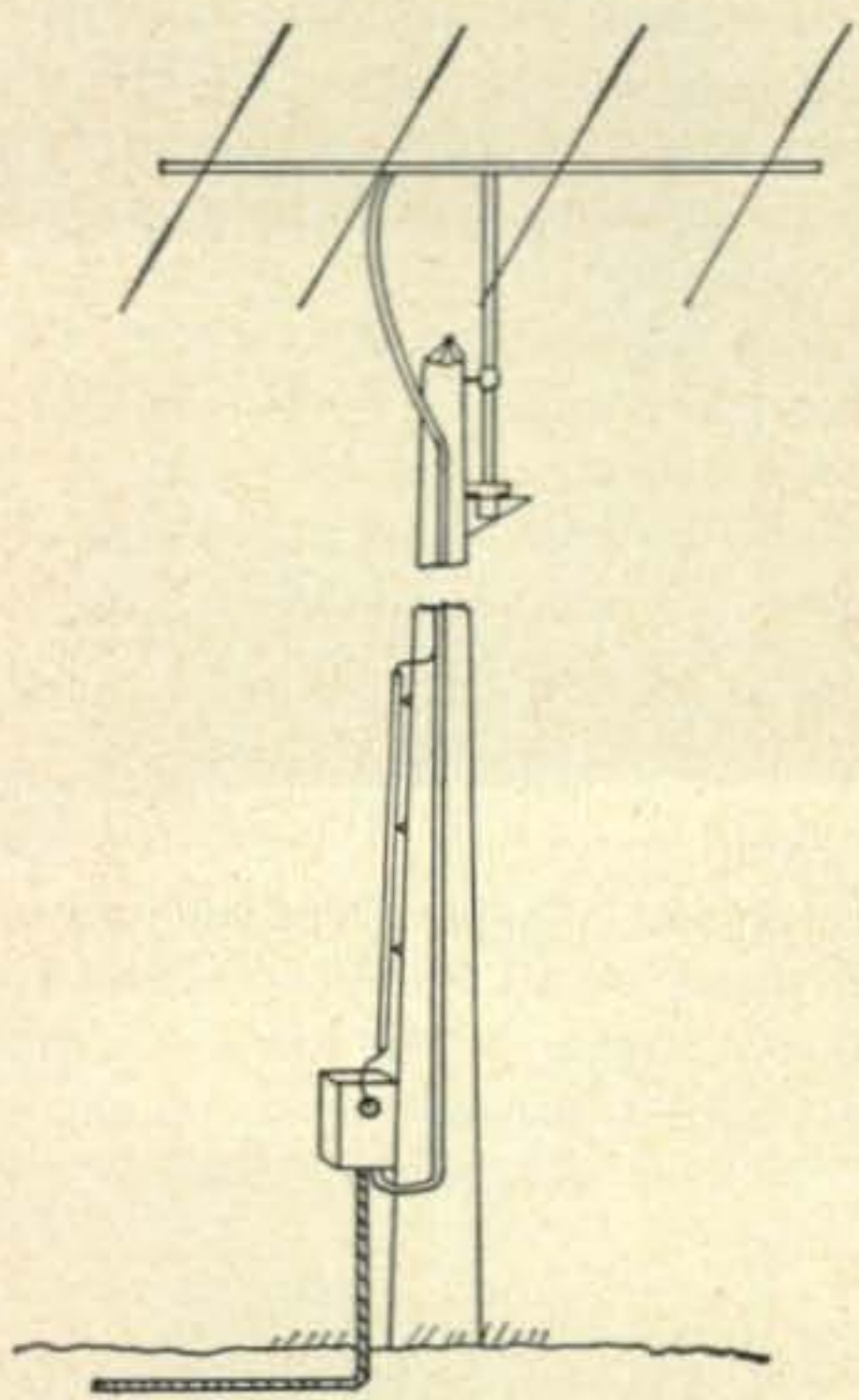

Fig. 2—Ideal situation where the coax and control cables are run underground in conduit.

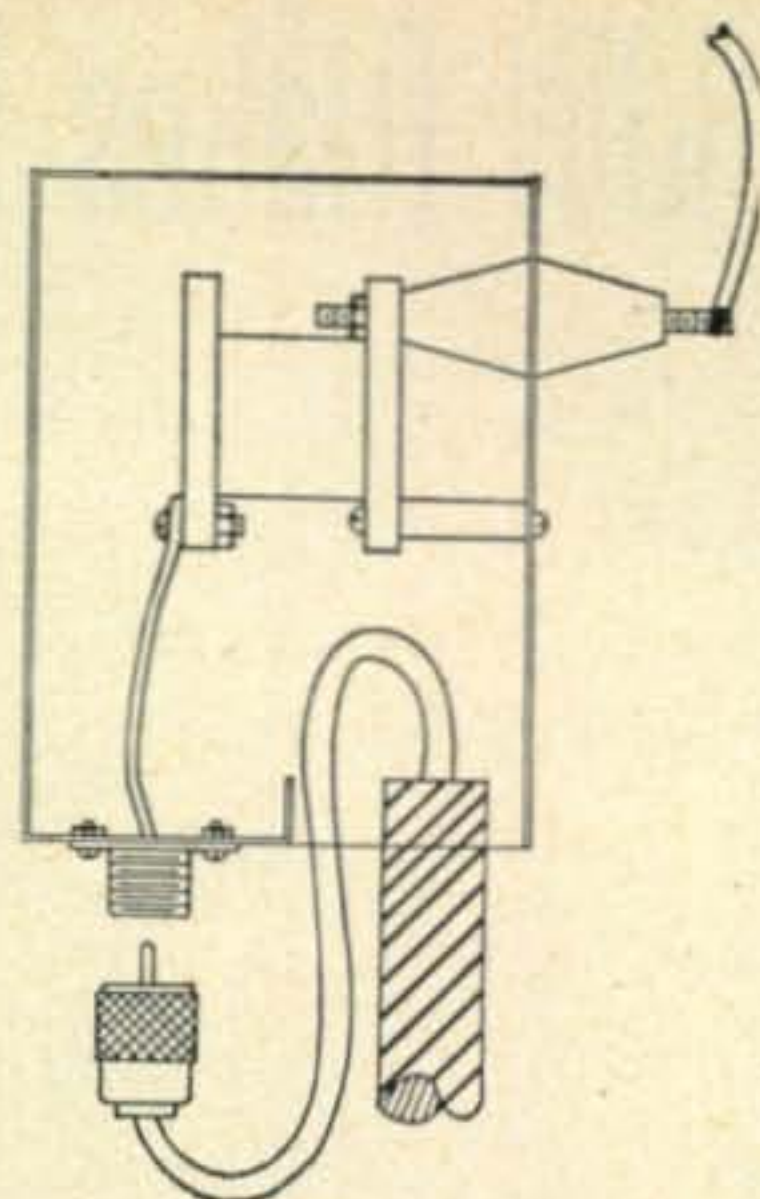
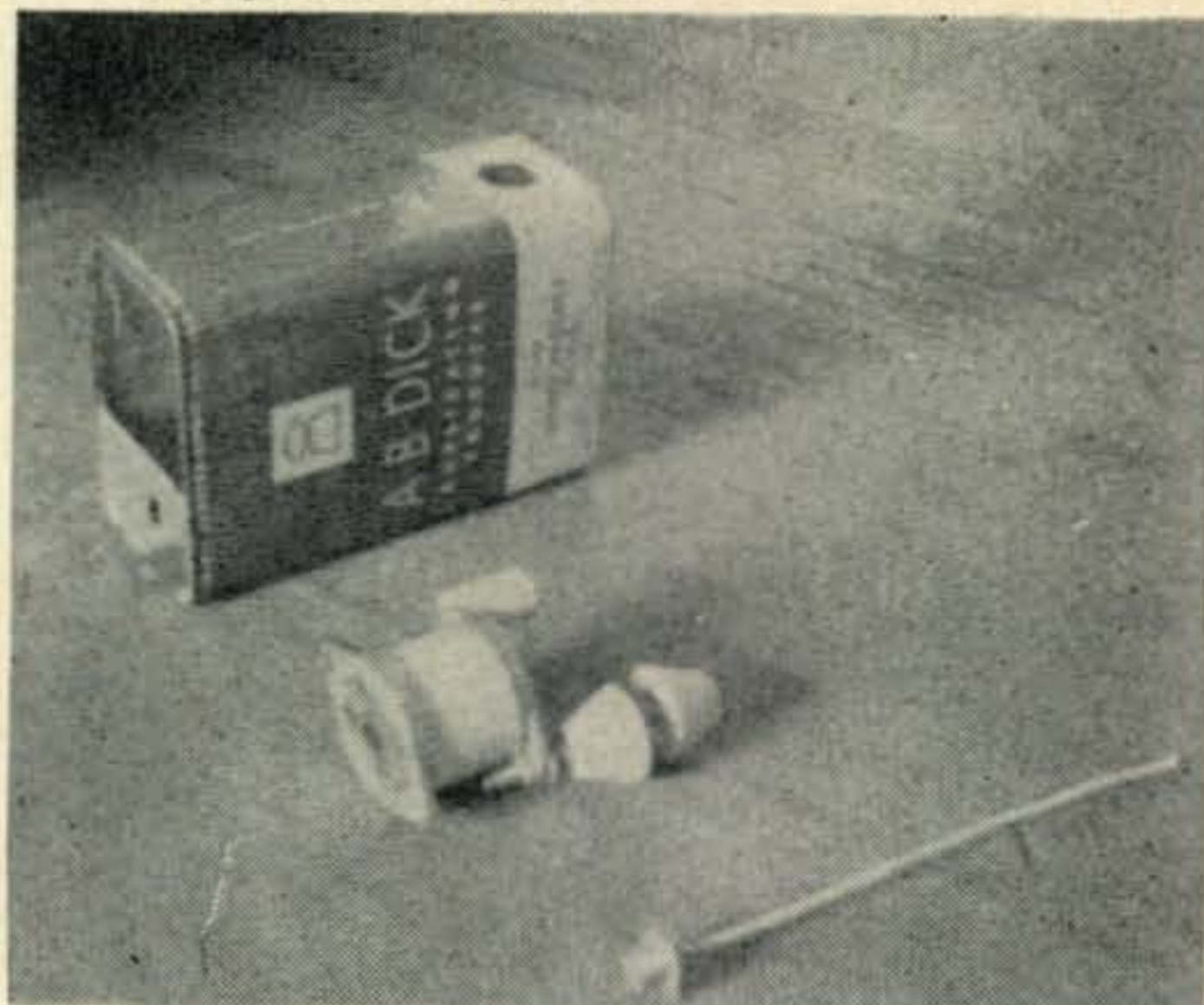

Fig. 3—Details of the weatherproof Gamma capacitor housing. Gamma rod may fasten directly to the feedthrough insulator or be strap connected as shown.

as a weatherproof pothead for the conduit if one is used. If a lip is provided on the bottom side of the inverted can, a standard coaxial fitting can be installed for quick attachment of the s.w.r. meter (fig. 3).

Adjustments

Use copper strapping or large size wire when making the gamma connections. Erroneous and confusing readings will result if long pieces of small hookup wire are used to make the gamma capacitor connections. Step by step procedure in gamma matching has been covered in detail in a previous article by the author⁴. Use a variable capacitor to make the initial adjustment of the gamma match and get an approximate idea of the capacitor required.



Raw materials before assembly. Can should be properly weatherproofed before installation.

A grid dip meter coupled through a two or three turn loop at the coaxial attachment may be used initially to see if you are "in the ball park." The lowest frequency dip is the correct one. There will be assorted dips at multiples of the lowest frequency and violent dips (coupled

[Continued on page 104]

⁴Nose, K., "Notes on Parasitic Beams", QST, March 1960, pg. 43.

W8JIN Makes History on the Ham Bands

by Carole F. Hoover, K9AMD

401 East Wood Street
Hillsboro, Illinois

“SOME amateur achievement awards seem almost impossible until you start looking around; then all at once you find they're within reach,” says Jim Ringland, W8JIN, of Cincinnati, Ohio, first member of the Certificate Hunters' Club (CHC) to win the 200 award seal. (The last count shows an unbelievable total of 237!)

A transmitter engineer at a Cincinnati television station, Jim has been a ham since 1933 when at age 15, his father built broadcast receivers with a curious and interested son looking on. Strangely enough, however, the hunt for achievement certificates didn't begin until 1958 when Jim got a look at the many awards displayed by W2SAW, at the Dayton Hamvention.

Working 160 through 6 meters, Jim operates c.w., a.m., s.s.b., and RTTY. With a Collins 75A-4 on the receiving end, he sends out CQs with a homebuilt s.s.b. exciter driving a kw final and a 310-B Collins Exciter driving an 813, as well as a kw final on c.w. Three element beams on 10 and 15 will soon be moved from a 45 to 65 foot tower; and another 3 element beam on his favorite band, 20 meters, tops a 100-foot tower just above a 3-element homebrew 40 meter beam with 40 foot boom and 45 foot elements. On 80 and 160 meters, Jim uses a 164 foot slanting vertical with a 2500 foot ground radial system. Needless to say, his station makes many a ham's mouth water!

While advocating CQ Worldwide-DX contests and others for picking up DX awards, Jim has a second word of advice for newcomers who really want to enjoy the fun and crash the

achievement certificate party.

“Certainly the first thing to do is get a copy of the *Directory of Certificates* published by Clif Evans, K6BX. A quick check of awards available against your own QSL file will probably make you eligible for several awards right off the bat. After that, the *Directory* keeps you posted on what awards are available and how you go about getting them.”

Just as proud of W8JIN's accomplishments as Jim himself, is energetic DX-er and founder of the Certificate Hunter's club, Clif Evans, K6BX. After taking over publication of the *Directory*, correctly subtitled “The Award Hunter's Bible,” Clif decided that by creating the CHC, he could do several jobs at once. The CHC certificate itself is a real challenge. Anyone holding at least 25 awards may apply to Clif and if all requirements are met, he will send an 11 × 14” award certificate designed for several gold seals with colored ribbons denoting 25, 50, 100, 150, and 200 awards as well as seals for obtaining awards from 25 or more countries and from all continents.

Those who are not CHC members can go after the HTH, or “Hunt the Hunters” award for confirming contacts with at least 25 CHC members. Another prize worth working for is a beautiful silver cup awarded by K6BX to anyone working 500 CHC members.

Aside from awarding achievement certificates to deserving hams such as W8JIN, Clif's primary purpose in founding the CHC was to promote amateur radio and to focus greater attention on contributions amateurs make to international



Jim Ringland, W8JIN, winner of 200 amateur achievement awards sitting at his operating position. Above the 75A-4 is his Collins 310-B all-band exciter. The panel at Jim's left is his 160 meter rig and on top, his home-brew s.s.b. exciter.



Here W8JIN displays his many awards. He is holding the Certificate Hunters Club Certificate. This shot was taken in the television studio where he works. (Photos by Bill Benesch and Jack Hessler.)

good will and the art of communications. Hoping to bring wider recognition to the achievements of all hams, Clif introduced a new idea in a worldwide achievements club with active member participation. The universal appeal of the CHC is heralded by the fact that within only a few months, membership has jumped to 225 representing 30 countries and all continents. Amazing also is the evidence that thousands of hams are working toward membership in CHC.

"The winner of 100 awards joins the Honors Roll, and 150 awards is needed for the Top Honors Roll," he says. "Of course, the ultimate is achieving 200 awards, as Jim did, and joining the special CHC 200 Honors Fraternity. My plan is that lifetime membership in this fraternity removes such members from active competition with due recognition and gives the other guys and gals a chance to reach the top of the totem pole, too. In Jim's case, honors are double because he hit the jackpot while he was CHC's President!"

Although the Fraternity probably won't be overrun with members for a few years, there's definitely a promise of greater activity to come.

W8JIN antenna system. In the foreground is a 45 foot wooden tower holding combination 10 and 15 meter beam. At the extreme right is a 7 mc ground plane and in the background is a 100 foot self-supporting tower (18 feet at base dimension) with lower beam being a 3 element forty meter beam. (The director was lost in a winter ice storm.) The boom for the 40 meter beam is 40 feet long and elements are shortened with coils to make it resonant at a length of 45 feet. Above the 40 meter beam is the 3 element Telrex for 14 mc which is 107 feet in the air. Not visible in the picture is a 164 foot semi-vertical running from top of tower (100 foot) to small "dog house" near base of vertical ground plane at extreme right. This is used as a $\frac{5}{8}$ wave on 3.5 mc and also for 160 meters.

Currently the second place spot is held by W6KG who moved forward from third at the recent death of Ev, KP4KD. Following close behind are UR2BU, W2QHH leading W2SAW, W8KPL, W4HWY, K6BX, K9EAB, OK1AEH, SM5WI, W8WT, W2FLD, and GB2SM, the Science Museum of London.

Just in case YL operators get the idea they're left out, Margery, ZS1RM, proves otherwise. In charge of the African Worked All YL Award, Margery is the official "Queen of the Hunt." Top YL awardster is Doris, K5BNQ with over 50 certificates.

Quick to recognize W8JIN's record-breaking achievement was Arne Trossman, W2DTJ, Editor of *CQ*, who decided he would heap still another honor on the famous Ohio DXer. He did so with the presentation of a special plaque at the annual Dayton Hamvention held April 29. In the presence of Trossman, Urb LeJeune, W2DEC, *CQ* DX Editor, and many other well-wishers and admirers from miles around, Jim Ringland modestly accepted his award—engraved with the call letters of W8JIN who truly has made history on the ham bands. ■



Transmitter Hunts on V.H.F.

Helen Signorelli, K6KUP

14221 Riverside Drive
Sherman Oaks, Calif.

We have been hunting and hiding transmitters on two meters for the past three years. Every other Saturday night, weather or not, the San Fernando Valley gang get out their two meter gear and get on the hunt. Everyone is invited and there are no rules or regulations. It is surprising to see the different ages of people who turn out for these hunts. We have had babies in baskets to the very young at heart. Everyone has fun.

We all meet in the Van Nuys, Sherman Oaks War Memorial Park. At eight P.M. sharp the hidden transmitter calls "CQ The Hunt." After checking in all the cars with the hidden transmitter we record each car's mileage. The winner will have the lowest mileage. This was done to eliminate rat racing and the possibility of someone getting hurt. The traffic here in the San Fernando Valley is very bad, especially on a Saturday night.

After three years there didn't seem to be any more good places to hide. We were stumped. So we decided on using strategy. Early one Saturday morning we went out looking, not so much for location, but for the unusual. After scouting around for sometime we found not only the ideal location, but the perfect place for our mad scheme.

At the end of a dead end street we found a gutter fed storm drain. On the sidewalk was a man hole

Gonset gear being lowered into the manhole.



cover. After taking off the man hole cover we found a space about six feet high, five feet wide and about five feet long. Here was a nice room built to order, and large enough for us to get into and set up the gear. The drain pipe leading from this space was about two hundred feet long and emptied into the Los Angeles river. We planned to use the drain pipe for a wave guide but being corrugated it didn't work out.

Three two meter Gonset Communicators were used for this hunt. Two Communicators powered with a large six volt truck battery were lowered into the manhole. These two Communicators were used as repeater receiver and transmitter. The audio from the repeater receiver was piped into the repeater transmitter. We used a nineteen inch whip on the repeater receiver and set it on receive. The repeater transmitter was set on transmit. The antenna for the repeater transmitter was at the end of two hundred feet of coax, which was run through the drain pipe. It took the thin man of the gang to crawl into the drain pipe (which was about three feet around) and two hundred feet over to the river to put up the spring steel center fed dipole. It all worked fine until he got to the end of the drain to install the antenna. Now, how to turn around and come back? Should he crawl backwards two hundred feet? No, that was too slow and uncomfortable. Going up was out of the question, as there is a storm fence six feet high running along the top of the river. So he hung on the edge of the drain pipe, turned himself around and crawled back, leaving behind him a very clean drain pipe. We heard later that we were putting out a five nine plus signal right in the middle of the river.

[Continued on page 100]



Helen, K6KUP, bossing the operation.

Big Things Come From Small Radio Clubs!

by Carole F. Hoover, K9AMD

401 East Wood Street
Hillsboro, Illinois

EVERY summer, hams by the hundreds hit the highways for Ottawa, Illinois, where the grand-daddy of Midwest hamfests has been held for over twenty-five years. Proof of its tremendous growth and success is the fact that some 5000 hams and their families attended in 1960, compared with 208 amateurs who registered in 1934 when the Starved Rock Radio Club sponsored the first shindig.

Just in case you've got the idea that the SRRC is a huge club with dozens of members to share the load, guess again, for amazing as it may

seem, most of the jobs fall to about half of the twenty-five member organization.

The man who really knows what it's all about is George Keith, W9QLZ, club secretary for more than twenty years and a charter member of the SRRC.

"Back in 1933 a group of hams and interested folks got together in a hayloft owned by W9MKS, Leslie Anderson, our club sponsor," George remembers. "There was our first president, W9IEP, Carroll Skeels, who became

[Continued on page 102]

From top to bottom, left to right; Paul, W9SEV is shown with the club "television" camera zeroing in on newcomers. The Possum Trot A.R.C. of Paris, Illinois takes time out for fried chicken. "Sonny", K9JAW, members of the SRRC drop leaflets from his plane when the weather permits. Ron, WØIFL represents one of the many manufacturers who set up exhibits of their products for the hundreds of visiting hams. K9AXL, Mike, takes a short nap in the car while his buddy, W9LZE, Dick, stays on the job at "Bargin Alley". "Bargin Alley": at least 100 cars unload their surplus gear and get ready to do some old fashioned "horse trading". Larry Shaw, W9OKI, leafing through some literature on design of new equipment. A look at the parking lot at the Starved Rock Hamfest shows that a lot of mobileers make the trip to Ottawa each year. Jim Voneman, W8KZL/9 looks over the bargains with the XYL and jr. opr.



The National NC-270

Lee Aurick, W2QEX
Technical Editor, CQ

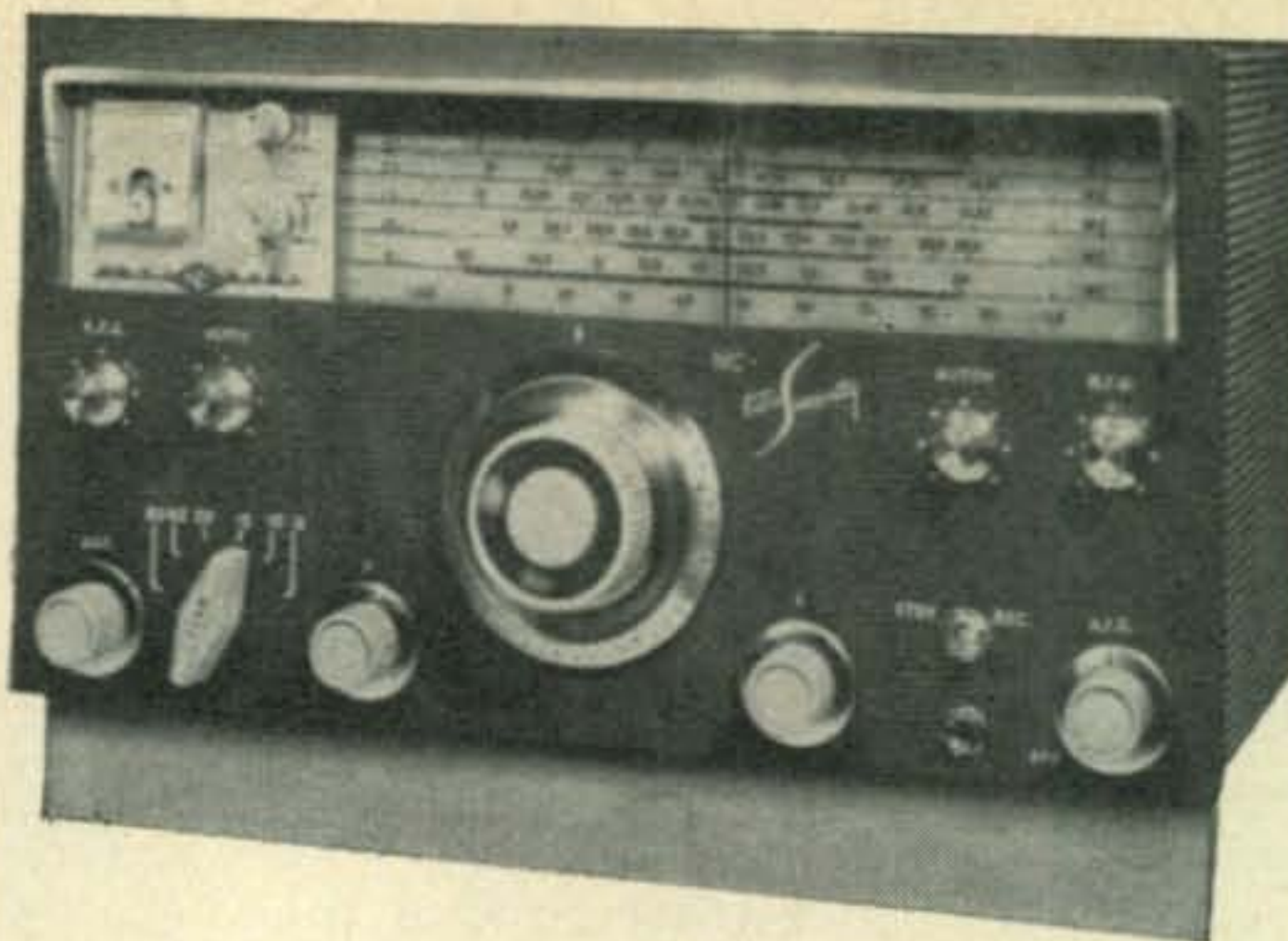

FOR THE past several months your reviewer had had the opportunity to operate and critically examine the new National "Cosmic Blue" NC-270 ham band receiver. It really didn't take that long to arrive at a decision about this receiver; it was just difficult to stop playing with it long enough to write this review.

The NC-270 retains all the "feel" of the more expensive receivers for which this company is known, and does it with fewer tubes and simpler circuitry, without sacrificing performance or operator convenience. There are, in fact, some features not found in receivers priced considerably higher.

In the area of operator convenience; the "flip foot" that tilts the receiver to meet the operator, the large, smooth-operating tuning knob, the knife-edge dial pointer, front panel headphone jack, and horizontally adjustable dial scale, all rate a bow from here.

The receiver also appears to be one of the first of the lower priced models to recognize that modern amateurs make wide use of coaxial line. The antenna input is designed for 52 ohm unbalanced line, and peaking on each band is accomplished by means of a trimmer control on the front panel.

Receiver Circuitry

The receiver employs double conversion on all bands and uses eight tubes plus one full wave rectifier and one voltage regulator.

From the antenna circuit, signals are fed to the 6BZ6 r.f. stage. A.g.c. is applied here to adjust the gain of this tube to a suitable level. R.f. stage output is capacitively coupled to the primary of the mixer coil for 40 and 80 meter operation and is directly coupled to the tuned interstage coil on all other bands. The secondary of the mixer coil is tuned to further add to the r.f.

selectivity. The signal is now fed to the signal grid of the 6BE6 first converter. The tunable local oscillator is a part of this converter tube. The antenna circuit and mixer stage, as well as this oscillator, are all gang-tuned by means of the main tuning knob on the front panel. A 6BE6 functions as the local oscillator and first converter tube. The oscillator is fully temperature compensated to provide an extremely high degree of stability. The oscillator frequency is always 2215 kc above the signal frequency, thereby generating a 2215 kc first i.f.

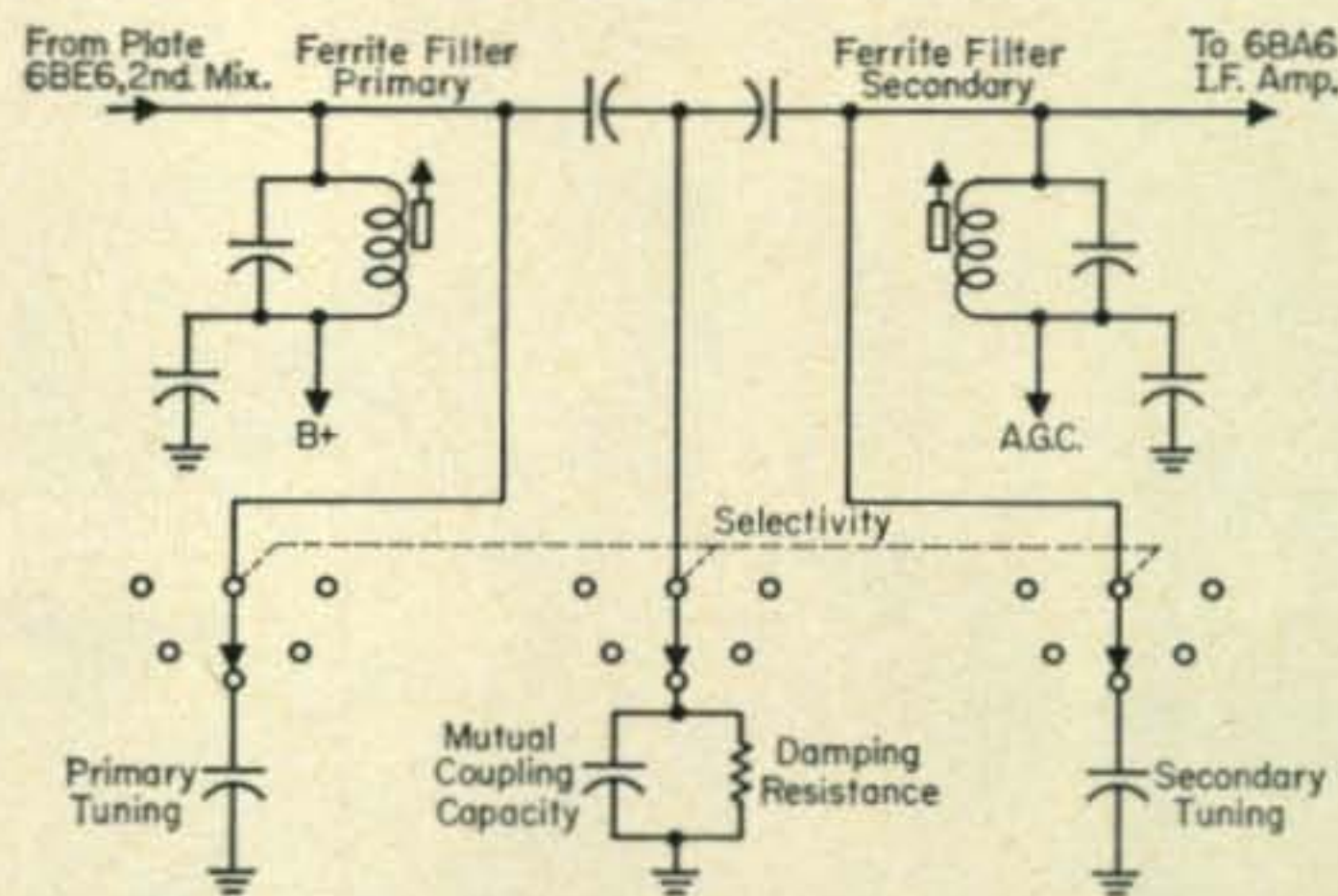

Fig. 2—Simplified circuit of the Ferrite Filter using coils with a Q of 500 each. Changing the coupling impedance varies the bandwidth from 600 cycles to 5 kc.

After going through a conventional double-tuned i.f. transformer, the new signal is fed to the signal grid of another 6BE6, the second converter tube. Considerable primary and secondary image rejection is obtained by the first i.f. stage. The primary image is reduced by the high i.f. frequency and secondary image by the excellent selectivity. The second converter oscillator is crystal controlled. It produces a second con-

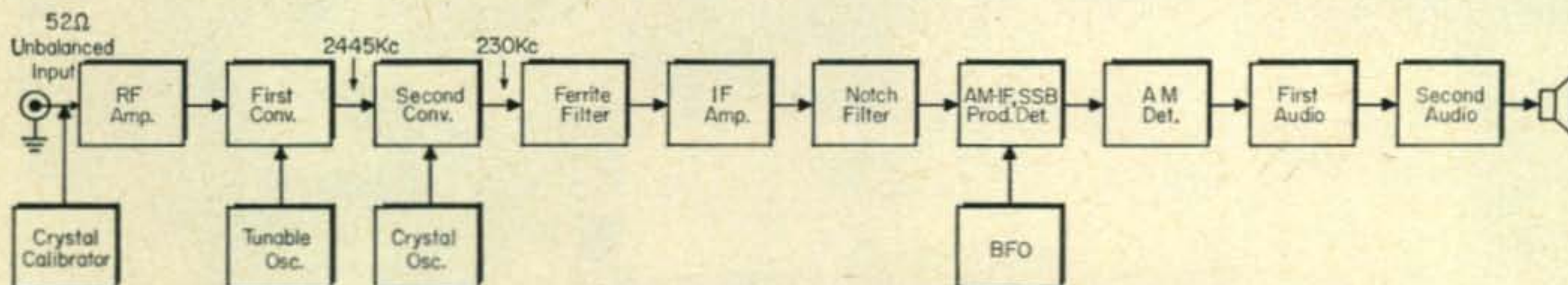

Fig. 1—Block diagram of the NC-270 receiver. It is a double superhet with a patented Ferrite Filter, a Bifilar "T" Notch circuit, a product detector and an S meter.

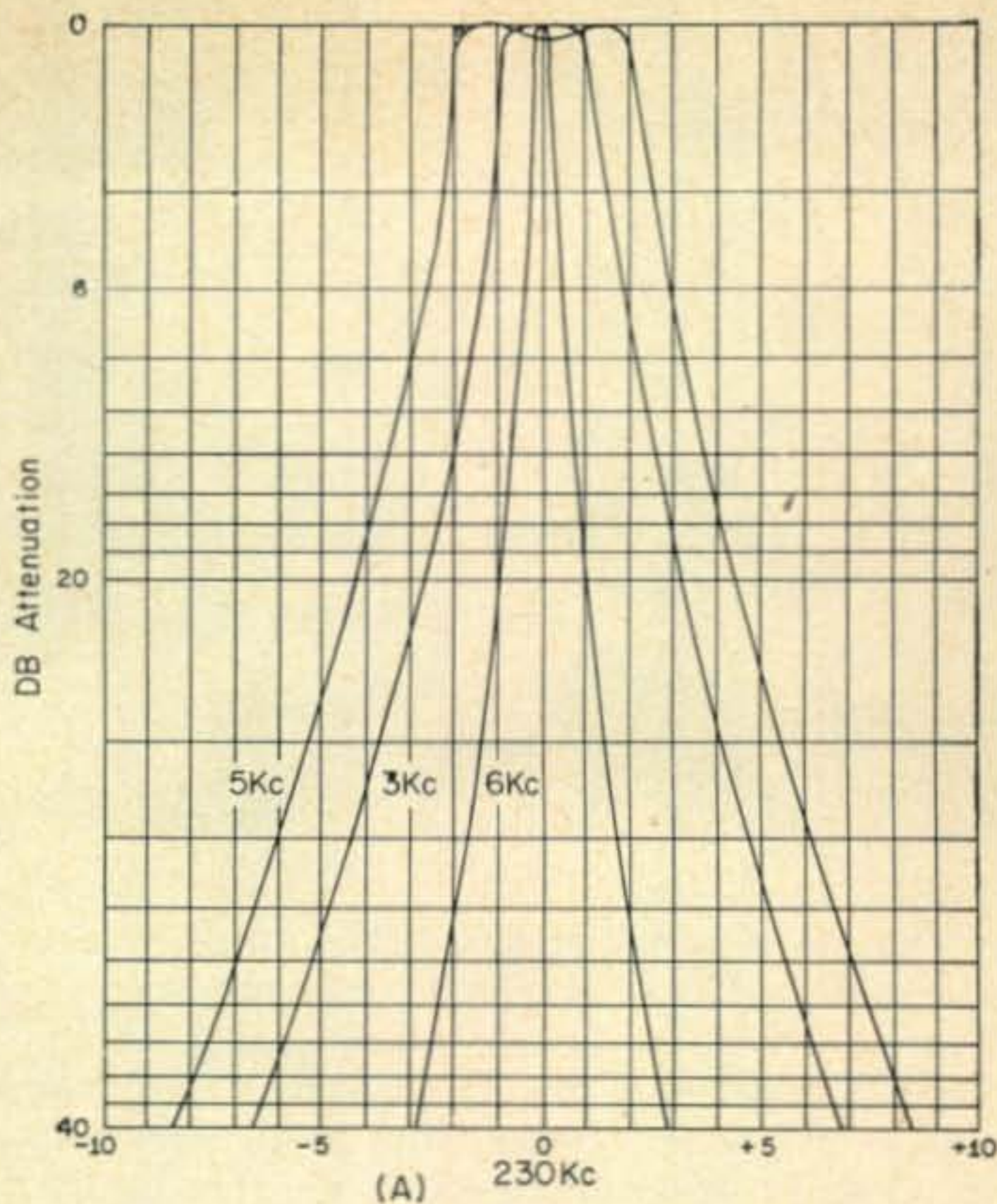
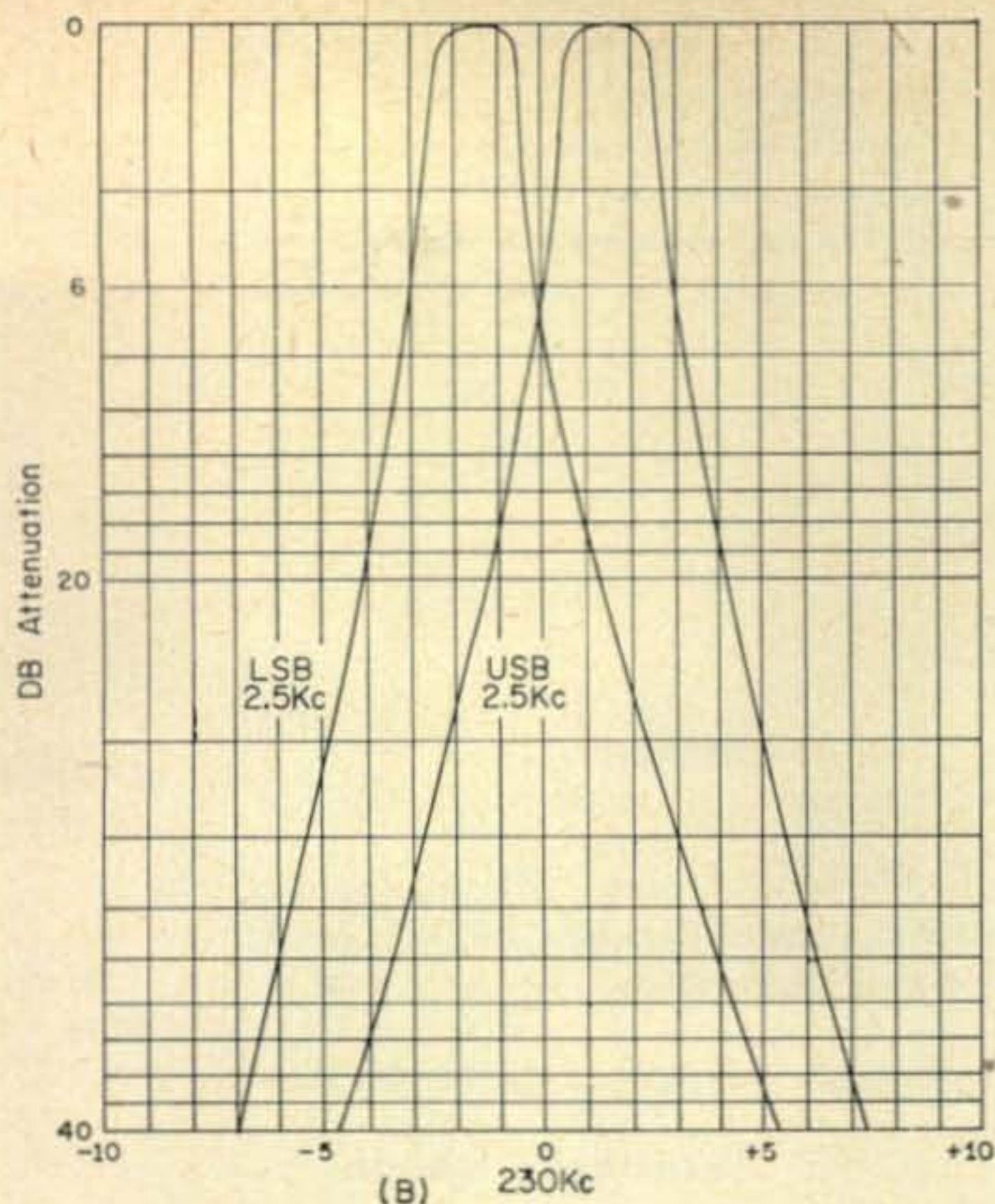

Fig. 3—NC-270 selectivity curves. Curves shown in A are 0.6, 3 and 5 kc for a.m. and c.w. The curves shown in B are for sideband. Each has a bandwidth of 2.5 kc and is centered symmetrically about the i.f. of 230 kc.

version frequency of 2445 kc that beats with the 2215 kc signal to arrive at the 230 kc i.f. output frequency. This low frequency i.f. signal is then coupled to National's patented Ferrite Filter. Shown here in fig. 2 is a simplified form of the filter and its two tuned circuits, each with a "Q" of about 500. A selectivity switch changes the coupling between the two coils and thereby varies the bandwidth from the wide 5 kc position to the narrow 600 cycle position in five steps which include two 2.5 kc positions for upper and lower sideband. The upper and lower sideband can be selected with shifting the oscillator frequency.

From the secondary of the Ferrite Filter the signal is fed to the first 6BA6 i.f. stage, which operates in the conventional manner. Output from this tube, at 230 kc, is coupled to the Bifilar "T" Notch circuit. This circuit employs primary and secondary tuned circuits tuned by series capacitors and the impedance of the Bifilar choke and notch frequency circuit. Front panel NOTCH and DEPTH controls tune this circuit. The circuit is so arranged that there is effective coupling throughout the i.f. bandpass except at the notch frequency. The DEPTH control provides a resistive balance and governs the depth of the notch. To a certain degree, these controls must be used together. By a proper combination of both, it is possible to achieve a rejection of greater than 50 db. This is deep and sharp enough to remove the carrier from a a.m. signal and cause it to appear as a d.s.b. signal. It is unusual to see a front panel NOTCH DEPTH control in this price class of receiver. The effectiveness of a T notch filter can be cancelled by tube and component aging as well as shift of the notch frequency. All can be compensated for by the

control, making it a worthwhile addition to the front panel. When not in use, the notch control is left in the full-clockwise "OFF" position. In this position, the notch is removed from the i.f. passband.

Signal output from the Bifilar "T" Notch is capacity coupled to the grid of the last 6BA6 i.f. stage. As well as the output of the b.f.o. When receiving s.s.b. signals this stage acts as a product detector with the audio signals taken from an RC network in the plate circuit. When receiving a.m. signals this stage is a conventional i.f. amplifier feeding the diode detector, a section of the 6T8.

A.g.c. derived from the diode detector is applied directly to the grid of the 6BA6 i.f. tube. A second diode in the 6T8 serves to provide delayed a.g.c. so that the r.f. stage may function at maximum gain on weak signals and still receive a.g.c. potential under strong signal conditions.

The FUNCTION switch on the front panel provides a choice between a variety of combinations of a.g.c. and a.n.l. The a.n.l. circuit in the NC-270 is exceptionally good, and there is practically no detectable difference in the signal itself when the a.n.l. is activated. There is no reduction in audio level and no distortion of the signal being copied. The average listener, I'll wager, will not be able to tell whether the limiter is in or out except by the noise level.

The amount of impulse noise to reach the a.n.l. has been reduced by careful choice of RC time constants in the i.f. so that i.f. limiting action occurs on s.s.b. and c.w. signals.

The power supply of the receiver uses a 5Y3GT full-wave rectifier and an 0B2 voltage regulator. With no antenna connected, and the audio gain at maximum, there is no audible hum

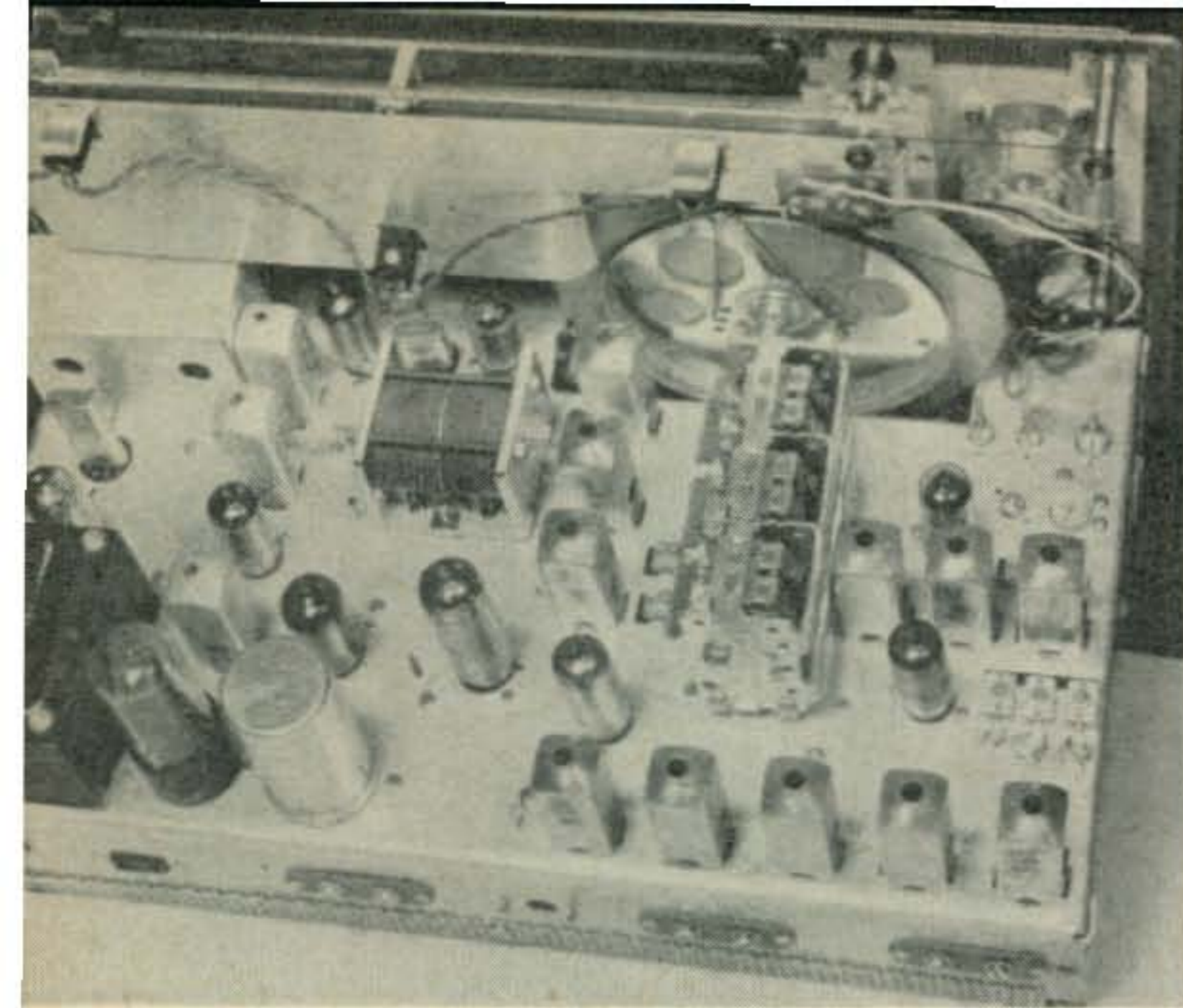

Top view of the new National NC-270. The Ferrite Filter can be seen just left of center on the chassis. The notch and b.f.o. coils (L_{12} & L_{13}) are located in the small shield can at the left just rear of the panel. The calibrator crystal and tube can be seen in front of the power transformer.

in the audio output.

The STANDBY/RECEIVE switch is somewhat of a departure from "accepted" amateur practice. The two position switch, when placed in the Standby position, mutes the receiver by removing plate and screen voltages from most tubes, and shorts a pair of terminals on the rear apron. The idea is that these terminals may be used to control an external relay circuit and in that way activate the transmitter and the antenna change-over relay. For the amateur who still wishes to control his station operation from the transmitter it is a simple matter to reverse the wires on this switch. When this is done, the receiver may then be disabled by an external relay.

Calibrator

The receiver includes a 100 kc crystal calibrator which utilizes one half of a 12AU7. The plate of this calibrator circuit contains a choke shunted with a resistor. It is peaked at 14 mc and provides ample output on this band. Sufficient output is also available on 3.5 mc, perhaps due to the great receiver sensitivity in this region. On 7 mc it can be difficult to find the 100 kc signal, though it can be heard if no other signals are present. The signal is adequate on 21 mc, and it is just audible on 28 mc. On 50 mc it just is not there.

Stability

Some of the outstanding features of the receiver are not apparent from the circuit description. One of the more important features this receiver exhibits is stability, both mechanical and thermal.

The thermal stability can be attributed to several facts. First, tubes are operated at a B+ of 145 volts, (except for the plate of the audio output which is at 165 volts) thus reducing operating temperatures. (This should also tend to prolong tube life.) Second, the bulk of the tuning capacity in the oscillator section, on each band, is a close tolerance zero temperature coefficient capacitor. Third, the cabinet is *fully* perforated giving excellent ventilation. The first conversion oscillator and the b.f.o. are also voltage regulated.

Mechanical stability is also impressive. It is possible to tune to a s.s.b. signal on one of the

high frequency bands, lift the front of the receiver up several inches and let go. Unless the main tuning knob moves, the signal will still be there. This appears to be due to husky oscillator components and the $\frac{1}{8}$ " steel front panel.

Secondary Image

A popular approach to selectivity in receiver design is double conversion with a 2 mc first i.f. and a 50 kc second i.f. This usually results in images from signals located 100 kc away from the desired signal. (Plenty of these in today's crowded bands.) For example, assume that the second conversion oscillator is fixed at 2050 kc. The first conversion produces a 2 mc signal that beats with the 2050 kc oscillator to produce a 50 kc last i.f. A signal 100 kc away from the desired signal is subject to only minor attenuation in the receiver front end and therefore appears at the second mixer 100 kc away from the desired signal; 2100 kc. This signal also beats with the second conversion oscillator at 2050 kc and the difference is 50 kc, appearing as a secondary image.

The '270 uses a 230 kc i.f. and thus the secondary image frequency copied is 460 kc away from the desired signal. The front end attenuation 460 kc removed is very adequate to eliminate the signal. The Ferrite Filter more than makes up the selectivity sacrificed by moving to a higher second i.f.

Instruction Manual

The instruction manual is also unusual in its organization. A detailed circuit analysis of the receiver is given in the usual step by step fashion. However at each point that a control function is mentioned the description is interrupted and the control function is analyzed. Digestion of the instruction manual content will give the operator a thorough knowledge of the receiver control operations as well as a short course in receiver circuitry.

Another bow to National for knowing some of the foibles of the average amateur. They have included, with the receiver, a control location and function chart which gives enough information to enable proper operation but which can

[Continued on page 104]

Results of the 1960 CQ World-Wide DX Phone Contest

By Frank Anzalone, W1WY
Chairman, CQ Contest Committee

OUR prediction that the returns for the Phone Section of our World-Wide DX Contest would be below normal, was premature. By coincidence we received the exact same total as last year, 569 logs. The country total of 116 however, was an increase of 19 over last year; a clear indication of the popularity of our World-Wide DX Contest. This, in spite of the sub-normal conditions and the below-par participation of the hams in this country.

There is no doubt about the winner. Henning Overgaard, VQ4DT leads by a decisive margin on all bands. Congratulations Henning, you finally won the Bill Leonard, W2SKE Trophy after trying all these years.

It might be interesting to note that practically all the Top Ten are in or adjacent to the Southern Hemisphere. Confirming the difficulty experienced by the northern boys.

The second position was taken over by VQ2WZ, ex-YL Susan Van Zyl. How about that; you fellows better watch out, this is her first contest. The OM, VQ2VZ was active in last year's contest and also placed in the Top Ten.

Third in line was PZ1AX, another new one in our Fall classic, followed by KH6IJ who made his first appearance after a two year lay-off. Nosey spent precious hours chasing transmitter trouble but still came up with the biggest total of contacts on all bands.

Don't recall having seen ZD2JKO in the top listing before but LU8CW has been trying the past few years and José finally made it.

It wouldn't be a contest without a 4X4 in the Top Ten and this year's representative was 4X4AU. Uri was the only real active single operator from Israel. Most of the other boys were over giving 4X4GB a hand in the multi-operator group.

Pierre Herbet, F8BO. All Band winner for France, home of past champions.



Over in the Ukraine UB5FJ and UB5WF were having their own little private war. However Anatoly had more 3 pointers and was able to overcome Vlad's larger multiplier.

And in the final spot ZK1BS, that rare one on Cook Island, who was active on all bands. Good to have Bill back after a short absence.

In the Single Band division, which is becoming more popular each year, we have a real winner, Ricardo Sierra, Jr., CX2CO who turned in the highest score ever made on a single band. Congratulations Ricardo II; polish off a spot in your shack for the Barry Briskman, K2IEG Trophy. Ricky said that almost 90% of his 863 contacts on 14 mc were made on s.s.b. You old hands in this contest business might recall that Ricardo Sr. was Top Man on phone back in 1955.

Trailing CX2CO on 14 mc were ZS5JM and KH6DLD. John and Sheila also used s.s.b. to great advantage. Another YL, just watch it fellows.

The next highest score on one hand was turned in by VQ4RF on 21 mc. Our friend R.F.B. Featherstone can always be depended upon to turn in a top

Ricardo Sierra, Jr., CX2CO. Single Band 14 mc Phone Champ for 1960. A young fellow with many years of DXing ahead of him.



score. This is a record for 15 meters but unfortunately came the wrong year.

The only other six figure score on 21 mc was made by G3FXB. This was quite an accomplishment considering his location was in the northern "no signal" area.

Scores on 28 mc were way below normal except for LU1DAB and CX1AK, with Juan taking top honors in the one time DX phone band. Two years ago OH5NW's score won the Single Band Trophy,

The group at DL1HC, winner in the Multi-Transmitter section. L. to r., DL9GU, DJ4OT, DJ3OU, DJ3YV, DL1HC and DL6NK. It seems they didn't get K2GL on 40.



but Axel didn't have a single W/K contact this year.

DX on 7 mc was poor for the phone men but YO9CN and K2DGT stuck it out to the bitter end and are being rewarded with a certificate. Bob was hearing the Europeans but they were not paying any attention to the American phone band.

Over in the Multi-Operator Section the Single Transmitter division turned in the most entries, especially from the club stations so popular in Europe.

However it was a familiar call, 4X4GB that won the Don Merten, K2AAA Trophy. You might recall that Yair was the Single Operator All Band winner last year. But the Champ took it easy this year and got 4X4KK, 4X4JU and K6UJW (how did he get in there?) to give him a hand.

A couple of APO operators over in Morocco gave it a good try at CN8HX but had to be satisfied with runner-up position. And the gang at DJ3VM was in there pitching for the German DX team.

The other half of the two operator team at CT1EY was another YL, so they were well represented this year.

Over in Cyprus, ZC4AK was being manned by a group from the Royal Air Force.

The "Big Guns" in the Multi-Transmitter division had the equipment and the operators but just couldn't find enough contacts to run up a big score. By sheer perseverance, Buzz Reeves and the gang at K2GL came up with a big enough multiplier to make their below average point total count and win the Don Wallace, W6AM Trophy. This being a new category in the Phone Contest, K2GL is eligible for the award, even though he won the multi-operator cup three years ago.

The fellows at GL tell the amusing story of EA0AC making an appearance on 14 mc only to be immediately clobbered by the multitude of stations calling him on his frequency. Being unable to cope with the situation, he made a recording of the mess and played it back to let them hear what it sounded like over there. He then signed off without making another call. Scratch one multiplier!

HV1CN was in the same predicament on 21 mc but Dom stuck it out for a while and made many of us happy with a rare contact on s.s.b. Unfortunately we did not get a log from him.

We were also disappointed in not receiving a log from Reg, FS7RT down in the Caribbean. That would have been a nice one to list in our results.

However a DXpedition to the British Virgin Islands by VP9L and a crew from Bermuda and the US served up a choice new one to almost 200 stations on all bands. Unfortunately sub-normal conditions and a poor location prevented them doing better even though they had two transmitters going at the same time.

Another rare spot was Christmas Island in the Pacific, put on the air by VR3L, with an assist from KH6DFC. Over 350 contacts were made on 21 and 14 mc. Nice going fellows.

That UA0KYA was in Zone 23, Tannu Tuva. But don't shed any tears, it was strictly an Asian affair with the JA's making hay.

The group of over-seas service men at Asmara put Eritrea on the map and gave it an all out try with three transmitters going but just could not buck Ole Sol, so ET2US had to settle for the second spot in the multi-transmitter division.

Don't let that GB2SM call confuse you. It was just a group of Gs putting on a demonstration at the Science Museum in London.

This was the first contest experienced by some of the operators at DL1HC and a swell time was had by all, even though they didn't work K2GL on 40 phone.

As for W3AOH, well it just wasn't their weekend.

There were many tales of woe. VR2BC, Greg had his receiver conked out after a few hours of successful operation and ZS7L lost his transmitter after Colin had made over 200 contacts on 28 mc. Here in the States, Dave, K5MDX had to pass up s.s.b. stations when his HC-10 went west, but with over 100,000 points he should complain.

Over here in the United States it was tough sledging for everybody and only a selected few made any worthwhile scores as compared to the past few years. Surprising enough the top score was turned in by W6GHM. However this should be no surprise to those in the know, Stew is an old hand at contests, back in 1957 he had the world high score as DL4AAP on 28 mc.

Last year's high scorer on All Bands, W1ONK, decided to go Single Band and take it easy this year. Can't say as we blame you Don, that all-band operation is a tough grind.

That's about it for this one, there's still a pile of c.w. results we have to get out, and what a pile!

So back to the salt mines Andy, Ben and Mac. As for me it seems I never can get my head above water.

73 for now, Frank, WIWY

Top Ten

ALL BAND - SINGLE OPERATOR

VQ4DT	558,285
VQ2WZ	411,344
PZ1AX	324,702
KH6IJ	312,223
ZD2JKO	28,732
LU8CW	220,492
4X4AU	213,990
UB5FJ	211,030
UB5WF	206,184
ZK1BS	188,496

Top Five

MULTI-OPERATOR SINGLE TRANSMITTER

4X4GB	729,135
CN8HX	381,416
DJ3VM	294,124
CT1EY	248,160
ZC4AK	192,770

Top Five

MULTI-OPERATOR MULTI-TRANSMITTER

K2GL	383,112
ET2US	258,427
GB2SM	186,660
DL1HC	180,048
W3AOH	136,799

Continental Leaders

SINGLE BAND

28 Mc		14 Mc	
LUIDAB	126,808	CX2CO	333,168
OH5NW	47,564	ZS5JM	138,118
ZS7L	35,160	KH6DLD	108,262
JA2AEY	32,074	OD5CV	68,056
W5LGG	10,890	G3NNT	54,944
		TI2HP	44,030
21 Mc		7 Mc	
VQ4RF	214,389	YO9CN	3,367
G3FXB	103,818	K2DGT	2,223
PY1AKT	73,225		
ZL1ACI	67,500		
CR9AN	32,448		
W9ZTD	19,800		

U.S.A. Leaders

All Band	W6GHM	113,520
28 Mc	W5LGG	10,890
21 Mc	W9ZTD	19,800
14 Mc	W1ONK	35,944
7 Mc	K2DGT	2,223

Number groups after call letters denote the following: Band, final score, number of QSOs zones, and countries. Letters designate power used, A—Up to 35 watts. B—Up to 150 watts. C—Up to 500 watts. D—500 watts and over. Winners are indicated by an asterisk.*

SINGLE OPERATOR

North America

United States					W2CYX*								
W1PDF*	A	84,632	208	55	94	D	W2JKH	14	4606	41	17	30	D
K1JTC*	A	55,198	162	48	95	D	WA2JAM						
W1FZ	A	25,208	115	34	58	D		14	12	2	2	2	B
W1BIH	A	15,360	70	30	50	D	K2DGT*	7	2223	31	15	24	D
W1WY	A	12,354	78	36	51	D							
W1YDO	A	9672	68	25	37	D	W3JNN*	A	100,744	211	67	129	D
K1MEM	A	5141	42	19	34	B	W3MSR	A	1768	25	15	19	B
W1TQS	A	1664	23	13	19	D	W3IPO	A	925	19	11	14	B
W1OJR	A	1368	21	9	15	B	K3BCX*						
K1KPS	A	1333	25	13	18	D		28	9405	64	19	38	C
W1WLG*							W3AYD	28	2752	37	10	22	C
							K3EUR	28	2108	33	12	20	B
W1NHJ*							W3HWE	28	288	13	10	8	B
							W3JTC*	14	25,380	112	32	58	D
W1ONK*													
							W4OM*	A	71,574	175	59	101	D
							K4YWZ	A	66,990	187	56	98	B
W2JT	A	84,846	219	58	109	D	K4JZH	A	33,930	109	54	76	D
K2GXI	A	58,905	164	63	102	D	K4CRX	A	5208	38	21	35	C
K2UVU	A	25,164	108	43	65	D	W4CMG	A	5063	55	28	33	C
K2BZT	A	11,584	81	27	37	D	W4DS	A	1800	18	13	15	D
W2AOX	A	11,448	74	31	41	D	W4KBP	A	690	14	11	12	B
K2KHR	A	9882	63	36	45	B	K4MAY*						
W2DGW	A	8850	56	28	47	D		28	7920	67	18	37	B
W2SNI	A	8125	60	25	40	D	W4CWO	28	4278	42	18	29	C
W2HMJ	A	4888	39	17	30	D	K4KYB	28	2278	33	14	20	C
W2QKJ	A	3724	39	21	28		K4HMX	28	1760	24	13	19	B
W2LV	A	1750	25	16	19	D	W4EEO	28	480	10	6	10	B
WA2IEK	A	180	6	4	6	B	W4DRW*						
W2FGD*								21	15,795	92	22	43	D
							K4BQU	21	3864	43	17	25	A
K2UVV	28	272	13	8	8		W4EZC	21	722	16	8	11	D
WA2CCF							K4BOE*	14	3053	44	18	25	D
							K4ODU	14	1428	19	12	16	B
W2WZ*	21	12,300	111	20	40	D	W4IRP	14	160	6	4	6	C
W2HAQ	21	4532	38	19	25	B							

K5MDX*	A	102,204	233	80	124	C	W0VXO*	28	6764	66	16	27	B
K5RIP	A	4350	41	25	33	C							
W5SU	A	1254	20	15	18		<i>Alaska</i>						
W5LGG*							K1IFS/KL7*	14	7,965	75	15	30	B
	28	10,890	72	24	42	B	W4ARH/KL7	14	4592	42	15	26	D
K5UFY	28	3131	45	11	20	C							
K5SBN	28	2275	34	13	22	C	<i>Bahamas</i>						
K5VBI*	21	7420	62	18	35	C	VP7BM	A	90	30	2	1	B
W5RIT	21	560	16	9	11	B							
W5KC*	14	13,962	95	26	52	D	<i>Barbados</i>						
W5INL	14	10,440	68	26	46	D	VP6AM*	28	2,300	94	9	11	B
K5JQB	14	540	12	7	11	C							
W6GHM*							<i>Bermuda</i>						
	A	113,520	272	69	103	D	VP9AK*	A	98,842	317	59	87	B
W6RCD	A	40,870	144	50	72	D							
K6CTV	A	34,272	125	53	66	D	<i>Canada</i>						
W6EKZ	A	23,762	100	48	61	D	VE1WG*	A	2752	28	16	27	
W6YEJ	A	3356	41	26	25	B	VE2GJ	A	638	15	15	14	B
W6IPH	A	1710	36	14	16	B	VE3BMB*	A	10,800	71	29	46	B
K6CT*	28	8190	72	18	27	B	VE3BOG	A	4692	48	22	29	D
W6NAT	28	4026	46	13	20		VE3PV*	21	4300	51	17	26	B
K6TFC	28	2754	39	13	14	B	VE3AHU						
K6RWO*								21	3999	43	15	28	C
	14	14,160	87	25	35		VE3ES	14	1276	24	12	17	B
K6UFX	14	700	21	10	10	D	VE3BSJ	14	918	25	9	18	B
W6EJA	14	231	11	3	4	C	VE4SD*	A	5016	66	27	30	B
W7VY*	A	17,888	92	40	46	D	VE6IN	A	920	27	11	12	
W7DQM	A	1500	24	16	14	C	VE7EH*	A	20,240	171	35	45	B
W7FYV	21	1944	20	12	9	B	VE7CE	A	3320	41	21	19	
W7ENA	28	720	16	8	10	B							
W8NXX*							<i>Canal Zone</i>						
	A	41,463	144	59	94	C	KZ5TD*	A	71,712	251	54	90	B
W8WT	A	11,840	74	35	45	B	KZ5LC*	14	14,352	312	18	28	D
W8UMR*													
	28	8692	73	17	36	B	<i>Costa Rica</i>						
W8UPN*							TI2RO*	21	9024	102	19	28	A
	21	9387	66	21	42	D	TI2HP*	14	44,030	352	32	53	D
K8CFU	14	2584	40	14	24	D							
W9EWC*							<i>Cuba</i>						
	A	72,834	189	73	110	D	CO8JK*	14	4066	71	16	22	C
W9NZM	A	45,570	157	60	95	D	CO8RA	14	882	43	9	9	
W9HT	A	7344	96	36	54								
W9AVO	28	950	20	9	16	B	<i>Guantanamo Bay</i>						
W9JJV	28	528	14	9	13	D	KG4AO*	A	58,860	375	41	67	C
W9ZTD*													
	21	19,800	114	24	51	D	<i>Guatemala</i>						
K9ECE	21	9555	65	21	44	B	TG5HC*	A	10,416	135	26	30	
W9LRH*													
	14	2613	38	15	24	D	<i>Honduras</i>						
W0NFA*							HR2MT*	A	30,184	166	40	58	B
	A	57,600	173	63	97	D							
W0MCX	A	14,896	88	43	55	D							

<i>Mexico</i>			
XE1CP*	A	109,900	525 55 102 C
XE1SN	A	90,390	503 59 79 C
XE1TJ	A	31,023	338 40 41 -
XE1CV*	14	21,060	262 21 39 B
<i>Panama</i>			
HP1AC*	A	26,967	153 37 52 B
<i>Puerto Rico</i>			
KP4ATU*	A	75,705	601 45 60 B
KP4AVQ	A	49,938	521 38 44 D
KP4AOD*	21	6755	91 14 21 C

Africa

<i>Angola</i>			
CR6DA*	A	6232	57 16 25 -
<i>Canary Islands</i>			
EA8CK	A	744	22 6 6 -
<i>Ghana</i>			
9G1DP*	A	73,830	226 38 77 -
<i>Kenya</i>			
VQ4DT*	A	558,285	725 80 193 B
VQ4RF*	21	214,389	608 33 90 B
<i>Liberia</i>			
EL4A*	A	138,920	331 67 84 D
<i>Libya</i>			
5A3TX*	A	24,543	105 28 53 B
<i>Madagascar</i>			
FB8CM*	A	34,299	132 40 63 B
<i>Morocco</i>			
CN8EU*	A	31,512	109 36 68 B
<i>Mozambique</i>			
CR7CR*	A	35,867	147 33 56 B
CR7LU	A	18,542	95 28 45 B
CR7CS	A	2080	25 15 17 B
<i>Nigeria</i>			
ZD2JKO*	A	281,732	454 61 148 A
<i>Rhodesia, Northern</i>			
VQ2WZ*	A	411,344	756 59 129 B
VQ2WR	A	151,074	554 55 99 B
<i>Rhodesia, Southern</i>			
ZE1JN*	A	176,456	393 59 102 -
<i>Ruanda-Urundi</i>			
9U5PD*	A	186,932	376 57 131 B
<i>Swaziland</i>			
ZS7L*	28	35,160	211 21 39 A
<i>Union of South Africa</i>			
ZS6AQI*	A	91,190	286 45 65 B
ZS5JM*	14	138,118	440 33 73 B

Asia

<i>Bahrain Island</i>			
MP4BCV*	A	85,158	201 52 114 B
MP4BBW*	14	63,994	242 31 67 B
<i>Ceylon</i>			
4S7YL*	A	72,504	186 67 104 -
<i>India</i>			
VU2BK*	A	152,040	330 56 125 A
VU2RM*	14	13,802	89 27 40 B
VU2CK	14	2982	41 15 27 B
<i>Iran</i>			
EPIAD*	A	25,122	119 29 50 B
<i>Israel</i>			
4X4AU*	A	213,990	367 63 147 -
4X4JA	A	15,822	106 12 42 A
4X4JM	A	3999	37 13 30 B
<i>Japan</i>			
JA1BK	A	28,917	142 32 49 B
JA1BQR	A	5858	48 26 32 A
JA3AA	A	5500	54 21 28 B
JA4AQR	A	2542	35 16 25 A
JA2AEY*	28	32,074	156 32 47 B
JA2XW*	28	20,808	125 27 41 B
JA1BWA*	28	14,632	99 28 34 B
JA6NP	28	11,368	84 24 34 A
JA3BRF	28	10,716	76 25 32 B
JA1BLC	28	10,530	83 24 30 B
JA1CEY	28	8600	64 24 26 B
JA3EK	28	7571	46 28 39 B
JA2AH	28	5085	46 20 25 -
JA1BTH	28	4530	56 12 18 A
JA1BZV	28	4485	47 18 21 A
JA1CBZ	28	4320	45 19 21 B
JA3CE	28	4320	46 21 27 A
JA8FC	28	3588	44 19 20 B

JA9CQ	28	3465	41 15 18 B
JA1GV	28	3432	32 20 24 B
JA3TC	28	3330	43 14 16 A
JA4AS	28	3315	37 15 24 B
JA7JU	28	2025	33 12 15 B
JA3ATP	28	1809	25 11 16 A
JA1CPM	28	1725	27 12 13 B
JA2AAT	28	1300	20 12 14 B
JA1BUN	28	1281	24 8 13 A
JA5CB	28	1100	19 10 12 A
JA4FM	28	741	19 10 9 A
JA1YL	28	660	12 10 12 B
JA1AAT	28	609	13 10 11 B
JA1ANA	28	516	15 6 8 B
JA7JW	28	390	12 8 7 A
JA6PN	28	330	10 7 8 A
JA1CLN	28	220	8 5 6 A
JA1BAJ	28	132	6 6 6 A
JA8AAC	28	108	5 4 5 A
JA3AVB	28	90	6 2 3 A
JA1AKH	28	42	3 3 3 A
JA7AD*	21	5896	57 19 25 B
JA6AV	21	3404	36 19 27 B
JA4EE	21	3096	42 13 23 A
JA5AF	21	1920	27 12 20 A
JA1LN	21	610	23 8 10 A
JA2JW*	14	13,702	90 25 37 B
JA0AC	14	2220	34 13 17 B
KA2JL*	A	60,006	178 53 84 B
<i>Lebanon</i>			
OD5CT*	A	119,048	248 62 122 -
OD5CV*	14	68,056	252 28 66 B
<i>Macao</i>			
CR9AN*	21	32,448	181 26 52 B
<i>Pakistan (West)</i>			
AP2Q*	A	44,544	174 37 79 B
<i>Thailand</i>			
HS1B*	A	51,562	192 45 82 B
<i>Ryukyu Islands</i>			
KR6DO*	28	4092	80 15 18 C
KR6IM*	21	25,165	135 31 54 C
KR6HS	21	7854	61 20 31 C
KR6CS*	14	19,530	128 26 36 B
<i>U. S. S. R.</i>			
<i>Asiatic</i>			
UA9KOC*	A	10,965	86 17 34 C
UA0KJA	A	5904	122 22 19 C
UA9XN	28	120	8 2 3 A
<i>Kazakh</i>			
UL7FA*	A	36,158	141 30 71 B
UL7JA	A	18,824	110 31 51 -
<i>Tadzhik</i>			
UJ8AC*	14	15,846	121 14 41 -

Europe

<i>Austria</i>			
OE1DH*	A	134,260	358 67 178 C
OE3NH*	21	14,628	112 20 49 -
OE1RZ*	14	30,560	190 30 59 B
<i>Balearic Islands</i>			
EA6AY	21	1080	41 6 12 -
<i>Belgium</i>			
ON4WI*	21	9796	82 20 42 B
<i>Bulgaria</i>			
LZ1KDP*	A	33,350	256 27 88 B
LZ1UF*	21	16,968	250 13 43 A
<i>Crete</i>			
SV0WO*	14	11,286	151 14 43 B
<i>Czechoslovakia</i>			
OK1KNL	A	2016	51 9 27 B
OK1VB*	21	13,987	131 20 51 B
OK3KGI	21	1872	75 6 18 B
OK2KOJ	21	1664	54 8 18 -
OK2KAU	21	1628	64 6 16 B
OK1XB	21	792	18 6 16 -
OK1KTI*	14	10,384	143 13 46 B
OK1JX	14	9804	141 15 42 D
OK1ZL	14	7436	149 9 35 C
OK2UX	14	494	39 2 11 B
OK1AVT	21	205	15 3 12 A



Ragnar Otterstad, LA5HE. All Band winner for Norway and a WAZ certificate holder.

<i>Germany</i>			
DL1JW*	A	163,044	347 79 173 C
DL7AD*	A	74,460	196 60 144 B
DL3DW	A	72,568	193 63 125 C
DL3HJ	A	51,051	241 37 106 B
DL1FK	A	34,888	164 53 71 B
DL7BQ	A	28,251	144 42 87 C
DJ4WN	A	24,360	132 34 71 B
DJ1KM	A	13,904	84 33 55 B
DL6WD	A	9380	94 18 52 -
DJ2UU	A	8240	100 19 61 B
DL9JLA	A	7104	91 19 55 B
DL8DG	A	6283	82 18 43 B
DL9YC	A	5400	72 13 32 -
DL7EN	A	5236	48 25 43 C
DL3DC	A	4300	51 15 28 C
DL7BK	A	432	16 8 10 B
DJ1LP*	28	21,040	117 25 55 B
DJ4YH	28	12,036	75 18 41 -
DJ4PU	28	11,172	89 16 41 A
DL7HU	28	9454	91 18 40 B
DJ2IV	28	3920	49 14 26 A
DL7FP	28	1032	27 10 14 B
DJ2AA*	21	51,728	265 30 76 B
DL7BA	21	45,344	159 32 77 B
DL3TJ	21	42,640	224 26 78 B
DJ1RJ*	14	4002	69 11 35 B
DJ2DW	14	1960	67 5 23 B
DM2AEE	14	1128	47 4 20 B
DL6QIA*	3.5	1764	61 4 24 -
DL4PI*	A	90,692	282 50 114 D
DL4XF*	21	8262	68 14 40 B
DL4ED*	14	25,179	183 26 51 C
DL2YU*	A	77,700	323 46 129 B
<i>Gibraltar</i>			
ZB2AD*	A	40,859	279 22 69 B
<i>Greece</i>			
SV0WL*	14	14,539	135 23 44 B



Yair Ben Nissim, 4X4GB. Multi-operator, Single Transmitter winner for 1960. Yair could afford to take it easy this year.

DX DX DX DX DX DX DX DX

URBAN LE JEUNE, JR., W2DEC

BOX 35, HAZLET, NEW JERSEY

The following certificates were issued between the period from February 13th, 1961 to and including March 12th, 1961:

WAZ		
1508	IT1AGA	Giuseppe de Luca
1509	K6RTK	Fred Hitchcock
1510	W4WDI	David A. Rawley
1511	HA5AM	Janos Emmer
1512	UAØOM	Michael Tihonov
1513	K6CTV	Richard W. Ehrhorn
1514	W3RBW	Robert O. Turner
1515	W2LSX	M. D. Hall

ALL-PHONE WAZ		
67	G3AAE	J. Douglas Kay
68	W6OBH	Marvin H. Smith
69	DL1IN	Hansheinrich Heider

CW WPX		
162	JA3FT	Kin-ichi Ikeda
163	ZL2GS	H. E. H. Green
164	W4SHX	Charles J. Hinkle
165	VE3JZ	P. H. Foley
166	K8GHG	Robert Bernstein

PHONE WPX		
24	VK6KW	R. W. S. Hugo

SSB WPX		
55	VE3BQP	Wm. A. Wragg

WPX HONOR ROLL

CW WPX			
W2HMJ	594	K5LIA	428
W6KG	528	OK1MB	428
W8KPL	520	WØPGI	420
W9YSX	517	W2HO	418
W5KC	505	W8PQQ	418
K6COM	500	W5AWT	412
W1NLM	491	W2PTD	411
W1EQ	464	K9AGB	409
W2EQS	464	W6WO	409
W4OPM	464	W5AFX	407
W8LY	456	W3OCU	405
W2MUM	450	W2NUT	403
K2UKQ	447	W8JIN	403
K6SXA	447	PY4OD	402
W9UXO	438	W5LGG	401
W3BQA	437	W9SFR	400
K9EAB	432		

SSB WPX			
TI2HP	328	K2JXY	206
HB9TL	315	W5RHW	203
K9EAB	301	W3VSU	200
MP4BBW	300	XE1AE	197
W4OPM	284	PZ1AX	189
K2MGE	263	K2HEA	181
W8PQQ	250	VE3BQP	181
W1GR	246	W6BAF	170
W3MAC	235	WØKFA	168
HB9TL	221	W8BKO	166
WØCVU	218	UA3CR	165
DL4AS	208	VE3MR	164

PHONE WPX

W8WT	510	SP7HX	323
G3DO	476	W3AYD	314
CT1PK	449	I1CBZ	312
W9YSQ	436	W3DJZ	306
W9WHM	367	ZP5CF	306
PAØHBO	363	SM3BIZ	304
W5ERY	358	VK6KW	303
W9UZC	356	F8PI	302
DL3TJ	354	PY1NC	302
PY2CK	354	EI3R	302
5A5TO	353	W9PQA	301
W8PQQ	327	VE1ADE	300

Letters

AC4 Tibet: The following letter was received from the Amateur Radio Society of India:

"Dear Sir, I am subjoining below the extract of the letter received from the licensing authorities regarding the operation of the Amateur Station, AC4AX.

'I am directed to refer to your letter dated nil (received on 5.1.60) regarding Shri D. S. Seal's (VU2AX) operation with call sign AC4AX from Lhasa, Tibet, and to state that Shri Seal has since informed this Ministry that he does not work any amateur contacts from Lhasa. He also informed that he has made a declaration to that effect to the Indian Consul General at Lhasa, and that he has not obtain any amateur license from the local authorities to work at Lhasa.'

As per above information, the operation of AC4AX is a pirate.

Thanking you.

Hon. Secretary."



Another entry in the home brew rig class Hiroo JA2CF. (Tnx DU7SV)

BV1 Formosa: The Americans in Taiwan have recently formed a radio club, which is known as the Taiwan American Radio Club (TARC). Membership is composed of American personnel on Taiwan, and there are presently some 25 club members. Officers include K9YLE as President, K7KLB as Vice President, W4OSG as Secretary and K4YJQ as Treasurer.

Some of the club's activities include Radio Theory classes, the operation of a QSL Bureau for BV stations and Code classes. Also under consideration is the establishment of a BV award. Formal announcement of this award will soon be forthcoming.

The address for QSL's handled by the club is as follows:

Taiwan American Radio Club
Box 24, USTDC
APO 63, San Francisco, California
Taiwan American Radio Club
United States Taiwan Defense Command
Taipei, Taiwan
Republic of China.

Logs at BV1US only date back through 1959, contacts prior to 1959 cannot, therefore, be confirmed. Due to the nature of operation, necessitated by the rapid turnover of operators at most BV1 stations, it is suggested that Hams who wish contact verifications QSL immediately after the QSO. (Tnx W4OSG, Sec. TARC)

The following is from W9PHY ex BV1USE: "Just to clear up a situation, here is some dope on BV1USE.

I was the first operator of that station with the first contact May 25, 1959 and the last May 4, 1960. All operation was on 14 mc s.s.b. with 2 contacts on 21 mc s.s.b.

Upon my departure, Tom (stateside call unknown) took over with his gear (a.m. c.w.) no s.s.b., and all operation was done by him. I do not know the present status of the station but I do know Tom (and the logs I presume) are all in France.

Regarding QSL's—I still have some cards and will take care of any contacts made during my sojourn. W9HCR very capably handled my QSL's during the latter portion of my tour. Anyone needing a card, send a s.a.s.e. to: M/Sgt. Don Merideth, W9PHY, 6401 Roselawn Ave., Madison 4, Wisconsin."

Danny: According to W6GIZ of the NCDXC, Danny has concocted a new drink, "The Yasm cocktail" consisting of two shots of whiskey; one shot bilge water; dash crankcase oil—served on the rocks.

This looks like a relay station of the VOA but it's the rig of IIRIF who recently operated as IM1RIF on Monty Carlo Island. (Tnx W2AGW)

EAØ Spanish Guinea: W2ESZ has been making lists for EAØAC on weekends at 1400 GMT on 21410 kc, s.s.b. (Tnx K2TDI)

FC Corsica: F9QV/FC has been very active on s.s.b. on 14305.

FF4 Ivory Coast: FF4AL has been active every day on 14042 c.w. He is frequently active between 220 0 and 2400 GMT. He is ex-EL3A and will be there for a period of two years.

FF7 Mauritania: 5A5TA of YA1IW fame may be going to FF7 land to work when his present job is completed. (Tnx NCDXC)

FO8 French Oceania: The FO8AO who has been active on 21 mc is a pirate advises the real FO8AO via W2BHM.

HB9 Switzerland: A new section of USKA has been formed and is known as ART (Associazione Radioamatori Ticinesi). Secretary, ART Section Franco will act as QSL Manager for TI contacts and will also arrange skeds for those requiring Canton Tessin. (Tnx WA2DIG)

LZ Bulgaria: LZ1DW is the first station in Bulgaria on s.s.b. He prefers 14315 kc around 2000 GMT.

SVØ Crete: SVØWN is on from Crete using s.s.b. on about 14310 around 1000 GMT.

SVØ Rhodes: SVØWV is the only station on Rhodes at the present time with s.s.b. preferred on 10, 15 and 20 meters.

UAØ Siberia: UAØLA made a brief appearance on s.s.b. on 14275 kc but understand he is now off the air because of TVI!

(Note:—Don't pass up any UAØ's in Tana Tuva as there is a possibility this country may be reinstated on the DXCC countries list)



Hans DM3CK (insert) and his home brew station.
(Tnx K2UKQ)

VRI British Phoenix: Unfortunately, the proposed trip of MP4BBW and VE7ZM to the British Phoenix group had to be cancelled because of conflicting job engagements of VE7ZM.

UA-U.S.S.R.: K6BX relays this interesting letter from UR2BU in which Karl describes Amateur Radio in the U.S.S.R. In the U.S.S.R. amateur radio is graded or classed in the following manner: When an amateur starts, he gets a station license of a 3rd category and has no amateur grade as a sportsman himself. When he has won a certain place in a contest, he becomes an amateur of the 3rd grade of radio. When he

gets a better place in the next contest or fulfills certain requirements in amateur radio communications, he gets a 2nd or even 1st grade of radio sports. When he wins an international or all union contest, or fulfills certain high requirements of amateur radio communications or makes an all union record, he becomes the Master of Radio Sports of the U.S.S.R.

The Flying Hams Club: A club has been started whose membership will be comprised of hams who have, at one time, held a pilot's license, either commercial or military. The two need not have necessarily been held concurrently. K6BX is the Secretary of the Club and full details may be received by dropping him a line at Box 385, Bonita, California.



Col. Brundyge and Capt. Groves officiate at the opening of BV1USG. The station will be operated 16 hours a day and a training program is under way for new operators.

QTH's and QSL Managers

CP5EL	via W1BAN
CR7CI	W/K only via K9GZK
CT2AH	via K8RTW
CT3AA	Box 257 Funchal, Madeira Islands
FB8CJ	via W6BAF
FB8CM	via W1YBO
FF4AC	Jean, Box 571, Abidjan, I. C.
FF4AH	Box 100, Agboville, Ivory Coast
FF4AK	Box 1813, Abidjan, Ivory Coast
FF8BQ	Pierre Maire, Box 190, Dakar, Senegal
FG7XH	Andre, Box 335, Pointe-a-Pitre
ex-FL8AB	now F8UD
FQ8AX	Box 218, Brazzaville
G3NUF	ex-VP8AQ who has VQ8AS, Rodriguez Island logs, G. D. Wilson, 154 Park Road, West Hartlepool Co., Durham England.
HSIR	Capt. L. P. Rose, 084509, Detachment VA USARELM JUSMAG APO 146 San Francisco, Calif., or c/o 5th RCT (RTA) Nakorn Srithamaraj, South Thailand.
ex-I5GN	15 Fawnrode Drive, Peekskill, New York
KC4AAB	Ellsworth Stn., QSL via W9LGR
KC6GJ	ex-KW6CY, Ponape E. Caroline Is. Pacific, Trust Territory
KH6ECD	U.S. Stations direct all others via KH6BPF via KM6BI, Ted Woods, Navy 3080, Box 18, FPO, San Francisco, California
MP4TAC	Cpl. Alan Dicker, Trucial Oman, Scouts, BFPO 64, Sharjah, Trucial Oman
MP4's	QAQ, TAI, and BDD via W2JXH
SV1AB	via W4HUE



Two of the boys from down under, tnx to K2UKQ. Andy, VK3UJ at his rig, and Laurie, VK2AMB.

SV0WZ	via W7FTU
VP2SL	via K4LRA
VQ2AB	via W6BAF
ex-VR3W	now ZC4WD
ex-VR3Z	now G3DAF
VS1JV	via W6BAF
VS6AE	via W6DIX
VU2IR	Bindu Madhav Rao, 56/1 Hindustan Park, Calcutta 29, India (new address)
W3RVM/KV4	via W3RVM
W3UWW/KV4	via W3UWW
W3ZA/3W	via W2JXH
W8OLJ/PK	via Project Hope, Box 9808, Washington, D. C.
XW8AM	via W2JXH
YN3KM	Jock, Box 14, Leon, Nicaragua
ZA1AF	Box 131, Durres, Albania
ZA1KB	Box 42, Tirana, Albania
ZE5JJ	via W6BAF
ZS3E	via K4PUS
ZS7P	Peter J. Lamont, Box 54, Mhlambanyati, Swaziland
3A2	Bureau (Nationals Only) via 3A2AH, 6 Rue Gastaldi, Monaco Ville, Monaco
6O2RS	Box 164, Berbera, Somali
6W8AF	Box 7, Ruefisque, Senegal
6W8BQ	Pierre, Box 190, Dakar
9Q5FD	P. O. Box 218, Kolowezi, Katanga, Congo
9U5VL	Box 1, Usumbura

Clif Evans, the tireless Certificate Directory keeper, has a list of over 25 QSL manager volunteers so if any DX station is having QSL trouble and would like help with his QSL's drop Clif a line at Box 385, Bonita, Calif., and help will be on the way.

[Continued on page 110]

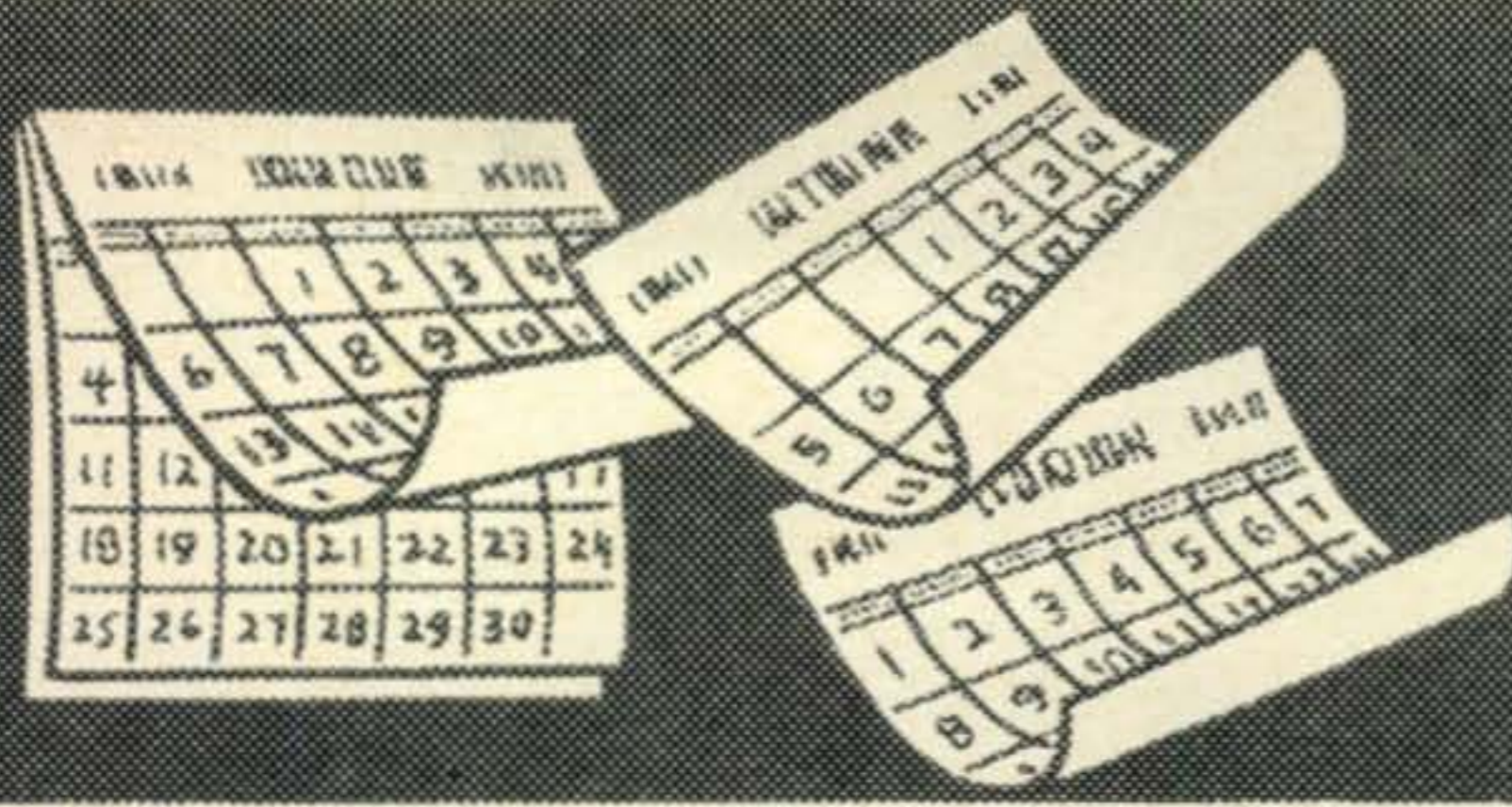

CONTEST CALENDAR

by Frank Anzalone, W1WY
14 Sherwood Road, Stamford, Conn.

CALENDAR OF EVENTS

April 29—30	PACC CW
April 29—30	USSR DX
May 6—7	PACC Phone
May 6—7	Bermuda
May 20—21	Bermuda

Results of the 1960 VE/W Contest

"Gordy" Webster, VE2BB, Contest Chairman, reported this as being the most successful contest they have held. Both from the standpoint of sections represented and logs received.

The Trophy winner was Thain MacDowell, VE2NI and the runner-up was Vince Rosso, W5KC.

Space does not permit listing all the scores, (QST will do that) but following is a list of winners in each section.

Canada

VE2NI151,528	VE5KY 84,240	VE1EK 65,121
VE7EH115,473	VE6AO 84,075	VE8GW 53,583
VE3AGX .. 91,575	VE4NR 72,000	VO2NA 36,750

United States

W1WY 81,387	K4BQU 36,551	W7ENA 31,190
K1CLT 65,630	W4OMW .. 34,115	K7DVT 26,002
W1GKJ 56,045	W4MLE 33,212	W7JLU 22,743
K1JYN 34,602		K7CRL 19,638
W1FZ 34,115	W5KC116,314	
W1AZW 26,642	W5WZQ100,881	W8OHW ..102,019
	K5UYF 74,564	W8APN 93,085
K2KFP 80,143	K5IID 59,944	K8MIH 19,494
K2UVV 73,965	W5AMZ 53,121	
K2IMK 67,080	K5OCX 43,213	W9PNE 95,551
W2EXB 64,980	K5TST 11,264	W9DYG 80,900
W2TER 54,583		K9KJD 70,665
	W6ZVQ107,704	
W3AIZ 86,205	W6NZW 59,457	K8SNC 65,305
W3AYS 77,976	WA6ECP .. 53,121	K8TMM 51,334
K3ATJ 18,294	K6EIE 37,526	K8UAF 50,684
	K6ROU 29,566	K8MPH 41,587
K4PUZ 98,770	K6SXX 22,743	K8UDQ 36,389
W4CHK 90,160	WA6HRS .. 15,512	K8QIX 29,565
K4RAD 77,976		K8BHM 16,450
K4BVD 73,103	K7CHH 49,221	KP4KD 3,682
W4BWZ 59,944	K7DAS 34,114	KH6CJG .. 20,794
W4PLL 50,360	K7CTI 31,678	KL7ALZ 11,696

"You mean to tell me you're going to use that on 160?" (Frank, W1WY and Bernie, W2HL of the WMGM Engineering Dept. inspecting the dummy antenna unit of the new 50,000 watt Continental transmitter).

PACC C.W.

Starts: 1200 GMT Saturday, April 29th.
Ends: 2000 GMT Sunday, April 30th.

Phone

Starts: 1200 GMT Saturday, May 6th.
Ends: 2000 GMT Sunday, May 7th.

The PAØ boys are in for a bit of trouble on their c.w. week-end. The USSR contest is pretty tough competition.

Check the March CALENDAR for details if you are interested.

The deadline for mailing your logs is June 15th and they go to: P.v.d.Berg, Contest Mgr., Keizerstraat 54, Gouda, Netherlands.

USSR DX

Starts: 2100 GMT Saturday, April 29th.
Ends: 2100 GMT Sunday, April 30th.

This is a world wide contest so don't concentrate on working USSR stations only if you want to run up a winning score.

Operation is confined to c.w. only with each contact counting one point. The multiplier is determined by the number of different countries worked on all bands, not the total from each band. Serial number exchange is the usual progressive 3 digit type. Your final score for contest competition, however, will only be taken from any consecutive 12 hours of operation out of the 24 hours contest period. Therefore plan your schedule accordingly.

There are a generous number of awards given in this contest so why don't you check last month's CALENDAR for more details.

[Continued on page 124]





ham clinic

CHARLES J. SCHAUERS, W6QLV/4

CQ, 300 WEST 43RD ST., NEW YORK 36, N. Y.

Recorders In The Ham-Shack

Many hams own magnetic tape recorders and know how to use them to obtain more enjoyment from their operating activities. However, there are some hams who know very little about recorders and have written HAM CLINIC seeking technical information, purchasing advice and suggestions on how to use them around the ham-shack. So this month we will lead off with a simple discussion relative to tape equipment and its use around the station operating position.

Today audio tape recorders are available for as little as \$49.50 and as much as \$5000.00. Some are so small they can be carried in a coat pocket, and some so large that they require a good sized room to contain them.

The unit in which most hams seem to be interested is the one which sells for around \$100.00 or so. For this amount they can obtain a multi-speed ($1\frac{7}{8}$, $3\frac{3}{4}$ and $7\frac{1}{2}$ inches per second) set which is capable of doing more than the average ham expects it to do.

Audio fidelity is a function of tape speed (among other things)—the faster the tape pull the higher the frequency response. Most commercial units used in BC stations etc., have a speed of 15 inches per second and are very expensive. Unless a ham is seriously interested in real high fidelity he should stick to the lower speed units.

Recorder Operation

For those not familiar with the technical intricacies of tape recorder operation, here is some brief and simplified information.

A tape recorder is an electro-mechanical device—that is, it contains mechanical as well as electronic parts, each of which plays a specific role in the recording and reproduction of sound on *magnetizable* tape.

The heart of the recorder is the recording-playback head (usually a single unit) over which the tape passes for either recording or reproduction. For recording, the output of the audio amplifier feeds the head; for playback, the head feeds the input of the amplifier.

Most recorders provide an automatic erase feature, which is not complicated to understand if one remembers that alternating current

through a coil placed near or around a magnetized item (in this case, the tape), will de-magnetize it. Nearly everyone of us has seen the simple apparatus used by the watchmaker to de-magnetize watches—it consists of nothing more than an induction coil through which is passed raw 60 cycle a.c.

When recording, just before the tape crosses the recording head, it is demagnetized. In most recorders, the demagnetizing head is fed with a voltage having a frequency of between 20 and 35 kc, from a special oscillator. Using such a high frequency (instead of say, 60 cycles) enables good erase action with a very small unit.

Sometimes, when too much audio is applied to the recording head, one can still hear traces of a previous recording. This is due in part to the inability of the erase portion of the head to "over-ride" the heavy magnetization. Special erase units are available which will erase tapes (in the reels) off the machine. The a.c. flux generated by these units is so strong that the heaviest magnetized tape can be "de-gaussed" in a few seconds.

The speed at which a recorder operates is usually governed by the capstan or special speed reduction gears and/or wheels. Most tape recorders in the medium price range are of the belt driven type, and speed selection is mechanically performed by mechanically switching in the correct size of driving wheel (made of rubber or metal edged with rubber).

Multichannel Recorders

Most recorders on the market today are "double channel." This means that once a tape is recorded one need only to switch the full tape reel and record on the other tape edge. The normal half hour tape then becomes an hour tape. After the last recording (second channel), the tape reel is switched back to its original position and you are ready to play the first side or first channel.

So-called four channel recorders use two heads—not four. These are usually the stereo type units. Instead of one amplifier, the recorder contains two. Generally, the upper and lower halves of the tape are recorded simultaneously from two amplifiers whose input devices *i.e.*, microphones, stereo record players; stereo radio

broadcasts (FM and BC) etc. are separated electronically.

As a tape is pulled over the recording head(s) it is magnetized at an audio frequency rate by the amplifier output. The density of recording depends upon the tape speed and so does the fidelity. Actually, one can think in terms of "bandwidth" here . . . you cannot compress a wide frequency spectrum into "space" one does not have. By speeding up the tape, frequency response goes up.

Basically then, the tape recorder contains an amplifier, head, erase oscillator, tape pulling mechanism and input-output circuits (microphone, radio, phono, loudspeaker, headphones).

Transistorized Recorders

Transistorized recorders are becoming more popular every day, but they lack the overall fine frequency response of their bigger tubed "brothers." The motor used for pulling the tape and rewinding it may be powered by batteries or a heavy hand-wound spring. Tape speed regulation is done by the use of other transistors (in the case of the battery operated motor) or by a specially designed mechanical governor (in the case of the handwound job).

A word of caution: when using a transistorized recorder around your transmitter where there is a lot of stray r.f., be very careful. Even with a good ground there is always the possibility of r.f. pickup which can ruin the best of transistors!

If you want to use your transistorized recorder around the shack, be sure that the mike or other input has an r.f. choke (2½ mh) in series, bypassed with a .002 mf ceramic capacitor. This simple filter will usually keep the r.f. out of the input transistor. Don't try to use a neon lamp like an NE-2—it takes too much firing voltage and will not be effective. If your transistorized recorder has capacitance input, be all the more wary about operating it around r.f. without the filter just described.

Input to recorders may be from a microphone, intercom system, audio oscillator, another recorder, radio receiver, transmitter (speech section or through r.f. pickup using a diode for rectification), phono amplifier, logic circuits, telephones etc.

Connections to a receiver (for recording on-the-air QSOs) should be made with shielded wire. The same considerations that apply on grounding, coupling and the feeding of speech amplifier circuits or phone patches apply to recorders. Whenever possible, use a low impedance connection, i.e., from speaker voice coil to special low Z recorder input—but lacking the latter, use an output transformer backwards; by so doing you will solve most of the noise problem encountered when using hi-Z input around r.f. equipment.

If you do run into noise problems when using hi-Z input, try using a separate ground to the recorder—remember this for phone patches too.

Applications

Tape recorders may be used by hams for: checking their mobile voice quality; recording DX QSOs; traffic recording for relay; making record discs (from tape) for friends; checking s.s.b. equipment by recording a good standard sine wave a.f. tone (usually 1000 cycles) and feeding the recorder into the transmitter instead of an a.f. oscillator; for recording satellite transmissions; an automatic (but short!) CQ tape; checking the field pattern of your beam antenna by using it to feed your transmitter while you are out physically doing the checking with a field strength meter etc. Actually, the use to which the ham can put a recorder is only governed by his imagination and ingenuity.

Choosing a recorder for your ham requirements is not difficult. As a general guide, before you take one out of the store, make certain that the recorder you choose has the following (minimum) features: at least one hi and lo-Z input (no microphone alone); recording level indicator (neon light or meter); stop or edit button (a mechanical, not electrical feature); easily removable headcover (so you can clean the head); it is fused; at least 2 speeds, i.e., 1⅞ i.p.s. for voice, 3¾ for voice and music and/or 7½ i.p.s. for good music reproduction.

Other desirable but unnecessary features include: monitoring jack or feature; additional speaker output jack; tape footage counter; multiple channel reproduction; public address position; tone control; automatic shut-off (very few recorders have this feature—but one is easily installed by yourself); forward fast rewind; individual mixing controls for multiple input (these are usually found on expensive units only) and erase off button (enabling dubbing on an already recorded tape).

Dealers such as Allied Radio, Lafayette, Henry Radio, Burnstein-Applebee, Harvey Radio, Van Sickle Radio Supply, (to name a few) all sell tape recorders that are ideal for the ham. A letter to these companies will bring you expert advice and suggestion.

Next month we will touch on trouble-shooting and maintaining the tape recorder . . . in and around the ham-shack.

Observation: QRM

"The time has come when it is necessary for the amateurs in the United States to take on themselves to make room on the bands for more amateurs and also make the use of the bands more enjoyable" . . . writes a reader. Continuing he says: "it is my belief that QRM is the most important source of dissatisfaction encountered and also that this is one of the most easily remedied troubles in amateur radio today."

He goes on to suggest the mandatory use of beam antennas with a minimum F/B ratio of 20 db or better; a maximum power input of 300 watts on 160-40 meters, and separation of s.s.b. and a.m. channel areas.

I do not agree with him. I feel that the prob-

lem is not as simple as he makes it out to be. As long as we have the bands we *do* and over 250,000 amateurs we will have an interference problem. True, not all 250,000 hams are on the air simultaneously, but there are enough to make operating difficult and *interesting*.

Why there continues to be under-current opposition to s.s.b. is hard for me to fathom. Used as the first line of radio communication by governmental agencies who are spending millions of dollars on it, it seems to me that those who oppose it would set their thinking straight, when all the facts are considered.

S.s.b. is here to stay and will (as I have said many times before) *eventually* make a.m. as ancient as spark-gap transmission. C.W. is here to stay too, and for those who have just a little more technical "moxie" so is RTTY.

Every agency in the world using radio frequencies has QRM problems. The truth of the whole matter is that we just do not have enough spectrum space, that is all there is to it! Of course we still have a lot of pioneering to do in the s.h.f. and higher frequencies, and herein may lay our salvation.

With relay and repeating satellites coming up, our world-wide communications problems will be partially solved, but there is no quick solution.

In a way I agree with our reader who wrote in on the subject of QRM. There *are* some things we hams can do with a little concerted effort to partially alleviate the situation, and reducing power is one of them.

Many hams live with the "brute force" theory of communication . . . if you can't get through with 100 watts switch to a kw; but this is wrong and unjust!

The ham who is banging in at 40 over 9 with a kw and does not reduce power after his report, is a "schmo" in my book! I'll continue to use around 100 watts and I'll operate. Oh I know I'll have to move occasionally, but I'll operate, kw or no!

Observed and recommended: too much power and fewer brains on the band these days. I do recommend a reduction in power, with the top limit 500 watts!

Questions

HQ-110—"Why do I seem to have low level hum modulation of the b.f.o. signal in my HQ-110C? What's the cure?"

Hammarlund HQ-110C receivers, following Serial Number 601 incorporate an electromagnetic shield on the top of the beat frequency oscillator shield can for the purpose of dispersing 60 cycle a.c. field radiating from the pole piece assembly of the Telechron clock-timer. Without this shield, it has been determined that a small percentage of the receivers exhibit low level hum modulation of the b.f.o. oscillator signal due to induced a.c. into the b.f.o. tuning coil.

Hammarlund makes and sells a field modification Kit #38978 which cures the condition that you mention. Write them for details or take your

set to an authorized Hammarlund service station for assistance. However, you can do the job yourself, it only takes a few minutes.

RCA WO-33A Scope Info—"How can I use my RCA WO-33A oscilloscope as an r.f. modulation monitor?"

Write RCA Ham Tips, RCA Electron tube Division, Harrison, N. J. and ask for Vol. 20, #3, September 1960 issue of *Ham Tips*. This issue contains a fine article by WV2LNQ and W2GQK on such a monitor. The modification requires only 3 capacitors (2 fixed and one variable). Thank you W2GQK! (Ham Tips are free at your RCA distributors—they may have a back issue file including the Sept. issue).

Geloso and SB-10—"Can I use the Geloso to drive the SB-10? As you know, the Geloso model 4/104 VFO made in Italy uses a 5763 output."

Yes it can be so used. However, you will find that your output drops off on 10, 15 and 20 meters . . . (when coupling thru a 75-100 mf capacitor to the SB-10 input). One "customer" found that he had to employ a tuned parallel circuit for 10, 15 and 20 coupled to the v.f.o. and SB-10 to get sufficient SB-10 output on these bands. Before you do this however, try a 100 mmf variable capacitor in series with the output of the 4/104. Make sure you do not use over 18 inches of coaxial cable for the coupling. Tune up the 10, 15 and 20 meter slug-tuned coils in the SB-10 after making the change, for maximum output of the SB-10.

Mike Input—"Why does one usually find a very high resistance placed in parallel with a crystal mike when going into the grid of a tube?"

1) proper load; 2) grid leak for tube and 3) to lessen variable shunt effect of the mike.

Antenna Coupling—"I have a 136 foot centered antenna with a feeder length of about 43 feet. What type of coupling circuit do I need on 28 mc and for 21 mc?"

For the 28 mc circuit use series; for the 21 use parallel.

CB Transceiver—"I own a little transistorized CB transceiver. This is a hand-held job which I plan to use on 10 meters, but I'd like to increase its power output by at least 50%. Any practical way of doing this without exterior circuitry?"

No.

S-38E—"How about adding another r.f. stage to my S-38E? Is it an easy task? If not, what do you suggest for a little more oomph?"

This is a question that HAM CLINIC has received many times. Let us hope that this will end this particular query.

The "simple" addition of another r.f. stage to any low priced receiver is *not* simple, mechanically or electrically. Adding an outboard pre-selector which will help as much as a haphazardly installed r.f. stage is the answer. See the simple but workable pre-selector in the March 1959 issue of *CQ* (page 61). Properly built for good output and input isolation (so there'll be no oscillation), this little unit *will* add oomph to your little receiver on 10 and 20 meters.

Receiver Choice—"What do you take into consideration when you are asked to help one choose a receiver within a particular price range?"

First of all, we try to be objective and take into consideration the features of *all* receivers within a particular price grouping. Then, based on *personal* test, letters from readers, over-the-air reports and comparative technical information, our recommendation is made.

One thing hams should remember when buying a receiver, is that they get what they pay for . . . nothing less, nothing more. Please do not ask us to compare receivers or any other ham gear where there *is* a price differential! It can't be done.

75S-1 Band Change Difficulty—"In making that excellent receiver—the 75S-1, Collins evidently had to conserve on space—especially where crystals are concerned. Finding the correct crystal in a group and unplugging it is not easy. Any of your readers come up with suggestions that will make crystal changing easier in this top-notch set?"

Yes! Thanks to Louis Smykal, W5ECB here is a good suggestion.

He writes: "Take a piece of Scotch brand white electrical tape #27, 1/2" wide, about 4" long and wrap around the crystal with the center of the four inch length of tape centered between the pins and the two ends extending out past the top of the crystal. The ends form an excellent tab not only with which to remove the crystal but gives a fine spot to identify the crystal with a ballpoint pen. I identify my crystals with the frequency in mc to the first decimal place. Now it is easy to spot crystals and to remove them from the cramped area without using long nose pliers."

A big 75 and a thank you, Louis! A fine idea.

Filament Choke—VE2QJ sends in an idea for a cheap but good filament choke for that grounded grid amplifier. He writes: "the core of a surplus or burnt out TV horizontal flyback transformer makes an excellent choke. It is a simple matter of winding about 15 turns of #12 wire or larger (depending upon current drawn) in parallel. The winding should be done off the core to prevent damaging it. The completed winding is then slipped into place and the core re-assembled using the original insulation material. The choke fabricated here does an excellent job on all bands with no loading problems. The core incidentally, is the old "630" vintage and has a large core area."

Thank you VE2QJ for passing your idea on for fellow hams and 75 to you too!

Grass-Non-Technical—"After planting my backyard lawn over which my doublet antenna passes, I noticed that the grass seems to be greener and higher directly underneath the length of the doublet. Could this be due to r.f.?"

I doubt it. Any readers have any ideas on this?

Globe 755A V.F.O.—"I have a Globe 755A v.f.o. On the 10, 15, 20 and 40 meter bands I can hear the beatnote in my receiver very well, but on 80 meters it is very weak. Any ideas?"

Your shielding must be very good at 80 meters. Sometimes when coax cable is used for inter-connection between a v.f.o. and a transmitter there can be a slight detuning (if the cable is long). It seems to me however, that the 80 meter signal should be pounding through instead of the higher frequencies. A weak v.f.o. signal (for zeroing purposes) can be strengthened by using a common ground (between v.f.o. and receiver). If this does not help, you might try a piece of wire (in the v.f.o. cabinet near the affected output coil) with a few inches left hanging outside the case. This on the other hand may lead to TVI, so do check for TVI after trying this gimmick.

Thirty

Our mail is so heavy that we cannot promise quick answers as we once did. Our backlog of questions would fill a bushel basket at this writing! Answering these questions and picking those used in the column takes the XYL and myself many hours in the evenings and weekends. So please be patient. Getting settled in the U.S.A. once again has taken the time we would normally spend on correspondence. When one considers the fact that over 200 letters have been coming in each week during the Winter months, you can easily understand why it is possible to have a backlog. So we ask your indulgence. We'll eventually get around to answering *all* communications.

I would like to remind those forgetful hams to whom I have sent my *only* copies of set diagrams to return them. I did *you* the favor and I expect you to once again make them available to me for mail troubleshooting as well as helping out other hams who need the same information.

For this month then, 72 to our DX friends, and 73 and 75 to you, our readers in the U.S. and the world at large.

Chuck



"Don't mind us, Mrs. Smythe, we're just helping your husband put up the new beam."

Space Communications

GEORGE JACOBS, W3ASK

11307 CLARA STREET
SILVER SPRING, MARYLAND

Project RELAY

In a public briefing held recently in NASA's newly-opened Goddard Space Flight Center in Greenbelt, Md., the Space Administration announced plans for its next communications satellite, called Project RELAY.

With the success of the experimental ECHO passive balloon satellite behind it, NASA's next effort will be an *active* satellite, which will be capable of relaying television and other wide band transmissions over great distances. NASA plans to launch its first experimental RELAY satellite about mid 1962.

The mission of this project, according to plans made public at the briefing, is to investigate in orbital flight the technological problems of transmission of wide band communications by means of a low altitude, active artificial earth satellite. The experiment will include communications between the east coast of the United States and the west coast of Europe. The type of communications to be transmitted will cover the

range of television signals, multi-channel telegraphy and data handling.

The ECHO passive communications satellite, launched last summer by NASA, was designed to scatter or reflect radio signals from its 100 foot spherical, aluminized outer covering. The ECHO satellite is still in orbit. Unlike ECHO, the planned RELAY satellite will carry receivers and transmitters aboard, so that signals received from ground stations can be amplified and retransmitted from the satellite to other ground stations within line-of-sight, thousands of miles away.

NASA's RELAY satellite will also differ considerably from the COURIER communications satellite placed in orbit by the Department of Defense during October 1960. The COURIER, designed exclusively for military global communications, was a "delayed repeater" type satellite. As the COURIER passed over a specific ground station, information previously stored at that ground station was beamed rapidly to the satellite, through a process of message compression.

The information was then stored in the satellite's magnetic tape memory system, until it arrived within line-of-sight transmission of the ground station to which the traffic was addressed. The information stored in the COURIER was then released in a rapid burst to the ground receiving station upon receipt of a secret coded command.

Unlike COURIER, RELAY will be a "real time" repeater station. It will receive and retransmit information simultaneously, without delay. NASA's RELAY satellite will be used for civil communication experiments in which other countries may participate.

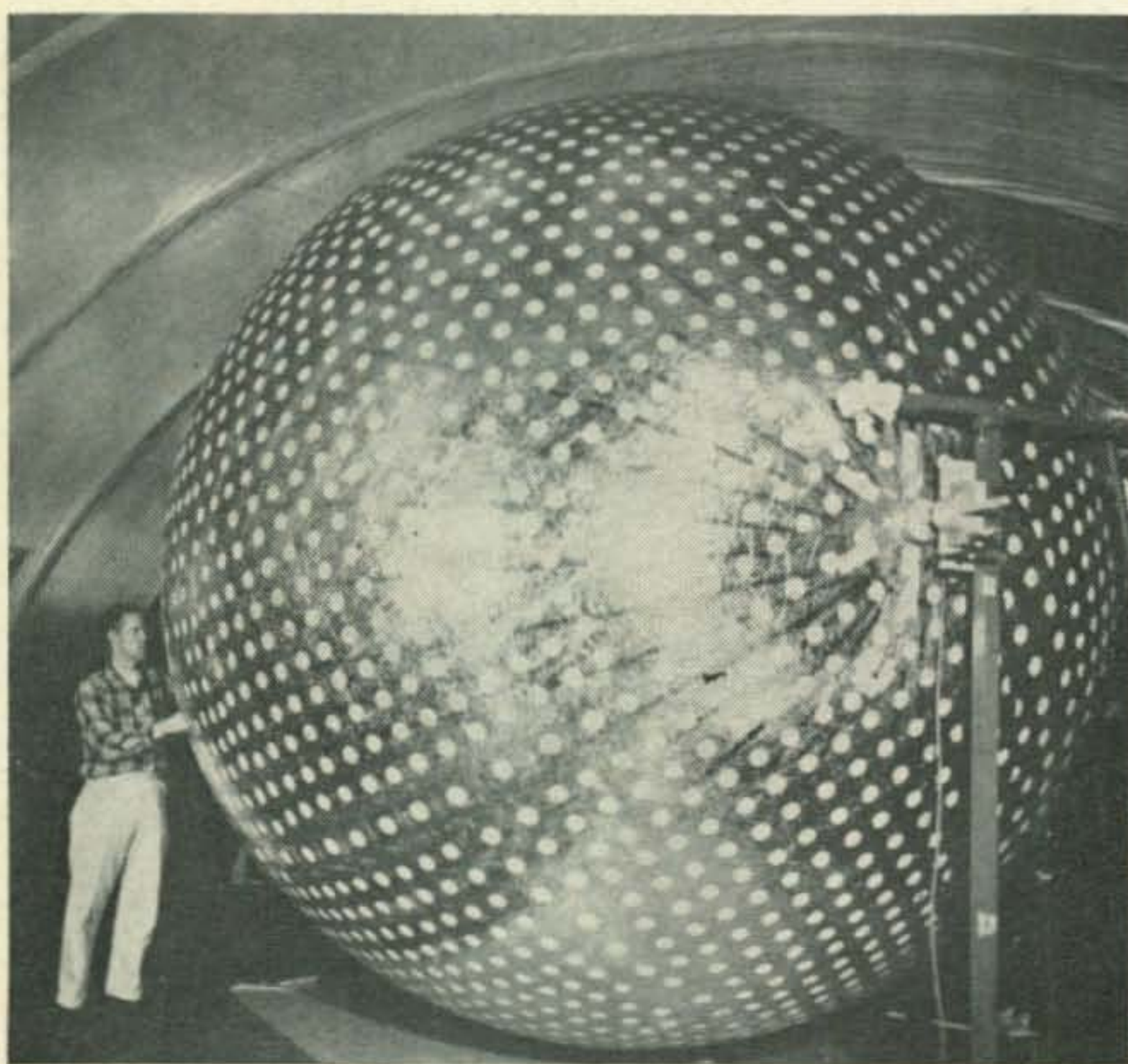

Explorer IX's 12-foot mylar covered, aluminized balloon which was placed in orbit during February. (Official NASA Photo).

Television Relay

In order to experiment with trans-Atlantic television relays, the RELAY satellite's technical specifications call for a video bandwidth of 3 mc, 6 db down. Voice signals will be of high quality, with specifications calling for an 8 kc bandwidth and a signal-to-noise ratio of at least 45 db.

The specifications also require the ground stations forming a part of the RELAY communications system to be able to convert from U.S. to European television standards and vice versa. U.S. television stations operate on a 525 line, 30 frame system; those in the United Kingdom on a 405 line, 25 frame system, those in France on an 819 line, 25 frame system, while those in the rest of Western Europe operate on a 625 line, 25 frame system. Television transmissions of one standard cannot be received properly on a receiver designed for another standard, without appropriate conversion of the signal. The RELAY communication system will take care of this conversion so that video transmissions received via the satellite can be fed to television networks with the correct standards for re-broadcast to the general public.

RELAY'S Frequencies

According to information given at the briefing conference, frequencies between 400 and 500 mc will be used for transmitting from the ground to the satellite, while frequencies in the 2200-2300 mc band will be used on the circuit from the satellite to ground.

The RELAY satellite is but one part of an experimental point-to-point space communications system. Very powerful ground transmitting stations will beam information to the satellite, while elaborate receiving facilities will pick up the signal re-broadcast from RELAY.

Low Altitude Satellite

It is planned to have RELAY orbit the earth once every three hours, with a high point of about 2800 to 3400 statute miles and a low point of 600 to 1600 miles. While this is higher than most satellites have been fired to date, it is considered to be a "low altitude" communications satellite in contrast to other systems recently proposed by several private communications organizations. These systems anticipate communication satellites orbiting much higher, at altitudes of 22,300 miles. At this distance, the satellite's rotation about the earth would be in synchronism with the earth itself, and it would appear to be stationary relative to ground stations. With a relatively small number of such "high altitude" satellites, it would be possible to have line-of-sight communications with almost any point on earth, at all times.

Many technical problems remain to be solved, however, before a high altitude satellite commun-

ications system can be demonstrated. NASA's RELAY project seems to be a giant step towards finding some of the answers.

We'll have more information on RELAY as plans develop towards its mid-1962 firing date.

Space Catalog

Radio transmissions may still be received from the following eight satellites:

Name	Period (Minutes)	Freq. (mc)	Type of Modulation
Vanguard I	134	108.022	Continuous Carrier
Explorer VII	101	19.9904	Frequency Modulation
Tiros I*	99	107.997	Continuous Carrier
Transit 2A	102	54,162, 216 & 324	Continuous Carrier, High Stability
Greb**	102	108.00	A.M. by Tones
Echo I	117	107.94	Continuous Carrier
Courier 1B	107	107.97	Continuous Carrier
Tiros II	102	108.00	Continuous Carrier

*The transmitter on Tiros I was designed to be shut off from the ground. Efforts to silence it, however, have so far been unsuccessful.

**The Greb listing was inadvertently omitted from the Space Catalog appearing in March. Many readers have reported reception of the Greb transmitter, and it is still active.

Explorer IX

On February 17, NASA placed Explorer IX into orbit. Launched from Wallops Island, Virginia with a solid fuel four-stage Scout rocket, Explorer IX is a 15 pound Echo-type balloon made of mylar plastic and aluminum foil. The balloon is 12 feet in diameter, small compared to Echo's 100 foot diameter, and will be used for obtaining information about the density of the earth's atmosphere at different altitudes extending deep into space.

The Explorer IX shot was marred by some difficulties. Although placed in orbit, the beacon transmitter on board failed during blast-off. A transmitter on the fourth stage of the rocket (on 136.35 mc) fortunately remained on the air for several days, permitting some degree of radio tracking.

Although not a complete success, the Explorer IX firing marked two important firsts in the U.S. satellite program:

1. It was the first time that the United States had successfully placed a satellite into orbit using a rocket fueled entirely with solid propellants;
2. It was the first time a satellite was launched from Wallops Island—the first time the U.S. has orbited a satellite from a site other than Cape Canaveral or the Pacific Missile Range.

S-45 Failure

An attempt to orbit NASA's S-45 ionospheric research satellite ended in failure on February 24th. The S-45 satellite was discussed in last month's column. A standby payload is now at the Cape and preparations are being made for another attempt in the near future.

73, George, W3ASK

PROPAGATION

George Jacobs, W3ASK
11307 Clara St., Silver Spring, Md.



LAST MINUTE FORECAST

The forecast indices for the month of May, shown in the Propagation Charts following the predicted times of openings, are expected to be related to day-to-day propagation conditions in the following manner:

Forecast Indices	Above Normal	Normal	Below Normal	Disturbed
	Days May 23-26	Days May 3-11, 18-22, 27-28, 31	Days May 1-2, 15-17, 29-30	
(1)	C-D	D-E	E	E
(2)	B-C	C-D	D-E	E
(3)	A-B	B-C	C-D	D-E
(4)	A	A-B	B-C	C-D

Where:

- A—Excellent circuit with strong steady signals.
- B—Good circuit, moderately strong signals, with some fading and noise.
- C—Fair circuit, signals fluctuating between moderately strong and weak, with moderate fading and noise.
- D—Poor circuit, signals weak, with considerable fading and very high noise level.
- E—Circuit not possible.

General Conditions

Fifteen meters is expected to be the best band for long-distance openings during the daytime hours. Although opening on fewer days than during the winter months, 15 meter reception is expected to peak to many areas of the world during the early afternoon hours.

Twenty meter openings to many areas of the world are expected to peak during the late afternoon and early evening hours. A second peak should occur for an hour or so after sunrise.

During the hours of darkness, reception should be best on 40 meters, with openings to some areas of the world also predicted for 80 meters. Despite higher static levels, don't overlook 160 meter nighttime openings, some fairly good ones are expected during May.

MAY & JUNE 1961

TIME ZONE: EST

EASTERN USA TO:

	10 Meters	15 Meters	20 Meters	40/80* Meters
Western Europe	NIL	7 A - 12N (1) 12N - 4 P (2) 4 P - 6 P (3) 6 P - 8 P (1)	4 A - 6 A (2) 6 A - 1 P (1) 1 P - 4 P (2) 4 P - 7 P (4) 7 P - 9 P (2) 9 P - 12M(1)	6 P - 8 P (1) 8 P - 11P (3) 11P - 12M(2) 12M - 2 A (1) 8 P - 12M(2)*
Eastern Europe	NIL	12N - 5 P (1)	5 P - 7 P (1) 7 P - 10P (2) 10P - 12M(1)	NIL
North Africa	NIL	7 A - 11A (1) 11A - 3 P (2) 3 P - 6 P (3) 6 P - 8 P (2) 8 P - 9 P (1)	4 A - 6 A (1) 12N - 3 P (1) 3 P - 6 P (2) 6 P - 8 P (4) 8 P - 10P (3) 10P - 1 A (1)	6 P - 8 P (1) 8 P - 11P (3) 11P - 12M(1) 8 P - 11P (1)*
South Africa	11A - 3 P (1)	6 A - 11A (1) 11A - 1 P (2) 1 P - 3 P (3) 3 P - 4 P (2) 4 P - 7 P (1)	1 A - 4 A (1) 1 P - 3 P (1) 3 P - 5 P (2) 5 P - 6 P (3) 6 P - 7 P (2) 7 P - 9 P (1)	8 P - 11P (1) 9 P - 11P (1)*
Eastern Mediterranean	NIL	1 P - 3 P (1) 3 P - 6 P (2) 6 P - 7 P (1)	4 A - 6 A (1) 2 P - 5 P (1) 5 P - 9 P (2) 9 P - 11P (1)	7 P - 11P (1) 8 P - 10P (1)*
Central Asia	NIL	3 P - 6 P (1)	5 A - 7 A (1) 6 P - 10P (1)	NIL
Southeast Asia	NIL	4 P - 6 P (1)	6 A - 8 A (1)	NIL
Far East	NIL	5 P - 7 P (1)	10P - 7 A (1) 7 A - 8 A (2) 8 A - 10A (1)	NIL
Pacific Islands	2 P - 6 P (1) 6 P - 8 P (2) 8 P - 10P (1)	8 A - 10A (2) 10A - 6 P (1) 6 P - 9 P (2) 9 P - 11P (1)	9 P - 11P (1) 11P - 6 A (2) 6 A - 8 A (3) 8 A - 10A (2) 10A - 12N (1)	2 A - 3 A (1) 3 A - 4 A (2) 4 A - 7 A (1) 3 A - 6 A (1)*
Australia	7 P - 9 P (1)	7 A - 10A (1) 4 P - 9 P (1) 9 P - 10P (2) 10P - 12M(1)	11P - 6 A (1) 6 A - 9 A (2) 9 A - 11A (1)	3 A - 4 A (1) 4 A - 6 A (2) 6 A - 7 A (1)
New Zealand	2 P - 5 P (1) 5 P - 7 P (2) 7 P - 9 P (1)	2 P - 7 P (1) 7 P - 9 P (2) 9 P - 11P (1)	8 P - 10P (1) 10P - 12M(2) 12M - 5 A (3) 5 A - 8 A (2) 8 A - 10A (1)	12M - 2 A (1) 2 A - 5 A (1) 5 A - 7 A (1) 2 A - 6 A (1)*
South America	7 A - 2 P (1) 2 P - 8 P (2) 8 P - 10P (1)	6 A - 7 A (2) 7 A - 9 A (3) 9 A - 3 P (2) 3 P - 5 P (3) 5 P - 8 P (4) 8 P - 10P (3) 10P - 1 A (2) 1 A - 3 A (1)	4 A - 7 A (2) 7 A - 3 P (1) 3 P - 6 P (2) 6 P - 8 P (3) 8 P - 1 A (4) 1 A - 4 A (3)	8 P - 10P (2) 10P - 2 A (3) 2 A - 4 A (2) 4 A - 7 A (1) 9 P - 3 A (2)* 3 A - 5 A (1)*
McMurdo Sound Antarctica	2 P - 5 P (1)	1 P - 4 P (1) 4 P - 6 P (2) 6 P - 8 P (1)	11A - 1 P (1) 4 P - 6 P (1) 6 P - 8 P (2) 8 P - 9 P (1)	10P - 3 A (1)

TIME ZONE: CST & MST

CENTRAL USA TO:

	10 Meters	15 Meters	20 Meters	40/80* Meters
Western Europe	NIL	12N - 2 P (1) 2 P - 4 P (2) 4 P - 6 P (1)	4 A - 6 A (1) 4 P - 8 P (1) 8 P - 9 P (2) 9 P - 10P (1)	8 P - 11P (1) 9 P - 11P (1)*

TIME ZONE: CST & MST, Con't.

CENTRAL USA TO:

	10 Meters	15 Meters	20 Meters	40/80* Meters
Eastern Europe	NIL	1 P - 3 P (1)	4 A - 6 A (1) 3 P - 7 P (1) 7 P - 10 P (2) 10 P - 12 M (1)	NIL
North Africa	NIL	8 A - 1 P (1) 1 P - 3 P (2) 3 P - 6 P (3) 6 P - 8 P (2) 8 P - 9 P (1)	4 A - 6 A (1) 12 N - 3 P (1) 3 P - 6 P (2) 6 P - 8 P (4) 8 P - 10 P (3) 10 P - 1 A (1)	8 P - 9 P (1) 9 P - 10 P (2) 10 P - 11 P (1) 9 P - 11 P (1)*
Central Africa	4 P - 6 P (1)	10 A - 12 N (1) 12 N - 3 P (2) 3 P - 6 P (3) 6 P - 9 P (1)	2 P - 4 P (1) 4 P - 6 P (2) 6 P - 10 P (3) 10 P - 12 M (2) 12 M - 3 A (1)	8 P - 11 P (1) 9 P - 10 P (1)*
Eastern Mediterranean	NIL	1 P - 5 P (1)	5 P - 7 P (1) 7 P - 9 P (2) 9 P - 11 P (1)	NIL
Central Asia	NIL	5 P - 8 P (1)	5 A - 7 A (1) 2 P - 5 P (1)	NIL
Southeast Asia	NIL	11 A - 2 P (1) 8 P - 12 M (1)	12 M - 5 A (1) 5 A - 8 A (2) 8 A - 11 A (1)	NIL
Far East	NIL	7 A - 9 A (1) 2 P - 6 P (1) 6 P - 9 P (2) 9 P - 12 M (1)	11 P - 6 A (1) 6 A - 8 A (2) 8 A - 10 A (1)	NIL
Pacific Islands	11 A - 2 P (2) 2 P - 5 P (1) 5 P - 8 P (2) 8 P - 10 P (1)	7 A - 11 A (1) 11 A - 2 P (2) 2 P - 5 P (1) 5 P - 9 P (2) 9 P - 2 A (1)	6 P - 8 P (1) 8 P - 10 P (2) 10 P - 2 A (4) 2 A - 5 A (3) 5 A - 8 A (4) 8 A - 10 A (2) 10 A - 12 M (1)	1 A - 5 A (3) 5 A - 8 A (1) 2 A - 5 A (2)* 5 A - 7 A (1)*
Australia	3 P - 8 P (1)	8 A - 10 A (1) 3 P - 5 P (2) 5 P - 8 P (1) 8 P - 10 P (2) 10 P - 12 M (1)	9 P - 11 P (1) 11 P - 6 A (2) 6 A - 9 A (4) 9 A - 11 A (2) 11 A - 3 P (1)	2 A - 3 A (1) 3 A - 5 A (3) 5 A - 7 A (2) 7 A - 8 A (1) 4 A - 7 A (1)*
New Zealand	1 P - 3 P (1) 3 P - 6 P (2) 6 P - 9 P (1)	11 A - 1 P (2) 1 P - 5 P (1) 5 P - 7 P (2) 7 P - 10 P (3) 10 P - 2 A (2) 2 A - 5 A (1)	6 P - 8 P (1) 8 P - 10 P (2) 10 P - 2 A (4) 2 A - 6 A (3) 6 A - 9 A (2) 9 A - 11 A (1)	12 M - 6 A (3) 6 A - 8 A (1) 1 A - 4 A (2)* 4 A - 6 A (1)*
South America	7 A - 11 A (1) 11 A - 2 P (2) 2 P - 4 P (3) 4 P - 7 P (2) 7 P - 9 P (1)	5 A - 7 A (1) 7 A - 9 A (3) 9 A - 2 P (2) 2 P - 4 P (3) 4 P - 7 P (4) 7 P - 9 P (3) 9 P - 1 A (2) 1 A - 3 A (1)	8 A - 2 P (1) 2 P - 6 P (2) 6 P - 11 P (4) 11 P - 1 A (3) 1 A - 8 A (2)	8 P - 10 P (2) 10 P - 1 A (3) 1 A - 4 A (2) 4 A - 6 A (1) 10 P - 2 A (2)* 2 A - 4 A (1)*
McMurdo Sound, Antarctica	12 N - 1 P (1) 1 P - 3 P (2) 3 P - 4 P (1)	11 A - 2 P (2) 2 P - 4 P (1) 4 P - 7 P (2) 7 P - 8 P (1)	4 P - 7 P (1) 7 P - 9 P (2) 9 P - 11 P (1)	10 P - 4 A (1)

TIME ZONE: PST

WESTERN USA TO:

	10 Meters	15 Meters	20 Meters	40/80* Meters
Northern & Central Europe	NIL	12 N - 4 P (1)	5 A - 7 A (1) 3 P - 10 P (1)	7 P - 9 P (1)
Eastern Europe	NIL	11 A - 1 P (1)	5 A - 7 A (1) 3 P - 11 P (1)	NIL
Southern Europe & North Africa	NIL	10 A - 1 P (1) 1 P - 4 P (2) 4 P - 6 P (1)	12 N - 4 P (1) 4 P - 6 P (2) 6 P - 8 P (3) 8 P - 10 P (2) 10 P - 6 A (1)	7 P - 9 P (2)
South Africa	NIL	11 A - 12 N (1) 12 N - 1 P (2) 1 P - 3 P (1)	2 P - 9 P (1) 9 P - 11 P (2) 11 P - 1 A (1)	7 P - 9 P (1)
Eastern Mediterranean	NIL	1 P - 4 P (1)	4 A - 6 A (1) 3 P - 10 P (1)	NIL
Central Asia	NIL	7 A - 9 A (1) 6 P - 10 P (1)	11 P - 8 A (1)	NIL
Southeast Asia	NIL	8 A - 10 A (1) 10 A - 12 N (2) 12 N - 10 P (1)	11 P - 1 A (1) 1 A - 3 A (2) 3 A - 6 A (1) 6 A - 8 A (2) 8 A - 1 P (1)	2 A - 6 A (1)

TIME ZONE: PST, Con't.

WESTERN USA TO:

	10 Meters	15 Meters	20 Meters	40/80* Meters
Far East	NIL	7 A - 9 A (1) 12 N - 7 P (1) 7 P - 10 P (2) 10 P - 1 A (1)	3 A - 6 A (1) 6 A - 9 A (3) 9 A - 11 A (2) 11 A - 9 P (1) 9 P - 11 P (2) 11 P - 1 A (3) 1 A - 3 A (2)	2 A - 5 A (3) 5 A - 7 A (1) 3 A - 6 A (1)*
Pacific Islands & New Zealand	11 A - 5 P (2) 5 P - 7 P (3) 7 P - 9 P (2) 9 P - 10 P (4)	9 A - 10 A (1) 10 A - 12 N (2) 12 N - 5 P (1) 5 P - 7 P (2) 7 P - 10 P (3) 10 P - 12 M (2) 12 M - 3 A (1)	10 A - 7 P (1) 7 P - 10 P (2) 10 P - 2 A (4) 2 A - 4 A (2) 4 A - 6 A (1) 6 A - 10 A (2)	11 P - 5 A (3) 5 A - 7 A (1) 12 M - 5 A (2)*
* Australia	2 P - 4 P (1) 4 P - 7 P (2) 7 P - 9 P (1)	7 A - 9 A (1) 12 N - 7 P (1) 7 P - 10 P (2) 10 P - 2 A (1)	6 A - 8 A (3) 8 A - 10 A (2) 10 A - 9 P (1) 9 P - 11 P (2) 11 P - 2 A (3) 2 A - 4 A (2) 4 A - 6 A (1)	12 M - 3 A (1) 3 A - 5 A (3) 5 A - 7 A (1) 2 A - 6 A (1)*
South America	7 A - 11 A (1) 11 A - 1 P (2) 1 P - 4 P (3) 4 P - 6 P (2) 6 P - 8 P (1)	5 A - 6 A (1) 6 A - 8 A (2) 8 A - 12 N (1) 12 N - 3 P (2) 3 P - 6 P (4) 6 P - 8 P (3)	2 P - 4 P (2) 4 P - 6 P (3) 6 P - 10 P (4) 10 P - 12 M (3) 12 M - 2 A (2) 2 A - 4 A (1) 4 A - 6 A (2) 6 A - 2 P (1)	7 P - 9 P (2) 9 P - 12 M (3) 12 M - 2 A (2) 2 A - 4 A (1) 9 P - 1 A (2)* 1 A - 3 A (1)*
McMurdo Sound, Antarctica	12 N - 2 P (1) 2 P - 4 P (2) 4 P - 6 P (1)	11 A - 4 P (1) 4 P - 6 P (2) 6 P - 7 P (1)	9 A - 11 A (1) 4 P - 6 P (1) 6 P - 7 P (1)	8 P - 6 A (1)

FORECAST INDICES

Circuits forecast to open:

- (1) Less than 7 days during each month of forecast period.
- (2) Between 8 and 13 days during each month of forecast period.
- (3) Between 14 and 22 days during each month of forecast period.
- (4) For more than 22 days during each month of forecast period.

A - A. M. P - P. M. N - Noon M - Midnight

See "Last Minute Forecast" in the text for the relationship between the Forecast Indices and the day-to-day propagation conditions expected during the month.

*Indicates expected 80-meter openings. On nights when atmospheric noise conditions are exceptionally quiet, 160-meter openings are likely to occur on circuits during those times 80-meter openings are rated (2) or higher.

The CQ DX Propagation Charts are based upon a CW effective radiated power of 150 watts at radiation angles less than thirty degrees. The Eastern USA chart can be used in the W 1, 2, 3, 4 and 8 areas; the Central USA chart in the W 5, 9 and 9' areas, and the Western USA chart in the W 6 and 7 areas. The charts are valid through June 30, 1961. Propagation forecasts contained in these charts are derived from basic ionospheric data published by the Central Radio Propagation Laboratory of the National Bureau of Standards, Boulder, Colorado.

There are plenty of NILS in the ten meter band column this month. The few DX openings predicted should occur on more or less north-south paths, during the daylight hours.

Static levels are expected to increase considerably on all bands during May, as thunderstorms become more numerous.

Sporadic-E propagation increases appreciably during May, and this should result in fairly numerous short-skip openings up to about 1300 miles on 15, 10 and possibly 6 meters.

A fairly large meteor shower, the *Aquarids*, is expected to occur during the first week of May. This should result in some meteor-reflection type openings on 10, 6 and 2 meters.

This month's Propagation Charts contain data for world-wide DX openings expected during May and June. See the "Last Minute Forecast" at the beginning of this column for the day-to-day conditions expected during May.

[Continued on page 110]

noted that the *space* tone (2975 cycles) is about 3 or 4 db lower in level than the *mark* tone (2125 cycles). This is normal.

Construction

The a.f.s.k. oscillator for the Twin City TU is built on a Millen #74400 shielded can plug-in assembly, like that used with the band-pass input filter described in last month's column. A hole is cut in the top of the shield can to ventilate the tube. Admittedly, things are a bit crowded in this particular arrangement. (We used what was in the junk box.) We would like to suggest that a larger "Mini-box," say 5" x 2 1/4" x 2 1/4", be utilized, with an octal plug mounted in one end. Such a box will also provide room for mounting an output control, which might be a very useful addition. This would be a 2000 ohm pot connected in place of the 1.8K cathode resistor of the cathode follower. The output coupling capacitor, of course, would connect to the arm of the pot.

Connections

Referring to the INPUT socket connections on the schematic of the Twin City TU, audio input at 600 ohms would be fed between ground (pin 1) and pin 3; or at 150 ohms (for bridging a receiver voice coil circuit) between ground (pin 1) and pin 6. The keyboard of the machine would be connected between ground (pin 1) and pin 7. Shielded wire should be used for this circuit to prevent any stray r.f., which might be floating around the shack, from getting into the diode switch and fouling up the keying. By the way, if there is an R-C spark suppression network connected across the sending contacts, be sure to disconnect it. Low impedance audio output of the two tones appears between ground (pin 1) and pin 8.

MARTS, Inc.

The Midwest Amateur Radio Teletypers Society, Inc., 1404 South Spring Street, Independence, Missouri, is greatly to be commended for tightening up the release of equipment. Before any equipment is released to a member he must sign an affidavit to contain the following information:

- 1—That he has either built or bought a TU and has it in operating condition.
- 2—That he has either built or bought a transmitting shifter, in operating condition, capable of either f.s.k. or a.f.s.k. and meeting the emission requirements of the FCC.
- 3—That the machine is the only piece of equipment necessary to get on RTTY.
- 4—That the above equipment is personally owned and not borrowed, leased, or rented in order to falsely obtain equipment.
- 5—That MARTS, Inc., shall have the right and privilege to ask for positive proof that the above requirements have been met.

Reason for the tightening up is that, in nearly four years of operation nearly 200 machines



K5OZO/AA5OZO RTTY from San Antonio, Texas.

Operator: James Knauss
Machine: Model 15
Terminal Unit: W2PAT
Receivers: SX-28; Drake 2A
Transmitters: TX-1; RCA, 6-meters

have been released, and a recent survey found less than one half this number actually on the air. MARTS, Inc. operates on a "request list" basis and serves the names in order, so it was felt that these new requirements would assure that those with TU's and shifters all built and ready would get the machines on the air much sooner.

Bob Atkeisson, WØIQC, is now President of MARTS, Inc. and D. L. McMullen, WØATM, is Secretary-Treasurer. Mac reports experimentation with narrow shift audio-type TU's with a center frequency around 600 cycles instead of the common 2550 cycles in order to utilize the greater selectivity available from the newer communications receivers. Mac would like to hear from any others working along those lines.

Across the Nation

WIMFJ of Auburn, Maine, demonstrated RTTY to the local radio club. George also reports the use of 2 meter f.m. gear for a.f.s.k. from Portland to the Lewiston/Auburn area. WIYDA near Presque Isle, Maine, worked G3BXI on 15. K1CLF reports four on RTTY in that area. W2BZN reports a rebirth of RTTY interest via a demonstration before the Rochester (N.Y.) Amateur Radio Association. K2MLT of Hammondsport, New York, has a Model 26 for sale. K2EWB of Woodmere, Long Island, New York, is on 20. Old timer RTTYer Ed Clammer, ex-W2BDI, is now back on RTTY with the call K3GIF.

[Continued on page 112]

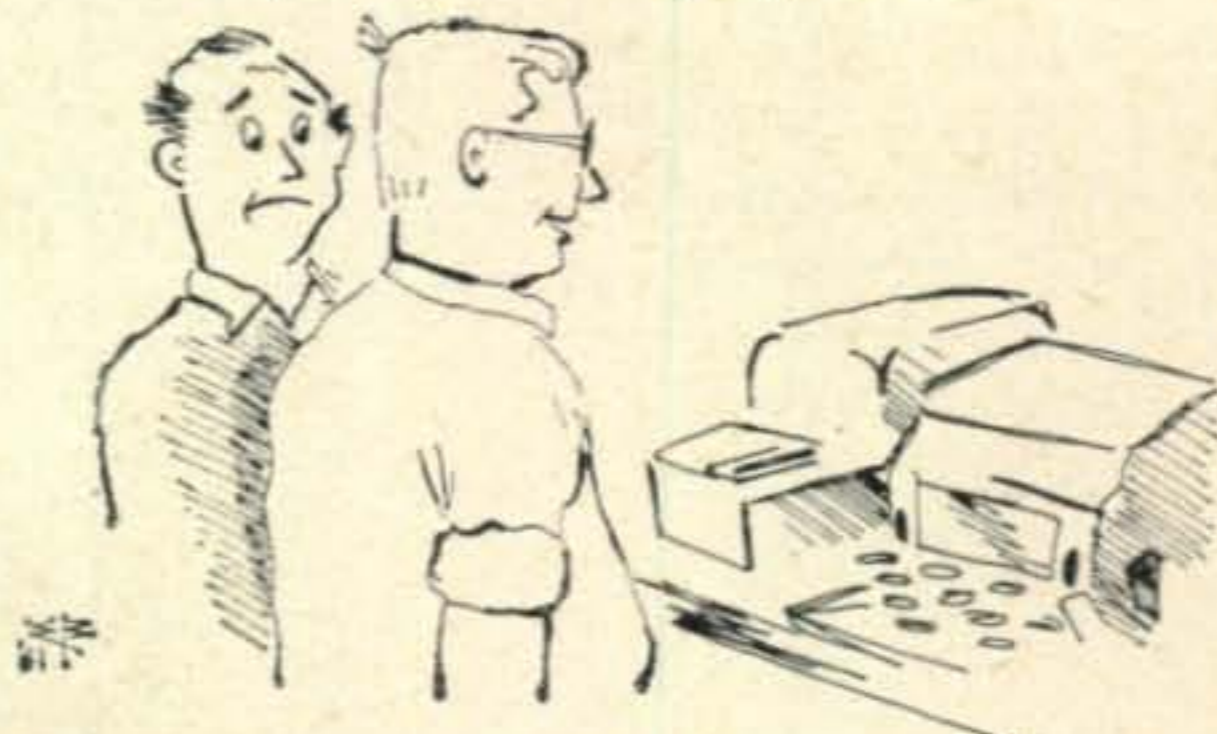

"So it was a steal at fifteen bucks, . . . but who needs a chinese alphabet?"



semiconductors

Just as I was about to post the SEMICONDUCTOR COLUMN to the waiting arms in New York, I received a letter which changed my plans considerably.

From Leo F. Gorzkowski, W4RDM, 2623 Locom Lane, Arlington, Va., I received details of a transistorized version of the TNS noise silencer. Quite candidly, I have been playing with the circuit off and on for several years without success. Leo has several novel ideas which make the difference between success and failure. I have not had the opportunity to test the circuit, because of the fast approaching deadline, but I see no reason why it should not perform as he says. To quote from his letter:

"In the process of building a transistor mobile receiver, and obtaining proper operation, it became apparent that none of the conventional noise limiter circuits were satisfactory. The series, shunt and four diode compound full-wave adjustable threshold limiters were tried and none compared favorably with the TNS used in conjunction with the present 1.4 volt battery tube mobile receiver or the TNS used in the home receiver. Eventually, the circuit shown (fig. 1) was tried after considerable experimentation. This was also used in the home station receiver. The results were identical to the TNS used, with additional characteristics of full limiting and compression. This latter characteristic had advantages on c.w. reception although the adjustment is critical. It is possible to bring about an almost complete phase cancellation or bring all signals and noise to the same level. The squelch is effective if desired but under heavy noise conditions the squelch level and optimum noise limiting setting do not correspond."

"The parts used in construction should be as small as possible. The regular size 0.1 mfd capacitors were tried but proved unsatisfactory because of noise pulse radiation and pickup, due to their large size. Parts are mounted on both sides of a phenolic sheet measuring 1 1/4" x 2 1/2" by drilling holes in the proper locations. Transistors and diodes are soldered in last, using short insulated sleeving over the leads. Use tweezers or long-nose pliers to hold the leads while connections are made to prevent damage or change in semiconductor characteristics. Both transistors should be the same type, although different types were tried and operation was successful. One version used sockets for transistors which permitted greater spacing between parts to minimize noise feedthrough or pickup."

The squelch threshold adjustment characteristic can be varied by slight changes in R_3 , R_9 and R_{10} . A higher output from the receiver i.f. requires higher bias on the transistors. Resistor R_9 should be selected to give a nosignal collector current of 1 to 3 ma through TR_1 . The value of R_3 , R_9 or R_{10} may be made to give complete limiting on c.w. If very high back-resistance diodes are available, such as those used in computers, all resistance values may be increased by the same multiplication factor and capacitor values divided by the same factor. The bias on each transistor base should be the same—about -0.2 volts. The demodulator circuit shown provides greater output than conventional circuits. When used with a tube receiver, the positive 9 to 15 volts may be obtained from the cathode of the audio output tube."

Leo's circuit should prove to be a real boon

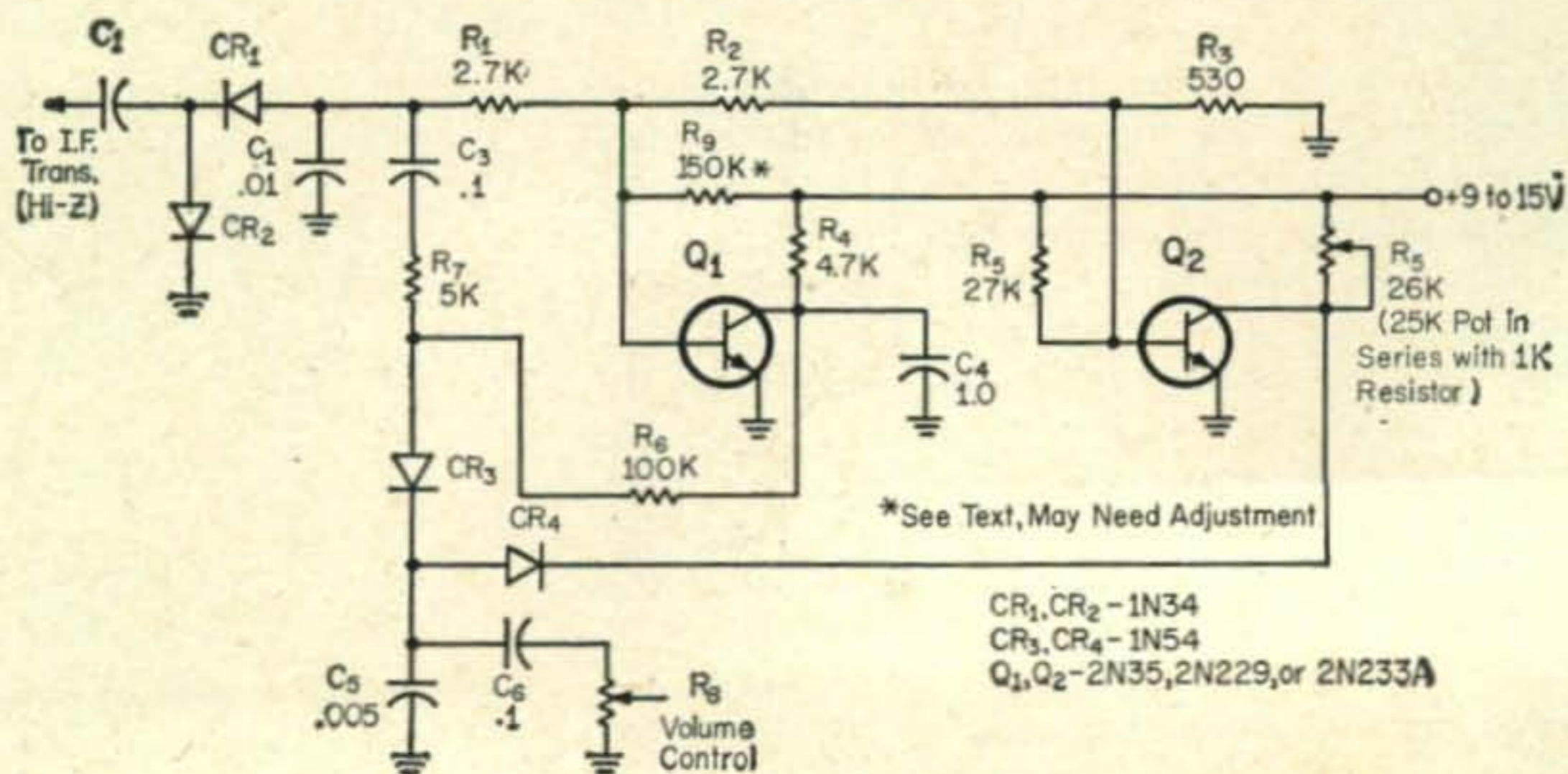
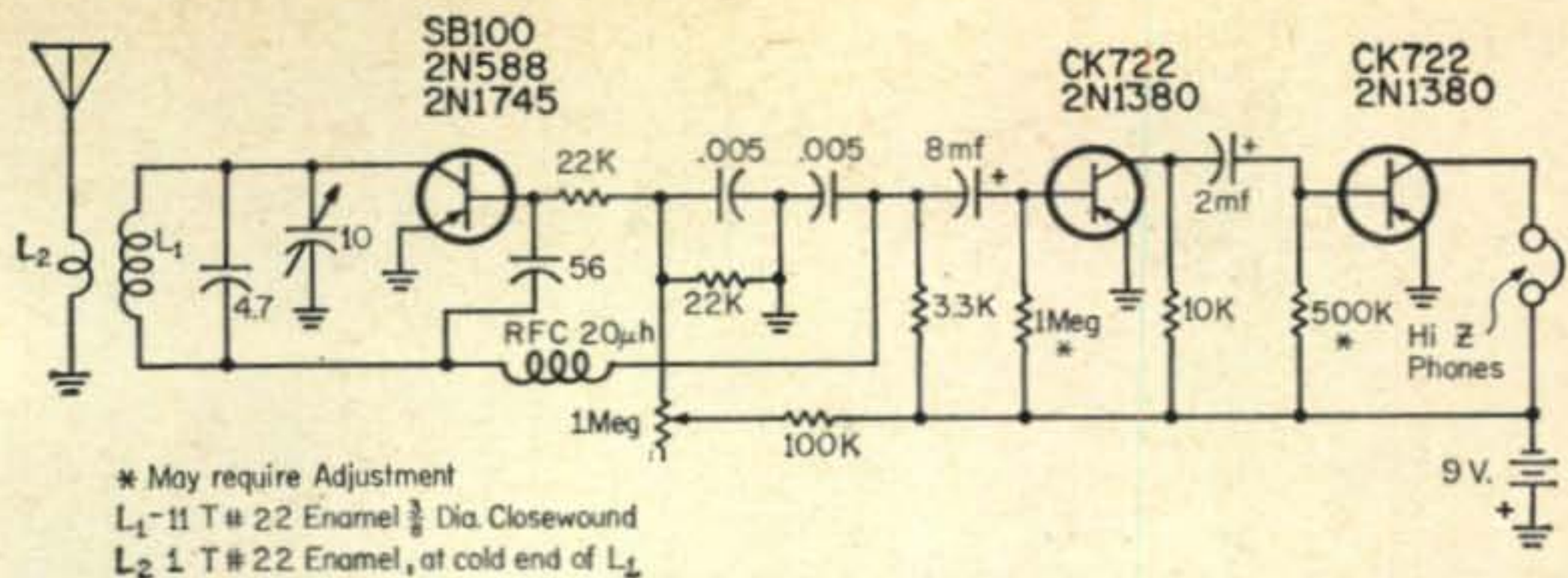

Fig. 1—Schematic diagram of the TNS transistorized noise silencer designed by Leo F. Gorzkowski, W4-RDM.

CR₁, CR₂ - 1N34
CR₃, CR₄ - 1N54
Q₁, Q₂ - 2N35, 2N229, or 2N233A

Fig. 2—Receiver section of the transistorized six meter handie-talkie built by Tony Sawicki, K1CRD.



* May require Adjustment
 L₁—11 T # 22 Enamel $\frac{3}{8}$ Dia. Closewound
 L₂ 1 T # 22 Enamel, at cold end of L₁

to mobile amateurs. All TNS circuits to date require a B+ voltage of at least 150 volts, which rules out (or at least complicates) their use with hybrid or transistorized automobile receivers. Note that a positive supply line has been used since most automobiles have the standardized negative ground.

Six Meter Handie-Talkie

Tony Sawicki, K1CRD, Birchwood Drive, Ansonia, Conn., combined the W6TNS Six meter receiver circuit (July 1959 *Electronics World*) with the 'Lil Nic transmitter into a superb six meter handie-talkie package measuring 1 $\frac{3}{8}$ " x 2 $\frac{3}{8}$ " x 5 $\frac{1}{8}$ ". The unit runs about 27 milliwatts input and Tony has worked one mile whip-to-whip and six miles with a 5 element beam. Also while cutting his lawn on a riding mower he worked K1AQB mobile. For the "I've heard of everything department," is this the first instance of lawn mower mobile?????

tuned by variable piston capacitors. The amplifier is matched to the source and load through the use of variable series matching capacitors.

It is difficult to obtain satisfactory operation as a straight class C amplifier using self bias due to excessive input loading. Ten milliwatts of r.f. at 420 mc is required to produce a collector current of 0.5 ma. The output under these conditions is about 3.0 milliwatts. This difficulty in driving the amplifier with self bias becomes evident at input frequencies above 350 mc.

A straight amplifier biased from a battery source, so that it operates as a class A amplifier, is more practical. Based on gain obtained at 200 mc, the gain measured at 420 mc indicates that the performance of the amplifier follows the 6 db per octave slope. It is necessary to ground the case of the transistor to minimize effects of feedback.

The frequency multiplier (Fig. 4) employs a linear tank circuit in the output and a conven-

Fig. 3—Schematic for the 420 mc amplifier using the 2N1742 MADT transistor.

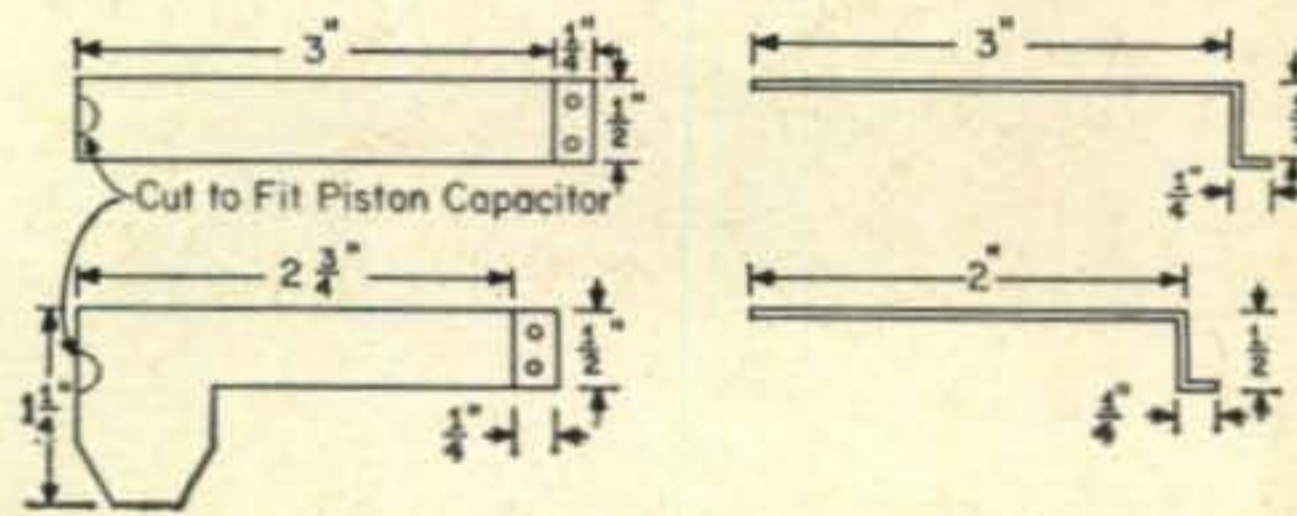
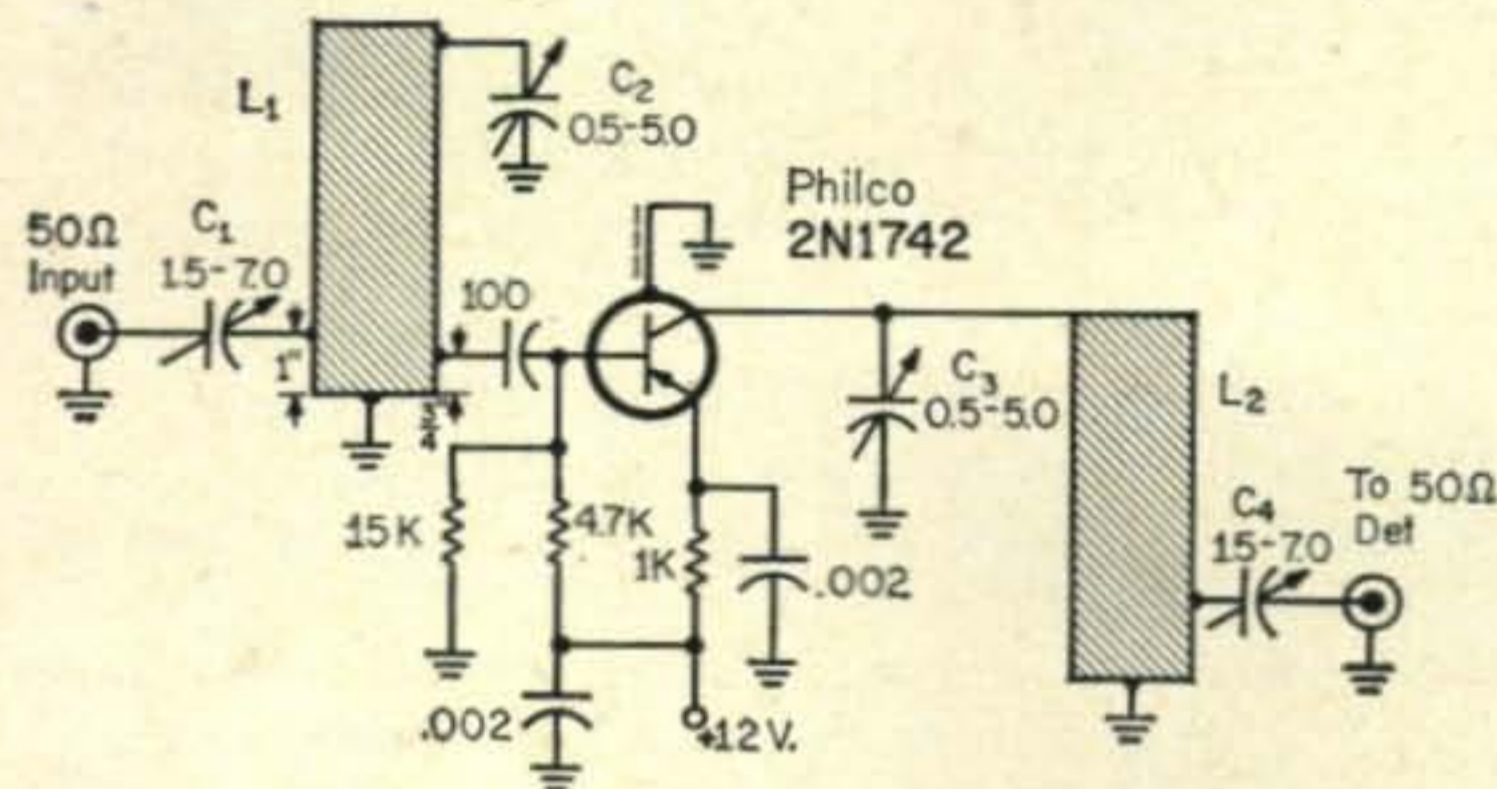

Philco MADT Transistors on 420 Mc

A new application lab report, #684, describes the use of the Philco 2N1742 v.h.f. MADT transistor on the 420 mc amateur band. Test results show that the transistor provides useful gain at this ultra-high frequency.

The circuit, Fig. 3, employs linear tank circuits in both the input and output which are

tional lumped circuit in the input. The input circuit is normally tuned to 210 mc for doubling. An additional 6.8 mmf capacitor is required across the input tuning capacitor for operation as a tripler. The input frequency in this case is 140 mc. Series capacitors are used to match the multiplier to the source and load.

The common base circuit (Fig. 5) is quite

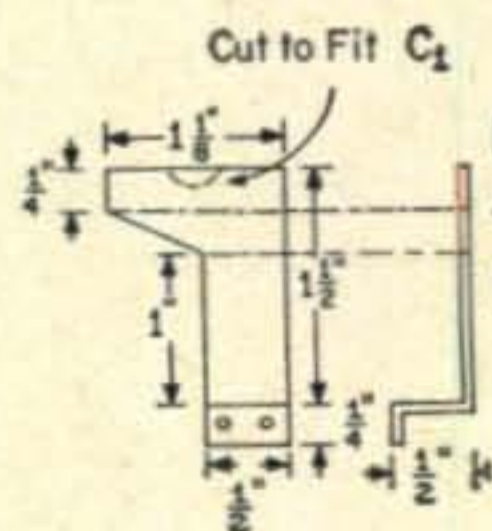
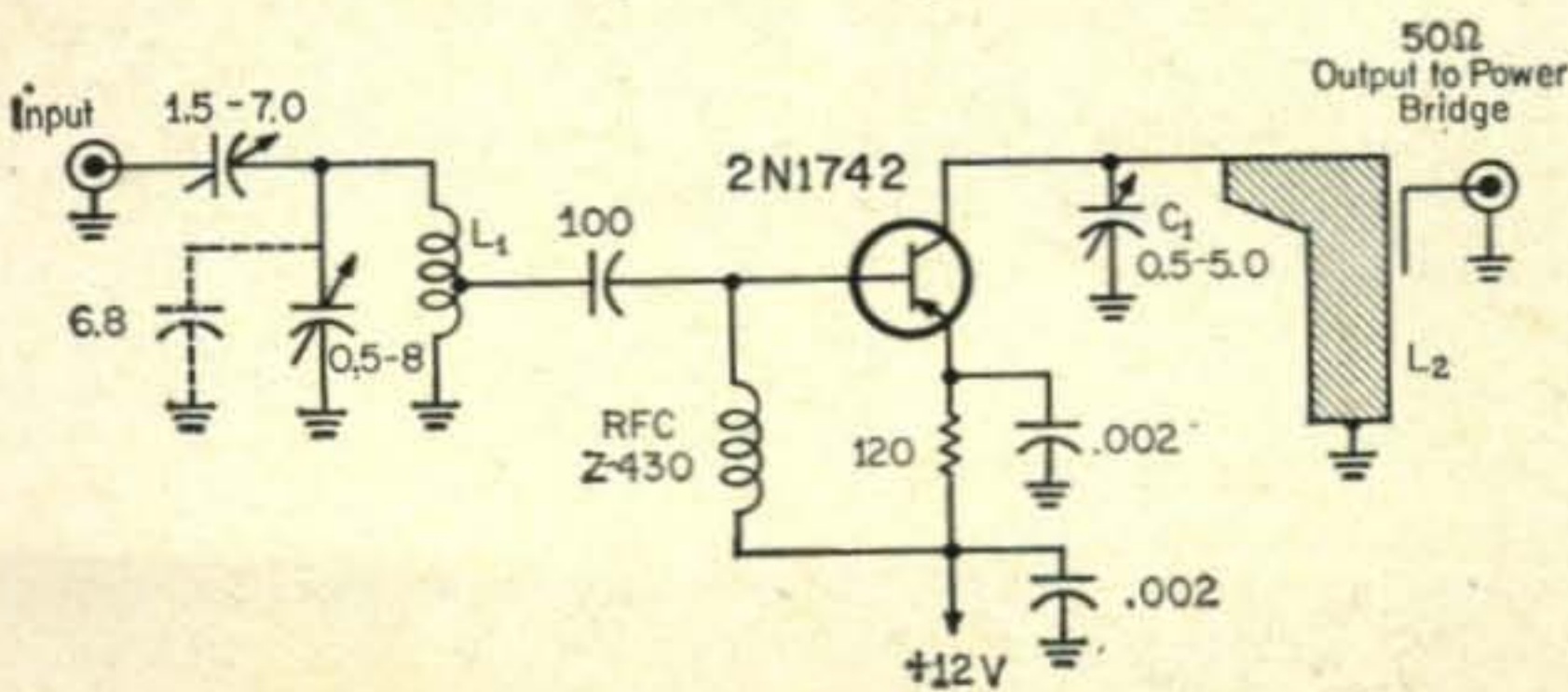

Fig. 4—Schematic for the 420 mc frequency multiplier using the 2N1742 MADT transistor.

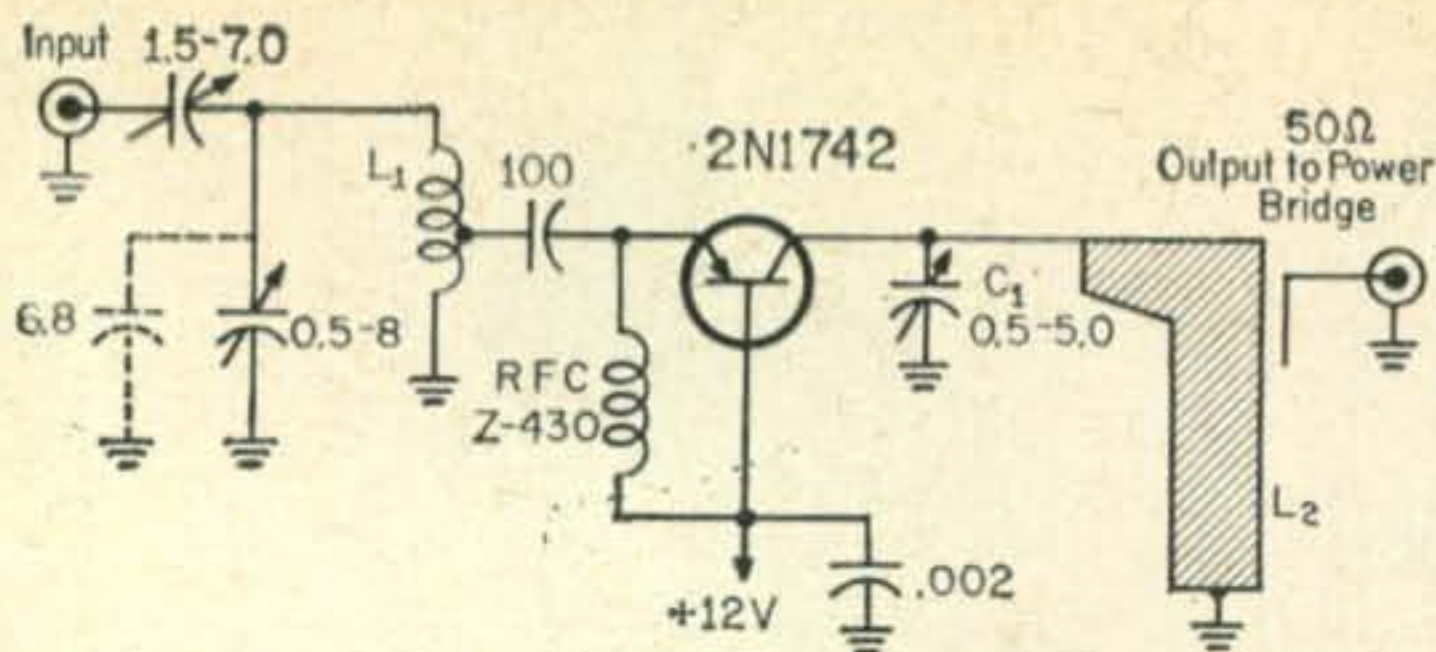

Fig. 5—Common base frequency multiplier for 420 mc.

similar to the common emitter except for the configuration. Performance data in the chart indicates that as a doubler the output is good. Tripling does not appear to be satisfactory.

Semiconductor Shirt

I have often wondered why enterprising manufacturers of wallpaper, drapes, lampshades and such, did not cater to the amateurs. It would appear that the large group of radio amateurs would be eager customers for items to dress up the ham shack.

Savada Bros., Inc., manufacturers of boys' wear are marketing a novel shirt which has a print of semiconductor symbols. The shirt, which comes in boys' sizes 6—20, will be available this Spring at department and specialty stores priced at approximately \$2.98. If you're a little guy, like me, the size 20 fits fine and is really the hit of ham clubs and conventions. Let's hope more companies will bring out apparel slanted to the amateur fraternity.

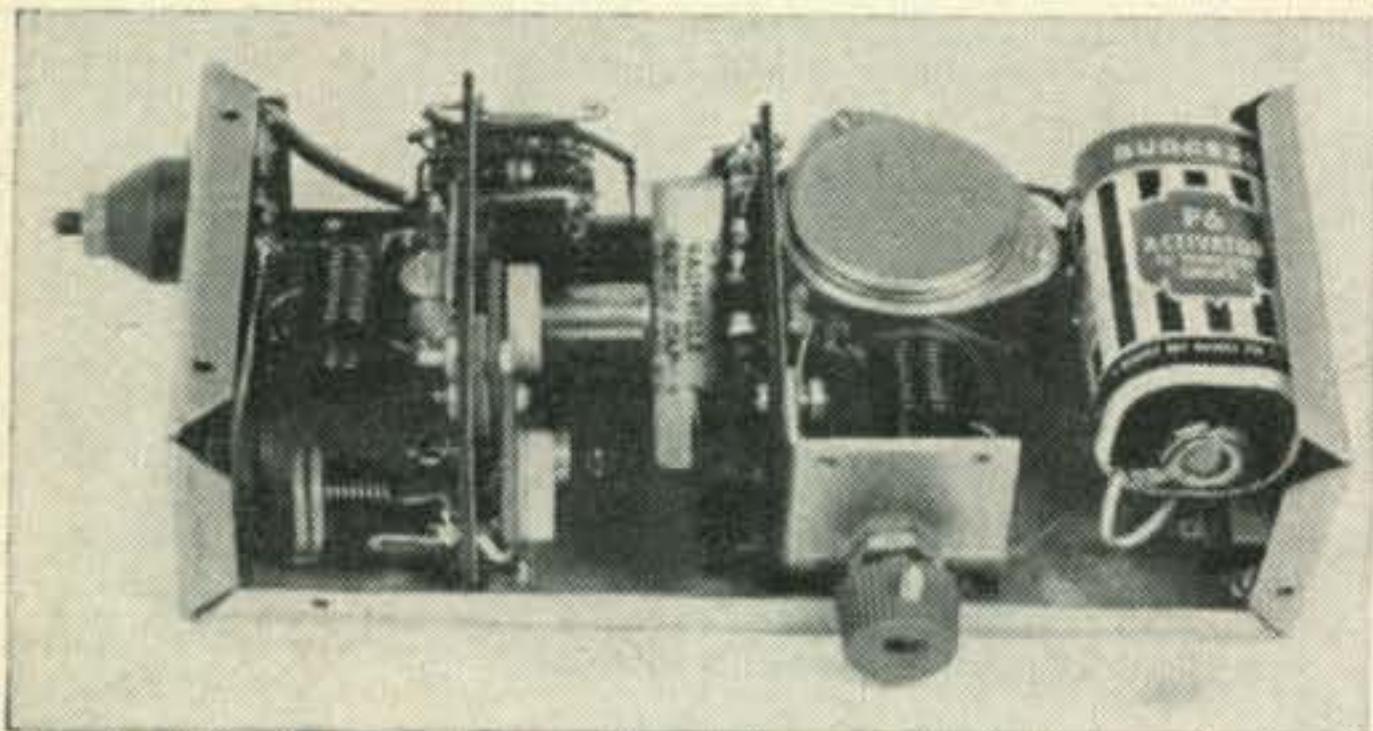

A beautiful piece of packaging by Tony, K1CRD. This transistor transceiver for six combines the 'Lil Nic circuit with the one shown in Fig. 2.

Semiconductor News

General Electric Co., has announced a 41% price reduction on three industrial models of silicon unijunction transistors. The new prices range from \$1.80 to \$2.15 in quantity. GE's potted low current silicon rectifier circuit assemblies have been reduced in price by 22 to 46 percent.

The December issue of *International Rectifier News* describes several interesting methods of protecting circuits with zener diodes. Also of interest from International is their new 1 and 10 watt Mil-approved zener regulators. New silicon photocells capable of reading 10,000 characters per second (response time 5 to 20 microseconds) are interesting to users of perforated tape and punched card data reading systems. For more information, ask for bulletin

SR-261 and SR-280 (IR, El Segundo, Calif.) A new 5 ampere controlled rectifier, available between 50 and 400 volts, features rapid switching time (1 to 5 μ sec.) and is described in Bulletin SRX-355.

Philco Corp., Lansdale, Pa., have just introduced their SPAT (Silicon Precision Alloy Transistor) PNP devices. The strip alloying process permits an accurate measurement of the diode voltage and beta of every SPAT transistor during the manufacturing process. Further, each transistor is indexed on a precision carrier which guides the device into a minified alloying furnace and positions the device in perfect alignment with the heat source. In this manner every transistor is heat-treated identically.

Spectrol Inc., 1704 So. Del Mar Ave., San Gabriel, Calif., is making an intriguing series of subminiature potentiometers in transistor cases. Shown in the accompanying photograph, these devices can be plugged into a regular transistor socket for rapid changing.

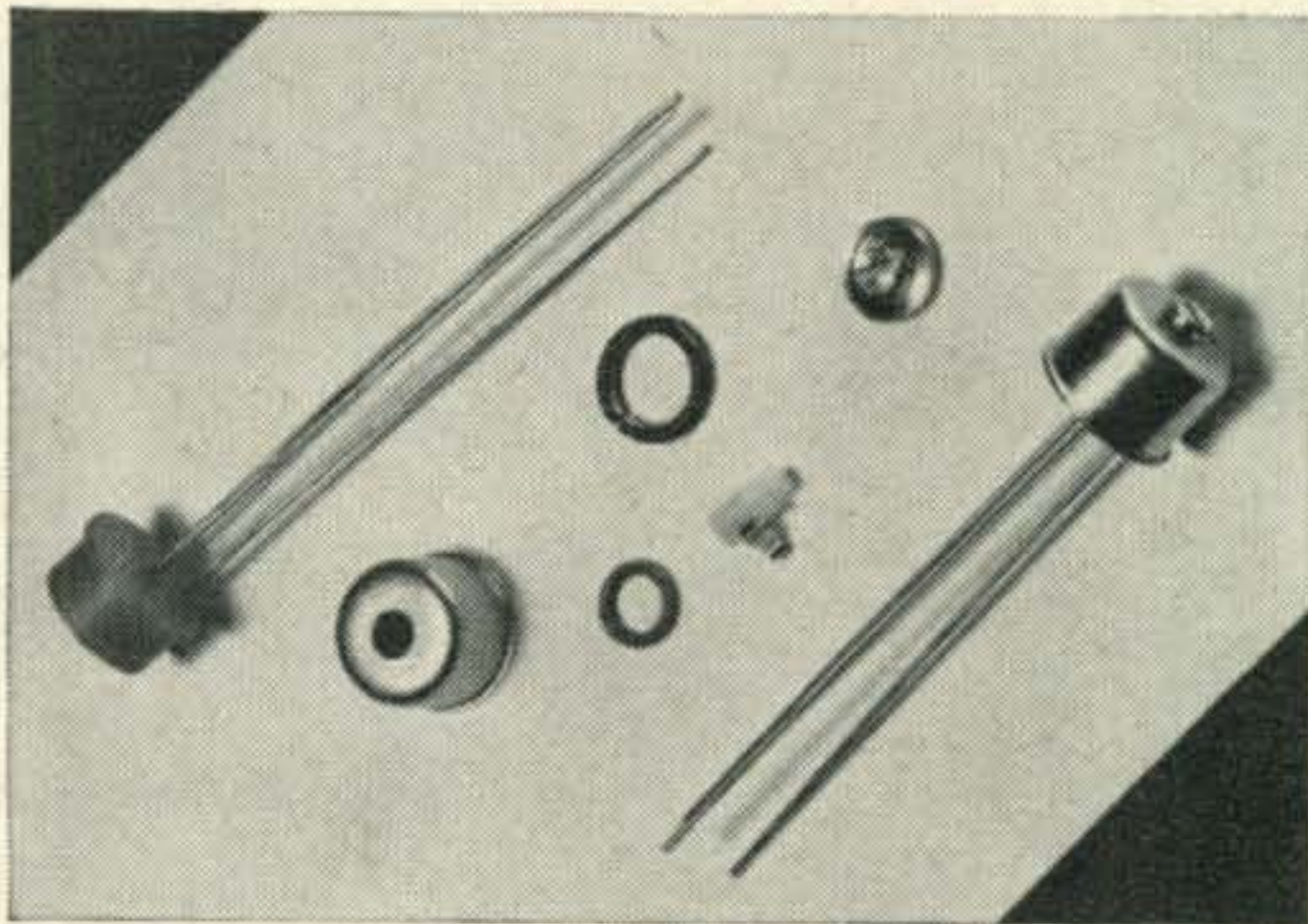

Miniature wire-wound potentiometers by Spectrol, Inc., are the same size and actually plug into transistor sockets.

The latest issue of Hoffman's *SPAN* describes an application for their solar cells, reliability of zener regulators, and several novel uses for the silicon tunnel diode.

Texas Instruments, Dallas, Texas, is marketing what is said to be the world's fastest silicon switching transistor. The new device, an epitaxial mesa unit type, 2N743 has a maximum switching time of 26 nanoseconds at 10 ma. A "slower" transistor, the 2N744 features a total switching time of 27 nanoseconds at 10 ma. Applications for these devices are described in TI's information bulletin, file #61-2. Also new from TI is their MICRO/G diodes which are actually smaller than the head of a pin. The package diameter is .040", length of .060" which provides a volume reduction of 50:1 over conventional diodes. Of particular interest to experimenters and amateurs is TI's low profile TO-36 industrial type transistors. The new series features 150 watts dissipation and includes the 2N173, 277, 278, 441, 442, 443 and 2N1099. The rating V_{eb} is as high as 80 volts in some units.

That's all the news and new circuits for another month. For now, 73, de Don, W6TNS

VHF

50mc. 144mc. 220mc. 420mc. and above

BOB BROWN, K2ZSQ
67 RUSSELL AVENUE
RAHWAY, NEW JERSEY

Aurora—Guest Editorial

To aid us this month in our propagation analysis we have selected an article written by Harold Grace, W3HFY, of Havertown, Pennsylvania, in the Philadelphia Mobile Sixers publication, *Six Only* . . .

"The following is presented for those who have observed or worked v.h.f. aurora, and who may be interested in recent IGY findings concerning this mode of propagation. The following material has been abstracted from three recent papers appearing in *The Journal of Geophysical Research* . . .

"Among the most interesting features of aurora reflected signals are their spectral characteristic which results in the garbing of a.m. phone and characteristic note of c.w. signals. It has been shown that c.w. signals reflected from the aurora have their spectra shifted and spread by as much as 300-900 c.p.s. at frequencies of 50-150 mc, and as much as 2.5 kc at operating frequencies of 400 mc. The following shows a typical transmitted and received (aurora reflected) signal for c.w. emission, illustrating both the Doppler shift and the Doppler spread in frequency spectra occurring. .

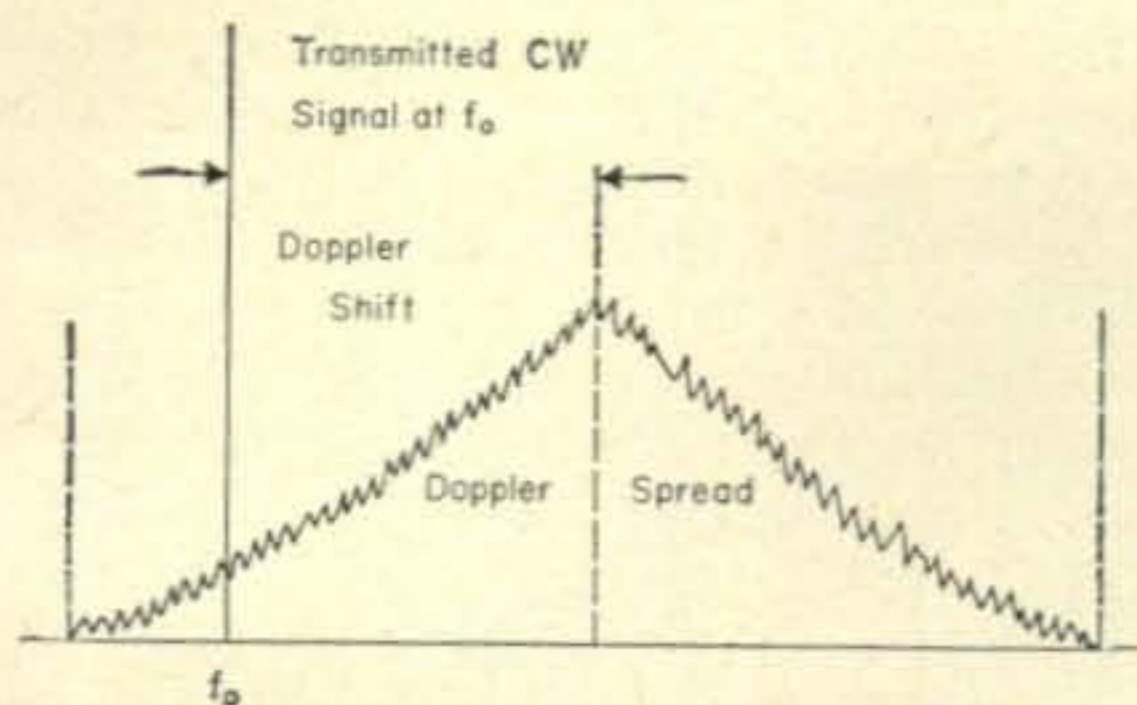

"The frequency components of the reflected signal fluctuate in amplitude in a noise-like fashion at a rate faster than the response of any spectrum analyzer used to date. The frequency shift may be either up or down, and may pass from one side through zero to a shift in the opposite direction over periods of time as short as one hour.

"Recent studies by Stanford Research Institute at both Palo Alto, California, and at College, Alaska, on frequencies of 50-400 mc using antennas of 3° beamwidth with both c.w. and pulse signals have shown:

1. That Doppler shift data indicate a predeominately east-west motion of the auroral forms. The velocity of motion is 500 meters/sec., and is independent of time of day.
2. That the magnitude of the Doppler spread on the reflected signal is proportional to frequency over the v.h.f.-u.h.f. range, *i.e.*, the spread at 144 mc is roughly three times that at 50 mc and that at 432 mc is about eight times that at 50 mc. Thus received signal distortion becomes progressively worse as the frequency is raised. It appears that this Doppler spread is due to a spectrum of different velocities of individual auroral reflectors in each small volume as would result from small scale turbulence.
3. That the Doppler shift appears to be unrelated to the position in space of the aurora.
4. That the magnitude of Doppler shifts and spreads for both discrete and diffuse echo returns is similar at a given frequency and is independent of local time.

"Using antennas of 3° beamwidth and frequencies from 50 to 800 mc, auroral signal returns (echoes) have been characterized as discrete (appearing over only a very narrow range of beam headings).

"Discrete echoes generally correspond to visual forms of aurora. For these discrete echoes, increasing signal frequency results in decreasing echo amplitude and decreasing average duration. These discrete echoes or reflections drift in position and are generally unstable in that they appear and disappear in a few minutes. Their occurrence shows a broad peak centered around local midnight, and they are most frequent during the winter months.

"Diffuse echo returns, on the other hand, do *not* correspond to anything seen visually. At all operating frequencies both large layers of reflection and isolated echoes are seen. All diffuse echoes are generally stable in that the echo remains unchanged once it is established, and, excluding a rapid fade rate, the duration of the echo return is long, *i.e.*, of the order of hours. The occurrence of these diffuse echoes shows two broad peaks, one centered at 0800 and the other at 1600 local time, while they appear to occur over the entire year in a randomly distributed manner seemingly related to solar activity.

"The variations of auroral echo power with operating frequency are poorly understood. For

discrete echoes, echo power decreases in direct proportion to increase in frequency up to about 400 mc, and then abruptly decrease over a thousandfold for a further doubling of frequency. For diffuse echo returns, echo power decreases as the inverse square of increase in operating frequency up to at least 800 mc, *i.e.*, the strength of the echo return at 200 mc is $\frac{1}{8}$ that at 50 mc and that at 400 mc is $\frac{1}{16}$ that at 50 mc.

"Although many characteristics of auroral signal returns have been defined, important questions remain concerning the effect of frequency of the probability of occurrence, the maximum frequency at which auroral propagation can occur (above 800 mc), and the latitude dependence of auroral propagation.

". . . So much for the scientific status of auroral propagation. However, in closing I would like to add a few pertinent observations drawn from amateur operating experience. The severe distortion of a.m. phone signals appears to result largely from the Doppler spread of the carrier rather than the Doppler spread of the sidebands. Thus reception of a.m. signals can often be improved from R0 to R2 or R3 by insertion of a stable carrier with your b.f.o. using the maximum of received selectivity (*i.e.*, using s.s.b. receiving techniques). Experience by the writer and many others with s.s.b. has shown this mode capable of getting through R4 to R5 signals on most 50 mc auroras when a.m. signals are unreadable."

Hamfest and Conventions

April 29, 1961: The Dayton Hamvention, at the Dayton Biltmore Hotel, Dayton, Ohio. If you can possibly make this affair, get there! This year promises to be the biggest and best yet with . . .

The V.H.F. Forum on Saturday, April 29th, at 900-1200 hours. Moderator will be Larry Brandenburg, W8TEK. Speakers will include Sam Harris, W1FZJ, and Bob Gooding, W3OII.

A Hidden Transmitter Hunt on 432 mc (!) at 1300-1330 hours on Saturday.

A talk on Semiconductors by Don Stoner,



Here is Richard Gibson, W8TY, at the controls of his TV station inside the Hotel at last year's Dayton Hamvention.

W6TNS, Semiconductor and Novice Editor, of *CQ*, 1540-1630 hours, on Saturday.

The Main Banquet on Saturday night at 1900 hours will feature Dana Atchley, W1HKK, President of Microwave Associates.

There are many other interesting things on the program so there will be no dull moments! This will be an outstanding ham gathering with an expected attendance far surpassing 2,000!

June 18: The Northeast Ohio V.H.F. Group is now preparing for its sixth annual Picnic to be held at Sunset Park, on Route 619, near Alliance, Ohio. The expected attendance should well top last year's record of 1,000! For further information write to the Chairman: Dave Butcher, K8NZU, 347 Wall Street, Ravenna, Ohio. And, before we forget, there will be plenty of big prizes! Don't miss it!

European News—G2DHV

A new reporter this month is George Haylock, G2DHV, of Sidcup, Kent, England . . .

"Conditions were good early March and the two recent v.h.f. contests here were *well* supported!

"From my log during the last nine months the following were active: G8DV/P, G3LCK/P, G2HIF/P, G3FKO/P, G3JZW/P, G3CZZ/M, G2DTO/P, G3LCH/P, G3FXG/P, G3JEM/P, G3JFH/M, G2DHV/P, G6NW/M, G3FRV/M, G3JMA/M, G6OX/M, G6YP/M, G3FP/P, G3FD/P, G3NNE/P, G3HGE/P, G3FEX/M, G3JMA/M, G3LAR/P, G3BA/A, G3BBR/A, G4AU/P, G3DIV/P, G2DSP/P, G3LTF/P, G3MI/P, G3OTS/P, G3AS/P, G3GKH/P, G8LM/P, G3DBO/P, G3KMT/P, G3AEX/M, G3ZZ/M, G3OBD/P, ON4ZN/P, F3LP, F9EA, PAØLQ, GW3DFF, F9II, F9MZ, F3NG, PAØWAR, and GW3GFY—which really shows the portable/mobile activity in the United Kingdom!

"The Radio Society of Great Britain (R.S.G.B.) v.h.f. band plan for two meters starts on 144.0 mc with South West England (Devon) across Southern England to London on 145 mc then to GW/GI and up north to Scotland at 146 mc. This will give you an idea where to look for area QSO's!

"The meteor shower in January produced G3CCH/OH1NL contact and G3HBW/HB9RG with OH1NL/OK2VCG two good QSO's. GM2FHH/OK2VCG and G8AO/MM contacts with two stations. Aurora contacts by SM6PU were DL1RX, DL1PS, DJ5HG, SP5PRG, UR2BU, OZ7IGY, LA4YG, LA4RD, LA3AA, LA9T. Scottish activity includes GM3DIQ, GM3DDE, GM2FHH, GM3GUI, GM4HR, GM3HLA/A, GM3BCD, GM3LAV, GM3FMD, GM2CHN, GM2DPW, and GI5AJ. Europe gave OH4VN, PAØCML, F8MW, F9NW, SM7BAE, and Germany, DJ5LZ, DL2XM, DL3FM, DJ5WC, DL3NI, DJ4OB, DJ1VK, DJ6BB, DL3VJ, DJ2FS, DL1PS and DJ6BN.

"420 mc stations are OE5HEP, G3MXT/T, and F2ZD.

"Four meters includes: G3NWX, GM3FHH, G2AYJ, G3MNQ, G3KPT, G3LZH, G3LZN.

"23 centimeters has G3KPT, G3HAZ.

"70 centimeters, G2XV, G2DQ, G3LTF, G3LQR/T, G3FIJ, G3CCH, G3MED, G3MXW, G3DFL, G3HXN, GW3MDY, G2CIW, G3KPT and G3HAZ.

"Cambridge University Station GD6UW was on 144.87 mc from April 5 to April 12 on an expedition to the Isle of Man.

"Jodrell Bank picked up the Russian Venus probe on 922.8 mc.

"UR2BU worked OH1NL, UQ2KAX, SM5ANH (870 km), the latter being the DX record for the USSR.

"SP5PRG, SP3GZ, SP3PK, SP1NK, SP1ABK, SP6LB, SP6PC, SP6FZ, SP6XU, SP6CT and IIXD are also active." *Wow! Really sounds like you fellows have put a big dent in the v.h.f. bands over there George! Keep us posted, and we'll keep waiting for a good F2 opening.*

More On Antennas

As you will remember, last month we discussed balance in an amateur v.h.f. station and application of a good antenna. The antenna is the only medium which will aid you in transmission as well as reception and with equal distribution. Therefore selection of a good antenna can well make the difference between snagging that choice DX and not even hearing it.

The trend over the last decade seems to be toward the long-john Yagi, the bigger the better. There was a time not too many years ago when the majority of stations on 144 mc were vertically polarized, with whips and what-have-you. Infiltration of the Yagi, probably due, in part at least, to commercial production of this type, seems to have completely taken over. 50 mc appears to be the long-time stalwart of horizontal polarization and the Yagi antenna, possibly accounted for by a faster moving population and earlier use. 220 and 432 are now primarily dominated by Yagis, but here other types have been put into use recently. In conclusion the long-john Yagi seems to be synonymous with v.h.f. . . . *But are we forgetting something?*

The true Ham spirit of experimentation, trial and error, has lost ground tremendously over recent years. Domination by the Yagi has all but left behind painstaking efforts by earlier pioneers in search of a better antenna to use at the v.h.f. frequencies. Admittedly, commercial manufacture of these long-johns has played a major role, resulting in a situation where it is actually less expensive to purchase a Yagi than it is to build one. But what has happened to vertical arrays, collinears, "bed-springs," helixes, slots, etc? We musn't close our minds to these other efforts. These antennas are good, some quite outstanding, but they have been left behind in a great sweeping attitude of "leave well enough alone," etc. Great records have been made recently using stacked Yagis over rough, long distance paths—But these same efforts

could have also been successful using, for example, vertical polarization. The pros and cons of horizontal vs. vertical have been batted back and forth for years, but the fact remains that there are other means, and sometimes vertical polarization will prove more successful; sometimes horizontal will come out on top; but neither should entirely dominate our thinking. We must leave our minds open to more experimentation in an effort toward a better v.h.f. antenna. A typical example was noted in a recent letter from Jack Reich, KL7AUV, commenting on news in his area . . . "An interesting development so far is that KL7CNN, Anchorage, and KL7IS, Minchumina, get best results from vertical polarization, apparently knife edge over Mt. Foraker. KL7DJI, in Nenana, can hear KL7CNN in Anchorage only if they use cross polarization. Apparently this is a bounce off the side of Mt. McKinley. KL7CNN has tried a circularly polarized array which does not improve his signal to Minchumina, and Nenana cannot hear him at all!" There are indeed many variables to be considered when trying to analyze a situation like the one reported by Jack, but in the overall concensus, neither circular, vertical, or horizontal seems to come out on top consistantly. Don't be satisfied to "fit in" with what the gang is using in your area, because it won't always work out best for *you*. The field of further antenna experimentation is wide open for further developments. We'd like to hear what you've come up with. Who knows? If enough fellows found substantial success with helixes, the antenna manufacturers would undoubtedly be in there competing with each other selling them at reasonable prices!



Here's a sample of what you can find in a junk pile. Note the parabola slightly left of center (arrow). About \$100 at Bickoff's in Newark, New Jersey.

Take, for instance, the case of the slot antenna. Flipping through the pages of last year's *CQ Bound Volume* recently, I came across an interesting item in the August issue on "The Skeleton Slot Antenna," by B. Sykes, G2HCG. He describes a new type slot antenna which should be highly successful at the v.h.f. frequencies, especially at 144 mc. The height of the antenna is only 45"! He reports that two eight over eights stacked two wavelengths apart result in measured gains of upwards of 20 db! And the "Skeleton Slot" is very broad-band fascili-

tating easy operation over the entire band without tricky re-tuning and adjusting the antenna. Look it up; it's on page 52.

Man of the Month

Our spotlight this month is on Bert Simon, W2UUN, of Holland Mt, Oak Ridge, New Jersey. Bert was first noted by your conductor during the CQ World Wide VHF Contest last February. He displayed a truly outstanding knowledge and actual practice of operating skill and genuine courtesy. Never before have we heard such outstanding courtesy on 6 meters, especially during a contest!

Bert is a real hard worker—you'll see that in the contest results—and certainly deserves all the credit he can get. He used low power, about 20 watts, into an 11 element Spiral Ray at an elevation of 1300 feet above sea level. But even with all this on his side, putting a real "dent" into the 6 meter band, he would sacrifice a few points rather than to QRM another contester or let the other fellow have that extra contact rather than jump on the frequency when he needed him more. W2UUN is a man to be admired and a good example of the best v.h.f. has to offer. Congratulations, Bert!

Hints for the V.H.F. Man

Here's an interesting letter from Denny Williams, K6UMM, of 7452 Lena Avenue, Canoga Park, California . . .

"With the sunspot cycle on the dip, the E and F2 gradually lessening, it seems the time to crank down the beams for an overhaul.

"Replacing the coax might be in order. But stop! Don't just take it down and replace it with identical stock. If you're using the popular RG8A/U, think about increasing you're transmitting and receiving signal and save up those nickels and dimes to invest in a more improved transmission line like RG14A/U or RG17A/U; both 50 ohm impedance. On six meters as much as 1 db or more can be obtained plus a good 2 db's on two meters. Keep those lines as short as possible.

"Check those connectors. Contact cleaner works wonders on corrosion.

"In the shack a few things can be done. Make a tube line-up of both converter and receiver. New tubes are born all the time and most of them are more durable and (note) have less noise. If finding the replacements becomes a task, write to RCA, GE, etc., stating the tube number and in some cases they'll refer you to the newer tubes.

"Get that contact cleaner out again and clean up those relays and connectors!

"Peaking the converter up and alignment of the receiver take little time and make a world of difference.

"A good ground at the base of the tower and into the shack, grounding all the equipment, makes for better operating and, above all, safety."

Mailbag

Bensonville, Illinois: A short note from Tom Mills, W9UCF. . . .

"I worked my first WAS 48 in 1957 on six meters and again in 1958 but waited too long to file. I now have 49 states confirmed and the following countries; W, VE1, VE2, VE3, VE4, VE5, VE6, VE7, VE8, KL7, KH6, CO2, KP4, HC, LU, XE, KG1, JA, SM6, SM7, F9, G3, EI, HB9, ZS3, ZE2, ZS9. Have also heard from here on 50 mc the following: VQ2, CT1, LA, TG9, PZ1, CX6, PY.

"Running all homebrew equipment, 150 watts, 6 element homebrew beam at about 60 feet. The receiver is an HQ-140 X." *Many thanks for the report, Tom, and keep us posted on that WAS! All those calls makes us dream of days gone by, eh?*



John Hall, W8RRJ, at the mike of his mobile television station. John gave a fine talk at the V.H.F. Forum at last year's Dayton Hamvention.

Brooklyn, New York: This one comes from Bill Pasternak, WA2HVK . . .

"I am pleased to announce the formation of a new radio club called the Brooklyn V.H.F. Association. All 6 meter amateur stations in the Brooklyn, New York area are invited to join. To qualify for membership the station wishing to join must sign into our net for three consecutive weeks, and attend one meeting to receive his membership card.

"Our net meets every Saturday afternoon at 2:30 EST on 50.4 mc. Time and place of our meetings is decided on the net.

"At our third meeting we elected the following officials to run the club, term beginning February 1961, ending February 1962:

"Charles Zussman, WA2AKX, President; Bill Regina, WA2PHR, Vice President; Bill Pasternak, WA2HVK, Treasurer; Jeff Feinberg, K2MOT, Recording Secretary; Charles Geller, WA2ADO, Activities Manager.

"We now have approximately 18 stations involved in our venture, including the club officials. I will keep you informed of the progress that we make in the future.

"Other news in the Brooklyn area is that the winner of the last monthly Bunny Hunt sponsored by the Kings County AREC, CD and RACES Net and the Brooklyn Traffic and Emergency Net was Larry, WA2INM. Our Bunny

[Continued on page 112]



Novice

No doubt the most important single device in electronics is the vacuum tube. Without it, modern radio science would be impossible. Although the first radio receivers used none, modern communications equipment is "chuck-full" of tubes having all sizes, shapes, and descriptions. Vacuum tube theory is very important to the Novice. What you learn about them will largely determine how much you will be able to understand of electronic circuits.

Electron Emission

In 1883, Edison was experimenting with an evacuated tube containing a heated filament and a metal plate. He discovered that when the plate was more positive than the filament, an electric current would flow between the two *elements*. Further, he found that the current did not flow when the plate was negative with respect to the filament. Edison thus discovered *thermal emission*, the process by which vacuum tubes obtain their supply of electrons from the heated filament or *cathode*.

Thermal Emission

The process of thermal emission, which is known as the *Edison effect*, may be explained by the electron theory of matter, which assumes that the outer electrons in the atoms of metals are loosely bound to the nucleus. When the filament in an evacuated tube is connected to a battery, the free electrons move along the filament and collide with other free electrons. The collisions between the electrons generate heat. They also give some of the moving electrons enough energy to overcome the attractive force within the wire and break out from its surface. These electrons are called *emitted electrons*. The filament which emits the electrons is called the *cathode*. When a plate, placed near the cathode, is made positive with respect to the cathode, it will attract these electrons. If the plate is more negative than the cathode there will be no current flow, as the electrons emitted from the cathode will be repelled by the negative plate.

The escape of electrons from the surface of a metal is analogous to the escape of molecules from a liquid during evaporation. In liquids, the molecules evaporated are those which possess

enough energy to overcome the force at the surface which tends to keep them within the liquid. In the case of heated metals, the process is similar, and in a sense, can be considered the evaporation of electrons from a heated surface.

Common substances suitable for use as *thermionic emitters* in vacuum tubes are tungsten, thoriated tungsten, and oxide coated materials. Oxide coated cathodes emit at much lower temperatures than either tungsten or thoriated tungsten. For tungsten to be a satisfactory cathode, it must be operated at very high temperatures. In spite of the large amount of power required to operate tungsten emitters, it is widely used in high power vacuum tubes because of its durability. Tungsten covered with thorium emits at temperatures appreciably lower than pure tungsten.

Directly and Indirectly Heated Tubes

Emitting surfaces are heated either by passing a current through them or by a heating element located near the emitting surface. A vacuum tube in which the emitter is heated directly is known as a *directly heated* tube and the emitting surface is called the *filament*. A tube in which the emitting surface is heated by a heating element is an *indirectly heated* tube, and the emitting surface is called the *cathode*. The heating element is known as the *heater*. Either d.c. or a.c. can be used to supply the current for heating in either type of tube. However, tubes directly heated with a.c. generate an objectionable a.c. hum in the form of a.c. variations in plate current.

Filament Voltages

The voltage and current required for heating the emitting surface to the proper temperature varies considerably in different tubes. Any tube manual will give the filament voltage and current rating of any particular tube. Current ratings vary considerably for different tubes even with the same voltage ratings.

Common filament voltages for tubes are 1.4, 3.0, 5.0, 6.3, 12.6, 25, 50, 70, and 117 volts. Tubes most commonly used are the 6.3 and 12.6 volt types. A 1.4 volt tube is designed for use where voltage is supplied by a dry-cell battery. A 117 volt tube can be heated directly from a

117 volt a.c. line. Tubes generally are referred to by their filament voltages. Thus, in the 6.3 or 117 volt tube, the voltages stated are required for filament operation. The numbers preceding the letter(s) in a tube designation usually indicate the filament voltage. A type 6C4 would have a 6.3 volt heater, while the 50L6 would have a 50 volt heater.

Connecting Filaments

Filaments may be connected in parallel when they have the same voltage rating. This is a common practice in receivers employing a power transformer for stepping down the line voltage. For example, a power transformer which is connected to the line may have three secondary windings, one to supply voltages for the plates of the tubes, one to supply voltage to the rectifier filament, and one to supply 6.3 volts for the filaments of tubes other than the rectifier. The 6.3 volt tubes can be connected in parallel across the 6.3 volt winding. The total current drain through this winding is equal to the sum of the currents for the individual tubes connected across it.

A.C.-d.c. receivers, which do not have a power transformer, obtain their power directly from the line. The filaments of these receivers are connected in series. However, for this connection to work properly, the combined voltage rating of all tubes must equal the power source voltage (117 volts). Furthermore, when tube filaments are connected in series, all tubes must have equal current ratings. If any tube has a lower rating than the others, excessive voltage will develop across the filament of this tube. This situation can be solved by connecting a resistor in parallel with the filament which requires less current. The resistor, in effect, "soaks up" the excessive current.

Let's finish this month's lesson by solving some Ohm's Law problems associated with filaments connected in series. In the circuit, Fig. 1, five filaments are connected in series and we wish to connect these to a 117 volt power line. Find the resistance and power rating of resistor R which is used to "soak up" the extra voltage.

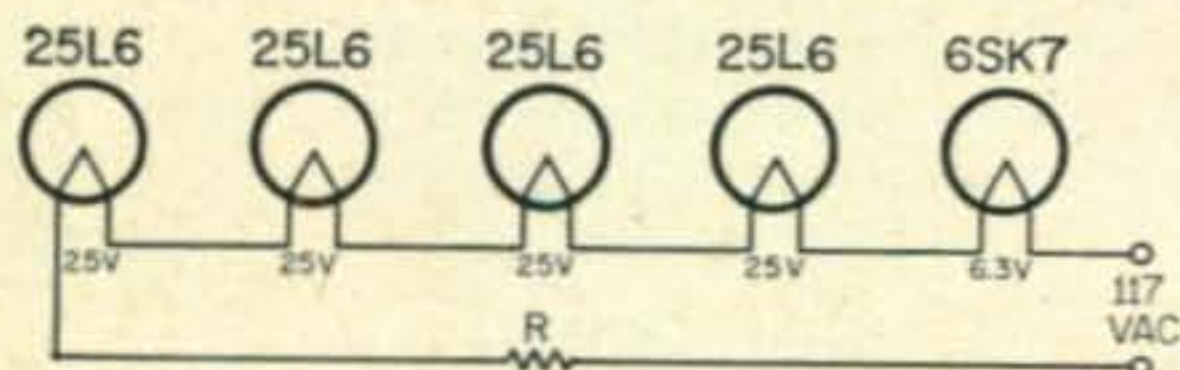

Figure 1

By adding the filament voltages up, we find that they total 106.3 volts. Obviously, if this string of filaments were connected across the line, excessive current would flow due to the large difference in voltage. Subtracting 106.3 from the source voltage (117 v.) leaves 10.7 volts which must be dropped across resistor R . Then, according to Ohm's Law;

$$R = \frac{E}{I}, \quad R = \frac{10.7}{0.15}, \quad R = 71 \text{ ohms}$$

The next standard resistor size is 75 ohms. To calculate the power drop in the resistor we use the formula;

$$P = EI, \quad P = 10.7 \times 0.15, \quad P = 1.605 \text{ watts}$$

Thus, for R , we would use a 75 ohm, 2 watt resistor, since 2 watts is the next largest size beyond 1.6 watts.

Let's try another problem. In the circuit shown in Fig. 2, two filaments are connected in series. Tube 2 requires 0.3 amperes, but tube 1 needs only 0.15 amperes. Find the value of R and its wattage rating.

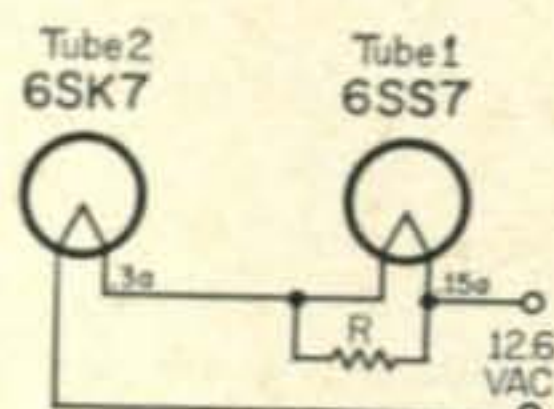

Figure 2

If 0.3 amperes is required for tube 2, and tube 1 needs only 0.15 amperes, then the extra 0.15 amperes must flow around tube 1, through resistor R . Then, by Ohm's Law;

$$R = \frac{E}{I}, \quad R = \frac{12.6}{0.15}, \quad R = 84 \text{ ohms}$$

The wattage rating for R is given by the same formula as used earlier;

$$P = EI, \quad P = 12.6 \times 0.15, \quad P = 1.89 \text{ watts}$$

Thus a 2 watt, 86 ohm resistor (the next standard size) would be required.

Next month we will return to the operation of vacuum tubes and study the action of the diode and triode.

Experimenter's Corner

Occasionally I like to toss out a circuit which will interest the advanced Novice. They are projects which do not include complete construction details but provide sufficient information for the sharp home-brew artist. I hasten to point out that I have not tested the circuit but have it on good authority that it really works.

Fig. 3 shows a simple two-tube screen modulator which can be used to convert the average Novice c.w.-only transmitter to phone operation. An r.f. filter, composed of a 3.3K resistor and 100 mmf capacitor is connected at the microphone input. The speech preamplifier tube, a 12AX7, is resistance coupled to the 12AU7 series gate. This tube varies the final amplifier screen voltage in accordance with the voice, which varies the r.f. output of the transmitter. To use the simple screen modulator, it is only necessary to break the lead to the final screen, connect the two modulator leads and the filaments. Most Novice transmitters will provide the extra plate and filament voltage required by the modulator. No volume control is included in the circuit. Modulation should be about right when you speak approximately 3 or 4" from the mike. For the modulator to work properly, the antenna must be

Fig. 3 — Simple adapter for converting most Novice c.w. rigs to fone.

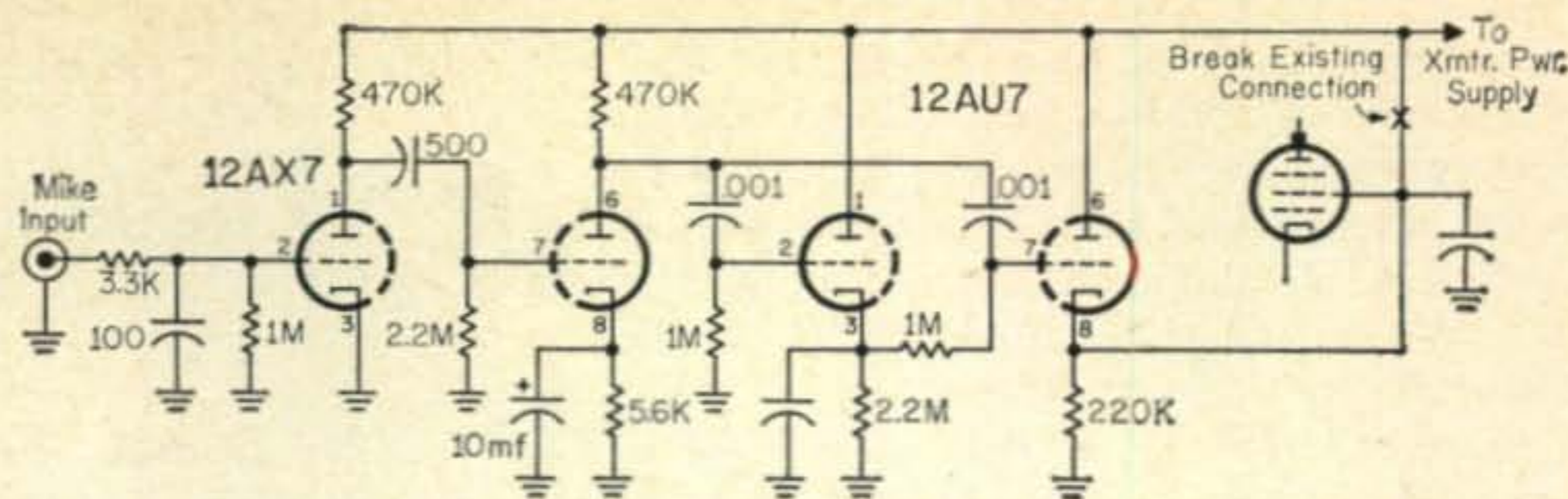

loaded much heavier than it would be for c.w. operation. To load the antenna, connect the two modulator leads (to re-apply screen voltage to the final) and dip the final. Keep increasing the loading until you can just barely detect a dip in plate current. At this point you will find that the transmitter is probably drawing more current than it would normally. However, when you reconnect the modulator, it will drop to its original value. When modulating, observe the plate current and kick the meter up to the normal c.w. current. A few quality reports from other amateurs will soon indicate the correct loading and modulation levels for your particular transmitter.



Shake hands with Randy Brook, WV2PPE, 25 Parkview Ave., Bronxville, N. Y. who has been on for a little over a month and has racked up a WAS of 20/8 along with RCC. Randy plans on replacing the RAX receiver with an HQ-100 soon.

International Ham-Hop Club

If you, or your parents, have the occasion to do any traveling in the coming months, you might be interested in the International Ham-Hop Club. The IHHC was started by amateurs interested in improving personal and international relationships through an organized system of hospitality between radio amateurs. For example, if you were planning on visiting England this summer you could join IHHC. By telling them your plans, the representative in England would make arrangements for you to visit and stay with various amateurs in G-land. You, of course, would be expected to reciprocate should a G-ham wish to visit your city. It's a marvelous experiment in understanding the people of other lands. The IHHC membership is \$1.40 per year, which includes a subscription to "Ham Hop News." If you are planning a trip overseas in the near future, or are interested in how this novel organization functions, drop a

line to the U.S.A. representative, Lee Gunther, W6THN, Box 1655, Vanderbilt University, Nashville 5, Tennessee.

Who's DX?

Our old friend Bill Stevenson, VK3AWS, 11a Maud St., Ormound S.E. 14, Victoria, Australia, reissues his invitation to work Novices on the 21 mc band. Bill expects to operate March through June on Fridays and says the best time for W's is 11 PM to 1 AM EST, 10 PM to 12 PM CST, and 8 PM to 10 PM PST. VK3AWS is particularly anxious to work the states of Montana and Vermont to complete his WAS but will naturally work any others that he can hear. As Bill says, "I enjoy giving them a new one, because they so obviously appreciate it." If any of the Novices I worked last year have not received my QSL through their bureau, I will send another direct-surface mail if they will let me know."



Hi, says Bunny Robinson, KN-5EVZ, 1847 Armstrong, Bartlesville, Oklahoma. Bunny stirs up the airways with a homebrew 35 watter and command BC-455 receiver into a 40 meter dipole. Bunny will sked anyone for any reason.

I don't have to introduce Ivor Stafford, VK3XB, 16 Byron St., Box Hill Sth., E 11, Victoria, Australia, for he is known to just about every Novice who operates 40 meters. Ivor has been plugging away on a 40 meter Novice—only WAS and needs only the state of Utah to complete it. If you could hear the junk that clutters the 40 meter band in his part of the world, you would realize what a tremendous accomplishment this will be. Ivor reports hearing and working (*italics*) the following stations since his last report: KN1NLD, *NOT*, PJT, *WV2IKN*, *KBK*, PJG, KN3KTT, MPT, NFW, *LXN*, NTA, KN4ABY, KNA, NPC, VRI, WMY, WNN, KN5DSI, DYR, DYX, GYS, WH6DUE, EUG, DUL, DUM, DVT, DWT, DXS, EAR, WV6-DXS, JRP, KAN, LKE, *MBH*, MCL/4, MVR, MZQ, MZU, *NET*, *NFR*, NUH, OFM, OHJ, KN7LES, LSM, LXJ, MUW, NIE, KN8NWG,

SIDEBAND

Irv and Dorothy Strauber, K2HEA/K2MGE

12 Elm Street, Lynbrook, New York

SSB DX HONOR ROLL

T12HP	231	K6ZXW	177
W6UOU	226	K4TJL	175
W8EAP	225	W5KFT	175
VQ4ERR	218	W2LV	174
WØQVZ	208	K6LGF	170
PY4TK	204	K2FW	167
HB9TL	203	KØCTL	162
W6PXH	203	4X4DK	161
W7VEU	202	W3LMA	155
K2MGE	202	PZ1AX	154
W2JXH	200	WØUUV	154
K9EAB	200	K8RTW	151
W6WNE	198	K2HEA	151
W6RKP	196	W2YBO	150
W6BAF	188	W6VUW	140
W5AFX	187	W6EKZ	138
ZL3IA	186	K2TDI	134
VK3AHO	185	W3CGS	134
W2VZV	182	K6MLS	132
ON4DM	181	W2MAF	129
W2ZX	180	K11XG	126
WØCVU	180	W1JSS	125
W5IYU	180	W1AOL	125
W2FXN	177	W2ATJ	125
MP4BBW	177	XE1SN	125

Bumper Crop of Certificates Issued

As you will see from the following listings, we were kept mighty busy this month checking cards and filling out certificates. A record number of five sidebanders were issued "Worked 200" Certificates—K2MGE, WØQVZ, W2JXH, W3NKM, and K9EAB. The "Mrs. Editor" of this column was very proud to be the first YL to earn this award. Bob Kelley, WØQVZ, wasn't



Cliff Corne, K9EAB, who, in the five years he has been licensed, has become one of the best known and most liked hams in the world not only because he has surmounted all obstacles but also because he is a top operator.

superstitious enough to refuse Certificate #13! Harry Whiting, W2JXH, is one of the pioneers in s.s.b. DXing and was often at the top of the Honor Roll during the race to get the first 100 on s.s.b. Stanley Springer, W3NKM, was a "dark horse" in the DX race. While the rest of the group were keeping us up to date with DX totals, Stan submitted no listings but came in strong in the stretch to win Certificate #15.

We extend our congratulations to all of the above but we're sure you and they will go along with us as we devote a few extra lines to a very special guy—Cliff Corne, K9EAB, who now has added "Worked 200" Certificate #16 to the 105 or so certificates he has earned over the past few years that he has been licensed. An outstanding record, indeed, but more so in the case of K9EAB who is confined to a respirator—the result of polio eleven years ago. Cliff doesn't need any morale boosting—he's strong and secure in the knowledge of his parents' love and devotion and the respect and admiration of his thousands of ham friends; but we never can resist a special salute to him as an inspiring example of how people can rise above their handicaps.

Doc, W8EAP, maintained his high DX standing by earning the 225 sticker while, at the starting post, "Worked 50" Certificates were sent to W3CLP, K5MDX, K5SEU, K4HPR, YV6BR, K1LRB, K9KZO, KP4ATU, and LA-



Paul, W3AQN, an outstanding member of the 40-meter sideband gang. Paul divides his time between operating and modifying his equipment to get the best possible signal as is quite evident when you hear him on the air.



How many of these well known sidebanders can you identify? They were photographed making merry at the 50th birthday celebration for Alan, W3ZP (front row, center). Among those present were W2LI, W2AQP, W2ZG, W3DHJ, W3LYP, W3BZ, W3YXG, W2UE, W2HYV, W3HFD, W3EOZ, W1PRI, W2AQK, W3UKZ, WA2KZR, W2HVJ/W4RNT and W2AWR. We'll give you one hint: the latter three were busy taking the pictures so don't hunt for them!

3SG. DL4LE and K5OGP received their "Worked 75" Certificates. And hold your hats—here's the great group who earned certificates for "Worked 100": W2ZX, G5BJ, G3CCN, VE3CIO, SM3BIZ, W4WDI, DL1IN, WA6HOH, WA6AMZ, EI8P, HB9J, K4PUS, VE3BQP, YN1CK, W5PQA, W6EKZ, K6CQM, K9PPX, W5PSB, G3NUY, W6DLY, ZS6ATA and W2VCZ! "Worked 125" stickers went to W2ZX, W3LMA, W0UUV, W2ATJ, W3CGS, and XE1SN; "150" stickers to W2ZX, W3LMA (where have we seen those calls before?); PZ1AX, W0UUV, and W2YBO, and "175" stickers to W2ZX (that man again!), W0CVU, W5IYU, W5KFT, ON4DM, K6ZXW, ZL3IA, and W2VZV. Who said there's no DX around?

More on Sideband Operation

We received a most interesting letter recently from a KZ5 sidebander who is in the enviable position of being able to evaluate operating techniques from both sides of the fence, being the possessor of a W call as well. He feels that "there has been a distinct lack of leadership in clean operating, courtesy to others on the air, and the necessity of knowing the limitations as well as the abilities of one's own equipment." He continues: "In all too many cases, the owner of costly equipment sets it up 'according to the book,' drives it 'according to the book' and believes he then must have a clean signal. Too often, the small print is ignored; the small warnings that a scope is advantageous; an antenna should be matched to the rig; and the many variables that can cause the book readings to be off. Tell some of these characters that they are 20 kc broad and see what happens! They are using 4000 dollars worth of equipment, running it 'as the book says,' so "Buddy, there's something wrong with *your* receiver!" This attitude is much too prevalent . . . It is becoming a case of dog eat dog in amateur radio in general, and, unfortunately, s.s.b. is tending to lead the unwholesome way. The competition to work that rare 19B6A makes too many operators reach for the gain control and blast away—the devil with any one else . . . The s.s.b. operator

should be noted *not* by how many QSLs he has collected by various means but by how *clean* an operation he runs!"

Needless to say, we have no quarrel with the above comments. From other letters received and on-the-air discussions, it is readily apparent that s.s.b. operation in general, and s.s.b. DX chasing in particular, is under fire from many quarters. The difficulty lies in the fact that no one particular operator or group of operators wants to stick his neck out by commenting on a poor signal or calling down a fellow for being rude and discourteous. But unless each one of us sets *and maintains* higher standards for s.s.b. operation than has been evident the past year or two, there will either be a mass exodus from amateur radio or such chaos such as has never been heard on the air before!

The first thing each of us must do is set our own house in order. Check your signal *regularly*—not once a year—to make sure that your audio has not become distorted and splattery and that your suppression and carrier are down where they should be. The best and most expensive of rigs can and will get out of kilter from time to time.

The next thing to do is change your mental attitude. You are but one of a tremendous group of operators, each of whom wants to enjoy this hobby as much as you do. Are you used to meeting on a certain frequency with your friends? Listen first and see if anyone else is operating there first; if so, be courteous and ask permission to contact your group and move them a few kc. When the band changes and you suddenly hear a conversation that had obviously also been on frequency but not formerly audible, don't indulge in childish sarcasm but move off the frequency a bit if you find the interference too much for you to continue your own chat. If you want that rare station at the same time as do thousands of others, exercise patience and restraint. Don't call incessantly, making it impossible for anyone else to hear what's going on and setting a dangerous example.

Once you become re-imbued with the old-fashioned, but never out-of-style habits of cour-

tesy and consideration, consider yourself a missionary of good will. The brawling and squabbling over DX contacts that have been on the increase lately mark the participants as mulish, childish, and unfit to be considered members in good standing of the amateur radio fraternity. Don't you allow yourself to become involved in such goings-on. Make it a point to let a fellow know if his signal is below par—courteously and in a spirit of good fellowship. Resist the impulse to cut the other fellows' throats over a DX contact. If we all are more courteous, more of us will get that contact, than if we indulge in the petty bickerings that have recently become so common. If your comments can't be constructive, keep your mouth shut! This business of calling in with unidentified remarks during QSOs and pile-ups should be curtailed. It solves nothing and merely raises the temperature and tempers of all on the frequency.

Unfortunately, a few of the worst offenders in lowering the standards of s.s.b. operation are the old timers, the "Big DX men," who should know better. Many of them are the ones who violently and vehemently resisted the trend toward s.s.b. in its early days but now that they have made the switch, they want everyone else to stand aside—they are on the frequency! And, conversely, many of our best sideband operators are rank newcomers, so don't let anyone look down his nose at an operator without 30 years of experience behind him! The newcomer is usually still imbued with the ideals of courtesy, helpfulness, and goodwill that he read about when studying for his license. For the betterment of amateur radio, we hope that all amateurs will keep these ideals uppermost in their minds!

The TI2RC Award

The TI2RC Award is offered by a group of friends of the late Roberto Castro, TI2RC, in



Major G. Ross Kent, ZS6L, fondly known the world over as "Joss", one of the finest gentleman it has been our privilege to meet on sideband. The certificate to the right of the globe signifies that, in 1937, Joss was made an Hon. Life Member of the SARL for meritorious services rendered to the League and to ham radio.

his memory. The Award will be presented to any amateur who has contributed to the advancement of the use of Single Sideband in any of the following fields:

1. Technically—by development of new circuits, publishing of articles, construction of equipment or any other similar accomplishment.
2. Public Service—Any action which directly or indirectly results in a public service emphasizing the role of Single Sideband.
3. Operation—Any achievement in this field which will constitute a definite way of promoting s.s.b., with special consideration to DXpeditioners.
4. Organization—The effort made by any organization in behalf of Single Sideband.

Designed to bring recognition to less publicized activities of sidebanders, the award will consist of 24 beautifully engraved Certificates to be given from time to time to a deserving amateur or group of amateurs. In addition, two Trophies will be donated in the years 1962 and 1963 to the respective winners of the CQ World-Wide S.S.B. Contest in a class to be determined.

Candidates for the award will be nominated in the following manner: By a group of at least five duly licensed and active amateurs or by the SIDEBAND Editors of CQ.

The Trust Committee, which will decide the winner of the Award, will consist of three members: The President of the Radio Club of Costa Rica, the Vice-President in Charge of International Affairs and one other amateur nominated by the Radio Club of Costa Rica. This Committee will consider the nominations and will announce them in CRM, the Official Organ of the Radio Club of Costa Rica and in the SIDEBAND Column of CQ.

The decisions of the committee are final. The awards are free and will be sent directly from Costa Rica to the recipient.

HT-33A Modification

For those among us who have the good fortune to own an HT-33A, a modification that will extend the life of that valuable PL-172 by reducing grid dissipation caused by accidental over drive and will reduce 3rd and 5th order distortion products by changing from Class AB-2 to Class AB-1 operation, is shown here.

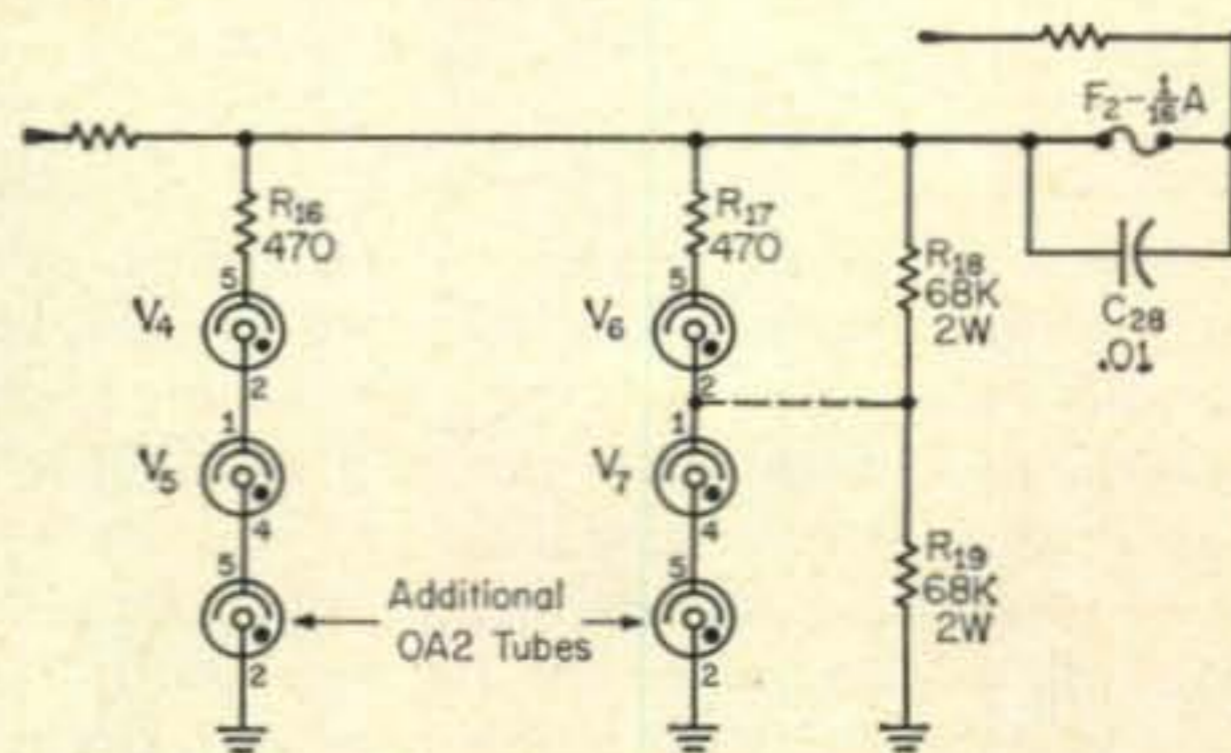

Wiring for additional 0A2 tubes for the Model HT-33A and HT-33A Mk II. The dotted line indicates this connection should be removed. This deletion has already been done on the Mk I.

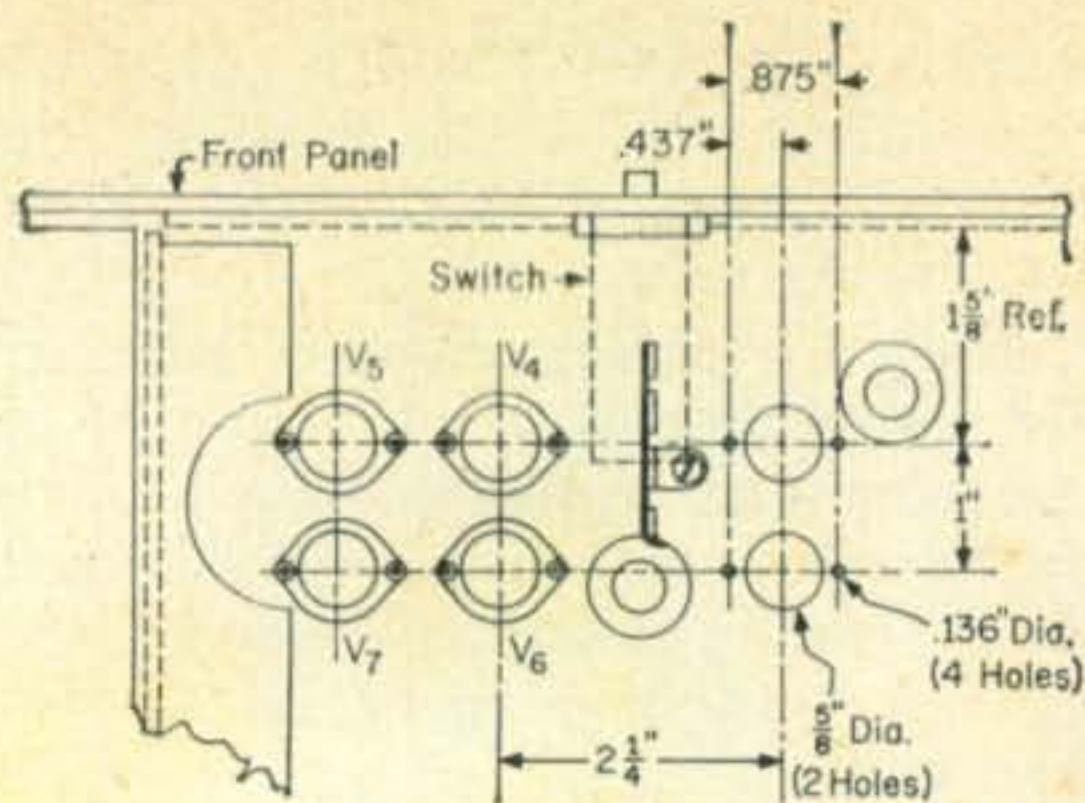

Thanks to Don, W9RRL, we can pass along the modification procedure suggested by Hallcrafters.

Parts Required:

- | | |
|---------------------------|--------------------------------------|
| 2 ea.—VR tube, 0A2 | 1 ea.—10K, 10W, wire-wound |
| 2 ea.—Socket, 7 pin min. | 4 ea.—Screw, binderhead, 4-40 × 1/4" |
| 2 ea.—470 ohm, 2W | 4 ea.—Washer, lock #4 |
| 1 ea.—2K, 10W, wire-wound | 4 ea.—Nut, hex 3/16" 4-40 |
| 1 ea.—270, 2W | |

1. Disconnect all power, remove chassis and all tubes. Drill or punch holes as shown on diagram.
2. Replace R_{21} (1K, 5 watt) with the 2K, 10 watt and the 270 ohm, 2 watt resistors wired in series to obtain 2270 ohms.
3. Replace R_{20} (1500 ohms, 5 watt) with the 10K, 10 watt resistor.
4. Replace resistors R_{16} (1K, 2 watt) and R_{17} (220 ohm, 2 watt) with the two 470 ohm, 2 watt resistors. On some units, R_{17} is a 1K, 2 watt resistor.
5. Mount and wire the two additional tube sockets. On the HT-33A, remove connection between the junction of R_{18} and R_{19} and the junction of V_6 pin 2 and V_7 pin 1. These have been deleted in the HT-33A, Mark I.
6. Remove R_1 . This is one of the Globar resistors in the shield box containing the PL-172 socket. You can get at it by removing the fan bracket assembly. Make sure that there is clearance between the fan duct and fan blades when re-assembling.
7. Install all tubes including the 0A2 tubes and replace the chassis in the cabinet.

Step 6 may be omitted since most PL-172's will receive enough drive from exciters having the same power capabilities of the HT-32 and HT-37.

Operating procedure is unchanged except that for s.s.b. and a.m. operation, the idling plate current should be adjusted for 200-210 ma and the audio adjusted so that the grid current meter barely flickers upwards on peaks. This is an indication of the start of "flat-topping" and the gain control should *not* be advanced any further!!!

Excitation should never be applied to the HT-33A with the high voltage switch in the OFF position.

Don writes that it took him two hours to make the modification and that it was worth every second of the time.



The famous DJ3JZ contest gang—four out of the six are sidebanders and we have no doubt the other two will join us soon. Left to right, Lot, DJ1BZ; Hardi, DJ3JZ; Kurt, DL1CR; Hel, DJ1BP; Rolf, DL3AO; Wolfgang, DJ4LI; and the small beauty in the foreground is Hardi's little daughter.

Sideband Around the World

Ed, K8RTW, has rendered another fine service to the sideband fraternity by sending a 500 watt rig to CR7CR who had to return the one he had borrowed. Ed is also the gentleman who so graciously permitted us all the opportunity to meet Gamboa, CT2AH, on sideband. Many thanks from sidebanders everywhere, Ed! . . . Warmest congratulations to Tom, GD3ENK, and his XYL, upon the celebration of their Silver wedding anniversary and the 21st birthday of their daughter. Tom is the most consistent sidebander on the Isle of Man and always puts out a fine signal . . . Wonder what the "Flatters' Society" is? We understand that Oscar, GW3EHN, is an active member of that organization. Make a note to ask him about it next time you hear him . . . It was quite a coincidence to mention Robbie, VQ4ERR, to Laurie, ZS4AF only to learn that they had worked together as pharmaceutical chemists in Nairobi during pre-World War II days. Speaking of Robbie, last we heard he was thoroughly enjoying his enforced retirement—sleeping, fishing, hunting, playing with his granddaughter—so much so that he was hoping the doctor would not suggest his returning to work!

John ZE4JN, ran into very poor propagation conditions during his visit to the Seychelles, and, in one direction, had to head his beam into a 3,000 foot mountain. Other than disappointment with hamming opportunities, John had a most enjoyable time of it . . . Roger Baines, who has been doing such an efficient job as QSL manager for Bryan Bisley, is acting as SWL manager for Andy Goodwin, ex-MP4DAA, now 5A3CAA as well as for MP4BCV . . . QSL manager for Kosie, ZS3E, here in the States is Jim, K4PUS . . . Good news for those who worry about DX activity during the sunspot minimum—Don, WØUUV, submitted a card from Win, ZL3DX, for a contact made with Win from Fiji as VR2CG. Don noted that the contact took place during the last sunspot minimum and he worked Win several times with ease using an *indoor antenna!* Want to try it now, Don?

Chick, YO3GK, was reported to be leaving the air for several weeks in order to make some changes in his equipment that will give him higher power. He had been using a long wire which probably

accounts for the fact that he has not been worked too consistently in the States . . . Bill, VE3BQP, plans to retire from his position as Toronto High School principal in June and, no doubt, is looking forward to many more hours of hamming . . . We've missed hearing Luk, VS6AZ, on s.s.b. His neighbor, Pat, VS6AE, had been putting through a very strong signal, so we imagine that Luk is just too busy putting the finishing touches to his transistorized exciter to do much operating . . . All his East Coast friends have been listening diligently for Harry, JA1ACB, now that he has such an improved set-up for 20 meters. But alas and alack, conditions to Japan have not permitted Harry's signal to break through . . . Francois, FB8CM, will be leaving Madagascar in September for a six-month visit to France. However, we understand that s.s.b. operation from FB8-land will be carried on by several of Francois' fellow hams on the island . . . Dusty, G3OUY, is with the regular Canadian Army on duty in England. He is an ex-VE4 . . . Bill, VO1EX, is in his glory now that he has the 75A-4 formerly used by Hugh, VO2AD . . . Had the pleasure of a first contact with Sils, DU1SA, who was doing a fine job taking over Filipino QSO chores now that Volt, DU7SV, has made himself so scarce on s.s.b. . . . Luvo, DJ1IM, injured himself so seriously in a skiing accident in March that it was feared he would be motionless for two months. We know that all sidebanders everywhere wish him a speedy recovery and hope that word-of-mouth reports on Luvo's condition had you flooding him with get-well-wishes . . . By now, there should be regular s.s.b. activity from Portugal, although, at this writing, it's still a mystery as to the call of the operator purchasing the equipment . . . Jo, CR6CA, has changed his address to P.O. Box 532, Benguela, Angola. Jo will be pleased to hear that when our daughter submitted one of Jo's intricate math problems to her math teacher, the teacher said it was the first problem he had not been able to solve in less than a day!

Although you can't prove it by us, we have it on good authority (Ron, G6LX, 3A2AY) that there is regular s.s.b. activity from Monaco from the station of Hank, 3A2AH. Now if they'd just move that mountain that prevents East Coast-Monaco contacts, we'd be happy . . . It was fine to learn that Jim, VS4JT, was safely back in the U.K. after a slight misunderstanding with authorities in one of the countries he visited. His good friend, Walt, K6GMA, kept the queries going thick and fast till he learned of Jim's safety . . . We are looking forward with great pleasure to meeting Hardi, DJ3JZ; Bob, TG9AD; and Monte, HC1JU, during their visit to the Sideband Dinner. Following a short stay in New York City, Hardi is winging down to Haiti to spend three weeks with his friend, HH9DL . . . Although we miss Mirko, YU1AD very much, it was good to meet a new Yugoslavian sidebander in the person of Matiya, YU2DB. Matiya is very pleasant to chat with and put out a good signal the day we contacted him for the first time . . . Their many friends will be happy to note the stateside address of Pat and Jere Knudson, ex-I5GN as Fawn Ridge Drive, Peekskill, New York. After the wonderful months of sideband operation from Italian Somaliland, it must be very frustrating to Pat and Jere to just listen while awaiting their stateside calls. Patience, dear friends—we hope it won't be too long!

Phabulous Phoenix Convention

It's westward ho to the Westward Ho Hotel in Phoenix, Ariz. for the Southwestern Convention on May 26, 27, and 28th. The big news for sidebanders

are the two pre-registration prizes: a Collins s.s.b. station in a suitcase—KWM-2, PM-2, Suitcase, Mike and Antenna; and the new Swan s.s.b. Transceiver. You're promised many other super prizes; technical sessions in abundance; a visit to the Mummy Mountain Radio Club station, K7LJA, one of the best equipped in the world; and a real Western Chuck Wagon Banquet with Senator Barry Goldwater as introductory speaker; plus many other innovations. Send your preregistration check to George Mezey, K7NIY, P.O. Box 814, Sun City, Arizona; and don't forget to write us when you win a phabulous prize in Phoenix.

Band Hopping

It sure was fun meeting Len, K5BGG, operating portable out of Valdosta, Ga., on the air. Len's XYL is Sammie, K5MGE, so you can imagine how we like to keep up with her. Talk about busmen's holidays—when Len has time off from his duties as AF jet instructor-pilot, he takes Sammie and their talented little daughter, Laura, back home to La. in his Cessna 172 . . . Ever hear of "The Fatbatters" or is it "Fat Batters"? It's a real lively group of sidebanders who meet nightly on 3885 from 0200-0330 GMT. Join the group at least 10 times and you are considered a member in good standing with a certificate to prove it! Those on the frequency the night we first tuned in were W3JDG, K2UKY, K3JLW, W2BD, K3AMC, WA2JCF, K3AXW, K3GZK, K3EBH and K3GUX . . . all very friendly and interesting to hear . . . Harry, W2JXH, claims that he is about to retire from DX competition—"too rugged" sez he—but we'll lay odds that, in his usual courteous and efficient manner, Harry will be upping his total. Harry has all of Rundy's logs from Laos and Viet Nam as well as from the latter rare spots Rundy visited. So if you're short a confirmation, send Harry a dime, a SASE, and of course your card . . . Jim, K4DOZ, made a very good point in his letter: "I am currently running over 600 watts with a rig costing less than \$150 . . . a Heath v.f.o. driving a Heath SB-10, driving one 837 which drives four 1625's in grounded grid. I have never received anything but outstanding quality signal reports and it looks fine on the scope. So I really chuckle when the a.m. boys complain they can't afford to go s.s.b". Yes, Jim has a good point and one which you might well pass along to your a.m. friends. Everyone can afford to go s.s.b.; there are many ways to make the big switch just to get started . . .

Should you have need of his services in one way or another when you're passing through Hopewell Junction, N. J., see Frank Denning, W2BZW—he's Justice of the Peace! . . . Vance, W4OVE, was kind enough to pass along the news that the Florida Sidebanders meet on 3940 kc. each Sunday at 2200 GMT . . . Although the westward trek of Joe, W2HQL, was marred by storms in Arizona and a beam and tower smashed in shipment, he is now well set in California and giving the W6's a run for their money in the DX race . . . And speaking of California, we hear tell that Dean, W8BF, is planning on a permanent move out there sometime after June of this year . . . What a pleasant surprise Jerry, W5CME, ex-K4SXO, had when he returned from a trip to discover that his XYL, Shirley, was now W5DVV. In four days, she worked 45 states and, no doubt, earned her WAS-SSB within the week! Welcome to the group, Shirley.

May is the time when flowers and new antennas bloom. Got your new beam or dipole up yet?

73, Irv and Dorothy

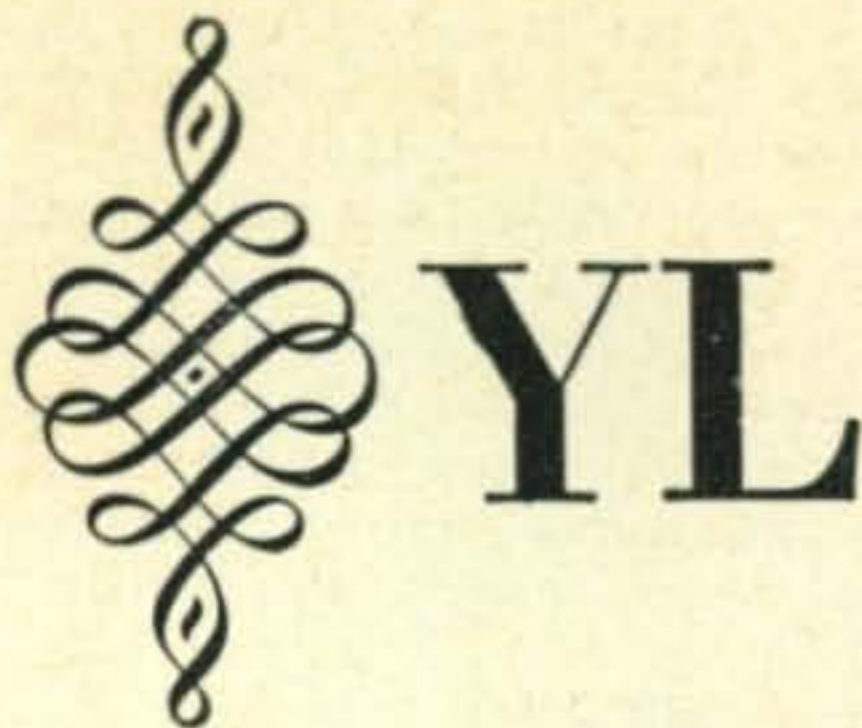

BY LOUISA B. SANDO, W5RZJ

4417 ELEVENTH ST. N.W.

ALBUQUERQUE, N. M.

W6NAZ Honored on TV Show

"W2LLZ, W2LLZ, this is W6NAZ calling you—come in, please." And W2LLZ did come in—right in through the door! If you saw Ralph Edwards' show "This Is Your Life" on NBC TV Feb. 26, then you know the look of utter amazement on her face as Lenore Kingston Conn, W6NAZ, turned from the Collins S-line station she was operating to greet her long-time friend, Dr. Elliot "Butch" Weyer, W2LLZ, with whom she has kept daily skeds for 15 years—and hadn't seen in all that time. Before that surprise could sink in Ralph appeared beside her to say, "Lenore, 'This Is Your Life!'"

Lenore's OM Joe, W6MSC, has been technical director for the "This Is Your Life" show ever since it was started and of course he was in on the surprise. "Even so," he commented, "I never before realized how complicated the arrangements must be—I was a total wreck by the time the night arrived!"

Lenore relates that they got her to NBC under the pretense that she was to be interviewed by Roy Neal, K6DUE, a news producer for NBC, for an upcoming documentary film on Hams. They had set up a Collins S-line station in a small studio and she was to pretend to be calling W2LLZ—then he walked in. "From there on it was like a dream," says Lenore. She adds, "I fully realize it might have been any of a thousand Hams, but I am deeply grateful to have hit



Ralph Edwards tells Lenore Kingston Conn, W6NAZ, "This Is Your Life!" Lenore has just been surprised by "Butch," W2LLZ, (right) with whom she's been keeping daily skeds for 15 years. K6DUE, Roy, (left) pretended an interview to get Lenore to the NBC studios.

the jackpot." And while the show honored her for all of the service she has provided via her Ham rig, Lenore was quick to state during the program that she was only one of many—that thousands of other Hams give of their time and talents to help other people through Ham radio.

Of course, there were many others on the show—OM Joe, who left his monitoring spot to sit with Lenore throughout the program; Lenore's parents, and MacDonald Carey, who starred with Lenore on bc radio serials in Chicago. Lenore was W9CHD then, having received her Ham license in 1939; she also joined YLRL the same year as a charter member. When she married Joe, who was W2MSC in N.Y.C., Lenore became W2NAZ. During WW II Lenore was chairman of the A.W.V.S., American Women's Voluntary Services, in N.Y.C. and helped train hundreds of women in radio theory and code. This, too, was mentioned on the program. It was also during this time that she became good friends with the Weyers—"Butch," W2LLZ, and Mina, W2OVV.

Two Air Force Colonels and a Navy Chief appeared on the show to tell of Lenore's help in providing communications from such isolated spots as McMurdo and Fletcher's Floating Island, mostly phone patching the GIs to talk with their families at home. A GI and his wife and little girl came to say "thanks" to Lenore for transmitting the message that told of the little one's arrival as a baby. Another terrific surprise was having Takeo Hama, JA8AA, walk in; he had been brought from northern Japan. Lenore has held many QSOs with JA8AA and was thrilled to meet him in person.



Lenore is surprised by Takeo Hama, JA8AA, who made a hasty trip from Japan to meet her on "This Is Your Life" show. Manager of a telephone construction company at Sapporo, Takeo received a royal welcome from U.S. Hams. W2LLZ in background.

Lenore Kingston Conn, W6NAZ, surrounded by family and friends on "This Is Your Life" show. L. to r., Ralph Edwards, Lenore's mother; Lenore, and her OM Joe, W6MSC. Second row: "Butch" Weyer, W2LLZ; Lenore's father; Chief and Mrs. Charles Landrum and Therese, who presented the lei to Lenore. Landrum was at McMurdo, KC4USV, when his daughter was born, and Lenore got word to him via W6NAZ. Back row: MacDonald Carey; Lt. Col. Marshall Hassenmiller and Lt. Col. Charles M. Taylor, former commanders of Ice Island T-3 (Bravo); and Takeo Hama, JA8AA. Bob Purcell, W6RGM, Lenore's boss at KFWB, joined the group a few minutes later.



Final guest was Bob Purcell, W6RGM, who sparked the whole thing by a letter to Edwards suggesting Lenore for the show. Bob is president of the Crowell-Collier BC Corp. as well as of KFWB where Lenore does her "Purely Personal" program. Bob commented that she has done over 6,000 tapes for this program—all to help others—to find some lost item, to contact a person, any kind of personal help needed. (Lenore also has had her own TV shows; she has had several of us YLs as guests on them during conventions.)

Of course, Ralph presented Lenore with a charm bracelet (as well as a movie projector and tape of the program). Lenore says the bracelet is remarkable—14 K gold, each charm an individually-designed delight: "My birthday on a map of Calif., my schools on a school house, an engraving of a photo of my first theatrical appearance, the A.W.V.S. era is in code, my first call W9CHD, our wedding bells beautifully engraved, a book with pages listing some of the radio shows I did in Chicago, and the prize is a world globe with gems studding the spots where I keep patch skeds. I am overwhelmed with it."

And the final whollop was a gift to Lenore of the complete S-line station she had been using at the beginning of the show! No wonder Lenore says she keeps thinking she'll wake up!

After the show Ralph gave a lavish dinner party at the Roosevelt Hotel for Lenore and Joe and 50 of their friends—where he did another hour of interesting emceeing.

Lenore says she is receiving a flood of mail from all over the U.S., all enthusiastic that Ham radio gets such a big plug. It was wonderful publicity for Ham radio, and we all are proud and happy that you were chosen to represent the Hams, as well as for all your own service to others, Lenore—it couldn't have happened to a grander gal!

SSB Award

Sincere congratulations to Dorothy Strauber, K2MGE, for being chosen "Sidebender of the Year, 1961!" Dorothy also is the first YL in the world to earn CQ's coveted "Worked 200" award, having received her last confirmation of contacts with 200 countries on two-way sideband on Feb. 16. The contest for "Sidebender of the

Year" was sponsored by the Single Sideband Amateur Radio Assn., whose members number about 1200. As you all know, Dorothy is co-editor, with OM Irv; K2HEA, of CQ's s.s.b. department. They also edit and publish *The Sidebender*, the publication of the SSBARA.



Dorothy Strauber, K2MGE, has been chosen "Sidebender of the Year." She also is the first YL in the world to earn CQ's "Worked 200" award.

Dorothy and Irv have four jr. ops, 2 boys and 2 girls, ages 4 to 13, and how does she manage as much Hamming with this family! Dorothy has had her General license since March '56 and except for 6 months K2MGE has been on sideband ever since.

Among others, K5BJU, Harriett, also was nominated for "Sidebender of the Year." Harriett writes the YL column, "The Sideband Sorority," for *The Sidebender*.

New Certificate

W7NJS, Beth, has announced the Oregon Elizabeth Certificate for proof of contacts with five "Elizabeth" YLs, or ones whose names are derived from that name, such as Betty, Bessie, Beth. They must have been in Oregon (home Qth or mobile) at time of contact. A seal will be issued for proof of five additional contacts with "Oregon Elizabeths." Mail QSL's or other proof to Beth Taylor, W7NJS, Manzanita, Ore.

[Continued on page 116]

The Finco Model A-62 V.H.F. Antenna

Lee Aurick, W2QEX

Technical Editor, CQ

A combination 6 and 2 meter high gain Yagi

The Finco Model A-62 Yagi, manufactured by the Finney Co., Bedford, Ohio, is a combination 6 and 2 meter high gain Yagi of novel design. It is novel in that it has only one pair of feed terminals for both bands and uses no special phasing or matching system to connect directly to the transmitter or receiver. The antenna functions as a 4 element beam on 6 meters and as an 18 element beam on 2 meters.

As shown in fig. 1A, the driven element of this array is a folded dipole cut for 6 meters. The dotted curve indicates the current distribution on this element when it is excited at 50 mc. If this dipole were fed by itself, with none of the parasitic elements present, the directivity pattern would be as shown in fig. 1B. This is the con-

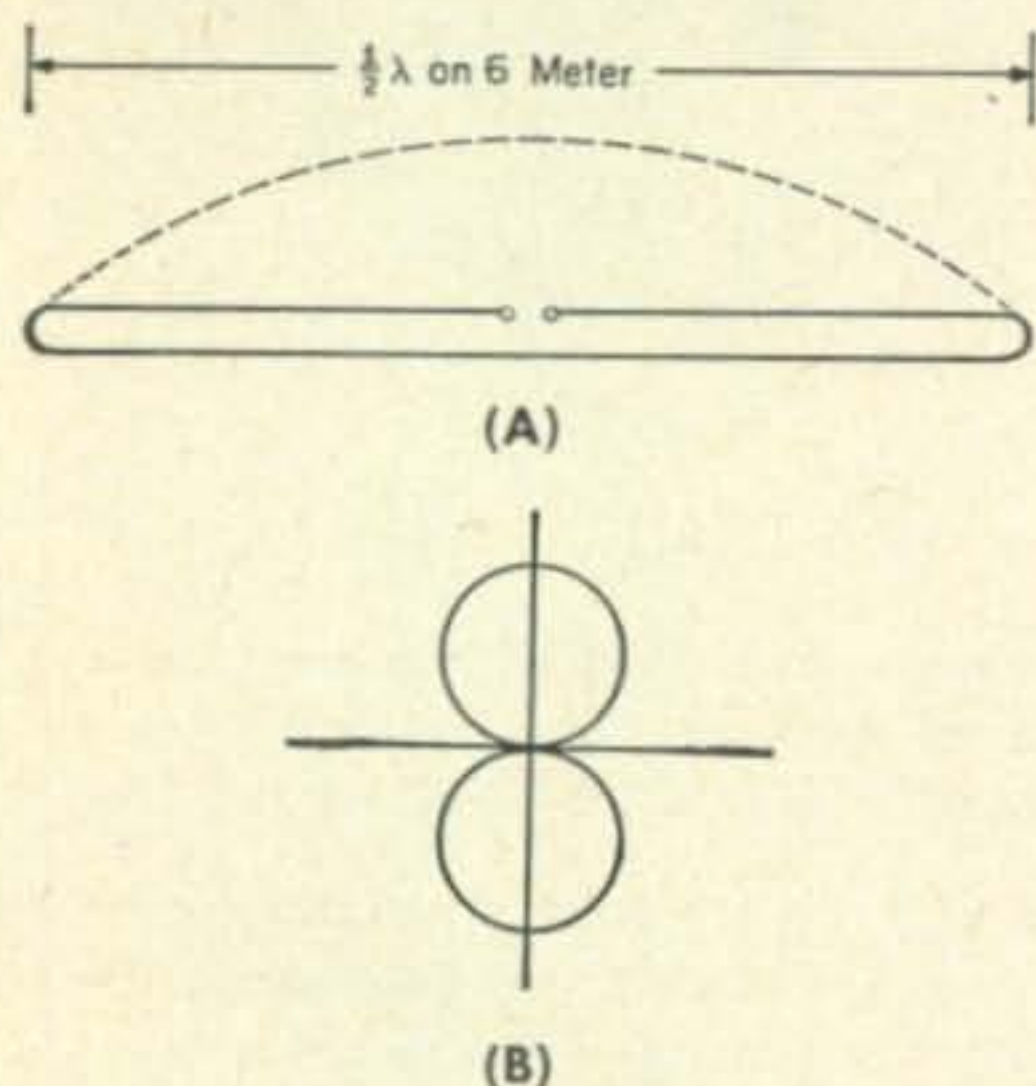

Fig. 1—(A) Current distribution on the dipole when excited on 6 meters. (B) Directivity pattern corresponding to the condition of fig. 1A.

ventional figure-eight pattern of a dipole excited on the frequency for which it is one half wavelength long.

Since 2 meters is approximately the third harmonic of 6 meters, the same folded dipole will be approximately three half wave lengths long on 2 meters, and will have a current distribution on this band as shown in fig. 2A. The polar directivity pattern of an element operating in this mode is shown in fig. 2B. The pattern has four major lobes with two small minor lobes. The minor lobes are in the normal "broadside" direction of radiation. An antenna operating in this mode will have its maximum radiation at approximately 40 degrees in each direction from

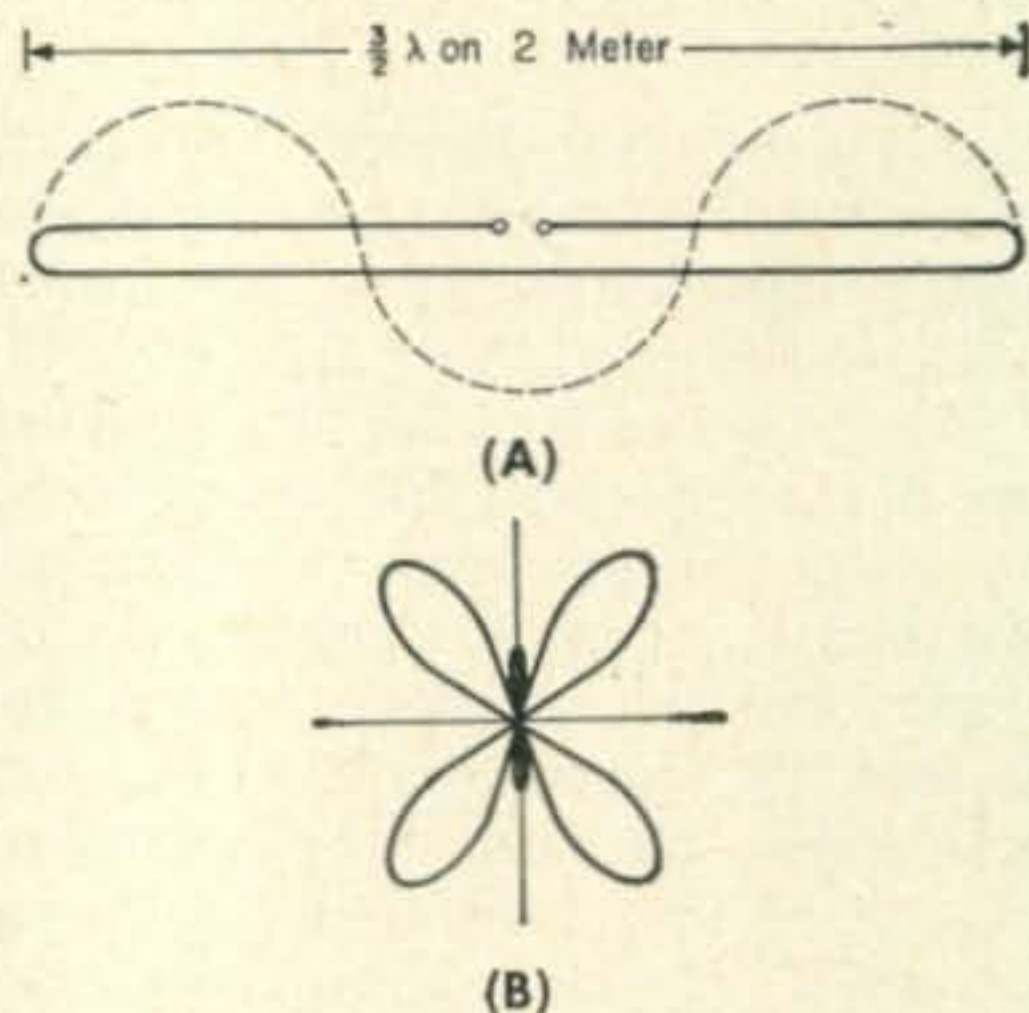

Fig. 2—(A) Current distribution on the dipole only when excited on 2 meters. (B) Directivity pattern corresponding to the condition of fig. 2A.

the normal "broadside" direction.

By placing the "Fidelity Phasing Stub," (Finco patent) precisely cut and positioned, in front of this element, the current distribution is changed to that shown in fig. 3A. Here we see an in-phase, 3 element colinear current waveform. The directivity pattern of this combination (a dipole three half wavelengths long with the Fidelity Phasing Stub present) on 2 meters will be as shown in fig. 3B.

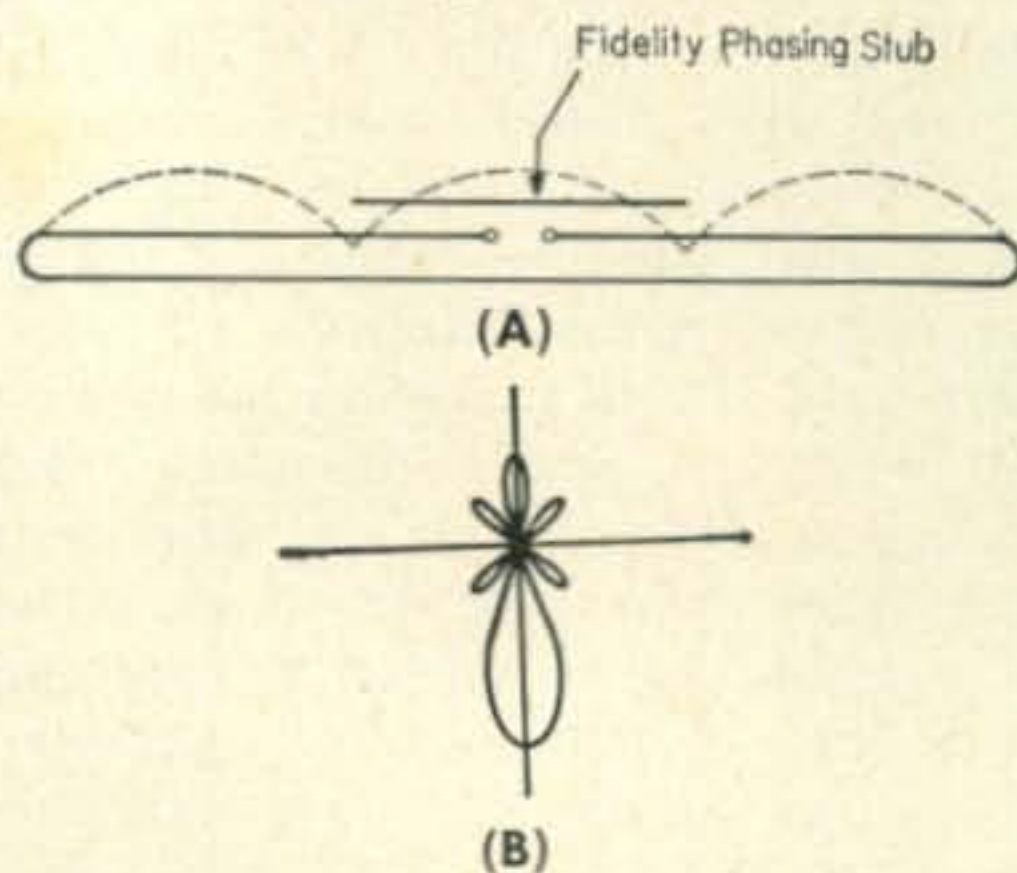

Fig. 3—(A) Current distribution on the dipole when Fidelity Phasing Stub is added and excited on 2 meters. (B) Directivity pattern corresponding to the condition of fig. 3A.

Customarily, a 3 element colinear antenna has a bi-directional pattern with the usual narrow forward and rear lobes characteristic of 3 element in-phase operation. Approximately 3 db gain may be anticipated in both directions.

However, fig. 3B indicates that the Fidelity Phasing Stub can be arranged to give some front-to-back ratio in this 3 element colinear configuration. Some additional forward gain is provided. A small rear lobe and some minor lobes are still in evidence.

From this it can be seen that the 6 meter folded dipole, together with the Fidelity Phasing Stub, can be operated as a single driven element on 6 meters, and as 3 colinear elements on 2 meters. This double duty design feature is the heart of the Finco Model A-62 combination 6 and 2 meter high-gain Yagi.

Figure 4 shows the composite array for both bands. Note the folded dipole and adjacent stub. Also shown are one reflector and two directors for 6 meters, and one 3 element colinear reflector and four 3 element directors for 2 meters.

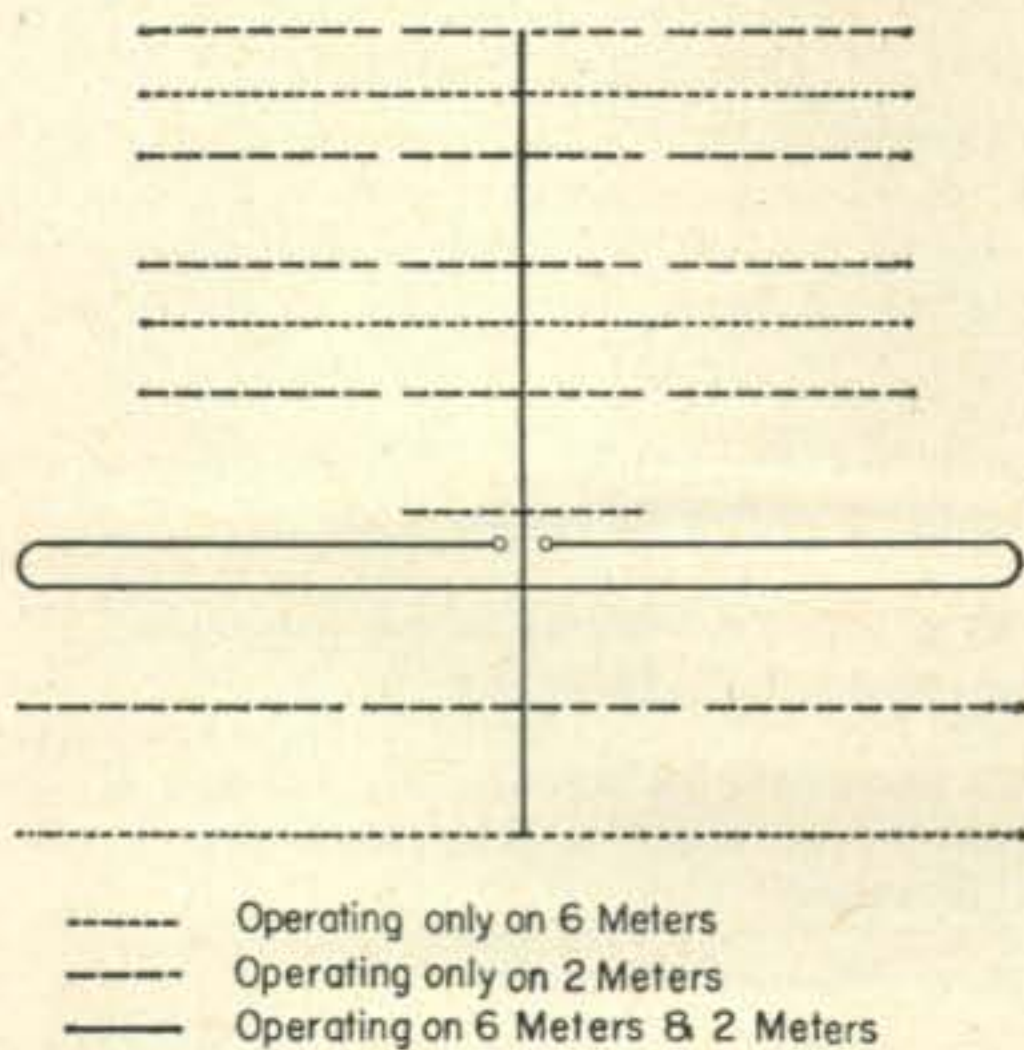

Fig. 4—Composite 6 and 2 meter array. Fibreglass insulators separate the segments forming the 2 meter directors and reflectors.

Figure 5 shows only the elements operating on 6 meters with the elements in line with the corresponding elements of fig. 4. This part of the array operates as a conventional, high gain, 4 element Yagi for 6 meters.

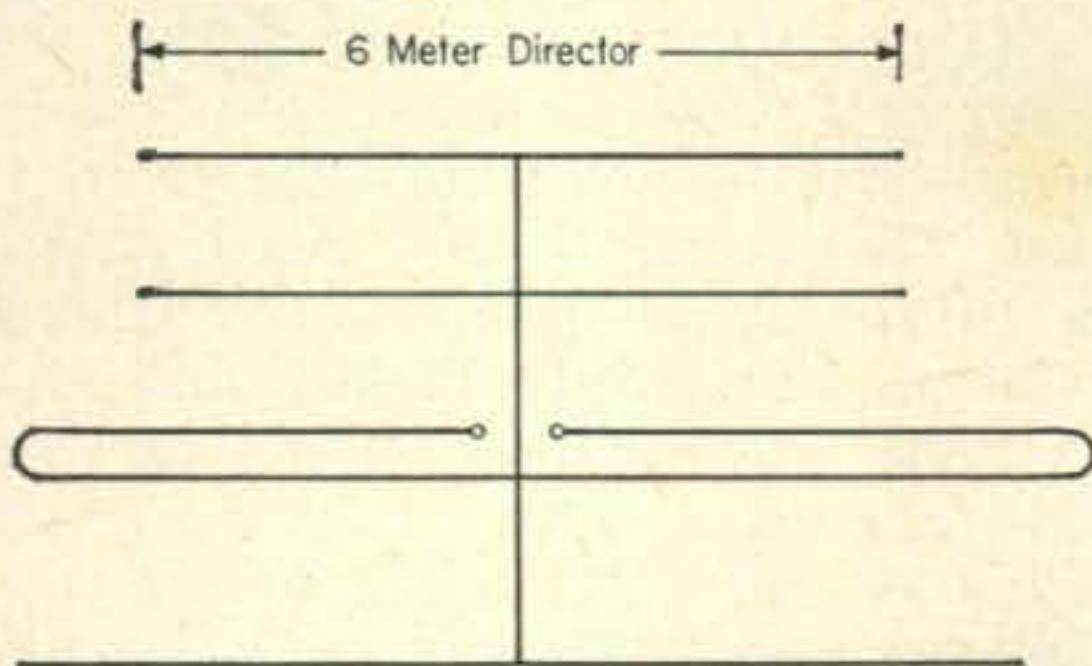

Fig. 5—Elements of the array that operate on 6 meters to form a 4 element Yagi.

Figure 6 also has its elements drawn in line with the corresponding elements of fig. 4, with only those elements operating on 2 meters shown. This figure more clearly indicates the one 3 element colinear reflector and the four 3 element colinear directors. Fiber glass insulators separate each element from its colinear companions, and effectively form three separate in-line directors for each colinear director, and three separate in-line reflectors for the colinear

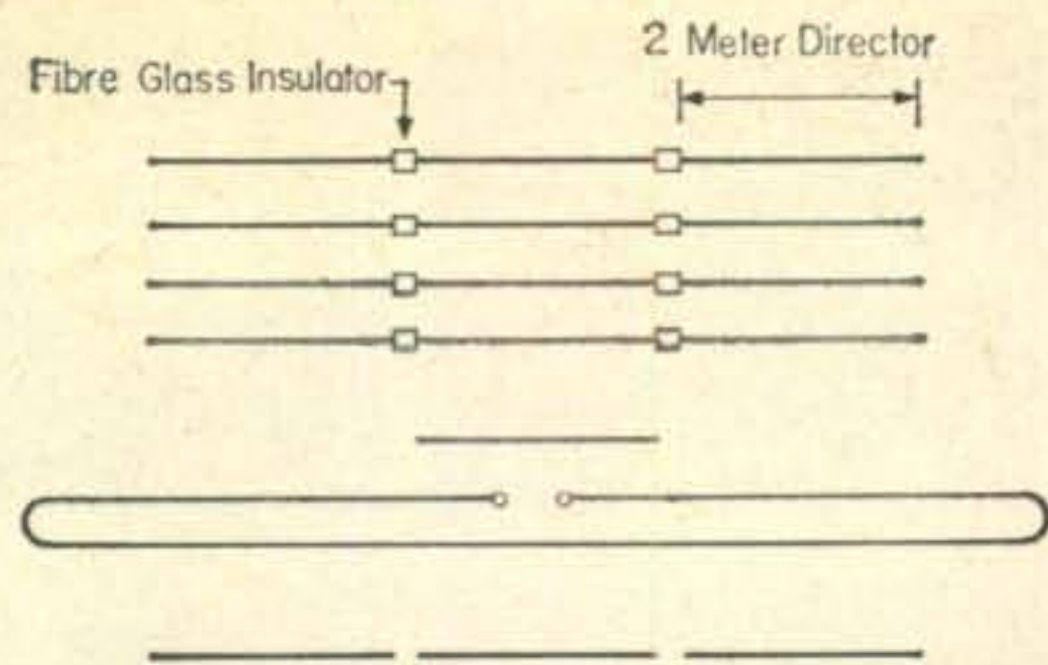

Fig. 6—Elements of the array that operate on 2 meters with the Fidelity Phasing Stub operating as shown in fig. 3A.

reflector. In fig. 6 the folded dipole and Fidelity Phasing Stub operate as shown in fig. 3A.

Figure 7 shows the schematic equivalent of fig. 6. It is three separate side-by-side 6 element 2 meter Yagis fed in phase. In an array of this type, in addition to requiring individual booms,

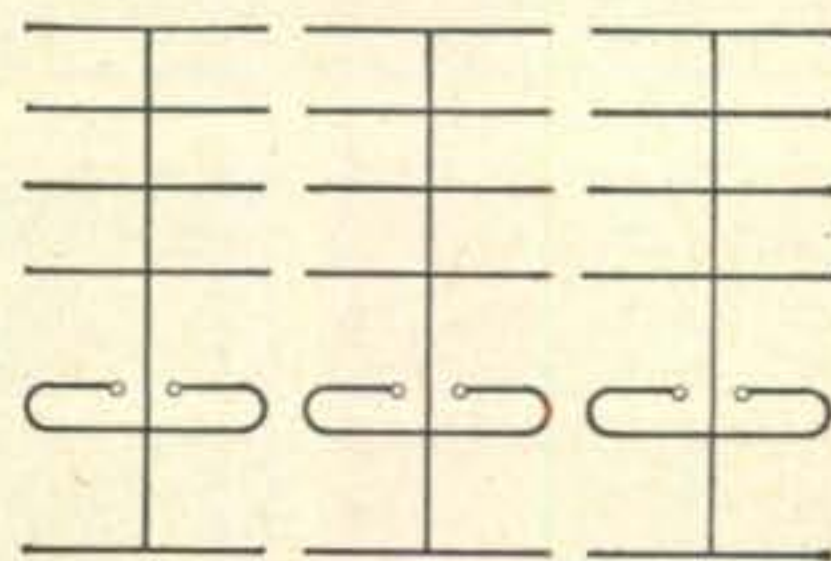

Fig. 7—The operating equivalent of fig. 6. It is effectively 3 side by side 6 element 2 meter Yagis fed in phase.

each antenna would have its own matching system. This would require three separate harnesses all fed in phase and cut to exactly equal length. Tied to a common junction point, this combined arrangement would then have to be matched to the impedance of the transmission line. The arrangement of fig. 6 is obviously much simpler mechanically and electrically as there is only one boom and one pair of terminals to which the antenna is directly connected. However, in electrical operation, the array shown in fig. 7 is identical with the one shown in fig. 6 if fig. 7 is fed in phase and properly matched to the transmission line system.

Precise spacing of all director elements for both bands is required to prevent interaction between the two arrays. The manufacturer appears to have accomplished his design objective in this respect also.

Your reviewer has operated one of these arrays on both 6 and 2 meters for several months at this writing, and measurements made in comparison with reference dipoles substantiate the manufacturers claims of 12 to 14 db gain on 2 meters and 8 db gain on 6 meters. Our "backyard" antenna range compares not at all with the elaborate facilities available to Finco, but it was interesting to observe that measurements made in this fashion were well within the limits of error of the relatively simple gear employed for this project. The antenna may be fed directly with 300 ohm twin-lead, or may be fed with 50 or 75 ohm coax through a balun. ■

**NEW P & H LA-400-C
LINEAR AMPLIFIER
NOW 800 WATTS PEP
FOR ONLY \$164.95**



PANORAMIC SPECTRUM ANALYSIS
Odd order distortion products (1kc, separation) using
popular 100 watt SSB exciter and LA-400C.

	3rd order	5th order
EXCITER ONLY	-37 db.	-47 db.
EXCITER AND LA-400C	-37 to -40 db.	-47 to -50 db.

Certified by ITT FEDERAL LABORATORIES

The 80 thru 10 meter band-switching pi network is designed for 800 watts PEP SSB, 400 watts CW, FM or FSK and 230 watts Linear AM (controlled carrier) or 185 watts (constant carrier) with 50-70 ohm output. Popular 100 watt SSB exciters require no swamping or matching networks to drive the low Z untuned input. Grounded grid circuit uses four 1625's or 837's on customers request. Meter reads RF drive, plate current, RF amps output. New modern compact 9" X 15" X 10 1/2" gray cabinet also contains power supply using 816's. TVI suppressed, Parasitic Free.

One-Year Warranty on all Parts and Tubes

SEE THE NEW LA-400C AT YOUR DEALERS

LA-400C Kit Complete with tubes\$164.95

LA-400-C Wired and tested\$219.95

P & H ELECTRONICS INC.
424 Columbia Lafayette, Ind.

For further information, check number 19, on page 126

TRI STATE AMATEUR RADIO SOCIETY, INC.

Publication: SPARKS

Mailing address: P.O. Box 51

Evansville 6, Indiana

Local Listening freq; 29.6 & 145.2

Club meetings are held at Community Center, 8th & Main Streets, 1930 hours last Wednesday of each month.

Visitors & inquiries invited.

ANNOUNCEMENTS [from page 20]

Southwestern A.R.R.L. Convention

The Hotel Westward Ho in Phoenix, Arizona will be headquarters for the S.E. A.R.R.L. Convention to be held on May 26th through 29th 1961. The Convention Committee has lined up a grand array of guests, prizes and exhibits which covers all facets of amateur radio. Special attention is being given to the XYL's with tours, luncheons, shopping etc. A KWM-2 will be awarded as a pre-registration prize. The cost of pre-registration is \$8.50 until May 1st. After May 1st, and at the door, admission is \$10.00. "Peter" Marshall, K7AWI is handling the tickets. He can be located at P. O. Box 7155, Phoenix, Arizona.

Hi-Plains, Kansas

The Hi Plains Amateur Radio Club is sponsoring its Twelfth Annual Hamfest to be held on May 21st at Plains, Kansas. Last year, nine states were represented and this year registration is expected to be bigger and better. Florence Hackenburg, K0CJM is the club's secretary and she will be glad to forward additional information from Kismet, Kansas.

Columbus, Indiana

The Columbus A. R. C. will sponsor their 2nd annual Ham picnic and Swapfest at Donner Park, Columbus, Indiana, Sunday, May 21st. For additional information contact Frank Reiser, W9AWH, at RR2, Columbus, Indiana.

Roanoke Virginia

The members of the Roanoke Valley A. R. C. most of whom are former members of the now inactive Blue Ridge Amateur Radio Society are sponsoring a Hamfest which will be held in Roanoke on Saturday May 20th and Sunday May 21st. Advance tickets for the dance, meals and reservations are available and a flyer can be obtained by writing to the Roanoke A. R. C. at Box 2002 Roanoke, Va.

Mecklenburg A.R.S. Inc.

Down Charlotte, North Carolina way, the date is June 3rd and 4th. On Saturday and Sunday the Mecklenburg Amateur Radio Society Inc. will hold their annual Swapfest at the National Guard Armory at the Municipal Airport. Everyone is invited to bring their gear and be ready to take home more than they bring.

TRANSMITTER HUNTS [from page 56]

In the meantime I was lying on the sidewalk very interested in bossing the job and completely unaware of anything other than the activities in the drain. Quite suddenly I heard a gentleman say, "Lady can I be of any help?" Well, I could have fallen through the manhole and floated down the river. I calmly answered, "No, thank you." As I look back I wonder, "What could this man have thought?" A lady lying on the sidewalk, looking down a drain.

We set the two Communicators into the drain pipe, then carefully laid padding and tumbleweeds on them to deaden the sound and cover up the dial lights. We then proceeded to the next step in our adventure.

The location for the third transmitter (the remote transmitter) was about three hundred feet from the storm drain and over a small hill, hidden from view. This was powered with a six volt battery and used a nineteen inch whip.

A dummy five element beam was put up on the fence across the river. The end of the coax was buried in the ground and a note which read, "You've got the antenna — Now What?" We figured the transmitter hunters would come directly to the dummy antenna as it was closest to our antenna in the river.

We started promptly at eight P.M. calling, "CQ The Hunt." The hunters were all gathered at the park and after checking in and being sure all could hear us they started out. From our remote transmitter we would transmit on the high end of the band. The repeater receiver would receive the signal and pipe it into the audio input of the repeater transmitter which was on the low end of the band. The repeater transmitter was licensed under a different call.

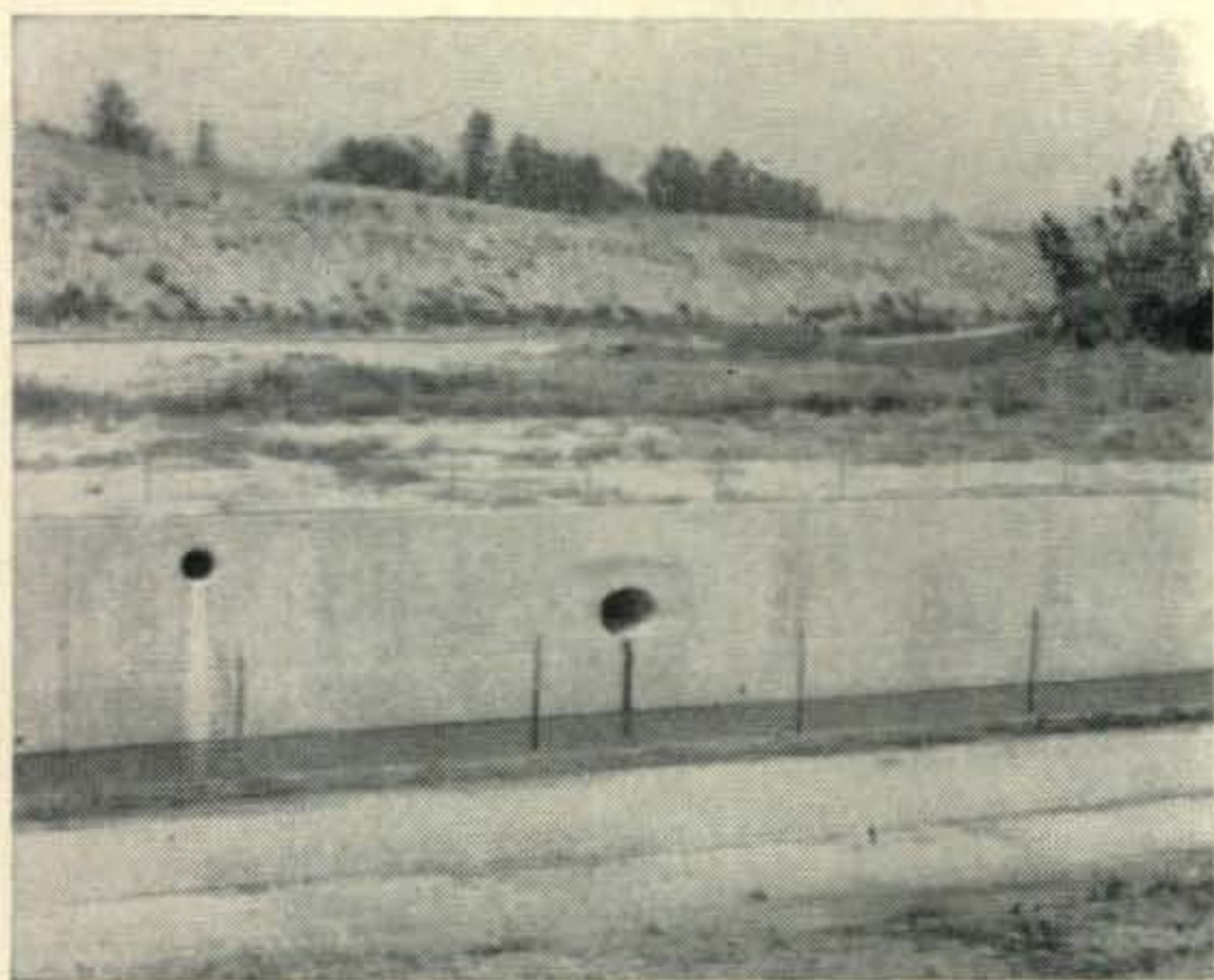

Large drain was where the antenna was installed.

In the middle of the hunt our six volt battery on the remote transmitter gave out. So off to the service station to get a new battery. This meant a wild dash on foot, as no cars were parked in this area. Dodging in and out behind bushes and houses and carrying a six volt battery was no easy chore. In the mean time, repeater receiver and repeater transmitter were putting out a fine carrier with no audio. Lucky for us we were close to a service station and it didn't take long to get another battery. We did manage to sign our call a few times before it finally gave up.

From our vantage spot we could see the beams on the hunters cars twisting under the street lights. With their spot lights they promptly discovered the dummy antenna and dug up the coax. They were quite upset at not finding a transmitter at the end of it. Then with a disgusted look they read the note and proceeded looking for the hidden transmitter. They even tried to climb the storm drain fence along the river, but the barbed wire on the top stopped them.

About eleven thirty the seekers decided we were neither in the river or on their side. Finally they came over to our side of the river, but as there was no signal and nothing to see they were lost again. One seeker had a coffee can walkie talkie and a very determined mind. He finally spotted the antenna in the gutter with his spot light. He decided that the antenna didn't go into the river so he figured it just had to go the other way into the pipe. So after scouting around for sometime on foot he heard the vibrators purring in the still of the night. I am sure the walkie talkie didn't help him in locating the transmitter but it did help to find the antenna.

About twelve thirty the remaining hunters finally gave up. They were quite amazed when we told them

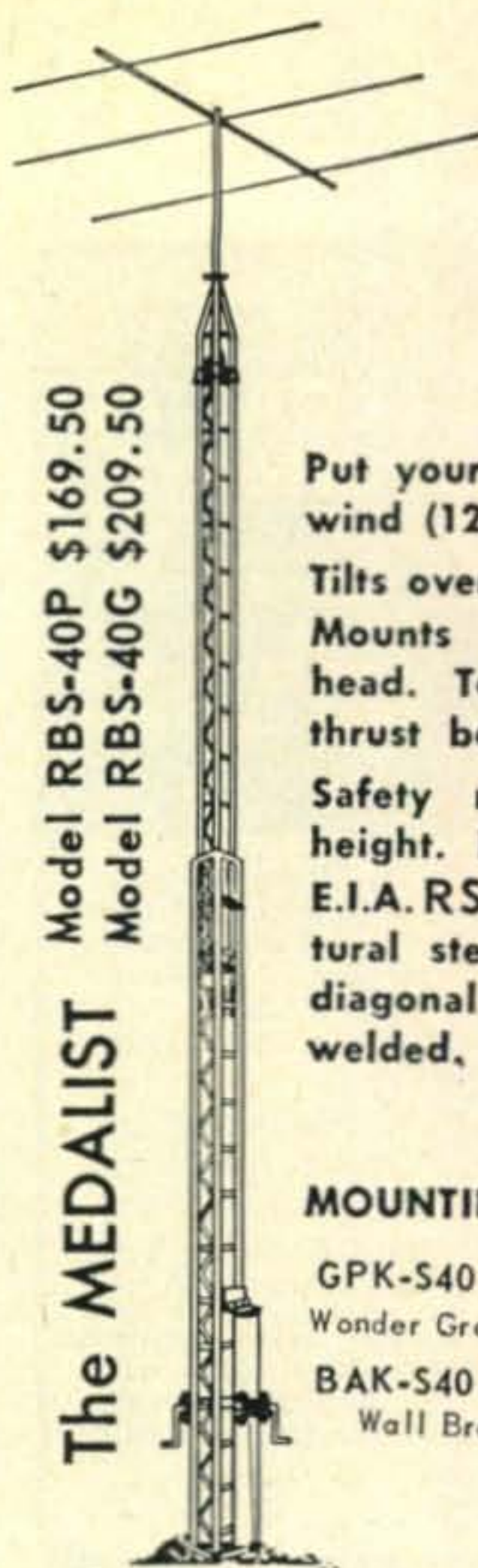

Model RBS-40P \$169.50
Model RBS-40G \$209.50

The MEDALIST

STURDY E-Z WAY TOWERS

Put your Tribander at 41' in 70 mph wind (125 mph cranked down to 24').

Tilts over for E-Z access to array.

Mounts Ham-M Rotor inside tower head. Top radial bushing - vertical thrust bearing.

Safety rest locks tower at desired height. No weight on cables.

E.I.A. RS-222 specs. Heavy wall structural steel tube legs, solid steel rod diagonal & horizontal bracing - arc welded. Sold by Top Flight Distributors Everywhere!

MOUNTING KITS:

GPK-S40 \$75.00
Wonder Ground Post
BAK-S40 \$10.50
Wall Bracket

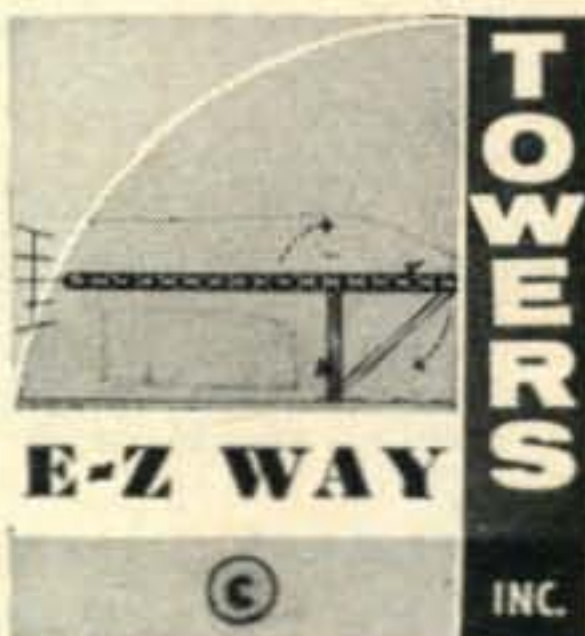

Write for Catalog 22-1

P.O. BOX 5767 TAMPA 5, FLORIDA

For further information, check number 20, on page 126

GOOD BUYS - ALL NEW

Extraordinary values await you in government surplus components. Our specialty is components; we have many of those hard to find items that you just won't see advertised elsewhere in surplus materials. Don't buy anything until you have our "Bargain Bulletin"; write for it today, it's free. New material is available to you for mere nickels and dimes on the dollar value. Here are some typical values:

RELAYS, all are beautifully constructed to govt specs.
13 VAC coil, DPDT + SPDT, 10 amps, ceramic.....1# \$2.89
12 VDC, 64Ω coil, DPDT, 20 a + SPST, 6 a, cer.....1# \$1.89
Differential, 2-9000Ω coils, 2-SPDT sect, 2 a.....1# \$3.39
115 VAC coil, DPDT at 5 amps, hermetic seal.....¾# \$1.95
Min. DPDT, 3800Ω coil, 1 amp cont, 28 VDC.....½# 89c

AUDIO TRANSFORMERS, a few typical values, many more.
5 w output, 5KΩ:15Ω, ±½ db 16-18,000 cps, per pr...3# \$2.22
Line match, 15KΩ to 600Ω, 50-10,000 cps, pot.....1½# 69c
25 w output, 8,000Ω ct, 15/125/250Ω, potted.....4# \$1.95
Line to v c, Thord. 2-16Ω v c to 500Ω line.....2# \$1.39

PLATE & FILAMENT POWER TRANSFORMERS, 115 volt, 60 cycle.
720 vet/135 mils, 5/3 and 6.3/3, potted.....12# \$3.79
490 vet/130 mils, 5/2, 6.3/3, potted.....9# \$3.19
800 ct/175, 80 v tap, 5/3, 6.3/2.5, 6.3/2.5.....9# \$4.44
600 vet/350 mils, 12.6 v/11 amps, potted.....18# \$4.29
Auto, 115 to 230 volts, 90 watts, potted.....7# \$2.29
HV scope, 4500 volts/5 mils, 10 KV RMS ins.....10# \$1.95

FILAMENT TRANSFORMERS, 115 volt unless otherwise shown.
5 vet/30 amps, 215/230 pri., 15 KV ins., Chi.....20# \$6.45
6.3/0.6 potted, uses only 3 sq in chassis areal.....1½# 79c
6.3/27 amps, four windings, 3 amps are ct.....9# \$3.29

MISCELLANEOUS VALUES, all are outstanding.
CW "Dream Filter", bandwidth 200 cps down 20 db...4# \$6.95
Oil cond., 15 mfd/330 VAC, HV ceramic terms.....3# \$2.29
BC-610 40 meter coils, C-390-A, three for.....1# \$1.79
3AP1 cathode ray tubes2# \$1.45
3C24 triodes, Lewis and Kauffman, a pair.....2# \$5.55

and hundreds of other equal values appearing in the "Bargain Bulletin". Write for yours today!

Send adequate postage with orders. We refund any overage. All prices are FOB Sacramento. \$3.00 minimum order please.

JOE PALMER
PO BOX 6188 CCC, SACRAMENTO, CALIF.

For further information, check number 21, on page 126

DOW-KEY DK60 SERIES



Small, Compact,
Light Weight,
Less than 9 oz.

4 VERSATILE
MODELS
A.C. or D.C.

COAXIAL RELAYS

Also Available
with Type C,
TNC, BNC, N &
UHF Connectors

Outstanding favorite for amateurs . . . Versatile combinations for industrials! Low VSWR — less than 1.15:1 from 0 to 500 mc. LOW LOSSES . . . High Contact Pressures. LOW CROSS-TALK through use of patented "isolated connector" arrangement. HIGH POWER RATING. All coils encapsulated in epoxy resin for quieter operation and resistance to moisture.

- ★ UNCONDITIONAL GUARANTEE for one year. (We will repair if faulty within 1 year.)
- ★ See one of our 700 dealers and distributors in U. S. and Canada for catalog sheets or write:

STANDARD RELAYS: DK60, DK60-G, DK60-2C and DK60-G2C — Priced from \$12.45.

Also available with Type C, TNC, BNC, N & UHF Connectors.

May be had with weatherproof boxes for exterior use. Also with ganged, multiple switch arrangement for remote control selection of antennas.

PRICED FROM . . . \$12.45

DOW-KEY COMPANY

Thief River Falls, Minnesota

For further information, check number 22, on page 126

S. A. R. L.

The Saskatchewan Amateur Radio League welcomes all visiting radio amateurs and their families to Saskatchewan the land of wheat and holiday fun. If mobiling, the net frequency is 3780 and net meets at 1830 daily, but call in any time! 1961 Hamfest is June 30, July 1 and 2 at the well known Prince Albert National Park. If you are planning to visit our fair country let us know at the SARL, Box 801, Saskatoon, Saskatchewan, Canada . . . drive carefully and keep your fingers out of the HV . . .

the story and showed them the three Communicators. Everyone was willing to admit that our mad strategy had really worked.

Now came the clean up work. We didn't think the antenna in the river would be a great loss so with a few yanks we managed to lose the dipole in the river. Our cars were all parked away from the street and it took lots of leg work to get the cars and pick up all the gear. It was a wonderful hunt and we all had lots of fun.

Our reward after a good days work? Off to a midnight snack and lots of discussion about the night's fun.

P.S. Don't go look for our very favorite spot. The Los Angeles City has recently put in a freeway and nothing is left. Well, we can always say we once had fun under the Hollywood Freeway. ■

Big Things [from page 57]

W8TBP; W9LIG, HAE, IJB, myself, and others. We decided to organize and try our hand at a hamfest. That was the beginning."

Following the death of W9MKS, the club petitioned the FCC who agreed to award the SRRC his call letters as the country's second memorial station—the first being a tribute to Hiram Percy Maxim, W1AW.

Now, 5000 cards are mailed to Midwest hams and countless letters written soliciting prizes, with work starting each January when new officers take over. This year, the hamfest is set for Sunday, June 4, with President Jack Ashley, K9KHZ, in charge.

A first time traveler to the SRRC hamfest will spot yellow pointer signs when he nears Ottawa, some 70 miles southwest of Chicago, and after winding along the Illinois River and climbing a few hills, he'll join a caravan of mobiles at a 4-H camp with buildings full of exhibits, parking spaces galore, and a welcome committee at the gate. Five longtime friends of the club get arrivals in a holiday mood while selling tickets, as they throw candy and balloons in the cars and shout "hello." Once inside, the fun really begins and most families have trouble deciding what to do first. Early arrivals will find the coffee and doughnuts free, but the kids are anxious to get to the game area. Mom wants to head for the ladies' contests and carry off a few prizes, and the OM, well, he just doesn't know where to start. He really ought to drop the ticket stubs in the prize box for afternoon drawings before perusing the exhibits of new gear and gathering pamphlets; but chances are he'll head for "bargain alley," a fabulous collection of surplus gear brought in for swapping and selling. A newcomer will catch his breath at the sight of some 100 cars backed up, forming a lane, with equipment of all kinds tumbling from trunks onto the ground.

"You can find anything you want to buy," said one excited Novice, "and even if you're broke, it's still fun to look."

Following basket lunches, barbecue parties, or snacks from the concession stand, the SRRC

Phone Results [from page 65]

<i>U. S. S. R.</i>		<i>Netherlands</i>	
UG6KAA	3660 46 12 28 B	PIIMID*	5040 69 19 41 B (Club Station)
<i>Armenia</i>		<i>Northern Ireland</i>	
UA0KKB*	13,650 115 28 42 B (Club Station)	GI3CDF*	55,080 182 47 133 B (GI3CDF, GI3CVH, GI3FJA, GI3GSB, GI3ILV, GI3JGZ, GI3ONF)
<i>Asiatic</i>		<i>Norway</i>	
UA0KIA	680 26 9 11 B (Club Station)	LA1K*	14,820 188 15 63 B (LA5UF, LA7SG LA7WG, LA7YG)
UA0KYA	462 40 5 6 — (Club Station)	<i>Portugal</i>	
<i>Azerbaijan</i>		CTIEY*	248,160 618 58 162 C (CTIEY, CTIYE)
UD6KAB*	91,464 449 17 57 — (Club Station)	<i>Sweden</i>	
<i>Georgia</i>		SL5AB*	59,400 311 40 110 C (Club Station)
UF6KAF*	20,119 127 16 43 C (Club Station)	SM5AZU	9238 104 18 44 B (SM5AZU, SM5BGM)
Europe		<i>U. S. S. R.</i>	
<i>Czechoslovakia</i>		<i>European</i>	
OK1KKR*	84,587 339 50 143 B (Club Station)	UA3KWA*	35,682 266 29 85 — (Club Station)
<i>England</i>		UA6KTB	1404 39 7 19 B (Club Station)
G3LCH*	24,750 173 26 73 B (G3LCH, G3LEV, G3LSP, G3NFA, G3NGY)	<i>Estonia</i>	
G3OHM	16,653 160 22 69 B (G3HZG, G3JPN, G3LMS, G3MZU, G3NKI, G3OMG, G3WXY)	UR2KAE*	53,336 401 31 87 C (Club Station)
G3NGZ	15,416 128 26 68 B (G3KTC, G3NAC)	UR2KAA	7860 133 17 43 B (Club Station)
G3AFM	3808 60 16 40 B (G3AFM, G2AHC)	UR2KAW	2752 51 15 28 C (Club Station)
<i>Finland</i>		<i>Moldavia</i>	
OH2AA*	12,707 117 24 73 A (OH2KH, OH2KK)	UO5KAA*	25,143 230 26 63 C (Club Station)
<i>France</i>		<i>Ukraine</i>	
F3JW*	102,160 389 44 100 B (F3JW, F3EG, F9WM)	UB5KAB*	102,879 350 48 113 C (Club Station)
F9WK	88,020 320 49 114 B (F9WK, F7BK)	UB5KDS	4410 64 15 30 C (Club Station)
<i>Germany</i>		Oceania	
DJ3VM*	294,124 467 83 195 C (DJ3VM, DJ1BP, DL1CR, DL1CX, DL3AO, DJ3JZ)	<i>Christmas Island</i>	
DL6KE	18,124 155 25 67 —	VR3L*	A 128,560 567 38 42 B (VR3L, KH6DFC)
<i>Italy</i>		South America	
IIDFB*	63,806 353 41 81 C (K2VAL, K8KSB, K0LRS)	<i>Paraguay</i>	
		ZP5CG*	91,908 170 43 68 C (ZP5CG, ZP5JP)

MULTI-OPERATOR Multi-Transmitter

North America

<i>United States</i>	
K2GL*	383,112 498 107 206 D (K2GL, W2GLM, W2IWC, W2HQL, K2TXX)
W3AOH*	136,799 269 79 142 D (W3AOH, W3LMM, W3MVQ, W3QJJ, W3UHN, W3VKD, W3WGH, K3DKD)
<i>British Virgin Islands</i>	
VP2VH*	37,024 252 40 64 B (VP9L, VP9BN, VP9EN, WINBA, W2YTH, W2YTI)
<i>Canada</i>	
VE6BY/6*	5940 64 26 28 C (VE6BY, VE6NX, VE6SZ, VE6TP)

Europe

<i>England</i>	
GB2SM*	186,660 457 64 180 B (Club Station)

Our thanks to the following stations for sending us their logs for checking purposes.

W1RWU	K8TGA	G3JFD	PA0TV	VR2DK
W2GT	K9JEL	G3MWZ	BRS-21457	YV5AK
W5EDX	CE1CK	HK3TZ	VE3DYB	ZS6AFJ
K6MQG	SKL-A-1623	LU9DAH	VK6VK	ZS6OM
W7AWD	EA6AR	OY7HL	VQ2EW	9Q5CK
W7KOI	EI4Q	PA0WFS	VQ3GL	KV4BQ

G3HTA	72,576 240 46 116 B (G3HTA, G3OIK, G3JW)
<i>Germany</i>	
DL1HC*	180,048 416 69 179 B (DL1HC, DJ3OU, DJ3YV, DJ4OT, DL6NK, DL9GU)
DL4HAB*	117,688 474 55 133 B (DL4AG, DL4FK, DL4GW, DL4PB, DL4UK)
DL4VF	106,640 377 51 121 —
<i>Ukraine</i>	
UB5KBB*	60,965 333 35 102 C (Club Station)

Africa

<i>Eritrea</i>	
ET2US*	258,427 471 57 136 D (W3NHK, W4DMS, W4FGZ, W4GUM, K5YCU, K9WLI)

FIELD ENGINEERS ACF ELECTRONICS

COMMUNICATIONS FIELD STATION ENGINEERS

Qualified engineers will develop a background in Ionospheric Physics and the study of Backscatter Phenomena through a training program in our Hyattsville, Maryland, Electro-Physics Laboratories. Engineers selected will have ample opportunity to develop professionally as part of a team extending experiments of the Research and Development Department to the field in both domestic and overseas assignments.

EE degree or equivalent, consisting of combined civilian or military technical school is required. Experience as a Field or Project Engineer with valid 1st or 2nd class FCC license is essential for senior level positions. A good command of some of the following is most desirable:

Radar; HF Long Distance or Meteor-burst Communications Systems; Scatter Systems; Propagation Prediction; Ionospheric Sounder Operations; RDF Systems; Short Wave (Amateur) Radio.

Interested engineers must be willing to accept assignments in areas where dependents are not permitted for periods up to one year. Differential paid for overseas assignments.

Please send resume to:
Mr. Robert J. Reid
Professional Employment, Dept. 432

ACF ELECTRONICS DIVISION
ACF INDUSTRIES
RIVERDALE, MARYLAND

TELEX®

SUPERIORITY IN SOUND

FIDELITY... FOR HAMS WITH A LIKING FOR LIGHTNESS

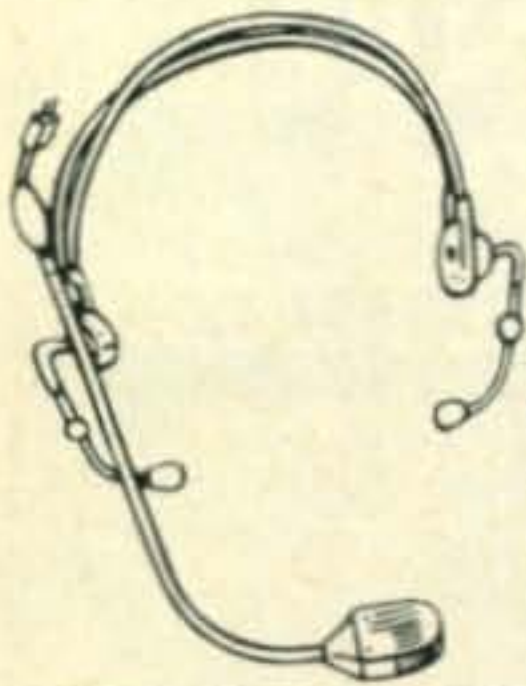

LIGHT...

Boom Mike Headset—Light 4 oz. parallel connected receivers transmit sound directly to ears through adjustable tone arms. Rubber or plastic tips block background noise without pressure, allowing continuous communication under the most difficult conditions. Available with a wide choice of

general or special purpose microphones. Mike boom, angled for best pickup, has 360° swivel. Ideal headset for mobile use. Impedance: 500 ohms. Frequency response: 50 to 5000 cps. Sensitivity: 114 db above .0002 dynes per sq. cm. for 1 milliwatt input.



LIGHTER...

Twinset—FAA approved, the 1.6 oz. Twinset is standard on airlines; fits any amateur, experimental or commercial installation. The lightest twin magnetic receiver headset ever made! Sound is piped through adjustable tone arm. Ear-

tips block out background without touching ears. Standard 5' cord and phone plug or optional cord with volume control. Frequency response: 50 to 5000 cps. Sensitivity: 101 db above .0002 dynes per sq. cm. for 10 microwatts input.



STILL LIGHTER...

Monoset—Under-chin 1.1 oz. set features removable eartips, optional volume controls. Durable aluminum construction, Monoset has 5' cord and standard plug. Frequency response: 100 to 5000 cps. Sensitivity: 88 db above .0002

dynes per sq. cm. for 10 microwatts input.

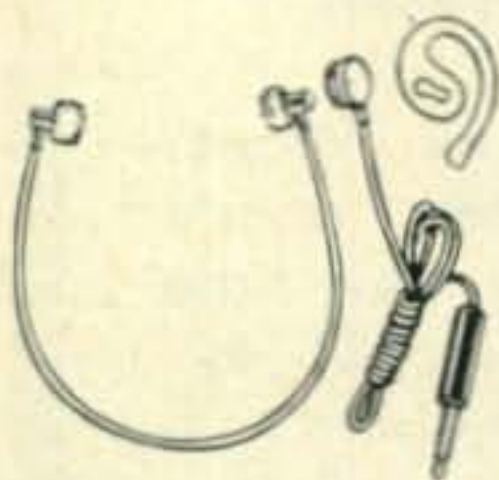

LIGHTEST...

Tele-Fi—True dimensional sound and 30% better understanding with this ½ oz. set because of a 1 millisecond delay in sound reaching ear opposite receiver. Replaceable ear tips. Change from headset to accessory earset in seconds. Standard phone plug and 5' cord included. Tele-Fi chin band usable with all TELEX transistor receivers. Frequency response: 50 to 5000 cps. Sensitivity: Comfortable at 1 milliwatt.

See your jobber today for superior quality communications accessories... by TELEX! Or, write for information to:

TELEX

Communications Accessories Division

Dept. CA-307, Telex Park, St. Paul 1, Minnesota

For further information, check number 23, on page 126

committee puts on an entertaining program. Besides introductions and speakers, added attractions keep hamfesters guessing. For instance, if the wind is right and his plane in flying shape, good-natured K9JAW, Sonny Hindson, showers tickets from the sky entitling finders to collect a variety of prizes. Of course, the big stuff is distributed at the last hour drawing, and thanks to an active committee and cooperating dealers and manufacturers, jubilant hams carry off valuable prizes including perhaps a beam, tower, receiver, or transmitter.

"We don't try to make money," says W9QLZ. "We just like to break even and see that everyone has a good time."

And if you don't believe it, just drop over to Ottawa on June 4; you won't be disappointed. ■

NC-270 [from page 60]

be read in 10 minutes. I suppose there are very few hams who would read 18 pages of data before operating their new receiver.

Your reviewer was disappointed not to find an accessory socket on the rear apron. This feature would be particularly useful since the excellent sensitivity of this receiver on 50 mc could be expected to encourage 220 mc, and higher, enthusiasts to utilize the 4 mc coverage of this band.

For a period of months this receiver has been operated on all bands from 3.5 mc to 50 mc, as well as on 144 mc by means of a converter, and on a.m., c.w., and s.s.b. It is an extremely stable and sensitive receiver with many operating conveniences and is capable of performing well in any mode of communication. ■

160 Vertical [from page 53]

at the high impedance point) due to various resonances of guy wires, cables etc. The proper dip is one which is smooth as you go through resonance, not one which will pull the grid dipper out of oscillation.

This same scheme can be used for 80 and 40 meters using shorter gamma rods and smaller gamma capacitors. Why let a perfectly good vertical go to waste? ■

Solid State [from page 33]

zation in the direction of maximum signal should be determined by rotating the receiving antenna about its axis. When measuring antennas, the unit should, of course, be oriented to produce the desired polarization.

Total power drain is about 18 mw (6v @ 3 ma), so with normal use the batteries can be expected to last their shelf life. Naturally, with this low power input, you won't get an indication on a field strength meter. But with any receiver worthy of the name, you'll have plenty of signal at distances around a few hundred feet. If more signal is required, the unit may be placed at the focus of a parabolic reflector. ■

**"CALL ME
for
Personal Service"**

**"CALL ME
for
Personal Service"**

Bob Henry
WØARA
Butler, Mo.
ORchard 9-3127



ON

Ted Henry
W6UOU
Los Angeles
GRanite 7-6701



**WORLD'S
BEST TERMS**

**Because we finance
our own terms...**

- Only 6% a year finance cost
- 20 months or longer to pay
- Only 10% down (or your trade-in as down payment)
- No finance charges if paid within 90 days
- Reduced charges if paid off ahead of time
- You get more flexibility of financing in the future (such as re-financing) because we handle our own financing

**Collins
S/LINE**



**A-1 Reconditioned
Apparatus**

Nearly all makes and models. Big savings!
Ten day trial—90 day warranty. 90 day full
trade back on new apparatus. Write for
bulletin.

KWM-2 Transceiver	\$1150.00
32S-1 Transmitter	666.00
516F-2 AC Power Supply	115.00
516E-1 12 V DC Power Supply	270.00
75S-1 Receiver	520.00
312B-3 Speaker	32.00
312B-4 Speaker Console	195.00
30S-1 Linear Amplifier	1556.00

*Write, phone or visit either store today!
Inquiries & orders from military men
and others outside USA wanted.*

Butler 1, Missouri
ORchard 9-3127



Henry Radio Stores

11240 West Olympic Blvd.



Los Angeles 64 Ph. GRanite 7-6701

BIG

TRADE-INS

World's Largest Distributors of Short Wave Receivers

OPEN NOW THE 3rd HENRY RADIO STORE 931 N. Euclid Ave., Anaheim, Calif.

For further information, check number 24, on page 126

2 meter transistor CONVERTER crystal controlled

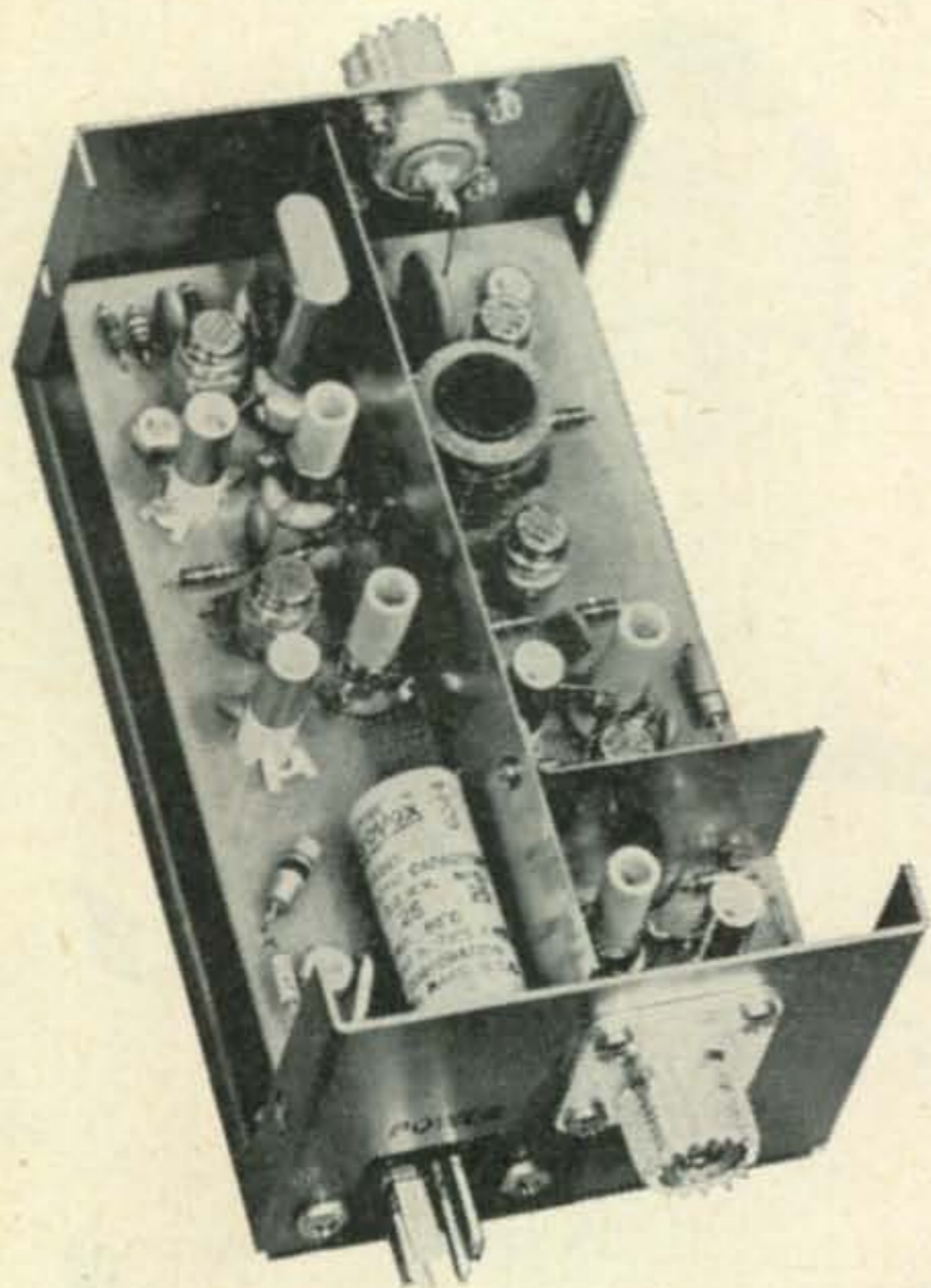

- **Noise figure 5 db or less**
(4.5 db typical)
- **.3 uv or better sensitivity**
- **Low current drain**
16 ma @ 12 VDC
- **5 new low-noise**
Philco VHF transistors
- **Epoxy fiberglass**
printed circuit board
- **Compact**, mounts in
5 1/4 x 3 x 2 1/8 Minibox

Kit (without case)	\$39.95
Assembled-Aligned	\$49.95
Kit, iridited case, RF and power connectors	\$45.95
Assembled-Aligned	\$54.95

Specify input and output frequencies with order.
Outputs available from 1 to 30 Mc. All prices
include crystal.

HAMBOARDS

P. O. BOX 13158 PINECASTLE, FLORIDA

For further information, check number 25, on page 126

Tube Tester [from page 47]

adjusted so that the listed plate current value is not exceeded. The shunt control and the bias (control "R") setting required for a GOOD indication should be recorded for future use.

Construction

The actual construction, physical size and tube sockets used will depend on your own requirements. Use of loctal and acorn tubes might not be anticipated as well as the large 7 pin tubes such as the 829B or 832. Subminiature sockets might be included. An extra set of banana jacks might be added for GRID 3 if desired.

The unit was constructed on a sheet of aluminum 6" x 9" but might also be built on a strong phenolic or bakelite sheet. This would eliminate the need of insulating the banana jacks.

Locate and mount the banana jacks as shown in the schematic of fig. 1. When the aluminum chassis is used be sure to insulate the jacks and employ grommets for the grid leads. Number and label all the leads and jacks with decals. Also be sure to make the leads long enough to reach any of the jacks on the panel. ■

Suppressed Carrier [from page 51]

frequency for the drive requirements.

The frequency dial calibration must now be multiplied by a factor of two in which case the settings for the 40 meter phone band extremities reference to the dial would be 3.6 to 3.65 mc.

In closing, may I suggest some interesting experiments others may desire to try. For example, the shorting of the 50K resistor inserts carrier for tuning purposes and with the addition of a keying relay or a change in potential balance of the beam deflecting electrodes by a small dry battery and resistive network for this function the procedure may be used for c.w. operation.

Another experiment would be to use a 7 mc BC-459 Command transmitter chassis for the construction of a three band d.s.b. transmitter. The original frequency range of the BC-459 adequately covers the 40 meter band, the $\times 2$ multiplication covering the 20 meter band, and the $\times 3$ multiplication covering the 15 meter band. Two points will require further consideration than was necessary on the above experimental transmitter. First, the oscillator stability requirement is a little more severe because of the $\times 3$ multiplication factor on the 15 meter band and a second frequency spread control for the oscillator would be required to provide adequate dial frequency change on the 20 and 15 meter bands.

Upon the examination of the Fourier Analysis made for a thin pulse, it was seen that harmonics appear infinite in number and of equal size. It would be interesting to drive a balanced modulator of the 6AR8 type and study the limitations of such a unit and examine the possibilities of continuous frequency coverage from a single variable frequency oscillator. ■

THE LAFAYETTE ROUNDUP OF HAMSHACK VALUES



MODEL HE-26 HYBRID PHONE PATCH

Perfect for AM-SSB Phone Patch operation. VU Meter monitors line level for Q5 phone patches. An unmatched low—

24.50

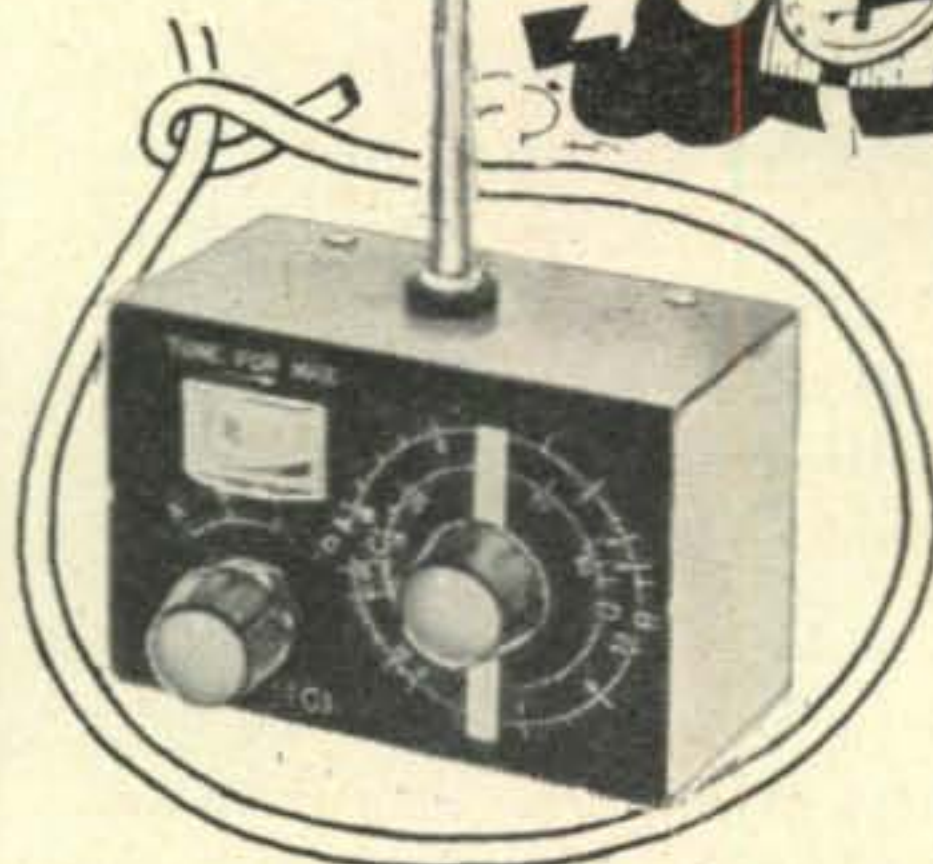

MODEL TM-15 WAVE METER

Checks transmitter output for harmonics, parasites, and out-of-band operation. Provided with magnetic feet. Perfect for the novice.

8.95



37.50

HE-28 RF WATTMETER AND SWR BRIDGE

150 watts full scale—Built-in dummy load—Wattmeter $\pm 5\%$ to 54 mcs. SWR $\pm 5\%$ for in line use.

MODEL TM-14 FIELD STRENGTH METER

Complete, no wires to connect. Monitor transmitter output, check antennas, etc. Perfect for mobile, provided with magnetic feet.

7.95

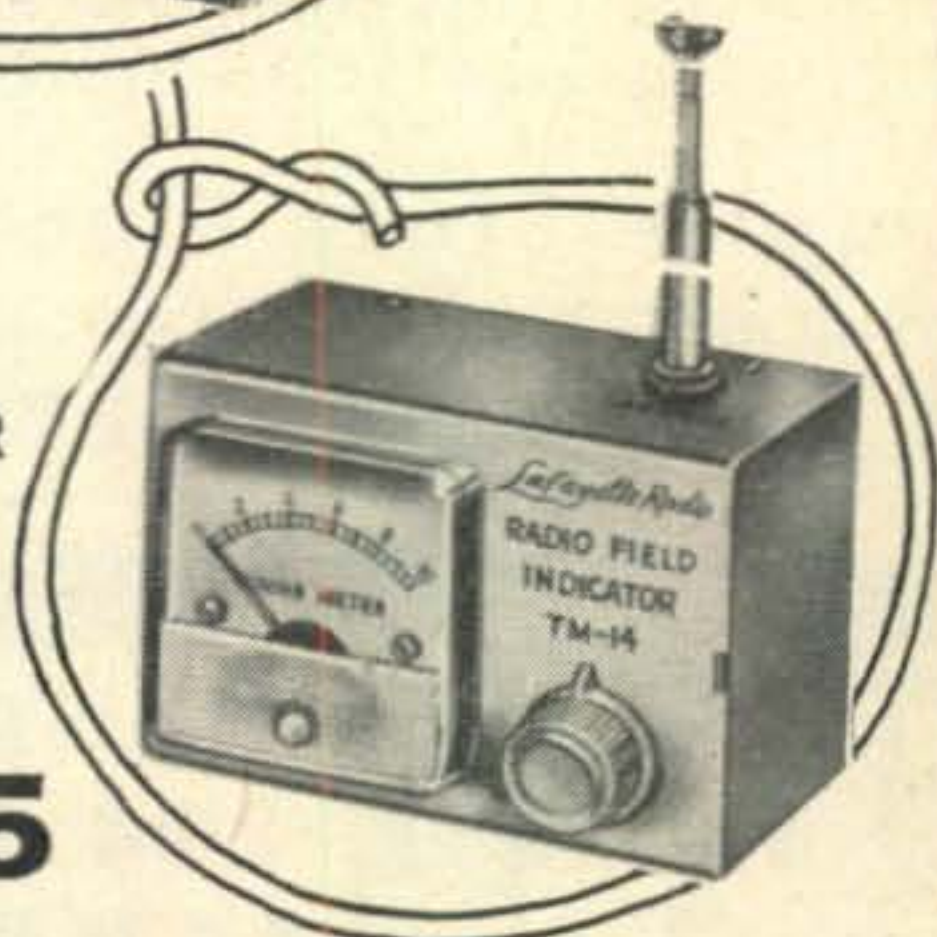

AN UNHEARD OF BREAKTHROUGH IN THE COMMUNICATIONS RECEIVER FIELD THE LAFAYETTE HE-30



99.50

- TUNES 550 KCS TO 30 MCS IN FOUR BANDS
- BUILT-IN Q-MULTIPLIER FOR CROWDED PHONE OPERATION
- CALIBRATED ELECTRICAL BANDSPREAD ON AMATEUR BANDS 80 THRU 10 METERS • STABLE OSCILLATOR AND BFO FOR CLEAR CW AND SSB RECEPTION • BUILT-IN EDGEWISE S-METER

THE DREAM RECEIVER FOR TODAY'S
CROWDED BANDS AND AT AN IDEAL PRICE

LAFAYETTE RADIO

NEW YORK, N. Y.
100 6th Avenue

NEWARK, N. J.
24 Central Avenue

BRONX, N. Y.
542 E. Fordham Rd.

PARAMUS, N. J.
182 Route 17

BOSTON, MASS.
110 Federal Street

PLAINFIELD, N. J.
139 W. 2nd Street

165-08 LIBERTY AVENUE, JAMAICA 33, N. Y.

OTHER LOCATIONS

Lafayette Radio Dept. CE-1 P.O. Box 190 Jamaica 31, N. Y.

- \$.....Enclosed. Send Stock #..... Rush FREE 324 Page Catalog 610
- \$.....Down Payment Enclosed for Stock #.....
- Lafayette Easy Pay Application Will Be Forwarded Upon Receipt of Down Payment

Name _____
Address _____
City _____ Zone _____ State _____



FREE 324-Page
1961
Catalog No. 610

Cut Out & Paste
on Post Card

For further information, check number 26, on page 126

PROFESSIONAL HAM GEAR SERVICING

The best man to service your ham gear is a licensed ham who specializes in servicing. That's what we are at Empire.

We have the quality replacement parts, the test instruments, the licensed manpower—and the long, diversified experience—to give your gear thorough professional care. That's why we are factory-authorized to service many ham lines including Gonset, Heath, Hallicrafter, Hammarlund, Globe, International Crystal, Central Electronics.

For any service problem, drop in, call or write to Russ, K2RLY. Or cut out this ad and paste it on the back of one piece of your gear as a reminder.

(See page 151, Nov. 1960 CQ)

Empire State Electronics
139-40 HILLSIDE AVENUE., JAMAICA, NEW YORK

For further information, check number 27, on page 126

400 W. Linear [from page 31]

tage is that their resistance changes considerably as the current through them varies, and this requires that tuning adjustments be done somewhat slowly and in successive steps because of the thermal lag of the lamp filaments. The lamps themselves indicate if you are tuning too rapidly: if their brilliance changes after you have stopped tuning, a retuning is indicated.

A 120 volt, 150 watt lamp has a resistance, at normal brilliance, close to 100 ohms. Two such lamps in parallel, or a single 120 volt, 300 watt lamp for that matter, will therefore have a resistance close to 50 ohms. Such is a suitable dummy load for this amplifier because the r.f. output is sufficient to operate them at normal brilliance. Likewise, two 120 volt, 150 watt lamps in series will provide a 200 ohm load. Two 300 watt lamps in series, however, will not provide a 100 ohm load because the total lamp wattage would be considerably more than the amplifier is capable of putting out, and the lamps will therefore operate at much less than normal brilliancy, causing their resistance to be much lower.

Results

To get the feel of tuning the amplifier, 40 meters is a good band on which to start. Apply reduced plate voltage, as described in the power supply section above. With the pi-output padding capacitors and the vacuum padding capacitor switched out, all bandswitches set in the 40 meter position, and the dummy load connected, set the pi-output variable capacitor to about half scale. Apply r.f. drive and tune the 814 plate capacitor for maximum 803 plate current. Then tune the 803 plate capacitor for maximum r.f. output as indicated by the glow of the dummy load lamps. Remove the r.f. drive from the exciter and connect full plate voltage to the amplifier. Trim the 814 tank capacitor for maximum output; then try various combinations in 803 plate tuning by arbitrarily changing the output variable capacitor a little and retuning the plate capacitor for maximum output. There will be many combinations which will produce good r.f. output, but only a few at which the efficiency and r.f. output are maximum. After the checkout with the dummy load, the amplifier is ready for use. Follow the same procedure of trying different combinations of pi-output capacity and 803 plate tuning capacity for maximum antenna current. A single setting of pi-output capacity should be sufficient for any one phone or c.w. band, but retune both plate capacitors for maximum output when going to different parts of the band.

Before doing any extended operating, check for TVI, which would be an indication of parasitics if the amplifier is on 80, 40, or 20 meters. The remedy for possible parasitics has been indicated earlier in the article. ■

FREE

GIANT 1961 204 PAGE CATALOG

BA

1961

ANNUAL CATALOG #11

Guarantee

SINCE 1927

SAVE UP TO
50% ON B-A
SELECTED
KITS

A Complete Buying Guide for Everything in

HI-FI AND
STEREO
SYSTEMS &
COMPONENTS

RADIO TV
ELECTRONICS

TOP VALUES
IN POWER,
AND HAND
TOOLS

BURSTEIN-APPLEBEE CO.

30 PAGES
OF BARGAINS
NOT IN ANY
OTHER CATALOG

Dept CQ, 1012 McGee St., Kansas City 6, Mo.

Send Free 1961 B-A Catalog No. 611

Name

Address

City..... State.....

SEND
FOR IT
TODAY

For further information, check number 28, on page 126

?
DO
YOU
KNOW

EVANS ▸ TAKES USED EQUIPMENT IN TRADE HAS LIBERAL TIME PAYMENT PLAN

AND as Northern New England's leading distributor, stocks ALL LEADING LINES. Twelve licensed Hams to serve you with an Engineering Department to maintain equipment purchased from us. Contact us TODAY, let us demonstrate 26 years as . . .

"YOUR FRIENDLY SUPPLIER"

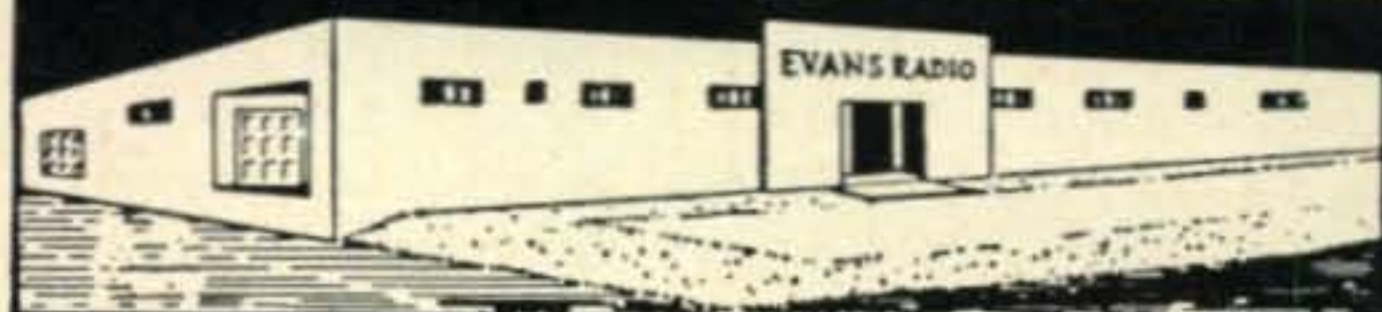

Evans RADIO

CA 5-3358 • ROUTE 3A • BOW JCT.
BOX 312 • CONCORD, N. H.

For further information, check number 29, on page 126

THE NEW SPACE RAIDER BEAM — A BEAUTIFUL JOB!

Nothing has been spared to provide maximum quality, maximum performance and long life in the new SPACE RAIDER BEAMS. These sturdy antennas have a built-in ruggedness unmatched in anything being offered to Hams anywhere at any price.

SPACE RAIDER BEAMS are pre-tuned and matching section comes pre-resonated so that when assembled according to simple instructions the antenna is all ready to go and will provide unity SWR in the middle of the band tapering to less than 1½ to 1 at band edges. Optimum forward gain and front-to-back ratio are standard on SPACE RAIDER BEAMS as is shown together with general specifications in the table below.

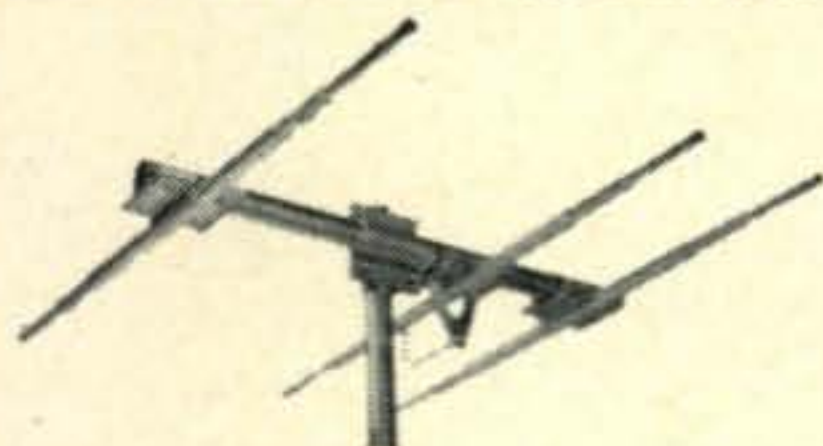

10 METER BAND

B-10-3-3 Element. 1¼" O.D. Center Sections; 1" O.D. adjustable end sections. Boom; 2" O.D. 12" long. .17-.17 wavelength spacing. Forward gain; 8 D.B. Front/back ratio; 20 D.B. 34.50 16 lbs.

B-10-4-4 Element. 1¼" O.D. Center Sections, 1" O.D. adjustable end sections. Boom; 2" O.D. 18" long. .17-.17-.17. Forward gain; 9.5 D.B. Front/back ratio; 30 D.B. 44.50 21 lbs.

15 METER BAND

B-15-3-3 Element. 1¼" O.D. Center Sections, 1" O.D. adjustable end sections. Boom; 2" O.D. 12' long. .12-.12 wavelength spacing. Forward gain; 8 D.B. Front/back ratio; 20 D.B. 44.50 19 lbs.

B-15-4-4 Element. 1¼" O.D. Center Sections, 1" O.D. adjustable end sections. Boom; 2" O.D. 18' long. .17-.17-.17 wavelength spacing. Forward gain; 9.5 D.B. Front/back ratio; 30 D.B. 54.50 27 lbs.

20 METER BAND

B-20-3-3 Element. 1¼" O.D. Center Sections, 1" O.D. and ¾" O.D. adjustable end sections. Booms; 2" O.D. 18' long. .12-.12 wavelength spacing Forward gain; 8 D.B., Front/back ratio; 20 D.B. 54.50 23 lbs.

Space-Raider
ANTENNAS & CRANK-UP ANTENNAS

PREPAID SHIPMENT U.S.A. — DIRECT INQUIRIES TO
1076 EAST WALNUT STREET, PASADENA, CALIFORNIA

For further information, check number 32, on page 126

Look for this emblem on CQ
Handbooks in your favorite
bookshop or ham dealer.



ARE YOU MOVING?

If you expect to move, and IF you know your new address now, and IF you don't want to miss any issue of CQ here are three things you can do right now!

1. Tear your name and address label off the wrapper of this issue and paste it in this box right over these words, or make a complete and accurate copy of your old address label
2. Print your name and NEW post office address in the lines below

(Name)

(Number and street—or Route)

(City)

(Zone)

(State)

3. Cut out this whole box and mail it to: CQ Magazine, 300 W. 43 St., New York 36, N. Y.

SEND FREE OF TIRING EFFORT
VIBROPLEX X
 With **VIBROPLEX X**
 SEMI-AUTOMATIC

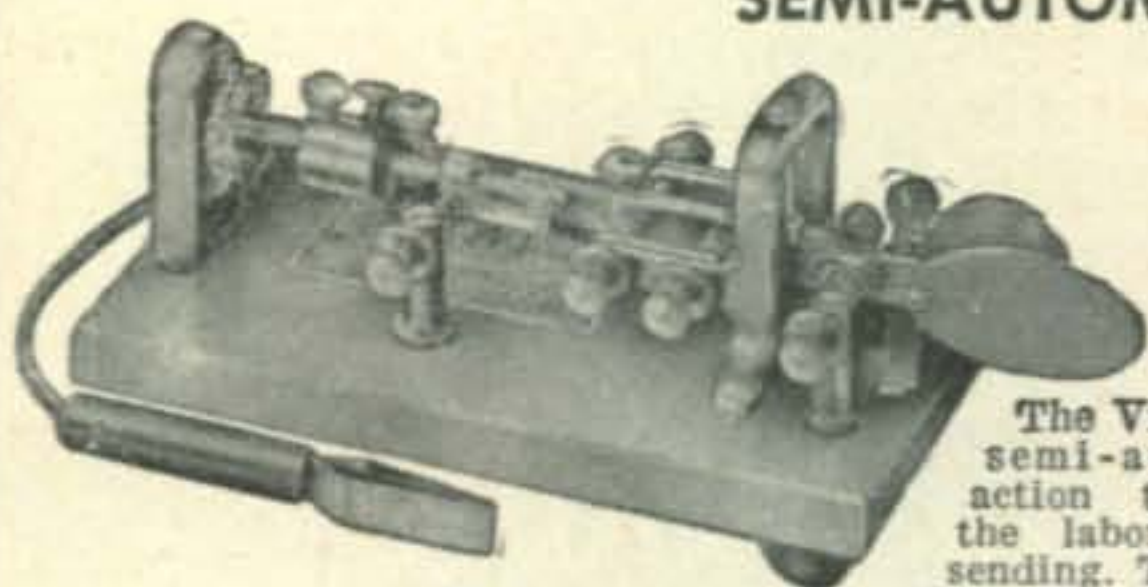

The Vibroplex's semi-automatic action takes all the labor out of sending. The Original Vibroplex gives sharp, clear signals

and is precision machined. Adjustable to any speed. Good for 30 or more years, even under tough usage. Comes in five models, standard or deluxe. Priced at only \$17.95 to \$33.95.



VIBROKEYER

In building an electronic keying mechanism, VIBROKEYER supplies the perfect part. With a base 3 1/2" by 4 1/2" and weighing

2 1/4 lbs. Has the same large sized contacts, main frame and trunion lever as the standard Vibroplex. Speed adjustable to suit your own taste. Standard model, priced at \$17.95. Deluxe, with Chrome Plated Base \$22.45

Order today at your dealers or direct.

THE VIBROPLEX CO., INC.
 833 Broadway New York 3, N. Y.

FREE Folder

For further information, check number 33, on page 126

MULTI-ELMAC MOBILE EQUIPMENT

CHOSEN
 for use aboard the S.S. HOPE!



AF-68

TRANS-CITER

PMR-8

RECEIVER



M-1070

POWER SUPPLY

Manufactured by
MULTI-PRODUCTS COMPANY
 21470 COOLIDGE HWY., OAK PARK 37, MICH.

For further information, check number 34, on page 126

DX [from page 68]

The 6 x 6 Award

The Kroonstad DX Club wish to bring to your notice their 6x6 Award. This award proves all round DX ability on both c.w. and phone inasmuch as a certain number of countries are to be worked on all continents in both modes of transmission.

The rules of the award are as follows:

The 6x6 Award is available to all amateurs who have proof of contact with six separate countries on each of the six continents. On each continent 3 must be on phone and 3 must be on c.w., that is, a total of 18 countries contacted on c.w. and 18 countries contacted on phone, all different.

Endorsements in the form of colored seals will be available for 12 and 18 countries on each continent and under the same conditions as the original award, i.e. half phone and half c.w.

QSL's need not be sent with the application if it is signed either by two other amateurs or an official of a recognized amateur club. The Kroonstad DX Club reserve the right, however, to request any QSL's from the applicant.

The cost of the award is 5 IRC's or 2/6 plus 1 IRC or 6d for each endorsement seal. For the U.S.A., the award will be sent air mail for \$1.00.

Apply to the Kroonstad DX Club, P. O. Box 378, Kroonstad, South Africa.

(Tnx ZS4MG)
 73, es DX, Urb, W2DEC

Propagation [from page 77]

Sunspot Cycle

The Zurich Solar Observatory reports a monthly sunspot number of 43.5 for February 1961. This results in a 12 month smoothed sunspot number of 101, centered on August 1960.

A smoothed sunspot number of 77 is predicted for May 1961, as the present cycle continues to decline.

Sunspot Story

Check the Table of Contents of this month's CQ for the second installment of "The Sunspot Story; Cycle 19; The Declining Years." Part II of this special report by Jacobs and Leinwoll, discusses sunspots and the sunspot cycle in considerable detail. Besides pointing out how sunspots affect the ionosphere and shortwave propagation conditions, the authors give their prediction of solar activity for the remainder of the cycle, which they expect will reach a minimum during early 1965. The report also hints that solar activity during the remainder of the present century may remain at relatively low levels.

Don't miss this special report which should be of interest to all amateurs.

73, George, W3ASK

the **LATEST** *Cesco* **Standing Wave Reflectometers**

available at

HARVEY'S



MODEL CM-52

For 52 ohm coaxial cable

MODEL CM-75

For 75 ohm coaxial cable

Contains phasing unit, loading control and reversing toggle switch, equipped with SO-239 at each end for inserting into feedline. Housed in an aluminum box, Hammertone finish.

Amateur and Industrial Net **\$29⁹⁵**

A quality instrument employing mutual inductance and capacity coupling between linear conductors for continuous measurement of standing waves on transmission lines. Suitable for frequency range from 3 to 200 megacycles. For continuous line insertion at power from 25 to 1,000 watts. Will work satisfactorily on power input of 10 watts at 7 mcs. and up. Will work on 5 watts output 100 mcs. and up. Line insertion power loss less than 1 DB at 30 mcs.

FEATURES

- Uses sensitive 0-100 microamp meter calibrated in SWR
- Has relative power scale
- For continuous transmission line insertion
- Power to 1,000 watts and over
- Prevents false loading from antenna tuner, match box, PI network etc.
- SWR observed immediately at all times without adjustment of Reflectometer
- Power output indicator
- Makes possible increased radiated power by reduction of line reflection
- Simplifies adjustment of antenna match
- No balancing adjustments, no reversing
- Each unit accurately calibrated and perfectly balanced
- Frequency tested from 3 to 200 mcs.



**DUAL UNITS
MODELS CM-52-2
AND CM-75-2**

Identical electrically to models CM-52 and CM-75 and has all features except in two units for remote control. Supplied with ten feet of cable and plug wired to control and indicator unit. Standard finish Dove Grey.

Amateur and Industrial Net Phase and Control Unit **\$34⁹⁵**



SPECIAL CONTROL PANEL

For Collins Speaker Grill or Built-In Installations

Special panel containing meter, control, reversing switch and with ten feet of cable and plug. For use with CM-52-2 or CM-75-2 phase units. Standard finish control panel and phase unit Machine Grey.

\$34⁹⁵

Amateur and Industrial Net Phase Unit and Control Panel



**MINIBRIDGE
MODEL CL-52-72**

A resistive type unit for observing line standing waves when adjusting antenna match. For use with either 52, 72 or 75 ohm coaxial line. Designed for use with small amounts of RF excitation or Grid Dip, Meter. Requires the use of an external indicator such as 0-100 Micro-amp meter.



\$12⁹⁵

Amateur and Industrial Net

HARVEY
RADIO CO., INC.
103 West 43rd Street, New York 36, JUDSON 2-1500

HARVEY is known the world over, as a reliable source for Ham Equipment. All orders shipped same day received. If you want to talk SWAPS and DEALS write or call W2DIO.

For further information, check number 35, on page 126



**FIELD ENGINEERS
ACF
ELECTRONICS**

**FLIGHT
SIMULATORS
COMPUTERS**

FIELD SERVICE ENGINEERS

Experienced engineers can enhance their careers in this expanding program by providing professional engineering services on complex electronic and electro-mechanical devices at military installations throughout the United States and overseas.

Challenging positions are available for those who possess a degree in electronics or an equivalent education, including experience in the design and/or maintenance of analog/digital computers, radar, or television systems. A knowledge of the theory of flight, navigation, aircraft pilotage techniques and instrument flight is desirable.

Please send resume to:
Mr. Robert J. Reid
Professional Employment, Dept. 434

**ACF ELECTRONICS DIVISION
ACF INDUSTRIES
RIVERDALE, MARYLAND**

RTTY [from page 79]

The annual meeting of the Florida RTTY Society was held on January 14, 1961, at Daytona Beach. President Dr. Albert Reilly W4WMN of Jacksonville presented "President Awards" to Fred W. DeMotte W4RWM of Daytona Beach for outstanding technical contribution to the Society, and to Dr. Tom Lipscomb, W4RTJ of Jacksonville, for Public Service. The Florida Net frequency is 7137 kc and it meets on Sunday right after the transmittal of Society bulletins at 1300 hours, EST.

Old timer RTTYer W5JBW and W5APH are on from Lake Charles, Louisiana. Can anybody help K5AUT, Box 208, Irving, Texas? Mac would like to identify a polar relay marked "MAS-D164816." W5PZA of Dallas, Texas, has a kw on 40 to go with his 14 and 15. Elden also uses a W4TJU TU with his NC240 receiver. W5CSN of Houston, Texas is on 20. W7FLD of Portland, Oregon, is a new member of the Portland Group. Eugene has a Model 15. K8NLM is looking for a keyboard for his Model 12. W8CSH of Athens, Ohio, is now on 40.

K9CNG, 839 N. 6th Street, Vandalia, Illinois, has polar relays and sockets for the Twin City TU for sale. W9IFZ of Evansville, Indiana, is on 3620 kc with his Model 26 and a W2JAV TU. K9DAS, Fort Wayne, Indiana, runs tape on 40. The Twin City (St. Paul-Minneapolis) RTTY Net is going strong on 52.6 mc f.m., with WØDKN, KØKBH, KØWMR, KØWTO, and KØZUX participating.

Comments

We just got the word before deadline that W6CQK, 1307 Alameda, Redwood City, California, can supply the band-pass TU input filter that we described in last month's RTTY Column for only \$6.50. Jack's band-pass filter (600 ohms) is built into a Bud #CU-3003 "Mini-box" 2¼" × 2¼" × 4", completely wired, and with the octal plug on one end so that it can be plugged into the ACCESSORY socket on the Twin City TU.
73, Byron, KØWMR

VHF [from page 86]

Hunts are held every four weeks. All 6 meter mobiles are invited." *Well, Bill, it really sounds as if you have a healthy group! Keep up the good work and keep in touch.*

Big Bear Lake, California: Here's a note from Jim Metcall, K6TUU, who sounds like a real active v.h.f.'er!

"I was on 6 meters from 1956 to 1958 using only a Gonset Communicator I and a four element beam. With this I worked 39 states, KH6, KL7, XE1, JA1, LU9, VE1, and VE2! All with 7 watts.

"Well, just got back on 6 again . . . Boy have things calmed down!!! Anyway, starting March 1st, I will be living in Big Bear Lake, elevation 7,000 feet!

"The rig I now have is a HQ-100C, Viking

PERFECT GIFT FOR YL OR OM

CQ YL

The only book about the YLs. 18 chapters, 500 photographs, covers all phases of YL participation in Ham radio. Autographed copy \$3.00, postpaid. Order from:

LOUISA B. SANDO, W5RZJ
212 Sombrio Dr. Santa Fe, N. Mex.

BC-603 CONVERSION

BC-603 Conversion article (Sept. & Oct., 1958 CQ)
Reprints available at 50¢ per set.

CQ Magazine, Book Div.,
300 W. 43 St.
New York 36, N. Y.

Give
**HEART
FUND**
Fight



HEART DISEASE



Looking for Something?

You'll probably find it in the pages of CQ Magazine
—The Radio Amateur's Journal.

IT'S A KNOCK-OUT!

BEST CATALOG EVER!! FULL OF VALUES FOR HAMS, SERVICEMEN,
EXPERIMENTERS, INDUSTRY. GET YOUR COPY OF THE NEW 1961
"GREENSHEET" CATALOG.

TUBES! COMPONENTS! EQUIPMENT!

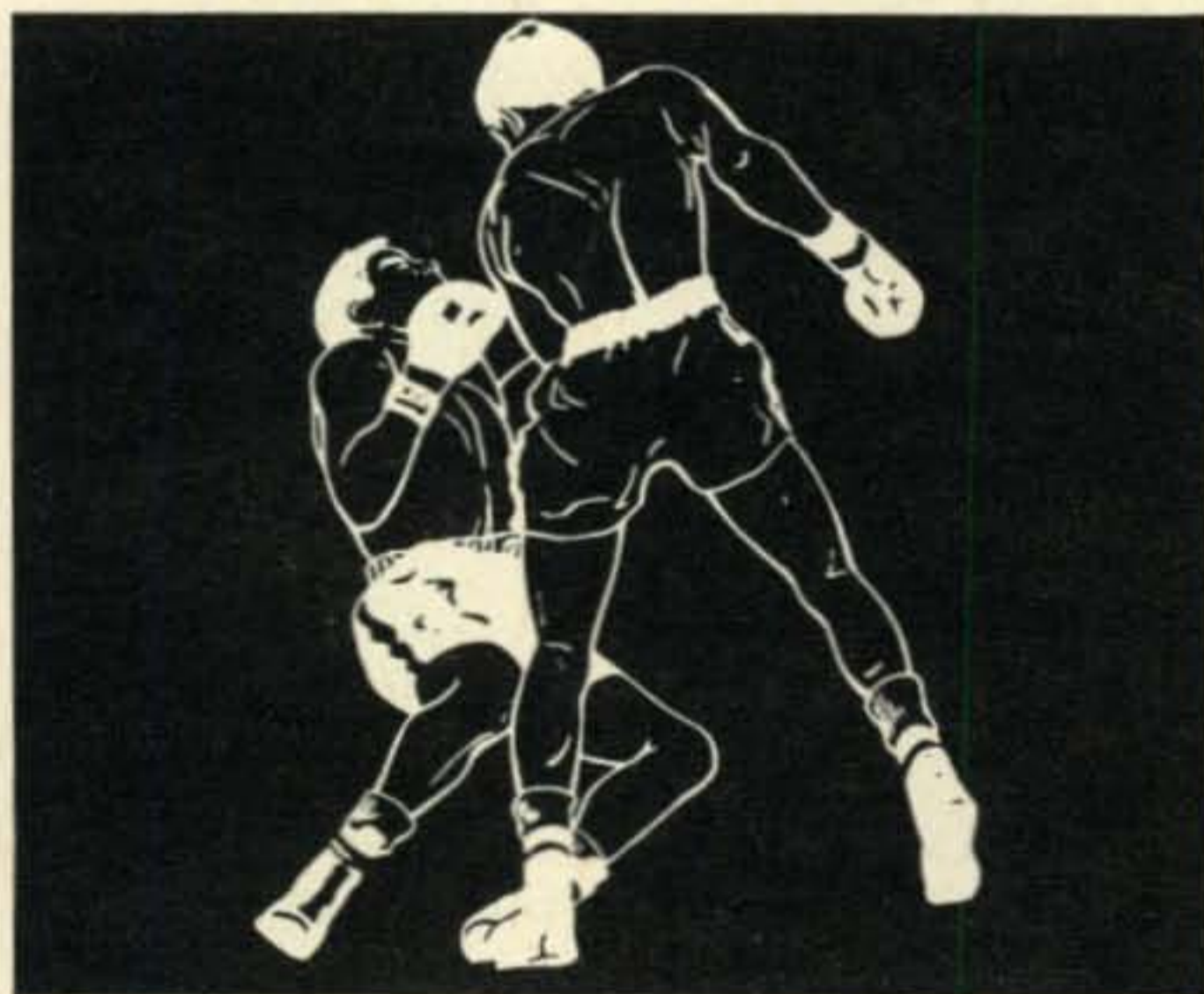

Hundreds of Buys. First quality at sensible prices. Buy with confidence. Prove these values to yourself. Complete and mail the coupon below for your copy of the "GreenSheet".

HERE ARE SOME SPECIALS

- CDR—Ham-M Rotator: Rotates largest Ham beams. Load rating: 1000 lbs. pls. Rugged break & motor on Rotator. Power cuts off at end of rotation. Direction can be read with starting motor off. Rotating torque: 365 inch-lbs. Breaking torque: 3500 inch-lbs. Fits all masts from 7/8" to 2" O.D. 23 lbs. Brand new, jobber boxed. \$115.00.
- Mosley TA-36 Beam for 10, 15 & 20. \$125.00.
- Pwr Xfmr: Pri: 115 VAC 60 CPS. Sec: 1260 VCT @ 425 Ma; also 30 V. @ 1.05 Amps. Filament (1) 6.4 VAC @ 7.5 Amps. (2) 6.3 VAC @ 3.7 Amps. (3) 5 VAC @ 4 Amps. Hermetically sealed. Order Hazeltine #TR-1285. \$12.50.
- RCA Mica Capacitor: 4,000 Mmfd. 3000 V. Peak. \$1.95.
- RCA Plate Xfmr: 1290 V.C.T. @ 360 Ma. Pri: 115 V. w/taps. 60 CPS. Herm. sld. \$4.95.
- Johnson Variable Capacitor: Dual 215/215 Mmfd. .125 spacing (4500 V.). \$7.75.
- RCA Plate Xfmr: 905 VCT @ 360 Ma. Pri: 115 V. w/taps @ 60 CPS. Herm. sld. \$3.95.
- Merit Choke: 10 Hy 2 250 Ma. #C-3182. \$2.95.
- Superior Powerstat Variable Auto-Xfmr Type 10: Input: 120 V. 60 CPS. 1 Phase Output: 0-120/132 V. @ 1.25 Amps. Removed from new equipm't. With knob & dial. \$5.95.
- Xmtg. Variable Capacitor: Approx. 20 to 750 Mmfd. @ 4,000 VDC. In oil-filled glass enclosure. 6 1/4" L x 3 1/2" H x 3 1/2" W overall. \$11.95.
- Johnson Socket #122-101: For VHF use w/tubes such as the 826, 832, 4D32, 4D22, PL6549 & PL6569, etc. Special terminals permit direct mtg of grid coils. This 7 pin wafer socket only \$1.00. (Brand New Surplus)
- Xmtg Variable Capacitor: 72 to 1,008 Mmfd. @ 3500 V. Ceramic ins. \$8.50.
- Variable Capacitor: 18 to 400 Mmf. 1000 V. Ceramic ins. \$2.50.
- Min. 125 Watt Modulation Xfmr: Pri: 10K P to P. Sec: 4550 Ohms. (Screen winding 3300 Ohms) Insulated for 5KV Peak. Orig. designed for PP 4-65A's. Approx. 3" x 3" x 3". 3 lbs. \$6.95.
- Special Eimac JAN 4-65A's @ \$10.00 each.

- Johnson #213 Sockets for 304TL & 304TH. Brand-new (surplus). \$1.15 each.
- Cathode Ray Tube Shield (for tube type 2BP1). \$2.95.
- Cornell-Dubilier 4 Mfd. @ 4000 VDC Oil Capacitor: \$9.95 each (3 for \$27.00).
- Hughes Swinging Choke: 20 Hy/3.5 Hy @ 50/250 Ma. 75 Ohms. \$1.95.
- UTC Type S-32 Swinging Choke: 5/25 Hy/225 Ma/120 Ohms. \$4.90.
- Plate Xfmr: Pri: 115 VAC @ 60 CPS w/taps. Sec: 3200 VCT @ approx. 300 Ma. \$10.50.
- Filter Choke: 8 Hy. @ 200 Ma. (90 Ohms D.C. Resistance). Herm. sld. \$1.75.
- RCA ATG TV Xmtg Equipm't. WRITE.

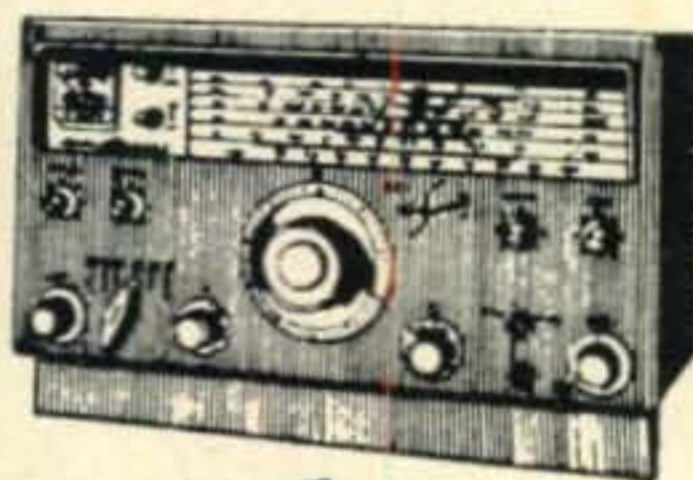

Factory
Authorized
Distributor for
National
Electronics

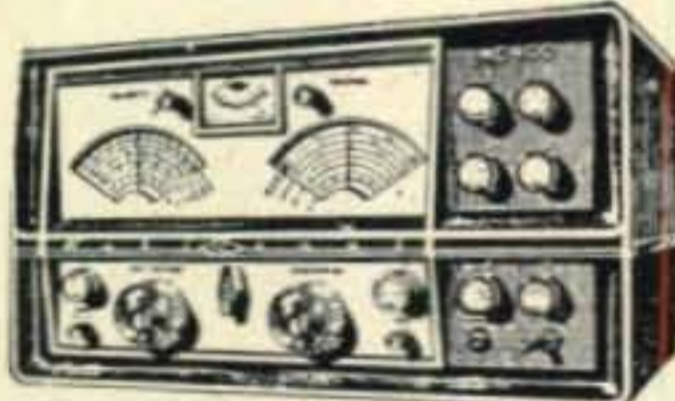

SPECIALS

- a — NC-270 (NTS-3 Matching Speaker included FREE). Price: \$249.95 Complete. No charge for shipping in continental USA.
- b — NC-400 @ \$795.00. No charge for shipping in Continental USA.
- c — RCA PRECISION 500 KC CRYSTAL OSCILLATOR.

Accuracy plus or minus 0.0012%. Contains Precision 500 KC crystal, BMS Labs Crystal oven, 5840 sub-miniature tube. Hermetically sealed, Nickel plated rectangular case. Mounts in standard 7 pin miniature socket. Requires 6.3 VAC or DC, 75 to 100 V.D.C. With schematic, RCA Type A838300-1. Size 4 1/2" H x 1-7/16" W x 1 1/8" D. Wt: 1 lb. Cat. #4-500 CRV. (Orig. Govt. Cost: \$172.00.) VERY SPECIAL ONLY \$3.75
304TL Sockets (New) \$1.15
4/\$4.00

NOTE: Cash paid for unused tubes and good comm'l equipment. Send details.

Add 50¢ Service Charge for orders under \$5.00. Prices are F.O.B. NYC.

Come in and browse. We are open Mon. to Fri. 9 to 6. Sat.: 10 to 2 P.M.

Subways: BMT: (Broadway local) to Prince St. Station—walk 1 block to Spring St.
IRT: Lexington (local) to Spring St.

Bus: Broadway #6 Bus to Spring St.
Car: We are 4 blocks North (uptown of Canal St.) Parking allowed on Broadway Sat., Mon. thru Fri. parking at 501 & 557 Broadway.

We'll also purchase your equipment and unused tubes. Send details: **BARRY ELECTRONICS CORP., 512 Broadway, New York 12, N. Y. Dept. C-5**

(C5)

Name Title

Company

Address

City State

For further information, check number 42, on page 126

50,000 SOLD IN 6 MONTHS! LEKTRON EXCLUSIVE
JUMBO PAKS by the POUND MONEY BACK Guarantee

RADIO-TV PARTS—500 to 1000 pcs per pound!

ONE POUND Precision Resistors WORTH \$100

ONE POUND Discs & Ceramics WORTH \$75

ONE POUND Disc Condensers WORTH \$50

\$3 per pound
 Clip out & mail

ONE POUND Discs, Ceramics, PRECISIONS WORTH \$70

ONE POUND Ceramic Condensers WORTH \$85

ONE POUND Tubular Condensers WORTH \$75

BUY 4 PAKS & PICK THE 5th FREE!

Free catalog Write!

LEKTRON

HOW TO ORDER: Include check or M.O. with sufficient postage; excess returned. C.O.D. orders, 25% down; rated, net 30 days. INCLUDE POSTAL ZONE in address.

241C Everett Ave., Chelsea 50, Mass.

BLITZ-BUG COAXIAL CABLE

Lightning Arrester Model # LAC-1 Pat. No. 2,922,913

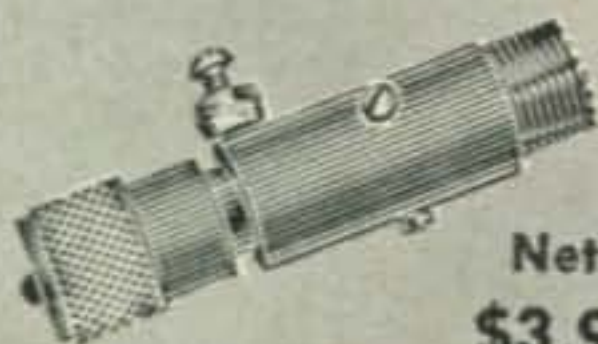

Net \$3.95

CUSHCRAFT

621 HAYWARD ST. MANCHESTER, N. H.

MATCHBUDDY COAX CONNECTOR

EPOXY INCAPSULATED high dielectric center connector for dipole antenna.

Non-reactive • Weatherproof • Maintains constant impedance No screws, bolts or cement required • #12 wire leads.

Price: \$3.95 (plus 15¢ for postage and handling)

Send check or money order to

BEAM RADIO, P.O. Box 131, Bronx 63, N. Y.

DOW-KEY CONNECTORS



PANEL MOUNT
 Durable, silver plated, precision made. Only 5/8" hole is needed, no screws.

ea.70

DOUBLE MALE
 Favorite everywhere. Precision made, rugged locking type. Silver plated.

ea.1.25



DOW-KEY COMPANY, Thief River Falls, Minn.

Groth TURN COUNT DIAL

Registers Fractions to 99.9 Turns FOR roller inductances, INDUC-TUNERS, fine tuning gear reducers, vacuum and other multiturn variable condensers. One hole mounting. Handy logging space. Case: 2" x 4". Shaft: 1/4" x 3". TC 2 has 2 1/2" dial—1 1/2" knob. TC 3 has 3" dial—2 1/2" knob. Black bakelite.

TC 2 \$5.50—TC 3 \$5.75—Spinner Handle 75c extra

Add 12¢ for Parcel Post

R. W. GROTH MFG. CO.

10009 Franklin Ave. Franklin Pk., Illinois

"HOW TO MAKE MONEY IN Mobile Radio Maintenance"

AUTHORITATIVE GUIDEBOOK ABOUT THE BOOM IN TWO-WAY MOBILE-RADIO: GIVES FACTS, FIGURES, PAY RATES. WRITE TODAY!

FREE



LAMPKIN LABORATORIES, INC. Electronic Div. BRADENTON, FLA.

GLOBAR DUMMY LOAD RESISTORS

Make the 50 ohm 1500 watt dummy load described in CQ March '61 using 12 of these special non-inductive resistors in parallel. Globar Res. 600 ohm 118 watt. Dozen for ONLY \$12.00 Mounting clips for above (24 required) ONLY .10 ea.

ULTRA MINIATURE 1" RD METERS

0-1 Ma DC mvmt 50 scale divns. Special \$2.70 ea. 2 for 5.00 0-400 microamps 8 scale divns. Special \$3.70 ea. 2 for 7.00

Please include sufficient postage—excess refunded immediately
 SPACE ELECTRONICS CO.
 P.O. Box 33, Ft. George Sta., New York 40, N. Y.

6N2 converter, Globe Hy-Bander (about 25 watts to the antenna) and a 5 element wide spaced beam. I also hope to have 790 watts on 6 about June!

"As I can be very active, and have probably one of the best v.h.f. DX locations possible, I would like to be a part of your mapping system and anything else you have cooking for 6!"
Okay, Jim! Will do—You're already on your list. By the way, we have a good location here in Rahway, also. How about trading QTH's, Hi.
Hultom, Sweden: K. G. Mohlin, SM3AKW, writes us from that rare Scandinavian country...

"I am operating on 144 mc with 500 watts input, 10 over 10 Yagi, converter with EC86 GG input (EC86, no U.S. equivalent, S 14 mA/V). I am building a rig for 432 mc. Transmitter is 500 watts to a 4X250B and a parametric amplifier. Still haven't managed to get hold of a varactor diode, though.

"I am located in the northern part of Sweden, lat. N 62.44 and very few stations QRV 144 mc up this way. Within 200 miles only 7 stations are on and they are on very irregularly. So the main mode of communication is via aurora which easily reaches down to the more v.h.f. populated southern parts of Sweden. The best DX via aurora is OZ7BR, the distance being 600 miles. No further southernly located station has been heard here via aurora. The UA's are not on 144 mc with well equipped rigs because the east-west path is better for aurora and the distance could have even been improved.

"Via meteor scatter I had a two-way QSO with OK2VCG on 144 mc during the August 1960 Perseids. The distance is 970 miles and is the best meteor scatter QSO distance in Europe. Had some promising tests with HB9RG during the Geminids and Aquarids; distance being a bit over 1100 miles."

Nuvistor 2 Meteor Converter

Our new products release this month came from Gem Electronics and K8GEM who mentioned that they now have a beautiful nuvistorized 2 meter converter on the market. Uses a 6CW4 nuvistor r.f. and a 6X8 as oscillator/tripler and mixer. This small unit will give maximum gain and sensitivity with a low noise level. Universal input and output for any antenna or receiver. The complete converter, wired and tested, goes for only \$5.50! Amazing! Write to Gem Electronics, R.R. #3, Springfield, Ohio, for further information.

Thirty

Before we close this month we'd like to remind you that we would like to get some technical construction items for this column. If you have a pre-amp, low noise converter, or any item at all of interest, just send it to me at the address at the head of this column. Let's hear from you next month!

73, Bob, K2ZSQ

ORDER YOUR COLLINS 500 WATT LINEAR FROM C & G NOW. The new compact 30L-1 500 watt linear is the same size as the famous Collins KWM-2, and has a self-contained power supply. Its price is quite reasonable, too—\$520. Order the Collins 30L-1 now for early delivery!



CG ELECTRONICS
 Northwestern headquarters for Collins
 2502 Jefferson Avenue 2221 3rd Avenue
 Tacoma 2, Wash. Seattle 1, Wash.

For further information, check number 36, on page 126

EASY TO LEARN CODE

It is easy and pleasant to learn or increase speed the modern way—with an Instructograph Code Teacher. Excellent for the beginner or advanced student. A quick, practical and dependable method. Available tapes from beginner's alphabet to typical messages on all subjects. Speed range 5 to 40 WPM. Always ready, no QRM, beats having someone send to you.



ENDORSED BY THOUSANDS!

The Instructograph Code Teacher literally takes the place of an operator-instructor and enables anyone to learn and master code without further assistance. Thousands of successful operators have "acquired the code" with the Instructograph System. Write today for full particulars and convenient rental plans.

INSTRUCTOGRAPH COMPANY

4711 SHERIDAN RD., CHICAGO 40, ILL.
 4700 Crenshaw Blvd., Los Angeles 43, Calif.

ALL BAND TRAP ANTENNA!



Reduces interference and Noise on All Makes Short Wave Receivers. Makes World Wide Reception Stronger. Clearer on All Bands!

For ALL Amateur Transmitters. Guaranteed for 500 Watts Power for Pi-Net or Link Direct Feed. Light, Neat, Weatherproof

Complete as shown total length 102 ft. with 87 ft. of 72 ohm balanced feedline, Hi-impact molded resonant traps. (Wt. 3 oz. 1" x 5" long). You just tune to desired band for beamlike results. Excellent for ALL world-wide short-wave receivers and amateur transmitters. For NOVICE AND ALL CLASS AMATEURS! NO EXTRA TUNERS OR GADGETS NEEDED! Eliminates 5 separate antennas with excellent performance guaranteed. Use as Inverted V for all band power gain. NO HAYWIRE HOUSE APPEARANCE! EASY INSTALLATION!

80-40-20-15-10 meter bands. Complete..... \$14.95
 40-20-15-10 meter bands. 54-ft. ant. (best for w-w swl's)..... 13.95
 20-15-10 meter bands. Dual Trap. 24-ft. antenna..... 19.95

SEND ONLY \$3.00 (cash, ck., mo) and pay postman balance COD plus postage on arrival or send full price for postpaid delivery.

Available only from:
 WESTERN RADIO • Dept. AC-5 • Kearney, Nebraska

ARMCHAIR PHOTOGRAPHER



IGOR-K2MIB

In this hectic era of space stations and amphibious autos, far be it from us to criticize progress. And yet, we shake our cranium a bit sadly, and we reminisce a bit remorsefully to the days not so long ago when we hadn't yet traded our souls for do-it-yourself kits. And looking back, we remember when the pioneer of the do-it-yourself phaze was the died-in-the-wool ham who built and serviced his own station.

Even so, we must force a faint smile as we remember that even the true-blue old timer occasionally referred to CQ to solve a tricky problem or refresh his memory on a technical point.

Mind you, we're not opposed to progress. We just realize that there are so many new phases of our hobby being developed today that CQ has become a second right arm to its regular readers. And those hams who only occasionally happen to browse through a copy of CQ... oh, well! Some hams still like to do things the hard way.

CQ Magazine CS
 300 West 43rd St. 1 year, \$5; 2 years, \$9; 3 years, \$13
 New York 36, N.Y. in U.S. Possessions, APO & FPO,
 Canada & Mexico

Enclosed is \$..... for a..... year new
 subscription to CQ, to be sent to: renewal

Name..... Call.....

Address.....

City..... Zone..... State.....

Pan-America and all other foreign: 1 yr. \$6; 2 yrs. \$11; 3 yrs. \$16.

EQUIPPED FOR SERVICE



Art Brown, W9IHZ

Your choice of new equipment is not limited at Brown Electronics. We carry all the major lines, among them the names appearing below.

- Barker & Williamson—Central Electronics**
Collins—Cushcraft—R. L. Drake
Elmac—Gonset—Hallicrafters
Hammarlund—E. F. Johnson—Mosley
National—P & H—RME

TRADES—Liberal allowances for commercially built ham equipment, especially late models in particularly good condition.

USED GEAR—A diverse inventory of late model used equipment, realistically priced. Our list is frequently revised and we guarantee satisfaction.

TERMS—We carry our own contracts. We're flexible, our charges low, \$6.00 per hundred per year on the unpaid balance over as long as 24 months or more.

RESPONSE to your inquiry will be rapid, will be by mail. We'll give you our best offer first and no high pressure. We would like very much to have the opportunity to quote on your requirements.

REQUEST FOR QUOTATION (Please Print)

I have the following used gear to trade: (Please use this code to describe it.) 3. Like new, little use; 4. Minor signs of use, no major blemishes; 5. Good condition, with minor modifications; 6. Has major modifications, or requires major repairs.

I am interested in purchasing the following equipment:

New _____

Used _____

No obligation to buy is implied.

----- * -----

Name: _____

Street No. of R.F.D.: _____

City: _____

State: _____

BROWN ELECTRONICS Inc.
 1032 Broadway • Fort Wayne, Indiana
 PHONE Anthony 3381

For further information, check number 37, on page 126

YL [from page 97]

Conventions

The All-California YL Convention will be held May 12-14 at the El Cortez Hotel in San Diego with the S.D. YLRC as hostess group. Out-of-state YLs will be welcomed. K6UTO, Betty, is handling registrations. There will be a prize for every YL attending and they are lining up some nice ones. While the YLs are busy, the OMs will have their own special luncheon and show.

The 11th Annual Midwest YL Convention will be held May 19-20 with convention hq. at Weller's Motor Lodge, 6450 W. Touhy Ave., Chicago. It is being sponsored this year by the LARKS, Ladies Amateur Radio Klub of Chicago, and convention chairman is W9SJR, Bernice. The FCC has issued the call W9YL for use during the convention and the station will be a complete kw s.s.b. set-up on loan from Halli-crafters Co. W9YL will be on all bands and a special QSL will be issued. Regular operators will be K9IVG, Roberta, and K9EMS, Eve. They plan to make contact with the German YL Anniversary Party being held at Dortmund on the same date. Also on the agenda—Friday night supper at the Classic Bowl and Saturday luncheon and banquet at the famous Tam O'Shanter Country Club.

The Southwestern Division Convention is scheduled for Phoenix, Ariz., May 26-29 at the Westward Ho Hotel. They have lined up fabulous prizes, fine speakers and all activities will be covered from space communications to spark gap. The YLs and XYLs will have a tour of the West's "most western town," luncheons, prizes and SWOOP initiation, as well as enjoying a plunge party and the banquet. W7KOY, Gert, is in charge of women's activities. For info or registration write K7NIY, George Mezey.

Going to one of the conventions? Take along your copy of "CQ YL" and have the gals auto-graph it. If you don't yet have a copy, order it, the one and only book about the YLs, from your column editor, QTH at head of column. Price \$3, postpaid.

The members of WRONE will hold their spring luncheon at the Publick House in Stur-bridge, Mass. on May 6. It is to be a buffet, price \$3.25 per person, to be sent to WRONE hospi-tality chairman, Mary McLam, K1ICW.

RTTY Award

Congratulations again—this time to Mary Schultz, K6OWQ, for earning the WAC-RTTY award! Mary is only the third Ham to achieve this award, and the first YL. WAC-RTTY is issued by the So. Calif. Amateur Radio Teletype Society. Details and pix next month; we've plain run out of space.

YOU ARE THERE!

telrex

with
—“the-performance-line”—
with a “MATERIAL” difference!

Send for (or, at your distributor), PL 77 Technical Specifications and Performance Bulletin describing 106 Antennas from $\frac{3}{4}$ through 80 meters including “BALUN”—FED ROTATABLE DIPOLES, MONO, DUO, TRI, 4-BAND AND “SPIRALRAY” ANTENNAS, ROTATOR/INDICATOR SYSTEMS, TOWERS, BROAD-BAND “BALUNS,” ACCESSORIES AND “NICE-TO-HAVE-AROUND-YOUR-SHACK” INFO.

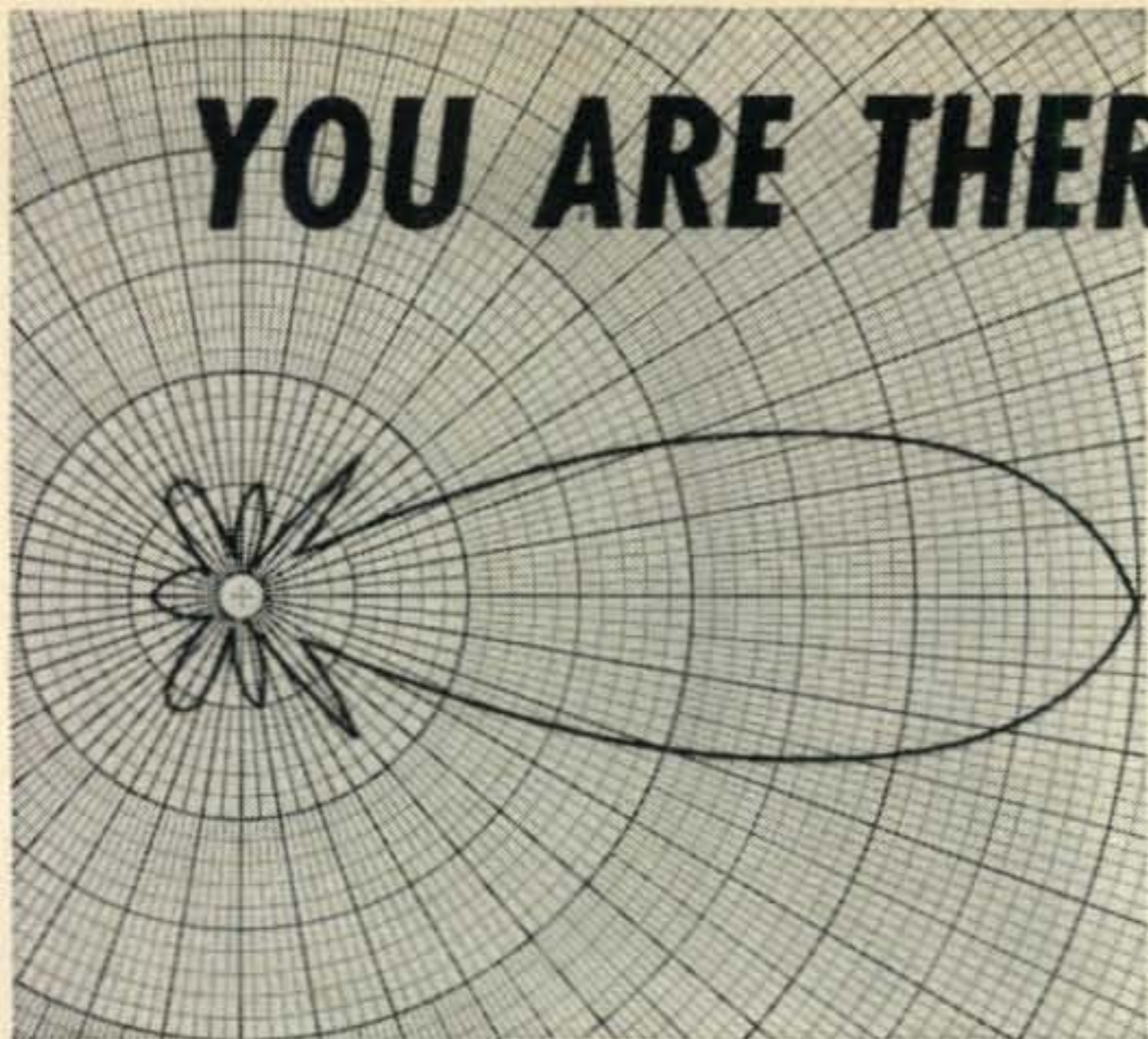

For TOP-MAN-ON-
THE-FREQUENCY results...

Install a Telrex antenna...dollar for dollar better in every way! Antenna systems from \$6.95 to \$12,000.00

ANTENNAS

SINCE
1921

Communication and TV Antennas
telrex LABORATORIES

ASBURY PARK 42, NEW JERSEY, U.S.A.

For further information, check number 38, on page 126

JAMES KNIGHTS CRYSTALS

AMATEUR TYPES

Transmitter and Receiver Crystals

H-43 or H73 low drift fundamental oscillator crystals. Will withstand high drive conditions. 20 mmfd load 1800 to 3000 kc $\pm .01\%$ \$2.95; 3000 to 9000 kc $\pm .01\%$ 2.95; 9000 to 15000 kc $\pm .01\%$ 3.95.

Type H173 plated, high stability oscillator crystals. 20 mmfd or series load 1800 to 3000 kc $\pm .01\%$ \$4.95; 3000 to 9000 kc $\pm .01\%$ 4.95; 9000 to 21 mc $\pm .01\%$ 4.95; 21 mc to 40 mc $\pm .01\%$ 4.95; 40 mc to 54 mc $\pm .01\%$ 5.95; 54 mc to 75 mc $\pm .01\%$ 5.95.

Special close tolerance crystals for the amateur. 20 mmfd or series load .005% H43 or H73 1800 kc to 18 mc \$4.80; H173 1800 kc to 75 mc 5.95.

MARINE CRYSTALS Type H-4 or H-7 marine tolerance high drive crystals. Frequency range 2 mc to 7 mc \$4.95.

AIRCRAFT CRYSTALS—All types available. State holder size, pin dimensions, and spacing, equipment model and manufacturer, crystal frequency and channel frequency. If receiver, specify IF frequency.

CITIZENS BAND

Transmitter and Receiver Crystals

Standard Transmitter Crystals. Type H-17 (H-C-6/U) 20 mmfd load, .005% tolerance. Crystal on any FCC channel frequency (C.B. only) \$2.00

Standard Receiver Crystals. Type H-17 (HC-6/U), 20

mmfd load. Crystal 455 KC lower than FCC channel frequency. $\pm .005\%$ tolerance (C.B. only) \$2.00

Special Transmitter Crystals. Type H-17 (HC-6/U), H-3 with pins, or H3W (HC-18/U) with wire leads. Any practical load, crystal on $\frac{1}{2}$ or $\frac{1}{3}$ FCC channel frequency. Give holder, load, frequency, and make of equipment. Also includes control frequencies of 26.995, 27.045, 27.095, 27.145, 27.195, and 27.255 MC. $\pm .005\%$ tolerance (C.B. only) \$2.95

Special Receiver Crystals. Same holders and loads options as special transmitters crystals but crystal frequency for IF other than 455 KC lower than channel frequency. Give holder, crystal frequency, load, IF frequency, and make of equipment. $\pm .005\%$ tolerance (C.B. only) \$2.95

MARS AND CAP—Type H-7 available on assigned frequencies. Calibrated to $\pm .005\%$. Frequency Range 2 mc to 10 mc \$4.80

TV & MARKER CRYSTALS

Calibrated $\pm .005\%$; Type H7, 3 mc to 18 mc \$4.80; Type H17, 4 mc to 30 mc 4.95; Type H17 3579.545 kc 4.80; Type H173, 1000 kc 7.95; Type H17TL, 100 kc 6.95. All prices postage paid. Send cash, check, or M.O. No COD's. Distributor inquiries invited.

THE JAMES KNIGHTS COMPANY
SANDWICH, ILLINOIS

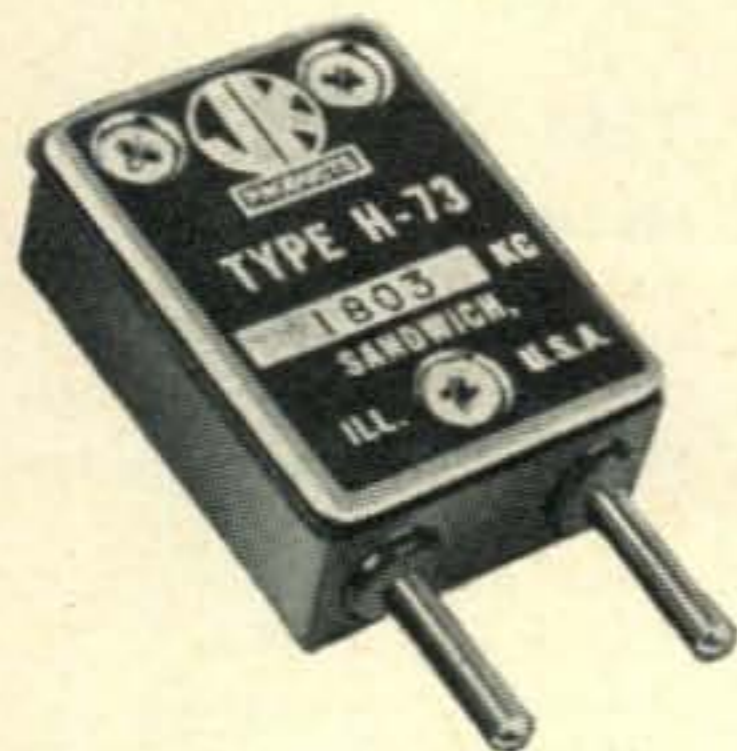

H-73 or H-7 (FT-243).
Pin Dia. .090" Pin Spacing .486"

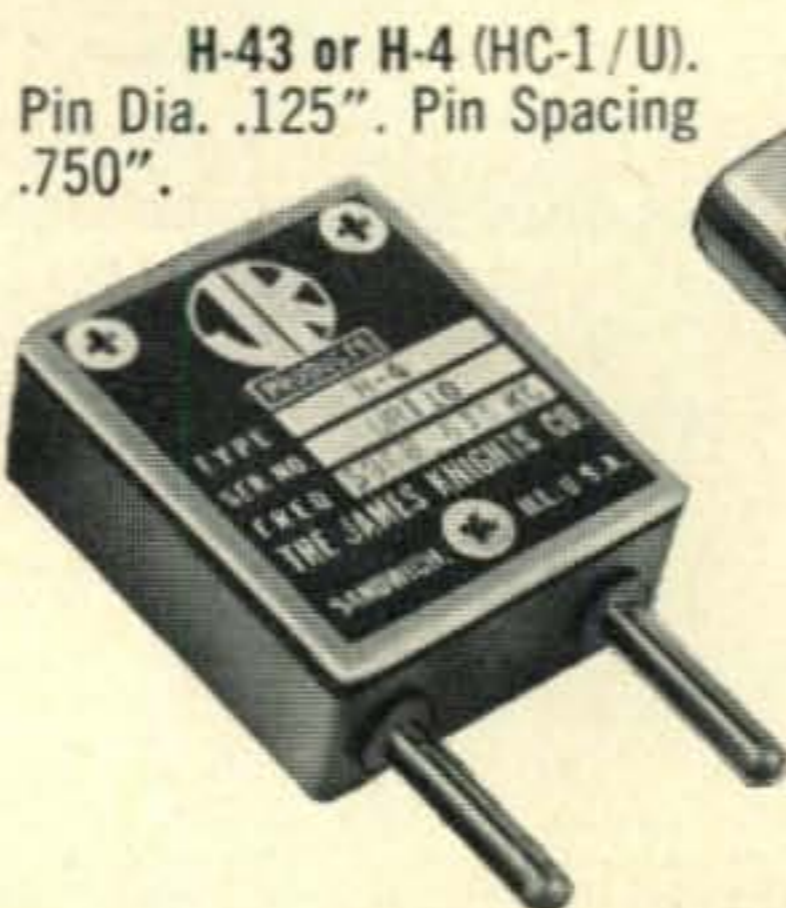

H-43 or H-4 (HC-1/U).
Pin Dia. .125". Pin Spacing .750"

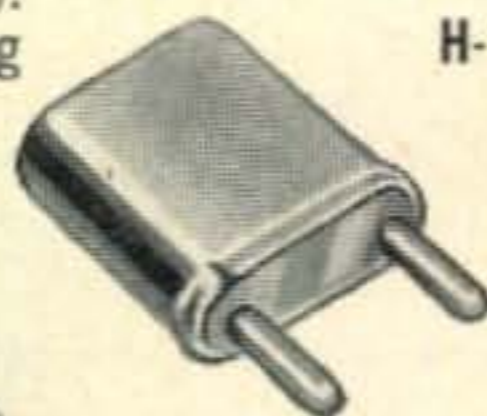

H-173 or H-17 (HC-6/U). Pin Dia. .050". Pin Spacing .486".
H-17W (HC-6/U With Wire Leads)



H-17TL (HC-13/U). Pin Dia. .090". Pin Spacing .468"

For further information, check number 39, on page 126

CQ

Introduces

VHF for the radio amateur. A new dynamic handbook that covers all phases of VHF activities.

INDEX

INTRODUCTION

1. VHF RADIO PROPAGATION

50, 144, 220, 432 and 1296 MC bands

2. ANTENNAS

- 2.1 Discussion
- 2.2 RF Transmission Lines.....
- 2.3 Types of Antennas
- 2.4 50 MC Antennas
- 2.5 144 MC Antennas
- 2.6 220 MC Antennas
- 2.7 432 MC Antennas
- 2.8 1296 MC Antennas

3. TRANSMITTERS

- 3.1A 50 MC Low Powered Transmitter
- 3.1B 6W6GT 50 MC Transmitter.....
- 3.1C 6W6GB 50 MC Transmitter.....
- 3.1D 50 MC Exciter
- 3.1E High Powered 50 MC Amplifier

- 3.2A Low Powered 144 MC Transmitter
- 3.2B 144 MC Exciter
- 3.2C High Powered 144 MC Amplifiers
- 3.3A 222 MC Exciter
- 3.3B High Powered 222 MC Amplifier
- 3.3C Single Tube 220 MC Amplifier
- 3.4A 2C39 Units on 432 MC.....
- 3.4B Coaxial Circuit Transmitter....
- 3.4C Flat Plate Line Transmitter....
- 3.5A 1296 MC Cavity Transmitter..
- 2.5B 1296 MC Flat Line Transmitter

4. MODULATION

- 4.1 6L6 Modulator
- 4.2 6W6 Class B Modulator
- 4.3 6Y6 Class B Modulator
- 4.4 50 Watt Modulator
- 4.5 Screen Grid Modulator
- 4.6 Frequency Modulator
- 4.7 Transistor Speech Amplifier.....
- 4.8 Phase Modulator
- 4.9 Vacuum Tube Keyer

5. POWER SUPPLIES

- 5.1 Small Power Supplies
- 5.2 Selenium and Silicon Rectifiers
- 5.3 Voltage Doubler

6. CONVERTERS

- 6.1 Converter for 50 MC
- 6.2 Converter for 144 MC
- 6.3 Converter for 220 MC
- 6.4 Converter for 432 MC
- 6.5 Converter for 1296 MC

7. RECEIVER IF SYSTEMS

- 7.1 Communication Type Receivers
- 7.2 14 to 18 MC IF Receiver
- 7.3 Audio Filter

8. PREAMPLIFIERS

- 8.1 220 MC Tube Preamplifiers.....
- 8.2 Parametric Amplifiers
- 8.3 Pump Oscillators
- 8.4 144 MC Parametric Amplifiers
- 8.5 220 MC Parametric Amplifiers
- 8.6 432 MC Parametric Amplifiers

9. TEST EQUIPMENT

- 9.1 Diode AC Voltmeter
- 9.2 AC and DC Diode Voltmeter....
- 9.3 F.S.-Monitors
- 9.4 Transistorized F.S. Meter.....
- 9.5 1296 MC Wavemeter and Noise Generator
- 9.6 SWR Meters
- 9.7A Frequency Marker
- 9.7B Transistor Frequency Marker
- 9.7C Dual Transistor Signal Marker
- 9.8 Transistor Audio Oscillator....

CQ MAGAZINE
BOOK DEPT.

300 West 43rd St.,
New York 36, N.Y.

VHF For The Radio Amateur, \$3.50

Sirs: I enclose.....Please send my VHF
For The Radio Amateur postpaid to:

C-5

NAME.....CALL.....

ADDRESS.....

CITY.....ZONE.....STATE.....

N.Y. City residents add 3% Sales Tax

VHF



FOR THE
**RADIO
AMATEUR**

FRANK C. JONES W6AJF



Extends
to 50
feet

Completely Self-Supporting MULTI-BAND VERTICAL

Hy-gain hy-Tower

COVERS 10, 15, 20, 40 AND 80 METERS
WITH SUPERB EFFICIENCY

Unique stub decoupling method makes possible extremely high radiation efficiency and low SWR. NO TRAPS USED! Feed directly with single 52 ohm coax. SWR less than 2:1 on all bands. Tower height: 24 ft. 2" OD to 3/4" OD aluminum top mast extends hy-Tower to total height overall of 50 ft. No guy lines required... Completely self-supporting in high wind velocities. Net weight: 90 lbs. Easy 2-man installation. Can be mounted on 2 sq. ft. of real estate. Ground rods (not furnished) required. Write for complete information.

ONLY
\$129⁵⁰
Complete

Most Distributors Offer Budget Terms.

Complete Hy-gain line displayed in



FREE
NEW
CATALOG

Ask Your
Local Dealer.

Hy-gain antenna
products

1135 NO. 22nd ST. • LINCOLN, NEBRASKA

Ham Shop

Rates for the HAM SHOP are 5¢ per word for advertising which, in our opinion is obviously of a non-commercial nature. A charge of 25¢ per word is made to all commercial advertisers or business organizations.

Your copy should be preferably typewritten, double spaced on one side of the page only.

We do not bill for advertising in the HAM SHOP. Full remittance *must* accompany all orders.

Closing date is the 20th of the 2nd month preceding date of publication.

We reserve the right to reject advertising which we feel is not of an amateur radio nature.

Because the advertisers and equipment contained in the HAM SHOP have not been investigated, the publishers of CQ cannot vouch for the merchandise listed therein.

FOR COLLINS in Detroit area it's Michigan Ham Headquarters. Also large selection of tradeins on display. M. N. Duffy Ham & Electronics, 2040 Grand River, Detroit 26, Michigan. WO 3-2270.

CASH for surplus tech manuals—W4FXQ, Box 2513, Norfolk, Va.

WANTED: World War I French L-3 Amplifier, Mu-Rad receivers and R.F. Transformers for electrical test. Buy, borrow, trade. Also UV206, UV208 tubes. Grote Reber, Research-Cottrell, Bound Brook, New Jersey.

QSL's—"Brownie" W3CJI, 3110 Lehigh, Allentown, Pa. Samples, 10¢, with catalogue, 25¢.

QSL's-SWL's: 100 2-color glossy \$3.00; 100 QSO file cards \$1.00; Sample 10¢. Rusprint. Box 7507, Kansas City 16, Missouri.

QSL's four colors glossy stock forty design send \$5 for 200 and get surprise of your life. 48 hour service satisfaction guaranteed, Constantine Press, Bladensburg, Md.

QSL's. Samples 15¢. Sims, 3227 Missouri Ave., St. Louis 18, Mo.

GLOSSY 3-color QLS cards 100—\$4.50. Free sampler. Rutgers Vari-Typing Service, 7 Fairfield Road, New Brunswick, N.J.

SWL's, QSL's Nicholas & Son Printery, P.O. Box 11184, Phoenix, Arizona. Samples 5¢.

C. Fritz for better QSL's! Samples 10¢. P.O. Box 1684, Scottsdale, Arizona.

QSL's-SWL's, samples 10¢. Malgo Press, 1937 Glendale Avenue, Toledo 14, Ohio.

QSL's. SWL's XYL-OM's. (Sample assortment approximately 9 3/4¢) Covering designing, planning, printing, arranging, mailing, eye-catching, comic, sedate, fantabulous, DX-attracting, protoypal, snazzy, unparagoned cards. (Wow!) Rogers, KØAAB, 1200 Marshall Ave., St. Paul 4, Minnesota.

QSLs. Large selection styles including photos. Lowest prices. Fast service. Samples dime. Ray, K7HLR, 679 Borah, Twin Falls, Idaho.

SNAPPY... Different QSL's... Dime... Filmcrafters... Martins Ferry, Ohio.

DISTINCTIVE QSLs!! Largest variety samples 25¢ (re-funded). Sackers, W3DED, Holland, Michigan. (Religious QSL samples 10¢).

QSL's, SWL's. That are different, colored, embossed card stock and "Kromekote." Samples 10¢. Home Print, 2416 Elmo, Hamilton, Ohio.

CALL LETTERS may be applied to any surface. 2" sets 60¢, 3" set 80¢. Send to C. Lee, P.O. Box 395, Times Square Station, New York 36, N.Y.

For further information, check number 40, on page 126

WANTED: Transceivers 27.43 mc, narrow band, 20F3 emission. HAM GEAR. CASH WAITING: S. Krzak, Pawt., R. I.

FOR SALE: G-66B, with 3-way power supply; G-77, complete all cables, fuses, brackets, manuals, mic., base loader, whip. \$350 Prefer local deal; will trade for Hi-Fi equipment. KØIAV/Ø712 Louisiana Street, Lawrence, Kansas.

Manual for BC-683-684, TM 11-620, \$3.25 Postpaid. Hiway Co., 1147 Venice Blvd., Los Angeles 15, Calif.

Knight VFO \$20, Hy-Gain Vertical 10-40 meters \$17. Kellick 2721 Stevens, Middletown, Ohio (K8EOZ)

BUILD \$12.00 microphone so sensitive and directional you can hear through walls blocks away. Pinpoint sound. Plans \$2.50. Dee Co., Box 7263, Houston, Texas.

If you held a two-way contact 40 or more years ago, you should join the Old Old Timer's Club. This is the Granddaddy of all Radio Clubs. Once a member, always a member because initiation fee covers life time dues. Write Sec-Treas., W2EG, Earl C. Williams, 507 Wayside Road, Neptune, N. J.

FOR SALE: Television Camera ATJ and transmitter T61/AXT-2 with all tubes and diagrams. D. H. Harrell, 315 Fourth St., Logansport, Indiana.

WANTED, Banjo, any style, condition. Buy or trade, good ham equipment. Richelieu, W9JS, Wheaton, Illinois.

LEARN about technical writing. New book tells how. M&W Box 98, Mendon, N. Y.

75S-1 Collins receiver. Perfect condition. I will ship upon receipt of certified check or PMO for \$400.00. KØCYM, 3095 19th Ave., Marion, Iowa.

FOR SALE: Hallicrafter S-86. Good cond. \$60.00, BC-453-F 110V. New \$15. BC-454 \$5., RCAF No. IOD/4713, ARTII \$10. L. J. Kistler, 856 W. Cottonwood, Freeport, Ill.

SALE: B&W TR switch 380-\$12.00. Johnson low pass new \$9.00. 813 tubes new \$5.00.

WANTED Johnson matchbox. W3YHQ 500 Hudson Ave., Altoona, Penna.

W9JS Spring House Cleaning Time. Big list, Richelieu, Wheaton, Ill.

RTTY-Extra HiQ Toroids. Q better than 200. Limits quantity of selected pairs. Complete specs with coils. \$8.00 pair, 2 pair \$15.00. C.O.D. W5EIX, 2228 NW 56, Okla. City.

FACTORY WIRED CE-20A with VFO and QT-1 \$225. Factory wired P&H LA-400 \$125. Drake 1-A \$200. 20-40M Birdcage less mast \$45. W8ZBD, 1605 Iowa, Midland, Mich.

WANTED: Collins filter F-455B-800 Cycle for Collins 75A-3 receiver. State price and condition in first letter. Sam Appleton, K5MKI, Tulia, Texas.

FOR SALE: SCR-522 & RA-62C, \$60. Heath TV alignment generator TS-4A \$50. Heath osc. OM-2 with probes, \$40. 2 ea 4-125's (tubes) \$30., 2 ea 4-65A's (tubes) \$15. K7IMA, P.O. Box 112, St. Johns, Arizona.

FOR SALE: Like new condition-6 mtr. Gonset Communicator III with mic. \$225., 5" EICO scope \$30., EICO RCL bridge \$12., Hy-Gain 6 mtr. halo ant. \$8.00. Good to excellent condition-Gonset super-six converter \$30, Mallory 100ma, 450V variable Vibrapack \$15, EICO battery eliminator 6-12V \$20, E. V. crystal mic. \$5. Paul Mayo, W1ADX, 200 North St., Danvers, Mass.

SURPLUS OWNERS-Pwr Sup 110VAC in. Out 24VDC @ 14 amps 475VDC @ 125 MA, 450 VDC @ 30 MA, 6.3V @ 16 amps-24V @ 30 MA. \$25 PP. Armstrong, 702 Union St., Schenectady, N.Y. DI 6-1266.

GIANT CALL SIGNS: Large extra bold print. Worded with your CALL and Amateur Radio on 11" x 7" cards. Surrounded with bright red splash. Attractive Decorative. Three for \$1.00 Post Paid. Call Signs, P.O. Box 933, Aurora, Illinois.

SACRIFICE, college expenses. NEW: 75A-4 \$495, 20-A \$150, CESCO SWRB, signal tracer, signal generator, Johnson Lo-pass rotator, \$500 new parts. Everything for \$795. Hardy, 2036 Strong Ave., Manhattan, Kansas.

WANTED, 4-1000A, Air System socket, chimney and Cardwell 1500 mmf variable capacitor. State price and condition. Box D, c/o CQ.

The World's Most Popular ANTENNAS . . . NOW

Over **21,683*** in Use!

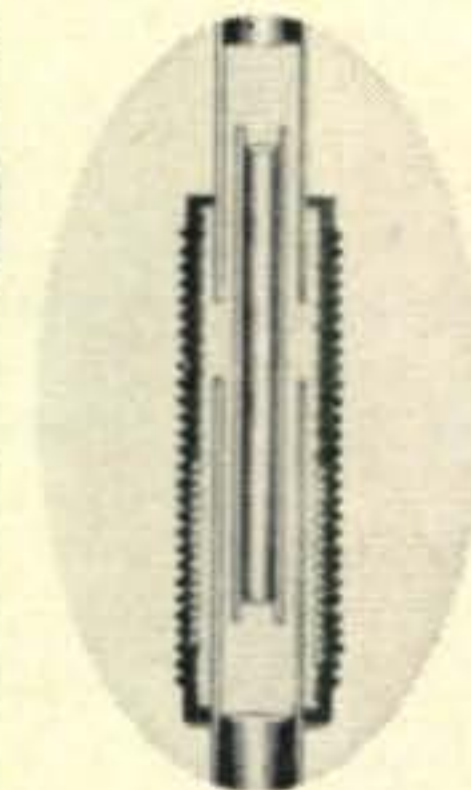

The exciting new hy-gain Slim-Trap (only 1 1/4" in diameter) is the world's smallest, lightest weight trap assembly. Its high efficiency coil and capacitor circuit is wound on and completely imbedded in the new, low-loss, polypropylene plastic. It is unconditionally guaranteed to be completely impervious to all weather conditions. Power rating: 1000w AM, 2 KW (PEP).

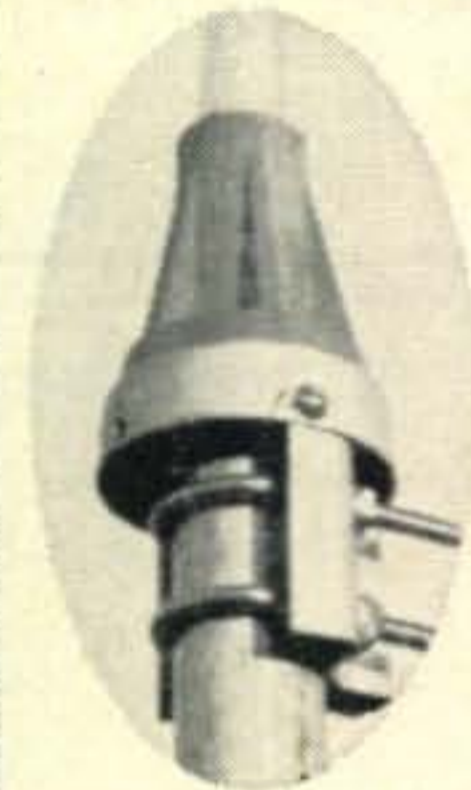

The Self-Supporting Hy-Gain Multiband Trap Verticals are completely factory pre-tuned with no further adjustment necessary, maintaining an SWR of 2:1 or less across the entirety of each band. 52 ohm coax feed line. True 1/4-wave marconi resonance on each band makes possible low angle DX radiation pattern. All top grade construction throughout. May be mounted on rooftops or directly on the ground.

Ribbed cycloc base insulator makes these hy-gain verticals completely self-supporting. Heavy ten-gauge formed steel mounting bracket is adjustable for various sizes of masts. Weatherproof internal coaxial fittings supplied.

Model LC-80 Loading Coil (\$7.95) adds 80M operation to the 14-AVS Vertical. Decoupling Stub (\$4.95) adds 6M operation to both models 12 and 14 AVS.

\$21.95 12 AVS VERTICAL
For 10, 15 and 20 Meters;
13.5 ft. high, 9 lbs.

\$27.95 14 AVS VERTICAL
For 10-40 meters; 21 ft. high,
11 lbs. Includes Capacity Hat.

For quick and easy assembly on rooftop, the combination mast and radial roof mounting kit, complete, for either Vertical. 12-AVS kit: \$8.95. 14-AVS kit: \$9.95.

*as of Jan. 1, 1961

Hy-gain
antenna products

1135 NO. 22ND • LINCOLN NEBRASKA

For further information, check number 41 on page 126.

May, 1961 • CQ • 121

J BEAM

J BEAM

THE J BEAM

NOW THE "SKELETON SLOT" ANTENNA YOU HAVE WAITED FOR — AVAILABLE IN "73" COMBINATIONS — FULL COVERAGE — 50 — 144 — 220 & 440 MC

CONSTANT IMPEDANCE — BROAD BANDED — LIGHT WEIGHT — RUGGED — COAX OR OPEN FEED — 2 TO 64 ELEMENTS — GAINS TO MATCH — LOW SWR

SAVE — SAVE — SAVE

GET OUR INFORMATION ON FULLY "MATCHED SYSTEMS".

G4ZU MINIBEAMS BIRD CAGES **TELREX** "J" BEAM—ANDREWS—ROHN

DICK BIRD "G4ZU" NOW ASSOCIATED WITH US

SEE JULY 1959
AUG. 1960 "CQ"

THE "J" AVAILABLE
THROUGH DEALERS

HOUSE OF ANTENNAS

1153 EAST 82ND STREET • CHICAGO 19, ILLINOIS
TEL. SO 8-9282

R W "SPECIAL" OF THE MONTH!

BC-604—FM TRANSMITTER, 20-27.9 Mc.
New **ONLY \$3.95**

All other new SCR-528 components in stock.
F.O.B. Los Angeles or Chicago at low, low prices! Write today!

ART-13 TRANSMITTER with tubes and meters.
F.O.B. Chicago only **\$39.50**

COLLINS ARC-2 TRANSCEIVER 2-9 Mc. with tubes. Shipping weight 100 lbs. F.O.B. Los Angeles or Chicago **\$59.50**

LM FREQUENCY METER. Excellent for checking Citizens Band Transmitter. With crystal and original Calibration Book. F.O.B. Chicago only. **WHILE THEY LAST** **\$49.95**

Send Money Order or Check with Order.
25% Minimum with C.O.D.'s

Write for Flyer—LOADS OF BARGAINS

R W ELECTRONICS

2430 S. MICHIGAN AVENUE • DEPT. CO
Phone CALumet 5-1281 CHICAGO 16, ILL.

2, 6, 10 — Meter

MOBILE EQUIPMENT

MOTOROLA, R.C.A., G.E., LINK, etc. 30-50 Mc., 152-172 Mc. Used Commercial F.M. Communications Equipment Bought & Sold. Complete two-way sets meeting F.C.C. Licensing Requirements for taxicabs, Police, Fire, etc. **\$169.00** and up.

Motorola F.M. Receivers, Double Conversion **\$55.00** each
Motorola F.M. Transmitters **45.00** each

COMMUNICATIONS ASSOCIATES INC.

21-27 Batchelder Street
Boston 19, Mass.

SB-10 OWNERS: We can modify your SB-10 for improved audio quality, better unwanted side band suppression and greater talk power without splatter. High and low pass filters and peak limiter installed in the audio system. We do the job complete or furnish instructions. W4KUV—W4NZS, Best Radio & TV Service, 610 N. Madison Ave., Goldsboro, N. C.

CASH FOR YOUR GEAR. We buy, sell or trade good commercially manufactured ham gear. Send for bargain listing. Ten percent off for cash and no trade on most used gear. H&H Electronic Supply, 506 Kishwaukee St., Rockford, Illinois.

FOR SALE: SX-100 Like new w/manual. \$185. W4DJJ, 2310 Lehigh Dr., NE, Huntsville, Ala.

A-1 reconditioned equipment. On approval. Trades, Terms. Hallicrafters S-40B \$69.00, SX-99 \$99.00, SX-100 \$199.00; HT-37, S-85, SX-110, SX-111, SX-101A, HT-32, HT-32A; HT-33A; Collins 75A-1, 75A-2, 75A-3, 75A-4, KWM-1, 32S-1, 75S-1, KWS-1; Central 20A \$159.00; Elmac PMR-6 \$69.00, AF-67 \$109.00; Gonset G-66B, G-77A, G-50, GSB-100, GSB-101; Hammarlund HQ-100 \$129.00, HQ-110 \$179.00, HQ-129X, HQ-140X, HQ-140XA, HQ-150, HQ-160, HQ-170, HQ-180; Johnson Adventurer \$29.00, 6N2 \$99.00, Viking II \$179.00, National NC-98 \$89.00, HRO-50T \$199.00, NC-300, HRO-60, NC-183D, NC-303; Heath, Globe, RME, and other items. List free. Henry Radio, Butler, Missouri.

FOR SALE: 2 new Eimac 4-125-As, \$17 each. BC-611-D Walkie-Talkie, excellent condition, with new Batteries, \$30.00. Telectro Tape Recorder, Model 1965, excellent condition, \$35.00. Stan Molstad, Dawson, Minnesota.

FOR SALE: Citizens 760K, Heathkit GW-30 transceivers with crystals, excellent \$70.00. FOB. Victor Novak, General Delivery, Shiner, Texas.

FOR SALE: Heath Sixer, Receivers, power supplies, other items. K4JCX, 121 Maple, Oak Ridge, Tenn.

SWAP HQ-160 receiver. Excellent condition for Valiant transmitter in excellent condition. J. Pyryt, W2ODH, 192 Norman Way, Paramus, N. J. CO 1-8655.

CALIVERTER. Broadcast band and WWV converter for ham band receivers. Transistorized. \$12.95. For info write Burk Electronics, Box 50-456, Miami (Gratigny Br.) 50, Fla.

KWM-2, Collins 516F-2 AC power supply, both in mint condition in original cellophane containers and cartons, operated 3 hours, Collins conversion bulletins; \$1000; Lt. Fred L. Capossela, NRTD, TAGSUSA, Fort Harrison, Indiana.

Aluminum for every ham need. Write to Dick's, 62 Cherry Avenue, Tiffin, Ohio, for list of tubing, angle, channel, castings, plain and perforated sheet, and complete beam kits.

WANT: Professional banjo and 4X250B tubes, trade ham gear or cash. Have unused 250TH, 250TL, 810, 833A tubes. W7AST, 1302 West 80th Street, Seattle 7, Washington.

HAMMARLUND HQ-180C \$350.00. Heath Apache TX-1 \$200.00. Will deliver up to 100 miles. Gene WA2LRV, 803 Bay Shore Ave., West Islip, L.I., N. Y. JUniper 7-2621.

JUST OUT: Our 1961 catalog, over 5000 items, receivers, transmitters, test equipment, tubes, tech manuals, schematics, walkie talkies, transformers, parts, plugs. Write Bill Slep Company, Drawer 178CQ, Ellenton, Florida.

SX-99 Receiver. Excellent condition. Used approximately 8 hours, \$110.00. A. F. Eisenman, 1030 West First Street, Oil City, Pennsylvania.

HIGHLY EFFECTIVE home-study review for FCC commercial phone exams. Free literature. Wallace Cook (C5), Box 10634, Jackson 9, Miss.

SELL OR TRADE like new Bolex H-16 reflex movie camera, FL.5 lens, with case and extras, \$500 value, for ham receiver of HQ-170, NC-303, SX-101, 75A or 75S series with appropriate cash difference, one way or other. Sell HT-37/HT-33A combination, \$1145 value, for \$795.00. Penta sez PL-172 is like new. Consider trades. Gene Hubbell, W9ERU, Box 273, R.R.4, Rockford, Illinois.

BARGAIN—National NC-98 receiver. Excellent condition \$85.00. Call Sal Scalice, DE 9-1785 at 1489 East 8th Street, Brooklyn 30, N. Y.

FOR SALE: Complete instructions for converting the ART/13 transmitter. Consists of 28 page booklet with pictures and drawings and a 22 x 36" schematic. Send \$2.50 to Sam Appleton, K5MKI, Box 717, Tulia, Texas.

FOR SALE: Mobile gear Babcock DXmitter 10 through 75 and Babcock PS4A matching power supply 325 at 240ma. Whip, loading coil, spring, decoupler coupling, Shure 100 series carbon make, Gonset Super six with Squelch SSB head and Gonset Audio unit (no connection to car radio for AM or SSB) Slides out of mobile case for quick use as medium power fixed AC supply use. Ham net total over \$500.00! No changes, no additions. Equipment as supplied by manufacturer. Trade for Ranger with PTT or first \$100.00. K8VRM, Box 728, Lima, Ohio.

PLEASE NOTICE: For the best new and reconditioned used ham gear, try Bob Graham, W1KTJ (Graham Radio) New England's only exclusive amateur radio stores. North of Boston, 505 Main Street, Reading, Tel 944-4000; South of Boston, 1105 No. Main Street, Randolph, Tel. WO 3-5005.

RECEIVER for sale. Allied R-100 receiver and matching speaker. 3 months old. Best offer. Cecil A. Moore, W5DXP, Box 184, Carrizo Springs, Texas.

WANT 250w station equip, all or any part. Will trade Federal 470 enlarger, accessories & dryer, Rolleiflex, case. G. Inglis, 1122-19th Street, Lubbock, Texas.

WANTED: TELETYPE TG-7, Model #15, #19, #26, #28, printers & reperforators; Rcvrs & xmtrs: AN/GRC-3 & higher, RT-66,-67,-68; Collins 51J, 17L3,-4, 18S-2, R-388, R-390/URR: ARN-14 and-30; APR-9,-10, ARC-21,-27,-34; APS-10,131,-33,-42, etc., and test eqp't, TS or AN/URM. We pay freight. Amber Industrial Corp., 75 Varick St., New York 13, N. Y.

HAMMARLUND HQ-140X with speaker. Recently recondx. Like new. Best offer. Also EX sig shifter \$40.00. FOB. Phil Perlman, K2GSE, 2830 Bedford, Bklyn 10, N.Y. GE 4-9097.

Laminate your ticket, cards photos at home. No heat! Guaranteed! 14 sheets of plastic, \$1.00. Namecraft, Box 56L, Fort Lee, New Jersey.

New TV Tubes—6198 or 5527—\$50.\$. W1BYX, Box 122, Rockville, Conn.

TECH MANUALS—BC-375 \$7.50; SCR-274N \$7.00; ARC-5 VHF \$8.50; ARC-1 \$8.50; ART-13 maintenance \$12.50, calibration \$5.00; operation \$3.50; URC/4 \$4.00; BC-224, 342, 348 \$6.00; ARC-5 LMHF \$12.00, LM manuals \$5.50 ARR-5,7, 7.00. All postpaid, thousands of others on hand, write your needs. Propagation Products Co., Box 2513, Norfolk, Va.

Collins 75S-1 \$385., 51J-3 \$675., 51J-2 \$495., 75A-2 \$295. SP-600 \$495., HQ-150 \$175., HQ-160 295., Valiant \$299., Ranger \$210., Teletype machines; R-390/URR. Alltronics-Howard Co. Box 19, Boston 1, Mass. (Richmond 2-0048).

ATTENTION Mobileers! Leece-Neville 6 volt 100 amp system, \$50; 12 volt 50 amp system \$50; 12 volt 60 amp system \$60; 12 volt 100 amp system \$100. Guaranteed no ex-police car units. Herbert A Zimmermann, Jr. K2PAT, 115 Willow St., Brooklyn 1, N.Y. Tel. Dickens 2-9121 or Jackson 2-2857.

For Sale: TV Cameras, Teletype, Panadaptors, Transmitting Tubes, Transistors, SSB gear. Write for list. Spera Electronics, 37-10 33 Street, L.I.C., N.Y. STilwell 6-2199.

ONE THIN DIME brings 50 page eye-popping war surplus electronics catalog. Fabulous bargains. Meshna, Lynn, Mass.

TOROIDS: Uncased 88 mhy like new. Dollar each. Five \$4.00 PP.DePaul, 309 South Ashton, Millbrae, Calif.

BEGNNERS: Code bothering you? Now learn in one hour. New Method. Quick approach towards your ham ticket. Used in Armed Services, Ham Radio, Scouting. Ketchum's One Hour Code Course \$1.00 postpaid. MONEY BACK GUARANTEED—O. Ketchum, 10125 Flaro Vista, Bellflower, California.

FREE! 1961 catalogs for newest, best electronic bargains available. Stereo, hi-fi, ham radio, 1000 other items, Alco Electronics, Lawrence 5, Mass.

WANTED: Teletype printers, perforators, reperforators, transmitter-distributors, test equipment: Model #14, #15, #19, #26 #28, GRC, TT, TGC, GGC, etc. All types Collins receivers, 51J, R-388, R-390, 75A, etc. Cash or trade for NEW amateur equipment. Write Tom, W1AFN, Alltronics-Howard Co., Box 19, Boston 1, Mass. (Richmond 2-0048).

WANTED: Military and Commercial laboratory test and measuring equipment. Electronicraft. Box 399, Mount Kisco, N.Y.

RCA RECEIVER R-320/AR-88



14 Tube superhetrodyne with a frequency range from 540 to 32,000 KC in six bands designed for reception of AM, MCW & CW signals; output impedance 2.5 & 600 ohm. One tuning control with band spread plus the following controls: R.F Gain, A.F Gain, On-Trans-Rec MW-Rec CW, HF Tone, Ant-Adj., Band change, selectivity, BFO BDJ, AVC—Manual—Manual Noise Limiter—AVC Noise Limiter, Noise Limiter; also Phone Jack. Complete with Tubes: 5/6SG7, 2/6J5, 2/6H6, 1/6SA7, 1/6K6, 1/5Y3, 1/6SJ7, & 1/VR-150; 456 KC IF. Operates from 115/230 volts 60 cycle. Rack panel mounting, 19 1/4 x 11 x 19 1/4" (No cabinet) Wt.: 98 lbs. Used, Checked for operation.

Price—As described above\$175.00
Price—With Crystal Phasing\$185.00

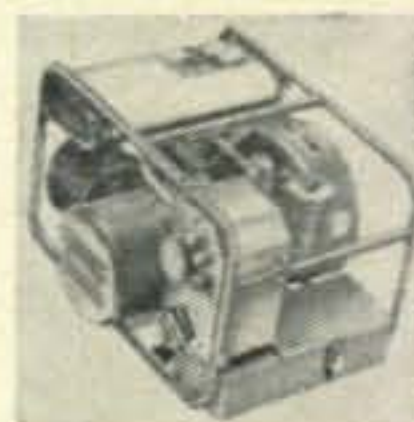

PE-162 GASOLINE ENGINE GENERATOR

FOR POWERING: RT-77/GRC-9
BC-1306/SCR-694

Compact, lightweight, portable electric generating set consisting of a 1 HP 3000 RPM 1 cylinder, air cooled, 2 cycle, manual rope starting gasoline engine directly connected to a DC, shunt wound, self excited, four pole generator contained in a frame of tubular construction mounted on rubber shock mountings. Generator is DC shunt wound, self excited, 4 pole, ball bearing, with output of 6.2/7 VDC 3.5 amp. and 500 VDC 230/250 MA. Unit has Junction Box for connecting cables for use with various radio equip. and is complete with tools & instruction book. Size: 17 1/2 x 16 1/4 x 11". Wt.: 57 1/2 lbs. Shpg. Wt.: 125 lbs.

Price—Re-New\$34.50
CD-1086 CABLE—for connecting above Power Unit to BC-1306 and RT-77 Rec.-Trans.\$5.95

FREE CATALOG Write us today, requesting your copy of Catalog!

Address Dept. CQ • All Prices are F.O.B., Lima, Ohio
25% Deposit Required on C.O.D. Orders

FAIR RADIO SALES 2133 ELIDA RD. • Box 1105 • LIMA, OHIO

For further information, check number 30, on page 126

NON-METALLIC GUY LINE — PERFECT FLEXIBLE INSULATOR — REVOLUTIONIZES HAM RADIO & TV ANTENNA SYSTEMS

Non-inductive, non-conducting, non-absorbing Glas-Line isolates systems from directional arrays, rhombics, etc.

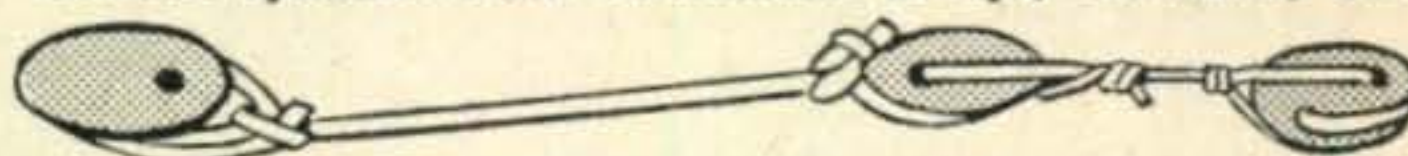

The new main insulator of W3UCT. The Glas-Line is between the two egg insulators running to the lower left. The copper link between the center egg insulator and the upper right egg insulator is for the dead-end feeder of a Zepp antenna.



View of an open thimble and eye bolt for coupling the Glas-Line guy wire to a tree. GLAS-LINE cannot rot, will not shrink, stretch or sag . . . has high breaking strength of over 500 pounds with proper use.

100' SPOOL \$3⁷⁵ Plus 50¢ for postage & handling
600' REELS \$17⁸⁴ Plus \$1.00 for postage & handling

'SUPER' GLAS-LINE

with 1,000 lb. TENSILE STRENGTH with proper use.
100' SPOOL \$6⁹⁵ Plus \$1.00 for postage & handling
600' REELS \$34⁷⁵ Plus \$2.00 for postage & handling

Send check or M.O. No C.O.D.'s please.
DEALER & DISTRIBUTOR INQUIRIES INVITED.

THE GLAS-LINE CO.

2751 NOSTRAND AVE., DEPT. 1, B'KLYN 10, N. Y. • CL 2-9851

For further information, check number 31, on page 126

RADIO HANDBOOK

- the comprehensive
reference source
- a problem solver for
**designers and
builders of radio
equipment**

Gives simplified theory on practically every phase of radio. Tells how to design, build, and operate the latest standard types of radio transmitting and receiving equipment. More "How-To-Build" articles than any book in the field.

All information is original, up-to-date, and complete. 800 pages of data, clearly indexed, between hard covers—the largest RADIO HANDBOOK ever published.



\$ 8.50 —at your distributor

*Order from your favorite electronic parts distributor.

If he cannot supply, send us his name and your remittance, and we will supply; foreign, add 10%.

EDITORS and ENGINEERS, Ltd.

Summerland 3, California



Dealers: Electronic distributors, order from us. Bookstores, libraries, newsdealers order from Baker & Taylor, Hillside, N. J. Export (exc. Canada), order from H. J. Snyder Co., 440 Park Ave. So., N.Y. 16.

For further information, check number 46, on page 126

Are You TRADING?

Let me make you a trade-in offer on your used amateur equipment. All name-brand merchandise—late serial numbers assured. Quick delivery.



WRITE TODAY! Bill W9ZSO-KØIUH

COMMUNICATIONS EQUIPMENT CO.

518 State St., LaCrosse, Wis.
Phone 4-7373

"The VHF Amateur"—At last a magazine for VHF'ers! Don't miss a single issue! Send \$2.00 for year or \$1.00 for six big issues . . . 67 Russell Ave., Rahway, N.J.

CALL LETTERS may be applied to any surface. 2" sets 60¢, 3" set 80¢. Send to C. Lee, P.O. Box 395, Times Square Station, New York 36, N.Y.

Interrogation: Applications are now being accepted for Election into our Research and Administration staff. The function of the organization is non-profit in nature, and will work under contributions and grants. The purpose of the organization is Research in Extra-Terrestrial phenomena; i.e. Radio Astronomy, Propagation, Scatter, etc. If you are seriously interested and would like more information write: Radiometric Research, Ltd., P.O. Box 4335-Annex, Las Vegas, Nevada.

PRESERVE YOUR HAM TICKET, Social Security Card, small photo, passes and anything else of value that is wallet-size. We will laminate it in clear plastic, guaranteed for life. Lamination will prevent it from getting torn, soiled or frayed. Send your ticket or anything of value with \$1 in stamps or cash for each item that you want preserved. 24-hour service. Send to C. Lee, P.O. Box 395, Times Square Station, New York 36, N.Y.

Contest Cal. [from page 69]

Mail your logs no later than May 15th to:
The USSR Central Radio Club, Att: Chief
Judging Board, P.O. Box 101, Moscow, USSR.

Bermuda

Sorry, no details on this one except the dates. A letter to the Contest Committee brought no response. Maybe they want to make this a private affair.

Ed. Note

We were more than pleased with the success of our 160 Meter Contest held the last week-end in February. It is estimated that approximately 700 stations participated and that every state that is allowed 160 meter operation, was represented.

The top contenders had in excess of 200 QSOs, coast to coast contacts were common place and several got across the pond. (Including WIWY) Even KH6IJ got into the act. That's a lot of stations crowded into two narrow 25 kc segments. Who said 160 was dead?

Say, how about that G3COI chap? How am I going to explain it to my c.w. buddies?

Have a pleasant summer.

73 for now, Frank, WIWY

PICON-ITE

PICON-ite, the South Dakota area Amateur news monthly, now in its 9th year.

Special area events—General interest news.
Emergencies—Public Service—Social Clubs—Nets—AREC—Hams—Discussions
Operating—Technical—Junk-Box (ads)
Handy-Hints—Editorials—Letters—Humor

non-profit basis, subscription \$1.00 per year

write to:

Lester Russell Lauritzen
Box 32, RFD Route 3, Centerville, South Dak.

BEFORE You Buy Tubes . . .

COMPARE

Rad-Tel's money-saving low prices . . .

UP TO 75% OFF

COMPARE

Rad-Tel's dependability . . .

BRAND NEW TUBES

COMPARE

Rad-Tel's reliable . . .

ONE FULL YEAR GUARANTEE

COMPARE

Rad-Tel's . . .

RELIABLE PERFORMANCE

SERVICEMEN: Now speedy one-day service.

Rad-Tel sells only Brand New Tubes, not used, not pulled out of old sets . . . reduce costly call backs.

THE SIGN OF RAD-TEL'S RELIABILITY



Qty.	Type	Price
—	0Z4M	.79
—	1AX2	.62
—	1B3GT	.79
—	1DN5	.55
—	1G3	.79
—	1J3	.79
—	1K3	.79
—	1LN5	.59
—	1R5	.62
—	1S5	.51
—	1T4	.58
—	1U4	.57
—	1U5	.50

Qty.	Type	Price
—	5CL8	.76
—	5EA8	.80
—	5EU8	.80
—	5J6	.68
—	5T8	.81
—	5U4	.60
—	5U8	.81
—	5V6	.56
—	5X8	.78
—	5Y3	.46
—	6AB4	.46
—	6AC7	.96

EACH TUBE INDIVIDUALLY & ATTRACTIVELY BOXED

Qty.	Type	Price	Qty.	Type	Price	Qty.	Type	Price
—	6AU7	.61	—	6SK7	.74	—	12CN5	.56
—	6AU8	.87	—	6SL7	.80	—	12CR6	.54
—	6AV6	.40	—	6SN7	.65	—	12CU5	.58
—	6AW8	.89	—	6SQ7	.73	—	12CU6	1.06
—	6AX4	.65	—	6T4	.99	—	12CX6	.54
—	6AX7	.64	—	6U8	.78	—	12DB5	.69
—	6BA6	.49	—	6V6GT	.54	—	12DE8	.75
—	6BC5	.54	—	6W4	.54	—	12DL8	.85
—	6BC7	.94	—	6W6	.69	—	12DM7	.67
—	6BC8	.97	—	6X4	.39	—	12DQ6	1.04
—	6BD6	.51	—	6X5GT	.53	—	12DS7	.79
—	6BE6	.55	—	6X8	.77	—	12DZ6	.56
—	6BF6	.44	—	7AU7	.61	—	12EL6	.50
—	6BG6	1.66	—	7A8	.68	—	12EG6	.54
—	6BH6	.65	—	7B6	.69	—	12EZ6	.53

—	6BH8	.87	—	7Y4	.69	—	12F8	.66
—	6BJ6	.62	—	8AU8	.83	—	12FM6	.45
—	6BK7	.85	—	8AW8	.93	—	12K5	.65
—	6BL7	1.00	—	8BQ5	.60	—	12SA7M	.86
—	6BN4	.57	—	8CG7	.62	—	12SK7GT	.74
—	6BN6	.74	—	8CM7	.68	—	12SN7	.67
—	6BQ5	.65	—	8CN7	.97	—	12SQ7M	.73
—	6BQ6GT	1.05	—	8CX8	.93	—	12U7	.62
—	6BQ7	.95	—	8EB8	.94	—	12V6GT	.53
—	6BR8	.78	—	11CY7	.75	—	12W6	.69
—	6BU8	.70	—	12A4	.60	—	12X4	.38
—	6BY6	.54	—	12AB5	.55	—	17AX4	.67
—	6BZ6	.54	—	12AC6	.49	—	17BQ6	1.09
—	6BZ7	.97	—	12AD6	.57	—	17C5	.58
—	6C4	.43	—	12AE6	.43	—	17CA5	.62

—	6CB6	.54	—	12AF3	.73	—	17D4	.69
—	6CD6	1.42	—	12AF6	.49	—	17DQ6	1.06
—	6CF6	.64	—	12AJ6	.46	—	17L6	.58
—	6CG7	.60	—	12AL5	.45	—	17W6	.70
—	6CG8	.77	—	12AL8	.95	—	19AU4	.83
—	6CM7	.66	—	12AQ5	.52	—	19BG6	1.39
—	6CN7	.65	—	12AT6	.43	—	19T8	.80
—	6CR6	.51	—	12AT7	.76	—	21EX6	1.49
—	6CS6	.57	—	12AU6	.50	—	25BQ6	1.11
—	6CU5	.58	—	12AU7	.60	—	25C5	.53
—	6CU6	1.08	—	12AV5	.97	—	25CA5	.59
—	6CY7	.71	—	12AV6	.41	—	25CD6	1.44
—	6DA4	.68	—	12AV7	.75	—	25CU6	1.11

RAD-TEL TUBE CO.

NOT AFFILIATED WITH ANY OTHER MAIL ORDER TUBE COMPANY

Qty.	Type	Price
—	1X2B	.82
—	2AF4	.96
—	3AL5	.42
—	3AU6	.51
—	3AV6	.41
—	3BA6	.51
—	3BC5	.54
—	3BE6	.52
—	3BN6	.76
—	3BU8	.78
—	3BY6	.55
—	3BZ6	.55
—	3CB6	.54
—	3CF6	.60

Qty.	Type	Price
—	3CS6	.52
—	3DK6	.60
—	3DT6	.50
—	3Q5	.80
—	3S4	.61
—	3V4	.58
—	4BC8	.96
—	4BN6	.75
—	4BQ7	.96
—	4BS8	.98
—	4BU8	.71
—	4BZ6	.58
—	4BZ7	.96

Qty.	Type	Price
—	4CS6	.61
—	4DE6	.62
—	4DK6	.60
—	4DT6	.55
—	5AM8	.79
—	5AN8	.86
—	5AQ5	.52
—	5AT8	.80
—	5BK7A	.82
—	5BQ7	.97
—	5BR8	.79
—	5CG8	.76

Qty.	Type	Price
—	6AF3	.73
—	6AF4	.97
—	6AG5	.65
—	6AH6	.99
—	6AK5	.95
—	6AL5	.47
—	6AM8	.78
—	6AQ5	.50
—	6AR5	.55
—	6AS5	.60
—	6AT6	.43
—	6AT8	.79
—	6AU4	.82
—	6AU6	.50

Qty.	Type	Price
—	6DB5	.69
—	6DE6	.58
—	6DG6	.59
—	6DQ6	1.10
—	6DT5	.76
—	6DT6	.53
—	6EU8	.79
—	6EA8	.79
—	6HG6T	.58
—	6J5GT	.51
—	6J6	.67
—	6K6	.63
—	6S4	.48
—	6SA7GT	.76

Qty.	Type	Price
—	12AX4	.67
—	12AX7	.63
—	12AZ7	.86
—	12B4	.63
—	12BA6	.50
—	12BD6	.50
—	12BE6	.53
—	12BF6	.44
—	12BH7	.73
—	12BL6	.56
—	12BQ6	1.06
—	12BY7	.74
—	12BZ7	.75
—	12C5	.56

Qty.	Type	Price
—	25DN6	1.42
—	25EH5	.55
—	25L6	.57
—	25W4	.68
—	25Z6	.66
—	35C5	.51
—	35L6	.57
—	35W4	.52
—	35Z5GT	.60
—	50B5	.60
—	50C5	.53
—	50DC4	.37
—	50EH5	.55
—	50L6	.61
—	117Z3	.61



SEND FOR FREE TROUBLE SHOOTER GUIDE AND NEW TUBE & PARTS CATALOG

RAD-TEL TUBE CO.

DEPT. Q-561 55 CHAMBERS STREET, NEWARK 5, N. J.

TERMS: 25% deposit must accompany all orders, balance COD. Orders under \$5: add \$1 handling charge plus postage. Orders over \$5: plus postage. Approx. 8 tubes per 1 lb. Subject to prior sale. No COD's outside continental USA.

**QUANTITY USERS • MACHINE OPERATORS
• MANUFACTURERS • EXPORTERS**

**HUGE STOCKS !!
OVER 175 TYPES SPECIALLY PRICED !**

All tubes fully Guaranteed — Brand New!

MINIMUM ORDER . . . 500 PER TYPE . . . NO ASSORTMENT

Write, Wire, Types Needed; get our Low "Large Quantity" price

For further information, check number 43, on page 126

ADVERTISING INDEX

BACK ISSUES FOR SALE \$1.00 per copy

- 1950—Jan., July, Oct., Nov.
- 1951—All issues, except Nov.
- 1952—All issues, except June, Aug.
- 1953—All issues, except May, July, Dec.
- 1954—All issues, except Feb.
- 1955—All issues, except Nov.
- 1956—All issues, except April
- 1957—All issues, except Jan., Feb. and Nov.
- 1958—All issues, except Jan., June, July, Sept., Oct.
- 1959—All issues except Jan. and June
- 1960—All issues
- 1961—All issues, 50¢ Per Copy

BC-603 Conversion article (Sept. & Oct., 1958 CQ)
Reprints available at 50¢ per set.

CQ Magazine
300 West 43rd St., New York 36, N. Y.

READER SERVICE

CQ Magazine, Dept. RS

300 WEST 43rd STREET
New York 36, N. Y.

Coupon E
Void after
May 26, 1961

Please send me more information on your ads in the May 1961 CQ keyed as follows:

1	2	3	4	5	6	7	8	9	10	A
11	12	13	14	15	16	17	18	19	20	B
21	22	23	24	25	26	27	28	29	30	C
31	32	33	34	35	36	37	38	39	40	D
41	42	43	44	45	46	47	48	49	50	D
51	52	53	54	55	56	57	58	59	60	E

NAME _____

(Please Print)

Call _____ Engineer

Type of work (specify) _____

ADDRESS _____

CITY _____

ZONE _____ STATE _____

ACF Industries, Inc.	103, 112
Allied Radio Corporation	128
Barker & Williamson Incorporated	19
Barry Electronics Corporation	113
Beam Radio Enterprises	114
Brown Electronic Inc.	116
Burstein-Applebee Company	108
C & G Electronics Company	115
Centralab	18
Central Electronics Incorporated	12
Cleveland Institute of Electronics	16
Collins Radio Company	Cover II
Communications Associates, Incorporated	122
Communications Equipment Company	124
Communication Products Company, Inc.	6
Cush Craft	114
CQ Back Issues	126
CQ Subscription	115
CQ VHF for the Amateur	118, 119
Dow-Key Company, Incorporated	102-114
E-Z Way Towers, Incorporated	101
Editors & Engineers Limited	124
EICO	15
Empire State Electronics	108
Evans Radio, Incorporated	109
Fair Radio Sales	123
Finney Company (The)	21
Glas-Line Company	123
Gonset Company	17
Groth, R. W. Manufacturing Company	114
Hallcrafters Company	4, 5
Hammarlund Manufacturing Company	2
Ham Boards	106
Harvey Radio Company, Incorporated	111
Heath Company	9, 10, 11
Henry Radio Stores	105
House of Antennas (The)	122
Hy-Gain Antenna Products	120, 121
Instructograph Company	115
International Crystal Manufacturing Co.	8
Jennings Radio Manufacturing Corporation	20
Johnson, E. F. Company	24, 25
James Knights Company (The)	117
Lafayette Radio	107
Lampkin Laboratories, Incorporated	114
Lektron, Incorporated	114
Master Mobile Mounts, Incorporated	13
Millen, James Manufacturing Co., Inc.	14
Multi Products	110
National Radio Company, Incorporated	Cover III
P & H Electronics	100
Palmer, Joe	101
Petersen Radio Company, Incorporated	1
Picon-ite	124
RCA (Tube Division)	Cover IV
R W Electronics	122
Rad-Tel Tube Company	125
S.A.R.L.	102
Space Electronics Corporation	114
Space Raider Antenna	109
TAB	127
Telex, Incorporated	104
Telrex, Incorporated	117
Tri State Amateur Radio Society, Inc.	100
Turner Microphone Company	19
Vibroplex Company, Incorporated	110
Western Radio Company	115

"TAB" FOR THE BEST KITS!

Each "TAB" Kit Contains The Finest Selection!!!

- Kit 75 Mica Condensers
- Kit 8 Crystal Diodes
- Kit 200ft Hook Up Wire
- 4 Rolls, 50ft/ea. Asstd. Color
- Kit 100 Ceramic Condensers
- Kit 5 FT243 Xtal Holders
- Kit 5 Microswitches
- Kit 8 Xtal Osc-Blanks
- Kit 4 Asstd Rectifiers
- Kit 5 UG/Connectors
- Kit 100 Self-Tap Screws
- Kit 4 Selenium "Suncells"
- Kit Adj Wire Stripper & Cut
- Kit Hi Gain Xtal Mike
- Kit 6 ea Photoplugs & Jacks
- Kit 2 pair SO239 & PL59
- Kit 12 Binding Posts Asstd

- Kit 35 Precision Resistors
- Kit 10 Switches
- Kit 75 Resistors 1/2" & 2W
- Kit 12 Electrolytic Cond's
- Kit 15 Volume Controls
- Kit 56 Tube Sockets
- Kit 65 Tubular Condensers
- Kit 500 Lugs & Eyelets
- Kit 10 Bath Tub Oil Cond's
- Kit 5 lbs. Surprise Package
- Kit 10 Transmit Mica Cond's
- Kit Glyptal & Cement
- Kit 3 Phone/Patch Xfms
- Kit 4 AN/Reflector Lites
- Kit 6 Insult Tuning Tools
- Kit 4 "Suncells" Asstd.
- Kit 5 Sub-Min Tubes

99¢

Order Ten Kits We Ship Eleven!!!
ONE EACH ABOVE KIT ONLY

GTD! POWER-DIAMOND-TRANSISTORS

Factory Tested
***MFGRD in U.S.A.
Replaces Medium & HiWattage Types
2N155, 2N156, 2N234,
2N256, 2N307, 2N554

GENERAL TO 3GP 80¢ @ 20 for \$15
PURPOSE 100/\$65
\$10 or more this item we pay P.P./U.S.A.)

8 TOPHAT SILICON DIODES \$1
EXPERIMENTERS KIT. USE AS
STABISTORS, ZENOR DIODES
METER PROTECTION CLIPPER
& RECTIFIERS! \$10 VALUE.

DIAMOND BASE MICA MTG KIT... \$.30
ROUND BASE MICA MTG KIT... \$.30
DELCO POWER HEAT SINK WITH
FINS 80 SQ"..... \$1.25
KIT DIODES COMPUTER..... 20¢, 8/\$1
KIT TRNSTR NPN or PNP .39¢ @, 3 for \$1
IN34A DIODES 23¢ @, 10 for \$2, 100/\$18
(\$10 or more this item we pay P.P./U.S.A.)

GTD! HIPOWER-ROUND-TRANSISTRS

Factory Tested
***MFG in U.S.A.
2N277 or 2N441 \$2.25,
2N278 or 2N442 \$3.75,
2N173 or 2N443 \$5.00 @,
4/\$16. (\$10 or more this item we pay
P.P./U.S.A.)

NEW POWER CONVERTER

12VDC to 500VDC
up to 200MA
100 Watts; Tap at 250VDC
*Type C1250E \$35
TYPE C650E FOR 6VDC INPUT \$35
12VDC to 250VDC up to 150MA
Type C1225E \$30
C625E for 6VDC input \$30

"TAB" TOROID XFMRs for
TRANSISTOR POWER CONVERTERS!
T6-500E/6VDC Impt, 500VDC & Tap, Max
200Ma \$15. T12-500E/12VDC Impt, 500VDC
& Tap, Max 200Ma \$15. T6-250E/6VDC
Impt, 250VDC, Max 150Ma \$14. T12-250E/
12VDC Impt, 250VDC, Max 150Ma \$14.

Leece Neville Charger Systems
"SILTAB" Silicon Rectifier Replacement
Non-Aging Hermetically Sealed
FOR 6 or 12VDC @ 100A, Type YJ9 \$24

SELENIUM F.W. BRIDGE RECTIFIERS

DC AMP	18VAC 14VDC	36VAC 28VDC	72VAC 54VDC	130VAC 100VDC
1/2	\$1.00	\$1.90	\$3.85	\$5.00
1	1.30	2.00	4.90	8.15
2	2.15	3.00	6.25	11.10
3	2.90	4.00	8.60	13.45
6	4.15	8.00	18.75	31.90
10	6.10	12.15	26.30	41.60
12	7.75	14.90	30.95	43.45
20	12.85	24.60		
24	15.00	29.45		

Write For Rectifier Catalog

Send 25¢ for Catalog

"TAB" THAT'S A BUY



"TAB" Tubes Factory Tested, Insptd,
Six Months Guaranteed! No Rejects!

GOVT & MFGRS Surplus! New & Used

0A2	.89	6BZ7	1.25	We Buy & Sell	
0A3	.80	6C4	.45	43	.75
0B2	.65	6C5	.69	45	.49
0C3	.70	6C6	1.08	50L6	.69
0D3	.50	6C8	1.08	RK59	1.39
0Z4	.79			RK60	1.17
1A7	.90			HY69	2.20
1B3	.99	6CB6	.89	75	.81
1L4	.82	6CD6	1.49	HY75	5.00
1R4	5/\$1	6CF6	.85	83V	.95
		6CL6	1.40		

We Swap Tubes! What Do/U Have?

IR3	.78	6CB6	.89	4PR60A	37.50
IS4	.78	6CG8	1.12	4-125A	27.50
IS5	.68	6CM6	.79	4X150G	15.00
IT4	.85	6CS6	.70	4X250B	41.00
IT5	.95	6CU6	1.29	4-400A	41.75
IU4	6/\$1	6D6	.99	4E27A	39.00
IU5	.75	6E5	.79	250TL	19.45
IX2	.99	6F4	2.49	307A	2/\$1
2C39A	Q	6F5	.63	316A	5/\$1
2C40	5.50	6F6	.99	VR92	5/\$1

Send 25¢ for Catalog!

2C43	6.50	6F7	.99	388A	3/\$1
2C51	2.00	6F8	1.39	350A	2.45
2D21	.65	6H6	.59	350B	1.75
2E22	1.75	6J4	1.72	371B	.95
2E24	1.90	6J5	.59	3146	3.90
2E25	2.50	6J6	.59	416B	16.00
2E26	2.75	6J7	.99	450TH	43.00
2E30	Q	6J8	1.39	450TL	43.00
2E35	1.60	6K6	.59	460	11.50
2K25	9.75	6K7	.79		

All Tubes Stocked at Low Prices!

2K26	34.00	6K8	.99	703A	Q
2K28	30.00	6L6	1.19	707B	3.50
2V3	2/\$1	6SN7	.72	715C	10.90
2X2	.48	6T8	.98	717A	5/\$1
3A4	.70	6V6GT	.90	723AB	5.00
3A5	1.00	6X5	.49	725A	2.75
3AP1	5.95	12AT6	.59	803	3.50
3BP1	3.99	12AT7	.89	804	9.95
3C24	3.50	12AU6	.63	805	6.00
3D23	3.95	12AU7	.69		

We Buy! We Sell! We Trade!

3E29	6.00	12AX7	.79	807	1.10
3Q4	.68	12AY7	1.29	5/\$5, 10/\$12	
3Q5	.86	12BA	.95	811	3.45
4-65A	13.50	12BA6	.65	811A	4.41
4-125A	27.50	12BA7	.99	812	3.95
4-250A	34.00	12BD6	.59	813	Q
4X150A	Q	12BE6	.59	815	1.75
4X250	36.00	12BH6	.79	826	.99
4X500	37.00	12BH7	.99		
5AP1	3.95	12BY7	1.00		

Wanted Test Sets and Equipment

5BP1	8.95	12BZ7	.99	828	9.00
5BP4	7.95	12H6	.75	829B	8.00
5CP1	4.99	12J5	.69	832A	6.00
5CP7	9.00	12J7	.69	833A	36.00
5R4	1.00	12J8	1.35	837	2/\$2
5T4	.90	12K8	.89	866A	2.45
5U4	.99	12SA7	.69	954	10/\$1
5V4	.89	12SC7	.89	955	3/\$1
5Y3	.60	12SF5	.69	957	3/\$1
5Z3	.89	12SG7	.89	958A	2/\$1

Send 25¢ for Catalog!

15GP22	89.00	12SH7	.89	991	5/\$1
6A7	1.00	12SJ7	.75	1614	2.75
6A8	.99	12SK7	.75	1619	5/\$1
6AB4	.59	12SL7	.79	1620	2.00
6AC7	.72	12SN7	.69	1625	3/\$1
6AG5	.65	12SQ7	.69	1626	5/\$1
6AG7	.75	12SR7	.69	1629	4/\$1
6AK5	.69	15E	1.19	2050	1.25
6AL5	.59	15R	4/\$1	5517	1.25
6AQ5	.66	FG17	Q	5608	3.95

Top \$\$\$ Paid for 304TL, 813, 811A, 812A Tubes

6AR6	1.95	19T8	1.16	5618	3.25
6AS7	3.49	24G	3.50	5651	1.35
6AT6	2/\$1	25A6	1.19	5654	1.20
6AU6	.79	25A7	2.19	5656	4.25
6B8	1.35	25C5	.81	5663	1.15
6BA6	.59	25L6	.72	5670	.90
6BE6	.59	25T	4.00	5686	1.75
6BG6	1.49	25Z5	.72	5687	1.15
6BH6	.79	25Z6	.75	5691	4.70
6BJ6	.72	26A7	3.69	5725	1.95

Top \$\$\$ Paid for XMITR Tubes!

6BK7	.99	FG27	8.28	5732	2.00
6BL7	1.35	HV27	19.39	5736	85.00
6BN4	.69	28D7	.89	5749	1.95
6BN6	1.08	FG33	15.00	5750	2.75
6BN7	1.99	EL34	3.49	5751	1.25
6BQ6	1.19	35A5	.69	5814	1.20
6BQ7	.99	35L6	.59	5879	1.20
6BX7	1.11	35T	4.49	5894	\$12.00
6BY5	1.19	35Z5	1.25		
6BZ6	.91	RK39	2.99	No See—Write!	

"TAB" TERMS: Min Order \$3—25%
with order F.O.B. New York.
Ten day guarantee, price of
mdse. only. Our 17th year.

Prices shown are subject to change.
111FE Liberty St., N. Y. 6, N. Y. RE 2-6245

NEW "VACDAC" SILICON TUBE REPLACEMENTS

WITH BUILT IN RF SURGE & SERIES BALANCING PROTECTION

TYPE	VRMS/PIV	AMPS	PRICE
ST866	5000/10400	0.3	\$20.00
ST816	5000/7000	0.3	\$16.00
ST5B4	1900/2800	0.5	\$15.00
ST5U4	1120/1600	0.6	\$ 8.00



"SUNTAB" SELENIUM PHOTOCCELL

2BP 75µa 3/4x3/4" e40@, 11 for \$4
5AP 1" Dia., 5BP/Sq & Reet 220µa, e55
15AP 750µa, 1 1/4" Dia., \$1.45@, 4 for \$5
10BP 350µa, 1-11/16" Reet. e75@, 10 for \$7
10CP 750µa, 1 7/8x1 1/8" e1.45@, 4 for \$5

SILICON DIODES 750MA* TOP HATS

General Purpose 400 PIV at 300 MA
Special 2 for \$1 20 for \$7

rms/piv 17/25 14¢	rms/piv 35/50 19¢	rms/piv 70/100 29¢	rms/piv 140/200 34¢
rms/piv 210/300 43¢	rms/piv 280/400 55¢	rms/piv 350/500 70¢	rms/piv 420/600 \$1.00
rms/piv 490/700 \$1.25	rms/piv 560/800 \$1.50	rms/piv 630/900 \$1.70	rms/piv 700/1000 \$2.00

Low Priced * T200 SILICON DIODES
rated 380piv/266rms @ 200Ma @ 100°C
36¢ each; 10 for \$3.25; 100 for \$27;

*CAPACITOR INPUT DERATE 20%:

(\$5 or more this item we pay P.P./U.S.A.)
SPECIAL! TRANSISTORS & DIODES!!!

Factory Tested & Guaranteed!
FULL LENGTH LEADS
2N123 PNP 45¢, 12 for \$5, 100/\$37
2N292 NPN 45¢, 12 for \$5, 100/\$37
2N293 NPN 45¢, 12 for \$5, 100/\$37
2N223 PNP 80¢ 100/\$65
2N597 PNP \$1.90 6/\$10
2N598 PNP \$1.90 6/\$10
2N599 PNP \$3.50 3/\$10

GENERAL PURPOSE—PNP—COMPUTER GRADE!

Use as Amplifier—Oscillator—HiFi
Logic—Servoamp—Power Supply
Pulse Amplifier or High Current Switch
Veb. Vee. Veb Approx 40V
GP3C rated 300 Milliwatts 65¢, @ 10
for \$5, 100 for \$39
GP10C Rated 1 watt 90¢, 6 \$5, 100 \$63

2N155 \$1.39, 2N176 \$1.80, 2N177 \$1, 2N178
\$1.75, 2N247 \$1.50, 2N255 \$1.20, 2N270
\$.95, 2N274 \$1.25, 2N408 \$.80, 2N544 \$1.20,
2N578 \$1.80, 2N579 \$2.20, 2N581 \$1.25,
2N582 \$2.10, 2N174 \$8.50, 2N443 \$6.50,
2N670 \$1.60, 2N671 \$2.

NEW BATTERY CHARGER BC6-12V

FOR 6V OR 12 VOLT BATTERIES,
TRICKLE & FULL CHARGE up to 4 AMP

Charges 6 & 12 volt batteries
Built BC6-12VB \$10.00
BC6-12VK Preassembled
Kit 7.50
Same except rated 2.5A
BC612AB 8.00
BC6-12AK Preassembled
Kit 6.00

!!! TUBE SPECIAL !!!

4X150D — Removed from Govt. equip-
ment. Tested. \$3 ea., 2 for \$5. Filament
Xfmr \$2. First come, first served.

"TAB"—THAT'S A BUY!—BARGAINS!!

TRANSISTOR POWER DIODE* up to
3 Amp 4 for \$1
TRANSISTOR POWER DIODE* up to
5 Amp 2 for \$1
*HEAT SINK MOUNTED
New Variacs/or equiv 0-135V/7.5A \$15.30
New Variacs/or equiv 0-135V/3 Amp \$10.65
New Variacs/or equiv 0-132V/1.25A \$7.25
RF-MTG GE/475 Ma & 5 Amp \$4@, 2/\$7
DC-METER Dejur 800 Ma/3 1/2" \$3@, 2/\$5
DC-METER One Ma/4" Rd. \$5@, 2/\$8
RF-HTR Weston 750Ma/TC \$4@, 2/\$6
DC MTR 100Ma/2 1/2" \$3@, 2/\$5
SNOOPERSCOPE TUBE 2" \$5@, 2/\$9
MINI-FAN 6 or 12VAC/60 Cys \$2 @ 3/\$5
NEW PRINT CKT-PANEL, 11x12x.062" \$2
IN34A 45¢@, 15/\$5; IN35 \$1; IN38 70¢@;
XTAL OVEN—115V&Thermostat \$2
Blower 24VDC/100CFM \$3.98
Xmitting Mica's .008 @ 2500V, 5 for \$1.00
4-1000A SOCKET LESS CHIMNEY \$9.95
829B Socket 85¢, 813 Socket \$1
4x150 Ceramic/LOKTAI, 2 for \$1.00

Wanted 304TL Tubes & ALL TYPES!!!

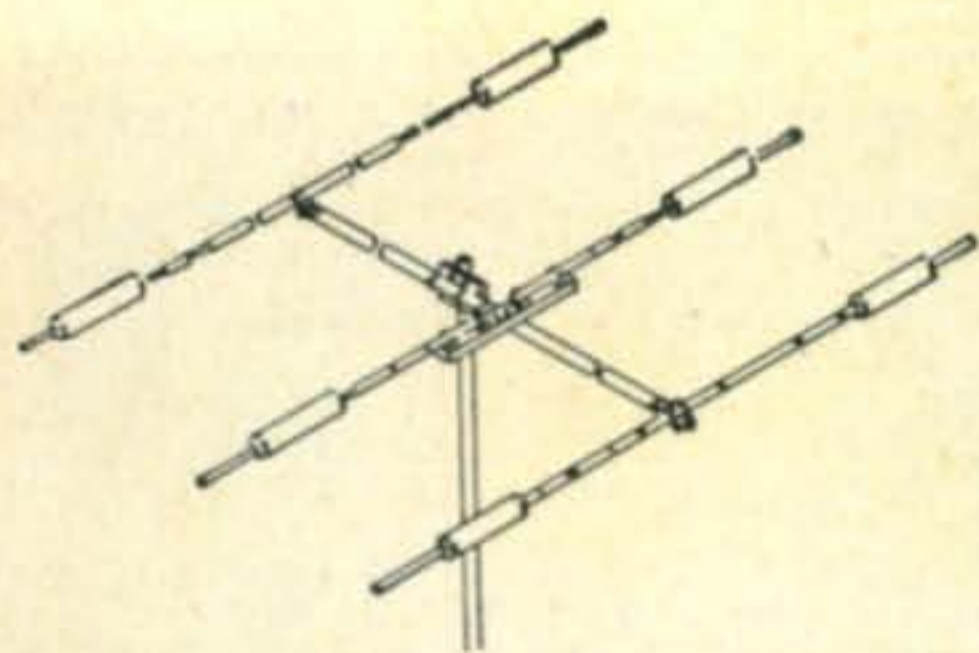

**Mosley Model TA-33
"Trap-Master" Antenna**
Stock No. 92 CZ 360.....\$97.75

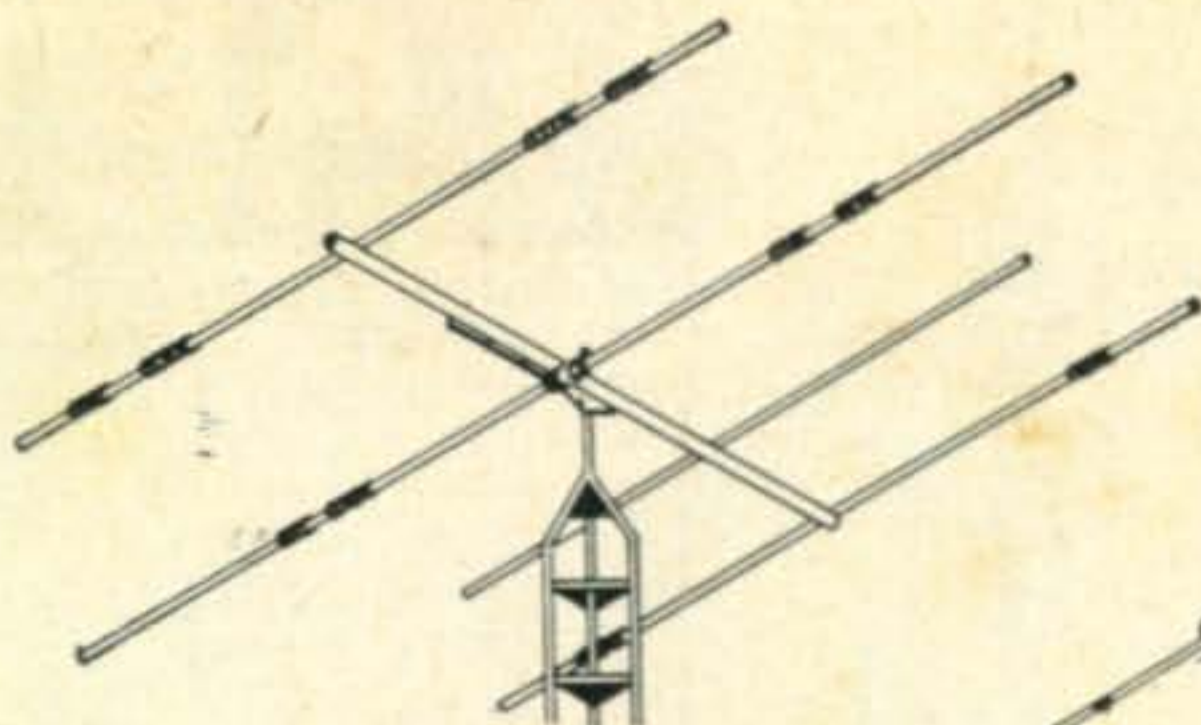

**Hy-Gain TH-4 4-Element
Thunderbird "Tribander"**
Stock No. 77 CZ 361.....\$117.50

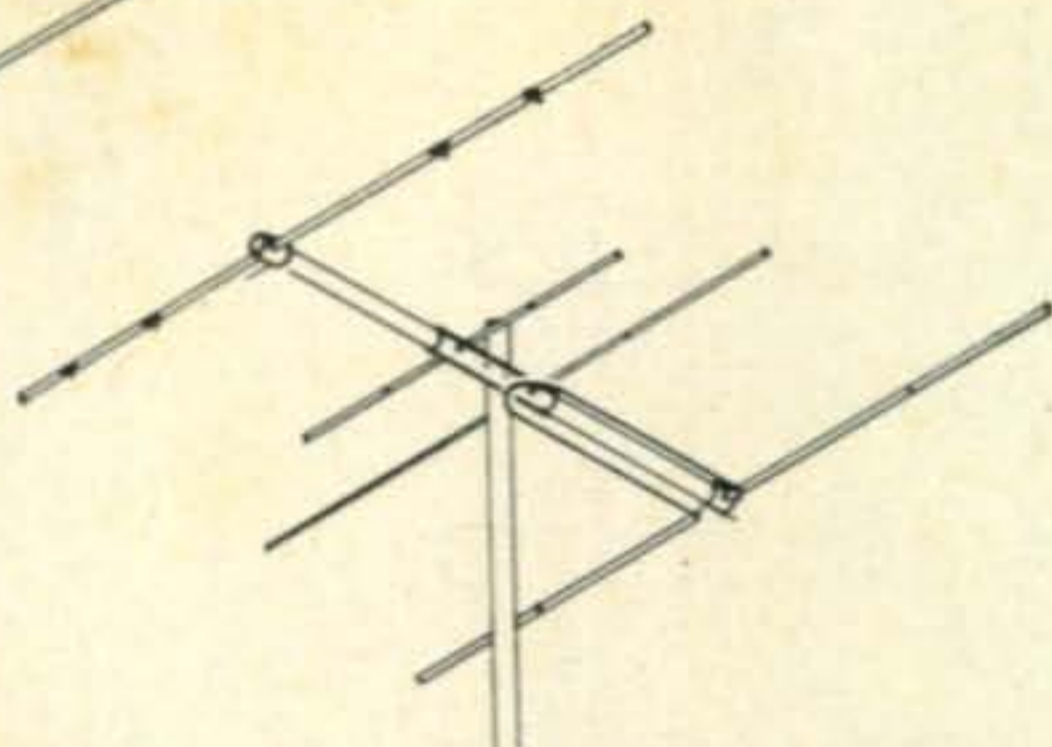

**Telrex TC-99 Challenger
"Tri-Band" Antenna**
Stock No. 99 CZ 964.....\$159.50

ALLIED has that
new antenna system
you need!

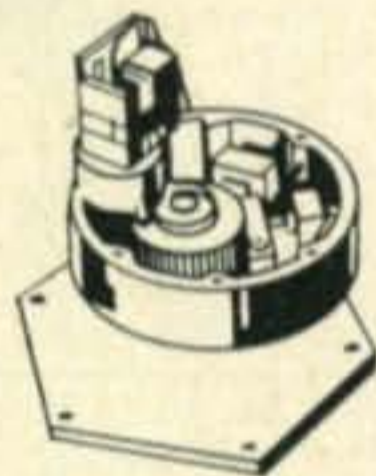

**Hy-Gain Rotator
Indicator System**

RBX-1 "Roto-Brake" (twin-motor unit). Stock No. 83 SU 691..\$129.95



CONTROL SYSTEM—world map indicator and control box.

83 SU 692. Central U.S.A.
83 SU 693. Far East Coast.
83 SU 694. Far West Coast. } Each \$70

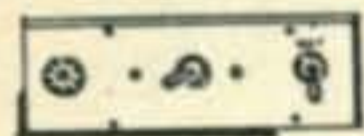

CDR Ham-M Rotator
Complete, heavy-duty system.
Stock No. 92 SX 357....\$117.11



E-Z Way Towers

The top-quality crank-up, tilt-over un-guyed tower. All models in stock at ALLIED, from \$90.00 up.

IN STOCK FOR IMMEDIATE DELIVERY!
All Mosley, Hy-Gain and Telrex antennas. Whatever your antenna needs, you'll save time and money by sending your order to ALLIED.

YOU GET MORE AT ALLIED

- Get our famous "King-Size" trades—they're highest!
- Only \$2 down on orders up to \$50—only \$5 up to \$200!
- Enjoy every buying advantage—top service and real "ham-to-ham" help!

FREE!
Send for our big Summer Sale Book today!



order from
ALLIED RADIO

ALLIED RADIO, Dept. 16-E1
100 N. Western Ave., Chicago 80, Ill.

Immediate Delivery

Ship me the following:

- | | |
|--|--|
| <input type="checkbox"/> 92 CZ 360 Mosley | <input type="checkbox"/> 83 SU 691 RBX-1 |
| <input type="checkbox"/> 77 CZ 361 Hy-Gain | <input type="checkbox"/> 83 SU 692 |
| <input type="checkbox"/> 99 CZ 964 Telrex | <input type="checkbox"/> 83 SU 693 |
| <input type="checkbox"/> 92 SX 357 CDR | <input type="checkbox"/> 83 SU 694 |

\$.....enclosed

Send Free Summer Sale Book No. 205

Name _____ Call _____

PLEASE PRINT

Address _____

City _____ Zone _____ State _____

For further information, check number 45, on page 126

with built-in PRODUCT DETECTOR

NC

270



THE "COSMIC BLUE" NATIONAL'S NEW HAMBAND RECEIVER

This newest and finest precision double conversion amateur receiver with 6 meter coverage, brings you an ease of sideband tuning previously available only in the most expensive equipment. The NC-270 features an exclusive "Ferrite Filter" for instant upper-lower SSB selection and a degree of selectivity to conquer even the toughest AM and CW signal conditions. The solid $\frac{1}{8}$ " steel panel, ceramic coil forms, double-spaced tuning gang, and full ventilation cabinet combine to give mechanical and thermal stability that will surprise even the most critical operator. Even the color of the NC-270 is outstandingly different, National's new duo-tone "Cosmic Blue." Write for detailed specifications.

Only \$24.99 down*

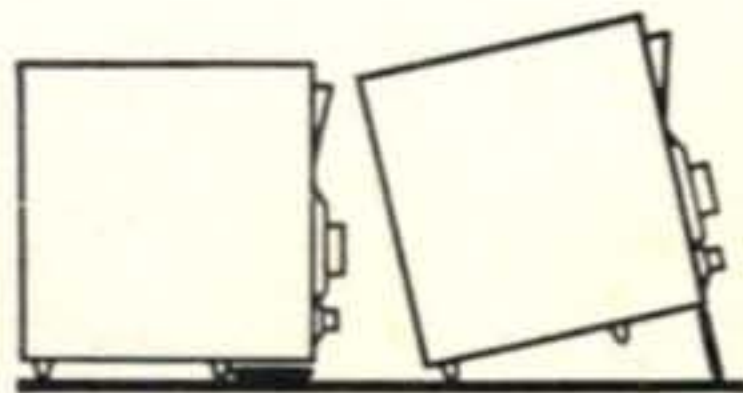

And National Radio's patented "Flip Foot" makes operating the NC-270 so easy.

Suggested cash price: \$249.95. NTS-3 Matching Speaker: \$19.95 (slightly higher west of the Rockies and outside the U.S.A.). *Most National distributors offer budget terms and trade-in allowances.

NATIONAL RADIO COMPANY, INC.



A WHOLLY OWNED SUBSIDIARY OF NATIONAL CO., INC.

MELROSE 76, MASS.

Export: AD AURIEMA, INC., 85 Broad St., New York, N. Y.

Canada: CANADIAN MARCONI CO., 830 Bayview Ave., Toronto 17, Ont.

SPECIFICATIONS SUBJECT TO CHANGE WITHOUT NOTICE

In the INVADER...

Johnson does it with

RCA-6146's

The RCA-6146's you see in the final of this versatile transmitter are, we think, dynamic tribute by an outstanding manufacturer of Amateur equipment—to the world's most popular transmitting beam power tube.

For high operating reliability and more watts per transmitter dollar, you can't beat the RCA-6146.

It is available at RCA Industrial Tube Distributors everywhere.

RCA ELECTRON TUBE DIVISION, HARRISON, N. J.



The Most Trusted Name in Electronics
RADIO CORPORATION OF AMERICA

90 watts CW input up to
60 Mc; 67.5 watts on
'phone. For free
technical bulletin, write
Sec. E-15-M Commercial
Engineering, RCA
Electron Tube Division,
Harrison, N. J.

