

November \$1.00

CQ

SPECIAL

19 61

ANNUAL

BUYER'S GUIDE

The Radio Amateur's Journal



The World Is More Compact With Collins S/Line

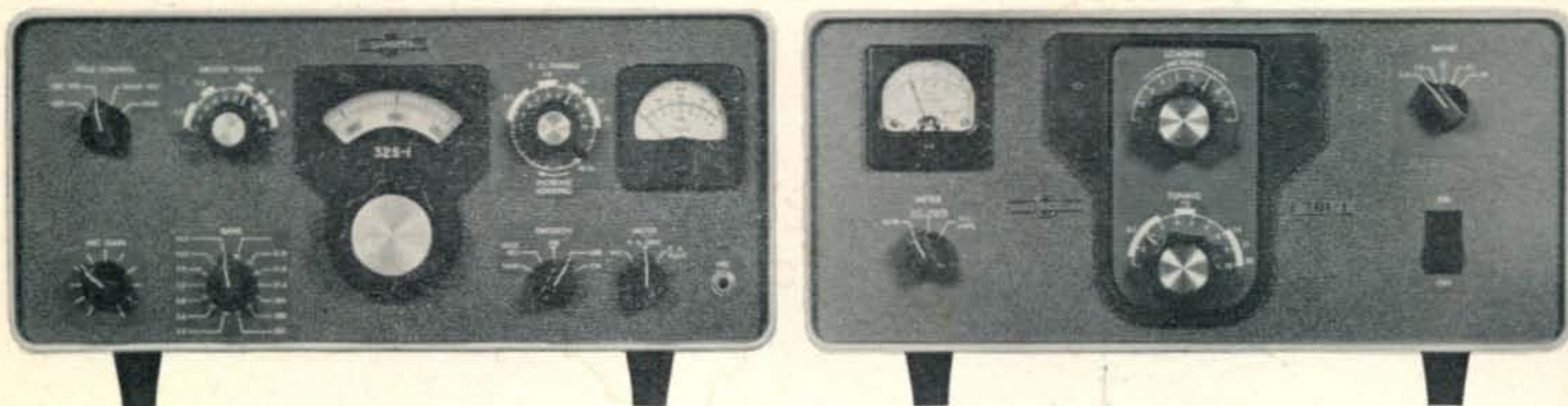

The world is no larger than your power of communication. It is as compact as the equipment in your shack. Never before have the features that give you this power been so efficiently engineered into so small a package.

The 32S-1 Transmitter provides nominal output of 100 watts — 175 watts PEP input on SSB and 160 watts input on CW. It gives you: superior stability • transceive operation • Mechanical Filter sideband generation, assuring clean voice signals • automatic load control • permeability-tuned VFO • crystal-controlled HF oscillator.

The 30L-1 Linear Amplifier, one of the newest members of the Collins line of quality equipment, provides: 1 kw PEP input on SSB and 1 kw average on CW • compatibility with Collins KWM-2 Transceiver or 32S-1 Transmitter and with most other 70-100 watt CW/SSB exciters • RF inverse feedback • automatic load control • self-contained power supply • silicon rectifiers • high-low power switch.

These features and more are available to you in units less than 15" wide and 8" high. Your authorized Collins distributor will show you this proof of compact power ... another reason why Collins equipment is the finest ham gear built.



QUALITY

IS THE CHEAPEST THING YOU BUY!

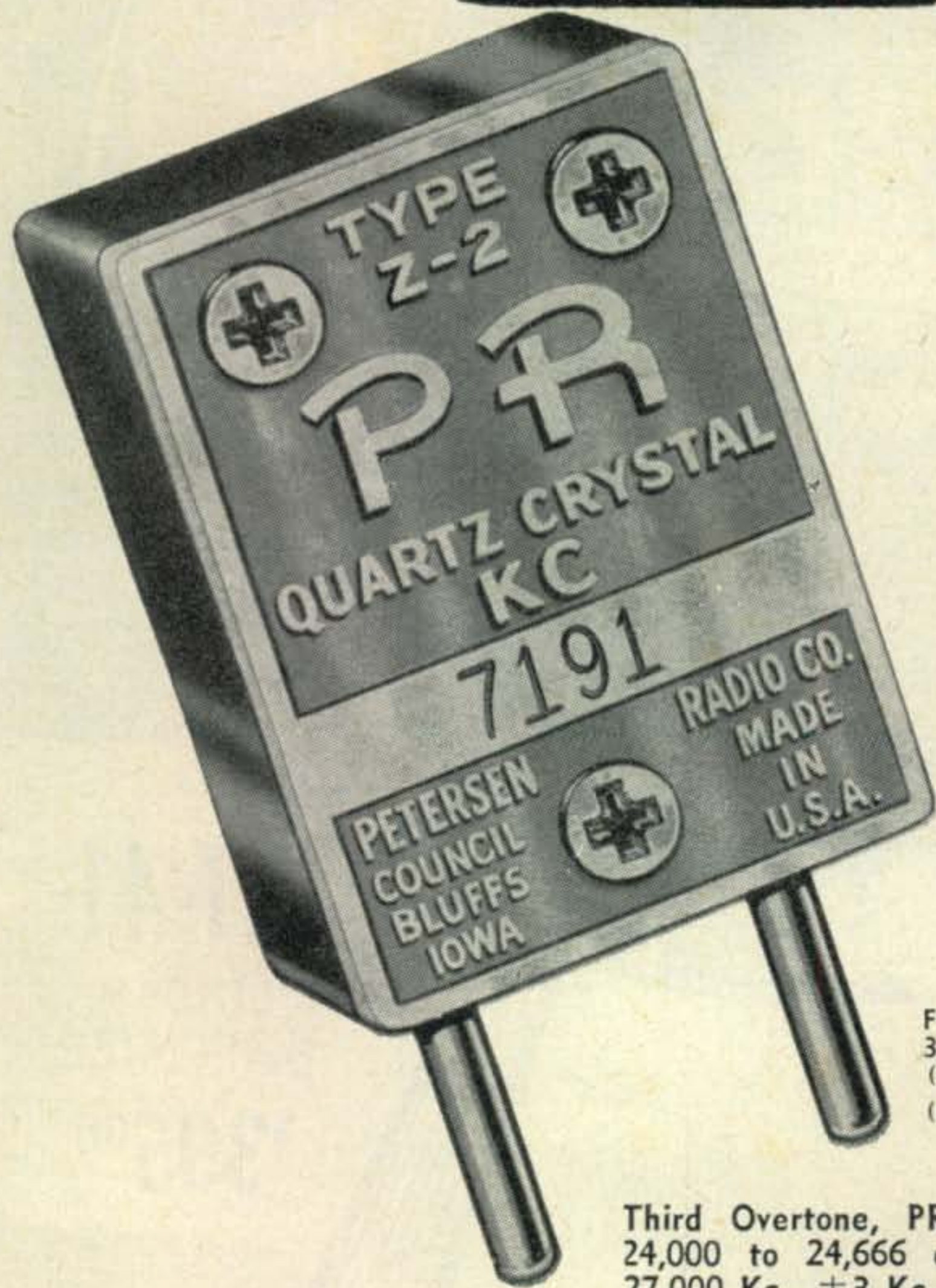

There is a deep, understandable satisfaction in owning something truly fine. It can't be exactly measured in dollars or in words. Maybe it boils down to this: A good thing is worth a hundred times its price; a poor thing isn't worth having around. It's this way with Crystals. When you buy PRs you know you're getting many times your money's worth. You're buying the finest precision frequency control that modern science has made . . . you get (in super-abundance) the things you want most . . . dependability, accuracy, long life, freedom from drift, unfailing activity. Yes—you can be proud to own PRs . . . everybody is!

FUNDAMENTAL, PR TYPE Z-2—Frequency Ranges in Kcs.: 3,500 to 4,000 (80M); 7,000 to 7,425 (40M); 8,000 to 8,222 (2M); 8,334 to 9,000 (6M). ± 500 Cycles.....**\$2.95** Net
(All Z-2 Crystals calibrated with a load capacity of 32 mmfd.)

Third Overtone, PR Type Z-9A, 24,000 to 24,666 and 25,000 to 27,000 Kc., ± 3 Kc.....**\$3.95** Net

6 Meters, Fifth Overtone, PR Type Z-9A, 50 to 54 Mc., ± 15 Kc. **\$4.95** Net

Citizens Band, PR Type Z-9R, .005%.....**\$2.95** Net

PR

Crystals



Since 1934

USE **PR** AND KNOW WHERE YOU ARE

PETERSEN RADIO COMPANY, INC.
2800 W. BROADWAY • COUNCIL BLUFFS, IOWA

EXPORT SALES: Royal National Corporation, 250 W. 57th Street, New York 19, N. Y., U. S. A.
For further information, check number 3, on page 163

MAGNIFYCENT!

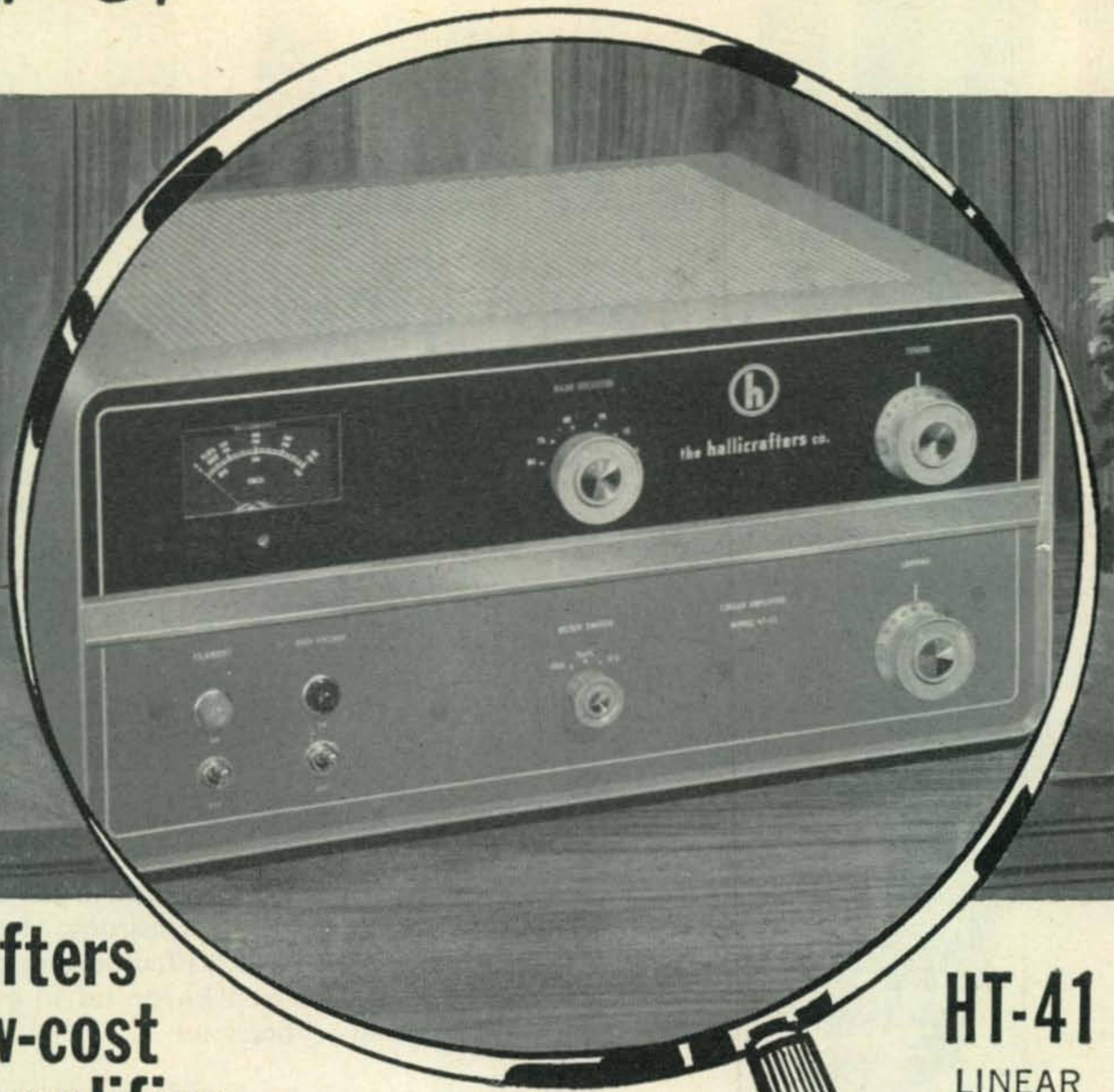

Hallicrafters new, low-cost linear amplifier

HT-41
LINEAR
AMPLIFIER
\$395⁰⁰

Built to Hallicrafters' highest quality standards . . . beautifully engineered to match the famous HT-37 and SX-111 . . . gives you the big signal you want, with conservatively rated components.

- Low or high-power drive adjustment (20-100 watts).
- Complete coverage, 80-10 meters.
- Adjustable Pi-network output.
- All important circuits metered.
- Built-in R.F. output meter to simplify tune-up.
- Standby bias supply for complete cutoff during receive.
- High-efficiency grounded-grid circuit.
- New 7094 beam-power pentodes.
- Highest performance on c.w. and a.m., too!

* FCC Rules and Regulations, Part 12, Paragraph 12.131

the new ideas in communications are born at . . .

h hallicrafters.
Chicago 24, Illinois

Export Sales: International Div., Raytheon Mfg. Co., Waltham, Mass. Canada: Gould Sales Co., Montreal, P.Q.
For further information, check number 4, on page 163



The Radio Amateur's Journal

EDITORIAL STAFF

Editor
A. S. TROSSMAN, W2DTJ

Assistant Editor
RICHARD A. ROSS, K2MGA

Technical Editor
IRVING TEPPER

Contributing Editors

Contest Calendar
FRANK ANZALONE, W1WY

V.H.F.
ROBERT BROWN, K2ZSO

USA-CA Custodian
CLIF EVANS, K6BX

Propagation
Space Communications
GEORGE JACOBS, W3ASK

RTTY
BYRON KRETZMAN, K9WMP

DX
URB LE JEUNE, W2DEC

YL
LOUISA B. SANDO, W5RZ

Ham Clinic
C. J. SCHAUERS, W4VZO

Novice
Semiconductors
DON STONER, W6TNS

Sideband
DOT STRAUBER, K2MGE
IRVING STRAUBER, K2HEA

BUSINESS STAFF

Publisher
S. R. COWAN

Advertising Representatives
JACK SCHNEIDER, WA2FPE
DICK COWAN, WA2LRO

Circulation Manager
HAL WEISNER, WA2OBR

Production Manager
CARY L. COWAN

OFFICES

300 West 43rd Street
New York 36, N. Y.
Telephone, JUdson 2-4460

CQ—(Title registered U.S. Post Office) is published monthly by Cowan Publishing Corp. Second class postage paid at New York, N. Y. and at Garden City, New York. Subscription Rates: U.S.A. and Possessions, APO, FPO, Canada and Mexico: one year \$5.00; two years \$9.00; three years \$13.00. Pan-American and foreign, one year \$6.00; two years \$11.00; three years \$16.00. Printed in the U.S.A. Entire contents copyright 1961 by Cowan Publishing Corp. CQ does not assume responsibility for unsolicited manuscripts. Postmaster: send Form 3579 to CQ, 300W. 43rd St., N. Y. 36, N. Y.

VOL. 17, NO. 11 NOVEMBER 1961

TABLE OF CONTENTS

Crystal Filter Type S.S.B. Exciter <i>Cmdr. Paul H. Lee, USNR, W3JHR</i>	32
Improving The Link 2365 and 2210 <i>Warren Rudolph, W4OHM</i>	40
A One Tube Electronic Keyer ... <i>Ed Stetzer, K2ZBA</i>	43
Photocopying Magazine Articles <i>E. H. Marriner, W6BLZ</i>	44
Low Impedance Coupling To Parallel Resonant Circuits <i>Joseph Zelle, W8FAZ</i>	47
Circuit Elements for Electronic Construction <i>Capt. A. B. Jones, USN, (Ret) W0ALO/2</i>	48
Transistor R.F. Power Amplifiers <i>Lester A. Earnshaw, VE7QL</i>	50
Transmitting Tubes—How To Use and Abuse Them; Part I <i>William I. Orr, W6SAI</i>	53
A High Efficiency Transistorized Modulator <i>Joseph L. Reiffin, W5CWP/4</i>	57
Unidentified Amateur Transmissions <i>Kermit A. Slobb, W9YMZ</i>	61
The Handy Dandy Transmitter Checker <i>Kenneth L. Ballard, K6UFA</i>	62
CQ Reviews: The Gonset G-76 Multi-band Transceiver <i>Lee Aurick, W2QEX</i>	64
CQ Awards Honor Roll	66

DEPARTMENTS

Announcements	22	Novice	93
Contest Calendar	75	Semiconductors	102
DX	69	Sideband	82
Ham Clinic	97	Propagation	77
Ham Mart	176	RTTY	108
Ham Shop	138	Space Communications	88
Letters	18	USA-CA	90
MARS Bulletin	56	VHF	105
New Products116, 118		YL	110
		Zero Bias	7

Announcing

hallicrafters

**OVER
\$10,000
IN PRIZES!**



SX-115 Receiver!
Ten **HA-2 or HA-6
Transverters, or
HT-37 Transmitters!**

PLUS OVER 100 HA-4 Keyers!

hallicrafters
HEADQUARTERS
...ENTER HERE!

ARIZONA

Phoenix: Southwest Electronic Devices

CALIFORNIA

Anaheim: Henry Radio, Inc.

Burlingame: Amrad Supply, Inc.

Long Beach: Scott Radio Supply Co.

Los Angeles:

Henry Radio, Inc.

Radio Products Sales, Inc.

Oakland: Elmar Electronics

Riverside: Mission Radio Ham Supplies

San Diego: Western Radio & Television Supply

San Francisco: Amrad Supply, Inc.

San Jose: Quement Industrial Electronics

Van Nuys: Valley Electronic Supply Co.

COLORADO

Denver: Radio Products Sales Co.

CONNECTICUT

New Haven: Radio Shack Corp.

Stamford: Radio Shack Corp.

West Hartford: Radio Shack Corp.

DELAWARE

Wilmington: Almo Industrial Electronics, Inc.

DISTRICT OF COLUMBIA

Washington: Electronic Wholesalers, Inc.

FLORIDA

Jacksonville: Kinkade Radio Supply, Inc.

Melbourne: Electronic Wholesalers, Inc.

Miami:

Electronic Wholesalers, Inc.

Walder Electronic Distributors

Tampa: Kinkade Radio Supply, Inc.

ILLINOIS

Chicago:

Allied Radio Corp.

Amateur Electronic Supply

Genoa: Crawford Electronics

IOWA

Council Bluffs: World Radio Laboratories, Inc.

INDIANA

Indianapolis:

Graham Electronics Supply, Inc.

Van Sickle Radio Supply Co.

SSB/CW/VHF Contest!

Here's a chance to get in your "two cents worth" to stimulate SSB operation on VHF frequencies . . . promote better CW on all bands . . . and win yourself a shackful of Hallicrafters equipment besides! Easy to enter, easy to win, through your own favorite distributor. He selects the local winner, who qualifies for grand prizes worth over \$1,000.

HERE'S HOW YOU ENTER:

1. Simply visit your Hallicrafters distributor listed below, and see his special display of Hallicrafters amateur equipment.

2. Your distributor will furnish an entry blank. Just fill in your name, address and call; then answer this easy question in 25 words or fewer: "I would like to see more SSB and CW operation on VHF because . . ."

3. Do not mail the entry blank—turn it in to your distributor. He will award to a winner in his local area a Hallicrafters HA-4 transistorized electronic keyer. Entries will be judged on a basis of originality and sincerity.

4. Local winners' names and winning statements

will be forwarded to Hallicrafters for entry in the national contest. A special panel of judges will select 10 semi-finalists, each of whom will be awarded their choice of an HA-2 Transverter, HA-6 Transverter, or an HT-37 Transmitter.

5. From the 10 semi-finalists, a **Grand Prize Winner** then will be selected by the panel, and he will be awarded in addition to his earlier prizes an SX-115 Receiver!

6. All entries become the property of The Hallicrafters Co. Winners' names and their statements may be published by Hallicrafters. Decisions of both local distributors' and Hallicrafters' judges shall be final.

Quality and Reliability in Communications . . .



hallicrafters

4401 W. Fifth Ave., Chicago 24, Illinois

LOUISIANA

Monroe: Davis Electronics Co.
New Orleans: Radio Parts, Inc.

MARYLAND

Baltimore: Uncle George's Radio Ham Shack
Div. of Electronic Distributors

MASSACHUSETTS

Boston: Radio Shack Corp.
Weymouth: Radio Shack Corp.
Worcester: Radio Shack Corp.

MICHIGAN

Detroit:
M. N. Duffy & Company
Radio Supply & Engineering Co., Inc.
Reno Radio Company
Grand Rapids: Radio Parts, Inc.

MISSOURI

St. Louis: Henry Radio Company
St. Louis: Burstein-Applebee Co.
St. Louis: Walter Ashe Radio Co.

NEW HAMPSHIRE

Concord: Evans Radio Co.

NEW JERSEY

Bloomfield: Variety Electronics Corp.
Camden: Almo Industrial Electronics, Inc.
Mountainside: Federated Purchaser, Inc.
Newark: Terminal-Hudson Electronics, Inc.
Paramus: Lafayette Electronics Corp.

NEW YORK

Jamaica: Harrison Radio Corp.
Mineola: Arrow Electronics, Inc.
New York:
Harrison Radio Corp.
Harvey Radio Co., Inc.
Terminal-Hudson Electronics, Inc.
Syosset: Lafayette Radio Electronics Corp.

OHIO

Cleveland: Pioneer Electronic Supply Co.
Columbus: Universal Service
Dayton: Custom Electronics, Inc.

PENNSYLVANIA

Chester: Bell Electronic Supplies
Norristown: Almo Industrial Electronics, Inc.
Philadelphia: Almo Industrial Electronics, Inc.
Pittsburgh: The Tydings Company
Reading: The George D. Barbey Company
Wyncote: Ham Buerger

RHODE ISLAND

Cranston: Radio Shack Corp.

SOUTH DAKOTA

Watertown: Burghardt Radio Supply, Inc.

TENNESSEE

Memphis: W & W Distributing Co.

TEXAS

Dallas:
Amateur Electronics, Inc.
Crabtree's Wholesale Electronics

VIRGINIA

Norfolk: Priest Electronics, Inc.

WISCONSIN

Milwaukee: Amateur Electronic Supply

BEST LIKED GIFT UNDER THE TREE!



See imaginative Mosley design of new CM-1
low cost ham band receiver at your dealer now!

FEATURES and PERFORMANCE:

Diode detector for AM and product detector for SSB, CW.

Calibration every 5 kc.

WWV reception at 15 mc.

SELECTIVITY: 2.5 kc. at -6 db.

Automatic noise limiter.

SENSITIVITY: $\frac{1}{2}$ microvolt for 10 db. signal-to-noise ratio on ten meters.

STABILITY: Less than 500 cycles drift after one-minute warm-up.

Less than 200 cycles change for 10% line voltage change.

IMAGE and IF REJECTION: 35 db. minimum.

The new Mosley CM-1 communications receiver offers you tried and proved components in a truly imaginative design concept. This compact new design gives you outstanding performance formerly only available in much higher priced receivers. Its unique crystal controlled first oscillator gives you excellent selectivity and freedom from image and other objectionable responses. The CM-1 employs five identical dual-purpose tube plus four semi-conductor diodes to perform all functions usually requiring more expensive 12 tube sections.

Net Price, only \$169.95

Matching Speaker, Model CMS-1. Net Price, \$16.95

(slightly higher west of the Rockies and outside the U.S.A.)

Write for name of dealer handling the CM-1 in your area.

Mosley Electronics, Inc.

4610 North Lindbergh Blvd.

Bridgeton, Missouri

For further information, check number 6, on page 163

ZERO BIAS

UP until a few short years ago, chasing certificates and award-hunting were the exclusive occupations of the DX man. In most cases, certificates were designed for that breed of amateur, and world-wide band conditions helped generate a need for this type of activity.

As the sunspots start to disappear, however, we find that more and more organizations, on a state and local level are beginning to issue certificates other than of a DX nature. V.h.f., rag chewers, the RTTY gang, etc., are now finding certificates available which fill their diverse interests.

CQ receives each week, information pertaining to many certificates. Most of the awards that pass through the office indicate careful planning. The majority of these represent work of individuals in clubs and organizations throughout the world. Time, as well as a considerable cash outlay is usually evidenced. Some of the certificates, esthetically speaking, are quite beautiful, while others are very simple and unadorned.

Some of the rules presented with these certificates are short, understandable and uncomplicated; others would be difficult to decode by a qualified C.P.A. Some awards are extremely simple to obtain; others are absolutely *impossible*. Ninety-nine per cent of all awards are issued by bonafide clubs with the other one per cent coming from individuals. Many awards symbolize great feats of operating skill, while others have "gag" and "comic" implications.

CQ feels that each award has its own place. IARU proposal #99, which has recently been ratified by our own member organization, indicates a desire to screen these awards and issue a list of such certificates which will bear official approval of the IARU. In their own words: "the number of awards and certificates at present in circulation are not in the best interest of amateur radio. . ."

We wonder what criteria will be used by the IARU to promulgate such a list. Will only IARU and IARU-affiliated awards qualify? Will those awards that do not succeed in reaching this list be considered as not being in the

interest of amateur radio? We hope not!

Yes—some awards are obviously perpetrated to fulfill an individual ego. Will a list which "99" intends to bring about keep this type of certificate out of circulation? Do these awards *really* demean amateur radio? We think not!

Well then, what are the factors which spurred the IARU to make this move? Is it possible that many of their awards that previously stood as firm as Gibraltar are now shaking at their foundations? Are they becoming too easy to obtain? Has pride of ownership diminished?

Apparently, these hundreds of newly issued certificates have begun to fill a long-existing gap in the operating routine of the average amateur. CQ, as a free press, now states that any and all certificates will be given ample publicity as received.

It would indeed be a shame to have a turly bonafide award, issued by a reliable organization, fall prey to "99". Would not a stigma of guilt-by-omission be reflected upon this award? Would not the issuing organization be burdened with a stain of misbehavior?

Acceptability of an award can not be regulated to the mere formation of a list. Awards and certificates are not "new countries"; they can not be determined by geographical boundary or political sovereignty. Each must be weighed for its individual merits . . . and who is to say what points are good or bad?

Proposal #99 has the earmarks of a snobbish, self-centered scheme, whereby a few sit as judge and jury for the many.

Does this have a connotation of censorship? Undoubtedly!

It is indeed sad to learn that our member society of the International Amateur Radio Union has fallen for this rather undemocratic and seemingly unimportant document.

"99" is in direct contradiction to democratic principles and we urge they wash their hands of the entire matter.

Are we in need of a list of certificates which Proposal #99 is expected to produce? Yes! Provided *no one* is overlooked!

FREE

INTERNATIONAL 1962 CATALOG



*... your buying
guide for precision
radio crystals
and quality
electronic
equipment ...*

- Amateur Crystals
- Commercial Crystals
- Citizens Band Crystals
- Transmitters
- Oscillators
- Converters
- Transistor Subassemblies
- Power Supplies
- Citizens Band Transceivers
- Citizens Band Antennas/Accessories

AMATEURS • EXPERIMENTERS • CITIZENS LICENSEES

Mail today for your FREE copy of International's 1962 complete catalog.

**INTERNATIONAL
CRYSTAL MFG. CO. INC.**

18 NORTH LEE — OKLA. CITY, OKLA.

.....
International Crystal Mfg. Co., Inc.
18 North Lee, Oklahoma City, Okla. Q2
Please rush FREE 1962 International Catalog.
NAME.....
Please Print
ADDRESS.....
CITY.....ZONE.....STATE.....
.....

For further information, check number 7, on page 163



Wherever you live throughout the world, an authorized Hy-Gain Amateur Antenna Systems Dealer is at your service. These Distributors stock the Hy-Gain lines, can offer you service and assistance. Glance through the list below and note the Dealer nearest to you. The next time you're shopping for antenna equipment displayed in the following catalog, ask him for the complete information.



- ALABAMA**
Birmingham—Ack Radio
- ALASKA**
Anchorage—Yukon Radio
- ARIZONA**
Phoenix—Southwest Electr.
Tucson—Elliott Electr.
- CALIFORNIA**
Anaheim—Henry Radio
Burbank—Valley Electr.
Burlingame—Amrad Supply
El Monte—Kimball & Stark
Hemet—Wholesale Electr.
Long Beach—Lynde Electr.
Scott Radio
Los Angeles—California Electr.
Henry Radio
Radio Product Sales
Oakland—Elmar Electr.
Pasadena—Dow Radio
Riverside—Mission Ham Supplies
Palo Alto—Zack Electr.
Santa Ana—Santa Ana Electr.
Sacramento—Selectronics
San Diego—Western Radio
San Francisco—Amrad Supply
San Francisco Radio
Zack Electr.
San Jose—Guement Electr.
Van Nuys—Valley Electr.
- COLORADO**
Denver—Radio Product Sales
- CONNECTICUT**
Hartford—Harty of Hartford
New Haven—Radio Shack
New London—Aikins Electr.
Demambro Radio
Stamford—Radio Shack
- WASHINGTON, D. C.**
Electronic Wholesalers
- FLORIDA**
Jacksonville—Kinkade Radio
Melbourne—Electr. Wholesalers
Miami—Electr. Wholesalers
Electronic Supply
Amateur Radio Center
Tampa—Kinkade Radio
- NEW HAMPSHIRE**
Concord—Evans Radio
Dover—Demambro Radio
Keene—Demambro Radio
Manchester—Demambro Radio
- HAWAII**
Honolulu—Honolulu Electr.
Radio Wholesale
- IDAHO**
Idaho Falls—Schwendiman Dist.
- ILLINOIS**
Benton—Lampley Radio
Chicago—Allied Radio
Green Mill Radio
Tryco Electronics
Heights Electr.
Newark Electr.
Dekalb—J & M Radio
Freeport—J & M Radio
Galesburg—Knox Electronics
Genoa—Crawford Electronics
- Peoria—Selectronic Supplies**
Rockford—H and H Electr.
J & M Radio
Springfield—Bruce Electronics
- INDIANA**
Evansville—Castrups
Tri-State Amateur
Fort Wayne—Ft. Wayne Electr.
Warren Radio
Indianapolis—Brown Dist.
Graham Electr.
Van Sickle Radio
Kokomo—George's Electr.
Lafayette—Lafayette Radio
South Bend—Colfax Company
Radio Distributing
- IOWA**
Council Bluffs—World Radio Lab
Des Moines—Bob & Jack's
Sioux City—Molstad Distr.
- KANSAS**
Salina—Electronics, Inc.
Topeka—Overton Electric
Wichita—Amateur Radio
- KENTUCKY**
Louisville—Arcby Electr.
- LOUISIANA**
Baton Rouge—Davis Electronics
Lake Charles—Wholesale Radio
New Orleans—Radio Parts
Southern Radio
Shreveport—Interstate Electric
- MARYLAND**
Baltimore—Amateur Radio Center
Wheaton—Key Electronics
- MASSACHUSETTS**
Boston—Bond Electronics
Demambro Radio
Radio Shack
Brocton—Demambro Radio
Fall River—Demambro Radio
Hyannis—Demambro Radio
Lawrence—Alco Electronics
Demambro Radio
Leominster—Demambro Radio
Medford—Demambro Radio
Randolph—Graham Radio
Reading—Graham Radio
Salem—Demambro Radio
Springfield—Demambro Radio
Worcester—Demambro Radio
- MISSISSIPPI**
Jackson—Swan Distrb.
- MICHIGAN**
Ann Arbor—Purchase Radio
Detroit—Midway Electronics
M. N. Duffy
Radio Supply
Reno Radio
Flint—Shand Radio
Grand Rapids—General Electr.
Radio Parts
Kalamazoo—Warren Radio
East Lansing—Tape Recrd. Ind.
Marquette—Northwest Radio
Muskegon—Electronic Distrb.
- MINNESOTA**
Duluth—Lew Bonn Co.
Stark Electr.
- Minneapolis—Electronic Center**
Harry Starks
St. Paul—Lew Bonn Co.
Stark Electr.
- MISSOURI**
Butler—Henry Radio
Kansas City—Burstein-Applebee
St. Louis—Van Sickle Radio
Walter Ashe
- NEW MEXICO**
Albuquerque—Radio Equipment
- NEBRASKA**
Lincoln—Scott Electr.
North Platte—Valley Electronics
Omaha—Ladd Electronics
- NEVADA**
Las Vegas—Metcalf's Radio
- NEW JERSEY**
Mountainside—Federated Purch.
Newark—Federated Purchaser
Lafayette Radio
- NEW YORK**
Albany—Fort Orange Radio
Amsterdam—Adirondack
Elmira—Chemung Electronics
Jamaica—Harrison Radio
Lafayette Radio
Middletown—Waterman Radio
Mineola, L. I.—Arrow Electr.
New York—Arrow Electronics
Harrison Radio
Harvey Radio
Rome—Clemons Sales
- NORTH CAROLINA**
Asheville—Freck Radio
Winston Salem—Dalton Hege
Womack Electr.
- NORTH DAKOTA**
 Fargo— Fargo Radio
Minot—Loud Noisey Amateur
- OHIO**
Canton—Walkeradio
Cincinnati—The Mytronic Co.
Cleveland—Pioneer Elect.
Columbus—Universal Service
Dayton—Custom Electr.
Srepco, Inc.
Dover—Southeastern Elec.
Elyria—El-A-Co
Mansfield—Wholesaling, Inc.
Marietta—Marietta Radio
Youngstown—Armies Electr.
- OKLAHOMA**
Lawton—Reynolds Radio
Oklahoma City—General Electr.
Radio Supply
- OREGON**
Albany—Oregon Ham Sales
Portland—Portland Radio
United Radio
- PENNSYLVANIA**
Allentown—A. A. Peters, Inc.
Elkins Park—A. G. Radio Parts
Pittsburgh—Tydings
Reading—George D. Barbey Co.
Wyncote—Ham Buerger
- RHODE ISLAND**
Providence—Demambro Radio
W. H. Edwards
- SOUTH DAKOTA**
Aberdeen—Burghardt Radio
Rapid City—Burghardt Radio
Sioux Falls—Burghardt Radio
Watertown—Burghardt Radio
- TEXAS**
Dallas—All State Electr.
Amateur Electr.
Grabtrees
Denison—Denison Radio
Houston—Busacker Electr.
Lubbock—R. and R. Electr.
Snyder—Jay Huckabee
Texarkana—Lavender Dist.
- TENNESSEE**
Chattanooga—McAllester Electr.
Jackson—L. K. Rush
Kingsport—Radio Electric
Memphis—W. & W. Distr.
Oak Ridge—The Music Box
- UTAH**
Salt Lake City—Manwill Supply
Standard Supply
- VERMONT**
St. Johnsbury—Demambro Radio
- VIRGINIA**
Arlington—Industry Services
Norfolk—Priest Electr.
- WASHINGTON**
Aberdeen—C. and G. Electr.
Bremerton—C. and G. Electr.
Centralia—C. and G. Electr.
Olympia—C. and G. Electr.
Seattle—C. and G. Electr.
Radio Supply
Seattle Radio
Spokane—Northwest Electr.
Tacoma—C. and G. Electr.
Yakima—Seattle Radio
- WEST VIRGINIA**
Wheeling—Radio Parts
- WISCONSIN**
Chippewa Falls—Royal Electr.
Fond Du Lac—Harris Radio
Kenosha—Chester Electr.
La Crosse—Communications Eqt.
Milwaukee—Amateur Electr.
- WYOMING**
Cheyenne—Houge Radio
- CANADA**
BRITISH COLUMBIA
Vancouver—
Taylor, Pearson & Carson
- MONTREAL**
P Q—Etco Electr.
- ONTARIO**
Downsview—Alpha Aracon Radio
Toronto—Electro Sonic
Montreal—Payette Radio
- ALBERTA**
Edmonton—Sacker Electr.
Calgary—Smalley's Radio
Export Sales Representative
E. D. MAGNUS and ASSOC.
188 West Randolph
Chicago, Illinois

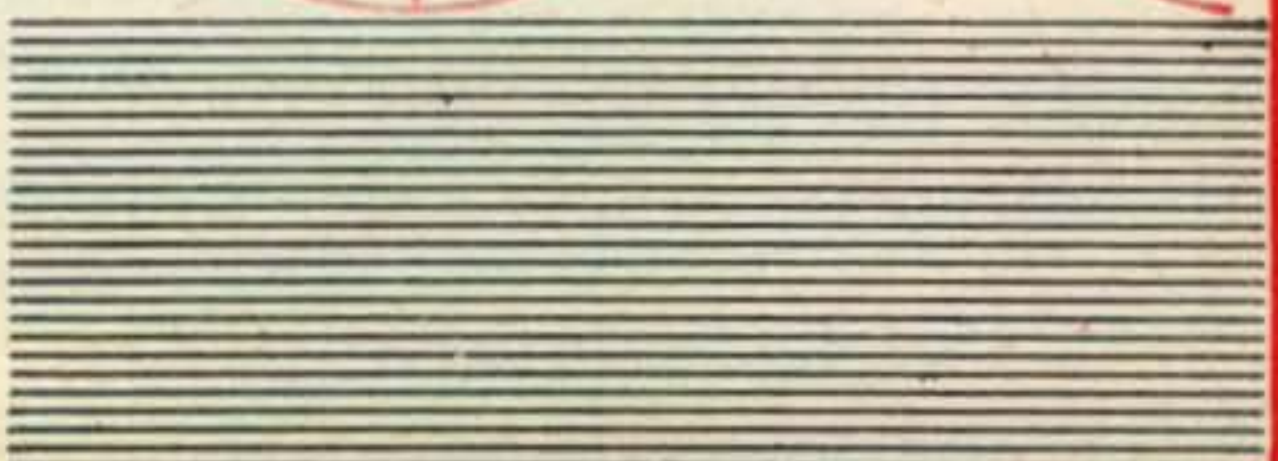

The Hy-Gain Duobander was designed specifically for the 20 and 40 Meter bands since sun spot activity has caused fewer openings on the 10 and 15 Meter bands. This beam consists of three full-sized elements on 20 Meters and two reduced-sized elements on 40 Meters in a lightweight, compact antenna.



DUOBANDER

Two band operation is made possible through a new Hy-Gain development — the linear decoupling stub, eliminating the use of inductance and capacity traps, yet performs extremely efficient decoupling of the various Duobander sections. The decoupling stubs also perform the second function of reducing the overall length of the 40 Meter element to about $\frac{2}{3}$ normal size.

The linear loading principle replaces the loading coil for increased efficiency, while the Hy-Gain Beta matching system makes possible maximum gain and low SWR into a single 52 ohm coax feedline. Perfect pattern symmetry is accomplished through a broad band balun.

Power capabilities: 5KW P.E.P., 3 KW AM; forward gain over a tuned dipole 20M - 8.1 db; forward gain over a tuned dipole 40M - 4.9 db; F/B ratio, 20M - 20 to 30 db; F/B ratio, 40M - 15 to 20 db. Boom is 24 ft, longest element approx. 40 ft. All aluminum construction with hardware iridite treated to military specifications. Turning radius: 24.2 ft. Weight: 54 lbs. **Model DB-24, \$149.50.**

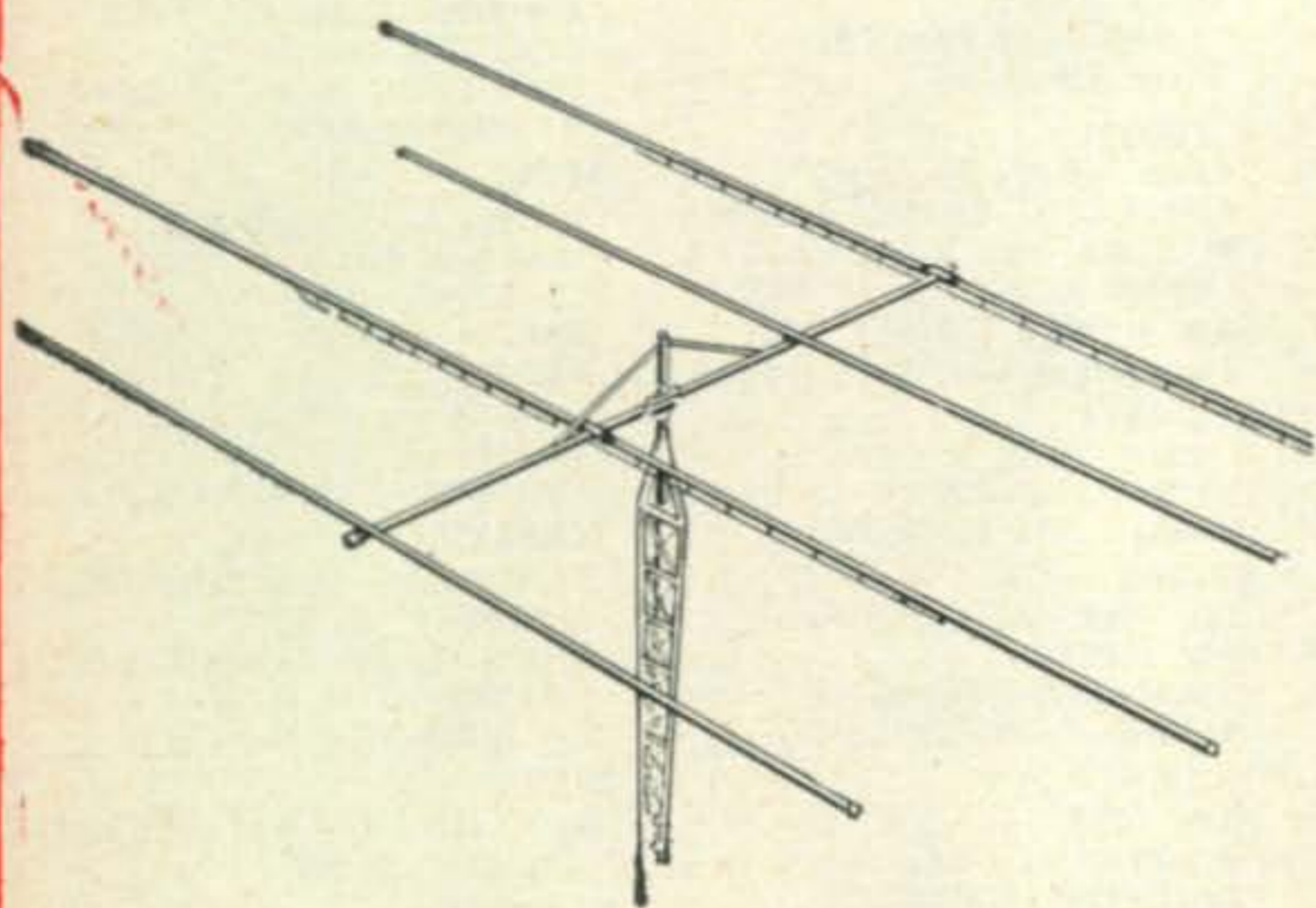

DOUBLET

HY-FAN DOUBLET TAKES UNLIMITED POWER ON 40 & 80 M

The new Hy-Gain HY-Fan doublet is a complete antenna system designed for efficient operation on 40 and 80 meters. It is fed with a single 52 ohm coax transmission line and will handle unlimited power on both bands. The HY-FAN is constructed of the highest quality copper clad steel stranded wire and cicolac insulators, and is furnished complete with the Hy-Gain coaxial center insulator assembly. The fan configuration eliminates traps, increases bandwidth and the HY-FAN is virtually impervious to all weather conditions.

The SWR is less than 1.5 to 1 on both bands. Net wt. only 3 lbs. Overall length approx. 130 ft. **Model No. 2BDP, \$19.95.**

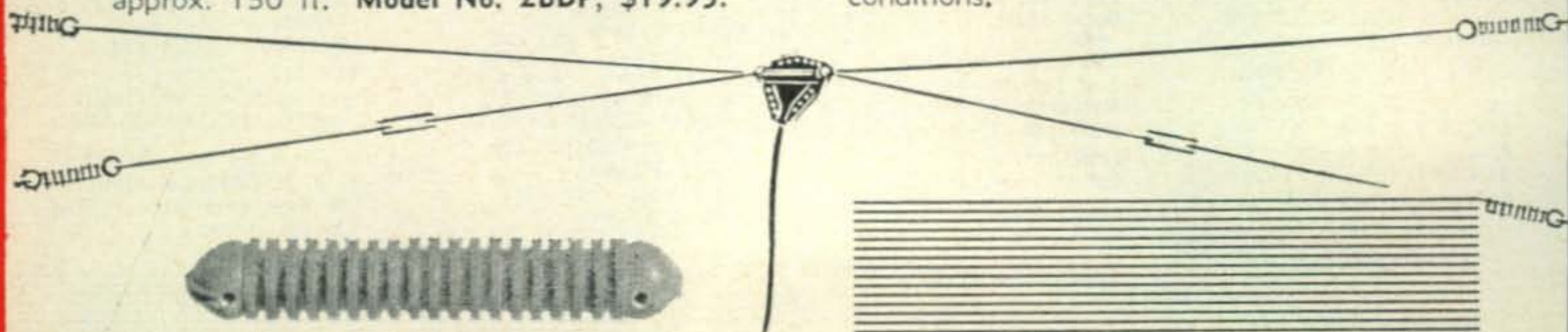
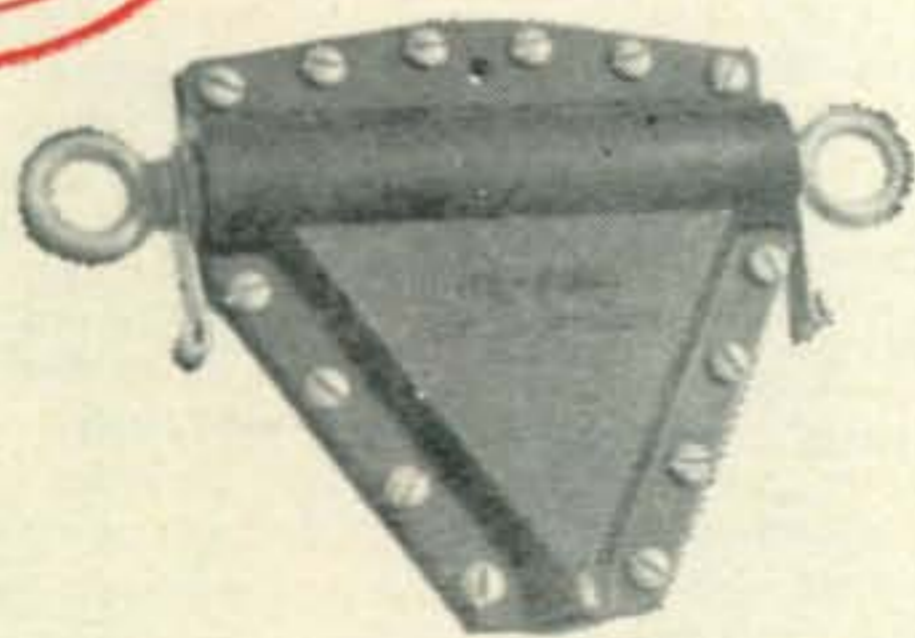

For further information, check number 9, on page 163

First to mass produce three band antenna systems for the 10, 15 and 20 meter bands, Hy-Gain Design Engineers now offer their latest series of tribanders — the Thunderbirds. These beams incorporate the solid state "slim traps", withstanding 1 KW CW or AM and 2 KW P.E.P.



TRIBANDERS

3 Element Thunderbird

The Standard tribander with 14 ft. boom, longest element 26 ft., and 2" OD boom. Elements telescope 1 1/4"-3/4". Less than 2:1 SWR. 100% rustproof. Weight: 33 lbs. **Model TH-3, \$89.95.**

4 Element Thunderbird

This full sized beam permits design of array for maximum gain and F/B with no compromise for matching. A 2" OD boom and 1 1/4" telescoping to 3/4" elements are all aluminum. Longest element, 32 ft. Full sized boom spacing of 16 ft. Interlaced fourth element makes possible choice of optimum spacing on all three bands. Dipole shunt fed with 52 ohm coax. Factory pre-tuned. Weight: 38 lbs. **Model TH-4, \$117.50.**

2 Element Thunderbird

An easy-to-install, featherweight beam with construction features equal to the TH-3. Rotates easily with TV rotator. Has 6 ft. boom, longest element 26 ft. Weight: 20 lbs. **Model TH-2, \$59.95.**

Pre-tuned Beta Match permits maximum gain and F/B, and low SWR over entire band, at resonance 1.05 on 10 meters, 1.15 on 15 meters, and 1.1 on 20 meters. No further adjustments necessary.



ROTO-BRAKE

Great Circle Indicator

Multi-colored 16" Wall Map with beam width and direction shown by moving wedge of light, 10° at perimeter. Centered East, West, or Midwest. Compass rose also available. Countries and call areas outlined and labeled.

Brake and Rotator

Spring actuated, solenoid released braking unit with 1000 In. Lbs. rotating power, 5 In. Tons braking power. High capacity starting torque motor assembly. Limit switches prevent continuous rotation. Mounts in 10-18" steel tower. Mount kits available for less than 10" dia. towers, pole or pipe masts, or telephone pole masts, \$34.50 each. Includes control box and Indicator. Weight: 42 lbs. **Model RBX-1, \$199.95.**

For further information, check number 10, on page 163



The popular Hy-Gain Multiband Verticals are self-supporting and require very little space for installation. As with all Hy-Gain antenna systems, top grade construction has been used throughout, with additional emphasis on handsome appearance.

VERTICALS



Trap Verticals

The Hy-Gain AVS Series incorporate the solid state "slim traps" which offer minimum wind loading and clean line silhouette. These antennas are completely factory pre-tuned with no further adjustment necessary, maintaining an SWR of 2:1 or less across the entirety of each band. 52 ohm coax feed line. True $\frac{1}{4}$ -wave marconi resonance on each band makes possible low angle DX radiation pattern. The Trap Verticals may be ground or roof mounted.

10-20 Meter Verticals

This Trap Vertical operates on the 10, 15 and 20 Meter bands with excellent efficiency and SWR of 2:1 or less. Completely weather-proof nylon base assembly makes the antenna self-supporting. It is 13.5 ft. high and weighs 9 lbs. **Model 12AVS, \$21.95.**

10-40 Meter Verticals

Operating on the 10, 15, 20 and 40 Meter bands, this Vertical includes the Hy-Gain Capacity Hat feature, as well as the weather-resistant nylon base mount. It is 21 ft. high, weighing 10 lbs. **Model 14AVS, \$27.95.**

The Hy-Tower

This trapless, multi-band vertical utilizes a stub decoupling system for the automatic band selection of the 10, 15, 20, 40 and 80 Meter bands with high efficiency and very low SWR. It is 52 ohm coax fed, and completely self-supporting with no guy lines required. The tower height is 24 ft.; a 2"- $\frac{3}{4}$ " OD top mast extends the overall height to 50 ft. X-braced steel tower, 15" at base is of maximum strength, commercial construction. Weight: 100 lbs. **Model 18HT \$129.50.**

Base Support

Three cyclac vertical base insulator assemblies insulate and support the Hy-Tower.

Accessories

Roofmounting kits are available for each of these Trap Verticals, the Model 12RMK for the 12AVS, weighing 6 lbs. (**\$9.50**) and the 14RMK for the 14AVS, weighing 7 lbs. (**\$11.95**).

The Model LC80 Loading Coil kit will add 80 Meter operation to the 14AVS, weighs 4 oz., and sells for **\$7.95**.

The Model 6MK kit will add 6 Meter operation to either the 12 or 14AVS, weighs 6 oz., and sells for **\$4.95**.

For further information, check number 11, on page 163

Each of the Hy-Gain Monobanders incorporates the exclusive Beta matching system, factory pre-tuned for an SWR of 1.5:1 or less. They are 52 ohm coax. fed, allowing tuning for maximum gain and F/B. The 40 Meter "Hy-Seven" also uses the "linear loading" concept which reduces element length and maintains generally higher efficiency than coil loading.



MONOBANDERS

40 Meter Monobander

Hy-Gain's "Hy-Seven" is a 2-Element, reduced size antenna due to incorporation of the "linear loading" concept which also increases its efficiency. Boom is 16 ft.; longest element, 43 ft., all aluminum. SWR 1.0:1. Also available tuned to commercial frequencies. Can be stacked with existing installations; extremely light weight. Weight: 24 lbs. 5.2 db gain; 15-30db F/B ratio. **Model 402B, \$99.75.**

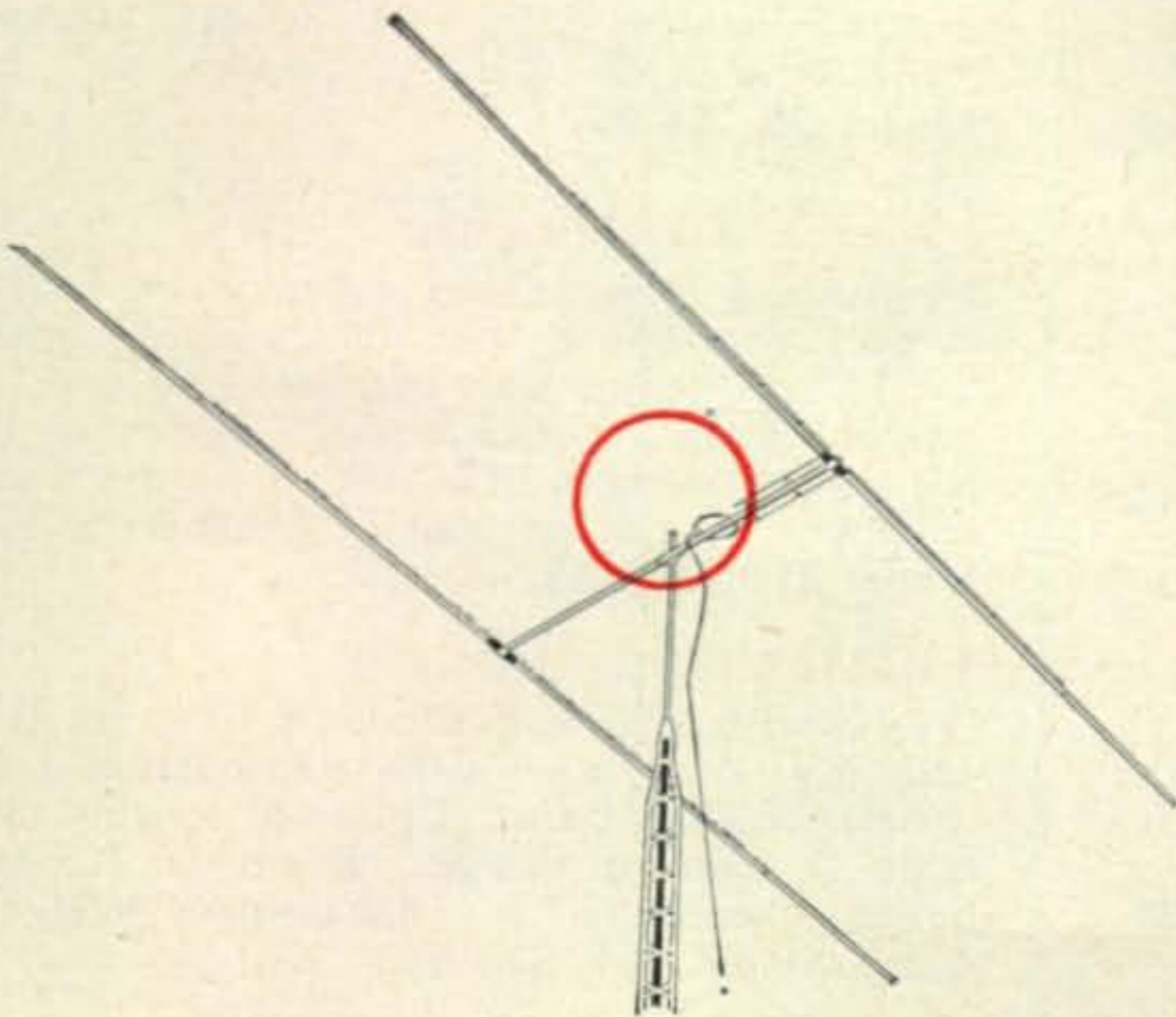

20 Meter Monobander

A full size 20 Meter array of commercial construction, with elements adjustable over entire 20 Meter band. Elements are telescoped three times to minimize sag. Boom is 212 in.; longest element, 35 ft. 9 in. Weight: 29 lbs. All aluminum construction. 8 db gain; 25 db F/B ratio. **Model 203B, \$65.95.**



15 Meter Monobander

A ruggedly built antenna adjustable over the entire 15 Meter band, yet may be rotated by heavy duty TV rotators. Quick to assemble and install. Boom is 142 in.; longest element 23 ft. 10 in. Weight: 30 lbs. 8 db gain; 25 db F/B ratio. **Model 153B, \$38.50.**

10 Meter Monobander

Weighing only 18 lbs., this antenna is small enough to be rotated by any TV rotator. Elements are adjustable for maximum gain over entire 10 Meter band. Easy to assemble; no further adjustments needed. Boom is 104 inches; longest element, 17 ft. 10 in. 8 db gain; 25 db F/B ratio. **Model 103B, 32.95.**

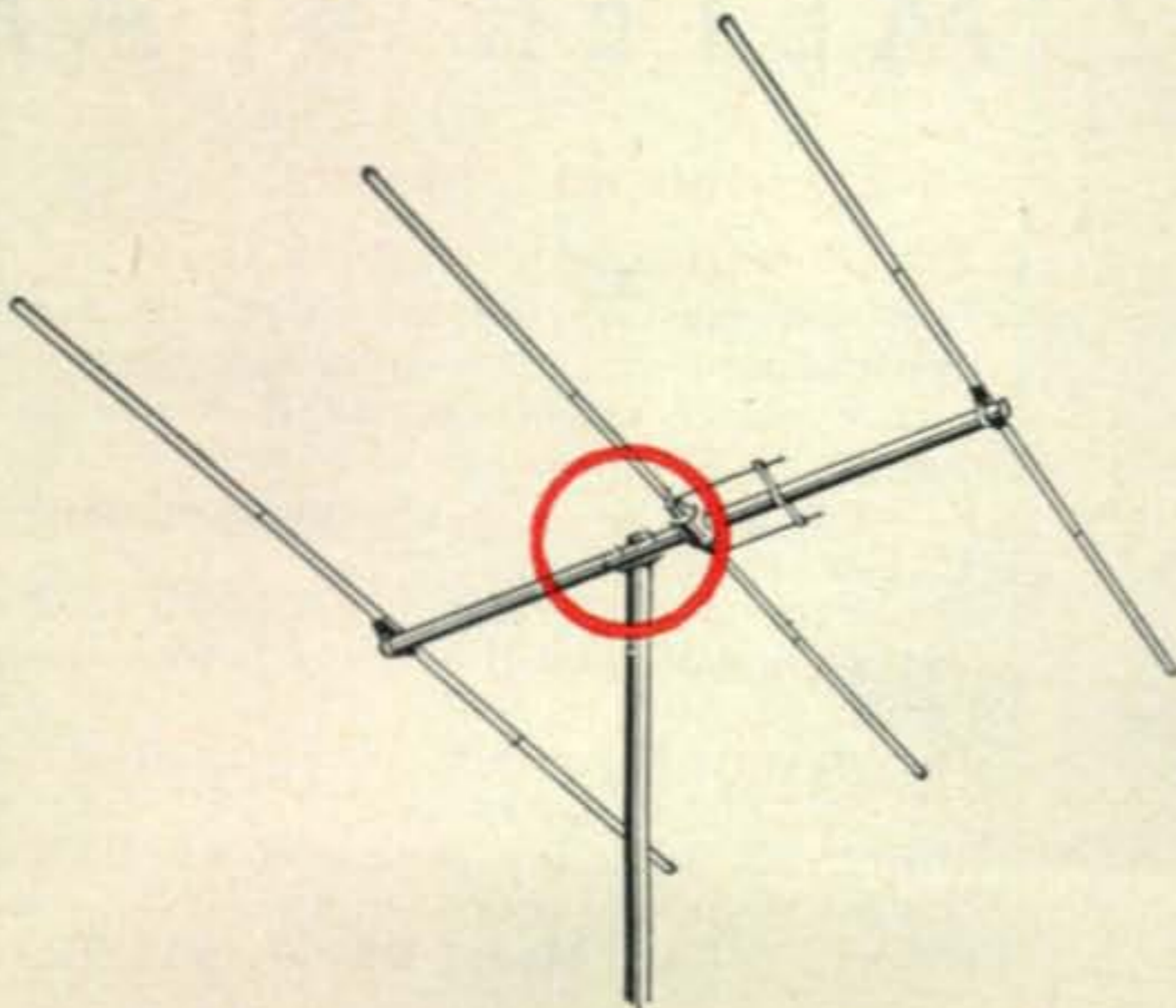

All Hy-Gain Monobanders may be stacked in the conventional manner.



VHF BEAMS

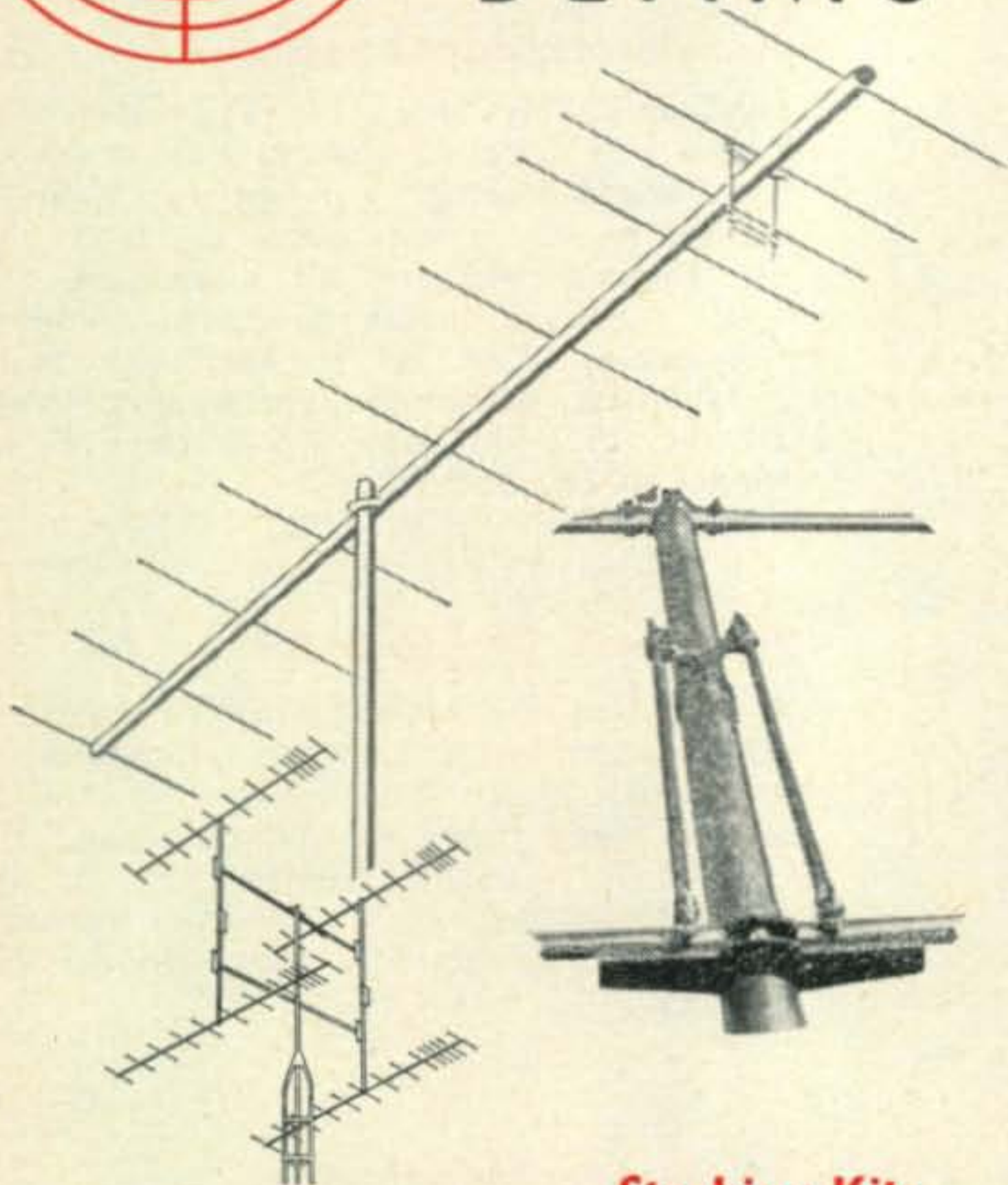

Stacking Kits

Kits are available for stacking any two of these beams for adding 3 db gain, any four of the beams for adding 6 db gain, as well as stacking frames for mounting four stacked beams. The Dual Stacking Kits (Model DS) are \$4.95. Quad Stacking Kits (Model QS) sell for \$15.96. Quad Stacking Frames (Model SF) are \$59.50. Beam Model Numbers must be specified when ordering these kits.



6 and 2 METER BEAM

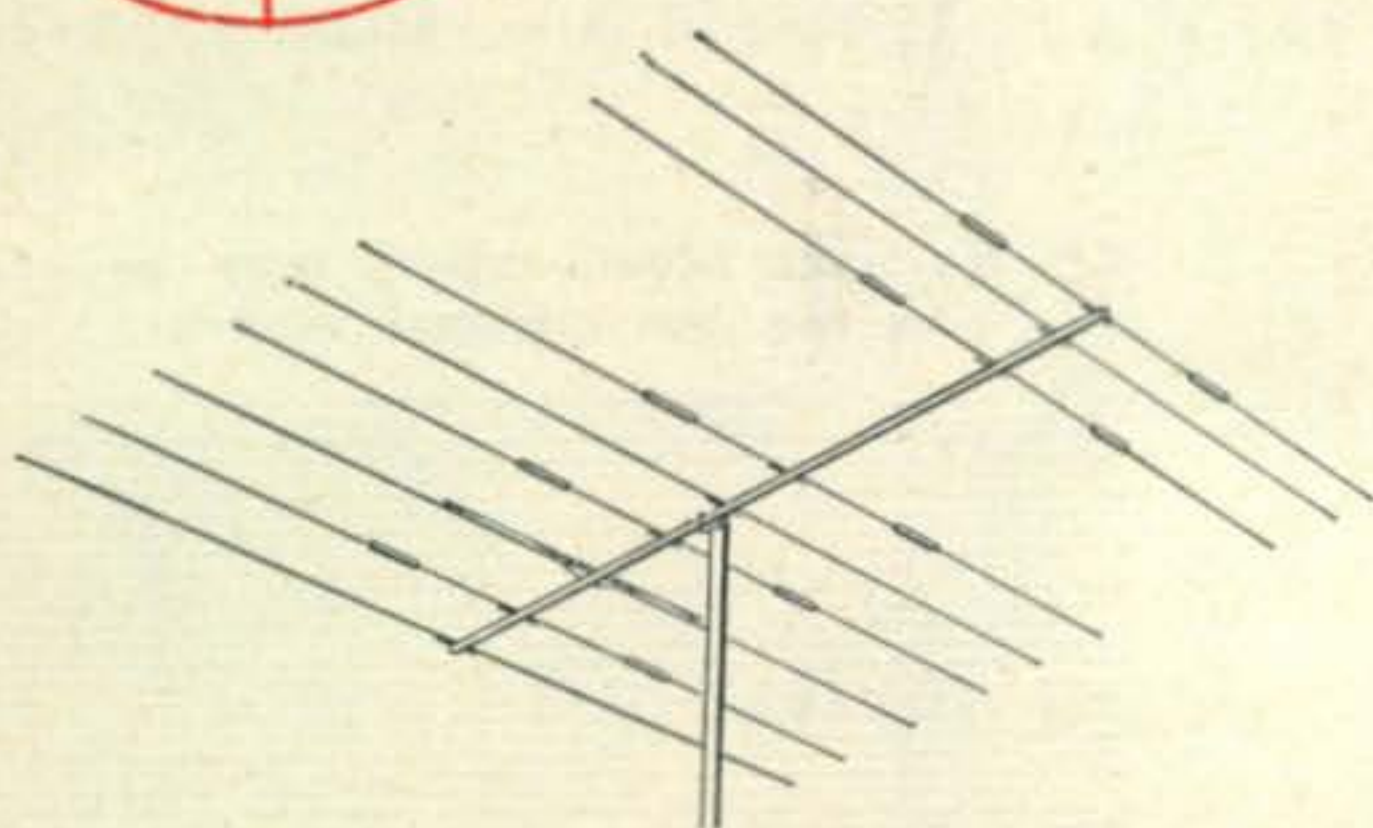

All Hy-Gain VHF Hi-banders* are constructed of heavy wall 1 1/4" dia. heat treated alloy aluminum tubing booms and 3/16" dia. solid rod elements. They are built to withstand extremely high wind velocities and heavy ice loading conditions. Optimum spacing and advanced high Q element design result in tremendous forward gain and excellent F/B characteristics. All VHF antennas match any impedance coaxial or parallel transmission line (52 and 72 ohm coax plus 200, 300 and 450 ohm parallel line).

2 Meter, 5 Elements

Ideal for semi-permanent or portable applications, this beam is extremely light weight, factory pre-tuned and easy to assemble. Can be either coax or parallel fed. Beta matching system. Boom is 5 ft. 4 in.; longest element 41 3/4 in. 9.0 db gain. Weight: 2 lbs. Model 25, \$8.95.

2 Meter, 10 Elements

Tremendous forward gain and excellent Front-to-Back characterize this light weight, popular 2 Meter beam. Can be rotated by any TV rotator. Coax or parallel fed. Boom is 12 ft.; longest element, 41 3/4 in. Beta matching employed. 13.4 db gain. Weight: 5 lbs. Model 210, \$14.95.

1 1/4 Meter, 11 Elements

Pre-tuned folded ratio dipole is used for low loss 450 ohm open wire transmission lines in this 220 mc beam. Optimum spacing and high Q element design. Boom is 12 ft.; longest element, 27 in. 14.2 db gain. Weight: 4 lbs. Model 111, \$13.95.

3/4 Meter, 13 Elements

One of the highest gain and efficient extended multi-element Yagi's ever commercially manufactured for the amateur. Specifically designed for 430 mc operation, this beam has a boom length of 8 ft.; longest element 13 3/4 in. 16.1 db gain. Weight: 2 1/4 lbs. Model 313, \$12.95.

4 Elements on 6 Meters

18 Elements on 2 Meters

The new Hy-Gain Model DB-62 is a single transmission line beam antenna system for 6 and 2 meter operation. It is fed with 52 ohm coax transmission line and develops a forward gain of 8.0 db on 6 meters and 15.0 db on 2 meters.

The front to back ratio averages 15 to 20 db and SWR will remain below 1.5 to 1 on both bands.

The antenna is ruggedly constructed of 1 1/4" O.D. aluminum boom and 7/16" O.D. elements and is factory preassembled.

Net wt. 8.5 lbs.; boom length 10 ft.; longest element 10 ft. Model DB-62, \$32.95.

For further information, check number 13, on page 163

Completing the Hy-Gain Ham line are the Hy-Gain 6 Meter Beams, Halos and Ground Planes, specifically designed for specific purposes. These antenna systems share the same top construction attention afforded every model in the Hy-Gain Antenna Series.



6 METER BEAMS

6 Meter, 8 Elements

Factory pre-assembled, this beam may be rotated with any TV rotator and includes the Hy-Gain exclusive Beta match. SWR less than 1.5:1. 52 ohm coax fed. Boom is 18 ft. long; longest element, 9 ft. 8 in. 10.1 db gain; 25 db F/B ratio. Stacking instructions included. Weight: 8 lbs. **Model 68B, \$32.95.**

6 Meter, 5 Elements

Simple and easy to install, this beam is easily rotatable. Elements and boom are factory pre-assembled. Include all details for stacking. Hy-Gain Beta matched for 9 db gain; 25 db F/B ratio. Boom is 9 ft.; longest element, 9 ft. 8 in. Weight: 5 lbs. **Model 65B, \$18.95.**



HALOS

2 Meter Halo

6 Meter Halo

High mechanical stability and minimum wind resistance with 1" dia. aluminum tubing halo, Beta matched, and mounts on any 1" mast. Tune to resonance quickly any frequency in 6 Meter band. Thoroughly weatherproof. Weight: 3 lbs. **Model HH-6, \$12.95.**

Heavy duty 5 ft. telescoping mast for 2 or 6 Meter Halo, **Model HM, \$4.95.**



GROUND PLANES

100-500 Mc Ground Plane

Covering any frequency between 100 and 500 megacycles, with solid 1/4" aluminum rod radials. Weight: 3 lbs. **Model GP-3C, \$14.97.**

50-500 Mc Discone

Vertically polarized, omnidirectional broad band antenna for covering 50 to 500 megacycles without adjustments. Low angle radiation, unity gain, 50 ohm nominal impedance, SWR less than 1.5:1. Weight: 9 lbs. **Model DS-1, \$29.97.**

The Hy-Gain Ground Planes are of heavy duty commercial construction with radiator and ground plane elements of heat treated aluminum alloy and all hardware iridite treated. Cyclocac base insulator adjusts to masts 3/4"-1 5/8" dia. 52 ohm nominal impedance. Better than 1.2:1 SWR. Radiation patterns are omnidirectional with unity gain. Complete instructions for easy, quick assembly.

25-50 Mc Ground Plane

Covering any frequency between 25 and 50 megacycles, with telescoping radiator and radials 7/8" to 3/4". Weight: 8 lbs. **Model GP-1C, \$32.70.**

50-88 Mc Ground Plane

Covering any frequency 50 - 88 megacycles, with telescoping radiator and radials 7/8" to 3/4" Weight: 5 lbs. **Model GP-2C, \$21.90.**

For further information, check number 14, on page 163

GET RELIEF FROM GRIEF

WITH

NEW-TRONICS COMMUNICATION PRODUCTS

Mechanically better . . .

. . . Electrically superior

MODEL NTS-1 — ALL STAINLESS
Ball, base and spring assembly
NO EXPOSED MOUNTING BOLT HEADS
(Long leakage path)

ONE MAN INSTALLATION

LIGHTER WEIGHT

REDUCED SPRING ASSEMBLY LENGTH

Engineered and built to meet the most critical standard, this base, ball and spring assembly has no equal. It will provide long and carefree service. Also available in chrome plated and cadmium plated models.

**TUNABLE ANTENNA for
COLLINS NOISE BLANKER**

MODEL NB-40 (40 MC)

Similar in appearance to MODEL CB-27. Has different electrical characteristics. Broad banding characteristics and tunable feature permits attenuation of power line and car ignition noises.

Complete line of stainless steel whips with set screw type removable adaptors, other antenna models, cable and accessories available for immediate delivery.

New-Tronic antennas look better, work better and last longer than any similar purpose types now available. They are engineered and built to meet the demands of modern communications. With all their extra features they are priced no higher than similar models. See them at your electronic distributors or write for literature.

FIRST

Corrosion-free
all stainless ball
and spring mount

FIRST

basically
improved design



Pat.
Pend

**TUNABLE ANTENNA FOR CB
and AMATEUR (28-30 MC)**

MODEL CB-27

Extends to 60".
Collapses to 27".
Swivel ball base.
Sealed loading coil
5' of RG58/U cable
PL-259 connector

Tunable stainless
top rod section
has etched tuning
scales permitting
field adjustment
for either 27 MC
Citizens Band or
28-30 MC Amateur
Bands.

Pat. Pend.

NEW-TRONICS

3455 Vega Avenue
Cleveland 13, Ohio

For further information, check number 15, on page 163

You asked for it!

The "Gooney Bird"
returns...

Follow me to page 123

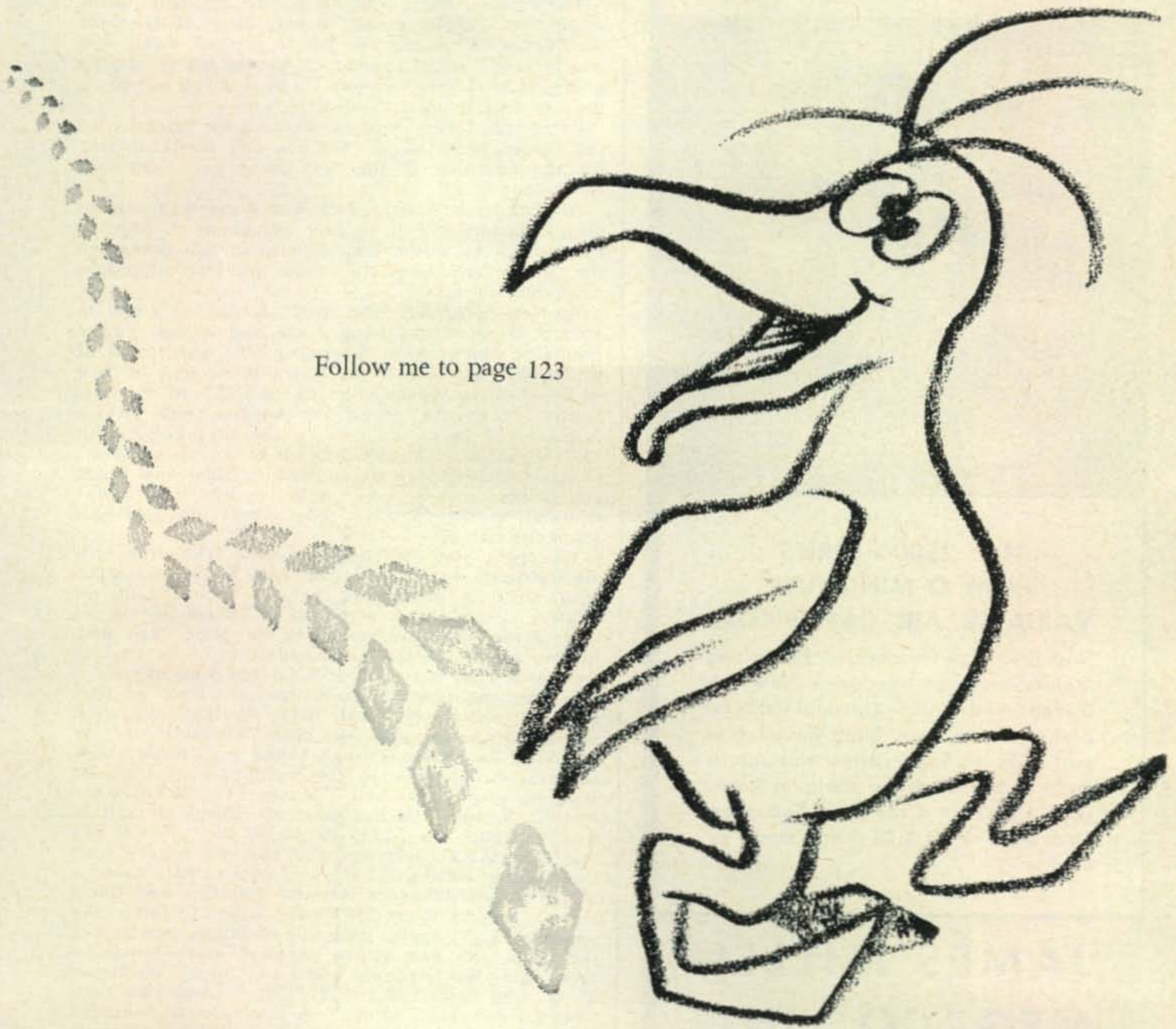

Designed for



Application

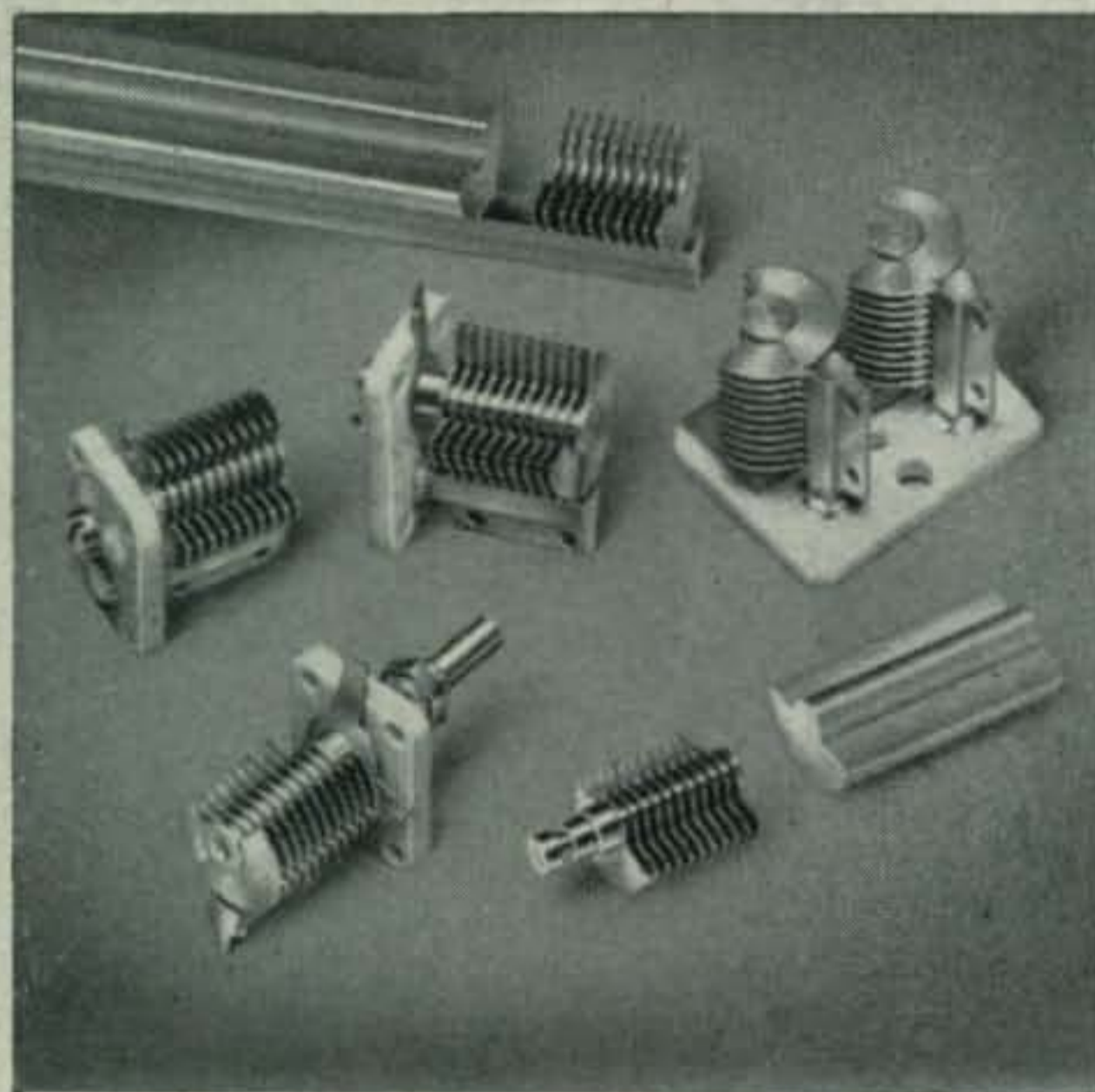

**NO. 25000 SERIES
HIGH Q MINIATURE
VARIABLE AIR CAPACITORS**

High Q at high frequencies. Rotors and Stators precision machined from extruded solid brass. Terminal integral part of Stator block. Shaft an integral part of Rotor. Screw-driver slot adjustment or $\frac{1}{8}$ " extended shaft for knob. Only 6 parts to a complete Capacitor. Stock sizes 15, 25 & 35 mmfd. single or dual units.

**JAMES MILLEN
MFG. CO., INC.**

MAIN OFFICE AND FACTORY
**MALDEN
MASSACHUSETTS**



**Letters.....
to the Editor**



Many letters were received concerning ZERO BIAS which appeared in the September issue of CQ. Below are two representative samples expressing opposite views. We are extremely sorry that space does not permit publication of all letters received.—[Editor]

To "V"

Editor, CQ:

September ZERO BIAS is a confused and confusing editorial, to which I wish to make objection, and the motive for it, I charge as being suspect.

The editorial starts with "It is now apparent." How much time did you permit to pass after ARRL made the "upper 15" suggestion, before you sat down with pen in hand? ARRL waited 15 months before making a suggestion. I very seriously doubt that you waited 30 days to tear it apart. Motive??

Paragraph 3 acknowledges the need for extension of the "upper 50 kc of 20" but you call ARRL to task for the extension in the next paragraph. Confused? Confusing?

If anything is "unreal, foolish and can lead only to chaotic conditions" it is your paragraph 9. Motive? Confusing? As to the last sentence in that paragraph the Ontario DX Association made just that suggestion many months ago.

Re: last paragraph; The ARRL conducted a poll to attempt to determine band usage and modes, partial results of which are in September QST and results of which were available to the Board at the time of their decision to recommend the "upper 15" to the fraternity. 15 months passed between the time of the extension of 20 to the time of the suggested "upper 15." If this is a "hasty" decision or a "hasty move," or one made without concrete backing, then what would you determine as a proper adjective for your (hasty) editorial written (hastily) some weeks after ARRL's recommendation?

We credit you with being sensible. Therefore, you are charged with suspect motives in writing ZERO BIAS since a reasonable person, without ulterior motives, would have permitted a decent period of trial of the ARRL suggestion before using ZERO BIAS to zero in on the leading organization of its kind in the world. Zero Bias indeed! What was your motive?

Is this the type of journalism we want in ham radio? I quote from ZERO BIAS; "further congestion and embarrassment will take place." Because you say so, does that make it true? I find no "further congestions, etc." where in the world do you find it? Back up your statements. You say "The Board voted that U. S. and Canadian amateurs voluntarily refrain from operating on 14.335 to 14.350 kc." This is not true. The ARRL recommended that we refrain from transmitting between those frequencies and there is a tremendous difference between operating and transmitting. Later you say "If we are willing to forego the upper 15 kc." Again, distortion, twisting, bending of the truth with one motive apparent, discrediting the opposition. We were not asked to "forgo" the upper 15 kc. Last paragraph repeats with "—American amateurs to relinquish 15 kc." A professional journalist just cannot repeat this many times, without someone brighter than I catching on, so only one answer is left, to us, a very deliberate and professional attempt to sway a segment of the fraternity against, not only the ARRL, but another segment of the fraternity. Shame! We need more cooperation among ourselves and cannot be helped by an organization which tries to do the opposite.

Three suggestions have been offered by various people to improve DX via s.s.b. Last month [August]

HQ

STANDS
FOR

Hammarlund Quality



TOP VALUE HQ-100A

NOW—even better CW and SSB reception with the new HQ-100A! Keeping all of the advanced features of the famous HQ-100, Hammarlund engineers added extra convenience and performance by providing independently controlled, continuously variable BFO and Q-multiplier — permitting simultaneous use of both. Another added extra is the handy citizens band channel marking—usable at your option. Plus Features at no extra cost.

\$189.00 Amateur Net*



HQ-145X WITH NEW CRYSTAL CONTROLLED CHANNEL

Important new features have been added to the general coverage HQ-145 to make it the Hammarlund HQ-145X — at no increase in price. Provision for a crystal controlled channel has been included for use at any point within the entire frequency range of the instrument (540 KCS to 30 MCS). Highly desirable in net operations, citizens band, to obtain weather information, and to calibrate test equipment against WWV standard. Also features optional use of citizens band channel markings. (Crystal not supplied.)

\$269.00 Amateur Net*

AND THE VERY BEST IN AMATEUR RADIO



ALL NEW HQ-105TR CITIZEN-HAM BAND TRANSCEIVER

NOW—for the first time, a citizens band transceiver with built-in provision for ham band operation. The general coverage receiver is continuously tunable from 540 KCS to 30 MCS—transmitter has a 5 watt input and is 100% modulated. The Hammarlund HQ-105TR can be utilized for both CB and ham operation simply by retuning the transmitter. Ideal for the citizens band operator who entertains the possibility of being a licensed ham—and the amateur radio operator who would like to use a single unit for both business and hobby. \$219.50 Amateur Net*

*24 hr. clock-timer optional—\$10



MR 50-X CRYSTAL- CONTROLLED MONITOR RECEIVER

The Hammarlund MR50-X Monitor Receiver is a true split channel instrument permitting clear, loud signals on the most congested communications bands. Crystal controlled to fixed predetermined channels within the frequency range of 147 MCS and 174 MCS, it provides a positive means for remote monitoring of two-way communications. Built-in whip antenna. Ideal for civil, industrial, or commercial use. \$199.50 Amateur Net



Established 1910

HAMMARLUND

MANUFACTURING COMPANY, INC.,
an affiliate of Telechrome
460 West 34th Street, New York 1, N.Y.

For further information, check number 18, on page 163

How To Get an FCC License (Commercial)



**GET
ALL 3
FREE!**

Just Mail Coupon

YOUR GUARANTEE:

Completion of the Master Course (both Sections) will prepare you for a First Class Commercial Radio Telephone license with a Radar Endorsement. Should you fail to pass the FCC examination for this license after successfully completing the Master Course, you will receive a full refund of all tuition payments. This guarantee is valid for the entire period of your enrollment agreement.

**Investigate our NEW
Training Program In
COMPUTERS,
SERVO MECHANISMS,
MAGNETIC AMPLIFIERS,
and others.**

Get This Handy POCKET ELECTRONICS DATA GUIDE

FREE

Puts all the commonly used conversion factors, formulas, tables, and color codes at your fingertips. Yours absolutely free if you mail the coupon today.

Mail Coupon TODAY!

CLEVELAND INSTITUTE OF ELECTRONICS

Desk CQ-82, 1776 E. 17th St., Cleveland 14, Ohio

Please send FREE Career Information Material prepared to help me get ahead in Electronics.

Name..... Age.....

Address.....

City..... Zone..... State.....

FOR PROMPT RESULTS SEND AIR MAIL

CQ-82

the MC method was blasted by W2DEC this month [September] the "upper 15" was blasted and I wonder if next month will find the suggestions for "cross-banding" made by the Ontario DX Association blasted in some part of CQ.

What is behind these "goings on"???

George Goodwin, Jr., KØRDP
Deer River, Minnesota

Or Not To "V"

Editor, CQ:

Your ZERO BIAS comments in September's CQ would appear to have broken the taboo that generally shrouds such controversial and political matters in the amateur radio press.

We have been patiently awaiting some editorial expression on the 14 mc segregation-suggestion wherein US/VE (although the recommendation includes all FCC licensed amateurs) would withdraw from the top kc of the 14 mc band. Aside from comments urging this segregation, no indication as to what the opposite side of the coin might read has been evidenced. Such a soft-sell exudes aromas akin to Madison Avenue ploys.

Yours is an appropriate suggestion, that if . . . "we are willing to forego the upper 15 kc for DX" . . . we should relinquish this segment legally. The FCC sweated this 50 kc phone expansion for several years, and only the amateur population explosion with emphasis on the s.s.b. element, under their jurisdiction, was the factor that finally brought about the "legal" expansion. Were spokesmen for the amateur (and their name is legion) to now request a 15 kc lop-off "legally" FCC might unofficially, and with considerable justification say: "Do you know just what in blazes you want?"

The 50 kc expansion "idea" was not born yesterday; but rather was a matter of some 12 long years a-borning. At conception of the "idea," US hams numbered just over 120,000; at delivery in March, 1960, another 80,000-plus had joined our ranks. In an era marked by an everyday commonplace which might be titled . . . "From Novice-to-Kilowatt In 2 Easy Steps" the leaders of amateur radio had best give their mature considerations to where the on-coming horde will have room to operate. That area from 14,100 kc to 14,200 kc, now occupied by less than 1% of W/K amateurs, should give these leaders some concern. Since, nearly every day, 14 mc will carry upwards to 50% of the active amateur population, this 100 kc segment should be of great importance. The opinion which appears to color the thinking of amateur radio's leaders is that we must remain squeezed into inadequate areas, lest we might offend operators in other countries, by expanding into areas not NOW being used. Any argument that we have a right to retain frequencies which we do not use, i.e. 28,150 kc to 28,500 kc . . . 14,100 kc to 14,200 kc must necessarily be very strong at future International Conventions. Apparently this was done prior to the Atlantic City Convention in 1947, when and where we lost 50 kc at the top end of 14 mc which had been the pasture wherein the elusive DX grazed. This situation which ended in our loss of 50 kc, was an ideal arrangement to a minority in the amateur ranks; whose political unawareness is exceeded only by their unbalanced attitude that the accumulation of new countries is the end of life.

In this discourse an attempt is being made to point up one thing only, which, if the end result comes to pass, should be sufficient to alert the fraternity of the perils ahead.

To maintain areas which are legally allocated to US amateurs for the express purpose of QRM-free DX operation is at once selfish, naive, and froth with danger. If we ignore history in our formation of future frequency-use policy we shall be guilty of a myopic approach to a vital matter.

Organizations within the Art who assume the right to advocate measures contrary to the above stated policy had better be well fortified to defend their non-usage recommendations beyond the borders of their own country, and mainly at International Conventions.

A simple question, fairly asked, "Do we have a right to frequencies we do not use" should be a part of all

[continued on page 122]

your choice of 2 GREAT **EICO**[®] TRANSMITTERS...

designed
by Hams...
for Hams...



to the highest
Ham standards



**90-WATT
CW TRANSMITTER* #720**
Kit \$79.95 Wired \$119.95
*U.S. Pat. #D-184,776
"Top quality"—ELECTRONIC
KITS GUIDE

Ideal for veteran or novice.
"Clean" 90W CW, 65W AM-
phone with EXT plate modu-
lation. 80 through 10 meters.

**60-WATT
CW TRANSMITTER #723**
Kit \$49.95 Wired \$79.95

"Compact; well-planned lay-
out. Clean-sounding, abso-
lutely hum-free carrier;
stable." — ELECTRONICS
WORLD.

Perfect for novice or ad-
vanced ham needing low-
power standby rig. "Clean"
60W CW, 50W AM-
phone with EXT plate modulation. 80
through 10 meters.



New!



**VARIABLE
FREQUENCY
OSCILLATOR
(SELF-POWERED)
#722**
Approaches
crystal stability.
80 through
10 meters.
Kit \$44.95
Wired \$59.95

New!



**CITIZENS BAND
WALKIE-TALKIE #740**
Complete with re-
chargeable battery
and charger. 9 tran-
sistors, 1 diode. Full
superhet. U.S. made.
Kit \$54.95
Wired \$79.95



**CITIZENS
BAND
TRANSCIVERS**
Superhet; pre-
aligned xmitter
osc; match differ-
ent antennas
by variable "pi" network. Single
& multi-channel models.
From Kit \$59.95 Wired \$89.95



**HIGH-LEVEL
UNIVERSAL
MODULATOR-
DRIVER #730**
Kit \$49.95 Wired \$79.95
Delivers 50W undistorted audio for
phone operation. Can plate-modu-
late transmitters having RF inputs
up to 100W. Unique over-modula-
tion indicator. Cover E-5 \$4.50.

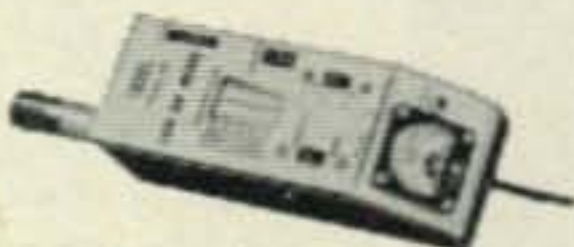

**GRID
DIP
METER
#710**
Kit \$29.95 Wired \$49.95
Includes complete set of coils
for full band coverage. Continu-
ous coverage 400 kc to 250 mc.
500 ua meter.



**PEAK-TO-PEAK
VTVM #232**
& exclusive
*UNI-PROBE[®]
Kit \$29.95
Wired \$49.95
VACUUM TUBE VOLTMETER #221
Kit \$25.95 Wired \$39.95

*U.S. Pat. No. 2,790,051



**DC-5MC
LAB & TV 5"
OSCILLOSCOPE
#460**
Kit \$79.95
Wired \$129.50
5" PUSH-PULL OSCILLOSCOPE #425
Kit \$44.95 Wired \$79.95



**DYNAMIC
CONDUCTANCE
TUBE
& TRANSISTOR
TESTER #666**
Kit \$69.95 Wired \$109.95
TUBE TESTER #625
Kit \$34.95 Wired \$49.95



**RF SIGNAL
GENERATOR
#324**
(150kc-435mc)
Kit \$26.95
Wired \$39.95
**TV-FM SWEEP GENERATOR
& MARKER #368**
Kit \$69.95 Wired \$119.95

EICO[®]

3300 Northern Boulevard,
Long Island City 1, New York
Export Dept., Roburn Agencies Inc.,
431 Greenwich St., N.Y. 13, N.Y.

EICO, 3300 N. Blvd., L.I.C. 1, N. Y.

Send free Catalog & name of
neighborhood distributor.
 Send free "Short Course for
Novice License." Send
36-page STEREO HI-FI GUIDE:
25c enclosed for postage
& handling.

Name.....

Address.....

City..... Zone..... State.....

Add 5% in the West.

CQ-11

ENGINEERS: Excellent career opportunities in creative electronics design. Write to the Chief Engineer.

For further information, check number 19, on page 163

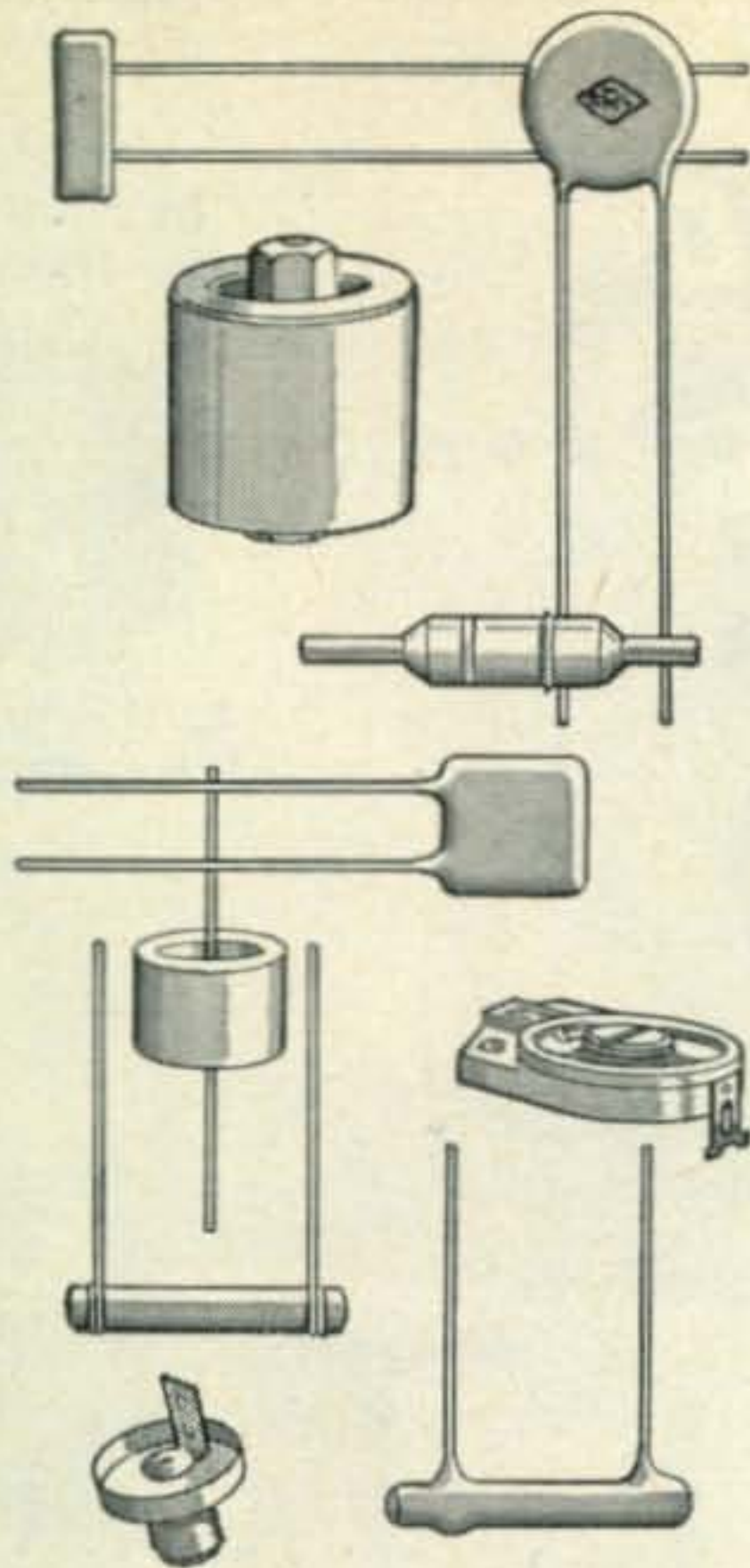

If you need a
**Ceramic
 Capacitor**
Centralab
 has it!

As the pioneer in the development and production of ceramic capacitors, Centralab has the industry's most complete line... and is your best source for ceramic transmitting capacitors!

No matter what your requirements—discs, tubulars, buffers, trimmers, feed-thrus, high voltage, low voltage—Centralab makes them, and makes them best.

Whether you need one capacitor or one thousand, your nearby Centralab distributor can supply them—probably right from his complete stocks.

For the complete list of stock capacitors, ask your distributor for Catalog 31, or write for your free copy. D-6136

Centralab

THE ELECTRONICS DIVISION OF GLOBE-UNION INC.
 954E EAST KEEFE AVENUE • MILWAUKEE 1, WISCONSIN
 In Canada: Centralab Canada Ltd.,
 P.O. Box 400, Ajax, Ontario

For further information, check number 20, on page 163



Duval County—Florida

The North Florida Amateur Radio Society and the Jacksonville Amateur Radio Society has jointly awarded W4QVJ a trophy for being voted the outstanding amateur in Duval County. The trophy was donated by K4YSP and it is expected that the award will continue on a yearly basis. Placing second and third respectively were K4PJJ and K4ICD. Nominations were graded on a point system involving DX activity, traffic handling, station capabilities, amateur education and non-operating activities.

P.V.R.C.

The Potomac Valley Radio Club sends along a list of newly elected members of their organization for 1962. President, Len Chertok, W3GRF; vice president, "Red" Redington, W4ZM Secretary, H. M. Austin, W3IPO, and Treasurer, Hal Leith, K4ORQ. All correspondence should be carried on with the secretary at 5624 67th Avenue, Riverdale, Maryland.

Amateur Story

If the XYL happens to have her head turned, grab her October copy of *Woman's Day* from the kitchen and have a look at a story written about amateur radio beginning on page 7. It's mainly about XYL's of course but we're sure everyone will enjoy reading about ham radio in other than amateur magazines.

Aeronautical Mobile Award

The Deep Freeze 62 Aeronautical Mobile Award, will be issued for contacts with any three of the stations listed below operating mobile or aeronautical mobile during September through December 1961 in support of *Operation Deep Freeze*. The expected route extends from Greenville South Carolina via California, Hawaii, Canton Islands, Fiji Islands and Christchurch, New Zealand into the Antarctic. Operation will be on s.s.b. and cw, mixed contacts are permissible. The frequencies to watch are 14,320 and 21,420 s.s.b., 14,020 and 21,020 c.w. The stations to look for are:

K1PZI, W1DBN, K4CNJ, W4BCX, W4SAL, W4SJU, W4RBF, W4WQP, W4YEI, and W8ESY. Send log data only, with your QSL's to the three stations worked to: Eloy Marez, W1DBN/4, 38 Foxhall Rd., Greenville, South Carolina. There is no charge to DX stations. U. S. and Canadian applicants can include, on a voluntary basis, enough stamps to cover which ever type of mail service they desire.

Teen Age Net

W9CTY and W9AMY are interested in starting a teen-age s.s.b. net the purpose of which is to promote better operating practices and s.s.b. techniques. If you qualify and you're interested, contact W9CTY at RR #1, Brocton, Illinois.

Synanon House

The Synanon Foundation, Inc. a non-profit Californian Corporation for the rehabilitation of narcotic addicts would like to know if anyone could spare a few parts or equipment so that they may set up an amateur station at their headquarters at 1351 Ocean Front, Santa Monica, California. Bob Metting, W8DYO/6 is handling all the incidentals and will be pleased to correspond with anyone who may be able to help.

Radio Amateur Yearbook

Paul Casling, G3MWZ has just completed the preparation and publication of the 2nd annual *International Radio Amateur Yearbook* which should be of interest to all active amateurs. Although originally conceived for British amateurs, U. S. hams will find it full of interesting and useful information. Propagation forecasts by W3ASK; Contest Results; leading amateurs of the world; Zone map etc., etc. Ye olde Clif Evans is Paul's U. S. Correspondant and will be more than pleased to hear from you for inclusion of material for future editions. The 1961-62 edition is available direct from Paul at Hutchinson's Ilkeston, Derbyshire, England; price postpaid, 70¢.

[continued on page 122]



= 3.75
WATTS
PEP

Get more watts per dollar with



GONSET GSB-201 LINEAR AMPLIFIER!

Here's proof that the powerful 1500 watt Gonset GSB-201 gives you greater value as well as top performance!

COMPARISON OF GONSET GSB-201 WITH 4 OTHER LEADING LINEAR AMPLIFIERS		
PEP		Watts per \$ of investment
1500 W.	GONSET GSB-201	3.75*
2000 W.	A	3.23
1000 W.	B	3.03
1000 W.	C	2.53
2000 W.	D	1.2

*Even more watts per dollar in terms of output due to high efficiency.
The Gonset Linear delivers a FULL GALLON of PEP output.

This little powerhouse is compact, finished in attractive blending colors. It's powerful in all transmission modes, versatile, with full band-switching with pi network output for five bands.

Compare Gonset GSB-201 with other leading makes for watts per dollar of investment... proof positive it's your best buy!

 **GONSET**[®]

DIVISION OF YOUNG SPRING & WIRE CORPORATION
801 SOUTH MAIN STREET, BURBANK, CALIFORNIA

For further information, check number 21, on page 163

HEATH AMATEUR GEAR

for a
Merry Xmas



New Kits

Forty new kits have joined the Heathkit line this fall...choose from over 250 quality kits...the world's most complete line!

New Guarantee

We guarantee you can build any Heathkit and have it perform to factory specifications...now you can buy in complete confidence!

New No-Money Down Terms

Now it's even easier to buy from Heath! Any order from \$25 to \$600 can be paid for on Heath's time-pay plan with no down payment!

New 1962 Heathkit Catalog

It's the world's biggest kit catalog...100 pages...complete descriptions, specifications and many schematics. It's yours FREE!



Specially-designed for CW work... new novice CW TRANSMITTER KIT HX-11

An excellent transmitter for the novice or CW amateur who appreciates a clean, quality signal and real distance getting power! Features 50 watt RF power input on 80 through 10 meters, built-in low pass filter, single-knob bandswitching, switched antenna relay power and pi-network output coupling for complete operating convenience. A "tune-operate" switch allows off-the-air tuning and a large "clear view" meter indicates final grid or plate current. Easy access to crystal socket is provided by a metal pull-out cabinet plug. Power supply is built-in. Careful design and high-quality components used throughout make this kit easy to assemble and assures long, reliable and trouble-free performance for years to come. An outstanding "watts-per-dollar" value in amateur gear. 17 lbs.

Kit HX-11...NO MONEY DOWN, \$5 mo.....\$43.50

The DX-60 Surpasses Quality and Performance of Transmitters Costing Far More!

This outstanding phone and cw transmitter offers far more in quality and performance than any other unit in its price and power class! A front panel switch selects any of four crystal positions or external VFO. Controlled carrier modulator and silicon diode power supply are built in. Single knob bandswitching for 80 through 10 meters and pi-network output coupling provide complete operating convenience. Panel meter shows final grid or plate current for easy tuning. Assembly is a marvel of simplicity with clean, rugged construction and thoughtful circuit layout. A pre-cut, cabled wiring harness eliminates tedious wiring and the informative instructions furnished make it an ideal kit for the novice. May be run at reduced power for novice operation. Less crystals. 25 lbs.

Kit DX-60...NO MONEY DOWN, \$9 mo.....\$82.95



**New low cost, broad coverage
Heathkit VFO HG-10**

Covers 80 through 2 meters with each band separately calibrated on a rotating drum-type slide-rule dial. Uses a series tuned Clapp oscillator with regulated plate voltage for stability and a cathode-follower output stage for load isolation. Features 28:1 vernier gear drive, and "spotting" switch for off-the-air tuning. Powered by transmitter. Styled like the Heathkit DX-60 and plugs into it directly. Easy to build. 12 lbs.

Kit HG-10... NO MONEY DOWN, \$5 mo. **\$34.95**



**Improve your receiver performance
with this new Heathkit "Q" MULTIPLIER**

May be used with any receiver having an IF frequency between 450 and 460 kc. This "electronic filter," with effective "Q" of approximately 4,000, provides either a sharply-peaked IF curve for CW, a broad peaked IF curve for AM or SSB, or a deep sharp notch for rejecting heterodynes on CW, AM and SSB. Both peak or notch positions are tunable to any point in the receiver's IF bandpass. Ideal for CW reception and heterodyne rejection on receivers or transceivers employing fixed bandwidth mechanical filters such as the Collins 75S-1. Power supply is built-in. 2 lbs.

Kit HD-11..... **\$14.95**



**New! ... nothing else like it anywhere ...
the Heathkit "TUNNEL-DIPPER" ...
exclusive tunnel-diode oscillator!**

First of its type! Performs like a "grid-dip" meter but uses a tunnel-diode oscillator and transistors—no tubes! Built-in battery supply for complete portability ... use it anywhere for alignment, trouble-shooting, etc. Features color-matched coils and dial scales for easy reading; printed circuit board for easy assembly. Protective cover has storage space for coils. Enclosed vernier-driven drum-type tuning dial prevents accidental change in settings. 3 lbs.

Kit HM-10... NO MONEY DOWN, \$5 mo. **\$34.95**

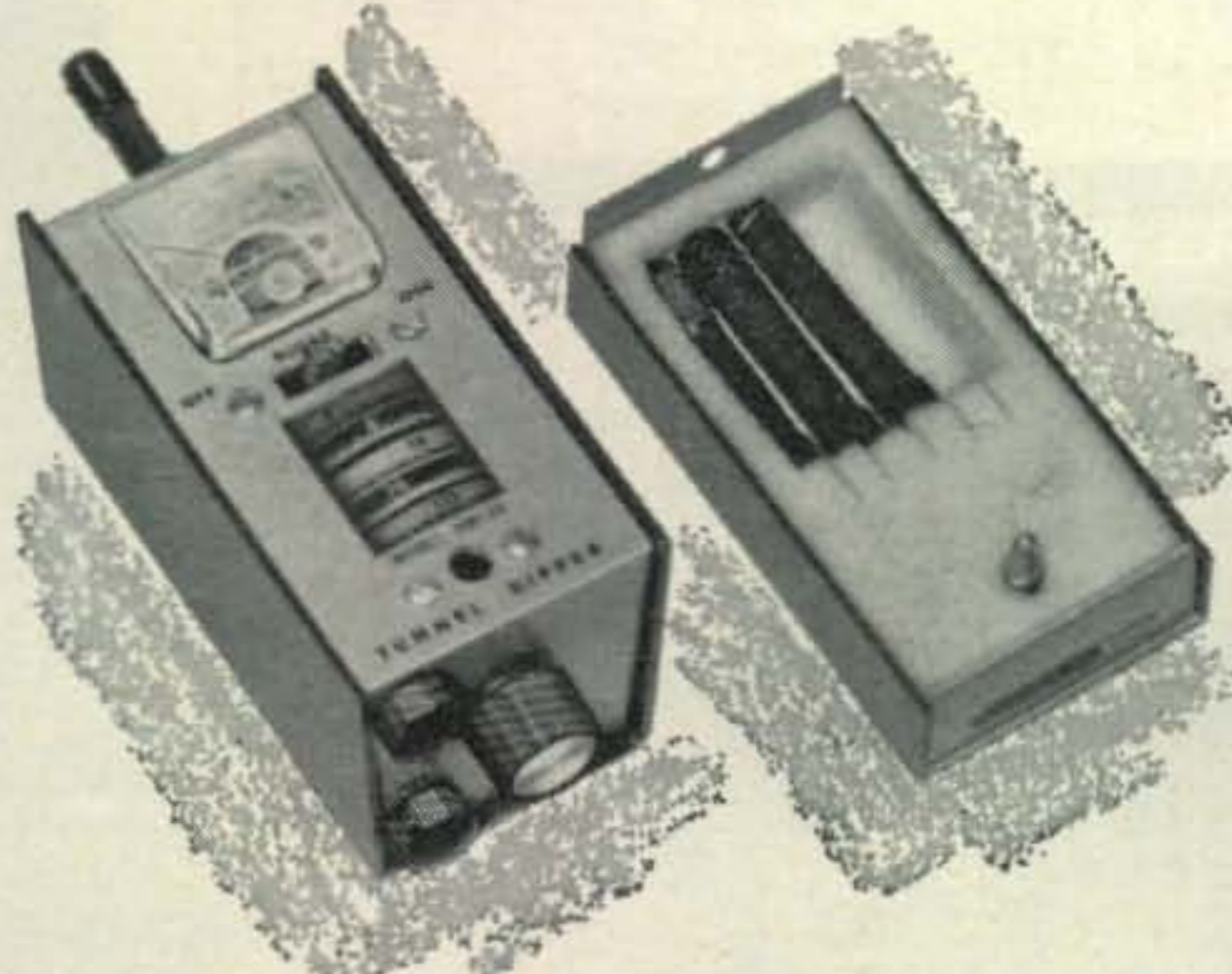

Free Catalog

Send For Your FREE 1962 Heathkit Catalog now! It details the complete Heathkit line of quality kits ... over 250 ... the world's largest selection. We'll send your friends free copies too!

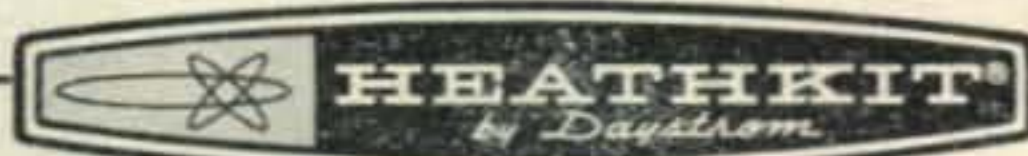

HEATH COMPANY

Benton Harbor 12, Michigan

Please send the Free Heathkit catalog.

Name _____

Address _____

City _____ Zone _____ State _____

For further information, check number 22, on page 163

The Least Expensive Way to Increase

Flat response penetrates QRM more effectively because it permits an actual increase in RF power output!

More effective cardioid pattern, essential for SSB, cuts accidental tripping of VOX circuit!

MODEL 664

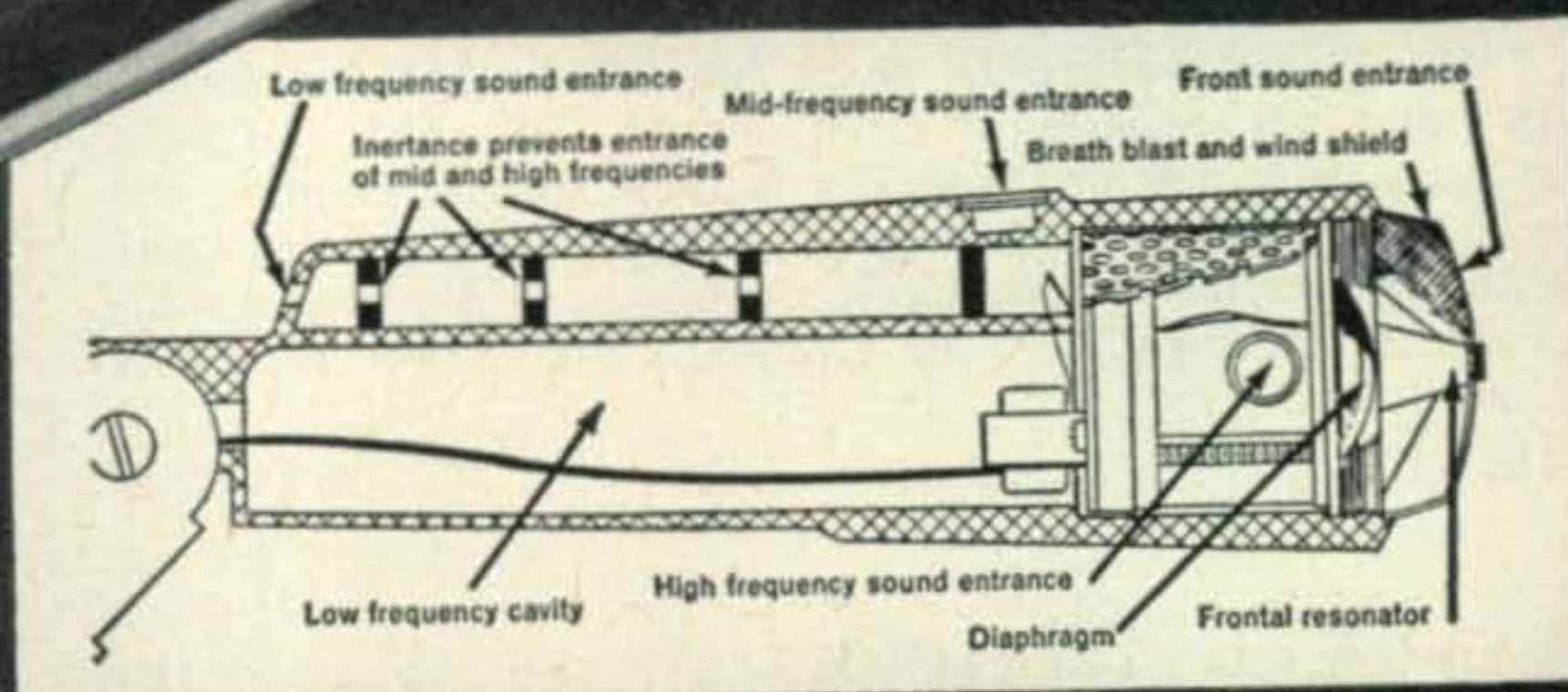

HERE'S HOW IT WORKS

Exclusive E-V Variable-D* (Variable Distance) provides three sound-cancelling entrances at different fixed distances in back of the diaphragm. These entrances, utilizing the proper acoustical impedances, combine to form an effective front-to-back spacing which varies in distance from the diaphragm inversely with frequency. The resulting phase and amplitude conditions provide a uniformly true cardioid pattern at all frequencies.

*Pat. Pending

Here's What the Top Radio Amateur Operators in the World Say About These E-V Microphones:

CX2CO "My new 664 resulted in better and more consistent QSO's."

W8KML "The 664 surpasses its claims in difficult operational environments."

ZL1HY "During QSO's . . . everyone preferred the 951."

W3JNN "I am really sold on the 664."

W8BF "I have had many unsolicited compliments since using the 729."

VQ4ERR "The performance of the 664 matches its thoroughbred appearance."

PY2CK "My 664 microphone vastly improved my SSB transmission."



Average Peak-Power and Intelligibility!

CHOOSE AN *Electro-Voice*[®] MICROPHONE

Model 664 for Highest Front-to-Back Discrimination Manufactured, Plus Peak-Free Wide-Range Response!

The effective strength of all sounds arriving at the sides of the 664 are reduced by as much as 50%, and arriving directly at the back of the microphone by as much as 90%. This uniquely effective design permits you to work at twice the distance from the microphone . . . a perfect invitation for "arm chair" QSO's—with no VOX tripping problems.

Smooth, peak-free response guarantees maximum P.E.P. Remember, a peak in response in or out of the voice range will limit maximum modulation and result in reduction of P.E.P. You do not have to talk with your lips on the mike. For best results, sit back and talk naturally.

Virtually indestructible Acoustalloy[®] diaphragm withstands high humidity, temperature extremes, corrosive effects of salt air and severe mechanical shock. Extra ruggedness means extra service, year after year.

MORE 664 FEATURES: Output—55 db. On-off switch (can be wired for relay control). 150 ohms or Hi-Z output selected at cable connector. Satin chromium finish. High-pressure die-cast case. Pop-proof filter plus magnetic shield. 90° swivel mounting. 18 ft. cable. 7 $\frac{3}{16}$ in. long (less stand coupler) by 1 $\frac{1}{8}$ in. diameter. Net Weight 1 lb., 10 oz. Amateur Net, \$51.00. Matching desk stand with DPDT switch. Model 419S, \$9.00. Less switch. Model 419, \$6.00.

The World's Finest Mobile Microphone. Model 600D Dynamic Widely Known As Military Types T-50 And M-105/U!

Designed for high articulation under rugged mobile conditions, the Model 600D provides all the advantages of a dynamic element with peak-free, flat response for maximum P.E.P.

High-impact case soaks up physical abuse, feels comfortable at any temperature, fits hand naturally. Extremely high output of -55 db. is ideal for mobile equipment with severe audio requirements. Available in 50, 250 ohms or Hi-Z. DPDT switch. 6 ft. coiled cord. Panel mounting bracket included. Model 600D Amateur net, \$28.50.



MODEL 600D

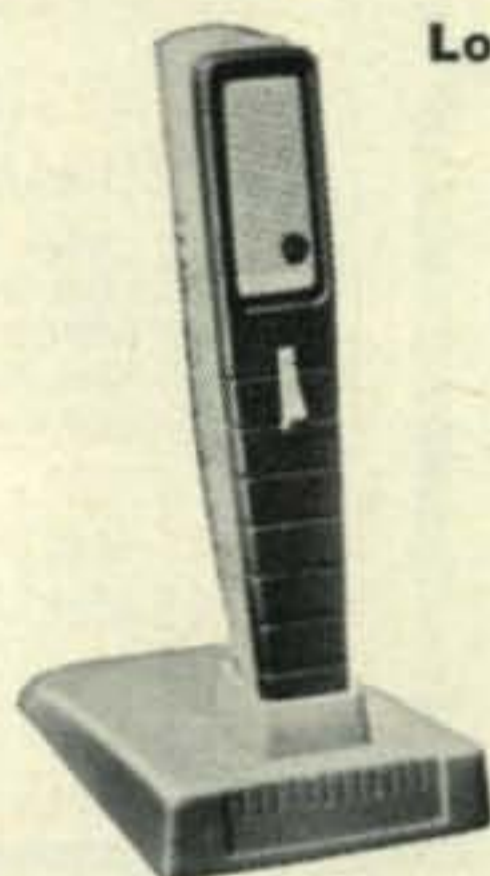

MODEL 729SR

Lowest-Cost Ceramic Cardioid Available ... Includes Every Feature Essential For SSB Operation. Flat, Smooth Response From 300 To 3,000 CPS!

Rugged enough for mobile operation, the slim, small Model 729 fits easily in your hand or slips into the desk stand or floor stand adapter provided, without any hardware adjustments. Hi-Z output -60 db. Two-tone grey, pressure die-cast and plastic construction. Shielded, 8 $\frac{1}{2}$ ft. cable. 7 $\frac{3}{4}$ in. long by 1 $\frac{1}{2}$ in. wide. Net weight 1 lb. Ceramic element unaffected by high heat, humidity. Model 729. Amateur net, \$14.70. Model 729SR with relay-control switch. Amateur net, \$15.90.



MODEL 951

First True Crystal Cardioid With Variable-D Design. Combines High Output With Excellent Noise Rejection At Modest Cost!

Finest crystal microphone available for SSB. Variable-D design of Model 951 cuts room noise, interference from receiver speaker to a minimum. Allows greater working distance to microphone. Peak-free rising response for high intelligibility. Hi-Z output -60 db. High-pressure, die-cast finished in Metalustre grey. On-off switch. Shielded, 18 ft. cable. 5 $\frac{3}{8}$ in. long (less stand coupler) by 1 $\frac{3}{4}$ in. diameter. Net weight 1 $\frac{1}{4}$ lbs. Model 951 Amateur net, \$32.70. Matching desk stand with DPDT switch. Model 418S, \$9.00. Less switch. Model 418, \$6.00.

See your Electro-Voice distributor and choose an Electro-Voice Microphone . . . For the fastest, easiest and least expensive way to boost the efficiency and quality of your rig! Satisfaction is guaranteed or your money refunded!

ELECTRO-VOICE, INC., Commercial Products Division
Department 1112G, Buchanan, Michigan

For further information, check number 23, on page 163

Electro-Voice[®]

MASTER MOBILE-TOPS IN QUALITY & PERFORMANCE

NEW DELUXE HI-"Q" COILS



New wide space deluxe antenna coil. Greater efficiency on individ. bands. Easily handles 750 W. P.E.P. Lightest coil of its kind commercially available. Use with 36" base sect. 60" whip.

15M	\$ 5.95
20M	6.95
40M	7.95
75M	9.95
160M	14.95

3 ELEMENT BEAM NO. SR-500

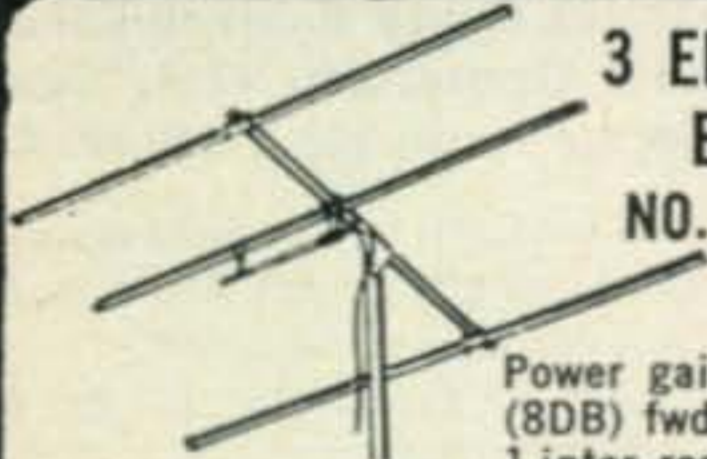

Power gain app. 2 1/2 (8DB) fwd. dir. 10 to 1 inter. red. from sides & rear VSWR-1 1-1 at band center when fed with 52 OHM coax.

SR-500-10	\$24.95	SR-500-6	\$12.95
SR-500-11	24.95	SR-500-2	10.95

FIBRE-GLAS ANTENNA

The Feather-Weight with Spring-Steel Strength. Completely weatherproof. Fibreglas covering, minimizes electrostatic noises generated by heat, moisture and foreign particles in the air.

FG-60 60"	\$4.95
FG-72 72"	\$4.95
FG-84 84"	\$5.15
FG-96 96"	\$5.25
FG-103 103"	\$6.95

MASTER-MAGIC TUNABLE WAND

New! easy-to-install, single band, top-loaded, plastic covered fiber-glas antenna. Maximum performance on the desired band.

10 Met.- 5 Ft. L	\$8.95
11 Met.- 5 Ft. L	8.95
15 Met.- 5 Ft. L	8.95
20 Met.- 5 Ft. L	8.95
40 Met.- 6 Ft. L	9.95
80 Met.- 6 Ft. L	9.95

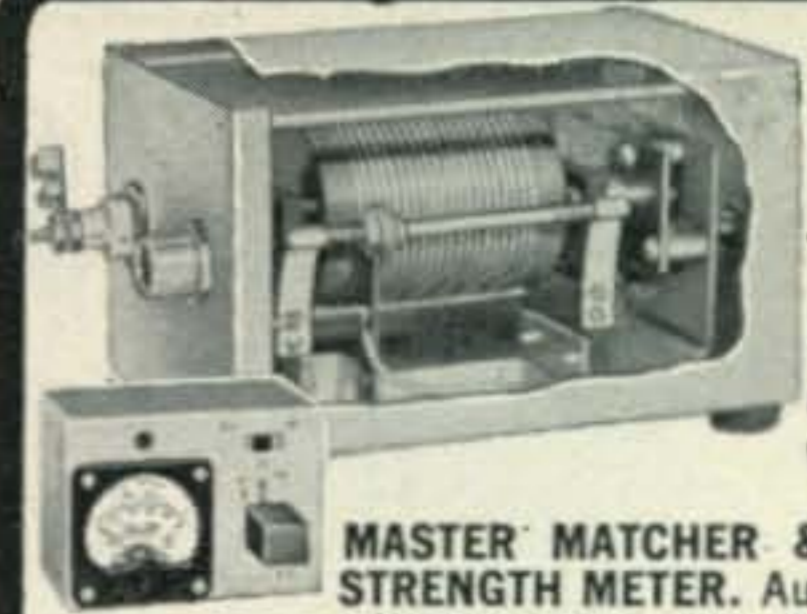

6 or 12 volt models

Complete \$24.95

MASTER MATCHER & FIELD STRENGTH METER. Automatically tunes entire band by remote control.

MULTI-BAND COILS



New plug-in type, operates with std. 3' base, 5' whip. Q of 525. 500 W input. Oper. with 52 ohm cable. Factory pre-tuned.

No. 900-10,15,20,40,75M
No. 999-10,15,20M
No. SSB-156-40, 75M

YOUR CHOICE

\$14.95

NEW! SLIM-JIM

ALL-BAND BASE LOADING ANTENNA COIL



96" WHIP

FOR 10, 11, 15, 20, 40, 80 METERS

SIZE 1 3/8" x 19"

Positive action, just slide whip in or out to loading point and lock nut into position.

NO. B-1080

\$17.95

MONOPOLE ANTENNA

Folded radiating element for installation requiring a ground plane configuration and a wider useful range.

SR-600-2	2 Met...	\$14.95
SR-600-6	6 Met...	16.95
SR-600-10	10 Met...	24.50
SR-600-11	11 Met...	24.50

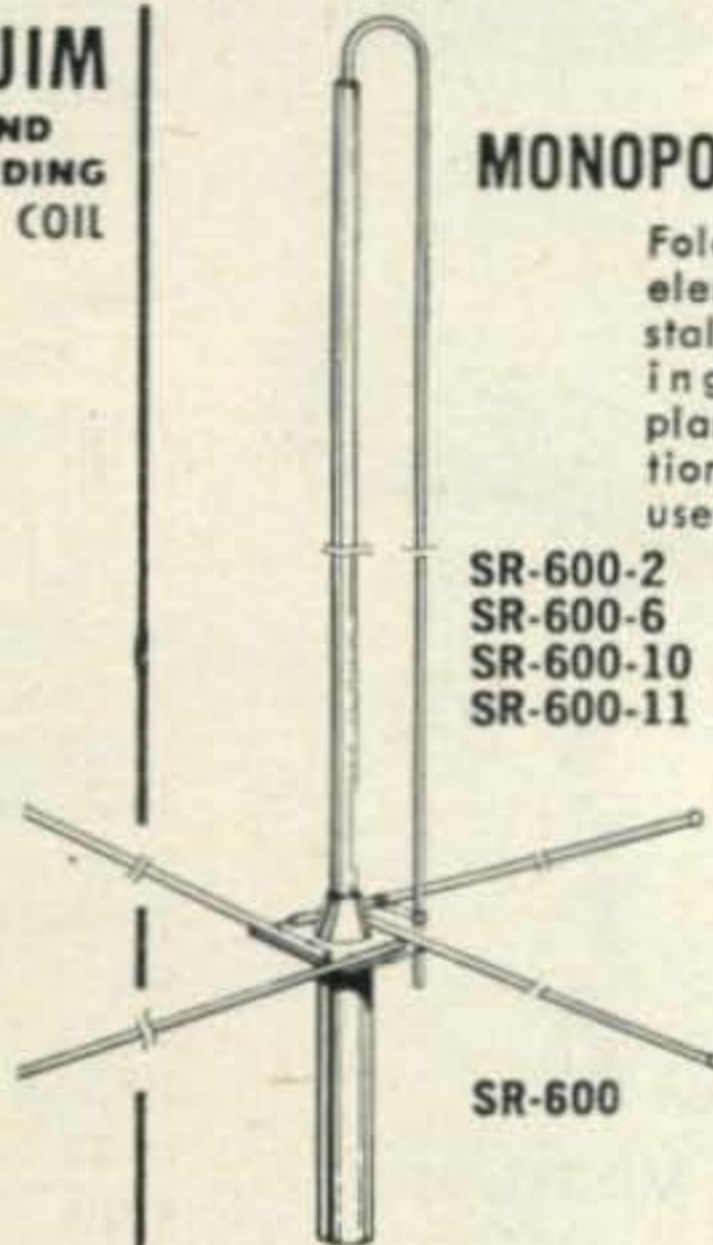

SR-600

WRITE FOR FREE CATALOG

TWIN 6 - 2 METER BEAM

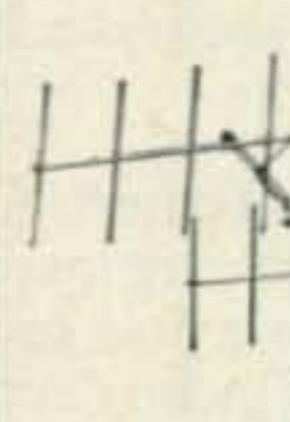

May be rotated by TV rotor. Complete with baluns, match. harness to 52 ohm. Vertical or horiz. pol. Trem. forward gain. Excell. front to back ratio. Lightweight, sturdy.

With PL-259 COAX \$16.95

UNIVERSAL MOUNTS



Heavy duty comm. ant. mts. Can be attached through opening as small as 3/16". For spring or whip. Pheno insulators. 3/8"-24 th.

530 Double SS.	\$21.95
531 Single SS.	11.95
520 Db. S-Cad. Pl.	7.95
519 Sl. S-Cad. Pl.	4.95

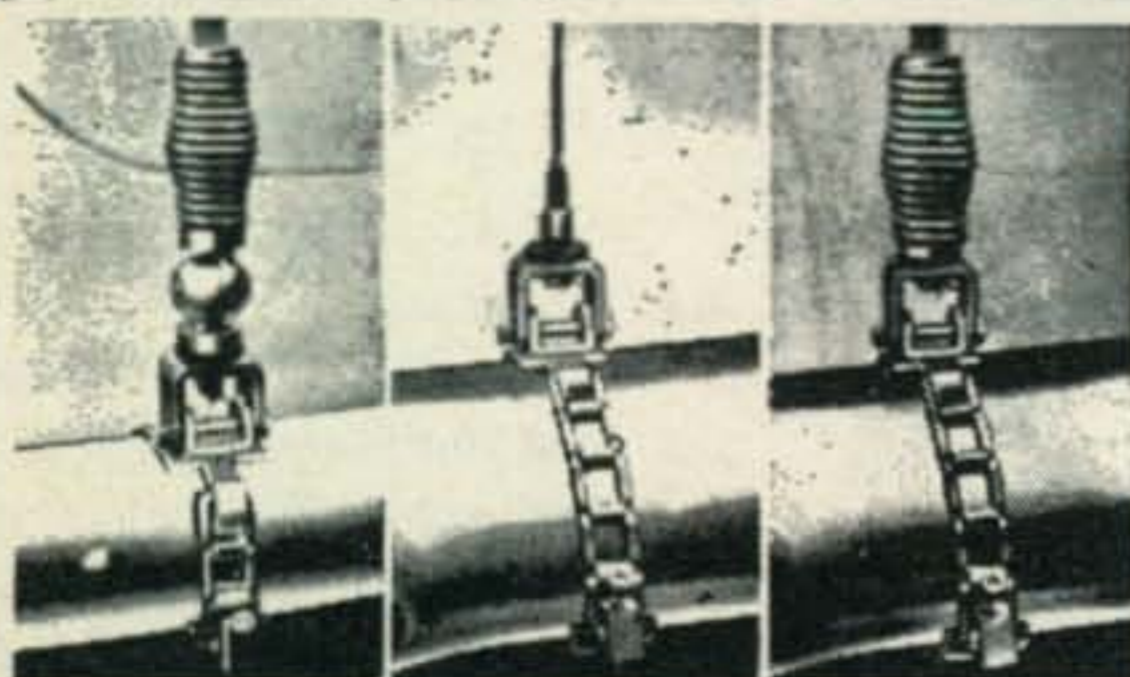

No.444 \$17.80 No.445 \$7.95 No.446 \$13.45
Adjustable to any bumper. No holes to drill.

MOUNTS

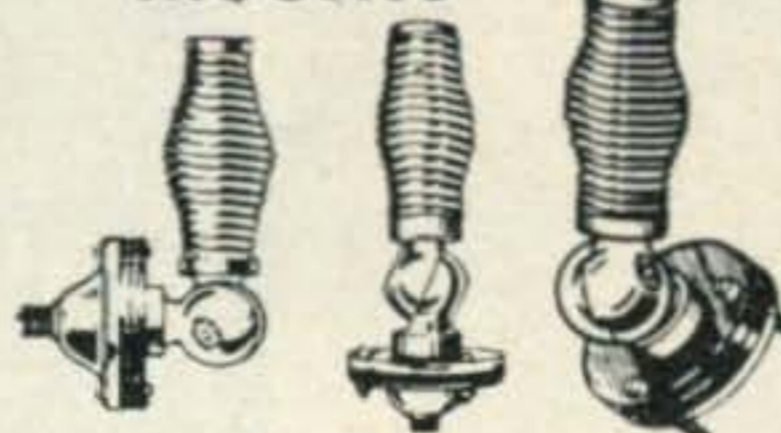

Model 232-C	232 Series	100X Heavy Duty	Model 142	100 Reg.	100WX	No. J-11 Swivel Mount Fits all antennas 3/8"-24th. \$2.95
232X	Base Mount—H.D.—Dble. Tpred. Spring—Swivel Base					\$ 9.85
232XC	Base Mount—H.D.—Dble. Tpred. Spring—Coax, Conn.					9.85
232XSSC	Base Mount—H.D.—D. Tpd. Sg.—Sp. Sless—Coax Conn.					14.95
232XSS	Base Mount—H.D.—Dble. Tpd. Spg.—Spec. Stainless					14.95
321 or 321C	Base Mount—Where no spg. des.—w. sp. rig. type ball jt.					7.95

All products are for Universal Use-Mobile, Home, Marine, C.A.P., Civil Defense, Emergency, etc.



Master Mobile Mounts, Inc.

4125 W. JEFFERSON BLVD. • LOS ANGELES 16, CALIF.

AT LEADING RADIO JOBBERS EVERYWHERE

For further information, check number 24, on page 163

WHAT MAKES THE VFO IN A 200V LINEAR?

A combination of a unique electrical circuit and mechanical correction system.

The main tuning is accomplished by turning a shaft ten times to cover one megacycle between 5 and 6 mc. The main tuning shaft advances a powdered iron slug into a coil to lower the frequency. The main tuning coil is wound at a non-uniform rate; so the frequency versus dial rotation approaches a linear characteristic. Since it is difficult to control the winding accuracy to provide exact dial linearity over the one megacycle range, a second coil is connected in series to provide vernier frequency correction. The slug of

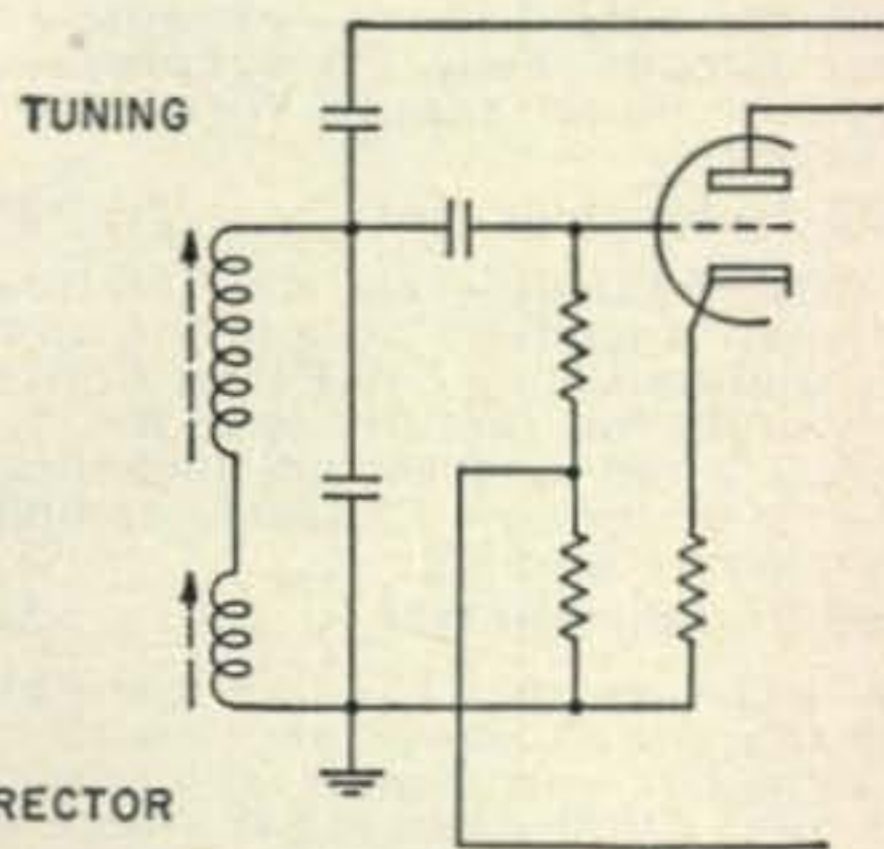
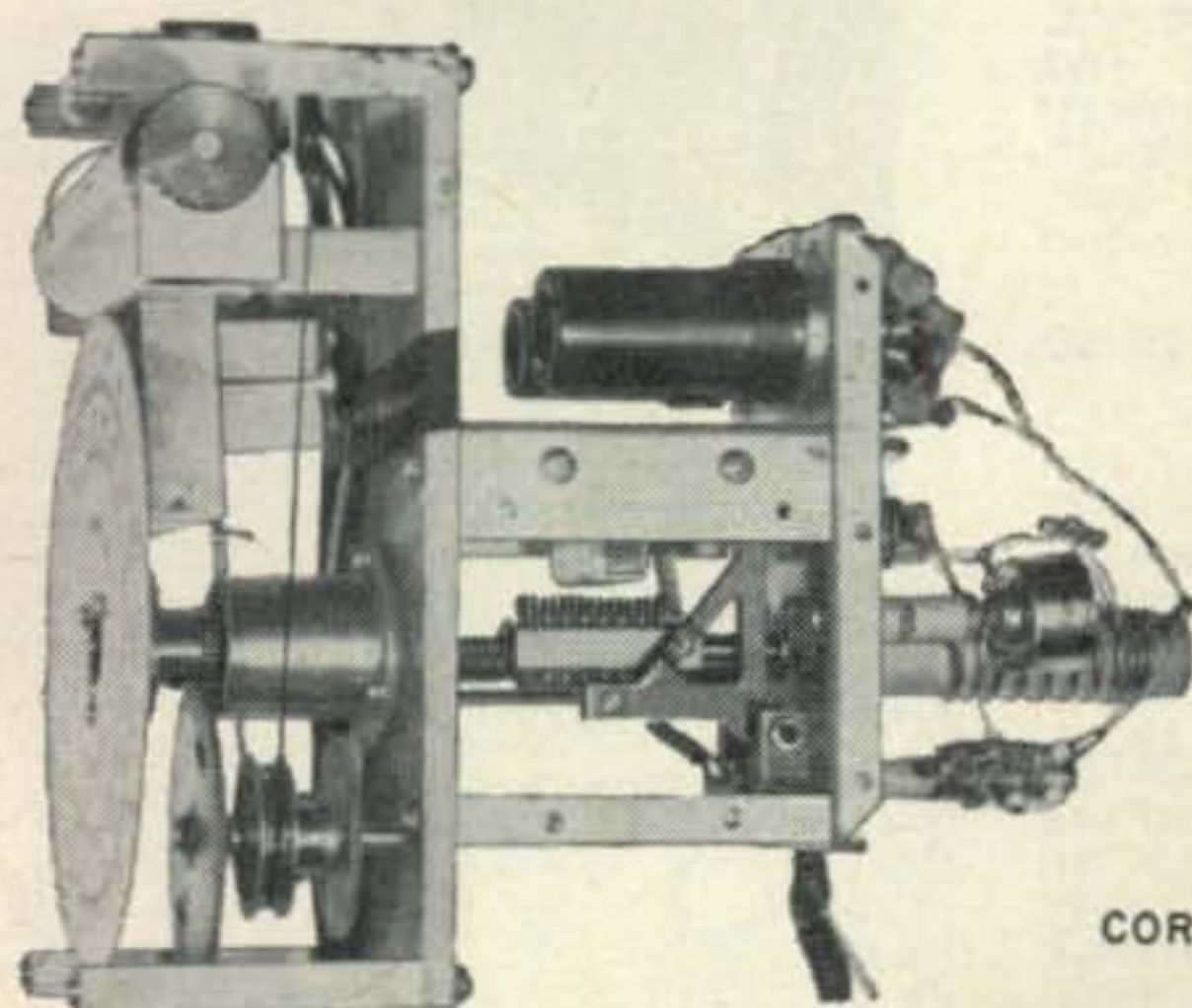

this second coil is mechanically arranged to obtain correction information from a hill and dale track created by the ball-shaped ends of 23 adjustable screws. One of the screws appears every 50 kc in an adjustment hole accessible through a plug button on top of the VFO. By progressively adjusting these screws, it is possible to make the output frequency zero beat with the kc scale every 50 kc across the VFO range.

The adjustments should be made using a crystal calibrator that has been set for zero beat with WWV.

73

Wes

Write for a 200V brochure
with detailed specifications

Wes Schum, W9DYV

Central Electronics, Incorporated

A subsidiary of Zenith Radio Corporation

1247 W. BELMONT AVENUE CHICAGO 13, ILLINOIS

For further information, check number 25, on page 163

November, 1961 • CQ • 29

Choose your next transmitter

3 of the hottest and newest!

INVADER—More exclusive features than any other Transmitter/Exciter on the market today! Specially developed high frequency, symmetrical, multi-section band-pass crystal filter for more than 60 db sideband suppression—more than 55 db carrier suppression! Instant bandswitching 80 through 10 meters—no extra crystals to buy—no realigning necessary. Delivers solid 200 watts CW and P.E.P. SSB input; 90 watts input AM. Built-in VFO—exclusive RF controlled audio A6C and ALC (limiter type) provide greater average speech power. Wide range pi-network output circuit—extremely smooth VOX and anti-trip circuits. Fully TVI suppressed. Self-contained heavy-duty power supply. Wired and tested with tubes and crystals.

Cat. No. 240-302-2—Amateur Net \$619.50

HIGH POWER CONVERSION—Take the features and performance of your "Invader" . . . add the power and flexibility of this unique Viking "Hi-Power Conversion" system . . and you're "on the air" with the "Invader 2000". Completely wired and tested, includes everything you need—no soldering necessary—complete the entire conversion in one evening.

Cat. No. 240-303-2—Amateur Net \$619.50

INVADER 2000—Here are all of the fine features of the "Invader", plus the added power and flexibility of an integral linear amplifier and remote controlled power supply. Rated a solid 2000 watts P.E.P. (twice average DC) input on SSB; 1000 watts CW; and 800 watts input AM! Wide range output circuit (40 to 600 ohms adjustable). Final amplifier provides exceptionally uniform "Q". Exclusive "push-pull" cooling system. Heavy-duty multi-section power supply. Wired and tested with power supply, tubes and crystals.

Cat. No. 240-304-2—Amateur Net \$1229.00

RANGER II—Now—a new version of the popular 75 watt CW or 65 watt AM "Ranger". The "Ranger II" transmitter also serves as an RF/audio exciter for high power equipment. Completely self-contained instant bandswitching 160 through 6 meters! Operates by built-in VFO or crystal control. High gain audio-timed sequence keying, TVI suppressed. Pi-network antenna load matching from 50 to 500 ohms. With tubes, less crystals.

Cat. No. 240-162-1
Viking "Ranger II" Kit—Amateur Net . . . \$249.50

Cat. No. 240-162-2—Viking "Ranger II"
Wired and tested—Amateur Net \$359.50

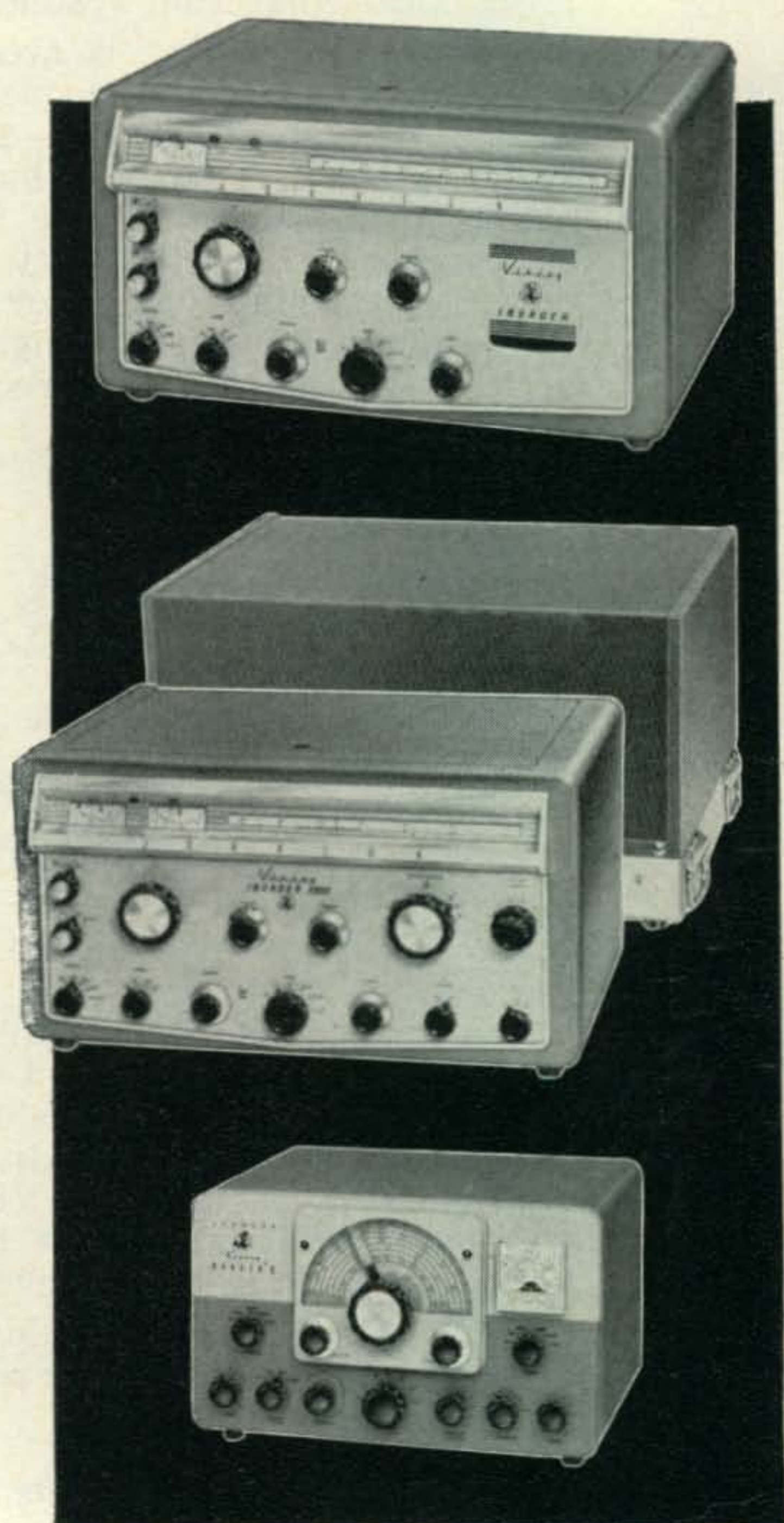

FREE
New Catalog
Write today for our newest amateur Catalog! Available now . . . contains photos, schematics and detailed specifications!

FIRST
CHOICE AMONG
THE NATION'S
AMATEURS



Viking

E. F. JOHNSON COMPANY • WASECA, MINNESOTA

from the VIKING line . . .

6 popular feature-packed transmitters!

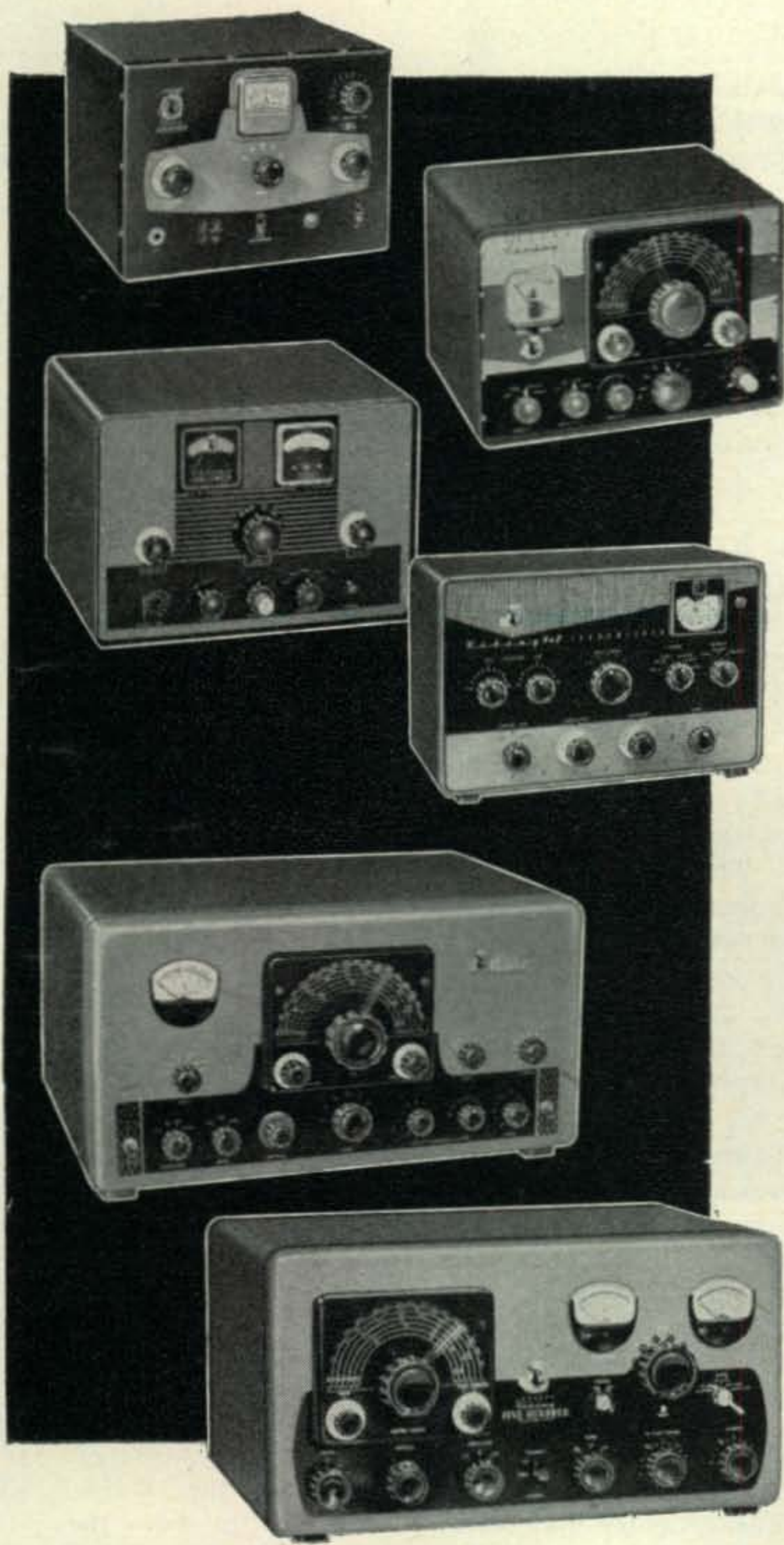

FACTORY AUTHORIZED SERVICE

Instead of shipping to our factory, equipment to be serviced may also be sent to:

Empire State Elect. Service
139-140 Hillside Ave.
Jamaica, New York

Park-Armature Co.
1218 Columbus Ave.
Boston 20, Mass.

For further information, check number 26, on page 163

ADVENTURER—Self-contained . . . 50 watts CW input . . . rugged 807 transmitting tube . . . instant band-switching 80 through 10 meters. Crystal or external VFO control—wide range pi-network output—timed sequence keying. With tubes, less crystals.

Cat. No. 240-181-1 Kit—Amateur Net . . . \$54.95

NAVIGATOR—40 watts CW input . . . also serves as a flexible VFO exciter. 6146 final amplifier tube—band-switching 160 through 10 meters. Built-in VFO or crystal control. With tubes, less crystals.

Cat. No. 240-126-1 Kit—Amateur Net . . \$149.50

Cat. No. 240-126-2

Wired and tested—Amateur Net . . . \$199.50

CHALLENGER—70 watts phone input 80 through 6; 120 watts CW input 80 through 10 . . . 85 watts CW on 6 meters. Two 6DQ6A final amplifier tubes. Crystal or external VFO control—TVI suppressed—wide range pi-network output. With tubes, less crystals.

Cat. No. 240-182-1 Kit—Amateur Net . . \$114.75

Cat. No. 240-182-2

Wired and tested—Amateur Net . . . \$154.75

6N2—Rated 150 watts CW and 100 watts phone—offers instant bandswitching coverage of both 6 and 2 meters. Fully TVI suppressed—may be used with "Viking I, II", "Ranger I, II", "Valiant" or similar power supply/modulator combinations. Operates by crystal control or external VFO with 8-9 mc. output. With tubes, less crystals.

Cat. No. 240-201-1 Kit—Amateur Net . . \$129.50

Cat. No. 240-201-2

Wired and tested—Amateur Net . . . \$169.50

VALIANT—275 watts input CW and SSB (P.E.P. with auxiliary SSB exciter) 200 watts phone. Instant band-switching 160 through 10 meters—built-in VFO or crystal control. Pi-network output matches antenna loads from 50 to 600 ohms. TVI suppressed—timed sequence keying—built-in low pass audio filter—self-contained power supplies. With tubes, less crystals.

Cat. No. 240-104-1 Kit—Amateur Net . . \$349.50

Cat. No. 240-104-2

Wired and tested—Amateur Net . . . \$439.50

FIVE HUNDRED—Full 600 watts CW—500 watts phone and SSB (P.E.P. with auxiliary SSB exciter). Compact RF unit designed for desk-top operation. All exciter stages ganged to VFO tuning—may also be operated by crystal control. Instant bandswitching 80 through 10 meters—TVI suppressed—high gain push-to-talk audio system. Wide range pi-network output. With tubes, less crystals.

Cat. No. 240-500-1 Kit—Amateur Net . . \$749.50

Cat. No. 240-500-2

Wired and tested—Amateur Net . . . \$949.50

Crystal Filter Type S.S.B. Exciter

COMMANDER PAUL H. LEE*, USNR, W3JHR

Here is a crystal filter type exciter using surplus crystals in lattice and half lattice circuits. It operates on 80, 40, 20 and 15 meters and has two 6146's in the output. An additional feature is the use of a modified LM (or BC-221) frequency meter as a v.f.o.

MY last article¹ has brought me many inquiries and comments, both by mail and over the air. Many of these were directed at the exciter used to drive the 4-1000A in the grounded grid zero bias mode. Some ask, "Doesn't this mode require considerable driving power?" Others ask, "How do you couple the driver to the final?" And still others ask for quite complete technical details of the exciter. I am therefore presenting this article for those who are interested in the exciter portion of this transmitter. It is apparent that the exciter is capable of use as a low powered transmitter in its own right, and so this article should also be of interest to those who do not have access to a 4-1000A or to the cash outlay required for a high powered linear and power supply.

To be quite honest, I did not build the original exciter. It was built by my good friend ex W6CAB, but I have made so many changes, rearrangements and improvements in it, that I now feel justifiable pride of authorship concerning it. The exciter can be seen in the photograph of the station. It is the 8 $\frac{3}{4}$ " panel with the single meter and various controls, located just above the center of the transmitter rack. The components are mounted on several small

chassis which are arranged to provide a layout with good mechanical and electrical design and easy accessibility for maintenance.

It is not the purpose of this article to provide complete mechanical construction details, but instead, I prefer to provide circuit information and diagrams. I shall also include information on the minor conversion work necessary to make the Navy Model LM Frequency Meter serve as a beautiful little v.f.o. unit for this exciter.

Mechanical Arrangement

Before getting into the details of the circuitry, a look at the photographs will show the mechanical arrangement. At the left end of the exciter is the i.f. chassis, which is 12" \times 8" \times 3" in size, and is mounted on the panel in an upright position. This results in considerable saving in space. At the right end you see the r.f. chassis, which is 12" \times 7" \times 3", and is mounted in the conventional horizontal position.

There is a small chassis, 5" \times 7" \times 3", which holds the vox tubes and relay. This is mounted between the r.f. chassis and i.f. chassis, at the rear. The 5" \times 6" \times 3" chassis which is mounted on the panel at the front and center portion of the exciter contains the LM frequency doubler, and a crystal oscillator. More will be said of these later. This particular chassis was formerly the original v.f.o. chassis. I took this v.f.o. out upon conversion to the LM, which has much greater stability, excellent accuracy of reset, and fine calibration. Use of the several



View of W3JHR's operating position. The exciter is located in the rack just above center. The LM frequency meter that serves as the v.f.o. is above the center receiver and the unit to the left is a pan-adaptor. The 51J-2's are operated in diversity reception and the receiver at the right is a surplus RBL which operates from 14.6 to 600 kc.

*5209 Bangor Drive, Kensington Maryland

¹Lee, Paul H., "Big Brother Linear," CQ, September, 1960, page 32.

Top view of the exciter. The chassis on the right is the i.f. section. The gear atop the chassis is fastened to the carrier balance pot and is adjusted from the front through the small hole drilled in the panel. The center rear chassis is the vox unit with controls R_1 and R_2 visible. The barrier strip is for connection to the coax antenna relay and the multi-pin connector to the right is for power input. The center chassis towards the front panel contains the LM doubler and the crystal oscillator for the third mixer. The coaxial connector is for the LM input. The chassis on the left is the r.f. chassis and is fed by the two coaxial cables coming from the i.f. chassis. The two modified i.f. transformers are in the front left corner. The copper neutralizing capacitor may be seen just below the plate blocking capacitor, mounted on a feed-through insulator. The 6BA7, third mixer, is up near the front panel and the 6CL6 driver is in the center.

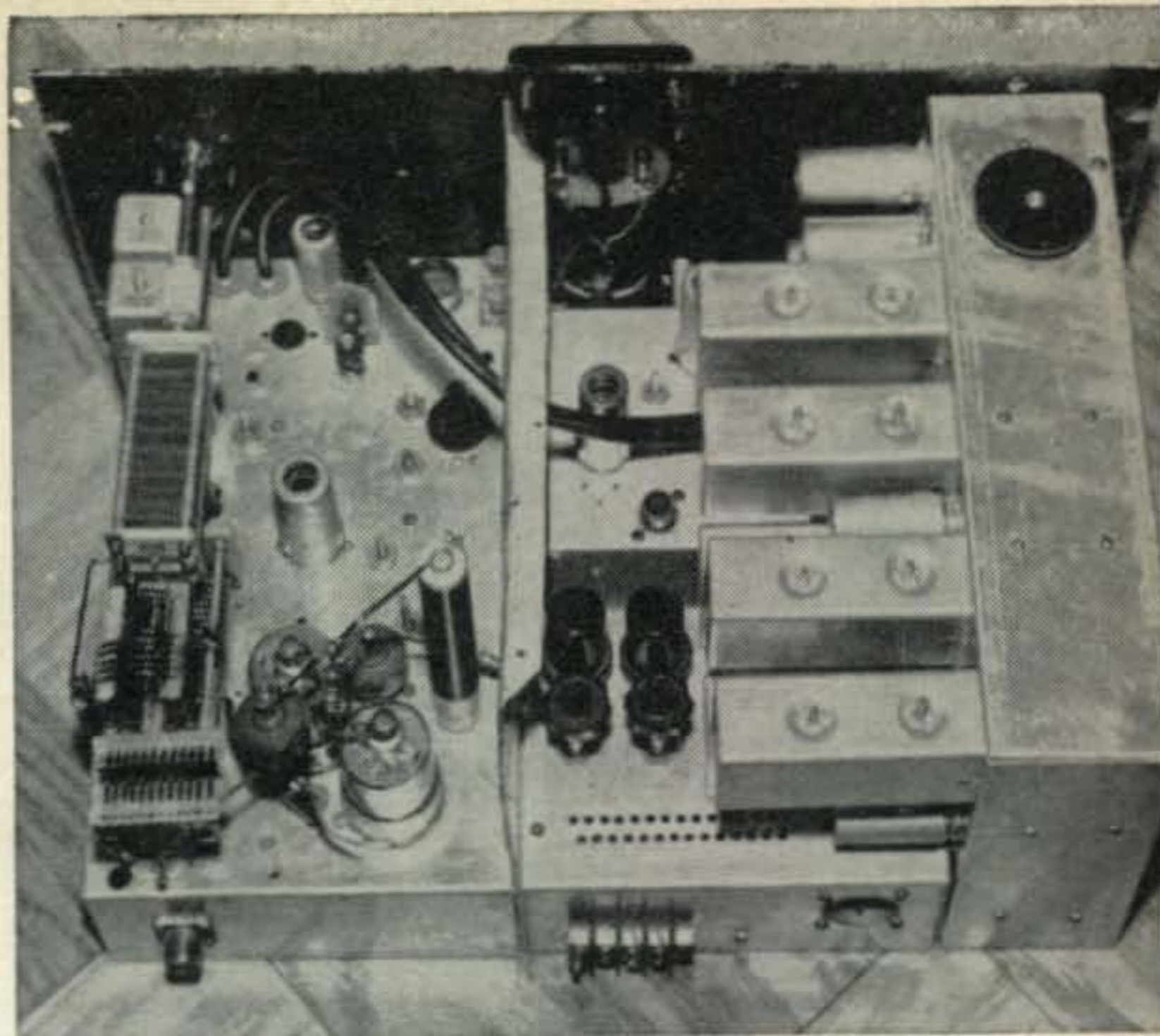

chassis provides for a modular type of construction, with shielding between portions of the circuits. All wiring of appreciable length which does not carry r.f. is done with shielded wire. This contributes greatly to the stability of the unit.

Block Diagram

A block diagram of the exciter is shown in fig. 1. A dual sideband signal is generated at 480 kc, and the upper sideband is removed by a two section crystal filter. Sideband reversal takes place in the first mixer whose output frequency is 1750 kc. The second mixer brings in the v.f.o. frequency of 5250 to 5750 kc. The sum or difference of the v.f.o. frequency and 1750 kc is then selected in the bandswitching to give variable output frequency

these bands. It is used as a mixer when on either the 3.5 or 7 mc bands. The third mixer is used as a straight-through amplifier on operating on the 14 or 21 mc bands, with a separate crystal oscillator on either 10.5 or 14 mc providing the injection frequencies for the 14 and 21 mc bands, respectively. The 3.5 mc signal is added to 10.5 mc to give 14 mc output, and the 7 mc signal is added to 14 mc to give 21 mc output. The crystal oscillator functions only when operating on these two bands.

The r.f. signal is then amplified on the desired operating frequency by a single 6CL6 pentode stage, followed by the 6146 output stage. The 6BA7 third mixer and the 6CL6 are bandswitched and gang-tuned with slug tuned coils for tracking. The 6146 stage is arranged so that it can operate with either one or

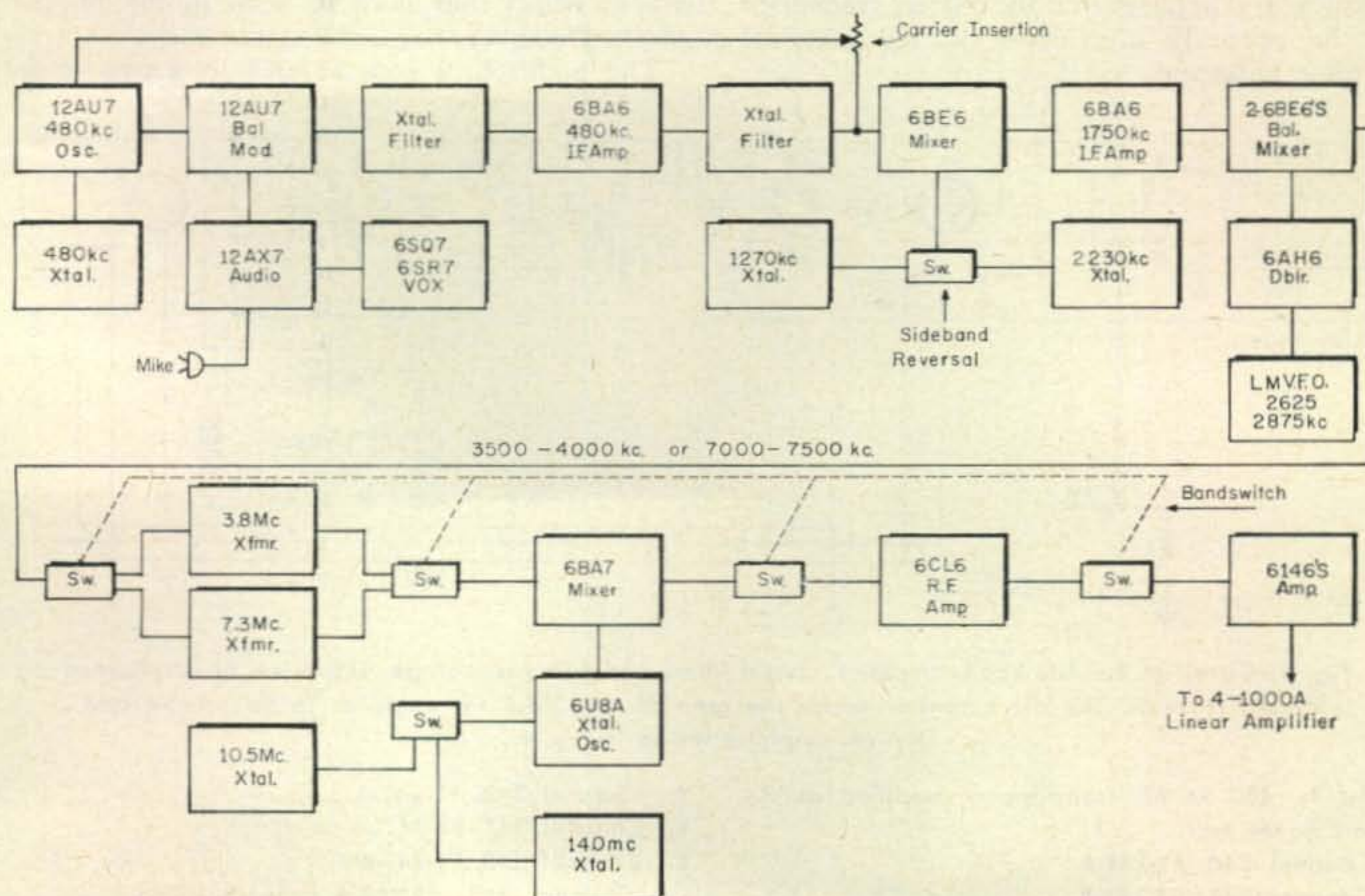

Fig. 1—Block diagram of the s.s.b. exciter. Upper or lower sideband output is available on 3.5, 7, 14 or 21 mc.

amplifier which drives not only the balanced modulator but also the vox circuit. This tube provides ample gain for use with a high impedance dynamic or crystal microphone.

The 480 kc i.f. portion of the exciter is shown in fig. 3. The balanced modulator feeds the first section of a crystal filter which uses FT-241-A crystals. Channels 343 and 345, with approximately 2.8 kc spacing, are employed in the series legs of a half-lattice circuit, with channels 346 and 348 in shunt to help knock down the unwanted sideband. The i.f. transformers are standard 455 kc types with a few turns stripped off each winding and adjusted with the grid meter to resonate at 480 kc. A single 6BA6 i.f. amplifier is used to feed the second section of filter.

Again, the i.f. transformers are standard types with turns removed to resonate at 480 kc. I had sufficient crystals to make a full lattice, with channels 343 and 345, with channels 347 and 349 in shunt to further reduce the unwanted sideband. Here the shunt crystals are on the output side of the filter which gave better rejection than putting them across the input.

The next stage is the 6BE6 first mixer. It is here that sideband reversal is accomplished. The 6BE6 oscillator section is crystal controlled with either a 1270 kc or 2230 kc crystal. The sum of 480 and 1270 kc is 1750 kc. Also, 2230 minus 480 kc equals 1750 kc. Thus, the crystal switch is the sideband selector.

Figure 4 shows the 1750 kc i.f. stage and the balanced mixer where the v.f.o. injection occurs. The i.f. transformers are standard 1500 kc types, with turns removed to give resonance at 1750 kc.

The tapped transformer, T_6 , is modified by the same technique used for T_1 in the balanced modulator. The number 3 grids of the 6BE6 mixers are driven in push-pull with the 1750 kc signal. The v.f.o. signal is applied to the number 1 grids in parallel. The 6BE6 plates feed in push-pull (through two short pieces of coaxial cable, to the bandswitch on the r.f. chassis.

The drive control is a 0.5 megohm potentiometer which varies the fixed bias on the two 6BA6 amplifier stages. This is shown in fig. 3.

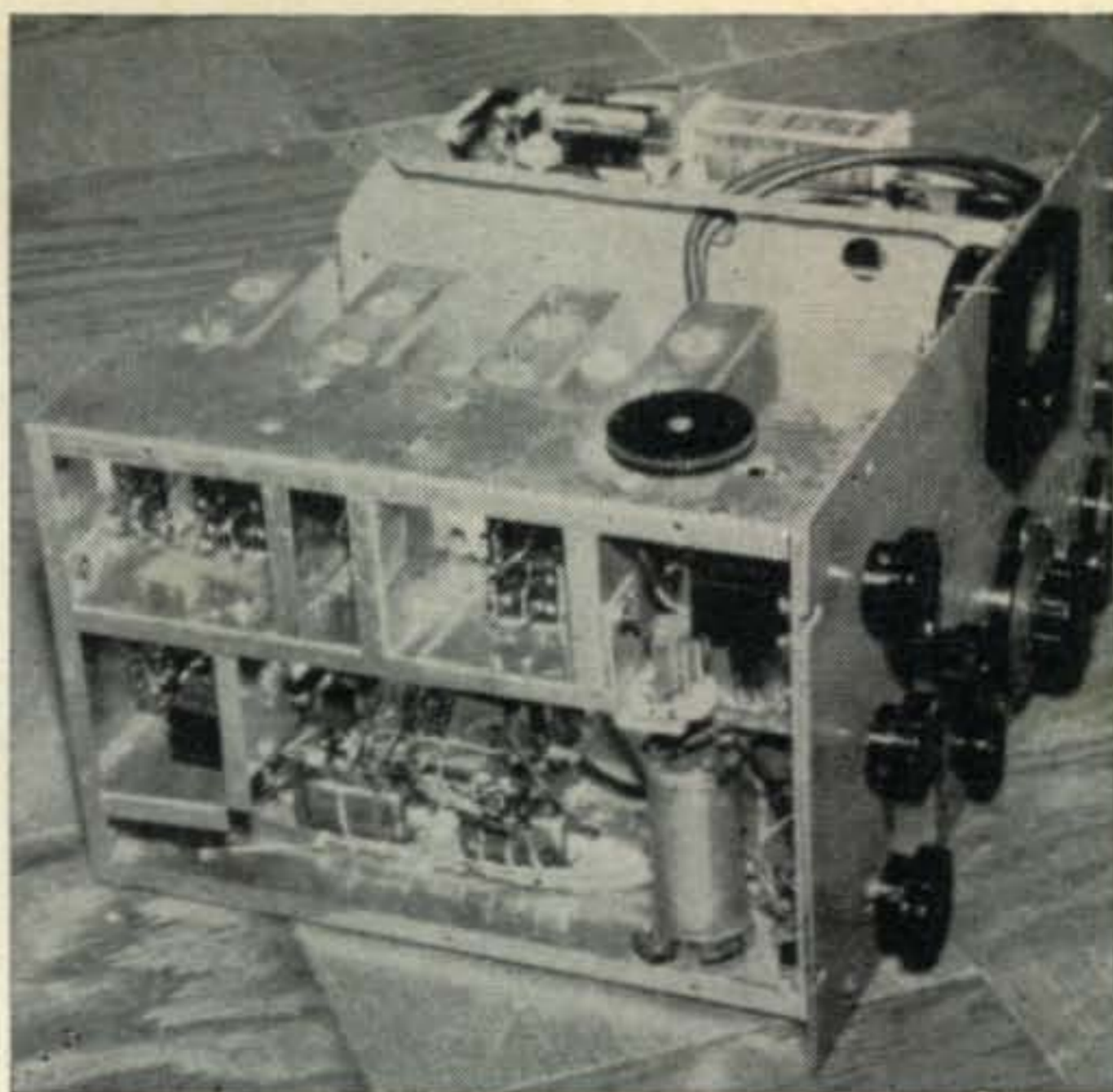

Side view of the i.f. chassis. Note the careful compartmentation. This is an absolute must if a clean and stable signal is desired. The variable capacitor in the upper right corner is C_1 in fig. 2 and is used to set the oscillator on the correct position of the bandpass curve of fig. 10. Note the crystals in each of the filter compartments. The chassis bottom is covered by aluminum screening to complete the shielding.

Carrier re-insertion in this exciter is accomplished, when desired, by means of a potentiometer on the i.f. chassis which allows some of the 480 kc master oscillator output to be fed around the crystal filters and directly into the first mixer grid circuit.

R. F. Chassis

Turning our attention now to the r.f. chassis shown in fig. 5, the output of the second mixer goes through the band change switch which selects one of two r.f. transformers, one tuned to about 3.8 mc and the other tuned to about 7.3 mc. These were standard 4.5 mc i.f. transformers which were rewound and slightly over-coupled to give a fairly broad bandpass. Thus, by means of the band switch and one or the other of these transformers, either the 3.5 or the 7 mc output of the second mixer can be selected to feed into the third mixer. This stage

Fig. 4—Circuit of the 1750 kc i.f. stage and the balanced mixer stage. The output from the LM doubler (fig. 7) is applied to point C. Outputs from D and D' are fed to the bandswitch through coaxial cable. Modification of T_6 is described in the text.

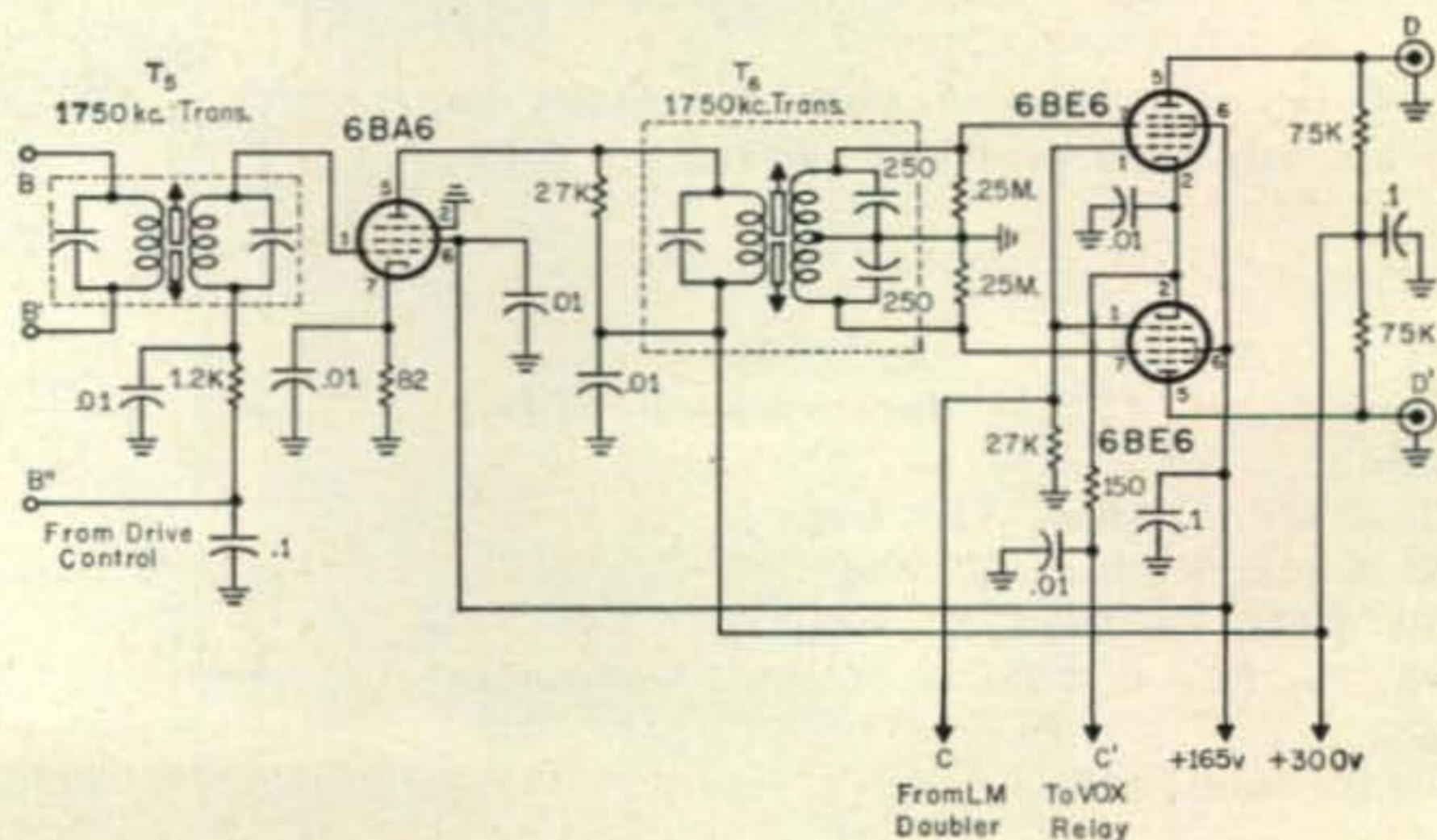

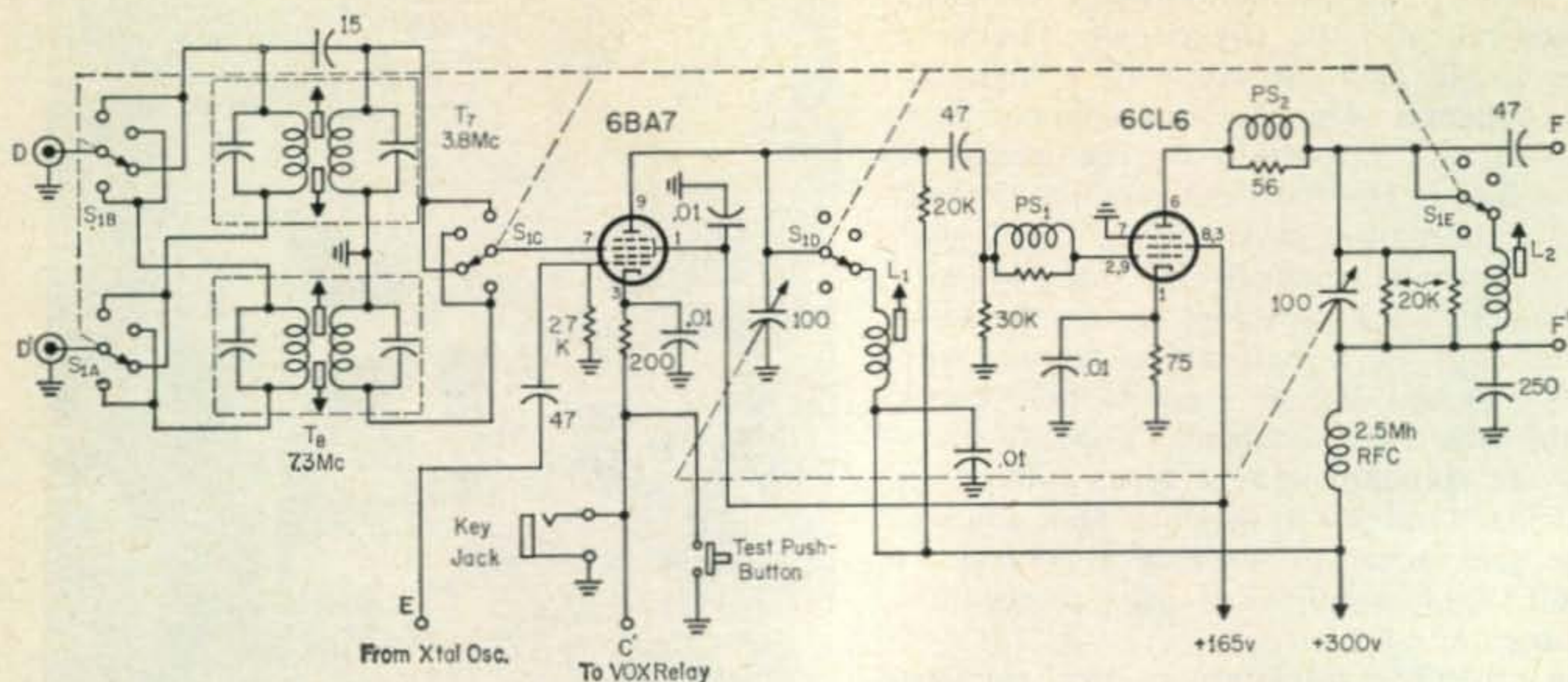

Fig. 5—Circuit of the r.f. section of the exciter. The 6BA7 acts as a straight through amplifier for 3.5 and 7 mc and as a mixer when operating on 14 or 21 mc. The mixing signal, fed to point E, is obtained from the crystal oscillator of fig. 7. The 6BA7 and 6CL6 outputs have individual slug tuned coils for each band.

PS₁, PS₂—4t #22E on 56 ohm 1 watt carbon resistor
 T₇—4.5 mc i.f. transformer with turns added and increased coupling

T₈—10.7 mc i.f. transformer with turns removed and increased coupling.

S₁—Bandswitch, 5 section, 4 position ceramic wafer

is a 6BA7 which operates straight through without any injection signal on the 3.5 and 7 mc bands. A 10.5 or 14 mc injection signal from the crystal oscillator is used when operating on 14 or 21 mc respectively. These crystals have trimmers for precise adjustment of operating frequency. The 6BA7 output is band-switched, with slug tuned coils, as is the following 6CL6. These coils are wound on National XR-50 slug tuned forms and the number of turns is selected to resonate on the desired band. Reference should be made to standard coil charts. A dual section variable tuning capacitor is used to resonate the 6BA7 and 6CL6 stages.

for driving a high powered final amplifier, the second 6146 is merely pulled from its socket. Slight readjustment of the 6CL6 plate slugs is required.

The 6146 plate circuit is a homemade multi-band tank, covering from 3.5 to 21 mc with one set of coils and one double section tuning capacitor. The output link is series tuned to provide a wide range of loading adjustments. A 12" length of RG-8/U coaxial cable connects the output jack to the jack on the final amplifier.

Parasitic suppressors are required in the grid and plate circuits of the 6146's and the 6CL6. These suppressors are 56 ohm 1 watt carbon resistors with 4 turns of #22 wire wound around each resistor. The plate tank circuit of the 6BA7 third mixer is loaded by a 2 watt 20,000 ohm carbon resistor, and that of the 6CL6 is loaded with two of the same resistors

Output Stage

The output stage uses either one or two 6146's as desired, and they operate in parallel, as shown in fig. 6. If only one tube is required

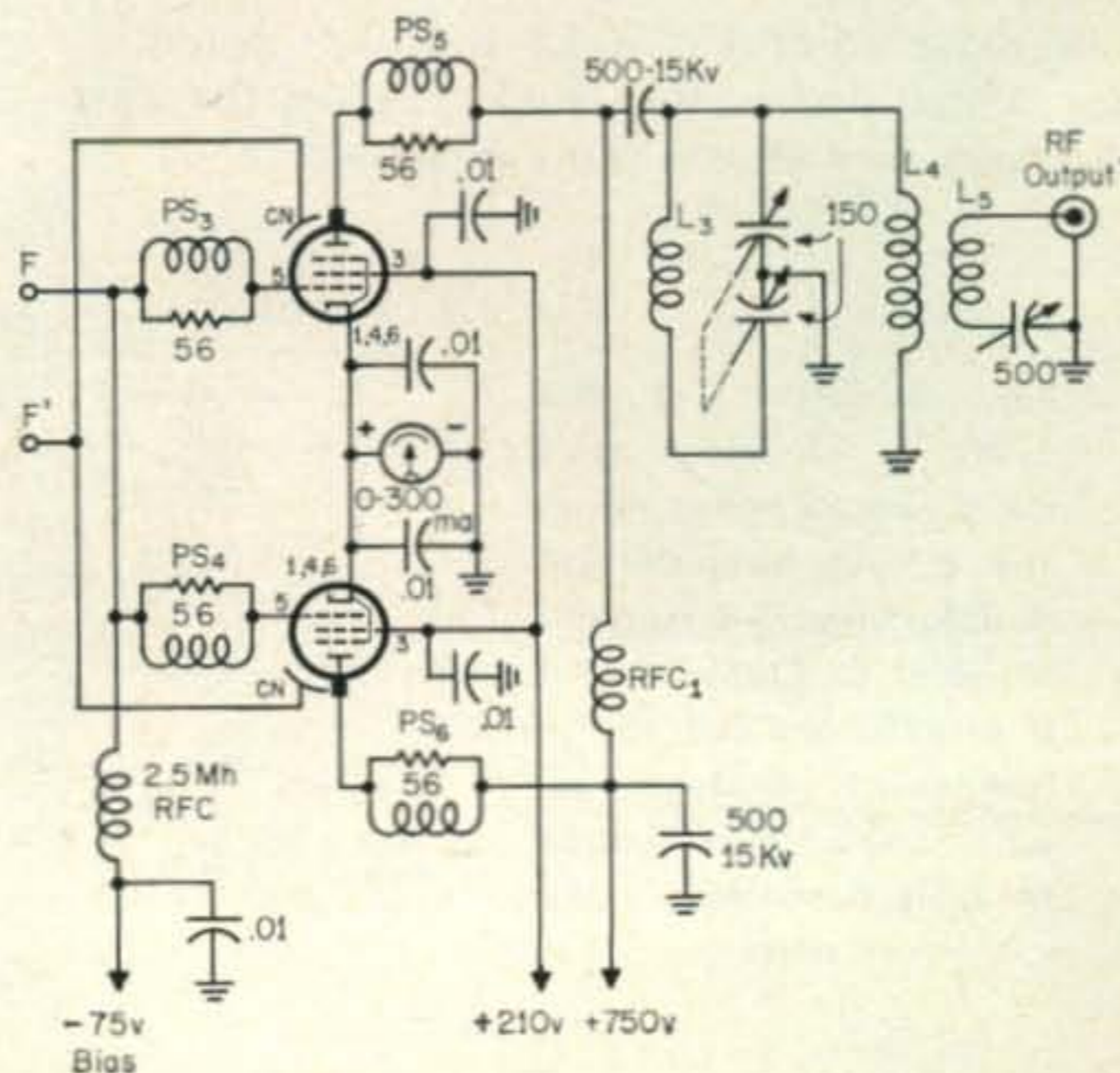

Fig. 6—Circuit of the final r.f. stage. Two 6146's are shown but only one is used when driving the linear.

C_N—Sheet cooper, 4" × 1" mounted about 1/2" from the 6146's.

L₃—12t #12E, 1" diam, 1 3/4" long

L₄—19t #12E, 1" diam, 2" long

L₅—5 1/2t #12E, 1 1/2" diam, 3/4" long

PS₃, PS₄, PS₅, PS₆—4t #22E on 56 ohm 1 watt carbon resistor

RFC₁—B&W Model 800 r.f.c.

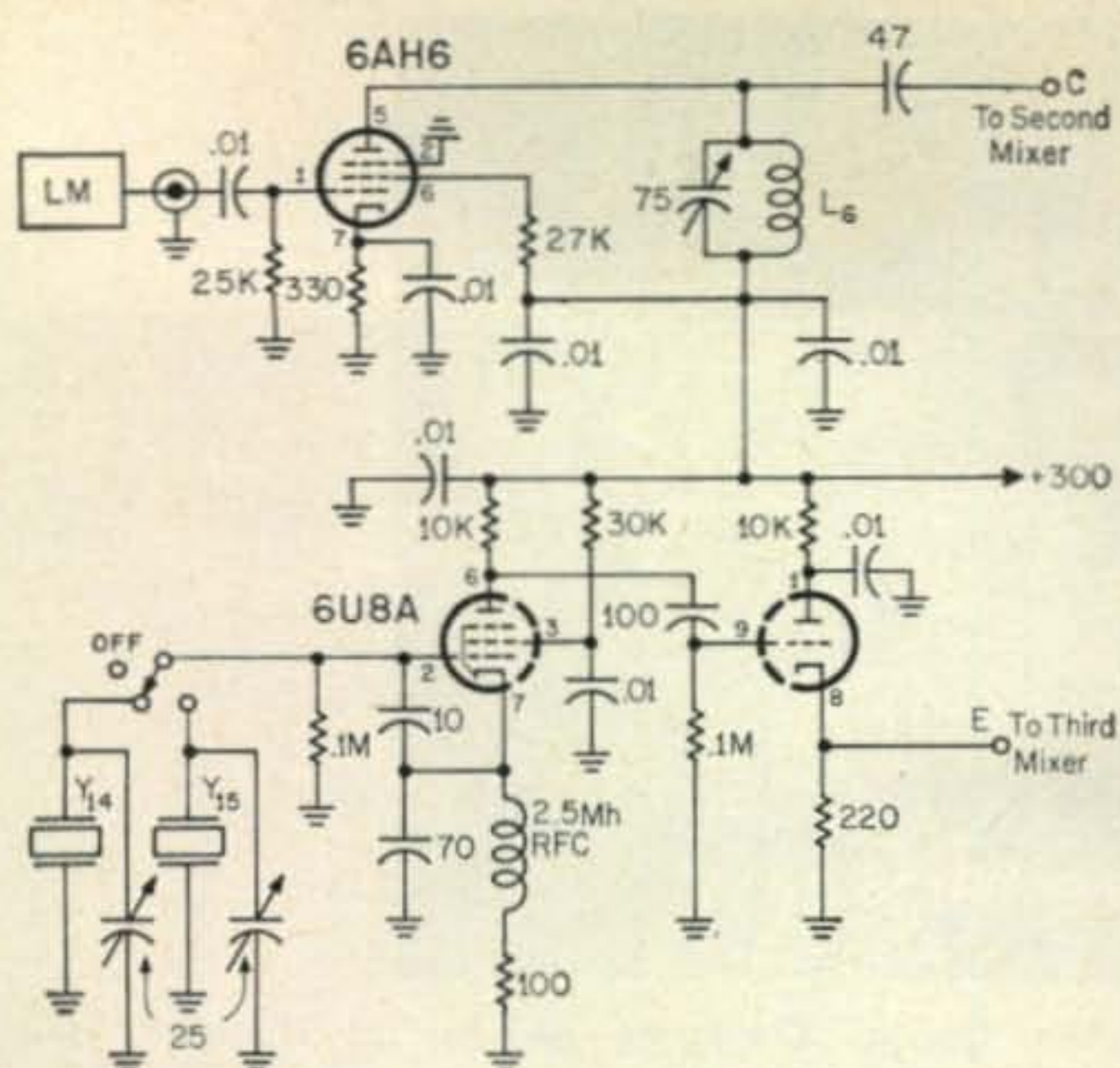

Fig. 7—Circuits of the doubler stage fed by the LM frequency meter and the crystal oscillator used for the third mixer stage in fig. 5. There is no r.f. connection between the two circuits. They merely share a chassis.

Y_{14} —10.5 mc

Y_{15} —14 mc

L_6 —15t #24E, 1/2" diam, 1" long, resonant at 5.5 mc

in parallel, to provide swamping for good linearity and very stable operation.

LM Doubler and Crystal Oscillator

Figure 7 shows the LM doubler stage and the 10.5 or 14 mc crystal oscillator. They are shown together because they are located together on the small chassis at the front of the unit. However, they have no r.f. connection with each other and their internal wiring is kept as separate as possible. The LM output on 2625 to 2875 kc is doubled by the 6AH6 stage to give the required injection frequency of 5250 to 5750 kc for the second mixer. The 6U8A pentode section is the 10.5 or 14 mc crystal oscillator, and the triode section is a cathode follower isolation stage which feeds the third mixer. On 3.5 and 7 mc, the crystal switch is in an "off" position.

LM Conversion

What I am going to say now regarding conversion of the Navy LM Frequency Meter will also apply to the Signal Corps BC-221 Frequency Meter. There are many of these two types in amateur stations, and with or without their calibration books they make excellent v.f.o.'s. In my case I added a small outboard power supply and mounted the unit on a standard 8 3/4" rack panel. A hole for an SO-239 coaxial connector was cut in the rear of the LM cabinet.

The filament circuit was changed quite easily from 12 volt series to 6 volt parallel operation by shorting out the 20 ohm resistor, R_{113} , in the 76 filament circuit, and by moving one filament lead on the 6A7 socket and connecting

that terminal to ground.

The next step was to provide increased output from the LM oscillator. Refer to fig. 8 Plate resistor R_{104} , 56,000 ohms, in the 77 oscillator circuit, was removed. This resistor is accessible through the two openings in the left end of the LM chassis. A standard 2.5 mh r.f. choke was installed in its place. It will fit in the space available. A lead from the plate end of the choke was then brought out to a 200 mmf blocking capacitor. A small, fixed tuned pi-network was installed at the rear of the chassis just behind the 77 tube. Its circuit constants are shown in the diagram. The number of turns in the coil was adjusted, by reference to the station grid dip meter, to resonate at about 2775 kc. The coaxial connector was installed using fairly heavy wire to make it sufficiently self supporting so that it fitted properly into the hole in the rear wall as the unit was pushed into the cabinet. The connector was fastened to the cabinet by inserting 6-32 screws into holes tapped in the flange of the connector. The output from the LM was then sufficient to drive the 6AH6 doubler to full output over the entire 500 kc range from 5250 to 5750 kc. The modifications to the LM in no way affect its stability, nor do they affect its usefulness as a frequency meter or signal generator when it is not being used as a v.f.o.

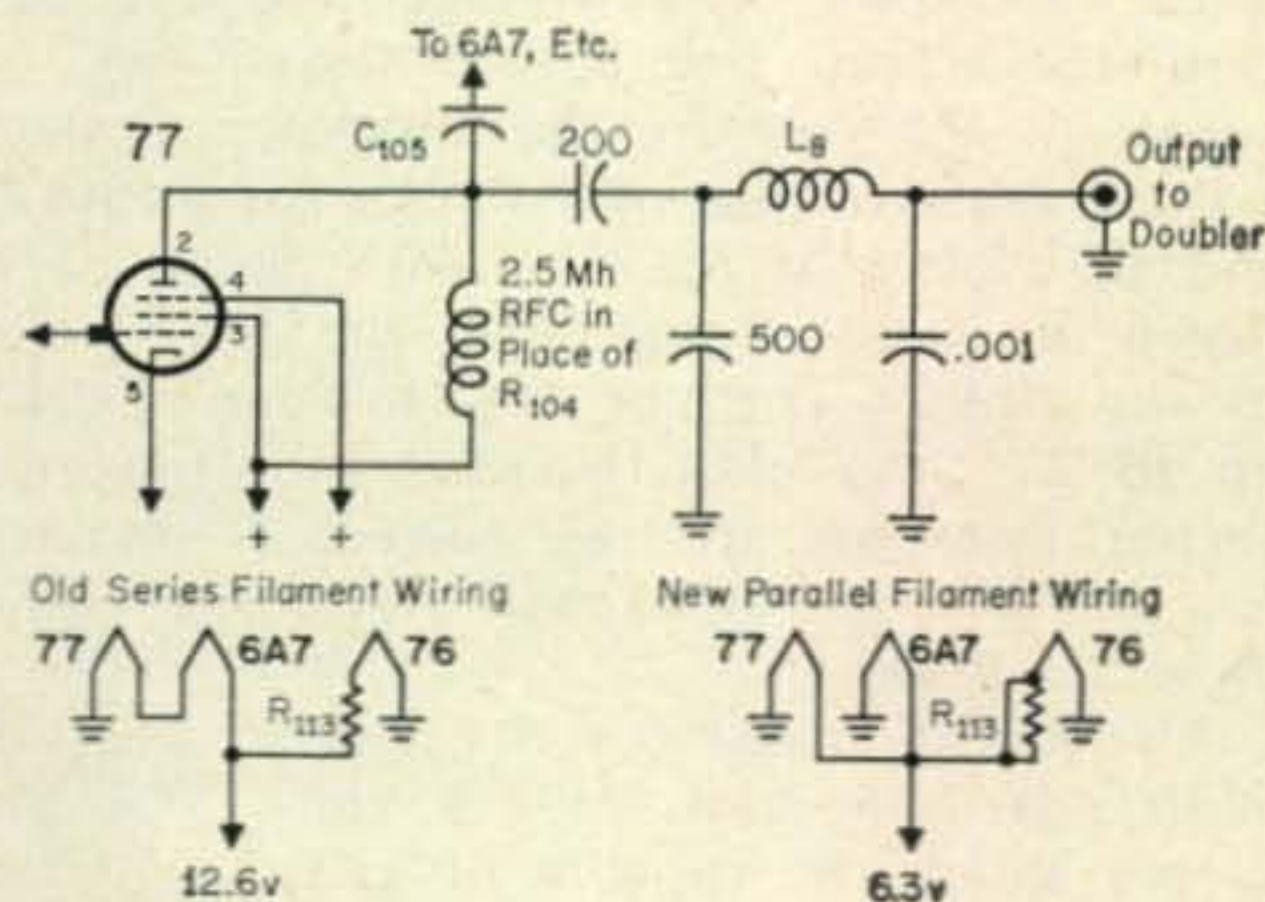
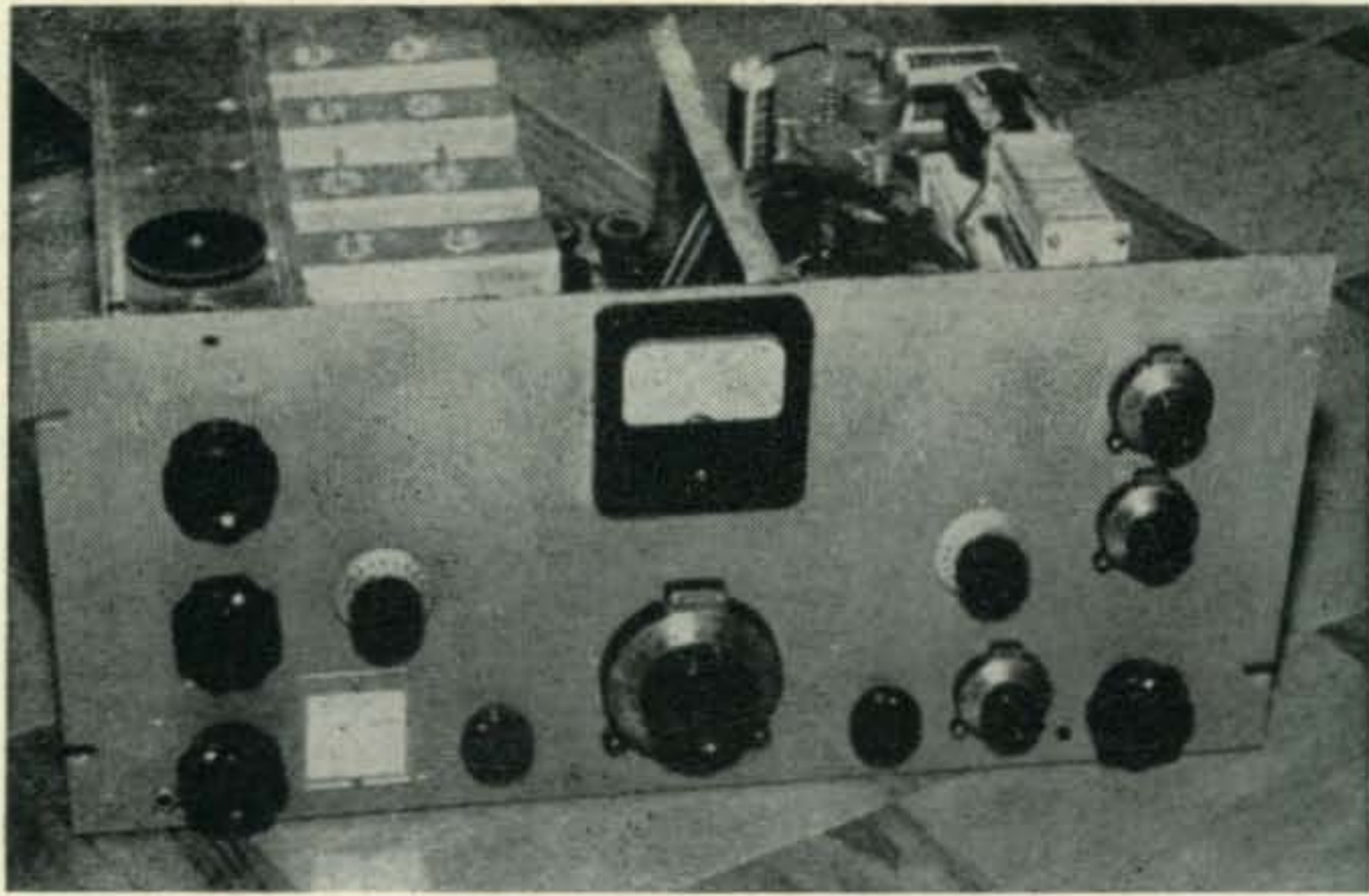

Fig. 8—Modifications made in the filament and output circuit of the LM so that it may be used as a v.f.o. This does not preclude its use as a frequency meter also. Inductance L_8 is 22 turns of #22E, 1" diameter, 1" long.

VOX Circuit

The vox stages are shown in fig. 9. A 6SQ7 amplifier is used to fully drive a 6SR7 which is used as a self-biasing rectifier. The vox relay is normally pulled in, but releases during talking. One set of vox relay contacts opens the d.c ground cathode returns of the second and third mixer stages when not talking, providing complete cutoff of carrier or any small mixer products which might leak through to produce interference in the local receiver. A second set of contacts on this relay operates the coaxial antenna changeover relay in the transmitter and the receiver silencing relay in the 51J-2



Front panel view of the exciter. The control functions are: Left top, Carrier Injection; center, Sideband Selector; bottom, Audio Gain. To the left of the Audio Gain Control is the mike jack. To the right of the Sideband Selector is the I.F. Gain control. Along the bottom row, to the right of the Audio Gain are,

receiver. The operating threshold and hold time of the vox are adjusted by means of the potentiometers R_1 and R_2 respectively.

Power Supply

The exciter is powered from a supply which gives 750 volts plate voltage and 210 volts regulated screen voltage for the 6146's, 300 volts and 165 volts for the low-powered stages, a fixed negative bias of 75 volts for the 6146's and 6.3 volts for the filaments. Some of the bias is also bled off and fed to the drive control for the 6BA6's. The pair of 6146's can be driven up to 275 ma plate current with maximum carrier insertion. Resting current is about 30 ma and a single 6146 will show one half of these readings.

The total filament power required, using two 6146's, is 7.35 amps at 6.3 volts. The plate supply should be capable of giving 750 volts at 275 ma for the 6146's, and 300 to 350 volts at 200 ma for the low power stages. The 6146 screen voltage is obtained from the 350 volt

the Crystal Oscillator switch; LM Doubler tuning, dummy knob, 6BA7-6CL6 Tuning and the Bandswitch. The upper right is the Output Link Loading and just below it is the 6146 plate tuning. To the left is the vox override switch. The meter is in the cathodes of the 6146's.

supply, using a dropping resistor and two VR-105's in series to hold it at 210 volts. The dropping resistor should be of such value that the VR105's do not extinguish during modulation. The 165 volts for the screen of the low power stages is obtained from a voltage divider on the 350 volt line and is not regulated. The 75 volt bias supply is obtained from a small 6.3 volt filament transformer, hooked up backwards and fed from the 6.3 volt filament circuit, in conjunction with a selenium rectifier and a VR75 tube. This supply must be regulated, to hold the grid bias on the 6146's steady.

Alignment

The i.f. strip should be aligned to obtain the curve shown in fig. 10. Since the crystal frequency rests on the edge, 480.55 kc, care must be taken to get the proper curve, particularly if the crystal oscillator is used as the signal source. A sweep alignment using a sweep generator and oscilloscope would be ideal but it can be accomplished with the LM frequency meter also.

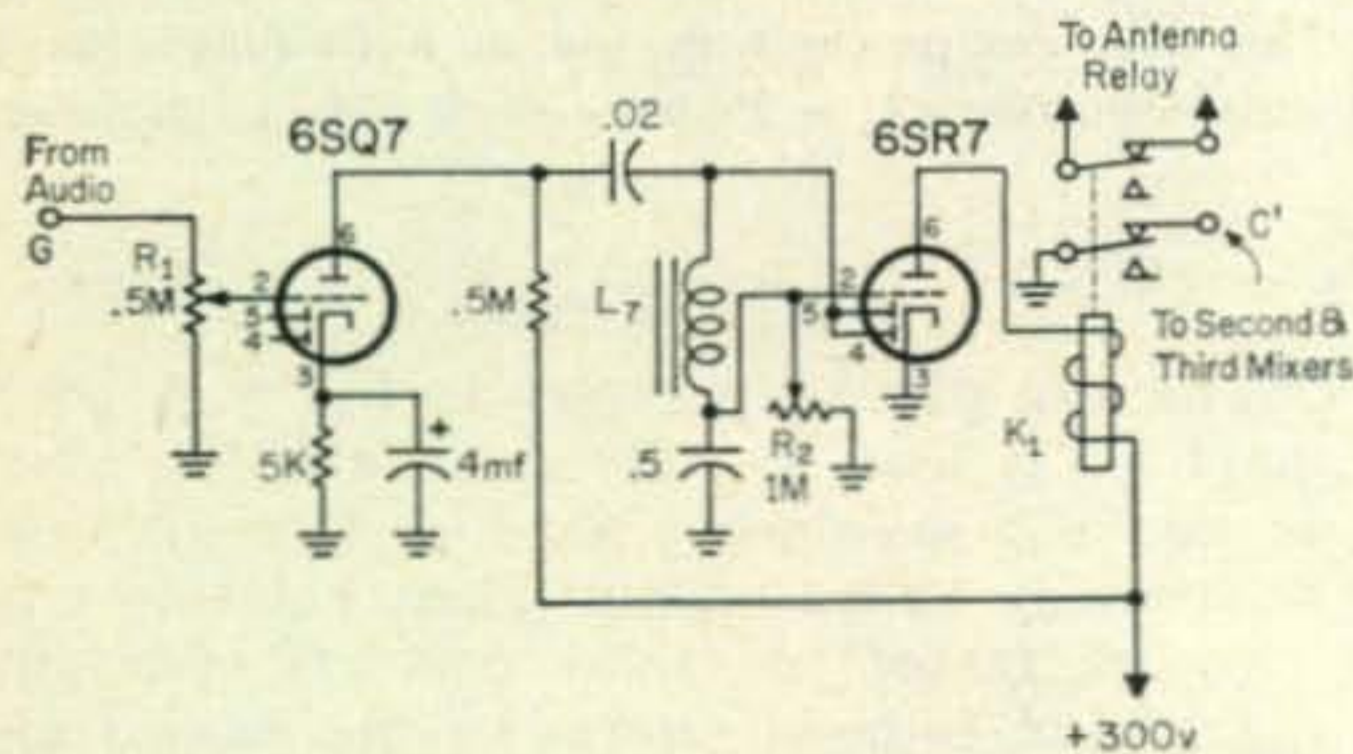

Fig. 9—Circuit of the vox stages. The audio signal, applied to G, is obtained from point C in fig. 2. Controls R_1 and R_2 adjust operating threshold and hold time.

K_1 —Potter Brumfield LM-11, 10 K coil
 L_7 —4.5 h @ 50 ma. Stancor C-1706

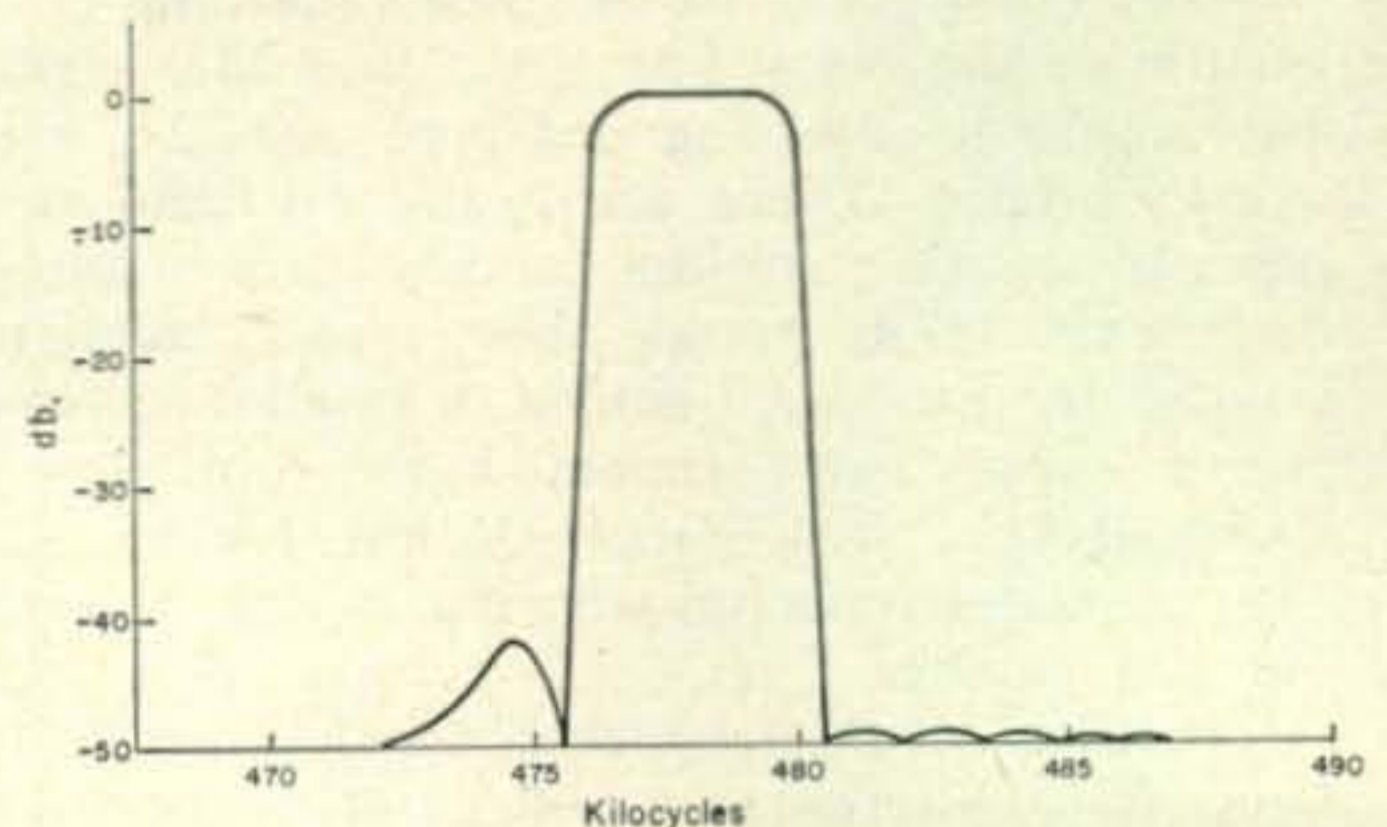
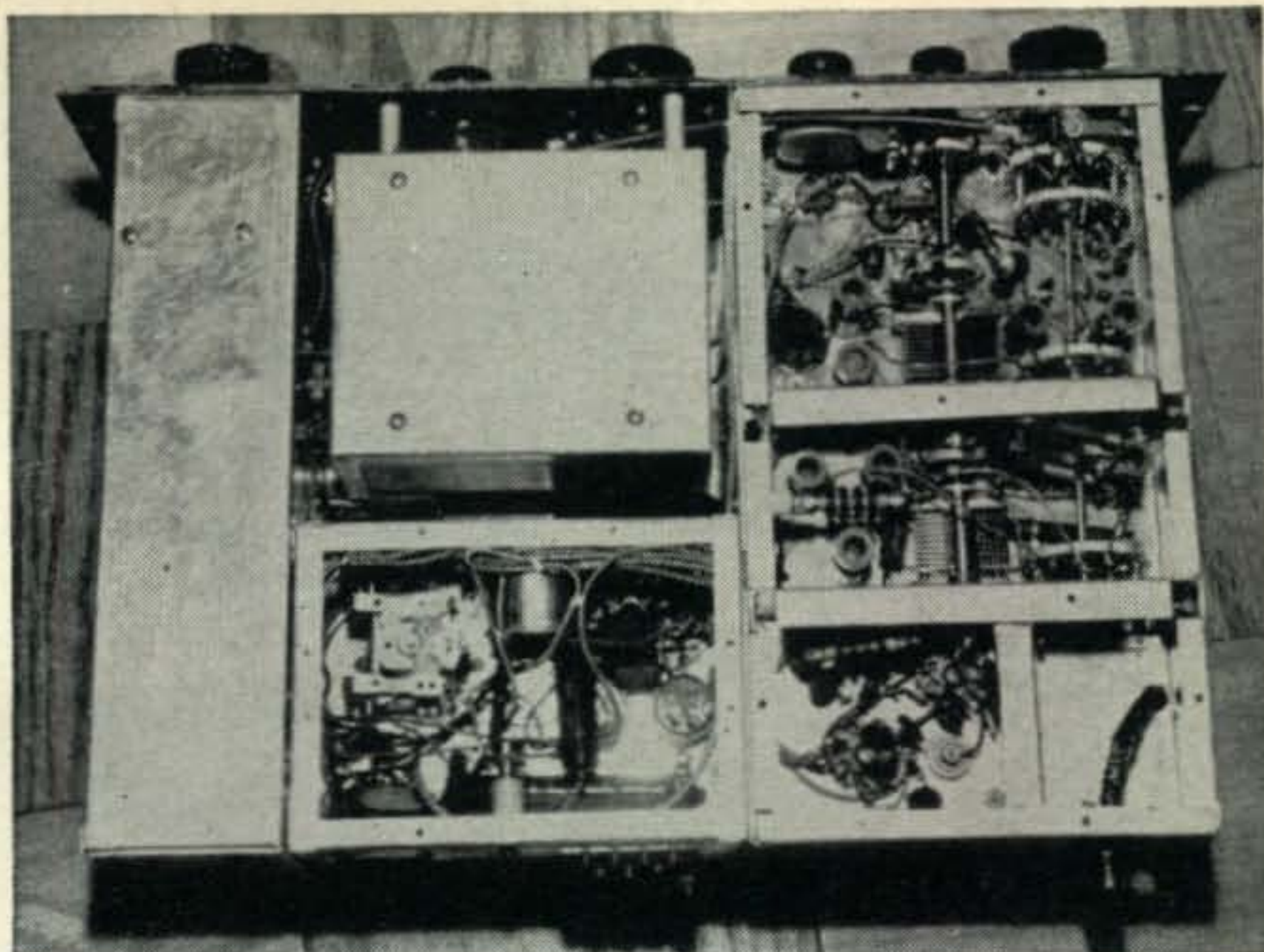

Fig. 10—Response curve of the 480 kc i.f. when properly adjusted.

Bottom view of the chassis shows the r.f. section on the right. Note the dividers between the third mixer, driver and final stages. This is covered by aluminum mesh to complete the shielding.



The LM, set up as a low frequency signal generator, may be fed into the i.f. strip and output measurements can be made with a v.t.v.m. and a diode probe at the required points. The LM frequency can then be shifted across the i.f. bandpass and the output plotted. The slug tuned coils in the r.f. stages can be set roughly with a grid dip meter, and then peaked to full output with the LM in the v.f.o. mode driving the exciter.

Operation

The controls on the front panel of the exciter are: CARRIER INJECTION, SIDEBAND SELECTOR, AUDIO GAIN, DRIVE CONTROL, CRYSTAL OSCILLATOR SWITCH, DOUBLER TUNING, dummy knob (for appearance), R.F. TUNING, BANDSWITCH, OUTPUT TUNING, OUTPUT LOADING, and VOX OVERRIDE SWITCH.

In spite of the number of front panel controls, the exciter is very easy to use. In operation, on one band, it hardly requires any adjustment. Some retouching of tuning is required in shifting from 3.8 to 4 mc, but on the other bands no retouching is required. In changing bands only six controls are moved; the BANDSWITCH, the CRYSTAL OSCILLATOR SWITCH, the R.F. TUNING, the OUTPUT TUNING, the OUTPUT LOADING, and the SIDEBAND SELECTOR.

The Japanese vernier dials, purchased from Lafayette Radio, are used on some controls. These are set to pre-calibrated positions by reference to a tuning chart which is mounted on the front of the transmitter. All the other controls, once set for a band, are normally left alone during operation. The sideband reversal switch may be operated as desired. Re-tuning of the complete transmitter to the pre-calibrated settings for another band, and remotely switching the four-band antenna has been timed at about 35 seconds.

A microphone jack and key jack are also provided on the front panel. The meter is in the 6146 cathode circuit, and it is one of the very fine 0-1 ma 3" square Japanese meters

currently being sold by Lafayette Radio for \$3.95 each. I carefully drew a 0-300 ma scale for it, and put a shunt of nichrome resistance wire across the meter terminals, calibrating it to 300 ma full scale reading. I might say in passing that the three meters in the final amplifier are now of the same type, re-calibrated for the desired ranges. They add much to the appearance of the transmitter.

It will be noted that no provision is made for operation in the 28.5 to 29.7 mc band. I did not feel it worthwhile to do so. It can be done with an additional crystal in the crystal oscillator, an additional bandswitch position, and the proper slug tuned coils.

Conclusion

This exciter gives excellent service, and puts out a beautifully clean signal. It was cleaned of every possible bit of distortion by the simple means of playing hi-fi music through it into a dummy load, listening to it on the 51J-2 receiver, and making the required adjustments. If there is anything that will show up distortion immediately it is listening to Freddy Martin's orchestra, Julie London singing, or a good organ record through this unit. I spent many hours adjusting cathode bias resistors, grid and plate loading resistors, and anything else that could contribute to distortion, with the result that I can proudly say that the unit is *clean!* On-the-air results prove this also, with wonderful signal quality reports from all stations contacted.

I wish all of you good luck in building this exciter. I personally find much pleasure and pride of workmanship in building a piece of fine equipment such as this, in preference to buying a new commercial unit off a dealer's shelf. The design and construction is an interesting challenge. I know what I have when I'm finished, and I know that it is *right*. For those of you who wish to write for further information, I will be glad to answer inquiries. Please include a stamped envelope. ■

Improving The Link 2365 and 2210

BY WARREN RUDOLPH*, W4OHH

The Link wide-band f.m. transmitter-receiver units are excellent buys on the surplus market. The 2365 can operate from 27 to 54 mc and the 2210 from 152 to 174 mc. The transmitter modifications kits are listed and the receiver modifications are described in detail.

RECENTLY a large number of the very excellent Link 2365 and 2210 transmitter-receiver units have become available at rather attractive prices. These units were originally designed for use in wide band f.m. service by police, commercial and industrial users. When used in the wide band systems for which they were designed they were capable of excellent performance, equaling, and in many cases exceeding, the performance of any other equipment of comparable price and vintage. However, when used in systems operating under the new narrow band regulations they suffer from several shortcomings. Fortunately the transmitter shortcomings have been taken care of by the manufacturer and his successor in the form of modification kits¹ which are readily available at reasonable cost. These consist of splatter choke and low pass filter kits for the transmitter speech amplifier, deviation limiting kits for the f.m. modulator and low pass filter kits for the r.f. output. However, on the receiver end very little has been done toward working out any thorough modification to improve the audio recovery and receiver i.f. gain. This, then, is the purpose of this article.

Description of Units

The 2365 is an f.m. transmitter-receiver unit capable of operation on the 10 meter band with no conversion whatsoever and, with very minor modifications, can be operated in the 6 meter band. It can also provide excellent performance on any other frequency in the 27 to 54 mc range. These units have a rated transmitter power output of 30 watts and a receiver sensitivity of well under $\frac{1}{2}$ microvolt.

The 2210 is designed for service in the 152-174 mc band but is also capable of operation in the 2 meter band with very minor modifications. This unit has a frequency modulated output of 10 watts and a receiver sensitivity of under $\frac{1}{2}$ microvolt. These units are normally supplied for use on 6 volts d.c. but are converted to a.c. operation by the simple ad-

dition of a power supply which consists of nothing more than a transformer, rectifier, relay, capacitor and fuse. This unit is shown schematically in fig. 1. The relay, K_1 , is tripped whenever the push-to-talk button is depressed. This raises the a.c. input to the power supply when the load is heaviest. When the handset button is released the load decreases and K_1 returns to the normal input. Conversion to 12 volts is a simple matter and the manufacturer has wisely provided conversion kits at very reasonable cost.

Commercial broadcast stations are not interested in narrow bandwidth but in audio fidelity and output level. The modifications described first will result in about a 2 to 1 gain in audio as well as a vast increase in fidelity. The improvements gained will of course, also be equally valuable to the amateur, civil defense or commercial operators. The other described modifications will result in about a 50% increase in the audio recovery from the discriminator and also in about a 20% increase in the gain of the i.f. strip. It will also considerably narrow the pass band of the i.f. strip with consequent improved rejection of



View of the Link 2210 showing the chassis, chassis cover and control head. The Jones plug on the chassis is for connection to the control head. The 2365 unit is identical in size but slightly different in appearance.

*743 Berryville Ave., Winchester, Virginia

¹Platt Electronics, 20 Murray St., N.Y.C. 7, N.Y.

Fig. 1—Circuit of the power supply used to operate either the 2365 or the 2210 from the a.c. line. The cable shown is used to connect the control head to the main chassis. When this circuit is employed the vibrator is removed and pin 2 of the vibrator socket must be grounded.

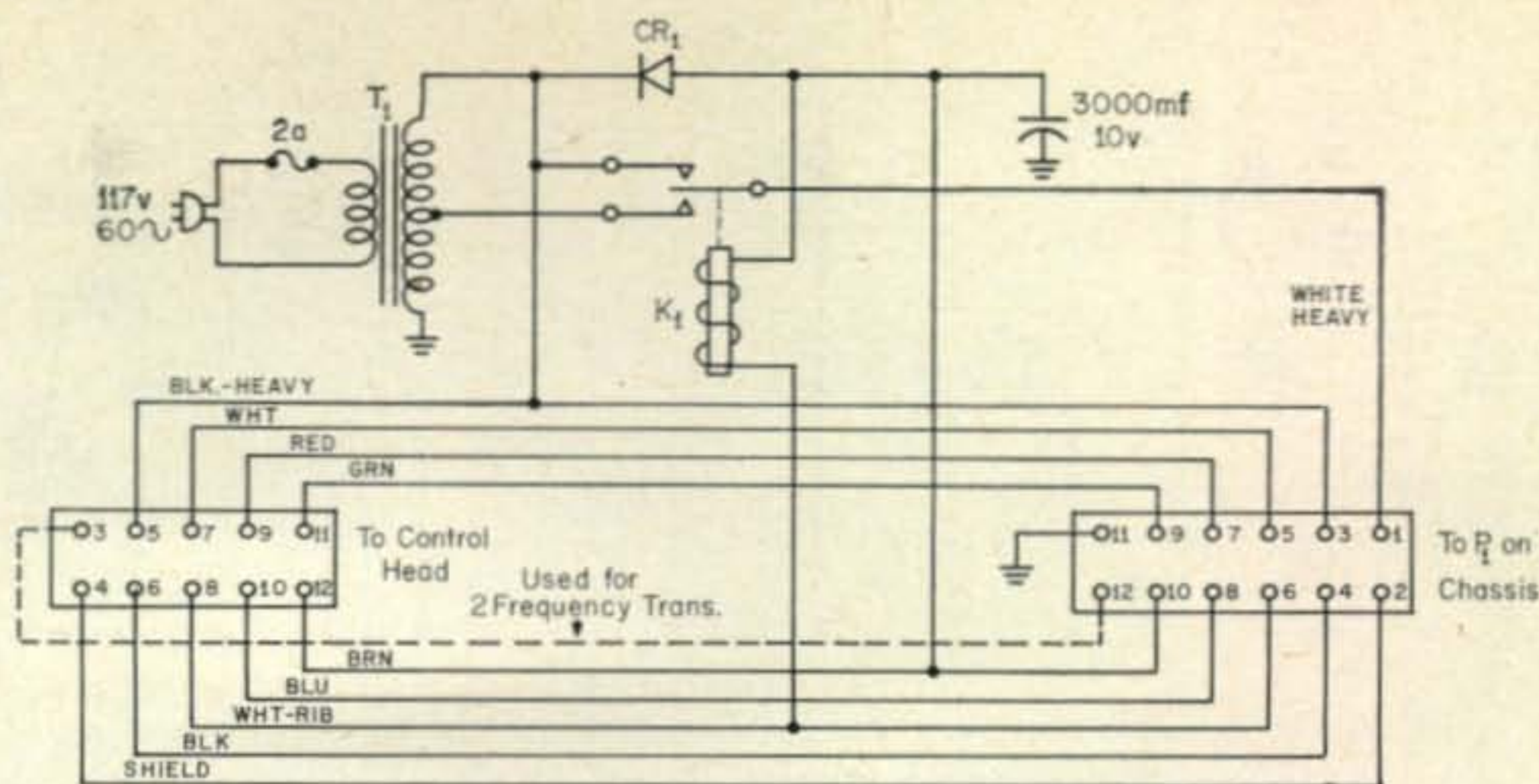

CR₁—Selenium Rectifier, 2A. Link #4H1B2.
K₁—Relay 6 volt, Link #204AM-LH6.

T₁—8 volts tapped at 6 volts 20 amperes, Link #TR-1049

adjacent channel interference. When all 3 modifications have been performed, the receivers audio recovery and output will be 3 to 4 times what it was before and the pass band will have been nearly cut in half.

Increasing Audio Output

A glance at the partial schematic of fig. 2, the 2210, and fig. 3, the 2365-ed2a, will show the general schematic layout of these two units and the basic similarity between the 2365 and the 2210. The following description refers to the 2210:

The discriminator output passes through resistor R₅₃, which is 220,000 ohms in some units and 100,000 ohms in others. It is then bypassed to ground through C₈₄, a 3900 mmf capacitor which drains off a good percentage of the audio as well as seriously attenuating the high frequency component. From here it passes through R₅₄ which is a 100,000 ohm resistor and is then connected to R₅₅, the 250,000 ohm volume control. On some models this is also shunted by C₈₅, a 2,000 mmf capacitor which further attenuates the audio. A little arithmetic will quickly reveal that the total audio appearing across the volume control and available to drive the audio stages is considerably less than half of the total actually available from the discriminator.

Locate and remove resistor R₅₃, 100K or

220K depending upon the model. Now wire in a jumper across the terminals where R₅₃ was connected, thus completing the circuit. Also remove C₈₄, the .0039 mf capacitor. If your model has a .002 mf capacitor, C₈₅, connected across the volume control, remove it also.

Increasing the Discriminator Audio Recovery Ratio

As the unit is originally supplied, resistors R₅₁ and R₅₂, the discriminator load resistors, are each 100,000 ohms. To provide an improvement at this point, remove these resistors and replace them with two 470,000 ohm ½ watt carbon resistors. Check several 470,000 ohm resistors with an ohm-meter and replace these with two that are matched as closely as possible to assure discriminator balance. The audio recovery for a given signal input and deviation will now be at least 50% greater than before.

Improving I.F. Bandpass

With the chassis upside down and the antenna and power plug end facing you, locate the bottom of T₁₀, which is located directly behind the selenium rectifier. Remove the nuts from the studs holding this transformer to the chassis. Now turn the unit right side up and remove the two nuts from the top of the transformer can marked T₁₀ and remove the can. (Note that the side of this can marked BAL is

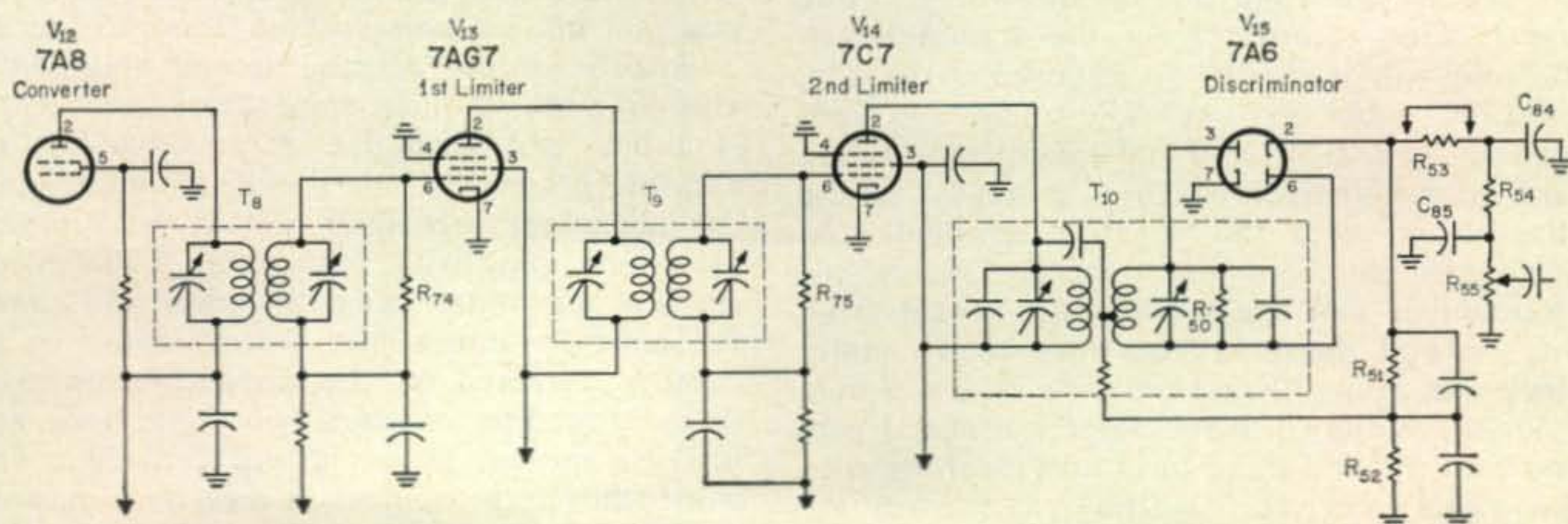

Fig. 2—Partial schematic of the 2210 i.f. and discriminator. All modifications are made in the second i.f. strip of the double superheterodyne and the discriminator.

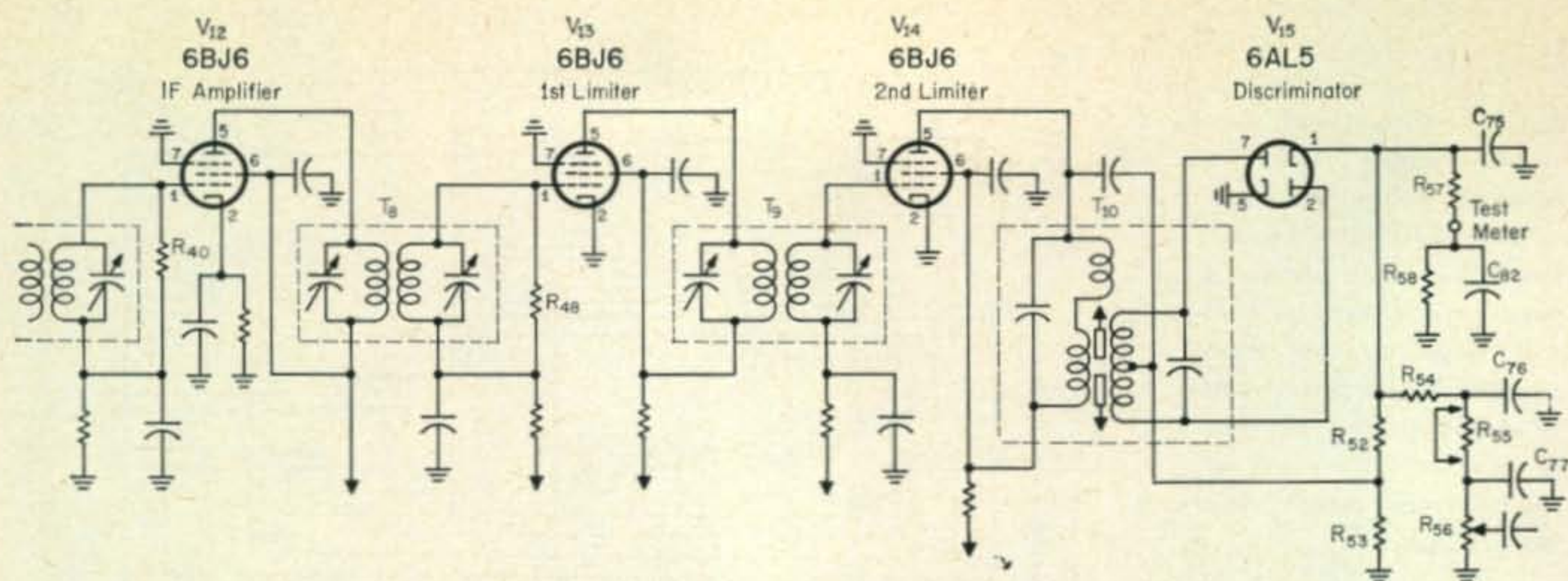

Fig. 3—Partial schematic of the 2365 ED 2-A i.f. and discriminator. This model uses miniature type tubes rather than the locktal series. Note the similar circuitry compared to the 2210. The following components are removed: R_{40} , R_{48} , R_{55} , C_{76} , C_{77} . Resistors R_{52} and R_{53} are changed to a matched pair of 470K units.

toward the outside of the chassis. Replace it in this position when through with the following operation) Now locate R_{50} , a 47,000 ohm resistor soldered between the upright support wires of T_{10} on the side next to the outer edge of the chassis. If V_{15} , the 7A6, is removed it will be easier to cut R_{50} loose with a pair of side cutting pliers. Remove and discard R_{50} and reassemble the transformer can, being certain to mount the can with the BAL side toward the outer edge of the chassis.

Again with the chassis upside down and the plug and antenna end facing you, locate the bottom of T_9 , the 2nd limiter i.f. transformer. Looking down the center of the chassis the first tube is the 7C7, second limiter. Immediately behind this is transformer T_9 . Note that a wire runs from pin 6 of V_{14} , the 7C7 2nd limiter, to the high side of the secondary winding of this transformer and that R_{75} , a 100,000 ohm resistor, is connected directly across the secondary. Remove this resistor and discard it.

Immediately behind T_9 is V_{13} , the 1st limiter, and just behind the center partition and to the rear of Y_{13} is T_8 . The first limiter grid transformer. Connected directly across the secondary of this transformer is R_{74} which is a 68,000 ohm resistor in some models and 220,000 ohms in other models. Remove and discard this resistor.

Turn the unit right side up and with a strong signal being received from the station which the unit will normally be required to receive, carefully rock the BAL adjustment for zero reading on a 0-50 or 0-100 microammeter the positive terminal of which is grounded to the chassis and with the negative terminal connected to pin 2 of the metering socket, J_2 . (Remember you are reading the socket from the top and therefore you must read counter clockwise rather than clockwise as you would from the bottom.) Now connect a signal generator to the first mixer grid and carefully rock the signal generator to zero reading on the discriminator. Make certain that the signal and rejection of adjacent channel interference.

generator is thoroughly warmed up so that it will not drift while you are completing the rest of the alignment. Now insert the negative lead from the microammeter into pin 4 of the metering socket after having switched to a slightly higher scale. Be certain to lower the signal generator input to the point where it just overrides the noise and carefully adjust the primary and secondary of T_9 for maximum reading. Repeat this adjustment several times as the primary and secondary will interact to some extent.

Next switch the microammeter back to 0-50 or 0-100 range and insert the negative lead into pin 3 of the metering socket. Carefully adjust the primary and secondary of T_8 , T_7 , T_6 and T_5 for maximum reading. Repeat the adjustments several times as some interaction will be noted. Be careful to keep the signal generator input just high enough to quiet the background noise. Before leaving this step, recheck the signal generator to make sure that it is still zeroed on the discriminator secondary pass band and then recheck against the station you plan to receive to make certain that it also still reads zero center on the meter connected from pin 2 to ground on the metering socket. If these tests check out, then the i.f. strip is accurately aligned. If not, repeat the alignment procedure.

Once the above has been checked out, remove the signal generator and with only the antenna and set noise riding through, the discriminator output reading should stay within plus or minus 2 microamperes of zero center. If it does not, then the i.f. pass band is not accurately centered on the discriminator and the alignment procedure should be repeated. Maximum sensitivity, maximum audio recovery and maximum signal to noise ratio cannot be achieved unless the discriminator is accurately centered on the carrier. Removal of these 3 loading resistors will very noticeably increase the i.f. gain and will provide a very worthwhile improvement in receiver bandwidth and rejection of adjacent channel interference.

[continued on page 174]

A One Tube Electronic Keyer

BY ED STETZER*, K2ZBA

A simple keyer, neither complex nor expensive, suitable for the amateur wanting to "wet his feet" in electronic keyer operation.

FOR 2 years I have been searching for a decent, inexpensive, electronic keyer. I built a few as described in various amateur publications, but was never satisfied with them. Buying one of many good ones on the market was out of the question because of the large outlay of cash. Then I spotted this unit which was modified slightly, mostly cut and try, until I came up with this circuit.

The relays were chosen because they were inexpensive. The Potter Brumfield LB5 relays cost about \$2.50 a piece, and the Sigma relay about \$1.85. With a reasonably well stocked junk box, it will cost very little to build this.

To make this keyer operate quietly (and it does) I used by XYL's sponge rubber powder puffs which cost about 10 cents a piece, for mounting the relays. Using an all purpose cement I glued them to the chassis.

I'm using a power supply I had on hand which delivers about 175 volts. The keyer will operate well at any voltage from about 175 to 300 volts. It would probably work well on 150 volts but I never tried it.

This keyer has been in operation in my shack practically every night for a year and a half with absolutely no trouble at all, and it keys beautifully.

Adjustment

Adjustment is easy; turn on the power supply, turn speed control, to about 8 or 10 w.p.m.; press dot side, and if you wired it up ok and

*8 Laurel Street, Floral Park, N.Y.

nothing is cooking, you should hear the dots. Try the dashes. Then adjust the various controls until you get it where you think the timing is right. There is a slight interlocking of controls, but once set, they will not have to be touched again.

Speed range is adjustable from 5 w.p.m. to as fast as you can use it. In fact it is much faster than I can think. The ratio over these extreme ranges, I have been told over the air, is very good.

Some fellows find a keyer much easier to use if you key it as you would a bug, as I do. I find this keyer extremely easy to use as compared to others I have tried.

Muting

I also discovered, that by placing K_3 in parallel with K_1 I had a f.b. break-in system, for my SX 111. I place the contacts across the muting terminals of the receiver, and used a separate antenna for receiving. When the key is touched, the receiver goes to stand by and remains there until there is a slight pause in sending (about 1 second) and then will come back on again.

With a little practice you will find you can send perfect code. So don't be discouraged, let's have some good c.w. men again.

Have fun building it, and more fun operating it. I key this setup with my bug, which involves a little modification. If you don't want to do that, you might build a key for it. Also there are ones on the market that you can buy. ■

Fig. 1—Circuit of a single tube electronic keyer. Relays K_1 and K_2 are 2.5K Potter and Brumfield LB5 and K_3 is Sigma 11F-9000G. Relay K_3 is optional and when paralleled with K_1 may be used for break-in.

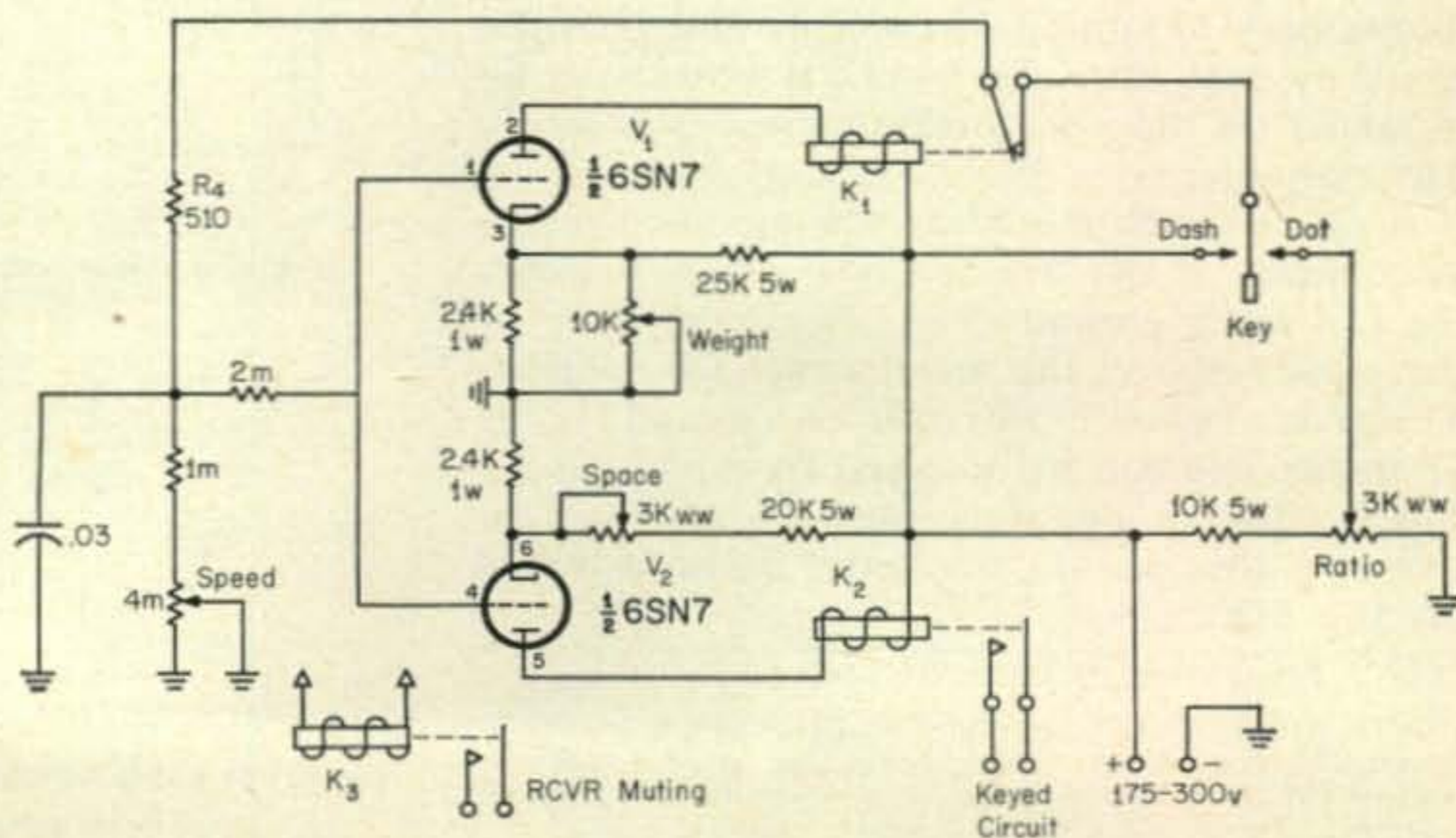

Photocopying Magazine Articles

BY E. H. MARRINER*, W6BLZ

This article describes a method of photocopying magazine pages for filing or reference purposes. It involves a little bit of electronics, mechanics, carpentry and plastics and therefore should be an interesting project for the home workshop.

ANYONE having an extensive collection of magazines will agree that locating articles 10 and 15 years old can sometimes be a problem. For convenience, filing technical articles in folders, cataloged and cross referenced, is the simple solution to the problem.

There was only one company that manufactured a suitable copying machine which would permit different sized magazines to be reproduced. This machine, however, was very expensive.

This article describes a step-by-step procedure for constructing a home made copying machine which results in a copied page as good or better than the commercial unit.¹

The Process

This process is a Photo Rapid Copy method using Gavaert sensitive negative paper and non-sensitive positive paper. A light box covered with a ground glass is used as the light source and after the paper has been exposed, it is placed in a solution and then squeezed, removing the excess developer. The positive and negative paper are separated and a perfect reproduction of the printed page is made.

Light Box

Figure 1 illustrates the dimensions of the light box which was constructed from $\frac{1}{2}$ " plywood. For simplicity a standard 7×19 " rack panel was used for the front of the unit. This allows easy mounting of controls and provides a sturdy and attractive unit. Handles can be mounted on the sides making the copier easily transportable.

A quarter inch moulding was mounted on all three walls of the wooden box which supports the $\frac{1}{4}$ " thick ground glass. The front edge of the glass rests on the metal panel for support. The ground glass in this case measures $12\frac{1}{8} \times 18$ inches and can be obtained from most paint stores. Milk or opal-type glass is more expensive and does not do any better a job of diffusing the light.

*528 Colima Street, LaJolla, California

¹There are certain legal or official documents which cannot be copied. It is suggested that proper authorization be obtained if there is any doubt about such matters.—Ed.

The box was nailed and glued and after it was finished several coats of white enamel paint was applied to the interior. Then eight porcelain light sockets were secured to the bottom, equally spaced as shown in fig. 1.

The 40 watt light bulbs used in the light box are especially made for this purpose. They are manufactured in Switzerland and imported from Belgium by the Pacific Copy Corp., El Segundo, California. If you write to them they will tell you where your nearest dealer is located. These bulbs are coated with a special material *inside* the bulb and after trying ordinary household light tubes, special decoration bulbs and insect repellent bulbs I came to the conclusion there is no substitute for the imported variety. These special bulbs are a little more costly than the ordinary 40 watt light bulb but they are certainly worth the extra cash outlay.

In order to be able to handle small magazines with the same ease as the larger ones, the $\frac{1}{4}$ "

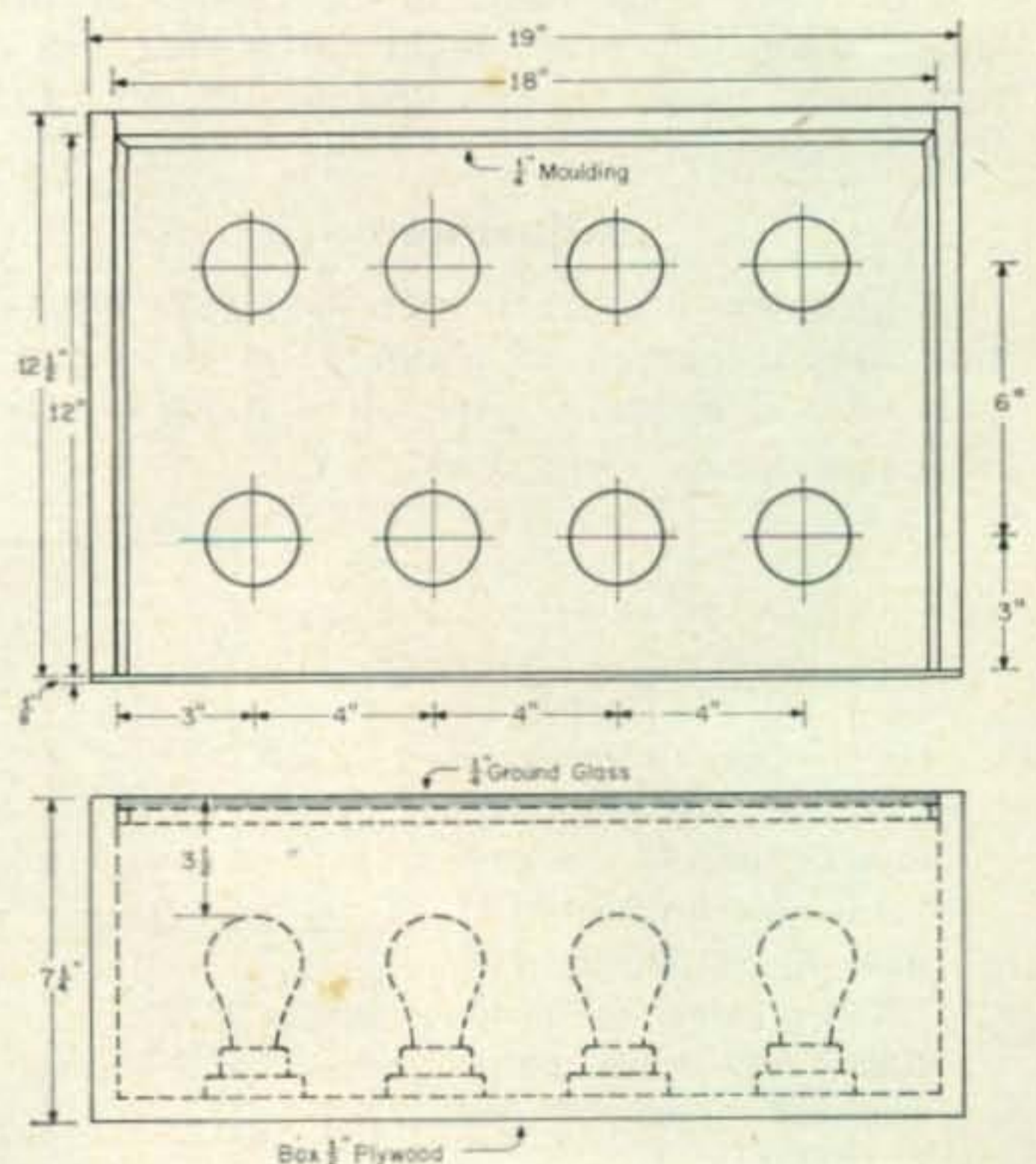
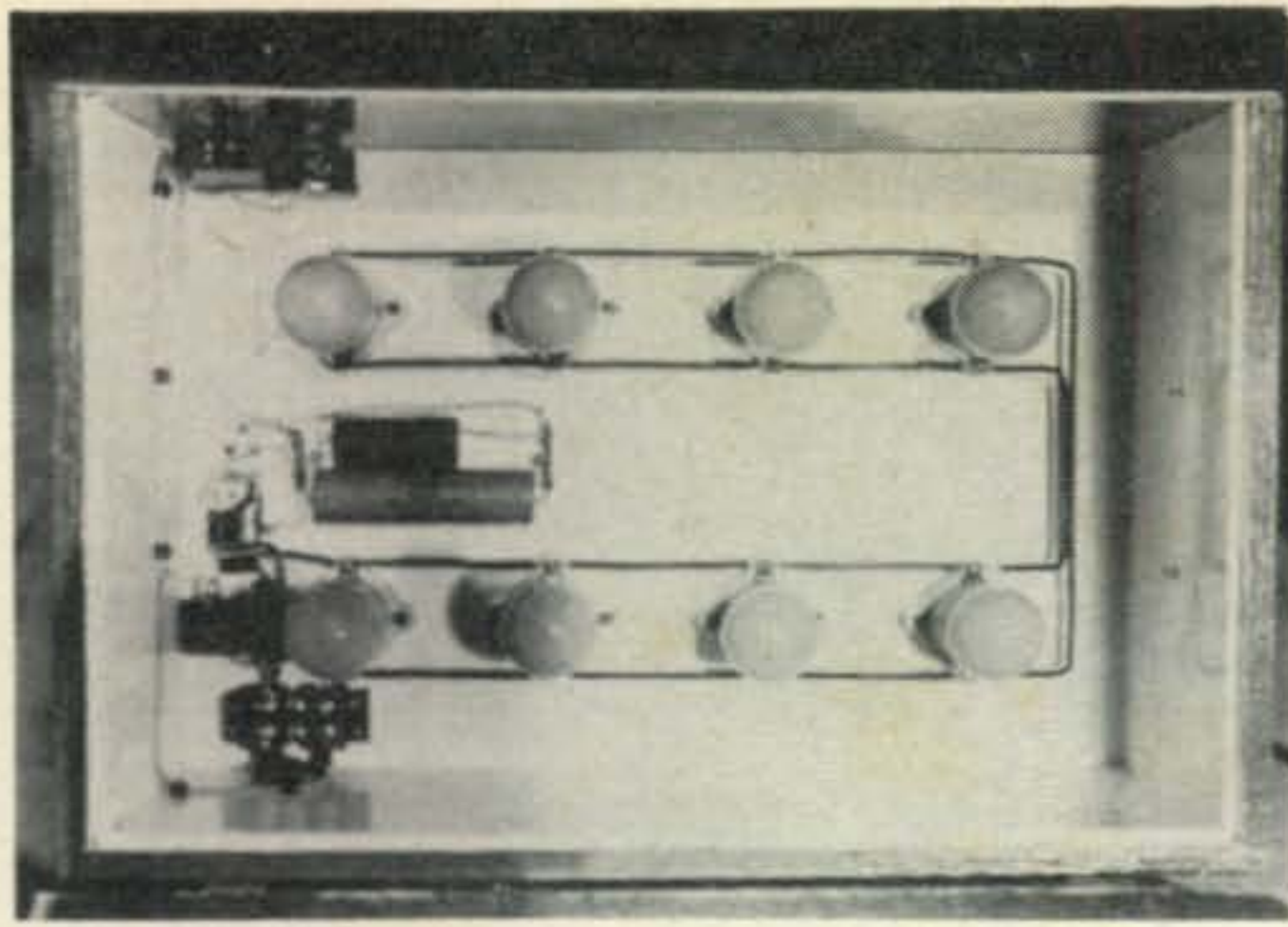

Fig. 1—Construction details for the light box. The ground glass must be $12\frac{1}{8} \times 18 \times \frac{1}{4}$ inches in size. The box is constructed of $\frac{1}{2}$ " plywood and a standard relay rack panel is used for the front.



Top view of the light box showing bulb spacing and timer component location.

masonite cover was split and fastened together with a piano hinge. A piece of felt, $\frac{3}{8}$ " thick was glued to the underside of the hinged cover to provide a soft base which is used to smooth down any wrinkled pages which may not reproduce properly.

Timing Circuit

The required exposure time is quite critical and a method of accurate exposure calculation is required. An ordinary stop watch and toggle switch can be used, but for large amounts of copy work an automatic system is much superior.

A simple timing circuit, shown in fig. 2, can be made by rectifying the a.c. line voltage which charges a high value capacitor. When the switch is opened the capacitor discharges through relay K_1 . The length of time the relay stays closed can be varied between 2 and 7 seconds with a potentiometer shunted across the relay. The dial of the potentiometer can be calibrated in seconds for easy exposure of different tones of paper.

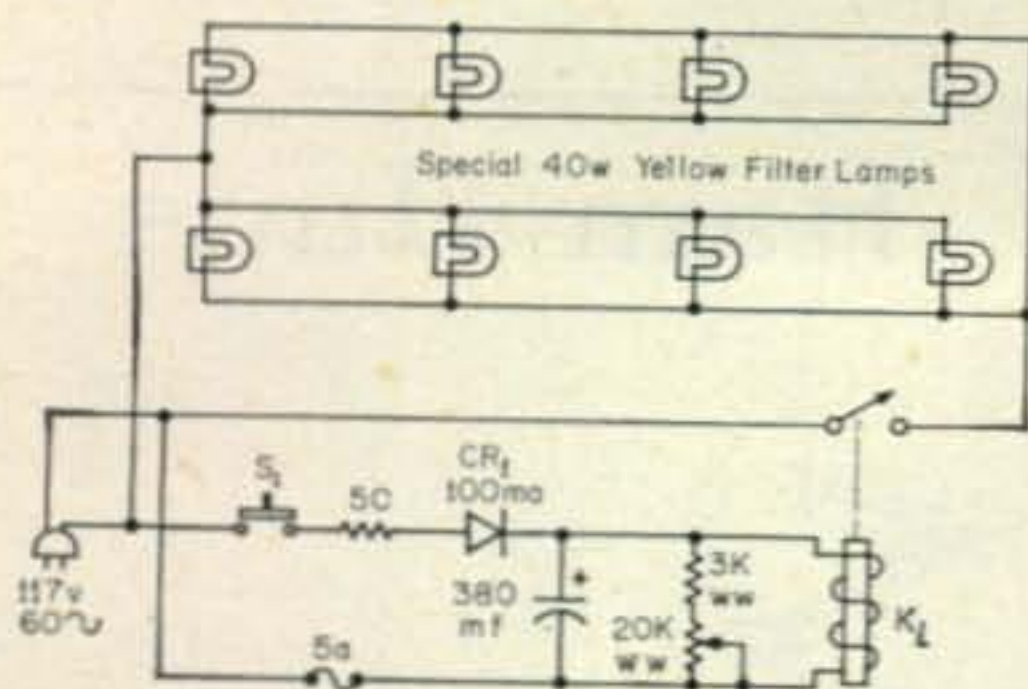
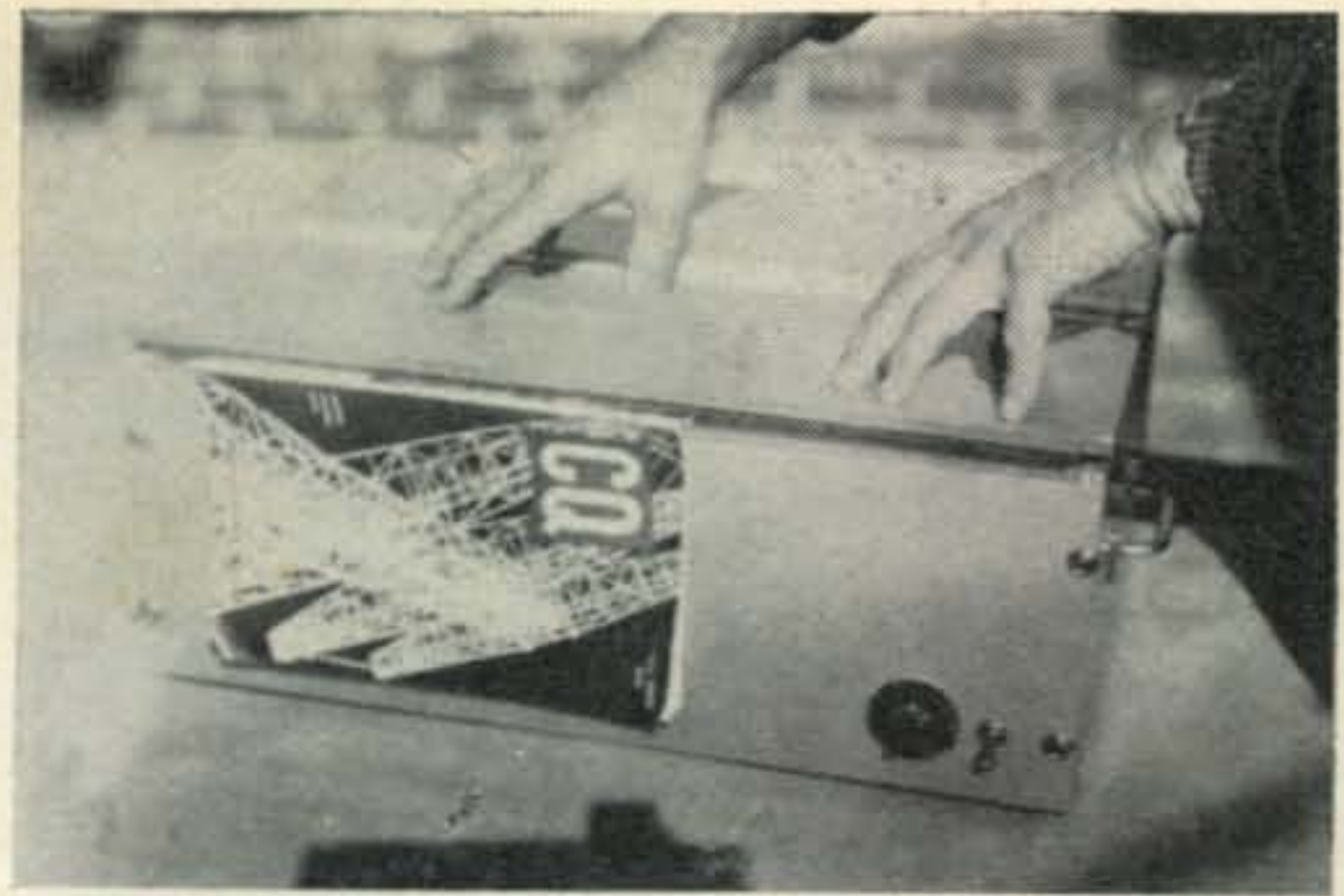

Fig. 2—Timer and bulb circuit used in the light box. The relay, K_1 , should have a coil resistance in the area of 30K as explained in the text. The switch may be either a push button type or a toggle. A toggle was used by the author to enable the light box to be used for viewing negatives and tracings.

The relay coil should have as high a resistance as possible. The relay resistance will determine the capacitor value of the R/C network. A surplus relay was used here with a resistance of 27,000 ohms. If a relay is used with a lower resistance than indicated, the capacitor value will have to be increased from 380 mf as shown in fig. 2.



Front view of the light box. The cover is split and fastened with a piano hinge to facilitate duplicating smaller size copy.

The processing of the paper may be done in a developing tray and the squeezing operations may be done with a hand operated clothes wringer. It is, however, more convenient to use a motor driven set of rollers.

Rubber rollers may be obtained from a printing or photographic supply shop. Since the rollers available are not likely to be the same, no physical dimensions are given.

The rollers used were made of soft rubber $\frac{3}{4}$ " in diameter and ten inches long. They were discarded by a printing shop because they were bowed in the center. By careful sandpapering they were aligned sufficiently for use in the copier.

The roller mechanism has to draw an eleven inch length of paper through the developing solution in 15 to 20 seconds. It was found, by experimentation, that a 1250 r.p.m. motor (#YAR368-International Radio and TV, 2722 W. Olympic Blvd., Los Angeles, California), with a worm reduction gear from the ARC-5 transmitter, drove the roller at about the proper speed. The motor driven roller is coupled to the second roller by a set of one to one gears (Boston Y-3228). The teeth on these gears were filed for a loose fit to enable the second roller be adjusted for the proper tension and still rotate.

The casting, housing the worm gear shaft, should be reamed out one thousandth to prevent binding when it heats during prolonged use.

The developing tray shown in fig. 3 is made from $\frac{1}{4}$ " lucite cemented together with methyl chloride daubed on with a brush. The sections are also secured with 4-40 machine screws after cementing. When the box is completed, place a few drops of methyl chloride inside and roll it around to seal the seams.

The curved paper guide was formed by softening the plexiglass over a rod shaped heater. When pliable it was bent over a curved surface and held in place until it hardened. The paper guide separators are also cemented in place with a $\frac{1}{8}$ " spacing between them. Three strips of $\frac{1}{4}$ " wide plastic are cemented on the curved plate to prevent the negative from sticking.

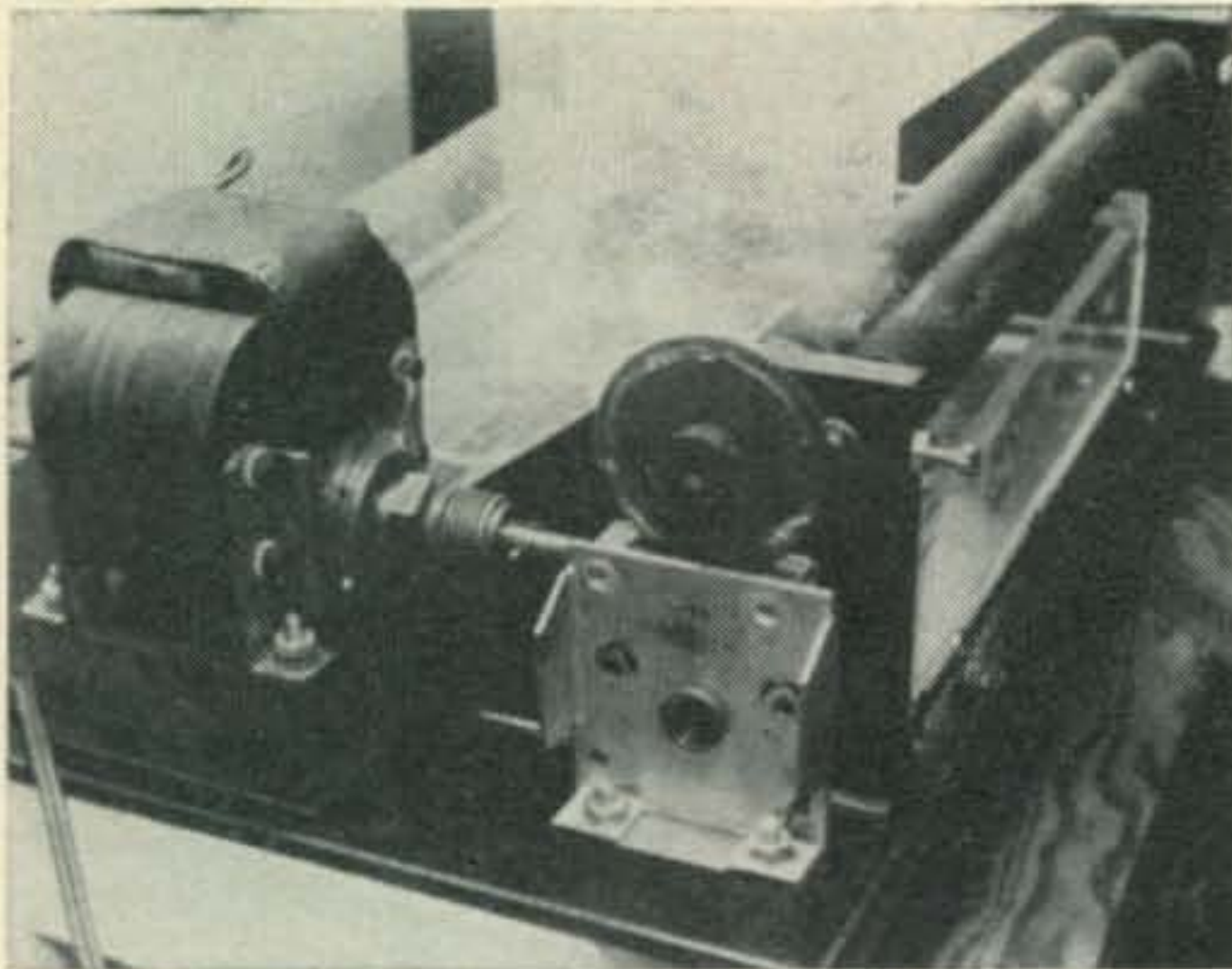

View showing the worm drive made from the ARC-5 capacitor gear. The rollers, set in brass bearings, have adjustable tension set by the screws in the supports.

Printing and Developing

The process used employs paper manufactured by Gavaert. The positive paper is called Gevacopy # 2 and the negative paper is called Gevacopy GS. The latter is quite sensitive to light and the former insensitive. The negatives should be stored in a light proof container.

The negative paper is placed on the ground glass with the emulsion side up away from the lights. The material to be copied is placed on the emulsion side of the negative paper, face down, and a positive sheet is used behind the page as a light reflector. All the paper is then pressed firmly down on the ground glass to ensure that the copy will be evenly exposed. The pushbutton switch is depressed momentarily. The exposure should be about four seconds. The light shines through the negative paper, hits the black ink of the page and is absorbed while the white areas reflect the light back on the emulsion.

The light box is then opened and the negative and positive papers are removed and placed in the tray filled with a special solution of Gevacopy developer mixed as directed on the container. The negative is fed into the curved sheet and the positive is fed into the separator just above. The papers are then slid

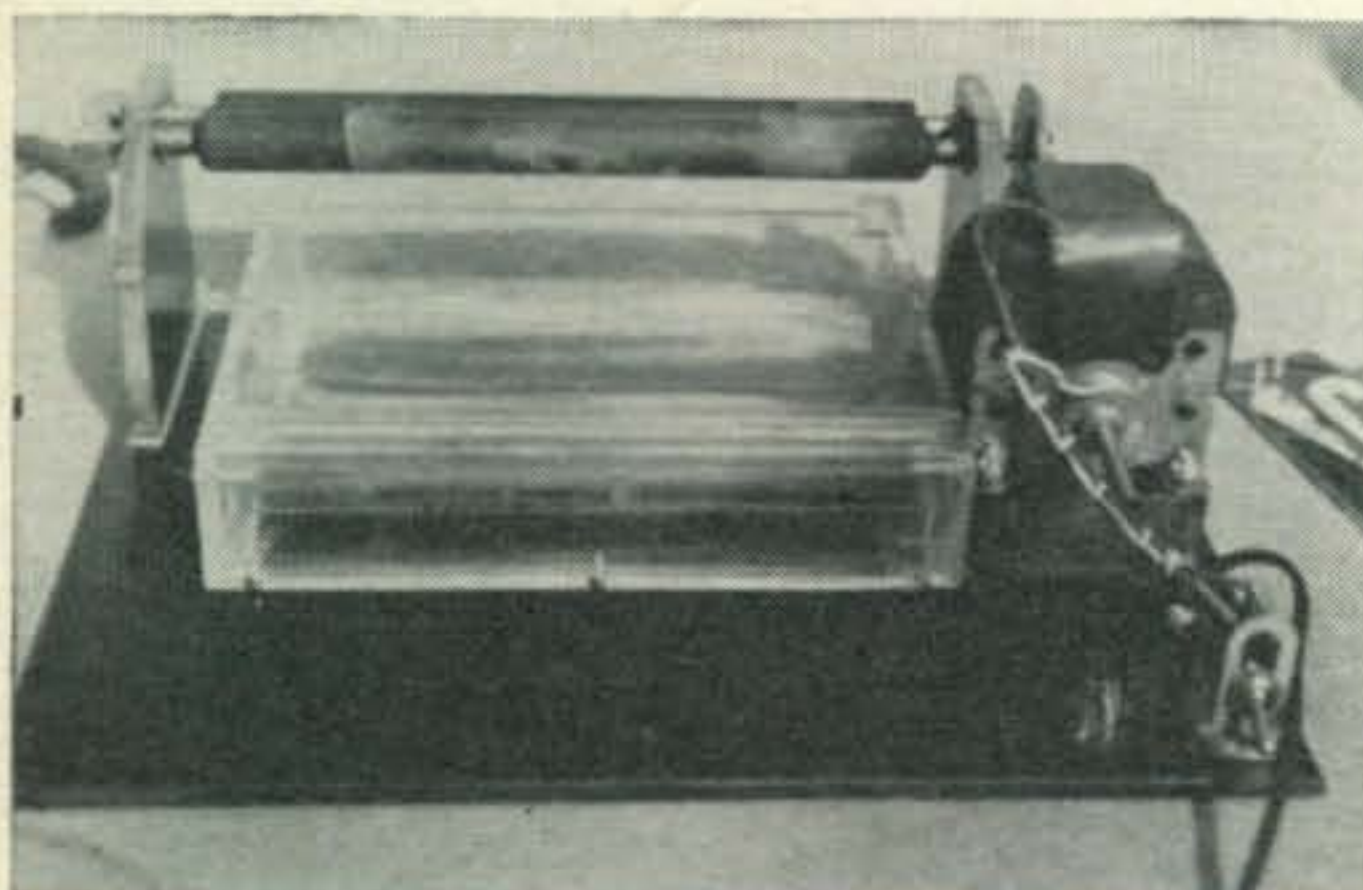

Plastic developer tank and roller assembly mounted on a base. The one to one gears that couple the rollers may be seen on the left end.

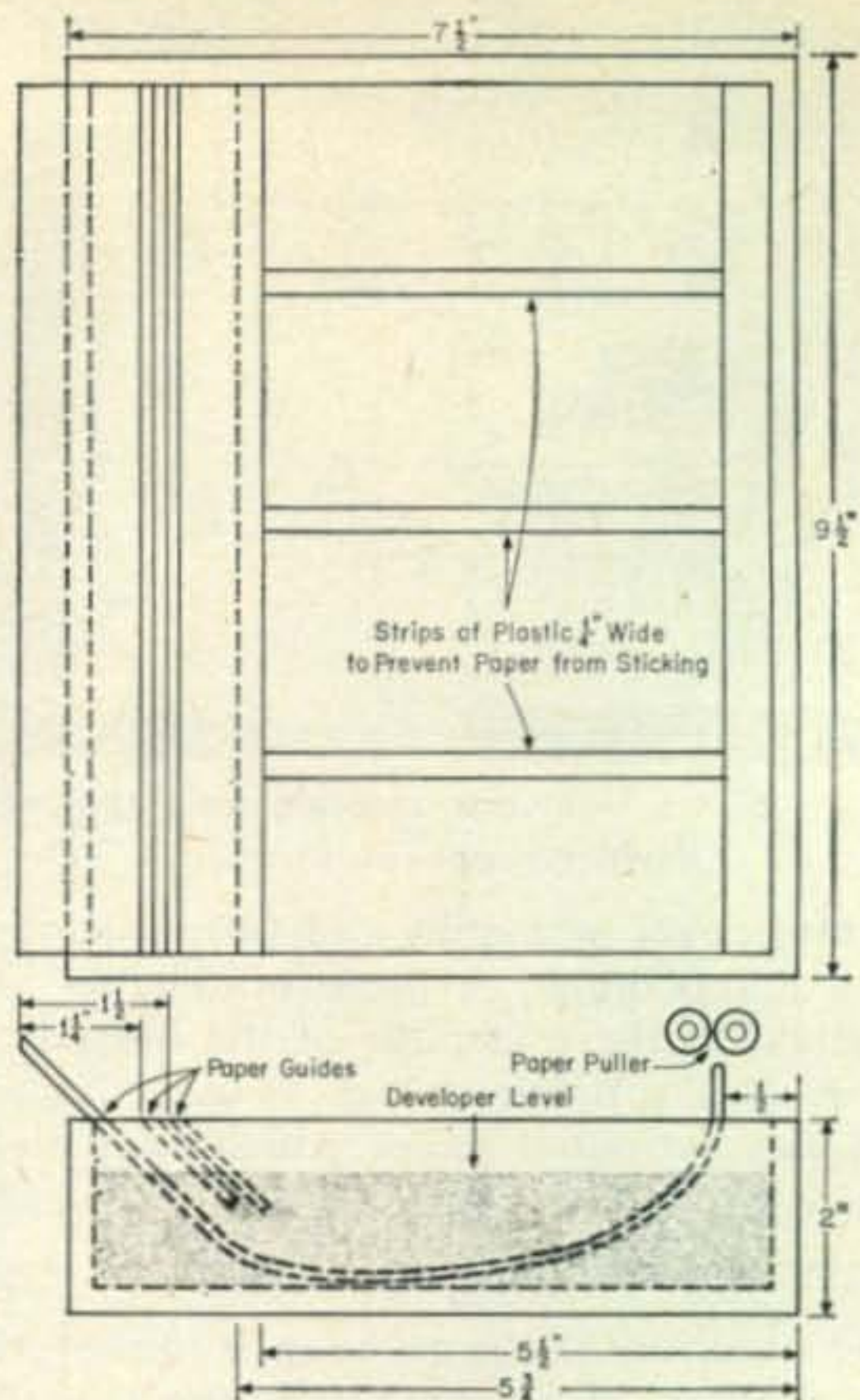

Constructional details of the developer tank and positioning of the roller assembly. The rollers, old photographic soft rubber rollers, may be either motor driven or hand cranked. The tank is constructed of $\frac{1}{4}$ " plexiglass sheet cemented together.

into the solution and up into the rollers. A few seconds after emergence from the rollers the negative and positive papers are peeled apart leaving an excellent reproduction on the positive paper. It is possible to get two prints from a single negative. Generally speaking, copying from glossy paper yields the best reproductions with ordinary newsprint providing the poorest. ■

Ham Hints

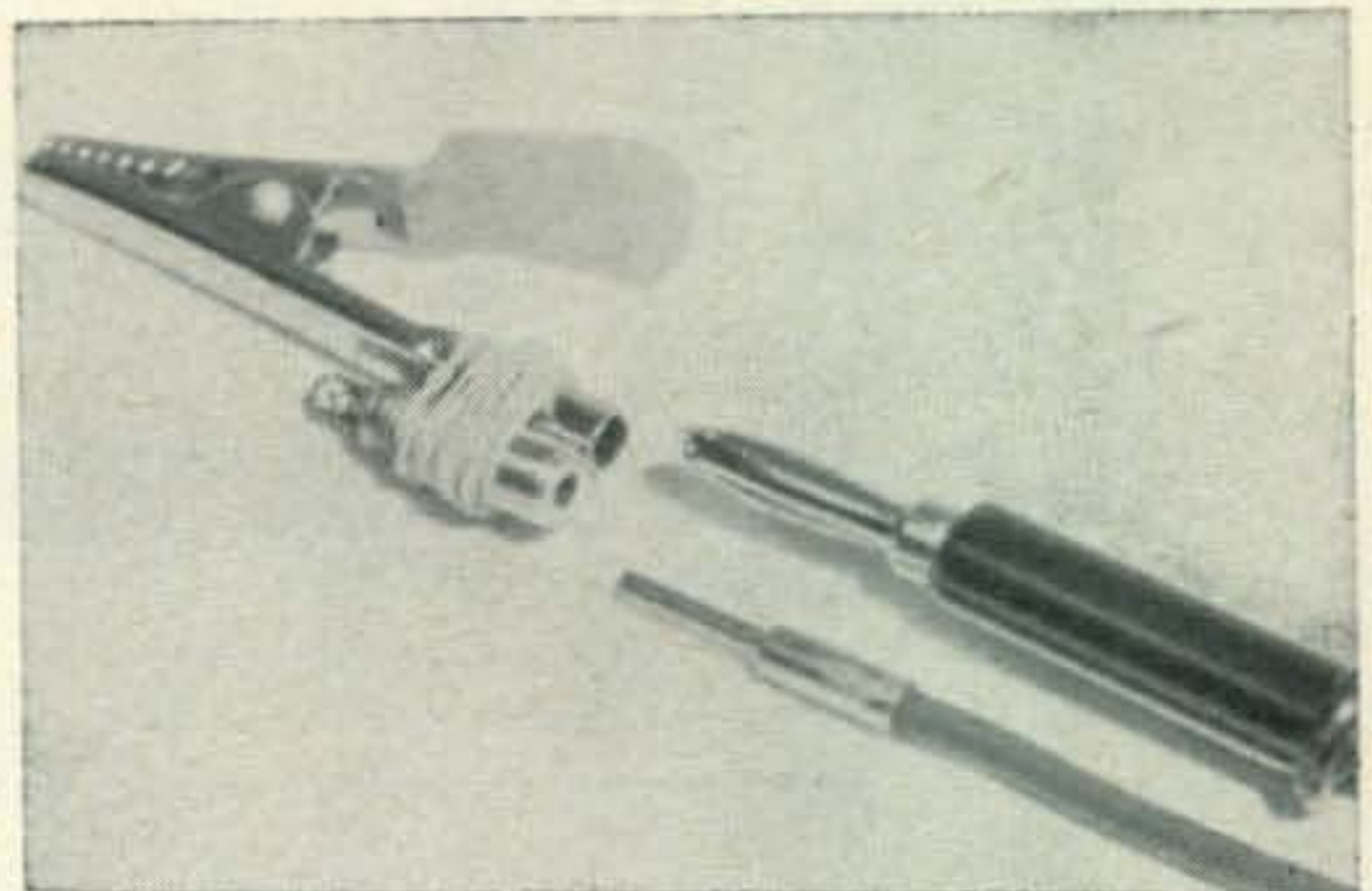

Making Test Clip More Versatile

Most alligator clips will only accept banana plugs. To adapt them to accept standard phone tip plugs, take a phone tip jack, remove the end cap, washer and nut, and attach the jack to the underside of the clip's barrel with a rubber band or tape. This over-under arrangement makes the clip more convenient in test set-ups.

Low Impedance Coupling To Parallel Resonant Circuits

BY JOSEPH ZELLE*, W8FAZ

GENERAL amateur practice calls for series tuning for very low r.f. impedance, and parallel resonant tuning for the higher impedances. Amateurs might, however, well borrow a technique from broadcasters for low impedance circuits. By connecting a second coil of nominal turns across a small portion of the parallel resonant coil, a kind of vernier control of low impedance is obtained. Figure 1 illustrates the circuit.

Fig. 1—Connection of inductor, X_2 , in parallel with X_1 , will provide lower impedance tap points than X_1 .

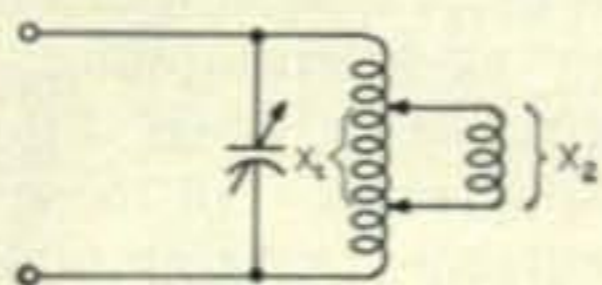

Briefly, when two or more inductive impedances are connected in parallel, the total reactance will always be something less than the reactance of the smallest inductor. It follows the well known formula:

$$X = \frac{1}{\frac{1}{X_1} + \frac{1}{X_2} + \dots + \frac{1}{X_n}}$$

This formula holds for two isolated inductors, and would hold for fig. 1, if the two portions, X_1 and X_2 , had no mutual coupling. In the actuality, though, the X_1 portion of the inductor is mutually coupled with the upper and lower portions of the inductor. If X_2 is placed favorably in the field, it too will effect a further change in addition to its self-inductance.

From a practical standpoint, however, all that does happen is that the entire coil inductance is affected. Secondly, the X_1 portion of the inductor is altered. Schematically this might be represented roughly in fig. 2, where the central

Fig. 2—The parallel circuit, X_1 and X_2 , results in a reduced overall inductance that can be compensated for by C.

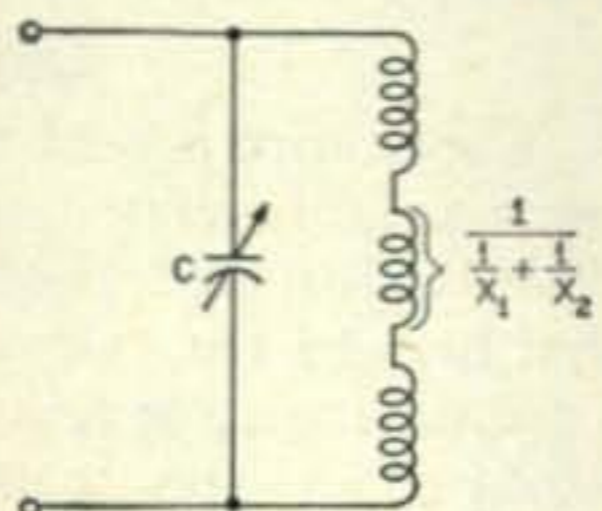

portion of the inductor now has definitely less reactance. This should not present a serious problem under tuning conditions, since the size

*Technical Staff, WERE AM-FM-TV, Cleveland 15, Ohio.

and number of turns of the inductor are arbitrary and controllable.

This system is workable because the impedance of a coil varies from zero at the very center to a maximum value at the very ends of the coil. Figure 3 illustrates how taps taken off

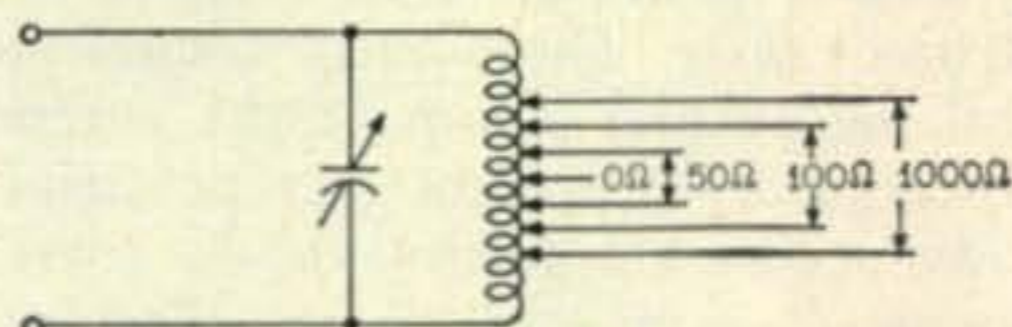

Fig. 3—Illustration of the relative impedance tap positions on a coil. The lowest practical value, without a vernier coil, is about 50 ohms.

turns of the inductor will offer various positive reactive impedances. Let us say that the smallest practical impedance that can be tapped off without complications is 50 ohms. By connecting inductance will be changed. It can be corrected, a large inductor across this 50 ohms, the total as previously mentioned, by the tuning circuits. Now, on the added inductor, there will be available a similar variation of impedance. Its variation, however, will only cover roughly 50 ohms. Thus, we can pick off taps at the 30, 20, and 10 ohm impedances (fig. 4). We have, there-

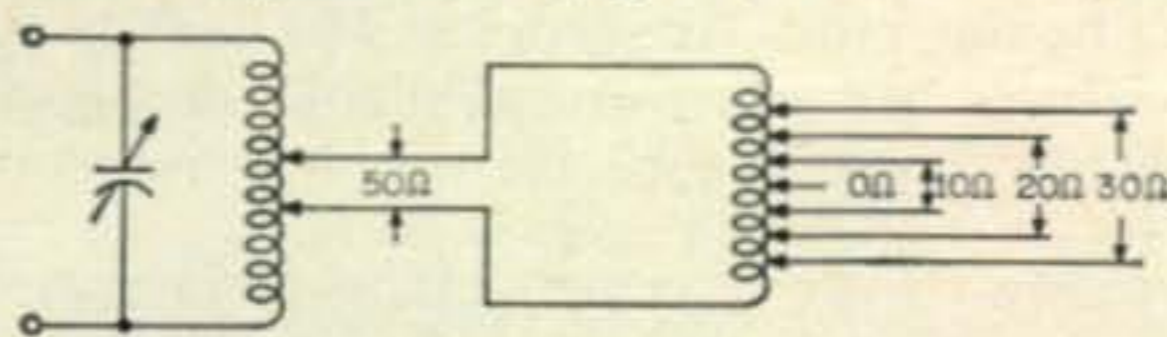

Fig. 4—Addition of a vernier coil makes possible matching impedances as low as 10 ohms.

fore, at our disposal, a "finer" selection of impedances to match our load, say the antenna. By varying the size of the added inductor, different combinations of impedances will be available.

When determining the vernier coil inductance many variables must be considered such as frequency, coil size and length, mutual and capacitive coupling (more critical at higher frequencies), mounting, shielding and so on. As a "rule of the thumb," I would suggest that a ratio of 5:1 to 10:1 for the vernier coil to the tapped portion be observed. Of course, the inductance of that tapped portion (including the mutual coupling) would have to be estimated. The vernier coil should be of small diameter (thus longer) to make available more turns for precise impedance matching. ■

Circuit Elements for Electronic Construction

CAPT. A. B. JONES, U.S.N. (RET), WØALO/2*

Some practical background information, for Novices, on the basic building blocks for all electronics equipment, resistors, capacitors and inductors.

THE components described in the following paragraphs are covered in all basic electronics texts. These texts discuss the fundamental nature and action of the components but do not usually present any practical data. More advanced texts do not discuss these basic components from any viewpoint. The information presented here is intended to fill the gap.

Resistors

In general, resistors are wire wound or of the carbon type. The wire wound types are usually used in higher current and power applications. These also tend to maintain their rated values more accurately than carbon types. Wire wound types, in addition to being resistive, are quite inductive at radio frequencies and should therefore not be used for r.f. applications unless a combination resistor and inductance is desired. Some wire wound types are so wound that they are called "non-inductive" but their residual inductance may be high enough to be detrimental at the higher radio frequencies. The carbon type of resistors are generally available in sizes up to 2 watt ratings. These have very low inductance

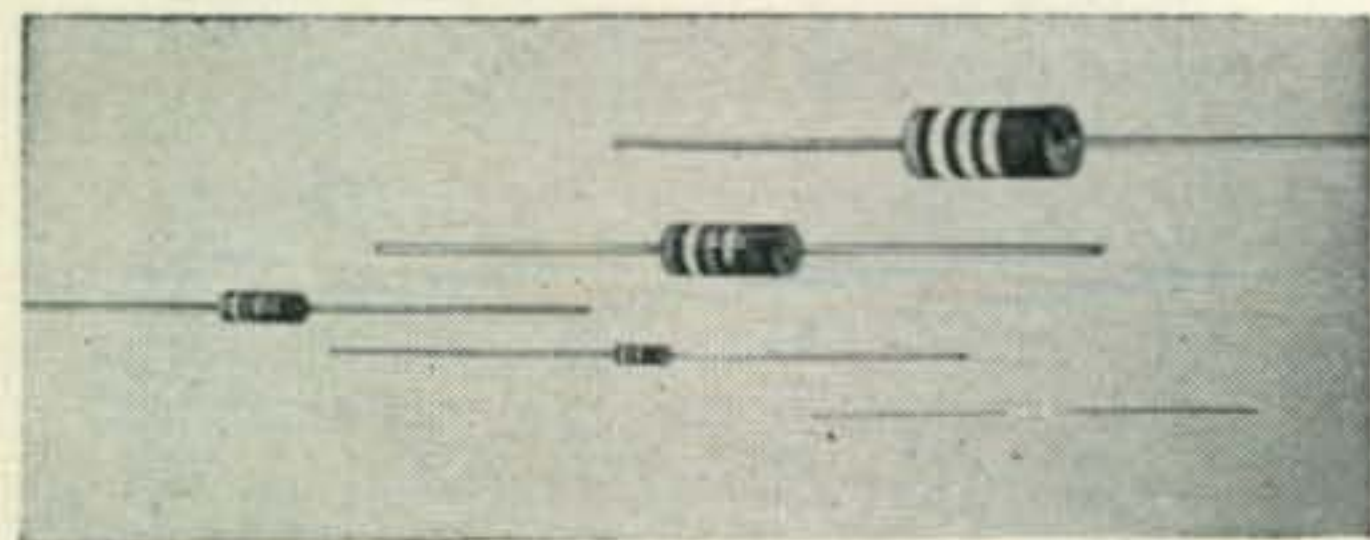

Typical molded composition resistors manufactured by Ohmite. The resistors are rated at 1/10, 1/4, 1/2, 1 and 2 watts. (Photograph courtesy of the Ohmite Manufacturing Co.).

and are suitable for use at high radio frequencies. The value of carbon resistors tend to change with age and may change quite radically when overloaded. It is generally considered good construction practice to use a margin of safety where practicable; *i.e.* when the resistor is called upon to dissipate 1/2 watt, use a 1-watt resistor. For

37 Rodney Ln., Westbury, L.I., N.Y.

very high resistances in the megohm region, where high stability is important the use of hermetically sealed resistors is desirable in order to minimize the effects of humidity.

Resistors in addition to their power rating also have a corresponding maximum current rating. It is important to calculate this current rating when tapping a resistor in voltage divider circuits or when using only a portion of a variable resistor. In these applications the maximum current rating may be exceeded without exceeding the power rating. Also, in using wire wound resistors of the sliding contact type, care must be exercised in moving the variable connectors so that the wire windings are not cut or damaged. For high voltage applications, resistors supported by metal should have a sufficient leakage gap to prevent breakdown to ground.

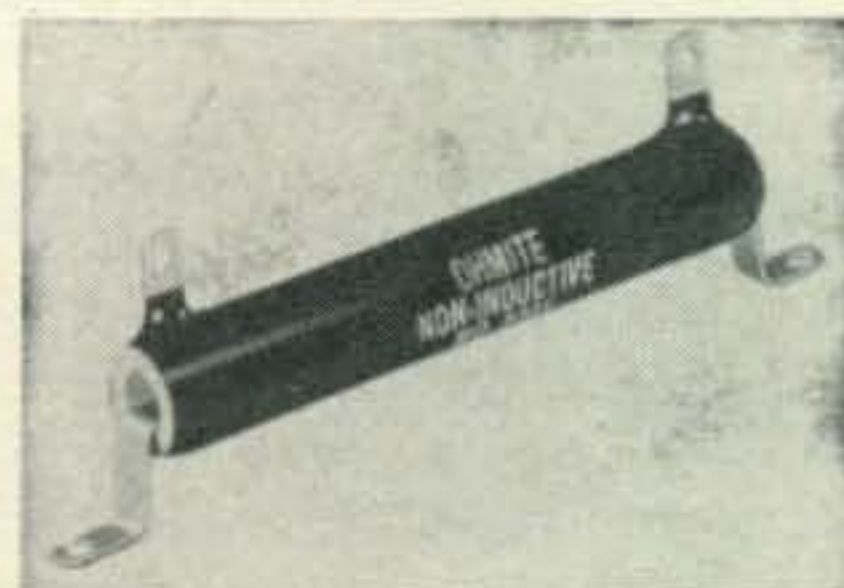

A 50 watt wirewound resistor that is non-inductive. It does not differ in appearance from the ordinary wire wound resistor and so can be distinguished only by its markings. (Photograph courtesy of the Ohmite Manufacturing Co.).

Capacitors

Capacitors are of two general types, solid or semi-solid insulated and those insulated with air, vacuum or gas. The latter are usually variable but may be fixed in capacitance. For high values of capacitance at relatively low voltages the electrolytic capacitor is usually the most economical and usually smaller in physical size. These should only be used in direct current or pulsating d.c. circuits since these capacitors are polarized and can be damaged by the application of reverse polarity. Their use is sometimes tolerated

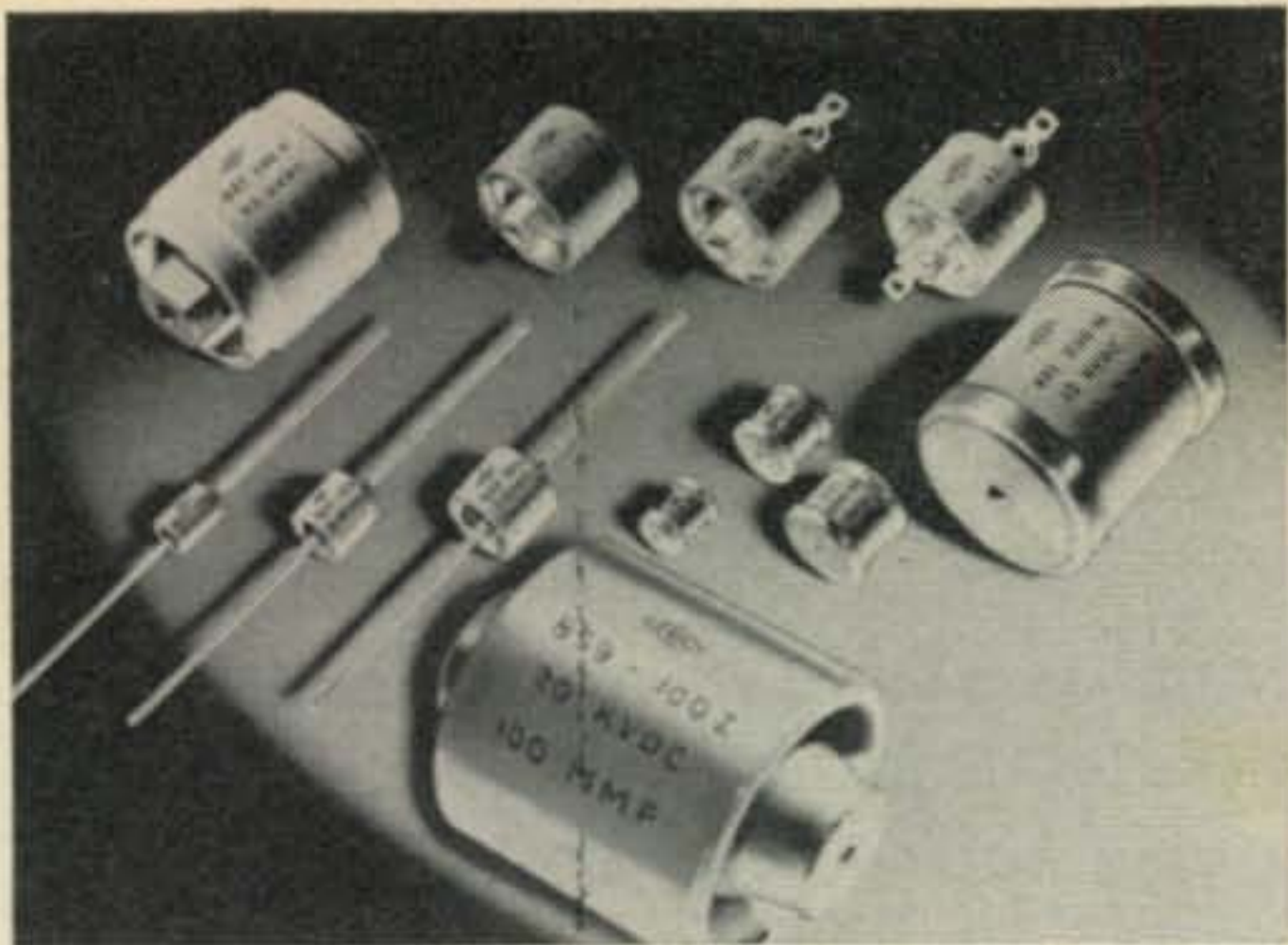

This series of capacitors is designed for use in transmitters and other equipment featuring high r.f. currents as well as voltages. The large capacitor in the foreground is rated at 20 kv and can carry more than 30 amperes of r.f. (Photograph courtesy of Centralab, The Electronics division of The Globe-Union Inc., Milwaukee, Wisc.).

in low level audio frequency circuits. In general, their life is limited to several years and during this period, the capacity may lower and eventually they may short. Whenever economics and space permit, it is better to use a non-electrolytic capacitor. It must also be remembered that electrolytic capacitors have a relatively high leakage current which may preclude their use in certain circuits.

At radio frequencies, the choice of a capacitor with regard to its inherent loss, resistance, and inductance is important. One factor sometimes overlooked, is the capacitor's current carrying capacity. When used in tank circuits, pi-networks and plate bypass circuits for high powered r.f. amplifiers, even the disc-ceramic types which have the necessary qualifications may not have heavy enough plates, leads and lead connections to carry the r.f. currents. For these applications special capacitors are available. In general, mica

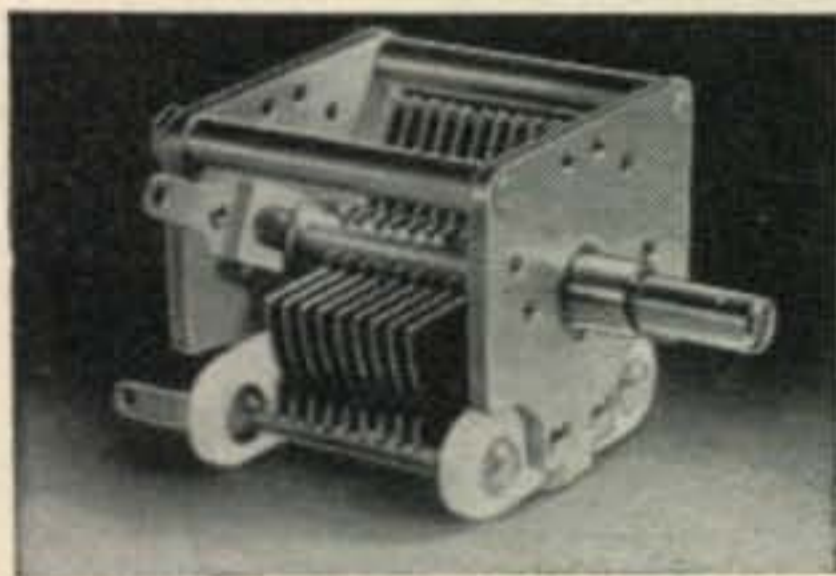

A rugged type of variable capacitor made by Hammarlund. This variable can withstand 1000 volts r.m.s. at 60 cycles and has a straight line capacity characteristic which means that each degree of rotation will produce an identical change in capacity. (Photograph courtesy of the Hammarlund Manufacturing Co., Inc.).

and disc-ceramics capacitors are preferable at amateur operating frequencies. whereas paper insulated capacitors are suitable for d.c. application, a.f. and low radio frequencies.

In h.v. power supplies, the use of oil filled capacitors is preferable. Most of these are rated in d.c. working voltage. Since rectifiers produce

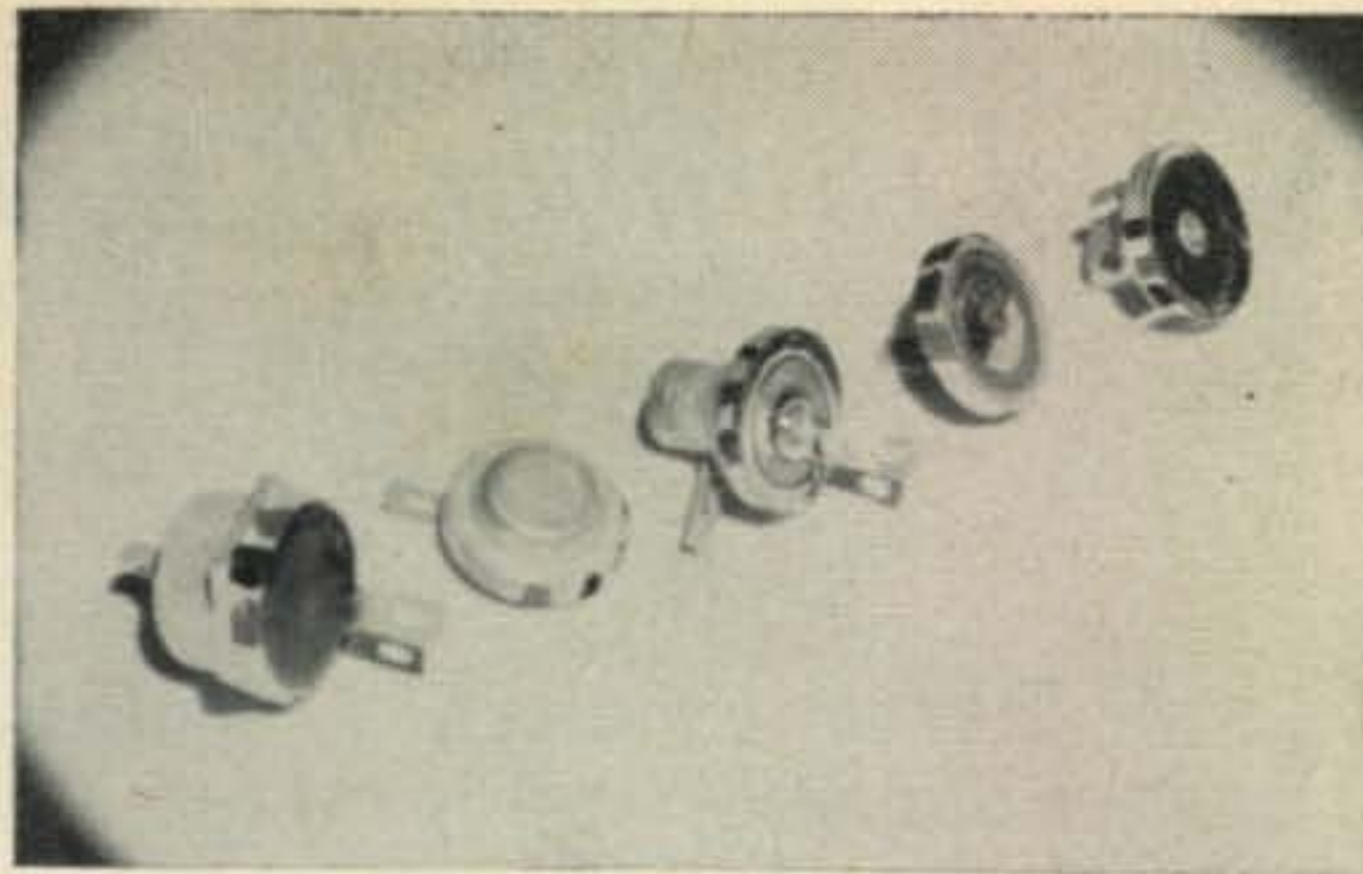

Typical low inductance type of capacitors for use as bypasses in ultra high frequency equipment. The construction permits some to be used as feedthrough capacitors while the others are stand off types. (Photograph courtesy of Centralab, The Electronics Division of the Globe-Union Inc., Milwaukee, Wisc.).

a voltage pulse which is about 40% higher than the r.m.s. value, this should be taken into account, especially where a capacitor input filter is being used. One word of caution regarding h.v. filter capacitors should be made. The practice of quickly shorting the power supply after the primary power has been removed will result in very heavy circulating currents which may damage or ruin the capacitors. When capacitors are used in series to obtain higher voltage ratings they should be of equal capacitance and each should be shunted with a high value resistor of the same resistance in order to equalize the voltage across them.

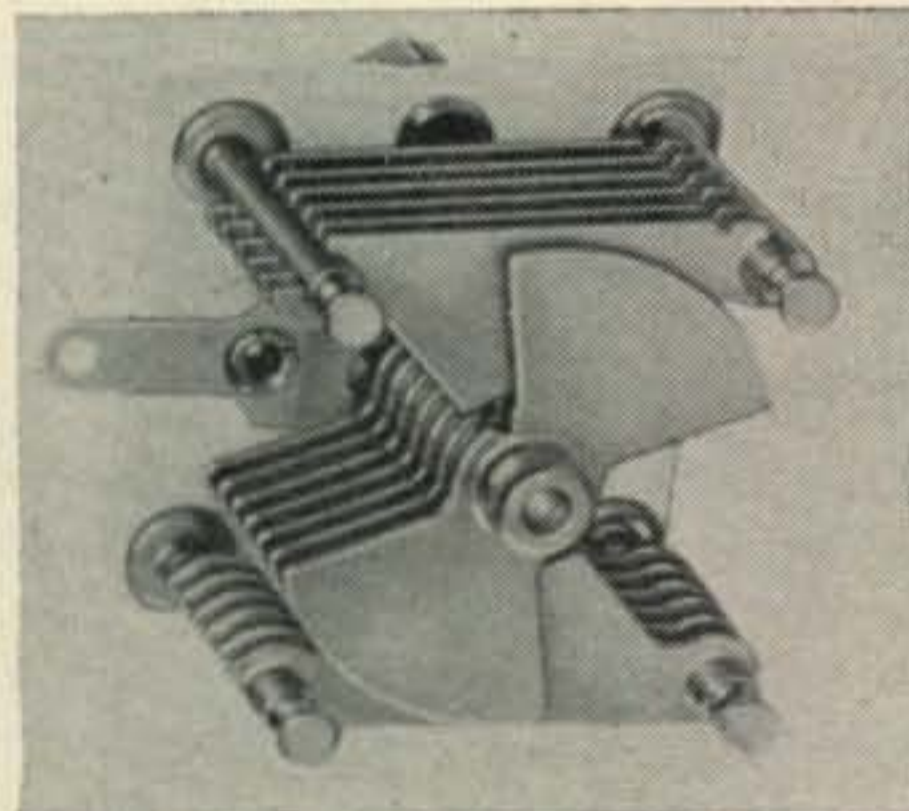

A Hammarlund BFC line butterfly variable capacitor. It features a very low minimum capacity, low inductance and an isolated rotor, all desirable for v.h.f. applications. (Photograph courtesy of the Hammarlund Manufacturing Co., Inc.).

For variable capacitors, besides the usual desirable characteristics, their inherent inductance and inductive loops must be considered. For high power amplifiers, the vacuum variable capacitors offer low inherent inductance values which are important above 20 mc. For ordinary variable air capacitors, the large capacitors, when used for high frequency applications, not only have a relatively large minimum capacity but often contain considerable inductance and inductive loops. These inductive loops increase the number of possible v.h.f. parasitic resonances. The use of "butterfly" type construction for balanced circuits is most suitable at h.f. and
[continued on page 173]

Transistor R.F. Power Amplifiers

LESTER A. EARNSHAW*, VE7QL

Ever since the 1961 Phoenix Hamvention, where this 80 meter transmitter was first displayed, the author has been deluged by inquiries for design data. Presented here are general hints on the design of transistor r.f. power amplifiers as well as some constructional details on the original unit.

RECENT advances in transistor manufacturing techniques have at last made possible power outputs of 10 watts, 20 watts and even higher on many of our amateur bands. And the prices of these transistors are such that "Mr. Ordinary Ham" may now, not only build them into his equipment, but actually save money in doing so. True, the transistor is still more expensive than the tube; we can't get away from that fact. But a power supply *and* a tube is likely to cost more than the transistor. This is taking advantage of the fact that, say in mobile installation, no power supply is required.

There are a number of r.f. power transistors available which are capable of delivering from 1 to 15 watts to an antenna and costing less than \$10. However, it is pointed out that many of these are still too new to be listed in catalogues.

The 2N1907 by Texas Instruments costs around \$10. This transistor is capable of considerable output as an oscillator or amplifier on either 160 or 80 meters.

The Amperex PADT50 also sells for less than \$10 and will give considerable output over most of the ham bands. ($f_T = 60$ megacycles)

Pacific Semiconductors Inc. also has a number of high power r.f. transistors and no doubt there are other manufacturers who could have been listed above but the list has been confined to those actually in the author's stable and of which first hand information can be presented.

Designing and working with r.f. power transistors calls for quite a different technique not found in tube or other circuitry. It is as well for the would-be builder to make himself familiar with the differences involved.

Coupling Power to The Load

Generally, in the higher power class B and C amplifiers and oscillators, no attempt is made to match the transistor to the load. A parallel in this may be found in the high power transistor class B audio stages.

In class C operation the transistor is shut down over a large portion of the cycle and at

*9851 Salina, Cucamonga, California.

other times varies between high and very low impedances. The transistor may be considered as a switch which every now and then feeds a pulse of energy into the tank circuit. The tank circuit, by its flywheel action, should turn the pulses into sine waves.

In order to develop a certain power, the transistor must look into a definite value of resistance. If the resistance is high in value, for a given supply voltage, it is obvious that only a small current may be drawn through it to the collector and as a consequence, the output power will be limited. The lower this resistance in value the greater the current which may be drawn by the collector and the greater the power output which may be developed. In fact, in order to develop a certain power, one must calculate and use a load of a definite resistance. This is given by the formula:

$$R_L = \frac{0.5 V_{cc}^2}{\text{Power Out}}$$

In this case, V_{cc} is the voltage supplied to the collector and will (providing the tuned circuit has a reasonable Q) be equal to the supply voltage. Taking a practical case, assume an output of 5 watts is required from the transistor and that the supply voltage is 12 volts.

$$R_L = \frac{0.5 \times 12^2}{5} = 14 \text{ ohms}$$

Note that the above formula assumes that the tank circuit has a reasonable Q and is capable of changing the transistor output pulse into a sine wave. If the tuned circuit has poor Q it is obvious that it will be impossible to develop the full required power unless the load resistance is lowered in value.

There are two ways by which the transistor may be connected to a 14 ohm load. In the first, the transistor may be tapped down the tuned circuit just as the antenna is tapped down the circuit to obtain say a 50 ohm match. In the second, we may considerably increase the C in the circuit at the same time reducing L . This will give us a circuit of low impedance but of high Q . Generally, it may be stated that

the lower the impedance the higher must be the C . This is demonstrated by the formula:

$$X_c = \frac{Z}{Q}$$

where X_c is the reactance of the capacitor and Z is the load on the tuned circuit. When the load resistance is very low in value, in order to maintain a workable Q , C may have to become unworkably large (and L impossibly small). In this case it is practical to combine the two methods, using a higher C than would be normal for tubes and at the same time tapping the collector down the tuned circuit at a point which gives the desired impedance. It is this method which is adopted in the circuit to be described shortly.

The Input Impedance

Not only may the input impedance of the r.f. power transistor be very low in value, it may also be highly reactive. As a consequence of this the importance of correct matching to the input cannot be too highly stressed. Also, in order to obtain maximum output from the stage it is often necessary to make the input resistive and to neutralize the feedback path between the collector and the base. This latter may not be necessary at the lower frequencies but is most likely necessary as the frequency of operation approached f_T (the frequency at which h_{fe} is equal to unity when the output is short circuited).

Matching is simply accomplished by tapping down the coil exactly as outlined in the case of the collector. Of course, a link of the same number of turns may be used to allow easier bias feed and d.c. return.

The input may be made resistive by adding capacitance, inductance or in some cases a combination of both, to the input circuit. Which is used is highly dependent not only upon the transistor but also upon the type of input circuit used. For example, in the amplifier circuit shown in fig. 1, inductance is added in series with the link. In an earlier amplifier using the same transistor but with link leads 10" long,

Fig. 1. The Amperex PADT50 drives a 2N1907 delivering 15 watts to the load. Coil L_n serves to make the input of the 2N1907 resistive. A key is inserted in series with the collector voltage to the oscillator.

All capacitors except C_1 and C_2 are ceramic discs.

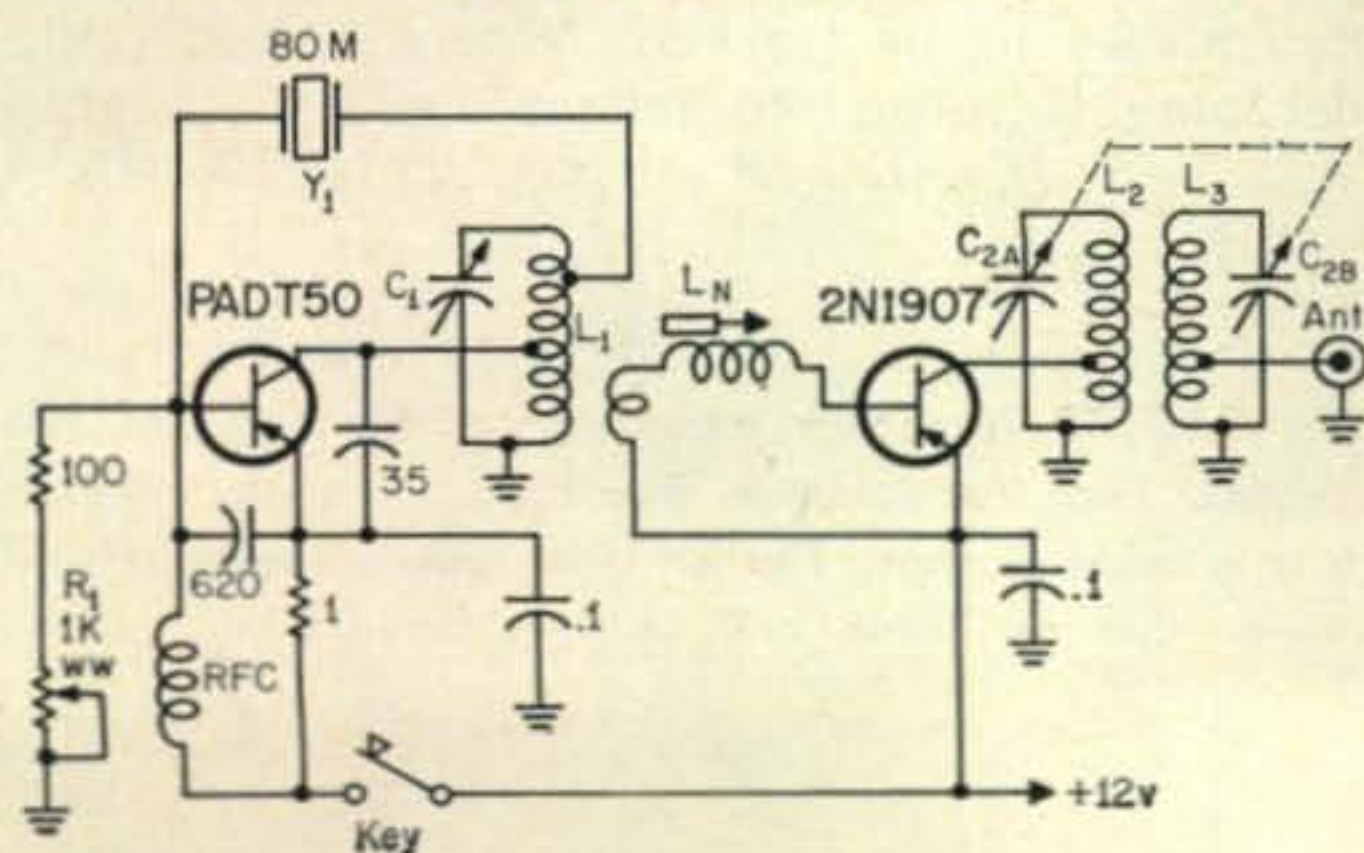

the inductance had to be in parallel with the input. In other cases, it has been found practical to add a phase shifting network of the type shown in fig. 2 to the input circuit. No hard and fast rule can be stated here as it may depend upon the practical layout as much as anything else. However, it can be stated that the improvement in both gain and stability is usually very marked particularly when the transistor is operating nearer its alpha cutoff.

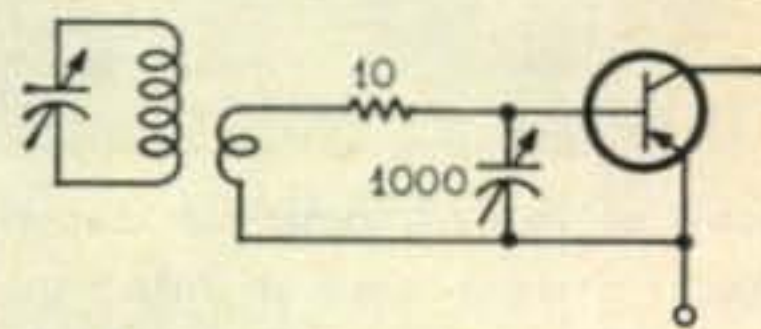

Fig. 2. A simple phase shifting network may be incorporated to make the input impedance of the final resistive. The 10 ohm resistor will absorb some of the driving power.

A 15 Watt Transmitter

The circuit of a 15 watt c.w. transistor for 3.5 mc operation is shown in fig. 1. Essentially the circuit is based on a Colpitts oscillator. The oscillator transistor is an Amperex PADT50. Designed as a core driver this transistor operates efficiently in r.f. service. As an oscillator it is capable of fully lighting a 6.3 volt .3 amp dial light bulb coupled to its tank circuit. This transistor was preferred to the 2N1907 in this position because of its higher alpha cutoff figure and therefore lower crystal current. The output stage is a Texas Instrument 2N1907. With this transistor in the output the transistor delivers approximately 15 watts of power to the load at a frequency of 3.5 megacycles and with a supply voltage of 16 to 18 volts. With a 12 volt supply the output is 10 watts. This is output power remember, not input.

Because the single tuned circuit is unable to completely restore the missing half cycle (as delivered by any single ended class B or C stage) it was found necessary to add a second tuned circuit inductively coupled to the first. Even although a 15 watt house type bulb will show the same output whether one or two tuned circuits are used, no attempt whatever

L_1 —3" length of B&W 8016. (46 turns no 22, 3" long, 1" dia.) Collector tap exactly 4 turns from bottom. Xtal tap 28 turns from bottom. Link, 2 turns of hookup wire at cold end of coil.

L_2 —29 turns B&W 8016. Collector tap exactly 2½ turns from bottom.

L_3 —Same as L_2 . Tap at 4 turns for 50 ohm load and approximately 10 turns for 300 ohm load.

L_n —10 turns #28 nylon covered wire closewound on Miller 5/16" slug tuned coil.

C_1 —Approximately 230 mmf. Miller 2110 with both sections in parallel.

C_2 —Two gang 385 or 420 mmf per section.

RFC—300 μ h with d.c. resistance of 7 to 10 ohms. D.c. resistance is of more importance than the inductance value.

Y_1 —3.5 mc FT243 type. Miniature crystals may heat and crack.

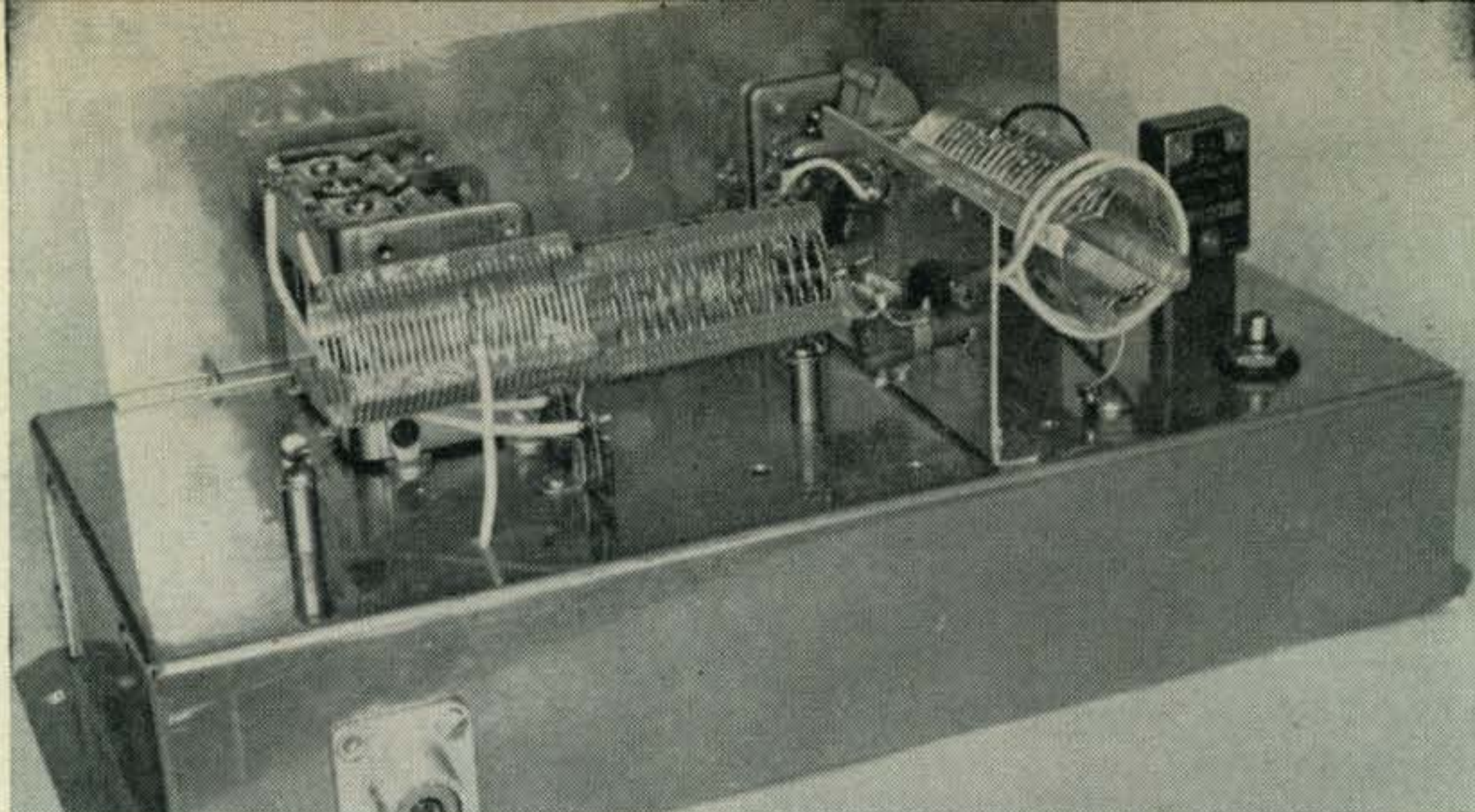

Rear view of the r.f. amplifier showing bandpass coupler coils and the neutralizing coil L_n . No transistor sockets were used in this rig. Wires are soldered directly on to the pin. Note the wire from the collector of the 2N1907 to the tap on coil L_2 .

should be made to eliminate the second for its purpose is to prevent the radiation of harmonics which are contained in the first circuit to a high degree. This may be observed simply by coupling an oscilloscope to the collector of the 2N1907 and noting the waveform. The waveform will look something like fig. 3. (The scope must be capable of operation at 3.5 mc.) The waveform at the output socket appears as a pure sine wave and indeed, contains few harmonics.

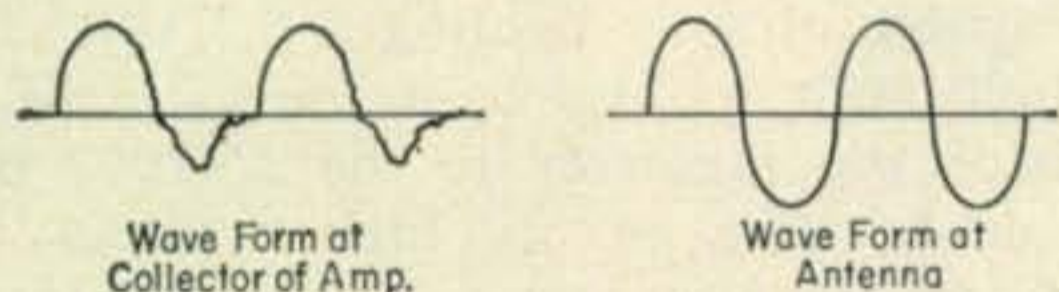

Fig. 3. The two tuned circuits are necessary at the output to put back the missing half cycle.

Adjustment

The amplifier draws no current unless the oscillator is oscillating. Turn the potentiometer R_1 until the bias on the PADT50 causes the collector to draw 50 to 100 ma. Now turn the tuning capacitor until the output current jumps up, indicating oscillation. The output stage should indicate collector current irrespective of where its output tank is tuned. Now adjust R_1 and C_1 and C_2 for maximum output and reliable oscillator starting. Resistor R_1 should not be run in a position of high collector current when the crystal is removed. By the same token, R_1 should not be run near the other

end of its range or the oscillator will not key well and may refuse to start. When operating, the PADT50 will draw around 400 to 500 ma.

Next adjust the final for maximum output. Always operate this stage into a load. If a 15 watt house type bulb is used it should be tapped about half way down the coil. L_n should now be adjusted for maximum output. The correct setting is not only indicated by maximum output but also by stable operation. Unstable operation is indicated by a rushing noise in a receiver tuned to a nearby frequency when the final is detuned. There should be no indication whatever of spurious oscillation no matter where the final capacitor is rotated.

Construction

Construction is not at all critical. The transmitter has been designed to have a negative ground to suit automobile operation and consequently, tuning capacitors are conveniently bolted directly down to the chassis. The 2N1907 is bolted to a small aluminum plate measuring $3\frac{3}{4}'' \times 2''$. The plate is mounted *exactly* 1" away from the coil. If these measurements are carefully retained L_n should peak with the slug *exactly* half way out. Other measurements and different link lengths will require adjustment of the turns on L_n .

The transistors are insulated from the chassis with mica washers and the holding down bolts are likewise insulated. Arrange the two output coils so that they are about $\frac{1}{4}$ apart. The coils are supported on a tag strip at the one end and a metal pillar at the other.

Trimmers on the output capacitor allow the two stages to be tracked. Where considerable detuning is caused to take place by a highly
[Continued on page 175]

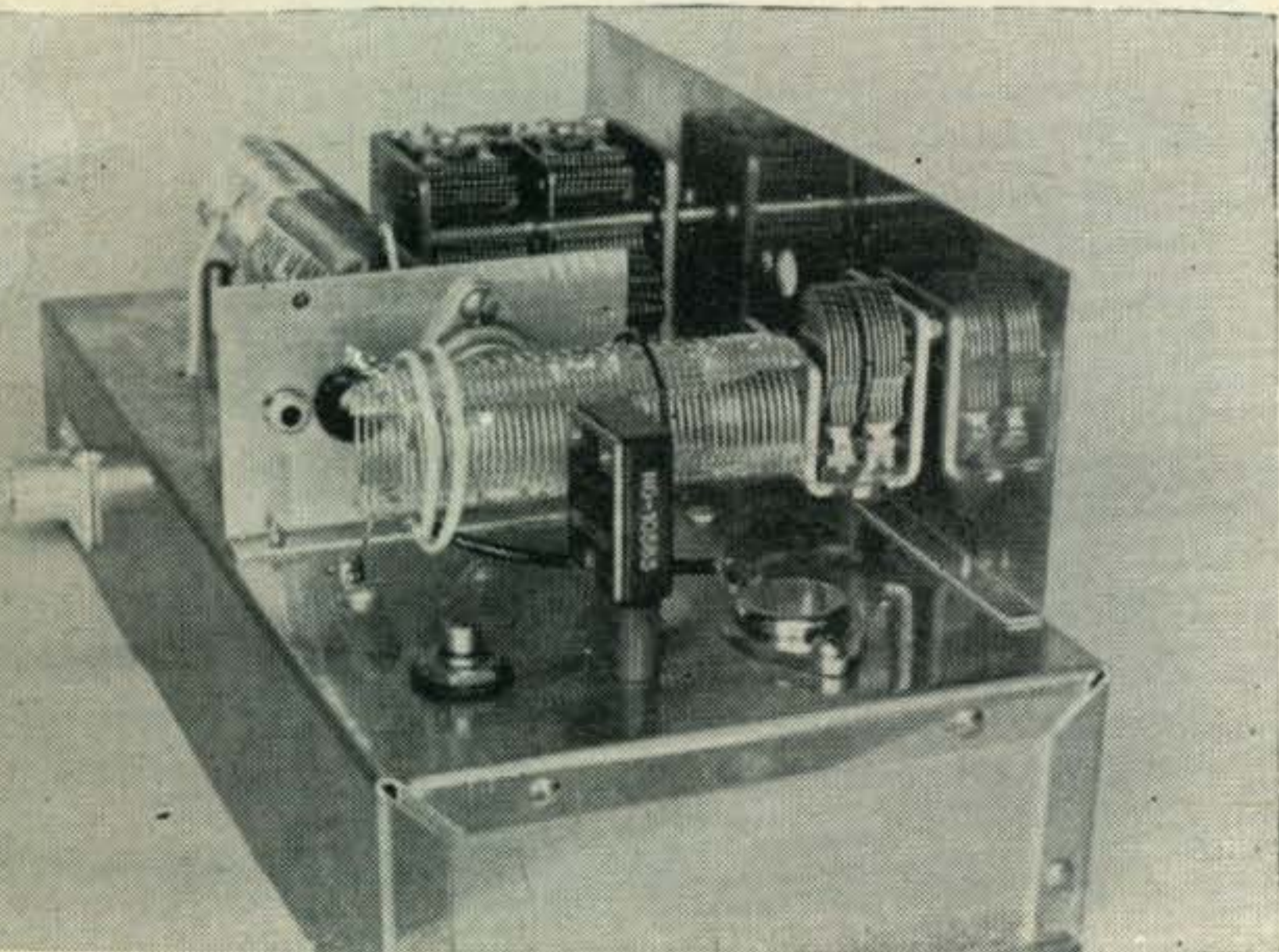

The PADT50 is shown mounted to the right of the crystal. The transistor is insulated from the chassis with a mica washer. The 2N1907 can be seen behind the oscillator coil in the foreground.

Transmitting Tubes—How to Use and Abuse Them; Part I

WILLIAM I. ORR*, W6SAI

Some of the finer points of transmitter design are covered in this article by W6SAI. A lot of the information herein was gained "the hard way" covering 25 years' experience in designing and building transmitting equipment. Other data has been compiled from the many questions on these topics that have arisen in his work with a leading transmitting tube manufacturer. This is "must" reading for all owners of transmitters!

THE story has been told at hamfests that the data sheet enclosed in a vacuum tube box was included with the intention that it should be thrown away with the box and packing material. Contrary to this little story, the data sheet has been placed therein with good reason; to inform the user of the tube of the capabilities and limitations of the tube. The data sheet is a summation of the functions of the tube and covers the electrical and mechanical characteristics, the maximum ratings, and the typical operating conditions.

The rugged individualist usually ignores the data sheet and runs his tube at a temperature just below that at which the plate will start to melt. This may be fun, and may even evoke "oh's" and "ah's" from the visiting hams, but it violates the old "watts-per-dollar" evaluation of the vacuum tube!

After all, let's face it; there is an economic point beyond which it is impractical on a "watts-per-dollar" basis to push a tube. In general, the harder the tube is pushed, the shorter will be its life. This is analogous to the story of the cowboy who wandered into a western saloon and saw an old, grizzled prospector at the bar, drinking whiskey neat from a bottle, and smoking a huge, black cigar taken from a box of stogies at his elbow. Striking up a conversation, the cowboy learned the old gent drank three quarts of booze a day and smoked five boxes of cigars a day, too. Said he, "You are amazing! All this hard living at your age! You look like you must be ninety years old!" "Ninety!" screeched the prospector slamming his drink on the bar and reaching for his gun, "I'm only twenty two!"

So it is with the vacuum tube. Moderation is the secret to a happy, long tube life. The tube manufacturer sets maximum ratings on a

basis of expected tube life. Each rating has been determined as the maximum value which will permit a reasonable life expectancy for the tube. The enemy of unlimited tube life is *heat*, but unfortunately heat is a natural consequence of making the tube work. A compromise of some kind must thus be made, and this is the purpose of the data sheet. Let's look into the compromise and see what establishes the various ratings given for transmitting tubes.

Plate Dissipation

The plate dissipation (rated in watts) of all radiation (air) cooled tubes is limited by the maximum safe temperature of the plate, and the effects of this temperature on parts of the tube other than the plate. In general, plates of radiation-cooled tubes will withstand several times their maximum rated plate dissipation *for a short period of time*. Other parts of the tube, however, are affected greatly by excessive heat radiated by the plate. High levels of plate temperature cause the grid, filament, and glass envelope to become overheated, while the heat conducted away from the plate by the plate lead contributes to the heating of the plate seal.

These effects are not instantaneous, and short overloads do not usually overheat the adjoining tube structure to a damaging extent. However, the user has no way of telling to what degree he can safely exceed the plate dissipation, or over what length of time this abuse can take place. The maximum plate dissipation rating is intended to set a point at which continuous operation may be carried out without damage to any part of the tube, even though the other tube elements may at the same time be operating at their maximum ratings.

Regardless of other conditions, the maximum plate dissipation should not be exceeded in continuous operation.

*Manager, Amateur Service Department, Eitel-McCullough, Inc., San Carlos, California

Maximum Plate Voltage

Voltage limitations are set at a point above which the internal insulators of the tube may arc over, or above which the glass envelope will become damaged from dielectric losses. In addition, a plate voltage ceiling tends to set a limit to the r.f. charging current flowing in the plate and filament leads. The charging current is a function of the r.f. plate voltage, which in turn is a function of the d.c. plate voltage; this makes it possible to set a limit on r.f. charging current without the difficult task of determining the current directly.

Tube envelopes having grid and plate leads in close proximity are subject to a greater degree of glass stress than those having widely separated electrode terminations. In general, however, most glass tubes have maximum plate voltage ratings that fall in the r.f. charging current limit category.

Minimum Plate Voltage

Each tube has a particular plate voltage below which it is uneconomical to operate the tube. That is to say, the filament power consumed by the tube (and the initial cost of the tube) are so high that the cost of power developed by the tube is high in comparison to the same power generated by a cheaper tube. Of course, if the tube is purchased "surplus" at low cost, the economic picture changes so that the initial cost is of secondary importance. Even so, tube efficiency tends to drop when extremely low values of plate voltage are employed. In addition, multi-element tubes, such as the tetrode (the 813 or 4-250A, for example) have a definite *minimum* plate potential below which it is not wise to operate the tube. As the plate potential is lowered, the average screen current tends to rise and the screen dissipation increases accordingly. It can be possible to thereby damage a tube by excessive screen dissipation by operating it at a low plate potential.

Lowering the screen voltage to decrease the screen dissipation is but a makeshift cure, as the power gain and efficiency of the tetrode tube drops sharply as the screen voltage is lowered beyond the normal operating range.

Maximum Plate Current

Maximum plate current is based upon the available supply of electrons emitted by the filament of the tube. Filament emission is therefore the controlling factor determining maximum allowable plate current. The maximum figure is intended to set a value which may be easily realized throughout the life of the tube. If operating conditions are chosen which require the maximum plate current limitation to be exceeded at the start of tube life, it may become increasingly difficult to maintain the desired plate current as the tube ages. To have ample filament reserve, it is important to make sure that filament voltage is "up to snuff" at all times.

Filament Voltage

Proper filament voltage and the allowable departures therefrom are usually specified in the tube data sheet. In general, quick-heating thoriated tungsten filaments used in the larger power tubes may be operated over a range of plus or minus 5 per cent of the recommended voltage. Slower heating cathode type filaments used in small power tubes and external anode types usually have a filament operating range of plus or minus 10 per cent of the recommended voltage. Some variation in power output must be expected as the filament voltage is varied in this range. Lower than normal filament voltage will impair the power output of the tube, and higher than normal voltage will cause critical parts of the tube to run at an excessive temperature, and may even cause damage to the grid structure in extreme cases. In passing, it should be noted that an inexpensive a.c. type meter of plus or minus 5% accuracy can tell the operator little about filament voltage, when the voltage must be held to the same value of accuracy. Use a *good* filament voltmeter of known accuracy.

Maximum Grid and Screen Ratings

Element dissipation sets the grid and screen power limits. Excessive dissipation can result in electron emission from the element (termed primary emission), or can cause deformation or melting of the structure through overheating. In addition, the grid and screen structures can be overheated by excessive radiation from the plate.

A common type of screen damage results when the tube is operated with full screen voltage and low or nonexistent plate voltage. The screen then tends to act like the plate, and excessive screen current quickly boosts the screen dissipation to the point where the structure is permanently damaged. Thus, the tetrode should be protected against loss of plate voltage. Either the screen and plate voltage should be taken from a common supply, or some form of overload relay or safety device should be used that will break the screen voltage lead when the screen current exceeds a predetermined value.

Bulb Temperature

The glass envelope and lead seals of a transmitting tube must be maintained below a temperature at which the glass will soften, or the seals "leak" air. Tubes and components tend to become smaller year by year, but nobody has yet been able to miniaturize the watt, and assemblies run hotter as they are reduced in size. Also the tube's glass envelope will act as a conductor when it is too hot. Adequate ventilation is very important if maximum tube life is to be achieved. Heat is the great enemy of the vacuum tube and pains should be taken to conduct the heat away from the tube as efficiently as possible.

The most popular tubes used in amateur service are air cooled. The smaller tubes (and the larger old ones having long element support stems) may be cooled by *convection*, the heat rising from the envelope creating sufficient air movement to ensure that excessive element and seal temperatures are not reached. Compact, higher power tubes that have to dissipate large quantities of heat in a small area must have assistance in the form of air blown across the envelope, seals, and pins by an auxiliary fan or blower.

Short, squat tubes may require more cooling than long, thin tubes as the lead seals of the "shorties" are nearer the elements and are thus exposed to higher temperatures.

For most tubes the flow of cooling air is upward, consistent with the normal flow of convection currents. Large transmitting tubes have an open base structure and a matching socket which permits cooling air to enter the base end of the tube. The grid circuit area under the chassis, therefore, may be pressurized and the air introduced into this chamber by means of an external blower. The plate circuit area may have a mesh cover which permits the air to vent out readily, yet which provides a degree of circuit shielding. No holes in the chassis should be provided for the air to pass from the lower to the upper compartment other than by passage through the socket and tube base.

Do not sub-mount a tube with a metal base shell so that the chassis comes above the vent holes of the base. *Do not* mount above the chassis a tube with a metal base shell or the proper circulation of air will be impaired.

In the case of the external anode-style tubes (4X150A, for example) complete air system sockets are available that permit air to be blown axially on the base of the tube, past the

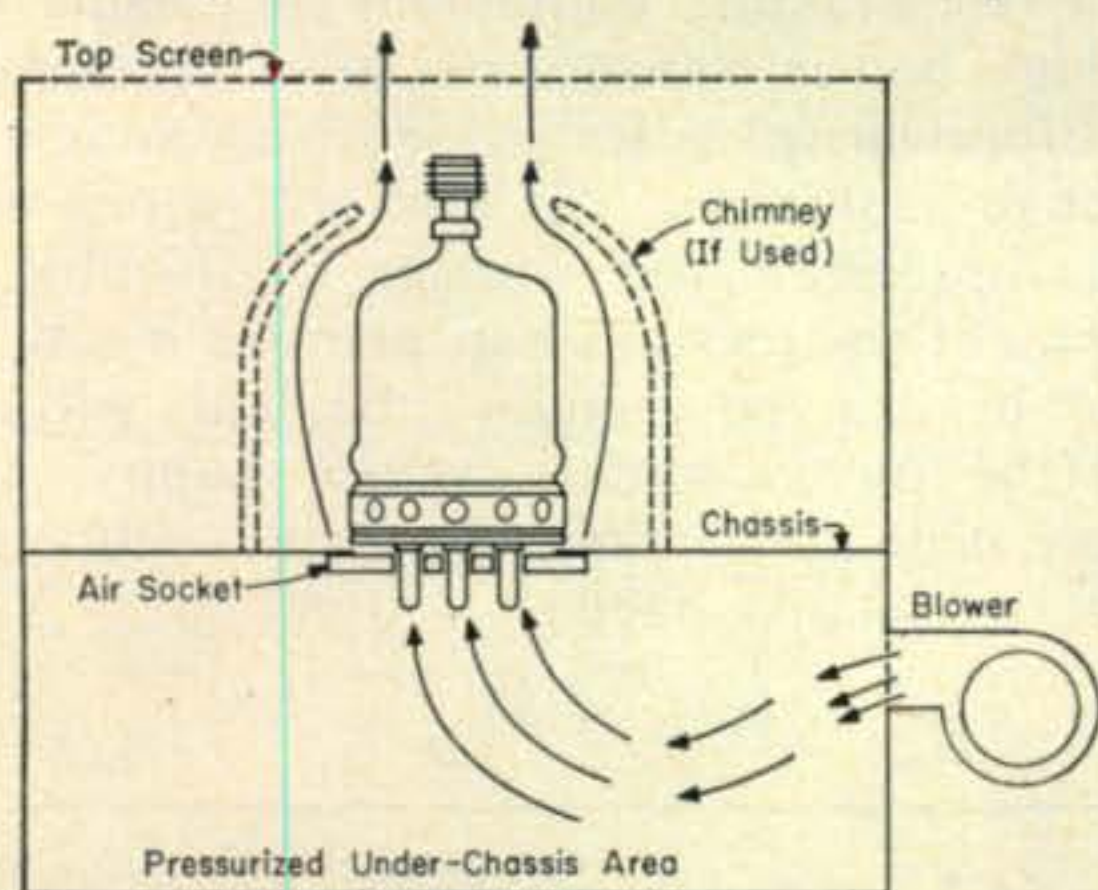

Fig. 1—Correct mounting of transmitting tube provides cooling, shielding, and isolation of input and output compartments. Cool air enters through grid circuit compartment below sockets, through a screened opening, passes through socket cooling the base end of the tube, sweeps upward cooling the glass envelope and into the output circuit compartment. The compartment has mesh-covered openings in top which permit heated air to vent out readily. This arrangement applies whether the tube is cooled by forced air or by convection circulated air.

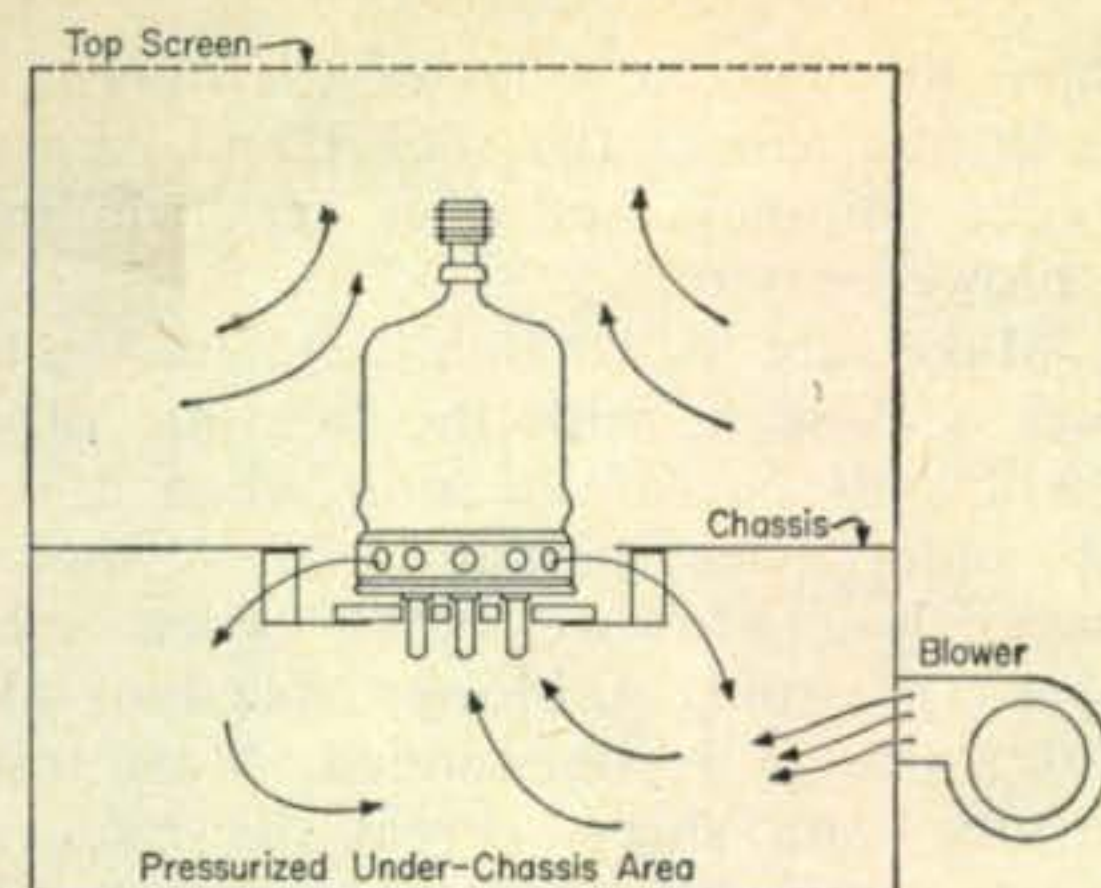

Fig. 2—Do not sub-mount a tube with a metal base shell so that the chassis deck comes up above the vent holes of the base shell of the tube. No improvement in isolating input and output circuits results, and such an arrangement prevents the flow of cooling air about the envelope and seals of the tube. If a tube must be recessed into the chassis because of space limitations, a recessing cylinder with wide clearances should be used to permit the air from the base holes to vent properly into the compartment above the chassis.

base to the envelope, and then over the plate cooler. Use of other than such a special socket is "bad medicine" for the external anode tube, as the tube temperatures cannot be adequately controlled.

Use of a receiving type loctal socket with external anode tubes is not recommended, as dangerously high stem temperatures will be generated from the heat of the filament unless the base structure is cooled by an air blast, and the solid construction of the loctal socket blocks the normal flow of air above the tube stem.

Construction Techniques for Forced-Air Cooled Tubes

In general, the under chassis area should be made air tight, and a suitable fan or blower used to pressurize the compartment. The intake air vent should have a large area to provide a minimum resistance to the flow of air. Air holes may be screened as a TVI-preventive measure, but such impediment reduces the passage of the air by a large degree.

As it is difficult to measure the air flow to a tube, and even more difficult to measure the envelope and seal temperatures of the tube, the following "rules of thumb" may be observed in order to achieve optimum cooling and longest tube life.

1—Use the maximum amount of forced air possible. It is wise to employ a blower delivering at least twice the recommended volume of air. Turn the air blast on at the same time the filament is turned on, and leave it on as long as the filament is lit.

2—Inexpensive squirrel-cage blowers often do not work properly when delivering air into a back pressure "load" created by the socket, tube and chimney. A large quantity of air

escapes through the sides of the blower. Make sure the air *enters* the socket and *escapes* via the tube chimney, and does not "windmill" in the blower cavity.

Make sure the rotatable cage of the blower makes a close fit with the housing; otherwise air will spill out of the unit when it is operated under back pressure. Most low speed blowers lose pressure badly when subjected to back pressure. A blower speed of at least 3,100 r.p.m. is recommended. Most transmitting tube data sheets reveal the required air pressure (in cubic feet per minute) and the back pressure (in inches of water) that must be developed as pressure-drop across the socket. Most blower manufacturers provide data sheets which show the blower output (in cubic feet per minute) that the unit develops for various values of back pressure (in inches of water, or static pressure). You can be reasonably sure your tube is adequately cooled if you choose a blower that develops about *twice* the required number of cubic feet you need at a specified back pressure. Beware of midget and surplus unmarked blowers, or blowers with loose fitting housings!

3—Make sure the cooling air reaches the socket and make sure the exhaust air leaves

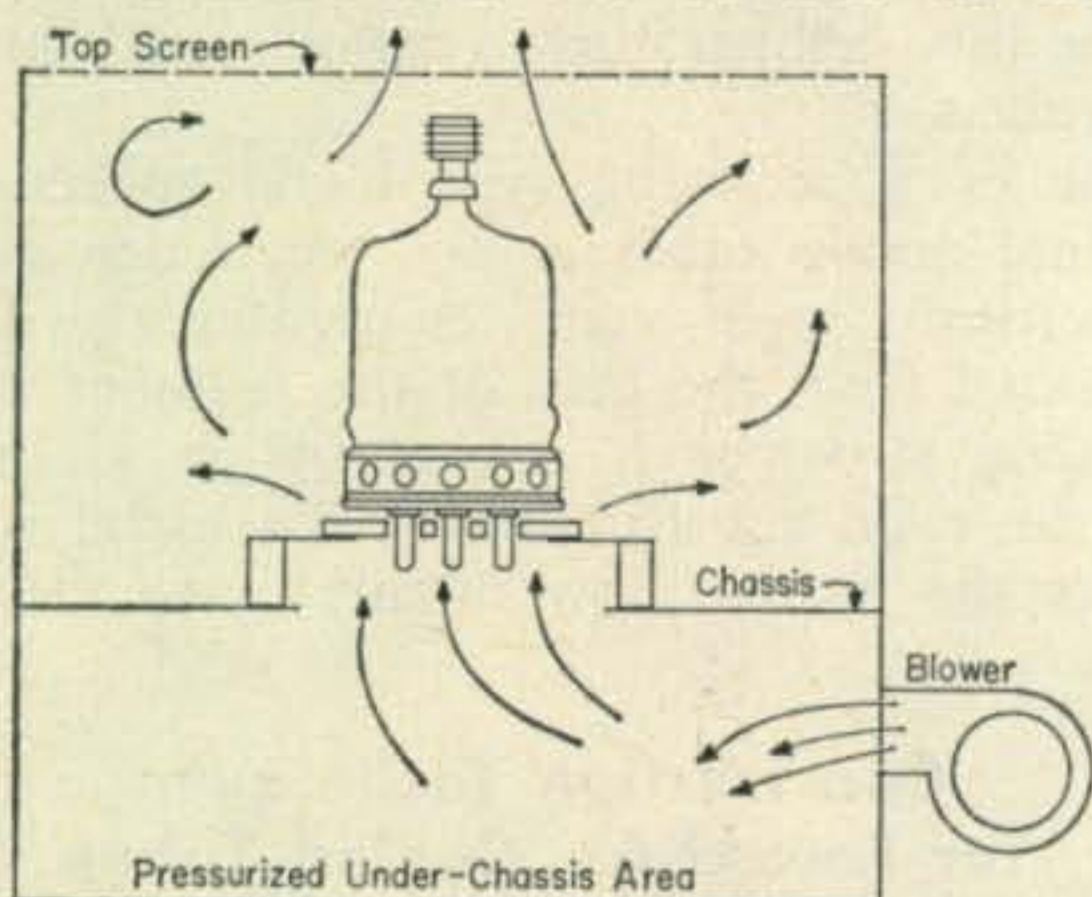

Fig. 3—Do not mount a tube with a metal base shell above the chassis unless the area between the socket and the chassis is sealed to prevent air from escaping from beneath the tube base. Circuit isolation is not improved by this form of mounting, and proper cooling is impaired. If the tube must be raised above the chassis for some reason, it should be mounted on the top surface of an air-tight cylinder that funnels the air up into the socket cooling holes.

the vicinity of the tube. It does no good to pump cooling air to a tube and then have no path for the warmed air to escape.

4—A large amount of heat escapes from glass tubes by radiation of energy from the tube plate. Placing the tube near polished metal surfaces that reflect radiant energy back to the elements of the tube is a sure way to raise the internal temperature of the tube. It is a good idea to space the tube away from such surfaces by at least the diameter of the tube envelope.

No simple rules can be given to accommodate all tube installations in all possible equipments. Tubes can be damaged by lack of air, but never by too much air, unless the blast is strong enough to lift the tube out of the socket and smash it against your ceiling! Use the largest blower you can afford. A great deal can be learned about air flow by puffing cigarette smoke into the blower and observing the path it takes in quitting the amplifier.

Connections to the Tube

Connections to the plate cap of transmitting tubes should be made with a section of flexible strap or braid to prevent any lateral strain from being placed on the tube electrode. Those tubes having a rod-type plate lead (such as the 304-TL) are prone to damage if the plate connector is forced on the rod until the former touches the glass envelope. Under heat, the expansion rate of the glass, the plate rod, and the connector are all different, and it is possible for the connector to press against the envelope and cause a fracture of the glass.

There Is Hope!

Don't let all this gloom and doom discourage you from building equipment and using modern high power transmitting tubes! It is merely that "forewarned is forearmed." By anticipating minor difficulties such as outlined in this article and eliminating the sources of trouble, the equipment in question can provide a long and happy life for the vacuum tube. This will make you (the owner and operator) happy, and—believe it or not!—make the vacuum tube manufacturer equally happy!

[To be continued]

Mars Bulletins

Air Force MARS Eastern Technical Net

Sundays 2 - 4 PM EST 3295kc - 7540kc - 15,715kc

Nov. 5th **Introduction To Sonar**—Thaddeus G. Bell, Scientist, U.S. Navy Underwater Sound Laboratory.

Nov. 12th **Underwater Communications** — Hugo J. Wilms, Jr., Engineer, U.S. Navy Underwater Sound Laboratory.

Nov. 19th **Modern Submarines** — LCDR James Bellah, U.S. Navy Submarine School.

Nov. 26th **Oceanography** — Dr. CDR George Bond, Officer in Charge, Naval Medical Research Laboratory.

A High Efficiency Transistorized Modulator

BY JOSEPH L. REIFFIN*, W5CWP/4

The use of transistors in this class B modulator provides advantages unattainable with vacuum tubes. Six amperes are drawn for an audio output of 50 watts and the idling current drawn is zero. A "talking" efficiency of 66% is obtained.

THE ability of the present day power transistors to develop large amounts of audio power makes them a "natural" for use as modulators in mobile transmitters. The unit described here is compact, inexpensive, and produces up to 50 watts of audio with an efficiency never before possible with vacuum tubes.

Efficiencies

The modern a.m. transmitter is a surprisingly low efficiency device. If the efficiency is calculated, as technically it should be, by dividing the total wattage output to the antenna by the total wattage input to all the stages, the efficiency of the best of our transmitters, commercial or home brew, is in the vicinity of 20%.

Most amateurs, and commercials too, generally only concern themselves with the power input to the final stage and compare that to the power output to the antenna to calculate the efficiency of the transmitter. With a final amplifier operating at class C, this efficiency may run as high as 70%. This is fine and everyone is quite happy. However, some thought should be given to all the wattage that is used to heat the filaments of all the tubes and all the wattage being used in the oscillator and driver stages and all the wattage used in the speech amplifiers and modulator stages of the transmitter. All of these stages are necessary to produce the desired output to the antenna.

For example, the popular Apache transmitter, when used on a.m., has a rated input to the final of 150 watts. It is estimated that the output to the antenna is approximately 100 watts. That adds up to a final stage efficiency of 67%. However, the specifications also show that the input wattage to the entire transmitter is 500 watts. Now we find that we have an overall efficiency of 20%. The generation of heat accounts for the lost 80% of the input power.

This is not a very serious thing to live with at the relatively low power used in our transmitters. We plug the sets into a convenient wall outlet and let the electric company supply us

with the necessary power. The rates are certainly low enough so that we really don't worry if our electric bill runs a dollar or so higher because of the power inefficiency of our transmitter.

On the other hand, when operating a mobile transmitter and being forced to supply all of the power from our over-worked car battery, we should take a very dim view of any situation that converts our hard earned battery power into useless heat. If you've ever turned the starter key in your car on the morning after a full evening of hamming and have been greeted with a dying grunt from your starter, I am sure you get the full picture.

The use of transistors for the power supply and for the speech and modulator stages of your mobile rig will greatly increase the overall power efficiency of the installation.

Class B Operation

For high efficiency, coupled with circuit simplicity, class B operation is still on top of the list for plate modulated a.m. transmitters. It is a very happy circumstance that power transistors are admirably suited for class B mode of operation.

Both the driver and output stages of this unit use transistors operating in class B. This may seem a bit unusual to those who are accustomed to having the speech amplifier and driver stages operating in class A for both voltage gain and good regulation to drive the class B modulator stage. With transistors this is neither necessary nor desirable if maximum efficiency is the goal.

When you are not talking into the microphone there is virtually zero current being drawn in the entire unit. On speech peaks, as much as 6 amperes may be drawn to produce an output of approximately 50 watts. The no-signal zero current characteristic results in high efficiency and a substantial saving of battery power.

A comparable vacuum tube modulator using 6L6 tubes for an output of approximately 50 watts has a no-signal (static) plate current of 88 milliamperes at a plate voltage of 360 volts.

*1151 Miller St., Winston-Salem, N.C.

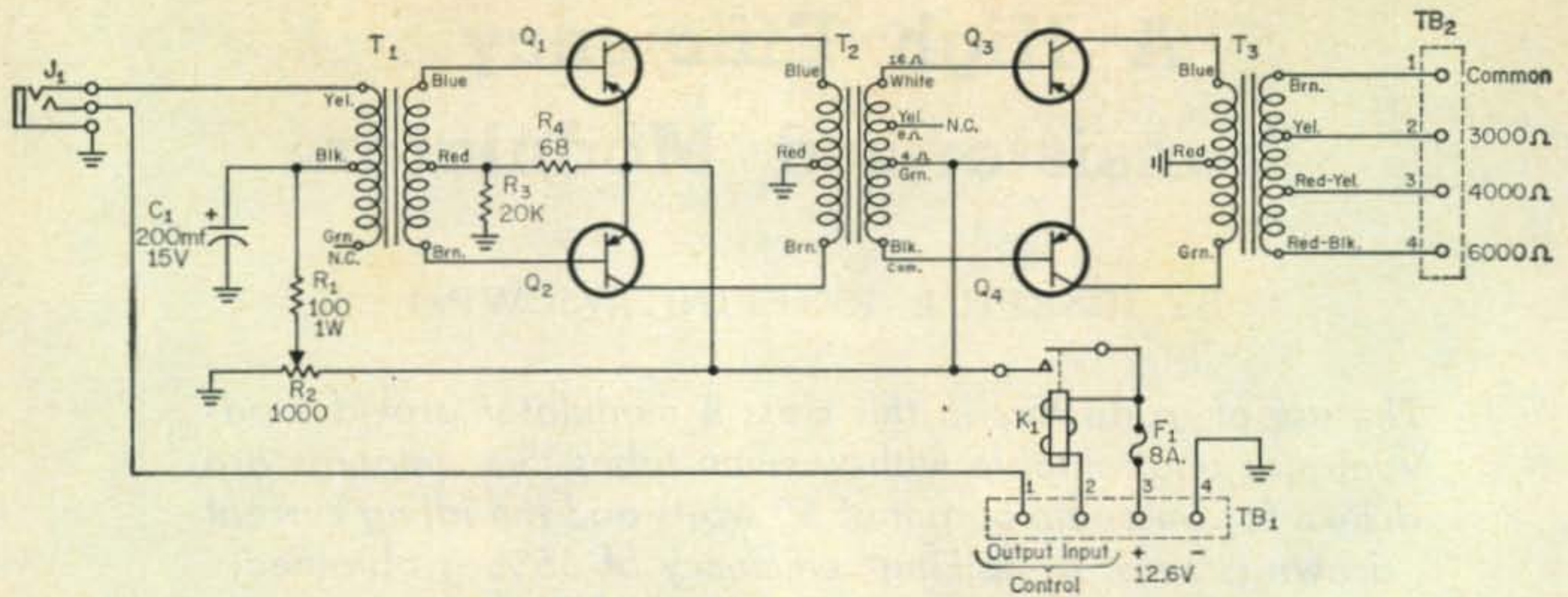

Fig. 1—Circuit of the high efficiency transistorized modulator.

- K₁—Relay, 12 volt d.c., s.p.s.t., contacts rated at 10 amps or more.
 Q₁, Q₂—2N301, 2N257, 2N457 or other types having similar characteristics.
 Q₃, Q₄—Delco 2N277, 2N173 or equivalent.
 R₂—1K potentiometer, linear taper.
 T₁—Carbon microphone to transistors, transformers, 150 ohm to impedance to 490 ohms—both windings center tapped. Argonne AR-163 or equiv.

- T₂—Transistor output transformer, 700 ohms impedance center tapped to 4/8/16 ohms impedance. Thordarson TR-115, Stancor TA-43 or equiv.
 T₃—Modulation transformer, class B transistors 6 ohm center tapped to class C load—2000/4000/6000 ohms. Triad TY-66A or equiv.
 2 Heat sinks—Delco #1221119
 2 Power Transistor Mounting Kits—Motorola MK-10 or equiv.

This is about 32 watts of plate power that is completely useless as far as modulating the final is concerned. Under full signal input for 47 watts output, the plate current is 205 ma at 360 volts and a screen current of 16 ma at 270 volts. All adding up to 77 watts input. To this must be added another 11 watts for heating the filaments. And if we consider, as we should, the entire speech and driver stages along with the modulator stage, we can approximate an additional 30 watts for the plate and filament power of these stages. This adds up to a grand total of approximately 120 watts to produce the 47 watts of audio we want. This is an efficiency of about 40%.

parative power saving is even greater when the no-signal zero current feature is considered.

The entire transistorized modulator unit consumes approximately 75 watts for 50 watts output—an efficiency of 66%. And the com-
 Three quarter view of the transistorized modulator built on a 4×5×6 inch chassis. The mike jack, gain control and two terminal strips are mounted on the front panel. The upper strip is TB₁. The two driver transistors, Q₁ and Q₂ are on the left flange while the two output transistors, with their associate heat sinks, are on the left and right sides.

Circuitry

The circuit used is not unusual and contains no new tricks. A single button carbon microphone is used because of its high gain, ruggedness, and desirable speech characteristics. Excitation voltage for the mike is obtained directly from the 12 volt battery source and is varied by means of the 1000 ohm potentiometer, R₂, which serves very nicely as a gain control. This solved a rather knotty problem in that it would have required a matched dual potentiometer if the gain control were used in the base circuit of the output transistors. The 100 ohm resistor, R₁, is used to limit the microphone current to a safe value in the event that the gain control is turned full on.

Transformer T₁ is the microphone input transformer with a primary impedance of 150 ohms and a secondary impedance of 490 ohms, both windings are center-tapped. Only one half of the primary is used as shown on the schematic diagram. This matches the impedance of the microphone and provides a good step-up ratio to the secondary winding which feeds the base of transistors Q₁ and Q₂. These are medium power transistors operating essentially at class B. The 700 ohm impedance of the primary of transformer T₂ provides the proper load for these transistors. The secondary winding of T₂ is usually used to match the impedance of a loud speaker voice coil, either 4, 8, or 16 ohms. By using the 4 ohm tap as the center-tap, and connecting the base of transistor Q₃ to the 16 ohm tap, and the base of transistor Q₄ to the common tap, we have

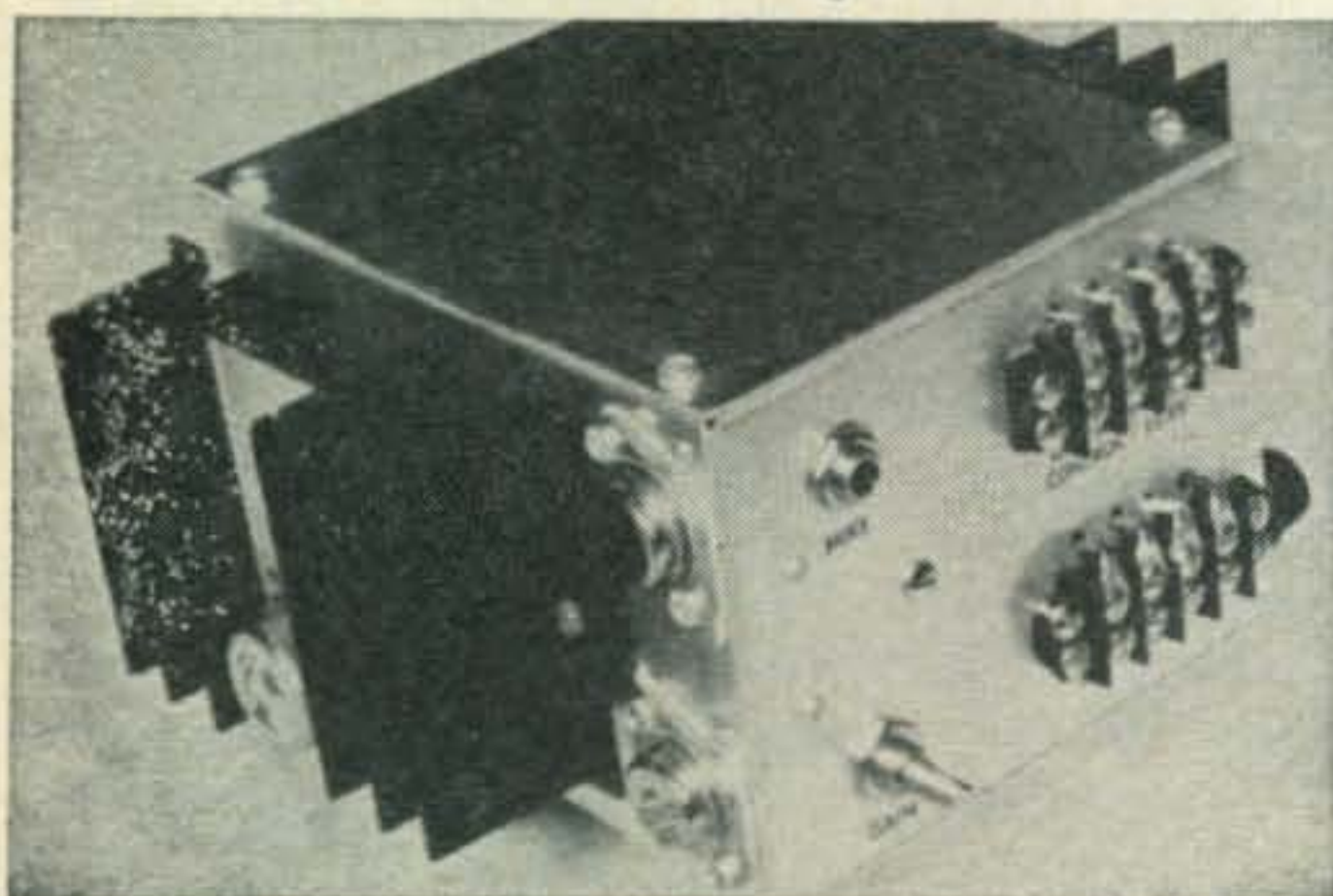

the low impedance necessary for correct operation of the modulator stage.

Resistors R_3 and R_4 form a bias network in the base circuit of the driver transistors, Q_1 and Q_2 . This network applies a slight forward bias to these transistors to eliminate the cross-over distortion that occurs at low signal levels.

It was not found necessary to add any resistors to the base circuit of the modulator transistors Q_3 and Q_4 to eliminate this cross-over distortion. Because of the high level of the signal being handled in this stage, the distortion that occurs at low levels was completely unnoticed in the output. It is a simple matter for the purist to add this bias in the same manner as in the driver stage. The resistive network should be calculated to produce approximately 1/10 of a volt on the base of Q_3 and Q_4 . This will slightly affect the efficiency of the stage, since there will be some small current drawn with zero signal input.

There will probably be some eyebrows raised over the fact that the usual emitter resistor is omitted in both the driver and output transistors. The usual function of a resistor in the emitter circuit is to prevent the thermal runaway that may occur with an increase of transistor temperature. The use of properly designed heat sinks for the output transistors, and the use of the cabinet itself as the heat sink for the driver transistors proved extremely effective in preventing thermal runaway.

The inclusion of a resistor in the emitters of the modulation transistors Q_3 and Q_4 would require a fractional ohm resistor capable of dissipating considerable power. Such a resistor would be difficult for the average ham to obtain. Also, its use would result in somewhat reduced power output.

This unit has been tested under conditions far more stringent than would ordinarily be met under actual operating conditions. With a 1000 cycle sine wave input and the battery voltage increased to 14 volts, no indications of thermal runaway were discernable after more than an hour of continuous operation.

Transformer T_3 is the modulation transformer. The one used in this unit is a Triad TY66A, nominally rated at 40 watts output. The primary impedance is 6 ohms, center-tapped, which is just about right for our output transistors. The secondary is tapped at 3000, 4000, and 6000 ohm impedance so that it can accommodate several different class C loads.

It is important here, as it is in every application of impedance matching with transformers, that the proper load be applied to the secondary so that the proper impedance will be reflected at the primary.

Relay K_1 is a 12 volt d.c. s.p.s.t. relay used to apply the 12 volt battery voltage to the modulator. By bringing the bottom of the relay coil to terminal 2 (CONTROL IN) of TB_1 and the control terminal of J_1 (microphone jack) to terminal 1 (CONTROL OUT) of TB_1 ,

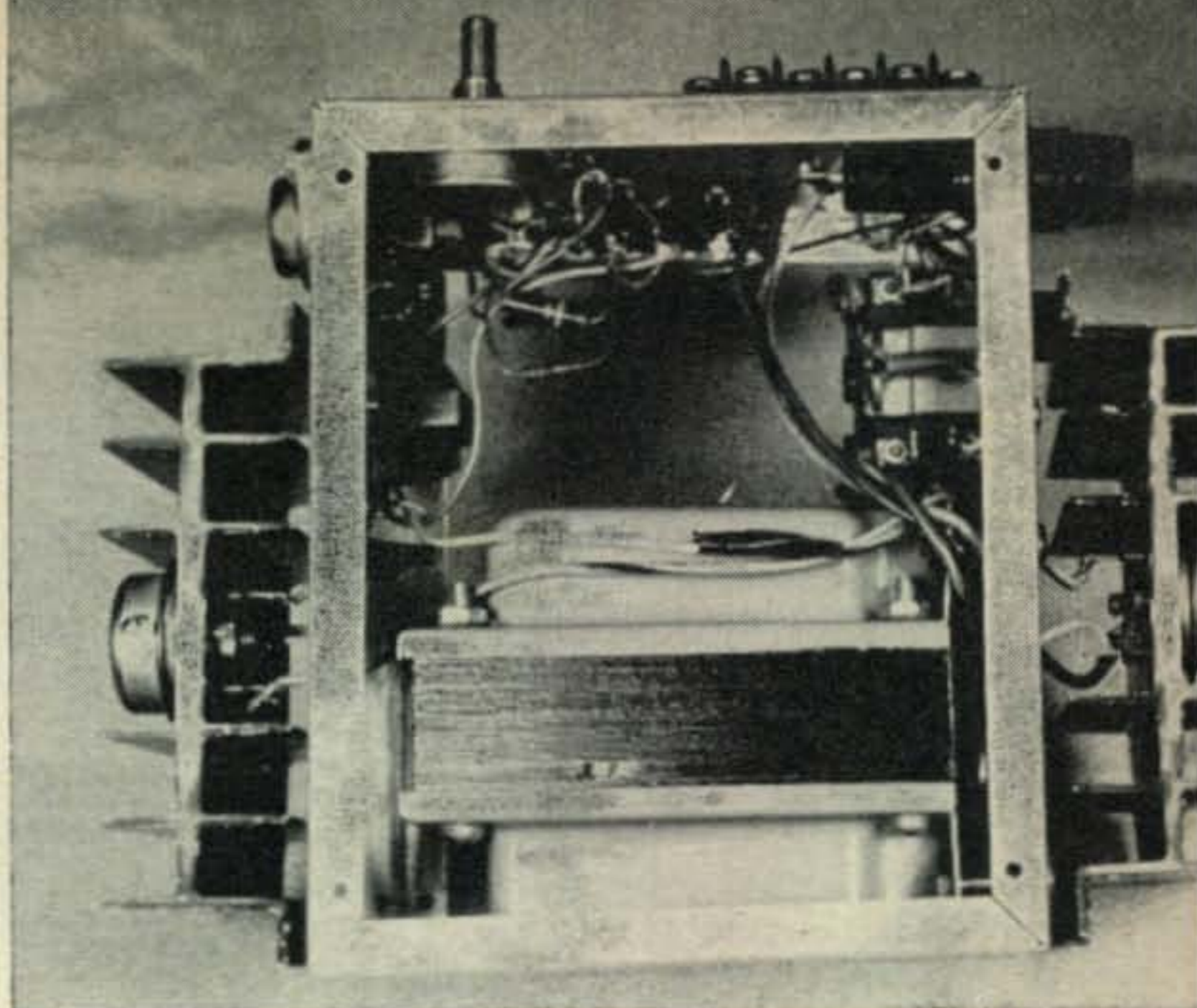

Bottom view of the transistorized modulator shows T_3 occupying the bulk of the internal space. Relay K_1 is on the right front chassis flange and transformers T_1 and T_2 are in the front left section of the chassis.

we can use the push button on the microphone to actuate a remote relay and have a remote relay actuate K_1 . This is desirable because it is necessary that the Class C amplifier that is being modulated be drawing normal current before the transistor modulator is turned on. This assures a proper load on the modulation transformer, T_3 . If it is desired to have the mike switch actuate K_1 , a jumper should be wired between 1 and 2 of TB_1 .

Construction

The complete speech amplifier and modulator is contained in a 4×5×6 inch aluminum utility cabinet. This is quite a compact unit especially when it is considered that 50 watts of audio are produced with this small package. There is no crowding of the components and wiring is quite simple. The modulation transformer is by far the largest and heaviest of all the components used. The two other transformers used are of the miniature variety and require very little space. The circuitry is extremely simple. This is borne out by the fact that only one capacitor, three small resistors, and one potentiometer are used in addition to the transformers.

The two power transistors in the modulator stage are mounted on individual heat sinks. The ones used are Delco #1221119 and are available from stock from any Delco dealer. These heat sinks are excellent for the job and come with the necessary insulator and mounting hardware. These heat sinks are mounted on opposite sides of the cabinet. The two driver transistors are mounted directly on the cabinet on one side right above one of the heat sinks. A Motorola MK-10 Power Transistor Mounting Kit is used for each of these transistors. This kit also contains the socket, teflon insulator, and mounting hardware. The photograph shows this mounting arrangement.

The modulation transformer is mounted inside the cabinet as shown on the photograph

of the interior of the cabinet. Four ½ inch spacers are used when mounting this transformer to provide space for the leads which come out on the bottom of the transformer.

The 4×5 inch side that is furthest from the end where the modulation transformer is mounted is used as the front panel. This holds the microphone jack, the gain control, and the two terminal boards *TB*₁ and *TB*₂.

The microphone input transformer is mounted inside the front panel near the mike jack and the two driver transistor sockets. The driver transformer is mounted inside the left side panel between the driver transistor sockets and the modulation transformer.

The control relay, *K*₁, is mounted in the cabinet on the right side between the front panel and the modulation transformer. The three small resistors and the filter capacitor are mounted on a 5 terminal tie point strip which is mounted on the inside of the front panel by means of a single screw.

It is a good practice in mobile installations to use fuses in all circuits that connect directly to the battery. A fuse holder is mounted on the lower right hand side of the cabinet as a safety feature.

Wiring is strictly point to point and no special precautions are necessary. The wires from the transformers go directly to the components indicated in the circuit. It will be necessary to extend two of the leads from the modulation transformer and one lead from the driver transformer.

Fairly heavy conductor should be used for all circuits that carry high currents. Number 16 wire should be sufficient. These leads are the ones used for the 12 volt input circuit to the fuse and to the relay. Also from the relay to the primary of the modulation transformer and the leads to the collector and emitter of both

output transistors, *Q*₃ and *Q*₄. Just about any hook-up wire can be used for the rest of the circuit since the currents involved are quite low.

In testing the modulator before connecting it to a transmitter, it is only necessary to connect a high wattage resistor (50 watts) of the proper resistance to the output terminal *TB*₂. The output can be monitored on an oscilloscope if one is available. If desired, a 100 ohm 1 watt resistor can be connected in series with the terminating resistor and the common terminal of *TB*₂. A pair of earphones should be connected across the 100 ohm resistor and the quality of the speech and modulator can be checked out by listening.

The speech quality is just about right for mobile use. The modulation transformer has a frequency range of 300 to 3000 cycles per second. This is the most potent frequency range for good crisp communication.

The gain control in the microphone circuit is the controlling factor in determining the wattage output. By adjusting the gain control and keeping the voice level to the mike fairly constant, any transmitter from 10 watts to 100 watts input can be fully modulated by this unit.

This modulator is being used at the present time to modulate a mobile transmitter using the popular 6146 in the final. The input to the 6146 is just about 60 watts—600 volts at 100 ma. This requires 30 watts of audio for 100% modulation. The modulator just coasts along at that output.

On the air reports have been very gratifying and we are anxiously awaiting the day—and it is surely coming—when we will be able to say that we are modulating a type XX transistor in the final running 250 watts with a pair of type YY transistors in the modulator. In the meantime, this transistor modulator is certainly a step in the right direction. ■

Statement of Ownership

STATEMENT REQUIRED BY THE ACT OF AUGUST 24, 1912, AS AMENDED BY THE ACTS OF MARCH 3, 1933, AND JULY 2, 1946 AND JUNE 11, 1960 (74 STAT. 208) SHOWING THE OWNERSHIP, MANAGEMENT AND CIRCULATION of CQ—THE RADIO AMATEUR'S JOURNAL, published monthly at New York, N. Y., for October 1, 1961.

1. The names and addresses of the publisher, editor and business manager are: Publisher: Sanford R. Cowan, 6 Embassy Court, Great Neck, N. Y.; Editor: Arnold Trossman, 300 West 43rd Street, New York 36, N. Y.; Managing Editor: none; Business Manager, Richard A. Cowan, 6 Embassy Court, Great Neck, N. Y.

2. The owner is: (If owned by a corporation, its name and address must be stated and also immediately thereunder the names and addresses of stockholders owning or holding 1 per cent or more of total amount of stock. If not owned by a corporation, the names and addresses of the individual owners must be given. If owned by a partnership or other unincorporated firm, its name and address as well as that of each individual member must be given.) Sanford R. Cowan, 6 Embassy Court, Great Neck, New York.

3. The known bondholders, mortgagees, and other security holders owning or holding 1 per cent or more of total amount of bonds, mortgages, or other securities are: None.

4. Paragraphs 2 and 3 include, in cases where the stockholder or security holder appears upon the books of the company as trustee or in any other fiduciary relation, the name of the person or corporation for whom such trustee is acting; also the statements in the two paragraphs show the affiant's full knowledge and beliefs as the circumstances and conditions under which stockholders and security holders who do not appear upon the books of the company as trustees, hold stock and securities in a capacity other than that of a bona fide owner.

5. The average number of copies of each issue of this publication sold or distributed, through the mails or otherwise, to paid subscribers during the 12 months preceding the date shown above was: (This information is required by the act if June 11, 1960 to be included in all statements regardless of frequency of issue.) 73,836.

(Signed) Richard A. Cowan, Business Mgr.

Sworn to and subscribed before me, this 19th day of September 1961.

HYMAN GORD, Notary Public

(Commisson expires March 30, 1962)

Unidentified Amateur Transmissions

BY KERMIT A. SLOBB*, W9YMZ

The general acceptance of VOX circuits, while desirable, does have certain drawbacks. W9YMZ elaborates on the pitfalls.

SOME call it "Voice Controlled Break In," others call it "Voice Actuated Relay Operation," still others call it (censored) because they associate it with s.s.b. But whatever you call it, the number of words involved makes it quite a mouthful on phone, so the boys on s.s.b. simply call it VOX, pronounced, "vox."

The thousands of shiny (and expensive) new commercial s.s.b. rigs coming out of the factories all have a little knob marked VOX GAIN or vox. With this control advanced to the proper position, the operator merely talks into the microphone and puts himself on the air without manually operating a switch.

It follows that since a switch needs a bit of pressure to be actuated it is rare when an ordinary transmitter is accidentally put on the air.

Not so with VOX! Since it is standard practice for many radio amateurs to leave their equipment in a standby position with the filaments on, if some of them forget and leave the function switch on vox instead of STBY; any noise or sound loud enough to actuate the vox relay will be transmitted. Only the sound of the relay, in most instances, is a clue that the transmitter is on the air, particularly when the receiver audio gain is down.

Which brings up an interesting point. Supposing we could make a collection of some of these accidental transmissions made when the vox was left on?

Here is a fictional report from the FCC on one ten hour period of monitoring, transcribed from the tape on the "automatic scanning receiver."

Unidentified Amateur Transmissions

March 22, 1961

Time	Freq.	Mode	Nature Of Transmission
0803	7.21	s.s.b.	(Man) When is breakfast gonna' be ready?
0820	14.29	s.s.b.	(Woman) What's the idea of waking me up with that infernal racket at this time of the morn . . . oops.
0901	28.62	s.s.b.	(Sound) Crash!

*1605 Oakwood Road, Northbrook, Illinois

0911	21.43	s.s.b.	(Man) !*%\$#!
1000	21.42	s.s.b.	(Woman) I'll be ready in a minute!
1017	28.63	s.s.b.	(Man) Ouch! That !*%\$#! soldering iron!
1055	21.43	s.s.b.	(Sound) Sneeze!
1106	14.33	s.s.b.	(Man) Who hid my pipe?
1138	14.27	s.s.b.	(Woman) Marge? Edith. George went to the basement so I'm using the phone on his desk. I'm dying to know what happened at the bazaar. Tell me about Barbara . . . funny, I seem to hear something clicking . . . well, go ahead and tell me about . . . (etc. for eight minutes.)
1200	7.21	s.s.b.	(Man) When is lunch gonna' be ready?
1231	21.41	s.s.b.	(Man) Get out of here!
1250	14.28	s.s.b.	(Man) Chlooooooeeeeee!
1342	14.34	s.s.b.	(Man) Meter man!
1414	21.41	s.s.b.	(Man) Ouch!
1455	28.64	s.s.b.	(Man) Sneeze!
1511	14.31	s.s.b.	(Child) Look, Mom, no cavities!
1532	21.44	s.s.b.	(Woman) Harry, don't . . .
1620	14.30	s.s.b.	(Man) Those !*%\$#! heterodynes!
1643	7.21	s.s.b.	(Child) Mommy! Daddy left his transmitter on!
1708	3.98	s.s.b.	(Sound) Dog barking.
1733	3.98	s.s.b.	(Child) Oh, goody, Daddy went to the garage, so I'll play radio man and talk to the moon. Hello CQ, mister radio man. Hello, zebra doggy Q D five, over and out. CQ moon. Oh, hi, Daddy . . . baaw!
1755	14.27	s.s.b.	(Man) !*%\$#!
1800	7.21	s.s.b.	(Man) When is supper gonna' be ready?

Perhaps it should be obvious by this time that the moral to this story is: *Watch that VOX, Pop!* ■

The "Handy Dandy" Transmitter Checker

BY KENNETH L. BALLARD*, K6UFA

K6UFA has combined some simple circuits to produce his "Handy Dandy" checker. This unit can help to remove much of the guesswork when checking your transmitter. The versatile checker can measure wattage, act as a relative r.f. meter, monitor modulation and perform as a field strength meter.

HAVING recently completed my new homebrew rig, running 25 watts input to a 2E26 final on 6 meters, I gave it a final check out using the old "tried" out not so true light bulb method. Then, feeling satisfied that all was working well, I connected the antenna and called CQ. My first contact was a local (2 miles away). He gave me a report of Q5-S9, then I asked him how the modulation sounded, and he said it "sounded very good". After a few more contacts and helpful reports, I figured I had the transmitter adjusted fairly well, when a fellow just 20 miles away jolted me out of my chair with "you sure are weak on modulation". Now how could that be? The meters indicated that everything was okay. I decided then and there that I needed some type of device to monitor my signal and help me check out the rig. After a few nights of thought and fancy stabbing with the soldering iron, I came up with the Handy-Dandy transmitter checker shown in fig. 1, and since all of the circuits are fairly common, I take no credit for circuit originality.

The checker consists of a 26 watt dummy load, a transistorized audio amplifier and an r.f. voltmeter and the combination can perform the following functions: 1) act as a dummy load, 2) measure relative r.f. voltage, 3) measure output wattage (if calibrated), 4) monitor modulation quality, and 5) act as a field strength meter.

*16126 Maidstone Ave., Norwalk, California

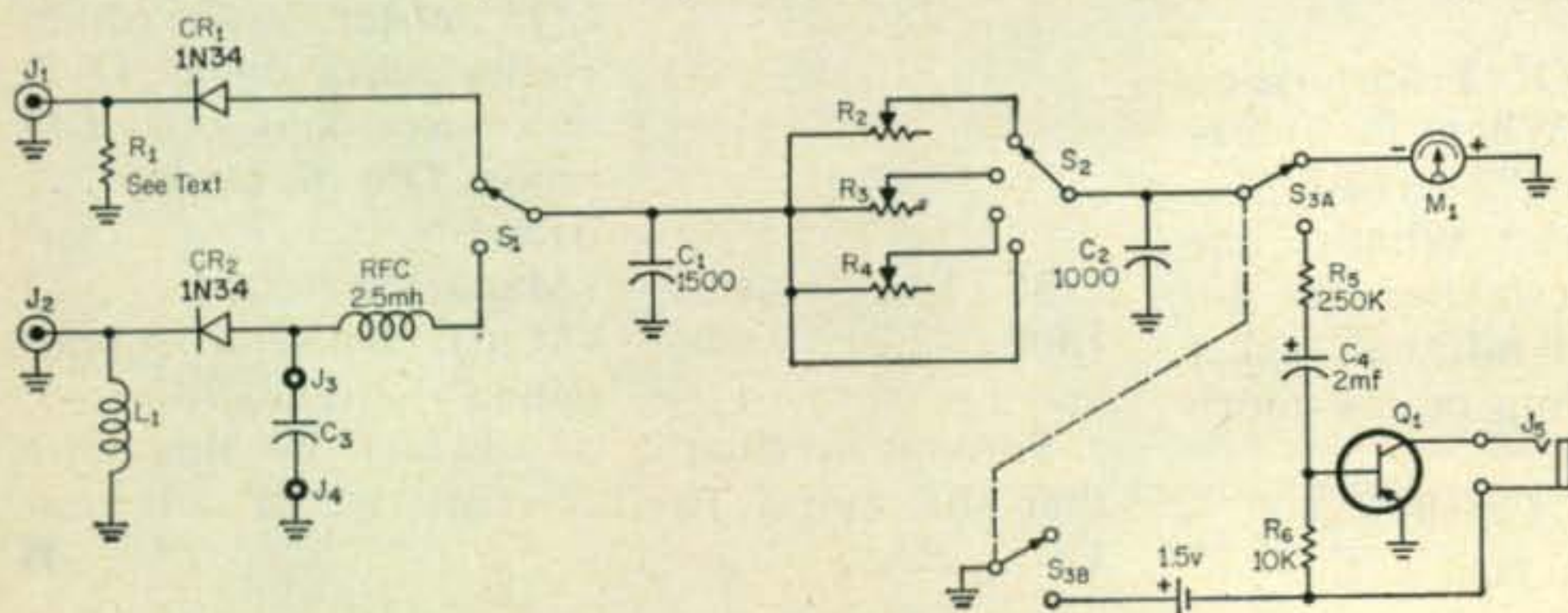

Fig. 1—Circuit of the Handy Dandy transmitter checker. Inductor L_1 is on r.f.c. and a tank circuit may be used if a specific frequency is desired.

Dummy Load

The dummy load, R_1 , is made by soldering thirteen, 680 ohm, 2 watt, non-inductive resistors, (carbon), in parallel between two brass plates, as shown in fig. 2. The load may be made up of almost any combination of resistors, for almost any power dissipation. Just keep them all the same resistance and wattage ratings. The resultant resistance of the load used is 52.3 ohms which is a good match for RG-8/U or RG-58/U coax. When assembling the load, be careful not to subject it to too much heat from the soldering iron as this may change the resistor values. Solder the center conductor of the r.f. jack, J_1 , directly to one side of the load. The other side is bolted to the chassis. The v.s.w.r. on 6 meters measured 1.08:1. The checker was calibrated on 6 meters so the calibration should hold fairly well on the lower bands, 10, 15, 20, etc. I haven't tried it on 2 meters and up, as yet, but I expect it to perform equally as well as it has on six.

Meter Circuit

The meter circuit is typical of any simple r.f. voltmeter. R.f. is rectified by CR_1 , dropped in amplitude by R_2 , R_3 or R_4 , depending on which scale is to read on the meter. Capacitors C_1 and C_2 are r.f. bypasses. Scale calibration may be obtained by adjusting R_2 , R_3 or R_4 , whichever is applicable.

Calibration of the checker is fairly simple. The first step is to make a conversion chart of

voltage to watts with the load resistance as a constant. There are two methods of doing this. Method #1 makes use of the formula:

$$P = \frac{E^2}{R}$$

where P is the power in watts, E the voltage across the load, and R the resistance of the load, a constant factor. For example; assume you read 5 volts d.c. at the test jacks J_3 and J_4 . The voltage E equals 5, R equals 52.3, therefore P equals .487 watts or about a half watt. By making a chart, ranging from 1 volt to about 36 volts, we can calibrate the meter for any full scale reading up to 25 watts. We can also calibrate the intermediate points on the scale.

In method 2, we can solve for 1 volt across the load. Divide the load resistance (52.3 ohms) into the voltage (1 volt) and you obtain a constant, K , in amperes. Multiply any voltage by K . This will give you the current through the load for the desired voltage. To convert this value to watts, multiply the desired voltage by the new current in amperes and you have the power in watts.

As any example; 1) $E = 1$ volt, $R = 52.3$ ohms; $1 \div 52.3 = .0191$ amperes. 2) Assume you wish to know what wattage 30 volts is equal to: $.0191 \times 30v = .573$ amperes. Now $30v \times .573 = 17.19$ watts. By keeping .0191 as a constant, K , you may find any value of wattage you wish.

Upon completion of the chart we can calibrate the meter. Turn all of the calibration pots to maximum resistance. Select the lowest scale with S_2 . Connect a v.t.v.m. to the test jacks, J_3 and J_4 , and apply r.f. until you get the desired full scale voltage. Adjust the meter multiplier until a full scale reducing is obtained on M_1 . Use your volts versus watts chart to determine the intermediate points and repeat the procedure for each range. You may make a chart to show the relationship between the voltage, wattage and your meter markings or you may calibrate the meter scale directly.

If you are not going to use a 0-1 ma meter, the following can help you determine the required multiplier values. Select the desired value of full scale voltage from your chart. Use the formula:

$$R = \frac{1000 E}{I} - R_m$$

where R equals the value of multiplier resistor (R_2 , R_3 or R_4), I equals the full scale current rating of meter in ma, E equals the required full scale voltage and R_m equals the internal meter resistance. As an example; assume you have available a 0-500 microampere meter with an internal resistance of 200 ohms. If you wish to read 30 volts full scale, you may solve as follows:

$$R = \frac{1000 \cdot 30}{.5} - 200$$

$R = 59.8K$ ohms. A 100K pot would work fine here.

Field Strength Meter

The field strength meter function is selected by switch S_1 . A pick-up antenna connected to J_2 causes the signal to develop across L_1 . Inductor L_1 may be an r.f. choke for broad band operation or a tank circuit for a specific frequency. The signal is then rectified by CR_2 , filtered by C_1 , C_2 , C_3 and the r.f.c. and applied to the meter, M_1 . The sensitivity of the field strength meter can be regulated by the setting of S_2 with the straight through position being the most sensitive.

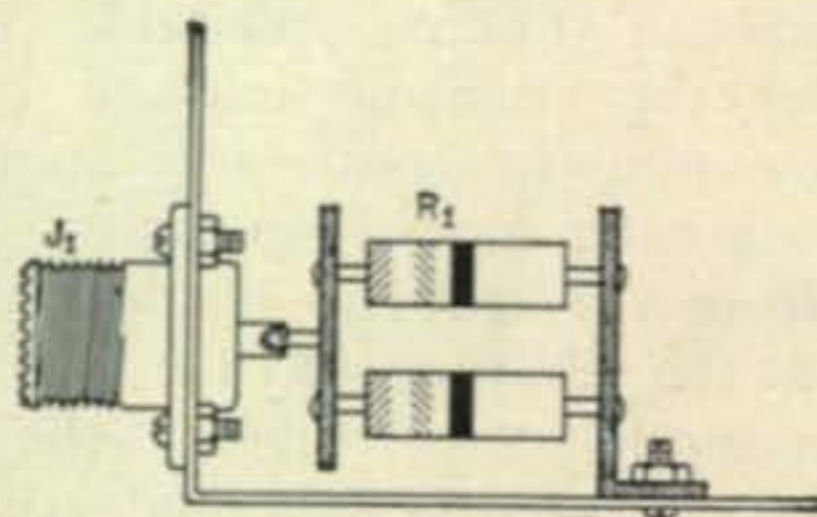

Fig. 2—Details of the dummy load construction.

Audio Amplifier

The audio amplifier is a simple single transistor type and almost any transistor from the inexpensive CK722 on up will work. I use a 2N525, as this one gives plenty of gain. The battery polarity shown on the schematic is for the PNP type of transistor. If you choose to use an NPN type, reverse the battery and the values of R_5 , R_6 and C_4 may be changed as desired, for best individual results. The output load may be one earphone from a headset, as I used, or a speaker. Care must be taken to prevent feedback to the microphone.

Operation

After calibration has been completed and everything checks out, plug in the phones, select the power range you wish to measure. When in doubt, always select the highest range first to prevent the meter from burning out. Connect up the coax to the rig and "fire up." Adjust the rig for maximum output as indicated on the meter. Then speak into the mike and adjust the rig for best modulation quality.

By hooking a short length of wire to the r.f. jack (J_1) enough signal will be picked up to enable you to monitor your "on the air" modulation. This is sort of a poor man's sidetone. Volume may be varied by setting S_2 to a lower scale or straight through.

There are many more uses for the Handy-Dandy, which will become apparent as you become familiar with it. No lay-out dimensions are given, as these will be dictated by size of the available parts. Needless, to say, the Handy-Dandy will save many hours of "on the air" guess work. I wish to express my thanks to Roy Gable, WA6IJY, for his help and encouragement. ■

The Gonset G-76 Transceiver

BY LEE AURICK*, W2QEX

THOUGH the G-76 is at home in either fixed or mobile operation, it is obvious that the mobile amateur was very much in mind when this unit was on the drawing board. The small size of the front panel (12 $\frac{5}{8}$ inches wide and 5 $\frac{1}{8}$ inches high) considerably eases the problem of finding available mounting space under the dash of modern cars. The compact grouping of controls is another contribution to greater mobile operating.

The G-76 is a transceiver by definition only. Other than the sharing of 1 $\frac{1}{2}$ audio tubes and a common power supply, the receiver and transmitter function independently of each other. In fact, it is necessary to zero beat the v.f.o. to the receiver frequency if transmission and reception on the same frequency are desired. This arrangement provides the flexibility required for convenient phone DXing where the receiver may be tuned to the DX portion of the band while the transmitter is operated in the U. S. allocation.

Receiver

The receiver is a "ham-bands-only" type in that it covers only the amateur assignments in the bands from 3.5 mc to 54 mc. The sensitivity of the receiver on the lower frequencies is quite satisfactory though there appeared to

The G-76, in a very successful effort to reduce the number of panel controls, incorporates the AUDIO and R.F. gain controls into one control. Switching is accomplished automatically. In the s.s.b. and c.w. position of the receiver function control, the volume control becomes the r.f. gain control. In the A.M. position the r.f. gain is fixed and it then becomes the volume control. The a.n.l. is activated in either operating mode by pushing this knob in. The b.f.o. has a convenient marking to indicate the correct setting for either upper or lower sideband reception.

An outstanding feature of the receiver is its inherent stability. It performs extremely well, in this respect, on both c.w. and s.s.b. where it would be noticed most if this consideration had been neglected. There was a tendency, however, toward premature overload when operating on c.w. and s.s.b. just prior to the point where sufficient audio output was available, on the unit reviewed. This condition was not observed on a.m. operation.

The antenna input, common to both receiver and transmitter, is designed for 50 ohm unbalanced (coax) line. The antenna change-over relay is included in the G-76 circuitry, and is automatically operated by the front panel TRANSMIT switch.



Front view of the G-76. Controls from l. to r., along the bottom edge: dual purpose r.f.-a.f. gain, function switch, calibration reset, rcvr. band switch, grid tuning, v.f.o. spot switch, 80-10 m v.f.o. In the second row from l. to r.: T-R switch, b.f.o. set, main tuning, drive switch, plate tuning and loading. The transmitter function switch, final bandswitch and main on-off switch are at the upper right.

be some lack of sensitivity on six meters. Recent correspondence from the manufacturer reports that present production has reduced the a.v.c applied to the first i.f. stage and corrected this condition. The unit your reviewer examined also seemed to be extremely critical in tuning on the higher frequencies. Gonset advises that a small amount of capacitive coupling has been added between the primary and secondary of each i.f. transformer to broaden the response. It is to be expected, therefore, that present production units will not be as critical in tuning on the higher bands.

*Mt Pleasant Rd., RD #1, Columbia, Pa.

In addition to oscillator temperature compensation for both transmitter and receiver, the manufacturer claims a tolerance of as much as a 30% decrease or a 50% increase in plate supply and heater voltages with negligible frequency shift.

The first i.f. is 2065 kc and the second i.f. is 262 kc. Selectivity is fixed, and there is no adjustment or change that can be made by the operator. The overall selectivity is approximately 3 kc at 6db down, and 14 kc at 60 db down.

The 100 k.c. crystal calibrator is an accessory, and was not included in the unit reviewed.

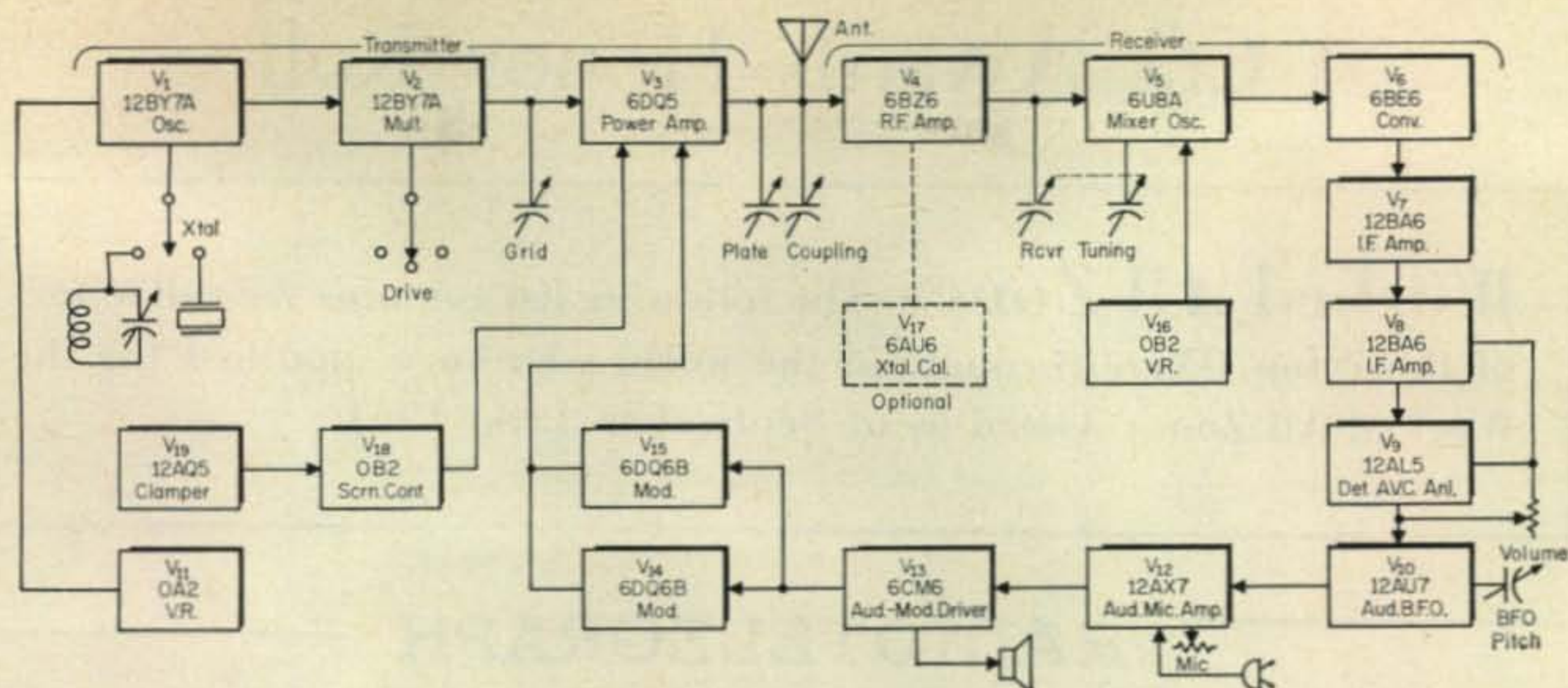

Fig. 1—Block diagram of the Gonset G-76 100 watt multi-band transceiver.

Transmitter

All reports, both on c.w. and a.m., have been excellent. The v.f.o. is extremely stable, and the "spotting" control makes it very easy to zero-in at any frequency to which the receiver is tuned. Either v.f.o. or crystal control may be used on all bands from 3.5 to 29.7 mc, while crystal control must be used on the 50 mc band. The v.f.o. does not cover the 8.334 to 9.000 mc range required for this band.

A 6DQ5 serves as the output power amplifier and it is rated by Gonset at 100 watts input on a.m., and 120 watts input on c.w. A pair of 6DQ6s do a fine job in providing the a.m. modulating power. A 100 watt light bulb, used as a dummy load, was lighted to approximately half brilliance on the lower frequencies.

External provisions must be made for monitoring when on c.w.; further evidence that the G-76 was designed with the mobile a.m. operator in mind. The cathode of the final amplifier is keyed on c.w., and curiosity as to the voltage present across the key prompted your reviewer to measure the potential at this point. It was an unhealthy 350 volts. Upon calling this to the manufacturer's attention he advised that all future units would be keyed in the cathode of the 12BY7A driver, and that two additional tubes had been added to the transmitter circuit; a 12AQ5 to clamp the final amplifier screen, and an OB2 voltage regulator, also in the screen circuit. Gonset has provided a new schematic, and on the basis of the changes indicated it appears that any potentially lethal voltage has been eliminated from the key.

The pi-network amplifier tuning controls also tune the receiver r.f. amplifier circuit, and once adjusted for optimum transmitting conditions should not be de-tuned in an effort to peak them for receiving conditions. Though they tune quite sharply when loading the transmitter, they are broad enough to amply cover each amateur band without the necessity for re-tuning.

Power Supplies

Two matching power supplies are available for use with the G-76, and each must be purchased separately. The d.c. supply is designed for 12 volt service, and the 115 volt a.c. supply includes a speaker and a headphone jack. The a.c. supply was provided for review. For several days, and a good number of contacts, this power supply functioned perfectly. Then trouble developed in the low voltage (280 volts) supply. Two silicon rectifiers were found shorted and they in turn had blown the line fuse on one side. Replacing them with heavier duty units provided satisfactory operation for a few days before the new rectifiers shorted. A telephone inquiry to the manufacturer brought the reply that current production was now incorporating units with a higher p.i.v. Samples of the new rectifiers, provided by Gonset, have been functioning now for several months without failure.

With the changes now incorporated in the G-76 I believe that this unit is everything it is represented to be. It is unquestionably a well designed and carefully built transceiver for the mobile a.m. amateur that will provide very nearly the ultimate in flexibility and operating convenience.

The experiences outlined here, in the review of the G-76, demonstrate the objectivity of the reviews published in *CQ* and the service that they can perform for the amateur fraternity. Each unit reviewed is tested under actual operating conditions, just as you would use the equipment, for at least a month and often longer. While consideration is given to circuit configurations of unusual design, their ultimate worth must bear the brunt of on-the-air performance, and not merely a dissertation on their technical novelty. Every effort is expended to insure that the manufacturer's equipment is fairly represented to you, and that on your behalf, your interests are brought to the attention of the manufacturer. Anything less would almost surely be a waste of your time and this space.

CQ Awards Honor Roll

Worked All Zones The following list contains the call letters of those top DXers throughout the world who have qualified for the Worked All Zones Award as of September 12th, 1961.

RADIOTELEGRAPH

W1AB	W2CNT	W2RDD	W3LMA	W4JV	W5MY	W6DQH	W6LN	W6SRU	W7FLD
W1ACB	K2CPR	W2REF	W3LMM	W4KFC	W5NOT	W6DUB	W6LRU	W6SUQ	W7FZA
W1AJG	W2CWK	W2SAW	W3LMO	K4KOY	W5NUT	W6DUC	W6LS	K6SXA	W7GBW
W1AZY	W2CZO	W2SHZ	W3LOE	W4KWC	W5NW	W6DVB	W6LTX	W6SYG	W7GHB
W1BFT	K2DCA	W2SSC	W3LUD	K4LNM	W5OGS	W6DZZ	W6LW	W6TEU	K7GIE
W1BGA	W2DEC	W2SUC	W3MCW	K4LPW	W5OLG	W6EAK	K6LZI	W6TI	W7GUI
W1BGW	W2DEO	W2TP	W3MFJ	W4LVV	W5PM	K6EC	W6MEK	W6TKX	W7GUV
W1BIH	W2DGW	W2TQR	W3MFW	W4LYV	W5PQA	K6EDE	W6MHB	W6TPJ	W7GXA
W1BIL	W2DOD	W2TVR	W3MJF	W4LZF	W5PSB	W6EFM	W6MJB	W6TT	W7HIA
W1BLO	W2DS	W2TWC	W3MSR	W4MCM	W5PZL	W6EFR	W6MJY	K6TXA	W7HKT
W1CKU	W2DSU	W2TXB	W3MVQ	W4ML	W5QN	W6EGB	W6MLY	W6TXL	W7HXG
W1CTW	K2DSW	W2UFT	W3NCF	W4MR	W5QVZ	W6EHV	W6MUC	W6TZD	W7IWH
W1DGT	W2EQS	K2UKQ	W3NKM	W4NBV	W5RS	K6ENL	W6MUF	W6UCX	W7IYA
W1DHO	W2ESO	K2UPD	W3OCU	W4OM	W5TIZ	W6ENV	W6MUM	W6UDR	W7KTN
W1DMG	W2FBS	W2UTH	W3OP	K4OMR	W5TPC	K6ENX	W6MX	W6UHA	W7KWA
W1DQH	K2FC	W2UVE	W3PGB	W4OPM	W5URU	W6EPZ	W6NGA	W6UJ	W7KWC
W1EIO	W2FCQ	W2UZF	W3PN	K4PDV	W5UX	W6ETJ	W6NHA	W6UNP	W7LYL
W1EOB	W2FSN	W2VCZ	W3RBF	W4PLL	W5VIR	K6EVR	W6NIF	W6UOV	W7MCT
W1EQ	W2FXA	W2VND	W3RBW	W4QT	W5WZQ	K6EWL	W6NJU	W6UQQ	W7MGT
W1FFO	W2FXN	K2VUI	W3RPG	W4QCW	W6ABA	W6EYC	W6NNV	W6UYW	W7NRB
W1FOA	W2FZY	W2VYX	W3RSR	K4QIJ	W6ADP	W6EYP	W6NRQ	W6UZX	W7OY
W1FZ	W2GDX	W2WS	W3RUT	K4RID	W6AFI	W6FHE	W6NTR	W6VFR	W7PB
W1GKK	K2GFQ	W2YTH	W3RZL	K4RPK	W6ALQ	W6FHW	W6NWI	W6VSS	W7PHO
W1GVZ	K2GMO	W2ZGB	W3SOH	W4SHX	W6AM	W6FLT	W6NXP	K6VVA	W7PQE
W1GYE	W2GNO	W2ZSV	W3SWV	W4SXE	W6AMA	W6FOZ	W6NZ	W6WJ	W7QGF
W1HGT	W2GT	W2ZXL	W3TMZ	K4SXR	WA6AMZ	W6FSJ	W6OBD	W6WJM	W7QON
W1HX	W2GVZ	W2ZY	W3UXX	W4TM	W6ANN	W6FUF	W6OEG	W6WKU	W7RT
W1HZ	W2HMJ	W3AEL	W3VKD	W4UXI	W6AOA	W6FWQ	W6OES	W6WO	W7SGN
W1ICP	W2HO	W3ALB	W3WGH	W4VPD	W6AOD	W6FZL	W6OF	W6WQT	W7STC
W1IJB	W2HSZ	W3AOH	W3WU	W4VYP	W6AQP	W6GAL	W6OMC	W6WTH	W7VY
W1JYH	W2HTI	W3ARK	W3WV	W4WDI	W6ATO	W6GDJ	W6OME	W6WWQ	W7WVE
W1KXU	W2HQL	W3AS	W3ZAO	W4YGZ	W6AUT	W6GFE	W6ONK	W6YMD	W7YGN
W1LHZ	K2HXL	W3AXT	W4AAU	W4YWX	W6AVM	K6GLC	W6ONZ	W6YMH	W7ZAS
W1LQ	W2HZY	W3AYD	W4AH	K5ABW	K6AYA	K6GMA	K6OPI	W6YMV	W7ZOH
W1LZE	W2ICO	W3AYS	W4AIS	W5ABY	W6BAF	W6GMC	W6OSU	W6YK	W8AE
K1MLI	W2IOP	W3BCY	W4AIT	K5ADQ	W6BAM	W6GMF	K6OWQ	W6YY	W8BHW
W1MV	W2IRV	W3BES	W4AIX	W5ADZ	W6BAX	W6GPB	K6OXU	W6YZU	W8BOJ
W1NHJ	W2IWC	W3BHV	K4AW	W5AFX	W6BIF	W6GSL	W6OYD	W6ZCY	W8BRA
W1NLM	K2JGG	W3BQA	W4AZK	W5AWT	W6BIL	W6GWW	K6OYD	W6ZEN	W8BSH
W1ODW	W2JT	W3CA	W4BFR	K5BGB	W6BPD	W6HDF	W6PB	K6ZMB	W8CDT
W1OJR	W2JVU	W3CGS	W4BJ	K5BGT	W6BSY	W6HJT	W6PCS	W6ZMX	W8CED
W1OOA	K2KCE	W3CPV	W4BPD	W5BRR	W6BUD	W6HX	W6PDB	W6ZUI	W8CLR
W1OOS	W2KED	W3DBX	K4BVQ	W5BUK	W6BUO	W6HVN	W6PFD	W6ZVQ	W8CRI
W1ORV	W2KJZ	W3DRD	W4BYU	W5BZT	W6BUY	W6IBD	W6PH	W6ZZ	W8CQ
W1OTX	W2KUV	W3DWY	W4CKB	W5CE	W6BVM	W6ID	W6PHN	W7ABO	W8CWY
W1PFA	W2LAX	W3ECR	K4CLT	W5CEW	W6BYB	W6IDZ	W6PKO	W7AC	W8DAW
W1QJR	W2LNB	W3EFZ	W4COC	W5CKY	W6BYH	K6IEC	W6PLK	W7ADS	W8DEN
W1QNC	W2LPE	W3EOB	K4CTU	W5DA	W6BZ	W6IFW	W6PQT	W7AHX	W8DFQ
W1TSL	W2LSX	W3EPR	W4CXA	W5DML	W6BZE	W6IPH	W6PUY	W7AJS	W8DHC
W1TYQ	W2LV	W3EPV	W4CYR	W5DRU	W6CAE	W6ITA	W6PZ	W7AMX	W8DLZ
W1WDD	K2LWR	W3EVW	W4CYU	W5EGK	W6CBE	W6JH	W6QD	W7AQB	W8DMD
W1WLW	W2MUM	W3FYS	W4CYY	W5FFW	W6CEM	W6JHV	W6QDE	W7ASG	W8DSZ
W1WY	W2NOY	W3GAU	W4DHZ	W5FNA	W6CG	W6JK	W6QNA	W7AUS	W8ELL
W1ZD	W2NUT	W3GEN	W4DKP	W5FXN	W6CGP	K6JQJ	W6RAN	W7BD	W8EWS
W1ZW	W2OBX	W3GHD	W4DQH	W5GEL	W6CHV	W6JZP	W6RDR	W7BE	W8EYE
W1ZZK	W2OCU	W3GRS	W4EO	W5GNG	W6CIS	W6KBC	W6RKP	W7BGH	W8FRW
W2AEB	K2OEA	W3IMV	W4EPA	W5HDS	K6CQM	W6KEK	W6RLN	W7BTH	W8GB
W2AGW	W2OGE	W3IPO	W4FFV	W5HJA	W6CTL	W6KEV	W6RLP	W7CAB	W8GLK
W2AQW	K2OLS	W3IXN	W4GD	W5IAH	W6CTO	W6KG	W6RLQ	W7CKY	W8HGW
W2AYJ	W2OTC	W3IYE	W4GRP	W5JUF	K6CTV	W6KIQ	W6RM	KL7	W8HMI
W2AYU	W2PCJ	W3JKO	K4GSU	K5JZY	W6CUL	K6KJR	K6RTK	W7CMO	W8HUD
W2AZS	W2PEO	W3JNN	W4GXB	K5KBH	W6CUQ	W6KRI	W6RW	W7CNM	W8IBX
W2BAC	K2PFC	W3JTC	W4HA	W5KES	K6CWS	W6KSM	K6RWO	W7CSW	K8IKB
W2BBS	K2PKT	W3JTK	K4HFS	W5KO	W6CYI	W6KUT	W6RSZ	W7CWE	W8ILG
W2BHM	K2PIC	W3JW	K4ICK	W5KF	K6CYO	W6KYG	W6SAI	W7DAA	W8IQS
W2BHU	W2PTD	W3JZY	W4IFN	W5KLB	W6CYV	W6KYT	W6SAI	W7DET	W8IRN
W2BOK	W2PTI	W3KA	K4IIC	W5KUC	W6CZQ	W6KZL	W6SC	W7DJY	W8JIN
W2BRR	W2PZI	W3KDP	W4IMI	W5LGG	W6DBP	K6LAE	K6SHJ	W7DXZ	W8JBI
W2BRV	W2QHH	W3KFP	W4JAT	W5LGS	K6DDO	W6LDD	W6SIA	W7DZ	W8JRB
K2BU	K2OHL	W3KPI	K4JEY	K5LIA	W6DFY	W6LEE	W6SN	W7EJD	W8JRG
W2BXA	W2QJM	W3KT	W4JII	W5LP	W6DI	W6LER	W6SQP	W7ENW	W8JSU
W2BYP	K2OXG	W3KVQ	W4JIL	K5LZO	W6DIX	W6LGD	W6SR	W7ETK	W8KIA
K2CD	W2RA	W3KZQ	W4JNE	W5MMD	W6DLY	K6LGF	W6SRF	W7FB	W8KML

W8KPL	W9LSV	W0NUC	DL3BL	G3CEG	HB9GJ	KL7PI	OK2AG	SM7TQ	VK2QL
W8KZT	W9MBF	W0OQK	DL3DD	G3CSL	HB9HZ	KL7PIV	OK2LX	SM7YO	VK3BZ
K8LSG	W9MQK	W0OUH	DL3FM	G3CQE	HB9IM	KL7PJ	OK2NN	SP1JV	VK3CN
W8LY	W9MUJ	K0PEF	DL3LB	G3DO	HB9J	KL7UM	OK2UD	SP2AP	VK3CX
W8MCC	W9MZP	W0PGI	DL3LL	G3DOG	HB9KB	KP4KD	OK2SO	SP3DG	VK3EK
W8MPW	W9NDA	W0PNQ	DL3RK	G3DOC	HB9KC	KP4YT	OK3AL	SP5AA	VK3HL
W8MTQ	W9NLJ	W0QDF	DL3SZ	G3DQO	HB9KU	KP6AA	OK3DG	SP6FZ	VK3JE
W8NBK	W9NRB	W0QGI	DL3TG	G3ESY	HB9MO	KV4AA	OK3EA	SP6RT	VK3NC
W8NJC	W9PIO	W0QVZ	DL3WV	G3EYN	HB9MU	LA1K	OK3EE	SP7HX	VK3RP
W8ONA	K9PJN	W0QYE	DL4BS	G3FKM	HB9MQ	LA2B	OK3HM	SP8CK	VK3YD
W8OYP	W9PQA	K0RAL	DL4OP	G3FPI	HB9NL	LA3DB	OK3KMS	SP9DT	VK3YL
W8PQQ	W9PVA	W0RBA	DL6DE	G3FUR	HB9PA	LA4DD	OK3MM	ST2AR	VK4AL
W8QFA	W9QGR	W0SMV	DL6EN	G3FXB	HB9TL	LA5HE	ON4DM	SV0WP	VK4DO
W8QFR	W9QIY	W0SNL	DL6EQ	G3GCD	HB9TT	LA6U	ON4FQ	UA1CB	VK4EL
W8RSW	W9QLH	W0SYK	DL6GB	G3GFG	HB9UL	LA7Y	ON4JW	UA3BN	VK4FJ
W8SDR	W9QNO	W0TJ	DL6GP	G3GGS	HB9X	LA7Z	ON4LB	UA3KND	VK4HR
W8SYC	W9QYW	W0UOX	DL6MK	G3GSZ	I1ALU	LA8LF	ON4MN	UA4IF	VK4SD
W8SZS	W9RBI	W0UQV	DL6OS	G3GYH	I1AY	LU5AQ	ON4QF	UA4KHA	VK5JS
W8TJM	W9RH	W0VBK	DL6TW	G3HCL	I1CHJ	LU6DJX	ON4QX	UA9CL	VK5KO
W8TLL	W9RKP	W0VBQ	DL6YK	G3HFL	I1ER	LU7AS	ON4TA	UA9CR	VK5MF
W8TMA	W9ROU	W0VKB	DL7AA	G3HLY	I1FO	LU8BAJ	ON4TX	UA9DN	VK6DX
W8TTN	W9RQM	K0WQI	DL7AB	G3ID	I1KN	LU8EN	OZ3GW	UA9VB	VK6KW
W8TTS	W9SFR	W0YTL	DL7AD	G3IMV	I1SM	OD5LX	OZ4RT	UA0OM	VK6RU
W8UAS	W9SWR	W0YXO	DL7AH	G3IOR	I1UA	OE1BH	OZ7BG	UB5AQ	VK6SA
W8UMR	W9TKD	W0ZYB	DL7CS	G3JAF	I1UB	OE1CD	OZ7SN	UB5CI	VK7CH
W8UPN	W9TPA	CE3AG	DL7CW	G3JHZ	I1XK	OE1FF	OZ8SS	UB5KAB	VK7LZ
W8VLK	W9TQL	CE3AX	DL7EN	G3JLB	I1ZN	OE1RZ	OY7ML	UC2AA	VO1DX
W8WBV	W9UX	CE3DZ	DL8CM	G3JZK	IT1AGA	OE3NH	PA0FAB	UC2CB	VQ2GW
W8WZ	W9UXO	CE3HL	DL9EH	G3KHE	IT1TAI	OE3RE	PA0FX	UF6FB	VS1JF
W8YIN	W9UZS	CN8BP	DL9KP	G3KKP	IT1ZGY	OE3WB	PA0LOU	UR2BU	VS6AE
W9ABA	W9VIN	CN8DJ	DL9PF	G3KZI	JA1AA	OE5JK	PA0LY	UQ2AN	VU2MD
W9ABB	W9VND	CN8GU	DL9PX	G3LET	JA1AB	OH1QE	PA0PN	VE1EP	XE1PJ
K9AGB	W9VW	CN8IF	DL9TJ	G3LHT	JA1AG	OH1SN	PA0TAU	VE1PQ	XZ2TH
K9AVQ	W9VZP	CN8JX	DL9YX	G3LP	JA1BF	OH1ST	PA0VB	VE1WL	YU1AG
W9BPW	W9WCE	CO2SW	DM2AEJ	G3TK	JA1CC	OH1PI	PA0RLF	VE2AIO	YU3OV
K9BVR	W9WFS	CR6BX	DU7SV	G3VA	JA1CR	OH1TM	PA0VDV	VE2NV	YV5FK
W9BZB	W9WHY	CR9AH	EA4CR	G3YF	JA1DM	OH2HK	PA0VO	VE2WW	ZC1CL
K9CAZ	W9WIO	CX1BZ	EI3R	G4CP	JA1GC	OH2HW	PK4DA	VE2YU	ZC4IP
K9CJK	W9WJH	CX1FY	EI4Q	G4MJ	JA2AT	OH2LA	PK6HA	VE3BMO	ZE3JO
K9CLO	W9WNB	CX2CO	EI9U	G4TM	JA2BL	OH2MB	PY1AJ	VE3BWY	ZE6JY
K9CUI	W9WYB	DJ1BZ	EI9Y	G5BJ	JA2DN	OH2NB	PY1BG	VE3CFG	ZL1AH
K9DNR	W9YFW	DJ1EE	F2BS	G5GK	JA2JW	OH2TM	PY1GJ	VE3CIO	ZL1AJU
W9DUY	W9YNB	DJ1JW	F3AT	G5RP	JA2KG	OH2XK	PY1HQ	VE3DIF	ZL1AV
W9DWQ	W9YOR	DJ1VP	F3CB	G5VU	JA3AA	OH2YV	PY1HX	VE3EU	ZL1BY
W9DYG	W9YSQ	DJ1VS	F3DM	G5YV	JA3BP	OH3NY	PY2CK	VE3IR	ZL1GX
K9EAB	W9YSX	DJ2AE	F3FA	G6BS	JA3DY	OH3OD	PY3QX	VE3JZ	ZL1HY
K9ECO	W9ZRG	DJ2BW	F3YR	G6QB	JA3FT	OH3QC	PY4AO	VE3KE	ZL1PV
W9EHW	W0AGO	DJ2KS	F3ZU	G6RC	JA3UI	OH3RA	SM2BCS	VE3QD	ZL1RD
W9ERU	W0AIH/VE3	DJ2LK	F8BS	G6RH	JA5AI	OH3RS	SM3AGD	VE3RE	ZL2AFZ
W9ESD	W0AIW	DJ2LM	F8TM	G6UT	JA6AD	OH3SE	SM3AKM	VE4RO	ZL2AI
W9ESQ	W0AJU	DJ2MN	F8VQ	G6VC	JA6AK	OH3TH	SM3AKW	VE5JV	ZL2CU
W9ETN	W0ANF	DJ2WN	F8WK	G6VQ	JA6AO	OH5NJ	SM3ATY	VE5KG	ZL2GX
W9EU	W0AUB	DJ2YA	F8XT	G6XA	JA6NW	OH5NK	SM3BIZ	VE5TK	ZL2HP
W9EXY	W0AZT	DJ3BB	F9EJ	G6XL	JA7AD	OH5OP	SM3EP	VE5VL	ZL3DX
W9FBI	W0BCI	DJ3JZ	F9ER	G6YQ	JA8AA	OH5OU	SM4AEQ	VE6AO	ZL3GU
W9FDX	W0BFB	DJ3KR	F9IL	G6ZO	JA9AA	OH5PE	SM5AHK	VE6BY	ZL3IS
W9FID	K0BIT	DJ3XK	F9MS	G8FW	JA0AC	OH5RH	SM5AJR	VE6JR	ZL4AW
W9FJB	W0BSK	DJ4DN	F9RS	G8GP	KA2DE	OH6OA	SM5AJU	VE6MN	ZL4BO
W9FKC	W0BTD	DJ4OP	F9TX	G8IG	KA2NY	OH6RC	SM5AOB	VE6NX	ZL4CK
W9FVU	W0CDP	DJ4SP	FA8RJ	G8IP	KG6AL	OH7OU	SM5AQB	VE6TP	ZS1OU
W9GDI	W0CTW	DL1AU	G2AJB	G8JO	KG6GD	OH8QA	SM5AQQ	VE6VK	ZS1RM
W9GFF	W0DEI	DL1BO	G2AOL	G8KP	KH6AUJ	OH9PF	SM5ARR	VE7AHG	ZS2CR
W9GHK	W0DMA	DL1BS	G2CNW	G8KS	KH6AYG	OH9RD	SM5BCE	VE7BW	ZS2EC
W9GIL	K0DMY	DL1DC	G2FFO	G8KU	KH6BA	OK1AEH	SM5BFE	VE7CE	ZS2AT
W9GRF	K0DQI	DL1DX	G2FSR	G8QZ	KH6BLX	OK1AW	SM5BPJ	VE7CQ	ZS2X
W9HCR	W0DU	DL1FF	G2FYT	G8TD	KH6BTX	OK1AWJ	SM5BRO	VE7HC	ZS6A
K9HOL	W0DVZ	DL1FZ	G2GM	G8UG	KH6BXU	OK1CG	SM5BZ	VE7JB	ZS6AJQ
W9HTY	W0ELA	DL1GU	G2IO	G13AXI	KH6CD	OK1CX	SM5BCE	VE7KC	ZS6ATA
W9HUZ	W0EWH	DL1GV	G2LB	G13NPP	KH6CT	OK1FF	SM5CO	VE7KJ	ZS6CT
W9IHN	W0FFV	DL1IA	G2MI	GM3ASM	KH6DKA	OK1GL	SM5CXF	VE7MD	ZS6DW
W9INN	W0FNN	DL1IB	G2PL	GM3CIX	KH6DLD	OK1HI	SM5DW	VE7PV	ZS6EU
W9IRH	W0FUH	DL1IN	G2VD	GM3DHD	KH6DLF	OK1JQ	SM5KP	VE7QL	ZS6FN
W9IU	W0GUV	DL1KB	G2YS	GM3EST	KH6DQ	OK1JX	SM5KV	VE7SB	ZS6IF
W9IVZ	K0GXR	DL1LT	G3AAE	GM3LYS	KH6IJ	OK1KKJ	SM5KX	VE7VC	3V8AB
W9IWX	K0HGB	DL1LZ	G3AAM	GM5RH	KH6KC	OK1KTI	SM5LL	VE7ZK	4X4CJ
K9IYW	W0HX	DL1MF	G3AGN	GM6MD	KH6LG	OK1LM	SM5LN	VE7ZM	4X4FQ
W9JUV	W0KOK	DL1QT	G3AIZ	GW3BNQ	KH6MG	OK1MB	SM5WI	VE8AW	4X4KK
W9KA	W0LPA	DL1YA	G3AJP	HA5AM	KH6MI	OK1MG	SM5WZ	VE8PB	4X4RE
W9KMN	W0LVA	DL1YQ	G3ATU	HA5BI	KH6PM	OK1MP	SM5YG	VK2ACX	5A5TE
W9KOK	W0MCX	DL1ZM	G3AZ	HA5BU	KH6PY	OK1PD	SM6AMR	VK2AM	5A5TH
W9KXK	W0MLY	DL2YU	G3BHW	HA5KFR	KH6QH	OK1RW	SM6VY	VK2DI	5A5TO
W9KXZ	W0NCS	DL3AO	G3BI	HB9DB	KH6VP	OK1SV	SM7ID	VK2HZ	9S4AX
W9LIL	W0NYL	DL3BJ	G3BKF	HB9ET	KL7BHE	OK1WX	SM7MS	VK2NS	
W9LNM	W0NTA	DL3BK	G3BVN	HB9EU	KL7MF	OK1XQ	SM7QY	VK2PV	

RADIO TELEPHONE

W2APF	W5AFX	W6YY	W9WHM	DL7AA	G3FKM	I1AOF	OE2YL	SM3AZI	VK4RQ
W2BXA	W5KBU	W7MGT	W9YSQ	DL7AB	G3FPQ	I1SM	OK1MB	SM3BIZ	VQ4ERR
W2DEC	W6AM	W7PHO	W9YSX	DL7AD	G3HLS	I1UA	OK2AG	SM3EP	ZL1ACI
W2HTI	W6GVM	W8BF	W0MLY	DL7BA	G8GP	JA1ACB	ON4DM	SM5CO	ZL1HY
W2JT	W6ITH	W8KML	CN8MM	F3DJ	G8IG	JA6CY	ON4RC	SM5LL	ZL1KG
W2OKM	K6LAS	W8PQQ	CX2CO	F8DC	G8KS	KH6OR	OZ7FG	SM5TR	ZL2GX
W2ZX	W6OBH	W8ZET	DL1IN	FA8RJ	G13IVJ	LA5HE	PA0HBO	SP7HX	ZL4BO
W3GHD	W6USG	W9JIF	DL1IN	G3AAE	G13KVQ	LU6AJ	PA0WWP	UR2BU	2S6Q
W3LMA	W6VFR	W9NDA	DL3DW	G3BYM	GW3AHN	MP4BCC	PA0WWP	UQ2AN	4X4DK
W4DQH	W6YK	W9RBI	DL3LL	G3DO	HB9J		PY2CK	VE7ZM	9K2AZ

WPX The following is a list of amateurs holding WPX and the number of prefixes worked. This list has been compiled as of September 29, 1961. Everyone is encouraged to work as many different prefixes as possible and submit their cards to the DX Editor, Urban Lejune, W2DEC, at Box 35, Hazlet, New Jersey.

C.W. WPX	SM5AJU ... 359	SM5AHK ... 311	ZL2GS ... 303	W9WHM ... 367	K2JXY ... 206
W2HMJ ... 607	W0MCX ... 357	K8LSG ... 310	K9CLO ... 302	PA0HBO ... 363	W2HXG ... 206
W8KPL ... 553	UC2AA ... 357	W3GHD ... 310	W1HGT ... 302	SM3EP ... 361	W5RHW ... 203
W9YSX ... 554	VE3DIF ... 357	W9BPW ... 310	W3DBX ... 302	W5ERY ... 358	W3VSU ... 200
W6KG ... 528	W5OLG ... 356	W9UX ... 310	W0DMA ... 302	W9UZC ... 356	XE1AE ... 197
W5KC ... 541	DL7CS ... 356	OH3TH ... 310	OK1KKJ ... 302	DL3TJ ... 354	EI8P ... 191
W2EQS ... 501	KL7MF ... 356	PA0LY ... 310	W2DGW ... 301	PY2CK ... 354	PZ1AX ... 189
K6CQM ... 500	W2GVZ ... 355	SM7TQ ... 310	W4HYW ... 301	5A5TO ... 353	K2HEA ... 181
W1EQ ... 500	DL1YA ... 354	W3AYD ... 309	W4IMI ... 301	W8PQQ ... 347	K5MDX ... 181
W4OPM ... 500	VE3JZ ... 354	W0AUB ... 308	W8IBX ... 301	LA5HE ... 337	VE3BQP ... 181
W1IJB ... 495	K4GSS ... 353	HB9EO ... 308	W8TTN ... 301	K9EAB ... 329	VE3CIO ... 175
W1NLM ... 491	W4DKP ... 353	DJ3BB ... 308	JA3FT ... 301	VE1ADE ... 325	W6BAF ... 170
SM5CCE ... 488	K2CPR ... 352	SM5AHJ ... 308	LU5AQ ... 301	SP7HX ... 323	VP6WD ... 169
W8PQQ ... 481	K2PFC ... 352	SM5BCE ... 308	OK1CX ... 301	F9MD ... 315	W0KFA ... 168
K2UKQ ... 480	W9WCE ... 352	W9YNB ... 307	ZL4CK ... 301	W3AYD ... 314	K4JEY ... 167
W8LY ... 475	F3DM ... 351	DU7SV ... 307	K4KOY ... 300	IICBZ ... 312	W8BKO ... 166
W6WO ... 468	HB9TT ... 351	SM5BBC ... 307	K4TEA ... 300	W3DJZ ... 306	ZS7P ... 166
K6SXA ... 464	W6UNP ... 350	SP6AAT ... 307	K5ESW ... 300	ZP5CF ... 306	UA3CR ... 165
K9AGB ... 454	W3GAU ... 349	SP9RF ... 307	K5LZO ... 300	SM3BIZ ... 304	VE6TF ... 165
W9UXO ... 453	W9IU ... 344	K4IEX ... 306	K9KDI ... 300	W5JCY ... 303	VE3MR ... 164
K9EAB ... 451	SM7ID ... 339	W2SAW ... 306	W1HWH ... 300	W8UMR ... 303	K6HFZ ... 162
W2MUM ... 450	DL1IA ... 337	W8RSW ... 306	W2DEC ... 300	VK6KW ... 303	YV5FK ... 162
W2NUT ... 450	W6YY ... 330	OK3DG ... 306	W2DEO ... 300	F8PI ... 302	W4WDI ... 160
W8JIN ... 449	DL1QT ... 328	UA9DN ... 306	W2QHH ... 300	PY1NC ... 302	TG9AD ... 160
W3BQA ... 437	K2QXG ... 327	K4HXF ... 305	W2FXA ... 300	EI3R ... 302	K4ASU ... 158
K5LIA ... 428	W0SNL ... 327	W2TP ... 305	W3BCY ... 300	W9PQA ... 301	ZS6ATA ... 158
OKIMB ... 428	SM7CNA ... 327	WA2DIG ... 305	W3LMA ... 300	K5MDX ... 300	W8YIN ... 157
W0PGI ... 420	LU8EN ... 326	W4LRN ... 305	W3SOH ... 300	XE1AE ... 300	XE1CV ... 157
W2HO ... 418	DL3RK ... 324	W4SHX ... 305	W4GXB ... 300		W1TYQ ... 155
W5AWT ... 412	F9IL ... 322	W5AZB ... 305	W4RVW ... 300	S.S.B. WPX	W9WIO ... 154
W5DA ... 412	W2KIR ... 320	W5WZQ ... 305	W4YWX ... 300	TI2HP ... 356	GW2DUR ... 154
W2PTD ... 411	KP4CC ... 320	W8ONA ... 305	W5ARJ ... 300	W4OPM ... 320	K2QXG ... 153
G2GM ... 408	SL5AB ... 320	W0GUV ... 305	W6WWQ ... 300	HB9TL ... 315	W2OTZ ... 153
K4JVE ... 407	UC2AR ... 319	VE3BWY ... 305	W7TPE ... 300	K9EAB ... 312	W2TP ... 153
W5AFX ... 407	EA4CR ... 318	K4DRO ... 304	W0DVZ ... 300	MP4BBW ... 300	W2VZV ... 153
K2ZKU ... 405	G3EYN ... 318	K5JZY ... 304	DL9KP ... 300	K2MGE ... 263	K2JFV ... 152
W3OCU ... 405	LA6CF ... 318	K6RTK ... 304	DL9PF ... 300	W2VCZ ... 250	W6VUW ... 152
JA2JW ... 403	SM7EH ... 318	K8GHG ... 304	OK1MP ... 300	W1GR ... 246	W8JIN ... 152
PY4OD ... 402	K4SXR ... 316	W1BFT ... 304	PA0ZL ... 300	W2HMJ ... 240	W8JXY ... 152
W5LGG ... 401	W2GT ... 316	W1EIO ... 304	PY4AO ... 300	W3MAC ... 235	W8YBZ ... 152
W9GFF ... 401	DJ1VS ... 316	W1FZ ... 304	SM2BCS ... 300	W6EKZ ... 233	VE3BWY ... 152
W5SFR ... 400	VK6WT ... 316	W6NWI ... 304	SM5BPJ ... 300	K4PUS ... 225	K2TDI ... 151
VK3KB ... 400	W2BYP ... 315	W6RLP ... 304	SP6FZ ... 300	W1EQ ... 224	W2BLP ... 151
F9MS ... 382	PA0VB ... 315	OK1AEH ... 304	ST2AR ... 300	VE3BKL ... 224	W2GNQ ... 151
W0QYE ... 377	PA0VO ... 315	OK2QR ... 304	VE3CIO ... 300	HB9TL ... 221	W9YHE ... 151
IT1AGA ... 374	W1NHJ ... 314	K8IKB ... 303		K1IXG ... 219	W0FUH ... 151
W5BUK ... 369	W1IUU ... 313	W7ABO ... 303	Phone WPX	W0CVU ... 218	K6HZN ... 150
W9DYG ... 367	K2ZRO ... 312	W8UMR ... 303	W8WT ... 531	OY7ML ... 216	W2FXN ... 150
W4AZK ... 365	SM5WI ... 312	W9VIN ... 303	G3DO ... 476	DL4AS ... 208	W5DA ... 150
W1WLW ... 362	W5BRR ... 311	OK3EA ... 303	W9YSQ ... 471	G8KS ... 208	W5PQA ... 150
W9QGR ... 361	W5EJT ... 311	OY7ML ... 303	CTIPK ... 471	W2YBO ... 207	W6TNS ... 150
W9WIO ... 360	W8RQ ... 311	VE3HB ... 303			LA3SG ... 150

SINGLE Sideband DX Chasers List. The following amateurs have received awards and endorsements for two-way single sideband contacts. The list is of station calls that have been active from September 1960 to September 1961. To keep current send your list and cards to K2HEA/K2MGE, 12 Elm St., Lynbrook, Long Island, New York.

250	216	W8YBZ	K2FW	158	W0PGI	HB9J	104	G3CCN	K8CFU
TI2HP	K2MGE	K9EAB	W2YBO	W7DLR	G3NUG	123	K5MDX	G3NUY	K8LSG
242	215	W0CVU	176	157	XE1SN	W5PQA	W5PSB	GW3AHN	W8WT
VO4ERR	W6BAF	193	TG9AD	W3CGS	149	122	W9YMZ	SM6BIZ	K9CRS
239	211	W3LMA	175	155	W6VUW	W6UPP	VE3BQP	100	W9EXY
W6UOU	W5AFX	191	W2VCZ	DL1IN	142	120	103	K1EJO	K9KHG
238	W6WNE	K6ZXW	W5KFT	G8KS	PJ2AA	W9YHE	W2HTO	W1FZ	W9SFR
W8PQQ	210	190	K6LGF	154	133	118	W4ERZ/1	W1UOP	W0BMQ
227	W6VEU	W2LV	K0CTL	W6EKZ	G3KHE	W7EOI	W4WDI	W2BQM	W0BSK
HB9TL	208	189	167	UR2AR	129	116	WA6AMZ	W2WJS	W0QGI
PY4TK	MP4BBW	W1LLF	XE1AE	152	W2MAF	W3COG	WA6EYP	K2YIY	EA8CT
226	205	186	166	W1ORV	K4ASU	112	W8JIN	K2ZKU	G3FKM
W3NKM	ON4DM	ZL3IA	K1IXG	W2HXG	126	OZ7FG	ZS6ATA	W3ATV	G6UT
225	204	185	165	W2NUT	W6DLY	111	102	W3KPP	KH6DLF
W2ZX	K4TJL	K2JFV	W3MAC	151	W9CYL	W4OM	K1IDW	W4WDI	LA6VC
W8EAP	202	W0UUV	K6MLS	K4AJ	125	K0RDP	K9PPX	W4IFN	OD5CT
220	W4OPM	182	163	K4JEY	W1AOL	110	G5BJ	W5KC	OE1RZ
VK3AHO	201	W2VZV	G2BVN	K4PUS	W1JSS	W9EYC	LA3SG	K5OGP	PJ2AF
219	W2FXN	PZ1AX	YV5AFF	G3DO	W2ATJ	108	SM5DW	K6CWS	SM5AQV
W0QVZ	W51YU	180	161	G6LX	W3KPP	DL7AP	YN1CK	W6DLY	SM5LL
218	G3AWZ	K8RTW	W3VSU	150	W4UWC	UA3FG	101	WA6HOH	UA3CR
W6RKP	200	179	159	W2QKJ	K6HFZ	105	W2SKE	K6QDD	VE3CIO
217	W1OOS	W3KT	K2HEA	K2TDI	W8ACT	EI8P	K6CQM	K6ZKH	VE6EN
W6PKH	W2JXH	177	W5RHW	W6YMV	DJ3CP	XE1CV	EP2AG	W7EUD	VP6WD

DX DX DX DX DX DX DX DX

URBAN LE JEUNE, JR., W2DEC

BOX 35, HAZLET, NEW JERSEY

The following certificates were issued between the period from August 12th, 1961 to and including September 12th, 1961:

WAZ

1581	W9IHN	Charles R. Pendl
1582	W6UDR	Paul V. Weller
1583	W3MSR	Lawrence T. Fadner
1584	K4JEY	Johnny Wood
1585	G5RP	E. Wake
1586	YV5FK	Gregorio Marin
1587	W8YCP	Frank J. Schwab
1588	HB9KU	Dr. L. Valpiana
1589	G3KZI	J. A. Steele
1590	W9UZS	W. W. Johler
1591	PA#FAB	F. A. Bannink
1592	W4CKB	Bev Cavender
1593	W4MCM	Robert J. Hudson
1594	G3BVN	R. F. Stevens
1595	W#OQK	R. W. Shaw
1596	KH6DLD	Sheila Goodhue
1597	KH6DLF	Ed Goodhue
1598	W1ORV	Leonard C. Pray
1599	W8ELL	Robert Mentzer
1600	W#NCS	Emil L. Martin

ALL-PHONE WAZ

94	ZL1ACI	R. E. Pearce
95	VK4RQ	H. C. Noble
96	DL3DW	Rudolf Riedel
97	W3GHD	Robert G. Wilson

TWO-WAY SSB WAZ

10	HB9TL	Jack Laib
11	W3EAP	Dr. W. M. Chambers
12	SM3BIZ	Curt Westling
13	SM5CO	Alex Alexanderson

CW WPX

195	K2ZRO	K. J. Deskur
196	W4YWX	Paul H. Newberry, Jr.
197	HB9EO	Ralph Graueb
198	SP6AAT	Jan Osowski
199	SM7ID	Karl O. Friden

PHONE WPX

31	K5MDX	David L. Thompson
32	F9MD	Marcel Pouchoux

SSB WPX

71	W6EKZ	R. M. Rothschild
72	K5MDX	David L. Thompson
73	K6HFZ	Andrew O. Adams
74	G8KS	S. L. Hill

IN the August DX COLUMN, I took a stand against the MC type of operation. This was done by quoting an article which appeared in the *NEDXA Bulletin* plus some comments of my own. This little bit of soapboxing has brought in more mail than any other single subject since I have been handling the DX department. Of the mail received to date, approximately 84% has been against the MC procedure, which is really

quite amazing since mail is usually received only from those who are opposed to what is being said. If a stand is taken against a particular subject and the mail shows 50% for and 50% against, it can safely be assumed that about three times as many people agree as disagree because it is simply human nature to take the time and effort to complain or disagree when you are not in complete accord. Using this guide, which I know is true from past experience, it would look as though approximately 95% of people would be against this type of operation. If this is true, then why does this method of operation persist. I think the answer is obvious. If this is the way the DX stations are working, then one must get on the list if the DX station is to be worked.

In a letter received from Joe, W4OPM, quite a bit of the history of this MC type of operation is explained

"MCing has been going on for quite a period of time but it has only reached the proportions of which we now know it with the advent of the KWM-1. Here is a transceiver which is small, compact and light weight and ideally suited for a DXpedition. The size and weight of the KWM-1 is achieved by sacrificing separate v.f.o.'s for transmitting and receiving.

"We are all aware of the pandemonium which exists when a DX station transmits and receives on the same frequency. With a rig such as a KWM-1 or KWM-2 to be operated on two separate frequencies without any additional auxiliary equipment requires that the operator change frequency on every transmission. This is obviously impractical.

"The result has been the increased use of the MC system of operation. Not all of these operations have been as bad as the East Pakistan debacle. In that one, the number of legitimate contacts made by W/K hams is questionable. From where I listened it seems that all hands were helping to pass along reports in the hopes they could get in there next. There have been other operations that were anything but smooth, but I don't believe any will approach that one for plain hoggish, dog-eat-dog type of operating. And it could have been avoided by the use of a DX adapter. There have been some very smoothly run MC type of operations, too. How about Bob, W2VCZ, when he Mcd Jan, 6W8CW. I heard no passing of reports except by Jan and the station he was in contact with. Then there was Aug, K2UVU and FR7ZD. He did a fine



This nice neat set up is none other than KX6BU on Kwajalein with Brad, K6HPR, in the driver's seat. The fellows there keep the station very active on 20 meter s.s.b. between 0400-1200 GMT and would like to pass along their 73 to the gang.

job and the night I got up there to work Guy, I heard nobody passing reports except the proper people. There have been many others and I don't think the MC system should be totally condemned because one or two have gotten out of line".

Joe goes on to say that before suggesting the elimination of this practice, something should be suggested to take its place. First, let us take the case of equipment deficiencies. At one time, Collins Radio had available a DX adapter as an accessory for the KWM-1. This unit is no longer available from Collins. If anyone has a DX adapter and would like to make same available on a loan basis for any legitimate DXpedition, I will be very pleased to act as intermediary. Likewise, anyone contemplating going on a DXpedition and is unable to obtain a DX adapter, let me know and I will try to obtain one on a loan basis.

There are two other alternatives. The *SSB Handbook* written by W6TNS and published by Cowan Publishing Company contains an article on the construction of a v.f.o. for the KWM-1. For sideband use there is one very simple operation that should prove to be very satisfactory. The KWM-1 and 2 tune 200 kc segments of the band. Thus, if the transmitter is put on 14125, a simple flip of one switch will let the operator receive on 14325, exactly 200 kc away. This method has worked very satisfactorily the few times I have heard it in operation. The DX station must, however, give the frequency at which he is listening rather frequently or else calling stations will be spread over the entire band. A DX adapter as such is not available for the KWM-2, however, Collins Radio advises that a *Novice* adapter will be available shortly. With a few simple modifications, this will permit basically the same operation as the DX adapter permits of the KWM-1. There is also a completely separate p.t.o. unit available for the KWM-2.

Now, this brings up the delicate question—

why do we have MC's when there is no equipment deficiency at the DX station. I am sure that almost everyone has heard operations in which a MC was used part of the time during the periods of time when the DX station was working on his own, his QSO output increased. The only reason that I can think of for a MC in many of these cases is that the MC simply enjoys MCing. In many cases, if as much time had been spent in instructing the DX operator in how to handle a pileup as in instructing him in the MC type of operation, there would have been no need for a MC. There are a few points which, if observed by the DX station, would result in more QSO's, less QRM, and a better chance for everyone to have a legitimate QSO. They are:

1. Never transmit and receive on the same frequency.

2. Frequently announce the frequency or part of band which is being tuned.

3. If possible, state that you are working stations by area, such as: Now W1's only, DX only, etc.

4. Limit QSO's to signal reports.

If these rules would be followed, many more stations would be worked and I think the MC practice could be reduced to its proper place. Set forth below are a few comments which I received and I am sure you will find interesting.

"Congrats on the stand you took re the 'MC' operating. Glad you printed it. Maybe it will help to put the kiss of death on this foul practice that eliminates all fair competition." W0AIW/VQ9AIW/XE4A, etc.

"I want to congratulate you and the editor of the *NEDXA Bulletin* on your comments on the Master of Ceremonies type of operation. I hope some of those people read *CQ* and take time out to see just how ridiculous they are. All we can say is that the practice serves no useful purpose." W4MR.

"There are a number of us here that are strongly opposed to this practice and we would like to do everything possible to eliminate it. Therefore, I have taken a rather strong stand against the 'ringmaster' type operation, as we call it out here and have created some friction as a result of it. However, we had this same problem on c.w. many years ago and it was solved only by the elimination of the practice by all concerned and actually was one of the bases for the formulation of the Southern California DX Club. I have discussed your editorial with a number of others who share our feelings on this problem and they heartedly concur and congratulate you on your stand. Please do some more about it and be assured of our backing." W6VFR.

"Congratulations on your MC stand." W5PQA/ZM7DA.

And this comment from an s.w.l.: "I was much amused by the editorial in your DX COLUMN in the August issue of *CQ*. I didn't



Alex, SM5CO, in his compact station in Stockholm, Alex, as you may have noticed, has just qualified for WAZ, All SSB which is his third. How about RTTY now Alex?

think that an unsportsmanlike operation like MCing would be going on in the DX-ing game."

Clif Evans, K6BX, in his inimitable way sums up why there is such strong feeling against MCing.

"Back in Arkansas where I grew up on the farm, my grandpa thoroughly indoctrinated me in sportsmanship principals. We were not very well off and not too well educated, but we did have pride and principal. Well, Grandpap showed me how obnoxious were the city slickers who shot quail on the ground while they were nesting, when for me it was a single-shot gun used only after the quail had been flushed the second time and were on the fly. Then he showed me how disgusting the hunter was who shot standing or running deer with a shot gun. With me, it was a rifle or no sport. Then he showed me that only commercial fishermen used nets to catch a mass of fish to put in barrels. At fish markets, many who could not catch fish themselves in honest competition would drop by the fish market, where the stench was high, and have a clerk (MC) hand them the fish over the counter, after which they would take it home and brag to their friends of their sporting catch. By its very mechanisms, an MC system destroys all vestige of competition and relegates results to paper credits of no more sporting value than buying fish across the counter from a clerk."

What Is FOC?

The following discussion on FOC is not presented because of the MC views shown herein, even though it may look that way. I have been asked many times what FOC is and a very good description of the Club was recently presented by Jim Price, W5FXN.

"The FOC is an international club with headquarters in England. The FOC stands for 'First-class Operators Club' and is set up something along the lines of the A1-OP club except that a newsletter goes out monthly to each member and contests are held between members.

"In 1931 a few dedicated c.w. men realized the growing need for an organization aimed at

maintaining a high level of operating ability amongst amateurs. This could best be achieved by 'First Class Operators' showing others on the bands for example, how to operate a radio station in the correct manner, to be exemplary in conduct and behavior on the bands and to extend a helping hand to the newcomer.

"Under the direction of the late G5BW and others, the First Class Operators Club was formed. Members were enrolled by a sponsoring system which, in fact, requires the consent of all the membership before nominees are admitted. To join the FOC, you must first be sponsored by one of the members. Once you are, your call is placed in the FOC newsletter for 3 issues. During this time four additional sponsors are required to write into HQ in support of the nominee and providing no objections are received after three months, the nominee is invited to join. Membership should *not* be bestowed lightly, and members should observe prospective candidates for a considerable period before deciding to sponsor. Soliciting for votes can disqualify.

"The club has gone from strength to strength and has undoubtedly contributed a great deal to the ham radio movement. Among its members are a few of the best operators in the business. Membership is limited to 350 (at full strength now). We have 59 countries represented in 6 continents.

"Operating technique, ethics, good manners and behavior, tolerance and a willingness to assist newcomers are the hallmarks of the FOC member."

Certificates

News of several new certificates reached our desk this month and is presented below. The interest in certificate hunting may be seen by the number of new certificates being offered. If you don't "chase" certificates other than DXCC and WAZ, give it a try and you'll be surprised how enjoyable it is. With any kind of a QSL collection, you probably qualify for quite a few.

Z-38-C

The rules of Z-38-C are as follows: The award is available for fone only, c.w. only, all bands or any single band, effective post-W.W. II. Required are 12 of the 21 available prefixes and 100 points made up of any of these:

- ZS1, 2, 4, 5, 6, ZE, each different station1 point
- ZS7, 8, 9, 3, each different station3 points
- ZS2MI, OR4, ZD9, KC4 (Little America only), each different station5 points.

Cost one U. S. Dollar or 7 IRC or equivalent British Postal Order. No QSL's required if certified list sent. Certification by RC official or two other licensed hams. Application must list station, date, band, mode and points claimed. All applications to Max Adler, ZS1ACD, Box 1167, Cape Town.

A-Z-5-C

The rules for obtaining the A-Z-5 Certificate are as follows:

1. Two way contact between one amateur station in each Radio District within Zone Five—VO1; VO2; VE1; VE2; FP8; VP9; W1; W2; W3; W4 (Fla., Georgia, S. Carolina, N. Carolina, or Virginia) and W8 (W. Va. only).

2. All contacts made on or after January 1959 are valid for credit.

3. QSL cards must be forwarded with the following charge to cover cost and mailing: (a) First Class Mail, 50¢ or 6 IRC. (b) First Class Registered, \$1.00 or 12 IRC.

4. All requests should be mailed direct to Secane Amateur Club, 2744 Springhill Road, Secane, Penna., U. S. A.

5. Endorsement for single band, single mode of operation, if requested.

COBRA

Award: COBRA (City of Baltimore Radio Award).

Award by: City of Baltimore Radio Association.

Address: Louis C. Bremer, W3LE, 7704 Old Harford Road, Baltimore 14, Maryland, U.S.A.

Requirements: Contact 25 different stations in the Baltimore Metropolitan area with at least 10 of them being members of the Association. Stations outside of North America and South of Panama need to contact 15 stations with at least 7 of them members of the Association. Members must receive your QSL card before Award will be issued. Effective date for qualifying contacts; May 1, 1961 with no time limit.

Application: U. S. and Canadian amateurs must send QSL's and list showing station, date, time, band and mode of transmission, others

need to send list only with the following certified by the applicant and two other licensed amateurs. "We hereby certify the above list is a true copy of Baltimore stations contacted, and the QSL's from these stations are in the possession of the applicant and reflect the information appearing on this list. The applicant certifies he/she has confirmed all contacts with the stations listed."

Charge: U. S. and Canadians: \$.50 for return of QSL's and certificate. Foreign: 5 IRC if QSL's are sent, and 2 IRC if list only.

Comments: (1) The awards will bear serial numbers and endorsements for "All Phone," "2 Way SSB," and "50 MC" where applicable. Such endorsements must be requested in application. Mixed modes of transmission and any band may be used to qualify for the general class award.

(2) Baltimore City and adjacent counties requirements same as first sentence under "Requirements" above except no QSL required unless requested for stations own use. Transcript of contacts will be all that is necessary but will be checked through for verification.

Shizouka Awards

The Shizouka (Japan) Amateur Radio Club (SARC) issues the Shizouka A-I and Shizouka A-II Certificates to licensed amateurs all over the world.

Shizouka A-1: Proof of contact with two members.

Shizouka A-II: Proof of contact with five stations in Shizouka Prefecture including at least two SARC members.

Contacts made after July 29th, 1952 are valid. Application, including QSLs, 6 IRC and list for the contact may be sent to Award Manager, JA2JW, Y, Hoshiyama, P. O. Box 147, Shizouka, Japan.



Bob, K4UFE, was kind enough to send these pictures which he had taken while on a recent vacation in Jamaica. On the left is a J33 tri bander on top of the Red Cross Building in Kingston. On the right, Ed, VP5EM, at the operating position inside. The call is VP5RA and the rig, in addition to the J33, includes a HQ-170 and 500 watt transmitter. On the wall is a large map on which they plot hurricanes. Bob would like to thank the VP5 gang for the wonderful time he was shown.



These two pictures show only part of one wall belonging to UR2BU. Karl has one of the finest certificate collections in the world. Sandwiched between the WAZ and Phone WAZ is the membership certificate in the Certificate Hunters Club with endorsements for 100 different certificates, certificates from 25 different countries and all continents. This is the one issued by Clif Evans, K6BX, who also publishes the *Certificate Hunter's Directory*. (Tnx K2UKQ)

Members of SARC: JA2BP, CU, HE, HF, JW, JZ, KB, MZ, SG, SK, TH, UJ, WB, YB, YK, ZJ, ZV, ACW, AEH, AER, AMP, ANA, AOF, APV, AQH, ASZ, AWB, AWF, AXD, BFD, BGS, BGY, BJB, BMQ, BOB, BOW, BUO, BVX, BWV, CCA, CCG, YAB.

A note was received from KR6CR, the KR6 QSL manager, and George advises that there are many cards on file for ex-KR6's. If they will send an s.a.s.e. to OARC QSL Bureau, APO 331, San Francisco, QSL's will be forwarded. **AC/AC5:** Look for a king-sized DXpedition to these places in January of 1962 by VU2NR and company. More, later.

AP East Pakistan: AP5CP in East Pakistan has been reported active by several sources. He has a v.f.o. but usually stays between 14050 and 14090 kc. The most common time seems to be between 1300 and 1600 GMT. See QTH in appropriate place.

CR8 Portuguese India: A recent DXCC directive has made Damao and Diu separate from Goa, that is, Goa will be one country and Damao and Diu another country. Those of you who were lucky enough to work both CR8AC and HB9QP/CR8 now have credit for both countries.

ET2 Eritrea: The following letter was received from K1KOM, who is the Sec/QSL Manager of ET2US—"This is to inform all amateurs that effective Friday, 21 July, 1961, all amateur radio operations conducted by Americans here in Eritrea have ceased until further notice. No information regarding status of any other stations.

"The following stations are now QRT. ET2US, ET2VB and ET2US/ET2. The reason for the QRT is the lack of clarity as far as station license, or permits is concerned.

"It is our hope here that in the near future we will be back on the air. When and if we are, another notice will be published to that effect, giving new call signs and pertinent data.

"For the present, for all amateurs who have contacted any of the above call signs only, we are still processing QSL cards here.

"All QSL cards for either ET2US or

ET2US/ET2 may be sent to the following address: Dick Cormier, USA MESA, APO 843, N. Y., N. Y., cards from USA and possessions, s.a.s.e. please. All QSL cards for ET2VB should be sent via ISWL. QSL cards for any other call sign are not processed, as we have no other records, or station logs for them, this includes old MI3US cards or prior to Feb 1958 where ET2US is concerned.

"Speaking for myself, and all the ops at ET2US and for Bob at ET2VB, we sincerely hope that we will soon be on the air again for RC with all you YL, XYL and OM."

We sure hope so, too, Dick. . . .

ET3 Ethiopia: The following letter from ET3RS should be of interest to anyone needing Ethiopia. . . . "After two years of formalities, I have been able to receive a special permission to operate an amateur radio station in Ethiopia and I have specially requested this particular month to be able to participate to your contest, as I always did from Switzerland (HB9RS) or from the Principality of Liechtenstein (HE1RS and HB1RS/FL). I will operate on 10, 15 and 20 m and in A3.

"My friend Albert Pierce who is in Addis Ababa, ex W4FPO and YN1EP will also operate the station during that month of October. We will send you pictures of the station, antenna, etc. very soon.

LA Jan Mayen: LA1LG/P will be there for another nine months. He is active almost every late afternoon and evening U. S. time.

LA Norway: Full list of Norwegian Suffixes for Portable Operation:

- | | |
|--------------|--------------------|
| A—Oslo Town | M—from a ship |
| B—Ostfold | O—Bergen Town |
| C—Akershus | P—Northern Ocean |
| D—Hedmark | R—Hordaland |
| E—Oppland | S—Sogn og Fjordane |
| F—Buskerud | T—More og Romadal |
| G—Artic | U—Sor-Trondelag |
| H—Telemark | V—Nord-Trondelag |
| I—Aust-Agder | W—Nordland |
| K—Vest-Agder | X—Troms |
| L—Rogaland | Y—Finnmark |
| | Z—Vestfold |

VK9 Nauru Island: The following letter from Laurie, VK9AM, was received by Bob, K6CQM: "The island of Nauru is a U. N. Trust Territory administered by Australia, although Australia, New Zealand and Britain are joint trustees. The island is about 3 x 2 miles and has a population of 4,500. It is a coral island, but has rich phosphate deposits. About 1,500,000 tons of phosphate are shipped away each year. There are about 2,500 indigenous Nauruans.

"Although we are about on the equator, the climate here is pleasant, and fairly constant. The temperature ranges from 75 degrees minimum to 86 degrees maximum most days. Humidity 70% and annual rainfall 80 inches.

"I am the Government Medical Officer on Nauru. I am 31, married with two daughters. I have been licensed since 1958 (VK3AMK) and have been active here since Feburay, 1961. I work 20 meter phone only. I am interested in s.s.b. and if I stay here more than one term (2 years) I may get some s.s.b. equipment. I am no good at c.w.

"All of my gear is home-brew, being from surplus equipment. The transmitter uses parallel 807's and will work all bands. Modulator uses class B 807's. The receiver is a D.C. super with plug-in coils. Antenna is a dipole on 20 meters. Other equipment: home-built frequency meter, 5" CRO, grid dip osc., aerial coupling unit.

"I operate most nights about 0700-0830 GMT."

VR3 Christmas Island: VR3L is active from 0500 to 1000 GMT. The operators alternate between 14035 kc c.w. and a.m. fone (Tnx WGDXC).

XT2 Upper Volta Republic: XT2A has been showing up on occasion on 14000 kc with a T7 note. He likes QSO in French and especially likes to work F's. See QTH in appropriate place.

XW8 Laos: XW8 is now off the "ban" list and XW8AL (after a 45 day vacation in France, should be making QSO's available.

ZD8 Ascension Island: ZD8JP has returned to Ascension Island and is now active on his old frequency of 14022 kc. Look for John around 2100 to 2230 GMT.

SU7 Niger: SU7AH is now on s.s.b. Look for him between 0630-0930 GMT and 1800 to 2000 GMT around 14300 kc or 21400 kcs.

QTH's

- AP5CP** Mhod Harwar, Dacca Signal, Dacca, East Pakistan
- BV2A** Box 101, Taipei, Formosa
- CNSJO** Box 1224, APO 216, N.Y., N.Y.
- CR6CA** Box 532, Benguela, Angola
- CR7IZ** via ZS Bureau
- CX1CA** Box 37, Montevideo, Uruguay
- CX5CO** Yamandu Luzardo, Cuaro 3159, Montevideo, Uruguay
- CX7BR** Lisandro Guianze, Colonia 1994, Montevideo, Uruguay
- DJØFB** M. Salam, Lucas Granach str. Heidelberg Rohrback, W. Germany
- (ex SU1MS)**
- DL4BS** Russ Lawson, Darmstadt Postfach, 3049 Germany or Box 614 6911th Radio Group Mobil, APO 175, N.Y., N.Y.
- DL4/5** QSL Bureau DL4VJ Base MARS Station APO 130, N.Y., N.Y.
- DL5QA** ... via W1YIS
- EA6AZ** Lorenzo Munar-Pons, Box 303, Palma de Mallorca, Balearic Islands via K2VQQ
- EA6AZ** Box 262, Malaga, Spain
- EASBA** via W4MXL
- HC5OSQ** ... via W5ZG
- HM4AQ** ... via W8BF
- JT1KAC** .. Box 708, Alan Baton, Mongolian Peoples Republic
- JZØPM** Brother Paul, O.S.C., Catholic Mission, Agate Netherlands, New Guinea
- K3HVN/PK** via K6LAS
- KSETO/KL7** via W8FMJ
- KA2YA** ... Box 181, 6102nd Supply Sqdn, APO 328, San Francisco, Calif.
- KA5KS** FERRO APO 925, San Francisco, Calif.
- KB6BR** ... USPO Box 06/50,000, Canton Is., South Pacific
- KC6CG** (after May 15, 1961), via VE7ZM
- KG1CC** c/o Mars Directorate, APO 23, N.Y., N.Y.

[continued on page 126]

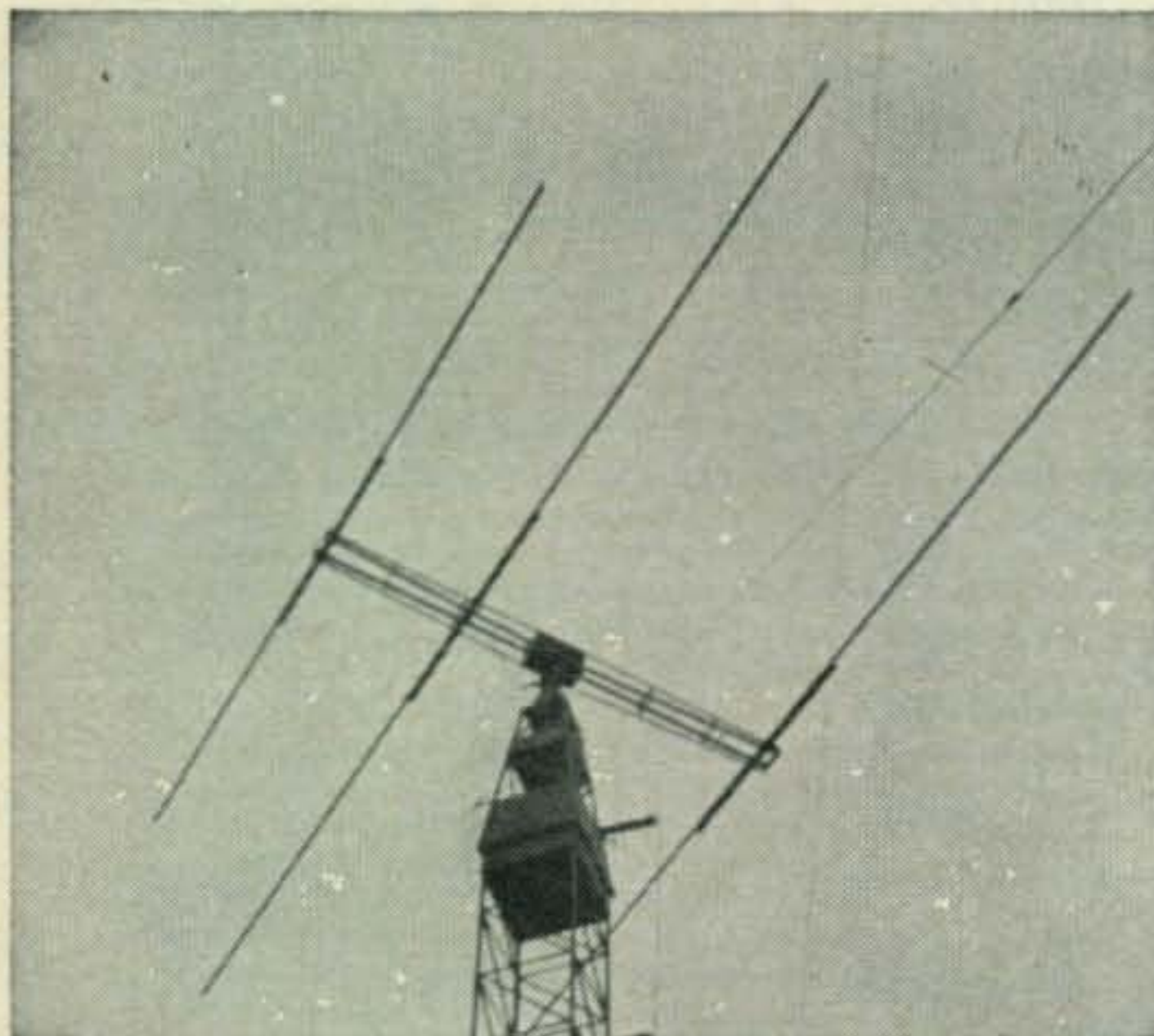

The shack, operator, and antenna of DU1EH, who is one of the newer Philippine hams. The rig is an HQ-110, Apache and homebrew minibeam and rotator. That's a fine looking job on the tower and beam. (Tnx DU1RTI)

CONTEST CALENDAR

FRANK ANZALONE, W1WY

14 Sherwood Road, Stamford, Conn.

Calendar of Events

October	25-26	YLRL C.W. Party
October	28-30	CQ WW DX Phone
November	4-5	NYC Party
November	8-9	YLRL Phone Party
November	11-13	ARRL SS
November	18-20	ARRL SS
November	25-27	CQ WW DX C.W.
December	2-3	RSGB 21/28 Phone
December	2-3	OK DX C.W.
December	9-10	Kansas QSO Party

YL RL

Phone

Starts: 1200 EST Wednesday, November 8th.
Ends: 1800 EST Thursday, November 9th.

The 22nd annual YLRL Anniversary Party is for YLs only and Louisa told you all about it in her column last month.

The c.w. section will be over by the time you receive this issue but the phone activity is still coming up so check the YL Column last month for any additional information.

ARRL SS

Starts: 2300 GMT Saturday.
Ends: 0801 GMT Monday.

November 11/13 and November 18/20

You either go all out for this one or stay off the air on both these week-ends.

This contest probably draws more entries than any other single activity in ham radio. All bands will be occupied and there is little room for any other operating let alone trying to work DX, as you who have tried it know.

But two week-ends, isn't that stretching it out a bit?

NYC Party

Starts: 2300 GMT Saturday, November 4th.
Ends: 2300 GMT Sunday, November 5th.

Here's an opportunity to work stations in the New York City area and gain as many as three separate awards, all in one week-end if the NYC boys stir up some activity.

The awards are: WNYC for working seven stations in each borough; Bronx, Brooklyn, Queens and Manhattan and two in Staten Island. WAB for working twenty (20) stations in The Bronx. And WAM for working ten (10) stations in Manhattan.

The boys up at the Bronx High School of Science dreamed up this one and full details were in last month's CALENDAR.

Logs go to: The Bronx H.S. of Science, Att: WA2BQK, 222 East 202nd Street, New York 58, N.Y.

RSGB 21/28

Starts: 0700 GMT Saturday, December 2nd.
Ends: 1900 GMT Sunday, December 3rd.

A phone only contest that is confined to the 21 and 28 mc bands. Conditions permitting it can be a very interesting affair if the boys in the British Isles show more activity than has been the rule in the past.

However with the fading MUF it could be almost a total washout. Last month's CALENDAR gave a complete run-down on all the details.

Your logs go to: The R.S.G.B. Contest Committee, New Ruskin House, Little Russell Street, London W.C.1, England. Deadline is December 18th.

OK DX

Starts: 0000 GMT Sunday, December 3rd.
Ends: 1200 GMT Sunday, December 3rd.

This is an international contest, starting local time Saturday night and ending early Sunday morning, 12 hours only. Rules were received too late to make this issue but see December CALENDAR.

Kansas

Starts: 1400 GMT Saturday, December 9th.
Ends: 2359 GMT Sunday, December 10th.

Continuing the Kansas Centennial celebration, another QSO Party is being held on the above dates.



The Trophies, Certificate and QSL cards available during the Kansas Centennial celebration. Still time to make a try for these attractive awards.

of state W/K's and VE's will give their ARRL section and DX stations will give their country.

No number is required and should not be used.

The same station can be worked on more than one band for point credit but not for an additional multiplier.

Each contact counts one point, but a county, section or country can be counted only once as a multiplier.

Certificates will be awarded to the winner of each section and in each country.

The top 25 Kansas c.w. contestants and the top 25 phone entries will also receive certificates.

Following are suggested frequencies to monitor: 3550, 3900, 7050, 7250, 14050, 14250, 21050, 21350, 28050, 29000, 52000 and 144-500.

Your logs must be in the hands of the Kansas Centennial QSO Party Committee, 414 Avenue C, Wichita, Kansas before Jan. 31st 1962.

The Sunflower Centennial certificate for contacting 25 Kansas stations and the Kansas Centennial Trophy awards for the top stations during 1961, are still available, and mighty attractive awards they are too.

In case you are still interested, check back to the January 1961 CQ or write to the Awards Committee, 1203 East Douglas, Wichita, Kansas.

CQ WW DX C.W.

Starts: 0200 GMT Saturday, November 25th.
9:00 P.M. EST Friday, November 24th.
6:00 P.M. PST Friday, November 24th.

Ends: 0200 GMT Monday, November 27th.
9:00 P.M. EST Sunday, November 26th.
6:00 P.M. EST Sunday, November 26th.

Not much more we can tell you at this late date. The Phone section is past history and the C.W. "brawl" will be coming up at the end of the month.

Once again we ask you to please send in your log regardless of the score.

[continued on page 160]

Kansas stations can work other Kansas stations, USA stations and DX stations on both phone and c.w.; there being two separate divisions. Stations outside of Kansas will try to contact as many Kansas stations as possible on both phone and c.w. and will be treated as one entry only.

Your QSO should have the time, signal report and location/multiplier. Kansas stations should give their county as their location. Out

CHC/HTH 1961 Contest Results

CONTINENTAL WINNERS

No. America	Europe	Oceania
KØIKL227	DL9PF108	KW6DG109
W5PSB215	DL6MK 70	KH6DLF108
W5WZQ181	IT1AGA 40	KH6DLD 44

COUNTRY WINNERS

United States	Wake Island	SM5CCE 15
KØIKL227	KW6DG109	SM5WI 15
W5PSB215	Canada	Netherlands
W5WZQ181	VE3BWY145	PAØLOU 27
Alaska	VE7BFN 33	Poland
KL7MF 63	England	SP2AP 17
Hawaii	G5GH 21	USSR
KH6DLF108	Germany	UC2AR 23
KH6DLD 44	DL9PF108	New Zealand
KH6DKA 38	DL6MK 69	ZL4CK 21
Puerto Rico	Italy	Japan
KP4CC 59	IT1AGA 40	JA2JW 15
	Sweden	
	SM5BPJ 16	

UNITED STATES WINNERS

Arkansas	WIHGT 85	W5CK 51
K5YNA 64	Michigan	New York
California	W8WT 88	W2SAW166
K6BX157	W8NAN 64	K2QXG122
K6CJF131	W8KPL 58	Ohio
W6YC 88	Minnesota	K8KFP 56
Florida	KØIKL227	Oklahoma
W4OMV103	Missouri	K5CWR 51
W4FNQ 59	WØMCX117	Pennsylvania
Georgia	WØAUB 62	W3AHX 60
K4BAI130	KØVMZ 52	Texas
Illinois	N. Carolina	W5PSB215
W9UX 68	K4IEX130	W5WZQ181
W9CLH 60	K4RID 82	W5LGG 81
Louisiana	K4MWB 50	Washington
K5LRQ 54	New Jersey	W7NNF100
Maine	K2UKQ 86	W. Virginia
W1GKJ 92	W2QDY 83	W8PQQ 95
Massachusetts	New Mexico	Wisconsin
W1JYH125	K5UYF 72	W9YNB 80

PROPAGATION

George Jacobs, W3ASK
11307 Clara St., Silver Spring, Md.



LAST MINUTE FORECAST

The forecast indices for the month of November, shown in the Propagation Charts following the predicted times of openings, are expected to be related to day-to-day propagation conditions in the following manner:

Forecast Indices	Above Normal Nov. 6-8	Normal	Below Normal	Disturbed 25-26
		Nov. 3-5, 9-12, 15-17, 23-24, 27-30	Nov. 1-2, 13-14, 18-19, 25-26	
(1)	C	D-E	E	E
(2)	B	C-D	E	E
(3)	A	B-C	D-E	E
(4)	A	A	B-C	C-D

Where:

A—Excellent opening with strong steady signals.

B—Good opening, moderately strong signals, with some fading noise.

C—Fair opening, signals fluctuating between moderately strong and weak, with moderate fading and noise.

D—Poor opening, signals generally weak, with considerable fading and a high noise level.

E—Opening very poor, or not possible.

Conditions are expected to be somewhat below normal at the beginning of the c.w. section of the *CQ* World Wide DX Contest on November 26th, but they are expected to improve, becoming normal on the 27th and 28th.

CQ DX Contest

THE c.w. Section of the 1961 *CQ* World Wide DX Contest will be held from 0200 GMT November 26 to 0200 GMT November 28. Special DX Propagation Charts for use during the contest appeared in last month's column. Be sure to check these Charts for predictions of band openings and for other propagation data which should be useful during the c.w. Section of the contest.

General Conditions

During November, a seasonal rise in maximum usable frequencies takes place during the daylight hours on circuits to most areas of the world. In the northern hemisphere, static and ionospheric absorption are at seasonally low

levels, and should result in strong signals occurring during many band openings.

The ten meter band is expected to open to many areas of the world during the daylight hours, although openings are expected to be less frequent than last winter as a result of reduced sunspot activity. Fifteen meters is also predicted to open to most areas of the world during the daylight hours.

Twenty meter openings are expected to peak shortly after sunrise, and again during the late afternoon hours. On some circuits, 20 meters may remain open through the early evening hours.

A greater number of nighttime openings are predicted for the 40, 80 and 160 meter bands during November. Signal levels are expected to be stronger and these bands will remain open for longer periods of time than during the summer and early fall months.

The 40 meter band is predicted to open on some DX circuits as early as the late afternoon hours. It is expected to remain open to one area of the world or another through the hours of darkness, and until shortly after dawn. Openings to many areas of the world during the nighttime hours are also predicted for 80 meters. Propagation conditions on 160 meters are improving and some DX openings during the nighttime hours are forecast for this band.

As a result of declining sunspot activity, nighttime propagation conditions on 40, 80 and 160 meters are expected to improve considerably this winter. Conditions on these bands are predicted to be better than they have been since the winter of 1954.

The *Leonids* meteor shower is expected to occur between November 14 and 18. This should result in an increase in meteor-type ionospheric openings on 10 meters and the v.h.f. amateur bands during this period.

This month's COLUMN contains Short-Skip Propagation Charts for use within the continental United States for distances up to approximately 2300 miles. Special Charts centered on the new states of Alaska and Hawaii are also included.

Sunspot Cycle

The present sunspot cycle continues to decline slowly, but steadily. The Zurich Solar Observatory reports a monthly sunspot number of 52 for August 1961. This results in a 12

CQ SHORT-SKIP PROPAGATION CHART

NOVEMBER, 1961

LOCAL STANDARD TIME AT PATH MID-POINT

BAND METERS	50-250 Miles	250-750 Miles	750-1300 Miles	1300-2300 Miles
10	NIL	NIL	9 A - 11A (0-1) 11A - 3 P (0-2) 3 P - 5 P (0-1)	8 A - 9 A (0-1) 9 A - 11A (1-2) 11A - 3 P (2-3) 3 P - 5 P (1-2) 5 P - 7 P (0-1)
15	NIL	9 A - 6 P (0-1)	7 A - 9 A (0-1) 9 A - 11A (1-2) 11A - 4 P (1-4) 4 P - 6 P (1-2) 6 P - 8 P (0-1)	7 A - 9 A (1) 9 A - 11A (2-3) 11A - 4 P (4) 4 P - 6 P (2-4) 6 P - 8 P (1-2) 8 P - 10P (0-1)
20	11A - 3 P (0-1)	5 A - 9 A (0-1) 9 A - 11A (0-2) 11A - 1 P (1-3) 1 P - 3 P (1-4) 3 P - 5 P (0-3) 5 P - 7 P (0-2) 7 P - 9 P (0-1)	5 A - 7 A (1) 7 A - 9 A (1-3) 9 A - 11A (2-4) 11A - 1 P (3-4) 1 P - 3 P (4) 3 P - 5 P (3-4) 5 P - 7 P (2-3) 7 P - 9 P (1-2) 9 P - 11P (0-1)	7 A - 9 A (3-2) 9 A - 3 P (4-2) 3 P - 5 P (4) 5 P - 7 P (3-4) 7 P - 9 P (2-3) 9 P - 11P (1-2) 11P - 4 A (0-1)
40	7 A - 9 A (1-2) 9 A - 5 P (3-4) 5 P - 7 P (2-3) 7 P - 9 P (1)	7 A - 9 A (2-3) 9 A - 3 P (4-2) 3 P - 5 P (4-3) 5 P - 7 P (3-4) 7 P - 9 P (1-3) 9 P - 3 A (0-2) 3 A - 7 A (0-1)	7 A - 9 A (3-2) 9 A - 3 P (2-1) 3 P - 5 P (3-2) 5 P - 7 P (4) 7 P - 9 P (3-4) 9 P - 3 A (2-4) 3 A - 7 A (1-3)	7 A - 9 A (2-1) 9 A - 3 P (1-0) 3 P - 5 P (2-0) 5 P - 7 P (4-3) 7 P - 3 A (4) 3 A - 7 A (3)
80	8 A - 9 P (4) 9 P - 1 A (3-4) 1 A - 4 A (2-3) 4 A - 7 A (1-2) 7 A - 8 A (2-3)	8 A - 9 A (4-2) 9 A - 4 P (4-1) 4 P - 6 P (4-2) 6 P - 1 A (4) 1 A - 4 A (3-4) 4 A - 7 A (2-4) 7 A - 8 A (3)	8 A - 9 A (2-1) 9 A - 4 P (1-0) 4 P - 6 P (2) 6 P - 6 A (4) 6 A - 7 A (4-2) 7 A - 8 A (3-1)	8 A - 9 A (1-0) 9 A - 4 P (0) 4 P - 6 P (2-0) 6 P - 8 P (4-3) 8 P - 4 A (4) 4 A - 6 A (4-2) 6 A - 7 A (2-1) 7 A - 8 A (1)
160	9 A - 5 P (1-0) 5 P - 7 P (3-2) 7 P - 7 A (4) 7 A - 9 A (3-2)	5 P - 7 P (2-1) 7 P - 7 A (4) 7 A - 9 A (2-1)	5 P - 7 P (1-0) 7 P - 9 P (4-2) 9 P - 4 A (4) 4 A - 6 A (4-2) 6 A - 7 A (4-1) 7 A - 9 A (1-0)	7 P - 9 P (2-1) 9 P - 4 A (4-3) 4 A - 6 A (2-1) 6 A - 7 A (1-0)

HAWAII

Openings given in Hawaiian Standard Time***

TO:	10 Meters	15 Meters	20 Meters	40/80* Meters
Eastern USA	6 A - 7 A (1) 7 A - 10A (2) 10A - 12N (3) 12N - 1 P (2) 1 P - 3 P (1)	6 A - 7 A (1) 7 A - 12N (2) 12N - 2 P (3) 2 P - 3 P (2) 3 P - 5 P (1)	6 A - 8 A (2) 8 A - 1 P (1) 1 P - 2 P (2) 2 P - 5 P (3) 5 P - 7 P (2) 7 P - 9 P (1)	4 P - 6 P (1) 6 P - 2 A (3) 2 A - 4 A (1) 6 P - 8 P (1)* 8 P - 1 A (2)* 1 A - 3 A (1)*
Central USA	6 A - 7 A (1) 7 A - 9 A (2) 9 A - 1 P (4) 1 P - 2 P (3) 2 P - 3 P (2) 3 P - 5 P (1)	6 A - 7 A (1) 7 A - 1 P (3) 1 P - 3 P (4) 3 P - 4 P (3) 4 P - 5 P (2) 5 P - 6 P (1)	6 A - 8 A (3) 8 A - 1 P (2) 1 P - 2 P (3) 2 P - 5 P (4) 5 P - 6 P (3) 6 P - 7 P (2) 7 P - 10P (1)	4 P - 6 P (1) 6 P - 2 A (3) 2 A - 4 A (1) 6 P - 8 P (1)* 8 P - 2 A (2)* 2 A - 4 A (1)*
Western USA	6 A - 7 A (1) 7 A - 9 A (2) 9 A - 2 P (3) 2 P - 4 P (2) 4 P - 6 P (1)	6 A - 7 A (1) 7 A - 8 A (2) 8 A - 2 P (4) 2 P - 4 P (3) 4 P - 5 P (2) 5 P - 6 P (1)	6 A - 7 A (2) 7 A - 10A (4) 10A - 3 P (3) 3 P - 5 P (4) 5 P - 6 P (3) 6 P - 7 P (2) 7 P - 11P (1)	4 P - 5 P (1) 5 P - 6 P (2) 6 P - 1 A (4) 1 A - 4 A (3) 4 A - 6 A (2) 6 A - 8 A (1) 5 P - 6 P (1)* 6 P - 8 P (2)* 8 P - 4 A (3)* 4 A - 5 A (2)* 5 A - 6 A (1)*

*Indicates predicted 80 meter openings. The 160 meter band is likely to open during those times when 80 meter openings are rated (2) or better.

**Hawaiian Standard Time is equivalent to:

Eastern Standard Time minus five hours;
Central Standard Time minus four hours;
Mountain Standard Time minus three hours;
Pacific Standard Time minus two hours.

month running smoothed sunspot number of 74 centered on February 1961. A smoothed sunspot number of 57 is predicted by CQ for November 1961. This is approximately the same level of sunspot activity as occurred during the winters of 1951, 1945 and 1941.

ALASKA

Openings given in Alaskan Standard Time**

TO:

	10 Meters	15 Meters	20 Meters	40/80* Meters
Eastern USA	9 A - 11A (1) 11A - 2 P (2) 2 P - 3 P (1)	8 A - 12N (2) 12N - 2 P (3) 2 P - 3 P (2) 3 P - 4 P (1)	7 A - 1 P (1) 1 P - 5 P (2) 5 P - 7 P (1)	9 P - 2 A (1)
Central USA	11A - 4 P (1)	9 A - 11A (1) 11A - 1 P (2) 1 P - 3 P (3) 3 P - 4 P (2) 4 P - 5 P (1)	8 A - 2 P (1) 2 P - 5 P (2) 5 P - 7 P (1)	9 P - 3 A (1)
Western USA	11A - 1 P (1) 1 P - 3 P (2) 3 P - 4 P (1)	10A - 11A (1) 11A - 12N (2) 12N - 3 P (3) 3 P - 4 P (2) 4 P - 5 P (1)	9 A - 2 P (2) 2 P - 5 P (3) 5 P - 6 P (2) 6 P - 7 P (1)	11P - 6 A (2) 1 A - 6 A (1)*

**There are four different time zones in Alaska. This Chart is based on standard time in the zone from Skagway to 141 degrees west longitude. Time in this area is equivalent to:

Eastern Standard Time minus four hours;
Central Standard Time minus three hours;
Mountain Standard Time minus two hours;
Pacific Standard Time minus one hour.

FORECAST INDICES

Circuits shown in the Propagation Charts are forecast to open:

- (1) Less than 7 days during the forecast period.
- (2) Between 8 and 13 days during the forecast period.
- (3) Between 14 and 22 days during the forecast period.
- (4) More than 22 days during the forecast period.

Where two forecast indices are shown within a parenthesis, the first applies to the forecast for the shorter distance range, and the second to the forecast for the longer distance.

A - A. M. P - P. M. N - Noon M - Midnight

The reception quality expected during openings (signal strength, noise and fading levels), as well as the specific days on which each circuit is likely to open, are shown in the "Last Minute Forecast" appearing elsewhere in the text.

The CQ Short-Skip Propagation Charts are based upon a CW effective radiated power of 75 watts from a half-wave dipole antenna, a half-wave or higher above ground. The Charts are valid through November 30, 1961. These forecasts are based upon basic propagation data published by the Central Radio Propagation Laboratory of the National Bureau of Standards, Boulder, Colorado.

The Central Radio Propagation Laboratory

Users of the Propagation Charts which appear in this COLUMN every month are aware of the great contributions to communications that the Central Radio Propagation Laboratory (CRPL) of the National Bureau of Standards has made in the development of techniques for predicting propagation conditions throughout the world. This month CQ visits the Boulder, Colorado Laboratory of CRPL to bring to its readers the inside story of this organization, which is made up of some of the world's leading experts in the field of wave propagation.

Propagation Research Begun In 1909

Research into radio propagation by the National Bureau of Standards dates back to 1909 when measurements were first made on long wave radio signals. Long before the actual discovery of the ionosphere, the Bureau had played an important role in the development of early propagation theories, many of which are still valid today.

After the discovery of the ionosphere in 1924, and the introduction of pulse techniques for measuring ionospheric densities and layer heights, the National Bureau of Standards ex-

Located at Boulder, Colorado, in the shadow of the Rocky Mountains, this reinforced concrete building houses the Central Radio Propagation Laboratory of the National Bureau of Standards. (Official National Bureau of Standards Photo)



tended its propagation studies to the high frequency range. In the following seventeen years, the Bureau was responsible for developing much of today's theories concerning the propagation of high frequency radio waves through the ionosphere, and many of the techniques used for predicting their behavior. The Bureau's program during these early years not only included the study of radio physics, but also the development of widely used navigational aids, such as the aircraft beacon and ILS blind landing system. Bureau engineers and scientists contributed much to this country's early development of radar systems and techniques.

Early during World War II, the Bureau of Standards scientists working in the field of radio propagation formed the nucleus for the establishment of the Interservice Radio Propagation Laboratory (IRPL). This Laboratory, under the command of the combined chiefs of staff of the U.S. Armed Forces, provided the Armed Services with valuable information on radio propagation conditions. Perhaps the greatest contribution made by the IRPL was the development of simplified radio frequency prediction techniques which made it possible to establish reliable, efficient communications in almost all areas of the world.

After the War, the functions of the IRPL were incorporated into a new organization called the Central Radio Propagation Laboratory. In civilian attire once again, CRPL became a separate division of the National Bureau of Standards in 1946 as a result of joint recommendation by a number of Federal Agencies and with the concurrence of Congress.

In 1954, CRPL transferred to its present location in Boulder, Colorado. The Boulder location for the Laboratory, in an uncongested area at the foot of the Rockies and neighboring the University of Colorado, is ideal for radio propagation experiments. Here the climate allows year-round field work, and the varied terrain makes it possible to use a wide variety of transmitter and receiving station arrangements for propagation experiments. A network of field stations, extending from the poles to the tropics, some operated by the National Bureau of Standards, others furnishing data on a contract or exchange basis, completes the facilities presently available to CRPL for radio propagation research and experimentation.

The Mission of CRPL

The Central Radio Propagation Laboratory is directed by Dr. Fred W. Brown. It is the central agency of the Federal Government for obtaining, analyzing, and disseminating information on the propagation of radio waves at all frequencies along the surface of the earth, in the atmosphere and in space. The Laboratory also performs scientific studies looking toward the development of new techniques for the efficient use and conservation of the radio spectrum. To carry out this responsibility, the CRPL:

1. Acts as the primary agency for the conduct of basic research on the nature of radio waves, the nature of the media through which radio waves are transmitted, the interaction of radio waves with those media, and on the nature of radio noise and interference effects. This includes compilation of reports by other foreign and domestic agencies conducting research in this field and furnishing advice to government and non-government groups conducting propagation research.
2. Performs studies of specific radio propagation mechanisms and performs scientific studies looking toward the development of techniques for efficient use and conservation of the radio frequency spectrum as part of its regular program or as requested by other government agencies. In an advisory capacity, coordinates studies in this area undertaken by other government agencies.
3. Furnishes advisory and consultative service on radio wave propagation, on radio frequency utilization, and on radio systems problems to other organizations within the United States, public or private.
4. Prepares and issues predictions of radio wave propagation and noise conditions and warnings of disturbances in these conditions.
5. Acts as a central repository for data, reports, and information in the field of radio propagation.
6. Performs scientific liaison and exchanges data and information with other countries to advance knowledge of radio wave propagation and interference phenomena and spec-

trum conservation techniques, including that liaison required by international responsibilities and agreements.

Although the basic objective of CRPL is to improve the quality of radio communication insofar as it is affected by propagation and by noise and interference effects, the investigations required to meet this objective have led to basic studies of the upper and lower atmosphere, the sun, relations between phenomena on the sun and in the earth's atmosphere, and studies of planets and stars which are emitting radio energy. To cope effectively with this wide range of scientific activity, the Laboratory is divided into four separate divisions: Ionospheric Research and Propagation, Radio Propagation Engineering, Radio Systems, and Upper Atmosphere and Space Physics.

Ionospheric Research and Propagation

The program of this division is directed toward a better understanding of the ionosphere, that portion of the earth's atmosphere lying between approximately 50 and 500 miles above the earth's surface, and toward solution of practical problems of radio communication via this medium.

The division investigates ionospheric propagation over a very wide range of frequencies from the very low (v.l.f.) to the very high (v.h.f.) areas of the spectrum. Much of the "raw data" concerning the ionosphere is collected by the Ionospheric Research and Propagation division from hourly soundings of the ionosphere taken at more than 100 different locations throughout the world.

Studies of an increasing interest now being carried out by this division deal with such subjects as v.h.f. equatorial propagation, the intensity and occurrence of sporadic-E propagation throughout the world, polar radio blackouts and their cause of effect on h.f. communication circuits, the relationship between the earth's magnetic field and the ionosphere in equatorial regions and in polar regions, and the mechanisms responsible for ionospheric propagation.

There is a close relationship between the ionosphere and solar activity. To determine its extent, CRPL's Ionospheric Research and Propagation division also conducts radio observations of the sun's activity, statistical studies of solar phenomena, and studies of the physics of the sun. These solar radio studies have immediate bearing on many aspects of ionospheric research including the investigation of the 11 year sunspot cycle on radio waves reflected from the ionosphere.

Prediction & Radio Warning Services

Prediction services and publication of solar and geo-physical data are an important aspect of the program of the Ionospheric Research and Propagation division. This information is needed on a prompt basis for use by commercial and government communication organizations

for operational and planning purposes. CRPL's prediction services are utilized in the preparation of the Propagation Charts which appear in this column every month.

The prediction services consist of the following (1) the CRPL-D series, *Basic Radio Propagation Predictions*, which are concerned with long-term predictions of ionospheric communication conditions, issued as a monthly publication, forecasting three months in advance maximum usable frequencies for radio sky-wave transmissions. This series is supplemented by the CRPL-Ja series, *Semi-Monthly Frequency Revision Factors for CRPL Basic Radio Propagation Prediction Reports*. (2) World maps of ionospheric characteristics for prediction of F2-layer ionospheric communications, prepared for sunspot number 50, together with maps showing the rate of change of critical frequency and factor with sunspot number. These maps can be used for calculating m.u.f.'s for any circuit for any period of solar activity. (3) The CRPL-F series, which is concerned with statistical analysis of ionospheric data for use in prediction studies and in research concerning the upper atmosphere and sun-earth relationships. This series consists of Part A: Ionospheric Data, and Part B: Solar-Geophysical Data. These publications go to institutions participating in the international program of cooperative exchange of ionospheric, solar and geophysical data, and are also available to research organizations throughout the world. (4) Final publication of data collected during the IGY and its extensions, including U.S. solar data, special sunspot number information, and a calendar record of solar activity and associated phenomena for each day of the IGY. Information on the conditions of sale for the above mentioned documents can be obtained directly from CRPL.

Of equal importance, but on an immediate availability basis, are CRPL's radio warning services. Forecasts of radio propagation conditions in the high frequency spectrum are distributed by mail, Teletype, telephone, and radio broadcasts. These forecasts are based on up-to-the minute analysis of prevailing radio propagation, solar, ionospheric, and geomagnetic activity as reported by a world wide network of cooperating solar and geophysical observatories. Most important of the services are the systematic forecasts of radio propagation conditions on radio paths in the North Atlantic and North Pacific areas. To implement the actual forecasts, a warning center at Ft. Belvoir, Virginia operates on a 24 hour basis, and another at Anchorage, Alaska on a 15 hour schedule. Research to improve forecasting techniques is carried on continuously by the Laboratory.

Forecasts of radio propagation conditions are broadcast twice an hour on National Bureau of Standards radio stations WWV and WWVH. Latest schedules for these broadcasts can be obtained directly from the Boulder Laboratory.

Several of the CRPL publications which make it possible to predict propagation conditions for an h.f. radio circuit. Top: F-Series, Part A, Ionospheric Data. Center: D-Series, Basic Radio Predictions. Bottom: F-Series, Part B, Solar-Geophysical Data. (Official National Bureau of Standards Photo)

Forecasts, and a record of observed conditions for the past week are distributed by mail in CRPL series J, Jp, Jb and Jb', which are available upon request from CRPL. Records of the forecasts for an entire month and the degree of their success are published monthly in the CRPL-F series.

In connection with obtaining ionospheric data for research studies and the prediction services, the Ionospheric Research and Propagation division maintains field stations located as far north as Barrow, Alaska and as far south as the South Pole, Antarctica. A rather extensive ionospheric physics program is carried out in the Antarctic.

Radio Propagation Engineering Division

In the troposphere (from the earth's surface to about six miles high) the strength and fading properties of radio waves are affected by the weather, climate and terrain. A basic limitation in all areas of the atmosphere is the interference or radio noise which the signal must overcome. These and other properties must be estimated to design and allocate communication, broadcasting, and navigational facilities and to meet urgent needs for increased circuit reliability and economy of operation in the v.h.f. and microwave areas of the spectrum.

Through experimental studies in radio meteorology, physics of the lower atmosphere, terrain effects and radio noise, this division attempts to describe the propagation phenomena involved (*i.e.* how a signal "bends" over a mountain peak, or how signal strength is affected by atmospheric variations, etc.). From such studies, methods are developed for predicting the characteristics of v.h.f. and microwave propagation and noise which must be known, for engineering application to actual radio circuits.

Consultative and advisory services, based on the work of the division, are provided to other government agencies, industry, and national and international technical organizations.

Inherent in the tropospheric propagation studies undertaken by the Radio Propagation Engineering division is the development of methods for predicting the performance of a radio system which is to operate in the v.h.f. or microwave region. The ability to predict the performance of a radio system often eliminates the necessity for making extensive test measurements, and makes it possible to rapidly evaluate a large number of sites and select the one best suited to fulfill the requirements. The prediction methods developed by the division are

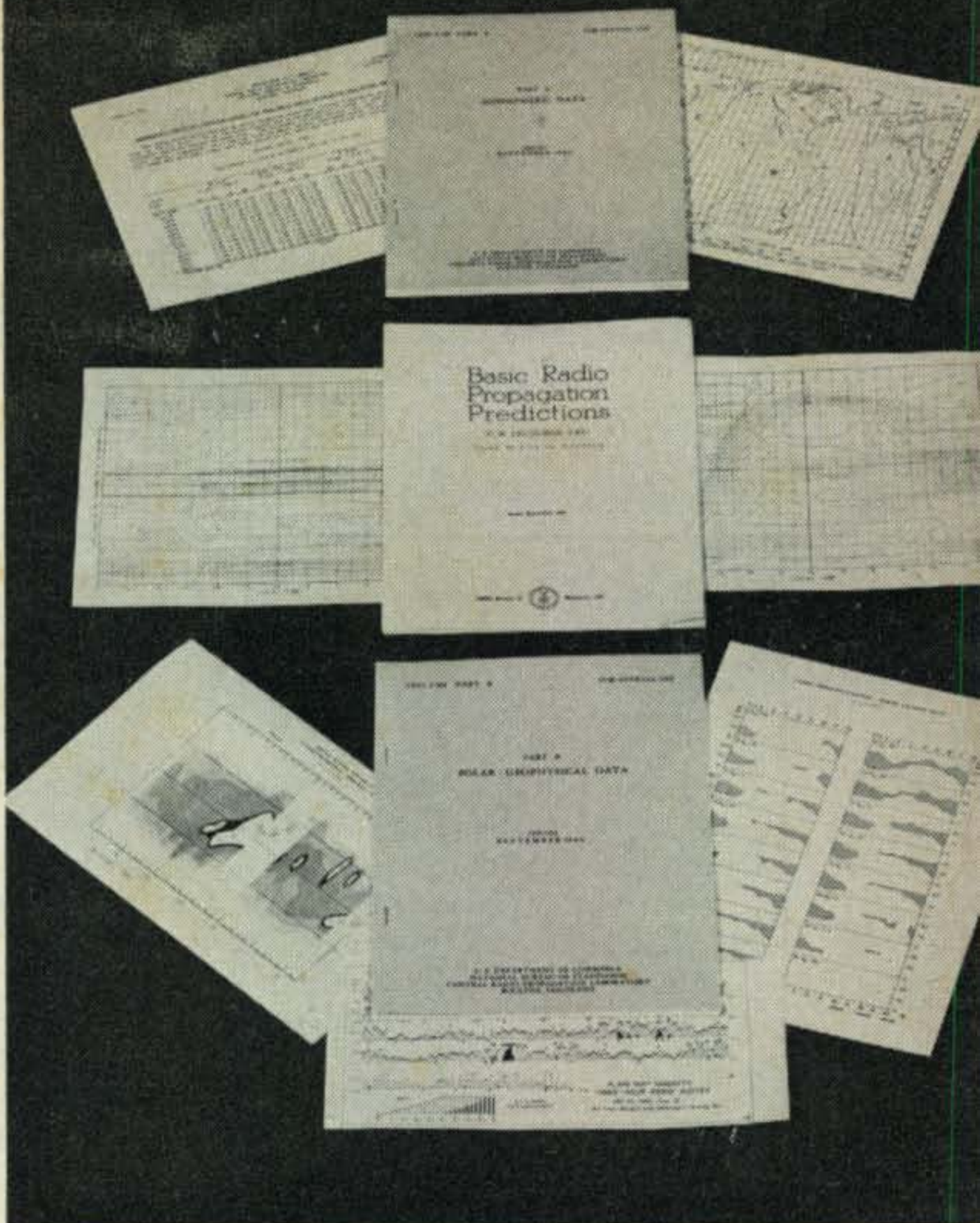

widely used to design long-distance tropospheric communication circuits. Optimum frequencies, antenna size, and transmitter power are determined by using information gained from site surveys conducted by the division, topographic map studies, and tropospheric propagation theory. These studies have led to the more efficient allocation of frequencies and to the development of more efficient radio circuits for v.h.f. and microwave communications.

Radio Systems Division

Experimental and theoretical studies of radio propagation, closely related to problems of antennas, noise, modulation, detection and band-width requirements, frequency utilization, and the operational requirements of radio services, are conducted by this division. The division investigates radio systems in their entirety.

Among the projects upon which the Radio Systems division is engaged at present is the investigation of h.f. trans-auroral communication. Ionospheric radio propagation is unstable over radio paths that cross the polar cap or pass through regions of maximum auroral activity which takes place in the high latitudes. The division is conducting extensive h.f. transmission tests through and within the northern auroral zone, and across the polar cap to determine typical circuit losses, evaluate special high frequency modulation techniques for reducing distortion, and to learn more about the propagation mechanism involved in order to develop a radio system which may eventually permit efficient communication in this area of the world.

[continued on page 162]

sideband
sideband
sideband

SIDEBAND

IRV and DOROTHY STRAUBER,
K2HEA/K2MGE

12 ELM STREET, LYNBROOK, NEW YORK

6th Annual CQ World Wide S.S.B. Contest March 24-25, 1962

THE 6th Annual CQ World Wide S.S.B. Contest is being re-scheduled for March 24-25, 1962 instead of late January in order to take advantage of the better conditions that prevail. Ordinarily, we would announce the rules in this issue for a contest in January. However, with the change in date, the contest rules will be included in our January column.

This advance notice will give you plenty of time to send for contest forms early. For a sufficient supply of these official forms, please send us a large self-addressed envelope with *double postage* for the type of mail service desired. Send your envelopes to us to the address at the top of this column for fastest service!

We are completing a brand new set of rules which will return the 6th Annual CQ Worldwide S.S.B. Contest to the status of strictly DX competition. Watch for the new rules in the January CQ!

S.S.B. DX Reaches New Pinnacle

A NEW milestone in s.s.b. DX operation was reached when Humberto Perez, TI2HP, received his 250th confirmation for a two-way DX contact. Only a scant two years ago, it was quite a distinction to be able to qualify for the "Worked 100" Certificate and now we have Humberto at the 250 mark, with several others close behind. Before too long, we imagine that the magic number of "Worked 300" on sideband will be achieved. Who will earn the first certificate?

Another event that pleased us was the qualification of George Pearson, G3AWZ, for the "Worked 200" Certificate. George has a host of good friends from his a.m. days and, when he appeared on sideband, he was issued a royal welcome. Having worked so much DX on other modes, George found himself with little interest in joining the race again for s.s.b. DX. But you can't keep a good DX man like George idle for long. With substantial encouragement and urging, George re-entered DX competition and, in record time, became the first station in the U.K. to be awarded the "Worked 200" Certificate. George has proved himself to be a staunch and true friend to many hams, always willing to extend himself to help where help is needed. It is truly fitting that G3AWZ should earn the distinction which he now holds.

Eeeny Meeny Mineey . . .

With a number of exciters, linears and receivers available, it has become increasingly

difficult for the neophyte sidebander to decide on what equipment he should spend his poker winnings (or do you have another way of explaining to the XYL how you came by the money honestly?). The ads in the various ham publications extoll the virtues of the "Super DX Sniffer", "Ultra Suppressed Sideband Exciter" and the "QRM Busting Linear". Asking your friends sometimes can add to the confusion by the facility with which they throw the terms "p.e.p.", "Filter", "Phasing", "Grounded Grid" and other esoterica around. Rest easy . . . before long you will be one of the gang and hep to the parlance.

We have been asked from time to time to recommend rigs to incipient sidebanders. We wish that there was a completely satisfactory answer. All the reputable manufacturers make fine equipment and back their gear with honest warranties. We feel the sensible way to start is to study the equipment you presently own. Can you add a sideband generator or is it preferable to start with a sideband oriented exciter or exciter/transmitter? Is your present a.m. final easily convertible to linear service?

Sideband exciters break down into three classifications: Generators for use with your present a.m. equipment, low powered exciters suitable for driving tuned grid linears and exciter/transmitters which can be used "barefoot" or as a driver for a grounded-grid linear.

The sideband generator, such as the Heath SB-10 or the B&W 51SB unit can be used with existing a.m. equipment to put a satisfactory signal on the air.

More sophisticated, specifically sideband gear begins with units such as the C.E. 10B or 20A which have most of the features of the higher priced units but are designed for use with linear amplifiers to boost their 10 to 20 watt p.e.p. input to higher levels. These units usually have a modest price tag but the addition of a linear, unless you make use of your old a.m. final or are adept at home-brewing, brings the price up to that of the medium powered exciter/transmitter units such as the HT-37, 32S-1, HX-500, 200V or Invader. With the medium power comes a higher price tag and more luxurious appointments and refinements. These units are complete transmitters and can be used directly into an antenna without the need of a linear amplifier.

Whatever your choice of equipment, we are sure that the brand of equipment you purchase will represent the best that the designer and the manufacturer can produce at the price. Properly adjusted and operated it will provide you with many hours of sideband fun.

Ham Radio TV Series Planned

An exciting new TV series, *The World is Yours*, based on the colorful experiences of amateur radio operators, has been developed by Don Cordray, WA6MSE, of Van Nuys, California. Don is well known on 20 meter sideband and has been a ham since 1926. His career includes 10 years of TV acting and announcing for NBC so he is particularly well fitted to act as host on this new series which he will also write and produce. Don plans to interview two outstanding hams weekly and has secured the cooperation of radio societies throughout the world who will send him films of amateurs in their countries. Since we all know how fascinating a program of this kind could be, we wish Don the best of luck in convincing the TV powers-that-be that time should be allotted to *The World is Yours*.

Chance of a Lifetime

Thanks to the efforts of Sid, G3NUY, and Bob, G3KGC, plans are now being made to fly a group of DX sidebanders to New York



City for the 11th Annual Hamfest and Banquet sponsored by the Single Sideband Amateur Radio Association in late March, 1962. The round trip fare will be 70 pounds or less (\$200) according to the number travelling. The entire round trip will be approximately 4 days and will include a visit to the IRE Convention, a tour of New York City and the Sideband Hamfest and Banquet. The trip will be made via a major international air line charter flight. Since the number of intended travellers is restricted, it is urged that anyone interested immediately contact Sid Almond, G3NUY, 265, Longley Lane, Gatley, Cheshire, or Bob Morgan, G3KGC, 12 Sussex Ring, London, N 12.

The trip will not be restricted to s.s.b. amateurs; all amateurs are welcome to join in this chance of a lifetime. Get in touch with Sid or Bob at once.

Marathon Sked Nears 2000 Mark

On April 30, 1954, Empty, ZS6KD, in Johannesburg, South Africa, and Butch, W9EWC, in Hilbert, Wisconsin, began a series of schedules between their two stations which they have maintained for 1,966 sessions. Their skeds culminated in a personal meeting between Empty and his charming XYL, Audrey, with Butch and his family in Wisconsin in 1959. In a recent contact with Empty on 15 meters, he mentioned that, except for those rare times when either he or Butch have been away on holiday, they have met their skeds with the regularity of clockwork. Bearing in mind the poor conditions that have, over the past few years, afflicted the low frequency bands, we take off our hats to these two gentlemen who have developed such a strong friendship and who have demonstrated the superiority of sideband schedules over the past 7 years. Listen for them on 15 meters and enjoy their 2,000th schedule celebration.

Getting The Right Start On Sideband

The big day has arrived! You've made your first contact on single sideband; a bit nervous perhaps because of your unfamiliarity with the new mode and a little upset by the constant

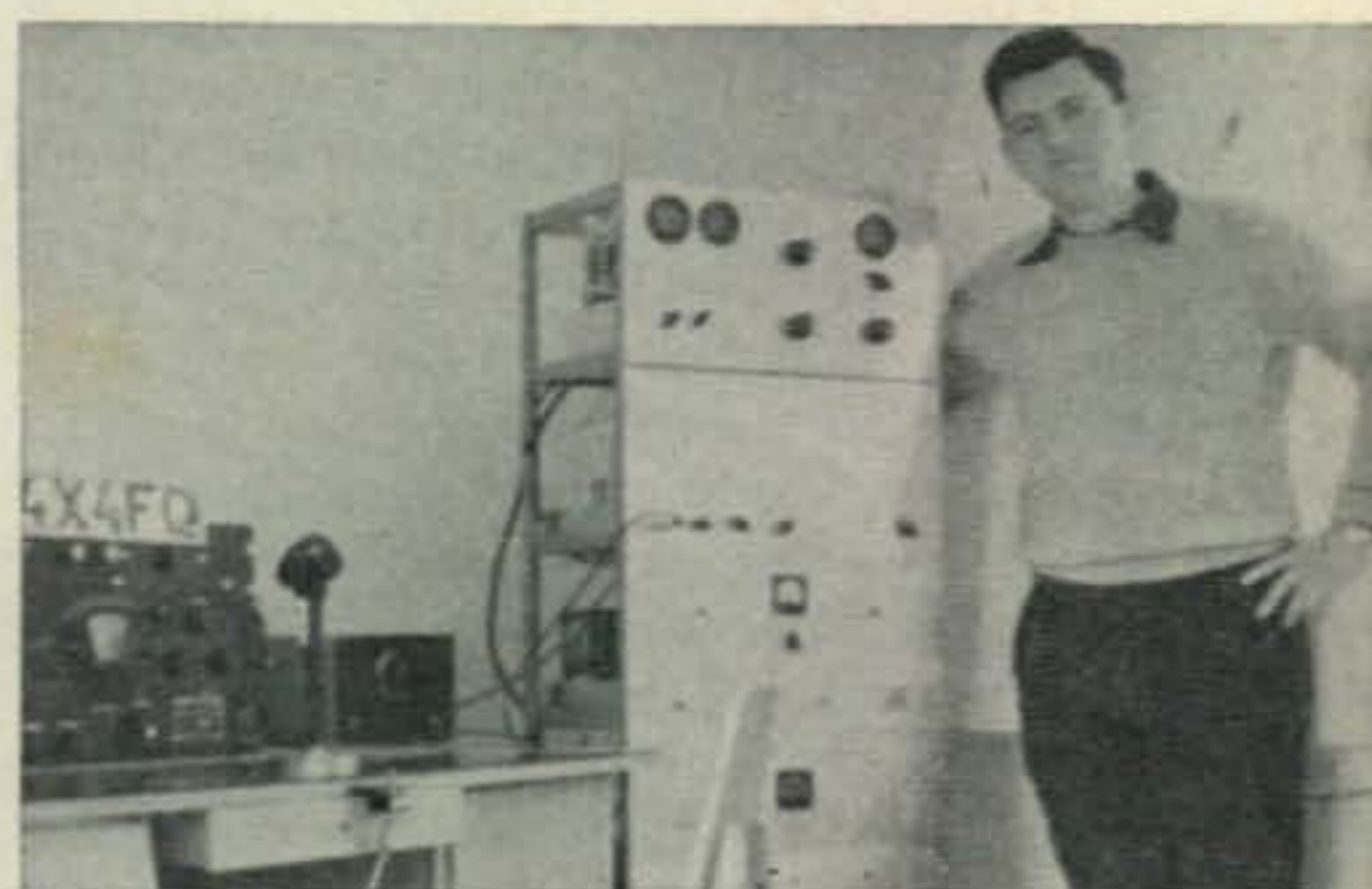

Two of the most active sidebanders in Israel are Mosh, 4X4FA, (l) and Aron, 4X4FQ, (r). Each runs homebrew equipment, Aron with a filter type exciter and Mosh with a phasing type exciter and they each put out a very fine signal. Aron informed us that the following are also now on sideband: 4X4 CW, DK, FA, FQ, IX, LC, JT, JM, CX, AS, and ES—quite a contingent!



Here is Camp Wafra in the Neutral Zone, site of 9K3TL/NZ operation. The air-conditioned trailer made life unexpectedly pleasant for the boys.

clicking of the relay during vox operation. You will find that, in a day or two, the relay will cease to bother you. Every rig has an adjustment which permits the operator to lengthen the time delay between relay clicks and another adjustment for the anti-trip control so that background noises or loud signals in your speaker will not cause the transmitter to go into operation. Experiment with these controls until you get the proper balance between them. With a little practice, your use of vox will improve to the point where you will not try to get the very last word out of that one breath intake but will speak with natural pauses, ignoring the changeover from transmit to receive.

As we pointed out in a previous issue, it is absolutely necessary that you zero beat the frequency exactly. This is important as it leaves more channels clear, facilitates break-in of additional stations when desirable, and also permits you to hear all parts of the QSO without constantly retuning. It is also a courtesy to listening hams who may be enjoying your conversation while doing other work in their shacks.

Here is an interesting point advanced by Alan, VK3AHR, (who, along with others, has contributed much to this series), regarding "title" to a frequency. If you find a clear channel, initiate a call and are answered by someone, the other station should vacate the frequency to you when the QSO is finished. If, at the end of the QSO, someone comes on and calls him, he should say, "Let's move off this frequency to kc." Of course, if you announce that you are closing down after the QSO, they may continue to use the frequency if they wish to. However, if you are called by a DX station who, in turn, is called by other W/Ks at the completion of the QSO, courteous practice dictates that you should relinquish the frequency to the DX station. With so many W/K stations interested in working DX, it is logical to move off the frequency and permit

your fellow hams to work the DX station now that he has broken through the QRM.

Speaking of breaking, yelling "break, break, break" is not the proper way to join a QSO. Good operators will probably ignore you completely if you choose this method of interruption. The right way to join a QSO is to call one of the stations on frequency by call and give your own call once or twice. However, you should realize that, when the parties to the QSO are engaged in earnest conversation, they may not wish to include a third party; that is their privilege and you should respect it. Listen to the conversation for a while to see if an addition would really be welcome. Don't try to break in in the middle of a subject or discussion, even if it means waiting for quite a while, or if they are two old friends enjoying a private 2-way chat. If you wish just a quick report, request it with due humility at the proper moment in the QSO and briefly. There



The top DX men who put 9K3TL/NZ on the air: l. to r.; Bryan, MP4QAO (and ten other calls); Vic, W1TYQ; Rundy, OD5CT; and Jack, HB9TL. According to Jack, they had everything: lots of heat, lots of sand, lots of beer, and lots of fun!

is absolutely no need to include an unsolicited, detailed description of your rig, your location, and a weather report.

There will be many occasions when you will hear a DX station in conversation with one of his friends. The mere fact that you need that country is not sufficient reason for you to interrupt the QSO. Most DX stations devote many hours to giving out rapid fire reports to satisfy the hordes of operators who have never worked their country before. However, the DX operator appreciates the opportunity even more than most to have an uninterrupted ragchew so, if you should come upon him in one of these moments, have the courtesy and good sense to leave him alone until he is finished with his chat, no matter how long it takes. There will always be another day when you can get your report.

On the subject of DX operation, despite all the recent controversy as to DX portions, the majority of DX stations still operate in the area between 14.300 and 14.320. We realize that it is only ignorance of this fact that causes so many high power W/K stations to consistently, though innocently, QRM this part of the band. However, with the frequencies 14.270-14.300 and 14.320-14.350 available for rag-

chewing, traffic handling, phone patching, etc., we suggest that the non-DXer consider the activities of the foreign sidebanders in this 20 kc segment above 14.300 and steer clear of this area. To be specific, many of the rare Russian stations are crystal controlled on 14.301, 14.303, and 14.310 as are many of the DXpeditions. The attitude of the ragchewers should not be "So what" but rather let's move down and leave these frequencies clear for those interested in DX work, never forgetting that 20 meters is the prime DX band. It takes so little effort to be courteous!

We'll continue next month with 40-80 s.s.b. operation, more on 20 meter DX, and other topics which we hope will be of interest to you.

Some Thoughts on Frequency Allocations

The result of the survey made by the ARRL recently affirmed what most sidebanders had suspected; s.s.b. operation has increased and is continuing to increase on all the bands. In case you did not happen to see the results of the summary, they ran this way: 46% of all phone operation on all the bands is now s.s.b. with the usage of s.s.b. about 50% on 75 and 15 meters. Our good friend Ted Wilds, KZ5SW/-W4GVD, in a recent letter made some observations which we think worthy of repeating in part. Ted points out that although s.s.b. usage is roughly 50% of phone operation, sidebanders



Lightning can't strike twice but we can goof twice. Every time we've mentioned Clair Miller of Cedar Rapids, Iowa, (right above) we've used the wrong call! This time we know we're right! Clair's call is WØKFA and he's shown above with another famous Cedar Rapids sidebander, Chuck, WØCVU, who recently earned Certificate #31 for "Worked 200."

have somewhat less than that amount of frequencies to move about in; 34% on 75 meters, 25% on 40 meters, 50% on 20 meters, 25% on 15 meters, 8.35% on 10 meters.

To quote Ted, "The a.m. attitude toward s.s.b. seems to be 'They are just a few crackpots who spread out all over my (obsolescent) trusty ole HQ-117. Pay 'em no mind!' Conversely, the rabid sidebander's opinion of the a.m. station operators seems to follow this line: 'Nobody who is anybody is still on a.m. Listen around, the whole gang is now on s.s.b.'

The results of the ARRL survey would give the lie to fanatics on both sides of the b.f.o. It is time for calmer minds to give serious thought to how best our bands be used in fairness to all. It seems unlikely that the FCC will do away with a.m. in the h.f. bands as has been predicted by some, but a glance at the ads will show that no major manufacturer is devoting much time, advertising or factory space to the production of high power a.m. equipment.

"It is apparent that a.m. and s.s.b. are not compatible frequency-wise. The 40 and 75 meter bands are a mess with the two modes competing throughout the bands. The time has come to remedy the situation by general agreement on these bands as well as on the DX bands. S.s.b. activity on 10 meters has been slim although the band has been open daily, as the a.m. gang will attest. S.s.b. space on ten should be a small slice due to the lack of usage and because the newcomer to the air can make good use of a.m. with low power and financial investment. But the s.s.b. segment should be kept carrier free. The table shows a suggested division of the h.f. bands that could be workable and would be fair to all phone operators for some time to come. As s.s.b. usage increases in the future, a re-alignment might be in order."

Phone band	Exclusive A.M.	Exclusive S.S.B.
28.500-29.700	28.500-28.650 28.750-29.700	28.650-28.750
21.250-21.450	21.250-21.350	21.350-21.450
14.200-14.350	14.200-14.275	14.275-14.350*
7.200- 7.300	7.250- 7.300	7.200- 7.250
3.800- 4.000	3.900- 4.000	3.800- 3.900

*If the s.s.b. group decides by an actual survey that it is desirable to take away the top 15 kc from the DX chasers stateside, the a.m. fraternity should *not* be penalized by a reduction of space.

A Letter From Sweden

"Hello there, Dorothy and Irv!

You are perhaps a little surprised to get a letter from Sweden? Well, we read CQ The Radio Amateur's Journal up here in Sweden also. The reason why we are writing is that we worked a lot of s.s.b. a couple of weeks



Looking cool, calm, and collected is Bob, K4AJ, of Largo, Fla. who has long been a sideband enthusiast.

ago. That was on the fieldcamp SM4XA in Dala-Storsund near Falun and we means in this letter the hamgang from Gävle most of the time hanging around the s.s.b. rig. All of us are members of the old-fashioned-boys-still-using-the carrier-club, but, after that week at the s.s.b. rig, we are all digging in our junk-boxes for something that can be useful in a s.s.b. transmitter. Before I go on in this letter, I must say please excuse my bad English and how I spell. Hope that you have fun when you read it, hi! (Ed. note: we wish we could write in Swedish as well as you write in English!)

"Every year we have a fieldcamp here in this part of Sweden. It is open for all hams all over the world. Of course, there are more SM-hams than hams from other countries (this year we were about 100, plus our families) and we were very glad to meet on the camp this year G3JUB, LA2AD, LA4K with family, and OH2KK with XYL, Sinni. G3JUB has been here 12 times on holidays and he visits first the camp and after he stays a couple of days with some of us hams around here.

"We had a lot of fine stations on the camp this year. We liked most of all the Collins KWM-2 transceiver and we used it, sometimes followed by the Viking Courier. The Viking Invader was used for local QSOs with SM, OH, LA, and OZ on 40 and 80 meters with an RME 6900 receiver. SM5EY had his s.s.b. exciter on the camp and we liked it very much. It is very simple to build that one and it works very fine. On 144 mc, we used SM3WB's rig and a 13 element long yagi.

"On Saturday afternoon when I arrived at the fieldcamp, SM3WB and SM4GL (the organizers of the camp) met me and told me that I was selected to watch over the KWM-2. I had never seen a KWM-2 before but I found it very easy to work that rig. At 0016 the first night on the camp, we started our s.s.b. working with a very nice and 100% QSO with K1JJJ in Mass. We got 5 and 8/9 and our antenna was a Hy-Gain Vertical for four bands. The conditions were not so good that night for DX so we worked only 10 QSOs before we went to bed. The day after, we worked a lot



Sideband operation at the Swedish fieldcamp, SM4XA, obviously had these boys enthralled. L. to r., Chris, SM3CFM; Andy, SM3CNN; and Dick, SM3CBR. (Photo courtesy of Lars, SM3AVQ)

of European stations and then at midnight we had a complete WAC s.s.b. 14 mc. The conditions were nearly the same the whole week, perhaps a little better when we got W2FGV, 1930 GMT and W8MEM, 1940 GMT. We pushed SM5BL's YL, Britta (SM5CEW) to the mike and that brought us YV5AFF, Susan (see CQ, Dec., 1960), W2NUT, K1LBL, and later PY4AS. We could not go on in that fine conditions because we had very bad GI (Gramophone Interference, hi). You see we had a dance every night and the s.s.b. rig was placed next door to the Gramophone they used for the dance music. We could never decide on what was most important: to dance or to work DX!

"Here is the result of our working with s.s.b.: 80 prefixes, 49 countries, WAC, WBE, and 2nd degree R6K, all on 14 mc s.s.b. Best of luck to all you s.s.b. hams over there and especially to the stations we worked from



Don Cordray, WA6MSE, who is writer-producer-host of a planned TV series on amateur radio *The World Is Yours*.

SM4XA camp. Do not worry about QSLs, we have them made out here. We hope that some of you can visit us on the SM4XA camp in the future and we are looking forward to working you from our own stations on s.s.b.!

73s and all the best,
Lars Olsson, SM3AVQ"

Remembering back to our own introduction to sideband, we can fully appreciate the delight that these boys found in working this new mode for the first time and we certainly hope that they will each be able to join us on sideband on a permanent basis.

Band Hopping

We keep hearing more and more reports about the friendly rivalry going on to see who can work what first. Gene, W5IYU, and Bryan, W5KFT, had a wager on to see who would reach 200 countries confirmed first with the prize being the best dinner in town. Well, Gene reached the finish line first but his certificate was accompanied by a congratulatory card from Bryan who airmailed it to us to be included with Gene's award. Inasmuch as Gene



Here's a famous amateur radio couple whose fine photograph will delight their many friends—Sophie, W6SH, and, Ralph, W6RH, of Los Gatos, California.

lives in Oklahoma City, Oklahoma and Bryan in Lubbock, Texas, the boys haven't decided where to let Bryan buy Gene that dinner! . . . Another friendly competition was between the two Moragrega brothers in Guadalajara, Mexico, Luis, XE1SN, and Miguel, XE1TJ. With Luis at 120 worked and Miguel at 60, the aim was for Luis to reach 150 before Miguel hit 100. After an intensive campaign for three months, the finale of the story is that each of them got the winning confirmation in the same mail! As a reward for the fun they had, each bought the other a 30L-1 but now they're so tired of chasing DX, they're taking a rest from radio for a while! The brothers visited Los Angeles in September and, at the time of this writing, are planning to visit Chicago, Philadelphia, and New York where we hope to meet them in person . . . Gene, W0BSK, whose cartoons have enlivened the pages of Don Chesser's *DX Bulletin* and *The Sidebander*, has a private DX dope sheet "The Backscratcher" which he and his cronies exchange to keep up with the latest . . . Dr. Dave Robertson, VK1ATR, and his XYL, Denise, VK1YL, are now living near Upton, Long Island. We are looking forward to having them attend some of our local radio meetings . . . Eddy, W5ZBC, sent welcome news of the first Louisiana s.s.b. Supper in Alexandria, Louisiana on August 26. Present were K5LYC, K5SNE, K5AQT, W5KUZ, K5SVD, W5IOF, K5ZRF, K5VMO, W5KYC, K5CTR, W5WYN, W5CIT, W5WNN, K5KMR, W5GKT, K5ANK, W5GQZ, W5ZBC, W5MXQ, K5AGJ, K5BLO, and W5EGN, all with their respective wives. Ed wrote that W5GKT and W5EGN acted as hosts and did a great job of making this first La. supper a great success. Ed also noted that any southland sidebanders are invited to join the 3905 Delta s.s.b. Net. Y'all join . . .

Here's a heart warming story from Len, K6QMT . . . "Last spring, as a lark, I patched my 'almost niece,' Mary Louise, to Ted, K2-CHV, who was portable KL7 on Shemya. After a series of patches including some to Honolulu when she was there, Ted made a quick trip to San Francisco to see what the

Worked 100 and 200 Certificates

All stations must submit QSL cards, clearly marked 2-way S.S.B., together with an alphabetized list and sufficient return postage for these certificates and your cards. Listing forms will be sent by Sideband Editors and below listed stations upon receipt of your self-addressed envelope, stamped or with IRC's.

Worked 50 and 75 Certificates, Stickers for 125, 150, 175 etc. Countries

All stations must submit only an alphabetized listing of confirmed 2-way S.S.B. contacts verified and attested to by another amateur. No cards need be submitted. Include letter postage.

African Stations

Send cards with lists to ZS6AMV, A. J. Louw, 52 Wargrave Ave., Auckland Park, Johannesburg, Tvl., South Africa from the following call areas: All ZS's, ZE, VQ2, ZD6, CR6 and CR7.

All sideband stations in the other African call areas send cards with lists to Awards Manager, R.S.E.A., QSL Bureau, Box 30077, Nairobi, Kenya.

United Kingdom and Ireland

R. F. Stevens, G2BVN, 51 Pettits Lane, Romford, Essex, England, will verify your cards provided they are accompanied by listings.

Europe

All European sidebanders may send their cards to Jakob Laib, HB9TL, Weinfelderstr. 29, Amriswil, TG, Switzerland.

Australia, New Zealand and other Oceania

All sideband stations in these areas may send their cards to Jock White, ZL2GX, 86 Lytton Road, Gisborne, New Zealand.

Other Areas

Direct to the Sideband Editors, 12 Elm Street, Lynbrook, L.I., N.Y.

In every area, return postage must be included!

nice voice looked like. Ten days later he bought a ring and the wedding will be November 11! Instead of studying cooking, Mary Louise is learning the code!"

Best wishes to Paul, W6YMV, who has moved to Costa Mesa and a hearty welcome to his father-in-law, L.T., WA6ESB, who is now on sideband . . . Claire, K6TQO, and Bob, K6TQN, are making Redwood City famous by

[Continued on page 164]

Space Communications

GEORGE JACOBS, W3ASK

11307 CLARA STREET,
SILVER SPRING, MARYLAND

President Kennedy's Statement On Space Communications

THE subject of space communication has drawn a tremendous amount of attention recently at the highest levels in the U.S. Government.

During late July, President Kennedy issued a policy statement on space communications. This statement is a clear-cut directive for the United States to take the lead in establishing a world-wide communication system using earth satellites in as short a time as practicable. The President emphasized that such an operational system must not only serve the public interest of this country, but must be of benefit to the entire world. Mr. Kennedy called for American private enterprise to work hand-in-hand with the government in order to accelerate the development of such a global communication system.

In his statement, the President stressed the importance of foreign participation in the operational system. He extended an invitation to all nations to take part, through ownership or otherwise, in the early development and use of such a system. Mr. Kennedy further stated that it will be the policy of the United States to provide technical assistance in the field of communications to newly developing countries in order that they too might share in the benefits of a communication satellite. The President's statement stressed that the global communication system envisioned by this country is to be used in the interest of world peace and closer brotherhood among peoples throughout the world.

Large NASA Budget Approved

Following closely on the heels of President Kennedy's policy statement on space communications, the Congress authorized a budget of \$94,600,000 for space communication programs to be carried out by the National Aeronautics and Space Administration during 1962.

Approval of this large budget, which includes \$50 million requested personally by President Kennedy in order to accelerate the development of a world-wide communication satellite system, marks the beginning of a rapid move forward by NASA towards demonstrating the operational feasibility of various types of systems.

During 1962, NASA plans to orbit no fewer than 5, and possibly as many as 10, experimental communication satellites. These will range in types from low altitude active relays (Projects RELAY and TSK), to a high altitude synchronous satellite (Project CYNCOM), and will also include at least one passive reflector (Project ECHO II).

As a result of its 1962 experimental program, NASA hopes to obtain enough first-hand technical data upon which can be based the development of an optimum operational system in line with the President's directive. Many communication experts are of the opinion that America's stepped-up space communication program may result in an operational system being brought into service, at least partially, by as early as 1964.

Project SYNCOM—Synchronous Orbit Satellite

Project SYNCOM, scheduled for launching during late 1962, will be the first attempt at placing a communication satellite in a 24 hour synchronous orbit at an altitude of approximately 22,300 miles. At this altitude the period of the satellite's orbit is equal to the period of rotation of the earth (approximately 23 hours 56 minutes), and the satellite appears to remain stationary with respect to a point on the Earth's surface. Because of this unique orbital characteristic, as few as three such satellites could provide complete global communication coverage with the exception of the polar regions.

Such a system has the further advantage that ground antenna aiming and tracking problems are minimized as compared to lower altitude systems where the satellite is continually moving with respect to the ground station.

A synchronous orbit satellite is far more complex than one orbiting at a considerably lower altitude. Not only must it carry active electronics and power supplies required for communications, but it must also carry a velocity control system. Such a system, by automatically adjusting the period of the satellite by fine adjustments in velocity, continuously keeps the satellite in a stationary position with respect to a point on the Earth's surface.

To successfully place a satellite in a synchronous orbit calls for great precision in

The octagon-shaped, paddle wheeled Explorer XII payload pictorially shown separating from the third stage of its Delta launching vehicle as it enters an elliptical orbit which will carry it between approximately 160 and 50,000 miles above the earth's surface. The paddle wheels contain solar cells which supply the satellite with part of the power it needs for its electronic equipment and instruments. The remainder of the power is supplied by silver-cadmium storage batteries. (Official NASA Photo).

launching and in guidance control. The satellite must also contain an orientation, or attitude control system to insure that its antennas are continually pointed towards the Earth.

NASA has granted a \$4 million contract to the Hughes Aircraft Corp. to build this country's first synchronous orbit communication satellite. Plans call for an initial launching during late 1962. A second launching may also take place during 1962, and a third satellite will be available for back-up purposes. This program, called Project SYNCOM, will test a small active communication satellite, weighing approximately 50 pounds, in a 24 hour orbit. The satellite will be boosted to the 22,300 mile altitude by a three stage Delta vehicle. Then it will be injected into the desired orbit by an additional solid propellant rocket attached directly to the satellite. This rocket is also expected to provide fine adjustments in orbit in order to maintain proper altitude and attitude. Project SYNCOM will provide early experience with an active system in high altitude orbit.

Two other active communication satellite programs are scheduled by NASA for 1962, Projects RELAY and TSX. These will test low-altitude systems up to 3,000 miles above the Earth's surface. They will be discussed in next month's column.

The initial synchronous communication satellites will be designed to relay telephone conversations and telegraph messages over near hemispheric distances. Future high-altitude satellites will have the bandwidth capacity for television transmission. Frequencies to be used will be in the neighborhood of 8,000 mc from ground to satellite and 2,000 mc from satellite to ground.

One problem that will be encountered with synchronous orbit communication satellites is the long time delay (approximately 0.6 of a second) incurred as a result of the radio wave travelling more than 45,000 miles on its path from the ground transmitting station to the satellite and back to a ground receiving station.

NASA plans to make available the test results of Project SYNCOM to communication interests, commercial and government, around the world.

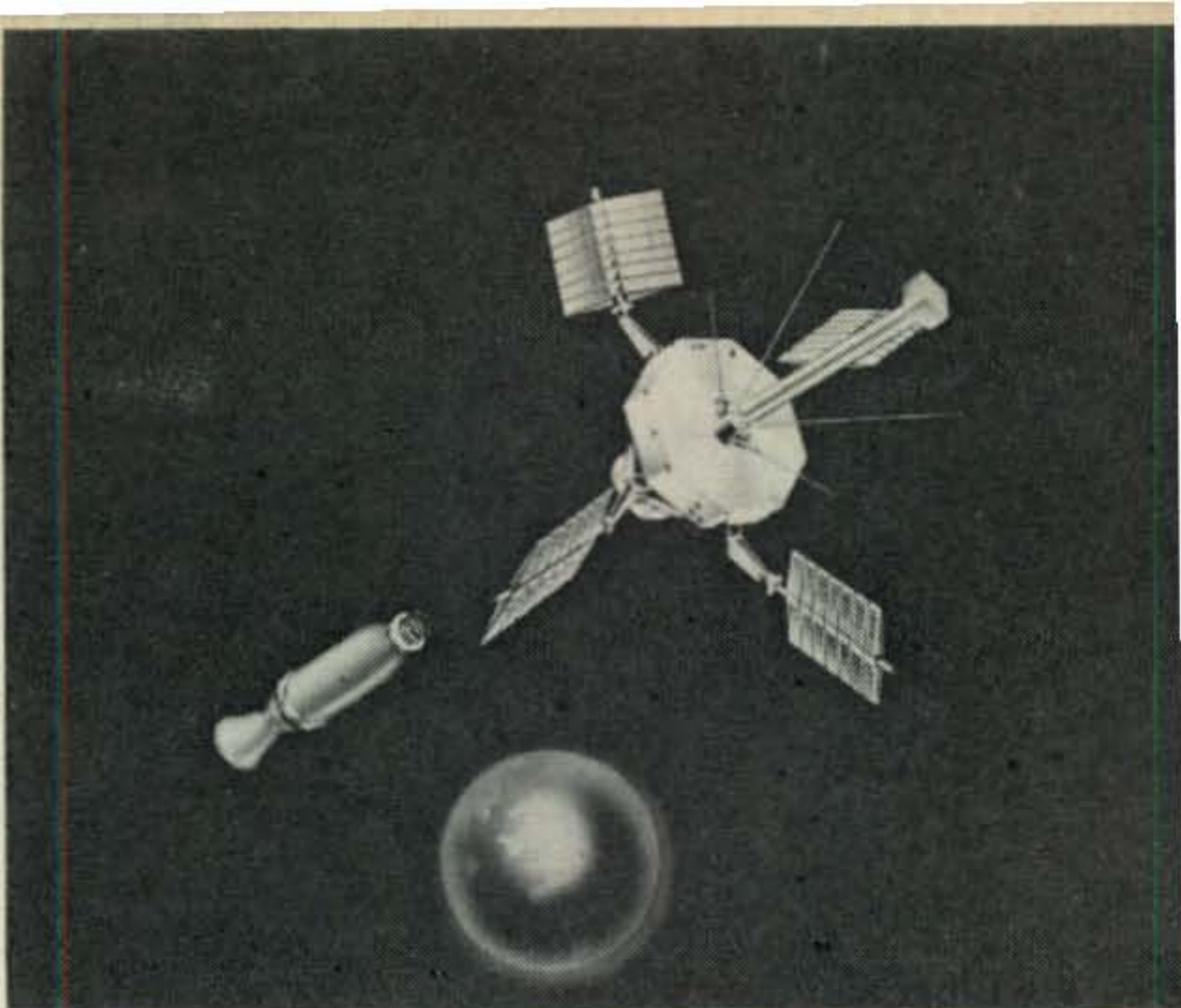

More On OSSC

The formation of the *Office For Satellite Scatter Coordination* (OSSC) was discussed in the June and July columns. The OSSC, created under the auspices of the Massachusetts Institute of Technology, is directed by Raphael Soifer, K2QBW. Its main purpose is to give radio amateurs interested in performing satellite scatter experiments an opportunity to coordinate their activities through a centralized group having real "know-how" in this challenging new field.

In a recent letter, Ray Soifer states that "As a result of the discussions in the June and July columns, about two dozen inquiries were received, most of them from amateurs of high technical competence, which resulted in a large number of new stations becoming affiliated with OSSC."

Ray points out, however, that many more amateur radio stations are needed to join the OSSC networks before many of the planned experiments can begin. What is "desperately" needed, according to K2QBW, are several high speed c.w. stations that can run powers as high as a kilowatt on 15 and 10 meters. These stations are needed in order to attempt to scatter signals from satellites over greater distances than have already been accomplished with lower power. Another shortage is the need for a medium to high power, high speed c.w. station for 50 mc experiments with "multiple scatter" transmission. Ray stresses the need for high speed c.w. proficiency for the scatter experiments, in order to extract as much intelligence as possible from the weakly scattered signal. As Ray puts it, "We have more Ph.D's in OSSC than CP-35's, but we need them both if the experiments are to be successful."

Additional details about OSSC and satellite scatter communications are available directly from Raphael Soifer, Director OSSC, Room 10-206, Mass. Institute of Technology, 77 Mass. Ave., Cambridge 39, Mass.

Russian Man In Space Frequencies

On August 6, the Soviet Union placed their second man into orbit around the earth. Major
[Continued on page 168]



The USA-CA Program



BY CLIF EVANS*, K6BX

BIG wheels move slowly! The 10,000 copies of USA-CA Record Books originally promised for July delivery, but plagued by repeated printer's delays, finally arrived at CQ's door-steps on September 13th. Three Cheers.

CQ, through USA-CA Custodian K6BX, humbly apologizes for this unforeseen delay which caused a flood of concerned inquiries that possibly some had missed out on opportunity for low numbers. Not so!

Here's payoff: As K6BX promised in the August column, a "system" has been devised giving equal opportunity to all for low numbers regardless of QTH and associated mail delays. To facilitate such "system", CQ mailed out all *Record Books* on order as a lot 9-14-61.

Already we are swamped with applications indicating that many had lists all ready for immediate transcribing. One enthusiastic fellow wrote he took the book apart and farmed it out in sections to his office force, and had finished application back at P.O. within 45 minutes after receipt.

First USA-CA-500 application to arrive was from K2PFC, and first and only USA-CA-1000 application to date was sent in by K4BAI. Following closely behind were W8IBX, W0MCX, K6YMZ, W8NAN, K5DGI, K6SXA, W5PSB, W4UF, W8WT, K9EAB, W6YC, K5UYF, W5NXF, K1BUR, W5AWT and W1GKJ in that order. The three days 'grace' period hasn't run out for most areas as we go to press so there will be many others to be considered for the Number ONE category.

Remember that it will take some time for overseas applications to arrive and be processed under the system of fair opportunity, so please be patient in awaiting announcement of first series of low numbers. We assure all that after this first processing hurdle is over, USA-CA applications will be acted upon within 7-10 days of receipt as folks have experienced in K6BX handling of CHC, HTH, FHC and QCWA applications.

Have heard a few rumors of many approaching the USA-CA 1000 level. Many DXers, especially Europeans say USA-CA is in the bag. Everyone seems amazed at the quality and map coverage of the *Record Book* and surprised that CQ could make it available at \$1.25. We agree. First, CQ got a special rate in mass quantity and secondly, CQ had no desire to make a profit on the USA-CA awards program. For example, K6BX has a catalog of the American Map Co. which on page 17 gives an almost identical series of maps less the ham record section. Price, \$2.95. Whether you enter

*Box 385, Bonita, California

into the USA-CA program or not, you cannot afford to be without one of these 108-page map-*Record Books* for reference purposes.

Mammoth Program

You may have noted that we do not call the USA-CA just an award. USA-CA was purposely designed to encompass, support and enhance literally hundreds of other U. S. Awards, therefore, rather than being just an award it is really a mammoth program. Regardless of what U. S. awards you may be interested in or working for, you are automatically building up credits toward USA-CA. Conversely, while working for USA-CA, one likewise is simultaneously qualifying for scores of other U. S. awards.

These USA-CA advantages also held true in connection with all contests, QSO Parties and Field Days by whomever sponsored. Regardless of U. S. QSO's, they have value toward USA-CA together with other awards. With USA-CA we have arrived at a situation wherein the QSL card of every U. S. ham now has more significant and appreciated value.

Along with the design concept of the USA-CA Program was the thought that greater publicity could and should be given to many U. S. awards programs and especially these in which county contacts are a prime factor. You must admit that this is a new and healthy approach whereby CQ does not consider other awards as competing but rather that all 'associated' awards are jointly promoting hamdom's pleasure interests, and merit support.

So, within limits of space that can be made available, this column will not only give USA-CA news coverage but will directly support 'associated' organization's activities whenever related news is of interest to all hamdom. By 'associated' organizations we mean any and all Clubs and organizations conducting activities the nature of which fall within the tremendous encompassing scope of the USA-CA Program.

As you know, one of the goals of USA-CA and also the Directory of Certificates and Awards published by the writer is that, eventually, each of the 50 U. S. states will have its own independently sponsored all-county award. Rapid progress is being made because many organizations are becoming aware that such awards programs offer outstanding opportunity for creating good public relations both for state, county, city and club, and all in one neat package. Likewise, such sponsors reap the world-wide publicity coverage that the USA-CA Program and Directory gives them for free. The writer, having had some experience in awards design, stands ready to

assist any organization in the design of all-county awards for those states now among the missing.

The following county awards programs representing New Mexico, Alaska, Ohio, Missouri and Texas are classic examples of state-county awards which will reap good public relations for both states and sponsors and will add considerably to hamdom's pleasures in certificate hunting.

New Mexico's All-County Awards Program

New Mexico now has an all-county awards program sponsored by the newly formed Certificate Hunters' Club Chapter No. 1, Albuquerque, N.M.

The N.M. award is issued in four classes for working various numbers of counties as follows: Class A requires confirmed contacts with all 32 counties; Class B requires 24; Class C requires 16 and Class D requires only 8, without restrictions as to dates, bands or modes, except that U.S. and Canadians must make all contacts from the same QTH whereas DXers are confined only to limits within one's own country.

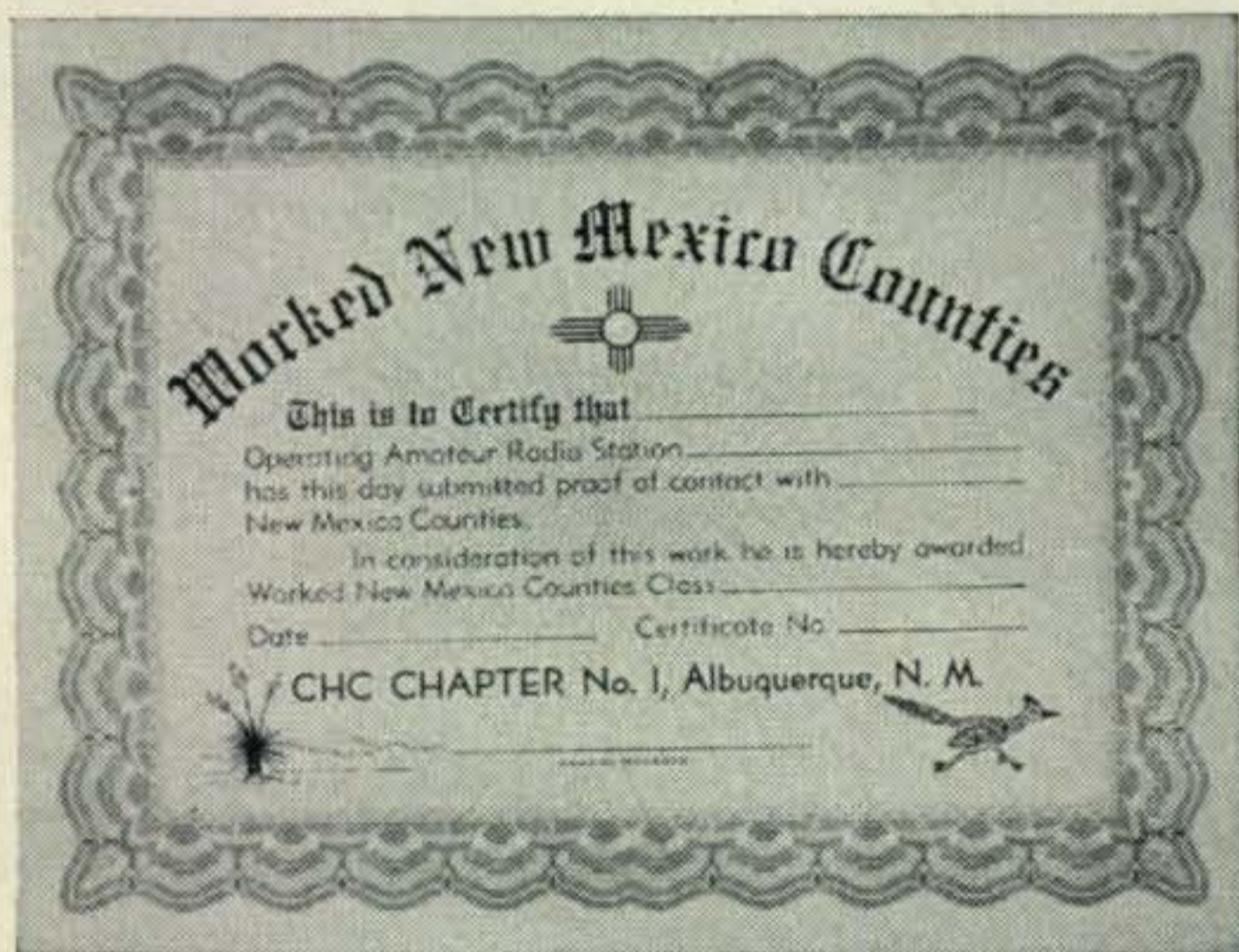

To get this beautiful award, send list, alphabetically by counties, certified by two other licensed amateurs or a radio club officer stating that cards were sighted, along with \$1 or ten IRC to the CHC Chapter No. 1, c/o Awards Manager, Willie Petty, W5LEF, 3107 Morning-side Drive, Albuquerque, N.M.

The Albuquerque Chapter also has taken over handling of the "Sandia Base Friendship" award issued for working 25 stations in the Albuquerque Area for U.S. hams and 10 for others.

To help all hamdom make N.M. contacts, the Chapter will conduct an annual N.M. QSO Party each year in January with first such QSO Party now scheduled for January 1962 and with dates to be announced in January issue of *CQ* and the *Directory of Certificates*.

As a further aid in working "rare" N.M. counties, the Chapter will conduct frequent excursions throughout the state and will operate from "rare" N.M. counties on Field Days.

This highly active CHC Chapter was formed

in July, 1961, when seven CHCers got together and signed a petition for Chapter formation. Seven CHCers in one city is the highest concentration of such world's leaders in the achievement field and speaks well for the N.M. hams. Original signers on Chapter petition were CHCers K5UYF, W5CK, W5LEF, W5PQA, W5NXF, K5BGT, W5ONK along with Associate members and CHCers to be, W5AX, W5II, W5STL, W5NTM, and K5ZHV.

Alaska All-Counties Award—(AACCA)

Alaska, the largest of the 50 states but with the next to the least amount of counties, or we should say Judicial Districts, now has an All-County Award in support of the USA-CA.

The Wildwood Station Amateur Radio Club, WSARC, has announced sponsorship of an award for confirmed contacts with each of Alaska's four Judicial Districts plus a fifth separate contact with a club member. The AACCA is issued in five classes as follows: Class I for All CW; Class II for All AM; Class III for All SSB; Class IV for RTTY and Class V for Mixed Mode. Endorsement suffix A is for all one band and suffix B is for mixed band.

To get the Alaska award, contacts must be after August 15, 1961, and reports from both stations must be at least Q-5 or RST 459. Send list, certified by two other licensed amateurs or a radio club officer stating cards were sighted, to WSARC Secretary, Bldg. T-308, Wildwood Station, Alaska.

When Alaska was admitted as a state, the only political sub-divisions were the Judicial Districts and folks up there haven't gotten around to Gerrymandering a batch of counties like we have in most states; however, the politicians are haggling over the prospects. In the interim, USA-CA accepts the four Judicial Districts for awards purposes. As a further aid to the Alaska map in the USA-CA Record Book, locations of most active Alaska stations are: First Judicial District; Juneau, Ketichican and all points East of 141 degrees. Second District; Nome; Barrow and entire Seward Peninsula. (Don't confuse this with city of Seward on the Kenai Peninsula). Third District; Kodiak, Seward, Anchorage, entire Alaska Peninsula, entire Kenai Peninsula and Wildwood Station. Fourth Division has Bethal, Northway and Fairbanks.

Remember, there must be two QSO's with Division Three; one with a WSARC member and one otherwise. WSARC is located NE of Kenai and about 65 air miles SW of Anchorage.

Certificate hunters can thank CHC'er Meade, KL7DIR, Editor of WSARC's newsy *Zero Beat* for spark plugging the AACCA in support of USA-CA and adding this big state to the growing list of states having all-county awards.

Ohio's New Cardinal County Awards

As you know, Ohio is the Buckeye state and has Buckeye awards, so when it came to naming a new series of seven awards for working Ohioans in different counties, the sponsors gave us the Ohio bird, the Cardinal.

The Ohio Radio Society, OARS, now offers seven different Cardinal Awards, each in different classes, and based on working different Ohio cities and counties. First in the series is the Cardinal All-County Award in Class A for confirmed contacts with all 88/60 counties (last figure applies to others than U.S. and Canada); Class B for 77/52 counties; Class C for 66/44 counties; Class D for 55/35 counties and Class E for 45/25 counties.

To get the above Cardinal award or any of the following listed Cardinal awards, send list, certified by two other licensed amateurs or radio club officer stating cards were sighted, along with 50¢ or 5 IRCs to OARS, c/o W8AJW, 2972 Clague Road, North Olmsted, Ohio. A rundown on the six other awards follows:

Cardinal SSB: For two-way s.s.b. contacts with Ohio stations in different counties. Ohioans must work 30 in 20 counties; U.S. and Canada work 25 in 15 counties and DX stations work 15 in 10 counties.

Cardinal VHF: For Ohio contacts on six meters and above with different counties. Ohioans work 30 in 20 counties; U.S. and Canada work 25 in 15 counties, and DX stations work 10 in 5 counties.

Cardinal NOVICE: For contacts with Ohio Novices in different counties. Requirements are same as stated for Cardinal VHF award.

Cardinal YL: For contacting Ohio YL's in different counties with ratio and requirements same as stated for Cardinal VHF award.

Cardinal MOBILE: For contacting mobiles in Ohio in different counties. Same requirement and ratio as stated in Cardinal VHF award. Mobile QSLs must show QTH at time of mobile contact.

Cardinal CITIES: For working Ohio's ten largest cities; Cleveland, Cincinnati, Columbus, Toledo, Akron, Youngstown, Canton, Parma, Dayton, and Springfield. Lakewood may be substituted for Parma for contacts before 1960. DX stations need contact only eight cities and may substitute Cleveland Heights, Lorain, Lima, Euclid, Warren or Hamilton for any of the larger cities.

There are no starting date or band or mode restrictions for any of the Cardinal awards.

Certificate hunters and all Ohio hams can thank CHC'er Jack, W8AJW, for ram-rodging the Cardinal series of awards into being and which will do much to put the Buckeye/Cardinal state more in hamdom's limelight. W8AJW is one of hamdom's world leaders having just recently won (August) the CHC-200 TOP HONORS Award together with the Arne Trossman Top Honors Plaque for being fourth ham in the world to possess over 200 amateur achievement awards. First to get this honor was another Ohioan, Jim, W8JIN, the story of which was featured in May 1961 *CQ*. Californian, Lloyd, W6KG was second to win the CHC-200 TOP HONORS award followed closely by New Yorker, Howy, W2QHH for

third honors. Fifth such honors following W8AJW went to world renowned DX'er Karl, UR2BU.

Worked All Missouri County Award

The "Show Me" state of Missouri has joined the long procession of states with worked all-county awards. The "Worked All Missouri" award, WAM, is sponsored by The Southwest Missouri Amateur Radio Club, Inc., for contacting at least 35 of Missouri's 115 counties without any restrictions.

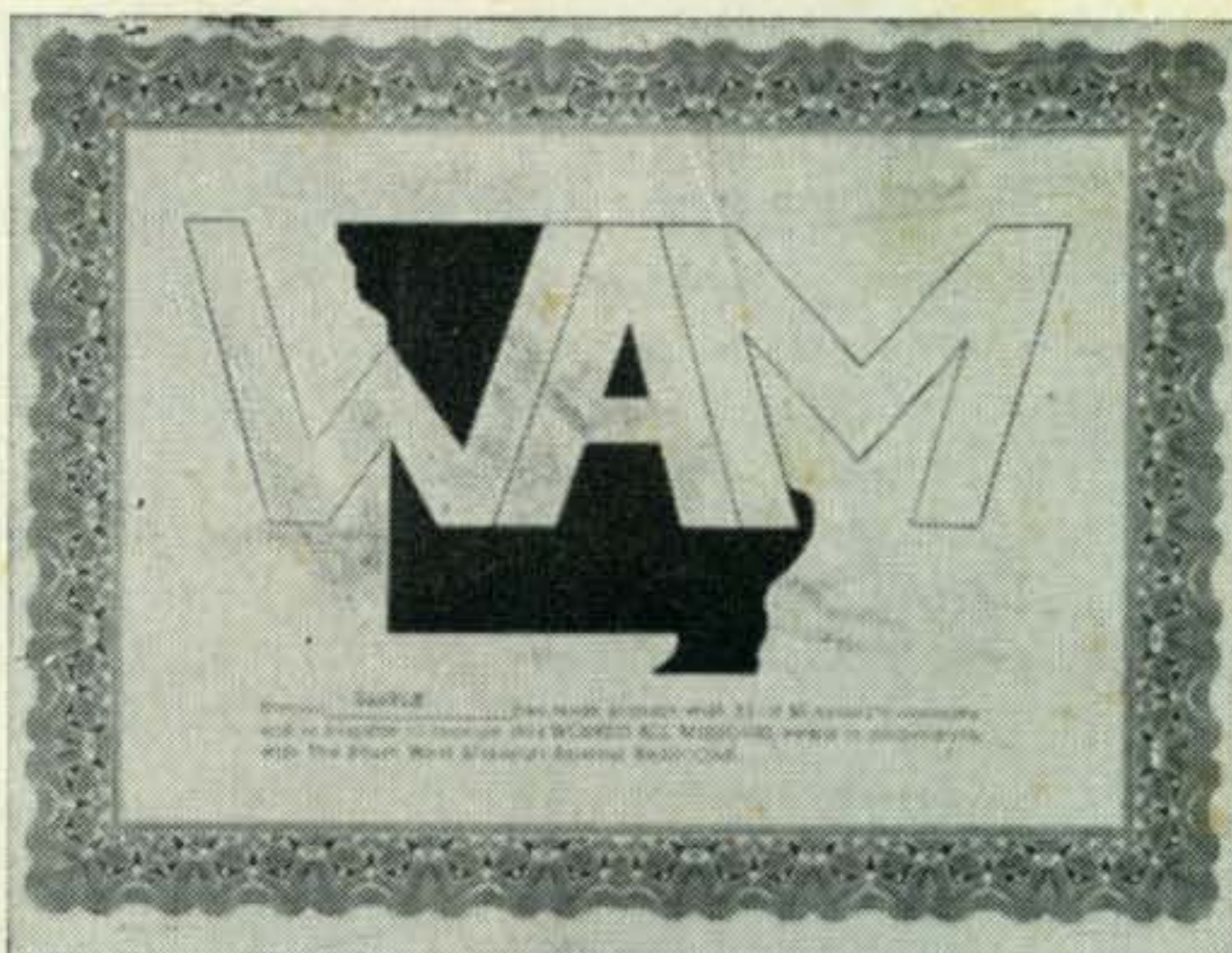

To get the WAM, send list, certified by two radio club officers that cards were sighted, along with 25¢ for W/K/VE stations and 4 IRCs for others, to WAM Custodian, KØJPJ, 560 S. Warren, Springfield, Missouri.

Ohio's Buckeye County Award

The live-wire Ohio Valley Amateur Radio Association, O.V.A.R.A., has come up with a second or I should say the *eighth* Ohio award to feature working of Ohio's Buckeye counties. O.V.A.R.A. now sponsors the Ohio Buckeye County Award for confirmed county contacts without date, band or mode restrictions as follows: U.S. and Canada stations work 44 Ohio counties and DX stations work only 22.

To get the Buckeye county award, send list, certified by two other licensed hams or radio club officer stating cards were sighted, along with 30¢ or 3 IRCs to Buckeye Custodian, K8VDV, 1317 Grace Avenue, Cincinnati 8, Ohio.

The Buckeye county award is in addition to the Cardinal award previously described and also different to the "Worked All Ohio Counties" award sponsored by the Ohio Council of Amateur Radio Clubs for contacting all 88 of Ohio's counties. The Buckeye award was the brainchild of W8VDV.

In order to give others opportunity to contact Ohioans, O.V.A.R.A., beginning December 22, 1961 and continuing through January 1, 1962, will hold an Ohio QSO party. O.V.A.R.A. members will operate 30 kcs above the low edge of all bands on c.w., 10 through 160 meters, and will call CQ/OVA and sign their

[continued on page 160]



Novice

AMPLIFIERS are named or classified in several ways. According to the results they achieve, there are two basic types—voltage amplifiers and power amplifiers. According to the conditions under which they operate, amplifiers (especially power amplifiers) are classified as Class A, Class B and Class C amplifiers. The class at which an amplifier operates depends on the amount of bias voltage applied to the grid of the tube and the portion of a.c. signal voltage cycle during which plate current flows. Depending upon the frequency range over which they operate, amplifiers may be further classified as direct current, audio frequency, intermediate frequency, radio frequency and video amplifiers.

Voltage Amplifiers

Voltage amplifiers are primarily intended for amplifying voltage. They are designed to develop the greatest amplified voltage possible across the load in the plate circuit of the amplifier. To accomplish this objective, it is necessary that the load resistance be as high as possible so that it will offer a large opposition to the plate-current change. This results in a large voltage being developed in the output circuit.

Power Amplifiers

Power amplifiers are designed to deliver large amounts of power to the load in the plate circuit without regard to voltage. Since power equals voltage times current, a power amplifier must have a large voltage across the load in addition to a relatively large current flow. In power amplifiers, the impedance (resistance to alternating current) of the load is smaller than that in voltage amplifiers.

Class A Amplifiers

An amplifier is considered as Class A when the grid bias and alternating grid voltages have such value that plate current flows continuously throughout the cycle of applied voltage and never reaches zero. Class A amplifiers are biased to about half of cutoff value. The basic amplifier shown in fig. 1 is a Class A amplifier.

Class A amplifiers are characterized by low efficiency and an output having a large ratio of power amplification. By efficiency it is meant the ratio of the power output to d.c. power

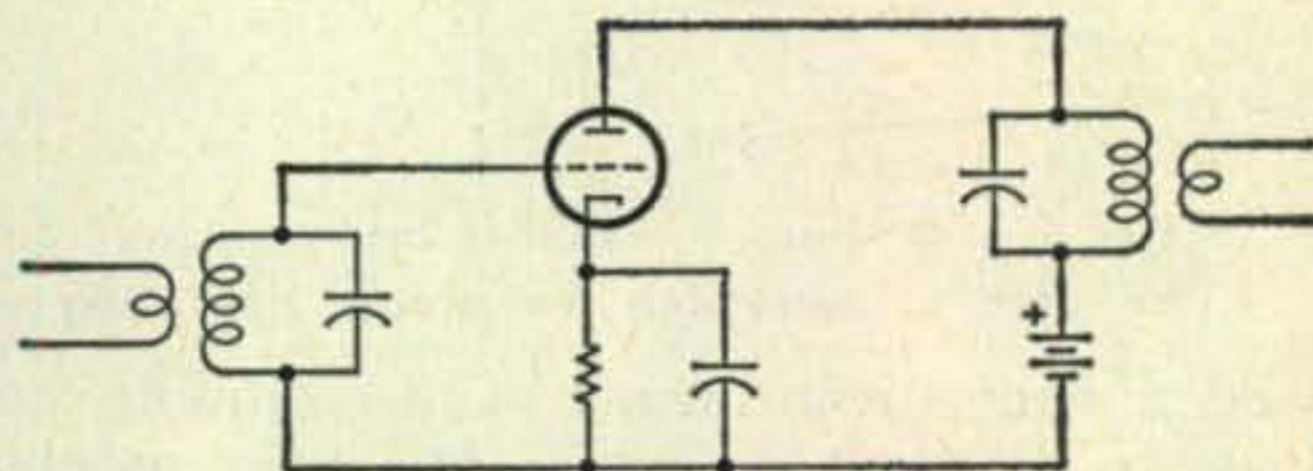

Fig. 1 — A typical Class A r.f. amplifier circuit.

input. For practical purposes the efficiency of a Class A amplifier ranges between 20 and 25%. Theoretically, it has a maximum efficiency of about 50%. Class A amplifiers are used as audio and radio frequency amplifiers in radio, television and sound systems.

Class B Amplifiers

Class B amplifiers are biased to approximately cutoff. Plate current therefore flows only during the positive half-cycle of the applied grid signal voltage. The efficiency is higher and the current consumption is less in a Class B amplifier than in one operating Class A. Power loss in Class B amplifiers is low for two reasons. First, plate current does not flow when there is no signal applied to the grid and thus there can be only very little power wasted during the non-operating periods. Secondly, plate current flows only during the positive half of the input cycle. This means that the average current flow will be only 32% of the peak current in the stage.

The illustration fig. 2A shows the relation between the grid voltage and plate current in a tube operated Class B. Note that plate current flows only during the positive half of the signal voltage. Grid current flows only during the time when the grid is driven positive.

Class B amplifiers are used mostly as power amplifiers. As power amplifiers, their power output is proportional to the square of the grid excitation voltage. The best bias for Class B operation is that which corresponds roughly to the cutoff bias that would be obtained if the main part of the characteristic curves shown in fig. 2B were projected as straight lines. Notice the dotted straight line extended from the straight line part of the characteristic curve labeled $E_b = 300$. The point at which this line strikes the grid voltage line, approximately -75 volts, gives the cut-off bias for 300 volts plate operation. Curves of this type pro-

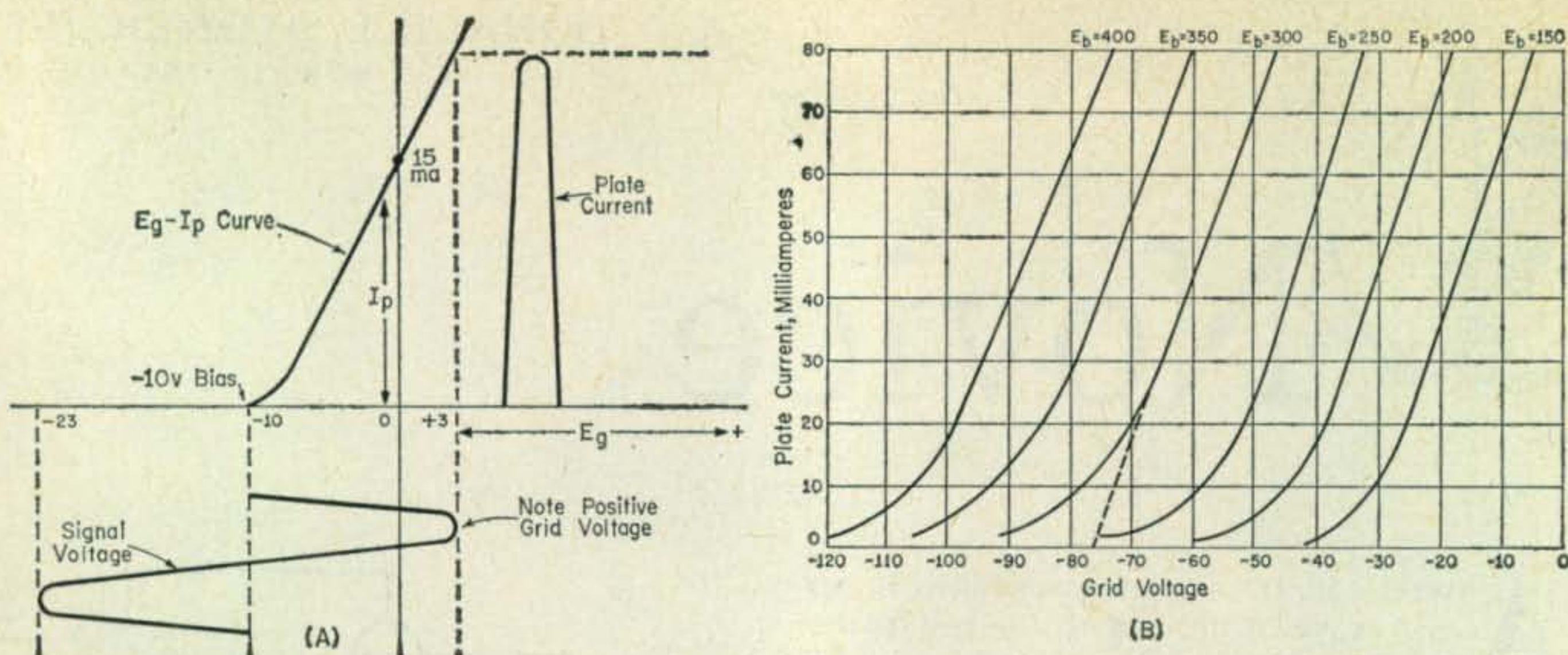

Fig. 2 — A Class B amplifier operates over only one half of the applied cycle. The E_g-I_p curve can be used to determine the proper operating point for the Class B stage as explained in the text.

vide a convenient means of determining grid bias for Class B operation for different plate voltage conditions.

Distortion occurs in Class B amplifiers under much the same general conditions as in Class A amplifiers. Frequency and phase-shift distortion are essentially alike in both. Amplitude distortion in the output of a Class B amplifier operating with the proper load resistance depends upon the departure of the characteristic curve from straight lines and upon the operating point. Refer to the Class B amplification curve shown in fig. 2A. Obviously, the half cycle output is far from the distortionless reproduction of the full cycle input. One-half of the cycle is missing. This missing half cycle can be replaced by one of two methods: by adding an additional Class B amplifier to work on the other half cycle or by the "flywheel action" of a resonant circuit. Distortion of the positive peaks of grid voltage may occur due to flow of grid current if the grid becomes positive.

The use of two tubes to supply both halves of the input cycle in the output constitutes a push-pull Class B amplifier. One tube operates during the first half cycle of the a.c. signal voltage and the other tube during the second half cycle, as shown in fig. 3. Since plate current flows during one half cycle in one tube and during the next half cycle in the other, the plate current wave-forms can be combined in the

load circuit. The load circuit of the push-pull amplifier is the center-tapped primary of the output transformer. During one half cycle, one tube generates a voltage across the transformer winding. During the next half cycle, the other tube generates a voltage of the opposite polarity across the winding. Since the plate currents of the two tubes flow in opposite directions through their respective halves of the transformer primary winding, the voltages across the primary windings of each tube combine in the secondary to produce a reasonably undistorted replica of the input a.c. signal voltage.

A single tube, Class B amplifier can be used successfully in r.f. amplifier stages having a parallel-tuned circuit as the plate load. A typical circuit is shown in fig. 4. The parallel tuned circuit is sometimes called a *tank circuit*, because it has the ability to store power. When it is used as the plate load of a single ended, Class B amplified stage, the capacitor in the parallel tuned circuit is charged by the output voltage produced by the flow of plate current through the load on the positive half cycles. Although no current flows through the tube on the negative half cycle of the applied signal voltage, the capacitor discharges into the inductor during this period and thus supplies the missing half cycle of output voltage. This so-called flywheel effect of the tank circuit occurs only when the resonant frequency of the

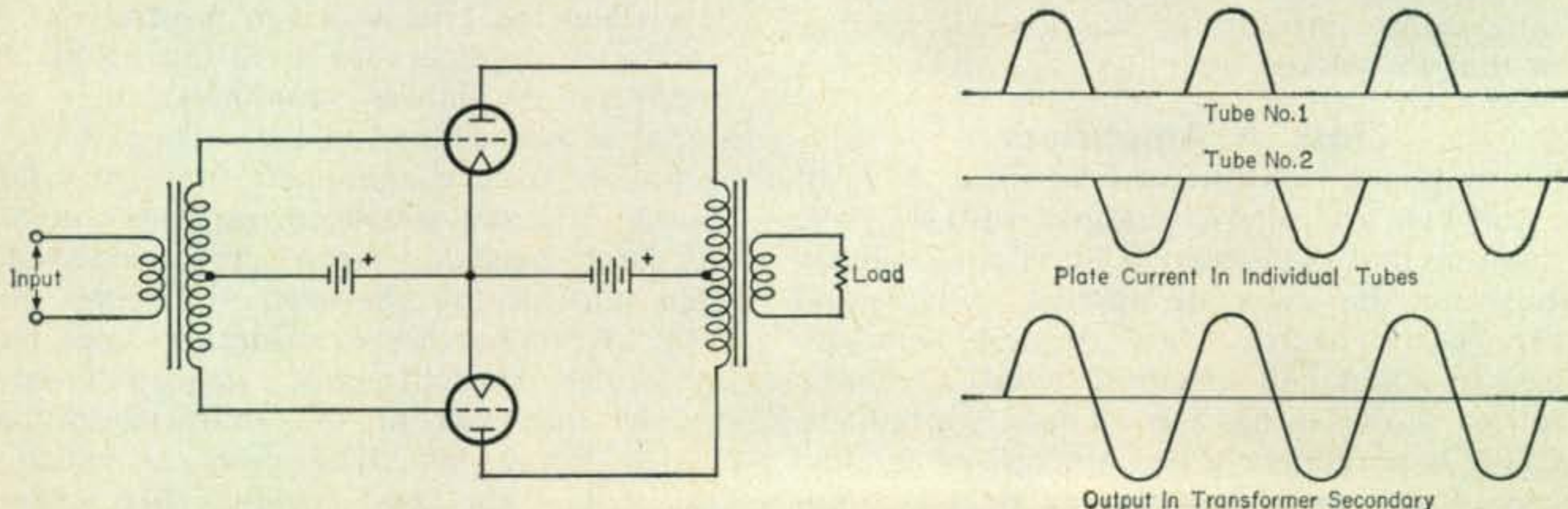

Fig. 3 — It is more common to find two tubes in a Class B r.f. circuit and mandatory in audio applications. In this circuit each tube amplifies alternate half cycles.

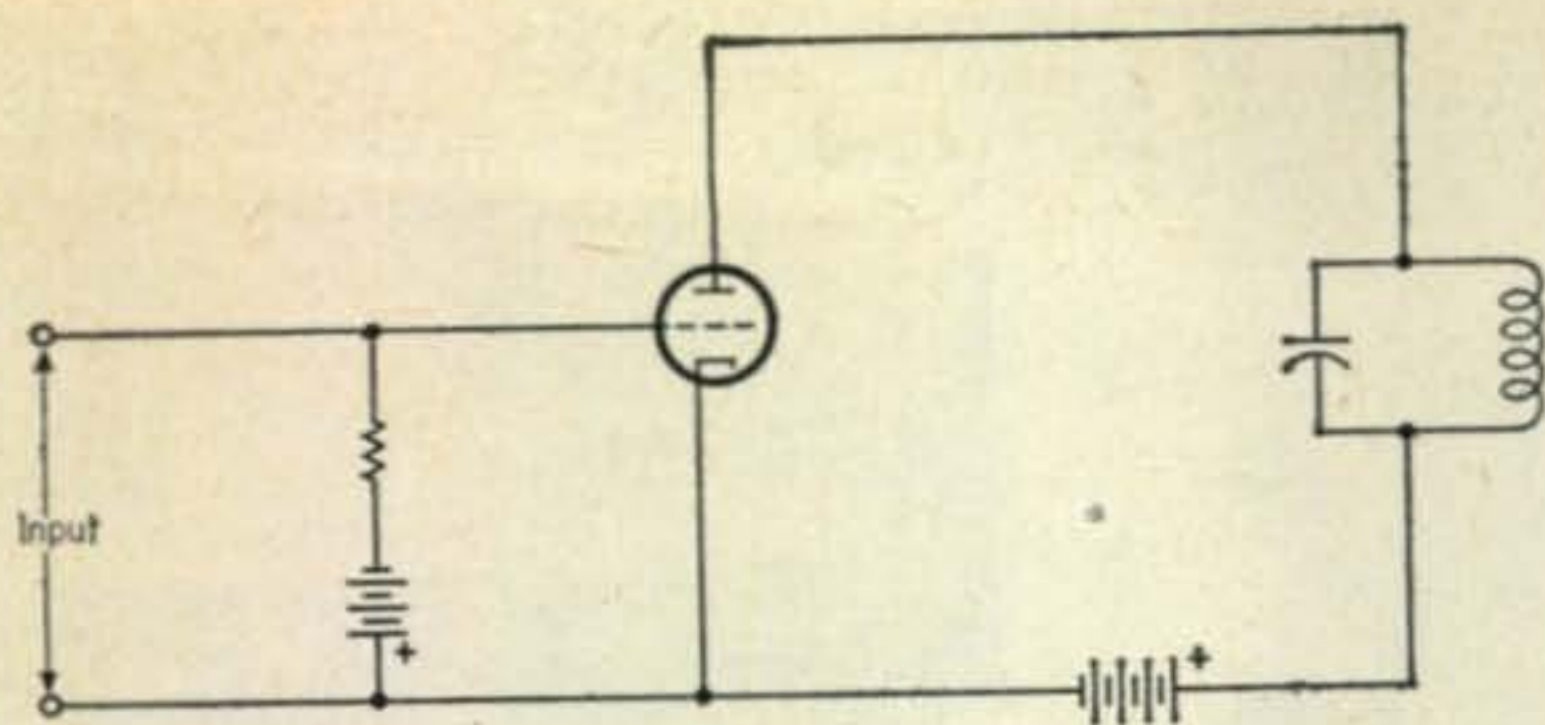
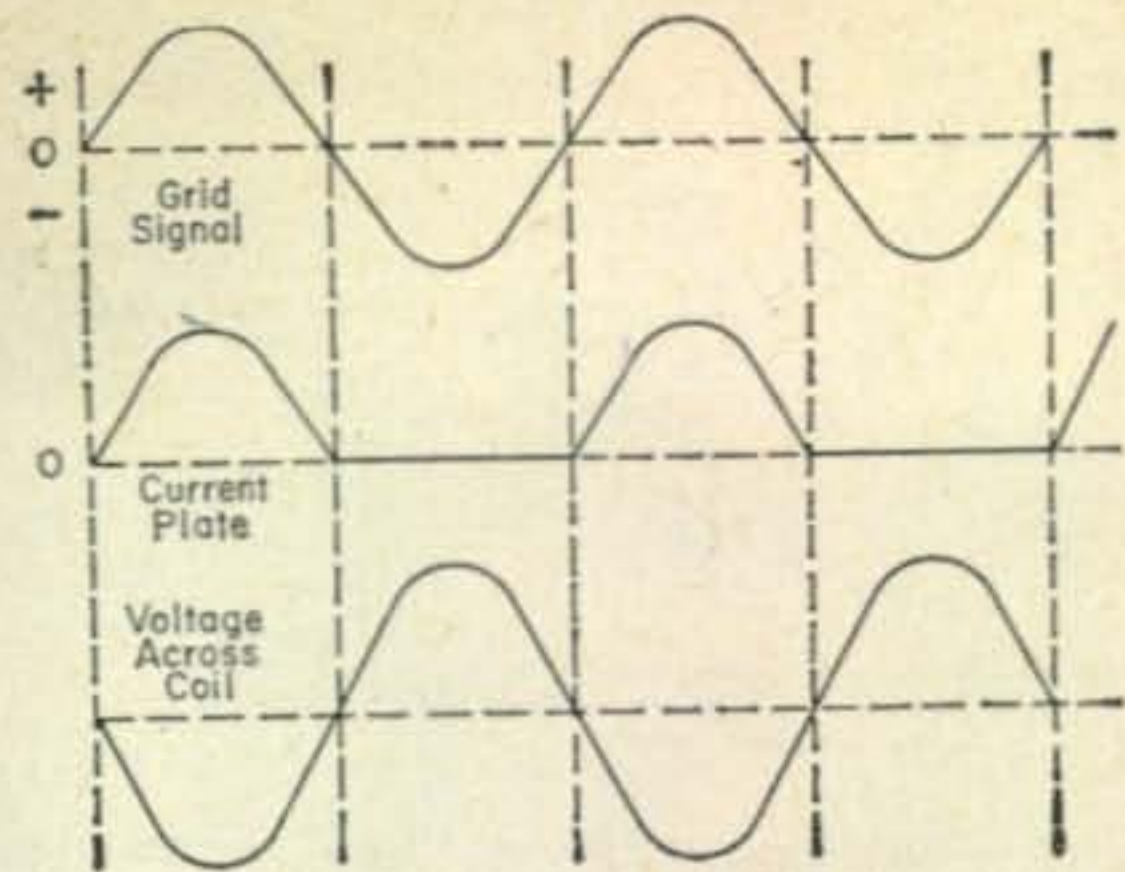

Fig. 4 — A single ended Class B circuit is useful in transmitters. The fly-wheel action of the tank circuit can be used to fill in the period between half cycles.



parallel tuned circuit is equal to the frequency of the applied signal voltage.

The maximum efficiency possible with Class B power amplifiers is theoretically 78.5%. In most practical applications, however, the efficiency attained is about 60 or 65%. Class B amplifiers are principally used in transmitters for either r-f amplification or for audio modulation.

Class C Amplifiers

A Class C amplifier is one in which the bias is appreciably greater than the cutoff value. When no alternating voltage is applied to the grid the plate current is zero. When an alternating voltage is applied to the grid, plate current flows for appreciably less than one half cycle, as shown in fig. 5.

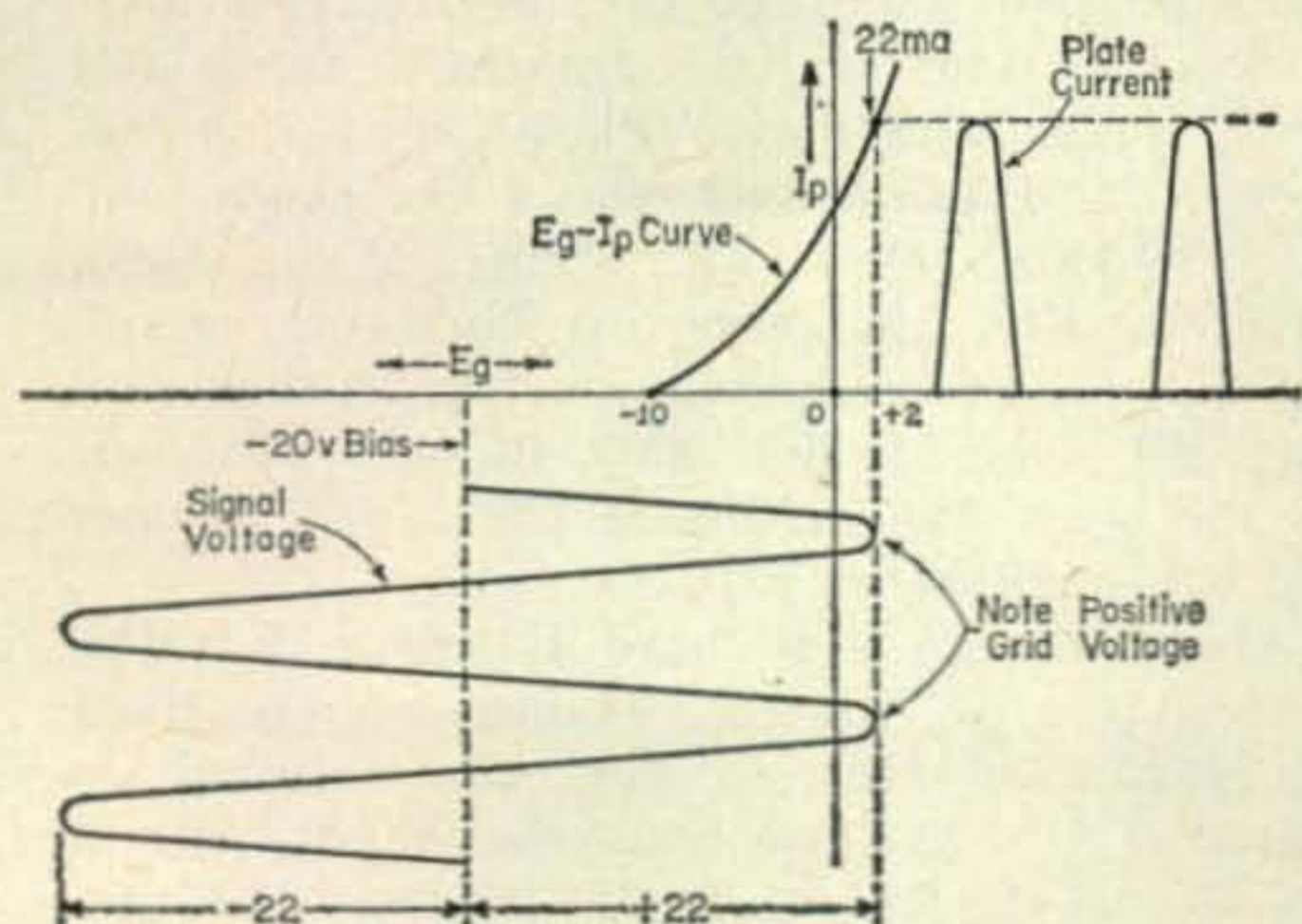

Fig. 5 — In Class C, the grid is biased beyond cut-off and the tips of the r.f. positive half cycles kick the tube into conduction.

Except for grid bias, Class C amplifiers operate in much the same way as Class B amplifiers. Since current flows for a small part of a cycle, the distortion in Class C amplifier is very great. A Class C amplifier is also characterized by the fact that it develops its output at a relatively low ratio of power amplification. Still another characteristic is that its grid usually swings sufficiently positive to allow saturation current to flow through the tube. As a result the plate output waves are not free from harmonics and suitable means must be provided to remove them from the output.

One means of doing this is demonstrated by the illustration fig. 6. The tuned tank circuit shown offers an impedance to the operating frequency that is quite high, but to the harmonic frequencies, it presents a low impedance, causing them to be attenuated due to low amplification by the tube. Due to the high impedance offered to the signal frequency, it is thus amplified to a much greater extent than are the harmonic frequencies.

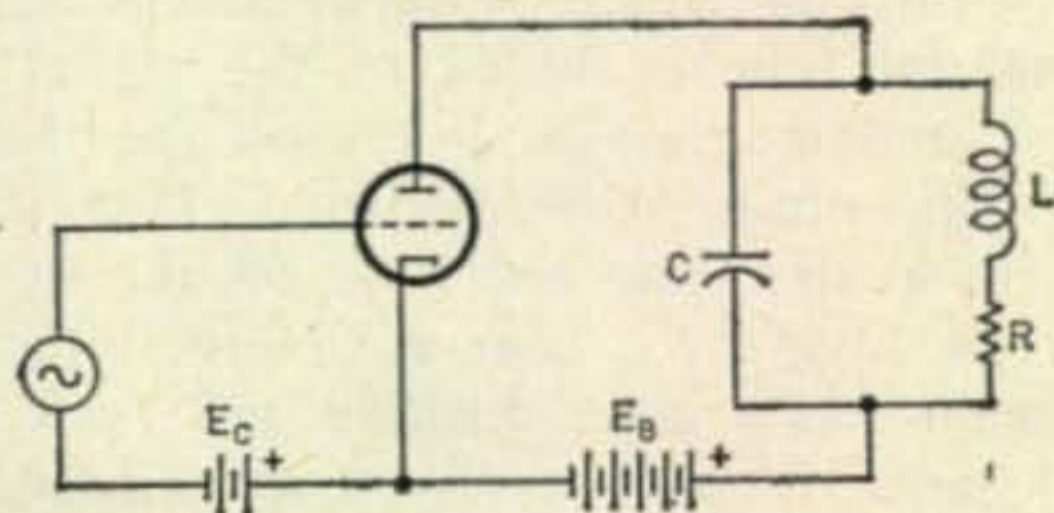

Fig. 6 — A selective tuned circuit can be used to remove the harmonic frequencies in the load.

The high efficiency of the Class C amplifier is due to the fact that when plate current is permitted to flow, the instantaneous potential of the plate is low compared to the plate supply voltage. In this way energy is supplied to the plate circuit only when most of the plate supply voltage is used up as a voltage drop across the tuned circuit. Therefore, most of the energy is delivered to the tuned circuit instead of being wasted at the plate. Principally because of this fact, the efficiency of the Class C amplifier is in the neighborhood of 60% to 80%.

Class C amplifiers are used as r.f. amplifiers in transmitters. They are very useful in high frequency equipment where it is necessary to deliver appreciable power.

Harmonics

The maximum amount of useful power available from a single power tube is limited by the amplitude distortion due to the introduction of undesired harmonic frequencies in the amplifier circuit. A harmonic frequency is a multiple of any given fundamental frequency. For example, the second harmonic of 1000 cycles is 2000 cycles, the third harmonic is 3000 cycles and so on. Second and higher harmonics are generated by a vacuum tube when its grid voltage, plate current changes are non-linear.

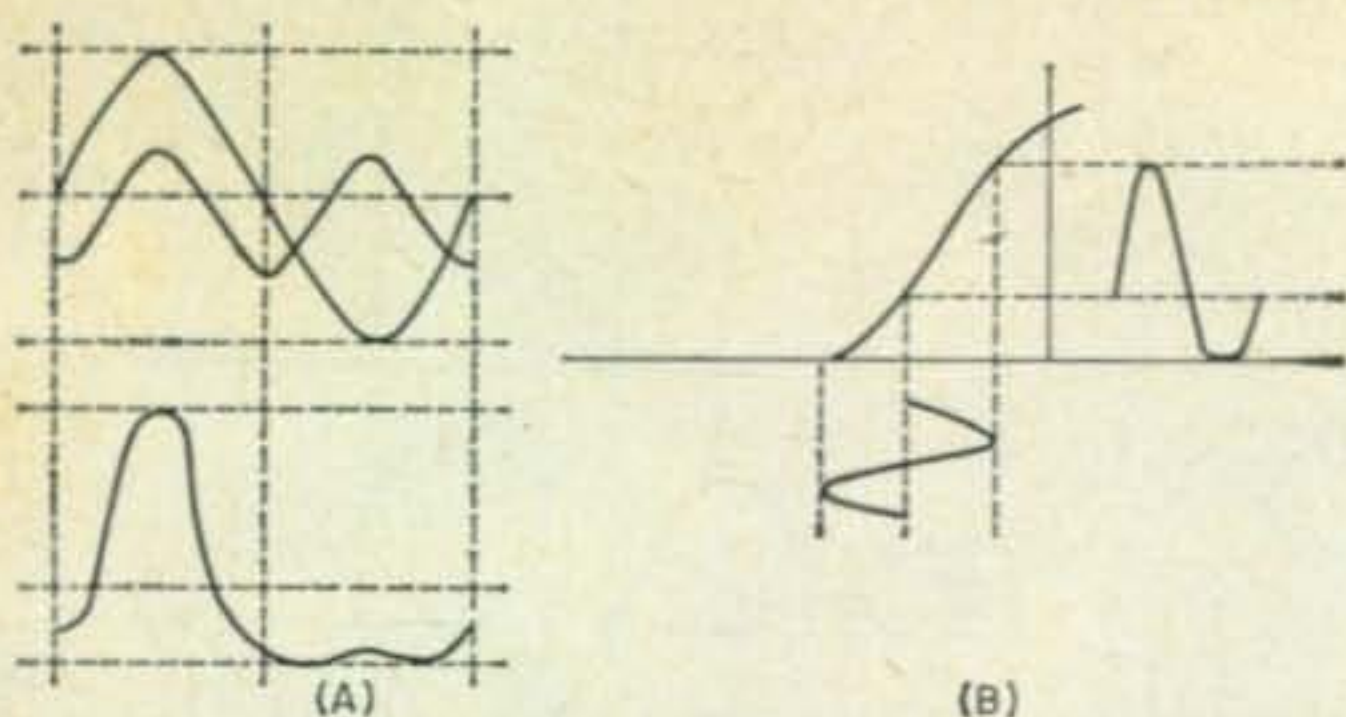

Fig. 7 — An illustration of how second harmonic distortion is produced by clipping and how it affects the wave-form.

The illustration in fig. 7 will help you in understanding the action of harmonics in vacuum tubes. Consider the top diagram (A) first. It shows two frequencies, a sine wave and its second harmonic. Just below the two frequencies is the waveshape produced by adding the two graphically. Notice that the sum is a distorted waveshape of the sine wave in which there is a large positive half cycle and a small negative cycle. The bottom diagram (B) shows similar results in which a harmonic generated in a vacuum tube is added to the signal frequency (fundamental) and causes the amplitude of the output to be distorted. This action results from operating the tube on the curved portion of the E_g-I_p curve. Here too, the output wave has a large positive half cycle and a small negative half cycle, a condition evidencing distortion. The output waveshape contains both the original fundamental signal waveshape and the harmonic which was generated in the tube and added to the fundamental by tube action.

Elimination of the even numbered harmonics (second, fourth and so on) is possible when a push-pull circuit arrangement is employed. Only the odd harmonics (particularly the third) will be left to limit the power output. However, the effect of the odd harmonics is minimized by connecting to each tube a load resistance which is more nearly equal to the dynamic plate resistance of the tube. The result of this is that the amount of undistorted power will approach the maximum amount of power obtainable, that is, the power if there were no distortion. Actually, two tubes connected in push-pull will give considerably more than twice the undistorted power which a single tube can deliver.

Help Wanted

- W1 — Thomas Cluope, 5 Stevens St., Lowell, Mass. phone GL-33350
 W4 — Bob Savoy, 1201 West Ave., Apt. 8, Miami Beach 39, Fla. phone JE 8-5231
 VE7 — Richard Matthew, 2972 West 2nd Ave., Vancouver 8, B.C. Canada

Letters

Most readers, like myself, don't remember the "good ole days" of ham radio. Howard V. B. Voorhis, 60 Remsen St., Apt. 9C, Brooklyn 1, N. Y., sent in a photograph, which

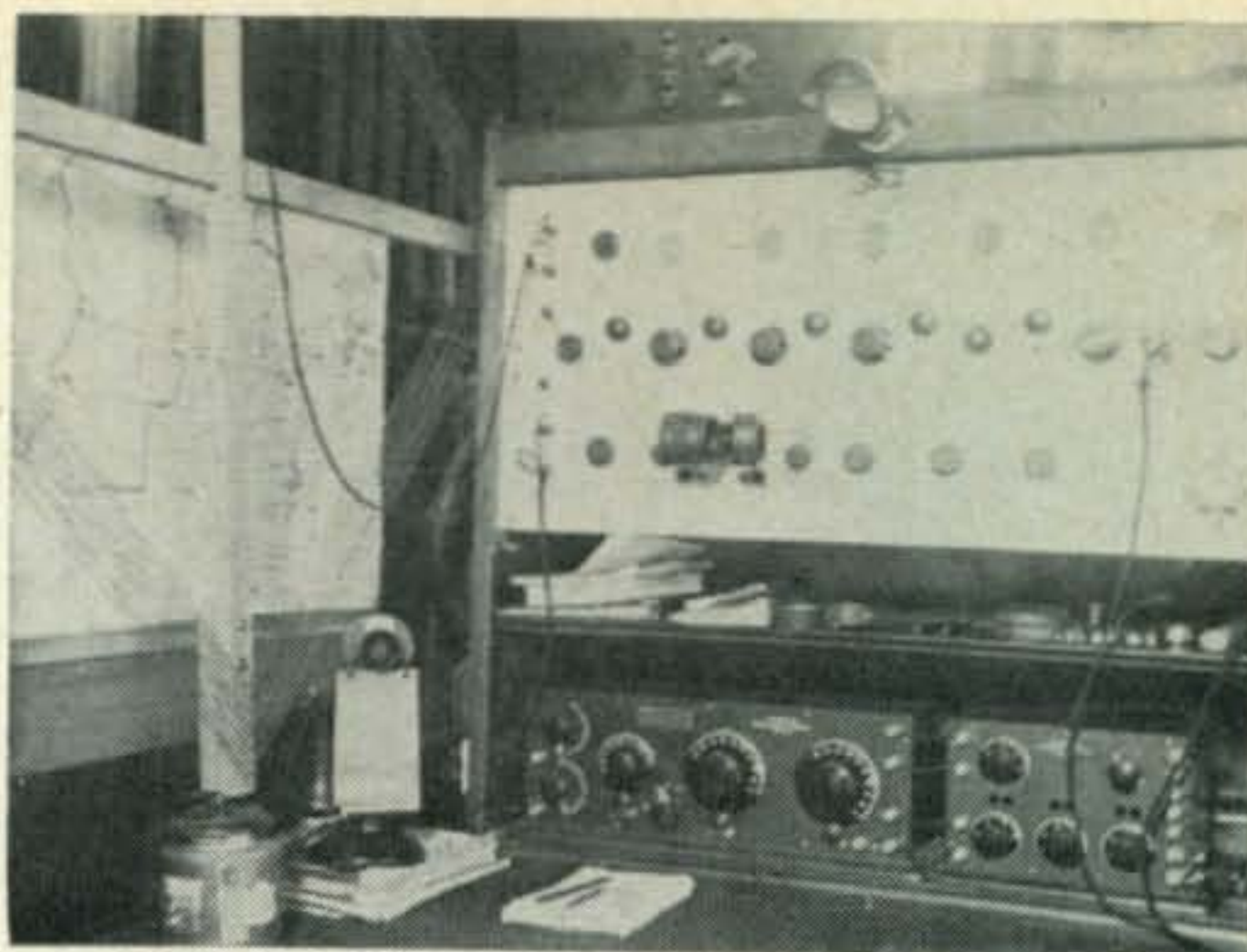

1923 Receiving station of Howard Voorhis.

is reproduced hereabouts, showing his receiving station located at Red Bank, N. J., in 1923, 38 years ago. Harold held the call letters NDM in 1908 and operated on the 121 meter band with a 1½ inch spark transmitter.

Fred Schwab, KN9HXX, 711 Fifth Ave., Sterling, Ill., is 13 and gasses 'em on 80 and 40 with a DX-40, NC-188 and dipoles for each band. Fred also extends his operation to two meters with a Health Twoer. In seven weeks Fred has snagged 75 contacts for a WAS of 11/6. Be looking for him on 3707, 3743, 7166, 7175, 21.207 mc and two meters. P.S. — Fred, sweep modulation was for April Fools-HI.

Wayne Cline, K4NNQ, 1116 Clydesdale, Anniston, Ala., shucked the "N" recently after working 41 states with 35 confirmed, along with HK3, VE's, VP9 and WP4 on only one frequency 7180 kc. Wayne would like skeds with Ida., S. Dak., Del., Vt., Maine, Wyo., Nev., KH6 and KL7. and hopes to work the remaining states with his homebrew rockcrusher running 60 watts input and BC-453 receiver. By the way, Wayne has a C.P. for 20 wpm and is a member of RCC.

Also "N-less" is Richard Eastman, K1OJN, 8 Mechanic St., Dexter, Maine, who received his Novice on May 6, 1961 and General on March 3, 1962. Dick hops the bands with a DX-40, VF-1, Knight R-100 receiver but prefers ragchewing on 80 to chasing the elusive DX. He is 16 and will be starting his Junior

[continued on page 169]

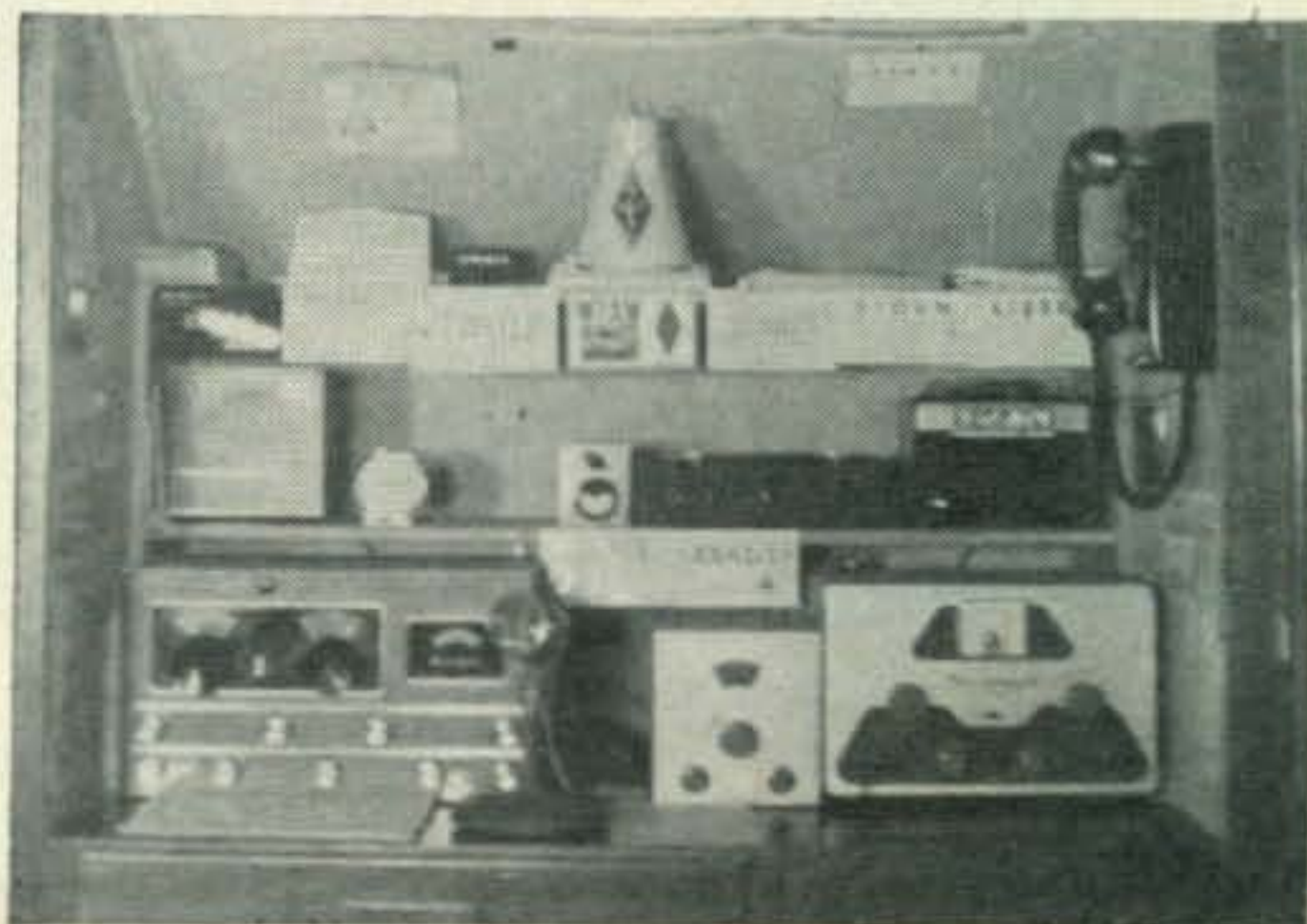

K1OJN QSO's from this neat setup.

bias circuit, just starting to draw grid current. Next, connect up a dummy load (preferably a dummy antenna) to the final tank. Switch on plate voltage or switch the screen voltage via S_2 and S_3 back. The PA tube should now load in normal fashion. Then modulate the rig. As you modulate, you will note that the PA tube grid and plate current will fluctuate *down*, but the plate and grid currents of the PM tube will fluctuate *up*. You will note that the PM tube plate current will hit as high as 100ma (or a little over). To obtain the true peak current indicated, merely multiply the average indicated reading by 2. Now connect the regular antenna and load up to about the same load settings obtained with the dummy antenna. Coupling to the output tank must be tight, even to the point where minimum dip at resonance is hard to determine. The setting of C_{67} governs the antenna loading.

Although Fred does not show a milliammeter in the plate of the PA tube, I have put in one. If only the PM meter is desired (shown in series with pin 10 of the power socket), you may eliminate the PA tube meter, the $2\frac{1}{2}$ mh choke and the .002 mf coupling capacitor C_c . The parasitic choke PC_1 then goes directly to the plate. The existing meter then reads current for both tubes when screen voltage is applied to both. Using S_2 or S_3 , screen voltage can be removed, thus removing the plate current from either the PM or PA tube. I am inclined to think this is what he had in mind. However, for tuning up (to "hit it on the nose") I recommend using two meters, and if possible, an oscilloscope.

Remember to keep the r.f. grid drive to the PA tube at $\frac{1}{2}$ the normal drive (5 ma is normal for the 1625), and the r.f. drive to the PM tube near zero. The PM tube does the hard work while the PA tube loaf.

Tuning With A Scope

The oscilloscope vertical plates are connected to the tank via coaxial cable and a three turn link, directly connected to the plates (not through the scope vertical amplifier) will give the patterns shown in fig. 2. A panoramic pre-

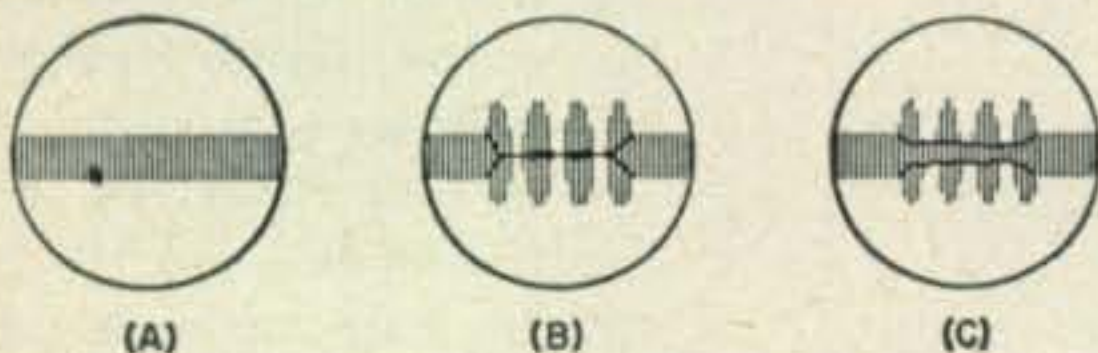

Fig. 2—Oscilloscope displays for Taylor Modulation. A—Unmodulated carrier. B—Overmodulation with some peak clipping. C—Less than 100% modulation.

sentation of the TM signal will look like the patterns in fig. 3. For comparison, fig. 3 also shows how an equal powered plate modulated a.m. signal will look.

Some important points to keep in mind regarding Taylor Modulation transmission and reception are: tell your contact to turn off his fast acting a.v.c., to use full audio gain and control a.f. output with the receiver r.f. gain

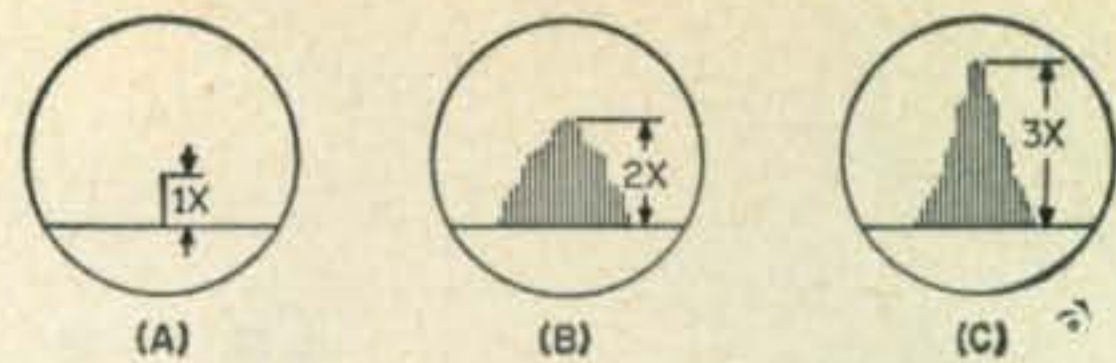

Fig. 3—Panoramic adaptor displays comparing the output of standard a.m. to Taylor Modulation. A—Unmodulated carrier. B—100% amplitude modulation. C—100% Taylor Modulation.

control. "S" meters will not indicate properly on TM signals, or at least cannot be depended upon to give a true signal strength picture. Remember that the modulating power is *not* audio frequency but *radio frequency* which is supplied by the r.f. modulator. There will be little TVI and BCI with the TM system inasmuch as there will be little or no negative peak clipping, no a.f. splatter or shot effect. Nearly complete suppression of heterodynes is possible because of carrier suppression during modulation periods. Tubes used in TM may be operated at full c.w. ratings because no audio frequency voltages are added to the final.

Now a few final words on the 274N conversion. The rig can be used very effectively for mobile operation, all that need be done is to supply the voltages required. The final tank will load fine into a loaded whip.

Coils T_{53} and T_{54} are modified with the aid of a grid dip meter to hit 20 meters. Capacitor C_{65} is also modified for split-stator operation. The tank in the output of the oscillator should double to 20 meters however, there is no reason why it cannot be cut for 40 meters and doubling accomplished in the output of the 6L6.

The power transformer (T) must have two 6.3 v. filament windings (connected as shown), and should be capable of supplying 600-700 volts at around 350 ma. Bias voltages may be supplied with a separate pack, or in case mobile operation is contemplated, with batteries or a small transistorized supply, which is preferred.

I like this little rig and think Fred did a fine job coming up with it. Who can say that this little rig with over four times the true sideband power with full modulation, and about one half the bandwidth of the average plate modulated rig with its bulky and costly modulator isn't worth playing around with? Take s.s.b? Perhaps, but it costs more and does take a good stable receiver. With TM, a product detector is not required. Any good receiver capable of receiving straight a.m. will do. This little rig really does have talk power! I'm sure we'll be hearing more of it.

Observation

Like the Volkswagen, Collins radio equipment is noted for maintaining its re-sale value. Any manufacturers changes or modifications made to Collins gear cannot always be seen with a casual glance; it may take a little digging, but they are there, for Collins only makes

technical changes to its line when these changes afford increased efficiency; they *never* come out with a new model in an attempt to compete with other manufacturers.

When one buys a Collins rig he is getting in addition to electrical and mechanical excellence, stability, operating ease, calibration accuracy and modern appearance. But the one ingredient that makes the Collins buyer a booster is "product integrity."

As everyone knows, a firm that lacks a good reputation soon goes out of business. How a product is designed, manufactured, sold and serviced determines a firm's reputation. Without product integrity, there are few customers.

True today as it was 25 years ago, the radio amateur is a discriminating buyer. Prove to him that he is getting his money's worth and he will buy, but he still wants (and has the right to demand) after-sale thoughtfulness on the part of the seller, or putting it another way, service.

What determines the price of a piece of ham equipment? Why are some manufacturers accused of over-pricing?

The total price of a piece of gear is determined by cost of research and development, engineering design, component cost, assembly (labor), administration, testing and advertising costs as well as many other factors.

So-called over-pricing seldom really exists. However, it is hard to convince some kit buyers of this. The most expensive item for any manufacturer is labor, skilled and otherwise. Mass production of ham gear does result in some price reductions but it depends upon the item.

Recently, a friend, who is a design engineer for a large firm, dissected a piece of gear to determine how much it could actually be made for. Using modern manufacturing techniques and figuring 40% dealer mark-up, he felt that he could produce 5000 of these sets for \$150.00 under the going price, *if* (and it's a big if) he did not have to worry about development costs, which include prototypes, testing, machine tool and jig purchases, assembly line mock-up and worker training! That \$150.00 covered these, plus administration and advertising.

You get what you pay for! What may seem high is not really high at all especially if its

long term depreciation is small.

We hams make our own market. What we get for used gear is up to us. If we keep our equipment clean, do not abuse it and service it (or have it serviced) properly, we can expect more for it when we sell. I still advocate however, trading an item in on new equipment rather than trying to sell it yourself. The reputable dealer will overhaul your equipment and give a better bargain to the guy who buys it. Few hams are equipped to do this.

When you buy, keep reputation in mind.

Questions

Warrior Linear—"I am experiencing a very annoying impulse type noise with my Heath Warrior Linear amplifier. It is noticeably worse on the 40 meter band and fairly makes my receiver 'jump.' Any cure?"

Joe, W1NXY sends in the following info on this. "A slight circuit modification and the addition of a few parts resulted in getting rid of the noise in the Warrior caused by the mercury vapor rectifiers. A couple of .001 mf condensers in parallel were connected from the mercury vapor rectifier heaters to ground. The 8 mf filter lead and the blue lead from the 811s were moved to the bleeder resistor directly and connecting a B&W Miniductor #3104 (4.5 μ h) between the bleeder resistor and the rectifier heater did the job."

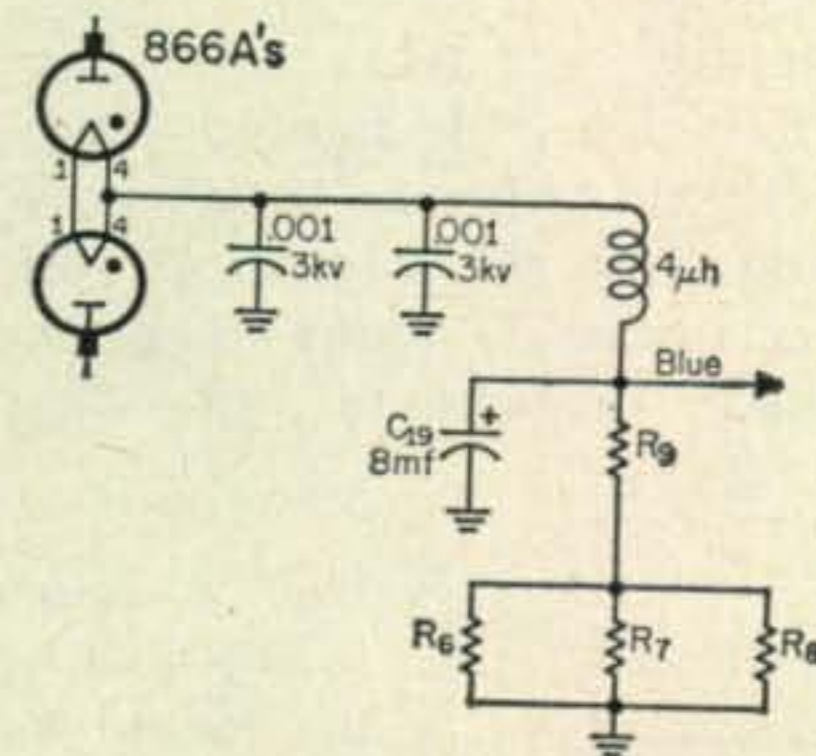

Fig. 4—Circuit for the suppression of mercury vapor rectifier hash in the Heath Warrior amplifier. The 866A filaments should be wired as shown and high voltage taken from pins 4.

Thanks Joe. See fig. 4 for the modifications. Note: Joe suggests rewiring the 866A heaters so that pin 1 is connected to pin 1 and pin 4 to pin 4 and take off the high voltage from

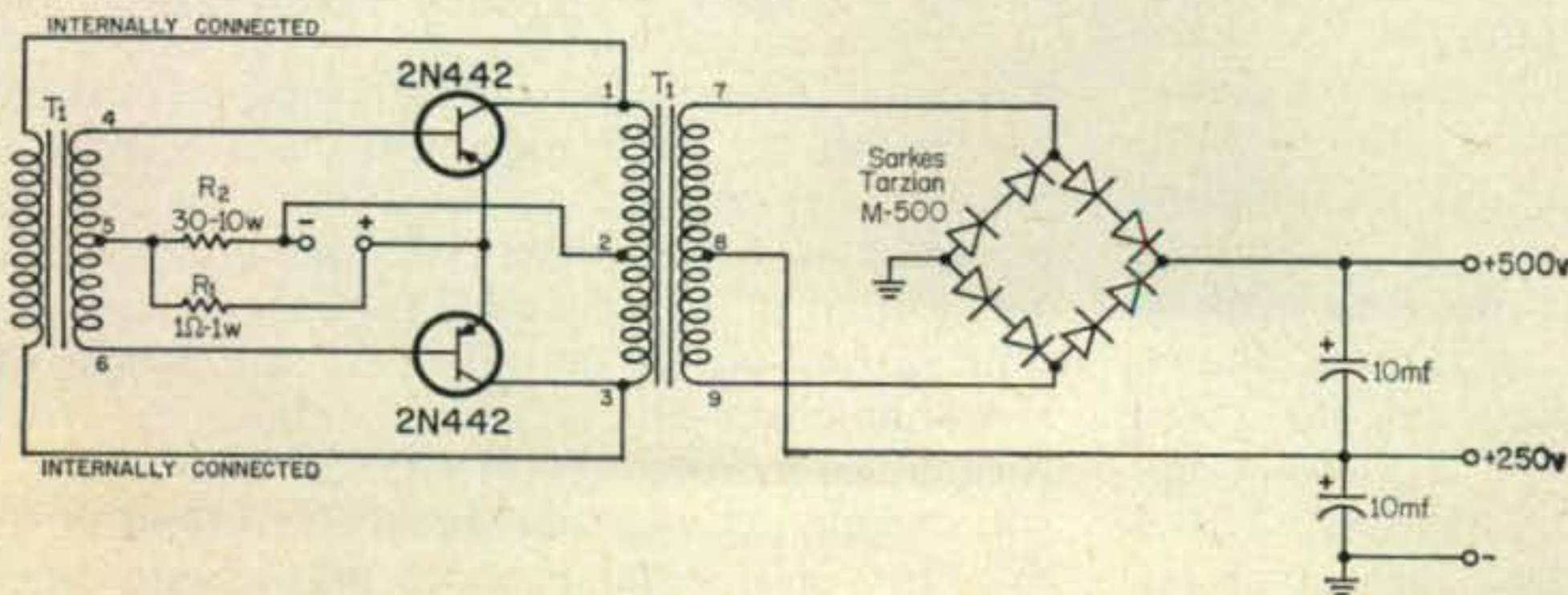

Fig. 5—Circuit for a transistorized d.c. to d.c. converter as suggested by the Microtran Co. Transformer T_1 is the Microtran M8035.

pin 4 as recommended by the tube manufacturer).

D.C. to D.C. Converter—"I need a good transistorized circuit (and the transformer to go with it) to convert 12 volts to 500 volts 250 ma d.c. and 250 volts at 420 ma. Any suggestions?"

Yes, write to Microtran Co. Inc., 145 East Mineola Ave., Valley Stream, N. Y. They have just what you need. In the meantime, if you can obtain a Microtran transformer #M8035, you can use the circuit in fig. 5 (p. 99). With 13.6 volts (generator output in the average car), you can obtain 500 volts in full-wave bridge connection at 250 ma and/or 250 volts at 420 ma in the center tapped full wave connection. R_2 and R_1 may have to be varied a bit if other transistors are chosen.

Better Warrior Bias Filtering—"While checking my Warrior the other day with my scope I noted that there was some ripple in the biasing voltage. My reports on quality etc., continue to be excellent, but I am a little worried. I checked C_{18} , the 100 mf capacitor in the circuit and it seemed to be okay. Is this condition normal for this circuit? What can I do to smooth out the voltage? Being a perfectionist, I'd like to do it. Any good suggestion?"

Yes, thanks to Joe Santangelo (WINXY) again!

"In carefully checking out my Warrior final," writes Joe, "I figured that the bias supply could do with a little more filtering. The existing 100 mf capacitor which has a reactance of about 27 ohms at 60 cycles never gets a chance to become fully charged with

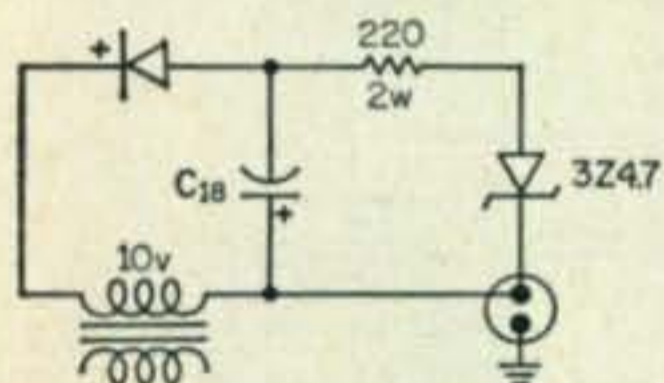

Fig. 6—Improved bias supply filtering circuit for the Heath Warrior.

the 11 ohm resistor across it. Hence a peak ripple of 14 volts appears on the bias supply line. By removing the 11 ohm resistor and installing a zener diode in its place with a current limiting resistor between the bias line and the 100 mf capacitor, the ripple is reduced to less than 0.15 volts peak to peak. This is insignificant compared to the drive signal voltage. The drive signal voltage will vary from about 25 to 120 volts depending on the band and the mode of operation. I used the International Rectifier Corporation's zener diode type 3Z4.7. This diode is capable of handling 3.5 watts dissipation. As I use it, it is dissipating less than 1 watt and no heat sink is necessary. The current limiting resistor shown limits the current through the diode to about 45 milliamperes. Perhaps there is another approach that might be less expensive, but I think I have found the method that gives me

a practical low source impedance to the bias line."

See fig. 6 for the modified circuit. We now consider Joe an expert on the Warrior and honorary technical assistant to HAM CLINIC on the set.

KE-93 Drift—"I have a KE-93 receiver which I have been using successfully on a.m. mobile. However, I am now on s.s.b. and find that the stability on 10, 15 and 20 meters s.s.b. is not good. On the lower (40 and 80 meter) bands I have little trouble. Anything suggested for bettering the stability on the upper bands?"

I too have a KE-93. I stabilized mine by replacing the tube shields with IERC heat-sink shields which lowered inside chassis temperature, and by stabilizing the screen voltages on the h.f. oscillator and b.f.o. It is now as steady as it can be! If this does not help, suggest you look into padding capacitor operation. Anyone have anything else, or a better way to do the job? Info will be appreciated.

Dual V.O.M.-V.T.V.M.—"I enjoyed your thoughts on V.O.M.s and VTVMs in the September issue of CQ very much. How come some enterprising manufacturer does not come out with a dual unit, a VTVM and VOM in one case? It seems to me that such a unit would really be grabbed up by those of us just starting out in ham radio for we would not have to worry about buying two units. Any information on the subject?"

Yes. Take a look at the photograph of Sencore's new dual VOM-VTVM. Although designed with the TV serviceman in mind, it is an ideal unit for the ham shack. It has

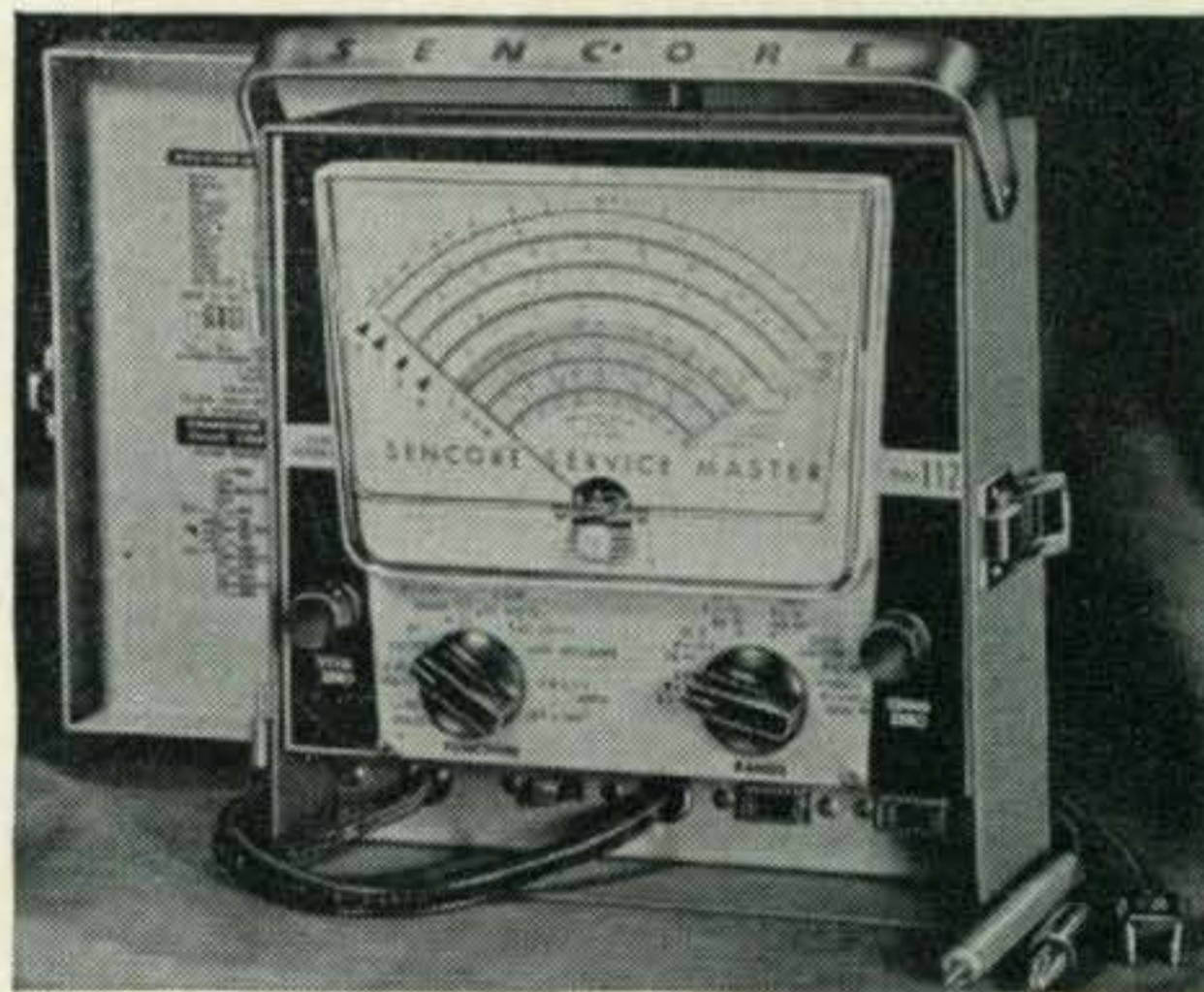

Sencore combination VOM-VTVM.

6 d.c.-a.c. ranges up to 1000 volts, 6 resistance ranges up to 1000 megohms, and 6 peak-to-peak ranges on a.c. up to 2800 volts. Its top accuracy is better than 3% and contains two a.c. outlet plugs for added convenience. The unit is housed in an all-steel case whose removable cover contains information on transformer color coding, resistance chart etc. If you want detailed technical information on this fine unit, write Sencore, 426 South West-

gate Drive, Addison, Illinois. Tell them you want the dope on their Model SM-112 Combination VOM-VTVM.

G-76 Info—Earlier production models of the G-76 transceiver which have the 12AQ5 clamper tube, developed a switching transient in the modulator section which in turn created a heavy pulse arc in the function switch or neutralizing capacitor. This transient can be eliminated by replacing C_{40} (.25 mf @600 v) with a 50 mf 25 to 50 v.d.c. capacitor.

Solderless Splice—“Any idea of how to tie two pieces of copper wire together for a real good connection without using solder?”

Yes. See fig. 7. This scheme used by many fishermen also works very successfully with

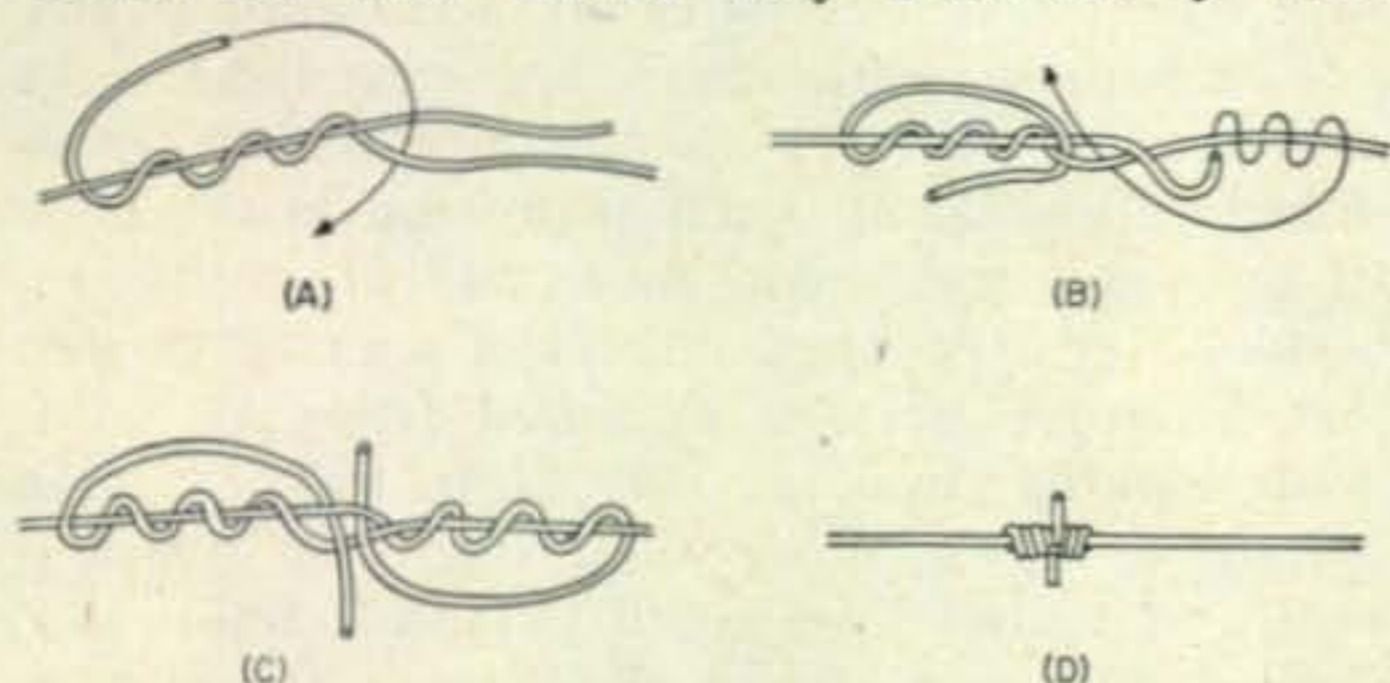

Fig. 7—Simple method of splicing wires securely without soldering; a handy item for Field Day operations. Both ends of wire are pulled tight with pliers for a good connection.

wire. If used with antenna wire however, it is a good idea to sweat solder the connection.

Capacity Alarms Etc.—We have received a number of letters (from non-hams) requesting information on items not even remotely connected with ham radio. These items were capacity alarm systems, special hi-fi circuitry, electronic counters, metal locators, etc. In most cases we have referred readers to existing publications containing information on the items requested. HAM CLINIC is solely for the purpose of assisting fellow hams with their ham radio technical problems. It does no commercial consulting; is impartial in its activities and accepts no fee or other remuneration from hams it helps. When writing HAM CLINIC be sure to enclose a self-addressed stamped envelope. Because your conductor must use his spare time to answer correspondence, do research and testing in his own private lab and prepare the column (with help from his able XYL), please allow at least three weeks for a reply. Whenever we can, we try to answer correspondence within 48 hours after receipt, but correspondence during the last four months has been so great that we had to extend our answering deadline. So be patient and bear with us. Perhaps if we are not snowed under we can arrange our schedule so that we can reply within a week.

Q Multiplier Hum—“I own a receiver which uses a 12AX7 as a Q multiplier tube and first

audio amplifier. I have checked this tube on a good tube checker and it is okay. I've also checked (what I could) most of the parts in the Q circuit, but I still cannot determine what is causing the hum. Any tips?”

Yes, take that 12AX7 out and replace it with another. Bet it has excessive heater to cathode leakage, something even a good tube tester won't always find.

Running Paint—“How do you keep paint from running? I use an enamel paint spray can.”

When using pressurized cans, paint running is due to spraying too close on a vertical surface. For a good even coat of paint, spray one side of a cabinet at a time on the horizontal (side top-up), and do not spray closer than about 9 inches.

Rotor Noise—“I use a prop-pitch motor to turn my beam but cannot 'zero' on a signal with the receiver. . . too much noise. I've tried filters of various types including a brute force to no avail. What can be done?”

You didn't say if the noise was heard on all bands. However, I am inclined to think that it is more bothersome on 10, 15 and 20. Suggest you use a tuned parallel (series connected) filter in series with the line at the rotor; one for each band. The filter I suggest is the same

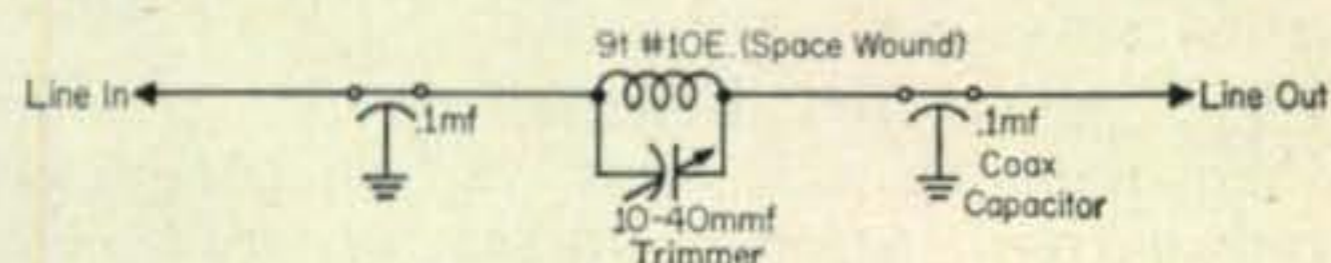

Fig. 8—Parallel resonant trap for eliminating rotator noise radiation on 10 meters. Other similar units may be necessary for 20 and 15 meters.

type used to reduce or eliminate auto generator whine and hash. See fig. 8 for an effective filter for 10 meters. Using a coaxial type condenser (case well grounded) in each leg of the line may be all that you need.

Simplest BC Set—“I need the circuit for a very simple BC set using only one transistor. I'd like to feed it into the phono input of a second receiver. Can you help? This will be used for CONELRAD.”

Sure. See fig. 9. Nothing could be simpler.

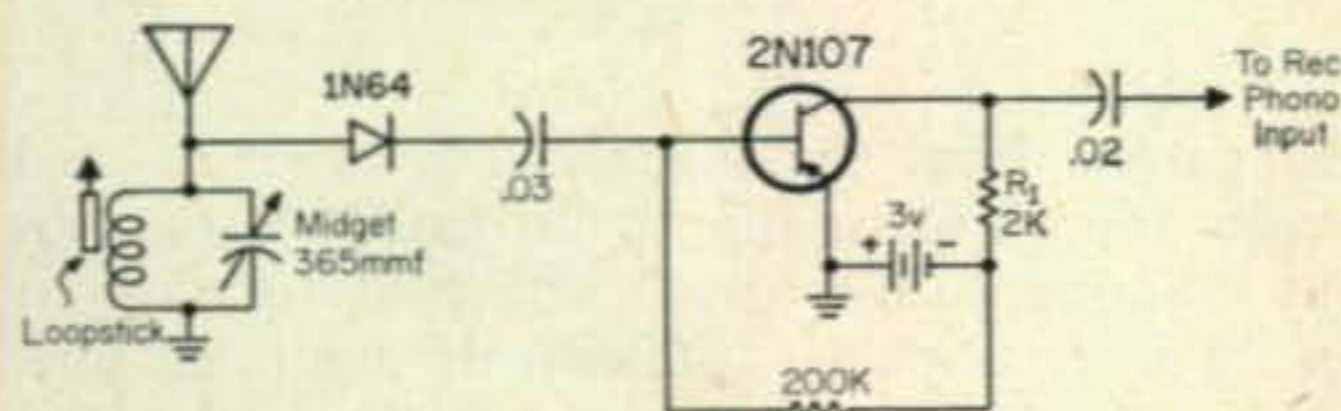

Fig. 9—Simple broadcast receiver suitable for Conelrad applications. Head phones may be substituted for R_1 if desired.

30

HAM CLINIC extends Thanksgiving greetings to all of its fine readers.

72, 73 and 75, Chuck



DONALD L. STONER, W6TNS
P.O. BOX 137, ONTARIO, CALIF.

semiconductors

Now that high power r.f. transistors are available, the problem of modulating these circuits arises. Circuits, of course, present no particular obstacles—class A and B modulators have been available for some time. The major difficulty is in locating suitable transformers for matching the modulation source to the load.

For example, let's say you wish to modulate a 30 watt transistor transmitter. Upwards of 15 watts of audio will be required. Commercial transformers jump from 10 watts to 40 watts with no intermediate values. The 10 watt transformer cannot be used, for core saturation or IR loss will prevent 100% modulation of the transmitter. If the 40 watt transformer is used, the efficiency will be very poor at the 15 watt level.

The author found himself in this position when designing a 30 watt, 12 volt completely transistorized aeronautical/marine transceiver for the 1.6- 5.0 mc range. Experimenters faced with this design problem, like the author, usually dig out the textbooks and do a bit of boning up on the subject. If you have faced a similar situation, the following discourse should be of interest.

Let's take the above application and design it from the ground up. We can take a few liberties, and use rules of thumb, to simplify the calculations involved. Actually all the facts required to design a suitable modulator and modulation transformer, are given in the preceding paragraph.

First, we will determine the class C stage load impedance. This is given by;

$$Z = \frac{E}{I}$$

Since the final must draw 2.5 amperes at 12 volts for 30 watts input, the load is established at 4.8 ohms. We also know that to modulate a 30 watt amplifier, at least 15 watts of audio is required. However, the transformer will be only 60- 90% efficient. Using the mean figure, 75% we find that an actual modulator power output of 20 watts is required.

The class B audio circuit is the most practical for battery operated equipment because of its low idling current, high peak power output and high efficiency. The efficiency of a typical class B amplifier averages about 66%.

This tells us that to run 20 watts input, we must draw 30 watts from the battery. Thus the modulator, as well as the final amplifier will consume 2.5 amperes on modulation peaks.

Once these parameters are established, we can proceed to calculate the modulation transformer impedance. Each transistor in the class B push-pull pair must look into a specific resistance or it cannot deliver a specific power. For example a stage operated from 12 volts, and looking into a 100 ohm load, cannot possibly deliver more than one and one-half watts of audio. This much is simple ohms law. Impedance is given by the expression:

$$Z = \frac{V_{cc}^2}{2 \cdot P_0}$$

For the example under discussion, we find:

$$Z = \frac{144}{40}$$

$$Z = 3.6 \text{ ohms}$$

Thus, each transistor must look into 3.6 ohms to deliver 20 watts of audio. This establishes the primary at 14.4 ohms centertapped (not 7.2, impedance changes with the square of the turns). Thus our modulation transformer must be 14.4 ohms center tapped to 4.8 ohms. The turns ratio required to accomplish this is given by the expression;

$$N = \sqrt{\frac{Z_s}{Z_p}}$$

$$N = \sqrt{\frac{4.8}{14.4}}$$

$$N = \sqrt{.33}$$

$$N = .575$$

Therefore the modulation transformer must have a stepdown ratio of 1 to .575.

This is fine, but where do we start in determining how many turns go on each winding? The same formula used for winding power transformers is applicable. After all, what is a modulation transformer but a power transformer operating over the audio spectrum. The formula is:

$$N = \frac{10^8}{4.4 \times f \times a \times G}$$

$$N = \frac{10^8}{4.44 \times 400 \times 1 \times 50,000}$$

$$N = \frac{10^2}{4.44 \times 4 \times 5}$$

$$N = 11 \text{ turns}$$

where;

N = turns per volt

4.44 = constant

f = minimum frequency with no loss

a = area of core in in.²

ϕ = flux density/in.²

In the formula, f is quite variable. In hi-fi applications 30 or 40 cycles would be used. For communications purposes, 400 to 600 cycles should be used. Only the efficiency will be down at the lower audio frequencies. Core heating would occur if a steady low frequency tone was applied but this seldom happens in communications service.

The core area, a , will require some fancy footwork, sprinkled liberally with logic. The core must handle the 2.5 ampere class C current and 2.5 ampere peaks with modulation. The push-pull class B configuration cancels out the flux saturation to a large extent, so that the primary current is not so important as the secondary current. The selection of a suitable core depends almost entirely on how much IR loss you can accept. Naturally the smaller the core, the more turns required per volt. This increases the copper loss. For example, if the secondary measured one ohm, the 2.5 ampere current would result in a loss of 2.5 volts. The final can ill afford to lose 2.5 volts! This represents some 20% of the available voltage! Additionally, if the core is small, the window (the winding area) will also be small, and it may not be possible to wind on a sufficient number of turns. As a rule of thumb, I recommend a core which is capable of carrying the flux on a continuous basis. For example, a total of 5.0 amperes flows in our modulation transformer (primary plus secondary) and at 12 volts this represents 60 watts. A power transformer of say 300 volts at 100 ma. (30 watts), 6.3 volts at 5 amperes (19.5 watts) and 5 volts at 2 amperes (10 watts) totals 59.5 watts capacity. A core which is suitable for this transformer will make an ideal core for our modulation transformer and permit maximum size wire with minimum IR losses.

Upon stripping off the windings for this transformer we find an E and I core measuring $2\frac{1}{2}'' \times 3'' \times 1''$. The center of the E, that is the part the wire is wound on, measures one square inch. This figure is inserted in the formula for a . For the last variable, flux density, another rule of thumb must be used unless you know the composition of the steel. A flux density of 50,000 lines for a power transformer or 70,000 lines for an audio

core is satisfactory. Now, let's insert all the numbers in the formula and see what comes out:

Thus 11 turns per volt are required on the primary. Due to the autotransformer action, the instantaneous end-to-end modulation transformer primary voltage will be $2 V_{cc}$ or 24 volts. Thus 264 turns, centertapped, are required on the primary. It should be pointed out that to achieve maximum coupling the primary must be bifilar wound, that is, the winding consists of two parallel wires. The centertap is made by connecting the start of one wire with the finish of the other. The remaining two wires are the ends of the center-tapped winding.

The secondary turns can be determined by referring to the winding ratio determined earlier. If the 264 turn winding equals 14.4 ohms, then .575 of this would equal 4.8 ohms. Thus 152 turns will be required for the secondary.

Once the number of turns have been established, we must refer to the copper wire table (see ARRL handbook) to determine the wire sizes. For modulation service we can use a current carrying capacity of 300 to 500 circular mils per ampere. At 2.5 amperes secondary current and 400 c.m. per ampere, a wire size of 1,000 c.m. is required. The nearest size is number 20 enamelled at 1022 c.m. Each half of the primary passes 1.25 amperes. Thus for 400 c.m./ampere the primary would be wound with #23 wire. If this wire size is not available, it can be wound with either #22 or #24 depending on what you are willing to accept in the way of IR loss and available winding area. It is permissible to use #24 since the primary current is pulsating and not continuous.

From this point on, the job becomes a physical one of winding the transformer. The winding will be easier and go much faster if you prepare a bobbin to fit the core, as shown in fig. 1. The primary generally goes on first.

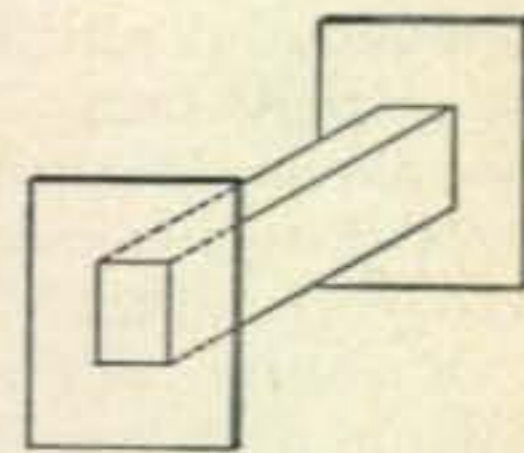

Fig. 1—A bobbin simplifies the winding of the transformer.

Be sure to fan the terminating wires out the long side of the bobbin so they miss the core.

According to the copper wire table, you can get 41.3 turns of #24 wire on a linear inch. If the window of the core is $1\frac{1}{2}''$ long it will hold slightly over 60 turns per layer. Thus 4.6 layers will be required to hold the primary. Five layers of 53 turns each can also be used. Because of the low peak voltages, no insulating paper is required between the layers. A paper stock, about the thickness of a business card, should be used between primary and secondary layers to support the heavier wire.

The secondary winding goes on next. The

copper wire table informs us that we can get in 29.4 turns of #20 wire per linear inch. On a 1½" layer this is 44 turns and it will require 4 layers to wind on the 151 turns of the secondary. Four layers of 38 turns each could be used to make each winding equal, also.

Admittedly we have taken a few liberties and the completed transformer will be rather crude. The fact remains, however, it will work as designed. It is rather amazing how much latitude the designer is permitted.

To illustrate the point, an f of 600 cycles was inserted into the turns/volt formula. This resulted in a transformer of 7.5 turns per volt and a 180 turn primary winding. Inserted into the ratio formula it produced a secondary winding of 105 turns. This permitted larger wire to be used with a subsequent reduction in IR losses. The performance was nearly identical with only slightly less gain below 200 cycles.

In retrospect it appears that the secondary winding should have been wound on first. It is far more important to have the least IR loss on the secondary winding. Placing this winding on the core first produces a smaller circumference.

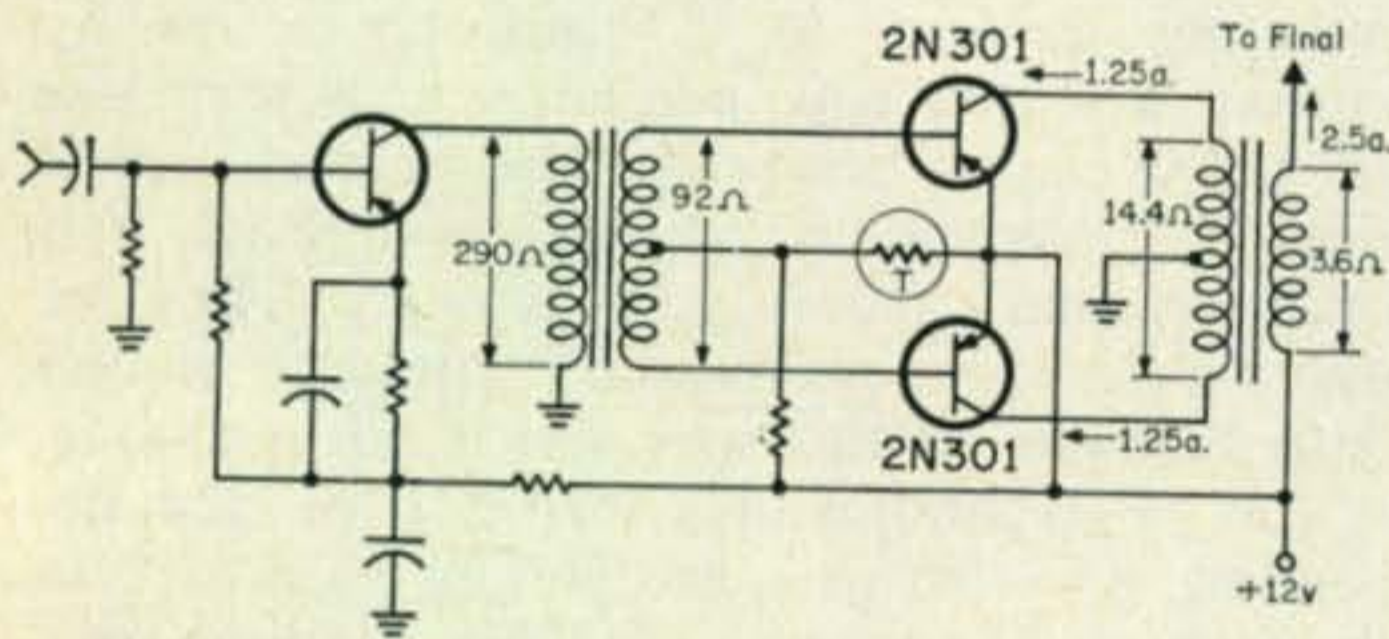

Fig. 2—Schematic diagram of the modulator discussed in the text.

Figure 2 shows the schematic for the completed modulator stage. Since the power input to this stage is 30 watts and the power output is 20 watts, the two transistors must be able to dissipate 10 watts. Transistors with 5 watts continuous dissipation will actually provide a wide safety factor since the dissipation is not continuous. Inexpensive RCA 2N301's, with 11 watts dissipation were used and eliminate the need for emitter stabilization.

Of course, our modulator is of little value without a driver. The driving power required by the class B stage is given by dividing the power output by the gain of the stage. The stage gain is given by the expression;

$$\text{Gain} = \frac{(h_{fe})^2 \cdot R_L}{h_{ie}}$$

where:

h_{fe} = forward current transfer ratio or simply current gain.

h_{ie} = input impedance

R_L = load resistance each modulator sees

The first two figures are given by the transistor data sheet. For a 2N301 h_{fe} and h_{ie} are

30 db and 23 ohms respectively. Thus:

$$\text{gain} = \frac{900 \times 3.6}{23}$$

$$\text{gain} = 141 \text{ (100 equals 20 db)}$$

The driving power can be determined by;

$$\text{drive} = \frac{20}{141} = 0.14$$

Thus approximately 140 milliwatts is required. Since the audio driving transformer will be only 50 to 75% efficient a driving power of at least 200 milliwatts should be available. To develop this power in a class A stage, as we have in fig. 2, 500 milliwatts (or ½ watt) of d.c. power is required from the supply, assuming an efficiency of 40%. This tells us that with a 12 volt supply, the driver transistor must draw approximately 42 ma. The primary impedance of the driver transformer may be found by using the impedance formula given earlier or simply by dividing the driver current by the driver collector voltage. In either case the answer is approximately 290 ohms. From the 2N301 data sheet we know the impedance of the input (23 ohms) and this should be the secondary impedance of the driver transformer. For two 2N301's in class B, a secondary impedance of 92 ohms centertapped would be required. As an exercise to see if the preceding discussion was absorbed, you might try calculating the winding data for the driver transformer.

The circuit for the completed modulator is shown in fig. 2. It is rather amazing to see the results when you consider that the only knowns, other than the transistor data, was the class C r.f. amplifier power input and the supply voltage. By using these bits of information all the values shown in fig. 2 can be determined. Other values, such as bias networks and high frequency bypassing must be determined by consulting the transistor characteristics. The thermistor in the class B stage prevents excessive current flow, and possible thermal runaway, at high temperatures. The fixed resistor in this network is set for minimum crossover distortion. It can be set empirically or by consulting the transistor curves. The network must furnish sufficient current to bias the transistor past the knee at the cutoff end of the curve. The remaining components are determined by the operating conditions in the driver stage.

Lapping Machine

Have you ever wondered what happened to the semiconductor wafer after the ingot was sliced? They are usually placed in a machine such as the one shown in the accompanying photograph. The slice is placed in one of 10 carriers and polished to a flatness and parallelism of 0.000005 inches and a mirror finish in

[continued on page 175]

VHF

50mc. 144mc. 220mc. 420mc. and above

BOB BROWN, K2ZSQ

C/O CQ, 300 W. 43 ST.,
NEW YORK 36, N. Y.

Now that the contests are all over, new feedlines installed, and new projects underway, our thoughts turn once again to the inevitable antenna changeover. What will it be next? Well, if the summer's hurricanes didn't take it down this year, it just isn't big enough. Why does Joe consistently work stations you're not even hearing? Ten to one it's his "eyesore" on the roof. If you are at all in the mood for improving your station at low cost, read on! The antenna you buy will by far give you more for your money in the long run than any piece of ham gear you purchase (including a receiver). Think it over. Your best investment is that antenna on the roof. Everything you do, everything you buy or build is entirely dependent on ye olde radiator. To expound upon this a bit further, we might even derive a formula which could conclude that your success on the v.h.f. bands is directly proportional to the improvements on your antenna system.

On the basis that in most receivers we use today, approximately 6 db equals one "S" unit, changing that 12 db system to a 17 db setup would give you almost another 6 db (or another "S" unit) of gain. This can well make the difference between hearing 'em and not hearing 'em.

We all know of certain local boys who put all their money into their antennas and end up with 25 watts into an 11 over 11. Crazy? Well maybe at first glance . . . but for some reason they always seem to do just a little bit better than the rest when it comes time to separate the men from the boys. After a time the disease catches and begins to leave you wondering. Well stop wondering and do something about it! Why be satisfied with a fair or good array just like everyone else has? Get the biggest and best antenna you can afford. The 6 meter antenna used here at K2ZSQ is an 11 element yagi 27 feet long. Our good friend Frank, K2MLB, on the other hand, uses two 36 foot 11 element Yagis stacked. I guess I don't have to tell you who gets out best.

While we're on the subject of antennas, it might be good to think about that all important link: the feedline. Both the antenna and the feedline contribute to that receiver noise figure which everyone seems to worry so much about. There will always be those to say that a better noise figure doesn't make the weak signals any better to read, but they're usually the ones with so much loss that they don't

FLASH

On Sept. 14th, K1HMU and W6ONG exchanged signal reports (S-3) via the moon on 144 mc. Details next month.

know what their antenna really sounds like. A 3 db loss in the coax may make your v.s.w.r. look good, but it sure soaks up those signals. Improve your antenna and feedline and you'll lower that noise figure and hear more.

Let us assume you now have one S unit of noise (6 db). Change your coax to something with 3 db less attenuation, and you've got 3 db more signals ($\frac{1}{2}$ S unit). Savy? What kind of cable to get? The best you can afford. Don't be taken in by some of the so-called "new" surplus coax. Much of this stuff is just plain pure junk at high prices. The secret to getting good cable is in finding out what type of jacket material is used. Let's divide our jacket types into two categories; Type I and Type II.

Type I jacket material contains a plasticizer substance of the migrating variety or one that migrates from the day of manufacture from the jacket to the inner dielectric. This plasticizer's purpose is to obtain flexibility; once it migrates, it hardens and cracks the dielectric material. This means, of course, that RG-8/U (which is type I) of WW II vintage is essentially worthless. Type I jacket coax cables have a useful life of one year. After that, watch that gain drop!

Our second category, Type II jackets, on the other hand, have a useful life of ten to fifteen years or longer. They are of a non-migrating



Neat station at WA2BDP, Ridgefield, N. J.

variety and last much longer. How to tell what jacket material is used on the cable? Here's a sampling:

Type I	Type II
RG-8/U	RG-8 A/U
RG-58/U	RG-58 B/U
RG-59/U	RG-59 A/U
RG-58 A/U	RG-59 B/U

On most cables today just plain /U generally indicates Type I. Those with A/U or B/U are usually Type II. RG-58A/U (52 ohms) is the exception in the table above. The difference in cost for the Type II jacket is usually only 1¢ per foot. What a small amount to pay for quality!

While you're mulling over the jacket types and longevity of your future installation, you might well consider one more factor: loss. As we mentioned earlier, this is a most important point. Assuming you'll be running approximately 100 feet of cable to the antenna, it figures out like so:

6 Meters

RG-8A/U	1.4 db loss
RG-58A/U	3.2 db loss
RG-58B/U	2.6 db loss
RG-59/U	2.4 db loss
RG-59A/U	1.25 db loss
RG-17/U	0.001 db loss

2 Meters

RG-8A/U	2.6 db loss
RG-58A/U	6.3 db loss
RG-58B/U	5.2 db loss
RG-59/U	4.5 db loss
RG-59A/U	2.5 db loss
RG-17/U	1.0 db loss

The last entries (RG-17/U) were thrown in for those who have money. RG-17/U runs about \$48.00 per hundred feet. Didn't list RG-19A/U (with 0.89 db loss at 2 meters); stuff runs 85¢ a foot. Might suggest to the 220 and 432 mc crowd: look into RG-17/U. Although it is priced awfully high, you need it at those frequencies. At 432 mc, for instance, 100 feet of RG-58A/U will cut things down 13 db! That's right; over two good S units down the drain. RG-17/U, on the other hand, results in only 2.2 db loss per hundred feet. Worth looking into, eh? Enough said this time. Maybe more heckling next month . . .

CQ's Century Club Awards

It's that time again . . . time to remind you of our new awards given to any and all v.h.f.-u.h.f. operators who qualify. The rules and regulations run something like this:

The CQ Century Club Award is offered to those who have met with the following qualifications in one year's time. (This means from March 1 to March 1, August 31st to August 31st; any period of 365 days. The year begins

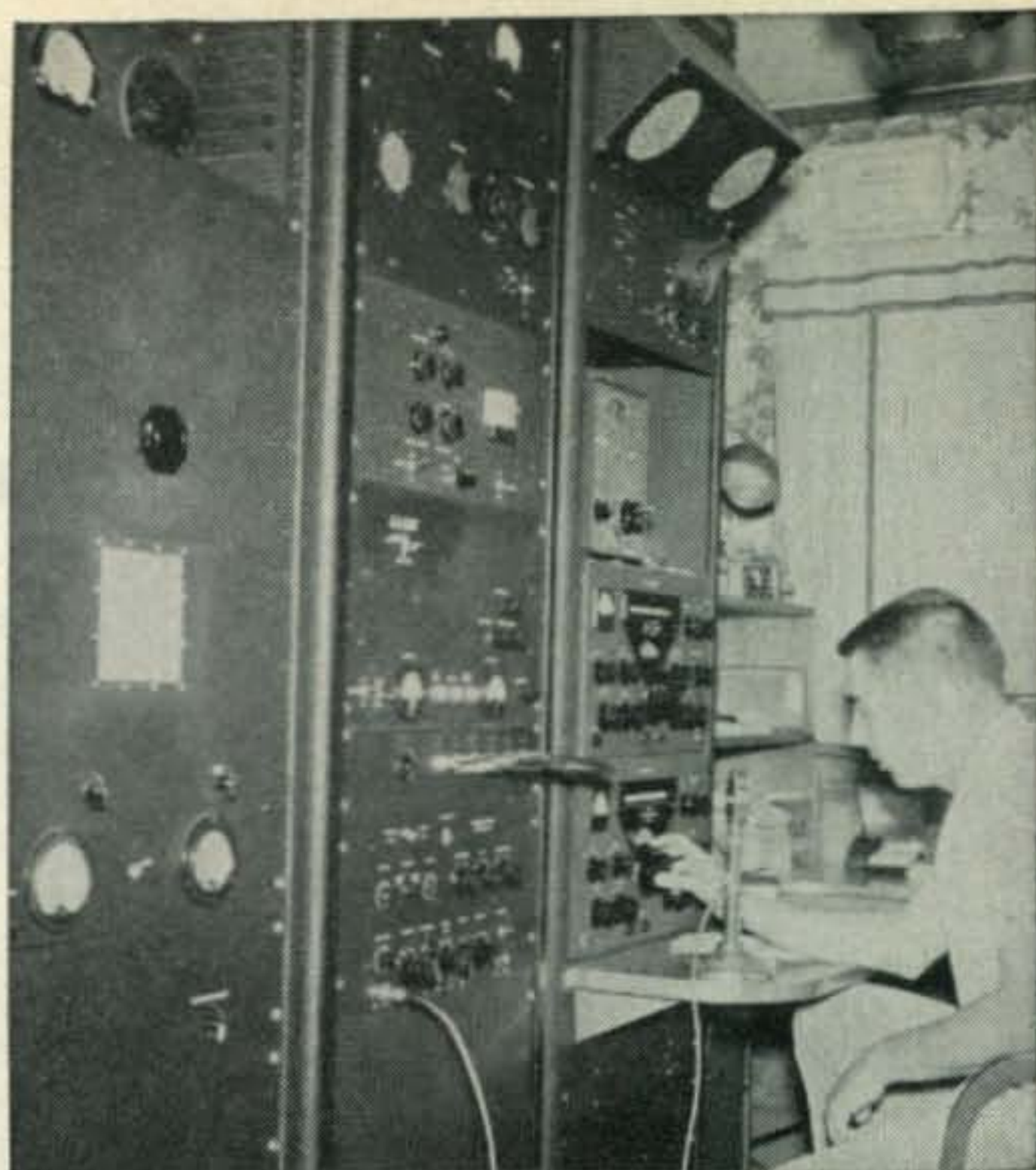

Operating position at K6QXY. Looks like he's tuning up at WMGM. Most impressive set-up with rack mounted kilowatt on the left.

with your first listed contact.

50 mc entrants must show a list of 150 contacts within one year with the proper QSL's on hand to present as verification if requested. This list must consist of just those whose cards you have received. Each entry must have the call of that station and the date worked. Number them one to one hundred fifty (in chronological order). Make sure that the two dates furthest apart do not exceed one year between. Each list must be headed by these two dates showing the span of time covered in the entries.

144 mc entrants must show a list of at least 100 confirmed contacts with the information above.

220 mc entrants must show a list of at least 50 confirmed contacts with the information given under the 50 mc award above.

432 mc entrants must show a list of at least 25 confirmed contacts with the information given under the 50 mc award.

Each list must be accompanied by a statement reading, "We, the undersigned, hereby verify that John Q. Ham, K5XXX, displays the cards listed from actual on-the-air contacts." This statement must be signed by at least two witnesses (preferably licensed amateurs).

The cards themselves may be sent instead of a list, but adequate postage must also be included for their return. This seems to average out to about 96¢ first class mail for 150 cards. When you mail your cards, note how much it takes and include the same amount of stamps or cash with your application.

There is no limit to how many certificates you may earn.

Processing of this award takes about three weeks. Take this fact into consideration when writing.

There is no charge for this award. This service is free for all who qualify.

Lists and statements should be mailed to: CQ Century Club Awards, c/o Bob Brown, K2ZSQ, 67 Russell Avenue, Rahway, New Jersey.

The certificates themselves are real beauts, well worth working for. They will be dated according to the dates you present on your list so that you can take off on a new award from the date appearing on the last. Good luck with the certificates, boys!

Project Moonbounce—144 mc

More word from Ned Conklin, K1HMU, on his now-famous moonbounce experiments:

"The moonbounce transmission and receiving systems are finished, and we are transmitting on 144.252 mc plus or minus about 3 kc with 1 kw input. The antenna is 176 elements in clockwise circular polarization. Due to the reflection, the best receiving antenna would be counterclockwise circularly polarized. A linear antenna, either horizontal or vertical, can be used, but with at least 3 db loss; clockwise polarization probably won't work at all. The antenna type used here is crossed yagis fed a quarter wave apart; this results in a clockwise transmitting pattern and counterclockwise receiving pattern. Another possible antenna is a counterclockwise helix. This also transmits counterclockwise, however.

"We will interrupt the constant transmission schedules to try to make a contact if requested; just let us know. Receiving is done with a parametric into a Collins receiver with audio filter. Please try to have your transmitting frequency on 144.250 mc plus or minus 50 kc to make it easier on the receiver and paramp.

"Transmissions for the present will consist of one second pulses, four seconds apart; identification every ten minutes will be MOONBOUNCE TEST DE K1HMU at 3-4 w.p.m. Please let us know if you hear the signal and good luck!"

Ned Conklin, K1HMU
Old Mountain Road
Farmington, Connecticut
Telephone: Or 7-1565

Write to Ned for an up-to-date day by day transmission schedule at the address above.

6 element 144 mc Yagi

George Haylock, G2DHV, came through with a new 2 meter antenna this way . . . "Have rebuilt my five element wide spaced beam to a six element close spaced yagi on the same length of boom. Results were increased gain and narrow angle of horizontal acceptance. Seems to work quite well from 144 to 146 mc. Close spacing of the first three directors helps the change of phase angle on reflected signals. Material used was ex-government 1/4" diameter wireless rods of 12" length. An extra one cut up to fit the ends of three foot sections to make up the required lengths.

The driven element was carefully bent to shape. Additional elements can be added using the same dimensions and spacings as the last director.

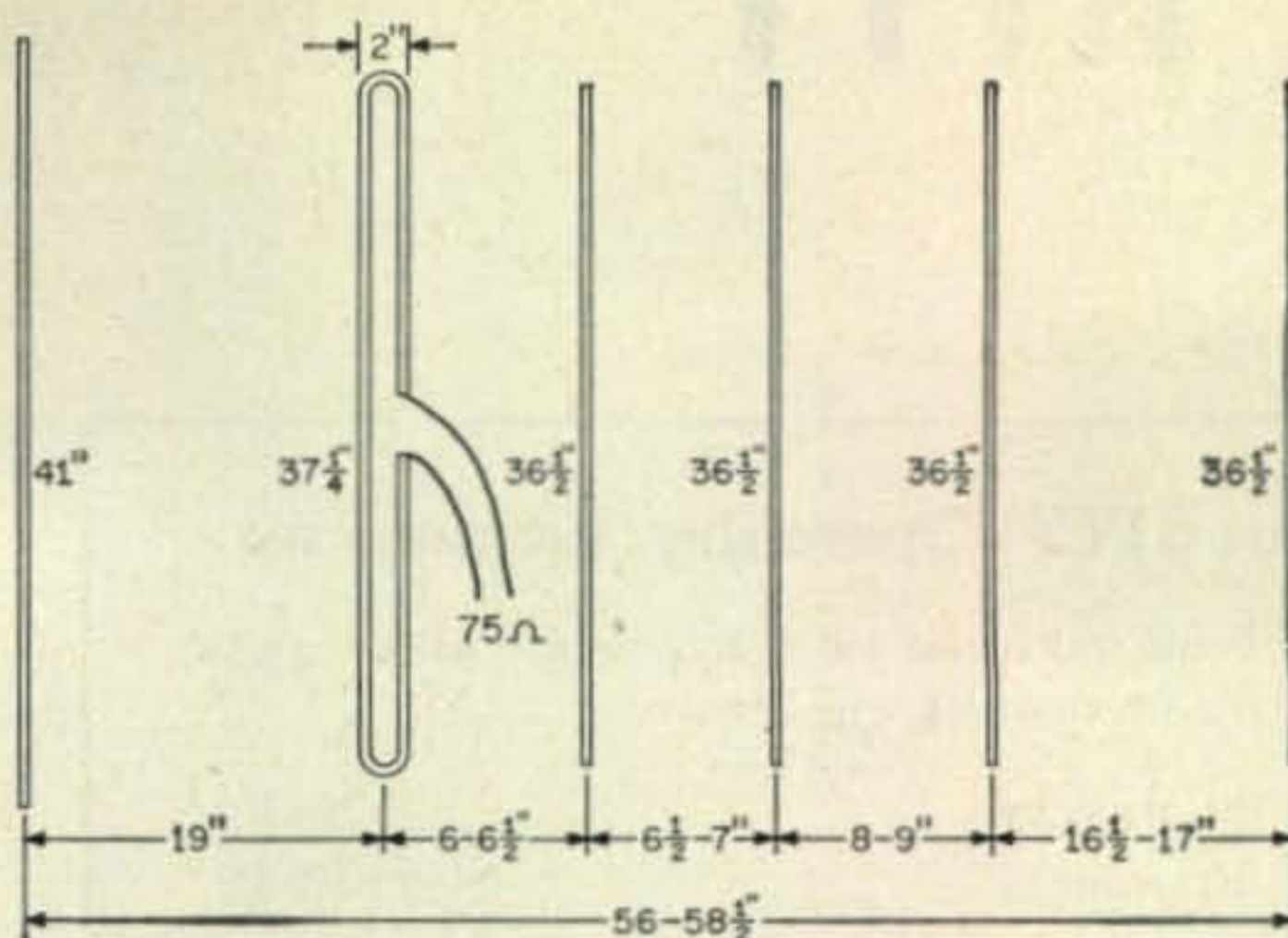

Fig. 2—G2DHU's 6 element 2 meter beam constructed of 1/4" aluminum rods. Element spacings are not critical and may vary between the limits shown.

Tip of the Month

A new member of our Tip of the Month club is the 'ole v.h.f.'er himself, John, K2ZBX, of Elberon, New Jersey. Here's a cheap and easy way (less than one dollar) to make a socket for that 4X150A or 4X250B. Only thing to remember is to run the screen bypass capacitor to the screw on the top of the socket. Good luck!

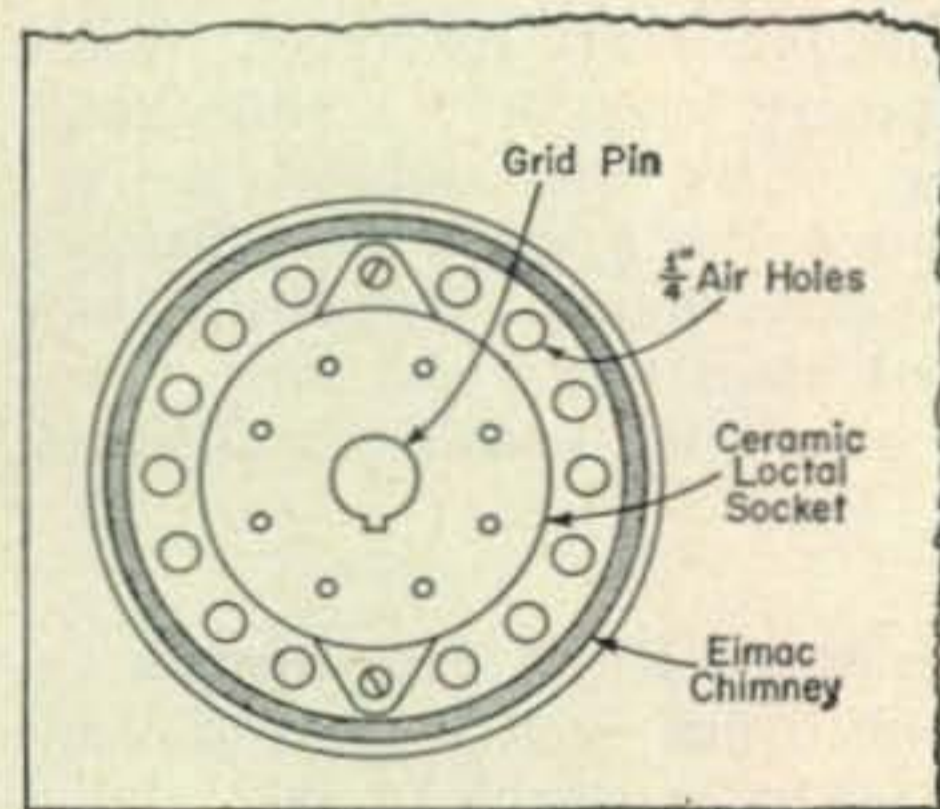

Fig. 1—Cheap and easy socket and air system for the 4X150A tubes. The ceramic loctal socket is mounted in a conventional manner on the chassis while the holes and Eimac SK-606 chimney direct air from a blower below chassis.

Mailbag

Spenard, Alaska: Jack Reich, KL7AUV, writes . . .

"Haven't had a moment to call my own for quite a while, but things are looking up now. Am getting rid of some of my extra-curricular projects and should have more time to pursue my own hobbies." *Make time, Jack!*

"Saw the boxed note in QST re the July 4th openings. As luck would have it, Margie and I were on our annual trip to the Fairbanks area Amateur Radio Picnic at Birch Lake (halfway

[continued on page 170]

RTTY

BYRON H. KRETZMAN, KØWMR

108 W. TERESA DRIVE,
WEST ST. PAUL 18, MINNESOTA

RTTY Operating Frequencies

Nets centered on frequencies given; operation usually ± 10 kc.

80 meters	3620 kc
40 meters	7140 kc
20 meters	14,090 kc
15 meters	21,090 kc
6 meters	52.6 mc

AMATEUR radioteletype holds a special fascination for those engaged in it. While a radio amateur will go from c.w. to 'phone, then to single-sideband, and then back again, those who try RTTY invariably stay with it throughout the years. There are several reasons for this. Probably the biggest reason is that RTTY, out of the necessity born of the lack of inexpensive commercially built gear, awakens the desire to create, to develop the extraordinary electronic transmitting and receiving equipment that enables us to talk across the miles with a speed and efficiency not possible with other modes. This is the same desire that fired hams thirty and forty years ago while probing the little-known world below 200 meters.

The New RTTY Handbook

For so long it has been so very difficult for the radio amateur in search of information on RTTY to find it all in one place. Now, at long

last, the Cowan Publishing Corporation has made available, as part of the *CQ* Technical Series, the *New RTTY Handbook*. This book was written to satisfy the need of the radio amateur still left with a spark of creativeness, a spark of courage, and an appreciation of accomplishment. At the very least it will enable you to get the dust off that machine you couldn't resist buying; and, incidentally, open up to you a whole new world in amateur radio.

Elsewhere in this issue of *CQ*, on page 140, there is the formal announcement and list of Contents of this new and fascinating book. Note that it is available directly from *CQ*, 300 West 43rd Street, New York 36, New York.

Something Else New

Ordinarily news of a new product would appear on other pages of *CQ*, but accessories purely for RTTY are so few and far between that we just had to tell you about it. Besides, the Old Man at the Green Keys has been growling so much about fellows not using the correct amount of shift that this just *might* keep him quiet for a while.

The photo shows a little black box, called the FSK Scope Calibrator, that enables the RTTYer to set his shift right smack on the nose with the aid of the usual inexpensive kit-type of 'scope found in the shack. In addition, it permits the 'scope to be used as a very accurate tuning indicator. This useful device is the brain-child of WØHZR, the originator of the phase shift tuning indicator described back in the May 1956 issue of *CQ*.

Operation is very simple. The device is hooked to either the 500 ohm or voice coil audio output of the receiver. A three-circuit plug and cord connects to the vertical and horizontal inputs of the 'scope. Putting the rotary

RTTY The Hard Way... No. 5



Baud FSK scope calibrator

switch in the CAL position and feeding *any* beat note to the unit gives a 45 degree trace on the 'scope when the vertical and horizontal gain controls are correctly adjusted. (A 45 degree triangle is supplied.) Little black adhesive triangles or arrowheads are provided to mark the face of the 'scope at 45 degrees and at 90 degrees. Putting the switch in the 850 position then indicates that amount of shift when the *mark* and *space* traces coincide with the angle indicators on the 'scope face. A 900 switch position is also provided to check to see that the legal maximum amount of shift is not exceeded. Price? \$29.75; from Baud, Inc., 620 North 6th Street, Minneapolis 11, Minnesota.

F.M. Nets

For many years 52.6 mc has been the established RTTY operating frequency on 6 meters. In the last few years considerable f.m. equipment, usually crystal controlled transmitters and receivers formerly used in taxicabs or police cars, has been finding its way into amateur hands. This fixed-channel equipment is naturally ideal for any net operation. Everyone is always on frequency, no tuning of the receiver is necessary, and the receivers are a great deal "hotter" than those found in the customary a.m. installation. The result is that many combination fixed and mobile nets have been formed for a variety of purposes.

This type of fixed-frequency operation, of course, is ideal for autostart RTTY. (For the benefit of the unwashed multitude, autostart is the system of controlling the receiving machines at unattended stations for directed messages.) As the result of the greatly extended range afforded by this f.m. gear, it has almost unanimously been adopted by RTTY nets on 2 meters as well as on 6. Such nets are in operation on 6 in the Minneapolis/St. Paul, Indianapolis, and in the Lafayette, Elkhart, and Ligonier, Indiana areas. On 2 meters such nets are in operation in Chicago, St. Louis, Cleveland, and in the Indiana areas.

Since so little publication has been given to this type of operation, three public-spirited amateurs, K4ZAD, W4DYE, and W4PDX, have published an *F.M. Net Directory* that gives the frequencies, the locations, and the calls of the associated liason stations for f.m. nets on 6 and on 2 meters. Because of the wide-spread

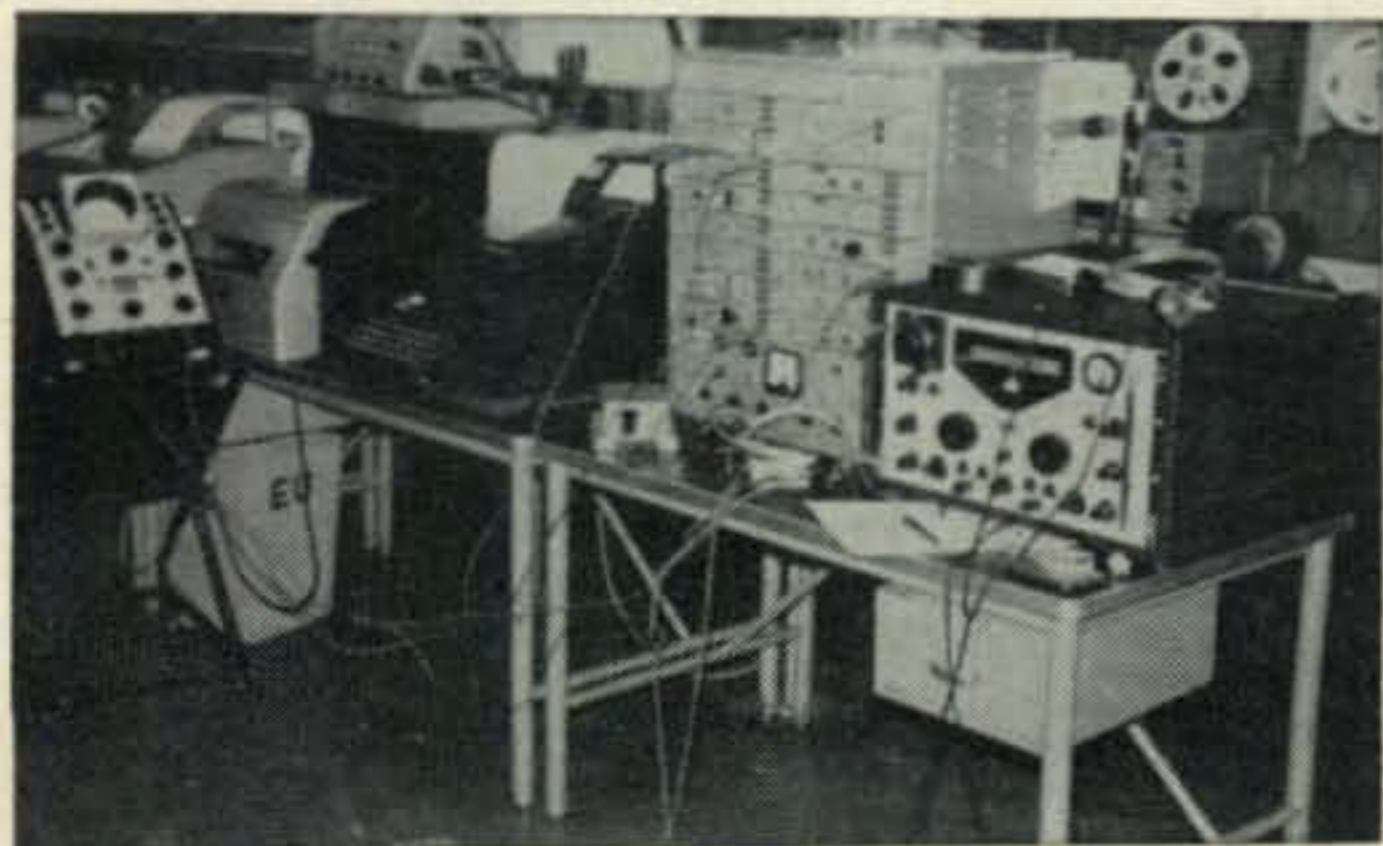

RTTY in the Netherlands, PAØCDV



K8KBO, Highland Park, Michigan

Operator:	Chuck Wakely
Machines:	Models 15 and 26
Receivers:	SP-400X, ARC-5, 40 meter
Transmitters:	500 watt, home brew, ARC-5, 40 meter
Converters:	W2JAV tube TU W2JAV transistorized TU

mobile operation that quite naturally takes place with this equipment, it is suggested that 52.525 mc and 146.94 mc be established as *National* calling and working frequencies. Since multichannel operation is frequently available simply by switching crystals, operation with (or as) transient mobiles is an easy matter. Our 52.6 mc frequency is conveniently close to 52.525 mc, so we can quickly jump from RTTY to 'phone to work mobiles and to talk with non-RTTYers. For more information on this type of operation for *your* net, contact T. A. McKee, K4ZAD, 1306 Grove Road, Lynchburg, Virginia.

Across North America

W1AW is keeping RTTY skeds on 80 and 40 for Project OSCAR, with casual RTTY operation Saturday evenings and Sundays. W1EFF of Gray, Maine, reports a visit to W1YDA and to K1CLF, two other active RTTYers in Maine. K1EFZ of Westbrook, Maine, just acquired his Model 15. W3GBU found a Model 15 for \$35 and is hooking it up to the Twin City TU. He also has 200 rolls of 3 copy paper. (*Anybody need paper? Contact Ron at 5783 Jonquil Ave., Baltimore 15, Maryland.*)

Don Wiggins, W4EHU, is designing converters for Alltronics-Howard (W1AFN). W4BKJ is on 20 from Decatur, Georgia. W6YJG transmits NCARTS, Inc. bulletins on 20. W7LPM in Seattle, Washington, is using a Model 19 and Model 14 typing reperforator on 20, running 400 watts to a 3 element beam. K8SOE of Loveland, Ohio, is on 6 meters with 60 watts, Model 14, 15, and 28 equipment, and a W2JAV TU. K8NLM, 1808 Timmonds Ave., Portsmouth, Ohio, will build the Twin City TU for anyone interested. KØYIW moved to Roselle,

[continued on page 166]



BY LOUISA B. SANDO, W5RZJ

4417 ELEVENTH ST., N.W.,
ALBUQUERQUE, N. M.

1962 YLRL Officers

THE Young Ladies Radio League is off to another big year, the 23rd of its existence. Leading this international club of women radio amateurs during 1962 will be these officers: President, W1ZEN, Onie Woodward; V.P., K2JYZ, Lillian Byrne; secretary, K1IZT, Blanche Randles; treasurer, K6OQD, Jean Kincheloe.

Serving as District Chairman will be: W1ICV, Jane Anderson; K2UKQ, Kay Gaynor; W3RXJ, Irene Akers; K4LVE, Gladys Biggs; W5DIV, Anna Harrison; K6JPY, Dee Gustafson; W7TGG, Vera Woods; W8OTK, Alice Geib; K9EMP, Marge Schum; K0HEU, Thelma Haas; VE3BFE, Bea King; KH6DLD, Sheila Goodhue; KL7ALZ, Geraldine Nichols.

As of this writing we know of no changes in the appointive offices and Onie hoped they would continue with their FB work: K6EXQ, Connie Hauck, Editor of *YL Harmonics*; K4TGA, Alice Ginsberg, Publicity Chairman; W6QYL, Martha Edwards, Advertising Mgr.; K0GZO, Ginny Bush, YLRL supplies.

Membership Correspondents are: Eastern, W8WUB, Marolyn Gwinn; Western, K6BUS, Midge Rommel; International, K6ENL, Aleta Cash; Novice, W7DVH, Alice Sturdevant.

Certificate Custodians are: WAS/YL, W9GME, Grace Ryden; WAC/YL, K5YIB, Barbie Houston; DX/YL, W6UHA, Maxine Willis; YLCC, W4SGD, Katherine Johnson.

K1IZT, Blanche, also handles YLRL affiliation; K7BED, Bettie Mayer, handles continu-

ous membership; W6CEE, Vada Letcher, is YLRL Librarian; and W7NJS, Beth Taylor, is budget and finance chairman.

Congratulations to the new officers; a vote of thanks to those who served YLRL so well during the last year; and our continuing appreciation to those who serve YLRL in the many other necessary posts.

YLRL welcomes licensed feminine radio operators throughout the world as members of this international organization. If you are not yet a member, write to one of the membership chairmen, or the chairman for your call area, for more information and membership application.

W1ZEN

W1ZEN, Onie Woodward, moves up to the position of YLRL president after serving so ably as Vice President during 1960. For a full write-up about Onie's activities check this column in *CQ* for Nov. 1960, p. 127. Since then Onie has added another sticker to her YLCC for 400 confirmed YL contacts. She has become a member of the Certificate Hunters Club and has received Colonial America Award endorsed "All YL #1."

K2JYZ

No stranger to these pages is the new YLRL V.P., K2JYZ, Lillian Byrne. Lil loves contests and YL nets and has been listed here frequently as a high scorer in the Anniversary Parties and YL/OM contests. She also has served as D/C in 2nd district in 1959. Lil has been on the air



W1ZEN, Onie Woodward, YLRL president for 1961.



K2JYZ, Lillian Byrne, V.P. for YLRL in 1961.

YL NETS

Day	Time (EST)	Freq.	Name	NCS or Mgr.
Mon.	0800	3920 kc	U.P. Michigan YL	W8HAV
	0900	7225 kc	Floradora	W4IUR
	1100	7235 kc	Loaded Clothesline (phone)	K0GAS
	1800	3890 kc	Oregon YL	W7HHH
	2300	29.6 mc	Darkeyed Queen	W9GME
	2300	50.56 mc	BAYLARC (6 m)	WA6ALK
Tues.	0830	3900 kc	Blue Ridge	K4CZP
	0900	7215 kc	Floradora YL SSB (l.s.b.)	W4UF
	0900	50.20 mc	HAWK Roost (6 m)	K9MZV
	1000	50.33 mc	Southern (6 m) Floradora	
	1030	3940 kc	Kansas YL	K0HEU
	1300	29.13 mc	Hairpin	K6JPY
	1600	7230 kc	Montana-Idaho Roundtable	K7BKH
	1700	7105 kc	Finger Tip (c.w.)	K6ZCR
	2000	51.0 mc	Rhode Island YL	W1GSD
	Wed.	0830	3900 kc	Yankee Lassies
0900		7185 kc	Floradora Novice	K4RDX
0930		3900 kc	YL Welcome	W8ATB
1000		3840 kc	Wisconsin YL	K9TUD
1130		7150 kc	Loaded Clothesline (c.w.)	K0EVG
1230		21.39 mc	Cross Country	KZ5VR
1400		14.26 mc	YL SSB (u.s.b.)	K5BJU
1400		7230 kc	HAWK Roost (40 m)	K9TCM
1400		50.56 mc	WRONE 6 M YL	K1IJV
2200		146.1 mc	LAYL 2 M	K6BUS
Thurs.	0900	3880 kc	TYLRUN	W5JCY
	0900	7260 kc	Georgia Peaches	K4ZZS
	0900	7270 kc	Friendly Forty	W3UUG
	1100	7235 kc	TYLRUN	W5JCY
	1300	14.24 mc	Tangle	K0EPE
	1900	50.50 mc	HAWK Roost (6 m)	K9IXD
	2000	50.30 mc	Floradora (6 m) Cen. Fla.	K4ANR
	2000	50.33 mc	Floradora (6 m) So. Fla.	W4LPR
	2000	50.25 mc	Oklahoma 6 M YL	
	2300	3915 kc	CHIRP	K6HHD
Fri.	1230	7250 kc	Calif. YL Roundtable (40 m)	W6QGX
	1400	3600 kc	WRONE YL C.W.	K1IJV
Sat.	0930	3910 kc	HAWK Roost (75 m)	K9ILK
	1300	3845 kc	Mermaid	W6QYL
Sun.	0900	7225 kc	Floradora Business Girl	K4UIZ
	1700	3940 kc	Kansas YL	K0HEU

WIZEN, Onie, supplied the above list. If any nets have been missed, let the YLRL vice-president know the day, time, name of net and call of NCS or net manager.

since 1954 (she also holds 3rd class commercial) and you can find her on 10, 15, 20 and 40 phone and cw. Among her awards Lil lists YLCC-350, WAC, WAC/YL, WAS, WAS/YL, DX-YL and CPC 20.

Lil's OM John is K2JYM, and he works for Sperry Gyroscope. They have six jr. ops: Maureen, 18, is K2ZUX; Jack, 15, is K2UNO; then twin girls 13, Kathryn and Lillian; Grace, 10, and Charles who is 6. Lil is a member of the N.Y.C. YLRL and HAWKS. She also is active in Civil Defense. Besides hamming she enjoys swimming, fishing and sewing.

K1IZT

Secretary Blanche Randles, K1IZT, is continuing in the position she carried so well during

1960. Full write-up and photo appeared in *CQ* for Nov. 1960, p. 127. To her list of certificates Blanche is proud to have added WAS/YL (#58) and she has a fifth endorsement on her YLCC (350 YLs). Blanche and her OM have been enjoying a newly acquired summer camp in New Hampshire. During the coming year she will be treasurer of the Framingham RC.

K6OQD

As YLRL treasurer, K6OQD, Jean Kinche-loe, will be serving her third year in this position. For photo and write-up see this column in *CQ* for Jan. 1960. Since then she earned CHC, the first YL to do so. Jean is one busy gal what with YLRL treasury work and compiling the new *Directory* of all YLRL members. (Non-members can obtain the *Directory* for 50¢; in addition to information on all members, it will include listing of all YLRL certificates and rules for obtaining them, plus a listing of other YL certificates available.) We don't doubt but that OM Bill, K6OQC, also has her involved in his work with radio controlled model planes!

YLRL A.P.

Remember the dates of the YLRL Anniversary Party: CW — Oct. 25-26; Phone Nov. 8-9, 1961. Complete rules in this column in October *CQ*.

"Mule Mobile"

The mule in the accompanying photo must be well trained to stay "mobile" — haven't you always heard how these "critters" refuse
[continued on page 171]



Ever try operating "Mule Mobile"? It's been done, and here's the proof. The occasion was a RACES test exercise held in connection with the Merced County Fair parade in Merced, Calif. Aug. 19, 1961. This was station K6VTT/MM (Mule Mobile) and consisted of a Communication III powered by a 12 v. storage battery lashed on opposite side of the mule. Holding the rope is Linda Margaretic, YL of W6PHL, and with the mike is WA6BWZ, Helen Ann Silveira. Others participating were K6DUU, K6RAU, W6BUA, K6RLX, K6LWO, K6ENF, K6LRR, WA6CWT. See text for more about Helen Ann.

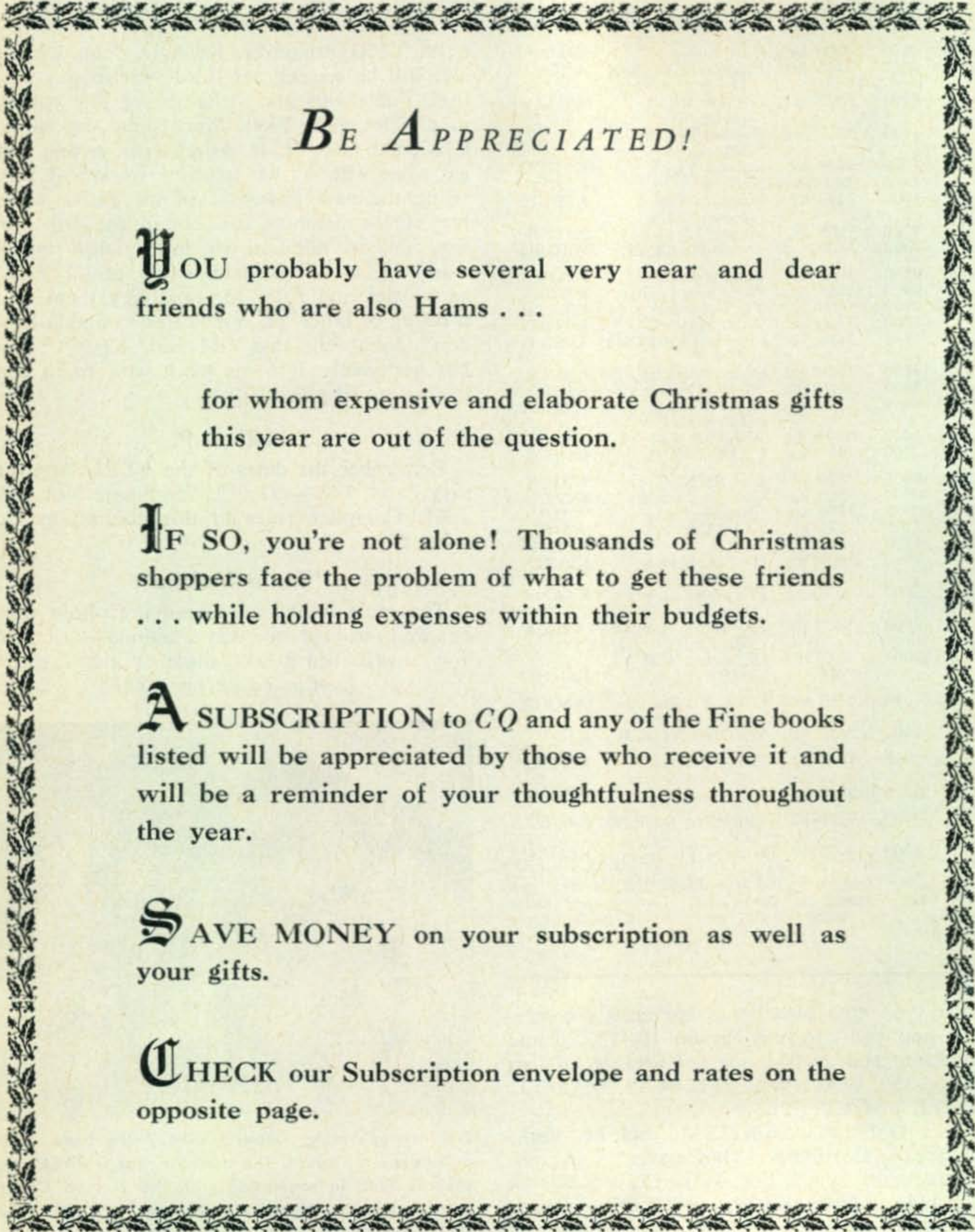

BE APPRECIATED!

YOU probably have several very near and dear friends who are also Hams . . .

for whom expensive and elaborate Christmas gifts this year are out of the question.

IF SO, you're not alone! Thousands of Christmas shoppers face the problem of what to get these friends . . . while holding expenses within their budgets.

A SUBSCRIPTION to *CQ* and any of the Fine books listed will be appreciated by those who receive it and will be a reminder of your thoughtfulness throughout the year.

SAVE MONEY on your subscription as well as your gifts.

CHECK our Subscription envelope and rates on the opposite page.

FOR SHARPEST, CLEAREST VOICE TRANSMISSION WITH ANY CITIZENS BAND TRANSCEIVERS, SPECIFY THE TURNER 350C

Even the best citizens band equipment is no better than the microphone it uses. That's why more Turner 350C microphones are used as original equipment in CB than any other. That's why it will pay you to specify the Turner 350C when you buy CB equipment or replace your microphone.

■ The 350C is furnished with an 11" retracted (five foot extended) coiled cord. Hanger button and standard dash bracket are included for mobile rig mounting. Response: 80 to 7000 cps. Output: -54 db. Net price: \$10.08. ■ See Turner microphones at your electronic parts distributor or send coupon for complete information and the name of your nearest Turner distributor.



TURNER 254C FOR BASE STATION

Desk type ceramic mike operates by a touch bar on-off switch and lever lock on-off switch. Response: 80-7000 cps. Output: -54 db. Net price: \$14.10.



THE TURNER MICROPHONE COMPANY

925 17th Street NE,
Cedar Rapids, Iowa

Gentlemen:

send me further information on the 350C and 254C CB microphones and the name of my nearest Turner distributor.

NAME _____

ADDRESS _____

CITY _____

STATE _____

For further information, check number 28, on page 163

NEVER BEFORE A HAM MAP LIKE THIS!

SO BIG! SO BEAUTIFUL! SO ACCURATE! SO FACT FILLED! SO UP-TO-DATE!

KNOW THE ZONES FOR WAZ
KNOW THE CONTINENTS FOR
WAC • KNOW THE COUNTRIES
FOR DX-CC ETC. • ETC. • ETC.

• NOW ON SALE • BRAND NEW •

We are proud to announce the publication of the long-awaited **AMATEUR RADIO WORLD-WIDE DX & ZONE MAP.**

This new map is complete, accurate and up to the minute with information that every amateur needs.

It contains:

Every prefix, including the newest additions and latest changes, printed in red, right in, or next to, the Country or Island, for accurate identification.

The most authentic Zone Boundaries, including the **ANTARCTIC CONTINENT for the FIRST TIME ANYWHERE!**

Great circle beam bearings for East, Mid-West and Western United States.

Attractively printed on heavy vellum map paper in four colors for easy location of Zones and Prefixes.

Size 36x42 inches for easy, no squint reading from operating position.

Price only **\$3.00** postage paid in the U.S.A. and possessions.

COWAN PUBLISHING CORP.

C-11

Map Division
300 West 43rd Street
New York 36, N. Y.

SIRS: My check (money order) for \$_____ is enclosed.

Please send _____ maps to:

(Additional name, or names, enclosed on separate paper.)

Name _____

Address _____

City _____

Zone _____

State _____

New York City residents add 3% Sales Tax



TWO-WAY RADIO

communications equipment

VHF-FM FOR:

MOBILE
AIRCRAFT
MARINE
MOTORCYCLE
PORTABLE
BASE

VHF-AM FOR:

AIRPORT VEHICLES
GROUND STATIONS
POINT-TO-POINT

VHF

ANTENNAS
REMOTE CONTROLS
ACCESSORIES



NEW! "680 BASECOM"

FOR VHF-FM TWO WAY
MOBILE RADIO

the new 680 series offers

**HIGH PERFORMANCE at
MODERATE COST with
LOW MAINTENANCE!**



"680 FLEETCOM" COMBINATION

- MOBILE CONTROL HEAD
- SPEAKER
- TRANSISTOR POWER SUPPLY

"680" FEATURES AND OPTIONS:

- ★ **PROVEN PERFORMANCE**... all the outstanding features of the popular "580" series, plus the following.
- ★ **HIGH POWER**... 100 watts output 25 to 50 mc, 75 watts 144 to 174 mc, both base and mobile.
- ★ **STONE SQUELCH**... two way tone squelch compatible with other systems to EIA standards.
- ★ **SIMULTANEOUS RECEPTION**... dual front end receiver for monitoring two frequencies anywhere in the band.
- ★ **TRANSMITTER FILAMENT SWITCH**... reduces battery drain when on "stand-by".
- ★ **MONITORS REMOTE CONTROL**... base station monitors remote transmissions. Intercom provided. All functions available at remote position.
- ★ Meets all FCC and ODCM requirements.

ATTENTION DEALERS!
Write for available territories.



DESIGNERS AND MANUFACTURERS OF

COMMUNICATIONS COMPANY, Inc.

RADIO COMMUNICATIONS EQUIPMENT

FOUNDED 1938

CORAL GABLES, MIAMI 34, FLORIDA

For further information, check number 29, on page 163



SEE IT HERE!

NATIONAL'S NC-155

New Ham Band Receiver

THE PERFORMANCE PACE SETTER OF THE YEAR

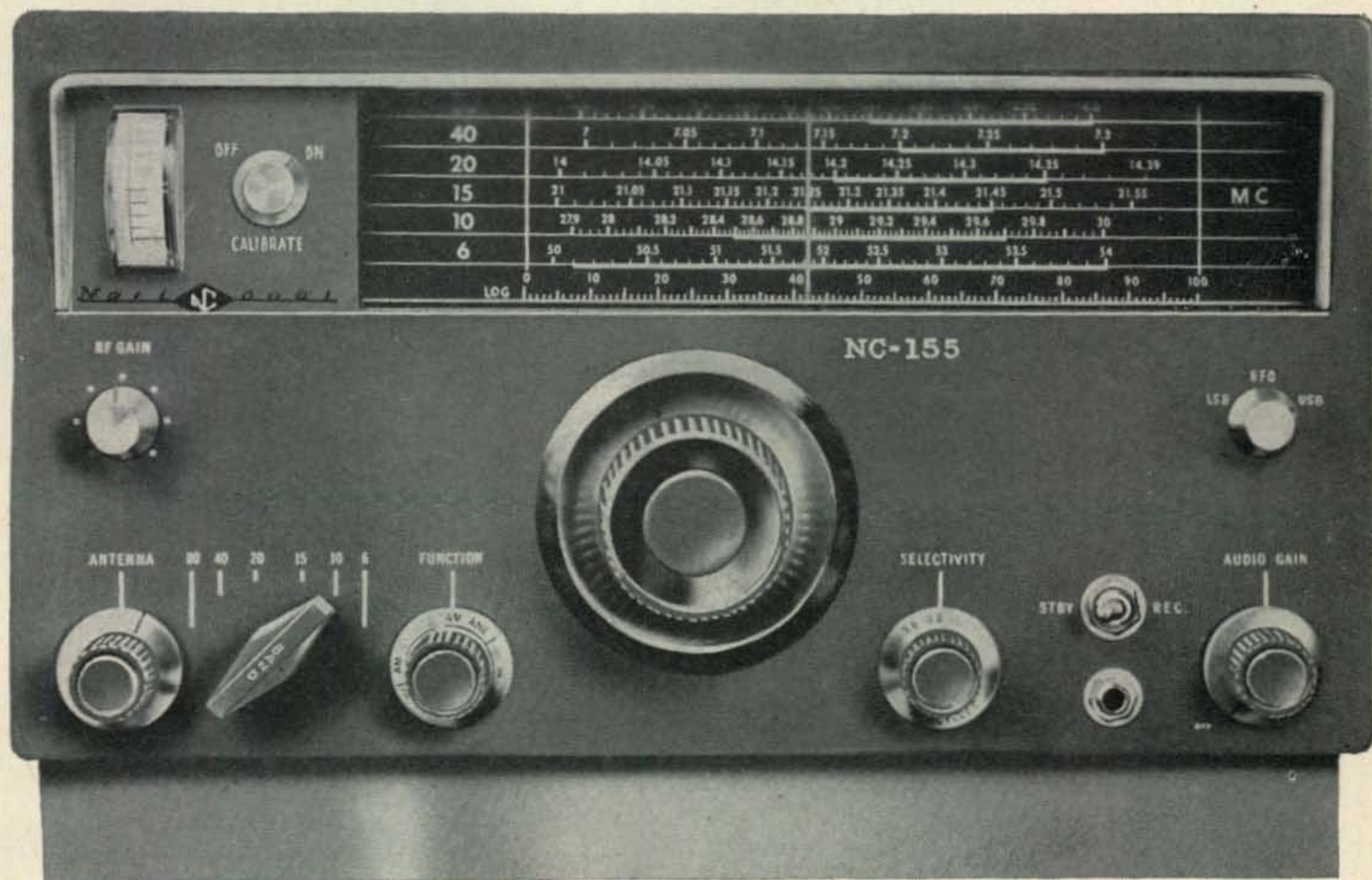

See inside back cover for more details!

Come in for a demonstration

RADIO PRODUCT SALES

1501 South Hill Street

Los Angeles, California

RI 8-1271

For further information, check number 30, on page 163

New Products

Eico 722 V.F.O.

A NEW self-powered, highly stable v.f.o. providing full coverage of the ham bands from 80 to 10 meters (10 meters covered in two ranges), is being produced by EICO, Inc., 33-00 Northern Boulevard, Long Island City, New York.

Basic design features of the new Model #722 include anti-backlash tuning, a low-heat silicon diode doubler power supply, a buffer-multiplier output stage, a very large and easy-to-read slide rule dial, and a velvet-smooth and extremely reliable drive. Output is high enough to drive any modern transmitter on all bands from 80 through 10 meters. Remote control operation is possible with an external switch or relay that is energized by the transmitter. A lever type spotting switch is provided on the front panel. Self-powered and self-contained, the new unit causes no drain on the transmitter with which it is operating. For further information check A* on page 163.



Vibrator Power Supply

THE new Heathkit GP-11 vibrator power supply recently announced, is a heavy-duty rated unit capable of converting 6 or 12 volt battery power to the plate power requirements of a wide variety of mobile or portable equipment. Its high power handling capabilities (250 v.d.c. @100 ma, i.c.a.s.) make it especially suited for use with the Heathkit models HW-19, HW-29A or HW-30 transceivers.

The GP-11 features silicon diode rectifiers and a simple change of wiring allows use in either 6 or 12 volt systems. Its small size is handy for the limited space availabilities in boats, cars, trucks, etc.

Easy to assemble with the famous Heath "check-by-step" instructions, the unit measures $4\frac{5}{8}$ " \times $6\frac{1}{2}$ " \times $4\frac{1}{8}$ " and weighs only 6 lbs. Check B in page 163 for more information on this versatile unit.

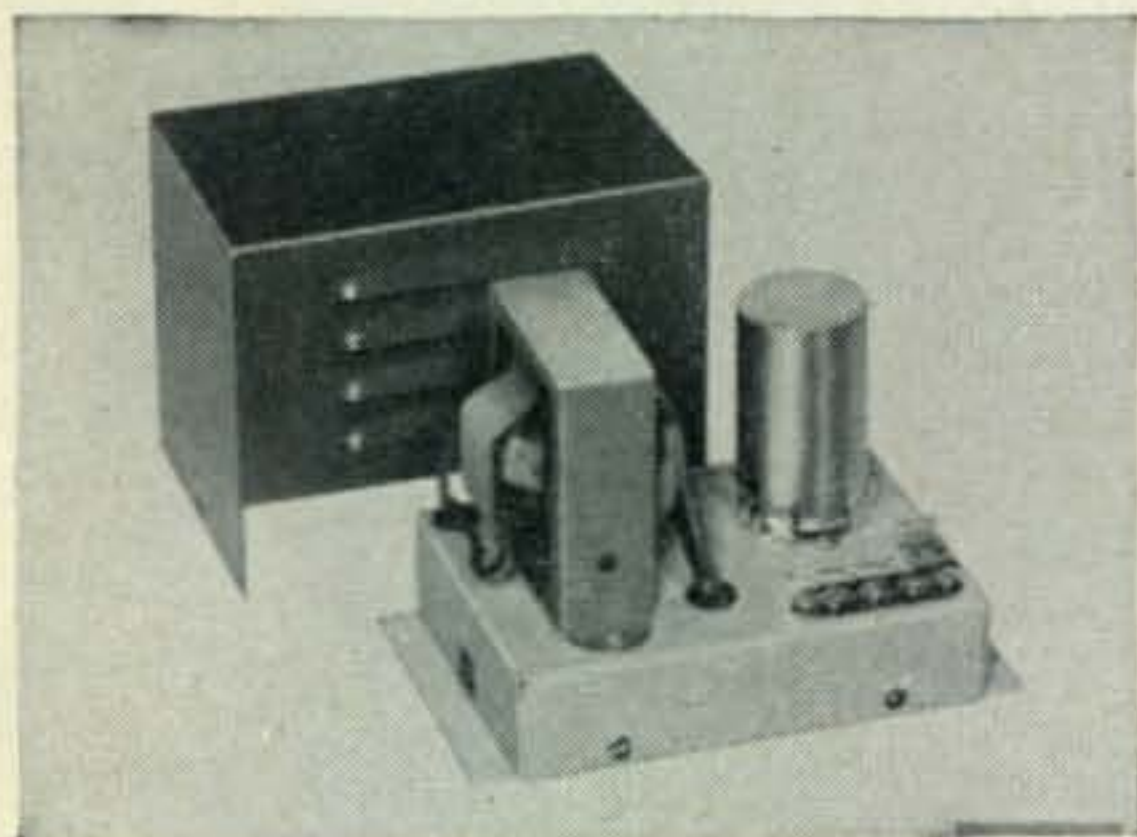

Field Strength - Power Meter

THE Plas-Tron Corporation of 815 S.W. Viewpoint Drive, Portland, Oregon has introduced a combination field strength meter and watt meter, designated the RWFS. It is an extremely rugged, highly accurate instrument which will indicate a maximum r.f. power output of 60 watts, from 2 to 250 mc, with less than 1.15 to 1 v.s.w.r. Two push-buttons are provided which, when pressed, give a full scale indication from 0 to 1.5 and 0 to 15 watts full scale. The termination unit is encapsulated in a high temperature, heat dissipating epoxy resin. The manufacturer claims an accuracy of +5% using a Triplet 0-20 μ a meter with a logarithmic scale. The sliding antenna is used as an r.f. pickup as well as a variable attenuator for relative field strength measurements. The coaxial connector is a standard SO-239 UHF-type; other types on special order. The case is handsomely designed, black anodized, $\frac{1}{8}$ " thick structural aluminum tubing. The unit measures 7 " \times 3 " \times $1\frac{3}{4}$ " and weighs 27 ounces. More information may be obtained by circling C on page 163.



KN1 KN9 WV6 WV2 KN0 KN9 KN7
 KN9 WV7 KN4 KN9 KN5 KN8 KN9
 KN3 KN1 KN9 KN4 KN9 WV6 KN4
 WV7 KN9 WV6 KN9 KN8 KN0
 KN4 KN9 KN8 WV2
 KN1 WV6 KN9
 KN3 KN5 KN8

NOVICES!

HERE'S YOUR BEST BUY IN A DUAL CONVERSION RECEIVER!

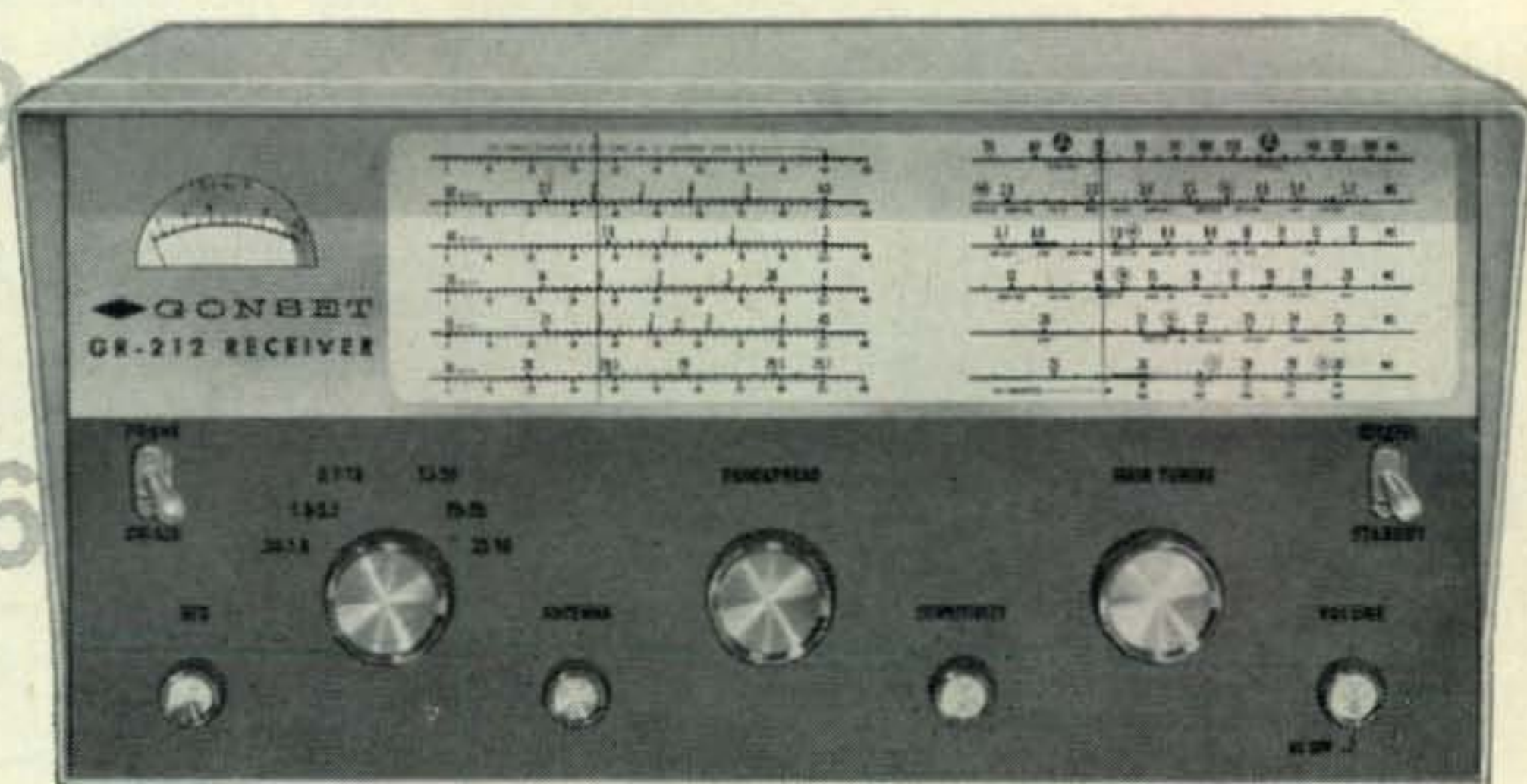

THE NEW GONSET GR-212

The only dual conversion receiver that is priced under \$100, the GR-212 provides the novice with superb performance at modest cost. It is designed for general coverage from standard broadcast through 34 mc band, including WWV, U.S. Bureau of Standards Time Signals, foreign & Voice of America.

Quality features include:

- Dual conversion for increased selectivity
- Variable BFO
- Sensitivity: at least 6db S + N at 1 uv. (mod. 30% at 400 cps) input on all H.F. Bands.
- Two full-vision, illuminated, slide-rule type dials provide instant identification of broadcast and short-wave frequencies.
- Panel-mounted "S" meter.
- Band-spread tuning knob is inertia fly-wheel weighted for smooth tuning.
- Separate band-spread dial for amateur bands.

Amateur net price **\$99⁵⁰**

 **GONSET**®
 DIVISION OF YOUNG SPRING & WIRE CORPORATION

801 SOUTH MAIN STREET, BURBANK, CALIFORNIA
 For further information, check number 31, on page 163

New E-Z Way Tower

E-Z WAY Towers, Inc., Tampa, Florida announces a new light weight, super strength, economy type tower that is designed for amateur use. Specially constructed for quick, simple installation and low maintenance it incorporates high tensile steel, (55,000 PSI) to provide a light weight tower, a 10 ft. section weighing only 29 pounds. The G-10 may be safely erected to 40 ft without guys or 280 ft with 30 pound windload, guyed. X-type bracing resists twist and torque caused by wind gusts and stopping rotor.

Electric arc welding throughout provides rugged construction. A climbable ladder is incorporated on three sides. Completely hot dipped galvanized after fabrication assures protection inside as well as out. For further details circle D on page 163.

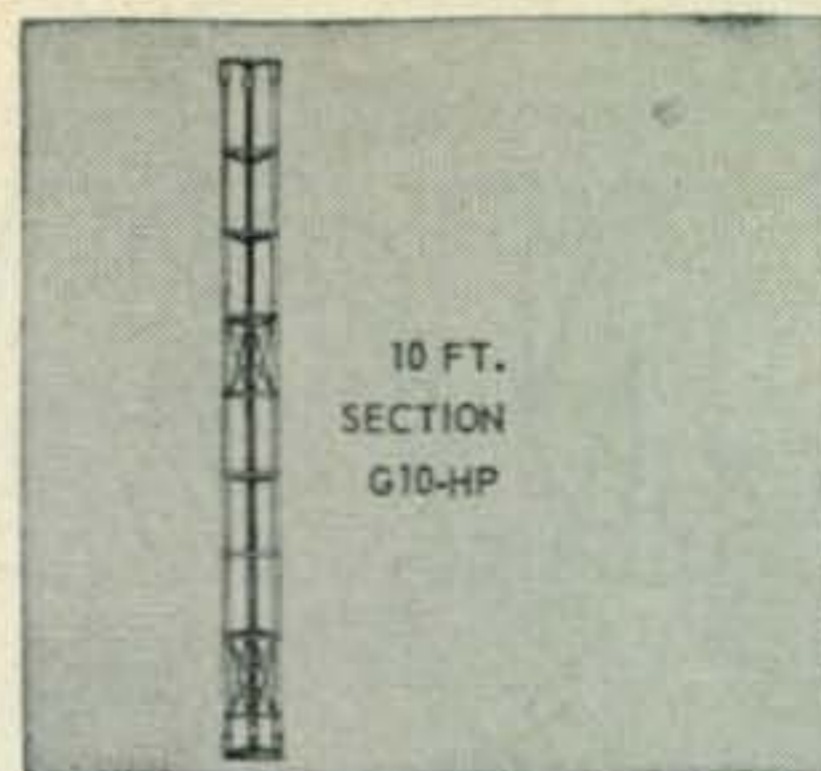

Lafayette S Meter

LAFAYETTE Radio, 165-08 Liberty Ave., Jamaica 33, New York recently introduced a new low price signal strength meter for hams. Designated the TM-59, the meter is furnished with 6C4 tube and complete installation instructions.

The S meter is a sensitive, high input impedance device which utilizes a v.t.v.m. type Wheatstone bridge circuit. When properly connected to any superheterodyne communications receiver or transceiver using an a.v.c. system, it will not load the a.v.c. line excessively. With only four leads, a.v.c. input, B+, filament and ground, simple installation is assured. The TM-59 meter is calibrated in S units from 1-9 and in db, up to S9 + 40 db, permitting accurate signal strength measurements for on the air reports, and tuning. The meter case has magnetic feet for mobile dashboard mounting. Check E on page 163 for further details.



Wire Stripper

YOU may have seen this little gadget advertised recently but we feel it certainly deserves further mention. Manufactured by the Bartley Manufacturing Co., Inc. this new wire stripper is well suited for "tight" operations such as hard-to-get-at corners, multi-conductor cables and short lengths of wire. The rugged tool will handle 16-26 gauge wire and spare parts such as blades are available from the manufacturer. For further information on the Bartley wire stripper, check F on page 163.



Tunnel Dipper

LONG awaited by amateurs is a new grid dipper from Heathkit. This new and different replacement for the popular GD-1B incorporates solid state circuitry throughout. A new tunnel diode is used as an oscillator, allowing complete portability; just the thing for field day operations, antenna adjustments and other measurements where light weight and freedom from power cords is demanded. A new and handy feature is the snap-on cover that stores the epoxy coated coils when not in use. The coils are color coded and keyed to the corresponding scale on the new precision drum dial. More information on this unit can be obtained by checking G on page 163.

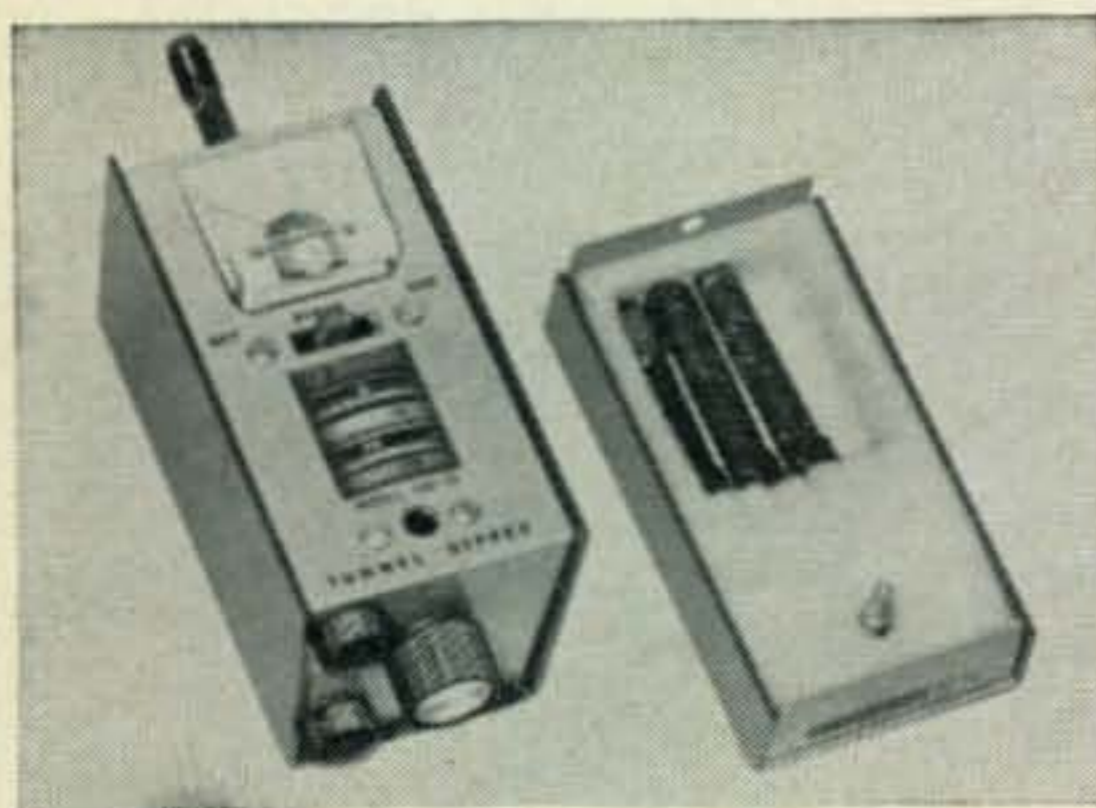



**JUST
OUT!**

SEMICONDUCTOR DIODE SOURCE BOOK

128
Pages

- CONTAINS COMPLETE CHARACTERISTICS OF MORE THAN 2,800 TYPES.
- TWO SETS OF CHARTS PROVIDE:
 - 1) NUMERICAL TABULATION
 - 2) LISTINGS IN ORDER OF MOST IMPORTANT DESIGN PARAMETERS.*
- CHARTS ARE NOTEWORTHY FOR THEIR EASE OF USE AND COMPLETENESS OF PARAMETERS.
- AN ADDITIONAL CHART LISTING AVAILABILITY OF DEVICES FROM VARIOUS MANUFACTURERS.
- PACKAGING INFORMATION INCLUDED.
- CHARTS PREPARED BY THE NATIONAL BUREAU OF STANDARDS.



\$2.50

*Separate charts are provided for each diode type. These charts are arranged in an ascending order of the numerical values of the most important parameter of the device. This permits a rapid selection of a specific type to meet the needs of the design engineer.

SEMICONDUCTOR PRODUCTS CQ11

300 W. 43rd St., New York 36, N.Y.

SIRS: My check (money order) for \$ _____ is enclosed.
Please send Semiconductor Diode Source Book to:

NAME _____

STREET ADDRESS _____

CITY _____ ZONE _____ STATE _____

N. Y. City residents add 3 % Sales Tax.

DX-QSL News Letter DX'ers----NOTICE!

Save Time & \$\$\$ DX QSL'ing

The DX-QSL-NL is printed 8½" × 11" for your loose-leaf binder.

Each time you work a 'rare' DX'er just flip the pages and check for possible listing before QSLing.

Unless you subscribe to dozens of DX Journals you couldn't possibly get such up-to-date information.

October, 1961 copy DX-QSL-NL has over 2000 listings.

Subscribe today and learn where to send for thousands of rare QSL's.

SUBSCRIPTION PRICES 1st CLASS MAIL

Single copies	\$.40
One Year to W/K/VE	\$1.25
One Year-Rest of World	\$1.50

EDITED, PRINTED & PUBLISHED BY

CLIF EVANS, K6BX

Box 385, Bonita, Calif., U.S.A.

Obtainable in U.K. from G2BVN, 51 Pettits Lane, Romford, Essex. New Letter 11/6

The Finest in Ham Jewelry

Special attention given to Xmas Orders

A complete line of personalized jewelry handsomely engraved with your call letters. All items available in choice of gold plate or silver plate. Mark appropriate box on coupon. Sandblast finish insures long wear. See pictures of these items on page 101, June 1961.

Money Clip	\$3.50*
Cuff Links	3.50*
Buckle	3.50*
Tie Bar	2.50*
Tie Tack	2.50*
Lapel Pin	2.50*

SPECIAL DISCOUNTS ON QUANTITY ORDERS
FOR: HAM CLUBS—HAMFEST PRIZES—
MANUFACTURERS
WRITE FOR FULL DETAILS SPECIFYING YOUR
PARTICULAR NEED

*Add 10% Federal Excise Tax to all items.

Hewlett Sales Co., Box 600CQ
300 West 43rd St., New York 36, N. Y.

NEW...

LOW-COST, NON-INDUCTIVE "HAM LOAD"

Here's a new 50-ohm resistive dummy load that's ideal for all types of amateur service—fixed, portable or mobile. By switching the "Ham Load" into your antenna circuit, you eliminate on-the-air tuning and needless QRM. The unit also provides a dependable, non-inductive termination for testing equipment, measuring power and antenna matching.

The Carborundum "Ham Load" is supplied as a single unit with standard coax connector for easy mounting on rack or cabinet, or for designing into home-brew equipment. Although small in size, the high-temperature ceramic resistance element dissipates up to 250 watts output for 5 minutes! Unlike bulbs or wire-wound resistors, SWR remains

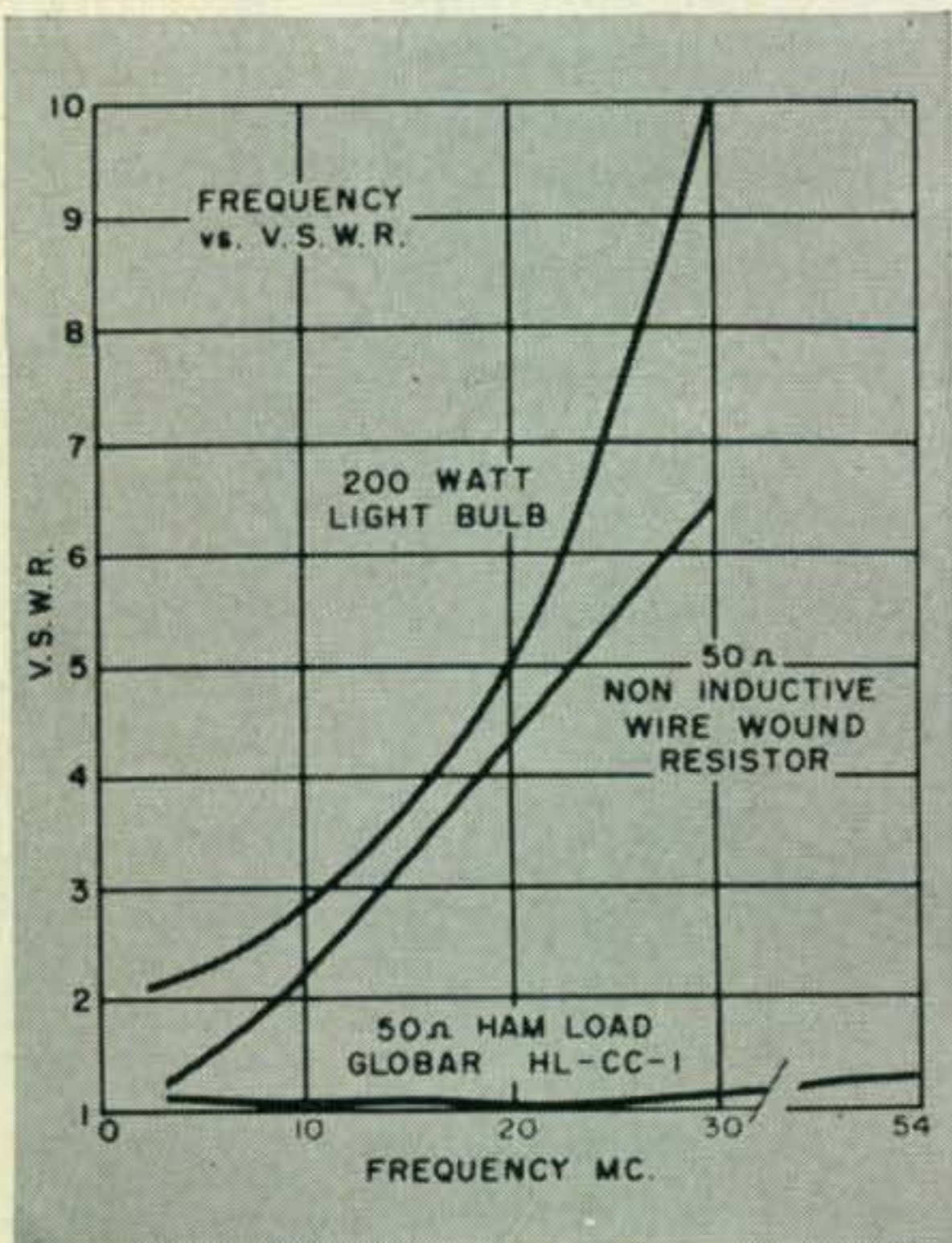

- Reduces QRM
- Increases Efficiency
- Dissipates 250
Watts Output

\$23⁷⁵*
only

*Suggested Retail

essentially flat at less than 1.5:1 up to 54 Mc (with the load mounted at least 5" from metal reflecting surfaces).

For the name of your nearest supplier, write: Dept. QS-11, Global Plant, Carborundum Company, Niagara Falls, New York.

SPECIFICATIONS

- Resistance: 50 ohms, non-inductive
- SWR: Less than 1.5 at 54 Mc
- Dissipation: 250 watts (up to 5 minutes); 150 watts continuous
- Connector: Standard coax (SO-239 type)
- Size: Approximately 13½" long by 1" diameter
- Mounting: Any convenient location
- Caution: Due to heating when loaded at high power, the unit should be mounted in freely circulating air.

CARBORUNDUM

Approx. one-half actual size

For further information, check number 33, on page 163

ALLIED really lets you write your "own ticket" on the great new

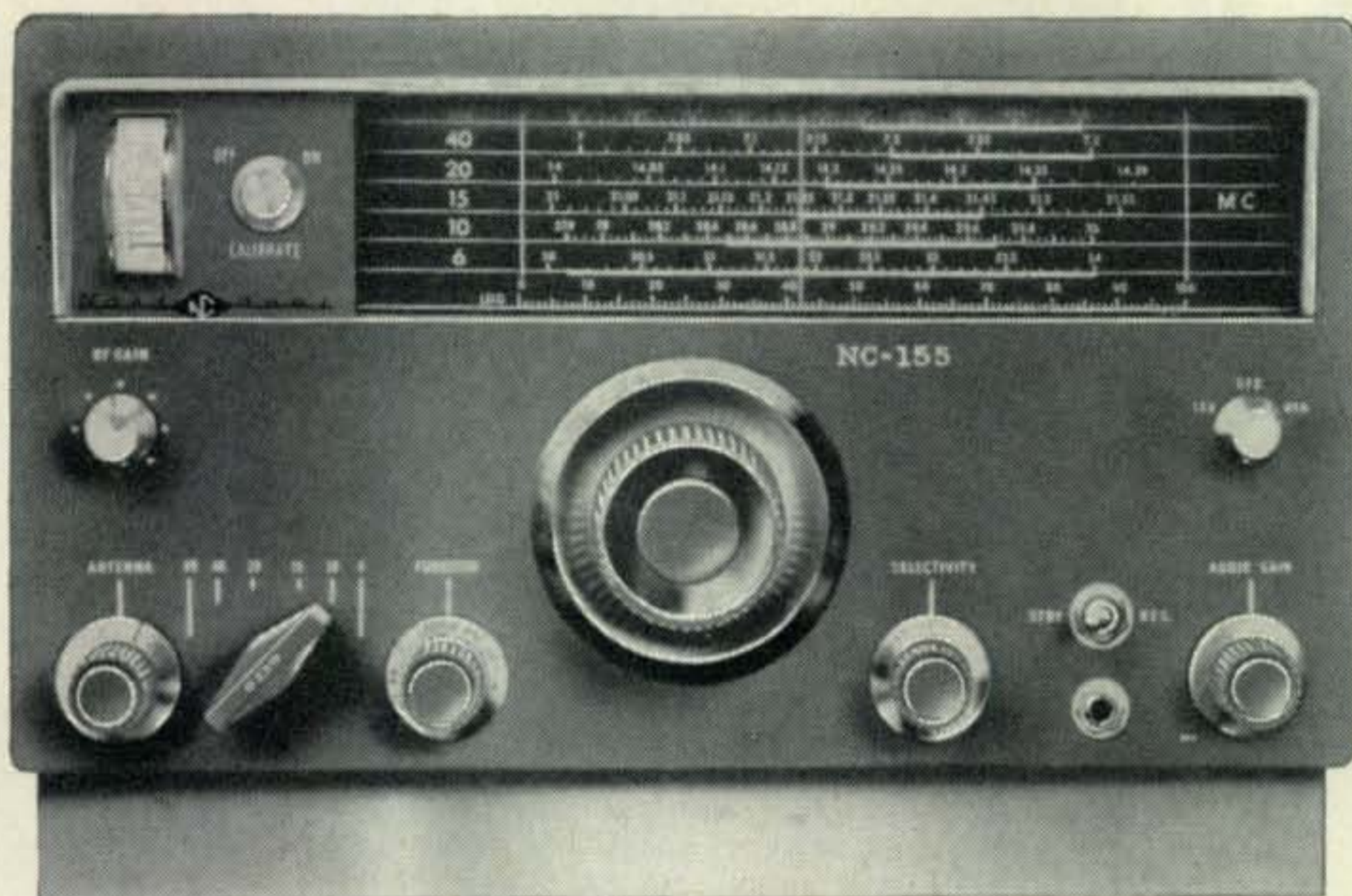

NATIONAL NC-155!



GET THE TOP TRADE-IN DEAL

Tell us what you want
to trade and what you
think it's worth—
chances are we'll beat
your estimate...

NO MONEY DOWN

on Allied's Credit Plan—
up to 50% more buying
power, up to 24 months
to pay...

THE NEW NATIONAL HAM-BAND NC-155

Here's real hamming enjoyment at an easy-on-the-ham price! Look at these features:

- Double conversion on 80 through 6 Meters
- 1 μ v Sensitivity—Even on 6 Meters
- 3 Selectivity Positions: 600 cycles, 3 and 5 kc
- Quick Warmup; "Rock-like" Stability
- Effortless Tuning with 60:1 Ratio Dial

NC-155 Receiver. Stock No. 90 SX 173. Only.....\$199.95
Matching NTS-3B Speaker. Stock No. 90 SX 174..... 19.95

**RESERVE YOUR NC-155 TODAY
USE THE HANDY COUPON!...**

For the absolute tops in
trade-ins, write or
phone "Trader Jim"
Sommerville, W9WHF,
for quick action!



at your service in our Chicago Ham Shack

Joe Huffman, W9BHD
Joe Gizzi, W9HLA

John Chass, K9LOK
Tasker Day, W9QBB

In Milwaukee: Lowell Warshawsky, W9NGV

**send
coupon
today**

ALLIED RADIO, Dept. 229-L1
100 N. Western Ave., Chicago 80, Ill.

Ship me the following:

- No. 90 SX 173 National NC-155 Receiver
 No. 90 SX 174 Matching Speaker

\$_____enclosed

- I am interested in buying the NC-155. Give me your best
offer on the following equipment I want to trade:

Name _____
PLEASE PRINT

Address _____

City _____ Zone _____ State _____

ALLIED RADIO

For further information, check number 34, on page 163



SATURN 6

the original

HALO

How come thousands of these little gadgets are riding around on the backs of cars all over the country? And how come so many are in use at fixed locations?

WELL

Verticals were tried first for mobile work. Most fixed stations used horizontal polarization and could hardly hear the mobiles. Flutter was a serious problem. When Hi-Par introduced the Saturn 6, mobiles found they could work fixed stations over amazing distances and that flutter was a thing of the past. Ignition noise was greatly reduced too. The antenna became very popular for fixed stations too since it was omnidirectional and horizontally polarized. Beams are great, but much of the time you want to talk to stations in more than one direction at a time.

Saturn 6 Antenna only.....\$11.95

Saturn 6 plus mast & bumper mount\$16.95

We make a lot of other antennas, but this is our best seller. Write for info on this and other antennas. Order through your local parts distributor or direct.

HI-PAR

Products Co.

FITCHBURG, MASSACHUSETTS

For further information, check number 91, on page 163

future recommendations of the type made in regard to the top 15 kc on 14 mc.

If the principal purpose of our existence is to be ever-upward-climbing on the ladder of DXCC, then let that principal be openly stated. We will then know where we are going. And it will be a short trip. . . .

It would seem that crowding the "family" into five rooms of a ten room house would be whimsical. How long can we afford such eccentricity?

As your editorial accurately appraised radio amateurs as being "somewhat related" to the human race, they do have preferences in their modes of operation, whether deservedly so or not. Further attempts at regimentation, *i.e.*, frequency segregation, would make one wonder if freedom in this direction is not more fancied than real.

Preferences as to mode might be accurately determined, if we had the figures on equipment sold over the past few years. . . . That to say some steps should be taken in the direction of finding out who-wants-to-work-what-mode-in-what-frequencies should not forthwith be classified as glaring heresy. However, from comments heard on the band, mostly in the order of pleas for operating space, none of these "outbursts" see the light of printers ink in the Amateur Press. Why is that?

From personal experience it has been evident that matters that tend to cause expressions seemingly "radical," *i.e.*, expansion of phone frequencies, are never to be read about in the fraternity's publications. Some "spokesmen" for the Art have even told ham gatherings that outspoken opinions on the air would lead to curtailment of amateur operations. Nice?

If more articles like "A careful look at S.S.B." reach the amateur readers some realism in our frequencies allocations considerations might seep down to the level of the policy-makers, *i.e.* sponsors of the 15 kc segregation on 14 mc.

To your attempt to bring about saner and more practical approaches to our problems let me conclude by saying . . . Good Show!

Leonard Collett, KZ5LC
Box 736, Balboa,
Canal Zone

Special Nets

Editor, CQ:

What gives with all these special nets? First it was c.w. nets, phone nets, then it went to s.s.b. nets, RTTY nets, traffic nets, etc. Then, for some reason or other boredom, I guess the chess-players, the weather forecasters, the doctors, the teen agers, and now, finally, the dentists, all formed their own nets. The only thing I haven't run into is fish nets! Come to think of it, I have, too!

Well, if you can't lick 'em, join 'em!

I trap pigeons commercially, and buy cats wholesale. Anybody interested in forming a net in either category?

Eugene Austin, WØLZL
Oakdale, Nebraska

Announcements [from page 22]

Corrections

The specifications for the transformer in the "Spectroscan" in last month's issue were omitted. They are as follows:

T₆—Triad F-25X, 12.6 v.c.t. @ 1.5a.

T₇—Special Dumont Scope transformer. Barry Electronics Stock nr. DSX-335 FNJ.

T₈—Stancor P-6134, 6.3 v.c.t. @ 1.2a.

W4RDM advises that an error exists in fig. 1 on page 80 of the May issue. R₇ should be labeled 15K instead of 5K.

Our apologies for reversing fig. 1B and fig. 2B of "A High Output Linear Amplifier" on pages 42 and 43 of the September issue.

The correction appearing on page 18 of the October issue failed to indicate the article. The article in question is "Modulation Analyzer" p. 37 of the January issue. Again, our apologies.

Here it is! **THE NEW
GONSET "GOONEY BIRD"
WITH MORE POWER
AND VERSATILITY!**

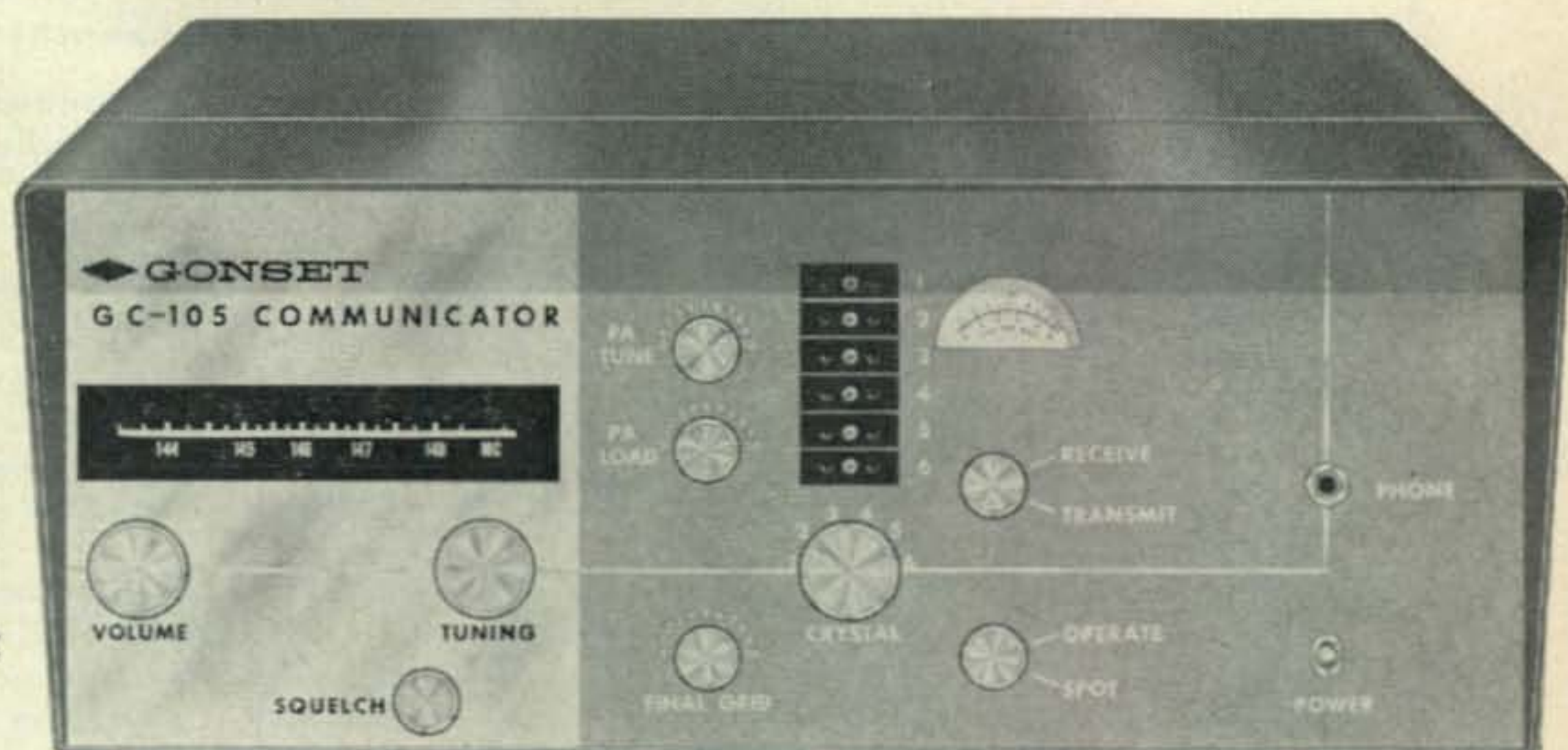

\$239⁵⁰
Amateur Net

Famous for more than a generation, the new Gonset "Gooney Bird" sets even greater standards of performance. It provides a complete station, with transmitter, receiver and self-contained power supply and a new low silhouette for convenient under-dash mounting. You get top performance at a moderate cost—plus built-in Gonset reliability.

The 2 meter Gonset GC-105 "Gooney Bird" offers these deluxe features:

Silicon diodes to save current drain • calibrated tunable receiver utilizes low-noise 6BZ8 RF tube in sensitive "Cascode" circuit • AVC is applied to avoid possibility of blocking by strong local signals • special gang-tuned circuits give high image rejection • dual purpose meter automatically switches from relative signal strength to relative output • increased modulation capabilities with high level clipping • all tunable circuits controlled from front panel • tune-up procedure simplified by use of broad-banded exciter stages • completely compatible with Gonset's new model 3357 VFO or 6 crystal positions available.

Input: 6/12 DC or 115 AC volt operation, power cables supplied

Output: 6 watts nominal

Dimensions: 6½" high, 15½" wide, 8" deep

See the all-new Gonset GC-105 at your Gonset Distributor NOW!



GONSET[®]

DIVISION OF YOUNG SPRING & WIRE CORPORATION

801 SOUTH MAIN STREET, BURBANK, CALIFORNIA

For further information, check number 36, on page 163

E-Z WAY QUALITY SERVES YOU BEST... Year After Year!

- NO GUYS
- TILTS OVER
- CRANKS UP & DOWN

55,000 PSI HIGH TENSILE
STEEL FOR MAXIMUM
STRENGTH!

CHALLENGER

Standard duty two section Tower. Cranks up to 40' and down to 24'. Will support 3 el., 15 M Mini-beam or 3 el. tribander at 40' in winds up to 50 mph without guys.

Model RBD 40-P (painted) \$ 99.50
Model RBD-40-G (galv.) 134.50
Model with GPK D-40..... 50.00
or BAK-D (building attach kit). 6.75

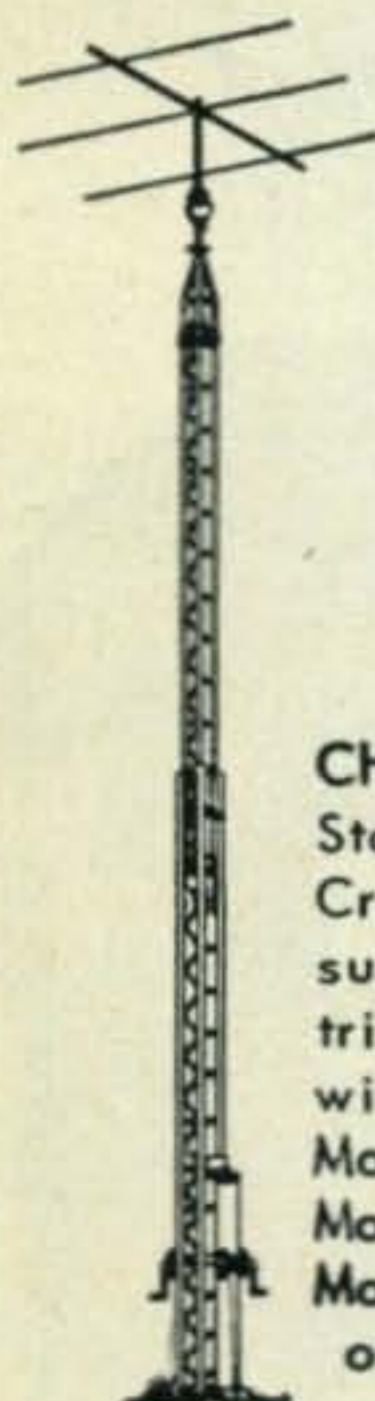

RBD-40

HOT DIPPED GALVANIZED
AFTER FABRICATION.

MEDALIST "40"

Sturdy two section tower. Cranks up to 41 ft. and down to 24 ft. Supports a triband or equivalent at 41' in 70 mph winds or 125 mph when cranked down.

Model RBS-40P (painted).....\$169.50
Model RBS-40G (galv.)..... 209.50
Model GPK-S40 (ground post).... 75.00
Model BAK-S40 (building attach).. 10.50

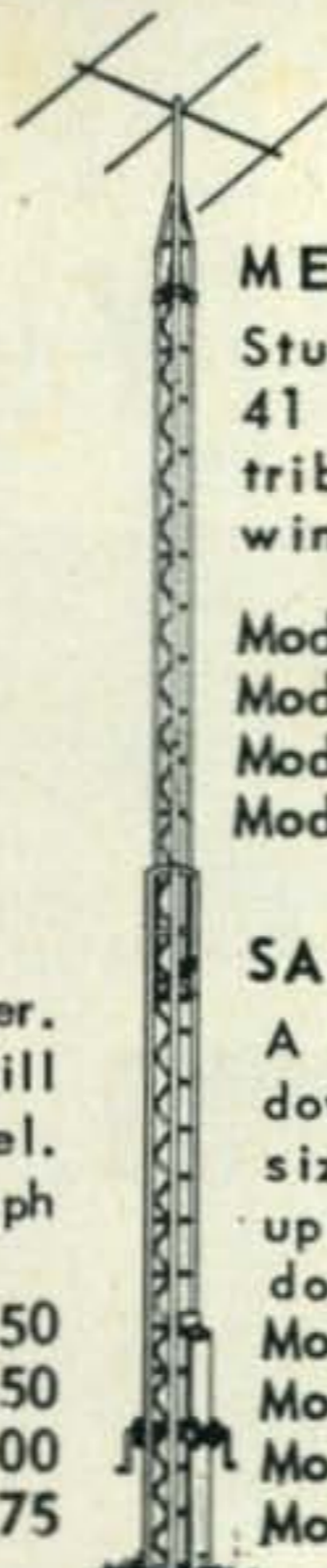

RBS-40

SATELLITE "60"

A 3 section tower. Cranks up to 58' and down to 25'. Will support a 4 el., 20M full size beam or a 6 el. triband at 60' in wind up to 60mph. . .NO GUYS! 140mph cranked down.

Model RBX 60-3p (painted).....\$335.00
Model RBX 60-3G (Galv.)..... 410.00
Model GPK 60-3 (ground post).... 120.00
Model BAK-X (building attach).... 17.00

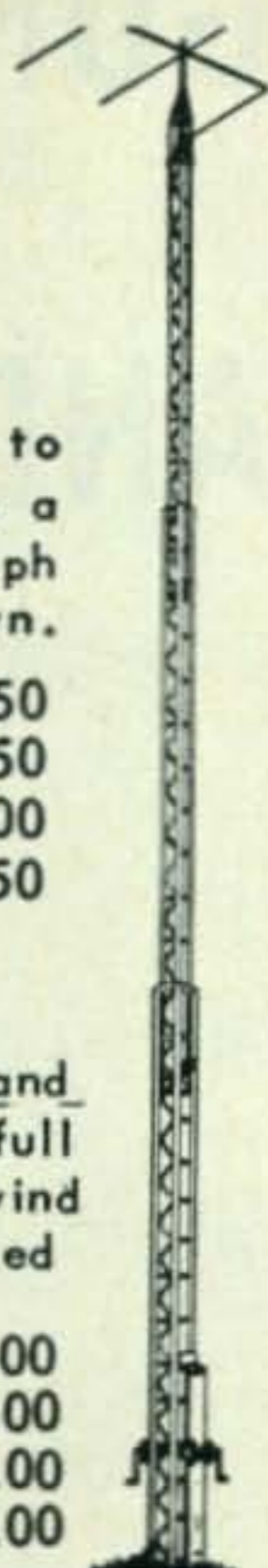

RBX-60-3

THE TOWER WITH ALL THE PLUS FEATURES

- * Self-supporting to 34 ft.
- * Famous E-Z Way Rotor Head.
- * Light weight 10 ft. section weighs only 29 lbs.
- * Climbable ladder on three sides.

NEW "HP" Economy Series

The HP series is a low cost Ham tower that is built to take it. The famous E-Z Way design has incorporated 55,000 PSI steel into the manufacture of all towers. Light weight and easy to erect. Hot dipped galvanized, electric arc welded and comes complete with base plate and wall bracket.

Model HP-34

only \$84.95

Model HP-44.....101.90
Model HP-54.....118.85



HP

G-10

G-10. . . FOR HAM, CB, TV or TWO WAY.

E-Z Way's "G-10" is all NEW! Here is the Tower designed to take it, with durability built-in every inch of its superb construction. 55,000 PSI steel ... X-Type bracing ... Light weight, 10 ft. sections weigh only 29 lbs. These are only a few outstanding features that make this tower the strongest of its kind in the field. Fast, easy erection, up to 280 ft. guyed, or 40 ft. self-supporting. Completely electric arc welded and hot dipped galvanized after fabrication.

The NEW "Stack Pole" lets you really get up there!

DETAILS TO BE ANNOUNCED
1962

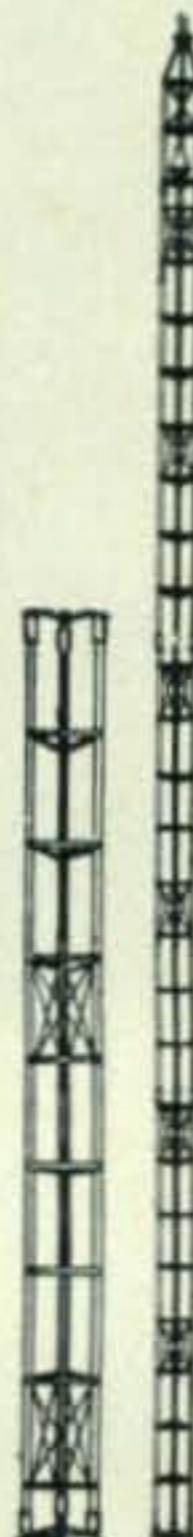
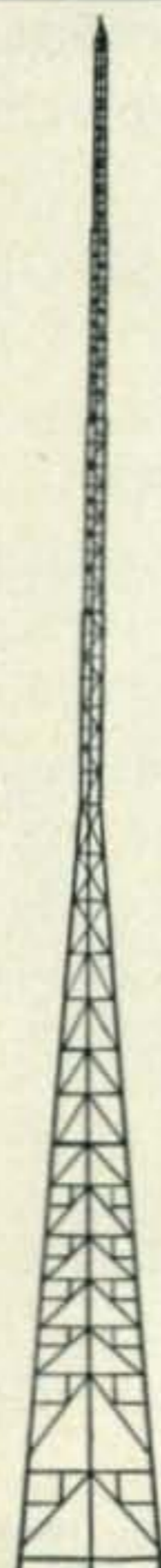

G-10

WRITE FOR COMPLETE DETAILS ON ALL E-Z WAY TOWERS.

E-Z WAY TOWERS, Inc.

P.O. BOX 5767

TAMPA 5, FLORIDA

For further information, check number 37, on page 163



SEE IT HERE!

NATIONAL'S NC-155

New Ham Band Receiver

THE PERFORMANCE PACE SETTER OF THE YEAR

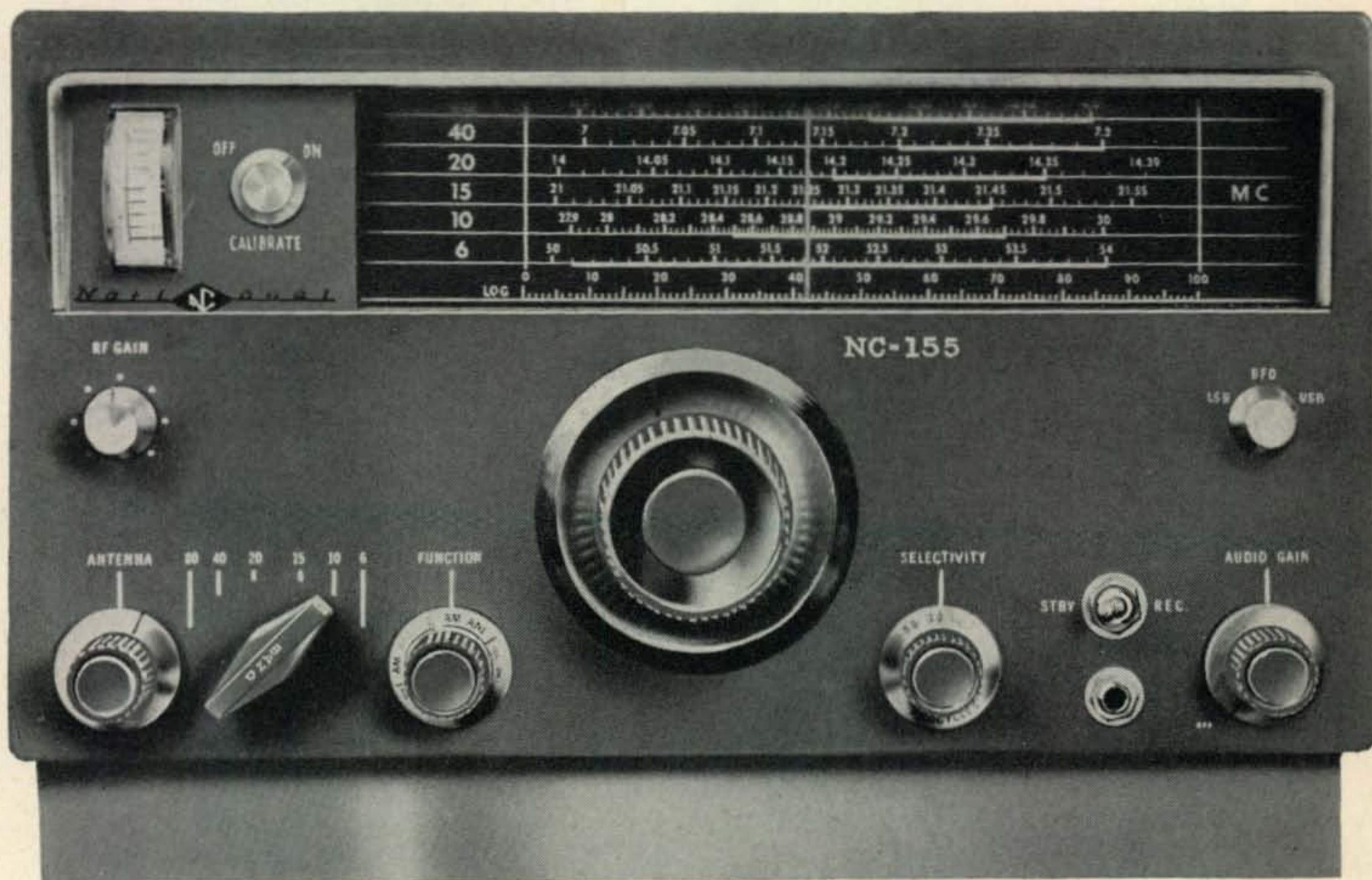

See inside back cover for more details!

Come in for a demonstration

KINCADE RADIO SUPPLY

1719 Grand Central Avenue
Tampa, Florida
TA 8-6043

1354 Laura Street
Jacksonville, Florida
EL 5-1594 — EL 5-1595

For further information, check number 38, on page 163



Priced
at only

\$279

THE NEW, COMPACT
Loudenboomer
MARK II RF
LINEAR AMPLIFIER

...TAKES LESS SPACE
...GIVES YOU MORE POWER!

New EIMAC ZERO-BIAS TRIODE TUBE
and modern simplified circuit design.

No screen or grid power supply needed. Operates with 2500 to 3000 volt plate supply. Use your existing plate power supply and have a new, compact, full kilowatt transmitter at a moderate price.

FEATURES

- Maximum legal input
- Modern EIMAC 3-400 Z triode, 400 watt plate dissipation.
- Grounded grid circuit.
- Wide band input circuit—50 ohm all bands.
- 45 watts of drive for full input.
- Bandswitching, 80-40-20-15 and 10 meters.
- Height 7 $\frac{1}{8}$ " , width 14 $\frac{1}{8}$ " , depth 12 $\frac{7}{8}$ " .
- Two-tone gray enamel "Eye-Appeal" styling.
- All controls on front panel.
- Metering: Grid current, plate current, plate volts, and relative power output.

All products of Radio Industries Inc. are unconditionally guaranteed against any defects in material or workmanship for a period of 90 days.

The LOUDENBOOMER Mark II
is your best buy!

See your distributor... NOW!



RADIO INDUSTRIES INC

1307 CENTRAL AVENUE
KANSAS CITY, KANSAS

(3084)

For further information, check number 16, on page 163

DX [from page 74]

- KG6IF** Iwo Jima AFB, APO 815, San Francisco, Calif.
KH6EDY .. (Kure Island) Operator, Jim, via VE7ZM; Operator, Bob, via W5QK
KL7CGB .. Box 46, Navy 230, Seattle, Washington
KP4BCA .. (K0QHF/KP4) Bill Nielsen, USAG & Tech Svc. Antilles APO 851, N.Y., N.Y.
KR6KL ... Detachment 2, 27th Comm. Sqdn., c/o SAC Liaison Office APO 239, San Francisco, Calif.
ex-KS6AG . Dotty Kellen, WA6FRU, 1836 N. Arthur Ave., Fresno, Calif.
KW6DB ... Wade Holcomb, Box 1266, Navy, FPO San Francisco, Calif.
KX6DB ... Box 1266, Navy 824, FPO, San Francisco, Calif.
KZ5RH ... Ray, Box 841, Ft. Kobbe, Canal Zone
LU1ZL via W9LGR
MP4QAQ .. via W2JXH
OYSRJ Box 184, Torshavn, Faeroe Islands
PJ2AF via K4OGT
PY5FO Box 54, Curitiba, Brazil
PY7NC Box 285, Josa Pessoa, Brazil
PZ1BR Box 1842, Paramaribo, Surinam
SM5ZS/4U . Uner Gaza, Palestine, UNTEF, Base PO
SP6FZ via W2JWK
SV0WG ... Ray Allen, USASG, JUAMAGG, APO 223, N. Y., N. Y.
SV0WO ... Bailey, APO 223, N. Y., N. Y.
TI2J via K5PSO
TL8AC via W8KML
TTSAG via W3KVQ
VE0MC ... Stonetown ARC, 202 Harbour Rd., Victoria, B.C., Canada
VK9AM ... L. L. McInnes, Nauru, Central Pacific
VK9PC via W0AKR
VK0VK ... via K2QXG
VP5BL/5 .. (Cayman DXpedition) via W3AYD
VP5GP ... Grand Turk AAFB, GMRD Box 4187, Patrick AFB, Fla.
VP5LG Grand Turk Is. Navy 104, FPO, N. Y., N. Y.
VP5MJ Dr. John Manley, Oracabessa, Jamaica, BWI
VQ8BR 160 Monaco Rd., Melbourne, Fla.
VR5RZ via VK4RZ
VS1 QSL Bureau, QSL Manager, Box 777, Singapore
W2EQS ... will try to help anyone who needs a QSL from CM8EM/CO8EM
XT2A Box 300, Bobo Haute Volta, Upper Volta Republic, West Africa
ex-YI2AM . G. C. Voller, 426 London Rd., Isleworth, Middlesex, England
YJ1ZA via VK2QJ
YN0KCV .. via K4KCV
YN0NWO .. via W8NWO
YV1EM ... Box 172, Maracaibo, Venezuela
YV3EC Box 445, Barquisimeto, Lara, Venezuela
YV4DF Gus Lovena, Box 4523, Maracay, Venezuela
YV5AIP ... Box 8026, Caracas, Venezuela
YV5AJK .. Box 8026, Caracas, Venezuela
YV5ANQ .. Box 8026, Caracas, Venezuela
YV5AQS .. Box 8026, Caracas, Venezuela
YV5AXO .. Box 8026, Caracas, Venezuela
YV5BED .. Box 8026, Caracas, Venezuela
ZE4JN via W5RHW
3A2BZ via DL9KP
3A2DA via HB9AAW
4S7OE Box 907, Colombo, Ceylon
ex-5A1TS . via W4DPX
5A4TH via K5ODD
5RSCH via FB8BC
7G1A/TZ .. QSL to OK1PD, c/o CAV, Box 69, Praha, Czechoslovakia
9G1DE Box 128, Dunkwa, Ghana
9K2AD Box 402, Kuwait
9K2AM Box 146, Kuwait, Persian Gulf
9M2GR ... Garrison HQ, Minden Barracks, Penang,
(ex VS1JV) Malaya

From Polytronics:

THE POWERFUL POLY-COMM "62" B, VHF TRANSCEIVER

**For Novice, Technician and General
COVERS BOTH THE
6 AND 2 METER
BANDS**



**Rugged...dependable...
feature by feature the
Poly-Comm "62" B outclasses them all!
O.C.D.M. Approved.**

The unbeatable Poly-Comm "62" B covers 250 kc either side of both bands for C.A.P. use . . . it has 18 watt power input . . . S meter doubles as tune-up meter, actually samples R.F. for maximum output . . . 100% plate modulation . . . V.F.O. or crystal control for transmit . . . built-in 115 VAC/12 VDC power supply . . . triple conversion on two, dual on six . . . (crystal controlled) . . . delayed AGC . . . all oscillators voltage regulated . . . squelch and automatic noise limiter . . . sensitivity: better than .8 microvolts on two, better than .2 on six for 10 db S/N/N ratio . . . selectivity: (6 kc @ 6 db pt.) and stability assured by all temperature compensated circuits and Hi-Q IF stages utilizing 12 tuned circuits . . . single knob bandswitching . . . sparkling modulation for solid contacts . . . complete with under-the-dash bracket and ceramic microphone.

\$349.50 amateur net COMPLETE

O.C.D.M. Model "62" CD...\$349.50 COMPLETE

Antennas: PCA-251: (illustrated) Whip only. 2 & 6 meter dual band antenna. Standing wave ratio 1.1 to 1 at resonance and no greater than 1.5 to 1 at any point in the band. **\$13.95**

PCA-249: Same as above with cowl mounting. Complete with 15 ft. RG-58/u cable and PL/259 connectors at both ends. **\$21.95**

PCA-250: Same as above with standard stud, ball mount, cable and connectors. **\$23.95**

At your electronics parts distributor or write for complete specifications to:

Clifton, N. J. • Phone: 772-1334

POLYTRONICS
LAB inc.

Manufacturer's Buyers Guide

ON the following pages are listed major manufacturers of amateur radio equipment and many of their products. In most cases a brief description of the equipment has been given. This list should be taken only as a representation of the complete line of the manufacturer; rather than a full catalogue of products produced.

Next to each manufacturer's name is a key number which may be used in procuring further information. These numbers may be circled on page 163, the coupon then cut out, and mailed to CQ, attention Reader Service Dept. These requests will then be forwarded to each manufacturer.

American Crystal

P.O. Box 2366
Kansas City 42, Missouri

Crystals—Two way communication crystals from 1000 kc to 60 mc. Custom made to major equipment of all leading manufacturers of communication equipment.

Astatic Corporation, The

Conneaut, Ohio

Microphones—Model 77 dynamic cardoid microphone. Output level at 1000 c.p.s.—52 db. Essentially flat frequency response range 30-15,000 c.p.s. Built in on-off switch with "lock-on" position. Suited primarily for quality audio reproduction in single sideband applications.

Model D104—The radio amateur's first choice. Available separately or in combination with Astatic "G" grip to talk stand. Balanced performance for maximum intelligibility throughout the voice range. Crystal.

Model 10-C (ceramic), **10-D** (dynamic)—Tailored response for higher talk power and balanced sibilance for ideal reproduction of speech. Outstanding performance when used with both s.s.b. and a.m. transmitters.

Model 331—Excellent mobile microphone. Has built-in momentary-on, spring-return switch. Die-cast black housing and grille with chrome cap. Complete with hang up bracket. Output—56 db. Frequency range 300-5,000 c.p.s. High impedance. Cable provides for audio and relay connections.

Model 150—(Crystal) Grey plastic body, aluminum anodized grille. Output level—44 db. Output impedance high (1.5 megohms). Frequency response range 30-10,000 c.p.s. 5 ft. extra flexible single conductor shielded cable.

Model 151—(Ceramic) Plastic grey body, black metal grille. Output level—48 db. Output impedance high (1.5 megohms). Frequency response range 30-8,000 c.p.s. 5 ft. extra flexible single conductor shielded cable.

Barker and Williams, Inc.

Canal Street and Beaver Dam Road
Bristol, Pennsylvania

101

Model 5100-B—Transmitter covering 80-10 meters bandswitching with either v.f.o. or crystal. Provides 145 watts input on a.m. and 180 watts c.w. Adaptable to s.s.b. when used with the B&W 51SB-B sideband generator.

Model 51SB-B—Single sideband generator designed for use with the B&W 5100-B transmitter. Draws power from the transmitter.

Model 51S-B—Similar to above with self contained power supply. Modification kits and step-by-step instructions available for most popular transmitters in the 100-200 watt class.

Model LPA-1—Table-top kilowatt linear amplifier designed for s.s.b. use. No larger than the average receiver, smartly styled cabinet. Less power supply. (Below)

Model LPS-1—Power supply unit for above linear amplifier. Can also be used in other applications requiring 1 kw d.c. power.

Model 600—Grid dip meter with self contained power supply. Covers 1.75-200 mc in 5 plug-in coil selected bands. Specially shaped cabinet for working in cramped corners. Color coded and keyed dial, makes frequency readout foolproof.

Model 650-651—Matchmaster. A versatile instrument combining dummy load, direct reading r.f. wattmeter and s.w.r. bridge. Useful from 500 kc to 30 mc at powers up to 125 watts.

Central Electronics, Inc.

1247 West Belmont Avenue
Chicago 13, Illinois

104

200V—Phasing type s.s.b. transmitter. 200 watts p.e.p. permeability tuned v.f.o. for extreme stability and linear dial calibration. Built-in monitoring scope. Band switching broad-banded circuits make band changing a matter of seconds. Covers 80-10 meters.

20A—Basic bandswitching s.s.b. exciter provides 20 watts p.e.p. Phasing type unit with v.o.x. and tuning eye built-in. No v.f.o.

10-B—Plug-in-coil type s.s.b. generator useable on all bands. Phasing type unit. Crystal controlled. Built-in v.o.x. 10 watts p.e.p.

MM-2—R.F. analyzer scope provides a visual check on any a.m. or s.s.b. signal, either as it is transmitted or as it is received. Check for splatter, flattopping, distortion, etc.

103

Clegg Laboratories, Inc. 105
Route 53
Mt. Tabor, New Jersey

Zeus V.H.F. Transmitter—Covers 6 and 2 meters. 185 watts on a.m. Highly stable v.f.o. Incorporates the famous Clegg speech clipping for up to 18 db audio clipping. Power supply separate. \$675.00

Interceptor V.H.F. Receiver—For 6 and 2 meters provides excellent stability and sensitivity (.25 microvolts) with practically no cross modulation. Puts the selectivity up where it does the most good; the front end. \$440.00

Clegg 99'er—Transceiver for six meters. Incorporates double conversion receiver offering high sensitivity and selectivity as well as freedom from images and cross modulation. The 8 watt transmitter employs a stable 8 mc crystal oscillator which may also be used with an external v.f.o. A combination S-meter/tune-up meter makes operation convenient. \$139.95

Collins Radio Company 106
Cedar Rapids, Iowa

Transmitters

30L-1 Linear Amplifier	\$520.00
30S-1 Linear Amplifier	1556.00
32S-1 Transmitter	666.00
32S-2 Transmitter	746.00

Receivers

75S-1 Receiver	\$520.00
75S-3 Receiver	620.00

Transceivers

KWM-2 Transceiver	\$1550.00
KWM-2 with 136B-2 Noise Blanker	1296.00

Speakers

312B-3 Speaker (S-Line)	\$32.00
312B-4 Speaker Console (S-Line, KWM-2)	195.00
312B-5 P.T.O. Console (KWM-2)	350.00
399C-1 P.T.O. Speaker	164.00

Wattmeters

302C-3 Directional Wattmeter	\$130.00
------------------------------------	----------

Columbia Products Company 107
Subsidiary of Shakespeare Company
R.F.D. 3
Columbia, South Carolina

Style 62—Distributed load fiberglass whip antennas with loading coils molded into length of antenna. Available for all bands from 10-80 meters. Ten and fifteen meter models (nos. 62-3 and 62-4) are only 4' long, 20, 40 and 80 meter models (nos. 62-5, 62-6, 62-7) are 6' long. Also available are 8' long 40 and 80 meter whips (nos. 62-8, 62-9). Prices: 4' models \$15.90, 6' models \$18.75, 8' models \$21.00.

Style 56-1—2 meter coaxial-type antenna providing 3 db gain over dipole. Cowl or bumper mounting fiberglass antenna is 50³/₈" high. Unit includes 10' of RG-58/U with either UHF or BNC connector. Fits standard mounts \$18.75.

Style 85-1—Similar in characteristics to above antenna except 53¹/₄" long and comes equipped with ball mount and flange for cowl mounting.

Cable passes through flange and ball. \$25.50.
Style 10—Mobile whip antenna and base extensions. 54"-60" #10-1, \$5.75, 60"-104" #10-2, \$6.95; 18" extension #29-1, \$4.80; 27" extension #29-2, \$5.48; 36" extension #29-3, \$5.82.

Cubex Company 108
3322 Tonia Avenue
Altadena, California

MK III Three Band Cubical Quad antenna for 10-15-20 Meters	\$67.50
MK III Three band cubical quad antenna for 10-15-20 meters for single feedline operation	67.50
MK II Dual Band Cubical Quad Antenna for 10-15 meters	49.50
Quad Foundation Kit (basic quad support structure for quad builders—spiders, boom & boom-mast coupler) ..	27.50
Quad End Spiders (heat treated cast aluminum quad spiders to fit 2" O.D. boom) w/8 radial arm clamps	7.50

Cush Craft 109
621 Hayward Street
Manchester, New Hampshire

Full Size Monoband Beams

10 Meter, 3 element, Model No. A28-3	\$28.50
10 Meter, 4 element, Model No. A28-4	42.50
15 Meter, 3 element, Model No. A21-3	32.50
20 Meter, 2 element, Model No. A14-2	45.00
20 Meter, 3 element, Model No. A14-3	62.50

V.H.F. Beams

2 Meter, 11 element, Model No. A144-11	\$12.75
2 Meter 7 element, Model No. A144-7	8.85
1 ¹ / ₄ Meter 11 element, Model No. A220-11	9.95
³ / ₄ Meter 11 element, Model No. A430-11	7.75

V.H.F. Dual Stacks

2 Meter, 22 element Dual, Model No. A144-11D	\$29.00
2 Meter, 14 element Dual, Model No. A144-7D	21.25
1 ¹ / ₄ Meter 22 element Dual, Model No. A220-11D	22.90
³ / ₄ Meter 22 element Dual Model No. A430-11D	18.50

V.H.F. Quad Arrays

2 Meter 44 element Quad, Model No. A144-11Q	\$76.00
2 Meter 28 element Quad, Model No. A144-7Q	62.50
1 ¹ / ₄ Meter 44 Element Quad Model No. A220-11Q	54.50
³ / ₄ Meter 44 element Quad Model No. A430-11Q	43.00

6 Meter Beams

6 Meter 5 element, Model No. A50-5	\$19.50
6 Meter 6 element, Model No. A50-6	32.50
6 Meter 10 element, Model No. A50-10	49.50
6 Meter 3 element, Model No. A50-3	13.95
6 Meter 3 element portable Model No. A50-3P	10.95

V.H.F. Mobile Halos

2 Meter with mast, Model No. AM-2M	8.70
2 Meter stacked complete Model No. AM-22	14.95
6 Meter Less mast Model No. AM-6	8.75
6 Meter with mast Model No. AM-6M	12.50
2 & 6 Meter Dual Halo Model No. AM-26	17.45
6 & 2 meter 10 element beam Model No. A26-9	27.50

V.H.F. Colinear Arrays

2 Meter 16 element, Model No. CL-116	\$16.00
1 1/4 Meter 16 element, Model No. CL-216	12.85
3/4 Meter 16 element Model No. CL-416	9.85

32 Element Colinear Arrays

2 meter, 32 element stacking kit, Model No. CK-132	\$32.50
1 1/4 meter 32 element stacking kit, Model No. CK-232	32.50
3/4 meter 32 element stacking kit Model No. CK-432	19.95

64 Element Colinear Arrays

2 Meter 64 element stacking kit, Model No. CK-164	\$69.50
1 1/4 Meter 64 element stacking kit, Model No. CK-264	59.50
3/4 Meter 64 element stacking kit Model No. CK-464	29.95

Amateur Ground Planes

6 Meter, ground plane, Model No. AGP-6	\$10.50
10 Meter ground plane, Model No. AGP-10	13.50
15 Meter ground plane, Model No. AGP-15	14.75
20 Meter ground plane, Model No. AGP-20	16.50
Tri band ground plane, 10-15-20 Model No. ATGP-3	28.50

"Blitz Bug" Coaxial Lightning Arrester
Model No. LAC-1, with type 83 UHF connectors 3.95

Dow Key Company

Thief River Falls, Minnesota

DK60 —Coaxial relay, u.h.f. connectors	\$12.45
DK60-G —Coaxial relay, u.h.f. connectors, receiver protecting connector	13.70
DK60-G2C —Coaxial relay, u.h.f. connectors, d.p.d.t. 5 amp external contacts, receiver protecting connector	15.65
DK60-T2 —Coaxial relay, u.h.f. connectors, 1 kw rating in both the normal receive and transmit positions. Used basically for antenna transfer etc.	12.45
DK60-T2C —Same as DK60-T2 but has d.p.d.t. 5 amp external contacts	14.35
DKC-TRM-1 — Electronic antenna change-over switch, UHF connectors 6 volt filament, 125 to 150 v B+, 1 kw 1.5 through 30 mc, external power source required	12.50
DKC-TR-2A —Same as DKC-TRM-1 but for operation 144-148 mc.	12.50
DKC - TRP — Electronic antenna	

switch in operation to DKC-TRM-1 except the "TRP" has built-in power supply, 115v.a.c. cord included 27.75

DKC-TRP-C — Electronic antenna switch, built-in power supply, 1 kw average, 1.5 through 30 mc, UHF connectors, with built-in direction coupler (Patent applied for) to preclude possibility of loss in receiver signal strength through coupling to transmitter, complete with 115v.a.c. cord. 37.95

DKC-TRM-1C—Same as DKC-TRP-C but requires external power source .. 22.70

DKC-RFB—Coaxial pre-amplifier (r.f. booster) 10.75

E-Z Way Towers, Inc.

111

5901 E. Broadway
Tampa, Fla.

E-Z Way can supply towers of all types and sizes suitable for amateur work. These types include tiltover towers and building anchored towers, painted or galvanized finishes, and heights varying from 40' to 73'. Various strength towers are also offered enabling the amateur to select a model that will adequately support his specific antenna system.

Eddystone Radio

112

Imported by: British Radio Electronics Ltd.
1833 Jefferson Place
N. W. Washington 6, D. C.

No. 898—Geared slow motion dial drive assembly excellent for receivers and v.f.o.'s. A high grade assembly, the movement is manufactured to fine tolerances for smooth, free, flywheel tuning. 110 to 1 tuning ratio with 5 slide rule type dial scales.\$16.50

Editors & Engineers Ltd.

113

Summerland, California

Radio Handbook, 15th edition	\$8.50
Surplus Radio Conversion Manual, Volume I	3.00
Surplus Radio Conversion Manual, Volume II	3.00
Surplus Radio Conversion Manual, Volume III	3.00
The Surplus Handbook, Volume I (Receivers & Transceivers)	3.00

EICO

114

33-00 Northern Boulevard
Long Island City 1, N.Y.

Model 723—60 watt c.w transmitter featuring band switching, v.f.o. power take off. 80 through 10 meters. Provision for external modulator input.

Model 720—A stable high efficiency unit housed in a modern "low silhouette" cabinet, providing 90 watts on c.w. 80 through 10 meters and is bandswitching. External plate modulation terminals provide up to 65 watts input on a.m. when a suitable modulator is connected.

Model 730—Low cost modulator delivering 50 watts of undistorted audio signal for phone operation—more than sufficient to modulate 100% the EICO Model 720 90 Watt c.w. transmitter, EICO Model 723 60 Watt c.w. transmitter or any transmitter whose r.f. amplifier has a plate input power of up to 100 watts. It features low lever speech clipping.

Model 722—Self powered variable frequency oscillator provides full coverage of the five bands from 80 to 10 meters in six ranges (the 10 meter band being covered in two ranges). Output is high enough to drive any modern transmitter on all the bands.

Model 710—Grid dip meter that determines frequency of other oscillators or tuned circuits, has a sensitivity control and phone jack to facilitate "zero beat" listening and excels as an absorption wave meter. Ham uses: pretuning and neutralizing transmitters, power indication, locating parasitic oscillations, antenna adjustment, correcting TVI, general debugging with transmitter power off, determining *C*, *L*, *Q*.

The Finney Company 115
34 West Interstate St.
Bedford, Ohio

- V.H.F. Antennas**
- A6-4 6 meters, 4 elements 8.0 db gain .. \$17.16
 - A2-10 2 meters, 10 elements 9.0 db gain 11.88
 - A1¼-10 1¼ meters, 10 elements 9.0 db gain 11.88
 - A62 Combination 6 and 2 meter beam of interlaced design. Four elements on 6 meters for 8.0 db gain and 18 elements on 2 meters for 15.0 db gain at 146 mc. 33.00

Globe Electronics Mfg. Co. 116
400 S. Wyman St.
Rockford, Ill.

Model 65-402—Globe Scout Deluxe Transmitter. Bandswitching 6-80m transmitter. 90 watts c.w., 75 watts phone input power. Final amplifier works straight through on all bands. High level plate modulation. Pi-Network output on 10-80 meters, efficient tuned link coupled output on 6 meters, matching low impedance beams.

Model 65-403—Globe Chief Deluxe. Modern new self-contained 90 watt transmitter for c.w., bandswitching 10-80 meters. 75 watt meter indication for novice use.

Model 65-409—Globe King 500C Transmitter. Completely Bandswitching 10-160m 540 w. am & cw: 700w max. on dsb or ssb (pep), with 15-20w external exciter.

Model 65-412—Universal Modulator. Class A or AB-2 modulator, driver for higher power modulator, or P.A. amplifier. Matches output impedances 500-20,000 ohms. Carbon or crystal mike usable. Supplies up to 40w audio.

Model 65-401—Variable Frequency Oscillator covers 6 through 160 meters. r.f. output will drive oscillator stage of any transmitter on the market.

Gonset Company 117
Div. of Young Spring & Wire Corp.
801 S. Main Street
Burbank, California

Communicator IV Complete, compact v.h.f. station for mobile or home station use. Runs 20 watts input to 6360 final on a.m. Sensitive receiver features triple conversion a.n.l., squelch Two meter model. \$369.00

Communicator IV 6 meter model. \$349.50

G-76 Transceiver. Advanced design a.m., c.w. mobile transceiver. Bandswitching 80-6 meters. 100 watts a.m. 120 watts c.w. V.f.o. 80-10 Stable, sensitive dual conversion receiver. Less power supply. \$399.50

GSB-201 Table-top kilowatt linear amplifier. Bandswitching 80-10 meters. Features 4-811A's in stable grounded grid circuit for 1.5 kw p.e.p., s.s.b. 1 kw, c.w. and 400 watts a.m. \$399.50

G-33 Low cost general coverage receiver for beginner and s.w.l. Covers 550 to 34 mc in 4 ranges. Bandspread dial calibrated for ham bands. 5 tubes plus rectifier. \$69.95

GE43 Moderately priced general coverage receiver covering 540 kc to 30 mc Drum type bandspread dial calibrated for ham bands. Extra scale for 2 and 6 meters. 7 tubes plus rectifier. \$99.50

G-63 Ham bands-only communications receiver covering 80 through 6 meters, exceptional sensitivity and s/n ratio on all bands. Product detector for s.s.b. and c.w., diode-type detector for a.m. Double conversion *Q*-multiplier, a.v.c., a.n.l. "S" meter, 9 tubes. \$239.50

Gotham 118
1805 Purdy Avenue
Miami Beach, Florida

- Two Meter Beams**
- D26N—6 elements, 11.3 db gain \$ 9.95
 - D212N—12 elements, 14.2 db gain 16.95

- Six Meter Beams**
- S63N—3 elements, 8.2 db gain 12.95
 - S64N—4 elements, 9.4 db gain 16.95

- Ten Meter Beams**
- S102N—2 elements, 6.5 db gain 11.95
 - S103N—3 elements, 8.3 db gain 16.95
 - S104N—4 elements, 9.5 db gain 21.95

- Fifteen Meter Beams**
- S152N—2 elements, 6.6 db gain 19.95
 - S153N—3 elements, 8.1 db gain 26.95

- Twenty Meter Beams**
- S202N—2 elements, 6.4 db gain 21.95
 - S203N—3 elements, 8.0 db gain 34.95

- Vertical Antennas**
- V40 vertical for 40, 20, 15, 10, 6 meters 14.95
 - V80 vertical for 80, 75, 40, 20, 15, 10, 6 meters 16.95
 - V160 vertical for 160, 80, 75, 40, 20, 15, 10, 6 meters 18.95

- Two Bander Beams**
- 6-10 meters—2 elements, 5.8 db gain 29.95

- 10-15 meters—2 elements, 5.8 db gain .. 34.95
 10-20 meters—2 elements, 5.8 db gain .. 36.95
 15-20 meters—2 elements, 5.8 db gain .. 38.95

Tribander Beams

- 6-10-15 meters—2 elements, 6.5 db gain
 on 6m, 7.8 db gain on 10m, 6.5 db
 gain on 15m 39.50
 10-15-20 meters—2 elements, 6.5 db gain
 on 10m, 7.8 db gain on 15m, 6.5 db
 gain on 20m 49.95

Greenlee Tool Co. 119

Rockford, Ill.

A complete line of round, square and special shape chassis punches for the amateur. Available in the round sizes from 1/2" to 3" and square sizes from 1/2" to 1".

Hallicrafters Company 120

5th and Kostner Avenues
 Chicago 24, Illinois

Receivers

- S-107** General coverage receiver covering 550 kc to 30 mc and 48 to 54.5 mc. 8 tubes built-in a.c. power supply and speaker \$94.95
SX-140 High performance, low cost ham band-only receiver. High sensitivity, sharp selectivity, slide rule dial with high tuning ratio. Includes S-meter, crystal calibrator. \$124.95
S-108 General coverage receiver covering 540 kc to 34 mc continuously in 4 ranges. Bandspread dial for 80-10 meters. Single conversion, built-in speaker. \$139.95
SX-110 General coverage receiver, bandspread dial calibrated for 80-10 meters S-meter, crystal filter, one r.f. and two i.f. stages for high sensitivity and selectivity. \$169.95
SX-111 Selectable sideband receiver; double conversion, ham bands only. Covers 80-10 meters with special 6th band for receiving 10 mc WWV. Tee-Notch filter, S-meter, 12 tubes plus v.r. and rectifier. \$279.50
SX-101A High quality deluxe communications receiver offering a high degree of mechanical and electrical stability. Covers ham bands only 80-10 meters with special band for 6 and 2 meter converters. \$445.00
SX-115 Triple conversion receiver employing a bandpass filter front-end. Crystal controlled first and third oscillators, gear driven linear dial mechanism. Ham bands only, 80-10 meters. \$595.00

Transmitters

- HT-40** Low power c.w.-a.m. transmitter for Novice or Old Timer. One knob bandswitching, 80-6 meters, 75 watts a.m. fully metered. \$109.95
HT-37 Moderately priced phasing-type s.s.b. transmitter. One hundred watts p.e.p. output on c.w. or s.s.b. Covers all bands, 80-10 meters. \$450.00
HT-32B Moderate power crystal filter type s.s.b. transmitter/exciter. One knob bandswitching, 80-10 meters. 144 watts p.e.p. Precision gear driven v.f.o. \$725.00

Amplifiers

- HT-41** 1 kw linear amplifier. One knob band-switching, 80-10 meters. Grounded-grid class-B circuit using two 7094's. \$395.00
HT-33B 1 kw input to a single PL 172 in class AB1 may be driven with any 100 watt exciter, built-in power supply. \$995.00

Miscellaneous

- FPM-200** Deluxe s.s.b. transceiver for a.m., s.s.b. and c.w. Fixed, portable or mobile operation. Runs 200 watts p.e.p. 80-10 meters. Employs 39 transistors and 3 tubes. \$1,995.00
HA-2 Transverter changes 10 meter a.m., s.s.b. and c.w. signal to 2 meters. Converts 2 meter signals to 10 for reception. 60 watts p.e.p. requires 10 to 100 watts drive. \$349.50
HA-6 Same as above but for 6 meters. \$349.50
P-26 Power supply for above transverter. \$99.50
HA-5 Deluxe v.f.o. Self-contained, self-powered heterodyne type covering all ham bands. 80-2 meters \$79.95
HA-4 Transistorized "TO" keyer. Employs modern digital computer techniques. 8 transistors and ten diodes combined to produce perfect c.w. \$59.95

Hamboards 121

Box 13158

Pine Castle, Florida

T-2 Transistorized 2 meter converter is available in four options: Kit without case, \$39.95; kit with case, r.f. and power connectors, \$49.95; with case, r.f. and power connectors, assembled and aligned, \$54.95.

Hammarlund Mfg. Co., Inc. 122

460 West 34 Street

New York 1, New York

- HQ-100A**—Receiver only, in cabinet \$189.00
HQ-100AC—Receiver only in cabinet, with clock 199.00
HQ-105TR — Receiver/transmitter, in cabinet 219.50
HQ-105TRC—Receiver/transmitter, in cabinet with 24 hour clock 229.45
HQ-110—Receiver only, in cabinet 249.00
HQ-110C—Receiver only, in cabinet with clock 259.00
HQ-145X—Receiver only, in cabinet .. 269.00
HQ-145XC—Receiver only, in cabinet, with clock 279.00
HQ-170—Receiver, in cabinet, less lock 359.00
HQ-170C—Receiver, in cabinet, with clock 369.00
HQ-180—Receiver, in cabinet, less clock 429.00
HQ-180C—Receiver, in cabinet, with clock 439.00
HX-500—Crystal filter type s.s.b. transmitter 695.00
HX-50—Phasing type s.s.b. transmitter 399.50

Heath Company 123

A Subsidiary of Daystrom, Inc.
 Benton Harbor, Michigan

Transmitter Kits

DX-60 90 watts c.w. or phone, grid block keying, built in low pass filter. Front panel switch selects any of 4 crystals or external v.f.o. Single knob bandswitching 80-10 meters. Fully metered. Controlled carrier modulation.\$ 82.95

TX-1 Apache. A self-contained 150 w. phone, 180 w. c.w. transmitter with built-in v.f.o., power supply and modulator. May be used with s.s.b. adapter. One knob bandswitching 80-10 meters, timed sequence keying, adjustable speech clipping. Excellent for the more advanced amateur.\$239.95

SB-10 Single sideband adapter designed for use with the TX-1 for "plug-in" s.s.b. conversion. May also be used with other a.m.-c.w. transmitters in the 100-200 watt class. Features phasing-type sideband generation, VOX, bandswitching 80-10 meters, panel meter for easy tune-up, 10 w. p.e.p. output.\$ 89.95

VHF-1 Seneca. A completely self-contained v.h.f. transmitter covering both 6 and 2 meters. Runs 120 watts on phone and 140 watts on c.w. Built-in v.f.o. for 6 and 2 with 4 crystal positions selectable from the front panel. Controlled carrier modulation. \$159.95

MT-1 Cheyenne. Mobile transmitter. Up to 90 watts c.w. 80-10 meters. Controlled carrier modulation. V.f.o. operation. Bandswitching 80-10 meters. Fully metered. Requires external power supply. Includes p.t.t. microphone.\$ 99.95

HA-10 Warrior. Full gallon (p.e.p.) linear amplifier. 1 kw c.w., 400 watts phone. Self-contained, desk-top amplifier using 4-811A's. TVI suppressed, forced air cooled.\$229.95

Receiver Kits

AR-3—Low cost general coverage receiver (550 kc—30 mc) Five tube superhet, transformer operated power supply.\$ 29.95

MR-1 Commanche 8 tube amateur bands-only superhet. Designed for mobile operation in conjunction with MT-1 transmitter. \$119.95

RX-1 Mohawk. Deluxe amateur band only receiver. 15 tubes, dual conversion, 160-10 meter coverage with calibrated scales for 6 and 2 meters.\$274.95

Transceiver Kits

HW-20 6 meter transceiver. Double conversion receiver, high selectivity, high stability. Built-in v.f.o. Tunes exciter stages also. 3-way power supply. Ideal for mobile or fixed station use.\$199.95

Hi-Par Products Company **124**
Fitchburg, Massachusetts

Saturn 6 Mobileer The original 3-loop halo for 6 meters provides omni-directional mobile

operation with minimum fade and flutter. Model S-1 antenna with mast, universal bumper hitch, less feedline.\$ 16.95

6 Meter broadband ring antenna. Half wavelength circular antenna for broadband operation around the design center of 50.5 mc. Low s.w.r. for mobile or fixed stations.\$ 14.95

Lunenburg 2-meter halo. Broadband omni-directional 2-meter antenna horizontally polarized. Antenna with mast, less amount.\$ 9.95

Hilltopper New portable 3-element 6-meter beam designed for quick assembly and knockdown on picnics, field day etc. Telescoping elements fold flat onto the sectional boom. Measures only 3½" × 40" when packaged.\$ 11.95

Hy-Gain Antenna Products **125**

1135 North 22nd
Lincoln, Nebraska

V.H.F. Beams

313—432 mc 13 Element Beam\$12.95
111—220 mc 11 Element Beam 13.95
25—144 mc 5 Element Beam 8.95
210—144 mc 10 Element Beam 14.95
65B—6 meter 5 Element Beam 18.95
68B—6 meter 8 Element Beam 32.95

Monobanders

103B—10 meter 3 Element Beam\$32.95
153B—15 meter 3 Element Beam 38.50
203B—20 meter 3 Element Beam 65.95
402B—40 meter 2 Element Beam 99.75

Ground Planes

GP-1C—10 meter ground plane antenna \$32.70
GP-2C—6 meter ground plane antenna 21.90
GP-3C—2, 1¼, ¾ meter ground plane antenna 14.97

Multiband Beams

TH-4—4 element deluxe Thunderbird Tri-Bander for 10, 15 and 20 m\$117.50
TH-3—3 element standard Thunderbird Tri-Bander for 10, 15 and 20 m 89.95
TH-2—2 element Thunderbird Tri-Bander for 10, 15, & 20m 59.95
DB-24—4 Element Duo-Bander for 20 and 40 m 149.50

Rotobrake

RBX-1—Rotator, Brake, Indicator and Control Box (Specify East Coast, West Coast, Central USA or Compass Rose Indicator)\$199.95

Johnson Company, E. F. **126**

Waseca, Minnesota

Viking Adventurer—Kit\$ 54.95
Viking Challenger—Kit 114.75
Viking Challenger—Wired & tested 154.75
Viking Navigator—Kit 149.50
Viking Navigator—Wired & tested 199.50
Viking 10 Meter Messenger—115V wired & tested 129.75

Viking 6N2—Wired & tested	169.50
Viking Ranger II—Wired & tested	359.50
Viking Valiant—Kit	349.50
Viking Valiant—Wired & tested	439.50
Viking "500"—Kit	749.50
Viking "500"—Wired & tested	949.50
Viking Courier—Wired & tested	289.00
Viking Invader—Wired & tested	619.50
Viking Invader hi-power conversion— Wired & tested	619.50
Viking Invader — 2000 — Wired & tested	1229.00
Viking Kilowatt—Wired & tested	1595.00
Viking Thunderbolt—Kit	524.50
Viking Thunderbolt—Wired & tested	589.50
Viking 6N2 Thunderbolt—Kit	524.50
Viking 6N2 Thunderbolt—Wired & tested	589.50
Viking Matchboxes—275 watt—With directional coupler & indicator	86.50
Viking Matchboxes—275 watt—Less directional coupler & indicator	54.95
Viking Kilowatt Matchbox—With di- rectional coupler & indicator	149.50
Viking Phone Patch—Wired & tested	25.00
Viking Directional Coupler & Indicator directional coupler wired	11.75
Indicator wired	25.00
Viking Signal Sentry—Wired & tested	22.00
Viking Low Pass Filter 52 ohms impedance	14.95
72 ohms impedance	14.95
Viking TR Switch—Wired & tested	27.95
Viking 6N2 V.F.O.—Kit	34.95
Viking 6N2 Converter—Wired & tested	89.95

Knight Kits

127

Allied Radio Corp.

100 No. Western Avenue

Chicago 80, Illinois

R-100 Communications receiver kit. Highly sensitive and selective receiver at low cost. General coverage 540 kc to 30 mc in 4 ranges; bandsread on 80-10 meter bands. Built-in Q-multiplier, 7 tubes plus rectifier v.r.\$99.95

R-55 Receiver kit. Ideal for beginners and s.w.l's. General coverage 530 kc-36 mc plus 47-54 mc 6 meter band. Bandsread calibrated for 80-6. Flywheel tuning\$67.50

T-60 60 watt a.m.-c.w. transmitter kit. Band-switching 80-6 meters, provides 60 watts on c.w. or controlled carrier a.m. Built-in power supply fully metered, silicon rectifier power supply. Pi-net output.\$49.95

V-44 Self powered v.f.o. kit. High quality stable v.f.o. Calibrated for 80-10 meter bands with output on 80 and 40 meters. Highly stable Clapp oscillator circuit used.\$29.95

Lincoln 6-meter transceiver. Crystal controlled, 7 watt a.m. transmitter, superhet receiver covering entire 6 meter band, built-in noise limiter and TVI filter with mike and 50.2 mc crystal.\$57.50

G-30 Rugged, versatile grid-dip meter kit cover-

ing 1.5-300 mc in 6 over-lapping ranges. Plug-in coils, color keyed to dial. Adjustable hairline cursor.\$22.95

Lampkin Laboratories, Inc

128

Bradenton, Florida

Model 105B—Micrometer Frequency Meter—A high precision unit capable of measuring frequency in the 100 kc to 175 mc range.

Master Mobile Mounts, Inc.

129

Los Angeles, California

Base Mounts. The 232 series of cowl-type base mounts is available in a wide variety of materials and spring types. Prices range from \$8.75 for the #232 mount with the standard double tapered spring and swivel base to \$15.95 for the #232XXSSC, equipped with an extra heavy duty stainless steel spring and coaxial connector.

Chain Bumper Mounts.

MM 519—Single chain mount, cadmium plated\$ 4.95

MM 520—Double chain mount, cadmium plated 7.95

MM 530—Double chain mount, stainless steel 21.95

MM 531—Single chain mount, stainless steel 11.95

Stainless Steel Whips

100-603—60" long, 3/8" stud\$ 4.95

100-72S—72" long, 3/8" stud 4.95

100-86S—86" long, 3/8" stud 5.15

100-96S—96" long, 3/8" stud 5.25

100-103S—103" long, 3/8" stud 6.95

Loading Coils.

#900—10-75m Multiband loading coil ..\$14.95

#999—10, 15, 20 m only Multiband loading coil 14.95

#333—10-40m Roller-type Multiband loading coil 9.95

#750—10-75m Roller-type Multiband loading coil 14.95

Ultra-Hi Q coils—Single band units for 80-15m 5.25

James Millen Mfg. Co., Inc.

130

150 Exchange Street

Malden 48, Massachusetts

A012—Right Angle Drive for 1/8" Shaft\$ 3.90

J300—Miniature R-F Chokes42

10000—Worm Drive 16:1 or 48:1 9.75

100008—Dial and Know 2.40

10012—Gear Drive 1:1 5.00

10035—Panel Vernier Dial 7.26

10039—Midget Panel Dial 3.24

33207—Ceramic Socket for 829-B 1.12

33405—Ceramic Socket for Eimac Tubes 2.25

33446—Contact Discs for Lighthouse Tubes 5.58

34150—Transmitting R-F Chokes ..1.14 to 1.95

34300—R-F Chokes42

46672—Baluns (Tuned) 7.50

61000—IF Transformers 7.50

74001—Permeability Tuned Coil Form	2.31
74002—Shielded Coil Form	1.89
74400—Octal Base and Shield	1.40
75012—SSB Phase Shift Network	9.75
75016—Audio Clipper	17.50
77083—83 Hash Filter	1.14
77866—866 Hash Filter (pair)	1.41
77872—872 Hash Filter (pair)	1.56
80000—Nicoloi Magnetic Shields	6.90 to 18.90
80070—Bezels for Cathode Ray Tubes	1.50 to 8.40
90201—Low Voltage Power Supply	52.50
90202—High Voltage Supply for Oscilloscope	21.00
90281—High Voltage Power Supply	94.50
90600—Set of Wavemeters 3 to 140 mc	33.00
90605—Absorption Freq. Meter 3 to 10 mc	7.50
90606—Absorption Freq. Meter 9 to 23 mc	7.50
90607—Absorption Freq. Meter 23 to 60 mc	7.50
90608—Absorption Freq. Meter 50 to 140 mc	7.50
90651—Grid Dip Meter	61.50
90671—Standing Wave Ratio Bridge	16.80
90672—Antenna Bridge	45.00
90711—V.F.O.	124.50
90751—Tone Modulator	15.00
90801—Exciter/Transmitter	75.00
90811—VHF Amplifier	45.00
90881—R-F Power Amplifier	100.50
90831—Modulator	45.00
90901—Oscilloscope—1"	21.00
90902—2" Oscilloscope	55.00
90903—3" Oscilloscope	60.00
90905—5" Oscilloscope	125.00
90932—Monitor Oscilloscope	87.00
92101—R'er	30.00

Mini-Products, Inc.

131

1001 West 18th St.
Erie, Pennsylvania

Model B-24—A compact, end loaded 2 element beam for 6-10-15-20 meters. 7 foot turning radius	\$54.95
Model C-4—A compact coaxial vertical (requires no radials) for 6-10-15-20 meters	\$34.95
Model C-50—6 meter coaxial vertical	\$14.95
Model M-4—4 band top loaded mobile for 6-10-15-20 meters 63 inches high	\$16.95
Model M-610—2 band top loaded mobile for 6 and 10 meters, 53 inches high	\$13.95
Model M-615—2 band top loaded mobile for 6 and 15 meters, 53 inches high	\$13.95
Model M-620—2 band top loaded mobile for 6 and 20 meters, 55 inches high	\$13.95

Mosley Electronics, Inc.

132

4610 N. Linbergh Blvd.
Bridgeton, Missouri

"Power-Master" beam antennas are full sized arrays each designed for a single band; 10, 15 or 20 meters.

Model A-310—10 meter 3 element beam, forward gain 8.9 db	\$ 39.39
--	----------

Model A-315—15 meter 3 element beam, forward gain 8.5 db	44.63
Model A-320—20 meter 3 element beam, forward gain 8.0 db	81.10
"Signal-Master" 2 element 40 meter beam. Forward gain 5.0 db. Rated at 1 kw. Model S-402	124.50
"Vest-Pocket" 2 element 40 meter beam. Similar to above but designed for limited clearance locations. Turning radius only 19½ feet. Forward gain 5.0 db	84.25
V.H.F. "Power Master" antennas are full size, high gain arrays offering optimum performance and rugged construction. Model A-142—2 meter, 14 element array, 13 db forward gain	51.18
Model A-56—6 meter, 5 element array, 11 db forward gain	44.05
Model A-2N6—Combination 2 and 6 meter beam, comprised of a 4 element 6 meter antenna (9.6 db forward gain) and a 5 element 2 meter antenna (11.4 db forward gain) both mounted on a single 14' boom	70.40

Multi-Products Company

133

21470 Coolidge Highway
Oak Park 37, Michigan

"Trans-Citer" Model AF-68—V.F.O. controlled 80 through 6 meters. 60 watts input. High level a.m. and c.w.	\$205.00
Model PMR-8—Covers 80 through 6 meter amateur bands and broadcast band.	\$189.50
Model M-1070—Operates from 6 or 12 volts d.c. and 115 volts a.c. Will power the above or similar equipment.	\$69.50
Model M-1071—Same as M-1070 but sold in kit form.	\$49.50
Model AS-1—4" Speaker mounted in metal enclosure with universal bracket.	\$9.95
Model ESS-3—2 inch "S" meter, calibrated in "S" units. Houses in metal enclosure with connecting leads.	\$16.50

National Radio Company, Inc.

134

37 Washington Street
Melrose 76, Massachusetts

NC-60 Special "B"—Receiver. Low priced all-band communications receiver	\$59.95
NC-190 Combination general coverage and ham bands only receiver. Double conversion	219.95
NC-270—Ham Bands only, double conversion receiver. Covers 80-6 meters	279.95
NC-303—High quality ham bands only receiver. Covers all bands 160-10 meters with additional "X" bands calibrated for 6, 2 and 1¼ meters. Use with converters listed below.	449.00
NC-300 C6A—6 meter converter for NC-303/MC-300	41.95
NC-300 C2—2 meter converter for NC-303/MC-300	43.95

- NC-300 C1**—1¼ meter converter for NC-300/MC-300 45.95
HRO-60 Laboratory quality general coverage communications receiver .. 745.00
NC-400 Laboratory quality band switching general coverage receiver adaptable for dual diversity reception 895.00

New-Tronics

135

3455 Vega Avenue
 Cleveland 13, Ohio

Mobile Ball Swivel Spring Mounts

- NTS-1** Complete base mount stainless steel spring and fittings\$19.44
NTC-1 Complete base mount, cadmium plated spring and fittings.\$11.34
NT-1 Complete base mount, chrome plated spring and fittings. \$8.49

Stainless Steel Whips

- SW60R** 60" Stainless whip\$3.27
SW96R 96" Stainless whip 3.93
SW102R 102" Stainless whip 4.23
SW108R 108" Stainless whip 4.50

Oil Tempered, Cadmium plated Steel Whips

- TW60** 60" Cadmium plated whip\$2.85
TW96 96" Cadmium plated whip 3.45
TW102 102" Cadmium plated whip 3.75
TW108 108" Cadmium plated whip 3.90

Pennwood Numechron Company **136**

7249 Frankstown Avenue
 Pittsburgh 8, Pennsylvania

- #124 Call-Ident Tymeter**, 10 Minute Timer, Station Call Reminder with 24 hour Tymeter clock, Wal. or Ebony Plastic Case \$22.50
#112 Call-Ident Tymeter, 10 Minute Timer, Station Call Reminder with 12 hour Tymeter Clock. Wal. or Ebony Plastic Case 17.50
#210 Call-Ident 10 Minute Timer, Station Call Reminder, Wal. or Ebony Plastic Case 12.50
#100-24H-¼ Jefferson Tymeter Numechron Clock Provides 24 hour G.M.T. time at a glance. A must in every ham shack 15.00

Peterson Radio Company, Inc. **137**

2800 West Broadway,
 Council Bluffs, Iowa

This complete line of crystals, applicable to amateur radio, can be seen in the Peterson Radio advertisement on page 1 of this issue.

Philmore Mfg. Co., Inc. **138**

130-01 Jamaica Avenue
 Richmond Hill 18, N. Y.

Model CT62—Bandswitching 6 and 2 meter am—c.w. transmitter. 55 watts phone, 60 watts c.w. Built in v.f.o. fully metered, with built in power supply and plate modulator. \$179.95

P&H Electronics, Inc. **139**

424 Columbia Street
 Lafayette, Indiana

- LA400-C** Linear amplifier kit\$164.95
LA400-C Linear amplifier wired & tested 219.95
6-150 6 Meter transmitting converter wired & tested 259.95
2-150 2 Meter transmitting converter wired & tested 274.95
AR-1 Transceiver antenna transfer unit wired & tested 32.50
DI-1 RF Distortion indicator wired & tested 99.95

RME Division **140**

Electro-Voice, Inc.
 Buchanan, Michigan

- 6900 Receiver**—Hambands only, double conversion, selectable sideband receiver includes all-mode noise limiting, high sensitivity and selectivity. Attractive and neatly packaged in a 10" x 13" d x 17" w grey cabinet\$369.00
6901 Speaker for above\$19.50
DB-23 Preselector—Provides from 26 to 35 db gain ahead of any receivers antenna input. Improves selectivity, sensitivity and signal to noise ratio on all bands from 80-10 meters\$49.50
VHF-126—Converter for the 50, 144 and 220 mc bands featuring tunable front end with large direct reading dial, high sensitivity, double conversion and dual speed tuning\$239.00

Seco Electronics, Inc. **141**

5015 Penn Avenue South
 Minneapolis 19, Minnesota

- Model 510**—Transmitter Tester\$46.95
Model 520—Antenna Tester 42.95
Model 511A—Attenu-Load 21.50

Shure Brothers, Inc. **142**

222 Hartey Ave.
 Evanston, Ill.

- Model 404B**—Controlled magnetic hand held microphone suitable for mobile operation in push-to-talk systems.
Model 44OSL—Controlled magnetic desk type microphone. Grip to talk stand. 300-3000 c.p.s. response.

Skylane Products **143**

406 Bon Air
 Temple Terrace, Florida

- Quad, Bamboo spreader model**\$59.95
Quad, Fiberglass spreader model 99.95
Cast Aluminum alloy end spiders for quads 9.50
Cast Aluminum alloy center castings for quads 9.50

Telrex Laboratories **144**

Asbury Park 42, New Jersey

Manufacturing over 100 different antennas for amateurs, Telrex is able to supply an antenna from stock to fill almost any amateur require-

ment. To list each of these antennas would be needless duplication of the fine technical information available from Telrex. Below, however, are listed a few of the most popular items.

"Duo-Band" Single Feedline Arrays

- DC-105** 3 el. on 10 m and 3 el. on 15 m. 9.5 db gain\$123.50
- DBM-152** 4 el. on 10 m and 3 el. on 20 m. 9.5 db gain\$310.00

"Tri-Band" Single Feedline Arrays

- TC-88** 2 el. on 10, 15 and 20 m. 5.5 db gain\$99.75
- TC-99** 3 el. on 10, 15 and 20 m. 8.0 db gain.\$159.50
- TM-30** 4 el. on 10, 15 and 3 el. on 20 m. 10 db gain.\$328.00

VHF Arrays

- 420M-1511** 420 mc 15 el. o.s. Yagi 17.2 db gain.\$21.50
- 420MSR-2009** 420 mc 20 el. w.s. Spiralray 17.2 db gain.\$25.00
- 220M-54** 220 mc 5 el. o.s. Yagi 12.8 db gain\$11.50
- 220M-2926** 220 mc 29 el. w.s. Yagi 19.2 db gain\$45.50
- 220MSR-2132** 220 mc 21 el. .7λ Spiralray 21.7 db gain\$69.00
- 2M-5C** 144 mc 5 el. ms Yagi 12.4 db gain \$9.75
- 2M-1114** 144 mc 11 el. c.s. Yagi 14.5 db gain\$19.50
- 2MSR-2022** 144 mc 20 el. Spiralray 17.5 db gain.\$32.95
- 6M-412** 50 mc 4 el. o.s. Yagi 11.7 db gain.\$22.50
- 6M-1127** 50 mc 11 el. c.s. Yagi 16.5 db gain.\$48.75
- 6MSR-1136** 50 mc 11 el. Spiralray 17.5 db gain.\$95.00

Texas Crystals

145

1000 Crystal Drive,
Fort Myers, Florida

Crystals of all types, holder styles and frequencies, too numerous and varied to list. However, for complete information on the complete line, with prices, circle 45 on page 63.

Tri-Ex Tower Corp.

146

127 East Inyo Street
Tulare, California

Tri-Ex features a complete line of tilt-over, telescoping towers, in height from 37' to 105'. Motor driven crank up towers as well as base rotatable towers are available complete with all mechanisms.

The Turner Company

147

Cedar Rapids, Iowa

Model 250—Dynamic microphone featuring—52 db output, 60-10,000 c.p.s. response and a radically new "Lift Switch" for the ultimate in "switch-to-talk" operation\$29.70

Also available in crystal versions.

Model 350X—Hand held crystal microphone

housed in rugged plastic case, wired for push to talk operation, output level—48 db, response 60-8500 c.p.s.\$10.80

Model 350C and 350R—Ceramic and carbon versions of above also available.

Model SR-90D—Hand held dynamic mobile mike. Wired for push-to-talk, in satin chrome finish, output level—48 db, high impedance, response 200-9000 c.p.s.\$25.50

Model 9D—Hand held dynamic microphone available plain or with push-to-talk switch (SR-9D). Can be stand mounted for desk use. Excellent response and output for mobile work: 150-7000 c.p.s., 52 db output. Hi or lo impedance models available.

Model 80—Very small, compact microphone versatile in its application, but ideally suited for fixed station s.s.b. work. Hi-impedance output, -54 db output level, 80-7000 c.p.s. frequency response. Satin chrome finish, with 7' cable.

Model C-4—Stand for above with weighted, adjustable base.

Model 82-3H—Same microphone as above but mounted on the Turner "Third Hand" permitting mobile-in-motion operation with both hands on the wheel. Third—Hand hangs around the neck while short gooseneck enables accurate positioning of microphone.

Vesto Company, Inc.

148

20th & Clay St.

North Kansas City 16, Mo.

Self supporting steel towers available in 10 sizes from 22 feet to 100 feet. Prices start at \$149.50. Sold direct only. Monthly terms available. Check number 48 on page 163 for further information.

Vibroplex Company, Inc., The

149

833 Broadway

New York 3, New York

"Champion" Without circuit closer.

Standard finish only. Chromium finished top parts, with grey crystal base \$17.95

"Lightning Bug" Flat pendulum model.

Standard—Polished Chromium top parts, grey base\$21.45

Deluxe model of above—Polished Chromium base and top parts, with jeweled movement\$25.95

"Blue Racer" Standard—Chromium finish top parts, grey base\$22.45

Deluxe model of above—Polished Chromium base and top parts, with jeweled movement\$26.95

"Original". Suitable for all classes of transmitting work where speed and perfect Morse are prime essentials.

Standard—Chromium top parts, grey base\$22.45

Deluxe model of above—Chromium base and top parts, with jeweled movement \$26.95

"Presentation" Super deluxe. The finest bug ever built! 24K gold-plated base top, patented jewel movement and super-speed control\$33.95

THE CQ HAM MART



MOBILE HANDBOOK

Anyone who tries to go mobile without getting this book, should register for a sanity hearing. Bill Orr, W6SAI has put everything you need to know in this book. Build-its by the dozen . . . solutions to ignition problems, keeping the battery charged, noise . . . only \$2.95 postpaid.



COMMAND SETS

This is a collection of reprints, containing all of the available information on the conversion of the popular "Command" transmitters and receivers into good ham transmitters and receivers. Invaluable for Novice, Technician, General, Advanced and Extra class operators. 136 fabulous, amazing terrific pages for only \$1.50 postpaid.



19" GLOBE

Here is a chance to preserve your breath for posterity! This beautiful World Globe, made by Hammond, is a must for every hamshack. Plain for \$19.95 or lighted for \$24.95. The first 10,000 people who jump at this bargain will get a year of CQ at no extra charge.

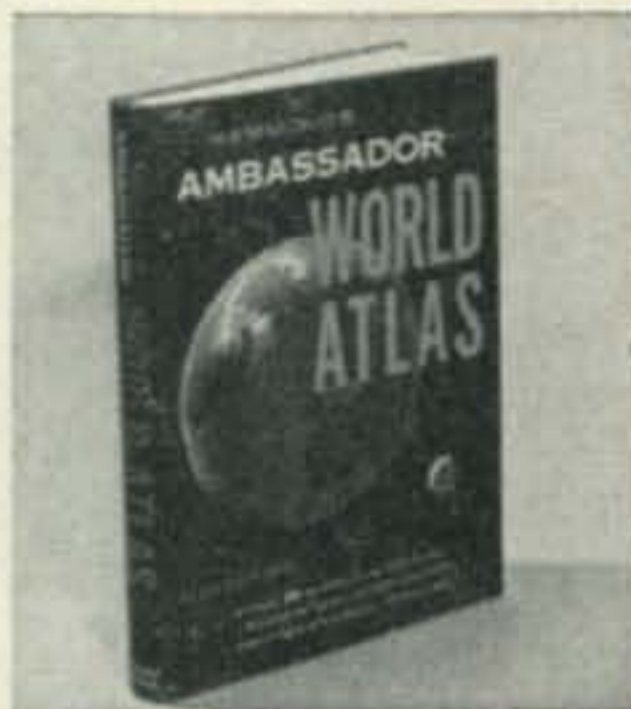

ATLAS

What! You don't know where Nicobar Island is? Incredible! And with the CQ deal on the Hammond Atlas so reasonable too. This is a reference book that will get good usage around your house if you have any kids. 7 lbs. of colored maps and a gazetteer for only \$12.50 . . . and you get a year of CQ.



HAM'S INTERPRETER

Now you can talk in broken French, Spanish, Italian, German, Swedish and Finnish. This handy little book gives all the popular ham conversation in seven languages, including letters and numbers. Only \$1.50 postpaid.

TVI HANDBOOK

W1DBM's newly written TVI book (2nd edition) covers all aspects of curing TVI from both the Ham's viewpoint and that of the TV viewer or the TV serviceman. It includes 2- and 6-meter TVI as well as Citizen's Band, Industrial, Medical and Utility TVI. Profusely illustrated with diagrams, photos, charts, tables and FCC regulations pertaining to radio and television interference. Price \$1.75 postpaid, USA, \$2.00 Foreign.



HI-FI BOOK

This nifty volume contains the latest dope on amplifiers, pre-amplifiers, and equalizers plus a buyer's guide of component manufacturers! Over 150—5½" x 8½" pages of heavily illustrated descriptions covering Hi Fi Audio Components—the greatest publication value in its field today. Only \$2.50 per copy.



BINDER

There is no other good way to keep your back issues. Make 'em neat. We supply the binder, with the year embossed in gold, not merely a sticker which will come off later. Specify what year you want stamped on your binder. \$3.50.



Log Sheets of the most astounding modern design. Infinitely superior to any others on the market. And they are only \$1 for a pad of 100 sheets. Specify Regular or SSB type.

CODE RECORD

Learning code is a snap with this record. Speeds from 3 to 16 WPM, depending upon turntable speed. This 12" LP record has on it all you need to learn the code for both the Novice and General License. \$3.50 each.

ELEKTRA CODE COURSE



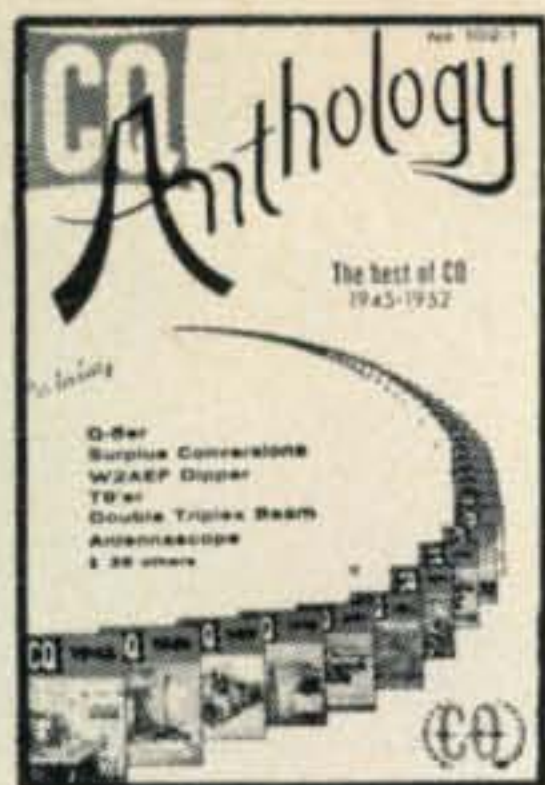

CQ ANTHOLOGY

Most amateurs do not have a good file of back issues of CQ. So we've looked back through the years 1945-52 and assembled all in one place the articles that have made a lasting stir. The issues containing most of these articles have long ago been sold out. The price is a mere \$2.00.



VHF FOR THE RADIO AMATEUR

You can't afford to be without this dynamic new handbook designed with the VHF amateur in mind. Filled from cover to cover with all new and original construction material presented so that you can understand it. Written by Frank C. Jones W6APF, nationally acclaimed for his VHF pioneering. Available now for only \$3.50.

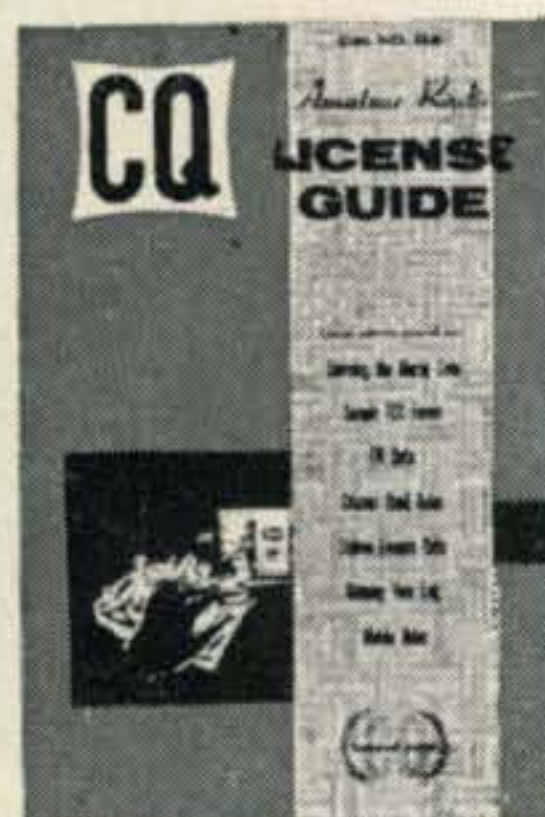

CQ LICENSE GUIDE

212 pages of everything the Amateur must have to get his license and progress toward the general class ticket. Plus many additional pages of vital information for the ham operator. All this for only \$2.50.

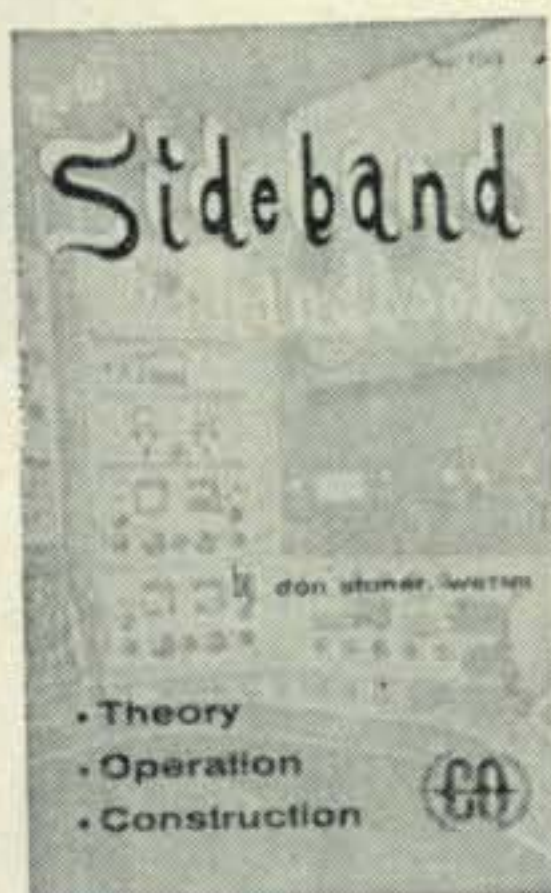

SIDEBAND HANDBOOK

Written by Don Stoner, W6TNS, was almost one full year in the preparation of this terrific volume. This is not a technical book. It explains sideband showing you how to get along with it . . . how to keep your rig working right . . . how to know when it isn't . . . and lots of how to build-it stuff, gadgets, receiving adaptors, exciters, amplifiers. Price, only \$3.00.

SURPLUS SCHEMATICS HANDBOOK

This is a book literally loaded with schematics for all the currently popular pieces of surplus gear. Most amateurs are well aware of the problems encountered in purchasing seemingly inexpensive surplus units, only to find that no schematic diagram is available. Trying to figure out the circuitry cold turkey can be many times more difficult than the most involved puzzle, and purchasing a single instruction book can run as high as \$3.50. Why knock yourself out when you can have a book with complete coverage on hand in your library? All this for only \$2.50.

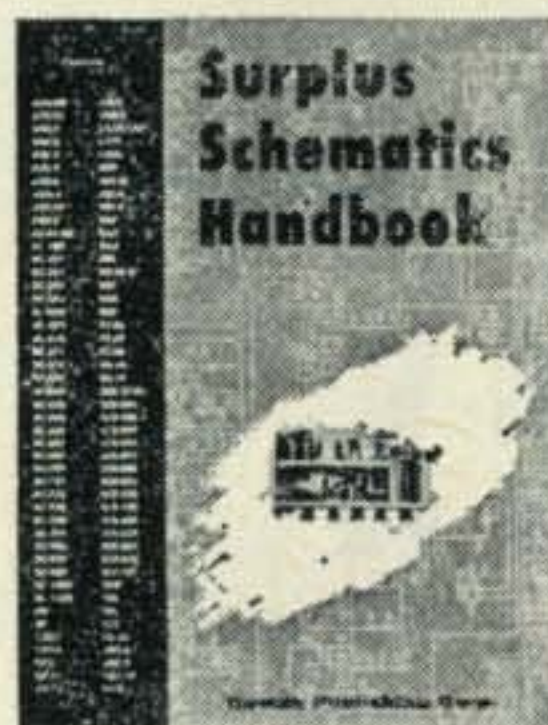

DX ZONE MAP

Brand New! Amateur Radio World-Wide DX & Zone Map complete, accurate and up to the minute with Prefix, Zone Boundaries, Great Circle beam bearings. 4 Colors, 36 by 42 inches on heavy vellum map paper. Mailed in heavy cardboard mailing tube. Only \$3.00.



COWAN PUBLISHING CORP. CQ-11
Book Division
300 West 43rd Street
New York 36, N. Y.

LIGHTED GLOBE	\$24.95	<input type="checkbox"/>
UNLIGHTED GLOBE	19.95	<input type="checkbox"/>
ATLAS	12.50	<input type="checkbox"/>
COMMAND SETS	1.50	<input type="checkbox"/>
MOBILE HANDBOOK	2.95	<input type="checkbox"/>
CODE RECORD	3.50	<input type="checkbox"/>
REGULAR LOG SHEETS (100).....	1.00	<input type="checkbox"/>
SSB LOG SHEETS (100)	1.00	<input type="checkbox"/>
HAM'S INTERPRETER	1.50	<input type="checkbox"/>
TVI HANDBOOK	1.75	<input type="checkbox"/>
BINDER—YEAR WANTED	3.50	<input type="checkbox"/>
VHF FOR THE RADIO AMATEUR.....	3.50	<input type="checkbox"/>
CQ ANTHOLOGY	2.00	<input type="checkbox"/>
HI-FI BOOK	2.50	<input type="checkbox"/>
SIDEBAND HANDBOOK	3.00	<input type="checkbox"/>
CQ LICENSE GUIDE.....	2.50	<input type="checkbox"/>
SURPLUS SCHEMATICS HANDBOOK.....	2.50	<input type="checkbox"/>
DX ZONE MAP.....	3.00	<input type="checkbox"/>

SIRS: My check (money order) for \$_____ is enclosed. Please send the following items to:

Name _____

Address _____

City _____ Zone _____ State _____

New York City Residents Add 3% Sales Tax

Special Distributor's Index

One problem that faces the amateur when he reads about something that interests him is, "Where Do I Get It?" This can be pretty frustrating at times. The handy lists on the following pages will tell you where you can buy what you want.

Alphabetical

List of Distributors

- | | | | | |
|--|---|--|---|--|
| 1 Adirondack Radio Supply Inc.
185-191 West Main St.
Amsterdam, N. Y. | 14 Consolidated Supply Co. Ltd.
86 Hollis Street
Halifax, Nova Scotia | 26 Graham Radio, Inc.
505 Main Street
Reading, Mass. | 39 Kincaide Radio Supply
1354 Laura Street
Jacksonville, Florida | 54 Radio Shack Corp.
730 Commonwealth Ave.
Boston, Mass. |
| 2 Allied Radio Corp.
100 N. Weston Avenue
Chicago 80, Illinois | 15 Crescent Electronic Supply, Inc.
537 S. Claiborne Ave.
New Orleans, La. | 27 Graham Radio, Inc.
1105 N. Main Street
Randolph, Mass. | 40 Knox Electronic Supply, Inc.
67 N. Cherry St.
Galesburg, Illinois | 55 Radio Shack Corp.
167 Washington St.
Boston, Mass. |
| 3 Allied Radio of Wisconsin
5314 N. Pt. Wash. Rd.
Milwaukee 17, Wisc. | 16 Custom Electronics, Inc.
1918 S. Brown Street
Dayton 9, Ohio | 28 Harrison Ham Hdqrs USA
225 Greenwich Street
New York 7, N. Y. | 41 Lafayette Radio Electronics
111 Jericho Turnpike
Syosset, L. I., N. Y. | 56 Radio Shack Corp.
39 S. Main Street
West Hartford, Conn. |
| 4 Amateur Electronic Supply
3832 W. Lisbon Ave.
Milwaukee 8, Wisc. | 17 Electronic Wholesalers, Inc.
NW 27 Ave. at 94 St.
Miami, Florida | 29 Harrison Ham Hdqrs USA
144-24 Hillside Avenue
Jamaica 35, N. Y. | 42 Lafayette Radio Electronics
165-08 Liberty Ave.
Jamaica 33, N. Y. | 57 Radio Shack Corp.
230-234 Crown Street
New Haven, Conn. |
| 5 Amateur Electronic Supply
6430 Milwaukee Ave.
Chicago 31, Illinois | 18 Electronic Wholesalers, Inc.
1301 Hibiscus Blvd.
Melbourne, Florida | 30 Harvey Radio Co., Inc.
103 West 43 Street
New York 36, N. Y. | 43 Lafayette Radio Electronics
100 Sixth Avenue
New York 13, N. Y. | 58 Radio Shack Corp.
South Shore Plaza
Braintree, Mass. |
| 6 Arrow Electronics, Inc.
525 Jericho Turnpike
Mineola, L.I., N.Y. | 19 Elliott Electronics Inc.
418 N. 4th Avenue
Tucson, Arizona | 31 Heights Electronics, Inc.
1145 Halsted Street
Chicago Heights, Ill. | 44 Lafayette Radio Electronics
542 East Fordham Rd.
Bronx 58, N. Y. | 59 Radio Shack Corp.
29 High Ridge Road
Stamford, Conn. |
| 7 Arrow Electronics, Inc.
65 Cortlandt Street
New York 7, N. Y. | 20 Elmar Electronics
140 11th Street
Oakland 7, California | 32 Henry Radio
11240 W. Olympic Ave.
Los Angeles 64, Calif. | 45 Lafayette Radio Electronics
110 Federal Street
Boston 10, Mass. | 60 Radio Shack Corp.
1301 Reservoir Ave.
Providence-Cranston, R.I. |
| 8 The George D. Barbey Co., Inc.
333 N. 4th Street
Reading, Pennsylvania | 21 Evans Radio
Route 3A, Bow Jct.
Box 312, Concord,
New Hampshire | 33 Henry Radio
Butler, Missouri | 46 Lafayette Radio Electronics
24 Central Avenue
Newark 2, N. J. | 61 Reno Radio Co.
1314 Broadway
Detroit 26, Michigan |
| 9 The George D. Barbey Co., Inc.
622 Columbia Avenue
Lancaster, Penna. | 22 Fort Orange Radio Dist.
904-16 Broadway
Albany 7, N. Y. | 34 Henry Radio
931 N. Euclid Avenue
Anaheim, California | 47 Lafayette Radio Electronics
139 West Second St.
Plainfield, N. J. | 62 Gil Severns Whsle Electronics
40400 E. Florida
Hemet, California |
| 10 The George D. Barbey Co., Inc.
821 Quentin Road
Lebanon, Pennsylvania | 23 Ft. Wayne Electronics
3606 Maumee Avenue
Ft. Wayne, Indiana | 35 John Iverson Co.
216 Second St. S.W.
Minot, N. Dakota | 48 Lafayette Radio Electronics
182 Route 17
Paramus, New Jersey | 63 Sunland Supply Co., Inc.
1200 E. Missouri Ave.
El Paso, Texas |
| 11 The George D. Barbey Co., Inc.
157 N. York Street
Pottstown, Penna. | 24 Fortune Electronic Suppliers, Inc.
930 El Camino Real
San Carlos, California | 36 Key Electronics
100 S. Wayne St.
Arlington 4, Virginia | 49 Melvin Electronics
541 Madison Street
Oak Park, Illinois | 64 Tydings Company
933 Liberty Avenue
Pittsburgh 22, Pa. |
| 12 Barry Electronics Corp.
512 Broadway
New York 12, N. Y. | 25 Graham Electronic Supply, Inc.
122 South Senate Ave.
Indianapolis, Indiana | 37 Key Electronics
11254 Triangle Lane
Wheaton, Md. | 50 The Mytronic Co.
2145 Florence Ave.
Cincinnati 6, Ohio | 65 United Radio Supply, Inc.
829 N. W. Burnside
Portland 9, Oregon |
| 13 Burghardt Radio Supply
Box 746A
Watertown, S. Dakota | | 38 Kincaide Radio Supply
1719 Grand Cen. Ave.
Tampa, Florida | 51 Oregon Ham Sales
409 West First Ave.
Albany, Oregon | 66 Van Sickle Radio Supply Co.
4131 N. Keystone Ave.
Indianapolis, Indiana |

Geographical

List of Distributors

- Elliott Electronics 19
418 N. 4th Avenue
Tucson, Arizona
- Henry Radio 34
931 N. Euclid Avenue
Anaheim, California
- Gil Severns Wholesale
Electronics 62
40400 E. Florida
Hemet, California
- Henry Radio 32
11240 W. Olympic Blvd.
Los Angeles 64, Calif.
- Radio Products Sales 53
1501 S. Hill Street
Los Angeles, California
- Elmar Electronics 20
140 11th Street
Oakland 7, California
- Fortune Electronics 24
930 El Camino Real
San Carlos, California
- Radio Shack Corp. 57
230-234 Crown St.
New Haven, Connecticut
- Radio Shack Corp. 59
29 High Ridge Road
Stamford, Connecticut
- Radio Shack Corp. 56
39 S. Main Street
West Hartford, Conn.
- Kincade Radio
Supply 39
1354 Laura Street
Jacksonville, Florida
- Electronic Wholesalers,
Inc. 18
1301 Hibiscus Blvd.
Melbourne, Florida
- Electronic Wholesalers,
Inc. 17
N.W. 27 Ave. at 94 St.
Miami, Florida
- Kincade Radio
Supply 38
1719 Grand Cntrl Ave.
Tampa, Florida
- Amateur Electronic
Supply 5
6430 Milwaukee Avenue
Chicago 31, Illinois
- Allied Radio Corp. 2
100 N. Western Avenue
Chicago 80, Illinois
- Heights Electronics,
Inc. 31
1145 Halsted Street
Chicago Heights, Ill.
- Knox Electronic Supply
Inc. 40
67 N. Cherry St.
Galesburg, Illinois
- Melvin Electronics 49
541 Madison Street
Oak Park, Illinois
- Ft. Wayne
Electronics 23
3606 Maumee Avenue
Ft. Wayne, Indiana
- Graham Electronic
Supply 25
122 South Senate Ave.
Indianapolis, Indiana
- Van Sickle Radio
Supply Co. 66
4131 N. Keystone Ave.
Indianapolis, Indiana
- World Radio
Laboratories, Inc. 69
3415 West Broadway
Council Bluffs, Iowa
- Crescent Electronic
Supply 15
537 S. Claiborne Ave.
New Orleans, La.
- Key Electronics 37
11254 Triangle Lane
Wheaton, Maryland
- Radio Shack Corp. 54
730 Commonwealth Ave.
Boston, Massachusetts
- Radio Shack Corp. 55
167 Washington Street
Boston, Massachusetts
- Radio Shack Corp. 58
South Shore Plaze
Braintree, Mass.
- Graham Radio, Inc. 27
1105 No. Main
Randolph, Massachusetts
- Graham Radio, Inc. 26
505 Main Street
Reading, Massachusetts
- Reno Radio Co. 61
1314 Broadway
Detroit 26, Michigan
- Henry Radio 33
Butler, Missouri
- Evans Radio 21
Route 3A, Bow Jct.
Box 312
Concord, New Hamp.
- Lafayette Radio
Electronics 46
24 Central Avenue
Newark 2, New Jersey
- Lafayette Radio
Electronics 48
182 Route 17
Paramus, New Jersey
- Lafayette Radio
Electronics 47
139 W. 2nd St.
Plainfield, New Jersey
- Ft. Orange Radio
Dis. 22
904-16 Broadway
Albany 7, N.Y.
- Adirondack Radio
Supply, Inc. 1
185-91 W. Main Street
Amsterdam, N.Y.
- Lafayette Radio
Electronics 44
542 E. Fordham Road
Bronx 38, New York
- Lafayette Radio
Electronics 42
165-08 Liberty Avenue
Jamaica 33, New York
- Harrison Ham
Headquarters USA
144-24 Hillside Avenue
Jamaica 35, New York
- Arrow Electronics,
Inc. 6
525 Jericho Turnpike
Mineola, L.I., N.Y.
- Arrow Electronics,
Inc. 7
65 Cortlandt St.
New York 7, New York
- Barry Electronics
Corp. 12
512 Broadway
New York 12, N.Y.
- Lafayette Radio
Electronics 43
100 Sixth Avenue
New York 13, N.Y.
- Harrison Ham
Hdqrs USA 28
225 Greenwich Street
New York 7, New York
- Harvey Radio Co.,
Inc. 30
103 West 43 Street
New York 36, N.Y.
- Lafayette Radio
Electronics 41
111 Jericho Turnpike
Syosset, L.I., N.Y.
- John Iverson Co. 35
216 Second Street SW
Minot, N. Dakota
- Consolidated Supply
Company Ltd. 14
86 Hollis Street
Halifax, Nova Scotia
- The Mytronic Co. 50
2145 Florence Avenue
Cincinnati 6, Ohio
- Custom Electronics,
Inc. 16
1918 S. Brown St.
Dayton 9, Ohio
- Oregon Ham sales 51
409 West First Avenue
Albany, Oregon
- United Radio Supply,
Inc. 65
829 N.W. Burnside
Portland 9, Oregon
- The George D Barbey
Co., Inc. 9
622 Columbia Avenue
Lancaster, Pennsylvania
- The George D. Barbey
Co., Inc. 10
821 Quentin Road
Lebanon, Pennsylvania
- Eugene G. Wile 68
218-220 South 11th St.
Philadelphia 7, Penn.
- Tydings Company 64
933 Liberty Avenue
Pittsburgh 22, Penn.
- The George D. Barbey
Co., Inc. 11
157 N. York St.
Pottstown, Pennsylvania
- The George D. Barbey
Company, Inc. 8
333 N. 4th Street
Reading, Pennsylvania
- Radio Shack Corp. 60
1301 Reservoir Ave.
Providence-Cranston,
Rhode Island
- Burghardt Radio
Supply 13
Box 746A
Watertown, S. Dakota
- W&W Distributing
Company 67
644 Madison Avenue
Memphis, Tennessee
- Sunland Supply Co.,
Inc. 63
1200 E. Missouri Avenue
El Paso, Texas
- Key Electronics 36
100 S. Wayne St.
Arlington 4, Virginia
- Priest Electronics,
Inc. 52
6431 Tidewater Drive
Norfolk 9, Virginia
- Allied Radio of
Wisconsin 3
5314 N. Port Washing-
ton Road
Milwaukee 17, Wis.
- Amateur Electronic
Supply 4
3832 West Lisbon Ave.
Milwaukee 8, Wis.

THE LATEST FROM
HALLICRAFTERS

in stock at
HARVEY

**New
Transverter
Designs For
SSB-AM-CW-
RTTY on
VHF Frequencies**



Hallicrafters HA-2 and HA-6 provide a new approach to VHF operation. Now, with great simplicity, operators with 10 meter transmitters and receivers can operate 6 or 2 meters and enjoy this extended coverage.

These new transverters change your present 10 meter transmitter output to the VHF range. They also convert the received VHF signals down to 10 meters for reception. The 5894 tube used in

the transmitter final amplifier can be driven up to 120 watts input.

All modes of transmission and reception are useable with these units depending on the type of 10 meter equipment used.

- A nuvistor front end in the receiver section provides excellent sensitivity and noise figure.
- Can be driven by exciters with 10 to 100 watt capability.
- Built-in coaxial antenna relay.

MODEL HA-2 — FOR 2 METERS/HA-6 — FOR 6 METERS \$349.50

Hallicrafters power supply for these units supplies all voltages. Only one supply necessary for operation of either the HA-2 or HA-6 when used in stations set up for 6 or 2 meter operation.

MODEL P26 — POWER SUPPLY \$99.50

For the discriminating C.W. operator who demands perfection, Hallicrafters brings the new transistorized T.O. Keyer.

Employing digital techniques, its advanced circuitry features a constant ratio of dot-to-space-to-dash over the entire speed range of the instrument. Dots and dashes are self-completing.

Price: \$59.95

Match your 'TO' Electronic Keyer with the VIBROPLEX VIBRO-KEYER for a perfectly matched sending team!

Standard Finish \$17.95 De Luxe Finish \$22.45

MODEL HA-4 "T.O. KEYER"

The Stradivarius of Electronic Keyers . . .



hrc HARVEY RADIO CO., INC.

103 West 43rd Street, New York 36, N. Y./Judson 2-1500

For further information, check number 41, on page 163

November, 1961 • CQ • 143

Alphabetical list of Manufacturers

KEY NUMBERS INDICATE DISTRIBUTORS HANDLING THEIR PRODUCTS

AMERICAN ELECTRONICS CO. (AMECO)

178 Herricks Road
Mineola, Long Island, N. Y.

Converters, Preamplifiers, Code Courses, Books

1, 2, 3, 4, 5, 6, 7, 8, 9, 10, 11, 12, 13, 15, 16, 17, 18, 19, 20, 21, 22, 24, 25, 26, 27, 28, 29, 30, 31, 32, 33, 34, 35, 36, 37, 38, 39, 40, 41, 42, 43, 44, 45, 46, 47, 48, 50, 51, 52, 53, 54, 55, 56, 57, 58, 59, 60, 61, 63, 64, 65, 66, 68, 69.

ANTENNA SPECIALISTS CO.

12437 Euclid Avenue
Cleveland 6, Ohio

Mobile Communication Antennas

2, 3, 4, 5, 6, 7, 8, 9, 10, 11, 13, 14, 15, 16, 17, 18, 19, 20, 21, 22, 23, 24, 25, 26, 27, 30, 31, 32, 33, 34, 35, 36, 37, 40, 41, 42, 43, 44, 45, 46, 47, 48, 49, 50, 51, 52, 54, 55, 56, 57, 58, 59, 60, 61, 62, 63, 64, 65, 66, 67, 68, 69.

ASTATIC CORP.

Conneaut, Ohio
Microphones

1, 2, 3, 4, 5, 6, 7, 8, 9, 10, 11, 13, 14, 15, 16, 17, 18, 19, 20, 21, 22, 23, 24, 25, 26, 27, 28, 29, 30, 31, 32, 33, 34, 35, 38, 39, 40, 41, 42, 43, 44, 45, 46, 47, 48, 49, 50, 52, 53, 54, 55, 56, 57, 58, 59, 60, 61, 63, 64, 65, 67, 68, 69.

BARKER & WILLIAMSON, INC.

Canal Street & Beaver Dam Rd.
Bristol, Penna.

Transmitters, Amplifiers, Baluns & Components

1, 2, 3, 4, 5, 6, 7, 8, 9, 10, 11, 12, 13, 14, 15, 16, 17, 18, 19, 20, 21, 22, 24, 25, 26, 27, 28, 29, 30, 31, 32, 33, 34, 35, 38, 39, 40, 41, 42, 43, 44, 45, 46, 47, 48, 49, 50, 51, 52, 53, 54, 55, 56, 57, 58, 59, 60, 61, 62, 63, 64, 65, 66, 67, 68, 69.

BRITISH RADIO ELECTRONICS, LTD.

1833 Jefferson Place, N.W.
Washington 6, D.C.

Dial Drives, Variable Capacitors, Temperature Compensating Capacitors, Air Trimmers

35.

CENTRAL ELECTRONICS, INC.

1247 W. Belmont Avenue
Chicago 13, Illinois

Transmitters, Amplifiers and Test Equipment

1, 4, 5, 6, 7, 8, 9, 10, 11, 12, 13, 14, 15, 16, 17, 18, 20, 21, 22, 24, 25, 26, 27, 28, 29, 30, 32, 33, 34, 35, 36, 37, 38, 39, 40, 41, 42, 43, 44, 45, 46, 47, 48, 50, 51, 52, 53, 54, 55, 56, 57, 58, 59, 60, 61, 62, 63, 64, 65, 66, 67, 69.

CENTRALAB

954K E. Keefe Ave.
Milwaukee 1, Wisconsin

Switches, Components, Transistors, Amplifiers

2, 3, 4, 5, 6, 7, 8, 9, 10, 11, 14, 15, 17, 18, 20, 21, 22, 23, 24, 25, 28, 29, 30, 32, 33, 34, 38, 39, 40, 41, 42, 43, 44, 45, 46, 47, 48, 49, 50, 53, 54, 55, 56, 57, 58, 59, 60, 61, 63, 64, 65, 67, 68, 69.

COLLINS RADIO CO.

855 35th Street, N.E.
Cedar Rapids, Iowa

Receivers, Transmitters

1, 2, 3, 4, 5, 13, 16, 17, 18, 19, 20, 21, 22, 25, 26, 27, 28, 29, 30, 32, 33, 34, 38, 39, 40, 53, 54, 55, 56, 57, 58, 59, 60, 67, 69.

CONTINENTAL ELECTRONICS & SOUND CO. (CESCO)

711 Liscum Drive
Dayton 7, Ohio

Antenna hardware, Accessories & Phone Patches

1, 2, 3, 4, 5, 6, 7, 13, 15, 16, 17, 18, 20, 22, 23, 24, 25, 26, 27, 30, 31, 32, 33, 34, 35, 40, 41, 42, 43, 44, 45, 46, 47, 48, 50, 52, 54, 55, 56, 57, 58, 59, 60, 61, 62, 64, 66, 67, 69.

CLEGG LABORATORIES

Rt #53
Tabor, New Jersey

VHF Transmitters and Transceivers

1, 4, 5, 12, 16, 21, 22, 26, 27, 30, 32, 33, 34, 36, 37, 41, 42, 43, 44, 45, 46, 47, 48, 54, 55, 56, 57, 58, 59, 60, 62, 64, 66, 67, 69.

COLUMBIA PRODUCTS CO.

P.O. Box 5207
Columbia, South Carolina

Mobile Antennas

4, 5, 6, 7, 17, 18, 21, 22, 24, 26, 27, 32, 33, 34, 36, 37, 49, 62, 69.

COMMUNICATIONS CO., INC.

Coral Gables
Miami 34, Florida

Two-Way Communications Equipment

36, 37, 69.

COMMUNICATIONS PRODUCTS, INC.

Marlboro, New Jersey
Antennas

20, 25, 52, 69.

For Superb Performance, Quality & Value

LOOK TO LAFAYETTE FOR THE BEST BUYS IN AMATEUR GEAR

THE LAFAYETTE HE-30 Professional Quality Communications Receiver



99.50

- TUNES 550 KCS TO 30 MCS IN FOUR BANDS
- BUILT-IN Q-MULTIPLIER FOR CROWDED PHONE OPERATION
- CALIBRATED ELECTRICAL BANDSPREAD ON AMATEUR BANDS 80 THRU 10 METERS • STABLE OSCILLATOR AND BFO FOR CLEAR CW AND SSB RECEPTION • BUILT-IN EDGEWISE S-METER

Sensitivity is 1.0 microvolt for 10 db, Signal to Noise ratio. Selectivity is ± 0.8 KCS at -6db with Q-MULTIPLIER. TUBES: 6BA6—RF Amp, 6BE6 Mixer, 6BE6 OSC., 6AV6 Q-Multiplier—BFO, 2-6BA6 IF Amp., 6AV6 Det-AF Amp. ANL, 6AQ5-Audio output, 5Y3 Rectifier.

TOP VALUE COMMUNICATIONS RECEIVER

KT-200WX ^{in Kit Form}
64.50

HE-10 ^{WIRED AND TESTED}
79.95



- SUPERHET CIRCUIT UTILIZING 8 TUBES AND RECTIFIER TUBE • BUILT-IN "S" METER WITH ADJUSTMENT CONTROL
- FULL COVERAGE 80-10 METERS • COVERS 455KC TO 31 MC
- VARIABLE BFO AND RF GAIN CONTROLS • SWITCHABLE AVC AND AUTOMATIC NOISE LIMITER

The Communications Receiver that meets every amateur need—available in easy-to-assemble kit form. Signal to noise ratio is 10 db at 3.5 MC with 1.25 microvolt signal. Selectivity is -60 db at 10 kc, image reflection is -40 db at 3 MC. Tubes: 3-6BD6, 2-6BE6, 2-6AV6, 1-6AR5, 1-5Y3.

SEND FOR LAFAYETTE'S NEW 1962 CATALOG

LAFAYETTE RADIO, Dept. CK-1
P. O. Box 10
Syosset 10, N. Y.

FREE!



Catalog 620
340 Giant Size Pages

Send FREE 1962 Catalog 620 featuring the full line of Lafayette Ham Equipment
\$ _____ Enclosed for Stock No. _____

Name _____

Address _____

City _____ Zone _____ State _____

New! LAFAYETTE HE-50 10 METER AMATEUR TRANSCEIVER



109.50 Made in U.S.A.

A significant step forward in 10-meter communications. The Lafayette HE-50 transceiver sets new standards of flexibility and performance in the 10-meter band.

- Superhet Receiver Section • Sensitivity $1\mu\text{v}$ • Image Rejection 45db • 12 Watts. Input To Final • Use on both 117 VAC & 12 VDC • Built-in Mobile Power Supply • Uses Standard 7 MC Fundamental Crystals with Sockets on Front Panel • Provision for External VFO on Front Panel • Adjustable Pi-Network • Contains Spotting Switch • Built-In Illuminated S Meter • Variable Tuning • Extremely Effective adjustable Noise Limiter • Complete with Rugged Push-To-Talk Ceramic Mike • Tubes: 1-6BA6 RF, 1-6BA6 IF, 1-6U8/6EA8 IF, 1-6U8/6EA8 IF, 1-6U8/6EA8 Transmit Osc. & Buffer, 1-2E26 Transmitter Output, 1-6AQ5 Audio Output, 1-6CN7 Det. & Noise Limiter.

HE-28 RF WATTMETER AND SWR BRIDGE **36.95**



Measures SWR & Relative Power up to 1 KW. 150 watts full scale—built in dummy load—Wattmeter $\pm 5\%$ to 50 mcs. SWR $\pm 5\%$ for in line use.

For further information, check number 42, on page 163

COSMOS INDUSTRIES, INC.

3128 Queens Blvd.
Long Island City, N. Y.

Transceivers

4, 5, 6, 7, 30, 69.

CUSH CRAFT

621 Hayward Street
Manchester, N. H.

Antennas

1, 2, 3, 4, 5, 6, 7, 8, 9, 10, 11, 13, 16, 17, 18,
21, 22, 24, 25, 26, 27, 30, 32, 33, 34, 36, 37, 40, 41, 42,
43, 44, 45, 46, 47, 48, 50, 51, 54, 55, 56, 57, 58, 59, 60,
61, 62, 64, 66, 67, 69.

DOW KEY COMPANY, INC.

Warren, Minnesota

Keys, Coaxial Relays, Switches and Connectors

1, 2, 3, 4, 5, 6, 7, 8, 9, 10, 11, 13, 14, 15, 16,
17, 18, 19, 20, 21, 22, 23, 24, 25, 26, 27, 28, 29, 30, 31,
32, 33, 34, 35, 36, 37, 38, 39, 40, 41, 42, 43, 44, 45, 46,
47, 48, 49, 50, 51, 52, 53, 54, 55, 56, 57, 58, 59, 60, 61,
62, 63, 64, 66, 67, 68, 69.

E-Z WAY TOWERS, INC.

5901 East Broadway
Tampa 5, Florida

Towers

1, 2, 3, 4, 5, 6, 7, 8, 9, 10, 11, 13, 16, 17, 18,
22, 25, 26, 27, 28, 29, 30, 31, 32, 33, 34, 35, 36, 37, 38,
39, 50, 51, 52, 53, 54, 55, 56, 57, 58, 59, 60, 61, 64, 66,
67, 68, 69.

EDITORS & ENGINEERS LTD.

Summerland, California

Books

1, 2, 3, 4, 5, 6, 7, 8, 9, 10, 11, 12, 13, 15, 16,
17, 18, 19, 20, 21, 22, 23, 24, 25, 26, 27, 28, 29, 30, 31,
32, 33, 34, 35, 36, 37, 38, 39, 40, 50, 51, 52, 53, 61, 62,
64, 65, 66, 67, 69.

EITEL-McCULLOUGH, INC.

798 San Mateo Avenue
San Bruno, California

Electron Tubes

2, 3, 4, 5, 8, 9, 10, 11, 12, 13, 14, 17, 18, 20, 21,
22, 23, 24, 25, 28, 29, 30, 32, 33, 34, 35, 38, 39, 40, 41,
42, 43, 44, 45, 46, 47, 48, 50, 52, 53, 54, 55, 56, 57, 58,
59, 60, 65, 67, 69.

ELECTRONIC INSTRUMENT CO., INC.

33-00 Northern Blvd.
Long Island City, N. Y.

Transmitters, Test Equipment

2, 3, 4, 5, 6, 7, 8, 9, 10, 11, 13, 14, 15, 16, 17,
18, 20, 21, 22, 23, 24, 25, 26, 27, 28, 29, 30, 31, 32, 33,
34, 35, 36, 37, 38, 39, 40, 41, 42, 43, 44, 45, 46, 47, 48,
49, 50, 51, 52, 53, 54, 55, 56, 57, 58, 59, 60, 61, 62, 63,
64, 65, 66, 67, 68, 69.

ELECTRO-VOICE, INC.

Buchanan, Michigan

Microphones

1, 2, 3, 4, 5, 6, 7, 8, 9, 10, 11, 12, 13, 14, 15,
16, 17, 18, 20, 21, 22, 23, 24, 25, 26, 27, 28, 29, 30, 31,
32, 33, 34, 35, 36, 37, 38, 39, 40, 41, 42, 43, 44, 45, 46,
47, 48, 49, 50, 51, 52, 53, 54, 55, 56, 57, 58, 59, 60, 63,
64, 65, 67, 68, 69.

THE FINNEY COMPANY

34 Interstate Street
Bedford, Ohio

Antennas

2, 3, 4, 5, 8, 9, 10, 11, 13, 16, 23, 25, 26, 27, 28,
29, 30, 35, 36, 37, 38, 39, 41, 42, 43, 44, 45, 46, 47, 48,
50, 53, 54, 55, 56, 57, 58, 59, 60, 62, 67, 69.

GENERAL ELECTRIC CO.

Electronics Components Div.
Owensboro, Kentucky

Electron Tubes

1, 2, 3, 4, 5, 6, 7, 12, 13, 14, 15, 17, 18, 20, 21,
22, 24, 25, 28, 29, 31, 32, 33, 34, 38, 39, 40, 41, 42, 43,
44, 45, 46, 47, 48, 50, 53, 63, 64, 66, 67, 69.

GLAS-LINE COMPANY

P. O. Box 2
New York 71, N. Y.

Transmission Line, Guy Line, Insulators

1, 4, 5, 6, 7, 8, 9, 10, 11, 12, 16, 17, 18, 20, 22,
32, 33, 34, 36, 37, 41, 42, 43, 44, 45, 46, 47, 48, 50, 51,
52, 61, 66.

GLOBE ELECTRONICS, INC.

3415 West Broadway
Council Bluffs, Iowa

Transmitters, Amplifiers and Test Equipment

1, 4, 5, 6, 7, 8, 9, 10, 11, 13, 16, 17, 18, 20, 21,
22, 24, 25, 26, 27, 28, 29, 30, 31, 32, 33, 34, 35, 36, 37,
38, 39, 40, 41, 42, 43, 44, 45, 46, 47, 48, 49, 50, 51, 52,
53, 54, 55, 56, 57, 58, 59, 60, 61, 62, 64, 65, 66, 67, 69.

GLOBE INDUSTRIES, INC.

Electronics Division
525 Main Street

Belleville, New Jersey
Power Supplies

1, 4, 5, 24, 41, 42, 43, 44, 45, 46, 47, 48, 51.

GONSET COMPANY

801 S. Main Street
Burbank, California

Receivers, Transmitters, Amplifiers, Antennas and Accessories

1, 2, 3, 4, 5, 6, 7, 8, 9, 10, 11, 13, 14, 15, 16,
17, 18, 19, 20, 21, 22, 24, 25, 26, 27, 28, 29, 30, 31, 32,
33, 34, 35, 36, 37, 38, 39, 40, 41, 42, 43, 44, 45, 46, 47,
48, 49, 50, 51, 52, 53, 54, 55, 56, 57, 58, 59, 60, 61, 63,
64, 65, 66, 67, 69.

GREENLEE TOOL COMPANY

2371 Columbia Avenue
Rockford, Illinois

Hole Punching Tools

1, 2, 3, 6, 7, 8, 9, 10, 11, 15, 16, 17, 18, 20, 21,
22, 23, 24, 25, 30, 35, 40, 49, 50, 52, 61, 64, 66, 67, 69.

HALLICRAFTERS COMPANY

4401 W. 5th Avenue
Chicago 24, Illinois

Receivers, Transmitters and Amplifiers

1, 2, 3, 4, 5, 6, 7, 8, 9, 10, 11, 13, 14, 15, 16,
17, 18, 19, 20, 21, 22, 23, 24, 25, 26, 27, 28, 29, 30, 31,
32, 33, 34, 35, 36, 37, 38, 39, 40, 41, 42, 43, 44, 45, 46,
47, 48, 50, 51, 52, 53, 54, 55, 56, 57, 58, 59, 60, 61, 62,
63, 64, 65, 66, 67, 69.

[continued on page 150]

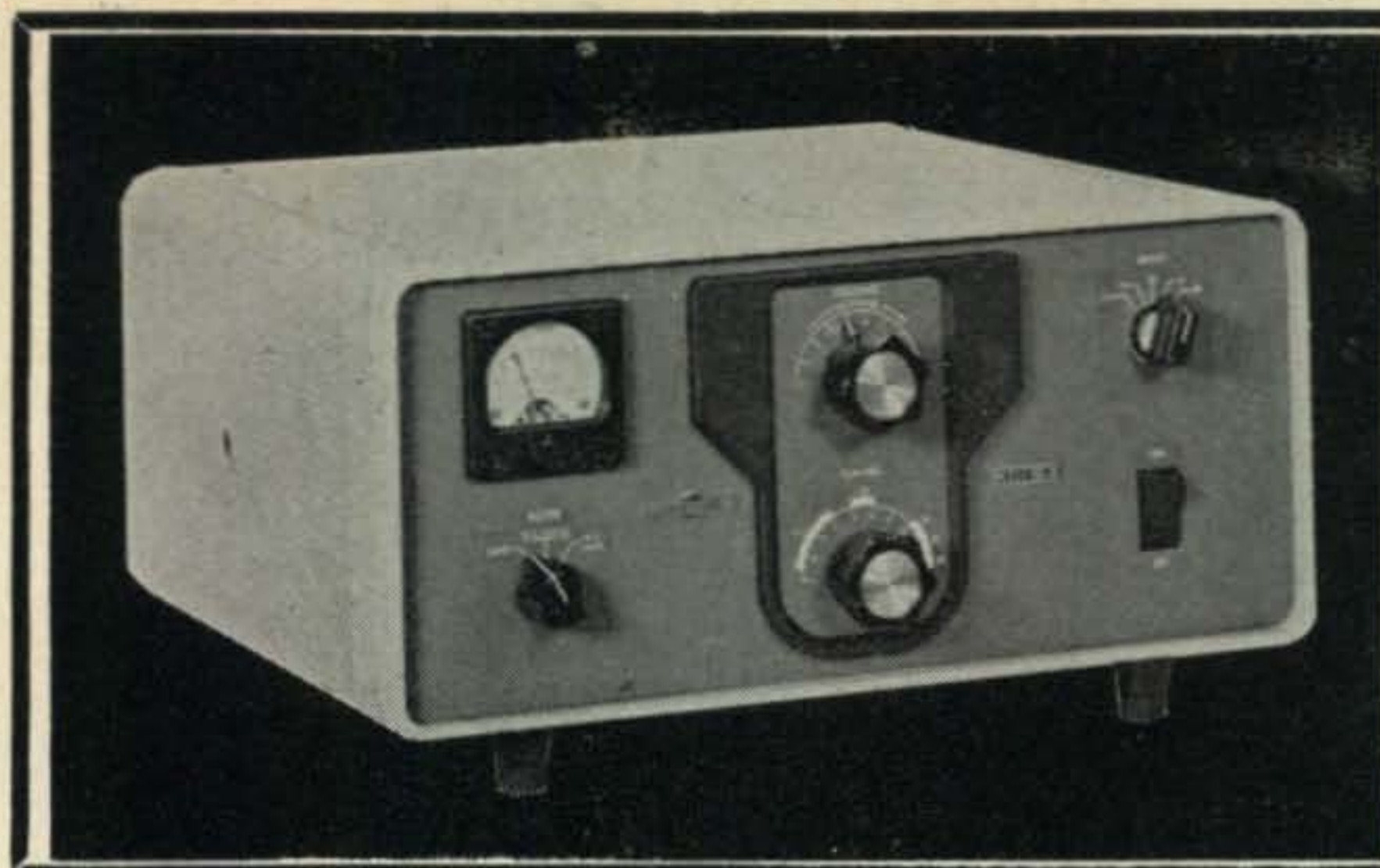

HOW COMPACT CAN YOU GET?
 (as compact as Collins has made the 30L-1). This tightly engineered, new 1000-watt linear amplifier is the same size as the famous Collins KWM-2. It has a self-contained power supply, too. Its price: \$520. Its appearance: "solid quality". Order the Collins 30L-1 now, for early delivery.



C & G ELECTRONICS

Northwestern headquarters for Collins
 2502 Jefferson Avenue 2221 3rd Avenue
 Tacoma 2, Wash. Seattle 1, Wash.

For further information, check number 43, on page 163

BARRY ELECTRONICS CORP.

***HAMMARLUND:**

- HQ-105-TR Recvr/Xmtr . . . \$219.50
- HQ-145-C Recvr . . . \$279.00
- S-100 Speaker . . . \$14.95

***NATIONAL:**

- HRO-60T . . . \$745.00
- NC-270 Recvr . . . \$249.95
- NC-190 Recvr . . . \$199.50
- NC-270 Speaker . . . \$19.95
- NC-303 Recvr . . . \$449.00
- NC-400 Recvr . . . \$895.00

***JOHNSON:**

- Messenger 115 VAC/12VDC#242-128 . . . \$144.95
- Ranger II (Wired) \$359.50
- Valliant (Wired) \$439.50
- Courier (Wired) \$289.50

***BARKER AND WILLIAMSON:**

- Model 650 (52 Ohms) Matchmaster \$47.50
- Model 712 Balun (20 Mtrs/75 Ohms Unbal In/300 Ohms bal. out.) \$10.20.
- Model 600 Dip Meter w/coils \$45.72
- Model 850A—KW Pi—\$35.00

***C.D. HAM-M ANTENNA ROTOR (Supports 1,000 lbs) \$119.50**

***MOSLEY ANTENNAS:**

- TA-36 (4 Element 10/15/20 Meter Beam) \$129.50.
- TA-33 (3 Element 10/15/20 Meter Beam) \$99.75.
- V-4-6 (10 to 40 Meter Vertical DX antenna) Hides up to 1 KW. No band switching. \$27.95.
- V-3 (10, 15, 20 Meter KW Vertical Antenna) \$22.95.

ANTENNA WIRE:

- 14 Ga. Formvar (order #ED-14) 100' @ \$1.85
- 12 Ga. Formvar (order #ED-12) 100' @ \$2.75
- Steel Guy Wire, galvanized—100' @ 99c (order #128)
- Aluminum Guy Wire 40' @ 99c (order #127).
- RG-58/U Coax Cable (order #139) 20' @ 99c

TUBES: (New Factory production)

0A3/VR75 at 80c	575A at \$15.00
0B3/VR90 at 95c	T55- at \$5.50
811A at \$4.95	5557/FG-17 at \$5.00
812A at \$4.95	5763 at \$1.75
816 at \$2.50	5842/417A at \$8.50
866A at \$1.70	5847/404A at \$5.75
872A at \$5.75	6080 at \$3.00
866JR at \$2.90	6146 at \$4.25
813 at \$13.50	6922/E88CC at \$3.50
	8008 at \$5.75

- Tubes (unused, lab tested) 5BP1 at \$7.95
- 2E26 RCA JAN at \$1.95 5BP4 at \$7.95
- 3B28 at \$2.75 4E27 at \$6.00

Jennings UCS Vacuum Variable Capacitor (10 to 300 Mmf, 10 KV) @ \$49.00

Dual Plate Xfrm: Pri: 115 VAC @ 60 CPS
 Sec. (1): 870 VCT @ 1.13 Amps., Sec. (2): 906 VCT @ 280 Ma. H'/Sid. \$5.95.

Collins Plate Transformer PRI: 115 VAC @ 60 CPS
 Sec: 800 VCT @ 270 Ma. \$3.95

6" Ceramic Bead Insulated flexible Wire for HV Rectifier Tubes @ 15c each.

*Prepaid/48 States

(50c service charge if order under \$2.00)

WRITE FOR YOUR COPY OF THE "GREENSHEET" CATALOG.

BARRY ELECTRONICS CORP. Dept. C-11
 512 Broadway
 New York 12, N. Y. Tel. WA 5-7000
 Area code 212

() Send copy of Fall 61 "Greensheet" Catalog.

() Enclosed are money order or check and my order.

NameTitle

Company

Address

CityState

For further information, check number 44, on page 163



Reconditioned Equipment Inventory SALE!

30 DAY EQUIPMENT WARRANTY

100% Satisfaction or Your Money Back

... Less Shipping Charges ... Within 15 Days

ENCLOSE PAYMENT IN FULL AND
WE WILL PAY ALL SHIPPING CHARGES

AMECO			
CB-6 Converter	\$ 19.00		
PS-1 Pwr Supply	9.00		
AC-1 Transmitter	9.00		
AMERICAN GELOSO			
G-212 TR Transmitter	149.00		
BABCOCK			
MT-5A Transmitter	54.00		
BARKER & WILLIAMSON			
5100 Transmitter	179.00		
5100S Transmitter	199.00		
5100B Transmitter	239.00		
370 SSB Slicer	39.00		
650 Matchmaster	29.00		
CENTRAL ELECTRONICS			
10B SSB Exciter	99.00		
20A SSB Exciter	159.00		
100V Transmitter	545.00		
600L Linear Amplifier	249.00		
458VFO/CE Cabinet	24.00		
Model B Slicer	45.00		
COLLINS RADIO			
75A-1 Receiver	239.00		
75A-2 Receiver	289.00		
75-A-4 Receiver	599.00		
75S-1 Receiver	379.00		
75S-1/ Blanker	449.00		
51J-4 Demonstrator	1400.00		
KWM-1 Transceiver	449.00		
KWM-1 Transceiver	499.00		
KWM-1 AC Supply	99.00		
KWM-1 Speaker	14.00		
KWM-1 Mounts	39.00		
KWM-2 Transceiver	875.00		
30S-1 Linear	1149.00		
32V-1 Transmitter	199.00		
32V-2 Transmitter	239.00		
32V-3 Transmitter	295.00		
32S-1 Transmitter	479.00		
312B-4 Console	139.00		
COSMOPHONE			
Cosmophone 35/Supply	449.00		
R. L. DRAKE COMPANY			
1A SSB Receiver	179.00		
2A Rec. New Display	219.00		
QXer Q Multiplier	9.00		
ELDICO			
SSB-100F Linear	399.00		
TR-75TV Transmitter	14.00		
EICO			
720 Transmitter	59.00		
762 CB Unit	49.00		
ELENCO			
Compression Amp.	9.00		
ELMAC			
A-54 Transmitter	49.00		
A-54H Transmitter	54.00		
AF-67 Transmitter	99.00		
PS2V AC Supply	29.00		
PMR-6A Receiver	59.00		
PMR-7 Rec.	89.00-99.00		
PSR-612 DC Supply	19.00		
PSR-117 AC Supply	19.00		
PSR-6 DC Supply	9.00		
PSR-12 DC Supply	9.00		
PSR-116 AC Supply	14.00		
M-1070 AC/DC Supply	39.00		
PMR-8 Receiver	129.00		
AF-68 Mobile	139.00		
GLOBE			
Scout Trans.	24.00		
65 Scout Trans.	39.00		
65-B Scout Trans.	49.00		
680 Scout Trans.	59.00		
680-A Scout Trans.	69.00		
SD75A Scout Deluxe	99.00		
DSB-100 Trans.	69.00		
Chief 90 Trans.	39.00		
Champ 300 Trans.	229.00		
Champ 350 Trans.	279.00		
King 400C Trans.	99.00		
King 500 Trans.	269.00		
King 500A Trans.	299.00		
755 VFO	29.00		
755A-VFO	34.00		
SM-90 Screen Mod.	8.00		
VOX-10	9.00		
GONSET			
Comm. I, 6 meters	129.00		
Comm. I, 2 meters	129.00		
Comm. IIB, 6 meters	149.00		
Comm. III, 6 meters	189.00		
Comm. III, 2 meters	189.00		
Comm. II, 6M. Amp.	89.00		
G-63 Receiver	169.00		
G-76 Transceiver	295.00		
G-76 DC Supply	109.00		
G-76 AC Supply	109.00		
GSB-100 Trans.	289.00		
GSB-101 Linear	229.00-249.00		
G-66 Receiver	109.00		
G-66B Receiver	124.00		
3-way Supply	24.00		
Thin pack supply	19.00		
30-40 MC FM Conv.	49.00		
Tri-band Conv.	19.00		
3066-6 meter Conv.	29.00		
G-77 Mobile Trans.	149.00		
G-77A Transmitter	169.00		
VHF-VFO 2 & 6	39.00		
VFO for commander	14.00		
HALLICRAFTERS			
S-38E Receiver	39.00		
S-120 Receiver	49.00		
HT-37 Transmitter	349.00		
HT-40 Transmitter	79.00		
S-38 Receiver	24.00		
S-41G Receiver	24.00		
S-38C Receiver	29.00		
S-38D Receiver	34.00		
S-40 Receiver	49.00		
S-40A Receiver	59.00		
S-40B Receiver	69.00		
SX-42 Receiver	129.00		
SX-43 Receiver	99.00		
S-53A Receiver	49.00		
SX-62 Receiver	199.00		
SX-71 Receiver	119.00		
S-85 Receiver	79.00		
SX-96 Receiver	169.00		
SX-99 Receiver	99.00		
SX-100 Receiver	199.00		
SX-101 Receiver MK. III	269.00		
S-102 Receiver	39.00		
SX-140 Receiver	89.00		
S-106 Receiver	39.00		
HT-30 Exciter	199.00		
HT-32 Exciter	399.00		
HT-32A Exciter	449.00		
HT-33 Exciter Linear	249.00		
SR-34AC Transceiver	269.00		
CB-1 Citizens Band	69.00		
HAMMARLUND			
HQ-100 Receiver	129.00		
HQ-110 Receiver	179.00		
HQ-129X Receiver	119.00		
HQ-160 Receiver	249.00		
HC-10 Slicer	79.00		
4-11 Modulator	19.00		
HARVEY-WELLS			
TBS-50 Transmitter	39.00		
TBS-50A Transmitter	44.00		
TBS-50C Transmitter	49.00		
TBS-50D Transmitter	54.00		
APS-50 AC Supply	19.00		
T-90 Transmitter	79.00		
R9A Receiver	69.00		
HEATH			
DX-35 Transmitter	44.00		
DX-40 Kit (new)	59.00		
DX-100 Transmitter	149.00		
RX-1 Receiver	229.00		
TX-1 Transmitter	229.00		
HW-29 Transceiver	39.00		
MR-1 Receiver	89.00		
MT-1 Transmitter	99.00		
MP-1 DC Supply	29.00		
AR-3 Receiver	24.00		
QF-1 Q Multiplier	8.00		
VF-1 VFO	19.00		
JACKSON			
CR0-2 TV Scope	99.00		
JOHNSON			
Adventurer Transmitter	29.00		
Challenger Transmitter	89.00		
Navigator Transmitter	129.00		
Ranger Transmitter	179.00		
Valiant Transmitter	289.00		
Courier Linear	149.00		
Thunderbolt Linear	389.00		
Mobile Transmitter	49.00		
Viking I Transmitter	99.00		
Viking II Transmitter	139.00		
I22 VFO for above	29.00		
KW Matchbox/Meter	109.00		
Viking-500 Transmitter	495.00		
Kilowatt Amplifier	795.00		
Desk for above	95.00		
KNIGHT			
C-27 Citizens Band	49.00		
50 Watt Transmitter	29.00		
R-100 Receiver	89.00		
VFO Built in Supply	24.00		
Spacespanner Receiver	9.00		
Model 600 Tube Checker	29.00		
LAKESHORE			
Phasemaster II Transmitter	149.00		
P-400GG Linear	109.00		
MECK			
T60-1 Transmitter (as is)	25.00		
MEISSNER			
EX Signal Shifter	15.00		
MONITORADIO			
30-50 MC Police Alarm Rec.	24.00		
MON-KEY			
Electronic Key	19.00		
MILLEN			
90881 500 Watt Amplifier	29.00		
MORROW			
3BR Converter	19.00		
5BR-2 Converter	29.00		
RTS-600S AC Supply	29.00		
MBR Mobile Receiver	89.00		
MB-560 Transmitter	109.00		
Falcon Receiver	59.00		
Falcon AC Supply	19.00		
Fixed Tune Receiver	29.00		
Citizens Band Unit	69.00		
NATIONAL			
NC-60 Receiver	39.00		
NC-66 Portable Receiver	49.00		
SW-54 Receiver	29.00		
NC-270 Receiver	169.00		
HRO-50 Receiver	159.00		
HRO-60 Receiver	299.00		
NC-98 Receiver	99.00		
NC-125 Receiver	109.00		
NC-173 Receiver	109.00		
NC-183 Receiver	149.00		
NC-188 Receiver	99.00		
NC-300 Receiver	199.00-229.00		
POLYTRONICS			
Poly Comm IIB Citizens Band	119.00		
P & H			
LA-400 Linear Amp.	79.00		
LA-400B Linear amp.	89.00		
RME			
6900 Receiver	259.00		
4300 Receiver	119.00		
DB-23 Preselector	34.00		
DB-20 Preselector	19.00		

RME-69 Receiver 49.00
SIMPSON
 383A Capacohmeter 49.00
SONAR
 CFC VFO 15.00
STANCOR
 ST-203A Mobile Transmitter 24.00
SURPLUS
 BC-221 Frequency meters 45.00

BC-458 VFO 9.00
 LM Frequency meter 40.00
 TG 34 Keyer 25.00
TAPETONE
 XC-50C Converter 49.00
 XC-50N Converter 49.00
 TC-220N Converter 49.00
TECHNICAL MATERIAL
 GPR-90 Receiver 349.00

TECRAFT
 CC/50 Converter 24.00
 CC/144 Converter 24.00
 TR50/20 Transmitter 34.00
VANTRON
 300W Linear Amplifier 69.00
VOCALINE
 ED-27M, New display 109.00
 JRC-400, 465 mc, as is 15.00
 ED-27 New display 89.00



Now! We're Nation Wide

Whether you want to *trade* or to *pay cash*, our local Sales Representatives can *save you big money*. All have a small stock of new and reconditioned equipment.



Terry W9DIA



ORLANDO, FLORIDA
 Phil LaMarche, W9DVM/4
 3617 Ranchwood Road
 Phone 295-2703



SCOTTSDALE, ARIZONA
 Fred Foss, W9TRU
 308 Davidson Street
 Phone Cherry 4-0677



SPRINGFIELD, ILLINOIS
 Jim Voelker, K7IXH
 22 West Citrus Drive
 Phone WH 6-7282



MADISON, WISCONSIN
 Ray Grenier, K9KHW/O
 2645 Airbase Road
 Phone Hemlock 5-1148



LINCOLN, NEBRASKA
 Bill Bryant, K9KKL
 2 Glen Aire
 Phone LA 902676



WASHBURN, WISCONSIN
 Joe Garland, W9YNR
 411 West 5th Street
 Phone DR 3-2162

HOW ABOUT YOURSELF? WOULD YOU LIKE EXTRA INCOME?
 We have openings for part time Sales Representatives in certain areas. No experience necessary. Write today.



SANDY, Sales Manager

CITIZENS BAND DEALERS—SAVE BIG MONEY ON ANTENNAS AND UNITS. Write me today for my special wholesale list.

AMATEUR ELECTRONIC SUPPLY

Two Stores to Serve You
 PLEASE SEND MAIL ORDERS TO MILWAUKEE STORE



Manager, Steve W9EAN

MILWAUKEE, WISCONSIN
 3832 Lisbon Ave.
 Phone: West 3-3262



Manager, "Doe", W9HJS

CHICAGO, ILLINOIS
 6430 Milw. Ave.
 Phone: RODney 3-1030

Terry Serman, W9DIA
 Amateur Electronic Supply—
 MAIL ORDER DEPARTMENT
 Dept. C-111, 3832 Lisbon Ave.,
 Milwaukee 4, Wisc.

Dear Terry:
 Please find enclosed \$.....
 for

NOTE: ENCLOSE PAYMENT IN FULL AND WE PAY ALL SHIPPING CHARGES

Name

Address

City State.....

() Please send latest reconditioned equipment bulletin

"LOUD NOISY AMATEUR"

JOHN IVERSON COMPANY

North Dakota's Only Ham Store

We Are Closer By Far

216 2nd St., S.W., Minot, North Dakota

VAN SICKLE Radio Supply Co.

BEST PLACE TO BUY HAM GEAR!

New and used bargains, big trades

4131 N. Keystone Ave., Indianapolis 5, Ind.

OREGON HAM SALES

409 W. 1st Ave. • Albany, Oregon

A complete stock for the Radio Amateur. Be sure and contact us before you trade.

W7SO & W7RAX

GRAHAM RADIO INC.

NEW ENGLAND'S ONLY EXCLUSIVE AMATEUR RADIO OUTLET—WE BUY, SELL, TRADE, SWAP, RENT, INSTALL, AND SERVICE HAM EQUIPMENT. TRY US FOR THE BEST DEAL — TWO STORES.

505 Main St., Reading, Mass., Tel. 944-4000

1105 No. Main St., Randolph, Mass., Tel. WO 3-5005

Amateur Electronic Supply THE BEST IN HAM GEAR! BIG TRADES!

3832 W. Lisbon Ave.,
Ph.: WEst 3-3262
Milwaukee 8, Wisconsin

A 6430 Milwaukee Ave.,
N Ph.: ROdney 3-1030
D Chicago 31, Illinois

KEY ELECTRONICS

SERVING THE NATIONAL CAPITAL AREA
AND HAMS EVERYWHERE

*For the best in ham gear
try Key and see!*

TRADES—TIME PAYMENTS

100 S. Wayne St., Arlington 4, Va.
11254 Triangle Lane, Wheaton, Md.

RENO RADIO CO.

1314 Broadway, Detroit 26, Mich.

WO 2-6851

*First and still Foremost in
Ham Radio in Michigan*

MELVIN

ELECTRONICS Inc.

541 Madison St., Oak Park, Ill.

EU 3-5800 — ES 8-7741

"EVERYTHING IN ELECTRONICS"

Manufacturers [from page 146]

HAMMARLUND MFG. CO., INC.

460 West 34 Street

New York 1, New York

Receivers and Component Parts

1, 2, 3, 4, 5, 6, 7, 8, 9, 10, 11, 12, 13, 14, 16,
17, 18, 19, 20, 21, 22, 23, 24, 25, 26, 27, 28, 29, 30, 31,
32, 33, 34, 35, 36, 37, 38, 39, 40, 41, 42, 43, 44, 45, 46,
47, 48, 50, 51, 52, 53, 54, 55, 56, 57, 58, 59, 60, 61, 62,
63, 64, 65, 66, 67, 69.

HEATH COMPANY

Benton Harbor, Michigan

Transmitters, Receivers & Accessories

6, 7, 8, 9, 10, 11, 15, 22, 23, 25, 26, 27, 30, 36, 37.

HI-PAR MANUFACTURING CO.

347 Lunenburg Street

Fitchburg, Massachusetts

Antennas

4, 5, 6, 7, 16, 17, 18, 21, 22, 23, 24, 25, 26, 27, 30,
32, 33, 34, 36, 37, 40, 41, 42, 43, 44, 45, 46, 47, 48, 50,
63, 64, 66, 69.

HOUSE OF ANTENNAS

1153 East 82 Street

Chicago 19, Illinois

Antennas

69.

HY-GAIN ANTENNA PRODUCTS CO.

1828 North Street

Lincoln, Nebraska

Antennas, Rotators, Mounts and Accessories

1, 2, 3, 4, 5, 6, 7, 8, 9, 10, 11, 13, 14, 15, 16,
17, 18, 19, 20, 21, 22, 23, 24, 25, 26, 27, 28, 29, 30, 31,
32, 33, 34, 35, 36, 37, 38, 39, 40, 41, 42, 43, 44, 45, 46,
47, 48, 49, 50, 51, 52, 53, 54, 55, 56, 57, 58, 59, 60, 61,
62, 64, 65, 66, 67, 69.

INSTRUCTOGRAPH CO., INC.

4711 Sheridan Road

Chicago 40, Illinois

Code Practice Equipment

1, 20, 22, 24, 25, 32, 33, 34, 62, 69.

INTERNATIONAL CRYSTAL MFG. CO., INC.

18 North Lee Street

Oklahoma City 2, Oklahoma

*Transmitters, Crystals and Accessories,
Printed Circuit Amplifiers, Test Equipment*

20, 24, 25, 26, 27, 36, 37, 41, 42, 43, 44, 45, 46, 47, 48.

JENNINGS RADIO MANUFACTURING CORP.

970 McLaughlin Avenue

San Jose 8, California

Vacuum Relays and Capacitors

4, 5, 6, 7, 12, 17, 18, 20, 25, 30, 32, 33, 34, 52, 65,
67, 69.

**"CALL ME
for
Personal Service"**

**"CALL ME
for
Personal Service"**

Bob Henry
WØARA
Butler, Mo.
ORchard 9-3127



ON

Ted Henry
W6UOU
Los Angeles
GRanite 7-6701



**WORLD'S
BEST TERMS**

**Because we finance
our own terms...**

- Only 6% a year finance cost
- 20 months or longer to pay
- Only 10% down (or your trade-in as down payment)
- No finance charges if paid within 90 days
- Reduced charges if paid off ahead of time
- You get more flexibility of financing in the future (such as re-financing) because we handle our own financing

**A-1 Reconditioned
Apparatus**

Nearly all makes and models. Big savings!
Ten day trial—90 day warranty. 90 day full trade back on new apparatus. Write for bulletin.

Collins

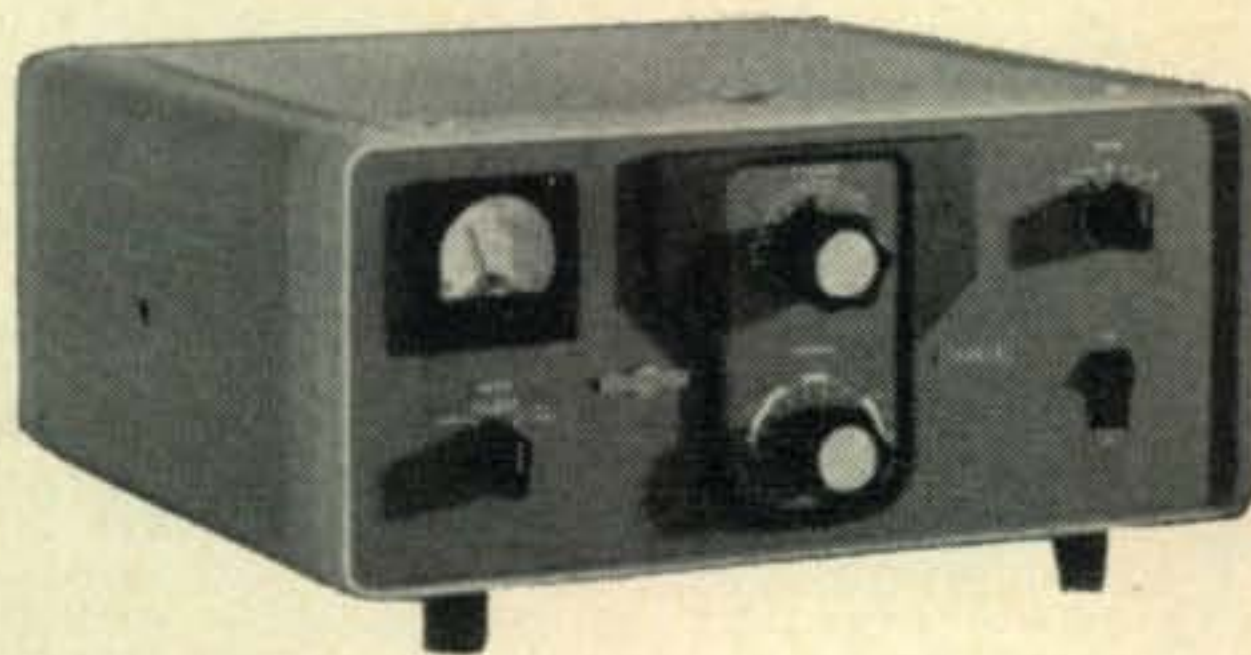

75S-3 Receiver.....	\$ 620.00
30L-1 Linear Amplifier	520.00
KWM-2 Transceiver	1150.00
32S-1 Transmitter	666.00
516F-2 AC Power Supply	115.00
MPI 12 V DC Power Supply.....	198.00
75S-1 Receiver	520.00
312B-3 Speaker	32.00
30S-1 Linear Amplifier	1556.00

*Write, phone or visit either store today!
Inquiries & orders from military men
and others outside USA wanted.*

Butler 1, Missouri

ORchard 9-3127

Henry Radio Stores

11240 West Olympic Blvd.

Los Angeles 64 Ph. GRanite 7-6701

BIG

TRADE-INS

World's Largest Distributors of Short Wave Receivers

OPEN NOW THE 3rd HENRY RADIO STORE 931 N. Euclid Ave., Anaheim, Calif.

For further information, check number 48, on page 163

"IN CENTRAL ILLINOIS IT'S"

KNOX ELECTRONIC SUPPLY INC.

NEW OR USED!

67 N. CHERRY ST., GALESBURG, ILLINOIS

East—Central Pennsylvania

EVERYTHING FOR THE HAM

WE TRADE and FINANCE

GEORGE D. BARBEY CO.

Reading • Lancaster • Pottstown • Lebanon

NEW LOW PRICES!!!

NEW • USED • SURPLUS HAM GEAR

MOTOROLA FM for CONVERSION to 6 METERS

Fort Wayne Electronics Supply, Inc.

Ft. Wayne, Indiana

W9TE—Art W9JRR—Bob K9JMZ—Tony

Crescent Electronic Supply, Inc.

Ham Hdqtrs. for New & Used gear.

Everything for the novice.

537 S. Claiborne Ave., New Orleans, La.

"SEASONS GREETINGS"

TO ALL MY FRIENDS AND FELLOW HAMS WHOM
I DON'T CONTACT AS OFTEN AS I WOULD
LIKE TO DO

GIL SEVERNS—W6QR

HAM GEAR-AT-HEMET, CALIF.

*If it's for amateur radio
try TYDINGS first*

TYDINGS COMPANY

**933 Liberty Avenue
Pittsburgh 22, Pa.**

GRAHAM ELECTRONICS

hoosier ham headquarters for a
quarter of a century

long trades — easy terms

INDIANAPOLIS, INDIANA

25% off (while they last)

RME4350A Dual Conversion Ham Band Receivers
(new) \$186.75 plus freight (Calif. add Sales Tax)

FORTUNE ELECTRONIC SUPPLIERS INC.

930 El Camino Real, San Carlos, Calif.

Manufacturers [from page 150]

JOHNSON, E. F., CO.
Waseca, Minnesota

*Transmitters, Amplifiers, Antennas, Rotators and
Components*

1, 2, 3, 4, 5, 6, 7, 8, 9, 10, 11, 12, 13, 14, 15,
16, 17, 18, 19, 20, 21, 22, 23, 24, 25, 26, 27, 28, 29, 30,
31, 32, 33, 34, 35, 36, 37, 38, 39, 40, 41, 42, 43, 44, 45,
46, 47, 48, 49, 50, 52, 53, 54, 55, 56, 57, 58, 59, 60, 61,
62, 63, 64, 65, 67, 68, 69.

KTV TOWER & COMMUNICATION CO.

5520 South Shore Drive
Chicago 37, Illinois

Towers

4, 5, 8, 9, 10, 11, 15, 51, 66, 69.

KNIGHTS, JAMES, CO.

Sandwich, Illinois

Crystals

2, 3, 4, 5, 15, 25, 26, 27, 36, 37, 40, 41, 42, 43, 44,
45, 46, 47, 48, 49, 62, 66, 69.

KNIGHT KIT

100 No. Western Avenue
Chicago 80, Illinois

Transmitters, Receivers, Test Equipment

2, 3, 67.

LW ELECTRONIC LABS

Route 2

Jackson, Michigan

Transmitters, Converters

4, 5, 62.

MARK MOBILE INC.

6416 W. Lincoln Avenue
Morton Grove, Illinois

Mobile Antennas

1, 2, 3, 4, 5, 6, 7, 8, 9, 10, 11, 16, 17, 18, 20,
21, 22, 25, 26, 27, 30, 31, 32, 33, 34, 35, 41, 42, 43, 44,
45, 46, 47, 48, 49, 62, 64, 69.

MASTER MOBILE MOUNTS, INC.

1306 Bond Street

Los Angeles 15, California

Mobile Antennas, Mounts, Coils, Field Strength Meters,

2, 3, 4, 5, 6, 7, 8, 9, 10, 11, 13, 14, 15, 16, 17,
18, 19, 20, 22, 23, 24, 25, 26, 27, 28, 29, 30, 35, 36, 37,
38, 39, 40, 41, 42, 43, 44, 45, 46, 47, 48, 49, 50, 51, 52,
53, 54, 55, 56, 57, 58, 59, 60, 61, 62, 63, 65, 66, 67, 68,
69.

JAMES MILLEN MFG. CO., INC.

150 Exchange Street

Malden 48, Massachusetts

*Transmitters, Amplifiers, Power Supplies
Component Parts, Test Equipment*

2, 3, 4, 5, 8, 9, 10, 11, 14, 15, 17, 18, 19, 21, 22,
23, 24, 25, 28, 29, 30, 32, 33, 34, 38, 39, 40, 41, 42, 43,
44, 45, 46, 47, 48, 49, 50, 53, 54, 55, 56, 57, 58, 59, 60,
63, 65, 67, 69.

MINI-PRODUCTS, INC.

1001 W. 18 Street
Erie, Pennsylvania

Antennas

6, 7, 16, 25, 30, 66.

MOSLEY ELECTRONICS, INC.

3622 St. Charles Rock Road
St. Louis 14, Missouri

Antennas and Accessories

2, 3, 4, 5, 6, 7, 8, 9, 10, 11, 12, 13, 14, 15, 16,
17, 18, 19, 20, 21, 22, 23, 24, 25, 26, 27, 28, 29, 30, 31,
32, 33, 34, 35, 36, 37, 38, 39, 40, 41, 42, 43, 44, 45, 46,
47, 48, 49, 50, 51, 52, 53, 54, 55, 56, 57, 58, 59, 60, 61,
62, 63, 64, 65, 66, 67, 68, 69.

MULTI-PRODUCTS CO.

21470 Coolidge Highway
Oak Park 37, Michigan

Citizen Band Transceivers

1, 2, 3, 4, 5, 6, 7, 13, 14, 16, 17, 18, 19, 20, 21,
22, 25, 26, 27, 28, 29, 30, 31, 32, 33, 34, 35, 36, 37, 38,
39, 41, 42, 43, 44, 45, 46, 47, 48, 50, 51, 52, 53, 54, 55,
56, 57, 58, 59, 60, 61, 62, 64, 65, 66, 67, 69.

NATIONAL RADIO COMPANY, INC.

61 Sherman Street
Malden, Massachusetts

Receivers, Component Parts

1, 2, 3, 4, 5, 6, 7, 8, 9, 10, 11, 12, 13, 14, 15,
16, 17, 18, 19, 20, 21, 22, 23, 24, 25, 26, 27, 28, 29, 30,
31, 32, 33, 34, 35, 36, 37, 38, 39, 40, 41, 42, 43, 44, 45,
46, 47, 48, 49, 50, 51, 52, 53, 54, 55, 56, 57, 58, 59, 60,
61, 62, 63, 64, 65, 66, 67, 68, 69.

NEIL COMPANY

1336 Calkins Road
Pittsford, New York

VHF Transmitters, Receivers, Transceivers

6, 7, 41, 42, 43, 44, 45, 46, 47, 48, 65, 69.

P&H ELECTRONICS, INC.

424 Columbia
Lafayette, Indiana

Transmitters, Amplifiers, Test Equipment

1, 2, 3, 4, 5, 6, 7, 24, 28, 29, 30, 32, 33, 34, 35,
38, 39, 53, 54, 55, 56, 57, 58, 59, 60, 62, 66, 67, 69.

PENNWOOD-NUMECHRON COMPANY

7249 Frankstown Avenue
Pittsburgh 8, Pennsylvania

Clocks, Timers

1, 2, 3, 4, 5, 6, 7, 8, 9, 10, 11, 13, 16, 17, 18,
20, 21, 22, 24, 26, 27, 30, 32, 33, 34, 35, 36, 37, 50, 54,
55, 56, 57, 58, 59, 60, 61, 64, 69.

PENTA LABORATORIES

314 North Nopal St.
Santa Barbara, Calif.

Transmitting Tubes

4, 5, 17, 18, 20, 24, 28, 29, 32, 33, 34, 38, 39, 52, 53,
62, 69.

CANADIANS

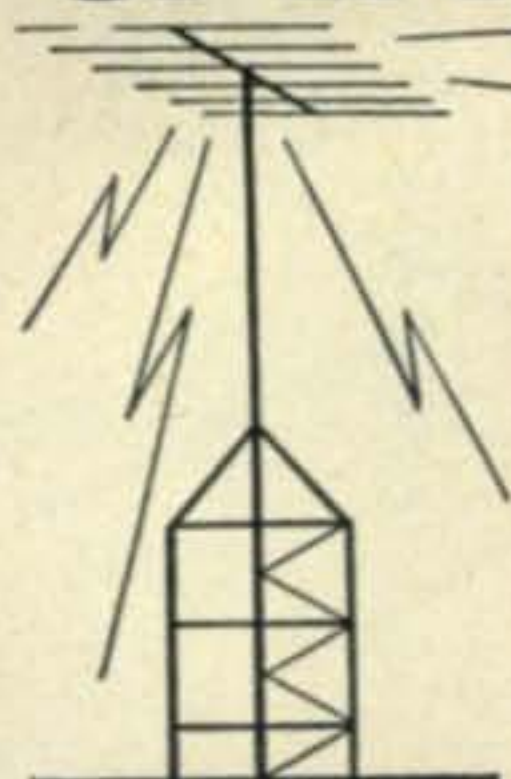

FLASH!
ALL ORDERS
SHIPPED ON
DAY RECEIVED

Complete stocks of nationally advertised products always available at SMALLEY'S — ham headquarters for Western Canada. Ten licensed hams on our staff to serve you.

- TRADE-INS ACCEPTED
- USED HAM EQUIPMENT
- SEND FOR SPECIAL FREE HAM BULLETIN

Pioneer ham suppliers since 1920. Specialists in HI-FI, TELEVISION and INDUSTRIAL ELECTRONIC EQUIPMENT.

Smalley's
RADIO LTD.

1105 - 7th Ave., S.W., Calgary, Alta.

For further information, check number 92, on page 163

Are You TRADING?

Let me make you a trade-in offer on your used amateur equipment. All name-brand merchandise—late serial numbers assured. Quick delivery.

WRITE TODAY! Bill W9ZSO-KØIUH

COMMUNICATIONS EQUIPMENT CO.

518 State St., LaCrosse, Wis.
Phone 4-7373



FREE Catalog

OF THE WORLD'S FINEST
ELECTRONIC GOV'T
SURPLUS BARGAINS

• Hundreds and hundreds of top quality surplus items: Receivers, Transmitters, FM Equipment, Mics., Headsets, Telephones, Generators, Motors, Amplifiers, Power Supplies, Meters, Test Equipment, Antennas, Cable, Dynamotors, Inverters, Transformers, Etc., Etc.

SEND FOR FREE CATALOG!
Address Dept. CQ

FAIR RADIO SALES
P.O. BOX 1105 LIMA, OHIO



Hy-Gain DUOBANDER

The Hy-Gain Duobander consists of three full-sized elements on 20M and two reduced-sized elements on 40M in a lightweight, compact antenna.

Two band operation made possible through the linear decoupling stub, eliminating the use of inductance and capacity traps.

Beta matching system for maximum gain and low SWR into a single 52 ohm coax.

Model DB-24
\$149.50

5 KW P.E.P., 3 KW AM; forward gain over a tuned dipole 20M - 8.1 db; forward gain over a tuned dipole 40M - 4.9 db; F/B ratio, 20M - 20 to 30 db; F/B ratio, 40M - 15 to 20 db. Boom is 24 ft., longest element approx. 40 ft. All aluminum construction with hardware iridite treated to military specifications.

Ward J. Hinkle W2JEL

Be Sure to Write for Our Latest Used List
Before you buy or trade, wire, write or call

ADIRONDACK RADIO SUPPLY

185-191 W. Main St., Amsterdam, N. Y.

Phone: Victor 2-8350

Ward J. Hinkle, Owner

For further information, check number 45, on page 163



YOU NEED THIS

FREE GIANT B-A CATALOG



SAVE UP TO
50% ON B-A
SELECTED
KITS

HI-FI AND
STEREO
SYSTEMS &
COMPONENTS

TOP VALUES
IN POWER
AND HAND
TOOLS

30 PAGES
OF BARGAINS
NOT IN ANY
OTHER CATALOG

BURSTEIN-APPLEBEE CO.

Dept. CQ 1012 McGee St., Kansas City 6, Mo.

Rush me New 1962 B-A Catalog No. 621

Name.....

Address.....

City..... State.....

SEND
FOR IT
TODAY

For further information, check number 46, on page 163

Manufacturers [from page 153]

PETERSEN RADIO COMPANY, INC.

2800 West Broadway
Council Bluffs, Iowa

Crystals

1, 2, 3, 4, 5, 6, 7, 8, 9, 10, 11, 13, 16, 17, 18,
19, 20, 21, 22, 23, 24, 25, 26, 27, 28, 29, 30, 31, 32, 33,
34, 35, 36, 37, 38, 39, 40, 41, 42, 43, 44, 45, 46, 47, 48,
53, 54, 55, 56, 57, 58, 59, 60, 61, 65, 67, 68, 69.

PHILMORE MANUFACTURING CO.

130-01 Jamaica Avenue
Richmond Hill 18, N. Y.

VHF Transmitter Kits

1, 2, 3, 4, 5, 6, 7, 8, 9, 10, 11, 13, 15, 16, 17,
18, 21, 22, 24, 25, 31, 32, 33, 34, 35, 36, 37, 40, 41, 42,
43, 44, 45, 46, 47, 48, 49, 50, 52, 54, 55, 56, 57, 58, 59,
60, 61, 63, 64, 66, 67, 69.

POLYTRONICS

Clifton, New Jersey

Transceivers

4, 5, 6, 7, 16, 19, 22, 25, 26, 27, 28, 29, 30, 36, 37,
38, 39, 41, 42, 43, 44, 45, 46, 47, 48, 50, 53, 54, 55, 56,
57, 58, 59, 60, 66, 69.

RCA ELECTRON TUBE DIVISION

Harrison, New Jersey

Electron Tubes

1, 2, 3, 6, 7, 8, 9, 10, 11, 17, 18, 20, 23, 25, 28,
29, 30, 31, 38, 39, 41, 42, 43, 44, 45, 46, 47, 48, 52, 53,
61, 65, 68, 69.

REGENCY DIV. OF IDEA, INC.

7900 Pendleton Pike
Indianapolis 26, Indiana

Receivers and Converters

1, 2, 3, 4, 5, 6, 7, 8, 9, 10, 11, 13, 17, 18, 19,
20, 21, 22, 23, 24, 25, 26, 27, 30, 32, 33, 34, 35, 40, 41,
42, 43, 44, 45, 46, 47, 48, 50, 54, 55, 56, 57, 58, 59, 60,
61, 62, 63, 64, 66, 67, 69.

RIDER PUBLISHING, INC., JOHN F.

116 W. 14 Street
New 11, N. Y.

Books

2, 3, 4, 5, 6, 7, 8, 9, 10, 11, 13, 14, 15, 16, 17,
18, 20, 21, 22, 23, 25, 28, 29, 30, 32, 33, 34, 35, 36, 37,
38, 39, 40, 41, 42, 43, 44, 45, 46, 47, 48, 49, 52, 53, 54,
55, 56, 57, 58, 59, 60, 61, 63, 64, 65, 66, 67, 68, 69.

ROHN MANUFACTURING CO.

116 Limestone
Bellevue, Peoria 5, Illinois

Towers and Accessories

4, 5, 6, 7, 15, 16, 20, 21, 24, 25, 26, 27, 28, 29, 31,
32, 33, 34, 35, 38, 39, 40, 41, 42, 43, 44, 45, 46, 47, 48,
49, 50, 52, 53, 61, 63, 64, 65, 66, 67, 69.

SECO ELECTRONICS, INC.

5015 Penn Avenue So.
Minneapolis, Minnesota

Test Equipment

1, 4, 5, 6, 7, 13, 15, 20, 21, 24, 25, 28, 29, 35, 36,
37, 38, 39, 40, 41, 42, 43, 44, 45, 46, 47, 48, 49, 50, 51,
52, 53, 62, 65, 67, 69.



SEE IT HERE!

NATIONAL'S NC-155

New Ham Band Receiver

THE PERFORMANCE PACE SETTER OF THE YEAR



See inside back cover for more details!

Come in for a demonstration

Henry Radio Stores

11240 West Olympic Boulevard
Los Angeles 64, California

931 North Euclid Avenue
Anaheim, California

Butler 1, Missouri

For further information, check number 50, on page 163

**NOW! 150 WATTS
VHF SSB
with P&H 6 METER
TRANSMITTING
CONVERTER**



**Complete — With Built-in Power Supply,
All Tubes and Crystal, for Only \$259.95**

- Converts the 20 meter output of your SSB, AM or CW exciter to 6 meters.
- Power input to 5894 final; 150 watts PEP on SSB, 120 watts CW, 67 watts linear AM.
- Resistive Pi-Pad permits operation with any 10 to 100 watt output VFO or crystal controlled exciter.
- Switchable Half-Power pad provided for AM exciters.
- Output jack provided to furnish oscillator injection for receiver converter.
- Meter reads PA Grid, PA Plate, Relative Output.
- 50-70 ohm input and output.
- Thoroughly shielded and bypassed. Parasitic free.
- Quiet forced air cooling.
- Modernistic, compact grey cabinet, 9" x 15" x 10½"

MODEL 6-150 . . . Amateur Net Price **\$259.95**

WRITE FOR COMPLETE INFORMATION

P & H ELECTRONICS INC.
424 Columbia, Lafayette, Ind.

For further information, check number 51, on page 163

DOW-KEY CONNECTORS	
 <p>PANEL MOUNT Durable, silver plated, precision made. Only 5/8" hole is needed, no screws. ea.70</p>	 <p>DOUBLE MALE Favorite everywhere. Precision made, rugged locking type. Silver plated. ea.1.25</p>
DOW-KEY COMPANY, Thief River Falls, Minn.	

Interested In
DUMMY LOADS?

Write W2IXU
HAM KITS, Box 175A, Cranford, N. J.

Manufacturers [from page 154]

SHURE BROTHERS, INC.

222 Hartrey Avenue
Evanston, Illinois

Microphones

1, 2, 3, 4, 5, 6, 7, 8, 9, 10, 11, 13, 14, 15, 16, 17, 18, 19, 20, 21, 22, 23, 24, 25, 26, 27, 28, 29, 30, 32, 33, 34, 35, 38, 39, 40, 41, 42, 43, 44, 45, 46, 47, 48, 49, 51, 53, 54, 55, 56, 57, 58, 59, 60, 63, 64, 65, 66, 67, 68, 69.

SKYLANE PRODUCTS

406 Bon Air
Tampa 10, Florida

Antennas

1.

SOLAR ELECTRONICS

149 Wooster Street
New York 12, N. Y.

VHF Transceivers

12, 67, 69.

SPRAGUE ELECTRIC CO.

467 Marshall Street
North Adams, Mass.

Semiconductor Devices

1, 4, 5, 6, 7, 15, 17, 18, 20, 21, 25, 28, 29, 30, 35, 38, 39, 40, 41, 42, 43, 44, 45, 46, 47, 48, 50, 52, 53, 54, 55, 56, 57, 58, 59, 60, 62, 65, 67, 68, 69.

TAPETONE, INC.

10 Ardlock Place
Webster, Mass.

Transmitters and Converters

8, 9, 10, 11, 13, 16, 17, 18, 19, 21, 22, 24, 26, 27, 30, 32, 33, 34, 36, 37, 50, 62, 64, 66.

TELEX, INC.

1633 Eustis St.
St. Paul 1, Minnesota

Head Sets

1, 2, 3, 4, 5, 6, 7, 8, 9, 10, 11, 13, 15, 16, 17, 18, 19, 20, 21, 22, 24, 25, 28, 29, 30, 32, 33, 34, 35, 36, 37, 38, 39, 40, 41, 42, 43, 44, 45, 46, 47, 48, 49, 50, 52, 53, 54, 55, 56, 57, 58, 59, 60, 61, 63, 64, 65, 66, 67, 68, 69.

TELREX, INC.

Asbury Park 2, New Jersey

Antennas, Rotators and Accessories

2, 3, 4, 5, 6, 7, 8, 9, 10, 11, 13, 16, 17, 18, 19, 20, 21, 22, 23, 24, 25, 26, 27, 28, 29, 30, 32, 33, 34, 35, 38, 39, 41, 42, 43, 44, 45, 46, 47, 48, 50, 52, 53, 54, 55, 56, 57, 58, 59, 60, 61, 62, 64, 66, 67, 69.

TEXAS CRYSTALS

1000 Crystal Dr.
Ft. Myers, Florida

Crystals

1, 4, 5, 6, 7, 15, 17, 18, 20, 24, 25, 28, 29, 35, 36, 37, 38, 39, 40, 41, 42, 43, 44, 45, 46, 47, 48, 49, 50, 52, 53, 63, 64, 66, 67.



SEE IT HERE!

NATIONAL'S NC-155

New Ham Band Receiver

THE PERFORMANCE PACE SETTER OF THE YEAR

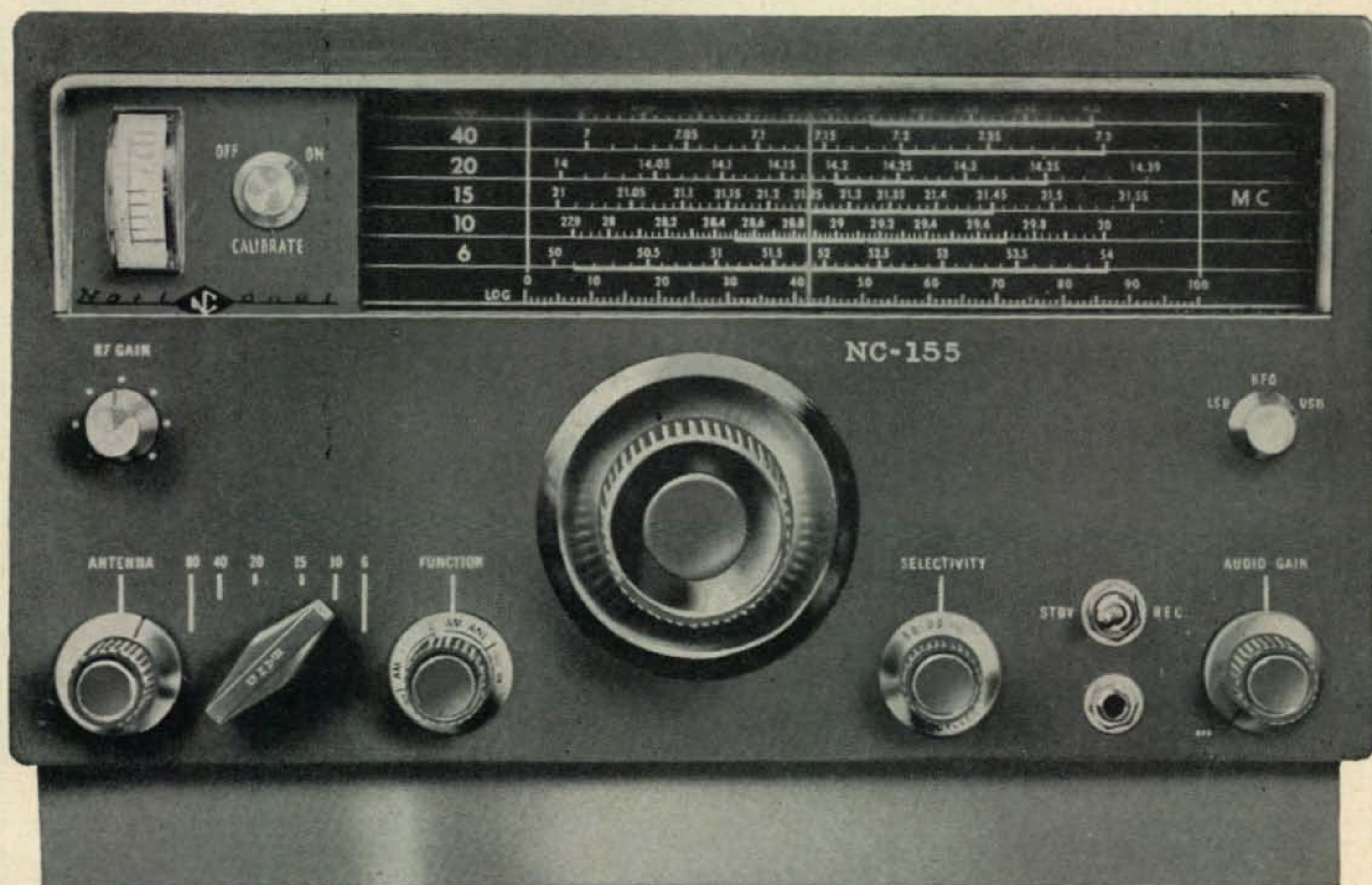

See inside back cover for more details!

Come in for a demonstration

VAN SICKLE RADIO SUPPLY COMPANY

4131 North Keystone Avenue

Indianapolis 5, Indiana

LI 7-3589

For further information, check number 52, on page 163

November, 1961 • CQ • 157

PLATT

FOREMOST SUPPLIER OF LINK EQUIPMENT & PARTS

- 12-VOLT CONVERSION KITS for ALL LINK MODELS
- MODIFICATION KITS in ACCORDANCE with LATEST FCC REQUIREMENTS

TAKE ADVANTAGE OF THESE TERRIFIC BUYS ON TOP-GRADE RECONDITIONED FM MOBILE EQUIPMENT

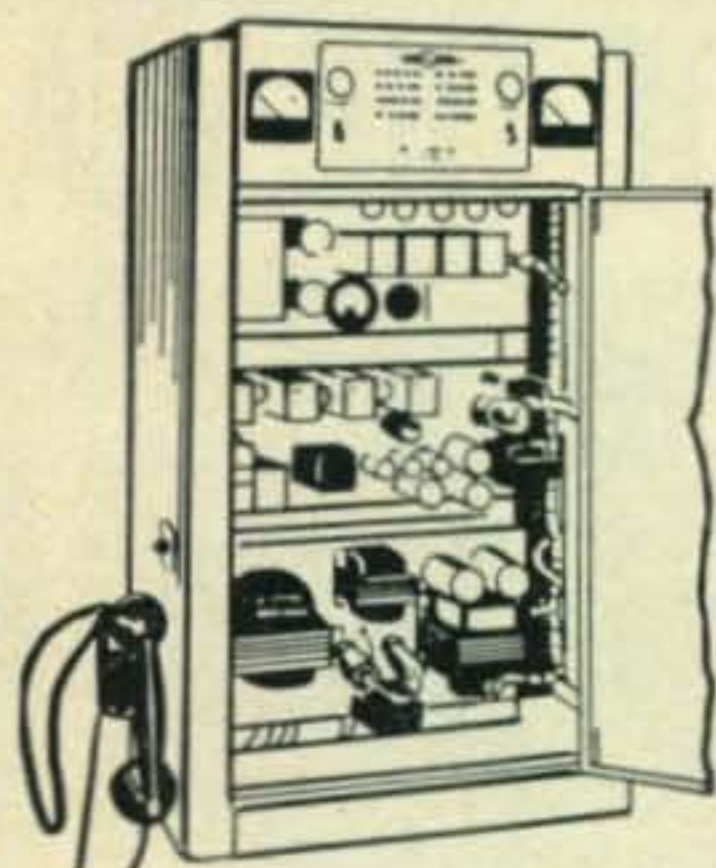

MODEL 50 UFS 60 WATT 30-50 MC BASE STATION

Housed in a 34" upright cabinet. Operates on 110 AC. Reconditioned, checked out, complete with accessories.

\$249.50

MODEL 1907 60 WATT FOR HIGH FREQ. OPERATION 152-174 MC—110 V.

Reconditioned, ch'ked out, complete with all accessories.

\$299.50

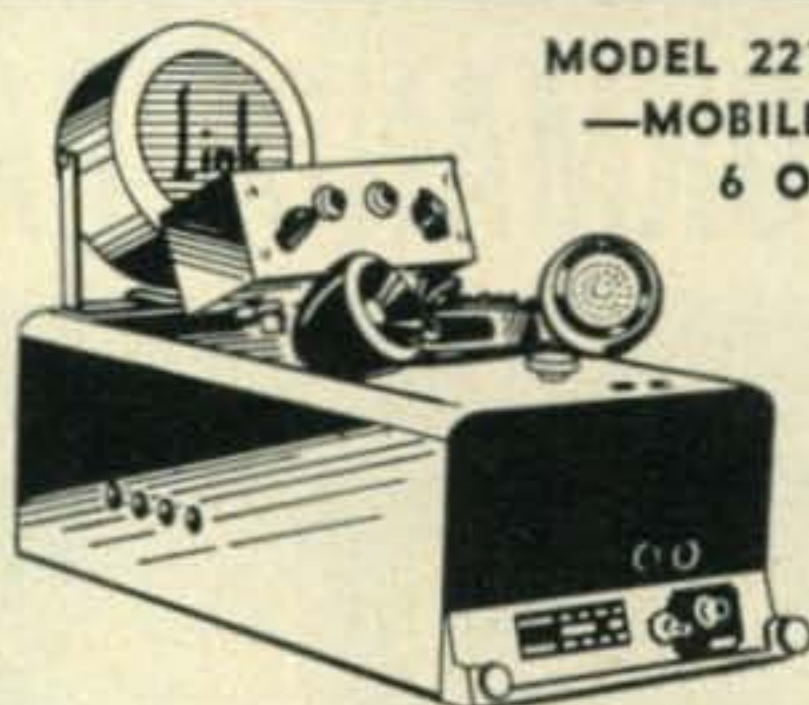

MODEL 2210 152-162 MC FM —MOBILE TRANS. & REC. 6 OR 12 VOLTS

Antenna, cables, control head, mike, crystals. Complete for immediate installation. Specially priced.

6 Volt
\$139.50

12 Volt
\$162.50

MODEL 2365 25-40 OR 30-50 MC FM MOBILE TRANS. & REC.—6 OR 12 VOLTS

Supplied as illustrated above. Complete for immediate installation.

6 Volt—\$119.50

12 Volt—\$149.50



2-PIECE MODEL FMTR 30-50 MC ED. 7 FM MOBILE TRANS. & REC.—6 OR 12 VOLTS

Unit complete with Peak Modulation control head, mike, antenna, cables & crystals ground to your specific frequency. Modified.

6 Volt \$109.95

12 Volt—\$149.95

2-PIECE MODEL FMTR 152-174 MC ED. 7, 25 W, FM MOBILE TRANS. & REC. —6 or 12 VOLTS

Supplied as illustrated above.

6 Volt—\$134.95

12 Volt—\$174.95

LIMITED QUANTITY— BRAND NEW! LINK MOBILE RADIO SET

Complete with crystals & all accessories. FCC approved. Low frequency: 25-50 MC, 30-40 watts power output.

Special Price
\$249.50



REMOTE CONTROL UNITS

Model 1890—for operation in the 25-54 megacycle band. Used for Link Base Station operation & can be adapted for any other type. Brand new.

\$169.50



NEW CHICAGO

PLATE TRANSFORMER TR-1040

115 VAC Primary, 2500 VDC @ 250 MA DC Secondary, 9" hi, 8 1/2" w., 7" dp.

\$49.95

Wt. 60 lbs.



FREQUENCY METERS



For the maintenance shop and field service. BC-221 Frequency Meters complete with original calibration book. Available in modulated and unmodulated types as well as a-c operated models. Factory tested, checked for frequency alignment and GUARANTEED.

Unmodulated Type	\$119.50
Modulated Type	\$139.50
Modulated Type with AC Power	\$159.50
Supply	\$159.50

NEW! Our own version of the famous BC-221 with built-in magic eye zero-beat indicator. Add \$25.00 to any model.

FEDERAL PORTABLE MOBILE SIGNAL GENERATOR 110 V AC POWER—TYPE 104A

Designed to facilitate alignment of FM mobile and land station receivers in the field. Provides a continuous source of frequency modulated carrier, the frequency of which is determined by the multiplier-type crystal that is used in the unit. It will, by the proper selection of crystals, provide a signal suitable for the alignment of FM mobile receivers in both the 25-50 MC band and the 148-174 MC band. In addition to these frequencies, the type 104A Mobile Signal Generator provides a 1000 cycle signal that may be used to check audio circuits. Unit has external power facilities

\$49.50



SPECIAL!!

17 LBS. of ASSORTED RADIO PARTS

Now at give-away price of only **\$1.59**



UNIVERSAL 6/12 VOLT VIBRATOR POWER SUPPLY

WIRED, Mfd. by DUMONT. Rating 300 V. @ 100 mill. Ideal for all types of mobile applications. Chassis measures 5 1/4" x 5 1/4" x 8". **\$11.95**

Brand New

Vibrator for above \$2.99

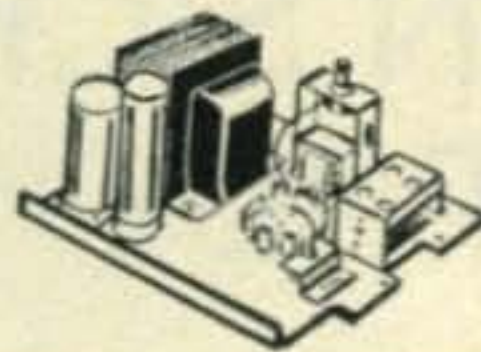

We invite inquiries on the New Link 2-way Mobile Equipment with TRANSISTORIZED POWER SUPPLIES. Models are available in 25-54 or 144-174 MC Freq. Range.

PLATT ELECTRONICS CORP.

23 PARK PLACE • NEW YORK 7, N. Y.

Telephone: COrtlandt 7-2575

Include 25% deposit with order.
Shipments F.O.B. our warehouse, N.Y.C.

For further information, check number 49, on page 163



SEE IT HERE!

NATIONAL'S NC-155

New Ham Band Receiver

THE PERFORMANCE PACE SETTER OF THE YEAR



See inside back cover for more details!

Come in for a demonstration

GRAHAM RADIO, INCORPORATED

505 Main Street
Reading, Massachusetts
944-4000

1105 North Main Street
Randolph, Massachusetts
WO 3-5005

For further information, check number 54, on page 163

November, 1961 • CQ • 159

Manufacturers [from page 156]

TRIAD TRANSFORMER CORP.

4055 Redwood Avenue
Venice, California

Transformers and Chokes

2, 3, 6, 7, 17, 18, 20, 21, 23, 24, 25, 28, 29, 30, 35,
36, 37, 38, 39, 49, 50, 53, 54, 55, 56, 57, 58, 59, 60, 66,
67.

TRI-EX TOWER CORP.

127 E. Inyo Street
Tulare, California

Towers and Accessories

4, 5, 6, 7, 12, 15, 17, 18, 19, 21, 24, 26, 27, 28, 29,
30, 32, 33, 34, 38, 39, 52, 53, 54, 55, 56, 57, 58, 59, 60,
62, 63, 65, 69.

TURNER MICROPHONE CO.

925 17th Street NE
Cedar Rapids, Iowa

Microphones

1, 2, 3, 4, 5, 6, 7, 8, 9, 10, 11, 13, 15, 16, 17,
18, 20, 23, 24, 25, 26, 27, 28, 29, 30, 31, 32, 33, 34, 35,
36, 37, 38, 39, 40, 41, 42, 43, 44, 45, 46, 47, 48, 49, 51,
52, 53, 54, 55, 56, 57, 58, 59, 60, 61, 62, 63, 64, 65, 66,
67, 69.

VESTO CO., INC.

20th & Clay St.
No. Kansas City, Mo.
Self-supporting Towers

52, 69.

VIBROPLEX COMPANY, INC.

833 Broadway
New York 3, New York

Keys

1, 2, 3, 4, 5, 6, 7, 8, 9, 10, 11, 12, 15, 16, 17,
18, 20, 21, 22, 24, 25, 26, 27, 28, 29, 30, 31, 32, 33, 34,
35, 36, 37, 38, 39, 41, 42, 43, 44, 45, 46, 47, 48, 50, 51,
52, 53, 54, 55, 56, 57, 58, 59, 60, 61, 62, 64, 65, 66, 67,
69.

WEBSTER MANUFACTURING

317 Roebling Road
S. San Francisco, California

Mobile Antennas

4, 5, 6, 7, 13, 15, 17, 18, 20, 21, 24, 26, 27, 32, 33,
34, 35, 36, 37, 41, 42, 43, 44, 45, 46, 47, 48, 49, 52, 62,
64, 67, 69.

BEN WOODRUFF CO.

6140 North Harding Ave.
Chicago 45, Illinois

Electronic Keyer Kits

31, 66.

**END OF ALPHABETICAL
LIST OF MANUFACTURERS**

Contest Calendar [from page 76]

A good carbon copy of the original is acceptable. A summary sheet with a breakdown of the scoring and a signed declaration is also requested. But PLEASE—print your name and address, you might be an excellent penman but we're not handwriting experts.

Don't let the 12 hour minimum requirement confuse you, that only applies to those eligible for an award, and it's obvious that you will put in more than 12 hours if you are out to win.

And you fellows in far away isolated places; don't worry about the mailing deadline, just get your log off to us as soon as is possible under your circumstances.

And another reminder, The Israel Amateur Radio Club is offering a Trophy for the highest score on 7 mc. That makes a total of five Trophies for the C.W. week-end.

Good luck—see you in the pile-ups come the last week-end this month.

73 for now, Frank W1WY

USA-CA [from page 92]

calls /OVA. Members will give the following times and bands special attention: 10 meters; 1400 to 1500 & 2200 to 2300 (all times GMT). 15 meters; 1500 to 1600 & 2100 to 2200. 20 meters; 1200 to 1400, 2300 to 000, 0200 to 0300 & 0600 to 0700. 40 meters; 1100 to 1200, 0000 to 0100 & 0300 to 0400. 80 meters; 0400 to 0500. 16 meters; 0500 to 0600 GMT. Contest logs go to CHC'er Jim, W8JIN, who is Custodian for O.V.A.R.A.'s award for working members and rules of which requires earning of 35 points with contacts on 80 or 160 counting 3 points, contacts on 40 counting 2 points, and contacts on 20, 15, and 10 meters counting 1 point.

Texas All-County Award

Texas may be the second largest state after Alaska, but Texas can still claim distinction of having the most counties; a whopping big 254. Not to be outdone by other states with all-county awards, the Dallas Amateur Radio Club has sponsored an award for working Texas counties in five classes; each of which may be endorsed for all one band, all one mode or mixed operations.

The Texas award follows the fair practice of not requiring DX stations to contact as many counties as required for U.S. and Canada stations. The five classes are: Class A for 100/75 Texas counties (last figure applicable to DX stations). Class B for 150/100. Class C for 200/175. Class D for 254/200 and Class E as a special award for any DX'er that works all Texas counties.

To apply for the Texas county award, send list, certified by two other licensed hams or radio club officer stating cards were sighted, together with \$1 or 10 IRCs to Dallas ARC, P.O. Box 9026, Dallas 15, Texas.



SEE IT HERE!

NATIONAL'S NC-155

New Ham Band Receiver

THE PERFORMANCE PACE SETTER OF THE YEAR



See inside back cover for more details!

Come in for a demonstration

EVANS RADIO

YOUR FRIENDLY SUPPLIER

ENGINEERING DEPARTMENT — TIME PAYMENTS

Backing all equipment sales

flexible, financed ourselves

Box #312

Concord, New Hampshire

CA 5-3358

For further information, check number 56, on page 163

November, 1961 • CQ • 161

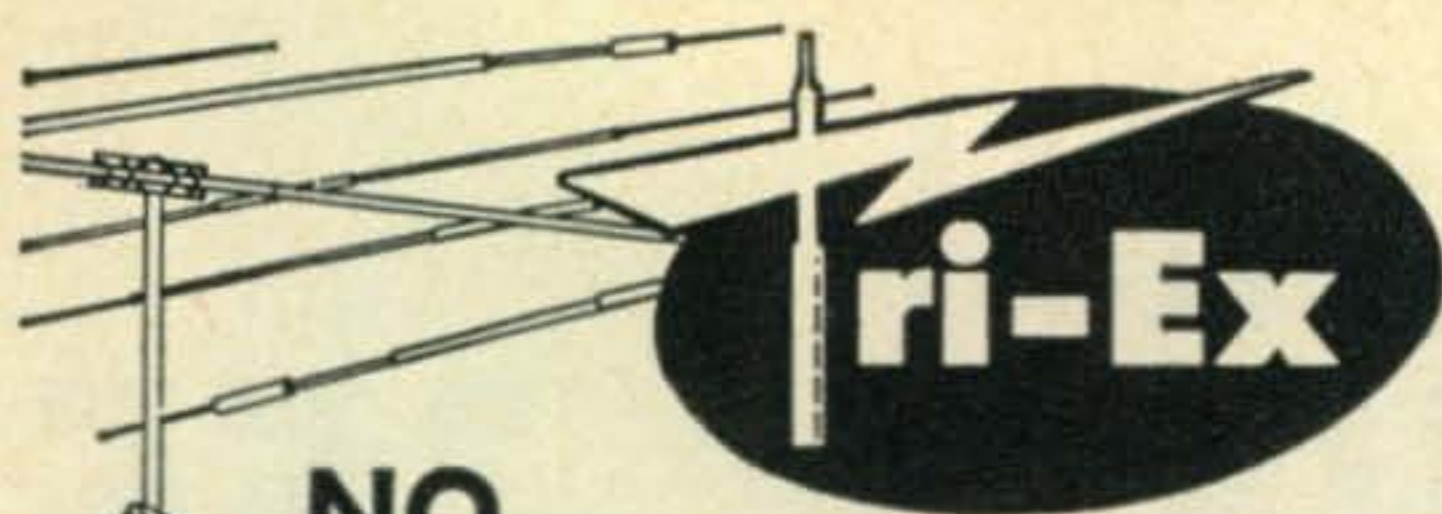

NO 'ANTENNA PARTIES' with the NEW TRI-EX CRANK-UP/CRANK-OVER TOWERS

New Two-Way-Hinge-Over Pilot Base, either in concrete or earth mounting models, eliminates climbing . . . eliminates cranes or A-frames . . . eliminates "antenna parties" (one man job) . . . gets your beam up faster . . . gets you on the air faster.

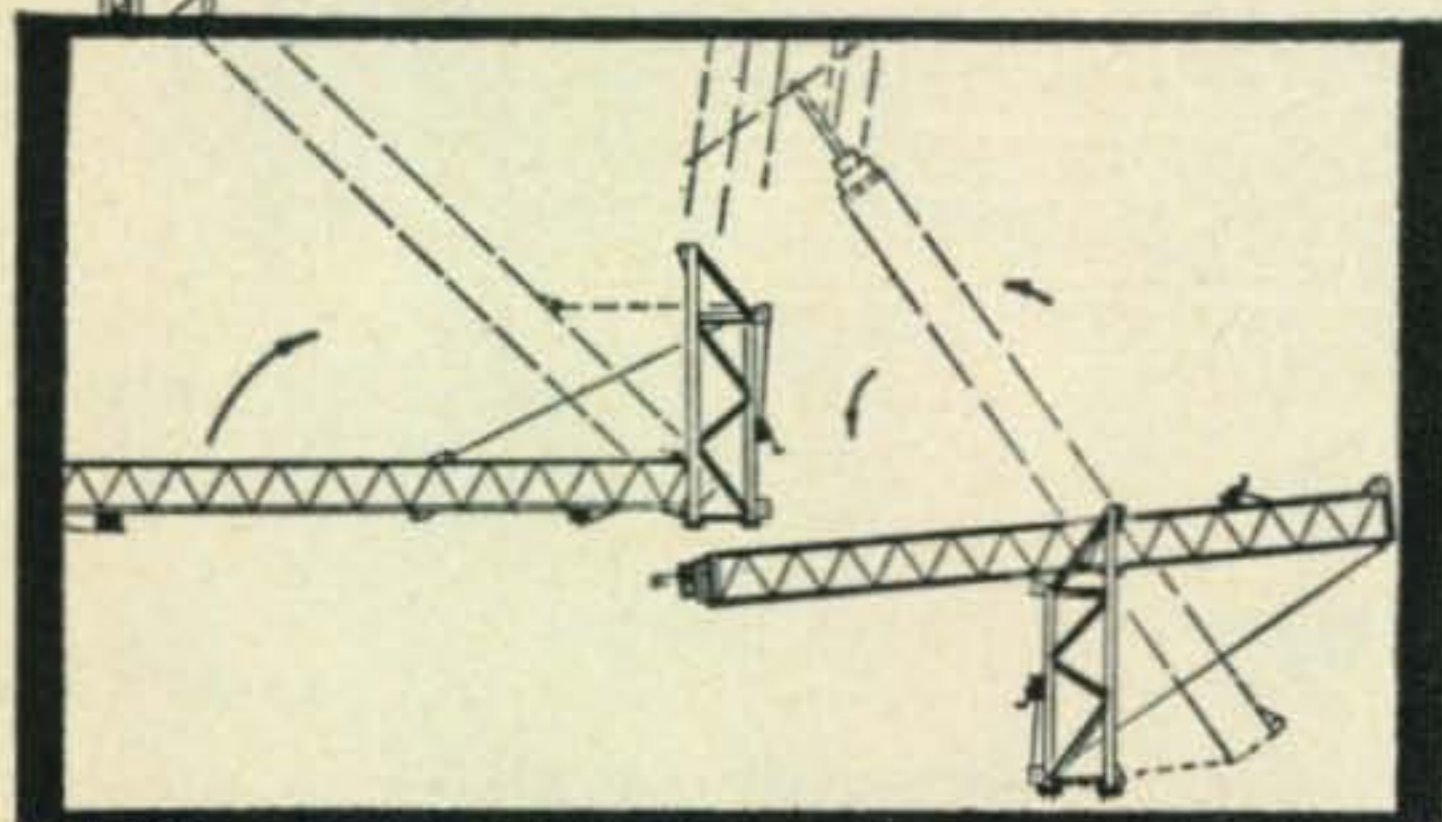

3-STEP INSTALLATION

- 1—Install foundation unit either directly in earth excavation, or concrete, as desired.
- 2—Attach upper base unit and fasten tower to lower bracket.
- 3—Raise tower to vertical position with 9-to-1 winch on pilot base, swap holding bolt positions, and you have a hinged, crank-up/crank-over SELF-SUPPORTING tower. That's all there is to it!

The new Tri-Ex series is available in 37 and 54 foot models (actual full height is exclusive of mast). Design of tower permits use without guying, and the unique 30-degree bracing of alternating design assures highest degree of strength and wind resistance.

STANDARD SERIES

Model HM-237	2 Section	37 feet
Model HM-354	3 Section	54 feet

HEAVY DUTY SERIES

Model HDM-237	2 Section	37 feet
Model HDM-354	3 Section	54 feet

See your distributor for complete literature and prices on the complete line of Tri-Ex Towers, or write direct to:

TRI-EX TOWER CORP.
2920 WEST MAGNOLIA BLVD.
BURBANK, 4 CALIFORNIA

Certificate hunters and Texans can thank CHCer W5JD/W5DWO, Lyle, for bringing the Texas award into the USA-CA all-county picture.

From the foregoing list of new states added to the all-county picture, you can see the tremendous interest being generated by the USA-CA Program and the manner in which USA-CA lends direct support to other awards sponsors. Yes, as the man said, USA-CA was purposefully designed to open the gates to unlimited fun in the field of certificate hunting and related achievements.

For those who are not up-to-date on the USA-CA Program, refer to complete Rules in CQ July issue, or if you'd like a special copy, drop K6BX an s.a.s.e. for same. The entire USA-CA program is, of course, carried in K6BX's *Directory of Certificates and Awards* which now lists upwards of 1000 awards.

See you with more USA-CA news next month and in the interim, Happy County Hunting.
Clif, K6BX

Propagation [from page 81]

The division has also carried out comprehensive system studies of ionospheric scattering and meteoric propagation in the v.h.f. region of the radio spectrum. These studies have established the optimum range of frequencies for each of these systems, special modulation techniques which avoid Doppler effects, and special antenna systems which permit optimum gain and directivity. The Radio Systems division's work in this area has contributed much to the successful establishment of the operational v.h.f. ionospheric scatter system which now bridges the Atlantic Ocean.

Upper Atmosphere & Space Physics Division

This division's interests lie in finding out more about the basic natural characteristics of the earth's atmosphere and space. Through a more complete knowledge of the physical and dynamic properties of the earth's upper atmosphere and interplanetary space there may eventually evolve a better understanding of how radio waves travel in these regions.

The division is presently investigating the influence of the sun's electromagnetic and corpuscular radiation upon the earth's atmosphere and space, and is conducting comparative studies of the earth's atmosphere and the atmosphere of other planets. Efforts are also being made to create in the division's laboratory, ionized gases which would stimulate certain conditions that exist in the atmospheres of the sun and the planets.

The need for greater knowledge about the properties of the upper atmosphere has assumed increasing importance as plans for human exploration of space move ahead. The Upper Atmosphere and Physics division is cooperating in this effort by having equipment

ADVERTISING RATES

Each month CQ's advertising department receives numerous requests for advertising rates from readers who are interested in marketing some new product or service to the amateur fraternity. To save valuable time and correspondence that may result in missing a closing date, we are listing below CQ's ad rates and other pertinent information on size, closing dates, etc.

Fractional Pages — Cost Per Insertion

Rate earned based on total space used within one year—12 issues.

	1 time	3 times	6 times	12 times
1 Page	\$430.00	\$390.00	\$350.00	\$320.00
1/2 Page	230.00	215.00	195.00	175.00
3/8 Page	175.00	165.00	158.00	150.00
1/4 Page	115.00	110.00	105.00	100.00
1/8 Page	60.00	58.00	56.00	54.00
1/16 Page	32.00	30.00	29.00	28.00

Mechanical Requirements

	Width	Depth	Width	Depth
1 Page	5 1/2	8-1/3		
1/2 Page	5 1/2	4	2 3/8	8-1/3
3/8 Page	5 1/2	3	2 3/8	6
1/4 Page	5 1/2	2	2 3/8	4
1/8 Page	5 1/2	1	2 3/8	2
1/16 Page			2 3/8	1

Bleed pages: full page plate size 6 3/8 inches wide by 9 3/4 inches deep which allows 1/8 inch for trim on top, bottom and one side; half page bleed plate 3 3/8 inches wide by 9 3/4 inches deep. Keep essential elements 3/8 inch, within plate borders. Trim size of page is 6 1/2 inches wide by 9 1/2 inches deep. Recommended half tone screen—110. On cover positions—120.

Color, Special Position and Bleed Rates

Color, Covers, inserts and special position rates given upon request.

Bleed rates: \$50 per page extra for full pages that bleed; \$35 extra for fractional pages that bleed.

Closing Dates

Publication date—25th of preceding month. Last forms close 20th of 2nd preceding month. Proofs furnished only if complete copy and cuts are received on or before closing date.

Cuts, designs, special borders, blocking of or foundry work on plates furnished by advertiser, charged at cost.

All advertising is subject to Publisher's approval and acceptance without recourse. All advertising material unused for 13 months will be killed.

The advertiser agrees to indemnify and protect the publisher from any claims or actions based upon the unauthorized use of any person's name or photograph, or of any sketch, map, words, labels, trademarks, or other copyrighted matter, or based upon libelous statements, in connection with the advertising referred to in this order.

— READER SERVICE —

CQ Magazine, Dept. RS

300 WEST 43rd STREET, NEW YORK 36, N. Y.

Coupon Void after November 24, 1961

Please send me more information on your ads
in the November 1961 CQ keyed as follows:

A	B	C	D	E	F	G	H	I	J										
1	2	3	4	5	6	7	8	9	10	11	12	13	14	15	16	17	18	19	20
21	22	23	24	25	26	27	28	29	30	31	32	33	34	35	36	37	38	39	40
41	42	43	44	45	46	47	48	49	50	51	52	53	54	55	56	57	58	59	60
61	62	63	64	65	66	67	68	69	70	71	72	73	74	75	76	77	78	79	80
81	82	83	84	85	86	87	88	89	90	91	92	93	94	95	96	97	98	99	100
101	102	103	104	105	106	107	108	109	110	111	112	113	114	115	116	117	118	119	120
121	122	123	124	125	126	127	128	129	130	131	132	133	134	135	136	137	138	139	140
141	142	143	144	145	146	147	148	149	150	151	152	153	154	155	156	157	158	159	160
161	162	163	164	165	166	167	168	169	170	171	172	173	174	175	176	177	178	179	180
181	182	183	184	185	186	187	188	189	190	191	192	193	194	195	196	197	198	199	200

Name _____ Call _____
(Please Print)

Address _____

City _____ Zone _____ State _____

Engineer Type of Work (Specify) _____

NEW FOR YOUR STATION

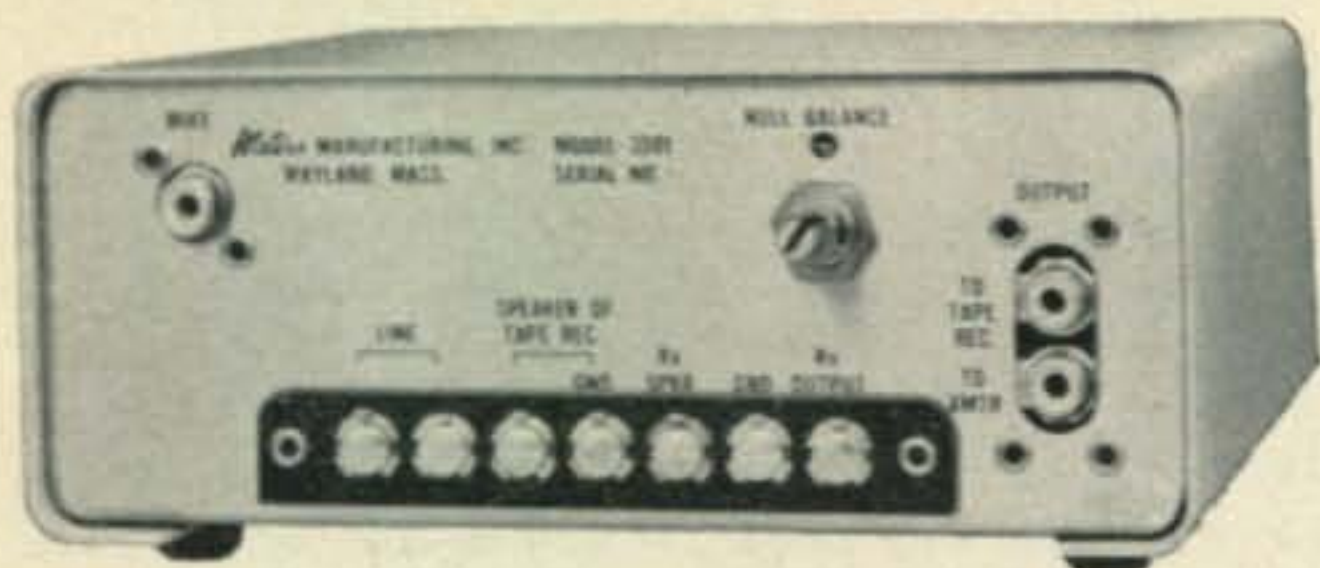

UNIVERSAL HYBRID COUPLER by *Waters*

Now you can use your tape recorder in your station. The universal Hybrid Coupler connects receiver, transmitter, tape recorder, speaker, microphone and 600 ohm line. With ONE switch and NO adjustment you are ready to:

1. Record BOTH sides of QSO.
2. Transmit recorded QSO on the air or to a 600 ohm line.
3. Record information from 600 ohm line now, transmit later.
4. Operate your transmitter from 600 ohm line.

Unique and simple to operate. Uses a new wide band hybrid network with an easy to set-and-forget broad balance null control. Convenient terminals and standard audio-type connectors. Operates either VOX or push to talk with AM or SSB with any high impedance microphone, crystals or dynamic. Mounts horizontally or vertically. Requires no power. Compact size: 6½" wide, 2½" high, 8¼" deep. Attractive two-tone gray finish. Furnished complete with installation instructions and easy-to-follow set-up procedures. Adds hours of pleasure and utility to your station. \$49.50. Order today from any of the following distributors:

HARRISON RADIO CORP., 225 Greenwich St., N. Y. 7, N. Y.
NEWARK ELECTRONICS CORP., 223 W. Madison St., Chicago 6, Ill.
RADIO SHACK CORP., 730 Commonwealth Ave., Boston 17, Mass.
EVANS RADIO, INC., P.O. Box 312, Concord, N. H.

WATERS MANUFACTURING, INC.
Wayland, Mass.

For further information, check number 58, on page 163

164 • CQ • November, 1961

designed that will be used for conducting satellite exploration of the ionization that may exist in the vast region of the unknown above the F layer level in the earth's atmosphere. The division is also engaged in extensive radio astronomy experiments for determining the density of ionization and the degree of ionospheric absorption by measuring the variation in signal intensity of radio energy which appears to originate from the sun, other planets, and some stars.

This month, *CQ* is proud to salute the hundreds of scientists and technicians who are working hand-in-hand at the Boulder headquarters of the Central Radio Propagation Laboratory and at field stations throughout the world in order to make world-wide radio communications more efficient and more reliable.

Thanks go to the Public Information Office of CRP for making available much of the information which has appeared in this article.

Sunspot Story Reprints

There are still a few copies left of the reprint of the Jacobs-Leinwoll report *The Sunspot Story, Cycle 19; The Declining Years*, which appeared originally as a three part article in the April, May and June issues of *CQ*. One of the most comprehensive articles ever to appear on this subject, the reprint contains the entire story under a single cover in booklet form. Single copies of the booklet are available for one dollar apiece, and in quantities of 10 or more the price per copy is only 75 cents. The booklet can be ordered through the *CQ* Circulation Dept., Box 55, 300 West 44th Street, New York 36, N.Y. Orders will be filled postpaid on a first come, first served basis while the limited supply lasts.

73, George, W3ASK

Sideband [from page 87]

being two very interesting people with a big signal . . . Rod, WA4ACA, in Paris, Tennessee, received a big, big welcome to sideband from the WPX hunters. In fact, the pileup was so big one afternoon we thought sure a super-rare DX station had made its appearance . . . Howard, W2UWT, kept us spellbound one quiet evening on 20, revealing details of another of his hobbies; the exchange of tape recordings via a club. He was kind enough to send us a sample of some of his tapes, including a foggy night near Puget Sound, a chorus of bullfrogs, a cuckoo calling in a London bird preserve, and the drilling of a woodpecker. You've got to hear these fascinating sounds to appreciate them and we're indebted to Howard for introducing this exciting hobby to us . . . It's wonderful how much you can learn through amateur radio. Joe, K5SQS, kept us enthralled with his detailed account of cotton growing on his plantation in Alligator, Miss. Ask a few questions and you get some mighty interesting and informative answers . . . It was a great pleasure to meet Ed, K4MO, of Largo, Fla. through our mutual good friend, George, K4AV, who

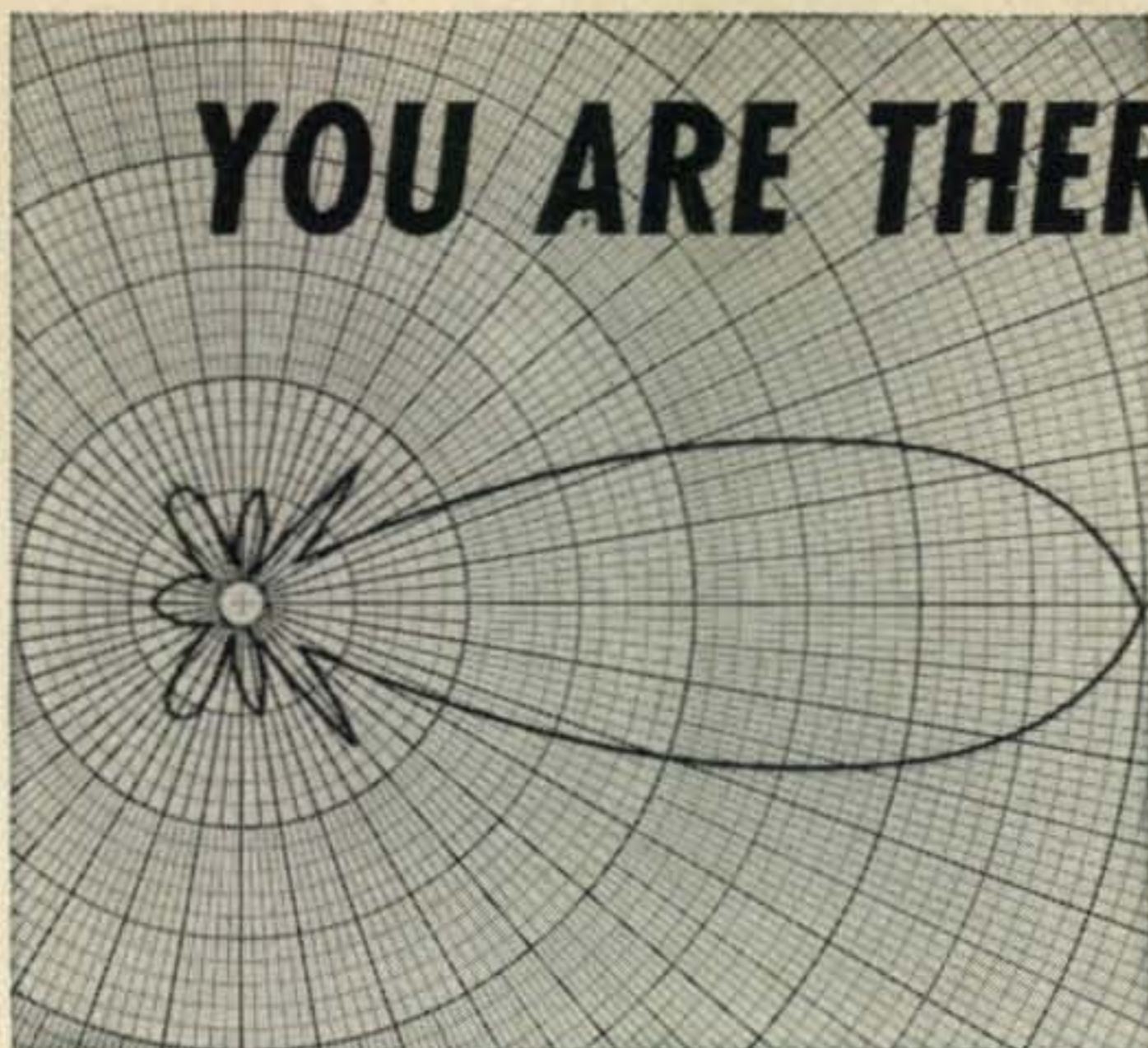

YOU ARE THERE!

with **telrex**
 —"the-performance-line"—
 with a "MATERIAL" difference!

NOW! A Broad-Band 'Balun' for your
 10, 15 and 20 Meter Tri-Band

\$1685

MODEL BA1430/1-1

For TOP-MAN-ON-
 THE-FREQUENCY results...

Install a Telrex antenna...dollar for
 dollar better in every way! Antenna
 systems from \$6.95 to \$12,000.00

For further information, check number 59, on page 163

ANTENNAS

SINCE
 1921

Communication and TV Antennas

telrex LABORATORIES

ASBURY PARK 40, NEW JERSEY, U.S.A.



Groth TURN COUNT DIAL
 Registers Fractions to 99.9 Turns
FOR roller inductances, INDUC-
 TUNERS, fine tuning gear reduc-
 ers, vacuum and other multiturn
 variable condensers. One hole mounting. Handy
 logging space. Case: 2" x 4". Shaft: 1/4" x 3". TC 2
 has 2 1/2" dial—1 1/2" knob. TC 3 has 3" dial—2 1/2"
 knob. Black bakelite.
 TC 2 \$5.50—TC 3 \$5.75—Spinner Handle 75c extra

Add 12¢ for Parcel Post

R. W. GROTH MFG. CO.
 10009 Franklin Ave. Franklin Pk., Illinois

Announcing the new **VERSA-TENNA VHF-UHF**
 mobile antenna with magnetic base.

- No mounting holes required
- 50 ohm impedance
- Secure at high speeds
- Self-leveling ceramic magnet in each corner
- May be readily removed

Write to **VERSA-TRONICS,**
 Box 223, Wheeling, Illinois

with the great new

SHURE

**440 SL
 HAM MICROPHONE**

**minimize
 splatter**

ONLY
\$2850*



- Sharp Cutoff Below 300 and Above 3000 cps — Minimizes Splatter, Reduces Unwanted Sideband.
- Elimination of resonant peaks permits higher average power — more audio punch.
- Shaped frequency response — Superb Intelligibility — Naturalness of voice.
- Trouble-Free Controlled-Magnetic Design — Hi-Output — 52.5 db — Extraordinarily Rugged — No humidity problems.
- Complete with Grip-to-Talk Switch, Desk Stand, 2-Conductor Shielded Cable. Will operate VOX and Grip-to-Talk.

Complete with stand, grip-to-talk switch, 7 ft. highest quality 2 conductor shielded cable. Cable connector equivalent to Amphenol MC3M plug.

WRITE FOR LITERATURE: Dept. No. 25-K

Shure Brothers, Inc., 222 Hartrey Ave., Evanston, Ill.

*Amateur Net

MICROPHONES, HIGH FIDELITY AND ELECTRONIC COMPONENTS

For further information, check number 60, on page 163



wire this balun coil kit
to suit yourself
...it's easy!

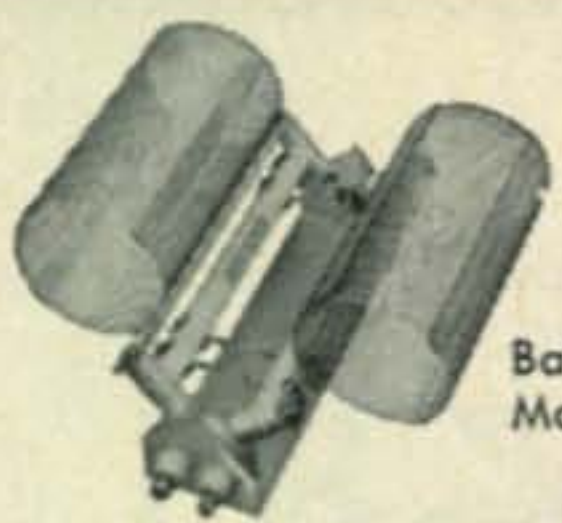

Balun Coil Kit
Model 3976
\$8.95

A brand new balun coil kit with exclusive B&W design features. Model 3976 has sturdy, air-wound bifilar inductors for multiband impedance matching.

Kit has full wiring instructions showing how to connect 75 ohms unbalanced to 300 ohms balanced, or 75 ohms unbalanced to 75 ohms balanced.

Balun operates on 80 through 10 meter bands without tuning or changing coils. Rated at 250 watts maximum AM phone, 500 watts CW and 1 KW on SSB.

Coils and space-saving mounting bracket also available separately.

Available at better dealers now, or write to B&W direct.

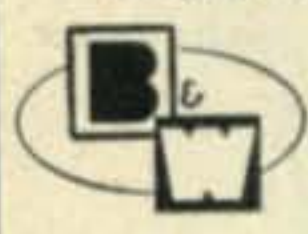

Barker & Williamson, Inc.

Bristol, Penna.

For further information, check number 61, on page 163

MAKES SENDING A PLEASURE

With **VIBROPLEX X**

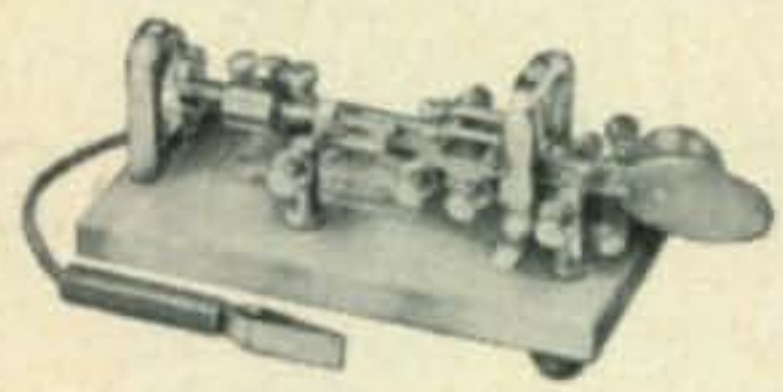

No special skill required. Just press the lever — Vibroplex DOES THE REST. All parts precision machined and key is adjustable to any speed. Will not tire the arm. Five models, priced at \$17.95 to \$33.95.

VIBRO-KEYER

In building electronic transmitting units, Vibro - Keyer supplies the perfect part. With a finely polished base 3 1/2" by 4 1/2" and a weight of 2 3/4 lbs. Has same contacts and finely finished Vibroplex parts. Standard, at \$17.95; DeLuxe, with Chrome Plated Base, priced at \$22.45.

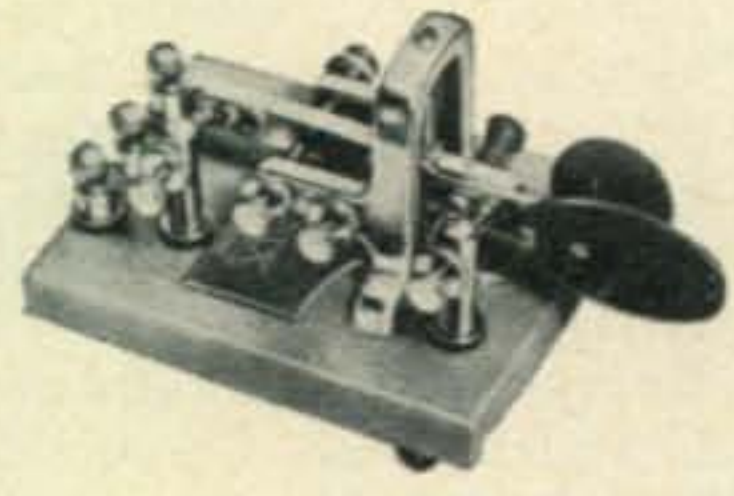

Order today at your dealers or direct.

THE VIBROPLEX CO., INC.
833 Broadway New York 3, N. Y.

FREE Folder

TELETYPEWRITER EQUIPMENT • COLLINS 51J-3 and R-390A RECEIVERS

Teletype: #14, 15, 19, 26, 28; Kleinschmidt: TT4A, TT76, TT98, etc. Telewriter Receiving Converter, etc. For general information & equipment list, write to TOM, W1AFN ALLTRONICS-HOWARD CO., Box 19, Boston 1, Mass. Richmond 2-0048.

told us that Ed was one of the earliest pioneers on sideband, having built an s.s.b. rig in the early 1940's!

Anne, K4QDR, and Larry, W4HNV, were bubbling over and justly proud of the fact that their 15 year old son, Rusty, had been appointed a page in the U.S. Senate for the remainder of the current session . . . You sidebanders in South Bend, Indiana, please keep an ear open for Harold, W5WAH, who's most anxious to keep in touch with his best gal at the University there. Harold's been scouring all bands but no luck with South Bend yet . . . One of the nice things about being an XYL operator is that non-licensed XYLs are more apt to join the conversation when you're chatting with their OMs. That's how we met "Bill," XYL of Gene, K5JTW and it was most interesting to learn of her interest in and skill with flower arrangements for which she's won many awards . . . His many friends will be happy to learn of the whereabouts of Norm, ex-WA2-AFX, who is now TF2WGE. According to his buddy, John, WA2BJJ, Norm was "Mr. 10 Meters" when he was stationed at the Brooklyn Navy Yard and he was one of the most helpful hams ever to steam into port . . .

Frank, WA2OZZ/MM, requests that all QSLs for the hams aboard the radar tracking ship, American Mariner, be sent to the following address: "American Mariner, PO Box 4187, PAAGMRD, Patrick AF Base, Florida."

With the advent of the Thanksgiving season, we are truly thankful for the many friends we have met and made in amateur radio and for our wonderful hobby which is the key to world understanding.

73, Irv and Dorothy

RTTY [from page 109]

Illinois, and has built the Twin City TU. VE4BJ, his brother VE7YC, and their father VE6HQ, are all on RTTY, all with Model 15's. (Is this an RTTY "first?") VE2AIP, St. Jean, P.Q., has a de-noised Model 12, and is now looking for a Model 12 keyboard. VE2HY is on 40 meters.

Comments

A novice from North Dakota writes to us with the complaint that RTTYers have been operating inside the novice portion of the 40 meter band. This we haven't heard, but since the novices are rock-bound, usually with few rocks, we would like to suggest that RTTYers avoid getting on the high side of 7150 kc. By the same token, we would like to suggest that 20 meter RTTY operators stay below 14,100 kc to stay out of the way of foreign stations. (Maybe then the Latin-American 'phone stations would stay above 14,100 kc?)

Post Script: Jack Pitts W6CQK, 1307 Alameda, Redwood City, California, still has left some of those adjusted 255A polar relays (with socket) for only \$3.25, postpaid.

73, Byron, KØWMR, ex-W2JTP

?
DO
YOU
KNOW

EVANS **TAKES USED EQUIPMENT IN TRADE HAS LIBERAL TIME PAYMENT PLAN**

AND as Northern New England's leading distributor, stocks ALL LEADING LINES. Twelve licensed Hams to serve you with an Engineering Department to maintain equipment purchased from us. Contact us TODAY, let us demonstrate 26 years as . . .

"YOUR FRIENDLY SUPPLIER"

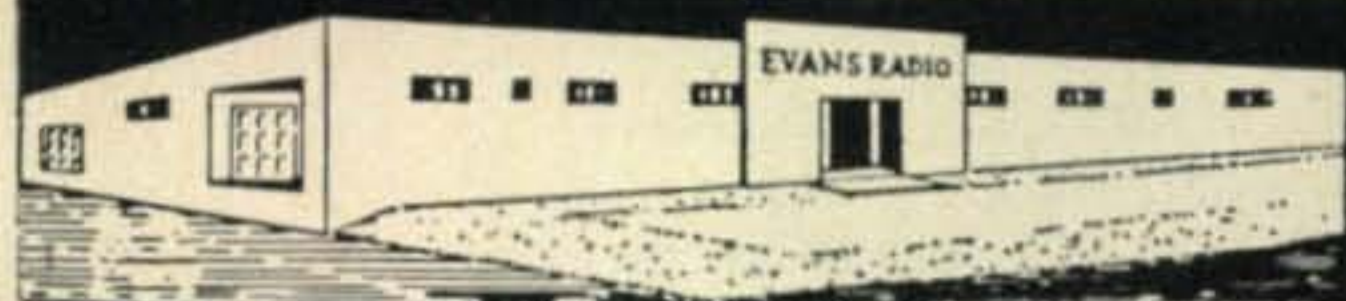

Evans RADIO

CA 5-3358 • ROUTE 3A • BOW JCT. BOX 312 • CONCORD, N. H.

For further information, check number 62, on page 163

NOW! SPACE-RAIDER brings you a major advancement in antenna design concept and performance.

The famous "K6CT POLARIZED DIVERSITY BEAM." One year of observation brought forth the design. More than another year in actual test (not range but normal installation) proved the validity of design concept, which vastly improves forward gain, front/back ratio and reduces the 80% of Q.S.B. caused by polarization shift to a very low minimum.

The new SPACE-RAIDER Polarized Diversity Beams provide the ultimate in performance, with forward gain, front/back ratio and side rejection advanced to a new all time high.

SPACE-RAIDER Beams priced from \$34.50 to \$114.50

Shipments U.S.A. Prepaid thru November 30th, 1961. Inquire Direct.

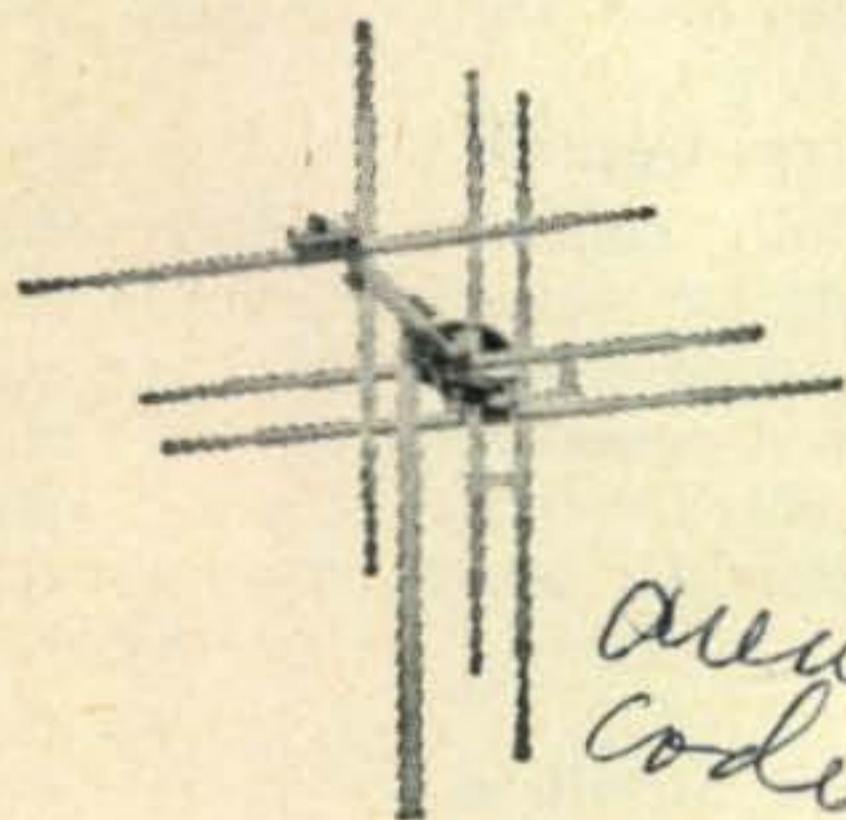

new code 213

Space-Raider
ANTENNAS & CRANK-UP ANTENNAS

1076 EAST WALNUT STREET
PASADENA, CALIFORNIA
TELEPHONE SYCAMORE 2-2526

For further information, check number 63, on page 163

EXPERIMENTERS • AMATEURS • HOBBYISTS

Save real money on radio parts. Write today for big free catalog of government surplus electronic materials, many items priced at 90% below list. All are new unless otherwise indicated. Here's a sample:

Save real money on radio parts. Write today

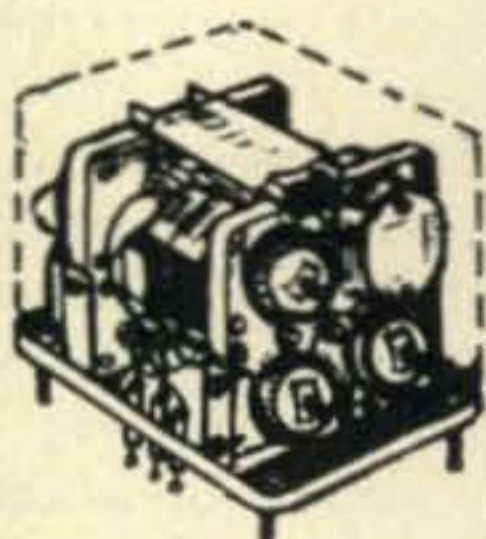

\$6.95

F.O.B. SACRAMENTO.

CW MAN'S DREAM FILTER

Here is a popular item. 600ohm input and output impedance makes this just what you want for matching; it cost Uncle over \$30.00, and today it would cost lots more. It has a middle frequency of 1105 cycles and the bandwidth is 200 cycles down 20 db, 250 cycles down 40 db. Manufactured by Federal Telephone and Radio Corporation, this filter incorporates six toroids in L/C circuit. Transmitting type mica capacitors padded by silver micas are used throughout as capacitive components to give rock solid characteristic stability. All is hermetically sealed in a single unit measuring just 3-1/2" by 4-1/4" by 3-5/8" high exclusive of mounting studs and terminals. Steal it! Shipping weight 4 pounds. (23J004)

**JOE PALMER
ELECTRONICS**

P.O. BOX 6188 CCC
SACRAMENTO, CALIFORNIA

WRITE TODAY FOR FREE CATALOG

For further information, check number 64, on page 163

F.M. STEREO MULTIPLEX COILS

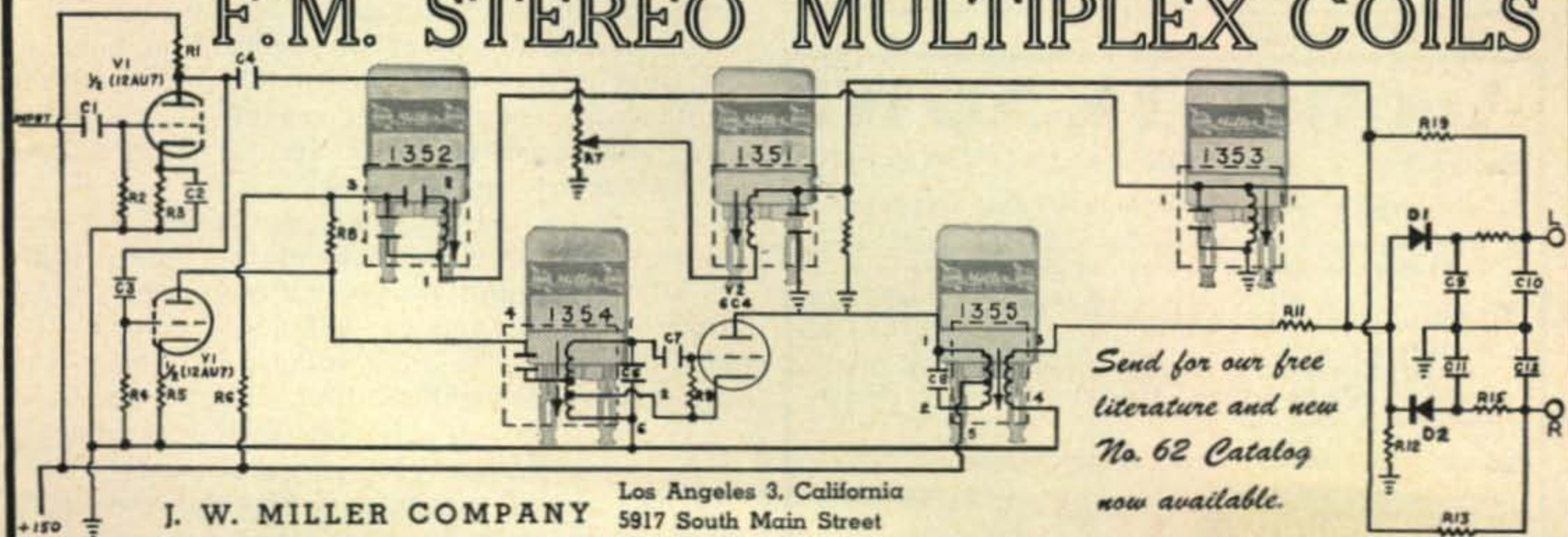

J. W. MILLER COMPANY Los Angeles 3, California
5917 South Main Street

Send for our free literature and new No. 62 Catalog now available.

For further information, check number 65, on page 163

ROHN "fold-over" TOWERS*

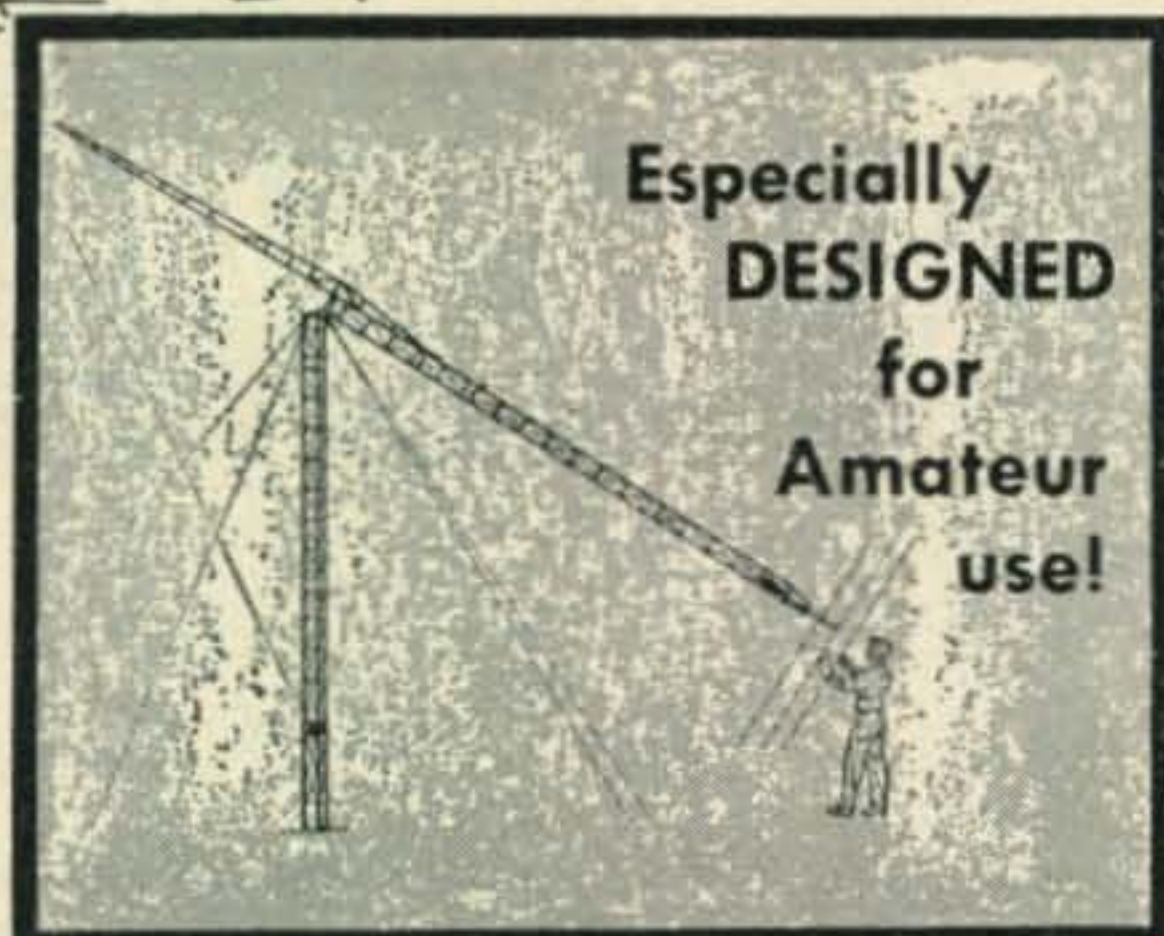

first IN DESIGN *foremost* IN SALES

ROHN "fold-over" towers are ESPECIALLY made for amateur use. They are the most practical tower in design because they allow you to work ON THE GROUND for antenna maintenance and servicing. You'll quickly agree that this is a most wonderful feature for an amateur tower. In addition, these towers are made and designed for true, heavy duty use. They are structurally sturdy for use up to 70 feet and in enough sizes for *all* types and sizes of amateur antennae. This means that they can easily handle your requirements. They have unexcelled workmanship. They are hot-dipped galvanized after fabrication which means you have no problem of maintenance. They come as a complete package with all materials and accessories included. Add all these wonderful features together and you see why they're the most demanded tower today! Priced from \$186.

FREE literature and near source of supply gladly sent. Be Sure you investigate ROHN towers before buying!

*Patent—2,875,865

ROHN

Manufacturing Company

Box 2000 • Peoria, Illinois

"World's largest exclusive manufacturer of TV-Communication towers"

For further information, check number 66, on page 163

Act-WRITE NOW!

Better Yet — WIRE OR CALL TODAY FOR

1. Burghardt's "Deal of the Month" For September
2. Our September Listing of Reconditioned Equipment Carrying Burghardt's "Seal of Satisfaction"

YOU'LL BE GLAD YOU DID!

* Featuring . . .
Central Electronics, Collins, Drake, Gonset, Hallcrafters, Hammarlund, Hy-Gain, Johnson, Mosley, National

* Your Direct Line to Every Manufacturer

Burghardt
RADIO SUPPLY

Phone TU 6-5749
Box 746A
Watertown, S. Dak.

Space [from page 89]

Gherman Titov, the world's newest spaceman, and his spaceship VOSTOK II, successfully re-entered the earth's atmosphere and landed at a pre-designated spot in Russia on August 7, after orbiting the earth 17 times.

The following frequencies were reported to have been used on the VOSTOK II spacecraft:

15,765 kc	telemetry
19,995 kc	telemetry
20,006 kc	voice
143.625 mc	10 pictures per second slow scan TV

Several radio amateurs reported hearing Major Titov's voice on the 20,006 kc channel as VOSTOK II orbited over North America.

Explorer XII

NASA successfully launched Explorer XII during mid-August. The newest satellite in the Explorer series is in an elliptical orbit varying in altitude between approximately 160 and 50,000 miles. On board the satellite is a 2 watt wideband PM transmitter operating on 136.02 mc.

S-3 Satellite

NASA's S-3 Energetic Particles Satellite, the twelfth satellite to be launched successfully in the Explorer series, is the first in a new satellite program designed to study the behavior of electron and proton energy particles present in space. These particles of energy often enter the earth's atmosphere in large streams and cause magnetic storms, auroral displays, ionospheric disturbances and high frequency radio blackouts. Three more satellites will be launched subsequently in this series.

The complex 83 pound octagon shaped spacecraft, instrumented with scientific experiments developed by several universities and government laboratories, is designed specifically to make repeated observations of the solar wind, the interplanetary magnetic fields, and the distant regions of the earth's magnetic field. Explorer XII will also traverse the Van Allen belts twice during each of its 31 hour orbits, collecting valuable data concerning these regions of intense radiation which surround the earth in two doughnut shaped belts at heights varying between 600 and 30,000 miles at all latitudes except the polar regions. These belts are considered to be a serious hazard for interplanetary space travel.

Energy for the electronic equipment and the instruments aboard the satellite comes from 13 silver-cadmium storage batteries which provide 15 watts, and an additional 5 watts is obtained from the 5600 solar cells which are mounted on the satellite's four outboard paddles.

The satellite will carry out eight independent experiments designed to yield much data about the physics of magnetic fields and energetic particles in space.

73, George, W3ASK

Novice [from page 96]

year at high school this fall.

Charles Beck, WV2RMP, 80 West Neck Road, Huntington, L. I., N. Y. just celebrated his 12th birthday and has been on the air for 6 months, earning RCC and a C.P. award for 25 w.p.m. His rig consists of a BC-312, home brew 50 watt transmitter feeding a 66' long-wire. Chuck can be found on either 7169 or 7181 but watch out for his bug.

Jack Ekstrom, KN9BQL, 169 South River Road, North Aurora, Ill., rushed a letter before his term expired. As you can see from the accompanying photograph, Jack tickles the ether



Neat layout at KN9BQL.

with a DX-40, Drake 2B receiver and a 40 meter dipole up about 20 feet. He has a WAS of 35/32 but no DX to brag about. Jack QSL's 100% and would like skeds for KN7 contacts, on 40 meters.

Randy ?????, KN9DKU, 1605 Ridge Rd., Green Bay, Wis., is 12 and has a WAS of 41/36 to his credit, not to mention some choice DX to the tune of 35 countries! Randy snagged it all with an Apache and HQ-140XA and would like to make skeds with KL7, Mont., Ida., Ky., Miss., N.D., S.D., and Nebr.

Warren Anderson, 1424 Quince St., Brainerd, Minn., hasn't taken the big step yet but he must be about ready for his letter requests information on transmitter recommendations from readers, and what band to operate for ragchews and DX.

Pat ????, WL7DYM, APO 728, Seattle, Washington, invites skeds from DX hunters and is on the air from 0400 to 0600 GMT operating on 7157. Pat runs a homebrew 6146 rig and SX-101 receiver.

Ronnie Bramhall, KNØ Kansas City Dude, 1413 Crawford, Wichita 17, Kansas, has been a Novice for 2 months and has already picked up a WAS of 34/31 out of 200 QSO's. Ron works 40 and 15 when it is open and plans to set for his General ticket this fall. He will sked anyone for any reason and QSL's 100%.

That flattens the file for another month. Don't forget to keep those cards, letters and photos coming. BCNU. 73 De Don, W6TNS

Sign up here!

ALLIED RADIO

100 North Western Avenue
Chicago 80, Illinois

hallicrafters SSB/CW/VHF Contest

You can win . . .

SX-115 Receiver

HA-2 or 6 Transverter

HT-37 Transmitter

HA-4 Keyer

Over \$10,000 In Prizes

For further information, check number 67, on page 168



"All-Weather" COAXIAL RELAY

MODEL NO. (UHF Connectors)	POWER	ONLY
CU 420	115v A.C.	18.95
CU 421*	115v A.C.	19.95
CU 121*	6v A.C.	19.95
CU 321*	6v D.C.	19.95
CU 421*	12v D.C.	19.95
CU 321*	24v A.C.	21.30
CU 921*	220v A.C.	22.30

*1P2T Aux. Contacts.

• Eliminate expensive coaxial cable • Mounts anywhere, outdoors or indoors • Mating power connector supplied • 1P2T construction — operates 0 to 225 mc. • Full 1000 watt capability • Extremely low insertion loss — less than 0.1 db. • Attractive gold anodized aluminum construction • Weatherproof — gasket sealing • High quality TR switch • Money back guarantee.
Write to Hal, WBYPT for catalog sheet. Dealer and distributor inquiries invited.

BAY-ROY ELECTRONICS, INC.

P. O. Box 7503 Cleveland 30, Ohio

THE Only Complete Line OF V. H. F. ANTENNAS

3/4 — 1 1/4 — 2 — 6 METERS

- BEAMS
- DUAL STACKS
- QUADS
- COLINEAR ARRAYS
- MOBILE HALOS

See your distributor or write for Free Catalog

CUSHCRAFT

621 HAYWARD ST.
MANCHESTER, N. H.

AVAILABLE NOW!
NUVISTOR

50 Mc.



Gain: 25 db

Noise Figure: less than 3.0 db
I.F.: 14-18 mc.
Input-Output: 50 ohms, BNC
Power Required: 6.3 v and 150 vdc
Tubes: 6CW4 and 6U8
Shielded Case: 6" x 3" x 1 1/2"

A carefully conceived design (featured in July QST, page 64) incorporating good quality at low cost.

Order direct from Tapetone:..... **\$37.40**
Matching power supply, Model 154.....\$15.40

TAPETONE ELECTRONIC LABORATORIES, INC.
99 ELM ST., WEST NEWTON 65, MASS.

For further information, check number 90, on page 163

Sign up here!

**GEORGE D. BARBEY
COMPANY, INCORPORATED**
Reading Lancaster
Pottstown Lebanon
PENNSYLVANIA

hallicrafters
**SSB/CW/VHF
Contest**

You can win . . .
SX-115 Receiver
HA-2 or 6 Transverter
HT-37 Transmitter
HA-4 Keyer

Over \$10,000 In Prizes

For further information, check number 68, on page 163

VHF [from page 107]

from Big Delta to Fairbanks). Spent the night with KL7BKB at Shaw Creek, 30 miles north of Big Delta and went through the agony of watching signals on every cotton picking TV channel, including a good solid program from Edmonton. Just knew I should have been home, but no such luck. As for the age-old query, 'Where were the KL7's?', I still don't know of anyone besides myself more than slightly interested in 50 mc. Rumor has it that someone in the Bristol Bay (Naknek) area is on six, but I haven't been able to confirm it." *Get busy!*

"Got several QSL cards from Bay area stations for 'phone contacts in May, but someone must have been pulling their legs. Wish it was true, but no such luck. I'm still on 50.084 mc, c.w. only.

"Due to two telephone calls last week from WA6DAW, Paul, just east of Los Angeles, I am now watching for him and another affiliated station at 0400 GMT nightly. He is on 50-140. Within the next couple of weeks, I hope to get my keyer back in operation and run the beacon as much as possible.

"Nothing else much in the line of news. Still pounding nails into my house and building on that new final. Guess I'd better get this in the mail." *Many thanks for the info, Jack, and keep us posted. Get that local crowd on v.h.f.!*

**Directory of
Certificates & Awards**

Over 650 awards from over 50 countries and how to achieve them.

The Directory contains 12 sections listing awards from all continents as well as special awards. For 8 1/2" x 11" looseleaf binder.

Quarterly Revision Service and News Letter keeps awards information up-to-date. The Directory is "The Awards Hunters Bible."

DIRECTORY PRICES:

Includes three free quarterly revisions and News Letters:
Entire World, 3rd Class Mail \$4.00
W/K/VE by 1st Class Mail \$5.00
W/K/VE by Air Mail \$6.00
Rest of World, 1st Class Mail \$5.50

REVISION RENEWAL SERVICE:

Year: As above: \$1.75; \$2.25; \$3.00; \$2.60
Edited, Printed & Published by

CLIF EVANS, K6BX

Box 385, Bonita, Calif., U. S. A.

Obtainable in U.K. from G2BVN, 51 Pettits Lane, Romford, Essex. 30/-post paid.

Crockett, California: Bob Magnani, K6QXY, writes:

"The activity here is centered on s.s.b. My rig on 50 mc runs the legal limit (1 kw) input to a pair of 250th's in Class B. Driven by a homebrew s.s.b. mixer and C.E. 20A s.s.b. exciter. Receiver is a 75A-3 with converters, pre-amps, and cavities for 50 and 144 mc. The antennas are a 6 element Long-John up 80' for 6 meters, and a 20 element Spiralray at 90'.

"We are presently holding schedules with Alan, W6FZA, at Porterville, approximately 230 miles from here, and Wayne, K7JTG, at Phoenix, Arizona, approximately 600 miles on 50 mc s.s.b. scatter with good results. Also hearing pings from W6NLZ, W6QMN, and other stations out of Los Angeles. The schedules here are held on Saturday and Sunday mornings from 0800-0900 on 50.110 s.s.b. Any interested stations in the range of either tropo or ionospheric scatter is invited to participate. Please write for schedules.

"Active s.s.b. stations out this way include W6FZA, W6YX, K6HCP, WA6AJV, K6ODV, K6VLM, W6NLZ, W6QMN, K6PYH, WA6JTG, and probably many more I'm not acquainted with." *Very fine, Bob! Sounds like quite a crowd you have going on s.s.b.! Keep up the good work.*

Thirty

Well, that just about wraps things up for another month. Let's hear from *you* next time, eh? Meanwhile start looking for OSCAR's HIs on 145.000 mc!

73, Bob, K2ZSQ

YL [from page 111]

to budge when one most wants them to move? Anyway, WA6BWZ, Helen Ann Silveira, (with mike) looks quite pleased with her "RM" operating position — hi! Helen Ann is only 14 but she's had several years of operating, starting as a Novice at age 10 in '57. She got her General in '59 and works 80, 40 and 2, and is active in RACES. She likes c.w. better than phone and assists her Dad, K6DUU, in putting on code instruction twice a year on 1985 kh, a program sponsored by RACES, Boy Scouts and Girl Scouts in the area. Helen Ann is in her sophomore year at El Capitan High where she plays flute in the marching band. Her brother is K6RAU, a soph at Fresno State, and at home all use the same gear. Though Helen Ann's Dad is a Ham, it was through Scouting that she got interested and she hopes for much more YL activity in the Merced area.

New YL Club

Welcome to the newest YL club — the Colorado YLs. KØEPE, Marte, tells us that at their second organizational meeting in August they had ten members. The September meeting was to be held in Boulder at QTH of KØBTV, Kay, where they planned to work out details for a club certificate. More on this later.

Sign up here!

EVANS RADIO

"your friendly supplier"

CA 5-3358

Route 3A. Bow Junction
CONCORD, NEW HAMPSHIRE

hallicrafters SSB/CW/VHF Contest

You can win ...

SX-115 Receiver

HA-2 or 6 Transverter

HT-37 Transmitter

HA-4 Keyer

Over \$10,000 In Prizes

For further information, check number 93, on page 163

MONTEREY PARK AMATEUR RADIO CLUB

Monterey Park, California

Meets First Monday • Each Month — 8 P.M.

COMMUNITY RECREATION CENTER

350 So. McPherrin Ave.

All Amateurs & All Interested In
Amateur Radio Welcome

BCNU

"HOW TO MAKE MONEY IN Mobile Radio Maintenance"

AUTHORITATIVE GUIDEBOOK
ABOUT THE BOOM IN TWO-WAY MOBILE-RADIO:
GIVES FACTS, FIGURES, PAY RATES,
WRITE TODAY!

FREE

LAMPKIN LABORATORIES, INC. Electronic Div. BRADENTON, FLA.

KEY.unicator TRANSISTORIZED

"PRO STYLE" TELEGRAPH KEY

Cast metal, transistorized oscillator, batteries last for months. Mounted on 9"x12" rugged base. At Electronics Dealers.

995

DOW-KEY COMPANY
Thief River Falls, Minn.

NEW



MODEL 381

T-R SWITCH

...with selectable bandswitching

This compact electronic T-R switch (4 $\frac{3}{4}$ " x 4" x 4 $\frac{1}{2}$ ") does a big job in automatic break-in operation on CW-SSB-AM-DSB. Bandswitch covers 80 through 10 meter bands. Integral power supply. For commercial applications, it will handle more than 1KW AM phone and up to 5KW SSB. "Fail-safe" design automatically keeps transmitter connected to antenna when unit is not energized. Matches 52-75 ohm coaxial lines.

This is the switch you've been looking for. See it at your local dealer, or write the factory direct.

Price: \$60.00

Barker & Williamson, Inc.

Bristol, Pennsylvania

For further information, check number 69, on page 163

Sign up here!

VAN SICKLE W9KJF

4131 North Keystone Avenue

Indianapolis, Indiana

hallicrafters
SSB/CW/VHF
Contest

You can win ...
SX-115 Receiver
HA-2 or 6 Transverter
HT-37 Transmitter
HA-4 Keyer

Over \$10,000 In Prizes

For further information, check number 70, on page 163



Would-be hams need never feel they are "too young" to learn. Barbara Combs of Cincinnati is only 10 years old and has been operating as KN8ZUG since May '61. Using a DX-20 with Mohawk receiver, as of July Babs had 23 states and Canada confirmed. According to her Dad, K8NWV, Babs can copy code at 15 w.p.m., and she hopes to have her General by her 11th birthday. Look for KN8ZUG on 7180 and 21,135; she'd be especially glad of any western states or DX contacts.

Here and There

From WIZEN we learn that WIYPG, Christine Sprague, became a Silent Key on August 11 following a heart attack. Christine was a member of WRONE and served on its executive board in '58.

K6BX sends the results of the CHC/HTH 1961 world-wide contest held the first week in June. Top world honors went to KØIKL, Joyce Polley, whose award was endorsed "high" for the world, North American continent, U.S.A., and Minnesota. Runners up to KØIKL were W5PSB, W5WZQ and W2SAW.

Clif also sends news of the Flying Hams' Club Award. This is actually a series of awards with many possibilities available, such as FHC for DX, Zones, WAS, Aero/mobile (in flight), Space, etc. For full data contact club secretary K6BX, Box 385, Bonita, Calif. Some YL members of FHC are W1SVN, W4UF, W4ZKD, W6QPI, K8OMH. Certificate appears on p. 12 of the Sept. 1961 issue of CQ.

Tnx to K5TYN for news of the Carlsbad, N.M. picnic. Despite rain (first in three months), Betty says over 200 enjoyed the get-together, sponsored by the Cavern City ARC on Aug. 20, including these LYs: W5's RFK (ex-DL4HO), DZB, GMG, OVH; K5's OHQ, YQG, DDS, GYZ, KOK, YOY, DPF, HNM, DAB, YTN, GSC; KN5KKP.

REX RADIO SUPPLY

1. Gas generator output variable 0-15 volts DC—30 amps—manual or battery start. Voltmeter, air meter, self contained gas tank. 60 lbs.—used—guaranteed—Tested \$49.95
2. BC 733—Ten tube UHF receiver with CQ conversion sheet—dynamotor excellent condition \$5.75.
3. 10,000 ohm plate relay DPDT, GE 98¢.

84 Cortlandt Street, New York 7, New York

Want to win *the* contest of all beauty contests? Then get into electronics. Note that the 1961 Miss Universe, tall blonde and beautiful Marlene Schmidt of Germany, earns her living as an electronics engineer. And in *TIME's* "Hams' Who's Who" (July 28, '61) the distinguished personalities include 1959's Miss Universe, Luz Buluaga of Colombia who operates as HK6LT.

Book Review

Troubleshooting Amateur Radio Equipment is the newest book off the presses of Howard Sams & Co. authored by Howard Sams & Co. authored by Howard S. "YB" Pyle, W7OE. 128 pages and including schematic diagrams and photos, it sells for \$2.50. In his Preface "YB" comments that the average ham often does not have the necessary equipment or background to perform intricate tests and repairs on his equipment. In this book he points out some of the causes of common troubles in his equipment and suggests home remedies that can be performed with a minimum of knowledge and test gear. Active in his radio for over 50 years, "YB's" first two books for Sams were *ABC's of Ham Radio*, and *Building Up Your Ham Shack*. A fourth, a preparation manual for amateur license exams, will be released soon.

33, W5RZJ

Circuit Elements [from page 49]

v.h.f. because of lower inductive values and the lack of sliding contacts.

Inductors

Besides resistors and capacitors, radio circuits are filled with various types of inductances. In general, the inductance should have a high value of reactance in relation to its resistance. Also, the current carrying capacity and voltage breakdown rating must be considered.

For r.f. applications it is generally desirable to use high quality inductors. Besides having a high value of Q , the inductance should not change appreciably in value with temperature and humidity. This is usually accomplished by using good coil form material, wire wound to be mechanically stable, and the absence of wax or other material which may flow at higher temperatures.

For power amplifiers, the coils are usually "air wound" to minimize heat, dielectric losses and inherent capacitance. In some cases, they are silver plated to lower their inherent resistance. In choosing or winding for this purpose, the material from which they are wound should not only have low r.f. resistance but must be capable of carrying the heavy circulating currents without undue heating. It is considered good practice to use heavy enough material so that the coils lightly loaded. To produce the best value of Q (reactance to resistance value) the form factor must be correct. Generally, a ratio of coil dia-

Sign up here!

CRABTREE'S
WHOLESALE
ELECTRONICS

2608 Ross Avenue
Dallas 1, Texas

h hallicrafters
SSB/CW/VHF
Contest

You can win ...

SX-115 Receiver

HA-2 or 6 Transverter

HT-37 Transmitter

HA-4 Keyer

Over \$10,000 In Prizes

For further information, check number 71, on page 163

* TWO-WAY * COMMUNICATION CRYSTALS



**UNCONDITIONALLY
GUARANTEED**

FAST — 24 HOUR SERVICE

American specializes in two-way communications. Frequency correlation data for G.E., Motorola, R.C.A., Collins, Lear, Narco, Hallicrafter, Link, Gonset, Aerotron, Heath, Bendix, Johnson, Globe, U.S. Gov't. and many other companies.

FREQUENCY RANGE	CALIBRATION TOLERANCE	PRICE
3001 KC to 9999 KC	.002%	\$3.50
15 MC to 30 MC TM	.0025%	\$3.50
30 MC to 50 MC	.0025%	\$4.00
10 MC to 17 MC Fund	.002%	\$4.00
2001 KC to 3000 KC	.002%	\$4.00
50 MC to 60 MC	.0025%	\$5.00
1000 KC to 2000 KC	.002%	\$7.50

Write for quantity discounts or phone Victor 2-5571

AMERICAN CRYSTAL CO.
P.O. BOX 2366 • KANSAS CITY 42, MO.

For further information, check number 72, on page 163

CQ YL

A Perfect Christmas Gift

THE only complete book about YL activities, containing eighteen chapters and over 500 photographs. Covering all phases of YL participation in amateur radio.

PERSONALLY autographed copies are available at \$3.00 postpaid direct from:

LOUISA B. SANDO, W5RZJ
4417 11th Street, N.W.
Albuquerque, New Mexico

PICON-ITE

PICON-ite, the South Dakota area Amateur news monthly, now in its 9th year.

Special area events — General interest news.
Emergencies — Public Service — Social Clubs — Nets — AREC — Hams — Discussions Operating — Technical — Junk-Box (ads) Handy-Hints — Editorials — Letters — Humor

non-profit basis, subscription \$1.00 per year

write to:

Lester Russell Lauritzen
Box 32, RFD Route 3, Centerville, South Dak

Sign up here!

PRIEST ELECTRONICS

Incorporated

6431 Tidewater Drive
Norfolk 9, Virginia

hallicrafters SSB/CW/VHF Contest

You can win . . .

SX-115 Receiver

HA-2 or 6 Transverter

HT-37 Transmitter

HA-4 Keyer

Over \$10,000 In Prizes

For further information, check number 73, on page 163

meter to coil length should be approximately in the ratios from 1 to 2—to 1 to 1.

General

For the amateur the choice of high quality, conservatively rated components adds little to the overall cost. The use of marginal components not only leads to their failure but in so failing may ruin or damage several other valuable components. The constructor should therefore ask himself what else will fail if this component "blows"? In the matter of personal safety, such components as bleeder resistors, interlocks, etc., should be most carefully chosen. ■

Link 2365 and 2210 [from page 42]

Summary

The 2210 and 2365 units are very similar and the only point where there is a major difference in them is in the r.f., mixer and oscillator section of the front end. Figure 3 shows a partial schematic of the 2365 ed2a with the parts to be changed or removed identified.

Since the operations are essentially the same as in the 2210, they are not elaborated on. Minor differences will be noted between the 2365 and the later editions such as the ed2a and the ed3. If you happen to get a model other than the ed2a, a good rule of thumb to follow is to replace the discriminator load resistors with matched 470,000 ohm units, remove all loading resistors across the i.f. transformers and remove all bypass capacitors which are connected from the discriminator output to ground before the volume control and all resistors appearing in series with the audio between the discriminator output and the volume control with the exception of a 100,000 ohm isolation resistor.

For the purist, I would like to point out that while the manufacturers refer to these units as "Frequency Modulated Transmitter-Receiver Units" and I have likewise referred to them in that manner, still, strictly speaking, they and virtually all other crystal controlled f.m. transmitters on the market are not frequency modulated but phase modulated which produces both phase and amplitude modulation. The amplitude modulation is effectively wiped out by the succeeding multiplier stages which are driven into plate saturation with the result that the final output is effectively frequency modulated.

These units can be bought for various prices from some gas and taxi companies who operate on a basis where they change their equipment after it reaches a certain age. They may also be bought on the open market where the transmitters have been reconditioned to meet FCC requirements and with crystals and antenna furnished for your frequency.

All things considered, these little units represent one of the best buys on the market and will give excellent service. ■

Semiconductors [from page 104]

the order of $\frac{1}{2}$ micron. Each of the 10 holders have a capacity from six $\frac{1}{2}$ " to one $1\frac{3}{4}$ " slices. This lapping machine is made by Dallons Laboratories, Inc., El Segundo, California.

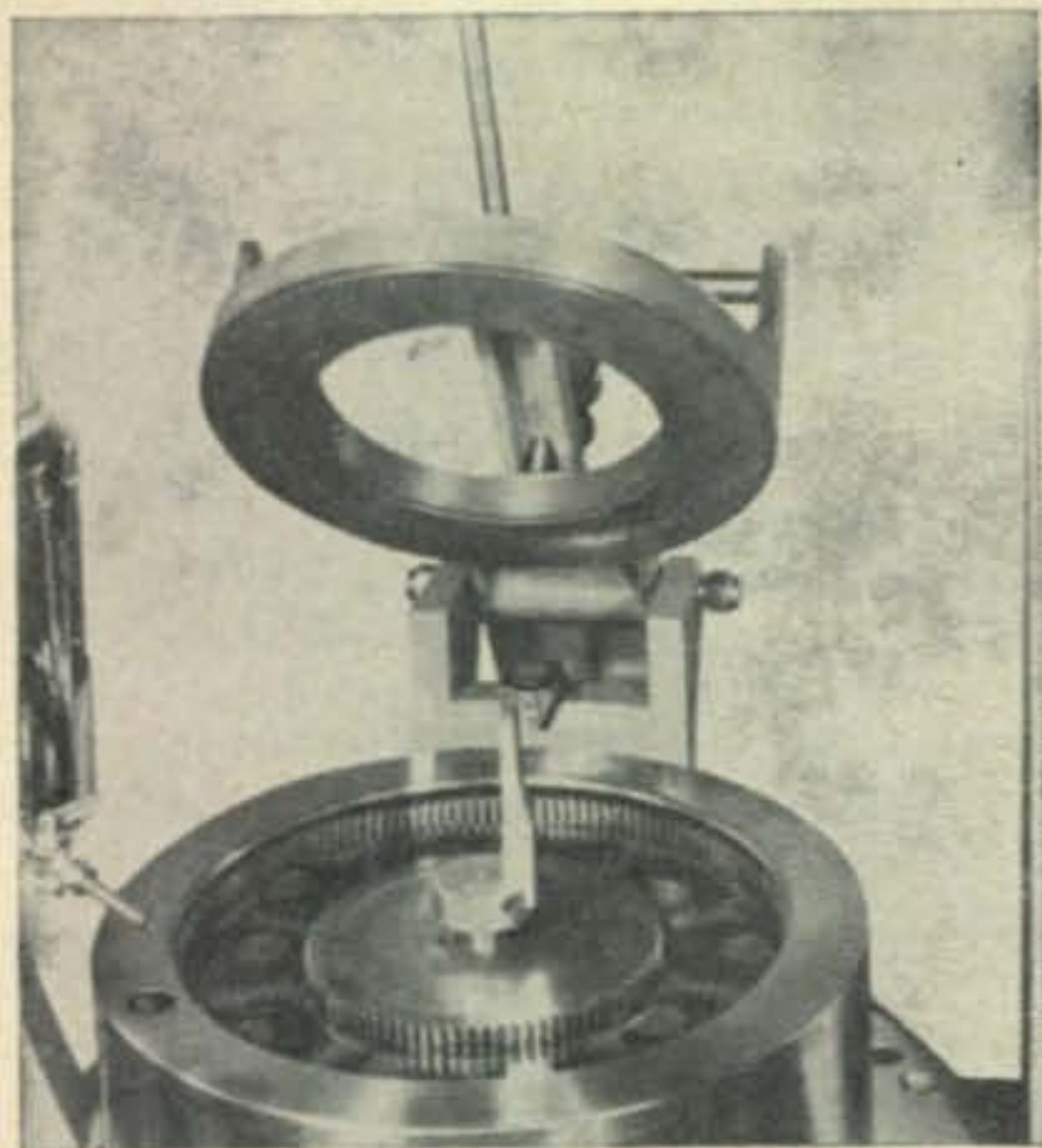

Semiconductor wafer lapping machine manufactured by Dallons Laboratories.

Twirl-Con

If you're like me, you use old resistors and capacitors 'til the leads are too short to solder. Henry N. Dittrich, W5IVU, 1101 N. E. St., Edna, Texas, has developed a tool for extending short component leads. It is extremely handy for prototype work or for testing components mounted on p.c. boards. At 11 cents each, it only takes 20 saved resistors to make the tool pay for itself! If interested, drop Hank a line for more information.

Because of the long-winded dissertation earlier, we are running a bit short of space. The new product announcements will be saved for next month.

73, de Don, W6TNS

Correction

In the SEMICONDUCTOR column for September 1961, (page 89), transistors Q_2 , Q_3 , and Q_4 were incorrectly identified. The proper designations for these transistors are as follows: Q_2 -2N223, Q_3 -2N223, Q_4 -2N226. Our apologies.

Transistor Amps [from page 52]

reactive load, the two capacitors may be separated. Alternatively, a small air trimmer may be placed across the output coil after having first of all removed a turn or two to compensate for the increased C .

Coupling to the Load.

The load should be correctly matched to the coil. Tap the output lead as far down the coil as possible consistent with highest output. This is true also of the oscillator and final collector taps. If the taps are too high, the Q of the circuits is considerably reduced and harmonics are radiated. ■

Sign up here!

**BURGHARDT
RADIO SUPPLY**
Box 746A
Watertown, South Dakota

h hallicrafters
SSB/CW/VHF
Contest

You can win . . .

SX-115 Receiver

HA-2 or 6 Transverter

HT-37 Transmitter

HA-4 Keyer

Over \$10,000 In Prizes

For further information, check number 74, on page 163

Are You Mobile?

Improve signal/noise
ratio up to 20 DB

with **MARK HW**

HELIWHIP* ANTENNAS



Mark HELIWHIP* Plastic Covered Fibre Glass Antennas noticeably improve mobile communications over long whips and base loaded antennas! Mark Mobile's exclusive "Static Sheath"* plastic covering reduces precipitation static—improves reception signal/noise ratio up to 20 DB! High radiation efficiency. Broadband with excellent VSWR. Mark HELIWHIPS are available in 4' to 8' lengths depending upon frequency, with models for all bands, 6 through 160; 2 meters with CVS-2144, 2.5DB gain $\frac{5}{8}$ wave whip. 50 ohm matching at resonant frequency. Non XYL resistive . . . actually improves the appearance of your car. Mount on trunk or cowl just like BC antenna. Step up to HELIWHIP and know the real joy of mobiling!

*HELIWHIP is a registered trademark

U.S. Patent 2,966,679

U.S. Process Patent 2,938,210

Write for technical data or visit your nearest
amateur equipment supplier



MMI

MARK MOBILE, Inc.

Dept. C-11, 5441 West Fargo Ave.
Skokie, Illinois

For further information, check number 75, on page 163

New EZ-IN QSL CARD PACKET

20 Cards Framed
in Clear
Polyethelene

Pockets of
"Double" Packet
Open At
Front-Center for
Quick Insertion
or Removal of
Cards

1 Packet—35c
3 Packets—\$1



W4LKZ Cards

Post Paid and Guaranteed By:
Tennessee Paper & Box Co.
Boyers St., Gallatin, Tennessee

For further information, check number 76, on page 163

Sign up here!

LAFAYETTE RADIO

P.O. Box 10

Syosset 10, New York

hallicrafters
SSB/CW/VHF
Contest

You can win . . .
SX-115 Receiver
HA-2 or 6 Transverter
HT-37 Transmitter
HA-4 Keyer

Over \$10,000 In Prizes

For further information, check number 77, on page 163

Ham Shop

Rates for the HAM SHOP are 5¢ per word for advertising which, in our opinion is obviously of a non-commercial nature. A charge of 25¢ per word is made to all commercial advertisers or business organizations.

Your copy should be preferably typewritten, double spaced on one side of the page only.

We do not bill for advertising in the HAM SHOP. Full remittance *must* accompany all orders.

Closing date is the 20th of the 2nd month preceding date of publication.

We reserve the right to reject advertising which we feel is not of an amateur radio nature.

Because the advertisers and equipment contained in the HAM SHOP have not been investigated, the publishers of CQ cannot vouch for the merchandise listed therein.

Radio and T.V. tubes jobber boxed R.C.A. G.E. Sylvania, Westinghouse 65% off list price, 25% deposit, on all orders, balance C.O.D. F.O.B., N.Y., Sutton Electronics Box 503, Hicksville, N.Y.

Opportunity to volunteer service to a non-profit scientific research project. Object: investigation of electromagnetic phenomena such as radio astronomy, scatter propagation, and moon-bounce. An administrative staff of 25 people with knowledge and skills in electronic and related fields is needed. For details write Radiometric Research, Ltd. Box 4335-Annex, Las Vegas, Nevada.

ATTENTION Mobileers! Leece-Neville 6 volt 100 amp system \$50; 12 volt amp system \$50; 12 volt 60 amp system \$60; 12 volt 100 amp system \$100. Guaranteed no ex-police car units. Herbert A. Zimmermann, Jr. K2PAT, 1907 Coney Island Ave., Brooklyn 30, N. Y. Tel. DEwey 6-7388.

For Sale: TV Cameras, Teletype, Panadapters, Transmitting Tubes, Transistors, SSB gear. Write for list. Spera Electronics, 37-10 33 Street, L.I.C., N. Y. STillwell 6-2199.

ONE THIN DIME brings 50 page eye-popping war surplus electronics catalog. Fabulous bargains. Meshna, Lynn, Mass.

TOROIDS: Uncased 88 mhy like new. Dollar each. Five \$4.00 P.P. DePaul, 309 South Ash'on, Millbrae, Calif.

BEGINNERS: Code bothering you? Now learned in one hour. New Method. Quick approach towards your ham ticket. Used in Armed Services, Ham Radio, Scouting. Ketchum's One Hour Code Course \$1.00 postpaid. MONEY BACK GUARANTEED—O. Ketchum, 10125 Flaro Vista, Bellflower, California.

WANTED: Teletype printers, perforators, reperforators transmitter-distributors test equipment: Model #14, #15, #19, #26, #28, etc. All types Collins receivers, 51J, R-388, R-390, 75A, etc. Cash, or trade for NEW amateur equipment. Write Tom, W1AFN, Alltronics-Howard Co., Box 19, Boston 1, Mass. (Rlchmond 2-0048).

WANTED: Military and Commercial laboratory test and measuring equipment. Electronicraft, Box 399, Mount Kisco, N. Y.

"The VHF Amateur"—At last a magazine for VHF'ers! Don't miss a single issue! Send \$2.00 for year or \$1.00 for six big issues . . . 67 Russell, Rahway, N. J.

GARAGE DOOR OPERATORS \$59.95. Rugged chain drive automatic units. Highest quality. Free literature. DEMSCO, INC., Sebring 22, Ohio.

Communication, Teletype, unusual surplus bargains. Free flyer, MDC, 923 W. Schiller, Phila. 40.

WANTED: TELETYPE TG-7, Models 14, 15, 19, 26, 28, printers & reperforators: Revrs & xmtrs: BC 610E, 1; AN/GRC-3 & higher, RT-66, -67, -69, Collins 51J, 17L3, -4, 18S-2, R-388, -390, -391; ARN-14 and -30; APR-9, -10, ARC-21, -34; APS-10, -31, -33, -42, etc., and TEST EQPT, TS or AN/URM. We pay freight. Amber Industrial Corp., 75 Varick St., New York 13, N. Y.

Wanted: R-388/URR receivers, any condition. Electroncraft, Box 399 Mt. Kisco New York.

W5QES looking for 51J-3, 51J-4, R-388, R-390, R-391. Cash or trade. 75A-3, 10B + v.f.o. 400 w. linear, 3 or 5 kw pool transformers, 4-1000A's. CU-7296-UPSB, 1438 Adkins Rd., Houston 24, Texas.

SELL: Used 200V Like new. \$639. Organs and Electronics, Lockport, Ill.

SP-600 JX26 Hammarlund receiver .54-54 mc, \$295.00. SP-600 JX17 \$395.00. Collins 51J-2, 51J-3, R-390A etc. Teletype, Kleinschmidt printers. RTTY converters. Alltronic-Howard Co., Box 19, Boston 1, Massachusetts (Richmond 2-0048).

A-5 — One-inch Vidicon Deflection Components. 5-Piece Model VK-100 Tube Type or Transformer Type Kit: Has deflection yoke, focus coil, alignment coil, horizontal and vertical output transformers. \$99 Net. Also, 3-piece Model VK-200 Direct Drive or Transistorized Kit: Has deflection yoke, focus coil and alignment coil. \$89 Net. Components available only as above kits. Send check or money order. 10 day unused-undamaged return privilege. Cleveland Electronics Inc., Deflection Components Div., 1947 E. 61st, Cleveland 3, Ohio.

QSL's four colors glossy stock forty design send \$5 for 200 and get surprise of your life. 48 hour service satisfaction guaranteed. Constantine Press, Bladensburg, Md.

GLOSSY 3-color QLS cards 100—\$4.50. Free sampler. Rutgers Vari-Typing Service, 7 Fairfield Road, Somerset, N.J.

QSL's SWL's. That are different, colored, embossed card stock and "Kromekote." Samples 10¢. Home Print, 2416 Elmo, Hamilton, Ohio.

QSL's Samples 15¢. Rubber stamps: Name, Call Address \$1.35. Harry Sims, 3227 Missouri Avenue, St. Louis 18, Missouri.

QSL's-SWL's samples 10¢. Malgo Press, Box 375 M.O., Toledo 1, Ohio.

QSL's. SWL's XYL-OM's (Sample assortment approximately 9¼¢). Covering designing, planning, printing, arranging, mailing, eye-catching, comic, sedate, fantabulous, DX-attracting, protoypay, snazzy, unparagoned cards. (Wow!) Rogers, KØAAB, 961 Arcade St., St. Paul 6, Minnesota.

QSL's—"Brownie" W3CJ1, 3110 Lehigh, Allentown, Pa. Samples, 10¢, with catalogue, 25¢.

C. Fritz for QSL's that guarantee better DX returns! Samples 25¢ deductible. Box 1684 Scottsdale, Arizona (formerly Joliet, Illinois).

QSL's-SWL's: 100 2-color glossy \$3.00; 100 QSO file cards \$1.00; Sample 10¢. Rusprint, Box 7507, Kansas City 16, Missouri.

QSL's SWLs 3-colors 100 \$2.00 samples dime, Bob Garra, Leighton, Penna.

QSL's, SWL's, CB, WPE, Nicholas & Son Printery, P.O. Box 11184, Phoenix 17, Arizona. Samples 5¢.

QSL's . . . \$1.80 up . . . Dime . . . Filmcrafters . . . Martins Ferry, Ohio.

QSL's? SWL's? WPE? CB? Variety samples 25¢ (re-funded). QSL's samples with bible verses 25¢. Sackers, W8DED, Holland, Michigan.

QSL's, Samples dime. Print Shop, Corwith, Iowa.

QSL's. Samples free. Phillips, W7HRG, 1708 Bridge Street, The Dalles, Oregon.

QSL's. Large selection styles, including photos .Lowest prices. Fast service. Samples dime, Ray K7HLR, 679 Borah, Twin Falls, Idaho.

FOR SALE: BC-640, \$200. TDT transmitter, 100-156 mc, \$150. ARC-4 with tubes and dynamotor, original, \$10. BG radio transmitter and receiver, UHF approx. 470 mc, rack mounted new, \$75. George L. Vance, WA6LAI, 2307 No. Gower St., Los Angeles 28, Calif.

COLLINS 75A-3, serial 1288, mint condition, \$325.00; Collins 75A-1, excellent \$215.00; 6 kc mechanical filter for 75A-4, \$35.00; 75A-4 speaker, \$17.50; 75A-3 Crystal Calibrator, \$17.50. Universal Service Product Detector for 75A-3 \$30.00; KWM 1 mobile mount & cable, \$49.00; MM-2 scope, \$89.00. W8WGA

Sign up here!

RSE Ham Shack
Charles Houser, W8YJY
Phone TE-1-3171
90 Seldon,
Detroit, Michigan

hallicrafters SSB/CW/VHF Contest

You can win . . .
SX-115 Receiver
HA-2 or 6 Transverter
HT-37 Transmitter
HA-4 Keyer

Over \$10,000 In Prizes

For further information, check number 78, on page 163

SOLA VOLTAGE REGULATORS

Input 95V-130V 60C
Constant Output 115 Volts

Cat. No.	Watts	Price
60176	500	\$ 35.00
30745	170	20.00
30307	500	35.00
30275	127	15.00
30639	2000	100.00

Input 190-260V 60C
Constant Output 230 Volts

30837	120	\$ 15.00
301583	1000	50.00
30M674	2300	75.00

Above Model Contains
variac for output voltage control.

All regulators excellent. Used condition checked and guaranteed. Priced F.O.B. Tulsa.

PRACTICAL ENGINEERING CO.
4611 S. Elwood, Tulsa, Okla.

For further information, check number 79, on page 163



Stop That Noise with HYPASS® FEED-THRU CAPACITORS

- Exclusive Sprague 3-Terminal Networks
- Extremely Effective as R-F Filters Above 2 Mc. Effectively Suppress TVI from Transmitters, Diathermy Equipment, etc.
- Mobile Applications Include Elimination of Generator and Regulator Hash, as well as Primary Ignition Noise
- Available in a Variety of Ratings from .002 to .5 μ F, from 15 to 40 amps, from 50 to 5000 volts
- GET THEM FROM YOUR LOCAL ELECTRONIC PARTS DISTRIBUTOR

SPRAGUE PRODUCTS COMPANY

world's largest manufacturer of capacitors
NORTH ADAMS, MASS.

For further information, check number 80, on page 163

Sign up here!

Reno Radio Company

Radio Parts Distributors
Amateur Equipment
1314 BROADWAY
DETROIT 26, MICHIGAN

hallicrafters SSB/CW/VHF Contest

You can win ...
SX-115 Receiver
HA-2 or 6 Transverter
HT-37 Transmitter
HA-4 Keyer

Over \$10,000 In Prizes

For further information, check number 81, on page 163

FOR SALE: NC-300 with speaker \$200.00—6 meter converter for NC-300 \$20.00 BC-312 receiver \$40.00—DX-100 good \$125.00—Heath Model 425 scope \$25.00—Heath Conelrad \$8.00—Heath Ba'un coils \$5.00—Heath Power Meter \$5.00—Eico battery eliminator model 1050 \$20.00—Eico Sig. Generator model 324 \$25.00. Many other small items, send for list. Frank R. Anderson, 2421 K Street, Bedford, Indiana.

SELL or trade Viking 6N2 with v.f.o. \$100, Ranger \$185, 2 meter Gonset III \$200. Want s.s.b. gear. KINGJ, E. Norton, Nantucket, Mass.

REBUILT BC 348 rec with power supply, v.h.f. 522 rec, 75m battery operated receiver. Make offer. E. J. Bissonette, 1278 Evermont Ave., Anaheim, Calif. K6LAC

SILVER plated brass 3½" x 13", 24 gauge excellent v.h.f. shield, \$1 sheet. Weston precision Photo-Densitometer, manual, as new, cost \$150, sell \$75. Parts from 1928 radio, 201A's, sockets, coils, etc. Volt-amp regulator tester, mobile 6-12v. List \$65, sell \$50. 35T 100 watt triode, \$10. Other tubes, meters, parts. List stamp. Box 175, RD 2, Middlefield, Ohio.

FOR SALE: Globe LA-1 linear amplifier \$69, Globe Scout 680 with Drake low pass filter \$70, Globe 755 v.f.o. \$30.00, Globe PA-1 power attenuator \$8.00. Eugene Triebold, K0MBO, Cooperstown, No. Dakota.

A-1 reconditioned equipment. On approval, trades. Terms. Hallicrafters S-85 \$79.00, SX-100 \$199.00, SX-111 \$199.00, SX-101 \$259.00, HT-32, HT-37; Hammarlund HQ-100 \$129.00, HQ-129 \$129.00, HQ-110 \$179.00, HQ-145 \$199.00, HQ-150 \$199.00, HQ-160 \$259.00, HQ-170 \$289.00; National NC-270 \$179.00, NC-183D \$199.00, HRO-60 \$345.00, NC-60, NC-173, NC-300; Central 20A \$149.00, Thunderbolt linear \$299.00; Collins 75A-2, 75S-1, 32S-1, KWS-1, KWM-2; Elmac, Globe, Gonset, Heath, Johnson, RME, other items. List free. Henry Radio Company, Butler, Missouri.

FOR SALE: 2500-2000 v.d.c. 425 ma Power Supply with Thordarson T-21P77 Xfmr and Aerovox 4000v 4mf condenser; 1250 v.d.c. Power Supply, with Thordarson T-19P65 Xfmr; 1250 v.d.c. Power Supply with UTC PA3-3 Xfmr and two Aerovox 4000v 4 mf condensers. Buy all three and get an 800w 10-20 meter rack & panel xmtr free. 100TH's in buffer & final. Best offer each supply or write for more information. Also complete RCA aircraft 75m (2500-6500KC) station with AVT-112A xmtr, AVR-20A receiver, AVA-126A power supply—to use on 6, 12 or 24 v.d.c., complete with RCA manual. \$50.00. Also various smaller power supplies in 400-600 v.d.c. range. C. W. Robertson, Jr. W5MBP, Terrell, Texas.

Current Transformers, 110 Volt Pri., 15 Volts at 20 Amps. Sec. with leads. \$5.95. J. F. Pyryt, 192 Norman Way, Paramus, N. J. CO 1-8655.

TM-11-1145 Technical Manual for Beacon Transmitter Receiver AN/PPN2-RT37. \$1.25 Postage Paid. Clack Radio, 1526 Merced St., Richmond 6, California.

WANTED: Teletype machines, used, bent or broken. Any condition. Write, R. Corbett, 46 Prospect St., Torrington, Conn.

WANTED: Gracie says I need another transmitter like I need another hole in my head but if you've got a good clean KWM-1 let me know your best price. Larry Kleber, W9CPD/K9LKA, Belvidere, Illinois.

FOR SALE: Globe Scout transmitter 680 (6m-80m), only \$64 (cost over \$100 new). Also Globe 6m v.f.o. new in '60 only \$29.00 (cost \$49.95). Both for \$88. W3IVU, 3921 Idaho Ave., N. W., Washington 8, D.C.

SELL—Apache AAA-1 condition, professionally wired, mike, relay, APN-4 scope; SX-99, speaker, headphones, QF-1, DB-23—all \$375—WA2EFN, NYC.

NOVICES! Complete transmitting setup! AT-1, coupler, xtal, key. \$27.50. Ron Pollack, 14 Osborn, Monticello, N. Y.

WANTED: Westinghouse 0-10 a.c., d.c. voltmeter style 1164772, U.S.N. type Cay-22246, Type NA-33. Westinghouse infinity to -5 DB meter. Style 1164771, U.S.N. Type Cay-22152, Type NC-33. Both meters for RAL-7 receiver. Larry Kleber, W9CPD/K9LKA, Belvidere, Illinois.

GOING MOBILE. Will sell HQ 160, \$275.00; Valiant \$300.00; Johnson 6N2 \$100.00; Johnson 6N2 converter \$40.00; Heath v.f.o. rewired for 6, \$20.00, all in excellent condition. Sell individually or as unit for \$600.00. K7LQI, 11557 Evanston Ave., N., Seattle, Washington.

WANTED: BC-221 or LM, with or without case or power supply. State model, condition, price. W. Bailey, 7122 Heathfield Road, Baltimore 12, Maryland.

FOR SALE: Instructograph code teacher with built-in ICA signatone code oscillator, \$10; Alliance Tennarotor model 98-U brand new, with thrust bearing bracket, \$20; 1/3 h.p. motor \$7.50; 12v dynamotor, 500 volts 200 ma, \$6.00; RCA 80 meter AVR-20A, AVT-112A, AVA-126A, \$25; Precision model 920 electrodynamic tube and set tester \$20.00; RCA AVT-15A transmitter \$10; Tubes three 4-65A, four 4D32, \$5.00 each; Two 810, two 829B, one 6146, \$3.00 each; six 837, fine 1614, six 6L6, six 5881, 50¢ each. KØACG, 125 N. Lake Avenue, Sioux Falls, S. Dakota.

FOR SALE Complete installation of mobile gear. Multi-Elmac AF-68 transmitter, PMR-8 receiver, mobile-fixed power supply M-1070. All like new. Bob Hartman, W9RQY, Cedarville, Illinois.

WILL TRADE RCA 5820 Image Orthicon Television pick-up tube for good receiver or s.s.b. transmitter or two 4-1000A tubes. Vern Slagle, 1704 Hale, Ft. Wayne, Indiana.

MECHANICAL FILTERS: I have just purchased 200 surplus units which contain 300 kc mechanical filters 4 slug tuned hi-Q i.f. coils, b.f.o. coil, over 75 half watt resistors 10 silver micas, 20 ceramics. Circuit of filter included. \$12.50 each postpaid. W. R. Seldon, 4021 West Broad St., Richmond, Va.

WANTED: Commercial or surplus aviation and ground transmitters, receivers, test sets, 18S, 17L, 51R, 618S, GRC, PRC, ARN14, MN85, Bendix, Collins, others. Ritco, Box 156, Annandale, Virginia.

TRANSMITTER, complete—1 kw phone, 10 through 75, pair 100TH's modulated by pair 100TH's, completely shielded \$250; Ten meter 3 element Cush Craft beam \$10, Fifteen meter 3 element Hy-Gain \$20; Prop-Pitch motor \$20; Hy-Gain Roto-Brake \$50. Heckman, 92 Lagoon Blvd., Massapequa, New York.

SIX METER converter—WRL factory wired 10-14 mc i.f., \$22.00; home brew ant. coupler. coils for 80-10 meters \$10.00; 37 two track stereo tapes costing \$300.00, half classical, sell lot only for less than cost of blank tape. \$75.00; Golf clubs, 3 woods, 7 irons and bag \$25.00; HRO coils, 1.7-4 mc., and 7-14.4 mc \$7.00 each; Polar relays \$3.00 each; New r.f. signal generator \$20.00. Tapes and clubs shipped collect, others prepaid. K4ZQR, 409 Kaelin Drive, Louisville, Ky.

BOUGHT MOBILE home must cut down station. Navigator, exc. \$100.00; Morrow MBR-5, w/p.s. and speaker, \$100.00; Match Box model 250-23-3, LN, \$55.00; Signal sentry \$10.00; Jones Micro Match model 261-262, LN, \$20.00; Electro Measurements impedance bridge model 250-C1, LN, \$100.00, BC-1335, New, \$20.00; R-110 38.5 to 55 mc f.m. receiver, exc, \$55.00. Portable mill, Remington, exc, \$30.00; More, test equipment, station accessories, stamp for list. WØWCR/4, Box 167-22-2, Route #1, Prince George, Virginia.

FOR SALE: Complete 6 and 2 meter station for either fixed station or mobile use. Hallicrafters SR-34AC 6 and 2 meter transceiver in excellent condition. Kupfrian transistorized inverter, 6 or 12 volts d.c. to 117 volts a.c. National 6 and 2 meter v.f.o. Hy-Gain 6 and 2 meter halo antenna with 25 feet of cable. Lafayette PA-42 crystal microphone. Will sell entire setup for \$350 or best offer above within 30 days of this issue. Will not ship equipment; must be picked up by buyer in New York area. Write, wire, or phone, Box CR, c/o CQ Magazine.

Philco VHF to UHF Signal generator G8000. UHF Audio Level Sweep generator G8002. Several new. Sell or trade. Dale Snell, Blue Mound, Illinois.

DX-100 for sale, \$160, has worked DXCC. Will also sell HQ-140X, relay, Millen preamplifier, 50kc calibrator, and phone patch. Don Strong, Rte 2, Batavia, New York.

TELETYPE EQUIPMENT for sale (tested); Model 14 typing-reperforator (some less cover) \$80.00. Model 15 page printer (with keyboard) & cover \$90.00. with auto-carriage return \$100.00. Used, good condition, Synchronous motors. Frank Holloway, Jr. 513 N. Pinehurst, Salisbury, Md.

WANTED—Patriotic American radio amateurs to join the Anti-Communist Radio Network. Use your rig to help bury socialism. Write Huntley, W6RNC, 972 Grizzly Peak Blvd., Berkeley 8, California.

FOR SALE: Custom made ceramic ash tray (green, brown, or white). Your handle and call letters in gold. Only \$5. Choctaw Ceramics, K5ZTH Jim, RR1, Box 14K, Choctaw, Oklahoma.

Sign up here!

Henry Radio, Incorporated

11240 West Olympic Boulevard
Los Angeles, California

931 North Euclid Avenue
Anaheim, California

hallicrafters SSB/CW/VHF Contest

You can win ...

SX-115 Receiver

HA-2 or 6 Transverter

HT-37 Transmitter

HA-4 Keyer

Over \$10,000 In Prizes

For further information, check number 82, on page 163

SURPLUS TECH MANUALS

All clean, complete, original manuals. Not reprints or abridged editions. Shipped postpaid.

APR-1	\$ 7.50	Check our last months ad for other scarce manuals.
APR-4	\$ 7.50	
APN-1	\$ 6.50	
APN-4	\$ 8.00	Complete Gonset Mobile rig, G-66b, G-77a, all cables, mic, Webster short band-spanner ant., 12vdc and 110 v.a.c. power supply-freight prepaid anywhere, guaranteed perfect—\$375.00
APN-9	\$10.00	
ARC-27	\$ 8.50	
BC375	\$ 7.50	
SCR-274N	\$ 8.50	
BC-603, 604	\$ 7.50	
PRC-6	\$ 6.00	

Full size, clear ozalid copy schematic for any receiver of transmitter listed above—\$2.00

Special — NEW ARN-6 manuals — \$3.50 (reg. \$8.50)

We have hundreds of other tech manuals, 25¢ for complete listing—refunded with first order.

PROPAGATION PRODUCTS COMPANY

P.O. Box 2513, NORFOLK 1, VA.

ALL BAND TRAP ANTENNA!



Reduces interference and Noise on All Makes Short Wave Receivers. Makes World Wide Reception Stronger. Clearer on All Bands!

For ALL Amateur Transmitters. Guaranteed for 500 Watts Power for Pi-Net or Link Direct Feed. Light, Neat, Weatherproof

Complete as shown total length 102 ft. with 87 ft. of 72 ohm balanced feedline, Hi-impact molded resonant traps. (Wt. 3 oz. 1" x 5" long). You just tune to desired band for beamlike results. Excellent for ALL world-wide short-wave receivers and amateur transmitters. For NOVICE AND ALL CLASS AMATEURS! NO EXTRA TUNERS OR GADGETS NEEDED! Eliminates 5 separate antennas with excellent performance guaranteed. Use as Inverted V for all band power gain, NO HAYWIRE HOUSE APPEARANCE! EASY INSTALLATION!

80-40-20-15-10 meter bands. Complete.....\$14.95

40-20-15-10 meter bands. 54-ft. ant. (best for w-w swl's.... 13.95

20-15-10 meter bands. Dual Trap. 24-ft. antenna..... 19.95

SEND ONLY \$3.00 (cash, ck., mo) and pay postman balance COD plus postage on arrival or send full price for postpaid delivery.

Available only from:

WESTERN RADIO • Dept. AC-11 • Kearney, Nebraska

MATCHED COMPANIONS

HIGHEST QUALITY VINYL COVERS
STANDARD SIZE LOOSE LEAF
COMPLETE VERSATILITY



STATION MANUAL
Amateurs everywhere
are proving it "The most
useful item in the shack"

A composite of 10 sections
of operating aids and station
records. Spacious log, prefixes,
Call-Name- QTH Index...etc. etc.
\$ 5.95* postpaid U.S.A.



QSL BOOK

Enhances, protects, displays QSL's. Ten clear holders
(8½ x 11) with heavy mounting sheets. \$ 3.95* postpaid U.S.A.
Additional holders 5 for \$ 1.00 when ordered with QSL Book.

* Add \$ 1.00 for your call on cover as illustrated.
Wn. res. add 4% St. sales tax.

The
ideal gifts for
the
radio amateur.



Order
direct or at
your
dealers.

Ham Aids

P. O. BOX 8072 SPOKANE, WASH

For further information, check number 83, on page 163

Sign up here!

**PIONEER
ELECTRONIC SUPPLY,
INCORPORATED**
5304 Prospect Avenue
Cleveland 3, Ohio

hallicrafters
**SSB/CW/VHF
Contest**

You can win . . .
SX-115 Receiver
HA-2 or 6 Transverter
HT-37 Transmitter
HA-4 Keyer

Over \$10,000 In Prizes

For further information, check number 84, on page 163

FOR SALE: Knight R-100 with built-in S-meter and matching speaker, \$85. T-50, \$25. Ken—K3OEO, 909 Blunston, Columbia, Penna.

ALUMINUM for every ham need. Write to Dick's, 62 Cherry Avenue, Tiffin, Ohio, for list of tubing, angle, channel, castings, plain and perforated sheet, and complete beam kits.

ELECTRONIC TECHNICIANS needed to install and service commercial sound systems. Full or part-time. Free details. Write: CSOE, Box 10634, Jackson 9, Miss.

PREMIUM QUALITY used equipment—over 1,000 units—reconditioned with trial plan and full 90 day guarantee. Terms available. Write for free lists and top trade-in offer on your present equipment. World Radio Laboratories, Box 919, Council Bluffs, Iowa.

MOBILE VIBRATOR power supplies. 6 volts in. 135 volts out @ 85 ma \$9.95 ea. Spare vibrators for same, \$1.55 ea. Send for free flyer. May Electronic Corp., 761 Elton Avenue, Bronx, N. Y.

Are you cashing in on the citizens band boom? Highly effective home-study review for FCC commercial phone exams. Free literature. Wally Cook, Box 10634, Jackson 9, Miss.

FOR SALE: Heathkit DX-20, Heathkit balun coil, Hallcrafters S-38D. All excellent condition. Also BC-455, 17" Olympic TV with UHF converter. Charles Helming, 36 Triangle Street, Amherst, Mass.

APACHE OWNERS: Increase power by 50%. Run 240 watts a.m.-300 watts c.w. or s.s.b. Complete kit and instructions for adding another 6146 to final only \$19.95. Similar kit for DX-100. Order or write. W4KUV-W4NZS, Best Radio Service, 610 N. Madison Avenue, Goldsboro, North Carolina.

273 WHITE ELEPHANTS! We bought a surplus lot—which was supposed to be 273 wire recorders . . . But all we got was the power unit and amplifier. The wire magazines were missing! The unit is called "Recorder unit RD-15A/ANQ-1A", manufactured by Daystrom and/or F. Hart & Co. All are new. Among the components are a beautiful 1/40 h.p. var. speed motor with offset coupling and right angle drive—28 v.d.c. A 200 ohm ceramic input and a 600 ohm ceramic output audio transformers. 2 nice d.p.s.t. 250 ohm 28v relays, a tiny micro-switch 15 amp 125v. Condensers, resistors, a 28D7 tube, Amphenols, hardware, chassis and sub chassis'. If you can use one, a \$5 bill plus postage (10 lbs) will bring it to you in the first mail. If you don't want to spend five bucks, we'll take anything useful in trade which is worth five bucks. One more thing, anybody who buys one and can figure out some useful purpose or adaptation of this item which will help to sell them will get a nice cut of the profits. Send your \$5 plus postage or a card with your trade offer to Bonwill, Box 73, Flushing 64, N. Y. EXPERIMENTERS GRABAG! 1 28 v.d.c. Var speed motor 1/40 hp w/offset coupling and right angle drive (geared down), 1-28D7 vac. tube. 2 d.p.s.t. 250-28v relays, 1 200 input xformer (ceramic, 1 600 ohm output push-pull xformer (ceramic), 1 micro switch (tiny) 15 amp @ 125v. w/brkt. Condensers: 1-.04 @200, 2 150 mf @50v, 1-1mf @100v, 2-.01 mf @300v, 2-4 mf @ 50v, 7 resistors (various sizes, 1/2 lb assorted sized hardware, screws, nuts, washers, etc. 1 main chassis and various sub chassis assemblies, 1 100 mil henry choke, 2-Amphenol receptacles.

WANTED: Two 4 X 150A chimneys and sockets. Trade or buy. Alan Yudell, 219 8th Avenue SE, Rochester, Minn.

Heath VF-1, 5 month old and not a scratch \$15. 3 Sangamo 4 mf 600 v.d.c. oil capacitors—80¢ each. 813 socket—90¢. 25k bleeder—200 watt, \$2.50. Simpson meter 0 600 volts—\$4. Larry Taaffe, K9APR, 2020 Walters, Northbrook, Illinois.

FOR SALE: 100 watt linear two 807's GG, pictures \$35; Command receiver and transmitter \$8 each; receiver BC348Q 110v. \$35; Harvey-Wells Z match antenna coupler new \$65; power unit PE-214 \$35; Tubes 813 3 \$3.00 each, 4 X 150A 3 \$3.00 each; Chelsea 24 hour clock \$10; Viking Valiant \$350. K4ACG, 125 N. Lake Avenue, Sioux Falls, S. Dakota.

FOR SALE: Hammarlund HQ-110C in original carton, \$145.00. Hammarlund SP-400X and power supply; excellent; \$90.00. Both with manuals. FOB. Send s.a.s.e. for large list of new component bargains. A. C. Cogle, 1667 Varina Avenue, Petersburg, Virginia.

Have surplus T-9 radar fire control computer. Will sell or swap for ham gear. Eugene Fleming, K5QWO/Ø, General Delivery, Naturita, Colorado.

SELL: Viking "500" transmitter kit, cartons (2) sealed. Unopened. Sacrifice \$550.00. Selling because of other interest. Will ship freight prepaid. Emil Grieco, 54 Andrews St., Meriden, Connecticut.

FOR SALE: Johnson Ranger xmtr \$190.00 and RME DB 22A \$25.00. Must sell to continue school. L. A. Jacobs, 422 Bellevue, Kalamazoo, Mich.

FOR SALE OR TRADE: 110v. a.c. Link 12 uf ed6-12uf ed7 crystal f.m. receivers 30-40 mc. 1-208 f.m. signal generator, 4-2C39A tubes (new)—W5DQX, Box 313M, Rt 11, San Antonio, Texas.

FOR SALE: Constant Voltage Transformer, 115v 65 watts, \$19.50; Tube Tester, Weston 788, like new, \$18.95; CW-60/ABM S-band wavemeter, operating cond., \$10.95; VRW-1 Recorder Magazines, case of 4, \$12.50; DC voltmeter, 0-150-300, Weston 430, \$20.00. Bruce Steller, 624 Drumwood, McMinnville, Oregon.

SELLING estate of W8EBG. Will sell Apache Transmitter—just completed—used only short time \$200.00. NC-109 receiver—like new \$125.00. Dow coaxial relay and Drake TV-1000 low pass filter. Mrs. Randall Wentz, West Liberty, Ohio.

TELETYPE model 14 strip printer—could be converted to typing reperforator. Also miscellaneous surplus gear including many telephone-type card resistors. Will trade for TD or non-typing reperforator or other teletype, telephone or computer equipment. Digby, 912 S. 11th, Corvallis, Oregon.

UNBELIEVABLE HAM SALE! Parts, receivers, transmitters; too many to advertise. Send addressed, stamped envelope for comprehensive list of sellouts. Box 262-A, Glenridge, N. J.

Homebrew TR switch, \$6.00. K11IK.

DRAKE 2-A in excellent condition. Original carton. \$250 FOB. K6HTM, Charles G. Bird, 617 E. Pine Avenue, Fresno 4, Calif.

FOR SALE: Complete instructions for converting the ART/13 transmitter. Consists of 28 page booklet with pictures and drawings and a 22 X 36" schematic. Send \$2.50 to Sam Appleton, K5MK1, Box 717, Tulia, Texas.

WANTED: Clean military surplus sets and component accessories on the following: RT-220/ARN-21, RT-263/ARC-34, RT-311/ARC-38, 180L-3 antenna loading units, ARC-44, ARN-30, APS-42 radar, 618S-1 transceivers, RT-175/PRC-9, RT-176/PRC-10, RT-77/GRC-9, AN/GMD-1 Rawin set, SG-1/ARN, SG-2/ARN, SG-13/ARN signal generators. Advise with best cash price, description, and condition. A chance to obtain cash to buy your ham equipment, Bill Slep Company, Drawer 178CQ, Ellenton, Florida.

Elmac PMR-7 receiver with M-1070 power supply both perfect condition \$160. Herb K7CWO, 527 S. Vancouver, Kennewick, Wash.

WANTED: Navy surplus tech manuals with R and T prefixes like TDQ, TCS, RBO, RBS, RBM. Send list of what you have for quick cash quote, Bill Slep Company, Drawer 178 CQ, Ellenton, Florida.

FOR SALE—2 meter kw amplifier, kw power supply components, heavy-duty 6N2 power supply, 40 & 80 meter xtal control converters for BC453 .100 watt modulator & supply. Very nice 2 meter xmtr r.f. only with 9903 tube. 500 volt supply metered and Variac control. 250 ma 522 xmtr & T23 v.h.f. less tubes, each \$6.00. Brand new BC 312 receiver. W2AZL type 2 meter converter, 220 mc, r.f. amplifier, 110 watts. 1500 watt modulation xfmr. 2 meter preamp with 6AJ4's, 110 volt double ended blower, pair 4-125A & misc. W3LST, Joseph Szabat, 228 Plummer, Oil City, Penna.

NOW PRODUCING the new Motorola designed electronic transistorized ignition system, the first major improvement in over 50 years—since the original Kettering 1910 ignition invention. It delivers peak performance and economy in any automobile, sports car, tractor, boat, or race car, giving quicker starts, improved acceleration, maximum high speed performance, constant engine timing, greater road horsepower, eliminates high speed "miss", more efficient combustion, longer spark plug life, smoother idling. Our test vehicles now have operated in excess of 50,000 miles without point replacement, or major tune-up. Race cars have won first and second prizes consecutively. Can be installed in any 6 or 12 volt engine with a negative ground, price \$44.95, add \$7.95 if positive ground. Give make, model, and year. Satisfaction guaranteed, free brochure. Bill Slep Company, Draker 178CQ, Ellenton, Florida.

Sign up here!

Radio Products Sales Company

1237 16th Street

Denver 2, Colorado

h hallicrafters
SSB/CW/VHF
Contest

You can win . . .

SX-115 Receiver

HA-2 or 6 Transverter

HT-37 Transmitter

HA-4 Keyer

Over \$10,000 In Prizes

For further information, check number 85, on page 163

AUTRONIC KEY AND KEYS

For Perfect, Faster CW

Send QSL or Postcard for full data



Fully transistorized, digital circuitry keyer eliminates erratic sending. Precision-made key will not walk, is fully adjustable.

FREE TRIAL

ELECTROPHYSICS CORP.

2502 West Coast Hwy.
Newport Beach, Calif.

EASY TO LEARN CODE

It is easy and pleasant to learn or increase speed the modern way—with an Instructograph Code Teacher. Excellent for the beginner or advanced student. A quick, practical and dependable method. Available tapes from beginner's alphabet to typical messages on all subjects. Speed range 5 to 40 WPM. Always ready, no QRM, beats having someone send to you.

ENDORSED BY THOUSANDS!

The Instructograph Code Teacher literally takes the place of an operator-instructor and enables anyone to learn and master code without further assistance. Thousands of successful operators have "acquired the code" with the Instructograph System. Write today for full particulars and convenient rental plans.



INSTRUCTOGRAPH COMPANY

4711 SHERIDAN RD., CHICAGO 40, ILL.
4700 Crenshaw Blvd., Los Angeles 43, Calif.

ADVERTISING INDEX

DOW-KEY DK60 SERIES



**4 VERSATILE MODELS
A.C. or D.C.**

COAXIAL RELAYS

Also Available with Type C, TNC, BNC, N & UHF Connectors

Small, Compact,
Light Weight,
Less than 9 oz.

Outstanding favorite for amateurs . . . Versatile combinations for industrials! Low VSWR — less than 1.15:1 from 0 to 500 mc. LOW LOSSES . . . High Contact Pressures. LOW CROSS-TALK through use of patented "isolated connector" arrangement. HIGH POWER RATING. All coils encapsulated in epoxy resin for quieter operation and resistance to moisture.

★ **UNCONDITIONAL GUARANTEE** for one year. (We will repair if faulty within 1 year.)

★ See one of our 700 dealers and distributors in U. S. and Canada for catalog sheets or write:

STANDARD RELAYS: DK60, DK60-G, DK60-2C and DK60-G2C — Priced from \$12.45.

Also available with Type C, TNC, BNC, N & UHF Connectors.

May be had with weatherproof boxes for exterior use. Also with ganged, multiple switch arrangement for remote control selection of antennas.

PRICED FROM . . . \$12.45

DOW-KEY COMPANY

Thief River Falls, Minnesota

For further information, check number 86, on page 163

Sign up here!

**Southwest
Electronic Devices**

129 East Jefferson
Phoenix, Arizona

hallicrafters
**SSB/CW/VHF
Contest**

You can win . . .
SX-115 Receiver
HA-2 or 6 Transverter
HT-37 Transmitter
HA-4 Keyer

Over \$10,000 In Prizes

For further information, check number 87, on page 163

Adirondack Radio Supply, Inc.	154
Allied Radio Corp.	121, 169, 184
Alltronics-Howard Company	166
Amateur Electronic Supply	148, 149, 150, 183
American Crystal Co.	173
Barbey, George D. Co., The	152
Barker & Williamson, Inc.	166, 172
Barry Electronics Corp.	147
Bay-Roy Electronics	169
Burghardt Radio Supply	168-175
Burstein-Applebee Co.	154
Carborundum Co.	120
C & G Electronics Co.	147
Centralab	22
Central Electronics, Inc.	29
Cleveland Institute of Electronics	20
Collins Radio Co.	Cover II
Communications Equipment Co.	153
Communications Company, Inc.	114
CQ Advertising Rates	163
CQ Classified	176
CQ DX Map	113
CQ Ham Mart	138, 139
CQ Subscription	112
Crescent Electronics Supply Inc.	152
Cush Craft	169
Custom Electronics Inc.	183
Crabtree's Wholesale Electronics	173
Diode Source Book	119
Dow-Key Co., Inc.	156-171-182
E-Z Way Towers, Inc.	124
EICO	21
Electrophysics Corp.	181
Electro-Voice, Inc.	26, 27
Evans Radio	161, 167, 171
Evans, Cliff	119, 170
Fair Radio Sales	153
Fort Wayne Electronics	152
Fortune Electronic Suppliers, Inc.	152
Gonset Co.	17, 23, 117, 123
Graham Elect. Supply, Inc.	150
Graham Radio, Inc.	152, 159
Groth, R. W., Mfg. Co.	165
Hallcrafters Co.	2, 4, 5
Ham Aids	180
Ham Kits	156
Hammarlund Mfg. Co., Inc.	19
Harvey Radio Co., Inc.	143
Heath Co.	24, 25
Henry Radio Stores	151, 155, 179
Hewlett Sales	119
Hi Par Products	122
Hy-Gain Antenna Products	9 thru 15

Instructograph Co.	181
International Crystal Mfg. Co.	7
Iverson, John Co.	150
Johnson E. F. Co.	30, 31
Key Electronics	150
Kincade Radio Supply	125
Knox Electronic Supply, Inc.	152
Lafayette Radio	145, 176
Lampkin Laboratories, Inc.	171
Mark Mobile Inc.	175
Master Mobile Mounts, Inc.	28
Melvin Electronics	150
Millen, James, Mfg. Co., Inc.	18
Miller, J. W. Co.	167
Monterey Park A.R.C.	171
Mosley Electronics Inc.	6
National Radio Co. Inc.	Cover III
New-Tronics	16
Oregon Ham Sales	150
P & H Electronics	156
Palmer, Joe	167
Petersen Radio Co., Inc.	1
Piconite A.R.C.	174
Pioneer Electronic Supply	180
Platt Electronics Corp.	158
Polytronics Labs Inc.	127
Propagation Products Co.	179
Priest Electronics Inc.	174
Practical Engineering Co.	177
Radio Corporation of America	Cover IV
Radio Industries, Inc.	126
Radio Product Sales Co. (Denver)	181
Radio Product Sales Co. (Los Angeles)	115
Reno Radio Co.	150, 178
RSE Ham Shack	177
Rex Radio Supply Co.	172
Rohn Manufacturing Company	168
Severns, Gil	152
Shure Brothers	165
Smalley's Radio Limited	153
Southwest Wholesale Radio Inc.	182
Space Raider	167
Sprague Products Co.	178
Tape Tone Inc.	170
Telrex Labs, Inc.	165
Tennessee Paper and Box Co.	176
Tri-Ex Tower Corp.	162
Tri-State A.R.C.	183
Turner Microphone Co.	113
Van Sickle Radio Supply Co.	150, 157, 172
Versa-Tronics	165
Vibroplex Co. Inc.	166
Waters Manufacturing Inc.	164
Western Radio Company	179

Sign up here!

Custom Electronics

1918 S. Brown St.
Dayton 9, Ohio

h hallicrafters SSB/CW/VHF Contest

You can win ...

SX-115 Receiver

HA-2 or 6 Transverter

HT-37 Transmitter

HA-4 Keyer

Over \$10,000 In Prizes

For further information, check number 88, on page 163

TRI STATE AMATEUR RADIO SOCIETY, INC.

Publication: SPARKS

Mailing address: P.O. Box 51
Evansville 6, Indiana

Local Listing freq; 29.6 & 145.2

Club meetings are held at Community Center, 8th & Main Streets, 1930 hours last Wednesday of each month.

Visitors & inquiries invited.

AMATEUR ELECTRONIC SUPPLY

has VHF FOR THE RADIO AMATEUR. This best seller by Frank Jones is ready for immediate delivery and an absolute must for all VHF enthusiasts. Order your copy today.

AMATEUR ELECTRONIC SUPPLY

3832 West Lisbon Avenue,
Milwaukee, Wisconsin
6450 N. Milwaukee Avenue,
Chicago 31, Illinois

here's the big hit of the 1962 **ALLIED** catalog! It's the new *knight-kit*



T-60 60-WATT AM-CW TRANSMITTER KIT

A SMASHING VALUE AT ONLY... **\$49⁹⁵**

No Money Down

- Covers 80 through 6 meters
- Tune-up position
- Pi-network antenna output
- Speedy bandswitching
- High-efficiency controlled-carrier modulation
- A pleasure to assemble

a word from W9BUD about the T-60...



"I'm convinced the new T-60 is the best buy there is for the Novice, or any other Ham looking for an efficient, compact rig that really punches out a signal. Looks great, tune-up is a breeze, exceptionally clean on both phone and CW. Worked UA1CE on 20 CW the first time I tried it out!"

—Larry Blostein, W9BUD,
Allied Ham Manager



GET THE FULL T-60 STORY in the new 1962 Allied Catalog. If you haven't your copy of this 444-page catalog, send coupon below and we'll rush it to you.

ENJOY EVERY BUYING ADVANTAGE AT ALLIED

- World's Largest Stocks for Same-Day Shipment
- Ham-to-Ham Service You'll Like in Every Way
- No-Money-Down Credit Plan—up to 50% More Buying Power

For expert technical advice, and for the absolute best in trade-ins, write or phone "Trader Jim" Sommerville, W9WHF at your service!



at your service in our Chicago Ham Shack

Joe Huffman, W9BHD John Chass, K9LOK
Joe Gizzi, W9HLA Tasker Day, W9QBB
Lowell Warshawsky, W9NGV

In Milwaukee: Burt Fischel, W9VOB

ALLIED RADIO

For further information, check number 89, on page 163

**send
coupon
today**

ALLIED RADIO, Dept. 207-L1
100 N. Western Ave., Chicago 80, Ill.

Ship me the Knight-Kit T-60 Transmitter Kit

\$ _____ enclosed.

Send Free 1962 Allied 444-Page Catalog

Name _____
PLEASE PRINT

Address _____

City _____ Zone _____ State _____

PERFORMANCE PACE SETTER OF THE YEAR-NATIONAL'S NEW HAM-BAND NC-155

National is proud to announce a new standard of comparison for ham-band receivers. In a price class by itself—the NC-155. With superb sensitivity, stability, and shaped selectivity, the NC-155 has the performance-engineered features vitally necessary for relaxed ham-band operation.

Double conversion on 80 through 6 meters

Sensitivity better than 1 μ V for 10 db S/N on all bands, including 6 meters!

600 cycle CW, 3 kc SSB, 5 kc AM true variable IF selectivity with National's Ferrite Filter

Full SSB/CW AGC and separate product detector

Extremely high (60:1) tuning ratio with built-in Velvet Vernier

High Zero temperature compensation and voltage regulated oscillators

Many other features, including, of course, the convenient Flip Foot and National Blue styling

Suggested amateur net \$199.95*
NTS-3B speaker 19.95

NATIONAL RADIO COMPANY, INC.
MELROSE 76, MASS.

A WHOLLY OWNED SUBSIDIARY OF NATIONAL COMPANY, INC.

*slightly higher west of the Rockies and outside the U.S.A.
Export: AD AURIEMA, INC., 85 Broad St., N. Y., N. Y., U.S.A.
Canada: TRI-TEL ASSOC., LTD., 81 Sheppard Ave. W., Willowdale, Ont.

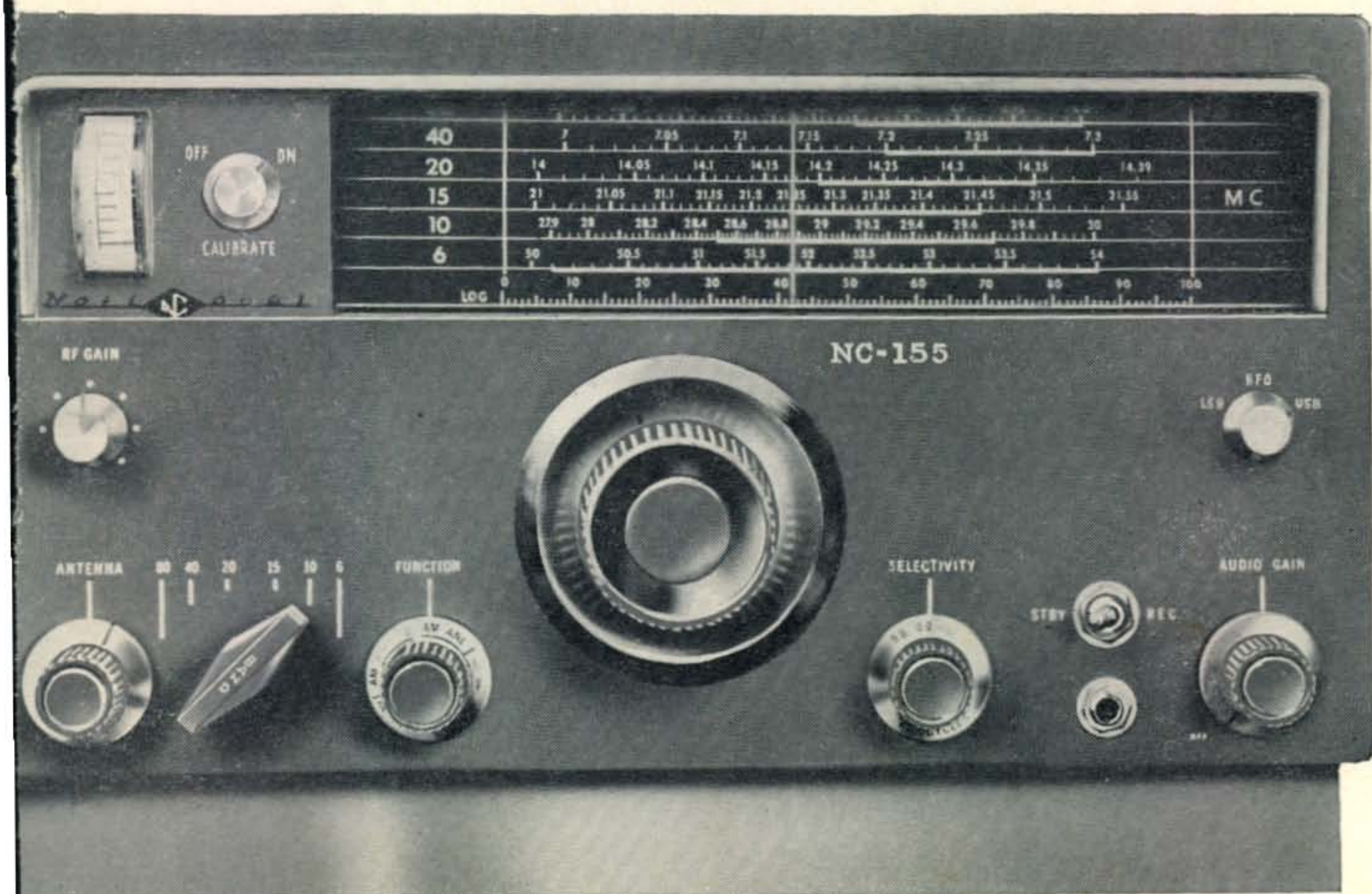

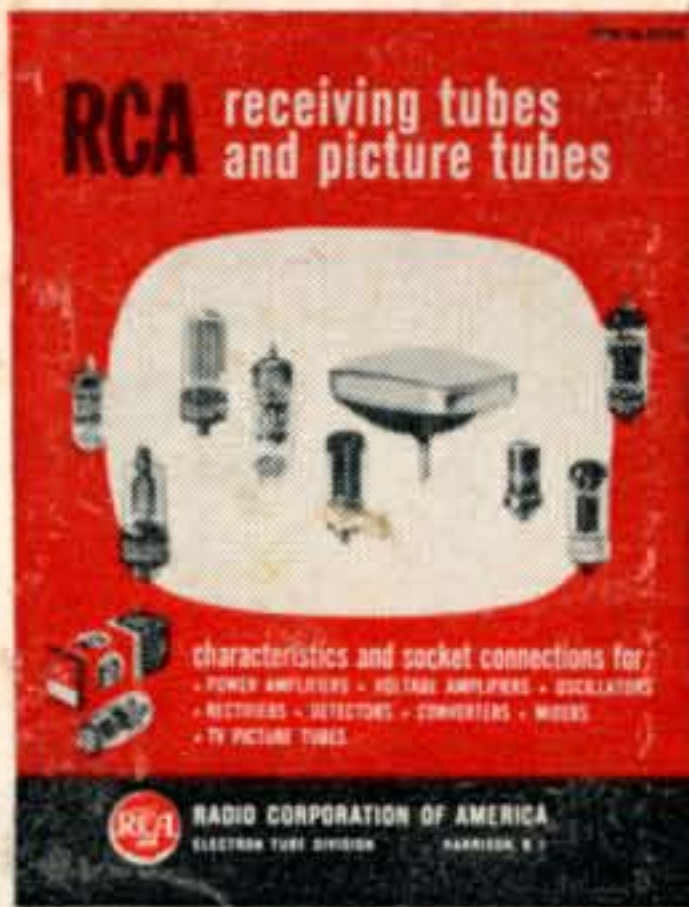
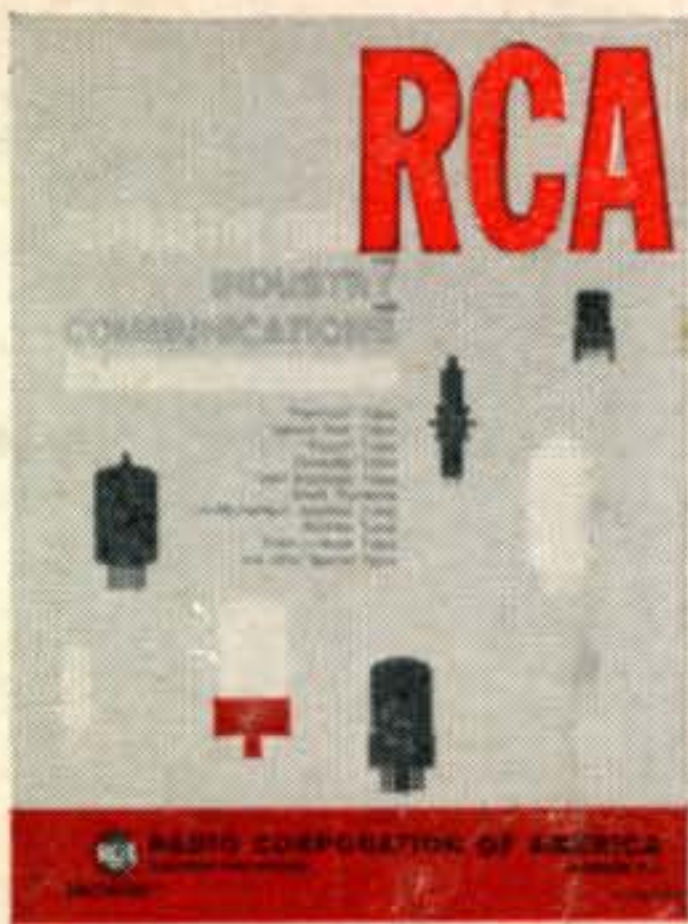
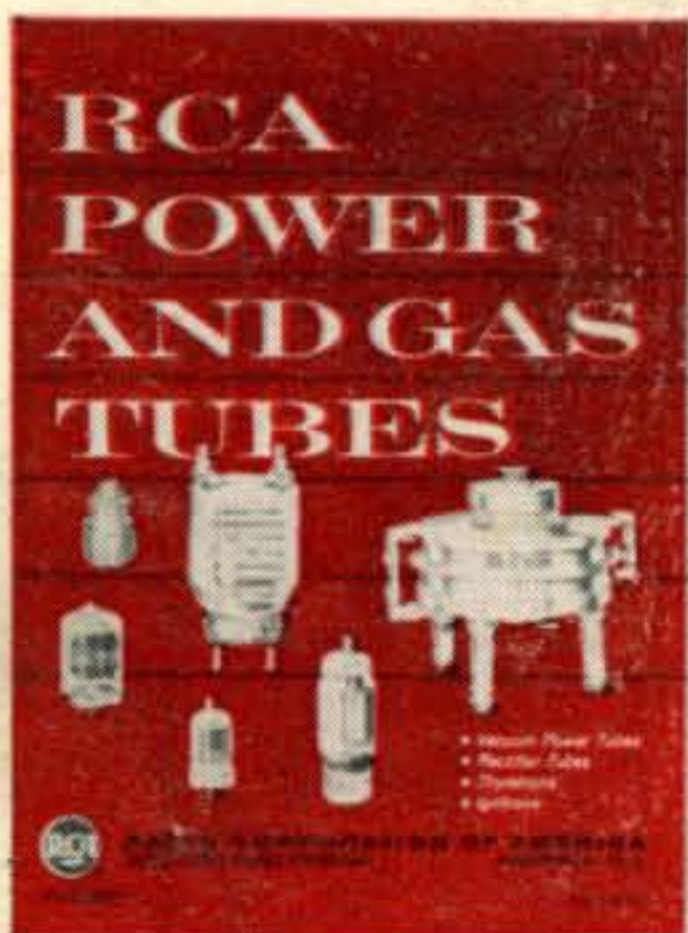
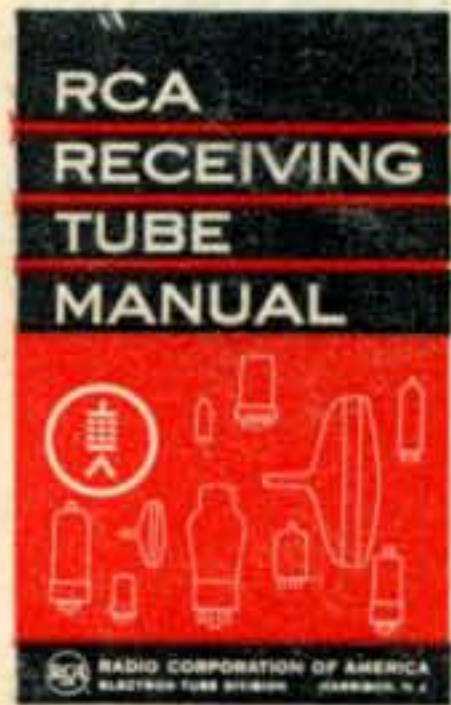

RCA Transmitting Tube Manual, TT-4. Covers power types having up to 4 Kw p input and associated rectifier types. 48 pages of data, theory, application, circuit diagrams. Price \$1.

RCA Power and Gas Tubes, PG101D. Illustrated 32 page booklet giving technical data in quick-reference form on 175 different types including RCA vacuum power tubes, rectifier tubes, thyratrons, and nitrons. Price 30 cents.

RCA Receiving-Type Tubes for Industry Communication, RIT-104B. 32 pages technical information on premium tube low-microphonic amplifier tubes, glow-charge tubes, pencil tubes, small thyratrons, and many others. Price 30 cents.

RCA Receiving Tube Manual, RCA-20. Revised, expanded, and brought up to date contains 432 pages of technical data on more than 760 receiving types and 170 picture-tube types. Features tube theory, circuits, resistance-coupled amplifier charts, curves, and socket diagrams. Price \$1.

RCA Semiconductor Products, SCD-108D. 48 pages packed full of technical data on PNP transistors and silicon rectifiers, plus circuit diagrams. Price 30 cents.

RCA Receiving Tubes and Picture Tubes, 1275-J. 48 pages of technical data on more than 900 receiving tubes and picture tubes. Price 35 cents.

Transistor Fundamentals and Applications, 4T37. Discusses transistor theory, applications, and servicing techniques. Price 50 cents.

Practical Transistor Circuits, 4T64A. 48 pages of practical circuits utilizing RCA-2N36 Power Transistor of special interest to the hobbyist and experimenter. Price 15 cents.

RCA Technical Bulletins. Individual technical bulletins are available for most power tube, industrial receiving-tube, transistor and silicon rectifier types. Single copy for specific type is available—free on request.

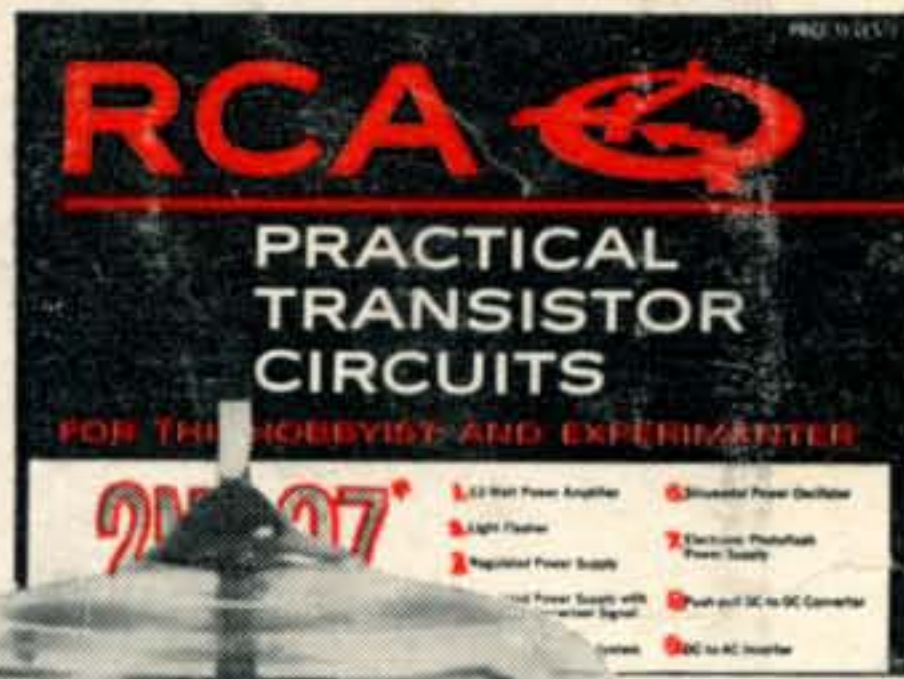

Amateur
Radio's Most
Comprehensive
Technical
References
on...

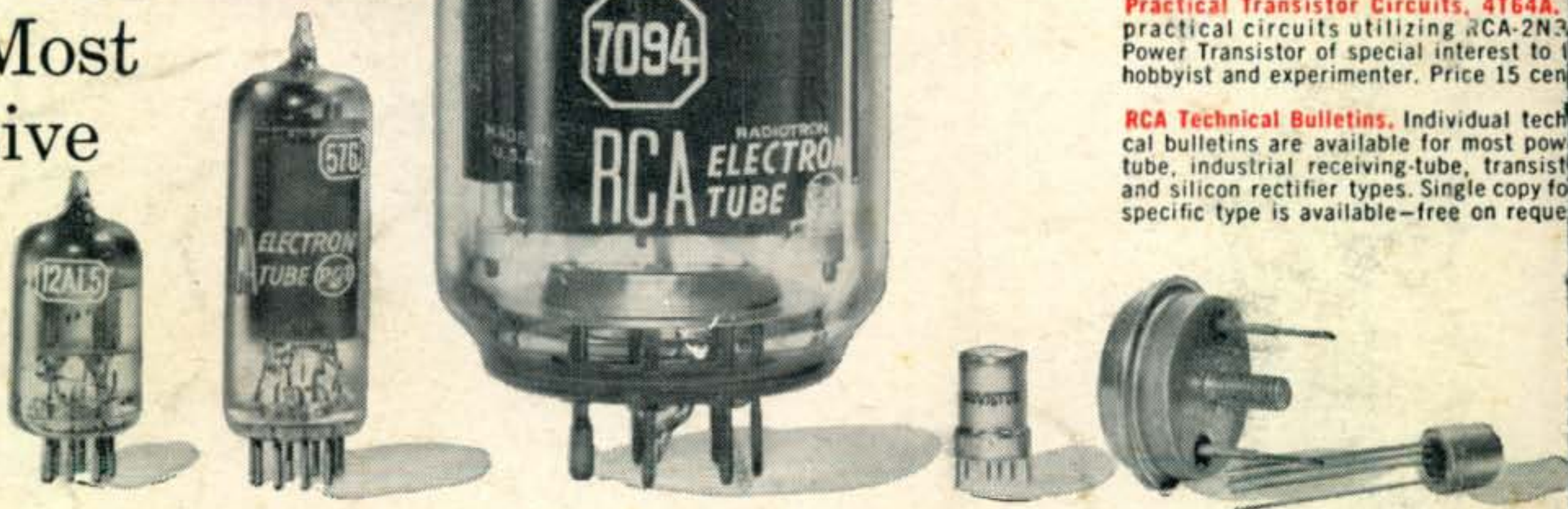

POWER TUBES • RECEIVING TUBES • SEMICONDUCTOR DEVICES... What's the best power tube for my final? Which tube combination will do the most for my receiver design? Which is the right transistor for my portable rig? You can get the answers to questions like these from the RCA publications pictured on this page.

Here, in easy-to-understand form, is a storehouse of technical facts you will want to know about hundreds of RCA tubes and transistors. In these publications you will find operating conditions, quick-reference charts, pages of circuits—application hints, installation tips, characteristics curves, all sorts of technical aids.

For copies of these authoritative ham-shack references, check the list above and contact your RCA Tube Distributor. Or remit payment with your order—direct to Commercial Engineering, Section K-15-M, RCA Electron Tube Division, Harrison, N. J.



The Most Trusted Name in Electronics
RADIO CORPORATION OF AMERICA