

DS-13 TBS ARR-2  
RAK ARC-5  
SCR-274N  
RT-13  
CR-5  
MMA  
34  
45  
BY  
BC-652  
RDC  
BC-191  
ARR-2  
ARC-5  
74N  
-7  
55  
221  
TBW  
54  
BM  
BC-312  
BC-191  
ARRB



May 1969  
75¢

# SPECIAL SUPPLUS ISSUE

The Radio Amateur's Journal

# To Get A \$500 Rig For \$240 . . .



## Build The Heathkit® HW-100

When the time comes for a new rig, most hams approach the task with enthusiasm . . . until financial reality invades their dreams. An ordinary 5-band transceiver, wired and ready to go, costs around \$500. Much of the reason for this price, of course, is that you are paying to have someone else wire your rig.

Heath also sells \$500 worth of transceiver — the HW-100 — but our price is a bit more realistic — \$240 — and the performance is better! We reason that if you can handle the FCC exam, you can also handle a soldering iron. And because we don't use any of your money to wire your rig, we can use more of it to provide advanced engineering. Check out a realistic \$500 rig . . . the Heathkit HW-100 . . . another hot one from the hams at Heath.

- Kit HW-100, 18 lbs., no money dn., \$22 mo. . . . . **\$240.00\***
- Kit HP-13A, DC power supply, 7 lbs., \$7 mo. . . . . **\$64.95\***
- Kit HP-23A, AC power supply, 19 lbs., \$5 mo. . . . . **\$49.95\***
- Kit SB-600, 8 ohm speaker, 6 lbs. . . . . **\$18.95\***

**HW-100 SPECIFICATIONS — RECEIVER.** Sensitivity: Less than .5 micro-volt for 10 dB signal-plus-noise to noise ratio for SSB operation. Selectivity: 2.1 kHz minimum at 6 dB down, 7 kHz maximum at 60 dB down (3.395 MHz filter). Input: Low impedance for unbalanced coaxial input. Output impedance: 8 Ω speaker, and high impedance headphone. Power output: 2 watts with less than 10% distortion. Spurious response: Image and IF rejection better than 50 dB.

**TRANSMITTER. DC Power input:** SSB: 180 watt P.E.P. (normal voice: continuous duty cycle). CW: (A1 emission) 170 watts (50% duty cycle). **RF Power output:** 100 watts on 80 through 15 meters; 80 watts on 10 meters (50 Ω nonreactive load). **Output impedance:** 50 Ω to 75 Ω with less than 2:1 SWR. **Oscillator feedthrough or mixer products:** 55 dB below rated output. **Harmonic radiation:** 45 dB below rated output. **Transmit-receive operation:** SSB: PTT or VOX. CW: Provided by operating VOX from a keyed tone, using grid-block keying. **CW Sidetone:** Internally switched to speaker or headphone, in CW mode. Approximately 1000 Hz tone. **Microphone input:** High impedance with a rating of —45 to —55 dB. **Carrier suppression:** 45 dB down from single-tone output. **Sideband suppression:** 45 dB down from single-tone output at 1000 Hz reference. **Third order distortion:** 30 dB down from two-tone output. **RF Compression (TALC):** 10 dB or greater at .1 ma final grid current. **GENERAL. Frequency coverage:** 3.5 to 4.0; 7.0 to 7.3; 14.0 to 14.5; 21.0 to 21.5; 28.0 to 28.5; 28.5 to 29.0; 29.0 to 29.5; 29.5 to 30.0 (meg-

- 80 through 10 meter coverage • Solid-s (FET) VFO • 180 watts input PEP SSB — watts input CW • Switch selected USB, or CW • Crystal filter for sharp 2.1 kHz selectivity • Full coverage on all bands with 500 per band segment • Better than ½ uV sensitivity • Smooth vernier control of frequency with patented Harmonic Drive® dial mechanism • Outstanding frequency stability • Excellent image and IF rejection • Built-in kHz calibrator • Separate offset CW crystal • Triple Action Level Control® for reduced possibility of overdriving & distortion • Built-in S-meter • Quiet, enclosed relays • fixed or mobile with HP-23A or HP-13A power supplies • Built-in VOX • Easy circuit board wiring harness construction

ahertz). **Frequency stability:** Less than 100 hertz per hour after 30 min warmup from normal ambient conditions. Less than 100 Hz for line voltage variations. **Modes of operation:** Selectable upper or sideband (suppressed carrier) and CW. **Dial calibration:** 5 kHz. **Calibration:** 100 kHz crystal. **Audio frequency response:** 350 to 24 kHz. **Front panel controls:** Main tuning dial. Driver tuning and Presel. Final tuning. Final loading. Mic and CW Level control. Mode switch. Function switch. Meter switch. RF Gain control. Audio Gain control. **Side controls:** Meter Zero control; Bias; VOX Sensitivity; VOX Anti-trip. **Internal controls:** Carrier null; neutralizing. **Tube complement:** OA2 Regulator (150 V); 6AU6 RF amplifier; 6AU6 1st receiver; 6AU6 Isolation amplifier; 6AU6 1st IF amplifier; 6AU6 2nd IF amplifier; 6BN8 Product detector and AVC; 6AU6 VFO Amp.; 6CB6 2nd transmitter mixer; 6CL6 Driver; 6EA8 Speech Amplifier and cathode follower; 6EA8 transmitter mixer; 6EA8 2nd receiver mixer and relay amplifier; 6EA8 sidetone oscillator and amplifier; 6GW8 Audio amplifier and audio output; 12AT7 Heterodyne oscillator and cathode follower; 12AT7 VOX amplifier and calibrator oscillator; 12AU7 Sideband oscillator; 6146 Final amplifier (2). **Diode complement:** 6 Germanium Diodes: Balanced modulator, RF sampling, and crystal calibrator harmonic generator; 9 Silicon Diodes: ALC rectifiers, anti-trip rectifiers, and DC blocking; 1 Zener Diode: carrier bias. **Transistors:** MPF-105 FET-VFO; 2N3393 — Voltage regulator. **Accessories:** CW Key jack; 8 Ω output; ALC input; Power supply; Power plug; RF output; Antenna; Spare. **Power requirements:** 120 to 850 volts at 250 ma with 1% maximum ripple; 300 volts at 150 ma with .05% maximum ripple; —115 volts at 10 ma with .5% maximum ripple; 12 volts AC/DC at 4.76 amps. **Cabinet dimensions:** 14-13/16" H. x 13-3/8" D.

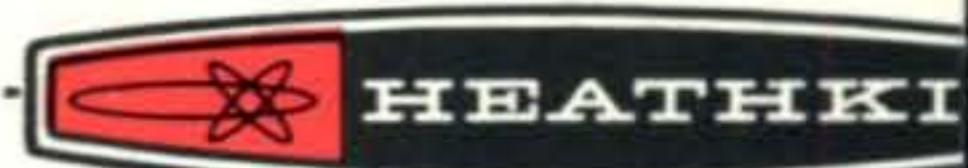

### FREE 1969 CATALOG

Describes these and over 300 kits for stereo/hi-fi, color TV, amateur radio, shortwave, test, CB, marine, educational, home and hobby. Save up to 50% by doing the easy assembly yourself. Mail coupon or write Heath Company, Benton Harbor, Michigan 49022.

HEATH COMPANY, Dept. 12-5  
Benton Harbor, Michigan 49022  
In Canada, Daystrom Ltd.

Enclosed is \$ \_\_\_\_\_, plus shipping.  
Please send model (s) \_\_\_\_\_

Please send FREE Catalog.

Name \_\_\_\_\_ (Please Print)

Address \_\_\_\_\_

City \_\_\_\_\_ State \_\_\_\_\_ Zip \_\_\_\_\_

Prices & specifications subject to change without notice.  
\*Mail order prices; F.O.B. factory.

# Who Said Ham Radio Was Expensive?

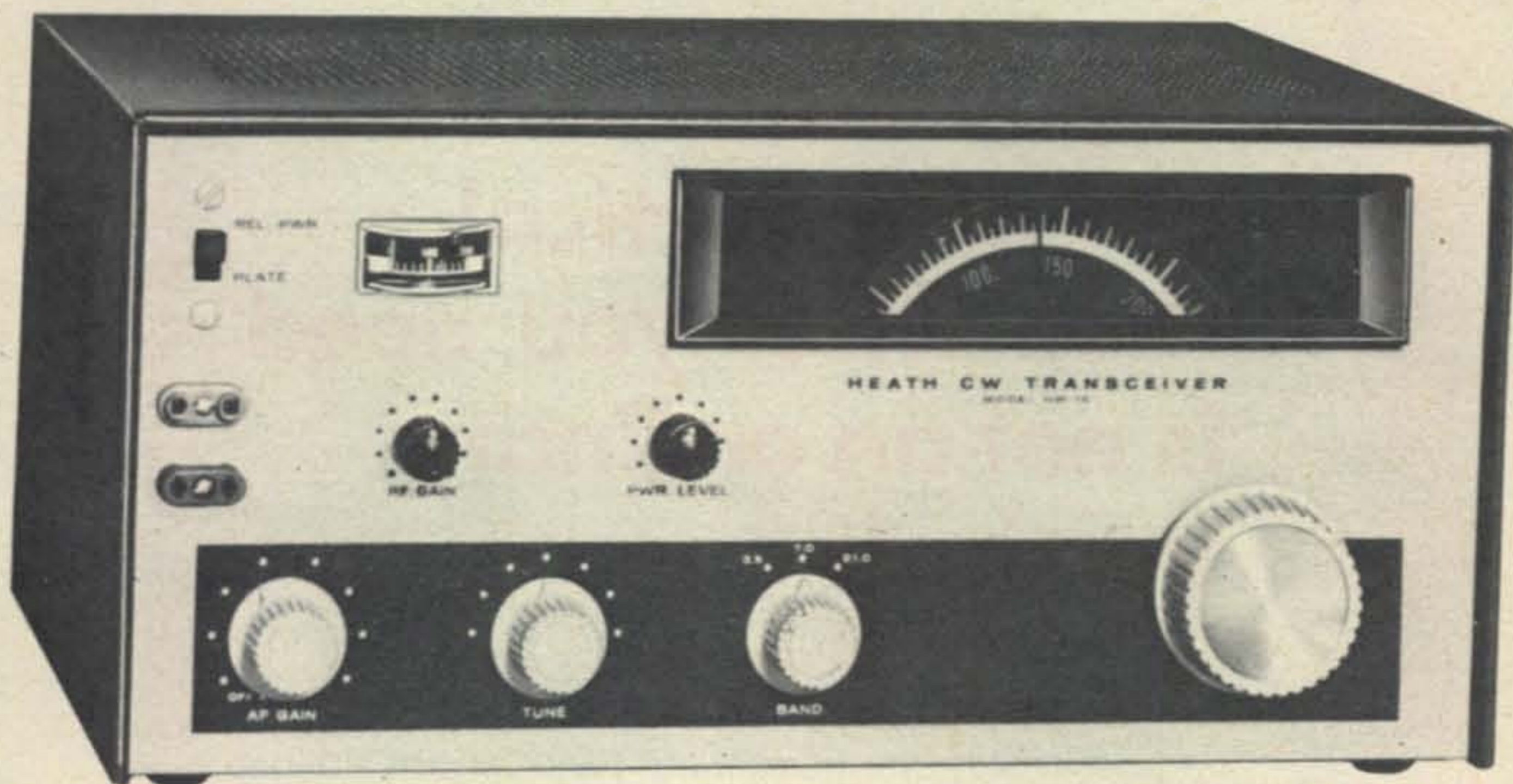

## The Heathkit® HW-16 CW Transceiver Costs Only \$109.95\*

- Covers the first 250 kHz of the 80, 40 & 15 meter bands
- True "Break-in" CW operation • Crystal controlled transmit with VFO receiver tuning • Adjustable 50-90 watts input • Crystal filter for razor sharp selectivity • High sensitivity • Built-in sidetone • Easy assembly

A Hot 3-Band Transceiver For All CW Operators. Novices can run the HW-16 at 75 watts input, and the built-in sidetone will help develop your fist. If you're General class, fire it up to 90 watts input, and add the HG-10B for VFO transmitter control. No matter what your license, the HW-16 is your kind of rig. The added gain of the dual conversion circuit, plus an RF amplifier stage, delivers the high sensitivity, excellent image rejection and superior weak signal capability you need for working DX. Rock solid frequency stability too from the crystal controlled first conversion oscillators & low frequency VFO. You'll appreciate the sharp (500 Hz) selectivity for peeling through crowded nighttime bands provided by the crystal filter. Better than 1 uV sensitivity plus solid-state TR switching means real performance . . . you'll work fast "break-in" rag chews and high speed traffic nets with ease . . . and your HW-16 will even outperform many of the "expensive" rigs on CW.

Easy Assembly Gets You On The Air Fast! Layout is clean, open . . . solder points easy to get at. The

HW-16 goes together with a combination of circuit board construction and rugged chassis mounting of components that assures electrical and mechanical stability. Checkout requires only a VTVM, dummy load and crystals for the bands in which you'll be operating. Headphones, a key and an antenna are all you need to get on the air. Who said ham radio was expensive? Order your HW-16 now.

Kit HW-16, 25 lbs. . . . .	\$109.95*
GD-396, Headphones (not a kit), 1 lb. . . . .	\$3.50*
Kit HS-24, Speaker, 4 lbs. . . . .	\$7.00*
Kit HD-10, Electronic Keyer, 6 lbs. . . . .	\$39.95*
Kit HG-10B, VFO, 12 lbs. . . . .	\$39.95*

**HW-16 SPECIFICATIONS — TRANSMITTER:** RF Power input: 50 to 90 watts (adjustable). Frequency control: 80-meter crystal or VFO on 80-meter band. 80 or 40-meter crystal, or VFO on 40-meter band. 40-meter crystal or VFO on 15-meter band. Keying: Grid-block. Break-in with automatic antenna switching and receiver muting. Output impedance: 50 ohm unbalanced. Sidetone: Neon lamp relaxation oscillator. **RECEIVER:** Sensitivity: Less than 1 microvolt for 10 dB signal-plus-noise to noise ratio. Selectivity: 500 Hz at 6 dB down. Intermediate frequency: 3396 kHz. Antenna impedance: 50 ohm unbalanced. External speaker impedance: 8 ohms. **GENERAL:** Frequency coverage: 3.5 to 3.75 MHz. 7.0 to 7.25 MHz. 21.0 to 21.25 MHz. Power: 120 VAC 50-60 Hz. Transmitter tube complement: 6CL6 Crystal Oscillator; 6CL6 Driver; 6GE5 Final. Receiver tube complement: 6EW6 RF amplifier; 6EA8 Heterodyne mixer-oscillator; 6EA8 VFO mixer-oscillator; 6EW6 IF amplifier; 12AX7 Product detector-oscillator; 6HF8 1st audio and audio output. Transistor complement: 2N1274 muting circuit. Dimensions: 13 $\frac{3}{4}$ " W. x 11 $\frac{1}{2}$ " D. x 6 $\frac{1}{2}$ " H.



### FREE '69 CATALOG

Describes these and over 300 other Heathkits. Save up to 50% by building them yourself. Use coupon and send for your FREE copy!

HEATH COMPANY, Dept. 12-5  
Benton Harbor, Michigan 49022

Enclosed is \$ \_\_\_\_\_, plus shipping.

Please send model (s) \_\_\_\_\_

Please send FREE Heathkit Catalog.

Name \_\_\_\_\_

Address \_\_\_\_\_

City \_\_\_\_\_

State \_\_\_\_\_

Zip \_\_\_\_\_

Prices & specifications subject to change without notice.  
\*Mail order prices; F.O.B. factory.

AM-217

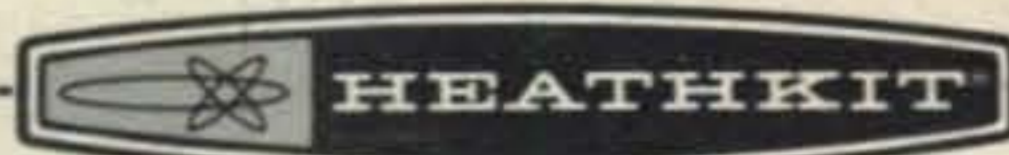

# If you want more out of a vertical, then what you need is not an ordinary vertical!

By any standard of measurement, the Hy-Tower is unquestionably the finest multi-band vertical antenna system on the market today. Virtually indestructible, the Model 18HT features automatic band selection on 80 thru 10 meters through the use of a unique stub decoupling system which effectively isolates various sections of the antenna so that an electrical  $1/4$  wavelength (or odd multiple of a  $1/4$  wavelength) exists on all bands. Fed with 52 ohm coax, it takes maximum legal power. . . delivers outstanding performance on all bands. With the addition of a base loading coil, it also delivers outstanding performance on 160 meters. Structurally, the Model 18HT is built to last a lifetime. Rugged hot-dipped galvanized 24 ft. tower requires no guyed supports. And, a special hinged base assembly permits complete assembly of antenna at ground level. . . easy raising and lowering. Top mast, which extends to a height of 50 ft., is 6061ST6 tapered aluminum. All hardware is iridite treated to MIL specs. And, for directional control, many amateurs have bought two Hy-Towers and "phased" them. So, if you want the best vertical. . . bar none. . . get down to the best distributor under the sun (he's the one that stocks the Hy-Tower).

## The Hy-Tower from Hy-Gain

HY-GAIN ELECTRONICS CORPORATION  
P.O. Box 868-2

Lincoln, Nebraska 68501 AC-5  
 THE STRONGEST SIGNAL UNDER THE SUN





The Radio Amateur's Journal

TABLE OF CONTENTS

**EDITORIAL**

**RICHARD A. ROSS, K2MGA**  
Editor  
**ALAN M. DORHOFFER, K2EEK**  
Managing Editor  
**IRVING TEPPER**  
Technical Editor  
**WILFRED M. SCHERER, W2AEF**  
Technical Director  
**JOAN WEILBACHER**  
Editorial Assistant

**CONTRIBUTING**

**FRANK ANZALONE, W1WY**  
Contest Calendar  
**GEORGE JACOBS, W3ASK**  
Propagation  
**BYRON H. KRETZMAN, W2JTP**  
RTTY Consultant  
**A. EDWARD HOPPER, W2GT**  
USA-CA  
**JOHN A. ATTAWAY, K4IIF**  
DX  
**LOUISA B. SANDO, W5RZJ**  
Staff Reporter  
**GORDON ELIOT WHITE**  
Surplus Sidelights  
**ALLEN KATZ, K2UYH**  
VHF Today

**BUSINESS**

**SANFORD R. COWAN**  
President  
**RICHARD A. COWAN, WA2LRO**  
Publisher  
**JACK N. SCHNEIDER, WA2FPE**  
Advertising Director  
**HAROLD WEISNER, WA2OBR**  
Circulation Director  
**GLORIA FORSYTH**  
Circulation Manager

**PRODUCTION**

**PAUL C. EDWARDS**  
Production Manager

THE ARC-5 RECEIVER/TRANSMITTER  
*Eric W. Crusier, W2DYR* 17

A Q5'ER FOR THE BC-454  
*Tom Gibson, W3EAG* 22

CONVERTING THE NO. 19 SETS  
*Sam Kelly, W6JTT* 25

SURPLUS BRITISH ELECTRONICS  
*Sam Kelly, W6JTT* 30

PUTTING THE RAYTHEON 21TR11A F.M. TRANSMITTER/RECEIVER ON 2 METERS  
*William J. Ryan, WA2DND* 33

PUTTING THE URC-11 ON 220 MC  
*Stanley F. Brigham, W3TFA* 40

PUTTING THE MOTOROLA R-394/U F.M. RECEIVER ON 2 METERS .....*Sam Kelly, W6JTT* 44

RE-INKING RTTY RIBBONS.....*Bernie Schreier, W2IDX* 47

2 METER N.B.F.M. WITH THE ARC-5  
*Frank A. Mohler, W2IAZ* 48

A POWER SUPPLY FOR THE URC-4 AND URC-11  
*Stanley F. Brigham, W3TFA* 51

CQ REVIEWS: THE GALAXY GT-550 S.S.B. TRANSCEIVER .....*Wilfred M. Scherer, W2AEF* 54

IT'S XYLEMENTARY .....*Roger Sklar, W9JWJ* 58

VERTICAL ANTENNAS, PART XII, CONCLUSION  
*Capt. Paul H. Lee, W3JM* 59

ANNOUNCEMENTS .... 14 Q & A ..... 83

CONTEST CALENDAR .... 74 SCRATCHI ..... 10

DX ..... 64 SURPLUS SIDELIGHTS .. 90

OUR READERS SAY ..... 8 USA-CA ..... 78

PROPAGATION ..... 70 VHF TODAY ..... 88

ZERO BIAS ..... 5

Offices: 14 Vanderventer Avenue, Port Washington, L. I., N. Y. 11050. Telephone: 516 883-6200.

CQ—(Title registered U. S. Post Office) is published monthly by Cowan Publishing Corp. Second Class postage paid at Port Washington and Miami, Florida. Subscription Prices: one year, \$6.00; two years, \$11.00; three years, \$15.00. Entire contents copyright by Cowan Publishing Corp. CQ does not assume responsibility for unsolicited manuscripts. Please allow six weeks for change of address. Printed in the United States of America.

Postmaster: Please send form 3579 to CQ Magazine, 14 Vanderventer Ave., Port Washington, L.I., N.Y. 11050

# Beneath this calm exterior lurks... Supertetrode!

Eimac's sensational new water cooled 50 and 100 kW tetrodes are the world's finest for high power applications. They're ideal for transmitters in HF, FM and broadcast bands, for over-the-horizon radar, distributed amplifiers, high energy physics and high power voltage regulation.

Both tetrodes feature transconductance double anything even we've been able to offer. They have greatly reduced cathode lead inductance and a unique re-entrant anode, permitting a shorter stem and lower input capacitance. Feedback capacitance also is much lower, simplifying tube neutralization and eliminating

any need for a neutralization circuit. In both tubes the screen base is designed to serve an electrostatic shield.

These tubes have 4 to 5 dB higher gain than comparable tetrodes, yet are very compact. 4CW50,000E (50 kW model) weighs only 35 pounds. It has 310 pF input capacitance,  $C_{out}$  and 0.6 pF feedback capacitance. The 4CW100,000E weighs 50 pounds, has 349 pF  $C_{out}$  and 0.8 pF  $C_f$ . For data and application assistance contact your nearest Varian/Eimac distributor or ask Information Operator for Varian Electron Tube and Device Group.

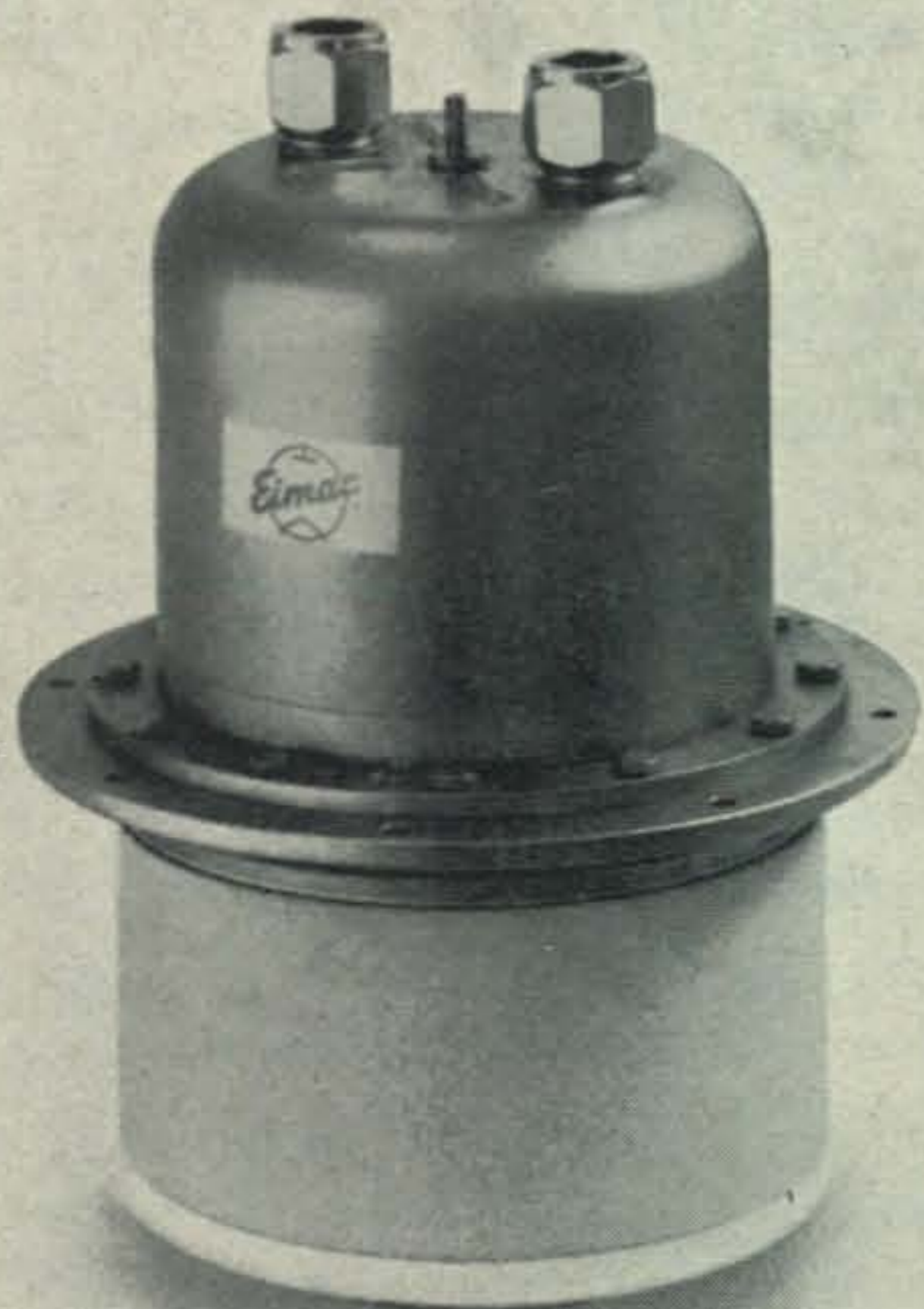

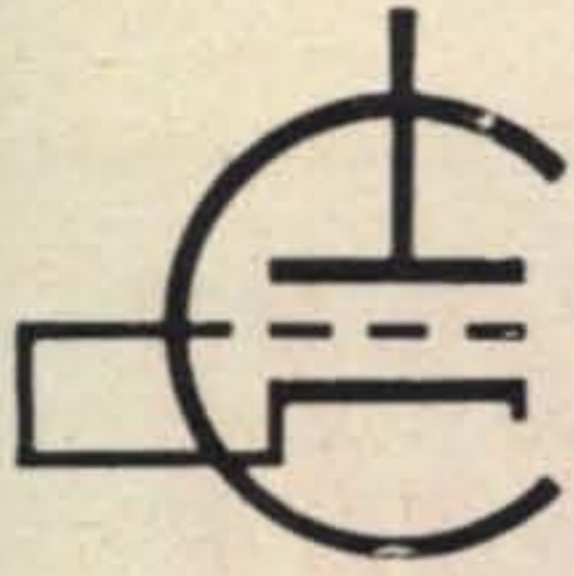

# ZERO BIAS

**T**HE "vanishing commodity is what it's been called. Its been the tonic that has stimulated more than one new ham's appetite for this hobby called radio. Surplus, of course, is what we're talking about.

It grew largely out of the mammoth industrial machine spawned by the second World War, with production rates and figures based on a war twice as long as it actually turned out to be, and when the war was all over it was dumped by the thousands of tons on the bruised world's retail markets. Yes, the electronic surplus which hams have devoured over the past 24 years has been quite a boon to us all as amateurs and businessmen, providing the expensive means for the vast majority of newcomers to first taste radio as a hobby.

It's changing fast, however, as this special Surplus issue of *CQ* will attest. The old ARC-5's are still the most popular single set of equipment with an unending variety of applications from v.f.o.'s to s.s.b. transceivers although we've seen a few "conversions" that began with "completely strip one BC-455 chassis..." You'll notice a few new type numbers mentioned from time to time such as the URC-4 and URC-11. This is part of the newer breed of surplus which doesn't date from the 1930's and 1940's, but rather from the Korean War years of the early 50's. Surplus of this era, though, will never be the same to the ham as the old WW II stuff simply because it wasn't made in such huge quantities. What's available from the early 50's is good performing, not-quite-obsolete equipment, but there's little of it around. The more recent output of the US military is even less encouraging largely because of the super-complex nature of military electronics since the mid-50's. B-52 bombers need more than ARC-5's.

And so to the amateur, surplus has indeed become the vanishing commodity. Stocks of

the rugged old dinosaurs—the ARC-5's, BC-348's, ARC-1's, *etc.* are depleted at all but a few surplus dealers in the U.S. although parts and subassemblies of more recent vintage will keep many dealers active for several years more. The new trend is to commercial surplus such as the Motorola and GE f.m. equipment, and to commercial surplus components and subassemblies. This new commercial atmosphere will no doubt be stimulating to the space-age newcomer, but to those of us who grew up in the WW II surplus era, it will somehow never be the same again.

## Late CQ Delivery

We've received numerous complaints over the past few months telling of the late arrival of subscription copies of *CQ*. We've tried to explain the reasons for such late deliveries and probably many people reading this would also like to know why.

First *CQ* is being mailed from a rather difficult location: Miami, Florida. Miami is not a major mail distribution center and thus all copies of *CQ* destined for delivery outside of Miami must travel by Post Office truck and train to Jacksonville, Florida, where copies can be routed throughout the U.S. This is time consuming.

In addition to the unavoidable mailing delays, some delays have crept into *CQ*'s advertising and editorial production over the past six months which have grown out of our change to a newer and better printing process. Unfortunately the small problems at the *CQ* offices coincided with other delays at the printer resulting in *CQ* being shipped late to Jacksonville. The end result for the reader has been rather late arrival of the magazine.

All this doesn't help the problem very much, but extra efforts of both *CQ* staff and printer over the past month or so have brought us back on schedule, with the first copies going into the mail around the 16th of the month preceding the date of publication. Therefore this May issue is being mailed around the 16th of April.

If you haven't received this issue in a reasonable amount of time from April 16, the man to see is your local Postmaster who can probably help prevent the local delays which we find most aggravating.

73, Dick, K2MGA

# SENTRY

# COAXIAL SWITCH

SAVE  
**\$2<sup>00</sup>**

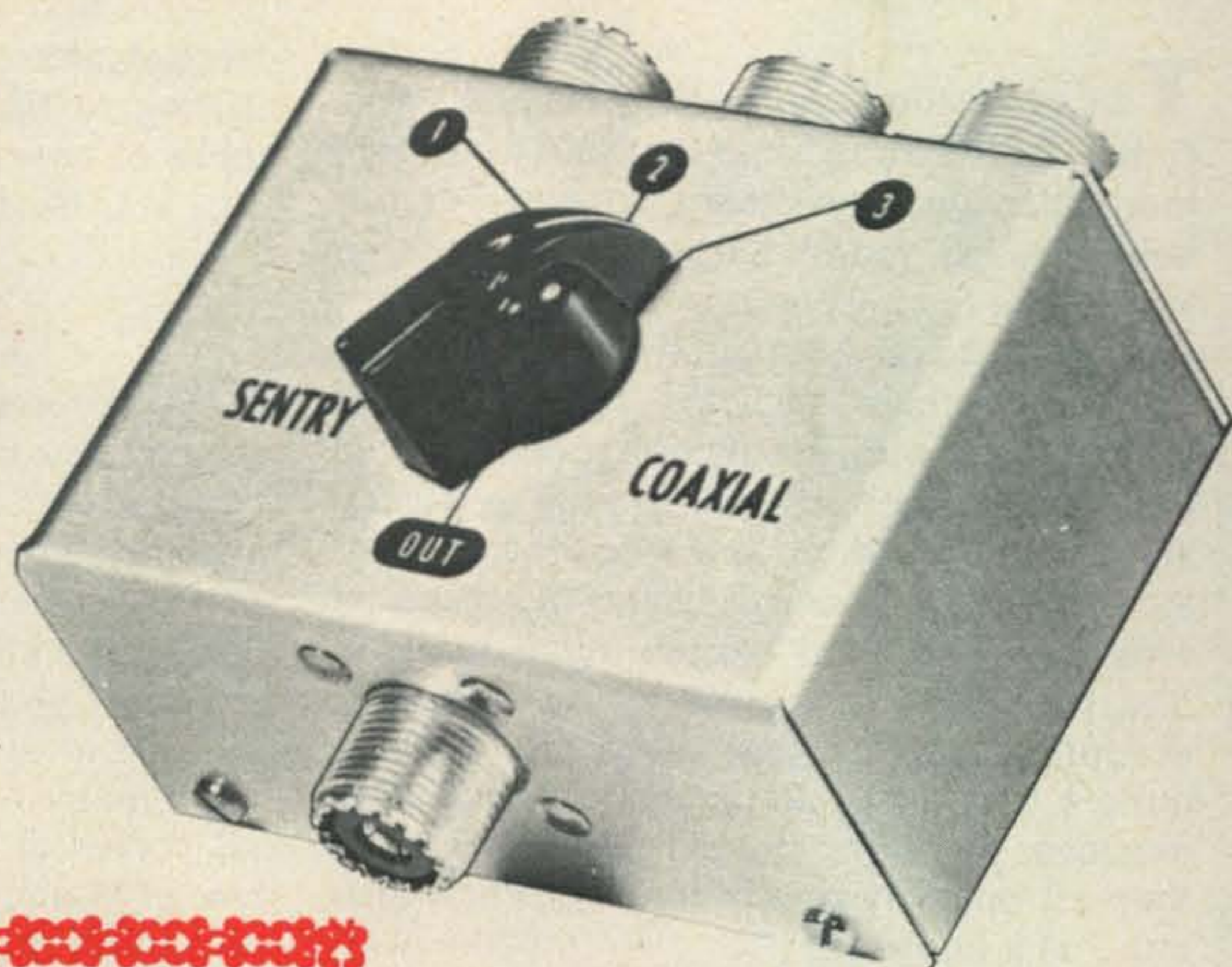
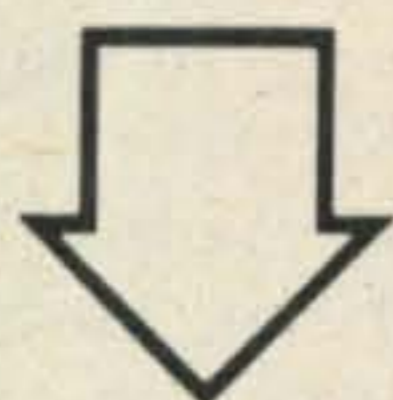

THIS COUPON GOOD FOR \$2.00  
ON THE PURCHASE OF A  
SENTRY COAXIAL SWITCH.

**\$5<sup>95</sup>**

WITH COUPON

PERFECT FOR SWITCHING YOUR TRANSMITTER/RECEIVER TO VARIOUS ANTENNAS.

EASILY HANDLES 1 KW AM or 2 KW LINEARS. NEGLIGIBLE INSERTION LOSS and LEAKAGE. STURDY CONSTRUCTION, DURABLE ANODIZED SATIN ETCHED FINISH.

SEND FOR OUR CATALOG OF PRECISION  
QUARTZ CRYSTALS AND ELECTRONICS  
FOR THE COMMUNICATIONS INDUSTRY.  
"Buy the Best"

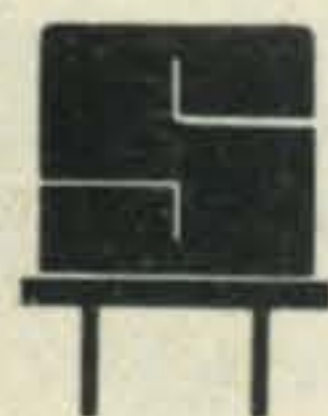
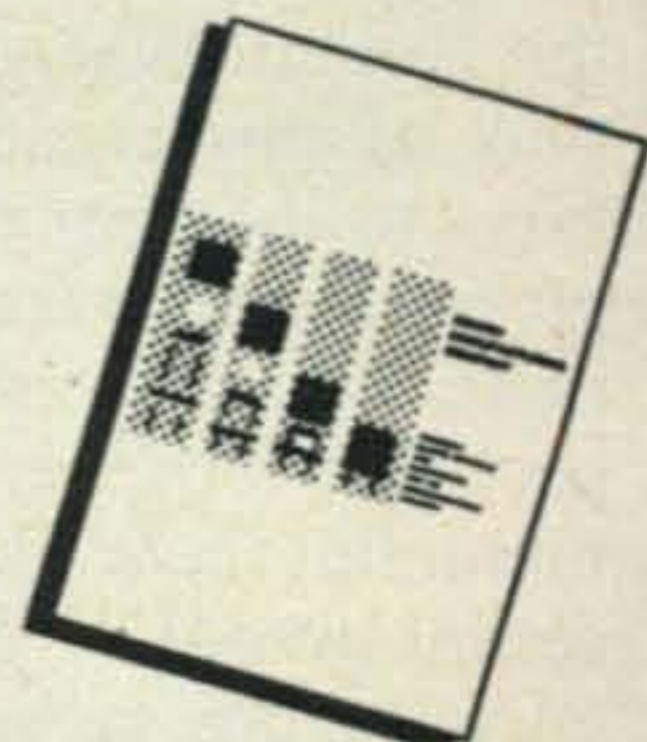

## SENTRY MANUFACTURING COMPANY

Crystal Park • Chickasha, Oklahoma 73018

Phone 405-224-6780





# OUR READERS SAY

## S. J. Res. 27

Editor, *CQ*:

Please accept my thanks and appreciation for your second recent article (*ZERO BIAS*, March 69) regarding licensing of immigrants in the U.S.

As an immigrant (now citizen) and an amateur radio operator in Israel and now in the U.S., I can only hope that the thousands of immigrants from all over the world who will follow me, and many in this country at present, will not have to wait five full years to obtain amateur radio licenses.

I was an active ham operator before leaving for the U.S., and believe me, the waiting period was not easy. I had the means, the know how and the experience to obtain and operate a ham radio station but was not permitted to do so because of the existing laws.

I believe that many hams, after such a long period away from their sets may never return to them, and the loss is also ours. I know of many such cases.

I would like to remind all my fellow hams in the U.S. about S.J. Res. 27 and urge all to show their support by writing their congressman to support that resolution in the 91st Congress.

I hope that our medieval laws regarding licensing of immigrants will be changed and thereby enable us to accept many excellent hams and old timers into our growing society.

Thanks again, Dick, for your support, your fine article, the use of your editorial column and the pages of your magazine for such a good cause.

Dan B. Liebrecht, WA2CRD/ex-4X4JS  
Riverdale, N. Y.

Editor, *CQ*:

I like to thank you for taking a stand in favor of Senate Joint Resolution 27, in your *ZERO BIAS* editorial, March 1969. This bill, introduced by Senator Barry Goldwater, K7UGA, would amend the Communications Act of 1934, allowing immigrant radio amateurs with permanent resident status, to apply for a W license.

I have talked to many radio amateurs about this problem. All agreed with this proposed legislation but few of them took time to do something about it.

Hearings will soon begin on S.J. Res. 27. I wrote to the United States Senate, Committee on Commerce, in Washington, D. C., and to my U. S. Senators, in favor of this bill, but this is not enough. I urge American radio amateurs to write now to their Senators expressing strong support for this bill.

We former DX stations, now living in the United States and future citizens of this country, sincerely hope that the American amateurs will help us in getting S.J. Res. 27 passed.

George Pataki, ex-YO2BO  
New York City, N.Y.

Editor, *CQ*:

Like most hams, I heard of the Goldwater

bill, Senate Joint Resolution 27, which would allow immigrants to this country the privilege of obtaining an American license, a privilege they are currently denied. Since many foreign nationals may operate here under reciprocal licensing agreements, it seemed only logical that immigrants who have applied for permanent residence in the United States be allowed the same privilege. Like most hams, I agreed with the idea of this bill and promptly forgot it.

Unlike many hams, however, I came in contact with several foreign hams who have actually been forced to give up their hobby because of the current regulations and whose only hope for operating is the passage of this bill. I have now written my Congressman urging support of Senate Joint Resolution 27 but my one letter will not do any good without support from others.

Will you be like most hams and forget the plea of the number of future Americans who are now denied operating privileges or will you take the few minutes required to write your Congressman and urge his support? Help someone else enjoy the privilege we have and send your letter today.

Dennis McAlpine, W1DYE/2  
New York, N.Y.

## *CQ's* Dog Team Delivery

Editor, *CQ*:

Yesterday, March 18th, I received in the mail my February issue of *CQ*—6 weeks after it is supposed to be here.

I would like to make several comments. It's 1,574 miles from Waterloo to Miami and 1,574 miles from Miami to Waterloo. February had 28 days and there were 18 days in March to the 18th. A total of 46 days or 34.2 miles per day. That's pretty good time for the old dog team—but not good enough since the January issue was received in 6 weeks time too!

Now what is happening? Why these delays—I missed the BERU contest and that's bad!

Why is this occurring? *QST*, 73 and several other magazines arrive on time—but what has happened to *CQ*? Are you trying to lose subscriptions—including mine—what's the use of receiving a magazine which is out-dated in time.

Please give us some action. Fire the dog team, use trucks or what have you, but get the magazine to the customer on time. *Please*.

W. Ross Carruthers, VE3CEA  
Waterloo, Ontario, Canada

Reader Carruthers is not alone in his plight, unfortunately. A series of production delays throughout the winter have combined to put *CQ* somewhat behind schedule, and the questionable efficiency of the U.S. Post Office in Miami has made matters worse. But as you probably noticed with the April issue, we're getting back in the "on-time" groove once again. The "dog teams" of the U.S. P.O. are the only remaining slow-downs. —Ed.

[Continued on Page 98]

# Looks aren't everything.

This new Ham Cat may be the best looking ham mobile antenna you've ever seen, but that's just the half of it.

After all, beauty is as beauty does, and this one does it better than any other ham antenna you can buy.

First of all, it's got a shake-proof sleeve clutch that folds over when you want to garage it.

Which also means you can change from one band to another in a couple of seconds by simply unscrewing one complete coil and tip rod unit and screwing another onto the foldover mast.

It's also strong enough to take a knock without bending. And the turnover mast is a hefty  $\frac{5}{8}$ " solid rod of highly polished, heat-treated aluminum.

We've also done away with the old-fashioned plastic shrink tubing and sealed the light-weight precision-wound coils in an indestructible epoxy-fiberglass sleeve. (Which is a distinctive white that'll add to the beauty of your car.) And, all fittings are heavy chrome-plated brass.

The new Ham Cat combines higher Q with wider bandwidth performance, without using a lossy-heat generating coil like the others use. So it not only looks beyond your wildest dreams, it works beyond them, too.

It's also designed on a nominal 52 ohm impedance so you don't have to have any special matching. (Any length coax will work.)

The Ham Cat mobile ham antenna is at your

Hy-Gain dealer (he's the best one under the sun) right now.

And it's there at a price all the others are charging for half of what you get in this antenna.

And that's the real beauty of it.

## ELECTRICAL

- Nominal 52 ohm impedance—no special matching device needed.
- Widest bandwidth, highest power handling—Vs.—heat drift ratio available.
- Lowest VSWR in any mobile available.

## MECHANICAL

- Turn-over mast is hefty  $\frac{5}{8}$ " dia. solid rod of highly polished heat-treated aluminum.
- All connections are standard  $\frac{3}{8}$ -24 thread.
- Mast folds over, swivels, and turns over. You can mount it on bumper deck. In addition, this flexibility makes it easy and simple to change coils.
- Coil and tip rods are a one-piece assembly. Coil diameters are constant, only lengths change.
- Shake-proof sleeve clutch facilitates quick band changeover and fold over for garaging.

THE  
**Ham  
Cat**

MOBILE HAM  
ANTENNA  
FROM HY-GAIN

HY-GAIN ELECTRONICS CORPORATION

P.O. Box 868-2

Lincoln, Nebraska 68501 AC-5



THE MOST ADVANCED ANTENNAS UNDER THE SUN



designed  
for  
application<sup>®</sup>

PRECISION COMPONENTS FOR THE RADIO AMATEUR



No. 10037  
NO-STRING  
DIAL

No strings—no backlash. The pointer is driven by a flexible toothed rack riding in an extruded aluminum channel. Illuminated slide rule dial with 11:1 ratio. Scale length 6½". For behind panel mount. \$13.05

R-F CHOKES

Band Use	Millen No.	Price
220 mc	34300-0.82	\$ .51
TWO Meters	34300-2.7	.51
SIX Meters	J300-8.2	.64
6/10 Meters	34300-22	.51
TEN Meters	J300-25	.70
10/15 Meters	34300-68	.51
10/15/20 Meters	34300-50	.51
20 Meters	34300-100	.51
40/20 Meters	34300-500	.51
80 Meters	J300-360	.83
80/40 Meters	34300-1000	.51
160 Meters	J300-1200	.83
LOW FREQ.	J300-1500	.83
ALL BAND	34300-2500	.51

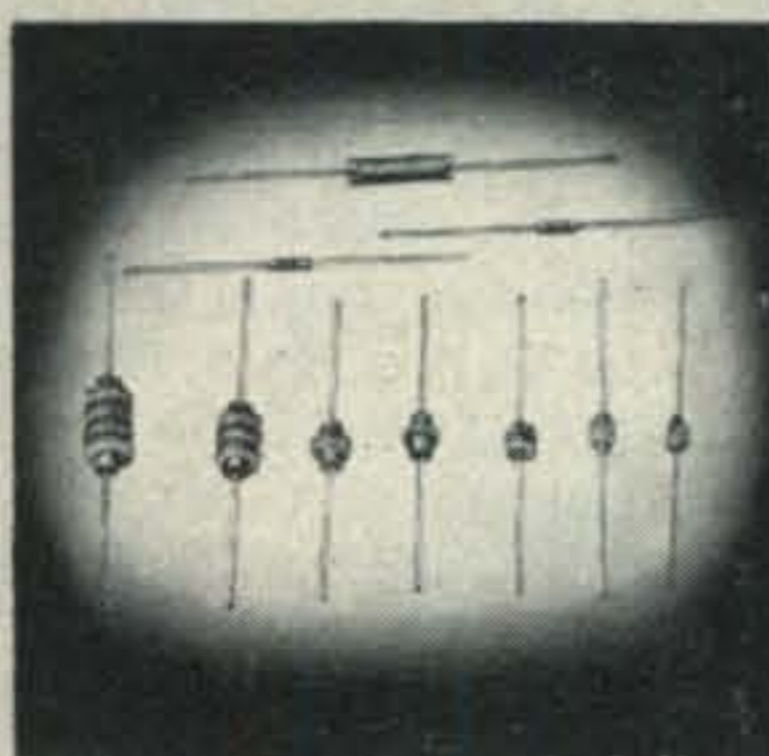

No. 25000  
CAPACITORS

Millen No.	Capacity	Price
25009-E	1.6 - 9.3 pf	\$1.90
25012-E	1.9 - 12.8 pf	1.97
25015-E	2.4 - 15.7 pf	2.00
25025-E	3.0 - 25.2 pf	2.35
25035-E	4.4 - 35.0 pf	2.54
25009-S	1.6 - 9.3 pf	1.60
25012-S	1.9 - 12.8 pf	1.71
25015-S	2.2 - 15.7 pf	1.71
25025-S	3.0 - 25.5 pf	2.11
25035-S	4.0 - 35.8 pf	2.34
25009-T	1.6 - 9.3 pf	1.60
25012-T	1.9 - 12.8 pf	1.71
25015-T	2.2 - 15.7 pf	1.71
25025-T	3.0 - 25.5 pf	2.11
25035-T	4.0 - 35.8 pf	2.34



No. 90651  
GRID DIP  
METER

Stable — reliable — accurate — convenient. Tunes 1.7 to 300 mc. 205° drum dial with seven equal length scales. Coils have protective covers. 3-3/16" x 3 3/8" x 7". Complete with carrying case. \$68.85.



INQUIRE ABOUT OUR COMPLETE  
LINE OF MINIATURIZED COMPONENTS

**JAMES MILLEN**  
MFG. CO., INC.  
MALDEN, MASSACHUSETTS



**SCRATCHI**

Feenix, Ariz.

Dear Hon. Ed:

Scratchi are just waking up from horribul nitemare. On acct. it all about Hon. Seek-You Magazine, I desiding to riting you about it while it still fresh in my stewpendous photographic memory.

In my droom I are reeding a copy of the May, 2069 issue of Seek-You! The issue one-hundred yeers from now! One part is speshally vivid—the Dee-X column. It going like this:

**DX Around The Galaxy**

We're sorry to have to report this, but those contacts you fellows have been telling us about from Antares II just can't be legitimate. WRX4PKSGL, skipper of a Pan-Planet space tug, has just returned from Sirius III, and he tells me he monitored the Antares II station in his spare time. He says those signals just don't come from the right direction for Antares II. His guess is that it's some bootlegger on Aldebaran IV. How common can you get!!

However, we heard of some goodies from WEV9IOP (aren't those ancient 3-letter calls something!) Taking a little time off from the business he inherited from his grandfather, he's worked Achernar VI, Regulus III, Formalhaut V and Pollux IX. Claims he's shelled out the credits for the sub-space-fax confirmations too! Not only that, but his (guy?) he worked on Pollux IX signed off with a FOTQK, and if you bother to look that up in the SPARE Handbook, you'll see that means "my confirmation fax is complete with a pix of myself." Wow!! Maybe the editor will have a real-something pix for the front cover. My guess is that the guy doesn't have two heads. I mean, who'd send a pix like that! (Editors note: Some guy who thought two heads were better than one).

# performance . . .

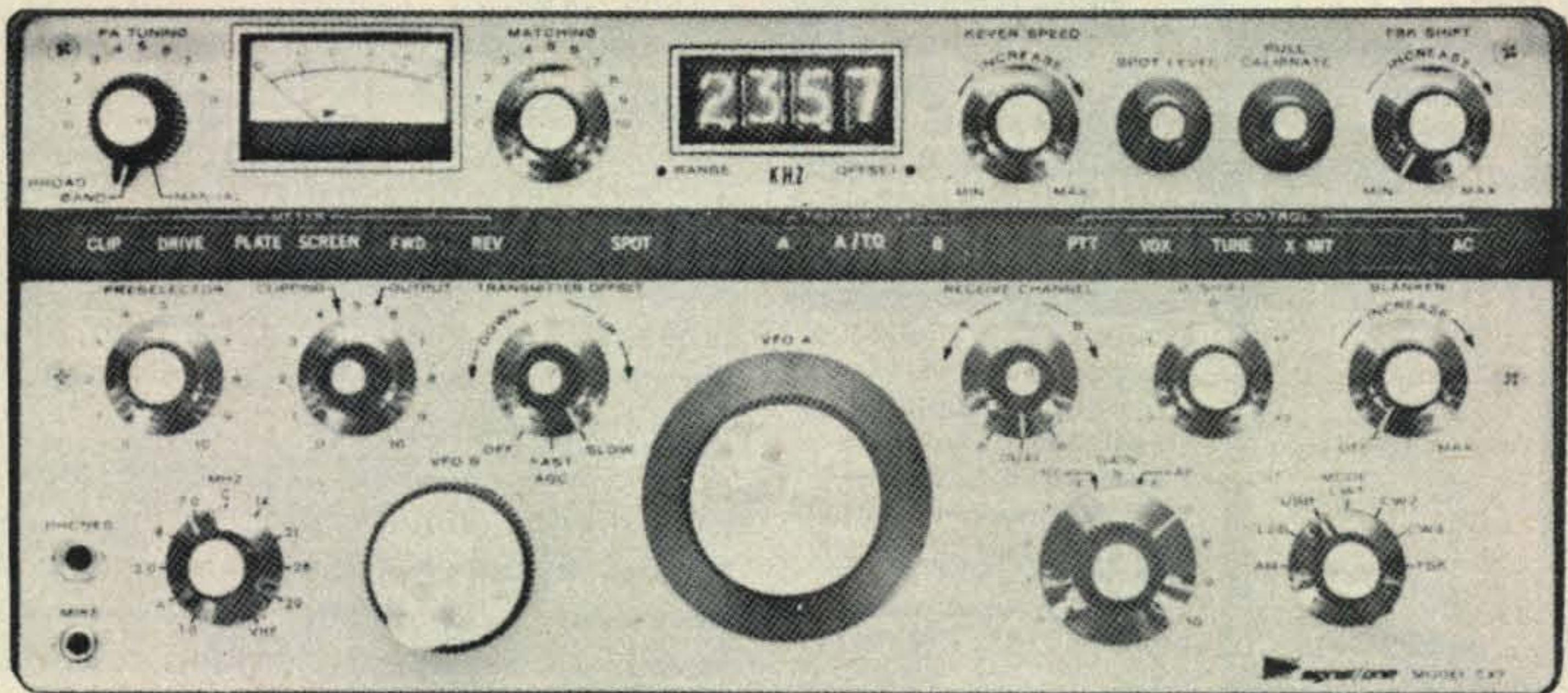

**RF ENVELOPE CLIPPING** delivers clean, crisp SSB with the talk power that no other type of speech processing can match. None of that mushiness typical of audio clipping and compression . . . This signal penetrates!



**HIGH EFFECTIVE POWER OUTPUT** . . . 300 watts PEP input combined with the high average power content of RF-clipped SSB makes the CX7 sound more like a KW . . . or several, when it's followed by a linear.

**RUGGED CONDUCTION-COOLED FINAL AMPLIFIER** has ample reserve power dissipation capability to run all day at full rated input . . .

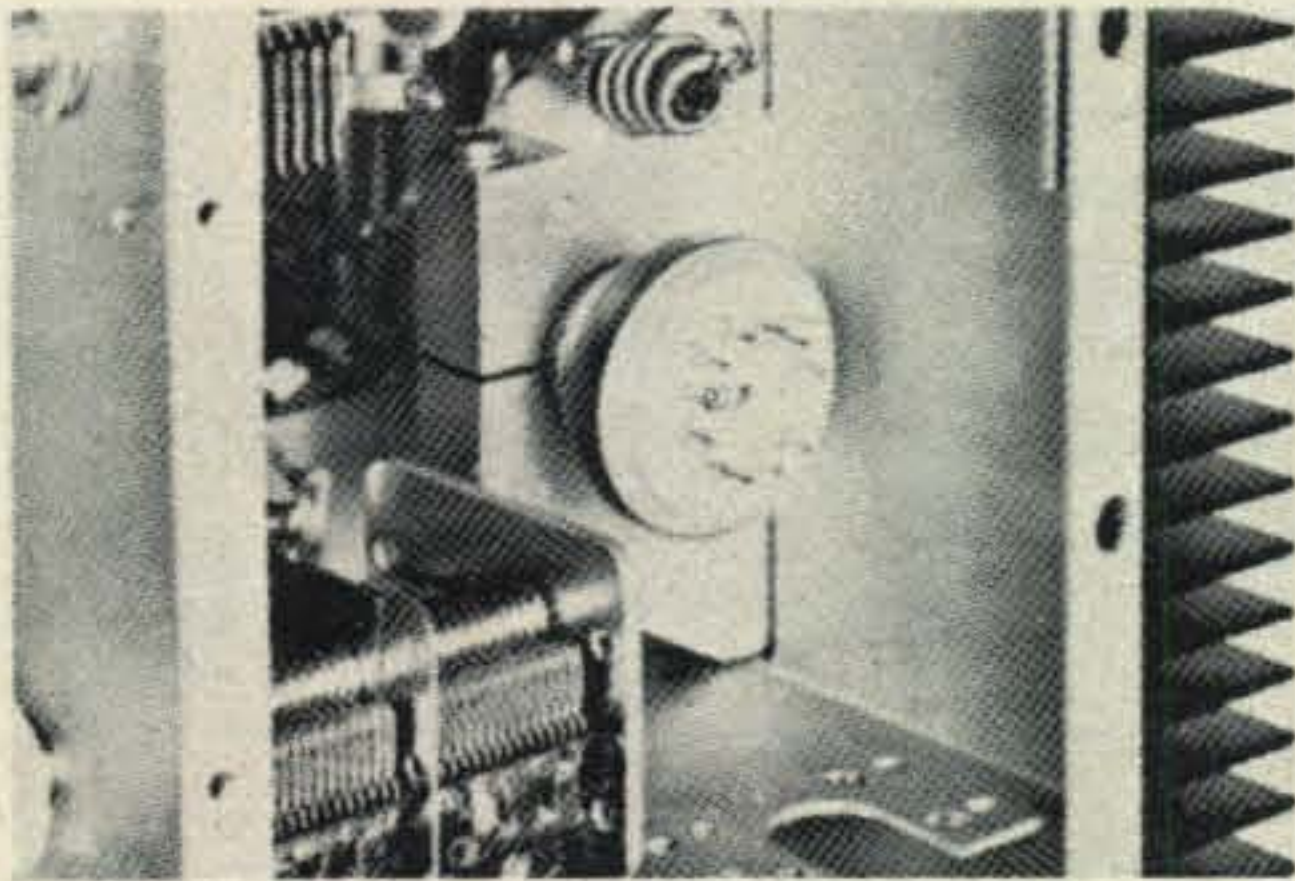

**DUAL-GATE MOSFET FRONT END** provides outstanding sensitivity plus exceptional resistance to overload. Toroidal preselector helps achieve superb cross-modulation and desensitization immunity. Steep-skirted bandpass first IF above 30 MHz yields excellent IF and image rejection while avoiding "forbidden bands" in frequency capability of the CX7.

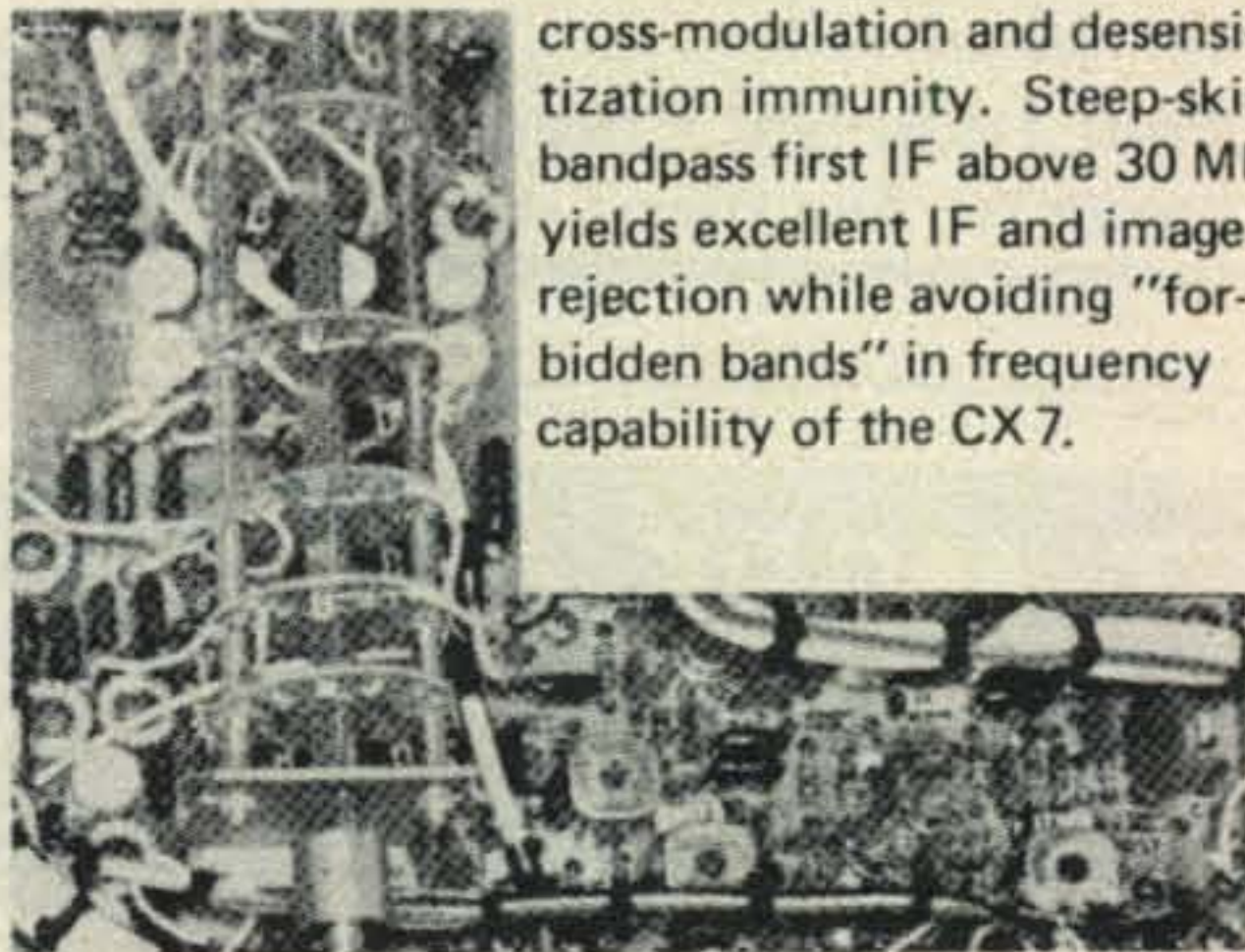

**IF SHIFT\*** control lets you move the received signal plus or minus 2kHz from nominal within the extremely steep-skirted IF filter passband to slice away QRM . . . attenuate a heterodyne by 50 db without affecting a desired signal only 500 Hz away!



\*Pat. Applied For

Some of the outstanding distributors who can give you the SIGNAL/ONE performance story are

- Harrison Radio - Farmingdale, Jamaica, and N.Y.C.
- Henry Radio - Los Angeles and Anaheim, California, Butler, Mo.
- Amateur Wholesale Electronics - Coral Gables, Fla.
- Amrad Supply, Inc. - San Francisco
- Stellar Industries, - Ithaca, New York.

Write for an illustrated brochure describing the SIGNAL/ONE Model CX7 "DELUXE INTEGRATED STATION"

"It Speaks for Itself"  
 **signal/one**

A Division of ECI (An NCR Subsidiary)

2200 Anvil Street N. • St. Petersburg, Florida 33710

NOW, FOR THAT

*"Extra Class"*

**2 POWERFUL LINEARS**

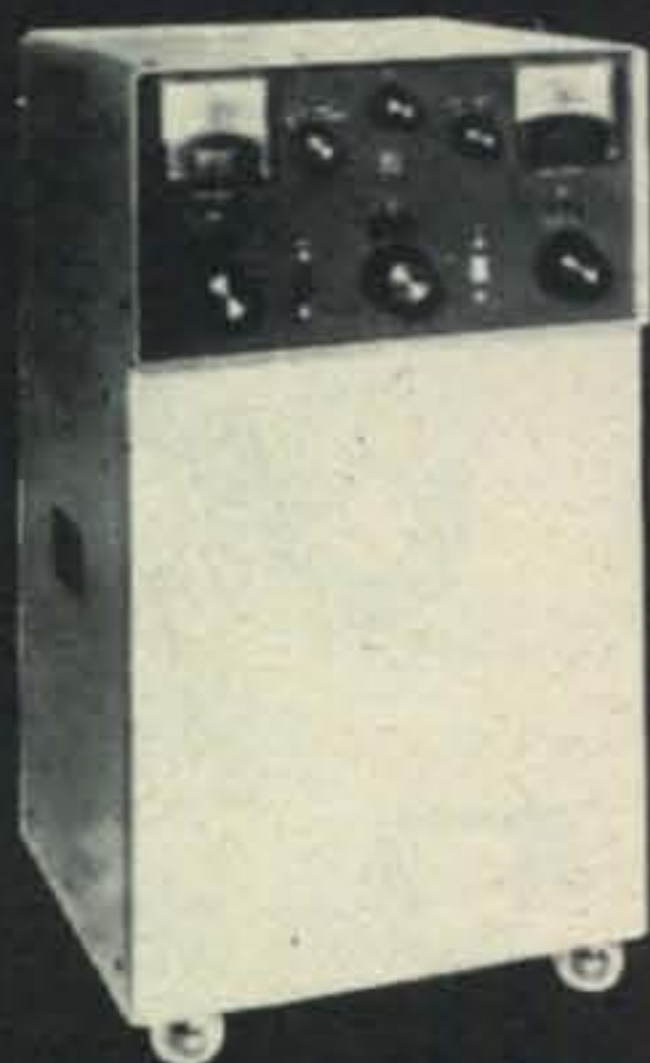

**Built to Operate Dependably With Plenty of Reserve**

- Dependable Operation
- Rugged Eimac 3-1000Z
- Instant Transmit • ALC
- Fast Band Switching
- Easy Load and Tune
- Real Signal Impact

**BTI LK-2000 . . .** For maximum legal amateur input . . . SSB, CW, RTTY. Price . . . . \$79500

**BTI LK-2000HD . . .** For heavy duty applications such as MARS, high power RTTY and SSB. Price . . . . \$89500

Listen for the hundreds of LK-2000 linears now on the air and judge for yourself. Write for free illustrated brochure or send \$1.00 for technical and instruction manual.

BTI AMATEUR DIVISION

**Hafstrom Technical Products**

4616 Santa Fe, San Diego, Ca. 92109



## GET MORE OUTPUT

from your HAM or CB RIG!  
with "KORECT-A-LINE" by Terado

### A.C. LINE MONITOR-REGULATOR

COMPENSATES FOR LOW OR CHANGING LINE VOLTAGE WHICH MAY BE REDUCING YOUR TRANSCEIVER OUTPUT.

- Positive Action, Six-Position Switch for Finger Tip Control
- Accurate, Easy-to-Read, Edge View Meter
- Will Increase 117V AC Line Voltage to 140V If Needed
- Will Decrease 117V AC Line Voltage to 80V for Test Purposes
- Easy, Plug-in Installation, Convenient Mounting Bracket

ONLY \$26.95 LIST



**KORECT-A-LINE MODEL 50-150**  
Capacity 300-500 Watts  
Size 5 1/2"x3"x2 1/4"  
Weight 3 lbs.  
Other Models up to 1500 Watts

For More Information, Write

*terado* CORPORATION

1058 Raymond Ave., St. Paul, Minn. 55108 USA

And, while we're talking about SPARE I'm just going to have to say that those directors up at Seven Planets Amateur Radio Empire have done it again.

The Awards Committee will not grant credit to those Spica II sub-space-fax confirms! Of course, it's known by practically everyone that the poor guy who made it to Spica II was a little radiated in the skull.

Obviously no guy who buttoned his cap would steal a spacecycle from the Spica I-Spica III spaceferry and land on Spica II. Those spacecycles only carry twelve standard-hours worth of oxygen.

The gang at New Newington aren't disallowing the contacts because the fellow has flipped his upper. Oh no! They claim there's no evidence he actually planet-grounded! I mean he'd just been in orbit around Spica II it's no-con, of course.

Well, your DX editor listened to tapes of two of those contacts, and you can't tell me that fellow was piloting a spacecycle, in or out of orbit, and sending that clean digicode you were hearing. Why a guy would have to have three or four arms to jet that 'cycle around and still have that sweet a fist-or claw-or whatever it was.

Don't toss your confirms on this guy away. I have a feeling we haven't heard the last of the Spica II thing. I Spica II you!! Just thought I'd sign off with a little funny! Happy sub-spacing and I'll see you next month maybe someone will finally have worked the 100th planet.

Well, Hon. Ed., that's the hole thing. What a nitemare—Hokendoke Hackensaki!! And the most nitemarish part of the dream is that in this issue of May, 2069, there was no Scratchi column! I'll rite more when I feelin' better.

Respectively yours,  
Hashafisti Scratchi

### CQ READER SERVICE

To obtain descriptive literature from advertisers, simply check the box next to the name of each advertiser listed in the left column on page 110. We will forward your name and address to the appropriate advertiser(s), and you will receive the literature in short order. This service is provided by the CQ staff at no additional charge to the reader or advertiser. Take advantage of this service as advertisers welcome the chance to discuss their product.



When hams  
discuss  
**OPTIMUM  
SPACING'**  
in single  
band beams . . .

..... *The subject turns to **Mosley***

Amateurs punch through the QRM on 20 meters with Mosley's A-203-C, an optimum spaced 20 meter antenna designed for full power. The outstanding, maximum gain performance excels most four to six element arrays. This clean-line rugged beam incorporates a special type of element design that virtually eliminates element flutter and boom vibration. Wide spaced; gamma matched for 52 ohm line with a boom length of 24 feet and elements of 37 feet. Turning radius is 22 feet. Assembled weight - 40 lbs.

**20  
meters**



**10 and  
15 meters**

A-310-C for 10 meters  
A-315-C for 15 meters  
Full sized, full power, full spaced 3-element arrays. 100% rustproof all stainless steel hardware; low SWR over entire bandwidth; Max. Gain; Gamma matched for 52 ohm line.

**40 meters**

S-402 for 40 meters  
Top signal and unexcelled forward gain - a 2-element optimum spaced beam. 100% weatherproof. Low SWR. Heavy duty construction. Link coupling results in excellent match over full bandwidth.

For detailed specifications and performance data, write Dept 157A.

**Mosley Electronics Inc.** 4610 N. Lindbergh Blvd., Bridgeton, Mo. 63042



# *action* speaks louder than words!

ASK THE MAN WHO USES ONE

## The **ESSCO** "aud-dit-or" model AD-1



*Solid  
State*

- ★ Pre-record a CQ or any traffic on your tape recorder, then play it back through the AD-1. It will key your transmitter using a high speed relay at speeds greater than 40 words per minute.
- ★ Use the AUD-DIT-OR with your code practice oscillator. Listen to your keying simultaneously with the CW transmission. Makes the old monitoring methods obsolete.
- ★ Re-generate a CW signal (where law permits) from your receiver.
- ★ Use the AD-1 for remote control\* operation of various appliances, television set, garage door, slide projector, etc. \* EXTERNAL RELAY REQUIRED

COMPLETE, READY TO USE, TESTED AND GUARANTEED **\$24.95**

F.O.B. CAMDEN, N. J.

# ESSCO

*"Teletype Specialists"*

Phone: (609) 365-6171

324 ARCH STREET CAMDEN, N. J. 08102

## Announcements

### RSGB QSL Bureau

The RSGB QSL Bureau (G2MI) will be closed May 14 through June 3. Please do not send any QSL's that will arrive during this period.

### Correction

RE: "Introduction To IC Binary Logic" by F. B. McWilliams, February 1969 *CQ*, page 14.  
Fig. 4(A)—The formula should read  $A \cdot B = C$ .  
On page 16, the second paragraph should read, "The Boolean algebra expression describing the nor gate is  $A + B + C = D$ ." On page 98 the eighth and ninth line should read, "shown in fig. 5(A), Q and  $\bar{Q}$ ;  $\bar{Q}$  is simply the inversion of Q." In the third line of the third paragraph on page 98 the Q should read  $\bar{Q}$ .

### Kansas City, Kansas

The Jayhawk Amateur Radio Society, Inc., announces another big Jayhawk Hamfest, Sunday, May 4, 1969, at the George J. Meyn Community Center, K-7 Highway and Kansas Turnpike (across from the Agricultural Hall of Fame), Bonner Springs, Kansas. Lots of gifts, refreshments, entertainment, swap tables, contests, displays, and group meetings. For more information contact: Jayhawks ARS, P.O. Box 1144, Kansas City, Kansas 66117.

### Greenville, South Carolina

The ninth annual Greenville Hamfest will be held Sunday, May 4, 1969, at the Cleveland Park, Greenville, South Carolina. Activities include swap shop, prizes, FCC exams, Display catered lunch, formal program and ladies bingo. For kids there is the Greenville Zoo, Playground equipment including tennis courts. The annual "Sideband Supper" will be held Saturday night May 3rd sponsored by the S.C. S.S.B. Net. For details on the supper, contact any net official at 3.915 kc 7 P.M. EST 7 days a week.

### St. Petersburg, Florida

The St. Petersburg Amateur Radio Club, Inc. will hold their annual Hamfest at Lake Maggio Park, entrance gate at 9th Street and 38th Avenue South, St. Petersburg, Florida, Sunday, May 18. Plenty of parking space. No charge to enter park. All amateurs cordially invited. Bring guests if you wish. This is an old fashioned Hamfest with picnic lunch, swap tables and prizes. Further details can be had by writing the St. Petersburg ARC, P.O. Box 4026, St. Petersburg, Fla.

### Pittsburgh, Pennsylvania

The 15th annual Breeze Shooters Hamfest will be held at White Swan Park near Pittsburgh, Pennsylvania on May 18, 1969. This is the largest non-profit amateur radio event in the Western Pennsylvania area attracting over 1200 amateurs annually. For more information contact R. I. Carnahan, K3UEO, 1422 Main Street, Bridgeville, Pa., 15017.



### Indianapolis, Indiana

The Indianapolis Ham Association announces their Indianapolis Ham Convention which will be held on Saturday, May 24, 1969 at Stouffer's Indianapolis Inn, 2820 North Meridian St. in the heart of town. Activities start Friday night with a Hospitality Hour sponsored by the Indianapolis DX Association. On Saturday there will be displays, technical sessions, and various demonstrations guaranteed to interest all. This event is open to the general public with about 10,000 attending. Over 2,000 amateurs are expected to turn out for the event. Sat. evening there will be a banquet with Sen. Barry Goldwater, K7UGA/K3UIF as the Guest of Honor, and Stu Meyer, W2GHK/4 as MC. For additional info please contact Joe Poston, K9GCE/5MM—Bell Tel. Labs., 2525 North Shadland Ave., Indianapolis, Ind., 46225. (tel. 317-356-8111, ext. 2539, 3557)

### Port Washington, Wisconsin

The Ozaukee R.C. will have its annual Hamfest at the Belgium Community Center at Belgium, Wisconsin on May 25, 1969. Further information from: Ozaukee, R.C., Box 13, Port Washington,

### Mobile, Alabama

The annual Hamfest sponsored by the Mobile Amateur Radio Club will be held on May 24 and 25 at Mobile Alabama. For prizes, entertainment, swap tables, eye balls and fun for the whole family, plan to attend. For further information and reservations call or write: Ham

Wentworth, W4IAX, General Chairman, P.O. Box 7232, Mobile, Alabama, 36601. (Phone 205-473-8561)

### Wabash, Indiana

The Wabash County Amateur Radio Club will hold its first annual Hamfest on May 25 at the Wabash County 4-H Fairgrounds. It will be held rain or shine. Advance donations \$1.00. Contact Alan Bateman, K9AYB, 434 Stitt St., Wabash, Indiana for additional information and advance tickets.

### Chadron, Nebraska

The Pine Ridge Amateur Radio Club will hold their 15th annual Hamfest, June 1, 1969 at Chadron State Park. As in past years, an attendance of over 100 amateurs representing Nebraska, Wyoming, South Dakota and Colorado is anticipated. For further details write to: Stanley Stumpf, Pine Ridge Amateur Radio Club, 234 Main Street, Chadron, Nebraska 69337.

### Columbia, South Carolina

The Palmetto Amateur Radio Club announces its second Annual Hamfest to be held indoors at the State Fair Grounds, Columbia, South Carolina on June 1, 1969. A Dutch supper is in the planning for the night before. The Hamfest will feature prizes, swapping, a transmitter building contest, home-brew contest, antique radio display, f.m. and MARS Forums, and bingo for the XYLs. More information may be obtained from C. W. Moorner, K4FNT, 227 Castle Drive, West Columbia, South Carolina 29169.

[Continued on page 108]

# action speaks louder than words!

ASK THE MAN WHO USES ONE

The ESSCO Model TU-7 Teleprinter Demodulator is a completely assembled, ready to run system, fully wired with loop supply, connectors, tuning indicator, reversing switch, modular tracks, scope outputs, 50 ua zero center meter, function switch and famous ESSCO solid state modular plug-in units.



## ESSCO's Complete Solid State RTTY DEMODULATOR

- |   |          |
|---|----------|
| TU-7B DUAL CHANNEL KIT                              | \$138.25 |
| TU-7 (As above) Factory wired, tested & guaranteed  | \$163.00 |
| TU-7C SINGLE CHANNEL KIT                            | \$132.25 |
| TU-7D (As above) Factory wired, tested & guaranteed | \$156.25 |

BASIC CABINET & INDIVIDUAL PLUG-IN UNITS AVAILABLE SEPARATELY

Complete Ready to Run  
**\$132.25**

Model TU-7C

# ESSCO

"Teletype Specialists"

Phone 609 365 6171

324 ARCH STREET CAMDEN, N. J. 08102

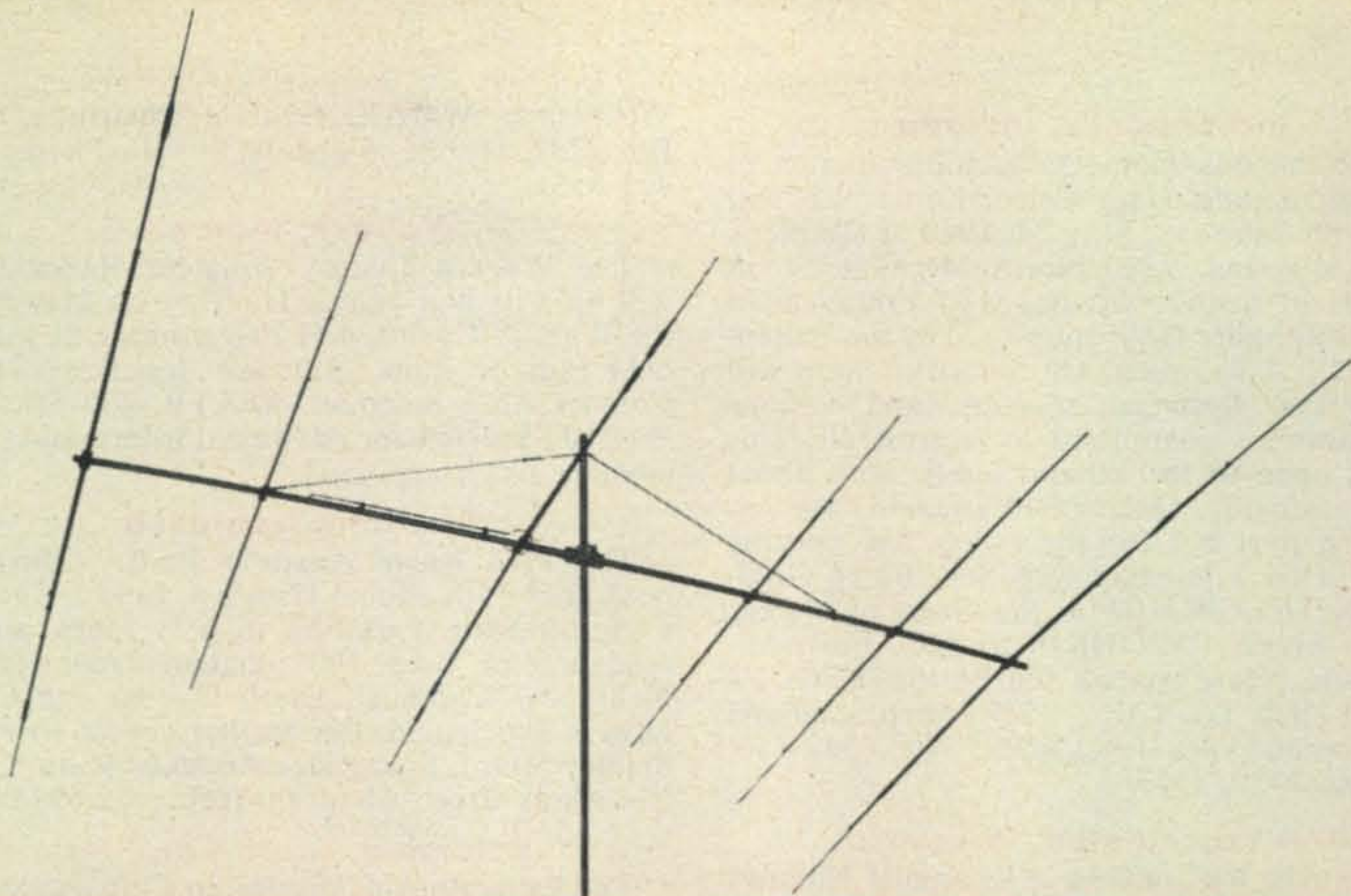

## NOW! A SUPER THUNDERBIRD!

### ALL NEW 6-ELEMENT SUPER THUNDERBIRD TH6DXX

The new Super Thunderbird TH6DXX offers the ultimate in tribander performance, with mechanical and electrical specifications unsurpassed for 10, 15 and 20 meters. This newest of Hy-Gain's amateur antennas is superb on DX and other long haul contacts, and gives peak performance on each band whether you're working phone or CW. Check the many features at right; you'll see why you should be using the new Super Thunderbird!

#### PLUS THESE OTHER GREAT THUNDERBIRDS

- New, improved 3-element Thunderbird—Model TH3MK3.
- Fabulous, 3-element Thunderbird Jr.—Model TH3JR.
- Popular 2-element Thunderbird—Model TH2MK3.

Buy one today at your favorite  
Hy-Gain distributor.

## Hy-Gain Super



The most advanced antennas under the sun.

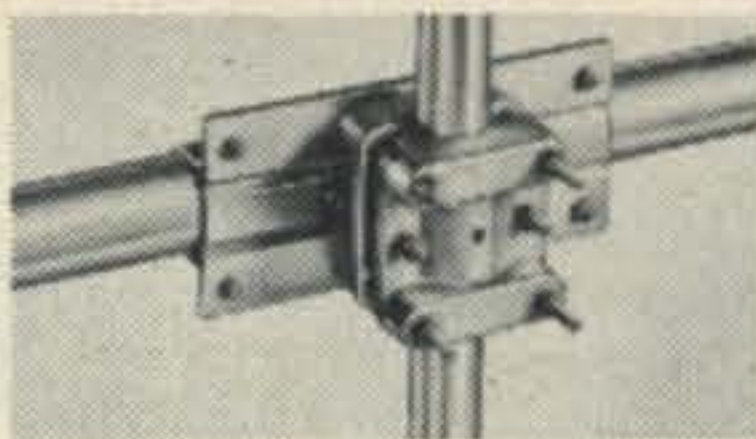

**Tilt-head, universal boom-to-mast bracket**—all new, cast aluminum bracket accommodates masts from 1 1/4" x 2 1/2". Allows easy tilting for installation, maintenance and tuning, provides mast feed-thru for beam stacking.



**Taper swaged, slotted tubing**—new tubing on all elements allows easy adjustment and re-adjustment. Taper swaged to permit larger diameter tubing where it counts! And, less wind loading. Full circumference compression clamps are mech. and elec. superior to self-tapping sheet metal screws.



**Hy-Gain Beta Match**—Advanced design from company that invented the Beta Match, achieves balanced input, optimum matching on all 3 bands, and provides DC ground to eliminate precipitation static.

### OUTSTANDING HY-GAIN FEATURES

- Tilt-head, universal boom-to-mast bracket (see details at left).
- Taper swaged, slotted tubing with full circumference compression clamps (see details at left).
- Hy-Gain's exclusive Beta Match (see details at left).
- New, improved "Hy-Q" traps... separate traps for each band.
- Up to 9.5 db forward gain.
- 25 db front-to-back ratio.
- SWR less than 1.5:1 on all bands.
- 24-foot boom...none longer in the industry.
- High-performance element spacing.
- Extra heavy gauge, machine formed element-to-boom brackets, with plastic sleeves used only for insulation. Bracket design allows full mechanical support.



## Thunderbird

Hy-Gain Electronics Corporation  
P.O. Box 868-2  
Lincoln, Nebraska 68501 AC-5

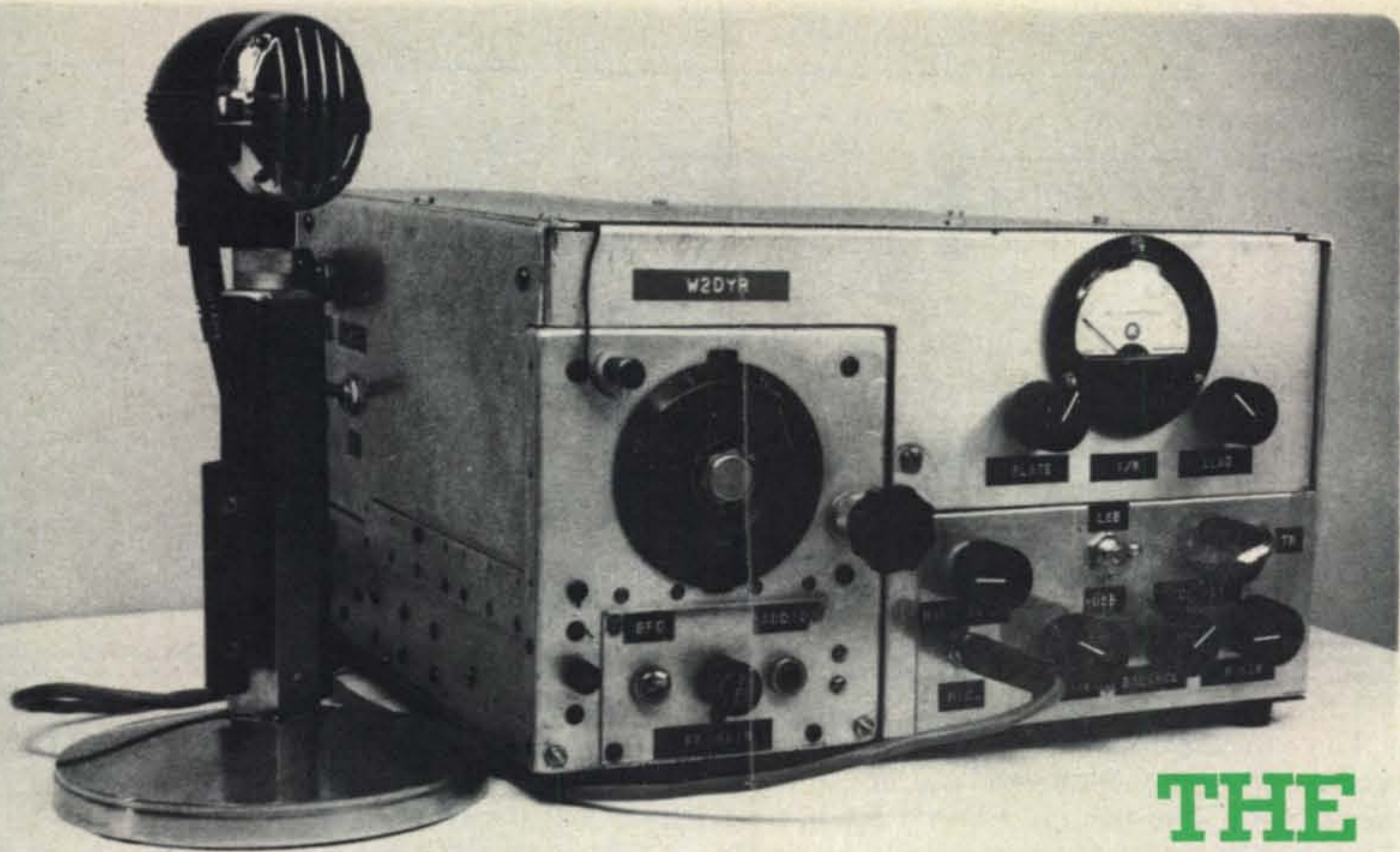

# THE ARC-5 RECEIVER/TRANSMITTER

BY ERIC W. CRUSER,\* W2DYR

**M**ANY of the popular command receivers of World War II remain in use today and others have been relegated to the shelf, closet or attic. The writer has for some time,

felt, that perhaps the receiver might serve as a nucleus for an s.s.b. transceiver. Exploration of the idea proved gratifying and perhaps there are others interested in putting one of these retired receivers back to work in an updated setup.

\*1 Lake Shore, Lakehurst, N. J. 08733.

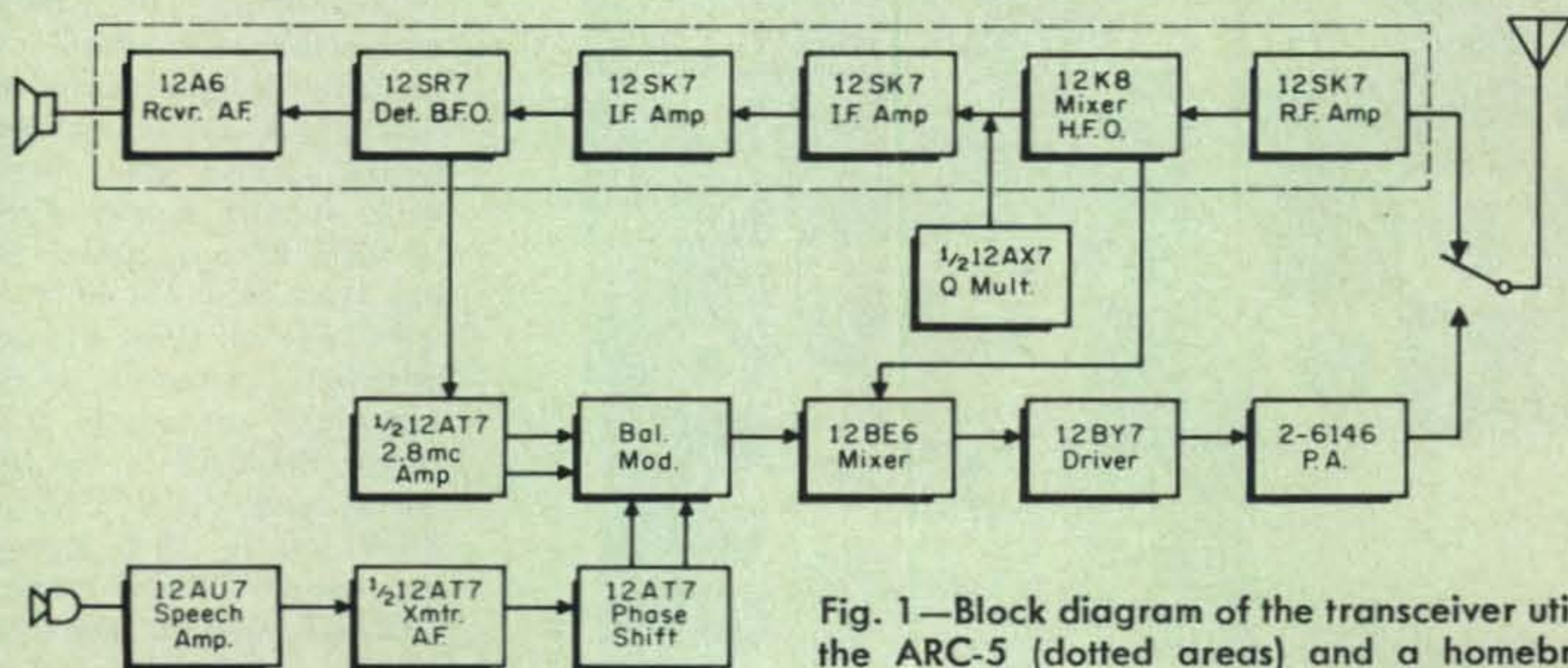

Fig. 1—Block diagram of the transceiver utilizing the ARC-5 (dotted areas) and a homebrewed s.s.b. phasing type transmitter.

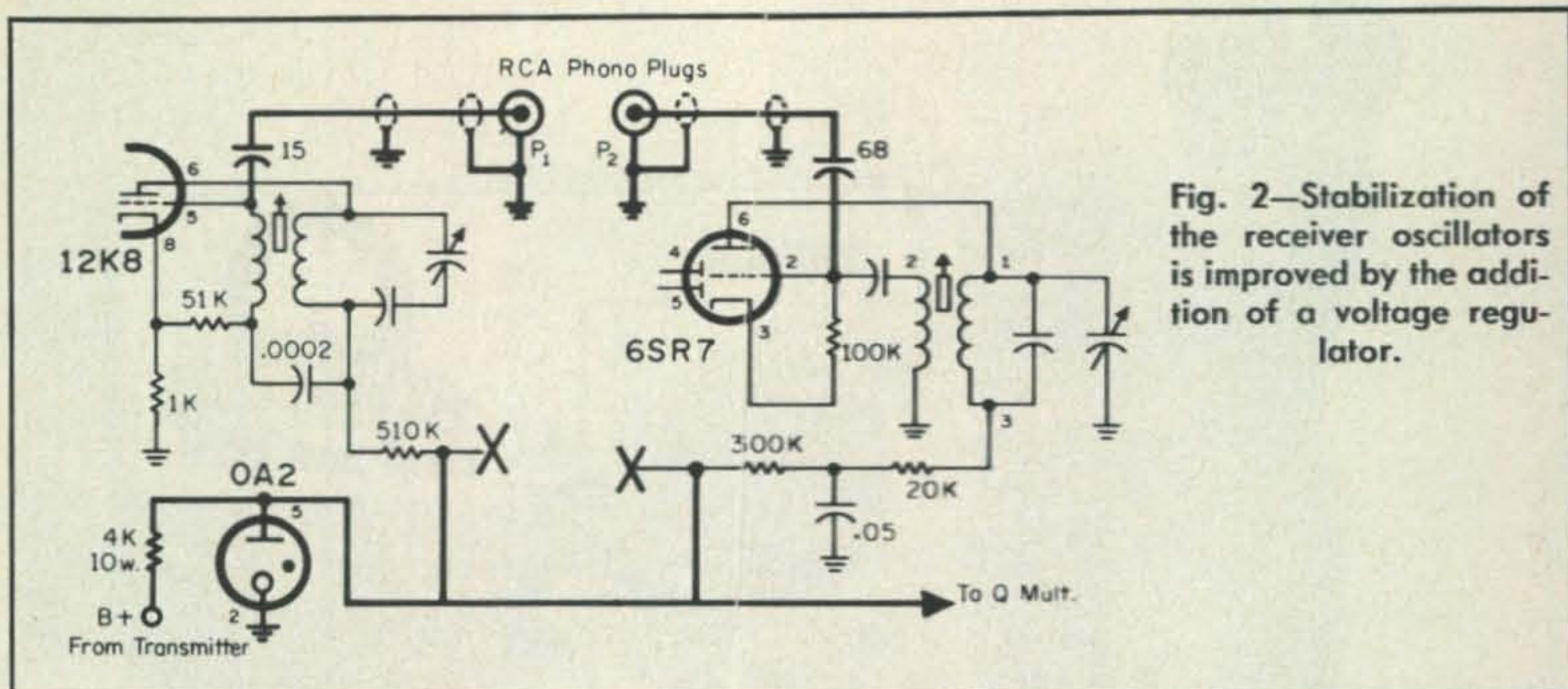

Fig. 2—Stabilization of the receiver oscillators is improved by the addition of a voltage regulator.

The experimental model utilized a BC-455 receiver (tuning 6-9 mc) for use in the forty meter band. The BC-454 (tuning 3-6 mc) or the model tuning 1.5 to 3 mc could be similarly used for 75 and 160 meter operation.

The basic concept of operation is to use the i.f. of the receiver (2830 kc for the BC-455, 1415 kc for the BC-454, 705 kc for the 1.5-3 mc model) as furnished by the b.f.o. as a frequency source for the phasing type side-band generator. This mixed with h.f.o. results in identical frequencies for transmitting and receiving controllable by normal receiver tuning.

### Receiver Modifications

Few changes are necessary in the receiver. Used in conjunction with the receiver is a transmitting section utilizing 8 tubes, includ-

ing parallel 6146 output tubes in the p.a. A block diagram is shown in fig. 1. Figure 2 indicates the receiver modifications.

Short shielded leads, terminated in RCA phono plugs, are used to bring the controlling frequencies from the receiver to the transmitter section as shown in fig. 2. The h.f.o. hot lead from the 12K8 oscillator/mixer is connected through a 15 mmf ceramic capacitor mounted at the pin 5 of the socket. The shield of this lead is grounded at the 12K8 socket. The b.f.o. hot lead is connected to pin 2 of the 12SR7 through a 68 mmf ceramic capacitor with the shield grounded at the socket.

To improve receiver selectivity a simplified Q multiplier (fig. 3) was constructed and mounted in the space originally occupied by the dynamotor. An OA2 regulator was also

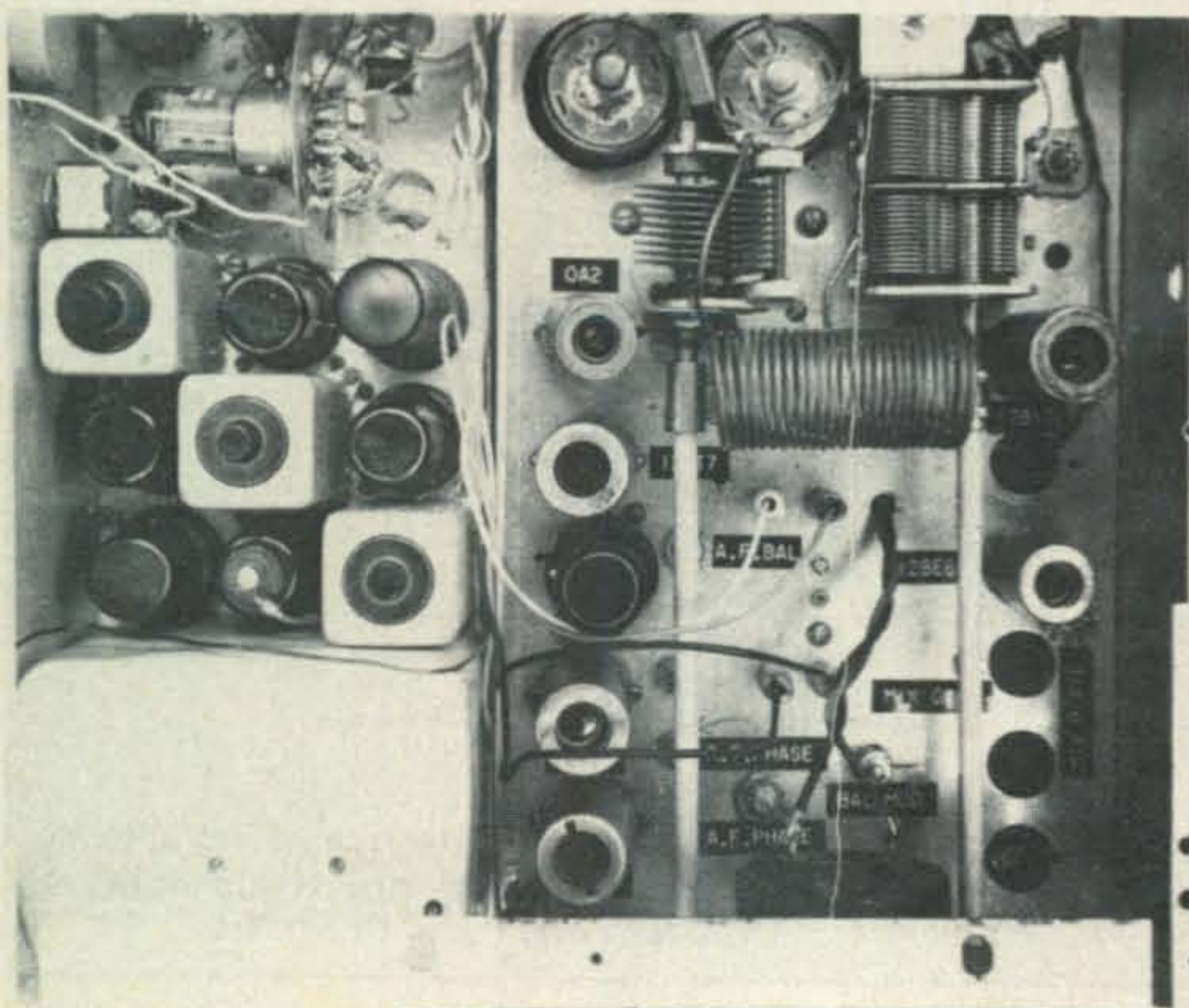

Top view "ARC-5 Receiver/Transmitter." At top left corner is the Q multiplier and controls, in the center note the 6146 tubes extending below chassis into shielded well, output tuning directly in front of p.a. tubes, loading capacitor to their right with neutralizing capacitor attached, antenna relay in top right corner. In a row below the 0A2 in the transmitter section is a 12A7, the B&W phase shift network, the other 12A7 and the 12AU7 speech amplifier.

installed in that area and is used for regulating the plate voltage for the two oscillators and the Q multiplier. The isolating resistors in the plate circuits of the h.f.o. and b.f.o. are removed from the B+ lead (as wired in the receiver) and reconnected to the regulated 150 volts.

To silence the receiver during periods of transmission the ground return of the sensitivity control is opened (fig. 4) and controlled by the send/receive relay in the transmitter section. This completes the receiver modification.

### Receiver Adjustments

The only adjustment needed in the receiver involves the Q multiplier. Tune in a sideband signal with the Q multiplier switch in the OFF position. Place the switch in the ON position and adjust  $L_1$  (fig. 3) until the signal peaks. The degree of selectivity is controlled by the 10K potentiometer and is maximum just before the stage breaks into oscillation.

### Transmitter

The transmitter section was constructed on a 3" x 7" x 11" chassis. Except for obtaining the controlling frequencies from the receiver the unit is quite conventional in design and circuitry. RCA phone jacks are used for the frequency control leads and banana jacks or any other suitable connectors can be provided for the receiver quieting control leads.

A small d.p.d.t. relay is mounted underneath the chassis for transmit/receive change-over and a small s.p.d.t. relay is adjacent to the BNC antenna jack and is used for antenna transfer. A portion of the heater voltage was rectified and used to operate the relays.

The output tubes and pi-network were mounted on top of the chassis to isolate them from the exciter. The schematic diagram for this section is shown in fig. 5.

### Testing and Adjustments

After wiring has been completed coils  $L_1$ ,  $L_2$ ,  $L_3$ , and  $L_4$ , should be adjusted to resonate at 2830 kc (with all tubes in their sockets) as indicated by a grid dip meter. The heater (12.6 a.c.) and the low B+ (300) voltages may now be applied. The audio phase shift network adjustments are made by feeding 1000 c.p.s. at a low level, to the microphone jack. The r.f. leads from the receiver *should not* be connected to the transmitter portion during this procedure. Con-

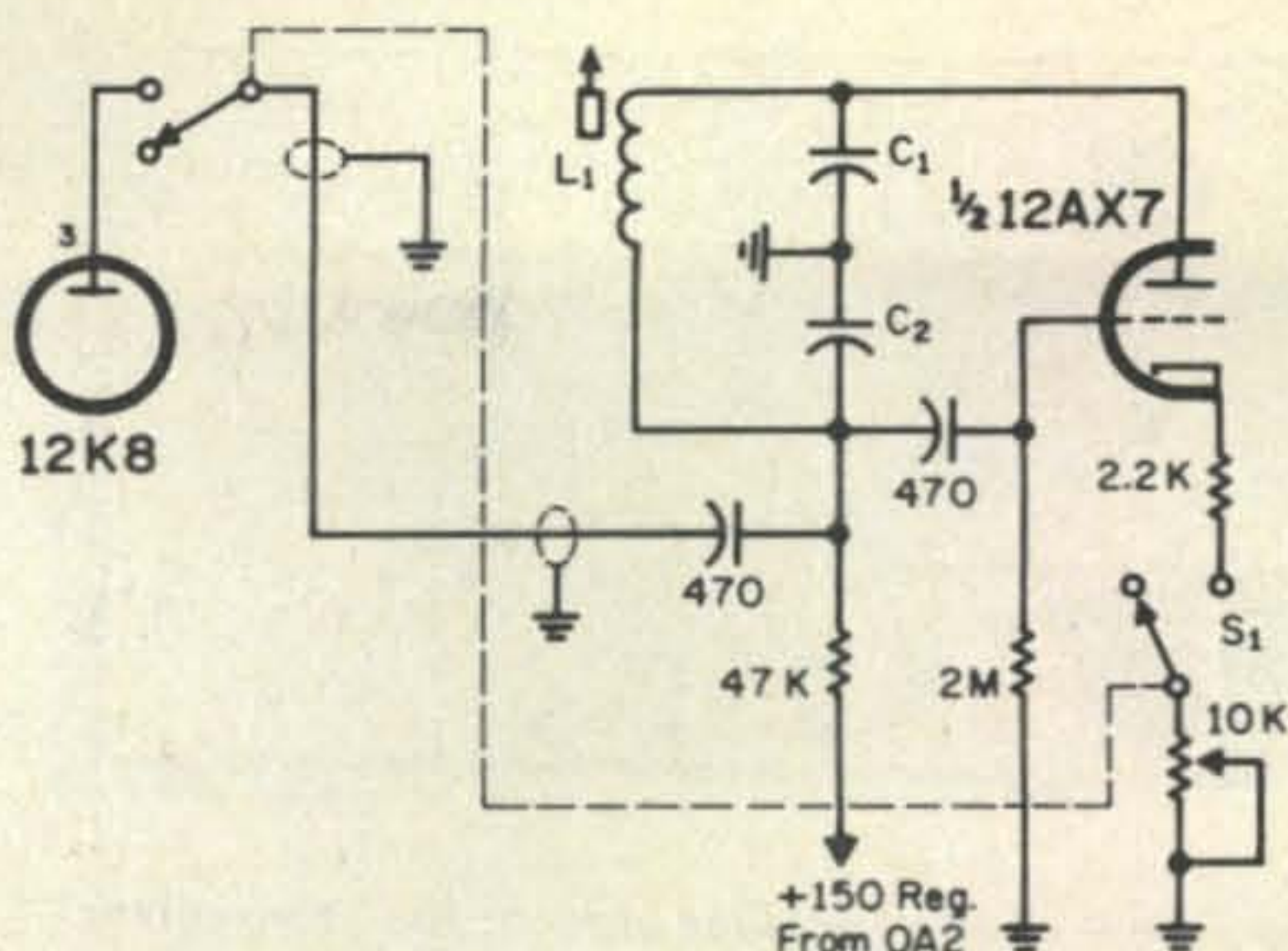
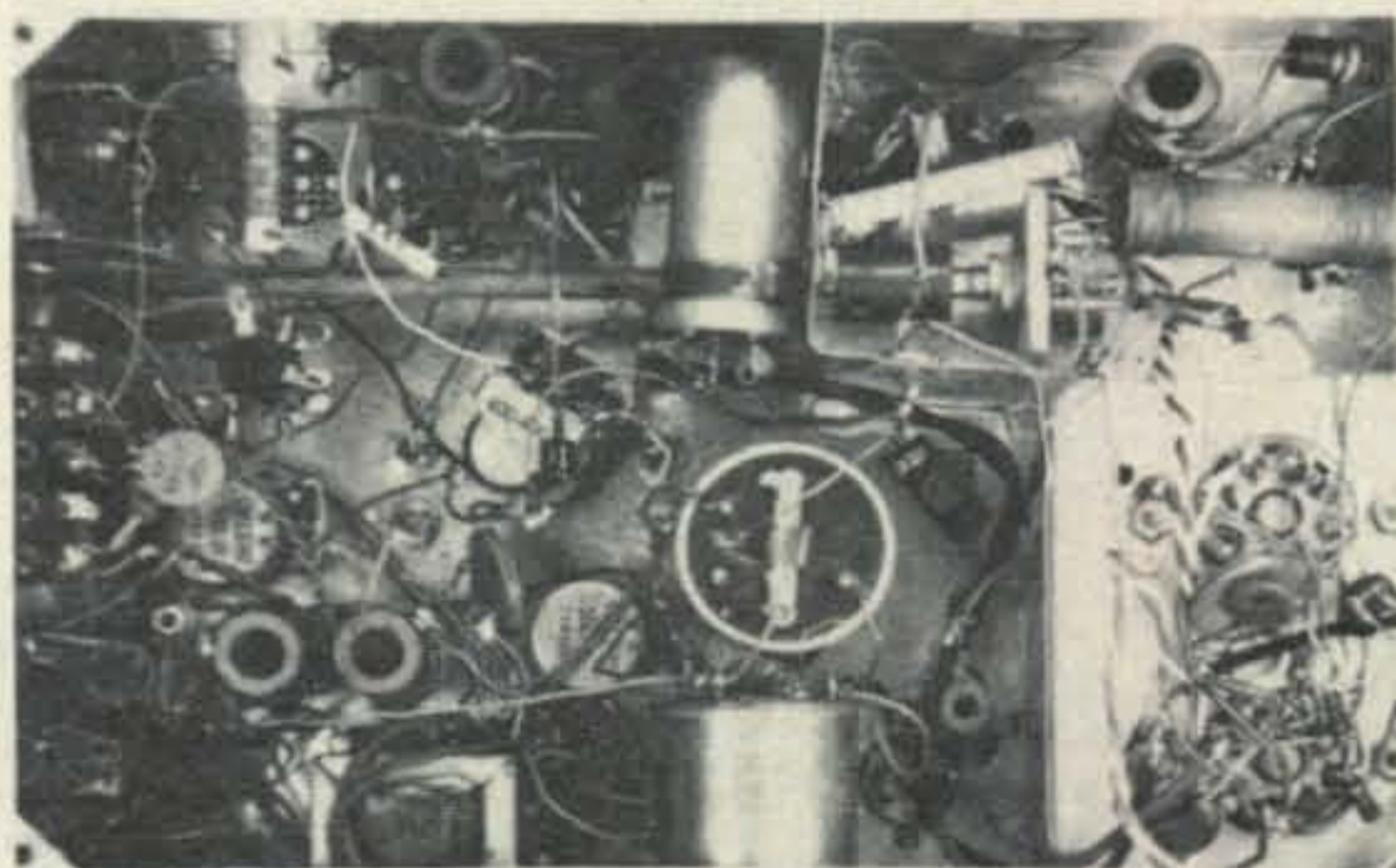

Fig. 3—Circuit of a Q multiplier needed to improve the selectivity of the ARC-5 receiver for adequate s.s.b. reception.

- $C_1$ —250 mmf silver mica.
- $C_2$ —500 mmf silver mica.
- $L_1$ —14.31  $\mu$ h. Miller 4407 or equiv.
- $S_1$ —D.p.d.t. toggle or rotary switch.

nect the vertical input of an oscilloscope to the arm of the CARRIER BALANCE potentiometer,  $R_1$ , and the horizontal input to the arm of  $R_2$ . Advance AUDIO GAIN,  $R_5$ , to the 9 o'clock position and adjust the scope controls until a convenient amount of deflection is noted. PHASING control,  $R_3$ , is now adjusted until a circle is discernible on the oscilloscope. This indicates the required 90 degrees of phase shift. Control  $R_4$  is now adjusted so



Bottom view of ARC5 Receiver/Transmitter showing transmitting section. Top right is the 12BY6 driver stage with the basis of p.a. sockets below. (A custom fitted aluminum shield separates them from the rest of the section.) Transformer  $T_2$  (mounted vertically) and  $T_3$  (horizontally mounted) are in the center.  $T_1$  is the open frame transformer mounted below  $T_3$ .  $L_1$  and  $L_2$  are to the left of  $T_1$ . The diode balanced modulators are wired to the terminal strip at the center front.

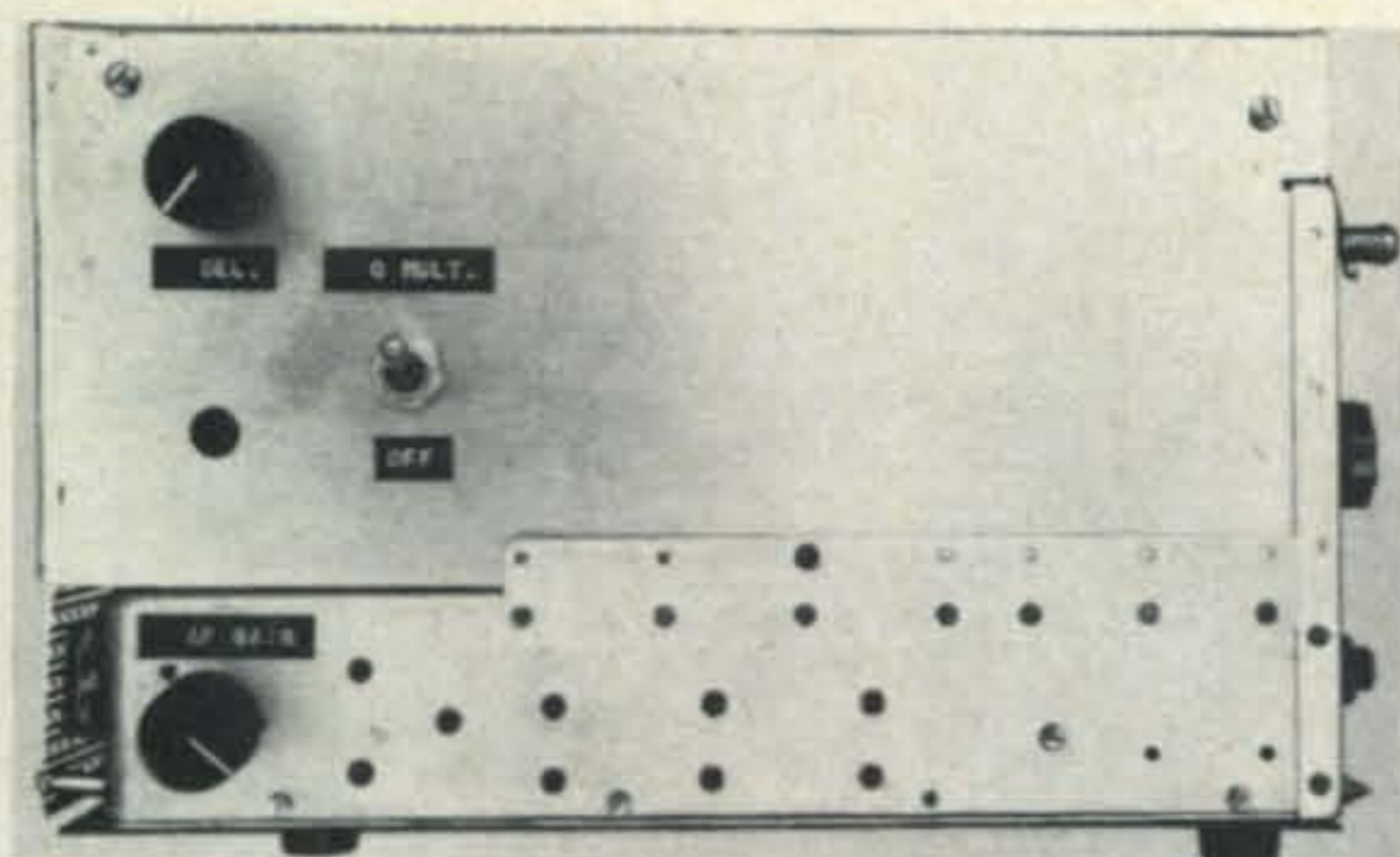

Side view of the receiver side of the transceiver showing the Q Multiplier switch and sensitivity control and the A.F. gain control.

that the voltages on the arms of  $R_1$  and  $R_2$  are equal in amplitude. Connectors  $P_1$  and  $P_2$  are now plugged into  $J_1$  and  $J_2$ ;  $S_1$  is placed in the TRANSMIT position and the receiver tuned to approximately 7250 kc.

Remove the tone from  $J_3$ . Install a temporary link of 4 turns at the cold end of  $L_6$  and connect it directly to the vertical plates of the oscilloscope. Unbalance  $R_1$  or  $R_2$  to inject carrier and peak  $L_1, L_3, L_4, C_1$  and  $C_2$  for maximum output. Now adjust  $R_1$  and  $R_2$  for minimum output and reapply the 1000 c.p.s. tone to  $J_3$ . While using a horizontal sweep of about 100 c.p.s. adjust  $L_2$  for minimum ripple as observed on the oscilloscope. This should be repeated with the sideband switch,  $S_2$ , in both positions. It may be necessary to go through this adjustment several times, also adjusting  $L_1$ , to obtain minimum and similar ripple patterns on both sidebands. The tone should be removed and  $R_1$  and  $R_2$  adjustments checked for minimum carrier.

The temporary pickup loop can now be removed from  $L_6$  and high voltage applied. Adjust  $R_6$  for a zero signal plate current of

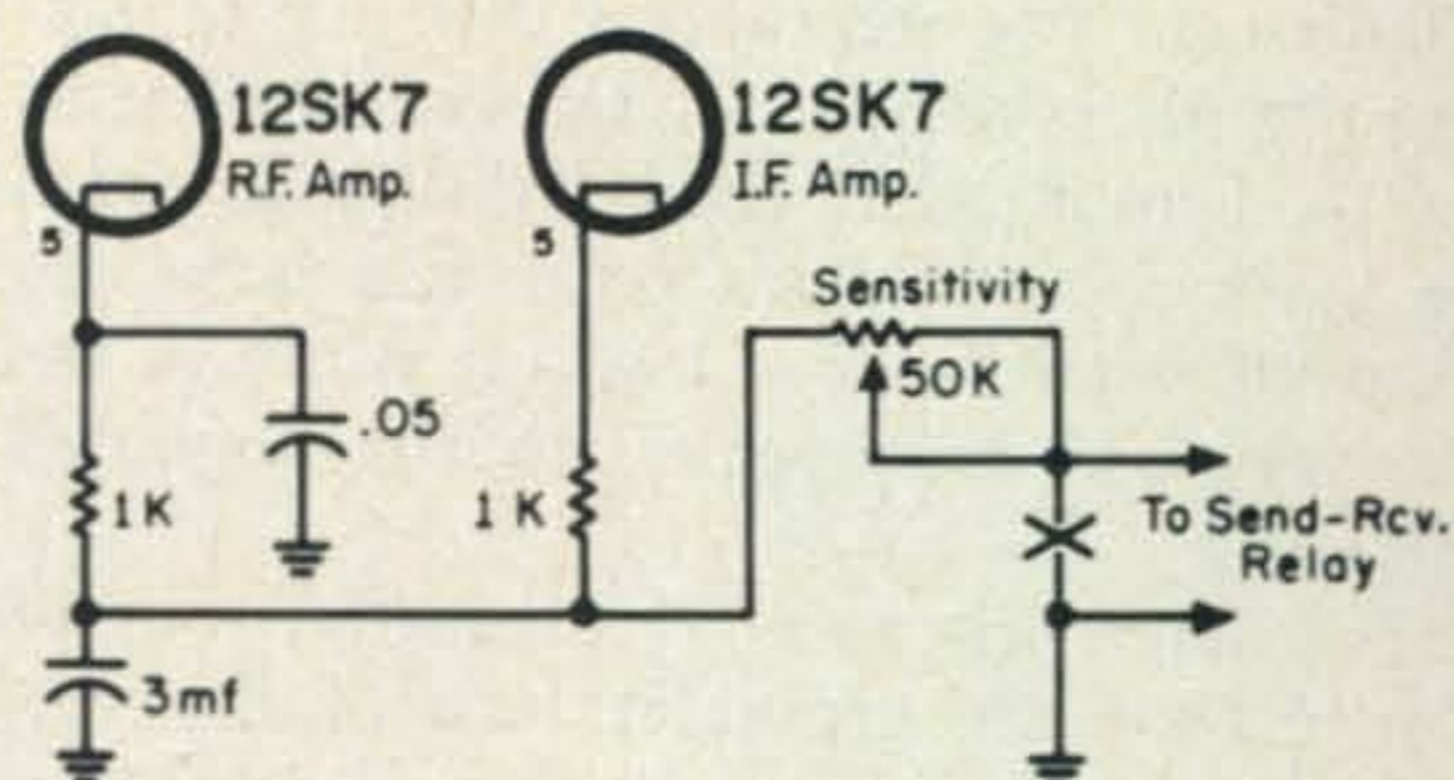

Fig. 4—Modification of the sensitivity control circuit of the ARC-5 receiver for muting completes the modifications for this section.

40 ma. Connect a 50 ohm dummy load to the antenna jack through an s.w.r. bridge. With  $C_4$  at maximum capacity, insert carrier by unbalancing  $R_1$  or  $R_2$  and tune  $C_3$  for a dip in current. Reduce  $C_4$  and redip  $C_3$ ; continue this procedure until maximum output is indicated on the bridge.

Neutralization is accomplished by adjusting  $C_N$  until minimum current on the milliammeter and maximum power shown on the s.w.r. indicator coincide.

### Operation

This completes the adjustments and the only thing remaining is the connection of the microphone, or key and a suitable antenna. Voltages up to 1000 have been used on the 6146 tubes but 750 is normal. The current indication on voice peaks averages 125 milliamperes. C.w. operation is available by inserting a key plug into  $J_4$  and closing  $S_1$  during the transmit period. Carrier is obtained by unbalancing  $R_1$  or  $R_2$ .

The Q multiplier makes possible a marked improvement in the selectivity and is of great help when the band is crowded. More band spread might be desired by some and is attainable by the sacrifice of some of the original frequency coverage. It could be accomplished by removal of some of the plates in the BC-455 tuning capacitors. For the more ambitious,

[Continued on page 98]

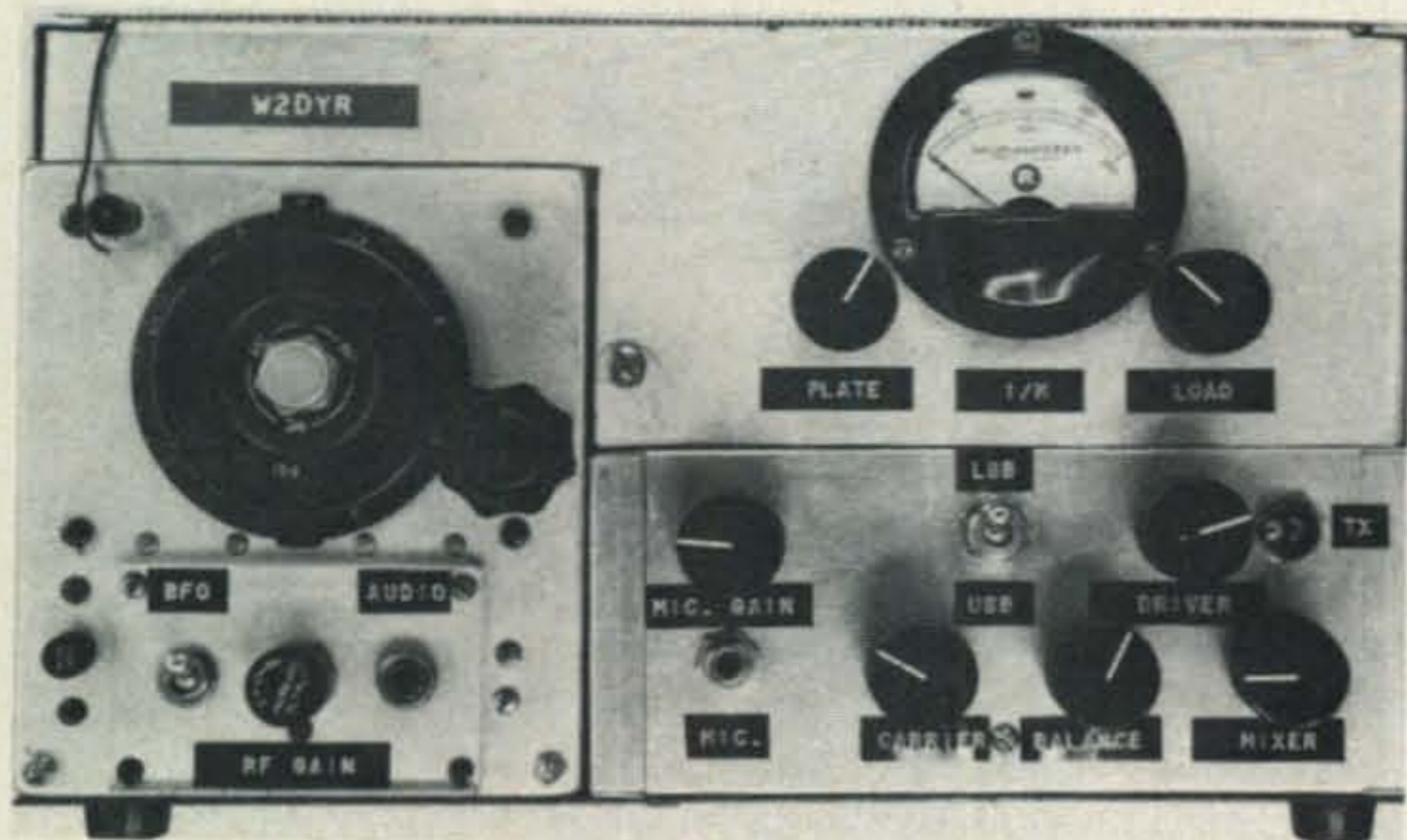

Front view of the ARC-5 s.s.b. transceiver showing all control locations.

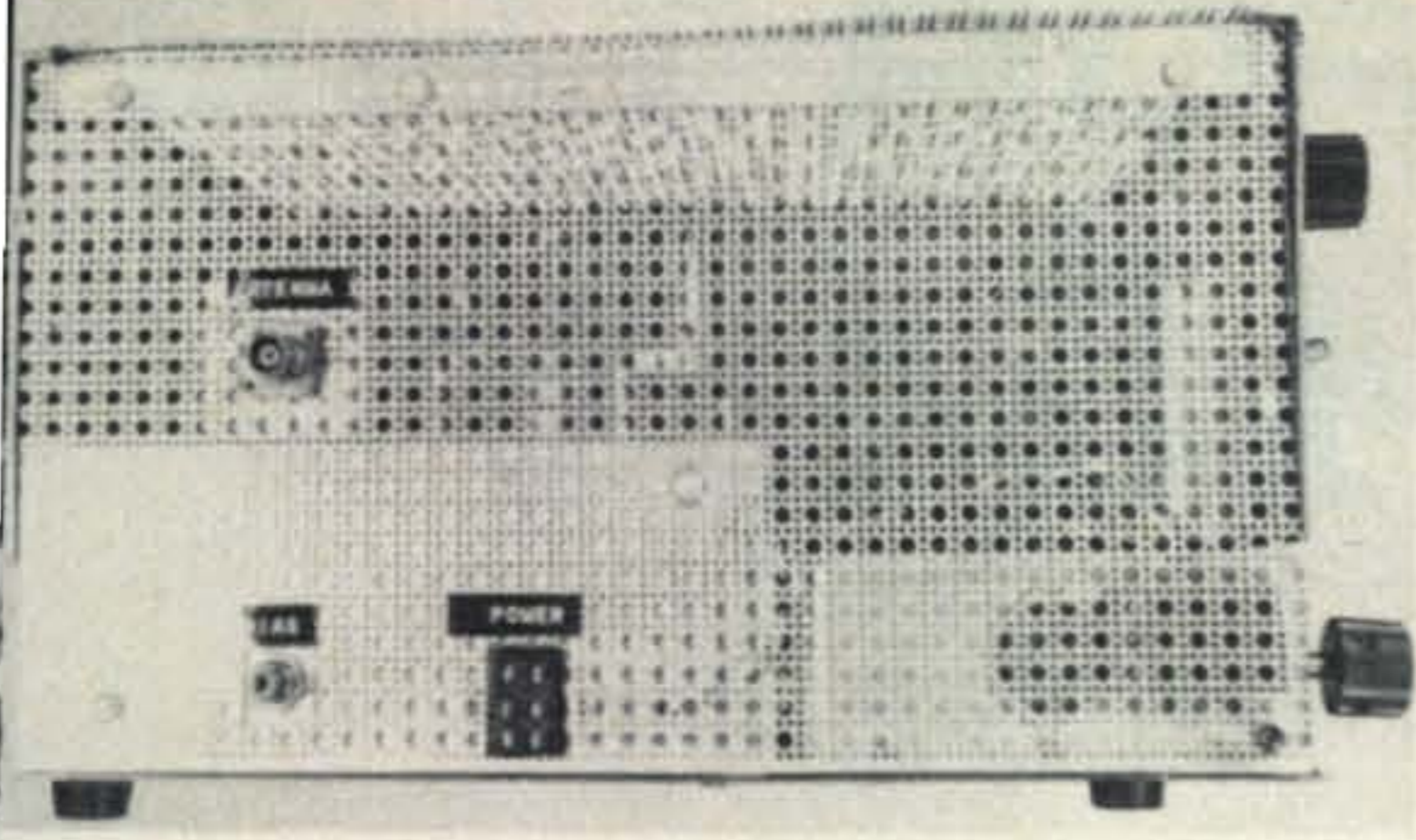

Rear view ARC5 Receiver/Transmitter. Shaft of Bias control for p.a. tubes is at bottom left and a 6 prong Jones plug for power to the right. The knob at the bottom right corner is for a.f. gain on the receiver. (It is not needed but was present on this ARC-5 when it was obtained.)

Fig. 5—Circuit of the phasing type s.s.b. exciter to be used with the ARC-5 receiver for transceive operation. All capacitors whose values are greater than one are in mmf. Capacitors with values less than one are in mf unless otherwise noted. All resistors are 1/2 watt except where otherwise noted.

- C<sub>1</sub>, C<sub>2</sub>—35 mmf, Hammarlund HF35 or equiv.
- C<sub>3</sub>—100 mmf, Hammarlund HF100S or equiv.
- C<sub>4</sub>—Dual 365 mmf broadcast variable, both sections paralleled.
- C<sub>N</sub>—15mmf, Hammarlund HF15X or equiv.
- K<sub>1</sub>—relay, d.p.d.t., 12 v.d.c. coil.
- K<sub>2</sub>—relay, s.p.d.t., 12 v.d.c. coil.
- L<sub>1</sub>, L<sub>2</sub>—Miller type 4408 ceramic r.f. coil, 30 to 69 μh with 8t. #24 plastic covered hookup wire on the cold end of each coil. The coils are spaced 1" apart center to center.
- L<sub>3</sub>—Miller type 4504 ceramic r.f. coil 2.8 to 5.0 μh. Add a center tap and wind 3 turns of #24 plastic hookup wire around the center.
- L<sub>4</sub>—Miller type 4408 ceramic r.f. coil. 30 to 69 μh connected in series with the winding on L<sub>3</sub>. There is no direct coupling between L<sub>3</sub> and L<sub>4</sub>.
- L<sub>5</sub>, L<sub>6</sub>—Miller type 4407 ceramic r.f. coil, 14.8 to 31 μh.
- L<sub>7</sub>—24t #14 e., 1 1/4" dia., 2 1/2" long.
- RFC<sub>1</sub>, RFC<sub>2</sub>—2.5 mh.
- T<sub>1</sub>, T<sub>2</sub>, T<sub>3</sub>—20K to 500 ohm a.f. transformer. (The W2EWL type, available surplus.)
- Z1—B&W phasing network type 350-2Q4.

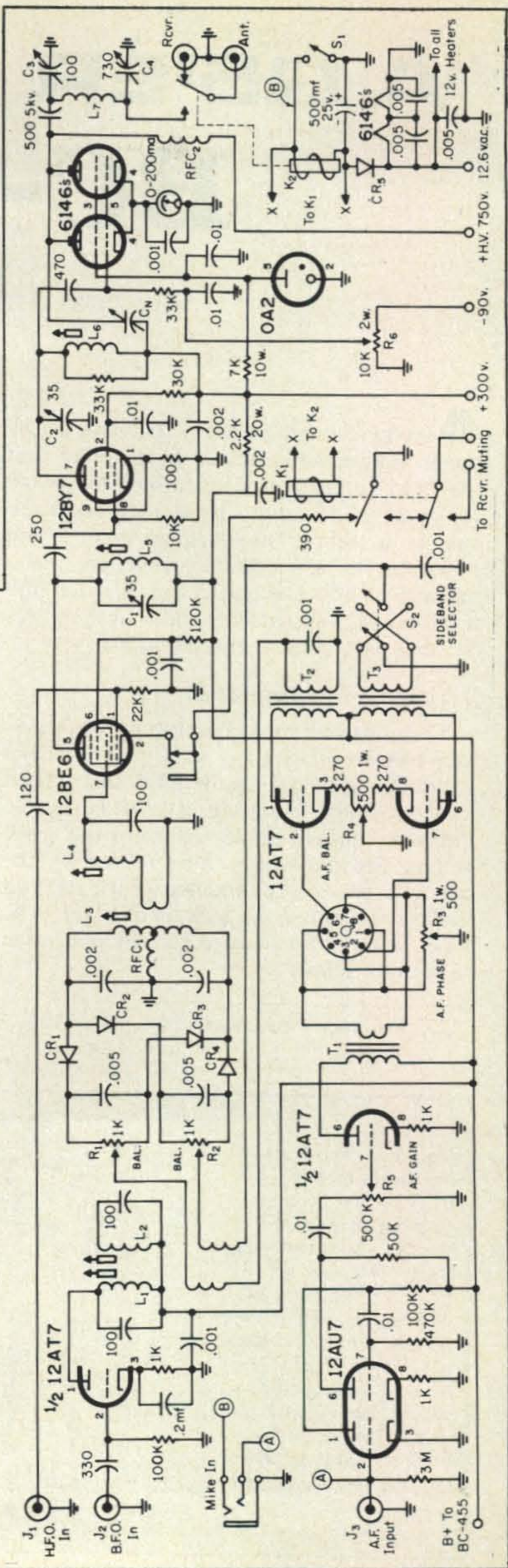





# POWER

NCL-2000 Linear Amplifier  
another great one  
from NRCI



The NCL-2000 is desk-top dynamite in the form of a 2000-Watt 5-band linear amplifier. If you want high efficiency, superb linearity, operator-oriented design, and contest-winning punch in a pile-up, the NCL-2000 is your kind of linear. NRCI reliability engineering also assures that there's no need to retune with every frequency shift. Turn on the legal limit in this beautiful package.

- Frequency Range: 80, 40, 20, 15 and 10 meter bands, with significant band-edge overlap for MARS service.
- Input Power: SSB — 1000 Watts average, 2000 Watts PEP. AM, CW, RTTY — 1000 Watts.
- Output Power: SSB — 1300 Watts PEP minimum

on all bands. AM — 300 Watts minimum. CW, RTTY — 600 Watts minimum.  Drive Requirements: 20 to 200 Watts, PEP, adjustable.  Output Impedance: 40 to 60 Ohms (minimum).  Power Supply: Built-in, solid-state design. 115 V.A.C. or 230 V.A.C. Draws 15 amperes maximum at 230V.  Tubes and Semiconductors: Two 8122 ceramic tetrode output tubes, plus 13 semiconductors.  Fully metered, safety engineered.

PLUS: ALC provisions, internal dummy exciter load, full-access front and rear panel design, and time delay, plate overload, plate power and antenna relays.

**AMATEUR NET PRICE: \$685.00**

See your favorite dealer, or write directly to factory for complete specifications and description.

**NATIONAL RADIO COMPANY, INC.**

**NRCI**

37 Washington Street, Melrose, Mass. 02176  
Telephone: (617) 662-7700 TWX: 617-665-5032

International Marketing through: Ad. Auriema, Inc., 85 Broad Street, New York, New York 10004

© 1969, National Radio Company, Inc.

**LIBERTY  
PAYS**      **MORE!**  
**WILL BUY**  
**FOR CASH**  
**ALL TYPES**

- **ELECTRON TUBES**
- **SEMICONDUCTORS**
- **Military Electronic Equipment**
- **Test Equipment**

---

**WIRE, WRITE, PHONE COLLECT! WE PAY FREIGHT ON ALL PURCHASES**

---

**Liberty Electronics, Inc.**

**548 Broadway, New York, New York 10012, Phone 212-925-6000**

**LIBERTY  
OFFERS**      **MORE!**  
**PRESTEL FIELD STRENGTH..METER**

**(Model 6T4G)**

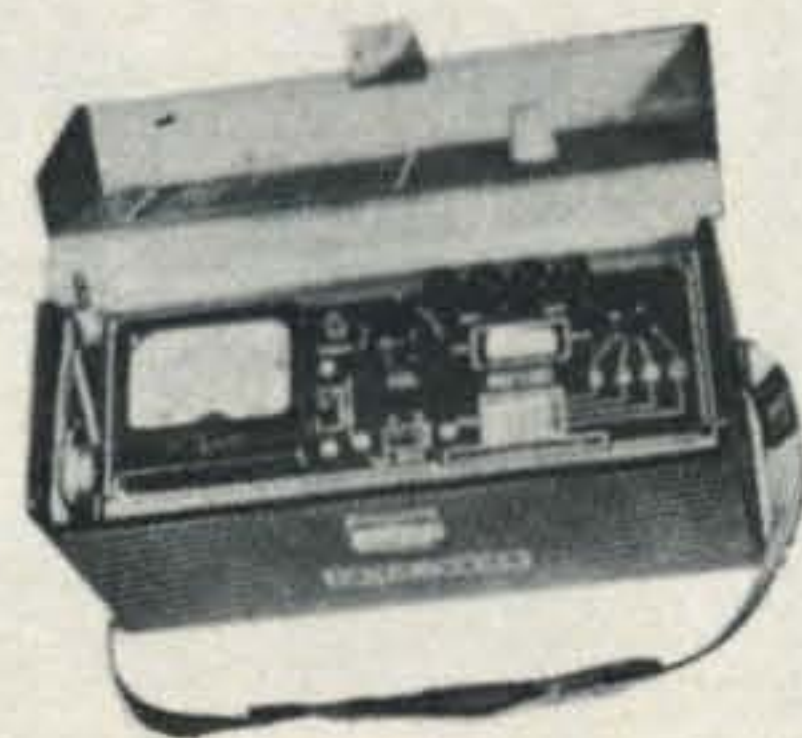

Frequency Range: 40 to 230 and 470 to 860 Megahertz. Calibrated outward from 10 to 50,000 Microvolts. Nothing makes it easier to properly and speedily find the correct place to install TV, FM and Communication Antennas. You can measure and hear the signals

with this 4½ volt battery economically powered unit. There is nothing else like it!

**Only \$120.00**

front view of the No. 19 transceiver, a British surplus job, showing the control locations. The control markings are in English and Russian.

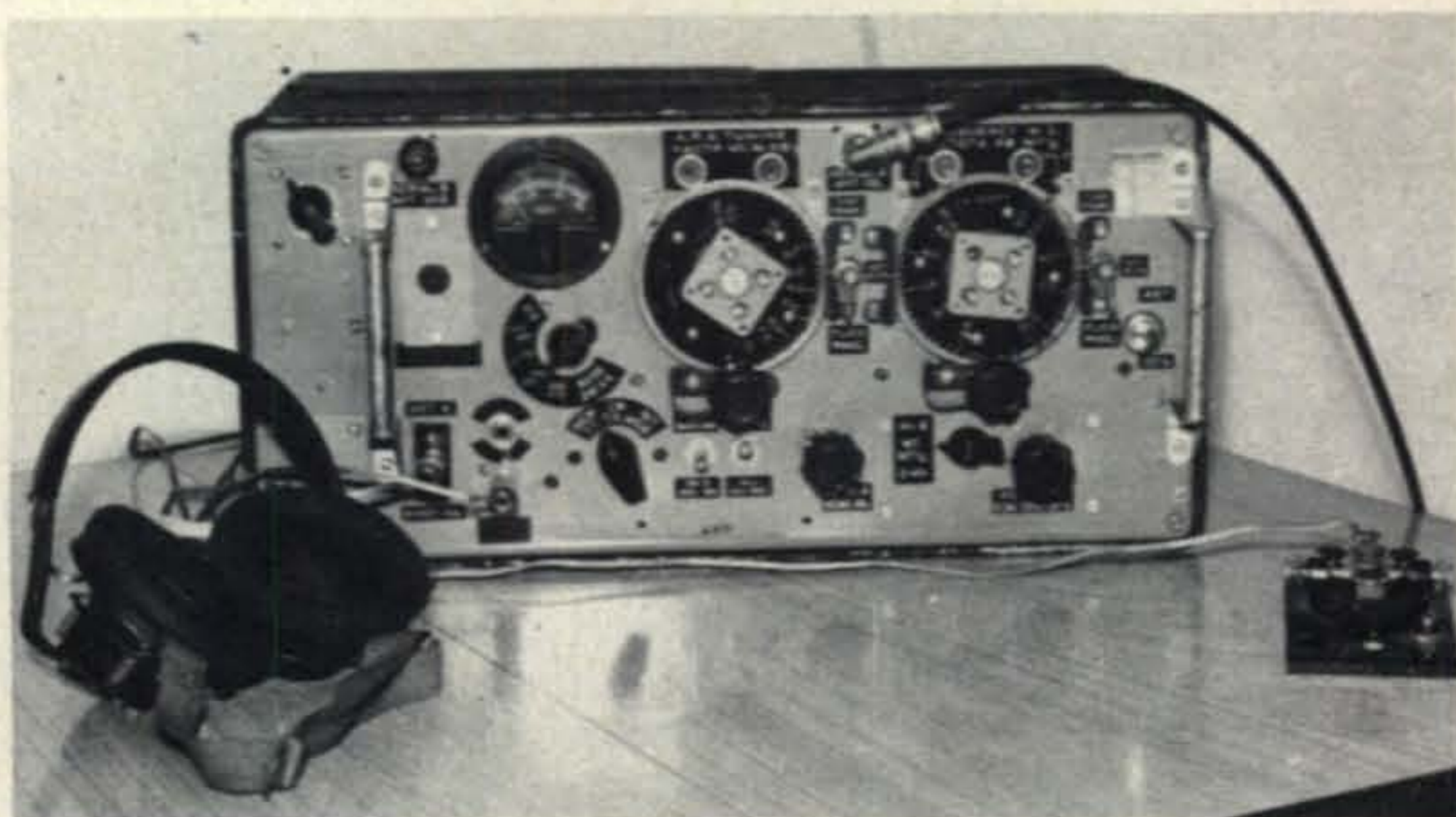

# CONVERTING THE NO. 19 SETS

BY SAM KELLY,\* W6JTT

Wireless Set No. 19 is a British surplus transceiver used in their tanks. Each set (there are three, the Mark I, II and III) includes a two tube interphone and a small regenerative v.h.f. transceiver. The conversion for the Mark II, which covers 2 to 8 mc in two bands, is outlined below.

ONE of the stranger pieces of equipment to reach the surplus market is the "Wireless Set No. 19." Large quantities of these sets were made in England, Canada and the U.S. during World War II. They appeared on the surplus market in the late '40's and for some reason they are again appearing. There are at least three models or "Marks" of this set in

12811 Owen St., Garden Grove, Calif. 92641.

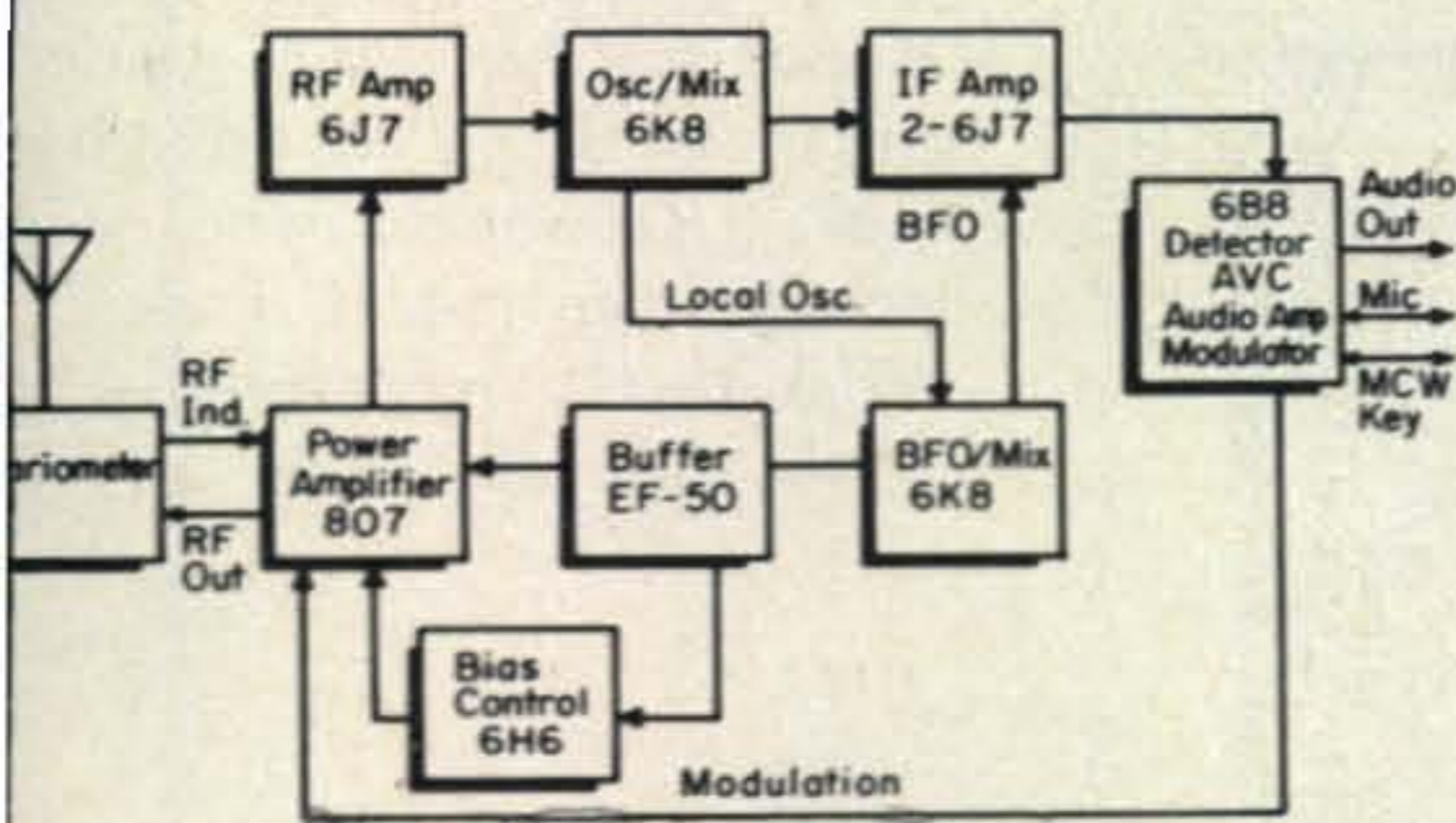

Fig. 1—Block diagram of the British No. 19 surplus transceiver.

existence. The Mark I covers from 2.5 to 6.5 mc in one band. The Mark II and Mark III sets cover 2 to 8 mc in two bands. In addition to the h.f. coverage (A set) each set includes a two tube interphone amplifier (IC) and a small regenerative v.h.f. transceiver (B set). The No. 19 was the standard British Army set for use in armored vehicles and some aircraft. While not too popular in the U.S., the set was far advanced for its time from a design standpoint, and with a little work can be made into a useful portable rig. It is a true transceiver, using the receiver local oscillator for both transmitting and receiving. Of the three versions, the Mark III is the most desirable as it has lower power drain, separate RF and AUDIO gain controls, better b.f.o. action and a c.w. filter.

## Accessories

Prices seem to range from \$10 for the set less accessories to \$45 for complete sets new in overseas packing with all accessories. In

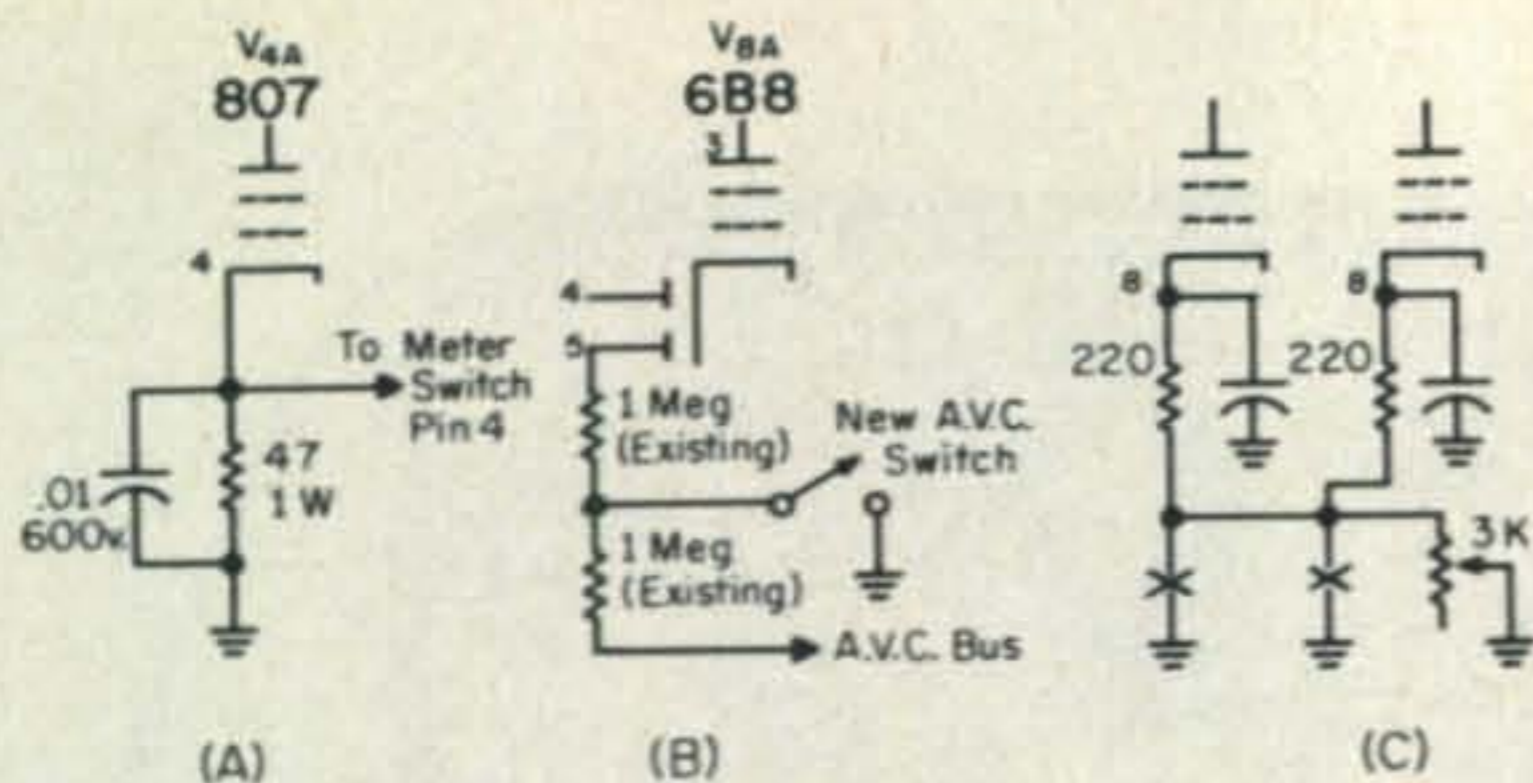

Fig. 2 (A)—Modification of meter switch wiring so that the filament position will read plate current of  $V_{4A}$ , the 807. Connect a wire to the cathode terminal and connect it, in place of the existing wire, to position 4 of the meter switch. The meter then reads plate current, 150 ma full scale. (B)—Addition of the A.V.C. On Off switch. (C)—Addition of a manual r.f. gain control.

order to get on the air with a minimum of problems it is advisable to get the antenna variometer, cable between set and variometer, key, and a set of headphones and microphone. The remaining accessories including the dynamotor and mounting base aren't very useful.

The conversion described applies mostly to the Mark II, the most commonly encountered version. It consists of building an a.c. supply and modifying the receiver to provide manual r.f. gain control and provision for turning off the a.v.c. If you have the Mark III the last two modifications won't have to be made.

### Description

Figure 1 is the functional block diagram of the set. The receiver is a six tube super-heterodyne with a 465 kc i.f.

The transmitter section has an 807 in the

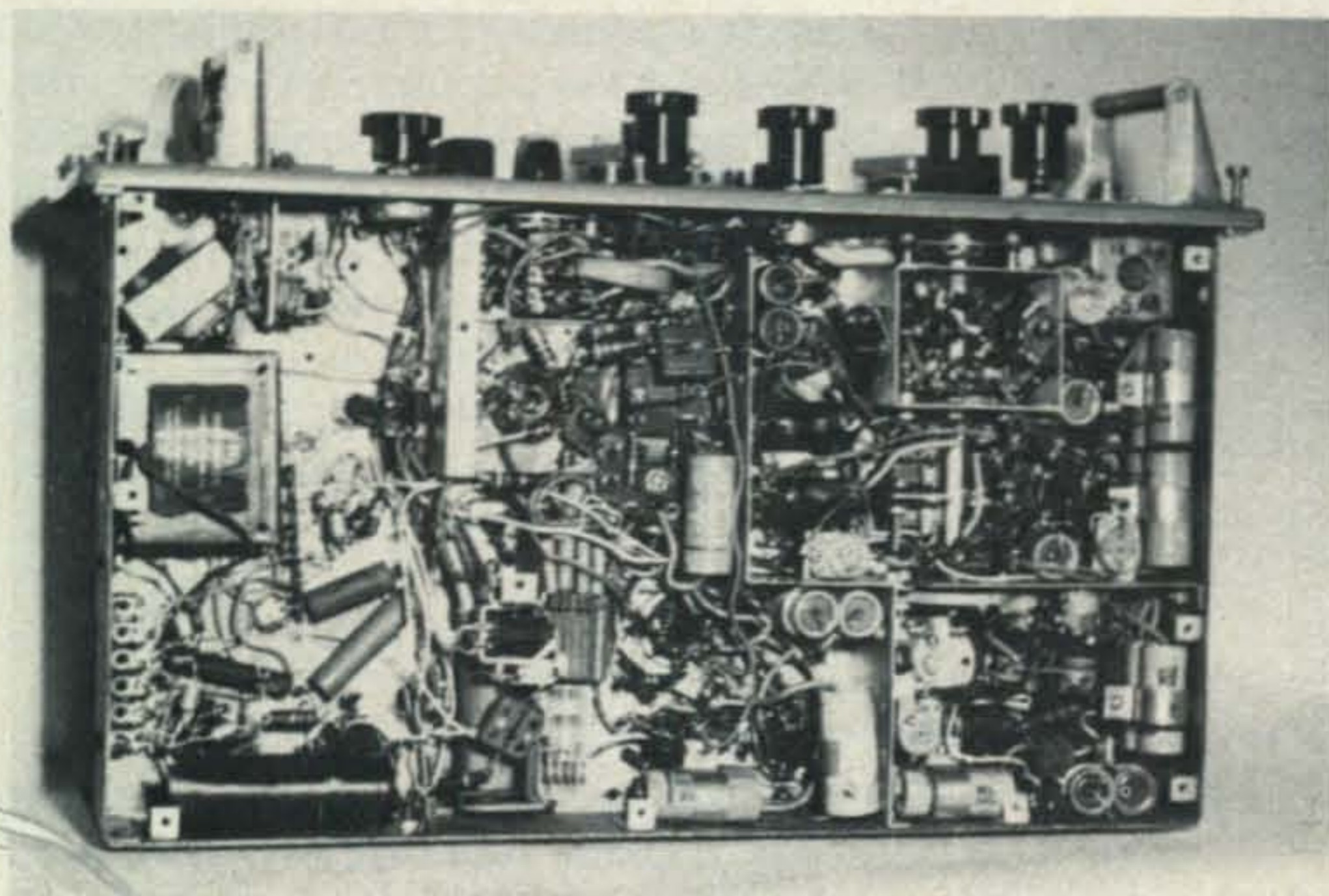

Bottom view of the modified N 19 Mark II transceiver.

final amplifier, a 6H6 for drive control, buffer stage and a mixer that mixes the receiver b.f.o. with the receiver local oscillator come up with the transmitter frequency control. The receiver audio stage is used to grossly modulate the transmitter for voice or m.c. On c.w. keying is accomplished in the screen of the final amplifier, buffer and mixer stage. A note of caution—if you don't get the original key make sure that you get a plastic barreled phone plug as the jack and leads are hot. Keying was surprisingly clean. Stability was good—less than 100 c.p.s. drift over 30 minutes (after a 5 minute warm up). The stability is dependent upon power supply regulation. Receiver sensitivity was 2 microvolts for a 10 db signal to noise ratio.

### Modification

The interphone amplifier and v.h.f. transmitter are useless and were removed for the conversion. To start, remove the set from the case and remove the tubes and bottom plate. Remove all components associated with the v.h.f. transceiver and interphone amplifier. This is quite simple as they are all grouped in the shielded compartment behind the v.h.f. tuner assembly with the exception of the tar dipped transformer behind the final amplifier. (The big one!). The components to be removed are:  $T_{6A}$ ,  $T_{4B}$ ,  $T_{5A}$ ,  $V_{1D}$ ,  $V_{8A}$ ,  $V_{8B}$ ,  $V_{1E}$ ,  $V_{1F}$ , Relay  $L_{19B}$  and the v.h.f. tuning assembly. Remove all the associated components and tube sockets except for the two sockets at the rear that held the 6V6. These will be used later for the v.r. tube and filter capacitor. Clip all leads going to the B Set ON toggle switch. This will be used for a.v.c. control.

Install a 3 conductor microphone jack at the rear of the chassis. Install a standard phone jack. Install a 3K pot in the hole vacated by the B Set gain control. This will be the RF GAIN control. Reconnect the wires going to pin 4 of  $PL_{2A}$  to the phone jack. Reconnect the wires going from pin 1 and 7 of  $PL_{2A}$  to the microphone and push to talk lugs of the

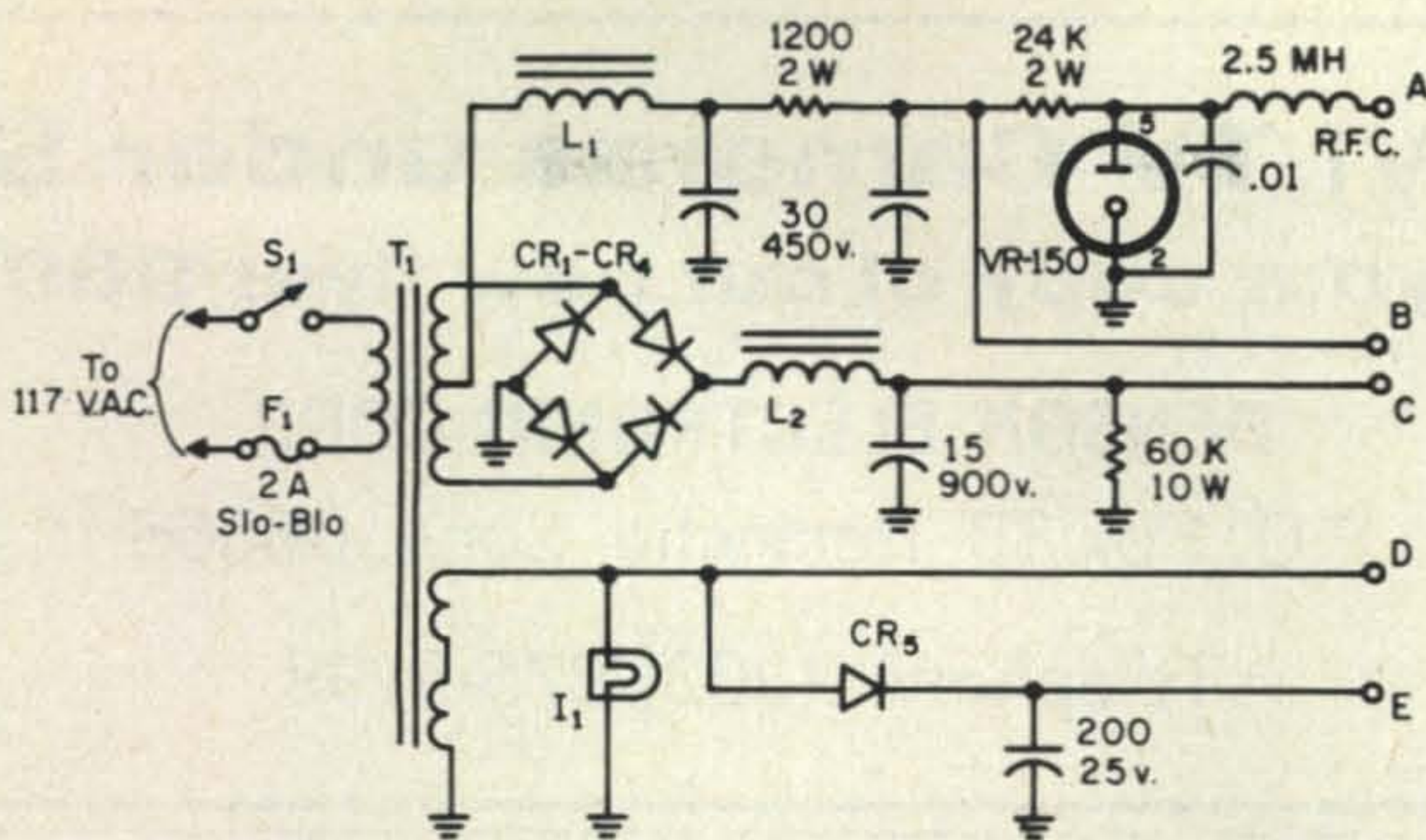

Fig. 3—Power supply that can be used to power the No. 19 transceiver. The wiring is as follows:

- A—Connect to pin 6 of  $V_{2A}$  in place of the 47K resistor.
- B—Connect to the red/black wire removed from pin 6 of  $PL_{1A}$ .
- C—Connect to the red wire removed from pin 4 of  $PL_{1A}$ .
- D—Connect to the white/black wire removed from pin 3 of  $PL_{1A}$ .
- E—Connect to relay  $L_{19A}$  in place of blue wire running to 807 filament.

### Parts List

- CR<sub>1</sub> to CR<sub>4</sub>—2A., 1500 p.i.v.
- CR<sub>5</sub>—1A., 50 p.i.v.
- L<sub>1</sub>, L<sub>2</sub>—10 h., 100 ma.
- I<sub>1</sub>—700 v.c.t., 100 ma; 6.3 v., 5A; 6.3 v., 5A.

### Operation

Turn the set on and let it warm up. Connect a 12' antenna to the output of the variometer. Place the function switch in the cw position and tune in a signal. The p.a. tuning capacitor must be set close to the incoming frequency since the p.a. tank is also the input to the first r.f. stage. Next pick a clear frequency in one of the ham bands and peak the p.a. tuning and variometer on noise. Close the key and check for grid drive. It should be

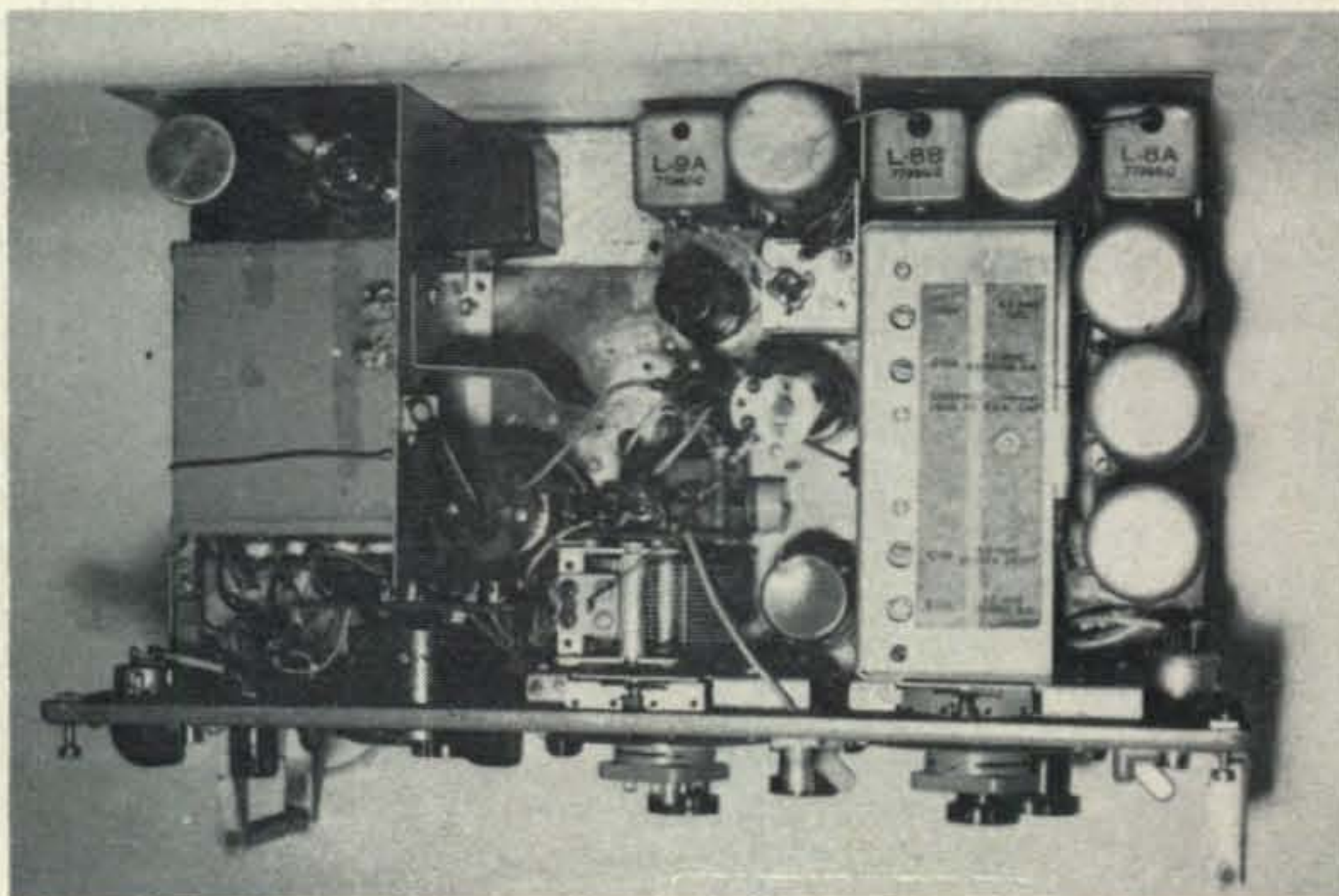

Top view of the No. 19 transceiver, a British surplus unit. The power supply is on the left in the space formerly occupied by the interphone amplifier and the v.h.f. transceiver.

# WOW! TV Cameras under \$50

Get your copy of our new flyer 969M1

DENSON ELECTRONIC CORP.

P.O. Box 85, Rockville, Conn. 06066

Telephone: (203) 875-5198



**FREE Catalog** Of The WORLD'S  
FINEST GOV'T  
SURPLUS ELECTRONIC BARGAINS

Now **BIGGER** and  
**BETTER** Than Ever!

MAIL THIS COUPON NOW

NAME: \_\_\_\_\_

ADDRESS: \_\_\_\_\_

CITY: \_\_\_\_\_ STATE: \_\_\_\_\_ ZIP: \_\_\_\_\_

For your FREE copy, fill out coupon and mail. Dept. CQ

**FAIR RADIO SALES**

P.O. Box 1105 • LIMA, OHIO • 45802

— SPRING SALE —

T. T. PAPER (BOX OF 12)	6
BC-223-AX TRANSMITTER TUBES NEW BOXED	1
LORAN (APN-9)	69
NAVY RECEIVER T.M.C. 2 TO 32 MCS	250
NAVY RECEIVER RCA AN/SRR13A 2-32 MCS	350
HAMMARLUND SP-600 .54 TO 54 MCS	350
STANLEY HINGES 1 x 1 INCHES BOX OF 48	
BOX OF 24, 1½ x 1½ INCHES	

MINIMUM ORDER 5.00

NO CATALOGS. WE BUY AND SELL TEST EQ

**COMMUNITY ELECTRONICS, INC.**

351 W. SUNRISE HIGHWAY FREEPORT, N.Y. 11731  
516-378-0527

approximately 1/3 of the meter scale. Place the meter switch in the AE (Aerial Energy) position, close the key and tune the variometer and p.a. tuning for maximum output. You are now ready to operate. The variometer must be used to get an r.f. output indication. Besides the conventional loading coil, the assembly contains a small r.f. transformer and bridge rectifier to rectify the r.f. voltage. The d.c. is sent back on the output coax. Pretty clever for a set designed in the late 30's.

While the antenna tuning system is designed to match a 12' whip, it will also match a variety of random length wires. To get the best results a good ground must be used.

The dial calibration is enough to scare those that are used to the 1 kc resolution of today's transceivers. It takes a bit of getting used to particularly on 40. While the bands are calibrated from 2 to 4.5 mc and 4.5 to 8 mc they actually cover from 1.9 to 4.5 mc and 3.5 to 8 mc. For those active on 160 it is an easy matter to retune the low band to cover all of 160 and recalibrate the high band from 3.5 to 8 mc. If this is done, additional

padding capacitance will have to be added to the final tank tuning capacitor.

### The Flick

An interesting provision is made for setting two frequencies. This is the mechanical FLICK assembly which consists of circular plates which can be locked to shaft of the tuning capacitors by means of clamping screws that protrude from the assembly. To set up a frequency, loosen two clamping screws having the same coding. Place the selector lever in the FLICK position and rotate the dials until the detent drops in. Place the selector lever in the position and tune in the desired frequency. Lock the clamping screws. The desired frequency can be retuned by simply placing selector lever in the FLICK position and rotating dials until the detent drops in.

Having an 807 in the final is a real temptation to jack up the power. A word of caution—don't try it. Most of the components are rated for 600 volts maximum. The sn

[Continued on page 102]

# HOWARD W. SAMS BOOKS FOR THE AMATEUR

Famous Editors & Engineers Books

## NEW AND IMPORTANT

### 73 Dipole and Long-Wire Antennas

by Edward M. Noll. The first compendium of virtually every type of wire antenna used by amateurs. Includes dimensions, configurations, and construction data for 73 types, plus appendices describing construction and operation of noise bridges and antenna line tuners, and data on measuring resonant frequency, velocity factor, and SWR. 160 pages.

65071, only.....\$4.50

### Amateur Tests and Measurements

by Louis M. Dezettel, W5REZ. Shows how to perform virtually all performance tests on amateur transmitters, receivers, and antennas, and how to make required adjustments. An invaluable book for the amateur who wants to maintain top operating efficiency. 192 pages.

65072, only.....\$4.95

## 17TH EDITION OF THE FAMOUS E & E Radio Handbook

Tells how to design, build, and operate latest types of amateur transmitters, receivers, transceivers, and amplifiers. Provides extensive, simplified theory on practically every phase of radio. All original data, up-to-date, complete, 848 pages.

EE-167, only.....\$12.95

### The VHF Amateur

by Robert M. Brown, K2ZSQ/W9HBF. Completely updated handbook incorporating the finest material on vital vhf subjects from the rare back issues of the famous VHF Magazine, plus new data of great interest to both old and new vhf men. 160 pages.

EE-65060, only.....\$4.50

### Commercial Radiotelephone License Q&A Study Guide

by Woodrow Smith & Robert Welborn. Invaluable preparation for the exams. Questions cover first four elements of the radiotelephone license exam. Answers are detailed and comprehensive. 272 pages.

EE-031, only.....\$6.95

### Single Sideband: Theory and Practice

by Harry D. Hooton, W6TYH. The one-source guide to ssb, covering origin and principles, derivation of ssb signals, carrier-suppression techniques, sideband selection, and a complete analysis of ssb equipment. 388 pages. EE-350, only.....\$6.95

### Transistor Radio Handbook

by Donald L. Stoner, W6TNS & Lester A. Earnshaw, ZL1AAX. Covers the use of transistorized communications equipment for amateur and commercial applications. Provides simplified theory, plus practical construction projects for solid-state equipment. 180 pages. EE-044, only.....\$5.00

### Amateur Radio Incentive Licensing Study Guide

by Robert M. Brown, K2ZSQ/W9HBF and Tom Kneitel, K2AES. Fully explains the new incentive licensing which affects both newcomers and old-timers. Covers all the new FCC Regulations and band allocations. Includes sample exams for Novice, Technician, Conditional, and General-Advanced- and Extra-Class licensing. 160 pages. EE-050, only.....\$2.75

### Advanced & Extra-Class Amateur License Handbook

by Howard S. Pyle, W7OE. Provides all the information you need to obtain your advanced—or extra-class license. Makes preparation for these top licenses far easier for present holders of lower licenses. Includes sample questions for each exam. 192 pages.

20649, only.....\$3.95

### General-Class Amateur License Handbook

by Howard S. Pyle, W7OE. A complete guide, including typical FCC test questions and answers, to help you prepare for the Technician, Conditional, or General-Class radio exam. 144 pages. 20639, only.....\$3.25

### Amateur Radio SSB Guide

by Harry D. Hooton. Invaluable to anyone owning or planning to buy ssb equipment. Explains basic principles and purpose of ssb transmission; analyzes in detail the balanced modulation circuit and its application in a typical transmitter. Includes schematics for building or troubleshooting ssb transmitters and receivers. 136 pages. 20629, only.....\$3.95

### Ham Antenna Construction Projects. 2nd Ed.

by J. A. Stanley. The antennas described are either homemade or represent major modifications of manufactured types. All designs are practical, and include improved new versions of the Marconi, Yagi, and 8JK, primarily for 10-500 watt PEP class rigs. 176 pages.

20654, only.....\$3.95

### Transistor Transmitters for the Amateur

by Donald L. Stoner, W6TNS. Shows how to build solid-state crystal checker/calibrator, low-power cw xmitter and eight other transistorized projects. 128 pages.

20450, only.....\$3.25

### Building Your Amateur Radio Novice Station

by Howard S. Pyle, W7OE. Provides complete, easy-to-follow construction details for building an inexpensive transmitter and receiver, plus several valuable accessory items, for Novice or General Class operation. 128 pages. 20050, only.....\$3.75

### Amateur Radio Mobile Handbook

by Charles Caringella, W6NJV. Provides complete information for going mobile. Explains circuitry and construction of commercially built mobile amateur equipment. Shows how to build mobile converters, transmitters, transceivers, and modulators, etc. 176 pages.

20035, only.....\$3.50

### Amateur Radio Construction Projects

by Charles Caringella, W6NJV. Shows how to build novice transmitters, converters, all-band phone-cw transmitter, and others. Provides detailed, easy-to-follow building and operating instructions. 136 pages.

20045, only.....\$3.25

### OTHER POPULAR TITLES

Transistorized Amateur Radio Projects. 20570.....\$3.50

So You Want to Be a Ham. 4th Ed. 20607..... 4.50

ABC's of Ham Radio. 3rd Ed. 20638..... 2.95

Practical Ham Radio Projects. 20042..... 2.95

International Code Training System. 20138..... 7.50

Amateur Radio Antennas. 2nd Ed. 20611..... 3.95

101 Easy Ham Radio Projects. 20674..... 3.95

## HOWARD W. SAMS & CO., INC.

Order from any Electronic Parts Distributor, or mail to Howard W. Sams & Co., Inc., Dept. CQ-59 4300 W. 62nd St., Indianapolis, Ind. 46268

Send the following books: Nos. \_\_\_\_\_  
 \_\_\_\_\_ \$ \_\_\_\_\_ enclosed

Send FREE 1969 Sams Book Catalog

Name \_\_\_\_\_  
 PLEASE PRINT

Address \_\_\_\_\_

City \_\_\_\_\_ State \_\_\_\_\_ Zip \_\_\_\_\_

## N. W. ELECTRICS

12 ST. ANCOATS STREET  
MANCHESTER 4  
M13 2JN

### G3MAX

Business hours: 9.30-4.30, Tuesday-Saturday  
CLOSED ALL DAY MONDAY

Specialist repaired emergency services for 1st and 2nd world wars

Marconi "SPRING" Allwaveband Wireless  
20 or 100 Watts with Collins Class C Output  
Power to 2000 W. 2000 W. 2000 W. 2000 W.  
Power 2000 W. 2000 W. 2000 W. 2000 W.  
Power 2000 W. 2000 W. 2000 W. 2000 W.

K.A.T. Modulator by TRIM VHF Trans  
Output 500-1000 W. 500-1000 W. 500-1000 W.  
100-100 W.

Control Unit Type 101 Control Unit  
with 1000 W. 1000 W. 1000 W. 1000 W.  
1000 W. 1000 W. 1000 W. 1000 W.  
1000 W. 1000 W. 1000 W. 1000 W.

Complete Working Unit 2000 W. 2000 W. 2000 W.  
2000 W. 2000 W. 2000 W. 2000 W.

3000 W. 3000 W. 3000 W. 3000 W.  
3000 W. 3000 W. 3000 W. 3000 W.  
3000 W. 3000 W. 3000 W. 3000 W.

5000 W. 5000 W. 5000 W. 5000 W.  
5000 W. 5000 W. 5000 W. 5000 W.  
5000 W. 5000 W. 5000 W. 5000 W.

Complete Station 1000 W. 1000 W. 1000 W.  
1000 W. 1000 W. 1000 W. 1000 W.  
1000 W. 1000 W. 1000 W. 1000 W.

Low Frequency Modulators 1000 W. 1000 W.  
1000 W. 1000 W. 1000 W. 1000 W.  
1000 W. 1000 W. 1000 W. 1000 W.

We will have other surplus equipment available  
on request.

G3SMI



FAMOUS ARMY NIGHT-WAVE TRANSMITTER M.11

THIS IS A VERY INTERESTING AND USEFUL SET...  
It is a very interesting and useful set...  
It is a very interesting and useful set...  
It is a very interesting and useful set...



THE TRANSMITTER M.11

THIS IS A VERY INTERESTING AND USEFUL SET...  
It is a very interesting and useful set...  
It is a very interesting and useful set...  
It is a very interesting and useful set...

### JOHN'S RADIO

1000 W. 1000 W. 1000 W. 1000 W.  
1000 W. 1000 W. 1000 W. 1000 W.  
1000 W. 1000 W. 1000 W. 1000 W.

FEW ONLY LEFT  
WALKER-DAVIS SET 11 and CRISTAL  
CALIBRATOR No. 7

THIS IS A VERY INTERESTING AND USEFUL SET...  
It is a very interesting and useful set...  
It is a very interesting and useful set...  
It is a very interesting and useful set...



SHIPPING BAND RECEIVER

THIS IS A VERY INTERESTING AND USEFUL SET...  
It is a very interesting and useful set...  
It is a very interesting and useful set...  
It is a very interesting and useful set...



COMMUNICATION RECEIVER

THIS IS A VERY INTERESTING AND USEFUL SET...  
It is a very interesting and useful set...  
It is a very interesting and useful set...  
It is a very interesting and useful set...



PLUG-IN TX RX  
FOR NO. 19 SET  
MAINS POWER SUPPLY UNIT  
ADDITIONAL SUPPLIES  
RECOMMENDED

THIS IS A VERY INTERESTING AND USEFUL SET...  
It is a very interesting and useful set...  
It is a very interesting and useful set...  
It is a very interesting and useful set...

**SURPLUS**

G. W. SMITH & CO. (RADIO) LTD.  
2-12 URBIN STREET, LONDON, W.C.2

### Fast Mail Order for the Amateur Radio Enthusiast!

TRANS-RECEIVER TWO TWO

LARGE QUANTITY OF VARIOUS SETS RECEIVERS  
AVAILABLE FOR IMMEDIATE SHIPMENT

**JOHN'S RADIO** OLD CO-OP, WHITSHALL ROAD,  
DEIGHTLINGTON, BRADFORD  
TELEPHONE: BRADFORD 3711

### RADIO SHACK LTD.

RESEARCH ANALYSIS RADIO STOCKISTS

10 BEDFORD SQUARE, LONDON, W.1  
We stock a wide range of surplus electronic equipment...  
We stock a wide range of surplus electronic equipment...  
We stock a wide range of surplus electronic equipment...

### POST COUPON NOW!

### G. W. M. RADIO LTD.

1000 W. 1000 W. 1000 W. 1000 W.  
1000 W. 1000 W. 1000 W. 1000 W.  
1000 W. 1000 W. 1000 W. 1000 W.

# BRITISH ELECTRONICS

BY SAM KELLY,\* W6JTT

**H**AM interest in surplus electronics is as varied as hams themselves. For some it has been an economical way to get on the air, while others have collected gear with the obsession of antique dealers. My interest has been in analyzing the design of the equipment and seeing how well it can be made to perform on the ham bands.

Our surplus market has been pretty bleak lately. Most recognizable sets are either badly damaged or priced unbelievably high. Faced with declining prospects for tinkering, I started reading the advertisements in *Wireless World* a prominent British publication, and lo and behold a new source of surplus!

\*12811 Owen St., Garden Grove, Calif. 92641.

British military electronics is much like their infantry weapons, not too much to look at, but perform well under rough conditions. The circuitry of many of the sets is cleverly designed for maximum performance from a minimum number of components. Reflex circuits are much in evidence. The 19 and 22 sets are the earliest examples of true transceivers (oscillator common to both the transmitter and receiver) I have encountered.

Due to shipping costs, the units of most interest to American hams are the field portable sets designed for Infantry and Armor use. These sets are relatively compact and lightweight. Some of the sets such as the 38 are small enough to be sent through the mail via parcel post. This is the most efficient way



Model	Freq. Range In MC	Power Out In Watts	Remarks
9	1.8-9	10	CW-MCW-Voice Armored vehicle set
11	4.2-7.5	7	Infantry Pack Set
12 LP	1.2-17.5	25	CW-MCW-Voice
12 HP	1.2-17.5	300	Xtal or MO control CW-MCW-Voice
17 Mk II	44-61	0.5	Voice only
18 Mk III	6-9	0.5	CW-Voice
19 Mk III	2-8	10	CW-MCW-Voice
	230-255		Tank set
21	4.2-7.5	2	CW-MCW-Voice
	19-31		
22	2-8	2	CW-MCW-Voice
38	7.3-8.8	0.5	Voice only small walkie-talkie
46	5.9-9.1	0.5	Xtal controlled commando set
48	5.9-9.1	0.5	CW-Voice
68P	1.7-3.0	0.75	MO-Xtal controlled CW-Voice
68Q	3-5.2	0.75	MO Only CW-Voice
76A	2-12	20	CW Only special airborne set
R-107	1.2-17.5	—	Communications receiver
19 Mk II	2-8	10	Airborne version of the 19 Mk III used in fighter aircraft
R 1155B	75 kc-1.5	—	Airborne receiver

Table I—A listing of British surplus equipment that may be of interest to American amateurs.

of importing as the duty is simply collected by the postman. The bigger pieces must be sent by freight and pass through a port of entry having a customs collector. The best bet is to arrange for a customs broker to handle the shipment.

Table I is a list of the sets most likely to be of interest to hams.

Some of the problems encountered in working with foreign equipment are the strange terminology in the manuals and the strange components. Fortunately, the British are pretty logical in their circuit symbols. Their tubes are another matter. They used some wild imagination in tube design. Fortunately, they sell spare "valves" very reasonably.

I had the opportunity of observing the use of some of this equipment in Korea by the Dorset Regiment. Most of their field equipment was powered either by "rotary transformers" or by dry batteries. Even their Infantry pack sets were dynamotor powered versus the hand generators used by our army. You could easily identify the unlucky individual that carried the lead acid storage battery on his pack frame—the seat of his pants was invariably perforated with battery acid holes. Our amusement over their equipment

quickly faded when we discovered that they were handling messages much more efficiently than we were with our more sophisticated sets.

If you are like me, you will find it quite interesting to work with equipment that is completely different. ■



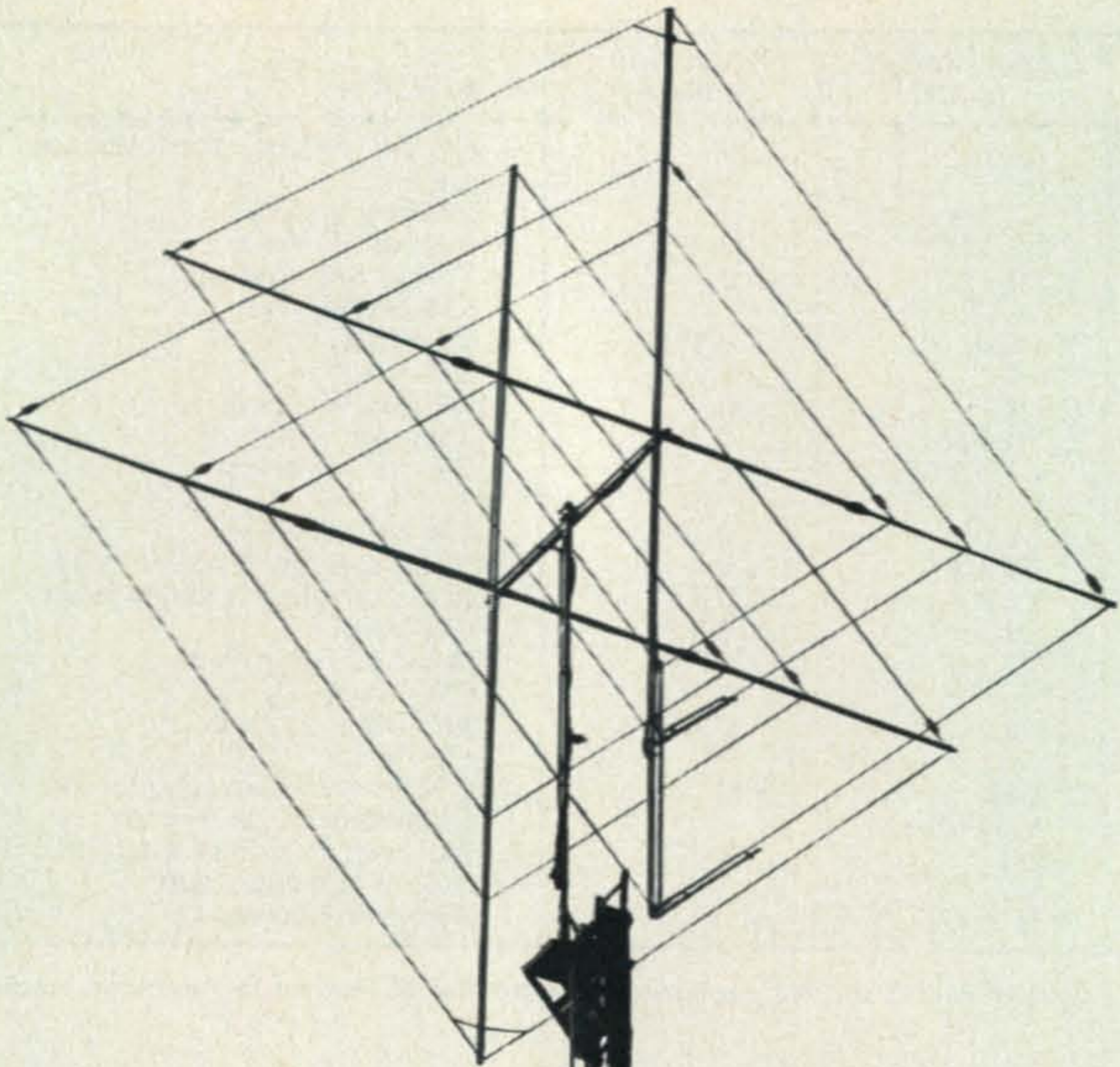

## The Quad that made

Hy-Gain's all new Hy-Quad will outdo all other quads because it's engineered to do just that. The Hy-Quad is new, it's superior, it's complete. It's the first quad to have everything.

- The Hy-Quad has all parts including those not supplied by others, like a boom, wire and all hardware.
- The Hy-Quad is constructed of aluminum. Spreaders are broken up at strategic electrical points with cyclac insulators.
- Tri-band 2 element construction with individually resonated elements with no inter-action.
- Hy-Quad requires only one feed line for all three bands.
- Individually tuned gamma matches on each band with Hy-Gain exclusive vertex feed.
- DC grounded elements to drain off precipitation static. Provides low-noise operation.
- Full wave element loops require no tuning stubs, traps, loading coils, or baluns.
- Heavy duty mechanical construction of strong swaged aluminum tubing and die formed spreader-to-boom clamps.

## all others obsolete!

- Extra heavy duty universal boom-to-mast bracket that tilts and mounts on any mast 1¼" to 2½" in diameter. So get in Hy-Gear to get a Hy-Quad from the best distributors under the sun—he's the one that stocks Hy-Gain!

### Specifications

Overall length of spreaders . . .	305"
Turning radius . . . . .	13'6"
Weight . . . . .	42 lbs.
Boom diameter . . . . .	2"
Boom length . . . . .	8'
Mast diameter . . . . .	1¼" to 2½"
Wind survival . . . . .	100 mph
Forward gain . . . . .	8.5 db
Input impedance . . . . .	52 ohms
VSWR . . . . .	1.2:1 or better at resonance on all bands.
Power . . . . .	Maximum legal
Front to back ratio . . . . .	25-35 db depending upon electrical height

## The Hy-Quad from Hy-Gain

**HY-GAIN ELECTRONICS CORPORATION**

P.O. Box 868-2

Lincoln, Nebraska 68501 Dept. AC-5



FOR THE STRONGEST SIGNAL UNDER THE SUN!

# PUTTING THE RAYTHEON 21TR11A F.M. TRANSMITTER/ RECEIVER ON 2 METERS

BY WILLIAM J. RYAN,\* WA2DND

**T**HE surge of enthusiasm for two meter f.m. is largely due to the advantages offered by repeaters located to give wide range mobile coverage. There have been articles in recent issues of *CQ*<sup>1,2</sup> that explained the hows and whys of this kind of ham operation. One of the writers mentioned the availability of "low cost, wide band f.m. equipment." This statement really raised my interest level. I checked the advertisements in my latest *CQ* only to

\*Coordinator of Audio Visual Services, Rensselaer Polytechnic Institute, Troy, N.Y. 12181.

<sup>1</sup> Hillman, R. L., "Amateur V.H.F. Repeaters," *CQ* June 1968, p. 47.

<sup>2</sup> Sessions, K., "An F.M. Primer," *CQ* April 1968, p.50.

find that my concept of low cost was not quite the same as the ad writers. There was another source mentioned, the local commercial radio communications firm. As might be expected, the chief technician was also a ham. I explained the situation, a budget that ruled out the G.E. Pre-Progress line or the Motorola FMTRU80 equipment. I was looking for some equipment that was not as well known to the amateur ranks but with a possibility of conversion for fixed station and mobile use. The only other criteria was of course the price; it had to be "low cost."

One dark corner of the shop cellar revealed a collection of dusty boxes that turned out to be the Raytheon 21TR11A and some of the

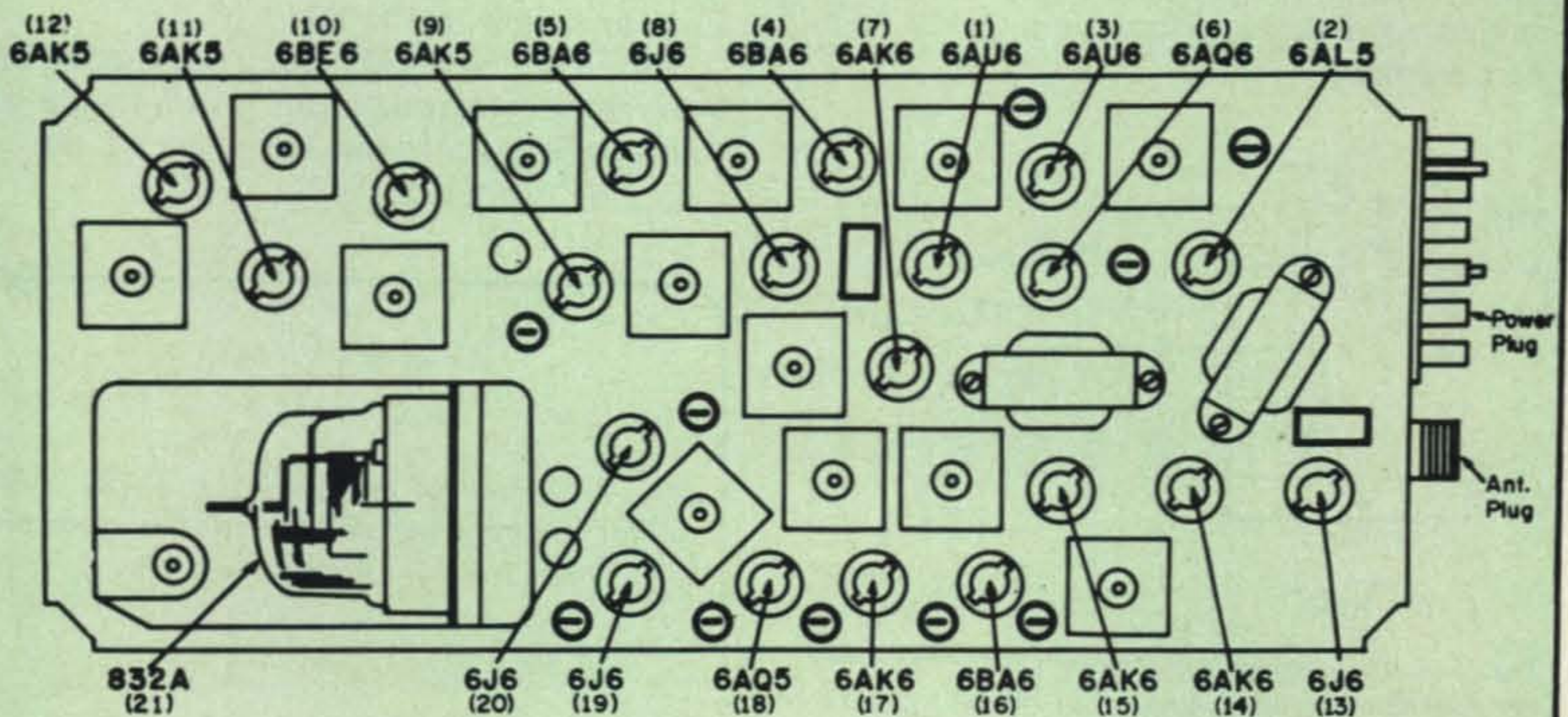
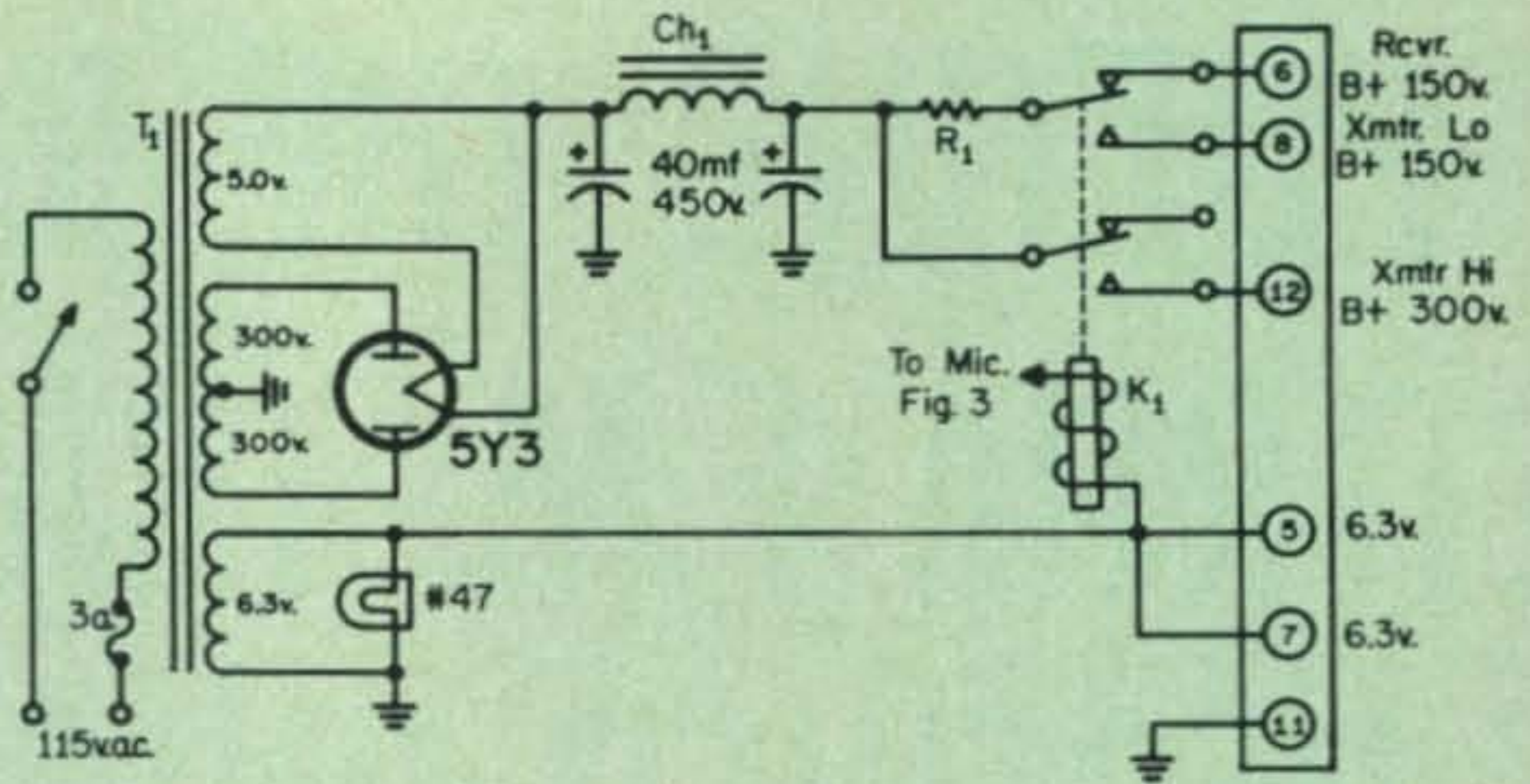

Fig. 1—Top view of the Raytheon 21TR11A transmitter-receiver showing tube placement.

Fig. 2—Circuit of a suitable a.c. power supply that can be used for fixed operation of the Raytheon 21TR11A. The transformer and filter choke are taken from an old TV set and relay  $K_1$  is a d.p.d.t. with a 6.3 volt coil.



associated equipment. The specifications read much the same as the others, a 20 watt transmitter-receiver that was designed to operate between the frequencies of 152 mc and 174 mc. The mobile units were made for 6 volt operation with a vibrator power supply-control head combination. The commercial shop owner was so happy to have me clean out the storage area that I also acquired extra units to use for spare parts.

Close inspection after cleaning off the dust showed that only slight modification, some small construction projects and routine alignment were required to put this equipment on the air. The first step should be to test all of the tubes. Don't be too discouraged if they check low; look for the "no emission" not the "low emission tubes." Check also to be sure that the sockets contain the correct tubes or an acceptable substitute. Figure 1 indicates the original tube line-up. Many of the tubes may have a more efficient replacement installed so a good replacement guide should be consulted.

For all of the preliminary tests the vibrator power supply and the battery eliminator were used. My units came complete with crystals for operation in the commercial band. A signal generator provided a test signal for the receiver checks and with a shielded dummy load the transmitter can be checked. Do not, under *any* circumstances, connect a transmitting antenna to the units until the correct amateur frequency crystals are installed.

The vibrator noise soon made it clear that the first construction project had to be an a.c. supply. The power transformer and choke came from an old TV set. (Are there any other sources for these parts?) The 12 prong power plug was removed from the d.c. supply and remounted at the back of the chassis. This allows the power cables and plugs to be used without modification. The schematic and parts list, fig. 2, indicate the terminals used to match the 21TR11A.

All of the additional control functions are also brought through the power cable and easily incorporated on the front of the a.c.

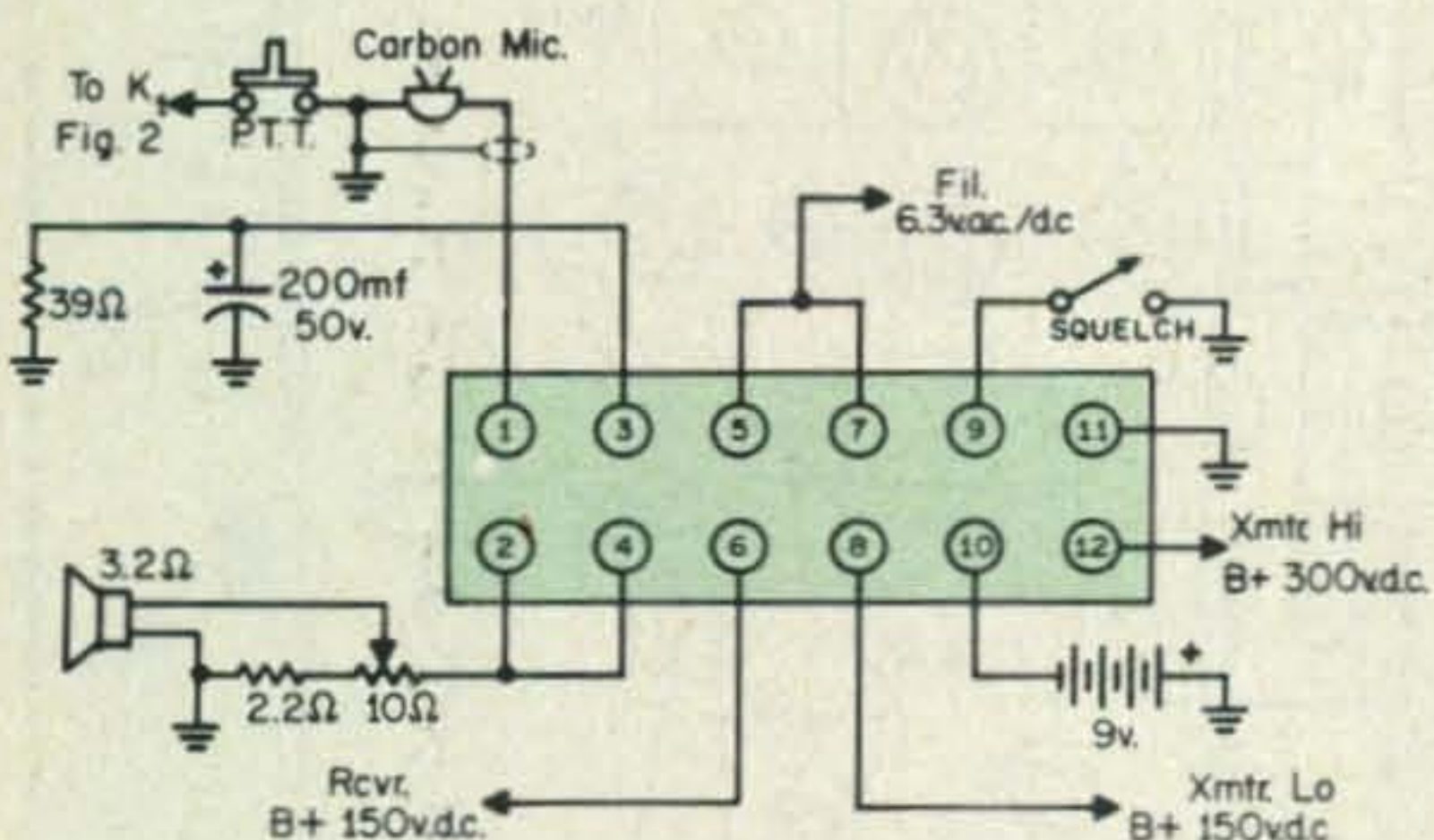
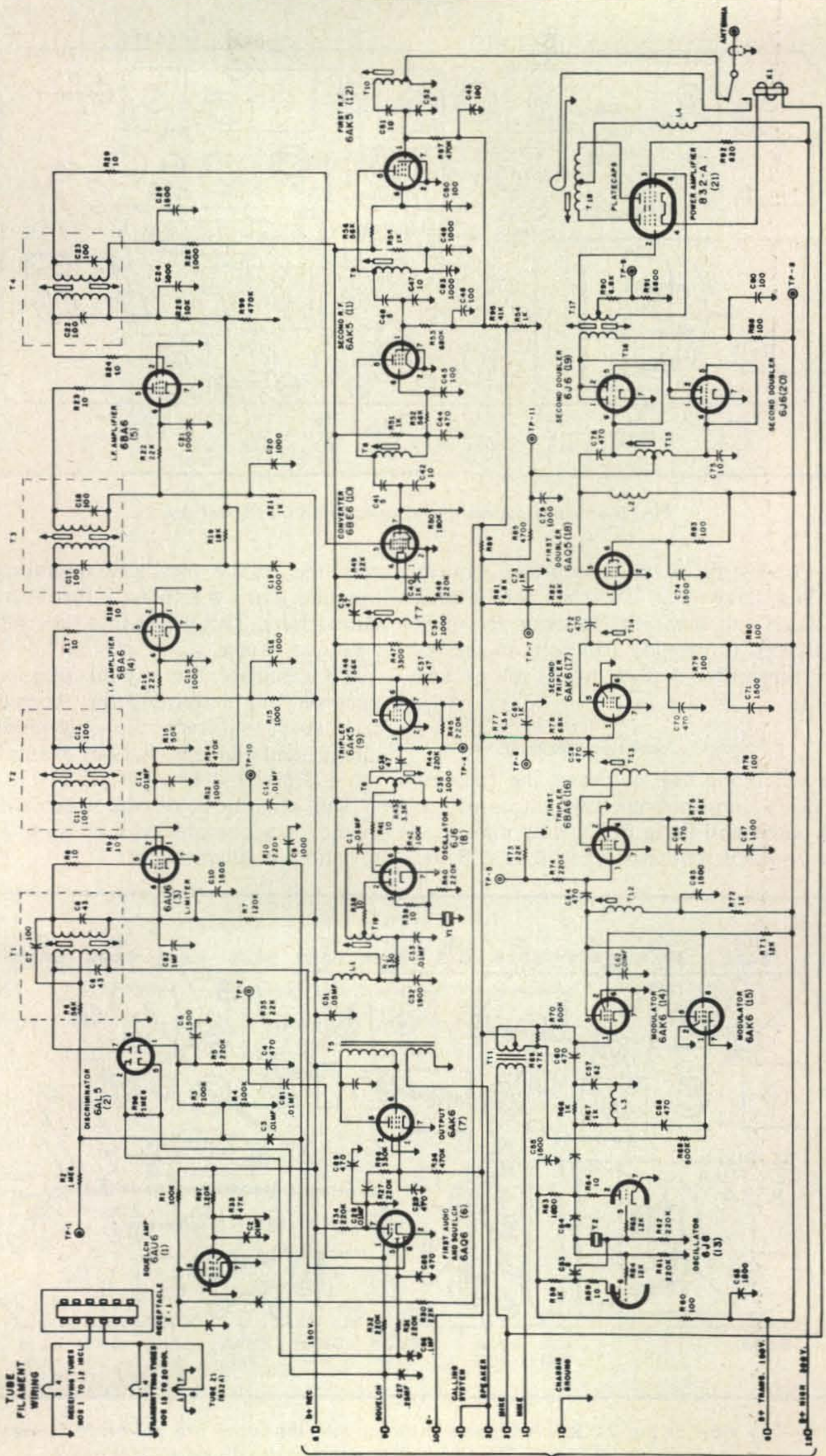

Fig. 3—Circuit showing the power plug connections for operation of the Raytheon 21TR11A transmitter-receiver for 2 meter operation. The 9 volt battery provides bias for several of the stages as can be seen in fig. 4.

Fig. 4—Circuit of the Raytheon 21TR11A Transmitter and receiver suitable for f.m. operation of 2 meters.



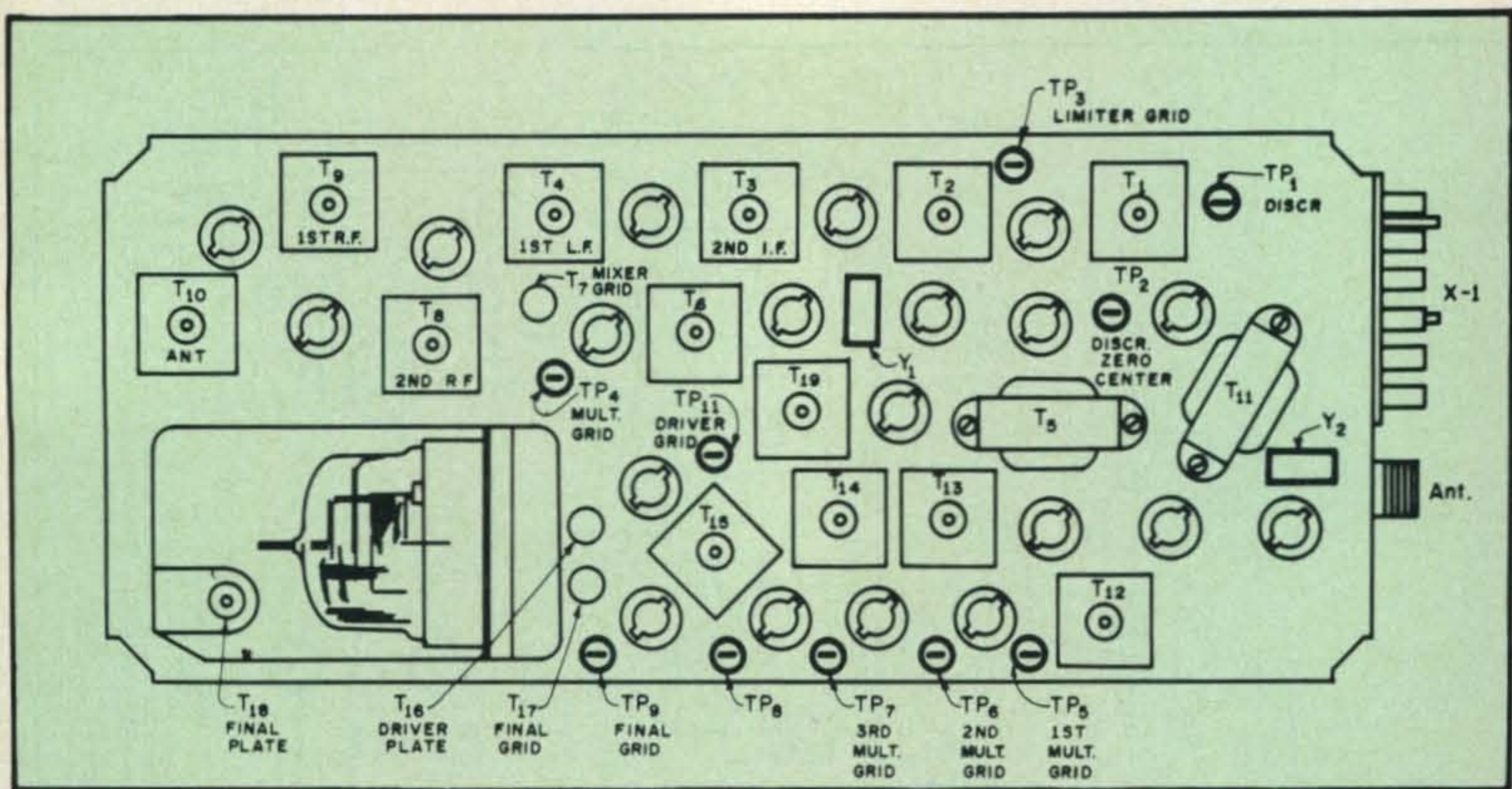

Fig. 5—Identification of the adjustments and test points.

supply chassis; fig. 3 indicates those connections. The relay ( $K_1$ ) switches the B plus from receive to transmit. Resistor  $R_1$  must be calculated to provide 150 volts to the receiver; transmitter B plus should not exceed 400 volts.

### Receiver Modifications

The schematic, fig. 4, shows the receiver to be fairly conventional; two stages of r.f. amplification and three of i.f. help make the unit reasonably sensitive. The i.f. is at 3 mc

with the crystal oscillator operating on the low side. Tube #8 (6J6) is the receiver oscillator-tripler. This works into tube #9 (6AK6) a second tripler.

To calculate the crystal frequency it is necessary to determine the desired receive frequency, subtract the intermediate frequency and divide by 9. (For example  $146.94 \text{ mc} - 3 \text{ mc}/9 = 15.9934 \text{ mc}.$ )

The alignment of the intermediate frequency is accomplished with a signal generator and a 0-10 voltmeter.

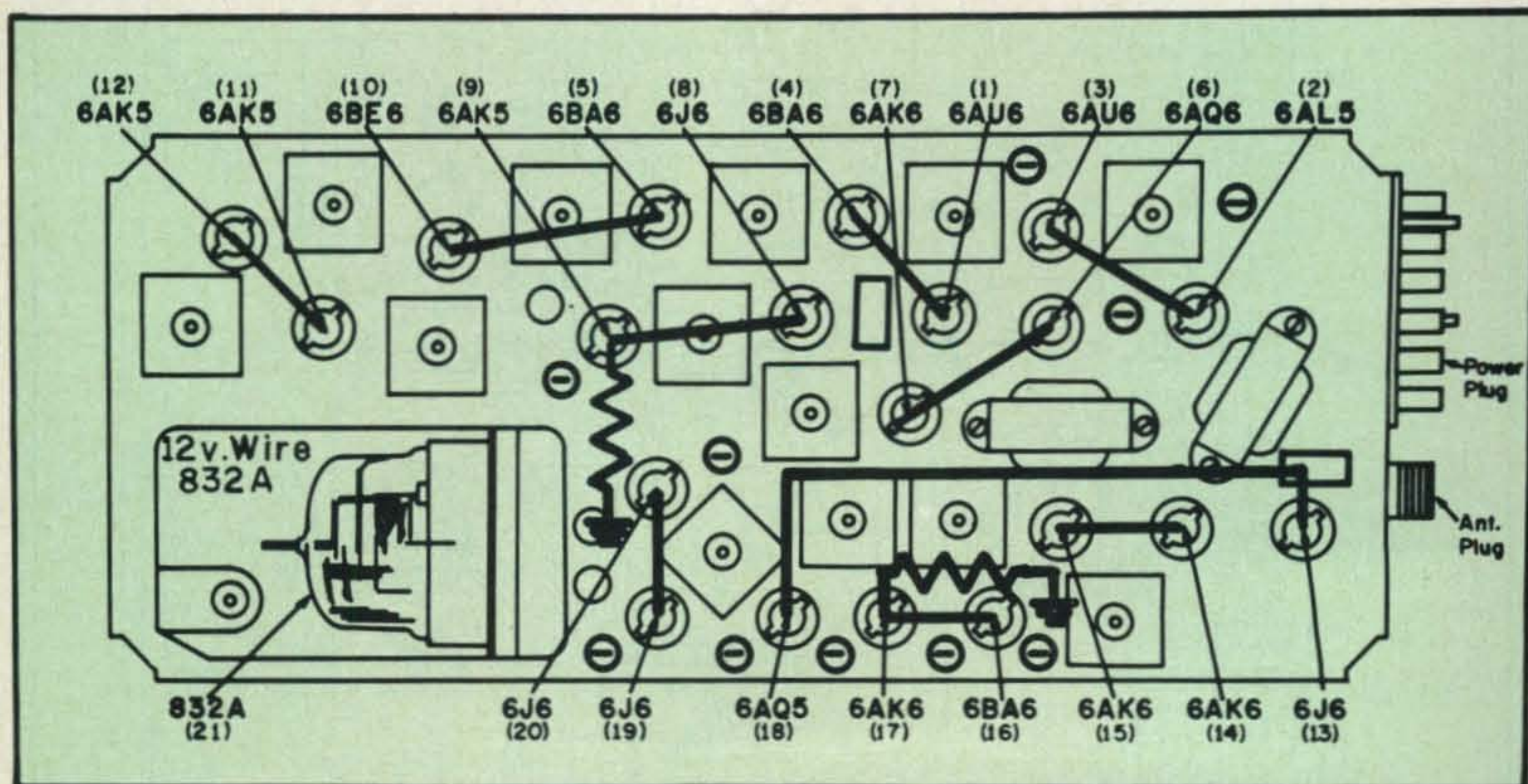

Fig. 6—Top view of the 21TR11A Chassis showing how the tubes are paired for series-parallel operation on 12 volts. The two resistors shown are discussed in the text.

Fig. 7—View of a control head for mobile operation of the Raytheon 21TR11A. The circuit for this unit is shown in fig. 8. The controls are, from l. to r.,  $S_1$ ,  $S_2$ , spare, Mike, Volume. The neon indicator above the Mike plug indicates the presence of B plus.



Figure 5 indicates the adjustment and test points; all voltages are read with respect to ground. Connect a 3 mc signal through a 0.001 mf blocking capacitor to pin 5 of the second r.f. amplifier tube #11 (6AK5). Connect the voltmeter to TP-3; adjust top and bottom of  $T_2$ ,  $T_3$  and  $T_4$  for maximum voltage. Reduce signal generator output as required.

Connect the voltmeter to TP-2, adjust  $T_1$  secondary, (top of can) for zero output.

Connect voltmeter to TP-1, adjust primary of  $T_1$  (bottom of can) for maximum voltage. It may be necessary to repeat the entire procedure for peak operation.

The crystal may now be inserted at  $Y_1$ . Connect the voltmeter to TP-4 and adjust  $T_{19}$  for maximum voltage. Adjust  $T_6$  for maximum voltage then return to  $T_{19}$  and rotate adjusting screw counterclockwise until the voltage drops to about 7 volts. Connect a receiving antenna and listen for a signal. Peak  $T_8$ ,  $T_9$  and  $T_{10}$  for maximum. It may be necessary to reset the discriminator (TP-2) to zero voltage; if this requires more than one quarter turn of  $T_1$  a realignment of the i.f. may also be required.

### Transmitter

The initial testing of the transmitter into the dummy load should be made if the commercial crystals are available. (Do not, under any circumstances, attempt to test or transmit on an antenna until the correct amateur frequency crystals are installed.) To calculate the transmitter crystal fundamental frequency it is necessary to determine the desired output frequency (for repeater operation this would be the receiver input frequency) and divide by 36. (For example  $146.34/36 = 4.06500$  mc.)

Transmitter alignment requires a 0-50 volt-meter and an r.f. output meter of some type. Insert the proper crystal into  $Y_2$  (fig. 5). All transmitter adjustments are made with key down (p.t.t. Switch) and voltages are read with respect to ground.

Connect voltmeter to TP-5, adjust  $T_{12}$  for maximum voltage.

Connect voltmeter to TP-6, adjust  $T_{13}$  for maximum voltage.

Connect voltmeter to TP-7, adjust  $T_{14}$  for maximum voltage.

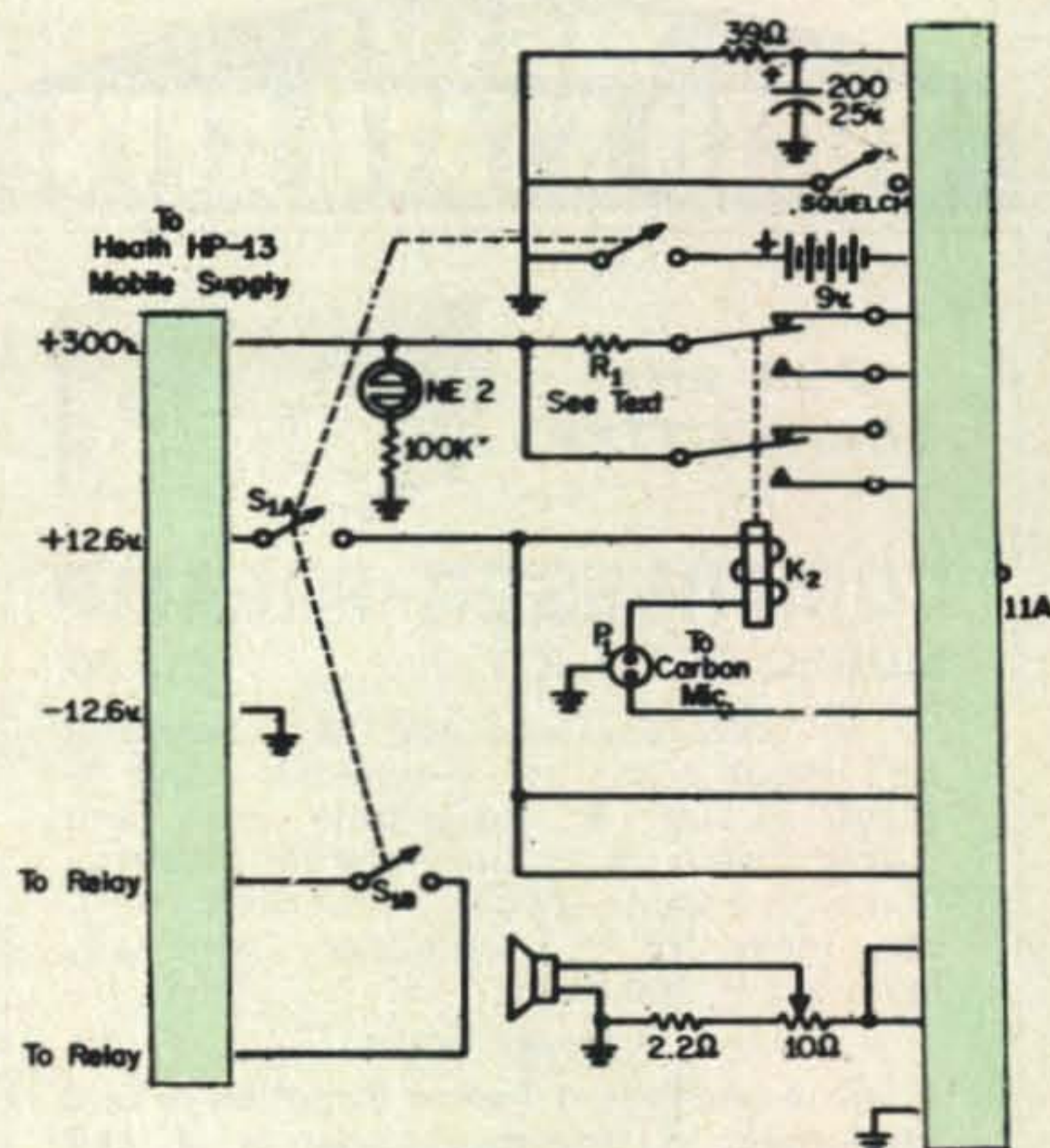

Fig. 8.—Circuit of the mobile control head. The power supply for high voltage is an HP-13. Switch  $S_{1A}$  controls the application of 12 volts to the filament circuit and  $S_{1B}$  controls the HP-13 relay. Switch  $S_2$  controls the receiver squelch and the 9 volt battery is for bias.  $K_2$  is a d.p.d.t. relay with a 12.6 v. coil.

## NEW QSL BUREAU

To handle all your QSLs, whether for next door, the next state, the next country or anywhere! No special membership fees, coupons, or rules; Just:

3¢ each for QSLs for USA, Canada or Mexico.

4¢ each for QSLs for any other place in the world.

Just bundle them up (please arrange alphabetically) and mail to:

**WORLD QSL BUREAU**  
5200 Panama Avenue  
Richmond, Calif. 94804, U.S.A.

**Attention Hams USA, Canada and Mexico:** Yes, we mean just what we say—at least a QSL bureau to handle QSLs for QSOs within your own country.

**Attention Hams outside USA, Canada and Mexico (and SWLs anywhere):** Please send us your QSLs for delivery anywhere—same rates as listed above.

**Attention Radio Clubs:** Here is a way to increase attendance at your club meetings. On application we will send QSLs received for your members to you for distribution at meetings. Also special plan at reduced cost for outgoing QSLs from clubs available. Send for details.

## NEW! SOLID STATE KITS

FOR ANY  
TRANSMITTER



### COMPRESSOR-PREAMP MODEL ACP-1 KIT.....\$18.50

30 db compression range ■ Low-noise FET input stage ■ 5-transistor and 1-diode circuit ■ Adjustable input and output levels ■ Printed circuit construction with easy-to-follow instructions ■ 3-way jacks for PTT operation ■ Easily installed in mike line

#### Other Kits

Audio Amplifiers ■ Power Supplies ■ Test Equipment ■ Treasure Locators ■ and many others

FREE Data sheets with circuit description, diagram, and specifications for all kits.



CARINGELLA ELECTRONICS, Inc.  
P.O. Box 327 ■ Upland, California 91786  
Phone 714-985-1540

TP-8 is a B plus test and in a key down position should read between 150 volts and 200 volts; be careful when making connections.

Connect voltmeter to TP-11, adjust  $T_{15}$  for maximum voltage.

Connect voltmeter to TP-9, adjust  $T_{16}$  and  $T_{17}$  alternately for maximum voltage.

Using the r.f. output meter adjust  $T_{18}$  for maximum output. A suitable indicator for output can be had by inserting an s.w.r. bridge between the transmitter and the dummy load.

It may be necessary to pad the crystal in order to zero on the exact desired frequency; connect a 4-25 mmf trimmer capacitor (Centralab 822CN) in parallel with the crystal and adjust for the correct frequency. For this critical peaking it is best to find a friend with a metered receiver.

### Mobile Operation

The physical size of the 21TR11A is such that it is highly suitable for mobile operation; it will fit under the hood or in the trunk without taking all the room. It will be necessary to convert the filaments to a series-parallel arrangement for 12 volts and to provide the necessary high voltages and control functions. It is necessary to select the proper combinations of tubes to wire in series-parallel for operation of the 6 volt tubes on 12 volts. Figure 6 indicates the correct pairs of tubes to match. Note that tube 9 (6AK5) requires a 20 ohm, 2 watt resistor in parallel with the filament and tube 17 (6AK6) a 47 ohm, 2 watt in parallel. This is necessary to balance the current load.

It is very likely that you may break a tube socket pin while rewiring, it then becomes necessary to slide out the broken piece and replace it with a new pin from a new socket. It is best to remove the tubes from their sockets while working on them. Take care to dress the new wiring close to the chassis and reground all previously removed grounds, especially the socket centers. Check all tubes after rewiring to be sure that there is a 6 volt drop across each.

The mobile control head is mounted in a metal box (Bud type CU 2106A). There is no excess of space but with careful packaging everything will fit. Figures 7 and 8 show the part placement and the necessary connections.

Special thanks to Raytheon Co. for permission to reproduce material from their service manuals. ■



# Want really full coverage? *(and who doesn't)*

## the **DRAKE 4 LINE CAN** **GIVE IT TO YOU**



### TR-4 SIDEBAND RECEIVER

You get full frequency coverage on all amateur bands 10 thru 80 meters, solid state VFO, automatic transmit/receive switching on CW, CW sidetone oscillator built-in, upper and lower sideband on all bands, separate receiver s-meter and transmitter plate ammeter and 300 watts PEP input on SSB.



### T-4XB TRANSMITTER AND R-4B RECEIVER

Transceive frequency control by VFO of either T-4XB or R-4B, or separate receiver/transmitter frequency control, selectable by a front panel switch on the T-4XB. No "cable juggling" necessary. Both units have linear, permeability tuned VFO's readable to better than 1 Kc and provide maximum effectiveness of operation on SSB, CW, and AM and is easily adaptable to RTTY. Automatic transmit/receive switching on CW activates transmitter and mutes receiver when key is depressed. A truly superior combination.

## Henry Radio gives full coverage too!

EASY FINANCING • 10% DOWN OR TRADE-IN DOWN • NO FINANCE CHARGE IF PAID IN 90 DAYS • GOOD RECONDITIONED APPARATUS • Nearly all makes & models. Our reconditioned equipment carries a 15 day trial, 90 day warranty and may be traded back within 90 days for full credit toward the purchase of NEW equipment. Write for bulletin.

TED HENRY (W6UOU)

BOB HENRY (W0ARA)

WALT HENRY (W6ZN)

**Henry Radio Stores**

11240 W. Olympic, Los Angeles, Calif., 90064

213 477-6701

931 N. Euclid, Anaheim, Calif., 92801

714 772-9200

Butler, Missouri, 64730

816 679-3127

*"World's Largest Distributor of Amateur Radio Equipment"*

# PUTTING THE

# URC-11

# ON

# 220mc



View of the URC-11 Walkie-Talkie showing attached power cable, and antenna partially extended. Scale illustrates very clearly the small size of this unit. (Photo Courtesy W3AY.)

BY STANLEY F. BRIGHAM,\* W3TFA

**I**N this day and age when our living pace becomes more accelerated all the time, the need or desire to travel is noticeably more prevalent. Accordingly, small, light weight portable equipment has become increasingly popular. The RT-285A/URC-11 Radio Receiver-Transmitter is ideal for this purpose. It is a walkie-talkie unit quite similar to the

\*7211-16th Avenue, Takoma Park, Md. 20012.

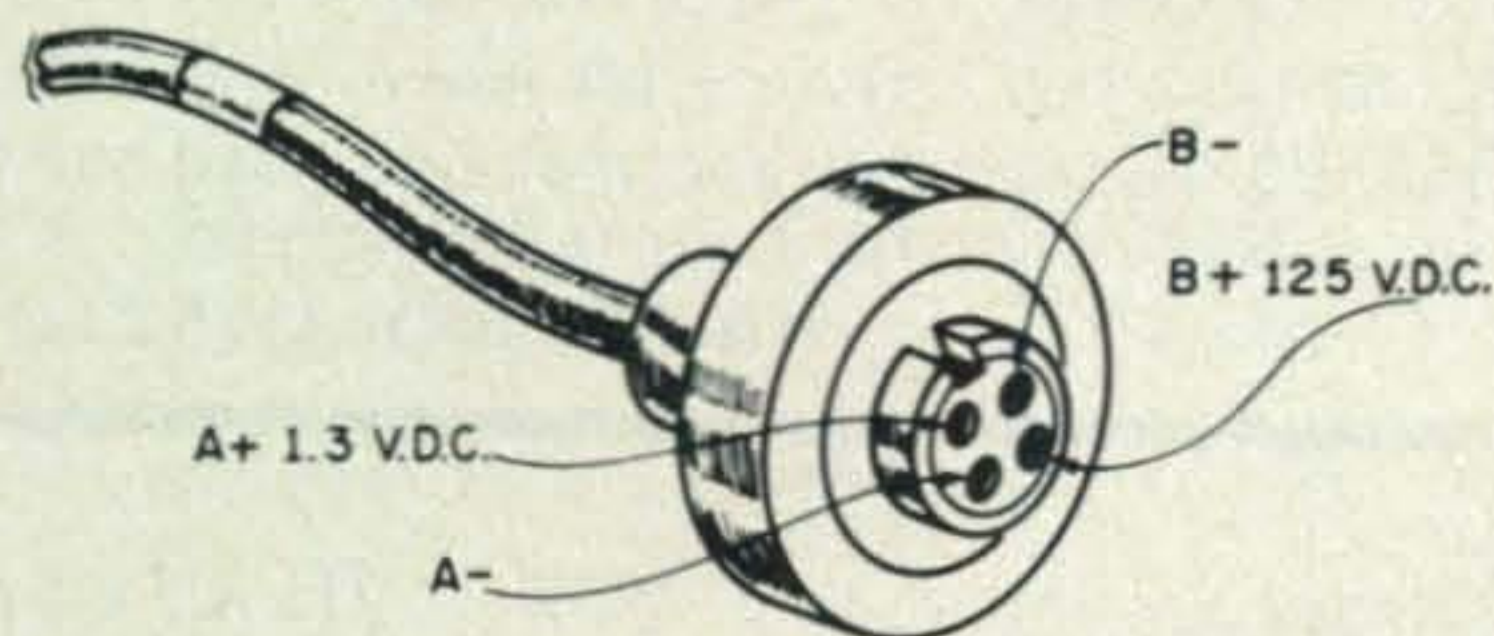

Fig. 1—Looking into the end of the plug terminating from the cable attached to the URC-11 unit. This view depicts connection points to which proper voltages should be made. Orient points by reference to "key" as shown.

URC-4 in performance, but considerably more palatable for portable operation because it is essentially one-third the size and one quarter the weight.<sup>1</sup>

It was designed for use operationally to be worn by pilots and used as part of their survival equipment to assist in their rescue in case they were downed. The dimensions of the URC-11 are approximately  $1\frac{3}{4} \times 3\frac{1}{4} \times 4$  inches exclusive of power.

The URC-11 is comprised of five filament type subminiature tubes and two transistors. The transmitter r.f. section has a crystal controlled oscillator followed by two cascaded r.f. amplifier doubler stages. The receiver is a single tube superregenerative detector. The combination audio amplifier and output stages consist of two transistors and a pentode. The audio output (tube type 6526,  $V_5$ ) serves also as a 1 kc audio oscillator to provide tone modulated c.w. Thus

<sup>1</sup>Brigham, S. F., "Putting the URC-4 on 50-144-220", *CQ*, October 1965, p. 26.

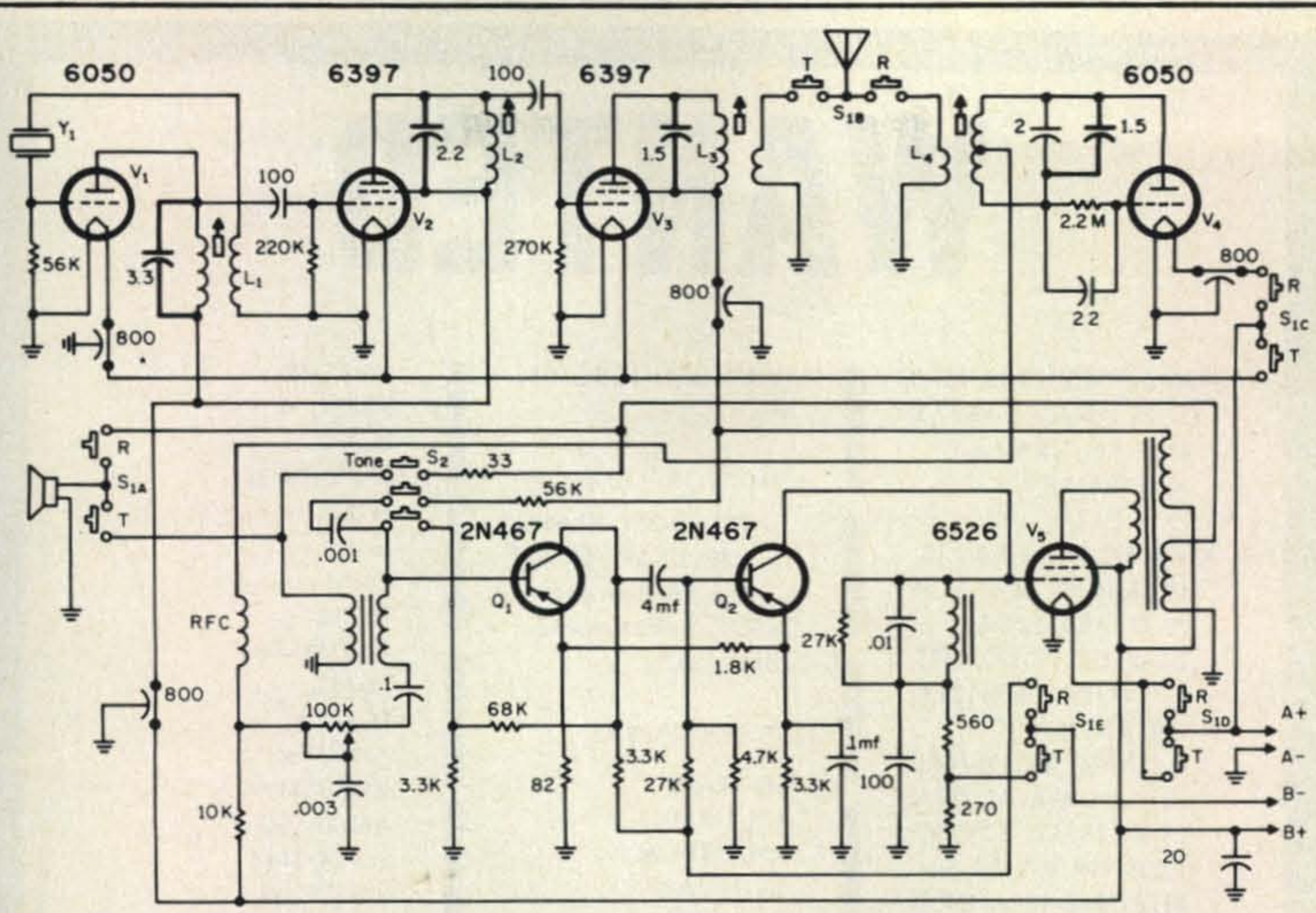

Fig. 2—Circuit of the URC-11 Walkie-Talkie showing the simple modifications of the tuned circuits needed to operate on 220 mc. Capacitor values one or greater are in mmf except where otherwise noted. Capacitor values less than one are in mf.

nodes  $A_1$ ,  $A_2$ , and  $A_3$ , continuous wave (c.w.), tone modulated continuous wave (m.c.w.), and phone are all capable of operation with this unit. The URC-11, designed for use at 243 mc, is easily converted for 220 mc operation.

**Preliminary Steps**

Before undertaking any attempts at converting the unit, make sure that it is operating in its original form for both transmitting and receiving. To do this, connect the proper voltages to the power plug terminating at the end of the cable attached to the URC-11. (See fig. 1)

All capacitors used in converting the URC-11 are Erie ceramic type NPO-A. Space is quite limited within the unit and these capacitors should be mounted perpendicular to the chassis.

When installing the capacitors across the tuned circuits it is necessary to remove the

[Continued on page 102]

terior view of the URC-11 modified 220 mc, showing the physical arrangement of components necessary to effect the conversion. (Photo Courtesy W3AY.)

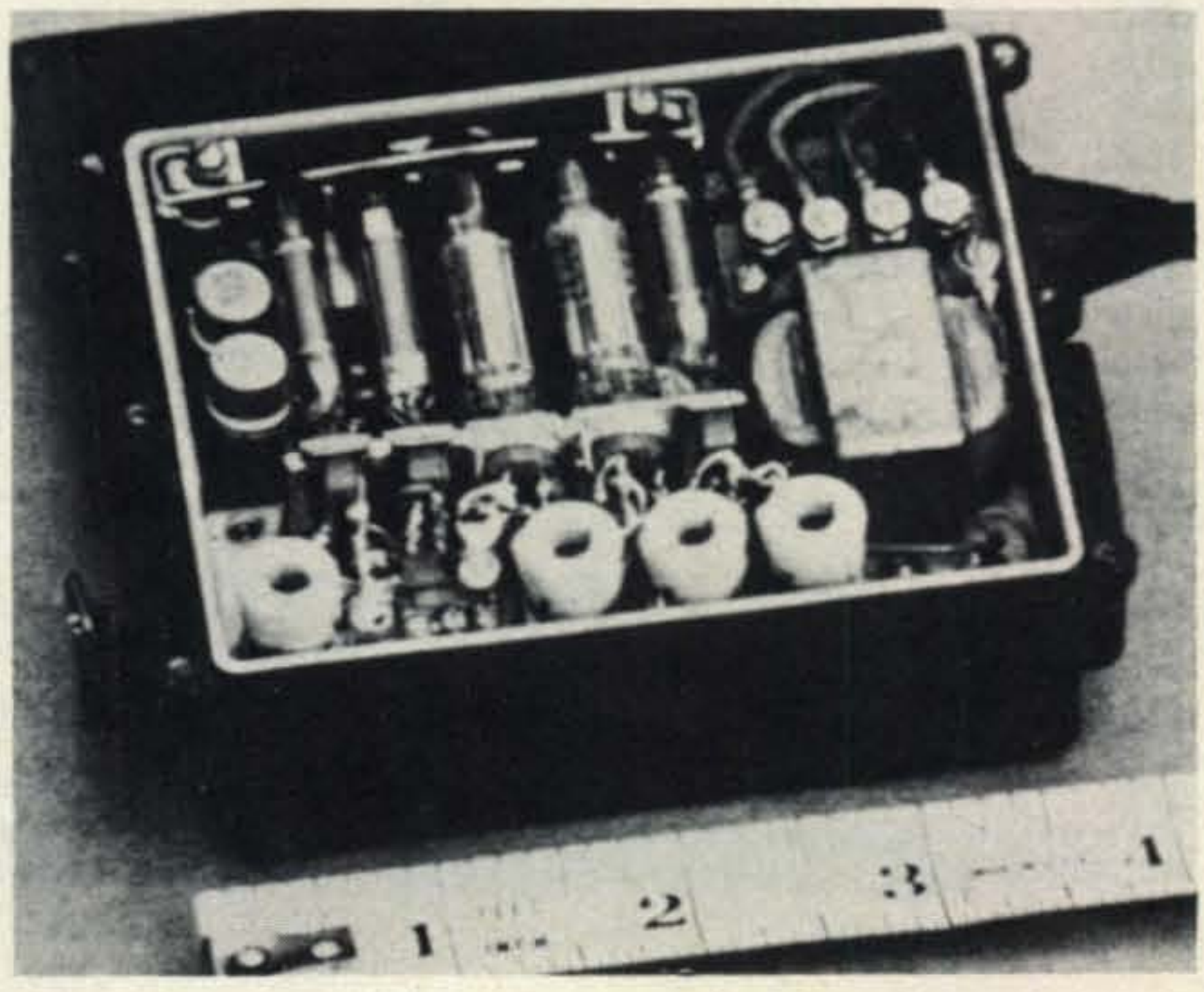

# WANTED

NAVY "TED" TRANSMITTERS AN/URR-13,27,35 etc., AN/URA-6,8,17; AN/SPA-4,8,9.

AN/GRC-3,4,5,6,7,8,9,10, 19,26,46; RT-66,67,68,69, 70,77; AM-65/GR, T-368/UR, PP-112/GR, RT-174/PRC-8, R-108,9/GR, RT-175/PRC-9, R-110/GR, RT-176/PRC-10, T-195/GR, AN/PRC-25, R-125/GR, T-217A, T-235/GR, R-278B, SB-22/PT, MD-129A/GRC-27, AN/VRC-12, etc.

AN/TRC-24:  
T-302A, AM-912,3  
R-417A, AM-914,5, PP-685A & accessories.

AN/TCC-3: AM-682, TA-219

#### COMMERCIAL AIRCRAFT COMMUNICATIONS:

Collins: 17L-4,7, 51X2, 51V3, 618S, 618T, 18S-4, 621A3, 860E-2, 618M, 51R3, 578D, 578X, 479S-3, 479T-2; ARC: R-30A, R-38A, R-34A, RT-11A, T-27A, T-25C, R-31A, T-27A, T-25C, R-31A, 21A system, IN-12,13,14.

Test Sets: H-14, H-14A, etc.

INDICATORS: ID-250,1, ID-387, ID-257, ID-663, ID-1103, ID-637, etc.; all Collins, Weston, and A.R.C. indicators and control units.

#### TEST EQUIPMENT

SG-12A/U  
AN/URM-25  
AN/URM-26  
SG-1A/ARN  
SG-2A/GRM  
AN/URM-80  
SG-13/ARN  
AN/URM-81  
AN/ARM-8  
AN/URM-32  
AN/ARM-25  
AN/ARM-68  
AN/URM-48  
AN/ARM-22  
AN/ARM-66  
AN/USM-26  
AN/ARM-65  
SG-66A/ARM-5  
AN/URM-43  
AN/UPM-98  
AN/ARM-68  
MD-83A/ARM  
AN/UPM-99  
AN/USM-16  
TS-723/U

OS-8E/U  
TS-757  
TS-330  
AN/UPM-32  
TV-2C  
TS-621  
TV-7  
TS-710  
AN/URM-44  
TS-683  
TS-510A  
AN/URM-52  
AN/USM-44  
AN/TRM-3  
SG-24/TRM  
ME-30C/U  
AN/PSM-68  
AN/GPM-15  
TS-505D/U  
AN/PSM-48

We also buy all H-P, Boonton, ARC, GR, Bird, Measurements, TEK, etc.

RECEIVERS: AN/APR-13, 14, 17; R-388, R-388A, R-390, R-390A, R-391, R-392, R-220, R-389, R-1125, R-1051, CV-253/ALR, 51J-2,3,4, AN/URR-, AN/FRR-, etc.

#### AIRCRAFT EQUIPMENT:

AN/ARC-27,33,34,38,44, 45,52,54,58,73; AN/ARN-14,21,54,56,59,65,67,52V.

## SPACE ELECTRONICS CO.

division of

## MILITARY ELECTRONICS, CORP.

11 Summit Ave. East Paterson, N.J.

201-791-5050

# SELL YOUR OLD GEAR TO GET BIG CASH DOLLARS NOW

URGENTLY NEED FOLLOWING EQUIPMENT

AN/AQS-4

AN/UPA-38

AN/UPX1, 5 and 12

AN/GMD-1

in stock: Collins 2084-10 Linear Amp. 2-30 Mcs.  
10Kw SSB.

We have immediate customers for your old equipment in any condition. We'll pay guaranteed highest price, shipping, insurance, etc. We'll pay in 24 hours, write or call collect for our high offer. P.S. We'll trade or swap equipment too.



**SPACE ELECTRONICS CO.**

division of

**MILITARY ELECTRONICS, CORP.**

11 Summit Ave. East Paterson, N.J.

201-791-5050

Please rush me a quote on the following gear that I have to sell:

\_\_\_\_\_  
\_\_\_\_\_  
Name \_\_\_\_\_  
Address \_\_\_\_\_  
City \_\_\_\_\_ State \_\_\_\_\_ Zip \_\_\_\_\_

# PUTTING THE MOTOROLA R-394/U F.M. RECEIVER ON 2 METERS

BY SAM KELLY,\* W6JTT

**A** RECENT arrival on the surplus market is the R-394/U v.h.f.-f.m. receiver. It is an early 1950 vintage modularized single channel f.m. receiver covering 152-174 mc and designed for 15 kc deviation. It comes in a wide variety of configurations but the most commonly encountered one is as part of the AN/VRC-19 transceiver. The receiver is a dual conversion type having a 7.8 mc first i.f. and a 455 kc second i.f. It uses 22 sub miniature tubes. The receiver consists of a base assembly and six or even plug in modules. The base contains the wiring harness and test points. The plug in modules are:

Power supply (PP-869 6v., PP-868 12v.,  
PP-867 24v.)  
Audio and squelch  
Local oscillator  
R.f. amplifier  
2nd i.f./discriminator  
1st i.f.  
Retransmission (rarely found, doesn't  
fect receiver).

The receiver makes a good single channel monitor for 2 meter f.m., police calls or MARS with a minimum of modification.

## Power Supply

First determine which power supply is installed. There is a 115 v.a.c. supply, getting one of those would be too good to be true. Power supply modification is simple and consists of simply removing the vibrator and supplying 6.3 v.a.c. to either the primary of the transformer (6 v. model) or to the 6.3 v. filament and heater windings. The transformers were designed for 95 c.p.s. operation but will operate nicely at 60 c.p.s.

For the PP-869/U (6 V.) remove the vibrator and tie pins 1 and 4 of the vibrator transformer to ground. Connect the 6.3 v. (at least 8 amps) to pins 1 and 2 of  $P_{252}$ .

Remember to use large enough wire to adequately carry the high current. For the 12 and 24 volt models remove the vibrator and connect the 6.3 v. between ground and pin 4 of the power transformer. If you have a 115 v. unit simply connect 115 v. to pins 3 and 5 of  $P_{252}$ .

## Controls

The next step is to wire in the controls. Figure 1 is a schematic of the control circuitry. After completing the control circuitry warm the set up and check for operation of the SQUELCH and VOLUME controls.

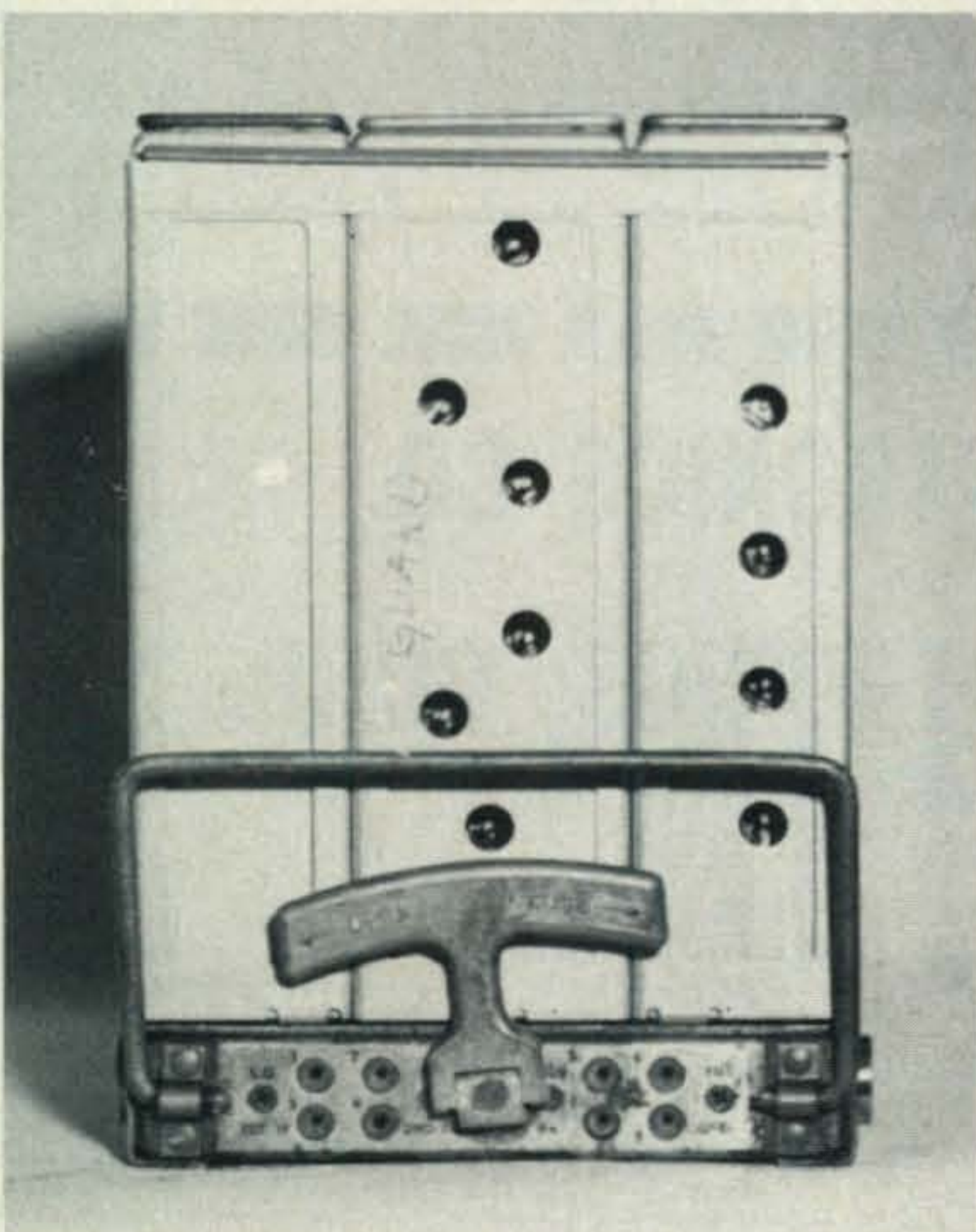

Front view of the R-394/U surplus receiver suitable for modification for single frequency reception of 2 meter f.m. signals.

\*12811 Owen St., Garden Grove, Calif. 92641.

Top view of the R-394/U receiver that can be modified for single frequency reception of f.m. on 2 meters. The missing module is for a special unit used for retransmission relay and seldom found.

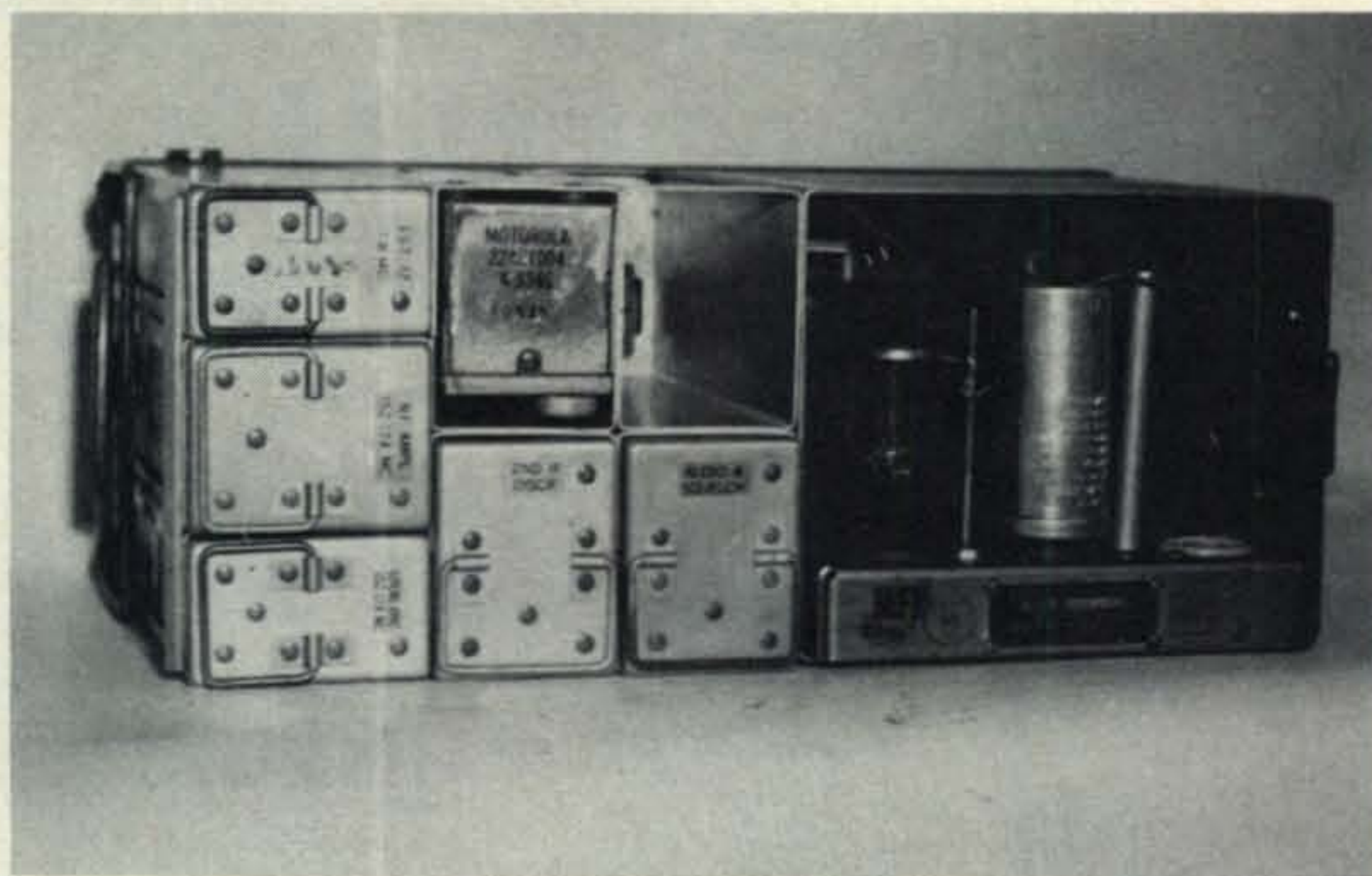

### Crystals

Once the receiver is operational get a crystal for the desired frequency. The crystal frequency can be calculated from:

$$\text{Crystal Freq. (mc)} = \frac{\text{Desired freq. (mc)} - 7.8}{6}$$

When ordering the crystal specify that it is to be used in an oven and is type CR-32/U.

### Alignment

Install the crystal and warm the set up. Remove the shield can from the Local Oscillator module (LO) and plug the LO back in. This exposes some needed test points. Place v.t.v.m. probe on the first terminal (TOP) of the small terminal board. (A 1 meg resistor connects to it.) Adjust the top slug (Z<sub>31</sub>) for a maximum negative voltage. Move the probe to the fourth terminal down on the terminal board. Adjust the second and third slugs (Z<sub>32</sub>, Z<sub>33</sub>) for maximum negative voltage. Replace the shield can and move the v.t.v.m. probe to the LO test point on the receiver panel. Adjust the bottom slug (Z<sub>34</sub>) for maximum negative voltage and recheck the other slugs.

### R. F. Modifications

Without modifications some of the r.f. modules will tune down to 147 or 148 mc. If you want to operate lower it will be necessary to solder small padding capacitors (5 pf) across pins 1 and 2 of Z<sub>1</sub> and across trim tabs protruding from Z<sub>2</sub>, Z<sub>3</sub>, Z<sub>4</sub> and Z<sub>5</sub>. Sometimes the trim tabs can be bent enough to bring the frequency down. Use

good quality ceramic padding capacitors.

After the above modification, install the r.f. module and supply r.f. from a signal generator or transmitter to P<sub>1</sub>. Connect the v.t.v.m. between the 2nd i.f. and ground test points. Adjust Z<sub>1</sub>, Z<sub>2</sub>, Z<sub>3</sub>, Z<sub>4</sub> and Z<sub>5</sub> for maximum. Repeat several times, reducing the input signal.

The set is now ready for operation by connecting an antenna to P<sub>1</sub>. Precise frequency adjustment can be made by tuning Z<sub>31</sub> (top coil in the LO module) for a +1 v. on the v.t.v.m. (between DISCR and ground) while receiving the desired frequency.

Modules for these receivers are readily available on the surplus market so it is a simple matter to set up frequencies in advance and change channels quickly by plugging in modules. The best bet for troubleshooting is to have several spare modules on hand for substitution. ■

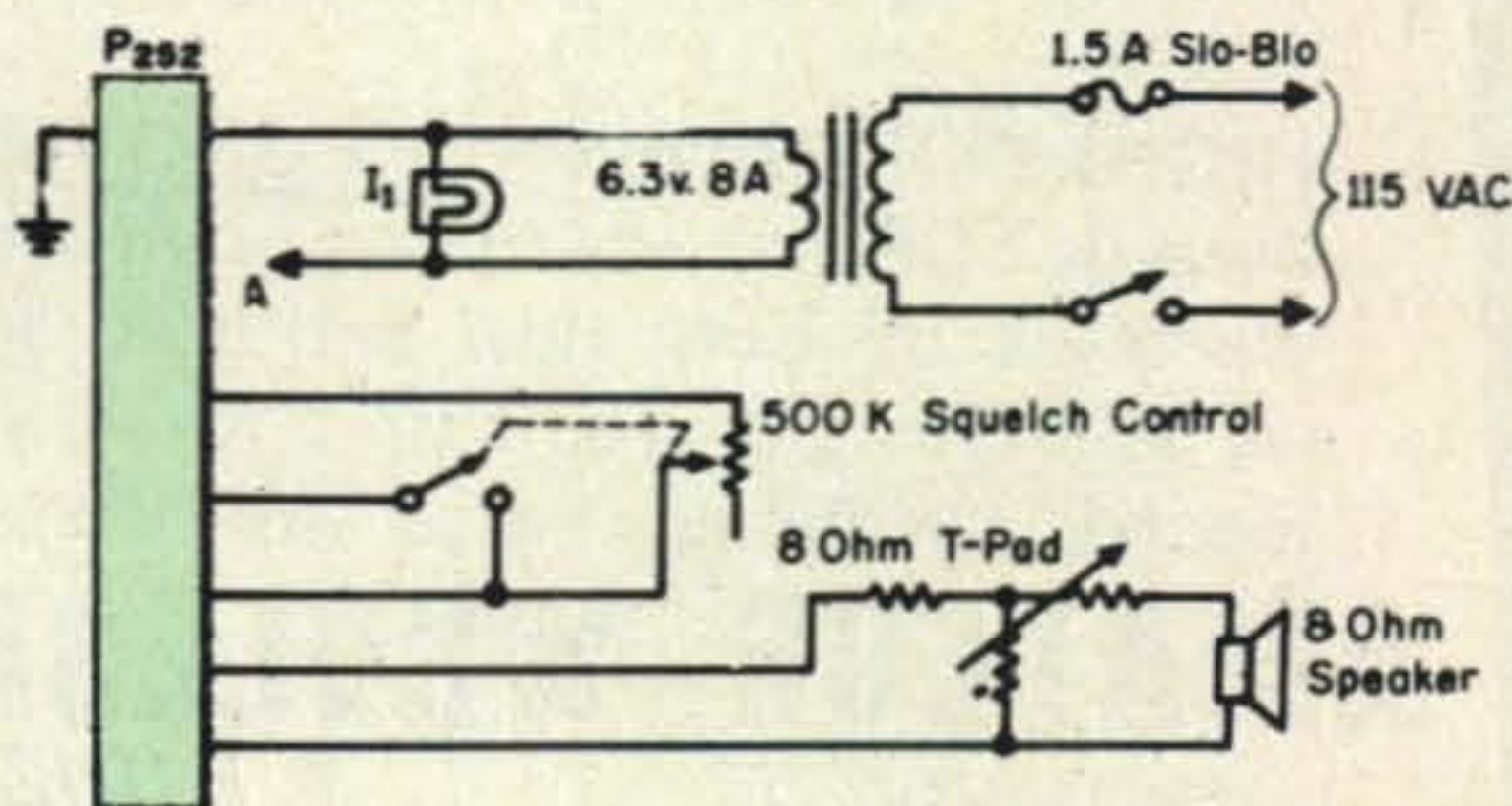

Fig. 1—Circuit of the controls needed for the R-394/U surplus single channel f.m. receiver. Designed for 152 to 174 mc it can be shifted down to 2 meters. Lead A on the transformer secondary goes to pin 4 on the power transformer for the 12 and 24 volt model. For the 6 volt module it goes to pin 2 of P<sub>252</sub>.

The **GREAT** NEW one  
**SWAN**  
 260



- AC and DC SUPPLIES BUILT IN!
- 5 BANDS
- 260 WATTS
- \$395<sup>00</sup>

RECONDITIONED

LIKE NEW TRADE-IN EQUIPMENT  
 30 DAY PARTS AND LABOR GUARANTEE

<b>CENTRAL ELECTRONICS:</b>	<b>SALAXY:</b>	<b>HEATH:</b>	<b>KNIGHT:</b>
10-A \$ 39.00	Galaxy V w/AC & Speaker \$345.00	GC-1A \$ 49.00	TR-105 and VFO \$109.00
MM-2 \$ 45.00	RV-1 \$ 49.00	HC-10 \$ 29.00	LAFAYETTE:
<b>CLEGG:</b>	<b>GONSET:</b>	SB-300 \$219.00	HE-45w/HE-61 VFO \$ 59.00
95'er \$ 79.00	G-63 \$ 89.00	SB-110Aw/HP-23 \$319.00	<b>NATIONAL:</b>
<b>COLLINS:</b>	G-77A w/AC-DC \$ 69.00	HP-20 \$ 29.00	NC-300w/Ameco CB-6 Converter \$ 79.00
32V-2 \$ 59.00	G-66B/3 way supply \$ 89.00	HA-10w/572B \$ 99.00	NCX-5w/NCX-A \$395.00
32V-3 (3x 1x) \$ 89.00	G-76 and AC \$ 99.00	Six'er \$ 45.00	NC-270 \$ 29.00
KW6-2w/Waters Q-Mult. \$895.00	Comm. VFO \$ 79.00	MO-10 \$129.00	667m. conv. and Conv. box \$ 29.00
KW6-2A \$525.00	<b>HALLICRAFTERS:</b>	VHF-1 (Seneck) \$ 55.00	NCX-500w/AC \$389.00
32S-3 \$115.00	SR-2000w/AC \$925.00	DX-60 \$149.00	<b>EME:</b>
516F-2 \$595.00	SX-117 \$ 89.00	<b>JOHNSON:</b>	DB-22A \$ 19.00
32S-3 w/516F-2 \$179.00	SX-110 \$ 89.00	Ranger I \$ 89.00	<b>SWAN:</b>
<b>DRAKE:</b>	SX-99 \$179.00	Ranger II \$179.00	410Cw/22B \$ 99.00
2-B \$179.00	HT-37 \$225.00	Valiant \$249.00	<b>T. M. Co.:</b>
2-C \$119.00	HT33A (Mod. to "B") \$349.00	Pyemaker \$ 99.00	CSB-1 \$ 65.00
L-4B \$195.00	SB-73 \$195.00	S and Z \$ 59.00	POLYCOM: \$ 24.00
L-A \$195.00	SS-115 \$ 19.00	Matchbox 275w/ind. 6 and 2 VFO \$ 24.00	PC-4 \$ 24.00
T-4 \$129.00	R-51 w/clock \$ 49.00	Adventurer \$ 24.00	UTIGA: \$ 15.00
<b>ETCB:</b>	<b>HAMMARLUND:</b>	HQ-145C \$189.00	650 and VFO \$ 89.00
753w/751 AC \$ 49.00	HQ-145C \$ 24.00		
720 \$ 24.00			
722 VFO \$ 24.00			

**HIGHEST TRADES! NO ONE ANYWHERE will beat our deal!**  
 We will **TOP** any advertised or written price from any other dealer.  
 We trade on both new and used equipment and we service what we sell. Instant credit on both new and used equipment. General Electric revolving charge and Master Card Credit.

## AMATEUR - WHOLESALE ELECTRONICS

A DIVISION OF



International Electronic Systems, Inc.  
 280 ARAGON AVENUE, CORAL GABLES, FLORIDA 33134  
 Cable "INTEL" 305-444-6207 Export orders our specialty



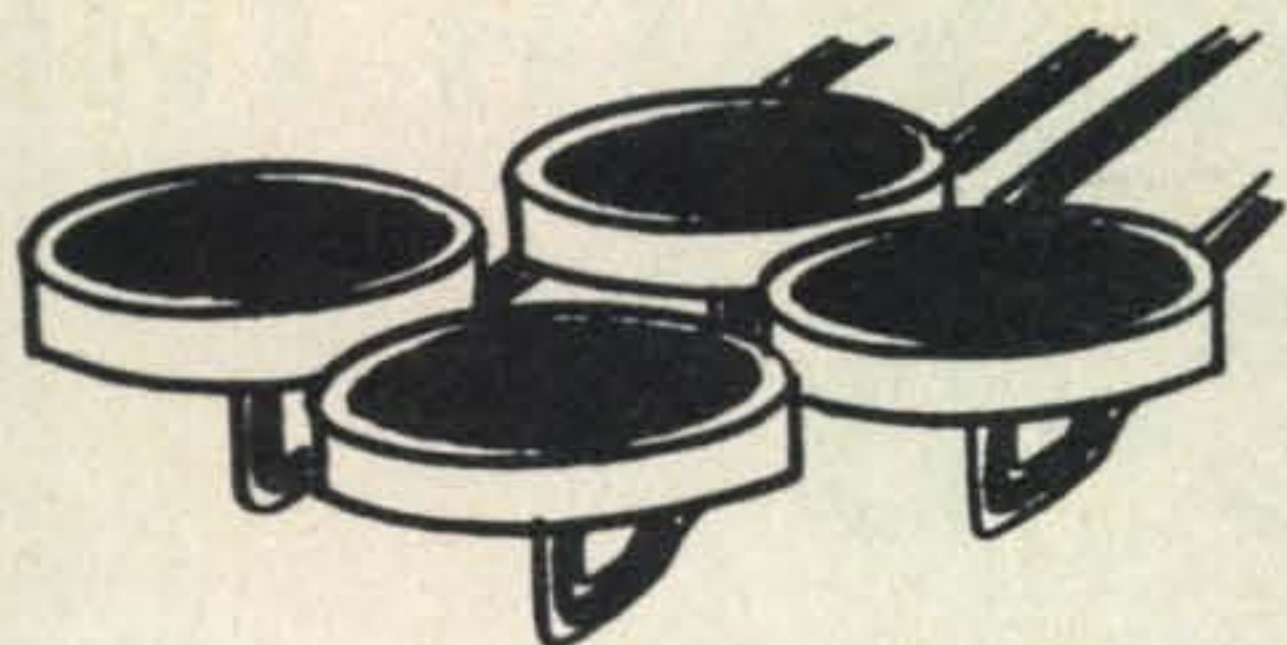

# RE-INKING RTTY RIBBONS

BY BERNIE SCHREIER,\* W2IDX

I HAVE experimented for a long time with a variety of homebrew inking arrangements for RTTY ribbons. Commercial re-inking devices are not always available or adaptable to your particular model and tend to be rather expensive, considering what they are. The advantages of re-inking are that the ribbon is provided with many more miles of heavy duty use and the printing is substantially darker and much easier to read both on RTTY paper and oiled reperforating tape.

## Type and Platen

A clean, sharp and intense black impression is very easy to obtain by the routine rejuvenation of either cotton or nylon ribbon through the simple process of re-inking. A finer ribbon will help cover up, to a degree, defects such as a worn platen and/or type. But for best results, the platen or type should be in reasonably good physical condition. It is also suggested that before installing a re-inker the type should be cleaned thoroughly with a good solvent (I prefer lacquer thinner) to remove the deep accumulation of hardened debris. The use of lacquer thinner will give the type a like-new appearance.

## Re-Inker

The simplest re-inker, and so far, the best I have made, costs practically nothing and takes but a few minutes to install. It works as well as, if not better than, the commercially manufactured counterpart. This method, I believe is applicable to practically all RTTY equipment having conventional ribbon feed assemblies.

In the ribbon feed assembly, there are two roller guides. Obtain a heavy piece of felt (1/8 to 1/4" thick) from either a fabric store or from an old felt hat. From this, cut a piece to the approximate dimensions of 1/4" x 1 1/2" and this should fit snugly around the roller guide. If it doesn't trim it carefully so that it does, without any overlap. Get your XYL into the act by having

her pull the edges together neatly with a couple of stitches.

When sewn together, shape the felt with your fingers so that it becomes uniformly round. On the same side as the installed felt, cement with Duco or Epoxy glue, a tiny piece of wire or wood toothpick across the top of the reverse arm (slotted ribbon guide) just barely above the ribbon. (See Fig. 1.) This crosspiece will prevent the ribbon from rising over the felt inker, a condition which occurs most often during high speed operation. The use of a double felt inker does not appear to offer any particular advantages.

## Inks

I have also tried a variety of inks from simple stamp pad formulas to thinned out bond and litho printing inks with only fair results. WA2RDO sells an RTTY ink which appears to be the best tried thus far. It never dries out on the ribbon but dries instantly on paper and oiled reperforating tape producing a very intense black.

Saturate the felt quite heavily at first with the ink, then make a couple of passes (reversals) until the ribbon absorbs the ink uniformly. After the ribbon is impregnated, it is necessary to add a few drops of ink each week. The results have been most gratifying. ■

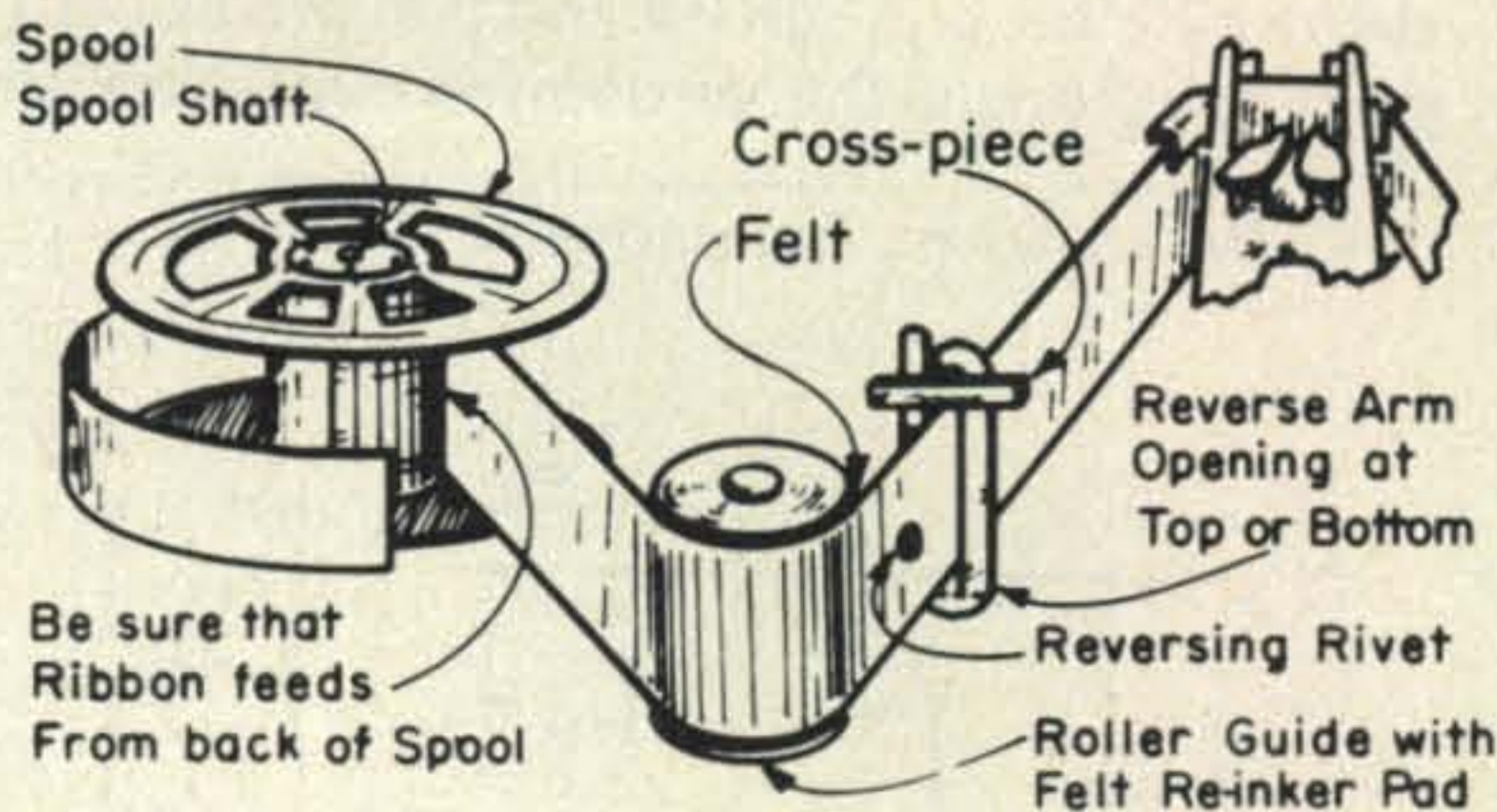

Fig. 1—Location of the felt re-inker pad and the cross piece on the reverse arm (slotted ribbon guide) is shown above.

\*699 Sherman Court, Westbury, N.Y. 11590.

# 2 METER N.B.F.M. WITH THE ARC-5

BY FRANK A. MOHLER,\* W2IAZ

**T**HE ultra-simple n.b.f.m. (narrow band frequency modulation) system uses only five parts (2 resistors, 2 capacitors, and a silicon diode) yet it provides more audio punch without distortion than the average a.m. system. Most radio amateurs, with one or more license renewals to their credit, have a tendency to shudder when reference to "frequency modulation" is made. Until recently, I was one of the shuddering multitude. My St. Vitus dance was cured completely after trying the amazing circuit shown in fig. 1.

Using an ordinary crystal high impedance microphone connected to the NBFM circuit, this ultra-simple circuit will furnish efficient, economical, and relatively distortionless n.b.f.m. voice transmission when used with an 8 mc v.f.o. driving a 2 meter transmitter. This n.b.f.m. circuit is a natural for the many radio amateurs who are currently using 8 mc v.f.o.'s with their two meter transmitters.

## Modifying The ARC-5

In my case, I use an ARC-5 (7 to 9.1 mc) as my v.f.o. source to drive my 2 meter transmitter. The ARC-5 requires no tedious rewiring or electronic surgery. All you have to do is lock the two relays in a closed position and apply a source of 90 volts d.c. and 24 volts a.c. The regulated 90 volts is applied to the oscillator, p.a. screen and p.a. plates completely ignoring the disdainful expression on

the 1625's for subjecting them to this meager voltage.

The 24 volts a.c. is for the filament supply. The low B-plus voltage is necessary to keep from overdriving the tripler stage in the meter transmitter. A short length of coaxial cable connects the v.f.o. output signal to the 2 meter transmitter. The variable output control on the ARC-5 allows a convenient method to adjust for the desired amount of drive to obtain optimum operation. For driving the 6U8 tripler stage in my 2 meter transmitter, I found that 8 volts of r.f. signal from the ARC-5 was just right. This was obtained with the output coupling control adjusted approximately three quarters of the full position, and using the low voltage stated.

## Recalibrating the VFO Dial

When the n.b.f.m. circuit is wired into the ARC-5 oscillator stage, the added capacitance placed across the oscillator tuning capacitor shifts the calibration. The tuning capacitor must be reduced in value (opened) to produce the same frequency. In reducing the value of the tuning capacitor to compensate for the added capacitance introduced by the n.b.f.m. circuit, the dial calibration will read too high by about 100 kilocycles. In other words, an actual output frequency

[Continued on page 100]

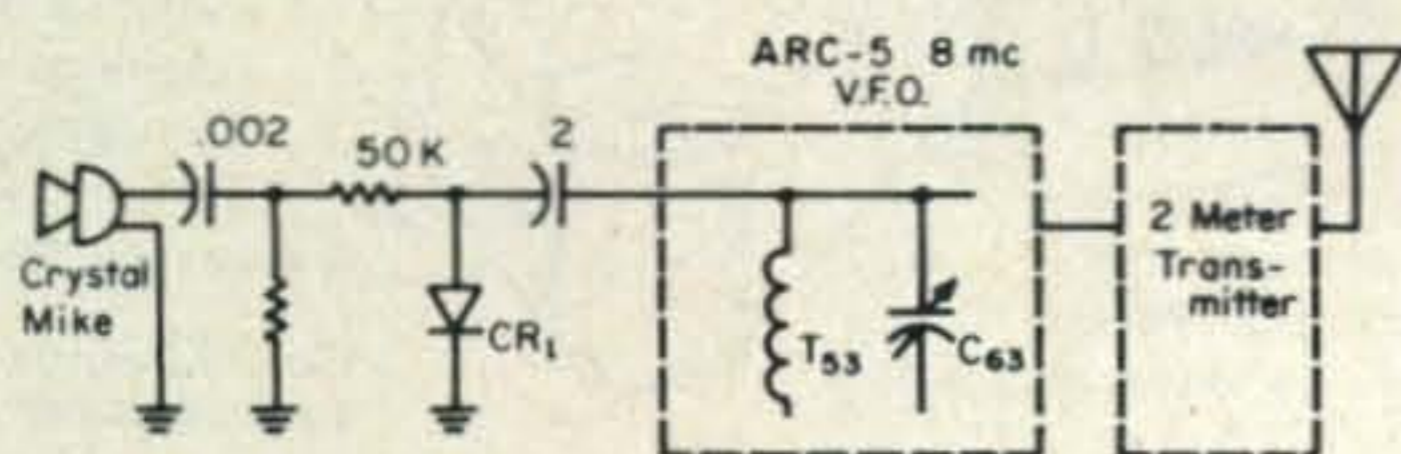

Fig. 1—A simple set up for narrow band f.m. operation with an ARC-5. The microphone is a high impedance crystal type and the diode needed is described in the text.

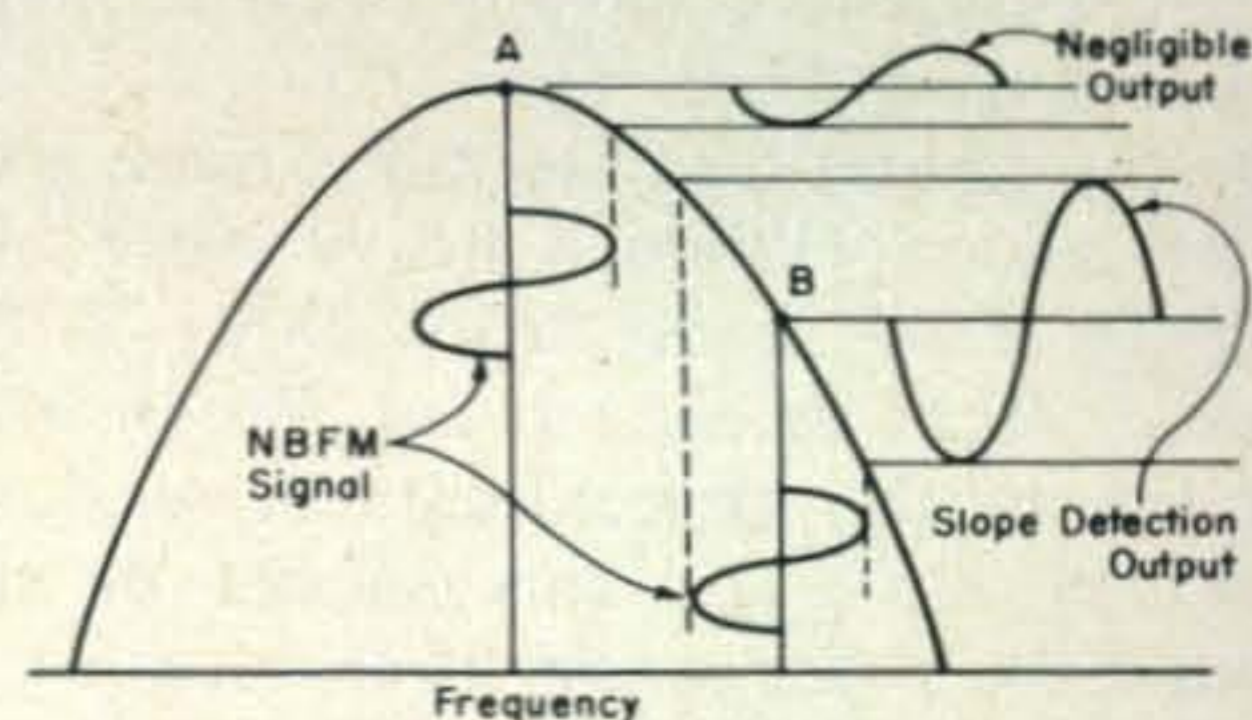

Fig. 2—Slope detection for simple reception of n.b.f.m. is illustrated above. The carrier must be set at point B rather than A.

# WHAT'S NEW?? 550 BIG WATTS!



The New Galaxy  
Wattmeter/Antenna Selector

The Powerful New Galaxy  
GT-550 TRANSCEIVER

The Beautiful, Matching  
Galaxy Speaker Console

## The GT-550 by Galaxy

Being featured by Amateur Radio's Newest Distributor

## L & S Electronics

"We sell satisfaction", and we know you will be satisfied with the New Galaxy GT-550 and all the fine new matching accessories. It comes with all new styling, 550 Big Watts, Receiver sensitivity second to none, the smoothest tuning, and many more fine features. "We know how it works", do you?

<b>GT-500</b> 550 watt transceiver	<b>449.00</b>
<b>AC-400</b> AC Power Supply, 110/230 VAC	<b>89.95</b>
<b>G-1000</b> DC Power Supply, 12/14/VDC, Neg. Ground	<b>125.00</b>
<b>RV-550</b> Standard remote VFO provides dual frequency control for GT-550 Only	<b>75.00</b>
<b>RF-550</b> 3000/400 watt Wattmeter/Antenna selector.	<b>69.00</b>
<b>SC-550</b> Standard speaker console, 5 x 7 speaker 8 ohms, (AC-400 will mount inside)	<b>19.95</b>

### May Special!

Buy a New GT-550, AC-400, SC-550, and RV-550, or RF-550, and we will give you a Free 40 foot Tower or we will give you a \$50.00 Bonus towards a purchase of Galaxy's many other fine accessories.

Call, or write to **John Linton, W8DKI**, or **Pete Smith, WA8PZA**

The hams that have the answer to your questions with 15 years of amateur sales between us, and many active hours on the air.

We sell New and reconditioned gear, and all of the popular accessories.

## *L & S Electronics*

*Electronic Supplies • Ham • CB • Hi-Fi • TV*

17813 EUCLID AVENUE

CLEVELAND, OHIO 44112

PHONE (216) 486-7330

## GOTHAM ANTENNAS ARE MUCH BETTER OF COURSE, YOU PAY MUCH LESS

*How did Gotham drastically cut antenna prices? Mass purchases, mass production, product specialization, and 16 years of antenna manufacturing experience. The result: The kind of antennas you want, at the right price!*

**QUADS** Worked 42 countries in two weeks with my Gotham Quad and only 75 watts...

**W3 CUBICAL QUAD ANTENNAS** — these two element beams have a full wavelength driven element and a reflector; the gain is equal to that of a three element beam and the directivity appears to us to be exceptional! ALL METAL (except the insulators) — absolutely no bamboo. Complete with boom, aluminum alloy spreaders; sturdy, universal-type beam mount; uses single 52 ohm coaxial feed; no stubs or matching devices needed; full instruction for the simple one-man assembly and installation are included; this is a fool-proof beam that always works with exceptional results. The cubical quad is the antenna used by the DX champs, and it will do a wonderful job for you!

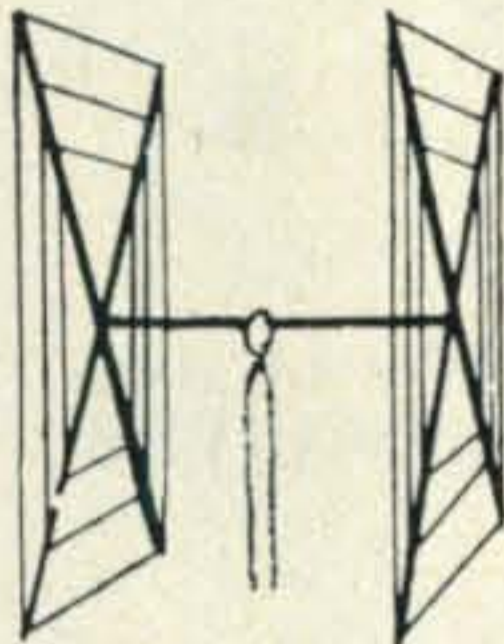

### 10/15/20 CUBICAL QUAD SPECIFICATIONS

Antenna Designation: 10/15/20 Quad  
 Number of Elements: Two. A full wavelength driven element and reflector for each band.  
 Freq. Covered: 14-14.4 Mc. 21-21.45 Mc. 28-29.7 Mc.  
 Shipping Weight: 28 lbs. Net Weight: 25 lbs.  
 Dimensions: About 16' square.  
 Power Rating: 5 KW.  
 Operation Mode: All  
 SWR: 1.05:1 at resonance  
 Gain: 8.1 db. over isotropic  
 F/B Ratio: A minimum of 17 db. F/B  
 Boom: 10' long x 1 1/4" O.D.; 18 gauge steel; double plated; gold color  
 Beam Mount: Square aluminum alloy plate incorporating four steel U-bolt assemblies. Will easily support 100 lbs. Universal polarization.  
 Radiating Elements: Steel wire, tempered and plated, .064" diameter.  
 X Frameworks: Each framework consists of two 12' sections of 1" OD aluminum 'hi-strength' (Revere) tubing, with telescoping 7/8" tubing and short section of dowel. Plated hose clamps tighten down on telescoping sections.  
 Radiator Terminals: Cinch-Jones two-terminal fittings  
 Feedline (not furnished); 52 ohm coaxial cable  
 Now check these startling prices—note that they are *much lower* than even the bamboo-type:

10-15-20 CUBICAL QUAD .....	\$35.00
10-15 CUBICAL QUAD .....	30.00
15-20 CUBICAL QUAD .....	32.00
TWENTY METER CUBICAL QUAD .....	25.00
FIFTEEN METER CUBICAL QUAD .....	24.00
TEN METER CUBICAL QUAD .....	23.00
(all use single coax feedline)	

**BEAMS** The first morning I put up my 3 element Gotham beam (20 ft) I worked

YO4CT, ON5LW, SP9-ADQ, and 4U11TU THAT ANTENNA WORKS! WN4DYN Compare the performance, value, and price of the following beams and you will see that this offer is unprecedented in radio history!

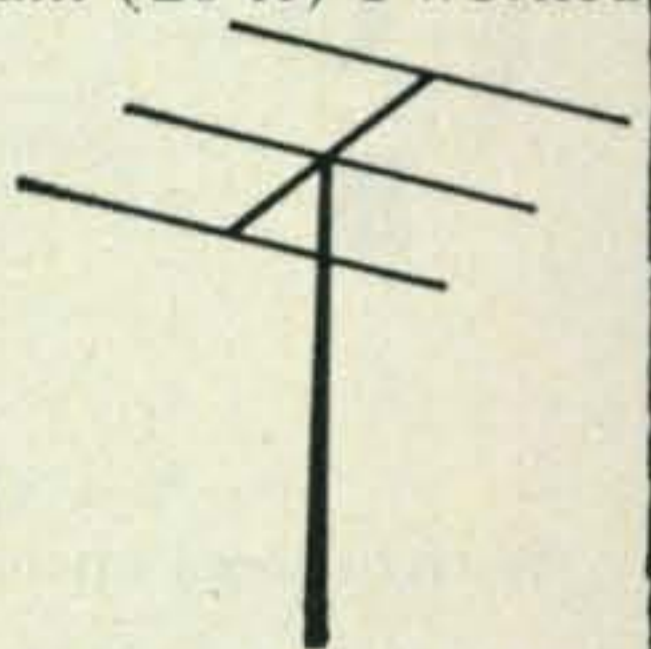

Each beam is brand new; full size (36' of tubing for *each* 20 meter element, for instance); absolutely complete including a boom and all hardware; uses a single 52 or 72 ohm coaxial feedline; the SWR is 1:1; easily handles 5 KW; 7/8" and 1" aluminum alloy tubing is employed for maximum strength and low wind loading; all beams are adjustable to any frequency in the band.

2 EL 20 .....	\$19	4 EL 10 .....	\$18
3 EL 20 .....	25	7 EL 10 .....	32*
4 EL 20 .....	32*	4 EL 6 .....	18
2 EL 15 .....	15	8 EL 6 .....	28*
3 EL 15 .....	19	12 EL 2 .....	25*
4 EL 15 .....	25*	*20' boom	
5 EL 15 .....	28*		

### ALL-BAND VERTICALS

"All band vertical!" asked one skeptic. "Twenty meters is murder these days. Let's see you make a contact on twenty meter phone with low power!" So K4KXR switched to twenty, using a V80 antenna and 35 watts AM. Here is a small portion of the stations he worked: VE3FAZ, T12FGS, W5KYJ, W1WOZ, W2-ODH, WA3DJT, WB2FCB, W2YHH, VE3-FOB, WA8CZE, K1SYB, K2RDJ, K1MVB, K8HGY, K3UTL, W8QJC, WA2LVE, YS1-MAM, WA8ATS, K2PGS, W2QJP, W4JWJ, K2PSK, WA8CGA, WB2KWY, W2IWJ, VE3-KT, Moral: It's the antenna that counts!

**FLASH!** Switched to 15 c.w. and worked KZ5-IKN, KZ5OWN, HC1LC, PY5ASN, FG7XT, XE2I, KP4AQL, SM5BGK, G2AOB, YV5-CLK, OZ4H, and over a thousand other stations!

V40 vertical for 40, 20, 15, 10, 6 meters .....	\$14.95
V80 vertical for 80, 75, 40, 20, 15, 10, 6 meters .....	\$16.95
V160 vertical for 160, 80, 75, 40, 20, 15, 10, 6 meters .....	\$18.95

HOW TO ORDER: SEND CHECK OR MONEY ORDER. WE SHIP IMMEDIATELY UPON RECEIPT OF ORDER BY RAILWAY EXPRESS. SHIPPING CHARGES COLLECT.

**GOTHAM, 1805 Purdy, Dept. CQ, Miami Beach, Fla. 33139**

# A POWER SUPPLY FOR THE URC-4 & URC-11

BY STANLEY F. BRIGHAM,\* W3TFA

**T**HERE is no substitute for batteries for many applications, however, the cost of batteries today is quite high, and although this may be not prohibitive, it instills an overly conservative attitude toward indiscriminate use. In support of this philosophy it was determined that a need existed to design and construct a power supply for operating both the URC-4<sup>1</sup> and URC-11<sup>2</sup> Radio Receiver-Transmitter walkie-talkie units under conditions where a source of primary power was available. Battery power could then be conserved and its use prescribed by environmental requirements.

Design and layout of the power supply evolved as a compromise between those com-

ponents available from the parts on hand, and the configuration most convenient to satisfy travel and luggage limitations. Power requirements for the subject URC units dictate an A+ source of 1.3 volts d.c. for the filamentary type subminiature tubes, and B+ of approximately 125 v.d.c. These voltages are attained from two separate supplies housed within a single chassis type enclosure.

## Circuit Details

The circuit diagram of the power supply appears in fig. 1. The high voltage which delivers approximately 125 v.d.c. is provided by a half wave selenium rectifier  $CR_8$ , isolated from ground by two 6.3 v.a.c. filament transformers wired back to back. Two 20 mf capacitors and the 1000 ohm resistor serve as a filter network, and the 51K resistor across the output provides a constant load when the transmit and receive buttons on the URC units are not depressed for operation. Note that this circuit is isolated above ground.

The low voltage, or filament supply consists of a bridge rectifier employing four 1N-1695's, which receives its input voltage from a small 6.3 v.a.c. transformer. The rectified d.c. output is then filtered by 4000 mf of capacitance and regulated by an N.P.N., 150 watt transistor, (Motorola type 2N3713). Three 1N254 silicon diodes cascaded between the base of the 2N3713 and ground limit the desired voltage under load. A 1K load resistor is placed across the output.

Note that the front view of the power receptacle,  $J_2$ , is shown in fig. 1 and must be wired accordingly by proper orientation of the pins to the "key." This point cannot be overemphasized because a voltage error

\*7211-16th Ave., Takoma Park, Md. 20012.

<sup>1</sup>Brigham, S. F. "Putting the URC-4 on 50-144-220," *CQ*, October 1965, p. 26.

<sup>2</sup>Brigham, S. F. "Putting the URC-11 on 220 MC," *CQ*, See page 40 this issue.

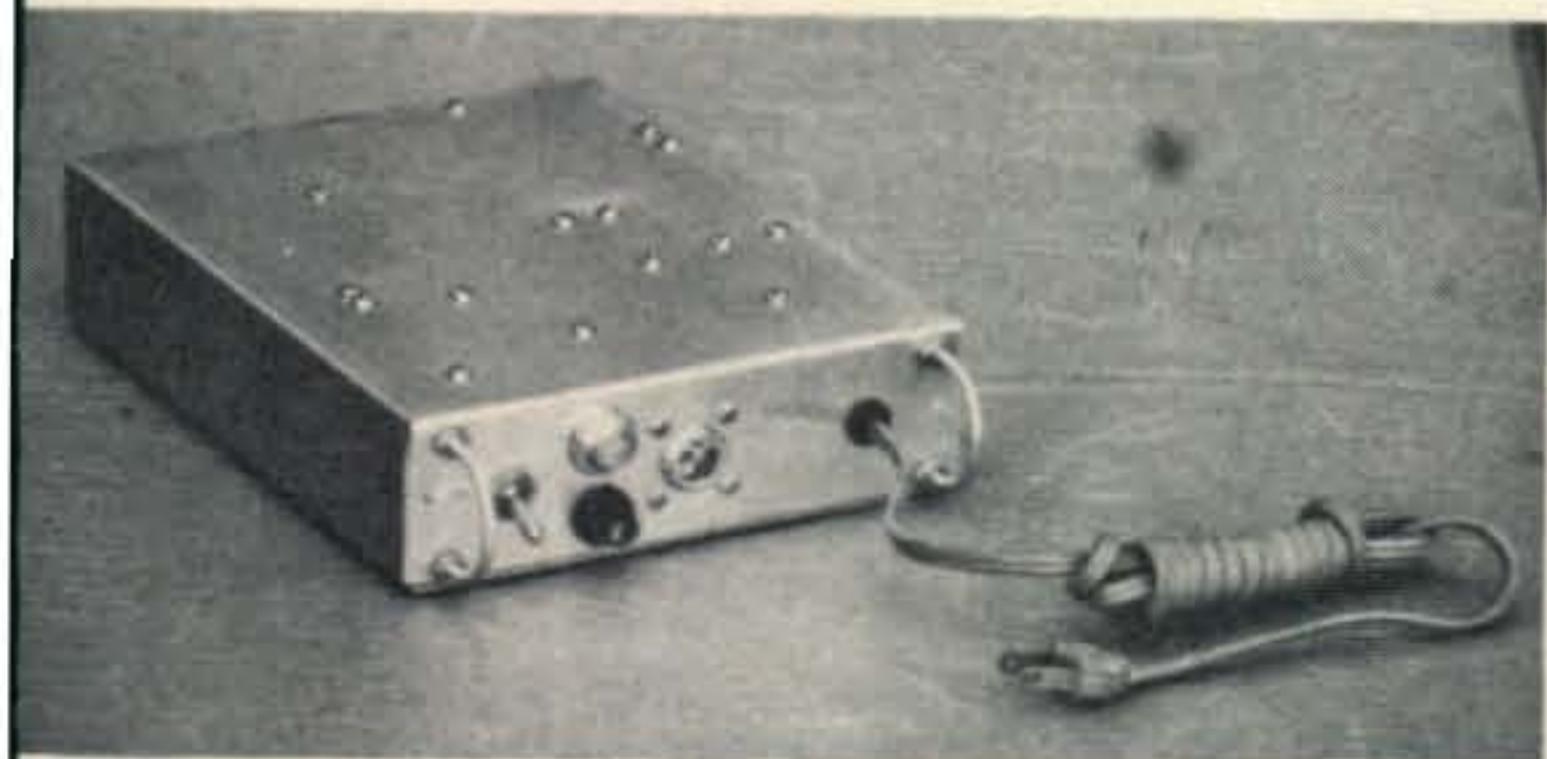

The power supply is contained within a 7 × 9 × 2 inch aluminum chassis complete with bottom cover. All controls are mounted on the front as indicated and the balance of the components inside the chassis are mounted on the top. (Photo courtesy W3AY.)

Fig. 1—Circuit of the power supply that can be used with both the RT-159A or B/URC-4 and RT-285A / URC-11 Radio Receiver-Transmitter units. All resistors are 2 watt, and CR<sub>8</sub> is a 65 ma general purpose selenium rectifier. Note that front view of power receptacle, J<sub>2</sub>, is shown. Orient pins by reference to the key. A bottom view of the 2N3713 power transistor is shown. The collector is connected to the case and if the 2N3713 is chassis mounted, it must be insulated.

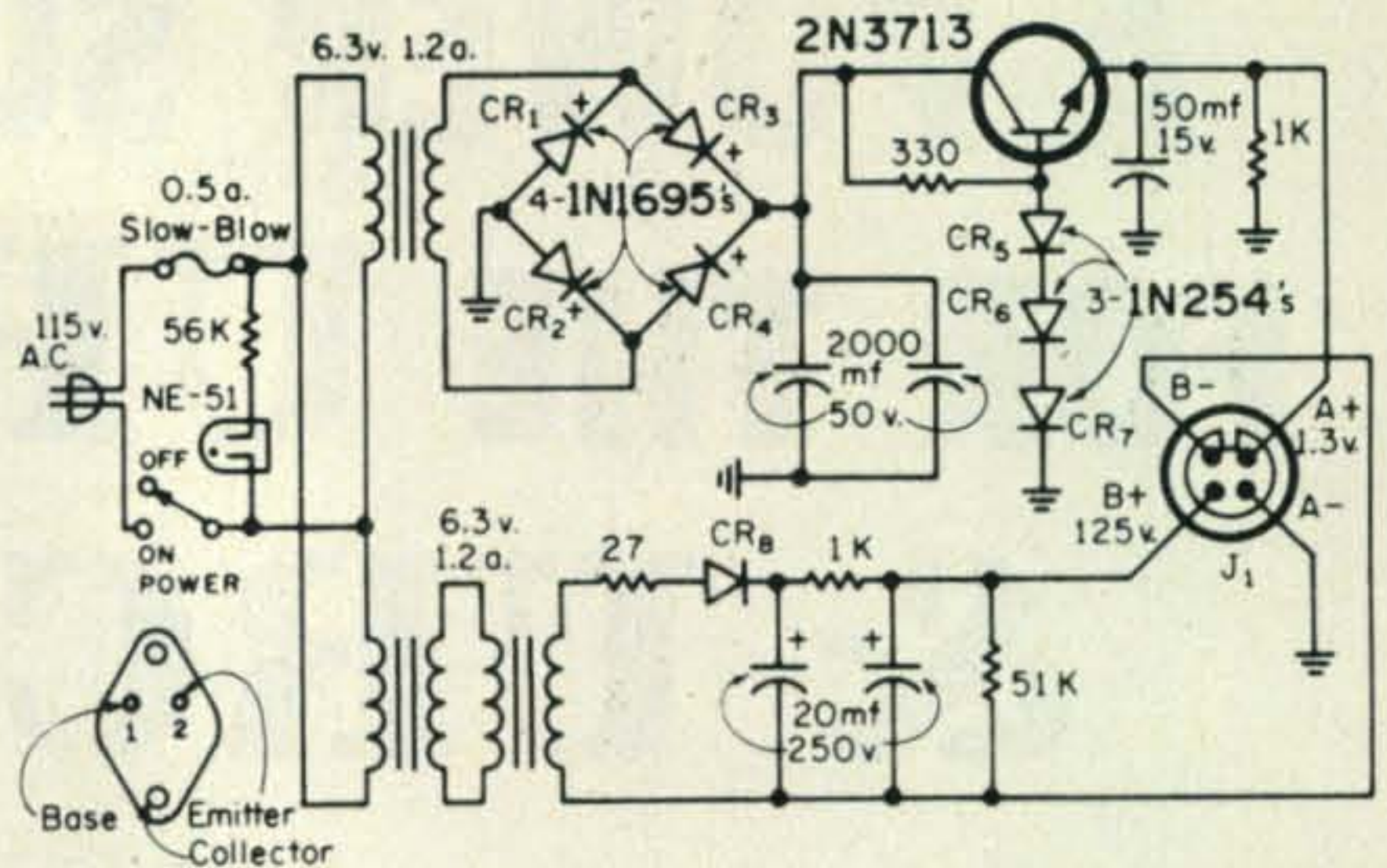

could be quite costly. Subminiatures are not inexpensive.

### Construction

The power supply described is contained within a 7 × 9 × 2 inch aluminum chassis complete with bottom cover as shown in the photographs. It should be noted that all controls, indicators, receptacles and cables as well as protective handles are mounted on the 2 × 7 inch small end of the chassis. The remainder of the components are mounted inside the top surface of the chassis with nickel plated brass binder head screws. This technique permits easy access when operating from a brief bag or as a packing convenience with standard luggage. The protective handles were made from 1/8 inch solid round aluminum clothes line wire cut 3 3/4 inches in length and threaded 1/2 inch on each end with a 6-32 die. The handles were then bent around a standard "D" cell thus forming the final U-shape configuration. Four 6-32 nuts either side of the chassis and

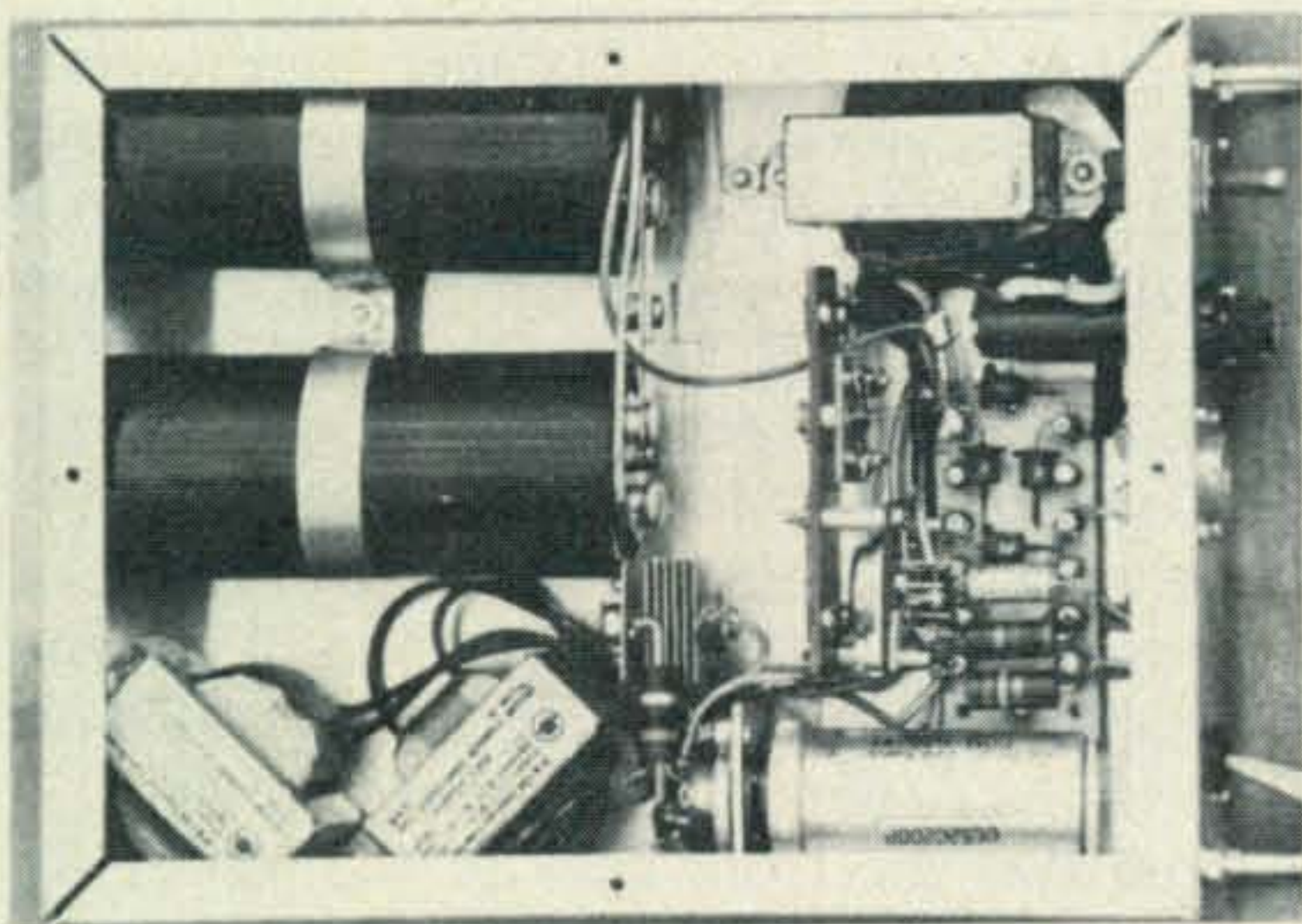

Interior view of the power supply showing the physical arrangement of the components. (Photo courtesy W3AY.)

threaded onto the U-shaped handles affix them in position. Lock washers are placed under the nuts on the inside of the chassis, and flat washers are placed beneath the nuts mounted on the outside front surface. This is done so that the front panel will not be scratched since the handles are secured by tightening the exposed nuts on the outside of the chassis.

As the photograph showing the interior view of the chassis reveals, most of the small parts such as resistors, diodes, capacitors and the transistor are mounted on either terminal boards or a vector board. This type construction assures minimum displacement of parts during transmit thus enhancing greater reliability. It can be seen that the 2N3713 transistor is mounted without a heat sink. The latter is not required because the transistor runs cool since it is operating well below its maximum ratings. Pin connections for wiring the power transistor are shown in the detail of fig. 1. This is a bottom view of the 2N-3713 and it should be noted that the collector is connected to the case of the TO-3 package.

The four pin power receptacle mounted on the front panel was salvaged from an expired mercury type primary battery, BA-1315/U manufactured by Mallory. This battery was designed specifically for use with the URC-4 and URC-11 units, measures about 1 × 3 × 6 inches, and delivers both 1.3 and 135 volts. The receptacle can be removed easily from the hermetically sealed can by using tin snips. Be sure to leave about a 1/2 inch flange in order to facilitate mounting the receptacle to the chassis. Another source of this type receptacle can be URC-4 units which can-

[Continued on page 98]

# NEW G&G CATALOG! MILITARY ELECTRONICS



24 PAGES crammed with Gov't Surplus Electronic Gear—the Biggest Bargain Buys in America! It will pay you to

**SEND 25¢**

for your copy—Refunded with your First Order!

**BC-645 TRANSCEIVER**, 15 tubes, 435 to 500 Mc. Easily adapted for 2 way voice or code on Ham, Mobile, Television Experimental and Citizens' Bands. With tubes, less power supply in factory carton.

Brand new.....\$16.95

**SPECIAL PACKAGE OFFER:** BC-645 Transceiver, Dynamotor and all accessories, including mountings, UHF Antenna Assemblies, control box, complete. **BRAND NEW**.....\$26.95

## AN/APR-4Y FM & AM RECEIVER

High precision lab instrument, for monitoring and measuring frequency and relative signal strength, 38 to 4000 Mc in 5 tuning ranges. For 110 V 60 cycle AC. Built-in power supply. Original circuit diagram included. Checked out, perfect, **LIKE NEW**.

All Tuning Units Available for Above.

**\$88.50**

## SCR-274-N, ARC-5 COMMAND SET HQ!

Freq. Range	Type	Exc. Used	Like New	BRAND NEW
<b>RECEIVERS, Complete with Tubes</b>				
190-550 Kc.....	BC-453	\$18.95	\$23.50	\$27.50
3-6 Mc.....	BC-454	\$16.50	\$19.50	\$22.50
6-9.1 Mc.....	BC-455	\$14.95	\$17.95	\$21.50
1.5-3 Mc.....	R-25	—	\$21.50	\$23.50
<b>TRANSMITTERS, Complete with Tubes</b>				
4-5.3 Mc.....	BC-457	\$ 6.95	\$ 8.95	\$11.95
5.3-7 Mc.....	BC-458	\$ 6.95	\$ 8.95	\$12.95
7-9.1 Mc.....	BC-459	\$17.95	\$19.50	\$23.50
2.1-3 Mc.....	T-18	—	\$ 9.95	\$11.95
3-4 Mc.....	T-19	\$10.50	\$12.50	\$16.95



## CARTER GENEMOTOR

**NEW...\$4.95**

INPUT: 5.9 VDC 32 Amps.  
OUTPUT 405 VDC .270 Amps.  
Fine for mobile ham gear.  
Built-in hash filter.



## CARTER MAGMOTOR

**NEW...\$2.65**

INPUT: 6 VDC 3.6 Amps.  
OUTPUT: 250 VDC .030 Amps.  
#MA2503S.

## BC-605 INTERPHONE AMPLIFIER

**BRAND NEW...\$3.45**

Excel. Used \$1.95  
Easily converted to home or office intercom system. Uses pair of 1619 tubes, delivering 10 watts of audio power. Massive construction, suitable for shops, factories. Finest parts used. Conversion diagram and instructions included.



## HEADSET

Low impedance. With large chamois ear cushions, 4-ft. cord and plug. Reg. \$12.50.

**OUR SPECIAL PRICE.....\$2.95**

Righ impedance adapter for above.

69¢



## TEST UNIT TS-16

Portable, self-contained, for checking altimeter counter & indicator circuits. Freq. read directly in Mc from rotary dial. Power input 27 to 28 V DC. Includes meter for line voltage.

Brand New.....\$14.95



## FREQUENCY METER BC-906

**NEW \$12.95**

Portable absorption type meter for determining frequency of CW MCW or pulsed radar transmitters and local osc. Also for calibrating, aligning and checking sensitivity of receivers. Battery operated: 1.5V, 45 V DC. Range 150 to 234 Mc.

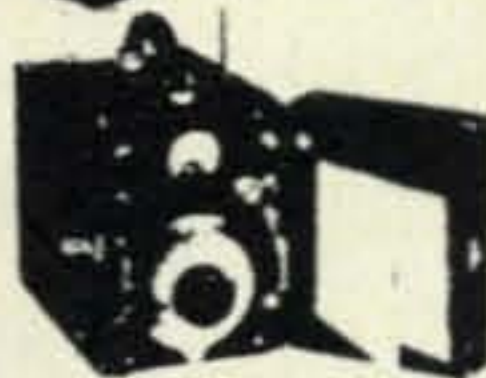

## TG-SB TELEGRAPH SET for CODE COMMUNICATIONS or CODE PRACTICE

**NEW \$8.95**

Portable, with hinged lid. Two or more units can be operated up to 25 miles apart, over land lines. Has bell call system, 1000 cycle howler, key, headpiece, canvas case, book. Wt. 10 lbs. Batteries not included: two 1½ volt and one 22½ V. Overall size 5½ x 5½ x 10".

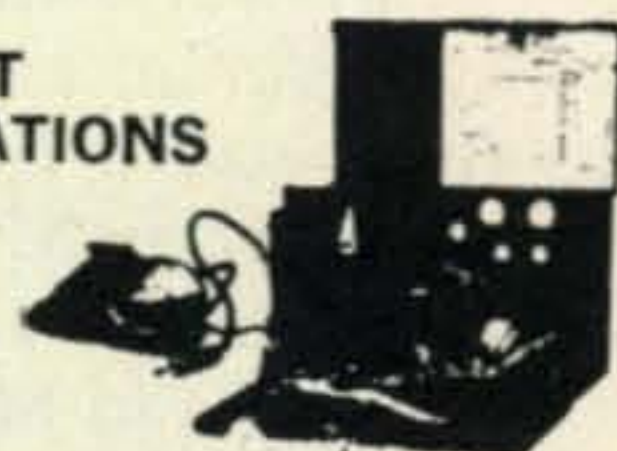

## DUAL AMPLIFIER

**NEW \$7.95**

Has two input circuits, each feeding a single 6SN7GT twin triode amplifier. The unit is complete with 115 volt 60 cycle power supply which uses 6X5GT rectifier. Finest components. All transformers hermetically sealed. Vibrationproof chassis on 4 rubber shock-mounts. Size: 5¾" x 2¼" x 4¾". Weight 11 lbs.



## NAVY BEAM FILTER

1020 cycles low impedance. Similar to the FL8 but more elaborate. With cord and PL55 and switching control on slant panel for easy viewing.

NEW.....\$2.25

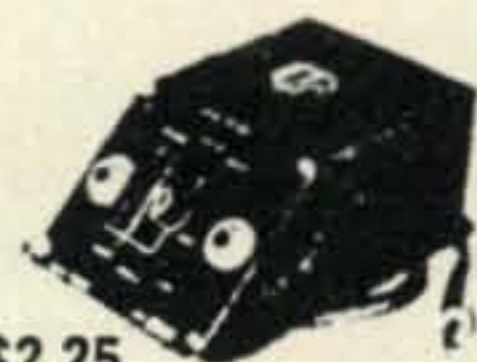

## WILLARD 2-VOLT STORAGE BATTERY

Rated at 20 Ampere-Hours. Model 20-2. Compact, rechargeable, fine for models, etc. Convenient non-spill construction. Lightweight polystyrene container, extremely sturdy. Size: 3 x 4 x 5½". Shipped dry, uses standard electrolyte (listing here). Shpg. wt., 3 lb.

NEW, Each.....\$2.75  
Lots of 36 to 99 each.....\$2.45  
Lots of 100 or more, each.....\$2.30



**TERMS** Either 25% Deposit with order, balance C.O.D.—OR—Remittance in Full. Minimum Order \$5.00. All shipments F.O.B. our warehouse, NYC. All merchandise subject to prior sale and price change.

## G & G RADIO SUPPLY COMPANY

77-C Leonard St., NYC 10013 • Ph. 212-267-4605

## CQ Reviews:

# The Galaxy GT-550 Transceiver

BY WILFRED M. SCHERER,\* W2AEF

It is hardly worthwhile to go to the expense of a 1 kw input linear when you have a transceiver that packs a 1/2 kw p.e.p. input, such as does the Galaxy Model GT-550.

This model is a revised version of the Galaxy V Mark II and Mark III units with some added improvements. Except to say that the GT-550 is newly styled and features relocation of the v.f.o.-dial window and an exceptionally nice tuning control, we'll not go into the differences between the other models, in order to devote space to the particular details of the GT-550.

This job is designed for c.w. and s.s.b. operation (u.s.b. or l.s.b. on any band) with an s.s.b. p.e.p. input of 550 watts with 500 kc segments on the 3.5-28 mc amateur bands (except 29-29.7 mc).

### Technical Details

As is the custom with our reviews, a block diagram is given at fig. 1 showing the basic functions of various sections in the GT-550. Specific technical details, not otherwise indicated, are as follows:

\*Technical Director, CQ.



The Galaxy Model GT-550 Transceiver.

### Conversion Scheme

As may be seen, single conversion is used throughout with a 9 mc i.f. The local-oscillator injection signals are obtained either directly from a 5.5-5.0 mc v.f.o. or by premixing the v.f.o. output with a crystal-controlled oscillator signal. The v.f.o. alone is used for the 3.5 mc band, in which case the sum mixture with the received signal produces the 9 mc i.f. On transmit the process is in reverse with the difference mixture, between the s.s.b. signal generated at 9 mc and the v.f.o. frequencies, used to produce the 3.5 mc-band output.

On the 7, 14, 21, 28 and 28.5 mc range the respective premixing-crystal frequencies are 21.5, 28.5, 35.5, 42.5 and 43 mc. The difference between the crystal frequency and the 5.5-5.0 mc v.f.o. signals then provides injection signals of 16.0-16.5, 23.0-23.5, 30.0-30.5, 37.0-37.5 and 37.5-38.0 mc for the respective bands. The difference or sum mixtures are used at the receiver or transmitter mixer, respectively, for the required conversion. The v.f.o. always tunes in the same direction; that is, 5.5-5.0 mc for increasing the transceiver frequency.

### V.F.O.

The v.f.o. employs a bipolar transistor in a series-tuned Colpitts circuit. The oscillator operates at a very low level to enhance stability. It therefore requires amplification by a 5.0-5.5 mc bandpass amplifier whose loading effects upon the oscillator frequency are virtually eliminated by a two-stage untuned transistor amplifier between the oscillator and the output amplifier.

A rear-apron phono jack on the set is connected to the v.f.o.-amplifier input to permit use of an external v.f.o.

Regulated-voltage powers the v.f.o., which together with good design and well chosen temperature-compensating capacitors, pro-



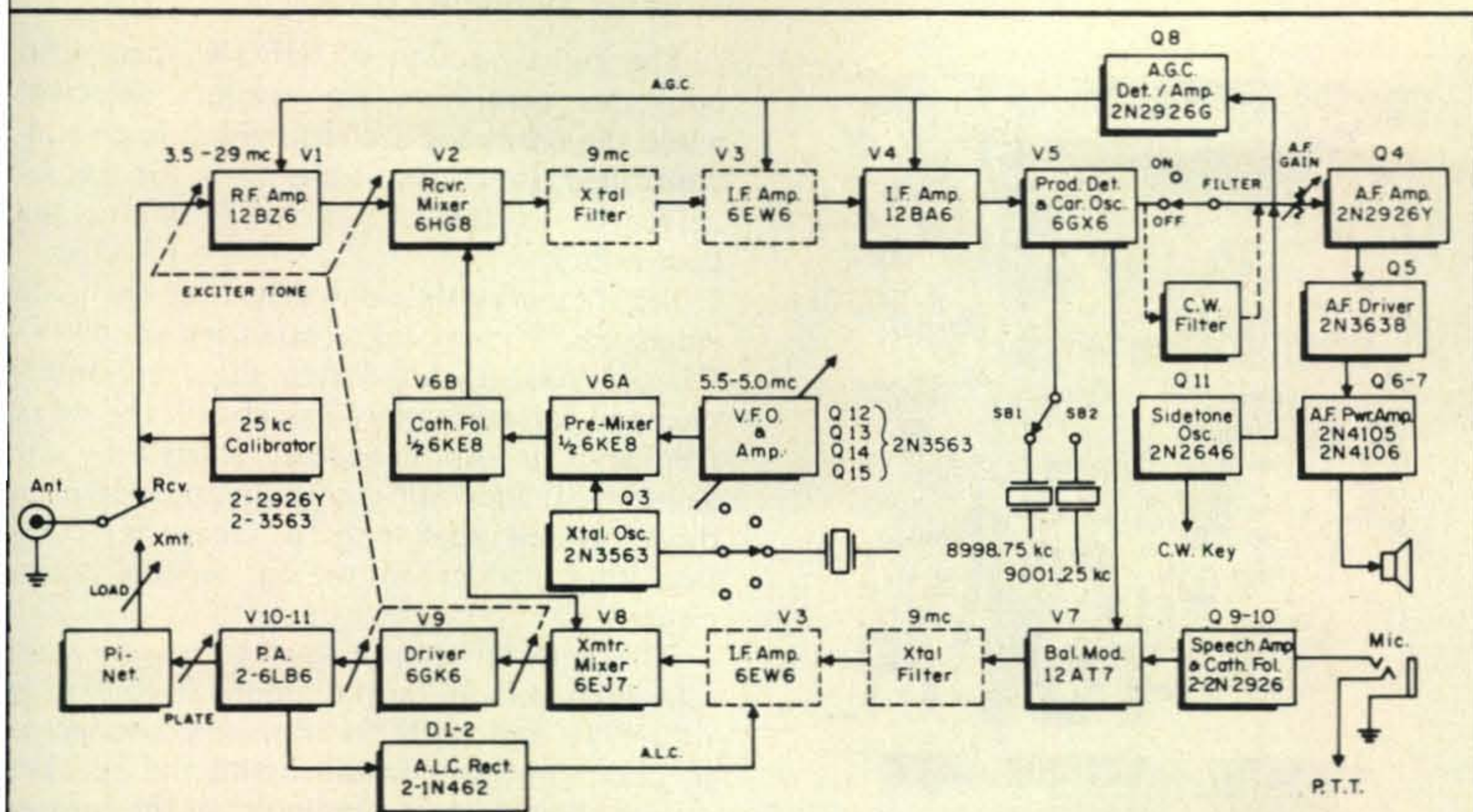

Fig. 1—Block diagram for the GT-550. Sections with dashed lines are common to both receiver and transmitter. Details are given in the text.

vides exceptionally good frequency stability under a wide range of conditions.

In this respect, the drift during the first 15 minutes of operation from a cold start at 70° F. ambient, was found to be 200 c.p.s. This tallies with results shown on a strip, supplied with our model, that was taken from a chart recorder used in conjunction with factory measurements. If such an inclusion is to be standard practice, we'd say it's a good idea. Drift during the subsequent hour was 90 c.p.s., and less than 50 c.p.s. per hour thereafter.

With  $\pm 10\%$  line-voltage variations, the frequency shift on any band (including that of the premixing crystals) was  $\pm 10$  c.p.s. or less. Banging the cabinet created no detrimental effects.

The v.f.o. capacitor mounts above the chassis deck and is not enclosed, so slight frequency excursions could be experienced as air, at varying temperatures and degrees of humidity, flows through the cabinet perforations and past the capacitor during mobile operation.

### Pre-Mixer

A transistor crystal-controlled oscillator, that functions in a tuned-collector circuit, furnishes the signals needed to be premixed with the v.f.o. at  $V_{6A}$ , the 6KE8 pentode section.

Bandpass circuits are employed at  $V_{6A}$

plate for each pre-mixer-output range to ensure a uniform injection level to the other mixers which is made through a cathode follower, the 6KE8 triode  $V_{6B}$ .

Anyone who has attempted alignment of bandpass circuits will appreciate a unique feature in the GT-550 that permits accurate adjustment of all the aforementioned bandpass circuits without the need of special equipment, such as a sweep generator, or of employing the expedient of temporarily soldering a swamping resistor across each circuit individually as they are progressively peaked.

The setup in the GT-550 is one that already includes swamping resistors that can be separately cut in as needed simply by using a screw driver to short a feedthru test point for each to ground at the top of the chassis. This is the first time we've seen such a wise and convenient provision in a piece of gear.

### Tuned R.F. Circuits

The input and output circuits of the receiver r.f. stage are capacitively gang-tuned, with the same circuits simultaneously employed for tuning the transmitter-driver output and input respectively, thus permitting the transceiver to be conjunctively peaked up both on receive and transmit. The r.f. stage input is not tuned by the transmitter p.a.-output circuit, as is sometimes done with

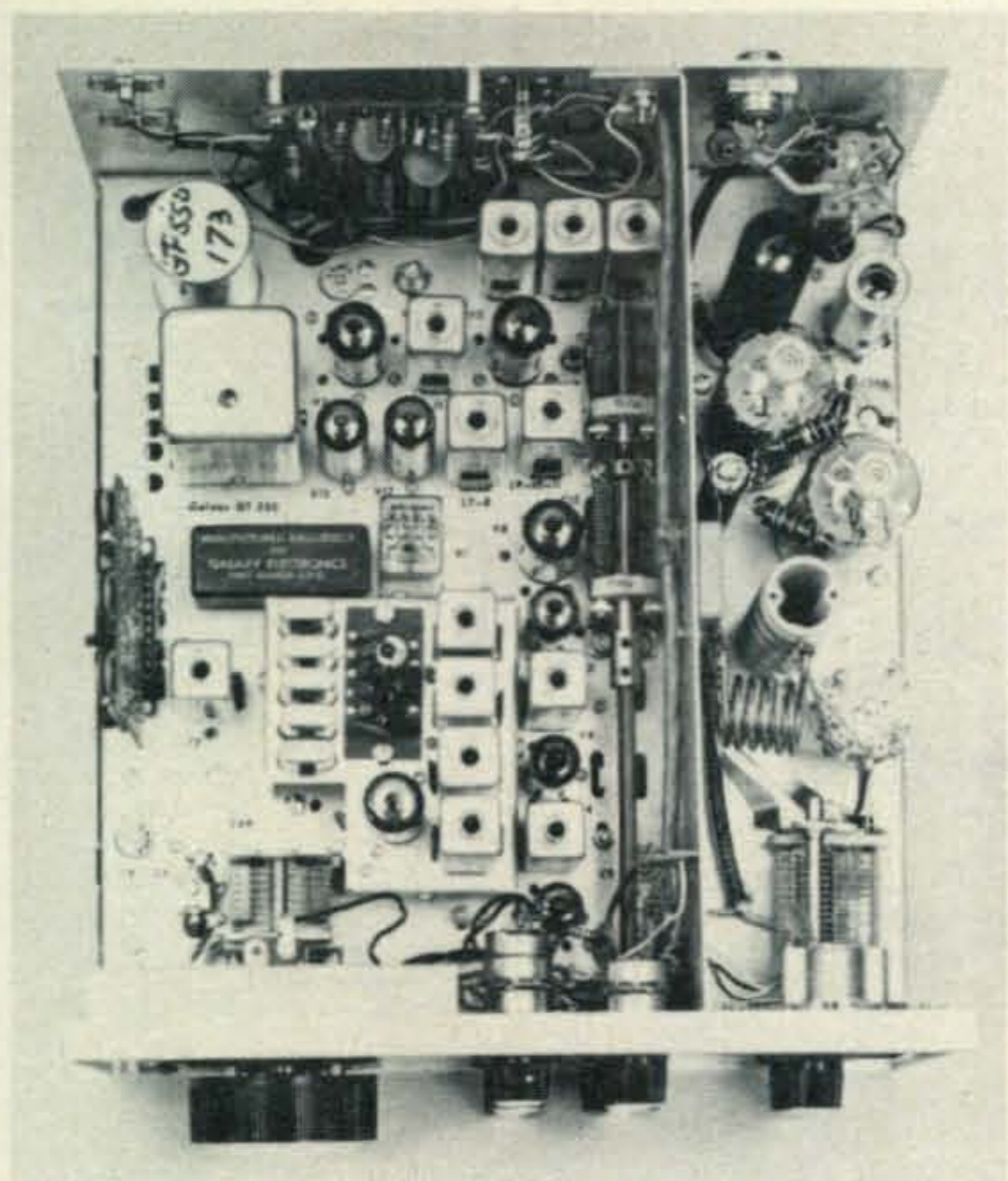

Top view of the GT-550. The p.a is along the right side with its perforated enclosure removed. The vertical circuit board at the center of the left edge is the v.o.x. accessory. The square can above is the 25 kc calibrator.

transceivers. Better front-end r.f. selectivity is thus realized which aids in the rejection of i.f. signals, image or other spurious responses. To further attenuate i.f. signals, a 9 mc trap is employed at the mixer grid.

The image rejection on our model measured 60, 70, 75, 62 and 58 db on the 3.5, 7, 14, 21 and 28 mc bands respectively, while i.f.-signal rejection was 70 db minimum on any band.

At this point it might also be mentioned that the sensitivity came up as  $0.4 \mu\text{v}$  or less for a 10 db S+N/N ratio on all bands. The band-to-band gain was within 2 db referred to 14 mc.

### Crystal-Lattice Filter

No data is given in the manual on the crystal filter which probably is an 8-pole job, inasmuch as measurements indicated it to have a 6 db bandpass of 2.3 kc and of 4 kc at 60 db for a shape factor of about 1.75:1; with the ultimate result that the unwanted-sideband suppression is higher than usually experienced, amounting to a minimum of 60 db at 500 cycles and 70 db at 1 kc or higher! Other beneficial results due to the filter characteristics will be given later.

### Product Detector/B.F.O.

The signal section of a 6GX6 pentagrid converter comprises the product detector; while the oscillator section, which is crystal-controlled, functions as the b.f.o. for the receiver or as the carrier oscillator for the transmitter.

Separate crystals are switched for changing sidebands. The crystal frequencies are 8998.75 and 9001.25 kc. When these are interchanged for the required sideband, the v.f.o. frequency is simultaneously shifted by the same frequency difference by means of a diode switch that cuts a frequency-compensating padder in or out of the v.f.o. circuit.

The detector output goes to a solid-state a.f. chain with an output amplifier consisting of a PNP and an NPN transistor connected in complimentary fashion with the speaker output taken from the midpoint of the emitter returns without the need of a transformer. An external 8-ohm speaker is required.

### A.G.C.

The a.g.c. system is the audio-derived type that utilizes a transistor to convert the a.f. output of the detector to an amplified variable-d.c. bias that automatically controls the gain of the r.f., mixer and the two i.f. stages. The transistor input is shunted across the a.f. feed ahead of the a.f. gain control, which then does not affect the a.g.c. voltage when the a.f. level is adjusted.

The a.g.c. time constants are fixed for fast attack and a slow release. The latter is about 1 second from an S-9 signal. The a.g.c. level-characteristic is very flat with a 10 db a.f. output change with input signals of  $1 \mu\text{v}$ , and only 1 db with signals of 3 to  $10,000 \mu\text{v}$ . An S-meter reading of S-9 is produced by a  $50 \mu\text{v}$  signal.

The initial r.f. level is adjusted by a threshold basis obtained from the r.f. gain control installed in the emitter return of the a.g.c. transistor.

### C.W. Filter

The c.w. filter, which is an optional plug-in outboard accessory, functions in series with the output of the detector where it peaks up the a.f. response at 1000 c.p.s.; however, the uniqueness of its setup in the GT-550 makes its operation more beneficial than a peaking device a conventionally employed.

is that it precedes the a.g.c. system which is activated by the detector a.f. output. This therefore provides increased selectivity for the a.g.c. too and thus minimizes the possibility of a.g.c. takeover at the skirts of the filter passband which otherwise can occur with the conventional a.f. filter arrangement where no improvement is realized in the i.f. selectivity on which the r.f.-derived a.g.c. systems depend.

This filter, which is the Model F-3, consists of four sharply-tuned circuits using very high- $Q$  inductors set up as two transformers critically-coupled for peaking at 1000 c.p.s. A transistor amplifier at the output makes up for insertion losses. A.f. connections are made with two shielded cables that plug into phono jacks at the rear of the transceiver, placing the device in series with the detector output. Operating power is obtained from the transceiver through another cable. A slide switch on the filter box enables it to be cut in or out.

On-the-air operation with c.w. signals proved it to be excellent without detrimental ringing or other side effects, while providing a sharp bandpass which measured 370 c.p.s. at the 6 db points, peaking sharply at 1000 c.p.s. At 30 db it was 765 c.p.s. and at 60 db, 1.8 kc. With the receiver tuned for a 1000 c.p.s. beat note, no change in a.f. output level was found with the filter in or out.

Its effectiveness in preventing a.g.c. takeover by an adjacent signal can be easily observed by tuning in a strong signal, such as from a calibrator, for a beatnote about 400 c.p.s. above or below 1000 c.p.s. while the filter is out. At this time a high S-meter reading will be noted that will drop to near zero when the filter is switched in.

### Calibrator

The crystal calibrator is another optional accessory. A departure here from the usual, is that the calibrator puts out markers at 25 kc intervals, thus providing an updated feature for accurately locating the limits of the restricted band segments in force under the incentive-licensing regulations.

The calibrator employs four transistors with a 100 kc crystal oscillator that drives a 4:1 frequency-divider setup for furnishing the 25 kc output. It is installed in a can that plugs into an octal socket in the transceiver.

### Transmitter

The balanced modulator for the trans-

mitter is the familiar type using a 12AT7 dual-triode in a modified push-pull circuit. A provision not usually made with this arrangement, is that the B-plus is regulated to ensure the maintenance of a good carrier null at all times. This measured at least -50 db. Circuitry is shown at fig. 2.

### Power Amplifier (P.A.)

The p.a. tubes are connected in parallel for class AB<sub>1</sub> operation with 850 volts. The screens are regulated to 180 volts by an 0C2 and an 0B2 connected in series. This optimizes performance under dynamic operating conditions which can be evidenced by good linearity exhibited by oscilloscope displays.

The p.a. output circuit is a pi-network with an adjustable loading control for operation into 40-100 ohm resistive impedances. The usual capacitance-bridge neutralization method is employed.

### A.L.C.

A.l.c. voltage is obtained in the customary way from a voltage-doubling rectifier at the p.a. grid return. On transmit, a transfer relay

[Continued on page 92]

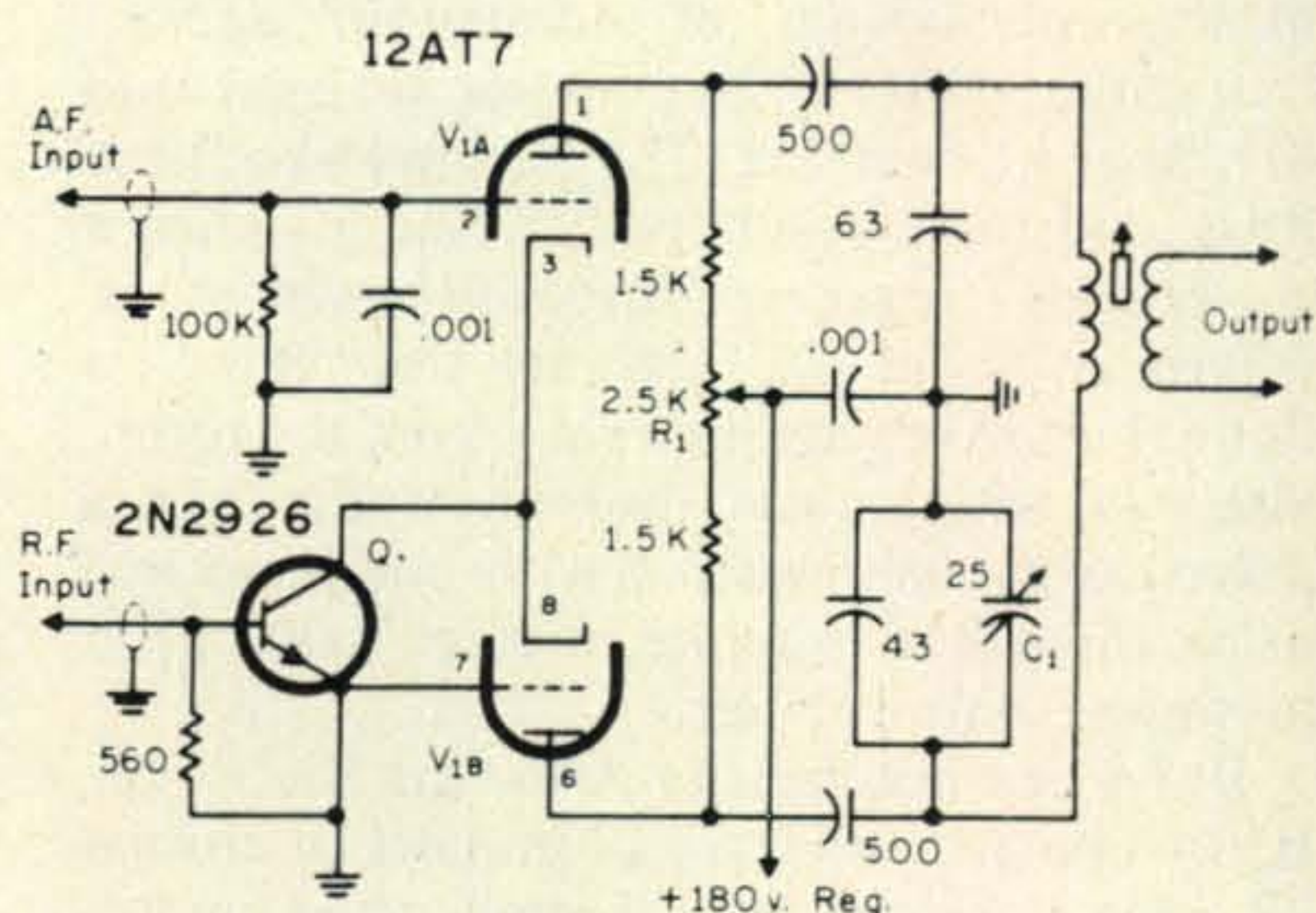

Fig. 2—Balanced-modulator setup for the GT-550. The r.f. carrier is parallel-fed to the tube cathodes through Q<sub>1</sub>. The grids are grounded for r.f. and their plates are connected in parallel. This causes cancellation of the carrier which is precisely made by balancing the circuit strays with C<sub>1</sub> and adjusting the individual plate voltages with R<sub>1</sub> to equalize the tube characteristics. The a.f. modulating signal goes to the grid of V<sub>1A</sub> only, which functions as a cathode-follower directly coupled to V<sub>1B</sub> cathode. The collector-base impedance of Q<sub>1</sub> serves as the common-cathode resistance across which the a.f. signal varies the bias, and thus the conduction, in such a way that r.f. output at the a.f. rate is obtained from only one tube at a time, in which case this signal is not cancelled.

# IT'S XYL- EMENTARY

BY ROGER SKLAR,\* W9JWJ

**T**HERE are some XYL's who tread softly near the shack, appreciating its sanctity. There are some XYL's who make their OM's coffee and sandwiches, and serve them at rig-side on contest weekends. There are some XYL's who do astonishingly marvelous things, like taking the kids *and* the dog to mother's, and letting the OM be, *all day long* while he tries for the Seychelles or whatever he's looking for.

These are some XYL's!

There are also others.

I am married to a wonderful woman. She can discuss the philosophy of Hegel, the art of Dufy, the music of Hindemith. She can talk for hours on psychic phenomena, the Montessori system of education, ancient Canaanite culture, Dr. Spock (babies) and Mr. Spock ("Star Trek"). She sews like Betsy Ross, and cooks like Escoffier. She is a master at putting together knocked-down toys, where '...flange "A" fits into slot "B"...', a thing that drives me jibbering from the room. She can whip a car through traffic like a seasoned cabbie, steering with one hand and using the other to make obscene gestures at motorists who bug her.

But when it comes to Amateur Radio, the IQ of this girl suddenly plummets to around 29. Don't ask me why; I shall never understand it. Take for instance, the day I worked my first UAØ. I ran breathlessly up from the basement to tell her the wond'rous news. She put down her sewing. "What are U.A. Zeroes?", she asked.

"They", I said, "clapping my astrakhan hat to my head", are the Soviet Union, the Land of the Bear and Bolshevik. In short, Russia!" I stressed the point by kicking my feet in a classic 'kazatsky'.

"You mean you talked to a Russian on that thing?"

"I sure did", I replied, bursting a few more buttons.

"What did he say?"

"He told me I had a very good signal, his name was Piotr, and he lived in a place called Krasnitograd."

"And?"

"And that's all."

"That's *all*?! Didnt you ask him what he thought were the chances for a lasting peace in Viet Nam?"

"Of course not", I answered.

"Or what it's like living under a Communist regime?"

"No. After all—."

"That wasn't a very culturally uplifting contact, I would say", she returned.

"Darling, you don't rag chew with the DX—."

"DX? I thought he was a U.A.W."

"UAØ. And you don't rag-chew. There were probably a thousand guys behind me waiting to talk to him."

Her eyes flashed. "I'll bet *they* weren't afraid to ask him about Viet Nam", she said haughtily, and turned back to her sewing.

What can you do? Anyway, it occurred to me that perhaps she felt so cold to The Hobby because she felt left out. And so I invited her down to watch the OM in action. She arrived some evenings later, all pink and white, and pulled up a chair next to mine. "May I see what you do? Would you talk to somebody for me?", she said almost sitting at the feet of her master. I told her I would be delighted, and even pulled the earphone plug out of the jack, so she could hear first hand the cacophony as it poured from the speaker.

Unfortunately, it had been one of those fruitless days when every station in the world decides arbitrarily to ignore you. I lamented that I wasn't having much luck, and naturally she asked 'why?' which was a very good question.

"Maybe it's because nobody hears me" I answered, hoping it wasn't true.

[Continued on page 98]

\*149 Dogwood, Park Forest, Ill. 60466.

# VERTICAL ANTENNAS

## Part XII (Conclusion)

BY CAPT. PAUL H. LEE,\* W3JM

*In this, the final part of the series, the author, in summary, lists and answers some of the questions he has received from readers during the series.*

ONE of the things that goes with writing articles for amateur magazines is the large amount of correspondence from readers seeking advice and assistance. I have always tried to answer all letters received, albeit not as promptly as I would like to have done it, due to the pressure of other things. One thing that any author appreciates is the enclosure of a stamped, self-addressed envelope. This is only common courtesy, and it usually brings a more prompt and complete answer. The mail from this series on vertical antennas has been considerable. In fact, it has been greater than that from anything else I have ever written, which shows that readers are interested in learning about antennas. This has been especially true of those who want to use verticals on 75 or 160 meters. The recent power increases on 160 meters and the increasing availability of s.s.b. equipment for 160 meters have led to considerable interest in antennas for that band, shown both in the correspondence and in my on-the-air contacts.

In thinking of what to say in this final installment of the series, I decided that it would be appropriate to give some practical information on problems which confront our readers, and what better way to do it can there be than to quote actual questions received, and the answers I have given? I am aware that this may lead to a flood of additional correspondence with questions, but I am sure that I can make some provision for handling it, and perhaps publishing the answers for the information of all. Incidentally, it is the plan of this publisher to put the twelve parts of this series together in small handbook form, together with other articles I have written in the past on vertical antennas. This has been something I have wanted to do

for a long time, to get out a small book on verticals, a subject which, until this series, has not been covered in any depth in print.

### Questions and Answers

**1. Q.** *I am new in amateur radio, and don't know much about antennas. What do you recommend for 80 meter c.w.?*

**A.** The answer to this will depend on several factors which I do not know, such as the space you have available, and what areas and distances you expect to work. If you have the space, and a pair of tall poles or other supports, you can put up a dipole cut for about 3650 kc, feeding it in the center with a balun and coaxial line. The height above ground will determine the vertical angle of maximum radiation, in general the greater heights giving lower angles. If it is only 30 to 40 feet above ground, for example (less than 1/4 wavelength), most of your radiation will be at high angles, which will give you good local area coverage within 200 or 300 miles. A vertical antenna of 1/4 wave height or less, with a good ground system, will give you a lower angle of radiation, which will extend your coverage out well beyond 1000 miles reliably. The vertical will take less space than the horizontal dipole, but it does require a ground system if it is to work efficiently.

**2. Q.** *What would be the result of turning my three element tri-band beam on end and operating it as a rotary vertical array? Could I still mount it on my 50 foot tower and pipe mount?*

**A.** This would be very nice if you could mount it somehow without any steel pole, tower, or supporting structure. However, the presence of such items will distort the beam pattern and one cannot predict the results. Also, there is the matter of feeding it. Unless

\*5209 Bangor Drive, Kensington, Md. 20795

you could devise some means of carrying the feedline out horizontally from the center of the driven element for considerable distance, you would have an unbalanced situation which would give you antenna currents on the outside of the feedline. (This would be the case if you were to bring the feedline down vertically, parallel to the elements.) It is impossible to predict what you would get from this installation without building a small model (v.h.f. or u.h.f. range) and actually measuring the patterns on a model range. I once considered using a 5/8 wave grounded base, gamma fed vertical as a driven element, mounting the rotor right in it at the proper distance above ground, mounting a crossboom above the rotor, and hanging vertical reflector and director from the crossboom. By this means one could solve the feed problem and the support problem in one stroke. However, such a thing would be a single band affair. I may yet do it as an experiment, on 10 or 15 meters, where the size would be reasonable and easy to work with.

**3. Q.** *Will a ground system under my horizontal beam give me improved performance? What should be its configuration?*

**A.** A ground system under a Yagi array is a waste of money and effort. The radiation from the array is horizontally polarized, and is mainly horizontal in direction. Therefore a ground system beneath it will not affect it. The ground (earth) which does affect it is that in the Fresnel Zone (first reflection zone) which is many yards away from your antenna. Of course this area is not usually under your control, and you are unable to do anything about its character. If you live on a body of water you will have an excellent, low loss reflecting surface in the Fresnel Zone, and you can consider yourself fortunate indeed.

**4. Q.** *I have a 40 foot cabin cruiser, and wish to operate mobile with my KWM-2 in it. What do you recommend for an antenna? How can I get a ground connection inasmuch as the boat has a wooden hull?*

**A.** I recommend you use one of the several good mobile whips now on the market, if your operation is going to be on the amateur bands only. One with traps or replaceable coils would be very good. Make sure it is one with the loading coil in the whip rather than at its base, inasmuch as this will bring your current maximum up into the antenna instead of having it appear in the loading coil

where it contributes nothing to the radiation. If you wish to operate in the ship-shore bands between 2 and 3 mc, I would suggest one of the wound whips for this service which you will find advertised in such sources as the Radio Master, etc. A ground connection can be obtained by installing a bronze plate about 2 by 4 feet on the bottom of the boat, and bringing several bronze bolts through the hull (approximately caulked, of course), for connections inside the boat. The motor, fuel tank, and other associated metal parts should be connected to this ground plate. You may have to install an ignition noise suppression system also, as you would do in an automobile. By the way, don't install the plate near the bow. Put it back near the stern, so that if you go fast in your boat it will not lift out of the water and unground you!

**5. Q.** *I have a Hy-Tower vertical, and for a ground connection I have connected to a well casing which goes down 40 feet. The water table is at about 25 feet. Is this sufficient, or do I need some radials? If the latter, how many?*

**A.** You have a good d.c. and lightning protection ground, but practically none for h.f. radio. If you will read Part XI, you will see that at h.f. the depth of penetration of the earth currents is very small, so what you have down there at 25 feet makes no difference. You need ground radials just below the surface to provide you with a low loss return path for the earth currents. Put in about 25 to 50 radials of number 16 wire, about 2 or three inches deep. This can be done with a powered lawn edger to make a slot in the sod, or by one of those half-round edger blades powered by your foot stepping on it. I did 50 radials (2000 feet of wire) in two Saturdays. When you get this ground system down and connected, you will be surprised at the increased performance of your vertical antenna.

**6. Q.** *I am in a house which is surrounded on three sides by other houses very close, and there is not much yard space. If I put a quarter wave vertical for 40 meters on top of the house, will it work? I can't put down any ground system.*

**A.** Yes, you can put a vertical on top of the house. For a ground plane of sorts, you can lay some radials on the roof of the house. I would lay down at least 16 of them, to assure a reasonable efficiency. They should be as long as possible. If necessary, run them over

the edge of the roof and down the sides a bit. You could even connect each one to a copper ground rod driven into the earth at ground level. Make sure that you do not have any unbonded contacts to gutter pipes, *etc.*, for non-linear joints which develop at such places will give you plenty of TVI problems. Of course, you will not get the classic patterns out of this antenna, but it will work reasonably well. Feed it with coaxial line run up to its base.

**7. Q.** *Doesn't a vertical cause more TVI and BCI than a horizontal antenna?*

**A.** I don't believe it does. I have used one ever since I moved to my present location in 1959. I have had several TVI complaints which have been solved in accordance with the FCC's established program, by having the set owner get from his set manufacturer, at no charge, the necessary filter, and I have installed them as a courtesy. I found that with my Mark IV Antenna, which uses the tri-band beam on 10, 15 and 20, and the tower (ladder) as a top-loaded vertical on 40, 75 and 160, I had more complaints from the high band operation on the beam than I did with the low band operation on the vertical. This is probably due to several factors. First, at the higher frequencies, house wiring, TV antennas, speaker leads, *etc.*, are a larger fraction of a wavelength than they are at the lower frequencies, and thus they tend to pick up more h.f. energy. Also, the beam concentrates its signal, and when it was pointed at certain neighbors they really got it! On the other hand, those with outdoor antennas (unnecessary in this area) had lower frequency energy picked up by the long downleads. This caused a beat between the TV sound carrier and the h.f. transmitter signal, which caused a spurious signal to appear in the TV set's picture passband. The filters solved this problem also. As I recall it, when I used a simple vertical on 15 and 20 meters, before putting up the beam, the TVI problems were less severe, and I feel this difference is due to the beam's present concentration of the energy in one direction. BCI, in the little transistor sets, is impossible to eliminate, and I don't see any difference between the beam and the vertical in this respect. If there is any difference, it is probably due to frequency more than to polarization.

**8. Q.** *I have a crank-up tower for my beam. How can I use it as a folded unipole? Where should I tap onto it?*

**A.** You have a problem! You can either choose to crank it up and down, or to feed it as a folded unipole, but not both. In the first place, you will have to bond the joints between sections of tower to assure a good connection, first from the standpoint of a good r.f. joint, and second, from the standpoint of preventing any non-linear joints which would generate TVI. When you have done this you will not be able to crank it up and down. Also, if you do not bond it each time you crank it up and down it is probable that the tower sections will not make connection with the same exact path length, and the tuning will change a bit. Where should you tap it? That depends on what bands you want to work. I suggest you see my article in February 1967 *CQ* on the Mark IV DX Antenna. I would go to the top of the tower with the 160 meter fold, and this could also be used for 75 meters if the tower is less than about 50 feet. If more, tap down at about the 30 foot level. For 40 meters, tap it at about 20 or 25 feet. Matching can be done with simple L networks consisting of two capacitors. See the Mark IV article for details.

**9. Q.** *I tried feeding my 50 foot tower on 160 meters by tapping onto it at about 20 feet above ground with the coaxial line, but it would not match, so I gave up the idea. Now, with your articles you make me think it can be done. Where should I tap on it and how should I feed it?*

**A.** Well, you tried, but forgot the fact that you have an impedance matching network in the circuit. As in the previous answer, take the fold wire all the way to the top of the tower and connect it there. Even though it is a 50 footer, the impedance looking into the fold on 160 meters will be of quite low resistance and rather high inductive reactance. This means that you have to use two capacitors in an L network to match it to RG-8/U line. Refer to the Mark IV article in February 1967 *CQ* for an example of this feed on 160 meters, and for typical capacitor sizes. I should mention one thing, though, and that is that your area is now allowed 500 watts daytime on 160 meters, and the voltage ratings of the capacitors will have to be increased over those used in the Mark IV. Those had only 0.1" spacing, and when I tried 500 watts they arced over due to the currents and voltages involved. I had a couple of vacuum variables which I put in, and now all is well. I also had to increase the contact

spacing on the relay that lifted the coax braid off ground. But perhaps you will not have that problem. If you are going to run only 100 watts or so, you won't have this arcing problem with 0.1" spacing capacitors.

**10. Q.** *I saw sometime ago in one of the magazines an article about verticals in an array which were grounded at their bases and fed at their tops. Why have you not covered this in your series? Where can I get information on this feed method?*

**A.** You have a good memory. That item appeared in QST for April 1959 in an article by R. W. Johnson, W6MUR, entitled, "The Groundpole Antenna." I did not cover it in my series because the configuration is not purely vertical, but also has horizontal elements which radiate. Basically, the idea is as follows. Take two 1/4 wave verticals, for example, separate them 1/2 wavelength, ground their bases and feed them by means of a center-fed half wave dipole whose ends are connected to the tops of the vertical elements. The radiation pattern from this combination will be complex, and would require computer analysis, or actual scale modelling for its determination. There are other configurations which may be used also, involving more than two elements. I should emphasize even more than W6MUR did that a good ground system is necessary for this type to work efficiently. In fact, inasmuch as maximum current occurs at the grounded ends of the vertical elements, ground currents will be quite high, because the whole thing can be considered as a closed loop with earth forming one part of the loop. It follows that this return path should be as low loss as possible, and even if many radials can not be put down, it is essential that there be a low resistance ground bus between the bottom ends of all vertical elements. This can be made of copper strap or several number 16 or number 12 wires run together in parallel. You might consider this type of antenna this way: normally, vertical arrays are fed from the base of the elements by a non-radiating system of transmission lines. In this case, the vertical elements are fed from the top with single wire transmission lines that are allowed to radiate and contribute to the pattern, which then becomes complex and requires considerable mathematical analysis for its determination. My congratulations to W6MUR for his fine article.

**11. Q.** *Will my Quad work as top loading on*

*my tower for 75 and 160 meters, as your tri-band beam does on your Mark IV DX antenna.*

**A.** I see no reason why not. The Quad element wires would constitute a considerable added top capacity on the tower, and it should work fine. I don't have a Quad but common sense tells me that it will work.

**12. Q.** *In your Mark IV DX antenna I notice that you have your CDR rotor motor physically and electrically in series with the vertical element of the antenna, with no bonding across it. Doesn't the motor winding burn up? Are you sure of the r.f. path through the motor housing? How do you protect it?*

**A.** Before making this installation I asked several CDR representatives whom I met at a local electronics show whether they had any reservations about the idea. They felt that the large number of ball bearings in the raceway would provide a good multiple contact between upper and lower portions of the housing. They did recommend that the rotor control cable conductors be bypassed to ground at the base of the antenna, inasmuch as the control cable is in effect in parallel with the tower itself r.f.-wise and will carry some r.f. current. I did this. Each of the seven conductors is bypassed to ground at the base of the tower with a 0.01 mf disc ceramic capacitor. These capacitors are housed in an aluminum beer can (empty), entrance to which is through the bottom end to keep water out. The can is mounted on one of the 4 x 4 tower supports. I do notice a very slight upward swing of the rotor indicator needle on 75 meters when I talk, but it is less than 1/4", and I attribute it to r.f. getting into the cable somewhere in the basement or the shack itself. Incidentally, there is an r.f. path across the rotor motor housing, and this is through the outer conductor of the coaxial line and through the balun coil. Obviously this is also a d.c. path for static discharges.

**13. Q.** *In finding the gain of a directional array, shouldn't you take the r.m.s. of the whole pattern through the vertical angles, instead of just the r.m.s. of the horizontal pattern?*

**A.** As I have said before, gain is meaningful only when referred to a specific direction (horizontal and vertical angle). It is standard practice among consulting engineers to use the horizontal pattern (vertical angle zero degrees) because that is the easiest one to

[Continued on page 96]



Buy

RAYTHEON

70% OFF LIST!

RECEIVING TUBES at

TYPE	NET EA.	TYPE	NET EA.	TYPE	NET EA.	TYPE	NET EA.	TYPE	NET EA.	TYPE	NET EA.
0Z4	1.05	5Y3GT	.75	6CG3	1.10	6GW6	1.40	6T10	1.45	12SK7GT	1.55
1AD2	1.00	5Y4GT	1.10	6CG7	.75	6GX6	.95	6U8A	1.00	12SQ7GT	1.55
1B3GT	1.10	6AF3	1.00	6CG8A	1.15	6GY6	.95	6U10	1.20	12X4	.75
1BC2	1.05	6AF4A	1.35	6CJ3	1.20	6HB6	1.55	6V6GTA	1.05	13EM7	1.85
1G3GT	1.10	6AG5	1.10	6CL6	1.40	6HB7	1.35	6W6GT	1.25	13FM7	1.10
1K3/1J3	1.10	6AH4GT	1.05	6CL8A	1.40	6HE5	1.25	6X4	.70	13GF7A	1.65
1V2	.85	6AH6	1.80	6CM7	1.05	6HF8	1.60	6X5GT	.95	15KY8A	1.95
1X2B	1.10	6AK5	1.65	6CM8	1.35	6HJ5	1.95	6X8A	1.10	15GK6	1.00
2AS2	.95	6AL5	.75	6CQ8	1.25	6HM5	1.30	6Z10	1.70	17AY3A	1.05
2AV2	.95	6AL11	1.60	6CS6	.95	6HQ5	1.55	7AU7	.90	17BE3	.95
2CY5	1.35	6AM8A	1.25	6CS7	1.10	6HS8	1.45	8AW8A	1.45	17BF11	1.60
2GK5	1.40	6AN8A	1.45	6CU5	1.15	6HZ6	.95	8BH8	1.10	17BS3A	1.10
3A3A	1.05	6AQ5A	.95	6CW4	1.70	6J6A	1.05	8CG7	.75	17C5	.90
3AL5	.90	6AR11	1.55	6CW5	.90	6JC6A	1.30	8CX8	1.50	17D4	1.25
3AT2	1.05	6AS5	1.05	6CY5	1.35	6JD6	1.15	8EB8	1.35	17DE4	1.20
3AU6	.95	6AU4GTA	1.35	6DA4	1.25	6JE6A	2.75	8EM5	1.25	17DM4A	1.25
3AV6	.95	6AU6A	.80	6DE4	1.15	6JH6	.95	8FQ7	.75	17DQ6B	1.60
3AW3	1.05	6AU8A	1.70	6DE6	.95	6JH8	1.65	8JV8	1.45	17GV5	1.40
3BN6	1.45	6AV6	.65	6DE7	1.40	6JK8	1.35	8LT8	.90	17GW6	1.60
3BU8	1.55	6AV11	1.50	6DK6	.95	6JM6	1.40	10DE7	1.55	17JM6A	1.40
3BZ6	.95	6AW8A	1.30	6DQ5	2.60	6JN6	1.30	10GN8	1.55	17JN6	1.30
3CA3	1.05	6AX4GTB	.95	6DQ6B	1.40	6JS6A	2.40	12AB5	1.30	17JZ8	1.15
3CB6	.95	6AY3	1.10	6DS4	1.70	6JU8A	1.30	12AD6	1.00	19AU4GTA	1.35
3CY5	1.30	6B10	1.20	6DT6A	.90	6JZ8	1.15	12AL11	1.40	21GY5	1.60
3DK6	.95	6BA6	.80	6DT8	1.25	6K6GT	.95	12AT6	.80	22DE4	1.25
3DT6A	.95	6BA8A	1.60	6DW4B	1.15	6KA8	1.55	12AT7	.95	22JG6A	2.10
3EH7	.85	6BA11	1.45	6DZ4	1.35	6KD6	2.55	12AU6	.85	23Z9	1.65
3EJ7	.85	6BC5	1.05	6EA7	1.80	6KD8	1.00	12AU7A	.85	25EH5	1.05
3GK5	1.40	6BC8	1.40	6EA8	1.15	6KE8	1.90	12AV6	.65	25L6GT	1.25
3GS8	1.55	6BD6	.75	6EB8	1.75	6KM6	2.65	12AV7	1.20	33GY7A	2.05
3HQ5	1.65	6BE6	.95	6EH7	1.30	6KT8	1.70	12AX3	.95	35C5	.90
4AU6	1.10	6BG6GA	2.05	6EJ7	1.15	6KZ8	1.25	12AX4GTB	.90	35L6GT	1.30
4BC5	.95	6BH6	1.05	6EM5	1.25	6L6GC	1.65	12AX7A	.90	35W4	.55
4BC8	1.35	6BH8	1.60	6EM7	1.80	6LE8	2.10	12AY3A	.85	35Z5GT	.90
4BQ7A	1.70	6BJ6	1.05	6ER5	1.25	6LFB	1.40	12AZ7A	1.05	38HE7	2.20
4BU8	1.55	6BJ8	1.35	6EO7	1.05	6LJ8	1.35	12B4A	1.05	50C5	.85
4BZ6	.95	6BK4B	2.50	6EV5	1.00	6LM8	1.55	12BA6	.70	50EH5	.90
4CB6	.95	6BK5	1.15	6EW6	.90	6LU8	1.65	12BE6	.85	50L6GT	1.15
4CS6	1.10	6BK7B	1.35	6EW7	2.00	6LY8	1.30	12BH7A	1.00		
4DT6A	.95	6BL7GTA	1.75	6FG7	1.40	6ME8	1.60	12BY7A	1.05		
4EH7	1.15	6BL8	.90	6FH5	1.30	6S4A	.95	12DQ6B	1.45		
4EJ7	1.15	6BM8	.95	6FH8	1.35	6SA7GT	1.50	12DS7	1.85		
4EW6	.95	6BN6	1.25	6FM7	1.05	6SW7GT	1.55	12DT8	1.35		
4GK5	1.30	6BN8	1.25	6FQ5A	1.30	6SN7GTB	1.00	12GN7A	1.55		
4GS8	1.55	6BQ5	1.05	6FQ7	.75	6SQ7	1.55	12SA7	2.00		
4HA5	.75	6BQ6TB	1.55	6FS5	1.35	6T8A	1.25	12SJ7	1.45		
5AM8	1.70	6BQ7A	1.40	6GC5	1.55						
5AN8	1.80	6BR8A	1.45	6GE5	1.30						
5AQ5	.95	6BS3A	1.25	6GF7A	1.70						
5CG8	1.25	6BU8	1.40	6GH8A	1.05						
5EA8	1.60	6BZ6	.90	6GJ7	1.00						
5GH8A	1.60	6BZ7	1.40	6GK5	1.40						
5GM6	1.05	6C4	.75	6GK6	1.10						
5KE	1.95	6BC6A	.95	6GM6	1.05						
5U4GB	.85	6CD6GA	1.95	6GN8	1.60						
5U8	1.30	6CF6	.95	6GU7	1.25						

ZALYTRON 469 Jericho Tpke., Mineola, N.Y. 11501

- Enclosed is \$\_\_\_\_\_ Please ship P.P. (Minimum Order \$10)
- Please send FREE Zalytron 1969 Catalog featuring Receiving, & Industrial Tubes, Transistors—All Brands at Biggest Discounts.

Name \_\_\_\_\_  
 Address \_\_\_\_\_  
 City \_\_\_\_\_ State \_\_\_\_\_ Zip \_\_\_\_\_

ZALYTRON Tube Corp. Tel.: (516) 747-3515  
 469 Jericho Turnpike, Mineola, N.Y. 11501



BY JOHN A. ATTAWAY,\* K4IIF

*"Nor fame I slight, nor for her favors  
call; She comes unlook'd for, if she  
comes at all."*

—ALEXANDER POPE

This month we honor another great DXer; one who has given more to DX than he could ever hope to receive in return, and who has been voted membership in the DX Hall of Fame. Although this gentleman's contributions do not completely dominate any single area of the sport, his versatility has made an impact everywhere. He has excelled as an organizer of DXpeditions, as an operator, as a QSL Manager, and as a DX writer.

To many, this amateur's efforts in training Danny Weil, VP2VB/MM, and in organizing the YASME Foundation, make him the father of the modern DXpedition. He is well-known as a QSL Manager for his handling of the cards for WØMLY's African DXpedition of 5 years ago, as well as a portion of the early YASME activity. In addition, his efforts as a DX writer are almost legendary. He served as DX Editor of *CQ* from January 1952 to December 1957, and was Publisher and Editor of the YASME Foundation Bulletin during the heyday of the "Danny years." As an operator he was once 2nd on the ARRL DXCC Honor Roll even though he has always operated from a QTH ringed by a high mountain and has worked long hours as the RCA distributor in the Virgin Islands. It is with great pleasure that the editors of *CQ* and the members of the *CQ* DX Award's Advisory Committee announce the newest member of the DX Hall of Fame, RICHARD C. SPENCELEY — KV4AA.

Although he was born in New Jersey and reared in New Hampshire, the island of St. Thomas has been home for Dick Spenceley for some 41 years. He was radio operator at the Naval station NBB in 1925. The early

NBB equipment was of the spark variety, but by 1928 they had graduated to tube gear. He got his first ham ticket as MP4AAN in 1927, became K4AAN shortly afterward, and finally KV4AA in 1946 when the prefix structure of U.S. possessions was reorganized. His earliest gear was a pair of 210's which operated off the 440 v.d.c. mains then available on St. Thomas.

Dick's fondest memories of the DX scene are those involving the intrepid Englishman Danny Weil, VP2VB, who appeared in St. Thomas harbor in 1955 pressing his ambition to be the first Englishman to circumnavigate the globe single-handedly. Danny mysteriously disappeared minutes after arriving at Dick's QTH only to be discovered sitting astride the boom of the 20 meter beam, 60 feet in the air, taking photographs of St. Thomas. The next several years of the VP2VB/MM operations, which included the loss of 3 boats and numerous brushes with death by the dauntless Mr. Weil, will never be forgotten. Nor shall we ever forget the war cry of the day, "Where's Danny???"

#### De Extra

*Madness, Reason, Wishful Thinking:* Several intelligent letters were received this month questioning the wisdom of the hullabaloo this column has raised with respect to "Incentive Licensing." Believe me, said hullabaloo is plenty worthwhile if it wakes up a few people.

Amateur radio has been put on trial. Foolishly it was put on trial by some of its own, but that's water over the dam. Whether the majority of hams wished to be put on trial or not, they are! And frankly, they're LOSING their case. The *QST* editorial of September, 1963, which was written to promote "Incentive Licensing," said: "In preparation for the next conference, amateur radio will be again held up to close scrutiny by government authorities to ascertain how well its purposes are being achieved. The

#### DX Hall of Fame

Gus M. Browning, W4BPD  
Nov. 1, 1967

John M. Cummings, W2CTN  
March 23, 1968

Stewart S. Perry, W1BB  
Aug. 16, 1968

Richard C. Spenceley, KV4AA  
March 1, 1969

\*P.O. Box 205, Winter Haven, Fla. 33880.



The old man himself at the rig, Dick Spenceley, KV4AA, DX Hall Of Fame. (Photo by K4IIF.)

ARRL Board of Directors is determined that the results of any official look at amateur radio will continue to be highly favorable."

Now that's a stirring phrase if I ever heard one. All it lacks is a military band playing a John Philip Sousa march in the background. However, despite all that determination it appears to this column that the thing is falling flat, and that's the point we're trying to hammer home. We thought that the League would be hard at work too, but they no longer seem sufficiently interested to write anything about it.

Let's not have wishful thinking!!! Three letters ventured that the figures in February's De Extra actually showed a 62% increase in the number of Extra Class Licensees. However, my Ph.D statistician tells me that the base is far too small for that approach. For significance you must consider each part in relation to the whole. The increase was 1% of the total number of U.S. amateurs, and that's all.

Another wishful thinker said that by November we would have 10,000 Amateur Extra Class operators. My, My!!! A whole 250%

increase if you use daydream statistics, but in reality only 4% of the ham population. That isn't going to impress anybody. It's going to take at least 20%, 50,000 Amateur Extra Class hams, to cut any mustard.

The figures do show that *DX'ers* are getting the job done. Most DX clubs show 50-70% of their memberships to be Advanced or Extra Class. Maybe this proves something. At least this column can get off the soapbox and let somebody else push for a while.

### The HKØTU Story

The LCRA DXpedition to Malpelo in February, 1969, commemorating the 150th anniversary of Columbian independence, will go in all the DX history books as one of the major achievements of DX. Even though I have lobbied long and hard for the elimination of uninhabited places as countries, my hat is off to this intrepid crew who literally risked their lives to put this rare spot on the air. Nothing I can say will express it as well as the words of Bill Elasmarr, HK3RQ, who organized and planned the whole affair, and without whom it would never have happened.



A portion of the HKØTU gang with some of the gear aboard the *Padilla*. Standing left to right HK5EV, HK5ASF and HK3BSU. Kneeling are HK3RQ and Carlos Valencia, Jr. (Photo courtesy HK3RQ.)



The Colombian Navy Destroyer "Padilla". This is the vessel that took the Liga Colombiana de Radioaficionados DXpedition to Malpelo. (Photo courtesy HK3RQ.)



Here is a view of the magnificent rock, HKØ—Malpelo. (Photo courtesy HK3RQ.)

Yet Bill never even got to operate. Here his story:

"As everybody knows by this time, Malpelo is the most difficult, risky, and dangerous operation.

"It took four months of preparation, during which I made over eighty official visits plus many contacts with W4DQS, WØD and W4VPD to line up the equipment which finally arrived in a Columbian Air Force plane. It then took five more days to get those things out of the Columbian Customs House. HK3UA was a great help in that.

"The day before our departure from Buenaventura in the Columbian Navy Destroyer *Padilla*, we flew with the rigs to Cali where we were received by a large delegation of HK5 hams. We went to the house of Jose Sauda, HK5BFJ, President of the Cali Section of LCRA, where we had a very nice and elegant party with more than one hundred guests.

"The next morning we sailed aboard the *Almirante Padilla* for Malpelo with more than 5,000 pounds of cargo. After a one day trip we were near the rock, but the sea was rough and the first landing try was not successful. It seemed an impossible task. A general meeting was called with the Captain, the ship's officers, and the hams, and a different plan for landing was discussed based on Valencia's experience on the previous trip. A very long and complex maneuver was finally designed by HK5EV, HK5ASF, and Carlos Valencia, Jr. With the help of Teniente Gavito as coordinator, it began at 1200 GMT on Feb. 22.

"Ten men were already on the Rock and was just landing when one rope became untied and I fell into the ocean where I was thrown against the Rock several times by waves of great force. The same thing happened to HK3HY but he was able to reach the Rock after a few minutes. I was in the water for ten minutes being walloped again and again against the Rock and unable to do anything about it as my left leg and several of my ribs were broken. Finally I reached a calm zone in the water and Joe, HK5BFJ jumped into the ocean and helped me aboard. Joe's gesture was very valiant and impressive as several sharks were nearby.

"When I was back on the ship Captain Gaviria insisted in cancelling the operation but I told him that we had a big promise to our country and the rest of the world and

t the operation should go on. The ship's doctor felt that my condition was not good and that I should return at once to Buenaventura, but after much argument we convinced them to stay.

The next day my condition had not improved so the Captain again insisted on cancelling the operation. I told him to ask the operators if they would stay on the island while the boat took HK3HY and myself to Buenaventura. They said yes so the operation was able to continue while I went to that port and then on to Cali where I stayed in one of the clinics for a week. I am feeling better and have begun to work on the HKØTU QSLs. Of course there are many more things to talk about and it will be a time before the complete story will be known. The final results, aside from my broken leg and ribs, was 100 QSO's with 104 countries. More than 100 were on c.w. and more than 3000 on phone during the 3 day operation. We made a lot of people happy.

"I think Malpelo should continue on the KCC list, but it is my personal opinion that nobody will go there in the near future or in any years to come.

"Again we are very proud of making this operation possible."

And well they should be. It was a magnificent accomplishment, by the complete crew which included HK3RQ, HK5BFJ, HK3HY, HK3VA, WØDX, TI2CMF, W4PD, HK3BAS, W4DQS, HK5EV, HK5CI, HK5ASF, HK3BSU and K6JGS.

### The WAZ Program

Two years ago the long range goal was to average 15-20 new applications per month for this, the toughest of DX Awards. However, we passed that goal long ago and this month we hit the 40 mark again. Interestingly enough, 27 of the 40 applications were from DX stations. The new winners were:

**WAZ S.S.B.:** SM5EAC-645, SMØBPZ-646, SM6CKU-647, SM6CKS-648, SM7ØIJM-652, K7UXS-653, JA2JKV-654, SM5UN-655, and VE3BSJ-656.

**WAZ C.W.—Phone:** SM5CXS-2594, SM7SN-649, WA4LSK-650, 4A1AE-651, SM5NE-2595, SMBNX-2596, SM5RC-2597, SM7H1VL-2598, OH2SF-2599, SM7BEM-650, K4ADU-2601, K8UDJ-2602, K5YB-2603, W6HHI-2604, W4HHN-2605, JA2AYX-2606, JA2JKV-2607, I1RC-2608, JA1AAT-2609, VO1AW-2610, SM3RB-2611, UA4QP-2612, UA4SM-26-

13, W1YPH-2614, W9OPD-2615, K5AEU-2616, OZ1LO-2617, W9KTR-2618, and 8P6BU-2619.

**WAZ Phone:** 4A1AE-406 and KØBUR-407.

For complete rules and an application blank for WAZ send a s.a.s.e. to DX Editor, P.O. Box 205, Winter Haven, Fla. 33880 U.S.A.

### The WPX Program

WPX Manager K4DSN is now sending out application blanks for the new WPX Honor Roll based on currently active prefixes. Send him a s.a.s.e. if you wish to apply. New WPX winners this month were:

**WPX S.S.B.:** W4WSF-393, WB6MVK-394, UA3HO-395, WA9NJB-396, KØSEA-397, and K3RZ-398.

**WPX C.W.:** PY4UG-914, UA6YD-915, UA1CE-916, UA1KAS-917, SP6AZY-918, W6KHS-919, and K7NHG-920.

**WPX Mixed:** W4WSF-193.

**WPX Phone:** W2LEJ-165 and W1PCD-166.

**Endorsements: S.S.B.:** UA3HO-400 and W3RZ-250.

**C.W.:** WB2FMK-600, WA6HRS-500, YU1SF-450, and W9CRW-350.

**Phone:** YV4IQ-450.

**Continental:** Asia: WA6HRS Europe: W4WSF, W9CRW, and YV4IQ.

### The WPNX Program

Only one new Novice DXer qualified this month for CQ's exclusively Novice DX Award. It can't be that hard Novices, let's go! The sharp-fisted winner was:

Judi L. Dunn, WN7JMV-WPNX11

Information and applications for WPNX may be obtained from the Award Manager, K4GRD, P.O. Box 524, Lakeland Fla. 33802.

### The VPX Program

This new award, Verified Prefixes, for s.w.l.'s is catching on fast. There were six new certificates authorized this month. The winner's were:

Fred Woodley, VE3-9301-VPX2

Stewart Foster, G-10173-VPX3 (SSB)

Stewart Foster, G-10175-VPX4 (Mixed)

Jorge Canges, EA4-1306-W-VPX5

Borje Jansson, SM4-3434-VPX6

Dave Thompson, ZL-190-VPX7

VPX endorsements were: G-10175, 500 prefixes s.s.b.; SM-3434, 250 s.s.b.; VE3-9301, 650 mixed; G-10175, 600 mixed. 80

meters, VE3-9301. 20 meters, G-10175 Africa, G-10175, VE3-9301, Asia, G-10175, VE3-9301, Europe, G-10175, VE3-9301, North America, VE3-9301, Oceania, VE-9301 South America, VE3-9301.

### The S.S.B. DX Award Program

Louise asks that we remind everyone to please keep a duplicate list of the countries you submit for the award. New certificates were authorized this month as follows:

**100 Countries:** K6ZXS-551, HS3DR-552, K9KXA-553, PY2GE-554, XE1NNY-555, W8PQD-556, and 4A1AE-557.

**200 Countries:** XE1YG-164, G3HDA-165, and PA0EEM-166.

### ICAA, International Call Areas Award

The Directors of ID XO, the International DX Organization are coming up with a real whing-ding of an award. It resembles CQ's WPX and WAZ in many respects and we think you are going to like it when it's ready to go.

### QSL Information

CN8GE—Via W2GHK.	HL9UX—c/o K0LCB, 1723 Drumm Ave., Independence, Mo. 64055
CN8HD—To W2GHK.	HV3SJ—To W6KNH.
CR5SP—c/o CR6IV.	KA1IJ and KG6IC— c/o Don Janicki, K8WXV/1, 161 First Ave., So. Portland, Maine 04106.
DU7SV—Norman Pos, WA6KGP, 5691 Mt. Acara Dr., San Diego, Calif. 92111	LX9LS—Via W0IYP.
EA6AR—Via DL7FT	MP4BGW—To K9CSM.
EA6BG—To DL7FT.	MP4DAT—c/o G3USK.
EA6BH—c/o DL7FT.	OA4DX—To W4TKN
EI0RF—Via EI2AW.	PJ5MG—Via W9IGW, Route 3, Bloomington, Indiana 47401.
EL2J—c/o WB2WOU.	PJ0MM—To W2GHK.
ET3REL—To W5RBO.	PX1BW—c/o W2GHK.
ET3USA—c/o VE3IG.	PY2PA—To W3DJZ.
F3KW—To WB2QXX.	PY2PE—c/o W3DJZ.
F9UC/FC—Via DL9PF.	SM7CRW—c/o WB2RLK.
FH8CF—To N. Antone, B.P. 304, Moroni, Comoro Islands.	TA2E—To VE3ABG.
GC3EML—Via K9KLR, P.O. Box 1816, Gary, Indiana 46409	TG9EP—c/o DL7FT.
HB0LL—c/o DL7FT.	TR8AG—Via CR6GO.
HCITH—Box 583, Quito, Ecuador.	TU2AY—To DL7FT.
HC8RS—Via SM5EAC.	TU2AZ—c/o DL7FT.

### SSB DX Honor Roll

W2TP ..... 317	K6CYG ..... 305	W9JT ..... 292	G3NUG ..... 2
WA2RAU ..... 316	K6YRA ..... 305	K1IXG ..... 288	G3WW ..... 2
VK3AHO ..... 315	W6YMV ..... 303	W2LV ..... 286	MP4BBW ..... 2
W9ILW ..... 315	W0QVZ ..... 303	W6EUF ..... 286	G2PL ..... 2
TI2HP ..... 314	W2BXA ..... 302	K8RTW ..... 286	G2BVN ..... 2
W3NKM ..... 314	G3AWZ ..... 301	W9EXY ..... 284	W2MJ ..... 2
WA2IZS ..... 312	G6TA ..... 301	F2MO ..... 283	DL3RK ..... 2
DL9OH ..... 311	W3DJZ ..... 301	W3KT ..... 281	G3DO ..... 2
G3FKM ..... 310	G3HDA ..... 298	W1LLF ..... 280	W6WNE ..... 2
KP4CL ..... 310	XE1AE ..... 298	W6UOU ..... 280	PJ2AA ..... 2
WA8AJI ..... 310	5Z4ERR ..... 298	W4RLS ..... 279	K1SHN ..... 2
W4OPM ..... 309	W4QCW ..... 297	K4OEI ..... 279	PA0EEM ..... 2
W2RGV ..... 309	W4SSU ..... 297	W3FWD ..... 277	WA2TOQ ..... 2
I1AMU ..... 308	K2DX ..... 297	DL1IN ..... 276	SM6CAS ..... 2
W4NJF ..... 308	W8BT ..... 297	K4HYL ..... 276	W6BAF ..... 2
W8DE ..... 308	W4UF ..... 295	W7DLR ..... 276	K6CAZ ..... 2
G8KS ..... 307	W4PAA ..... 29	PZ1AX ..... 274	PA0SNG ..... 2
W5KUC ..... 307	W8EVZ ..... 293	K9EAB ..... 273	VE6TP ..... 2
K6LGF ..... 307	K8ONV ..... 293	K9LUI ..... 273	W1AOL ..... 2
W2ZX ..... 305	W2FXN ..... 292	W6RKP ..... 272	

TU2CF—Via DL7FT.	3A2CN—c/o DL7FT
UA0KIP—To UW3FD.	3A0CU—Via DL7FT
VK0IA—c/o VK3IS.	3V8BZ—To DL7FF
VP1TC—Via WA4FGX.	4A4J—c/o XE1J.
VP2AA—To VE3ACD.	4A4IX—Via XE1J.
VP2GN—c/o VE3DLC.	4S7DA—To W6FJ.
VP2GRN—To W4YHB.	4X4CY—Via WB2WOV.
VP2GSM—c/o W4YHB.	4X4SK—To WB2WOU.
VP2MK—Via W8EWS.	4X4UF—c/o WA4WTG.
VP2SU—c/o WB2WOU.	4X4UL—Via WB2WOU.
VP2VW—John Irwin, General Post Office, Tortola, British Virgin Islands.	4X4WP—To WB2WOU.
VP5CB—To K3NAU.	4Z4HF—Via WB2WOU.
VP8KD—c/o K2JXY.	4Z4NPS—c/o WB2WOU.
VU2CK—Via Box 534, New Delhi, India.	6W8DY—To VE4SK.
VU2JA—To W2CTN.	5L2J—c/o WB2WOU.
WB4GCL/YB0—c/o American Embassy, APO San Francisco, Calif. 96346.	5L2VAT—Via Dave Green, EL2BJ (Special LRAA Club Station).
WB4JSV/KG6, /KS6, or /KH6— Bill Beggs, 420 Ocean Spray Ave., Satellite Beach, Fla. 32935.	7Q7AM—c/o Dr. M. S. Mittelholzer PO Box 215, Lilingwe, Malawi.
XW8CR—Via W2CTN.	8QALK—Via 4S7YL.
YA1DAN—To KP4CL.	8R1S—To VE3DLC.
YA2HWI—c/o W9FLJ.	9E3FMA—c/o W7WLL.
ZD5R—Via VE4OX.	9K2CF—Via P.O. Box 12112, Kuwait.
ZL3BS—c/o WB2RLK.	9M2RH—To Box 777, Kulal Lumpur Malaysia.
ZS3HF—To P.O. Box 100, Windhoek, Southwest Africa.	9N1BG—c/o VE4OX
	9Y4AR—Via Box 1167, Port of Spain, Trinidad.
	9Y4VT—To W3DJZ.

73, John, K4II

# THE HAM SHACK

*proudly presents . . .*



## THE FABULOUS NEW GT-550 TRANSCEIVER

*by*



*"Grid" says: "Hotter than ever! Look at these features":*

- Power . . . 550 watts SSB
- Single-scale VFO
- Skirted knobs
- Even HOTTER receiver
- No frequency jump changing sidebands
- Still most compact
- Matched accessory line

Write for free spec. sheet.

**THE HAM SHACK IS FACTORY-AUTHORIZED SERVICE-CENTER FOR GALAXY**

Write for quotes and trade-ins for your complete station requirements, from antenna to microphone.

You'll like our clean, guaranteed reconditioned ham gear. What are you looking for?

### LOW LOSS ANTENNA CONNECTOR - INSULATOR

SO-239 feedline connector.  
Low SWR - No impedance bump.  
Sturdy copper leads.  
Antenna tie points.  
Famous WHF-Ham Shack design.  
\$1.95 postpaid in 48

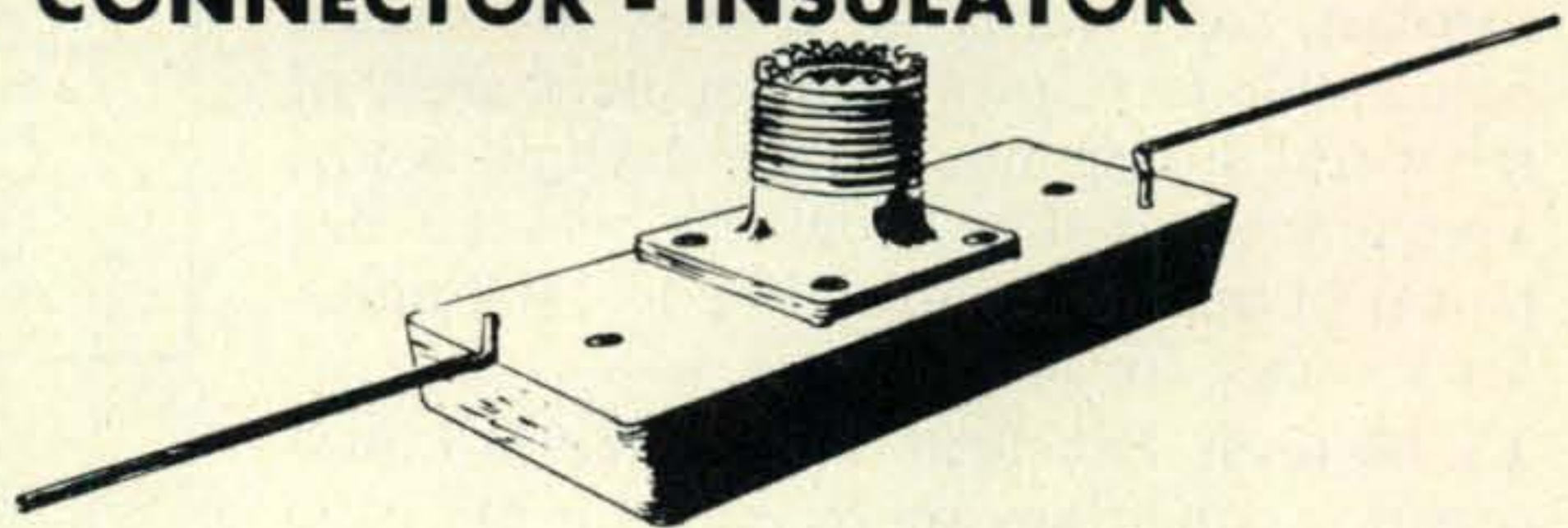

## THE HAM SHACK

1966 HILLVIEW STREET  
SARASOTA, FLORIDA 33579

TEL: (813) 955-7161 ANSEL E. "GRID" GRIDLEY, W4GJO



BY GEORGE JACOBS,\* W3ASK

**A**s the sun rises higher in the northern sky, optimum frequencies for long-distance propagation become *lower* during most of the daylight hours, and somewhat *higher* during the late afternoon, early evening and nighttime hours, than they were during the winter months. Static levels also increase noticeably during May, and signals may be somewhat weaker on DX openings during the daylight hours.

The following is a thumb-nail picture of h.f. amateur band propagation conditions expected during May, 1969. For specific times of DX openings, refer to the DX Propagation Charts which appeared in last month's column. This month's column contains Short-Skip Propagation Charts for the period May 15-July 15, as well as Charts centered on Alaska and Hawaii. The Short-Skip Charts contain propagation forecasts for openings varying in length between distances of 50 and 2300 miles.

For day-to-day propagation conditions expected during May, see the "Last Minute Forecast", which appears at the beginning of this column.

**10 Meters:** A seasonal decrease is expected in DX propagation conditions on this band during May. While fewer DX openings are forecast, some fairly good ones still should be possible to tropical and southern areas of the world during much of the daylight hours. Frequent short-skip openings, between distances of approximately 750 and 1400 miles, are forecast for May.

**15 Meters:** Excellent world-wide DX propagation conditions are forecast for this band during May. World-wide DX conditions should be optimum during much of the late morning and afternoon hours, with excellent openings forecast to tropical and southern

\*11307 Clara Street, Silver Spring, Md. 20902.

## LAST MINUTE FORECAST

Day-to-Day Conditions and Quality for  
May 1, through June 15, 1969

	Forecast Rating & Quality			
	Days (4)	(3)	(2)	(1)
Above Normal: May 3, 8, 13, 20, 30; June 3, 8, 12	A	A-B	B	B
Normal: May 1-2, 4-5, 9-12, 15-16, 19, 21, 23, 26-29; June 1-2, 4-7, 9, 11, 13-14	A-B	B	C	D
Below Normal: May 6-7, 14, 17, 24-25, 31; June 10, 15	B-C	C-D	D	E
Disturbed: May 18	C-D	D-E	E	E

### HOW TO USE THESE CHARTS

The following is an explanation of the symbols shown above, and instructions for the use of the CQ propagation predictions:

1—Enter Propagation Charts on following page under appropriate band and distance or geographical area columns. Read predicted times of band openings at intersection of both columns.

2—Following each predicted time of band opening is a forecast rating which indicates the relative number of days the band is expected to open during each month of the forecast period. The higher the rating, the more frequent the opening, as follows: (4) band open more than 22 days each month; (3) between 14 and 22 days; (2) between 8 and 13 days; (1) less than 7 days.

On the "Short-Skip" Chart where two numbers are shown within a single set of parenthesis, the first applies to the shorter distance for which the forecast is made, and the second to the greater distance. Note the forecast rating for later use.

3—With the forecast rating noted above, start with the numbers in parentheses at the top of the "Last Minute Forecast" appearing above. Read down the table for a day-to-day forecast of propagation conditions in terms of Above Normal (WWV rating higher than 6); Normal (WWV rating 5-6); Below Normal (WWV rating 4); Disturbed (WWV rating less than 4). The letter symbols (A-E) describe reception conditions (signal quality, noise and fading levels) expected for each day of the month and have the following meaning: (A)—excellent opening with strong, steady signals; (B)—good opening, moderately strong signals, little fading and noise; (C)—fair opening, signals fluctuating between moderately strong and weak; (D)—poor opening, signals generally weak and considerable fading and noise; (E)—poor opening, or none at all.

4—This month's Propagation Charts are based upon a transmitter power of 75 watts c.w.; 100 watts s.s.b., or 300 watts d.s.b., into a dipole antenna one quarter-wave above ground on 160, 80 and 40 meters and a half-wave above ground on 20, 15 and 10 meters. For each 10 db increase above these reference levels, reception quality shown in the "Last Minute Forecast" will improve by one level; for each 10 db loss reception will become poorer by one level.

5—Local Standard Time for these predictions is based on the 24-hour system.

6—These Propagation Charts are valid through July 15, 1969. These Charts are prepared from propagation data published monthly by the Institute For Telecommunication Sciences And Aeronomy of the U.S. Dept. of Commerce, Boulder, Colorado.

regions during the early evening hours as well. Numerous and widespread short-skip openings, over distances between approximately 600 and 2300 miles are also forecast from shortly after sunrise, through hours of daylight, and into the early evening hours.



**Meters:** The band is expected to remain open to one DX area or another practically around-the-clock during May. It should be the best band for DX openings during the evening hours, the hours of darkness and the sunrise period. Exceptionally high static levels are expected during many 20 meter DX openings, especially during the evening hours. Numerous and widespread short-skip openings are forecast for this band at distances ranging between 350 and 2300 miles. During the late afternoon and early evening hours, excellent propagation conditions will exist for openings as short as a few hundred miles and as long as several thousand miles. This mix between short and long skip is often expected to result in an exceptionally high level of interference.

**Meters:** With higher static levels and longer hours of darkness, 40 meter DX conditions are expected to decline somewhat during May. Some fairly good openings, however, are predicted to many areas of the world during the hours of darkness and the sunset and sunrise periods. Excellent daytime short-skip openings are forecast for distances between 150 and 750 miles, with nighttime openings extending out to the short-skip limit of approximately 2300 miles.

**Meters:** Higher static levels and fewer hours of darkness are also expected to restrict DX openings on this band during May, but a few fairly good ones are forecast to many areas of the world during the hours of darkness and the sunrise period. Excellent short-skip openings are forecast during the daylight hours over distances ranging between 50 and 250 miles. During the hours of darkness, the short-skip range is expected to extend up to approximately 2300 miles.

**Meters:** There is little chance during May for more than a very occasional DX opening on this band. What few DX openings do occur, will take place during the hours of darkness and the sunrise period. Short-skip openings beyond a groundwave range of about 50 miles are also very unlikely during the daylight hours. After sunset, short-skip openings should be possible up to a distance of approximately 1200 miles. Occasional openings beyond this range may be possible on some nights, when static levels are lower than usual.

#### **V.h.f. Ionospheric Openings**

Some fairly good meteor-scatter openings of short duration should be possible on the

v.h.f. bands during the period May 3-5, when the *Aquarids* meteor shower is expected to take place. The *Aquarids*, a major shower, should peak during the evening hours of May 4, with an hourly meteor count in excess of 20.

A considerable seasonal increase in sporadic-E ionization is expected during May, which should result in some fairly frequent 6 meter short-skip openings over a range of 1000 to 1400 miles. During periods of intense sporadic-E ionization, two-hop 6 meter openings may occasionally take place over distances up to approximately 2200 miles. Short-skip 6 meter openings are most likely to occur between 9 A.M. and 1 P.M., and between 5 P.M. and 9 P.M., local standard time.

An occasional F-layer 6 meter opening between the southern tier states and South America may be possible during May, between 1 P.M. and 6 P.M. EST. There's also a fairly good possibility that some 6 meter trans-equatorial scatter (TE) openings may be possible during the early evening hours.

Auroral activity is generally at a low level during May, but some displays may occur this month during periods of below normal or disturbed ionospheric conditions. During such periods, openings are likely to occur on 10, 6 and 2 meters for distances up to approximately 1200 miles, as a result of reflection or scatter from ionized patches produced by an auroral display. Check the "Last Minute Forecast" at the beginning of this column for those periods during May that are expected to be below normal or disturbed.

#### **Sunspot Cycle**

The Swiss Federal Solar Observatory at Zurich reports a monthly mean sunspot number of 121, for February, 1969. This results in a 12-month smoothed sunspot number of 105, centered on August, 1968. A smoothed sunspot number of 100 is forecast for May, 1969, as the present cycle continues to decline slowly from maximum intensity.

The Swiss Federal Observatory has also released the following official monthly mean sunspot numbers recorded during 1968. These values vary slightly from the provisional numbers reported previously in this column.

#### **Official Zurich Monthly Mean Sunspot Numbers-1968**

Jan.	121.8	Jul.	96.1
Feb.	111.9	Aug.	109.3

Mar.	92.2	Sep.	117.2
Apr.	81.2	Oct.	107.7
May	127.2	Nov.	86.0
Jun.	110.3	Dec.	109.8
Yearly Mean: 106			

The yearly mean level of solar activity observed during 1968 was the highest level of the present cycle, and the highest observed since 1960. ■

### CQ Short-Skip Propagation Chart

MAY 15-JULY 15, 1969

LOCAL STANDARD TIME AT PATH MIDPOINT  
(24-HOUR TIME SYSTEM)

Distance From Transmitter (Miles)

Band (Meters)	50-250 Miles	250-750 Miles	750-1300 Miles	1300-2300 Miles
10	Nil	07-09 (0-1) 09-13 (0-2) 13-17 (0-1) 17-21 (0-2) 21-23 (0-1)	07-09 (1-2) 09-13 (2-3) 13-17 (1-2) 17-21 (2) 21-07 (1)	07-09 (2-0) 09-13 (3-0) 13-17 (2-0) 17-21 (2-1) 21-07 (1-0)
15	Nil	06-09 (0-2) 09-13 (0-3) 13-17 (0-2) 17-19 (0-3) 19-23 (0-2) 23-06 (0-1)	06-09 (2) 09-13 (3) 13-17 (2-4) 17-19 (3-4) 19-21 (2-3) 21-23 (2) 23-06 (1)	06-09 (2-1) 09-13 (3-2) 13-15 (4-3) 15-19 (4) 19-21 (3-2) 21-23 (2) 23-06 (1-0)
20	09-12 (0-1) 12-18 (0-2) 18-00 (0-1)	06-09 (0-2) 09-12 (1-3) 12-18 (2-4) 18-20 (1-3) 20-00 (1-2) 00-06 (0-1)	06-09 (2-3) 09-12 (3-4) 12-18 (4) 18-20 (3-4) 20-22 (2-4) 22-00 (2-3) 00-06 (1-2)	06-09 (3) 09-15 (4-3) 15-22 (4) 22-00 (3-4) 00-02 (2-3) 02-06 (2)
40	06-08 (1-2) 08-11 (2-4) 11-19 (3-4) 19-21 (2-3) 21-00 (1-2) 00-06 (0-1)	06-08 (2-4) 08-09 (4-3) 09-15 (4-2) 15-17 (4-3) 17-19 (4) 19-21 (3-4) 21-00 (2-3) 00-06 (1-3)	07-09 (4-3) 09-15 (2-1) 15-17 (3-1) 17-19 (4-2) 19-21 (4) 21-02 (3-4) 02-07 (3)	07-09 (3-1) 09-17 (1-0) 17-19 (2-1) 19-21 (4-3) 21-02 (4) 02-05 (3-4) 05-07 (3)
80	07-10 (4) 10-18 (4-3) 18-22 (4) 22-07 (3-4)	07-10 (4-1) 10-16 (3-0) 16-18 (3-1) 18-20 (4-2) 20-05 (4) 05-07 (4-3)	07-08 (1) 08-10 (1-0) 10-16 (0) 16-18 (1-0) 18-20 (2-1) 20-22 (4-3) 22-05 (4) 05-07 (3-2)	07-08 (1-0) 08-18 (0) 18-20 (1-0) 20-22 (3-2) 22-03 (4-3) 03-05 (4-2) 05-07 (2-1)
160	05-08 (4-1) 08-09 (3-0) 09-18 (2-0) 18-20 (3-1) 20-22 (4-2) 22-05 (4-3)	05-08 (1) 08-18 (0) 18-20 (1-0) 20-22 (2-1) 22-00 (3-2) 00-03 (3) 03-05 (3-2)	07-08 (1-0) 08-20 (0) 20-22 (1) 22-00 (2-1) 00-03 (3-2) 03-05 (2) 05-07 (1)	07-20 (0) 20-00 (1) 00-03 (2) 03-05 (2-1) 05-06 (1) 06-07 (1-0)

### ALASKA

OPENINGS GIVEN IN GMT‡

To:	10 Meters	15 Meters	20 Meters	40/80 Meters
Eastern USA	Nil	18-20 (1) 20-22 (2) 22-00 (1) 00-02 (2) 02-04 (1)	20-22 (1) 22-02 (2) 02-06 (3) 06-08 (2) 08-10 (1) 10-14 (2) 14-16 (1)	07-11 (1)

Central USA	Nil	18-21 (1) 21-23 (2) 23-01 (1) 01-04 (2) 04-06 (1)	02-08 (3) 08-14 (2) 14-22 (1) 22-02 (2)	07-12
Western USA	Nil	18-20 (1) 20-23 (2) 23-02 (1) 02-05 (2) 05-06 (1)	02-04 (3) 04-08 (4) 08-14 (3) 14-18 (4) 18-20 (3) 20-02 (2)	07-09 09-15 15-17 12-15

### HAWAII

OPENINGS GIVEN IN  
HAWAIIAN STANDARD TIME†

Eastern USA	15-17 (1)	07-12 (1) 12-15 (2) 15-17 (3) 17-18 (2) 18-19 (1)	07-15 (1) 15-18 (2) 18-20 (3) 20-22 (4) 22-00 (3) 00-02 (2) 02-04 (3) 04-07 (2)	19-20 20-23 23-02 20-21 21-23 23-01
Central USA	13-15 (1) 15-17 (2) 17-18 (1)	06-09 (1) 09-12 (2) 12-16 (3) 16-18 (4) 18-19 (3) 19-21 (2) 21-22 (1)	08-12 (1) 12-16 (2) 16-18 (3) 18-22 (4) 22-00 (3) 00-02 (2) 02-06 (3) 06-08 (2)	19-20 20-21 21-01 01-02 02-04 20-21 21-00 00-03
Western USA	10-13 (1) 13-17 (2) 17-19 (1)	06-09 (1) 09-11 (2) 11-14 (3) 14-17 (4) 17-19 (3) 19-21 (2) 21-23 (1)	06-08 (4) 08-16 (3) 16-21 (4) 21-01 (3) 01-06 (2)	18-19 19-20 20-02 02-04 04-05 05-07 19-20 20-21 21-03 03-04 04-05

†Hawaiian Standard Time is 5 hours behind EST, 8 hours behind CST; 3 hours behind MST; 2 hours behind PST and 10 hours behind GMT. For example, when it is noon, or 12 hours, in Honolulu, it is 5 P.M. or 17 hours in NYC and 2 P.M. or 14 hours in Los Angeles.

\*Indicates predicted 80 Meter openings. Opening at 160 Meters are also likely to occur during those times when 80 Meter openings are shown with a forecasting rating of (2) or higher.

‡To convert to Local Standard Time in Alaska, subtract 8 hours from the times appearing in the Chart in the Pacific Standard Time Zone; 9 hours in the Yukon Time Zone, and 10 hours in the Alaskan Standard Time Zone. To use GMT in other areas of the United States, subtract 5 hours in EST Zone; 6 hours in the CST Zone; 7 hours in the MST Zone and 8 hours in the PST Zone. For example, when it is 18 GMT, it is 10 A.M. in San Francisco and 1 P.M. in NYC.

### CQ READER SERVICE

To obtain descriptive literature from advertisers, simply check the box next to the name of each advertiser listed in the left column on page 110. We will forward your name and address to the appropriate advertiser(s), and you will receive the literature in short order. This service is provided by the CQ staff at no additional charge to the reader or advertiser. Take advantage of this service as advertised. We welcome the chance to discuss the product.

Dr. William Kennedy  
1365 Thurston Avenue  
Olympia, Wash. 98502

Dear Sirs:

The speech  
processor is work-  
ing like a million  
dollars. It really  
comes up to every-  
thing you said  
it would do.  
I am very happy  
with it and really  
talking it up.

73  
Bill

## COMDEL

The Comdel Speech Processor, a unique device, providing a substantial advantage to a select number of hams, has been successfully sold by us for the last six months. That it is an unqualified success can be verified by the typical testimony shown herewith. We have the Comdel Speech Processor in stock for immediate delivery at the price of \$120.00, postpaid within the continental United States.

Other popular Comdel items are also handled, including the conservatively designed and constructed watt meter, scaled 0-15/150/1500 watts. This is the best VSWR combination watt meter available to the ham and at a new attractive price of only \$73.00, also postpaid within the continental United States.

Comdel is one of our finest suppliers, and we unhesitatingly recommend these two fine devices. Write for your literature today, or better still, send in your order.

## HERBERT W. GORDON COMPANY

Harvard, Massachusetts 01451 • Telephone 617 - 456 - 3548

*"Helping Hams to Help Themselves"*



# Contest Calendar

BY FRANK ANZALONE,\* W1WY

## Calendar of Events

May	3-4	USSR DX C.W. Contest
May	3-4	OZ-CCA DX Contest
May	3-4	Nebraska QSO Party
May	3-4	Ohio QSO Party
May	10-12	Georgia QSO Party
May	17-18	Michigan QSO Party
May	18-25	Michigan Week Party
May	24-25	YL International SSB
June	6-9	CHC/FHC/HTH QSO Party
June	7-9	New York State Party
June	15-21	Mass. Amateur Radio Week
June	28-29	ARRL Field Day
July	5-6	Venezuela DX Contest
July	19-20	Columbia DX Contest
July	19-20	Minnesota QSO Party
July	19-20	Ontario QSO Party
Aug.	2-3	Illinois QSO Party
Oct.	4-5	VK/ZL/Oceania Phone
Oct.	11-12	VK/ZL/Oceania C.W.
Oct.	11-12	RSGB 28 MHz Phone
Oct.	18-19	Boy Scouts Jamboree
Oct.	25-26	CQ WW DX Phone Contest
Oct.	25-26	RSGB 7 MHz C.W.
Nov.	8-9	RSGB 7 MHz Phone
Nov.	8-9	ARRL SS Phone Contest
Nov.	15-16	ARRL SS C.W. Contest
Nov.	29-30	CQ WW DX C.W. Contest

### OZ-CCA C. W. Contest

Starts: 1200 GMT Saturday, May 3  
Ends: 2400 GMT Sunday, May 4

Mailing deadline June 15th. Logs go to:  
E.D.R. Contest Committee, P.O. Box 335,  
Aalborg, Denmark.

### Nebraska QSO Party

Starts: 1600 GMT Saturday, May 3  
Ends: 2200 GMT Sunday, May 4

Mail logs to: Lincoln Amateur Radio Club,  
Att: WAØKGD, 4921 Tipperary Trail, Lin-  
coln, Nebraska 68512.

### Ohio QSO Party

Two Periods

1900 GMT May 3 to 0300 GMT May 4  
1500 GMT May 4 to 2300 GMT May 4

Logs go to: Ohio QSO Party, Att: W8ERD,  
311 E. Kelso Road, Columbus, Ohio 43202.

\*14 Sherwood Road, Stamford, Conn. 06905.

### Georgia QSO Party

Starts: 2100 GMT Saturday, May 10  
Ends: 0300 GMT Monday, May 12

Mailing deadline June 4th to: Columbus  
A.R.C. Att: J. T. Laney, 3500 14th Ave.,  
Columbus, Georgia 31904.

Preceding four events were fully covered  
in last month's CALENDAR.

### Michigan QSO Party

Starts: 2100 GMT Saturday, May 17  
Ends: 2100 GMT Sunday, May 18

This is the 2nd annual QSO party spon-  
sored by the Central Michigan A.R.C.

The same station may be worked on each  
band and mode for QSO points.

EXCHANGE: RS/RST plus a three digit QSO  
number starting with 001 for the first con-  
tact, and QTH. County for Mich., state,  
province or country for all others.

SCORING: One point per QSO. Mich. mul-  
tiply by state, provinces and countries. Out-  
of-state use Mich. counties for their multi-  
plier (max. of 83) Mich. stations may con-  
tact in-state stations for QSO and state  
multiplier.

FREQUENCIES: C.W.—3560, 7060, 14060,  
21060, 28060. Phone—3930, 7235, 14240,  
21310, 28650, 50400, 52525, 144500, 144-  
694.

AWARDS: Certificates to top stations in  
each state, province and country. And to  
first 5 places in Michigan. There are two  
Trophies, one for top Mich. station, other  
for top out of state score.

Mailing deadline is June 30th to: Cen-  
tral Michigan A.R.C., P.O. Box 73, Lan-  
sing, Mich. 48901.

### Michigan Week QSO Party

Starts: 0500 GMT Sunday, May 18  
Ends: 0500 GMT Sunday, May 25

This is week long activity and takes place  
during "Michigan Week" each year.

Try to work as many Michigan counties,  
and CHCers as possible. A station may be  
worked only once unless he is mobile or por-

table operating in different counties, and then he will only count as a county.

**EXCHANGE:** For Mich. RS/RST, county and CHC number, and Nr. 13 if a chapter member. (If not a CHC'er, send HTH)

Others: RS/RST, state or country.

**SCORING:** 1 point for each Mich. county, 1 point for each Mich. CHC'er, 2 points if QSO is with a Chapter 13 member, and 1/2 for each out-of-state or DX station worked by Michigan stations. Total QSO points is your final score.

**AWARDS:** To the highest scoring Michigan, out-of-state and DX station.

Logs must be in the hands of Kurt R. Schmeisser, W8LZV, 20114 Houghton Avenue, Detroit, Mich. 48219 before June 30th.

### **YL Int. SSBers QSO Party**

Starts: 0000 GMT Saturday, May 24

Ends: 2400 GMT Sunday, May 25

There are three categories and the scoring system is a bit involved. I hope you took my advice and wrote to WØGNX for rules and log information last month.

Both phone and c.w. may be used and non-members are invited to participate.

**CATEGORIES:** 1. DX/WK Teams; composed of a DX and a state-side station. The sum of their combined scores is the team score. 2. YL/OM Teams; composed of related pairs, wife/husband, sister/brother and etc. Operation must be from same QTH but with each one's call. 3. Single operator; non-members will use this category, as well as members.

**EXCHANGE:** RS/RST, SSB nr., state, province, or country, and partner's call if a team station (non-members send "no number").

**SCORING:** Same for all. Contacts between members, 4 points. Member to non-member, 2 points. Contacts between non-members have no point value.

**MULTIPLIER:** Sum of different prefixes, countries, states, VE provinces, CQ Zones and teams, where both stations are worked. (KH6 and KL7 count both as country and state.)

**FINAL SCORE:** Total QSO points times the sum of the multipliers. The same station may be worked on different bands and modes for QSO points but *not* for additional multipliers.

**FREQUENCIES:** Phone—3873, 7273, 14,332, 21,373. (DX—3773, 7090, 14,332) c.w.—3565, 7065, 14,070, 21,070, 28,070.

**AWARDS:** Certificates to the first 3 places in the different categories and sections. There

are also many Trophies and Plaques to the world leaders in the different categories.

**LOGS:** Must show time and date in GMT and the information listed under exchange. You must also take a rest period of 6 continuous hours in each 24 hour period. To qualify for an award each operator must show a minimum of 6 hours of operating time, in each mode if score is combined.

Submit logs no later than June 30th to: Woody Bennett, WØGNX, 8939 E. 31st Street, Kansas City, Missouri 64129.

### **CHC/FHC/HTH QSO Party**

Starts: 2300 GMT Friday, June 6

Ends: 0600 GMT Monday, June 9

This one has a lot going so read rules carefully. It is highly recommended that you write K6BX for rules sheet. (Include s.a.s.e.)

**EXCHANGE:** CHCers and FHCers: QSO nr., RS/RST, name, CHC/FHC no., state, county. (DX-Laam, Dok, province and etc.) Non-members: (HTHers) same as above less membership no.

**SCORING:** CHCers: CHC to CHC 1 point, CHC to HTH 2 points, CHC to Novice 3 points; YL and FHC contacts 1 additional point.

HTHers, FHCers, SWL: HTH to CHC 3 points, YL and b/p CHCers 5 points; FHCer contacts one additional point. HTH to HTH, no value.

Same station may be worked on different bands and modes for QSO points. S.s.b. and a.m. are considered diff. modes.

**MULTIPLIER:** Sum of different continents, countries, VE provinces, US states. Own counts. KH and KL are both state and country.

**FINAL SCORE:** Total QSO points times the sum of the multiplier.

**FREQUENCIES:** U.S., C.W.—3575, 7070, 14075, 21075, 28090. Novice—3710, 7160, 21140. Phone—3943, 7275, 14340, 21440, 28690. DX—3770, 3790, 3960, 7090, 7210, 7260, 14,320, 21360, 28620.

**AWARDS:** 1st, 2nd and 3rd place certificates for world, continents, countries, states and VE provinces. Plus many Trophies for the many categories.

It is again recommended that you contact K6BX for official forms so that you can get the most credits for your efforts.

Mailing deadline is July 5th to: Clif Evans, K6BX, 3212 Mesa Verde Road, Bonita, Calif. 92002. Include s.a.s.e. when requesting forms.

### **New York State QSO Party**

Starts: 1700 GMT Saturday, June 7

Ends: 0100 GMT Monday, June 9

The South Shore Amateur Wireless Association once again invites all to join in its annual QSO party.

Use all bands and modes, the same station may be contacted once per band and mode for QSO points.

EXCHANGE: QSO no., RS/RST and QTH. County for N.Y. stations; state or country for all others.

SCORING: One point per QSO. New York use states and country for their multiplier; out-of-state stations the number of different N.Y. counties worked. Max. of 62.

FREQUENCIES: 3560, 3900, 7060, 7225, 14060, 14250, 21060, 21300, 28060, 28600.

AWARDS: Certificates to the high scorer in each New York county, state and country. Provided a minimum of 100 points are scored (50 for DX, incl. KH6 and KL7).

Mailing deadline is July 15th to: South Shore A.W.A., 116 Locust Street, Valley Stream, N.Y. 11581. Include s.a.s.e. if results are desired.

### **Mass. Amateur Radio Week**

Starts: 0001 GMT Sunday, June 15

Ends: 2400 GMT Saturday, June 21

This has been proclaimed as Amateur Radio Week by the Governor of Massachusetts.

If you meet the following requirements you will earn a certificate signed by the Governor.

1. Mass. amateurs, work at least 16 other Mass. stations.
2. Ret of New England, 8 Mass. stations.
3. All other U.S., 5 Mass stations.
4. DX (inc. KH & KL) 2 Mass. stations.

Use any band or mode, and exchange a signal report, your county and state.

Your log must show date, time and frequency.

Certificates will be endorsed for band and mode if requested.

Applications must be received no later than July 31st and sent to: Bill Holliday, WA1EZA, 22 Trudy Terrace, Canton, Mass. 02021. Include a large sized s.a.s.e. for your certificate.

### **Venezuela Contest**

Starts: 0000 GMT Saturday, July 5

Ends: 2400 GMT Sunday, July 6

This is the annual phone *only* contest sponsored by the Radio Club Venezolano com-

memorating the anniversary of Venezuela's independence.

Use all bands, 10 thru 80. Three categories, single operator, both single and all band, and multi-operator, both single and multi transmitter.

EXCHANGE: The RS report plus a 3 figure contact number starting with 001.

CONTACTS: *Stations in Americas:* With YV's other American countries, and the world. *Stations in other continents:* With YV's and other American countries only.

SCORING: One point per contact, 2 points if it's with a YV station.

MULTIPLIER: A multiplier of one for each country, YV call area and USA call area.

FINAL SCORE: For a single band, total QSO points times the sum of the multiplier. All band, QSO points times the total multiplier from all bands.

LOGS: Date/time in GMT, station worked, number sent/received, multiplier (only first time worked) and QSO points. Use separate sheet for each band. Also include a summary sheet with computed score and your name and address in BLOCK LETTERS.

AWARDS: A certificate to each station with the following number of contacts. *Americas:* With 20 YV's and 10 other countries. *Other continents:* With 5 YV's and 5 other American countries. (s.w.l.'s with 50 different confirmed stations)

There are also Trophies and medals for leaders in each category. A remittance of \$1.00 or its equivalent in IRC's is requested for each award application.

Entries must be postmarked no later than Sept. 1st and they go to: Radio Club Venezolano, Independence Contest, P.O. Box 2285, Caracas, Venezuela.

### **Editor's Notes**

If you have not sent in your log for the PACC contest, send it to the new contest manager of the VERON, W.J.M. Paas, PA0ABM, Zwerfruststraat 1, Middelburg, Netherlands. The old address is OK too, so don't worry if you have already sent it there.

In the past, June and July CQ's have been the issues when we report the results of our World Wide DX Contest. However we are unable to make it this year. The long east coast dock strike really fouled up the surface mail. We are still receiving logs for the phone contest at this late date. (early March) So the results will be published a month later this year. Sorry fellows.

73 for now, Frank, W1WV

# WANT MORE FOR YOUR MONEY?

This new Galaxy "550" line of coordinated equipment is winning plenty of plaudits from hams who find it gives plenty of performance for surprisingly few dollars investment.

It's real value, plus Harrison unique services gives you truly MORE for your money.

For the very best deal, visit any of our stores, or drop me a line today. TNX

73 *Bil Harrison* W2AVA



## THE EXCITING NEW "550 LINE"

**GALAXY GT550 TRANSCEIVER.** Highest power in a compact design, 550 watts SSB, 360 watts CW, with tune power provisions for longer life — Solid-State circuits where they provide maximum performance and reliability — Selectable Sideband without frequency jump — Audio derived AGC — Sharpest filter for minimum QRM — King size finger-tip VFO tuning knob — Size: 6" X 11<sup>1</sup>/<sub>4</sub>" X 12<sup>1</sup>/<sub>2</sub>" (HWD) — Weight: 17 pounds

... \$449<sup>00</sup>

**CAL-25.** Plug-in 25KH<sub>2</sub> solide state calibrator ..... \$25.00

**VOX35C.** Plug-in VOX control unit ..... \$29.95

**F3.** Plug-in 300 Hz CW filter ..... \$29.95

**RF550 R.F. CONSOLE.** A precision wattmeter in the range of 3.5/30.0 mHz — Contains switch to select 5 antennas or a dummy load (not supplied) ..... \$69.00

**SC550 SPEAKER CONSOLE.** A matching speaker with headphone jack — AC400 power supply will mount inside ..... \$19.95

**AC400.** Full power, heavy duty state supply for 115/230 volts ..... \$89.95

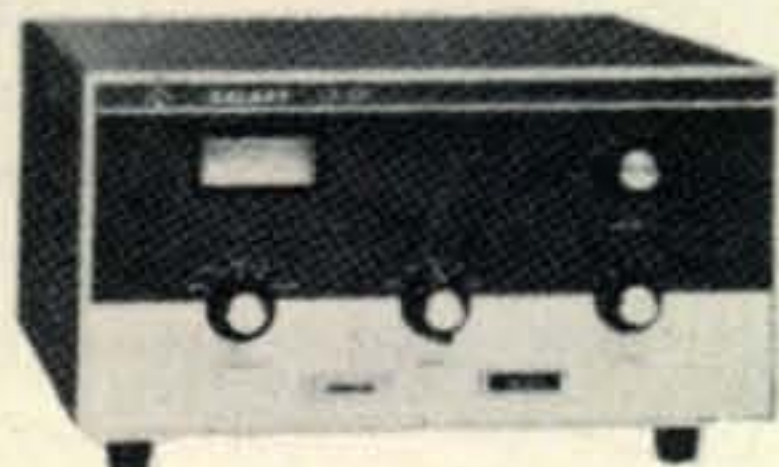

**GALAXY LA550 LINEAR AMPLIFIER.** 200 watts PEP input on SSB, 1000 watts DC input on CW/RTTY. Band switching 80 thru 10 meters, with some adjacent MARS and special frequencies.

... \$495<sup>00</sup>

**GALAXY RV550 REMOTE VFO.** A solid state VFO complete with simple plug-in cables. Gives flexibility of a separate transmitter and receiver.

... \$75<sup>00</sup>

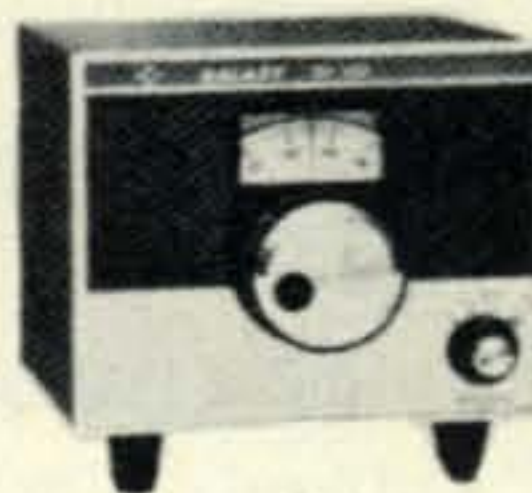

### PROMPT ORDER DEPT.

We carefully pack and ship ham gear, accessories and parts to most any part of the world.

Address your orders to:

22 SMITH STREET  
Farmingdale, N.Y. 11735

Please include ample postage (plus \$1 handling cost with orders under \$10.)

OR, PHONE YOUR ORDERS TO  
(212) BA 7-7922 OR (516) 293-7990

SINCE  
1925...

*Harrison*

"HAM HEADQUARTERS, USA"®

NEW YORK CITY • 8 Barclay St. • BARclay 7-7922

JAMAICA, L. I.  
139-20 Hillside Ave.  
REpublic 9-4101

FARMINGDALE, L. I.  
Route 110 at Smith St.  
(516) 293-7990



# THE awards PROGRAM



BY ED HOPPER,\* W2GT

**T**HE May, *Story of The Month* re Al Pulling, K1WQU, after this data on awards issued. USA-CA-3000 awards (Mixed) went to Earl Shobe, W7KOI and Phil Carlson, WA0EVO. Mixed USA-CA-2500 and 2000 awards were issued to Ben Harris, K5DRF and George Caron, W1EQ. Jack Prichard, W9CNG qualified for Mixed USA-CA-2000 and 1500 awards. John McCaa, W4HA gave me a little work by winning a USA-CA-1500 award endorsed Mixed and All 14 mc A3A; and a USA-CA-1000 award endorsed Mixed and All Mobiles and All 14 mc A3A. Lou Wenisch, WB2AHB received a USA-CA-1500 award endorsed All 14 mc A3A. Mixed USA-CA-1000 awards went to Wilberta Longwell, WA7IRD; Clarence Blalock, W4EO; and Bayard Smack, W3NB. Richard Harris, W5-10353 qualified for a USA-CA-1000 award endorsed All Phone, the only s.w.l. in the 5th call area to qualify for USA-CA. John Polus, WA8YSQ received a USA-CA-1000 award endorsed All 2 x S.S.B. Shohei Numoto, JA2WB, qualified for a USA-CA-500 award, endorsed All A-1 and the 3rd award to an Asian station. Mixed USA-CA-500 awards went to William McDoniel, WA1KDC; James Walker, K8TDJ; The San Antonio Radio Club Station, W5SC; and to Keith Neighbors, W4HHN.

### Alfred L. Pulling, K1WQU

Al was born in Rutland, Vermont, July 28, 1925, where he was raised and went to school.

An interest in wireless was born in grade school, but he never actually built his own set until becoming a freshman in high school about 1941. The teacher asked him to bring the set to school for a demonstration, and much to everyone's surprise, it worked fine.

USA-CA HONOR ROLL		
<b>3000</b>	<b>1500</b>	<b>W3NB</b> .....149
W7KOI ..... 16	W4HA ..... 84	W5-10353 ..150
WA0EVO ..... 17	W9CNG ..... 85	
<b>2500</b>	WB2AHB ..... 86	
K5DRF ..... 40		JA2WB .....697
W1EQ ..... 41		WA1KDC .....698
<b>2000</b>	<b>1000</b>	K8TDJ .....699
K5DRF ..... 56	W4HA .....145	W5SC .....700
W9CNG ..... 57	WA7IRD .....146	W4HHN .....701
W1EQ ..... 58	W4EO .....147	

Entering the U.S. Army in July 1945, Al went through regular basic training, then attended Finance School, preparing to work at pay figures for officers and enlisted men upon their discharge. He was later transferred to the athletic branch of the Special Services where he stayed until being discharged in November 1946—and he continues to correspond with one buddy in California.

In early 1950 on a trip to California with a buddy, it was suggested that Al write and get to meet "Roma" who lived in Woodstock (Windsor county), where Al has a brother. The writing and visits developed into a real serious romance and they were married in 1951 and they have a daughter, Cynthia (15) a sophomore in high school and a son Stephen (13) in the 8th grade.



Al Pulling, K1WQU at rig.

\*103 Whittman St., Rochelle Park, N.J. 07662.



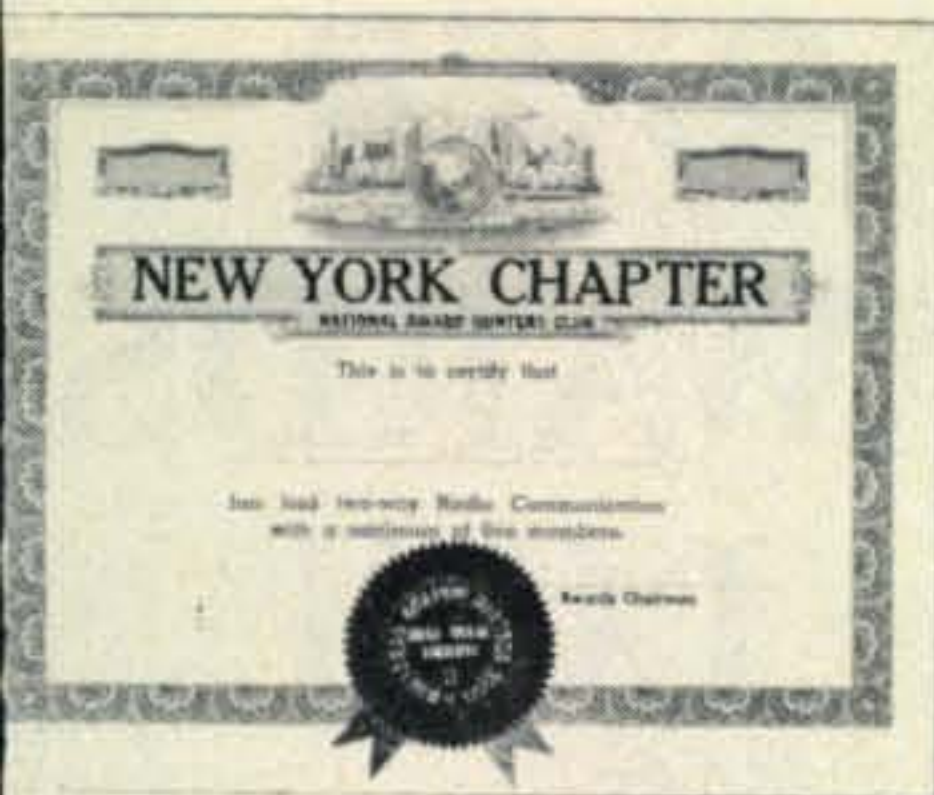

NAHC Worked All Members. Missouri—Worked All County Seats. Worked Ten Ceylon.

Al was a member of the Grange Club and was also involved in 4 H Club activities for 5 years.

His first license came in 1962 and county hunting started about 1964 when some chap told him he needed a K1WQU QSL for a county award. Al now has about 2870 confirmed with 12 states completed and several others nearing completion. Our records show the following: USA-CA-500 Award #537 issued in November 1965; 1000 Award #109 dated January 1967; 1500 Award #61 dated June 1967 and USA-CA-2000 #52 and 2500 #35 dated October 1968. Believe it or not, the hold-up for 2000 and 2500 was the need for a QSL from KH6.

The first rig was a Globe Scout, model 10-A, which still works fine. Most "hunting" has been with an Eico 753 with a Hy-Gain vertical beam for 10-15-20 and doublets for 40 and 80.

Some 260 different awards are held by K1WQU. Other hobbies include stamp and coin collecting.

As Al reminds me, one of the biggest jobs in county and award hunting, is the paper work, and he suggests we all be most careful with QSL's. Ever so often, he discovers some new county QSL's that have been used for some other award and then forgotten.

Quite by accident, he discovered that a cousin was also an amateur, W2ERF, so they had fun keeping schedules and doing some checking on their genealogy.

Al is, and has been for the past ten years, a Star Route Mail Carrier. I like to hear about hams being Mail Carriers, this helps to take good care of our QSL's—ever so often I get a QSL, that has gone astray, forwarded by a mailman with a note and *his* QSL.

### Awards

**San Diego 200th Anniversary Awards Program:** Effective October 1, 1968 to September 30, 1969. Basic Award: (Second figure for DX including KH & KL)—San Diego

Anniversary QSL Award for 10/5 contacts with San Diego County Amateurs, may be repeated over for class endorsements and towards Major Award, "Don in the Legion of Portola". Major Award for top contact winner each state, VE province, county and continent. Contacts on different bands or modes with the same station are considered new contact. Class Endorsements: Class A-4 for 20/15; Class A-3 for 30/25; Class A-2 for 40/30; Class A-1 for 50/50; Class AA DX only 50. Directory Codes will apply: GCR, MER, TCR, SWL, No charge. Novice, s.w.l., B/P and v.h.f. will be scored for awards separately. Additional Special San Diego Days Contest will be held from 3 July 1969 to 16 July 1969, contacts during this contest will each count for 2 and apply toward the Major Award. Contacts with K6SD, the "Official San Diego 200th Anniversary Radio Station" will count for 2 at all times. Log information must be received no later than 15 October 1969. Send to: San Diego 200th Anniversary, Inc., QSL Program Coordinator W6CCM 635 "C" Street, San Diego, California 92101.

**Worked All Members Award:** NEW YORK CHAPTER of the National Award Hunters Club offers this Award for working 5 members with seals for working 15 and 25. Send \$1.00 and GCR list for each request to:

[Continued on page 82]



San Diego 200th Anniversary.

# A MUST FOR EVERY DXER

# DX AWARDS LOG



This fabulous book sells for \$3.95 anywhere in the U.S. and is available for immediate delivery from the CQ Technical Library. However, with any subscription to CQ you can obtain a copy of the *DX Awards Log* for just \$1.50 (a \$2.45 savings). To obtain your DX Log at the discount price it must accompany a subscription order to CQ, but that order can be for renewals or extensions as well as for new subscriptions.

**SUPPLY IS LIMITED—ACT NOW!**  
Without subscription, cost price is \$3.95.

This new 150-page log book has been published for use by all DX'ers to keep an organized log of contacts and confirmations for the many DX awards now available.

Complete details are provided on the number and type of contacts needed for over 100 major awards made by amateur radio clubs throughout the world. In addition to specific award qualifications and costs, the method of confirmation and how and where to apply are also listed under each individual award.

Special individual logs are set up under each award providing space for a complete record of contacts and confirmations including log data required to be submitted with the award application.

The *DX Awards Log* required over two years preparation in order to contact radio clubs throughout the world for the latest data on awards currently being offered. It is the most complete and up-to-date source for such information. It will be invaluable to the "wallpaper collector" as well as any amateur of SWL making DX contacts.

Circulation Department, CQ Magazine  
14 Vanderventer Ave., Port Washington, N.Y. 11050

MAY '69

Gentlemen:

Your offer is too good to miss. I have indicated my preference below.  
(Payment must accompany order.)

NAME.....CALL.....

ADDRESS.....

CITY.....STATE.....ZIP.....

I want the DX Awards Log with a CQ subscription for:

1 yr. at \$7.50    2 yrs. at \$12.50    3 yrs. at \$16.50

I just want the DX Awards Log at \$3.95

New Subscription    Renewal    Extension

# CQ BOOK MART

## ANTENNA ROUNDUP Vol. II

Cat. #119-2. Here's your chance to get a copy of one of the most comprehensive books on antennas ever offered to the Amateur. Ten big theory articles backed up by 82 detailed and illustrated construction projects for VHF on into microwave, from long-wires to 17 element beams and Sterba Curtain arrays.



## THE NEW RTTY HANDBOOK

Cat. #116. A treasury of vital and "hard to get" information. Loaded with equipment schematics, adjustment procedures, etc. A valuable asset to both the beginning and the experienced RTTY'er. Special section on getting started, written by Byron Kretzman, a well known authority in the field.

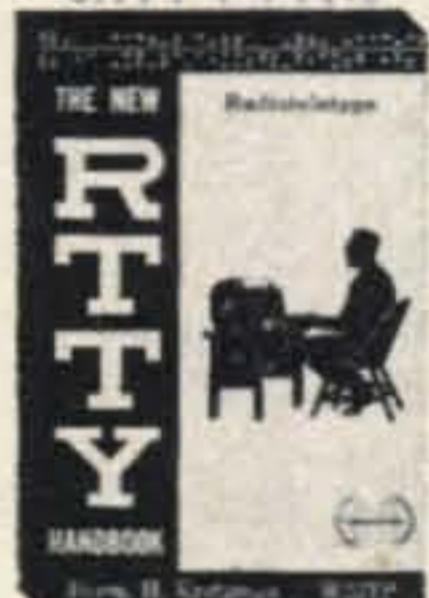

## CQ ANTHOLOGY I

Cat. #102-1. We've looked back through the years 1945-1952 and assembled all in one place the articles that have made a lasting stir. The issues containing most of these articles have long ago been sold out and are unavailable.



## SURPLUS SCHEMATICS

Cat. #117. This is a book literally loaded with schematics for all the currently popular pieces of surplus gear. Most amateurs are well aware of the problems encountered in purchasing seemingly inexpensive surplus units, only to find that no schematic diagram is available.



## VHF FOR THE RADIO AMATEUR

Cat. #115. If you are, or are planning to be a VHF operator you can't afford to be without this dynamic new handbook written especially for you. Filled from cover to cover with all new and original construction material presented so you can understand it.



## ANTENNA ROUNDUP Vol. I

Cat. #119. A common denominator for all ham stations is the antenna. Here at last is the cream of antenna information packed into a 160 page book. Forty-seven information-packed articles that will dispel much of the mystery surrounding antennas.



## SIDEBAND HANDBOOK

Cat. #103. One full year in the preparation of this terrific volume. This is not a technical book. It explains sideband, showing you how to get along with it . . . how to keep your rig working right . . . how to know when it isn't . . . and lots of how to build-it stuff, gadgets, receiving adaptors, exciters, amplifiers.



## SURPLUS CONVERSION HANDBOOK

Cat. #122. Contains 192 pages of conversion articles including the famous Command Set's plus a whole slew of the most popular military surplus gear including such gems as: SC9322, ART-13, BC603, BC659, ARC 1, ARC 3, etc. Actually, it covers almost every piece of surplus gear worth the effort to convert for ham use.



## ELECTRONIC CIRCUITS HANDBOOK

Cat. #121. Describes and discusses in detail 150 of the most often needed circuits around the shack. Novices and old-timers alike will find many valuable circuits here ideal for construction projects. Eleven great chapters cover a multitude of circuits for all.



## SHOP & SHACK SHORTCUTS

Cat. #120. Here is a collection of hundreds of hints, kinks and shortcuts which should be part of the library of every experimenter ham and CB'er. A veritable gold mine that will help save time, improve their shop techniques, dress up their shacks, and increase the efficiency of their equipment.



## CQ ANTHOLOGY II

Cat. #102-2. Top favorite CQ articles from 1952 to 1959 . . . including some you may have missed . . . compiled into one new information-packed book! No more need to try to locate sold out back copies of CQ. This Anthology includes past articles of lasting interest to every amateur radio enthusiast. Over 250 pages of text.



## ELECTRONIC CIRCUITS HANDBOOK VOL. II

Cat. #121-2. Tom Kneitel, K2AES, does it again with this sequel to his best selling Volume I. This time it's 159 additional circuits which will appeal to all. Every shack will have a spot for this book. All circuits fully described in text with complete detailed construction steps plus schematics.



NAME \_\_\_\_\_  
 ADDRESS \_\_\_\_\_  
 CITY \_\_\_\_\_  
 STATE \_\_\_\_\_  
 Zip Code \_\_\_\_\_

Cat. No.	Name	Price	Order	Cat. No.	Name	Price	Order
99	TVI Handbook	1.75		115	VHF for the Radio Amateur	3.50	
102-1	CQ Anthology vol. 1	2.00		116	The New RTTY Handbook	3.95	
102-2	CQ Anthology vol. 2	3.00		117	Surplus Schematics	2.50	
103	New Sideband Handbook	3.00		119-1	Antenna Roundup vol. 1	3.00	
105	New Mobile Handbook	2.95		119-2	Antenna Roundup vol. 2	4.00	
109	Ham's Interpreter	1.50		120	Shop & Shack Shortcuts	3.95	
112-A	Reg. Ham Log Sheets, per C	1.00		121-1	Electronic Circuits Handbook vol. 1	3.00	
112-B	SSB Ham Log Sheets, per C	1.00		121-2	Electronic Circuits Handbook vol. 2	3.00	
113	CQ Binders (Indicate year)	5.00		122	Surplus Conversion Handbook	3.00	

New York City and State residents must add sales tax applicable to your area.

COWAN PUBLISHING CORP. Book Div. • 14 Vanderventer Avenue • Port Washington, L.I., N.Y. 11050

## USA-CA [from page 79]

Joseph Tricarico, WA2MWO, Awards Chairman, 448 Keller Ave., Elmont, L.I., N.Y. 11003. (Other Awards issued by the New York Chapter are: Worked All Boroughs Award, New York County Award—send s.a.s.e. to WA2MWO for complete details).

**Worked All County Seats—Missouri:** This Award sponsored by Three Rivers Amateur Radio Club and issued to all amateurs and s.w.l.'s for contacts (or heard) with 25 county seats of the state of Missouri for the basic award, with seals for 50, 75 and 115. No date or time limits. For a list of the county seats, send s.a.s.e. to custodian. Cost of certificate \$1.00 or 10 IRCs, free to B/P. Send GCR list of counties, county seats and call of station worked to Award Custodian: Orville Taylor, K0IHK, Rt. 4, El Dorado Springs, Missouri 64744.

**Worked Ten Ceylon:** This WTC Award sponsored by The Radio Society of Ceylon and is issued for working ten different 4S7 stations after January 1, 1964, any mode, any band. Send GCR list and 7 IRCs to The Awards Manager, P.O. Box 907, Colombo, Ceylon. All applicants must have the ten 4S7 QSLs in their possession.

### Notes

A late note from WA3FED, B. L. Lindley, 8524 Central Ave., Landover, Maryland 20785, to say that he and K3WUW plan a county trip along the Virginia line. It is planned for the "Memorial Day" weekend at the end of May and they hope to hit about 60 counties. It is also hoped that WA3LKH will go with them. They will be active on 80, 40 and 20 s.s.b., and will stay on for long hours as a Pick-up Camper will be used. A list of the counties they will hit is available for a s.a.s.e. A big help would be to use county hunter QSL's to them and be sure and put a stamp on it or send a s.a.s.e.

As mentioned in *CQ*, July 1968, Dick Bentley, K2UFT and Rick Lobdell, K2VGR—both members of the South Shore AWA of Valley Stream, N. Y., do issue a monthly bulletin The CW County Hunter, and they have a c.w. County Hunter Net at 1700 GMT on 14070 with K2UFT and W4RNL as NCS but are looking for more midwestern stations to participate and help as NCS. Sunday they are on 7055.

NOW, H. A. "BING" Miller, W0GV, of 1381 E. Bates Parkway, Englewood, Colorado 80110 hopes to start a news-letter for

### FLASH!

**Willard W. Waite, W8GDQ**  
Holder of the only USA-CA-500  
endorsed ALL 160 Meters  
#500 dated June 18, 1965  
**NOW ENDORSED**  
**ALL 160 METER PHONE!**

late news of doings and proposed mobile trips, needed counties and such improvements. It is hoped to mail the letter the first Monday of each month and news deadline the last weekend of each month. The first issue will be mailed April 7 and copy for it by Saturday, March 29. The subscription rate will be \$1.50 for 12 issues or \$2.00 for air mail. "Bing does not expect nor hope to make money on the news-letter, but hopes he can meet the costs. So, when you subscribe, please send him some news. Oh yes, it will be mostly news for the Independent County Hunter Net—14336 s.s.b.

Regarding the willful QRMing being done on the 14336 Net by several individuals. We (meaning we county hunters) have a friend who is keeping close check on it and is also keeping the FCC advised, but as the FCC says, no one *owns* a frequency on the amateur bands. A suggestion is that we *ask* a QRMer to move and if he persists, a smart thing to do would be to move the whole NET perhaps 7 kc up or down and if he follows, then the FCC has got him on a good violation. But I guess we best keep in mind that although we have been using a certain frequency for a long time, we do NOT own it and although we do, and have every right to, get angry when others come on top of us, don't let our anger show—Hi...

What a pleasant surprise to have KH6TS check into the Net on Feb. 23rd, who is KH6TS? Well just a nice chap (also named Ed.) in **KALAWAO COUNTY**—Yes, I'll admit it did not dawn on me at the time and I nearly rushed off to eat without calling him.

The **EXTRA CLASS AWARD**, as described in *CQ*, September 1968, apparently is not now available, as mail to W0AUB (NOT WA0AUB as listed) goes unanswered.

My apologies to Carol Kimber, K7WUR. In mentioning that she received USA-CA-500 & 1000 Awards in March *CQ*, I left her call out.

Sorry, no more time nor space, send along any QTH changes and I'll mention them and also write and tell me—How was your month?

73, Ed., W2GT.

# Q AND A

BY WILFRED M. SCHERER,\*  
W2AEF

**T**HIS month we'll dispense with the usual introduction in order to get to a number of questions that require rather lengthy replies. The first one is particularly involved, but we have selected it, as a matter of interest not only for those who might like to use such a setup, but also for others as a basis on how to approach a solution using other gear under similar circumstances.

## 6N2 with DX-100

**QUESTION:** I am looking for information on using my Heathkit DX-100 modulator and power supply to drive my Johnson Viking 6N2 Transmitter. Do you have any information concerning this?

**ANSWER:** *CQ* has not published any data on such a setup. Although we do not have these two pieces of gear on hand to personally check the necessary steps for setting up the specified arrangement, we have worked out what appears to be a proper method. Some difficulties were experienced in doing so, since the equipment manuals which were used as a guide, are somewhat deficient in various details; nevertheless, our suggestions should turn out satisfactorily.

For those not familiar with the gear, it is first pointed out that the 6N2 is not equipped with a power supply or a modulator; but, as described in its manual, these needs may be provided by other gear such as the Johnson Ranger, Viking I or II and Valiant.

The 6N2 requires approximately the same operating power and modulating facilities as used in the popular Heath DX-100, thus making it feasible to use this rig, also, in conjunction with the 6N2.

To do so, modifications must be made in the DX-100 to remove +300 volts from the low-power r.f. stages, modulated +750 volts from the p.a., and 6.3 volts from the p.a. heaters when power is to be used for the 6N2. The power connections are then made through a new accessory socket on the DX-100.

The procedure is as follows:

1. Install a 9-pin octal-type socket (female) for new accessory power outlet on rear of DX-100. Call this  $J_1$ .
2. Ground pin 1 of  $J_1$ .
3. Remove jumper from terminals 1 and 2 on tie strip FF (see Pictorial 5).
4. Connect pin 5 of  $J_1$  to terminal 2 of tie strip FF.
5. Connect pin 6 of  $J_1$  to terminal 1 of tie strip FF.
6. Disconnect lead that runs between the terminal strip next to the 5763 socket and the electrolytic filter capacitor in the power-supply section.
7. Connect this lug of the capacitor to pin 8 of  $J_1$ .
8. Connect pin 9 of  $J_1$  to the tie strip next to the 5763 socket.
9. Remove the twisted leads from terminal 7 on the 6146 socket nearer the front of the DX-100.

\*Technical Director, *CQ*.

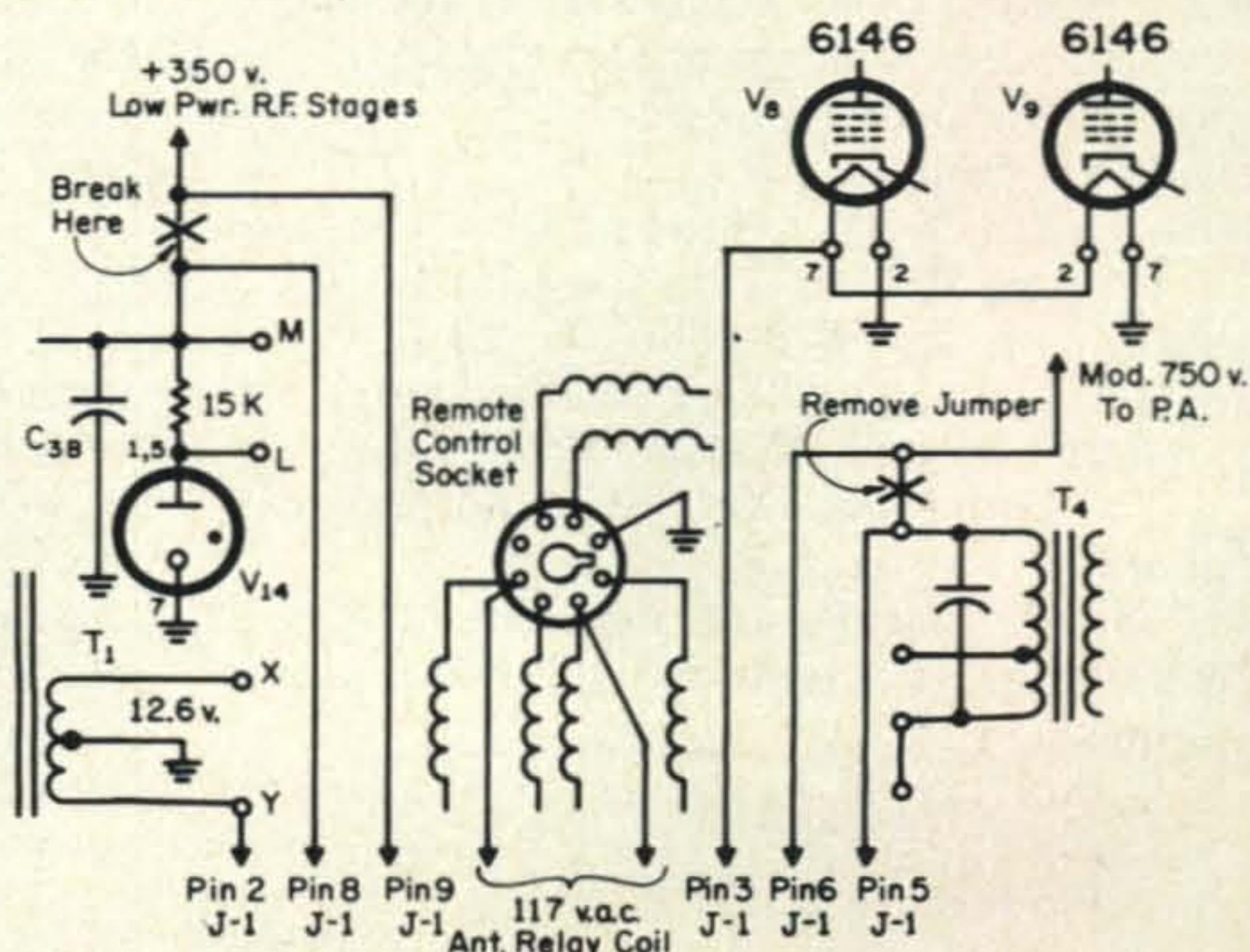

Fig. 1 — Wiring changes required in DX-100 for using its power supply and modulator to drive the 6N2. Only the circuit elements of concern are shown as they appear on the DX-100 schematic. See text for procedure and other details.

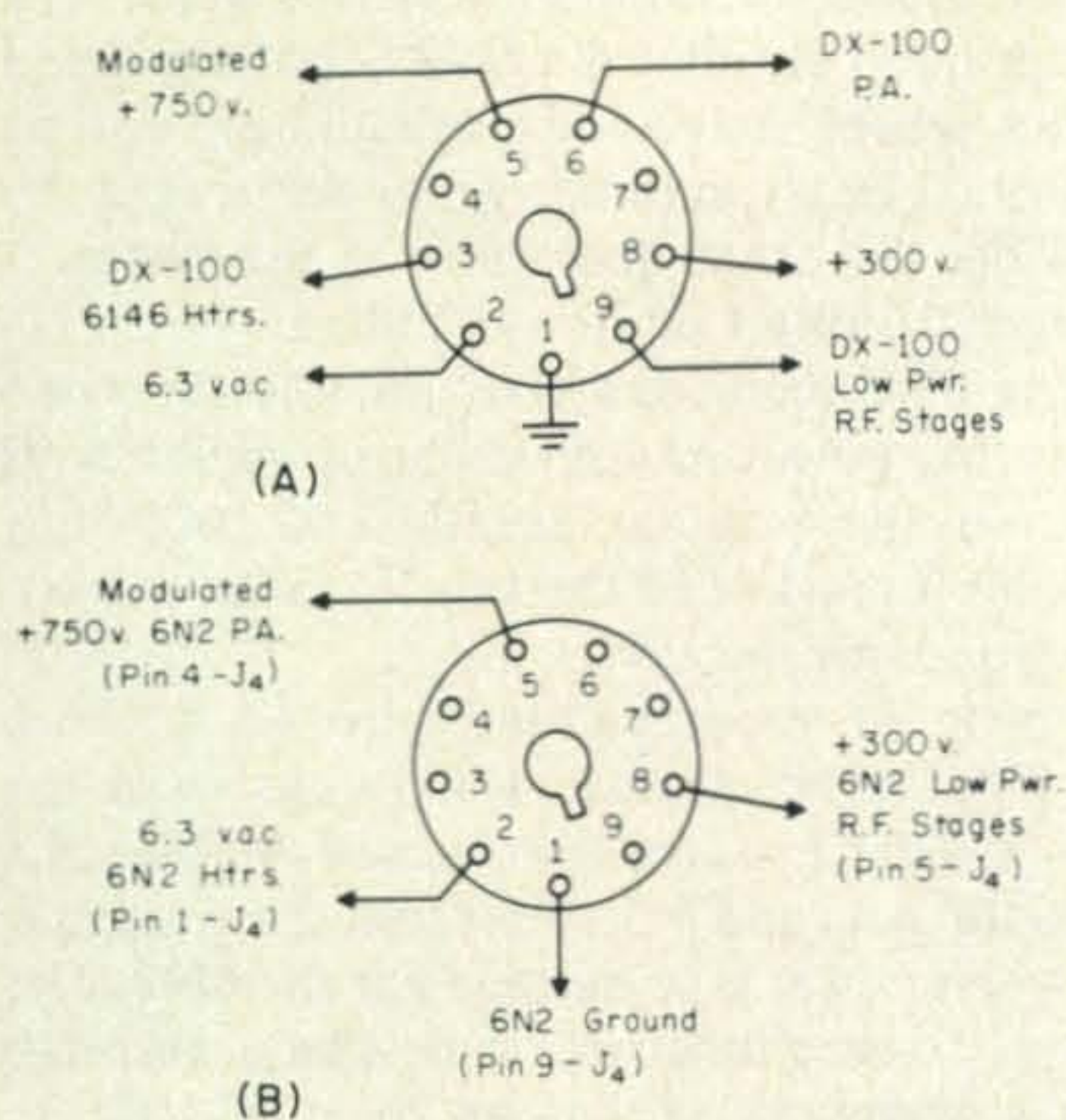

Fig. 2 (A)—Internal wiring to new power outlet ( $J_1$ ) on DX-100. For DX-100 operation, connect 2 to 3, 5 to 6 and 8 to 9. (B) External connections required at DX-100 outlet  $J_1$  for operating 6N2. Also connect antenna-relay coil to 2 and 4 on DX-100 remote-control socket, as explained in text.

10. Splice another pair of twisted leads onto the twisted ones, just removed, and connect their other ends to pin 2 of  $J_1$ . (Twisted leads are used to increase the total current-carrying capacity).

11. Connect another pair of twisted wires between pin 3 of  $J_1$  and terminal 7 on the 6146 socket.

For 6N2 operation:

12. Make up a power cable with a male 9-pin ("octal"-type) plug ( $P_5$ ) on one end and a female 8-pin octal ( $J_6$ ) on the other end.

13. Connect the following together:

- Pin 1 of  $P_5$  to pin 9 of  $J_6$ —use pair of twisted wires or large size conductor.
- Pin 2 of  $P_5$  to pin 1 of  $J_6$ —use pair of twisted wires or large size conductor.
- Pin 5 of  $P_5$  to pin 4 of  $J_6$ —use wire with h.v. insulation.
- Pin 8 of  $P_5$  to pin 5 of  $J_6$ .

14. Plug  $P_5$  into  $J_1$  on the DX-100 and  $J_6$  into  $J_4$  on the 6N2. This should now feed heater, low plate voltage and modulated high voltage from the DX-100 to the 6N2.

To restore the DX-100 to normal operation:

15. Remove  $P_5$  and insert another male 9-pin plug ( $P_6$ ) with the following jumper connections:

- Pin 2 to pin 3.
- Pin 5 to pin 6.
- Pin 8 to pin 9.

For transmit-receive control using the two units:

Employ a 117 v.a.c. antenna-changeover coax relay with s.p.d.t. auxiliary contacts, such as the Dow-Key series 60.

16. Connect the relay coil across terminals 2 and 4 of the DX-100 remote-control outlet.

17. Connect relay auxiliary contacts as needed to disable receiver on transmit.

18. Connect antenna, receiver input and transmitter output to relay coax connectors in the normal manner.

Note that the relay-control terminals on the 6N2 are not used, because in the tuneup position, the circuitry of the 6N2 OPERATE switch will not make the relay operate. The transmitter p.a. then would be unloaded.

To operate, place 6N2 OPERATE switch at STANDBY and turn on the DX-100 POWER SWITCH,  $M_2$ . After the tubes have heated, place the 6N2 OPERATE switch at TUNE, apply power and transfer antenna by closing DX-100 PLATE switch,  $M_3$ . After the 6N2 is tuned up, place its OPERATE switch at TRANSMIT and you're ready to go; but before doing so, check the 6N2 p.a. screen voltage and make necessary adjustments, if needed, as per the data and formula on page 8 of the 6N2 manual.

Transfer between receive and transmit is now conducted by opening or closing the DX-100 PLATE switch,  $M_3$ , but before going on the air, check the modulation with an oscilloscope to make sure there is no overmodulation, inasmuch as the DX-100 modulator will supply more audio power than needed. A.m. operation is otherwise conducted normally through the DX-100.

### Correction

One of the transmitting frequencies listed for WAX in last month's Q & A Column should have read 8525 kc instead of 8526 kc.

### WWV with SX-146 Receiver

QUESTION: How can I receive WWV on the Hallicrafters SX-146 receiver for checking purposes? No provisions are made on the receiver for this, except by using an external oscillator.

ANSWER: Try using a 24.010 mc pre-mixer crystal in the 40-meter position. If it will oscillate with the particular circuit constants ( $L_{14}$ - $L_{15}$ ) WWV may be received on 10 mc by peaking the preselector near  $6\frac{1}{2}$  (band selector at 40 m.) and tuning the receiver v.f.o. to the 7.490 mc calibration. The re-

ceiver also will tune 10-10.5 mc.

A similar setup might be used for receiving WWV on 20 mc using the 21 mc-band position with a 23.995 mc crystal substituted for the 25 mc one supplied for the pre-mixer. The preselector would then have to be peaked near  $7\frac{3}{4}$  and the receiver v.f.o. set at the 21.005 mc calibration. The receiver also will tune about 20-20.5 mc. The odd crystal frequencies are required to place the v.f.o. harmonics at least 20 kc away from WWV's frequency thus eliminating interference with the signal. These crystal substitutions, of course, put either the 40- or 20-meter amateur band temporarily out of business.

Otherwise you'll have to set up a fixed channel for any of the WWV frequencies by using an external crystal-controlled oscillator with its output plugged into the external-oscillator jack on the receiver and the associated slide switch placed at EXT OSC. The required frequencies are listed on the chart on page 11 of the manual. In addition, a 6 mc crystal may be used for WWV on 15 mc. A suggested crystal-oscillator circuit is shown at fig. 3.

### Warbling and Frequency Shift with NCX-5

QUESTION: I have a National NCX-5 Transceiver that had a slight warble in the tuning between 250 and 325 kc when I obtained it second hand. Now I have reports of voice shift in my signal on 15 and 10 meters. It does not happen on 80, 40 and 20. The warble is now getting worse, but it is not noticeable when I operate at 21.4 mc, yet the voice shift is still there. Can you suggest any possible remedies?

ANSWER: You evidently have *two* problems which are due to different causes.

The seat of the warbling situation probably is at the ground wipers for the v.f.o. tuning capacitor. These wipers are secured to the capacitor frame by eyelets which may work loose; therefore, at each end of the wipers make a firm connection by soldering together the wiper end, the eyelet and the capacitor frame.

When doing so, work from the rear and keep the soldering iron away from the plastic gears for the counter which would otherwise be susceptible to damage by heat.

A little added pressure for the wiper surface at the capacitor rotor shaft also may be required. This can be done by bending a

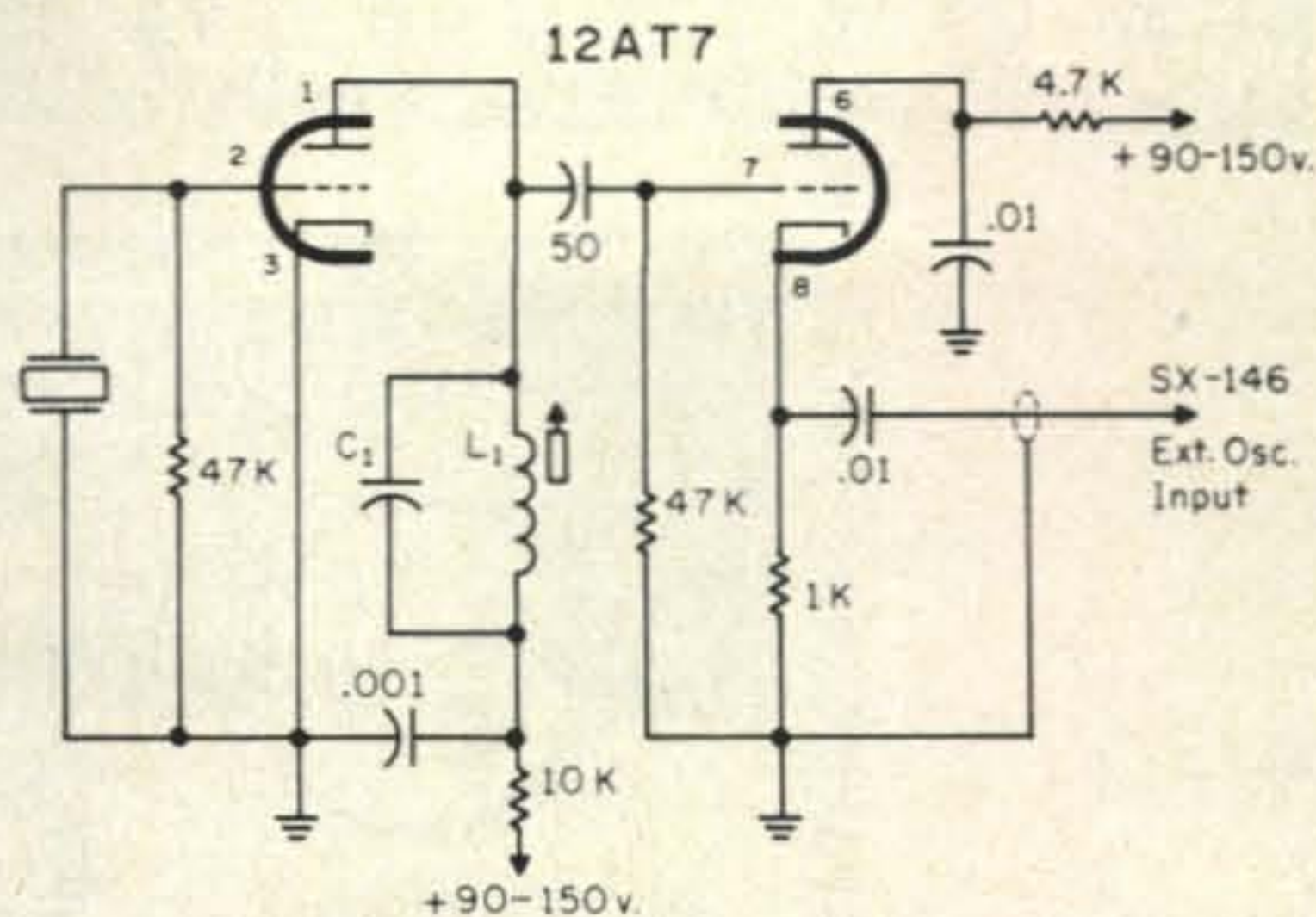

Fig. 3—Suggested crystal-controlled external-oscillator circuit for use with SX-146 receiver. For 6, 11, 19 or 24 mc crystals, make  $C_1$ —56, 33, 22 and 22 mmf and  $L_1$ —12, 5.5, 2.3 and 1.6  $\mu$ h, respectively (Miller No's. 4205, 4204, 4202 and 4202, respectively).

slight kink in the wiper.

Another precautionary measure might be to make sure the contacts are clean and have good pressure for the involved band positions on  $S_1$ ,  $S_{1A}$  and  $S_{2A}$ . If needed, a squirt of contact cleaner may help, as it also might do at the v.f.o. capacitor wipers.

Warbling also could be due to a defective transistor at the v.f.o. ( $Q_1$  or  $Q_2$ ), or it could arise with a defective regulator tube at  $V_{20}$ . Sometimes these tubes tend to twitter or oscillate, in which case a change to a new one or one of different manufacture is a help. Neither of these two possibilities, nor the regulation situation mentioned next, seem likely in this case, however, inasmuch as the difficulty is limited to a small range of the v.f.o.

As for the frequency shift with voice on transmit, this could be due to poor voltage regulation. The OA2 ( $V_{20}$ ) regulator would be the prime suspect here as might be the zener-diode/regulator.

The most probable cause would be r.f. feedback either to the regulator tube or to the v.f.o. This may be due to a high s.w.r. on the bands concerned or to inadequate grounding.

Make a good connection from the transmission-line shield directly to a solid ground. Also make a good ground connection to the chassis of the set. Then too, add a ground connection between the mic cable shield and the transceiver chassis. Do *not* rely on the ground at the panel jack through which a difficulty with an r.f.-ground "loop" could exist. Changing the length of the mic cable

[Continued on page 98]

**A GREAT BUY FROM ARROW —**

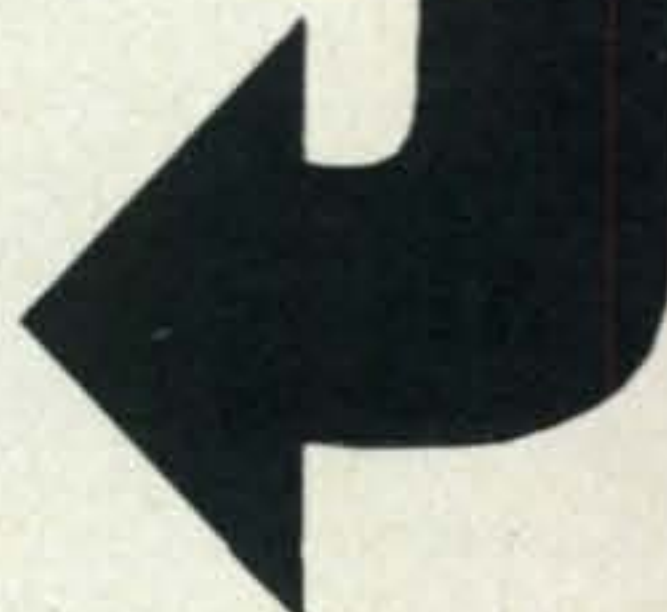
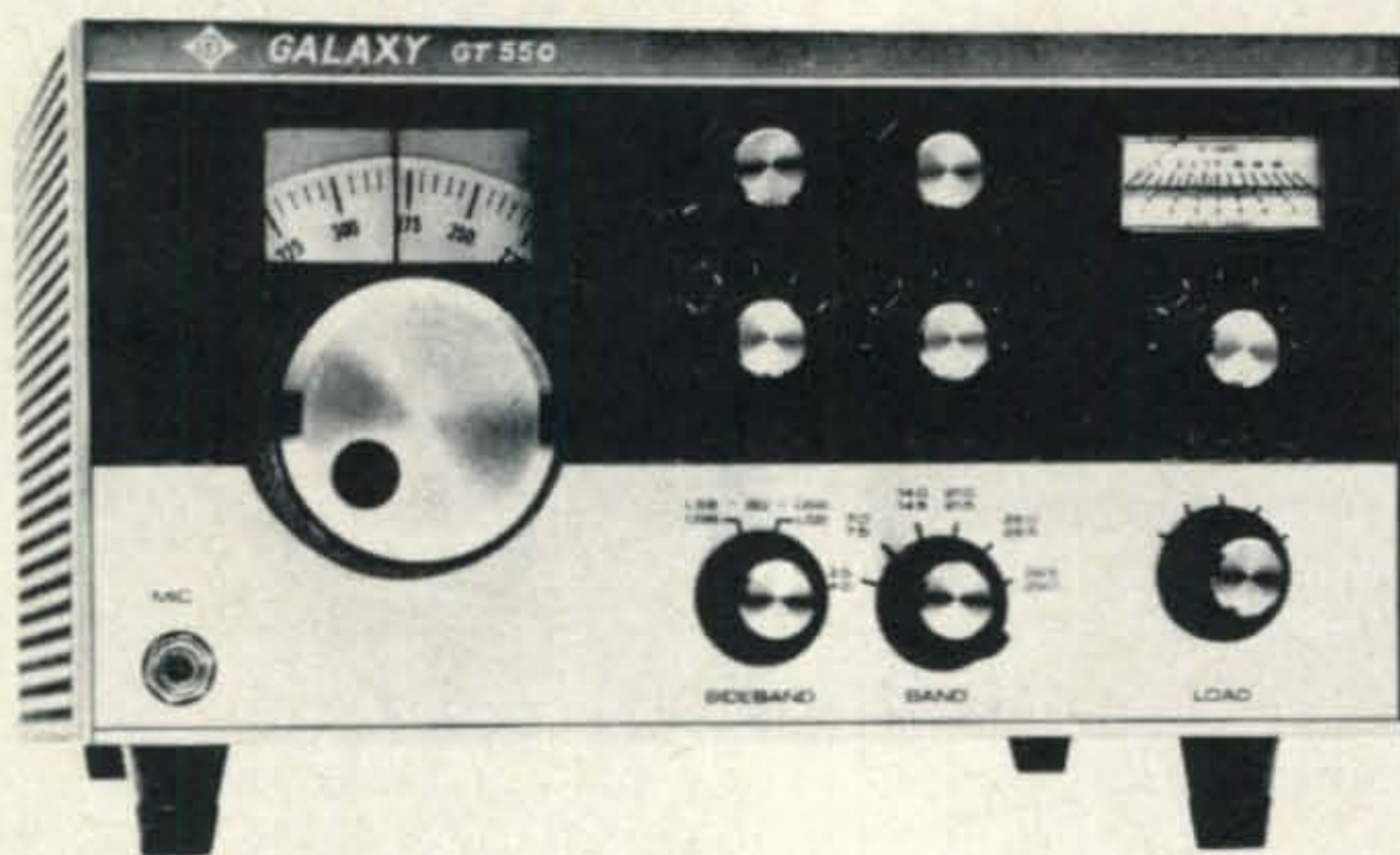

# THE GALAXY GT-550 TRANSCEIVER

**TRANSMITTER:** 550 watts PEP-SSB, 360 watts CW. Manual keying for SSB/CW, or VOX operation with accessory installed. Also, break-in CW with accessory VOX installed. Built-in audio side-tone for CW monitoring through speaker or headphones. Selectible sideband without 2 kHz jump when changing sidebands. Shifted carrier CW to prevent "leap-frogging" with another transceiver. Stable, -45DB carrier suppression. Unwanted sideband suppressed over -55DB. Sharp, 2.1 kHz filter with better than 1.8:1 shape factor. ALC circuitry automatically reduces gain level to prevent "flat-topping." High impedance microphone circuit (use -50/60 DB microphones) with PTT control circuit. Audio Response @ -6DB points approximately 300 and 2400 Hz. Adjustable Pi-Network antenna matching for resonant 40/100 Ohm loads.

**RECEIVING:** Nominal 50 Ohm input with relay control for antenna switching. Preselection coupled to exciter tuning. Sensitivity better than 1/2 uv for 10 DB S+N/N ratio. Selectivity 2.1 kHz with same, outstanding 1.8:1 shape factor for SSB/CW, or 300 Hz sharp selectivity with optional plug-in CW filter. Full AGC on receive modes with fast attack and slow release characteristic. Nominal 1 watt audio output with -6 DB points @ 300/2400 Hz. External 8 Ohm speaker required.

**FREQUENCY COVERAGE:** Crystals supplied for 3.5-4.0, 7.0-7.5, 14.0-14.5, 21.0-21.5, 28.0-29.0 mHz. Optional crystals may be installed for other 10 meter coverage. A solid-state VFO operates, without switching, in the range of 5.0-5.5 mHz at all times. Double regulation and temperature compensation makes this VFO extremely stable. An illuminated dial with over 12 inches of linear bandsread. Primary dial calibration marks of 5 kHz. Smooth vernier dial provides 72:1 vernier tuning for ease of operation.

**BACK PANEL CONTROLS:** Bias Adjust. "S" meter zero.

**BACK PANEL JACKS:** Antenna • CW Filter (three jacks) • PTT • External VFO (Power) • External VFO (RF in) • ALC (Input) • EXT. (For Linear keying) • Microphone • Power Plug (From AC-400 or G1000DC) • Key (For CW operation) • Speaker.

**SIDE ACCESS CONTROLS:** VOX Gain • VOX Hold Time • Anti VOX.

**FINISH:** Cabinet in mar-resistant black crackle finish. Front panel in two-tone brushed aluminum.

**SIZE:** 6" x 11 1/4" x 12 1/2" (HWD)

**WEIGHT:** 17 pounds.

**\$449.00**

## R.F. CONSOLE RF550

The RF550 contains a precision wattmeter with a high degree of accuracy in the range of 3.5/30.0 mHz. Calibrated scales are 400 and 4,000 watts full scale, switch selected for forward or reflected power. Also contains a switch to select 5 antennas plus a dummy load (not supplied), and all unused connections are grounded. SO239 coax-connectors. Approx. 7x7 1/4x 6 1/2" (HWD). Weight 5 1/2 pounds.

**\$69.00**

## SPEAKER CONSOLE SC550

A matching speaker with headphone jack for the transceiver, complete with cable. AC400 power supply will mount inside the console. Size - approximately 6x10x9 1/2", weight 6 lbs.

**\$19.95**

## REMOTE VFO RV550

A solid-state VFO like that in the transceiver, complete with simple plug-in cables. Function switch selects the remote unit to control Receive - Transceive - Transmit frequency independently. Gives about the same flexibility as a separate transmitter and a receiver with the GT-550. Approx. 7x7 1/4x6 1/2" (HWD). Weight 4 lbs.

**\$75.00**

**ARROW**  **ELECTRONICS, INC.**

• 900 Rte. 110, Farmingdale, N.Y.  
516 Myrtle 4-6822

• 97 Chambers St., N.Y., N.Y.  
212 - Digby 9-4411

• 525 Jericho Tpke. Mineola, N.Y.  
516 - Pioneer 2-2290

• 18 Isaac St., Norwalk, Conn.  
203 - 838-4877

• 225 Rte. 46, Totowa, N.J.  
201 - 256-8555



The Amateur Radio DX Handbook is off the presses and on dealers shelves. It is not a compilation of past articles appearing in CQ nor is it a discourse on amateur politics or "who did what to whom." It is in fact a 200 page volume detailing every aspect of working DX and understanding how you did it. It is the difference between occasionally working DX by accident and being a consistently good DXer.

The chapter headings listed below only give a general idea of the type of material covered in great detail throughout the volume. This information is not only vital to American amateurs but is applicable to every active amateur in the world.

Inspect a copy at your local distributor or use the coupon below to order a copy direct.

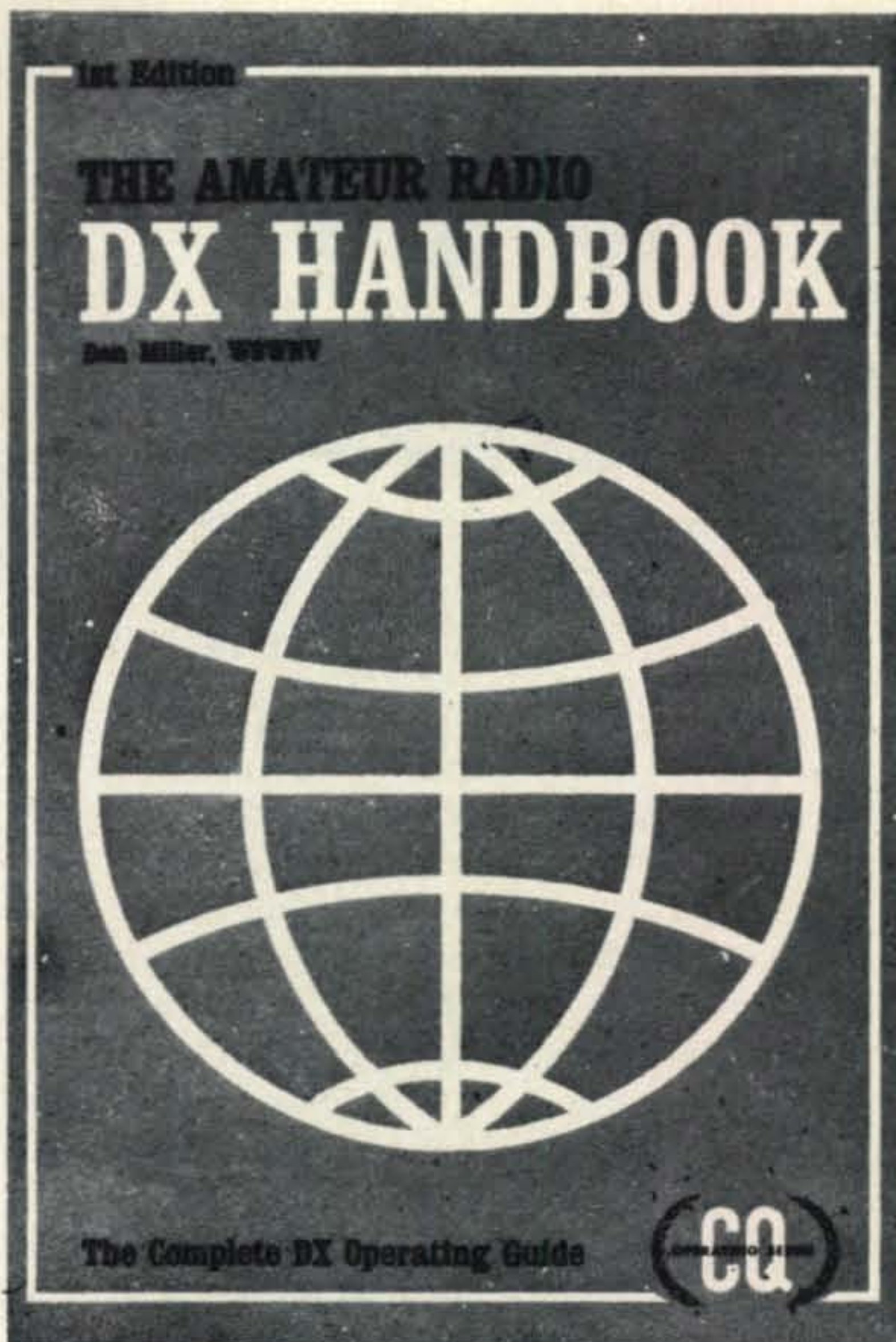

### Introduction

- Dx Propagation
- Amateur Frequencies and the DXer
- The DXer: International Factors and Local Regulations
- The DX Station
- Working DX From the Home Station
- Mobile DXing

### DXing From the Rare Location

- QSLing
- The SWL DXer
- DX Contests
- DX Awards
- DX Clubs
- Great Circle Bearing Charts (from over 50 major geographic centers in the world)

Cowan Publishing Corp., Book Division  
14 Vanderventer Ave., Port Washington, L.I., N.Y. 11050

Enclosed is \$\_\_\_\_\_ for \_\_\_\_\_ copy(ies) of the **AMATEUR RADIO DX HANDBOOK**

Name ..... Call .....

Street .....

City ..... State ..... Zip .....

New York City and State residents add applicable sales tax.

Price:

\$ **5.00**

# VHF TODAY

BY ALLEN KATZ,\* K2UYH

**T**HERE are many fellows who operate the 6 and 2 meter bands who would like to extend their capabilities to something a little more exotic, but do not know quite where to begin. We feel that the 432 mc band makes an excellent launching point for u.h.f.-microwave activity and we will devote this column to answering some common questions on this band.

The first question about 432 mc (from amateurs who have never operated above 144

\*66 Skytop Road, Cedar Grove, N.J.



Allen Katz, K2UYH, and his 432 mc rig.

mc) is about activity. This question is difficult to answer since activity varies so widely across the country. In most of the large metropolitan areas, there are several stations on every night. In more sparsely populated sections of the country, there are 432 mc stations who have never made a contact less than 200 miles in length. Asking around on two meters may give some indication of the activity level in your area, but not always. There are many stations who operate 432 mc exclusively.

Another difficult question to answer is that of location. We used to live in an exceedingly poor v.h.f. location. Results were so poor on 144 mc, that although we had 432 equipment for several years, we never put it on the air from our home QTH and used the gear only from portable locations. Then one warm November day, we decided to put our 432 mc antenna up on the tower (more or less just for kicks), since 432 mc most certainly would yield much worse results than 144 mc, which was indeed poor. Much to our surprise we had a contact within 10 minutes, completely unscheduled and with a station we did not even know existed. We went on to work 9 states on 432 mc, from that so-called "impossible" u.h.f. location. This is not to say that a good location does not help—it does, but a given location may not be as bad as you may think. You can only find out by trying.

Next on the list is power generation which is definitely not a problem on 432 mc today. If you already have a 144 mc transmitter, a varactor tripler will supply you with a 432 mc signal in an evening's effort. Varactors usable on 432 mc have been advertised for as little as five dollars and there are plenty of circuits around. We particularly like the circuit in the February 1966 *CQ* VHF Column, although the ones in the *VHF Manual* (or similar references), should work just as well. The major disadvantage of varactor triplers is that they can not be modulated directly. Modulation of the two meter driver, along with careful adjustment of the varactor's tuning can yield reasonably good audio, but never as good as by direct means.

Fortunately, during the past few years a large number of 450 mc mobile radio units have become available. The transmitter strip from these units can be made to tune down to 432 mc very easily and can produce more power than most varactor triplers. In some units we have converted, we were able to make the transmitter tune down to 432

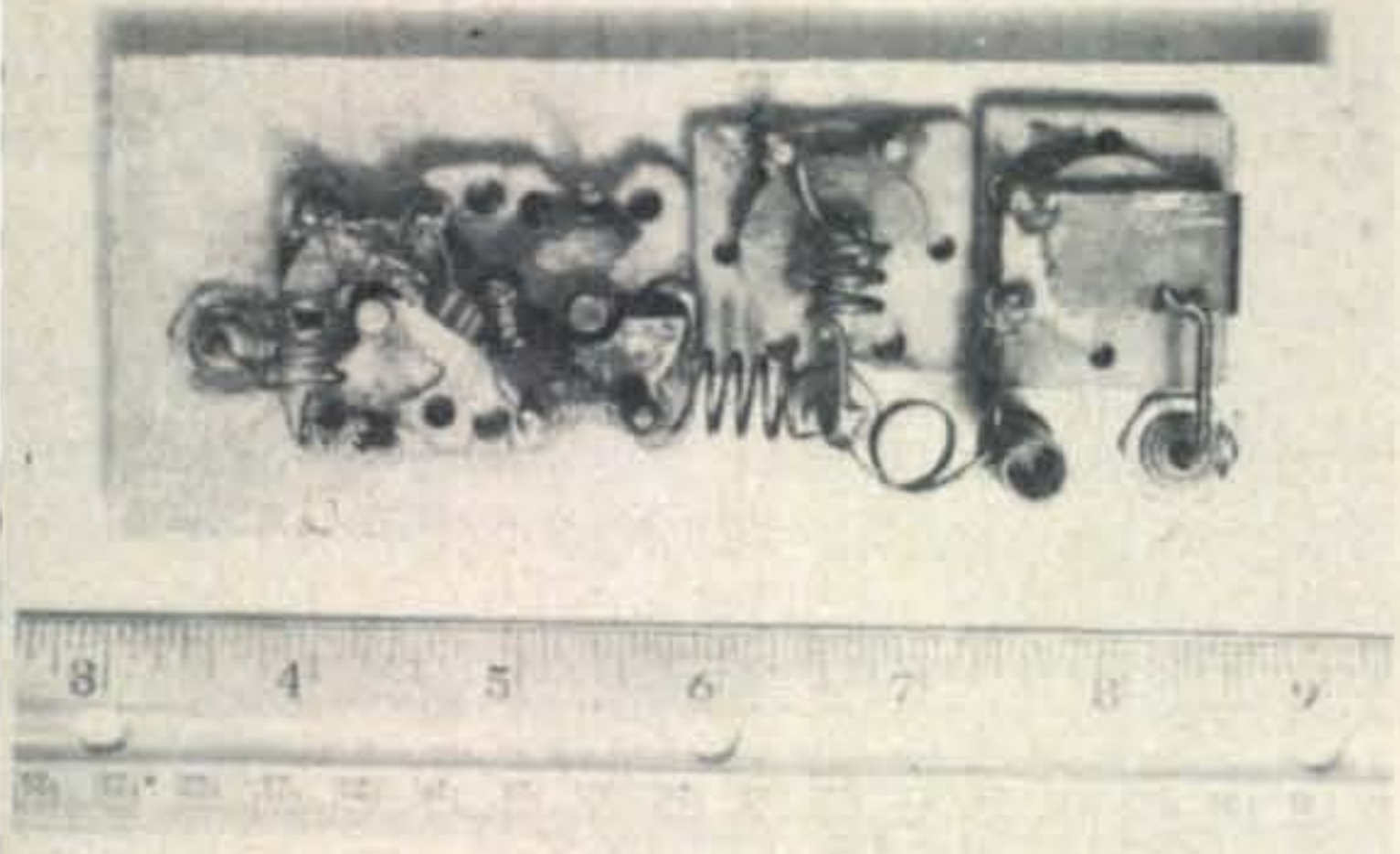

A typical 432 mc varactor tripler.

mc without the addition of a single padder capacitor. The deviation control can be turned way down and the unit used on narrow band f.m. with its original modulator essentially unmodified. N.b.f.m. can be received on a conventional receiver by slope detection. It is not quite as effective as a.m., but becomes close (particularly with the addition of a little clipping). We have used a converted Motorola transmitter as our basic exciter on 432 mc for some years. We follow this unit with a -4CX250 amplifier, although we know many stations who run the f.m. rigs barefoot with satisfactory results.

The f.m. receiver strips offer possibilities for 432 mc reception which have not been adequately investigated as yet. Many of these units have i.f. frequencies in the 3.2 mc range. It would seem possible that a communications receiver could be tapped into the unit at the i.f. amplifier output and the f.m. receiver could be used in the same way as a conventional crystal controlled converter. Since practically all narrow band 432 mc operation is confined to the 100 kc region from 432.00 to 432.100 mc, and the f.m. receivers were originally used to copy signals 25 kc wide, it should be possible to stagger tune the i.f. amplifiers to pass this whole range.

As far as conventional converters are concerned, I hope it is not necessary to point out that transistors are the only way to go! The transistor preamp described in the September VHF TODAY Column is as good as any design. However, good 432 mc converter circuits are rather scarce. Of the few that are around, most of these designs are several years old and do not reflect the rapid changes

[Continued on page 102]

### PASS FCC EXAMS EASILY with AMECO CODE & THEORY COURSES

Three new License Guides contain detailed, easy-to-understand answers for FCC study questions PLUS sample FCC-type exams, using multiple-choice questions.

NOVICE & GENERAL CLASS GUIDE,  
 Cat. #5-01 .....50¢  
 ADVANCED CLASS GUIDE, Cat. #16-01.....50¢  
 EXTRA CLASS GUIDE, Cat. #17-01.....75¢

EXTRA CLASS CODE COURSE. Increase code speed from 13 to 22 wpm in ten lessons. Sample Extra Class FCC-type code exam included.  
 Cat. #104-33. One 12" LP, 33 RPM.....\$3.95

EXTRA CLASS SUPPLEMENTARY CODE COURSE. Additional concentrated code practice between 19 and 24 wpm. Includes sample Extra Class FCC-type code exam.  
 Cat. #106-33. One 12" LP, 33 RPM.....\$3.95

GENERAL CLASS SUPPLEMENTARY CODE COURSE. Additional concentrated code practice between 12 and 15 wpm. Includes sample General Class FCC-type exam.  
 Cat. #105-33. One 12" LP, 33 RPM.....\$3.95

COMPLETE RADIO AMATEUR THEORY COURSE. Simplified home study course in radio-electronics covering Novice, Technician and General Classes, with over 400 sample FCC-type exam questions. Brush up for all ham exams. No technical background required.  
 Cat. #102-01. 256 pages.....\$3.95

At leading distributors, or write for free information on the above and other courses to:

**AMECO PUBLISHING CORP.**  
 314 Hillside Avenue  
 Williston Park, New York 11596

# SYNCOM

## OPENING DISCOUNT SALE

Write or call for that special deal on:

### AMATEUR RADIO EQUIPMENT

Collins, National, Swan, Drake, Hallicrafters, Hammarlund, Gonset, Clegg, Mosley, Hy-Gain, CushCraft, Rohn, Tristao, CDR, Collins R-388, 389, 390, 391

### CLOSED CIRCUIT TV-ATV

Ampex, Sony, Diamond Power, Concord, TV Utilities, Memorex, Canon Lens, Dynair, Riker-Video, Pelco, Jerrold Systems

### HEWLETT-PACKARD-TEXTRONIX

(Buy-Sell)

### SYNCOM ELECTRONICS UNLTD.

726 Cypress Drive  
 Franklin Square, L.I., N.Y. 11010  
 (516) 489-7662  
 (HOURS BY APPOINTMENT ONLY)

# SURPLUS sidelights

BY GORDON ELIOT WHITE\*

**T**HE Western Union Telegraph Company is an old-line outfit which is moving into state-of-the-art telecommunications, and spreading quantities of commercial surplus electronic gear in the process. We discussed the W-U Telefax units last month, and want to mention here other equipment now showing up.

Until quite recently, W-U lived in the past, relying on such standby equipment as the Morkrum 2B tape printer, built in 1924, for producing gummed message tape to be stuck on those yellow message blanks and delivered by a messenger boy on a bicycle. W-U apparently never threw anything away, and its stock of 40-year-old machinery filled warehouses in Allentown, Philadelphia, Chantanooga, Chicago, and points west. All this has now changed, and so much old gear has flooded onto the market that Teletype Model 14 machines (which most W-U gear was) can be picked up for \$5 or so.

\*5716 N. King's Hwy., Alexandria, Va. 22303.

More recently Western Union has built up its own version of the European TELEX network, with about 28,000 machines now installed on a switched network much like a telephone dial system.

Last January, W-U negotiated a deal with American Telephone and Telegraph Company to buy Bell's switched-network, the 40,000-unit TWX system, which will be integrated with TELEX. These two systems use the late #32, #33 and #35 Teletype machines. The tone carrier equipment used between central offices is also becoming modernized, and some of the prototype sets have showed up in surplus already.

W-U is theoretically supposed to smash its obsolete equipment when it is scrapped, but most of it goes out in fairly good shape, although Teletype equipment scrapped by W-U is usually nominally inoperative. I have seen three pieces of Western Union gear recently, which might be of interest to the RTTY crowd, or to the growing number of amateurs who are setting up their own terminals to work with university computers.

Figure 1 shows four transistorized units used with data circuits. The 11622 data network provides 3 or 4-way half-duplex hubbing (12-V, 10 ma polar legs) at speeds up to 2400 Baud. The 11623 data regenerative repeater re-times and regenerates 12-V, 10 ma polar signals at any speed up to 300 Baud, using a crystal-controlled clock. (The crystal

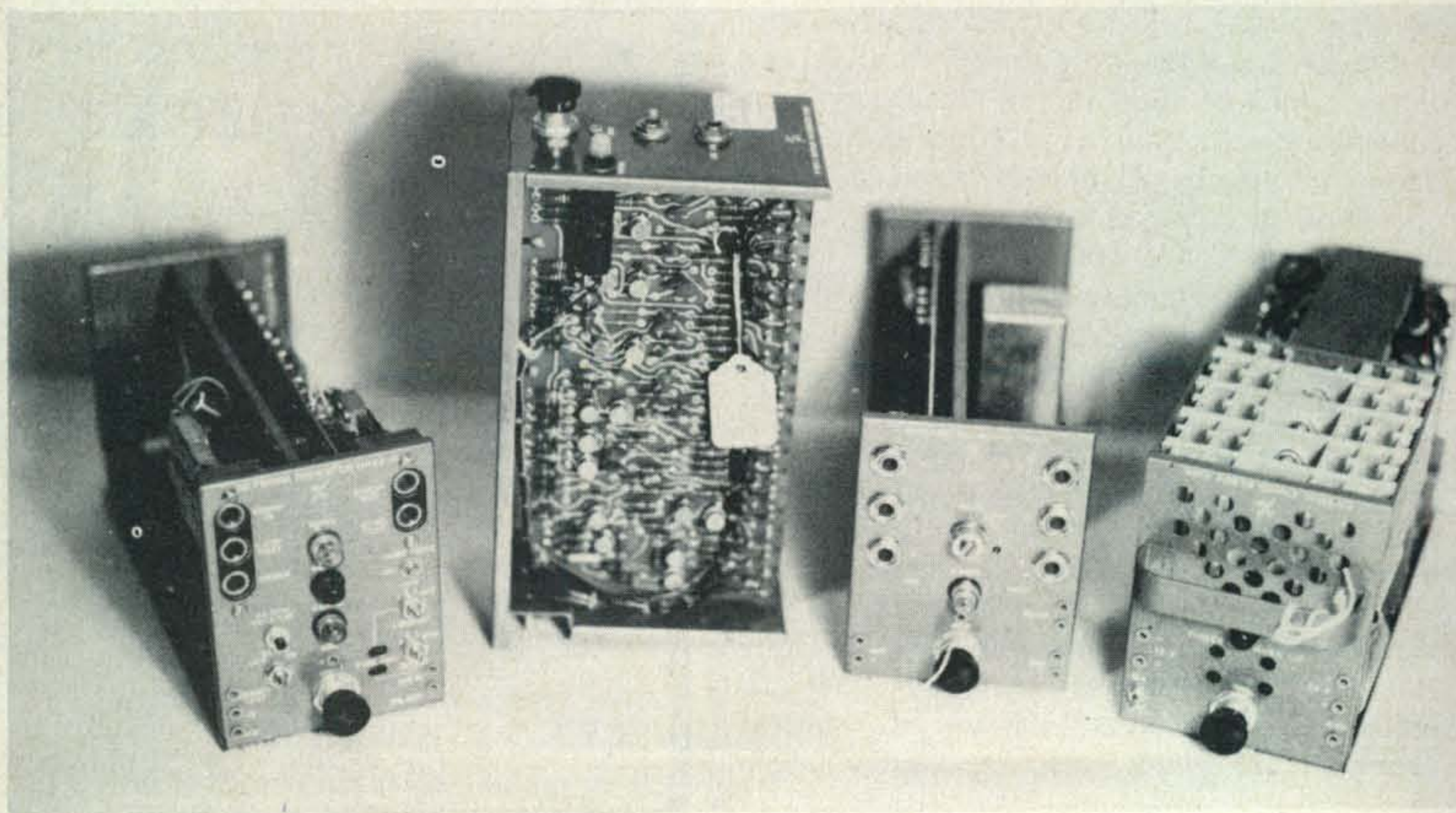

Fig. 1—Four transistorized units used with data circuits.

### COAX CONNECTORS

PL259	45¢
SO239	45¢
M359	30¢
U/175	15¢
T-M358	\$1.95
PL258	85¢
Double Male	95¢
UG27C/U	75¢
UG18C/U	75¢
UG349A/U	75¢

R & R DOZEN (13)  
for Price of 12.



7 TUBE 2nd IF  
Discriminator  
455 KC IF—  
5 stages, 2  
stages limiting  
diode. Discrim-

inator output  $\pm 15$  KC.  
NEW \$3.00 ea.

### COPPER P.C. BOARDS

2" x 2"	15¢ ea.	} R & R DOZEN (13) for PRICE of twelve.
3" x 6"	35¢ ea.	
4" x 6"	45¢ ea.	
12" x 12"	\$2.25 ea.	

FERRIC CHLORIDE etching solution  
99¢ a pint

### BLOWERS

standard 19"  
rack cabinet  
size; 110v 60  
cycle General  
Electric 1/3 HP  
3750 R.P.M.  
motor with 5"  
squirrel cage  
blower. Mfg.  
McLean Engi-  
neering Lab.  
with dust filter  
Ship. wt. 55  
lbs. MOTOR  
ALONE WORTH  
MUCH MORE  
THAN THIS



PRICE, NEW... \$17.95.

### TELETYPE PAPER

8 1/2" wide.....75¢ ea.  
SALE.....12/\$4.95

### DIODES

#### 1000 PIV 1 1/2 AMP EPOXY

40¢ ea. ....10/\$3.75  
50 PIV 6 AMP. ....25¢ ea.—10/\$2.00

### TRANSISTOR HEAT SINK

Drilled for 8 Power Transistors. 12 1/2" l  
x 4" w x 1 1/4" h.....NEW \$2.00

#### P.C. BOARD Rosin SOLDER

30 ft. ....59¢

#### Parasitic Suppressors #P-300

15¢ ea. ....10/\$1.25

#### BUTTON Feed Throughs

500 MMF 500 V.....20/\$1.00

#### 100 RESISTORS 50 different

popular values .....\$2.50—10/\$20.

#### Tank Periscope Prisms

NEW .....\$1.95 ea.

### NEW METERS

Weston 301 0-100 VDC 3" R.....\$4.95

Aircraft type 0-60 Amp 2 1/2" R.....\$2.95

Simpson 20 25-0-25 ma 4 3/4" S.....\$7.95

Switch 6 Push Button—push to set push to  
release button .....75¢ ea.

Toggle Switch SPST w/long handle.  
25¢ ea. ....10/\$1.99

Utility Case NEW with leather handle for  
instrument case. Mint green crinkle finish.  
7 1/2" H x 8" D x 9" W.....\$3.95 ea.

#### Cathode Magnetic Tube SHIELD

3"—\$2.95

5"—\$3.95

DRAWER SLIDERS. Heavy duty for 16"  
deep rack cabinet, extends 8" out for easy  
disconnect. ....SET \$4.49

### TRANSFORMERS

115 volt 60 cyc input, 24 volt 2 amp out  
w/circuit breaker .....\$1.50

120 volt 60 cyc input, 6.4 volt CT 4.5  
amp out .....\$2.50

120 volt 60 cyc input, 12 volt 5 amp out  
w/circuit breaker .....\$3.00

### MOTORS

110 volt 60 cyc, 2000 RPM.....99¢

12 volt DC 5000 RPM 4 1/4 x 3.....\$1.25

110 volt 60 cyc, G.E. 1/3 HP 3450 RPM  
NEW...\$14.95

### TOROIDS 88MH

35¢ each .....10/\$3.00

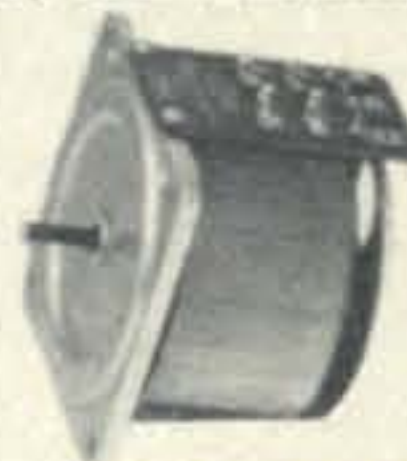

#### VARIACS GENERAL

#### RADIO AND OHMITE

60 cyc. Input 120 V

output 0-280 V 1 amp

or Input 240 V output

0-280 V 2 amp. Pull-

outs in excellent con-

dition. (10 lbs).

\$6.95 each

### VARIABLE CAPACITORS

20 to 120 mmf per sec. Butterfly 8 3/4" x

6 3/4" x 5" d. 1/4" shaft. 7500 VAC \$7.50

12 to 244 mmf Johnson #154-1-5, 1800

VAC. ....\$2.75

3 Sec. (16 to 415 mmf) (16 to 415) (16

to 530) .....\$1.50

3 sec. 100 MMFD per sec Variable.

\$1.00 ea.

100 BUD 100 MMF.....\$1.50

### MINIATURE VARIABLES

Butterfly 2.3-8 mmfd. ....75¢

Butterfly 5-1.5 mmf.....75¢

Variable 5-25 mmfd. ....75¢

MAPC-35 3-25 mmfd. ....50¢

Cardwell 2-2.8 mmf. Duel .....50¢

### TRIMMERS

CLR 20-125 mmf. ....25¢

CLR 12-62 mmf. ....25¢

3-12 mmf. ....25¢

### FAIRCHILD I.C.'S

#### NEW FACTORY FRESH!!!

UL 914 .....80 ea. 10/\$7.50

100/\$65.00

UL 923 .....\$1.50 ea. 10/\$13.50

100/\$110.00



### CRYSTAL OSCILLATOR KITS

using I. C. UL 914 Stable, harmonic-  
rich output osc. range 100 KC to 10  
MC - Kit includes Fairchild I.C. UL  
914, crystal sockets, resistors, capaci-  
tor, & PRINTED CIRCUIT BOARD,  
with instructions for assembly.

\$2.00 per Kit.

### PC BOARD KIT

3 ea. 3 x 6 copper boards, etching  
solution and etching resist paint.

\$2.49

### LOW COST BINARY COUNTER

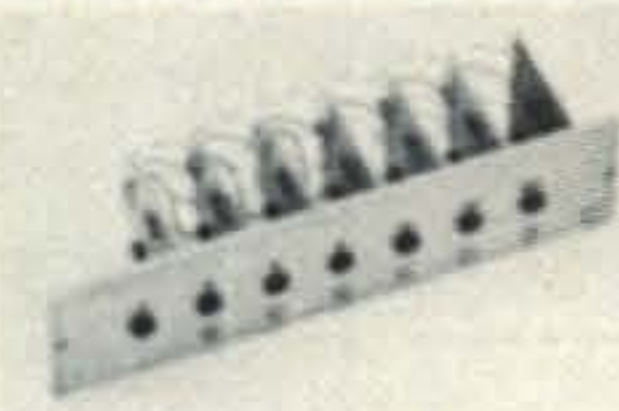

Has many uses such as frequency counter,  
electronic stop watch, frequency meter,  
event counter, etc.

This unit is a binary counter, the first  
light reads -1- each lite (stage) you  
add doubles the count. Example:

No. of stages	Lite no.	Count
2	2	3
3	4	7
5	16	31
10	512	1,023
15	16,384	32,767

No limit to the stages you can add. The  
total count is twice the value of the  
highest numbered light minus -1. Each  
kit contains one complete stage with in-  
structions for assembly in minutes.

Diagrams for power supplies included.  
Printed circuit board measures 2" square

#### Kit for stages

\$2.49 ea. ....2 to 9 — \$2.29 ea.

10 or more \$1.99 ea.

mechanical trigger or Schmit (electrical)  
trigger. Photo shows sample mounting of  
7 stages. Additional information upon  
request.

### KIT NO. 1.

**K100C-2** 100 KC CRYSTAL CALIBRA-  
TOR. First P.C. board kit contains  
components for 100 KC output. The  
output of this little unit is really very  
stable,  $\pm .005\%$  or better at 100 KC.  
Voltage requirement is 4.5V DC (3 —  
1 1/2 V flashlight batt.). Complete with  
crystal, integrated circuits and all com-  
ponents. ....ONLY \$4.95

### KIT NO. 2.

**K100C-2A** Contains two P.C. boards  
with components of Kit No. 1. and has  
additional components to deliver outputs  
of 50 KC & 25 KC band edge markers.  
Complete Kit K100C-2A (shown in photo)  
will deliver stable harmonic-rich outputs  
of 100 KC, 50 KC, and 25 KC band  
edge markers. Units deliver a square  
wave which gives useful harmonics up  
to 50 MC. ....ONLY \$7.95

CRYSTAL CALIBRATOR PRINTED  
CIRCUIT BOARD ASSEMBLY ETCHED  
AND DRILLED READY FOR  
ASSEMBLY IN 5 MINUTES.

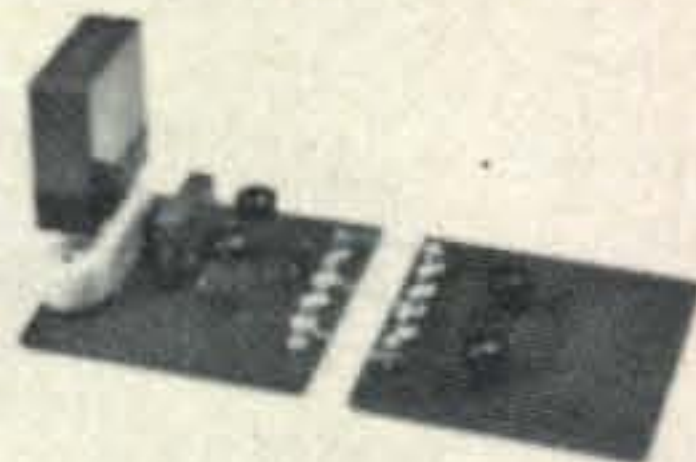

### R & R ELECTRONICS

247 S. Meridian St.  
Indianapolis, Indiana  
46225



### R & R ELECTRONICS

1953 S. Yellow Springs  
Springfield, Ohio  
45506 Dept. C69

PLEASE  
refer all  
mail order  
to Ohio store.

TWO  
LOCATIONS

\$2.00 minimum order FOB Springfield, Ohio. Please add sufficient postage; we refund unused amount. Ohio customers add 4% sales tax. WATCH for our booth at this summer's "Hamfests".



Fig. 2—The Stelma IBCTU data carrier subset.

frequency in kilocycles is 256 times the Baud rate). The 11624 data loop transceiver (not shown) converts 24-V, 1-ma signals into 12-V, 10-ma signals to interface with other data equipment, speeds to 180 Baud.

Another interesting data unit is the Stelma IBCTU/RU data set, useful for connecting a teleprinter to a tone-signalling line. (fig.2)

This is in sharp contrast to the tube-type facsimile gear we described last time, and which is being rapidly replaced by TELEX/TWX machines. The Telfax units are now available from Atlantic Surplus, 300 7th Street, Brooklyn, N.Y., in addition to the sources listed in April's column. FAX paper for the Telfax may be obtained from Gateway Electronics, St. Louis.

Another source for FAX, RTTY, and f.m. gear is Van, W2DLT, 302 Passaic Avenue, Stirling, N.J. 07980.

Switching topics, I want to correct an error

**WE PAY HIGHEST CASH PRICE FOR  
ELECTRON TUBES & SEMICONDUCTORS  
IMMEDIATE PAYMENT ON  
UNUSED TUBES**

**H & L ASSOCIATES**  
ELIZABETHPORT INDUSTRIAL PARK  
ELIZABETH, NEW JERSEY 07206  
(201) 351-4200

## PERSONALIZED ENGRAVING

ELECTRIC  
**ON-THE-AIR  
SIGN**  
WITH CALL



Works on  
110 VAC

**\$10.95**



Metallex Label Bar — \$1.50

Metallex Tie Clip — \$2.25

SEND FOR FREE CATALOG

**ARNOLD'S ENGRAVING**

2041 Linden St.

Ridgewood, N.Y. 11227

in my discussion of the AN/ARC-21/-65 transceivers in the February column. I said the set offered 44,000 crystal-controlled h.f. channels in 500 kc steps; actually spacing is in 500 c.p.s. steps, and the variable b.f.c. allows virtually continuous coverage for s.s.b. and RTTY signals.

Also, Bill Pearre, K5MMP, has sent me a table of the voltages and current requirements for the AN/ARC-21, which I reproduce below:

**Receiver plate supply**—+140 volts d.c. at 240 ma

**Receiver bias supply**—neg. 20 volts d.c. at 2 ma

**Receiver tube filaments**—ac/dc 27.5 volts at 4 amps

**Receiver tube filaments**—d.c. 27.5 volts at .45 amps

**Transmitter medium plate supply**—+40 volts d.c. at 190 ma

**Transmitter high plate supply**—+100 volts d.c. at 300 ma

**Filament supply for 4-65 PA tubes**—27.5 volts at 3.5 amps

(the above is for c.w./FSK. On voice transmission the high voltage plate requirement is 100 volts d.c. at 450 ma)

These figures ought to make it relatively easy to build up a power supply to run the transceiver directly from 117 volts 60 c.p.s. a.c., eliminating the necessity for supplying 400 c.p.s. power.

Manuals on the AN/ARC-21/-65 sets are available from Columbia Electronics, in Los Angeles, at \$10. At this writing, RITCO electronics, box 156, Annandale, Va. has the AN/ARC-21 and the AN/ARC-65 set. C&H Sales, Pasadena, California, also stocks them, and they are reported available from other surplus outlets.

### CQ Reviews: Galaxy [from page 57]

removes the a.g.c. line from  $V_3$  and switches the a.l.c. line to it instead. A jack is provided for external-a.l.c. input also.

Oscilloscope observations showed up what at first appeared to be flattopping when the a.l.c. was working, but closer scrutiny revealed such effects were due to compression of the modulation peaks and were not attributable to p.a. overload; except in cases where the a.l.c. was worked excessively, an abuse often noted with on-the-air signals.

### V.O.X.

Push-to-talk operation is inherently pro

vided with the GT-550, but a v.o.x. accessory also is available. It is a solid-state job assembled on a small printed-circuit board that can be inserted vertically in a special socket in a way that allows access to its screwdriver-adjust controls through openings in the side of the transceiver case.

## C.W.

For tuneup and c.w., the function switch opens a diode switch that then inserts a capacitor into the circuit for the 8998.75 kc crystal in the carrier generator. This moves the crystal frequency 700 c.p.s. higher and into the filter passband, so that a carrier may go through the filter. This also provides a frequency offset during c.w. transmissions. The transmitter frequency is 700 c.p.s. higher than that of the receiver on the 3.5 mc band. With the other bands it is 700 c.p.s. lower than the receiver's. The carrier is obtained by unbalancing the modulator with a bias applied to one of its grids.

Blocked-grid keying is employed at the transmitter mixer. The key also activates a transistor sidetone oscillator for c.w. monitoring through the speaker output.

The key jack is located on the rear of the set. A headphone jack is furnished only on the matching-speaker panel.

When the v.o.x. unit is installed, v.o.x. type break-in for c.w. may be had; otherwise, the transceiver must be manually transferred between receive and transmit. The v.o.x. functions quite normally with either c.w. or s.s.b.; however, when the v.o.x. releases at pauses, there is quite a plop heard in the speaker. This can be quite annoying when fast release times are used, particularly with c.w. The effect also is evidenced with p.t.t. s.s.b. operation.

## Operating Power

Operating power for the GT-550 is obtained from an external 115/230 v.a.c. supply, the Model AC-400 that furnishes 850 v.d.c., 350 v.d.c., -100 v.d.c., 16 v.d.c. and 2.6 v.a.c. A 12 v.d.c. mobile supply, the Model G-1000 also is available.

The 16 v.d.c. potential is reduced to 12 volts by a transistorized voltage regulator built into the GT-550.

## Tuneup and R.F. Power

During tuneup the modulator is only slightly unbalanced and the p.a. screen voltage is lowered. This holds down the p.a.

## RADIO OFFICER TRAINEES

A limited number of openings are available to men willing to train for the interesting and well-paid career of Marine Radio Officer aboard U. S. Flag merchant vessels. An F.C.C. 1st or 2nd Class Commercial Radiotelegraph license is required. These openings will be particularly appealing to younger men who have completed their military obligations. Write to The Radio Officers' Union, Room 1315, 225 West 34th Street, New York, N.Y. 10001.

**R13B** Command receiver, 108-132 mc am, 9 tube, 2 uv sensitivity. No dial. We give knob, tuning graph, technical data. Needs power supply & controls as other Commands. NEW \$27.00  
**R22** Command receiver, 540-1600 kc, with knob and tuning graph & technical data. OK \$17.95  
**R11A** Modern Q-5'er 190-550 kc, 85 kc IF, no dial. Brand new \$12.95  
**R23/ARC-5** Command Rcvr. (Q-5'er) 190-550 kc, has dial, w/ knob & tech. data. OK, guaranteed, tested. \$14.95  
**SP-600-JX** receiver, 540 kc to 54 mc, in cream puff condition. \$325.00  
**AN/ALR-5**. Tunes 38-1000 mc with ONE tuning unit CV-253 included. Brand new, w/rcvr late type converted to 60 cy (R-444) also new or like brand new, with book. \$275.00  
**LM-14** freq. meter, 125-20 mc, 01%, w/ ser.-matched calib. & tech. data. 100% OK. \$57.50

**TECHNICIANS:** We have new arrivals... BARGAINS... in Scopes, Counters, Signal Generators, etc. ASK!

### WANTED—GOOD LAB TEST EQUIPMENT & MIL COMMUNICATIONS

We probably have the best inventory of good lab test equipment in the country, but please do not ask for a catalog! Ask for specific items or kinds of items you need! We also buy! WHAT DO YOU HAVE?

**R. E. GOODHEART CO. INC.**

Box 170, CQ, Beverly Hills, Calif. 90212  
 Phone: Area 310, office 777-2000, residence 775-1112

## ARCTURUS SALE

1700 transistor types at 39¢ each.  
 40 watt germanium power transistor, same as Delco 501, 2N278 (etc.). Cat: 349, 59¢ each.  
 Color TV cartridge focus rectifier 6.5 kv. Used in every color TV. Cat: CFR-20, 99¢ each.  
 Motorola 2500 ma. at 1000 piv, high voltage/current epoxy silicon rectifier, axial leads. Cat: HEP-170, 49¢ each.  
 2 Printed circuit I.F. transformers, 4 lug, 455 kc input and output, Cat: 1909P4, 99¢ each.  
 RCA UHF transistor type TV tuners, KRK-120 (longshaft) cat: UHF-20; KRK-120 (short shaft) cat: UHF-21, each \$4.98.  
 RCA VHF transistor type TV tuners, KRK-146, cat. VHF-74, \$9.99 each.  
 Transistorized U.H.F. tuners used in 1965 to 1967 TV sets made by Admiral, RCA, Motorola, etc. Removable gearing may vary from one make to another. Need only 12 volts dc to function. No filament voltage needed. Easy replacement units. Cat: UHF-567, \$4.95.  
 U.H.F. Tuner original units as used in TV sets such as RCA, Admiral, etc., covering channels 14 through 82, as part no. 94D173-2. Complete with tube. Drive gearing is removable. Can be used in most sets. Cat: UHF-3, \$4.95.  
 Color yokes, 70° for all around color CRT's. Cat: XRC 70, \$12.95, 90° for all rectangular 19 to 25" color CRT's, Cat: XRC-90, \$12.95.  
 Kit of 30 tested germanium diodes. Cat: 100, 99¢.  
 Silicon rectifier, octal based replacement for 5AS4-5AW4-5U4-5Y3-5T4-5V4-5Z4. With diagram. Cat: Rect-1, 99¢ each.  
 7", 90° TV bench test picture tube with adapter. No ion trap needed. Cat: 78P7, \$7.99.  
 Tube cartons 6AU6 etc., size, \$2.15 per 100, 6SN7 etc., size \$2.55 per 100, 5U4GB size \$2.95 per 100, 5U4G size \$.03 each.  
 Send for complete free catalog. Include 4% of dollar value of order for postage. \$5 MINIMUM ORDER. Canadian check, 8% dollar differential.

**ARCTURUS ELECTRONICS CORP.**  
 502-22nd St., Union City, N.J. 07087, Dept. MCO  
 Phone: 201-UN 4-5568

plate current to a low-power-input level and minimizes the possibility of tube damage due to inadvertent off-resonant conditions that may occur during tuneup. With the transmitter tuned up for the recommended p.a. cathode current, the input power is about 250 watts. The r.f. output in this state measured 100-125 watts, depending on the band.

C.w. operation can be conducted in the tuneup position for low-power work and the power can be reduced to an even lower value by a panel control that lessens the modulator unbalance and thus lowers the drive. With this position, transmit-receive transfer must be manually made by shifting the function switch.

For normal, or high-power c.w. work, a fixed bias highly unbalances the modulator and allows an input of about 360 watts with a measured r.f. output of 200-225 watts. In this case, in the absence of the v.o.x., manual control may be handily conducted by the mic p.t.t. switch or a foot switch for which there is a rear-apron phono jack.

With s.s.b. operation, the p.e.p. input

under dynamic conditions runs up to about 550 watts with a measured p.e.p. output of 300-340 watts.

### Dial and Tuning

The dial is calibrated in 5 kc steps spaced a good 1/8" apart with calibration numerals at the 25 kc intervals from 0-500. The frequency is read out by adding the dial readings to the lowest frequency marked at the band-switch position. A mechanical arrangement permits the hairline fiducial to be moved to the left or right for calibration.

An outstanding operating feature on the GT-550 is the new high-ratio tuning drive, one revolution of which covers only 15-20 kc. Furthermore, it is provided with a large knob that has a round recess in its face which permits fingertip operation. This facilitates fast rotation for large band excursions. Unlike a crank-type knob, there is no protruding handle to get in one's way or to be accidentally bumped, detuning the v.f.o. The whole setup has a solid feel to it and functions easily, making it a pleasure to handle.

### Performance

Most of the performance data has been interspersed with the technical details and therefore are not listed separately as is our custom.

In conclusion, however, we might add that the overall response on receive, which is also reflected on transmit, is exceptionally pleasant, particularly when the matching speaker is used. There is not the usual s.s.b. harshness to grate on one's nerves. This is mainly due to the steep-skirted filter which permits the carrier frequency to be placed closer than usual to the filter passband for a given unwanted-sideband suppression, resulting in an overall response of 400-2700 c.p.s. (at 6 db). The mid-passband is flat with no sharp peaks as we've experienced with some filters.

The size of the Galaxy Model GT-550 Transceiver is only 6" x 11½" x 12¾" (H.W.D.) and the weight is 14½ lbs. It is priced at \$449. The Model AC-400 a.c. power supply (unhoused type) is \$89.95 and the Model SC-550 matching speaker is \$19.95. The power supply may be installed in speaker case. A mobile power supply, an external v.f.o. and a wattmeter/antenna selector also are available. These are products of Galaxy Electronics, 10 South 34th Street, Council Bluffs, Iowa, 51501. —W2AEF

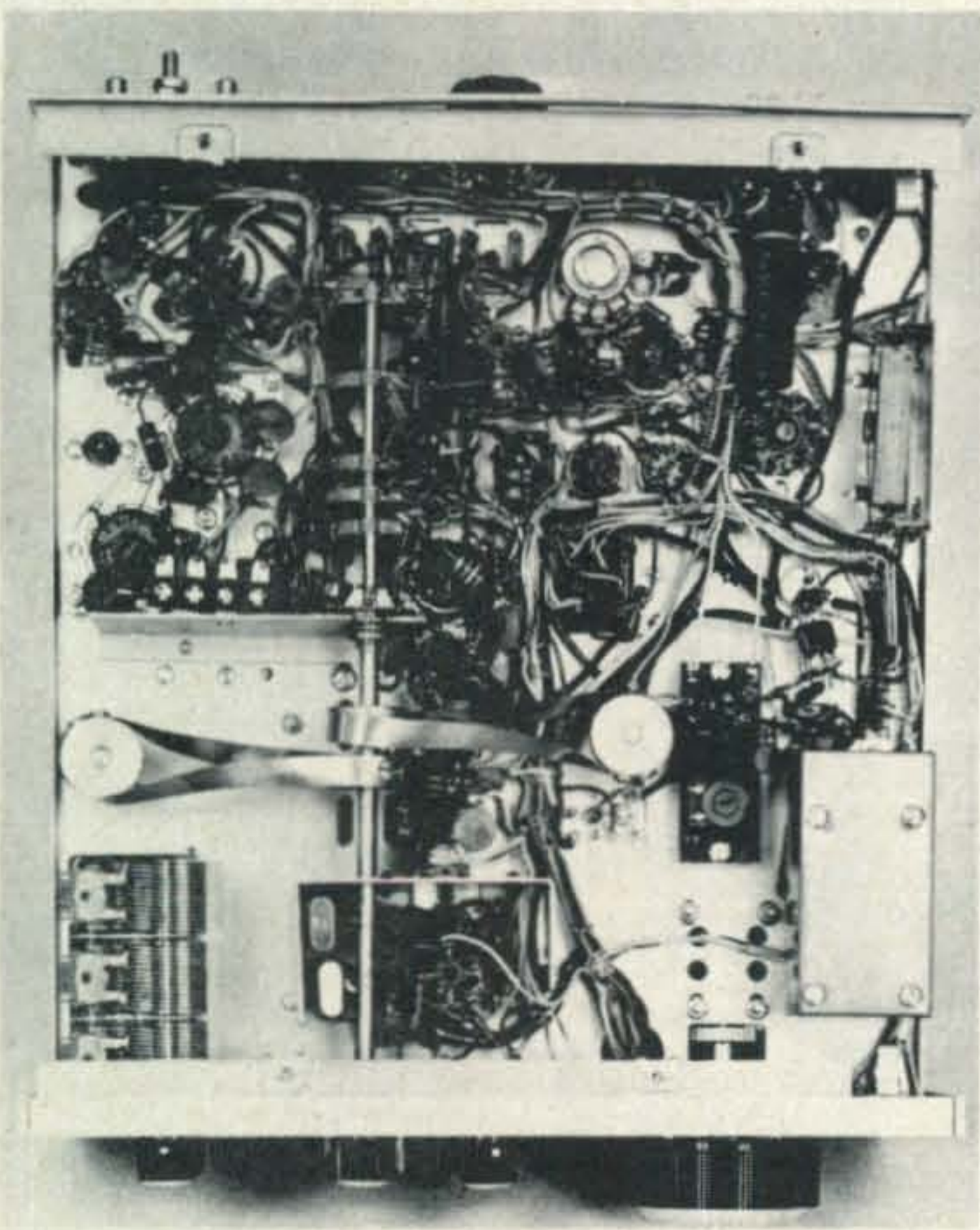

Bottom view of the GT-550. The v.f.o. section is built on a printed-circuit board installed in the metal box at the lower right. The straps extending from each side of the band-switch shaft conjunctively operate vertically-mounted switches on the chassis for the p.a. tank and the pre-mixer. The p.a. loading capacitor is at lower left.



# COLUMBIA MARCH SPECIALS

## COMMAND RECEIVERS

190-550KC Q-5er Good Condition	\$14.95
190-550KC A.R.C. Type R-11 Commercial Late Model Exl. Condition	\$14.95
540-1600KC A.R.C. Type R-22 Commercial Late Model Exl. Condition	\$17.50
1.5-3MC Marine Band Exl. Condition	\$19.95
3-6MC 75 & 80 Meters Exl. Condition	\$14.95
6-9MC 40 Meters Good Condition	\$14.95

## COMMAND TRANSMITTERS

2.1-3MC T-18/ARC-5 New	\$9.95
3.4MC T-19/ARC-5 Exl. Condition	\$8.95
4-5.3MC T-20/ARC-5 Exl. Condition	\$5.95
4-5.3MC BC-457 New	\$9.95
5.3-7MC BC-458 Good Condition	\$5.95
5.3-7MC BC-458 Poor Less Tubes & Xtal For Parts	\$1.95
MD-7/ARC-5 Plate Modulator For Above Xmtrs Exl. Condition	\$6.95

## COLUMBIA RECEIVER SPECIALS

BC-312 1.5-18MC Reconditioned 12V.DC	\$ 85.00
BC-342 1.5-18MC Reconditioned 115/1/60	100.00
BC-348 200-500KC & 1.5-18MC Recondi- tioned 24V. DC	100.00
ARB 190-9000KC Good Condition with Control Box	24.95
RBS 2-20MC Reconditioned with AC Power Supply	59.95
R-444/APR-4Y AM & FM Exl. Condition	49.95
RBB 600-4000KC Reconditioned 115/1/60	89.50
RBC 4-27MC Reconditioned 115/1/60	100.00
ARC-3 100-156MC 24 Channel Exl. Condi- tion	24.95
RAL 300KC-23MC Good Condition 115/1/60	49.95
BC-639 100-156MC Tunable Receiver 115/1/60 Reconditioned	99.50

## 30MC OUTPUT TUNEABLE CONVERTERS

CV-253/ALR 38-1000MC Exl. Condition Late Model	\$150.00
TN-1/APR-1 38-90MC Exl. Condition	24.95
TN-3/APR-1 300-1000MC Exl. Condition	24.95
TN-18/APR-4 300-1000MC Exl. Condition Late Model	49.50
TN-19/APR-4 975-2200MC Exl. Condition Late Model	65.00
TN-54/APR-4 2000-4000MC Exl. Condition Late Model	99.50

THE ABOVE CONVERTERS CAN BE USED WITH ANY RECEIVER THAT TUNES 30MC

## TRANSMITTERS & TRANSCEIVERS

T-47/ART-13 2-18 Mc transmitter Less tubes Good Condition	\$24.95
T-47/ART-13 with tubes Exl. Condition	49.95
BC-669 Transceiver 1.7-4.4 Mc Exl. Condition	99.50
RT-18/ARC-1 transceiver 100-156 Mc Exl. Condition	39.95
ARC-3 transmitter 24 channel 100-156 Mc Exl. Condition	\$24.95

## TELETYPE EQUIPMENT

	UNTESTED	TESTED OK
M-15KSR Page Printer with Keyboard	\$135.00	\$170.00
M-19ASR with table & Power Supply	200.00	275.00
M-14TD Tape Reader	50.00	75.00
M-14RO Tape Reperforator No Keyboard	50.00	75.00
M-14KSR Tape Reperforator with Keyboard	75.00	100.00

All above units have sinc. motor and will be complete and in good Physical condition as removed from service

MX-949/U tube tester adapter with this late model adapter you can test 9 pin tubes on your I-177 Tube Tester. Excellent cond. \$9.95

## TELETYPE CONVERTER TERMINAL UNIT

AN/FGC-1C Dual Diversity Audio RTTY Converter can be used with any type receiver. These are new and shipped in original factory crates with all spares

\$149.50

## IP-69/ALA-2 PANADAPTER

This compact unit can be used with most Ham Receivers after conversion. Complete with conversion info and schematic. Like new condition

\$24.95

## ARNOLD MAGNETICS TRANSISTORIZED POWER SUPPLIES

Model 838 input 12V.DC output 400V.DC @ 100MA. New \$19.95  
Model 834 input 6V.DC output 150V.DC @ 130MA. New \$12.95  
SIZE: 4 1/2" x 3 1/2" x 2" in enclosed metal case. These units had a retail price of \$49.50

## NEW UNUSED GUARANTEED TUBES & ACCESSORIES

4-1000A by EIMAC or PENTA	\$95.00
4-400A by EIMAC or PENTA	29.95
SK-400 EIMAC Airflow Socket for 4-400A with SK-406 Chimney New	12.95
Johnson 4X150A & 4CX250B sockets New	3.95
810 tubes	14.95
902-A 2" CRT	4.95
450-TL EIMAC	49.95
803	4.95
5CPI	4.95
5BP4	4.95

## MICROPHONES & HEADSETS

HS-23 Headset 2000 ohm New	\$ 6.95
HS-33 Headset 600 ohm New	6.95
Perma Flux HiFi Headsets w/chammis cushions. New	\$14.95
T-17D Carbon Microphone New	12.95
RS-38A Carbon Microphone with coil cord New	9.95
52AW telephone operators headset mic New	24.95

## TAMAR 12V. MOBILE RF POWER AMPLIFIER

This is a very compact RF Amp. Originally mfg. for light aircraft. Frequency 118-128MC. Easily converted to 2,6 or 11 meters. Has built in transistorized power supply. Uses 1 ea. 6360; 1 ea. OB2, supplied with schematic. Less tubes. Special closeout price

\$9.95

**DON'T SAVE IT!!**

**SELL IT!!**

Don't clutter up your home with all that stuff! Better to clutter up our warehouse — and get paid in the bargain! Don't waste time asking us for prices. **Tell us exactly what you want** for your Gen Radio, H-P, Tektronix, ARC, GRC, TED, PRC, VRC, ARN, URR, APN WE WILL BEAT ALL OFFERS. WRITE TODAY!

**COLUMBIA ELECTRONICS, Dept. E**

ALL PRICES F.O.B. LOS ANGELES, CALIF.

**COLUMBIA ELECTRONIC SALES, INC.**

4365 W. Pico Boulevard • Los Angeles, Calif. 90019

Telephone (213) 938-3731

## Verticals [from page 62]

measure by walking or driving to measuring points. Also, consultants are interested in ground wave coverage, usually. In some cases it is necessary to know the skywave pattern at a particular horizontal azimuth angle. The FCC insists on knowing the predicted vertical patterns, taken every  $10^\circ$  vertically, for all horizontal azimuth angles. If one wishes to know the gain of an array at a particular vertical angle, he can compute it by putting the vertical angle into the pattern equation, computing the pattern at that vertical angle, finding its r.m.s., and computing the gain, as I did for the horizontal plots in Parts VIII and IX. I did not do it for the vertical angles because I felt it would add too much complication to the articles for the average reader to follow. However, it can be done by anyone so deeply interested. (This item came from a college professor who had worked out a computer program for deriving the whole three-dimensional pattern of an array, and he felt that to know the gain of the array one should base it on the r.m.s. of the three-dimensional pattern. It is very commendable that he has worked this out. I wish I had such facilities at my disposal. However, I reiterate that gain is meaningful to the communication system user only when referred to his specific direction of interest. The gain at other directions is nice to know because he can then tell whether his antenna is wasting power in spurious lobes, but it is not essential to the basic question of gain in the desired direction. And in my case I chose the horizontal plane for ease in measurement.)

**14. Q.** *In your directional computations you show only the horizontal patterns. What about the vertical angles? These antennas can't be as perfect as you have shown them. Isn't there power lost in high angle skywave lobes?*

**A.** Yes, there is power in skywave lobes, but in the case of the simple two and three tower patterns shown, the skywave lobes are small, relatively. In the case of in-line arrays, one can generalize and say that in each null of the horizontal (groundwave) pattern there will be a small skywave lobe. Its angle above the horizontal will depend on several parameters of the array, the most important of which is the factor  $f(\theta)$  for the tower heights involved. In the case of arrays of other configurations and more elements, such as parallelograms or "dog-legs," the skywave lobes

can be found only by computation. A computer does indeed come in handy for this. I know of one consultant who designed a multi-element array of irregular configuration for a client some years ago, who did not compute the whole pattern at  $10^\circ$  vertical angle increments (before it was required). When the array was built, he could not make his horizontal r.m.s. come up to the value required by the FCC. In other words, he was losing too much power in skywave lobes and in circulating power within the array. It was a "losser." The array had to be torn down and redesigned. Naturally the client became quite irate, instituted a law suit, etc. This was quite embarrassing as well as costly to all concerned. So, the answer is, "Yes, there are skywave lobes, but in the simple patterns they are minimal."

**15. Q.** *My radio room is on the third floor of our house. I would like to use a vertical on the roof, but how do I make a ground connection from this height?*

**A.** Obviously you cannot make a good r.f. ground connection to earth from this height, because your ground lead will be a part of the radiating system and will place your entire installation at some r.f. potential above ground, besides introducing possible losses from coupling to house wiring, plumbing, etc. I suggest you install a ground plane antenna on your roof, feeding it with coaxial line, in the same manner as I suggested to the writer of question 6.

## Conclusion

This concludes the present series on vertical antennas. I want to thank those who have written, and to those who have expressed your interest over the air. Your number has been considerable, and it is very gratifying to an author to know that his works are read and appreciated. It is also pleasing to the publisher, who wants you to know that back issues containing these articles which began in June 1968 are available. Please do not write to me for reprints. I cannot furnish them. Write to *CQ*. The handbook containing all of the articles will be published as soon as possible. I have enjoyed writing for you and thank you for your interest.

## Erratum

In Part IV, fig. 32, the labels "reactance" and "resistance" on the curves were inadvertently interchanged. Please correct them.

many have tried

# but SWAN SUCCEEDED

complete station  
for only

**\$395<sup>00</sup>** Just hook the Model 260 to an antenna and you're on the air.



is that simple! There is nothing else on the market comparable to the 260. Look what you get for \$395.00.

Complete frequency coverage on all five bands ★ 10 meters ★ 260 watts PEP  
Built-in power supply . . . AC and DC ★ Portable . . . only 26 pounds,  
complete with handle, built-in speaker and mike ★ Designed and built with the  
same ruggedness, reliability and craftsmanship that has made Swan a household  
name the world over.

And coming very soon will be another star in the Swan line, the 270 deluxe.  
Everything that the 260 has, plus many additional features for those who can pay  
a little more. The 270 will sell for \$495.00, still a low price for a complete station.

And if you need an antenna, Henry Radio can make that a simple matter with its  
cost saving Antenna Package Program.

We know it's hard to believe, but come on in to a Henry Radio Store for a demon-  
stration. If you can't come in . . . write or phone. We'll give you more informa-  
tion, terms, and will ship anywhere.

EASY FINANCING • 10% DOWN OR TRADE-IN DOWN • NO FINANCE CHARGE IF  
PAID IN 90 DAYS • GOOD RECONDITIONED APPARATUS • Nearly all makes & models.  
Our reconditioned equipment carries a 15 day trial, 90 day warranty and may be traded back  
within 90 days for full credit toward the purchase of NEW equipment. Write for bulletin.

BOB HENRY (W6UOU)

BOB HENRY (WØARA)

WALT HENRY (W6ZN)

CALL DIRECT . . . USE AREA CODE

**Henry Radio Stores**

Butler, Missouri, 64730

816 679-3127

11240 W. Olympic, Los Angeles, Calif., 90064

213 477-6701

931 N. Euclid, Anaheim, Calif., 92801

714 772-9200

"World's Largest Distributor of Amateur Radio Equipment"

See page 110 for New Reader Service

May, 1969 • CQ • 97

### Voice of Apollo 8

Editor, CQ:

I read with considerable interest the article in the March issue, "The Voice of Apollo-8." Many of your readers will be interested to know that the Command Module Communication and Data System and the Unified "S-Band" ground station network were provided by Collins Radio Company and a team of their sub-contractors.

Perhaps those of us who use Collins equipment will feel a little closer to our nation's space program.

Earle L. Grandison, K6YRD  
Calabasas, Calif.

### Q & A [from page 85]

also may help.

R.f. feedback can be prevented from affecting the VR tube by installing a 2.5 mh r.f. chock between the tube-socket terminal and the 150-volt lead to the equipment. Also bypass the 150-volt lead-end of the choke with a .01 mf disc capacitor.

73, Bill, W2AEF

### GEM-QUAD FIBRE - GLASS ANTENNA FOR 10, 15, and 20 METERS.

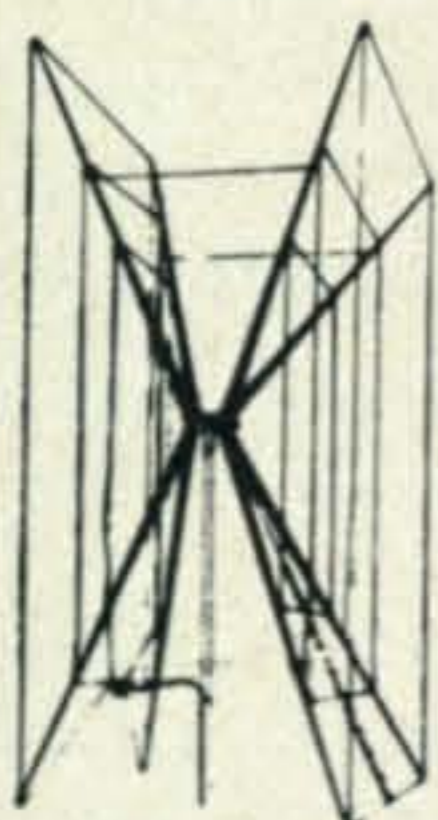

Two Elements \$77.73  
Extra Elements \$45.00 ea.  
Price is F.O.B. Winnipeg.  
INCLUDES U.S. Customs Duty.

KIT COMPLETE WITH  
\* SPIDER  
\* ARMS  
\* WIRE  
\* BALUN KIT  
\* BOOM WHERE NEEDED

WINNER OF MANITOBA DESIGN  
INSTITUTE AWARD OF EXCELLENCE

Buy two elements now - a third and fourth  
may be added later with little effort.

Enjoy up to 8 db forward gain on DX, with a  
25 db back to front ratio and excellent side  
discrimination.

Get a maximum structural strength with low  
weight, using our "Tridetic" arms.



AVAILABLE NOW FROM

**Structural Glass**

20 Burnett Avenue, Winnipeg 16, Manitoba, Canada.

### URC Power Supply [from page 52]

not economically be repaired.

Arrangements of components is not critical, and no unusual precautions need be taken other than those previously mentioned. The power supply described herein is not built within too confined a space or with marginally rated components, therefore, heating poses no problem; the unit runs very cool. Other configurations may readily be adapted to duplicate this power supply with parts of a different physical size and equally satisfying results should be possible.

### Application

Although the author has not tried it, mobile operation from a hilltop appears to be quite feasible if an inverter (such as a small Torado which can be plugged into the cigarette lighter receptacle) is used to provide 115 v.a.c. Such versatility can be achieved and wider application of the hand held units enjoyed. Since no warm-up is required this combination also provides an ideal way of checking band activity from the fixed station thus precluding the necessity of warming up the high powered equipment. ■

### ARC-5 R/T [from page 20]

multi-band operation is foreseen as a possibility. This would necessitate switch- $L_5$ ,  $L_6$ ,  $L_{10}$  and another band-switching mixer for both the transmitter and receiver.

During on the air tests reports of signal strength, audio quality, carrier rejection, stability and unwanted sideband rejection have all been excellent. Performance has exceeded expectations. ■

### It's XYlementary [from page 58]

"That's easy to fix", said Little Miss Electronic Engineer brightly, "Make it louder."

Yeah. Sure. So I fiddled with the controls, tuning the tank out of resonance and bringing it back up to where it had been. "There!", I announced benevolently, hating myself for being such a liar, "we'll try it that way."

I called a W1, but he came back to a 5.  
I called a W4, but he came back to an 8.

I called a VE3 but he didn't come back to anybody. Finally I tuned right smack into a thumping signal that almost blocked the receiver. I knew who it was.

"Isn't that a CQ?", my wife asked already recognizing the rhythm. (I told you she was

When it comes to antenna systems...

IS YOURS

a space problem?

a budget problem?

or simply a problem of where to buy?

an installation problem?

an applications problem?

Your one-stop solution is **ANTENNAS, INC.**

*Exclusively specialists in radiating systems*

**Complete systems or any component part**

Arrays—complete or in kit form, quads, yagis, dipole assemblies, verticals—fixed or mobile, towers, masts, rotors, guy and control cable, transmission line, coax relays and switches, connectors and adaptors, test gear, technical publications, corrosion resistant hardware, corrosion proofing chemicals, insulators, installation and wiring hardware, aluminum tubing and plate, wire, and much, much more.

If your requirements are for a complete system, major components, or the smallest yet important piece of hardware—**ANTENNAS, INC.** has:

AMPHENOL  
ANTENNA SPECIALISTS  
BELDEN  
BILADA  
BIRNBACH  
CALCON WIRE  
CDE ROTORS  
COMDEL

CUBEX  
CUSHCRAFT  
DGP  
DPZ  
DOW-KEY  
E Z WAY  
R. L. DRAKE  
HAM-KITS

HY-GAIN  
GENERAL ELECTRIC  
GENTEC  
GOLDLINE  
GOTHAM  
HI-PAR  
E. P. JOHNSON  
MILLEN  
MINI-PRODUCTS

MOR-GAIN  
MOSLEY  
NEWTRONICS  
OMEGA-T  
POLYGON PLASTICS  
POMONA  
ROHN  
SKYLANE

SWAN  
TELREX  
TIMES WIRE  
TRI-EX  
TRISTAO  
UNADILLA  
VESTO  
WATERS

**ANTENNAS, INC. CAN BE YOUR ONE-STOP, SINGLE-SOURCE.** Write today for our catalog—no charge, of course.

**ANTENNAS, INC.,** Dept. D, 512 McDonald Road, Leavenworth, Kansas 66048

★ **CONQUER NEW HORIZONS** ★

WITH  
**CONTROLLED QUALITY CRYSTALS**



- **Tried and True**
- **Complete Range**
- **Guaranteed**
- **Ready for you at your dealer**



**CRYSTEK**

**TEXAS CRYSTALS**

*Division of Whitehall Electronics Corp.*

**1000 CRYSTAL DRIVE  
FORT MYERS, FLORIDA 33901**

*Plants in Fort Myers and Los Angeles, Calif.*

smart.)

"Yeah, but it's only Otto. He lives down the street."

She clapped her hands. "Good! Then you can have a nice chat."

"Er—honey", I said, "I don't think Otto really wants to talk to me."

"Why? Are you two mad at each other?"

"No, but you see, if I answer *him*, he'll be obliged to answer *me*, since he *knows* me. And unless I have something important to say—. Well, the guy only lives three blocks away."

"So what", she shot back. "Mary Jane and I call each other up all the time, and she lives right next door."

"Forget Otto", I muttered, gritting my teeth ever so slightly, and tuning across the band. I could sense her shrug.

"Why don't *you* call CQ then? If this Otto person can do it, you can too. Or do you consider yourself above that sort of thing?"

"I've been calling CQ all evening, and nobody comes back to me", I growled.

She pondered this for a few moments, and then with the air of one who has found the answer to every lost CQ in hamming history, she asked: "Have you tried saying please?"

"PLEASE???"

"If you're nice to them, they might feel more inclined to talk to you, that's all. You can catch more flies with honey, you know."

I began to count to ten... in c.w., turning every mental 'dit' and 'dah' into a dart which I threw with unerring accuracy—. Then I heard the KH6. "Good gravy", I exclaimed, a Hawaiian!" (Except I really didn't say 'good gravy'.)

She pulled her chair up closer. "Really?"

"It won't do any good, but I'm gonna give him a blast!" I listened. The KH6 was coming in S-7 and in the clear. There was a W2 above him, and somebody pounding brass a mile-a-minute below him, but he was solid copy all the way. I zero-beat the v.f.o. The Hawaiian signed, and I called him: a nice, steady call at his own speed. I sent AR K and listened. After all, it *could* happen.

"R...R...", I heard and tightened the grip on my pencil. "W...9...."

"WHOOOP-dee WHOOOP-dee, WHOOOP-WHOOOP-dee-WHOOOP!" Some clod with a chirp that sounded like all the canaries in Christendom landed smack on top of my Islander.

"Oooh, the # \$ & ! ! ; \* !", I swore, throwing

in every filter I had. "The lousy x \* ; (!) % !"

"W...9...." went the Hawaiian.

"WHOOOP-dee WHOOOP-dee....", went the lid.

"There's a strong CQ, and it's different, too", said my wife. "Why not answer *him*?"

"Aww, shuddup!", I yelled.

I heard her chair scrape back, and her heels tap-tap-tap angrily up the basement steps. Thus ended the introduction of the XYL to amateur radio.

Later, when I was doing penance at the kitchen sink she said to me, "You know, Roger, you ought to consider giving up Amateur Radio. Any hobby that will cause a man to shout at his wife and use abusive language can't be worth much."

I snorted. "Ha! And what about you? I've seen you go to pieces when a dress you were working on went to pieces."

Her answer to that came from under arched eyebrows. "That's quite a different matter. I have a perfect right to do so if I choose."

"Why?"

"Because", she said prettily, "I'm a girl."

And with this I cannot argue. So I ham, and she sews; and when she sews, her machine makes some pretty outrageous QRN all over the bands. I'm going to let it remain like that, because if I put any sort of a filter on that machine, I'll be blamed for the next twelve crooked zippers, and frankly, I prefer QRN.

## 2M N.B.F.M. with ARC-5 [from page 48]

8 mc (equivalent to 144 mc) will read 8.1 mc on the ARC-5 dial. This error can be most simply corrected by scotch-taping a recalibrated paper dial on top of the original dial markings.

## Realigning the PA Ganged Tuning

The added capacitance introduced across the oscillator tuning circuit of the ARC-5 will disturb the alignment of the p.a. tuned circuit which is ganged tuned to the oscillator circuit. This slightly out-of-resonance condition may be corrected by resetting the adjustable padder capacitor which is in parallel with the ganged p.a. tuning capacitor. Just make a screwdriver adjustment of this padder capacitor for maximum r.f. voltage output as measured by a VTVM.

## Silicon Diodes

The first diode I tried was the U-54 (Texas

# SLEP ELECTRONICS COMPANY WANTS YOUR MILITARY SURPLUS EQUIPMENT **BUY—SELL—TRADE**

**Airborne Equipment:** ARC-34, ARC-38, ARC-44, ARC-45, ARC-51, ARC-52, ARC-54, ARC-55, ARC-59, ARC-60, ARC-73, ARC-95, ARC-102, ARC-111, ARC-115, ARC-131, ARC-134, ARN-14, ARN-18, ARN-21, ARN-30D, ARN-31, ARN-32, ARN-52, ARN-59, ARN-67, ARN-68, ARN-82, ARN-83, ART-34, APN-9, APN-22, APN-70, APN-117, APN-122, APN-129, APN-133, APN-134, APN-141, APN-158, RT-279A/APX-25, APX-44, APX-68, APX-72, ARA-25, ARA-31, ARA-41, ARA-48, ARA-50, ARA-54, ARA-56. COUPLERS, CU-527/AR, CU-942, CU-991/AR, CU-1658. ASQ-3, ASQ-18, ASQ-19, SCR-695A IFF, APA-69, APA-89, ASA-13, ARR-36, VHF-101, 102. COLLINS 17L-6, 17L-7, 51X-2, 18S-4A, 618S-1, 618T, 618F, 618M, 51RV-1, 51Y-4.

**Ground Equipment:** RT-66, 67, 68, 70, 77, PP-112/GR, PRC-8A, 9A, 10A, PRC-25, PRC-41, TRC-24, VRC-24, GRC-9, GRC-19, GRC-27, GRC-46, T-217A, R-278B/GR, MD-129A, UPX-1, UPX-5, UPX-7, UPX-12, TMQ-5, TED, TDE, SPA, URA, SRA, SRT.

**Receivers:** R-220/URR, R-388/URR, R-389/URR, R-390A/URR, R-391, R-392/URR, R-836/ARN, R-1051, R-1125, R-1297/AR, R-1388/ARN, R-1391/ARN, R-1433/U, COLLINS 51J-3, 51J-4, 51S-1, URR-13, URR-27, URR-29, URR-35, APR-5A, 13, 14, 17, RDO, RAL, SP-600JX, ARR-41.

**Test Equipment:** SG-1A/ARN, SG-2/ARN, SG-3/ARN, SG-12A/U, SG-13/ARN, SG-24/TRM-3, SG-66A/ARM-5, SG-92/U, ARM-5, ARM-8, ARM-11, ARM-22, ARM-25, ARM-31, ARM-45, ARM-47, ARM-63, ARM-66, ARM-68, ARM-69, ARM-92, UPM-98, UPM-99, URM-25, URM-26, URM-32, URM-43, URM-47, URM-

48, URM-52, URM-76, URM-78, URM-79, URM-80, URM-81, URM-103, URM-105, URM-120, URM-127, BC-376, ARC H-14, H-16, H-23. Hewlett Packard 606A, 608D, 612A, 616B, 618A, 620A, 626A, etc. Boonton "Q" and RX Meters. HLI-103 Tacan Tester. 479S-3, 479T-2. TS-505D/U, TRM-1, TRM-3, TS-183/U, TS-330/U, TS-510A/U, TS-683/U, TS-710, TS-723/U, etc. MD-1, MD-2, MD-83A/ARN. Also other surplus equipment with PRM, PSM, UPM, USM, URM, GPM, SG, APA, ASA, APR, ASG, ASM, ASN, GRR, PRC, GRC, URC, VRC PREFIXES.

**Commercial Test Equipment By:** BIRD, BOONTON, MEASUREMENTS, H-P, NARDA, GR, SPERRY, ARC, GERTSCH, EMPIRE DEVICES, STODDART, LEEDS & NORTHRUP, BENDIX, NORTH ATLANTIC, ESTERLINE ANGUS, CMC, FAIRCHILD.

**Microwave Test Equipment:** All Types

**Aircraft Instruments By:** BENDIX, COLLINS, KOLLSMAN, SPERRY, WESTON.

**Radiosonde Equipment:** AMT, TMQ, GMD.

**Radar:** All Types, Airborne or Ground, any part.

**Aircraft Inverters:** 400 Cycle Type by BENDIX, LELAND, JACK & HEINTZ.

**Technical Manuals:** Buy and Sell, Military and Commercial Books.

**Tubes:** Transmitter Type by EIMAC, RCA, AMPEREX, VARIAN, RAYTHEON, WESTINGHOUSE, ETC.

**FM Mobile Equipment:** Buy and Sell

**Wanted:** Surplus scouts in everytown, worldwide. Tell us what equipment is available and we will advise you what it is worth in "cash". Earn good money spare time. Refer to this ad for type equipment needed.

**Trade Your Surplus For New Ham Gear:** We stock; AMECO, BTI, DRAKE, EIMAC, E-Z WAY, GONSET, GALAXY, HAMMARLUND, HAM-M, HY-GAIN, MOSLEY, NATIONAL, SWAN, SBE, SHURE, SONAR, WEBSTER, TRI-EX. We pay shipping on trade-ins. Cash deals paid at once upon receipt. Trades shipped from stock. Complete packing facilities, export orders shipped F.O.B. Seaport, Tampa, Florida.

## SLEP ELECTRONICS COMPANY

2412 Highway 301 N. • ELLENTON, FLORIDA 33532  
WRITE-WIRE-PHONE (813) 722-1843 BILL SLEP, W4FHY

Crystals) unit and it gave immediate satisfaction. Other U-54's were substituted with equal results. To satisfy my curiosity I then tried a number of other types and sizes of silicon diodes. Some, like the M500, also worked fine but most of them did not give enough deviation or produced distortion. The smaller sized units, in general, will work if a stage of audio amplification is used. The U-54 and M500 diodes perform perfectly without the need of speech amplification. I use an Astatic D-104 microphone and over-the-air reports have invariably favored the n.b.f.m. signal over the a.m. signal for clarity and audio punch.

### Receiving NBFM

NBFM signals do not require a special detector circuit, such as needed for single sideband or regular f.m. signals. An ordinary a.m. receiver will produce excellent quality of reception without finicky tuning adjustments. It is interesting to note that tuning a n.b.f.m. signal for a maximum S-meter reading will produce the weakest audio signal. The strongest audio signal is received when the receiver tuning dial is turned slightly to one side of the carrier peak. In actual practice, this slight detuning will result in an S-meter drop of 5 to 10 db from the peak reading. An explanation for this phenomenon is graphically portrayed in fig. 2.

The response curve for a typical a.m. detector is shown in fig. 2. When a n.b.f.m. signal (which deviates a few kilocycles) is set at "A", which is equivalent to tuning "on the nose" of the response curve, the deviations in frequency of the applied signal produce a negligible amount of change in the detector current. A weak audio output signal, at best, may be produced from these small current variations.

When the n.b.f.m. signal is slightly detuned so that it is set not at the peak but on the *slope* of the curve, as at point "B", the deviations in the signal frequency produce relatively large variations in the detector output current. These large current variations result in a much louder audio signal in the receiver output. It is obvious from the figure why this type of f.m. detection is referred to as "slope detection." ■

### Model 19 Sets [from page 28]

ferrite cored tank coil would probably saturate if the 807 was run at its ICAS ratings. With this conversion, the power input on c.w.

is about 25 watts—plenty for short haul QSO's.

Complete circuit information for this and other British equipment can be obtained from Instructional Handbook Supplies, Talbot house 28, Talbot Gardens, Leeds 8, England. A circuit of the Mark II version is in the Surplus Schematics Handbook (Cowan Publishing Corp. 1962). ■

### VHF [from page 89]

that are taking place in solid state technology. In any event, because of the narrow range actually used for (narrow band) communication on 432 mc (100 kc) as good a receiver as possible should be used after the converter. For weak signal work, a 1 or 2 kc readout can be quite helpful. And of course, any sort of tunable converters are out.

As for 432 mc antennas, I think we covered that subject adequately last month. Be sure and note the feedback on the printing errors in the schematic diagrams in the January column. Exasperating isn't it! We do not see the schematics any earlier than you do. B.C.N.U. on 432 mc.

73, Allen Katz, K2UYH

### URC-11 on 220 mc [from page 41]

plastic locking caps of the coil forms. They are threaded and easily removed by rotating them counterclockwise.

It was found that the assistance of a tensor lamp and magnifying glass of the type worn on the head by jewelers was of immeasurable help when working on the unit. Further, a small soldering iron is a prerequisite when undertaking the modification because of the small physical size of the components and the limited space available. A 37½ watt Ungar soldering iron proved satisfactory.

### Conversion to 220 mc

Once it has been established that the URC-11 is working, remove the back cover by loosening the six captive screws. Next remove the chassis from the base by loosening the three captive mounting screws. These screws are easily identified by the heads which are encircled in red on the chassis. Next remove the neoprene waterproof cover over the microphone/earphone grill. This will improve the modulation. To do this it is first necessary to loosen the two screws which secure the microphone/earphone button in position.

[Continued on next page]



### Transmitter Modification

A transmitter crystal between 55.000 and 56.250 mc must be used for 1¼ meter service. A series resonant, fifth overtone type CR-56U crystal installed in an HC-18/U holder equipped with wire leads is recommended. This is the same type as that originally supplied with the unit. To replace the crystal in the unit, it is necessary to remove the oscillator tube (type 6050,  $V_1$ ) and the 1st r.f. amplifier doubler (type 6397,  $V_2$ ). In order to remove the tubes first loosen the screws that secure the retaining wire which passes through the mounting trough of the rubber grommets. These in turn cap the top of the subminiature tubes and affix them in position. Both tubes  $V_1$  and  $V_2$  may now be removed thus permitting access to the crystal which may also be removed. Trim the wire leads of the new crystal to the same length as those of the crystal being replaced and install it in the appropriate socket. Be sure it is properly seated. Then replace tubes  $V_1$  and  $V_2$  in their former sockets.

The first step in modifying the tuned circuits is to increase the  $C$  of the crystal oscillator plate circuit (tube 6050,  $V_1$ ) by soldering a 3.3 mmf capacitor across  $L_1$ . This is easily accomplished by soldering the capacitor between pin 1 of  $V_1$  and the feedthrough capacitor mounted on the subchassis extending toward the coils and located between the two r.f. amplifier doubler tubes (type 6397  $V_2$  and  $V_3$ ). The plate coil of  $V_1$  is also terminated at this point where the B+ voltage is fed to the first two r.f. stages. This change will now permit the oscillator plate circuit to be tuned to resonance with the new lower frequency crystal operating around 55 mc.

The next step is to lower the tuning frequency of the 1st r.f. amplifier doubler (tube type 6397,  $V_2$ ) by soldering a 2.2 mmf capacitor across  $L_2$ . This is best done by soldering the capacitor between pin 3 of  $V_2$  and the feedthrough capacitor to which the other end of the coil  $L_2$  is attached.

In order to modify the r.f. output amplifier doubler stage (tube type 6397,  $V_3$ ) to resonate in the 220 mc band, a 1.5 mmf capacitor must be installed across the final tank coil,  $L_3$ . To do this, solder the capacitor across the plate coil  $L_3$  between pin 3 of  $V_3$  and the feedthrough capacitor located on the subchassis upon which the tubes are mounted between  $V_3$  and  $V_5$ . This completes the trans-

mitter modification. These changes are shown in fig. 2.

### Receiver Modification

The only modification required to be made to the receiver is merely to increase the capacitance of the tuned circuit of the super-regenerative detector (tube type 6050,  $V_4$ ). This is best accomplished by soldering a 1.5 mmf capacitor between pin 1 of  $V_4$  and the other end of the inductor at the base of the coil form. This change is also shown in fig. 2.

### Testing the Unit

Connect the power cable to the voltage source, either batteries or a power supply. Filament voltage should be 1.3 v.d.c. and plate voltage 125 v.d.c. Release the locking slide for the operating controls on the side of the unit by pulling the slide down to the "unlock" position. Press the TRANSMIT button and listen for the carrier in a nearby receiver. If no signal is heard on the proper frequency slowly unscrew the slug of coil  $L_1$  until the oscillator starts operation. Rotate 1/2 turn counterclockwise beyond the point where oscillation is first determined. Peak coils  $L_2$  and  $L_3$  in that order for maximum received signal with the telescopic antenna fully extended. A field strength meter provides an accurate and realistic indicator for revealing when all stages have been tuned for maximum output.

To align the receiver, press the RECEIVE button and adjust the slug of  $L_4$  until local 1¼ meter signals are heard. The slug should be about halfway inside the form. Placing the cover on the URC-11 may detune the circuits slightly so final slug adjustments should be made with the cover off and then readjusted as necessary so that optimum signal performance is achieved when the cover is placed in position and secured.

This procedure is considered preferable to drilling holes through the cover opposite the coil slugs and adjusting the tuned circuits to resonance externally. The holes in the cover provide an access for dirt which will reduce reliability, a prerequisite for portable operation.

Results on 220 mc have been good. The best DX has been 35 miles when operating portable from a high location.

The author wishes to extend appreciation and thanks to Harry J. Blutstein, W3AY, for the photography. ■

# Ham Shop

**Advertising Rates:** Non-commercial ads 10¢ per word including abbreviations and addresses. Commercial and organization ads, 35¢ per word. **Minimum Charge \$2.00.** No ad will be printed unless accompanied by full remittance. **Closing Date:** The 10th day in the second month preceding date of publication.

Subscribers to **CQ** are entitled to one free 3-line ad per month. Ad copy must be accompanied by mailing label from subscription copy of **CQ**.

Because the advertisers and equipment contained in Ham Shop have not been investigated, the publishers of **CQ** cannot vouch for the merchandise listed therein.

Direct All Correspondence & Copy to: **CQ Ham Shop, 14 Vanderverter Ave., Port Washington, L.I., N.Y. 11050.**

**NEW ACCURACY** for your receiver; IC-3 Divider produces 25KHz marks from your 100 KHz Calibrator. Specify 3-200 Volts DC. \$7.25 postpaid. Paxitronix, Box 1038, Boulder, Colorado. 80302.

**CLEGG APOLLO SIX LINEAR AMPLIFIER** for sale! Brand new. Substantial discount, contact Jack Batts, Five Old Tavern Road, Wayland, Mass. 01778. Phone: 617-653-6891.

**HALLICRAFTERS HT-32.** \$225. Mark Timpany, 209 West Racine Street, Janesville, Wisconsin. 53545.

**FOR SALE:** Gonset Super-six converter w/squelch & noise limiter. \$25.00. Switchboard type headset w/ mic \$15.00. 1 hour wire spools for 80-1 Webcor recorder \$5.00. (postpaid). R. Cartier, K1ANH, 1035 Cilley Rd., Manchester, N.H. 03103.

**COLLINS 351D-2** mobile mount and 516E-1 12 volt power supply \$100. Michael Halle, 1520 Turcot Dorval Province of Quebec, Canada, 514-631-6676.

**WANTED:** Very low frequency receiver (MSL-5) write WA7KZ, Box 355, Kent, Washington. 98031.

**WANTED:** Antique Radio receivers, transmitters and components prior to 1926. Give description, price and condition. Also want 75A4 mechanical filter 455J05 and 455J21. W5MMD, Tom Wherry, 1432 Osage, Bartlesville, Oklahoma. 74003.

**SOMERSET COUNTY HAMFEST**—June 8th, Casebeer Church Grove, Route 219. 7 miles north of Somerset, Pa. (9 am to 5 pm). Write Theodore J. Leonberger, K3RCI, Rd. 2, Rockwood, Pa. 15557.

**INDIANAPOLIS DX ASSOCIATION:** Will provide a hospitality suite for DX'ers on Fri-nite, May 23rd—write Joe Poston, 309 Benton Dr., Indy., Ind. 46227.

**INDIANAPOLIS HAM CONVENTION** (Sat.) May 24, (9 to 5) at beautiful Lafayette Square Mall. Indoor Manufacturers displays—for sale or auction. Free outdoor flea market. 80+ shops, Cinema, for XYL & kids, inside air conditioned MALL. Airports & Interstate—1/2 mile. Write Indianapolis Ham Association, 309 Benton Drive, Indianapolis, Ind. 46227.

**RTTY** gear for sale. List issued monthly, 88 or 44 Mhy toroids, uncased, five for \$2.00. postpaid. Elliot Buchanan and Associates, Inc., 1067 Mandana Blvd., Oakland, Calif. 94610.

**Florida home** built with hamming in mind/must sell account health. Three bedroom on beautiful lake. Bargain-interested write A. T. Tidwell, W4ASM, Route A2, Dunnellon, Florida 32620.

**HAMFEST** sponsored by Lancaster & Fairfield County ARC at Derby Downs, one mile south of Lanchester, Ohio on B15 road, Route 793, June 8th. Gigantic Swap Shop. \$1.00 registration with gifts every half hour. Lots of surprises. Good food at reasonable prices.

**FOR SALE:** Drake 2B-2BQ '/Q' multiplier-2AC Xtal Calibrator-Perfect condition. \$180.00. Joseph Patocka, W2KIJ, Rd 3, Horseheads, N.Y. 14845.

**DRAKE** L-4 Linear \$500. R4-A receiver \$295. Both \$775. Like new with original cartons and manual. Dr. Morris, Box 309, Ripley, W. Va. 25271.

**SELL:** Drake 2C—\$170. National NCX-3—\$170. NCXA—\$45. all excellent condition, best offer accepted. D. Ostroy, WB2TUL, 2 Tropical Drive, Middletown, New Jersey. 07748.

**WANTED:** PL172—Have new 4CX 1000A, never used \$60.00. 4-1000A never used \$50.00. John Bricker, W8IJZ, 3893 Glenwood Rd., Cleveland Hts., Ohio 44121.

**SELL:** Drake TV-1000 LP filter \$11; Turner 454C microphone, \$13. Cartons & manuals. WB22QE 31 Eaton Rd., Syosset, N.Y. 11791. (516-931-2966).

**SELL** Communicator II-B 6 Mtr. 12v \$85. 4D32 tubes Ind. Surplus Test o.k. \$10. WE 275/B or Clare HG 1017 Relay (50) \$1. ea. Sola CV xfmr mod. #20-20 210 (1000VA) make offer. E. F. Lankford, W4HHY, 511 Purnell Dr., Nashville, Tenn. 37211.

**WANTED—QST's**—Last four issues needed to complete 1916—FEB, MAY, JUNE, JULY. Any reasonable price paid. K2EEK, CQ Magazine, 14 Vanderverter Ave., Port Washington, L.I., New York 11050.

**TEKRONIX** #511 'scope, very good shape, converted to late-model power transformer, \$150.00. G.E. White 5716 N. King's Highway, Alexandria, Va. 22303.

**FOR SALE:** Heath Tower, slight modification to transmitter section. \$35. Bay area only. WA6PXG, 44 Laurel Ave., Millbrae, Calif. 94030.

**WANTED:** 500 or 800 cycle filter for 75A-4 and Heath kit capacitor decade box. R.D. Rossi, 4111-55th St. N.W., Rochester, Minn. 55901.

**WANTED:** SSB xcvr. All band with dc supply. Swa 500, Drake TR4 or equiv. Jerry Molaver, 34 Collins St Waterbury, Conn. 06704.

**SELL:** CQ's from 47 and QST's from 46, 25¢ each plus postage. Send your list for quotation. E. Rasmussen 164 Lowell St., Redwood City, California 94062.

**FOR SALE:** Tri-Ex T588 88' tower, \$150. Abt 90' 5 ohm alum coax, \$30. Delivery within 100 miles. Paul Etchberry, 1220 S. Marsh Ave., Reno, Nev. 89502.

**FOR SALE:** Central Electronics 458 all band VFO with manual, mint condition. \$25.00. Hal Smith, W2GK 26 Linden St., Bayonne, N.J. 07002.

**WANTED:** Heath QM-I Q meter, IT-II or IT-28 capacitance checker. Working or repairable. David R. Coahran, 70 Olson St., Pullman, Wash. 99163.

**HW**—12A Mobile supply, Calibrator, Cables, all mounting hardware, manual and microphone. Less than year old. EXC—\$150.00. C. Getter, W1MIJ, 58 Feld Road, Natic, Ma. 0k760.

**Gud Luck, WN2HMU,** and keep those "dirty" diodes clean!

**FOR SALE:** NC-300 RCVR with speaker & Calibrator \$150., local only, National 6 meter Conv, like new \$25, Philip D. Greenway, W4LRR, 234 Elden Drive N.E., Atlanta, Georgia 30305.

**GALAXY V MK II**—like new—and AC Power Supply \$359.00, post paid. John Schroeder, W6UFJ, 562 Quinn St., Bell Gardens, Calif. 90201.

**SWAP:** DAVCO-DR-30WAC/CD PS SPKR, Factory updated and overhauled for SBE-33 w DCPS or SBE-3 or transceiver. Rankin, W4ZUS, NAVEODFAC, Indian Head, Md. 20640.

**FOR SALE:** VIKING IIVFO—\$85, modified BC-348Q \$60 or swap any unit for HW-12. W3BJZ, Dave Knepper, Sidman, Pa. 15955.

**CQ & QST** back issues for sale. Reasonable. SA3 brings list. W8RBW, G. A. Thiele, 3267 Redding Rd Columbus, Ohio. 43221.

**DRAKE R-4A**, like new condition. \$250. Ameco CMA Allband converter, 1.7, 54MC and/08-174 mc, like new \$30. Ameco PCL-P, Preamp 1.8-54 mc \$15. Sid Levinson, 3406 Church Ave., Bklyn., N.Y. 11203. Phone 856-9862.

**GONSET G50** six meter transceiver, less than 10 logged hours, like new, \$175.00; Gonset 6 meter converter, like new, \$12.00. F.O.B. Gary Wolverton, 1042 Keegan Lane, Twin Falls, Idaho. 83301.

**AUCTION**—June 8th Manchester Radio Club at Tower Hill Canida N.H.—Map and information S.A.S.E. W1HPM, Post Office Box 661, Manchester, N.H. 03105.

**FOR SALE:** Heath DX-60 transmitter w/relay \$60; Heath H-G 10 VFO \$23; Hammarlund HQ-110 rcvr with speaker \$125; KW using Two 813's with power supply \$130; Johnson KW low pass filter \$6; hand-book keyer using two 12 AU 7's \$11; all equipment in excellent condition! WA2YYJ, 700 West 178 St., New York, N.Y. 10033.

**WRL's** used gear has trial-terms-guarantee! KWM1—\$299.95; SR34AC—\$149.95; HE45B—\$79.95; Swan 240—\$179.95; Galaxy V—\$229.95; B & W 5100B—\$109.95; HX50—\$249.95; AMECO R5—\$59.95; SX146—\$189.95; HR20—\$79.95; NC303—\$199.95; SB301—\$269.95. Hundreds more. Free "Blue-Book" list. WRL, Box 919, Council Bluffs, Iowa. 51501.

**NORTHERN California Hams:** Best deals—new and reconditioned equipment. Write or stop for free estimate. The Wireless Shop, 1305 Tennessee, Vallejo, Calif. 94590.

**FOR SALE:** Drake 2B with 2BQ Q multiplier, Heath DX 60 and HG 10. Need money for school, make me an offer. WA8LRU, 1501 40th Avenue, Menominee, Michigan 49858.

**3 Plastic Holders** will frame and protect 60 cards, \$1.00—or 10 holders \$3.00. Prepaid and guaranteed. Patent 3309805. Tepabco, Box 198Q, Gallatin, Tennessee 37066.

**TEST EQUIPMENT WANTED:** Any equipment made by Hawlett-Packard, Tektronix, General Radio, Stoddart, Measurements, Boonton. Also, military types with URM—( ), USM—( ), TS—( ), SG—( ) and similar nomenclatures. Waveguide and coaxial components also needed. Please send accurate description of what you have to sell and its condition to Tucker Electronics Company, Box 1050, Garland, Tex. 75040.

**AMATEUR RADIO CERTIFICATE:** Display impressive 8½" x 11" personally endorsed certificate in your shack. Send \$1.00 to, Amateur Certificate, P.O. Box 244, Miami, (Kendall Br.), Fla. 33156.

**ATTENTION 160 METER FANS:** Change any coax fed 75/80 meter inverted vee/dipole into an efficient 160 meter antenna. Adapts within seconds, right in the hamshack PL-259 and SO-239 connectors. Perfect for residential areas. TOP BAND SYSTEMS' MODEL 86ADP 160 meter adaptor \$4.75 ppd. Martin Hartstein, 5349 Abbeyfield, Long Beach, Calif. 90815.

**CANADIANS:** Complete amateur equipment guaranteed, gov't licensed technician. Bob Fransen, VE6TW, Box 197, Sherwood Park, Alberta.

**WANTED:** J Coil for HRO or what have you. For sale 4D32, new. W4JZB, F. Brauner, 5719 Taylor St., Hollywood, Fla. 33021.

**SELL** Heath Marauder HX-10 with pair of spare new finals. Exclnt. cond. \$200.00. HQ-180 C with matching spkr. Exclnt cond. \$250. W9ALP, 4522 So. Kedvale Ave., Chicago, Ill. 60632.

**HEATH HR-10** for sale, pro-wired, and in excellent physical/electrical condition, xtal. calib. incl. for \$65. B. Malt, 10 Woodridge Rd., Wellesley, Mass. 02181.

**FOR SALE:** HQ170AC; 6er; Heath HA20 6M linear. Best offer takes all or part. C. B. Honess, 403 Delieesseline Rd., Cayce, S. C. 29033.

**TOROIDS** 44 & 88 mhy. center-tapped, never potted. 5/\$2.00 postpaid. Teletype 32KSR page printer \$300. or trade for FM. Johnson KW matchbox with SWR \$120. B&W 5100B & 51SB transmitter \$145. Stamp for list. Van W2DLT, 302X, Passaic Avenue, Stirling, N.J. 07980.

**LOOK** for KL7GKW at the El Dorado Hotel in Sacramento during the ARRL Pacific Division Convention on 13/14/15 June. The convention with dimension!

**SELL**—Synchronometer, Telephone parts, APR-4, SRT Subchasses, pr. 6155. W4NYF, 405 N W 30 Terr, Ft. Lauderdale, Fla. 33311.

**NAMEPINS:** \$1.20 pp call, name, catalog for stamp, club rates, Rick Zack, WB2AEB, Pike Place, RD-4, Mahopac, N.Y. 10541.

**FOR SALE:** SX111, good condx, \$100. Also, Heath HW12 and HP13 D.C. supply, good condx., \$100. W. R. Downs, 3120 Dunbar Rd., Attica N.Y. 14011.

**WANTED:** Copy of "Radio Reminiscences: A Half Century" by Dr. Hoyt Taylor. M. Gauthier, 10425 San Jose Ave., South Gate, Calif. 90280.

**FOR SALE:** HT41 Linear and 2 extra rectifier tubes for \$210.00 plus shipping—Contact L. Covey K1JAR, 238 Jenness St., Lynn, Mass. 01904.

**HAVE PAIR NEW,** 4-250, BC221 with calibrations. Want pair 4CX250B and Swan 450 or 450X oscillator. Les Basham, 735 Coves Hwy, Cave Junction, Ore. 97523.

**SSB xciter builders:** Collins 250 kc mech. filter with matching USB and LSB xtals—248.350 kc and 251.-700 kc. Best offer. WZEHB, 32 Bryant, Blackwood, N.J. 08012.

**FOR SALE:** Stepping Switches 6 pole/26 position Clare Type 26, 48 VDC, 2 for \$15—G. Smith, 915 Lovera, San Antonio, Texas. 78201.

**AMATEUR-ELECTRONIC AUCTION**... The "key clickers" of Stirling (N.J.) will hold their gala auction on Friday April 11, 1969 at 8 pm in the gymnasium of Central School, Central Avenue, Stirling, N.J. Over 250 attended the Stirling auction last year; Refreshments served. Come early and bring items to sell. Easy to reach by major highways, everyone welcome.

**COLLINS 75A4**—Serial 4789—2 filters, mint condx. No reasonable offer refused. W2ASI, 15 Kensington Oval, New Rochelle, N.Y. 10805.

**F.M. 12/W Transceiver** on 146.94 MC, like new, w/ control & manual \$75. W. Davis, 4434 Josie Avenue, Lakewood, Calif. 90713.

**WANTED:** Heathkit Mohican, GC-1A, either kit or complete, or partly finished with manual. W.G. Martin, Box 1304, Hq 5AF, APO San Francisco.

**TEKTRONIX 310** \$375., mite KSR Teleprinter \$500., Monitoradio M-160 \$75. Unimat \$85. Tom Perera, K2-DCY, 410 Rierside Dr., N.Y.C. 10025.

**CRYSTAL LAB.,** several thousand xtals, blanks, holders, electrodes, etc., Also Lab. manuals and etching compound. \$150.00 or trade. Glen Richie, 643 Diamond Road, Salem, Va. 24153.

**FOR SALE:** DX-40 trans. \$25; NC-98 rcvr \$50; Mint condition ARC-S BC-457-A xmtr—\$5. All plus postage. Glenn, WB6ZQQ, 3592 Valencia Hill Dr., Riverside, Calif. 92507.

**CLEANING SHACK!** Sell R55A receiver and Eico 722 VFO. \$25. a piece. Wat say? Kirt Fanning, 6021 Edgewood, LaGrange, Ill.

**FOR SALE:** Tri-Ex T588 88' tower \$150. Abt 90' 50 ohm alum coax, \$30. Delivery within 100 miles. Paul Etchberry, 1220 S. Marsh Ave., Reno, Nev. 89502.

**SELL:** HP 560A digital printers—\$200 each. HP560A-58 comparator plug-ins \$15. each. HP AS4-A G indicating decade counters—\$3. SASE brings list—WA4RGL, GR Trammell, 1507 White Oak Court, Va. 24112.

**WANTED:** April 1968 Ham Radio magazine. Dave Cook, 3917 A Kingsbridge Rd., Chattanooga, Tenn. 37416.

**SELL** HW32—\$80.; KWM2-A-790 32S1—\$400.; Drake T4X—\$250.; R4A—\$260.; BTI-LK2000—\$550. like new. F. L. Baker, Box 546, McComb, Ohio 45858.

**RTTY INFORMATION** for the Amateur interested in RTTY. F. DeMotte, P.O. Box 6047, Daytona Beach, Florida 32022.

**WANTED:** Linear Amplifier. 30L1 or 2K2/3. Please quote lowest cash price. K4IE, 705 L. W. Towers, Lake Worth, Fla. 33460.

**1969 ARRL S. W. Division convention.** San Diego, California. October 17-19, 1969. P.O. Box 1469, San Diego, Calif. 92115. Don't miss it. WB6SQZ.

**SELL** BC-453 \$10; 375 Rotor-Inductor \$8. Smith; 915 Lovera, San Antonio, Texas. 78201.

**WANTED:** Used comm. Rcvrs. in bad but serviceable condx. must be cheap. W3SHP, Herb, 202 W. Pine, Selingsgrove, Pa. 17870.

**TOWER:** Rohn SD1-5-88G New 88' crank-up/tilt-over. Cost me \$1500, you \$750. Bill Costello, W3BQN, Rt. 2, Box 192-B, Annapolis, Md. 21401. (301) 757-2637.

**SELL** Three unused perfect 826 tubes for \$8.50 each. H. A. Roddick, 5105 East Sunset, Yakima, Wash. 98901.

**FOR SALE:** Viking 500, Al condx, manual, orig. cartons. Best offer F.O.B. Omaha, Neb., Lee Menshik, W0NNW, 4538 Polk, Omaha, Neb. 68117.

**FOR SALE:** Heath VF-1 VFO, in good condx, \$9.00. AR single speed turntable with older empire cartridge, \$45.00. K9WVJ, Box 3679, U.S. Air Force Academy, Colo. 80840.

**FOR SALE:** Antique 1938 Chevrolet 1-ton pickup truck. \$125.00. Good condition. Rudolph, 743 Berryville Ave., Winchester, Va. 22601.

**FOR SALE:** Collins commercial transmitter converted for the amateur bands, 160 thru 10 meters. 1000 watts am, cw, ssb. Might trade for five band transceiver or FM gear. Interested parties contact Ike Blevins, 424 Lynn St., Richardson, Texas. 75080.

**RANGER II,** Excellent condition. Best offer over \$110. Will ship. Bro. D. Gerald Malseed, Calvert Hall College, Towson, Md. 21204.

**MINT CONX:** Central Electronics 100V, \$3.75. Also, matching 600L Linear, \$150.00. The 600L needs some work. WA5RTG, P.O. Box 486, Siloam Springs, Ark. 72761.

**B & W 5100 and 51SB** combination Chester Ludlam, 2309 Bullington, Wichita Falls, Tx.

**FOR SALE:** Globe Champion 300A and Hallicrafters SX96 \$200.00. Art Winnike, KOPDL, Rockwell city, Iowa. 50579.

**GENERAL COVERAGE HALLICRAFTERS:** Best SX122 mint condx. \$185. K4JK, 2804 Broadway Dr., Huntsville, Ala. 35810.

**FOR SALE:** Oscilloscope heathkit model 10-18 completely wired and in good operating condition 2 months old \$90. WA1ING, RFD #1, Box A-9, Saunderstown, R.I.

**GOING TO SCHOOL:** Selling a precision built Heath HW-100 XCVR & HP23A P.S. Factory tuned and aligned. Make offer. A.H.S., WB4KQV, 805 Burton Street, Rocky Mount, N.C. 27801.

**SBE SB-34** transceiver, latest factory mods, factory manual, mobile mount. \$275. WA6AVJ, 4135 Jackson St., Riverside, Calif. 92503.

**WANTED:** Antique radio tubes made prior to 1920. W2EZM, 431 Oakland, Maple Shade, N.J. 08052.

**WANTED:** Novice transmitter or transceiver under \$100. Will trade or sell a Nat. 183-D receiver. K. Metzgar, RD #3, Stoystown, Pa. 15563.

**I have two fine transceivers,** will sell only one. Min condition NCX-5 with NCX-A AC power, both \$450. Also brand new Hallicrafters SR-400 with PS-500 AC power unused, both \$755. Plus shipping. Merrill Eidson, W5AMK, Temple Texas. 76501.

**OLD OLD TIMERS CLUB** membership open to all amateurs on the air for forty years. Send your QSL card to W0CVU, Chas. W. Boegel, Jr. 1500 Centerville Point Road, NE, Cedar Rapids, Iowa.

**FOR SALE:** SR-150 with 120 & 12 volt power supplies plus 15/20 Hustler antenna \$400. local pickup. W2DEW, 70 Basswood Tr., Wayne, N.J. 07470.

**COLLINS 51-J-3-\$400.00,** NCX-5 MK II with AC supply and Calibrator—\$550.00. VK-501 Remote V.F.O. for NCX-5 New \$150.00. Stamp for list. J. Shank, 21 Terrace Lane, Elizabethtown, Pa. 17022.

**SELL:** Excellent HW-22 w/AC, \$119. Perfect HA-14 "Kom-compact" w/AC \$135. Viking I, vy clean, \$39. All w/cables & manuals, FOB. Bill Lindblom, 512 Grandview, Chillicothe, Mo. 64601.

**FOR SALE:** Revised plans and Specs. 42' crank-up tower—\$2.00. 1007 Janlee, Burkburnett, Texas. 76354

**WANTED:** Old battery operated radios of the early 1920's. Need not be in working condition. Also want early wireless gear and CQ & OST magazine binders. D. T. McKenzie, K0SVJ, 1200 W. Euclid Ave., Indianola, Iowa. 50125.

**HAVE** Mint oscilloscope AN/USM 38 to trade for HA Transverter & supply. Also have Jackson Condense checker model 650. Trade for TWER or Sixer. K5BTC, J. P. Fuqua, Route 1, Box 1, Box 118, Anderson Texas. 77830.

**WANTED:** OMNIGRAPH Automatic Code Sender. W7BIF, 107 Wyoming St., Boulder City, Nev. 89005.

**COMPLETE STATION:** WRKED 92 countries, WAQ was so far. Trans, Rec, VFO, Relays, Breakin, other ACCS. \$200, write for info. Ed, WA3GVP, 1320 Taney Dr., Beltsville, Md. 20705.

**WANTED:** 220 volt Variac 2 to 4 KVA. Sell 4 almost new 813's \$7. each. Paul Bittner, 814 4th St. South Virginia, Minn. 55792.

**NOVICES:** Heath rig-HW-16 transceiver, HS-24 spkr 5 crystals, key, all for \$100.00. E. Stirratt, 76 Woodridge Ave., Buffalo, N.Y. 14225.

**GENERAL COVERAGE:** Heath receivers, GR-64 \$25 GR-54 \$60. Both for \$75, plus shipping. E. Stirratt 76 Woodridge Ave., Buffalo, N.Y. 14225.

**FOR SALE:** CE 100V, GSB-101, 75A4 (#4566) 4 e quad, 88ft. c.u. tower. Send SASE. J. Walker, 32 Carpio Dr., Diamond Bar, Calif. 91766.

**FOR SALE:** Hammarlund SP-600-JX-17 receiver good condition for \$285.00. Heathkit DX-60, HG-10 VF for \$70.00. Dale L. Sommers, 200 West Paradise Street, Orrville, Ohio. 44667.

**WANT TO BUY** old radio gear, call books, Handbook magazines, and books prior to 1925, for amateur museum. Want early broadcast receivers as well. Erv Rasmussen, 164 Lowell, Redwood City, Calif. 94062.

**HEATH HW22** 40 meter SSB transceiver FB condition \$70. plus shipping. Art Johson, K2POA, 2 Boone Street, Bethpage, N.Y. 11714 Phone 516-933374, evenings.

**BACK ISSUES:** CQ & QST excellent condition. Most all issues. 1957 through 1968. Best offer. Robert David, Jr., K0KJV, 837D N. McKnight, St. Louis 63132.

**SALE:** Swan 412 DC mobile supply & VOX same as new. Will pay delivery charge. W4ALG, \$125.00. M Johnston, 2625 University Blvd., Tuscaloosa, Al 35401.

**WANTED:** Gonset model 3349 AC power supply for G-76 Transceiver. Indicate condition when stating price. W3PVZ, 300 Third Avenue, Burnham, Pa. 1700

**AM TRANSFORMERS** rewound, Jess Price, W4CLJ, 11 Gunby Ave, Orlando, Fla. 32801.

**THE AUSTRALIAN EEB** is an informal electronics experimenters bulletin covering many subjects of interest to hams. Send for sample copy: Box 177, Sandy Bay, Tasmania 7005, Australia.

**WANTED:** Contact with anyone who has converted the V.U. Fax units or is now converting with possible schedule. Also SSTV. Al Johnson, W6EPO, 594 Alderson St., El Cajon, Calif. 92021.

**WANTED:** 3 or more elements 10-15-20 mtr. beam, Collins 312B-4, F455Q-5 filter for sale: Drake T4X mtrs. and supply. F. Higson, 14 Foster Rd., Bedford, Mass. 01730.

**TRADE:** Nicca III-s with t2 lens 1/500 shutter and Canon 135mm f3.5 telephoto lens for good transmitter + P.S. KORFX, 1409 Bel Air Dr., Junction City, Kansas. 66441.

**FOR SALE:** Wheatstone perforator tape. P. Lemon, 154 Stony Pt. Rd., Santa Rosa Calif. 95401.

**ATTENTION:** I need a Heath HG-10, HG-10A, or a HG-10B VFO. Will pay your fair price, must be in operating condition, requiring no alignment. Cabinet can be in any condition. If you have one, phone (505) 393-3998 or write L.D. Sweet, Box 51, Hobbs, N.M. 88240.

**WANTED—Collins KWS 1—**Must be in good condition and available for test. Will pay a reasonable value for the transmitter and power supply, etc. Kenneth L. Schwartz, 10 Fiske Place, Mount Vernon, New York 10550, (914) 668-3534.

**FOR SALE:** 2 If translator—Collins 544-9286-00 \$50. each, 3 Collins PTO for R-392/URR \$75. each, or best offer. All new. K25MA, Box 1657, Balboa, CZ.

**SELL:** Ranger and Couvier Amp. Both excell. and with manuals. Pick-up. R. Schweizer, 240-27-145 Ave., Rosedale, L.I., N.Y. 212-LA 8-6124.

**SAROC** Fun Convention in Las Vegas, January 7-11, 1970. QSP QSL for details SAROC, Box 73, Boulder City, NV 89005.

**SALE:** Misc. parts, tubes, X formers, Var. caps, resistors, etc. Priced very low, SASE for list. A.M. Fox, Box 895, Greeley, Colo. 80631.

**75A4** used less than 10 hrs., extra-mint condx, all modifications, manual, \$390. S. A. Tucker, 51-10 Little Neck Pkwy, Little Neck, N.Y. 11362.

**FOR SALE:** Collins 75A-1 rx perfect mint condx—\$150/trade toward another RX. Eico 723, mint—\$35. Gross, 36 Gerhard Rd., Plainview, N.Y. 11803.

**SALE:** Hammarlund HX-50 transmitter 90 watts A. condition \$190. P.P. James C. Owen, III, K4CGY/3, 15 W. Harrison St., Rockville, Mo. 20850.

**SELL:** 75A-2 w/spkr, calib, Prod. Det., \$225; LM-5 req Meter; 4-125 A's \$18.00; Motorola 150 mc FM MTR 60 watts; Gonset 10 mts Mobile Converter; N-50w \$30. or trade for CN-144. WA3BGN, 6117 Smithfield St., Harrisburg, Pa. 17112.

**COLLINS** 75S3 Rcvr., \$425. Collins 32S3 XMTR with 16F-2 supply, \$575. WA8ONP, Al Schnorrenberg, 612 Jennings Ave., Salem, Ohio. 44460. Phone (216) 37-7518.

**WANTED:** Schematic for BC-1995 A receiver that tunes 18-65 Mhz. Please give your price in the first letter. WA4FCC, John E. Carr, Route #2, Rockmart, Ga. 30153.

**FOR SALE:** Perfect Hallicrafters SX-99 \$75., with Heath Q-Multiplier & FET preselector \$85. KOWTS, Schrimsher, 7004 N. W. Hwy. 9, K. C., Mo. 64152.

**WANTED:** Master mobile #2495 motor driven loading coil with control. George Rice, WB6NPC, 5001 Milton Street, San Diego, Calif. 92110.

**WANTED:** Handbooks & old QST. Sell QST after 1930, Guimares, 17 West End Ave., Middleboro, Mass. 02346.

**FOR SALE:** HQ145C great condx! \$160; Globe Scout model 680, 65 wts 80 to 6 mtr \$30; call 201-376-2679, write Tim Wilson, WA25JR,, 9 Denham Rd., Springfield, N.J. 07081.

**FOR SALE:** 40 meter transmitter/receiver \$35., Eddy-stone dial #893, \$15., 4-65 tube \$5., 40 meter Novice transmitter \$30., W6BLZ, 528 Colima St., La Jolla, Calif. 92037.

**HEATH** HW-16 CW transceiver, \$85. and Heath HW-32A SSB 20 meter rig, \$95.00. also Vibroplex Deluxe Original key, \$30.00. Jim Honey, Box 362, Anna, Illinois. 62906.

**SELL OR TRADE:** B & W Switch 380 and Drake TV-100-LP for matchbox, or \$25. Also need Dow-key 5 position coax switch. WAZDEY, J. Randel, 86 Fairmount Ave., Chatham, N.J. 07928.

**FOR SALE:** Low capacity filament transformer for 4-1000 G.G. amplifier 20 MMF. W4GD, 3087 Carnes Ave., Memphis, Tenn. 38111.

**KWM-2 PM-2** \$750., 75A4 matching spkr \$375, HT-32 \$275., Jones MicroMatch \$25, Eico 147AK tracer \$25., K2SRO RFD 1 Millville N.J. 08332.

**FOR SALE:** Send SASE for list of Amateur crystals for sale all bands 160 through 2 meters in FT-243. Also many novice Freqs available K8LJQ, 351 Mower Rd., Pickney, Mich. 48169.

**DANGER:** Your progress line FM gear collecting dust is needed by me! Send list and price to WA4ZYU Rich. Beatie, 1904 114 Ave., Tampa, Fla. 33612.

**FOR SALE:** Eico 753, d.c. supply, SX-101A mint with speaker, Heath Marauder. John Wagner, 662 W. Lincoln, Caro, Mich. 48723.

**SELL:** Like new NCX-3 with AC supply. No scratches or marks. Absolutely perfect condition. \$250. Two telrex six element meter beams with stacking harness, Craig Pitcher, 829 S. 20th St., Terre Haute, Ind. 47803.

**SELL:** 42 foot Spalding self-supporting tower, TR-44 rotor, and TH-3 beam with coax, \$200. Will separate if you take down. Tower located in Barrington, Illinois. Contact Craig Pitcher 829 S. 20th St., Terre Haute, Ind. Ph. 235-6302.

**WANTED:** Schematics and manuals for—RCA Receivers RBA, 15-600 kc.; RBB 500 kc. to 4 mc., RBC 4-27 mc. Will buy, borrow or pay for copy privilege. J. I. Lisaius, 116 Orton Rd., W. Caldwell, N.J. 07006.

**FOR SALE:** 75A4 three filters and speaker recently modified, excellent condition \$400.00. Reynolds, 40 Fern Ave., Box 443, Buzzards Bay, Mass. 02532.

**LINEAR POWER** Sup. qual comp w/ART-13, \$50. Want 4CX-250. Tape record. Bell Mono—\$25. Webcor Stereo \$50. W6RTD, 31 Celine Dr., Santa Barbara, Calif. 93105.

**WANTED:** 592/3-200A3 tubes, for cash or trade. A. Burgstahler, WA6AWD, 8631 Willis Ave., 9, Van Nuys, Calif. 91402. (213-894-7685)

**FOR SALE:** Gonset G-11 CB. Rx works, needs minor repair, no mike, otherwise in good condition. Will ship PPD. \$20.00. WA8KJJ, Fred Clinger, 640 Grove Ave., Galion, Ore. 44833.

**WANTED:** Hallicrafter FM Receiver S-36A 27-143MC, or low band Monitor Receiver 30-50-MC. Reasonable. Edward Weeb, 306 Walker Street, No. Adams, Mass. 01247.

**SAROC** fun Convention with entertainment only Las Vegas can present, January 7-11, 1970. QSP QSL SAROC Box 73, Boulder City, Nev. 89005.

**WANTED:** Hallicrafters SX-16 with manual, condition unimportant. E. A.Sjolander, 119 7th St. W, Ashland, Wisc. 54806.

**WANTED:** DeForest Audion, original spherical design for display in my original DeForest unit. State price or trade. R. W. Field, K41v, RR2, Owensboro, Ky. 42301.

## Announcements [from page 15]

### Rome, New York

The Rome Radio Club presents their 16th annual Ham Family Day on Sunday, June 1 at Beck's Grove, ten miles west of Rome, N.Y. Features include technical talks, a mobile DX contest, a technical quiz and door prizes. Also, participants in the flea market are invited. An afternoon of entertainment for the ladies and children is planned. Registration starts at noon with that famous chicken and steak dinner at 5 P.M. Advanced adult reservations \$5.00, at the gate \$5.50. Children under 12 \$2.00, under 6 free. Send reservations and direct inquiries to Rome Radio Club, Box 721, Rome, N.Y. 13440.

### Somerset, Pennsylvania

The Somerset County Amateur Radio Club will hold its Hamfest on June 8th, at the Casebeer Church Grove, located on Route 219, about 7 miles north of Somerset, Pa. (or exit #10 of the Pennsylvania Turnpike). Hours will be from 9:00 A.M. until 5:00 P.M. Plenty of free parking. Special catering group will sell refreshments. Flea market and ham swaps. Tickets in advance \$1.50, at the door \$2.00. Tickets and additional information can be obtained from Theodore J. Leonberger, K3RCI, Rd. #2, Rockwood, Pa. 15557.

### Winfield, Pennsylvania

The sixth annual Penn-Central Hamfest by the West Branch and Milton groups will be held Sunday, June 8th, starting 12:00 noon, at the Union Township Volunteer Fireman grounds, on Route 15, Winfield, Pa. Informal, picnic style, no speeches, no banquet, snack bar handy or bring your own lunch...come and go as you please. Auction, contests, swapping, gabfest. Free parking, with both indoor and outdoor facilities provided. Registration at the gate \$2.00, XYL and children admitted free. Exhibits welcome. For information Contact: Milo H. Frey, K3MSG, Quarry Road, Muncy, Pa. 17756.

### Humboldt, Tennessee

The Humboldt Amateur Radio Club will hold its fourth annual Hamfest on Sunday, June 8th, at Scoutland Camp, located one mile north of Humboldt, Tennessee on U.S. Hwy. 45-W. Participants are invited to bring their picnic lunch or use suitable restaurant facilities near-by. There will be eyeball QSO's and programs of interest to the hams and ladies. Items to swap or sell are welcome. For more information, contact Ed Holmes, W4IGW, 501 N. 18th Ave., Humboldt, Tenn. 38343.

### Augusta, Maine

The Augusta (Maine) Amateur Radio Club will hold their 10th annual Hamfest at the Calumet Club, Route 104, Augusta on June 15th. It will be preceded by an open house and get-together on Saturday evening (June 14th) at the same location. Pre-registration, adults \$4.25, children under 12, \$3.25. At the door \$5.00. For further details contact R. H. Parker, W1TO.

### Atlanta, Georgia

The Atlanta Radio Club will hold its annual

Hamfest, June 14th and 15th at the North D Kalb Shopping Center, Atlanta, Georgia. The first prize in their drawing will be a color television set, along with other prizes to be announced later. In addition to regular Hamfest activities, they are aiming for the largest amount of equipment to be bought, traded and sold, any Hamfest in the southeastern United States. Further details may be obtained by writing Joe Fearon, 3384 Peachtree Rd., N. E., Suite 777, Atlanta, Georgia 30326.

### Massachusetts A. R. Week

The amateur radio operators of Massachusetts invite all amateur radio operators to participate in the First Massachusetts Amateur Radio Week. A certificate of recognition will be issued to amateurs who take part in the operating award program during the week. Operating times are from 0100 GMT on June 15th to 2400 GMT on June 21st. Rules to earn the certificate are as follows:

1. A. Massachusetts amateurs must work 5 other Massachusetts amateurs.  
B. The rest of New England state amateurs must work 8 Mass. amateurs.  
C. All other amateurs in the U.S. must work 5 Mass. amateurs.  
D. DX, including KH and KL, must work 5 Mass. amateurs.
2. Any band and mode may be used. All amateurs who submit logs meeting the above requirements will be issued a certificate signed by the Governor who has proclaimed June 15-21, 1969 to be Massachusetts Amateur Radio Week.
3. All stations participating will exchange a personal report, county & state. Logs must show date, time, and frequency of contact. Certificates will be endorsed for band and mode only if requested.
4. Applications must be received no later than July 31, 1969, and accompanied by a business size self-addressed stamped envelope. DX enclose one IRC.
5. Submit applications to Bill Holliday, W1EZA, 22 Trudy Terrace, Canton Mass. 02026

### BC-454 Q5er [from page 22]

#### Alignment

Alignment can be accomplished by tuning in a strong signal in the usual manner on the BC-454 while listening to the BC-454 audio. Once a signal is tuned in, shut off the audio from the BC-454 and tune the BC-454 by ear tuning (which is now second l.o. tuning) until the same signal is maximized on the BC-453 audio. Do *not* turn the BC-454 tuning while making this adjustment. You will note a considerable improvement in selectivity which is sufficient to make this a good second receiver for eighty meter MARS frequencies out of the range of 1.8 MHz. Band only receivers can be satisfactorily worked using this arrangement.

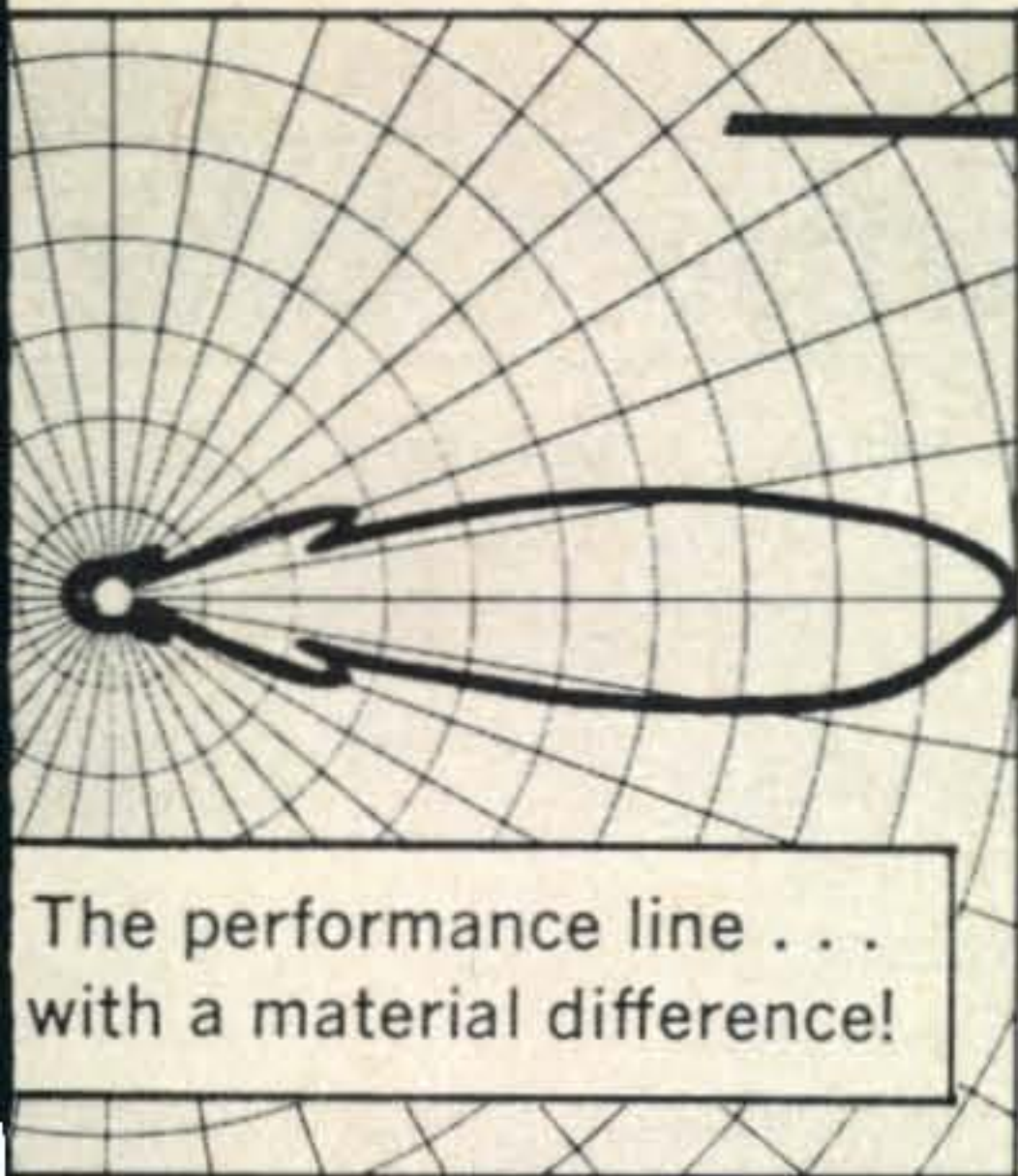

# telrex

PREFERRED AND SPECIFIED WORLD-WIDE BY  
COMMUNICATION ENGINEERS AND ADVANCED AMATEURS

Don't settle for anything less than the very best! Use Telrex Communication products — for long lasting optimum performance and value!

FREE . . . Tech data and pricing catalogs describing off-the-shelf and custom-built antennas, systems, "Inverted-vee kits"®, towers, mono-poles and rotatable "Berthas".

For commercial and military applications write for CM69 . . . for amateur applications write for PL69.

COMMUNICATION SYSTEMS SINCE 1921  
**telrex** Laboratories  
 Communication Engineering

ASBURY PARK,  
NEW JERSEY 07712, U.S.A.

The performance line . . .  
with a material difference!

LARGEST SELECTION IN UNITED STATES  
AT LOWEST PRICES — 48 HR. DELIVERY

Thousands of frequencies in stock.  
Types include HC6/U, HC18/U,  
FT-241, FT-243, FT-171, etc.

Send 10¢ for catalog with oscillator  
circuits. Refunded on first order.

2400A Crystal Dr., Fort Myers, Fla. 33901

**IAN**  
CRYSTALS

## EASY TO LEARN CODE

It is easy and pleasant to learn or increase speed the modern way—with an Instructograph Code Teacher. Excellent for the beginner or advanced student. A quick, practical and dependable method. Available tapes from beginner's alphabet to typical messages on all subjects. Speed range 5 to 40 WPM. Always ready, no QRM. Beats having someone send to you.



### ENDORSED BY THOUSANDS!

The Instructograph Code Teacher literally takes the place of an operator-instructor and enables anyone to learn and master code without further assistance. Thousands of successful operators have "acquired the code" with the Instructograph System. Write today for full particulars and convenient rental plans.

## INSTRUCTOGRAPH COMPANY

1746-C WEST BALMORAL, CHICAGO, ILL. 60640  
4700-C Crenshaw Blvd., Los Angeles, Calif. 90043

## HOW TO MAKE MONEY IN Mobile Radio Maintenance



AUTHORITATIVE GUIDEBOOK  
OUT THE BOOK IN TWO-WAY MOBILE-RADIO;  
GIVES FACTS, FIGURES, PAY RATES,  
WRITE TODAY!

FREE

PKIN LABORATORIES, INC. Electronic Div. BRADENTON, FLORIDA 33505



## MODEL RTY-3

Improved model of our solid state RTTY receiving converter. Three shift frequencies, 850, 425, and 175 cycles. This audio filter converter has proved itself in many ham shacks. The circuit is made up of limiter, amplifier/filter driver, 3 stage filter, detector, pulse shaper, and selector magnet keyer. 100 volt 60 ma. loop supply included.

Model RTY-3SB filters, tuned for operation  
with SSB transceivers

179.95

Model RTY-3K same as Model RTY-3 but  
with built-in AFSK keyer.

159.95

Still only

139.95

# AQUADYNE INC.

P.O. Box 175 EAST FALMOUTH, MASS. 02536

## READER SERVICE

To obtain literature from advertisers, simply check the box next to the name of each advertiser listed below whose product or service is of interest to you. We'll pass your name on and you'll get literature from the advertiser in short order.

**This Form Expires May 31, 1969**

- Ameco Publishing Corporation
- Antennas, Inc.
- Aquadyne, Inc.
- Arcturus Electronics Corp.
- Arnold's Engraving
- Arrow Electronics
- Barry Electronics
- Caringella Electronics
- Columbia Electronics
- Community Electronics
- Crystek
- Denson Electronics Corporation
- Eimac, Division of Varian
- Essco
- Fair Radio Sales
- G & G Radio Supply Co.
- Goodheart, R. E.
- Gordon Company, Herbert W.
- H & L Associates
- Hafstrom
- Ham Shack
- Harrison
- Heath Company
- Henry Radio Stores
- Hy-Gain Electronics Corporation
- Instructograph
- International Electronic Systems, Inc.
- Jan Crystal
- L & S Electronics
- Lampkin Laboratories, Inc.
- Liberty Electronics, Inc.
- Millen Mfg. Co., James
- Mosley Electronics Corporation
- National Radio Company
- Radio Officers Union
- R & R Electronics
- RCA Electronic Components
- Howard W. Sams
- Sentry Mfg. Company
- Signal/One
- Slep Electronics Company
- Space Electronics Corp.
- Structural Glass Co., Ltd.
- Syncom Electronics Unlimited
- Telrex Communications Engineering Laboratories
- Terado Corporation
- WRL World Radio Laboratories
- World QSL
- Zalytron Tube Corporation

**CQ Reader Service**

14 Vanderventer Ave.  
Port Washington, N.Y. 11050

Sirs:

Please send me information on the products and services which I have checked above.

Name ..... Call .....

Street Address .....

City..... State..... Zip.....

## Advertiser's Index

Ameco Publishing Corporation	.....
Antennas, Inc.	.....
Aquadyne, Inc.	..... 1
Arcturus Electronics Corp.	.....
Arnold's Engraving	.....
Arrow Electronics	.....
Barry Electronics	..... 111, 1
Caringella Electronics	.....
Columbia Electronics	.....
Community Electronics	.....
Crystek	.....
Denson Electronics Corporation	.....
Eimac, Division of Varian	.....
Essco	..... 14,
Fair Radio Sales	.....
G & G Radio Supply Co.	.....
Goodheart, R. E.	.....
Gordon Company, Herbert W.	.....
Gotham	.....
H. & L. Associates	.....
Hafstrom	.....
Ham Shack	.....
Harrison	.....
Heath Company	..... Cover II
Henry Radio Stores	..... 39,
Hy-Gain Electronics Corporation	..... 2, 9, 16,
Instructograph	..... 1
International Electronic Systems, Inc.	.....
Jan Crystal	..... 1
L & S Electronics	.....
Lampkin Laboratories, Inc.	..... 1
Liberty Electronics, Inc.	.....
Millen Mfg. Co., James	.....
Mosley Electronics Corporation	.....
National Radio Company	.....
Radio Officers Union	.....
R & R Electronics	.....
RCA Electronic Components	..... Cover
Sams, Howard W.	.....
Sentry Mfg. Company	..... 6
Signal/One	.....
Slep Electronics Company	..... 1
Space Electronics Corp.	..... 42,
Structural Glass Co., Ltd.	.....
Syncom Electronics Unlimited	.....
Telrex Communications Engineering Laboratories	.....
Terado Corporation	.....
WRL World Radio Laboratories	..... Cover
World QSL	.....
Zalytron Tube Corporation	.....



Tubes... Largest diversified stocks in USA. Our specialty: Tubes, Semiconductors, Ham, CB, Electronic Equipment and Parts. Write for catalog #19... Cash paid for Unused tubes, and good Equipment & parts. Write us today for items you wish to sell. When in NYC, visit us. Hours: Mon.-Fri. 9-5:30 and Sat. 10-2:30. Free parking on street on Saturdays.

### G.E. RADIO NOISE FILTER

Power rating: 25A. @ 440 VAC. 3 Phase power lines may be filtered by using 3 of these units (1 unit in each leg). \$1.50 Cat. #20-42.

### MAGNIFIER MODEL 500

All purpose magnifier. Excellent for easy reading of callbooks, etc. 6" Wide. Comes with built-in stand that rests over lines to be read, and allows magnifier to slide down easily as one reads. Unbreakable plastic. Only \$1.95.

### BIRNBACH #765 ANTENNA SPRING ADJUSTER

Automatically takes up slack in doublet or wire antenna systems via built-in spring. Also good for taking in slack out of coax lead-in cables. Ceramic insulator on each end has 3/8" dia. hole. Accommodates RG58/U or RG59/U coax thru eye of insul. 9 1/4" L x 1 1/4" W x 7/8" D. \$1.00 each. Cat. #20-7.

### RG-58/U COAX CABLE SPECIAL

Consists of 21 feet of RG-58A/U coax with phono plug on one end and the other end stripped, tinned and ready to hook up. 52 Ohms Imped. Ideal for mobile stations. Plugs right into many CB Transceivers. .95 Cat. #20-6.

### 0-1 Ma. D.C. MILLIAMETER

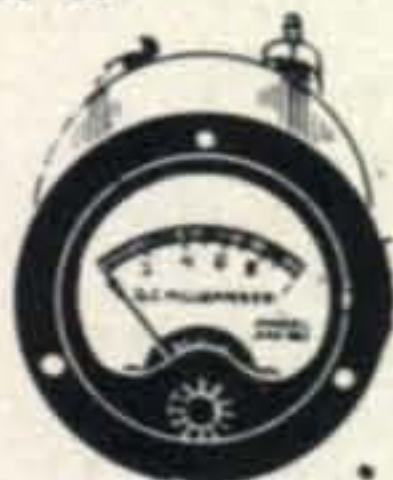

2 3/4" Round. Shielded against RF. Mts. in stan. 2 1/4" Dia. hole. Sun Mfg. Co. Model 2AU321. Unused, in orig. Gvt. Boxes. Ltd. qty. Cat. #20-26. \$2.95.

### TUBE TYPE 6DJ8/ECC88

Twin Triode. Amperex. Designed for use in cascode circuits, RF and IF Amplifiers, mixer & phase-inverter stages through use of sep. cathodes.

## BARRY ELECTRONICS

Lower input cap. & higher transconductance (12,500 Micromhos) will improve most Ham converters and TV tuners that use 6BK7, 7BQ7 & 6BZ7 tubes, just by using one or two resistors to reduce voltage in the circuit. Heater 6.3 V. @ 365 Ma. for parallel fil. oper. only AC or DC. Cat. #20-24. \$1.20. 10-99 @ .90; 100 & Up @ .80 each.

### ALLEN-BRADLEY .001 MFD. STANDOFF BY-PASS CAPACITORS

Tested @ 1,000 V. Mts directly on chassis via a #6-32 x 1/4" L Mach. screw stud. Excel. as a VHF or Gen. Purp. By-Pass Cap. 3/8" Diam. x 5/8" H. Cat. #20-19. .20.

### 3" DIAM. CAP. BRACKET

Clamps cap. in place by simply flipping locking Tab. Sim. to Bircher type Clamp. Mfd. by Auguat. Cat. #20-18. 1-99 @ .25 each; 100-Up @ .20 each.

### DELUXE



### PORTABLE

### SCOPE/INSTRUMENT CART

The equipment cabinet is divided into 2 adjacent bays, each bay accommodating a standard 19" wide rack panel up to 14" high. Depth of cabinet is 15 1/4". The instruments set into the cabinet with front panels tilted back at a 45° angle to permit viewing while standing or sitting. A 14" x 39" panel at rear of cart is easily removed for quick access to equipment. Handy accessories bin in front of cart. Four 8" diam. ball-bearing wheels have rubber tires, set in swivel caster mounts. Bar handles at ends of cart facilitate easy mobility. A hinged cover protects instruments when not in use. Units are unused, in orig. crates, completely assembled and ready for use. Attractively finished in beige and polished aluminum. Overall size: 51"W x 23 1/2"D x 45"H. 305 lbs. crated. Excellent value. Cat. #20-17. Only \$129.00 each.

### ITT/KELLOGG INTER-OFFICE COMMUNICATOR

Designated "Director Cabinet Circuit". All units in original factory cartons. This handsome unit, when used in conjunction with the proper telephone access, becomes the heart of a 12 stat. intercom system. Con-

trol board has 12 illum. buttons for signalling ea. station. Has standard telephone dial on face and handset with hanger/switch on side. Copy of blueprint available. New, unused, in orig. Kellogg/ITT cartons. 14"W x 13 1/2"D x 8 1/4"H. 22 lbs. each unit. Cat. #20-12. \$75.00 each.

### 2.5 KVA ISOLATION TRANSFORMER

Pri: 115 VAC @ 50/60 Hz., 1 Phase. Sec: 115 VAC @ 2.5 KVA (22 A.) 2 Trans. may be combined to obtain the following: 5 KVA (115 VAC) Isolation Xfmr. 115 VAC input to 115 VAC output. (Parallel secondaries). 5 KVA. Isolation Step-Up Xfmr. 115 VAC in. to 230 VAC out. (parallel primaries; series secondaries). 5 KVA (220 VAC) Isol. xfmr. 230 VAC in. to 230 VAC out (Series Primaries, series sec.). 5 KVA Step-Down xfmr. 230 VAC in. to 115 VAC out. (series pri.; parallel sec.). Packed in orig. wooden boxes, unused. Excel. Cond. FOB, Ga. warehse. Cat. #20-34GA. \$29.95 each.

### NOISE-CANCELLING CARBON COMMUNICATIONS MICROPHONE



Brand new. Hand held. P.T.T. Switch (D.P.S.T.). One pair of contacts N.O., 1 pair contacts N.C. With Coiled Cord. High impact plastic case. Sensitivity better than minus 57 db at 300 Hz. Freq. Response: Plus or minus 10 db at 300 to 2500 CPS. Finest quality, for Amateur, Commercial and Industrial use. Purchased new from Raytheon. Special Price \$4.95 each. (Ten or more at \$4.50 each.) Only 6 Ozs. With spec sheet. Cat. No. 19-412.

### MECHANICAL FILTERS



These filters can be used in the construction of SSB and AM type communication equipment. COLLINS TYPE F250A-67 Center frequency 250kc Bandwidth -6db is 6.7 kc ±5% Bandwidth @ 60 db is 14kc Reasonating capacity 110 mmfd. Sig. input voltage from 0 to 5v RMS DC voltage 300 volt maximum Signal source impedance 50kc Load impedance 50kc. \$9.75.

### HALLICRAFTERS SR-42A

Two meter Transceiver. Very good condition. 117 VAC or 12 VDC. Reg. net \$219.95. SPECIAL \$125.00.

## NATIONAL NCX-3 SSB

Transceiver with National NCX-A 115 VAC P.S. and Speaker combination. \$195.00 for both units... Very good condx.

## ANDREWS

68 ft. of gas-filled Coax Cable. Highest-quality, with built-in air pressure meter. \$95.00.

## ANTENNA GROUNDING SWITCH

15,000 Volts @ 2,000 Amps. Unused. Weighs about 100 lbs. \$55.00

## ANTENNA WIRE

3 twisted #8 ga. one roll of 650 ft. and one roll 1300 ft. 5¢ per foot. Sold by the full roll.

## CRD ANTENNA ROTORS /CONTROL BOXES

AR22R @ \$34.95—TR-44 @ \$69.95. Ham-"M" @ \$129.95. All prepaid continental U.S.A.

## SPECIAL

## PURPOSE



## TRANSMISSION LINES

Open Wire Transmission line. Lowest Loss of all lines. Air dielectric styrene spacer. Ideal for hilly areas with long runs. No. 2500 Copperweld 450 Ohms—250 Foot Spool \$8.20, No. 2502 Copperweld 300 Ohms—250 Spool \$8.20 per 250 Feet.

## EIMAC SK-630 SOCKETS

For 4CX250B or 4CX250F, or the 4X150A series. Special price only \$8.50 each.

1296 Mcs, CAVITY 2C39A 3CX100A5 Tuned Cavity. Super-Deluxe (Made for Litton/Westrex for over \$300.). Cavity New at \$24.95. 1296 Mcs. w/Data.

## JENNINGS UCS 300 VACUUM VARIABLE CAPACITOR

Tuning Range: 10 to 300 Mmfd @ 7,500 Volts. Supplied with tuning head and mounting brackets. Shaft dimensions: 1/4" diameter x 1" Long. Unused, Lab-Tested OK 2 1/2"W x 2 1/2"H x 9 1/4"L. Cat. No. 19-249GA. Including Shaft. \$65.00.

## BC-1000 TRANSCEIVERS

940 thru 48 MHz.) VFO. \$29.50.

# BARRY ELECTRONICS

## BARRY ELECTRONICS

## GENERAL RADIO TYPE 240-B CAPACITANCE TEST BRIDGE

Measures from 5 uuf to 1100 uf. plus or minus 1%. Operates from 115 VAC 60 Hz. Good, used condition. With instructions. \$115.00.

## JOHNSON COMPACT

Medium Power Deluxe Rotary/Inductor. Johnson or similar. \$7.95.

## NEW LONDON INSTRUMENT MODEL 252 AM MODULATION MONITOR

Rack mtd. \$75.00.

## CARDWELL TYPE PL-8048 VARIABLE CAPACITOR

Tunes from 20 pf. thru 220 pf. .062" Air gap (2500 V.) Mycalex insulation. Orig. Cardwell boxed. \$7.95.

## CARDWELL TYPE PL-7114 VARIABLE CAPACITOR

Tunes from 10 pf. thru 20 pf. 0.187" air gap (6500 V.) Mycalex insul. Orig. boxed. Useful as plate or neutralizing capacitor. \$6.50.

## WESTINGHOUSE

160 AMP at

MINIMUM

## PIV SILICON DIODE RECTIFIER

Guaranteed minimum voltage rating: 50 PIV or better. Anode connection is made via 1 1/4" long flexible cable. Terminal lug hole Dia: 5/16". Worth many, many times our low price of only \$3.95. Order now, while we have an ample supply. Diameter: 1 1/8". Net Wt: 4 oz. Cat. No. 19-10 \$3.95.

## SUPER FLEXIBLE RG8A/U COAXIAL CABLE 20¢ per ft.

Unusual flexibility. Distinctive outer white jacket. Finest quality you can buy. Non-contaminating. Can be buried for up to 20 years. Outdoor use, better than 10 years. 50 Ohms nominal impedance: The extra

quality of this quality cable makes it worth much more than our selling price of .20¢ per ft.

## UHF 10 MMFD

VARIABLE

CAPACITOR

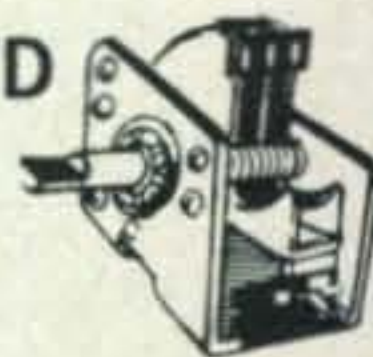

Tunes from 3 Mmfd. minimum to 10 Mmfd. maximum. Spacing: .06". Ideal for UHF applications: Mounts with 3 tapped 6/32" screws. Standard 1/4" shaft diameter x 5/8" Long. Flatted shaft for push-on knob, or screw-tightening knob. Net Wt: 2 ozs. Size: 1 3/8"W x 1"D x 1 1/2"H. Two stator plates and two rotor plates. Soldering lug on either side of stator. Ball-bearing rotation. Cat. No. 19-209. 39¢ each (ten for \$3.50).

## WESTINGHOUSE "OZ-PAK"

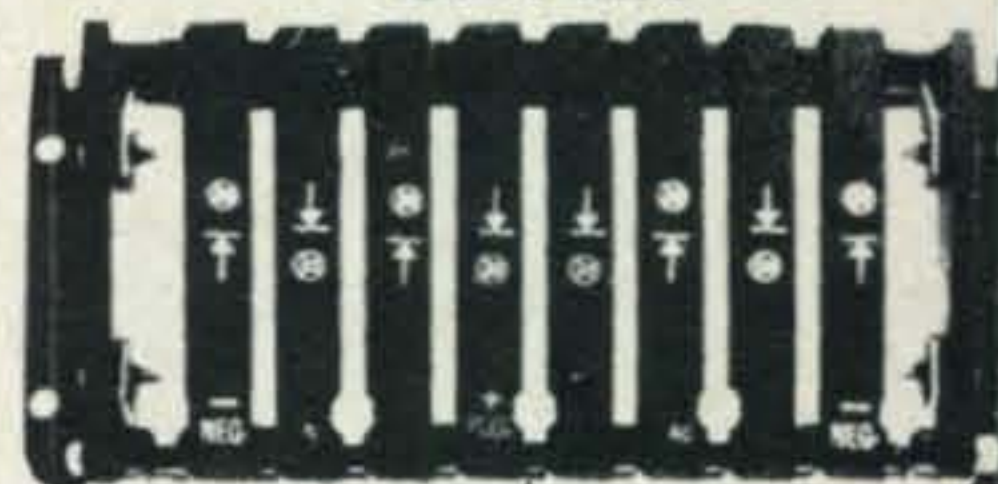

## HIGH VOLTAGE SILICON RECTIFIER

The OZ-Pak operates as a full-wave center-tap, or as a full-wave bridge rectifier up to 4000 V.D.C. @ 1.0 Amps. For amateur use the current drawn should not exceed 1 KW at the voltage used. Special units can be made for high voltages at slightly higher price. The OZ-PAK kilowatt silicon rectifier unit will replace the following popular tube types: 816, 866A, 872A, 8008 3B28, 4B32, 575A. These can be in either a full-wave center-tap configuration or a full-wave bridge assembly. Send for Westinghouse literature for further details of Standard OZ-Pak. Westinghouse #509C906K01. Size: 2" x 4" x 9 1/2" Net wt. 3 Lbs. Cat. #14-58. Covered by Westinghouse factory guaranteed \$69.50.

## RCA 6146 TUBES

@ \$3.25 each. (Two or more @ \$2.75 each.)

## 572-B TUBES

Brand New. Factory G'tee—\$13.99

## BARRY IS TUBE HQ. FOR USA/WORLD

6,000 Types Stocked—Unused/1 Quality. Name Brands—Try us. (V buy and sell and Swap as Well!)

**ONLY WRL MAKES THIS OFFER!**



**The Powerful New Galaxy  
GT-550 TRANSCEIVER**

The greatest break-through in 1969 Transceivers is Galaxy Electronics "hot" new GT-550.

It has all the great qualities of Galaxy engineering, plus a lot of great new features—yet is still a compact 11¼ x 12¾ x 6".

They call it "HOT, Husky and Handsome" and you will have to agree! The GT-550 has new Power... 550 watts SSB, is engineered like a fine watch and is a real beauty. Now available with a complete line of handsome matched accessories.

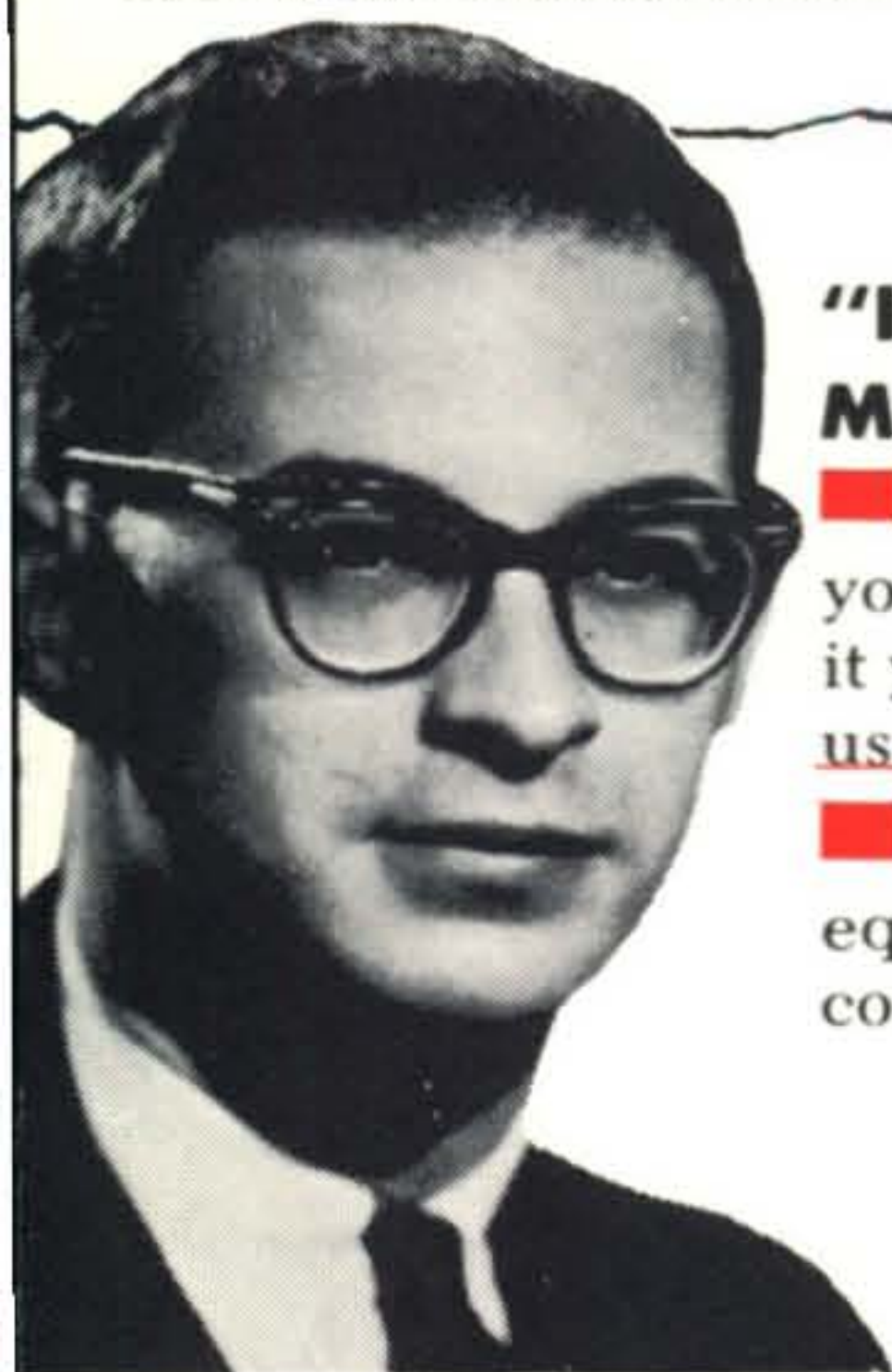

erry Meyerson  
WØWOX  
World Radio  
Labs



**"The House the  
HAMS Built!"**

**"You've Heard  
about it—read about it**

**NOW TRY IT —  
on a Two week  
FREE TRIAL\*  
in your Home!**

**—the Exciting NEW  
GT-550  
FIVE-BAND  
TRANSCEIVER!**

**"If you don't agree this is the greatest RIG  
Money can Buy—just send it back to us!"\***

■ We have the great new GT-550 in stock and we're so confident you'll like it that we're going to let you try one...actually operate it yourself on "no risk" two-week FREE trial in your home! Write us for Free Two-Week Trial information.\*

■ Remember, WRL gives the highest trade-in on your present equipment...offers an easy monthly payment plan (no finance company—direct with us.)

Check off your interests and mail in coupon!

**WORLD RADIO LABORATORIES** Dept. CQ-BB41  
3415 West Broadway, Council Bluffs, Iowa Zip 51501

Please send me the following: (F.O.B. Council Bluffs, Iowa)

- |   |   |
|---|---|
| <input type="checkbox"/> Information on GT-550 2-Week Trial | <input type="checkbox"/> Quote me a trade |
| <input type="checkbox"/> Free Galaxy GT-550 Brochure        | <input type="checkbox"/> Enclosed is      |
| <input type="checkbox"/> Free 1969 WRL Catalog              | Money Order                               |
| <input type="checkbox"/> Galaxy GT-550 Transceiver (\$475)  | <input type="checkbox"/> Check            |
| <input type="checkbox"/> SC550 Speaker Console (\$19.95)    | <input type="checkbox"/> Charge it        |
| <input type="checkbox"/> AC400 Supply (\$89.95)             |   |

Name \_\_\_\_\_ Call \_\_\_\_\_

Address \_\_\_\_\_

City \_\_\_\_\_ State \_\_\_\_\_ Zip \_\_\_\_\_

# When you look into your final look for the RCA-8122

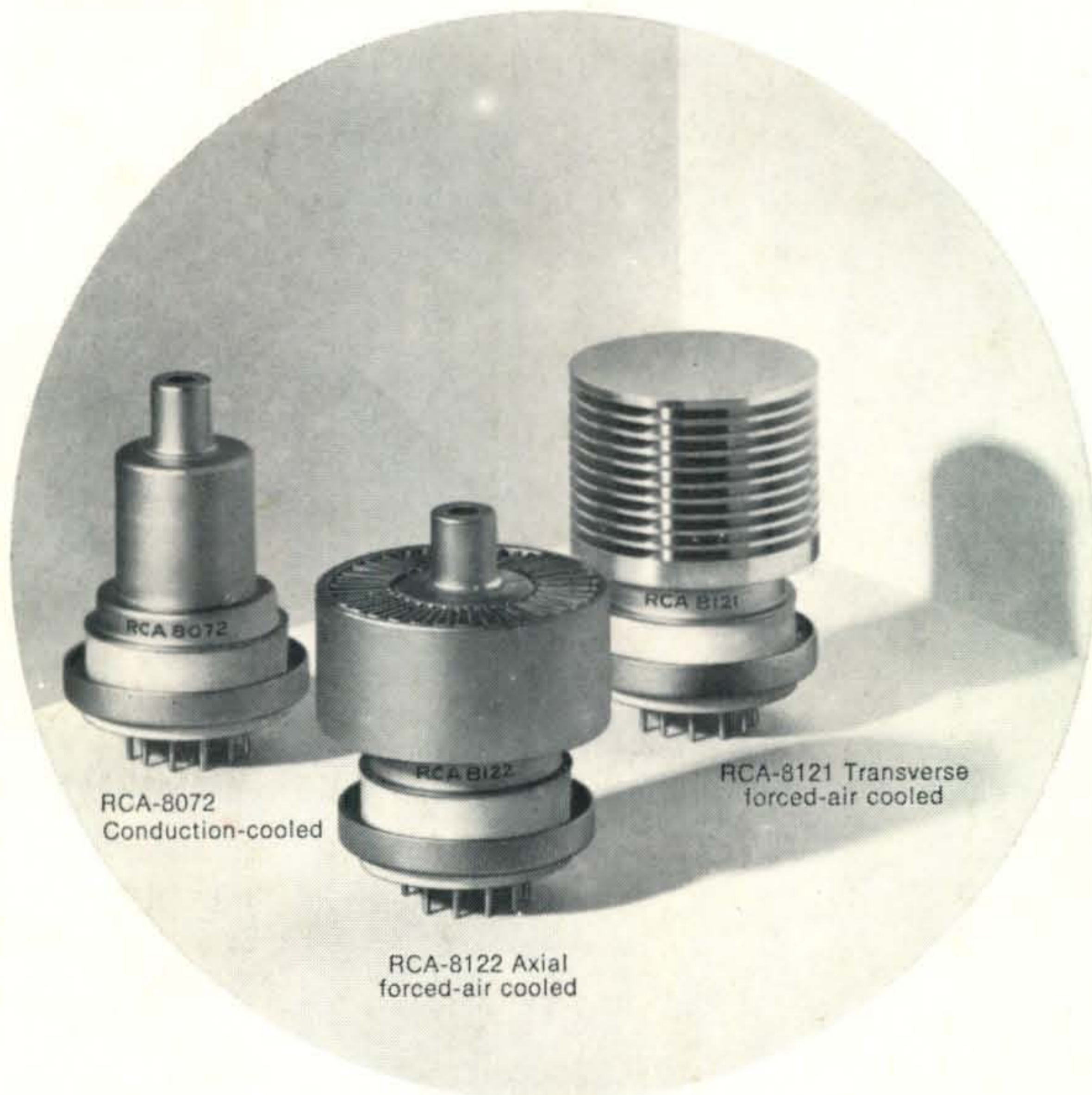

RCA-8072  
Conduction-cooled

RCA-8122 Axial  
forced-air cooled

RCA-8121 Transverse  
forced-air cooled

Not just because it's an RCA beam power tube, either! We think you deserve power and reliability—and we know, just as leading manufacturers of communications equipment know, that the RCA-8122 has more of both. For a starter, it has more than 50% greater dissipation capability than older tubes of comparable size...and delivers up to full rated output with as little as 5 Watts drive all the way to UHF. It gives you design options, too; the RCA-8122 is usable with coaxial, strip-line, or conventional lumped component tank circuit.

Reliability? This amateur type tube is a member of the same family as the 8072 and 8121 that brings the latest in tube technology to both medium and high power commercial and military equipments.

Ceramic-and-metal construction, exclusive electrode configuration, and precision-aligned grids eliminate mechanically-caused noise even at the high temperatures and severe vibration levels encountered in mobile service.

So whether you plan to buy or build, get the full story on the RCA-8122 as your first step. Write for a copy of the RCA-8122 Data Bulletin to RCA Electronic Components, Commercial Engineering, Section E15M, Harrison, N.J. 07029. Or see your local Authorized RCA Industrial Distributor for a copy of the new Power Tube Product Guide, PWR-506C.

**RCA**