

<http://www.cq-amateur-radio.com>

\$6.99

Amateur Radio

COMMUNICATIONS & TECHNOLOGY
OCTOBER 2023

CQ

- **Youth on the Air Camp, p. 8**
- **1000 Portable Operations, p. 12**
- **1A0C: DXpedition to the Heart of Rome, p. 32**
- **VHF: Spectacular Heat Brings Spectacular Tropo, p. 91**

On the Cover: "Mr. Portable" ... Vladimir Kovaceski, Z35M, uses his bicycle as an antenna support during one of his 1000 portable operations, this one at Ohrid Lake in Albania. Details on page 10; story on page 12.



Heard It.
Worked It.
Logged It.



IC-7851
The Ultimate HF / 6M Transceiver



IC-7300
HF / 6M SDR Transceiver



IC-7610
HF / 6M SDR Transceiver

For the love of **ham radio.**



www.icomamerica.com/amateur
insidesales@icomamerica.com



Upgrade Your Antenna, Get The Best Mag Loop Today!



HG1 Deluxe MLA

Portable & Quick Setup

- 80m to 10m *
- 45W PEP
- LMR600 Radiation Loop
- Calibrated 6:1 Manual Tuning Dial

\$535

HG3 Pro MLA

Remote Control & Auto Tuning

- 80m to 10m *
- 45W PEP
- LMR600 Radiation Loop
- Integrated SWR Bridge

\$1,335

HG3 QRO-A MLA

Precise Remote Tuning & High Power

- 80m to 10m *
- 1000W PEP
- LMR600 Radiation Loop
- Integrated SWR Bridge

\$3,025

When it comes to antennas, nothing beats the convenience and performance of our top-rated Magnetic Loop Antennas (MLA). Its compact and lightweight design makes it easy to deploy in any setting, making it the ideal solution for those with HOA restrictions. But don't let its size fool you, our MLA is a powerhouse performer, able to match or even exceed a dipole antenna. And with the integrated digital SWR bridge and precision stepper motor, in our HG3 series, auto-tuning has never been easier or more efficient.

Take your radio operations to the next level with a Magnetic Loop Antenna from PreciseRF®. When you choose our antennas, you're choosing a trusted brand with a proven track record. PreciseRF® is dedicated to providing our customers with the highest quality products and customer service. So, what are you waiting for? Get the best of the best and get on the air!

Visit us at [preciserf.com](https://www.preciserf.com) to purchase your MLA today!

Tested and Proven on Mt. Kilimanjaro

Get ready for your next Field Day with our SOTA-1 MLA. Crafted with lightweight materials, our MLA is the perfect companion for your SOTA expeditions. At only a fraction of the weight of traditional antennas, you'll be able to easily carry it with you on your hiking adventures.

Thanks to its quick and easy deployment, you'll be up and running in no time, ready to make the most of your SOTA experience. And with its QRP power handling capability of up to 15W PEP, you can trust that you'll be getting the most out of your radio while still keeping the weight of your gear to a minimum. Order your SOTA-1 MLA today and get ready to conquer the summits with your best SOTA performance yet!



SOTA-1 MLA \$435

- High-Q Capacitor
- 3:1 Reduction Dial
- 15W PEP
- LMR400 Radiation Loop
- Lightweight Nylon Bag

**Ideal for
Field Day**

• email: sales@preciserf.com • phone: 503-915-2490 •
• some features are optional • some limitations may apply • prices subject to change •
PreciseRF® LLC © 2023 V1.6



announcements

EDITORIAL STAFF

Richard S. Moseson, W2VU, Editor
Sabrina Herman, KB3UJW, Associate Editor
Susan Moseson, Editorial Consultant

CONTRIBUTING EDITORS

Kent Britain, WA5VJB, Antennas
Martin Butera, PT2ZDX / LU9EFO, At-Large
Gerry L. Dexter, The Listening Post
Joe Eisenberg, K0NEB, Kit-Building
John Ferguson, K3PFW, Emergency Communications
Trent Fleming, N4DTF, VHF Plus
Tomas Hood, NW7US, Propagation
John Kitchens, NS6X, Mobiling
John Langridge, KB5NJD, MF/LF Operating
Anthony Luscre, K8ZT, Ham Radio Explorer
Irwin Math, WA2NDM, Math's Notes
Joe Moell, K0OV, Homing In
Steve Molo, K14KWR, Awards
Eric Nichols, KL7AJ, Analog Adventures
Ron Ochu, KO0Z, Learning Curve
Jeff Reinhardt, AA6JR, Magic in the Sky
Scott Rought, KA8SMA, QRP
Don Rotolo, N2IRZ, Digital
Bob Schenck, N2OO, DX
Tim Shoppa, N3QE, Contesting
Jason Togyer, W3MCK, Spurious Signals
Gordon West, WB6NOA, Short Circuits
Wayne Yoshida, KH6WZ, The Ham Notebook

AWARD MANAGEMENT

Brian Bird, NX0X, USA-CA Custodian
Steve Bolia, N8BJQ, WPX Award
Jose Castillo, N4BAA, WAZ Award
Keith Gilbertson, K0KG, CQ DX Award

CONTEST MANAGEMENT

Andy Blank, N2NT, CQ 160 Meter Contest
John Dorr, K1AR, CQWW DX Contest
JK Kalenowsky, K9JK, CQ VHF Contest
Ed Muns, W0YK, CQ RTTY Contests
Joseph "Bud" Trench, AA3B, CQWW WPX Contest
Mark Wohlschlegel, WC3W, CQ DX Marathon

BUSINESS STAFF

Richard A. Ross, K2MGA, Publisher
Dorothy Kehrwieler, Associate Publisher,
Advertising
Richard S. Moseson, W2VU, Associate Publisher,
Editorial
Emily Kreutz, Sales Coordinator

CIRCULATION STAFF

Cheryl DiLorenzo, Customer Service Manager
Taylor Gilligan, Circulation Assistant

PRODUCTION STAFF

Dorothy Kehrwieler, Production Director
Emily Kreutz, Production Manager, Illustrator

A publication of



CQ Communications
45 Dolphin Lane
Northport, NY, 11768 USA.

CQ Amateur Radio (ISSN 0007-893X) Volume 79, No. 10, Published monthly by CQ Communications, Inc., 45 Dolphin Lane, Northport, NY, 11768, Telephone 516-681-2922. E-mail: cq@cq-amateur-radio.com. Fax 516-681-2926. Web site: www.cq-amateur-radio.com. Periodicals Postage Paid at Northport, NY 11768 and at additional mailing offices. Subscription prices (all in U.S. dollars): Domestic-one year \$42.95, two years \$77.95, three years \$111.95; Canada/Mexico-one year \$57.95, two years \$107.95, three years \$156.95; Foreign Air Post-one year \$72.95, two years \$137.95, three years \$201.95. Single copy \$6.99. U.S. Government Agencies: Subscriptions to CQ are available to agencies of the United States government including military services, only on a cash with order basis. Requests for quotations, bids, contracts, etc. will be refused and will not be returned or processed. Entire contents copyrighted 2023 by CQ Communications, Inc. CQ does not assume responsibility for unsolicited manuscripts. Allow six weeks for change of address.

Printed in the U.S.A.

POSTMASTER: Send address changes to:

CQ Amateur Radio, P.O. Box 1206, Sayville, NY, 11782

OCTOBER

FAIRBANKS, ALASKA – ARCTIC ARC, - from 10 a.m. to 4 p.m. on October 7. Bentley Mall, 32 College Rd. Talk-In: 146.88 (103.5Hz). Free Adm! www.kl7kc.com

LAKESIDE, CALIFORNIA – LAKESIDE ARC, - from 6 a.m. to 3 p.m. on October 7. Lakeside Rodeo Arena, 12584 Maplevue St. Talk-In: 146.55. Free Adm \$5 www.lakesidearc.org

NEW HOLLAND, PENNSYLVANIA – RED ROSE REPEATER ASSOCIATION, - from 8 a.m. on October 7. Garden Spot Fire Rescue, 339 E. Main Street. Talk-In: 147.015 (118.8Hz). Adm \$5 www.w3rrr.org

CRESTVIEW, FLORIDA – NORTH OKALOOSA ARC, - from 8 a.m. on October 14. Crestview Community Center, 1446 Commerce Dr. Talk-In: 147.36 (100 Hz). Adm \$7 www.w4aaz.org/noarc-hamfest

BEDFORD, INDIANA – HOOSIER HILLS HAM CLUB, - from 8 a.m. to NOON. on October 14. Lawrence County 4-H Fairgrounds, 11265 US 50. Talk-In: 146.73 (107.2 Hz). Adm \$5 www.w9qyq.org

LYNNVILLE, INDIANA – TRI-STATE ARS, - from 7 a.m. to NOON. on October 14. Lynnville Community Center, 416 W. IN-68. FREE Adm www.hamtoberfest.com

HOLLYWOOD, MARYLAND – ST. MARY'S CO. ARC, - from 8 a.m. to 1 p.m. on October 14. Hollywood Volunteer Fire Department, 24801 MD-235.. Talk-In: 141.19 (156.7Hz). Free Adm! www.k3hkli.org

MUSKEGON, MICHIGAN – MUSKEGON CO. EMERGENCY COMMUNICATION SERVICES, INC., - from 9 a.m. to NOON on October 14. Fellowship Reformed Church, 4200 E. Apple Ave. (M-46). Talk-In: 146.820 (94.4Hz). Adm \$5 www.mcecs.net/hamfest.htm

OLIVE BRANCH, MISSISSIPPI – CHICKASAW ARA, - from 9 a.m. TO 3 p.m. on October 14. Olive Branch City Park, 8267 Goodman Rd. Talk-In: 147.255 (79.7Hz). Free Adm! www.arrlmiss.org

SEDALIA, MISSOURI – SEDALIA-PETTIS AMATEUR RADIO KLUB - from 8 a.m. to NOON on October 14. Our Savior Lutheran Church Gymnasium, 3700 W. Broadway Blvd. Talk-In: 147.030 (179.9Hz). Adm \$5 www.wa0sdo.org

MORRILTON, ARKANSAS – RANDY GRIFFIN MEMORIAL RADIO CLUB, - from 8 a.m. on October 14. Petit Jean Lutheran Camp, 110 Montgomery Trace. Talk-In: 146.520. Free Adm! www.k5boc.net

SPRINGTOWN, TEXAS – AMATEUR RADIO CLUB OF PARKER CO./TRI-CO ARC - from 8 a.m. to NOON on October 14. Cornerstone Community Church, 2233 E. Hwy 199. Talk-In: 147.16 (110.9 Hz). Adm \$1 www.w5pc.org

BREMERTON, WASHINGTON – KITSAP CO. ARC - from 9 a.m. to 1 p.m. on October 14. West Side Improvement Club, 4109 W. E. St. Talk-In: 145.43 (88.5 Hz). Adm \$5 Email n7cis@kcarc.org

MINERAL WELLS, WEST VIRGINIA – WOOD CO. EMERGENCY COMMUNICATIONS, - from 8 a.m. to NOON on October 14. Wood Co. 4-H Campground, 2203 Butchers Bend Rd. Talk-In: 147.255 (131.8 Hz). Adm \$5 www.wc8ec.org

COLBY, WISCONSIN – BLACK RIVER ARA, - from 8 a.m. to NOON on October 14. Colby Lion's Shelter Pavilion, 103 W. Adams St. Talk-In: 147.75 (114.8 Hz). Adm \$5 Email kb9blv@yahoo.com

AIKEN, SOUTH CAROLINA – PFC WILLIAM H. KILBURN POST 26 AMERICAN LEGION RADIO CLUB, NORTH AUGUSTA BELVEDERE RADIO CLUB, - from 8 a.m. to 2 p.m. on October 14. American Legion Post 26, 636 Old Airport Rd. FREE Adm! www.legionpost2alkensc.com/about-6

EAST RIDGE, TENNESSEE – CHATTANOOGA ARC, - from Noon to 3 p.m. on October 20 and from 8 a.m. to 3 p.m. on October 21. East Ridge Community Center, 1515 Tombras Ave. Talk-In: 146.790. Adm \$10 www.hamfestchattanooga.net

GAFFNEY, SOUTH CAROLINA – CAROLINA AMATEUR RADIO EMERGENCY SERVICES, - from 7 a.m. on October 21. Southside Baptist Church, 204 W. O'Neal St. Talk-In: 145.430 (162.2Hz). Adm \$5 Email ki4mjk@gmail.com

TRUMAN, ARKANSAS – CROWLEY'S RIDGE ARC, - from 8 a.m. to NOON on October 21. Truman Sports Complex, 16179 Pecan Grove Rd. Talk-In: 146.610 (107.2Hz). Adm \$5 www.crarc.net

BRADENTON, FLORIDA – MANATEE ARC, - from 8 a.m. to 1 p.m. on October 21. Bible Baptist Church of Bradenton. 2113 Morgan Johnson Rd. Talk-In: 146.820 (100 Hz). Adm \$5 www.manatee-arc.org

SOCORRO, NEW MEXICO – SOCORRO ARA, TECH ARA, - from 8 a.m. to 2 p.m. on October 21. City of Socorro Lodgers Tax/Firefighters Training Academy, 600 Aspen. Talk-In: 146.68 (100Hz). FREE Adm! www.socorroara.org

RICKREALL, OREGON – MID-VALLEY ARES, - from 9 a.m. to 3 p.m. on October 21.

(Continued on page 93)

FCC Back to Full Strength

The FCC is finally back to having five commissioners, after the Senate voted in early September to confirm the nomination of Anna Gomez to fill a long-vacant seat. This will allow the Commission to take action on significant issues, as it previously had been deadlocked with two commissioners from each major political party. Gomez is a former high-level FCC staffer, and just prior to her appointment was working for the State Department, leading the U.S. preparations for the upcoming World Radiocommunication Conference (WRC-23). According to the *ARRL Letter*, Gomez has been succeeded in that role by Steve Lang, the State Department's Deputy Assistant Secretary for International Information and Communications Policy. He had already been working closely with Gomez on WRC-23 preparations.

ARRL Asks Hams to Comment on FCC 60-Meter Proposal

The ARRL is asking hams who use the 60-meter (5-MHz) band to file comments in response to the FCC's proposal to bring the U.S. allocation for the band into conformity with the structure approved several years ago by a previous WRC. The effect of the change would be to replace the five discrete channels on the band with a continuous 15-kHz-wide band segment. It would also reduce permitted power from the current 100-watt ERP (effective radiated power) maximum to 15 watts EIRP (effective isotropic radiated power), which is equivalent to 9.1 watts ERP, per the *ARRL Letter*. The docket number is WT 23-120, and the comment period runs through October 30.

The League encourages amateurs to urge the FCC to maintain the 100-watt power maximum and to keep secondary amateur access to the four current channels that are not included in the proposed new allocation.

Solar Maximum May Be Approaching

We may be nearing the maximum of Solar Cycle 25, based on observed weakening of the sun's north and south poles. According to *SpaceNews*, this is typical as solar max approaches, as the polarity of the sun's poles reverses with each new cycle. According to the report, recent measurements by NASA's Solar Dynamics Observatory, or SDO, indicate that the magnetic fields in the sun's polar regions are rapidly weakening and are likely to disappear entirely before flipping polarity. This phenomenon has been observed at the peak of every solar cycle since scientists learned how to measure the strength of the sun's magnetic field.

Three Hams Among RCA Honorees

The Radio Club of America's annual list of honorees for radio-related accomplishments includes three hams this year. According to *Newsline*, they are Ruth Willett, KM4LAO, first recipient of the club's Carole Perry Young Professional Award; ICOM's Ray Novak, N9JA, recipient of this year's special service award; and the RCA Business Award goes to Tim Duffy, K3LR, and DX Engineering, of which he is CEO. Duffy is also a past president of RCA, a longtime member of the CQ Contest Committee and a member of the CQ Contest Hall of Fame.

Intrepid DX Group Announces 4th Youth Essay Contest

The Intrepid DX Group is again sponsoring its Youth Dream Rig Essay Contest, in which the top prize is – you guessed it – a really great ham rig! Entrants must be age 19 or younger, hold a U.S. or Canadian ham license and submit a two-page essay describing what attracted them to amateur radio. Entry deadline is November 30 and winners will be announced in December. More information is available at <<https://intrepid-dx.com/news/>>.

Software for Digital Voice Modes Getting an Upgrade

The Multimode Digital Voice Modem project, which supports most of the digital voice modes used in amateur radio, is about to get a software upgrade through the efforts of Jonathan Naylor, G4KLX, and with funding from ARDC, the Amateur Radio Digital Communications foundation. According to *Newsline*, the open-source modem project supports D-STAR, Yaesu System Fusion, NXDN and more than 80% of the hotspots and repeaters on the Brandmeister-DMR network. In addition, Naylor is working on developing high-speed packet modes that will support narrow-bandwidth digital voice signals.

Air Force MARS Turns 75

The Air Force arm of MARS, the Military Auxiliary Radio Service, is celebrating its 75th anniversary next month with special event stations operating from the Pentagon and all ten of the system's "wings." *Newsline* reports that certificates will be awarded for contacts with multiple AF MARS special event stations, which will be on the air between November 5th and Veterans Day, November 11th. Certificates will be downloadable and will be available after November 30th.

ARRL Foundation Turns 50; Accepting Grant Applications

The ARRL Foundation is observing its 50th anniversary this year, and is now accepting applications for grants to be awarded next year. According to the *ARRL Letter*, clubs and other amateur radio organizations may apply for grants for ham-related projects and initiatives, especially those related to education and licensing, and particularly those with a focus on young people.

The application deadline for grants to be awarded next June is October 31. Details are available at <<http://www.arrl.org/amateur-radio-grants>>.

ARRL Launches New Newsletter

The ARRL has added "The NTS Letter" to its roster of newsletters, focusing on message-handling and the NTS 2.0 vision of a 21st-century National Traffic System. The newsletter will be published online monthly and is edited by Marcia Forde, KW1U, the Section Traffic Manager for the Western Massachusetts, Eastern Massachusetts and Rhode Island ARRL sections. The first issue was e-mailed to ARRL members in early October. Input is solicited for future issues. Marcia may be contacted at <ntsletter@arrl.org>.

contents

OCTOBER 2023 • VOLUME 79 NUMBER 10



ON THE COVER: Each year since 2015, Vladimir Kovaceski, Z35M, has made one-day bicycle DXpeditions to Albania from his home in North Macedonia. These trips are among the 1000 portable operations Vlado writes about on page 12. Additional details on page 10. (Cover photo by Vladimir Kovaceski, Z35M)



features

8 YOUTH ON THE AIR CAMP IN THE AMERICAS – THE BEST WEEK EVER

Helping young hams learn new skills at a week-long ham radio summer camp

By Abby Kimi Matsuyoshi, KK7CFJ and Jack Roberts, W9RFT

12 SNAKE ISLAND: Z35M'S 1000TH PORTABLE OPERATION

For Z35M amateur radio is not just a hobby but a lifestyle; a look back at 14 years of portable hamming
By Vladimir Kovaceski, Z35M

20 THE RADIO ROOM OF THE KON TIKI EXPEDITION

An expedition in 1947, by Thor Heyerdahl, that used ham radio to communicate with shore stations
By Mike Malloy, WD5GYG

26 CQ CLASSIC: RADIO AND THE LURE OF THE SEA

QRP in the South Pacific
By Cam Hartford, N6GA (August 2012)

31 CQ BOOK REVIEW: A RADIO HISTORY—SHIP SHORE

Reviewed By David J. Ring, Jr., N1EA

32 DXPEDITION TO THE HEART OF ROME

The return of one of the most requested, mysterious and fascinating DX entities in the world
By Nicola Burdiat, IUØNIC

40 AN ASYMMETRIC MULTI-BAND VERTICAL DIPOLE ANTENNA

A variation on the use of stacked coffee cans
By Hiroki Kato, AH6CY

43 RADIO RENAISSANCE: A RETIREMENT STORY

The role of ham radio after retirement
By Bob Hopkins, WB2UDC

48 USING VERIFICATION REPLY CARDS TO INCREASE QSL RETURN RATES

A method to improve one's response rate with stations that aren't used to having QSLs requested
By Mark Hughes, WB4UHI

50 THE PORTABLE TELEPHONE COMPANY

A system that interconnects cellphones, corded phones and the ham radio cloud, and best of all it's portable
By Bob Dixon, W8ERD

54 "MUSEUM QUALITY"—A VISIT TO THE ORKNEY WIRELESS MUSEUM, GB2OWM

Even on a "non-radio" vacation...
By Hy Chantz, W2HY

58 AT THE INTERSECTION OF ASTRONOMY AND AMATEUR RADIO

Bringing the best of two hobbies, astronomy and amateur radio, together
By Paul Signorelli, WØRW

65 TRANSCEIVER TO COMPUTER INTERFACE

An interface to reduce the risk of RFI
By Alan Hoffmaster, WA3EKL

FOCUS ON Young and Old(er) – We start out this month with the Young Ham of the Year award ceremony, a report from the Youth on the Air Americas summer camp, and how Z35M stays young by making lots of portable operating trips, many by bicycle. Then we shift to the other end of the age spectrum with a report from WB2UDC on how ham radio is helping him adjust to retirement, a look back at the radio gear on Thor Heyerdahl's *Kon Tiki*, a radio museum in Scotland, the history of maritime radio, "analog computers" from the mid-20th century and the way things "used to be" in the world of DX.

columns

- 70 **EMERGENCY COMMUNICATIONS:**
Ethereal Adornments – Part 2: A Close Look at End-Fed Antennas
By John Ferguson, K3PFW
- 73 **LEARNING CURVE:**
CQ Profile: Corey Caskelson, NØVKR
By Ron Ochu, KOØZ
- 78 **KIT-BUILDING:** Perfect Timing
By Joe Eisenberg, KØNEB
- 80 **ANTENNAS:** Sum and Difference
By Kent Britain, WA5VJB
- 82 **ANALOG ADVENTURES:** Analog Computing
By Eric P. Nichols, KL7AJ
- 84 **GORDO'S SHORT CIRCUITS:** Is There a Hitch in 'Ur Git-Up Dial Knob? Plus, LDG's Meter Set and Gordo's New General Class License Manual
By Gordon West, WB6NOA
- 87 **QRP: LOW-POWER COMMUNICATIONS:** POTA's Plaque Event...Should a QRP'er Bother?
By R. Scott Rought, KA8SMA
- 95 **AWARDS:** Summits on the Air Awards
By Steve Molo, KI4KWR

departments

- 91 **VHF PLUS:** Spectacular Heat Brings Spectacular Tropo
By Trent Fleming, N4DTF
- 98 **DX:** Used to Be...
By Bob Schenck, N2OO
- 103 **CONTESTING:** Solar Flare vs. NAQP CW Contest Plus Tweaks to ARRL Club Contest Rules and WRTC 2026
By Tim Shoppa, N3QE
- 108 **PROPAGATION:** October Shortwave Propagation
By Tomas Hood, NW7US

miscellaneous

- 2 **ANNOUNCEMENTS**
- 3 **HAM RADIO NEWS**
- 6 **ZERO BIAS**
- 7 **NEWS BYTES**
- 18 **OUR READERS SAY**
- 56 **OOPS!**
- 59 **BEHIND THE BYLINES**
- 77 **SPURIOUS SIGNALS**
- 93 **LOOKING AHEAD**
- 112 **HAM SHOP**

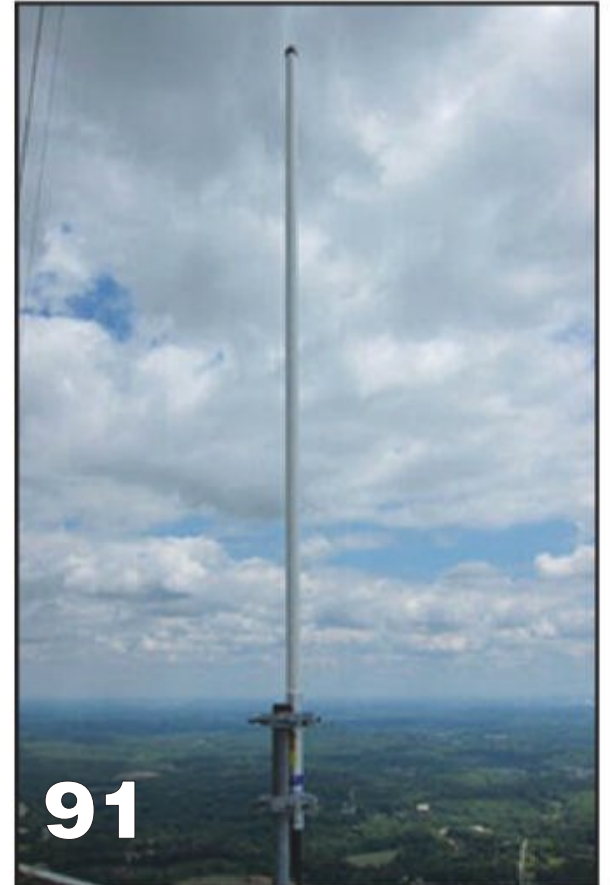
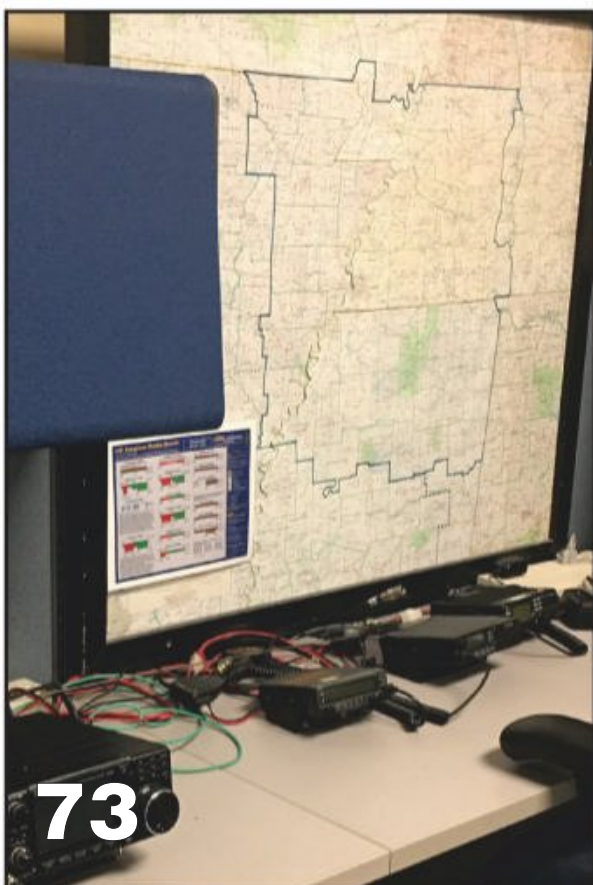

zero bias: a cq editorial

BY RICH MOSESON,* W2VU

Voices From the Air

One of the interesting things about being a magazine editor is that sometimes an issue “talks to you” as it’s being put together. I’ve written here a couple of times about issues that tell me what’s going to be in them rather than the other way around. This is *not* one of those issues, but it is talking to me and is telling me what to write about right here (and if I know what’s good for me, I’ll listen, HI). It wants me to talk about the magic of “voices from the air” and to urge all of us never to lose that magic in the name of “progress” as our analog world becomes more and more digital.

For many of us, our love affair with radio began with voices from the air, whether it was listening to a faraway station on the AM broadcast band on a winter night or listening to voices and music from halfway around the world on the short-wave bands ... or maybe, just maybe, a trucker a thousand miles away on CB “skip.” Regardless of the source, it was those voices that drew us in – distant voices snagged magically from the air by our antennas and coming through our headphones or speakers. They provided us with a connection to other humans across the country and around the world, and a reminder that, regardless of language or politics or anything else, people everywhere have more similarities than differences. For us hams, that reminder is reinforced by being able to send our own voices through the air, to talk back to those faraway humans and maybe make new friends a half a world away.

Today, though, many of these voices are disappearing from the airwaves. AM broadcast radio is becoming an endangered species, with homogenized content from megagroup owners and struggles for financial survival in smaller markets. Car manufacturers would love to drop the AM band from their “entertainment centers” in favor of subscription satellite services that earn them commissions from every new subscriber.

The international broadcast bands on shortwave are getting less and less crowded, as government “broadcasters” shift their signals to satellites and the internet. I am reminded of this by reader Kris Herzog, WPC9WHO, who complains in our letters column on page 18 that he not only has trouble finding new stations to tune in but finds that fellow shortwave listeners are becoming more and more scarce as well. The shortwave bands themselves are unlikely to be abandoned, though, as a group of international stock traders is petitioning the FCC to allow high-speed, high-power, digital transmissions on multiple frequencies that threaten to cause significant interference to adjacent ham bands.

On the ham bands themselves, the explosive growth of FT8 and its cousins has come mostly at the expense of our traditional voice and CW modes. While FT8 “came of age” during our most recent sunspot minimum and essentially saved DXing during that timeframe, conditions are spectacular right now but it can still be difficult to find someone to chat with on SSB or CW. And FT8 definitely is not a “chat” mode.

Don’t get me wrong. I have nothing against digital modes. I was a very early adopter of packet radio and, in fact, wrote

the first user guide to operating packet (“... How to Work it, Not How it Works”) in these pages back in the 1980s. In the ‘90s, Digital Editor Don Rotolo, N2IRZ, and I wrote about early efforts in digital voice in *CQ VHF*. Digital modes are in my ham radio DNA. But there is still something special, something different, something magical, about hearing distant voices coming through your speaker vs. seeing words from a distant computer scrolling across your screen. And we need to be careful not to lose that magic in pursuit of digital “progress.” We need to maintain a balance and exercise our microphones as well as our keyboards and keyers.

There will be a great opportunity to do that at the end of this month, when the HF ham bands will be packed with voice signals during the SSB weekend of the CQ World Wide DX Contest, ham radio’s most popular contest and perhaps the world’s largest participation sporting event. It doesn’t matter if you’re a contester or not. It doesn’t matter if the QSO is very brief. There will be voices out there, voices from all over the world, voices from distant places, all with a common goal – to talk, yes, talk – with as many other people as possible in as many different places as possible within a 48-hour window. The best solar cycle in decades promises to make the CQWW weekend all the more exciting as we welcome hundreds of “voices from the air” into our stations and send ours back across the airwaves to theirs. Please dust off your mic and join the fun on October 28th and 29th.

In This Issue...

This issue is chock-full of great articles (even if they didn’t try to tell me what to write about here!), starting with a project in keeping with the theme above, a transceiver-to-computer interface (p. 65) that lets you easily switch between voice and digital modes without needing to adjust audio levels. We’ve got our eye on youth as usual, with reports on the Newsline Young Ham of the Year presentation ceremony in Huntsville (p. 7) and this year’s Youth on the Air Americas summer camp in Ontario (p. 8). In our cover story, Z35M celebrates his 1000th portable operation on page 12, a trip to a place called Snake Island and a look back at his out-of-shack experiences over the past 14 years. We also take a couple of trips back in time with WD5GYG’s article (p. 20) on the radio gear aboard Thor Heyerdahl’s Kon Tiki raft, a *CQ Classic* look (p. 26) at “QRP in the South Pacific” and a review by N1EA of VE1BC’s book on the history of ship-to-shore radio (p. 31).

Next, we head to Rome for a behind the scenes look at last summer’s 1A0C activation from the Sovereign Military Order of Malta (SMOM) for the first time in four years (p. 32) and a visit to a radio museum in Scotland’s Orkney Islands. And while we’re visiting the distant past, Analog Adventures editor KL7AJ takes a look at “Analog Computers” that a few of you out there might still use (p. 82).

There’s much, much, more, so I won’t hold you here any longer and cordially invite you to read on, but be sure to take a break on the 28th and 29th of this month to be one of the “voices from the air” that keep the magic of radio alive!

73, W2VU

*Email: <w2vu@cq-amateur-radio.com>

Discover a better way to program your radio

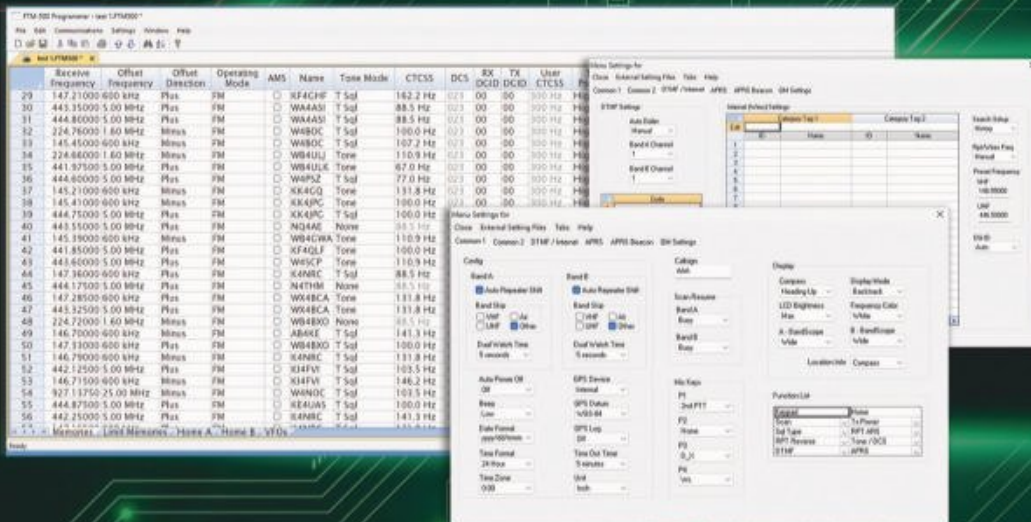

Over 500 unique radio programmers! Check rtsystems.com today for your radio.

Explore all the features of your radio... with the RT Systems Programmer designed specifically for it

Available from RT Systems or your local radio dealer
800-476-0719 | www.rtsystems.com



Photo A. 2023 Newsline Young Ham of the Year Kees Van Oosbree, W0AAE, wearing his Youth on the Air (YOTA) t-shirt. His leadership in that program was among the accomplishments for which he was recognized.

news bytes:

Young Ham of the Year Award Presented to W0AAE



Photo B. Kees receives his Young Ham of the Year certificate from MC and Newsline anchor Don Wilbanks, AE5DW.

Kees Van Oosbree, W0AAE, a 19-year-old ham from Maple Grove, Minnesota (Photo A), was presented with the 2023 Bill Pasternak Memorial Newsline Young Ham of the Year award at the Huntsville Hamfest in Alabama on August 19. Van Oosbree was honored for his leadership in both the Youth on the Air (YOTA) Americas program and the Remote Ham Radio Youth Network. (For more background on Kees, see the August 2023 issue of CQ.)

(Continued on page 110)



Photo A. YOTA group photo with the campers, chaperones, and staff. (All photos courtesy YOTA Americas)

How do you help young hams learn new skills, have fun on the radio and perhaps become leaders of amateur radio's next generation? Bring them together for a week-long ham radio summer camp! Two of this year's participants share their stories.

Youth on the Air Camp in the Americas – The Best Week Ever

BY ABBY KIMI MATSUYOSHI,* KK7CFJ, AND JACK ROBERTS,# W9RFT

This past July, 29 campers from all over the US, Canada, and Argentina, along with guests from Germany and Croatia, met for a week at Carleton University in Ottawa, Ontario, Canada to participate in the third annual Youth on the Air (YOTA) Americas camp (Photo A). YOTA camp is a weeklong summer camp for youth operators ages 15-25 from North, Central, and South America. The goal

* Email: <kk7cfj@gmail.com>
Email: <jack@w9rft.com>

of the program is to build skills and foster lasting friendships and mentors with younger operators. Throughout the week, the focus is on hands-on, peer-led activities.

YOTA camp is different from other youth programs in that the campers share each other's expertise whenever possible. The young hams are the ones setting up the shacks, deciding on and planning activities and outings, promoting the camp, and even travel... with some oversight from the adults. Research has shown that young peo-

ple are much more likely to ask questions of their peers than from adults unless they feel overwhelmed by the difficulty of the topic. By bringing together a diverse group of campers with a diverse set of expertise and passions, youth are much more likely to share skills and ideas. Some of the activities led by young operators at this year's camp included: CW, Parks On the Air (POTA), kit & antenna building, satellite operation, contesting, digital modes, mid-altitude ballooning with APRS tracking, slow-scan television



Photo B. A group of campers after riding the two-person tube slide.

(SSTV), and an ARISS (Amateur Radio on the International Space Station) contact. There were also some train-the-trainer sessions to gather ideas of how youth can be supported more in ham radio and continue to expand YOTA camps in the future.

Friendships for a Lifetime

In addition to the countless exciting ham radio activities we participated in, we also spent time creating lasting friendships with a diverse group of campers. For several, this was their first time meeting other young operators in person outside of their area and even country. Social activities are another important aspect of YOTA. Memorable activities from this year included a fun-filled day at the Calypso Water Park (Photo B), an enjoyable evening in downtown Ottawa watching the Northern Lights Show at the Parliament of Canada (Photo C), and evening gaming sessions playing Super Bomberman in the lounge (Photo D). One of the things that makes YOTA so valuable is the total collective of all the campers who have different specialties within ham radio. So whenever a question arises, whether it be a general or specific question, we now all have a strong network of hams to turn to for help.

On the Air

Between sessions and during the evening social hours, campers were able to operate on HF, VHF, and satellites using the special event callsign VE3YOTA at a state-of-the-art shack recently installed at Carleton University. The equipment used for the shack was donated by ICOM Canada, DX



Photo C. The Canadian Parliament lit up during the Northern Lights light show.

On the Cover ...



Vladimir Kovaceski, Z35M, is ham radio's "marathon man." His first CQ article, back in 2005, described his making more than 43,000 contacts the previous year. He's checked in periodically with us since then, writing about various additional feats and adventures, such as operating from a cable gondola going up a mountain and pioneering the concept of "guerilla QRP portable" operation.

In this issue's cover story, Vlado takes us through nearly 15 years of portable operations as he celebrates portable expedition number 1,000! In the photo, he's using his bicycle as an antenna support during one of his annual bicycle mobile trips from his home in North Macedonia around Ohrid Lake, which borders both North Macedonia and Albania. The trips cover more than 100 kilometers (62 miles).

For his 1000th portable activation, Vlado visited Golem Grad Island in Prespa Lake in North Macedonia, also known as Snake Island. He explains the source of the name in his article and photo journey that begins on page 12.

So if you're feeling that you can't have fun with ham radio because of antenna restrictions or other limitations, Vlado proves that a QRP rig and portable antenna are all you need to get on the air in style while enjoying fresh air and nature. And if you think QRP won't cut it for you, here are a few more Z35M numbers for you: During his ham radio career, Vlado has made more than 500,000 QSOs – ALL QRP – including more than 12,000 during the solar minimum years of 2016-2018. As he puts it, the bands weren't closed, the operators were! (Cover photo by Vladimir Kovaceski, Z35M)

Engineering, and Heil Sound. In addition, campers were able to operate a station (both remotely and in person during a visit) at the Diefenbunker: Canada's Cold War Museum. The museum is the former refuge for important Canadian government officials in the event of a nuclear war. The station is located inside the radio room of the bunker, and operated by the Diefenbunker Amateur Radio Club, VE3CWM (Photo E).

Even though many were inexperienced in the ham radio hobby, YOTA camp gave everyone so many valuable

first-time experiences. Some made their first HF contact, while others completed their first satellite contact or POTA activation.

Here are some individual observations from each of us...

Abby Kimi: "At camp, I discovered new facets of ham radio that I had never considered before. I learned about RTL-SDRs, how to contact satellites with a handheld, explored digital modes,



Photo D. Campers gathered around a TV playing Super Bomberman.



Photo E. The Diefenbunker museum's ham radio shack.

made my first FT8 contact, and participated in my first POTA activation. YOTA camp overall is one-of-a-kind because you get the full experience from start to finish. For example, you get to build your own antenna, use it as part of your Parks on the Air setup, and then make a contact with it.

A memorable moment at camp was setting up the antenna and IC-705 with another camper, Adam Nissem-Stem, VA3BHT, and making a contact with Germany using only 5 watts. Even though contacting Germany was exciting, my favorite memory was when I was honored and blessed with the opportunity to contact the ISS NASA Astronaut Stephen Bowen, Commander for NASA's SpaceX Crew-6 Mission, which was orchestrated by Ruth Willet, KM4LAO, and the Amateur Radio on the International Space Station program, ARISS. I am forever grateful to camp for introducing me to the world of ham radio and the unforgettable new friendships and interests. Since camp, I am working on a project with a RTL-SDR dongle, regularly catching satellite passes, and practicing CW daily to become proficient. I have learned that there is so much to the ham radio hobby, and that I will never run out of things to learn or try!"

Jack: "My fondest memory of camp was when I was given the opportunity to talk to an astronaut on the International Space Station 254 miles above the Earth's surface. When the eight of us

were lined up and heard NASA Astronaut Stephen Bowen, KI5BKB, come into range, I could not believe it was happening; My dream of talking to an astronaut on the ISS had finally become a reality (Photo F).

One awesome thing about YOTA camp is that it is mainly orchestrated and led by youth, including the activities and lessons. I had the privilege of leading the digital modes session—it was exciting being able to share my passion with young operators like myself. Because of YOTA camp, I have become a stronger operator having been given a strong foundation of skills to help me branch out in the hobby. Not only that, but it helped me develop my public speaking skills, writing, and web design skills by giving me the opportunity to volunteer for YOTA as a PR specialist and assistant webmaster. Even after camp, I continue to discover new facets of ham radio every day and am currently working on strengthening my contesting skills in hopes of participating in December YOTA month. Overall, I am grateful for the knowledge I have gained and the friendships I have made because of YOTA camp. I cannot wait for next year's camp!"

See You in 2024!

The campers are forever grateful to the Youth On the Air program and its supporters, Radio Amateurs of Canada, and ARISS, for making dreams come true. In addition to those who donated equip-

ment, the funding from Amateur Radio Digital Communications (ARDC), the World Wide Radio Operators Foundation (WWROF), IARU Region 2, the Yasme Foundation, Radio Club of America Youth Activities, the Tennessee Contest Group and many individual donors made this camp possible. A huge thank you to all of you. Youth operators from everywhere eagerly await for the next YOTA camp in 2024! If you are interested in applying or volunteering for next year's camp to experience the best week ever, please visit our website: <youthontheair.org> and social media pages to learn more. Details will be available this winter.

YOTA would also love for young operators to participate in this December's YOTA month special event. All operators are age 25 or younger, and take turns activating special event call signs throughout the entire month. To sign up or ask questions, please email: <yotamonth@youthontheair.org>. See <events.ham-yota.com> for information about the award program for stations who work the December YOTA month stations.



Photo F. The young operators chose to talk to an astronaut on the International Space Station. Top row: Abby Kimi Matsuyoshi, KK7CFJ; Oktay Comu, VE3IQO; Jack Roberts, W9RFT; Tripp Sanders, WT5A. Bottom row: Finn Tidd, KD2WTR; Alex Lammers, KO4ZMC; Ethan Rushton, KO4VXD; Grace Papay, KE8RJU, and Ruth Willet, KM4LAO.

Young Ladies' Radio League, Inc. Since 1939

For 75 years the Young Ladies' Radio League, Inc. (YLRL) has helped women find their voice in Amateur Radio with members of all ages and interests.



The YLRL sponsors a number of certificates for both YLs and OMs. Members can earn special YL Certificates.

YL-Harmonics is our bi-monthly publication highlighting what women are doing in Amateur Radio.

YLRL gives out scholarships to YLs each year.

For more information on the YLRL, the current dues amounts, weekly YL Net locations or how to join please go to our website at www.ylrl.org or contact the Publicity Chairwoman, Cheryl Muhr, NØWBV at n0wbv@earthlink.net. All Officer information is also listed both on the website and in each edition of the



magazine and you may contact any Officer as well.

With thanks to the OMs who encourage and support us.

Visit us at www.ylrl.org

Lightweight gear and a rising sunspot cycle are making portable operations more and more popular. But it takes something extra-special to take your ham gear to the field 1000 times! Z35M has reached that milestone and explains that, for him, amateur radio is not just a hobby but a lifestyle.

Snake Island: Z35M's 1000th Portable Operation

A Look Back at 14 Years of Portable Hamming

BY VLADIMIR KOVACESKI,* Z35M

On September 3, 2023, I conducted my 1000th HF portable operation using ultralight equipment, independent battery power, temporarily-deployed antennas and QRP transmitter output power.

My jubilee portable activation was conducted from the uninhabited island of Golem Grad in Prespa Lake, North Macedonia (Z3), also known as Snake Island due to the high density of snakes there. This was considered the first-ever radio amateur activity from this relatively difficult to reach location (Photos A and B).

I have been operating portable for the past 14 years, with 30,000 QRP QSOs with all continents. Most of these operations have included non-motorized access (walking up to 20 kilometers and cycling for 100 kilometers per day), visiting attractive locations such as mountain summits, historical fortresses, lake, sea and river coasts, islands, national parks and other protected areas in North Macedonia and 14 other European countries (ZA-Albania, ON-Belgium, E7-Bosnia and Herzegovina, YU-Serbia, 9A-Croatia, 4O-Montenegro, SV-Greece, LZ-Bulgaria, HA-Hungary, OE-Austria, DL-Germany, F-France, PA-Netherlands and LX-Luxembourg) (see photos C, D, and E).

At the very beginning I started by activating mountain summits (Photo F), which is the most demanding type of portable operation, then I continued with activation from historical fortresses and protected natural areas, beaches (Photo G) and other interesting locations (see more in the article "Flight of the QRP Bird ... or the Freedom of QRP," June 2012 *CQ*).

Only outdoor and off-grid activations were planned. Most of the time, CW was the mode of choice, with phone on some occasions, and digital modes were tried few times.

HF activations have been implemented both as a mobile pedestrian (Photo H) and from moving objects, such as a bicycle (Photo I), boat, ship, canoe (Photo J), car, and cable gondola. (For cable gondola portable, see "Z35M ... Riding High in the Sky!", August 2018 *CQ*). I consider the bicycle mobile as most challenging portable operation (Photo K).

Expedition Highlights

Using the "Guerrilla QRP Portable" operating style (which I pioneered), I have made 14 cross-border bicycle radio amateur expeditions in Albania, as well as one in Greece. Each year since 2015, I have made one-day bicycle QRP Mini-DXpeditions to Albania which involve a 100-kilometer solo



Photo A. Z35M on his 1000th portable operation on Golem Grad Island, Prespa Lake, North Macedonia (Photos by the author)

ride around Ohrid Lake (Photo L), with stops to activate some of the protected areas (Photo M). (For my first bicycle DXpedition to Albania, see "Bicycle QRP Mini-DXpedition to Albania", June 2016 *CQ*).

In 2016, I was the absolute world winner in the year-long "Field Flowers QRP Portable Marathon", with 142 portable activations and 3736 QSOs, the most distant of which was with New Zealand (17.670 KM). Some days ended with up to five portable activations (Photo N).

In 2016, I founded the "Z3 Portable Group" which promotes radio amateur activities from outdoor locations, and whose experiences may be applied from fixed locations, especially in conditions of insufficient space for installing antennas and other restrictions. Several meetings of the group with

* E-mail: <vkovaceski@yahoo.com>



Photo B. Golem Grad Island can be accessed only by boat.

domestic and foreign radio amateurs have been held so far, during which various styles of portable activities have been presented. Some activations were in a group of two or more operators (Photo O).

My most unusual activation locations were the zoo in Bitola, an inactive volcano near Ohrid (Photo P) and, as mentioned previously, a cable gondola on Vodno mountain near Skopje, all in North Macedonia. My most unusual access was walking to and back from a nearby island along the Albanian coastline at low tide, holding all of my equipment high above my head (Photo Q). The highest operating position was the summit of Golem Korab, 2764 meters (9068 feet) above sea level, the highest summit in North Macedonia (Photo R); the lowest was on the seashore.

A (Very) Few Failures

The few failures included my first activation when I forgot to take the coaxial cable. One other time, due to my ultra-light equipment, I didn't notice that the entire radio station was left at home! I went to a location with a dead battery only once. Not bad at all for 1000 outings!

Some Stats...

The average number of QSOs per activation was around 30, but there were activations with only one or two QSOs. On the other hand, one all-day-long operation from a mountain summit ended with 337 QSOs. The QRP power level works, even during a solar minimum. The proof for that is my statistics for 2016-2018, with a total of 12,635 QSOs, of which 8,249 were from portable operations and 4,386 from home, using only single-element antennas. *The bands are not closed – the operators are closed!* It is very important while working at QRP levels to avoid an inferior operating

approach. Just behave as though you have 100 watts and the number of QRP QSOs will rise. Sometimes less than 5 watts were used, including less than 1 watt (QRPP), always with satisfactory results.

Keeping it Light

For frequent portable activations, the station setup has to be small, lightweight, and always ready to be taken in a small backpack. Setting up and disassembling in the field has to be a matter of no more than 5 to 10 minutes. The station



Photo C. Z35M's first portable operation, back in 2009.



Photo D. Ten years in, operating picnic-table portable near Brussels, Belgium in 2019.



Photo E. A relaxed lakeshore operation in 2010.



Photo F. Vlado's first mountain summit activation in 2009. He is now the Summits on the Air (SOTA) coordinator for Z3.

setup must be flexible for various types of portable activations and different kinds of transportation to the operating position, including non-motorized access (Photo S). Few or even no comfort devices in the location must be accepted in order to move with less weight. Simple and lightweight equipment results in more activations (see more in the article, "Guerilla QRP Portable," February 2017 CQ).

My equipment evolution from heavier and bulky to ultralight has been a constant process. Back in 2009, I started with a more-than 7-kilogram (15-pound) station setup, including an Alinco DX-70T, sealed lead-acid battery, dipole and coaxial cable, a 5-meter fishing rod, manual Morse keyer and other stuff. Later the same year, I got an Elecraft K1, a smaller battery and used thinner antenna wires and coax to bring the total weight down to 2 kilograms (4.4

pounds). In 2018, I upgraded my setup with the Elecraft KX2 with internal antenna tuner and battery, and switched to a 5.2-meter (17-foot) telescopic vertical antenna to reduce the weight to 1.5 kilograms (3.3 pounds). Sometimes I use a QCX-Mini for 20 meters and a tree wire vertical with one ground radial, making an effective ultra-light portable station of 800 grams (1.75 pounds).



Photo G. From the mountaintops to the seashore, Z35M keeps active and always has his ham gear handy.



Photo I. Improvised bicycle mobile setup in 2011. The arrangement has become more streamlined in recent years.

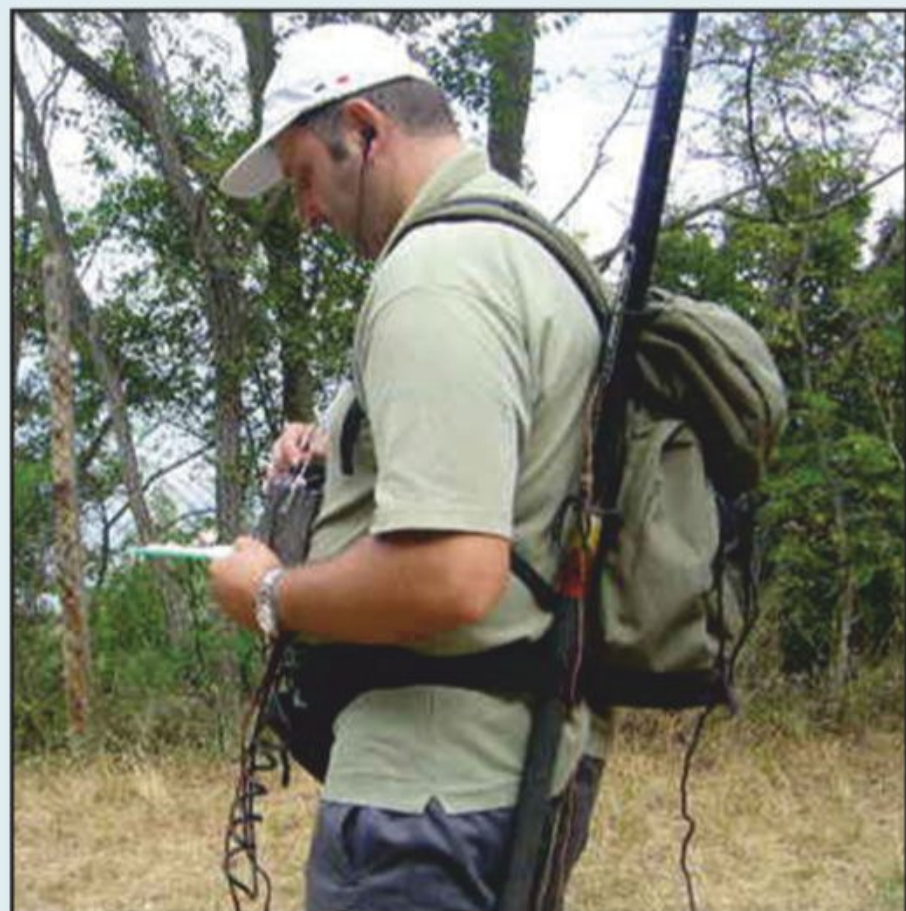

Photo H. Operating pedestrian mobile in 2010.

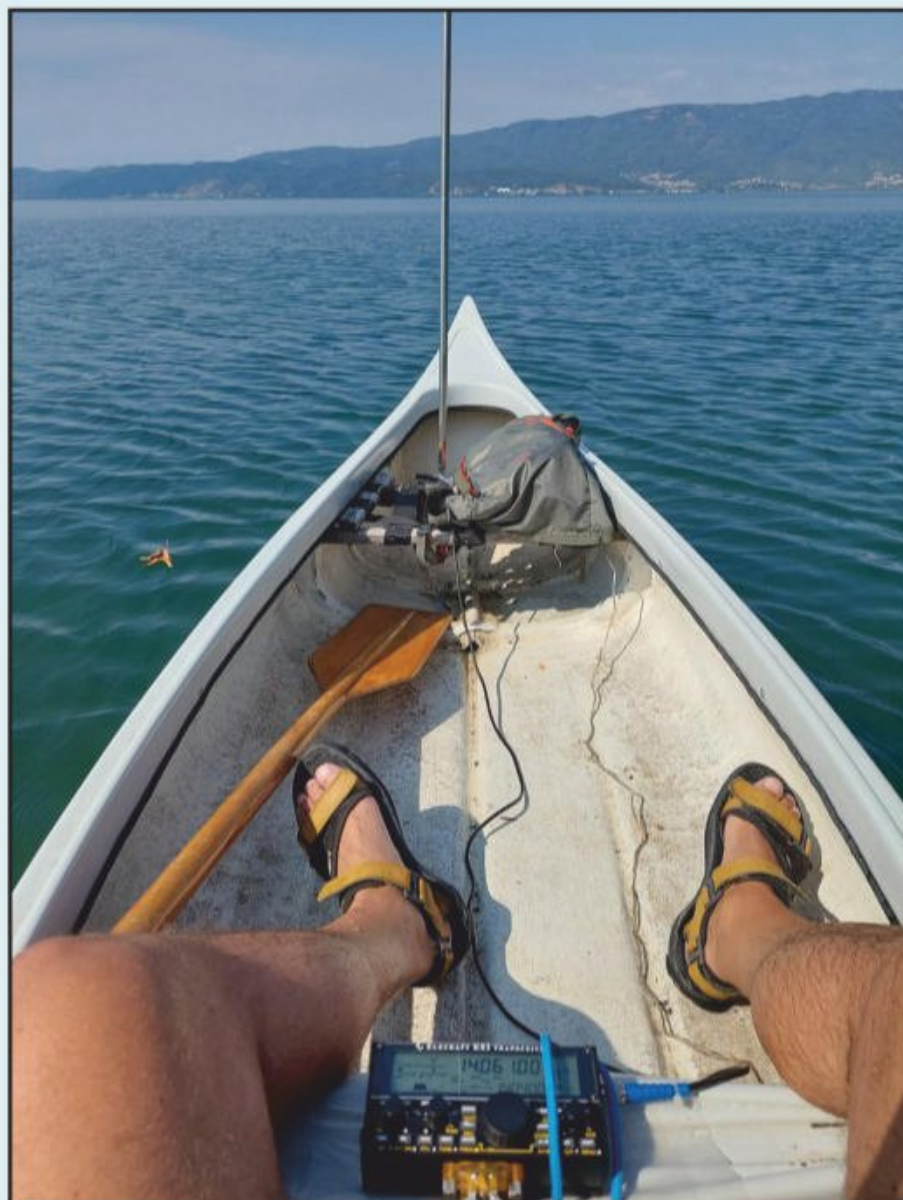

Photo J. Operating canoe mobile in 2022.

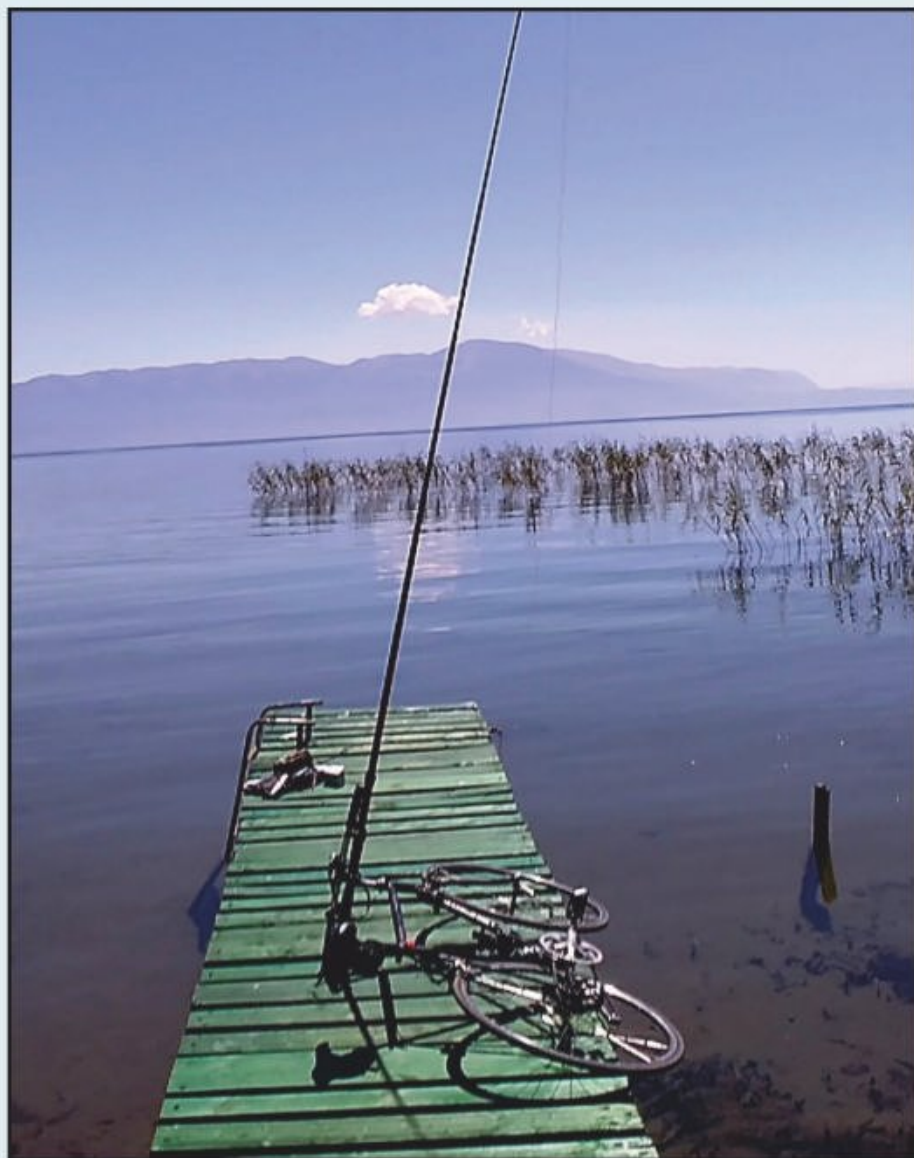

Photo K. The author considers bicycle mobile operating to be the most challenging portable operation “mode.”



Photo L. Each year since 2015, Z35M has made one-day bicycle expeditions to Albania which involve a 100-kilometer solo ride around Ohrid Lake.

Encountering different site conditions forced me to implement appropriate antenna configurations, such as placing the antenna at a less-than-optimal height. I found that low-mounted antennas work satisfactorily. Even having the antenna deployed directly on the ground (rock) can bring a lot of QRP QSOs (Photo T). It was a real surprise that poses the question of whether we radio amateurs limit ourselves with low expectations. (For more on the ground level deployed antenna test, see “Z35M Strikes Again,” April 2019 *CQ*.)

During the activations, I often attract strange looks and sometimes received funny questions, like whether I am fishing, catching birds, flying a drone, etc. I was questioned by police officers three times, and once was detained at the police station for several hours until the situation was clarified.

Exceeding Expectations

Outdoor QRP portable operating has exceeded my expectations. It is an eye-opener even for a very experienced operator. The lessons learned from portable operations may be implemented with the fixed station. I suggest QRP operating and especially QRP portable to be an obligatory part of ham radio education, because this can change a lot of the operating mindset.

In that direction, I have published several articles on HF portable operating here in *CQ Amateur Radio* and other magazines, and have given several presentations on portable activations on site (Photo U) and on W5KUB’s “Amateur Radio Roundtable” program.

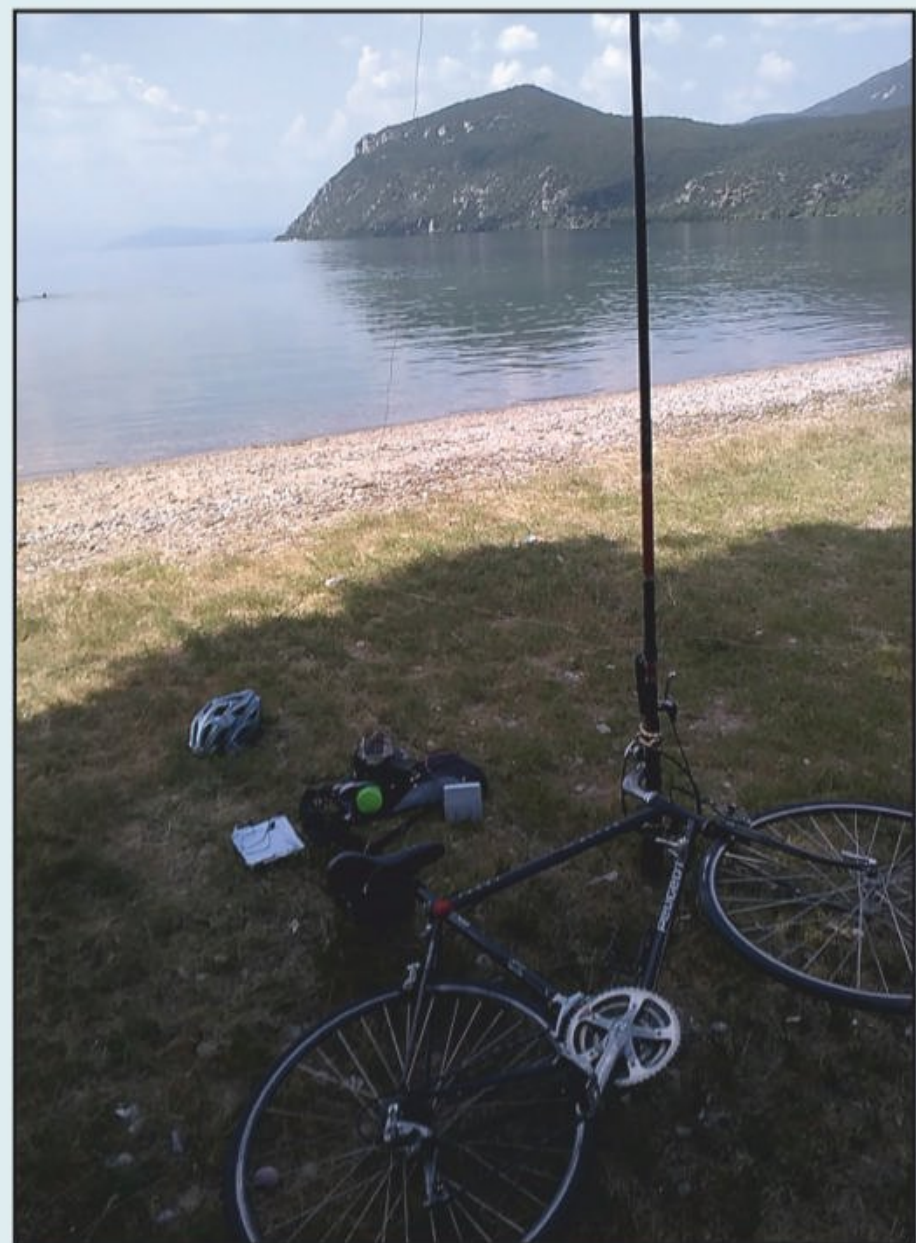

Photo M. Returning from his trip to Albania, Z35M stops to operate from the Macedonian side of Ohrid Lake.



Photo N. One of the author's favorite parts of his trips is the opportunity to enjoy nature while hamming.



Photo O. A meeting of the Z3 Portable Group, which brings together area hams who share an interest in portable operating.

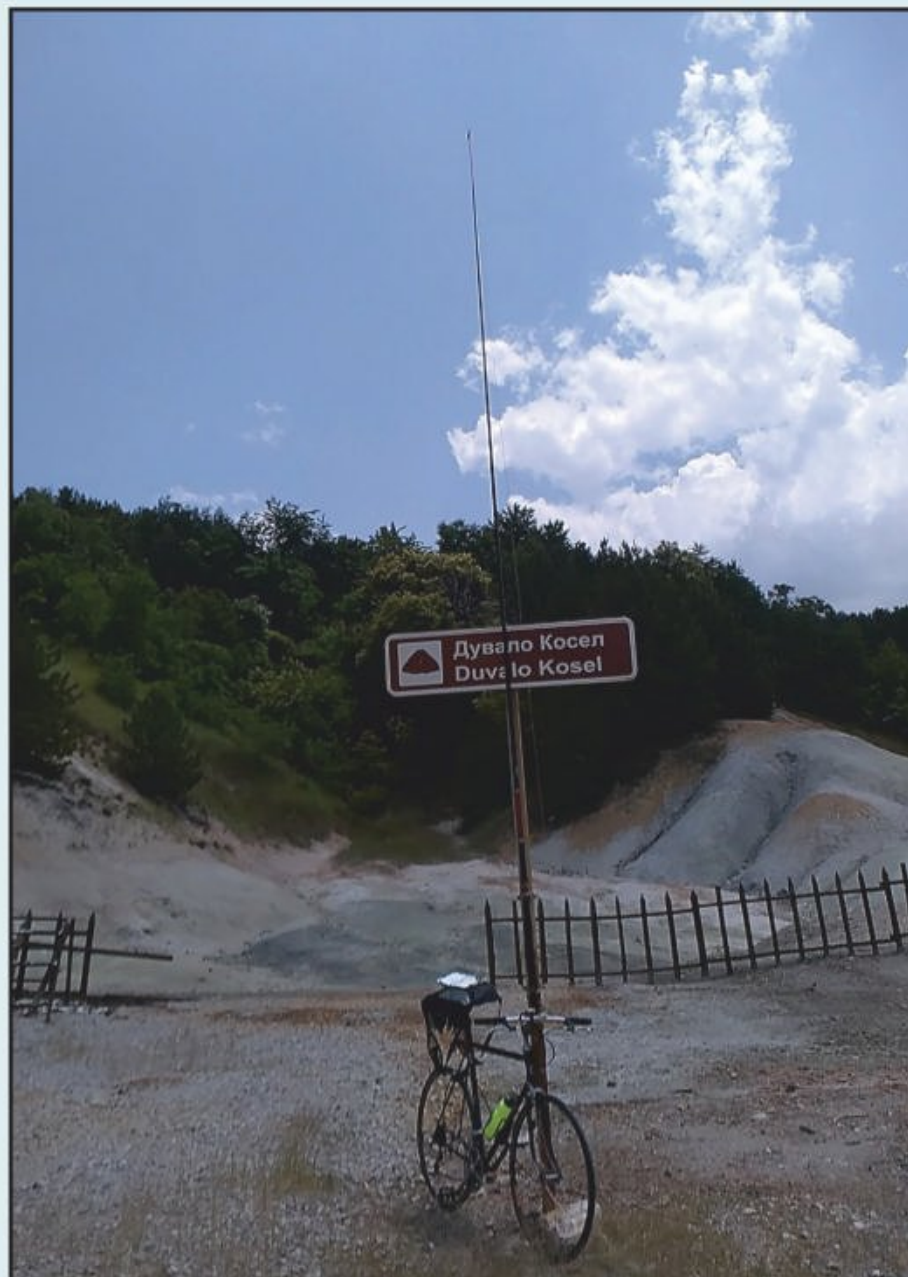

Photo P. One of the more unusual operating spots for Z35M was an inactive volcano in North Macedonia.



Photo Q. The only way to access this uninhabited island in Albania was by wading through the water while holding the radio gear overhead.

our readers say...

Off-Air QSOs

Editor, CQ:

Your editorial last March about not all QSOs being on the air came back to my mind when participating recently at a conference hosted by Internet2 in Atlanta. Internet2 is an organisation that provides high-performance optical fibre networks connecting universities across the country. While the topics at the conference focused on hard wired fibre networks and services, one of the delegates was bemoaning challenges in deploying RF Wi-Fi and wished for greater RF spectral precision. RF was my cue to show him my WSPR beacon propagation. He stopped me short... "I'm a ham, too," he said. Someone else overheard the conversation. Other hams joined us. I had a few blank QSL cards that I started giving out instead of business cards. Word spread. And before you know it we were having a weird kind of hamfest discussion. It was great fun and brought an unexpected angle to my meetings.

Rich, your editorial was correct in recognising the community of amateur operators and we can turn up in unexpected places.

73,
Rod, VE3RXN

Room Under Our Umbrella for SWLs?

Editor, CQ:

I'm a shortwave listener, and I've found it very hard to connect with any community in-person, as almost of the hams in my area are strictly that. Hams.

It's funny, that with your recent interview with the head of HRO, I find myself thinking about the trips I've made to my local HRO in Milwaukee, Wisconsin. I went a few years back to an open house held there, and only a handful of people could speak to my particular corner of the hobby. The staff, while very knowledgeable, could only speak to shortwave with regards to knowing the frequencies and making some broad guesses from that. Not to pick at HRO for their excellent service and mostly knowledgeable staff, as I have mostly a positive experience from there.

But it's even just hams in general. My adopted 'uncle', a family friend of over 60+ years, hasn't dabbled in SW for some time, so he honestly told me that there wasn't much he remembered.

I do realize that SW seems to be a dying art in the telecommunications world, with many countries ending their service. I have many happy memories from my time in SW, from listening to Radio Australia and actually ringing the engineer on-duty who was very impressed with the signal, to just getting a QSL or two now and again.

But I'll be honest, outside of Facebook and the various remainders of *Popular Communications* in CQ, it's hard to talk to anyone about it. I just find it very telling that when I try to find out things from hams, and I'll be honest here, they tend to look down their noses at me, and act like I'm a second class citizen. It's not just around here, it's people I've met through the years at swapmeets, open houses like the HRO show... I just get brickwalled.

"Get a license," they say. Thing is, I have no real interest in participating in a hobby that is just too high priced to

(Continued on page 107)

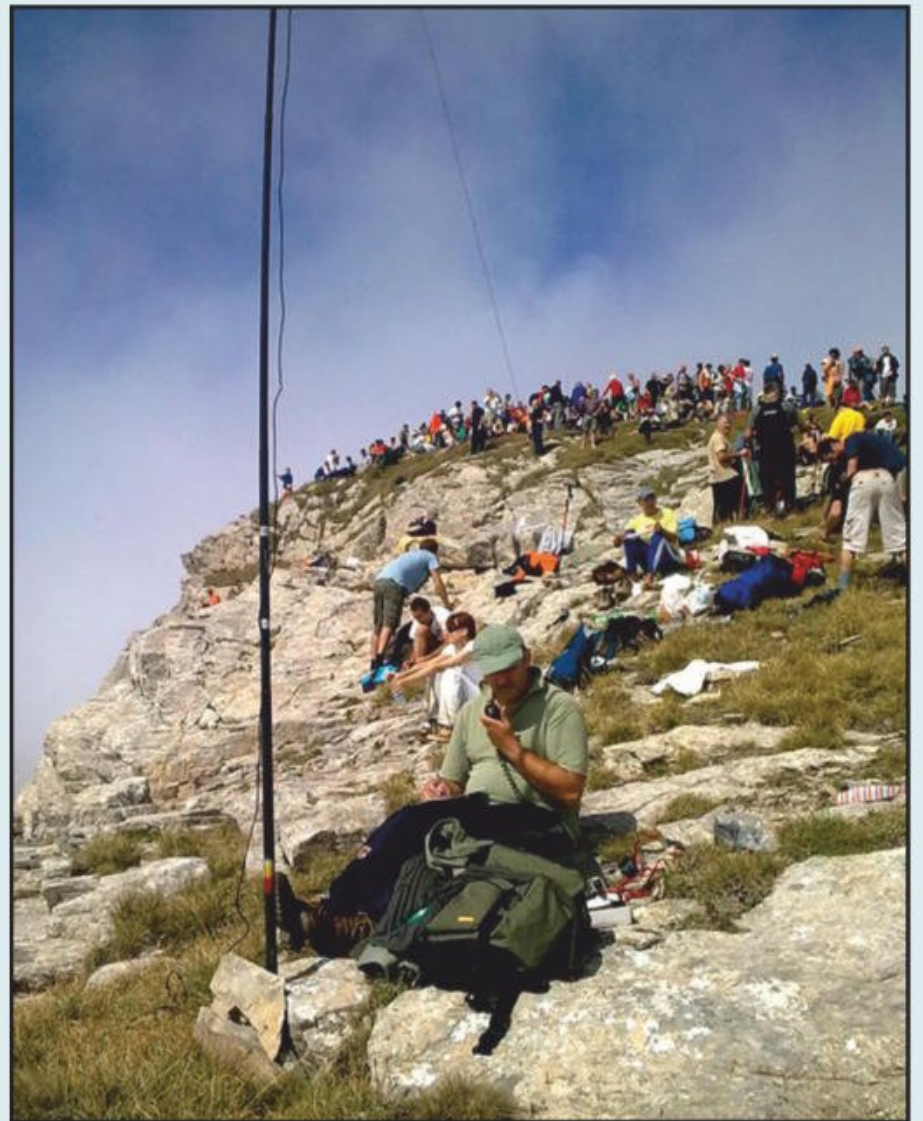

Photo R. Golem Korab is the highest summit in North Macedonia at 2764 meters (9068 feet) above sea level. This activation was in 2009.



Photo S. Sometimes, the only way to reach an operating point is on skis! This photo was taken in Bosnia and Herzegovina in 2021.

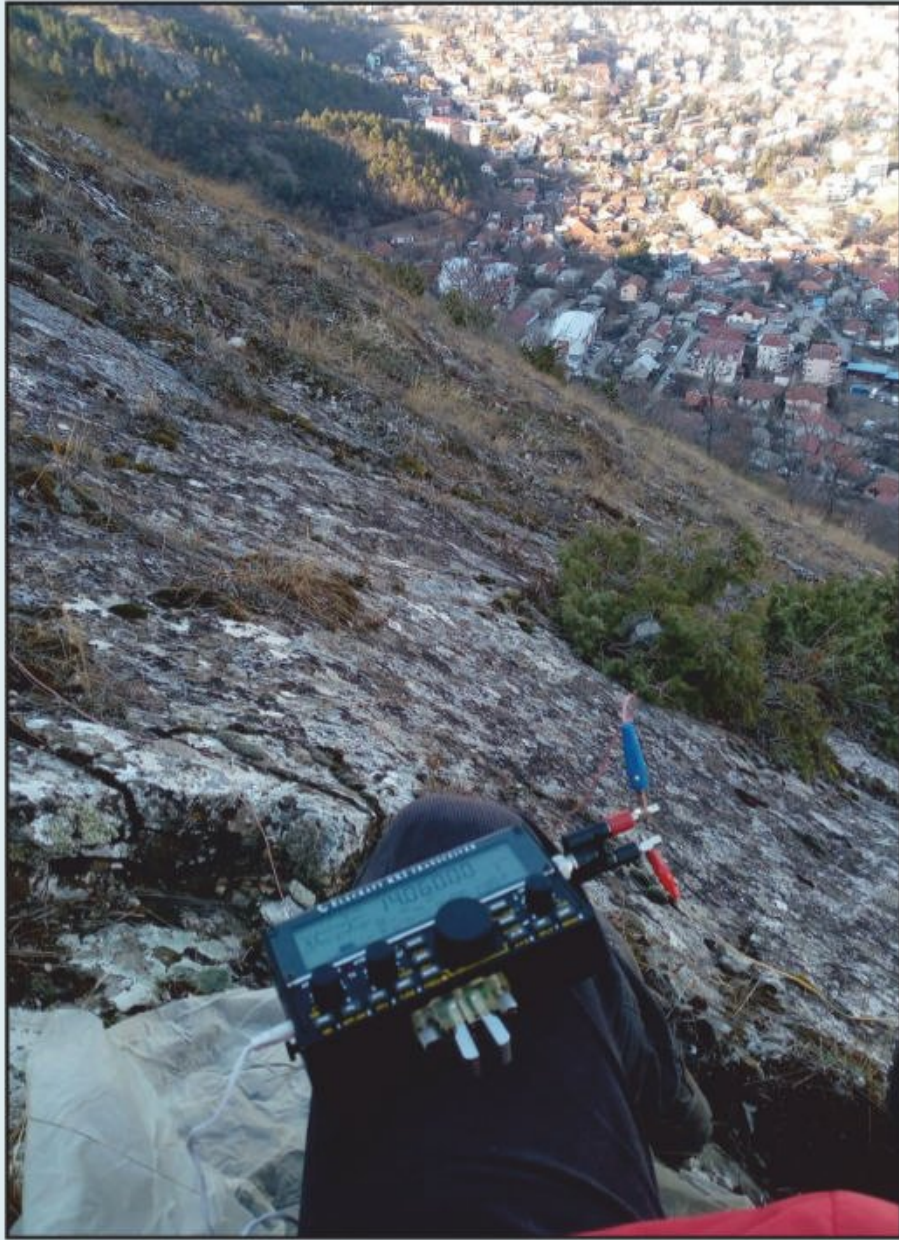

Photo T. Mountaintops are not always antenna-friendly, but Z35M discovered that he could get out just fine with a wire laid out on the rocky ground.

Portable activities enrich outings in nature and give them the feeling of a kind of adventure. The benefits are that you always have a different view from the outdoor shack, fresh air, low noise level and you attract more callers. Unlike big DXpeditions, portable activities are much cheaper, less logistically demanding, can be realized in a short period of time at not-too-far distances, so they can be practiced more often. In the last decade we have seen the expansion of various “on the air” programs (SOTA, WWFF, WCA, POTA, LH etc.) that add challenges for both the activator and the hunters. This development of activities has been followed by equipment manufacturers, which now offer a lot of portable radio devices and other equipment.

Apart from portable, with 500,000 QSOs so far, I’m also active on daily basis from my fixed radio stations in Skopje and Struga in North Macedonia, as well from Albania, Belgium and Bosnia and Herzegovina, where I stayed for several years for work (for my stationary station operating approach see more in the article, “A Personal QSO Marathon: 43,300 QSOs in One Year!” May 2005 CQ).

Portable operating has become part of my lifestyle and I have enjoyed a lot of outdoor activities. In order to keep up the adrenaline level after such a number of portable operations, I need to add some other challenges like multi-day bicycle QRP expeditions, overnight activations from a camping tent, testing temporary antennas from superior locations, or operating portable every day during a year.

For more info and additional photos, visit my QRZ.com page at <www.qrz.com/db/z35m>.



Photo U. Z35M promotes portable operation through talks and demonstrations for various ham groups, such as this get-together in Macedonia, and by writing magazine articles ... like this one!

Old-timers may recall Thor Heyerdahl's Kon Tiki expedition in 1947, when he sailed a raft from South America to the South Pacific (others may have read his book or seen one of three movies based on his adventure). His crew used ham radio to communicate with shore stations. WD5GYG shares his research on the radio gear and more.

The Radio Room of the Kon Tiki Expedition

28 April to 7 Aug 1947

BY MIKE MALLOY,* WD5GYG

I first read Kon Tiki as a 12-year-old, and have been fascinated by this wonderful story my entire life. As an adult, I read it again (pre-Internet) and now as a 75-year-old, I have just finished rereading this tale of a high seas adventure once again.

While reading the story as an older person, I began to read between the lines of the exploits of the Kon Tiki. It was not a trip planned by James Cameron, the famed director of the movie *Titanic*, where everything falls into place at the exact moment it was supposed to. It was a sea adventure that almost did not happen. Heyerdahl was laughed at and insulted by various

corporations, including the National Geographic Society. I suppose in modern terms they did not want the insurance liability of six foolish young men fresh from World War 2 killing themselves on a crazy adventure with a balsa raft lashed together with hemp rope. No modern materials, such as bolts, screws, or wood cut to precise measurements. The Kon Tiki was to be a simple design as had been used 1500 years ago. The notion of drifting and sailing thousands of miles from Peru out to somewhere, but where exactly no one knew, was considered a foolish adventure.

The most recent movie on Kon Tiki, ("Kon-Tiki," 2012), with Norwegian actors (speaking English) was a fair



Photo A. Thor Heyerdahl, leader of the 1947 Kon Tiki expedition (courtesy Kon Tiki Museum, Oslo, Norway)

* E-mail: <mmalloy100@gmail.com>



Figure 1. The approximate route of the Kon Tiki's 1947 voyage. (Source: Montres Publiques: "The Story of the Eterna Kon Tiki: An Expedition from Peru to Polynesia by Raft")



Figure 2. The Marquesas Islands, with Fatu-Hiva highlighted in red. (Wikimedia Commons map by Godefroy, Creative Commons licensing <<https://commons.wikimedia.org/w/index.php?curid=3951973>>)

representation of the actual story, but I recommend reading the book. The movie showed the difficulties Heyerdahl encountered when trying to launch his grand adventure. It was quite discouraging. Most men would have given up and gone home, but he did not.

This trip only lasted for a total of 101 days at sea. Sailing from Callao, Peru, (a subdivision of Lima), to Raroia Atoll in French Polynesia (4300 miles total – see Figure 1), created a story that will live in perpetuity.

The Story of the Kon Tiki

Before we dive into the radio room, let us first explore how and why the Kon Tiki came into being.

Thor Heyerdahl (Photo A) was a zoologist who graduated Oslo University in 1937. From there he went to the Polynesian atoll of Fatu Hiva, which is in the southern part of the Marquesas Islands in French Polynesia (Figure 2), to collect biological samples. A side interest of his was a fascination with ancient cultures of both South America and the South Seas, specifically Polynesia. During his time on Fatu Hiva, he began to talk to some of the older residents at night after collecting bug specimens all day. The conversations lead to the explanation of how the natives believed they came to be on these islands.

During his 8-month stay, an old chief, Tei Tetua,¹ told Heyerdahl stories relayed to him by his father and grandfather about the Polynesian god; Tiki, sun Tiki or Illa Tiki, the fire Tiki.² Heyerdahl had studied the culture and history of

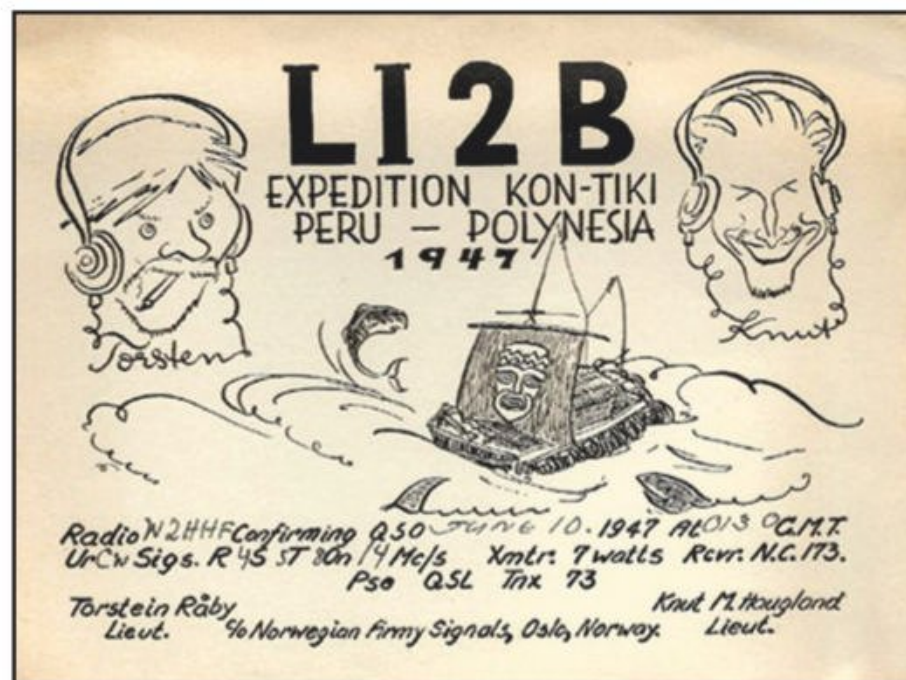

Figure 3. LI2B QSL card (courtesy K8CX Ham Gallery <hamgallery.com>)

South America in great detail. When Heyerdahl heard this story of how Tei Tetua's long-dead relatives came from a place where the sun rises (east), he began to realize that this old man was telling a tale very similar to one he had heard while studying South American folklore. Specifically, in the eastern part of South America, there was a sun king god named Virakocha, which is an Incan name. However, the more modern name (in antiquity) for this god was Kon Tiki, and this name was also a common reference to the sun god in Peruvian culture. This South American legend states that there was a massacre, but somehow Kon Tiki escaped to the coast and built a raft then took off due west, never to be seen or heard of again on the shores of Peru. The first part of the Norwegian movie "Kon Tiki" (English speaking) from 2012, covers this section quite well if you are interested in learning more.

Soon after returning to Denmark, WWII broke out, 1 Sept 1939. Heyerdahl went into the Norwegian military for about five years and there was no more talk of Polynesia.

Radio Room (LI2B)

The two Kon Tiki radio operators, Knut Haugland or Torstein Raaby, were not licensed amateur radio operators at the time of the voyage. The Norwegian call sign LI2B (Figure 3) was assigned to the raft. It was a ship station's amateur radio call but not an individual license. Here in the U.S., our amateur radio license is in reality two licenses in one, a combination of an operator license, which is the authorization from the Federal Communications Commission (FCC) to transmit on amateur radio frequencies, and a station license, to which a call sign is assigned. In the case of the Kon Tiki, licensed by Norway, the ship's license issued to the raft allowed the operators to transmit on both amateur radio and commercial marine HF frequencies.

Technical Analysis

In the book "Kon Tiki," Heyerdahl mentioned multiple times in various chapters that both radio operators were electrically "shocked" (RF burns, but close enough) the first 30 days or so out to sea. At some point during the voyage, the "shocking" ended (we think). So, why is that? There is no explanation in the book about this matter. Heyerdahl was really not interested in the radios.

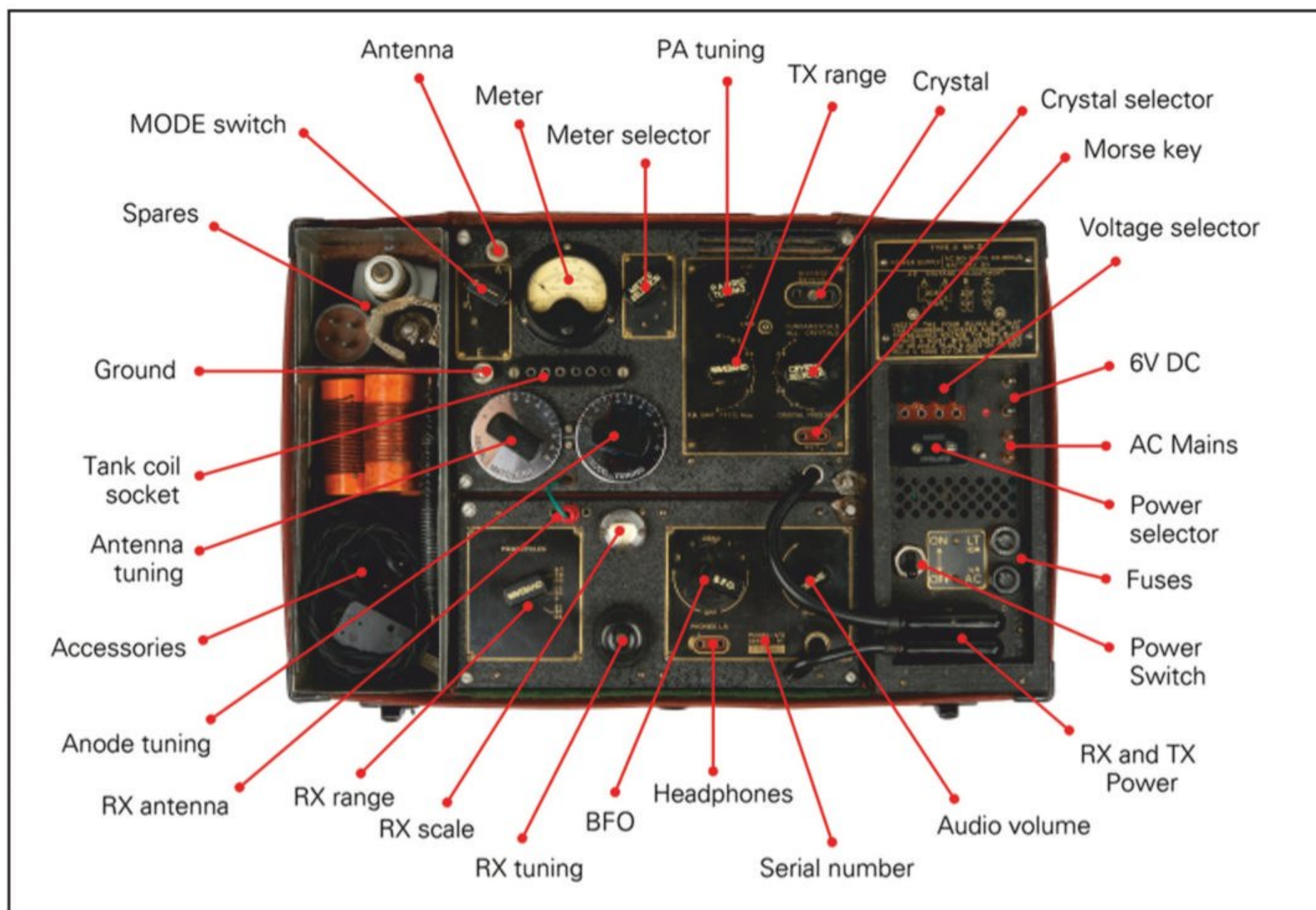

Figure 4. Type 3, MKII, B2. (courtesy Cryptomuseum.com)

Heyerdahl was quoted in his book when told of the necessity of having radios on board the Kon Tiki: *"Radio! I said, horrified. What the hell do we want with that? It's out of place on a prehistoric raft."*³

The counterargument of safety made radios a necessity and he was also presented with the notion that a radio will not have any effect on his migration theory. Heyerdahl was eventually convinced a two-way radio was important to maintain contact with shore, but his main focus was keeping the Kon Tiki afloat and proving his theory that the Polynesian peoples came from the west coast of South America (generally) and not from the orient.

The radios were installed on board, most probably with insufficient time for testing before launch. This is conjecture, but their main transmitter (7-14 MHz), built by Calvin Hadlock, W1CTW, was the radio that would "shock" the operator: *"...one got electric shocks both in the hinder parts and in the finger tips if one touched the Morse key. And, if one of us outsiders tried to steal a pencil from the well-equipped corner (radio room) either his hair stood*

*straight up on his head or he drew long sparks from the stump of the pencil."*⁴

Great, but why the electrical "shocks"? Well, let me state for the record that any conclusions I draw are based on synthesizing the information from the book "Kon Tiki." I attempted to research how these shocks occurred. I could find no definitive answer. I am sure that there was a radio log kept at one time, but it appears that it has been

lost to time. That log might have been able to answer a number of important questions. The answer is most probably the radio team did not install a proper electrical ground on the ship before setting sail. I contacted the Kon Tiki Museum in Oslo about this matter, but no explanation was to be found. However, I had a discussion on Facebook (Radio Telegraph Operators) with Mr. Hans Saethre, LA9LT,⁵ who lives in Norway.

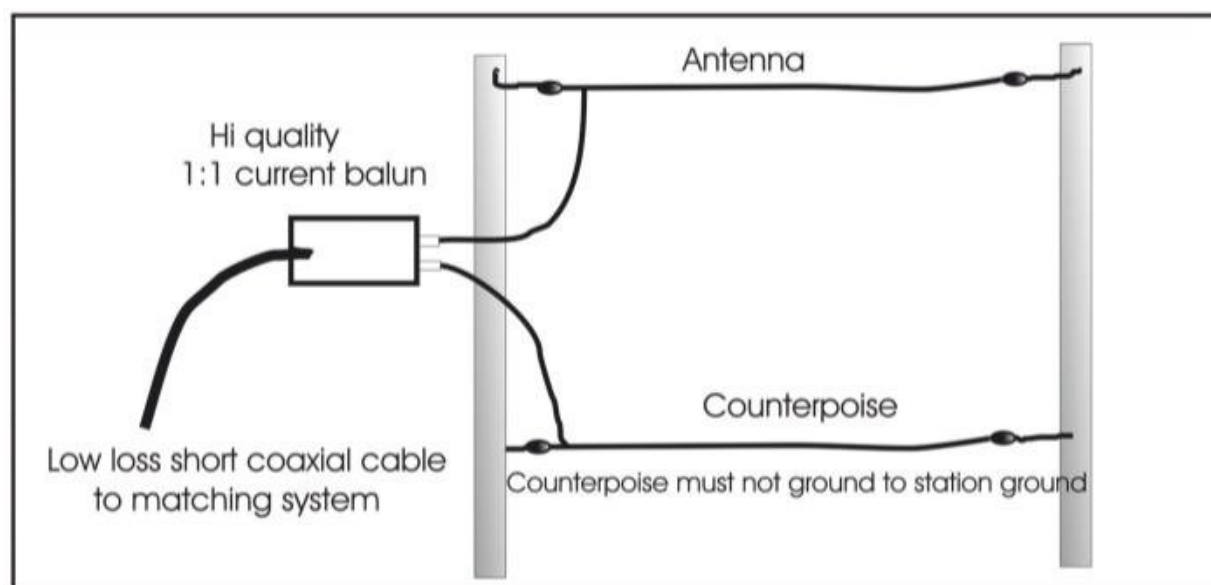

Figure 5. Basic long-wire antenna. (Source: < http://www.w8ji.com/long_wire_antenna.htm>)

He knew Knut Haugland (one of the two radio operators) before he passed. Mr. Saethre stated that the Kon Tiki did in fact have a "ground" for their radios. He called it an "electrode." If so, then why the multiple shocks?

Side note: Mr. Saethre said that after the voyage, the original radio equipment was stored in a military warehouse, and at some point was thrown away. So we have no physical components to examine.

I can only speculate as to what produced these "shocks":

a. They were using a longwire (end-fed, sometimes called a voltage-fed antenna); more on this later.

b. The radio room was always wet because water would come up between the logs.

c. The grounding "electrode" must have been very small and did not represent a proper counterpoise to the transmitting antenna.

By definition, a counterpoise is a "mirror" image of the antenna. In effect, it must be a true reflection of the transmitting antenna. You may argue that they had the entire Pacific Ocean at their disposal, so what is the problem? It appears likely that the electrical counterpoise and the Pacific Ocean were not touching each other.

If I were to design a counterpoise for

this system, I would have built a series of three or four 8-foot ground rods on the bottom of Kon Tiki. They would have been connected in parallel, and connected at each end, making a nice submerged rectangle. Floating in salt water, spread out on the underside of the Kon Tiki, the multiple ground rods all connected would have presented a

6 On Raft Drift Across Pacific

KON-TIKI EXPEDITION PICKS NATIONAL RECEIVERS

Somewhere in the vast loneliness of the Pacific a frail, balsam wood raft is drifting westward, carrying six Norwegian scientists toward the Polynesian Islands. Their mission: to prove that the Polynesians could have been settled by prehistoric Peruvian Indians.

Courage, yes, recklessness, no. These adventurers are scientists, not stunt men. Before setting out from Peru they made sure that they would have the finest radio equipment in the world . . . National receivers, of course (Models NC-173 and HRO-7).

For safety . . . to bring in the weakest signal in the worst kind of weather . . . for science . . . to exchange vital weather and navigational data with land stations thousands of miles away. Battered by wind and sea for months on end these superb National receivers aboard the Kon-Tiki Expedition raft are still functioning as reliably as ever.

What better testimonial than operator Knut Haugland's cheerful "All's Well" radioed from the Tuamotu Archipelago . . . 4000 miles across the Pacific, and still going strong.

Congratulations are also in order to W6AOA, W6EVM, and W3YA who have been in regular contact with LI2B. 27.98 and 14.142 megs have been assigned for general contact. Next time you go on the air, why not see if you can contact Haugland and get the Expedition's story first-hand.

National Company, Inc.
Malden, Mass.

MAKERS OF LIFETIME RADIO EQUIPMENT

September, 1947 47



Photo C. Knute Houglund, one of the two radio operators aboard the Kon Tiki. Haugland was also a cinematographer who shot the first Kon Tiki movie in 1950. (Photo courtesy <digitalmuseum.no>)



Photo D. Kon Tiki radio operator Torstein Pettersen Raaby. (Harris Ewing photo from the Kon Tiki Museum, Oslo, Norway)

sufficient surface area (electrically) to bring any transient voltages running around the radio room to zero.

I don't think this happened. So then why, all of a sudden during the voyage, did the radios start working and the complaints about the lack of reception of radio signals and "shocks" on transmissions end? Probably because they switched radios after all the trouble with the first transmitter. They had a MK-3, Type 2, SOE portable radio system (Figure 4). Both Raaby and Haugland had used these radios in WW2 reporting on German troop movements. The radio also had as part of its kit a long piece of wire to be used as a counterpoise. It would have been a very simple operation to work the wire down in-between the logs and let it trail under the raft as they sailed along. That would allow the MK-3 to work like a sewing machine. The principal receiver on board was the National NC-173 (Photo B).

Antenna

The main antenna used on the Kon Tiki expedition was made of wire. I hesitate to use the word "long wire" because there is an exact definition of this type of antenna. That is, the wire is at least one wavelength long ($L=984/F$ MHz).

The first radio contact while out at sea was with the military radio station in Lima, Peru (where they launched from). The Kon Tiki was using a true long wire at that time, vertically supported by either a kite or balloon. This did not last. The winds were unpredictable and would drive the kite into the water, and the heat of the equatorial sun would melt the balloon supporting the wire. However, this was not the final demise of the "long wire" antenna.⁶

The radios and antennas were working at this point (if you did not mind the "shocks" while transmitting), but there was trouble brewing. The Kon Tiki had a radio saboteur on board, the green parrot. For whatever reason, it decided to chew on the vertical long wire supported by a kite or balloon and the antenna floated away in the noon day sun and all communications stopped.

"At first the parrot was the bane of our radio operators. They might be sitting happily absorbed in the radio corner with their magic earphones on and perhaps in contact with a radio 'ham' in Oklahoma. Then their earphones would suddenly go dead, and they could not get a sound however much they coaxed the wires and turned the knobs. The parrot had been busy and bitten off the wire of the aerial".⁷

E-mail correspondence with LA9LT alluded to the fact that after this incident occurred, the two radio operators took the remaining wire, strung it across the mast and fastened it to the bow of the raft.⁸ This undoubtedly changed the radiation pattern of their radio emissions dramatically, but now they were able to communicate on a regular basis. The antenna became a random length, non-resonant antenna, probably at least a half a wavelength at 20 meters. It worked and that is all that mattered!

A really excellent reference to long wires with more information that you may need can be found at <www.w8ji.com>. This is the home page. He has developed a repository of information on all sorts of problems and designs from baluns to Rohn towers to long wire antennas. I recommend you bookmark his index page.

Why Not?

The Kon Tiki expedition almost did not happen, but it did. This story will live in perpetuity. We should be thankful that ham radio was a big part of this adventure. The two men who ran the radio room (Photos C and D) were in Norwegian special forces in WWII, parachuting behind enemy lines. They would provide communications back to their headquarters on enemy positions and troop movements. It was only natural that Thor Heyerdahl contacted them about joining his grand adventure on the high seas. To paraphrase the late Robert F. Kennedy, some men may have asked "why?" They asked, "why not?"

Notes:

1. Heyerdahl, "Kon Tiki" (see Reference 1), p. 13
2. Heyerdahl, p. 18
3. Heyerdahl, p. 31
4. Heyerdahl, p. 149
5. H. Saethre correspondence, Dec. 2022
6. Heyerdahl, p. 83
7. Heyerdahl, p. 146
8. op. cit. 6

REFERENCES:

- Heyerdahl, T. (1990), "Kon Tiki," Enriched Classics, Simon and Schuster.
- Saethre, Hans (2022), Facebook, Group: Radio Telegraph Operators.
- TITANIC, (1997) [Feature film], Paramount Pictures, Los Angeles, CA.
- <www.w8ji.com>, long wire antenna drawing.
- Kon Tiki, (2012) [Feature film], Weinstein Company, NY,NY.
- Kon Tiki Museum, Oslo, Norway. Email communications, Dec 2022.
- For 75 years the Kon Tiki Museum have kept her a secret (.pdf article). Kon Tiki Museum Publication. March 2022. Pages 1 to 43.
- Brenda Torrejon Estrada, Biblioteca Nacional del Peru. E-mail correspondence. Jan, 2023.

DITS and DAHS

The A B C's of Morse Code Operating

BY ED TOBIAS, KR3E

This small but solid guide is the perfect read for those interested in learning or improving CQ operating techniques!

Within its pages you'll find

- The secret of becoming a proficient CQ Operator
- Where and how to practice, practice, practice.
- Straight Key or Paddle?
- Keyers, Iambic Keying and Bugs
- Contests & Events, DXing
- Operating QSK
- CW Filters
- Signs, Signals and Procedures
- Tips on Taking CW On the Road...

and much, much more!

Order your copy today!

Shipping and Handling US and Possessions \$3,
CN/MX \$5, All Other Countries \$10

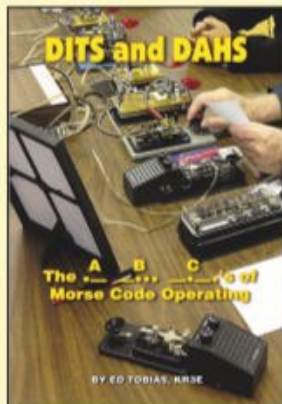

6 x 9 Paperback
Only \$15.95

CQ Communications

<http://store.cq-amateur-radio.com>

Falling Leaves... ...Falling Prices

DITS and DAHS

The **A B C**'s of Morse Code Operating

by Ed Tobias, KR3E

This small but solid guide is the perfect read for those interested in learning or improving CQ operating techniques!

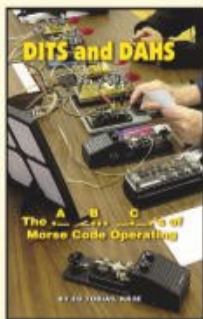

Within its pages you'll find

- The secret of becoming a proficient CQ Operator
- Where and how to practice, practice, practice.
- Straight Key or Paddle?
- Adjusting your Straight Key or Paddle
- Keys, Iambic Keying and Bugs *and much, much more!*

6 x 9 Paperback \$15.95

Lew McCoy on Antennas

by Lew McCoy, W1ICP

Unlike many technical publications, Lew presents his invaluable antenna info in a casual, non-intimidating way for anyone!

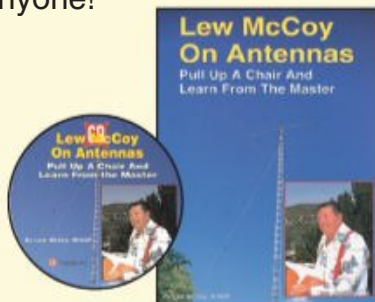

8.5 X 11

Paperback \$19.95

CD Version \$14.95

Buy both for only \$29.95

Understanding, Building & Using Baluns & Ununs

by Jerry Sevick, W2FMI

The successor to the popular and authoritative Baluns and Ununs. Great deal of new tutorial material, and designs not in previous book, with crystal clear explanations of how and why they work.

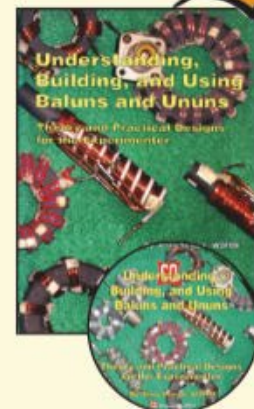

8.5 X 11 Paperback \$21.95

CD Version \$15.95

Buy both for only \$32.95

The Short Vertical Antenna and Ground Radial

by Jerry Sevick, W2FMI

This small but solid guide walks you through the design and installation of inexpensive, yet effective short HF vertical antennas. With antenna restrictions becoming a problem, it could keep you on the air!

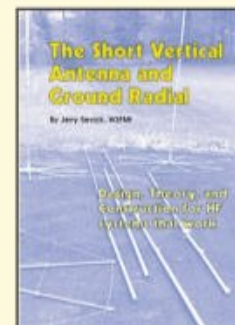

6 X 9 Paperback \$10.00

The CQ Shortwave Propagation Handbook-4th Ed.

by Carl Luetzelschwab, K9LA

Fully updated and expanded to include the latest propagation forecasting tools, as well as our time-tested "analog" tables for making your own customized predictions, the 4th edition of *The CQ Shortwave Propagation Handbook* is a must-have resource for any DXer, contester or emergency communicator.



8.5 X 11 Paperback \$42.95 CD Version \$32.95

Buy both for only \$61.95

Reflections III

by Walt Maxwell, W2DU

All the info in Reflections I and II and more! This completely revised and updated, 424-page 3rd edition is a must-have!

8.5 X 11 Paperback \$42.95 CD Version \$32.95

Buy both for only \$65.95



Please note: Prices listed above do not include applicable shipping charges. Shipping prices listed here are for most, but not all products.

Shipping & Handling

U.S.A. add \$8 for the first item, \$4.50 for the second and \$3 for each additional item.
All other countries \$35 for the first item, \$20 for second and \$10 for each additional.

CQ Communications, Inc.

Phone: 516-681-2922 <http://store.cq-amateur-radio.com>



CQ CLASSIC:

Radio and the Lure of the Sea

To accompany this issue's article about the radio gear aboard the Kon Tiki during Thor Heyerdahl's 1947 expedition by raft from South America to Polynesia, we thought it would be fun to reprise a QRP column from just a little over 10 years ago, when N6GA reported on a ham who was installing a Heyerdahl-inspired (but solar-powered) transmitter on his sailboat. The August 2012 column also takes a look at a QRP mini-expedition to Easter Island. Enjoy...

qrp

BY CAM HARTFORD, N6GA

QRP in the South Pacific

This month we turn our attention to the South Pacific for a couple of QRP adventures. Remember the Kon-Tiki? (See opening photo.) It was the raft used by Thor Heyerdahl to sail from Peru to the Polynesian islands in 1947. His purpose was to show that the South Seas islands could have been populated by people who traveled from South America. To this end, he built the raft using materials and techniques that would have been available to the native population at the time, using balsa logs and other materials gathered locally in Peru. Heyerdahl permitted himself a deviation from the "original equipment" track by including some modern-day communications equipment. This consisted of transmitters for the 40-, 20-, 10- and 6-meter bands. These were tubetype rigs with about 10 watts input, which would fall pretty close to our current definition of QRP. The receiver they carried was a National NC-173. After the first 20 days of the trip, communication via ham radio frequencies was established and continued for the remaining 80 days of the voyage. An article describing the radio operation aboard Kon-Tiki was published in the December 1947 issue of *QST* magazine.

I was reminded of the Kon-Tiki adventure by Gary Davis, KD9SB. Gary wrote: "I have recently completed a 20-meter 1-watt output QRP transmitter for use on my sailboat (photo A). My transmitter was inspired by Thor Heyerdahl's 1947 *Kon-Tiki* balsa-raft voyage across the Pacific from Peru to Polynesia.

"The solar-powered transmitter has one sixth of the power output of the Kon-Tiki raft's 20-meter 6-watt transmitter. The transmitter has a loop-through connection for the receiver, weighs 5.5 oz., and has diode protection for high SWR. It can also be built for 40 meters, with 1.5 watts out. The inductors for the oscillator, RF amp, and Pi output filter are off-the-shelf miniature parts from Mouser Electronics."

The schematic of Gary's transmitter is presented in fig. 1. For a complete parts list, contact the author at <gdavisKD9SB@sbcglobal.net>.

Gary uses a Yaesu VR500 pocket communications receiver with his homebrew transmitter. His best DX



Courtesy of Science Illustrated

KON-TIKI EXPEDITION PICKS NATIONAL RECEIVERS

Somewhere in the vast loneliness of the Pacific a frail, balsa wood raft is drifting westward, carrying six Norwegian scientists toward the Polynesian Islands. Their mission: to prove that the Polynesians could have been settled by pre-historic Peruvian Indians.

Courage, yes, recklessness, no. These adventurers are scientists, not stunt men. Before setting out from Peru they made sure that they would have the finest radio equipment in the world... National receivers, of course (Models NC-173 and HRC-7).

For safety... to bring in the weakest signal in the worst kind of weather... for science... to exchange vital weather and navigational data with land stations thousands of miles away. Battered by wind and sea for months on end, these superb National receivers aboard the Kon-Tiki Expedition raft are still functioning as reliably as ever.

What better testimonial than operator Knut Haugland's cheerful "All's Well" radiotele from the Tuamotu Archipelago... 4000 miles across the Pacific, and still going strong.

Congratulations are also in order to W6AOA, W6EVM, and W3YA who have been in regular contact with L12B, 27.98 and 14.142 megas have been assigned for general contact. Next time you go on the air, why not see if you can contact Haugland and get the Expedition's story first-hand.

National Receivers of the Type Selected for the Kon-Tiki Expedition



HRC-7

Brand new successor to the famous HRC used throughout the world. 11 tubes plus a voltage regulator. Frequency coverage from 30 to 430 and 480 to 30,000 kc. Adjustable threshold noise limiter. Unsynchronized grey cabinet. All phone and code reception.



NC-173

A new and versatile receiver, popularly priced. Frequency coverage from 160 kc to 30 mc plus the 48 to 24 mc range. Colored receiver band spread on 8, 10, 11, 20, 40 and 80 meter bands. Photograph or microphone pick-up jack.

National Company, Inc.
Malden, Mass.

MAKERS OF LIFETIME RADIO EQUIPMENT

September, 1947

47

Thor Heyerdahl sailed his raft Kon-Tiki on an adventurous voyage shared by hams around the world. National Radio provided the receivers and made sure everybody knew it, as seen in this ad from the September 1947 issue of *CQ*.

so far was with KD6JUI, a distance of 1886 miles. For an antenna, Gary uses a Zepp that is fed with window line. A full description of the antenna can be found in his article entitled "A 20 Meter Antenna for Sailboats," published in the October 2006 issue of *QST*.

CE0/YV5IAL: A QRP Digital Portable Mini-Dxpedition

If *Kon-Tiki's* path across the Pacific had dipped about a thousand miles to the south, it might have encountered Easter Island, from where our next story comes. Many of us dream of someday doing a portable operation from an exotic location. Roberto, YV5IAL, has done just that, and not from any ordinary, remote locale (photo B). Easter Island claims to be the most remote inhabited island in the world. Roberto journeyed there for a QRP mini-DXpedition. Here's his account:

"On the first days of January 2010, I made my dream come true—transmitting from an exotic DX entity in the middle of the Pacific Ocean. Easter Island is the most isolated island on the planet, thousands of miles away from anywhere.

Easter Island is more than 14 hours by plane from Caracas. The airfare is very expensive and the maximum weight of luggage allowed is less than 40 pounds per person.

I decided to work QRP, because the Yaesu FT-817ND, portable antenna, and accessories weighed less than 14 pounds, and the full station fit in two small bags (one for the radio and accessories and another for the antenna). I decided not to take the 100-watt station (Yaesu FT-857D and accessories) because the weight would have been twice or more. . . .

"After 20 hours of travel, I arrived at the hotel in Hanga Roa (the only town on the island). Immediately, I asked permission to install the antenna. Thirty minutes after, the Buddipole antenna was installed on the balcony and the radials (counterpoises) were spread all along the wood hotel room railings. CE0/YV5IAL, QRP digital portable station was ready to start the First World Easter Island PSK activation (January 9 to 11, 2010).

Roberto's station components can be seen in photo C. His QRP PSK station consisted of an FT-817 and an HP 1910 IPAQ Pocket PC running PocketDigi software. Roberto continues with his observations about operating low power from a place where your signal has to travel for thousands of miles before it gets to the first available ham stations: "Wasting valuable time insistently calling DX will not work. Never forget that you're at a disadvantage. Only good antenna stations will be able to copy you. Avoid competing with another station, and wait patiently for the DX station calling CQ again."

When it came time to pack up and leave, Roberto's log included QSOs with the USA, Hawaii, Marshall Is., Uruguay, Argentina, Chile, Colombia, and Brazil. His most distant QSO: V73RS, 9750 km (6,058 mi) for 2437 km/watt. A very good show for a QRP rig and a portable antenna!

Flyweight Feedline

The subject of Flyweight Feedlines surfaced on QRP-L a couple of months ago. That prompted me to make a trip to the garage to retrieve some lightweight stuff with which I had experimented. My motivation for fabricating this feedline is now lost in the mists of time, but I think it had something to

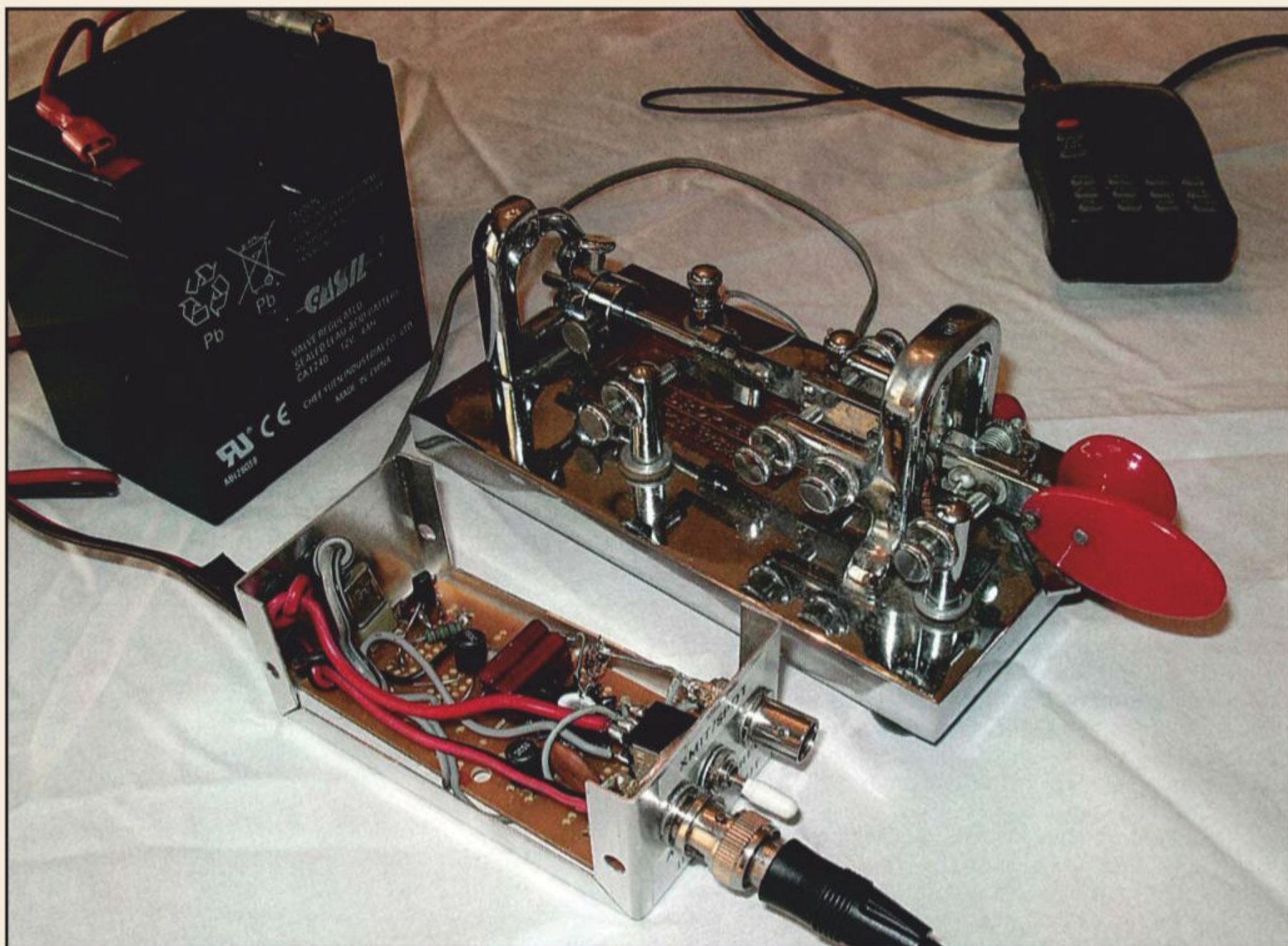

Photo A- KD9SB's Kon-Tiki inspired 20 meter CW transmitter.

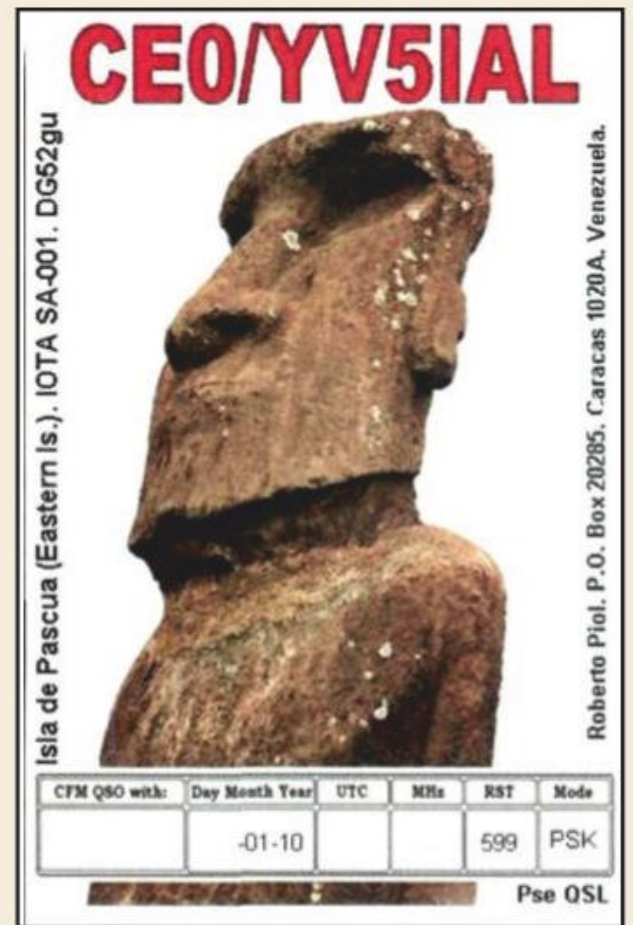
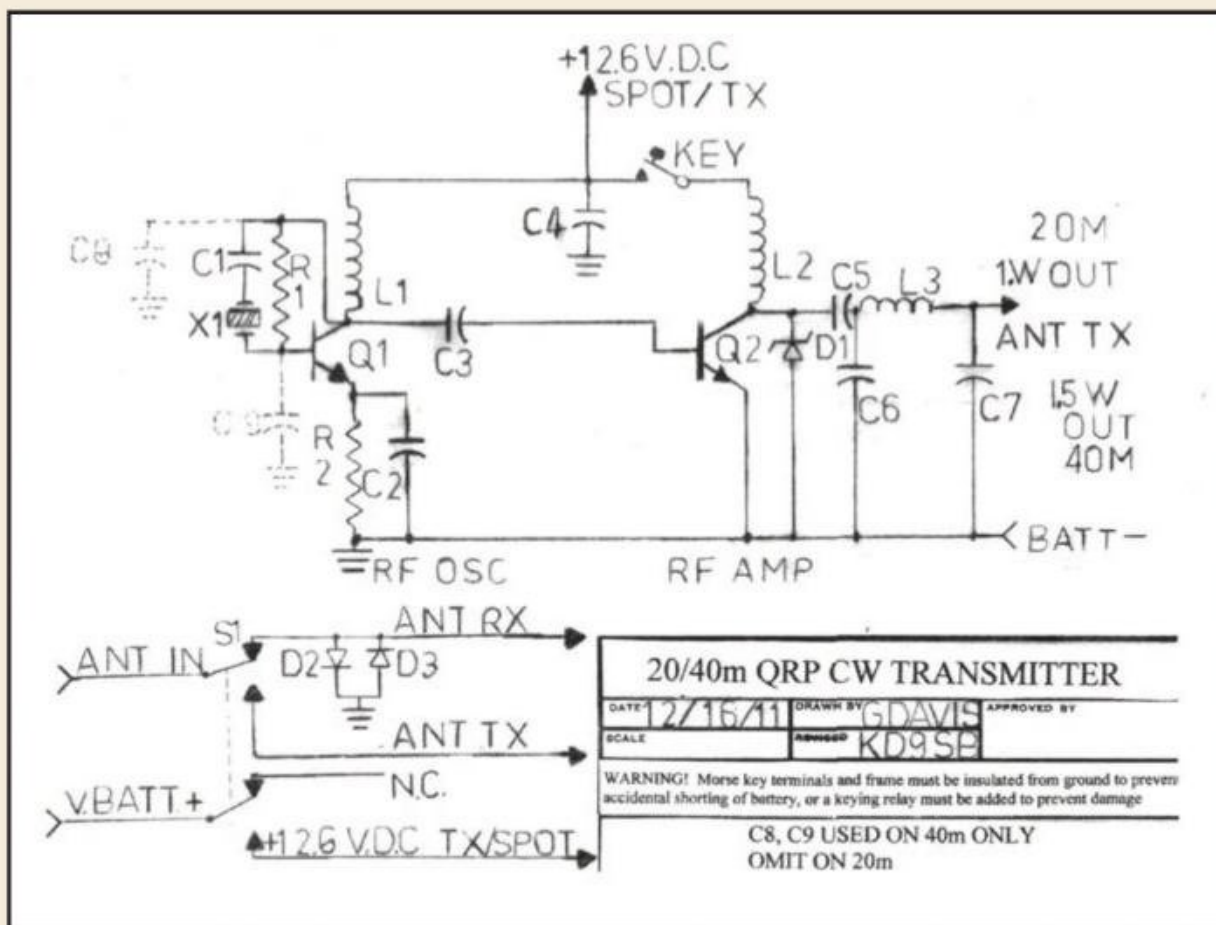

Fig. 1- This is the schematic of KD9SB's transmitter. The parts list can be obtained from the author. (See text for details.)

Photo B- YV5IAL's QSL card from Easter Island.

do with trying to make a portable antenna that would work well with my 4-band Elecraft K1.

I've used short lengths of RG-174 to feed a well-matched 20-meter dipole, but this little coax would never do well in feeding a non-resonant 4-band antenna. The feedpoint impedance would be all over the map, and the resulting feedline loss would gobble up most of my RF. Over the years people have pressed zip cord, computer ribbon cable, and all manner of hookup wire into feedline service, with varying results. The first use of computer ribbon cable I could find

was "The St. Louis Doublet" by Dave Gauding, NF0R, published in *QRPP*, Spring 1999. Dave used a length of 2-conductor computer ribbon cable. This was followed by Doug Hendricks' KI6DS "Norcal Doublet" published in the Winter 2002 issue of *QRPP*. Doug's feedline was a length of 4-conductor flat ribbon cable, of which he used the outer two conductors for the feedline, the inner conductors providing only spacing.

Fast forward several years. A box of flat-ribbon cable caught my eye at a swap meet and followed me home. It was

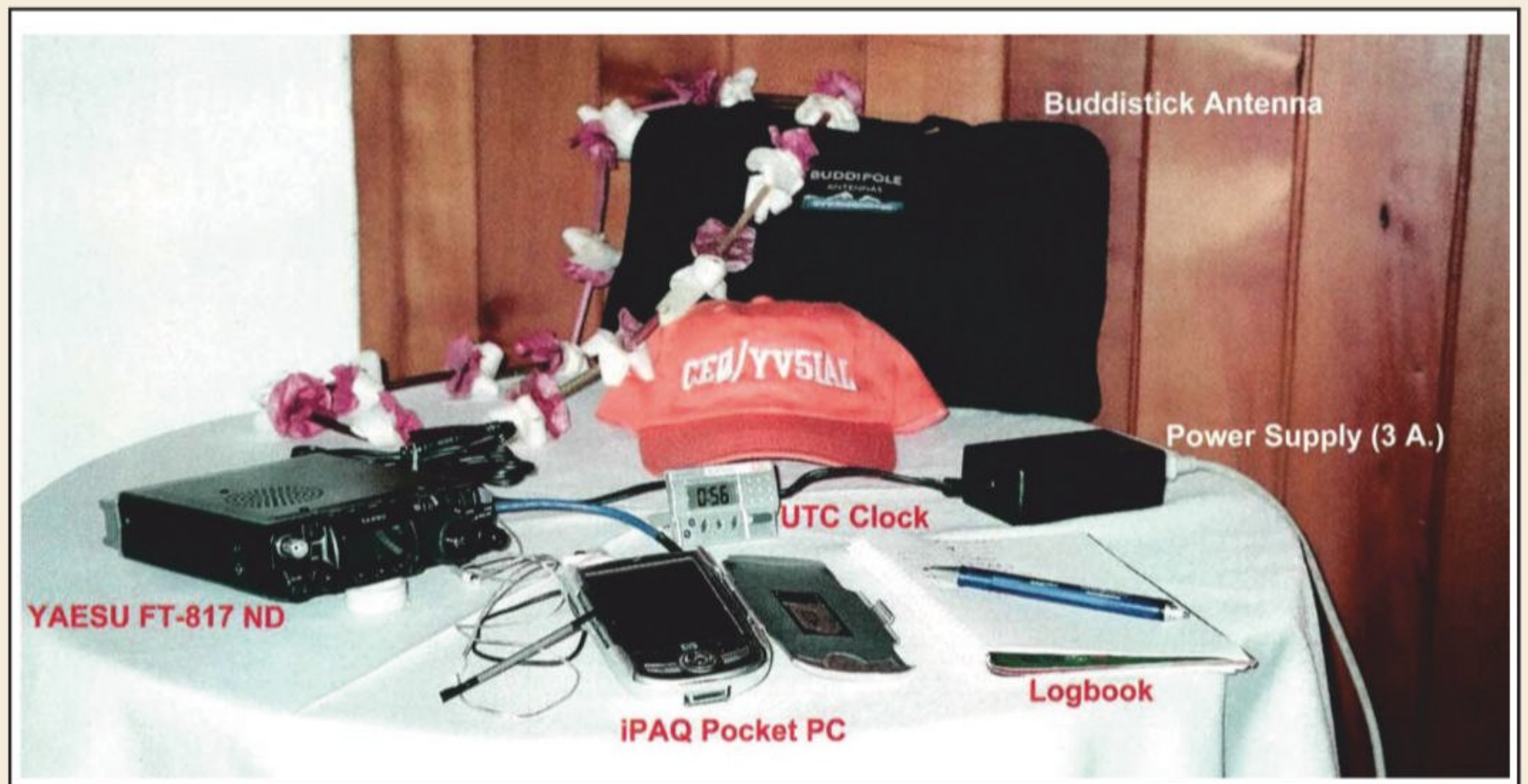

Photo C- The portable QRP PSK setup used by Roberto, YV5IAL, on Easter Island.

100 feet of 37-conductor cable, enough to build 18 NorCal doublets. Since there was so much of it, I decided I could easily experiment and hopefully find something that would represent an improvement over the existing designs.

After many iterations I ended up with the feedline that you see in photo D. I peeled off a seven-conductor strip of the

flat cable, used the two outer strands on each side for the conductors, and cut out the inner three conductors to make faux window line. Why? The losses in a feedline come primarily from the I²R losses in the conductors and dielectric losses in the space between the conductors. In this ribbon cable the conductors are #28 stranded wire, which

seemed a little wimpy to me. Doubling up on the conductors is a fairly painless way to cut down the ohmic losses. Likewise, air is the best dielectric we know other than vacuum, so by removing most of the inner three conductors we have a fairly good dielectric—not perfect, but pretty darn good.

Admittedly, constructing this feedline is a little more labor-intensive than making the NorCal Doublet feedline, which requires practically no work at all. However, the results are fairly impressive. I enlisted the help of Charlie, W6JJZ, and his AIM 4170 VNA to run some tests on this feedline. It ends up having a characteristic impedance of 280 ohms, a velocity factor of .87, and .9 dB loss per 100 feet at 10 MHz, which means this feedline weighs about the same as RG-174 but has the loss characteristics of RG-59 with foam dielectric.

The hard part is making it. I did it in three passes. The first pass was to mark the 7-conductor cable where the windows were to be cut out using a permanent marking pen. To speed up this task I made a template on a sheet of paper which I attached to a clip board. I laid the cable next to the template and marked it, and then slid the cable forward to the place where I could mark the next set of cuts.

In the next pass I made the slits in the cable between the conductors and the inner part which was to be cut out. A hobby knife worked well for this.

The last pass was to cut out the window sections, and this was done easily with a small set of diagonal cutters, as seen in photo E. It is a time-consuming process, but I found the time passed more quickly if I listened to code practice. Nothing like multi-tasking to make the time fly!

April Reader Survey—QRP

A monthly feature in *CQ* is the Reader Survey, wherein the editorial staff asks a series of questions aimed at learning more about our readers and, hopefully, improving the focus of the magazine. The subject of the April survey was QRP, and I found the results to be illuminating, if not downright profound.

This survey is voluntary, and of course not a statistical cross-section of the whole ham spectrum, so you'd expect that the ones who responded have at least a passing interest in low-power operating. Their attitude toward QRP operating bears this out, with the answers "I enjoy it when I do it" and "Love it" comprising 75% of the responses. "Great for Others" scored



Photo D- Balanced feedline made from flat ribbon cable, flanked by RG-58 and RG-174.

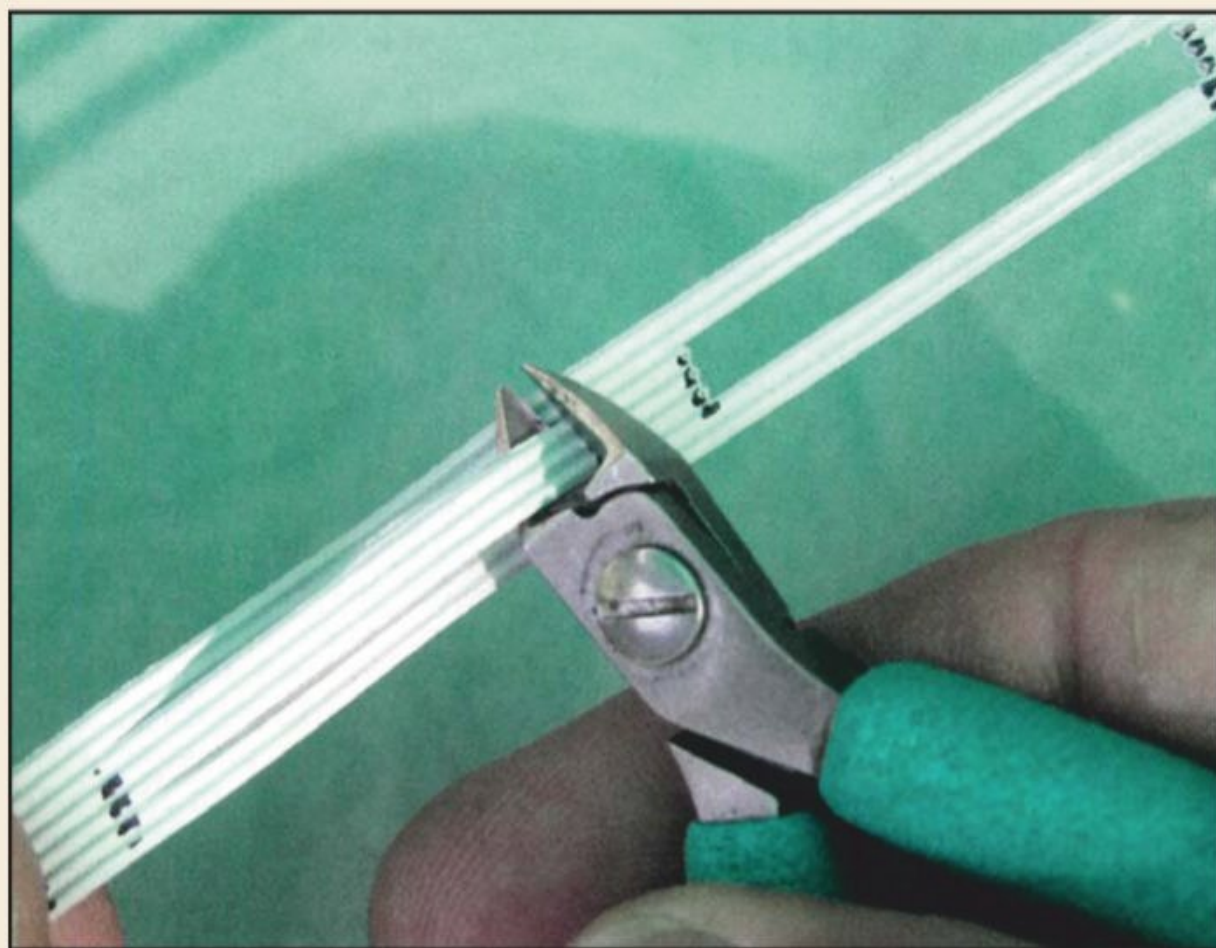

Photo E- The last step in fabricating the flyweight feedline.

10%; "Life's Too Short" came in at 9%; and "Hadn't thought about it" rounded out the responses with 7%.

The responses to the "Time devoted to QRP operating" question were skewed by the 19% who answered "Don't operate QRP at all," so I tossed out the non-QRPs and rearranged the numbers. The biggest response was in the 1-25% group, with 43% of QRPs responding. If you then add the 26-50%

group (13%), the conclusion indicated is that a majority of QRPs spend less than half of their time operating QRP. Which means that half the time they are doing something else, from which it follows that they do have a variety of interests in the radio world. Psychiatrists would probably say that this indicates a healthy state of mind, unlike the 18% of respondents (myself included) who operate 100% of their time at QRP lev-

els. At least we're not irradiating our brains with dangerously high levels of RF, though.

The answers to the question about what modes are most often used are not surprising, with 61% of respondents using CW, followed by 32% for SSB, 16% Digital, 14% FM, and 2% Other. If the survey were to be run again in a couple of years, it wouldn't surprise me if the results showed an increase in the use of digital modes. Newer modes such as PSK, WSPR, and JT65 work quite well at QRP levels.

"Where" you operate QRP is pretty much what you would expect: 68% of respondents said Home, followed by 27% for Remote/Off Grid, 21% for Vacation Home/Hotel, 20% for Car/Truck, 6% for Other, and 2% for Boat/Plane.

The last two questions were about the equipment we use. In the "Antenna" category, the home antenna was mentioned 61% of the time, a likely answer in that we operate from home most of the time per the answer to the "Where" question above. This was followed by portable homebrewed at 38% and portable purchased at 26%. Finally, 20% of respondents say they use a mobile antenna, which is notable because I've often heard it said that one can't operate mobile with anything less than 100 watts. 20% of the respondents would disagree.

Regarding what rigs we use, commercial QRP rigs edge out QRP kits 36% to 34%, meaning that we buy and build a kit almost as often as we buy a factory-built rig. 21% say they use the "Big Rig" by turning down the power. Way down the list is Scratch Built at 5%. I'll have to admit that I last scratch built a rig about two years ago. It's getting harder to scratch build with through-hole parts becoming scarcer and so many more designs using surface mount parts and on-board processors. It appears that QRPs still have a desire to build their rigs and kits are fulfilling that need.

Thanks to the editorial staff here at CQ for running the monthly Reader Survey. From the 2012 April survey I feel like I have a more-focused picture of who we QRPs really are.

Signing Off

As I'm writing these words, Field Day plans are coming into focus and gear is being retrieved from storage in anticipation of another good weekend in the woods. As you're reading this, FD'12 is history. I hope you had as great a time as I hope to! 72/73, Cam, N6GA



*Were you first licensed
25 years ago
and licensed today?*

**Then you should join the
Quarter Century
Wireless Association, Inc.**

The Quarter Century Wireless Association, Inc., celebrates Amateur Radio operators achieving 25 years in Amateur Radio and develops resources to assist young Amateur Radio operators in furthering their education through the QCWA Scholarship Program.

To Join or Renew, Visit:

<http://www.qcwa.org/join-renew.php>

**For more information please contact
om@qcwa.org**

Maritime radio evolved alongside amateur radio, sometimes involving the same cast of characters. Marine radio historian (and former ship's radio officer) N1EA takes a look at a history of ship-to-shore radio penned by another radio officer/ham.

CQ Book Review:

Radio History - Ship Shore

by Spurgeon G. Roscoe, VE1BC, former Radio Officer, VCS and other stations and ships

REVIEWED BY DAVID J. RING, JR.,* N1EA

From flags and pennants to Morse code and complex telecommunications, "Radio History: Ship Shore" is a treatise on the navigational aids vessels have used over the centuries. Author Spurgeon "Spud" G. Roscoe takes the reader on a journey through the evolution of communication systems globally, from the days of Columbus to modern times.

Roscoe also mines his first-hand experience as a radio officer who sailed on a dozen ships, including a reproduction of the ill-fated HMS Bounty. Now in his eighties, he has been meticulously collecting the content for "Radio History: Ship Shore" for more than five decades. The result is a hefty tome in which Roscoe shares his encyclopedic knowledge and unyielding fascination with communications systems.

The book includes all the vessels in the Royal Canadian Mounted Police marine section (and, later, marine division), the Royal Canadian Air Force marine squadrons, the Royal Canadian Navy, the Canadian Government Merchant Marine, and the Canadian Coast Guard, including the weather ships and icebreakers.

"Radio History: Ship Shore" is complemented by a wealth of historic photos of everything from warships to Canada's famous Bluenose schooner.

Spurgeon G. Roscoe has been fascinated with living the life of a radio operator since the age of seventeen. In fact, he became so enthralled with his work that, one year, he was at home for only six weeks. Although he officially retired years ago, Roscoe's interest in the navigational aids and communications systems used by ships has never waned. He belongs to a number of organizations, including the Halifax Amateur Radio Club, American Radio Relay League, Radio Amateurs of Canada, the Nova Scotia Lighthouse Preservation Society, and the California Historical Radio Society. Spurgeon G. Roscoe lives with Joan, his beloved wife of 61 years, in Halifax, Nova Scotia.

I highly recommend this book to anyone with an interest in the history of radio on the high seas. It's available from Amazon at <<https://amzn.to/3BTPNNO>>.

* E-mail: <n1ea@arrl.net>

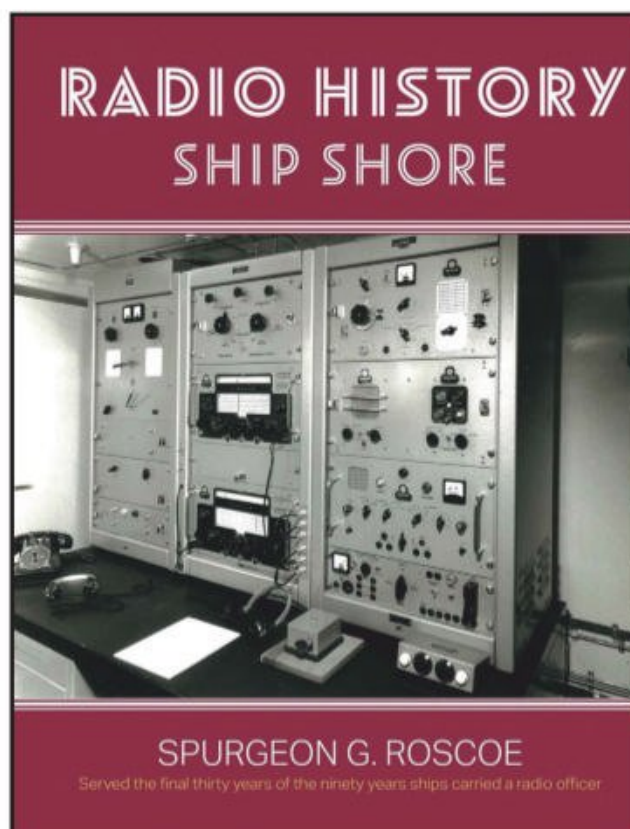

From **MILLIWATTS**
To **KILOWATTS**SM
More Watts per DollarSM

Transmitting & Audio Tubes



COMMUNICATIONS

BROADCAST

INDUSTRY

AMATEUR

Immediate Shipment from Stock



3CPX800A7	4CX1000A	810
3CPX1500A7	4CX1500B	811A
3CX400A7	4CX3500A	812A
3CX800A7	4CX5000A	833A
3CX1200A7	4CX7500A	833C
3CX1200D7	4CX10000A	845
3CX1200Z7	4CX15000A	6146B
3CX1500A7	4CX20000B	3-500ZG
3CX3000A7	4CX20000C	3-1000Z
3CX6000A7	4CX20000D	4-400A
3CX10000A7	4X150A	4-1000A
3CX15000A7	572B	4PR400A
3CX20000A7	805	4PR1000A
4CX250B	807	...and more!

Se Habla Español • We Export

Phone: **760-744-0700**

Toll-Free: **800-737-2787**
(Orders only) **800-RF PARTS**

Website: **www.rfparts.com**

Fax: **760-744-1943**
888-744-1943

Email: **rfp@rfparts.com**



After an absence of four years, the 1A prefix returned to the air in July 2023, thanks to a DXpedition to the heart of Rome, or better yet, to the heart of the Order of Malta, one of the most requested, mysterious and fascinating DX entities in the world.

DXpedition to the Heart of Rome

1A0C Sovereign Military Order of Malta - Where Extraterritoriality Makes the Difference

BY NICOLA BURDIAT,* IU0NIC



Photo A. Blessed Fra' Gerard, founder and first Master of the Order (Photos courtesy of the Sovereign Military Order of Malta, except as noted)



Photo B. The journey of the Order from Jerusalem to Rome

For a week this past summer, hams around the world were treated to the first operation in four years from the Sovereign Military Order of Malta, an extraterritorial entity headquartered in the heart of Rome that has its own place on the ARRL DXCC list. An international team of 15 amateurs operated 1A0C for eight days in late July and early August, making nearly 80,000 contacts and helping to raise funds for the Order's worldwide relief efforts.

While many amateurs are familiar with "SMOM" as a DX entity, far fewer know much about its nearly thousand-year history or its humanitarian mission. So let's start there...

The Order of Malta

The Sovereign Military Hospitaller Order of St. John of Jerusalem, of Rhodes and of Malta (this is the complete name of the Order, also known as SMOM) is one of the oldest institutions of Western and Christian civilization. It was founded in 1048, when a group of merchants from the maritime republic of Amalfi, in southern Italy, obtained authorization from the Caliph of Egypt to build in Jerusalem a church, convent and hospital named after St. John the Baptist to assist pilgrims and, later, all those in need, regardless of their origin or religion.

* E-mail: <nicola.burdiat.iu0nic@gmail.com>

It was under the leadership of Blessed Fra' Gerard, founder and first Master (Photo A), that the religious community became a lay religious order of the Catholic Church. Thanks to the bull of February 15, 1113, Pope Paschal II recognised the Order of St. John, placing it under the protection of the church and granting it the right to freely elect its superiors, without interference from other lay or religious authorities, thus creating a sovereign entity, subject only to the Holy See.

After the loss of the Holy Land in 1291, the Order of St. John moved its seat and hospital to Limassol on the island of Cyprus, acquiring more possessions on the shores of the Mediterranean Sea (Photo B shows the Order's travels from Jerusalem to Rome over a period of more than 500 years). In 1307, the knights of the Order landed on Rhodes, where they transferred their seat in 1310. At that time, the defense of Christendom required a naval force, so the Order navigated the eastern Mediterranean with its powerful fleet, thanks to its independence from other nations, with the right to maintain and deploy armed forces and to appoint ambassadors.

In 1523, after six months of siege and fierce combat against the fleet and army of Sultan Suleiman the Magnificent, the knights were forced to surrender and left Rhodes with military honors. Seven years later, in 1530, an order by Emperor Charles V with approval of Pope Clement VII granted the



Photo C. Aerial view of Magistral Villa on the Aventino Hill (Photo by IK5RUN)



Photo D. Magistral Villa is an extraterritorial seat



Photo E. The "buco della serratura," or keyhole, with a spectacular view of St. Peter's Basilica

Order of St. John the possession of the Maltese islands. Since then, the Order has been known as the Order of Malta and its members as the Knights of Malta.

The Order's fleet joined the Holy League, set up by Pope Pius V to prevent the advance of the Ottoman Empire and, on 7 October 1571, it contributed to the victory of the Christian fleet in the battle of Lepanto, that marked the turning point of Ottoman expansion in Europe. The Order of Malta became the most important fleet in the Mediterranean Sea and its naval school was famous and trained numerous French and other European naval officers.

Unfortunately, its strategic position in the Mediterranean led Napoleon Bonaparte to occupy Malta during his Egyptian campaign of 1798. The knights were forced to leave the island, also because the Order's code prohibited them from raising arms against other Christian nations. The Treaty of Amiens, signed in 1802, confirming the Order's sovereign rights over the island of Malta, was never applied and the Order's government had to face one of the most dramatic historic and political moments of its long existence.

In 1834, the Order finally settled in Rome in the then Pontifical State (Photo C), where it was able to focus on its original charter of assistance to the poor and the sick. During the 19th and 20th centuries, the Order thoroughly updated its statutes, Constitutional Charter and Code. The first National Associations (the German one in 1859, followed in 1875 by the British one and in 1877 by the Italian one) were created.

In the second half of the 19th century, the Order's original mission of medical and social assistance again became its main focus, intensifying during the last century thanks to the work of the Grand Priorities and National Associations in many countries worldwide. Large-scale medical and charitable works were carried out during World Wars I and II. In the second half of the 20th century, the Order's activities grew until they reached the furthestmost regions of the world.

Today, the Order of Malta is active in 120 countries, caring for people in need through its medical, social and humanitarian works, providing a constant support for forgotten or excluded members of society. It is especially involved in helping people living in the midst of armed conflicts and natural



Photo F. The Magistral Villa on the Aventino Hill, seen from the Tevere (Tiber) River (Photo by EA5C)

disasters by providing medical assistance, caring for refugees, and distributing medicine and basic equipment for survival. Across the world, the Order of Malta is dedicated to the preservation of human dignity and the care of all those in need, regardless of their origin or religion. It is made up of more than 13,500 Knights, Dames and Chaplains. Next to them stand 95,000 permanent volunteers and 52,000 employees, most of them medical personnel.

The Sovereign Military Order of Malta has diplomatic relations with 112 states and the European Union, and permanent observer status at the United Nations. It operates through 11 Pories, 48 National Associations, 133 diplomatic

missions, 1 worldwide relief agency and 33 national volunteer corps, as well as numerous hospitals, medical centres and specialist foundations. It does not pursue any economic or political goal and, now as 900-plus years ago, does not depend on any other state or government.

Full Sovereignty and Amateur Radio

Recognized as a sovereign entity by 112 states, the European Union and many international organizations, the Order of Malta has its seat of government in Rome, where it is guaranteed full extraterritorial rights by the Italian government (Photo D).



Photo G. The 1A0C 2023 Team (Photo by EA5Z)



Photo H. Giorgio, IZ4AKS, in action (Photo by F2JD)



Photo I. Author Nicola Burdiat, IU0NIC, who is also the Order's Post and Philately Director, on the air from 1A0C. (Photo by IZ4AKS)

The extraterritorial seat of the order is composed by two different buildings: the Magistral Palace, situated in the heart of Rome's historical center, on Via dei Condotti, home of the Grand Master, seat of all the government's bodies and headquarters of the Grand Magistry's administration; and the Magistral Villa on Aventino Hill, seat of the Grand Priory of Rome and the Embassy of the Order to the Italian Republic, famous for its marvelous gardens (where the Grand Master receives heads of state and representatives of governments) and for its "buco della serratura," a keyhole framing the dome of St. Peter's Basilica (more on this below and in Photo E).

Thanks to its extraterritorial status, the Order of Malta, as a sovereign authority, has the right to run its own Amateur Radio Service. To understand how the Order's ham radio was born and how it works, it is necessary to start by saying that it is completely functional to the achievement of the Order's high purposes (i.e., providing assistance to those in need). Since the Order, strictly speaking, has no population, except the Grand Master and a few Professed Knights who permanently live in the Magistral Palace, there is no need for private amateur stations. Members of the Order throughout the world use their own national call signs, according to the regulations of the country in which they live or operate.

The need for a unique call sign of the Order of Malta first came in late November 1980, when a group of volunteers of the Order operated an extraordinary ham radio station after the devastating earthquake that caused more than 2,900 deaths and 280,000 displaced people in southern Italy. The station having been operated from the extraterritorial seat of Magistral Villa on



Photo J. The 5-band Spiderbeam Yagi on the terrace of Magistral Villa (Photo by IZ4AKS)

Aventino Hill (Photo F), the group of radio hams, with the permission of the Order's authorities, started using the unique 1A prefix. The 1A0KM station (in which KM stands for "Knights of Malta") relayed thousands of messages from people hit by the earthquake to relatives and friends in Italy and abroad, in addition to those sent to the Order's relief corps operating in the devastated area.

After the emergency was over, the team kept operating 1A0KM, to let the ham radio community throughout the world know the existence of the Sovereign Military Order of Malta and its Radio Service.

The next step was the official inclusion of the Order in the DXCC list of the ARRL. A first positive opinion was adopted by majority by the DX Advisory

Committee, but not all members of the committee were convinced by the status of the Order (then, as now, the United States had no diplomatic relationship with the Order of Malta). Thankfully, further examination of the huge amount of legal documentation provided by the radio team of the Order (mostly composed by lawyers) and a visit to Rome by the DXAC Chairman led to a positive response. On September 29, 1981, the ARRL announced that the Sovereign Military Order of Malta was finally added to the DXCC List. Since then, a very limited number of ham radio stations with 1A prefix have been activated at the extraterritorial seat of Magistral Villa in Rome.

It is important to note that only institutional stations (i.e., stations activated



Photo K. A vertical antenna in the gardens of Magistral Villa (Photo by EA5C)



Photo L. Cross Yagi antennas for satellite contacts (Photo by F2JD)

under the authority of one of the Order's entities) have been authorized by the Grand Magistry of the Order in recent times. Namely, all these ham radio stations are linked to the Italian Relief Corps of the Order of Malta (CISOM), under the supervision of radio amateur members of the Order and with the primary aim of raising funds for specific projects.

In 2007, a DXpedition worked with call sign 1A4A, raising funds for the School of Rumbek in South Sudan. Both the 2012 and the 2014 DXpeditions raised funds for the CISOM assistance to refugees in the Mediterranean Sea, running the 1A0C station. The last activation from the Order of Malta in 2019, again with call sign 1A0C, allowed CISOM to buy radio equipment for emergency use.

The 2023 1A0C DXpedition

After the Covid-19 hurricane, which kept us from celebrating the 40th anniversary of both the first activation of a 1A station and the recognition by the ARRL as a new country, the CISOM ham radio team planned a new DXpedition to take place in 2023.

Rome is definitely a very easy city to reach, but it is not so easy to obtain all the necessary permissions to use the Magistral Villa for a couple of weeks, even for an institution belonging to the Order of Malta itself. The Villa is an important institutional venue, with many official events planned every week, most of them with the Grand Master's presence. Thus, CISOM was allowed to operate its ham radio station from July 26 to August 2, during the less busy summer season. We hoped that this week would coincide with a period of very good propagation!

The 1A0C team leader, Antonio Gonzales, EA5RM, planned all the organizational details with CISOM. This meant that, first of all, a project to be financed with the proceeds of the DXpedition had to be found. Since the Italian region of Emilia-Romagna was hit in May 2023 by a severe flood, with many victims, people forced to leave their homes and very bad damage to infrastructure, it was decided to donate all the proceeds to a reconstruction project in that area. By the way, the radio equipment bought with the proceeds of the 2019 DXpedition was used by CISOM during the 2023 emergency in Emilia-Romagna.

CISOM also provided lodging for members of the 1A0C team at its dormitory located within the Magistral Villa area. A good chance to sleep in an extraterritorial zone! Meals would come from the many "trattorie" around Aventino Hill. A good chance to enjoy typical Roman food!

The team was made up of 15 expert ham operators from many countries (Photo G), able to ensure top performance to the DXpedition, working as many stations as possible (as we all know how important it is for a DXer to log such a prestigious prefix). The team included: Fernando Conde, EA5C; Eugene Mosiychuk, EA5EL; Raul Blasco, EA5KA; Javier Dominguez Ferrer, EA5KM; Antonio Gonzales, EA5RM (Team Leader); Angel Turpin Guillamon, EA5Z; Arturo Rivera Gallardo, EA7KE; Jose Ramon Hierro Peris, EA7X; Gerard Jacot, F2JD; Simone Sarti, IK5RUN; Fabrizio Vedovelli, IN3ZNR; Nicola Burdiat, IU0NIC (Photo H); Giorgio Minguzzi, IZ4AKS (Photo I); Junichi Tanaka, JH4RHF, and Dmitry Zhikharev, RA9USU.

The team members, coming by car, train or plane, met in Rome on July 25 and immediately started raising the first nine antennas on the grounds and roof of the Magistral Villa: a 5-band Spiderbeam Yagi (Photo J), a 5-element 6-meter Yagi, three monoband verticals with elevated radials for 30, 40 and 80 meters (Photo K), a 60-meter inverted V and, for satellite, a Wimo cross Yagi 432 2x10 elements, a Wimo cross Yagi

Falling Leaves... ...Falling Prices

DX World Guide-4th Edition

by Franz Langner, DJ9ZB

This is the fourth edition of Franz Langer's series of books bearing the title *DX World Guide*. This 380-page, fourth edition, full color throughout, includes information on well over 300 DX entities.

Whether used as a desk reference for the DXer of any level of proficiency or as a "wish book" for DXers just starting his or her DXCC journey, the new *DX World Guide* is a worthy and pleasant companion!

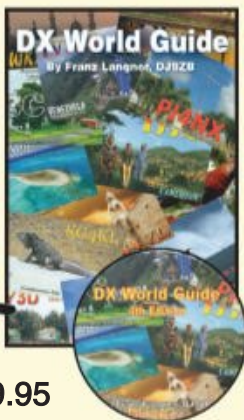

6 X 9 Paperback – \$49.95
CD Version – \$34.95

Buy both for only \$68.95

Sloper Antennas

by Juergen A. Weigl, OE5CWL

Single- and Multi-Element Directive Antennas for the Low Bands

With calculations and practical experience, this book shows which basic concepts have to be considered for sloper antennas for the low bands.

6 X 9 Paperback \$25.95
CD Version \$19.95

Buy both for only \$38.95

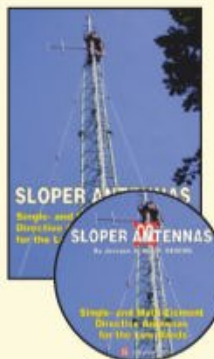

W6SAI HF Antenna Handbook

by Bill Orr, W6SAI

W6SAI was known for his easy-to-understand writing style. In keeping with this tradition, this book is a thoroughly readable text for any antenna enthusiast, jam-packed with dozens of inexpensive, practical antenna projects that work!

8.5 X 11 Paperback \$21.95
CD Version \$15.95

Buy both for only \$32.95

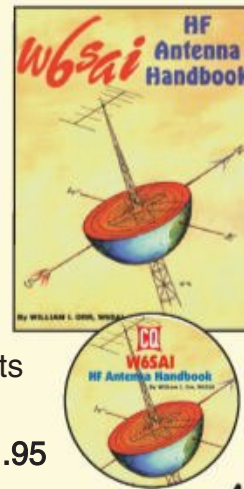

33 Simple Weekend Projects

by Dave Ingram, K4TJWJ

Do-it-yourself electronics projects from the most basic to the fairly sophisticated. Also, practical tips and techniques on creating your own projects.

6 X 9 Paperback \$17.95



The Quad Antenna

by Bob Haviland, W4MB

Comprehensive guide to the construction, design and performance of Quad Antennas.

General Concepts, Circular-Loop & Arrays, Rectangular & Square Loops, Multi-Element Quads and more!

8.5 X 11 Paperback \$21.95
CD Version \$15.95

Buy both for only \$32.95

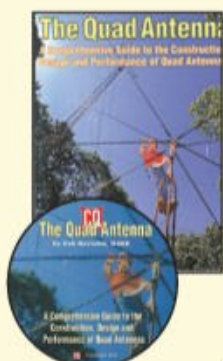

Lew McCoy on Antennas

by Lew McCoy, W1ICP

Unlike many technical publications, Lew presents his invaluable antenna info in a casual, non-intimidating way for anyone!

8.5 X 11
Paperback
\$19.95
CD Version
\$14.95

Buy both for only \$29.95

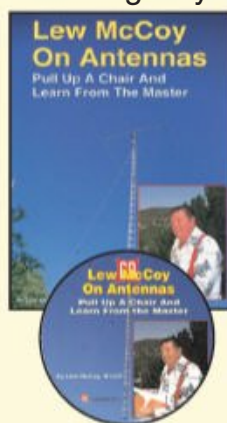

Please note: Prices listed above do not include applicable shipping charges.
Shipping prices listed here are for most, but not all products.

Shipping & Handling

U.S.A. add \$8 for the first item, \$4.50 for the second and \$3 for each additional item.
All other countries \$35 for the first item, \$20 for second and \$10 for each additional.

CQ Communications, Inc.

Phone: 516-681-2922

<http://store.cq-amateur-radio.com>



Photo M. The radio station inside the Coffee House
(Photo by EA5Z)



Photo N. The Receiver of the Common Treasure of the Order of Malta, Fabrizio Colonna, sending a message to all radio hams listening (Photo by EA7X)

144 2x7 elements (Photo L) and a 100-centimeter dish plus homemade helix for QO-100. An additional inverted V antenna for 160 meters was raised on July 29, because of the high demand for this band.

A total of ten antennas were thus raised, and this was a record, because of the size of the Magistral Villa area. All operations were even more difficult because of the need to avoid discomfort to the many tourists standing at the famous keyhole of the Villa. From the monumental portal of Magistral Villa, you can enjoy one of the most intriguing views of the dome of St. Peter's Basilica: Framed by a thick laurel hedge, it gives the illusion of being larger and, therefore, closer through the keyhole. Some of the antennas on the ground of the panoramic terrace of the Villa had to be raised in such a way not

to interfere with the trajectory of the view seen from the keyhole!

An Outstanding Achievement

The team decided to be active from 6 to 80 meters (including WARC bands) on CW, SSB, RTTY and FT8 with at least three stations on the air simultaneously on different bands and modes. As noted above, the 160-meter band was eventually added as well. The station was also active on LEO (low Earth orbit) and QO-100 satellites (*QO-100 is the first and so far only geostationary amateur satellite, covering much of the Eastern Hemisphere and some of South America. – ed.*).

Operating from 10:24 UTC Wednesday July 26, to 07:15 UTC Wednesday August 2 (Photo M), the 1A0C 2023 station reached the record result of 79,959 QSOs, working 20,599

different stations in 157 DX entities, mostly in the United States (12,004 QSOs) and Japan (5,532 QSOs). It was an outstanding achievement, with demand increased by the lengthy inactivity of the 1A prefix.

The operation was a great satisfaction for the entire team, which also received a special visit on the second day of the DXpedition. The Receiver of the Common Treasure (i.e., the Minister of Finance of the Order, also responsible for the telecommunication sector), His Excellency Fabrizio Colonna dei Principi di Paliano, accompanied by the Post and Philately Director of the Order of Malta, Nicola Burdiat, IU0NIC, visited the 1A0C station and transmitted a special announcement to all radio hams listening (Photo N). Introduced by Giorgio Minguzzi, IZ4AKS, Colonna said:

First of all, good morning and thank you all for your work, for what you do. This is not just a hobby or a sport, it is an activity which is supporting a lot of other activities throughout the world. It is an activity which is saving lives throughout the world. For us, it is supporting our works, our mission, which is to help the sick, and the poor and the refugees. So we will continue in improving this activity in time being and we will certainly need your competence, your help, your support, your knowledge, your assistance, your suggestions on what we want to achieve. First of all, in order to improve the message of peace coming from the Holy Father which we try to deliver through our works and through our mission. Thank you all, thank you!

A meaningful message, able to summarize the nine-century-old work of the Order of Malta at the service of all those who are in need.

SMOM Ham Radio Postage Stamps



Photo O. As a sovereign entity, the Order of Malta operates its own postal service



Photo Q. A special postmark was put into use on July 27, 2023, to celebrate the 1A0C DXpedition

Just like all the sovereign entities of the world, the Order of Malta runs its own postal service and issues its own postage stamps. Since 1966, "Poste Magistrali" (Photo O) is the postal operator of the Sovereign Military Order of Malta, designated for the collection and dispatch of correspondence originating within the extraterritorial seats of the Order (the Magistral Palace and the Magistral Villa in Rome). It is currently possible to send mail franked with stamps issued by the Order of Malta to Italy and other 57 countries with which the Order has concluded bilateral postal agreements.

The postage stamps and stationery issued by Poste Magistrali have always stood out because of their topical content and image, closely linked to the Order of Malta.

On July 23, 2023, the Order paid tribute to its radio amateurs with a set of four stamps depicting different historical and operational contexts related to ham radio communications within the Sovereign Military Order of Malta (Photo P). The first stamp depicts Guglielmo Marconi wearing the insignia of the Order of Malta: he was indeed a Knight of Malta!

In addition to the set of stamps, a special postmark was put into use on July 27 to celebrate the 1A0C 2023 DXpedition (Photo Q). All the mail posted at Magistral Palace received this special cancellation and a special souvenir card was produced for philatelic collectors. Stamps and souvenir cards are available until exhaustion of stock directly from the postal administration of the Sovereign Military Order of Malta. For more info, visit <<https://postemagistrali.orderofmalta.int/en/>>.



Photo P. On September 22, 2023, the Order of Malta issued a set of four stamps dedicated to its Amateur Radio Service. One of the stamps is dedicated to Guglielmo Marconi, who was a Knight of the Order.

ADVANCED SPECIALTIES INC.

Orders/Quotes 1-800-926-9HAM

www.advancedspecialties.net

BIG ONLINE CATALOG



VX-6R
Triband
Submersible
Hand Held



FTM-300DR
Dual-Band Digital

AMATEUR RADIO EQUIPMENT &
ACCESSORIES · SCANNERS
ANLI · COMET · UNIDEN · YAESU

(201)-VHF-2067

114 Essex Street, Lodi, NJ 07644

Closed Sunday & Monday



HamCall™

US and International
Callsign Database

The most current and complete
source for over 2.5 million callsigns!

Available on DVD
(\$50), USB (\$54), and Download (\$45).

BUCKMASTER
INTERNATIONAL, LLC

HamCall.net 540-894-0907



HamTestOnline™ students are
50 times more likely to give us
5 stars than request a refund
because they failed an exam!

eHam.net reviews

★★★★★ 1040

5.0 out of 5 stars

5 star	1015
4 star	20
3 star	3
2 star	1
1 star	1

Best study method, study materials, customer
support, and guarantee in the industry!

www.hamtestonline.com

Repurposing coffee cans or beer cans as an antenna is a concept that's been around for a while, but AH6CY has brewed up a variation that puts his stacked coffee cans between a copper tape base below and a capacitive top-hat above.

An Asymmetric Multi-Band Vertical Dipole Antenna

BY HIROKI KATO,* AH6CY

I have been experimenting for many years with large diameter metal tubes to build vertical antennas. It all started when I built a portable vertical antenna by repurposing Illy coffee cans.¹ I have discovered that the larger the diameter of the vertical element, the shorter the element needs to be to be resonant on a given frequency. In other words, the usual formula to calculate the length of the quarter-wave vertical antenna ($234/\text{freq}$ in MHz) does not apply. I also learned that the larger the radiating surface, the more efficient the antenna becomes.

* Email: <hiroki@pacbell.net>

My latest project, presented here, utilizes a 12-inch diameter construction form made of cardboard for the bottom half of the antenna as well as a stack of Illy coffee cans for the top half (Photo A and Figure 1). I wrapped the entire surface of the construction form with an adhesive copper tape (Photo B). Electromagnetic signals radiate only from the surface of the antenna, so it does not matter how thin the copper surface is.

Doing the Can-Can

The Illy coffee can makes an ideal antenna building material. It is light (after the coffee is consumed!) but relatively stur-



Photo A. AH6CY's asymmetric vertical dipole works on any three bands between 20 and 10 meters.



Photo B. The bottom part of the antenna is made from a 12-inch diameter cardboard construction form covered with adhesive copper tape. Also note the tuned radials, which are actually Hustler resonators.

dy and, best of all, it is made of steel and therefore is solderable with an ordinary soldering iron (100 watts or more). I soldered the lid to the bottom of each can's body as shown in Photo C. Be sure to have the screw-on part of the lid facing down and to sand off nonconductive paint where the lid contacts the can. You can then connect and stack as many or as few cans as you like by screwing them together (Photo D). This makes it possible to experiment with various

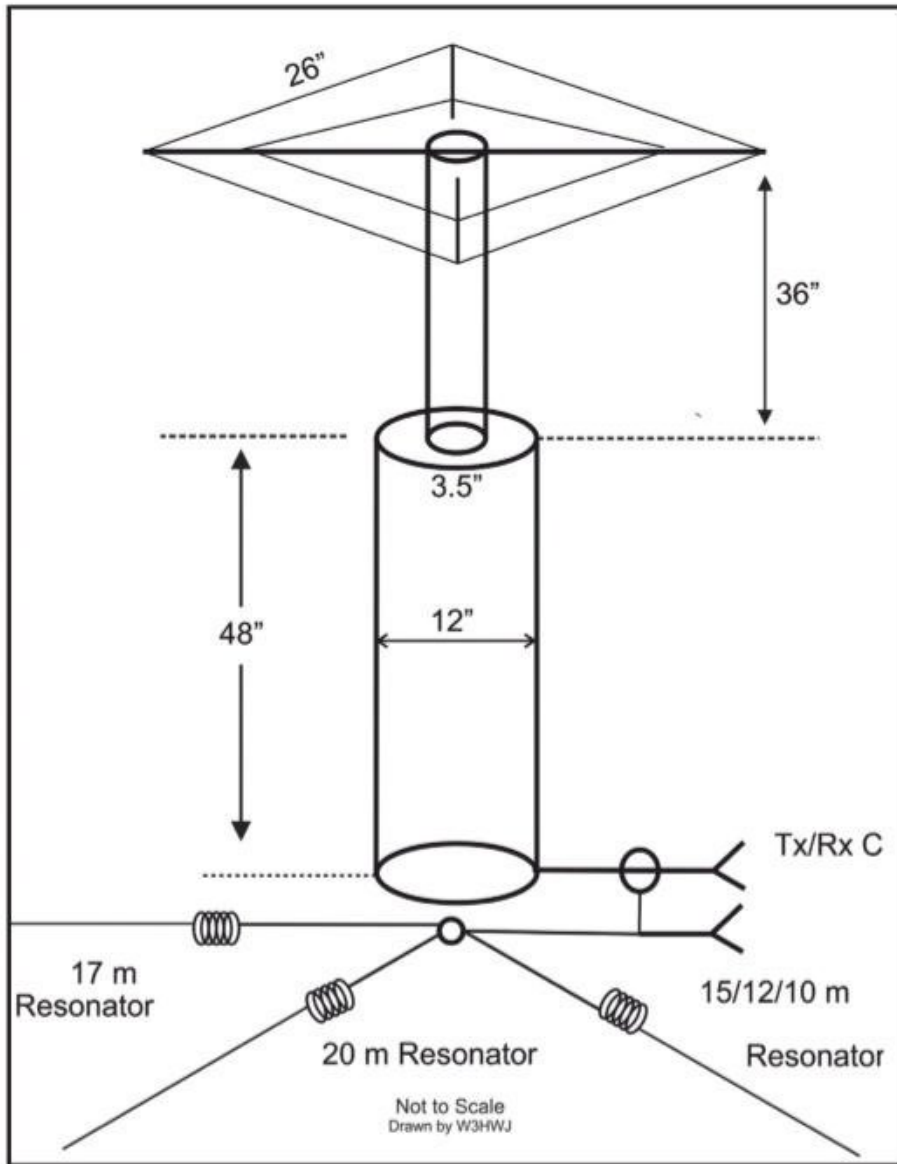

Figure 1. Dimensions of the antenna components. Note the resonators for each band at the base. (Drawing by Richard Bonkowski, W3HWJ)



Photo C. The screw-on lid of each of the Illy coffee cans is soldered to the bottom of the can with the screw-on section facing down.



Photo D The modified coffee cans may then be screwed together to form a stable stack.

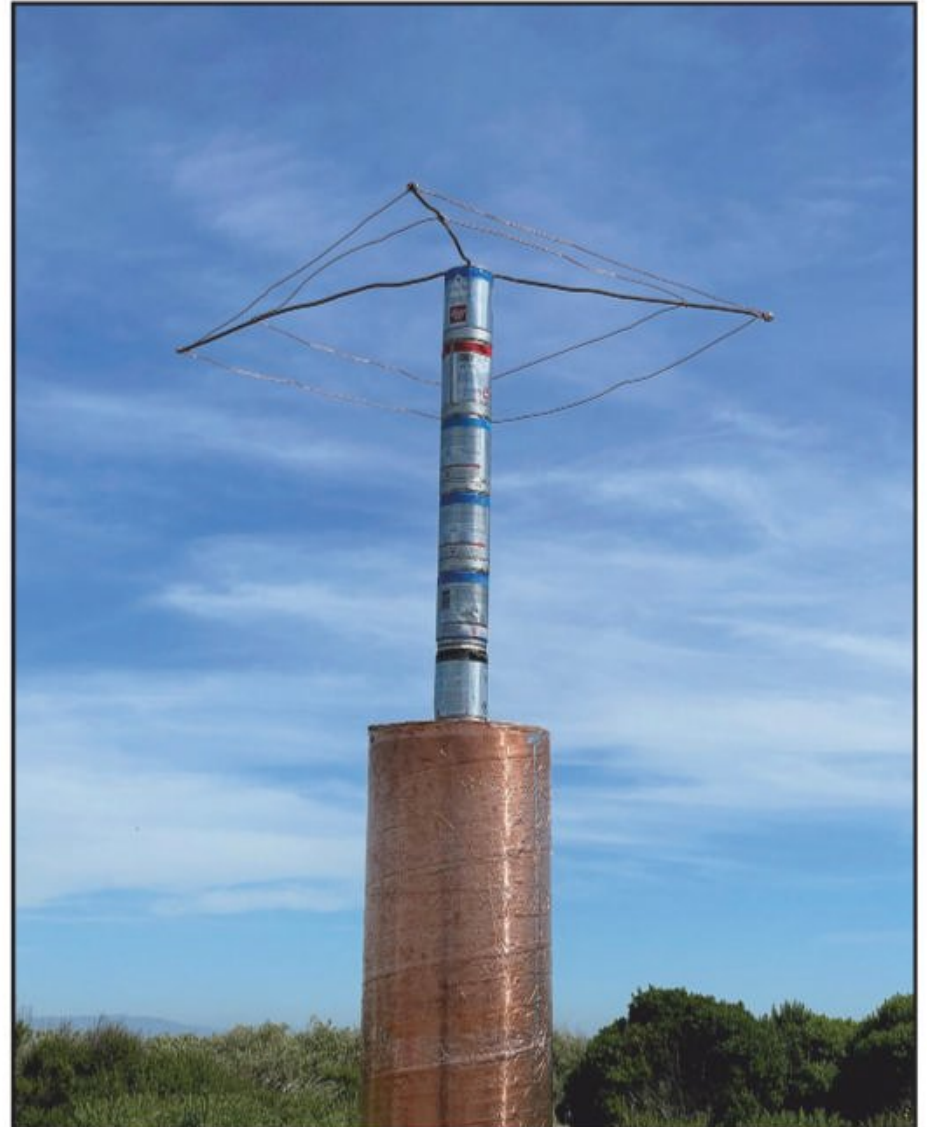

Photo E. The capacitance hat helps increase useable tuned band coverage. It is attached to the top coffee can.

NEW!

BUDDIPOLE POWERMINI 2

Compact Portable DC Power Management System with built-in Solar Controller.

- High contrast OLED display
- Power management includes current and voltage readout
- Powerpole input/output
- Now with higher power USB output!
- User-definable Low Voltage Alarm + Cutoff
- Solar controller for use with panels up to 11 amps
- Increased current handling capacity – now 32 amps Max!



BUDDIPOLE
PORTABLE, VERSATILE, AND EFFICIENT

T 503-591-8001
F 503-214-6802

E info@buddipole.com

Secure online ordering at
BUDDIPOLE.COM



Photo F. The antenna may look funny, but it has a low SWR, broad bandwidth and works well!

length/height of the tower with ease. The resultant tower is sturdy but light, which makes it easy to transport for portable application.

The resonant radial spokes (again, see Photo B) are the “resonators” made by Hustler which are originally meant to be used to construct 1/4-wave mobile/portable short vertical antennas. BuddiPole, Super Antenna’s MP-1 rods or MFJ’s Ham Sticks can also be used for this purpose. You can choose a set of any three different band resonators between 20 and 10 meters.

The top capacitance hat (Photo E) helps increase useable tuned band coverage. It is made of a copper tubes and wires and is attached to the top coffee can.

On the Air

The antenna resonates each band well, producing three low SWR points on any three selected bands. You can get pretty wide band coverage under 2:1 SWR without resorting to an antenna tuner.

I am happy with the result of this “funny-looking” antenna (Photo F), but I plan to further experiment with different materials and design. I would love to hear from readers to exchange ideas.

Note:

1. The article about one of my projects appeared in the August 2021, issue of *QST*. For another design with a large diameter vertical antenna, see “Little Boy & Fat Man,” *CQ* February 2023, p. 23



Photo A. My 40-foot tower and 3-element beam

WB2UDC has always been a great storyteller, sharing many of those stories in these pages. This one is personal, about his transition to (unplanned) retirement and the increased role that ham radio is playing in keeping him active and engaged. Bob invites you to share the journey with him.

Radio Renaissance: A Retirement Story

BY BOB HOPKINS,* WB2UDC

Here I am, it is late afternoon and I'm sitting in the backyard with Paula, my bride of 53 years. We are sipping wine and enjoying the end of the day. This is a regular experience for us now. We chat and relax around what I like to call the "eternal flame," a small table with a propane tank below giving us sort of a campfire effect. The yard has a magnificent flower garden as well as two antennas, a vertical and a small three-element beam on a 40-foot tower (Photo A). Times like this cause me to reflect on my radio hobby. I credit my youthful interest in technology as a gateway to my life in engineering education. So here's my story about my *Radio Renaissance*.

Life Events...

Five years ago, I experienced one of those "life-changing

events". After 46 years of working for the same organization, the management changed, and it wished to move in *another direction*. After further review and discussion, I came to the realization that the other direction did not include me. So I pulled the switch on that part of my life and moved into retirement mode.

If only ...? Only if I would have ...? and What if?

Well, thinking back to that time, I can honestly say that it was not the most productive period of my life. Sure, I had plenty of free time on my hands, but it seemed that I was spending way too much time asking myself questions beginning with the words "What if I did something different, perhaps..." or "If only ...?". The pulling of the retirement switch didn't come easily. After all, before this happened, I really was not considering retirement. I had no thoughts about what should come next.

* E-mail: <wb2udc@gmail.com>

I sadly spent way too much time trying to figure out how I got into this situation and not thinking about moving forward and getting on with life. Fortunately, I am blessed with friends and a wonderful family who have grown to tolerate me quite well. To quote my darling wife, "Well, at least you'll be able to have more fun with your ham stuff, and perhaps you can do something with that large amount of aluminum that is on the ground in the back yard."

The Beginning of My Radio Renaissance

That was an excellent idea. I've always been reasonably active, but other things always seemed to get in the way of really passionate operating. I felt that, in order to get back into the groove, I needed to polish up my ham radio skillset as I did back in the day when I was just a novice.

First, I thought it would be a good idea to build a kit or two or three. The kit building process was always great fun for me, and it really taught me once again the importance of following directions and not taking any shortcuts. I built three kits, all receivers, two AM radios and one FM set. All for the broadcast band. Once I conquered those projects, I bought an extra kit and talked my young granddaughter into building her own with my help.

I approached my *Radio Renaissance* with enthusiasm. I wanted to try new things and really have some fun, and maybe, just maybe, I might even learn something.

FT8

The first challenge I presented to myself was to figure out what this FT8 mode was all about. I had read some articles about this digital mode and chatted with others at hamfests and on the air, and heard some interesting comments. The comments ranged from "it will kill the hobby..." or "I don't want a robot running my radio" to "a very interesting mode that can teach you a bit about weak signal operating." So I thought I'd give it a try. FT8 is not something that you can just turn your rig on and expect to listen to a few QSOs and get a feeling for what exactly is going on.

This was going to take some work and some time. To bring myself back to my early ham radio experiences, I looked over my ancient collection of QSL cards and pulled out my old logbooks. Back in the day, one was supposed to keep a log of all your radio adventures and I really did that! I was sure that each and every



Photo B. The Phaser

contact I made was the result of some small miracle. I made a lot of contacts, in spite of the fact that the Novice license mandated that the transmitting frequency be crystal-controlled and limited to CW mode on the HF bands. I had two crystals, or 'rocks', as they were called. The crystals were for 7.154 and 7.168 MHz. (or Mc... we changed from calling it cycles to Hertz sometime during my first years of hamming). As a novice bound to the CW mode, I would write down every character that I copied on the back side of my logbook sheet. During the day, I would connect with locals and a few out-of-state hams; in the evening, I would compete with various shortwave broadcast stations and every now and then I'd hit the jackpot and work someone a couple of thousand miles away.

The fond memories of the early times returned. My father, who referred to himself as the Old Man, found me a mentor/Elmer who provided me with slightly used Heathkit DX-40 transmitter. The Old Man bought me a brand new Heathkit HR-10 receiver, that I built under the supervision of my Elmer, Ed Miller, WA6OXE. Building this kit was done under strict supervision. It required an amount of discipline that I was not used to. Every connection that required soldering had to be verified twice. Of course, because of the supervision and discipline, the radio pretty much worked upon completion.

The cool thing about that time was that I would often try some things that, according to laws of nature, should never work. Ignorance is indeed bliss. Since I didn't know any better, I actu-

ally had a QSO once with a ham in Oregon from my Redwood City, California QTH with the DX-40 still attached to my "dummy load" (only dummies would believe that works). Now this dummy load really was nothing more than a 60-watt light bulb in a socket with a PL-259 connector hooked up to both sides of the bulb's filament. I later learned that wasn't the best dummy load anyway and the DX-40 was a very forgiving piece of gear. Or perhaps some ungrounded length of wire in the shack coupled into the system and served as an antenna. One never knows. Just another one of ham radio's amazing miracles

So back to the present, I was still clueless regarding how to make an FT8 QSO or even what one sounded like, other than the pulsating tone bursts that were happening on a section of the CW band that I assumed was digital ham radio. I picked up Steve Ford's *Get on the Air with HF DIGITAL*, and read the chapter on FT8. It is a very useful book, but I felt I needed more.

What I discovered is that FT8, and I assume the other digital modes, need to have some sort of connection with a computing system. When a signal is to be sent, the computer encodes the message into a series of audio tones and sends that series of tones to the radio and an SSB signal of the tones is transmitted. Once the transmission is finished, the radio goes into receive or listening mode and the computer software displays the messages it finds on the channel. The computer and the needed software are the user interface for the experience.

What is needed is an SSB rig capable of connecting the input and output of the audio to the computer via a sound card interface and some sort of connection to switch the transceiver from receive to transmit and back. I have plenty of computers, and I have several SSB transceivers at my disposal. However, I really wanted to figure out the “magic.” I thought it would be fun to build a dedicated system. In my research, I found an article in *CQ* magazine talking about the FT8 Phaser designed by Midnight Design Solutions (Photos B and C). This is a single-band QRP transceiver designed specifically for doing digital communication. This transceiver is a kit, with all the parts on a single board and an output of about 5 watts. It is initially set up to work on the agreed upon segment of the band for FT8 commonly called the watering hole. Since the Phaser is configured for a single band, I chose 20 meters. The original cost back in 2020 was \$60.00. Another \$25.00 got you a case for the radio. Now, for about \$85 plus shipping, I would get to assemble and play with a new toy. The software recommended was WSJT-X (<<https://wsjt.sourceforge.io/wsjt.html>>). It can be installed on Windows, Linux, and MacOS systems. I’ve installed it on my Windows laptop as well as my Linux laptop. This software is very good. I can really appreciate good software and I know it when I use it. The Phaser connects to the computer by two stereo cables, one to the mic input of the computer’s sound card and the other to the audio output of the sound card. Sadly, after selling over 1,000 of these kits, the Phaser has been retired. But I’m sure there are many other choices out there to help you jump into the pool.

The kit arrives and I’m ready to go. Even though I successfully constructed the kits earlier, and over the years many Heathkits, the Phaser was not something I could build in a couple of days. But it was very possible to build in a month, so I took my time and actually tried to follow directions, unlike my “learning experiences” in the old days. By the way, the components that were surface mounted to the board came already installed, something for which I was very thankful. At my age, some of the parts are tiny and I had to use a multi-meter to verify resistor values, etc., or a magnifying glass to read values on the small capacitors. The design of the whole process was to get each of the various stages of the radio built one at a time, and then follow some diagnostic steps to ensure I didn’t foul it up. If there was an indication something was wrong, I would backtrack through the steps and verify every connection. After about two or three weeks, I finished building the radio and now it was time for the smoke test. I can honestly say that my understanding of FT8 was greatly improved because I built the radio. Please note, I did make a few stupid errors in building the kit and lessons were learned from that, but with the help of the user community and designers, I was successful in finishing the job.

Downloading the software was straightforward. I first installed it on my Windows system and got it working. At this point, in order to test the rig, I connected the radio to my antenna, then instead of connecting the audio output to the computer, I plugged my headphones into the audio output of the transceiver and turned on the radio. Held the headphones near my ear and I could hear the noises familiar with signals

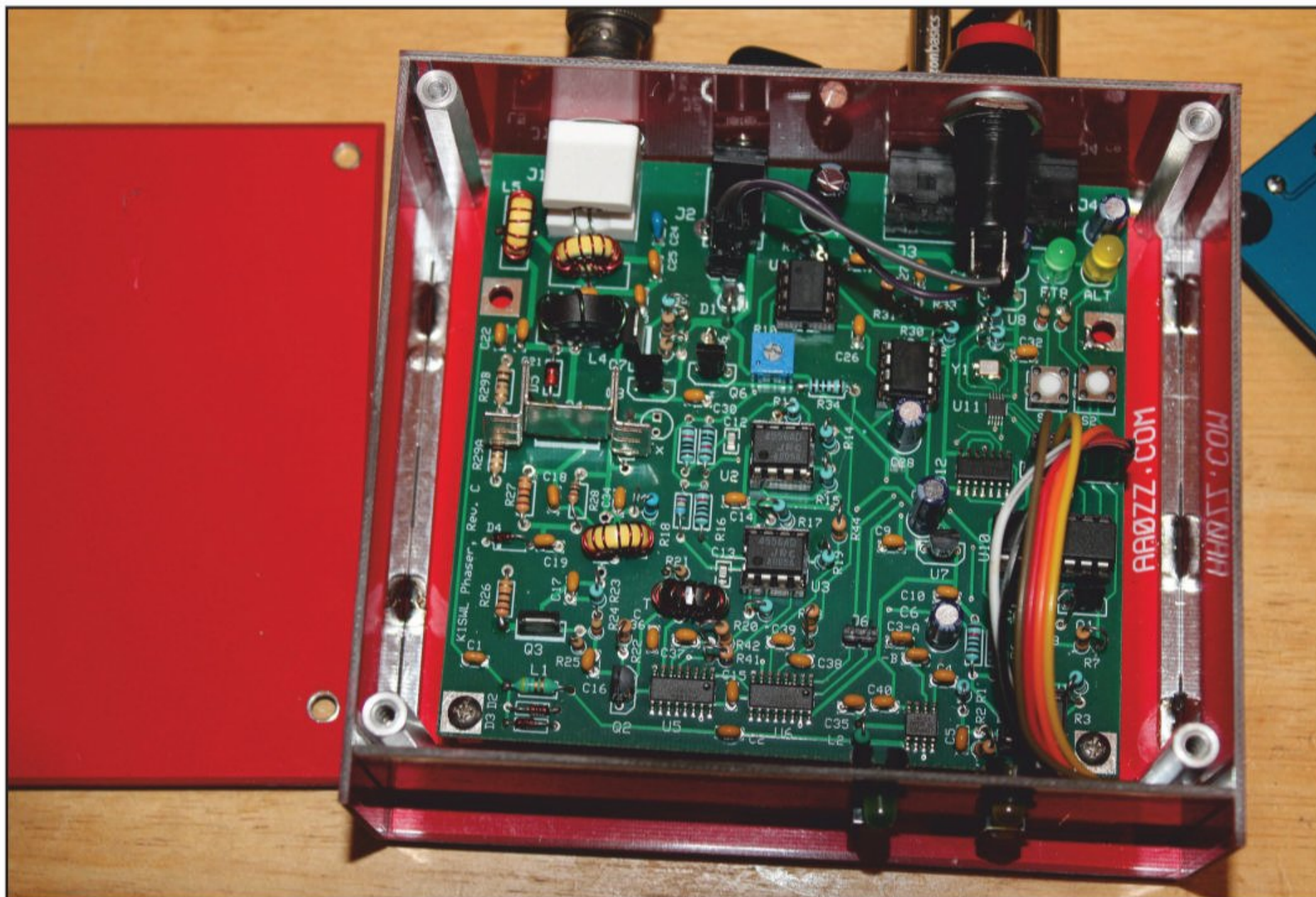

Photo C. An under-the-hood view of the Phaser FT8 transceiver

on the 20-meter band and the tones start and stop in 15 second intervals. Yet again another miracle. On 20 meters, the frequency where the FT8 action happens starts at 14.074 MHz. I then turned off the radio and connected the audio output from the rig to the audio input of the computer and started up the software. Two windows appeared on my screen. One window was what I call the control panel and the other screen was a spectrum display of the frequency channel, about 4 kHz of the band.

I do not intend this story to be a how to do FT8, but rather to talk about my experience in learning a new mode and some of the steps I took to overcome a few challenges I encountered.

So building a new toy was a great idea. It saved me from possibly breaking one of my big rigs by connecting new stuff and heaven forbid making a mistake. The Phaser uses a VOX circuit to control transmit and receive. VOX is voice (or sound) operated transmission. So if the radio was connected to the computer and a noise came out of the sound card, then that sound would be sent out into the vast ether of the radio spectrum. When the sound stops, the radio would go into receive mode. The computer would then listen to the incoming noise and magically decode and display the information on the control panel segment of its window.

Originally, I wasn't quite sure how well the rig was matched to my antenna, and exactly how much power, if any, was being sent out. To address this question, I used my "big rig," well, not exactly too big, an Elecraft KX3 with its own spectrum display to monitor the frequency where the Phaser was supposed to transmit, 14.074 MHz. The KX3 was not connected to any antenna. The Phaser was then connected to my vertical antenna. The supporting software was running on the computer, and the Phaser was powered up. The software spectrum display came alive with a waterfall display of signals displayed over time. A good thing, as that indicates the receiver is working and 'hears' signals.

The computer user interface has many options that one can move the mouse over and right or left click to cause events to happen. I moved the mouse over the *tune* button and clicked. The software generated a continuous tone and the audio subsequently was sent to the transceiver and was heard and seen on the "big rig" radio. So far, so good.

I was still uncomfortable using the rig without some tangible evidence of transmission and power output. In my vast collection of radio stuff, I found an old QRP SWR/power bridge. Great!!! I connected it and it didn't work. Not so great. Found a manual for the bridge, and fixed a bad solder connection and we're ready to go. The bridge was able to display the SWR between the Phaser and my antenna as well as the power output. While the Phaser has an option to install an LED on the circuit board that would light up when in transmit mode, it was inside the case and not as useful as a continuous monitoring solution. We were up and running. Later, I found an even better solution from the QRP GUYS.com for a Power/SWR/Dummy Load, a 2-by 2-inch board with the whole deal on it (Photo D). Another kit to build. Can it get any better than that?

I can honestly say I'm now pretty comfortable using FT8. It is not really too social. When I want to find out the band conditions, I can turn it on and observe all the signals in the FT8 watering hole. When I'm operating, there are sites on the web such as <<https://pskreporter.info/pskmap.html>>. This tool displays a world map and can show locations where your signal is heard. This can be very useful. I was operating one evening on 20 meters with pskreporter on my other screen. I made a few contacts, and then noticed that my sig-

nal was heard by DP0GVN in Antarctica, where I received a -18db report from the station 13,445 kilometers or 8,354 miles from me. Not bad for 3 watts going into my small beam. It was not a contact, but only a signal report that I was heard down there. Nonetheless, that is something pretty cool.

I'm at the point where I can make FT8 contacts easily. It is a nice demonstration tool when the shack has visitors. Very visual.

I consider the FT8 experience a success, and certainly fun. It has some limitations, as you can't really rag chew. But it is good for weak signal work and some experimenting, especially with different antennas. It also seems to be active even when the band is closed.

Contesting Renaissance

On this Radio Renaissance, I have participated in more contests than I did before retirement. I discovered I really could improve my score if I had some automated logging to keep track. So I wrote my own logging program by dusting off my programming skills. Just saying, I'm happy to have kept a few manuals around as my skills needed some reinforcement. I initially wrote the program to work with Field Day. I used AWK as the programming language of choice. It has some useful features, especially associative arrays, that were useful for duplicate contact checking. AWK is a scripting language that is fun to learn. Runs on Linux and Windows and probably

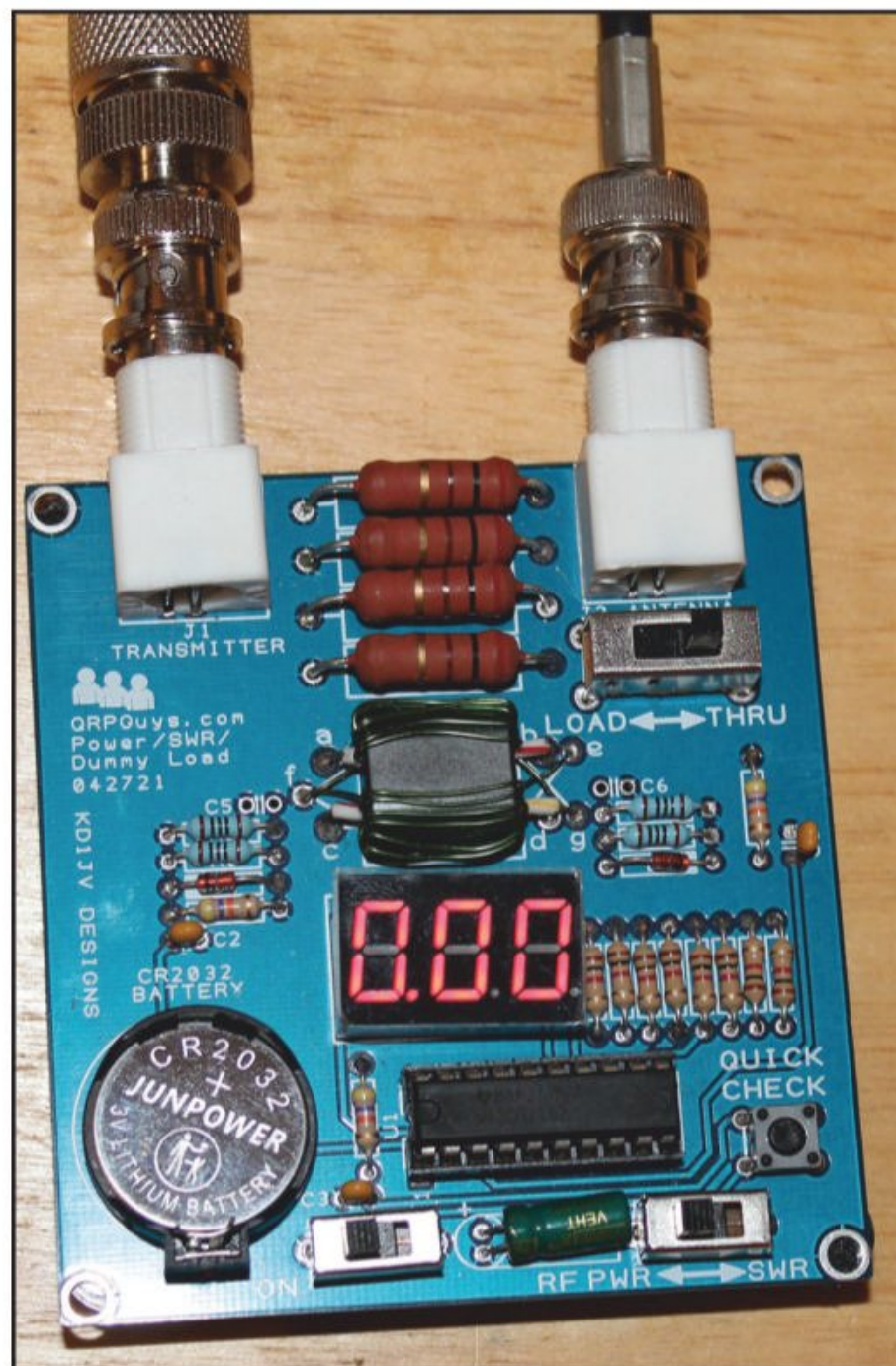

Photo D. The QRP SWR/power meter and dummy load from QRP GUYS.

many other environments as well. For each additional contest I participate in, I add additional code to record that data correctly as well.

Some Things Better Left to the Pros

I also managed to get my tower and 3-element beam professionally installed. As I said earlier, my patient wife suggested that I do something with all the aluminum that was in the back yard. Specifically, a tower that was not in the vertical position. I was given this tower by my mentor, Don Lawshe, W2DL (SK), before he passed away. This tower was made by Aluma Tower Company Inc. It is lightweight, cranks up to 40 feet from 20 feet and can be tilted over when work needs to be done on it. This was not a project that I could have accomplished while employed, and not something easy enough for me to attempt doing it myself in any case. I found a fellow ham who has an antenna installation business and got him to consider the project. He agreed, but he did insist that I really need to get the proper permits and approvals before we began. Since I had more free time, I was able to navigate the process with city hall successfully. There were a few issues that I needed to address, but none were insurmountable. I must say this was the first time I've been able to use a directional antenna for HF. I love low power operation and the antenna was a game changer. I believe that the rotor for the antenna is close to my age, and consider it a miracle that it worked on my bench as well as when we put it up in the sky. I suspect that it will need some tinkering at some time, but if it's not broke I'm not going to try to fix it.

I also brought back to life a Ten-Tec Argonaut 509 CW/SSB transceiver. I was given this radio by a student of mine, years ago, as he found it frustrating to only work low power and wanted to upgrade. Over the years, I used it less and less and put it on a shelf. One day I thought I'd get it on the air and found that the dial cord for the VFO had problems, thus making the idea of where one was on the band a guessing game. Taking the radio apart to get to do the fix proved challenging and my 70ish eyes aren't as good as they were when I first got the rig. My patience, on the other hand, has improved with age and I ultimately got the rig up and running and it now has a spot on my antenna switch.

Back to Dayton

Traveling to the annual Dayton/Xenia pilgrimage with my youngest son Kevin,

KC2KFP, has been a long-standing tradition. Covid-19 kind of put a pause in the trip for a couple of years, but this year we accomplished our goal. The journey from New Jersey to Xenia and back has always been a high point. Listening to country music or recordings of my favorite late night radio person Jean Shepherd, K2ORS (SK), and our discussions of the greatness of grandchildren or whether the Mets/Jets will 'do it' this year enhanced the experience. There seems to be some discussion as to what 'do it' actually means, by the way.

Retirement Plus Five Years

It may seem that I spend a great deal of time playing radio. That's not totally true. Retirement was difficult for me at the beginning. But, over the course of five years, thanks to my wife, family and friends for their support, my life is full. I'd be lost without them. I'm also grate-

ful for all the hams who made the miracles of QSOs with me so far. By the way, as a novice, I would love to send and receive QSL cards. This practice has continued and I find it very rewarding. I look back at the teenager I was when I discovered this hobby, and put that in my collection of my many miracles. It became the gift that created a career for me in technology and something to share with whoever listens.

Thinking back over the last five years, I feel I have adjusted well to retirement. Keeping active in many areas is important to my state of mind. I enjoy being radio-active more than ever. I continue my interest in traveling, and watching my children and grandchildren continue to grow. The future looks bright, and I have transitioned away from the anger and sadness.

Enjoy every day!
73, Bob, WB2UDC

Amateur Radio Roundtable

'Bringing Ham Radio to You'

Tuesdays at 8:00 PM CT youtube.com/w5kub

@W5KUB Also on Shortwave WBCQ on 7490 KHz W5KUB.COM



W5SWL Electronics

Premium Quality

RF Connectors

Order Direct!

Wide Selection of Connectors

- UHF & N
- MC MCX & MMCX
- Reverse Polarity
- BNC & SMA
- QMA SMB & SMC
- RF Adapters
- Mini-UHF & FME
- DIN & Low PIM
- Bulkheads
- TNC & C

And Much More!

- Dave's Hobby Shop by W5SWL
- RF & Technical Parts
- Ham Radio Gadgets
- New & Surplus Materials

Order at www.W5SWL.com

Ships Fast From The Arkansas River Valley

Getting the confirmations needed for many awards is always a challenge, especially for awards – such as CQ’s USA Counties Award (USA-CA) – that involve contacts with stations that aren’t used to having QSLs requested. WB4UHI has developed a method that helps improve his response rate.

Using Verification Reply Cards to Increase QSL Return Rates

BY MARK HUGHES,* WB4UHI

While I have been a county hunter for years, I still need QSL cards from about 350 counties to complete CQ’s USA-CA All Counties award. To increase my QSL return rate, I always include a self-addressed stamped envelope (SASE) with my QSL certificate (Figure 1). The certificate includes information on the Battle of Kings Mountain, the turning point of the American Revolution in the south. The battle was fought a few miles from my farm. While the certificate originally increased my QSL rate, the return rate has slowly decreased.

I have discovered many hams do not have QSL cards. I’ll often hear: “I’ll send you a card when I get some QSLs printed.” A few hams offer to send me an electronic verification. Because of vision problems, I cannot use electronic verifications. Paper QSL cards can be used for awards from different magazines. For example, the QSLs I submitted for Worked All States (WAS) also counted for my first USA-CA award (2,000 counties).

* 850 Dixon School Road
Kings Mountain, NC 28086
Email: <wb4uhi@carolina.rr.com>

For several years I sent a Mobile Reply Card (MRC) with my QSL. County hunters have used MRCs for years. An MRC has space to record the details of several QSOs. The ham who needs verification of a contact records information about the contact(s) and sends the MRC to the ham who ran (transmitted) from a particular county. The ham receiving the MRC simply signs and returns the card. Many hams have been active as mobiles on the county hunter nets. MRCs work well for verifying QSOs with active county hunters.

Using MRCs did not increase my QSL return rate, however. Since MRCs were designed to be sent to other county hunters, I suspect many hams I sent them to were confused and simply discarded them. I needed a way to explain my request for verification of a contact.

Since I needed a card that explained why I was requesting verification of the QSO, I developed a Verification Reply Card, or VRC (Figure 2). The VRC has a short explanation of why I am requesting verification of the contact. The VRC has spaces for my QSL manager to record all required QSL details. All the other operator has to do is sign and return the VRC in the enclosed self-addressed stamped envelope (SASE).

A local office supply store printed the VRC’s. The card is the same size, 5.5 by 3.5 inches (140 by 89 mm), as most

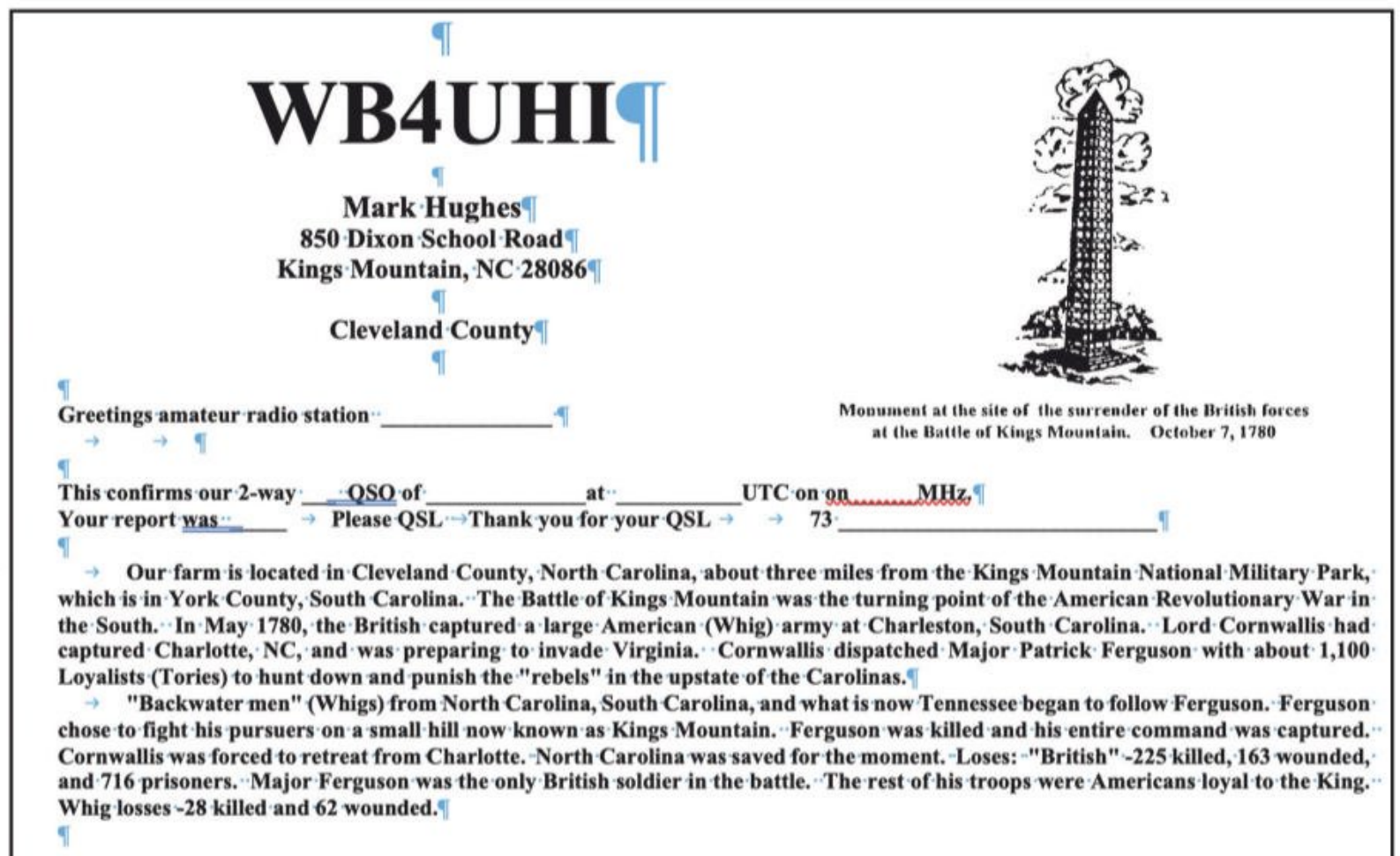

Figure 1: WB4UHI’s QSL certificate, providing a historical reference for his station’s location.

QSL cards and MRC's. This allows me to file the VRC in my QSL file boxes.

Beyond County Hunting

Lately I have used VRCs to confirm contacts with hams activating parks for POTA (Parks on the Air) awards. My QSL manager records the park's POTA number on the VRC to aid the activator in locating the contact in their log. The POTA website <<https://pota.app/#/parklist>> has a database of parks that is searchable by park number. This database lists the park's name. I use Internet search engines to determine the county where the park is located. Some parks are located in more than

one county or state. For example, Yellowstone National Park is in parts of three states. Often an email to the activator will clarify the county from which the activator was transmitting.

Since I started using VRCs, my QSL return rate has increased. If I do not receive a reply within a month, I follow up with a brief email asking if the ham has received my QSL. QSLs do get lost in the mail. One ham in a rare state told me he had a stack of QSLs "a foot high." His QSL arrived about six months later.

Unfortunately, some hams will never QSL. When that occurs, remember the county hunter's mantra: "The county will be there tomorrow."

What Data Should Be On a VRC?

The VRC needs to show which ham is verifying the contact. On my VRC the sentence "From ARS (Amateur Radio station) _____ to WB4UHI" leaves no room for doubt who is receiving credit for the QSO. I chose to put a space for the mode (SSB, CW, and RTTY) after "2-way". The statement "2-way" shows a contact occurred.

The time needs to be given in Coordinated Universal Time (UTC). Most hams and nearly all hams operating in contests use UTC. Clocks that display UTC are cheap. Keeping a log in local time and then converting local time to UTC can cause errors. Once I received a QSL card with the note: "Your clock was two hours off." I was lucky. A busy contester might not take the time to search their log for a contact.

There are several ways to record the date of a contact. I prefer the military format of day – month – year for example 22May23. The date can also be listed by month – day – year, for example May 22, 2023. Using numbers to record the month can cause confusion since many amateurs in other countries write the day before the month. Thus 4 – 7 – 23 may mean April 7, 2023 or July 4, 2023. Using an abbreviation for the month saves confusion. (Some hams also use Roman numerals for the month – ed.)

My VRC has a space to record the frequency of the contact in MHz. The exact frequency need not be recorded. For example, 14 MHz shows the contact was on 20 meters. Some hams record the meter band where the QSO occurred. Either method is acceptable.

Record the report the station you worked gave you on the VRC. Record the report you gave the station you worked on your QSL.

The line "fixed/mobile/portable" requires a bit of explanation. A mobile station is capable of moving without any wires being disconnected. Portable stations are transportable but some wire such as an antenna lead or power cord must be disconnected before moving. Fixed stations are not designed to be moved.

I am attempting to verify contacts with all 3077 counties in the United States. Please QSL by signing and returning this card in the enclosed self-addressed stamped envelope.

Thanks and 73 Mark

• From A.R.S. _____ to WB4UHI This verifies our
2-way _____ QSO of _____ at _____ UTC on
_____ MHz. Report _____

• I was fixed/ mobile / portable in _____
_____ County _____

• Verified by _____

Figure 2: The Verification Reply Card, or VRC, sent out by WB4UHI to help generate needed confirmations for USA-CA and Parks on the Air awards.

LiFePO4 Batteries
Bioenno Power®
sale@bioennopower.com
(888) 336-7864
www.bioennopower.com

ELECTRIC RADIO Magazine

Now in circulation over 30 years, ER is a bi-monthly publication celebrating classic equipment that was the pride of our shacks just a few years ago. Send \$1 for a sample.

Electric Radio Magazine • PO Box 242
Bailey, CO 80421-0242 • 720-924-0171
WWW.ERMAG.COM

W2IHY Technologies *Outstanding Transmit Audio Is Our Specialty*

8 Band EQ
W2IHY 8 Band EQ & Noise Gate Thousands of Satisfied Users Worldwide

EQplus By W2IHY
Premium Audio Processing

Did you turn on an amplifier? Your signal is loud and squeaky-clean. EQplus users hear that report all the time. Compressor/Limiter increases talk power without the distortion and restricted frequency response of ordinary speech processors. Dual Band EQ, Downward Expander for noise reduction, Effects for psychoacoustic magic. LED Bar Graph. Front panel controls. Universal Interface matches most all mics, all radios. I-K-Y mic selector. Switched outputs for 3 radios. Headphone Monitor. RFI protection. Powerful stand alone system or combine with W2IHY 8-Band EQ for maximum adjustability.

Products purchased from W2IHY include 30 Day Money Back Guarantee and 3 Year Parts/Labor Warranty. Top-rated Product Quality, Technical Support and Customer Service.

Awesome Audio Demonstrations
www.w2ihy.com

845-889-4253
email: julius@w2ihy.com
order online at
www.w2ihy.com

W2IHY Technologies Inc.
19 Vanessa Lane
Staatsburg, NY 12580

VISA

When you're providing communications in a makeshift response center, it's often helpful for different participants there to be able to be able to talk directly with each other. W8ERD expanded his ham radio "go-kit" to include internal communications capability accessible to all.

The Portable Telephone Company

BY BOB DIXON,* W8ERD

The Portable Telephone Company is the result of several years of on-and-off effort to create a system that could be used in disasters or temporary use anywhere. It interconnects cellphones, corded phones and the ham radio cloud. The system initially was installed in a luggage

* Email: <w8erdbob@gmail.com>

train case, but like most things it grew to require the addition of a branch office (Photos A, B, and C).

Referring to Figure 1, the heart of the system is the wireless router, to which everything connects. The PBX makes for easy dialing, allowing simple extensions such as 23, rather than the much more difficult IP addresses such as 192.168.0.105 that would otherwise have to be used. The



Photo A: The portable telephone company and its "branch office."

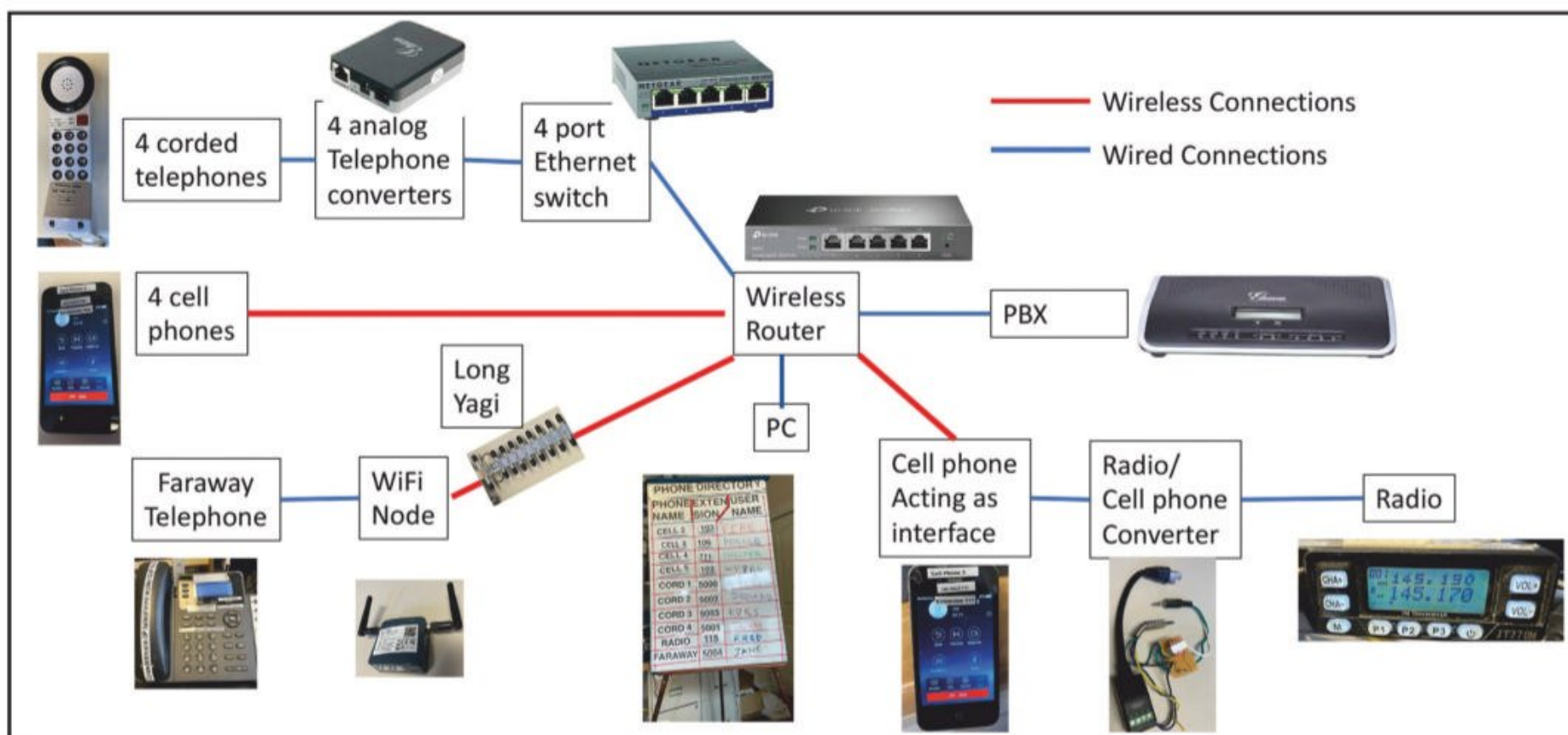
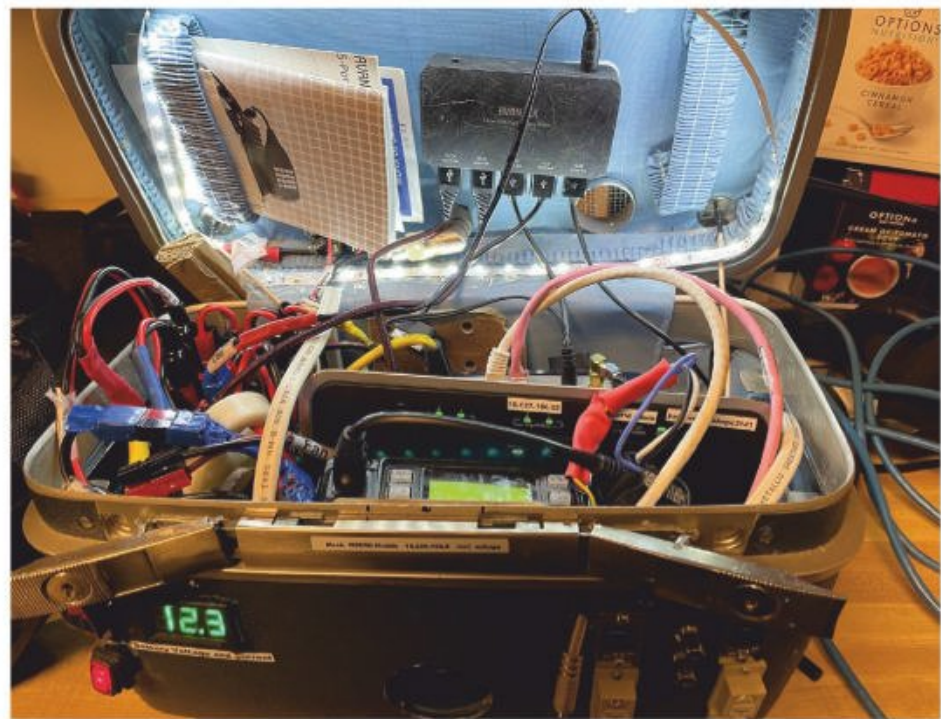

Figure 1: Portable telephone company functional diagram.



PBX
WiFi Router
10 Watt 144/450 Mhz Radio Transceiver
7 Amp-Hour 12 VDC battery
5 Cell Phones
Charger for 5 cell phones
24 Power Pole outlets
Cooling Fan, Exhaust Vent



Interior Lighting, with SPHT Switch
Standard antennas for WiFi and Radio
Battery Volt/Amp meter
Equipment Manuals
2 Exterior ethernet sockets
Outside 4 conductor plug for radio controller cell phone
Interface converter board between radio and cell phone

Photo B: Contents of the telephone company train case.

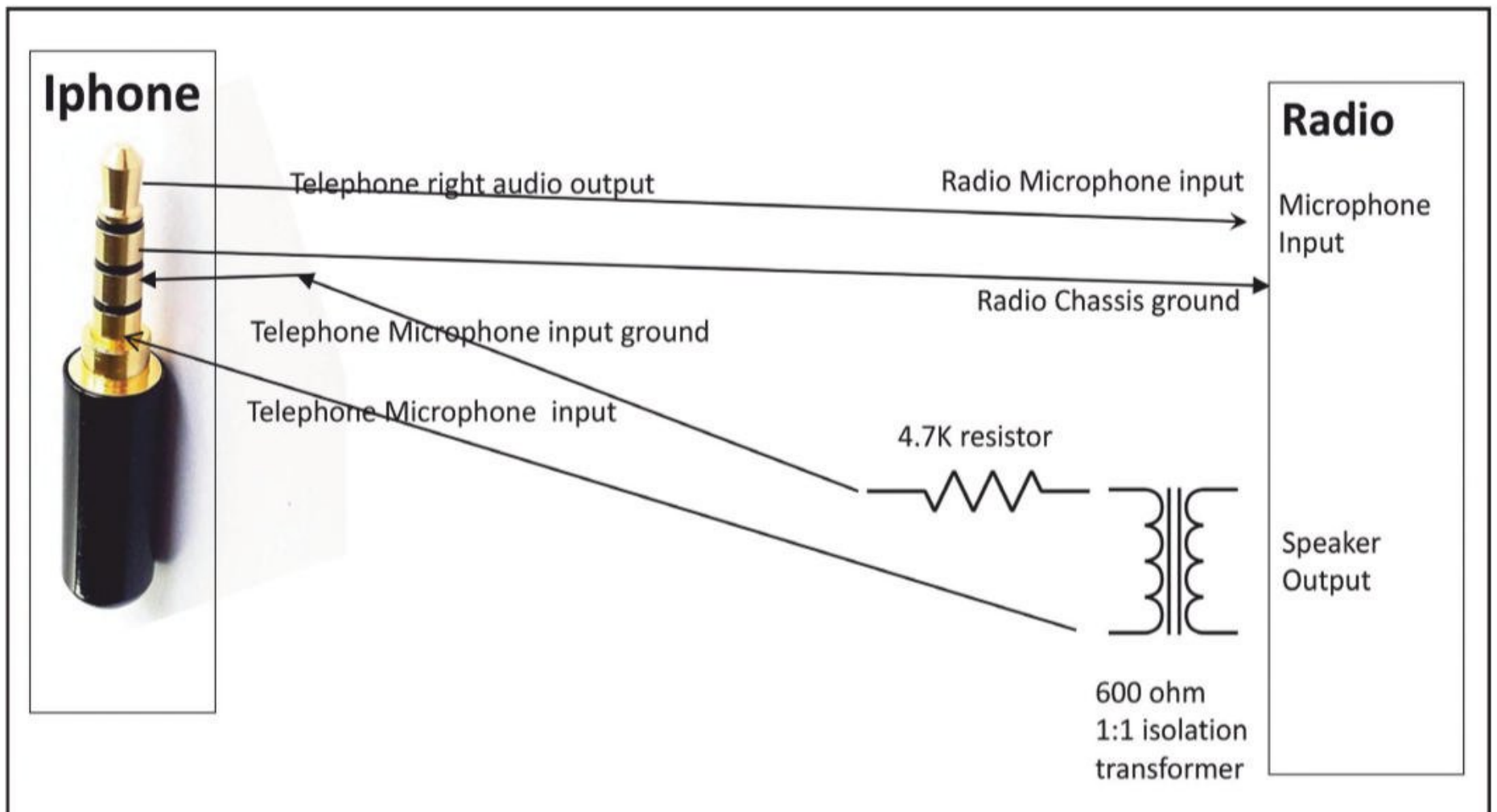

Figure 2: Telephone-radio audio adapter.



4 Corded analog telephones. Long 12 foot cords.
4 analog to digital telephone converters
4 telephone 7 foot extension cords
4 port Ethernet switch
12 VDC battery charger for heavy loads
12 VDC battery charger for battery maintenance
Exterior 3 foot ethernet cable to Train Case
Exterior 3 foot 12 VDC cable to Train Case
Exterior 10 foot 120 VAC power cable.
Long Range Antennas for Wifi and Radio.
Radio microphone.
Relay Station Number Two.

Photo C: Contents of the branch office bag.



Photo D: The faraway telephone.

PC allows the administrator to log into the router and the PBX, to be sure everything is operating correctly.

Any of the telephones can dial each other, or connect to the simple radio extension and be on the air with whatever stations are on the frequency to which the radio is set. VOX in the radio handles the switching between send and receive. A dedicated cell phone handles the translation between RF and audio, and the audio is translated via a small circuit (Figure 2). A commercial version of the circuit is also available which may work, the iRig 2 guitar interface.

There are four iPhones and four corded phones. The iPhones run Grandstream Wave Lite software. There is also a separate large IP telephone which can be located a long distance away from the central site, so it is called the Faraway Telephone (Photo D). It has Yagi antennas (Photo E) for great distance, and a separate big battery for long running (Photo F).

There are two relay stations that can provide greater than

normal distance for any of the cell phones. They can run off their own included batteries or 120 VAC (Photo G).

All of the telephones have a small open envelope glued to their backs (Photo H), which contains pull-out instructions for use of that telephone, plus a rudimentary dialing directory.

A critical part of the system is the phone directory, which allows everybody at the central location to call others. It is on a large dry-erase board containing all the necessary information (Photo I). Dry-erase technology allows all the entries to be made and changed very quickly and easily. Different ink colors can be used to indicate different types of end points.

The Wave Lite software supports conference calling with up to six participants. If one of the participants is the radio, then there is no limit to how many people can be in a conference.



Photo E: Long-range Yagi antennas for the faraway telephone.

Photo F: The faraway telephone battery case contains two 7-amp-hour batteries.



Photo G: One of the relay stations. Contents include a 7-amp-hour 12VDC battery, a 12-5VDC converter (required by the relay station), a 10-foot-long 120VAC extension cord, a 2-foot-long 12VDC power cable, and four antennas:



Photo H: Instructions attached to all telephones.

PHONE DIRECTORY		
PHONE NAME	EXTENSION	USER NAME
CELL 2	103	FIRE
CELL 3	106	POLICE
CELL 4	111	SHELTER
CELL 5	102	WARD
CORD 1	5000	CHEEF
CORD 2	5002	SQUAD
CORD 3	5003	K&ES
CORD 4	5001	JOHN
RADIO	115	FRED
FARAWAY	5004	JANE

Photo I: The "phone book" – dry-erase marker technology makes it adaptable as needed.



Photo A. The Orkney Wireless Museum is housed in a building that's just a little bit older than radio itself! (Orkney Radio Museum website photo)

Even on a non-radio vacation, a dedicated ham can find something radio-related to occupy at least a little bit of time...

“Museum Quality” - a Visit to the Orkney Wireless Museum, GB2OWM

BY HY CHANTZ,* W2HY

The Orkney Islands are a remote and fabled archipelago of more than 70 islands and fewer than 25,000 people situated off the northern coast of Scotland. In addition to breathtaking scenery and deep history – and a 2-meter repeater - among the islands’ amazing attractions is an extensive, well-curated, and compact radio museum (Photo A), with station GB2OWM – for Orkney Wireless Museum (Photo B). The museum, located in a small and picturesque stone building, features in its dense but accessible layout hundreds of radios and artifacts, depicting all aspects of the radio art from the earliest days to television, transistors and cell phones (Photo C).

As is often the case, the history of the Orkney Islands is an intertwined one of romance, ocean waves and radio

waves, and particular attention is paid to its place in radio’s ongoing journey. Until 1472 – quite recently by European standards - the islands were the property of Norway. As it happens, they were considered security for the dowry of a Norwegian Queen; as the dowry was not paid, Orkney became the property of Scotland. There is still a strong Scandinavian presence, and the Orkney and Norwegian flags are very similar. During both the First and Second World Wars, due to its strategic location, Orkney was heavily fortified, and was a telecommunications hub with the latest direction finding, communications, and radar equipment.

Old MacDonald Had ... Lots of Radios!

One person who worked on the prototype World War II radar and many other electronic advances was James MacDonald (1927-1988), who was the museum’s founder and guiding

* hdc2112@columbia.edu



Photo B. The main operating console of museum amateur station GB20WM. (W2HY photo)

force. He maintained a large collection of radios in his home, and later transferred them into the museum of today.

For me, an exhibit of special note was one of the most prosaic, the Wireless Set #19 Transmitter/Receiver (Photo D). Many thousands of these were produced in Canada, and they were widely available as inexpensive surplus all over the US decades after the end of World War II. I was surprised to learn from the Museum that the post WWII path of surplus communications equipment in the UK was marked-



Photo D. The World War II-vintage Wireless Set #19 Transmitter/Receiver had a special meaning for the author (www.orkney.com photo)



Photo C. The museum is filled with well-cared examples of old radios in like-new condition (W2HY photo).



Photo E. Everyone who restores old radios makes the occasional mistake ... but how many of them end up as museum exhibits? (W2HY photo)

... radio enthusiasts are also often involved in hobbies such as astronomy, photography, machining, aviation, automobile hotrodding etc.

ly different than that of the US. In the UK, the release of large quantities of inexpensive material post World War One had a very negative effect on local manufacturers, which became especially significant in the lead-up to the Great Depression. Thus, unlike in the US, after the Second World War relatively little equipment was released as surplus in the UK. Thus, a ubiquitous radio in the US such as this was a rarity in the UK.

Another exhibit which “touched” me was a blown capacitor, recovered from the ceiling after a perhaps sub-optimal component replacement and test (Photo E). Every ham who has had a similar experiment may have wished he or she had seen this exhibit earlier. There are also many displays of battery evolution (Photo F), tubes and transistors in display cases, each of which might warrant a room to itself in a larger museum.

Happy Fever

The happy fever of ham radio and radio collecting is often not a “ailment” in itself,



Oops ...

Dyslexic Error

In September’s digital edition cover story, and on the cover, we repeatedly (but not consistently) transposed the suffix of Terezinha Felix Cordoso’s call sign. It is **PT2TF**, not **PT2FT**. We apologize for the errors, especially to Terezinha!

but rather a symptom among a much larger syndrome – radio enthusiasts are also often involved in hobbies such as astronomy, photography, machining, aviation, automobile hotrodding etc. As such, I often pondered the concept of keeping a rig in “museum quality”. Unless it was truly a rare collector’s item, for me, the constant modification and upgrading of a common workhorse such as my Hallicrafters S-76 was not a desecration of it, but rather a further compliment to its original designer and manufacturer, not unlike how the restomodding of a ‘55 Chevy (or B-52 bomber!) is

an homage to its inherent build. But after seeing GB2OWN, I’m not so sure this is always the case. The many pristine radios and other items James MacDonald assembled are a great testament to the electronics men and women who created them. Some of these radios – particularly consumer ones - were common in their day, but probably can now be found in few, if any, other museums. Perhaps it teaches that even with many artisans, one man – in this case James MacDonald along with the Museum’s dedicated volunteers – can make a large and inspiring difference in radio art and artisanship.

More information on the Orkney Wireless Museum can be found at gb2owm.org.uk.



Photo F. Exhibits include not only radios, but accessories as well. This display traces the development of batteries from wet cells to dry cells. (W2HY photo)



Playing With Meteors

Exploring the Universe With Amateur Radio

By Eric Nichols KL7AJ

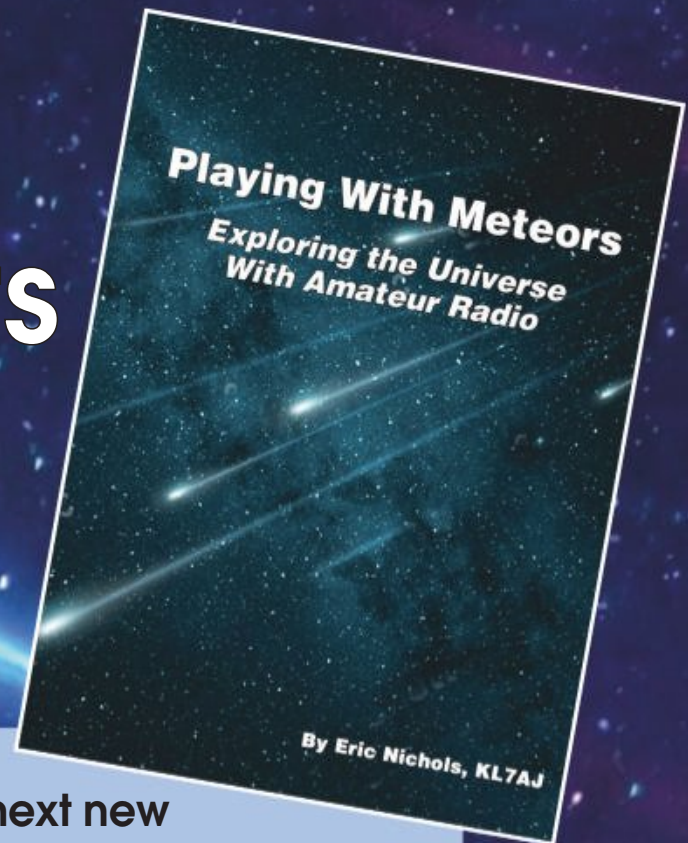

Wouldn't it be a blast to be a master of technology rather than to be at its mercy? Or better yet, to actually create the next new thing? While it's true that a lot of what we consider high-tech involves computer technology, an equal or greater part of the next new thing is going to involve wireless, also known as radio. In fact, our entire universe is connected by radio, and the entire universe is the radio amateur's sandbox.

In *Playing With Meteors*, author Eric Nichols takes you on a tour of the opportunities that amateur radio can bring you, and how you can leverage the knowledge you gain in "hobby radio" to a career in hi-tech, or just to being smarter than your "smart devices" (and maybe even some of your friends).

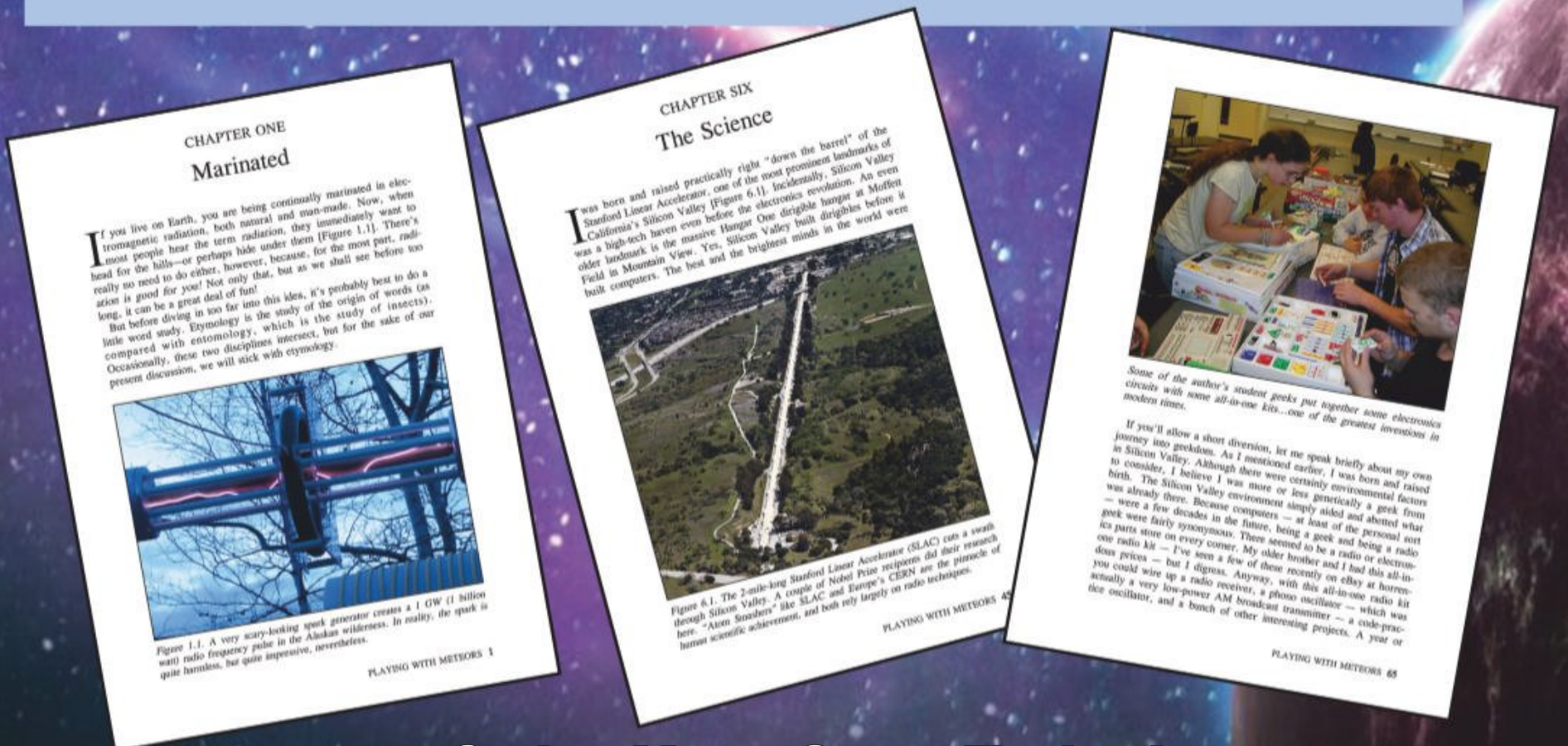

Order Your Copy Today!

6 x 9 (150 page) Paperback—Only \$26.95 (Plus applicable shipping!)

CQ Communications, Inc.

Phone: 516-681-2922 <http://store.cq-amateur-radio.com>

Amateur radio and astronomy share many common elements and WORW, an amateur astronomer as well as an amateur radio operator, does his best to bring the best of both together.

At the Intersection of Astronomy and Amateur Radio

BY PAUL SIGNORELLI,* WORW

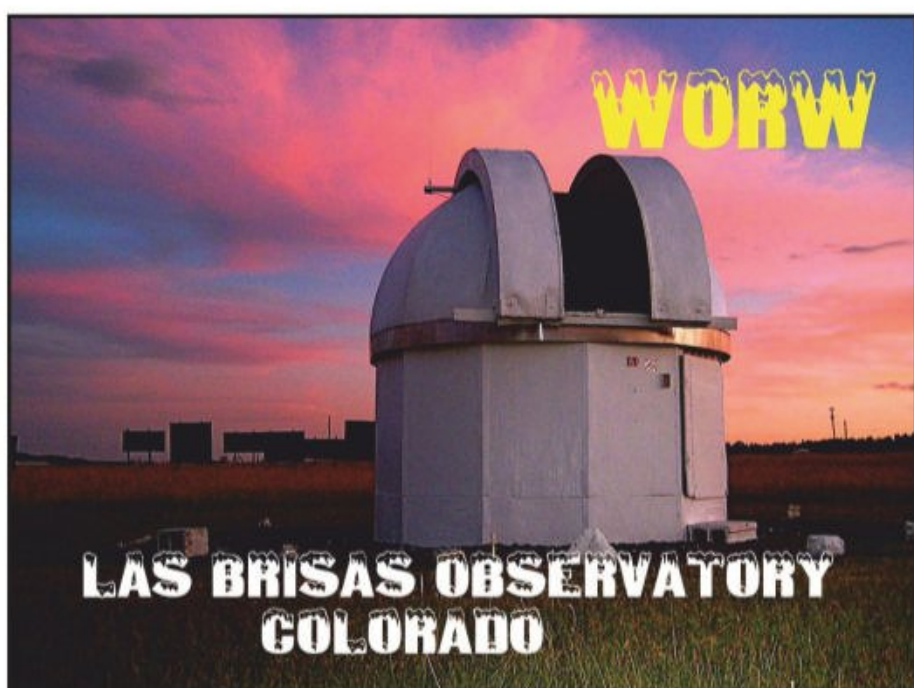

Photo A. WORW is as serious about astronomy as he is about ham radio. This is his personal observatory, which also makes a great spot for low-noise hamming when it's cloudy!

Both hobbies, astronomy and amateur radio, have unique and separate paths, yet they meet at a confluence. Short version: When the bands are dead and sky is clear, do astronomy; when the sky is cloudy, do radio.

My astronomy observing location (Photo A) is in a remote dark location which is also away from all power line noises that limit weak signal reception. That also makes it a great radio location. If I am waiting for the skies to clear or the Moon to set, I turn on my radio and check the band conditions. If I get a good astrophotography night, I get a nice star or comet picture (Photos B and C); if I get some radio DX, I get a cool QSL card (Photos D and E).

Most of my star pictures were taken with a Celestron C14 telescope or an 8-inch Schmidt camera. The radio equipment has been a DX60/75A4, TS440, or a PRC319 using a vertical antenna.

Advance Planning Needed

You don't need your own observatory ... a telescope and a dark sky will do ... but getting ready for these activities requires some planning and prediction of conditions. The prediction of good sky conditions is pretty accurate by using the "Clear Sky Clock." It is available for all parts of the USA.

* E-mail: <w0rw1@msn.com>

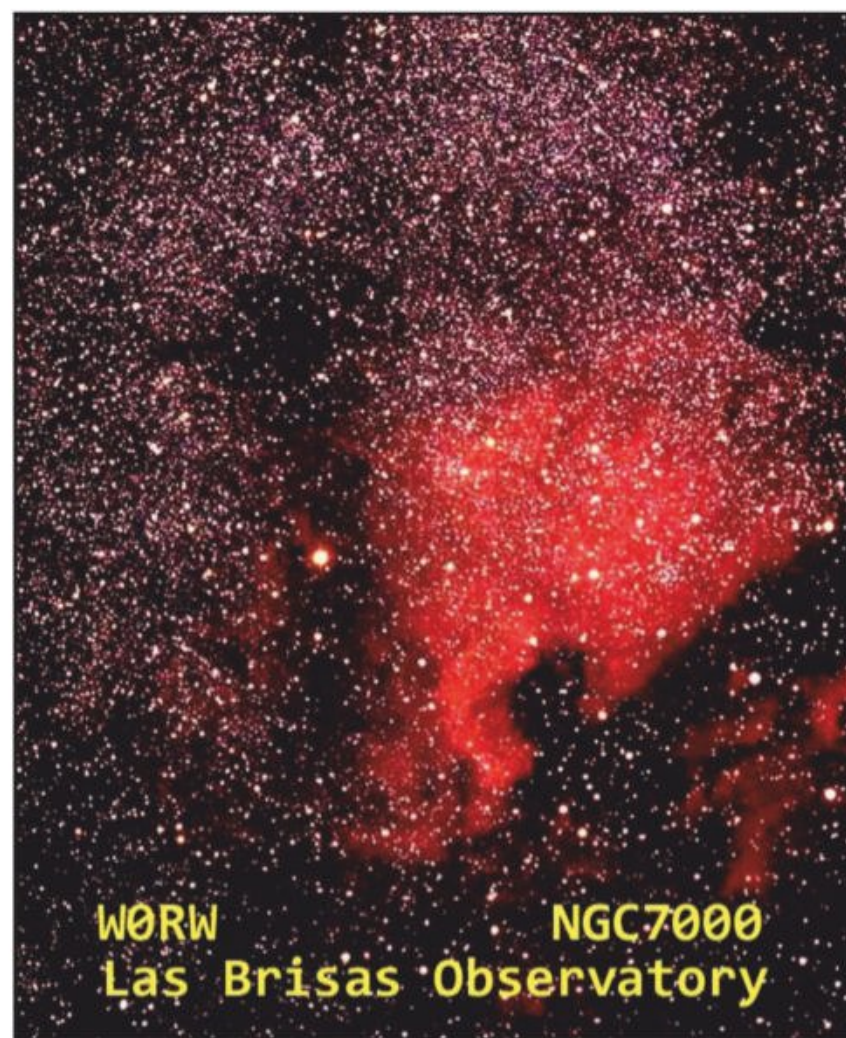

Photo B. On a clear night, Paul can get some great star photos ... which can also make very cool QSL cards!



Photo C. Comet photos are among the most striking.

My chart is at <<https://tinyurl.com/y54ksywz>>. From that site, you can find a chart near you or search for “Clear Sky Clock” plus your city. So before you get your telescope out and set it up, you will know when the sky will be clear.

The prediction of good radio conditions is not that simple but there are a lot of resources. You can watch the DX Cluster <<https://dxheat.com/dxc/>> and see what DX signals are being heard. The Reverse Beacon Network (<<http://reversebeacon.net>>) and WSPRNet (<www.wsprnet.org>) can also be very helpful. Radio DX is worldwide; astronomy DX is measured in light-years and is always on the air.

If bad conditions shut everything down, it is time for pizza!



Photo D. Two of the QSL cards received for contacts made from the observatory.



Photo E. High-flying QSO ... AP2FLY is a pilot, which puts him just a little bit closer to the stars than WORW's telescope!

behind the bylines...

... a little bit about some of the authors whose articles appear in this issue.

Abby Kimi Matsuyoshi, KK7CFJ (co-author, “Youth On the Air Camp in the Americas,” p. 8), hails from Arizona and has been a ham since November 2021 after being introduced to the hobby by a local ham. She is passionate about amateur radio, finding herself exploring the many facets of it such as CW and kit building. Outside of ham radio, she is a student pilot and full-time staff assistant for a local office.

Jack Roberts, W9RFT (co-author, “Youth On the Air Camp in the Americas,” p. 8), has been a ham since January 2020. After a slow start, Jack is beginning to branch out into the broad world of radio and finds himself learning new things about it every day. He currently serves as a PR specialist and the Assistant Webmaster for Youth on the Air. Outside of ham radio, he is a freshman at Indiana University-Purdue University Indianapolis, studying cybersecurity.

Mike Malloy, WD5GYG (“The Radio Room of the Kon Tiki Expedition,” p. 20), first read about Thor Heyerdahl’s adventure as a 12-year-old in the 1960s. He re-read it more recently with a more critical eye, after being a ham for 46 years and working as a marine electronic technician and merchant marine radio officer. He followed up with additional research to produce this article. Mike lives in Corpus Christi, Texas.

Nicola Burdiat, IU0NIC (“DXpedition to the Heart of Rome,” p. 32), is a member of the Sovereign Military Order of Malta and serves as the storied entity’s Post and Philately Director. As such, he was responsible for the issuance of the special postage stamps honoring amateur radio and the commemorative postmark used during this year’s 1AOC expedition.

Bob Hopkins, WB2UDC (“Radio Renaissance: A Retirement Story,” p. 43), is a recently retired professor of computer science and technology director at a major New York City university. His first article for CQ, “The Nine-Minute QSO – Ham Radio Brings Space Down to Earth,” published 20 years ago, began a long and delightful relationship with our readership and a great friendship with your editor.

Hy Chantz, W2HY (“‘Museum Quality’ – A Visit to the Orkney Wireless Museum, GB2OWM,” p. 54), passed his Advanced Class license exam in November, 1968, on the first day of “incentive licensing,” and was originally issued the call sign WB2HYW. He lives in Scarsdale, New York and is a member of the Yonkers Amateur Radio Club.



Arcing in power line equipment can cause significant broadband radio interference, and poses a potential fire hazard as well. WA9PYH shows us how to couple a surplus satellite TV dish with a previously-described circuit to help you become a successful arc detective.

A (Much) Less Expensive Ultrasonic Line Arc Detector

BY JIM KOCSIS,* WA9PYH

This article describes the use of a satellite TV dish along with a circuit described in an earlier article in *QST* that can be used to locate arcing on power poles. The original article can be found in the *QST* archives (April 2006, “A Home-made Ultrasonic Power Line Arc Detector” by James Hanson, W1TRC). I highly recommend reading it to get a full understanding of this project. A circuit board is available from FAR Circuits for \$5.50 and includes an updated parts list and extensive instructions.¹ Using that circuit board will prevent wiring errors, make the electronics compact and speed construction time. The \$5.50 is well worth the price. No special parts are used in this project.

Project History

My ham friend and fellow homebrewer, Bob Sumption, N8RS, built the board that appeared in the original article.

* E-mail: <sadiekitty@sbcglobal.net>

He also purchased the microphone (sensor), checked it out then gave it all to me “on loan.” The original article specified an 18-inch plastic dish that is very expensive (\$91). Instead, Bob used a small plastic cup to shield the microphone from sounds coming in from the sides. It wasn’t very directional. While out for a bike ride, I stopped by a yard sale and found a 9-inch diameter pan lid (50 cents) that appeared to have the correct curvature (a parabolic curve as in a parabolic dish). Since the surface was very shiny, I used a flashlight as a light source from across the room and found it had a definite focal point 8 inches from the dish surface. I fabricated the necessary bracketing to hold the ultrasonic microphone at the focal point (Photo A). To produce a “target” for the circuit, I connected a small 2-inch speaker to an audio generator set to 40 kHz at 6 Vp-p and measured the beamwidth of the 9-inch dish from 15 feet away. It did show a definite peak but the beamwidth was pretty wide – approximately 30 degrees – not nearly narrow enough to zero in on the arcing on a power pole. Plus, there is no way to look through the dish to see what you’re pointing at when you find a peak. In my attic/junk box I had a satellite TV dish (Dish500) that I’d picked up for free – it was lying along the side of the road. I had no purpose in mind at the time, but I brought it home “in case I need it for something.” (Does that sound



Photo A. Nine-inch dish with wide beamwidth



Photo B. Completed dish with microphone and supports

familiar?) It still had the feedhorn attached so the location of the focal point was known. If you find one at a hamfest, yard sale, on the side of the road, etc., make sure the feedhorn is attached, you will need it to find the focal point.

Modification of the TV Satellite Dish

The satellite TV dish was a bit heavy, so using a reciprocating saw, I cut it down to an 18-inch diameter round shape. (Draw lines top-to-bottom and side-to-side, then draw a circle around the dish from that intersection to map out an 18-inch diameter). Now it was much lighter and the same size as the dish specified in the original article, so I figured it would have about the same gain. I used some brackets from my junk box to place the microphone at the focal point of the dish (Photos B and C). Since the dish surface is an offset feed, I knew my target would not be directly "in front" of the dish but instead *below* straight out from the dish.

A 1-1/4-inch length of 1/2-inch schedule 40 PVC is used to hold the micro-



Photo C. Support hardware for microphone and locator



Enjoy the hobby that connects people throughout the world...

The Radio Club of Junior High School 22

Bringing Communication to Education Since 1980



DONATE YOUR RADIO

Radios You Can Write Off - Kids You Can't

- Turn your excess Ham Radios and related items into a tax break for you and a learning tool for kids.
- Donate radios or related gear to an IRS approved 501(c)(3) charity. Get the tax credit and help a worthy cause.
- Equipment picked up anywhere or shipping arranged.



PO Box 1052, New York, NY 10002
E-mail: crew@wb2jkj.org www.wb2jkj.org
Call 516-674-4072

Falling Leaves... ...Falling Prices



VHF, Summits and More – Having Fun with Ham Radio

By Bob Witte, K0NR

This 234 page book is an easy-to-understand introduction to VHF/UHF ham radio, including practical tips for getting on the air and having fun messing around with radios. Learn about FM, SSB, repeaters, equipment, band plans, phonetics, portable operating, Summits On The Air (SOTA) activations and more. Included within you'll find a compilation of the best articles from the k0nr.com website plus some brand-new material.

The first section explains VHF/UHF concepts via tutorial articles such as "VHF FM Operating Guide," "Getting Started on 2m SSB" and "How to Work a VHF Contest." The second section includes blog posts from the k0nr.com website, such as "Choose Your 2m Frequency Wisely," "VHF Grid Locators," "Phonetic Alphabets" and "VHF FM: The Utility Mode." The final section helps the reader understand mountaintop operating, especially Summits On The Air (SOTA) activations, including operating tips and trip reports.

Only \$22.95 (plus S&H)

Shipping & Handling

U.S.A. add \$8 for the first item, \$4.50 for the second and \$3 for each additional item.

All other countries \$35 for the first item, \$20 for second and \$10 for each additional.

CQ Communications, Inc.

<http://store.cq-amateur-radio.com>

phone. I drilled a small hole in the PVC for a small screw to secure it to the support. A few layers of electrical tape will ensure a tight fit of the microphone (Photo D).

I used some electrical terminals (Photo E) as locators to tell where I'm pointed when the signal peaks. One is mounted at the top edge of the dish. The other is at the end of the extended bracket holding the microphone. The holes line up to tell me the exact location of the noise source.

The electronics are inside a small plastic box attached to the back of the dish (Photos F and G). The box measures 6 x 3 x 1-1/2 inches and is available at Hobby Lobby. It has a hinge on the lid and a snap to hold it shut. I used a 1/8-inch jack for the earphone and an RCA plug and jack for the microphone connections to the box. A handle is

attached (Photo G) so I can point and support the dish. It flops back and forth a bit so I found it best to support the dish with one hand on the handle and the other hand on the side of the dish to keep it steady.

Checkout and Use

This setup provides an approximately 5-degree beamwidth. When you're pointed at a signal source at 40 kHz, it is very obvious where that source is located as it lines up with the two "locators." It peaks very nicely! You might build in some means of adjusting the location of the microphone to be closer and farther away from the dish to locate it at the exact focal point – I didn't but I was pleased with the beamwidth so I called the project done. Use an audio generator driving a small speaker (as above) to verify you have the "locators"



Photo D. Microphone, tape and PVC holder



Photo E. Electrical terminals locators before and after

USB cables that work!

Radio programming is frustrating enough without having to wonder if your cable will work



We work hard to give you cables and software designed specifically for your radio.



It's all good on our ends!

Check for your model at rtsystems.com
Sales: 800-476-0719 | Tech Support: 404-806-9661
Mon - Fri: 9 am - 6 pm, Sat. by appointment



(the wire terminals) positioned properly. Figure 1 shows the dimensions for my dish. Yours may be different.

After You Find the Offending Pole(s)

When you've determined that a particular pole has arcing hardware on it, DO NOT HIT THE POLE TO SEE IF THE

NOISE STOPS AND DO NOT CLIMB THE POLE! Get the number of the pole (a small metal tag near ground level in our city) and contact your local power company, providing the location and pole number of the suspected pole. They have the equipment and knowledge to perform a proper repair. Of course, you should try to stop by and see what

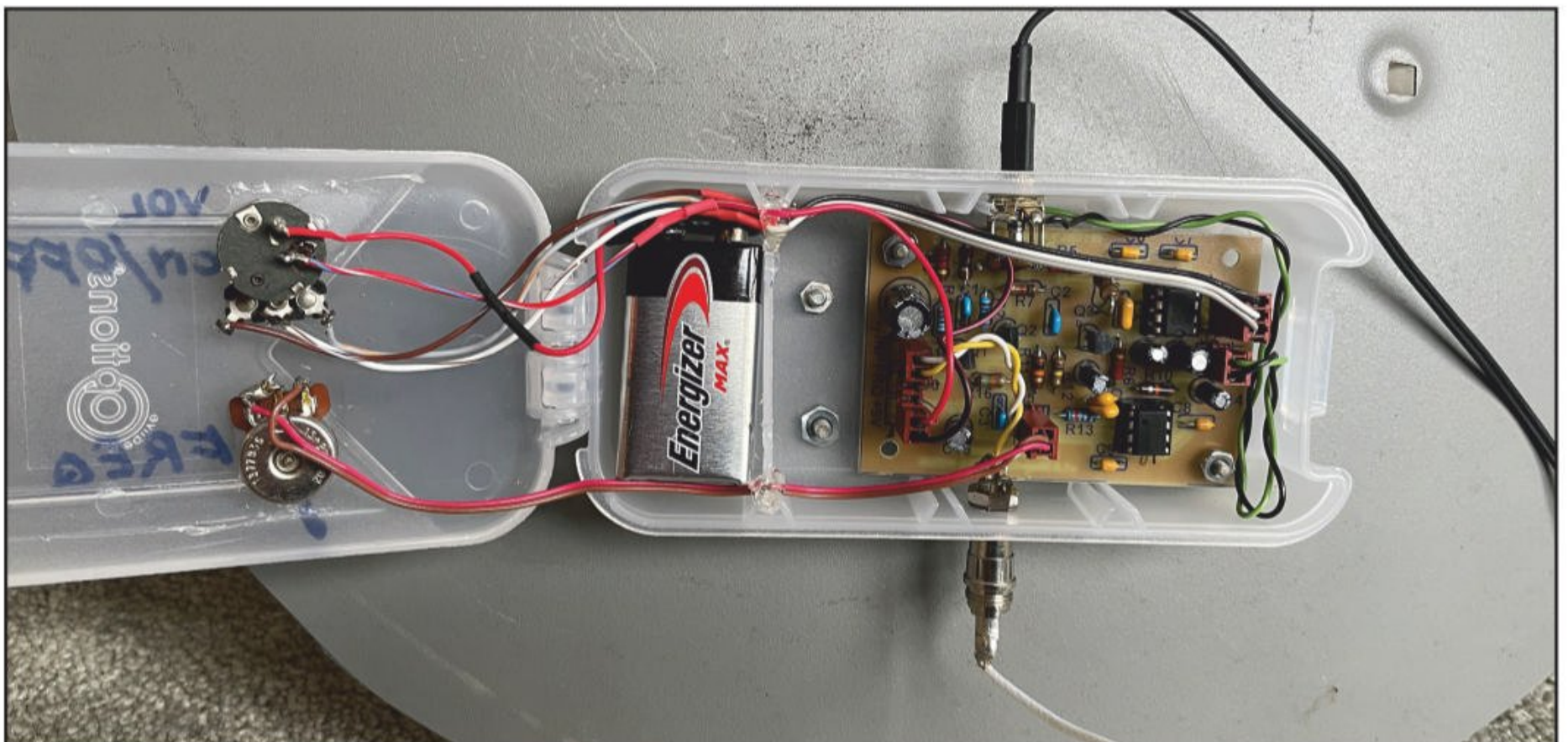

Photo F. Plastic enclosure open showing contents

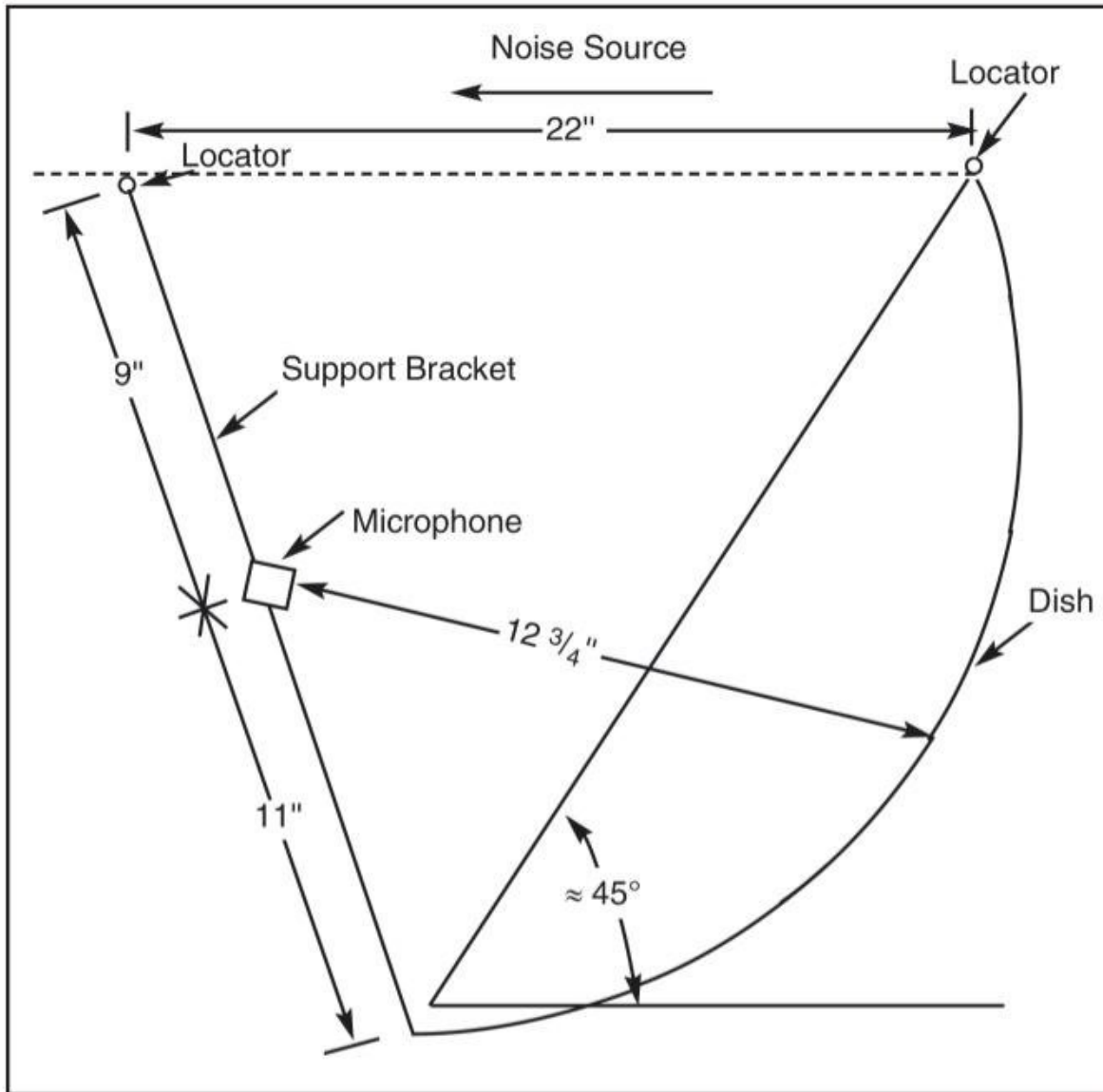

Figure 1. Dimensions of modified satellite dish

they find! You might offer to explain ham radio to them and how fixing the problem will help you in your hobby. If you're into emergency communications (Win-Link is my specialty), stress how important clear reception is to getting the messages through.

Summary

I thought I would monitor the spark igniter on our gas stove to see what it sounds like at 40 kHz. I was just a few feet away with just the microphone and electronics. It sounded like a gunshot! I've taken it outside to see what else I can hear such as birds, flying insects, bats but so far nothing. As they say: "The world is your oyster" (from Shakespeare in 'The Merry Wives of Windsor') so get out and see what you can hear beside arcing power poles!

Send a follow-up letter thanking your utility company for fixing the hardware that caused the problem. It's in their best interest to fix arcing hardware as it may result in power outages, a fire on the pole and/or wasted power. It may also improve reception for some non-ham neighbor.

Finally, a BIG THANK YOU to Bob, N8RS, for loaning me the circuit! I wouldn't have started this project on my own.

Notes:

1. See <www.farcircuits.net/w1rtc_notes1.pdf>



Photo G. Back of dish showing enclosure closed

Here's an interface you can build that reduces the risk of RFI interrupting your computer-to-transceiver communications and eliminates the need to adjust computer sound settings every time you change modes.

Transceiver to Computer Interface

BY ALAN HOFFMASTER,* WA3EKL

Many modern-day amateur radio programs use a single USB cable between the transceiver and computer to transfer three basic types of information; audio signals which can include SSB, RTTY, digital or CW signals, critical transceiver control and polling data, and transceiver transmit activation signals. Any RFI (radio frequency interference) in your radio room could disrupt the data flow on any one of these signals, necessitating a program reboot or, worst case, a system reboot.

One purpose of this circuit design is to greatly reduce the chance of RFI interrupting the data flow by separating the three specific signals into separate pathways between the transceiver and the computer; the audio signals, the transceiver control and polling data, and the transmit enable signal.

Another purpose of this interface is to eliminate the time-consuming nuisance of having to adjust Windows® sound settings each time you switch from phone to digital to CW or back again. This interface will allow up to four separate amateur radio programs access the transceiver's PTT (push to talk) line to key the transceiver.

Many modern amateur radio programs state you must use CAT (computer aided transceiver) to key the transceiver, yet they still provide the choice of using a communications port (COM Port) for keying. As long as you can activate the PTT line in your transceiver, you can key your transceiver and not have to use CAT. This circuit eliminates the need to use CAT.

Putting the CAT Back in the Bag

I designed this interface because using CAT with many of the new digital modes caused me a problem when I wanted to switch quickly from digital to voice mode. Digital modes need some type

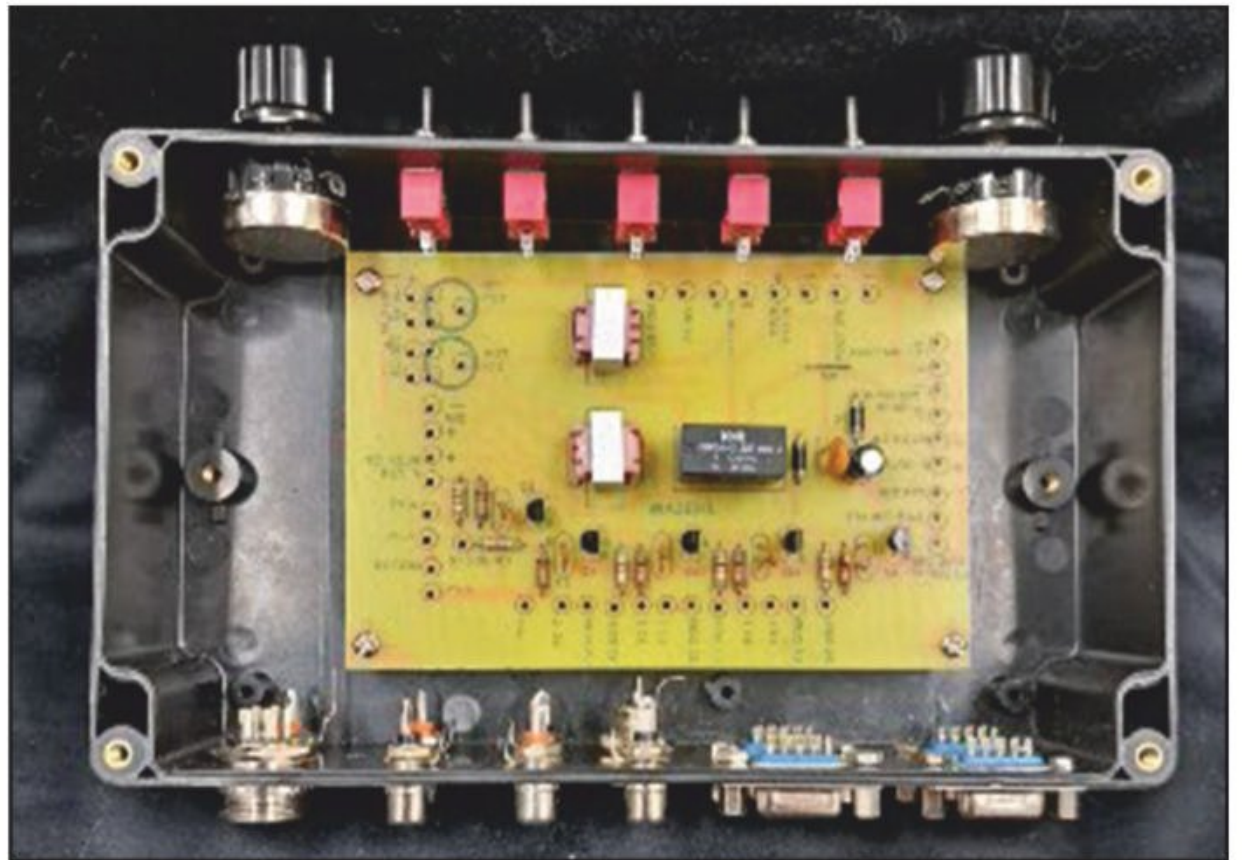

Photo A. Computer-to-transceiver interface board mounted in enclosure

of codices to translate the digital signal into an audio signal that is then routed into the mic circuit of your transceiver for transmission. The reverse happens with received digital signals, which also need codices and routing. In Windows 10®, I had to go into my sound setting and reset from “codices sound” to “High Definition Audio Device” in both mic and speakers every time I wanted to change from digital to SSB or CW or back again. If you are a contester doing a multimode contest using .wav files and digital signals, switching modes is a real time consuming process.

Most sound cards seem to have built in codices. This interface will route the digital signals through the sound card plus the audio wave files, giving you instantaneous mode switching. For the non-contester who operates all modes, you no longer need to change your sound card settings just to simply switch modes.

As a practical example, let's say you are in a contest that allows FTx, phone and CW. You expand the WSJTx win-

dow from your tray and start working FTx stations. To change to CW or phone, you simply reduce the WSJTx window, expand an N1MM window that is running in your tray and start immediately making CW or phone contacts. Even for non-contesters, this is almost instant mode switching.

Technical Details

On receive, the audio from your transceiver comes through a 5k potentiometer, through a 1:1 isolation transformer and into your sound card input where your program picks up the data and decodes it. The 5k potentiometer provides sound level into your sound card input which is very helpful on digital modes with signal levels varying as band conditions change. It saves you from having to change your sound card levels in Windows. T1 also isolates the audio from your transceiver to your sound card input, reducing differential ground hum. Your mic ground carries through on a separate ground to both front and rear transceiver mic inputs

* 1318 Paul Drive
Severn, MD 21144
alanbhof@gmail.com

and the sound card audio is also isolated from your transceiver mic input by T2, further reducing differential ground hum.

On the left side of the schematic (Figure 1) the mic normally feeds through the NC (normally closed) contacts of relay K1 directly to the mic input of your transceiver. When in digital mode or SSB mode that is using an audio wave file, the audio comes from the output of your computer's sound card and enters the schematic on the left through SC (sound card) out. The sound goes through K1's NO (normally open) contacts and is routed to your transceiver's mic input, either XCVR MIC Front or XCVR MIC Rear. The 10k potentiometer R12 provides level balance between the sound card output and your live mic. The arrows on the schematic indicate signal flow.

In order for the sound to come through the NO contacts, the K1 relay needs to be activated. This is done by the lower half of the circuit. The collectors of Q1

through Q4 are all tied together and connected to one of the terminals of K1's coil, a 12-volt DC DPDT relay. The other side of K1's coil is attached to a voltage source which could be a wall wart or your radio's 12 volt DC supply. "B" on the schematic is connected to the negative side of your power source. Q1 through Q4 transistor bases are each connected to Pin 7 of P1 through P4 DB9 connectors, respectively. P1 has an additional connection, Pin 4, which is the DTR line normally used for CW. When you build this circuit, you can mount the four DB9 female connectors on your box (Photos A & B) or bring out four short cables with DB9 female inline connectors on the ends, which will allow for a smaller enclosure box. If you still have COM ports on your computer, then you can attach any of P1 through P4 connectors to your computer com ports. However, if you only have USB ports, then you can obtain RS232 to USB serial adapters of the appropriate length for your setup. Most programs nowadays

want to see the FTDI chip in the adapter. If you have put female connectors on your box or the extensions cables, make sure you buy male RS232-to-USB adapters. They come in both genders! Most adapters are plug and play but some you have to go to the manufacturer's web site, download its software and install it before Windows will recognize the adapter.

A couple of additional circuit notes: P1 through P4 (one program at a time) keys the XCVR into transmit, which also switches the audio from the MIC to your sound card out, and your computer program plays the digi signal or wave a file into the mic input of your XCVR. The level is adjusted by R12, the 10K potentiometer, to match your normal voice mic level. Relay K1A switches from MIC to Sound Card Out and K1B is grounding the PTT line in the XCVR causing it to go into transmit. You still retain Mic PTT and foot switch control with this circuit.

Mic Connections

On the left side of the schematic, MIC +, MIC -, MIC PTT and Mic Bias If Needed all go to the mic connector mounted on your box. There is no connection on the board for Mic PTT on the left side of the schematic. However, you can attach a wire from the PTT pin on the mic connector to either the Foot SW + terminal connector or the XCVR PTT In + terminal connector on your box.

On the right side of the schematic, XCVR +, XCVR -, MIC PTT and XCVR Mic Bias all connect to a length of shielded 4-conductor cable that extends out of your box which will be terminated in a mating connector that will plug into your transceiver's front MIC jack. Also on the left side of the schematic, another shielded 2-conductor cable connected to XCVR + and XCVR - will extend out of your box, terminating in a mating connector that will plug into your transceiver's rear mic input jack if you chose.

Setting Parameters

In the WXJTx program's Configurations/Radio tab/PTT Method box, check RTS, then click the port arrow and select the port you want WSJTx to key the PTT on your transceiver. When the WSJTx starts to send data, it also sends a signal to the RTS line of the COM Port you chose. That signal causes the transistor you have routed it to through one of the "P" ports to turn on and pull current, thus causing the relay to close. Then the audio from the sound card is routed to your transceiver's mic input. In addition, the second set of contacts on K1 shorts

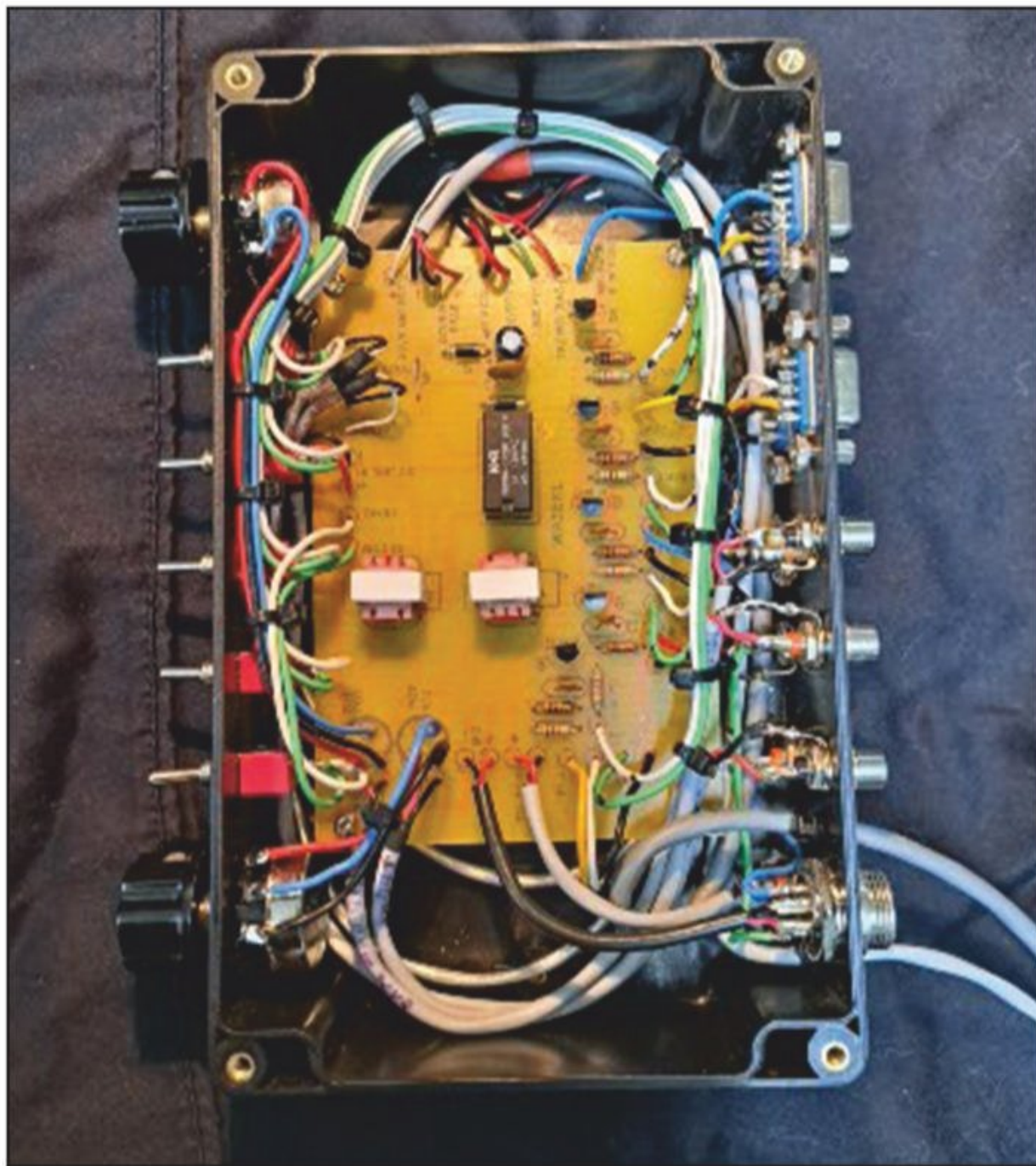

Photo B. Internal wiring has been added to connect board to various inputs and outputs

the PTT line to your transceiver's ground, thus keying your transceiver while the data is being sent.

CW Connection

This interface can activate the PTT line by four different programs, one at a time, and turn off the RTS signal when in CW mode on Port1. Whatever program is going to send CW for you, making use of DTR, be sure that com port number line from your computer is physically attached to P1 on the interface box. The extra pin #4 on P1 I use for the N1MM Plus program. In the N1MM Plus program; Config/Configure Ports, Mode Control, etc./Hardware Tab, the first top port is assigned a port number that goes to the transceiver with no checks in either of the two boxes. This is the normal transceiver control and polling port. On the first port under "Set," both DTR and RTS are set to *always OFF*. The next port down I assign another port number. In the check CW/other column, I then set the DTR (pin 4) box to CW and the RTS (pin 7) box to PTT for this port. When Switch #1 selects CW, Q5 acts like a switch so that N1MM can send a CW signal via DTR into the straight key jack of your transceiver.

The Elecraft K3 has a rear jack input for a straight key and a rear jack input for paddles; my Icom 9700 only has paddles input. However, the Icom paddle input can be set for straight key. In order to use paddles and a program to key

an Icom, you need a small external keyer for the paddles and a "Y" connector. The "Y" plugs into the Icom, the keyer plugs into the "Y" and the keyer output of the box plugs into the other jack of the "Y" connector.

Switch S5 Decode ON/OFF is provided to turn off any extraneous sounds coming from the transceiver's audio source when not using signal decoding. I usually turn it off when working SSB.

The mic connector can be placed anywhere on your box for your mic as well as the cable coming out of the box that goes to the mic connector on your transceiver. Note that the PTT line is attached to five places; + XCVR PTT In box jack; + Foot SW box jack; MIC PTT (mic connector PTT pin on box), K1's second contact set K1B wiper, and MIC PTT cable that goes out to your transceiver's front mic jack. This allows the transceiver to be keyed with the computer, the foot switch or a mic switch.

Mic connectors are specified in the parts list if you have the standard 8-pin used by Icom and Elecraft. If you are using headsets and not using a stand or hand mic, you can plug the adaptor supplied by the manufacture of the headsets into your box mic connector or make you own adapter as I did for my headset mic which was an 8-pin male aviation connector to 1/8 - 3.5 mm inline female stereo connector both available on Amazon.

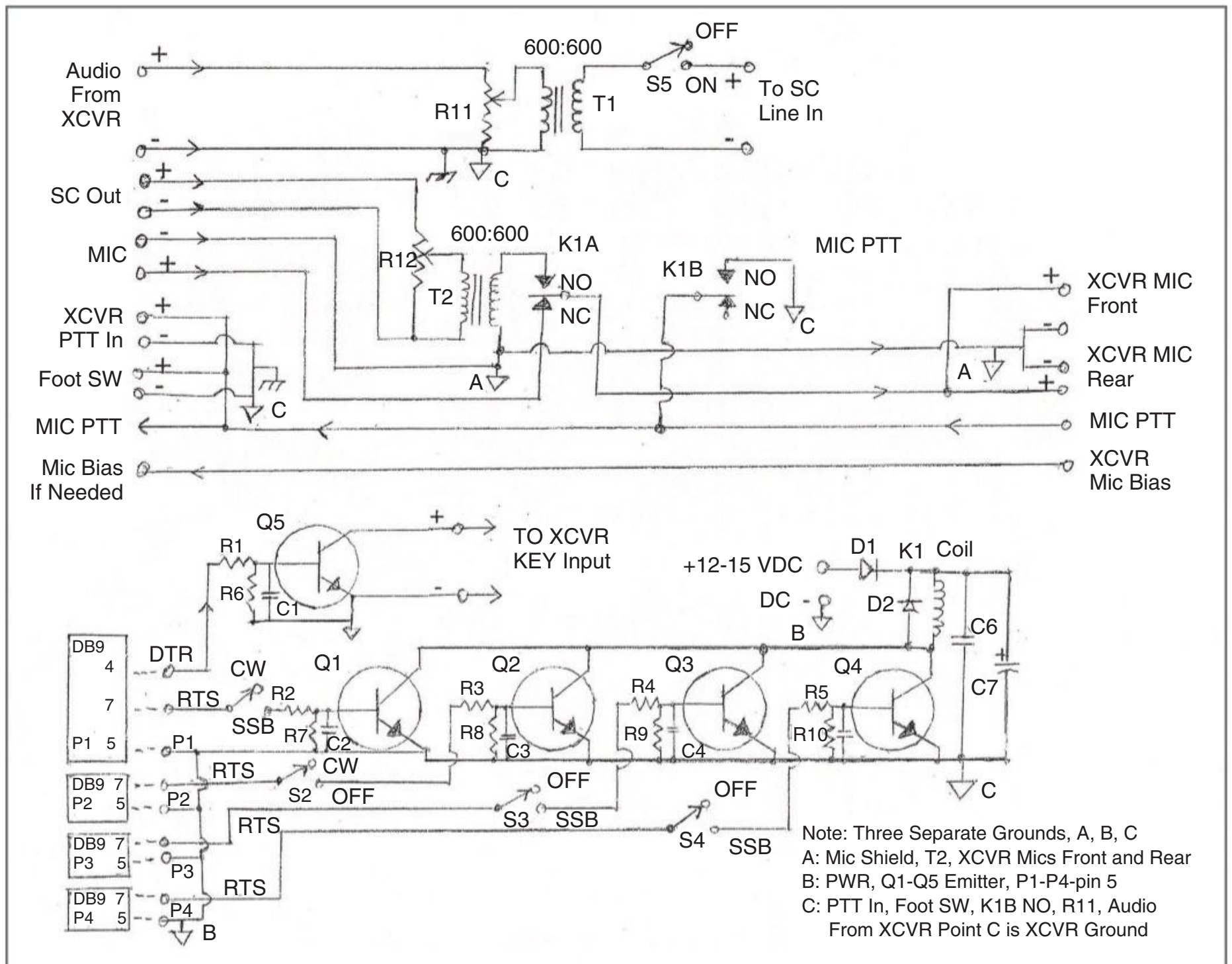

Figure 1. Schematic of the interface circuit

You may choose your own power connector or just bring out a shielded two wire cable to connect to your power supply.

All my original interfaces are wired on perf boards and are in plastic boxes 6 inches wide x 3 inches deep x 2 inches

high (Photos C & D), but I am only using two Com lines; one for WSJTx to key the transceiver PTT and the other for N1MM to key the transceiver PTT.

You can breadboard your own interface from my schematic (see sidebar #1) or you can purchase a circuit board with

this design on it from Far Circuits.¹ The Far Circuits board measures, 3-5/16 inches x 5 1/16 inches. This circuit board requires a box at least 7-7/8 x 4-3/4 x 2-1/8 inches to comfortably mount the board, the four DB9 connectors, all the connectors, switches and potentiometers, and attach all the wiring. If you choose to bring four wires out of the box for the four DB9 connectors instead of mounting them, then the width of the box can be made smaller. I leave it up to each builder to choose their own housing box.

Table 1. Parts List

All Resistors are 1/4-watt

R1, R2, R3, R4, R5: 1K, Digi Key CF14JT1K00CT-ND - Cut Tape(CT)

R6, R7, R8, R9, R10: 10K, Digi Key CF14JT10K0CT-ND - Cut Tape(CT)

R11: 5K single-turn linear taper potentiometer, Digi Key 987-1311-ND or Amazon ASIN # B0744G6JDN

R12: 10K single-turn linear taper potentiometer, Digi Key 987-1724-ND or Amazon ASIN #B00DN7P2QE

C1, C2, C3, C4, C5: 2200 pF ceramic monolithic disk capacitor, Digi Key BD1074CT-ND, Amazon ASIN #B00E6P11R4 (see note in text)

C6: .1 μ F 35-volt ceramic disk capacitor, Digi Key BC1084CT-ND - Cut Tape(CT)

C7: 47 μ F 35-volt electrolytic capacitor, Digi Key 732-9213-1-ND - Cut Tape(CT) [This capacitor adds additional filtering to your voltage source and is not critical. It can be anything from 20 μ F to 100 μ F at 35 volts as long as it fits on the circuit board.]

Q1, Q2, Q3 Q4, Q5: 2N2222 transistor, Amazon ASIN # B09N1DZHQM (good for numerous projects)

T1, T2: 600-ohm audio isolation transformers, Digi Key 237-1130-ND or EI14 Amazon ASIN #B073P XK2RX, #B07Q6RSWYC or #B07HTBQ7FY

K1: DPDT 12-volt DC relay, Amazon ASIN #B005ETA3P4 (Plug In) or ASIN #B005ETA282 (PC Board Mount); or Digi Key 2368-R40-11D2-12-ND (I am using the Digi Key type)

S1, S2, S3, S3, S4, S5: SPST mini toggle switch, Digi Key 2368-54-395-ND or Amazon ASIN #B07QGDDTWJ or ASIN # B07SVWYKG1

P1, P1, P3, P4: Female chassis mount DB9 connectors with hoods (hoods used when extending DB9 connector out of box), Amazon ASIN #B07QXWW8T (example1) or ASIN #B0HM6UBN0 (example 2) or ASIN #B07LCM7F1H (connector only, better for first time soldering people!), ASIN #B015MVGHZ8 (hoods only for DB9 connectors)

1 16-pin (solder in board) IC socket, Digi Key 2368-NTE416-3-ND or Amazon ASIN #B00SW03UIC (as example)

6 - Female chassis mount RCA connectors for: Audio From XCVR, SC OUT, SC IN, XCVR PTT IN, FOOT SW, and TO XCVR KEY IN. Examples: Amazon ASIN # B093YVBP38 or ASIN # B01FX5TQ1U (suggest you read reviews before you buy)

ONE set of 8-pin male & female aviation connectors (mic connectors), Amazon ASIN # B07ZYRVVV9 (You get both... The male goes on your box and the female goes on the wire coming out the back of your box to your XCVR mic connector. Or a set of the mic connectors that matches your XCVR.

20 pcs uxcell M3 brass insert thread 8x10mm insulated standoffs, Amazon ASIN #B00X77872Q (for mounting circuit board to bottom of box)

4 #-40 5+8mm uxcell F/M brass hex standoff spacer screws PCB nickel, Amazon ASIN #B07KWVPZC2 (for mounting the DB9 connectors; 4#-40 is the thread size which you need because that is the normal size of the screws in the RS232 to USB adapters. 5 mm is the minimal cup length and 8 mm is the minimal screw length so you have enough screw threads sticking through the inside of your box to put on a lock washer and 4-40 nut. I could only find this source.)

8 stainless steel 4-40 machine nuts and lock washers. (local hardware store)

8 feet #22 or #24, 2-wire shielded with ground wire for builders to make four 24-inch cables when extending the DB9 connectors out of their box and labeled P1, P2, P3, P4 when not mounting the DB9 connectors on your box)

All switches, potentiometers and DB9 connectors are off-board so builders can mount to suit themselves on their boxes. Builders can construct or buy interconnecting cables between their box and SC in, SC out, Foot SW, PTT to XCVR, key in of XCVR and Audio out from XCVR.

Construction Procedure

I recommend the following construction procedure:

First, lay out how you want your box to look and cut all the holes for the mic connectors, RCA jacks, potentiometers, switches, DB9 connectors, power jack and two holes for the extension cables. Mount all the parts except for the DB9 connectors.

Next, center the bare board in your box or between all your mounted parts and mark all four board mounting holes. Next, install the four board spacers. Check to see if the board fits on the spacers correctly, but don't mount it.

Now, solder in all the circuit board components. Then, solder wires of different colors from the circuit board long enough to reach each connector, switch, jack and potentiometer. Also solder on the two extending mic cables that have no connectors on them yet. These two cables need to be long enough to reach from your radio to wherever your box will be sitting.

Solder the wires on the DB9 connectors before mounting in the box and make sure their wires are long enough to reach the board in their appropriate

Guidelines for Breadboarding This Circuit

Point "A" MIC on left side minus "-" needs a connection plus XCVR Front and Rear "-" MICs and board connections point "A" output side of T2. Three points to connect wires to.

Point "B" is the 12 VDC ground point and board common of all 5 transistors. "B" also needs 4 more points to connect each of P1, P2, P3, P4.

Point "C" needs board connection points for "-" "Audio From XCVR" left side, plus foot switch "-" and PTT "-" contact points. The normally-open contact of K1B also attaches to "C," which is what keys the MIC PTT line in the transceiver



Photo C. Front view of the completed interface box

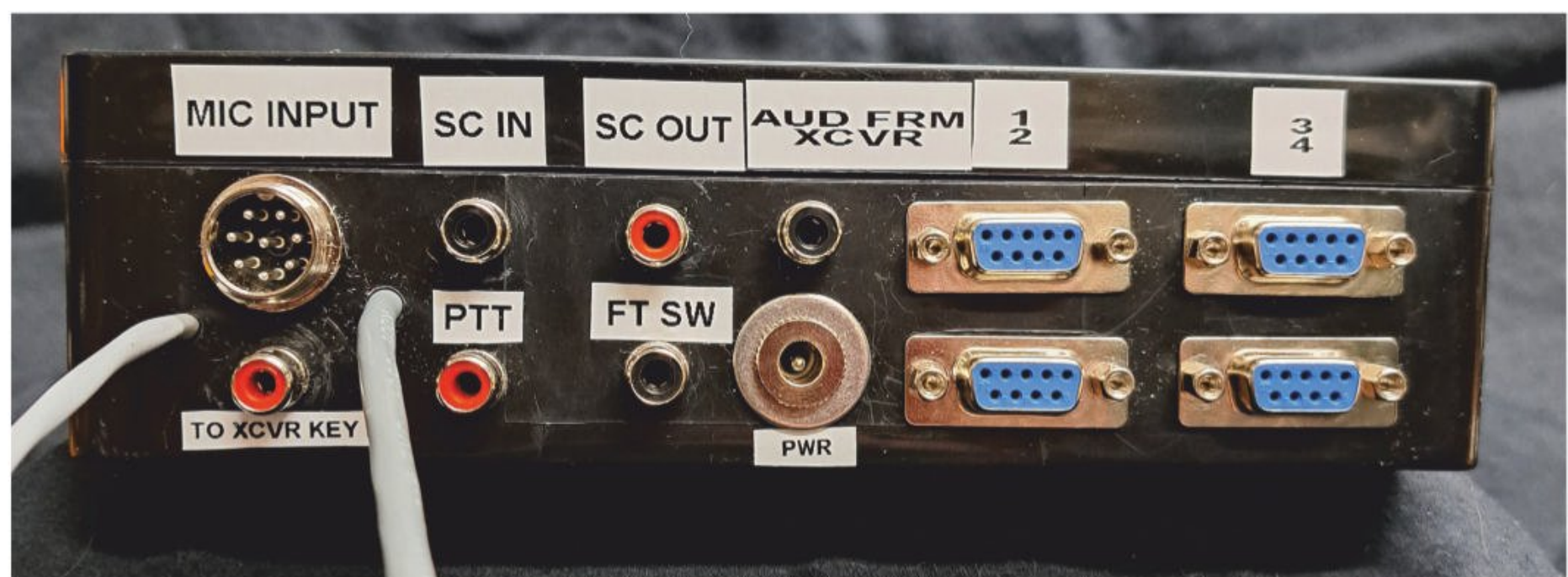

Photo D. Rear view, prior to connecting cables to computer and transceiver

holes. Mount the DB9 connectors, then solder their wires into the board.

Now, slide the two mic cables from the inside of the box out through the two holes you made for them and mount the board to the spacers in the box. Connect all wires extending from the board to the appropriate connectors.

I also recommend using an adjustable low wattage soldering iron for this project. I used the PINE64 which is a very small lightweight, temperature-controllable, USB-powered iron that my son gave me for a holiday gift in December. Amazon ASIN number #B096X6SG13. Just put this number into the Amazon search window. You cannot plug this iron into your computer. It requires a good USB power supply. I am presently using the ZMI zPower Turbo 65 Wall Charger (Amazon ASIN number #B07D64QLQ1). If you do a lot of small component or small connector soldering, you will most likely enjoy using this iron when you learn how to control it! You are less likely to burn your parts up or melt your connectors, but it will take a little practice.

Closing Notes

A complete parts list for this project, with suppliers, is in Table 1. I have no financial affiliation with either of these suppliers.

Note: Capacitors C1, C2, C3, C4 and C5 (2200-pF 50-volt ceramic disc capacitors) are not needed unless you have RFI issues triggering the transistors. However, after building the first prototype box, I highly recommend you install the capacitors to begin with because you don't want to try to install them later!

I designed and built my first interface box about 17 years ago, then continued building more of them as my station grew. None of these boxes has ever failed.

This interface box works very well with the program I wrote that allows WSJTx and N1MM to run at the same time with VFO and other function tracking in both programs, plus it runs very fast with very little CPU usage.

The freedom of not having to use CAT control has allowed me to easily integrate amateur radio programs that normally require time-consuming setup or additional programs to run correctly. Any RFI issues I had in the past are now gone.

I hope this interface will allow you to change modes more quickly, make your station more efficient and increase your enjoyment of this great hobby.

Note:

1. Far Circuits, 18N640 Field Ct., Dundee Township, IL 60118; Phone: (847) 836-9148

emergency communications

BY JOHN FERGUSON,* K3PFW

Ethereal Adornments - Part 2

A Close Look at End-Fed Antennas

Two months ago, in August, we started with a discussion of fundamental antennas and how they evolved. Probably 90% of the antennas you will work with over your amateur radio career will be one of those basic ones or a derivation of one. This month I want to discuss one of the currently popular antenna types that we are seeing a lot of in portable HF operations, the “end-fed.” These antennas come in two varieties, so similar to each other it is sometimes hard to tell which is which.

The *end-fed half-wave* (EFHW) is a resonant antenna, with a fundamental half-wave electrical length which will work on its fundamental frequency and multiples of it. The other “end fed” could rightfully be called a “random wire” since it is not an electrical half wave, or multiple thereof, on any of the bands on which you might operate. It is reminiscent of the early days of the hobby when

the antenna was “just a wire.” As with any amateur radio antenna that must work on multiple bands, understand that it will be somewhat of a compromise in performance from that of an ideal single-frequency radiator. The trade-off for the family of end-fed antennas is found in their adaptability to portable operation and their convenience in many home station installations. The end-fed family of antennas is extremely popular with activators in the Parks on the Air (POTA) and Summits on the Air (SOTA) programs.

Some wire, a couple of insulators, and an *unun*, and you have the makings of an end-fed antenna. What’s an *unun*? It’s an impedance transformer that’s a close relative of the *balun*, which is short for *balanced to unbalanced*, while the *unun* is *unbalanced to unbalanced*.¹ The turns ratio of the unun and the electrical length of the wire determine whether it will be a true end-fed half-wave or “just a wire.” From our previous discussion of basic antennas, the voltage at the ends of a resonant half-wave dipole is very high, indicating a very high impedance. We

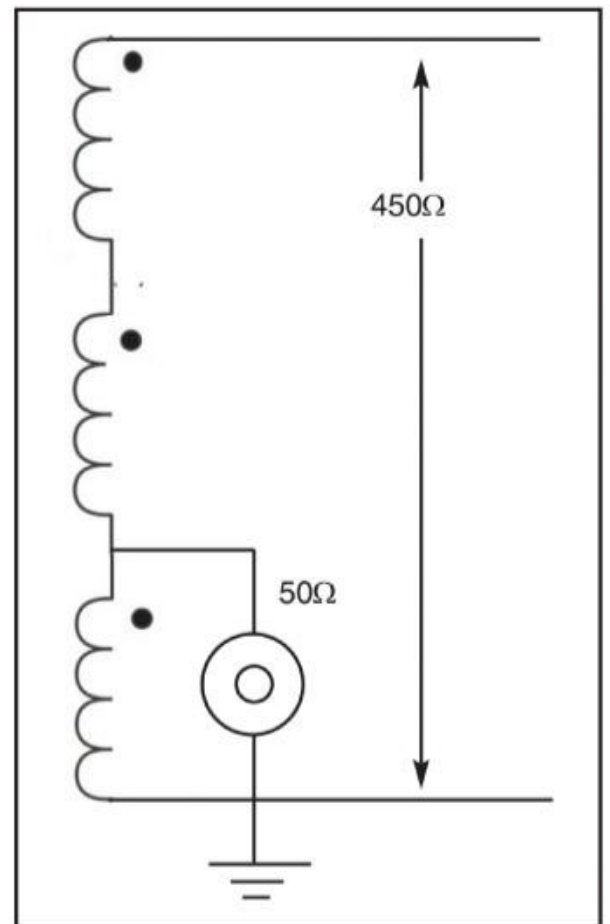

Figure 1. Schematic of 9:1 unun, in this case for feeding a 50-ohm unbalanced load with a 450-ohm balanced feedline. See text for an explanation of the dots.

* 20116 Donovans Rd.
Georgetown, DE 19947
Email:
<K3PFW@cq-amateur-radio.com>



Photo A. Unun enclosure with hardware

Photo B. The assembled 9:1 unun



normally feed our dipoles at the center, a high current point, with low impedance coaxial cable. For the EFHW, using a high-ratio unun (i.e., 49:1 or higher), we can usually provide a match at the end of the antenna using the built-in tuner in most modern transceivers. For the non-resonant end feds, a 9:1 unun is usually used. The appropriate random length of the wire for the non-resonant end-fed can be found in several tables online listing lengths that are not resonant on any of the HF bands.

In a previous column I related that I was going to replace my off-center fed (OCF) dipole with an end-fed antenna of some type. I decided on a random wire, end fed with a 9:1 unun, 137 feet long. This should work on 160 through 10 meters. Since I had wire and insulators, I looked for an unun, ready-made or kit. A quick internet search will show you a myriad of possibilities out there. I chose a kit from Palomar Engineers, their model BA-9-1000 balun/unun kit, that looked like it would meet my requirements. A trip to a local hardware store acquired a suitable enclosure, a plastic 4 x 4 x 2-inch weatherproof junction box.

Off to the shop to start the project. Layout and drilling of the enclosure for the hardware was the first step. Because of the thickness of the box material, and wanting to mount the SO-239 coax connector from the inside, I first counter-bored, slightly oversize, about an eighth of an inch, from the outside and about an eighth of an inch in deep to allow the PL-259 connector on the coax to seat tightly. Then I drilled through for the coax connector. Using the coax connector as a guide, the holes for the mounting screws were drilled next. A quarter-inch hole on the opposite side for the hanging hardware finished the machining. This will also be where the connection to the antenna wire is made. Photo A is the enclosure with hardware mounted.

Winding the wire on the toroid core for the unun was next. Three pieces of wire for the three separate windings were laid side by side and taped together in a flat cable. There are no half turns on a balun or unun. If it goes through the middle, it's a turn. Figure 1 is the schematic that shows the three separate windings. The three dots are polarity marks, showing the "start" of that winding. The flat cable was wound on the core for six turns. The turns ratio between the primary and the whole assembly as a "secondary" is 3:1. ($18 \div 6 = 3$) The impedance transformation is the square of the ratio, in this case a 9:1 impedance transformation. Winding the core is simple and straight-

forward. Having some small tie-wraps to hold the beginning and the end in place is helpful. The directions with the kit suggested starting with the middle of the flat cable and winding the turns in each direction for a total of six. Photo B shows the winding process completed. Then, paying attention to the polarity dots on the schematic, start making the connections between the turns. Photo C is the unun in the enclosure. The wires are stiff enough to hold it in place.

The Counterpoise Question

With the end fed family of antennas, there is a question of counterpoise or no counterpoise. For this antenna, I'm using the coax shield as the counterpoise and putting a choke at the base of the pole where the antenna terminates at the unun. (Photos D and E). There will be approximately 50 feet of the feedline exposed, before it goes underground in conduit another 50 feet to the entrance panel where the surge protector will ground the shield.

Earlier, I referred to the adaptability and convenience of the end-fed family as opposed to dipoles. For portable and other deployed operations, they can't

be beat. Using a single high support of some sort, run the antenna back to the operating position, with a short length of coax to the transmitter, and you're ready to go, and it will be multi-band too! Here's where I would recommend a counterpoise connected to the shield of the coax or a ground connection.

If I had sat down and really worked at completing the project, I doubt that it would have taken more than two hours start to finish for the unun. Projects like this would give you the satisfaction of making something to use with your ham station.

On-Air Testing

The initial testing of the 9:1 unun with 137 feet of antenna, at 50 feet, with the tuner in the Icom 756 Pro II, showed it was capable of matching 1:1 on 160, 75/80, 20, 15, and 10 meters. The WARC bands (30, 17 and 12 meters) were around 2:1, usable, maybe.

You can tailor this approach for a deployable antenna to your own situation. The 137-foot length was a good fit between the pole and a convenient tree, plus I wanted something to try on 160 meters. For an example, looking at a

**Real Hams
Do Code**

**Learn code with
hypnosis today.
Download Now!**

www.success-is-easy.com
561-302-7731
Success Easy
568 SE Maple Ter., Port St. Lucie, FL 34983

IMPULSE ELECTRONICS.COM

**WILL YOU BE ON THE AIR
WHEN THE GRID GOES DOWN**

DC12 GO-BOX SERIES



MAX GO-BOX

12 to 50 Ah Bioenno LiFePO4 Battery
Powerpole Port - DVM - USB Charger
CHARGED - READY TO GO
(866) 747-5277

**RF TRANSFORMERS
2-54MHz**

We stock the rugged 1KW transistor and parts for the 2M and 88-108MHz amplifier designs. We also stock the NXP MRF101 LDMOS transistors.

COAX WIRE





RF400



RF600



RF800



RF1000



RF2000

FLEXIBLE

TC-12 - 10.7 ohm
TC-18 - 17.1 ohm
TC-20 - 18.6 ohm
TC-22 - 21.7 ohm
TC-24 - 26.8 ohm
SM250-50 50 ohm

SEMI-RIGID

UT-141C-25 25 ohm
260-4118-0000 25 ohm

CCI

Communication Concepts, Inc.

508 Millstone Drive, Beavercreek, OH 45434-5840

Email: cci.dayton@pobox.com

www.communication-concepts.com

Phone (937) 426-8600

Established in 1979



Type "U"
2 to 300MHz



Photo C. The unun installed in its enclosure with connecting hardware



Photo D. Unun installed on an end-fed antenna



Photo E. An ugly but effective RF choke on the feedline

length chart online (such as <https://udel.edu/~mm/ham/randomWire/>), a suitable length for 40 through 10 meters would be 34 to 43 feet; certainly an easily-deployable length in the field. With a laptop, a sound card interface for your transceiver, and a 36-foot end-fed antenna, you could handle emergency digital communication traffic in the field. When selecting a length for an end-fed random wire type antenna, make it at least a quarter wavelength long for the lowest frequency you want to use for the best results with this type of antenna.

The kit I selected, Palomar Engineers BA-9-1000, can also make a 50-ohm unbalanced to 450-ohm balanced balun. This would be ideal for matching a Zepp-type antenna fed with ladder line. Also consider, for all-band coverage, a dipole of whatever length you can fit, fed at the center with ladder line, and a 50-to-450 balun. End-feed it with ladder line and it's a Zepp type, particularly if it is a resonant half wave. And, yes, it will work on multiples of the fundamental frequency of resonance.

If you are going to pursue the emergency communications aspect of ham radio, you should get all the knowledge and experience you can with antennas of all types, and develop your knowledge of why they work. Then when you run into the "it's impossible," you might just be able to make it possible with a little ham ingenuity and some help from your fellow hams. A comment I frequently make is that "no one of us is as smart as all of us." My wife complains that I use the same phrases over and over, and I ought to just number them. I haven't got around to that yet.

Projects like this are not difficult to accomplish. You don't need a well-equipped shop and a bunch of power tools. The plastic box could have been drilled with a hand drill, and the hole for coax connector enlarged with a rattail file. Don't have everything you think you need? Ask around the local ham community. Try something like this as a group project for your club. Then all of you take to the field for a deployable antenna contest!

73, K3PFW

Note:

1. To learn more about these transmission line transformers, CQ recommends Jerry Sevick's *Understanding, Building and Using Baluns and Ununs*, available from the CQ Bookstore in print or CD format.

learning curve

BY RON OCHU, KOØZ

CQ Profile: Corey Chaskelson, NOVKR

As many readers are aware, I am a retired public high school teacher. I am fortunate and pleased when I meet former students, for they greet me with all five fingers extended! It's always a pleasure to see them, to catch up and to hear about their successes, their families, and their careers. For me, when I taught, I didn't have students for one hour a day, five days a week for a school year. Instead, students became extended family members. Some talking heads with 24-hour cable news shows will have you think otherwise about public school teachers, but such is not the case. Before you think to yourself that I'm an exception, I assure you I am not. Almost every colleague I've worked with feels the same way and we relish student successes. Classroom success translates into societal success on multiple levels, which can, as this article will attest, include public service and emergency communications!

High School Influence and Elmers

So, what does the preceding paragraph have to do with public service and emer-

gency communications? Upon first glance, not much. But please read on. Almost everything we do as radio amateurs has either a direct or an indirect impact on public service/emergency communications. During my teaching career, I sponsored a high school ham radio club, and I taught a mass media and communications course. Many high schoolers were introduced to amateur radio. One of my students developed an especially keen interest in public service

and meteorology. He joined my high school ham radio class. At the time, I was one of the SKYWARN® net control operators (Photo A) with the National Weather Service (NWS) St. Louis office. Even as a high school sophomore, Corey Chaskelson, NOVQR (Photo B), knew he wanted to be an NWS meteorologist (Photo C). On many occasions, I would invite Corey to accompany me to the St. Louis NWS office to assist me with net control duties. Corey was a natural! He was in his element! His inquisitive, eager mind absorbed all there was to absorb. Corey networked with the meteorologists. St. Louis NWS meteorologists Jim Kramper, N0LSX (Photo D), and Ron Przybylinski, KC0WWE (SK) (Photo E), took Corey under their wings and encouraged him to pursue a meteorological career. On the emergency management side of amateur radio, my friend and former St. Charles County Emergency Management Director Rod Zerr, KA0MJI (SK) (Photo F) introduced Corey to the ins and outs of emergency communications. Rod immediately saw



Photo A. Trained amateur radio weather spotters are a crucial part of the National Weather Service's SKYWARN® program (Photos by Corey Chaskelson, NOVQR, except as noted).



Photo B. As Corey Chaskelson, NOVQR's, former teacher, I was able to catch up with him in Memphis, Tennessee. (KOØZ photo)



Photo C. NWS logo



Photo D. Retired NWS meteorologist Jim Kramper, N0LSX, taking a break from manning the SKYWARN® booth at a hamfest.

*Email: <ko0z@cq-amateur-radio.com>



Photo E. NWS's Ron Przbylinski, KC0WWE (SK), staffing the SKWARN© booth at a hamfest.

Corey's potential and enthusiasm for emergency preparedness and quickly involved him with his office and ARES (Amateur Radio Emergency Service). Kramper, Przbylinski and Zerr could see this young teenager was well worth elmering!

Parks College of St. Louis University

Upon graduating from high school, Corey attended Parks College of St. Louis University where he earned his bachelor's in meteorology. Professor Ben Able influenced him greatly and taught him very beneficial forecasting insights. Corey was doing some graduate work when a position became available with the NWS in Gaylord, Michigan. He took the position and began his NWS career forecasting Michigan weather for several years. When an opening in Memphis, Tennessee, was posted, Corey moved to the NWS office there (Photo G). Memphis is closer to his hometown of St. Louis, which makes visiting family and friends more convenient. Even more important, Corey met his wife Ashleigh there!



Photo F. Former St. Charles County EMA director Rod Zerr, KA09MJI (SK), pictured on the right with the ball cap.

Early Interests

N0VQR finds weather fascinating. He always has. When he was a tiny tot, Corey would sit on his family's porch watching an approaching storm and getting frightened by the lightning and thunder. While initially frightening, storms piqued Corey's interest and he soon developed an aptitude and a love for science and weather. While in fifth grade, his class had a ham radio presentation from Carl Lee, KJ0A, and Corey was bitten by the ham radio bug. When he went to high school, he met me and joined the ham radio club and operated the high school club's station. Naturally, my interest in SKYWARN© was right up N0VQR's alley. Today, Corey has an Extra Class license, and still involves himself with both meteorology and amateur radio.

"Weather-Ready Nation

N0VQR's involvement with ham radio combines pleasure with business. Corey's "business" is to provide up-to-date,



Photo G. Interior shot of the NWS Memphis office.



Photo H. Exterior shot of the NWS Memphis office. Note the tower with amateur radio antennas supporting SKYWARN®.

accurate weather forecasts for the Memphis NWS (Photo H) CWA (county warning area) (Photo I). The Memphis CWA is unique in that it includes counties from four states: Missouri, Tennessee, Arkansas, and Mississippi. Along with his fellow NWS meteorologists, this office diligently works to provide information, education and community involvement in the National Weather Service's mission to have a weather-ready nation. To better explain the premise of weather-ready nation, I found this information on an NWS website <<https://www.weather.gov/wrn/about>>:

NOAA's Weather-Ready Nation is about readying your community for extreme weather, water, and climate events.

The devastating impacts of extreme events like record breaking snowfall, violent tornadoes, destructive hurricanes, widespread flooding, and devastating drought can be reduced by taking advance action, which is why the Weather-Ready Nation initiative is so important.

What is NOAA doing to build a Weather-Ready Nation?

NOAA's National Weather Service is transforming its operations to help America respond. Offices now provide forecast information in a way that better supports emergency managers, first responders, government officials, businesses and the public make fast, smart decisions to save lives and property and enhance livelihoods.

NOAA's Office of Oceanic and Atmospheric Research and National Environmental Satellite, Data, and Information Service are moving new science and technology into National Weather Service operations that will improve forecasts and ultimately increase weather-readiness.



Photo I. The ham radio SKYWARN® station at the Memphis NWS. Note the Memphis CWA map.



Photo J. Mid-South SKYWARN ARS supports SKYWARN®.



Photo L. DMR is another vital communications tool for Memphis NWS. The advantage is that geographical groups within the CWA can give storm reports with clear reception as long as there is a reliable internet connection or DMR repeater coverage back to the Memphis NWS office.



Photo K. Analog FM VHF/UHF is still used by ham radio storm spotters.

While we at NOAA are taking steps towards building a Weather-Ready Nation, we cannot do it alone!

What can you do to help us build a Weather-Ready Nation?

Become a Weather-Ready Nation Ambassador! Building a Weather-Ready Nation requires action from other government agencies at the national, state, and local levels, America's Weather Industry, emergency managers, researchers, the media, nonprofits, and businesses. Any organization committed to serving as an example and engaging their stakeholders to make this country ready, responsive, and resilient can be an Ambassador.

Weather-Ready Nation can help start a dialog within our local communities that will ultimately reduce the risk of being adversely impacted by extreme weather and water events and increase community resilience (the ability to recover) for future extreme events.

Whether talking about preparedness and resilience in your home, office, at community centers, within schools or local businesses, on your website, or on social media, you will be helping to spread the word, inspire

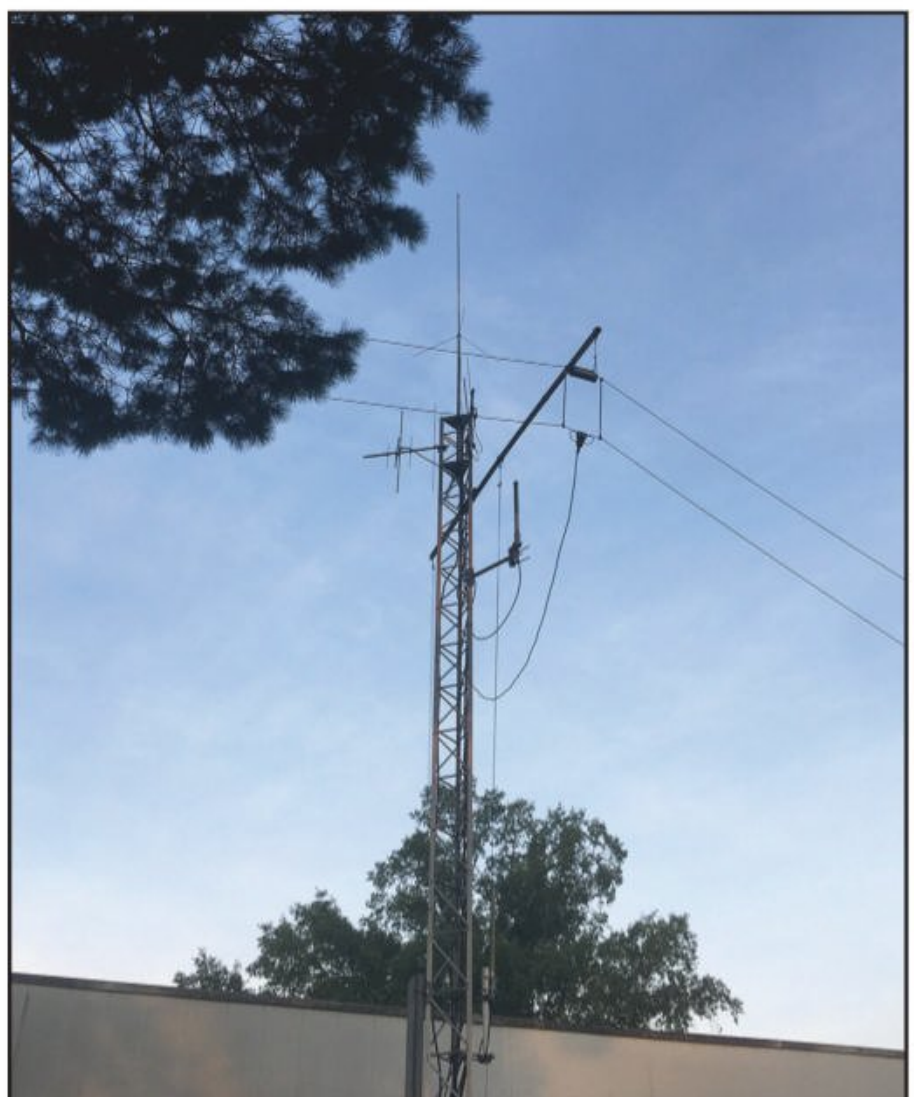

Photo M. Close up picture of the Memphis NWS tower and antennas used to support the SKYWARN® program.



Photo N. Corey Chaskelson, N0VQR, on the job as an NWS meteorologist.

others to take action, and helping our great nation become more weather-ready.

Memphis NWS & Amateur Radio

I asked Corey if amateur radio still plays an important part within the NWS's plans to create and maintain a weather-ready nation. He said amateur radio is a vital contributor to the Memphis office. During severe weather events in the Memphis CWA, such as severe thunderstorms, tornadoes, torrential/flooding rainfall, blizzards, and accumulating snow and ice, members of the Mid-South SKYWARN® ARS (Photo J) volunteer their equipment and time to provide timely, accurate, ground-truth weather information to the Memphis meteorologists. The Memphis NWS call sign is WX4MEM, and Corey is its trustee. Corey encourages ham radio liaisons throughout the Memphis CWA. The more spotter-trained "eyes-to-the-sky" reports, the more timely weather warnings can be issued. There is a real need for spotters; especially in rural, sparsely-populated areas within a CWA. The NWS utilizes social media, but ham radio has the additional advantage of giving meteorologists real-time, two-way communications. Meteorologists can ask a spotter for additional information regarding a report in a specific geographic region of the CWA in real time. In addition to analog VHF FM (very high frequency, frequency modulation) (Photo K), DMR (digital mobile radio) is an important component at the Memphis NWS ham radio communications plan (Photo L). DMR allows for regional talk-groups specific to the CWA to communicate with the NWS office such as the Missouri Bootheel, West Tennessee, North Mississippi, NE Arkansas. It is another tool for the SKYWARN® storm spotter's toolbox, which is fine as long as there is internet connectivity. The Memphis NWS ham radio station consists of a Kenwood TM 732, an Icom 7300 HF transceiver, an Icom IC-V8000, a MFJ 993B tuner, an Astron 35 A power supply, a CS800 dual-band DMR/Analog transceiver and a DMR HT. Along with the radios, the office is equipped with a tilt-over tower section with antennas (Photo M). N0VQR and two other radio amateurs in the Memphis office serve as links to the greater Memphis ham radio community.

Providing Public Service or EmComm?

Do NWS offices in conjunction with SKYWARN® nets pro-

vide public service or emergency communications? The NWS issues products to the public and local EMA (emergency management agency) directors which alert everyone to the potential and duration of severe weather events. In that regard, the NWS provides a valuable public service. When a SKYWARN® net is activated, it starts off as a public service, but if weather deteriorates, the net can quickly become an EmComm function. In that regard, SKYWARN® net control operators can serve a dual capacity. With regards to N0VQR, he's dedicated his talents and made it his mission to predict severe weather so as to protect others and ham radio is part of his mission.

Exceeding Expectations

Imagine a tiny third grader sitting on a porch watching a frightening, approaching thunderstorm, overcoming his trepidations, getting bitten by the ham radio bug as a youngster, earning a ham radio license in high school and studying graduate level meteorology before working as a NWS meteorologist. Every teacher strives for and hopes to have a positive impact on students. Teachers hope their students will excel in their ambitions and become successful societal contributors. I'd say Corey Chaskelson, N0VQR (Photo N) meets that expectation and then some!

Thank you for reading CQ and I hope to hear you on the air. 73 from Ron KO0Z



spurious signals

By Jason Togyer W3MCK
www.jaythurbershshow.com



© 2023 Jason Togyer • jtogyer@gmail.com • CQ Amateur Radio Magazine

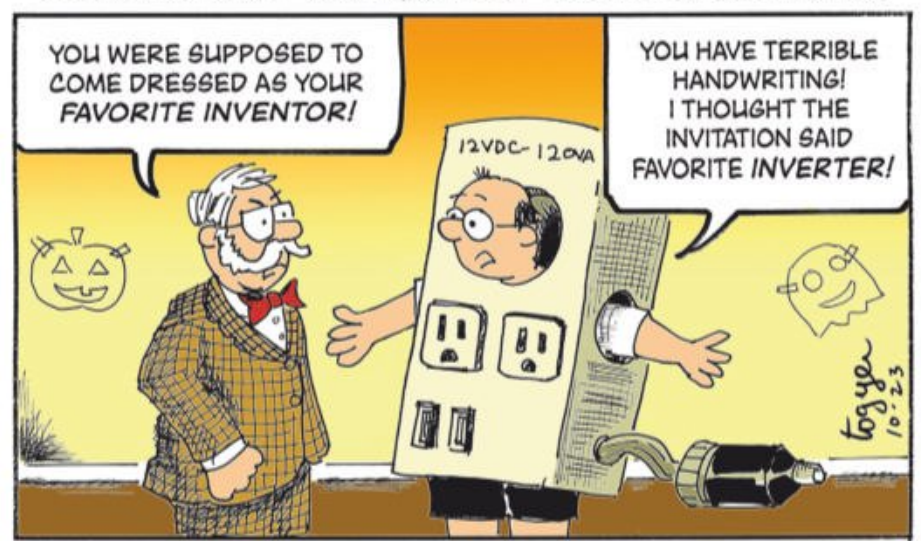

kit building

BY JOE EISENBERG,* KONEB

Perfect Timing

In the last issue, I began working on the QRP Labs Clock Kit. I have completed it and it dealt me a few surprises along the way to completion.

I did not set my kit up to put out external serial data, just use the onboard display. I did use the QL2 GPS kit to provide the kit with accurate timing and location data. When assembling a kit, things don't always work out the way you thought they would. One thing that had me doing some troubleshooting was the power leads coming from the buck converter module. I was using ribbon cable leads most commonly used for solderless breadboards. With the pin type connectors on the PC boards in this kit, I found it very easy to use them as easy plug-in interconnects.

Some of them were used to plug in pin-to-pin, while others were soldered on one end and plugged on the other. When I initially powered up the kit, I only had the buck converter connected so I could adjust it to be sure not to supply too high or too low voltage levels to the kit boards. I simply let the two DC output leads hang loose and I adjusted the buck converter trimpot for 5.00 VDC. With the output voltage calibrated, I turned off the power supply and connected it using two of those ribbon wires to the +5 and GND connections on the clock board. Then, the clock board supplies the 5 VDC to the GPS board.

When I connected them and turned the kit on, nothing happened. No LEDs on the GPS board and nothing on the LCD display. Checking the DC voltage on the board coming from the buck converter against chassis ground showed 5 volts, so the problem must be elsewhere, or so I thought. I checked numerous other connections and they seemed to have continuity. But when I returned to the clock board, I tried to measure the 5 VDC input, this time using both contacts under the PC board where the two wires plug into it. No voltage! So that pointed to the negative connection coming from the buck converter and checking that wire showed it was open!

Changing out that wire and plugging it in lit up the display and the GPS status LEDs. What a relief! I was worried I had damaged something along the way, but it was just a bad wire. So, be sure to check the continuity of all interconnecting wires in a kit like this, especially where there are a lot of wires. I was greeted by the "Diagnostic Mode" message once I had adjusted the LCD contrast pot and pressing the menu button once got it out of that mode and running. I had to enable the external GPS module with a menu setting and then it began receiving time data. The Clock Kit defaults to UTC (ZULU) time and in a couple of seconds displayed the current date and UTC time as well as GPS status information as to how many satellites it was receiving and how many satellites were correlated to get a fix.

When I saw that it was seeing 23 satellites while still in my basement, I was wondering how that was possible. Reading

the specifications on the GPS module, I discovered that, like my cell phone, it uses multiple satellite constellations. This module can receive signals from the USA GPS system, the European Galileo, the Russian GLONASS and the Chinese Beidou systems. Many newer cell phones, both Apple/iOS and Android models, incorporate some or all these systems as well. By using multiple systems, it can get an initial lock quickly before choosing the best combination to use to set the clock.

Menu Options

In other menu choices, there are ways to remove some display items and replace them with others, like removing the GPS stats on display line 2 and replacing them with your 4 or 6-character Maidenhead grid square information. There are programmable alarms that can trigger relays as well as many other customizable features, including displaying your local time. There is also an extra toggle switch included with

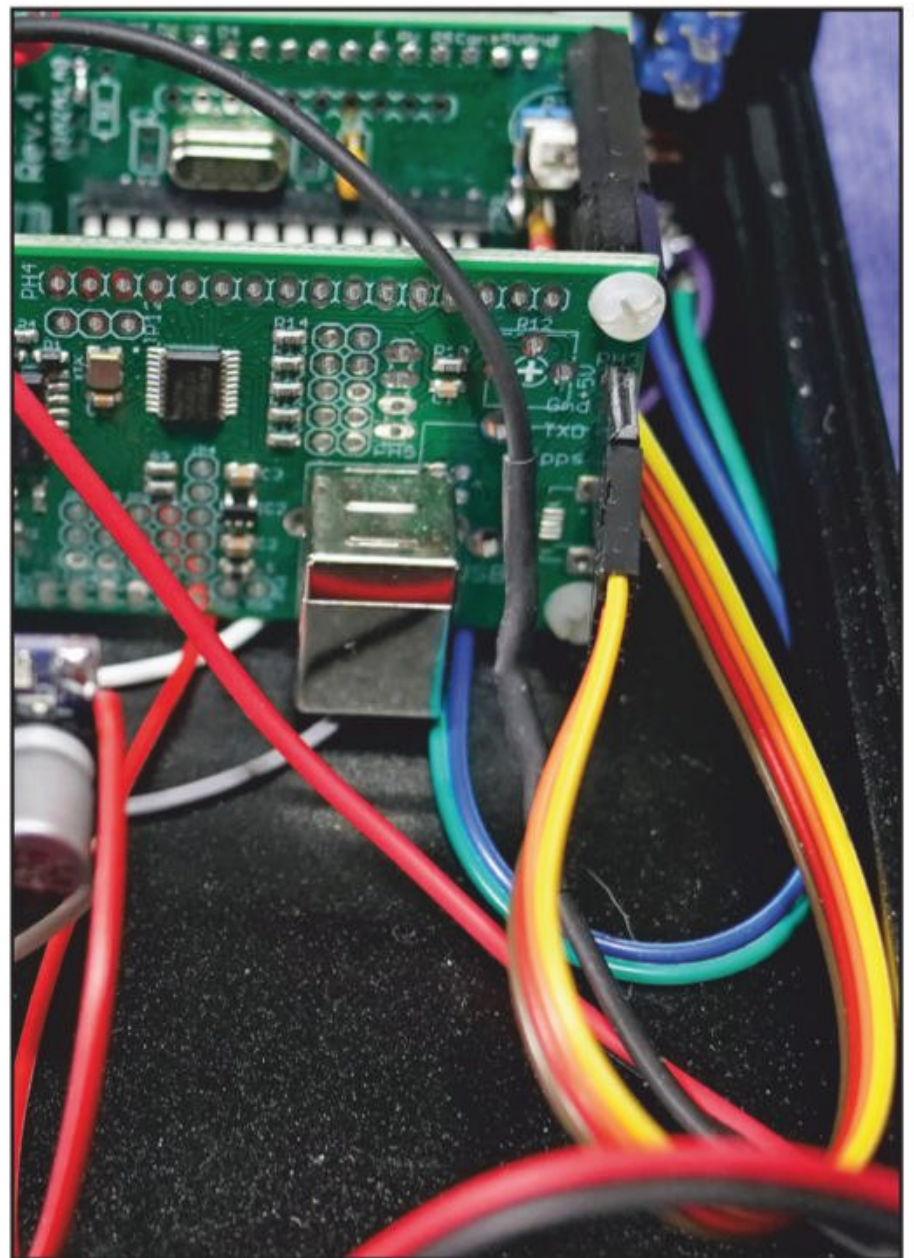

The boards on the QRP Labs Clock Kit are interconnected by ribbon cables plugged into pins as well as rows of pin socket connectors. The GPS module connects via an SMA connector to the GPS board.

*7133 Yosemite Drive,
Lincoln, NE 68507
email: <k0neb@cq-amateur-radio.com>
Hamfest Hotline #5855

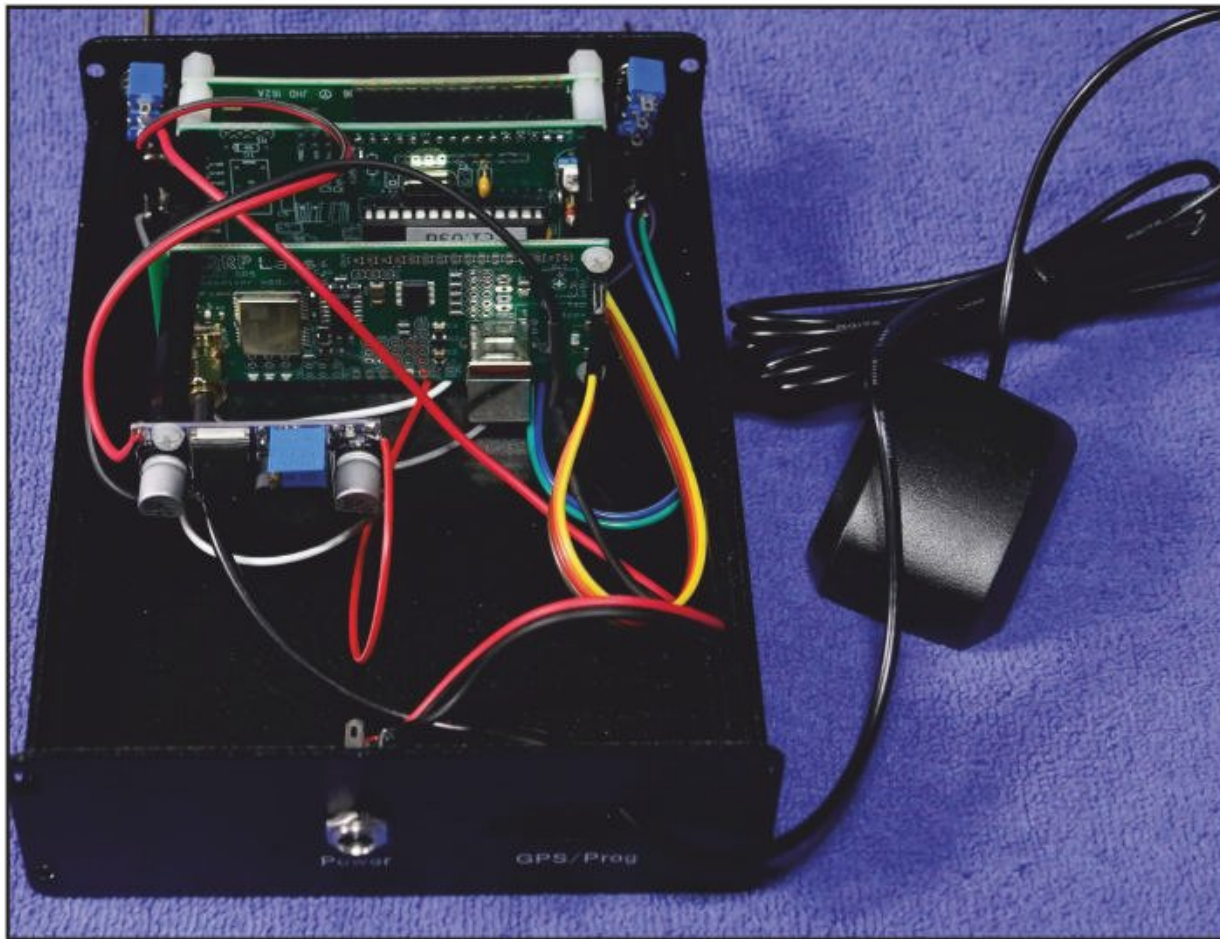

Top photo– Rear view of the assembled kit with the add-on buck converter board attached as well as the GPS module.

Middle photo– Front view of the Clock Kit just before configuration.

Bottom photo – Front panel displaying the UTC date and time and the GPS status including the type of fix as well as the number of satellites used to make the fix and the total number of visible satellites. This view is from my basement, so a more unobstructed view will show possibly even more active satellites.

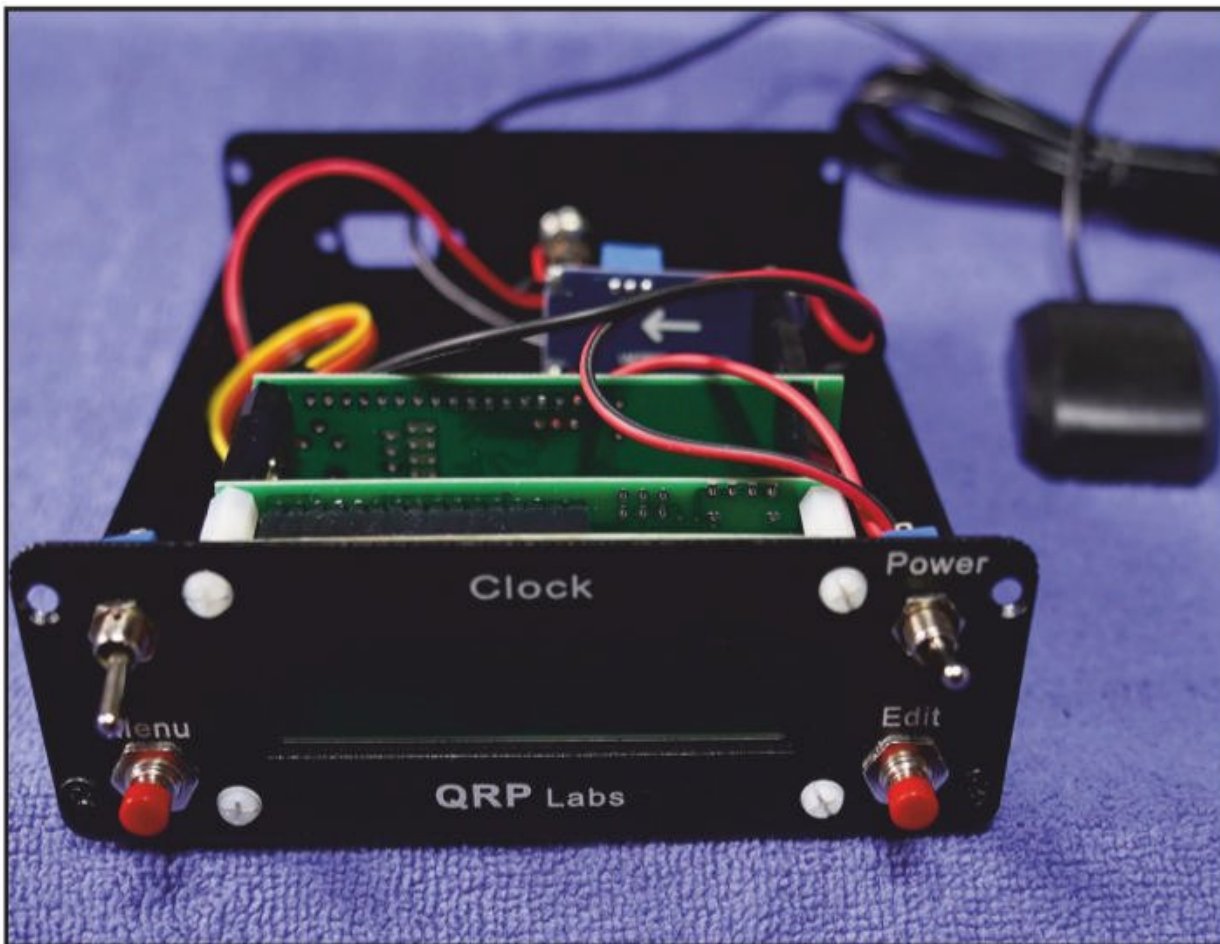

the kit that can be used to turn on or off an alarm, or it can be wired to dim or darken the display backlight as well as other functions.

Although this is not a beginner's kit, it is a good one to spend some time with as an intermediate or advanced builder, yet simple enough to not take up a lot of time in assembly. Using the ribbon wires in conjunction with the pin connectors supplied can make it look nicer, but as I mentioned earlier, be aware and check the continuity of each lead and double check which pins are being connected to be sure to not apply the wrong voltage or signals to the wrong pins.

You can order the QLG2 GPS, the Clock Kit and the Clock Case from <www.qrp-labs.com>. These kits are usually in stock and ready to ship. The case comes separately and can take a couple of weeks or more to arrive after the other kits are delivered.

On to the QMX!

I am about to dig into the QMX kit I unveiled previously. With the passage of time, there have been many assembly bugs that have been swatted and newer versions of the firmware have been issued. In addition, there is now an updated assembly manual that incorporates these changes, making the tasks involved a lot easier to follow. Although the SSB mode has not been implemented yet, the assembly does include a built-in microphone as well as connections for an external mic. More fun things to come on this great kit! I will match it up with some other kits and accessories to create a great little all-mode multi-band go kit suitable for POTA and SOTA.



Until next time,
73 de K0NEB

antennas

BY KENT BRITAIN*, WA5VJB

Sum and Difference

I have been doing a lot of work on direction-finding antennas lately, so it sure seemed like it would be a good topic for this issue.

In Photo A, we have the classic ferrite rod antenna used in most AM radios, often called a *wave magnet* in the early days. You can use your simple AM radio for direction finding. Rotate it slowly a full turn and you will see two signal peaks and two signal nulls. The peaks are off the flat side of the rod, the nulls are off the ends. The peaks are broad, but the nulls are sharp. Those nulls are when the ends of the rods are pointing at the AM transmitter. Nice sharp nulls pointing the direction to within a few degrees, but we have two of them. Is the transmitter to the north? Or is it to the south?

Photo B shows a navigational direction-finding system for boats. In that top rotating section is a ferrite rod antenna much like the one in that little transistor radio. While sailing in the Bermuda Triangle, our intrepid sailor gets a bearing on a Miami radio station. Ahhh, but we have that uncertainty of two nulls. Is he heading for a safe harbor, or deeper into the Bermuda Triangle?

This is where that 'sense' antenna in Photo C comes into play. The coil of wire changes phase compared to the whip antenna when the two are combined. This cancels out one of the nulls. Now our intrepid sailor, who hopefully has other navigational skills than just this box, gets only one null, the correct one.

Now we go on to Photo D. The large board is a set of direction-finding antennas for 1575 MHz, where GPS operates. The little one on top is part of a set for direction-finding antennas for 2.4 GHz. The first prototypes are currently looking for interference to GPS systems around two airports.

Note how the antennas are connected. On the bottom antenna section, the patch elements are summed, or as we like to say in the antenna world, *in phase*. This gives the antenna pattern shown in Figure 1. It is used to peak on

the signal of interest. This locates the direction to 20 degrees or so. Then you use the top section. The antennas are 180 degrees out of phase. A signal coming right down the center is canceled out, nulled, or differenced. This gives the pattern shown in Figure 2. It

is that sharp null in the center of the antenna pattern we want to use. You already know the general direction of the signal, now by careful tweaking on that null in that same general direction, you can determine the direction to about 1 degree.

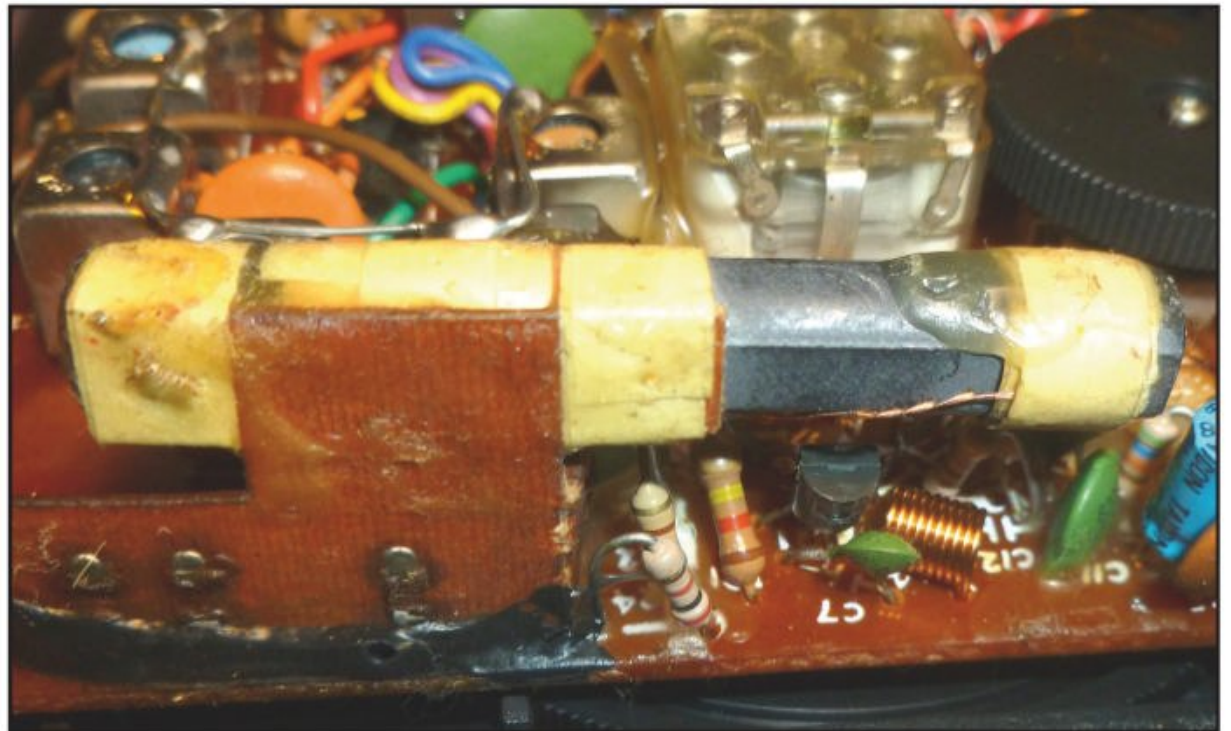

Photo A. AM band ferrite rod antenna



Photo B. Ferrite rod antenna in a direction finder

* E-mail: <b.rose@comcast.net>

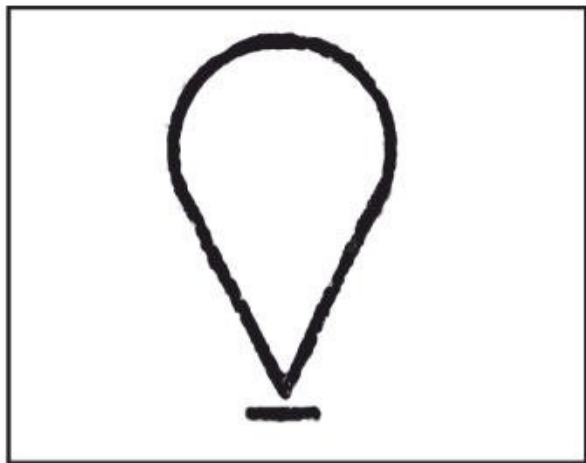

Figure 1. Pattern of 'summed' antennas

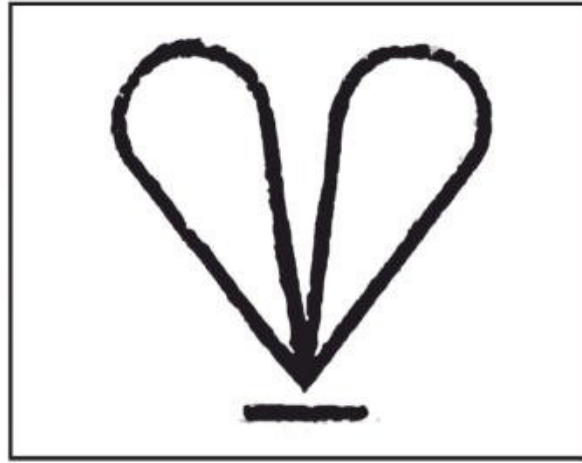

Figure 2. Pattern of 'differenced' antennas

In the early days, this technique would be automated by having the receiver quickly switch between peak and null. The antennas would be rotated looking for the greatest difference between peak and null. Today you could connect an SDR and again switch between the two antennas or connect an SDR to each antenna and do that same search in software. Probably best to do a 360-degree calibration sweep first. There will be multipath reflections and the antennas will have sidelobes, so the software might go after the wrong null.

Looking Ahead

Still working on that overview of slot antennas for the next column. And I have some more direction-finding material I want to go over. But as always, you all are a great source of column topics. If you have any antenna questions or a possible column topic, you can use snail mail to my QRZ.COM address. For e-mail, use <wa5vjb@cq-amateur-radio.com>. For many additional antenna projects have a look at <www.wa5vjb.com>.



Photo C. Sense antenna

Air Boss Antenna Launcher
www.olahtechologies.com
 See Video
 For when you want your antenna on top **\$99.99**
 Free shipping to lower 48
olahtechologies@gmail.com

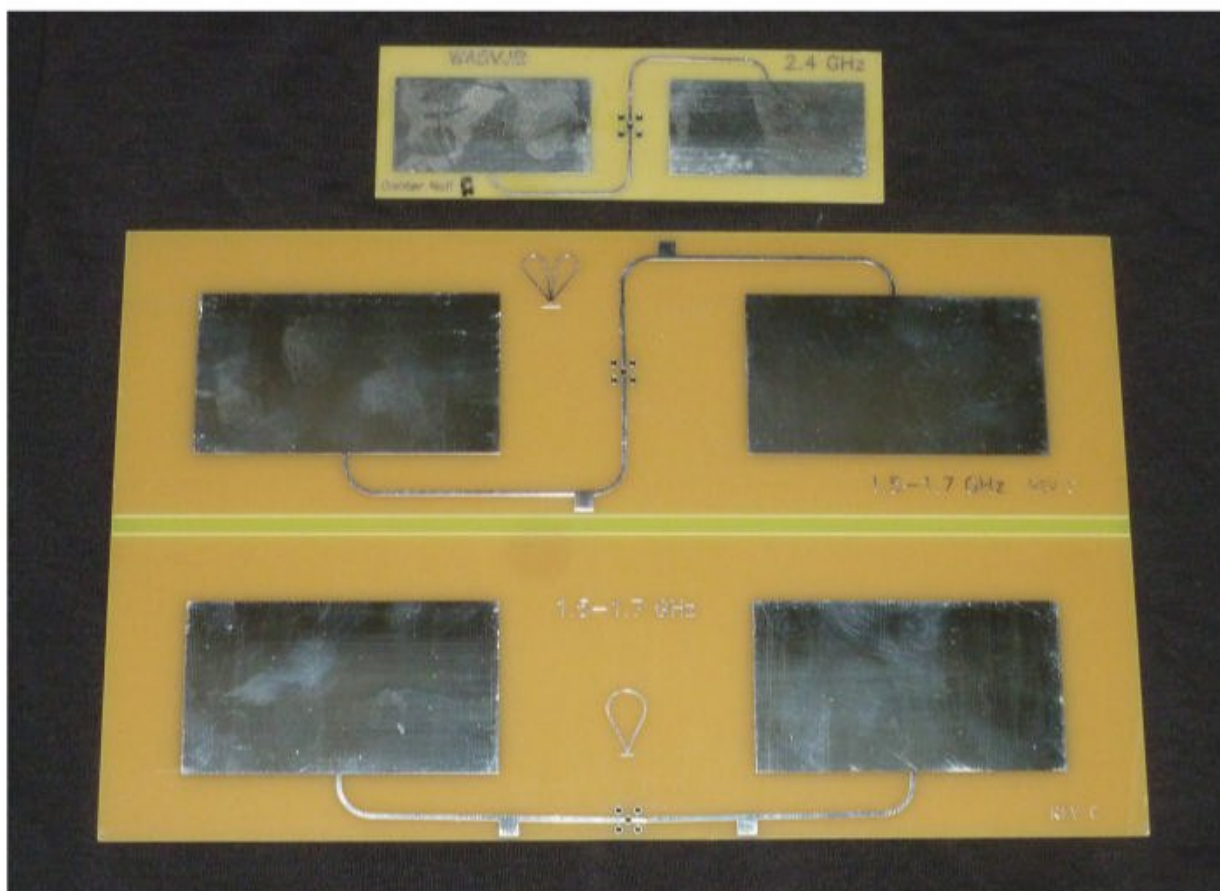

Photo D. PCB direction-finding antennas

Microwave DX!
 For Your New ICOM IC-905 Radio
 32" Grid
 48" Mesh
 Linear Pol. 900, 1200, 2400, 3400, 5700
 Gain 13 to 26dBi
 Dual Linear & Circular Pol. 900, 1200, 2400, 3400, 5700, 10.3GHz
 14 to 38 dBi
One Antenna Covers It All!
 Made USA
 305-471-9507 order@antennaworld.com
www.technicalantennas.com

analog adventures

BY ERIC P. NICHOLS,* KL7AJ

Analog Computing



Photo A. Eric's excellent collection of "analog computers," commonly known back in the day as slide rules.

When I was attending El Camino College, all the engineering majors were required to take a one-semester class in slide rule. The spring semester of 1972 was the first year they allowed calculators in math classes, and our slide rule instructor, whose name I regretfully have forgotten, was not particularly amused. He said "a calculator is a machine that will give you the wrong answer to fifteen decimal places." That was a pretty insightful statement, and one that I've never forgotten.

My dad made me learn how to use a slide rule at the tender age of nine, when he had me figuring out all the gas mileages for our two gas guzzlers. It was cruel and unusual punishment, but I somehow managed to survive the ordeal, and it certainly helped me understand some crucial math concepts, some of which can be learned in no better way than slipping and sliding with the slip-stick.

As you can see in Photo A, I have a fair-sized collection of slide rules, but nothing to compare with that of Bill Beam, NL7F, who also has a vast collection of mechanical clocks of every sort (another great way to learn some physics).

For those not familiar with slide rules, they all perform their magic by the addition and subtraction of logarithms...just as an electrical analog computer does. Every known arithmetic function can be performed by the judicious use of logarithms and antilogarithms.

*3763 Lyle Avenue, North Pole, AK 99705
email: <kl7aj@cq-amateur-radio.com>

All of the slide rules shown, except for the Pickett Electrolog, third from the left, and an 'el cheapo' to its immediate right, were my dad's. He attended Rensselaer Polytechnic Institute (RPI) for his mechanical engineering studies, and ended up designing helicopters for Hiller Helicopters, in Palo Alto, California, where he earned several patents. (Many folks don't realize that Silicon Valley was an aeronautics hub long before it was an electronics hub.) The Pickett Electrolog was geared specifically for electrical engineering, and has a lot of additional scales besides the traditional "log-log decitrig" scales used by engineers all around the planet for decades. By the way, the higher quality slide rules were constructed of ivory laminated on bamboo. Nobody knows how many elephants were sacrificed in the name of engineering education and practice.

Specialized Slide Rules

In addition to "real" slide rules, numerous companies had specialized slide rules geared to their specific products, as shown in Photo B.

These "giveaway" slide rules are exceptionally useful; a transmission line calculator, shielding calculator, motor sizing calculator, antenna gain calculator, ferrite core calculator, and even a circular cropdusting calculator are represented.

Now, let us revisit the "normal" slide rule for a moment. One of the things a slide rule does is force you to make reasonable estimations. Whereas a calculator's "wrong answer to fifteen decimal places" can cause you to "strain at a gnat

and swallow a camel,” a slide rule’s inherent imprecision nudges you toward the correct answer, even if slightly less precise. I mentioned a while back that when I teach electronics, some student will invariably ask something like, “Should we use 3.14159 for pi, or 3.1416?” I always answer, “How about 3.1?” I explain that resistor color codes only have two significant digits, so why would we use five or six significant digits for formulas using pi? A little consistency with respect to precision is in order. A slide rule will always give you two significant digits, and sometimes three, but in either case, it’s more than adequate for 95% of all we do in radio calculations. (Frequency determining components need a bit more precision, of course, but most radios will WORK with two significant digits of precision in the components from which they’re constructed...or 20% tolerance, whichever comes first!)

The slide rule reminds us that radio by its very nature is an analog phenomenon (as are most other physical phenomena). To be fair, on a minuscule level, we do have “digital” things like photons and other particles, but we don’t normally think on a “photonic” level in radio. Our radio signals involve massive mobs of particles, the collective behavior of which is very strongly analog.

For those of you whippersnappers who have no clue how to use a slide rule, here is a great tutorial, along with the justifi-

cation of *why* it works, by Professor Peter Alfeld of the University of Utah: <<https://tinyurl.com/yc67zmr5>>.

Now, while it’s probably true that nothing short of the Zombie Apocalypse will make the use of a slide rule *necessary*, it’s certainly an educational thing to know, and a great deal of fun. On a similar note, it’s gratifying to know that the U.S. Army is teaching orienteering again, using analog compasses. It’s probably far more likely that the GPS

system will fail than for every calculator to suddenly drop dead. But it doesn’t hurt to be prepared for any scenario.

I’m curious as to how many fellow Analog Adventurers have some slide rules they’d like to show off. I’ll be happy to share them in a future episode.

Coming up next time, we’re going to take another look at instrumentation and measurement. Until then, keep those soldering irons hot and shiny!

73, Eric



Photo B. Examples of specialized slide rules geared to various companies’ specific products. These were usually giveaways.

gordo's short circuits

BY GORDON WEST, * WB6NOA

Is There a Hitch In 'Ur Git-Up Dial Knob?

Plus, LDG's Meter Set and Gordo's New General Class License Manual

For those of us with the Kenwood TS-2000 HF/V/U transceiver, it's a keeper, even though an oldie! Some use it just for HF, some for cross-band multimode satellite contacts, and many didn't realize this classic rig has a built in TNC for digital modes, direct to your computer! It's a workhorse, but many are now getting an ailment to the main tuning dial (Photo A) - on every 360-degree revolution, the dial hangs up until you give it a new spin nudge.

Oh no, a \$400 replacement of the optical shaft encoder to get the dial to spin freely? Some of you may have already boxed up the unit to retirement! EASY FIX, as the problem is likely *not* an internal optical shaft encoder issue!

Have you seen the clear film manufacturers put over a new mobile/base radio's LCD plastic frequency readout, to protect it from errant scratches? Most of us just peel it off after it begins to "shed" from age. Presto, nice new plastic underneath!

We're dealing with something similar here. On the back side of the main tuning dial on the TS-2000, a thin clear film covers the aluminum knob's smooth rear. No problem when the rig is new. But after a few years, this plastic begins to lift and edge slightly, and catches on the radio's inner knob nest. So each time you spin the big frequency knob, it catches on this errant plastic tag, and gets worse as the knob again catches the lifted plastic, now a blob. Some knobs even freeze!

Fixing the Problem

To clear the plastic mess, first remove the black outer rubber ring (Photos B and C) - but be gentle, as you do not want

*CQ Contributing Editor
2414 College Dr., Costa Mesa, CA 92626
emial: <wb6noa@cq-amateur-radio.com



Photo A. The main tuning dial on the Kenwood TS-2000 can get "sticky" after years of use. Very often, the fix is easy, as long as you're careful.



Photo B. The first step is to gently remove the rubber outer ring on the tuning knob.



Photo C. Once you've loosened it up by hand, the ring can be gently pried off.



Photo D. A tiny hole in the tuning knob contains a set screw which needs to be loosened.

to tork the expensive optical shaft encoder mechanism inside the rig.

Next, find the tiny hole (Photo D) to loosen the set screw to gently pull off the knob from the shaft. This is a tiny METRIC Allen set screw, so make sure your Allen wrench (Photo E) is METRIC. Loosen it, and the knob is free to remove (Photos F and G).

Wow, what a plastic mess on the back side of the knob, huh? Or maybe just a little “tag” of the clear protective plastic catching the inner workings - so peel it off with your fingertip (Photo H).



Photo E. Be sure that your Allen wrench of choice is metric.



Photo F. Loosen the set screw with your metric Allen wrench, and ...



Photo G. ... gently pull off the knob.

Maybe a dab of solvent next to clean the smooth back side of any goo left over from the plastic removal (Photo I).

Now re-assemble the knob, tighten the set screw, and give it a spin. SUCCESS!

Finally, slide back the rubber knob cover (Photo J), and enjoy a knob that spins without a hitch.

Find One!

LDG Inc , the manufacturer of low-cost high-performance antenna tuners, came out last year with a limited production dual analog variable color meter set (Photo K) that plugs into



Photo H. There should be a thin plastic film on the back of the knob, which will likely be starting to come loose (and is generally the cause of your tuning dial problem). Peel it off with your fingertip.



Photo I. Make sure the back of the knob is clean and smooth after you've removed the plastic.



Photo J. Once you've put the knob back on the shaft and tightened the set screw, you can slide the rubber ring back on and you should be good for a few million more spins!

VHF Propagation

A Practical Guide for Radio Amateurs

Second Edition

By Ken Neubeck, WB2AMU,
Gordon West, WB6NOA

With New Digital Mode Revolution Chapter

By Chip Margelli, K7JA

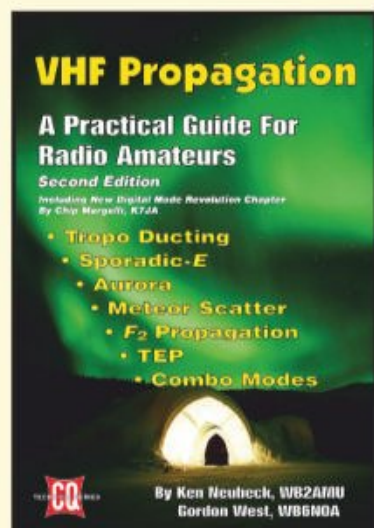

New from CQ—the **VHF Propagation Handbook—Second Edition**, written by three of Amateur Radio’s well-known authors: WB2AMU, WB6NOA and K7JA!

Just about all radio amateurs in the United States, as well as those in many other areas of the world, have access to VHF radio frequencies, regardless of their license class. And, the propagation modes that are often seen on these frequencies make for some pretty incredible operating conditions.

You will find a wealth of information within this book – beginning with Chapter 1: *Introduction to the Troposphere and Ionosphere* to Chapter 12: *New Digital Mode Revolution in VHF+ DXing*. Chapter 12 will bring you up-to-speed on the revolution in tools and techniques for VHF+ DXing. This new found-knowledge will certainly add to your enjoyment of the hobby!

This 6 X 9, 148 page paperback is only **\$21.95**

(Plus applicable shipping charges.)

CQ Communications, Inc.
Phone: 516-681-2922
<http://store.cq-amateur-radio.com>



Photo K. The limited-production LDG dual analog color meter set is “plug and play” with most larger rigs that have a “meter” jack on the rear panel. The meters will give you a much larger display of various parameters.

the rear of large HF transceivers, such as my Kenwood TS-990, Icom IC-7610 and IC-7800, Yaesu FTdx-101, and possibly other big rigs with a “meter” jack on the rear panel.

This LDG meter system gives you a much larger display of all the radio’s color LCD mini-meter readouts. Meter colors are totally variable, and the twin meters will track S-meter readings, final amplifier voltage and current readings, power output, SWR, compression levels and ALC levels! You can also adjust meter brightness! Just plug them in to your big rig’s “meter” mini-jack, and they are on the air.

But these were a limited production item for LDG, and it’s hard to find any new ones left in the ham dealer network. But now and then, I see them pop up on internet swap sites! So, if you have a big Kenwood, Icom, or Yaesu rig with a meter output on the rear, grab one if you can. This LDG meter system is the best analog system for sore eyes when working DX!

General!

The new Master Publishing 2023-2027 General Class study book (Photo L) is available from Amazon and ham radio dealers. It is in full color, and after each General Class question, I author a fun explanation on why the correct answer is indeed the answer you check on your upgrade test! I also have recorded an audio course that parallels the book.

I have re-arranged the Q and As to more logically follow the specific topic in the question pool, and I even point

out answers that may look correct, but are not!

Best of all, I come with the courses - I am the only writer of ham radio study materials who welcomes students to call me during the day with any questions they have on what they are studying! 714 549-5000.

See you at a hamfest soon!

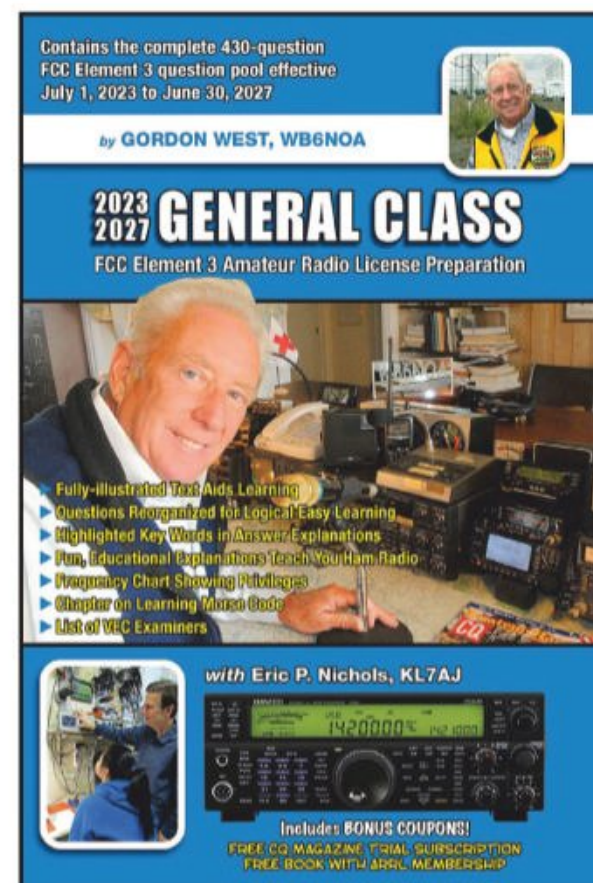

Photo L. Gordo’s updated General Class license manual is available at many ham dealers and on Amazon.com. There’s a companion audio course and students with questions can even call Gordo on the phone!

qrp: low-power communications

BY R. SCOTT ROUGHT,* KA8SMA

POTA's Plaque Event...Should a QRP'er Bother?

Earlier this year, the Parks on the Air (POTA) program announced a new contest called the POTA Plaque Event. The Plaque Event is the program's answer to those hams who have been asking for a contest-like event. In the past, the Plaque Event was part of POTA's summer "Support Your Parks Weekend" but is now its own event and held the first weekend in June.

This year's event was held from 0000 UTC June 3rd to 2359 UTC June 4th with park hunters (amateurs who contact stations operating from POTA-designated parks) and activators (amateurs who operate portable from designated parks) contacting as many stations as possible. All amateur radio bands except the WARC bands (12, 17 & 30 meters) and 60 meters are fair game. The contest recognizes the winning activator and hunter in each of several categories (i.e., SSB, CW, digital, etc.) with a plaque, hence the name of the contest the "POTA Plaque Event."

*[<ka8sma@cq-amateur-radio.com>](mailto:ka8sma@cq-amateur-radio.com)

A unique category in this contest is Rover, in which a plaque is awarded to the operator activating the most POTA-designated parks during the contest. I may receive a lot of flak from fellow contesters, but in my opinion POTA's Rover category is the *crème de la crème* of contesting as it requires participants to travel to a designated park, set up an antenna (if not using a compromised antenna on a vehicle) and make a minimum of 10 contacts before moving to the next location. In addition to endurance and stamina, one's planning and organizational skills are put to the test to create a route that incorporates the activation of as many parks as possible in the 48-hour period.

No QRP Category

Unlike many other contests, there is no QRP category for activators or hunters. For those activating a park, a QRP operator running 5 watts is competing against the operator running 100 watts (or more if using an amplifier). Likewise, a hunter operating QRP at their QTH is competing against

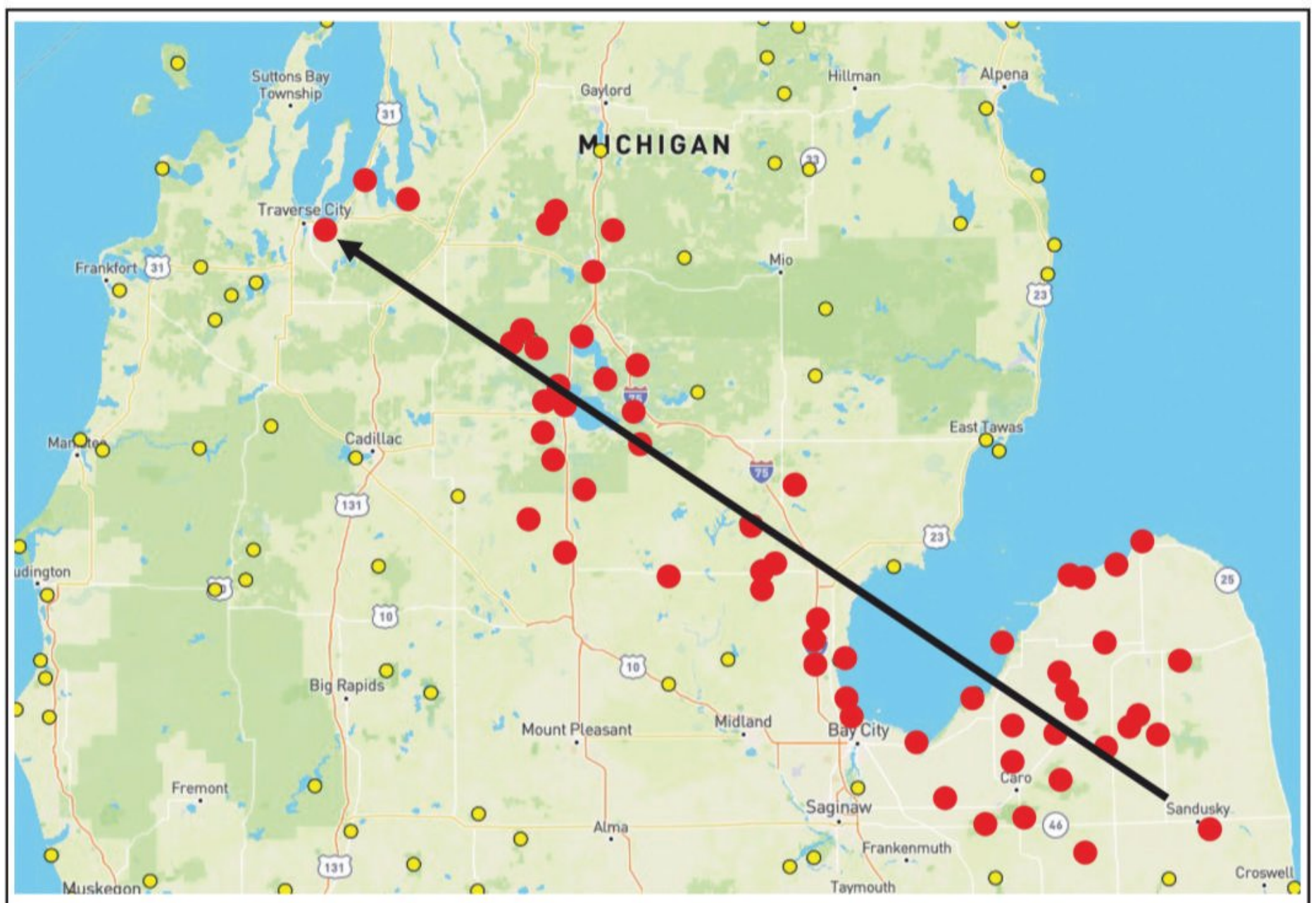

Figure 1. Snip from the POTA website showing designated parks (red dots) to be activated. Unfortunately, I fell short on time and could not activate them all. Yellow dots are POTA-designated parks not part of the route.



Figure 2. Page from my Route Book. Snip from the POTA website (upper left corner), aerial photo from Google Maps (upper right corner) and driving directions to the park (bottom).

hams running “power and a tower.” This begs the question, should the serious contender who chooses to run QRP bother operating POTA’s Plaque Event?

As most readers know, I’m 100% QRP and abide to a strict power protocol of 5 watts or less, regardless of mode. To paraphrase fellow QRPer Randy Shirbroun, ND0C, “If it cannot be done with 5 watts, then it’s not going to get done.” As I’ve told my wife, this can be my epitaph - HI! Last year, I participated in POTA’s Plaque Event (before it was separated from the Support Your Parks summer event) and activated 43 parks in 48 hours. I placed 5th (4th to lose) and lost to a ham in Canada who activated 65 parks in Ontario. To the best of my knowledge, the top four hams were all running a lot more power than 5 watts. No complaints, I choose to operate QRP and understand this puts me at a power disadvantage. However, I don’t like to lose so I began planning this year’s event soon after this year’s contest weekend was announced.

In it to Win it!

A well-planned route for activating POTA-designated parks (state parks, national parks, state and federal game land areas, etc.) is a necessity for the Rover category. I live in Michigan, which has 341 POTA designated parks. Although Michigan has a fair number of parks in comparison to other states, it is a large state with parks spanning both the lower and upper peninsulas and travelling between parks can take anywhere between five minutes and an hour. Based on the number and location of designated parks within several hours of my QTH, a well-planned strategic route to activate as many parks as possible was critical.

After reviewing POTA’s Map of Entities (parks map), I created a route that began in Michigan’s thumb (several hours from my QTH) and spanned across the state with an end

point at Traverse City State Park approximately five miles from my QTH (Figure 1). During the planning phase, I considered the location of each park in relation to main roads, access (some locations are not accessible 24 hours), and most importantly, a stopping point so that around 0600 UTC (2:00 a.m. eastern) each day, I could get a little shuteye in the backseat of my pickup. I learned last year that this is a great time to sleep as it is difficult to activate a park (make 10 contacts) in the wee hours of the morning. Regardless of band conditions, not everyone is crazy enough to stay up all night, so there are few hunters to contact!

After finalizing my route, I created a book with a page of information for each park in their order of activation. Each page contained a snip from the POTA parks map, an aerial photo of each park (I snipped images from Google Earth) and directions to the operating location (Figure 2). The aerial photos were very useful in identifying access drives, parking lots and potential obstacles (i.e., power poles and overhead electrical wires) near operating locations. Additionally, I used a county atlas that detailed the boundaries of state game lands and other designated parks.

Although I was comfortable with my route, I felt the need to proof my driving directions and ground-truth each location before the contest. Last year, time was lost (especially at night) due to poorly marked roads and “hidden” entrances to parks. I knew a dry run would help alleviate any issues. A month before the contest, I called my daughter and son-in-law for dog sitting services, put my wife in the co-pilot seat, and left for an overnigher to check out each operating location. This exercise proved invaluable as I discovered one of the primary roads leading to several parks had been closed for bridge construction and that I needed to rework a portion of my route before the contest. For once, I was ahead of Murphy (as in Murphy’s Law: “Anything that can go wrong

will go wrong") and I was not going to let him prevail.

Go Time

The day of the contest, I filled a cooler with ice and packed it full of deli sandwiches, high caffeine energy drinks and water. I had thought about taking a propane-fired camp stove for a hot meal but knew that after last year's event, I could not spare time for anything finer than a cold sandwich. My wife, who accompanied me during last year's contest, went along for the ride again this year (with her knitting bag in tow). By early afternoon, we were on the road for the 3.5-hour trip to Michigan's thumb where the adventure would begin at 0000 UTC (8:00 pm eastern).

Dinner before the contest was at Zehnder's, a landmark Michigan restaurant famous for its chicken dinners, located about an hour from K-6776, Sandusky State Game Land, the first park to be activated. I incorporated Zehnder's as part of my contest route as I knew it would be the last good meal for a couple of days, but more importantly, I could get an order of liver pate to go, the perfect energy boosting snack for the contest.

By contest time, I was set up at my first park and ready to transmit my QRP signal into the ether. My portable station consisted of a Yaesu FT-817 (5 watts), the QRPGuys Portable No-Tune End-Fed Half-Wave (EFHW) antenna, and the Spiderbeam 33-foot fiberglass telescoping pole. For a power source, I took my Bioenno 20Ah Lithium Iron Phosphate battery. I also borrowed a 30Ah battery from work and took my Lab 599 TX-500 QRP transceiver (both for backup) in the event Murphy decided to pay a visit!

A few days before the contest, I ran a piece of RG-8X coax from my operating position in the front of the truck to the rear of the pickup for connection to the EFHW. The 33-foot telescoping pole was fastened to a homebrew hitch mount that I set in the truck's hitch. My wife timed how long it took me to erect and take down the antenna at each stop (her fun while knitting). For the better part of the contest, it took me just over two minutes to stretch out the antenna wire, connect it to the telescoping pole, and raise the pole to 33 feet. Takedown was a little quicker. However, near the end of the contest, my time was lagging by a good 30 seconds. This came as no surprise considering I had little sleep during the contest.

Band conditions were good and fortunately there were no solar storms that

could have turned a fun weekend of contesting into a nightmare. My bread-and-butter band for most of my contacts was 40 meters. I dabbled a bit with 20 meters, but heavy QSB made it difficult to secure contacts. Since 40 meters was producing contacts day and night, I did not want to jinx myself by spending too much time trying 10 or 15 meters.

By mid-day Sunday, it became apparent that I was not going to end the contest as I had hoped near my QTH at K-1547, Traverse City State Park. Although I was not going to be able to

activate all the parks I had planned, I kept working them in the order of my route. At 2348 UTC, I pulled into K-6783, Skegemog Lake State Wildlife Area, set up my EFHW and within a few minutes secured the 10 contacts needed to activate my last park. In all, I activated 56 parks.

A Couple of Hiccups

Reflecting on the contest, all went as planned except for two oversights on my part. Like most POTA activators, I use POTA's spotting network when I arrive at a park to announce



Last Year, our members worked thousands of hours for

NO PAY

And this year are well on their way to doing

EVEN MORE!

WHY?

Because they are giving back to their communities! They are helping with civic events, motorist assistance AND MORE, yes even emergencies and disasters, if needed!



**CONTACT
REACT INTERNATIONAL
301-316-2900**

Or write to
**REACT INTERNATIONAL
P.O. Box 21064, Dept CQ100
Glendale, CA 91221
RI.HQ@REACTIntl.org**

Join the Nuts & Volts Community!

When you subscribe to the Nuts & Volts Print Edition, you get it ALL! That means full access to our Digital Edition at no extra charge! So, YOU can choose how you want to read your issues!

Some readers prefer a paper copy they can hold in their hands or keep on their bench. But if that's not you, then get the Online Only Edition and save a few trees and some cash. Just review the options at <https://www.nutsvolts.com/subscribe-to-nuts-volts>, and click the Subscribe button to make a selection, and place your order. Easy!

What you'll get:

- Full access to ALL web content
- Replica Digital Edition
- Mobile optimized (App) versions of articles for viewing on your phone or tablet
- Downloadable PDFs of issues
- New content delivered via email
- E-newsletters containing evergreen articles from past issues
- Six bi-monthly print magazines (with print subscription)

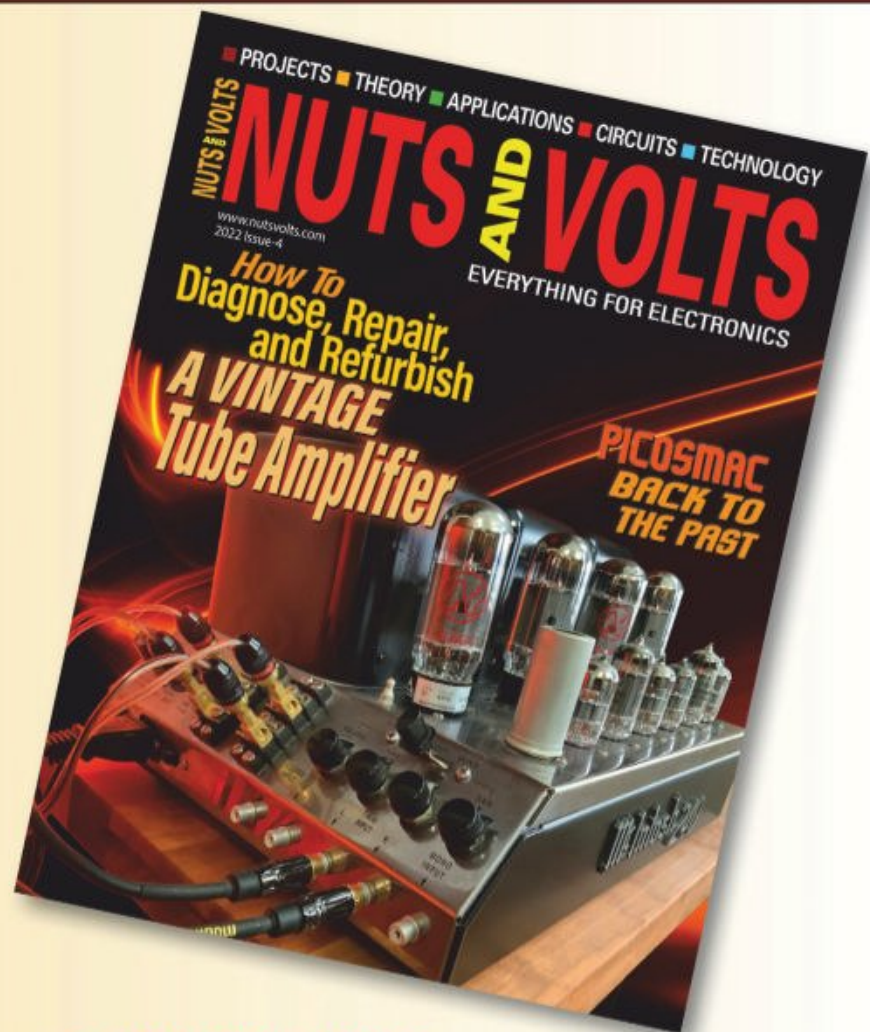

Call **1-800-783-4624** for customer service

"I'm here – come and get me." This is typically done via a cellular device and, as it turns out, there were locations in north-central Michigan that did not have cellular coverage. The lack of a cell connection cost me time since some hunters only follow the spotting network in search of parks and seldom tune across the bands. Fortunately, a few hams scrolling across the bands in search of contacts heard my CQ and spotted me on the network, which quickly got the word out. Another hiccup was QRM from wind turbines. Michigan's thumb region is home to over 800 operating turbines, which is more than half the total in the state. One of the state game land areas I activated was located across the street from several turbines. Here I learned that, when in close proximity, turbines are easily heard (RFI) on 40 meters. Thankfully, these giants were only seen as eyesores at most of the locations I activated and were far enough away that I had no significant RF interference.

A third "issue" I had was the curious onlookers. The mast and wire drew several folks who wanted to chat about what I was doing. One elderly lady insisted I set up operations in her driveway and stay for a bowl of soup! Normally, I welcome questions and will stop operating to chat and answer questions. During a contest, though, when every minute wasted could be another contact, I am less enthusiastic about spectators. For future time-critical events, I may entertain the idea of printing out some Q&A pamphlets to hand out to folks.

The Results

So ...; to answer the question of whether a QRPer should bother with POTA's Plaque Event, the answer is a resound-

ing yes! On Saturday, July 8th the results of the contest were released. There was a lot of excitement at my QTH when I learned I had won the Rover category with 56 park activations. The next ham in line had activated 40 parks. My score was lower than last year's winner (65 parks); however, last year's event allowed multiple-reference parks ("N-fers") to be used in the contest. Multiple-reference parks allow a single park that is located within a boundary of two or three other designated entities to count as multiple parks from one location. Several hams (including myself) successfully petitioned POTA to change the rules for this year's event to eliminate N-fers from this contest which helped level the playing field. Until now, I have not announced that I was working this contest QRP. Now that the cat is out of the bag, I suspect some in the POTA community may be miffed that a QRP operator can win Rover against those using 50, 100, or more watts. I think the winning edge for Rover, or any contest for that matter, is not power, but rather dedication, efficiency, a well thought-out strategy, and good operating skills. The operator who has the best performance in each of these categories during a contest will win most every time, whether they are operating QRP or QRO.

Next Year...

Will I do the Rover category again? I am currently undecided; however, the idea of operating in a less stressed contest environment from the comfort of my camp chair, roasting hot dogs over an open campfire, and handing out POTA contacts from my local park sounds good, too.

Until December, 73

Spectacular Heat Brings Spectacular Tropo

During August, an impressive high-pressure system was in place over the middle of the country, bringing sweltering heat and weeks without rain. A silver lining to the weather, however, was the tropospheric ducting that resulted across the region. Photo A from August 22 is a great example of the size and intensity of this opening! (On a personal note, it is clear that my home grid of EM55 was outside the favored area and I had no contacts as a result of this opening. Not that I'm bitter or anything.) From Ohio to Kansas, and Minnesota to Texas, contacts were made on bands and modes ranging from 2-meter SSB to 10-GHz CW. Long-distance contacts were made on rarely used bands like 902 and 1296, for example. One of the most faithful

microwave hams is Greg Cerny, WQ0P, in eastern Kansas, EM19. Greg was active on many bands and made an impressive number of contacts by making himself available and trying skeds with anyone who wanted. Greg used the Midwest Microwave Slack channel as well as text messaging to coordinate his activities. Table 1 is a chart that Greg provided detailing his contacts during that recent opening.

Slacking (On, Not Off)

While many of us still enjoy turning the dial and finding contacts, on the higher frequencies there is just not much opportunity, because of the nature of propagation and fewer folks on the bands. The use of cell phones, spotting applications and websites, and real-time social media like Slack can make a real difference in communicating band openings and

* <n4dtf@cq-amateur-radio.com>

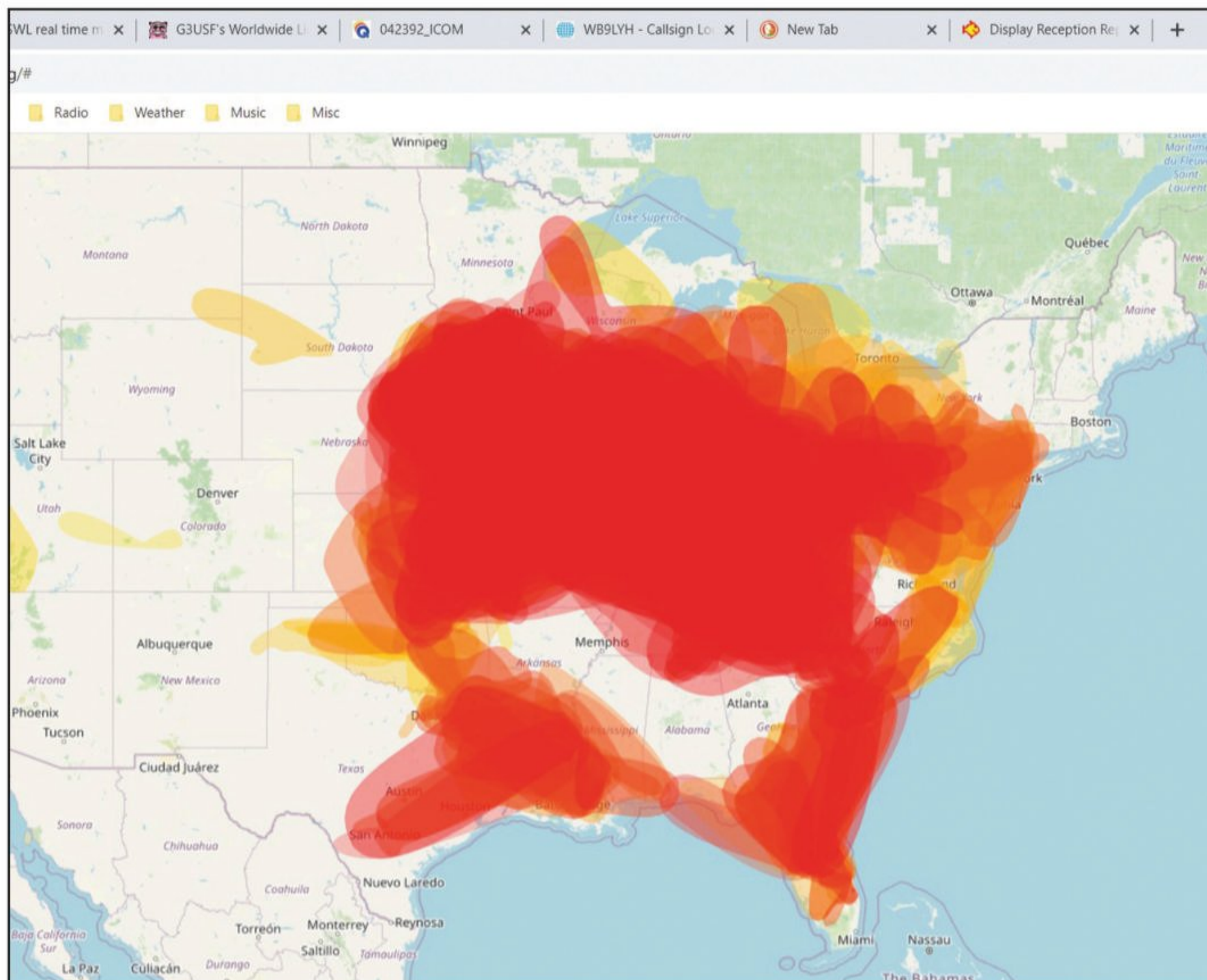

Photo A. August 22 Hepburn Map showing tropospheric opening

6	2	1.25	70 cm	33 cm	23 cm	13 cm	9 cm	6 cm	3 cm
0 / 0	227 / 94	63 / 36	77 / 41	10 / 7	23 / 15	0 / 0	0 / 0	0 / 0	21 / 10
	EM13 ^ EM15 EM17 EM26 EM29 EM38 EM39 EM45 EM47 EM48 EM49 EM53 EM55 EM56 EM57 EM58 EM59 EM63 EM64 EM65 v	EM04 ^ EM13 EM17 EM34 EM55 EM57 EM58 EM59 EM64 EM85 EN24 EN33 EN37 EN41 EN44 EN50 EN51 EN52 EN61 v	DN70 ^ EM04 EM27 EM29 EM39 EM53 EM57 EM58 EM64 EM69 EM78 EM79 EM84 EM95 EM97 EN00 EN13 EN34 EN40 v	EM13 EM89 EN24 EN40 EN61 EN70 EN92	EM04 EM13 EM79 EM89 EM95 EN24 EN34 EN40 EN50 EN52 EN61 EN70 EN71 EN80 EN90				EM13 EM15 EM18 EM48 EN13 EN21 EN22 EN32 EN70 EN71

Table 1. WQ0P's contacts from EM19 during the August 22 tropo opening



Photo B. KG5CCI mobile setup in EM24 for FFMA (Fred Fish Memorial Award) activation

coordinating our activities. There is a general VHF Slack channel, plus more specific ones directed toward the microwaves, FFMA activities, etc. I'd encourage you to take a look at these for your own purposes when operating 50 MHz and above. Depending on the geography being served, FM simplex or repeaters might also serve to help coordinate. In the western states, the famous Cactus Net is a series of linked repeaters that serves this purpose well, especially for rovers on the microwaves.

While some contests make distinctions between assisted and non-assisted contacts, that should never be a concern during normal activities. When there is a band opening, I would say that any serious VHF/UHF/SHF operator is duty-bound to let others in on the opening! We all benefit from increased activity. (There may not be a law here, but there should be!!!)

August brought some Gulf Coast and east coast tropo, as well. Our friend David Thier, WA3GWK, in EM60, offered the following report on August 19: "Tremendous 2-meter long haul tropo opening this morning! Here are my stats from this morning from EM60: SSB, EN52 and EN54 WI. FT8 states, WI, IL, IN, MO, TX. FT8 grids, EN41, EN43, EN50, EN52, EN53, EN54, EN60, EM48, EL09. Made my best SSB tropo DX from this QTH, WB9LYH in EN54 WI 970 miles. I would like to have heard more SSB activity since the propagation was there to support it. All in all, a great morning. Stay tuned for the rest of the week!"

Stay tuned, indeed. As I write this column, it appears that the aforementioned high-pressure system will set up again over the Labor Day weekend. I also wanted to comment on David's statement regarding SSB activity. When FT8 and CW signals are strong, I encourage you to try voice contacts as well, just to understand the scope and capabilities of the propagation.

Huntsville Hamfest

Billing itself as the friendliest hamfest in America, and living up to the billing, the folks at Huntsville do a great job. This year's event was very well attended, and both commercial vendors and flea market sellers were out in force! As always, there was a great lineup of presentations, and I made it to three of them. Both Flex and Elecraft gave presentations about the current and future state of their product lines. Mike Walker, VA3MW, did a great job demonstrating enhanced functionality of the Flex line involving amplifiers and

tuners that are able to interact with Flex or other radios to create a fully automated remote station experience. Eric Swartz, WA6HHQ, gave a presentation of the current state of the Elecraft line, focusing on the K4 and some new remote-control capabilities. He also teased us with the promise of VHF/UHF modules for the K4, perhaps as early as this fall. Hopefully by the time you read this, we will have more details on these modules! Finally, I was privileged to hear Larry Savage, WA4CAX, speak about RF amplifiers. His presentation was both educational, as he started with block diagrams, and technical, in the sense that he discussed building your own amplifiers, the types of components and their characteristics, and related matters, especially regarding solid-state amplifiers. While I may not actually build my own RF amplifier, I certainly left Larry's session with a better understanding of these devices and how they fit into an amateur station. The rest of my time was spent perusing the flea market, where I found a number of small but needed components, and actually bought a loop antenna from David Kirk, WT4E, for use in testing my 222 setup. I also enjoyed eyeball QSOs with hams far and near, some of whom I only see once or twice a year (it's common to recognize a voice before you recognize a face). Huntsville is a great, family-friendly city, and while it is warm in August, the hospitality is also great, and there are many activities around the area, including NASA exhibits and a new radio museum.

On the Air

Dave Swanson, KG5CCI, posted that he was going to make a "quick run" down to EM24 on the evening of August 11, starting around 7 PM CDT, and operate until dark (or until he decided to quit) and then again in the morning, probably starting around 5 AM CDT until 8 or 9. "I'll be wherever the action is, on 50.313 FT8 if there's any E-Skip or Tropo, or on 50.260 QSYing to another frequency for rocks in the morning. Setup is my 3-element Loop Yagi at 45' in the truck bed, running 1 KW from the top of Rich Mountain at around 2700' MSL."

He then provided an after-action report: "I operated from 7 PM to 9 PM local Friday the 11th, then for 3 hours 5 AM until 8 AM on the 12th. Made 48 contacts in those 5 hours, I had a little bit of e-skip the night of the 11th out to the east coast so made some quick FT8s then; everything else was done on MSK144. Longest true scatter contact

announcements *(from page 2)*

Polk County Fairgrounds, 520 S. Pacific Hwy, W. Talk-In: 145.330 (186.2Hz). Adm \$10 www.swaptoberfest.org

WESTMINSTER, MARYLAND – CARROLL CO. ARC, - from 8 a.m. to NOON on October 22. Door to Virtue Masonic Lodge, 46 Monroe St. Talk-In: 145.410 (114.8Hz). Adm \$5 www.k3pzn.net

PERKASIE, PENNSYLVANIA – RF HILL ARC - from 7 a.m. to 1 p.m. on October 22. Upper Bucks Campus-Bucks County Community College, 313 Blooming Glen Rd. Talk-In: 145.310 (131.8 Hz). Adm \$7 www.rfhillarc.club

ARDMORE, OKLAHOMA – CENTRAL OKLAHOMA RADIO AMATEURS, - from 3 p.m. to 5 p.m. on October 27 - from 8 a.m. to 1 p.m. on October 28. Ardmore Convention Center, 2401 N. Rockford Rd. Talk-In: 147.075 (123.0Hz). Adm \$10 www.hamarama.org

HARRISBURG, PENNSYLVANIA – HARRISBURG RADIO AMATEURS CLUB, - from 7 a.m. to 11 a.m. on October 28. Vietnam Veterans Association Bldg., 8000 Derry St. Talk-In: 147.075 (123Hz). Adm \$5 Email wb3kn1@gmail.com

GALES FERRY, CONNECTICUT – SOUTHEASTERN CONNECTICUT ARC, - from 10 a.m. on October 28. Our Lady of Lourdes Parish Hall, 1650 CT Route 12. Talk-In: 146.730 (156.7 Hz). Adm \$5 www.secars.org

HAZARD, KENTUCKY – KENTUCKY MOUNTAINS ARC, - from 8 a.m. to 11 a.m. on October 28. DAV Chapter #64, 165 Industry Dr. Talk-In: 146.670 (103.5 Hz). Adm \$7 www.facebook.com/kymarc

KIRKWOOD, MISSOURI – ST. LOUIS ARC, - from 7:30 a.m. to 1 p.m. on October 28. Kirkwood Community Center, 111 S. Geyer Rd. Talk-In: 147.75. Adm \$10 www.halloweenhamfest.org

HEADLAND, ALABAMA – WIREGRASS ARC, - from 8 a.m. to NOON on October 28. Headland Town Square, 100 Park St. Talk-In: 144.430 (186.2Hz). Free Adm! w4dhn.org

NORTH CANTON, OHIO – MASSILLON ARC, - from 8 a.m. to 2 p.m. on October 29. Military Air Preservation Hangars, 2260 International Pkwy. Talk-In: 147.180 (110.9Hz). Adm \$5 www.w8np.net

NOVEMBER

WICKENBURG, ARIZONA – HASSAYAMPA ARK, - from 8 a.m. on November 4. Redeemer Lutheran Church Annex, 470 Rose Lane. Talk-In: 146.580. Free Adm! harkaz.org

LAKEWOOD, COLORADO – TECHCONNECT RADIO CLUB, - from 9 a.m. to 3 p.m. on November 4. The Bridge Church at Bear Creek, 3101 S. Kipling St. Talk-In: 147.330 (100 Hz). Adm \$10 www.na0tc.org/doku.php?id=techfests

APOPKA, FLORIDA – BAHIA SHRINE AMATEUR RADIO UNIT, - from 8 a.m. to noon. on November 4. Bahia Shrine Center, 3101 E. Hwy 436. Adm \$5 Email dba327@hotmail.com

BOURNE, MASSACHUSETTS – FALMOUTH ARA, - from 9 a.m. to NOON on November 4. Upper Cape Regional Technical School, 220 Sandwich Rd. Talk-In: 146.655 (88.5Hz). Adm \$5 www.falara.org

BELTON, MISSOURI – SOUTHSIDE ARC, RAYTOWN ARC, - from 7:30 a.m. to NOON on November 4. Mill Creek Elementary School, 308 S. Cleveland Ave. Talk-In: 147.12 (151.4Hz). FREE Adm! www.southsidearc.net/hamfest2023

Looking Ahead in CQ

Here are some of the articles we're working on for upcoming issues of CQ:

- Results: 2023 CQ WPX CW Contest
- US Medalists at 2023 World ARDF Championship
- Rules: 2024 CQ DX Marathon; 2024 CQWW 160-Meter Contest

Plus...

- Sweepstakes Success Tips
- A "Sherlock" Sampler
- An EmComm Exercise Regimen

Do you have a hobby radio story to tell? A new circuit you've designed? An operating adventure? CQ covers the entire radio hobby. See our writers' guidelines on the CQ website at <http://bit.ly/2qBFoDU>.

was right at 1148 miles, which is just pretty good. Like always, I heard more than I could work, bonus of operating out on a mountain in the national forests. Here's the obligatory antenna pic!" (Photo B)

Thank you Dave! His activity is in support of those who need EM24 in their chase for the Fred Fish Memorial Award (contacting all 488 CONUS grids on 6 meters).

Art, K7DWI, faithfully keeps up with the various SWOT (Side Winders On Two) nets. In this case, he reported on the North Texas SWOT Net August 16: "Check-ins as follows: Bob W5FKN out of Decatur, Texas, had 33 check-ins (maybe 32) from Texas, Louisiana, Arkansas, Kansas, Oklahoma and Missouri. Be sure to look for Bob each Wednesday at 8 PM Central on 144.250 MHz, and remember to check the SWOT page <<https://www.swotrc.net/>> for info about nets in your area."

Steve Koone, KA4YMY, posted the following on a 23-centimeter email reflector. He's a proponent of 23 cm and to that end has brought up a repeater in the Charlotte area: Steve offers:

Hello to the group! I am new here. It is great to meet like-minded amateurs interested in the 23-cm band. Just to add my voice of support to the band's activity. I have a 23-cm D-star repeater on the air just west of the Charlotte, NC metro area. It is located on a TV broadcast tower platform at the 1,500-foot level. The call sign is KA4YMZ-A; the frequency is 1292.00, -20 MHz offset. (I'm sure Steve would appreciate signal reports. - TF) Equipment includes a new Generation 3 Icom RP-1210 repeater. I started out using an RP-2V and it was performing well, however it had developed

an issue in the transmitter where it was drifting down almost 2 kHz low after about a minute of transmit time. The new RP-1210 so far is an excellent performer, stable on both transmit and receive. I'm hoping that trend will continue!

Other equipment includes a Wacom WP-698 duplexer, a DCI front-end receive filter to keep out digital TV artifacts and an Angle Linear preamp for that little extra 'edge' on receive. Antenna is a Hustler Spirit 12-db base/repeater antenna fed with 15 feet of 1/2" Heliax. Network of choice is G4KLX/ircDDB using an RP-2C for the controller interface. Internet is fed via Ubiquiti 5-GHz Wi-Fi, it's around a 7-mile path from the access point dish. Very stable and has been in service for several years with zero issues.

If you live in and around the Charlotte area or are just passing through, please feel free to use the repeater anytime. It is typically connected to Ref54C (Carolina reflector); however it is available for access to any other reflector or service.

The local users are getting at least 60 miles of service from the repeater and that's really good for this part of the country. No major high-end amateur stations involved, however. Most are using Yagi directional antennas such as the Diamond and M² types. There are also a couple of vertical base station antenna users around 25 miles out. (See Photos C and D)

Thank you, Steve, for your work in supporting 23-centimeter activity, and for the report.

That's all for this month! Please keep your activity reports and project information coming!



Photo C. An inside look at the KA4YMZ-A repeater



Photo D. KA4YMZ-A repeater antenna setup

awards

BY STEVE MOLO,* KI4KWR

Summits on the Air Awards

In the last few weeks, a local HF net I sometimes check into has been chatting up SOTA, or Summits on the Air. Before we get into the awards offered, here is an introduction to the SOTA program and the overall rules set by their committee for activating summits and “chasing” them. A listing of the group’s awards and how to earn them follows. Everything is directly from the <<https://www.sota.org.uk/>> website. – KI4KWR

The purpose of SOTA (the Programme) is to encourage Amateur Radio based activity from the summits of hills and mountains in countries around the world and to provide an award system for Radio Amateurs in all DXCC Entities. The Programme is intended to encourage activity from clearly defined peaks, including major mountains. To enable participation in the Programme to be as wide ranging as possible, lesser peaks may also be included. An incremental scoring system recognizes the higher peaks accordingly. The Programme is intended for portable operation (/P) and does not accept operation from a motor vehicle. The Programme provides for participation by Activators who do QSOs from the Summits, Chasers who make contact with the Activators, and Short-Wave Listeners. In addition to Amateur Radio Awards, the SOTA Programme encourages activity in amateur radio operation, increasing knowledge and skills in the use of equipment, particularly in antennas, as well as encouraging new skills, for example, in operating CW and data modes (for those who do not already possess them).

There are three Classes of Participant: Activators, Chasers and SWLs. Points are awarded in each Class and awards are available recognizing specified levels of achievement. Teams may be formed to participate in the Activator Class, but points scored may accrue only to individuals. Club stations may not participate as Activators, Chasers or SWLs but individuals may use club call signs as long as these are recorded against the individual. I have just touched the basis quickly, but it is a twenty-three page documents that covers everything.

Awards

Certificates are available for gaining 100, 250, 500, 1000 points (Activators and Chasers). These handsome certificates are printed in color and are personally signed by a member of the SOTA Management Team. Each certificate is individually numbered and printed with your own callsign or SWL number. Endorsements such as “All CW” or “VHF” can be added on request at no extra charge. The certificates are posted to you in a board-backed envelope to ensure that they arrive in good condition. For those with boundless energy and enthusiasm there are additional certificates for 2,500, 5,000, and 10,000, and even higher points.

Shack Sloth and Mountain Goat

At 1,000 points, Activators achieve “Mountain Goat” status and Chasers/SWLs are “Shack Sloths.” Achieving “Mountain Goat” and “Shack Sloth” status requires considerable dedication and effort and so, trophies can be claimed to mark this

significant milestone. Each 9-centimeter by 9-centimeter “Ice block” is made entirely by hand in the Scottish Highlands. Craftsmen create a unique “running scallop” along each edge of the raw glass so each trophy will be unique. The trophy will be individually engraved with your callsign and the year in which you reached 1,000 points. Endorsements like “All CW” or “VHF” can also be engraved for a small additional charge.

SOTA Unique Awards

The SOTA Uniques is a count of the number of different summits in an activator’s, chaser’s or SWL’s record. It is purely the number of distinct summits activated or chased regardless of SOTA points. The SOTA Online Database keeps track



The basic Summits on the Air award certificate is endorsed for various categories and levels of achievement.



Participants who achieve either “mountain goat” or “shack sloth” status are awarded an individualized glass “ice cube.”

*Email: <KI4KWR@cq-amateur-radio.com>

of your progress. Certificates are available for the usual thresholds of 100, 250, 500 and 1000. There being over 100,000 summits in world associations at present, further thresholds of 2500 and 5000 theoretically apply at least! It is felt that this award will extend the challenge, particularly for our leading activators and chasers, where point scores are large and well beyond Mountain Goat/ Shack Sloth, but often with less than 200 unique summits. It also addresses something that activators and chasers have been doing since the launch of the programme - counting their unique summits worked and activated. The same awards are available in the SWL section. It is possible to obtain a Shack Sloth Trophy for contacting 1000 unique summits. These trophies are identical to the standard SS trophy but have the word "Unique" engraved into the design.

Mountain Explorer and Mountain Hunter Awards

Each award is a certificate based using a different format from existing SOTA certificates. These awards recognize that there are now well over 100 SOTA associations around the world and that many activators take the opportunity presented by the CEPT regulations to take their equipment with them on vacation. This award rewards those activators who operate in associations which are not necessarily their home association. Chasers make every effort to help activators qualify their summit but often they are looking for that unique summit that presents a true challenge to the dedicated chaser and the Mountain Hunter Award has been created for them. In brief the requirements needed to claim an award are as follows:

Mountain Explorer

The essence of the award is to recognize the activation and qualification of Summits, in accordance with SOTA General Rules and the local association's rules, in a number of different associations.

- Bronze Award – confirmed activation of at least one summit in each of 5 associations
- Silver Award – confirmed activation of at least one summit in each of 10 associations
- Gold Award – confirmed activation of at least one summit in each of 15 associations
- Platinum Award – confirmed activation of at least one summit in each of 20 associations
- Globetrotter Award – confirmed activation of at least one summit in every participating association

Example: To claim the Bronze Award an activator would need to have activated one summit in at least five qualifying associations - these could be GM, G, F, DL and ON as an example.

Following the increasing trend for Activators to visit summits when on a foreign vacation or business trips, we have decided to introduce a variation of the award which recognizes visits to continents other than the Activator's home continent. The Activator will need to activate in several Associations on different continents, including their home continent. The distribution of the number of Associations activated over the Continents activated is left to the individual provided *at least* one Association per continent claimed is activated.

- Tourist – confirmed activation of at least one summit in each of 5 Associations on at least 2 continents

- Frequent Traveller – confirmed activation of at least one summit in each of 10 Associations on at least 3 continents
- Business Class – confirmed activation of at least one summit in each of 15 Associations on at least 4 continents
- Globetrotter – confirmed activation of at least one summit in each of 20 Associations on at least 5 continents

Example: To claim the Tourist award, the Activator could claim one summit in EA8 for Africa and one summit in each of GM, ON, PA and DL for Europe (5 Associations / 2 Continents)

Summary table:

Award Level	No. of Associations	No. of Continents
Bronze	5	Not counted
Silver	10	Not counted
Gold	15	Not counted
Platinum	20	Not counted
Amethyst	50	Not counted
Tourist	Minimum 5	2
Frequent Traveller	Minimum 10	3
Business Class	Minimum 15	4
Globetrotter	Minimum 20	5

Mountain Hunter

VHF (70 MHz and above) Award

Chaser should contact (or hear for the SWL award) at least 2 different summits in each of 5 associations using just VHF/UHF, any mode.

Endorsement for UHF-only qualification (430 MHz and above) [see note below]

Steps of 5 Associations for each award: 10, 15, 20, etc.

Award	No. of Associations
Bronze Award	5
Silver Award	10
Gold Award	15
Platinum Award	20+

All Bands Award

Chaser should contact (or SWL, hear) at least 2 different summits in each of 5 associations. The higher-level awards require that at least one association claimed is on a different continent from the claimant's normal residential QTH. Level 1 can be claimed with contacts only on the claimant's own continent (1 continent); higher level awards require inter-continental contacts.

Endorsement for all-50 MHz qualification [see note below]

Steps of 5 Associations for each award: 10 (including 2 continents), 15 (including 2 continents), 20 (and 3 continents), Worked all Associations (all qualifying continents)

Award	No. of Associations	No. of Continents
Bronze Award	5	1
Silver Award	10	2
Gold Award	15	2
Platinum Award	20+	3
Worked All Associations	ALL	4 or 5

Please note: Limitations to the database structure may require manual checking for the endorsements (UHF / 50MHz) and for the VHF only award.

Summit to Summit Awards

The rules are as follows:

1. The award will be scored by taking the sum of the points value of the activated summit and the chased summit.
2. The rules for activators will apply to the activated summit score i.e., the summit may be scored only once per calendar year. If subsequent activations take place from the same summit in the calendar year only the chased summit score will count for the award
3. Only the points value of the activated summit will be counted, summer or winter bonuses will not be included as they are already used for activator awards.
4. The rules for chasers will apply to the chased summit i.e., the summit may only be counted for the award once per day.
5. Commencement date 1 February 2013 to allow for modifications to the database to collect the relevant information. S2S prior to this date will not be counted.
6. Only cross-matched entries will count for the award. If an activator does not enter their activation into the database, or your S2S contact does not match then it will not be included in the scoring.
7. The database will be revised so that summit to summit contacts can be indicated.
8. Award qualifying points values are 250, 500, 1000, 2500 and 5000. Additional endorsements will be available for 10000 and upwards.

See the Summit to Summit award page at the shop site <<https://tinyurl.com/3ajmbbus>> for some examples.

Microwave Awards

This award will be achieved by making contact at least 50 kilometers in distance between two stations, at least one of which must be activating a qualified SOTA summit. The elevation of the summit(s) is not relevant, unlike most awards in the SOTA program. Instead, increasing distances beyond 50 km between the two stations leads to higher level awards within each of these UHF bands: 1.2, 2.3, 3.4, 5.6, 10, 24, 47, 76, 123, 136, & 248 GHz. The distance involved in each single contact is analyzed for potential qualification for higher awards, and distances in two or more contacts cannot be combined to qualify for an award. As indicated in the microwave certificate illustrated in the SOTA shop, higher award intervals are all 50 km (up to 1,000 km). It is not necessary to earn microwave awards in sequence from low to high distances; one may jump to any distance, even working from high to low if desired. Award colors are similar to those used in the Summit-to-Summit Award, with distances broken down within each color: red for distances of 50, 100, 150 and 200 km; bronze for 250, 300, 350, 400 & 450 km; silver for 500, 550, 600, 650 & 700 km; gold for 750, 800, 850, 900 & 950 km; platinum for 1,000 km and above.

The provisions in the General Rules apply, with a few more exceptions. There is no seasonal bonus period. There is no SWL microwave award. There are no yearly limits on how often activators and chasers can score, but only one award claim may be made per summit per activating day due to the extensive distance-checking process at the award department. There is no scoring incentive for using more difficult modes. Microwave contacts can be used to support other SOTA awards, including summit to summit (which will be annotated on microwave certificates). For summit-to-summit microwave contacts, the database calculates the distance. For single activator contacts, one must enter the decimal lat-



The Summits-to-Summits (S2S) certificate recognizes contacts between activators on different summits.

itude-longitude coordinates of the chaser in the notes section of the log in this manner: %QTH%37.3765,-121.8012% (leave no spaces). The award manager then calculates the distance manually.

UHF signals can be a biohazard, and the operator bears all responsibility for resulting injury. The sponsors of the award, UK Microwave Group & SOTA, bear no responsibility for such injuries.

SOTA Complete

The SOTA Complete award is issued in recognition of an individual both activating AND chasing a summit. The award commences when an individual has "Completed" 100 summits and is issued in the regular steps of 250, 500 and 1000 unique summits. This may be one of the most difficult of the SOTA awards to achieve and demonstrates the achievement of a significant milestone and the all-round nature of the participant.

Claiming ...

Awards are not sent automatically - you must claim them!

IMPORTANT

You can order trophies and certificates by visiting the SOTA Shop (<http://www.sota-shop.co.uk/>)

Ensure that the SOTA on-line database is up-to-date with your entries.

All claims will be checked and only allowed if supported by matching logs on the database.

PayPal is the preferred method of payment.

All certificates and trophies are provided on a *not-for-profit* basis by the SOTA Management Team. Any surplus is used as a contribution towards SOTA's running costs. If you have any problems or questions, contact GM4TOE as per the website.



Used to Be...

Lately, I have been thinking (very dangerous territory) about the “good old days” of DXing. I got my license (WB2RJJ) in 1965 and was almost immediately immersed in the world of chasing DX. Back then, chasing DX was just a little bit different than today. Not better. Not worse. Just different. It was common to tune the bands for stations either calling CQ or running a pileup. I always tell the story about two “happen chance” DX contacts that I made back then.

While tuning around on 20-meter CW one night at 0130 UTC (8:30 PM EST) with my old HT-37 transmitter and Hammarlund HQ110AC receiver, I came across VU2DIA calling CQ. I thought “INDIA!” I’d never worked India! I answered his CQ and he came right back, giving me a 349 report. I was truly excited that I worked my first INDIA station! 100 watts! I’m not sure which antenna I was using then, I think it was probably a Gotham (aluminum spreader) quad. But that worked too poorly, so it could have been the replacement W2AU quad which I put up at one point. Not sure. Regardless, I thought I’d worked my first station in India! Wow! I was truly excited! I immediately mailed my QSL to him with an IRC. Some months later I received my VU2DIA QSL card in the mail. (see Photo A). Hold on I thought! Didn’t I see Andamans on my ARRL DXCC list? Yup, there it was! Andamans! I worked the Andaman Islands! Then I looked at the map and was even more surprised to see just how far away Andaman was from me! Incredible! So, I asked my DX chasing buddy Steve (then WB2VFT, now KZ2I) about the Andamans and he said something like “YOU worked Andaman? That’s one of the rarest ones around!”. Yes, back then I believed that the only ham on Andaman was Hegde, VU2DIA. As I understand it, he was really VU2DI but when he was in the Andamans, he had to add the “A” onto the end of his call. Photo B shows the VU2DIA QSL card for W3EJF that shows the “A” added with a pen. Again, Andamans was EXTREMELY rare back in 1967. I believe that India did not

allow any “portable” activity back then. So, it was not possible for anyone, not even a ham in India, to travel to Andaman and activate it for a DXpedition, or for any temporary timeframe. It had to be a resident who could get permission somehow. Guest operators were similarly forbidden to operate in India, including Andamans and Laccadives (now called Lakshadweep), as I recall. Apparently, Hegde was a resident and not a visitor and was probably the last ham on Andaman for a VERY

long time before more recent operations were allowed. It took me another 41 years to work another Andamans station (VU4MY in 2008).

But what about INDIA? I still needed India for my DXCC! After hunting for 7 more months, I finally worked my first INDIA station, which was Bala, VU2LE, on 20-meter CW, receiving a report of 559. (See Photo C).

Moving forward to 1968... By this time, for some reason I decided to buy a Heathkit HW-32 transceiver which

The WPX Program

CW
4093.....AE3J
4094.....WØGN

SSB
4500.....I2OLV
4501.....W1MKC
4502.....WØGN

Mixed
4651.....I6JOW
4652.....HB9HZC
4653.....DL6ED
4654.....DL1KJ
4655.....JS6UAK
4656.....VC7BEPIS
4657.....W8IJN
4658.....VE4ZIM
4659.....W1MKC
4660.....VE9EX
4661.....KQ4CQA
4662.....N6ACA

Digital
1974.....HB9HZC
1975.....DS4OMS
1976.....KQ4BBC
1977.....JS6UAK
1978.....KC3WDW
1979.....VC7BEPIS
1980.....VE4ZIM
1981.....W1KMC
1982.....SP9IZV
1983.....W8MEJ
1984.....JF1TFC
1985.....JK1OGT
1986.....N6ACA
1987.....AA4PB
1988.....WØGN

CW: 350: AE3J. 450: AA8SW. 1200: WØGN. 1400: WS9V

SSB: 350: DL1KJ. 400: W1MKC. 450: N5JED, W3RFX. 500: WØLMU. 600: GØOFD, WØGN. 900: IZ4DPV. 1150: W4TTO. 1200: WS9V

Mixed: 450: DL1KJ, KQ4CQA, DU3GKT. 500: I6JOW, SP9IZV, DL6ED, VE9EX, VC7BEPIS, WØLMU. 550: EI4GEB. 600: JS6UAK, SP9IZV. 700: HB9HZC. 800: VE4ZIM. 850: GØOFD. 900: W1KMC. 1000: JQ2MPJ. 1100: KD2RUY, N2YU. 1150: KDØBQS.

1200: OE7BJT. 1350 N5JED, IZ4DPV. 1400: WØGN. 1500: K5DB. 1600: JG1JPE. 1800: WR7X. 2100: WU9D. 2300: WS9V. 2900: TF5B

Digital: 350: JF1TFC. 400: GØOFD, N6ACA. 450: ACØDH. 500: I6JOW, VC7BEPIS. 550: JS6UAK. 650: HB9HZC, OH6HSD. 700: IZ4DPV. 750: W1MKC. 800: VE4ZIM. 950: N2YU. 1000: JQ2MPJ. 1050: N5JED, IU1HGN. 1100: KD2RUY, OE7BJT. 1150: WS9V, KDØBQS. 1200: W4DWS. 1600: JG1JPE. 1700: WR7X. 2000: WU9D. 2350: AA8SW. 2800: TF5B

160 Meters: WS9V, AE3J, WØGN
80 Meters: WS9V, KDØBQS, VE4ZIM, WØGN, OE7BJT
40 Meters: WS9V, KDØBQS, VC7BEPIS, VE4ZIM, W1MKC, WØGN, W4DWS
30 Meters: WS9V, KDØBQS, WØGN, OE7BJT
20 Meters: WS9V, HB9HZC, N2YU, ACØDH, I2OLV, VC7BEPIS, VE4ZIM, W1MKC, VE9EX, N6ACA, WØGN
17 Meters: WS9V, WØGN, OE7BJT
15 Meters: WS9V, KDØBQS, WØGN, OE7BJT
12 Meters: WS9V, KDØBQS, WØGN
10 Meters: WS9V, KDØBQS, WØGN
6 Meters: WS9V, IZ4DPV, WØGN

Asia: WS9V, I6JOW, HB9HZC, N5JED, DS4OMS, KDØBQS, I2OLV, OH6HSD, JS6UAK, SP9IZV, JK1OGT, N6ACA, WØGN, OE7BJT, DU3GKT

Europe: I6JOW, HB9HZC, DL6ED, DL1KJ, JS6UAK, KC3WDW, W8IJN, VE4ZIM, W1MKC, SP9IZV, VE9EX, WØGN

Oceania: K5DB, I2OLV, JS6UAK

North America: HB9HZC, I2OLV, KQ4BBC, IZ4DPV, JQ2MPJ, VC7BEPIS, W8IJN, VE4ZIM, W1MKC, AE3J, W8MEJ, VE9EX, KQ4CQA, N6ACA, AA4PB, WØGN

South America: WS9V, K5DB

Complete rules and application forms may be obtained by sending a business-size, self-addressed, stamped envelope (foreign stations send extra postage for airmail) to “CQ WPX Awards,” P.O. Box 355, New Carlisle, OH 45344 USA. Note: WPX will now accept prefixes/calls which have been confirmed by eQSL.cc. and the ARRL Logbook of The World (LoTW).

*Please Note: The price of the 160, 30, 17, 12, 6, and Digital bars for the Award of Excellence are \$6.50 each.

*email: <n200@comcast.net>

was a 20-meter-ONLY SSB-ONLY transceiver. Why? I have no idea. I had no CW gear for a period of time in 1968. Add to that, my quad was destroyed by an ice storm so I concocted a 20 meter rotary dipole out of the junk pile from my Gotham quad. I spent a lot of my time on the "YL International SSB System." My number was 6223 which was a pretty low member number. I had found a way to chase some pretty

good DX there. My little HW32 worked fine on 14.332 MHz. I vividly remember Ellie ,K4RHL, running the net almost every day. Don't ask who I worked there. That was a long time ago. But it was definitely a sidebar to my DXing life. One QSO that I remember having with that HW32 was not on the net. I was scanning the band for a clear spot to call CQ. When I found one, I asked if the frequency was in use. I immediately got a

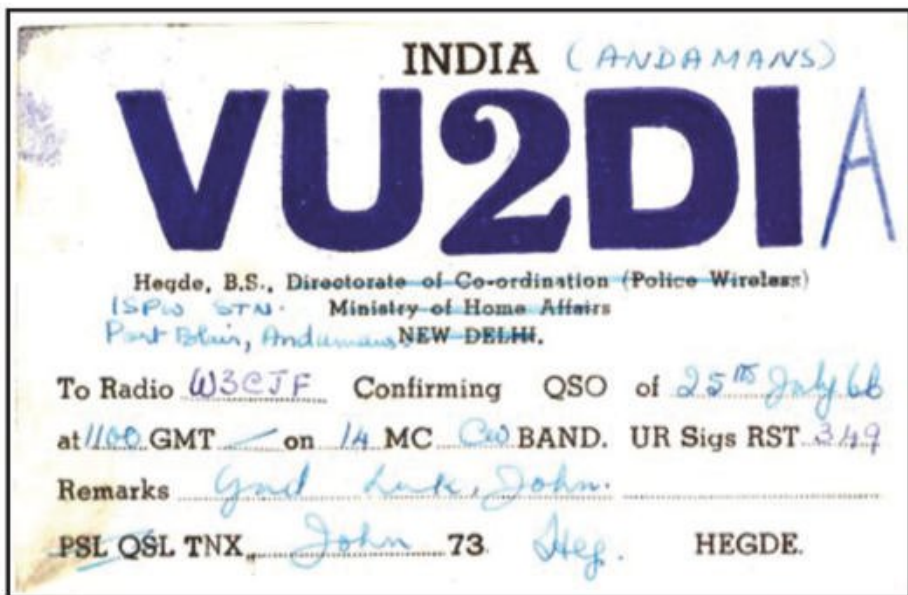

Photo A. When Bob had this QSO with VU2DIA in 1964, he thought he had finally worked India ... but was amazed to discover that the station was actually in the very rare Andaman Island

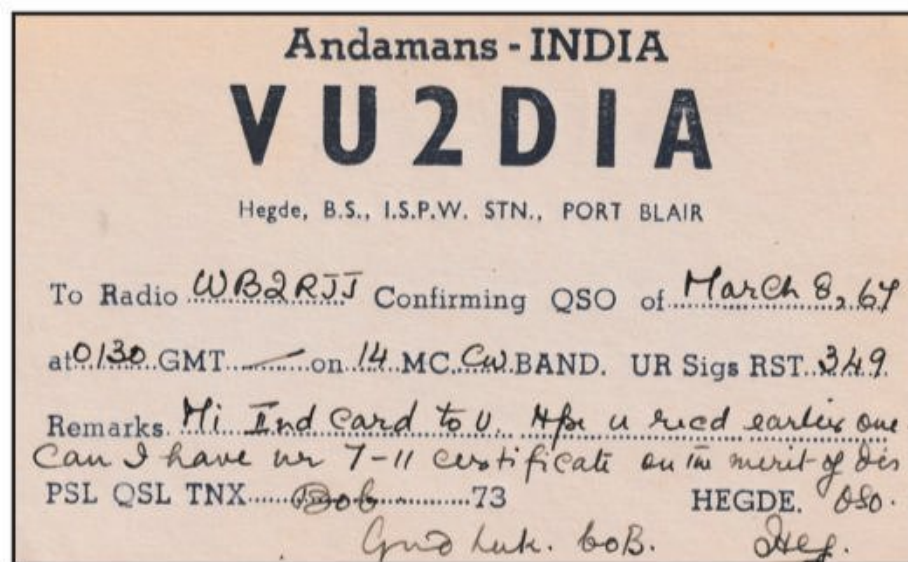

Photo B. VU2DIA was actually VU2DI when at home in New Delhi, but had to add the "A" to his call when operating from Andaman.

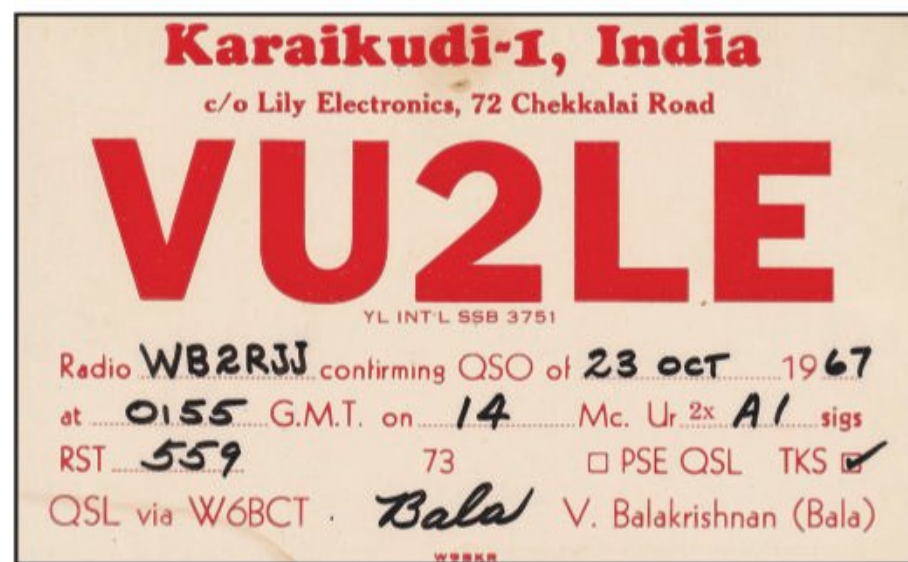

Photo C. Bob finally got his first mainland India contact three years later when he worked VU2LE.

QSL of the Month: JT1YL

JT1YL (home call OK1KX) was Milada (Mila) Klouckova. Her husband was Ludvik Kloucek, JT1AA (OK1KW). In 1957/58 Ludvik was a radio operator at the Czechoslovak Embassy in Ulan Bator, Mongolia's capital. Mongolia was in great demand on the ham bands, not just for a new country, but for CQ Zone 23.

Ludvik decided to get on the air with a homemade call sign, JT1AA. The Mongolian government tracked him down, but a few strings were pulled and Ludvik was given the official call JT1AA, while Mila was given JT1YL. They were both very active on 15- and 20-meter CW. This was the only activity from Zone 23 at the time. They operated in the 1958 CQWW DX contest. Milada went QRT on December 29, 1958. They returned to Prague on February 3rd, 1959.

(Photos and information courtesy Tom Roscoe, K8CX, <<https://hamgallery.com>>)



Photo D. This QSO with ZD9BE in Tristan da Cunha happened when Bob asked if a frequency was in use and Alan came back and said "no, but would you like a QSO?"

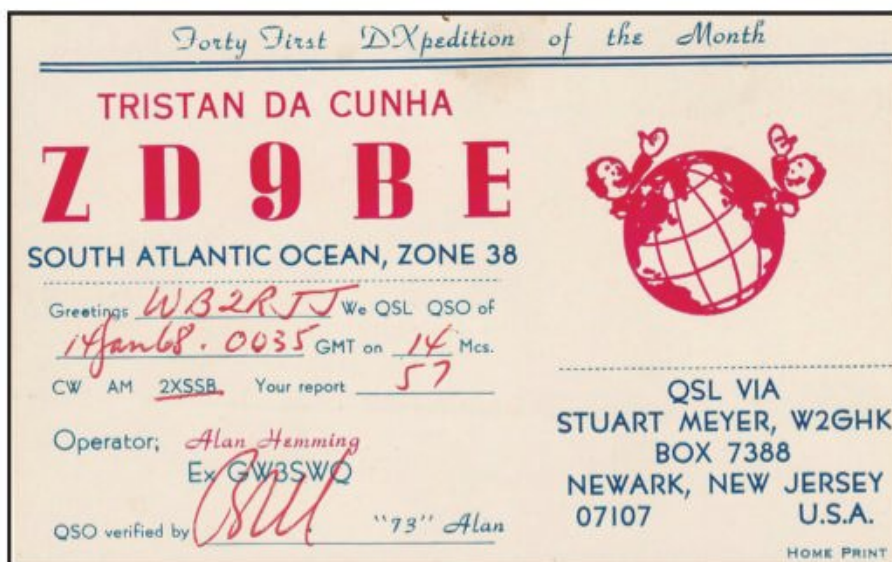

reply saying "No, the frequency is not in use but would you like a QSO? This is Zulu Delta 9 Bravo Echo (ZD9BE was Alan ex-GW3SWQ) on Tristan da Cunha in the southern Atlantic Ocean." (See Photo D for that QSL.) Now, again, for me, this was another one of those "moments" I will never forget. I had never heard a ZD9 before and it took me another 35 years to work another one (ZD9IR in 2002).

So, that was how I started chasing DX. Tuning the band. As I got older, I would subscribe to the DX newsletters that were mailed in the US Mail. Yeah, no internet. We relied on either word of mouth on the air, or those super DX newsletters. The ones that I primarily got were the "West Coast DX Bulletin" by Hugh Cassidy, WA6AUD, and his XYL, Virginia, which were published weekly from 1968 thru 1979. If you would like to reminisce, go to <http://tinyurl.com/yjkahc66>. There were others I remember, like "DXer's Magazine" by Gus Browning, W4BPD; "The DX Bulletin" by Jim Cain, K1TN, then later by Chod Harris, VP2ML; "QRZ DX" by Carl Smith, N4AA, and the Long Island DX Bulletin. Probably many others. All were "mailed" to you, normally weekly. So, your DX news was never "instant" news like we have today. That is how it "used to be."

The WAZ Program

SINGLE BAND WAZ

6 Meter	
232JA1BK, 39 Zones
233F6DAY, 30 Zones
234EA5CI, 26 Zones
10M Digital	
14CT1BWU
15W4UM
16F6DAY
10M SSB	
614EA3EQT
12M CW	
119JI2UDK
12M Digital	
20CT1BWU
21W4UM
22F6DAY
23EA3EQT
24EA5CI
15M Digital	
32W4UM
33EA3EQT
15M SSB	
694EA3EQT
17M CW	
149EA5CI
17M Digital	
51CT1BWU
52W4UM
53N1RR
20M Digital	
97CT1BWU
98W4UM
99EA3EQT
20M SSB	
1279WK9R
1280OE2KGL
30M Digital	
31CT1BWU
32W4UM
33EA3EQT
34EA5CI
40M Digital	
37W4UM
38EA3EQT
39K3FRK

MIXED WAZ Mixed

10613CT1BWU
106149A5R
10615IZ3AYS
10616IK4SBR
10617EA9ACR
10618K6RM

10619JJ1JMZ
10620JG1GJH
10621JA1PTO
10622DL6ED
10623NX4DP
10624W5BR
10625LU3DDH
10626JA1BK
10627N7GVV
10628D44PM
10629JA4NIM
10630JE1PHH
10631EA3EQT
10632OE2KGL
10633N8XE
10634K7CTV
10635PD0WAG
10636W9DCT

SINGLE MODE WAZ CW

1280W4UM
1281JA1BK

Digital

554JA4SSM
555CT1BWU
556IK4SBR
557EA9ACR
558N3RC
559JJ1JMZ
560JG1GJH
561W4UM
562JA1BK
563K3NF
564JE1PHH
565K7CTV
566PD0WAG
567W9DCT

SSB

5581SQ5EBM
5582DK9HN
5583LU3DDH
5584OE2KGL

SAT

95XE1AO, 25 Zones
96JI5USJ, 25 Zones
97JE1FQV, 25 Zones
98K6FW, 25 Zones
99N6UK, 25 Zones
100AG7NR, 25 Zones
101NS3L, 30 Zones

Rules and applications for the WAZ program may be obtained by sending a large SAE with two units of postage or an address label and \$1.00 to: WAZ Award Manager, Jose Castillo, N4BAA, 6773 South State Road 103, Straughn, IN 47387. The processing fee for all CQ awards is \$6.00 for subscribers (please include your most recent CQ mailing label or a copy) and \$12.00 for nonsubscribers. Please make all checks payable to Jose Castillo, N4BAA. Applicants sending QSL cards to a CQ checkpoint or the Award Manager must include return postage. N4BAA may also be reached via email: n4baa@cq-amateur-radio.com.

Personal Spotting System

In the 1970s, after I moved to southern New Jersey (from North Jersey), my friend Steve, KZ2I, also came south and bought a house a few hundred feet down the street from me. A wonderful idea, I guess, if we were not both hams running full power. But we learned to live with each other's QRM. After moving

CQ DX Awards Program

NO UPDATES

The basic award fee for subscribers to CQ is \$6. For non-subscribers, it is \$12. In order to qualify for the reduced subscriber rate, please enclose your latest CQ mailing label with your application. Endorsement stickers are \$1.00 each plus SASE. Updates not involving the issuance of a sticker are free. All updates and correspondence must include an SASE. Rules and application forms for the CQ DX Awards may be found on the www.cq-amateur-radio.com website, or may be obtained by sending a business-size, self-addressed, stamped envelope to CQ DX Awards Manager, Please make checks payable to the Award Manager, Keith Gilbertson, KØKG, 21688 Sandy Beach Lane, Rochert, MN 56578-9604 USA. We recognize 341 active countries. Please make all checks payable to the award manager. Photocopies of documentation issued by recognized national Amateur Radio associations that sponsor international awards may be acceptable for CQ DX award credit in lieu of having QSL cards checked. Documentation must list (itemize) countries that have been credited to an applicant. Screen printouts from eQSL.cc that list countries confirmed through their system are also acceptable. Screen printouts listing countries credited to an applicant through an electronic logging system offered by a national Amateur Radio organization also may be acceptable. Contact the CQ DX Award Manager for specific details.

To wrap this up, the nostalgia of how it “used to be” will always be in my memory as a fun time chasing DX. It is so much different today. Again, not better, not worse, just different.

down, we befriended Gary, W2EQK, who later became N2CW. The three of us had our own “personal” spotting system. We shared each other’s DXCC want lists and if any one of us came across anything that any of us needed for our mixed DXCC, we would call them on the telephone. Yes, our XYLs just “loved” this system, especially if the call was made at 3 A.M. But that is how we started our spotting system. After a bit, we went to the “one ring” telephone call system. Hear one ring? Get on 2 meters. Then we would “coach” each other on 2 meters to help try to work the DX station. This system was “a little” more tolerable by our XYLs. But probably not much. That’s how it used to be for me with DX spotting.

To wrap this up, the nostalgia of how it “used to be” will always be in my memory as a fun time chasing DX. It is so much different today. Again, not better, not worse, just different. With the internet, everything changed drastically for

helping find that rare DX entity that you need for your awards. We have gotten to the point where a spot for a needed entity can come in from the spotting network that will instantly check your logging program to see if it is an entity that you NEED. That will automatically switch your radio to the proper band and mode, select the correct antenna and turn your antenna to the right heading. This still leaves you to actually work the station. But we sure have come a long way, baby. Then there is the Reverse Beacon Network (RBN) that surely would have detected that CW signal of VU2DIA on the Andamans and would have instantly generated a HUGE pileup. My RST 349 signal would never have gotten through.

The RBN (<<http://reversebeacon.net>>) is a network of so-called *skimmers*. These are broadband receivers that listen to the CW portions of ham radio bands. These skimmers report every CQ call (also beacons, etc.) back to a central server. These reports contain the call of the transmitter, signal-to-noise ratio and speed (WPM) of the transmitter. I will try to tell you more about the RBN another time.

So, is it better today? Yes of course. But in reality, it is just different today than the way it “used to be.”

See ya’ in the pileups! De N2OO

5 Band WAZ

As of September 15, 2023

2538 stations have attained at least the 150 Zone level, and **1148** stations have attained the 200 Zone level.

As of September 15, 2023

The top contenders for 5 Band WAZ (Zones needed on 80 or other if indicated):

Callsign	Zones	Zones Needed
AJ9C	199	23
AK8A	199	17
DF2GH	199	31
DM5EE	199	1
EA5RM	199	1
EA7GF	199	1
H44MS	199	34
HA0HW	199	1
HA5AGS	199	1
I5REA	199	31
IK0XBX	199	19 on 10M
IK1AOD	199	1
IT9GSF	199	1
IZ3ZNR	199	1
JA1CMD	199	2
JA5IU	199	2
JA7XBG	199	2
JH7CFX	199	2
JI4POR	199	2
JK1BSM	199	2
JK1EXO	199	2
K1LI	199	24
K3LR	199	23
K4HB	199	26
K5TR	199	22
K7UR	199	34
KZ4V	199	26
N3UN	199	18
N4NX	199	26
N4WW	199	23
N4QS	199	18
N4XR	199	27
N8AA	199	23
N8DX	199	23
N8TR	199	23 on 10M
RA3S	199	1 on 10M
RA6AX	199	6 on 10M
RU3DX	199	6
RW0LT	199	2 on 40M
RX4HZ	199	13
RZ3EC	199	1 on 40M
S58Q	199	31
SM7BIP	199	31
SP9JZU	199	19 on 10M
SV8CKM	199	1
US0SY	199	1 on 15M
VE2EBK	199	26
VK3HJ	199	34
VO1FB	199	19

Callsign	Zones	Zones Needed
W1FJ	199	24
W1FZ	199	26
W3NO	199	26
W4LI	199	26
W6DN	199	17
W6RKC	199	21
W6TMD	199	34
W9OO	199	18 on 10M
W8CZN	199	24
W9XY	199	22
ZL3CW	199	34
9A5I	198	1, 16
AB4IQ	198	23, 26
DL6JZ	198	1, 31
EA5BCX	198	27, 39
F5NBU	198	19, 31
F6DAY	198	2 on 10M & 15M
G3KDG	198	1, 12
G3KMQ	198	1, 27
G4OWT	198	1, 27
HB9FMN	198	1 on 80M & 10M
I1EIS	198	1 & 19 on 10M
JA1DM	198	2, 40
JA3GN	198	2 on 80M & 40M
JA7MSQ	198	2 on 80M & 10M
JH1BNC	198	2 on 80M & 10M
JH1EEB	198	2, 33
K0DEQ	198	22, 26
K1BD	198	23, 26
K2EP	198	23, 24
K2TK	198	23, 24
K3JGJ	198	24, 26
K3WA	198	23, 26
K3XA	198	23, 34
K4JLD	198	18, 24
K9MM	198	22, 26
KI1G	198	24, 23 on 10M
KZ2I	198	24, 26
LA3MHA	198	31 & 32 on 10M
N4GG	198	18, 24
N5AO	198	22, 23
N7IR	198	17, 22
NX0I	198	18, 23
ON4CAS	198	1, 19
OZ4VW	198	1, 2
RL3FA	198	2 on 80 & 10M
UA4LY	198	6 & 2 on 10M
UN5J	198	2, 7
US7MM	198	2, 6
W5CWQ	198	17, 18
W7AH	198	22, 34
W9RN	198	26, 19 on 40M
WC5N	198	22, 26
WL7E	198	34, 37
Z31RQ	198	1, & 2 on 10M
ZL2AL	198	36, 37

The following have qualified for the basic 5 Band WAZ Award:

Callsign	5BWAZ #	Date	# Zones
NN4Q/QRP	2519	06/17/2023	192
WB5TOI	2520	06/21/2023	188
ON6QRP	2521	07/03/2023	152
DJ3ZF	2522	07/08/2023	150
NA5Z	2523	07/11/2023	178
JE2EBT	2524	07/11/2023	158
W3KB	2525	07/11/2023	195
JE4RAL	2526	07/22/2023	163
PY5EW	2527	07/22/2023	200
K2CYS	2528	07/22/2023	156
KD0BQS	2529	07/24/2023	160
JR3PKO	2530	07/29/2023	150
DL2RPN	2531	07/29/2023	161
WA9GON	2532	08/02/2023	181
LA2IR	2533	08/05/2023	172
LU6ETB	2534	08/12/2023	197
JA4SSM	2535	08/19/2023	181
W4MAY	2536	08/19/2023	196
CT1BWU	2537	08/19/2023	187
JE1PHH	2538	09/09/2023	188

Updates to the 5BWAZ list of stations:

Callsign	5BWAZ #	Date	# Zones
EC7B	2524	11/20/2022	157
HB9ECS	2307	6/12/2021	190
EC7B	2425	11/20/2022	165
WT2P	2420	10/25/2022	180
JA2MNB	2237	8/6/2020	190
TF5B	2093	12/7/2018	163
N8MR	1359	12/29/2003	165
HI3T	2318	8/19/2021	193
W4JS	2277	2/1/2021	190
RA3S	1952	5/9/2017	199
W0DJC	1706	12/24/2010	187
NT9J	2320	9/16/2021	170
EA3EQT	1005	5/9/1996	191

Rules and applications for the WAZ program may be obtained by sending a large SAE with two units of postage or an address label and \$1.00 to: WAZ Award Manager, Jose Castillo, N4BAA, 6773 South State Road 103, Straughn, IN 47387. The processing fee for the 5BWAZ award is \$10.00 for subscribers (please include your most recent CQ mailing label or a copy) and \$15.00 for nonsubscribers. An endorsement fee of \$2.00 for subscribers and \$5.00 for nonsubscribers is charged for each additional 10 zones confirmed. Please make all checks payable to Jose Castillo. Applicants sending QSL cards to a CQ checkpoint or the Award Manager must include return postage. N4BAA may also be reached via email: <n4baa@cq-amateur-radio.com>.

*Please note: Cost of the 5 Band WAZ Plaque is \$100 shipped within the U.S.; \$120 all foreign (sent airmail).

CQ DX Honor Roll

The CQ DX Honor Roll recognizes those DXers who have submitted proof of confirmation with 275 or more ACTIVE countries. With few exceptions, the ARRL DXCC Countries List is used as the country standard. The CQ DX Award currently recognizes 340 countries. Honor Roll listing is automatic when an application is received and approved for 275 or more active countries. Deleted countries do not count and all totals are adjusted as deletions occur. To remain on the CQ DX Honor Roll, annual updates are required. All updates must be accompanied by an SASE if confirmation of total is required. The fee for endorsement stickers is \$1.00 each plus SASE. (Stickers for the 340 level and Honor Roll are available.) Please make checks payable to the Award Manager, Keith Gilbertson. Mail all updates to Keith Gilbertson, KØKG, 21688 Sandy Beach Lane, Rochert, MN 56578-9604 USA.

CW

DL3DXX.....339	K7LAY.....339	W8XD.....339	K1FK.....334	OZ5UR.....328	W6YQ.....319	K4IE.....295
HB9DDZ.....339	K7VV.....339	WK3N.....339	K9OW.....334	AB4IQ.....327	HA1ZH.....318	YU1YO.....295
K4IQJ.....339	K8LJG.....339	WØJLC.....339	PY2YP.....334	K6CU.....326	N4RF.....318	WA2VQV.....292
K9MM.....339	N4AH.....339	WØVTT.....339	WG5G/ QRPP.....334	KE3A.....326	N6PEQ.....318	4XIVF.....286
N4MM.....339	N4CH.....339	YU1AB.....339	WD9DZV.....334	EA5BY.....325	CT1YH.....316	K6YR.....284
WB4UBD.....339	N4JF.....339	K8SIX.....338	K2OWE.....333	KA3S.....325	EA3ALV.....315	PP7LL.....282
WS9V.....339	N4NX.....339	KA7T.....338	K5UO.....333	K7CU.....324	RA1AOB.....313	WR7Q.....282
EA2IA.....339	N5ZM.....339	WA5VGI.....338	N6AW.....333	N3RC.....324	WA4DOU.....312	N2VW.....280
F3TH.....339	N7FU.....339	W9RPM.....338	W4MPY.....333	N7WO.....324	YO9HP.....312	K4EQ.....280
K2FL.....339	N7RO.....339	G3KMQ.....337	K6LEB.....331	KEØA.....322	W6WF.....309	W8BLA.....280
K2TQC.....339	NØFW.....339	KØKG.....337	K9VKY.....331	YT1VM.....322	KT2C.....307	WB5STV.....277
K3JGJ.....339	OK1MP.....339	W1DF.....337	N7WO.....331	4Z5SG.....321	K4DGJ.....307	YO6HSU.....275
K3UA.....339	W3GH.....339	W7IIT.....337	OK1DWC.....331	N2LM.....321	W4ABW.....306	
K4CN.....339	W4OEL.....339	K8ME.....336	K6YK.....329	ON4CAS.....321	K7ZM.....305	
K4JLD.....339	W5BOS.....339	W6OUL.....336	W9IL.....329	W2OR.....320	HA5LQ.....301	
K4MQG.....339	W7CNL.....339	JA7XBG.....335	IKØADY.....328	HB9DAX/ QRPP.....319	RN3AKK.....300	
K5RT.....339	W7OM.....339	F6HMJ.....334			WA9PIE.....298	

SSB

AB4IQ.....340	KE5K.....340	W7BJN.....340	W9IL.....338	WD9DZV.....333	KE4SCY.....326	KA1LMR.....308
DJ9ZB.....340	KM2P.....340	W7OM.....340	N4FN.....337	AA1VX.....332	KF4NEF.....325	RA1AOB.....308
DL3DXX.....340	KZ2P.....340	W8ILC.....340	IØZV.....336	KE3A.....332	W6WF.....325	XE1MEX.....308
DU9RG.....340	N4CH.....340	W9SS.....340	K3LC.....336	N2VW.....332	W9GD.....325	IK5ZUK.....307
EA2IA.....340	N4JF.....340	WB4UBD.....340	K8ME.....336	N5YY.....332	VE7EDZ.....324	IØYKN.....306
EA4DO.....340	N4MM.....340	WK3N.....340	EA3BMT.....335	W1DF.....332	WA5UA.....324	XE1MW.....305
HB9DDZ.....340	N5ZM.....340	WS9V.....340	F6HMQ.....335	K5UO.....331	F6BFI.....323	K4IE.....304
I8KCI.....340	N7BK.....340	XE1AE.....340	HB9DQD.....335	KC2Q.....331	ON4CAS.....323	K4ZZR.....304
IK1GPG.....340	N7RO.....340	YU3AA.....340	IKØAZG.....335	SV3AQR.....331	VE6MRT.....323	K7ZM.....303
IN3DEI.....340	NØFW.....340	JA7XBG.....339	IW3YGW.....335	WØROB.....331	W5GT.....323	4Z5FL/M.....302
K2FL.....340	OK1MP.....340	KØKG.....339	OE2EGL.....335	W6OUL.....331	N6PEQ.....322	K7SAM.....301
K2TQC.....340	OZ3SK.....340	W2FKF.....339	VK2HV.....335	XE1MEX.....331	W4MPY.....322	KA8YYZ.....301
K3JGJ.....340	OZ5EV.....340	W4UNP.....339	W4WX.....335	KD5ZD.....330	K8IHQ.....321	4X6DK.....298
K4CN.....340	VE1YX.....340	W9RPM.....339	WB3D.....335	WA4WTG.....330	KW3W.....320	K2HJB.....295
K4IQJ.....340	VE2GHZ.....340	EA3EQT.....338	AA4S.....334	WØYDB.....330	T18II.....320	F5MSB.....293
K4JLD.....340	VE2PJ.....340	K3UA.....338	EA5BY.....334	ZL1BOQ.....330	YO9HP.....320	W9ACE.....291
K4MQG.....340	VE3MR.....340	K7LAY.....338	K9OW.....334	AD7J.....329	XE1RBV.....317	N3KV.....289
K4MZU.....340	VE3MRS.....340	K9HQM.....338	PY2YP.....334	N3RC.....329	N7YB.....315	W6MAC.....289
K5OVC.....340	VE3XN.....340	N4NX.....338	VK4LC.....334	VE7SMP.....329	IV3GOW.....312	N5KAE.....283
K5RT.....340	VK2HV.....340	YU1AB.....338	W8AXI.....334	WØULU.....329	N8SHZ.....312	IZ1JLG.....282
K5TVC.....340	W3AZD.....340	4Z4DX.....338	XE1J.....334	CT1AHU.....328	K7CU.....311	WA9PIE.....282
K6YRA.....340	W3GH.....340	K1UO.....338	CT3BM.....333	N1ALR.....328	OK1DWC.....311	WD8EOL.....281
K7VV.....340	W4ABW.....340	N7WR.....338	IK8CNT.....333	N2LM.....328	KU4BP.....310	IWØHOU.....277
K8LJG.....340	W5BOS.....340	WA5VGI.....338	K8LJG.....333	AE9DX.....327	W6NW.....310	AKØMR.....276
K8SIX.....340	W6BCQ.....340	W2CC.....338	N6AW.....333	K7HG.....327	I3ZSX.....309	NØAZZ.....275
K9MM.....340	W6DPD.....340	W7FP.....338	OE3WWB.....333	K6GFJ.....326	G3KMQ.....308	SQ7B.....275

RTTY

NI4H.....338	N5ZM.....338	K8SIX.....334	K3UA.....332	N4MM.....302	IN3YGW.....275
WB4UBD.....338	OK1MP.....337	W9RPM.....334	AB4IQ.....323	K4IQJ.....300	
WK3N.....338	K4CN.....334	W3GH.....333	K4WW.....323	K8ME.....278	

DX World Guide 4th Edition!

By Franz Langner, DJ9ZB

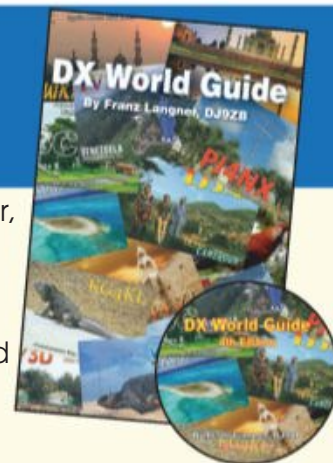

Known throughout the DX and DXpedition world as a meticulous and tireless operator, Franz Langner, DJ9ZB, is also noted as one of the most knowledgeable individuals in Amateur Radio in terms of documenting DXCC entities.

This is the fourth edition of his series of books bearing the title *DX World Guide*. It was first published in Germany in 1988 and followed by a second edition, also in Germany in 1977. The third edition, published in the U.S.A in 2012 was the first to use color throughout. This 380-page, fourth edition, also full color throughout, includes information on well over 300 DX entities.

**This 380-page, Fourth Edition is available in paperback and on CD! 6 X 9 Paperback - only \$49.95
Book on CD - only \$34.95 Buy both the Paperback and CD - only \$68.95**

Plus applicable shipping and handling charge. Single item shipping charge applies when you purchase both the book and CD together.

CQ Communications, Inc. 516 681-2926 <http://store.cq-amateur-radio.com>

Solar Flare vs. NAQP CW Contest

Plus Tweaks to ARRL Club Contest Rules and WRTC 2026

This past fall and winter, better-than-projected solar flux resulted in the 10-meter band being open for DX in all the major contests as we enter the peak of Solar Cycle 25. The peak of the solar cycle also brings with it an increased likelihood for **solar flares which can cause radio blackouts**. Let's look at how an X1.6 class flare impacted the August 5 CW North American QSO Party.

Almost a third of the 891 hams who submitted logs for the NAQP CW were calling CQ around 2200Z, right before the flare began. In that hour, as is typical for a domestic event, hams on the east coast had begun shifting their activity to the 40-meter band, but the bulk of activity was still on 20 meters. Callsigns of stations CQing were captured by several dozen CW skimmers across the US; timestamped skims are archived by the Reverse Beacon Network (RBN). In the hours before 2200Z, a sustained rate of over 400 CQs was being recorded each minute by RBN, as plotted on the left side of Figure 1.

I had been on the air since the NAQP's starting gun at 1800Z, exercising my 2BSIQ (Two-Band Synchronized Interleaved QSO) skills. In the hour before 2200Z, I was having great success with alternating CQs between the 20- and 40-meter bands. My 20-meter run rate dried up abruptly right around 2200Z; I shifted to search and pounce activity on 20 while continuing to call CQ on the 40-meter radio. By about 2210Z, the 40-meter run had obviously been afflicted as well; I did another 5 minutes going search and pounce on 40 before deciding that something had happened to the bands or my station.

A quick inspection of SWR on my different antennas convinced me that it was unlikely my deteriorating results were because my antennas had fallen down. I pulled my phone out of my pocket and checked my favorite amateur solar data website, <<https://solarham.net/>>, where Kevin Gibeau, VE3EN, collects many real-time space weather

data sources into a single webpage. Prominent at the top of his web page is the X-ray flux recorded by the GOES-16 satellite, and I could clearly see the leading edge of a sharp rise in X-ray flux that had already reached the X-class flare stage. The thick black line on Figure 1 shows the GOES X-ray flux before, during, and after this flare.

The deep dive in skimmed CQs synchronized with the arrival of the X-ray flare is compelling. At the same time, the skimmer counts are hardly "science-quality" data because contesters on a nice summer weekend afternoon will vote with their feet and find activities other than the radio when the bands become useless. In particular, this flare hit just four hours into a contest that requires full-time operators to choose at least two hours of offtime in the 12-hour contest period. In my case, the

2200Z radio blackout corresponded to 6 PM my local time; I hadn't quite scheduled the exact time when I was going to take a break from the NAQP CW to prepare dinner and eat with the family. The poor conditions easily convinced me to the flare's wipeout of the HF bands as a sign that it was also time to go upstairs to start cooking dinner.

Every couple of minutes while in the kitchen, I would refresh my phone's browser to check the solar data websites. Estimates for the severity of the event began to roll in from the Space Weather Prediction Center, first classifying the flare as X1.3, and soon X1.6, both of which (according to the NOAA Space Weather Scale) are expected to result in a R3 event with a radio blackout. Dinner with the family was wrapping up by 7 PM and by then, it was obvious from browsing the solar data

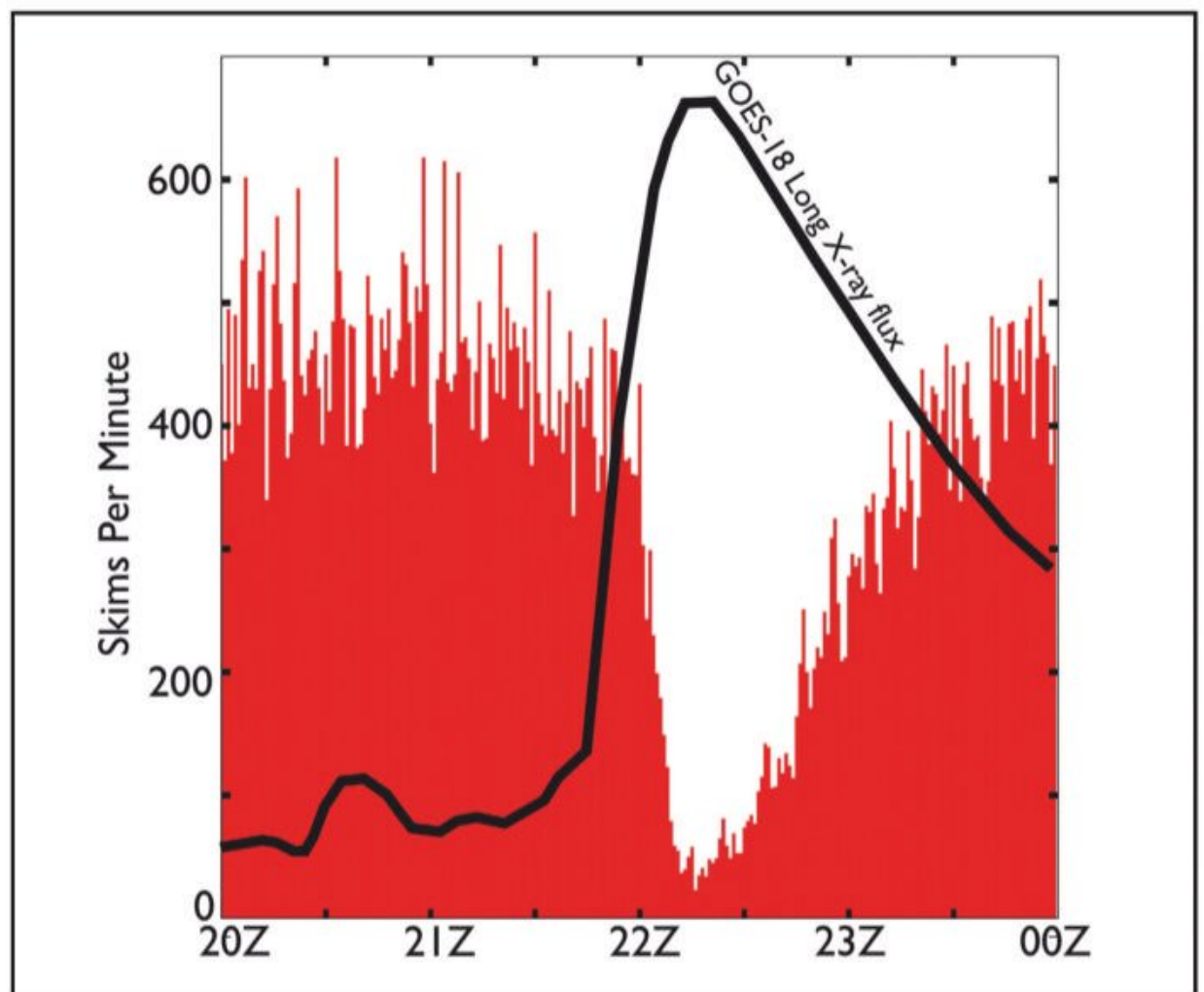

Figure 1. The rapidly rising flux (thick black curve) from an X-ray class flare the afternoon of August 5, wiped out the HF bands as seen by the rapid drop in number of NAQP contesters CW skims recorded by the Reverse Beacon Network. X-ray data is from NOAA/SWPC website <<https://tinyurl.com/33rmbc7c>>; skimmer data is tabulated from the downloads section of <<https://reversebeacon.net/>>.

email: <n3qe@cq-amateur-radio.com>

websites that the X-ray flux had fallen considerably, so I headed back down to the shack to find the bands usable again.

Usable bands weren't entirely normal, however. Calling CQ on the 20-meter band was quite ineffective and I fell back to search-and-pounce activities on that radio. Running on 40 meters was productive but I noticed most of my callers were in the US Midwest and few were coming back from nearby states. The CW tones had a hollow quality which is quite unusual for summer late afternoon 40-meter conditions – I would associate those qualities with 40-meter propagation during darkness in winter. It was several more hours before 40 meters had straightened out.

Not only is the solar flux for Cycle 25 proving to be higher than the very subdued activity of Cycle 24, but the rate of solar flares is higher as well. Eleven years ago in 2012, there were seven X-class flares the entire year. In the first eight

months of this year, we've already had 11 X-class flares. Cycle 24 not only had low sunspot counts, it had only a few dozen X-class flares across the roughly 3 years of its peak. In a more typical solar peak, we would expect more than 100 X-class flares across a 3-year peak. With extensive HF propagation – in the form of the Reverse Beacon Network for CW and RTTY, and PSKReporter for the FT4 and FT8 modes – I expect that we'll have many opportunities to observe in contest data the impact of solar flares through this entire cycle.

Solar flares give little to no warning before their X-ray flux hits the Earth's ionosphere. In contrast, solar eclipses are completely predictable and planning contest-type activity is a great way for hams to contribute to the science of propagation. At the HamSCI website, you can find details of the **October 24 Solar Eclipse QSO Party (SEQP)**. Activation on multiple bands in both CW and PSK modes before, during,

Calendar of Events

All year	CQ DX Marathon	bit.ly/3FyPiui
Sept. 30- Oct. 1	AWA Amplitude Modulation QSO Party	bit.ly/3Qkdp4w
Sept. 30-Oct. 1	UK/EI DX Contest, CW	https://www.ukeicc.com/dx-contest-rules.php
Oct. 1	Peanut Power QRP Sprint	http://www.nogaqrp.org/
Oct 1	UBA ON 80M SSB Contest	https://www.uba.be/en/hf/contest-rules/contest
Oct. 2	RSGB Autumn Series CW	bit.ly/3TxCrxl
Oct. 3	German Telegraphy Contest	https://www.agcw.de/contest/dtc/
Oct. 4	432 MHz Fall Sprint	http://svhfs.org/wp/
Oct. 4	UKEICC 80m Contest SSB	https://ukeicc.com/80m-rules.php
Oct.4	VHF-UHF FT8 Activity	http://www.ft8activity.eu/index.php/en/
Oct. 5	SARL 80m QSO Party	http://bit.ly/H0lqQf
Oct.7	Collegiate QSO Party	https://collegiateqsoparty.com/
Oct. 7	Microwave Fall Sprint	http://svhfs.org/wp/
Oct. 7-8	California QSO Party	http://www.cqp.org/Rules.html
Oct. 7-8	Oceania Phone DX Contest	http://www.oceaniadxcontest.com/
Oct. 7-8	SKCC QSO Party	http://bit.ly/2Xl2vyx
Oct. 7-8	TRC DX Contest	https://trcdx.org/rules-trc-dx/
Oct. 8	UBA ON 80M CW Contest	https://www.uba.be/en/hf/contest-rules/contest
Oct. 10	10-10 Intl. 10-10 Day Sprint	http://bit.ly/1FrFeBc
Oct. 11	RSGB Autumn Series Data	bit.ly/3TxCrxl
Oct. 11	VHF-UHF FT8 Activity	http://www.ft8activity.eu/index.php/en/
Oct. 14	Solar Eclipse QSO Party	https://hamsci.org/seqp-rules
Oct. 14	QRP ARCI Fall QSO Party	http://www.qrparci.org/contests
Oct. 14-15	Arizona QSO Party	https://www.azqp.org/
Oct. 14-15	Makrothen RTTY Contest	http://bit.ly/2uZd6oF
Oct. 14-15	Nevada QSO Party	http://nvqso.com/contest-rules/
Oct. 14-15	Oceania CW DX Contest	http://www.oceaniadxcontest.com/
Oct. 14-15	Pennsylvania QSO Party	http://paqso.org/
Oct. 14-15	PODSX 070 Club 160M Great Pumpkin Sprint	http://bit.ly/2RUkcE6
Oct. 14-15	Scandinavian SSB Activity Contest	https://www.sactest.net/blog/rules/
Oct. 14-15	Veron SLP Contest	http://bit.ly/2L9eT1L
Oct. 15	Asia-Pacific CW Sprint	http://jsfc.org/apsprint/
Oct. 15	UBA ON 2M Phone/CW Contest	https://www.uba.be/en/hf/contest-rules/contest
Oct. 16	RSGB FT4 Contest Series	bit.ly/3TxCrxl
Oct. 16-20	ARRL School Club Roundup	http://bit.ly/MaLmBs
Oct. 18	AGCW Semi-Automatic Key Evening	https://www.agcw.de/contest/sta/
Oct. 18	VHF-UHF FT8 Activity	http://www.ft8activity.eu/index.php/en/
Oct. 20-21	Telephone Pioneers QSO Party	http://tpqso.tparca.org/
Oct.21	Argentina National 7 MHz Contest	https://www.lu4aa.org/wp/concurso-nacional-40m/
Oct. 21	Feld Hell Spooky Sprint	https://bit.ly/3g8gpxD
Oct. 21-22	10-10 Intl. Fall CW Contest	http://bit.ly/1FrFeBc
Oct.21-22	JARTS WW RTTY Contest	http://jarts.jp/rules2022.html
Oct. 21-22	New York QSO Party	http://www.nyqp.org
Oct. 21-22	Stew Perry Topband Distance Challenge	https://www.kkn.net/stew/stew_rules.html
Oct. 21-22	Worked All Germany Contest	http://bit.ly/2uDQRSV
Oct. 21-22	YBDXPI FT8 Contest	https://contest.ybdxpi.net/rules/
Oct. 21-23	YLRL DX/NA YL Anniversary Contest	https://ylrl.net/contests/
Oct. 22-23	Illinois QSO Party	https://w9awe.org/ilqp/

and after the solar eclipse is encouraged, as skimmers for those modes allow through data collection. Find full details at <<https://hamsci.org/seqp-rules>>.

New Club Competition Rules Announced by the ARRL Contest Branch

In mid-August 2023, new ARRL Contest Club Competition Rules were announced. The most obvious shift in Version 1.4 of these rules – online at <<https://bit.ly/45LlCoZ>> - allows Unlimited and Medium category clubs to claim members within a **250-mile circle** on the club roster, replacing the previous ARRL 175-mile circle. My research first finds mention of the 175-mile club circle in November 1975 *QST*, which also included a number of complex clauses requiring attendance at in-person club meetings. The CQ World-Wide DX Contest

(CQWW) rules didn't mention a club circle at all – silently assuming clubs would self-organize around the same ARRL 175-mile circle - until 2013 when a 175-mile US club circle radius was explicitly included in the rules. By fall 2015, the CQ contest circle had been enlarged to 250 miles for US clubs, so in a way ARRL is catching up to the concept of a new and larger club circle.

The top panel of Figure 2 maps the 175-mile club circles for the top ten large Unlimited-category contest clubs. There's certainly some overlap between these existing club circles, especially in the densely populated northeast corridor where the Potomac Valley Radio Club (PVRC), Frankford Radio Club (FRC), and Yankee Clipper Contest Club (YCCC) have their traditional territories.

The bottom panel of Figure 2 shows the result if we simply draw 250-mile circles around the existing 175-mile club

Oct. 22-25	Fall Classic Exchange Phone	https://www.classicexchange.org/
Oct. 25	UKEICC 80m Contest CW	https://ukeicc.com/80m-rules.php
Oct. 26	RSGB Autumn Series SSB	bit.ly/3TxCrxl
Oct. 27	Zombie Shuffle	http://www.zianet.com/qrp/ZOMBIE/pg.htm
Oct. 28-29	ARRL EME Contest	http://www.arrl.org/eme-contest
Oct. 28-29	Veron SLP Contest	http://bit.ly/2L9eT1L
Oct. 28-29	CQ WW DX SSB Contest	http://www.cqww.com/index.htm
Oct. 29-Nov. 1	Fall Classic Exchange CW	https://www.classicexchange.org/
Nov. 1	Silent Key Memorial Contest	https://skmc.hu/en/rules.html
Nov. 1	VHF-UHF FT8 Activity	http://www.ft8activity.eu/index.php/en/
Nov. 4-5	IPARC Contest	http://www.iparc.de/
Nov. 4-5	Ukrainian DX Contest	http://urdx.org/rules.php?english
Nov. 4-6	ARRL CW Sweepstakes	http://www.arrl.org/sweepstakes
Nov. 5	High Speed Club CW Contest	http://www.highspeedclub.org/
Nov. 6	RSGB Autumn Series, Data	bit.ly/3TxCrxl
Nov. 6	UKEICC 80 Meter Contest SSB	https://ukeicc.com/80m-rules.php
Nov. 8	VHF-UHF FT8 Activity	http://www.ft8activity.eu/index.php/en/
Nov. 11	FISTS Saturday Sprint	http://www.fistsna.org/operating.html#sprints
Nov. 11-12	10-10 Digital Fall Contest	http://bit.ly/1FrFeBc
Nov. 11-13	CQ-WE Contest	https://w8zpf.com/cqwe-contest-information/
Nov. 11-12	JIDX Phone Contest	http://www.jidx.org/
Nov. 11-12	OK/OM CW DX Contest	http://bit.ly/19rrRjl
Nov. 11-12	Worked All Europe RTTY Contest	https://bit.ly/36ubggF
Nov. 11-12	AWA Bruce Kelley 1929 Memorial QSO Party	https://bit.ly/2FtzQEn
Nov. 11-13	PODXS070 Club Triple Play Low Band Sprint	http://bit.ly/2Cq2yUA
Nov. 12	North American SSB Sprint	https://ssbsprint.com/rules/
Nov. 12	FIRAC HF Contest	http://www.firac.de/html/contest.html
Nov. 14	DARC FT4 Contest	https://www.darc.de/der-club/referate/conteste/ft4-contest/ft4-rules/
Nov. 15	RSGB Autumn Series, SSB	bit.ly/3TxCrxl
Nov. 15	VHF-UHF FT8 Activity	http://www.ft8activity.eu/index.php/en/
Nov. 17	YO International PSK31 Contest	http://www.yo5crq.ro/index.htm
Nov. 18	All Austrian 160M Contest	https://bit.ly/3fgsiUo
Nov. 18	Feld Hell Turkey Sprint	https://bit.ly/3asfcjj
Nov. 18	RSGB 2nd 1.8 MHZ Contest CW	bit.ly/3TxCrxl
Nov. 18	SARL Newbie Party	http://bit.ly/H0lqQf
Nov. 18-19	LZ DX Contest	http://lzdxbfira.bg/rulesen.html
Nov. 18-19	REF 160-Meter Contest	https://bit.ly/3iHzsQU
Nov. 18-19	SARL Field Day Contest	http://bit.ly/H0lqQf
Nov. 18-19	South American Integration Contest CW	bit.ly/45iH6K9
Nov. 18-20	ARRL SSB Sweepstakes	http://www.arrl.org/sweepstakes
Nov. 18-20	AWA Bruce Kelley 1929 Memorial QSO Party	https://bit.ly/2FtzQEn
Nov. 19	FISTS Sunday Sprint	http://www.fistsna.org/operating.html#sprints
Nov. 19	Homebrew & Oldtime Equipment Party	http://www.qrpcc.de/contestrules/hotr.html
Nov. 23	RSGB Autumn Series, CW	bit.ly/3TxCrxl
Nov. 25-26	CQ WW DX CW Contest	http://www.cqww.com/index.htm
Nov. 25-26	ARRL EME Contest	http://www.arrl.org/eme-contest
Nov. 27	RSGB FT4 Contest Series	bit.ly/3TxCrxl
Nov. 29	UKEICC 80 Meter Contest CW	https://ukeicc.com/80m-rules.php

centers. FRC's territory seems to be almost entirely overlapping with one of more of its neighboring large clubs, including even Contest Club Ontario (CCO). The urban area around Philadelphia simultaneously falls into all three of YCCC, PVRC, and FRC circles when extended to 250 miles. Extending the Southern and Northern California Contest Clubs (SCCC and NCCC) circles to the new limit, almost all of California now falls into one or both of these mega-clubs that previously didn't overlap at all. The Society of Midwest Contesters (SMC) boundaries extends to include several large cities along the Great Lakes, and the expanded Minnesota Wireless Association 250-mile circle includes a crescent of SMC overlap.

Before the enlarging of the ARRL circle, seven of these ten club circles included at least some of the ocean – this was necessary to maximize the length of high-population densi-

ty coastline. Florida Contest Group (FCG)'s territory becomes even more dominated by water when drawn with a 250-mile radius. Some clubs may decide to relocate their club center for ARRL circle purposes to increase the amount of land covered, and others may shift to include members who had moved outside the circle yet are still active and wanting to contribute, or to reduce unnecessary overlap with neighboring clubs. Other clubs may elect to not move their club center at all, as providing in-person meetings across even the previous 175-mile circle could be geographically challenging, never mind the 250-mile circle. Clubs that have emphasized communications through videoconferences, email reflectors, and messaging platforms like Discord and Twitter might find themselves better prepared to handle the challenges of meeting all needs of their members in an expanded club circle.

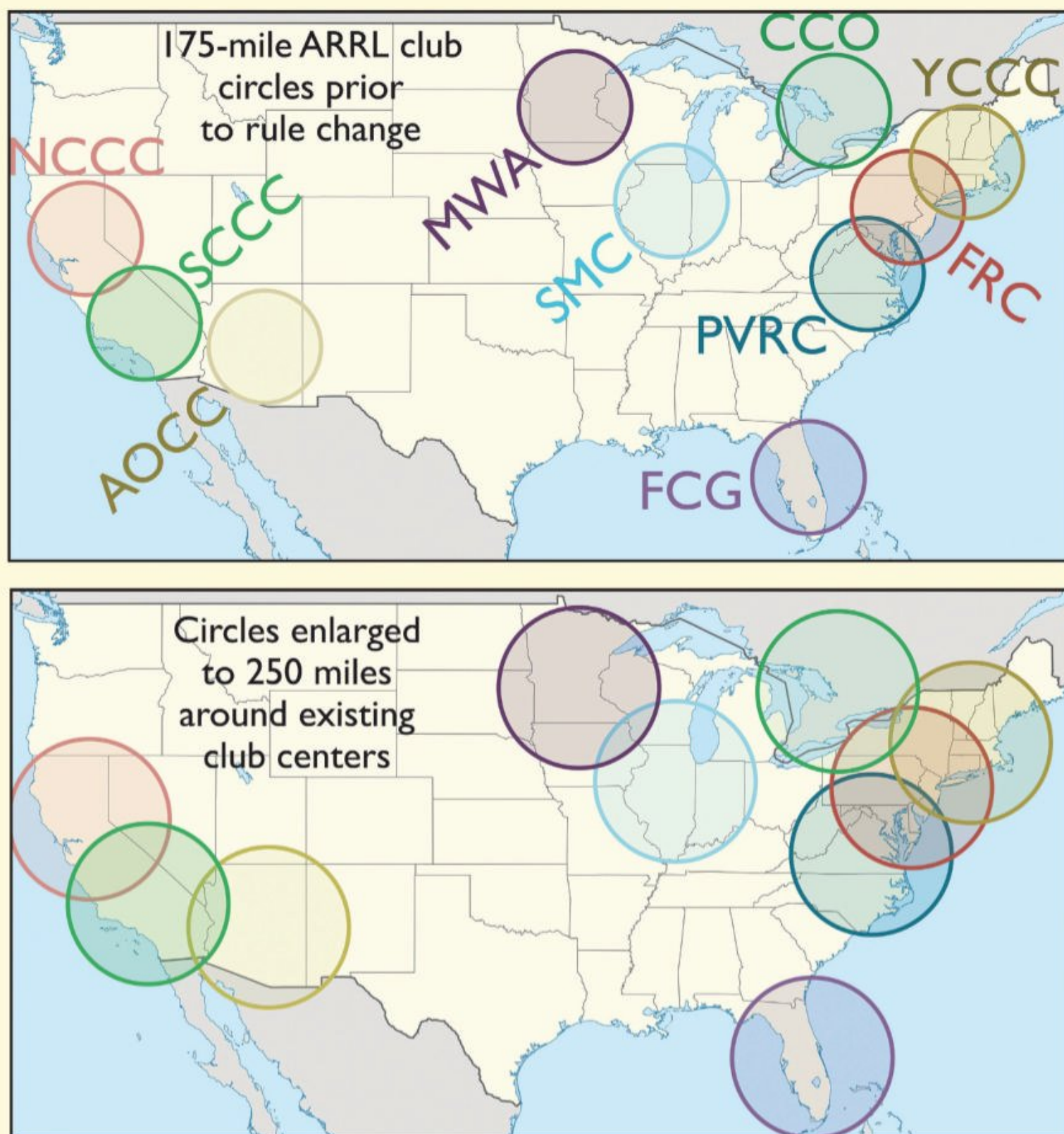

Figure 2. The upper panel shows the 175-mile club circles as claimed by the ten largest contest clubs in the US and Canada. The lower panel shows the increase in each club's territory – and in many cases their overlapping territory – resulting from simply increasing their club circle to 250 miles around the same club center. All club data from the ARRL Contest Portal at <<https://contests.arrl.org/>>. The list of top ten clubs is from the ARRL DX 2023 club results.

(from page 18)

In all previous versions of ARRL Club rules, the only way the two modes of the ARRL DX contests allowed out-of-circle operations to count towards club scores was through DXpeditions. Under the new rules, **out-of-circle operations can count towards all ten ARRL Contests with a club competition.** This change is obviously impactful in the ARRL 10-Meter and 160-Meter contests where previous DXpeditions by members couldn't count towards their club's total.

Even domestic (US and Canada) efforts can count towards a club score if they are multi-operator efforts. In particular, new ARRL club rules seem likely to entice club-based efforts to activate "rare" ARRL and RAC sections in Sweepstakes. Remember how last November, it was very difficult to find the Los Angeles (LAX) section in ARRL Sweepstakes CW? Imagine an east coast club, for example, putting together a multi-operator road-trip effort to activate that ARRL section this year! Remote activation of the rarer ARRL and RAC sections is another exciting possibility: Gerry Hull, W1VE, has been engineering remote access to VY1 (Canada's Northwest Territories) across multiple contests. When I pointed out the new ARRL rule change, he immediately made the logical leap, "So VY1 counts for YCCC credit!" With Gerry having arranged for regular remote operations, it seems entirely feasible for a club to get a couple ops to remote in, meeting the ARRL requirement of a multi-operator activation for domestic expeditions for club credit.

Qualification Rules announced for WRTC2026

The UK organizers of the World Radiosport Team Championship 2026 have announced qualification details for the next WRTC. From the CQ WW DX SSB contest at the end of October through the ARRL DX SSB contest in spring 2025, there are 15 contests included in the slate, including for the first time ever a "M2 LP" category in the 2025 IARU HF contest. Look for intense activity across the world in these qualification events as contesters strategize within the complex selection rules to claim one of the scarce 42 qualifying team leader slots. Full details can be found at <<https://www.wrtc2026.org/>>.

October and November Contest Highlights

The **California QSO Party** begins Saturday October 7 with several rule changes, including an M/2 category. You can read about the incentives for activating the rarest of the 58 California counties and full rules at <<https://www.cqp.org/>>.

Chase German districts (the first letter of the DOK exchange) as multipliers in the Worked All Germany contest running 24 hours on October 21 and 22. Full rules and recommended frequencies are at <<https://bit.ly/3qORN8f>>.

Ham radio's largest contest of all, the **CQ World Wide DX SSB Contest**, is the 48 hours of October 28-29. Find full rules and an insightful FAQ at <<https://cqww.com/>>. Also check out NG3K's ever-growing list of planned DXpeditions that will be active for this contest – it's online at <<https://bit.ly/3OXpRqK>>.

Get your logging computers ready for the new RAC section abbreviations used as the exchange in both modes of the November ARRL Sweepstakes. What had been called GTA for Greater Toronto Area, is now GH for Golden Horeseshoe. The previous Martimes RAC section is now split into two independent multipliers, New Brunswick (NB) and Nova Scotia (NS). With this change, there are now a maximum of 84 multipliers in the ARRL Sweepstakes. CW Sweepstakes starts Saturday November 4th, and the SSB Sweepstakes begins Saturday November 18th. The ARRL has a full package of literature online at <<http://www.arrl.org/sweepstakes>>.

get into, and the fact of just how 'well' I've been treated. I'm not interested in broadcasting, more just interested in DXing on not only the SW bands, but the AM/FM bands as well.

SW/AM/FM DXing is a very easy entrance into the world of ham radio, but it just feels like it's ignored to rush people into the ham bands. If I had to succinctly describe it, it's like the old *Twilight Zone* episode, "Eye of the Beholder." Where it's not based on looks, good, bad or otherwise, it's more that those who don't dive deeply into the field are exiled to this island far away from the community, labeled as 'freaks' or 'nerds' or the like.

I don't really know what effect this will have, but I've been doing SW for almost 45 years, never really dipping my toe into the deep end, but with the modern technology, with SDRs and the like, it's easier to find equipment to move into the ham bands than it is to pick up a good easy antenna, and to find someone who actually knows about it.

DX'ers like me are supposed to be siblings to the ham bands, but it's more like we're that irritating, older, crazier sibling you keep locked up when company is over.

Thanks for listening, anyways.

Kris Herzog, WPC9WHO

W2VU responds: Thank you for the eye-opening letter, Kris. Broadcast DXing was certainly a gateway to amateur radio for many of us (along with CB, although few are willing to admit it), and I'll bet that more than a few of us still at least occasionally spin our tuning dials beyond the borders of the ham bands to see what else is out there. I am sorry that many of the hams you encounter in person are less-than-welcoming of SWLs. We are all radio hobbyists, and sharing our knowledge and experience has always been a hallmark of the radio hobby.

The shortwave spectrum is in a state of flux right now, in terms of who is using it for what purposes. While many of us bemoan the loss of favorite international broadcasters to satellites and the internet, the absence of those powerhouse signals opens the door for tuning in weaker signals and perhaps catching some rare DX, especially with a great sunspot cycle under way. In addition, other interests are looking at possible uses of the shortwave spectrum, such as the finance folks who want to use big chunks of it (often right next to the ham bands) for high-powered high-speed data transmissions to inform traders of trends and transactions a few milliseconds sooner than data sent via satellite or over the internet.

Here at *CQ*, with the approaching retirement of "Listening Post" editor Gerry Dexter, we're looking at our options for the future direction of our SWL coverage ... Do we keep it the same? Do we focus on what else is out there to listen for? Do we add info on finding "broadcasters" online or on satellite feeds? We'd love to hear ideas and suggestions from you and other readers, as well as anyone interested in taking over the "Listening Post" column and leading it in whatever direction the future takes us. If you have input or would like to volunteer, please contact me at <w2vu@cq-amateur-radio.com>. Tnx & 73.

propagation

BY TOMAS HOOD,* NW7US

October Shortwave Propagation

Quick Look at Current Cycle 25 Conditions: (Data rounded to nearest whole number)

Sunspots:

Observed Monthly, August 2023:115

Twelve-month smoothed, February 2023:118

10.7 cm Flux:

Observed Monthly, August 2023:154

Twelve-month smoothed, February 2023:153

One Year Ago:

(Data rounded to nearest whole number)

Sunspots:

Observed Monthly, August 2022:70

Twelve-month smoothed, February 2022:64

10.7 cm Flux:

Observed Monthly, August 2022:118

Twelve-month smoothed, February 2022:109

The following is a band-by-band summary of DX propagation conditions expected from mid-October through mid-December and centered on the two CQ World Wide DX contest weekends, hence we will focus on bands active in the contests. Next month's column will update this summary.

160 Meters: Considerably decreased static levels, and longer hours of darkness in the northern latitudes should provide good DX openings on this band. These openings will often be weak due to the relatively high signal absorption since we are not yet to the longest periods of daily darkness. But give this band a try, as fairly good openings should be possible toward Europe and the south from the eastern half of the United States, and toward the south, the Far East, Australasia, and the South Pacific from the western half of the country. Other DX openings might also be possible. The best propagation aid for this band (and for 80 and 40 meters as well) is a set of sunrise and sunset curves, since DX signals tend to peak when it is local sunrise at the easterly end of the path. A good Internet web site featuring a greyline map display is found at <<https://www.fourmilab.ch/earth-view/>>. Follow the link, "map of the Earth" showing the day and night regions.

80/75 Meters: These should be good for DX openings to many areas of the world during the hours of darkness and into the sunrise period. The band should peak towards Europe and in a generally easterly direction around midnight. For openings in a generally western direction, expect a peak just after sunrise. The band should remain open towards the south throughout most of the night. Propagation in this band is much like what we expect on 40 meters, except that signals will be somewhat weaker on average, noise levels will be a bit higher, and the period for band openings in a particular direction will be a bit shorter.

40 Meters: This should be the hottest DX band during hours of darkness as the seasonal static levels are lower than they were during the summer. The band should be open first for

DX toward Europe and the east during the late afternoon. Signals should increase in intensity as darkness approaches. During the hours of darkness expect good DX openings to most areas of the world. Signals should peak from an easterly direction about midnight, and from a westerly direction just after sunrise. Excellent openings toward the south should be possible throughout most of the nighttime period. When the Last-Minute Forecast indicates **Above Normal** or **High Normal**, the choice for best nighttime band will be between the 40- and 20-meter bands.

20 Meters: DX openings should be possible on this band both day and night. Conditions should peak from about an

LAST-MINUTE FORECAST

Day-to-Day Conditions Expected for October 2023

Propagation Index	Expected Signal Quality			
	(4)	(3)	(2)	(1)
Above Normal: 2,4-9,13-14,19-21,29,31	A	A	B	C
High Normal: 3,11,15,18,25-26,30	A	B	C	C-D
Low Normal: 12,22	B	C-B	C-D	D-E
Below Normal: 1,10,16,23,28	C	C-D	D-E	E
Disturbed: 17,24,27	C-D	D	E	E

Where expected signal quality is:

A--Excellent opening, exceptionally strong, steady signals greater than S9

B--Good opening, moderately strong signals varying between S6 and S9, with little fading or noise.

C--Fair opening, signals between moderately strong and weak, varying between S3 and S6, with some fading and noise.

D--Poor opening, with weak signals varying between S1 and S3, with considerable fading and noise.

E--No opening expected.

HOW TO USE THIS FORECAST

1. Using the Propagation Charts appearing in "The CQ Shortwave Propagation Handbook, 4th Edition," by Carl Luetzelschwab, George Jacobs, Theodore J. Cohen, and R. B. Rose.

a. Find the *Propagation Index* associated with the particular path opening from the **Propagation Charts**.

b. With the *Propagation Index*, use the above table to find the expected signal quality associated with the path opening for any given day of the month. For example, an opening shown in the **Propagation Charts** with a *Propagation Index* of 4 will be fair on October 1, excellent from October 2 to October 9, then fair on October 10, and so forth.

2. Alternatively, you may use the *Last-Minute Forecast* as a general guide to space weather and geomagnetic conditions throughout the month. When conditions are *Above Normal*, for example, the geomagnetic field should be quiet, and space weather should be mild. On the other hand, days marked as *Disturbed* will be riddled with geomagnetic storms. Propagation of radio signals in the HF spectrum will be affected by these geomagnetic conditions. In general, when conditions are *High Normal* to *Above Normal*, signals will be more reliable on a given path, when the ionosphere supports the path that is in consideration. This chart is updated daily at <<https://SunSpotWatch.com>> provided by NW7US.

* P.O. Box 110

Fayetteville, OH 45118

Email: <nw7us@nw7us.us>

@NW7US (<https://Twitter.com/NW7US>)

@hfradiospacwx (<https://Twitter.com/HFRadioSpaceWX>)

The **CQ** Shortwave Propagation Handbook-4th Edition

Your indispensable guide to HF propagation for the new sunspot cycle!

Fully updated and expanded to include the latest propagation forecasting tools, as well as our time-tested "analog" tables for making your own customized predictions, the 4th edition of *The CQ Shortwave Propagation Handbook* is a must-have resource for any DXer, contester or emergency communicator.

This 8.5 x 11, full-color title explains the many ways in which radio signals can travel long distances and how to use this knowledge to maximize your DX success. Also, includes sections on low-frequency and VHF/UHF propagation in addition to its main focus on shortwave (HF) propagation. Finally, it's all in plain English with a focus on practical applications, making it a valuable reference for the ham radio DXer as well as the ionospheric scientist and anyone in between.

This fourth edition was spearheaded by propagation authority Carl Luetzelschwab, K9LA, merging his updates with the earlier work of the previous editions' authors, Dr. Theodore Cohen, N4XX, George Jacobs, W3ASK, and Robert Rose, K6GKU (SK).

So don't miss your opportunity to take full advantage of Solar Cycle 25 as it brings life back to our shortwave bands!

Order Your Copy Today!

208-page Paperback—Only \$42.95

Book on CD—\$32.95

Buy Both the Paperback and CD—Only \$61.95

Plus applicable shipping!

CQ Communications, Inc.

Phone: 516-681-2922 <http://store.cq-amateur-radio.com>

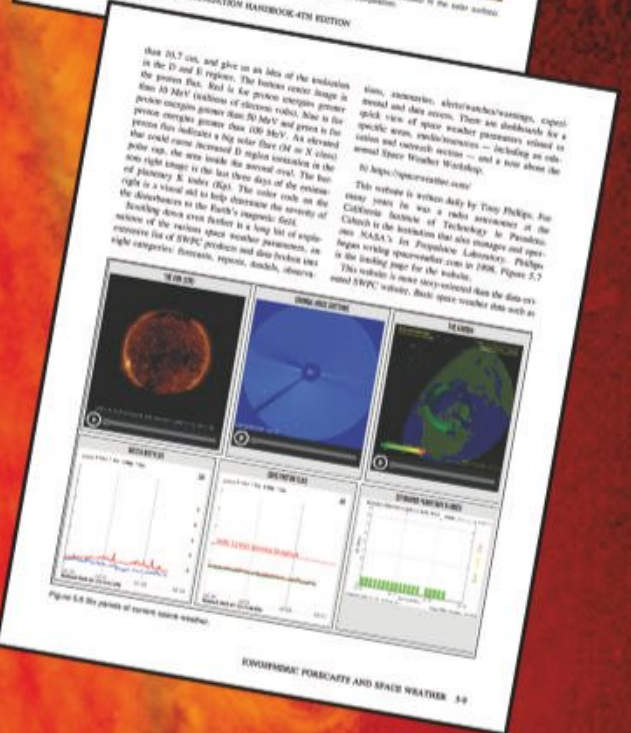
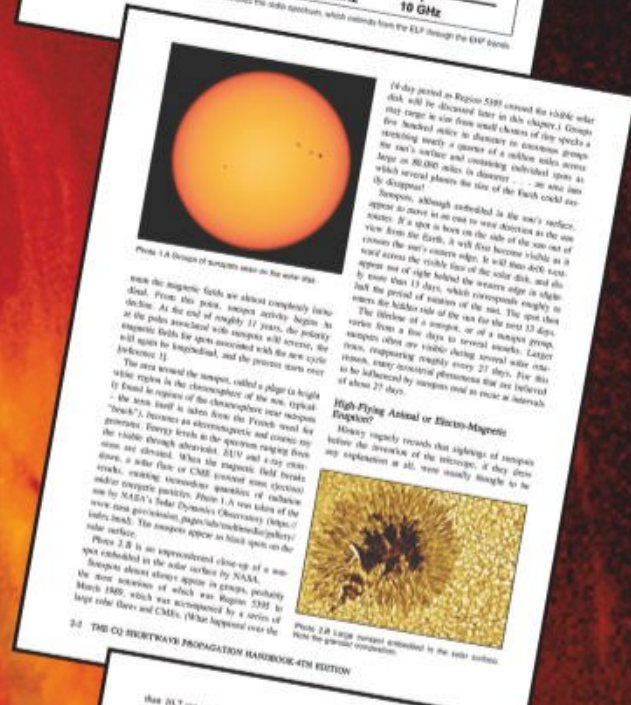
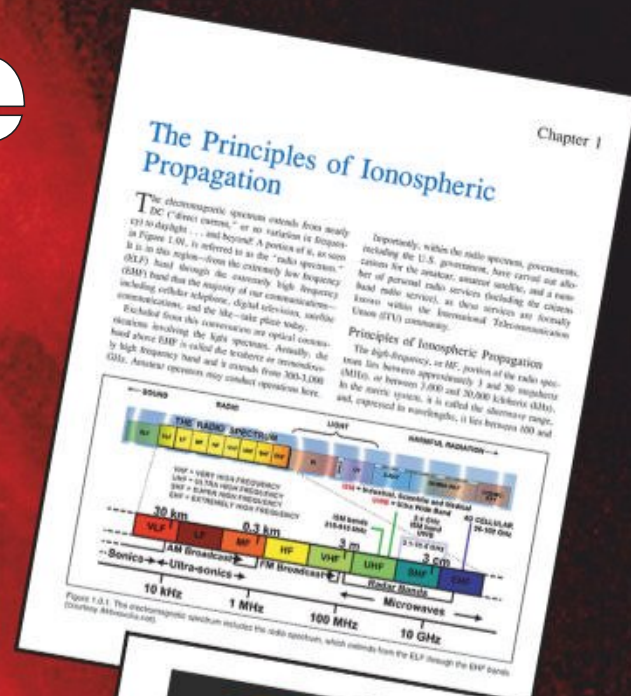

hour or two after sunrise and again during the late afternoon and early evening hours. Expect to work into some areas of the world between sunrise and sunset when conditions are a mix of low geomagnetic activity and an increase in solar activity. Good openings should be possible between many areas of the world during the dusk and dawn periods, following the greyline. When conditions are above normal, expect 20 meters to offer a few worldwide DX openings during the night.

Look for long-path openings for about an hour or so after sunrise and again for an hour or so before local sunset. Signal levels are expected to be exceptionally strong during the October contest period.

15 Meters: This year, 15 meters will be a hot DX band. During the daylight hours, this band provides significant action. Expect great conditions from shortly after sunrise through the early evening hours. The band could remain open into the evening toward southern and tropical areas.

10 Meters: This band will yield a plethora of daytime contacts during the contest weekends, especially between the points in the southern hemisphere, and along paths crossing the equator. This band can even provide some DX during hours of darkness.

VHF Conditions

Sporadic-E activity is very rare during October in the northern temperate zone (where much of the U.S. is located). While the contest weekend looks like a quiet period, there are a few days forecast with moderate geomagnetic activity and possible radio storms. It is possible to have a few auro-

ra-mode (Au) propagation events during October. Remember that digital modes and CW are the best way to go with aurora, particularly on 144 through 432 MHz, as the voice modes become extremely distorted and unrecognizable because of the aurora. The best times to check for VHF aurora openings are when conditions are expected to be Below Normal or Disturbed, as shown in the *Last-Minute Forecast* included in this column.

There is some possibility of extended tropospheric conditions during October because of changing weather patterns. Two meters is the best band to watch for this.

October has the Draconids meteor shower, active between the 6th and the 10th, and expected to peak on October 8. The shower could reach storm levels—hundreds of meteors per hour. The best time to check for radio propagation would be from about midnight until dawn.

The Draconids is primarily a periodic shower that has twice produced spectacular, brief, meteor storms in the last century, in 1933 and 1946. In 1999, a wholly unexpected minor outburst was witnessed from the Far East. Draconid meteors are exceptionally slow moving, a characteristic which helps separate genuine shower meteors. This shower could produce meteor scatter mode (Ms) propagation openings on VHF and UHF.

Check out <<https://www.imo.net/files/meteor-shower/cal2023.pdf>> for a complete calendar of meteor showers in 2023.

If you use “X” (formerly Twitter.com), you can follow <[@hfradiospacewx](https://twitter.com/hfradiospacewx)> for hourly updates that include the K index numbers. You can also check the numbers at <<https://SunSpotWatch.com>>, where this columnist provides a wealth of current space weather details as well as links. Please report your observations of any notable propagation conditions, by writing this columnist via X, or via the Space Weather and Radio Propagation Facebook page at <<https://fb.me/spacewx.hfradio>>.

CURRENT SOLAR CYCLE PROGRESS

The Royal Observatory of Belgium reports that the monthly mean observed sunspot number for August was 114.9. The twelve-month running smoothed sunspot number centered on February is 117.9. A smoothed sunspot count of 110, give or take about 9 points, is expected for October 2023.

The Dominion Radio Astrophysical Observatory at Penticton, BC, Canada, reports a 10.7-cm observed monthly mean solar flux of 153.92 for August 2023. The twelve-month smoothed 10.7-cm flux centered on February is 152.5. The predicted smoothed 10.7-cm solar flux for October is 136, give or take 7 points.

Geomagnetic activity level this month is expected to range from quiet to very stormy, resulting in periods of degraded propagation this month. Remember that you can get an up-to-the-day *Last-Minute Forecast* at <<https://SunSpotWatch.com>> on the main page.

I welcome your thoughts, questions, and experiences regarding this fascinating science of propagation. You may e-mail me, write me a letter, or catch me on the HF Amateur bands. If you are on Facebook, check out <<https://fb.me/spacewx.hfradio>> and <<https://fb.me/NW7US>>. Speaking of Facebook—check out the CQ Amateur Radio magazine fan page at <<https://fb.me/CQMag>>. Also, please check out the new alternative social networking ham radio group at <<https://amateurhamradio.locals.com/>> and please share this with your amateur radio friends and clubs.

73, Tomas, NW7US

news bytes: (from page 7)



Photo C. Yaesu's Nori Romero presented Kees with two new radios, an FT-70DR digital/analog 2-band handheld, and an FTM-6000 dual-band FM mobile transceiver.

Amateur Radio Newsline anchor Don Wilbanks, AE5DW (Photo B), was the master of ceremonies at the annual presentation. Joining Don and Kees on stage was Yaesu USA Sales Office Manager Nori Romero (Photo C), who came bearing gifts! Yaesu is a corporate sponsor of the Newsline Young Ham of the Year award, along with CQ, Heil Sound and RadioWavz antennas. (Photos by Joe Eisenberg, K0NEB)

ADVERTISERS' INDEX

SEPTEMBER 2023

Advertiser	Page	Phone	Website
Advanced Specialties Inc.	39	201-VHF-2067www.advancedspecialties.net
AirBoss, Olah Technologies LLC	81	336-457-7783www.olahtechnologies.com
Alaskit	24	907-371-7120www.alaskit.net
Amateur Radio Roundtable	47	901-570-2188www.W5KUB.com
Bioenno Power	49	888-336-7864www.bioennopower.com
Buckmaster International LLC	39	540-894-0907www.HamCall.net
Buddipole Antennas	42	503-591-8001www.buddipole.com
CQ Merchandise	25,37,Cov III	516-681-2922http://store.cq-amateur-radio.com
CW	71	561-302-7731www.success-is-easy.com
Communications Concepts, Inc.	71	937-426-8600www.communication-concepts.com
Electric Radio Magazine	49	720-924-0171www.ermag.com
HamTestOnline	39	888-857-6164www.hamtestonline.com
Icom America Inc.Cov II,Cov IV		www.icomamerica.com
Impulse	71	www.impulseelectronics.com
LDG Electronics	83	410-586-2177https://groups.io/g/lidgelectronics
Nut & Volts	90	www.nutsvolts.com
Playing with Meteors	57	516-681-2922http://store.cq-amateur-radio.com
PreciseRF	1	503-915-2490www.preciserf.com
PreppComm	39	www.PreppComm.com
QCWA	30	352-425-1097www.qcwa.org
RF Parts	31	800-921-4834www.rfparts.com
RT Systems	7, 63	800-921-4834www.rtsystemsinc.com
Radio Amateur Club of JHS 22	61	516-674-4072www.wb2jkj.org
REACT Int'l	89	301-316-2900www.REACTintl.org
Shortwave Propagation Handbook	109	516-681-2922http://store.cq-amateur-radio.com
Technical Antennas	81	305-850-7779www.TechnicalAntennas.com
W2IHY Technologies	49	845-889-4253www.w2ihy.com
W5SWL	47	www.W5SWL.com
YLRL	11	www.ylrl.org

Let **CQ** help you get the most for your advertising dollar!
Contact Dottie K, **CQ**'s Advertising Director
at 516-681-2922 x 106 or via email at ads@cq-amateur-radio.com

Advertising Rates: Non-commercial ads are 20 cents per word including abbreviations and addresses. Commercial and organization ads are \$1.00 per word. Boldface words are \$1.50 each (specify which words). Minimum charge \$2.00. No ad will be printed unless accompanied by full remittance. All ads must be typewritten double-spaced.

Closing Date: The 10th day in the third month preceding date of publication (example: Jan. 10th for the March issue). Because the advertisers and equipment contained in Ham Shop have not been investigated, the Publisher of CQ cannot vouch for the merchandise listed therein. The publisher reserves the right to reject any advertisement. Direct all correspondence and ad copy to: CQ Ham Shop, P.O. Box 1206, Sayville, NY, 11782 (e-mail: <hamshop@cq-amateur-radio.com>).

**RF Connectors & Gadgets
Parts — Products — More
www.W5SWL.com**

WANTED: General Electric Wall Clock 2915_. Or 24-hour sister. W0EVC (573) 248-2043.

FLASH CARDS for all FCC Exams, Amateur and Commercial. VIS Study Guides <www.visradio.com> 800-655-HAMS and on Amazon Marketplace.

WWW.CABLEHELP.COM 160M antennas for small spaces. (662) 332-8454.

For Sale: HF RADIO ICOM IC-78 TRANSCEIVER. New, unused, perfect condition. Includes power supply. Make offer. chuck_kaptain@wycliffe.org

WANNA START A RAG-CHEW WITH THE GENERAL PUBLIC ABOUT THE VALUE OF AMATEUR RADIO? Introduce them to Harold, a ham who is trying to keep his day job post-Pandemic, and his wife, Sabrina, who is hoping to keep her yarn shop alive. SIDEWALK SALE ACROSS AMERICA, available Amazon Kindle, paperback. Peg Nichols, KD0VQO@arrl.net.

FOR SALE Rare Collins KW-1, serial number 96. Only 150 made and it still works! \$16,000 firm. Pictures upon request. Contact Teresa: <Trjtwo@gmail.com> or via telephone 805-878-1691.

Wanted: Original set of knobs for my Heathkit HW-8. Paul, WB0MPG, 538 North Walnut, Wichita, KS 67203. (316) 351-7717.

Wanted: Old slide rules for personal collection. Send info to db_cunningham@hotmail.com

Morse Code on a CD. Just want A to Z and Zero to 9 in code only. Contact Ronald (KD7FWC) (775) 962-5437.

AMECO AC-1 DIY Kits: www.thenewameco.com

Affordable Custom Antenna Design www.ant-build.com

Recognize the signature CW sounds of over 4000 words! Start to read whole words sent in fast Morse code! <https://www.hearcwwords.com>

Yaesu FT-100D (HF-VHF-UHF). Great mobile rig with manual, internal keyer and mike. \$300. (281) 934-8783.

Keychain QRP: Worlds Smallest HF Transmitter. Handmade in the USA. <www.bit.ly/KeychainQRP>

GET THE F.C.C. "COMMERCIAL" RADIOTELEPHONE LICENSE! Fast, inexpensive home study course. Command Productions. www.LicenseTraining.com. Free info: (800) 932-4268.

NEVER have another faulty patch cable! 15-page, photo-illustrated manual details a revolutionary procedure for assembling failure-proof coaxial cable patches. \$10 postpaid U.S., \$15 foreign. R.W. Parker, 1205 Sleepy Hollow Road, Pennsburg, PA 18073.

CallSign Stuff www.hamQRU.com KTØMMY

WANTED: 500-Kc Ships Transmitter. IE: MACKAY MARINE 2017A. w8wz@aol.com

NO NONSENSE LICENSE STUDY GUIDES: kb6nu.com/cq

Wanted: Channel Master model 110 Quantum Antennas 1 or more in box good condition! W.J. Gibbs, Jr. 601 Howard Street. Columbia, NC 27925

QRP J-36: 1/2-Scale Microkey. Full-Functional "BUG" Made in the USA by KA6IRL. <QRPJ36.com>

WANTED: IBM Model M, Space Saving Keyboard, Call KØKG, (218) 850-1500 or email: <keith.gilbertson@q.com>.

AMATEUR RADIO ELECTRONICS: Home Study Software, Apps, and eBooks \$2.99. <www.eptsoft.com/HomeStudy>

POLYESTER ROPE: excellent for antenna support and guying. Go to <www.audiotronics.us>.

REAL HAMS DO CODE: Move up to CW with **CW Mental Block Buster III**. Succeed with hypnosis and NLP. Includes two (2) CDs and Manual. Only \$29.95 plus \$7.00 s/h US. FL add \$2.14 tax. Success Easy, 568 SE Maple Terrace, Port St. Lucie, FL 34983, phone 561-302-7731, <www.success-is-easy.com>.

TWO NEW NOVELS involving ham radio: *Full Circle*, and *Frozen in Time*, by N4XX. Visit <<http://www.theodore-cohen-novels.com/>>.

QSLing SUPPLIES. e-mail: <plumdx@msn.com>.

CASH FOR COLLINS, HALLICRAFTERS SX-88, & DRAKE TR-6. Buy any Collins equipment. Leo, KJ6HI, phone/fax 310-418-9269, e-mail: <radioleo73@gmail.com>.

MicroLog by WAØH

Easy to use logging program.

Free download . . . www.wa0h.com

www.oldqslcards.com

OVERSEAS AIRMAIL POSTAGE plus complete line of airmail envelopes. Order directly from our website. James E. Mackey, proprietor. website: <www.airmailpostage.com>

TOWER ACCESSORIES Gin Pole Kits – stand off brackets – antenna mounts – vehicle radio mounts – for 30 years. IIX Equipment Ltd., 708-337-8172, <<http://www.w9iix.com/>>.

HOMEBREW! "Recollections of a Radio Receiver" a 565 page book on HBR homebrew receivers. \$10 delivered (eBook on CD-ROM). Details <www.w6hht.com>

DXPEDITION DVD VIDEOS: For full description and how to order . . . <www.k4uee.com/dvd/>.

ARMS – Amateur Radio Missionary Net. Christian Fellowship Net, Everyone Welcome. 14.3075 Daily except Sunday 1500–1700Z, –1 Hr DST. Website: www.qsl.net/arms

VORTEX ANTENNA SYSTEMS specialist in HF and VHF high performance antennas. Yagis and Delta Loops. Linear Loaded 30 and 40m Arrays. OWA Arrays, bespoke individual design solutions. Antenna related hardware. We ship worldwide including North America. <www.vortexantennas.co.uk/>. or by e-mail to <enquiries@vortexantennas.co.uk>.

"World of Keys – Keys III" book features highly detailed views and photos of keys, bugs, and paddles like few people have ever seen (\$18)!. Also still available, **"Keys II"** (\$16) and **"QRP Romps!"** (\$18), plus **"Your Guide to HF Fun"** (\$16). Available from dealers nationwide.

PACKET RADIO AND MORE! Join TAPR, connect with the largest amateur radio digital group in the U.S. Creators of the TNC-2 standard, working on Software Defined Radio technology. Benefits: newsletter, software, discounts on kits and publications. For membership prices see the TAPR website: <<http://www.tapr.org/>>.

HONDURAS DX VACATION: K3, Alpha 86, SteppIR, Meals, Private Facilities. HR2J, (206) 259-9688.

HY POWER ANTENNA COMPANY <<http://www.freewebs.com/hypower>> Multiband dipoles, delta loops, half squares and QRP antennas.

NEW AMATEUR RADIO MAP with DXCC list updates. Full color 22 x 34" – \$10. Free shipping on club orders. <http://www.hamradiomap.qth.com/>

Wanna ham in the **CAYMAN ISLANDS?** Go to <www.martykaiser.com/24a.htm>.

WWW.ISOTRONANTENNAS.COM FOR HF. CHECK IT OUT! Call: 719-687-0650; <wd0eja@isotronantennas.com>

RADIO SHINE TM - Make your Radio Shine! Cleaner for plastics, paint and glass in electronic equipment **See video on Youtube Search for "Radioshine" or "K8BYP"**

**RF Connectors & Gadgets
Parts — Products — More
www.W5SWL.com**

CRANK-A-WATT Power & More via KE5NYS. Visit <www.FactorReady.com>

NEED ROPE? All kinds, types, including: antenna rope, hauling, gin. **FREE**, free consultation, Go to <<http://www.davisropeandcable.com/>>. Veteran owned, K1PEK, 978-369-1738.

FUTURE TIMES: Dreams and visions of Disasters. Great guide book for Hams. www.xlibris.com/futuretimes.html

HAWAII DX VACATION: SteppIR antennas, amplifiers, private. KH6RC, <www.leilanibedandbreakfast.com>.

HAM TRAVELERS Discount travel, tours, cruises, more. www.GreatExpectationTravel.com

www.peidxlodge.com

NEAT STUFF! DWM Communications: <<http://qth.com/dwm>>

PROMOTIONAL VIDEO: 15-minute DVD describes amateur radio's fun and public service. Details: <www.neoham.org>.

HAM RADIO GIFTS: <www.mainestore.com>

WANTED: OLD QSL CARD COLLECTIONS. Collector seeks US & DX cards. W2VRK, 5 Mohawk Trail, Branchburg, NJ 08876; e-mail: <tplrs@comcast.net>.

TELEGRAPH KEY INFORMATION AND HISTORY MUSEUM: <<http://w1tp.com>>

FT243 AND HC6U CRYSTALS: www.af4k.com

OLD QSLs Available. 50's and 60's, DX and USA. Specify call, send SASE. W5SQA@arrl.net

QRP KITS: <www.breadboardradio.com>

RFI Filters <www.RFchoke.com>

FMTV ARTICLES: Comprehensive transmitter and receiver deviation calibration, standards, intermodulation, power amplifier calculations. WB9OQM, <http://mathison.freeshell.org>

www.SecondHandRadio.com

HF Mobile or Fixed Virtual X Antenna Patent: For Sale or License. Request Free Power Point Presentation file. Shows design details, pictures, prototype tests. Design applies to a broad frequency range for mant antenna arrays/beams/verticals. <lgslay@sbcglobal.net>. Larry Slay, K5WUL

FOR SALE: Samlex Power Supply Model SEC 1223, 13.8V @ 25 amps. Not working. Includes operating manual and schematic. Price \$50 or best offer. Contact Harry, W9HRQ, at <harrygraziano@gmail.com> or phone 1-773-334-4492.

ANTENNA & TOWER HARDWARE: Aluminum plates: Boom to elements, boom to mast, GP/Vertical antennaground plates, Rohn 25/45 to cross arms plates, Hexabeam / spiderbeam Hubs, Moxon hubs, U bolts with sadles. **All info at: e78WW@yaho.com or at e-bay store: stores.ebay.com/yz4iz0**

Amateur and Premium Stereo Equipment Repaired / Calibrated / Restored. Please see us at www.chfelectronics.com.

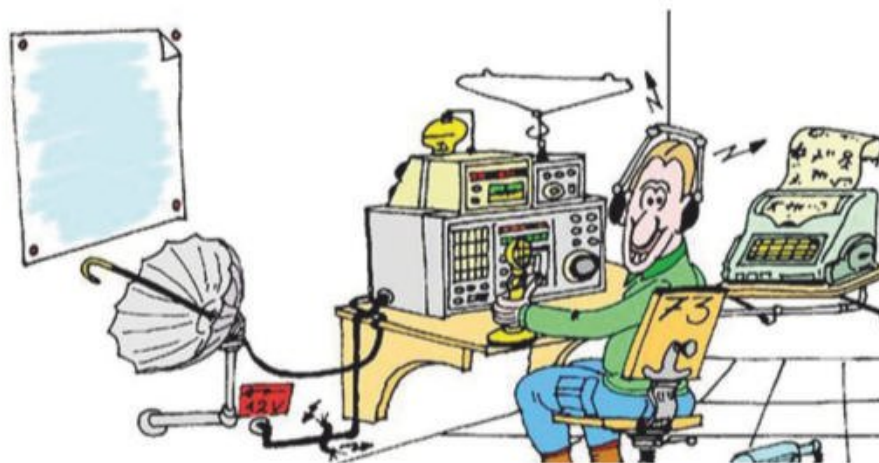



CQ **Amateur Radio**
Connecting Generations!

Fun to read, interesting from cover to cover, written so you can understand it. **That's CQ.** Read and enjoyed by thousands of people each month!

The changes in amateur radio over the years have been astounding. Still some things have remained remarkably the same, namely the type of people who are drawn to the hobby. As a group, hams have a tremendous amount of knowledge on a wide array of topics, an amazing willingness to share that knowledge with each other, and an unwavering commitment to helping neighbors, near or far, in times of need.

So whether you are an old-timer or new to the hobby accept the challenge and read **CQ. SUBSCRIBE TODAY!**

Print or Digital...Your Choice

PRINT EDITION ONLY

1yr—12 issues \$42.95 2yrs—24 issues \$77.95 3yrs—36 issues \$111.95

DIGITAL EDITION ONLY

1yr—12 issues \$30.00 2yrs—24 issues \$57.00 3yrs—36 issues \$83.00

COMBO Subscriptions - Get BOTH the PRINT & DIGITAL EDITIONS

1yr—12 issues \$61.95 2yrs—24 issues \$112.95 3yrs—36 issues \$161.95

CQ Communications, Inc.

Phone: 516-681-2922 <http://store.cq-amateur-radio.com>

**Heard It.
Worked It.
Logged It.**



IC-7851
The Ultimate HF / 6M Transceiver



IC-7300
HF / 6M SDR Transceiver



IC-7610
HF / 6M SDR Transceiver

For the love of **ham radio.**



www.icomamerica.com/amateur
insidesales@icomamerica.com

