

## Contents

Contents .....	1
Committee Contacts.....	2
Editorial .....	4
Post and News.....	5
Bob Roberts, BATC President 1972 - 1977 .....	7
Improving VIC20 Video.....	9
Circuit Notebook #59.....	12
CAT 96 REPORT, "by an observer" .....	17
In Retrospect .....	20
Amateur Television Repeater GB3TM.....	21
Satellite Pictures.....	23
Mods for the Tatung Earlybird Satellite Receiver.....	24
Satellite TV News.....	26
Subscription Renewals for 1997 .....	37
New World Record on 10 GHz ATV, 592 km .....	39
Narrow Band FM ATV Reception.....	41
The Chrominance Equaliser .....	47
Contest Calendar 96/97 .....	50
Pictures to Holland? .....	51
Video Editing on a PC.....	55
405 Alive – Can They Be Serious?.....	58
GUNNMOD2 & TVRO3 a Review.....	60
I <sup>2</sup> C Logic for the GB3EY Repeater.....	64
Enhancements to the Sony Video Printer .....	70
A Bit of Pan and Tilt.....	74
Repeater Update.....	83
TV on the Air.....	84
The NE568 as a Wideband FM Demodulator .....	89
For Sale.....	93
Wanted.....	96

CQ-TV is produced on a P6 Gateway 2000 PC computer system, using the Word for Windows word processing package. The camera ready artwork is produced on an Hewlet Packard LaserJet 4 printer.

Edited by Trevor Brown, compiled by Ian Pawson, proof read by Clive Reynolds. All rights reserved, all wrongs denied. © 1996 by the BATC.

Printed by *Cramphorn Printers Ltd.*, 15c Paynes Lane, Rugby

## Committee Contacts

### **BATC Chairman Trevor Brown G8CJS**

Club affairs, Video tape library, Technical queries, especially relating to handbook projects. 14 Stairfoot Close, Adel, Leeds, LS16 8JR. Tel: 01132 670115. E-mail: ???

### **BATC General Secretary Paul Marshall G8MJW**

General club correspondence and business. Library queries relating to the borrowing or donation of written material. Fern House, Church Road, Harby, Notts., NG23 7ED. Tel: 01522 703348. Email 101573.2170@compuserve.com

### **BATC Hon. Treasurer Brian Summers G8CQS**

Enquiries regarding club finances, Donations, and constitutional enquiries. 11 Harefield Road, Uxbridge, Middx, UB8 1PH. Tel: 01895 810144, Mobile 0850 014892

### **CQTV Magazine Editor Trevor Brown**

Anything for publication in CQ-TV, Articles, Review items, Advertisements, Letters to the editor, and other material except as below.

**Photographs for the CQ-TV covers:-** Patrick White, Swyncombe, 8 Kingswood Court, Maidenhead, Berkshire, SL6 1DD, England

**TV on the Air:-** Graham Hankins G8EMX, 11 Cottesbrook Road, Acocks Green, Birmingham, B27 6LE. Tel: 0121 707 4337

**Satellite TV News:-** Paul Holland G3TZO, Chatterton, Chapel Lane, Threapwood, Nr. Malpas, Cheshire, SY14 7AX. Tel: 01948 770429, Email: 101705.137@compuserve.com

**CQ-TV Advertising Manager:** Dave Hemingway, Ivanhoe, Glen Road, Hindhead, Surrey, GU26 6QE. Tel: 01428 604645

**CQTV Awards:-** Bob Webb G8VBA, 78 Station Road, Rolleston on Dove, Burton on Trent, Staffs., DE13 9AB. Tel: 01283 814582

**Rally 96:-** Mike Wooding G6IQM, 5 Ware Orchard, Barby, Nr. Rugby, CV33 8UF. Tel: 01788 890365, Fax: 01788 891883, Mobile: 0860 857434 Email: vhf-comm@g6iqm.demon.co.uk

**CAT 96:-** General arrangements and information about talks to clubs, demonstrations, lectures, etc. Paul Marshall G8MJW - Details above.

## Club Sales

**Members Services:-** PCB's, components, camera tubes, accessories, etc. (NOT PUBLICATIONS). Peter Delaney G8KZG, 6 East View Close, Wargrave, Berkshire, RG10 8BJ. Tel: 0118 940 3121

**Publications:-** Handbooks, Back copies CQTV, and anything related to the supply of BATC publications. Ian Pawson G8IQU, 14 Lilac Avenue, Leicester, LE5 1FN. Tel: 0116 276 9425. E-mail: ian@ipawson.compulink.co.uk

## Membership

Anything to do with membership, including new applications, queries about new and existing membership, non-receipt of CQ-TV, subscriptions, membership records, data protection act. Dave Lawton G0ANO, 'Grenehurst', Pinewood Road, High Wycombe, Bucks., HP12 4DD. Tel: 01494 528899

**Club Liaison:-** And anything of a political nature, co-ordination of ATV repeater licences. Graham Shirville G3VZV, The Hill Farm, Potsgrove, Milton Keynes, Bucks., MK17 9HF. Tel: 01525 290343. Email g3vzv@amsat.org

**Contests:-** Richard Guttridge G4YTV, Ivy House, Rise Road, Skirlaugh, Hull, HU11 5BH. Tel: 01964 562498

**BATC BBS Sysop:-** Brian Kelly GW6BWX, 12 Cotswold Way, Risca, Gwent, NP1 6QT. Tel: 01633 614376, BBS: 01633 614765. Email:brian.kelly@betwixt.dircon.co.uk

**Repeater Liaison:-** General enquiries and repeater affiliation. Graham Hankins G8EMX, 11 Cottesbrook Road, Acocks Green, Birmingham, B27 6LE. Tel: 0121 707 4337

**Editorial**

Subscriptions for the year 1997 have been set at £12. Sorry about the price hike but the printing and postage costs of CQTV have risen to the point where it is not possible to maintain the £9 subscription. This would have been inevitable even if we had not upgraded CQ-TV to colour pages and printed it on 90 gram paper. The feedback from CAT 96 was very positive about CQ-TV and the general view was that we are still good

value for money. Another success along with CQTV is the Web site with guests at the BGM from Australia reporting that they regularly visit the site.



The Video Titler that first appeared in CQ-TV 173 is still causing problems in that a source of programmed 87C075s has not been found and as a result PCBs have not been commissioned. Steve Mitchell G8JMJ has come up with an alternative design and has promised it for CQ-TV. This could be a first for Steve who has been a BATC member to my knowledge for over 20 years and has so far avoided publishing anything in CQ-TV so watch this space.

Contributions to CQ-TV are finding their way down the Internet to us. One picture turned up as a JPG file. Ian put this on a disc and sent it to Dave Lawton to print on the club's colour Printer. The resultant picture went to the printer who sends it out for processing. The process involves scanning the picture and converting it to..... you've guessed a JPG file. Just to prove we are still learning, a process that may go on for some time.

I cannot close without thanking Paul Marshall for his efforts in organising CAT 96 I certainly enjoyed the event and with guests from as far a field as Holland and two Australian members Neil and John who extended their holiday to include the event.

**([trevor.brown@betwixt.dircon.co.uk](mailto:trevor.brown@betwixt.dircon.co.uk))**

## Post and News

Please send all correspondence for **Post and News** to the CQTV Editor. Trevor Brown. 14 Stairfoot Close, Adel, Leeds, LS16 8JR England. Tel 0113 2670115. E-mail [trevor@betwixt.dircon.co.uk](mailto:trevor@betwixt.dircon.co.uk)



Dear Trevor

Can you please help and advise me. I use a Yaesu FT736 R, on 6 Mtrs , 2 Mtrs, 70 Cms and have been offered a 1.2 Ghz module for this TX / RX. I would like to use the new module on ATV on 1.2 Ghz, but reading the handbook with the module, it states it can be used in the NTSC format. Are there any articles or comments in previous CQ-TV, in the use of the Yaesu FT 736 R. I should add I am active on 10 Ghz, using a Gunn Diode and modulator, and satellite receiver. Not really a builder, (if complex) as my working life was spent as a shift worker in the NW Gas industry, not the electronic field. Now an OAP aged 67 and enjoying every day. Thanks a lot, I trust all is well at your end. Bill Atkinson G1 LDG, 2 Bowland Road. Denton, Manchester M34 2GD

Dear Trevor

I read the copy of your letter to the RSGB, in the last CQ-TV, on the subject of repeater licences with some sympathy. We in the CRG (Cambridgeshire Repeater Group) are also suffering from the RSGB lethargy, but fortunately over communications and not television repeaters.

However I feel that the BATC needs to be just a little bit careful when it comes to throwing stones. The CRG have been in contact with the BATC for several years, firstly with Dave Lawton and subsequently with Graham Hankins, over the affiliation of our TV repeater GB3PV but so far with little success.

The most recent entry on the file is a letter from Graham dated 27 February 1996. He said that he had all the facts in the repeater folder, he would raise the matter at the nexty BATC committee meeting in March and would keep me informed. You might care to ask some questions.

It does not matter much to us as most of the active TV group are long standing members of the club in our own right but we feel that PV should be affiliated in the interests of solidarity. Ian M Waters, G3KKD Hon Chairman CRG, 39 Stow Road Stow-cum-Quy, Cambridge, CB5 9AD

*ED I will raise your problem at the next BATC Committee Meeting.*

Dear Trevor

I was very impressed with the format and presentation of CQTV 175, well done. Also I have found the web page useful. Perhaps there ought to be a list of BATC members with E-mail/Internet addresses.

I subscribe to the G-QRP club E-mail server and that is very useful. Best Regards and well done again with new style CQTV. 73 Graham G4GUN E-Mail glegood@iee.org

*ED I have had a lot of feed back on the web pages, all of it good. I hope we can expand this operation in the future.*

Dear Peter

I have got the EPROM and now is my CPU and VDU up and running. I'm getting the main page on a RGB monitor. I can't find a keyboard with a parallel interface but I'm using a PC keyboard with an interface. The serial port card doesn't seem to be available? What it can be used for? I've sent an intended article about stereoscopic TV to Chris but he is no longer the ED. I will have to write to the new one.

73 Ladislav Vig Dipl.-Ing. Leisibachstr. 20 A CH-6033 Buchrain

*ED pleased you have I2C running, The serial interface was never committed to PCB. Always pleased to receive copy for CQ-TV.*

**Bob Roberts, BATC President 1972 - 1977****By Trevor Brown****Sadly Died on May 26 1996**

Bob was not only a BATC member but a Fellow of both the IEE and RTS. He Pioneered the first ever colour TV courses held in this country from the North London Polytechnic where he was deputy head of Electronic and Telecommunications Engineering. His work with the RTS resulted in a two volume book “Television Engineering”. He also published a complete series of circuits known as Robert Universal charts. He assisted in the writing of a standard text-book on the subject of plastics in the Radio Industry.

I first came into contact with Bob when I co-wrote the Amateur Television Handbook (Blue Cover) with John Wood. Bob Roberts answered one of my cries for help in CQ-TV . Bob wrote the Principles chapter and is credited along with what has now become quite a distinguished list of talented engineers.

Bob’s qualifications are endless but amongst them are:-

Chartered Engineer

Fellow of the I.E.E.

Senior Member of the Institute of Electrical and Electronic Engineers (USA)

Fellow of the Royal Television Society

Hon Fellow of the confederation of Aerial Industries

He will be sadly missed by all BATC members past and present.

# GB3XT Kits & Bits.

**GUNNMOD2 3CMs.** Full feature Gunn diode modulator/TX. Very popular, high performance, easy to construct kit. Full Kit including PCB. all board mounted components, full instructions and pre-tuned 10.278GHz oscillator head. £30.00 inc.

PCB kit less oscillator £20.00 inc. PCB with full instructions £5.50 inc.

**TVRO3 ATV Tuneable IF / RX.** Fully featured. 750 - 1700MHz input. Comp. video o/p. Loudspeaker O/P 12vDC. Kit consisting of PCB. all board mounted components and full instructions. £50.00 all inclusive.

**3CMs LNB's** Circular input, fit standard satellite dishes with 38-40mm mounting

0.8db noise fig. brand new, 9GHz LO.	<b>£40.00</b> all inclusive
1.1 - 1.2db " " " " " "	<b>£35.00</b> " "
1.6 - 1.8db lower gain for local working	<b>£25.00</b> " "

Good second hand unit sometimes available. Please contact.

**24CMs GASFET pre-amp.** 40db gain. 1db NF. GASFET input. MMIC gain stages with interstage helical filtering. Strong tinplate box BNC in/out 12 - 18vDC via coax. Complete kit £60.00

**24CMs ATV TX.** Full spec. 5CH synth. 1.5 - 2Watts O/P. About 3" X 3". 12vDC. 1v video input with 5.5MHz video filter. Mic input. Filtered 6MHz (5.5 or 6.5) subcarrier.

High quality PCB. with all board mounted components and full instructions £125.00 inc.

**Domestic satellite to ATV adapter kit.** Allows an SRX100 / 200 or similar satellite RX. to be used as an ATV RX without having to perform any modifications. Simply plug into decoder output socket. Video processing with AGC. 1V Pk-Pk O/P. Audio processing with active limiting. 0.775V max. O/P. Approx 3" X 3" PCB. all board mounted components and full instructions. £25.00 inc.

**DTMF. Decoder kits.** Wide input voltage range. All outputs buffered. 1 through to # single output decode, or, 1 though to # plus ABCD decode 4 bit output. Uses high quality decoder chip 12vDC supply. Full PCB. kit and instructions. £12.00 inc.

**Available from, or for further details contact.... Bob Platts G8OZP. 220 Rolleston Road, Burton upon Trent, Staffs, DE13 0AY. Phone 01283 531443 7PM - 9PM weekdays please.**



## Improving VIC20 Video

### By G8MNY

These old computers can offer a cheap colour source for ATV, but they often suffer from colour problems and patterning. As GB3HV is based around one, some time has been spent sorting out the problem.

Depending on when the VIC20 was made the VIDEO chip (MPS6550) and or the 8.86MHz Colour Osc may be enclosed in a metal box in the middle of the main PCB.

As these faults are the result of poor/compromised circuitry in the single "DATA to PAL" colour chip, these mods only deal with the worst of the problems. However once sorted the 100% colours available are fairly good, and compare well with many other sources.

### Video Patterning

This shows up as fixed vertical lines on the picture. They are easily hidden with picture detail, but on empty screens are quite apparent. Several attempts at a cure with different layouts & filters (ferrite beads) were tried by the makers, but with not much success.

1/ Add a 220uF directly across the +5V supply (Convenient track connected to pins 40 and 20) next to the video chip slightly reduces it.

2/ The rest of the patterning noise is from strong 1MHz clock pulses for some reason present on the colour Output pin 2. Replacing the simple colour coupling Capacitor for a better high pass C-L-C filter does the rest. There is room in the board for these extra 2 components after removing the odd Ferrite bead link! The L between 10-50uH is best found on test so that the colour delay is not too apparent but the patterning is well down, so start with 10 turns on a ferrite tuning core.

### Colour Phase

This is difficult to recognize on a small picture, but adjacent coloured lines show up as having different colours and brightness.

3/ RED and CYAN Fault.



These are due to incorrectly biased colour O/P stage. Placing a 2K7 (Select on test) from Colour O/P pin 2 to +5V (nearby pin 40) track pulls the O/P voltage up and stops the clipping, the affect can be seen on the the Vector scope (or 2 line scope display).

4/ BLUE and YELLOW Fault.

Also due to uneven pairs or vectors (Blue = POKE 36879,30 and Yellow = POKE 36879,31). These subcarrier carrier levels (but not phases) are affected by rebiasing the 8.86MHz clock to the video chip on pin 39. Ferrite beads links can be removed to add the series cap. or on some models by rebiasing the incoming 8.86MHz clock IC on its pin 2 with a pull up 1K and a pot.

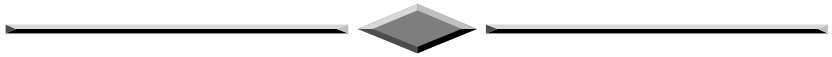

## Test Card Generator PCBs

GB3UD Amateur Television Group offer test card generator PCBs for sale

The board has been produced professionally for the group and is of very high quality, through hole plated holes and double sided eurocard size.

The PCB contains the colour circuit and a 1KHz tone oscillator. It uses easy to obtain 74LKS type IC devices.

The board is priced at **£18.00 + £1.50 p&p** and is available from:-

**Trevor Burndred G0KBI, 53 Everest Road,  
Whitehall, Kidsgrove, Stoke-on-Trent, ST7 4DY  
Tel: 01782 782886**

**Circuit Notebook #59**

**By John Lawrence GW3JGA**

This is a simple wired communication system originally intended for 'engineering talk-back' between three remote-camera operators and the vision controller, but having other hands-free uses, such as aerial adjustments etc.

The original system was built some 25 years ago and used Newmarket PC2 Module amplifiers, full of germanium transistors, made, I think, by a now defunct division of PYE.

Each station in the system comprises a headset with a boom microphone (the type I have come from a scrapped language laboratory). The dynamic microphone is connected to a small microphone amplifier, the output from which is taken to a 'signal' line connected to all other stations and to its own local headset. All units are powered from a single supply of +12 volts through an interconnecting 3-core cable carrying 0V, +V and Signal. This overcomes the problem of providing separate batteries at each station (which may be left on by accident and flat when required!) and allows relatively cheap 3-core unscreened cable to be used.

The present system has been updated and uses the National Semiconductor LM386 low voltage IC amplifier. Maplin supply an LM386 Amplifier Kit complete with PCB, components etc. This Maplin Kit, No. LM76H, has been used in the new version.

The amplifier can be configured in various ways, but in this application it is used in the maximum gain condition of X200. This is almost, but not quite, enough gain for my headset, so a single transistor microphone pre-amp has been tacked on to the PCB and now the on-board gain control can be set with plenty of gain in hand. Your headset may not need this.

The circuit is shown in Fig.1. The inner dotted area represents the Maplin PCB and the connection pins P1 to P6 are those printed on the board. The output of the amplifier is taken to the signal line through a 10R resistor, this allows other amplifiers to be connected to the same line without excessive loading. Up to four units have been used together successfully, using identical headsets. In my system the +12 volt supply is fed in at the 'base' unit and this could be located at any position in the system. To prevent accidental wrong connections, I use 5-pole, 180 deg,

DIN sockets with pins connected as shown. The supply current for each unit is about 10mA at 12V and the system will work with a lower supply voltage if required.

Fig. 1. Headset Amplifier

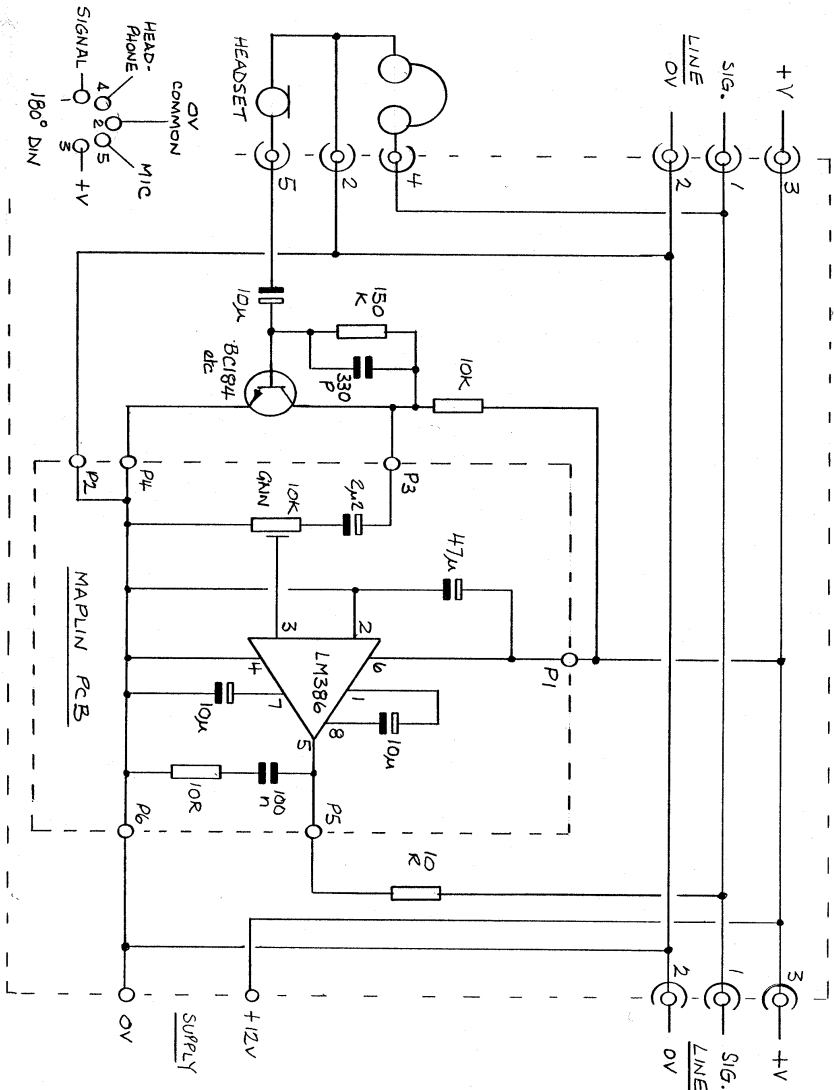

The LM386 is a versatile low-cost device and could have many other applications in the audio side of your station. Full information is given in the 'Data File' leaflet supplied with the Maplin Kit, this leaflet may be obtained separately as Item No. XU38R.

Whilst on the subject of audio, here is a cheap and cheerful audio monitor which has many uses. It can be used for general audio testing, boosting the output from a portable tape recorder etc., but in my shack it is connected to the audio output from a satellite receiver operating on 24cms and tuned to the local ATV repeater GB3TM.

The audio monitor consists of a Maplin 8 Watt amplifier kit (LW36P) built and housed, with its mains power supply, in a loudspeaker cabinet. The cabinet and existing 4 ohm speaker came from a junked hi-fi system. The complete amplifier circuit is shown in Fig.2. The Maplin part is at the top. The Maplin kit is easily assembled and although it operates here with a 12 Volt supply, instead of the recommended 21 Volt one, the volume level is more than adequate when using a 4 ohm speaker. The Maplin data sheet, that comes with the kit, gives details of a 21 Volt supply if you need the full 8 Watts output.

I have incorporated two modifications to the circuit both of which are wired across R2. One is a treble cut control, consisting of C7 and RV2, this reduces the gain at higher frequencies, depending on the setting of RV2. The other is a muting circuit for remote muting of the audio output.

In my location, when working through GB3TM and using two aerials, I am able to view and listen to my return signal whilst transmitting. However, it is necessary to reduce the received audio level when I am transmitting to prevent audio howl-round and then increase it again when I am receiving normally. This seems to be a common problem which other stations experience when 'looking through'.

In my station, I use a common transmit control line which is switched to ground for transmit and left open for receive. Each piece of kit is controlled by an internal relay with one side of the relay coil connected to an internal +12 Volt supply and the other taken through a diode to the control line as shown in Fig.2. In this way only items which are powered up are controlled.

The mute circuit is controlled by a relay which is connected to the transmit control line and mutes or partly mutes the audio when transmitting. A variable control RV3 is used to set the level of mute, about 10dB of mute is usually enough to prevent howl-round whilst still providing enough audio to monitor the return signal when transmitting a tone or recorded material with the microphone left on. The mute operates by shunting R2 and reducing the gain accordingly. The need for R4 is not immediately obvious but its purpose is to keep C8 charged so that when the relay closes there is no pulse of charging current which would otherwise cause a loud thump in the speaker!

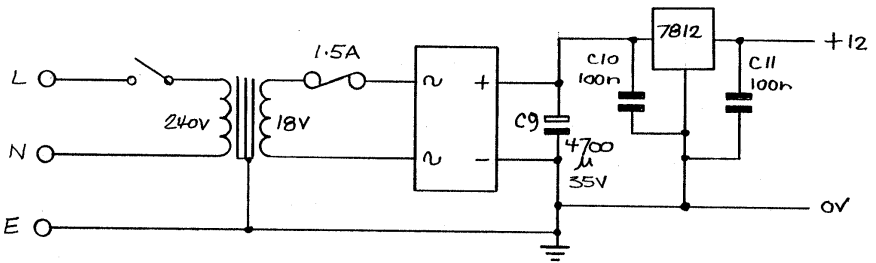
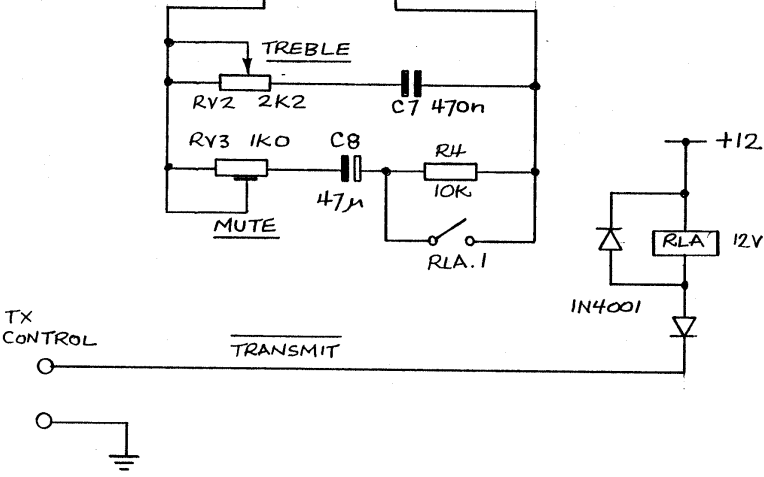
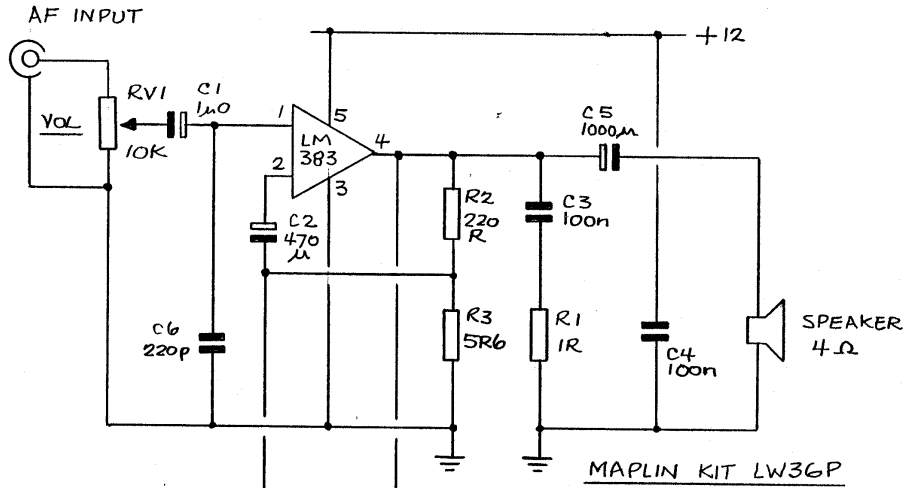

The 12 Volt power supply is quite conventional and is shown here for completeness.

### Technical Information on offer

A free CD-ROM is available from Farnell Components which runs on an IBM 486 compatible PC with a dual speed CD-ROM drive and contains 'Semiconductor Data from over 50 major manufacturers'.

**Farnell Components, Canal Road, Leeds, LS12 2TU, Tel. 0113.263 6311 Fax. 0113.263 3411**

A new 1996 Data Book of Gennum Specialised Video ICs is available from Colson Microelectronics Ltd., Monachus House, High Street, Hartley, Wintey, Hampshire, RG27 8NW. Tel. 01252.845590 Fax. 01252.845777

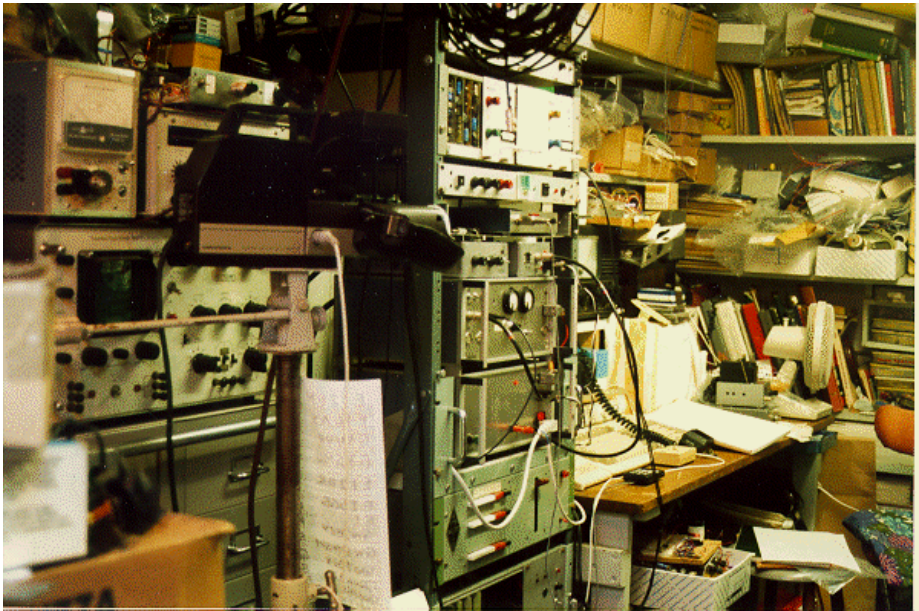

**The heart of GW3JGA**



**CAT 96 REPORT, "by an observer"****By Andy Emmerson G8PTH**

Some dreams are nightmares; other dreams pass so pleasantly that it's a shame when you wake up and try hard to remember what left you with that vague but solidly satisfying feeling. In the latter vein, CAT 96, held at the Post House, Crick on Sunday 1st September, is already little more than a fading memory but a most pleasant one.

The omens were good: the weather was fine and the club was back on old territory where many a pleasant meeting had been held in the past. The heavy machinery in the form of Paul Marshall's 'new' ex-Southern Television OB van and Steve Mitchell's ex-TVS microwave links van were acting as welcoming landmarks for the faithful. In fact it was just like old times.

Indoors club supplies, new components and second-hand goodies were being sold and a steady stream of lectures and video tape screenings were conducted. Outside people clambered aboard the vans or struck their bargains in the outdoor flea market.

Highlights of the lecture stream included Bob Platts on 10GHz operation, Graham Shirville on repeater co-ordination and Dicky Howett on television history. Norman Ash held a seminar on video production techniques, an area in which we ought to become far more creative. The general meeting closed the day's formal events.

We were pleased to welcome visitors from near and far, include 'the men from across the North Sea', who may in future be able to help us break the world distance record for 10GHz ATV (with a little help from sea level ducting). Also on site were two Australians, who adapted their British itinerary specially to fit in CAT 96.

Above all it was a day to chat, make new friendships and renew old ones. Disappointments were few. Yes, we could have done with a few more members and visitors but these CAT events were always geared towards quality, not quantity, of attendance. As it was, two rallies (at Telford and Bletchley Park) drew away some of our potential audience but who cares? The people who mattered were at Crick!

Photos from CAT 96 can be found on the following pages



**Bob, Bob, Hans and Fred spotted at CAT 96. Left to Right Bob Robson G8AGI, Bob Platts G8OZP, Hans PE1ECO, Fred. The Map they are pouring over is the North Sea and I am sure I heard them mention 520km (Watch out F1JSR) photo captured by Trevor Brown. Below: some of the exhibits on show.**





Scanners exterior, left scanner owned by Steve Mitchell G8MJM, right scanner owned by Paul Marshall G8MJW



Left:

Interior view of Paul's scanner.

Right:

Steve Mitchell inside his scanner



# In Retrospect

## 8 Channel Audio & Video Mixer in CQ-TV 175

In the circuit diagram on page 70, there are three points marked "CHBLE". The first two go to the "LE" pins on the selector ICs which I think most people would realise, but the third is mislabelled, it should go to pin 6 on IC4B, ie. the other output amp.



## 12V to 24V Transformer in CQ-TV 175:

A couple of mistakes on page 46. Both the diodes should be cathode side downward. The 4u7 capacitor polarity is reversed. The timing capacitor, pin 2 to 0V, is shown as 0.1 μF, it should be 0.01 μF

The corrected circuit diagram is shown below

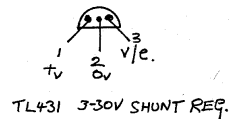
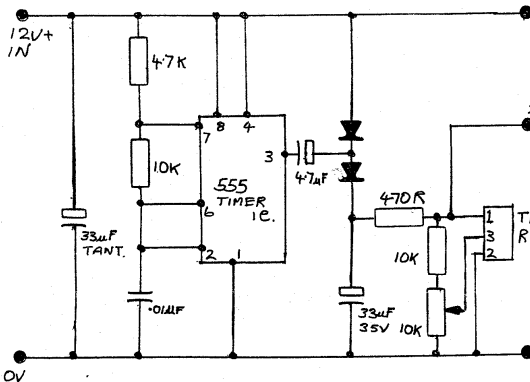

PCB TRACK SIDE 25x60mm.

## Amateur Television Repeater GB3TM

### Press Release.

The Amateur Television Repeater GB3TM, which is located near Amlwch on the Isle of Anglesey in North Wales, came on air on Thursday 14th July 1994.

The allocated Channel is RT1-2 which specifies an input frequency of 1249 MHz and an output of 1316 MHz. The repeater accepts 625 line fast scan FM TV signals with 6 MHz inter-carrier FM sound and re-radiates these in the same mode.

The station is located 154 metres above sea level and has a clear signal path over the sea in virtually all directions covering the Lancashire and North Wales coast, to Ireland, Isle of Man and possibly Scotland.

The transmitter uses the Worthing phase locked loop transmitter, as a drive unit, followed by a Mitsubishi M57762 broad band integrated module providing a power output of 10 watts.

The receiver is a modified professional satellite receiver preceded by a GaAsFET pre-amplifier and followed by a video amplifier to provide a standard video output signal.

The home-constructed aerial system consists of two Alford slot aerials machined into a common vertical aluminium tube, one above the other providing omni-directional horizontal polarisation. The aerial system is fitted in a plastic tube (drain pipe) for complete weather protection and is mounted on an existing radio tower about 10 metres above the ground.

A five element band-pass filter, centred on 1249 MHz is connected between the receive aerial and the receiver to prevent the repeater transmitter causing breakthrough.

The control logic is based on the BATC I2C Teletron system and contains a caption generator, Z80 processor, video signal detector, video and audio switching, keyboard decoder and PAL coder. The transmitter, receiver and control logic are housed in 19inch rack cabinets, fitted in a dedicated cubicle.

The repeater operates continuously, in beacon mode, displaying a variety of captions, news pages with audio morse code identification. When accessed by a valid signal the repeater provides through transmission of video and sound. The usual 'K' and 'time out' functions are provided and the news pages can be up-dated remotely.





**GB3TM received at GW3JGK shack. A distance of 61km (38 miles)**

Software for the project has been written mainly by G1FEF with additional programming by G8VAT and GW8PBX.

GB3TM is the only ATV repeater within the Arfon Repeater Group which serves Amateur Radio and now Amateur Television, in West Wales. The technical team includes GW3JGA, GW3MEO, GW4KAZ, GW8FEY and the

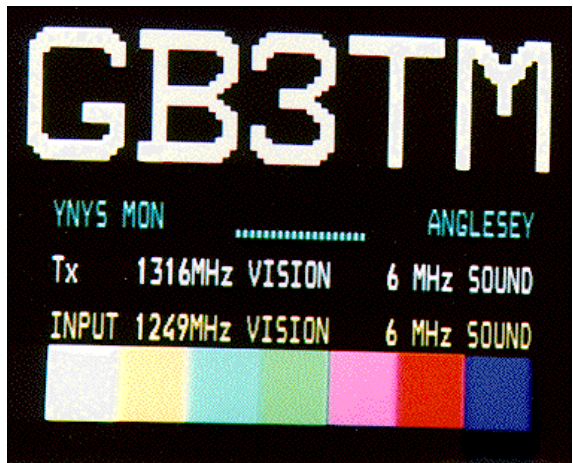

Repeater Keeper, GW8PBX. Reports would be most welcome and should be sent to GW8PBX, QTHR.

**Satellite Pictures**

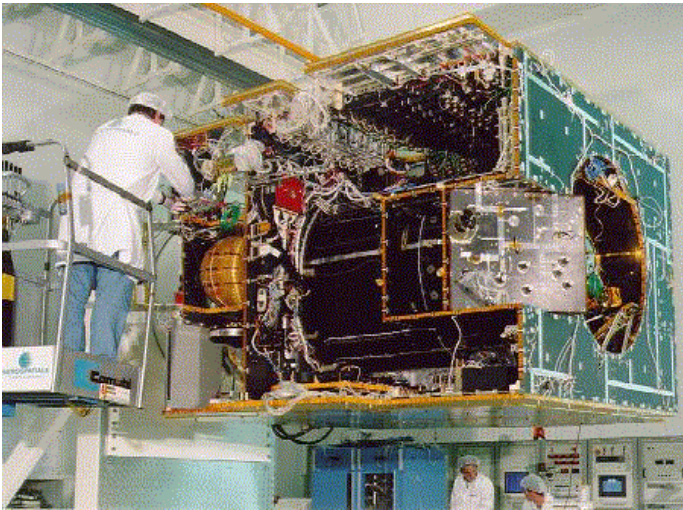

See **Satellite TV News** starting on page 26.

**Left:**  
**ARABSAT 2A**

**Below:**  
**Turksat 1C**



**Mods for the Tatum Earlybird Satellite Receiver**

**By G8MNY**

This small old Sat Rx can be modified for 23/24cms ATV use. But as with most Sat Rx it is insensitive and its wide IF bandwidth makes it no good for DXing or keeping the radar out, but it is a useful starting point.

These mods are to get the video gain up for the lower ATV deviation, improve LF Video response (no 25Hz ramp on ATV), Correct circuit design mismatches, and change the sound demodulator to 6MHz.

Remove case and top metal guard if present. Cut away the unwanted Poloriser wiring. Unplug membrane keypad ribbon from PCB socket, fold it back on itself and holding it there remove the PCB. Check for PCB track cracking around the mains transformer, as this is a common fault.

Do	Part	Old Value	New Value	Reason
Cut	K208	Link		Aerial DC feed
Swap	K202	Link *	68 Ohm	Video O/P Z
Swap	C232	100uF	* 470uF 16V (-ve to scart)	LF response
Swap	C212	0.047uF	0.2uF	LF response
Swap	C203	10nF	0.1uF	AFC LF response
Swap	L201	33uH	Link	HF resonance
Add	Cap	18pF	across L204 (under PCB)	HF correction
Swap	R201	75 Ohm #	Link	Video Z (gain)
Add	Electrolytic		220uF 10v IC201 5-7 (+ve on 7)	Video Gain
Swap	FL201	6.5MHz	6.0MHz one	Sound Filter
Swap	FL203	6.5MHz	series L201 & 180pF	Sound Trap

\* Components wrongly fitted by makers?

# already a 75 Ohm series R in demod box!

The sound "Tank" coil L203 slug will need retuning to 6MHz for best Audio. With a full deviation 1KHz tone (loud) source on an ATV signal tune the coil for loudest and best symmetry of output (scope).



Video Gain is set up with R226 and should produce 1V P-P terminated into 75 Ohms & with a source Z of 75 Ohms. With some UHF modulators this is a bit over the top and trimming the DC level may improve this. Put a hole (soldering Iron) in plastic back for external access to the UHF Modulator DC level pot.

The sound trap C & L (L to ground) is a useful 6 MHz frequency counter test point for non invasive checking of TX sound oscillator..

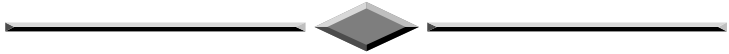

## CQ-TV Copy Rules for Submissions

Market Place is free to **paid up** members (please include your membership number) and is intended for individual items of equipment. The copy should be in plain text no boxes or diagrams.

Trade Advertisements are available for all other types of equipment. These advertisements are charged for but a discount is available if you are a repeater group. These adverts should be sent to the CQ-TV Advertising Manager: Dave Hemingway, Ivanhoe, Glen Road, Hindhead, Surrey, GU26 6QE. Tel: 01428 604645

Reproduction of CQ-TV articles in other Amateur magazines is permissible providing the source is acknowledged. Please send us a copy of any magazine you use CQ-TV material in; we are always interested.

Reproduction of CQ-TV material in the non Amateur Press or any magazine that pays for contributions is also possible but please clear the copy with us first.

Articles for CQ-TV are always welcome. You can post them to the Editor (see "Committee Contacts" on page 2), if possible please enclose any text on a PC format floppy disk in word 6 or plain ASCII, or you can E mail copy to us on [ian@ipawson.compulink.co.uk](mailto:ian@ipawson.compulink.co.uk) or drop it in my mail box on the club BBS 01633 614765. FAX & MODEM of copy is also possible at my home number 0113 2670115 but ring first and I will switch it on.

**TREVOR BROWN - BATC Chairman**

**Satellite TV News**

**By Paul Holland G3TZO**

Welcome to another edition of Satellite TV News. As the Summer fades into a distant memory thoughts naturally turn to those long Winter nights with only the satellite receiver for company! If this sad prospect is not too hard to stand then take comfort from the thought that at least there is plenty going on in the world of Satellite TV to keep us all amused until the sunshine returns next year. As usual there is the crop of new Satellites and channels to report on in this issue

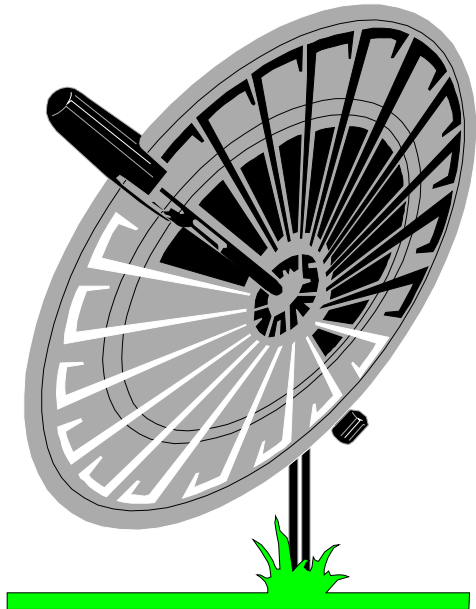

together with news on the latest Digital TV developments. There is no post bag this month so let's get straight on with the news.

**Launch News**

Satellite	Launcher	Position	Date	Payload	Use
Hotbird 2	Atlas II	13.0 Deg E	Oct/Nov 96	20 Ku	Analogue & Digital TV
Thor 2A	Delta 2A	1.0 Deg W	Feb 97	15 Ku	Digital TV

**Hot Bird 2**

Hot Bird 2 should be launched and testing as you read this. Sixteen of Hot Bird 2's transponders are expected to be in Superbeam mode and will carry primarily digital TV services. Each of the 20 transponders can transmit between 4 and 8 digital TV channels depending of the type of compression used.

The current reservations are as follows: Telepiu (4), RAI (2), Berlusconi's TV holding Mediaset (1), Cecchi Gori - owner of TMC and Videomusic channels (1) and Stet - state run telecommunications company (2). Telepiu will use its transponders to transmit its 3 existing terrestrial channels as well as a package of foreign satellite channels and PPV football. Mediaset is planning to offer several pay TV channels on its transponders. RAI who has leased transponder space for 8 channels will probably transmit only 2 or 3, but will use a different decoder than Telepiu.

Reception should be possible over the entire UK with 45cm antenna. Hot Birds 3,4 & 5 will have the same characteristics but will also have steerable spot beams. Additionally Hot Birds 4 & 5 will be fitted with Eutelsat's Skyplex multiplexing technology allowing Eutelsat to effectively create their own digital multiplex services.

A summary of Hot Bird 2 characteristics is reproduced below;

<b>Transponders</b>	20
<b>Frequency Bands</b>	11.7 - 12.10 GHz
<b>Bandwidth</b>	33 MHz
<b>EIRP (Beam Centre)</b>	Superbeam 53 dBW Widebeam 49 dBW
<b>Output Power</b>	120W
<b>Lifetime</b>	14.5 years
<b>Polarisation</b>	Linear

### Launch of DF1 Digital Multiplex

The German media giant, Kirch Group, launched DF1 on July 28 with the transmission of the Formula 1 Grand Prix races held in Mochenhum, Germany and with an initial offering of 17 additional television and radio channels. The new digital technology allowed Grand Prix viewers to follow the races from five different camera angles on five separate channels, using the new electronic program guide, T.O.N.I. (Tele Online Navigation Instrument). BetaDigital, a newly founded Kirch Group company, provides the digital technical service for DF1, by employing TV/COM's Compression NetWORKS, the world's first DVB compliant MPEG-2 system digital video compression system. Unlike proprietary systems, Compression Networks provides an open standards based platform that ensures that current equipment will be fully interoperable with future source, editing, storage, broadcast and consumer equipment.

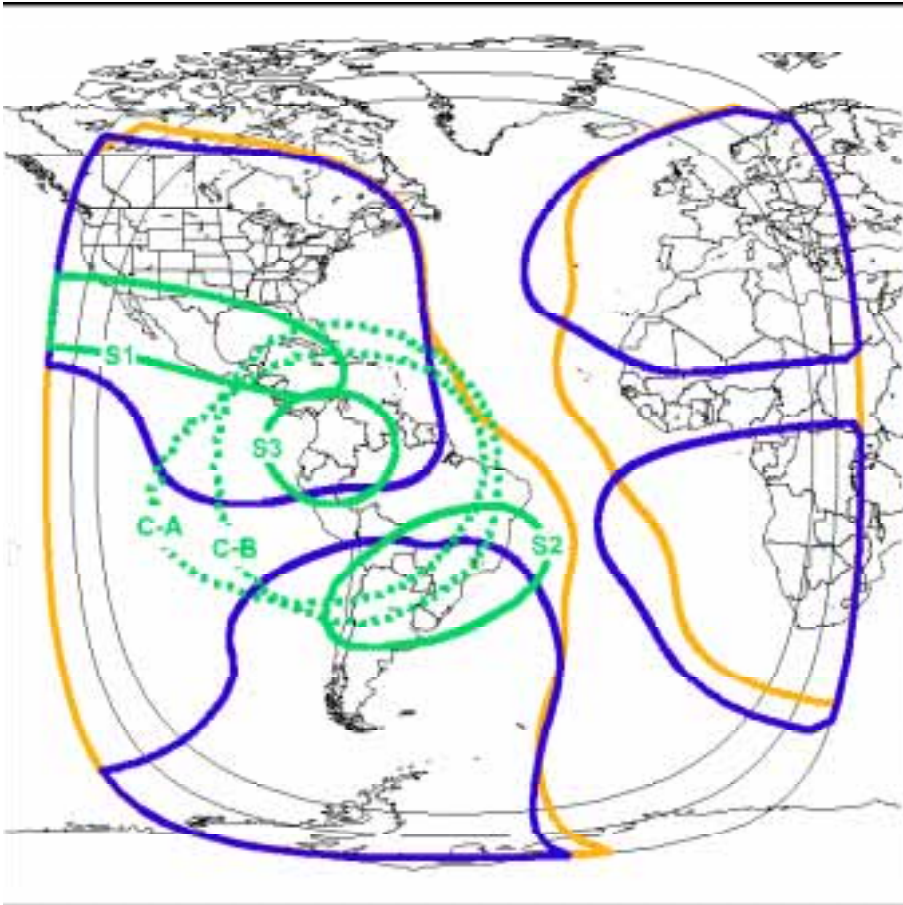

### IS-705 at 18.0 Deg W

Intelsat 515 was reported to have replaced Intelsat 512 at 21.3 Deg W. Intelsat 703 has replaced Intelsat 510 at 57 Deg E. Plans to locate Intelsat 709 at 18.5 Deg W have been dropped with Intelsat 705 now moving to this location. Intelsat 709 is now at 50.0 Deg W with some question marks over on board power problems affecting its overall serviceability.

## **New Channels**

As with the last edition of Satellite TV News I am not fully reporting the almost continuous launch of new digital services hitting the Ku Band airwaves at the moment. Even in the countries targeted by these services there is an acute shortage of digital receivers. Here are the reducing number of new primarily analogue services we can expect to see soon;

Ireland's Tara TV and the Bloomberg business channel are expected to join Sky's Multichannels this Autumn. Other channels hoping to get on Astra include: Connect TV (a computer-oriented channel), Hallmark Entertainment Network, Carlton, World Health Network, the Virgin Channel, Vedic TV (Asian plays), the Asian Music Channel, and Ace TV (Islamic news).

The English language version of Onyx UK has postponed its launch until next year. Other channels considering launches next year: MSNBC, Animal Planet, The Crime Channel, Sundance, Rainbow TV (Gay TV), Cultural TV (Christian), and E! Entertainment.

The BBC has held talks with Flextech a subsidiary of TCI to buy part or all of satellite channels UK Gold and UK Living. Included in the venture could be up to six new cable and satellite channels, some or all of which could be available on DBS systems world-wide.

According to a report in Italian magazine "Musica", the Argentine Tango music channel Solo Tango is to start broadcasting to Europe, Canada and the USA in September. Solo Tango is already enjoying cult status in Argentina where it broadcasts via cable, 24hours a day.

The Quantum Shopping Channel is looking to launch a 24 hr service on Intelsat 601 about now. It plans to relocate to Hot Bird 4 when that launches in late 1997.

A Finnish service FTV, made up of programming from Finlands two domestic terrestrial channels, will operate a digital pan European starting about now from an as yet unnamed Eutelsat satellite.

## **AFRTS TV**

The American Armed Forces Radio & Television Service have announced plans to switch from B Mac to digital MPEG2 by the summer of next year. The service will use Scientific Atlanta's PowerVu system which will be capable of carrying 6 TV and 6 stereo radio channels together with other data and file transfer services. AFRTS uses transponders on the GE SATCOM SN2, INTELSAT - 707 (Atlantic), INTELSAT - 702 (Pacific), and EUTELSAT II - F2 satellites.

Gorizont 27 & 32 53.2 Deg E

Launched in May Gorizont 32 has been observed testing at this location.

Gals 1 & 2 36.0 Deg E

These satellites have moved from 71.0 Deg E

Turksat 1C 31.0 Deg E

Turksat 1C was successfully launched back in July and was initially located at this position for testing before being moved to its final position of 42.0 Deg E. Turksat 1C is equipped with 16 Ku Band transponder and after testing at this position will be moved to 42.0 Deg E.

### Arabsat 2A 26.0 E

The Aerospatiale Space and Defence Division built Arabsat 2A launched on July 9th carrying 22 C Band & 12 Ku Band transponders. C Band coverage in the UK should be possible with antenna sizes of 1.8 - 2.4M. Ku Band transmissions are receivable only over the Middle East. Services previously on Arabsat 1C at 31 Deg E and Arabsat 1DR at 20.0 Deg E have or will transfer here. A test card has been seen on 12.661 GHz. Other test cards have been seen on 12.536 and 12.521 GHz.

### C Band Frequency Plan

Tp	Service	Freq	Pol	Tp	Service	Freq	Pol
1	Mauritania TV	3.720	RHC	12	Canal France Intl	3.945	LHC
2	ART	3.740	LHC	13	Saudi TV2	3.978	RHC
3	Egypt TV	3.761	RHC	14	Feed	3.998	LHC
4	ART	3.781	LHC	15	Not assigned	4.043	RHC
5	Nile TV	3.802	RHC	16	Dubai TV	4.057	LHC
6	Bahrain TV	3.822	LHC	17	Not assigned	4.084	RHC
7	CNN	3.843	RHC	18	MBC	4.098	LHC
8	Future Vision	3.863	LHC	19	Not assigned	4.125	RHC
9	Morocco TV	3.884	RHC	20	Oman TV	4.139	LHC
10	Sudan TV	3.904	LHC	21	Libya TV	4.166	RHC
11	Saudi TV1	3.925	RHC	22	Yemen TV	4.180	LHC

### Astra's 1A,1B, 1C, 1D, 1E 19.2 Deg E

Transponder changes known or rumoured as we go to press are as follows;

Tp	Former Service	New Service
3	TV3 Sweden	Granada Plus/Men & Motoring
7	TV1000	Fox Kids Channel/Sky 2
24	CMT/JSTV	TBA
27	TV3 Denmark	Nickelodeon Germany
31	TV3 Norway	Sky Sports 3
49	Nickelodeon/Arte	ARD/ZDF Childrens Channel/ Arte
51	Veronica 6	CMT (24hr)
52	RTL4	QVC Germany
53	Racing Channel	Racing Channel/JSTV
57	SBS6	Warner Brother Channel
58	Digital Promo	TV High Street/Health & Beauty/Food & Wine/Home & Garden
Tp	Former Service	New Service
59	Astra Promo	Granada Talk
60	Sky Movies Gold	Weather Channel/Sky Movies Gold
64	RTL5	TM3

The "Club RTL" digital multiplex is now finishing tests on Astra 1E Tp 75 11.915 GHz (H). The MPEG 2 service uses Mediabox encryption and launches about now with RTL Movie, RTL Blue, RTL Kids, RTL Country, RTL Melody, RTL World and programme information guide RTL Guide. Adult Channel Eurotica is to join the Nethold digital package on Astra 1E.

### **Eutelsat II F3 16.0 Deg E**

Tp 45 at 12.538 Ghz (V) will no longer carry analogue feeds having now been leased by the European News Consortium (ENEX). The 33 Mhz transponder is now divided into 4 digital slots of 8 MHz bandwidth and 18 SCPC carriers (200 kHz bandwidth max). Centre frequencies are 12528.166 MHz, 12538.166 MHz, 12546.166 MHz and 12556.166 MHz. Transmissions are in MPEG 2 at 6 Mbit/s and will carry news and sports feeds. The Thaiwave channel was reported to be returning to this satellite on September 1.

### **Eutelsat's II F1,II F6 (Hot Bird 1) IIF7 (Hot Bird 2) 13.0 Deg E**

BBC Prime have started a digital MPEG 2 version of the D2MAC service carried over Intelsat 601 and are doubling up with the BBC World channel on Tp 38 11.602 GHz (V). Newly launched Hot Bird 2 will carry only four analogue services on Tp 50 11.728 GHz (V), Tp 51 11.747 (H), Tp 52 11.766 (V), Tp 53 11.785 (H). Services known to be launching on these transponders are RTP and EDTV.

### **Eutelsat II F2 10.0 Deg E**

Bosnia's BHT TV has now replaced MED TV on Tp 37 11.575Ghz (V). MED TV is apparently moving to Intelsat 603 at 34.5 Deg W

### **Telecom 2C & 2D 3.0 Deg E**

Sentanta Sport has been seen on Sundays at 12.606 GHz (V) in PAL clear with a parallel on feed on 12.522 GHz (V).

*Telecom 2D* was successfully launched aboard Ariane space Flight 90 on August 9th. The payload is as follows;

C Band	:	10 Transponders, 11W each
Ku Band	:	11 Transponders, 55W each
X Band	:	5 Transponders, 20 & 40W

Manufactured by Matra Marconi Space and Alcatel Espace (France) Telecom 2D is primarily intended for business TV, telephony and data applications with no planned DTH TV services.

### **Intelsat 707 1.0 Deg W**

Danish channel DR2 launched in late August on 11.666 GHz (V) in D2Mac and will be eventually encrypted using Eurocrypt M. NRK 1 is now encrypted in Eurocrypt together with NRK 2 which launched on 11.486 GHz (H) in late August.



**Amos 1 4.0 Deg W**

Despite the footprint being centred on Central Europe this satellite can be received in the south of the UK with as little as an 80cm antenna (check 11.350 GHz (H) and 11.346 GHz (H)). Early analogue tests have been replaced by MPEG-2 test transmissions for Antenna Hungaria's 4-channel digital package. Transponder frequency and programming details have not been released yet. Also, Nethold will launch a digital package from Hungary, which will include HBC's A3 Television. An Internet service is also to be launched via AMOS providing users with a 128 Kbit/s downlink to their PC. Initially the service will be treated as a pilot before full commercial launch.

**Intelsat K 21.5 Deg W**

Reuters digital feeds are on 11.551 & 11.559 GHz (H) and uses 5.632 Msymb/sec with FEC 3/4.

**Intelsat 601 27.5 Deg W**

There are reports that both CMT and the Travel Channel will close there analogue

**Orion F1 37.5 Deg W**

ASIANET has moved to a digital feed on this satellite 11.680 GHz (v) 8.5 M Bit/s

**TDRS 6 47.0 Deg W**

New at this position TDRS6 is carrying C Band traffic and has a footprint that extends from Los Angeles to Eastern Europe.

**Digital Video Broadcasting Update**

VLSI Technology, Inc. has announced an innovative, universal digital satellite receiver device, VES1777, compliant with both the DVB (Digital Video Broadcasting) and the DSS (Digital Satellite System) set-top box standards. The VES1777 is a further addition to VLSI's integrated set-top architecture and is based on and pin-compatible with the VES1789 architecture, a recently introduced IC for DVB compliant satellite receiver applications. This new single-chip satellite receiver integrates VLSI's true variable-rate QPSK demodulation and forward error correction (FEC) functions for set-top box applications in both DSS and DVB systems. The required mode of either DSS or DVB operation is simply selected via software through the I2C bus by the design engineer. The chip enables set-top manufacturers to design a universal receiver for

satellite TV, which can be used anywhere in the world where the DVB or DSS standards have been adopted. The VES1777 universal satellite receiver chip offers the following DSS and DVB programmable features: half-Nyquist filter roll-off factor; interleaver depth; packet length; and Reed-Solomon decoder. The chip also has the ability to disable the energy dispersion descrambler (a feature used only for DVB). The device has true variable-rate functionality which supports any symbol rate from quasi DC to 30 Mbaud with the use of only one 60 MHz crystal. Auto-synchronisation, auto-depuncturing and auto spectral inversion are all VLSI-unique features that provide for a simple, easy-to-use solution.

The VES1777 is both 100% DVB- and DSS-compliant. In addition to its dual-compliance, this chip offers further key advantages over other available solutions. VLSI's satellite channel receiver is a completely digital design allowing true variable-rate operation from anywhere between 1 MHz and 60 MHz (500 Kbaud to 30 Mbaud) without the limitations imposed by the pseudo variable-rate feature of other products on the market. VLSI provides optimal price/performance options for the needs of each system and each set-top manufacturer. While other solutions available on the market require the use of an external voltage-controlled crystal oscillator (VCXO) and low-pass filter (LPF), the VES1777 operates with only a simple external crystal for reduced cost and complexity. The VES1777 satellite channel receiver also includes Viterbi-rate auto-depuncturing, automatic spectral inversion resolution support, and advanced bit error rate (BER) output measurement. Automatic Viterbi rate depuncturing and spectral inversion resolution support provide for true automatic synchronisation of the satellite receiver with no intervention required by the system operator. Advanced BER output measurements facilitate complete flexibility and accuracy for satellite dish targeting and tuning. An I<sup>2</sup>C interface is integrated to provide necessary flexibility for command and control of the VES1777.

### **Digital TV - current experiences.**

Many Satellite TV enthusiasts are now starting to see advertisements for digital satellite TV receivers appearing in magazines such as "What Satellite" for figures around £800. With the increasing migration from analogue to digital and with many digital channels being "in the clear" there will no doubt be some who are tempted to raid their piggy banks. Information being provided by the German Tele Satellit Magazine on experiences with the both first German digital set top boxes (the D Box and Mediabox) and some grey imports should give rise to a little caution. The following notes summarise the facts emerging so far;

- Digital receivers equipped with a Conditional Access Module (CAM) such as Irdeto used for the South African Market will not necessarily receive Nethold's digital service for the Benelux countries which also uses Irdeto (even for unencrypted channels).
- Some receivers (such as the D Box) currently on the market are specific to a programme provider. Even unencrypted services can not be received without a valid smart card.
- Data rates in some receivers cannot be adjusted to receive Single Channel Per Carrier (SCPC) signals such as those carried by Eutelsat II F3 at 16 Deg E. The D Box for example runs at 15 to 30 Msymb/s whereas to receive the Dutch TV10 and TMF services from 16.0 Deg E you will need to set the receiver to 5.632 Msymb/s with a Forward Error Correction (FEC) of 3/4.
- Set top units in the US have tumbled from \$399 to \$199 dollars with the launch of Echostar's "Dish" network though unfortunately the Echostar Digital receiver is apparently incompatible with the current European Digital Video Broadcasting implementation.
- Software control allowing considerably greater flexibility than the current user interface provided in early receivers will give increased scope for digital multi-satellite reception.
- The Canal Plus "Mediasat" receiver has been reported to be capable of receiving MPEG 2 services from Astra 1E such as ARTE and 3Sat well as Filmnet 1 & 2 which at the time of writing are "in the clear".

From all of this it can be judged that early receivers on the market have very different specifications and implementations of the DVB standard. The speed of change however is so great that within 12 months we should be able to see a much clearer picture of what performance is available and avoid the pitfalls of purchasing too soon.

## Satellite on the WEB

For those suitably equipped point your browsers to ;

France Telecom home page [HTTP://www.francetelecom.fr](http://www.francetelecom.fr)

Drake Receivers [HTTP://www.rldrake.com](http://www.rldrake.com)

Aerospatiale [HTTP://telecom-valley.fr/aeroca/sat/sat.html](http://telecom-valley.fr/aeroca/sat/sat.html)

That's all for this issue of Satellite TV news. The lack of letters following the last issue could mean that all you ever wanted to read about Satellite TV news was covered. It could however mean quite the reverse and you were straight onto Members Ads!

With no feedback or input from you the column will be boring to read and boring to write so please get those pens or PCs in action. My E-mail address is paul.holland@BTinternet.com.

Pictures of **ARABSAT 2A** and **Turksat 1C** being worked on by the ground crew can be found on page 23.

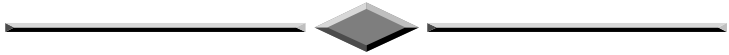

A camera being used to get pictures during the CAT 96 exhibition. There are some more pictures from CAT 96 in the article starting on page 17.



## Subscription Renewals for 1997

### By Dave Lawton, Membership Secretary

Subscription time will shortly be upon us again. The subscription for 1997 will be **£12.00**. This is the first increase for Six years and is brought about by the continuing rise of postage and printing costs of the magazine. In 1996 the cost of printing and posting the magazine outstripped the income from subscriptions, leading to the inevitable rise in subscription rates. We have however continued to upgraded the quality of the magazine and this increase will allow us to continue to do so for the foreseeable future without the need for any further subscription increases. This also allows us to give a larger discount for multi-year subscriptions.

The rates for 1997 will be as follows .....

<b>1997</b>	<b>£12.00</b>
<b>1997 + 98</b>	<b>£22.00</b>
<b>1997 + 98 + 99</b>	<b>£32.00</b>
<b>1997 + 98 + 99 + 2000</b>	<b>£40.00</b>

Overseas Members, outside Europe, will receive their magazine by Surface mail. If anyone wishes their magazine sent by Airmail the additional cost will be **£6.00** per year. This figure reflects the additional cost to the Club to send magazines by Air. Please note that there is no additional airmail charge for Members who live in the EEC and Europe.

As in the past, along with Club policy, we will not be asking for any top up subscriptions from those Members who took advantage of our multi-year discounts and therefore have already paid for future years.

## Important

How do you know your subscription is due for renewal? If your subscription is now due, a renewal form will have been enclosed with your magazine. Please fill out the form and return to the Membership Secretary as soon as possible. Take advantage of the multi-year discounts which saves you money and helps the Club's administrative costs.

# Sevenside Television Group

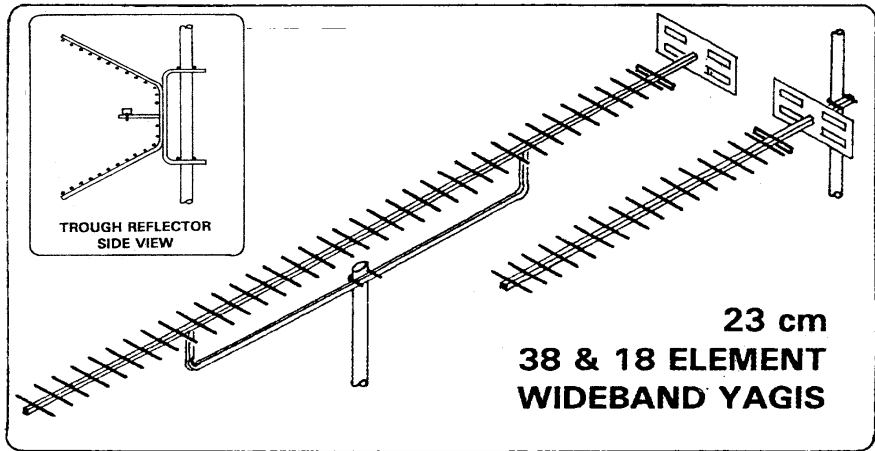

All of our 23 cm Aerials are specifically designed for ATV use - although they can be used for other modes as well. Wideband characteristics mean that you need only one aerial to cover the repeater input and output channels. Our famous wideband yagis come fully assembled in two versions :

**38 ELEMENT HIGH GAIN :** 14 dB gain, 1.8 m long, **£26.00** plus postage.

**18 ELEMENT STANDARD :** 10 dB gain, 0.9 m long, **£15.00** plus postage

Don't forget our **20 ELEMENT CONVERSION KIT**, which converts your existing 18 element aerial to the full **38** element high gain specification : **£13.00** plus postage. Our 23 cm **TROUGH REFLECTOR** is quite unique, combining 11dB gain with wide bandwidth *and* wide beamwidth. It's also compact, just 0.55 m high, 0.35 m wide and 0.3 m deep. Supplied as a kit of predrilled and preformed parts. for easy "Screwdriver" assembly : **£19.00** plus postage. All aerials feature an SWR of less than 1.5:1 and are supplied with mast clamps suitable for masts up to 55 mm diameter. Mast poles shown are not supplied.

**POSTAGE:** **£3.75** for one aerial, **£5.00** for two or more. Telephone orders with cash on delivery: **£2.75** supplement per order, Orders from outside of the UK - please write for carriage quotation.

**CHEQUES** payable to "SEVERNSIDE TELEVISION GROUP" and send to 18, Linnet Close, Patchway, Bristol BS12 5RN. Telephone ( evenings & weekends only please ) 0117 969 8136. Please allow 28 days for delivery.

**New World Record on 10 GHz ATV, 592 km****By Michel Vonlanthen HB9AFO/21.5.96**

On May 18 1996, F1JSR and HB9AFO exchanged pictures on 10 GHz over a path length of 592 km, between Corse Island and Spain. Is this a new world record for 10 GHz ATV ??.



F1JSR spent one week in Corse Island at location JN42RQ, in the Serra di Pigno at a height of 960 meters above sea. His equipment was a DRO synthesised transmitter on 10.450 MHz followed by a travelling wave tube amplifier delivering 20 Watts to an "Ikea" parabolic antenna of 40 cm in diameter. The receive equipment was an offset antenna of 85 cm, a non-modified Astra LNB, a "+500 MHz" converter and a standard tv-sat receiver in parallel with receiver to aim the tv-sat antennas.

From his side, HB9AFO, after successive attempts beginning in the region of Toulon (France), and finishing in the Sierra de Montseny, near Barcelona (Spain) in JN11ET, at an altitude of 1650 meters above sea level. He had a DRO transmitter on 10.480 MHz followed by a 1 Watt transistorised power amplifier driving an "Ikea" 40 cm parabolic antenna. His receiver system consisted of a parabolic antenna of 1 meter of diameter with high precision azimuth/elevation gear, an Astra

modified LNB with a noise factor of 0.7 dB and a AR3000 modified receiver followed by a narrow band ATV FM demodulator in parallel with a normal 12V tv-satellite receiver.

The qso was bi-directional, the signals varying between P0 and P5 colour, with very quick level variations due probably to the strong wind, the fog and the intermittent rain in Corse. Two days before, the same qso was done, HB9AFO being on the Pic de Nore, in the department of Tarn (France) in JN13FJ (574 km). In both cases, the qso were consistent and lasted for more than two hours and took place in the evening.



A detailed report will be publicised in the French and Swiss ATV associations magazines "B5+" (ANTA) and "SWISS ATV NEWS". A VHS video cassette is now in production and will be obtainable at the address of: SWISS ATV, PO box 301, 1024 Ecublens/Switzerland.



## Narrow Band FM ATV Reception

By Serge Riviere F1JSR, translated by Grant Dixon

### The Project

Most amateurs equipped to send FM ATV have pass-bands in the region of 16MHz (even 27MHz). I am not going to repeat here the explanation of the characteristics which determine the need for such a large bandwidth, but I will remind you that 16MHz is more or less the minimum bandwidth needed to receive correctly a FM signal together with its colour and sound carriers. Given that wide bandwidth is important one can still understand an interest in reducing this bandwidth in an effort to improve the signal to noise ratio on reception. If the bandwidth is reduced by a factor of 10..(27 MHz to 2.7MHz) this will give an increase of 10-fold to the signal strength at the receiver ..(-90dBm /-80dBm). It is quite obvious that such a restriction of bandwidth will be detrimental to the quality of the signal. Actually it will be possible to receive neither the sound sub-carrier nor the colour. Further, the video passband will be limited to 400kHz ,which is quite a reduction, but it will be sufficient to decode the 4 digits used in contests !

The present article describes an ATV FM Demodulator which has a bandwidth of 2.7MHz on an I.F. frequency of 70MHz, which can find its place behind the old system of F3YX which modified the local oscillator frequency from 1185MHz to 1180MHz to bring the I.F. frequency from 75MHz down to 70MHz

### Description

The unit can be divided into three parts.....

- a) RF Amplification & Filtration
- b) Demodulation
- c) Video processing.

#### a) Amplification

Signal amplification is done by Avantek type MSA885 MMICs which have a gain of >20dB at 1GHz and a gain of 32dB at 70MHz. As we shall see later, the advantage of using these wide-band amplifiers is to be able to use this circuit at frequencies up to 1GHz with very little modification. The MMICs are linked by small, surface mount, 3dB

attenuators to better define the matching impedances viewed from one to the other as well as to avoid accidental latching given such a high gain circuit.

A surface wave device, Plessey DW1102 is used for filtering. It has a bandwidth of 2.4MHz at -1dB and 2.54MHz at -3dB. The -40dB pass-band is 3.6MHz and an in-band insertion loss of 23dB; this explains the necessity for the three MMICs in series. Note in passing that for those who want to amuse themselves a little, the pass bands of the DW11xx series extend from 0.65 to 26MHz!

Finally, an AGC system limits the level at the input to the discriminator. This acts on two of the MMICs. The dynamic action is approximately 70dB for an input level at the discriminator of 0dBm. The total gain is near to 70dB including losses in the attenuators and the surface wave filter. The maximum input power of the circuit is 40mW.

### **b) Demodulation.**

The demodulator uses a Plessey IC...SP1454. With only 6 external components it can demodulate an FM signal between 70 and 150MHz. The RLC circuit placed in parallel across terminals 2 and 3...

1. controls the frequency, by means of the LC time-constant, at the fundamental frequency with values calculated using the Thomson formula.
2. controls the slope of the discriminator by means of the resistance R. The lower the resistance the larger the bandwidth of the discriminator (low slope). Note that this circuit can also be used for high definition TV signals. Photo 2 shows the action of the resistance R on the slope of the discriminator, while photo 1 shows the linearity of the discriminator.

Note the possibility of using the twin IC SP1452 which is pin for pin compatible and functions from 300 to 1000MHz. The frequency is adjusted in the same way but the RC time constant is set for the fundamental frequency/4. By replacing the surface wave filter by another filter, possibly external to the PCB, you can serve up this circuit with all the sauces. (Trust the French for gastronomic comparisons! CGD)

### **c) Video processing.**

The last part of the circuit is a stage of de-emphasis followed by an NE592 video amplifier which is quite suitable here as the video bandwidth is restricted. One important point is that the circuit must be modified; the usual circuits using this IC work with a centre frequency of



mounted as close as possible to the PCB. Make sure to have good screening around the circuit to avoid interference from stray signals.

### Setting up.

The most difficult part is to get hold of an FM TV signal on 70MHz. Once this has been done, inject an unmodulated carrier at the input with a level between -30 and 0dBm. Adjust the AGC potentiometer to obtain a DC voltage of about 0.25v at the positive input of the amplifier. Varying the signal input voltage check that this level remains practically constant, thus verifying the reliability of the AGC.

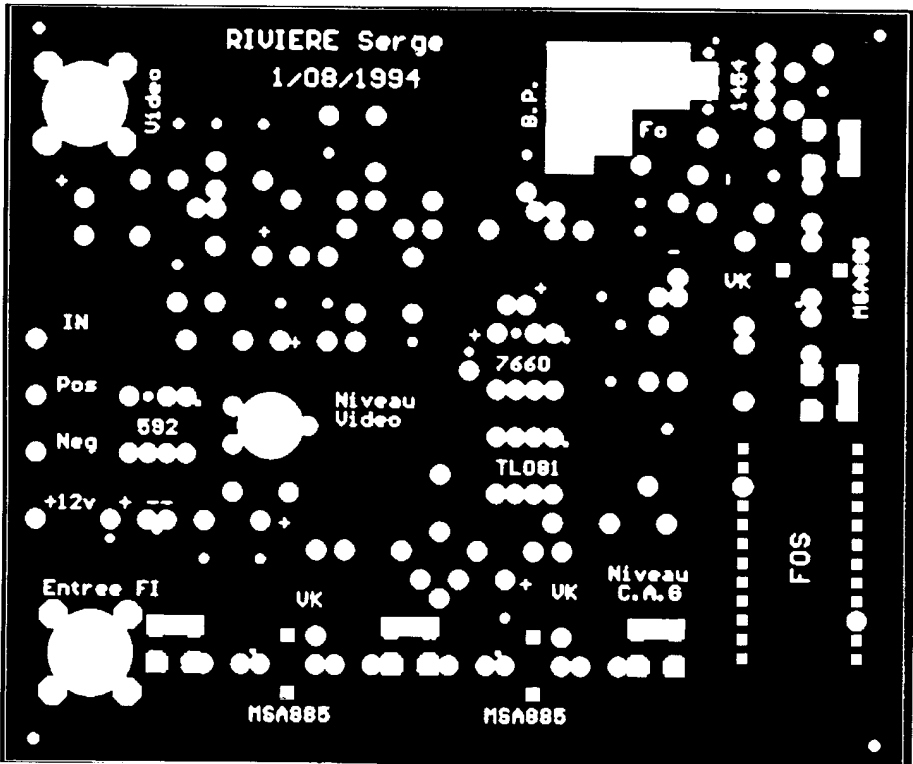

### Component side of the printed circuit, showing the ground plane.

Then centre the discriminator. Inject an unmodulated carrier as before and adjust the 18pF trimmer located near the SP1452 whilst measuring the DC volts on pin 5, set the video gain resistor to a low value. You can to begin with replace the de-emphasis stage with a CCIR one (33μH and 5nF) in order to make life easier. Now adjust the video gain control to get the correct video level at the output.

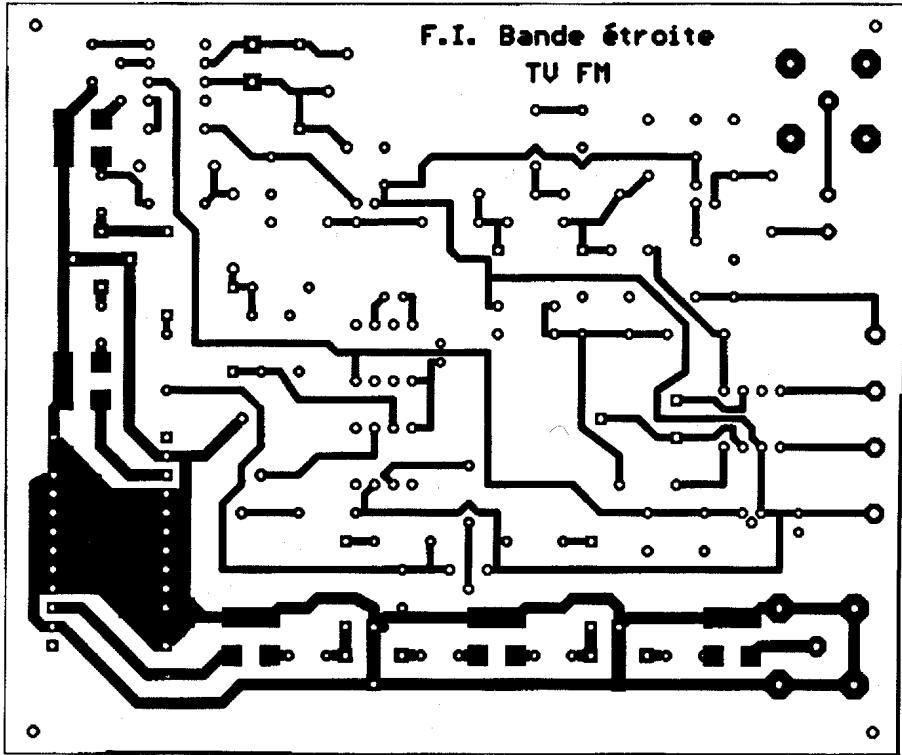

Copper track side of the printed circuit.

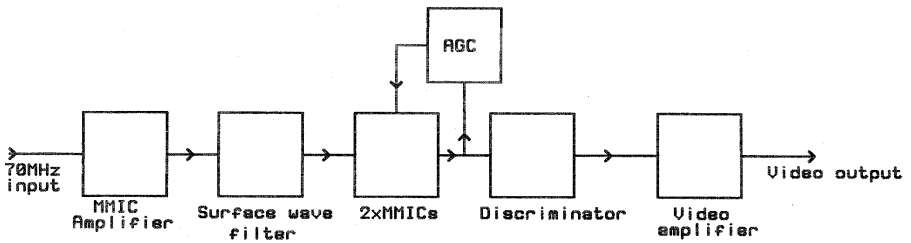



## The Chrominance Equaliser

### By John Cronk GW3MEO

I had just been experimenting with some video peaking circuits when CQ-TV 174 arrived. I was instantly inspired by G6TVJ's circuit (page 60). I did not have any of the specified components, so, eager to try the method, I devised this economy version of the circuit. It selectively boosts the 4.43 MHz beautifully, but as Ian says there are certain limitations.

### Design

A length of coax could be substituted for the delay line, but what a length! The PAL sub carrier frequency has a wavelength of 67m, so 180 degrees would be 33.8m even adjusted for the velocity factor of solid coax (0.66) it would still be 22.347m long and even then one is limited to 50 or 75 ohms. There is a special delay type coax, but I do not think it is easy to obtain, so the lumped constant delay was considered. After some self education, I felt I had sufficient information to attempt a design. Half a cycle at 4.43MHz takes 112nS.

It was intended to produce a design using preferred value components. The first effort was far from this aim so the C and R values were 'adjusted' to 1.5 $\mu$ H and 68pF (T sections). I made up the inductors on a Bic ball pen former, with the aid of the RSGB handbook inductor chart.

A double beam scope was used to check the delay (signal before, beam 1, delayed beam 2). It was found the delay was spot on, to my surprise. The characteristic impedance had to some degree been left to chance when 'adjusting' for preferred values. The impedance is quite easy to measure with a scope and pulse source, by the reflection method if the delay line is terminated with a variable resistor. I had been aiming for over 100 ohms; the measured value was 280 ohms.

A practical and cheap 112nS, 280 ohm delay line is the result. The former is 4" of a 'Bic' ball pen, octagonal in section (nominal 0.3" dia.) small holes were drilled at 0.4" centres to anchor twisted loop taps every 23 turns of 30 SWG enamelled wire, each winding will be 0.3" long. It took about half an hour to make.

I must agree with G6TVJ that the NE592 does not give  $\frac{1}{2}$ Vs on the output when input is set at  $\frac{1}{2}$ Vs. I have indicated the DC states on my circuit. But referring to Ian's article on the NE592 in CO-TV 175 page



34, the Signetics data book shows it is not intended to be used with output loads less than 1K ohms (max op 10mA).

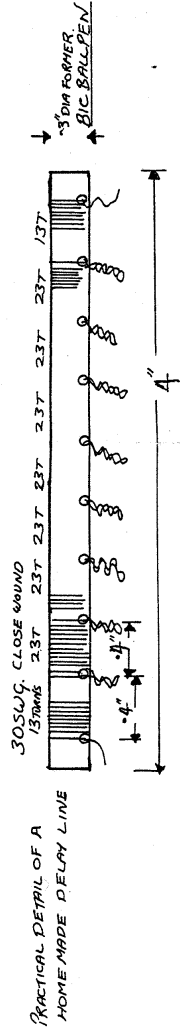
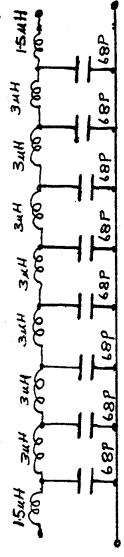
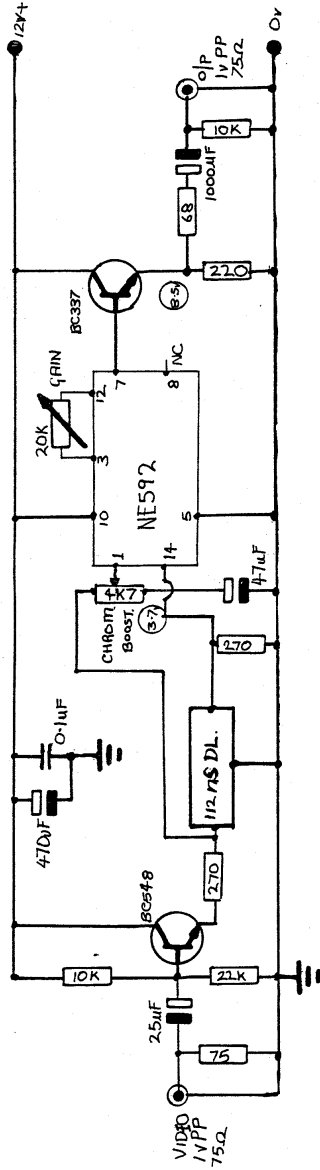

VIDEO CHROMA BOOST CIRCUIT. GJW3MEO.

SC. 17.5.96.

Incidentally the next page in the data book is for the  $\mu A733$  IC which is said not to be a substitute for the NE952, but as far as I can see the main difference is in the name, the  $\mu A733$  is described as a 'differential video

amplifier' and the NE592 as a 'video amplifier'. In practice there is not much difference, but on the face of it the  $\mu$ A733 should be the more correct device for this circuit.

### Results.

If an undistorted video waveform is applied the colour burst (and Chrominance information) can be boosted until it reaches the sync. bottom without affecting the sync. amplitude, magic, but as Ian says large, spikes will be produced at the fast transitions. On a weak received signals, when the colour burst is lost in the noise, it will not find one, but brings up the noise to no benefit. Between these two extremes it is a very useful circuit to correct for equipment deficiencies, without adding noise from frequencys above the wanted video band.

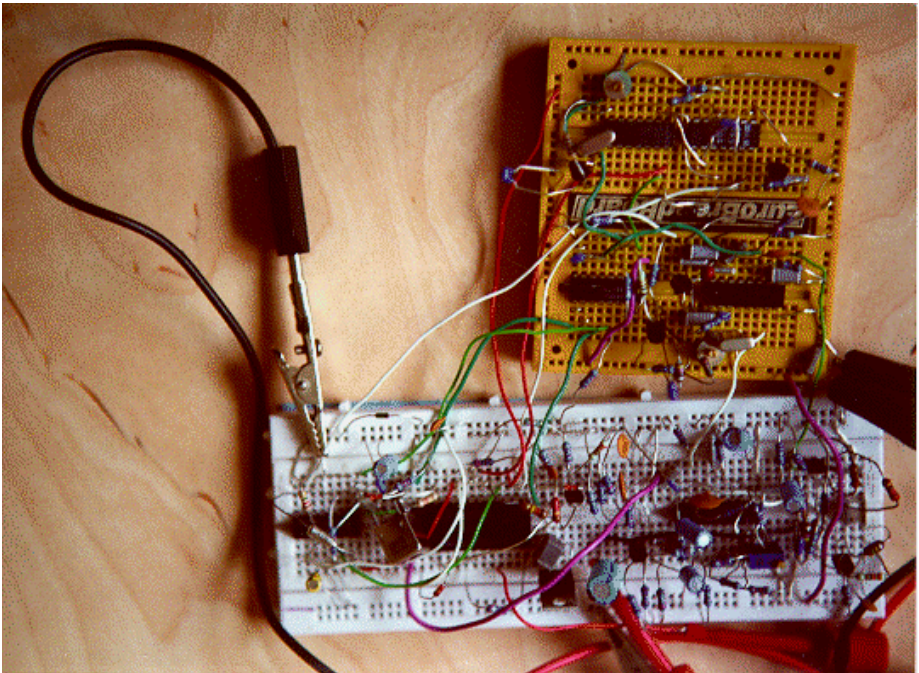
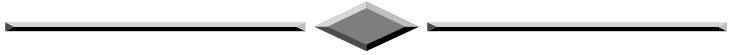

**An early prototype of the Star Ship Enterprises Warp Drive control system by Peter Delaney. It's prototyping Jim, but not as we know it.**

**Contest Calendar 96/97**

**By Richard Guttridge G4YTV**

**AUTUMN VISION 96** .....9th/10th November 1996  
All bands fast and slow scan 18.00 hr. GMT Saturday to 12.00 hr. GMT Sunday

**MAY MICROWAVE 97** .....10th/11th May 1997  
24cm and above fast scan 18.00 hr. GMT Saturday to 12.00 hr. GMT Sunday

**SUMMER FUN 97** .....12th/13th July 1997  
All bands fast and slow scan 18.00 hr. GMT Saturday to 12.00 hr. GMT Sunday

**THE INTERNATIONAL 97** .....13th/14th September 1997  
All bands fast scan 18.00 hr. GMT Saturday to 12.00 hr. GMT Sunday

It's our turn to organise the IARU INTERNATIONAL.

**THERE WILL BE NO OTHER ATV CONTESTS ORGANISED BY THE BATC DURING 1997 DUE TO THE LOW NUMBER OF ENTRIES IN 1996.**

The contests that have been cut from the calendar are as follows:-

Winter Vision 96, Winter Cumulatives 97, Spring Vision 97, Autumn Vision 97 and Winter Vision 97. All except the Cumulatives are normally held on the second full weekend in the months of December, March, and November. The four Cumulatives start on the first Thursday in January and are held at eight day intervals. The contest manager will reconsider the position, if he receives pledges of at least six fast or slow scan entries from fixed or possible portable stations one month before the normal date for a contest. He will gladly reinstate it. A message to that effect will be put into the Club's BBS and onto the Packet Network .

I would like to give up the post of contest manager, if someone else would like to have a go. I don't really have the time to give to it and it's fairly obvious it requires a new hand on the tiller to turn the contest scene in the UK around. "Things can only get better," as they say! I will keep going until someone can be found.

Contest rules and details from :- **RICHARD GUTTRIDGE G4YTV, IVY HOUSE, RISE ROAD, SKIRLAUGH, HULL, EAST YORKSHIRE. HU11 5BH.**

## Pictures to Holland?

**By Bob Robson GW8AGI**

I woke up with the sun in my eyes. The single brain cell added that bit of information to the fact that I was in a strange room. After a lot of effort it worked out that I was in a hotel room in Bridlington, and it was Saturday 17th August. What was I doing there you might wonder; so did I for a few minutes and then the penny dropped! I was there to 'help' Bob Platts G8OZP in attempting to send and receive TV signals to Holland.

Bob had arranged this weekend with Hans PE1ECO to explore the enhanced propagation that appears to occur when a belt of moist air builds up in warm conditions about 10 metres above the surface of the sea. The weekend's exercise was to try for a longer sea level path than they had had the previous year between Holland and East Anglia and today was the day. The weather forecasters had promised a hot, calm day with temperature in the 80s, so conditions should prove ideal.

After breakfast (full English fried!) we gathered in the carpark in front of the hotel which had been chosen as it was right on the sea front about 10 metres above the high tide level. We being Bob G8OZP, Malc G3GRM, Malc's wife Kim G0SIP, and yours truly Bob G(W)8AGI. (See the picture on page 73) Our support crew were Sue (Bobs wife) aided by his daughter Helen and Betty, my wife. In addition to the TV activities Betty & I had a second reason to be there as Bridlington was where we first set up home forty years earlier.

The forecasters were not wrong and the sun was building up to a hot day, but the lack of breeze meant that the mist was still in evidence. You could not see Flamborough Head across the bay, and the harbour was hard to make out. This was going to make accurate setting up of the dish heading a little difficult as the reference line for calculating the dish heading was rather short and none too accurate.

We got all the gear out of the cars and set up shop to be ready for the planned start at 10 o'clock. First snag of the day! My receiver wasn't going to play, and my monitor was a little akin to a TOC H lamp in the bright sunlight, but the camera was giving cracking pictures (how did I know? I tried it in Malc's monitor!).

A call to PE land at 10 o'clock on two metres established that Hans was all fired up and radiating as planned. Patient searching failed to find any signals on 10 Gigs, was it going to be a failure? The two metre signal was only S2 with QSB to S5. We tried sending signal to Holland, but

with the same results. Conditions were slowly improving as was the two metre path so we decided to try again after lunch when we hoped that there might be a better path as the moisture layer we needed might have established itself by then.

Bob had written a note to CQ-TV telling everybody that we would be operating this weekend and anybody interested was welcome to come along and join in the fun. On the Saturday and Sunday we had visits from Dave G3ZTR, Richard G7MFO and Geoff G3PWN and several others who didn't get entered in the log.

We then received a call on two metres from Peter G4NJJ saying that he and Peter G8JAN were on the sea front at Well-next-the-sea and would like to try sending signals to us. This they did and P5 signals were soon the order of the day. Malc had set up his, as yet, untried transmitter and dish and was radiating for test purposes when he heard his callsign on the two metre calling frequency. The fact that somebody in Norfolk could see his signals took a while to sink in! Yet another QSO, Malcs first long distance QSO on 10Gigs.

Bobs first contacts were using his 1 metre prime focus dish with a 1.2dB noise figure LNB, and a 900mWatt TX . With this setup he was receiving and sending P5 pictures. Later he downgraded to his 10mWatt gunn-mod TX with 60cm offset dish with a similar low noise LNB and still had P5 pictures. Malcolm G3GRM with similar transmitter into a 50cm prime focus dish achieved similar results on transmit, but was not equipped for receive.

We next had a call from G4PFG who was a little way inland from the Norfolk coast at Salthouse Heath. His signals were about P4/5 and we believe that was because he was away from the sea.

The two Peters were highly delighted with the morning's contacts as previously the record for DX on 10G was about 6 miles, and they had been planning to try for DX by crossing the Wash! The path to Bridlington added a 1 & a 0 to the front of their previous DX to make about 106 miles. I think their post lunch trip was to the nearest hostelry to celebrate !!

The Norfolk contacts were useful to us at Bridlington as they gave us a very long, accurate baseline to calculate the correct heading to Hans PE1ECO. Swinging Bob's dish onto the calculated heading and a call to Hans rewarded us with pictures. They were varying between P2 & P5 but rapidly settled down to a steady P5 Not bad for a sea level path of about 350 Km! The afternoon was spent exchanging high quality pictures, and explaining to bemused passers by what we were doing.

About 6 PM we closed for the day as we decided that it was politic to join our support crews, and as lunch had only been sandwiches, a shower, change out of shorts and a stroll into Bridlington town for a meal and a little 'light' refreshments was the order of the day.

Next day staggered into action in a similar manner to Saturday! Our Landlady handed me a note asking me to ring the local stringer for YTV, which I eventually did. He had been told that 'something to do with TV was going on' What was it all about? An explanation as to 'what was going on' was given and later that morning he turned up at the Hotel with a cameraman and got some footage of our setup, and an interview with Bob Platts. This resulted in a 40 second snippet on the local news program from Yorkshire TV. More exposure for ATV.

Before the YTV man arrived, we had to explain all about what we were doing to the man from the Hull Daily Mail. He interviewed both Bob and myself and took several still shots of the setup. The owner of the Hotel we were at had contacted him.

Back to the real reason for our being there! Our first contact was with Peter PEIDCD who was on the Hook of Holland. This was a distance of 366 Km. We spent about half an hour exchanging pictures before re-adjusting the dishes to receive pictures from Hans, which were captured on video by the YTV cameraman via his camera.

Like the day before pictures were again exchanged between the two sites. As there are a limited number of views that can be sent from a fixed location, I decided to take my walkabout 10Gigs setup and to go to the harbour which is a focal point in Bridlington. Malc & my XYL came along to cover talkback and general help. Bob set up a second dish to receive my signals and rebroadcast them on to Holland.

Some of you may have seen my walkabout rig at Coventry this year. For those who haven't a thumbnail sketch herewith:- The TX is a Gunn diode in a short section of waveguide, which is coupled to a second short section with a clamp nut mounted on the 'flat' (long) wall through which a piece of semi-rigid coax is fitted. The semi-rigid coax has 5mm of the outer copper removed to reveal the insulation. The other end of the semi-rigid coax has the outer copper stripped off for 10mm, and the inner conductor soldered to a nut used to mount a potentiometer. A slot is cut in the nut and the coax inner is soldered to one side of the cut, and a piece of copper wire soldered to the other. The second end of the wire is soldered to the coax outer. the two conductors are bent to a right angle so the coax would have gone through the centre of the nut. - Simple when you see it, not too easy to describe!

The electronics to drive the Gunn diode are in a diecast box clipped onto a leather belt, as are two 6 Volt accumulators linked together to supply the camera and Gunn diode driver unit.

Back to the main plot. I sent pictures from the harbour for about 40 mins. then returned to the main site. By about 12-30 the wind had started to blow a bit, and Peter reported that the sky in his area was starting to become overcast. The 10 Gigs signal were starting to QSB rather a lot and the two metre talkback was also falling off. Obviously conditions were failing. At about one o'clock we called Hans and decided to call it a day.

Was it all worth it? YES. We were fortunate to have ideal weather for the event, the wives enjoyed themselves on the beach, Bobs daughter Helen certainly enjoyed herself and we have more data to think about for sea-level contacts on 10 Gigs. Will we do it again? Yes is also the answer to that, in fact we have even talked about making it an annual event, although we will have to find a new site in Bridlington as the Hotel that allowed us full use of their car park has been sold and after the holiday season will be converted back into a large private house again, but we have a suitable site in mind and will talk to the owners in the near future..

***STOP PRESS Bob and Hans have provisionally agreed to carry out similar tests on the same weekend next year Watch this space.***

News just in! At Crick they were seen in a huddle and rumour has it that they are hatching something even more spectacular. See the report and pictures starting on page 17.

73 de G8OZP & GW8AGI

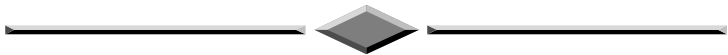

**Please mention that you saw it in CQ-TV  
when responding to advertisers**



## Video Editing on a PC

### By Jeremy Power G1WVK

Non-linear editing is one of the 90s buzz words in TV broadcasting. The ability to edit material within a computer gives the editor instantaneous access to any material stored on the machine's hard disks. Gone are the days of spooling up and down tapes, changing tapes, and the resulting generation loss from adding a shot to a cut sequence. The non-linear editor has made big inroads into off-line editing (the output off which is not broadcast quality) and now we are seeing on-line (broadcast quality) non-linear equipment. BBC TV's Here & Now and Tomorrow's World have both used on-line systems for the production off their final transmission programme. Well once again it has not been long for a domestic / semi-pro system to become available. I have had a system up and running (and crashing) since February so I thought it would be about time to give my honest opinion on it, and in one word ARGHHHHH it's slow!

My PC started off as a 66MHz Pentium, 8Meg ram, Soundblaster 16, 540M IDE drive, and a 2.1G SCSI drive. In late '95 MiroVideo released the DC20 video capture card so I ordered one of those. The card came with the limited edition version of Adobe's Premiere 4 video editing software which recommended a minimum 16M of ram. I decided a bit of headroom could be an idea so I bought 32M of ram, only a few months before the prices fell dramatically! The card arrived, I plugged it in, configured the software, and it worked - first time. A few weeks later my motherboard blew-up, Oh well another good reason for upgrading to a 100MHz board.

The DC20 card has both composite and S-VHS inputs and outputs. Before you start editing you have to digitise the material onto you hard disk. It is possible to digitise the incoming material to virtually any combination of line / field rate and compression ratio but there are presets available so that you can select CD-ROM standard or full 625 PAL without having to change about a dozen parameters. There are in fact 28 presets to chose from, and each one can be modified to suit your project's requirements. When you first install the DC20 it runs a test programme which analyses the speed of your hard disks and tells you what the optimum capture parameters are. This is where you realise that a SCSI drive is absolutely essential.

I normally input from my S-VHS camcorder with a horiz. resolution of 720 lines and a compression ratio of 15:1, using Miro's own MJPEG

algorithm. The sound is digitised at the same time by the Soundblaster 16 and both sound and vision are stored as an \*.AVI file. As a rule of thumb 15 mins of 15:1 625 line 25 Fps vision with 16 bit mono 44.1kHz audio is just over 1Gigabyte of memory. I recently added another 4.2G SCSI drive because in producing a promo video I managed to shoot too much material to be stored on my 2.1 SCSI drive; an expensive mistake.

Once the material is inside the PC editing becomes a bed of roses, only with a few thorns thrown in to keep you awake. The limited edition of Premiere 4 is too limited so I had to upgrade to the full version. This upgrade does add some essential features like programmable video effects. Incidentally if you are going to produce 625 25Fps material then you need a PAL monitor as well as the PC's S-VGA monitor. The screen for Premiere 4 can become a bit cluttered with windows; there is the project window, where you store the library of video clips for the project, the transition window, where you select the desired transition, wipes mixes, zooms etc. (I normally keep it closed as nothing beats a cut) and the most important one, the construction window. As with all non-linear editors the construction window is arranged horizontally with a variable time scale. There are two main video tracks with a transition track between them. Below are the special effects tracks which you can have up to 99 vision tracks in total! Below the vision tracks are those for the audio and again 99 are available.

To edit all you do is click and drag a clip from the project window and drop it onto the timeline in the construction window. If it is a video clip with audio then the audio follows onto the audio tracks. Video and audio are editable independently of course. If you overlap 2 clips, one on video A and the other on video B, and select a transition then the transition automatically becomes the duration of the overlap. In order to preview the transition you just select preview, wait a few seconds for the effect to be rendered and then it will appear on your PAL monitor. When you like what you see you then make the final AVI file. Again the machine has to render the data and this can take a very long time. So long in fact that this could be a good time for a snack, or even a 3 course meal! The rendering time does depend on the required quality and the complexity of the transitions and effects. This is definitely one of the system weak points. Another weak point is the captions. There is no straightforward way of previewing rollers or crawlers; in fact there is no easy way of making them especially if they are long. Filters can be applied to video clips. These range from coloured tints and inverted video to ripples and blurring. Filters can also be applied to the audio such as echo and panning. Although the audio fades smoothly from one volume level to another you can not set a level any more finely than in steps of 10%.

The manual for Premiere 4 is very comprehensive, 317 pages, and manages to answer most questions. If you have some editing knowledge, however, it is possible to use the programme without even opening the manual. Yes there are some very annoying “features” like the slowness to render but having a non-linear editor for a fraction of the price of a broadcast machine is a big plus. The technical quality is very impressive and the 15:1 compression ratio hardly ever produces any visible artefacts. It would be difficult to justify the price of such a system for the average domestic user but prices are falling all the time so soon every shack will have one.

This is only a very small amount of what it can do and, of course, you are only limited by your own imagination.

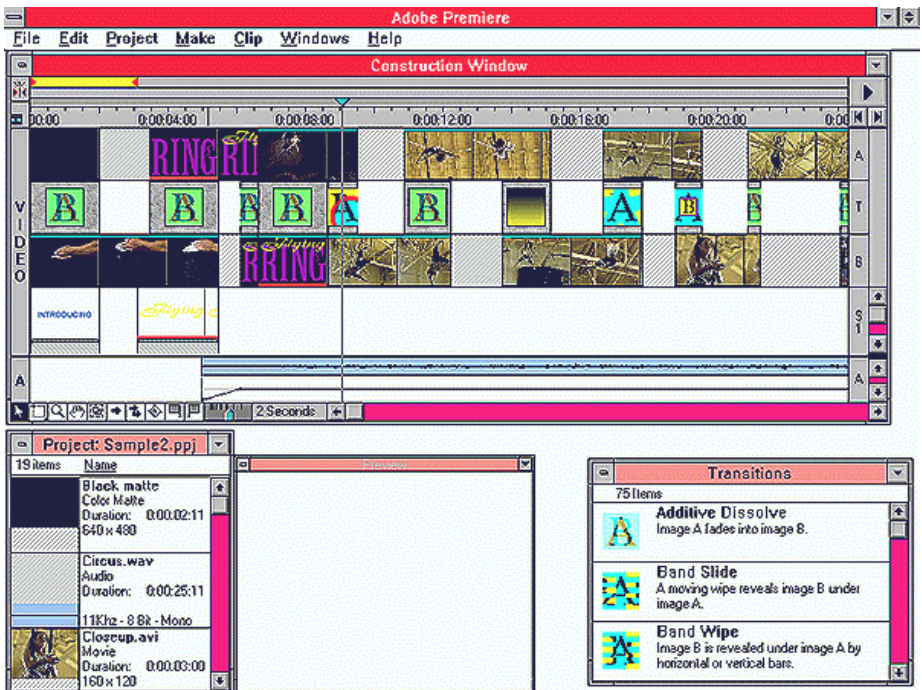

A screen shot of the Adobe software in action.

## 405 Alive – Can They Be Serious?

**By Andy Emmerson, G8PTH.**

Here we are, eleven years after the final close down of 405-line transmissions and yet there are still people fooling with 405-line televisions and other equipment. What's the fascination, what can you do and how do you go about it?

Actually it's highly appropriate to discuss 405-line television in 1996, the 60<sup>th</sup> anniversary of the start of what were called high-definition transmissions from London. The technology designed by those pioneers from the Marconi and EMI companies has served us well and forms the basis of today's 625-line system.

Many BATC members cut their teeth on what we today consider museum-piece equipment, using valves, image orthicons and of course 405 lines, and a number of these people find it therapeutic and still enjoy working on the older equipment. The motivation is similar to the way in which other folk enjoy restoring classic cars or working on a steam railway. But not all 405 Alivers are old fogies – a number of people in their twenties also find the 'retro' technology strangely fascinating.

Some people collect old TVs for their own sake and are not particularly worried whether they work or not. Most enthusiasts want at least one set which really works and a well-restored sets not only looks great, it gives excellent pictures as well – in restful black and white of course. Acquiring the source material is still fairly inexpensive. One of your friends or relatives probably has an old set in the loft, and you can also pick them up cheaply in charity shops or at furniture auctions. Others also collect and restore to working conditions cameras, sync pulse generators and the whole gamut of studio equipment.

Being interested in old TV receivers usually leads on to a wider appreciation of old television. It's hard not to share an interest in vintage programmes or the old commercials of the 405-line era. There's also the fascination of tracking down old programmes (recorded off TV, transferred from old 16mm telerecordings found in attics or junk shops, 'leaks' from the TV companies' archives, and so on).

In general old TVs are easy to renovate and repair – they are not very complicated or intricate inside. There is no real shortage of valves and other spares. Only some picture tubes are hard to find now. And whilst there are no programmes on the 405-line system now, that doesn't mean people just watch blank screens! In fact it's no great problem getting 405

line TVs to work with programmes recorded on a VHS (or Betamax) recorder. Most VCRs will record and play back 405 line material quite well, even though they were not designed to do this. Obviously the TV must be in good working order, then all you need do is build or buy a modulator which translates the video signal from your recorder onto a VHF channel suitable for the TV.

Modulators, also a superb 625-to-405 standards converter, even a solid-state Test Card C generator are all available from an enthusiast-run outfit called Dinosaur Designs.

Finding technical information is not hard of course. There are countless textbooks in libraries and second-hand book shops. There have also been several articles on restoring old TVs in Television magazine.

Some people ask us why we don't just convert the old sets to work on the current 625 line system or indeed why bother at all, if the only point is watching old programmes. We respond that they're missing the point and in any case, converting an old 405-line set to work on 625 lines is usually as much work as converting a gas cooker to electric! It's much better to use a standards converter and watch in 'genuine' 405-lines (albeit at a cost of around £300).

There's a notion that all old TVs must be valuable now but this is not the case, unless they date back to the pre-war period and are in fine condition (then you can expect to see price tags of £2,000-plus). One or two sets for instance the moulded bakelite Bush TV22 – are considered design classics and have become very popular as "yuppie antiques". This has pushed up their price but true collectors are not concerned with the cash value of their collections. You can easily pick up a set from the 1950s or 60s for under £50.

We have a very good support group for 405 enthusiasts with a magazine called 405 Alive. It is run on a not-for-profit basis and produces a magazine four times a year. Currently there are more than 300 members around the world (mostly Britain but also the USA, Canada, Japan and Europe).

Information about subscribing to the '405 Alive' magazine can be found on page 87.

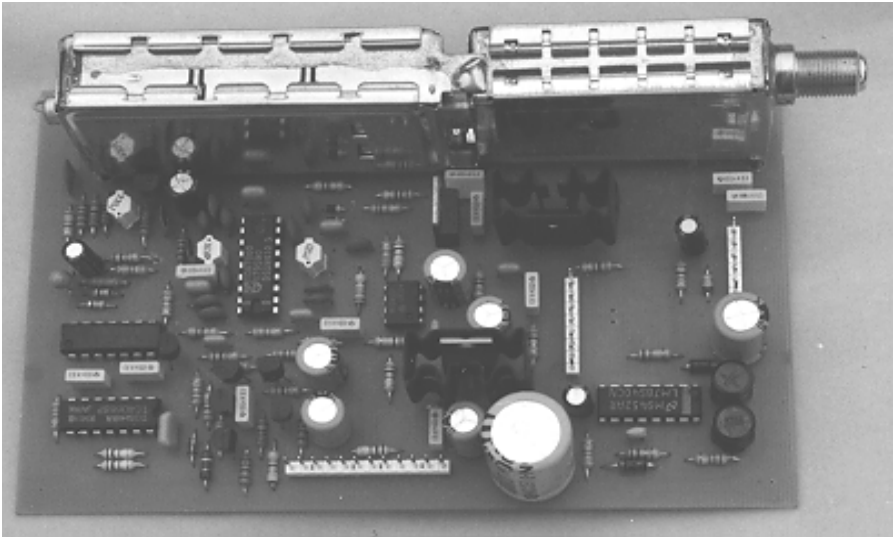
**GUNNMOD2 & TVRO3 a Review****By Malcolm Cox G3GRM**

Whilst at the Leicester rally last year I was attracted to a demonstration of some new 3cms ATV kits produced by Bob Platts G8OZP. After a chat with Bob a set of kits were obtained. The transmitter consists of a small pre-tuned Gunn oscillator module and a small Gunnmod 2 PCB kit. For receive, an LNB converted for 3CMs and a TVRO3 receiver kit was obtained.

The Gunnmod 2, together with the Gunn oscillator module, forms a 3cms ATV transmitter complete with intercarrier sound. The kit consists of a small quality glass fibre PCB together with all the board mounted components. No surface mount or specialist components are used. All the parts were packed in a small plastic bag with two pages of comprehensive assembly instructions, together with diagrams and general information on Gunn diode oscillators. I was impressed on how straight forward assembly was. The component layout drawing, parts list, information on component markings and semiconductor lead outs, were all on one side of a single A4 sheet which made the job very easy. Assembly took less than an hour and only required the use of a soldering iron and small wire cutters. Heat sinking is required for a small TO126 transistor which could be mounted on the side of a metal case. Four pre-sets are mounted on the board: Gunn diode volts, audio sub carrier level, audio gain and video deviation.

The Gunn oscillator head is separate from the PCB and after testing I decided to mount this in a separate small aluminium box.

Testing and setting up proved straight forward. After ensuring it was correctly assembled but without the Gunn oscillator connected, power was applied for preliminary testing. A meter was connected to the Gunn diode output and the voltage set to 7V. Next the audio sub-carrier frequency was set to 6MHz. I used my counter but an HF receiver could have been used just as well. The supplied instructions provide two ways of setting up. One with an oscilloscope and one by setting the three remaining pre-sets to recommended positions. I chose this simpler option. The Gunn oscillator head was connected and I was ready to transmit on 3cms ATV for the first time.

My attention now turned to the TVRO3 kit. A couple of things attracted me to this RX. Firstly it operates from 12v and has a built in SMPSU to provide 13V or 18V for an LNB or a pre-amp. The board is compact being just under 4" by 6" and has several useful and desirable features. The tuning is continuous from 750MHz to 1700MHz so it also covers the 24cms band. The sound is fully tuneable from 5.5MHz to 7.5MHz. Other features are adjustable video gain, audio squelch, signal strength meter output and video polarity selection. A very useful feature is the signal finder. This is an audio oscillator, the frequency of which varies with signal strength. The RF input to the board is by an F connector. The outputs are 1v PK-PK composite video and loudspeaker.

The kit contained the PCB and all board mounted components. These were all packed in several plastic bags for resistors, capacitors, semiconductors, etc. together with the PCB and a tuner module, which appears to be a unit designed for satellite receivers. Full instructions, diagrams etc, are on four double sided A4 sheets.

Construction again proved fairly straight forward though there are a lot more components involved. The most difficult task was fitting the tuner module. There are six lugs and 12 pins to line up. After a first abortive attempt, I tried by inserting one end first and worked along the module easing it into the board. A pair of fine nosed pliers came in handy and soon the module was snugly located. Everything else was straight forward though there were times I thought there was not enough room for some of the components. In every case I was proved wrong and everything fitted well. Construction took just under two hours.

Three connectors are used for all board connections. These are of the 0.1 Molex type and are supplied with the kit. Again I found this a good feature as nothing has to be soldered or unsoldered when fitting or removing the board. In my haste to try the system out, I decided that for



testing I would not use a case, so the controls and connectors etc. were wired up and simply laid on the bench.

A novel feature of the design is that there are no adjustable components at all. Hence no alignment or setting up. I just checked my work and prepared for a test.

I have a feed from my satellite dish in the shack so as a first test I decided to use that. Powering up immediately provided noise free signals from Astra. I was pleasantly surprised to discover that despite my standard LNB (Marconi blue cap) I could receive all the lower 1D channels. This is due to the unit tuning down to 750MHz. I found the audio tuning rather critical with the single turn pot I had used. A slow motion drive or multiturn would have been better. I checked the polarity switch and all the other controls. They all appeared to function fine.

Now back to the transmitter. The 3cms LNB was connected to the TVRO3 and simply laid on the bench. My Copredy test card generator and a microphone were connected to the Gunnmod 2. On powering up and tuning the RX, the transmission was quickly found, though very over deviated and not frame locked. The video gain control on the TVRO3 was at minimum, so my attention turned to the Gunnmod 2.

I turned the deviation control down, reducing it to almost zero to obtain a good picture. In fact the picture quality was very good indeed. The audio quality also proved very good. A link on Gunnmod 2 provides audio pre-emphasis which provided good HF lift. Some music was tried and the quality was very impressive for such a small and simple transmit system.

Later the RX was taken out in the car to see if I could receive the 3cms repeater GB3XT over a distance of 16 miles. With only a small horn fitted a near noise free signal was quickly found and the sound tuned in but despite having the video gain control at maximum, the video level was rather low and colour could not be resolved.

The equipment has now been fitted in cases. On the transmitter the audio and video deviation controls have been panel mounted and the Gunn oscillator head is mounted in a separate small box with a WG16 flange output. The system is very sensitive. With the transmitter set up in the front garden and pointing at the house, strong signals were still present in the back garden after passing through the brick walls. Strong scatter signals were also found from most directions. At present there is little 3cms activity in my area but a lot of interest is being shown. Now as the weather is improving I intend to mount the Gunn oscillator and the LNB together at the focal point of my 60cms dish and mount it up on the roof, from which I should be able to see GB3XT. My successful foray into



3cms has encouraged others in the area to try. There is even talk of putting up our own local repeater.

I have been in contact with Bob Platts regarding the problems encountered with the low video level and lack of colour from GB3XT, the rather critical audio tuning and the video deviation control on the Gunnmod 2 being at nearly minimum. He proved very helpful and has provided the following information.

The gain of the video modulator was deliberately fairly high. This is to enable it to be used with certain types of Gunn oscillators which require fairly high signals. However due to the fact that they are not particularly common, the modulator gain has been reduced on subsequent kits. The low video gain on the TVRO3 has been addressed with modifications that now allows variation from almost a blank screen to a level that is more than sufficient. In future a multiturn pot or reduction drive will be recommended for the audio tuning. Alternatively by the addition of two resistors the tuning range can be restricted which can also alleviate the problem. Bob also mentioned that like other satellite tuner modules the IF bandwidth is a little wider than we need for ATV use. To this end, Bob is developing an add-on narrow bandwidth IF module for use with the TVRO3. A optional video filter will also be offered.

Until speaking to Bob I did not realise how simple it was to become active on 3cms. I am very impressed with the simplicity and performance of the Gunnmod 2 Kit which is a very good performer and excellent value for money. At £30 it must be the cheapest ATV TX around. The TVRO3 impressed me and the lack of any setting up or alignment makes it a winner. Performance is good now the mods supplied by Bob have been made. The signal aligner is a first rate feature when it comes to aerial alignment. It has proved to work superbly right down to the noise floor. With just a horn antenna fitted to the LNB a change in tone was clearly detectable between pointing the LNB at the sky and then the ground. The TVRO3 covers the 24cms band directly and with an aerial pre-amp it should make a good RX for this popular band, particularly when the narrow band option is available. As for value for money it does cost a bit more than some surplus domestic satellite receivers but it has a lot of extra and very useful features. It is also well supported by Bob.

## I<sup>2</sup>C Logic for the GB3EY Repeater

**By Bill Hall G3RMX**

Towards the end of 1995 a decision was taken by the East Yorks ATV Repeater Group to update the logic for GB3EY. At the time the repeater was using a temporary logic system based on a Sinclair Spectrum which whilst being very reliable was somewhat limited in its ability to be expanded to provide some of the sophisticated features which were being considered for the future of the repeater. The BATC I<sup>2</sup>C boards were considered to be a good basis for the new system since these were themselves fairly expandable and were also fairly easy to interface to other more dedicated or sophisticated modules as future needs dictated.

An initial wish list of features was drawn up which included :-

- 24cm receiver input
- 3cm receiver input
- User selectable aerials on the 24cm RX ( to combat the radar problem )
- Several remotely updateable news pages
- The ability to shut down the 24cm Tx from a remote site

A further consideration was that the GB3EY location is extremely exposed and there can be fairly long periods during the winter when we dare not open the cabinet to get access to the equipment. This meant that the new logic must be able to survive and/or recover from mains interruptions ranging from a few milliseconds up to a whole day.

Discussions with Chris Smith G1FEF revealed that he had developed a number of different versions of I<sup>2</sup>C repeater software for GB3ET, GB3TM and GB3KT and he very kindly supplied us with a copy of the software for each of the above repeaters. Examination of the source code showed that most of the features we wanted had been implemented on these repeaters. A pair of I<sup>2</sup>C boards (CPU and VDU) were duly purchased and populated with the necessary IC's and we then looked at the software.

The GB3ET software was initially chosen as a starting point since this allowed both 24cm and 3cm reception (as did GB3TM). The caption pages and the morse ident were modified for GB3EY, an EPROM was blown and the logic was switched on. Everything burst into life but as testing progressed a number of features became apparent which were not quite what was wanted for GB3EY.

The polling between the 24cm and 3cm receivers was done on a caption page by page basis and since some pages were required to be displayed for 30 seconds it could happen that if you were very unlucky in your timing it could take over half a minute to get the logic to accept your signal and go into repeat mode. The other disadvantage was that only one news page had been implemented and as we wanted to allow some of the local radio clubs to have news pages on the repeater we would need at least six pages.

Going back to the source code it was fairly easy to change this so that polling between 24cm and 3cm was done on a half second basis which was felt to be much more acceptable. Increasing the number of news pages did not turn out to be so simple and I rapidly ran into major problems largely because I was not sufficiently familiar with the detailed design of the software. Fortunately I found that the GB3KT software had implemented nine news pages and although it had been written only for 24cms I was able to modify it fairly easily to include 3cms as well as the half second polling. A new EPROM was blown and I started testing again and after fixing a few minor bugs I very soon had the new logic performing extremely well.

Having now got the core system working I now concentrated on the peripheral switching boards for controlling video, audio and syncs. Composite video was fed from either the 24cms RX or the 3cms RX via a bilateral CMOS switch under CPU control to a sync detector using a 567 PLL the output of which was fed back to the CPU to signify the presence



**The Equipment Stack**

or absence of incoming video. When syncs have been present for 60% of a half second polling period the system switches into repeat mode for the appropriate receiver.



### The Control Box

The video switch which had its own pcb used a MAX 441 controlled from the I<sup>2</sup>C CPU board. This selected the appropriate video signal to be routed to the 24cms transmitter under software control from the CPU. The sound from both receivers was routed via another bilateral CMOS switch in sympathy with the video to the 24cms TX. The Morse Identification Tone was generated by a standard phase shift oscillator keyed by the CPU and mixed into the 24cms TX audio channel. The sync detect, audio switch and Morse Oscillator were all built on another single board.

It would have been possible to do all the video, audio and sync switching using good quality relays with gold plated contacts, however, as we had decided to poll the 24cms and 3cms receivers at the higher rate of 0.5 secs I felt that the sync switching would be unreliable in the long term and so opted for electronic switching for the syncs. Considering possible future applications we may need high speed switching of video and audio and so I decided to make all signal switching electronic except for

switching of 24cms RX aerials and power to the 24cms TX which is discussed later.

The next part of the design was to implement the keyboard interface to the I<sup>2</sup>C CPU remotely over the receiver sound channel. This was done by using an RS232 serial to parallel converter and a tone demodulator. This interface was designed to be able to use both non-



**Off air shot of the Information page**

standard baud rates and modem tones and as there is no visual feedback until access has been established, unauthorised modification of the news pages would be quite difficult. This interface is implemented using an AY-5-1013 UART with a 555 monostable chip for the baud rate clock and connecting directly to Port A on the CPU board. The tone demodulator is more complex using active operational amplifier filters which are tuneable by single variable resistors for each channel and is a circuit which I have used in the past with success on noisy signals. I did not use one of the modern modem chips since this would have limited the options for non-standard tones and baud rates.

Aerial switching for the 24cms receive channel was required to be achieved by the use of DTMF tones superimposed on the 24cms audio channel. The receiver was normally connected to an omnidirectional Alford Slot but as the repeater suffers from radar interference four 28 element JVL beams were fitted pointing in the directions of major usage. Having accessed the repeater on the Alford slot, sending the appropriate DTMF tone causes the receiver to be switched to the relevant JVL beam. The repeater will remain on this beam until ten seconds after syncs are lost when it will return to the Alford Slot. If syncs return before the ten second time out then it will stay on the selected antenna, this allows a local station working DX through the repeater to select the beam for a distant station.

The hardware for the aerial switching was based on a standard DTMF tone decoder with a PIC16C84 microcontroller doing the aerial selection

and timing. This same unit was also used to detect a coded DTMF sequence which when received with the correct tone and timing sequence would shut down the 24cms TX. This was one of the reasons why I chose to use a separate microcontroller instead of using the I<sup>2</sup>C logic since if the repeater is misbehaving it is unlikely that we could access the normal logic to shut it down.

During early testing of the system it was found that the MAX691 Power Management chip was not foolproof and that if the mains was pulsed on initial application then the system could lock up with the CPU halted and no Watchdog pulse was generated. I decided therefore to use the same arrangement as was proven to be very reliable with the Sinclair System. This consists of a 38 ampere hour 12 volt sealed lead acid emergency storage battery which is continuously float charged from a 13.8 volt stabilised PSU via a 3 amp diode to prevent self discharge during long power outages. The subsidiary power rails (+5 and -12) are derived from the +12 volts by switch mode converters. This arrangement allows the logic to continue operating for up to two days without mains power.

The new system went live on air on the 6th May 1996 and apart from a couple of very minor problems one software and one hardware it has behaved impeccably. The remote update of the news pages exceeded our wildest expectations and text pages can be prepared off line and downloaded in a matter of seconds completely error free. We found that even graphics pages which take some 3 minutes to download were received without errors even when the radar was doing its worst. In spite of the battery backed up power supply we have had problems with spikes on the mains supply, once during a severe thunderstorm and once in the middle of the night (cause unknown). These caused the loss of the user pages due to corruption of RAM and therefore an invalid checksum. This is not a major problem since the pages can be corrected over the remote link very easily; we are however looking at providing more efficient filtering of the mains input to the whole repeater system.

The logic is fully operational as described but two aspects of the system are not available to normal users. The 3 cms receiver has not been activated pending discussions with the Repeater Management Group and the Aerial Switching requires the four JVL Antennae to be installed on the tower. This is not a trivial task and needs a fine day with virtually zero wind at the same time as the maintenance team is available. It is quite surprising how strong the wind is at 25 metres even with a flat calm at ground level but we confidently expect to install the aerials during the Summer.

# VHF COMMUNICATIONS

VHF COMMUNICATIONS magazine is published quarterly and is available from **KM Publications**, 5 Ware Orchard, Barby, Nr. Rugby, CV23 8UF, UK.

Telephone: 44 (0) 1788 890365, Fax: 44 (0) 1788 891833

Email: 100441.377@compuserve.com



The yearly subscription is £16.00 for cash or personal cheque (drawn on a UK bank, or bearing the name of a UK banking agent), postal orders or bankers draft made payable to VHF Communications. Payment may also be made by any major credit card at £16.80. The subscription included surface mail charges, airmail is extra at £6.00 per year (£6.30 by credit card). The magazine is a **MUST** for the radio amateur and professional engineer interested in VHF, UHF and Microwave working, containing, as it does, detailed construction articles for equipment operating in these bands.

**Back Issues: special offer - enquire for details**

**Binders to hold 12 issues £5.50**

**Complete Index 1970 - 1995 £2.75**

**URL UK Site <http://www.eolas.co.uk/ag/vhfcomm.htm>**

**URL USA Site <http://clearlight.com/~vhfcomm>**



## **Enhancements to the Sony Video Printer**

### **By G8MNY**

After recently been given a Text/Video Graphic Printer Model UP-101UB, I decided to have a go at some enhancements to it. Several features were easily added, but some things could not be improved on.

#### **Poor Definition.**

The format seems to be only 256 x 256 black or white pixels. The vertical pixels are set by the number of heater segments in the write head so no improvement is possible and there will always be loss of a few lines at top & bottom (VDL preset) of the printout.

The horizontal pixels are laid down as the paper is moved forward one vertical column per 25th second. Altering the pixel counter by a factor of 2 in the clock counter chain changes the format to 512 pixels/line. Unfortunately further divides, just give 2 pictures. There is also a time penalty to pay, as the thermal head takes time to warm up/cool per pixel, so a slower 10 second print results. But the new speed does now print the whole picture width.

#### **Modification.**

Cut the CLK2 PCB track going to IC227 pin 1, and wire it via the spare counter in IC224 pins 11, 13 & 12 as per diagram. The linear Motor Speed (MS Preset) will need re-setting to correct the aspect ratio. This not so easy as the 256 line print loses some top & bottom lines of the picture. With a good Camera (CCD) input a picture of round object (tape spool), measure the printed ellipse and adjust MS preset accordingly until the printout is round. After adjusting the Motor Speed adjust the O-E preset for blackness so the paper is not too hot with the slower paper speed.

#### **Poor Sync Lock.**

There is no flywheel sync circuit so any video noise corrupts the line counter clock or odd frame recognition timebase and the print automatically aborts. Low pass filtering of the video before the sync detector does help. With this modification the printer should print OK down to P3. Also too much will delay the start of picture (moves picture left), which can be used to better centre the picture after the above Pixel mod.



### **Modification.**

On the rear PCB, remove R118 & C105, replace C105 in R118 location. Build up the Active Butterworth filter circuit as an ugly construction on the PCB component side of the PCB or on a separate vero board alongside the PCB.

### **Form Feed.**

The printer has a permanent feed of a couple of inches after each print to allow the picture to pass the tare off edge. As this can be a waist of thermal paper if your are doing multiple prints, I have added 2 switches to facilitate auto on/off and a manual feed.

### **Modification.**

Cut +ve end of diode D203 and wire pair of wires from the diode and bottom of R222 (cut off end of diode) to a locking front panel switch. Also mount a press switch wired to ground from the diode wire. Be careful with the location of the front panel switches, so they do not foul the metal chassis or cable connector.

### **In Sync LED.**

As the print can fail in the middle if the syncs are poor or too noisy some indication of their status could be useful. I found several points on the logic could give an indication, but the one shown was generally the best. It gives a steady 25Hz flicker when all is OK, and an on/off or unstable pulsing if disturbed syncs are detected.

### **Modification.**

Mount a PNP transistor and 2 resistors on to of IC208. Wire away to a front panel LED, that can have its ground soldered to the front chassis bar/tag.

### **Preview Output.**

As the printout is only black or white, the slice and gain thresholds are critical for a good picture. A method of showing a picture with these setting on a monitor is possible. Just 2 resistors can remake inverted composite video from the TTL levels. This is inverted to normal in a 1 transistor PNP amp to give 1Vp-p into 75ohms.

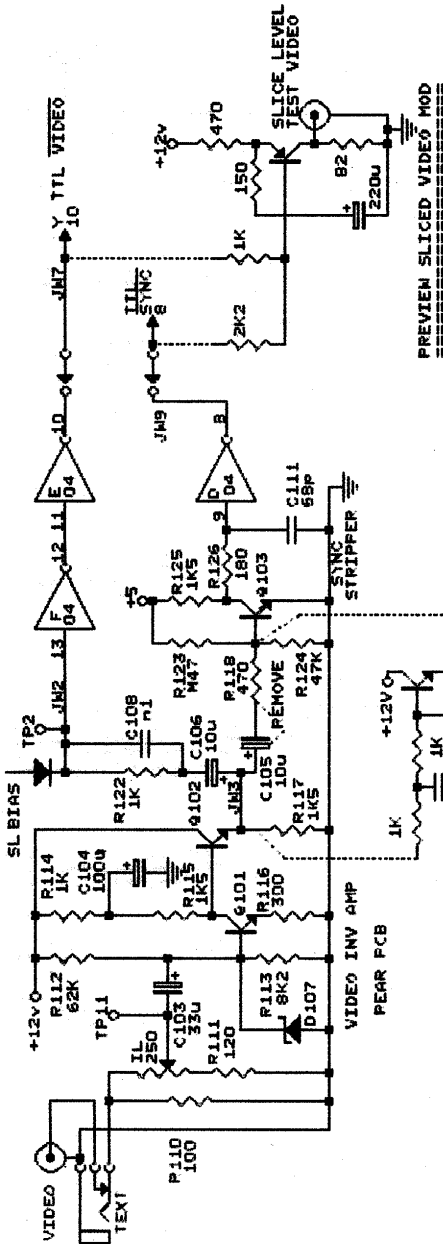

PREVIEW SLICED VIDEO MOD

SYNC FILTER MOD

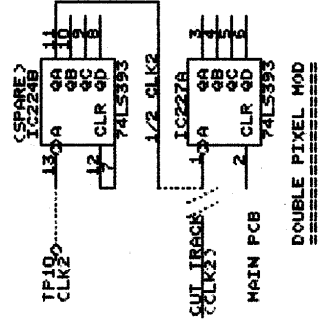

DOUBLE PIXEL MOD

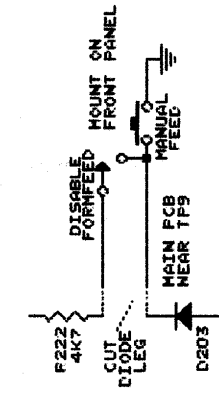

FORM FEED MOD

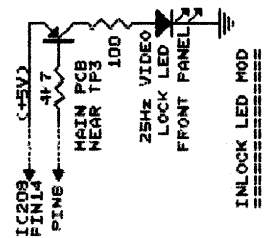

INLOCK LED MOD

**Modification.**

Build up the Amp circuit as an ugly construction on the copper side of the rear PCB or on a separate vero board alongside the PCB. Cut a slot in the connector plate under the DATA socket, to take a screw mount BNC socket and wire up. Drill hole in plastic back to match BNC.

**Thermal Paper Source.**

I have not found an outlet for the 105mm wide thermal paper yet. But I have had no problems hacking a standard (& cheap) 210mm 15m fax paper rolls into 2 for it, after first marking it and taping the cut line.

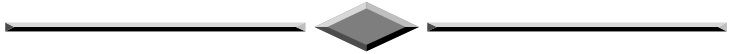

Bob, G8OZP and Malcolm, G3GRM with their equipment managed two 100Km+ contacts to Norfolk and Wells plus two 350Km+ contacts to Hans, PE1ECO near Den Helder and to PE1DCD near Hook van Holand. See the article on page 51.

## A Bit of Pan and Tilt

### Dicky Howett talks to innovative TV industry pioneer Bill Vinten.

Bill Vinten is the man who invented the unique “Vinten Mk III” pan and tilt head. This fact might not mean much to the ordinary citizen, but TV industry veterans have much to thank Bill Vinten for. It was he and his company who introduced, in the mid nineteen fifties, correctly designed and ergonomically functioning television studio camera mounts. Things that actually worked and made life just a bit easier!



### A rare Marconi Mk 2 perches on a quite common Vinten Mk 3 pan and tilt head.

Since retirement, for the past 12 years, Bill Vinten and his wife have lived in the rural splendour of their 17th century home near Bury St Edmunds, Suffolk. Bill's home boasts a huge and ancient barn that has been sympathetically converted into a workshop. The barn houses lathes and timber cutting tools. Bill is now turning eight Dutch Elms (felled due to disease) into exquisite furniture for the family. The barn provides also shelter for a ping pong table, a church organ, two classic cars, a clutch of motor cycles and, shrouded in dust sheets, a few items of

veteran Vinten camera equipment. When the mood takes him, Bill occasionally ventures out to shoot wild fowl from a punt (using his home-made gun) and come holiday time, sails members of his family around the Mediterranean in his yacht.

Bill, who's 76 this year confesses, "I don't seem to get much time for 'retirement'. I left the group board of Vinten's three years ago. I still take an interest in the company, Vinten Broadcast and in various new products such as the latest 'Vector' pan and tilt head. You may have spotted this being used with cameras at the recent Atlanta Olympic Games. Lately they wheeled me in to ask my opinion on a future development. This was for a new drag and friction control on a forthcoming pan and tilt head design."



**Bill Vinten with a pristine example of a model 'J' pan and tilt head, inertia flywheel drag**

One way and another, pan and tilt heads have featured frequently in Bill Vinten's life. Born in 1920, Bill was one of five children. His father was William Vinten the renowned cinematographic engineer, and Bill's early years found him being raised literally over the shop floor. During the 1930's, the Vinten family lived in a spacious flat on the top story of the Cricklewood factory. Bill recalls that his introduction to engineering was prompted by his father who when asked for the money to buy a part for a bike told Bill to go down and make it himself!

"My father would let me use most of the machines on the factory floor. By the age of fourteen I was quite proficient at metal work."

Later Bill attended the Northampton Engineering College. At the end of the course he sought employment with optics manufacturer, Taylor Hobson in Leicester but a car accident badly damaged his left eye, permanently blinding it.

Bill recalls, “The car rolled over and flying glass cut my cornea and lens. To this day I can only distinguish light and dark in that eye. Understandably, a job with Taylor Hobson’s was out of the question. When I recovered from the accident, the war had just started. I saw an advertisement asking for tool makers at the Rawlplug Company in Mill Hill. I spent a year there and then moved to Cooper Stuarts in Hendon making speedos for Ford vehicles.”

Back at the family firm, the early stages of the Second World War was putting pressure on the Vinten company. There was a government order for two thousand F24 reconnaissance cameras which sorely stretched Vinten’s resources. The Company urgently need engineers and so Bill returned. With his poor eyesight, coupled with a job in a pivotal 'war effort' industry, all this now threatened to keep Bill stuck in Cricklewood for the duration. Family friction didn't help matters, and this was exacerbated by a regret of being left behind as all Bill's friends were mobilised.

Bill relates, “I wasn't about to be called up, not with my C3 eyesight, so family friend, Claude Friese-Green offered me a job as a clapper/loader. I know it might seem a strange thing to go from mechanical engineering into the artistic world of film making, but at least I knew how cameras actually worked, especially the Vinten 'H' model. I also hoped to get a shoulder up into the Services. The first film I worked on was the story of Dr Carey and his missionary work. This was shot in a small studio near Crystal Palace.”

As the War progressed the Services urgently needed skilled people, and Bill eventually joined the Royal Navy Film Unit. This was based at Tipnor, Portsmouth. Working with silent cameras, notably the Newman-Sinclair model 'G' clockwork variety, Bill worked on an extensive collection of training films on the subjects of gunnery, deck landing and radar. Some of these films were photographed in the Mediterranean. “If nothing else, I got on a lot of ships”, says Bill.

After the War, Bill Vinten joined the Rank Organisation at Elstree. “I worked for a small company there called Gate Studios. I even filmed the opening title shot, a model of a gate opening. Basically, though we made a lot of modest films suitable for showing on Sundays. If you recall, Rank cinemas were always closed on Sundays. But times were moving on and finally Rank gave in and set up Gate Studios to make films with a moral



or uplifting theme. So then it was all right to show them on Sunday. But it was all good practice, I was learning as I went along. I became a 1st and then an operator. I got a lot of good advice from cameraman Francis Carver who would always stop and encourage you. I had only been operating for about three years when I became a lighting cameraman. I think I went much too quickly up the ladder to have been amongst the best.”

During his time at Gate Studios, Bill first became involved with television. The Cintel Company (part of Rank) had shipped from the USA three TV cameras. These cameras were from an electronics company called Allen B. Du Mont Labs Inc, who made broadcast equipment and who also ran an American tv network. The Du Mont cameras were early image orthicons and Rank had the idea to produce movies via telerecording techniques. It was a bold, (or perhaps desperate) measure, with the promise of a quick turnaround and the enticing prospect of cutting studio costs. To record the TV image, a 35mm back-projector was modified and positioned in front of a TV monitor. According to Bill, the results were atrocious.

“Those Du Mont TV cameras weren’t really up to it. They were 3 inch image orthicons with four-lens turrets. The tubes were not very easy to light for, all halos and crushed whites. Also the image would stick on the tube from time to time. However, we did make a 35 minute children’s film called ‘Mr Marionette’ using just one of the TV cameras and editing it like an ordinary film. It wasn’t all that good, but I could see that the potential for television was enormous. That was the business I wanted to be in for the future.”

Because of Bill Vinten’s experience at lighting these early telerecordings, in 1949 he was invited to light some special recording trials being undertaken by the Pye Company. Bill visited Pye’s Cambridge factory and found he had to work, not in a studio but in an old corrugated shed. Pye at the time were pushing into all areas of broadcast technology (including colour) and these recording trials were an attempt to overcome the serious loss of definition associated with existing monochrome film/TV recording systems. The ultimate aim was for a system that could be applied successfully to full-scale movie making using two or more linked high-resolution cameras, recording onto 35mm film. The result had to be suitable for projection onto a large cinema screen. Initially, the cameras used in the Pye experiments were Pye Photicons (Image Iconoscope types). Later, an improved version, the Pye P.E.S. Pesticon camera was used. Progress was swift but the results were not altogether satisfactory.



**Bill Vinten examines a hand applicator for colouring movies. Built in 1920 by his father for William Friese-Green.**

In 1950, the old Highbury Studios in North London were taken over by Norman Collins and Terence Macnamara (formally both of BBC Television). There they continued Pye's experiments, (with Pye's equipment and money) re-naming the enterprise High Definition Films. The high definition film system differed from the conventional British broadcast standard in several important areas. To simplify the recording system, HDF used a sequential non-interlaced frame rate of 24fps scanning at between 625 and 834 lines per frame. The monochrome pictures were recorded using a Moy RP30 35mm recording camera. The overall bandwidth of the system was 12MHz, a big achievement in those days. (Some of those test recordings still exist). Bill Vinten spent 18 months lighting several HDF productions, including short tests and commercials which were made to a high standard with real products. These commercials were then shown to members of Parliament in an attempt to convince them that commercial television in Britain might not be such a bad thing. Norman Collins was one of the leading lobbyists for the introduction of commercial television in Britain and his production studio at Highbury was established in anticipation of the event. But after four years of trials and much tribulation, Collins fell financially at the



last post and the studios of High Definition Films were acquired by Associated TeleVision (ATV) for use in 1955 for the opening of ITV.



**Bill gets to grips with a 1938 Vinten model 'H' 35mm camera**

Bill Vinten adds, "I once lit a HDF production for Orson Welles. He came over for a week and we shot a short extract from a Shakespearean drama. He did it like any film shoot, with one camera. Working with Orson Welles was quite an experience and not something that many can boast of. Also the Pye Pesticon cameras we used were lovely to light for with a good grey scale. The final filmed recordings were of very good quality."

In 1952, Bill Vinten returned to the Vinten company to concentrate on starting TV equipment manufacture. Until that time, British television studios had to rely on film studio gear from companies such as Debie, Newall or Mole Richardson. This equipment was fine for shot-by-shot movie making, but plainly inadequate for continuous live tv.

One of Bill's first Vinten products was a camera pedestal. The BBC had tendered a specification for an entirely new type of pedestal that could

support cameras up to 200lbs. Also, the spec required the pedestal to be capable of being operated by a single cameraman with as varied a height range as possible without the cameraman losing sight of the viewfinder. Finally, the pedestal had to be highly mobile and capable of manoeuvre whilst on air. Very important. This specification was dished out to several manufacturers, but Bill Vinten was determined to get this order. He favoured an hydraulic solution and with the team of Ivor Dunningham and Ted Galione, they set about winning the race. The end result was the classic HP 419 three-stage hydro-pneumatic pedestal balanced on compressed nitrogen. The first two examples (with tillers only-no central steering wheel) were delivered to the BBC in 1956 and installed in Studio E at Lime Grove where they had heavyweight Marconi Mk III cameras sitting on them.

Bill Vinten remembers, “The BBC were extremely patient with us. The hydraulics in the HP 419 ped were designed against the advice of the hydraulics industry who said it couldn't be done. With a light touch you always get leaks they said. In fact it took us 2½ years to finally cure all the problems. The initial eight pedestals were delivered to the BBC at a price of £800 each. This was way below developments costs but we reaped the benefit because 40 years later we're still selling the descendants of the old HP 419.”

The BBC next required a design for a new pan and tilt head. In 1956, Vintens had two on the market. The Mk I which was an adaptation of a pre-war film model and the Mk II which utilised compression springs. Neither could tilt more than 35°. The BBC (who were also using Debrie heads) wanted a flexible head that had a tilt angle of at least 50°. As before, this specification was thought unachievable. It was then that Bill remembered a statement made by one of his lecturers at engineering college. The lecturer had said that work is only done when a mass is raised or lowered. So if a camera could actually tilt without altering the height of its centre of gravity, then no work or effort would be needed. If the centre of gravity remained on a horizontal plane, gravity would not effect it and a camera would remain always in whatever position it was left. This novel idea lead directly to the now familiar concept of a fixed cam resting on rollers. With this innovative design it was now possible for cameras of various weights to be tilted to 50° with little more effort than a push on the pan bar. When the Research Director at Marconi 5 saw it (they had been working on their own torque-bar head) they immediately stopped work on their design. They saw the Vinten Mk III as one of the greatest breakthroughs in camera mountings. Introduced in 1956, the latest world sales for the Mk III head (and its more recent versions) have exceeded 20,000 units.

In the late 1950's Vinten's received a request via the BBC from the Queen. This pivoted on the fact that as she was soon to broadcast her Christmas Day Message from Sandringham and as she didn't fancy the idea of large dollies rumbling over her carpets, could the BBC please arrange for something smaller and neater and less rumbly....? Enter the Lightweight Outside Broadcasting Camera Dolly. Bill Vinten designed the basic outline over one weekend. The light tubular frame incorporated a new steering system giving perfect steering geometry through 360° rotation. The chassis was built within six weeks and a method of raising and lowering the frame devised by Assembly Shop Foreman Tom Lilly. In manufacturing terms this is an extremely short time scale. The dolly itself was quite narrow (28 inches) so it could be wheeled easily along a narrow passage or through a royal living room doorway. The dolly (which ran on solid or pneumatic tyres), was 51 inches long and had a turning width of 54 inches. The O.B. Dolly is still in operational use throughout the world.

Bill Vinten: "Also around that time we were working on an entirely new type of crane. We called it the Peregrine and it was designed to yet another BBC specification. The BBC wanted a crane that could raise and lower a camera more quickly than any existing, go higher, use a minimum crew and occupy a very small floor area. In fact they wanted a crane that could follow and keep up with a ballet dancer across the studio floor. Our design separated the camera from the cameraman. We put the camera at one end of a pivoted jib and the cameraman sat at the back on the chassis controlling pan, tilt, zoom and focus via servo motors. The tracker sat beside the cameraman. The jib could be raised ten feet in four seconds and the six-wheeled base was little wider than a normal pedestal."

Bill Vinten muses, "The design didn't take off even though it was given a Queen's Award for Technical Innovation. In fact the Peregrine crane just never got past the prototype stage. Our existing two-man Heron crane was doing almost the same job, but not with the camera separated from the cameraman. An important point. The trouble was that with the Peregrine, camera crews would have had to re-train to work it. No one seemed very keen on that idea. Also servo-motor technology wasn't very smooth or reliable then. In any case the first generation of 4-tube colour cameras would have been much too heavy for the Peregrine crane to lift."

Bill Vinten recognises that it isn't an easy task to change working practices and alter standard methods of camera operating. The Vinten Swan Post Head is a case in point where the camera's centre of gravity is pivoted at the side and not underneath. Bill adds, "I made a short film using a camera conventionally mounted and a camera side-mounted on

the post head and then asked cameramen to spot the visual difference. Of course there wasn't any, apart from the greater flexibility of the post head design."

Bill still holds high hopes for another of Vinten's products, the Merlin crane arm. "I thought that that crane would have sold better than it did. I still think it has a very good future, but again, it needs a fair bit of camera operator practice and skill to get the full benefit of the system."

Bill Vinten put a lot of work into his product designs. His overall philosophy was to get the basic design right and then pass it to a good, practical engineer. Bill confesses, "I tended to lose interest after I've got the principal right. I was fortunate during my working life to be able to turn to engineers like Ted Galione. For example, it was Ted who really made the Fulmar pedestal work."

Recently Vinten Broadcast received another prestigious award. This was from the American 'Society of Operating Cameramen' and it was their 1995 Technical Achievement Award. The Award reads:

'Presented to Vinten Broadcast Ltd, Ted Galione and Bill Vinten, inventors. For the introduction and development of the Fulmar Pedestal in 1972. The first extended range pneumatic camera pedestal which has significantly contributed to the art and craft of the camera operator.'

## Repeater Update

By G3VZV

As mentioned in the loose leaf flyer included in the previous CQ-TV the RSGB has now issued for use a new procedure for determining the possibility of ATV repeaters on 23cms in relation to the presence of radar.

A new application was received in May (96!) from G3ZYY of the West Devon ATV Group. This satisfies the requirements of the procedures and was included in the June batch of applications sent to the RA. The RA print out of 24th July shows that the application is in the "system" and more news is awaited with interest.

The application for GB3AT in Hampshire with a 1316Mhz output has now been accepted by the Repeater Management Group Chairman Geoff Dover, G4AFJ. He has written to the group confirming that it will be included in the next batch so long as the "close down" list originally submitted in 1994 has been confirmed as still current.

The GB3KT application for North East Kent with a proposed output of 1310Mhz has also been approved by the RMG subject to the group confirming their agreement to the revised output frequency and an update on the close down list.

GB3VX, somewhere in Sussex, is presently having a new site found as the original proposal would not have been satisfactory in relation to radars in the vicinity.

Little has been heard about a proposed Derby ATV repeater for the past few months but rumour has it that there is a new application about to appear for North Yorkshire.

The CAT96 meeting had a "repeater forum" session. As might be expected, the performance of the various RSGB committees was discussed! It was suggested that maybe the BATC could deal directly with the RA and be more responsive to its member's wishes.

At a technical level the new procedure for 23cms procedure was discussed and a number of those present offered to review this for technical accuracy and precision.

The next real event will be when the GB3WV application is either accepted or rejected by the CAA/NATS. Only then will we know whether the system is now working properly.

## TV on the Air

By Graham Hankins G8EMX.

So much to report this time that I'll mention it all now so that, hopefully, a bit of each will survive Trevor's snowpake!

There is a new and well-known name starting up on 70cm; Bletchley Park

Museum ATV station comes on-air; a microwave expedition works ATV near Skegness; mods. to the New Zealand repeaters and news of digital ATV experiments in the U.S.A.



### 70cm

John Badger G4YJO, of 'Badger Boards' phoned me from Sutton Coldfield, where he is line-of-sight from the BBC mast. John had constructed an ATV up-converter but is not getting any results - can I help? I find the circuit in CQ-TV 112 (Nov 1980) so go over to his QTH with counter. John already has the test gear so we establish that the L.O. is oscillating, but too low. We play with components for a while, before I leave him with a known good converter, BATC 70cm Tx (yes we do still build them Trevor) and camera. Good news is that, after changes to the coil and a cap., John sees ATV pictures on his monitor AND boxes my 'Wood and Douglas' converter!. Welcome to 70cm - and to the BATC John!

### Microwave

The Bletchley Park Museum, which houses a reconstruction of the 'Colossus' WWII code-breaking computer, has opened an amateur radio

station - GB2BP - which as well as the h.f. bands runs microwave ATV. There are two receivers for 10GHz and one for 24cm, and repeaters GB3TG and GB3TV can be accessed.

The museum is open September 21/22, October 5/6, 19/20 then on alternate weekends. Museum enquiries to 01908 640404. Thanks to Tom Mitchell G3LMX for this info.

## **SKEGNESS ATVP**

Scanning the List Category (LC) ATV from my packet BBS, GB7SOL, came notice that a microwave dxpedition, to include ATV, was happening over the weekend August 23 - 26. A QRA was quoted but a call to the mobile phone number in the message established they would be on a site near the village of West Keal. SO, drove up to take a look.

There were five of them, all from the Telford area. Martyn G3UKV was using 10GHz narrow-band s.s.b., Dave G8VZT had 10GHz w/b ATV and 24GHz ATV with w/b audio. Also helping were Jim G8UGL, Tony G0UYE and John G4ZJY. A Worthing Tx and PA were running 24cm ATV, and repeater GB3TN (Fakenham) was being monitored at about P4.

Len G8ONX (Skegness) gave the group a direct P5 contact, showing his 24cm Solent TX and home-brew loop Yagi, then through TN the expedition worked Adrian G0FVF, with a 10GHz home-brew antenna and radome. Robert G4TUK in Norwich, appeared, with a fascinating scanned shot of his 'shack'.

Far away to New Zealand, where Michael Sheffield send this letter (yes, by post - he had included a newspaper cutting too)

Hi Graham,

An ATV repeater station operates from the Hamilton Branch clubrooms. It is a joint effort between the Hamilton Branch and the Waikato VHF Group. The output frequency is 615.25 MHz vision, 620.75 MHz sound, which is in the amateur 50cm band allocation. This is channel E39 in the u.h.f. TV broadcast band, so it can be tuned by any VCR or TV set fitted with a u.h.f. tuner

The input frequency is 443.25 MHz vision, 448.75 MHz sound, which is in the amateur 70cm band allocation. Transmitters for this band are readily constructed from parts locally available or from kitsets (Wellington VHF Group, South East Queensland ATV Group, PC Electronics in California to mention a few possibilities). Ready built transmitters are sometimes for sale in 'Break In', 'Q-Bit' or 'Spectrum'.

They can also be purchased from suppliers in the USA (PC Electronics or Pauldon to mention only a couple).

The Hamilton ATV repeater transmits a colour test pattern when it is not repeating a signal through. Thus it doubles as a beacon also. The test pattern uses text and graphics like that of the teletext system seen on TV1 & TV3. Stored in a 27C256 EPROM are 16 pages of text and graphics that are automatically cycled through, giving station identification, addresses for Hamilton Branch & Waikato VHF Group, NZART information & ARDF information. Periodically new pages are composed to give a fresh look to the beacon transmissions. The idea is to present the many interesting aspects of amateur radio to amateurs and non-amateurs who may tune into UHF TV. Suggestions for new pages of information are welcomed.

The local persons to contact about ATV are Jerry ZL1RN and Bill ZL1BRI.

73 de Michael Sheffield ZL1ABS

Finally, an American experiment with digital ATV, found on the Internet in Germany and placed on the world-wide packet network!

'Digital ATV First!' by Ned Mountain, WC4X Mike McCombs, KM4YW.

"I thought the ATV community might be interested in what we think is a 'first'. On 1 August, 1996, WC4X and KM4YW achieved the first 2 way MPEG-2 digital ATV QSO on 1290.00 MHz over an obstructed 3 mile path using 32 mW of power and antennas made out of coffee cans.

The video data rate was 2.5 Mbits/sec with a bandwidth of 2.7 MHz. Modulation type was QPSK and rate 1/2 error correction was used. If we had more power available, we would have used higher data rates and higher bandwidth. These tests will be done next.

The equipment we used is manufactured by Wegener Communications, our employer. It is designed for digital satellite news gathering and is currently used around the world by major broadcast organizations like CNN.

The equipment is too expensive for hams but we are doing this experimental work to show what can be done in the future.

Further experiments are planned in September using higher power and higher data rates, and real antennas between the QTH of WD4MBK in Atlanta, and the two of us from various mountain tops in Georgia and



North Carolina. Using digital ATV, we enjoy approximately 15 to 20 dB advantage over conventional VSB-AM transmissions. Thus, we expect to easily communicate over paths that would be impossible using normal analogue transmission".

Well, I bet all that won't get in. Please keep sending by letter or packet to me, G8EMX @ GB7SOL. #29.GBR.EU

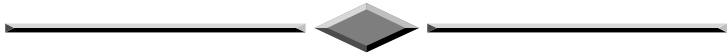

## **Fast Facts**

The magazine 405 Alive is published by The Radiophile, Larkhill, Newport Road, Woodseaves, Stafford, ST20 0NP (tel: 01785-284696 office hours only). Subscriptions cost £16 inland and BFPO, £20 all other territories and over four 96-page magazines.

Small ads for disposing old 405-line equipment are free, to non-subscribers as well, so why not clear out your loft or shed? There is always a ready market for sets, cameras, valves, service sheets and books. The address for advertisements and all editorial matters is 71 Falcutt Way, Northampton, NN2 8PH.

A 405 fact sheet is available free if you send a stamped addressed envelope to the Northampton address.

Dinosaur Designs. To receive information on their standards converters, modulators and testcard generators send SAE to Dinosaur Dave, 4 Kemble Drive, BROMLEY, Kent, BR2 8PZ.

# Worthing & District Video

## Repeater Group

### GB3VR & GB7VRB

#### 1996 Prices

#### 1 Watt FM-TV 24cms Transmitter

The 1 watt transmitter generates its signal at the wanted frequency which can be set anywhere in the band, colour or B/W. On board intercarrier sound and fixed pre-emphasis are standard features. The kit includes the PCB all the on board components, pre-drilled heat sink, an Eddystone Di-cast box and full and comprehensive instructions. Building time is three evenings work. The 1996 price for this kit is **£60.90**. With over 600 units sold to the Amateur market alone, this is probably the biggest selling TX kit in the world!

#### Two channel phased locked loop kit.

This add-on kit vastly improves the overall stability of the 1 watt transmitter. Two crystal locked channels and a third free running tuning position are available. Kit price **£30.00**

#### Amiga ATV Program-2

The New Amiga ATV program has more features than ever, up to 56 testcards, 20 wipes, superb text control, 30 screens of text messages, QRA calc, Testcard music, selectable displays and this version has a DTMF tone pad to control your repeater. All testcards are over-scan i.e. the whole screen is used. Load in your own customised testcards, Extra large text, scrolling text, clock, callsign extensions, Hot key operation, Doc reader, ATV Cli, Cross Hatches, Purity and a comprehensive section for genlock users. For any Amiga with Imeg or more. State callsign and QRA (if known) when ordering. This three disk set is now only **£15.00**

#### Spectrum ATV Program

Still selling after all these years. Why? It's good, its cheap and it works on all spectrum based machines. The 48k version has over 60 commands which include 7 Testcards, Memo pad, clock, maps, tones, QRA locator, various size printing, plus disk transfer routines and much more. Now only **£5.00**.

Orders should be sent to:

Treasurer of GB3VR, R Stephens, 21 St. James Ave., Lancing, Sussex, BN15 0NN. Cheques payable to **W&DVRG**" Tel (01903) 765760 7 to 8pm.

# The NE568 as a Wideband FM Demodulator

By M. A. Pinfeld ZL1BTB

The NE565 phase lock loop IC has a number of shortcomings. The NE568 from Signetics could be seen as the answer to most of these. It is a 20 pin DIL IC, so is not a pin for pin replacement. It is rated for use from 1Hz to 150MHz (without any fudging to get it there).

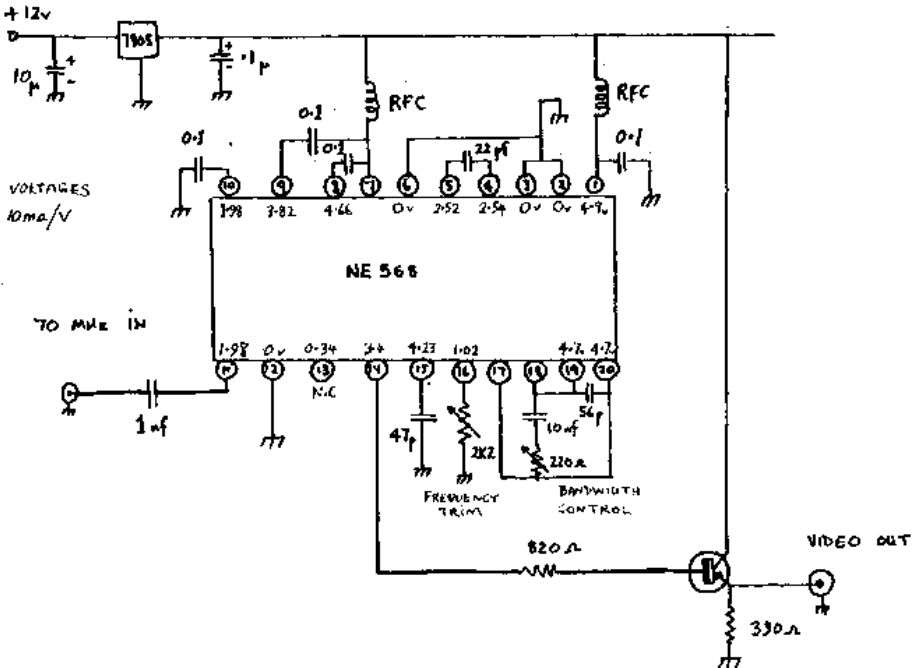

The IC contains a limiting amplifier, a current-controlled oscillator, a phase detector, voltage-to-current converter, a current-to-voltage converter and buffer amp. This IC is well-suited to the demodulation of WBFM ( $\pm 13$  MHz) in systems which require a good linearity (better than 1.5 per cent and low parts count). It has excellent sensitivity and is easy to line up. The overall bandwidth is controlled by the loop filter components and can be configured to cope with narrow or wideband systems. Thus one can optimize the receiver for best signal-to-noise ratio as in TVRO systems.

The input to the chip is to pin 11 with pin 10 capacitively decoupled to earth. The input impedance is about 500Ω, but it can be driven directly

by a 50Ω to 75Ω source. The centre frequency of the oscillator is set by the capacitor between pins 4 and 5. There is a frequency-trimming variable resistor (2k2) between pin 16 and earth which allows fine tuning of the oscillator frequency if a fixed capacitor is between pins 4 and 5.

To calculate the value of the capacitor between pins 4 and 5 with a trimming value of resistance set to 1.2k from pin 16 to earth:

$$C = \frac{0.0014}{f_{osc} \text{ (MHz)}}$$

The loop connection between the phase detector and the VCO is by electrically connecting pin 17 to 20 and pin 8 to 19. This means the designer has a variety of possible loop filter configurations to suit the requirements of the PLL. The loop constants are:

Phase detector constant  $K_d = .127 \text{ V/radian}$

VCO constant  $K_o = 4.2 \times 10^9 \text{ radian/V S}$

The loop filter determines the dynamics of the Phase Lock Loop. The capacitor between pins 19 and 20 helps suppress the VCO feed through. This capacitor value is found by:

$$C = \frac{1}{100\pi f_{osc} \text{ (Hz)}}$$

The natural frequency of the loop is set by the series resistor/capacitor network between pins 17 and 18. This is calculated by:

$$C = \frac{1}{2\pi R_1 BW_{video} \text{ (Hz)}}$$

The resistor value chosen is used to calculate the series capacitor. I actually used a 220Ω variable in my circuit. This enabled me to vary the bandwidth of the demodulator to suit the bandwidth of the signals received. Empirically, I used 10nF as a capacitor value. It appeared to work extremely well and really clean up the video noise when adjusting the 220Ω pot to optimise the signal-to-noise ratio.

There is a capacitor from pin 15 to ground. This, together with an internal resistor of 350Ω, forms a single pole filter. The value of this capacitor is found by:

$$C = \frac{1}{700\pi BW_{video} \text{ (Hz)}}$$

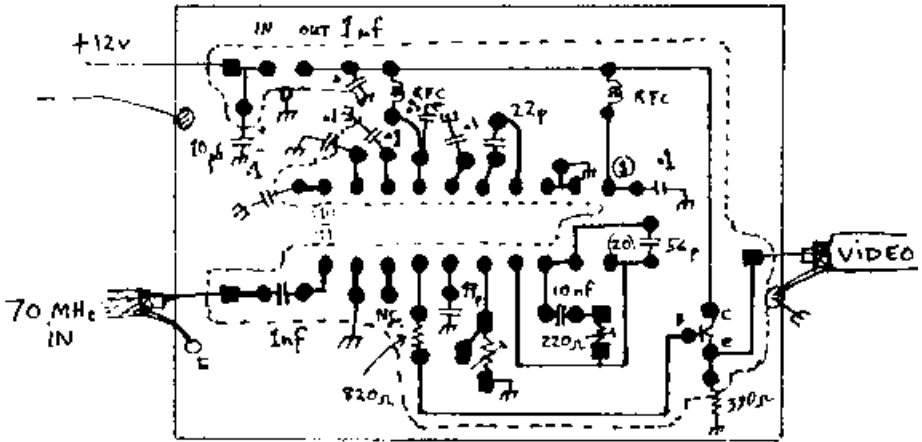

It is tempting fate to build this circuit on single sided board. The transistors used in this chip have an Ft greater than 6GHz. You must use a well designed double sided PC board with due consideration to bypassing, component lead length, and placement to keep this circuit stable and obtain maximum performance.

I made up a double sided circuit board used good quality bypass capacitors with the shortest possible lead lengths. The ground plane on my board is topside with all earth connections soldered directly to it. Even the pins of the IC are soldered to the surface when required. The data sheet says not to use an IC socket. The RF chokes in my circuit were a few turns around a ferrite bead. The V<sub>cc</sub> pins of the IC (7) (1) are bypassed as close as physically possible to their respective pins to ensure good decoupling at VHF.

In the original application notes, it was advised that one use chip capacitors. Not having those at hand, I used good quality dipped epoxy ones and have had no problem with stability or performance of the circuit.

The circuit uses a 5V supply rail and draws about 60mA when running at 70 MHz (the IF of my TVRO system receiver).

The video output level is only about 0.5V P-P with a deviation of 20 per cent of the centre frequency.

The circuit is quite sensitive as it stands. Look at the data which I have measured with a HP608E signal generator and HP8554 spectrum analyzer. You can see the relationship between input level and locking bandwidth. You can see the level at which the limiter begins to take effect. The lock width appears to stop widening. I run the demodulator directly off the 70MHz IF output port of the 950-1750MHz tuner without additional amplification. The video performance of the PLL does exceed the original Quadrature detector when looking at weak signals with the WR3500 Receiver. This enables much clearer and cleaner signals off the various satellite transponders. I have the added ability to optimize the received bandwidth easily (although the WR3500 has an existing IF bandwidth control, its shape factor leaves a lot to be desired). However, if you go too narrow on the loop filter you start to get bad tearing on sharp edges of the picture, smearing of colour, a loss of fine detail, the sound subcarrier amplitude begins to fall off and you start to lose sound quality.

I will note at this stage that the Quadrature demodulator does give a more colour-true picture and despite the noise, it is somewhat more detailed due to its inherently wider bandwidth. (It would leave the PLL for dead in picture quality once the signal-to-noise began to climb). The video drive circuitry in my receiver is DC coupled so I could not capacitively couple video out of the NE568. I did this via a simple emitter follower in the form of a BC547 to maintain the DC levels.

That is all there is to it. The ICs were only about \$6.00 each and the board was very simple to make. If there is any way I can help, just send me an SAE and I will be glad to be of assistance in any way.

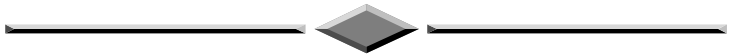

## **BATC on the Internet**

The URL (address) is:-

**<http://ourworld.compuserve.com/homepages/fpawson>**



Copy should be sent to 'The Editor' at:  
14 Stairfoot Close, Adel, Leeds, LS16 8JR.  
Tel: 01132 670115.

E-mail: [trevor.brown@betwixt.dircon.co.uk](mailto:trevor.brown@betwixt.dircon.co.uk)

**For Sale**

OKI OL400 laser printer, needs new drum, otherwise ok. Previously used for printing CQ-TV. Best offer over £25. 3M lettering system with tapes and six font wheels. Also used in CQ-TV production. Best offer. Proceeds to BATC funds. Contact Brian

**B. Summers GSGQS QTHR 01895 810144/ 0850 01489** The mobile is subject to battery and not being down the tube.

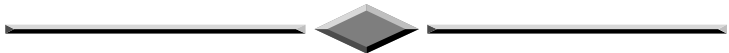

BBC ANNUAL 1935. £15. Very rare in this larger 'annual' format. This copy is in excellent condition. Usually sells for twice the price.

BBC HANDBOOK 1939. £10. Another reasonably scarce edition. Some nice pictures of the BBC's pre-war 'Mobile Television Unit' and studio scenes. VGC. No d/w.

ATV SHOW BOOK No. 1. Adprint 1957. £8 Almost mint copy of this popular ATV picture-book series. Plenty of early ATV shows featured with lots of production photographs of ITV stars.



SEE IT HAPPEN--The Making Of ITN. Geoffrey Cox. 1983. £6.  
Fascinating illustrated history of ITN.

ITV 1982. £6. Getting scarcer.

ITV ANNUAL 1963 £3. No spine paper. Plenty of ATV studio shots.

WORLD RADIO AND TV HANDBOOK. 1973. 1975. £3 each.

Dr Who Annual No. 1. £5. Slightly scuffed cover.

The Blue Peter Book Of Television. £3 VGC

'Essentials Of Electricity For Radio and Television'. Slurtzberg and  
Osterheld. Pub. McGraw Hill 1950. Illustrated. No d/w £5.

All books clean and in vgc. Postage £1 per book.

Contact **Dicky Howett 01245 441811**

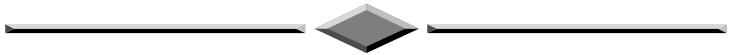

OFFERS invited for:- Sony CCU type CCU-M3 (no details)... Sony car  
battery adapter type DCC-3000 10v - 30v in 2 x 12v out 3.5A total...  
BBC-B computer. (above collect only).

EPROMS (Ex Equipment - erased) 2716, 2732 ... 10 for £7.00 ...2764,  
27128, 27256... .10 for £8.50 2 each 2716, 2732, 2764, 27128, 27256 ...  
£8.00. **D. Hemingway, Ivanhoe, Glen Rd., HINDHEAD, Surrey,  
GU26 6QE. Tel 01428 604645**

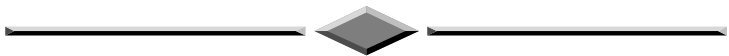

BBC'B', Watford ROM RAM, Silicon disc, ZIF socket, Dual disk drive,  
Eprom programmer, Till roll printer, Cumana drawing tablet, lots of  
S/W, Worthing TV disc, lots of books, Etc., Etc., Taxan/Kaga 9 pin  
printer, best offer secures. Good home needed. **G.R. Farmaw G4CRF  
(Aylesbury) 01296 714888.**

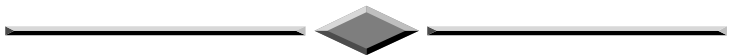

Spectrum Analyser - Large, lots of valves, Ex. GPO working with  
circuits £50.00 **D.Griggs G01QT (London N10). 0181 883 3474**

---

Studer B62 1/4" IEC twin track audio recorder. 7.5/15 i.p.s. Service manual. very good condition. £3300 o.n.o.

ITC triple stack mono cart machine (+extra triple cart as spare + manual), BE mono cart recorder/player, lots of cart of various lengths £3250 for the lot. **Jeremy Power G1WVK (Berkhamstead) 01442 871386.**

---

23 cm. Severnside wide band Yagi, 38 element, brand new, unused with leaflet £15.00 (postage £3.00 extra) **Tony Naylor, G3GHI (Croydon) 0181 660 4068.**

---

GML "X-Calibre 3-machine editing mixer with 2 channel D.V.E built in TBC, full colour proc-amp on each channel; Station lock or stand alone operation; Advanced synch. or non-synchronised inputs. originally intended for High-Band U-matic VCR suite. Withdrawn from service but working when last tried (June 1996); full operation and technical manuals; electronics 6u x 23" panel 7u x 4". All usual programmable 2D digital moves including squeeze-zoom.

Two off 1" 'C' format VCR. Ampex VPR80 + TBC2B + dual channel Dolby-A One machine has timecode board but original head (~ 1500 hours), the other has no timecode but virtually new head (<200 hrs). All above items £500.00 each Collect London West End. Other items, picture monitors, A.T.R's odds & ends available **Stephen Dyke G3ROZ 0171 631 7621 (Office hours).**

**Wanted**

LENSES WATSON 8" f/4.5 image orthicon turret camera lens. (ie fixed focus). Please search in your cupboards for any optics to offer, even broken items. Also old STUDIO LIGHTS. MICROPHONES, stands etc. Plus books/brochures on TELEVISION. **Contact Dicky Howett 01245 441811**

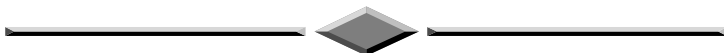

WANTED: A welcoming home is offered for a Pye 3-inch image orthicon camera and/or any other matching blue/mauve accoutrements of this era (CCU, SPG, mobile monoscope, etc.). Definitely not for selling on to speculators but for serious renovation. Very adequate recompense offered. **Andy Emmerson G8PTH, 71 Falcutt Way, Northampton, NN2 8PH or ring 01604-844130.**

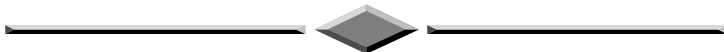

Circuit and handbook for Sony Black and White Camera AVC3450CE - Buy or loan Please. **Tony Naylor G3GHI (Croydon) 0181 660 4068.**

OPUS DISCOVER I Manual **Jose Robot ON7TP Rue Th., Cuitte 41, B-4020, LIEGE, BELGIUM.**

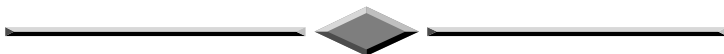

Have you got one of those Pye 8-inch valve picture monitors you'd be prepared to sell? I'm looking for the 405-line model, type 2823/C4Z. My offer of a four-figure sum for a viable Pye Mk 3 or Mk4 camera chain still stands. Andy Emmerson G8PTH, 01604-844130.

**Index of Advertisers**

GB3XT Kist & Bits .....	8
Sevenside Television Group .....	38
VHF COMMUNICATIONS .....	69
Worthing & District Video Repeter Group .....	88