

Contents

Contents .....	1
Committee Contacts.....	2
Editorial.....	4
Solid State Image Iconoscope, Part One.....	6
Setting FM Levels.....	13
New frequency for amateur radio .....	16
Television Simply Wonderful.....	17
November 1997 UK ATV Repeater Update.....	21
Shedding Some Light.....	22
TV on the Air.....	28
CMOS image sensor offers CCD quality.....	35
Satellite TV News .....	38
Rally 98.....	50
Create an ATV Transmitter for 1.25GHz.....	52
Where will ATV develop? .....	61
A 3cms 50mW DRO Stabilised GaSFET Transmitter.....	64
A 23cm TV Transceiver .....	69
A Common Date/Time Standard for Amateur Radio - Update.....	75
A Note from the Membership Secretary.....	77
Post and News .....	79
For Sale.....	90
Wanted.....	93
Index of Advertisers.....	96

CQ-TV is produced on a P6 Gateway 2000 PC computer system, using the Word for Windows word processing package. The camera-ready artwork is produced on an Hewlett Packard LaserJet 4 printer.

Edited by Ian Pawson, circuits drawn by Allan Robinson, proof read by Peter Delaney. All rights reserved, all wrongs denied.

© 1998 by the BATC.

Printed by *Cramphorn Printers Ltd.*, 15c Paynes Lane, Rugby, CV21 2UH, England

181  
CQ-TV

## Committee Contacts

### **BATC Chairman: Trevor Brown G8CJS**

Club affairs, Video tape library, Technical queries, especially relating to handbook projects. 14 Stairfoot Close, Adel, Leeds, LS16 8JR. Tel: 01132 670115. E-mail: [chairman@batc.org.uk](mailto:chairman@batc.org.uk)

### **BATC General Secretary: Paul Marshall G8MJW**

General club correspondence and business. Library queries relating to the borrowing or donation of written material. Fern House, Church Road, Harby, Notts., NG23 7ED. Tel: 01522 703348.  
Email [secretary@batc.org.uk](mailto:secretary@batc.org.uk)

### **BATC Hon. Treasurer: Brian Summers G8CQS**

Enquiries regarding club finances, Donations, and constitutional enquiries. 9 Prior Croft Close, Camberley, Surrey, GU15 1DE. Tel: 01276 677879, Mobile 0850 014892

### **CQTV Magazine: Editor Ian Pawson**

Anything for publication in CQ-TV, Articles, Review items, Letters to the editor, and other material except as below. 14 Lilac Avenue, Leicester, LE5 1FN, England. Tel: 0116 276 9425 Email: [editor@batc.org.uk](mailto:editor@batc.org.uk)

**Photographs for the CQ-TV covers:-** Please send any photographs by post, electronic images by email, to the editor at the above addresses.

**TV on the Air:-** Graham Hankins G8EMX, 11 Cottesbrook Road, Acocks Green, Birmingham, B27 6LE. Tel: 0121 707 4337

**Satellite TV News:-** Paul Holland G3TZO, Chatterton, Chapel Lane, Thrapwood, Nr. Malpas, Cheshire, SY14 7AX. Tel: 01948 770429, Email: [satnews@batc.org.uk](mailto:satnews@batc.org.uk)

**CQ-TV Advertising Manager:** Chris Smith (G1FEF) 35 Pytchley Road, Rushden, Northants, NN10 9XB. Tel: 01933 777385 Fax: 01933 777577. Email: [adman@batc.org.uk](mailto:adman@batc.org.uk)

**CQTV Awards:-** Bob Webb G8VBA, 78 Station Road, Rolleston on Dove, Burton on Trent, Staffs., DE13 9AB. Tel: 01283 814582

## Exhibitions

Mike Wooding G6IQM, 5 Ware Orchard, Barby, Nr. Rugby, CV33 8UF.  
Tel: 01788 890365, Fax: 01788 891883, Mobile: 0860 857434  
Email: [rally98@batc.org.uk](mailto:rally98@batc.org.uk)

## Club Sales

**Members Services:-** PCB's, components, camera tubes, accessories, etc. (NOT PUBLICATIONS). Peter Delaney G8KZG, 6 East View Close, Wargrave, Berkshire, RG10 8BJ. Tel: 0118 940 3121

**Publications:-** Handbooks, Back copies CQTV, and anything related to the supply of BATC publications. Paul Marshall, Fern House, Church Road, Harby, Notts., NG23 7ED, England.

E-mail: [publications@batc.org.uk](mailto:publications@batc.org.uk)

## Membership

Anything to do with membership, including new applications, queries about new and existing membership, non-receipt of CQ-TV, subscriptions, membership records, data protection act. Dave Lawton G0ANO, 'Grenehurst', Pinewood Road, High Wycombe, Bucks., HP12 4DD. Tel: 01494 528899. E-mail: [memsec@batc.org.uk](mailto:memsec@batc.org.uk)

**Club Liaison:-** And anything of a political nature, co-ordination of ATV repeater licences. Graham Shirville G3VZV, The Hill Farm, Potsgrove, Milton Keynes, Bucks., MK17 9HF. Tel: 01525 290343. E-mail [g3vzv@amsat.org](mailto:g3vzv@amsat.org)

**Contests:-** Richard Guttridge G4YTV, Ivy House, Rise Road, Skirlaugh, Hull, HU11 5BH. Tel: 01964 562498

**BATC BBS Sysop:-** Brian Kelly GW6BWX, 12 Cotswold Way, Risca, Gwent, NP1 6QT. Tel: 01633 614376, BBS: 01633 614765. E-mail: [bbs@batc.org.uk](mailto:bbs@batc.org.uk)

**Repeater Liaison:-** General enquiries and repeater affiliation. Graham Hankins G8EMX, 11 Cottesbrook Road, Acocks Green, Birmingham, B27 6LE. Tel: 0121 707 4337.

## BATC web master

Anything to do with the BATCs web site. E-mail: [webmaster@batc.org.uk](mailto:webmaster@batc.org.uk)

If you did not notice CQ-TV 180 had a varnished front cover. This process is to prevent scratching and provide a better finish to the magazine. The same process has been applied to this issue and I hope that along with the colour pictures it becomes standard from now on. This has added to the production cost of CQTV and we would benefit from some additional members to share the printing costs, so if you know anyone that might be interested in subscribing to CQ-TV we would be pleased to hear from them.

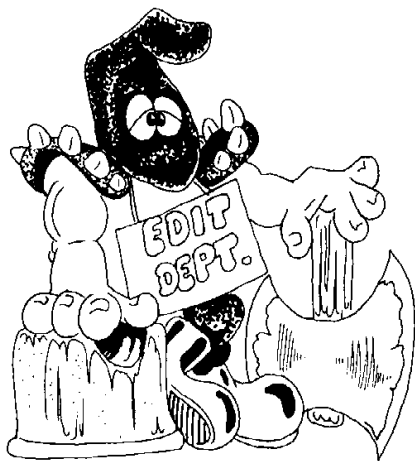

The club web site [www.batc.org.uk](http://www.batc.org.uk) has also had a make over and now occupies some 20Mb, it has several hundred visitors each week and many of them join the club via the web site. While still on the subject of cyber space, Chris Smith has come up with an offer of free email for our members, which although it will not let you visit the web site, you can subscribe to news groups and it will provide you with your own email address, in all its worth looking out for a cheap PC and modem and with the BATC rally coming up on April 26, should I say more.

Last but not least when you read this we will be into 1998 and for UK ATV repeater operators the new repeater specification will be active. The RMC sent the document to RA late March, they have not as yet (December 18) had any response. Since the document went to RA we have produced our own repeater specification and have sent this to RMC and asked that the original specification be withdrawn and that the BATC specification be submitted in its place. Chris Goadby the RMC Chairman has yet to respond to our criticism of the RSGB specification. On the more practical front Ian Waters is working on a 5 pole filter that he hopes can be used to meet the 13 MHz bandwidth required by the new document. I hope to have a meeting with Chris early in the New Year to see if something can be worked out. With this lack of response from the RA, I can only assume that we are not causing problems to CAA radar.

**TREVOR BROWN - BATC Chairman.**

# GB3XT KITS & BITS

**GUNNMOD2 3cms ATV. TX.** kit. Very popular full feature Gunn diode TX. Complete with pre-tuned oscillator head. £30.00. PCB. kit less oscillator head £20.00

**TVRO3 ATV Tuneable IF/RX.** kit. Fully featured 750-1700mhz input. 12vDC operation. No setting up or alignment required. SMPSU for LNB. 5.5 - 8MHz subcarrier. vid gain. etc, etc. £50.00

**24cms HIGH GAIN LOW NOISE GASFET PRE-AMP** kit. 40db gain 1db NF. band pass helical filtering. 12-18vDC feed via co-ax. 40db gain. Designed specifically for ATV. but good for all modes £60.00

**DTMF DECODER** kit. Very high quality decoder IC. All o/p's buffered. Will directly drive TTL/CMOS or relays. Can be used to control whatever your imagination thinks of. £12.00

**3cms LNB's.** All 9.0GHz LO. Brand new circular input. 38-40mm mounting. will mount directly on most offset satellite dishes. 0.7db NF. £43.00. 1.0 - 1.2db £37.00.. 22mm Circular wave guide input types 0.7db £45.00 1.0 - 1.2db £40.00. Brand new with integral 20db antenna 0.8db NF £50.00 Several other types available. Please contact.

**STOP PRESS. Under development and available soon.**

**COLLINEAR ANTENNAS** Several types of collinear antennas are under development. The range will provide gains up to 20 db with either circular or coroidal beam patterns. These will be ideal for local working, band monitoring or for a repeater. All types will be fully weather proofed.

**22mm CIRCULAR TO WG16 TRANSITIONS** Yes copper pipe can be used as waveguide. I have developed and will shortly make available a transition to convert WG16 to 22mm circular pipe. It operates over the whole band with very low S.W.R. (< 1.2 - 1) and may be used in either direction, i.e. 22mm circular to WG16. These allow my 22mm LNB's to be used with WG16 waveguide.

**DIELECTRIC LAUNCHER (ANTENNA)** My new design of dielectric launchers provide a novel compact type of antenna for the 3CMs amateur service. They will be available in a range of gains (Beamwidths) and supplied with WG16 square flange (circular flange to special order) or 22mm circular wave guide connection.

Assuming all goes to plan I should have these exiting new products available for early next year. (I only have my 'spare' time for this work).

**24cms ATV TX.**

Unfortunately the old TX kit had to be discontinued due to a major component being no longer available. A new design is under development. Watch this space.

All kits contain all board mounted components and full comprehensive instructions.

Prices are all inclusive of P&P etc. (+ 10% abroad) PCB's are available assembled and tested at extra charge. **SAE. (to take A4 paper) for further details or call.**

**Orders and enquiries to:- BOB PLATTS G8OZP. 220 ROLLESTON ROAD. BURTON UPON TRENT. STAFFS. DE13 0AY. PHONE 01283 531443 7 - 9PM WEEKDAYS PLEASE.**

## Solid State Image Iconoscope, Part One.

**By Paul Marshall**

Why would anyone want to build a working Image Iconoscope from scratch in this day and age?

The answer is to see how bad (or good) they were way back 50 years ago. Another answer (in this particular case), is to burn up most of the authors 'spare' hours throughout this year's summer so that the Club had a centrepiece for it's stand at IBC '97 in Amsterdam in September (see report in CQTV 180). The aim was to use new, solid state electronics to a genuine old tube.



**An external view of the completed camera at the recent IBC**

In this first part, we will look at the background to the project, some of the design goals and difficulties and how these were overcome. In part two, some of the circuit techniques and alignment will be covered with a review of future possibilities.

Originally, the plan had been to build a straight Iconoscope camera using a newly built tube but there were difficulties in finding an organisation with the necessary glassware and vacuum deposition skills willing to do the job.

## *Solid State Image Iconoscope, Part One.*

Out of the gloom came two Pye Photicon tubes (Image Iconoscopes made by the Cathodeon division of Pye), courtesy the National Museum Of Film, Photography and Television. In fact, one is a Pesticon (Photo Electric Stabilised Image Iconoscope), as described by Dicky Howett in CQTV 178. Having two tubes meant (hopefully) that we would have an operational tube and a spare.

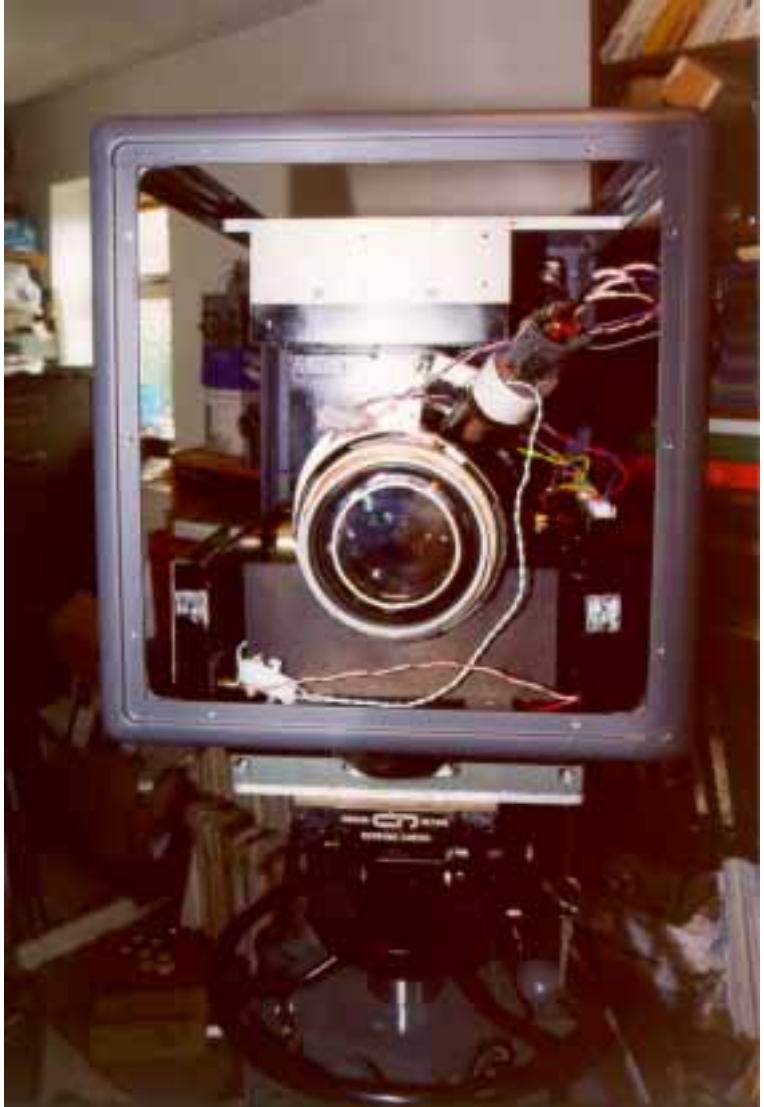

**Look Mar – no case!**

## *Solid State Image Iconoscope, Part One.*

Sometime towards the beginning of June, work began in earnest.

Contacting Ian Waters who worked with these tubes and actually made an amateur camera with one, produced a collection of circuit diagrams from his lab book of the time and some slides. This was a very good start as this gave a clue about the tube operating potentials and setting up procedures. I am very much indebted to Ian for this information as without it a lot more initial guesswork would have been necessary.

Peter Delaney of Club Sales fame kindly produced an extremely sad looking, very broken, Photicon with potted coils attached which, despite appearances, proved to be very useful. This gave a set of deflection, image focus and beam focus coils. Well, so I thought. When club Chairman Trevor Brown brought over the two tubes we tried offering the coils up to them each in turn. There was no way any of the coils would fit either of the tubes! This was a major set back as coils would now have to be designed and wound. Vital information on the magnetic fields and deflection requirements could be determined by measuring the coil LRIs (Inductance, Resistance, Sensitivity). Knowing the approximate currents and voltages from Ian's circuits gave a fairly clear picture of what was required.

At this point a decision was taken to ditch the old 'high voltage' type of coil used with the original valve circuitry, and design the new coils for 'low voltage' operation which would make driving them with modern electronics much easier. This was one of the key decisions in the whole project. Once the pain of designing the coils and then winding them was out of the way, driving them fell into place fairly easily.

The design goal (self-imposed) called for linear deflection with multi-standard operation, thus enabling the camera to be driven from 405, 441, 525 or 625 pulses (even VGA is actually possible!). At the exhibition, only 625 was used but the camera can run on any of these standards with no physical changes.

In order to progress the project as quickly and efficiently as possible two further decisions were taken:

'Out source' the video processor. Bob Robson volunteered to do this part, with a design brief showing quite high gain and needing to work over a wide range of line and field rates.

Linear horizontal and vertical deflection sub-systems to be done by adapting circuits that I had designed for work. I am indebted to the Directors of SEOS Displays Ltd. for permission to do this.

It would have been very desirable to do the same with the case metalwork design and fabrication, but no bites. Ah well, at least I found out that I can



still do metal bashing! Help was forthcoming with the actual Photicon support metalwork.

In amongst preparing two genuine vintage cameras and all the IBC stand logistics, it was beginning to look as if the project might actually come off - if one or more of the tubes actually worked.

By the beginning of August, with about four weeks to go, the moment of truth arrived. Everything was ready to energise the first and best looking Photicon. How close would the calculations be? Would the electronics behave as expected? Above all else, **WOULD THE TUBE WORK???**

Late one Saturday evening when most sane people were down the pub, the tube testing began. With no data whatsoever about the tube other than rough photocathode and beam accelerator potentials, I began with the heater voltage. It had been suggested that it was a standard 6.3V, but being of a doubting turn of mind, the temporary floating supply (the bottom end of the tube sits at -1KV) was set to 2V and slowly advanced. At almost 4V on the nose a constant current plateau was reached and a satisfactory glow from the heater appeared; 4V was good enough for me.

Moving on, the beam focus coil current was advanced to the calculated 1.5A, the horizontal and vertical scans adjusted to the estimated values and the HT energised.

Advancing the beam current pot revealed what can only be described as a white 'blob' on the monitor - a vague image of the target. Over the following hours, well into the small hours things progressed until a vague shadow graph picture could be resolved. Over the next week progress was swift and with aid of a 300W halogen lamp at a range of 1ft the first real, recognisable image was produced. Refinements were slowly brought on line, horizontal keystone (EW) correction, vertical tan theta correction (both required due to the offset angled nature of the electron gun with respect to the target) and proper shielding of the tube from external RF (the first tests were conducted with the tube wrapped in earthed aluminium cooking foil!).

Then, disaster.

For no apparent reason, the getters on the tube turned white, thus indicating the ingress of air into the tube. After consulting with EEV in Chelmsford it became apparent that the tube face plate had never been properly attached nearly 50 years ago when it was made. It had taken this long to show up. I was assured that I had done nothing wrong and that it was probably a reject or a prototype. Repair was out of the question as the Silver-Caesium photocathode would have oxidised, along with the target and possibly the cathode of the electron gun. Carefully, the second tube

## *Solid State Image Iconoscope, Part One.*

was offered up and pictures were soon as good as the first. How long would this one last, the first had run for 6 hours, not a good life at all!

EEV had warned me earlier in the year that if I did succeed, a tube of this age would be suffering from helium contamination giving a diffuse white cloud in the middle of the picture. They were right. Both tubes showed this characteristic. It comes about because Helium is the simplest single atom molecule and it can slip between the lattice structure of glass. The minute quantities of atmospheric Helium pass through the glass only to become trapped in the evacuated bulb by air pressure. Over the years this builds until it is in a significant quantity.

The race was now on to complete the casing for the head and build the CCU/PSU into a small 19" cabinet. All of this had to be done with virtually no budget, very little time, no machine tools and yet it still had to look presentable.

In deference to the age of the tube, racked mechanical focussing was not attempted. It was thought that all mechanical un-necessary movement should be avoided. Suffice to say that many hours with a hacksaw, drill, file and little else produced something acceptable. The head is not quite what I originally had in mind, but time being short, it had to do.

Shortly before we were due to pack the 1 ton of gear up to go to Amsterdam, a BATC member, David Mann of Link Electronics fame sent some Polaroid photographs of a Pesticon tube that dropped on to the doormat between a ghastly assortment of un-wanted bills. 'Would the club be interested in this tube?', asked David. You bet it would. We now had a spare tube again to take with us.

Another problem came to light with the transportation. How do you safely transport such fragile, ancient pieces of glass across the North Sea without specialist, expensive help? Discussions with John Trenouth (Senior Curator, National Museum of Photography, Film and Television) and Ben Gawthorp of EEV were not encouraging. EEV said that such tubes would never have been made with this sort of travel in mind. John favoured a ferry as he feared for the tube in the event of a bad landing in an aircraft.

We decided to hedge our bets. One tube would go by ferry, in the actual camera, relieved of its beam focus and deflection coils, the other by air. I went by air with the spare tube at my feet in a well packed box. I had in mind a 737 with full pressurisation, not the bus with wings that greeted us on the tarmac. These suffer some degree of pressure change during ascent and descent. I had visions of the tube imploding and being surrounded at gun point as an IRA suspect! Fortunately it survived. Curiously, airport authorities never once showed any interest in the strange package.

## *Solid State Image Iconoscope, Part One.*

From a technical point of view, attending the exhibition was an anti climax - the camera performed (and continued to perform) as it had done. Worries about tube life began to fade and instead of a few hours it was running all day completely stable and as good as could be expected.

The camera is seriously insensitive by modern standards, a poor 1960's vidicon is 'see in the dark' compared to these. A 2KW lamp at 4ft range gives acceptable pictures, provided you don't want any depth of field. Remember that these tubes are IMAGE Iconoscopes, optimised for sensitivity! The lack of a black level and the Helium cloud were all strong talking points. It is slow to warm up, some ten to fifteen minutes is required for optimum performance, but once there it is completely stable. Controlling the inherent secondary emissions which affect picture shading is just as difficult as it says in all the text books - the 'tilt' and 'bend' controls need continual adjustment.

It was all a worthwhile exercise, but a huge amount of work in a short space of time.



**Paul driving the camera on the BATC stand at the recent IBC**

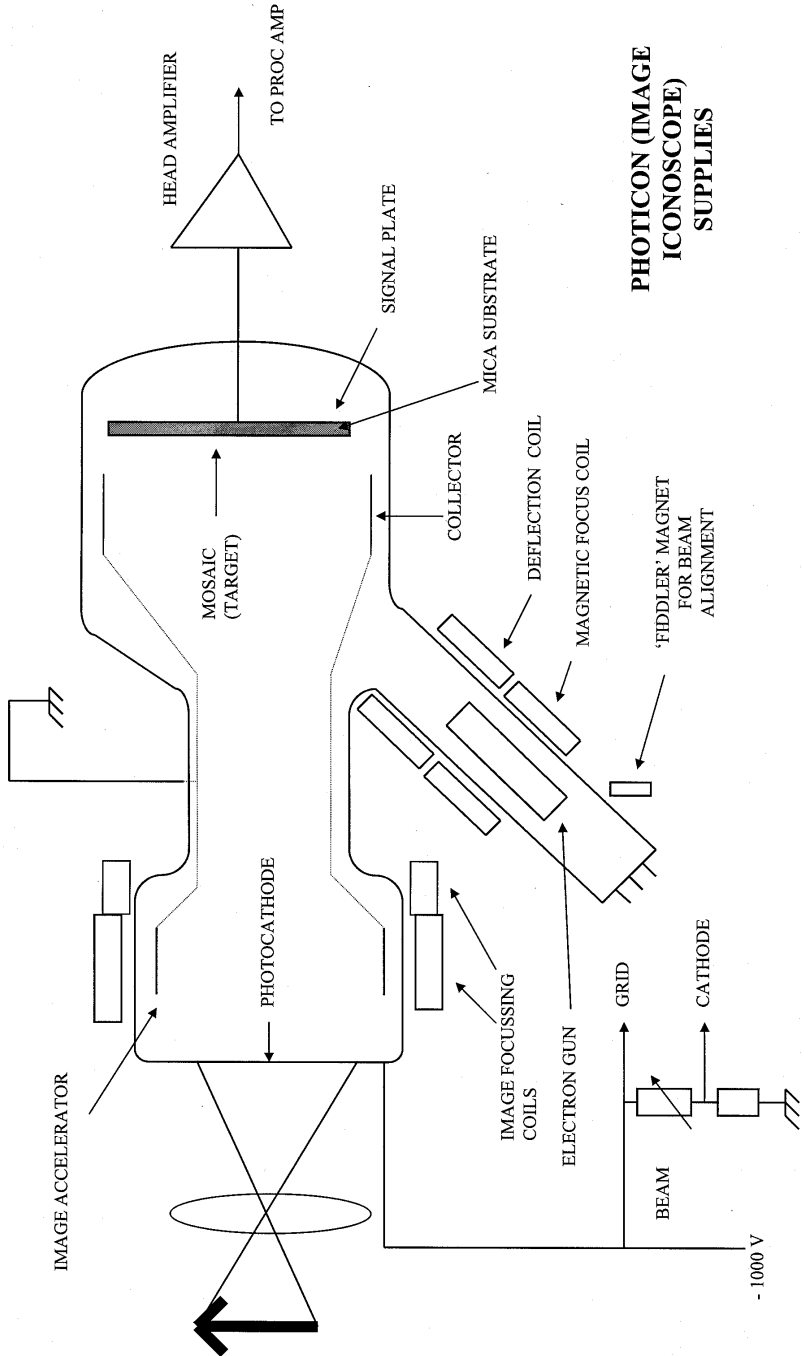

**PHOTICON (IMAGE  
ICONOSCOPE)  
SUPPLIES**

## Setting FM Levels

### By G8MNY

For FM ATV there are 2 deviations & 1 injection level to set;-

- 1/ The Video Peak-to-peak. +/-3.5MHz
- 2/ The sound subcarrier injection. -18dB on peak-peak vision (+/-3.5Mhz).
- 3/ The sound subcarrier deviation. +/-50KHz

### Video Level

If hard video clipping was used after the pre-emphasis the clip points could be accurately set to full deviation, but with colour & sound subcarriers this would cause problems. A SatRx is designed for wide deviation so correctly adjusted ATV modulation levels will be seen as quite underdone on an unmodified SatRx. The Video peak to peak is difficult to measure as the pre-emphasis means even on a calibrated oscilloscope & discriminator, there is little to see of the wide deviation caused by the spiky video edges.

A better approach is to set the LF deviation some 14dB below the maximum. This allows for the edges that can be lifted 14dB by the pre-emphasis CCIR network.

Although the largest video edge swing is only 0.7V at any one time, allowance for the sound subcarrier component of deviation will take up this small error.

14dB down on +/-3.5MHz = 1.4MHz peak-peak or 932KHz White-Black.

With a 50Hz 1V peak-peak square wave or 1/2 white/black video (top & bottom of frame) the measurement can be made several ways:-

- a) Calibrate a Rx, (no AFC) connect the discriminator DC O/P to an oscilloscope & the Tx (or an IF osc) connected to a frequency counter. QSY the Tx/osc 1MHz & calibrate the scope trace. Then apply the test waveform & adjust video gains for the correct LF deviation.
- b) A narrow band scanner can also be used either on 23cms or on a RX IF. Then 2 methods can be used:-

The 1st carrier null method, with FM this occurs at a M.I. of 2.4. So for +/- 3.5MHz deviation a 1V peak-peak test video carrier of 1.46MHz is needed. This may not be practical as the pre-emphasis in the video circuit

## Setting FM Levels

will not be flat at this frequency (+11dB?) and confuse the calibration process! However if testing just the UHF Modulator it will be OK.

The second method it just to tune in to the 2 energy peaks that correspond to the 50Hz square wave steady states or 50Hz White-Black picture frequencies, and adjust the video gain to obtain the desired deviation.

c) Use a spectrum analyser to do the any of the above.

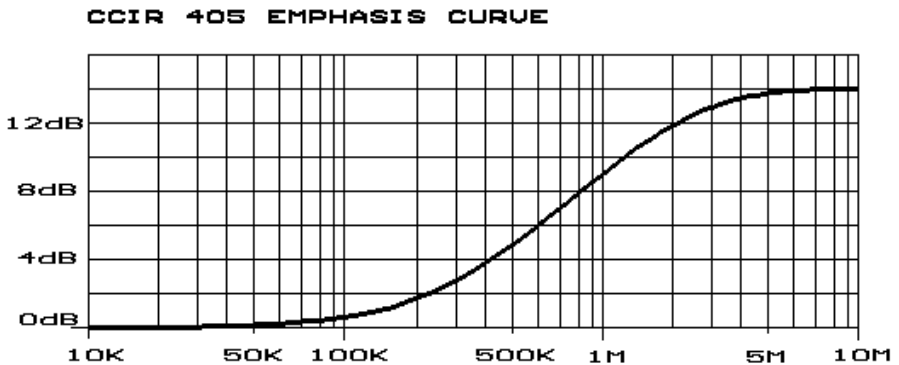
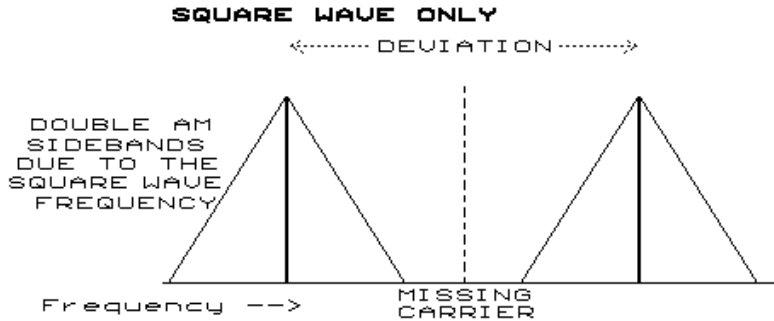

## Sound Subcarrier Level

The recommended level is -18dB, this is 8dB weaker than for an AM TV broadcast system, but making it any stronger greatly increases the bandwidth used for FM ATV. Although this level looks large compared with the LF video in the sketch, it is soon lost in the HF Rx noise as FM noise is proportional with frequency (6MHz) in a RX.

The simplest method is to scope the peak-peak level subcarrier injection level just before the UHF Varicap diode (not UHF point) with a high

impedance oscilloscope probe. For 18dB below the peak-peak video deviation this peak-peak level is just 4dB below the LF video level. This is 1dB (10%) less in amplitude than the black to white of the picture.

### Sound Deviation.

This is also pre-emphasised (on some Tx) and as it contains no added subcarriers (eg no MPX stereo/data) it can be allowed to clip in an AF amp. As the audio is the weak link on ATV, some amount of AF clipping (not over deviation) can be an advantage.

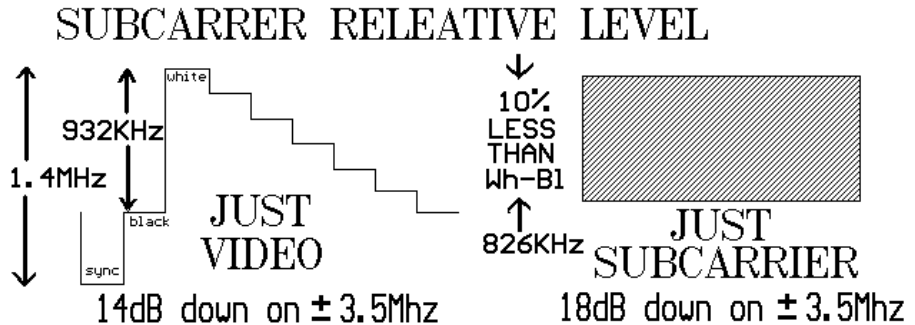

Deviation can be set up by using a scope and a frequency counter or HF Rx. (NB. counter may pull the osc when connected!). First set frequency to 6 MHz, then put the scope probe on the output of the preset deviation control. Connect up a pot (1k-100k) across a supply rail and use the DC on the slider to swing the opamp's bias up & down, and hence the Varicap DC high & low. This then lets you calibrate the scope for +/- 50KHz points (note it won't be symmetrical due to the Varicap characteristics). Now remove the added bias circuit, apply overloading audio, adjust the deviation preset so that the clipped waveform is at the same level.

For more info on..

HiFi sound in CQTV 159 page 34.

FM ATV Spectrum in CQTV 179 page 76.

## New frequency for amateur radio

**By David Lamer**

Amateur radio is set to receive a boost in the UK with the allocation of a new part of the radio spectrum. The Radio Communications Agency (RCA) plans to withdraw the current 73kHz band in June 2000 and release a low-frequency band of 136kHz to licence holders.

At present, the UK is the only country to use the 73kHz band, making world-wide communication impossible. According to the Radio Society of Great Britain (RSGB), although amateur radio has to compete with technologically more advanced hobbies like Web surfing, there are still 60,000 radio hams in the UK.

Insiders at the RSGB say the narrow band LF of 135.7 to 137.8kHz should be available from January.

The band will only be suitable for Morse transmission because of the bandwidth limitations. But in the USA, where this band is called the Experimenters' Band, trials have been carried out for voice systems. Cave and mine rescuers have also been able to make use of the long wavelengths for UK radio communications underground.

The long wavelength of >2km makes coupling power into the antenna a challenge. To achieve an effective radiated power of 1W an RF amplifier of several hundred watts is required. Despite early pessimistic forecasts regarding the propagation of these long wavelengths, UK amateurs have achieved ranges of up to 400km on the 73kHz band. The RSGB is confident that this distance will be greatly exceeded on the 136kHz band, as the antennas will be more efficient.

Cambridge Kits is already producing receiver kits for home assembly at £30 each. Martin Mann, director, says that "with only around a couple of hundred people in the UK who will use the LF band", he does not expect to be able to retire on the sales of these.

The allocation of the new band will be added to the UK table of allocated frequencies for licence holders.

*Reprinted from Electronic Times, 1<sup>st</sup> December 1997.*



## Television Simply Wonderful.

**By Dicky Howett**

In 1993 DICKY HOWETT visited the studios of Television South West. There he found out about an auction and got the word on Westward.

Of course, the ITV company Television South West is no longer transmitting, swept away by the 'de-regulated' 1992 Tory government-inspired commercial television franchise farce. At precisely midnight on Dec 31st 1992, TSW ceased broadcasting, thereby ending what amounted to a 32 year association with the South West of England.



**TSW Derry's Cross, Plymouth. August 1993**

The main studio base for Television South West was located at Derry's Cross, a busy thoroughfare and roundabout in Plymouth. The studio was designed originally in 1961 by architects Treadgold and Elsey, who had previously designed the Pontcanna studios at Cardiff and Arnos Court Studios in Bristol for TWW.

In 1981, TSW inherited the building from Westward Television, who were, in 1961, the initial franchise holders. The original Westward TV centre consisted of Studio 1 (50ft x 40ft) and a presentation studio (23ft x

## Television Simply Wonderful.

17ft). During the Westward years the studio building had remained superficially unaltered. Soon after TSW took over, further accommodation was added to the site. Basically, however, the studios retained the look of a typical 1960's television centre design.



1961

A plan of the television centre:

- A—Master control room,
- B—Technical area,
- C—Scene dock,
- D—Studio 2,
- E—Studio 2 control room,
- F—Announcers,
- G—Carpenter's shop,
- H—Drawing office,
- I—Technical maintenance,
- J—Public viewing corridor,
- K—Oil storage,
- L—Green room.

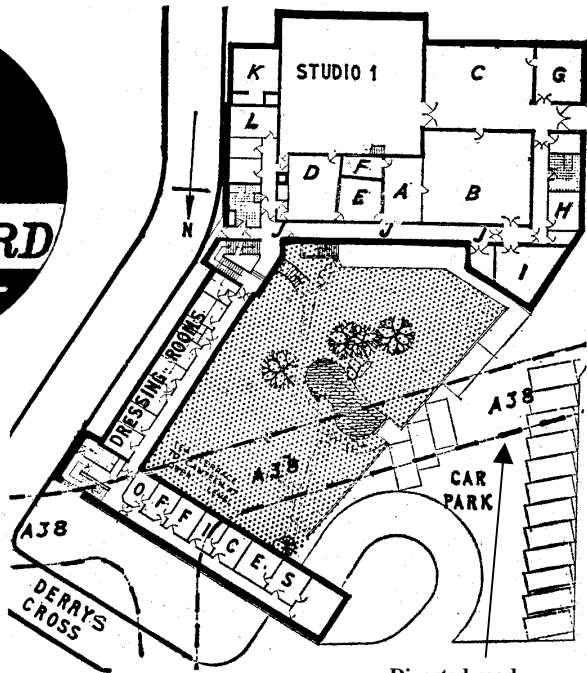

Westward Studio Plan

Television South West as a company had energetically fostered the traditions of the area, forging links with many local institutions. When TSW lost the franchise, it came as a great shock, especially to all the staff who lost their jobs. (Only a handful were re-employed by the new franchise holder). As a parting gift, (and as a poke in the eye to the new franchise incumbent, Westcountry TV) TSW donated its entire film and videotape library to the people of the South West. This archive, complete with replay equipment and infrastructure (with a book value of £500,000), is housed at present in the basement of the Derry's Cross studios. Now known as the TSW Film and Videotape Archive, it has charity status and is an adjunct to the National Film Archive. However, the TSW Archive pays its way, servicing telecine requirements for local clients like the tape-only BBC.

After the bitterness of losing the franchise lottery, Television South West decided to sell the entire studio and its contents. In April of 1993, an ‘all-comers’ auction was held, spanning three days. Apart from the actual studio buildings, all the technical kit was up for grabs. This equipment included, lighting, sound and vision mixers, video electronics, camera mounts and the seven main studio cameras (Hitachi SK 110).

By August 1993 most of the equipment had been sold (some bargains—a Vinten H.P.419 pedestal went for £150 and a Mk3a pan and tilt head for £100!) When the present writer arrived all that was left were a few large items, including a grand piano, an AMS digital/stereo 48 channel mixing desk (this desk is an expensive ‘as new’ piece of hardware that had only been used for *three* programmes) and a few monitors. Also lying in a storeroom and unsold were seven Hitachi studio cameras.

Present on the day in question was Peter Rodgers, who until 31st Dec 1992 had been TSW’s Head of Broadcast Engineering. He commented on the lack of a sale for the seven studio cameras.

“Actually we nearly did find a buyer, but at £1,500 or so per camera channel the asking price was too LOW for their accountants to put on the books. If the cameras had been the next generation up, we could have perhaps asked £5,000 each and sold them on. In fact the Hitachi SK110 cameras are old technology, 30mm picture tubes, been here since 1982, but they are fully automatic and are in good working order.” (The cameras as old technology were eventually sold in 1996 combined with a Central TV sale for £150 each!)

In 1961 Peter Rodgers joined Westward TV. He was in at the beginning, having migrated from the hurly-burly of ATV’s London studios. “This was no time to relax. Westward may have been a comparatively small regional set-up but it was a seven day a week operation. It was all go from the start!”

Westward began as it meant to continue. The station was no cheap-jack vidicon operation. The ‘ITV 1963’ book lists proudly Westward’s top-of-the-range studio equipment including Marconi Mk 4 Image Orthicon cameras, Vinten pedestals, Mole-Richardson lighting and RCA VTR machines.

Peter Rodgers: “The station always had a very strong engineering background. This carried through from Westward to TSW. In 1981, most of the Westward staff were re-employed by TSW. From the start, where we could afford it, we bought the best. Westward was a Marconi deal. We got them to set up the station. The big ITV company ABC TV had a hand in it too. Throughout the years we always consulted with all the technical staff, got them to try out various cameras to see if they liked them. Sadly,

these days it seems to me that engineers are seen as being not required by the industry. Equipment today is very complicated and robust but has a perceived user life of only two or three years, giving no chance for an engineer to work on or repair it. The stuff is all software driven with software changes rather than hardware changes. In the monochrome days, equipment needed constant attention. Cameras could go out of line sometimes even during a programme. Actually, I reckon that the accountants will realise that it's getting a bit too expensive to keep on changing the kit every five minutes just to keep up with the latest fad. Regional companies, which are now more and more just live video news operations, will make do with what they've got - and perhaps get us engineers back to keep things running?"

The transmitted television image in the West County has to leap and bound over difficult terrain. The two main transmitters are sited at Caradon Hill near Liskeard and Stockland Hill near Honiton, with many small repeater stations dotted about.

Peter Rodgers: "Transmission could be pretty tricky. We needed lots of fill-ins, especially along the North Devon coast. Conservation considerations don't help. After all, you can't just plonk a repeater on any hill or headland. It's the same across the water. Some of our northern coast viewers got marvellous pictures from HTV. On the other hand, the Welsh valleys who couldn't get HTV, picked up perfect TSW signals!"

During the early 1990's and after some uncertainty, the TSW Derry's Cross studio site was bought eventually by a firm of solicitors, Foot and Bowden who now occupy all the street-front offices. The rear sections of the building are currently sublet including the old o.b. base and part of the master control and continuity studio (to freelance operators). Studio A is also back in service. It has been re-equipped with cameras and is now used by a local production company producing daily a chat show for BBC Television.

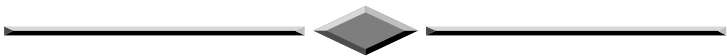

**Please mention that you saw it  
in CQ-TV when responding to  
advertisers.**

## November 1997 UK ATV Repeater Update

### By Graham Shirville G3VZV

Currently there are 22 ATV repeaters licenced for operation and all are believed to be active except:

GB3MV Northampton has sadly lost access to its site so is temporarily off the air.

### New proposals include:

GB3AD Proposal for Stevenage. Presently with the RA for licensing and the NOV is expected in the next couple of months. Will be active using 1249/1316MHz

GB3VX Proposal for Eastbourne. Presently just arrived at the RA for licensing and the NOV should be issued well before Easter 98. Will be active using 1249/1310MHz

GB3VL Proposal for Lincoln. Presently awaiting a couple of details before it can go to the RA, so should be with them by the time this is read. Will be active on 1248/1310MHz.

GB3DJ Proposal for Telford. Presently just about to go to the RA. Will be active using 10.425input/10.135GHz output.

GB3BG Proposal for N Birmingham. Presently awaiting a couple of details before it can go to the RA so, again, should be with them by the time this is read. Will be active using 10.425 input/10.135GHz output.

### Other News:

GB3WV This unit, on Dartmoor, has suddenly started to suffer from bad radar type QRM on the input. The group are currently trying to track down the source.

A proposal for an area north of Derby is presently in hand pending clarification of the proposed coverage in relation to existing nearby ATV units and CAA radars.

A letter of intent has been received from the Worthing Group for a 3cms ATV repeater to be co-sited with GB3VR on the south coast.

Further information on any of the above is always available. Please contact Graham Shirville G3VZV at the address given in the front, or by e-mail.

## Shedding Some Light.

### **By Dicky Howett**

Dicky Howett illuminates the world of production lighting and talks to lighting designer Jim Laws.

In the beginning there was Light. Photography wouldn't much exist without it and television would still be in the dark. However, levity aside, in the old pre-war television studios there was lots and lots of light. They needed high light levels because the early Emitron television cameras lacked efficient image storage on the photo-sensitive 'mosaic' signal plate. This meant that the cameras scoffed vast quantities of light (typically 300ft candles at f 3) in order to energise properly the pick-up picture tube. Ancient BBC-TV engineers will tell you that up at Alexandra Palace it was quite common for a programme to be lit by several huge mobile Mole Richardson 5k's which, if the picture got too dim, could be wheeled in and positioned on cue. That way each sweating performer got to bask under his very own live 5,000 watts!

These days, TV lighting is artful and logical (apart from Australian soaps where the sun appears to shine through solid ceilings!) Lighting technology has moved on, but basically it's still all about angling a bulb in a tin box with a condensing lens attached. Lights ancient and modern have arcane names such as Sputniks, Double Scoops, Horizon Floods and Mammoth Coolees.

Down north Suffolk way lighting designer Jim Laws has definitely the largest collection of bulbs in tin boxes this side of Beccles. It's all for hire, although Jim has been known to sell the odd period artefact to theme bars and collectors. Jim recalls that when he moved his business to his current spacious farm residence, it took the combined efforts of twelve pantechincons to shift the kit. The removal man remarked that moving Jim's lights was one of those jobs where, 'it just came out of the walls at you!'

Jim Laws primary occupation is that of a lighting designer and supplier. He runs his company 'Jim Laws Lighting' to furnish modern rigs for pageants and stage performances. If, for example a concert is being performed at a church, Jim can erect the stage, sling the lights and control the effect. His dedicated band of freelance assistants can help perform similar functions at theatres or stadia. Delivery of equipment can be accomplished by using the Jim Laws dedicated horse box. Jim can also advise and equip film and television productions. Jim Laws elaborates, "I started out as a scene shifter. I then got a job at Southwold Rep as deputy

stage manager which meant I did everything including lighting plots. Eight plays in eight weeks is good training for anyone. Later I attended drama school just to see the other side of the footlights as it were. Jim Laws' vast lighting collection was formed more by design than accident. "When I started working as a theatres electrician I found that some of the theatres didn't have much lighting equipment of their own," says Jim. "I bought ex rental stuff for a fiver and loaned it out to them. Then in the 1970's out of the blue I was asked to provide lights for a pop video for Kate Bush, set in a deserted music hall. My involvement with film and tv grew from there. I formed a company called 'Ancient Lights'. Later it became Jim Laws Lighting. Now I have five barns and storage sheds full of every conceivable type of lighting. We can supply just about anything, including candles, gas lamps, even a couple of signalling lamps off a battleship"



**Jim Laws attends to a Sputnik**

Jim Laws still gets offered redundant lighting. In the past he acquired lighting from TV studios such as Anglia and Central. However, he doesn't attend redundant kit sales anymore. Says Jim "I'm not really interested these days in bidding against ex-BBC staff with fat redundancy cheques, trying to set up on their own. I still get approached with an offer to remove lighting. I'm looking these days for unusual items like a Hewitt and Doubleday Compact Source light. However, I treat everything on its

## Shedding Some Light.

merits. If they tell me it's a sale or the skip, sometimes I'm tempted to offer the skip!"

All of Jim Laws lighting is refurbished to modern standards. He has a local 'metal basher' who can repair and restore or even recreate from scratch. "I have a lot of original data on lights and lighting practices. I lecture on the subject of lighting history and can advise film and tv producers on the correct usage of equipment. Also I can adapt lighting to suit. The exhibition industry will sometimes ask for a 2K light but with only a 300w bulb in it. I have supplied historic



**Part of the Jim Laws collection. A BBC radio studio light**

display equipment for museums such as The National Museum of Photography Film and Television and have also been involved with the Society of Television Lighting Directors. In 1995 I took a carload of lights to a hotel in Bournemouth to help celebrate 25 years of the Society."

Jim Laws and his old lights have featured on many TV productions. "A few years ago we supplied lights for BBC 2's '60's' weekend. A panic-stricken researcher phoned me and had to know instantly exactly what lighting was used for the 1966 World Cup studio which they wanted to recreate. I phoned my friend Bob Anderson, who had then worked at the BBC and he said that as the TV centre was still in part under construction, the studio lighting rig was a temporary lash-up of scaffolding, some odd lamps and a Strand Electric 10-20 board. I rang back the researcher and gave the news. There was a three second silence. Oh", came the reply, "we



## *Shedding Some Light.*

didn't see it that way Okay, said I, if you don't want an exact recreation, lets compromise on a fair example of the period, which is really the best that anyone can expect, especially with only 24 hours notice.



**Jim Laws down amongst his lights**

## *Shedding Some Light.*

Another TV production, 'In the Cold Light Of Day' with Ronald Pickup required Jim Laws to furnish an entire 1930's electrical shop. "We supplied reels of flex, wet cells, light sockets and bulbs. All authentic," enthuses Jim. But he's in his element when asked to re-create theatre lighting. "I worked on the recent BBC TV production of 'The Entertainer' with Michael Gambon", Jim recalls. "We kitted out The Hackney Empire as a 1950's music hall, and then relocated later in Studio One at Television Centre. I installed there two vintage Strand Electric Grand Master lighting boards with main dimmer wheels. We also used the same boards ten years ago for a BBC TV play called 'The Fools on the Hill', about the start of tv in 1936 at Alexandra Palace. The lighting board was correct for both periods."

Jim Laws' latest project was the recently-released motion picture 'Fairy Tale-A True Story' which relates the adventures of two school children who in the 1920's created fake photographs of fairies at the bottom of their garden. In the story the children get the idea of fake fairies from seeing, in 1917, a stage production of Peter Pan with Tinkerbelle. Jim Laws, "We chose the Wimbledon Theatre for the location shots. The Wimbledon Theatre is one of the few left with a 'Hemp House' for flying scenes. The director wanted moths flitting amongst the ropes. I supplied and advised on all the correct lighting suitable for a typical 1917 stage production."

49-year-old Jim Laws has been in the business for 30 years. Understandably, he still has the occasional industry gripe. "I do wish people wouldn't chop off my plugs. Don't ask me why sometimes they do it. For some reason the stuff gets returned with plugs hacked off. All my lights have passed the Portable Appliance Test and the plugs are quite okay as they are. Also, I wish people wouldn't use parcel tape on my lamps. If my address label falls off then please use string. Parcel tape is damaging to old paintwork. What some people don't realise is that it's the surface finish of an object that gives it its special appeal. It's very difficult to reproduce an 'old' look. Parcel tape doesn't help in any way. The problem arises when we try to remove it. There's every chance that the paint work will get damaged. By peeling off the parcel tape you also run the real risk of peeling off history

Jim Laws and others will continue for years to provide the industry with key ancient lighting and the historical information to back it up. The fact that this lighting has been preserved is due entirely to the foresight of people such as Jim Laws. They relish the old technology and more importantly are prepared to make light work of it.

# Worthing & District Video Repeater Group

## GB3VR & GB7VRB

### 1Watt FM-TV 24cms Transmitter

The 1 watt transmitter generates its signal at the wanted frequency which can be set anywhere in the band, colour or B/W. On board intercarrier sound and fixed pre-emphasis are standard features. The kit includes the PCB all the on board components, pre-drilled heat sink, an Eddystone Di-cast box and full and comprehensive instructions. Building time is three evenings work. The new price for this kit is £80.00, P&P £2.50. Over 650 units sold to the Amateur market alone.

This is probably the biggest selling TX kit in the world!!!

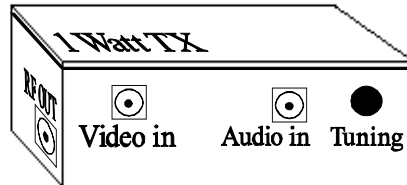

### Two channel phased locked loop kit.

This add-on kit vastly improves the overall stability of the 1 watt transmitter. Two crystal locked channels and a third free running tuning position are available. Kit price £30.00

### Amiga ATV Program-2

The New Amiga ATV program has more features than ever, up to 56 testcards, 20 wipes, superb text control, 30 screens of text messages, QRA calc, Testcard music, selectable displays, and this version has a DTMF tone pad to control your repeater. All testcards are over-scan i.e. the whole screen is used, Load in your own customised testcards, Extra large text, scrolling text, clock, callsign extensions, Hot key operation, Doc reader, ATV Cli, Cross Hatches, Purity and a comprehensive section for genlock users. For any Amiga with 1meg or more, state callsign and QRA (if known) when ordering, this three disk set is now only £10.00 P&P 75p

### Spectrum ATV Program

Still selling after all these years, why, its good, its cheap and it works on all spectrum based machines. The 48k version has over 60 commands which include 7 Testcards, Memo pad, clock, maps, tones, QRA locator, various size printing, plus disk transfer routines and much more. Now only £5.00 P&P 75p

PC ATV is coming.

Orders should be sent to:-

Treasurer of GB3VR, R. Stephens, 21 St. James Ave., Lancing, Sussex, BN15 0NN. Cheques payable to "W&DVRG" Tel (01903) 765760 7 to 8pm.

**By Graham Hankins G8EMX.**

November's TVOA was put together in some haste, due to the stated early deadline, so no mention was made in TVOA of the new 'Beacons Repeater Group' in the West Midlands. The BRG intends to provide a 10GHz ATV repeater in Sedgley, plus a 1.3GHz ATV repeater to the north of Birmingham.

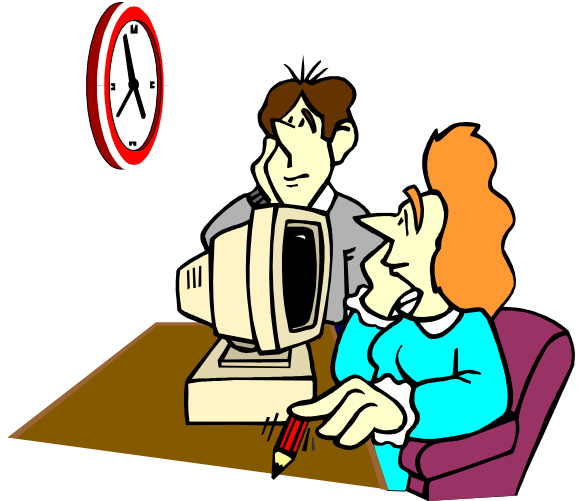

Substantial progress has been made towards the 10GHz (3cm) unit. Most of the hardware is being home-constructed, or modified by BRG members. Credits so far go to Alan G7UMW who has built the video modulator board, Chris G7IPT for the audio filter and sound sub-carrier p.c.b., while the Group's chairman Alan Kendall G6WJJ has been working on the transmitter and receiver.

The repeater will be using slot antennas to provide the omni-directional, horizontally-polarised radiation or sensitivity pattern normally required. The two antennas have been constructed by BRG members but required careful checking to determine how close to truly circular their polar diagram was going to be.

Alan Kendall describes how the antennas were tested: "The slotted waveguides were placed 20 metres away from the detector in an 'open field' site - my back garden! The deviation from circularity was found to be no worse than 3dB so it was agreed that this performance was very acceptable. The gain was measured at 10dB relative to a dipole, which again was satisfactory for an omni-directional antenna".

Alan Kendall and Graham Hankins G8EMX have also visited the site where the 1.3GHz repeater will be located. A screened housing for the r.f.

and logic modules is already available, because the 24cm ATV unit will co-exist with a 70cm voice repeater and other radio services.

A single-pipe dual Alford-Slot antenna has been obtained for the 1.3GHz unit, so the first job has been to mount it high enough up on the surrounding buildings. Lengths of very low-loss feeder, a transmitter and receiver plus a spare BBC Model B computer await installation, so watch for updates on both projects in 'TVOA'

Not every ATV repeater needs all-round coverage. The West Devon ATV Repeater Group runs 24cm unit GB3WV, which opened in April 1997 using three trough-reflector antennas. These were intended to point at Torbay, Plymouth and Bude - unfortunately, the Bude antenna had been aligned roughly at Exeter.

Dartmoor weather and the planning required for antenna work delayed corrective action, but the 'rogue' antenna was eventually cranked towards Bude. This done, a lightning strike then put an end to the output P.A. stage! A replacement was soon installed to bring GB3WV back to 18W e.r.p.

The West Devon ATV Group has produced the first edition of its newsletter 'WDATV News', which contains an update on 'WV' contributed by chairman Tony G8CEQ. Tony comments: "GB3WV has actually set a record for the speed of its conception to operation. 'Teething' problems are inevitable, but we can all look forward to a high-quality service. Please use it!"

The Group was invited to the Launceston Computer Club to give a talk on the use of computers within amateur radio and TV. Tony relates what took place: "An ATV station was set up and the whole evening was sent through GB3WV. Various other stations joined in to demonstrate how their computers were applied to ATV, producing weather pictures, graphics and suchlike. The whole event was thoroughly enjoyed by everyone present and on the air."

Now for some updates from other ATV Repeater Groups. Long time no hear from the Chesterfield Repeater Group who run GB3TT. However, a packet message brought results from Tony G0NHF: "Hi Graham, apologies for the lack of response from me, but yes I'm still the contact for GB3TT TV Repeater in Chesterfield.

Yes GB3TT is still on air, but can only be used after 6pm evenings up until about 2am. GB3TT now uses timed control to cut down on electricity costs during the daytime when the repeater is little or never used. The only time it now transmits during the day is for identification purposes. It still gives its ID TESTCARD and CW at the required intervals to conform to licensing conditions".

GB3TT is very active most evenings with regular users being G1XRA Ian, G1HFT Malcolm, G6AMM Paul, G7TZQ Ray, G6ZVE Ian, G7AVU Bob and of course the odd sighting of myself G0NHF Tony. All of the above are local to Chesterfield, except Bob G7AVU who is located in Gainborough, Lincolnshire. Bob spends a lot of time building amps. and bits and pieces to get that little bit further (obviously).

Repeater keeper for 'TT is now Ray G4AGE who lives at Bolsover, close to the repeater site. Ray took over the keeper's job from Richard G1IOR who has taken a backseat on the radio scene at present to do other things.

At the last meeting of the Chesterfield Group, a substantial amount of funds were raised in order to keep the repeater on air for the coming year.

No antenna changes have been made for some time now, but the repeater continues to cover the required area very well.

We do have a Newsletter from time to time, but find it rather difficult to find enough information to fill our pages. The last Newsletter was over a year ago.

If you would like to visit our site on the Internet, it can be found at: <http://visitweb.com/hamnet-uk/>

HamNet-UK Online contains a list of many licensed amateurs who have pages on the internet, as well as a section especially designed for the GB3TT repeater group. As and when we have a new Newsletter it can be accessed via the above Internet site.

Now some news around other Repeater Groups. Home Counties have added a new 'tone' to 24cm repeater GB3HV; this will alert any stations monitoring 'HV when incoming video is detected from the sync. pulses.

The November 1997 edition of Home Counties ATV Group mag. 'Line Out' mentions the North Kent repeater GB3KT. Apparently one of the Alford Slot antennas at 'KT became waterlogged and needed replacement, which caused 'a large drain on finances'. Well, I have not been sent any recent newsletter from the Kent Television Group but, as I understand it, such things are where the BATC MAY (emphasise MAY) be able to help **AFFILIATED GROUPS.**

GB3PV is part of the Cambridge Repeater Group and is in use nearly every day, especially during the Thursday activity evenings. Group chairman Ian Waters G3KKD highlights some of the changes being planned for 'PV: "We will be adding another sideband filter to the transmitter to comply with the latest Repeater Specification; more video processing too - chroma boosting and black-level clamping for the received video." Ian also has plans for a 70cm ATV facility, adding: "We

hope to also use part of the 430 - 440MHz band for monochrome direct station-to-station links.”

The Solent Club for Amateur Radio and Television (SCART) in Southampton is trying to find a better site for ATV repeater GB3AT, but without much success so far. Mike Sanders G8LES explains: “At the moment coverage is poor in certain directions, but trials at another location failed from physical problems - the antenna and mountings produced excessive wind-loading stress on the mast”. So, the hunt continues.

One of the 10GHz ATV repeaters currently off-air for re-tuning is GB3TG at Milton Keynes. Meanwhile, keeper Dave McQue G4NJK is busy with modifications: “We are rebuilding the logic so that a P.C. can be used for control instead of the ‘Spectrum’. Hopefully, GB3TG will be back in service very soon.”

## **Repeater Affiliations**

A few completed forms have ‘trickled’ back to me. Club has decided to make basic affiliation free for 1998, unless a Group requests copies of this magazine, in which case the normal £12 will apply.

To date, (Dec 5 '97) returns have been received from GB3WV, ‘TG, ‘PV, ‘HV and ‘LO. Conversely, if any Group has not been sent an affiliation form yet, please let me know! Latest information is that there are 18, 1.3GHz and four 10GHz FM ATV repeaters around the U.K. plus one 1.3GHz unit (GB3UT, Bath) which uses AM.

So yet another plea for replies AND for those newsletters! If newsletter editors or distributors use a ‘name and address’ database or list, then add my details to it please.

## **Licensed 1.3GHz f.m. ATV repeater list:**

GB3TM Amlwch (North Wales)	GB3VR Brighton
GB3ZZ Bristol	GB3PV Cambridge
GB3TT Chesterfield	GB3RT Coventry
GB3TV Dunstable	GB3HV High Wycombe
GB3ET Huddersfield	GB3EY Hull
GB3KT Kent	GB3GV Leicester
GB3LO Lowestoft	GB3MV Northampton
GB3NV Nottingham	GB3WV Plymouth
GB3AT Southampton	GB3UD Stoke on Trent

## **News from North Wales**

On an excursion to the North Wales Amateur Radio Show held on the weekend of the 1<sup>st</sup>/2<sup>nd</sup> November, Derek GW3FDZ from Dyffryn Ardudwy in North Wales and Pat GW0GZQ from Moylgrove in South Wales (who have regular scheds on 23cms between each other) decided to take their equipment with them.



The first two photos were taken on the top of the Great Orme at Llandudno when in contact with GW3JGA via the repeater GB3TM at Amlwch on Anglesey. The third photo shows playback (deep analysis!) of the recordings taken by John GW3JGA at Prestatyn.

So cheerio and P5 for now. More progress reports, ATV news and newsletters next time - when I may even have an internet address! Please keep posting all that news to me, Graham Hankins G8EMX at 11, Cottesbrook Road, Acocks Green, Birmingham, B27 6LE.





**GB3TM (Anglesey) as received in Dublin by Dave Hooper, EI2HR**

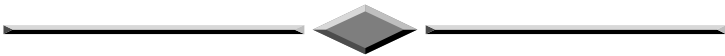

# World Wide Web

The BATC web pages have moved yet again. This time we have taken space with a commercial web service provider. We hope that this will be a permanent address. The URL is:-

**<http://www.batc.org.uk>**

A feature is a software download area. This page contains programs, data and code from articles in CQ-TV as well as other programs related to amateur television.

# VHF COMMUNICATIONS

VHF COMMUNICATIONS magazine is published quarterly and is available from **KM Publications**, 5 Ware Orchard, Barby, Nr. Rugby, CV23 8UF, England.

Telephone: 44 (0) 1788 890365, Fax: 44 (0) 1788 891883

Email: [vhfsubs@vhfcomm.co.uk](mailto:vhfsubs@vhfcomm.co.uk)



The 1997 subscription rate is £18.00 for cash or personal cheque (drawn on a UK bank, or bearing the name of a UK banking agent), postal orders or bankers draft made payable to VHF Communications. Payment may also be made by any major credit card at £18.90. The subscription included surface mail charges, airmail is extra at £6.50 per year (£6.85 by credit card). The magazine is a **MUST** for the radio amateur and professional engineer interested in VHF, UHF and Microwave working, containing, as it does, detailed construction articles for equipment operating in these bands.

## **Back Issues: special offers - enquire for details**

**Binders to hold 12 issues ..... £5.50**

**Complete Index 1970 - 1995..... £2.75**

Email: [vhfsubs@vhfcomm.co.uk](mailto:vhfsubs@vhfcomm.co.uk) Web site: <http://www.vhfcomm.co.uk>

Secure credit card page: <https://www.vhfcomm.co.uk/saleform.htm>

CMOS image sensor offers CCD quality.

CCD imaging systems, while providing broadcast quality pictures, presents difficulties to the designer. First, the CCD requires non-standard voltage levels and multi-phase clocks. Second, the data from the imager has to be read serially. So to gain access to data in the centre of the field of view, all the data has to be clocked out. CMOS imagers, on the other hand, allow random access and simple drive electronics, but with a poor dynamic range in comparison to the CCD. Until recently, Imec concentrated its CMOS imager technology on machine vision systems. But two developments for which patents have been filed, could bring the image quality of the CMOS imager closer to that of a CCD.

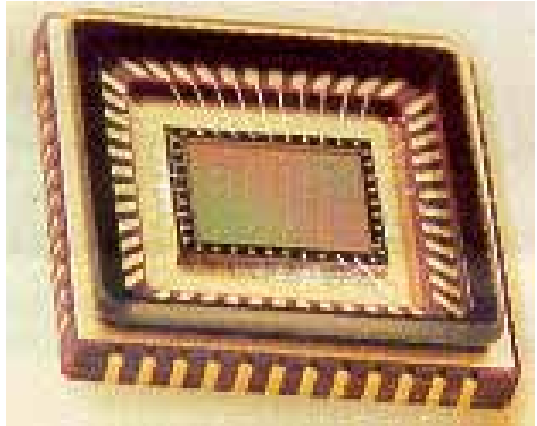

CMOS Image sensor

Imec says the first commercial products will be on the market within two years, and could slash the cost of video cameras, security systems and digital stills cameras. The two inventions that make this possible is a small pixel based on PiN diode technology. This gives a fast opto-response time and a lower dark current than other CMOS-based sensors.

The chopper amplifier used to read out the pixel data reduces the fixed pattern noise (FPN) that manifests itself as a snow-like shade over the image.

The signal of the active pixel has non-uniformity caused by technology variations of the components which make up the pixel. If no precautions are taken, FPN causes poor video signal quality.

During the readout of pixels, sw1 and sw2 are closed, and sw3 and sw4 are open [see diagram]. Gate voltage M will be regulated by the charge/discharge capacitor C, until the current through the drain of M is equal to the current source I. During and after reset, sw1 and sw2 are

*CMOS image sensor offers CCD quality.*

open, and sw3 and sw4 are closed. The output signal is now equal to the difference between the pixel signal and the reset level, and does not contain any device non-uniformity. The other large drawback with the CMOS sensor is the fill-factor.

Because PiN diode arrays require a significant surface area for the read-out circuitry, this limits the number of pixels and hence the resolution of the sensor. Light that falls on to the read-out circuitry is effectively lost.

The solution is to place an electrostatic barrier between the photosensitive area and the readout circuitry. Using this method, electron hole pairs generated in the electrostatic barrier (area beneath the read-out circuitry) diffuse sideways into the substrate and are collected there. With photo-generated charge being collected from the whole pixel, it should now be possible to reach a 100% fill factor, with 2000 X 2000 active pixel sensors arrays being possible.

**Imec's chopper amplifier is used to lower the fixed pattern noise of the active pixel array**

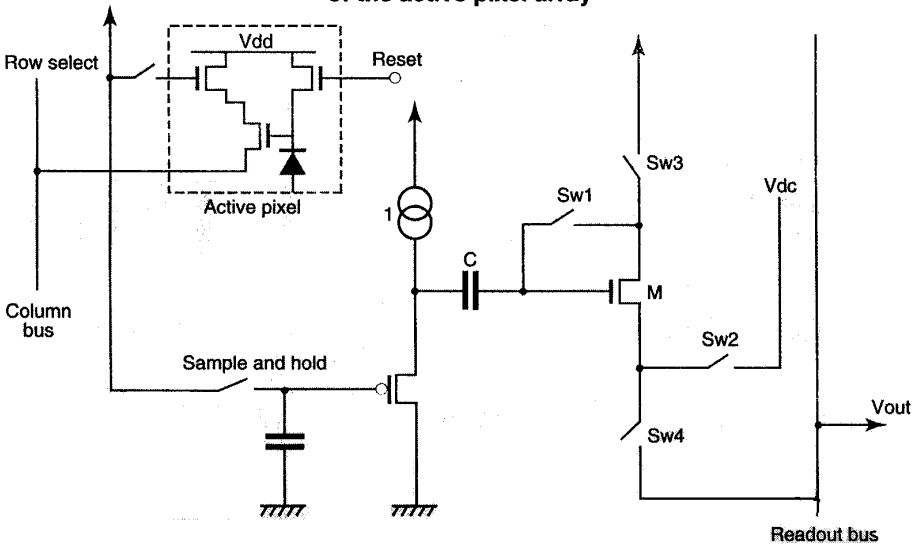

*Reprinted from Electronic Times, 1<sup>st</sup> December 1997.*

# Sevenside Television Group

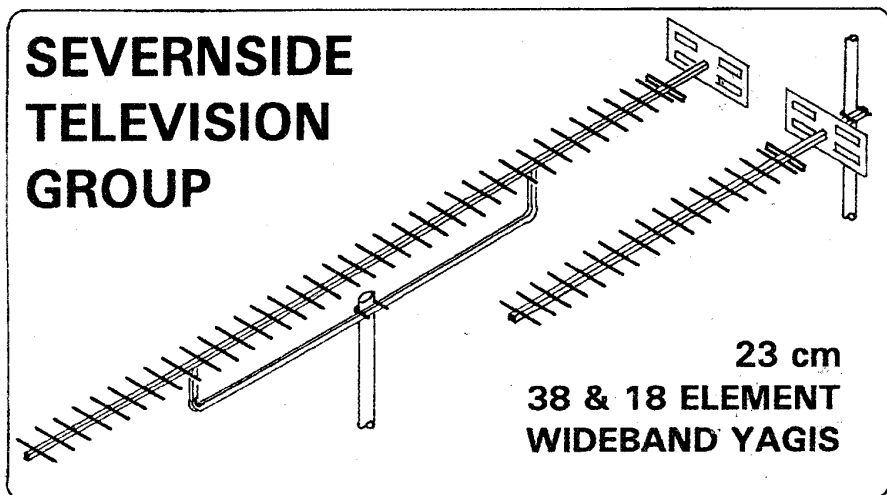

All of our 23 cm Aerials are specifically designed for ATV use - although they can be used for other modes as well. Wideband characteristics mean that you need only one aerial to cover the repeater input and output channels. Our famous wideband yagis come fully assembled in two versions:

**38 ELEMENT HIGH GAIN:** 14 dB gain, 1.8 m long, **£26.00** plus postage.

**18 ELEMENT STANDARD:** 10 dB gain, 0.9 m long, **£15.00** plus postage

Don't forget our **20 ELEMENT CONVERSION KIT**, which converts your existing 18-element aerial to the full **38-element** high gain specification: **£13.00** plus postage. Our 23cm **TROUGH REFLECTOR** is quite unique, combining 11dB gain with wide bandwidth *and* wide beamwidth. It's also compact, just 0.55 m high, 0.35 m wide and 0.3 m deep. Supplied as a kit of predrilled and preformed parts for easy "Screwdriver" assembly: **£19.00** plus postage. All aerials feature an SWR of less than 1.5:1 and are supplied with mast clamps suitable for masts up to 55mm diameter. Mast poles shown are not supplied.

**POSTAGE:** **£3.75** for one aerial, **£5.00** for two or more. Telephone orders with cash on delivery: **£2.75** supplement per order, Orders from outside of the UK - please write for carriage quotation.

**CHEQUES** payable to "SEVERNSIDE TELEVISION GROUP" and send to 18, Linnet Close, Patchway, Bristol BS12 5RN. Telephone (evenings and weekends only please) 0117 969 8136. Please allow 28 days for delivery.

By Paul Holland G3TZO

As we look forward to another year the shape of events to come is looking even more predictable. There are few if any new analogue channel launches to report, but the rate of launches for digital services is almost too fast to keep up with. This year will almost definitely see the largest number of new channels launching for the UK and other European countries than in any year previously. The launch of new satellite TV channels will be also be accompanied by new data and audio services with the prospect of high speed internet access and CD quality audio. All these changes indicate that the writing is on the wall for analogue delivered services, although it is likely that the majority of existing channels will survive for a few more years to come. This expansion of digital services will be accompanied by an accelerating introduction of new technology aimed at receiving the new services. Satellite TV News will as usual keep you abreast of all that is happening as events unfold !

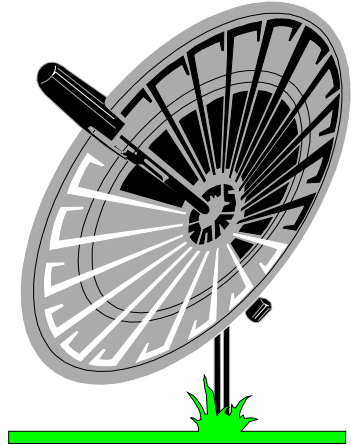

## Launch News

The table below illustrates that the number of satellites being launched continues to grow. Nearly all these satellites will carry digital services for both DTH and business applications. The most significant launch for the UK will be Astra 2A which is to carry the proposed 200 channel service from B-Sky-B and other UK broadcasters.

### Eutelsat W4

Eutelsat has signed a contract with Aerospatiale for a fourth satellite (to be called W4 ) in the W series to be operational at 36 degrees East from early 1999. It will be one of a number of Eutelsat satellites at 36 degrees East including TDF2, which was due to commence service at this position late last year, and the new SESAT satellite which will go into service in early 1999. Equipped with 32 transponders and including in particular a

steerable beam, W4 will mainly be used with fixed beam coverage over Russia for analogue and digital television transmissions by a private Russian broadcaster with the agreement of the Russian government.

<b>Satellite</b>	<b>Date (all 1997)</b>	<b>Position</b>	<b>Launcher</b>
Intelsat 804	1st Qtr 1998	29.9 Deg W	Ariane
Astra 2A	Jan 1998	28.2 Deg E	Ariane
Nilesat 1	Feb 98	7.0 Deg W	Ariane
Hot Bird 4	Feb 98	13.0 Deg E	Ariane
Eutelsat W1	Mar 98	10.0 Deg E	Atlas
Intelsat 806	Apr 98	40.5 Deg W	Atlas
Hotbird 5	May 98	13.0 Deg E	Ariane
Thor 3	Aug 98	1.0 Deg W	Delta 2
Sirius 3	Aug 98	5.0 Deg E	Ariane
Amos 2	Mid 98	4.0 Deg W	TBA
Astra 1H	Nov 98	19.0 Deg E	Proton
Eutelsat	Jan 99	36.0 Deg E	Proton
Astra 2B	Feb 99	28.2 Deg E	TBA
Turksat 2A	1st Qtr 99	42.0 Deg E	TBA
Arabsat 3a	1st Qtr 99	26.0 Deg E	Ariane
Eutelsat W4	1st Qtr 99	7.0 Deg E	TBA
Hispasat 1C	4th Qtr 98	30.0 Deg W	TBA

**Astra 2A**

Astra 2A was to be launched about the time you read this into the new ASTRA orbital position of 28.2° East and has been built by Hughes Space and Communications International. The new satellite is an upgraded HS 601HP model similar to Astra 1G and 1H with an xenon ion propulsion system, called XIPS, for orbital control. Astra 2A will have 28 active Ku-band transponders (32 for the first five years) operating in the Broadcast Satellite Service frequency band (11.7-12.5 Ghz) and is powered by 100-watt travelling-wave tube amplifiers. The HS 601HP satellite is a high-power version of Hughes' successful body-stabilised design. It uses gallium arsenide solar panels to generate more than 6 kilowatts of payload power.

**Astra 1H**

The next satellite to be placed at 19.2 Deg E will be Astra 1H which will provide full back-up for Astra 1E-1G, as well as 2 Ka-Band transponders for two-way communication. Astra 1H will be launched later this year and will carry the first commercial Ka-band payload technology ordered by SES. Ka band is being used with the objective to optimise the use of frequency spectrum from the same orbital position. The two transponders in Ka-band will operate in the 18.8-19.3 GHz downlink band and use the

29.5-30 GHz uplink band. The Ka-band payload will allow SES to launch services for point-to-point or point-to-multipoint interactive applications across Europe.

### Sirius 3

The first available footprint chart for Sirius 3 which will launch this Summer is shown below.

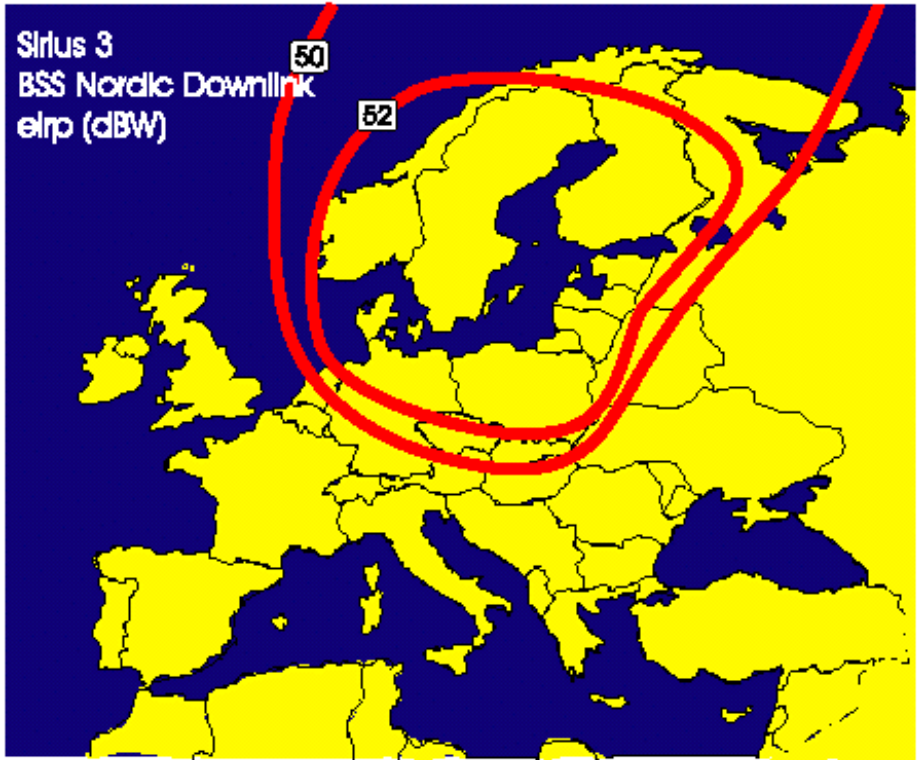

### Amos 2

Amos 2 is reported to be presently testing in Israel and should be launched in the middle of the year. Polarisation of the Israeli and Central European beams will be opposite to the present Amos-1 with horizontally polarised Tp's for the Middle East and vertical Tp's for Central Europe. Amos 2 has been built by Israel in co-operation with a Hungarian contractor and will be co-positioned with Amos 1 at 4° West. Amos 2 already has bookings from Duna TV (from Eutelsat II-F3) and the domestic channels TV 1 and TV 2. One Tp is reserved for radio transmissions, including the foreign service of Radio Budapest. The satellite will have 10 35 W Tp's (8 active)



with linear polarisation and footprints with an EIRP of 55 dBW across Europe and the Middle East (54 dBW). Each Tp has a bandwidth of 36 MHz and can be used in the Ku band ranges from 10.95 to 11.20 and 11.45 to 11.70 GHz.

### **Hispasat 1C**

Hispasat has ordered another satellite from France's Aerospatiale. Hispasat 1C will be used to transmit all-digital TV channels on 24 transponders to Spain and Latin America and will be located at 30.0 Deg W. The launch vehicle for Hispasat has still to be decided upon.

## **Digital Receivers**

SGS-Thomson Microelectronics and BSKyB have announced that they are collaborating to create a development environment that will allow digital receiver manufacturers to commence mass production in Spring this year to support the launch of BSKyB's digital satellite TV service. SGS-Thomson will develop a complete hardware and software reference platform aimed at significantly reducing the time to market for receiver manufacturers. The first customers for the reference platform include the 4 manufacturers already announced by BSKyB. SGS-Thomson will supply chips for all of the major receiver functions, including the 32-bit microcontroller (ST20-TP2 and TP3), the MPEG-2 decoder (STi3520L), the PAL/NTSC encoder (STV0119), the link/tuner interface (STV0199), the front panel microcontroller (ST7) and will also include support for the NDS conditional access technology. In addition, the reference design will use SGS-Thomson memory components, including serial EEPROMs and flash memories. The software for the reference design is also being developed by SGS-Thomson, in co-operation with OpenTV Inc., and will provide support for all of the hardware components. SGS-Thomson also intend to use the same reference platform as the basis for its own Digital Terrestrial Decoder reference design, thus assisting the achievement of interoperability between Digital Satellite and Digital Terrestrial platforms.

## **Recent Launches**

### **Sirius 2**

The opening of services on the new Sirius 2 satellite was gathering pace as we closed for press with Sweden's Kanal 5 and TV8 the first to appear on 12.476 Ghz (V) and 12.207 Ghz (V) both in clear PAL. The Sci Fi Channel/EBN launched in D2Mac on 12.322 Ghz (V) in Eurocrypt. Swedish Television's SVT Europe started transmissions on 12.380GHz (in MPEG-2 -- SR 27500, FEC 3/4, encoded in Viaccess) in mid December. About 90 percent of Sirius-2 capacity is now already booked. The satellite which Sirius 2 replaces, Tele-X, will be removed from service as soon as

Sirius 2 is fully checked out in orbit. Sirius 1 (the former Marco Polo bird) will remain in service until early 2000 but according to reports will have to be moved in August 1998 to make room for Sirius 3. Sirius 1 will then either be used by NSAB at another orbital slot or will be leased to someone else. The transponder plan for Sirius 2 is given below;

**NORDIC BEAM EUROPEAN BEAM CENTRAL BEAM**

11,747 V 11,727 H 12,604 V  
11,900 V 11,767 H 12,646 H  
12,092 V 12,073 H 12,646 V  
12,130 V 12,111 H 12,687 H  
12,169 V 12,149 H 12,687 V  
12,207 V 12,188 H 12,729 H  
12,245 V 12,226 H  
12,283 V 12,265 H  
12,322 V 12,303 H  
12,360 V 12,341 H  
12,399 V 12,380 H  
12,437 V 12,419 H  
12,476 V 12,456 H

**Astra 1G**

Astra 1G was successfully launched into geostationary orbit by a Proton 1-D-e launcher from the space station at Baikanur in the former USSR in early December. The rocket took off as planned at 23.10 UK Time. Astra 1G will be located at 19.2° east alongside Astra 1A-1F. Astra 1G is an HS 601 HP type spacecraft carrying thirty-two active transponder equipped with 98-watt travelling wave tube amplifiers providing digital programming to Europe, as well as back-up for Astra 1F. Astra 1G is the seventh satellite in the Astra constellation to be co-positioned at 19.2° East.

The transponder plan for Astra 1G is given below

Tp 105: 12.51525 GHz H  
Tp 106: 12.52200 GHz V  
Tp 107: 12.54475 GHz H  
Tp 108: 12.55150 GHz V  
Tp 109: 12.57425 GHz H  
Tp 110: 12.58100 GHz V  
Tp 111: 12.60375 GHz H  
Tp 112: 12.61050 GHz V  
Tp 113: 12.63325 GHz H  
Tp 114: 12.64000 GHz V  
Tp 115: 12.66275 GHz H  
Tp 116: 12.66950 GHz V  
Tp 117: 12.69225 GHz H

Tp 118: 12.69900 GHz V

Tp 119: 12.72175 GHz H

Tp 120: 12.72850 GHz V

Early reservations for ASTRA 1 G include; 2 Tp's for ARD, 1 Tp for ZDF, 1 Tp for Canal Satellite Espana, 2 Tp's for Canal + Niederlande and 1 Tp for the German DF1 service. Tp117, 12.692 Ghz will be used by ORF Austria/SRG Switzerland.

The footprint chart for Astra 1G is reproduced below.

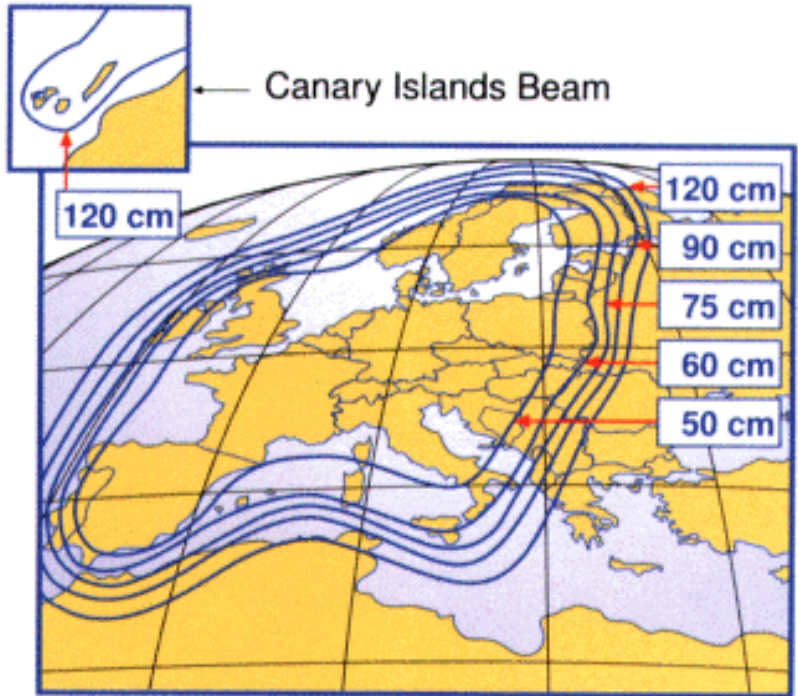

## New Channels

**Thai TV5** are launching a global TV service which will consist of 8 hours of programming repeated 3 times, to cover the whole 24 hours. The European service will be downlinked via EUTELSAT Hot Bird 1, 13 Deg East in MPEG2 SCPC format. The service was due to start on January 1st

**SCT** the Italian adult channel has started a digital package on Hot Bird 3 on 12.149 Ghz (V) with 3 "thematic channels". The digital service is in addition to its analogue service on Hot Bird 2, Tp 63 11.977 Ghz (H)

which is encrypted in 'Ping-Pong'. Reception of the digital service will require an MPEG-2 compliant receiver with an additional NS1 decoder connected to the Scart socket of the receiver.

**Eros TV**, another French adult service, was due to launch as we closed for press. Testing was observed on Eutelsat II-F3, 11,575 V in early December. The service will encrypt in Eurocrypt using D2MAC if it gets on air.

**New Italian Channels.** The Italian pay-TV network Telepiù will add new thematic channels to its digital platform D+ during this year. In January, the third CineCinema channel is expected to appear, followed soon after by Classica (a classical music channel) and finally at Easter, the Italian version of the Disney Channel is set to launch. Telepiù D+ package will continue to be transmitted in the Simulcrypt conditional access system, enabling viewers both with Irdeto and Seca digital boxes to receive the service. Italian state television RAI will launch three or more new channels which will join the already existing thematic channels RaiSat 1-3. There are reports of a news channel, a religious channel, a Parliamentary channel and a "Gold" channel which would transmit the best programs from RAI's extensive program archives. People wanting to subscribe to the Telepiù D+ package can either lease a digital receiver/decoder (at the cost of 14 DM a month) or buy a digital box, which costs more than 1,000 DM. Those viewers who only want to receive the free-to-air RAI and Mediaset digital channels can buy a digital box (without a CAM) costing between 750 and 1,000 DM.

## Transponder News

Just a few brief notes on just some of the changes to be observed on satellites visible throughout most of the UK. (NB minus sign equals West - precise orbital positions courtesy The Satellite Encyclopaedia)

### **-27.48 INTELSAT 605**

Despite Intelsat reporting an "anomaly" on its Intelsat 605 satellite previously at 24.5 Deg W the satellite has apparently been moved here to replace Intelsat 803 which has relocated to 21.5 Deg W. Intelsat had originally reported a deficiency of telemetry causing the satellite not to send attitude control information and which could have affected Intelsat's ability to monitor the satellite in a normal operational manner. This may be only a temporary move as Intelsat plan to locate a series 7 satellite at this position eventually. WorldNet has left 3.742 GHz in PAL, and is now in MPEG-2 on 3.715 GHz, East Hemi beam. CFI Afrique has moved from 3.910 to 3.886 GHz. Music Choice Europe in MPEG-2 has switched from

11.609 to 11.631 GHz. The South American package has moved from 3.889 to 3.924 GHz.

### **-0.99 INTELSAT 707**

Estonia's TV1 has started here on 11.014 GHz in clear MPEG-2

### **-0.76 THOR 2**

When Norway's new Thor 2 satellite began operation recently there was surprise that the polarisation on the various transponders was the opposite of what had been publicised before launch. Now "Aviation Week & Space Technology" reports that a wiring error in the antenna waveguides lead to reversed polarisation, an assembly mistake that was not caught in testing.

### **13.01 EUTELSAT 2F1**

A new German religious TV-channel called EWTB launched here in December on 11.678 Ghz (H) in MPEG2 clear.

### **13.16 HOTBIRD 1**

The Polish Tylko Muzyka can now be seen here on 11.457 GHz in clear MPEG-2.

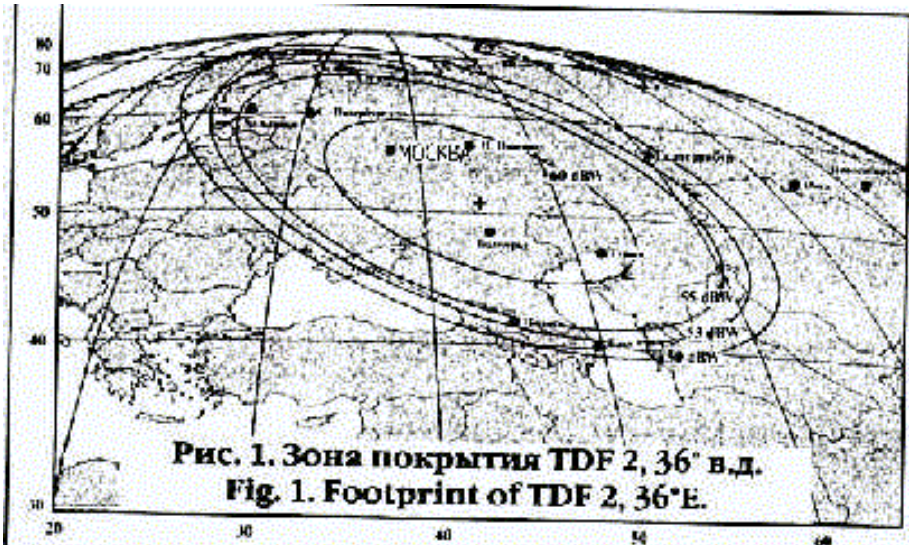

### **13.27 HOTBIRD 3**

Free Iranian television channel, Jaam-e-Jam TV Network, has begun in clear PAL on Hot Bird 3, 12,437 H. The channel appears to be a "best of Iranian terrestrial TV" channel, and is operated by the national broadcaster IRIB.

### **19.22 ASTRA 1C**

A new educational channel called Der Bildungskanal has replaced Sportmania on Tp 32, 11.686 (V) in clear PAL.

### **19.23 ASTRA 1D**

Phoenix has replaced Minimax and Documania on Tp 36, 11.009 (V) and the German channel Hessen Fernsehen has replaced Cine Classics on Tp 40 11.068 (V). Both channels are in clear PAL.

### **27.58 ASTRA 1F**

TW1 the new tourism and weather-channel from ORF is on 12.168 Ghz (V) in MPEG2 clear.

### **41.67 TDF 2**

TDF-2 was observed to be in operation from here in mid December rather than the published Eutelsat position of 36 degrees East. Russia's NTV and Detskij Mir (The Children's World) are testing on 11.881 GHz in Syster-encoded Secam, sound 6.80 MHz, at around 10:00- 15:00 hrs Moscow time. A rather poor reproduction of the new footprint is shown below with the beam centre on Moscow.

## **Intelsat News**

Intelsat have announced that an Intelsat 7 series craft will eventually be placed at 27.5 Deg W. Intelsat 601 has replaced Intelsat 603 at 34.5 Deg W. Intelsat 603 is moving to 24.5 Deg W to replace Intelsat 605 which has temporarily moved to 27.5 Deg W.

## **New Russian Satellite - Bonum 1**

Hughes Space and Communications has been awarded its first Russian contract for a telecommunications satellite, launch-vehicle services and ground-station control equipment from BONUM-1. The new satellite, called BONUM -1, will be an HS 376 high-power model satellite and will provide digital direct-to-home television services to the western part of Russia. The satellite is scheduled for delivery in-orbit in November 1998 and will be launched on a Boeing Delta II launch vehicle. BONUM-1 will contain eight active Ku-band transponders, which, as a result of digital compression technology, will be capable of providing up to 50 channels using 75-watt travelling wave-tube amplifiers. It will be located at 36 degrees East longitude and will have a service life of 11 years.

## Satellite Software

**AcuSat** . Those who like playing with new software may wish to try AcuSat which is a new software program for Broadcast TV, SNG, Ku trucks, Satellite Dish installers and DBS owners. It computes Elevation/Azimuth look angles for geostationary satellites and comes with a database of 130 satellites and 500 world-wide cities. All of the databases are fully customisable. What sounds rather interesting is that the program (Windows 95 or NT 4.0 only) takes magnetic azimuth bearing into account, so there is no need to consult maps and input magnetic variations. AcuSat automatically computes individual site values and determines elevation and compass bearings. Key features include;

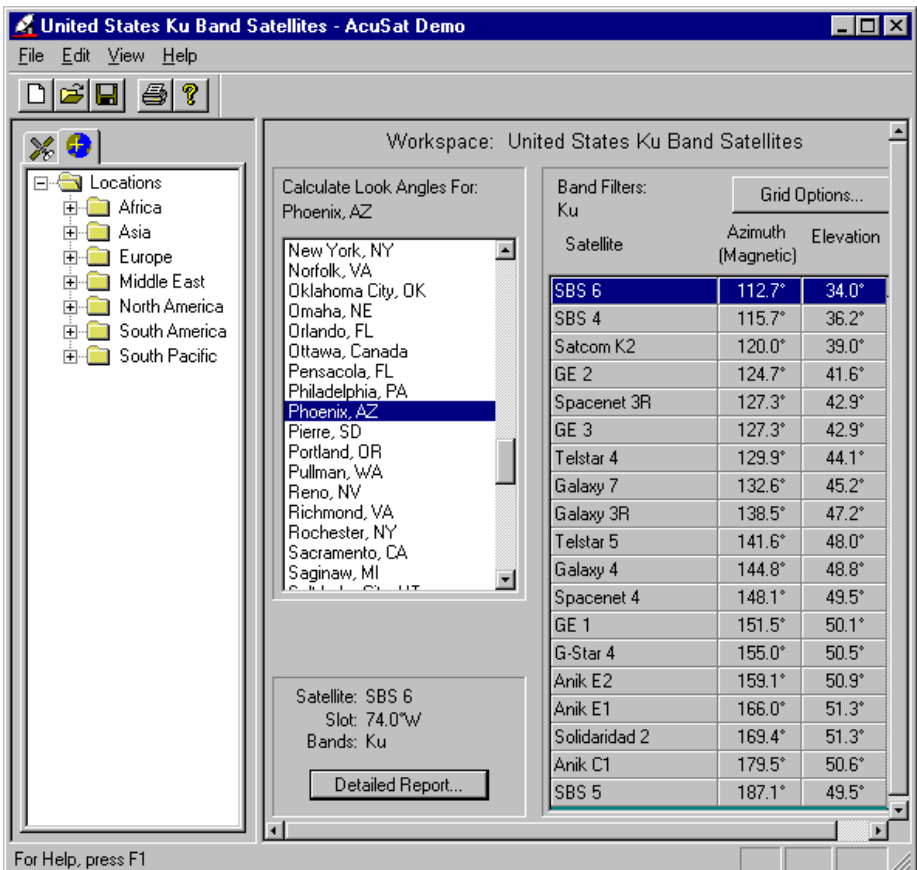

A screenshot taken from AcuSat

- Instant Elevation, Azimuth Calculations for any Geostationary Satellite from any selected Location in the World
- Magnetic plus True Azimuth Calculations
- 32-bit Drag and Drop Editing Features
- Extensive World-wide Satellite and City Database
- All Databases are Fully customisable
- Produces Professional Printed Look Angle Reports
- Context Sensitive Help File
- Fast! Compiled from C++ source code

More information and a demo version (download time some two minutes) is available at <http://www.acusat.com/>

**Satellite Tool Kit (STK)® 4.0** is another satellite system analysis software tool which is available free by download via the Internet (<http://www.stk.com/newweb/product.cfm> ). A free CD ROM will also be sent to those requesting a copy from this the Satellite Toolkit home page. Key features of Satellite Tool Kit (STK)® 4.0 are as follows;

- Propagation of a satellite's position in time;
- Evaluation of complex geometric relationships between orbiting satellites and the earth to determine visibility "footprints;"
- Determination of times one object can "see" or access another object;
- Computation of a satellite or ground-based sensor point angles;
- Presentation of results in graphical and text formats for interpretation and analysis.

The Satellite Tool Kit's Graphing Tool uses the software's sophisticated report properties to provide a

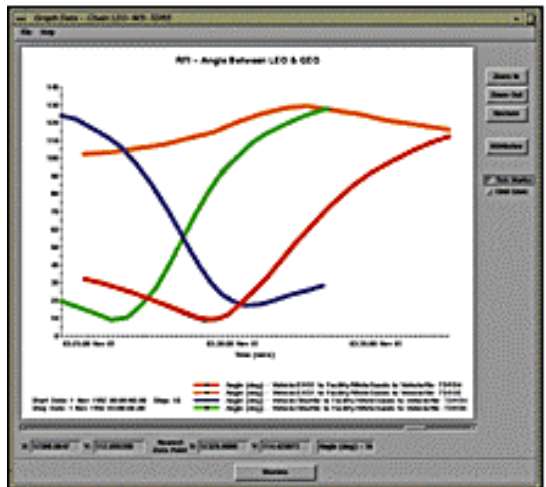



generic graphing capability (see illustration below). You can graph any data in STK on an xy graph. This allows you to visualise relationships among any series of data element sets, seeing either the big picture or zooming in for a refined view of activity over a short period of time. The graph uses vivid lines to represent each set of data elements. In addition, a time bar chart in the graphing tool can be used to provide a picture of access times. The CD ROM is on order for this QTH so I will pass on any personal experiences in due course.

## Conclusion

That's it again for this edition of "Satellite TV News". With no post bag this time around it is difficult to judge if the column is still of interest given that so much of the news is of the move to digital transmissions. Feedback is the lifeblood of a column like this - with no feedback it will fold due to lack of interest. Do write and let me know what you think. As usual I can be contacted by E-mail at [paul.holland@btinternet.com](mailto:paul.holland@btinternet.com), by fax on 01948 770552 or by telephone on 01948 770476.

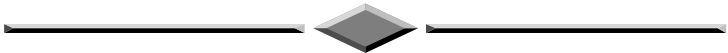

Visit our Web site at [www.batc.org.uk](http://www.batc.org.uk) to view or download electronic versions of recent issues of CQ-TV



# **Sunday April 26th SPORTS CONNEXION COVENTRY**

**Doors open at 10.00 (09.30 for disabled)  
Entrance £1.00 & 50p for OAP and under 14**

**All the usual features of BATC rallies: over 200 trading tables, Bring & Buy, large outdoor flea market, specialist more television displays, ex broadcast vehicles, etc.**

**GB6ATV talk in on S22 and GB3CV (RB9)**

**Full refreshment facilities - licensed bar.**

**All enquiries: Mike Wooding G6IQM**

**Tel: 01788 890365 Fax: 01788 891883**

**email: [rally98@batc.org.uk](mailto:rally98@batc.org.uk)**

## The Location

The **Sports Connexion** lies approximately 3 miles south of Coventry city centre and is at the junction of the A445 and the A423, the full address is: *Sports Connexion, Leamington Road, Ryton-on-Dunsmore, Nr. Coventry*. It is within easy reach of the M1, M6, M40, M42 and M45. The major road links to and from Coventry and bypasses around the city make the location very easy to get to.

For those who wish overnight accommodation in the area the nearest hotel/motel is the Coventry Knight Hotel (01203 301585) which is approximately 2 miles from the venue and is located at the junction of the A45 and the A445.

For those who wish to camp or caravan, as usual the site at the Bull and Butcher (01203 301400) on the A445 1 mile south of the venue is ideal. The pub does excellent meals too - maybe I shall see you there on Saturday night - mine's a pint of Kilkenny's.

Coventry Amateur Radio Society will be providing the talk-in station again on S22 and GB3CV (RB9) using the special callsign GB6ATV. Many thanks to the GB3CV repeater group for allowing us to use the repeater again for this purpose.

There will be a specialist area available in the Banbury Room (adjacent the bar) for anyone wishing to display ATV equipment. If you wish to do this please contact me as shown below to book a table, these are free of charge and only available to members, trading from them will not be permitted. Other specialist groups may also have displays in this area.

Finally, as ever, the usual plea for help. I have to admit that to some extent it actually worked last year! I shall be on site on Saturday from around 1500 setting up the hall and from 0630 on Sunday morning. If you can spare an hour or two on either day please come and help.

If you can help on Saturday please telephone me during the previous week or on my mobile on the Saturday, to confirm the time we can have access to the hall. Thanks in advance!

OK that's it. I hope to see you ALL there. Please come and make yourself known to me and the rest of the Committee.

73 ... Mike

Tel: 01788 890365; Fax: 01788 891883; Mobile: 0468 925351; email: [rally98@batc.org.uk](mailto:rally98@batc.org.uk)

## Create an ATV Transmitter for 1.25GHz

By Jean-Matthieu Stricker F5RCT (F6KFG.fcal.fra.eu)

This television transmitter for the 1.25GHz band enables the amateur to transmit video images. The output power is 10mW and can be raised to 1W by the use of a hybrid amplifier.

Nowadays the reception of FM TV pictures no longer presents a problem. Satellite tuners or the kits for ATV receivers do all the hard work for us. Transmitting at 1.2GHz is a little more tricky, however. The use of surface-mount components becomes obligatory for perfect repeatability in construction. At the same time the links between components and to ground must be as short as possible, to avoid losses. The transmitter presented in this article is frequency-synthesised and requires the minimum of fine-tuning.

### Circuit description

From the video input all the way to the antenna... In frequency modulation we often talk about pre-emphasis and de-emphasis. There's nothing peculiar about these concepts; they just serve to improve the signal-to-noise ratio on reception. In effect, when the received signal gets weaker the noise gets worse, particularly for the higher frequencies. So the idea consists of putting a low-pass filter in the receiver output in order to reduce noise. To compensate for this attenuation and to recreate the original pass-band, we apply the inverse of this filter to the transmitter.

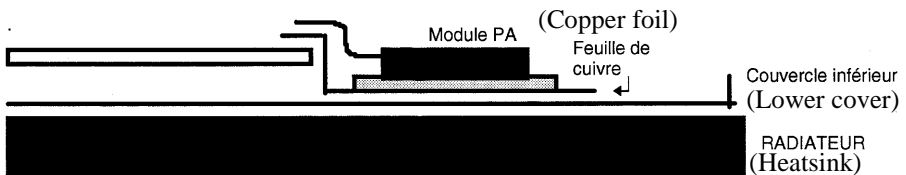

Fig. 1 Mounting the hybrid module.

In the circuit diagram it's the filter at top left (C4, C5, L1, R3, R4, R5 and R6), which is responsible for boosting the higher frequencies. This signal is controlled by potentiometer P3 to FM-modulate the oscillator directly.

To design a stable and reproducible 1.2GHz oscillator is not always easy. The first condition is that we use *exactly* the same components every time around and place them in circuit in exactly the same position and manner.

Surface-mounted components are obligatory. The second call is for a frequency synthesiser which is simple and not heavy in energy demands. The oscillator uses a BFR93A, a varicap diode and a printed stripline.

Numerous tests and simulations have demonstrated that the frequency of oscillation is closely linked to each component and the layout of these components. Output coupling is effected by the collector, so the RF level is perfectly stable, regardless of frequency. Amplifier ERA5 isolates the oscillator and brings the level to 15dBm (40mW). The resistor network R27, R28, R29 separates the signal for the output and the prescaler of the synthesiser. Any attenuation here is compensated by greater stability. If there is any SWR at the output, the reflected signal will be attenuated to the same degree towards the amplifier and the latter will see a larger actual load. The prescaler takes a signal between -5 and +5dBm (approx. 1mW) and divides the frequency by 256. Output power is approximately 10mW (R24=39 ohms) or else 6mW (R24=68 ohms) to be compatible with the hybrid amplifier M67715. One could also use the MAR8 with R24=68 ohms to deliver 1 to 2mW.

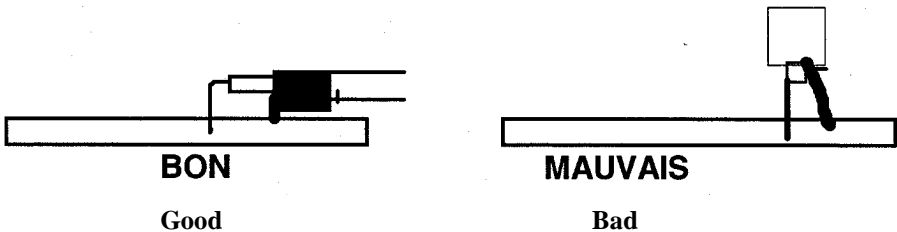

**Fig. 2 Mounting the coaxial cable**

The frequency synthesiser MC145151 used in this circuit is one of the classics of radio. Its parallel programming inputs allow the frequency to be changed easily and absolute precision is not necessary. A few tens of kHz divergence from the nominal frequency will pass totally un-noticed and for this reason there is no frequency adjustment on the crystal. Synthesis is in 0.5MHz steps and the internal comparison frequency is 256 times less than the prescaler. To program a frequency all that is necessary is to remove from the starting frequency the strongest power of division and then from the remainder, cut out the next lower weighting if there is one.

*Example:*

$$1255\text{MHz} - \underline{1024}\text{MHz} = 231;$$

$$231 - \underline{128} = 103;$$

$$103 - \underline{64} = 39;$$

$$39 - \underline{32} = 7;$$

# Create an ATV Transmitter for 1.25GHz

$$7-4=3;$$

$$3-2=1.$$

The weightings of division are obviously powers of 2 – 0.5, 1, 2, 4, 8, 16, 32, 64, 128, 256, 512, 1024. I think you can see the analogy with a balanced set of scales and a box of weights which you put on and take off successively to measure the exact weight. Each weight that you need to keep corresponds to a logic 1, the absence of a link to ground or a DIP-switch in the open (OFF) position. In the contrary situation, a logic 0 becomes a strap to ground or a closed (ON) DIP-switch.

This gives the following table:

1024	512	256	128	64	32	16	8	4	2	1	½
1	0	0	1	1	1	0	0	1	1	1	0

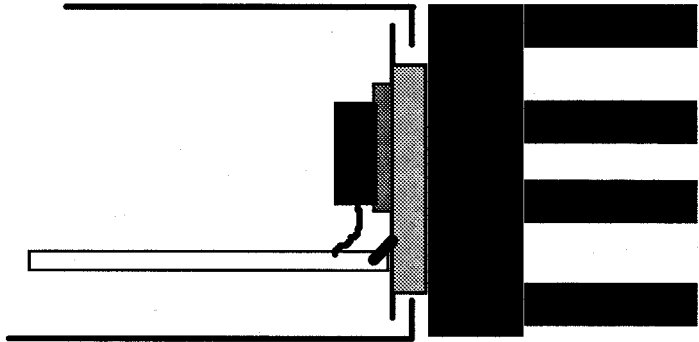
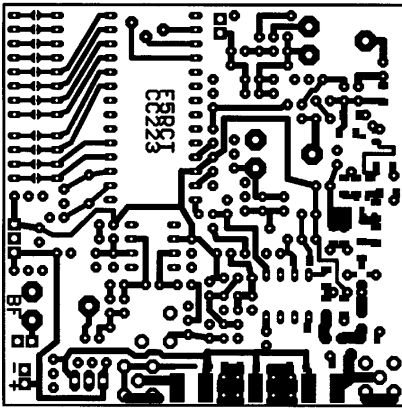

**Fig. 3 Lateral mount for the hybrid module**

At the output of the MC14515 we find a loop filter (R33, R32, R31, C33, C37). You will note that this filter is cleverly arranged so as to inject the video signal across it. To avoid curtain effects at the top of the picture, the time constant of the synthesiser is close to 10Hz. The sound subcarrier is injected directly into the oscillator across R21. The subcarrier level is set by P2, which is preceded by a low-pass filter.

By combining the video with an audio subcarrier of around 5.5MHz (Note: in the UK the audio intercarrier is normally 6MHz and the filter C25,26,27, L4 would need possible alteration as well as the oscillator) compatibility with the transmission mode of satellites is maintained. The audio input level is set in the right proportions by P1 before undergoing a normalised pre-emphasis of 50 microseconds and ten-times amplification. The 5.5MHz is generated by a Colpitts oscillator; the negative temperature

coefficients (determined by C12 and C13) and the diode D5 contribute to the temperature stability of the oscillator.



Component side

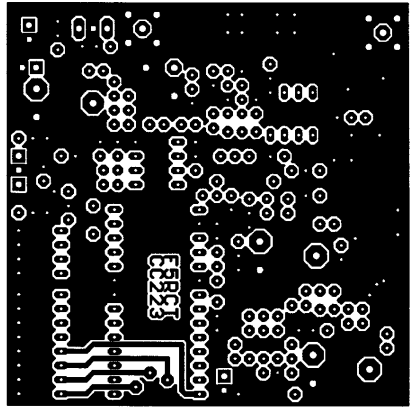

Solder side

## Practical realisation

All the components are available from the well-known French company Cholet Composants, either separately or as a kit. The way the transmitter has been designed means it should work as soon as the last soldered joint is made. With a little care and method, plus some good tools, you should manage this without error along the way. Each time you solder a component, tick it off on the list. Use two soldering irons, one with a fine tip for the surface-mount components and another with a 'screwdriver' tip for classic components.

Start by soldering in the surface-mount components. The best way of doing this is to tin the 'land' on the printed circuit board first, then drop a surface-mount capacitor into place with tweezers, at the same time flowing hot solder into the joint. Then solder the other side. Be warned that the metallisation on the side of these capacitors can easily become detached if the soldering iron is too hot or if it is put under mechanical stress (always apply the iron to the PCB, not to the component). Capacitor C99 and resistor R26 are soldered one to the other (doesn't matter which way round). When fitting C1 and C20 avoid blocking with solder the holes needed for components to be fitted afterwards (finish soldering C1 and C20 when you fit them). Solder transistor Q3, then varicap diode D3 and amplifier U3 proceeding as above. ERA5 is fitted on the solder side; the spot indicates the input.

# Create an ATV Transmitter for 1.25GHz

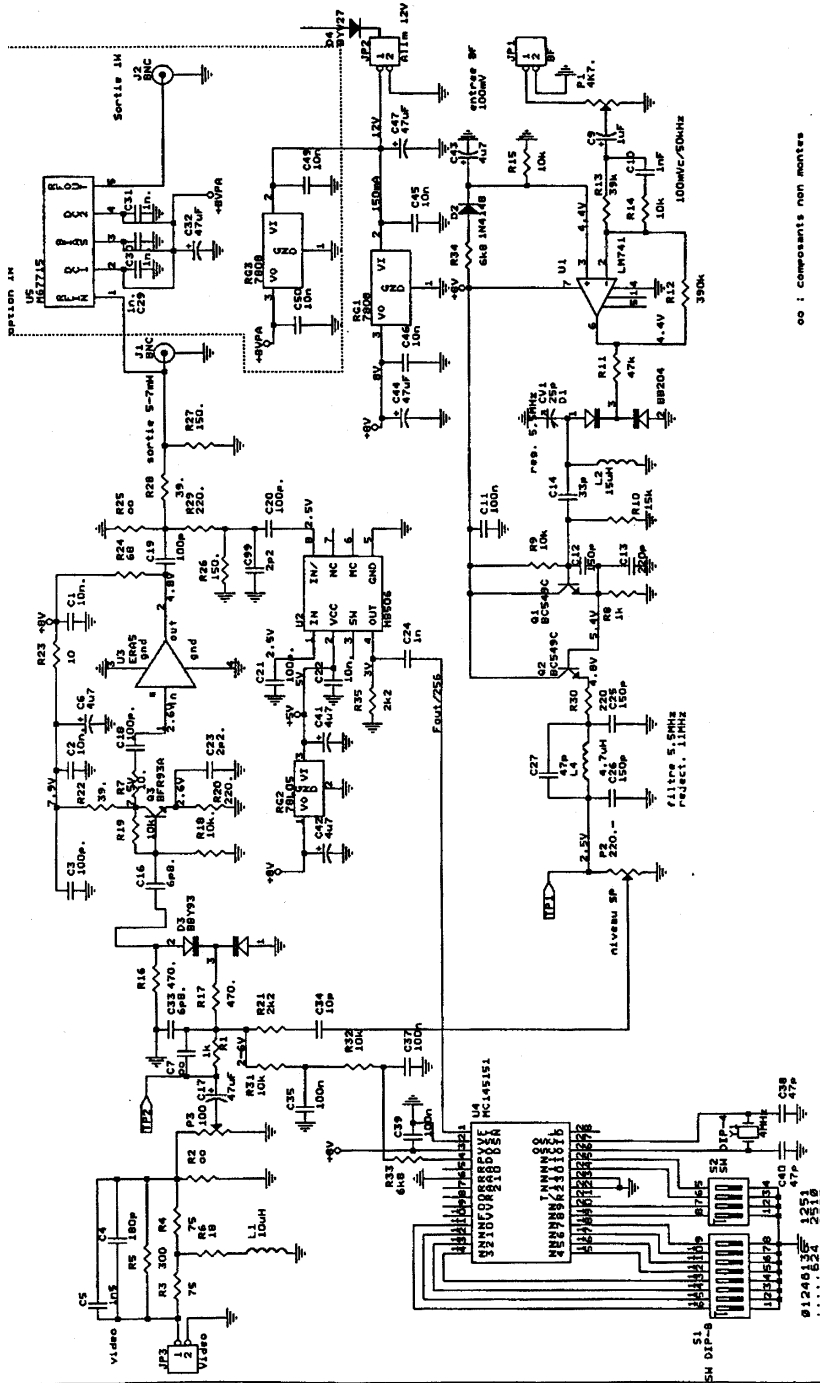

US	MEZZLE
1	2
3	4
5	6
7	8
9	10
11	12
13	14
15	16
17	18
19	20
21	22
23	24
25	26
27	28
29	30
31	32
33	34
35	36
37	38
39	40
41	42
43	44
45	46
47	48
49	50
51	52
53	54
55	56
57	58
59	60
61	62
63	64
65	66
67	68
69	70
71	72
73	74
75	76
77	78
79	80
81	82
83	84
85	86
87	88
89	90
91	92
93	94
95	96
97	98
99	100

oe : composants non montés

1.25GHz : 0=non=00= =002  
 5 RAS de départ  
 0 STRAP au PT de soudure

01240135  
 5...624  
 522  
 1.1.4

US	MEZZLE
1	2
3	4
5	6
7	8
9	10
11	12
13	14
15	16
17	18
19	20
21	22
23	24
25	26
27	28
29	30
31	32
33	34
35	36
37	38
39	40
41	42
43	44
45	46
47	48
49	50
51	52
53	54
55	56
57	58
59	60
61	62
63	64
65	66
67	68
69	70
71	72
73	74
75	76
77	78
79	80
81	82
83	84
85	86
87	88
89	90
91	92
93	94
95	96
97	98
99	100

oe : composants non montés

1.25GHz : 0=non=00= =002  
 5 RAS de départ  
 0 STRAP au PT de soudure

01240135  
 5...624  
 522  
 1.1.4



## Create an ATV Transmitter for 1.25GHz

When soldering the sockets for ICs U1 and U3, take care you get them the right way round. U2 does not need a socket. Next solder the capacitors, not forgetting to tick them off on the list as you do each one. On the overlay the electrolytic capacitors are indicated with a solid rectangle on the negative side.

Varicap diode D1 resembles a small transistor. Connector BNC is pushed into the bottom of its holes and its body is soldered to the ground plane.

Regulator RG1 is also pushed fully home into its holes so that the whole assembly is easily fitted into the tinplate box. If the holes for RG1 are a little tight, they can be opened up with a mini-drill or a broach; the regulator does not need to be screwed to the case.

Fit the ICs LM741 and MC145151 in their sockets and splay their legs if necessary to ensure they fit.

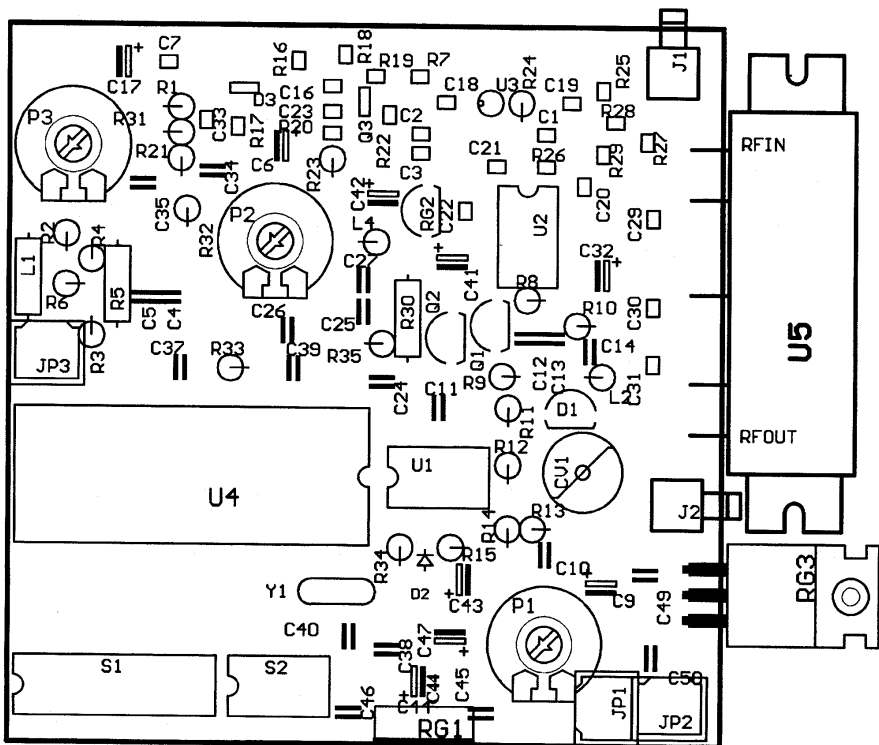

**Component layout (R2 and C7 not fitted)**

Before testing and lining up the circuit make a visual check of your soldering and the correct implementation of all components.

## Alignment

This operation can be done before mounting the PCB in its case. The hybrid module should be fitted after these tests. Before applying power, make one last check and do not forget to solder in diode D4, which protects against accidental polarity reversal. Apply volts and check the +8V and +5V lines. Set all pots to mid-position. Program the MC145151 for 1255MHz by referring to the table and method given earlier. The low weight (0.5MHz) can be found right in the corner of the PCB. The synthesiser should lock in immediately and on a receiver you should see a black screen. Measure the locking voltage between R1 and C17 or between R32 and R33; this should be between 2V and 6V. If you find 0V or 8V, the synthesiser is not locked!

You can check the frequency divided by 256 on pin 4 of MB506. An RF milliwatt meter or an RF detector will indicate the presence of a signal at the antenna output.

Connect a frequency meter on the cold end of P2 and adjust CV1 to read 5.5MHz (*6MHz for the UK*) plus or minus 5KHz. Apply audio and video, then adjust P3 and P1 whilst avoiding saturation. Subcarrier level is adjusted coarsely with P2 up to the threshold point where the sound disappears on a receiver. With a spectrum analyser you can adjust P2 to achieve a gap of 20dB between the subcarrier and the 5.5MHz (*6MHz for the UK*) signal. If you want to maintain compatibility with satellite tuner standards you need to adjust video deviation with P3 to achieve 1V peak to peak into a 75-ohm load on the output.

The cabinet intended for this project is by Schuber and has the dimensions 74 x 74 x 30mm for the 10mW transmitter and 74 x 111 x 30mm with the 1W amplifier (Cholet has a heatsink which fits the larger case). When drilling the side of the case, arrange the hole for the BNC connector so that there is 2mm or 3mm between the solder side and the lower cover. You will also need to drill three holes for the power feed and video and audio inputs. The protection diode D4 is soldered between the feedthrough and the power connector on the PCB.

## From 10mW to 1W

Raising power levels in the 23cm band is not always easy without taking precautions. The hybrid amplifier modules are extremely practical but if you don't pay attention to their groundplane requirements, you risk losing most of the power and destroying them. Always consider the signal path and links as short as possible. But what is ground? If a signal goes from one place to another by the shortest route, this must always be

accompanied by a corresponding ground path – otherwise you are creating a microminiature antenna or a parasitic inductance!

Here is a handy technique for mounting hybrid modules properly without losing the watts.

1. Drop the PCB into the tinplate case, leaving 3mm maximum between the bottom of the tin box and the lower surface of the PCB. Crop all component legs close to avoid short circuits. A small piece of cardboard or sheet plastic will guarantee good insulation.

Cut out some copper foil 1cm larger than the module. Cut out some slots of 7mm to 10mm to enable soldering to the ground areas of the PCB (component side). This will assure continuity of the ground between the PCB and the base of the module.

Place everything on the heatsink and line up the holes of the module for screwing everything together (see fig. 1). You can tap the heatsink or use self-tapping screws. There is no need to cut a rectangle in the tinplate box to let the module butt against the heatsink. The contact surface is ample to transfer the heat to the heatsink.

Heatsink paste can be used between the different surfaces but you need very little on the underside of the hybrid module if you are to optimise contact at the higher frequencies. Regulator RG3 should be well endowed with paste and screwed.

Replace resistor R24 by 68 ohms to drop power to 5mW and avoid overloading the input of the module.

Output connections should be carried out with the same level of care. The PCB has been laid out for a Subclac connector (KMC12) but you could also directly connect subminiature Teflon co-ax cable (RG-316) as long as this is laid flat to avoid ground loops (fig. 2).

In the 1W version the output should be a BNC or N-type connector (again solder the co-ax flat against the edge of the case – cut back some of the Teflon and shorten the centre pin of the connector). It is better to have a co-ax cable 1cm or 2cm too long than a cable that is too short and a ground connection too long (like a pig's tail!).

It is also possible to mount the hybrid module another way. Fit the PCB in a 74mm x 74mm box, either 30mm or 50mm tall. Solder the ground surfaces to the sides of the case and fix the hybrid module vertically. The heatsink is placed against the side, with some 1mm material inserted to allow room for the edge of the covers (fig. 3). In some versions built with this method, it has been possible to double the output power using other modules – 2W of RF with the M67715 and 3.5W with an M57787.

## Component list

C1, 2,22	10nF	R22,28	39R
C3,18,19,20,21	100pF	R16,17	470R
C16,33	6.8pF	R18,19	10k
C23,99	2.2pF	R20,29	220R
C29,30,31	1nF	R7	10R
C4	180pF	R27,27	150R
C5	1.5nF	R1,8	1k
C6,41,42,43	4.7µF 25V	R5	330R
C9,24	1nF	R3,4	75R
C12,25,26	150pF	R6	18R
C13	220pF	R9,14,15,31,32	10k
C14	33pF	R10	15k
C17,32,44,47	47µF 25V	R11	47k
C27,38,40	47pF	R12	390k
C34	10pF	R13	39k
C11,35,37,39	100nF	R23	10R
C45,46,49,50	10nF	R24	68R
CV1	25pF	R30	220R
D1	BB204 varicap	R33,34	6k8
D2	1N4148	R35,21	2k2
D3	BBY93	RG1,3	7080 1.5A
D4	BYV27 2A	RG2	78L05
L1	10µH axial	S1	dip-8
L2	15µH axial	S2	dip-4
L4	4.7µH axial	U1	LM741/TL081
P1	4k7 variable	U2	MB506
P2	220R variable	U3	ERA5
P3	100R variable	U4	MC145151
Q1,2	BC549C	U5	M67715
Q3	BFR93A	Y1	4MHz xtal

The address for Cholet Composants is as follows:-

Cholet Composants Electroniques S.A.R.L. ,B.P. 435, F-49304 Cholet  
CEDEX, FRANCE. Tel: 00 33 2- 4162 3670, Fax: 00 33 2- 4162 2549

Mail order only, credit card orders accepted.

First published in the October 1997 issue of B5+, the magazine of ANTA  
(French ATV Association).

Translation by Andy Emmerson G8PTH - technical writing (and  
translation) is my business. For commercial enquiries ring 07000-405 625.

## Where will ATV develop?

### Translations from TV-AMATEUR 106

#### AGAF collaboration in the DARC VHF/UHF/SHF section.

The previous DARC committee decided already in 1996, to offer AGAF the advocacy of analogue and digital picture transmission within it's V/U/S section. That means also SSTV and FAX besides classical as well as digital ATV. At HAM RADIO 1997 this collaboration has been confirmed by the new DARC committee (DK9HU, DL3OAP and DL9KCX), the head of the V/U/S section (DK2NH) and the AGAF committee.

The following was not published in "CQ DL". To succeed to the ATV repeater co-ordinator Joseph Grimm, DJ6PI (who resigned after a long and successful period of activity in his special field) are Bernard Villwock, DL6XG and as representative Björn-Iwo Schulz, DG0CBP.

Both are members of the BD0HEX team (ATV repeater on Brocken mountain, Harz), and are very experienced in a picture transmission. They should be given all possible support for the difficult task of ATV repeater co-ordination. Until now, unfortunately, this agreement has seen little activity.

#### Channel spacing of FM ATV

At the FM ATV workshop of the DARC V/U/S section in spring 1997 in Bebra it was stated that the IARU FM ATV parameters must be defined correctly considering the actual channel bandwidth of 20 MHz. Therefore a working group – hopefully with AGAF participation – will now develop an FM ATV channel spacing plan from 1240 to 24250 MHz in order to simplify and speed up the co-ordination of repeaters in the future. That also means giving new frequency slots to existing ATV repeaters. The DARC V/U/S section proposed definite channels for transmitting, others for receiving and some more for linking possibilities.

According to the present regulations (in Germany) ATV linking is forbidden, expressly in licence papers of late. On behalf of many ATV repeater sysops the linking possibility should arise in the next issue of regulations (now under discussion). The DARC committee has voted for only local linking in spring 1996. With the provision of ATV channels the V/U/S section has answered the ISM problem on 434 MHz and considered allowing ATV also in the 13 cm ISM range (2400 – 2450 MHz) before it is filled up with commercial applications.

## *Where will ATV develop?*

I shall not comment on the reaction of the DARC coordinator of amateur satellite and space projects (DF5DP). You will not be surprised to see that DARC digipeater co-ordinator Fritz Schaumann, DG1DS, takes the opinion that any linking of different modes – even at mixed mode locations – cannot be approved apart from control purposes. We as television amateurs have a different view, of course, for we are performing an experimental service! It is up to you to participate in the development of the new regulations, use your rights! And to proceed towards a channel plan for ATV between 23 and 1.5 cm we need your provisions too. What is your local situation? Which experiments and modes do you want to integrate into your repeater? What is your opinion on linking possibilities?

## **Monitoring – a different linking method**

ATV repeaters have one or more inputs and outputs possibly on different bands that must be co-ordinated. With real links a remote repeater can be activated without having to contact the local user group. This could lead to rivalry even with existing written definitions about the precedence of links or local usage. The “monitoring” mode can offer an alternative way. Independent of co-ordinated in and output channels you could install additional receiving equipment for the output frequencies of neighbour repeaters. Their activities could be watched as picture-in-picture or full screen without interfering with the local traffic there. If that repeater has similar equipment, it is possible to realise a duplex connection without collision.

Manfred, DJ1KF (2. chairman of AGAF e.V., recently elected chairman of DARC district G)

## **AGAF at HAM RADIO 1997**

Soon after opening on Friday morning our member Alois, DJ8NC, told us of the big attraction at the DARC press conference on the Monday before in Friedrichshafen: a complex ATV live conference on air with operators from all 3 countries around the “Bodensee”, which was covered in newspaper and television reports. At our AGAF stand in Hall 2 we were able to receive the 2m-FAX/SSTV beacon HB9AK from “Hoernli” mountain this year. Our first prominent visitor was Juri, UA9MAR, withXYL Valentina, UA9MIL, from Omsk, where he founded the only world-wide YL clubstation RZ9MYL (many young ladies!) 25 years ago. The AGAF committee got his promise that at his university technical articles from TV-AMATEUR will be translated and spread in Russia.

Furthermore we will give him some help with constructing a (first) ATV repeater in Omsk. Some weeks ago the YLs Linda, UA9MRG, and Monika, UA9MRF, from the club station RZ9MYL were guests at the

home of our script reader Ernst, DF3DP. That was an opportunity for OM Takashi Aoki, JQ1NFY, from ICOM Europe to grant them a transceiver IC-738. More guests at the AGAF stand were DL9KCX, DJ3EO, DL2CH, DL7TZ, OE1RZB, ON4VT, DC0BV, DL6YCL, DJ2NL; all in all 79 friends put their signature into the AGAF guestbook, some 180 fresh smelling TV-AMATEUR copies found their way directly to members passing by, and 14 new members subscribed. At HAM RADIO 1997 we gained Dr. Ing. Franco Segna, IW3HQW, as our new correspondent in Italy after the sudden death of Egidio Rossi, I3AM.

(PS 1: "Repeater" is an independent magazine from the Netherlands dedicated to ATV, issue 3 and 4 have arrived at AGAF recently; its E-Mail address is: HYPERLINK [rulrich@euronet.nl](mailto:rulrich@euronet.nl) [rulrich@euronet.nl](mailto:rulrich@euronet.nl))

PS 2: Good news from Austria, according to OEVSV headquarters and OE3REB their ATV repeaters working above 1 GHz are officially allowed to be linked together now.) VY 73 Klaus, HYPERLINK [DL4KCK@t-online.de](mailto:DL4KCK@t-online.de) [DL4KCK@t-online.de](mailto:DL4KCK@t-online.de)

## **Free Internet Dial-Up Accounts for BATC members**

Caladan Communications, a UK based Internet Services Provider are pleased to be able to offer BATC members free dial-up access to internet e-mail and news services.

Contact Chris Smith (G1FEF) for more details:

E-mail: [sales@caladan.co.uk](mailto:sales@caladan.co.uk) Fax: 01933 777577

Web site: <http://www.caladan.co.uk/batc>

Or write to:

'Free BATC offer'  
Caladan Communications  
35 Pytchley Road,  
Rushden,  
Northants NN10 9XB

## A 3cms 50mW DRO Stabilised GaSFET Transmitter

**By Bob Platts G8OZP**

This novel and simple design provides a high quality ATV TX from a surplus Marconi blue or black cap satellite LNB. The design provides a useful power output level together with the improved stability of a DRO (Dielectric Resonance Oscillator).

The output can, via a co-ax to waveguide transition, feed an antenna directly, or may as in the authors unit, feed a two stage PA (RSGB Microwave committee) which develops about 900mW.

The RF section is based on the modified internals from a Marconi blue cap LNB. These can be found on the surplus market for as little as £1.00. The modulator uses a slightly modified Gunnmod2 TX kit (less Gunn oscillator) to process the video, regulate the supply and process and produce the audio subcarrier signals. *See the advert for Kits & Bits on page 5.* A power supply is also required. This could be built on the artwork provided or on Veroboard.

By drilling remove the rivets from the LNB, then prise open. With an Allan key remove the screws which locate the screening cover. *Once the cover has been removed, common sense static precautions must be employed.*

The PCB must be removed from the case. Cut or unsolder the wire link from the F connector first. Some adhesive secures the PCB. Lift the PCB at the end near the horn antenna, slide a screwdriver or similar object under it and carefully prise the board out.

The local oscillator and the two stage RF amp needs to be cut from the PCB. The lines drawn on Fig 1 indicates where the PCB should be cut with sharp scissors.

Free off the tuning screw, which can be tight due to the sealant used. With a hacksaw, cut out the section of the screening cover that goes over the oscillator to form a screening cover complete with tuning screw.

With a small strip of thin copper or brass foil (this can sometime be found inside the lids of old TV tuners) solder together the two ground planes of the PCBs such that the output line from the oscillator matches up with the input to the amp section. On the topside the output of the oscillator should be coupled to the input of the amp by a surface mount capacitor removed from the unused LNB PCB.



## A 3cms 50mW DRO Stabilised GaSFET Transmitter

Use the capacitor marked Cap A on fig. 1. Carefully unsolder this from the old board. The best way I have found is to apply fresh solder to the joints. Then alternatively apply an iron to each end until they are both molten. Then push the device to one side off the pads. Check the two tracks do not touch each other. If they do cut back with a sharp knife, then solder the cap in position. *Remember static precautions.*

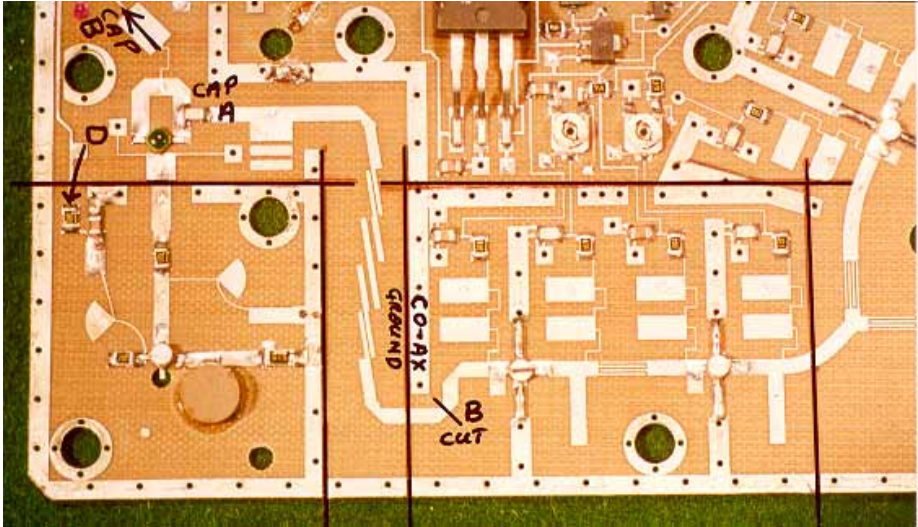

Fig. 1. Lines indicate where the board is cut with scissors. The points mentioned in the text are also indicated.

From the old LNB PCB remove the capacitor marked Cap B. This is off the top of fig. 1.

At the output end of the RF amp cut the track at the point B indicated in fig. 1 and fit the cap across the cut to isolate the output from the FET supply.

The RF output may be by either an SMA connector or via semi-rigid or similar microwave co-ax.

For a SMA the body must be soldered directly to the bottom ground plane.

For co-ax, solder the outer along the top ground track indicated in fig. 1. The exposed inner must be kept as short as possible.

The RF section must be mounted on the copper side of a piece of PCB that is large enough to also accommodate the modulator and PSU board. The Gunmod 2 modulator PCB should be mounted such that the output is fairly close by the supply input to the DRO oscillator.

## A 3cms 50mW DRO Stabilised GaSFET Transmitter

The PSU section should mount on the other side by the RF amp DC inputs.

Secure the RF PCB by means of the three bolt holes available. The same screws secure the screening cover for the oscillator. Also, secure the amplifier section by means of four or five short pieces of tinned wire from the top ground tracks down to the main PCB.

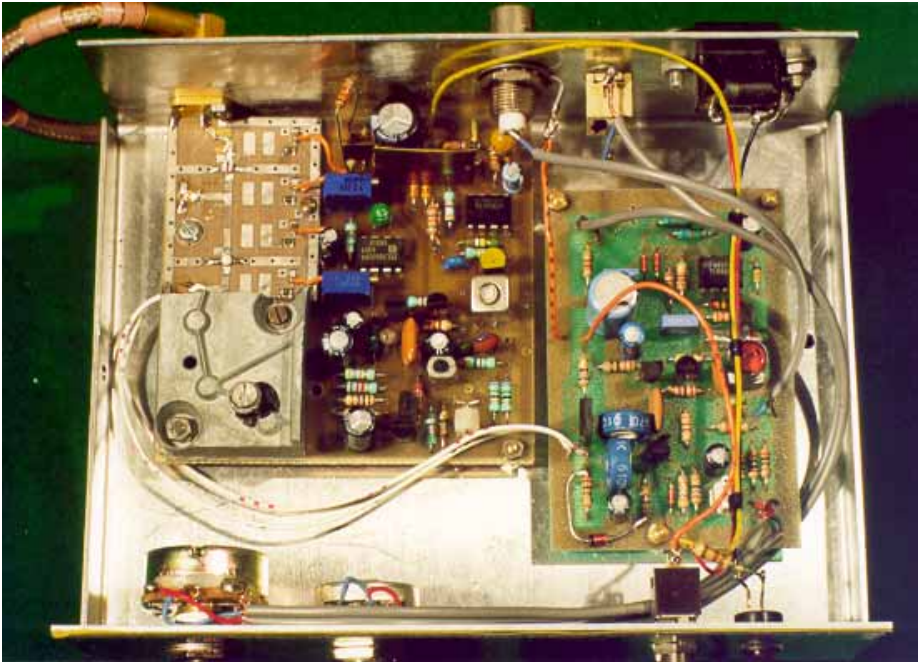

**Fig. 2. Prototype unit. PCB in centre is Mk1, PSU with subcarrier oscillator. In the Mk2 design the PSU is separate and Gummod2 PCB is used as modulator**

Assemble the Gunmod 2 PCB kit, replacing the 3v3 zener ZD1 with a 1N4148 diode. A 4.7v 1.3mW zener must be fitted across the output to prevent the possibility of excessive voltage being applied and destroying the oscillator FET.

The Gunmod 2 peripheral 0 volts track must be connected to the main PCB ground.

The connection from the modulator to the oscillator should be made with fine wire. At the oscillator end make the supply connection onto the FET

### *A 3cms 50mW DRO Stabilised GaSFET Transmitter*

supply decoupling capacitor at point D indicated on fig. 1. A small recess in the screening cover allows the wire to exit from under the screening cover. *Do not make this connection until the output voltage of the Gunmod 2 PCB has first been set.*

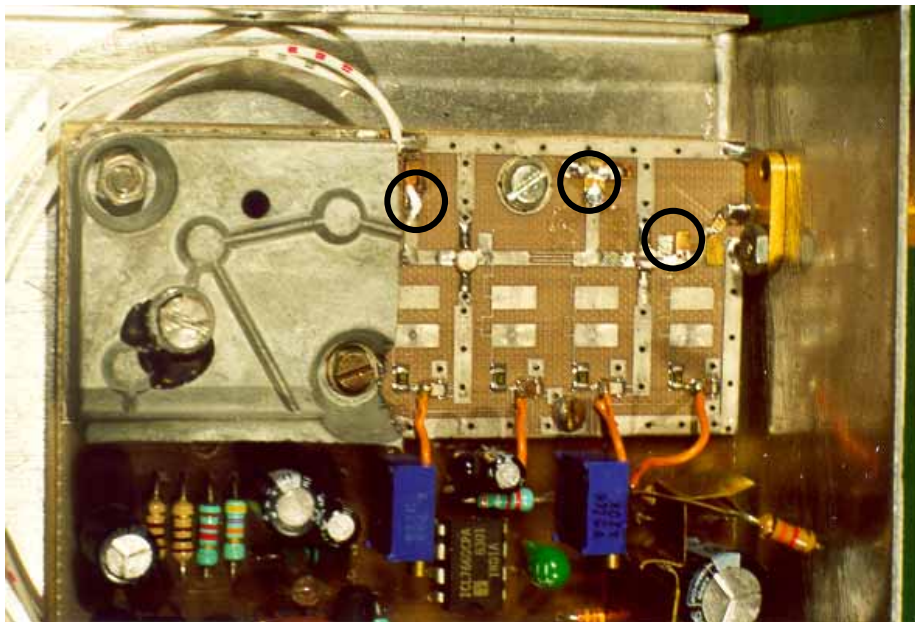

**Fig. 3. Close up of the oscillator and PA showing the position of tuning foils. (Circled). With care, 50mW output can be obtained.**

The PSU can be built on Veroboard. Again ensure a good ground connection. The supply connections are again made with fine wire onto the appropriate supply decoupling capacitor. From the oscillator end these are in order VGI, VDI, VG2, VD2. *Again these connections should not be made until after the PSU voltages have been set.*

SETTING UP. With VR1 (1k) on the PSU, set the FET supply voltage to 4 Volts. Set the two bias voltages by means of VR2 (10k) and VR3 (10k) to 0.5 Volts.

Set the output voltage of the Gunmod 2 PCB to 4 Volts. Other adjustments on the Gunmod 2 PCB are as in the kit instructions.

SETTING UP 2. (Very poor film industry joke)

## A 3cms 50mW DRO Stabilised GaSFET Transmitter

With a suitable load connected to the output apply power and video, adjust the tuning screw on the oscillator for the desired frequency. Advance the video gain control. A picture should be seen on a receiver.

The sound is set up as in the Gunmod 2 instructions.

Some method of monitoring output power is required. An attenuator and a diode detector are ideal. (See various microwave manuals). Alternatively a detector diode held very close to the output may be used. (Take care not to short out to anything)

Small brass or copper foils are required to tune the amplifier section. Fig. 3 shows the sizes and positions. They will need to be adjusted for optimum output. A cocktail stick makes an ideal moving tool for fine adjustment. When the positions for maximum output have been found, solder in position with the minimum of solder. (*Remember anti static procedures*)

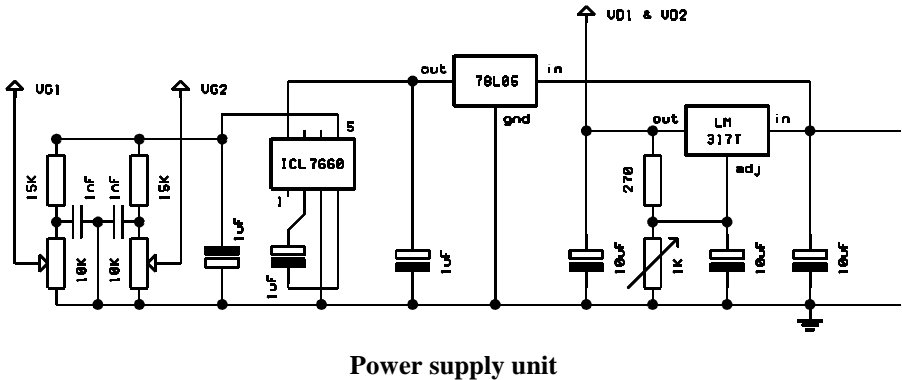

Finally, adjust the bias voltages for max output.

With care and patience an output of 50mW will be achieved.

This design with minor modifications is also capable of transmitting data at rates in excess of 4M-bits/sec. Details can be obtained from the author.

See the advert on page 5 for the address, and send an SAE requesting a Gunmod2 data mod.

## A 23cm TV Transceiver

**By John Cronk. GW3MEO.**

This project resulted from my desire to check out the 23cm repeaters around the country when visiting my family and friends without the need to spend half a day loading my home station into the car before each trip.

It consists mainly of surplus and junk box parts rather than a well considered design. So instead of describing the circuit and construction in detail, quite a lot of which has already been published in CQTV previously, I thought just a few comments on my experiences would be of more interest.

The receiver section (Fig.1) starts with a tuner module removed from a BSB satellite receiver. These receivers were available at rallies for £5, in new condition. The box is marked ITT / NOKIA model 5903. Most of the internal components are LSI custom chips and only useful for their original function, but the tuner, a tin boxed module, marked SXT 014, is ideal for 23cm FM TV receivers.

Briefly the specification is 950-1350MHz with 1-12v on the LO tuning pin (7). The IF frequency is 480MHz, bandwidth 27MHz, the input impedance is 75 Ohms, sensitivity is sufficient without a preamplifier for most applications. However as the input stage is untuned it is wide open to strong RF energy from mobile telephones, UHF TV, radar and other transmitters that are omnipresent on the sites I choose, so a selective pre-amp. is more than a luxury, although there was no problem at my home QTH.

A suitable filter-amplifier is likely to be my next project.

The IF selectivity is due to two L/C band pass circuits that could possibly be narrowed by adjusting the spacing of the small self supporting coils if required. The input socket is a Belling Lee type (not an F type) . I wrenched this off and replaced it with a BNC which can soldered into the hole. The centre pin is internally DC connected via a diode to pin 1 for an LNB power feed, which is also a useful means of powering a pre-amp. So a switch was fitted on the rear panel to allow for the direct use of an aerial that would otherwise short circuit this supply.

The tin box requires 5v (pin4) and 12v (pin6). There is an AGC output (pin8) which is at 7.5v with no signal and reduces on strong signals when the AGC delay is exceeded. This can be used as an S meter connection. As it would make a normal meter work in reverse an edgewise meter could be mounted upside down.



There is an output from a SAB8726 (2.6 GHz±2 prescaler) on pin 5 should it be required. The baseband video from the SL1455 FM discriminator comes out on pin 9, with our deviation about 100mv pp can be expected.

I mounted the tin box with the input socket through the rear panel next to the transmitter output socket, so I can either use two aerials or change one over by hand, thus overcoming aerial relay losses to both the signal and my pocket.

The remainder of the receiver circuit FIG.1 was built on a piece of strip board the same size as the tin box, (72 x 94mm), and then mounted on it.

An IC video amplifier uA733 was used for some gain before an impedance scaled up version of the standard de-emphasis network, then a section of a TEA5114 buffer / video switch feeds the monitor. This changes the monitor between the receiver and camera as the transmitter is turned on.

Another section of the TEA5114 buffers the video from a camcorder or the pattern generator ensuring a 75-ohm source to the transmitter pre-emphasis network.

A TDA1190Z IC is used as the complete sound section. A 10-ohm resistor in the power supply feed (pin 10) will give the output stage a few more lives at the cost of some slight amplitude distortion. An AF input can be made to pin 12 which if linked to the video output can be useful when searching for weak signals and making aerial adjustments when one is out of sight of the monitor.

The tuning voltage required on pin 7 of the tin box is 8v for 1249MHz and 9.75v for 1316MHz. I used a 555 oscillator type stabilised supply, (CQ-TV 175/76) but a simple passive supply will be sufficient if the whole tuning range is not needed.

The transmitter (FIG.2) uses a BLV90 output transistor, I have a couple of these that were available cheaply from a surplus supplier, and this is my sole reason for this choice. Without a data sheet I decided to limit the collector current to 150mA hence the output power 0.6Watt. This has proved to be quite a useful power, though given the choice I expect most people would go for more.

The crystal lock has obvious benefits for portable repeater use but I found a problem with frequency bounce. When switching on the transmitter by means of the 12v supply, the frequency sweeps up and down the band a few times before settling. Carefully selecting the time constant of the negative feedback (pin8 of the SP5060) does help, but the only real cure I can suggest will be to apply the power to the PA, after the oscillator frequency has settled.





All the circuits shown in FIG.2 were accommodated in a 110x72mm module. Most of the parts were mounted on a PCB material ground-plane, the lines (L1--L4) were made from single sided PCB material and then glued in place to preserve the continuity of the ground plane of the transmitter. There is some etching around the SP5060 IC which is a 14pin DIL package, the legs were bent out and used surface mount style. The 20-ohm wire wound resistor is a life saver while setting up the PA and can be left in circuit.

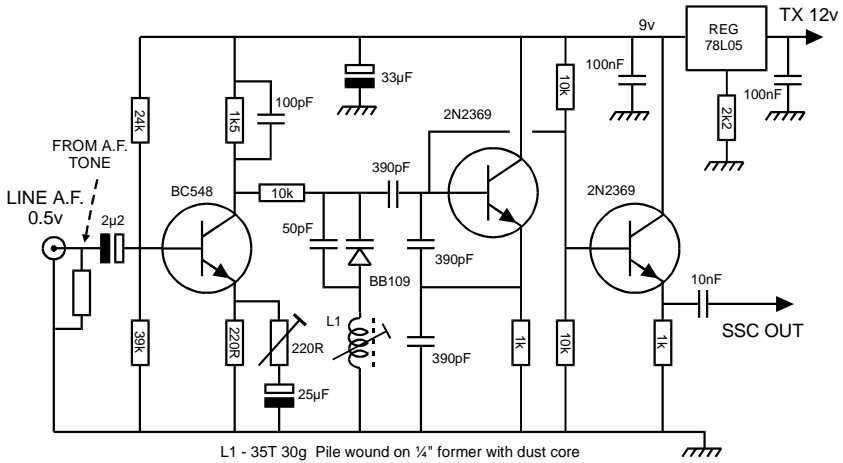

**Figure 3. 6MHz Sound Sub-Carrier Generator**

The sound sub-carrier generator, FIG.3 is intended to be used with the audio output from a camcorder to take advantage of the internal auto-level control (VOGAD), so another gain stage will be required if a separate microphone input is wanted. The use of the VariCap diode in a series tuned oscillator gives plenty of deviation and taking the RF from across the tuned circuit ensures a very good 6MHz sine waveform.

Lastly FIG.4 shows the optional AF tone and greyscale generator. The power for this board is via the same switch that controls the video select voltage to pin12 on the TEA5114. The frequency of the AF tone is determined by the values of C and R, as the same R decides the bias for the transistor an additional resistor can be used to set the current through the transistor.

The 4060B is a binary ripple counter with an extra inverter that can be used as a clock oscillator. It is configured to use an 8MHz crystal but can be rearranged to also use 4, 2, or 1MHz crystals. The capacitor across the emitter resistor of the output stage is to slow down the transitions in keeping with television waveforms. This step waveform displays as a good



## **A Common Date/Time Standard for Amateur Radio - Update.**

**By Ian Galpin, G1SMD, QTHR.**

The details of the proposal having been described in CQ-TV 180 (1997-Nov, Page 9 to 11), several people have now enquired as to how they can best implement the standard in their work.

For software writers: Add the required format to the available options in your software, preferably making the new format the default option. Use it on screen and on printouts, as well as in data storage and interchange. Some UK users may find the change from '25/02/98' to '1998-02-25' or '1998-Feb-25' a bit of a culture shock, at first. However, on a global scale, many people are already comfortable with this format and use it in daily life due to its logical and unambiguous meaning.

Every European country has now implemented the EN 28601 standard (the EuroNorm version of ISO 8601), and the benefits will be best seen on, and soon after, '2001-01-01' (other systems showing '01/01/01' then either '02/01/01' or '01/02/01' the following day, for example).

In America see the ANSI X3.30 standard. A number of American software producers (including several well known amateur radio products) having realised that the '12/31/97' format is often confusing outside of the US, are now changing to the new format in their work; as recommended by IBM and many others.

For computer users: If available, select the 4-digit year, Year-Month-Day, and '24-hour clock' options in all of the software packages that you are using. It is already possible to use the ISO date format on some Amateur Radio computer software. Check the user documentation of the program to see what is available.

Many contest rules already call for entries to use the Year-Month-Day format on any computer generated logs. The Year-Month-Day format is also specified in two recent standards defining Amateur Radio data storage formats. These are the ADIF standard written by WN4AZY and WF1B and the REG1TEST format devised by OZ1FTU and OZ1FDJ. The proposal featured in CQ-TV 180 is intended to extend the usage of this method to computer screens and printouts, Web Pages, email messages, magazine articles and data, even hand-written material (eg on QSL cards).

For DOS users (Version 5.0 or later), add the line 'COUNTRY=086' in the CONFIG.SYS file. Note that the DOS 'DIR' command will still only use a 2-digit year. However, many programs (eg Norton Utilities Ver 4.50

## *A Common Date/Time Standard for Amateur Radio - Update.*

etc) will pick up the new country information and start working in the Year-Month-Day format automatically.

For Windows 3.x and 95, look at the options available in the 'Control Panel'.

In Windows 3.x look at the 'International' Settings. In 'Date', click on 'Change'. In the 'Short Format Date' box, select 'YMD', Hyphen Separator, 'Show Century', 'Month Leading Zero' and 'Day Leading Zero'. In 'Long Format Date' select 'YMD' and using the pull down options select a 4-digit year, 3-letter month, leading zero on the day number, then click on OK. In the 'Time Format' option ensure that '24-hour' is selected, and that a leading zero is shown for digits '00' to '09', then click on OK.

Under Windows 95 (*and NT4 ed*) look at the 'Regional Settings' option. Select the 'Date' tab first. In 'Short Format Date' select 'yyyy-MM-dd' (this will give the '1997-10-11' format in programs). In 'Long Format Date' select 'yyyy-MMM-dd (for '1997-Oct-11') or 'yyyy-MMMM-dd' (for '1997-October-11'). Next, Select the 'Time' tab, and change the format to 'HH:mm:ss' (this gives the standard 24-hour system). At all stages, several options are available in the drop down boxes on screen. If the option that you want isn't listed, just go to the main box where the definition is shown and type the new definition in, in place of the one shown. Finally, click on 'Apply'.

Other operating systems may also allow the Year-Month-Day format to be used. Consult the appropriate operations manual for details.

For editors of magazine columns and features, people writing email or packet messages, collating information, or designing Web pages on Internet: Simply ensure that dates are written in the '1997-08-09' or '1997-Aug-09' or '1997-August-09' format (rather than the ambiguous '8/9/97' or '9/8/97' style) in band reports, rally calendars, events diaries, messages, and so on. Will that date be equally readable to all your readers all over the world? Stop and think before writing something that may be misread by some.

The following people have recently endorsed their support for the proposal to use the ISO date format in Amateur Radio: G8EXV, G0RUR, GM3JZK, G4IFB, N0ED (G3SQX) and G3SEK and will be incorporating this format in their software releases in 1998.

### **Further Information:**

New Scientist (UK) 1997-Nov-08 Page 59 Last Word on Y2K.

- CQ-TV \* (BATC, UK) 1997- November Issue 180 Page 9 to 11.

## A Note from the Membership Secretary

- OSCAR News (AMSAT-UK) 1997-December Issue 128 Page 37 to 40.

- Internet: <<ftp://ftp.funet.fi/pub/ham/misc/g1smd.zip>>.

- Internet:

<<http://ourworld.compuserve.com/homepages/dstrange/y2k.htm>>.

- Internet: Send an email message as follows:

To: [info@arrl.org](mailto:info@arrl.org) Subject: <Leave 'Subject' blank>

In the message text, put the following on 3 separate lines:

Send index.txt send g1smd.txt quit

- Files Y2KHAM-1.TXT, Y2KHAM-2.TXT, and G1SMD.ZIP from your nearest

'CLIVE' server on AX.25 Packet Radio.

You may contact the author by Internet email at:  
[mail://g1smd@amsat.org](mailto:g1smd@amsat.org).

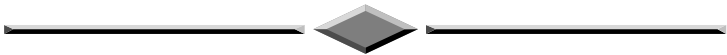

## A Note from the Membership Secretary

Thank you to all those members whose subscription was due in January 1998 and have renewed promptly. If you have not renewed yet, this will be the last magazine you receive.

A membership renewal form has been enclosed with the magazine if your subscription is due. So don't delay, renew today to avoid disappointment (as the adverts say).

<b>One year</b>	<b>£12.00</b>
-----------------	---------------

<b>Two years</b>	<b>£22.00</b>
------------------	---------------

<b>Three years</b>	<b>£32.00</b>
--------------------	---------------

<b>Four years</b>	<b>£40.00</b>
-------------------	---------------

If you are an overseas member, you may wish to pay extra for Airmail service.

See the renewal form for airmail rates. Extra for airmail is only required outside Europe.

# MAINLINE ELECTRONICS

*2 exciting new kits recently added to our catalogue*

## DIGITAL FREQUENCY DISPLAY

A high-quality microcontroller based unit capable of measuring up to 32 MHz as a basic unit, or by preselecting an IF offset by means of a trimpot it can be used as the frequency readout of a Tx or Rx by adding/subtracting the offset from the LO. Also, by adding a suitable prescaler it can be used up to 8 GHz. 16 character LCD display with 100 Hz resolution - e.g. 14.257 MHz USB - the mode display is set by external resistors and can be programmed to show: AM, FM, CW, USB, LSB, FSK, FAX, or can be left blank.

Kit (no case):                      DFD1              £42.46 + VAT

Assembled (no case):            DFD2              £47.20 + VAT

## DIGITAL INDUCTANCE/CAPACITANCE METER

A real breakthrough in L/C measuring equipment at the price. A must for home constructors to help identify components and as an aid to winding coils, etc. At 5 samples per second the unit will also track whilst checking adjustable components. Microcomputer based.

*Once you own one you will wonder how you managed without it!*

Basic specification: 0.001  $\mu$ H to 100 mH (150 mH typical)

0.1 pF to 1  $\mu$ F non-polarised (1.5  $\mu$ F typical)

Auto-ranging and self-calibrating - 16 character intelligent LCD display

4 digit resolution - accuracy typ. 1% of reading - direct display in engineering units,  $\mu$ H, pF, etc. Powered by 9V battery.

Kit inc. box and hardware:LCMKIT£79.00 + VAT

Built and tested (no battery):LCMBLT£94.00 + VAT



P&P free in UK, Overseas extra. VAT is 17.5%



**MAINLINE ELECTRONICS, P.O. BOX 235, LEICESTER,  
LE2 9SH, UK.**

**TEL: (0)116 277 7648/278 0891 FAX: (0)116 247 7551**

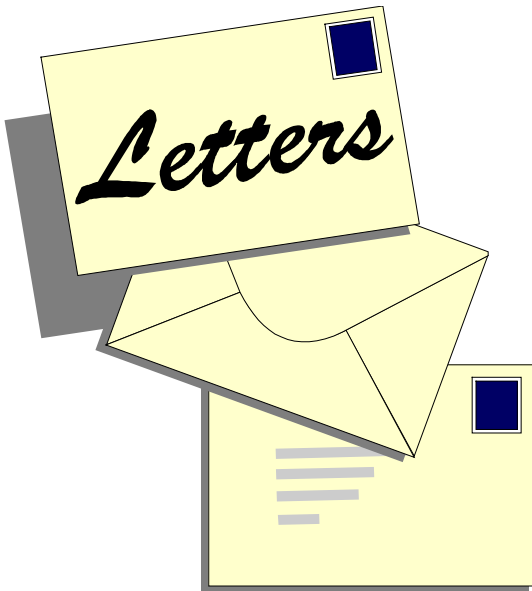

Please send all correspondence for **Post and News** to the CQ-TV Editor. Ian Pawson, 14 Lilac Avenue, Leicester, LE5 1FN, England.

Tel: 0116 276 9425.

E-mail [editor@batc.org.uk](mailto:editor@batc.org.uk)

Members sales and wants should be sent to the editor at the above address.

Trade adverts should be sent to the advertising manager,

Chris Smith,

E-mail [adman@batc.org.uk](mailto:adman@batc.org.uk)

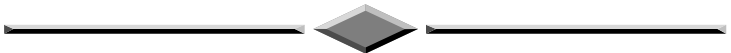

220 Rolleston Road  
Burton upon Trent  
STAFFS DE13 0AY

21/11/97  
Letters to the Editor

Dear Ian

Recently there has been some moaning and groaning about the Radio Society of Great Britain and their apparent attitude towards the ATV side of the hobby. Most of the complaints relate to operation on the 24CMs band. To a greater or lesser extent I agree with many of the comments (and have a few of my own).

However before we get to vocal perhaps we should take a look at ourselves. FM ATV is a wide band mode but some TX equipment and designs I have come across produces signals wider than the proverbial

barn door. There are cases where it is hardly surprising we cause interference and hence make ourselves unpopular.

Take a look at a basic 24CMs TX. Video often simply passes through a pre-emphasis network and onto a varicap on the TX oscillator. Next time you have a scope on, look at what really comes out of a pre-emph network, you may be in for a surprise. All that overshoot often greater than the video itself. Now feed it with electronically generated graphics which can often have video components as high as 8MHz. Oh, and what about the 2nd, 3rd and 5th harmonic of the colour subcarrier!

Audio subcarriers are often run at levels greater than -14db. then start thinking about the 2nd & 3rd etc. harmonics of that.

Now lets add a touch of non-linearity and what do we have. Yes a right mess on the band.

Now start to think about receivers. Surplus satellite units are often used. With the necessary mods to the video amps they can work well, but how often do we hear the request to turn the dead up a bit “your” pictures a bit dim. (I know of one repeater(they now who they are) which provides a reasonable picture on a satellite RX without any mods!).

Lets make sure our deviation is at the recommended 2.5 - 3MHz.

We are not help by the cowboys who use ATV equipment for “security” purposes. (Usually with the deav flat out so they don’t have to bother moding the RX. If you come across signals that are not amateur Follow them up and report it. They could loose us our band.

Lets get our own house in order first. Then we can make a noise with a clear conscience.

PS. Question. How do I now what my deviation is?

Here is an accurate way that only needs a frequency counter, a scope and meter. If your TX is synthesised first disable it. You will need to feed a tuning voltage from a preset to the frequency determining device. Let the TX warm up and stabilise. Monitor the output frequency. Make a note of the voltage that is applied to the device which modulates the oscillator. Alter this voltage (install a preset) and make a note of the frequency shift versus the change in voltage. From this can be established the frequency shift in Volts per MHz. Note the voltage for 2.5MHz shift. Apply 1V PK/PK video and adjust the PK/PK voltage at the modulating device to the voltage required for the 2.5MHz shift. Hey presto your deviation is now 2.5MHz. If the received picture is a bit dim, it’s not your TX that’s at fault.



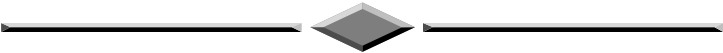

PROMINENT ATV ENTHUSIAST WINS EMMY AWARD Henry Ruh KB9FO, known to many ATVerS as until recently the publisher of ATVQ magazine and a visitor to the BATC convention, has helped win an Emmy award for his employer, television station WSNS in Chicago. Take a bow Henry – this has got to be a first!

The text of the press release reads as follows:

**WSNS CHANNEL 44 TELEMUNDO EMPLOYEES HONORED WITH THE PRESTIGIOUS EMMY AWARD IN INVESTIGATIVE REPORTING AND TECHNICAL ACHIEVEMENT**

On Saturday, November 1st the Chicago Midwest Chapter of the National Academy of Television Arts & Sciences awarded two Emmies to employees of WSNS Channel 44 Telemundo during the 39th Annual Emmy Awards Ceremony held at the Fairmont Hotel.

Noticiero 44 5pm and 9pm news anchor Carla Sanchez was awarded an Emmy for her work on the investigative series “Envio de Dinero: A Que Precio?” a series of hard hitting reports on wire transfer money fraud.

In the technical achievement category, director of engineering Henry Ruh and engineering supervisor Rick Morris received an Emmy for their unique design of WSNS-TV’s “Live News and Production Truck” which is the first and only truck to incorporate state-of-the-art digital editing equipment.

Telemundo 44 was also recognised for its many contributions to the Chicago Midwest Chapter of the National Academy of Television Arts & Sciences.

“I’m very proud of what we can do at Telemundo 44. To win an Emmy in the investigative category which is one of the toughest categories to compete in, reaffirms the capabilities and commitment of our news team and employees,” expressed WSNS station manager David Cordova, “Being awarded an Emmy in the technical achievement category demonstrates our ability to be innovative and resourceful at the same time.”

Telemundo Group, Inc., based in Miami, Florida, is a Spanish-language television network that reaches 85 per cent of all U.S. Hispanic households through its owned and operated stations and affiliates in 57 markets. Telemundo also owns and operates the leading television station and related production facilities in Puerto Rico.

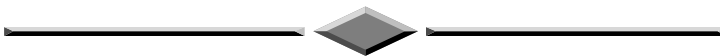

Subject: W3HMS Returning from Swiss ATV Meeting From: [W3HMS@aol.com](mailto:W3HMS@aol.com) To: [midshires@cix.compulink.co.uk](mailto:midshires@cix.compulink.co.uk)

Gentlemen, delighted to report I arrived home late Thursday 23 Oct after a super time at the Swiss ATV meeting near Lausanne on 18 Oct. and QTH visits in France and Switzerland. Lausanne is east of Geneva in the French speaking region of HB9.

I also visited with several hams while there and set up many future contact possibilities with Swiss and French ATVers. I was pleased to dine and visit with Michel and his XYL, Simone, in their home and station. Michel Vonlanthen is HB9AFO and he is the President of the Swiss ATV organization. I was happy to discuss mutual ATV organization issues with him. This was my second visit to his QTH so we spoke of many topics ATV being very prominent.

I was also delighted to visit and dine in the Geneva home of Dr. Angel Vilaseca , MD, and his XYL, Antoinette. He is HB9SLV and he has done much fine work on 10 GHZ; I was pleased to see his shack and film his 10 GHZ projects. He is active, as is HB9AFO, on ATV via the 23/13 cm FM ATV repeater located at Dole not too far from Geneva. I communicate 2-3 times each week with Angel and Michel via Internet. In France, I spent an enjoyable dinner evening with Denys and Sylvia Roussel. He is F6IWF and his QTH is near Reims. We spoke of ATV and many other topics. I had been there in November 1996. Denys is the creator of the method of using modified LNBs for Ku band satellite reception for 10 GHZ reception and for work on DROs for 10 and 24 GHZ.

I also spent two days in the home of Roland and Annette Cornuel, F8MM, and his XYL in the suburbs of Paris. He is the President of the French national ATV association, ANTA . There I got to film ATV ops at 90 miles on 23 and 70 cm simultaneously as well as a QSO 23/70 cm at 18 miles with Marc, F3YX, the father of French ATV. Roland's tower is the local landmark in his small village. The aroma of his local bakery with French bread in the making was heavenly.

The QSO F8MM/F3YX was 70 cm AM and 23 cm FM. Pictures were perfect P-5 closed circuit monitor quality in PAL. Marc has a super video mixer/processor and showed us the received signal from F8MM in a small window on screen plus a VHS film clip in the background with another small box of himself with the mike. He sent the same signal via 10 GHZ FM using 10 mw with the Gunnplexor in his shack. F8MM has an LNB modified and offset dish of about 50 cm mounted at 70 feet on his 74 foot self supporting tower which looks like a miniature Eiffel Tower.

In Europe, signal reports are expressed B1-B5 from the German B for Bild (picture). I saw some really neat 10 and 24 GHz ATV gear at the Swiss ATV meeting and a film of the 434 mile ATV 10 GHz FM world record by F1JSR whom I spoke with and HB9AFO. One of the neatest things was a demo by a non-ham of a lens for 11 GHz made from ordinary plaster. It was 30 cm wide by 6 cm deep in front of the LNB placed on the ground. Pictures were P-5 plus from the European Astra satellite.

The lens follows optical rules and he said improvements are possible in both receiving and transmitting. A P-5 pix is super for a 12 inch device in front of an LNB. The meeting itself was nicely organized starting at 0900 with business till 1000 then time to chat informally/see demos/buy at the small flea-market. Then several videos on ATV progress/events were shown followed by a FB catered luncheon.

I was pleased to greetings from North American ATVer's to the group at the opening and to talk later for about 15 minutes on US ATV operations and our progress on establishment of a North American ATV organization. The afternoon sessions were

all technical and made maximum use of rear TV projection on a large screen for both objects and VHS cassettes. One funny thing.....when I



**F8MMs aerials**

asked Michel, HB9AFO, how I was doing for time, he said look at the screen....there he had written a message that I was out of time!!! The Swiss are great linguists....I saw the German/French translator speaking with folks in French, German and English. I was pleased to talk with him and also to spend several hours with Carlo Lue, HB9MPL, and his wife of Lugano, Switz. Carlo and I can speak quite well together in French both using hand-gestures, HI! All in all, I was just delighted with the marvelous hospitality and courtesy shown to me by all those who hosted me in their homes and to those I met.



**A view of F8MMs shack**

ATVers and their wives are VERY nice people. The chaps in Europe are quite advanced in FM, 10 and 24 GHZ work...I was impressed. Don't hesitate to ask questions which I will answer here on the list nor to use my thoughts in your local ATV newsletters/Home Pages as you may desire. I will speak with John, W3SST, whom I thank for serving as Acting IC Chair. and resume regular growth issues on the list ASAP. 73, John Jaminet, W3HMS Chair, IC. 26 Oct

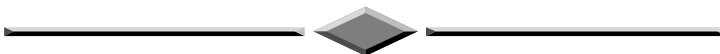

The national organisation that is forming to promote ATV in North America has been working to resolve several administrative issues regarding forming a group of this large size and importance. The group after careful deliberation has decided to name itself: Amateur Television of North America or ATNA for short. ATNA has set up a web page at <http://www.smart.net/~brats/atna.html> to post information about the club, and the organisations progress. In the near future, we will be posting information about membership dues and the organisation's projects for the future.

ATNA's Mission:

1. Protect our ATV interests and frequencies.
2. Use video transmission methods to support public service.
3. Plan for the amateur radio adoption of new technology.
4. Advance the state of the art of video and video transmission methods.
5. Work with Frequency Coordinators as the official coordinating body for Fast Scan ATV in North America.
6. Associate in an equal role with other like minded societies. Our Treasurer has received funds from the following organisations to help start the group:

Donation At CAATN meeting (passing hat) Donation From CAATN  
Donation From BRATS Donation From HATS Donation From Arizona  
Amateurs on Television Inc The total amount in the treasury is now  
\$263.00.

We look forward to serving the ATV community, and I look forward to keeping you informed about the workings and project of ATNA.  
Sincerely, Fred Juch, N5JXO Chairman of Publicity

Officers:

John A. Jaminet, W3HMS (President) [w3hms@aol.com](mailto:w3hms@aol.com)

John H. Shaffer, W3SST (Vice Chairman) [w3sst@juno.com](mailto:w3sst@juno.com)

Harry F. Deverter, N3KYR (Treasurer) [hdeverter@redrose.net](mailto:hdeverter@redrose.net)

Ronald B. Cohen, K3ZKO (Secretary) [ronk3zko@juno.com](mailto:ronk3zko@juno.com)

Fred Juch, N5JXO (Chairman of Publicity) [n5jxo@stevens.com](mailto:n5jxo@stevens.com)

Arthur C. Towslee, WA8RMC [towslee@ee.net.com](mailto:towslee@ee.net.com)

Jim R. Tury, KA4CKI [jury@erols.com](mailto:jury@erols.com)

John O. Hey, W8STB [w8stb@juno.com](mailto:w8stb@juno.com)

## Post and News

Bill J. Brown, WB8ELK [bbrown@hiwaay.net](mailto:bbrown@hiwaay.net)

John D. Hays, K7VE [jhays@hays.org](mailto:jhays@hays.org)

Fred Juch N5JXO (713) 465-0360 13054 Pebblebrook Houston, TX 77079  
[juch@flash.net](mailto:juch@flash.net)

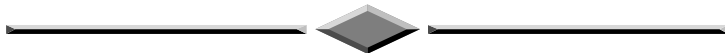

Many readers will remember the name of John Ingham, who was very active on the ATV scene in Australia and took part in an exchange of video tapes with the BATC. Andy Emmerson has recently had an e-mail from John, who writes: "Many years ago the Technical Institute at which I was a student had an old closed circuit TV system donated by Philips which had an Iconoscope camera and Telecine chain. The camera was so insensitive we used to point it out of the window to get enough light for it to produce any sort of worth-while image. One day I went home without capping the lens and when the sun came up next day it burned a nasty track on the mosaic, so we had to replace the tube. I took the old tube home and it still shows the burn as a reminder of my mistake so many years ago!

I am still in video production - and video conferencing - at work but I have ceased activity as a Radio and TV Ham although I still pay my annual licence fee. So there is some hope that when I retire (in about 6 years) I might take it up again. In the meantime I have become interested in video over the Internet and regularly connect with a TV Ham friend of mine in Alabama. We have "ATV QSOs" which would be (and still are) impossible over ham radio.

The local ATV scene is still (I believe) bubbling along, although most of those active are now well into retirement and there is very little real development going on. I thought when I instigated ATV Repeaters in this country that it would lead to experimentation, but alas there are probably as many now really experimenting in ATV as there would have been without ATV repeaters. The rest simple use ATV to yak over test cards and bars etc."

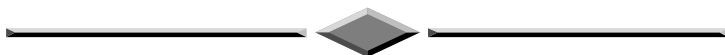

## SSTV News

The TBL Club, well known among French slow-scan circles, is now issuing a bi-monthly club magazine on diskette. Edited by F6AIU, it cost

FF 250 (about UKP26) for an annual subscription of six issues. All subjects of SSTV interest are covered but the emphasis is on circulating shareware programs for SSTV, wherever possible with instructions in French.

Obviously you will need to speak French to benefit from this but you may well make some valuable new contacts in the process.

Information from TBL Club, Rue du Bas, F-70120 La Roche Morey, France (tel: 00 33 3-8941 0455).

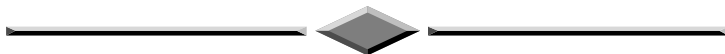

## Email

The following items were plucked from the Internet or sent to me directly as email.

If you have any snippets of news of information, then please send them in to my mailbox.

A SSTV resource is to be found at [ftp://nic.funet.fi/pub/ham/fax\\_sstv/](ftp://nic.funet.fi/pub/ham/fax_sstv/)  
It contains

An illustration showing three silhouettes of people sitting around a computer monitor. The monitor is in the foreground, displaying some text. The background is a light gray triangle pointing downwards.

Directory: /pub/ham/fax\_sstv  
00Index      This file  
(/pub/ham/fax\_sstv/00Index)  
atfax53.zip      Colour SSTV, FAX and weathersatellite programs -  
OZ1AT  
ef110.exe      Easyfax 1.10 FAX reception - IK1IZA  
ezsstv.zip      Easy to use color SSTV reception program v3 - WB2OSZ  
ftv-demo.zip      FAX & SSTV software for Sound Blaster cards v0.98g -  
9H1JS  
ftv-noaa.zip      Weather Satellite Samples for FTV - 9H1JS  
ftv-sstv.zip      SSTV Samples for FTV - 9H1JS  
gshpc12.zip      GSH-PC SSTV Converter v1.2 - DL4SAW  
hiscn702.zip      HiScan SSTV Program for ViewPort v7.02 - OZ2LW  
jvfax70.zip      FAX receive with a simple modem - DK8JV  
jvfax71.zip      FAX receive with a simple modem - DK8JV

## Post and News

jvfax71a.zip	FAX receive with a simple modem - DK8JV
jvfaxgif.gif	FAX receive with a simple modem (Schematics for HW needed)
k_fax.zip	Fax Display for Kantronix KAM and KPC3 - N8WLC
mscan13p.zip	MicroScan v1.3p (64k color VGA adapter not required) - PA3GPY
mscan211.zip	MicroScan SSTV & FAX Program for PC v2.11 (ShareWare) - PA3GPY
proscan.zip	Pro-Scan SSTV/FAX program v3.01 - KA1LPA
rh223a.zip	Robot Helper SSTV utility for Windows and Robot 1200 - VE3EC
rh312.exe	Robot Helper SSTV program v3.1.2 for Windows 95 - VE3EC
sslogtd.zip	SSTV Picture Database - VE4RZ
sstvsou1.zip	SSTV with Sound Card (Evaluation Copy) - DL1UR
sstvbl.zip	Slow Scan TV with Soundblaster adapter - WB9MMM
vester_m.zip	SSTV/FAX400/WEFAX system described in QST - K3BC
vpstr.zip	Utility TSR to run JVFAX on ViewPort - KA2PYJ
w95sstv/	W95SSTV for Windows95/NT
winpix16.zip	WinPix v1.6 SSTV program (demo) for Win 3.1/Win95 - KOHEO
winskans.zip	Proscan for Windows v1.0
wxfax3_2.zip	Weather Faximile Database Program v3.2
wxman201.zip	WeatherMan 2.01 WEFAX Receive and Display with SoundBlaster
wxsat230.exe	Weather Satellite Faximile Program using Sound Card

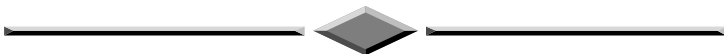

Klaus Kramer  
15.10.97  
DL4KCK  
Arminiusstr. 24  
50679 Cologne  
Germany

2. editor TV-AMATEUR (AGAF e.V.)  
E-Mail: HYPERLINK <mailto:DL4KCK@t-online.de> [DL4KCK@t-online.de](mailto:DL4KCK@t-online.de)

To: EATWG member groups and ATV friends in Europe and USA Hello dear ATV friends,



Because of different black clouds above our fine hobby (i.e. EMC regulations, lacking new recruits and rising Internet/World Wide Web competition) and in the spirit of a good talk between Paul, PA0SON, Heinz, DC6MR, and me at Weinheim this year I want to test the possibilities of E-Mail as a contact medium between EATWG groups at least. This way we can exchange urgent news or interesting views on developments around amateur television, using English language more or less fluently.



**Dicky Howets Lightweight OB unit.**

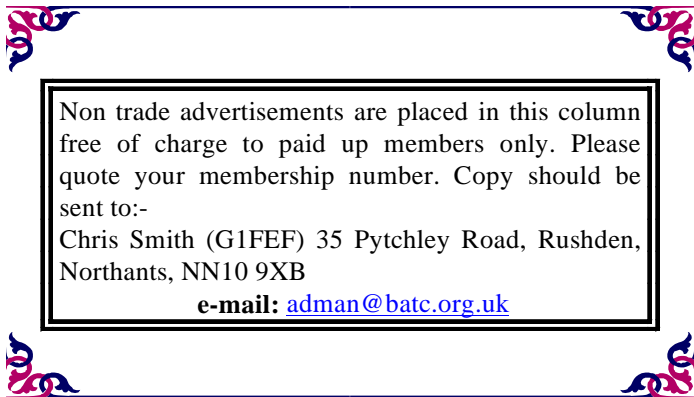

**For Sale**

FOR SALE: Marconi Instruments TF 1706 4½” image orthicon industrial camera, valve technology, looks quite modern all told (possibly early 1970s). Camera head is complete and in good condition but lens assembly is missing. There is no viewfinder. Lots of cables supplied too. Pickup tube – no markings other than it’s a development type of EEV with no guarantee of further supplies being available – has unusual slightly convex faceplate and may be a low-light tube (the camera came from a space physics department). There is also a second identical tube in its original transit case. The whole thing is probably worth more for its camera cables/connectors and scan coils than as its entirety but there you go... it cost me £50 so that’s what I’ll ask for it. I also have a yoke assembly for a 3” I.O., believed to be from a Marconi Mk I, II or III (it’s certainly not Pye) and some large I.O. lens elements (unmounted, so for replacements only). **Andy Emmerson, Northampton 01604-844130.**

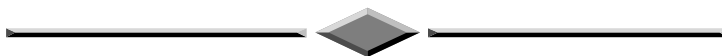

Set of extenders for BVW70 (Nos. 116, 134, 151) £15. 15 PCB’s for VPR2 or MR2B suitable for spares £15. 28 small plug in modules for LDK5 camera & module extender & filter wheel £30. Small case with LDK5 slot in optical filters £10. Glass BBC test transparency No. 52 (12” \* 10” test slide) Swap for something of equal interest. Systems Video Dif. Phase & Gain test set 1407 for use with Vectorscope. Crow TV period meter (pulse duration) ...£15.00...BCC221 wavemeter £25. 3 modern lenses of various focal lengths with iris, ok for experiments. They do not

“fit” any particular camera £10. Wayne Kerr video oscillator, 10 kHz to 10 MHz. £10. Large (6’ tall) Fridge and matching Freezer Made by “UPO” . White finish. Grubby but working OK, good for garage £65 for both. Three DTL video distribution amplifiers with gain & EQ controls, modern design, part filling a 3U 19” rack, £20. Marconi VTR monitoring unit for MR2B or VRP2 model no. B000 4624 with circuit. £20.00. Ampex VTR monitor bridge for VPR2 £3 collect only. BBC timecode reader, no details. I may have some matrix units as well no details yet. Grass Valley 1600 vision mixer, big mixer with 3 effects rows and lots of factillities phone for details. I am Happy to consider swaps for any of the above.

### **Cameras for Sale**

Marconi Mk8 studio colour camera available for sale or swaps. Details on request. Link 125 studio camera in nice clean condition. Ex. studio use complete with viewfinder hood, lens hood, shot box, camera cable, ccu, viable. £175.00. Second Link 125 in poor condition incomplete but could be made to work if missing lens found. Offers. Nice spare viewfinder for link 125.. £25.00 Spare viewfinder for LDK5/25... £25.00. box of spare boards for Marconi Mk8 CCU. Ikegami HL79D with lens and flight case, working order please enquire for details.

### **Camera cable**

Long length of Mk4b cable bit grubby (200’). £20.00. Short length BICC Mk4b £10. Long length of TV81 cable for RCA TK46 or Hitachi SK110 cable may be faulty and one short length in poor condition £10 each.

If any of the items take your fancy, give me a ring. I would point out I am not into parcels or interesting conversations with Parclforce etc. so except for that which will go into the post box it’s collect only.

***B. Summers G8GQS not QTHR 01276 677879***

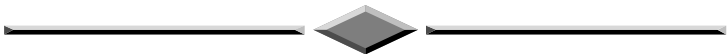

TELEVISION BY DESIGN. Richard Levin. Bodley Head 1961. Superior and lavishly illustrated large book about tv design, lighting, studios, sets. Many photographs, some in colour. Sought after book. With dust wrapper. VGC £18.

SEE IT HAPPEN. The Making of ITN. Geoffrey Cox. Bodley Head 1983. Facinating illustrated history of ITN. d/w.VGC£5. BBC YEARBOOK 1949. D/w tatty.VGC£6. BBC HANDBOOK 1955. No d/w.VOC£5. BBC HANDBOOK 1956. No d/w.VGC£5. BBC HANDBOOK 1958. d/w VGC £8.

BBC HANDBOOK 1959. d/w with section of rear cover top missing.VGC £7. BBC HANDBOOK 1960. d/w.VGC £8. TELEVISION ENGINEERING. Broadcast, Cable & Satellite Pt 1 Fundamentals. R.S.Roberts. RTS Publication 1985 ex-library copy. d/w.VGC £5.

THE TECHNIQUE OF TELEVISION PRODUCTION. Gerald Millerson. Focal Press 1979. Illustrated.VGC £6. ATV SHOW BOOK. 1960. Lots of pictures of ATV shows! VGC £6. TV UNFORGETTABLES. Over 250 legends of the small screen. Anthony & Deborah Hayward. Guinness p/b 1993VGC £3.

GIRL Film & TV Annual No. 1. 1957. no d/w. 1st appearance of this well-illustrated and attractive series of annuals from Hulton. VGC £5.

WONDER OF THE WAVES. Eduard Rhein. 1940. The Scientific Book Club. Illustrated. Sections on Radio and TV including items about Nipkow, Zworykin and Baird. no d/w.VGC £5.

All items clean and intact. Postage £1.50 per book. **Contact Dicky Howett 01245 441811. Fax, 01245 442816**

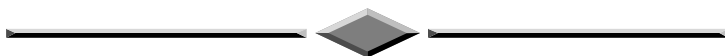

Trio ts430s with drae 24amp psu and atu mobile bracket £550, yaues ft708 hand held with base charger £50, gdo £20. Osker swr bridge /power meter £8. **Contact G8GON qthr. Exmouth Devon 01395 264872**

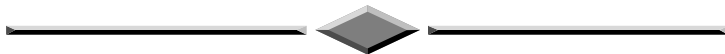

Six Microvitec series 6 M2250HL series definition monitors. TTL or analogue input. 25khz of 31KHz line time base, 20inch tubes. £200 the lot. **Phone for details. 01268 793256 day, 01268 565760 evenings.**

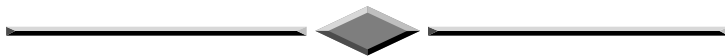

A Good home is required for an Outside Broadcast Van. This is a large (24' 6" long) ex BBC van recently repainted in grey. A picture of a sister vehicle can be found in CQTV 156 on page 73. It is in need of considerable restoration inside and loving care of the mechanics of this 34 year old vehicle. There is no equipment inside except for two AVR's in one of the equipment lockers. It should be understood that this is not a project for the faint hearted. For further details please **contact Brian Summers 01276 677879.**

For sale, SECAM coder to full broadcast spec., made in France by Matra (model T06A). Standard 19-inch size, just 1U tall, takes sync, luminance and RGB in, three coded outputs. Untested but looks clean, straight from Pompidou Centre in Paris, price £10. Dallmeyer C-mount lens, 36-inch focal length (yes, you can almost see into the future with this!) still available at £100. Also for sale: motorised zoom lens by Canon, again C-mount, 15-170mm, F2.5, very clean, UKP50. Cox Source Ident Generator 288, 1U high by 19 inches wide, currently says "ANGLIA OBU2", UKP25. American pulse or video distribution amplifier, one in, eight out, 1U by 19 inches, 110V AV, £5. Gresham Lion BBC-design PLUGE, switchable 405/525/625, 2U by 19 inches, £10. *All from Andy Emmerson G8PTH, 01604-844130.*

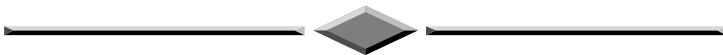

## Wanted

### **Books Wanted**

BBC Yearbooks. Early Pye, EMI, and Marconi television product catalogues for 1946 - 1960 wanted for research for article / book. TV related books wanted, in particular; "Electronic Motion Pictures" by Albert Abramson and the McGraw-Hill "Television series" with Donald G. Fink as the consulting editor, the following volumes; Television Broadcasting by Chinn, Theory and design of Television Receivers by Deutsch, Television Principles by Dome, Television Fundamentals by Fowler and Lippart, Colour Television Engineering by Wentworth. Also "The Services Text Book of Radio" vols. 2,4,5,6 & 7 "cd. or 3rd. edition.

***B. Summers G8GQS not QTHR 01276 677879***

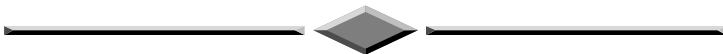

LDK5 camera SURVEILLANCE UNIT. Must be a worker! Also CCU spares for LDK5 channel and Marconi Mk9 portable. Cash or swap. ***Contact Dicky Howett 01245 441811.***

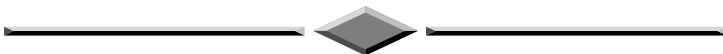

## Wanted

WANTED: Barco, Tectronix or what have you rack type monitor for Ampex or B/W. also require vectorscope & w/form monitors for the same kit. Technical reference /service handbooks for Ampex VPR20B portable "C" - PAL processor colour boards wanted for IVC 1" Models 761P & 801A. - Scrap Marconi Pic & W/form monitor (MKV) for top & side panels/cabinet bits. - Marconi or EMI Video Dist Amp. - CCU /Camera cable for Hitachi FP1500 camera. - Monoscope camera & Pye valved picture monitors to complete 405 line setup. Equipment must be clean & complete. Servicing no problem. If you can help with any of the above a cash reward is waiting. **Contact Terry Martini, 122B Cannon Street Road, Whitechapel, London E1 2LH. Tel: 0171 702 8774 - Fax: 0171 702 8216 Email: [terrym@globalnet.co.uk](mailto:terrym@globalnet.co.uk)**

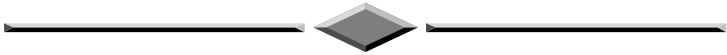

WANTED Any information and/or accessories (lens, viewfinder, CCU, cables, connectors, microphone etc.) for Sony Model DXC-6000P colour TV camera. Will pay sensible price.

Four video colour encoder pc boards to convert composite video to RGB. **Contact. Trevor Wiltshire G8AKA, Reading 01189 701163.**

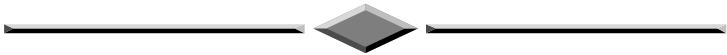

HELP WANTED: Has anyone knowledge of any amateur in the Hart District Council area obtaining planning permission for a 40/60 foot Versatower or similar, or any information that might assist me in dealing with that Council **Please contact Ray brooke G8KPS on 0118 932 6465**

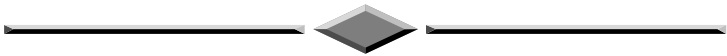

Ferguson portable VCR model 3V24. **Contact Dave Hemingway Tel: 01428 604645.**

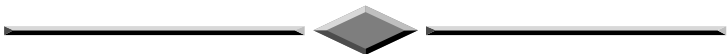

Where have all the LARGE LENSES gone? The 'Folded 40' or anything of that ilk wanted urgently. TURRET camera lenses only. Any crusty item considered. Also INTERNATIONAL TV TECHNICAL REVIEW. **Contact Dicky Howett Tel. 01245 441811 Fax. 01245 442816.**

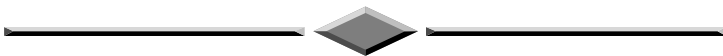

Tektronix Vectorscope. Manual for Tektronix RM 529 waveform monitor, or circuits. Lenses and any information on Pye Mk4 camera and a CCU etc. **Contact: M.D. Bond, 153 Welland Road, Dogsthorpe, Peterborough, PE1 3SU. Tel: 01733 553998**

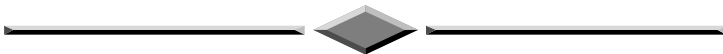

Student requires your unwanted publications. TRN (Uk), BATC(Uk), Telle. Satter;ite(German), Television Magazine(Uk), Monitoring Times(USA), Satelliet Times(USA). Also a Workshop Manual for a (Intrinsically safe) Motorola UHF hand held receiver, model 330X. A FDX RX40 hand held receiver 140MHz to 174MHz. A Belcome 506 hand held transceiver (*battery only*). An orbital cellular phone (*batteries only*). **Please telephone 01455 851521.**

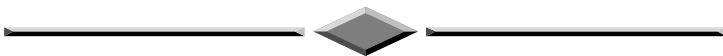

### **Camera bits Wanted**

A viewfinder for a Philips LDK15 portable camera. A Philips LDK14SL. To complete restoration of NEC 100 camera; A pal encoder board No.11 and a suitable lens. A scrap camera or any other bits would also be most welcome. Bosch KCN portable camera circa 1975 to match the CCU I have already got. A Marconi MKIII camera or parts to make my incomplete camera whole again, any bits most welcome. A Nagra VPR5 portable Video recorder. Old Microphones, I am always interested in Items of old broadcast equipment for my collection.

**B. Summers G8GQS not QTHR 01276 677879**

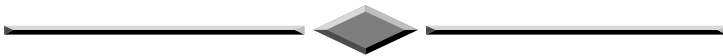

Wanted. Handbook, service information or photocopies of JVC colour video camera model number GX-N70E and JVC electronic view finder model number VF-C514E. **Please contact John Piggott GW7WF1 telephone 01443 834055.**

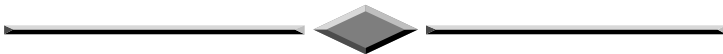

*Index of Advertisers*

Wanted: I can still provide a paying home for Pye model 2823 valve-type 8.5-inch picture monitors (and for other Pye goodies of this era). **Andy Emmerson G8PTH, 01604-844130.**

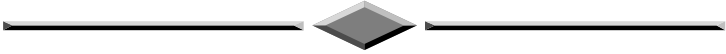

**Model EMITron 1937, by Bernard King**

**Index of Advertisers**

Caladan Communications .....	63
GB3XT Kits and Bits .....	5
Mainline Electronics .....	78
Sevenside Television Group .....	37
VHF Communications .....	34
Worthing & Districe Video Repeater Group.....	27