

**Amateur FM
and Repeaters**

HAM RADIO HORIZONS

OCTOBER 1979 / \$1.25

**LONG WIRE ANTENNAS
THAT REALLY WORK**

**DESTINATION: OX —
NAVASSA ISLAND**

**YOUR S-METER,
MORE THAN MEETS
THE EYE**

PLUS:

- Amateur Radio In Greece
- An Alternative To TV —
Relax With Ham Radio
- The Landtubber Radioman — Part 2
- And Much, Much More...



THE GREAT TEN-TEC ACCESSORY GIVEAWAY

Buy your TEN-TEC transceiver by Nov. 1, 1979* and receive these accessories absolutely FREE!

- **FREE**—Up to \$85.00 in Accessories with an OMNI purchase
- **FREE**—Up to \$69.50 in Accessories with a 540 or 544 purchase
- **FREE**—Up to \$29.50 in Accessories with an ARGONAUT purchase
- **FREE**—Up to \$29.00 in Accessories with a CENTURY/21 purchase

(See accessory choices below)

*The TEN-TEC Accessory Giveaway offer applies to any new TEN-TEC transceiver purchased between Sept. 15 and Nov. 1, 1979 from any franchised TEN-TEC dealer. Just pick up a TEN-TEC Merchandise Coupon at the time

of your purchase, have the dealer fill it out for you and return it with your transceiver Warranty Card to the TEN-TEC factory before Nov. 15, 1979. We will ship your FREE accessories to your home.

Buy TEN-TEC OMNI 160-10M Transceiver
Choose up to \$85 in FREE accessories below



Model 545 Series B OMNI-A Analog Dial \$949
Model 546 Series B OMNI-D Digital Dial \$1119

- FREE:**
1. Model 645 Keyer (\$85), or:
 2. Model 215P Microphone (\$29.50) and Model 217 500 Hz 8-Pole CW Filter (\$55), or:
 3. Model 215P Microphone (\$29.50) and Model 218 1.8 kHz 8-Pole SB Filter (\$55).

Buy TEN-TEC 540 or 544 80-10M Transceiver
Choose up to \$69.50 in FREE accessories below

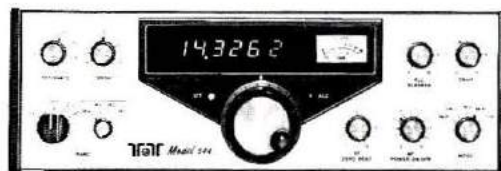

Model 540 Analog Dial Transceiver \$699
Model 544 Digital Dial Transceiver \$869

- FREE:**
1. Model 247 Antenna Tuner (\$69), or:
 2. Model KR-20A Keyer (\$69.50), or:
 3. Choice of Two: Model 249 Noise Blanker (\$29), Model 245 CW Filter (\$25), Model 215PC Microphone w. coiled cord (\$34.50).

Buy TEN-TEC ARGONAUT QRP 80-10M Transceiver
Choose up to \$29.50 in FREE accessories below

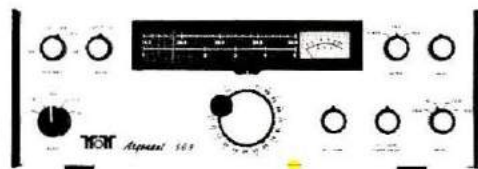

Model 509 Argonaut \$389

- FREE**
1. Model 215P Microphone (\$29.50), or:
 2. Model 206A Crystal Calibrator (\$29), or:
 3. Model 208 CW Filter (\$29).

Buy TEN-TEC CENTURY/21 CW Transceiver
Choose up to \$29 in FREE accessories below

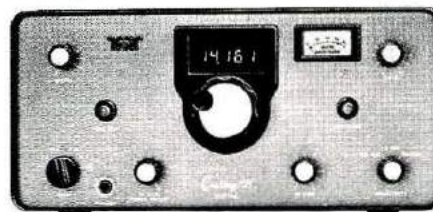

Model 570 Analog Dial Transceiver \$349
Model 574 Digital Dial Transceiver \$449

- FREE:**
1. Model 670 Keyer (\$29), or:
 2. Model 276 Crystal Calibrator (\$29).

See your TEN-TEC dealer before Nov. 1, 1979. Get the best deal you can, get FREE accessories, and get the best performance in Amateur Radio.

TEN-TEC, INC.
SEVIERVILLE, TENNESSEE 37862
EXPORT 5715 LINCOLN AVE. CHICAGO, ILL. 60646

Discover the unrivaled ASTRO 102BX with Dual PTO's

Plus IF Passband Tuning/Full Band Coverage, Speech Processing, 235 Watts PEP All Bands and Much More.

4-Function Meter
reads "S" units in receive, and selects forward power, reflected power, or ALC in transmit.

Visual Display of Passband Tuning
A series of 8 LED's indicate the equivalent band width and position of the passband from 0.6 to 2.7 KHz as the passband tuning knob is rotated.

300Hz Crystal CW Filter
Cascaded with the passband filters and tunable through the passband. Combined with notch filter yields unrivaled CW performance.

Full or Semi CW Break-in
A must for the avid CW operator!

2 Position CW Wave Shaping
Your choice of soft or hard CW rise and decay time!



Variable AGC Decay
Continuously variable to suit your preference.

Passband Tuning with 16 Pole Filters
Two 8-pole crystal filters in cascade provides a 1.4:1 shape factor at -100dB! The ultimate in selectivity.

Tunable Notch Filter
Provides the ability to "notch out" QRM. When used in conjunction with the passband tuning, provides the ultimate in removing interference.

Dual PTO's
Two independent high stability PTO's provide true split band operation. The digital counter reads the PTO selected, or in split band reads the PTO used for receive, then switches to the transmit frequency selected when the mic is keyed.

All Band Coverage using PLL and Synthesizer for Band Selection
Full coverage of 160 meters through all of 10 meters in 9 ranges . . . diode matrix programmed for now — or for the future!

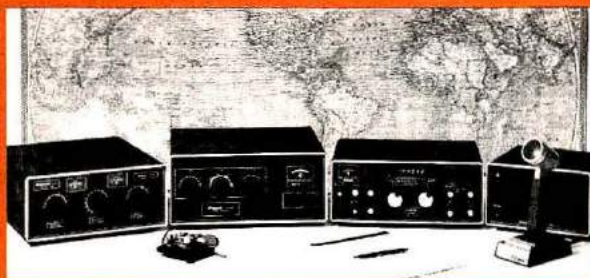

The ASTRO 102BX with it's companion PSU-6 Power Supply, 1500Z Linear Amplifier and ST-2A Antenna Tuner provides a matched and highly efficient 1500 watt PEP or 1000 watt CW complete station to be complemented by a great Swan antenna.

All Solid State
Quality American
Construction

ASTRO 102BX

SWAN
ELECTRONICS

A member of the Cubic Corporation family of companies

305 Airport Road / Oceanside, CA 92054 / 714-757-7525

THIS MONTHS

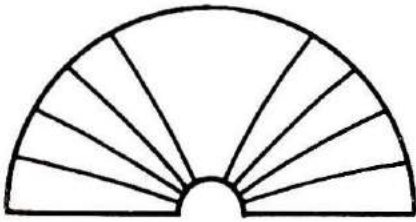

HORIZONS

FM And Repeaters For Everyone

Mobile and portable vhf operation has always suffered from lack of range, caused by the power limitations of battery-operated equipment and by the line-of-sight characteristics of the signals. Then, someone hooked up an automatic relay station at a high location, and it became a whole new ball game! Author W1XZ explores some of the history of repeaters, then shows you some of the gear available, and hints of the operating fun and reliable communications you can obtain while using it.

Navassa Island Vacation, DX Included

What do you do when a rare DX spot doesn't have any people? You can wait, hoping that someone will go there, or you can get a group together and give the rest of the world a treat. That's just what W6OIG and some Missouri, New Jersey, and Georgia hams did, and they soon had the pile-ups, long nights of operating, and overflowing logbooks that are essential to a good DX-pedition. Even if you never want to duplicate their feat, read the story and appreciate the work that goes into supplying a QSL card for your collection.

The Landlubber — Part 2

In last month's episode, Radioman Bark seemed to be having

one problem after another as he became acquainted with his new post on the *Torfin*, a requisitioned fishing vessel made into a coastal-patrol craft. His radio went dead, and no spare parts to fix it with; a skipper who had little use for modern gadgets; high seas that tried to drown him; and a German radio set that was almost undecipherable and on the wrong frequency. Will Andy draw upon his ham background to find a way out? I'm betting that he will. Turn to page 24 and find out.

Getting Acquainted With Your Receiver's S-Meter

Do you really know what your S-meter is saying? Is it honest in what it says? Do you know how to interpret its reading? W8FX discusses a familiar instrument found in almost all ham stations — how it works, how to calibrate it for true indications, and how to obtain meaningful information from it.

Long Wire Antennas

That city lot, or even one in the country, is so inviting — you're going to put up a really great antenna; a long wire. It's logical, after all, that if a short antenna works well, then a longer one will work better. Well, they do, if you follow the rules, and W7CSD spells the rules out for you, starting on page 42. They're not very complicated, and the result of doing it right will be that you have an antenna that can compete with beams on any terms except rotation.

A Stress-Relieving Hobby

Don't sit in front of your TV set and stew about the traffic jam that kept you tied up, the pile of paperwork that will greet you tomorrow morning, or the production schedule that can't be met. Immerse yourself in a hobby that will prove there are still real people in the world; friendly, helpful

neighbors you can relax with. Join WD6FJC as he tells you what got him started and what Amateur Radio can do.

A Stop In SV Land

The chance to be part of a group touring Greece was something not to pass by, and a little 20-meter homework before the trip lined up some people to make the visit interesting and personal. Author W3CRG met SV0 and SV1 hams, and learned a bit about the life of Radio Amateurs in the land of the Parthenon.

The Cover

You are apt to find Amateur repeaters almost anywhere there's a tall structure to support an antenna. An enterprising group put one on the tower in the National Historical Monument at Gettysburg, Pennsylvania, where the signal not only provides good vhf communications for nearby Amateurs, but also guides visiting hams to the Battlefield site, a popular tourist attraction. Background photograph by Clarence Snyder, W3PYF; the operator of the handheld is Dave Mackey, K1KA.

HAM RADIO HORIZONS October 1979, Volume 3, Number 10. Published monthly by Communications Technology, Inc., Greenville, New Hampshire 03048. Telephone (603) 878-1441. Second Class Postage paid at Greenville, New Hampshire and at additional mailing offices. ISSN 0147-8818.

Subscription price: Domestic, one year, \$12.00; two years, \$20.00; three years, \$27.00. Canada and Worldwide, one year, \$12.00; two years, \$22.00; three years, \$30.00, payable in United States funds.

Subscription inquiries and changes of address should be directed to Ham Radio Horizons, Greenville, New Hampshire 03048. Please include address label from most recent issue if possible.

This NEW MFJ Versa Tuner II . . .

has SWR and dual range wattmeter, antenna switch, efficient airwound inductor, built in balun. Up to 300 watts RF output. Matches everything from 1.8 thru 30 MHz: dipoles, inverted vees, random wires, verticals, mobile whips, beams, balanced lines, coax lines.

MFJ LOWER PRICES!

NEW, IMPROVED MFJ-941B HAS . . .

- More inductance for wider matching range
- More flexible antenna switch
- More sensitive meter for SWR measurements down to 5 watts output

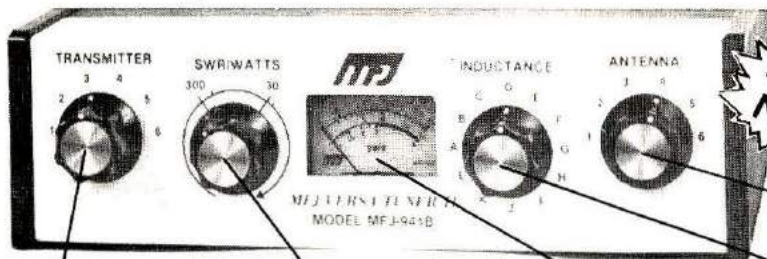

NEW LOWER PRICE
\$79⁹⁵

Transmitter matching capacitor. 208 pf. 1000 volt spacing.

Sets power range, 300 and 30 watts. Pull for SWR.

Meter reads SWR and RF watts in 2 ranges.

Efficient airwound inductor gives more watts out and less losses.

Antenna matching capacitor. 208 pf. 1000 volt spacing.

Only MFJ gives you this MFJ-941B Versa Tuner II with all these features at this price:

A SWR and dual range wattmeter (300 and 30 watts full scale) lets you measure RF power output for simplified tuning.

An antenna switch lets you select 2 coax lines direct or thru tuner, random wire/balanced line, and tuner bypass dummy load.

A new efficient airwound inductor (12 positions) gives you less losses than a tapped toroid for more watts out.

A 1:4 balun for balanced lines. 1000 volt capacitor spacing. Mounting brackets for mobile installations (not shown).

With the NEW MFJ Versa Tuner II you can run your full transceiver power output — up to 300 watts RF power output — and match your

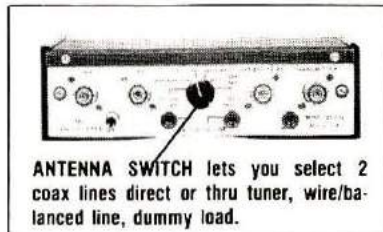

ANTENNA SWITCH lets you select 2 coax lines direct or thru tuner, wire/balanced line, dummy load.

transmitter to any feedline from 160 thru 10 Meters whether you have coax cable, balanced line, or random wire.

You can tune out the SWR on your dipole, inverted vee, random wire, vertical, mobile whip, beam, quad, or whatever you have.

You can even operate all bands with just

one existing antenna. No need to put up separate antennas for each band.

Increase the usable bandwidth of your mobile whip by tuning out the SWR from inside your car. Works great with all solid state rigs (like the Atlas) and with all tube type rigs.

It travels well, too. Its ultra compact size 8x2x6 inches fits easily in a small corner of your suitcase.

This beautiful little tuner is housed in a deluxe eggshell white Ten-Tec enclosure with walnut grain sides.

SO-239 coax connectors are provided for transmitter input and coax fed antennas. Quality five way binding posts are used for the balanced line inputs (2), random wire input (1), and ground (1).

NEW 300 WATT MFJ VERSA TUNER II'S: SELECT FEATURES YOU NEED.

NEW MFJ-945 HAS SWR AND DUAL RANGE WATTMETER. NEW LOWER PRICE

\$69⁹⁵



Same as MFJ-941B but less 6 position antenna switch.

NEW MFJ-944 HAS 6 POSITION ANTENNA SWITCH ON FRONT PANEL. NEW LOWER PRICE

\$69⁹⁵



Same as MFJ-941B but less SWR/Wattmeter.

NEW MFJ-943 MATCHES ALMOST ANYTHING FROM 1.8 THRU 30 MHz. NEW LOWER PRICE

\$59⁹⁵



Same as MFJ-941B, less SWR/Wattmeter, antenna switch, mounting bracket. 7x2x6 in.

ULTRA COMPACT 200 WATT VERSA TUNERS FOR ALL YOUR NEEDS.

MFJ-901 VERSA TUNER MATCHES ANYTHING, 1.8 THRU 30 MHz. NEW LOWER PRICE

\$49⁹⁵



Efficient 12 position air inductor for more watts out. Matches dipoles, vees, random wires, verticals, mobile whips, beams, balanced lines, coax. 200 watts RF, 1:4 balun, 5x2x6 in.

MFJ-900 ECONO TUNER MATCHES COAX LINES/RANDOM WIRES. NEW LOWER PRICE

\$39⁹⁵



Same as MFJ-901 but less balun for balanced lines. Tunes coax lines and random lines.

MFJ-16010 RANDOM WIRE TUNER FOR LONG WIRES. NEW LOWER PRICE

\$29⁹⁵



1.8 thru 30 MHz. Up to 200 watts RF output. Matches high and low impedances. 12 position inductor. SO-239 connectors. 2x3x4 inches. Matches 25 to 200 ohms at 1.8 MHz. Does not tune coax lines.

For Orders **Call toll-free 800-647-1800**

Order any product from MFJ and try it. If not delighted, return within 30 days for a prompt refund (less shipping).

Order today. Money back if not delighted. One year unconditional guarantee. Add \$2.00 shipping/handling.

For technical information, order/repair status, in Mississippi, outside continental USA, call 601-323-5869.

Order By Mail or Call TOLL FREE 800-647-1800 and Charge It On



MFJ ENTERPRISES, INC. P. O. BOX 494 MISSISSIPPI STATE, MISSISSIPPI 39762

CUSHCRAFT IS THE HF MULTI- BAND ANTENNA COMPANY.

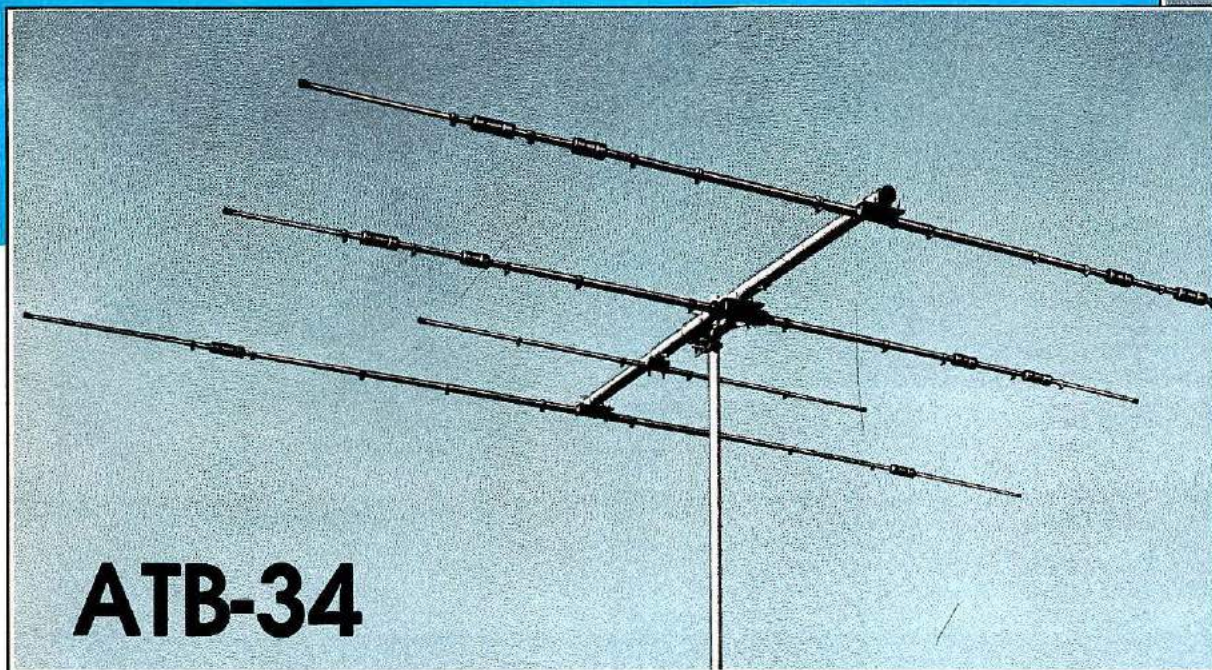

ATB-34

Punch through the pile-ups with an ATB-34. The only three band beam to give you real full size performance. Check ATB-34 element lengths, check the trap design and construction. Check the spacing and the specially developed balun. All of these features add up to the no compromise performance that you expect from Cushcraft.

SPECIFICATIONS

Gain	7.5dBd
F/B Ratio Avg.	24dB
3dB Beam Width	62°
Nominal Impedance	50 ohm
Power Handling	2000 Watts PEP
Boom Length	18'
Longest Element	32'8"
Turning Radius	18'9"
Wind Area	5.4 Ft ²
Weight	42 lbs.
Maximum Mast O.D.	2.5"

ATV-3

10-15-20 Meters
Height 13.8' [4.2mtrs.]

ATV-4

10-15-20-40 Meters
Height 19.4' [5.9mtrs.]

ATV-5

10-15-20-40-80 Meters
Height 24.4' [7.4mtrs.]

ALL MODELS

Power Handling 2000 Watts, Nominal Impedance 50 ohms, Maximum Mast Size 2" O.D., Termination: accepts PL-259

Cushcraft vertical antennas are designed to meet the exacting demands of your amateur radio station. They give top performance in easy to use packages. They can be installed at ground level or roof top.

Durability is guaranteed with double wall seamless aluminum base sections and fiberglass high Q traps. If you are interested in local contacts or long path DX communications, a Cushcraft vertical antenna is your best choice.

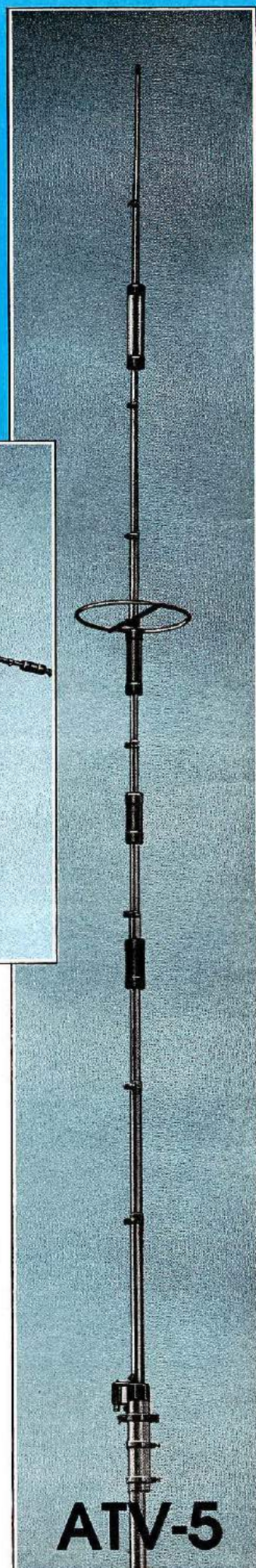

ATV-5

UPS SHIPPABLE



cushcraft
CORPORATION

THE ANTENNA COMPANY

IN STOCK WITH DEALERS WORLDWIDE P.O. BOX 4680 • MANCHESTER, NH 03108

October, 1979
Volume 3, Number 10

T. H. Tenney, Jr., W1NLB
Publisher

James R. Fisk, W1HR
Editor-in-Chief

Editorial Staff

Thomas F. McMullen, Jr., W1SL
Managing Editor

Patricia A. Hawes, WA1WPM
Executive Editor

Martin Hanft, WB1CHQ
Administrative Editor

Joseph J. Schroeder, W9JUV
Alfred Wilson, W6NIF
Assistant Editors

Publishing Staff

J. Craig Clark, Jr., N1ACH
Assistant Publisher

T. H. Tenney, Jr., W1NLB
Advertising Manager

James M. Gray, W1XU
Assistant Advertising Manager

James R. Wales
Art Director

Harold P. Kent, WA1WPP
Dorothy A. Sargent, KA1BEB
Advertising Sales

Susan Shorrock
Circulation Manager

Copyright 1979 by Communications
Technology, Inc. Title registered
at U.S. Patent Office.

Microfilm copies
are available from
University Microfilms, International
Ann Arbor, Michigan 48103

Cassette tapes of selected articles
from *Ham Radio Horizons* are available to
the blind and physically handicapped
from Recorded Periodicals
919 Walnut Street, 8th Floor
Philadelphia, Pennsylvania 19107

Ham Radio Horizons
is published monthly by
Communications Technology, Inc.
Greenville, New Hampshire 03048
Telephone 603-878-1441
ISSN 0147-8818

HAM RADIO HORIZONS

CONTENTS

Repeaters for Your FM Signals	12
James E. Kearman, W1XZ	
DXpedition to Navassa	20
Jon R. Lindsay, W6OIG	
The Landlubber Radioman, Part 2	24
Joseph M. Boyer, W6UYH	
Receiver S-Meters, and What They Do	30
Karl T. Thurber, Jr., W8FX	
Long-Wire Antennas	42
Robert E. Baird, W7CSD	
Amateur Radio — A Cure for Stress	48
J. H. Feingold, WD6FJC	
Greek Hams I've Visited	52
Donald L. Peck, W3CRG	
Activities Calendar	76
Ad Check	78
Ad Scan	71
Advertiser's Index	78
Benchmarks	60
DX Forecaster	74
Focus and Comment	8
Horizons Locator	68
Newsline	11
Post Box	54
Product Showcase	62
Propagation Chart	75
This Month's Horizons	2
The View From Here	6

THE VIEW FROM HERE



I've been interested in the history of radio nearly as long as I've been a Radio Amateur, and am continually on the lookout for old wireless equipment to add to my collection. Local ham flea markets and auctions are often the source of unexpected treasures, and I attend as many as I can; not too long ago I *missed* an opportunity of a lifetime when I passed up an auction of surplus electronic equipment at an old, respected New England college. Much of the "surplus" gear dated back to the 1920s and was built into custom-made wooden cases which were the style of the day; most of the buyers, unfortunately, were antique dealers who were interested only in the finely crafted cabinets — the priceless equipment inside was destined for the trash heap.

In many respects it was a replay of an event in Oklahoma several years ago: The auction of the electronics equipment and *junk* collection of a prominent local amateur. From all reports, it was quite a collection, filling four large warehouses. Except for the huge volume (and original cost) the collection resembled the typical "hell box" of every amateur who lived through the halcyon days when building your own transmitter was conventional practice and everyone eagerly added to his junk collection at every possible opportunity.

However, there was one big difference in the Oklahoma collection. Where most radio amateurs painfully part with dollars, this amateur painlessly parted with thousands of dollars. Think back a few years — what was the most delectable piece of radio gear you could imagine? It was probably in the Oklahoma collection. And not just one, but several. Parts, radio sets, test equipment, you name it, it was all there in unimaginable profusion. One whole warehouse floor was crammed full of big transmitters, spark coils, and rotary gaps for 1920-style transmitters, spiderweb coils and thousands of variable capacitors of every possible make and description. The list could go on for pages.

Now here's the tragedy: These priceless articles, which belong in a museum, were grouped in huge lots with utter junk and sold to junk dealers! The probability that these dealers could differentiate between valuable antiques and valueless junk is frighteningly small. Antiques that can never be replaced, items not preserved in any collection, were probably bulldozed under at a county landfill dump.

This scene, on a much more modest scale, is probably repeated many times a year. Without getting morbid, each one of us should realize that we are not immortal. Each of us has a collection of electronic gear that we've acquired over the years that will, if someone doesn't know any better, be bulldozed under with the trash at the city dump when we join the list of *Silent Keys*. Each item, when you acquired it, represented a jewel to be treasured and was carefully put away. If you were ever so careless as to toss out one of these treasures, you could be sure you would have an almost immediate pressing need for an identical article. I know, because it's happened to me every time I've cleaned house!

The point is this: Talk to your heirs. Clue them in as to what items, if any, belong in a museum. Better yet, make arrangements with the executor of your estate to donate certain prized items to the museum of your choice. The same sort of foresight applies to your newer equipment as well. Give your executor the names of several trusted amateur friends who will help dispose of modern radio gear and test equipment. They will know the fair market value — your executor may not. There have been more than a few cases where an amateur's survivors have been ripped off to the tune of thousands of dollars. Don't let it happen to your family.

Jim Fisk, W1HR
editor-in-chief

Imagine All The Places You Can Tuck ICOM's Remotable IC-280. (Think small.)

The **IC-280** 2 meter mobile comes as one radio to be mounted in the normal manner: but, as an option, the diminutive front one third of the radio detaches and mounts by its optional bracket, while the main body tucks neatly away out of sight. Now you can mount your 2 meter radio in pint-sized places that seemed far too cramped before.

Measuring only 2 1/4" h x 7" w x 3 3/8" d, the bantam-sized microprocessor control head fits easily into the dash, console or glove box of even the most compact vehicle. Or if those places are already taken by the rest of your "mobile shack," the **IC-280** head squeezes into leftover niches under the dash, overhead, under the seat or even on the steering column.

But don't be misled by the petite size of this subdivided radio: the **IC-280** is jam packed with the latest state of the art engineering and convenience features. No scaled down technology here!

With the microprocessor in the detachable control head, your **IC-280** can store three frequencies of your choice plus the dial, which allows you to select from four frequencies with the front panel switch without taking your eyes off the road. These frequencies are retained in the **IC-280**'s memory for as long as power is applied to the radio, even when power is turned off at the front panel switch. And if power is completely removed from the radio the ± 600 KHz splits are still maintained!

The **IC-280** works frequencies in excess of the 2 meter band with ICOM's outstanding single-knob tuning, so you can listen around the entire band without fooling with three tuning knobs. With steps of 15 KC or 5 KC, the **IC-280** puts rapid and easy frequency change at your single fingertip and instantly displays bright, easy to read LED's.

- Available Options:**
- Touch Tone pad/microphone combination, which fits the mic plug on the radio face with absolutely no modification
(Fits all ICOM 4-pin mic radios.)
 - 15' unassembled cable kit for long distance remote mounting of the detachable control head



IC-280
2 meter FM, 4+ MHz
Mobile Transceiver

If you are a newly licensed novice, send for ICOM's catalog and discount purchase coupon. Mail your name, call sign and date of license to your ICOM distributor (see the bottom of this ad).

All ICOM radios significantly exceed FCC regulations limiting spurious emissions.

Specifications subject to change without notice.

IC-280 Specifications: Frequency Coverage: 143.90—148.11 MHz Operating Conditions: Temperature: -10°C to 60°C (14°F to 140°F), Duty Factor: continuous Frequency Stability: ± 1.5 KHz Modulation Type: FM (F3) Antenna Impedance: 50 ohms unbalanced Power Requirement: DC 13.8V $\pm 15\%$ (negative ground) Current Drain: Transmitting: 2.5A Hi (10W), 1.2A Lo (1W), Receiving: 0.630A at max audio output, 0.450 at SQL ON with no signal Size: 58mm (h) x 156mm (w) x 228mm (d) Weight: approx. 2.2 Kg Power Output: 10W Hi, 1W Lo Modulation System: Phase Max. Frequency Deviation: ± 5 KHz Spurious Output: more than 60 dB below carrier Microphone Impedance: 600 ohms dynamic or electret condenser type, such as the SM-2 Receiving System: Double superheterodyne Intermediate Frequency: 1st: 10.695 MHz, 2nd: 455 KHz Sensitivity: 1 μ v at S +N/N at 30 dB or better, Noise suppression sensitivity 20 dB, 0.6 μ v or less Selectivity: less than ± 7.5 KHz at -6 dB, less than ± 15 KHz at -60 dB Audio Output: More than 1.5W Audio Output Impedance: 8 ohms

HF/VHF/UHF AMATEUR AND MARINE COMMUNICATION EQUIPMENT

DISTRIBUTED BY:



ICOM

ICOM WEST, INC.
Suite 3
13256 Northrup Way
Bellevue, Wash. 98005
(206) 747-9020

ICOM EAST, INC.
Suite 307
3331 Towerwood Drive
Dallas, Texas 75234
(214) 620-2780

ICOM CANADA
7087 Victoria Drive
Vancouver B.C. V5P 3Y9
Canada
(604) 321-1833



FOCUS & COMMENT

I've received a few letters asking what "that funny sounding signal" is on our ham bands. It has been described with various analogies, from "a stick on a picket fence," to a "machine gun." I thought everyone knew what it was by now, but then I realized that if you are new to Amateur Radio, or have been off the air for a while, perhaps you missed the fussing a couple of years ago.

The noise is the notorious Russian "woodpecker." At least, all attempts to pinpoint the direction from whence it comes place the transmitter somewhere in northern Russia. The Russians are not saying where it is, or what they are trying to do with it. Rumors and theories abound — it has been called everything from over-the-horizon radar to experiments in weather control. We may never know the truth.

However, it is downright annoying. Also, I must admit to being taken in by it. A friend and I were working on an i-f amplifier strip to be used with some vhf and microwave gear, and it appeared to be oscillating at a rather low, pulse-like rate. Additional bypass capacitors and resistors to decouple the stages didn't cure it, and we were really scratching our heads when we noticed that the signal strength varied with the nearness of our hands to the input terminal of the amplifier. Just on a hunch, I placed a 10-inch clip lead on the input terminal, and the "woodpecker" came roaring through. All this in a basement workshop, with only a couple of inches of exposed conductor on the amplifier board. We don't know what kind of power this transmitter is running, but to produce a signal like that, my guess is in the megawatts!

What can be done? That's hard to say. Complaints through diplomatic channels have largely been ignored, in spite of the fact that this is direct interference with the communications of other nations — something that is forbidden under the terms of previous International Telecommunications agreements. Even threats of strikes by commercial communications-systems operators all over Europe (and other parts of the world) produced no reduction in the interference.

Perhaps something will be resolved at the WARC meetings this year in Geneva — let's hope so.

Second subject: I've noted some pretty weird antennas being touted as the greatest thing since popcorn. Some of them are pure hokum, others do work after a fashion, but not to the extreme degree claimed by the authors. All of them gain popularity mostly because they are presented to an unknowing audience — beginners and non-technical people who do not have the solid foundation in antenna theory to know the difference between what should work and what should not.

A case in point — the half-wave coaxial dipole. I've recently seen gain figures that claim 3.2 dB over a half-wave wire dipole! No way!

It's just a plain fact of life that you cannot stuff 3 pounds of baloney into a 1-pound bag.

Let's look at some basics. The standard engineering reference for antennas is the Isotropic Radiator. This is a theoretical source of radiation, and it's only a pin-point in size. Energy radiates from that point in ALL directions. A common wire dipole, one-half wavelength long, has a gain of 2.15 dB over the isotropic radiator. It obtains this gain by being physically larger than the point source, which means that the current cannot flow in equal amounts in all parts of the antenna. This causes the center of the dipole to radiate more energy than the ends, and this provides the familiar "doughnut" shaped pattern (in free space). The energy that is missing from the "hole" in the doughnut is added to that on the "rim," and that's where the gain comes from. *The only way to change the gain is to change the dimensions, thereby changing the pattern!* This fact of life has been backed up by some pretty sharp engineers who have built antennas for commercial use, the Government, NASA, etc. Their success in the field certainly backs up the theory learned in school.

Why this abysmal lack of knowledge on the part of many amateurs, allowing them to be taken in by such outlandish claims? I'm not sure. Perhaps it's because the theory behind antenna performance is a dry subject in the first place, and most antenna books were written in the style of textbooks, either by design or because the authors could not express themselves in other than engineering terms. Most Amateurs don't want to be engineers; they just want to make their station work properly. Perhaps it's time for an antenna manual written in English, instead of Algebra and Calculus.

Then there is the matter of SWR . . . but that's a good subject for another soapbox sermon.

Thomas McMullen, W1SL
Managing Editor

WHEN OUR CUSTOMERS TALK... WE LISTEN.



Jim Clouse, K5JN
Oklahoma City, OK



Phil Litchfield, WA1OFP
New Canaan, CT



Colin Richards, 9M2CR
Singapore



Ed Trego, W9WKC
Hoopeston, IL



Reinhard Richter, DJ1KM
Hannover

From around the world their RTTY messages read loud and clear.

At HAL we *want* to hear what our customers have to say about RTTY practices, problems, and possibilities. So when they talk . . . we listen . . . and respond.

The result is that HAL Communications equipment

stays at the leading edge of RTTY design with . . . features that open up new capabilities for greater enjoyment of RTTY operation. And with performance reliability so certain, we offer a full one-year warranty.

Write or give us a call. We'll be glad to send you our new RTTY catalog.



HAL COMMUNICATIONS CORP.

Box 365
Urbana, Illinois 61801
217-367-7373

For our European Customers Contact:
Richter & Co., D3000 Hannover 1
I.E.C. Interelco, 6816 Bissone/Lugano

Wilson...

has your needs well in hand.

Today's Amateur demands rugged, rapid and accurate communications between Hams in the know. That's why they choose the Wilson Mark Series of hand-held radios. With exceptional qualities like these . . . why not choose the most popular radio available for yourself?

FEATURES

Advantages such as solid state circuitry, rugged Lexan® case, removable rear panel (enabling easy access to battery compartment) and compact mini-size enhance the Mark Series portable radio's versatility. In addition, Wilson carries a full line of accessories to satisfy almost any of your requirements.

SPECIFICATIONS

The Mark radios offer: • 144-148 MHz range • 6 Channel operation • Individual trimmers on TX and RX xtals • Rugged Lexan® outer case • Current drain: RX; 15 mA, TX; Mark II: 500 mA, Mark IV: 900 mA • A power saving Hi/Lo Switch • 12 KHz ceramic filter and 10.7 monolithic filter included • 10.7 MHz and 455 KHz IF • Spurious and harmonics, more than 50 dB below quieting • Uses special rechargeable Ni-Cad battery pack • LED battery condition indicator • Rubber duck and one pair Xtals 52/52 included • Weight: 19 oz. including batteries • Size: 6" x 1.770" x 2.440".

OPTIONS

Options available, include Touch Tone Pad, CTCSS, Leather Case, Chargers for Desk Top, Travel or Automobile, Speaker Mike and large capacity, small size batteries.

For more details and/or the name of your nearest dealer, contact: Consumer Products Division, Wilson Electronics Incorporated, 4288 So. Polaris Ave., P. O. Box 19000, Las Vegas, Nevada 89119. Phone 702/739-1931.

 **Wilson Electronics
Incorporated**

A Subsidiary of REGENCY ELECTRONICS, INC.

**ACTUAL
SIZE!!!**

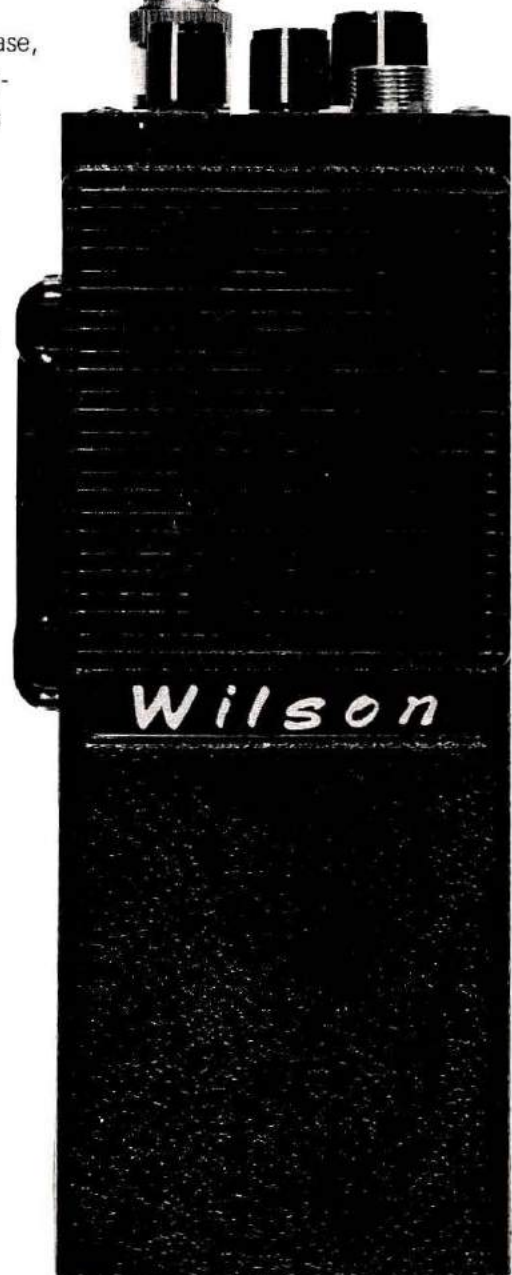

Prices and specifications subject to change without notice.

NEWSLINE

A WELL-PLANNED ATTACK on malicious interference, led by ARRL Southwestern Division Director W6EJJ, has been started on the West Coast. Enlisted in the battle are area congressmen, including Representative James Corman of Van Nuys, a nine-term veteran of the House of Representatives and long-time friend of Los Angeles attorney N6AHU, and Senator Alan Cranston. Both have met with concerned local Amateurs for briefings on the jamming problem, as well as rundowns on Amateur Radio's value on the local, national, and international level.

Decision To Mount The Attack came out of the ARRL's July board-of-directors meeting in Baton Rouge, when the directors approved W6EJJ's resolution directing League General Council Bob Booth to meet with FCC senior officials and push them for Commission aid in combatting the on-going problem. At an August 6 meeting with W6EJJ and N6AHU, Rep. Corman pledged his assistance in the effort, and promised to take it right to FCC Chairman Ferris. He also promised to work on related items with the Commission, but to coordinate his work with Bob Booth.

AMATEURS FILING COMMENTS on FCC dockets are warned never to include questions on other FCC communications with their comments. Comments are logged and filed with other comments immediately upon receipt, so any non-pertinent inclusions could very well be "buried" for weeks, or even months, before that docket is brought up for discussion.

THE SECRECY PROVISIONS of Section 605 of the Communications Act apply to Amateur transmissions "except when such transmissions are intended for the general public," the Commissioners have decided. The potentially far-reaching decision denied a Freedom-of-Information-Act request for FCC's Jonestown tapes by a writer who's doing a book on the People's Temple.

NON-IONIZING RADIATION is the subject of a study published in August by the U.S. Department of Commerce. The 266-page report summarizes the research and findings of ten federal agencies studying safety aspects of electromagnetic radiation. Copies are available for \$10.75 from the National Technical Information Service, 5285 Port Royal Road, Springfield, Virginia 22161. The accession number is PB 296-907/AS.

NEW EAST-GERMAN PREFIXES in the Y2-Y9 block have been announced, with special call-signs for individuals, clubs, and special-purpose stations. Under the new system, DM2AAO would become Y21AO, while DM2CAO would be Y23AO. Club stations will begin with Y3 (Y31AA, Y37AB, for example). Short calls are for repeaters (Y21A-Y29Z), contest teams (Y31A-Y39Z), beacons (Y41A-Y49Z) and bulletin stations (Y61A-Y69Z).

A STATEWIDE EMERGENCY COMMUNICATIONS link for daytime hours has been established in Florida, using a network of 2-meter repeaters to notify 40-meter operators to put their stations on the air. Whenever emergency communications are needed, each major city in the state will be informed through a predetermined series of 2-meter repeaters, and will then put one representative on 7247 kHz. The system was inaugurated by the Florida Midday Traffic Net.

FIRST 432-MHZ HAWAII to mainland U.S. contact was made July 17, when KH6HME worked WB6NMT at 0517Z on SSB. Three more stations, W6YDF, WB6ESQ, and WB6WLR, all made the grade during the next hour, with signals generally well above the noise level.

KH6HME's Beacon was actually heard much earlier in the evening, but it took some time to alert Paul, and for him to arrive at the station site 8200 feet up on Mauna Loa. His beacon was heard from southern California to north of San Francisco, and W6XT heard it again on the 22nd.

633 KILOMETERS ON 3 CENTIMETERS is the new DX record set on July 27 by I4CHY/7 and I2FZD/2. I2FZD/2 operated from a mountain top northeast of Milan, while I4CHY/7 was in Testa del Gargano on the Adriatic coast. Both used Gunnplexers and 1-meter dish antennas. I4CHY/7 made 20 contacts on 10 GHz during his two-week operation, including one at 571 km with I3ZJL's homebrew 3-mW rig, and another with YU3JN/2 near Trieste (about 400 km).

A WARC COMMEMORATIVE POSTAGE STAMP has been issued by the Federal Republic of Germany. The 60-pfennig stamp shows the front panel of a Collins KWM-2 amateur transmitter tuned to the 21-MHz CW band. Now that this WARC commemorative has been printed, plans for a separate Amateur Radio commemorative have been dropped.

FM and Repeaters for Everyone

BY JIM KEARMAN, W1XZ

*Extend your range,
multiply your enjoyment*

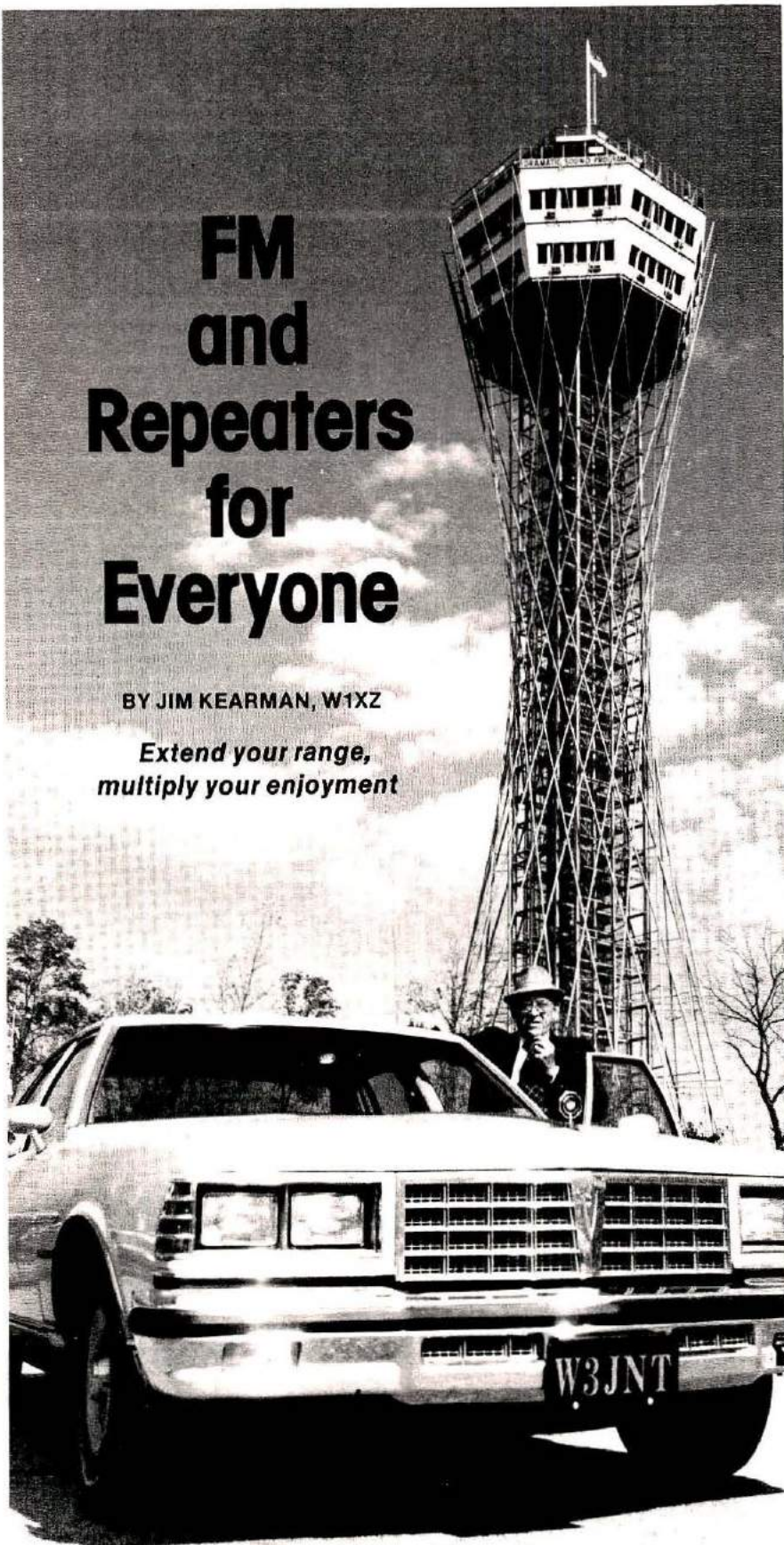

Once upon a time, there were no fm repeaters. Surprised? If you've been to a hamfest recently, you've probably noticed a whip antenna on almost every car and truck. Chances are most of the antennas are for one of the popular vhf bands, where fm is king. There seems to be a portable fm rig in every pocket! This article explains how the all-time most popular mode of Amateur communications got started, and what it's all about.

Police and fire departments, taxicab companies and other similar services have used fm two-way radio for over 30 years. By the early 1960s, the commercial frequencies were so crowded that FCC ordered equipment improvements to reduce interference. Rather than modify them, owners of older radios purchased new sets that complied with the regulations. Old rigs no longer usable in commercial service were dumped on the surplus market. These rigs operated in the 150-160 MHz range, and it didn't take hams long to start converting them for use on the Amateur two-meter band (144-148 MHz). Amateurs have been fooling around with frequency modulation since Edward Armstrong built the first fm equipment in the mid 1930s. Thirty years later, the ready availability of cheap fm rigs got the mode off the ground. Now, almost 20 years after the first cranky old tube-type gear was converted, ham radio magazines are filled with ads for small solid-state radios. The Amateur-fm boom shows no signs of slowing down.

Repeaters weren't allowed on Amateur bands at first, and all early operation was simplex: stations transmitted and received on the same frequency. Back then the most popular simplex frequency was 146.94 MHz. Commercial operators had used repeaters for some time, for reasons we'll discuss later, and progressive Amateurs pressured FCC to allow their



One way to save money on a synthesized 2-meter rig is to build the Heathkit HW-2036A. It covers the entire band. Output power is 10 watts. An optional *Touch-Tone* encoder microphone is available (photo courtesy Heathkit).

use on the 2-meter band. Once convinced of their value to the Amateur service, FCC relented and the fm-repeater boom began. There are now nearly three thousand repeaters in the U.S. and Canada, on bands from 29 to 10,000 MHz.

Fm rigs are portable and easily used in restricted locations, such as apartment houses and compact cars. As a result, many old timers have come back to the hobby they gave up when their circumstances didn't allow big rigs or outside antennas. Amateur fm

operation is more orderly than CB, and it often lures disenchanted CBers to ham radio. Fmers are a cross section of the Amateur population. In a repeater conversation, you're likely to find old-time hams and newcomers swapping notes and helpful hints. You'll hear housewives comparing recipes, and even an occasional chess game. At almost any time, from nearly anywhere in the U.S., you'll be able to make an fm contact. It's safe to say that nearly every active ham has tried fm at one time or another.



The name of PACE has long been familiar in other communications circles, and can now be found on equipment for the Amateur vhf bands as well. This is their new synthesized 2-meter fm transceiver, the Communicator II.

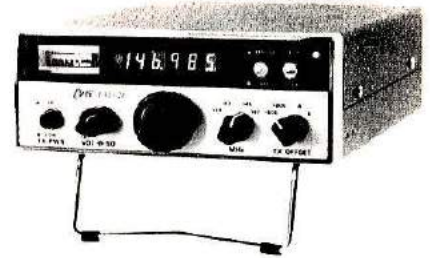

Many an Amateur became acquainted with 2-meter fm through Clegg equipment, and that early gear evolved into a modern package. Here is the synthesized FM-28, their newest offering for the Amateur fm enthusiast.

The first technique for transmitting voice was amplitude modulation, in which the operator's voice signal is superimposed on the radio carrier. Sidebands generated above and below the carrier frequency rise and fall in step with the voice signal. The frequency difference between the sidebands and the carrier at any given instant is the same as the frequency of the voice signal at that moment, and varies with it. Single-sideband signals are similar, except that the carrier and one sideband are suppressed in amplitude before the signal is transmitted.

If sideband is good enough for around-the-world contacts, why not use it for local work? As you drive your car around the countryside, buildings, overpasses, and hills obstruct signal paths and cause fading. Fading makes a sideband signal difficult to copy. Electrical noise, generated by automotive ignition systems, power lines, and neon signs is also amplitude modulated and seriously interferes with communication.

A sideband signal must be accurately tuned for proper reception. If the receiver and transmitter are not tuned to nearly the same frequency, the signal is difficult to understand. Mechanical and electrical stabilities required for quality sideband operation are difficult to achieve in a small, low-cost mobile or portable transceiver.

Glossary Of Fm And Repeater Terms

Autopatch — Telephone line-to-repeater connection.

Closed repeater — Repeater available for use by club members only.

Control operator — A licensed Amateur Radio operator designated by the repeater licensee to assume responsibility for the proper operation of the station.

Duplexer — Highly selective tuned circuits connected to the repeater transmitter, receiver, and a single antenna to reduce interference to the receiver. A duplexer also allows the use of one antenna.

Full quieting — A condition that exists when the received signal is strong enough to completely blanket the receiver internal noise.

Intermod — Intermodulation distortion (IMD). Nonlinear

condition in transmitter final amplifier, or receiver rf amplifier, resulting in generation of spurious signals.

Open repeater — Repeater available for use by any licensed Radio Amateur.

Picket fencing — Rapid flutter in signal from a mobile station, caused by signal reflection from trees or telephone poles.

PL — Private Line, a Motorola trademark. Used by many hams to mean any type of continuous-tone-coded squelch system (CTCSS) used to limit access to a repeater. The repeater is activated only by a received signal with this tone superimposed.

Remote base — A remotely controlled simplex station. Used extensively in mountainous areas to improve range of home stations.



The Icom IC-245 FM transceiver provides 5-kHz steps from 146 to 148 MHz, and has switch positions for normal or inverted split operation through repeaters. An adapter, shown here, adds CW and SSB capability to the rig.

An fm signal is formed by varying the frequency of the transmitter with the voice signal. Transmitter output power is constant; only the frequency varies. An fm receiver detector responds only to frequency variations of incoming signals. Any amplitude variation in received signals is smoothed out with limiter stages. Once the signal strength exceeds the limiter threshold, any further increase in strength cannot be noticed by the listener. Below the threshold, also called the capture point, the signal sounds noisy. The noise level goes up and down as the signal fades. A squelch circuit is used to turn off the receiver audio stages when no signal is being received. The squelch threshold is generally just below limiter threshold. The small difference between the two prevents noisy signals from being heard.

Why use repeaters?

The amount an fm signal varies in frequency is called its deviation. A deviation of 5 kHz above and below the unmodulated carrier frequency, or a total of 10 kHz, is common. This is the maximum amount of spectrum space the signal occupies. Our receivers aren't perfect, and we have to space the signals a little farther apart to prevent interference. A typical sideband signal uses

about 2.5 kHz of spectrum, about one-fourth that of our fm signal. There isn't room for fm signals on our crowded high-frequency (160-10 meter) bands. (On fm we call them the "low bands.") Our vhf bands are wider, and there is more room for fm signals. Vhf signals don't travel as far as those on the low bands. This makes it possible for two stations about



Repeaters take advantage of high terrain or buildings to increase their coverage. Here some members of the Penn-Mar Amateur Radio Club are ready to take some equipment up the 300-foot Battlefield Tower at Gettysburg, Pennsylvania. This installation will provide improved normal and emergency communications for Amateurs in Central Pennsylvania as well as portions of Maryland, Virginia, and West Virginia.

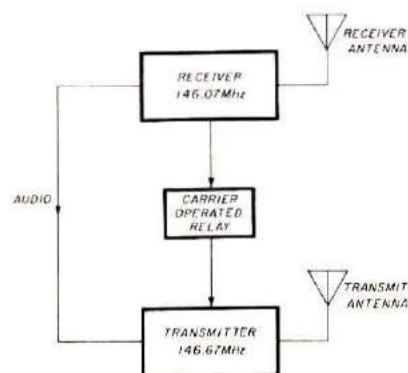

Fig. 1. The inner workings of a repeater in simplified form can be two paths — one path for the audio, and another for control voltages to turn the transmitter on and off. The transmitter usually has a timing circuit built into it, to prevent long transmissions. Some control systems become very complex, including a means of sending "housekeeping" signals back to a monitoring point so the operators can be sure all is well at the remote site.

80 km (50 miles) apart to use the same frequency without mutual interference. Unfortunately, the limited range and the fact that vhf signals are particularly affected by natural and manmade obstructions limits the reliable range of a vhf-fm signal. This is especially true for mobile and portable stations. Their antennas are often less than optimum and the stations are low in relation to obstructions. In open country, mobile-to-mobile range is typically 15-20 km (12-16 miles). In the city it may be impossible to cover more than a mile. If we take our mobile or portable station to a nearby hilltop, we can probably talk to all the other mobiles and portables in town because we're above most of the obstructions. A repeater station is installed in a location that allows it to overcome nearby obstructions. Users of the repeater take advantage of its superior location to work each other from normally poor locations.

Fig. 1 gives a block diagram of a simple repeater station. The receiver (input) and transmitter (output) frequencies are not the same. They operate at the same time and would inter-



The Midland 13-513 is a synthesized 220-MHz fm transceiver. It provides an output power of 2, 10, or 20 watts from 220-225 MHz (photo courtesy Midland International).

ferre with each other if separate frequencies weren't used. The carrier-operated-relay (COR) circuit turns the transmitter on when a signal is received. Some hams like to "key up" the "machine" (transmit a short, unidentified signal to see if they can "bring up" the repeater). This causes the squelch burst (or "tail") between the time the input signal is removed and the transmitter drops out, to make a "kerchunk" sound. Kerchunking is annoying to stations monitoring the repeater. To discourage the practice, many repeaters are equipped with voice-operated-transmit (VOX) circuits. The transmitting operator has to begin talking to activate the repeater transmit-

ter. Audio quality on fm is usually good enough to allow the person to be recognized, and thus superfluous repeater keying is brought to a halt.

Who pays for the repeater?

Because they are called upon to provide long hours of reliable operation, repeater stations must be more rugged, hence more expensive, than home-station gear. When the cost of accessories, and perhaps a rental fee for the site (good locations are at a premium, especially in metropolitan areas) are added, the cost of putting a repeater on the air may be several thousand dollars. Some repeaters are operated by individuals, but most are owned by clubs. Repeater clubs range in size from three members to several hundred. Club dues are generally about \$15 a year. That's a real bargain when you consider the time and money invested by the club. When you become active on fm, join at least one local club to add your support. You may not wish to attend meetings but if you use the repeater you should, in good conscience, support the club. Your club allows hams traveling through the area to use the repeater, and you'll receive the same courtesy when you're on the road. You'll

Table 2. In an effort to squeeze more repeaters into the 146-148 Mhz subband, some repeaters operate on 15-kHz "split" channels. This list shows the frequencies used. To reduce interference, some repeaters reverse the input and output frequencies shown.

Input Output	Input Output
146.025/146.625	147.615/147.015
146.055/146.655	147.645/147.045
146.085/146.685	147.675/147.075
146.115/146.715	147.705/147.105
146.145/146.745	147.735/147.135
146.175/146.775	147.765/147.165
146.205/146.805	147.795/147.195
146.235/146.835	147.825/147.225
146.265/146.865	147.855/147.255
146.295/146.895	147.885/147.285
146.325/146.925	147.915/147.315
146.355/146.955	147.945/147.345
146.385/146.985	147.975/147.375

find more than companionship when you take your rig along; it will be invaluable for summoning aid or just asking directions. If every fm operator supports his hometown repeater, it all balances out.

What kind of equipment do I need?

The early fm rigs retired from commercial service operated on one or two frequencies, as that's all the first owners required. When there was only one repeater in an area, it was possible for Amateurs to get by with a two-frequency radio. The second frequency was used for simplex operation. Today, having fewer than six frequencies available can be a handicap. Crystals cost about \$10 a pair. At that price, you'll want to check with friends to see what repeaters they use before you invest money in crystals. Chances are you'll be satisfied with using two or three local repeaters and one or two simplex channels. **Tables 1 and 2** list the common two-meter repeater frequencies and **Table 3** lists the most popular simplex channels. The national simplex frequency is 146.52 MHz, and

Table 1. Standard U.S. and Canadian repeater input and output frequencies. Below 147 MHz the lower frequency of a pair is generally used as the repeater input. Above 147 MHz the higher frequency is used as the input in most cases.

Input Output	Input Output	Input Output	Input Output
144.61/145.21	144.85/145.45	146.28/146.88	147.69/147.09
144.63/145.23	144.87/145.47	146.31/146.91	147.72/147.12
144.65/145.25	144.89/145.49	146.34/146.94	147.75/147.15
144.67/145.27	146.01/146.61	146.37/146.97	147.78/147.18
144.69/145.29	146.04/146.64	146.40/147.00	147.81/147.21
144.71/145.31	146.07/146.67	or	147.84/147.24
144.73/145.33	146.10/146.70	147.60/147.00	147.87/147.27
144.75/145.35	146.13/146.73	146.43/147.03	147.90/147.30
144.77/145.37	146.16/146.76	or	147.93/147.33
144.79/145.39	146.19/146.79	147.63/147.03	147.96/147.36
144.81/145.41	146.22/146.82	146.46/147.06	147.99/147.39
144.83/145.43	146.25/146.85	or	
		147.66/147.06	

Table 3. You don't need a repeater to work other stations on fm! Try this list of popular simplex or "direct" frequencies.

MHz	MHz
146.52	223.46
146.55	223.50
146.58	223.54
146.49	223.58
147.48	223.62
147.51	
147.54	446.00

you'll definitely want to have crystals for it. If you travel, add one or more common frequency pairs you don't use at home. ARRL publishes an annual *Repeater Directory* which lists most repeaters in the U.S. and Canada by state or province and area.

What about synthesized rigs?

Let's assume that a 10-watt-output, crystal-controlled transceiver costs \$250. To that price add the cost of crystals for six channels at \$10 per pair. Your investment now exceeds \$300 and you can use only six repeater or simplex frequencies. Even if the radio has room for twenty-three crystal pairs, a \$480 investment still won't allow you to use all possible frequencies. A synthesized rig will operate on any standard repeater pair or simplex frequency within its range. New rules changes recently allowed repeaters to be operated below the old cutoff frequency of 146 MHz. Newer rigs will operate over the entire 2-meter band, 144-148 MHz. The latest rigs will also let you use "split" repeaters as listed in **Table 2**. Most new rigs tune across the band in 5-kHz increments. The catch is that a synthesized rig is more expensive than its crystal-controlled cousins. Competition and improved manufacturing techniques are bringing the prices down. If you'd like to operate on many different frequencies, you

should consider a synthesized rig. When you calculate the cost of a few dozen crystals, the synthesized rig may actually be cheaper! You can even buy a synthesized hand-held transceiver or add a synthesizer to your present "HT," if you're an experienced builder. Some synthesized rigs offer a frequency memory that you can program for your favorite channel. Others allow you to scan the band and will stop when they receive a signal. This is a useful feature when you travel to an unfamiliar area and don't know what repeater frequencies are used. The latest thing in synthesized rigs is pushbutton remote control of operating frequency, scanning, and memory. These "bells and whistles" don't make your signal stronger, but they do make operation a little easier.

Amateur fm rigs are usually supplied in three basic power-output categories: 1, 10, and 25 watts. Hand-carried 5-watt rigs are available, but they have short battery-discharge times because of the high current



Trio-Kenwood recently announced the TR-7625 transceiver, a synthesized 25-watt output two-meter rig. Some of its features include a frequency memory, provision for subaudible tone encoder and remote tuning and scanning with the addition of the RM-76 accessory shown in an adjoining photo (photo courtesy Trio-Kenwood).



Synthesized rigs are the "in" thing today, and this FM2016A from KDK offers many convenience features as well, including scanning and memory, coverage of CAP and MARS frequencies, plus a selection of frequency-offset positions. A microphone with a built-in tone pad is available. KDK also has a similar model, the FM6016A, for 6-meter fm operation.

drawn by the transmitter. For a portable rig, one or two watts out is usually enough. For more power at home or in the car, you can add a 10-watt-output amplifier. Fixed-station and mobile rigs don't often need more than 10-watts output. With a reasonable antenna you should be able to work local repeaters and do well on simplex. Remember, fm is a local mode. DXing, even on simplex, is rude because it usually interferes with other stations. There may be times when 25 or 40 watts are desirable, but don't run more power than you need. The two-meter band is saturated with repeaters in most areas of the country. Chances are you'll hit more than one repeater if you run over 10 watts. If you can't make it with that, wait until you're closer or try another repeater.

How about the antenna?

If you have trouble hearing and working other stations, the

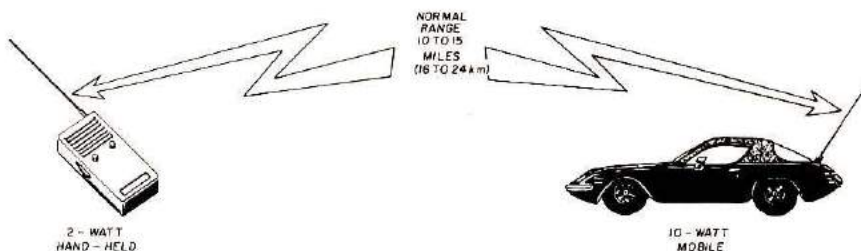

Fig. 2. The normal range between two 2-meter fm rigs, such as a mobile unit and a portable one, is not very great, and between two mobile units is not much more. They're useful for strictly local communications, however.



The Icom IC-280 has a control-head unit that mounts near the driver, while the body of the rig goes out of sight in the trunk. It also has a provision for storing a frequency in memory, to be recalled later.

best improvement is a better antenna. An amplifier increases your signal strength and a receiver preamplifier makes other signals seem stronger. A better antenna does both, often at lower cost! Mobile operators mostly use 5/8-wavelength whips, commonly mounted on the trunk lid. Putting the antenna on the car roof gives better coverage, but drilling a hole in the roof is frowned on by car salesmen and spouses! One alternative is the magnet-mount antenna. There are many brands; my favorite is by Larsen. I've used this antenna at highway speeds on several cars. It has never slipped off and definitely works better than an antenna mounted on the trunk lid. When I park I can hide my rig and the antenna and no one can tell I have a radio in the car.

At home you have a wider choice of antennas,

depending on what type of installation is permissible. In general, put the antenna as high and clear of obstructions as possible. If you use one particular repeater more than others, you may want to point a four- or five-element beam at it. The gain of the beam lets you run less power to put in a good signal. If you can, mount the beam on a small tv-antenna rotor. Now you can share a simplex frequency with stations in the area with less interference, by pointing the beam at the station you're working. If you can't put up a beam you'll want an omnidirectional antenna, commonly called a vertical. Fmers use vertical antenna polarization, while CW and ssb are done with horizontally polarized antennas. It's easy to keep them straight: the plane of the antenna elements is the same as that of the polarization.

Although you'll want to put your antenna up in the clear, there's a point of diminishing returns, determined by the signal loss in the feedline. RG-8/U-type coaxial cable absorbs a fair amount of power at vhf. I wouldn't use more than 15 meters (49 feet) of it for a 2-meter antenna. On the higher bands, use a good foam-dielectric line such as Times Wire and Cable FM-8. Most mobile antennas are equipped with thinner RG-58/U cable. It's adequate for 3-meter



The Heath VF-2031 is a crystal-controlled, handheld 2-meter transceiver. The flexible antenna shown in the photo is called a "rubber duckie" (photo courtesy Heathkit).

(9.8-foot) runs but none longer. If the supplied length is too short, use lower-loss cable to extend it.

Operating on fm

Fm operation is done on fixed frequencies and the signals tend to be stronger than those on the low bands. Operating techniques are much different from those on the low bands. If someone is listening on the simplex channel or repeater-output frequency you're tuned to, he'll hear you immediately. Fmers don't tune the band as is done on the low bands. Scanning rigs are so fast they'll detect even the briefest call. If you want to talk to just anyone on a frequency and no one's using it, just say, "W1XZ listening." That's all. Anything additional is superfluous. If someone listening wants to talk to you, he'll give your call and his and, if he doesn't know you he'll probably tell you his name. He may also tell you he's operating mobile

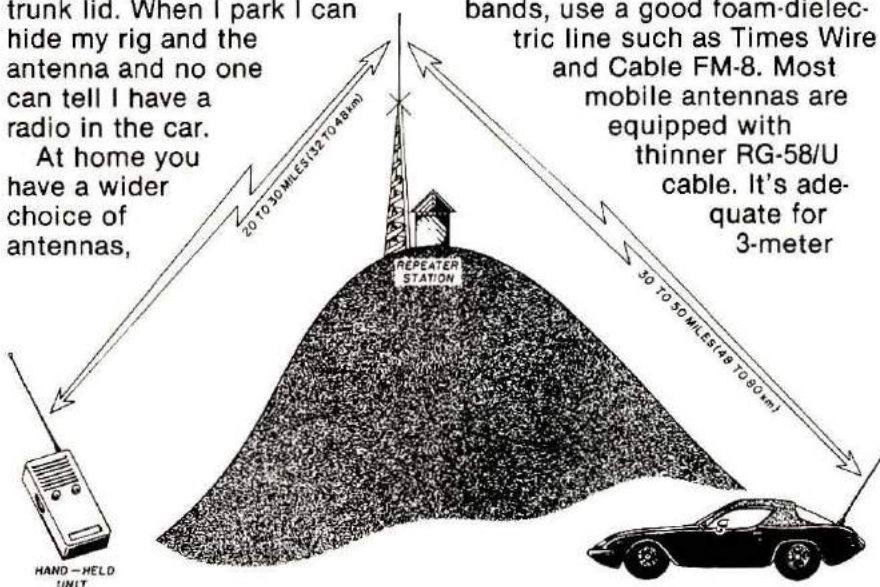
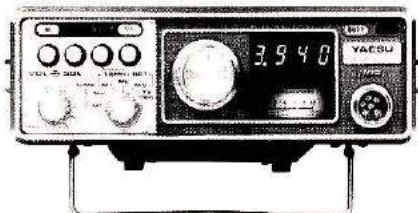

Fig. 3. Coverage of 146-MHz fm signals is greatly improved by placing a repeater on the highest hill or building in the area. Equipment designed for the 420-MHz band benefits even more from repeater use, especially where there are tall buildings and trees which tend to absorb and reflect these signals.



Another rig with memory features is the Yaesu FT227R Memorizer. The bright digital display allows you to see what frequency you have tuned in, and the memory lets you check back to see if a channel is busy with the flick of a switch.

or portable, although such information is no longer required by FCC. All repeaters are equipped with timers to shut off the transmitter if a user transmits for more than 5 minutes or so. To discourage long-winded orators, some timers are set as short as 2 minutes. If you talk too long you'll "time out" the repeater. When you stop transmitting the timer will reset and you'll probably be subjected to some good-natured kidding by those on frequency! Some clubs levy a nominal fine (in cash, coffee, or refreshments) if you time out the machine.

When another station turns the conversation over to you, wait a few seconds before transmitting. This courtesy may save a life. Many times a third station will be waiting to break in, often with an accident report or other message. Failing to stand by for breaking stations is very poor repeater etiquette. Procedures for breaking vary at different repeaters. When in doubt don't say "break" unless you have an urgent message. If you just want to join in an on-going conversation, give your call only. The station whose turn it is to transmit should stand by for you. Then you can ask to join in. If you want to call a friend who isn't involved in the conversation, give your call sign and ask to "make a call." The other stations will stand by. Make contact with your friend and arrange to move to another frequency. Don't forget to thank the other stations for their courtesy. If you have an

urgent message, say "Break, W1XZ priority." Again, procedures on your repeater may be different, but using the information given here on an unfamiliar machine will leave no doubt of your intentions.

Many synthesized rigs have provision to "reverse" the frequency. This allows you to listen to the input frequency of a repeater and transmit on the output. Many times you'll be able to hear the other station "direct," without going through the repeater. Move off to a simplex frequency if possible. You'll be amazed at how far you can work on simplex with even modest equipment. Repeaters were originally intended as an aid to mobile and portable stations, not for use by home stations. Today they're the local gathering place for everyone. But, that's no reason to tie them up unnecessarily.

Many repeaters are equipped with phone patches. In repeater service such a device is called an "autopatch." Transmitting the proper sequence of Touch-Tone* signals will connect you to the telephone line and you

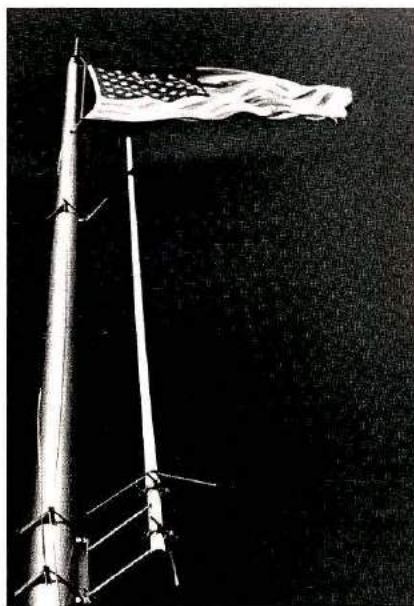

Repeater antennas are ruggedly built to withstand severe weather, and usually provide gain for both transmitting and receiving. The Penn-Mar Club has theirs securely fastened to the flagpole atop the Gettysburg Battlefield Tower, ready for communications in any weather.

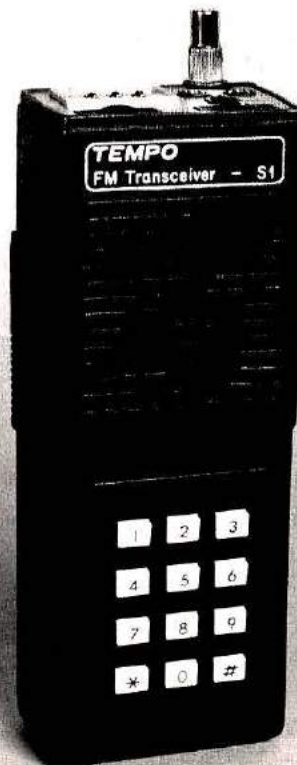

The Tempo S1 is the first synthesized handheld. Shown here with optional Touch-Tone encoder installed, the rig operates anywhere in the 144-148 MHz band. Frequency selection is by means of thumbwheel switches on the top panel. The entire rig weighs only 400 grams (1 pound)! (Photo courtesy Henry Radio.)

can make calls by punching the correct numbers. You'll need a Touch-Tone "pad" connected to your transmitter. Microphones with pads built in are available from some manufacturers. FCC regulations prohibit transmissions of a commercial nature, so don't use the autopatch to order a pizza, make a doctor's appointment, or call your stock broker. It's also illegal to call your office to check for messages or tell them you'll be late to work. An autopatch is useful for calling the police when you spot an accident, but the privilege is often abused. If you can't decide whether or not your call is legal, don't use the autopatch.

When repeaters were first authorized by the FCC, the licensee used his regular Ama-

*Touch-Tone is a registered trade name of AT&T

teur call. FCC was eventually persuaded to issue distinctive WR-prefix calls, such as WR1AAD. In a cost-cutting move, FCC recently did away with distinctive repeater call signs. New repeaters must again use the licensee's regular Amateur call. As the old WR calls expire, the stations will have to use the call of the owner or trustee.

The 2-meter repeater sub-band formerly extended from

146-148 MHz. Operation is now permitted from 144.5-145.5 MHz also. If you're buying a rig, be sure it covers the new frequencies. The 220-MHz band offers coverage similar to that on 2 meters, and is already crowded in some parts of the country. There had been a possibility that 220 might become the Class E citizen's band, but that threat was done away with last year. We may have to share the band with the maritime mobile



If you're looking for one rig that will provide fm communications on three Amateur bands, the Drake UV-3 will fill the bill. It works on the 144, 220, and 420 MHz bands, has a tone-signalling pad built into the microphone, and many other features.

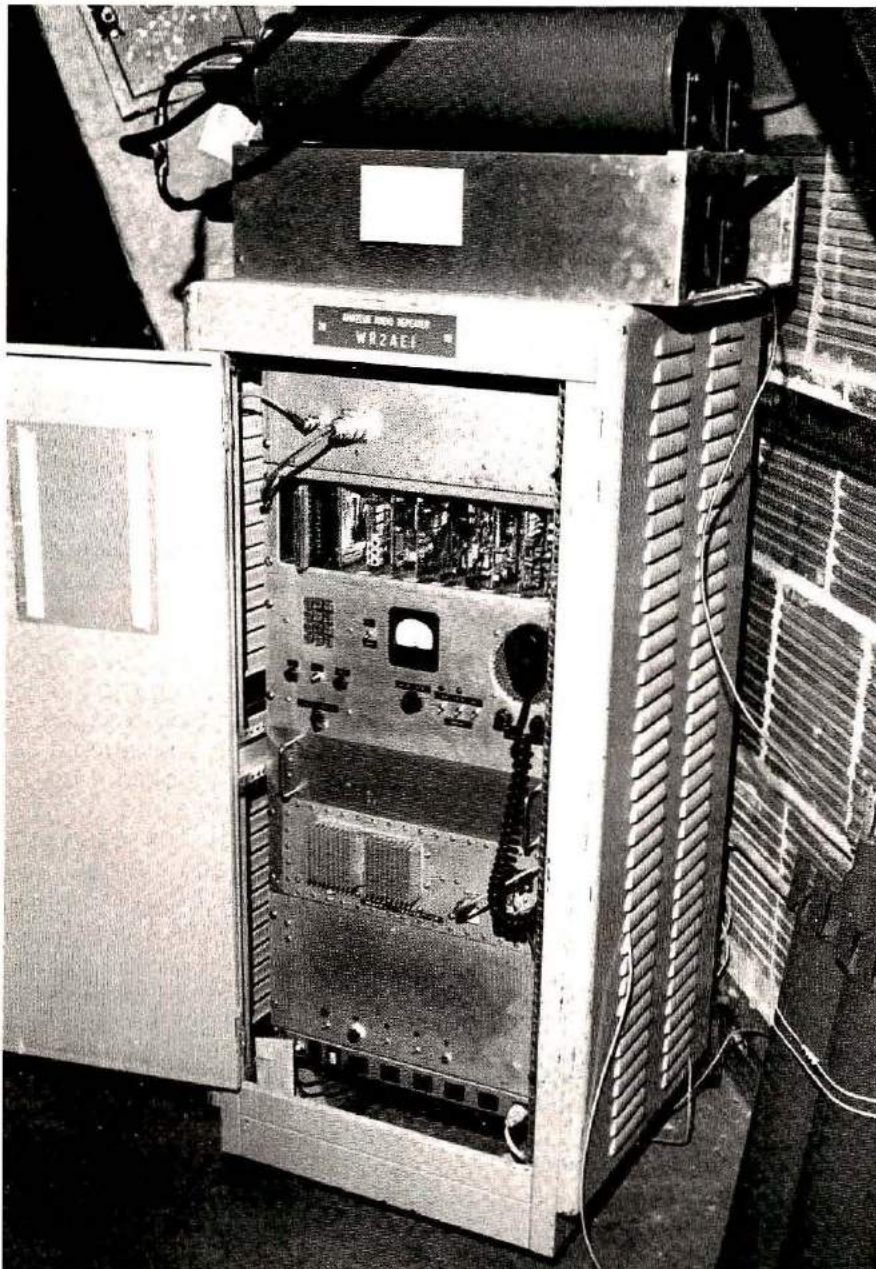

WR2AEI, operated by the Rochester, New York, Radio Repeater Association, is installed in the Kodak Building in downtown Rochester. From top to bottom the equipment includes the duplexer cavities (outside cabinet), receiver, control circuits, transmitter, and power supply. To the right of the cabinet are two additional cavities to filter the transmitter output (photo courtesy K2YA).

service at some point in the future, but showing our interest in 220 by using it now will greatly reduce the chances of losing it. The 450-MHz and 6-meter repeater subbands aren't as popular as 2 meters. Users of these bands usually get on because they know someone who is active there, rather than just to try it out, as is done on 144 and 220 MHz. One way to operate on 144, 220, and 450 with one rig (but not all at once) is to use a Drake UV-3 transceiver. This rig allows you to start with one band and expand to two or three in the future. If you want to operate on all three bands, the UV-3 costs less than three separate radios.

From its humble beginnings, Amateur fm has grown to the point where the hams who use it as their only mode of operating outnumber any other group. Dozens of new manufacturers have entered the market with dazzling new equipment never thought possible. Fm operators have taken the lead in Amateur public service, reporting thousands of auto accidents, stranded motorists, fires, and other emergencies every year. Now that you know about Amateur fm I'm sure you'll want to join us!

Bibliography

Jim Kearman, W1XZ, editor, "Fm And Repeaters For The Radio Amateur," 2nd edition, ARRL, 225 Main St., Newington, Connecticut 06111, 1979.

ARRL Repeater Directory, available from ARRL for \$1. **HRH**



NAVASSA ISLAND DX

BY JON LINDSAY,
W6OIG

"How would you like to go on a DXpedition?" These were the first words coming over the telephone on a spring day in 1978. They were spoken by Tony Trice, AD0P, an aeronautical engineer at McDonnell-Douglas in St. Louis. "Sure," I said, thinking this must be a joke, but willing to accept the idea for the moment. "When do we leave?"

"Probably in the fall, maybe around November," Tony said.

"You are really serious. Who else is going?"

Well, several other hams here in McDonnell," Tony replied in a matter-of-fact tone.

The "several other hams" turned out to be Randy Rowe, N0TG, Dave Bowker, W0RJU, Myron Kern, W0ZH, and Joe Markowski, N0WL. None of the group had ever been on a DXpedition before, though several were avid DXers. All had at one

time or another kicked around the idea of going on such a trip, but each time it seemed too unlikely to be taken seriously.

"Where are we going?" I asked enthusiastically, at the same time mentally packing my bags.

"Navassa Island," came the reply.

"Great!" I responded. I was trying to figure out a way to learn where this unheard-of-place was without giving away my ignorance. "Now let's see," I began, "that's in the Pacific, isn't it?"

"No, it's in the Caribbean, just south of Cuba."

"Why that island?"

"Well, because it's relatively accessible and because for Japan, it's their number one DX priority. And also because it hasn't been activated for four years."

The conversation ended and I dug out an atlas, hoping to find this "country" among the many in the Caribbean Sea. No map was found which contained a Navassa Island. I looked it up in the encyclopedia and, to my surprise, found it. The location of a lighthouse and a former guano farm, this 1 by 1-1/2 mile island was to be the site of another invasion by hams. Over the previous decade the little island had been used by hams on three different occasions. Its official call prefix was KP4; this soon would be changed to KP1.

Further conversations on the telephone and 20-meters revealed that the gang in St. Louis had made the decision final. They were going to handle all of the logistics and paper work. My role: operator and medic. We were six in number, but soon grew to ten

with the addition of three hams from Cherry Hill, New Jersey, who had already been to the island, and one from Atlanta, Georgia. They were Sy Adler, K2KA; Miles (Brownie) Brown, W2PAU; and Joe Duffin, W2ORA; all with RCA. There was also an outstanding phone operator, Dave Johnson, WA4SSU.

What had apparently started as an idea had now become quite a workable endeavor. Job assignments were made. Randy, NØTG, was essentially the coordinator of job tasks and correspondence. The other St. Louis hams began assembling four complete stations, each housed in special shipping crates designed by WØRJU. The crates would themselves become the operating desks for that particular station. The Cherry Hill hams were able to give excellent advice and council regarding the terrain and island layout. They suggested that two operating sites might be more productive than the one usually used by hams upon first landing on the island, *i.e.*, near the edge of the water and landing site. A higher, though more

difficult to reach, site would be on top of the island near the lighthouse, and would afford better propagation toward Europe and Japan, two parts of the world not well covered during previous operations.

As the word got out that this project was under way, NØTG began receiving support for the trip on a regular basis. In an effort to collect funds to finance shipping and boat costs, Joe, NØWL, was able to obtain an excellent computer program for producing individual azimuth-distance printouts. These were offered to hams interested in contributing toward this DXpedition. By the time we finished, hundreds of these printouts had been mailed.

Atlas Radio was, once again, gracious enough to lend support to Amateur Radio by offering several of their excellent high-frequency transceivers. Two 2-meter rigs would be used for communications between the sites, which were separated by almost a half mile. Two 3-element, 3-band Yagis were acquired, one for each site. The group's feeling was that only with such an

antenna system would we be able to ensure positive contact with the rest of the world. Though wire antennas could have been used (and in fact were used as back-up), they were much inferior to a more directional antenna. The Yagis were turned by simply hand-rotating the entire mast. This was quite easily done, thanks to the specially designed masts of WØRJU. Everything that was to be used on the island, including water, had to be carried ashore.

As the months went by, the group's enthusiasm grew. Monday night progress reports were made on 14.250 MHz. Problems, and some decisions, were considered at that time. A "dress rehearsal" was run through during Field Day. All of the equipment was set as planned, the masts raised with Yagis on top, and the generators fired up. The first run was considered successful. Randy had managed to contact Lloyd, 6Y5LA, in Kingston, Jamaica, our designated departure point, and made arrangements for handling the two thousand pounds of equipment that was to be shipped to Kingston by air. Lloyd's help was invaluable.

I can't imagine trying to arrange this trip without his help. Not only was he ready with advice but gave generously of his time and energy to see that we were well looked after. Because of this, our stay in Jamaica was really delightful.

The day finally arrived for departure. I flew to St. Louis to join that group. The New Jersey hams had preceded us by one day and were already in Kingston. While talking with them, we learned that all of our equipment had arrived and had been cleared through customs. Of course, 6Y5LA was there, making sure it was all together. The next day the St. Louis group flew to Kingston. Dave, WA4SSU, arrived that same day and we were all together for the first time.

The charter boat, scheduled to depart the following day, was delayed due to a generator

From left to right (standing), Joe (W2ORA), Joe (NØWL), Randy (NØTG), Myron (WØZH), Sy (K2KA). From left to right (kneeling), Tony (ADØP), Dave (WØRJU), and Brownie (W2PAU). All photographs by ADØP.





Our transportation was the 85-foot fishing vessel, the *Annency II*.

failure. Since DXing was our primary purpose, we hastened to set up a station at the hotel, signing our calls with /6Y5. To our delight, Iris and Lloyd Colvin were at the same hotel. Lloyd had his antenna system humming away on all bands. As many of you know, Iris and Lloyd are rather famous for their many trips to interesting places. They were a delight to meet and know, and allowed us unlimited use of their equipment.

Except for the delay by the boat that was to take us to Navassa, (about 135 miles from Kingston), everything was running quite smoothly up to this point. When the 85-foot fishing boat finally did show, it was not what I'd had in mind (not that I had any particular boat style in mind). I had some doubt as to its sea-worthiness, though the boat had only recently been completely refurbished. This doubt was quickly dispelled by the Jamaican captain. The boat was soon loaded and the journey began, eleven months after the conception of an idea.

The next fourteen hours at sea, beaten by the wind and waves, were probably the worst I've ever experienced. Our gear, carefully stored in the boat's

hold, was well protected. Good thing, since the decks were awash with sea water most of the time. But we did arrive!

The island was really a beautiful sight in the morning sun. Rising out of the sea was the distinctive lighthouse, the last a sailor sees before reaching the South American mainland. The air was thick and warm, and the sea calm at last. The captain carefully positioned the boat near the landing site, and the unloading process began. Access to the island was by means of a forty-foot "rope" ladder up to a small platform on the rock. Fortunately for us, the ladder was made of steel and in good repair. The U.S. Coast Guard has jurisdiction over this island and is responsible for maintaining the battery-operated lighthouse.

Island operation

Within thirty minutes a station was set up, a dipole strung, a generator unpacked, and KP1-land was on the air! While the rest of the gear was unloaded from the boat, Sy and Brownie hastened to notify the world that Navassa Island was on the air again.

As planned, there were two operating sites: the lower one (easily reached from the land-

ing platform) and the upper site. Within several hours, most of the equipment and antennas had been set up at the lower operating site and were functioning. It wasn't until the following day that we were able to cart all of the equipment necessary for the top location into place. One station was used at the upper site, along with the efforts at 6-meters and OSCAR.

The excitement of adventure mellowed as the reality of the effort required to meet our goal came back into focus. We were going to attempt to contact 30,000 stations during the six-day period. We each took turns at operating with no special assignments. Brownie, with his mechanical Vibroplex keyer, and Dave Bowker, with his electronic keyer burning at better than 30 words per minute, were the mainstay CW operators. Any of us not engaged in operating were either lending support by carrying gasoline to the generators, or catching up on needed sleep. We tried to maintain a 24-hour operation when band



Let's see now . . . if that's 180 degrees, and Oscar crosses at 47 degrees west, I should point this thing right about there!

conditions permitted. However, in those late-hour lulls when the generator was shut down, only the throaty sounds from frigate birds nesting in the tree tops would permeate the hot, humid air.

The high-frequency SSB bands were operated under the call of NØTG/KP1. CW was under the call of WØRJU/KP1 and OSCAR operation under WØZH/KP1. It was a thrill for me to hear those pile-ups from Europe and Japan, where reaching the Caribbean is difficult. Of course, there were the usual problems that could be expected. The manifold on one of the generators broke and had to be "glued" back together again. Six-meter propagation seemed poor, much to the chagrin of Joe, W2ORA. And the OSCAR receiver headed north without us after a couple of days. But, for the most part, everything continued to work well.

The island itself is basically rocky and often hostile. Cactus of a kind that seemed to be alive and jumping was a constant threat to the unwary. The rock appeared to be limestone, with deep cavities washed out over the surface. At the top of the island are the remains of a



Tony, ADØP, and Dave, WA4SSU, are busy operating two of the four complete stations. Interference between the two positions was not a problem when compatible bands were selected.

dwelling that supposedly was the living quarters of those who took care of the lighthouse before it was automated. Occasionally, I could get a glimpse of the goat herds, left by the early inhabitants, roaming freely over the island. The Haitian natives come to this island often for the purpose of capturing goats. The island is

also a way station for the Haitians when they're on fishing trips. Though officially a possession of the United States, the island is considered by those living in the Caribbean area as the "people's island" and is used freely by Haitians and Jamaicans. There was evidence of recent occupation: bags of salted meat hung on the walls of the remaining buildings.

When the last day of operation rolled by, the final tally was 22,303 contacts made on all bands, including 160-meters. It was with curious sadness that we broke camp and prepared to return to Jamaica. Exhausted and dirty, I felt some remorse in leaving this beautiful and strange place after so many months of preparation, planning, and effort. It was satisfying to know that the project had been executed smoothly.

The return to Jamaica on smooth seas ended with a hearty breakfast and more effort to pack equipment for return to the States. It was a delightful adventure. I hope you had a chance to work us on Navassa; if not, maybe there will be another time. **HRH**



Dave, WØRJU, was one of the main CW operators.

The Landlubber

Part 2

BY JOSEPH BOYER, W6UYH

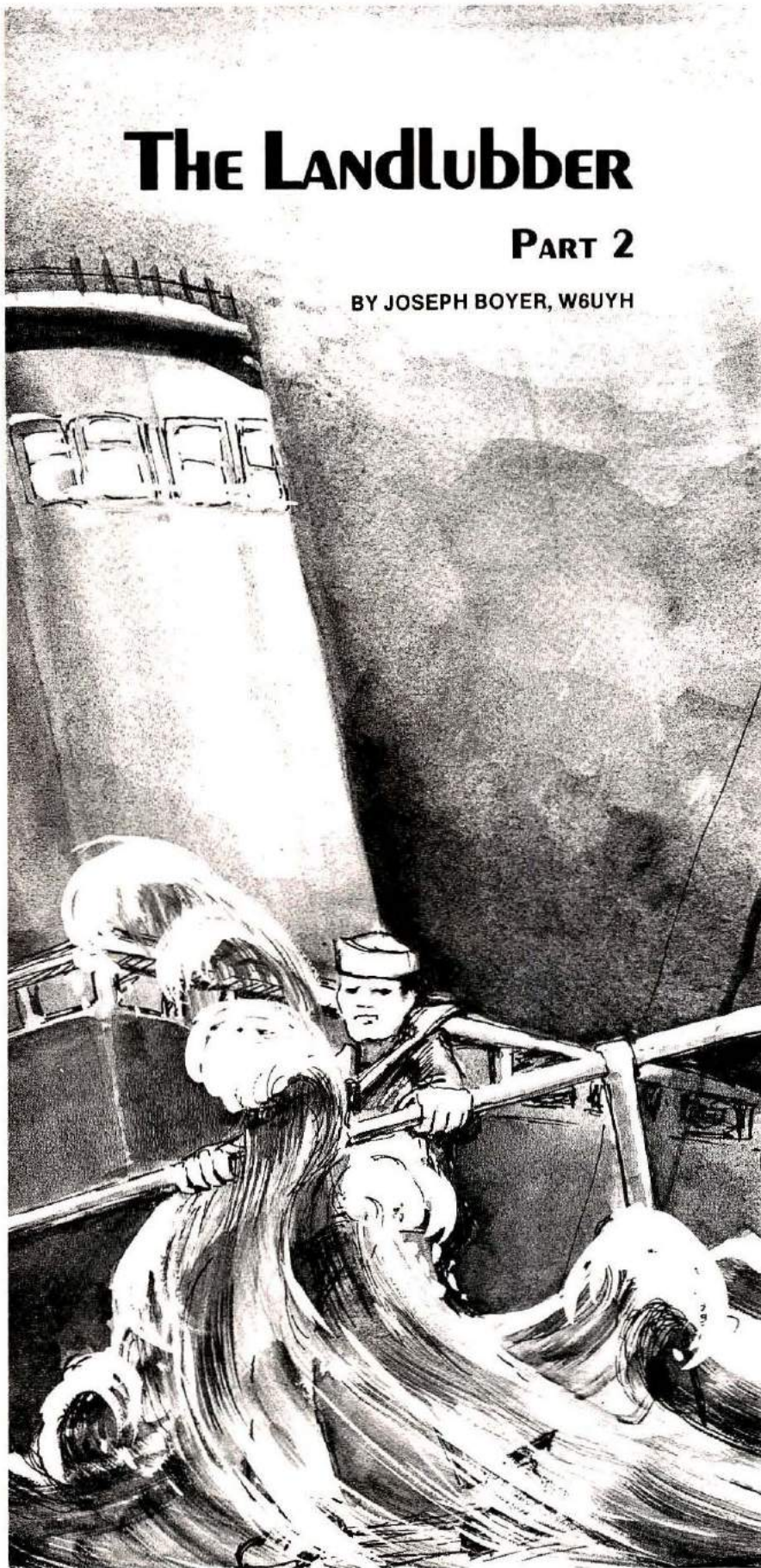

Radioman Andy Bark, W8PVL, new to the Navy in the early 1940s, found himself aboard a hastily rebuilt fishing vessel which was on coastal patrol off southern California. The seas are rough (at least to a landlubber from the Ohio flatlands), and his receiver died in the middle of a message. His skipper, Lieutenant Larry Smith, doesn't think very highly of electronic gadgets or of the people who run them. Further, the weather is bad, it's getting dark, and they don't know for sure where they are because the ship's navigator goofed.

Andy found that the radio room included some old German radio equipment, left over from the ship's Norwegian days, but some of it is indecipherable, part of it is a useless arc transmitter, and it's on the wrong frequency anyway. Andy is thinking all this over when someone comes into the radio room:

"Yer relieved, Bark," a cheery voice said in his ear, and Andy turned to see a broad smile on a homely freckled face. Freckles, dressed in dungarees, blue denim shirt and rolled white hat, stuck out a hand.

"I'm Tolin, radioman second. You kin go on down to chow now. I'll mind the baby."

Andy introduced himself then added, "You won't need to do any minding. The receiver power-supply transformer went up in smoke a few hours ago and there are no spares aboard. We're dead so far as Dove is concerned."

"Say, that's great," Tolin chuckled, "I brought something along to read between transmissions anyway." He laid a couple of comic books on the operating table, saying, "Ain't these tubs great! They don't make you sit at no mill and copy FOX for four hours straight."

Andy shrugged. "I don't read you people at all. Here we are poking around in lanes haunted by enemy subs that are waiting to waste oil tankers coming down from El Sugundo or trans-

ports from L.A. harbor. We could be torpedoed, or this puddle jumper flattened by even a submarine's deck gun, and yet the skipper doesn't seem to care one whit that our ship-to-shore communications is out . . . and you, a radioman, apparently feel the same way."

"Yeah," Tolin replied, "Well it's the skipper's show. Me, I just follow orders. It's a lot easier that way. You did tell the Old Man about the radio, right?"

"I sure did, loud and clear, but he didn't flicker an eyelash. Even seemed glad to hear the news, just like you. Then there's something else, and I sure hope you can give me the word."

"Yeah, what's that?"

"Well, it's the skipper. He doesn't act like one . . . or even like an officer. Treats the crew like they were all his old buddy-buddies. I don't get it."

"That's cause he's ex-Merchant Marine; signed up just before Pearl when he lost his ship to a German

sub in the Atlantic. He don't know much about goin' by the book and stuff like that, but he's the best skipper afloat and straight as an arrow."

"Thanks for telling me, Tolin," Andy said. "I sure wish he had a better appreciation for electronic gear."

"Well, I kin tell ya one thing; he still won't hold them lightn' bolts on yer sleeve agin you, friend. Hey, you better get on down to chow before the steaks are all gone."

"Sure, sure. Steak! That'll be the day, brother!" Andy laughed, struggling back into his blouse and heading for the door.

Andy's steak was so tender he could cut it with a fork, and so large it almost filled his

platter. He hadn't tasted anything like this since December 7, 1941. But that was only half of it. In boot camp, and in the shore stations he'd been to, the enlisted men had their own mess. Even at the smaller stations officers ate by themselves at a separate table. Here, the skipper, Lt. Larry Smith, sat big as day right up at the head of the common table in the mess. He had to admit it was kind of nice;



as if everybody here were just one big family.

There was only one thing that took the edge off his good feeling; that was the eerie experience he'd had getting down to the mess. The fog out there was so thick he couldn't see more than two inches beyond his nose. He'd had to creep along holding on to the bulkhead safety rail, constantly reaching out with his toe to feel for the first rung of the ladder leading down to the lower decks. Twice, he had almost fallen because the metal was dripping wet and slippery. Smith might be a great guy, but anyone who actually liked sea duty must be out of his mind.

Andy was just finishing a

large slice of ship-baked pumpkin pie when he sensed someone lean down near his left ear.

"You didn't just happen to get that radio telephone working again, did you Sparks?" Andy looked up at the skipper.

"No sir. Without a spare power transformer, it's hopeless." He felt relieved, however, by the skipper's sudden concern. "Why do you ask, sir?"

"Well I had hoped that if you could reach NMQ we might have got them to order radio

bearings taken on us. After all, we don't know our position and there are other ships out here in the fog, running blacked out just like us."

At that moment, the *Torfin* swung hard to starboard, spilling men and food onto the deck. Without a word, Smith scrambled to his feet and ran from the mess followed by two officers. Andy felt a little dazed for a moment and sat shaking his head. A hand reached down

and gripped his wrist. On the back of that hand was the tattoo of a pig. Lifting his eyes slightly, Andy saw the mate to that hand resting on a bent knee. It bore the tattoo of a chicken. Looking higher he saw a broken nose which had never been fixed, in a face covered by a maze of tiny creases, the skin burned almost black by years of sun. China blue eyes under shaggy blonde eyebrows regarded him without blinking. The thin lips in the weather-beaten face parted:

"You okay, son?" Andy nodded. The hand on his wrist tightened and a muscular arm lifted Andy erect without apparent effort.

Andy faced a man of uncertain age wearing a peacoat. The

tight, black, watch cap on his head was still beaded with drops of moisture. The man hadn't been at chow; Andy would not have forgotten a face like his. Evidently he'd just come from outside.

"What happened just now?" Andy asked.

"We almost went aground on the beach. Bow lookouts heard the surf in time and we were able to swing ship while still in deep water. We haven't got the faintest idea whether that beach was Catalina, San Clemente, or Oceanside." The man's eyes narrowed. "Don't recognize you, you must be new aboard." The eyes swept Andy's sleeve. "Radioman. We're getting up in the world, I see. How long you been at sea?"

Andy felt strangely dejected at the question. "As the captain said, I'm a land lubber. Until this afternoon my experience afloat had been confined to occasional ferry-boat rides on the Detroit River." He tried to grin.

The grizzled face smiled warmly.

"Don't apologize, son, any shellback was a lubber some time in his life. You'll get your sea legs in no time. Where you headed for?"

"The radio room, I guess. I'm officially off watch but it is my emergency-duty station. I guess you people must be ready to admit we are in some kind of emergency condition now."

"You sure can say that. By the way, my name's Peacock. As long as you didn't try to tell me you've squeezed more salt water out of your socks than I'll ever see, I'll be equally frank and admit this mess we're in is all my fault. They tell me I crapped out cold on the bridge after coming aboard tanked."

"Wow . . . I mean, sorry to hear that, sir." Andy said, remembering the skipper's remark about the warrant bos'n just in the nick of time. "If you'll pardon me, sir, how in

the world did you find your way to the bridge in that condition?"

"That's easy. I've been aboard this vessel longer than any other member of the crew, even the captain. I could find my way anywhere on this ship, or a hundred others, blindfolded in a force 10 gale." When Warrant Peacock made that statement, something which had been slowly circulating in Andy's subconscious suddenly crystalized.

"Mister Peacock, were you aboard when this ship was in the yards being refitted?"

"Sure was. Why?"

"Do you happen to remember seeing a loop antenna up on some part of the ship's superstructure? It would have been made of pretty large metal tubing, could have been in the shape of a circle or a diamond, maybe from one foot up to six feet or so in diameter."

"Now that you mention it, I do recall a loop antenna fitting that description up on the bridge." Peacock frowned for an instant. "Probably removed by the yard crews, though."

"Why?"

"Well, when this vessel came to us she didn't have what we would call a bridge. There was just an open deck platform, with a railing around it, that the whalers used only when chasing an animal. But the yard installed a sort of jury-rigged bridge on that platform, using double plywood wall bulkheads on all sides, and added an overhead. American's don't like to freeze their ears off on watch if they can help it. It's comfortable, but will go up like a match if we ever take shell fire."

At that moment Andy saw the skipper come back into the mess and begin drawing a mug of hot coffee from the big pot.

"Mister Peacock, could you and I talk to the captain for a minute?"

"Why, sure thing. Come along."

Even before they reached the

Old Man, Andy began waving his hands and talking.

"Sir, I've thought of a way to get a position fix, but I need to make an experiment on the bridge first."

Lieutenant Smith smiled at Peacock, but his eyes wore a look of concern. "What kind of experiment you fix'n to conduct on my bridge in this kind of weather, Sparks?"

"Well, I think there's a loop up there!"

"What kind of loop?"

"A D.F. A direction-finding loop antenna."

The captain squinted at the radioman. "Sorry Sparks, but even if I don't cotton to your radio gadgets I've seen quite a few D.F. loop antennas on ships in my time. I can promise you that there's nothing like one either on the bridge or anywhere else on this hulk."

"But I can *feel* it up there, sir."

"You all okay, Sparks? I mean, you didn't happen to hit your head hard on something when that swell grabbed hold of you today?"

"No, I'm just fine. But please, if we could just go up on the bridge I think I can prove my point."

"Why not." The skipper shrugged. "We've got nothing better to do right now. Let's go."

With Peacock leading Andy by the hand as if he were blind as a bat, the three men reached the bridge in short order. Andy immediately strode over to the man at the wheel and stood peering about in the dim light. Finally, Andy said:

"I saw an overhead speaker and a telephone in the radio room. Is there a way to call the radio room from up here?"

"Sure," Smith replied. He reached down and twisted a multiple-position switch on a panel board, then picked up a phone.

"Radio room?"

"Yes sir," a voice issued from a bulkhead speaker, "This is Tolin. Bark's off watch and

went down to chow."

"Hang on," the skipper grunted, and handed the phone to Andy.

"Tolin?"

"Oh, hi!"

"Listen, I want you to do something for me."

"Shoot!"

"See that big black panel across the cabin — the one with a large steering wheel mounted above it on the overhead?"

"Yeah."

"Good. Go over and keep turning that wheel back and forth as far as it will go until I tell you to stop. Okay?"

"Can do!"

The line went dead.

Andy stood in the reddish battle light of the bridge, feeling the engines pulse under his feet, swaying rather nice and easy now, even though the ship was still rolling. He felt like praying, but he crossed his fingers instead.

It happened just as he'd figured it would: a muffled knocking sound began very near the men.

"What the blazes is that?" the skipper asked.

"The loop antenna, sir. When they put in the double bulkhead, the yard crew just walled up the antenna inside without bothering to remove it." Andy began walking along the gray painted plywood, listening carefully and feeling the surface with his finger tips.

"It's about here," he said, moving his hand in a small circle, "But we can't get to it because of the plywood barrier."

The skipper stepped away and almost immediately

reappeared. There was a fire axe in his hands. He stepped up to the bulkhead and listened carefully for a moment or so, then suddenly swung the axe. The blade bit deeply into the plywood. With repeated blows, the skipper partially cut and partially crushed a long vertical slot in the bulkhead inner panel. Then he stepped about eight feet to his left

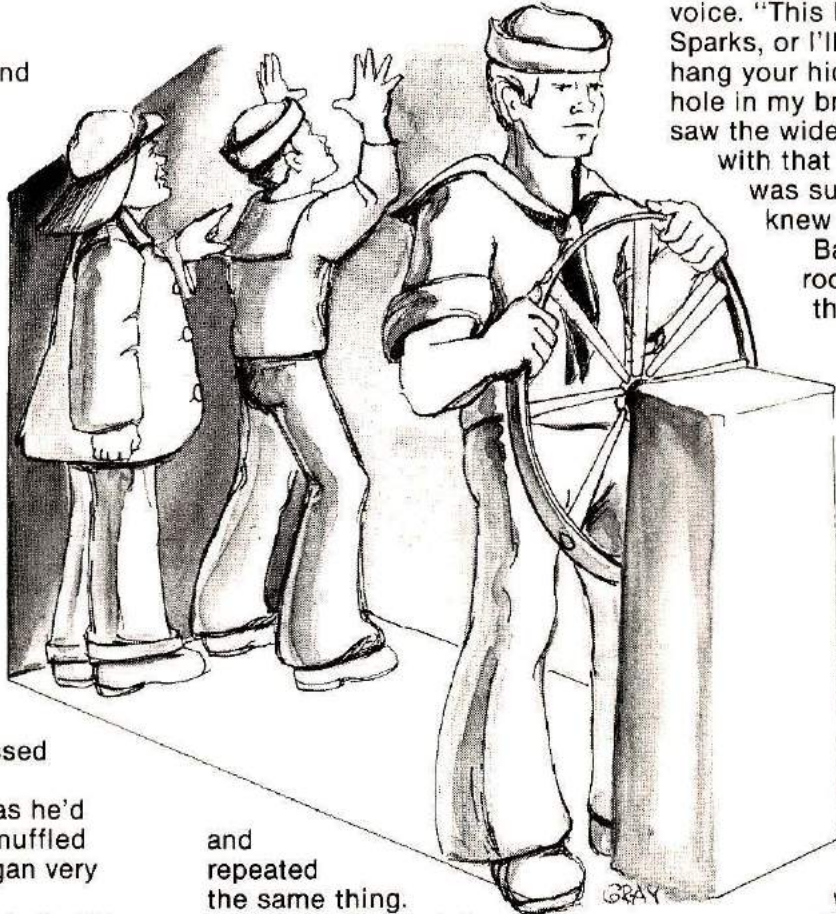

and repeated the same thing.

"Mister Peacock," the Old Man ordered, "get the carpenter up here on the double with a key-hole saw, brace, and large auger. Also tell him to bring a bos'n's chair. We'll need it to get at the outer panel."

Twenty minutes later a rough hole about eight feet in diameter was letting fog pour into the bridge. Andy had his head halfway through the hole, carefully inspecting the big, diamond-shaped loop for damage. He straightened up, turning off a small battle light. "It's perfect — just like new."

He looked at the skipper. "Do we have a stop watch aboard?"

"Sure do!" The Old Man opened a small cabinet and handed the timepiece to Andy. Andy immediately took off at a trot toward the bridge wing.

"Where you headed now, Sparks?"

"The radio room, sir."

"Mister Peacock, see that he gets there all in one piece, will you." The Old Man lifted his voice. "This better be good, Sparks, or I'll skin you and hang your hide up to cover that hole in my bridge shield." Andy saw the wide grin that went with that last remark, and was sure the skipper now knew what he was up to.

Back in the radio room Andy fired up the Telefunken D.F.

set and tuned in the beacon at Point Loma. He first rotated the wheel until the signal dipped almost to inaudibility.

"Mister Peacock, do you read German?"

"A little."

"Fine. Would you please look over this panel and see if there's a switch or button

labeled with a word meaning something like sense.

That's s-e-n-s-e."

Studying the panel, Peacock finally reached out and pressed down on a flush black square that Andy hadn't even noticed before. The signal in Andy's phone instantly became very loud. "Thanks sir," Andy grunted over his shoulder. "I can take over now."

Andy now rotated the wheel a full 180 degrees, until the signal coming from just north of San Diego again dipped into the noise. He stabbed the square patch on the panel. No signal increase occurred. Andy

called out a D.F. bearing and Tolin wrote it down. Without thinking, busy as he was, Andy snapped:

"Mister Peacock. Get the bridge on the horn. I want the ship's bow heading."

"Yes sir," the warrant officer laughed.

Just then the skipper came pushing into the radio room, his arms filled with rolled maps. Parallel rules protruded from his coat pocket. He went over and held a booklet in front of Andy's eyes. "I think we can use this, Sparks." The cover said SOUTHERN CALIFORNIA AREA MARINE RADIO BEACON LISTINGS.

Working from the bearings Andy kept calling out, the skipper and Peacock looked up the latitude and longitude given for each beacon, then drew a line on the chart from each of these land points out to sea along the D.F. bearings Andy gave them. Three of the lines intersected at a point to the south of Catalina Island, but the fourth missed that intersection by about 10 degrees.

"Sparks," the skipper asked, "how good is that thing? I mean, how accurate a bearing can those sets produce?"

"In this frequency range about plus or minus one degree if you are an experienced operator, if you're not looking parallel to a coast of land, and if your D.F. set's been recently calibrated. I wouldn't trust my bearings too far."

"Why not?"

"First," Andy said, "I've never operated a D.F. set before; just going by the theory I learned in radio school. But the worst thing about our situation is that conductors like metal braces, pipe supports, and stuff like that surely must have been added near the loop at the yard. They will introduce an error in the loop bearings."

"Okay," the skipper said, drawing a small circle around the intersection of the four bearing lines, "I'll look on this as a sort of dead reckoning position. Now I'm curious

about why you asked for that stopwatch."

"Oh that," Andy smiled, "Well, you see I'd like to keep taking bearings while we make a course for the Long Beach breakwater light at the harbor. When we get close enough, we should be able to hear the fog horn. That horn blast starts at the same instant the radio key of the beacon there starts sending that long radio dash. Now . . ."

"Say, I'm way ahead of you," the skipper put in. "Sound travels at about point two miles per second. You'll have to tell me how fast radio waves go, but, if I remember right, their speed is damn near instantaneous compared with that of sound. So when you hear the start of that radio dash, you start the stop watch. When a man on deck outside that porthole hears the horn, he sings out and you stop the watch. The time difference in seconds, times the speed of sound, is our distance off shore. You're using that as a check on my navigation."

"That's about the size of it, sir. Now, if we only had radar to keep clear of other ships in the fog on the way in."

* * * * *

Chief Radioman Andrew Bark kissed his new wife at the gate to the North Point pier, then beamed with pride as he watched her smoothly turn the beat-up Ford and move off into traffic. The Marine guards at the gate waved him through and Andy began to whistle *Don't Sit Under The Apple Tree With Anyone Else But Me*. The California sun was shining, the oily water in the harbor sparkled, and he felt ten feet tall in his new tailor-made dress uniform. In the distance, along the long gray lines of AK's and DE's tied up to the pier, he made out the *Torfin* with her silly little 20-mm cannon perched on her homely nose. In a few effortless strides he went up the boarding ramp,

halted, and snapped a salute to the flag on the stern. The seaman on ramp watch said laconically:

"Captain says he wants to see you, Chief, the moment you hit the deck."

Andy knocked, even though the cabin door was open, and grinned as he observed the newly installed kick-out panel. At the sound of the skipper's voice, he shoved his cap under his arm and entered.

"Sit down, Chief, sit down," the Old Man said, shoving some paperwork across the desk. He carefully cleared his throat.

"Now, as you can see, I wasn't able to procure a new issue D.F. set right now. Didn't try too hard, either. Instead, I've arranged for us to make a run off Vicente and recalibrate that old Telefunken job. After all, it does sort of belong aboard, so why not use it. Anyway, Bark, you've got the whole job. Just spell out what you want us to do and we'll snap to."

"That's great, sir. It'll sure be handy to have that thing working accurately."

"You don't have to convince me, Bark. After all, I kind of recall having a fine ship of mine saved by some landlubber using a set just like it once." The Old Man leaned back expansively in his chair.

"Now, I've got a few old shipmates in the right places at Eleventh Naval District. I'm figuring to do a little arm twisting to get us a radar, one of those new Identity, Friend or Foe gadgets, and a set of hydrophones. That stuff can be installed when we put in the yards next month before heading for the Pacific Theater." The skipper paused and looked Andy straight in the eye.

"As I always say, there's nothing like having your ship outfitted with good electronic aids, eh, Chief?"

Men working on deck looked up at the sound of uproarious laughter coming from the direction of the captain's cabin.

HRH

WHERE RELIABILITY AND ACCURACY COUNT

INTERNATIONAL CRYSTALS 70 KHz to 160 MHz

CRYSTAL TYPES

(GP) for "General Purpose" applications
(CS) for "Commercial" equipment
(HA) for "High Accuracy" close temperature tolerance requirements

International Crystals are available from 70 KHz to 160 MHz in a wide variety of holders.

WRITE FOR INFORMATION

International
Crystal Manufacturing Co., Inc.
guarantees
every crystal against defective
materials and workmanship for
an unlimited time, when used in
equipment for which they were
specifically made.

HOLDER TYPES

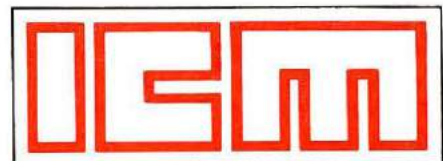
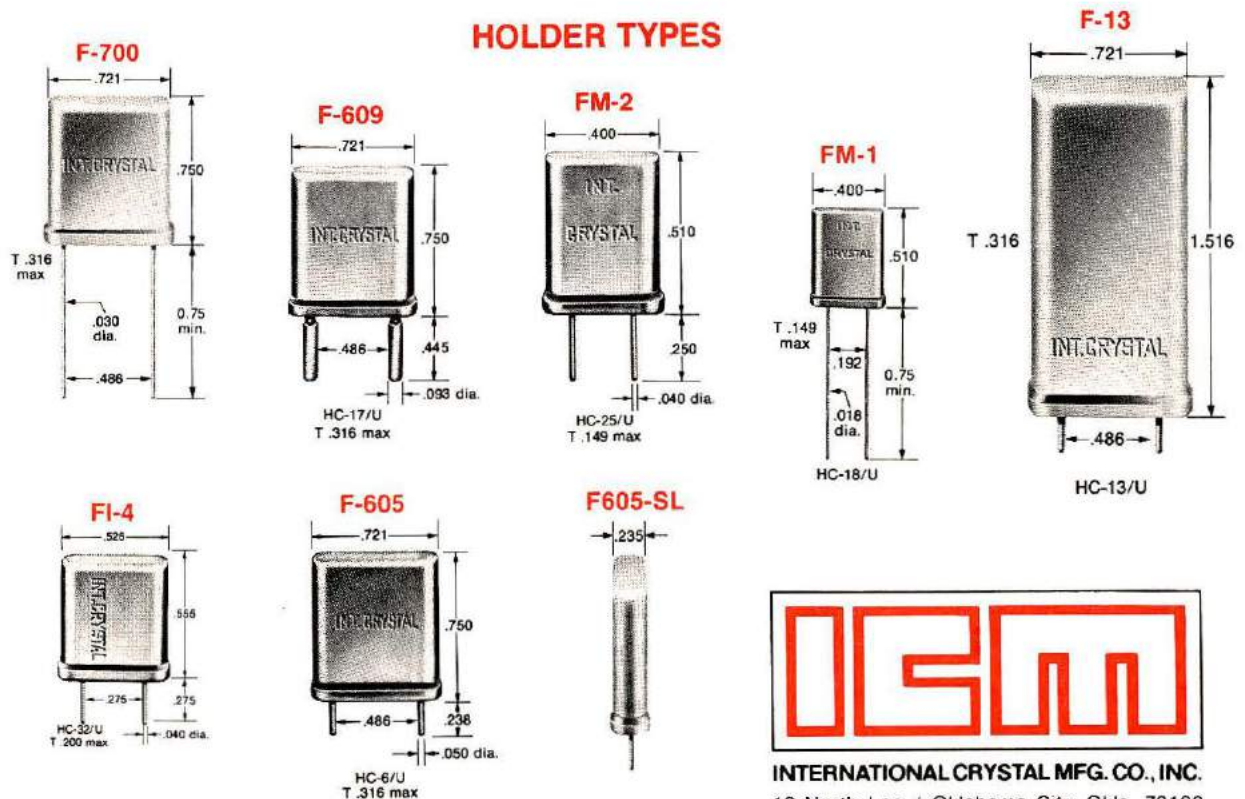

INTERNATIONAL CRYSTAL MFG. CO., INC.
10 North Lee / Oklahoma City, Okla. 73102

S-METERS AND SIGNAL REPORTS

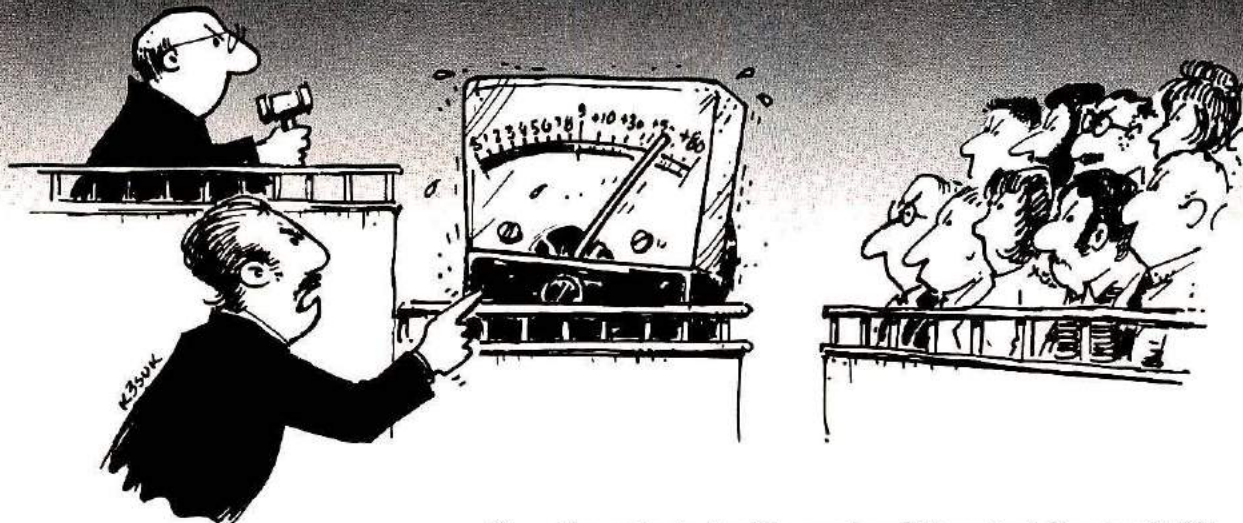

“... the whole truth, and nothing but the truth?”

BY KARL T. THURBER, JR., W8FX/4

“Forty dB over S9.” Not a bad signal report, indeed — certainly it’s as much fun to receive as to give. But does it mean that your signal is being received some 10,000 times better (stronger) than if you had received a mere S9 report, as the math would suggest? The answer to that question is both yes and no. In this article, we’ll try to see just why that is the case.

True, it’s a matter of pride to see how many “dB over S9” we can push up the other fellow’s S-meter with our signal. But, as we shall see, there’s a bit of flim-flam associated with S-meter readings — and the readings themselves really can’t be taken at face value. They must be interpreted, and a little judgment must be applied to both the receiving and giving of signal-strength reports. In this article we’ll take a look, first, at the RST (readability/signal-strength/tones) system of reporting, then we’ll talk about

how S-meters work and touch lightly on the mathematics of the decibel. We’ll also point out some S-meter calibration pitfalls and suggest how to realistically use your own S-meter. Finally, we’ll ask if there may be a better way of signal-strength reporting.

The RST system of signal reporting

Over 40 years ago the RST signal reporting system came into general use by amateurs who realized the value and importance of being able to determine how well their signals were being received on the other end of a contact — and, of course, every ham still wants to know how well reception is on the other end. The RST system, from the beginning, was recognized as being relative but at the same time objective. After all, if you didn’t give and receive useful reports, what was the sense of exchanging them? See **Table 1**.

The first element in the code is that of readability. It ranges

from a 1 for *unreadable* to a 5 for *perfectly readable*, with three intermediate, in-between shadings possible. This part of the system gives us few problems.

The second element in the code is signal strength — this gives us the most trouble. S1 indicates a barely perceptible signal and is supposed to represent the weakest signal that could be detected on receivers of the period when the system was developed. From S1, numbers increase to S9, which indicates an extremely strong signal. The scale was set up so that the difference between consecutive S units or numbers represented the minimum change in apparent volume that the average person could detect by ear; this works out to be roughly a four-to-one change in power level. Since there are 8 S units or intervals between S1 and S9, the total change is about 50 dB, a very considerable signal range. (Until about 30 years ago, most

S-meters registered to S9 and no higher. Later on, however, it became fashionable to allow for even stronger signals to be indicated on the meter without running out of S units — driving offscale or pinning meter readings on the right.)

From this you can see that if the S-meter is really calibrated along these lines, each S unit represents an approximate 6 dB change in received signal strength (that is a change by a factor of four). To increase the strength of your received signal on the other end of your QSO by 6 dB requires increasing your transmitter power four times, other factors being equal. Or, if the other fellow should be so unkind as to give your QRP rig an S1 report (he obviously doesn't want a QSL card from you), you'd have to increase your power by 100,000 times, or go from about one watt to 100 kW, to reach S9 on his meter, to use but one example!

The last part of the RST code refers to signal tone, which is used to indicate CW signal quality. This was a very important indicator in the days when power supplies were barely filtered and keying

techniques weren't nearly as sophisticated as they are today. The scale runs from 1 to 9, a 1 indicating an "extremely rough hissing note," a 9 standing for a "purest dc note." It later became a courtesy to add letter suffixes to the report: if the signal had the steadiness of crystal control (no drift), the letter X was added to the report. But if the signal had a chirp, the letter C was added. And if key clicks were heard, K was added.

The "tone" part of the RST system doesn't present much of a problem, although it is actually the most subjective part. However, many hams have trouble reconciling what they should give a station for the tone element with what they actually give. Many chirpy, clicky signals are heard, which often receive ritual RST 599 reports.

The RST system is used in phone operation as well, but the tone part is, of course, eliminated. In working through fm repeaters, however, the RST code isn't too useful because what you're really reporting is how well you're receiving the repeater. More helpful to the other fellow is a plain-English

description of his signal through the repeater or how noise-free his signal is (what degree of receiving quieting it possesses), especially when working direct or simplex.

As we've seen, the R and T portions of the system don't cause too much concern, but the S part is a good deal more troublesome — yet it's supposed to be the most objective and "scientific" part of the whole thing. For an answer to this apparent contradiction, we must understand how S-meters work and also know a little more about the decibel.

How S-meters work

Many kinds of S-meter circuits prevail, but most of them work indirectly from the agc (automatic gain control) or avc (automatic volume control) bias voltage developed in the receiver. As the agc or avc voltage increases, the meter swings up-scale. Most S-meter circuits detect changes in the current of the i-f amplifier stages as the signal level rises or falls. Either way, some of the i-f signal is tapped off, amplified, rectified, and produces a dc current or voltage for the S-meter.

The meter can't be connected directly across the agc or avc line because the meter would appear as a short circuit. Instead, amplification is provided through a separate agc/avc amplifier stage. (Some inexpensive tube-type receivers have this amplification in a stage already serving as an rf or i-f amplifier. This is economical but can interfere with the normal operation of the stage.)

You may wonder why some S-meters appear to be built backward, so that the needle rests on the right side of the scale (rather than on the left) and moves to the left as current increases, or even appear to be mounted upside down with the meter scale inverted so that it reads "right-side up." This is because

Table 1. The RST system of signal reporting. Many short wave listeners prefer the more comprehensive SINPO code for signal reporting, as described in the text. Whichever system you use, be honest in your signal evaluations. Use the definitions in the table as a guide for reporting realistic signal information.

readability	tone (CW only)
1 Unreadable	1 Rough hissing note; very rough ac tone
2 Barely readable	2 Very rough ac note; harsh and broad
3 Readable with considerable difficulty	3 Rough ac note; appears rectified but not filtered
4 Readable with practically no difficulty	4 Rough note; some trace of filtering
5 Perfectly readable	5 Filtered and rectified ac but with strong ripple modulation
signal strength	6 Filtered tone but with trace of ripple modulation
1 Faint signals, barely perceptible	7 Near pure note, some trace of ripple modulation
2 Very weak signals	8 Near perfect tone, slight trace of modulation
3 Weak signals	9 Perfect dc note, no trace of ripple modulation
4 Fair signals	
5 Fairly good signals	
6 Good signals	
7 Strong signals (moderately so)	
8 Strong signals	
9 Extremely strong signals	

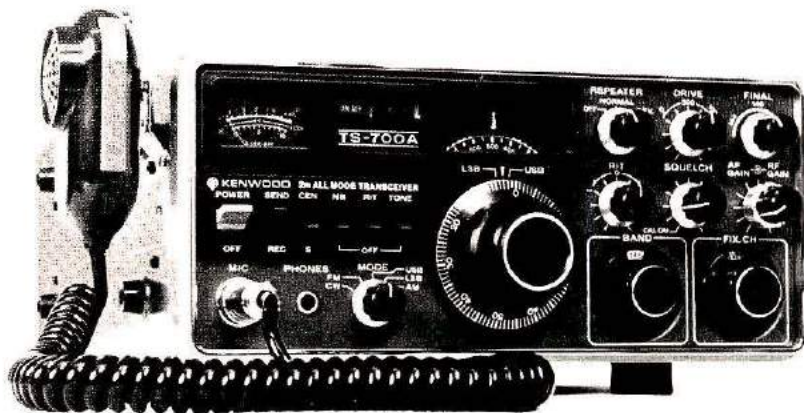

Manufacturers use a wide variety of calibration standards and dynamic ranges for their S-meters. This transceiver S-meter is calibrated from S1 to S9 plus 40 dB.

(especially in older tube-type equipment), the avc line feeding the S-meter produces a larger negative voltage on strong signals, reducing the current flow through the S-meter amplifier. Without special construction, many S-meters would read backward, with strong signals indicated on the left side of the face and weak signals on the right. Most S-meters are fairly heavily damped so that they don't swing too widely on small variations in signal strength caused by rapid flutter or fading.

An ideal S-meter would be calibrated in microvolts rather than in S units, since the latter is only a very indirect indication of signal strength at the receiver antenna terminals (which is what we're really interested in). Such an ideal meter would read near zero on background noise, and readings would be constant when switching between bands. Readings wouldn't be affected by impedance mismatch at the antenna terminals, by different i-f gain-control settings, by tube and component aging, or other factors that make accurate and consistent readings hard to come by. Such a meter would really be a precision field-strength meter — an instrument we're not likely to

see in any reasonably priced Amateur or SWL communications receiver.

Before discussing the problems of S-meter calibration and suggestions as to how to best use your S-meter, it's useful to get ourselves firmly grounded in just what constitutes an S unit. Let's look now at the basic unit of signal change, the *decibel* (dB).

Decibels and S-meters

The decibel isn't at all forbidding once you understand a few basic facts about the subject. A little knowledge about decibels will also help you interpret antenna, microphone, and receiver-gain advertising claims.

Understanding the decibel: the decibel, which is 1/10 of a *bel* (named for Alexander Graham Bell), is simply the *logarithm of the ratio of two power levels*. It's not a real or absolute quantity at all — just a ratio of relative measurement. The decibel is supposed to represent the change in audio power level that's just detectable by ear under ideal conditions, based on the fact that the human ear has a logarithmic response to sound. Stated mathematically:

$$dB = 10 \log P_2/P_1 \quad (1)$$

This ratio is basically a

power ratio (what we're most concerned with in communications work) where the output power, P_2 , is some ratio of the input, P_1 .

The decibel can also be expressed in terms of either voltage or current. (However, note that voltage or current gain or power comparisons expressed in dB should be measured across the *same value* of impedance otherwise the ratios won't be correct — it's sort of an "apples and oranges" type of comparison if you don't have a common impedance base for measurement.)

When used to compute decibels in terms of voltage or current, eq. 1 becomes:

$$dB = 20 \log E_2/E_1 \text{ or } I_2/I_1 \quad (2)$$

where E_2/E_1 and I_2/I_1 are the voltage or current ratios respectively.

The mathematics aren't really as formidable as they appear. It's a matter of simple arithmetic, really, with the use of published logarithm tables. (Or perhaps your calculator has a key for obtaining logarithms.) For example, here's how the first entry of **Table 2** was obtained mathematically:

$$dB = 10 \log P_2/P_1 \text{ (for power)}$$

The ratio is 1.25, which is the ratio of 100 watts to 80 watts (for example). So,

$$dB = 10 \log 1.25$$

The logarithm of 1.25 is 0.09691. Multiply this number by 10 and you have 0.9691, which rounds off to 1.0 dB. Now, to find the dB equivalent for the same voltage or current ratio, all you do is multiply the log of 1.25 by 20 (eq. 2), which yields 2 — just twice that for power.

If you work out the math you'll see that a four-to-one power increase is equivalent to a 6-dB increase, or one S unit; a two-to-one increase is a 3-dB (half S unit) change; whereas a 25 per cent power increase is but a 1-dB change. The process also works in

reverse; if P1 exceeds P2, you have a negative change, or a dB loss. **Table 2** gives common dB, power, and voltage ratios.

The beauty of the decibel system is that you can add decibels (just as you can logarithms) rather than multiplying. For example, you can just add circuit gains of successive amplifier stages, or even add and subtract power amplifier gain, transmission-line loss, and beam antenna gain to arrive at composite gain figures.

Most amateurs think of the dB as a simple ratio — a relative unit, as used in the S-meter. However, you can increase dB flexibility by assigning to it a reference level as a basis for comparison or measurement. Any signal characteristic and level can be used as a reference so long as the reference is related to power. For example, in antenna measurements, gain is usually compared with a simple dipole (dBd) or an isotropic or "point-source" radiator (dBi).*

Audio or rf power levels may be stated in terms of dBm, which is becibels referenced to



S-meters are relative signal-strength indicators. But an attenuator such as this can be used to reduce the signal passing through the meter and thus can be used to make accurate comparisons of different signal levels feeding your receiver. Such a device is useful in working with antennas, checking preamplifier gain, or evaluating the real effect of a friend's linear amplifier or a beam antenna (*Photo courtesy B&W.*)

a level of 1 milliwatt through a known resistance, usually 50 ohms. You may see other references, too, such as dBW (1 watt) or dBn (thermal noise). In receivers, sensitivity is often shown as being so many microvolts for a "10-dB signal-to-noise plus noise" ratio, and so on — the possibilities are endless.

Guidelines for using decibels

From this discussion of decibels there are some rules of thumb to remember that will

come in handy when evaluating signal reports, buying antennas, or deciding whether to invest in a new rf amplifier.

The first is that, whenever you double the power ratio, you add 3 dB on the decibel scale (6 dB if you're working with voltage).

The second thing to remember is that each 10 dB represents a power-of-ten change in the power ratio (20 dB for voltage). You can also state this rule another way: for each zero in the power ratio, add 10 dB. Thus, a ratio of 1000-to-1 in power is equal to 30 dB (three zeros in the number).

Related to this rule-of-thumb is a third thing to remember when working with decibels: adding decibels is just like multiplying power ratios.

A fourth point to remember is that the rules of thumb we've mentioned for power ratios also hold for voltage ratios — that is, the voltage ratio in dB is just twice what the rules for power ratios would have it. Still unclear? A look at **Table 2** will show how these rules-of-thumb are related. See if you can verify the tables yourself!

Decibels and the S-meter: this discussion of decibels and a glance at **Table 2** should make it plain that if S-meters were perfectly calibrated and could therefore be taken at face value, there's a really whopping change between an extremely weak S1 signal and a needle-pinning signal of 60 dB over S9. Next time you're pleased to receive an exceptionally complimentary signal report, you might want to try reducing

*We're a bit afield of our S-meter discussion, but no mention of decibels is complete without cautioning you to read antenna gain figures very carefully. Antenna gain can be referenced against either the dipole or the isotropic source. A dipole is a better antenna than an isotropic radiator, having a theoretical gain of 2.1 dB over the latter. Thus you may possibly see an ad for a "wonder dipole" that advertises a "2.1 dB gain." Beware!

Table 2. Handy decibel chart showing relationships between dB ratios in terms of power and voltage. (For convenience the values have been rounded off, and some values have been deleted when odd ratios occur.) The chart can be used to obtain dB changes instead of working out the mathematics in the text.

dB power	ratio	dB voltage	dB power	ratio	dB voltage
1	1.25	2	21	125	42
2	1.56	4	22	156	44
3	2.0	6	24	250	48
4	2.5	8	25	312	50
5	3.125	10	27	500	54
6	4.0	12	28	625	56
7	5.0	14	30	1000	60
8	6.25	16	31	1250	62
9	8.0	18	33	2000	66
10	10.0	20	34	2500	68
11	12.5	22	35	3125	70
12	16	24	36	4000	72
13	20	26	37	5000	74
14	25	28	38	6250	76
15	32	30	39	8000	78
16	40	32	40	10,000	80
17	50	34	41	12,500	82
18	63	36	44	25,000	88
19	80	38	47	50,000	94
20	100	40	50	100,000	100

power from, say, 1000 watts to 250 watts, or from 100 watts to 1 watt to see where you now fall on the other fellow's S-meter. The odds are that (assuming stable band conditions) you won't drop as much on his meter as you might expect; or at least you won't drop exactly in proportion to the drop you might expect from a look at the dB chart of **Table 2**.

Reducing power: How much should your signal change on the other fellow's S-meter if you reduce power? Assume that he has given you an S9 signal report and you're running 500 watts output. In that case — given no fading and an accurate S-meter with 6-dB S-unit intervals; if you cut your power to 125 watts, your signal should now read S8; reducing to 31 watts, S7; 8 watts, S6; 2 watts, S5.

If he's still copying you, reducing power to 0.5 watt, you should read S4 and so on. If the band isn't too noisy or plagued with interference, he may still hear you at these QRP levels, since S1 represents a signal level of about 0.4-0.5 microvolts. This point lies just on the threshold of hearing of most modern receivers and transceivers.

Armed with this knowledge of decibels, you might want to construct a simple experiment on your own S-meter, not only as a check on it, but to get a feel for what really happens to signal strength on the other end of a contact when a linear amplifier or beam antenna is used.

Often you'll hear reports indicating that when a linear is kicked in, the signal improves 20-30 dB on the other end. Normally, such a dramatic increase in signal strength just isn't real, since you'd have to increase power from 10 to 1000 watts for a 20-dB increase. (Typically, if you go from 100 watts "barefoot" to a full kW, your signal should increase more like 10 dB, remembering

our "power-of-ten" rule, or going to **Table 2**.

That matter of calibration

S-meters vary widely in their calibration accuracy. This isn't surprising when you consider the fact that, first, the meter only indirectly represents some quantity (received signal strength at the antenna terminals, as measured in microvolts); and second, many variables in different receivers (and even identical receivers of the same type) affect S-meter readings as well. Let's now turn to some of the problems of calibration.

Hams have been complaining since the first S-meter was tacked onto a receiver that his meter was either "scotch" or "Santa." Some meters could barely be coaxed up to S9 on the strongest of signals, while others read S8 on background noise. Normally, S-meter calibrations are set so that the noise runs about an S1 to S3 and an extremely strong, noise-free signal registers S9 or higher. The average signal reads S6-S7 with just a trace of noticeable background noise.

Manufacturers' standards:

Probably the most important reason why S-meter readings are hard to compare with each other is that the different

receiver and transceiver manufacturers don't all use the same standard. Each has his own method of calibration as well, and component variations in receivers of the same model and make may cause the S-meters to act differently.

Around World War II some attempt at standardization was made, with most (but not all) manufacturers agreeing that a signal of 50 microvolts at the antenna terminals would represent an extremely strong, or S9, signal on the meter. Most meters were physically designed so that this occurred at about midscale. The divisions below S9 were marked in 6-dB units down to S1, and increments above S9 were ticked off in 10 dB chunks of up to 40 or 50 dB (or more).

Looking at some of the more popular manufacturers' products, National, Drake, Hallicrafters, and Hammarlund receivers all register S9 with a 50-microvolt signal input. However, Swan and Collins equipment requires a 100-microvolt signal for an S9 reading. All have 6-dB S units, except for Drake, whose scale is divided into 5-dB S units. (See **Table 3**.)

Most of these "standards" assume a 50-ohm receiver input impedance with readings accurate only on a stated



This Yaesu hf transceiver S-meter is calibrated to S9 plus 60 dB and therefore represents a total dynamic range of about 110 dB. Thus, the strongest signal that can be registered on the meter will be millions of times stronger than the weakest detectable signal. Actual S-meter readings will vary from band-to-band and from receiver-to-receiver. (Photo courtesy Yaesu Electronics.)

frequency band. (Many imported radios use different standards, and some don't seem to use any at all — or they're not saying so in the instruction manual!)

S-meters, old and new: after World War II, when S-meters became fairly common on ham receivers, most went only to S9, which was considered to be an extremely strong signal; stronger signals just pinned the needle on the right. The recent trend has been to higher and higher calibrations, up to 80 dB or more above S9. A glance at **Table 2** shows how unrealistic the very high dB scales probably are. For example, a 100-microvolt signal (S9 on many meters) would rise to a full 1 volt at the antenna terminals at 80 dB over S9. This is a voltage ratio of 1:10,000. Over long signal paths, only super-power transmitters, very high-gain antennas, and good propagation conditions can really produce signal levels such as these! (See **Figs. 1** and **2**.)

S-meter variations: besides the differences between manufacturers as to how their S-meters should read, many other complications make S-meter readings suspect at best.

Table 3. Comparative S-meter calibration standards used by various American receiver manufacturers in terms of microvolts required at the receiver antenna terminals to produce an S9 reading. Some overseas manufacturers use different standards, and some don't say what standards they're using.

manufacturer	microvolts at antenna terminal for S9 reading
Hammarlund	50
National	50
Hallicrafters	50
Swan	100
Collins	100
Drake	50

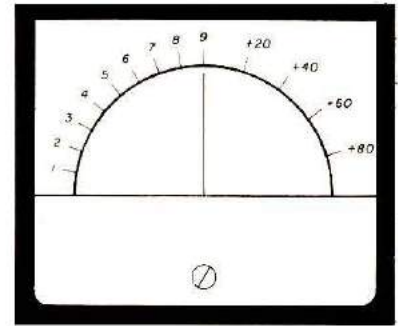
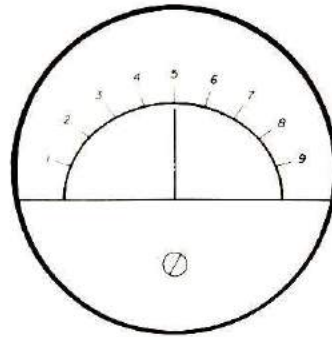

Fig. 1. When S-meters first became popular the scale usually went to only S9, which represented an extremely strong signal. On today's meters, S9 is usually at midscale and readings progress to 40, 60, or even 80 dB above S9. Are such readings realistic?

For example, most receivers and transceivers have an S-meter adjustment control, which is used to zero set the S-meter with no signal input and with the rf-gain control at minimum. The meter can get out of adjustment. Also the setting of most receivers' rf gain or attenuator controls affects S-meter readings. In most cases, the controls must be set all the way open for the meter to read as it should. Change the settings and you change your S-meter calibration.

Variations in the tubes or transistors in the S-meter amplifier circuit, as well as components in the rf and i-f amplifiers, can and do affect meter accuracy. As components age meter readings are affected, although overall receiver performance may not be noticeably affected. Variations in receiver gain between bands can also cause wide differences in S-meter readings from band-to-band. Usually, the lower bands favor more generous S-meter indications. (Ham-band-only equipment is a little better than general-coverage gear in this respect.)

Even variations in the receiver local-oscillator injection level from band to band may cause S-meter readings to be inconsistent. And, of course, the manufacturer's S-meter calibration standard assumes a given receiver input impedance;

if this changes, readings will not be uniform or accurate.

One other important factor in S-meter variations is that the characteristics of the avc or agc circuit affect readings. Different avc circuits have different time constants or response times. Component values can change, which in turn affects the overall avc or agc voltage levels from which the S-meter derives its input. Also, when tuning a weak signal close to a very strong one (especially with the rf gain wide open), the stronger signal is likely to take control of the agc circuit and cause the S-meter to respond to it rather than to the signal you're actually trying to copy. This effect is especially pronounced in receivers with insufficient i-f skirt selectivity to reject strong adjacent signals.

When receiving CW and ssb, another problem arises. The S-meter may not be able to follow the CW keying or ssb voice modulation fast enough; it tends to bounce like a rubber ball trying to keep up with signal peaks (some receivers have selectable agc time-constant speeds, which help to minimize, though not eliminate, this problem.)

Using rf and af gain controls: While it's usually necessary for the meter's electrical and mechanical zeroing controls to be accurately set, and for the rf gain control to be run wide open for reliable readings, bear

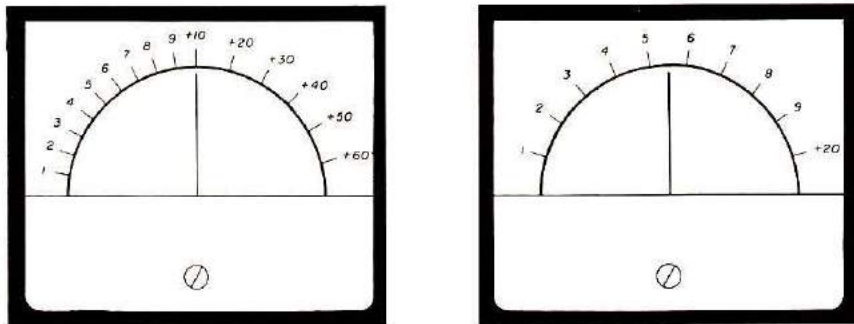

Fig. 2. S-meter scales are suspect just from an examination of their physical appearance. The scale at left is designed to produce very inflated readings compared with the more modest scale of the meter at right. As indicated in the text, neither should be taken at face value.

in mind that the purpose of the rf gain control is not to fine-tune the S-meter. Instead it should be used to help ensure that the proper signal level is presented to the receiver i-f strip and detector. There's usually an optimum setting or balance for your rig's rf and af (audio frequency) gain controls that will minimize signal distortion yet provide adequate sensitivity without overloading. Try running with the audio gain control advanced about halfway (especially for CW and ssb reception). Then adjust the rf gain control for clearest reception, forgetting for the moment about the S-meter. This procedure usually produces the best signal-to-noise ratio with minimum distortion.

How to calibrate your S-meter: to custom-calibrate your S-meter for more accurate signal reporting, you can use a signal generator with a calibrated attenuator and known output level to calibrate your S-meter in terms of microvolts. You can establish a 50-microvolt reading at midscale (S9), with weaker signals spread out on the lower end of the scale, and stronger signals on the right, above S9.

Using the signal generator, you can tick off markers at every 6-dB point to indicate S1 through S9; markers can be established at any convenient interval above S9, say at every 10-dB point. Another even simpler way to calibrate is to

run the generator output into your receiver and note the signal level that just *barely* moves the meter; call this point S1. Advance the signal generator in 5- or 6-dB steps, marking the S-meter with another S-unit at each step until S9 is reached. Mark off 10-dB steps thereafter.

Most of us don't have access to such elaborate rf test equipment, and going through such tedious calibration procedures probably isn't worth the trouble. But you might try something like the following procedure, which should serve well enough for most purposes:

1. Disconnect your antenna and short circuit the antenna terminals.
2. Tune the receiver or transceiver to a given band.
3. Mechanically and electrically zero the S-meter according to instruction-manual procedures.
4. Reconnect the antenna and remove the short from the antenna terminals.
5. Adjust the S-meter sensitivity control (if there is one) until the receiver S-meter reads full scale on the very strongest signal you can find, as from your own transmitter or a very strong local station.
6. Adjust the receiver rf gain control or attenuator control until the receiver S-meter reads between S1 and S3 on background noise. Note this setting.

7. Use the rf gain control or attenuator to adjust incoming signals, then return it to the setting marked in step 6 when you want to make a calibrated S-meter reading.

You may have to modify this procedure to coincide with your own equipment calibration procedures contained in the instruction manual. You may also find that you'll have to repeat the procedure when changing bands in order to get consistent readings.

Realism: is there a better way?

After saying all this, just what can your S-meter reasonably be used for? We've shown that it's difficult to calibrate the S-meter accurately, and it can't be relied on for true measurements of signal strength. However, there are some practical and prudent uses for your S-meter:

A. As a *relative signal strength indicator*, to help you compare apparent differences in signal strength of signals on a given band at a given time.

B. As a *tuning meter* to help you tune in an incoming signal and center it in your receiver's i-f passband. You can't place a signal right on the nose using your S-meter alone, but you can at least get into the ballpark by using the meter as a convenient tuning aid. (However, be aware that in fm work, a zero-center deviation meter is more useful in accurately positioning received signals in the i-f passband.)

C. As a *relative field strength meter*. This is useful in working with a nearby ham in helping him adjust or tune his antenna system. Received signal-strength indications on your meter will follow the results of his adjustments (such as tuning, positioning, cutting beam elements, and making comparisons between two or more antennas).

Note that while your S-meter can't be used to make absolute

readings, if you use it with a calibrated rf attenuator as shown in Fig. 3, you can obtain fairly accurate measurements of dB changes in received signal levels; this would be helpful, for example, in checking the front-to-back ratio of a friend's beam antenna.

Reliable results depend on a stable transmission path with no fading, so it's practical to make such checks and comparisons only with a local ham — if you try it on DX, you can't be sure of the results.

To use the attenuator, try the following procedure:

1. Set the attenuator for zero or no attenuation.
2. Observe and note the two signal levels on the receiver S-meter.
3. Adjust the attenuator to cause the same change in signal level as previously noted on the meter.
4. The amount of attenuation needed to cause an identical change in S-meter reading is the actual number of decibels the signal varied, regardless of any S-meter inaccuracies.

This technique should be useful in conducting antenna experiments and for measuring the true gain of preamplifiers used with your transceiver or receiver. Barker and Williamson make an inexpensive attenuator, or you can build your own from designs in the *Radio Amateur's Handbook*.

Note: If you use such an attenuator with your transceiver, be sure to switch it out of the line or disconnect it before applying rf (transmitting). Step attenuators of this kind are designed for very low power levels!

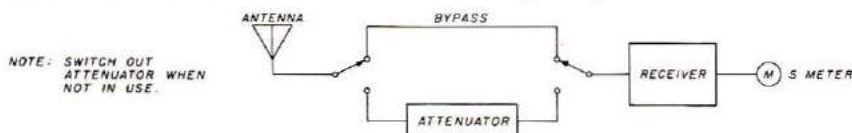
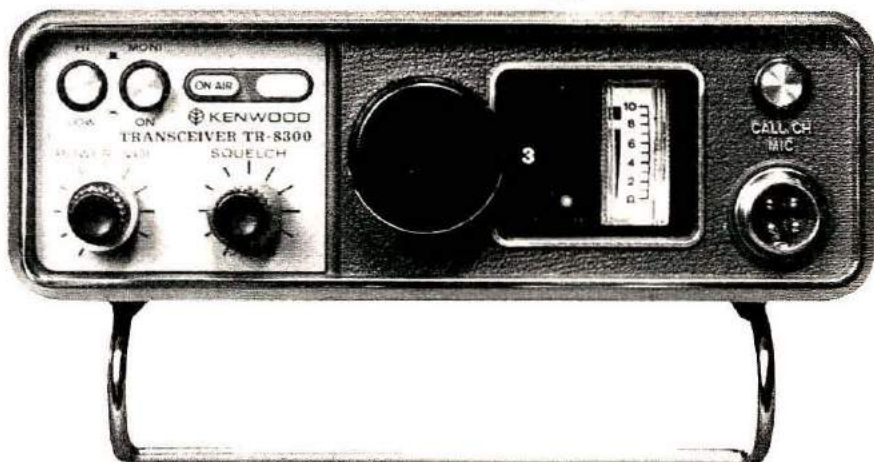

Fig. 3. Measuring signal-level changes with a step attenuator. Signal levels are relative. However, we can still make a fairly accurate comparison of signal-level changes between two signals of interest by inserting a step attenuator in the coax cable to the receiver. It's important that the attenuator be switched out when not in use if your rig is a transceiver (see text).



There really isn't a great need for an S-meter when operating through repeaters. But it's a handy device to use as a tuning meter during transmitter hunts and for simplex work. All S-meter calibrations are relative despite what the instruction manual may say. This Kenwood transceiver goes all the way in this respect; it doesn't even use regular S units on its scale but rather a simple 0 to 10 calibration. (Photo courtesy Kenwood.)

D. As a *rough beam-positioning indicator*. You can use your S-meter as a cross check on your beam directional indicator by peaking it on received signals after first roughly positioning your antenna by the compass. (See if they coincide.)

E. As a *peak or null meter for rf bridges*. These devices need some kind of indicator of bridge balance or tuning. Most receiver noise bridges (used to tune and adjust antennas of all kinds without requiring you to feed rf into the antenna) make use of your receiver S-meter to detect a noise peak or null, which in turn indicates antenna resonant frequency.

S-meter psychology

Various writers have suggested technical improvements in S-meters, such as spreading out scale units to create wider spacings with 9- or 12-dB intervals, thereby requiring much stronger signals to drive the

meter to full scale. Others have suggested trying to compress the total S-meter range into a 70-dB scale, based on the fact that, on peaks, normal human speech exceeds the audibility threshold by about this much. These suggestions are good attempts at realism, but they don't solve the calibration problems we have highlighted, not to mention the psychological aspects of signal reporting.

The business of "S-meter psychology" is very real indeed, and has a considerable impact on all aspects of reporting. Even assuming a perfectly calibrated S-meter, two persons observing the very same signal on the same receiver may not agree as to the correct S reading. Many operators also add or subtract a personal fudge factor, which takes into consideration their own estimation of their equipment and antenna as well as subjective factors such as whether the other station is DX, is using flea-power (QRP) equipment, and so on. And, sadly, many operators (particularly in contests) can't be bothered to separate the men from the boys in doling out reports, giving 579 CW and 59 phone reports as a matter of ritual, regardless of signal strength and quality.

While we've talked here mostly about S-meters themselves, it may just be that our whole system of RST reporting needs revamping. It may be that the full 9-unit-plus S-meter scale may be a bit misleading and perhaps even ridiculous. Back in the thirties, the simple QSA scale (S1 to S5, from weakest to strongest signal) had a lot going for it, because the five possible reports were really all you could say about a signal.

The present RST system has been used for over 40 years and has served its purpose well. But it doesn't tell the fellow at the other end anything about propagation conditions, interference noise level (which may itself be S9), or overall signal merit. Serious swls (short-wave listeners) have for years used a system known as SINPO for signal reporting, and it may be well to consider this system for amateur use. If you're not familiar with the code, the letters stand for **S**trength, **I**nterference, **N**oise, **P**ropagation, and **O**verall average; following each element or letter is a number from one to five. The code looks something like this:

S	I	N	P	O
(signal strength)	(interference)	(noise)	(propagation)*	(overall merit)
5 excellent	5 nil	5 nil	5 nil	5 excellent
4 good	4 slight	4 slight	4 slight	4 good
3 fair	3 moderate	3 moderate	3 moderate	3 fair
2 poor	2 severe	2 severe	2 severe	2 poor
1 barely audible	1 extreme	1 extreme	1 extreme	1 unusable

*degree of disturbance

Using this system, a super signal in all respects would receive a maximum **SINPO** rating of 55555. But if the signal were weak, bothered by QRM (interference) and QRN (noise) together with bad band conditions, it might receive a report of 23323, the last number being mentally averaged from the first four; it can also be used to denote signal quality.

This system has the

advantage that it is much more descriptive of a signal's true merit than the much simpler RST system, and it lets the other fellow know *all* the factors affecting his signal on your end. It, too, tends to eliminate the ridiculous "more is better" type of report (80 dB over 9) so often heard on the bands. But this system takes more time to calculate and transmit, so it might be of limited usefulness during a contest when brevity is required. It also throws out direct S-meter readings, which may offend operators who must know how far they can kick up the S-meter on each and every QSO.

Giving honest reports

This discussion brings us to a final word about honesty in signal reporting — not just in terms of S-meter readings, but in terms of the whole system. The reason we give signal reports is not out of ritual or the need to inflate (or sometimes deflate) the other fellow's ego, but to report on the overall merit of his signal. Why give reports at all if they have no meaning but simply fill a square in a logbook? The

fellow on the other end needs an honest, thoughtful report to help him optimize adjustments on his equipment and to detect malfunctions.

When giving reports pay close attention to just what you're telling the other fellow. If he has splatter, chirps, birdies, clicks, or whatever on his signal, by all means tell him so. It helps your credibility to tell him just why you gave him an uncomplimentary report,

since most of those he receives won't reveal his signal problems.

Helpful, informative, and realistic reports are necessary in today's crowded and competitive bands, not only for the other fellow's benefit, but for your own and for the benefit of Amateur Radio. Our privilege of using valuable spectrum space depends, in large measure, on keeping our act clean!

Summing up

We've tried to separate fact from myth concerning the use and interpretation of S-meters — to debunk the considerable nonsense that envelops the whole subject. We've presented the basic system of signal-strength reporting, we've seen just how S-meters work, and we've looked at a bit of math behind the decibel.

We have also shown some of the major S-meter calibration problems, and given some pointers for realistically using and interpreting your S-meter. Finally, we've made some suggestions for improved signal reporting that will be thought-provoking.

The bottom line is that the S-

meter is a *relative* signal-strength indicator or tuning meter for your receiver or transceiver, but little more. It's wise to take all signal-strength reports you may receive with an air of skepticism and to be judicious in the reports you award, for S-meters are indeed vanity instruments. If you appreciate the limitations of S-meters, you know all there really is to know about them.

HRH

DSI HAS DONE IT AGAIN

QUIK-KIT II®

INCLUDES PROPORTIONAL OVEN TIME BASE

- DC-BATT-AC (W-AC9)
- 95% Factory Assembled
- 100% Factory Tested
- .2 PPM 10° to 40° C Accuracy
- 9 Digits .5 Inch LED's
- 0.1 HZ Resolution
- Auto Zero Blanking

\$149⁹⁵
MODEL 5600A KIT



WHY BUY A 5600A: Because 95% of the assembly is completed by DSI and you are only one hour away from solving all those difficult bench problems, from setting the frequency of a audio signal to within 1/10 of a HZ, to checking the frequency of a 486 MHz mobile radio. Whether you are servicing a VTR, trouble shooting a PLL circuit, the 5600A is the right counter with accuracy that will meet any FCC land mobile, broadcast, or telecommunications requirements. On the bench or in the field the 5600A will do the job you need. The 5600A includes a self contained battery holder providing instant portability or we offer a 10 hour rechargeable battery pack option. Other options include a audio multiplier which allows you to resolve a 1/1000 of a HZ signal and finally a 25db preamplifier with an adjustable attenuator making the 5600A perfect for communications, TV servicing, industrial testing or meeting your QSO on the correct frequency every time.

FACTS ARE FACTS: With the introduction of the 5600A. The sun has set on the competition. This may sound like a bold statement on the part of DSI BUT FACTS ARE FACTS. No counter manufacturer except DSI offers a Full Range 50 HZ to 600 MHZ counter with — 9 Digits — 0.1 HZ resolution — .2 PPM 10° to 40° C proportional oven — RF pre-amp — 600 MHZ prescaler — three selectable gate times — oven ready, standby and gate time indicator lights as standard features — For only **\$149.95** kit and **\$179.95** factory wired. In fact the competition doesn't even come close unless you consider **\$200.00** to **\$800.00** close. With DSI having the best price to quality features ratio in the industry, no wonder we've become one of the world's largest manufacturers of high quality frequency counter instrumentation.

FOR INFORMATION — DEALER LOCATION — ORDERS — OEM
CALL 800-854-2049 CALIFORNIA RESIDENTS CALL 800-542-6253

Model	Price	Frequency Range	Accuracy Over Temperature	Sensitivity			Number of Readouts	Size of Readouts	Power Requirements	Size		
				@ 100Hz-25MHz	@ 50-250MHz	@ 250-450MHz				H	W	D
5600A-K	\$149.95	50Hz-600MHz	Proportional Oven	10MV	10MV	50MV	9	.5 Inch	*115 VAC or 8.2-14.5 VDC	3 1/4"	x 9 1/2"	x 9"
5600A-W	\$179.95		.2 PPM 10° - 40° C									
3550	99.95	50Hz-550MHz	TCXO	25MV	25MV	75MV	8	.5 Inch	*115 VAC or 8.2-14.5 VDC	2 1/8"	x 8"	x 5"
500HH	\$149.95	50Hz-550MHz	TCXO	25MV	20MV	75MV	8	.4 Inch	*115 VAC or 8.2-14.5 VDC or NICAD PAK.	1"	x 3 1/2"	x 5 1/4"

*5600A wired factory burned in 1 year limited warranty. 5600A kit 90 day limited warranty. Prices and/or specifications subject to change without notice or obligation.

*With AC-9 Adaptor.



- T101 Ant. **\$3.95**
- AC-9 AC Adaptor **7.95**
- 35P.2 **29.95**
- Factory Installed **49.95**

3550 OWNERS
 You can add the 35P.2 .22 PPM 10° to 40° C proportional oven to your existing 3550



DSI INSTRUMENTS, INC.
 7924 Ronson Road
 San Diego, California 92111

TERMS: MC - VISA - AE - Check - M.O. - COD in U.S. Funds. Please add 10% to a maximum of \$10.00 for shipping, handling and insurance. Orders outside of USA & Canada, please add \$20.00 addition to cover air shipment. California residents add 6% Sales Tax.

- 5600A Kit **\$149.95**
- 5600A Wired **179.95**
- AC-9 AC Adaptor **7.95**
- T600 BNC Ant. **7.95**

BUILT-IN OPTIONS

- BA56 Rechargeable 10 Hr. Bat. Pack **24.95**
- AM56 Audio Multiplier **34.95**
- .001Hz Resolution **34.95**
- PA56 25dB Preamplifier with Attenuator **59.95**

HF TRANSCEIVERS — DELIVERED TO YOUR DOOR



**200 WATTS PEP!
KENWOOD
TS-180S
All solid state
HF transceiver
with Digital Frequency Control**



TS-180S has 4 memories, manual scanning, tuning in 20 Hz steps with recall of stored frequency. Covers 160 to 10 meters. Needs no tune up. Built-in microprocessor, digital display, IF shift, selectable bandwidth, tunable noise blanker, RF AGC, dual RIT, improved speech processor, 13.8 VDC operation. Adaptable to proposed bands.
1149.95 List. Call for quote.

NEW!

**NEW KENWOOD
TS-520SE
High quality
HF transceiver**



With no heater switch, DC-DC converter terminals, or converter terminals the TS-520SE features 200W PEP SSB, 160 thru 10 meters, noise blanker, RIT, 8-pole crystal filter, built-in 25 KHz calibrator, semi-break-in CW, VOX/PTT/MANUAL operation, 20 dB RF attenuator, provisions for 4 fixed channels, and speech processor. It's an affordable quality HF transceiver.
629.95 List. Call for quote.



**YAESU
FT-901DM
All mode
HF transceiver**

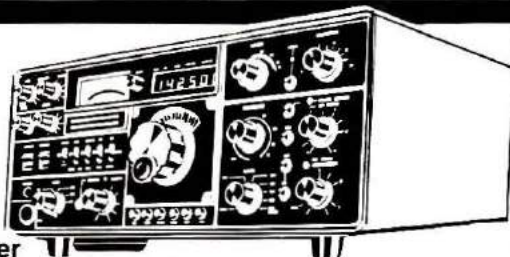

Covers 160 thru 10 meters. Variable IF bandwidth, rejection tuning, CW audio peak filter, built-in Curtis keyer, RF speech processor, 10 second tune mode timer, 6146 finals, auto. mic gain control, 25 KHz crystal calibrator and ± 5 KHz clarifier, VOX built-in power supply, 180W DC input for SSB/CW, 80W AM/FSK/FM. DC-DC converter.
1459.00 List. Call for quote.

YAESU

**YAESU
FT-101ZD
High performance
HF transceiver**



Covers: 160 thru 10 meters plus WWV, modes: LSB, USB, and CW, built-in power supply, input power: 180 WDC, digital and analog frequency readout, 6146 final tubes, RF speech processor, variable IF bandwidth (300 Hz to 2.4 KHz), noise blanker, VOX, attenuator 10 dB or 20dB, 100-234V operation, TX/RX freq. offset.
895.00 List. Call for quote.



**TEN-TEC
Omni D Series B
HF transceiver**



Totally solid state. 200W all bands with 50 ohm load. Covers 160 thru 10 meters. Features digital readout, VOX and PTT, 4-position CW/SSB filter, 8 pole crystal filter, crystal calibrator, notch filter, zero beat switch SWR bridge, adjustable sidetone, operates on 12 VDC for mobile, power supply required for fixed station.
1119.00 List. Call for quote.

**TEN-TEC
Century 21
CW transceiver**



Great for the novice or the dedicated CW operator! Featuring full break-in, 70 watts input, all solid state, built-in speaker, overload protection, offset receiver tuning, linear crystal mixed VFO, adjustable sidetone level, built-in regulated power supply. Receives CW or SSB but transmits CW only. Crystals provided for 80 thru 10 meters.
349.00 List. Call for quote.

You can use your
Master Charge or
VISA when you order.



Long's

MAIL ORDERS: P.O. BOX 11347 BIRMINGHAM, AL



CALL TOLL FREE 1-800-633-3410

IN ALABAMA CALL 1-800-292-8668 9 AM TIL
5:30 PM CST, MONDAY THRU FRIDAY

200 WATTS PEP! KENWOOD TS-120S All solid state HF SSB transceiver



No tune up! Miniaturized circuits, solid state construction, built-in digital display, IF shift, final transistor protection, VOX, noise blanker, 25 KHz marker. Frequency range is 80 to 10 meters and WWV, modes: SSB and CW, power requirements: RX-0.7A 13.8 VDC, TX-18A 13.8 VDC. 3 1/2" H x 9 1/4" W x 13 1/2" L. Weight: 11.7 lbs.

699.95 List. Call for quote.



KENWOOD TS-820S HF transceiver with digital display

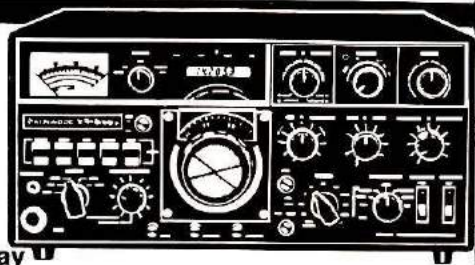

Featuring a frequency range of 160 thru 10 meters, modes: CW, USB, LSB, FSK, input power SSB: 200W PEP, CW: 160W DC, FSK: 100W DC, AF output power more than 1.5W, power requirements: 120/220 VAC 50/60 Hz, power use transmit: 280W, receive: 26W, noise blanker, speech processor, PLL, CW side tone, semi-break-in, and digital readout built-in.

1299.00 List. Call for quote.



DRAKE TR/DR7 Solid state synthesized HF transceiver



Covers 160 thru 10 meters, reception from 1.5-30 continuous, 0-30 MHz with optional AUX-7, modes: USB, LSB, CW, RTTY, AM. True passband tuning, RIT, built-in RF wattmeter/SWR bridge, SSB 250 watts PEP, CW 250 watts, AM 80 watts. Power supply required for AC operation, PS-7 120/240V power supply available.

1395.00 List. Call for quote.

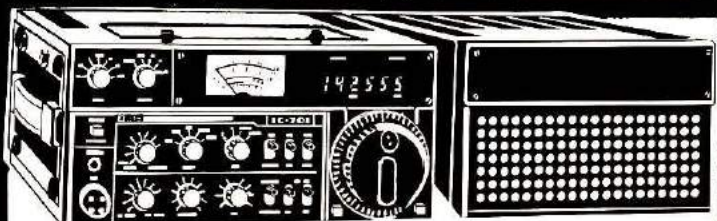

ICOM IC-701 HF transceiver

All solid state, 100W continuous duty on all bands, all modes. 160 thru 10 meters, dual built-in digital VFO's for split freq. operation, VOX, semi-break-in CW, RIT, AGC, noise blanker and built-in speech processor. IC-701 PS needed for AC operation. Power supply requirements: DC 13.6V negative ground.

1169.00 Call today!

Shown with power supply.

TEN-TEC 544 digital transceiver

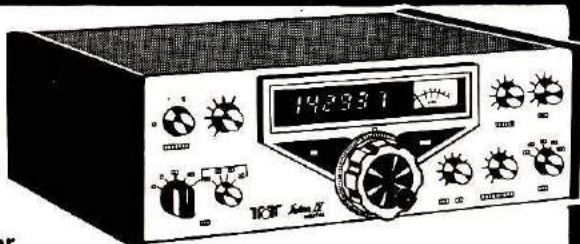

Completely solid state. Featuring instant band change, covers 3.5 to 30 MHz, 200W input all bands, 8-pole crystal filter, full CW break-in, 100% duty cycle, "S" meter and SWR bridge, LED display, 12-14 VDC operation required, offset receiver tuning, separate receiving capabilities and more!

869.00 List. Call for quote.

**ORDER
NOW!**

TEN-TEC 509 Argonaut transceiver

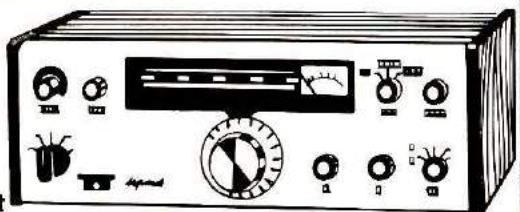

Work the world QRP with the Argonaut! Covers all the amateur bands, 10-80 meters. Feature 9 MHz crystal filter, 2.5 KHz bandwidth, automatic sideband selection, reversible, solid state design, power required: 12-15 VDC, CW break-in, SWR bridge, TVI filter, CW sidetone, automatic CW offset.

389.00 List. Call for quote.

Electronics

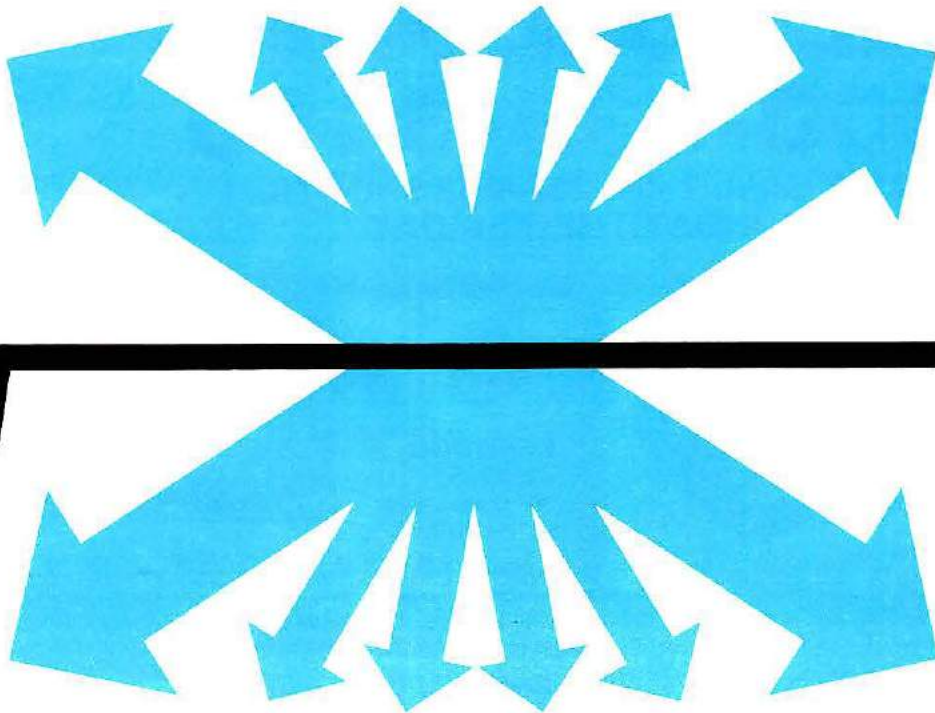

The Much Misunderstood LONG-WIRE ANTENNA

BY BOB BAIRD, W7CSD

A long wire is a great antenna, but be sure you have one

I have a small cabin about 8 km (5 miles) north of Bonanza, Oregon, in ponderosa pine country. Pine trees are very convenient to hang wire antennas on. So, about five years ago I put up a long wire on the order of ten wavelengths long for 15 meters. As a result of the orientation chosen, I obtained a northeast by southwest figure-eight pattern, and an east by west figure-eight pattern, with some minor lobes in between. It could be called a four-leaf clover pattern. The antenna does just exactly what it is supposed to do, and I like it very much.

This antenna has been the object of a lot of questions on the air. It is amazing how many hams, some with many years of experience, have never read page one of an antenna handbook of any kind — not even

The Radio Amateur's Handbook antenna section. It seems a little enlightenment might be in order.

What is a long wire antenna?

A true long-wire antenna is a straight piece of wire at least several wavelengths long, held up by a support on either end. A 15-meter (50-foot) piece of wire strung from your window to the nearest tree is *not* a long-wire antenna. A piece of wire that starts from your window and goes up to a tree, and then meanders around the real estate in six directions is *not* a long-wire antenna. A barbed wire fence is *not* a long-wire antenna.

I have talked to all kinds of hams who have tried a "long wire" and who say it's no good. Upon further questioning I find that something was wrong,

usually one of the characteristics just mentioned. I frequently work hams using 40-meter dipoles, center-fed on 15 meters. This is a true long-wire antenna, but not very long. Furthermore, it is properly fed, and exhibits the directional characteristics of a $1\frac{1}{2}$ -wave antenna. Then, they tell me, "You should be getting the maximum signal. It's broad-sided right at you." Not so! Maximum signal from a long-wire antenna is about 45 degrees off the wire, see Fig. 1. Most hams do not know this. The broadside signal is considerably weaker, coming as it does from minor lobes.

Reasons for building a long wire

The most common reason for building a long wire is that you have two tall trees, or other

supports, widely spaced, that are already in place. The only expense is wire. And, with a little finagling, you can make it work on all bands — a good reason. The only other valid reason is to get some desired directional characteristics. As noted before, you can get a four-leaf-clover pattern with considerable gain. With ten wavelengths you get 7 or 8 dB over a dipole, at about 20 degrees off the wire in four directions. If you put up two long wires in the shape of a properly designed "V," you can get a figure-8 pattern, bisecting the V, with perhaps 3 dB more gain. Of course, for the ultimate, you can go to four long wires in the form of a terminated rhombic. Now you have a lot of gain in one direction.

I was interested in working New Zealand, but not exclusively. My single long-wire drops a nice signal into New Zealand, Australia, and the Southwest, and provides a signal to KH6 land. The west lobe catches additional Pacific areas. The northeast lobe catches southern Europe, a big

Fig. 2. A graph of expected gain of major lobes from a long-wire as compared to a half-wave dipole.

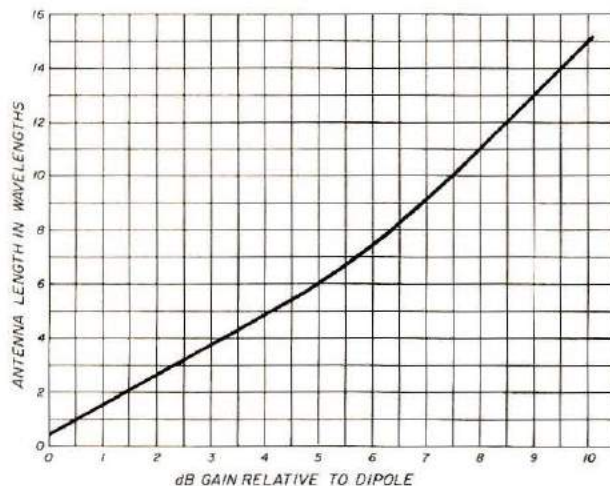

chunk of Canada, and part of the Eastern seaboard. The east lobe catches part of Africa, southeastern U.S., and part of the Caribbean. South America and Japan are both in pretty deep nulls. Generally, by the time propagation to the South Pacific is good, most of the signals from the northeast and east have pretty well subsided, so QRM from the back side is not too bad. By the same token, if Europe or Africa just happen to come in in the morning, there isn't much QRM from the west or southwest.

Feeding a long wire

Feeding seems to be the second most misunderstood part about operating a long-wire antenna. First of all, if you feed the long wire direct from the rig, you are going to destroy the antenna's directional characteristics unless you maintain a *straight* wire from one end to the other. You cannot go up to a tree top with a single wire, and then go straight for 120 meters (400 feet). The wire going to the tree top will radiate and spoil your pattern. You must get to the flat top with a nonradiating feeder system. The best way for all-band operation is to end feed the antenna, using old fashioned "Zepp" feeders, and an antenna tuner at the bottom. You may have heard "you can't beat a center fed long wire." This is true only if you feed an odd number of quarter wavelengths each side of center. If you go to an even number of quarter wavelengths each side of center you no longer have a single harmonically operated antenna; you have two. The pattern will no longer be that of a single long wire. This is reiterated in every antenna handbook you pick up, but nobody reads them. If you *center* feed with an odd number of quarter wavelengths on 15 meters, you will not have an odd number on 20 or 10. If you *end* feed you will be okay

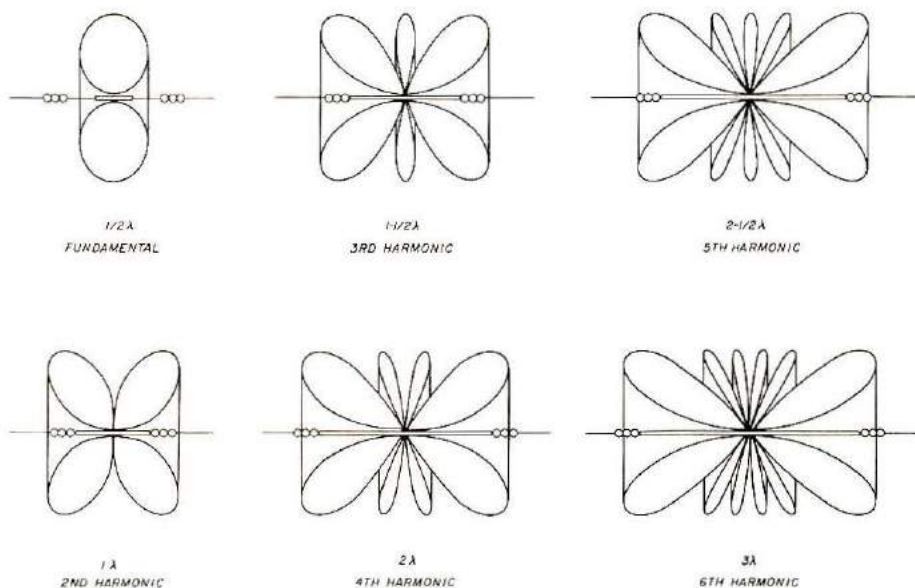
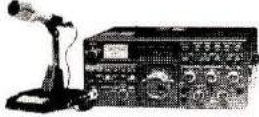

Fig. 1. The radiation pattern changes as the wire is made longer in terms of wavelength. These are cross-sectional views of the pattern, and assume an antenna suspended in free space. Height above ground will modify the pattern in a horizontal plane, but these are essentially correct as viewed from above. See Fig. 2 for an approximation of the gain along major lobes of long-wire antennas.

Reliability Service Experience



NEW KENWOOD TS-180S
\$1145*



*Package price: includes
TS-30 power supply
In Stock

CORNELL DUBILIER



HAM IV
\$149⁰⁰

ANTENNA ROTOR

ALLIANCE

HD-73
\$109⁹⁵

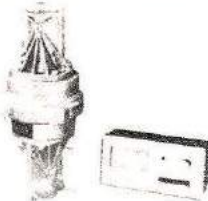

ANTENNA ROTOR

NEW KENWOOD TS-120S
\$629



In Stock

PREPAID FREIGHT ON ALL



Quantities limited. Michigan residents add 4% sales tax. Please include your area code and telephone number with any correspondence.



RSE HAM SHACK

1207 W. 14 MILE, CLAWSON, MI 48017
(313) 435-5660

31155 PLYMOUTH, LIVONIA, MI 48150
(313) 522-4232

MAIL ORDER TELEPHONE
(313) 435-5660

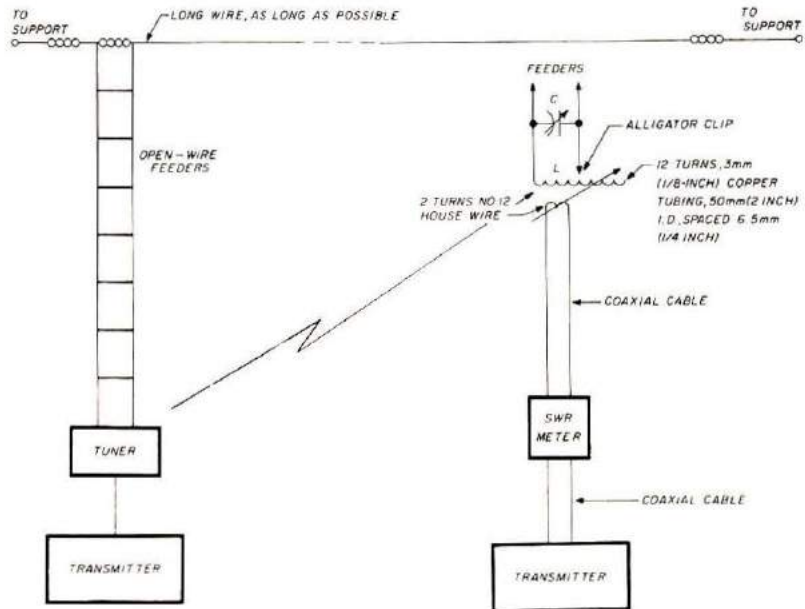

Fig. 3. Open-wire feeders allow you to use an end-fed long-wire antenna on many bands. The tuner is a simple means of matching your transmitter to the feeders. The number of turns shown will work well for 20, 15, and 10 meters — use more turns if you intend to work 80 or 40. Rough tuning can be accomplished by listening on a receiver while moving the alligator clip from turn to turn; pick the spot that increases signal strength the most. Final tuning should be done with a low-power transmitter and SWR meter — adjust tuning and link position for lowest reading.

on any band. And, the flat top can be just about any length.

Feeders and tuning unit

Open wire feeders can be built with ordinary wire and spacers made of maple dowel. Since the whole system is resonant, the spacing is not critical; 10 to 15 cm (4 to 6 inches) will work well. If you live where the humidity is high, boil the dowels in parafin. The vertical spacing between spreaders can be 1 to 1.5 meters (4 to 5 feet). An alternative would be to use 450-ohm open-wire TV transmission line.

Most standard tuning units will work into an open wire line. I would not want to leave a \$200 tuning unit in an unoccupied cabin, however, so I use a simple coil-and-capacitor circuit, link coupled to the rig, see **Fig. 3**. I can get an SWR of 1:1 in about two minutes, by adjusting the tuning and the position of the link.

Conclusions

It is not true that "any random chunk of wire thrown

up in a blizzard will outperform any commercial antenna," but a carefully built long wire, on a big piece of real estate, will compete, in its favored directions, with the average beam.

HRH



"His name has been drawn to win a free \$600 receiver, eh? He has too much gear as it is — give it to somebody else!"

TOWERS

by ALUMA

HIGHEST QUALITY
ALUMINUM & STEEL

60 Ft. Aluminum
Crank-Up
Model T-60-H

40' Steel
Crank-Up
Model SHD-40

★ **TELESCOPING**
(CRANK UP)

★ **GUYED** (STACK-UP)

★ **TILT-OVER MODELS**

Easy to install. Low Prices.
Crank-ups to 100 ft.

**EXCELLENT FOR
HAM COMMUNICATIONS**

SPECIAL
Four Section 50 Ft.
Van Mounted Crank-Up
Aluma Tower

Over 36 types aluminum
and steel towers made—
specials designed and
made—write for details

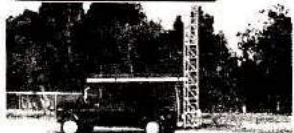

ALUMA TOWER CO.

Box 2806 HH
VERO BEACH, FLA. 32960
PHONE (305) 567-3423
TELEX 80-3405



Looking For:

a place to have your
radio gear serviced?
LOOK NO MORE!!
ALL WE DO IS AMATEUR
SERVICE, SO...
WE HAVE TO BE GOOD!!

INTERNATIONAL
ELECTRONIC
COMMUNICATIONS,
INC.

503 Avon St.,
Mocksville, NC
27028
704 634 5661



Loop Antenna

All Palomar Engineers products are
made in U.S.A. Since 1965, manufacturers
of Amateur Radio equipment only.

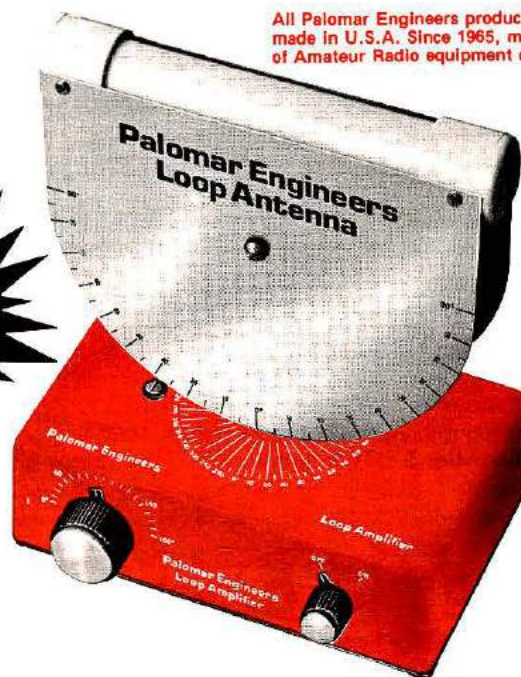

Here is an exciting new device to improve your reception on 160, 80, the broadcast band, and on VLF.

It is well known that loops pick up far less noise than most other antennas. And they can null out interference. Now Palomar Engineers brings you these features and more in a compact, carefully engineered, attractive desktop package.

Unlike ordinary direction-finder loops, it tilts to match the incoming wave front. The result: Deep nulls up to 70 db. You have to listen to believe it!

Does the Loran on 160 give you a headache? The loop practically eliminates it. Broadcast station 2nd harmonic ruining your DX? Turn and tilt the loop and it's gone. Does your friend in the next block with his kilowatt block those weak ones? Use the loop and hear him fade out.

Loop nulls are very sharp on local and ground wave signals but usually are broad or nonexistent on distant skywave signals. This allows local interference to be eliminated while DX stations can still be heard from all directions.

The loops are Litz-wire wound on RF ferrite rods. They plug into the Loop Amplifier which boosts the loop signal 20 db and isolates and preserves the high Q of the loop. The tuning control peaks the loop and gives extra preselection to your receiver.

Plug-in loops are available for these bands:

- 150-550 KHz (VLF)
- 540-1600 KHz (Broadcast)
- 1600-5000 KHz (160 & 80 meters)



Send for free descriptive brochure.

Order direct. Loop Amplifier \$67.50; Plug-in Loop Antennas \$47.50 each [specify frequency band]. Add \$3 packing/shipping. Calif. residents add sales tax.

Palomar Engineers

Box 455, Escondido, CA. 92025 • Phone: [714] 747-3343

The antenna with a big difference... the five band trap vertical Hustler 5-BTV™

The 5-BTV is made heavier for better performance and quality. Heavier traps assure accurate and permanent trap resonance. Solid one-inch fiberglass trap forms give optimum electrical and mechanical stability.

One setting provides total band coverage from 40 through 10 meters. SWR is 1.6 or better at the band edges.

The 5-BTV is top loaded at 80 meters (tunable to 75 meters). This means greater bandwidth and lower angle of radiation.

Easy to assemble and install, the 5-BTV features 1¼" high strength aluminum construction. And an extra-heavy bracket with low loss-high strength insulators. Feed with any length 50 ohm coax.

For the big difference in performance, it's the Hustler 5-BTV antenna.

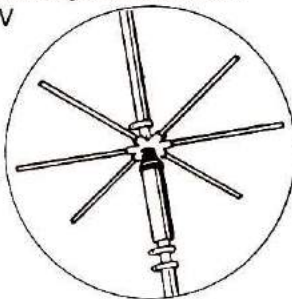

3275 North B. Ave. • Kissimmee, Florida 32741

Clearly the choice of those who know quality.



DEALERS

Electronics, Inc
227 N. Sante Fe
Salina, KS 67401
913-827-7377

Ham Radio Outlet
6265 Sepulveda Blvd.
Van Nuys, CA 91401
213-988-2212

Power Communications
6012 N. 27th Ave.
Phoenix, AZ 85017
602-242-6030

Radios Unlimited
1760 Easton Ave.
Somerset, NJ 08873
201-469-4590

Slep Electronics Co.
Box 100 - Highway 441
Otto, NC 28763
704-524-7519

Bob Smith Electronics
RFD #3
Ft. Dodge, IA 50501
515-576-3886

ROSS DISTRIBUTING COMPANY



Ross J. Hansen, WB7BYZ
78 South State, Preston, Idaho 83263
(208) 852-0830

Ross Specials: Looking for a good buy in Ham Gear? Call all the Wats lines first, then call me. I will be \$1.50 to \$40.00 less depending on the amount of your purchase. We have Kenwood, Yaesu, Icom, Ten-Tec, Drake, DenTron, Hy-Gain, ETO, Mosley, Cushcraft, Hustler, Larsen, Taylor, MFJ, etc. We have the largest stock and best selection of amateur equipment in the Intermountain West. Call (208) 852-0830. Closed Mondays at 2 p.m. **This Month's Special:** Kenwood TS-120S, save over \$100.00! Icom IC-701S (with AC supply) \$1169.00. (display model).



"CALL FOR QUOTE"

KENWOOD TS-520SE



MADISON ELECTRONICS SUPPLY, INC.

1508 McKinney • Houston, TX 77002

(713) 658-0268

MASTERCARD • VISA



Puts the World at Your Fingertips

Get your antenna high enough
with a TRI-EX tower and bring
the world to you.

Receive signals which you have
never heard before.

Send your call to other HAMS
who have never heard you.

A TRI-EX tower will give you
listening power . . . calling power
. . . and stay-up power that
means durability.

Durability comes from TRI-EX's 25 years of
building quality towers. These years of
experience combined with the latest
engineering knowledge and materials are used
to design and build towers which stay up under
the antenna loads and wind speeds specified.

Take your choice of two super qualities:

- All Steel Towers which after manufacture are
hot-dipped in molten zinc (galvanizing) with
all exposed steel covered inside and out,
including the inside of the tubing.
- Or, our new TRIEXIUM™ Towers, extra
lightweight, so easy to handle yet so super
strong and maintenance free.

TRI-EX TOWERS makes them all. Guyed
Towers, Crank-Up Towers, Free Standing
Towers, Stacked Towers, Accessories — and
we will install a tower on your site upon
request.

Call or write TRI-EX now for complete
information, price lists and the name of your
nearest dealer.

Call TOLL FREE
1-800-344-7200



™ Trademark for TRI-EX TOWER's space-age technology metal alloy.

7182 Rasmussen Avenue, Visalia, California 93277

AMATEUR RADIO



stress
reliever

BY J. FEINGOLD, WD6FJC

Medical researchers have found that certain hobbies can be stress relievers. People under high stress sometimes bring their tensions from work or school home with them, then relive their problem-filled workdays in their minds during the evening hours, even while watching TV. Afterwards, they go to bed for an uncomfortable night of poor sleep.

The ideal hobby would totally engross such an individual and compel him to concentrate only on the pleasures of the hobby. Ham radio can satisfy this requirement.

I work as the manager of a large manufacturing plant just outside Los Angeles. The job carries tremendous responsibility and, of course, equally tremendous

headaches (and stomachaches). For some time, my wife had been critical of the fact that my life consisted of going to work — staying in the plant for long hours — coming home, eating, watching TV, and usually falling asleep on the couch. I would, at times, become engrossed in a hobby, but after a few weeks, it would become boring and I would revert to TV watching and couch sleeping. I tried in vain to convince my wife that I never really slept on the couch — that just happened to be my favorite spot for checking my eyelids for pinholes.

In September of 1977, she

handed me the pamphlet for the Adult Education Program conducted at the local high school during evening hours. She said that there had to be something that I could learn to do at this program that would be more meaningful than watching "Lucy" reruns. Mostly to satisfy her, I casually looked through the booklet and half-heartedly picked "Amateur Radio for Novices" and asked her to sign me up.

By the next week, I had forgotten the incident, and on Tuesday night at dinner she told me that my class was starting at the high school that evening. I really didn't want to go, but she was so concerned with the fact that I had no outlets that, essentially to please her, I reluctantly agreed.

On the ten-minute drive to the high school, I tried to visualize what kind of people I would meet in the classroom that evening. I had decided that the class would probably be made up of three or four junior-high-school boys and me — a 35-year-old balding executive. What a mental image!

The class

To my astonishment, the classroom was filled with about forty people of every background and age group. Most of the people were older than I, and about ten of them were women. The instructor had everyone introduce himself, and I was truly impressed with this room of really nice people.

I guess my reluctance to sign up for any class stems from my feeling that "I had done my time." I spent five years getting an engineering degree; then I went to night school for four more years for a master's degree in business administration. I had always rated the classroom learning experience somewhere halfway between getting haircuts and root-canal work.

But I must say that this class was really fun. There were two instructors — one for code and the other for theory. The class was split into two rooms. While

Group 1 was getting theory lessons, Group 2 was getting code practice. After 20 minutes, the two instructors would switch classrooms and the group that just had 20 minutes of theory would then get 20 minutes of code practice, and vice versa. The curriculum followed the format of the ARRL "Tune in the World" book and tape cassette.

Both instructors were enthusiastic about the classes and were able to make the 3-hour sessions fly.

I was actually enjoying reading the theory and listening to the code practice tapes. I looked forward to evenings of study for the first time that I could remember.

I become a Novice

I was determined to pass my Novice exam by December! I bought an ancient Hallicrafters general coverage receiver for \$75, but tried in vain to copy even the slowest Novice. The theory wasn't giving me much of a problem, but the code was murder.

As the classes progressed, and with more attention to the code practice cassette, I was finally able to copy some Novice QSOs.

In December, I was one of the last people in my class to pass the code test. Then, as a group, we took the theory exam. It took forever to hear from the FCC, but in February of 1978, my Novice ticket came. I was WD6FJC.

The family revolts

During the period while I was waiting for my license to arrive, I became totally engrossed in picking up my code speed. As soon as dinner was over, I would rivet myself to my Hallicrafters and copy code while the family watched TV or read. I'm ashamed now to admit it, but my time usually devoted to playing with my kids really diminished during that period. They were starting to call me "Uncle Daddy."

The family was really astonished that I had become

so totally absorbed in this hobby; they really didn't believe that this interest would last. I didn't realize, though, that I had been filling the house with the whoops and screeches of the tuning sounds of my black monster. The family asked — no, actually, they demanded — that I use earphones.

The first QSO

In February, I traded my receiver for a used National NCX 3 transceiver. I paid \$239 and was given a generous trade-in allowance on the Hallicrafters. To keep the antenna simple, I bought an antenna tuner and ran a random wire inside my attic.

I remember sending my first CQ on 40 meters and, for some unexplainable reason, being relieved that no one replied. The second time, I got a reply from a fellow in Marysville, California. What a thrill! Six months of effort all building up to this one moment. My hands were actually shaking with excitement!

Upgrading

Almost all the people in my Novice class signed up for the next semester. The Adult Education Program was sponsoring an Amateur Radio course for the General-class ticket. I passed the theory portion of the exam in May, but flunked the code. Determined not to be one of those guys who never upgrade, I avoided the temptation of buying a 2-meter rig and instead bought a thirteen-word-per-minute code cassette. By September, I had my code speed up, and scored 100 per cent on the FCC General code test.

My hobby

Ham Radio has been the most compelling and enjoyable hobby I have ever pursued. It provides an opportunity to forget the day's tensions and frustrations and become totally absorbed in a rewarding world of construction, study, and operation. As a stress reliever, it's hard to beat!

HRH

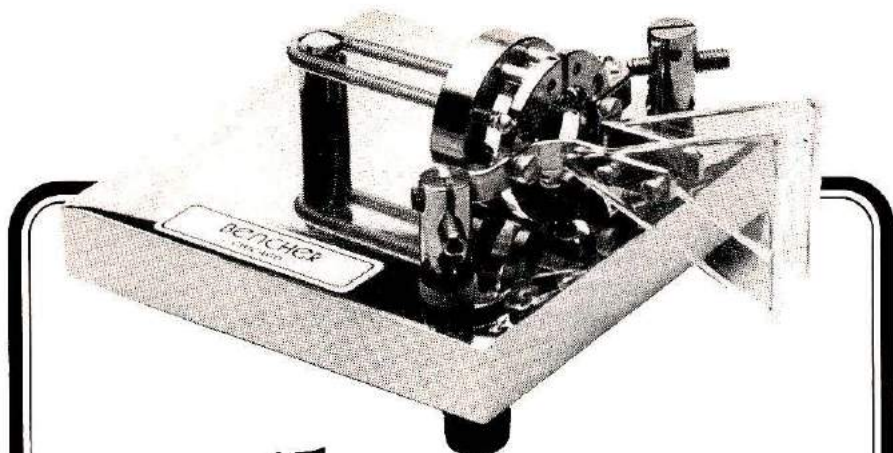

the Ultimate LAMBIC PADDLE

- Full range of adjustment in tension and contact spacing.
- Self-adjusting nylon and steel needle bearings.
- Solid silver contact points.
- Polished lucite paddles.
- Precision-machined, chrome plated brass frames.
- Standard model has black, textured finish base; deluxe model is chrome plated.
- Heavy steel base; non-skid feet.

WRITE FOR LITERATURE

BENCHNER, INC.

333 W. Lake Street, Dept. A
Chicago, Illinois 60606 • (312) 263-1808

Available at selected dealers or send \$39.95 (\$49.95 for chrome model) plus \$2.00 shipping and handling. Overseas amateurs invited to request quotation for air parcel post shipment.

MAXI TUNER SOLVES ANTENNA PROBLEMS

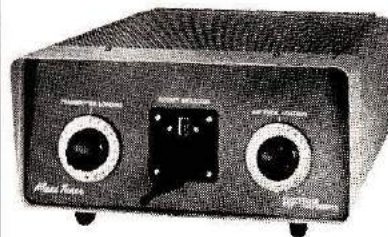

THE FINEST ANTENNA TUNER AVAILABLE

- Presents 50-75 Ohm Resistive Load to Your Transmitter Using Virtually Any Antenna System
- Improved Ultimate Transmatch Circuit Matches Coax, Random Wire and Balanced Antennas
- Continuous 1.7-30 MHz Coverage
- 229-203 Rotary Inductor (28 μ H)
- Rugged Cast Aluminum Turns Counter
- Handles 3 KW PEP
- Heavy Duty Balun
- Velvet-Smooth 6 to 1 Vernier Tuning
- 0-100 Logging Scale on Capacitors
- Available in Kit Form or Assembled
- One Year Factory Warranty
- Use with your present SWR meter or wattmeter.
- Custom Vacuum Capacitor Designs and Individual Components Available

Call or Write for Pricing, Spec Sheet, and FREE Amateur Market Antenna Tuner Comparison Chart That Tells It Like It Is!

**RF POWER
COMPONENTS**

P. O. Box 11
Ladysmith, WI 54848
(715) 532-3971

ALL BAND TRAP ANTENNAS!



PRE-TUNED - COMPLETELY ASSEMBLED - ONLY ONE NEAT SMALL ANTENNA FOR UP TO 6 BANDS! EXCELLENT FOR CONGESTED HOUSING AREAS - APARTMENTS LIGHT - STRONG - ALMOST INVISIBLE!

FOR ALL MAKES & MODELS OF AMATEUR TRANSCEIVERS - TRANSMITTERS - GUARANTEED FOR 2000 WATTS SSB 1000 WATTS CW INPUT FOR NOVICE AND ALL CLASS AMATEURS!

COMPLETE AS SHOWN with 90 ft. RG58U-52 ohm feedline, and PL259 connector, insulators, 30 ft. 300 lb. test dacron end supports, center connector with built in lightning arrester and static discharge - molded, sealed, weatherproof, resonant traps 1"X6"- you just switch to band desired for excellent worldwide operation - transmitting and receiving! WT. LESS THAN 5 LBS.

160-80-40-20-15-10 bands 2 trap--209 ft. with 90 ft. RG58U - connector - Model 777BU ... \$64.95
80-40-20-15-10 bands 2 trap --- 102 ft. with 90 ft. RG58U - connector - Model 996BU ... \$59.95
40-20-15-10 bands 2 trap --- 54 ft. with 90 ft. RG58U coax - connector - Model 1001BU ... \$58.95
20-15-10 bands 2 trap --- 26 ft. with 90 ft. RG58U coax - connector - Model 1007BU \$57.95

SEND FULL PRICE FOR POST PAID INSURED DEL. IN USA. (Canada is \$5.00 extra for postage - clerical - customs - etc.) or order using VISA Bank Americard - MASTER CHARGE - AMER. EXPRESS. Give number and ex. date. Ph 1-308-236-5333 9AM - 6PM week days. We ship in 2-3 days. ALL PRICES WILL INCREASE MAR 1-SAVE - ORDER NOW! All antennas guaranteed for 1 year. 10 day Money back trial! Made in USA. FREE INFO. AVAILABLE ONLY FROM.

WESTERN ELECTRONICS

Dept. AH-10

Kearney, Nebraska, 68847

THE **BIG** SIGNAL

**UNADILLA
"W2AU" Baluns**

DEMANDED BY
PROFESSIONALS
WORLD-WIDE
OVER 12 YEARS

Still
Only
\$14.95



FULL-POWER, QUALITY
HAM ANTENNA PARTS

AT YOUR DEALER

- BALUNS - TRAPS - INSULATORS
- QUAD PARTS - ANTENNA KITS
- BOOM/MAST MOUNTS - WIRE
- CABLE - CONNECTORS

1:1 OR 4:1
2,000 W
PEP

WRITE FOR FULL CATALOG
[Enclose 30¢ Stamps]

- The Original Lightning Arrest
- 650 π Strength
- Stainless Hardware
- Sealed
- GUARANTEED ASSISTANCE?

Call: HUGH GUNNISON, WA2EOT
Toll-Free 800-448-1666

[NYS Collect 315-437-3953]

MICROWAVE FILTER COMPANY, INC. UNADILLA/REYCO DIVISION [Dept. HRH]
5743 KINNE STREET EAST SYRACUSE, NEW YORK 13207

DEALERS WANTED - OVER 300 WORLD-WIDE

HELP!

Anytime you have a question about your Ham Radio HORIZONS subscription, please include a mailing label to insure prompt service on your inquiry.

CHANGE
OF ADDRESS

Moving? Please let us know 4-6 weeks beforehand. Or, if anything is wrong with your current mailing label, please carefully print the updated information below and affix your present label above.

PLEASE HELP US TO SERVE YOU BETTER

**HAM RADIO
HORIZONS**

Greenville, NH 03048

Call _____

Name _____

Address _____

City _____

State _____ Zip _____

COMPACT ANTENNA HEADQUARTERS

Below are listed only some of our products. We have chosen for the most part to concentrate on high-efficiency compact antennas designed for limited-space locations, realizing that lack of space for full-sized "farms" is a major problem for many of today's amateurs. All traps, coils, baluns, and center connectors used in our systems are fully assembled, adjusted, and weather-proofed here at our plant, and are rated for full legal power input. Our wire antennas are complete with Z-1 balun (A-1 center connector with 160 meter models), #14 solid insulated copper wire, dielectric insulators, and 100 feet of nylon support rope. We include what we believe are the most comprehensive instructions in the industry with each model, making installation and accurate tuning relatively easy.

APARTMENT—PORTABLE—TRAILER AV-1 ALLTenna

Low-profile no-radial antenna your neighbors and landlord can live with! Ideal for Apartments, Condos, Campsites, Mobile Homes or RV's, Boats, Field Days and Emergencies. 80-10 meters by quick, no-tool band change—takes full legal power—full quarter wave on 10, 15 and 20—16' maximum height—mounts anywhere a ground can be established—a balcony rail, patio yard or out a window. Mounting post included. Breaks down to 5" package for easy storage and transport, reassemble in seconds without tools—broad-banded—no adjustment across 10, 15, 20, or 40, 200 kHz on 80 without adjustment, full 80 coverage with several settings—adjusts to a virtual 1:1 VSWR in seconds. No tuner needed—extend coverage to all of 160 with the optional AO-160 add-on coil section.

Model	Bands	Height	Price
AV-1	80-10	16'	\$89.95
AO-160	160	21'	\$28.95

COMPACT TRAPPED DIPOLES

Shorter than usual trapped antennas, they provide effective multiband operation with a single set of elements and a single coax feedline, providing a practical method of compressing a multiband antenna onto a smaller city lot. Our 160 meter models use the only commercially-available traps that will permit full power on 80 meters at this price and overall length.

Model	Bands	Lgth.	Price
TD-1684	160, 80/75, 40, 110'		\$74.95
TD-16080	160, 80/75, 160'		\$59.95
TD-8040	80/75, 40, 78'		\$54.95
TD-4020	40, 20, 40'		\$49.95

COMPACT SHORTENED DIPOLES

These are standard dipoles shortened to half-size by using loading coils. Good for small lots, attics, and constructing slopes. The SP-40 works very well on 15 meters as well as 40.

Model	Bands	Length	Price
SP-160	160	130'	\$42.95
SP-80	80/75	63'	\$41.95
SP-40	40, 15	33'	\$39.95

MULTIBAND SHORT DIPOLES

These provide absolute maximum performance possible in a minimum space location by combining shortened elements with full-size elements connected to a single coax feedline at the balun.

Model	Bands	Length	Price
MSP-8010	80/75, 40, 74'		\$69.95
	20, 15, 10		
MSP-1	80/75, 74'		\$59.95
	40, 15		

MULTIBAND FULL SIZE DIPOLES

These antennas provide uncompromised multiband operation by connecting separate half wave elements to a single coax feedline at the balun.

Model	Bands	Lgth.	Price
PD-8010	80-10	130'	\$54.95
PD-8040	80, 40, 15	130'	\$49.95
PD-4020	40, 20, 15	66'	\$39.95
PD-4010	40-10	66'	\$44.95



Illinois residents add 5% sales tax.
COD's to U.S.A. only

Shipping and handling (U.P.S. Surface)	
Dipoles	\$2.50
Verticals	3.00
Add to above for	
Parcel Post	2.00
APD and FPO	3.00
Canada and Mexico	4.00
COD's	1.00

Call or write for complete catalog describing all 24 antennas we make, with prices.

ANTENNA SUPERMARKET

P.O. Box 563 • Palatine, IL 60067 • (312) 359-7092

Phone orders welcome — 9:30 to 5:00, Monday thru Friday
Include Interbank acct. number and expiration date on credit card orders.
Prompt shipment • 30-day guarantee • Components available separately

target your signal with a Ham IV rotor

the Engineered
Choice for
Antennas Up
to 15.0
Sq. Ft.



The New HAM IV — just one of six rotors from CDE to professionally target your signal for better communications . . . exclusive features like all-steel gear systems and positive power brake make the HAM IV the newest standard by which all other rotors are judged.

ON TARGET KIT

Send for your EMBROIDERED PATCH, WALL CERTIFICATE, TIME ZONE

GUIDE. Plus details on the CDE Rotor to match your antenna.

Enclose \$1 for handling and mailing costs. Send to:



CDE CORNELL-DUBILIER

CORNELL-DUBILIER ELECTRIC CORPORATION
Box 162, Essex Fells, New Jersey 07021

358R

I'm On Target—Send Kit To: H4

Name _____

Address _____

City _____

State _____ Zip _____

Enclosed \$1. for kit handling & mailing.

or
 Send free details on all CDE rotors.

Radio World

CENTRAL NEW YORK'S FASTEST GROWING HAM DEALER

Featuring Yaesu, Icom, Drake, Atlas, Ten-Tec, Swan, DenTron, Pace, Palomar, Alda, Midland, Wilson, KDK, MFJ, Microwave Module, Standard, Tempo, Astron, KLM, Hy-Gain, Mosley, Larsen, Cushcraft, Hustler, Mini Products, Universal and Tristao Towers. We service everything we sell! Write or call for quote. You Won't be Disappointed.

We are just a few minutes off the NYS Thruway (I-90) Exit 32

Warren K2IXN
Call Toll Free: 1-800-448-7914

ONEIDA COUNTY AIRPORT TERMINAL BUILDING
ORISKANY, NEW YORK 13424

Bob WA2MSH
New York State Residents Call: 315-337-2622 or 315-337-0203



W7PFW PLASTIC NOTE PAD

- Use pencil and eraser on one side
- Draw on other side with crayon or grease pencil
- Wipes clean, great for mobile use
- Write call signs, frequencies, handles, etc. Lasts indefinitely

Check or Money Order **2.95** ppd.

Order from:
TRI PLASTICS, INC.
530 N.E. Liberty Ave. • Gresham, OR 97030



BY DONALD PECK, W3CRG

Have you ever wanted to visit a rare DX country and find out what's going on? Well, this past October, I had a chance to visit Greece with a group from the University of Maryland Alumni Association. Since Greece is a country with few active hams, I spent considerable time in my ham shack beforehand, trying to contact someone there.

In June, I worked Costas,

SV1GR, on 20-meter CW in the middle of the night. Costas' command of English, however, was limited (and my knowledge of Greek nonexistent), so it was difficult to explain about the upcoming trip and make arrangements to meet him later in Athens. Using a phrase book, provided by a tour company, I tried sending an explanation in Greek — which brought back a torrent of words, all in Greek!

Since I did not receive a QSL card from Costas through the mail, I decided to look him up when I got to Athens, and visit him if possible.

Later, I heard Dennis, SV0WA, on 20-meter sideband. Since Dennis is an American and speaks both English and Greek, I wrote him a letter about the trip and asked his help in contacting Costas when I arrived. Dennis sent his own



SV0WA, Dennis, at the rig. He's either deep into a DX contest or talking to his relatives in South Carolina.

telephone number and address and agreed to meet me during my stay in Athens.

After arriving at the hotel in Athens on Wednesday, October 25th, I called Dennis. A few minutes into the conversation, the phone went dead on my end and Dennis ended up talking to two other people. On the second try, Dennis located Costas' phone number in the ham-club directory. We decided to meet Jack, SV0WTT, the following Sunday afternoon at Dennis's apartment near Athens. Later the same day, using the services of an interpreter who was with our tour group, a meeting was arranged with Costas for the following evening at the hotel. After work, Costas stopped by the hotel and I finally received my Greek QSL card. We had an interesting conversation by using an interpreter from the hotel front desk.

Costas operates CW using a homebrew transmitter with a military surplus receiver and a beam antenna. Dennis uses a Collins KWM-2A transceiver driving a Heathkit SB-200 linear, and a homebrew two-element triband beam on 20, 15, and 10 meters. Jack uses an ICOM 701A with a homebrew vertical antenna on 80 meters, an inverted-V on 40 meters, and a dipole on 20, 15, and 10 meters. Although Dennis and Jack live only a block from each other, QRM is no problem. Dennis operates ssb and Jack operates CW.

*An oblast is a larger-city area in the U.S.S.R.

Dennis and Jack are the only two active American hams in Greece now because no reciprocal licenses have been issued since 1975. At present, there are about 40 American hams waiting for the Greek Communications Agency to issue new licenses. Contests are a good deal for Dennis and Jack — all they have to do to win is enter, because there is little competition. Just about every time they go on the air there is a pileup. Jack has three file drawers full of QSL cards from the Soviet Union. He has about 140 oblasts confirmed.* There are some problems, however, because any equipment the SV0s acquire must be declared as home furnishings and be taken with them when they leave the country.

The Radio Amateur Association of Greece (RAAG), which is the radio club in the Athens area, meets every Wednesday. About twenty members attend on a regular basis to pick up and send out their QSL cards, as well as have a general meeting. They purchase blue stamps to send out the cards for about one cent each. Most Greek hams are professional people, such as dentists and physicians. Greek hams are

"Costas, SV1GR, and I had a nice meeting at my hotel."



"I met Jack, SV0WTT, at Dennis's apartment for a most enjoyable visit."

generally not active DXers and operate mostly ssb. The type of license issued depends on the age of the applicant. Code-speed tests are six, eight, and ten words per minute. English is taught as a second language in Greece, therefore many Greek hams understand English and are able to read American and English radio magazines.

Greek law requires that rf power be measured at the base of the antenna, just as some commercial broadcast stations do in the United States. Power is limited to 300 watts. Mobile operation is not permitted and hand-held units are illegal. Both homebrew and military surplus equipment are popular; store-bought equipment is mostly Heathkit. There is an approximately 30 per cent duty on imported equipment.

There are no hamfests in Greece; however, the U.S. military hams did have one in Athens this year.

If you need a Greek QSL card, look for Dennis. He is glad to QSL and can be found on 15 meters every Monday and Wednesday. He talks to his brother, Joe, WB4IMO, and his father, also named Joe, WB4OTL, in South Carolina. Some stations try to break in and interrupt contacts with his family, and he asks them to wait until the QSO is finished. If you can't go to Greece to meet them in person, the next best thing is to talk to Dennis, Jack, and Costas on the air.

HRH



Dear Horizons:

Hurray! Hurray! Your editorial in the May *HRH* "View," smacks mightily of the truth. In fact it doesn't just smack, it downright hits very hard.

Now, I've been a ham since 1964, and being like many, I became inactive for about 2 years. I then got the bug again, stronger than ever, and rebuilt my station.

After the initial contacts to make sure everything was working, I settled down to some serious hamming (ragchews, DX chasing, nets). It didn't take long for me to run into some of the lids you speak of. It didn't take much more time to find out they were all over the bands.

Maybe times and methods have changed. Whatever happened to "limited to the power necessary to complete communications?" As to vhf-fm for crosstown, if you don't have the facilities that's rather a difficult solution. But what about a "dead" band, say 10 meters at night, or how about zeroing a broadcaster on 40 meters? I've done this, and for crosstown it works fine.

I don't know quite what we can do about the nut that interferes with nets and QSOs on purpose; I don't understand their thinking at all. I ran into one guy who apparently doesn't like YLs, so he followed one all over 10 meters and purposefully kept tuning up on her frequency. It's a shame his final didn't burn to ashes.

In regards to the language heard, I remember when a good Radio Amateur wouldn't think of saying hell, damn, or anything like that on the air. In fact, the meanest and most derogatory remark you could make was to call another ham a lid.

Now I'm no prude, and being a city firefighter I could probably

keep up with the truck drivers and dry-wall men, but I think there is a time and place for everything, and where millions of people can hear you isn't the place.

As to signal reports, I give what my S-meter and my ear say. I gave a K6 an S1 signal report and he was very happy; he was running QRPp. As long as they tell me I'm Q3, 4, or 5 I don't really care what my S-meter reading is. They're hearing me, that's what counts.

Back to the power of a transmitter — I run 180 watts and have nothing but dipole antennas. I can honestly say I've worked the world. It just takes a little patience and, after all, it is a hobby.

Maybe I do have a solution of sorts. When was the last time a lot of you hams with the higher class licenses went into the Novice bands and worked some beginners? These guys are not just learning to copy code faster, they are also learning procedure, techniques, and etiquette. Why don't we work them and teach them the correct way?

I don't subscribe to any ham magazines, and I don't promise I'll subscribe to yours, but I'll be honest enough to say I do look for it on the newsstands. It is a good and informative magazine. Thanks.

**Steve Schwab, WA8MJP
Toledo, Ohio**

Dear Horizons:

Although I don't own one of the rigs in your "Amateur Radio Equipment Survey," I do believe you have hit upon a winner! I am looking forward to the results.

This looks like material for a regular feature in a fine publication.

I would personally like to see the survey include all phases of Amateur Radio.

**Sam Grider, WD8LIK
Cincinnati, Ohio**

Dear Horizons:

For several reasons, I have decided not to renew my subscription to *Ham Radio Horizons*. Of course, cost is part of it, but it is by no means the major reason. I am headed for college next year, and I think my leisure reading time will be restricted by studying.

I now hold a General-class license. I do not have an Extra because I haven't worked on the

code enough. Theory has always been pretty easy for me. (I don't have the Advanced because I am about 200 miles from the nearest FCC testing station. It's hard to miss school for a day to get there, and the test is given only four times per year. I figure that, if I'm going to spend that much time and money, I might as well go for Extra.)

HRH presents the theory well, but I prefer a little more challenge. Perhaps that is why I hope to become an electrical engineer. Don't change your approach to theory, however, because I believe that *Ham Radio Horizons* is probably the best magazine around for beginners and those experienced hams who are less interested in "real meaty theory." Keep up the good work!

**Kevin Holsinger, WB7BDI
Burley, Idaho**

Dear Horizons:

Bill Orr's article "The Golden Years of Radio" took me back more than 50 years to the mid 1920s. I had a Crosley 51 receiver (regenerative detector and one audio stage) with WD-12 type tubes. That started my interest in radio.

My first short wave set was, of course, homemade with an 01A. The coils were wound on electrical fuses.

I got a type 22 screen grid tube when they first came out, but didn't think it was worth the extra problems with the odd filament voltage (3.3 V) and screen supply. Later sets had coils wound on tube bases. I have a set that should still work.

Your publication, *Ham Radio Horizons*, most nearly resembles the old *Short Wave Craft*, *Radio Craft*, and *Radio News* of the late 1920s and early 1930s. Keep up the good work.

**Donald A. King, W1YCW
Manchaug, Massachusetts**

Dear Horizons:

As a Novice of about three months, I greatly enjoy each issue of *Ham Radio Horizons*. Your balanced format is much appreciated. My wife is now studying for her Novice ticket. Thanks for a fine quality magazine.

**Bill Wolf, KA2EEV
Newark, New Jersey**

ATTENTION:

TO: All Amateurs
FROM: Wilson Systems, Inc.

Inflation . . . gas shortages . . . etc., all leading to higher prices each week, and cutting into the amount that we have to spend on our hobby. And face it, our hobby is what keeps us sane in this runaway inflation period, our escape from the hustle and hectic grind of working to make a living. We know — we see the same price increases at the grocery store, the same increases in the gas prices. Wilson Systems, Inc., is going to do something to help ease the purchase of your new tower and antenna.

As you may know, in January of 1979, Regency Electronics, Inc., purchased Wilson Electronics Corp. What you may not know is that in August, 1979, Jim Wilson purchased back the antennas and towers. There is now a new name to look for — WILSON SYSTEMS, INC. — With the new name and new company comes new ideas, methods, products and prices. Yes, prices. But not what you might expect. Wilson Systems is LOWERING the prices to where you will find it hard to believe. Check them out in the following pages of this issue. You will be surprised and pleased at what you will find.

What are we doing that will enable us to lower the prices? Well, we are Hams, too. We like to pay the lowest price possible and will spend much time assuring ourselves this is accomplished. We feel the same higher demands on our money for the house, food, and bills. And as this demand increases, the amount of money left for our hobby decreases. So when money is spent, we want the best quality for the best price.

There are a number of ways to bring the cost of a product down. By using a cheaper grade of material, buying raw materials in larger quantities to obtain a better discount, by cutting the profit ratio, and by eliminating the middle man. Wilson Systems will not lower the quality of the product. In fact, we have improved the strength and quality of almost every antenna in the line. The newly designed monobanders will stay up under heavy icing conditions when others are falling apart. Wilson Systems is currently purchasing at the lowest price possible from the aluminum companies, so these methods of cost reduction are eliminated. The third method mentioned is one that we have decided to consider as a part of the overall cost reduction plan, yet leaving room for research and development expense, so we may bring you the products you want and at a price you will like.

The last method mentioned is always a risky one. The dealers do not want their profits cut back just as you do not want your pay check cut. If you cut the dealers' profits back, some of them will just push the product that will tend to give them the most profit, rather than the one that will be the best performing for you. A rather drastic form of this method is the one that Wilson Systems will be choosing. You will not be able to find the Amateur products of Wilson Systems in stock at the dealers, nor will they probably recommend them. (After all, as long as they're not handling them and making a profit, why should they promote or even recommend them?) No, you will only be able to enjoy the most product for the least money by dealing with Wilson Systems factory direct. We will be offering you the amateur antennas and towers at prices that are below, in most cases, what the dealers pay for the products of other companies. And to make it even easier, we have a toll-free number for you to place your order. Now isn't this what you've been looking for? The best product for the least money!

Just remember these four points:

1. Highest Quality
2. Lowest Price
3. Toll-Free Order Number

The fourth point? Remember the name . . . WILSON SYSTEMS, INC.

Yours Truly,
Jim Wilson
Wilson Systems, Inc.

**W S I WILSON
SYSTEMS, INC.**
4286 S. Polaris Ave., Las Vegas, Nevada
(702) 739-7401 — Toll-Free Order

WILSON SYSTEMS INC. MULTI-BAND ANTENNAS

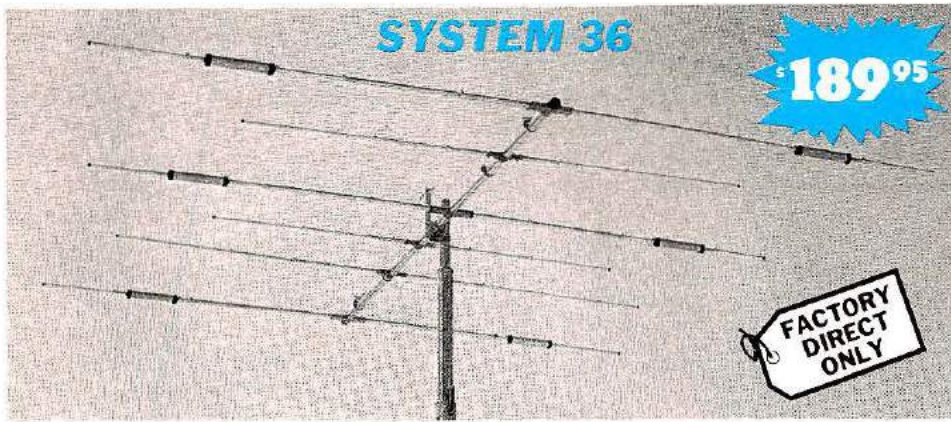

A trap loaded antenna that performs like a monobander! That's the characteristic of this six element three band beam. Through the use of wide spacing and interlacing of elements, the following is possible: three active elements on 20, three active elements on 15, and four active elements on 10 meters. No need to run separate coax feed lines for each band, as the

bandswitching is automatically made via the High-Q Wilson traps. Designed to handle the maximum legal power, the traps are capped at each end to provide a weather-proof seal against rain and dust. The special High-Q traps are the strongest available in the industry today.

SPECIFICATIONS

Band MHz 14-21-28	Boom (O.D. x Length) . . . 2" x 24'2 1/2"	Wind loading @ 80 mph . . . 215 lbs.
Maximum power input . . . Legal limit	No. of elements 6	Maximum wind survival . . . 100 mph
Gain (dBd) Up to 9 dB	Longest element 28'2 1/2"	Feed method Coaxial Balun (supplied)
VSWR @ resonance . . . 1.3:1	Turning radius 18'6"	Assembled weight (approx. 53 lbs.
Impedance 50 Ω	Maximum mast diameter, 2"	Shipping weight (approx.) . 62 lbs.
F/B ratio 20 dB or better	Surface area 8.6 sq. ft.	

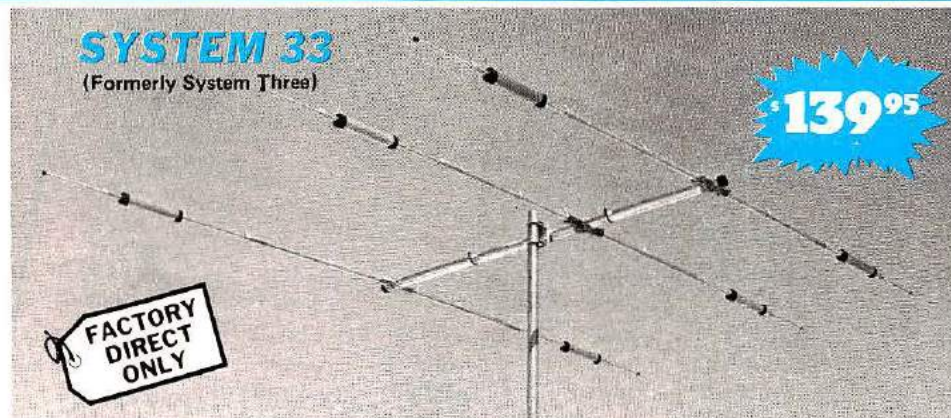

Capable of handling the Legal Limit, the "SYSTEM 33" is the finest compact tri-bander available to the amateur.

Designed and produced by one of the world's largest antenna manufacturers, the traditional quality of workmanship and materials excels with the "SYSTEM 33".

New boom-to-element mount consists of two 1/8" thick formed aluminum plates that will provide more clamping and holding strength to prevent element misalignment.

Superior clamping power is obtained with the use of a rugged 1/4" thick aluminum plate for boom to mast mounting.

The use of large diameter High-Q Traps in the "SYSTEM 33" makes it a high performing tri-bander and at a very economical price.

A complete step-by-step illustrated instruction manual guides you to easy assembly and the lightweight antenna makes installation of the "SYSTEM 33" quick and simple.

SPECIFICATIONS

Band MHz 14-21-28	Boom (O.D. x length) . . . 2" x 14'4"	Wind loading at 80 mph 114 lbs.
Maximum power input . . . Legal limit	No. elements 3	Assembled weight (approx.) . . 37 lbs.
Gain (dbd) Up to 8 dB	Longest element 27'4"	Shipping weight (approx.) . . . 42 lbs.
VSWR at resonance . . . 1.3:1	Turning radius 15'9"	Direct 52 ohm feed—no balun required
Impedance 50 ohms	Maximum mast diameter, 2" O.D.	maximum wind survival 100 mph
F/B ratio 20 dB or better	Surface area 5.7 sq. ft.	

\$44.95

WV-1A

4 BAND TRAP VERTICAL (10 - 40 METERS)

No bandswitching necessary with this vertical. An excellent low cost DX antenna with an electrical quarter wavelength on each band and low angle radiation. Advanced design provides low SWR and exceptionally flat response across the full width of each band.

Featured is the Wilson large diameter High-Q traps which will maintain resonant points with varying temperatures and humidity.

Easily assembled, the WV-1A is supplied with a hot dipped galvanized base mount bracket to attach to vent pipe or to a mast driven in the ground.

Note:

Radials are required for peak operation. (See GR-1 below).

SPECIFICATIONS:

- Self supporting—no guys required.
- Input Impedance: 50 Ω
- Powerhandling capability: Legal Limit
- Two High-Q Traps with large diameter coils
- Low Angle Radiation
- Omnidirectional performance
- Taper Swaged Aluminum Tubing
- Automatic Bandswitching
- Mast Bracket furnished
- SWR: 1.1:1 or less on all Bands

GR-1

\$9.95

The GR-1 is the complete ground radial kit for the WV-1A. It consists of: 150' of 7/14 stranded copper wire and heavy duty egg insulators, instructions. The GR-1 will increase the efficiency of the WV-1A by providing the correct counterpoise.

Prices and specifications subject to change without notice.



4286 S. Polaris Avenue
Las Vegas, Nevada 89103
(702) 739-7401
Factory Direct Toll Free 1-800-634-6898

New, Improved Wilson Towers



Hinged Base Plate - Concrete Pad, Heavy Duty Winch

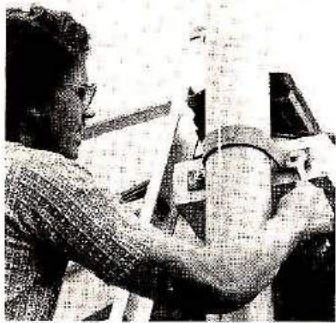

Mounting the House Bracket

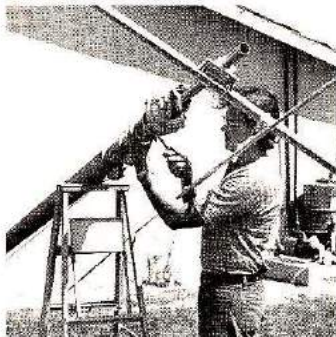

The Hinged Base Plate allows tower to be tilted over for access to antenna and rotor from the ground.

FACTORY DIRECT
\$219⁹⁵

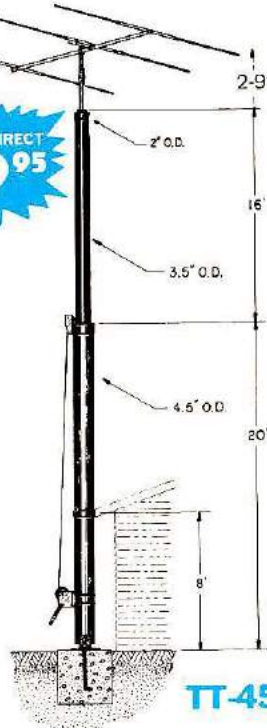

FEATURES:

- Maximum Height: 45' (will handle 10 sq. ft. at 38')
- 800 lb. winch
- Totally freestanding with proper base
- Total Weight, 189 lbs.

The TT-45A is a freestanding tower, ideal for installations where guys cannot be used. If the tower is not being supported against the house, the proper base fixture accessory must be selected.

GENERAL FEATURES

All towers use high strength heavy galvanized steel tubing that conforms to ASTM specifications for years of maintenance-free service. The large diameters provide unexcelled strength. All welding is performed with state-of-the-art equipment. Top sections are 2" O.D. for proper antenna/rotor mounting. A 10' push-up mast is included in the top section of each tower. Hinge-over base plates are standard with each tower. The high loads of today's antennas make Wilson crank-ups a logical choice.

FACTORY DIRECT
\$399⁹⁵

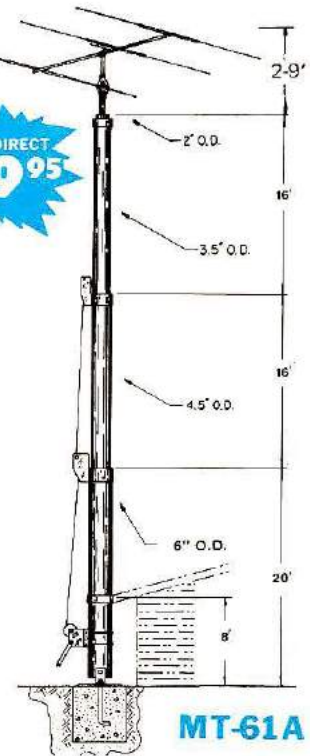

NEW IMPROVED FEATURE
Heavier wall tubing greatly increases the stress capabilities over the older TT-45 and MT-61.

FEATURES:

- Is freestanding with use of proper base
 - Maximum Height is 61' (will handle 10 sq. ft. at 53')
 - 1200 lb. brake winch
 - 4200 lb. raising cable
 - Total Weight, 350 lbs.
- Recommended base accessory: RB-61A, FB-61A.

The MT-61A is our largest and tallest freestanding tower. By using the RB-61A rotating base fixture the MT-61A is ideally suited for the SY33 or SY-36. If you plan to mount the tower to your house, caution should be taken to make certain the eave is properly reinforced to handle the tower. If not, one of the base accessory fixtures should be used.

TILT-OVER BASES FOR TOWERS

FIXED BASE

The FB Series was designed to provide an economical method of moving the tower away from the house. It will support the tower in a completely free-standing vertical position, while also having the capabilities of tilting the tower over to provide an easy access to the antenna. The rotor mounts at the top of the tower in the conventional manner, and will not rotate the complete tower.

FB-45A
FB-61A

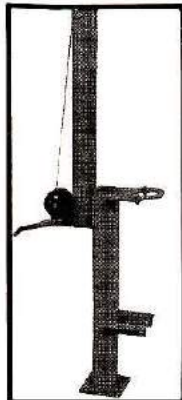

ROTATING BASE

The RB Series was designed for the Amateur who wants the added convenience of being able to work on the rotor from the ground position. This series of bases will give that ease plus rotate the complete tower and antenna system by the use of a heavy duty thrust bearing at the base of the tower mounting position, while still being able to tilt the tower over when desiring to make changes on the antenna system.

RB-45A
RB-61A

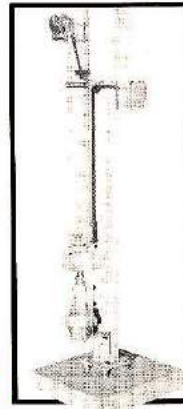

Tilting the tower over is a one-man task with the Wilson bases.

(Shown above is the RB-61A.)

W S I WILSON SYSTEMS, INC.

4286 S. Polaris Avenue
Las Vegas, Nevada 89103
(702) 739-7401

Factory Direct Toll Free 1-800-634-6898

Prices and specifications subject to change without notice.

WILSON MONO-BAND BEAMS

At last, the antennas that you have been waiting for are here! The top quality, optimum spaced, and newest designed monobanders. The Wilson Systems' new Monoband beams are the latest in modern design and incorporate the latest in design principles utilizing some of the strongest materials available. Through the select use of the current production of aluminum and the new boom to element plates, the Wilson Systems' antennas will stay up when others are falling down due to heavy ice loading or strong winds. Note the following features:

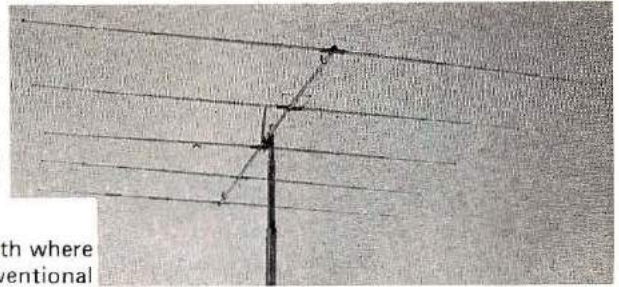

M-520A

- Taper Swaged Elements** — The taper swaged elements provide strength where it counts and lowers the wind loading more efficiently than the conventional method of telescoping elements of different sizes.
- Mounting Plates — Element to Boom** — The new formed aluminum plates provide the strongest method of mounting the elements to the boom that is available in the entire market today. No longer will the elements tilt out of line if a bird should land on one end of the element.
- Mounting Plates — Boom to Mast** — Rugged 1/4" thick aluminum plates are used in combination with sturdy U-bolts and saddles for superior clamping power.
- Holes** — There are no holes drilled in the elements of the Wilson HF Monobanders. The careful attention given to the design has made it possible to eliminate this requirement, as the use of holes adds an unnecessary weak point to the antenna boom.

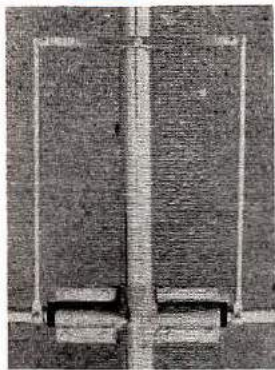

Wilson's Beta match offers maximum power transfer.

With the Wilson Beta-match method, it is a "set it and forget it" process. You can now assemble the antenna on the ground, and using the guidelines from the detailed instruction manual, adjust the tuning of the Beta-match so that it will remain set when raised to the top of the tower. The Wilson Beta-match offers the ability to adjust the terminating impedance that is far superior to the other matching methods including the Gamma match and other Beta-matches. As this method of matching requires a balanced line, it will be necessary to use a 1:1 balun, or RF choke, for the most efficient use of the HF Monobanders.

The Wilson Monobanders are the perfect answer to the Ham who wants to stack antennas for maximum utilization of space and gain. They offer the most economical method to have more antenna for less money with better gain and maximum strength. Order yours today and see why the serious DXers are running up that impressive score in contests and number of countries worked.

SPECIFICATIONS

Model	Band Mtrs	Gain dBd	F/B Ratio	Bandwidth w/ Resonance 2:1 SWR Limit	VSWR @ Resonance	Impedance	Matching	Elements	Longest Element	Boom O.D.	Boom Length	Turning Radius	Surface Area (Sq. Ft.)	Windload @ 80 mph (Lbs.)	Maximum Mast	Assembled Weight (Lbs.)
M520A	20	11.5	25 dB	500 KHz	1.1:1	50 Ω	Beta	5	36'6"	2"	34'2½"	25'1"	8.9	227	2"	68
M420A	20	10.0	25 dB	500 KHz	1.1:1	50 Ω	Beta	4	36'6"	2"	26'0"	22'6"	7.6	189	2"	50
M515A	15	12.0	25 dB	400 KHz	1.1:1	50 Ω	Beta	5	25'3"	2"	26'0"	17'6"	4.2	107	2"	41
M415A	15	10.0	25 dB	400 KHz	1.1:1	50 Ω	Beta	4	24'2½"	2"	17'0"	14'11"	2.1	54	2"	25
M510A	10	12.0	25 dB	1.5 MHz	1.1:1	50 Ω	Beta	5	18'6"	2"	26'0"	16'0"	2.8	72	2"	36
M410A	10	10.0	25 dB	1.5 MHz	1.1:1	50 Ω	Beta	4	18'3"	2"	12'11"	11'3"	1.4	36	2"	20

WILSON SYSTEMS, INC. — 4286 S. Polaris
Las Vegas, NV 89103 — (702) 739-7401

FACTORY DIRECT
ORDER BLANK

Toll-Free Order Number
1-800-634-6898

WILSON SYSTEMS ANTENNAS

Qty.	Model	Description	Shipping	Price
	SY33	3 Ele. Tribander for 10, 15, 20 Mtrs.	UPS	\$139.95
	SY36	6 Ele. Tribander for 10, 15, 20 Mtrs.	UPS	189.95
	WV-1A	Trap Vertical for 10, 15, 20, 40 Mtrs.	UPS	44.95
	GR-1	Ground Radials for WV-1A	UPS	9.95
	M-520A	5 Elements on 20 Mtrs.	TRUCK	199.95
	M-420A	4 Elements on 20 Mtrs.	UPS	139.95
	M-515A	5 Elements on 15 Mtrs.	UPS	119.95
	M-415A	4 Elements on 15 Mtrs.	UPS	79.95
	M-510A	5 Elements on 10 Mtrs.	UPS	84.95
	M-410A	4 Elements on 10 Mtrs.	UPS	64.95
	WM-62A	Mobile Antenna: 5/8 λ on 2, ¼ λ on 6	UPS	19.95
ACCESSORIES				
	HD-73	Alliance Heavy Duty Rotor	UPS	109.95
	RC-8C	8/C Rotor Cable	UPS	.12/ft.
	RG-8U	RG-8U Foam-Ultra Flexible Coaxial Cable. 38 strand center conductor, 11 gauge	UPS	.21/ft.

WILSON SYSTEMS TOWERS

Qty.	Model	Description	Shipping	Price
	TT-45A	Freestanding 45' Tubular Tower	TRUCK	\$219.95
	RB-45A	Rotating Base for TT-45A w/tilt over feature	TRUCK	119.95
	FB-45A	Fixed Base for TT-45A w/tilt over feature	TRUCK	79.95
	MT-61A	Freestanding 61' Tubular Tower	TRUCK	399.95
	RB-61A	Rotating Base for MT-61A w/tilt over feature	TRUCK	179.95
	FB-61A	Fixed Base for MT-61A w/tilt over feature	TRUCK	109.95
	STB-50	Thrust Bearing	UPS	18.95

Nevada Residents Add Sales Tax

Ship C.O.D. Check enclosed Charge to Visa M/C

Card # _____ Expires _____

Bank # _____ Signature _____

Please Print

Name _____ Phone _____

Street _____

City _____ State _____ Zip _____

Note: On Coaxial and Rotor Cable, minimum order is 100 ft. and in 50' multiples. Prices and specifications subject to change without notice. Ninety Day Limited Warranty. All Products FOB Las Vegas, Nevada.

Call Toll Free 1-800-243-7765

FREE

- Monthly Used Equipment / New Specials List
- ★ New 1979 Retail Catalog!
- Courteous, Personalized Service

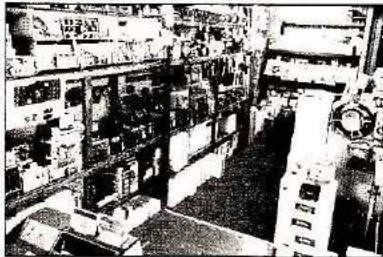

New Equipment — All new equipment on display is operating for actual "on the air" QSO's. We really know our gear!



Used Equipment — We recondition and guarantee all our used equipment. We make sure it satisfies you!

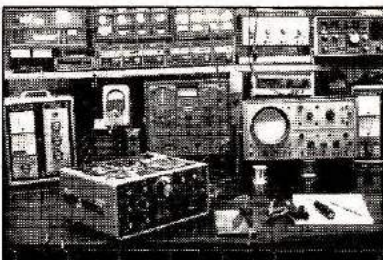

Service Shop — You've probably heard of our fine service reputation — using Cushman CE4B signal generators, Hewlett Packard oscilloscopes, Bird wattmeters — we fix it right!



Inventory Warehouse — Our large volume assures you the best prices!

PARTIAL USED EQUIPMENT LIST (Guaranteed 30 Days — 7 Days Refund Policy)

COLLINS RADIO

75S3 Receiver With CW FILTER	\$ 479.00
75S1 Receiver	299.00
75S3B Receiver	685.00
KWM-2 With 516F2 (Round Emblem)	1299.00
30L-1 Amplifier	495.00
32S1 Transmitter	349.00

DRAKE

R-4 Receiver & T4 Reciter	449.00
RV4-C VFO	89.00
R4-B Receiver	349.00
T4-X With Drake Desk Mic.	359.00
2NT Transmitter	99.00
2-C Receiver W/2CQ Multiplier	219.00
ML-L 2M FM Transceiver	128.95

HEATHKIT

Digital Multimeter SM-1210	80.00
SB-650 Digital Display	139.00
HW-16 XCVR W/VFO	159.00
SB104 W/H.P. 1146 P.S.	599.00
SB102 W/H.P. 23B & SP-600	443.00
Freq Counter IB-1103	100.00
HR-10B Receiver	69.00
SB-630 Console	99.00
SB-303 Receiver W/CW Filter	259.00
SB-300 Receiver W/SP600 Speaker	219.00
DX-60B Transmitter	69.00

KENWOOD

R-599 Receiver	299.00
TR-7200 FM XCVR	189.00

SBE

SB-36 Transceiver	449.00
-------------------	--------

ICOM

22-S FM XCVR	209.00
--------------	--------

TEMPO

VHF One Plus	299.00
Tempo I W/AC-1	399.00
Henry 2K-4 Amplifier	899.00

ATLAS

210X W/NB & DMK & Mobile Mount	679.00
--------------------------------	--------

HAMMARLUND

HQ-170A RX	189.00
------------	--------

NATIONAL

NC-300 RX	129.00
-----------	--------

HALLICRAFTERS

SX-111 Receiver	142.95
SX-115 Receiver	299.00

CLEGG

FM-27B FM XCVR 2M	179.00
-------------------	--------

AUTHORIZED DEALER . . .

FOR OVER 50 MAJOR LINES .

NEW AND USED EQUIPMENT "Get on our used equipment mailing list."
 TRADES WELCOME "The best allowances anywhere" "We buy good used SSB gear"
 OUR EVERYDAY LOW PRICES "remain the same for cash or trade-ins!"
 SAME DAY U.P.S. SHIPPING "Just a phone call away"
 COMPLETE RADIO SERVICE SHOP "Mail Order Repair Service"

- Fast Efficient Service
- We Repair All Brands
- All Work Guaranteed
- Most Repairs Done and Shipped Within 7 Days
- Amateur Extra / First Class Licenses
- Include Manuals and Power Supply
- Send Us Your Defective Equipment Prepaid Shipping

OUR FINE REPUTATION SPEAKS FOR ITSELF . . . "YOU SHIP IT — WE FIX IT"

We Sell and Service the following New Equipment:

Alda	B & W	Drake	JW Miller	Mosley	SST Electronics	Vibroplex
Alliance	Callbook	DSI	KDK	Murch	Swan	Wilson
Ameco	CDE	ETO Alpha	KLM	PIPO	Telex	Wilson Commercial
ARRL	CES	Ham Key	Larsen	Robot	Ten Tec	Yaesu
Atlas	Covercraft	Hustler	MFJ	Rohn	Trac	
Bencher	Cushcraft	Hy-Gain	Microlog	Saxton Wire	Unadilla	
Bird	Dentron	ICOM	Mirage	Shure	VHF Engineering	

"We want your used gear!
 We Buy or Trade!"

THOMAS COMMUNICATIONS

95 Kitts Lane, Newington, Conn. 06111
 "Near ARRL Headquarters"

Connecticut Residents Call: 203-667-0811
 OPEN MON.-FRI. 10-6 • THURS. 10-8 P.M. • SAT. 10-4
 EASY DIRECTIONS: Rt. 15 South — 2 blocks past McDonald's (Berlin Turnpike)

Call or Write for your super quote today!



WE EXPORT (Sub-Dealers wanted in foreign countries)

Sub-Dealer Inquiries Invited (Send Letterhead for Complete Package).

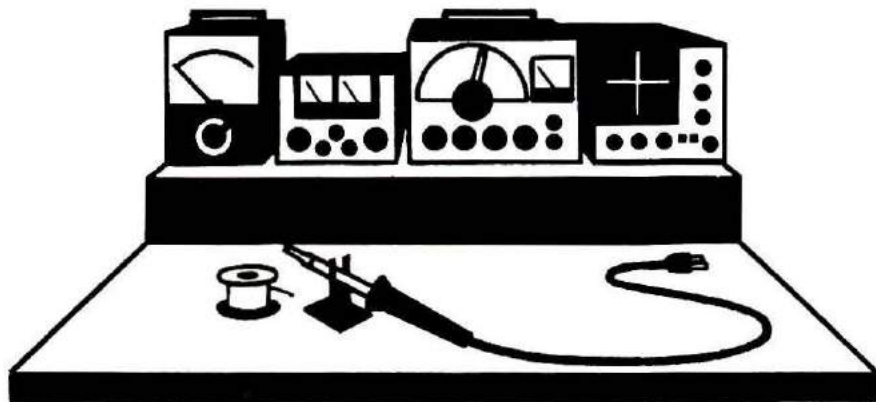

BENCHMARKS

Keyer Paddles for "El Cheepo"



Fig. 1. My version of "El Cheepo" as it looks assembled. This version is set up as a "squeeze key," and the paddles are made of Plexiglas.

The electronics of "El Cheepo" keyer, described by WA0UZO in *Ham Radio Horizons* for October, 1978, work beautifully, but the key lever suggested by Shriner in the article is not what this excellent keyer deserves. Besides, what fun is it to copy something exactly? I felt that I could make an improvement over a piece of PC board material flexed between two machine screws.

Being somewhat lazy and very inept, I immediately ruled out a

lot of metal work, hard-to-get materials, and fussy adjustments. This left me with the original idea of a springy arm (or arms), preferably ready-made, some way of making contact to the keyer, and a couple of simple paddles. But what comes ready-made like that . . . and cheap?

Since a ham's best friend is his junk box (my XYL's term for the entire basement) I looked close to home first. The leaves from an old relay seemed ideal. They are designed by the manufacturer to be very flexible, last a long time, and they have built-in contacts. With the addition of

paddles, they could be set up to work with "El Cheepo" and at the same time could be adapted for an iambic keyer should one be acquired later.*

Start by finding a suitable relay, and remove the leaf assembly. The leaves should be as long as possible for best leverage and smoothest action. Try to find the type in which the longer leaf has a fiber pad at one end, as in **Fig. 2**. When you remove this pad, you have a handy hole for later attachment of the paddle. You will want two similar sets of leaves. Do not lose the fiber spacers and tubular insulators which hold the leaf assembly together. Get, or make, a pair of light angle brackets about 25 mm (1-inch) wide, and high enough to raise the leaf assembly a fraction of an inch off the base. Drill the brackets on the vertical faces to match the mounting holes in the leaves, and drill the horizontal faces to take a pair of 6-32 (M3.5) screws. This is shown in **Fig. 3A**.

Decide whether you want a "side swiper" (**Fig. 3B**) or a "squeeze key" (**Fig. 3C**). Either will work with "El Cheepo," but if you have an iambic keyer you will prefer the squeeze key.

Now you are ready for the heavy assembly work. Arrange the leaves according to **Fig. 3B** or **3C**, using the original fiber spacers and tubular insulators.

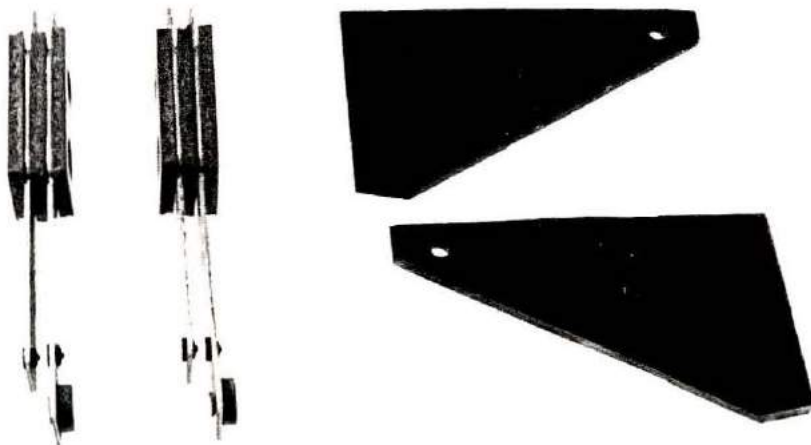

Fig. 2. Relay leaves (left) as they come off the relay assembly. The fiber pads at the ends of the longer leaves are easily clipped off with diagonal cutters, leaving holes to match those in paddles (right). Paddles shown were cut from PC board material, after which the copper was etched off, an unnecessary refinement.

*Iambic keyer — one in which dots and dashes automatically follow each other in alternating sequence when both sets of contacts are closed, or when the opposite contact is closed before the preceding character has been completed.

Add the angle brackets on each side as shown in the photograph of the completed key (Fig. 1) and bolt the whole works together with a pair of machine screws. Be sure that everything is square and that the contacts on the matching leaves meet.

Cut a pair of paddles something like those in Fig. 2D and Fig. 3. The exact shape is unimportant, but you will want some part of the paddle to extend beyond the base for easy keying. Material can be plexiglas, PC board, or any other nonconductor. If you use PC board, make the pieces "mirror images" so that you can mount the paddles with the copper sides facing in, away from your fingers. Drill a small hole in each paddle, to mate with the hole in the leaf. You will need a small screw, about a No. 2 (M2), which can be obtained in a model-railroad or model-aircraft hobby shop. I tried all sorts of ways to achieve a connection between leaf and paddle which would be more solid than a single screw, but came to the conclusion that a single screw, turned up tight, would do the job.

If there are no holes in the leaves you have, you will have to drill these — a difficult job in spring metal. You might try one of the "magic" glues (Eastman 910, for example), or epoxy, to bond the two parts.

There is one fussy adjustment. *Carefully* bend the shorter leaves so that the spaces between each shorter-leaf contact and its matching longer-leaf contact are about equal. Spacing should be close — about as wide as three or four thicknesses of typing paper. You'll be surprised by how long these adjustments will hold . . . and how unimportant they really are.

If you make a "side swiper," the center leaf is ground, the right-hand leaf (looking at the paddle end) is for dashes, and the left-hand leaf is for dots. If you make a "squeeze key" the same connections are used, but both center leaves (short) are connected together for ground.

I made the base pretty much as WA0UZO did for El Cheepo, but — preferring to smoke a pipe over eating sardines — I used an imported tobacco tin. Any can about 63 mm x 90 mm

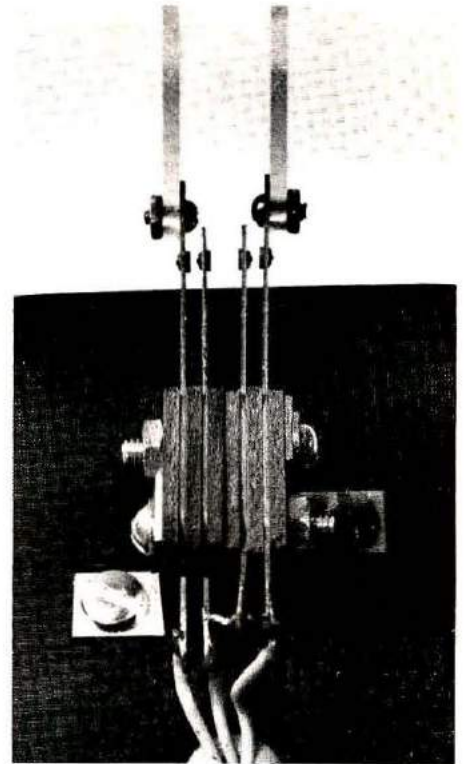

Fig. 4. The business end of the key shows leaf arrangement and connections for a "squeeze key," and contact spacing. Two small angle brackets for holding the leaf assembly to the base are satisfactory, but could be replaced with a more stable pair of wider brackets drilled to take both bolts of the leaf assembly.

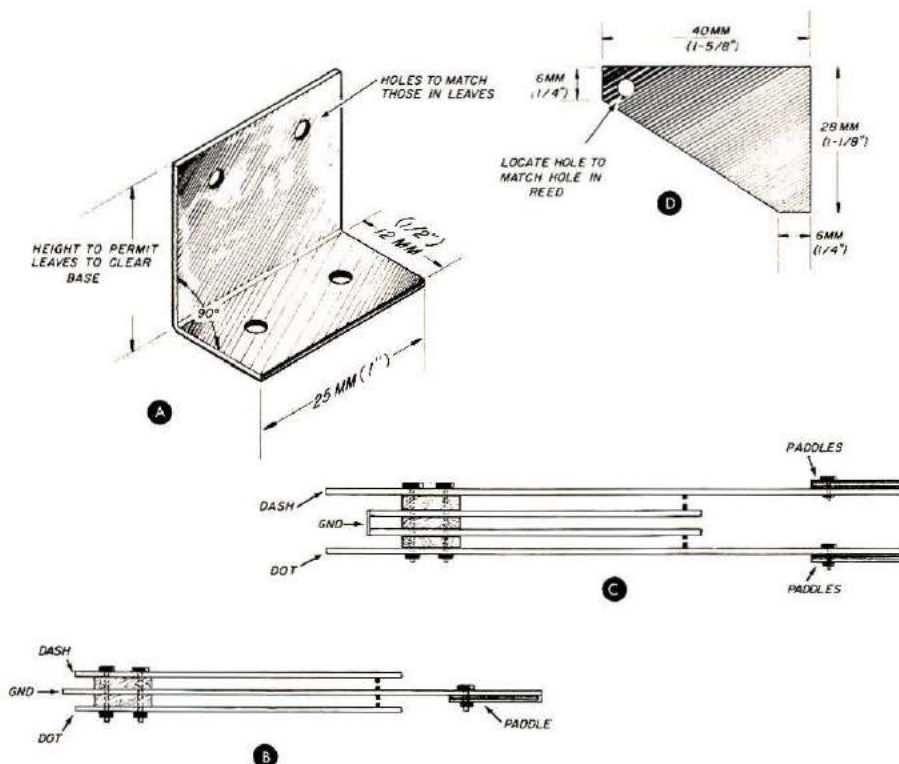
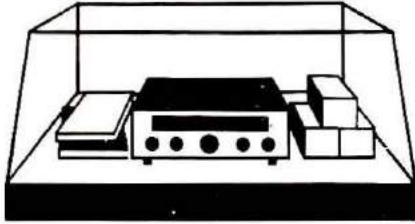

Fig. 3. Components for assembling the paddles. You can use three leaves as a "side-swiper" arrangement, B, or use four leaves, C, if you have an iambic keyer.

x 12 mm (2 1/2 x 3 1/2 x 1/2 inch) thick will be adequate. The leads from the key go into the can, through a grommets hole in the top, to a three-wire cable inside the can. If possible, use cable that has two conductors and a shield; the shield is the ground lead. This cable comes out through a grommets hole in the back of the base. The same weighting of the base described by WA0UZO, scrap lead and epoxy, is used. In mounting the key on the base, I turned the tin over and mounted the "works" on the bottom, using the lid (with four rubber feet attached) as the new bottom of the base. Before the final assembly, I spray the base flat black, this being my own preference. I would be interested in knowing whether the key works as well with the base sprayed charcoal or lavender.

Julian N. Jablin, W9IWI

PRODUCT SHOWCASE



For literature on any of the Product Showcase items use our ad-check service on page 78.

Pace Communicator II



Pace Communications Division of Pathcom, Incorporated, has been known for its superb CB and Commercial fm two-way radio products for many years. A few months ago, the Amateur Radio Products Group of Pace introduced its Communicator Line. Top of the line is a 4-MHz, 800-channel, all synthesized 2-meter fm mobile transceiver, the Communicator II.

By using three knobs, (MHz, 100 kHz, and 10 kHz), and an in-out pushbutton for 5 kHz, you can rapidly dial the receive frequency into the unit and see it displayed on the six-digit LED readout. Transmit frequency is selected by a five-position rotary switch giving Simplex, ± 600 kHz, and ± 1 MHz splits. When the microphone button is pressed, the digital readout automatically shifts from receive frequency to transmit frequency, leaving no doubt as to where the unit is set. Also of note is a push-on, push-off power switch that relieves the user of having to reset the volume control.

Using 52 diodes, 8 LED units,

32 transistors, 6 FETs, and 18 ICs, the Communicator II operates in a 16F3 mode. Power output is 1 to 25 watts, pushbutton controlled (with the 25 watts being adjustable for those who wish QRP). Frequency deviation is ± 5 kHz maximum. Spurious harmonics are 65 dB below carrier.

The Communicator II has incorporated a novel mounting bracket which allows forward and backward slide adjustment to accommodate virtually any mobile mounting position. The transceiver mount mates with the mounting-bracket slides, and the unit is secured in place with two quick-turn knobs. Also included with the Communicator II is a desk-top bracket which snaps in place to elevate the front of the unit for indoor use.

The Communicator II, priced at \$399.00, carries a dealer-backed factory warranty of one full year. Write to Pathcom, Inc., Amateur Products Group, 24105 South Frampton Ave., Harbor City, California 90710.

Kantronics' Amateur Upgrade

Kantronics' Amateur Upgrade is an educational board game that familiarizes players with FCC rules governing Amateur Radio, and elementary radio concepts. The game comes complete with playing surface, playing pieces — coils, grommets, etc. — a die, a deck of exam cards, and corresponding answer sheets.

Game pieces and exam cards fit in a pocket adjacent to the support tray. The game surface is printed in five colors corresponding to beginner, Novice, General, Advanced, and Extra-class. Players roll the die to determine the number of spaces to move. Some spaces players land on have a consequence such as "taught a Novice Class — move again," or "exceeded 1000 watts — answer question, if wrong go to start," or "illegal third party traffic — lose one turn."

When a player lands on an exam space, he must take an exam card from the card pile corresponding to the license level he is trying to upgrade to. After three cards have been collected by one player, he must "Take the exam." All three questions must be answered correctly to pass the exam. Answers can be checked against the answer sheets. If the exam is passed, the player moves up (upgrades) to the adjacent exam space on the next license level. If the exam is failed, the player remains on the same level and must collect another three exam cards.

The first person to progress through all levels to obtain the



Extra-Class license wins! Novice, General, Advanced and Extra-Class questions are included. For a less advanced game, the Novice cards can be used exclusively for all license levels. Upgrade includes 45 Novice questions, 30 General questions, 20 Advanced questions, 10 Extra-class questions, a die, and 4 player pieces. Suggested retail price is \$9.95. Write Kantronics Inc., 1202 E. 23rd St., Lawrence, Kansas 66044.

CDE Antenna Rotor Brochure

Cornell-Dubilier Electric Corporation has released a new eight-page color brochure presenting their complete line of antenna-rotor systems. Each of the six rotor systems is illustrated and described. They include the Taitwister,TM designed for king-sized antenna arrays of up to 30 square feet wind load area; the new Ham IV,TM the latest version of the world-famous Ham Series; the new

CD-45, incorporating professional features at a popular price; the Big Talk,™ with IC control that lets you preprogram locations most commonly used; the AR-40, a deluxe unit with solid-state accuracy and silent operation; and the AR22XL, a popular-priced system with automatic control.

Included in the CDE Antenna Rotor Systems brochure is a breakaway photograph of the time-tested Bell Rotor, which illustrates the ruggedness and quality construction that has made CDE world famous. A complete specification chart is also included covering all six models.

For additional information, contact Leonard Sabal, Cornell-Dubilier Electric Corporation, subsidiary of Federal Pacific Electric Company, 150 Avenue L, Newark, New Jersey 07101, telephone (201) 589-7500.

New 60-Watt Amateur and Business Radio



A rugged new 60-watt vhf/fm two-way radio is now available from Standard Communications Corporation of Carson, California. Designated 890L-60, this transceiver is available with one, two, or twelve channels, and is designed for operation in the 138- to 174-MHz range. It incorporates a built-in 8-ohm speaker, external-speaker jack, and has separate transmit and receive crystals for maximum flexibility. The 890L-60 measures 16.5 x 6 x 24.7 cm (6½ x 2¾ x 9¾ inches), and comes complete with a dynamic microphone. For further information on 890L two-way radios write Standard Communications Corporation, P.O. Box 92151, Los Angeles, California 90009.

More details? Ad Check page 78.

... at last ...
your shack organized!

A beautiful piece of furniture — your XYL will love it!

\$149⁹⁵ S-F RADIO DESK
Deluxe - Ready to Assemble

Designed with **angled** rear shelf for your viewing comfort and ease of operation.

FINISHES: Walnut or Teak Stain.
Also available in Unfinished Birch, \$134.95.
Additional information on Request.

Checks, Money Orders, BankAmericard and Master Charge Accepted.
F.O.B. Culver City. (In Calif. Add 6% Sales Tax.)

S-F AMATEUR RADIO SERVICES
DEPT. HZ-12 • 4384 KEYSTONE AVENUE • CULVER CITY, CALIF. 90230 — PHONE (213) 837-4870

KLAUS QUALITY AMATEUR RADIO EQUIPMENT & ACCESSORIES

KENWOOD

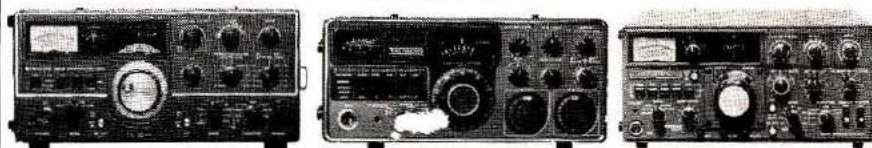

TS 520 S
HF TRANSCEIVER

TS 600
MULTIMODE 6-M
TRANSCEIVER

TS 820 S
HF TRANSCEIVER

... call or write for the KLAUS price ...

YAESU

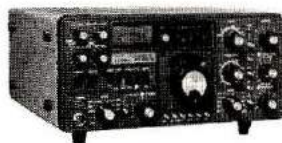

FT-901 D
HF TRANSCEIVER

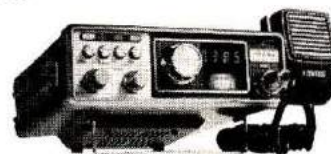

FT-227 R
2-METER FM TRANSCEIVER

... call or write for the KLAUS price ...

CUSHCRAFT

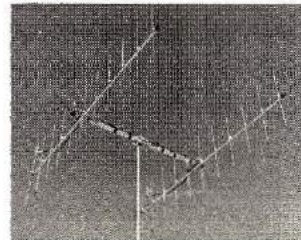
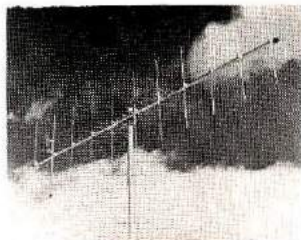

We have a complete stock of Cushcraft antennas — too many to mention in detail, so ask about our 2-meter line of verticals and beams for special low, low prices.

KLAUS RADIO Inc.

8400 N. Pioneer Parkway, Peoria, IL 61614

Phone 309-691-4840

Tim Daily, Amateur Equipment Sales Manager

ANNUAL LAS VEGAS PRESTIGE CONVENTION

SAROC™



DUNES HOTEL & COUNTRY CLUB

Las Vegas, Nevada

JANUARY 10-13, 1980

BIG HAM SHOW

*What's all the chatter and noise we hear?
It's HAMS! Checkin' out mobile gear.
It's SAROC time in the gamblin' State
Send your reservations in, before it's too late.
January 10 thru 13 that's the time to go
To see ham friends and attend a show.
The YL's will love it — so much to do
One arm bandits and a luncheon too.
There's a great first prize — Many others,
as well
You might be a winner — You never can tell.
You missed the ham convention that's rated
best.
So let's get ready, get set and go
To eye ball at SAROC — THE BIG HAM
SHOW!*

by xyl of K6SF

Advance Registration \$15.00 per person*

Special **SAROC** rate \$33.00 plus tax per night — single or double occupancy

A Dunes Hotel reservations request card will be sent to exhibitors and delegates

Send check or money order to **SAROC**
P.O. Box 945, Boulder City, NV 89005

**Refunds will be made if requested in writing and postmarked before January 9.*

SAROC™

BOX 945

BOULDER CITY, NEVADA 89005

CALL TOLL FREE 1-800-228-4097

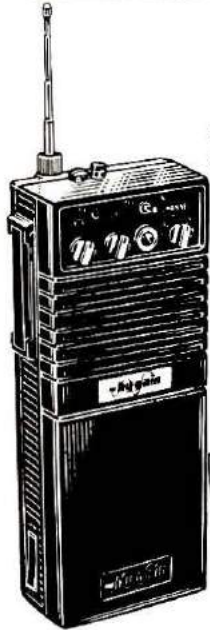

Hy-Gain 3806 2-Meter Hand-Held Amateur Transceiver

SPECIALLY PRICED ONLY \$119.⁹⁵

- Low cost, 6-channel hand-held provides superb voice transmission over short to medium distances
- Sharply tuned on-frequency selectivity in the RF amplifier stages plus FET's in the 1st and 2nd mixers for virtual immunity to out-of-band signals intermodulation distortion and cross-modulation
- Separate microphone and speaker elements for enhanced audio
- Internally adjustable mic preamp—a Hy-Gain exclusive
- Specially gasketed case seals out water, dirt and corrosive salt air
- Watertight, high-impact ABS plastic case—ribbed for non-slip grip
- Top-mounted controls for instant access



Accessories:

Model No.	Description	Price
3807	Nicad Battery Pack	\$31.95
1104	Touch Tone Pad	\$44.95
1106	AC Battery Charger	\$ 9.95
1107	Cigarette Lighter Adaptor Cord	\$ 9.95
1108	Antenna Adaptor Cord	\$ 9.95
1110	Carrying Case (Leather)	\$17.85
1111	Carrying Case (Vinyl)	\$ 9.95
269	Rubber Duck Antenna	\$ 5.95
	Crystal Certificates	\$ 3.95

PLEASE ENCLOSE \$2.50 FOR SHIPPING AND HANDLING PER UNIT

CALL TOLL FREE 1-800-228-4097

for Quality Ham Radio Products at Discount Prices

YAESU
KENWOOD
DRAKE
ICOM
STANDARD
EDGE COM
KDK
PANASONIC

DENTRON
HY-GAIN
MOSLEY
CUSHCRAFT
WILSON
HUSTLER
LARSEN
BENCHER
ROBOT

TAYLOR
SWAN
TEMPO
TEN-TEC
MIDLAND
CDE
AUTEK
MIRAGE
AEA

E.T.O. ALPHA
VHF ENGINEERING
BERK-TEK CABLE
CONSOLIDATED TOWER
SAY
SHURE
TELEX
ROBOT-SSTV
BENCHER

Our Mail Order Hours (CST)

M-F 8 am to 12 Midnight
Saturday 8 am to 6 pm
Sunday 12 Noon to 8 am

Call and Talk to

Don	WBØYEZ	Ken	WDØEMR
Denny	WØQR	Eli	KAØCEJ
Bill	WBØYHJ	John	WBØMTS
Joe	WAØWRI	Blaine	WBØQLH
Jim	KAØCRK	Bob	WBØRQZ



Communications Center

443 N. 48th, Lincoln, Nebraska 68504

In Nebraska Call (402) 466-8402



HamGearMart Has A Perfect Match For You

If you're in the market to buy or sell equipment, you're in the market for HamGearMart. We match individual buyers and sellers - economically, efficiently, effectively.

At least once each week, HamGearMart matches buyers' requirements against available equipment. Buyers are advised of the equipment that meets their needs. Then, they contact the sellers directly; all negotiations are strictly between buyer and seller.

Using HamGearMart is easy and economical. Send one registration form (below) and \$3.73 for each piece of equipment. Your entries remain active for 17 unique matches or for one year. **SELLERS:** Provide price, type, brand, and model of equipment. The optional monitoring information is sent to buyers for RF inquiries. **BUYERS:** Specify gear either by brand and model, or by type and price range.

Register now with HamGearMart - a great service for Hams.

(HamGearMart is not an equipment dealer, and it cannot warrant or guarantee equipment or data associated with this service.)

P.O. Box 66, 1879 Post Rd., Southport, CT 06490

YES, register me with HamGearMart.

(For each additional item, use an extra page or facsimile copy of form.)

SELLER Monitoring data for buyers' RF inquiries [optional].	PRICE	GEAR YEAR	GEAR TYPE:XCVR,TEST,etc	PRICE RANGES:	BUYER
	Day of Week	BRAND:MANUFACTURER	For Type and Price Option [Circle One]		
	Hour [UTC]	GEAR MODEL NUMBER	A. 40 - 99	F. 525 - 699	
	Freq.:Novice		B 100-199	G. 700 - 899	
			C.200-299	H. 900-1099	
			D.300-399	I.1100-1399	
			E.400-524	J.1400 & UP	
NAME		CALL		CLASS	
ADDRESS		TELEPHONE			
CITY		STATE	ZIP		
P.O. Box 66, 1879 Post Rd., Southport, CT 06490					

THIS IS IT

WAVE



MODEL 4431 THRULINE®

RF DIRECTIONAL WATTMETER
with **VARIABLE RF**
SIGNAL SAMPLER - BUILT IN
IN STOCK FOR PROMPT DELIVERY

AUTHORIZED DISTRIBUTOR

Webster
associates

115 BELLARMINE
ROCHESTER, MI 48063

CALL TOLL FREE

800 - 521-2333

IN MICHIGAN 313 - 375-0420

State of the art

TECHNICAL EXCELLENCE

in RTTY



The FSK-1000 Demodulator

If you demand the finest, no compromise technology, you need the FSK-1000 demodulator. Can't be outcopied because its design, computer grade parts, and modern technology offer landline copy over radio circuits.

Stops QRM with selectable 55 or 100 Hz. filters and two tone limiterless operation

Decision level correction improves selective fading

Uses either 170 volt, 60 Ma. or RS-232 loops

Video operation available. Interfaces microcomputers. We can install your Xitex SCT-100 board inside, too

Continuously adjustable shift from 100 to 1000 Hz.

Write for details. Visa and Master Charge accepted.

\$449.00

FOB Columbus, Ohio

Dealer Inquiries Welcome

IRL

700 Taylor Road
Columbus, Ohio 43230
(614) 864-2464

omni-j

ANTENNAS

Model OJA-146

TWO METER AMATEUR BAND 146-148MHz

- NO GROUND PLANE REQUIRED
- USE FIXED, MOBILE, OR PORTABLE
- 5dB GAIN OVER ISOTROPIC IN MOST MOBILE APPLICATIONS
- OVERALL LENGTH: LESS THAN 64 INCHES
- COLLAPSIBLE TO 22 INCHES. MAY BE PACKED IN SUIT-CASE FOR THOSE OUT-OF-TOWN TRIPS
- STEEL WHIP AND ADAPTER INCLUDED FOR MOBILE AND FIXED APPLICATIONS
- VSWR: LESS THAN 1.2:1

PRICE \$39.95 UPS Prepaid

220 MHz — \$37.95 450 MHz — \$37.95

MADISON
ELECTRONICS SUPPLY, INC.

1508 MCKINNEY • HOUSTON, TEXAS 77002
713/658-0268

MASTERCHARGE • VISA

W5GJ, W5MBB, K5AAD, N5JJ, AG5K, W5VVM, W5EGP, WA5TGU, WB5AYF, K5BGB.

fact: this mic gives you universal impedance matching!

NEW!
526T SERIES II
designed
for
expanded
compatibility

For: High/Low Impedance SSB/NBFM

The Shure 526T Series II SUPER PUNCH® features variable output level to match any input impedance. It's a perfect match for almost any transceiver made, from 500 ohms and up. Use it to turn a mobile-NBFM unit into an indoor base station! Super for SSB operation. Replaces either ceramic or dynamic, low- or high-impedance microphones. Transistorized preamplifier. It's like several microphones in one.



Ⓐ Dynamic Element Gives clean, clear, smooth transmissions. Rising response characteristic — tailored for SSB and FM communications.

Ⓑ ARMO-DUR® Case Virtually indestructible non-metallic construction — can't cause RF "burns." Fully shielded for low hum pickup, minimum susceptibility to RF interference.

Ⓒ Adjustable Volume Control Helps cut through QRM with maximum intelligibility — allows you to optimize transmitter modulation.

Ⓓ "Million-Cycle" Switch Trouble-free — won't fail. Closes with a self-cleaning wiping action for noise-free switching with momentary or locking operation. New on the Series II — accessory switching for speech processors, antenna relay, receive or transmit standby, on-the-air lights, etc.

Ⓔ Universal Six-Wire Coil Cord Compatible with virtually every transceiver input. New on the Series II.

Model 526T Series II Super Punch®

®  SHURE ®

Shure Brothers Inc., 222 Hartrey Ave., Evanston, IL 60204. In Canada: A.C. Simmonds & Sons Limited
Manufacturers of high fidelity components, microphones, sound systems and related circuitry.

HRH LOCATOR

TO HELP YOU FIND YOUR LOCAL AMATEUR RADIO DEALER

Arizona

POWER COMMUNICATIONS

6012 N. 27 AVENUE
PHOENIX, AZ 85017
602-242-6030
Arizona's #1 "Ham" Store,
Kenwood, Yaesu, Drake, ICOM,
& more.

California

C & A ELECTRONIC ENTERPRISES

22010 S. WILMINGTON AVE.
SUITE 105
P. O. BOX 5232
CARSON, CA 90745
800-421-2258
213-834-5868 - Calif. Res.
Not the biggest, but the best —
since 1962.

JUN'S ELECTRONICS

11656 W. PICO BLVD.
LOS ANGELES, CA 90064
213-477-1824 Trades
714-282-8682 San Diego
The Home of the One Year
Warranty — Full Service.

SHAVER RADIO

3550 LOCHINVAR AVE.
SANTA CLARA, CA 95051
408-247-4220
Atlas, Kenwood, Yaesu, KDK,
Icom, Tempo, Wilson, Ten-Tec.

Connecticut

THOMAS COMMUNICATIONS

95 KITTS LANE
NEWINGTON, CT 06111
800-243-7765
203-667-0811 - Conn. Res.
Call Us Toll Free —
See Our Full Page Ad in this Issue.

Delaware

DELAWARE AMATEUR SUPPLY

71 MEADOW ROAD
NEW CASTLE, DE 19720
302-328-7728
Delaware's Largest Stock of
Amateur Radio Equipment
& Accessories.

Florida

AGL ELECTRONICS, INC.

1800-B DREW STREET
CLEARWATER, FL 33515
813-461-HAMS
West Coast's Only Full Service
Amateur Radio Store

AMATEUR RADIO CENTER, INC.

2805 N.E. 2ND AVENUE
MIAMI, FL 33137
305-573-8383
The Place For Great Dependable
Names in Ham Radio

RAY'S AMATEUR RADIO

1590 US HWY. 19 SOUTH
CLEARWATER, FL 33516
813-535-1416
Atlas, B&W, Bird, Cushcraft,
DenTron, Drake, Hustler, Hy-Gain,
Icom, K.D.K., Kenwood, MFJ,
Rohn, Swan, Ten-Tec, Wilson.

SUNRISE AMATEUR RADIO

1351 STATE RD. 84
FT. LAUDERDALE, FL 33315
(305) 761-7676
"Best Prices in Country.
Try Us — We'll prove it."

Illinois

AUREUS ELECTRONICS INC.

1415 N. EAGLE STREET
NAPERVILLE, IL 60540
312-420-8629
"Amateur Excellence"

ERICKSON COMMUNICATIONS, INC.

5456 NORTH MILWAUKEE AVE.
CHICAGO, IL 60630
312-631-5181
Illinois (Outside 312)
800-972-5841
Outside Illinois 800-621-5802
Hours 9:30-5:30 Mon., Tues., Wed.,
Fri.; 9:30-9:00 Thurs.; 9:00-3:00 Sat.

KLAUS RADIO, INC.

8400 NO. PIONEER PARKWAY
PEORIA, IL 61614
309-691-4840
Let Us Quote Your Amateur Needs.

SPECTRONICS, INC.

1009 GARFIELD STREET
OAK PARK, IL 60304
312-848-6777
One of America's Largest
Amateur and SWL Stores

Iowa

BOB SMITH ELECTRONICS

RFD #3, HIGHWAY 169 & 7
FORT DODGE, IA 50501
515-576-3886
For an EZ deal
800-247-2476/1793
Iowa: 800-362-2371

Kansas

ASSOCIATED RADIO COMM

8012 CONSER
OVERLAND PARK, KS 66204
913-381-5900
America's No. 1 Real Amateur Radio
Store. Trade - Sell - Buy.

Maryland

THE COMM CENTER INC.

9624 FT. MEADE ROAD
LAUREL PLAZA RT. 198
LAUREL, MD 20810
800-638-4486
R. L. Drake, Ten-Tec, ICOM, Swan,
Tempo, Wilson, DenTron, Mosley.

Massachusetts

TEL-COM, INC.

675 GREAT RD., RT. 119
LITTLETON, MA 01460
617-486-3040
The Ham Store of New England
You Can Rely On.

Minnesota

PAL ELECTRONICS INC.

3452 FREMONT AVE. NO.
MINNEAPOLIS, MN 55412
612-521-4662
Midwest's Fastest Growing Ham
Store. Where Service Counts.

Nebraska

COMMUNICATIONS CENTER, INC.
443 N. 48 STREET
LINCOLN, NE 68504
800-228-4097
Kenwood, Yaesu, Drake and More
at Discount Prices.

Nevada

COMMUNICATIONS CENTER WEST
1072 RANCHO DRIVE
LAS VEGAS, NV 89106
800-634-6227
Kenwood, Yaesu, Drake and More
at Discount Prices.

New Hampshire

EVANS RADIO, INC.
BOX 893, RT. 3A BOW JUNCTION
CONCORD, NH 03301
603-224-9961
Icom, DenTron, Yaesu, Drake.
We service what we sell.

New Jersey

ATKINSON & SMITH, INC.
17 LEWIS STREET
EATONTOWN, NJ 07724
201-542-2447
Ham supplies since "55".

**BARGAIN BROTHERS
ELECTRONICS**
216 SCOTCH ROAD
GLEN ROC SHOPPING CTR.
WEST TRENTON, NJ 06828
609-883-2050
A million parts — Lowest prices
anywhere. Call us!

**BARGAIN BROTHERS II
ELECTRONICS**
181 HADDON AVENUE
WEST BERLIN, NJ 08091
609-767-5252
Surplus Parts and Equipment
Bought — Sold — Traded.

METUCHEN RADIO
216 MAIN STREET
METUCHEN, NJ 08840
201-494-8350
New and Used Ham Equipment.
WA2AET "T" Bruno

RADIOS UNLIMITED
P. O. BOX 347
1760 EASTON AVENUE
SOMERSET, NJ 08873
201-469-4599
New Jersey's Fastest
Growing Ham Store.

WITTIE ELECTRONICS
384 LAKEVIEW AVE.
CLIFTON, NJ 07011
201-772-2222
Same location for 62 years.
Full-line authorized Drake dealer.

New York

AM-COM ELECTRONICS INC.
RT. 5
NORTH UTICA SHOPPING CTR.
UTICA, NY 13502
315-732-3656
The Mohawk Valley's Newest and
Largest Electronics Supermarket.

**HAM-BONE RADIO
(Div. Stereo Repair Shop)**
3206 ERIE BOULEVARD EAST,
SYRACUSE, NY 13214
315-446-2266
We Deal, We Trade,
We Discount, We Please!
2-Way Service Shop on Premises!

HARRISON RADIO CORP.
20 SMITH STREET
FARMINGDALE, NY 11735
516-293-7990
"Ham Headquarters USA®"
since 1925.
Call toll free 800-645-9187.

RADIO WORLD
ONEIDA COUNTY AIRPORT
TERMINAL BLDG.
ORISKANY, NY 13424
800-448-7914
315-337-2622 } NY
315-337-0203 } Res.
New & Used Ham Equipment. See
Warren K2IXN or Bob WA2MSH

Ohio

**AMATEUR RADIO
SALES & SERVICE INC.**
2187 E. LIVINGSTON AVE.
COLUMBUS, OH 43209
614-236-1625
Antennas and Towers
for all services.

Pennsylvania

ELECTRONIC EXCHANGE
136 N. MAIN STREET
SOUDERTON, PA 18964
215-723-1200
Demonstrations, Sales, Service.
New/Used Amateur Radio Equip.

**HAMTRONICS, DIV. OF
TREVISE ELECT.**
4033 BROWNSVILLE RD.
TREVISE, PA 19047
215-357-1400
Same Location for
More Than 30 Years.

LaRUE ELECTRONICS
1112 GRANDVIEW STREET
SCRANTON, PENNSYLVANIA 18509
717-343-2124
ICOM, Bird, Cushcraft, CDE,
Ham-Keys, VHF Engineering,
Antenna Specialists.

South Dakota

**BURGHARDT
AMATEUR CENTER, INC.**
P. O. BOX 73
WATERTOWN, SD 57201
605-886-7314
"America's Most Reliable
Amateur Radio Dealer".

Texas

HARDIN ELECTRONICS
5635 EAST ROSEDALE
FORT WORTH, TX 76112
817-461-9761
You Bet Fort Worth
Has A Ham Store!

Dealers:

You should be
here too! Contact
HORIZONS today
for complete details.

TOLL
FREE **800-258-5353**

CALL TOLL FREE

For the best deal on

- AEA • Ameco • ASP • Atlas
- Belden • Bencher • Bird
- CDE • CIR • CES • Cushcraft
- DenTron • Drake • Hy-Gain
- Icom • KLM • Kenwood
- Larsen • MFJ • Midland
- Mosley • NPC • Newtronics
- Nye • Palomar • Regency
- Shure • Swan • Standard
- Tempo • Ten-Tec • Tonna
- Transcom • Wilson • Yaesu

This Month's SPECIALS!

Yaesu FT-202 Hand Held only
\$25 with each FT-901DM
bought at \$1299!

PS-30 Power Supply FREE
with each TS-180S bought at
\$1149.50!

FREE! \$50 in crystals (or
crystal certificates) with
each Wilson MK II or MK IV!
(Yaesu special good through Sept. 15)



CALL TOLL FREE
(outside Illinois only)
(800) 621-5802
for the Erickson price!



Hours:

9:30-5:30 Mon., Tues., Wed. & Fri.

9:30-9:00 Thursday

9:00-3:00 Saturday



ERICKSON
COMMUNICATIONS, INC.
5456 N. MILWAUKEE AVE
CHICAGO, IL 60630 (312) 631-5181

STEP UP TO TELREX

Professionally Engineered Antenna Systems

Single transmission line "TRI-BAND® ARRAY"

MONARCH
TB5EM/4KWP

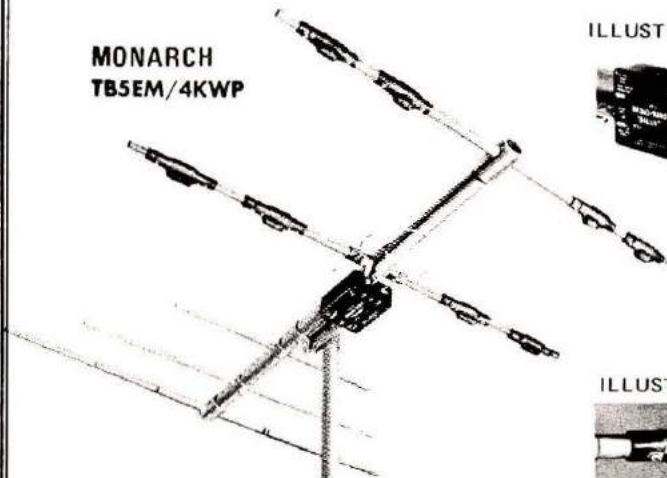

ILLUSTRATION BALUN



ILLUSTRATION TRAP



By the only test that means anything... on the air comparison... this array continues to outperform all competition... and has for two decades. Here's why... Telrex uses a unique trap design employing 20 HiQ 7500V ceramic condensers per antenna. Telrex uses 3 optimum-spaced, optimum-tuned reflectors to provide maximum gain and true F/B Tri-band performance.

For technical data and prices on complete Telrex line, write for Catalog PL 7



New! General Theory Tapes and simulated on-the-air QSOs



Cassette yourself! Upgrade!
only \$4.95 each

Start upgrading today with **Kantronics Super 5 WPM, QSO, Super QSO, QXX** or Q-signal code tapes or theory tapes:

New Super 5 WPM Morse Course, message at 5 wpm, characters at 13. Introduces characters in small groups and builds from there.

QSO series, simulated exam type "on-the-air" messages, including simulated exam questions too.

QSO or QSO-2, contain 7½, 10, 13 & 15 wpm QSOs.

QSO-13, contains all 13 wpm QSOs.

New Super QSO-13, contains all 13 wpm QSOs, characters sent at 20 wpm.

QXX or QXX-2, contain all 20 wpm QSOs.

Q-Signal Tape, contains common Q signals and short words at 22 and 40 wpm.

Novice Study Cassette, rules and regulations, basic theory too.

New General Theory Cassettes, a two tape set, including rules, regs., and general theory. Two tape set is \$8.95.

KANTRONICS

The Training Company

1202 East 23rd Street
Lawrence, Kansas 66044

Phone 913 842 7745

We accept Visa, Master Charge, check and money orders.



RATES Regular classified is available at 50¢ per word. Display classified (1 inch deep x 2 1/4 inches wide) is \$65, or at the 12x rate is \$50. All Ad Scan payable in advance. No cash discounts or agency commissions allowed.

HAMFESTS Sponsored by non-profit organizations receive one free regular classified ad (subject to our editing). Repeat insertions of hamfest ads pay the standard rate.

COPY No special layout or arrangements available. Material should be typewritten or clearly printed (not all capitals) and must include full name and address. We reserve the right to reject unsuitable copy. *HORIZONS* cannot check each advertiser and thus cannot be held responsible for claims made. Liability for correctness of material limited to corrected ad in next available issue.

DEADLINE 15th of third preceding month.

SEND MATERIAL TO: Ad Scan, Ham Radio Horizons, Greenville, N. H. 03048.

QSLs & RUBBER STAMPS — Top Quality! QSLs: Glossy Inks and Cardstock. Rubber Stamps: Report forms, Call Letter, Address, State outlines — More! Stamp Catalog and Card Samples 50¢. Ebbert Graphics 5H, Box 70, Westerville, Ohio 43081.

SCANNER/MONITOR ACCESSORIES, kits or factory assembled. Free catalog. Capri Electronics, Route 1H, Canon, GA 30520.

MOBILE IGNITION SHIELDING provides more range with no noise. Bonding strap sale less than 50¢ each. Literature. Estes Engineering, 930 Marine Drive, Port Angeles, Wash. 98362.

HAMS, SHORTWAVE LISTENERS, SCANNERS. Unique chart, "Worldwide Listeners Guide to the Radio Spectrum". 0 to 30 GHz. Find the QEI's frequency. 35" x 25" Full color. Guaranteed satisfaction or money refunded. \$4.50. Radio Publication, P.O. Box 28-H, Lake Geneva, WI 53147.

CRYSTALS: 2-meter, Wilson, Yaesu, Kenwood, Drake, Icom, Regency, guaranteed! \$8.00/pair. Williams Radio, Route 1, Box 806, Colfax, N.C. 27235.

QSLs — 24-HOUR SERVICE. Why wait? New, strong designs. Get more action for your money. Send 25¢ for catalog, samples. DX Majic, 2448 Channing, Dept. A, Berkeley, California 94618.

QSLs SECOND TO NONE. Same day service. Samples 50 cents. Include your call for free decal. Ray, K7HLR, Box 331, Clearfield, UT 84015.

HEATH SB-101 TRANSCEIVER, HP-23B Power, SB-600 Speaker — All \$395. SB-630 (SWR, Phone patch, Clock, etc.) \$95. Sharp Heath CW filter \$30. All Mint. Also HAL CW Keyboard in attractive Univac Keypunch case \$95. Satisfaction guaranteed on all. W4UKU Jerry Flanders, 411 Urquhart Dr., Beech Island, S.C. 29841. (803) 827-1629.

HAM RADIO REPAIR, alignment. Hassle-free from anywhere via UPS. Expert, prompt, reasonable. Modern lab. "Grid" Gridley, W4GJO, 3824 Malec Circle, Sarasota, Florida 33583. (813) 922-1781.

QSLFILE is the only way to protect and display your QSLs. Working on DXCC or 5BWAS? QSLFILE shows the countries/states you still need, too. For details, write: QSLFILE, 1472 SW 13th St., Boca Raton, FL 33432.

ELECTRONIC BARGAINS, CLOSEOUTS, SURPLUS! Parts, equipment, stereo, industrial, educational. Amazing values! Fascinating items unavailable in stores or catalogs anywhere. Unusual FREE catalog. ETCO-059, Box 762, Plattsburgh, N.Y. 12901.

CLUB CALL PINS 3 lines 1 1/4 x 3 1/4 \$1.55 each. Call first, Name and Club. Colors: Blue, Black or Red with White letters. (Catalog) Arnold Linzner, 2041 Linden Street, Ridgewood, N.Y. 11227.

QSL CARDS — Eyeball Cards — Rubber Stamps — Name Tags — Emblems — Gift Items — Free Catalog — Rusprint, Box 7575, Kansas City, MO 64116.

INDIANA: Hoosier Hills Ham Club Hamfest, October 14, 1979, Lawrence County 4-H Fairgrounds. Prizes, swapshop, concessions, bingo, Talk-in, W9QYQ, 146.13-146.73 duplex.

NEW CONCEPT — Novice instructional package, theory tape & study material. Complete license study package, \$18.95. General study package, \$21.95. MARI, 1320 Canary Drive, West Columbia, SC 29169.

TEXAS: Confederate Air Force Airshow '79, October 4-7, Harlingen, Texas. Airborne Mobile operation from WWII B-29 bomber. Try 14,285 and 21,385 kHz between 12 noon and 5 PM Central time.

QSLs with class! Unbeatable quality, reasonable price. Samples: 50¢ refundable. QSLs Unlimited, 1472 SW 13th Street, Boca Raton, FL 33432.

TENNESSEE: Memphis Hamfest and ARRL Tennessee State Convention, Saturday and Sunday, October 13th and 14th, 1979 at Youth Building, Mid-South Fairgrounds. Exhibits, forums, FCC exams at 8AM sharp on Saturday (bring completed Form 610 and copy of license), flea market (\$3/day — tables free) dealers and manufacturers displays, ladies activities, and Saturday night party. Hourly prizes, Admission: \$3 adults; children 14 and under, free. Trailer hookups available on site. Talk-in 146.34/.94 and 146.25/.85. For information including special motel accommodations, write Memphis Hamfest, P.O. Box 3845, Memphis, TN 38103.

CODE got you stumped?

RELAX and worry not! Learn international Morse Code the EASY, Rus Farnsworth way. No books, no gimmicks, just listen & learn. Using the word method, based on modern psychological techniques, you can zoom past 13 w.p.m. in less than half the time! Available in cassettes @ \$10.95 and LP records at \$9.95 — you get over two hours of instruction!

EPSILON RECORDS

P.O. Box 626, San Jacinto, CA 92383

CALIFORNIA: ARRL Southwestern Division Convention, October 19, 20, 21, 1979, at the Sheraton-Anaheim Hotel located at Ball Road and Interstate 5 in Anaheim, California. Friday, 4 P.M.-9 P.M.; Saturday, 8 A.M.-3:30 P.M.; 4 P.M. to 5:30 (ARRL FORUM); 5:30-7:30 P.M. cocktail party; and 7:30 P.M. Banquet. Sunday, 00:01 A.M. P.S.T. the WOUFF HONG Pageant; 9 A.M. breakfasts, and exhibits until noon. Pre-registration deadline September 15, 1979. Advanced registration, including complete program, banquet, exhibits and tech sessions, \$17 (\$19 at door). Banquet only \$12. Exhibits and tech sessions \$5 (\$6 at door). Ladies program and luncheon \$6 pre-registration only. For more information and pre-registration, contact: HAMCON, P.O. Box 1227, Placentia, CA (714) 993-7140.

CUSTOM Printed and photo QSL's, very economical: free samples, stamp appreciated. Stu, K2RPZ, Box 412, Rocky Point, N. Y. 11778. (516) 744-6260.

DX — YOU BET! The DX Bulletin — Best weekly DX info in the world — send for FREE sample copy. K1TN, 306 Vernon Avenue, Vernon, Connecticut 06066.

STOP LOOKING for a good deal on amateur radio equipment — you've found it here — at your amateur radio headquarters in the heart of the Midwest. Now more than ever where you buy is as important as what you buy! We are factory-authorized dealers for Kenwood, Drake, Yaesu, Collins, Wilson, Ten-Tec, Atlas, ICOM, DenTron, MFJ, Tempo, Regency, Hy-Gain, Mosley, Alpha, Cushcraft, Swan and many more. Write or call us today for our low quote and try our personal and friendly Hoosier service. HOOSIER ELECTRONICS, P.O. Box 2001, Terre Haute, Indiana 47802. (812) 238-1456.

NEW YORK: LIMARC's Hamfair '79, Sunday, October 14, Islip Speedway, Route 111 (Islip Ave.) 1 block south of Southern State Parkway, Exit 43. 9 AM to 4 PM. Loads of door prizes with special categories. Contests. Admission: \$1.50; \$3.00 per seller's space (admits one person). All Hams must pay admission, others free. For information: Hank Wener, WB2ALW nights (516) 484-4322 or Sid Grossman, N2AOI nights (516) 681-2194.

INTERNATIONAL POLICE ASSOCIATION RADIO CLUB contest open to all Radio Amateurs and SWLs for the Sherlock Holmes Award. Saturday, November 10, 1979: 0800-1000, 1400-1700, 1800-2000 UTC; and Sunday, November 11, 1979: same hours. Call CW IPA; mode SSB and CW. No crossband, no crossmode. Members exchange IPA + RS(T) and serial number of contact; non-members exchange RS(T) and serial number. Frequencies: CW: 3575, 7025, 14075, 21075, 28075 kHz +/- 25 kHz; SSB: 3650, 7075, 14295, 21295, 28650 kHz +/- 25 kHz. Information from Vince Gambino, WB4QJO, 7606 Kingsbury Road, Alexandria, Virginia 22310.

INDIANA: Allen County Amateur Radio Technical Society's Fort Wayne Hamfest, Allen County Memorial Coliseum, off U.S. 30 northeast of Ft. Wayne, November 18. Set-up 6 AM. Public admitted 8-4:30 PM. Programs for spouses. Camping facilities, nearby motels. For info: AC-ARTS, Victor M. Locke, 1415 Edenton Dr., Fort Wayne, IN 46804. (219) 432-8047.

MICHIGAN: 3rd Annual RADAR Swap & Shop, Radio & Electronics Equipment, Sunday, October 7, Kennedy High School, Taylor. Admission \$2.00. 9 AM to 3 PM. Door prizes, refreshments. Talk-in 93-33, 52-52, 99-39. Write: RADAR, Inc., P.O. Box 1023, Southgate, MI 48195.

Call or Write for Delivery or Quote

ICOM IC701 with AC/MIC



LEAVE A MESSAGE & WE'LL CALL YOU BACK!

All prices fob Houston, except where indicated. Prices subject to change without notice, all items guaranteed. Some items subject prior sale. Send letterhead for Dealer price list. Texas residents add 6% tax, please add postage estimate. \$1.00 minimum. W5GJ W5MBB K5AAD N5JJ AG5K W5VVM WD5EDE K5ZD WA5TGU WB5AYF K5RC K5BGB WB5USV

MASTERCARD • VISA

MADISON ELECTRONICS SUPPLY, INC.

1508 MCKINNEY • HOUSTON, TEXAS 77002

713/658-0268

RAVE REVIEWS

"I want to express my thanks for a beautiful job. They fit just fine and I am very well pleased."

Norm Howard, W1JBV

"The workmanship and quality are excellent. Well worth the money."

Gene Amaral

"Thanks for the 'expedite' on the covers! As usual, they fit fine!"

Keith Baker, WD8CMU

"Again, thank you for the covers. They fit perfectly as have the other covers I've ordered from your company in the past."

Phil Wilson, WA4MCP



And "Thank you, Folks," for your kind words.

Cover Craft Dust Covers are available at more than 90 Amateur retailers.

Why wait any longer?

COVER CRAFT

P.O. Box 555, Amherst, NH 03031
Telephone (603) 673-8592

Gift a ham.

Anytime is a great time to give HORIZONS!



Share the fun and excitement of Ham Radio HORIZONS with a special friend — that would-be ham, beginner or old-timer. HORIZONS is definitely a thoughtful, inexpensive, and unique gift . . . actually it's 12 gifts all year long. Just for the fun of it, **GIFT A HAM today!**
1 year (12 issues), \$12.00

**ORDER TOLL FREE
800-258-5353**

or send gift instructions and payment to:

**Ham Radio
HORIZONS
Greenville, NH 03048**

Introducing Microcraft's New MORSE-A-WORD

- Eight character moving display
- All solid state reliability
- Compact size — fits almost anywhere
- Complete — no CRT or expensive extras needed
- Built-in code practice oscillator
- Ideal for beginners, SWL's and seasoned amateurs
- 5 to 35 WPM speed range
- Connects to your receiver speaker

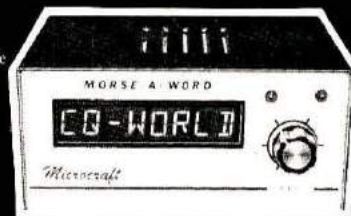

The MORSE-A-WORD decodes audio signals from your receiver's loud-speaker and displays letters, numbers, punctuation and special morse characters visually as the code is received. Excellent for learning the code and great for general short wave listeners. Write for special information on building the MORSE-A-WORD units as a club project.

MORSE-A-WORD Kit with 4 character readout MAWK-4 \$149.95
MORSE-A-WORD Kit with 8 character readout MAWK-8 \$169.95
MORSE-A-Word wired & tested with 8 character readout: MAW1 . . . \$249.95

Send check or money order. Use your VISA or Master Charge. Add \$3.50 shipping and handling. Wisconsin residents add 4% State Sales Tax.

Microcraft

Corporation TEL: (414) 241-8144
P. O. Box 513, Thiensville, Wisconsin 53092

The QSL Organizer

Holds 240 QSL's



FREE ALBUM
with every 40 pages.

NEW!

Tired of cluttering up your walls, stuffing QSL's in drawers and boxes? A great new way to organize, preserve and display your QSL cards is in clear vinyl pocket pages. Each specially designed, crystal clear heavy duty page, holds 6 cards (back to back). The roomy 4" x 6" pockets even hold those extra large Japanese QSL's. With every 40 pages (minimum) ordered, you'll receive a handsome 9" x 14" sturdy 3-ring album, fully padded, in durable 'Brown-Hide' vinyl.

As gifts for friends, as valuable club prizes, or as a treat for yourself - the QSL Organizer is a must, for every radio shack. Try it for 30 days. If you're not delighted, return it for full refund.

FREE Album and 40 pages (min) at .47 each.
Total \$18.80 plus \$1.95 shipping.

Send check, money order (No COD) to:

MIL INDUSTRIES Dept H
P. O. Box #44457 Panorama City, CA 91402

Hobbyists

Here is an interesting general electronics hobby magazine. It's loaded with lots of interesting simple circuits and ideas, not only about radio, but in all phases of electronics including test gear, audio, remote control and security systems. We are sure that you will find a number of worthwhile projects in this British magazine. For a sample copy, please send \$1 to cover postage and handling costs. Your dollar is applied to the cost of the subscription when ordered.

1 Year (12 issues) \$15.00
Radio & Electronics
Greenville, NH
03048

Larsen Kūlrod.®

the
antenna
that
keeps
its cool!



Looking for a mobile antenna that goes on easily, looks super . . . and performs like gangbusters! Then you should take a squint at the Larsen Kūlrod Antenna. It's the *cool* one.

Yes, the fact is that Larsen Kūlrod Mobile Antennas are built differently for a communications *difference you can HEAR*. You can easily prove it to yourself with this simple touch test:

Apply 100 watts of power for a full minute or so to a competitive brand antenna A, B or C . . . any brand with the usual stainless steel whip. Then turn off the power and feel the antenna . . . carefully. It'll likely be hot, even hot enough to raise a blister.

Now put a Larsen Kūlrod to the same test. Surprise! That's right . . . *no* heat! The power has gone into communicating—not heating. The Larsen isn't called the Kūlrod for nothing.

Larsen Antennas fit all styles of mobile mounts and cover Amateur frequencies from 10 meters through the 440 MHz band.



Write for antenna catalog and name of Larsen dealer nearest you.

Larsen Antennas

11611 N.E. 50th Ave.
P.O. Box 1686
Vancouver, WA 98663
Phone: 206/573-2722

In Canada write to:
Unit 101
283 E. 11th Avenue
Vancouver, B.C. V5T 2C4
Phone: 604/872-8517

*Kūlrod is a Registered trademark of Larsen Electronics, Inc.

FREE!
RADIO AMATEURS
WORLD ATLAS
 with purchase of famous
CALLBOOK
MAP LIBRARY!

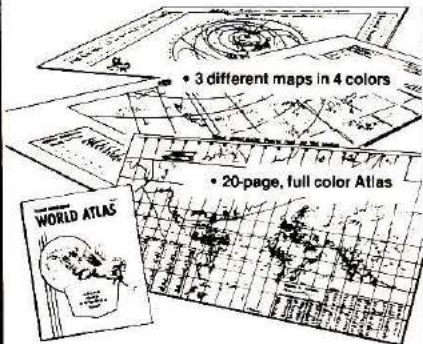

Here's an offer you can't refuse! You receive three, information-packed, Amateur Callbook maps, folded, plus the World Atlas for only \$3.75 plus \$1.50 shipping and handling. If purchased separately, total value of map/atlas offer would be \$6.25, plus shipping. You save \$2.50 and get these invaluable radio amateur aids!

1. **Prefix Map of the World**, folded. World-wide prefixes. Shows 40-zone map on one side, 90-zone map on the other. Size 40" x 28"
2. **Map of North America**, folded. Includes Central America and Caribbean to the Equator. Shows call areas, zone boundaries, prefixes, etc. Size 30" x 25"
3. **Great Circle Chart of World**, folded. Centered on 40°N, 100°W. Shows cities, latitude, longitude, great circle bearings and more! Size 30" x 25"

Plus special FREE bonus!

The Callbook's own **Radio Amateur World Atlas**, FREE with the purchase of the 3 maps. Contains eleven full color maps of the world, looking at things from the radio amateurs point of view.

Callbook Map Library	\$3.75
Shipping	\$1.50
Total	\$5.25



Special Limited Offer!
Amateur Radio
Emblem Patch
 only \$2.50 prepaid

Pegasus on blue field, red lettering. 3" wide x 3" high. Great on jackets and caps. Sorry, no call letters.

ORDER TODAY!

Order from your favorite electronics dealer or direct from the publisher. All direct orders add \$1.50 for shipping. Illinois residents add 5% Sales Tax.



callbook INC.
 Dept. EN
 925 Sherwood Drive
 Lake Bluff, IL 60044

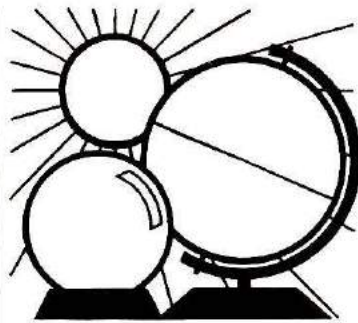

DX FORECASTER

Band-by-band summary

Six meters — You can expect frequent band openings in the afternoon hours, with long-haul DX possible to many areas of the world. **Ten meters** — the band will peak for DX during the afternoon hours, but will be open from sunrise to just after sunset, and you can expect excellent long-haul openings to most areas of the world.

Fifteen meters will provide excellent openings to all areas of the world, particularly into the southern hemisphere. Try an hour or so after sunrise until well after sunset. Note: Times of band openings and closings are *local* times. **Twenty meters** will peak in the morning and again in the late afternoon, but will be open around the clock to one area of the world or another. **Forty meters** — should provide excellent DX opportunities from after sunset until after sunrise to most parts of the world, particularly the southern hemisphere between midnight and dawn. **Eighty meters** will also provide some good DX openings, but you must be able to burn the midnight oil because the best DX will take place in the early morning hours. **One sixty meters** will provide DX to some parts of the world for dedicated "top banders" but only between midnight and sunrise.

Short skip possibilities

Short skip openings are due to sporadic E ionization, that is, the ionizing of parts of the "E layer" of the ionosphere at somewhat unpredictable times and places, due to intense solar radiation. Because the "E layer" is lower than the "F

layer" skip is shorter. Skip distances you can expect on the bands are: *ten meters*, 1600-3700 kilometers (1000 to 2300 miles); on *fifteen meters*, beyond 1200 kilometers (750 miles); *twenty meters*, 800-3700 kilometers (500 to 2300 miles) (daytime) and 2000-3700 kilometers (1300 to 2300 miles) after dark; *forty meters*, up to about 1600 kilometers (1000 miles) (daytime) and 800-3700 kilometers (500 to 2300 miles) at night; *eighty meters*, up to about 400 kilometers (250 miles) during the day, and up to about 3700 kilometers (2300 miles) at night. *One sixty meters* will show short skip propagation up to about 1600 kilometers (1000 miles) and occasionally 3700 kilometers (2300 miles), but only at night.

Last-minute predictions

The month of October is expected to be rather uneventful, ionospherically speaking, with the exception of unpredictable mini-flare activity which could occur any time. In general, look for possible upsets in the geomagnetic field and ionospheric disturbances during the seven-day period between October 11th and 17th. Minor upsets could occur on the 1st or 2nd, and again on the 25th. Perigee and full moon occur on October 4th and 5th, respectively.

Don't forget to turn your clocks *back* one hour on the last Sunday of this month — October 28th — at 2:00 AM local time. If you're not likely to be up at that hour, turn them back Saturday night before going to bed.

HRH

WESTERN USA

MID USA

EASTERN USA

GMT	WESTERN USA										MID USA										EASTERN USA									
	ASIA	FAR EAST	EUROPE	S. AFRICA	S. AMERICA	ANTARCTICA	NEW ZEALAND	OCEANIA	AUSTRALIA	JAPAN	ASIA	FAR EAST	EUROPE	S. AFRICA	S. AMERICA	ANTARCTICA	NEW ZEALAND	OCEANIA	AUSTRALIA	JAPAN	ASIA	FAR EAST	EUROPE	S. AFRICA	S. AMERICA	ANTARCTICA	NEW ZEALAND	OCEANIA	AUSTRALIA	JAPAN
	N ↑	NE ↗	E →	SE ↘	S ↓	SW ↙	W ←	NW ↖			N ↑	NE ↗	E →	SE ↘	S ↓	SW ↙	W ←	NW ↖			N ↑	NE ↗	E →	SE ↘	S ↓	SW ↙	W ←	NW ↖		
PDT	MDT										CDT										EDT									
0000	10	20	20	10	10	10	10	10	10	10	—	—	—	—	—	—	—	—	—	—	—	—	—	—	—	—	—	—	—	—
0100	10	20	20	10	15	10	10	10	10	10	—	—	—	—	—	—	—	—	—	—	—	—	—	—	—	—	—	—	—	—
0200	10	20	—	—	15	10	10	10	10	10	—	—	—	—	—	—	—	—	—	—	—	—	—	—	—	—	—	—	—	—
0300	10	—	—	—	15	10	10	10	10	15	—	—	—	—	—	—	—	—	—	—	—	—	—	—	—	—	—	—	—	—
0400	—	—	—	—	15	10	10	10	10	15	—	—	—	—	—	—	—	—	—	—	—	—	—	—	—	—	—	—	—	—
0500	—	—	—	—	15	15	—	—	15	20	—	—	—	—	—	—	—	—	—	—	—	—	—	—	—	—	—	—	—	—
0600	—	—	—	—	20	20	—	—	15	20	—	—	—	—	—	—	—	—	—	—	—	—	—	—	—	—	—	—	—	—
0700	20	—	—	—	20	20	40	40	20	20	—	—	—	—	—	—	—	—	—	—	—	—	—	—	—	—	—	—	—	—
0800	20	—	—	—	20	20	40	40	20	20	—	—	—	—	—	—	—	—	—	—	—	—	—	—	—	—	—	—	—	—
0900	20	—	—	—	20	20	40	40	20	20	—	—	—	—	—	—	—	—	—	—	—	—	—	—	—	—	—	—	—	—
1000	20	—	—	—	20	20	40	40	20	20	—	—	—	—	—	—	—	—	—	—	—	—	—	—	—	—	—	—	—	—
1100	20	—	—	—	40	20	40	40	20	20	—	—	—	—	—	—	—	—	—	—	—	—	—	—	—	—	—	—	—	—
1200	20	—	—	—	40	20	40	40	20	20	—	—	—	—	—	—	—	—	—	—	—	—	—	—	—	—	—	—	—	—
1300	20	—	—	—	40	40	40	40	20	20	—	—	—	—	—	—	—	—	—	—	—	—	—	—	—	—	—	—	—	—
1400	20	20	—	—	20	—	20	20	20	20	—	—	—	—	—	—	—	—	—	—	—	—	—	—	—	—	—	—	—	—
1500	20	20	—	—	10	—	20*	20	—	—	—	—	—	—	—	—	—	—	—	—	—	—	—	—	—	—	—	—	—	—
1600	15	15	—	—	10	—	15	20	—	—	—	—	—	—	—	—	—	—	—	—	—	—	—	—	—	—	—	—	—	—
1700	15	15	10	10	—	—	15*	20	—	—	—	—	—	—	—	—	—	—	—	—	—	—	—	—	—	—	—	—	—	—
1800	15	15	10	10	—	—	10	—	—	—	—	—	—	—	—	—	—	—	—	—	—	—	—	—	—	—	—	—	—	—
1900	15	15	10	10	—	—	10	—	—	—	—	—	—	—	—	—	—	—	—	—	—	—	—	—	—	—	—	—	—	—
2000	15*	15	15	10	—	—	10	—	—	—	—	—	—	—	—	—	—	—	—	—	—	—	—	—	—	—	—	—	—	—
2100	10	15	15	10	10	10	10	10	—	—	—	—	—	—	—	—	—	—	—	—	—	—	—	—	—	—	—	—	—	—
2200	10	20	20	10	10	10	10	10	10	10	—	—	—	—	—	—	—	—	—	—	—	—	—	—	—	—	—	—	—	—
2300	10	20	20	10	10	10	10	10	10	10	—	—	—	—	—	—	—	—	—	—	—	—	—	—	—	—	—	—	—	—

SUNDAY	MONDAY	TUESDAY	WEDNESDAY	THURSDAY	FRIDAY	SATURDAY
<p>All international events such as contests are shown on the GMT days on which they take place even though they may actually begin on the evening of the preceding day in North America.</p>						
<p>Radar, Inc., Swap & Shop — Kennedy High School, Northline Rd., Taylor, MI — Costa Valley Fairgrounds, Bens, CA — WRLASG — 7 Blomington Hamfest — Berrien County Youth Fairgrounds, Berrien Springs, MI — 7 York County ARC Hamfest — Galin Park, Rock Hill, SC — WA4DQG — 7</p>	<p>FLORIDA HAM NEWS — SWAP NET By the Broward ARC 145.31-31.37 2:30PM GLENDURST RADIO SOCIETY Transmits Amateur Radio News — 222.66-224.26 MHz via WR2APC and 21.400 MHz USB WEST COAST BULLETIN Edited & Transmitted by W6ZF 9PM PST 3540 KHZ. A-1, 22 WPM</p>	<p>AMSAT Eastcoast Net 3850 kHz 9PM EDT (0100Z Wednesday Morning) AMSAT Mid-Continent Net 3850 kHz 9PM CDT (0200Z Wednesday Morning) AMSAT Westcoast Net 3850 kHz 8PM PST (0300Z Wednesday Morning)</p>	<p>AMSAT Eastcoast Net 3850 kHz 9PM EDT (0100Z Wednesday Morning) AMSAT Mid-Continent Net 3850 kHz 9PM CDT (0200Z Wednesday Morning) AMSAT Westcoast Net 3850 kHz 8PM PST (0300Z Wednesday Morning)</p>	<p>AMSAT Eastcoast Net 3850 kHz 9PM EDT (0100Z Wednesday Morning) AMSAT Mid-Continent Net 3850 kHz 9PM CDT (0200Z Wednesday Morning) AMSAT Westcoast Net 3850 kHz 8PM PST (0300Z Wednesday Morning)</p>	<p>FLORIDA HAM NEWS — SWAP NET By the Broward ARC 145.31-31.37 2:30PM GLENDURST RADIO SOCIETY Transmits Amateur Radio News — 222.66-224.26 MHz via WR2APC and 21.400 MHz USB WEST COAST BULLETIN Edited & Transmitted by W6ZF 9PM PST 3540 KHZ. A-1, 22 WPM</p>	<p>FLORIDA HAM NEWS — SWAP NET By the Broward ARC 145.31-31.37 2:30PM GLENDURST RADIO SOCIETY Transmits Amateur Radio News — 222.66-224.26 MHz via WR2APC and 21.400 MHz USB WEST COAST BULLETIN Edited & Transmitted by W6ZF 9PM PST 3540 KHZ. A-1, 22 WPM</p>
<p>Blair Hamfest — Fairgrounds Bldg., Beaver, OK — W8AVUN — 14 New England — 14 Hooper Hills Hamfest — Lawrence Co. 4-H Fairgrounds, Bedford, IN — W9DVO — 14 Northwestern States 160 Meter AFA — Annual Banquet, Kozel's Restaurant, West Ghent, NY — 14 Long Island Hamfest '79 — Ispco Speedway, Islip, NY — 14</p>	<p>FLORIDA HAM NEWS — SWAP NET By the Broward ARC 145.31-31.37 2:30PM GLENDURST RADIO SOCIETY Transmits Amateur Radio News — 222.66-224.26 MHz via WR2APC and 21.400 MHz USB WEST COAST BULLETIN Edited & Transmitted by W6ZF 9PM PST 3540 KHZ. A-1, 22 WPM</p>	<p>AMSAT Eastcoast Net 3850 kHz 9PM EDT (0100Z Wednesday Morning) AMSAT Mid-Continent Net 3850 kHz 9PM CDT (0200Z Wednesday Morning) AMSAT Westcoast Net 3850 kHz 8PM PST (0300Z Wednesday Morning)</p>	<p>AMSAT Eastcoast Net 3850 kHz 9PM EDT (0100Z Wednesday Morning) AMSAT Mid-Continent Net 3850 kHz 9PM CDT (0200Z Wednesday Morning) AMSAT Westcoast Net 3850 kHz 8PM PST (0300Z Wednesday Morning)</p>	<p>AMSAT Eastcoast Net 3850 kHz 9PM EDT (0100Z Wednesday Morning) AMSAT Mid-Continent Net 3850 kHz 9PM CDT (0200Z Wednesday Morning) AMSAT Westcoast Net 3850 kHz 8PM PST (0300Z Wednesday Morning)</p>	<p>FLORIDA HAM NEWS — SWAP NET By the Broward ARC 145.31-31.37 2:30PM GLENDURST RADIO SOCIETY Transmits Amateur Radio News — 222.66-224.26 MHz via WR2APC and 21.400 MHz USB WEST COAST BULLETIN Edited & Transmitted by W6ZF 9PM PST 3540 KHZ. A-1, 22 WPM</p>	<p>FLORIDA HAM NEWS — SWAP NET By the Broward ARC 145.31-31.37 2:30PM GLENDURST RADIO SOCIETY Transmits Amateur Radio News — 222.66-224.26 MHz via WR2APC and 21.400 MHz USB WEST COAST BULLETIN Edited & Transmitted by W6ZF 9PM PST 3540 KHZ. A-1, 22 WPM</p>
<p>Plymouth Swap & Shop — National Guard Armory, Plymouth, IN — W8SMGF — 21</p>	<p>FLORIDA HAM NEWS — SWAP NET By the Broward ARC 145.31-31.37 2:30PM GLENDURST RADIO SOCIETY Transmits Amateur Radio News — 222.66-224.26 MHz via WR2APC and 21.400 MHz USB WEST COAST BULLETIN Edited & Transmitted by W6ZF 9PM PST 3540 KHZ. A-1, 22 WPM</p>	<p>AMSAT Eastcoast Net 3850 kHz 9PM EDT (0100Z Wednesday Morning) AMSAT Mid-Continent Net 3850 kHz 9PM CDT (0200Z Wednesday Morning) AMSAT Westcoast Net 3850 kHz 8PM PST (0300Z Wednesday Morning)</p>	<p>AMSAT Eastcoast Net 3850 kHz 9PM EDT (0100Z Wednesday Morning) AMSAT Mid-Continent Net 3850 kHz 9PM CDT (0200Z Wednesday Morning) AMSAT Westcoast Net 3850 kHz 8PM PST (0300Z Wednesday Morning)</p>	<p>AMSAT Eastcoast Net 3850 kHz 9PM EDT (0100Z Wednesday Morning) AMSAT Mid-Continent Net 3850 kHz 9PM CDT (0200Z Wednesday Morning) AMSAT Westcoast Net 3850 kHz 8PM PST (0300Z Wednesday Morning)</p>	<p>FLORIDA HAM NEWS — SWAP NET By the Broward ARC 145.31-31.37 2:30PM GLENDURST RADIO SOCIETY Transmits Amateur Radio News — 222.66-224.26 MHz via WR2APC and 21.400 MHz USB WEST COAST BULLETIN Edited & Transmitted by W6ZF 9PM PST 3540 KHZ. A-1, 22 WPM</p>	<p>FLORIDA HAM NEWS — SWAP NET By the Broward ARC 145.31-31.37 2:30PM GLENDURST RADIO SOCIETY Transmits Amateur Radio News — 222.66-224.26 MHz via WR2APC and 21.400 MHz USB WEST COAST BULLETIN Edited & Transmitted by W6ZF 9PM PST 3540 KHZ. A-1, 22 WPM</p>
<p>London ARC Swap & Shop — Lord Dornchester High School, Dornchester, Ontario, Canada — VE3BV — 28 Heart of Ohio Hamfest — National Guard Armory, Mansfield, Ohio — W8CAX — 28 OST ends — Set clocks back one hour — 2 AM</p>	<p>FLORIDA HAM NEWS — SWAP NET By the Broward ARC 145.31-31.37 2:30PM GLENDURST RADIO SOCIETY Transmits Amateur Radio News — 222.66-224.26 MHz via WR2APC and 21.400 MHz USB WEST COAST BULLETIN Edited & Transmitted by W6ZF 9PM PST 3540 KHZ. A-1, 22 WPM</p>	<p>AMSAT Eastcoast Net 3850 kHz 9PM EDT (0100Z Wednesday Morning) AMSAT Mid-Continent Net 3850 kHz 9PM CDT (0200Z Wednesday Morning) AMSAT Westcoast Net 3850 kHz 8PM PST (0300Z Wednesday Morning)</p>	<p>AMSAT Eastcoast Net 3850 kHz 9PM EDT (0100Z Wednesday Morning) AMSAT Mid-Continent Net 3850 kHz 9PM CDT (0200Z Wednesday Morning) AMSAT Westcoast Net 3850 kHz 8PM PST (0300Z Wednesday Morning)</p>	<p>AMSAT Eastcoast Net 3850 kHz 9PM EDT (0100Z Wednesday Morning) AMSAT Mid-Continent Net 3850 kHz 9PM CDT (0200Z Wednesday Morning) AMSAT Westcoast Net 3850 kHz 8PM PST (0300Z Wednesday Morning)</p>	<p>FLORIDA HAM NEWS — SWAP NET By the Broward ARC 145.31-31.37 2:30PM GLENDURST RADIO SOCIETY Transmits Amateur Radio News — 222.66-224.26 MHz via WR2APC and 21.400 MHz USB WEST COAST BULLETIN Edited & Transmitted by W6ZF 9PM PST 3540 KHZ. A-1, 22 WPM</p>	<p>FLORIDA HAM NEWS — SWAP NET By the Broward ARC 145.31-31.37 2:30PM GLENDURST RADIO SOCIETY Transmits Amateur Radio News — 222.66-224.26 MHz via WR2APC and 21.400 MHz USB WEST COAST BULLETIN Edited & Transmitted by W6ZF 9PM PST 3540 KHZ. A-1, 22 WPM</p>
<p>Arizona Mobile operation from WW2 B-29 bomber — Confederate Air Force, Aviano 79, Harrington, TX — 14, 28B and 21.385 kHz 17.5 PM CDT — 4-7 ARR, Dakota Div. Conv. — Airport Ramada Inn — Sioux Falls, SD — 5-7 ARR, Waco Div. Conv. — Houston TX — 5-7 Hampden County PA Auction — Pedding Hills, PA — 7 PM — 5</p>	<p>AMSAT Eastcoast Net 3850 kHz 9PM EDT (0100Z Wednesday Morning) AMSAT Mid-Continent Net 3850 kHz 9PM CDT (0200Z Wednesday Morning) AMSAT Westcoast Net 3850 kHz 8PM PST (0300Z Wednesday Morning)</p>	<p>AMSAT Eastcoast Net 3850 kHz 9PM EDT (0100Z Wednesday Morning) AMSAT Mid-Continent Net 3850 kHz 9PM CDT (0200Z Wednesday Morning) AMSAT Westcoast Net 3850 kHz 8PM PST (0300Z Wednesday Morning)</p>	<p>AMSAT Eastcoast Net 3850 kHz 9PM EDT (0100Z Wednesday Morning) AMSAT Mid-Continent Net 3850 kHz 9PM CDT (0200Z Wednesday Morning) AMSAT Westcoast Net 3850 kHz 8PM PST (0300Z Wednesday Morning)</p>	<p>AMSAT Eastcoast Net 3850 kHz 9PM EDT (0100Z Wednesday Morning) AMSAT Mid-Continent Net 3850 kHz 9PM CDT (0200Z Wednesday Morning) AMSAT Westcoast Net 3850 kHz 8PM PST (0300Z Wednesday Morning)</p>	<p>AMSAT Eastcoast Net 3850 kHz 9PM EDT (0100Z Wednesday Morning) AMSAT Mid-Continent Net 3850 kHz 9PM CDT (0200Z Wednesday Morning) AMSAT Westcoast Net 3850 kHz 8PM PST (0300Z Wednesday Morning)</p>	<p>AMSAT Eastcoast Net 3850 kHz 9PM EDT (0100Z Wednesday Morning) AMSAT Mid-Continent Net 3850 kHz 9PM CDT (0200Z Wednesday Morning) AMSAT Westcoast Net 3850 kHz 8PM PST (0300Z Wednesday Morning)</p>
<p>Aspenite Autumfest — Civic Center, Asheville, NC W0JUI — 13 ISSB 21.278 MHz Contest — 13 RAGS Hamfest — NY State Fairgrounds, Syracuse, NY — 13 WZL/Oceano DX Contest — CW — 13-14 Mammoth Hamfest/ARRL State Convention — Mid-South Fairgrounds Memphis, TN — W4AJPN — 13-14</p>	<p>AMSAT Eastcoast Net 3850 kHz 9PM EDT (0100Z Wednesday Morning) AMSAT Mid-Continent Net 3850 kHz 9PM CDT (0200Z Wednesday Morning) AMSAT Westcoast Net 3850 kHz 8PM PST (0300Z Wednesday Morning)</p>	<p>AMSAT Eastcoast Net 3850 kHz 9PM EDT (0100Z Wednesday Morning) AMSAT Mid-Continent Net 3850 kHz 9PM CDT (0200Z Wednesday Morning) AMSAT Westcoast Net 3850 kHz 8PM PST (0300Z Wednesday Morning)</p>	<p>AMSAT Eastcoast Net 3850 kHz 9PM EDT (0100Z Wednesday Morning) AMSAT Mid-Continent Net 3850 kHz 9PM CDT (0200Z Wednesday Morning) AMSAT Westcoast Net 3850 kHz 8PM PST (0300Z Wednesday Morning)</p>	<p>AMSAT Eastcoast Net 3850 kHz 9PM EDT (0100Z Wednesday Morning) AMSAT Mid-Continent Net 3850 kHz 9PM CDT (0200Z Wednesday Morning) AMSAT Westcoast Net 3850 kHz 8PM PST (0300Z Wednesday Morning)</p>	<p>AMSAT Eastcoast Net 3850 kHz 9PM EDT (0100Z Wednesday Morning) AMSAT Mid-Continent Net 3850 kHz 9PM CDT (0200Z Wednesday Morning) AMSAT Westcoast Net 3850 kHz 8PM PST (0300Z Wednesday Morning)</p>	<p>AMSAT Eastcoast Net 3850 kHz 9PM EDT (0100Z Wednesday Morning) AMSAT Mid-Continent Net 3850 kHz 9PM CDT (0200Z Wednesday Morning) AMSAT Westcoast Net 3850 kHz 8PM PST (0300Z Wednesday Morning)</p>
<p>25th Annual VHF Conference — Western Michigan University, Kalamazoo MI — 27</p>	<p>AMSAT Eastcoast Net 3850 kHz 9PM EDT (0100Z Wednesday Morning) AMSAT Mid-Continent Net 3850 kHz 9PM CDT (0200Z Wednesday Morning) AMSAT Westcoast Net 3850 kHz 8PM PST (0300Z Wednesday Morning)</p>	<p>AMSAT Eastcoast Net 3850 kHz 9PM EDT (0100Z Wednesday Morning) AMSAT Mid-Continent Net 3850 kHz 9PM CDT (0200Z Wednesday Morning) AMSAT Westcoast Net 3850 kHz 8PM PST (0300Z Wednesday Morning)</p>	<p>AMSAT Eastcoast Net 3850 kHz 9PM EDT (0100Z Wednesday Morning) AMSAT Mid-Continent Net 3850 kHz 9PM CDT (0200Z Wednesday Morning) AMSAT Westcoast Net 3850 kHz 8PM PST (0300Z Wednesday Morning)</p>	<p>AMSAT Eastcoast Net 3850 kHz 9PM EDT (0100Z Wednesday Morning) AMSAT Mid-Continent Net 3850 kHz 9PM CDT (0200Z Wednesday Morning) AMSAT Westcoast Net 3850 kHz 8PM PST (0300Z Wednesday Morning)</p>	<p>AMSAT Eastcoast Net 3850 kHz 9PM EDT (0100Z Wednesday Morning) AMSAT Mid-Continent Net 3850 kHz 9PM CDT (0200Z Wednesday Morning) AMSAT Westcoast Net 3850 kHz 8PM PST (0300Z Wednesday Morning)</p>	<p>AMSAT Eastcoast Net 3850 kHz 9PM EDT (0100Z Wednesday Morning) AMSAT Mid-Continent Net 3850 kHz 9PM CDT (0200Z Wednesday Morning) AMSAT Westcoast Net 3850 kHz 8PM PST (0300Z Wednesday Morning)</p>
<p>*Scouts Jamboree in the air — Oct. 20, 21 — Triate Cubs Scouts. Explorers to your shack to talk to JOTA stations. Suggested frequencies: U.S. (phone) — 3.940, 7.290, 14.290, 21.360, 28.590, 50.500 kHz. International (phone) — 3.740, 7.090, 14.290, 21.360, 28.590. All (CW) — 3.590, 7.090, 14.070, 21.040, 28.190, 50.150. Advice — 3.750, 7.125, 21.140.</p>	<p>AMSAT Eastcoast Net 3850 kHz 9PM EDT (0100Z Wednesday Morning) AMSAT Mid-Continent Net 3850 kHz 9PM CDT (0200Z Wednesday Morning) AMSAT Westcoast Net 3850 kHz 8PM PST (0300Z Wednesday Morning)</p>	<p>AMSAT Eastcoast Net 3850 kHz 9PM EDT (0100Z Wednesday Morning) AMSAT Mid-Continent Net 3850 kHz 9PM CDT (0200Z Wednesday Morning) AMSAT Westcoast Net 3850 kHz 8PM PST (0300Z Wednesday Morning)</p>	<p>AMSAT Eastcoast Net 3850 kHz 9PM EDT (0100Z Wednesday Morning) AMSAT Mid-Continent Net 3850 kHz 9PM CDT (0200Z Wednesday Morning) AMSAT Westcoast Net 3850 kHz 8PM PST (0300Z Wednesday Morning)</p>	<p>AMSAT Eastcoast Net 3850 kHz 9PM EDT (0100Z Wednesday Morning) AMSAT Mid-Continent Net 3850 kHz 9PM CDT (0200Z Wednesday Morning) AMSAT Westcoast Net 3850 kHz 8PM PST (0300Z Wednesday Morning)</p>	<p>AMSAT Eastcoast Net 3850 kHz 9PM EDT (0100Z Wednesday Morning) AMSAT Mid-Continent Net 3850 kHz 9PM CDT (0200Z Wednesday Morning) AMSAT Westcoast Net 3850 kHz 8PM PST (0300Z Wednesday Morning)</p>	<p>AMSAT Eastcoast Net 3850 kHz 9PM EDT (0100Z Wednesday Morning) AMSAT Mid-Continent Net 3850 kHz 9PM CDT (0200Z Wednesday Morning) AMSAT Westcoast Net 3850 kHz 8PM PST (0300Z Wednesday Morning)</p>



See October 4, 6, 8, 11, 13, 20

Halloween

31

30

29

28

27

20

13

12

11

10

9

8

7

6

5

4

3

2

1

First family of power...

ALPHA



Photo By RIC HELSTROM

Glen Eyrie, Garden of the Gods, in ETO's back yard

THE VERY FINEST ANSWER TO YOUR NEED for one to two kilowatts of solid HF power: a superlative **ALPHA** linear amplifier - FIRST in performance, in convenience, in quality and durability.

Brute RF power without time limit, whisper-quiet operation, instant no-tune-up bandchanging, high speed

break-in (QSK), the ability to cover any newly-assigned HF band - there's an **ALPHA** perfectly suited to YOUR requirements.

ALPHA: power in a class by itself. For complete details, contact your **ALPHA** dealer or ETO direct.



EHRHORN TECHNOLOGICAL OPERATIONS, INC.
BOX 708, CAÑON CITY, CO 81212 (303) 275-1613

AD CHECK

... for literature, in a hurry — we'll rush your name to the companies whose names you check.

Place your check mark in the space between name and number. Example: HRH 150.

Aluma ___ 589	Madison *
Antenna Supermarket *	Microcraft ___ 774
Bencher ___ 629	Microwave Filter ___ 637
Commun. Center ___ 534	Palomar Eng. *
Cornell-Dubilier ___ 241	Pathcom ___ 705
Cover Craft ___ 685	RF Power Comp. ___ 542
Cushcraft *	RSE Ham Shack ___ 607
DSI ___ 656	Callbook ___ 100
E.T.O. *	Constructor ___ 586
Erickson *	Radio World *
Hal *	Ross Distr. ___ 581
Ham Gear Mart ___ 784	S-F A. R. S. ___ 640
HRB ___ 150	SAROC *
Horizons ___ 150	Shure Brothers ___ 771
Heath ___ 060	Standard Comm. ___ 109
Hustler ___ 171	Swan ___ 111
Icom *	Telrex ___ 377
IRL ___ 781	Ten-Tec *
Int. Crystal ___ 066	Thomas Comm. ___ 730
IEC ___ 793	Tri-Ex ___ 116
Kantronics *	Trionyx ___ 796
Kenwood *	Triplastics ___ 794
Klaus ___ 430	Webster Assoc. ___ 423
Larsen ___ 078	Western *
Long's ___ 468	Wilson Elec. ___ 123
MFJ ___ 082	Wilson Sys. ___ 787
MIL Ind. ___ 795	

* Please contact this advertiser directly.

Limit 15 inquiries per request.

OCTOBER 1979

Please use before November 30, 1979

Tear off and mail to
HAM RADIO HORIZONS — "Ad Check"
Greenville, N. H. 03048

NAME _____

CALL _____

STREET _____

CITY _____

STATE _____ ZIP _____

AUTUMN ACTION

Cushcraft "boomer"	\$69.95
KLM 144-148 · 13 lb.	59.95
OMNI-J & heavy duty magnet mount complete	49.95
TRIEX W-51 FT self-support tower (Reg. \$89.1) Your cost (FOB California) ..	791.00
Tonna F9FT Antennas 144/16 el.	69.95
Klitzing VHF-UHF Amplifiers	
2M 10W in - 100W Out	179.00
432 10W in - 50W Out	189.00
Bird 43 and slugs, UPS paid in USA ..	stock
Microwave Modules 432-28S.	299.00
Deluxe Amp. 432-100W output	449.00
Telrex TB5EM, in stock	415.00
New Palomar Engr. Trans. Preamp. ..	89.50
Bencher Paddles — 39.95 Chrome ..	49.95
ETO 76 Amplifiers	stock
Lunar 6M-2M-220 In Line Preamps. ..	49.95
Lunar 2M Amp 10-80 w/Preamp, UPS Paid USA	198.00
Janel QSA-5	41.95
Ham X	189.00
NEW Ham-4	139.00
VHF Engrs. blue line amps	stock
VHF Kits	stock
Cetron 572B	29.50
Midland 13-509 220 MHz - 12ch - 10W	159.00
13-513 220 MHz synthesized 20-10-2W	389.00
Motorola HEP 170	0.29
Mallory 2.5A/1000 PIV Epoxy Diode ..	0.19
Non Linear Systems Miniscope - 15. 318.00	
Miniscope - 215.	435.00
— 10%, accessories available	
Aerovox 1000PF/500V Feed thru.	1.95
GE6146B or 8950.	7.95
Technical Books: Ameco, ARRL, Sams, Tab, Rider Radio Pub., Callbook, Cowan, etc.	Call
NEW Belden 9405 (2#16)(6#18) 8 wire rotor cable, heavy duty for long runs.	0.28
8448 std. 8 wire rotor, per ft.	0.17
9888 doubleshield RGB Foam, per ft. 0.42	
8214 RG8 Foam	0.26
8237 RG8	0.23
8267 RG213	0.27
Amphenol Silver Plate PL259	0.69
Times 1/2" Foam Hardline \$0.65/ft. — Connectors	ea. 15.00
7/8" Hardline \$1.50/ft. — Connectors	ea. 25.00
Berktek RG8X, 52 ohm, KW.	per ft. 0.16
Consolidated HD-18 Ga. Galv. Tower, 10' section	29.95
Robot "Slow Scan" Now in Stock	Call
Alliance HD73 Rotor	109.95
Teletow'r self support- 55 ft/w breakover	549.00
40 ft/w breakover	399.00
Swan TB4ha, TB3ha, TB2-	20% off list
Collins replacement parts available.	

Telrex Antennas? In Stock!

Looking for antique parts?

Write specific need to W5GJ.

THIS MONTH'S SPECIALS:

Icom IC280 — \$349.00

DenTron GLA 1000 Amp. \$319.00

Bearcat 250, 220 — \$299.00

DenTron Clipperton L — \$599.00

MASTER CHARGE • VISA

All prices FOB Houston except where indicated. Prices subject to change without notice, all items guaranteed. Some items subject prior sale. Send letterhead for Dealer price list. Texas residents add 6% tax. Please add postage estimate \$1.00 minimum.

MADISON ELECTRONICS SUPPLY, INC.
1508 MCKINNEY
HOUSTON, TEXAS 77002
713/658-0288

AD INDEX

Aluma Tower Co. 45	Antenna Supermarket 51
Bencher, Inc. 50	Communications Center 65
Cornell-Dubilier 51	Cover Craft 72
Cushcraft 4	DSI Instruments 39, 80
Ehrhorn Technological Operations 77	Erickson Communications 70
Hal Communications Corp. 9	Ham Gear Mart 66
Ham Radio's Bookstore 72	Ham Radio Horizons 50
Heath Company Cover IV	Hustler 46
Icom 7	IRL 66
International Crystal 29	International Electronic Communications 45
Kantronics 70	Trio-Kenwood Communications, Inc Cover III
Klaus Radio, Inc. 63	Larsen Antennas 73
Long's Electronics 40, 41	MFJ Enterprises 3
MIL Industries 73	Madison Electronic Supply 46, 66, 72, 78
Microcraft Corporation 72	Microwave Filter, Inc. 50
Palomar Engineers 45	RF Power Components 50
RSE Ham Shack 44	Radio Amateur Callbook 74
Radio & Electronics Constructor 73	Radio World 51
Ross Distributing Company 46	S-F Amateur Radio Services 63
SAROC 64	Shure Brothers, Inc. 67
Shure Electronics 1	Telrex Laboratories 70
Ten-Tec Cover II	Thomas Communications 59
Tri-Ex Tower Corp. 47	Trionyx Industries 79
Triplastics, Inc. 51	Webster Associates 66
Western Electronics 50	Wilson Electronics 10
Wilson Systems, Inc. 55, 56, 57, 58	

Foreign Subscription Agents for Ham Radio HORIZONS

Ham Radio Austria
F. Basi
Hauptplatz 5
A-2700 Wiener Neustadt
Austria

Ham Radio Holland
MRL Electronics
Postbus 88
NL-2204 Delft
Holland

Ham Radio Belgium
Stereohouse
Stusselsteeweg 416
B-9218 Gent
Belgium

Ham Radio Italy
STE, Via Maniago 15
I-20134 Milano
Italy

Ham Radio Canada
Box 444
Ontario, Canada N7A 4C7

Ham Radio Switzerland
Karin Ueber
Postfach 2454
D-7850 Loerrach
West Germany

Ham Radio Europe
Box 444
S-194 04 Upplands Vasby
Sweden

Ham Radio France
Christiane Michel
F-89117 Parly
France

Ham Radio UK
P.O. Box 63, Harrow
Middlesex HA3 6HS
England

Ham Radio Germany
Karin Ueber
Postfach 2454
D-7850 Loerrach
West Germany

Holland Radio
143 Greenway
Greenside, Johannesburg
Republic of South Africa

TRIONYX^{IND}

TR-1000 600 MHz FREQUENCY COUNTER

THE BEST VALUE IN FREQUENCY COUNTERS COMES TO YOU FROM TRIONYX INDUSTRIES . . .

THE NEW TRIONYX TR-1000 HAS BEEN DESIGNED TO SUCH STANDARDS THAT ONLY MODERN DAY TECHNOLOGY CAN GIVE YOU WITH FEATURES YOU'D EXPECT ONLY FROM FREQUENCY COUNTERS COSTING MANY TIMES MORE. THE TR-1000 FEATURES AN ATTRACTIVE HEAVY BLACK ANODIZED ALUMINUM CABINET. LARGE .4" LED DIGIT DISPLAYS, SELECTABLE GATE TIMES WITH GATE INDICATORS, DIRECT AND PRESCALED INPUTS FROM 10 Hz to 600 MHz, 50 OHM AND 1 MEG OHM INPUTS BOTH WITH AMPLIFIED SUPER SENSITIVE DIODE PROTECTED CIRCUITRY, AUTOMATIC DECIMAL POINT, FULLY SOCKETED IC'S, PORTABLE POWER PACK (4 AA NICAIDS), AND RAPID AND TRICKLE CHARGING CIRCUITRY.



SPECIFICATIONS

FREQUENCY RANGES: Direct • 10 Hz to 60 MHz
Prescaled • 10 MHz to 600 MHz

SENSITIVITY: <15 mv at 30 MHz typical
25 mv at 150 MHz typical
<50 mv at 450 MHz typical

TEMP. STABILITY: .09 PPM/C° (± 1 PPM
20° to 40° typ.)

GATE TIMES: Selectable — 1.0 second
0.1 second

RESOLUTION: 1 Hz - 10 Hz to 20 MHz
10 Hz - 10 MHz to 60 MHz
100 Hz - 10 MHz to 600 MHz (Prescaled)

INPUT IMPEDANCE: 60 MHz - 1 Meg shunted by 20 pf
600 MHz - 50 ohm

INPUT PROTECTION: Direct input —
100 V up to 10 MHz
50 V up to 60 MHz
Prescaled input —
2 V max.

DECIMAL POINT: Automatic placement

POWER REQUIREMENTS: 9 to 15 V AC or DC 300 ma.

BATTERIES: 4 each AA Ni-Cad.
SIZE: 3 3/4" H x 5" W x 5 1/2" D.
WEIGHT: 1 Lb. 9 Oz. with batteries.

Look to TRIONYX Industries
for your best value in
Frequency Counters.

ORDER YOURS TODAY

Master Charge, VISA, Check,
Phone Orders Accepted

TRIONYX INDUSTRIES

4994 Olympia Drive

INDIANAPOLIS, IND. 46208

317-297-2717

Completely Assembled
with a
1-Year Warranty

PACKAGE INCLUDES:

TR-1000 freqcy. counter
telescoping antenna
AC power pack
4-AA nicad battery pack

ALL FOR **\$159.95**

FOB Indianapolis, Ind.
Indiana residents add 4% tax

NEW FROM DSI!

50 Hz — 500 MHz 8 DIGITS
1 Meg INPUT — 1 Hz RESOLUTION — 1 PPM TCXO



- AC—DC Operation
- BNC Inputs 1 Meg Direct 50 Ohms Prescaled
- 8 Large .4" LED Readouts
- Auto Decimal Point & Zero Blanking
- 1 Year Limited Warranty Parts & Labor
- 100% Factory Assembled in U.S.A.

\$149⁹⁵

MODEL 500 HH
50 Hz — 500 MHz
Without Battery Capability

MODEL 100 HH
50 Hz — 100 MHz

\$99⁹⁵

Without Battery Capability

SAVE \$5⁰⁰

With Battery Capability

MODEL 500 HH ... \$169.95

MODEL 100 HH ... \$119.95

Includes AC-9 Battery Eliminator

The 100 HH and 500 HH hand held frequency counters represent a significant new advancement, utilizing the latest LSI design ... and because it's a DSI innovation, you know it obsoletes any competitive makes, both in price and performance. No longer do you have to sacrifice accuracy, ultra small readouts and poor resolution to get a calculator size instrument. Both the 100 HH and 500 HH have eight .4 inch LED digits — 1 Hz resolution — direct in only 1 sec. or 10 Hz in .1 sec. — 1 PPM TCXO time base. These counters are perfect for all applications be it mobile, hilltop, marine or bench work. **CALL TODAY TOLL FREE: (800—854-2049) Cal. Res. CALL (800—542-6253) TO ORDER OR RECEIVE MORE INFORMATION ON DSI'S FULL PRODUCT LINE OF FREQUENCY COUNTERS RANGING FROM 10 Hz TO 1.3 GHz.**

FREQUENCY COUNTER CONSUMER DATA COMPARISON CHART

MANUFACTURER	MODEL	SUG'STD. LIST PRICE	FREQUENCY RANGE	TYPE OF TIME BASE	ACCURACY OVER TEMPERATURE		SENSITIVITY			DIGITS		PRE-SCALE INPUT RESOLUTION	
					17° - 40°C	0° - 40°C	100 Hz - 25 MHz	50 MHz - 250 MHz	250 MHz - 450 MHz	No.	SIZE IN INCHES	.1 SEC	1 SEC
DSI INSTRUMENTS	100 HH	\$ 99.95	50Hz-100MHz	TCXO	1 PPM	2 PPM	25 MV	NA	NA	8	.4	100 Hz	10 Hz
DSI INSTRUMENTS	500 HH	\$149.95	50Hz-550MHz	TCXO	1 PPM	2 PPM	25 MV	20 MV	30 MV	8	.4	100 Hz	10 Hz
CSC†	MAX-550	\$149.95	1kHz-550MHz	Non-Compensated	3 PPM @ 25°C	8 PPM	500 MV*	250 MV	250 MV	6	.1	NA	1 kHz
OPTOELECTRONICS	OPT-7000	\$139.95	10Hz-600MHz	TCXO	1.8 PPM	3.2 PPM	NS	NS	NS	7	.4	1 kHz	100 Hz

* 1 kHz - 50 MHz † Continental Specialties Corp.

The specifications and prices included in the above chart are as published in manufacturer's literature and advertisements appearing in early 1979. DSI INSTRUMENTS only assumes responsibility for their own specifications.

100 HH... \$ 99.95 W/Battery Pack... \$119.95
500 HH... \$149.95 W/Battery Pack... \$169.95

Prices and/or specifications subject to change without notice or obligation.

These prices include factory installed rechargeable NiCad battery packs.



DSI INSTRUMENTS, INC.
7924 Ronson Road, Dept. G
San Diego, California 92111

T-500 Ant. \$ 7.95
AC-9 Battery Eliminator \$ 7.95

TERMS: MC - VISA - AE - Check - M.O. - COD in U.S. Funds. Please add 10% to a maximum of \$10.00 for shipping, handling and insurance. Orders outside of USA & Canada, please add \$20.00 addition to cover air shipment. California residents add 6% Sales Tax.

TR-7600

TR-7625



RM-76



TS-700SP

**Compact in size...
big on performance!**

TR-7625

Featuring 25 watts RF output (switchable to 5 watts low power), the TR-7625 is a high-performance 2-meter FM transceiver with memory, and is designed to permit multi-channel (800-channel) operation. Compact and perfect for mobile or ham shack use. When used with optional RM-76 Microprocessor Control Unit, the TR-7625 offers a whole new dimension in channel memory and scanning capability.

TR-7600

Looks the same as the TR-7625, but offers 10 watts RF output (switchable to 1 watt low power). Also uses RM-76 Microprocessor Control Unit. For the Amateur Operator who's looking for optimum versatility in a 2-meter FM transceiver!

RM-76

Combined with either the TR-7600 or TR-7625, this optional Microprocessor Control Unit allows the operator to store frequencies in six memories (simplex/repeater); scan all memory channels; automatically scan up the band in 5-kHz steps; manually scan up or down in 5-kHz single or fast continuous steps; set lower and upper scan limits; clear scan (for transmitting); stop scan (with HOLD button); scan for busy or open channel; select repeater mode (simplex, transmit frequency offset (± 600 kHz or ± 1 MHz), or one memory transmit frequency. Operates on 143.95 MHz simplex (MARS). Display indicates frequency (even while scanning) and functions (such as autoscans, lower scan frequency limit, upper scan limit, and error, i.e., transmitting out of band).

TS-700SP

Here's an outstanding 2-meter all-mode transceiver that provides an extra dimension of versatility over the entire 2-meter band. Feature-packed and equipped for SSB, FM, CW and AM. Complete with built-in digital frequency readout, receiver preamplifier, VOX, sidetone, and microphone.

SPECIFICATIONS	Models TR-7600/TR-7625*	Model TS-700SP	Model TR-8300
Frequency Range:	144.00 to 147.995 MHz	144.0 to 148.0 MHz	TX: 445.0 to 450.0 MHz RX: 442.0 to 447.0 MHz
Mode:	FM	SSB (USB, LSB), CW, AM, FM	FM
Dimensions:	161mm (6-5/16") wide 61mm (2-3/8") high 230mm (9-1/16") deep	276mm (10-7/8") wide 124mm (4-7/8") high 320mm (12-5/8") deep	180mm (7-1/16") wide 60mm (2-3/8") high 240mm (9-7/16") deep
Weight:	1.75kg (3.85 lbs) Approx.	11.0kg (24.2 lbs)	2.3kg (5.1 lbs)
RF Output Power:	High: 10(25) watts (min.) Low: 1(5) watt approx. (adjustable to 10 watts)	SSB, FM, CW—10 watts AM—3 watts FM (Low)—Approx. 1 watt	High: 10 watts Low: 1 watt Approx.
Modulation:	Variable reactance direct shift	SSB: Balanced modulation FM: Variable reactance frequency shift AM: Low power modulation	Variable reactance phase shift
Microphone:	Dynamic microphone with PTT switch, 500 Ω	Low-impedance microphone (500 Ω)	Low-impedance microphone (500 Ω) with PTT switch
Sensitivity:	Less than 0.4 μ V for 20 dB quieting	Less than 0.4 μ V for 20 dB quieting SSB & CW: 0.25 μ V for 10 dB (S+N)/N AM: 1.0 μ V for 10 dB (S+N)/N	1 μ V for 30 dB (S+N)/N 0.5 μ V for 20 dB noise quieting
Squelch Sensitivity:	Less than 0.25 μ V	0.25 μ V	0.3 μ V
Selectivity:	More than 76 dB at 30 kHz of adjacent channel	SSB, CW & AM: 2.4 kHz/-6 dB, 4.8 kHz/-80 dB FM: 12 kHz/-6 dB, 24 kHz/-60 dB	20 kHz/-6 dB 40 kHz/-70 dB
Image Rejection:	More than 70 dB	Better than 70 dB	

ACCESSORIES — VFO-700 remote VFO; SP-70 external speaker; KPS-7 power supply; MC-50 base microphone; MC-30S mobile noise-cancelling microphone, and MC-45 Touch-Tone microphone.

See your Authorized Kenwood Dealer for more details.



TR-8300

Designed for use in the 70-cm amateur band. Unique design of the TR-8300 makes it a great choice for mobile or fixed-station use. This FM transceiver is capable of F3 emission on 23 crystal-controlled channels (three supplied). Transmitter output is 10 watts.



KENWOOD
...pacesetter in amateur radio

TRIO-KENWOOD COMMUNICATIONS INC.
1111 WEST WALNUT COMPTON, CA 90220

Heathkit® service is at the other end.



(616) 982-3296

WA8ZVO

Heathkit Service Techs know their stuff and you can count on them for answers on any Heathkit HAM gear. Most problems can be solved right over the phone. Those that require hands-on service can be brought to one of the 55 Heathkit Electronic Centers throughout the U.S. or sent in to the Heathkit factory. Either way, you'll find reliable, experienced people who know what they're doing. And that's a very good reason to con-

sider Heathkit when you considering amateur radio gear.

free catalog

For all the newest in Heathkit Amateur Radio, send for the latest, free Heathkit Catalog. It's loaded with nearly 400 exciting kits for your home, work or pleasure. Send for yours today or pick one up at your Heathkit Electronic Center.

Heathkit®

Heath Company, Dept. 348-580, Benton Harbor, MI 49022

Heathkit Products are also sold at Heathkit Electronic Centers
(Units of Schlumberger Products Corp.) in major cities throughout the U.S.
See your white pages.

HEATH

Schlumberger